

# Operation & Maintenance Manual

Dump Truck

**930E-4**

Serial Numbers

A31693 & UP

**⚠ WARNING**

Unsafe use of this machine may cause serious injury or death. Operators and maintenance personnel must read this manual before operating or maintaining this machine. This manual should be kept near the machine for reference and periodically reviewed by all personnel who will come into contact with it.

**NOTICE**

Komatsu has Operation & Maintenance Manuals written in some other languages. If a foreign language manual is necessary, contact your local distributor for availability.

**KOMATSU**



---

INTRODUCTION	
FOREWORD .....	1-2
ABOUT THIS MANUAL .....	1-3
WARNINGS.....	1-4
CALIFORNIA PROPOSITION 65 WARNINGS.....	1-4
ALERTS .....	1-5
TRUCK MODEL ILLUSTRATION .....	1-6
NON-OEM PARTS IN CRITICAL SYSTEMS.....	1-7
STANDARD CHARTS AND TABLES	
GENERAL INFORMATION.....	2-2
EFFECT OF SPECIAL LUBRICANTS .....	2-2
SUGGESTED SOURCES FOR RUST PREVENTIVE GREASE .....	2-2
STANDARD TIGHTENING TORQUES.....	2-3
CLASS 10.9 CAP SCREWS & CLASS 10 NUTS .....	2-3
SAE GRADE 5 AND GRADE 8 CAP SCREWS .....	2-4
SAE GRADE 9 CAP SCREWS .....	2-5
T-BOLT CLAMPS .....	2-5
SPLIT FLANGE CLAMPS .....	2-6
FLARED TUBE AND HOSE FITTINGS .....	2-6
JIC 37° SWIVEL NUTS .....	2-7
PIPE THREAD FITTINGS .....	2-8
O-RING BOSS FITTINGS .....	2-9
O-RING FACE SEAL FITTINGS .....	2-10
CONVERSION MULTIPLIERS.....	2-11
METRIC TO ENGLISH.....	2-11
ENGLISH TO METRIC.....	2-12
TEMPERATURE CONVERSIONS .....	2-13
GENERAL SAFETY	
GENERAL SAFETY .....	3-2
Safety Rules.....	3-2
Truck Safety Features.....	3-2
Clothing And Personal Items .....	3-2
Unauthorized Modification .....	3-2
Leaving The Operator's Seat.....	3-2
Mounting And Dismounting .....	3-2
Fire Extinguishers And First Aid Kits .....	3-3
Precautions For High Temperature Fluids.....	3-3
Asbestos Dust Hazard Prevention .....	3-3
Fire Prevention .....	3-3
ROPS Precautions.....	3-3
Preventing Injury From Work Equipment .....	3-4
Precautions For Optional Attachments .....	3-4
Precautions When Starting The Machine.....	3-4
PRECAUTIONS FOR TRUCK OPERATION .....	3-5
Safety Is Thinking Ahead .....	3-5
Safety At The Worksite .....	3-5
Preparing For Operation.....	3-5
Ventilation For Enclosed Areas.....	3-5
Mirrors, Windows, And Lights .....	3-5
Before Starting The Engine .....	3-5
Seat Belts .....	3-5
Emergency Egress Ladders .....	3-6
OPERATING THE MACHINE.....	3-7
General Information .....	3-7

---

Starting The Engine .....	3-7
Traveling In The Machine .....	3-7
Traveling In Reverse .....	3-7
Traveling On Slopes .....	3-8
Traveling On Snow .....	3-8
Traveling Near High Voltage Cables .....	3-8
Traveling On Loose Ground .....	3-8
Ensuring Good Visibility .....	3-8
Avoid Damage To The Dump Body .....	3-8
Safe Parking Of The Machine .....	3-8
Loading The Machine .....	3-9
Dumping The Machine .....	3-9
Towing The Machine .....	3-9
EXTERIOR LIGHTING .....	3-10
Fog Lights .....	3-10
Headlights .....	3-10
Brake Light .....	3-10
Retard Light .....	3-10
Clearance/Turn Signal Lights .....	3-10
Backup Lights .....	3-11
Retard Lights .....	3-11
Brake Lights .....	3-11
Backup Alarm .....	3-11
HID Backup Light .....	3-11
PRECAUTIONS FOR MAINTENANCE .....	3-12
BEFORE PERFORMING MAINTENANCE .....	3-12
Securing The Dump Body .....	3-12
DURING MAINTENANCE .....	3-13
Warning Tag .....	3-13
Proper Tools .....	3-13
Attachments .....	3-13
Working Under The Machine .....	3-13
Keeping The Machine Clean .....	3-13
Adding Fuel Or Oil To The Machine .....	3-13
Radiator Coolant Level .....	3-14
Use of Lighting .....	3-14
Handling High Pressure Hoses .....	3-14
Precautions With High Pressure Oil .....	3-14
Maintenance Near High Temperatures and High Pressures .....	3-14
Rotating Fan and Belts .....	3-14
Waste Materials .....	3-14
Use of Tie-Off Anchor During Maintenance .....	3-15
Handling Tires .....	3-15
Tire Maintenance .....	3-15
Storing Tires After Removal .....	3-16
BATTERY HAZARD PREVENTION .....	3-16
Jump Starting With Booster Cables .....	3-17
Jump Starting With Receptacles .....	3-17
WHEN REPAIRS ARE NECESSARY .....	3-18
Observe The Following Precautions .....	3-18
SPECIAL PRECAUTIONS .....	3-19
Preliminary Procedures Before Welding or Performing Maintenance .....	3-19
Engine Shutdown Procedure Before Welding or Performing Maintenance .....	3-19
Before welding on the machine, obey the following guidelines: .....	3-19



Discharging Control Cabinet Capacitors .....	3-20
WARNING AND CAUTIONS	
GENERAL INFORMATION .....	4-2
PIN PLATE .....	4-2
GRADE SPEED CHART .....	4-3
MACHINE SAFETY .....	4-3
KEY SWITCH .....	4-5
OIL FILL AND CHECK .....	4-5
HIGH PRESSURES .....	4-6
BATTERY AND ISOLATION BOX .....	4-9
HIGH VOLTAGE .....	4-11
WELDING .....	4-13
LIFTING POINTS .....	4-14
EMERGENCY DUMPING .....	4-15
AUTOMATIC LUBRICATION FILL .....	4-15
ROPS/FOPS .....	4-16
TOWING .....	4-16
LUBRICATION CHART .....	4-16
OPERATING INSTRUCTIONS	
PREPARING FOR OPERATION .....	5-2
Safety Is Thinking Ahead .....	5-2
Walk Around Inspection .....	5-2
RETRACTABLE LADDER SYSTEM (If Equipped) .....	5-6
GENERAL INFORMATION .....	5-6
LADDER SYSTEM DESCRIPTION .....	5-6
LADDER SYSTEM OPERATION .....	5-6
In-Cab Control Panel .....	5-7
Ground Level Control Box .....	5-9
Emergency Down Valve .....	5-10
PRE-SHIFT BRAKE TEST .....	5-11
OPERATION .....	5-11
Service Brake Test .....	5-12
Parking Brake Test .....	5-12
Retard System Test .....	5-13
Brake Test Exit Criteria .....	5-13
TRUCK OPERATION .....	5-14
ENGINE START-UP SAFETY .....	5-14
After Engine Has Started .....	5-14
MACHINE OPERATION SAFETY PRECAUTIONS .....	5-15
Machine Operation on the Haul Road .....	5-15
Starting on a Grade With a Loaded Truck .....	5-16
Retarding on a Grade .....	5-16
Passing .....	5-17
Loading .....	5-17
Overload Speed Limit Function .....	5-18
Dumping .....	5-18
Lowering the Dump Body (When Dumping on Flat Ground) .....	5-19
Lowering the Dump Body (When Dumping Over a Berm Or Into a Crusher) .....	5-19
SUDDEN LOSS OF ENGINE POWER .....	5-20
EMERGENCY STEERING SYSTEM .....	5-20
Operation .....	5-20
Pre-Operation Testing .....	5-21
Additional Guidelines .....	5-21
FUEL DEPLETION .....	5-21

SAFE PARKING PROCEDURES .....	5-22
NORMAL ENGINE SHUTDOWN PROCEDURE .....	5-22
DISABLED TRUCK CONNECTORS .....	5-23
GENERAL INFORMATION .....	5-23
HOIST SYSTEM .....	5-23
Hookup .....	5-23
Dumping Procedure .....	5-23
TOWING .....	5-25
SPECIAL WIRING HARNESS .....	5-25
TOWING PROCEDURE .....	5-25
PAYLOAD METER III SYSTEM .....	5-27
GENERAL INFORMATION .....	5-27
Data Summary .....	5-27
Data Gathering .....	5-27
COMPONENT DESCRIPTION .....	5-27
Operator Display .....	5-27
Operator Switches .....	5-27
Brake Lock Switch .....	5-27
Payload Meter Module .....	5-28
Communications Ports .....	5-28
Load Lights .....	5-28
OPERATOR'S DISPLAY AND SWITCH .....	5-28
Reading the Load Display .....	5-28
Setting the Operator ID .....	5-28
Load and Ton Counter .....	5-29
Viewing Live Sensor Data .....	5-29
Other Display Messages .....	5-29
HAUL CYCLE WARNING FLAGS .....	5-29
Haul Cycle Data .....	5-29
Haul Cycle Warning Flags .....	5-31
PC SOFTWARE OVERVIEW .....	5-32
SYSTEM CONFIGURATION .....	5-33
Connecting to the Payload Meter .....	5-33
Displayed Payload Units .....	5-33
Connection Menu .....	5-34
Configure the Payload Meter .....	5-34
Setting the Date and Time .....	5-34
Setting the Truck Type and Serial Number .....	5-35
Setting the Gauge Display Units .....	5-35
Setting the Carryback Alarm Threshold .....	5-35
Setting the Truck Number .....	5-35
Setting the Komatsu Distributor .....	5-36
Setting the Komatsu Customer .....	5-36
Clean Truck Tare Calibration .....	5-36
Inclinometer Calibration .....	5-37
DOWNLOADING PAYLOAD DATA .....	5-37
UPLOADING DATA .....	5-38
DATA ANALYSIS .....	5-39
Creating a Query .....	5-39
Payload Detail Screen .....	5-39
Creating Reports .....	5-40
Creating Graphs .....	5-40
Exporting Data .....	5-41
Importing Data .....	5-41

Deleting Haul Cycle Records .....	5-41
Viewing Alarms.....	5-42
Deleting Alarm Records .....	5-42
Patent Acknowledgment.....	5-42
AUTOMATIC LUBRICATION SYSTEM.....	5-43
GENERAL INFORMATION .....	5-43
COMPONENT DESCRIPTION.....	5-43
Filter .....	5-44
Hydraulic Motor and Pump.....	5-44
Grease Reservoir .....	5-44
Pressure Reducing Valve.....	5-44
Flow Control Valve.....	5-44
Solenoid Valve.....	5-45
Vent Valve.....	5-45
Interface Module.....	5-45
Pressure Cut Off Switch.....	5-45
Injectors.....	5-46
Grease Pressure Failure Switch .....	5-47
Relief Valve (unloader valve).....	5-47
SYSTEM OPERATION .....	5-47
Filling The Reservoir.....	5-47
Priming The Automatic Lubrication System.....	5-48
PREVENTIVE MAINTENANCE PROCEDURES .....	5-48
Daily Lubrication System Inspection.....	5-48
250 Hour Inspection.....	5-49
1000 Hour Inspection.....	5-49
SYSTEM CHECKOUT.....	5-49
General Checks.....	5-49
Lubrication Cycle Operation .....	5-50
RESERVE ENGINE OIL SYSTEM .....	5-51
Operation.....	5-51
LED Monitor Light.....	5-51
Changing Oil .....	5-51
OPERATOR CAB AND CONTROLS .....	
CAB INTERIOR .....	6-2
STEERING WHEEL AND CONTROLS.....	6-3
Horn Button.....	6-3
Tilt / Telescope Lever .....	6-3
Multi-Function Turn Signal Switch .....	6-3
Turn Signal Operation .....	6-3
High Beam Headlight Operation .....	6-3
Windshield Wiper Operation .....	6-3
PEDALS AND RETARDER LEVER.....	6-4
DYNAMIC RETARDING.....	6-4
RETARDER LEVER.....	6-4
BRAKE/RETARDER PEDAL .....	6-4
ACCELERATOR PEDAL.....	6-4
OVERHEAD PANEL AND DISPLAYS.....	6-5
RADIO SPEAKERS .....	6-5
WARNING ALARM BUZZER.....	6-5
CAB RADIO .....	6-5
AIR CLEANER VACUUM GAUGES .....	6-5
CAMERA MONITOR (OPTIONAL).....	6-5
CENTER CONSOLE .....	6-6

---

DIRECTIONAL CONTROL LEVER .....	6-6
OVERRIDE/FAULT RESET SWITCH .....	6-6
ENGINE STOP SWITCH .....	6-6
WINDOW CONTROL SWITCHES .....	6-7
HOIST CONTROL LEVER .....	6-7
Raising The Dump Body .....	6-7
Lowering The Dump Body .....	6-7
RETARD SPEED CONTROL (RSC) ADJUST DIAL .....	6-7
RETARD SPEED CONTROL (RSC) SWITCH .....	6-8
DATA STORE BUTTON .....	6-8
12V AUXILIARY POWER OUTLETS .....	6-8
FIRE SUPPRESSION CONTROL OUTLET .....	6-8
COMMUNICATION RADIO OUTLET .....	6-8
DIAGNOSTIC PORTS .....	6-9
KOMTRAX Plus .....	6-9
INTERFACE MODULE (IM) .....	6-9
PAYLOAD METER .....	6-9
DRIVE SYSTEM OR MODULAR MINING .....	6-9
DRIVE SYSTEM CONTROLLER (DSC) .....	6-9
ENGINE (CENSE) .....	6-9
ENGINE (QUANTUM) .....	6-9
OPERATOR SEAT (Standard) .....	6-10
SEAT BELTS .....	6-10
ADJUSTMENT .....	6-10
PASSENGER SEAT (Standard) .....	6-12
SEAT BELTS .....	6-12
ADJUSTMENT .....	6-12
OPERATOR SEAT (Optional) .....	6-13
SEAT BELTS .....	6-13
ADJUSTMENT .....	6-13
PASSENGER SEAT (Optional) .....	6-14
SEAT BELTS .....	6-14
ADJUSTMENT .....	6-14
HEATER / AIR CONDITIONER CONTROLS .....	6-15
Fan Speed Control Knob .....	6-15
Temperature Control Knob .....	6-15
Air Flow Directional Knob .....	6-15
Heater/Air Conditioner Vents .....	6-15
INSTRUMENT PANEL .....	6-16
CONTROL SYMBOLS .....	6-16
Cab/Air Conditioner Vents .....	6-17
Status Indicator Light Panel .....	6-17
Hydraulic Oil Temperature Gauge .....	6-17
Coolant Temperature Gauge .....	6-17
Speedometer/Digital Display .....	6-17
Fuel Level Gauge .....	6-17
Drive System Temperature Gauge .....	6-17
Hazard Warning Light Switch .....	6-18
Pre-Shift Brake Test Switch .....	6-18
Wheel Brake Lock Control Switch .....	6-18
Rest Switch .....	6-18
Engine Warm Up .....	6-19
Key Switch .....	6-19
Warning Light .....	6-19

Digital Display Contrast Buttons.....	6-19
Turn Signal Indicators .....	6-19
Panel Light Dimmer .....	6-19
Mode Switches .....	6-19
Fog Light Switch.....	6-20
Backup Light Switch .....	6-20
Ladder Light Switch .....	6-20
Headlight/Panel Illumination Light Switch .....	6-20
STATUS INDICATOR LIGHT PANEL.....	6-21
STATUS INDICATOR LIGHT SYMBOLS.....	6-21
Body Up.....	6-21
Parking Brake.....	6-21
Propel System Not Ready .....	6-21
No Propel.....	6-22
Engine Warm Up .....	6-22
Engine Shutdown Delay.....	6-22
Retarding Grid Drier.....	6-22
Wheel Brake Lock .....	6-22
Traction Control.....	6-22
Repair Monitor.....	6-22
Retractable Ladder Down.....	6-22
Snapshot In Progress .....	6-22
Pantograph Energized .....	6-22
Pantograph Up .....	6-23
Service Brake.....	6-23
Dynamic Retarding .....	6-23
No DC Link Voltage .....	6-23
DIGITAL DISPLAY OPERATION .....	6-24
Toggling Through Main Level Screens.....	6-24
Toggling Through Warning Screens .....	6-25
Entering Payload Meter Data.....	6-26
KOMTRAX Plus.....	6-27
KOMTRAX Plus OPERATION .....	6-27
Basic Precautions.....	6-27
Interface Module.....	6-28
DOWNLOADING KOMTRAX Plus DATA .....	6-29
GENERAL INFORMATION.....	6-29
KOMTRAX Plus DOWNLOADING PROCEDURE.....	6-29
Location of Downloaded Files.....	6-30
UPLOADING KOMTRAX Plus DATA .....	6-30
ORBCOMM .....	6-32
KOMATSU WIRELESS BRIDGE (Optional).....	6-32
General Information .....	6-32
Communication Setup.....	6-33
Switching to the KWB_SETUP Network .....	6-33
Setting the Computer Subnet Mask and IP Address.....	6-33
Setting Up the KWB.....	6-34
Adding Encryption .....	6-34
Final Computer Settings.....	6-35
Downloading Data .....	6-35
Resetting the KWB .....	6-35
FUSES AND CIRCUIT BREAKERS .....	6-37
VEHICLE ELECTRICAL CENTER 89 .....	6-37
VEHICLE ELECTRICAL CENTER 90 .....	6-39

VEHICLE ELECTRICAL CENTER 91 .....	6-41
CIRCUIT BREAKERS.....	6-43
LUBRICATION AND SERVICE	
GENERAL INFORMATION.....	7-2
HYDRAULIC SYSTEM SERVICE.....	7-2
Hydraulic Tank.....	7-2
Hydraulic Filters.....	7-3
Hydraulic Pump Drive Shaft.....	7-3
WHEEL MOTOR SERVICE.....	7-3
COOLANT LEVEL SERVICE .....	7-3
Radiator Filling Procedure .....	7-4
Coolant Specifications.....	7-4
Unacceptable Practices .....	7-4
RESERVE ENGINE OIL SERVICE.....	7-4
Reserve Oil Tank Filling Procedure (Remote Fill) .....	7-5
Inline Screen .....	7-5
CAB AIR FILTER SERVICE .....	7-5
FUEL SYSTEM SERVICE.....	7-6
Fuel Tank Cleaning .....	7-6
Fuel Filter Service.....	7-6
INTAKE AIR CLEANER SERVICE.....	7-7
QUICK FILL SERVICE CENTER.....	7-8
TIE ROD INSPECTION AND TORQUE PROCEDURE .....	7-8
LUBRICATION CHART .....	7-9
EVERY 10 HOUR (DAILY) MAINTENANCE .....	7-10
INITIAL 50 HOUR LUBRICATION AND MAINTENANCE INSPECTION.....	7-12
INITIAL 100 HOUR LUBRICATION AND MAINTENANCE INSPECTION.....	7-13
EVERY 250 HOUR LUBRICATION AND MAINTENANCE .....	7-14
EVERY 500 HOUR LUBRICATION AND MAINTENANCE .....	7-16
EVERY 1000 HOURS LUBRICATION AND MAINTENANCE .....	7-18
EVERY 5000 HOUR MAINTENANCE .....	7-19
SPECIFICATIONS	
MAJOR COMPONENT DESCRIPTION .....	8-2
Truck and Engine .....	8-2
Traction Alternator .....	8-2
Main Control Cabinet.....	8-2
AC Induction Traction Motorized Wheels.....	8-2
Suspension.....	8-2
Operator's Cab.....	8-2
Power Steering .....	8-2
Dynamic Retarding Grid.....	8-2
Brake System .....	8-2
SPECIFICATIONS .....	8-3
Engine.....	8-3
AC Electric Drive System .....	8-3
Dynamic Retarding.....	8-3
Battery Electric System.....	8-3
Service Capacities.....	8-3
Hydraulic Systems.....	8-3
Service Brakes.....	8-4
Steering.....	8-4
Standard Dump Body Capacities and Dimensions .....	8-4
Tires .....	8-4
Weight Distribution .....	8-4

---

Overall Truck Dimensions .....	8-4
RADIO	
RADIO OPERATION .....	9-2
GENERAL RADIO RECEIVER FUNCTIONS .....	9-2
Turning On the Power .....	9-2
One-Hour Timer .....	9-2
Finding a Station .....	9-2
Setting the Presets .....	9-3
Adjusting the Receiver Audio Settings .....	9-3
Display .....	9-4
Adjusting the Receiver Menu Settings .....	9-4
Front Auxiliary Mode .....	9-4
Rear Auxiliary Mode .....	9-4
CLOCK .....	9-5
Clock/Alarm Button .....	9-5
Setting the Clock .....	9-5
Setting the Alarm .....	9-5
Turning the Alarm Off .....	9-6
Activating Snooze .....	9-6
CD PLAYER .....	9-7
Playing a Compact Disc .....	9-7
Playing an MP3 DISC .....	9-7
CD Mode Displays .....	9-7
Button Functions .....	9-7
MP3 PLAYER .....	9-9
Playing MP3 Files .....	9-9
MP3 Mode Displays .....	9-9
Button Functions .....	9-9
iPod® .....	9-11
Playing an iPod® .....	9-11
iPod® Mode Displays .....	9-11
Button Functions .....	9-11
WEATHERBAND (USA Only) .....	9-13
TROUBLESHOOTING .....	9-14
Tips About the Audio System .....	9-14
Understanding Radio Reception .....	9-14
Care of the Compact Discs .....	9-14





# INTRODUCTION

**FOREWORD** F.1-0000051238

This manual is written for use by the operator and/or the service technician and is designed to help these persons become fully knowledgeable of the truck and all its systems in order to keep it operating safely and efficiently.

All operators and maintenance personnel must read and understand the materials in this manual before operating the truck or performing maintenance and/or operational checks on the truck. All safety notices, warnings and cautions are to be understood and followed when operating or accomplishing repairs on the truck.

The illustrations used in this manual are typical of the component shown and may not be an exact reproduction of what is found on the truck.

A product identification plate is located on the frame in front of the right side front wheel and designates the truck model number, product identification number (vehicle serial number), and maximum GVW (Gross Vehicle Weight) rating.

The KOMATSU truck model designation consists of three numbers and one letter (i.e. 830E).

The three numbers represent the basic truck model.

The letter "M", when present, designates a Mechanical drive system;

The letter "E", when present, designates an Electrical wheel motor drive system.

The product identification number (vehicle serial number) contains information which will identify the original manufacturing bill of material for this unit. This complete number will be necessary for proper ordering of many service parts and/or warranty consideration.

The GVW is what determines the load on the drive train, frame, tires, and other components. The vehicle design and application guidelines are sensitive to the total maximum GVW. GVW is TOTAL WEIGHT: the Empty Vehicle Weight + the fuel & lubricants + the payload.

To determine allowable payload: Service all lubricants for proper level and fill fuel tank of empty truck (which includes all accessories, body liners, tailgates, etc.) and then weigh truck. Record this value and subtract from the GVW rating. The result is the allowable payload.

**NOTE:** *Accumulations of mud, frozen material, etc. become a part of the GVW and reduces allowable payload. To maximize payload and to keep from exceeding the GVW rating, these accumulations should be removed as often as practical.*

Exceeding the allowable payload will reduce expected life of truck components.

 **DANGER**

- **Unsafe use of this machine may cause serious injury or death. Operators and maintenance personnel must read and understand this manual before operating or maintaining this machine.**
- **This manual should be kept in or near the machine for reference, and periodically reviewed by all personnel who will come into contact with it.**

**ABOUT THIS MANUAL** D.3-0000051237

This manual is written for use by the operator and/or the service technician. It is designed to help these persons learn how to operate the truck and its systems in order to keep it operating safely and efficiently. All operators and maintenance personnel must read and understand the materials in this manual before operating the truck or performing maintenance and/or operational checks on the truck. All safety notices, warnings, and cautions should be understood and followed when operating or performing repairs on the truck.

The front cover of this manual includes a form number. This form number should be referenced when ordering additional copies of this manual, or for any other correspondence regarding the coverage in this manual.

Direct all inquiries to:  
Komatsu America Corp.  
Peoria Technical Publications  
P.O. Box 240  
Peoria, IL 61650-0240  
United States of America  
Fax (309) 672-7072

If there is ever a question regarding the information in a particular section, refer to the manual form number, and use the address shown above to correspond.

The illustrations used in this manual are typical of the component shown and may not be an *exact* reproduction of what is found on the truck.

This manual shows dimensioning of U.S. standard and metric (SI) units throughout. All references to “right”, “left”, “front”, or “rear” are made with respect to the operator's normal seated position, unless specifically stated otherwise.

When assembly instructions are provided without references to torque values, standard torque values should be assumed. Standard torque requirements are shown in torque charts in the following section and in the General Information section of the truck service manual. Individual torques when provided in the text are in bold face type, such as **135 N·m (100 ft lb)**. All torque specifications have  $\pm 10\%$  tolerance unless otherwise specified.

**WARNINGS** F.2-0000051687

This material is proprietary to Komatsu America Corp (KAC), and is not to be reproduced, used, or disclosed except in accordance with written authorization from KAC.

It is the policy of the company to improve products whenever it is possible and practical to do so. The company reserves the right to make changes or add improvements at any time without incurring any obligation to install such changes on products sold previously.

Because of continuous research and development, periodic revisions may be made to this publication. Customers should contact their local Komatsu distributor for information on the latest revision.

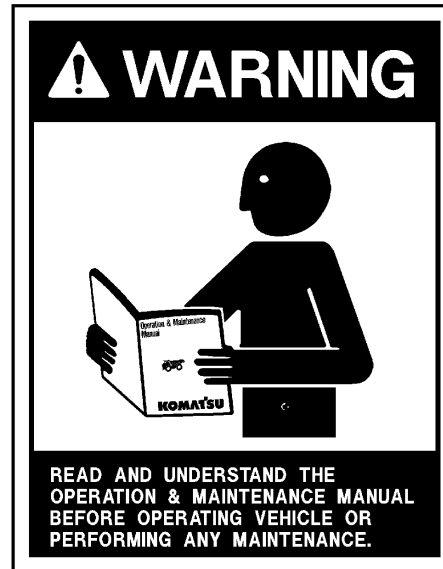
**! DANGER**

- Unsafe use of this machine may cause serious injury or death. Operators and maintenance personnel must read and understand this manual before operating or maintaining this machine.
- This manual should be kept in or near the machine for reference, and periodically reviewed by all personnel who will come into contact with it.

**CALIFORNIA PROPOSITION 65 WARNINGS****! WARNING**

- Diesel engine exhaust, some of its constituents, and certain vehicle components contain or emit chemicals known to the State of California to cause cancer, birth defects or other reproductive harm.

**! WARNING**

- Battery posts, terminals and related accessories contain lead and lead compounds, chemicals known to the State of California to cause cancer, birth defects or other reproductive harm. Wash hands after handling.

**! WARNING**

- Mercury and mercury compounds are known to the State of California to cause developmental problems. This machine may be equipped with optional HID lamps which contain mercury. There is no risk of exposure unless the lamps are broken. However, the lamps must be reused, recycled or properly disposed of in accordance with Local, State and Federal Laws at the end of their useful lives.

**ALERTS** D.2-0000051268

83403

The ALERT symbol is used with the following signal words:

- DANGER
- WARNING
- CAUTION

This symbol is used to alert the reader of hazards that can arise from improper operating and maintenance practices.

**! DANGER**

- **DANGER** identifies a specific potential hazard WHICH WILL RESULT in either INJURY OR DEATH if proper precautions are not taken.

**! WARNING**

- **WARNING** identifies a specific potential hazard WHICH COULD RESULT in either INJURY OR DEATH if proper precautions are not taken.

**! CAUTION**

- **CAUTION** is used for general reminders of proper safety practices OR to direct the reader's attention to avoid unsafe or improper practices which may result in damage to the machine.

**TRUCK MODEL  
ILLUSTRATION** A.2-0000058551

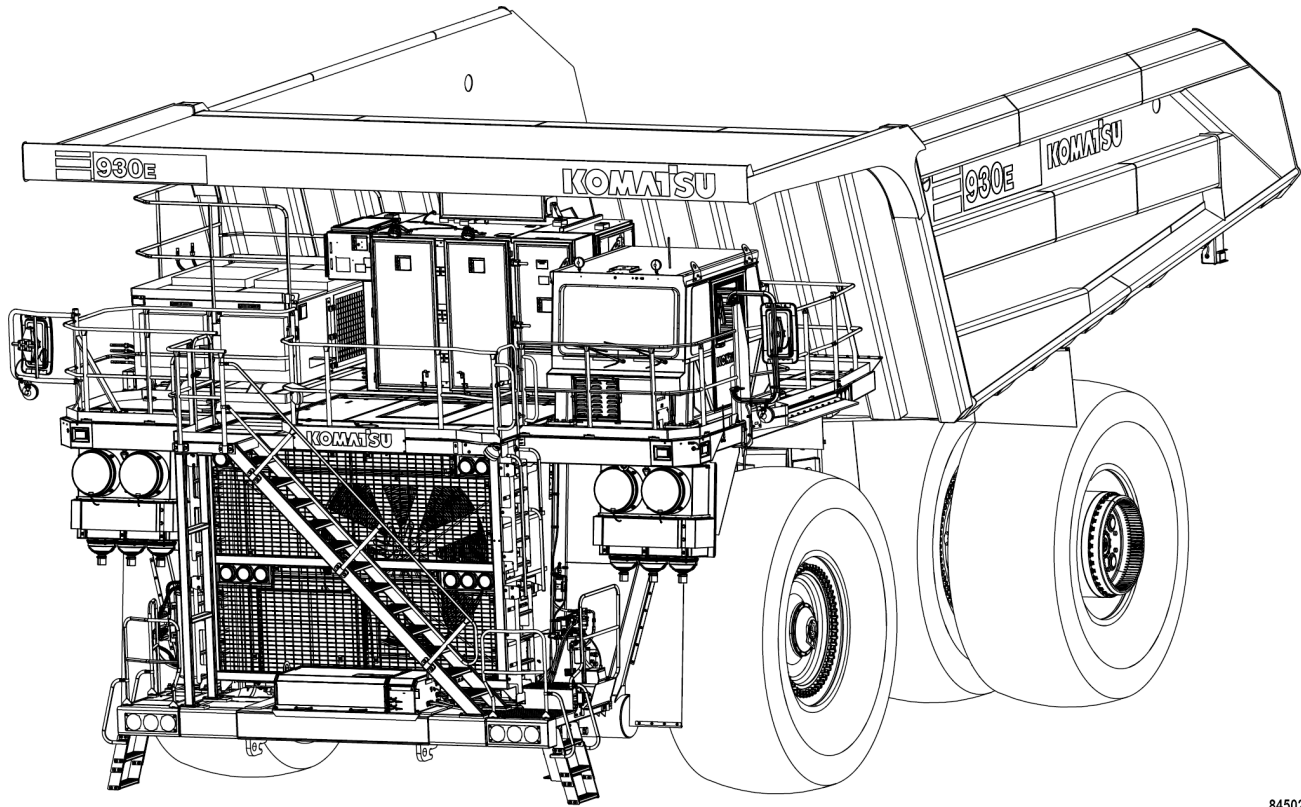

84502

**NON-OEM PARTS IN CRITICAL SYSTEMS** C.3-0000051235

For safety reasons, Komatsu America Corp. strongly recommends against the use of non-OEM replacement parts in critical systems of all Komatsu equipment. Critical systems include but are not limited to steering, braking and operator safety systems

Replacement parts manufactured and supplied by unauthorized sources may not be designed, manufactured or assembled to Komatsu's design specifications; accordingly, use of such parts may compromise the safe operation of Komatsu products and place the operator and others in danger should the part fail.

Komatsu is also aware of repair companies that will rework or modify an OEM part for reuse in critical systems. Komatsu does not generally authorize such repairs or modifications for the same reasons as noted above.

Use of non-OEM parts places full responsibility for the safe performance of the Komatsu product on the supplier and user. Komatsu will not in any case accept responsibility for the failure or performance of non-OEM parts in its products, including any damages or personal injury resulting from such use.





# STANDARD CHARTS AND TABLES



## **WARNING**

**Read and follow all safety precautions. Failure to do so may result in serious injury or death.**

---

This safety section also contains precautions for optional equipment and attachments.

**GENERAL INFORMATION** D.3-0000051234

This manual provides dual dimensioning for many specifications. Metric units are specified first, with U.S. standard units in parentheses. When torque values are not specified in the assembly instructions contained in this manual, use the standard torque value for the hardware being used. Standard value torque tables are contained in this chapter for metric and SAE hardware.

This truck is assembled with both metric and SAE (U.S.) hardware. Reference the correct table when determining the proper torque value.

**⚠ CAUTION**

- **References throughout the manual to standard torques or other standard values will be to one of the following tables. Do not use standard values to replace specific torque values in assembly instructions.**

For values not shown in any of the charts or tables, standard conversion factors for most commonly used measurements are provided in the following tables.

**EFFECT OF SPECIAL LUBRICANTS**

The Komatsu engineering department does not recommend the use of special friction-reducing lubricants, such as Copper Coat, Never-Seez®, and other similar products, on the threads of standard fasteners where standard torque values are applied. The use of special friction-reducing lubricants will significantly alter the clamping force being applied to fasteners during the tightening process.

If special friction-reducing lubricants are used with the standard torque values listed in this chapter, excessive stress and possible breakage of the fasteners may result.

Where the torque tables specify “Lubricated Threads” for the standard torque values listed, these standard torque values are to be used with simple lithium base chassis grease (multi-purpose EP NLGI) or a rust-preventive grease (see below) on the threads and seats unless specified otherwise.

**NOTE:** *Ensure the threads of fasteners and tapped holes are free of burrs and other imperfections before assembling.*

**SUGGESTED SOURCES FOR RUST PREVENTIVE GREASE**

**NOTE:** *This list represents the current engineering approved sources for use in Komatsu manufacture. It is not exclusive. Other products may meet the same specifications of this list.*

- American Anti-Rust Grease #3-X from Standard Oil Company (also American Oil Co.)
- Gulf NoRust #3 from Gulf Oil Company.
- Mobilarma 355, Product No. 66705 from Mobil Oil Corporation.
- Rust Ban 326 from Humble Oil Company.
- Rustolene B Grease from Sinclair Oil Co.
- Rust Preventive Grease - Code 312 from the Southwest Grease and Oil Company.

## STANDARD TIGHTENING TORQUES

F.1-0000051233

### CLASS 10.9 CAP SCREWS & CLASS 10 NUTS

The following specifications apply to required assembly torques for all metric class 10.9 finished hexagon head cap screws and class 10 nuts.

DO NOT lubricate cap screw threads and seats during assembly. These specifications are based on the following hardware:

- All cap screws
- All nuts
- All hardened washers being phosphate and oil coated

**NOTE:** If zinc-plated hardware is used, each piece must be lubricated with simple lithium base chassis grease (multi-purpose EP NLGI) or a rust preventive grease (see list, this page) to achieve the same clamping forces provided below.

**NOTE:** Torques are calculated to give a clamping force of approximately 75% of proof load. The maximum torque tolerance shall be within  $\pm 10\%$  of the torque value shown.

In the following table under "Cap Screw Size", the first number represents the shank diameter (mm). The second number represents thread pitch in millimeters.

Example: M20 x 2.25

M20 = shank diameter (20 mm)

2.25 = thread pitch in millimeters

Table 2-1

Standard Tightening Torque for Metric Class 10.9 Cap screws & Class 10 Nuts			
			
Cap Screw Size	Torque N·m	Torque ft·lb	Torque kg·m
M6 x 1	12	9	1.22
M8 x 1.25	30	22	3.06
M10 x 1.5	55	40	5.61
M12 x 1.75	95	70	9.69
M14 x 2	155	114	15.81
M16 x 2	240	177	24.48
M20 x 2.25	465	343	47.43
M24 x 3	800	590	81.6
M30 x 3.5	1600	1180	163.2
M36 x 4	2750	2028	280.5

**SAE GRADE 5 AND GRADE 8 CAP SCREWS**

The following specifications apply to required assembly torques for all grade 5 and grade 8 cap screws.

**NOTE:** Cap screw threads and seats shall be lubricated when assembled. Unless instructions specifically recommend otherwise, these standard torque values are to be used with simple lithium base chassis grease (multi-purpose EP NLGI) or a rust-preventive grease (see list, previous page) on the threads.

**NOTE:** Torques are calculated to give a clamping force of approximately 75% of proof load. The maximum torque tolerance shall be within ±10% of the torque value shown.

In the following table under Cap Screw Size, the first number represents the shank diameter (in.). The second number represents threads per inch.

Example: 7/16 - 20

7/16 = shank diameter (7/16 inch (0.438 inch))

20 = threads per inch

Table 2-2

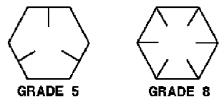
Standard Tightening Torque for SAE Hex Head Cap Screw And Nut Assembly						
						
Cap Screw Size	Torque Grade 5			Torque Grade 8		
	N·m	ft·lb	kg·m	N·m	ft·lb	kg·m
1/4-20	9.5	7	0.97	13.6	10	1.38
1/4-28	10.8	8	1.11	14.9	11	1.52
5/16-18	20.3	15	2.07	28	21	2.90
5/16-24	22	16	2.21	30	22	3.04
3/8-16	34	25	3.46	47	35	4.84
3/8-24	41	30	4.15	54	40	5.5
7/16-14	54	40	5.5	79	58	8.0
7/16-20	61	45	6.2	84	62	8.57
1/2-13	88	65	9	122	90	12.4
1/2-20	95	70	9.7	129	95	13.1
9/16-12	122	90	12.4	169	125	17.3

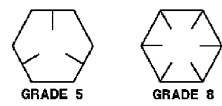
Standard Tightening Torque for SAE Hex Head Cap Screw And Nut Assembly						
						
Cap Screw Size	Torque Grade 5			Torque Grade 8		
	N·m	ft·lb	kg·m	N·m	ft·lb	kg·m
9/16-18	129	95	13.1	183	135	18.7
5/8-11	169	125	17.3	237	175	24.2
5/8-18	183	135	18.7	258	190	26.2
3/4-10	298	220	30.4	420	310	42.8
3/4-16	319	235	32.5	454	335	46.3
7/8-9	475	350	48.4	678	500	69.2
7/8-14	508	375	51.9	719	530	73.3
1.0-8	712	525	72.6	1017	750	103.7
1.0-12	759	560	77.4	1071	790	109.3
1.0-14	773	570	78.8	1085	800	110.6
1 1/8-7	881	650	89.9	1424	1050	145
1 1/8-12	949	700	96.8	1546	1140	158
1 1/4-7	1234	910	125.9	2007	1480	205
1 1/4-12	1322	975	134.8	2142	1580	219
1 3/8-6	1627	1200	166	2630	1940	268
1 3/8-12	1776	1310	181	2874	2120	293
1 1/2-6	2142	1580	219	3471	2560	354
1 1/2-12	2305	1700	235	3756	2770	383

**SAE GRADE 9 CAP SCREWS**

The following specifications apply to required assembly torques for all 12-point, grade 9 (170,000 psi minimum tensile), cap screws.

**NOTE:** Cap screw threads and seats shall be lubricated when assembled. Unless instructions specifically recommend otherwise, these standard torque values are to be used with simple lithium base chassis grease (multi-purpose EP NLGI) or a rust-preventive grease (see list, this page) on the threads.

**NOTE:** Torques are calculated to give a clamping force of approximately 75% of proof load. The maximum torque tolerance shall be within ±10% of the torque value shown.

Table 2-3

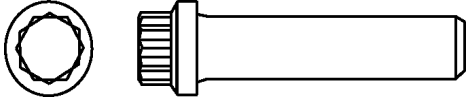
Standard Tightening Torque for 12-Point, Grade 9 Cap Screws			
			
Cap Screw Size <sup>1</sup>	Torque N·m	Torque ft·lb	Torque kg·m
0.250 - 20	16	12	1.7
0.312 - 18	33	24	3.3
0.375 - 16	57	42	5.8
0.438 - 14	95	70	9.7
0.500 - 13	142	105	14.5
0.562 - 12	203	150	20.7
0.625 - 11	278	205	28.3
0.750 - 10	488	360	49.7
0.875 - 9	780	575	79.4
1.000 - 8	1166	860	119
1.000 - 12	1240	915	126
1.125 - 7	1670	1230	170

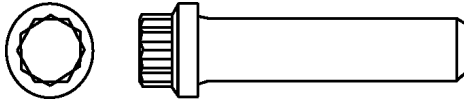
Standard Tightening Torque for 12-Point, Grade 9 Cap Screws			
			
Cap Screw Size <sup>1</sup>	Torque N·m	Torque ft·lb	Torque kg·m
1.125 - 12	1800	1330	184
1.250 - 7	2325	1715	237
1.250 - 12	2495	1840	254
1.375 - 6	3080	2270	313
1.375 - 12	3355	2475	342
1.500 - 6	4040	2980	411
1.500 - 12	4375	3225	445

**T-BOLT CLAMPS**

Table 2-4

Tightening Torque For T-Bolt Type Hose Clamp (SAE J1508 Type TB)			
			
Thread Size	Band Width	Newton meters (N·m)	Inch Pounds (in·lb)
0.25-28 UNF	19.05 mm (0.75 in.)	8.5 ± 0.6	75 ± 5

1. Shank Diameter (in) — Threads per inch

## SPLIT FLANGE CLAMPS

Table 2-5

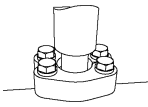
Tightening Torque For Split Flange Clamp Bolts				
				
Cap Screw Thread Diameter (mm)	Width Across Flat (mm)	Newton meters (N·m) ± 10%	Foot Pounds (ft·lb) ± 10%	Kilogram meters (kg·m) ± 10%
10	14	66	48	6.7
12	17	112	83	11.5
16	22	279	206	28.5

## FLARED TUBE AND HOSE FITTINGS

Table 2-6

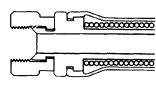
Tightening Torque For Flared Tube And Hose Fittings				
				
Thread Diameter of Nut (mm)	Width Across Flat (mm)	Newton meters (N·m) ± 10%	Foot Pounds (ft·lb) ± 10%	Kilogram meters (kg·m) ± 10%
14	19	25	18	2.5
18	24	50	36	5
22	27	80	58	8
24	32	140	101	14
30	36	175	130	18
33	41	195	145	20
36	46	245	180	25
42	55	295	215	30

## JIC 37° SWIVEL NUTS

Table 2-7

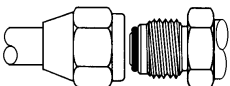
Torque Chart For JIC 37° Swivel Nuts With Or Without O-ring Seals				
				
Size Code	Tube Size (OD)	Threads UNF-2B	Newton meters (N·m)	Foot Pounds (ft·lb)
- 2	0.125	0.312 - 24	5 ± 1	4 ± 1
- 3	0.188	0.375 - 24	11 ± 4	8 ± 3
- 4	0.250	0.438 - 20	16 ± 4	12 ± 3
- 5	0.312	0.500 - 20	20 ± 4	15 ± 3
- 6	0.375	0.562 - 18	24 ± 7	18 ± 5
- 8	0.500	0.750 - 16	40 ± 7	30 ± 5
- 10	0.625	0.875 - 14	54 ± 7	40 ± 5
- 12	0.750	1.062 - 12	75 ± 7	55 ± 5
- 14	0.875	1.188 - 12	88 ± 7	65 ± 5
- 16	1.000	1.312 - 12	108 ± 7	80 ± 5
- 20	1.250	1.625 - 12	136 ± 14	100 ± 10
- 24	1.500	1.875 - 12	163 ± 14	120 ± 10
- 32	2.000	2.500 - 12	312 ± 27	230 ± 20

## PIPE THREAD FITTINGS

Table 2-8

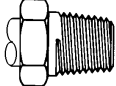
Torque Chart For Pipe Thread Fittings					
					
Size Code	Pipe Thread Size	With Sealant N·m	With Sealant ft·lb	Without Sealant N·m	Without Sealant ft·lb
- 2	0.125 - 27	20 ± 4	15 ± 3	27 ± 7	20 ± 5
- 4	0.250 - 18	27 ± 7	20 ± 5	34 ± 7	25 ± 5
- 6	0.375 - 18	34 ± 7	25 ± 5	48 ± 7	35 ± 5
- 8	0.500 - 14	48 ± 7	35 ± 5	61 ± 7	45 ± 5
- 12	0.750 - 14	61 ± 7	45 ± 5	75 ± 7	55 ± 5
- 16	1.000 - 11.50	75 ± 7	55 ± 5	88 ± 7	65 ± 5
- 20	1.250 - 11.50	95 ± 7	70 ± 5	108 ± 7	80 ± 5
- 24	1.500 - 11.50	108 ± 7	80 ± 5	129 ± 14	95 ± 10
- 32	2.000 - 11.50	129 ± 14	95 ± 10	163 ± 14	120 ± 10



## O-RING BOSS FITTINGS

Table 2-9

Torque Chart For O-ring Boss Fittings				
				
Size Code	Tube Size (OD)	Threads UNF-2B	Newton meters (N·m)	Foot Pounds (ft·lb)
- 2	0.125	0.312 - 24	4 ± 3	4 ± 2
- 3	0.188	0.375 - 24	7 ± 3	5 ± 2
- 4	0.250	0.438 - 20	11 ± 4	8 ± 3
- 5	0.312	0.500 - 20	14 ± 4	10 ± 3
- 6	0.375	0.562 - 18	18 ± 4	13 ± 3
- 8	0.500	0.750 - 16	33 ± 7	24 ± 5
- 10	0.625	0.875 - 14	43 ± 7	32 ± 5
- 12	0.750	1.062 - 12	65 ± 7	48 ± 5
- 14	0.875	1.188 - 12	73 ± 7	54 ± 5
- 16	1.000	1.312 - 12	98 ± 7	72 ± 5
- 20	1.250	1.625 - 12	109 ± 7	80 ± 5
- 24	1.500	1.875 - 12	109 ± 7	80 ± 5
- 32	2.000	2.500 - 12	130 ± 14	96 ± 10

## O-RING FACE SEAL FITTINGS

Table 2-10

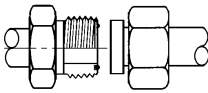
Torque Chart For O-ring Face Seal Fittings				
				
Size Code	Tube Size (O.D.)	Threads UNF-2B	Newton meters (N·m)	Foot Pounds (ft·lb)
- 4	0.250	0.438 - 20	15 ± 1	11 ± 1
- 6	0.375	0.562 - 18	24 ± 3	18 ± 2
- 8	0.500	0.750 - 16	48 ± 5	35 ± 4
- 10	0.625	0.875 - 14	69 ± 7	51 ± 5
- 12	0.750	1.062 - 12	96 ± 10	71 ± 7
- 16	1.000	1.312 - 12	133 ± 8	98 ± 6
- 20	1.250	1.625 - 12	179 ± 10	132 ± 7
- 24	1.500	1.875 - 12	224 ± 20	165 ± 15

## CONVERSION MULTIPLIERS F.3-0000051232

### METRIC TO ENGLISH

Table 2-11

Common Conversion Multipliers Metric To English		
To Convert From	To	Multiply By
millimeter (mm)	inch (in.)	0.0394
centimeter (cm)	inch (in.)	0.3937
meter (m)	foot (ft)	3.2808
meter (m)	yard (yd)	1.0936
kilometer (km)	mile (mi)	0.6210
square centimeters (cm <sup>2</sup> )	square inch (in. <sup>2</sup> )	0.1550
square centimeters (cm <sup>2</sup> )	square feet (ft <sup>2</sup> )	0.001
cubic centimeters (cm <sup>3</sup> )	cubic inch (in. <sup>3</sup> )	0.061
liters (L)	cubic inch (in. <sup>3</sup> )	61.02
cubic meters (m <sup>3</sup> )	cubic feet (ft <sup>3</sup> )	35.314
liters (L)	cubic feet (ft <sup>3</sup> )	0.0353
grams (g)	ounce (oz)	0.0353
milliliter (mL)	fluid ounce (fl oz)	0.0338
kilogram (kg)	pound (mass)	2.2046
Newton (N)	pounds (lb)	0.2248
Newton meters (N·m)	kilogram force meters (kgf·m)	0.102
Newton meters (N·m)	foot pounds (ft lb)	0.7376
kilogram force meters (kgf·m)	foot pounds (ft lb)	7.2329
kilogram force meters (kgf·m)	Newton meters (N·m)	9.807
kilopascals (kPa)	pounds/square inch (psi)	0.1450
megapascals (MPa)	pounds/square inch (psi)	145.038
kilograms/cm <sup>2</sup> (kg/cm <sup>2</sup> )	pounds/square inch (psi)	14.2231
kilograms/cm <sup>2</sup> (kg/cm <sup>2</sup> )	kilopascals (kPa)	98.068
kilogram (kg)	short ton (tn)	0.0011
metric ton	short ton (tn)	1.1023
liters (L)	quart (qt)	1.0567
liters (L)	gallon (gal)	0.2642
Watts (W)	horsepower (hp)	0.00134
kilowatts (kW)	horsepower (hp)	1.3410

## ENGLISH TO METRIC

Table 2-12

<b>Common Conversion Multipliers English to Metric</b>		
<b>To Convert From</b>	<b>To</b>	<b>Multiply By</b>
inch (in.)	millimeter (mm)	25.40
inch (in.)	centimeter (cm)	2.54
foot (ft)	meter (m)	0.3048
yard (yd)	meter (m)	0.914
mile (mi)	kilometer (km)	1.61
square inch (in. <sup>2</sup> )	square centimeters (cm <sup>2</sup> )	6.45
square feet (ft <sup>2</sup> )	square centimeters (cm <sup>2</sup> )	929
cubic inches (in. <sup>3</sup> )	cubic centimeters (cm <sup>3</sup> )	16.39
cubic inches (in. <sup>3</sup> )	liters (L)	0.016
cubic feet (ft <sup>3</sup> )	cubic meters (m <sup>3</sup> )	0.028
cubic feet (ft. <sup>3</sup> )	liters (L)	28.3
ounce (oz)	kilogram (kg)	0.028
fluid ounce (fl oz)	milliliter (ml)	29.573
pound (lb)	kilogram (kg)	0.454
pound (lb)	Newton (N)	4.448
inch pounds (in. lb)	Newton meters (N·m)	0.113
foot pounds (ft lb)	Newton meters (N·m)	1.356
foot pounds (ft lb)	kilogram force meters (kgf·m)	0.138
kilogram meters (kgm)	Newton meters (N·m)	9.807
pounds/square inch (psi)	kilopascals (kPa)	6.895
pounds/square inch (psi)	megapascals (MPa)	0.007
pounds/square inch (psi)	kilograms/square centimeter (kg/cm <sup>2</sup> )	0.0704
short ton (tn)	kilogram (kg)	907.2
short ton (tn)	metric ton (t)	0.0907
quart (qt)	liters (L)	0.946
gallon (gal)	liters (L)	3.785
horsepower (hp)	Watts (w)	745.7
horsepower (hp)	kilowatts (kw)	0.745

## TEMPERATURE CONVERSIONS

Table 2-13

Temperature Conversions								
Formula: $F^{\circ} - 32 \div 1.8 = C^{\circ}$ or $C^{\circ} \times 1.8 + 32 = F^{\circ}$								
Celsius C°		Fahrenheit F°	Celsius C°		Fahrenheit F°	Celsius C°		Fahrenheit F°
121	250 <sup>2</sup>	482	63	145	293	4	40	104
118	245	473	60	140	284	2	35	95
116	240	464	57	135	275	- 1	30	86
113	235	455	54	130	266	- 4	25	77
110	230	446	52	125	257	- 7	20	68
107	225	437	49	120	248	- 9	15	59
104	220	428	46	115	239	- 12	10	50
102	215	419	43	110	230	- 15	5	41
99	210	410	41	105	221	- 18	0	32
96	205	401	38	100	212	- 21	- 5	23
93	200	392	35	95	203	- 23	- 10	14
91	195	383	32	90	194	- 26	- 15	5
88	190	374	29	85	185	- 29	- 20	- 4
85	185	365	27	80	176	- 32	- 25	- 13
82	180	356	24	75	167	- 34	- 30	- 22
79	175	347	21	70	158	- 37	- 35	- 31
77	170	338	18	65	149	- 40	- 40	- 40
74	165	329	15	60	140	- 43	- 45	- 49
71	160	320	13	55	131	- 46	- 50	- 58
68	155	311	10	50	122	- 48	- 55	- 67
66	150	302	7	45	113	- 51	- 60	- 76

2. The numbers in the unmarked columns refer to temperature in either degrees Celsius (C°) or Fahrenheit (F°). Select a number in this unmarked column and read to the left to convert to degrees Celsius (C°) or read to the right to convert to degrees Fahrenheit (F°). If starting with a known temperature (either C° or F°), find that temperature in the marked column and read the converted temperature in the center, unmarked column.



# GENERAL SAFETY

## **WARNING**

**Read and follow all safety precautions. Failure to do so may result in serious injury or death.**

---

This safety section also contains precautions for optional equipment and attachments.

## GENERAL SAFETY E.15-0000051262

### Safety Rules

Safety records of most organizations will show that the greatest percentage of accidents are caused by unsafe acts of persons. The remainder are caused by unsafe mechanical or physical conditions. Report all unsafe conditions to the proper authority.

The following safety rules are provided as a guide for the operator. However, local conditions and regulations may add many more to this list.

### **⚠ WARNING**

- **Read and follow all safety precautions. Failure to do so may result in serious injury or death.**

- Only trained and authorized personnel can operate and maintain the machine.
- Follow all safety rules, precautions and instructions when operating or performing maintenance on the machine.
- When working with another operator or a person on work site traffic duty, ensure all personnel understand all hand signals that are to be used.

### Truck Safety Features

Ensure all guards and covers are in their proper position. Repair any damaged guards and covers. (See [Walk Around Inspection, page 5-2.](#))

Learn the proper use of safety features such as safety locks, safety pins, and seat belts. Always use these safety features properly.

Never remove any safety features. Always keep safety features in good operating condition. Improper use of safety features may result in serious bodily injury or death.

### Clothing And Personal Items

Avoid wearing loose clothing, jewelry, and loose long hair. They can catch on controls or in moving parts and cause serious injury or death. Additionally, never wear oily clothes as they are flammable.

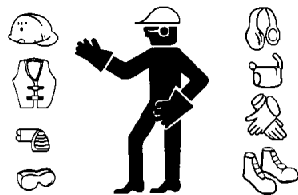

Wear a hard hat, safety glasses, safety shoes, a mask and gloves when operating or maintaining a machine. Always wear the proper safety equipment required for the job. Also, ensure that the work area is clear of other personnel during hazardous jobs.

### Unauthorized Modification

Any modification made to this vehicle without authorization from Komatsu America Corp. can possibly create hazards.

Before making any modification, consult your authorized regional Komatsu America Corp. distributor. Komatsu will not be responsible for any injury or damage caused by any unauthorized modification.

### Leaving The Operator's Seat

**NOTE:** *DO NOT touch any controls while leaving the operators seat.*

To prevent accidental operations from occurring, always perform the following:

- DO NOT apply the wheel brake lock. Move the directional control lever to the PARK position (this will apply the parking brake).
- Lower the dump body, and move the hoist control lever to the FLOAT position.
- Turn the key switch to the OFF position and wait for the engine to stop.
- After the engine has stopped, wait two minutes before exiting the cab. DO NOT leave the cab if any warning messages are illuminated or warning horns are sounding. Notify maintenance personnel immediately.
- When exiting the machine, always lock compartments, and take the keys with you to prevent entry from unauthorized persons.

### Mounting And Dismounting

When mounting and dismounting the machine obey the following guidelines:

- Never jump on or off the machine. Never climb on or off a machine while it is moving.
- When climbing on or off a machine, face the machine and use the hand-hold and steps.
- Never hold any control levers when getting on or off a machine.
- Always maintain three-point contact with the hand-holds and steps to ensure that you support yourself.
- When bringing tools up to the operating deck, always pass them by hand or pull them up by rope.
- If there is any oil, grease, or mud on the hand-holds or steps, wipe them clean immediately. Always keep these components clean. Repair any damage and tighten any loose bolts.



## Fire Extinguishers And First Aid Kits

Ensure fire extinguishers are accessible and proper usage techniques are known. Provide a first aid kit at the storage point.

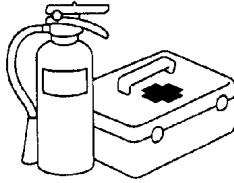

Know what to do in the event of a fire and keep phone numbers of persons you must contact in case of an emergency in the cab.

## Precautions For High Temperature Fluids

Immediately after machine operation, engine coolant, engine oil, and hydraulic oil are hot and pressurized. If the cap is removed or the system is opened in any way, there is danger of serious burns.



Allow heat and pressure to dissipate before performing such tasks and follow proper procedures as outlined in the service manual.

To prevent hot coolant from spraying:

1. Stop the engine, and wait for the coolant temperature to decrease.
2. Depress the pressure relief button on the radiator cap.
3. Turn the radiator cap slowly to allow pressure to dissipate.

To prevent hot engine oil spray:

1. Stop the engine.
2. Wait for the oil temperature to cool down.
3. Turn the cap slowly to allow pressure to dissipate.

## Asbestos Dust Hazard Prevention

Asbestos dust is hazardous to your health when inhaled. If you handle materials containing asbestos fibers, follow the guidelines below:



- Never use compressed air for cleaning.
- Use water for cleaning and to control dust.
- Operate the machine or perform tasks with the wind to your back, whenever possible.

- Use an approved respirator, when necessary.

## Fire Prevention



83548

**NOTE:** DO NOT operate the machine near open flames. Always ensure a fire extinguisher is present and in proper working condition.

Remove any debris from the engine compartment. Check and repair any fuel, lubrication, and hydraulic systems leaks. Clean any excess oil, fuel or other flammable fluids, and dispose of properly.

Keep oil and fuel in a designated location and accessible by authorized personnel only. Fuel, oil, and antifreeze can be ignited by a flame. These fluids are extremely flammable and hazardous.

When handling fuel and oil obey the following guidelines:

- Keep flames away from flammable fluids.
- Stop the engine while refueling.
- Never smoke while refueling
- Tighten all fuel and oil tank caps securely.
- Refuel and maintain oil in well ventilated areas.

## ROPS Precautions

**NOTE:** When modifying or repairing the ROPS, always consult your nearest Komatsu distributor. Even with the ROPS installed, the operator must always use the seat belt when operating the machine.

The ROPS is intended to protect the operator if the machine rolls over. It is designed not only to support the load of the machine, but also to absorb the energy of the impact. ROPS structures installed on equipment manufactured and designed by Komatsu fulfill all of the regulations and standards for all countries. If the ROPS is modified or repaired without authorization from Komatsu, or is damaged when the machine rolls over, the strength of the structure will not be able to fulfill its intended purpose. Optimum strength of the structure can only be achieved if it is repaired or modified as specified by Komatsu.

## Preventing Injury From Work Equipment

Never position any part of your body between movable parts such as the dump body, chassis or cylinders. If the work equipment is operated, clearances will change and may cause serious bodily injury or death.

## Precautions For Optional Attachments

**NOTE:** *DO NOT use attachments that are not authorized by Komatsu, or the authorized regional Komatsu distributor. Use of unauthorized attachments could create a safety problem and adversely affect the proper operation and useful life of the machine.*

When installing and using optional equipment, read the instruction manual for the attachment and the information related to attachments in this manual.

Any injuries, accidents, and product failures resulting from the use of unauthorized attachments will not be the responsibility of Komatsu America Corp., or the authorized regional Komatsu distributor.

## Precautions When Starting The Machine

Never attempt to start the engine by shorting across the starter terminals. This may cause fire, or serious injury or death to anyone in the machine's path. Start the engine from the operators seat only.

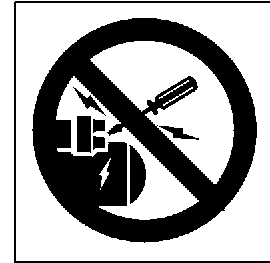

## PRECAUTIONS FOR TRUCK OPERATION

F.8-0000051230

### Safety Is Thinking Ahead

Prevention is the best safety program. Prevent a potential accident by knowing the employer's safety requirements and all necessary job site regulations. In addition, know the proper use and care of all the safety equipment on the truck. Only qualified operators or technicians may attempt to operate or maintain a Komatsu machine.

### Safety At The Worksite

When walking to and from a truck, maintain a safe distance from all machines even when the operator is visible. Before starting the engine, thoroughly check the area for any unusual conditions that could be dangerous. Examine the road surface at the job site and determine the best and safest method of operation. Choose an area where the ground is as horizontal and firm as possible before performing the operation. If you need to operate on or near a public road, protect pedestrians and cars by designating a person for work site traffic duty or by installing fences around the work site.

Before operating the machine, the operator must check the work area for obstacles and road conditions. Always determine the travel roads to be used at the work site. Travel roads must be maintained in order to ensure safe machine travel. If travel through wet areas is necessary, check the depth and flow of water before crossing the shallow parts.

### Preparing For Operation

Normally use handrails and the diagonal stairway when mounting or dismounting the truck. Become familiar with the emergency egress paths and their operation. Always face vertical ladders and use handrails. Check the deck areas for debris, loose hardware, and tools. Check for people and objects that remain on or around the truck.

Become familiar with and use all protective equipment devices on the truck and ensure that these items (anti-skid material, grab bars, seat belts, etc.) are securely in place.

### Ventilation For Enclosed Areas

If it is necessary to start the engine in an enclosed area, provide adequate ventilation. Exhaust fumes from the engine can be lethal.



### Mirrors, Windows, And Lights

Remove any dirt from the surface of the windshield, cab windows, mirrors and lights. Good visibility may prevent an accident. Adjust the mirrors to a position where the operator can see best from the operator's seat. Ensure headlights, work lights and taillights are in proper working order. Ensure that the machine is equipped with the proper work lamps needed for the operating conditions. Always replace any broken mirrors, windows or lights.

### Before Starting The Engine

**NOTE:** DO NOT leave tools or spare parts lying around or allow trash to accumulate in the cab of the truck. Keep all unauthorized reading material out of the truck cab. Keep the cab floor, controls, steps, and handrails free of oil, grease, snow, and excess dirt.

Before starting the engine perform the following:

- Read and understand the contents of the Operation & Maintenance manual. Read safety and operating instructions with special attention. Become thoroughly acquainted with all gauges, instruments and controls before attempting operation of the truck.
- Read and understand the **WARNING** and **CAUTION** decals in the operator's cab.
- Ensure the steering wheel, horn, controls and pedals are free of any oil, grease, or mud.
- Check operation of the windshield wiper, condition of wiper blades, and check the washer fluid reservoir level.
- Be familiar with all steering and brake system controls, warning devices, road speeds and loading capabilities, before operating the truck.
- If equipped, ensure the Retractable Ladder System (RLS) is raised.

### Seat Belts

On both driver and passenger seats, check the seat belt fabric, buckle, all belt retractors, and hardware for damage or wear. Replace any worn or damaged parts immediately.

Even if there are no signs of damage, replace both driver and passenger seat belts 5 years after seat belt manufacture, or every 3 years after start of use, whichever comes first. The passenger seat belt date of manufacture label is sewn into the seat belt near the buckle. The driver seat belt date of manufacture label is sewn into the shoulder harness belt, near the retractor end.

## Emergency Egress Ladders

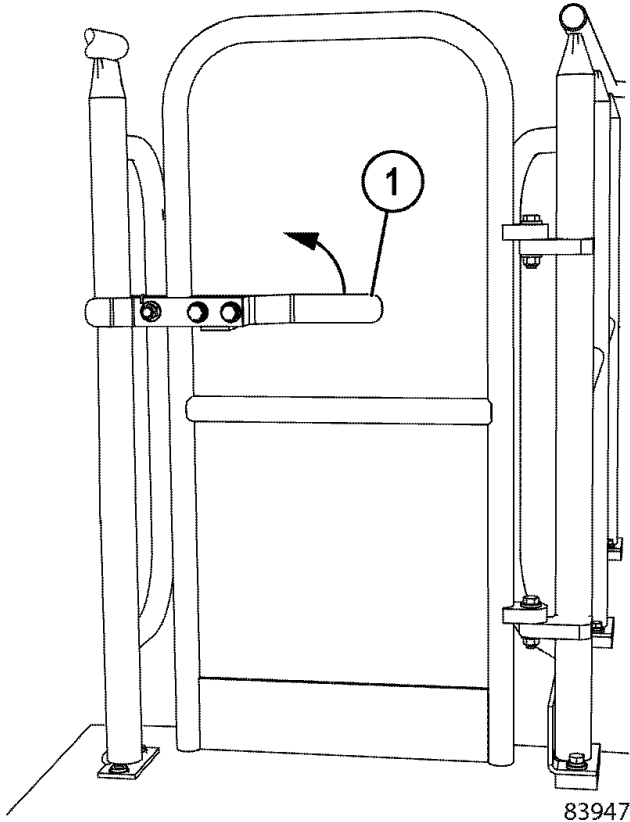

1. Emergency Egress Latch

### Figure 3-1 EMERGENCY EGRESS GATE

Be familiar with the emergency egress locations and their operations. At each emergency egress location, there is a gate that allows access to the ladder. Lift up on emergency egress latch (1, [Figure 3-1 EMERGENCY EGRESS GATE, page 3-6](#)) to gain access to the emergency egress ladder.

## OPERATING THE MACHINE

F.8-0000051287

### General Information

While operating the truck obey the following guidelines:

- Wear seat belts at all times. Only authorized persons are allowed to ride in the truck.
- Passengers must be in the cab and belted in the passenger seat.
- DO NOT allow anyone to ride on the decks or on the steps of the truck.
- DO NOT allow anyone to get on or off the truck while it is in motion.
- DO NOT move the truck in or out of a building without a signal person present.
- Keep serviceable fire fighting equipment on hand. Report used extinguishers for replacement or refilling.
- Always move the directional control lever to PARK (this will apply the parking brake) when the truck is parked and unattended. DO NOT leave the truck unattended while the engine is running.

**NOTE:** DO NOT use wheel brake lock when parking the truck.

- Park the truck a safe distance away from other vehicles as determined by the supervisor.
- Stay alert at all times! In the event of an emergency, be prepared to react quickly and avoid accidents. If an emergency arises, know where to get prompt assistance.
- Know and obey hand signal communications between the operator and spotter. Use a signal person when other machines and personnel are present, the operator must move in and out of buildings, and traveling through traffic.
- Immediately report any adverse conditions on haul road, pit or dump area that may cause an operating hazard.
- Check for flat tires periodically during a shift. If the truck has been operating on a "flat", the truck must not be parked indoors until the tire cools. DO NOT stand in front of the rim and locking ring when inflating a tire mounted on the machine. Observers must not be permitted in the area and must be kept away from the side of such tires.

### **⚠ DANGER**

- A tire and rim assembly may explode if subjected to excessive heat. Personnel must move to a remote or protected location if there is a fire near the tire and wheel area or if the smell of burning rubber or excessively hot brakes is evident.
- If the truck must be approached, such as to fight a fire, those personnel must do so only while facing the tread area of the tire (front or back), unless protected by use of large heavy equipment as a shield. Stay at least 15 m (50 ft) from the tread of the tire.
- In the event of fire in the tire and wheel area (including brake fires), stay away from the truck for at least 8 hours or until the tire and wheel are cool.

### Starting The Engine

- DO NOT attempt to start the machine by shorting across the starter terminals. This may cause fire, or serious injury or death to anyone in machine's path.
- DO NOT start the engine if a warning tag has been attached to the controls.

When starting the engine, sound the horn as an alert. Start and operate the machine only while seated in the operator's seat. DO NOT allow any unauthorized persons in the operator's compartment or any other place on the machine.

### Traveling In The Machine

When traveling on rough ground, travel at low speeds. When changing direction, avoid turning suddenly. Lower the dump body before traveling. If the engine stops when the machine is in motion, the emergency steering system will be activated. Apply the brakes immediately and stop the machine as quickly and safely as possible (off of the haul road, if possible). Apply the parking brake.

### Traveling In Reverse

Before operating the machine or work equipment, do as follows:

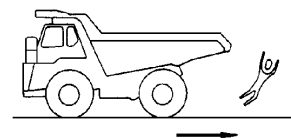

- Ensure the backup alarm works properly.
- Sound the horn to warn people in the area.
- Check for personnel near the machine. Do a thorough check behind the machine.

- When necessary, designate a person to watch the area for the truck operator. This is particularly necessary when traveling in reverse.
- When operating in hazardous areas and areas with poor visibility, designate a person to direct work site traffic.

**NOTE:** *DO NOT allow any one to enter the line of travel of the machine. This rule must be strictly obeyed even with machines equipped with a back-up alarm or rear view mirror.*

**Traveling On Slopes**

Traveling on slopes could result in the machine tipping over or slipping. The retarder must be used to reduce speed when traveling downhill. If the engine shuts down on a slope, apply the service brakes to fully stop the machine. Park the machine.

- DO NOT change direction on slopes. To ensure safety, drive to level ground before turning.
- DO NOT travel up and down on grass, fallen leaves, or wet steel plates. These materials may make the machine slip on even the slightest slope. Avoid traveling sideways, and always keep travel speed low.
- DO NOT turn the steering wheel suddenly.
- DO NOT use the foot brake except in an emergency.

**Traveling On Snow**

When working on snowy or icy roads, there is danger that the machine may slip to the side on even the slightest slope. Always travel slowly and avoid sudden starting, turning, or stopping in these conditions. Be extremely careful when clearing snow. The road shoulder and other objects are buried in the snow and cannot be seen.

**Traveling Near High Voltage Cables**

Driving near high-voltage cables can cause electric shock. Always maintain the safe distances between the machine and the electric cable as listed below.

Voltage	Minimum Safe Distance
100–200 V	2 m (7 ft.)
6.6 kV	2 m (7 ft.)
22 kV	3 m (10 ft.)
66 kV	4 m (14 ft.)
154 kV	5 m (17 ft.)
187 kV	6 m (20 ft.)

Voltage	Minimum Safe Distance
275 kV	7 m (23 ft.)
500 kV	11 m (36 ft.)

The following actions are effective in preventing accidents while working near high voltages:

- Wear shoes with rubber or leather soles.
- Use a signalman to give warning if the machine approaches an electric cable.
- If the work equipment touches an electric cable, the operator must not leave the cab.
- When performing operations near high voltage cables, DO NOT allow anyone to approach the machine.
- Check with the electrical maintenance department about the voltage of the cables before starting operations.

**Traveling On Loose Ground**

Avoid operating the machine near cliffs, overhangs, and deep ditches. If these areas collapse, the machine could fall or tip over and result in serious injury or death. Remember that ground surfaces in these areas may be weakened after heavy rain or blasting. Freshly laid soil and the soil near ditches is loose. Avoid these areas whenever possible.

**Ensuring Good Visibility**

When working in dark places, install work lamps and head lamps. Discontinue operations if visibility is poor, such as in mist, snow, or rain. Wait for the weather to improve to allow the operation to be performed safely.

**Avoid Damage To The Dump Body**

When working in tunnels, on bridges, under electric cables, or when entering an enclosed area where there are height limits, always use extreme caution. The dump body must be completely lowered before driving.

**⚠ WARNING**

- **Driving with a raised dump body or raising the dump body in an enclosed area, may result in serious damage and bodily injury or death. Always drive with the dump body resting on the frame.**

**Safe Parking Of The Machine**

The operator must continue to use safety precautions when preparing for parking and stopping the engine.

**NOTE:** In the event that the machine is being used in consecutive shifts, any questionable truck performance the operator may have noticed must be checked by maintenance personnel before the truck is released to another operator.

Park the truck on level ground, if possible. If it is necessary to park on a grade, the truck must be positioned at right angles to the grade. Turn the wheels into a suitable bank, when possible.

Haul roads are not safe parking areas. In an emergency, pick the safest spot most visible to other machines in the area. If the truck becomes disabled where traffic is heavy, mark the truck with warning flags in daylight, or flares at night.

**NOTE:** If the engine is running, and the truck is stationary and no brakes are applied, the red warning light will illuminate and the warning buzzer will sound. The operator must apply one of the following braking systems: the service brakes, the wheel brake lock or the parking brake to prevent truck roll away and to silence the alarms.

### Loading The Machine

**NOTE:** DO NOT leave the operator's seat during the loading operation.

Ensure the surrounding area is safe. If so, stop the machine in the correct loading position and evenly load the body.

### Dumping The Machine

Before dumping, check that there is no person or objects behind the machine. Stop the machine in the desired location. Give the determined signal, then

slowly operate the dump body. If necessary, use blocks for the wheels or position a flagman. When dumping on slopes, machine stability is poor and there is danger of tip over. Always perform such operations using extreme care. Never travel with the dump body raised.

### Towing The Machine

Improper towing methods may lead to serious personal injury and/or damage.

Please refer to the following towing methods:

- Tow with a solid tow bar. DO NOT tow with a cable.
- Use a towing device with ample strength for the weight of this machine.
- Never tow a machine on a slope.
- When connecting a machine to be towed, DO NOT allow anyone to go between the tow machine and the disabled machine.
- Set the coupling of the disabled machine in a straight line with the towing portion of the tow machine, and secure it in position.
- DO NOT stand next to the towing device while the truck is moving.

Refer to Operating Instructions- [TOWING](#), page 5-25 for the towing procedure.

## EXTERIOR LIGHTING D.7-0000054339

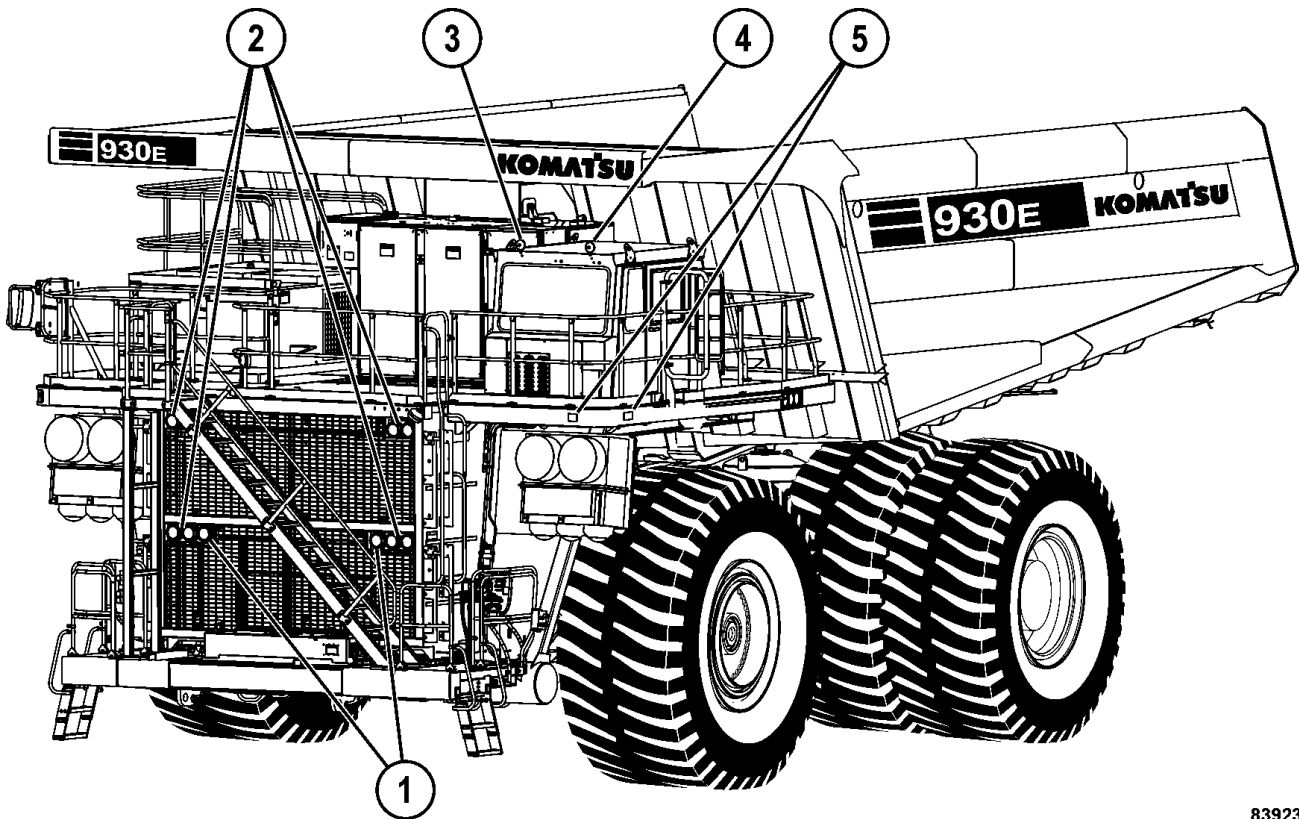

83923

1. Fog Lights
2. Headlights
3. Brake Light

4. Retard Light
5. Clearance/Turn Signal Lights

Figure 3-2 FRONT LIGHTS

### Fog Lights

Fog lights (1, Figure 3-2 FRONT LIGHTS, page 3-10) illuminate when the operator actuates the fog light switch located on the dash. The fog lights are low beam, low level lights used to illuminate a foggy work area.

### Headlights

Headlights (2) consist of high beam and low beam headlights. Low beam headlights illuminate when the operator actuates the headlight switch. The multi-function lever must be in the low beam position for the low beam headlights to work. High beam headlights illuminate when the operator actuates the high beam function on the multi-function lever. The headlight switch must be on for the high beam headlights to work. These lights are functional regardless of key switch position.

### Brake Light

Brake light (3) will illuminate when the operator depresses the brake pedal. The red light signals to traffic that the truck is stopping.

### Retard Light

Retard light (4) will illuminate when the operator uses the retard function to slow the truck. The red light signals to traffic that the truck is slowing.

### Clearance/Turn Signal Lights

Clearance/turn signal lights (5) are dual function amber lights. When the headlights are on, a low beam clearance light will illuminate. When the operator signals a left turn using the multi-function lever, the left light will flash. When the operator signals a right turn using the multi-function lever, the right light will flash. These lights are functional regardless of key switch position.



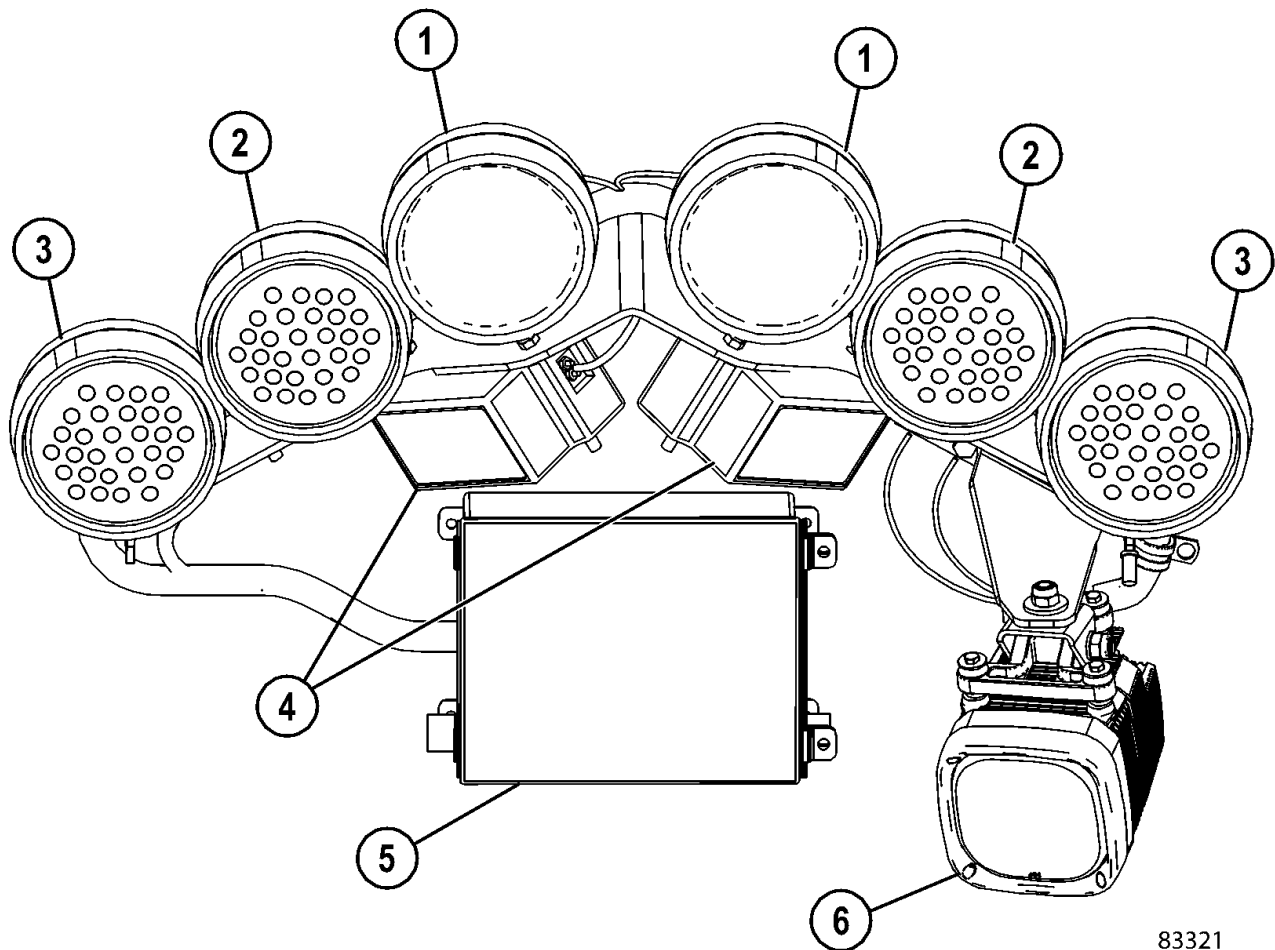

83321

1. Backup Lights
2. Retard Lights

3. Brake Lights
4. Backup Alarm

**Figure 3-3 REAR AXLE LIGHT BAR**

**NOTE:** The brake light is functional at all times regardless of key switch position. All other lights (and the backup alarm) are only functional with the key switch in the RUN position.

### Backup Lights

Backup lights (1, Figure 3-3 REAR AXLE LIGHT BAR, page 3-11) illuminate when the operator moves the directional control lever to REVERSE. The lights can also be activated by using the backup light switch in the cab. Using the switch turns the lights on regardless of directional control lever position.

### Retard Lights

Retard lights (2) will illuminate when the operator uses the retard function to slow the truck. The amber light signals to traffic that the truck is slowing.

### Brake Lights

Brake light (3) will illuminate when the operator depresses the brake pedal. The red light signals to traffic that the truck is slowing.

### Backup Alarm

Backup alarm (4) will sound when the operator moves the directional control lever to REVERSE. The alarm can also be turned on by using the backup light switch. Using the switch turns the alarm on regardless of directional control lever position.

### HID Backup Light

HID backup light (6) illuminates when the operator moves the directional control lever to REVERSE. The light can also be activated by using the backup light switch in the cab. Using the switch turns the light on regardless of directional control lever position.

**PRECAUTIONS FOR MAINTENANCE** C.3-0000051285

**BEFORE PERFORMING MAINTENANCE** G.10-0000051284

Before performing maintenance on the machine, perform the following:

- Before performing inspections or maintenance, stop the machine on firm, flat ground. Lower the dump body, place the directional control lever to the PARK position (this will apply the parking brake), and turn the key switch to the OFF position and wait for the engine to stop.
- Wait two minutes after the engine has stopped, and if no warning message is displayed, then turn the battery disconnect switches to the OFF position. Verify that the disconnects are functioning.
- Place wheel chocks around the wheels to prevent the truck from rolling.
- If the engine must be operated during maintenance, always move the directional control lever to the PARK position (this will apply the parking brake). Always perform this work with two people. One person must be in the operator's seat to stop the engine if necessary. Never move any controls not related to the task at hand during these situations. Apply the propel lockout lever to prevent the truck from moving if the engine must operate during maintenance. When the propel lockout lever is in the OFF position and the LED light is illuminated, the drive system is locked out and the truck will not propel. When the propel lockout lever is in the ON position and LED light is illuminated, the drive system is active and the truck can be driven.
- When servicing the machine, use care not to touch any moving parts. Never wear loose clothing.
- When performing service with the dump body raised, always place the dump lever in the HOLD position, and apply the lock (if equipped). Install the body-up safety cable securely.
- Use caution in the work area and be aware of any potential overhead debris or objects.

**Securing The Dump Body**

**⚠ WARNING**

- To avoid serious personal injury or death, the body retention sling must be installed whenever personnel are required to perform maintenance on the truck while the dump body is in the raised position.
- The Komatsu body-up safety sling can only be used with a Komatsu body. Non-OEM body may not accommodate the Komatsu body-up safety sling. The end user must ensure that a proper cable/sling is used.

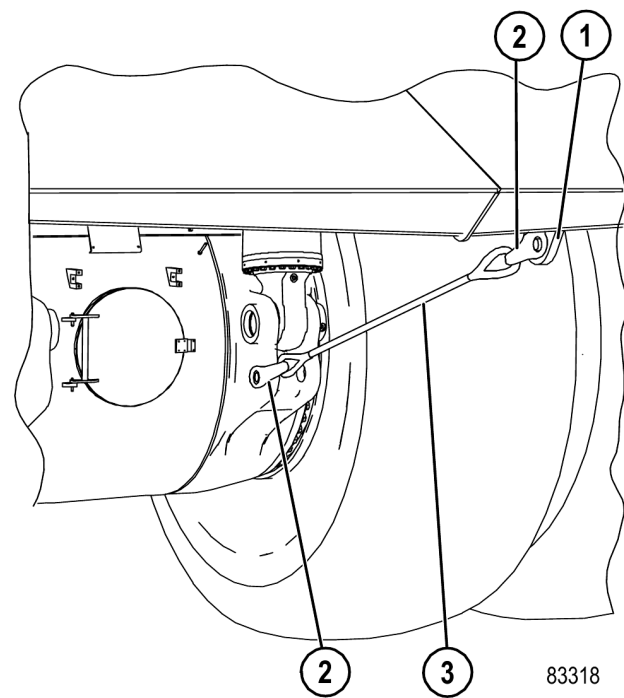

- 1. Rear Body Ear
- 2. Shackle and Pin
- 3. Body Retention Sling

**Figure 3-4 BODY RETENTION SLING INSTALLATION**

To hold the dump body in the up position, perform the following:

1. Raise the body to its maximum height.
2. Install two shackles (2, Figure 3-4 BODY RETENTION SLING INSTALLATION, page 3-12) and body retention sling (3) between rear body ear (1) and the axle housing.
3. Secure the shackle pins with cotter pins.
4. Move the hoist lever to the FLOAT position to slowly lower the body until the cable is

supporting the full weight of the body. Then move the hoist lever to the HOLD position.

- 5. After maintenance work is completed, return the sling to stored position.

**DURING MAINTENANCE** G.7-0000051281

**Warning Tag**

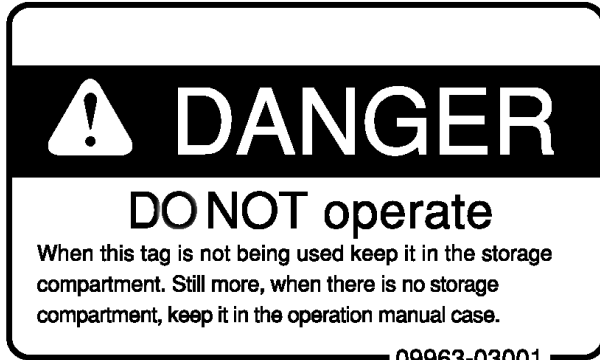

Always attach a warning tag to the control lever in the operator's cab to alert others that you are working on the machine. Attach additional warning tags around the machine, if necessary. Never start the engine or operate the controls while a person is performing maintenance. Serious injury or death may result.

These tags are available from your Komatsu distributor. Part No. 09963-03001

**Proper Tools**

Use only tools suited to the task. Using damaged, low quality, faulty, or makeshift tools can cause personal injury. Extra precaution must be used when grinding, welding, and using a sledge-hammer.

**Attachments**

Place attachments, that have been removed from the machine, in a safe place and manner to prevent them from falling.



**Working Under The Machine**

Always lower all movable work equipment to the ground or to their lowest position before performing service or repairs under the machine.



Always block the tires of the machine securely. Never work under the machine if the machine is poorly supported.

**Keeping The Machine Clean**

**⚠ WARNING**

- If equipped, **DO NOT** aim high pressure spray equipment at or near the Retractable Ladder System (RLS) power pack, actuator box, bearings or electrical harnesses. Moisture introduced in the electrical harnesses may result in uncontrolled ladder movement.

Spilled oil, grease, scattered tools, etc. can cause you to slip or trip. Always keep your machine clean.



If water gets into the electrical system, there is danger that the machine may move unexpectedly and/or damage to components may occur. **DO NOT** use water or steam to clean any sensors, connectors, or the inside of the operator's compartment.

**NOTE:** *DO NOT spray water into the retarding grids. Excess water in the retarding grids can cause a ground fault, which will prevent propulsion. Never spray water into the rear wheel electric motor covers. Damage to the wheel motor armatures may occur.*

Use extreme care when washing the electrical control cabinet. **DO NOT** allow water to enter the control cabinet around the doors or vents. **DO NOT** allow any water to enter the cooling air inlet duct above the electrical control cabinet. If water enters the control cabinet (through any opening or crevice) major damage to the electrical components may occur.

**Adding Fuel Or Oil To The Machine**



83548

When adding fuel or oil to the machine, obey the following guidelines:

- Spilled fuel and oil may cause slipping. Always clean up spills, immediately.

- Always tighten the cap of the fuel and oil fillers securely.
- Never use fuel for washing any parts.
- Always stop the engine before adding fuel or oil.
- Always add fuel and oil in a well-ventilated area.

**Radiator Coolant Level**

If it is necessary to add coolant to the radiator, stop the engine. Allow the engine and radiator to cool down before adding the coolant. Lift the pressure relief lever on the radiator cap and slowly loosen the cap to relieve pressure during removal.

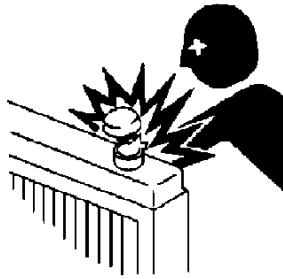

**Use of Lighting**

When checking fuel, oil, coolant, or battery electrolyte, always use lighting with anti-explosion specifications. If lighting without this protection is used, there is a danger of explosion.



**Handling High Pressure Hoses**

DO NOT bend high-pressure hoses or hit them with hard objects. DO NOT use any bent or cracked piping, tubes or hoses. They may burst during use. Always repair any loose or broken hoses. Fuel and/or oil leaks may result in a fire.

**Precautions With High Pressure Oil**



When working with high pressure oil, obey the following guidelines:

- Always remember that work equipment circuits are always under pressure.
- DO NOT add oil, drain oil, or perform maintenance or inspections before completely releasing the internal pressure.

- Small, high pressure pin-hole leaks are extremely dangerous. The jet stream of high-pressure oil can pierce the skin and eyes. Always wear safety glasses and thick gloves. Use a piece of cardboard or a sheet of wood to check for oil leakage.
- If you are hit by a jet of high-pressure oil, consult a doctor immediately for medical attention.

**Maintenance Near High Temperatures and High Pressures**

Immediately after stopping the truck, the engine coolant and operating oils are at high temperature and under high pressure.



In these conditions, opening the system or replacing filters may result in burns or other injury. Wait for the temperature to cool and pressure to subside before performing the inspection and/or maintenance as outlined in the service manual.

**Rotating Fan and Belts**

Keep a safe distance from rotating parts such as the radiator fan and fan belts. Serious bodily injury may result from direct or indirect contact with rotating parts and flying objects.

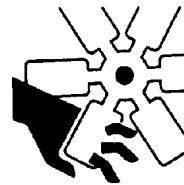

**Waste Materials**

Obey appropriate laws and regulations when disposing of harmful objects such as oil, fuel, coolant, solvent, filters, batteries, and others.

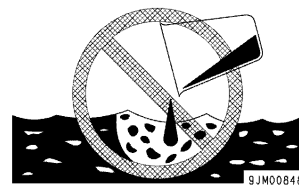

Always put fluids drained from your machine in appropriate containers. Never drain fluids directly onto the ground. Never dump oil or other harmful fluids into a sewer system, rivers, etc.

The machine may be equipped with optional high intensity discharge lamps which contain mercury. These lamps must be reused, recycled or properly disposed of in accordance with applicable local, state and federal laws.

## Use of Tie-Off Anchor During Maintenance

While working at heights during assembly, maintenance or repair of the haul truck, workers should wear an appropriate fall protection harness and attach it to a tie-off anchor or tie-off point.

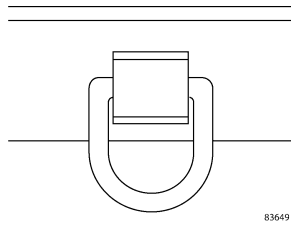

Komatsu anchor (58B-98-75190) is available for use with fall protection harnesses. Carefully read and understand the harness maker's instructions before using any fall protection harness.

The load carrying capacity of anchor (58B-97-75190) is 2 270 kg (5,000 lbs).

**NOTE:** The anchor must not be used for lifting.

## Handling Tires

### ⚠ WARNING

- **DO NOT stand in front of a rim and locking ring when inflating a tire mounted on the machine. Observers must not be permitted in the area.**
- **DO NOT weld or heat the rim assembly with the tire mounted on the rim. Resulting gases inside the tire may ignite, causing explosion of the tire and rim.**

Rim and tire maintenance can be hazardous unless the correct procedures are followed by trained personnel.

Improperly maintained or inflated tires can overheat and burst due to excessive pressure. Improper inflation can also result in cuts in the tire caused by sharp stones. Both of these conditions can lead to tire damage, serious personal injury, or even death.

To safely maintain a tire, adhere to the following conditions:

- Before a tire is removed from a vehicle for tire repair, the valve core must be partially removed to allow deflation, and then the tire/rim assembly can be removed. During deflation, persons must stand outside of the potential trajectory of the locking ring of a multi-piece wheel rim.
- After the tire/rim assembly is installed on the vehicle, inflate the tires to their specified pressure.

Abnormal heat is generated, particularly when the inflation pressure is too low.

- Use the specified tires.

To prevent injury from the wheel rims during tire inflation, use one of the following:

1. A wheel cage or other restraining device that will constrain all wheel rim components during an explosive separation of a multi-piece wheel rim, or during the sudden release of air.
2. A stand-off inflation device which permits a person to stand outside of the potential trajectory of the wheel components.

The tire inflation pressure and permissible speeds, given in this manual, are general values. The actual values may differ, depending on the type of tire and the specific operating conditions. For details, please consult the tire manufacturer.

**NOTE:** DO NOT weld near the rim or tire if the tire is inflated.

When the tires become overheated, a flammable gas is produced inside the tire which can ignite. It is particularly dangerous if the tires become overheated while the tires are pressurized. If the gas generated inside the tire ignites, the internal pressure will suddenly rise, and the tire will explode, resulting in danger and/or death to personnel in the area. Explosions differ from punctures or tire bursts because the destructive force of the explosion is extremely large.

## Tire Maintenance

If the proper procedure for performing maintenance or replacement of the wheel or tire is not used, the wheel or tire may burst, causing damage, serious injury, or even death. When performing such maintenance, consult your authorized regional Komatsu distributor, or the tire manufacturer.

Refer to the Society of Automotive Engineers (SAE), SAE J1337, Off-Road Rim Maintenance Procedures and Service Precautions, Section 4.2 for additional information on demounting the tires and rim assemblies. Also, refer to Section 4.4 of SAE J1337 for assembly and inflation recommendations.

The U.S. Department of Labor Mine Safety and Health Administration (MSHA) addresses tire repairs in its Title 30 Code of Federal Regulations, 30 CFR 57.14104.

**Storing Tires After Removal**

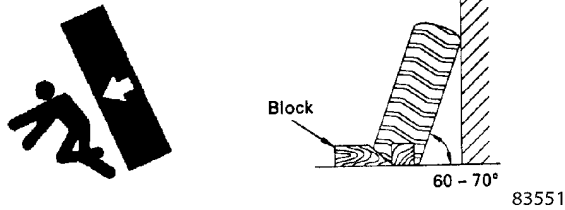

Store the tires in a warehouse in which unauthorized persons cannot enter. If the tires are stored outside, erect a fence around the tires with warning signs. Stand the tire on level ground, and block it securely so that it cannot roll or fall over. If the tire falls, flee the area as quickly as possible. The tires for mining equipment are extremely heavy. DO NOT attempt to hold a tire upright when the tire is falling. The weight of these tires may lead to serious injury or death.

Mounted tires stored as spares must be inflated to the minimum inflation pressure necessary to keep the tire beads properly seated. Maximum inflation pressure of the stored tire must, in no instance, exceed 15% of the tire's cold inflation pressure.

**BATTERY HAZARD PREVENTION**

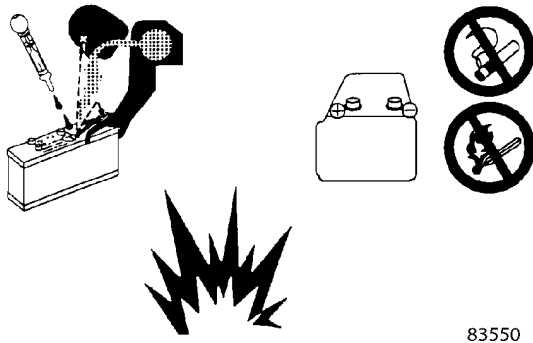

Before repairing the electrical system or when performing welding, turn the key switch to the OFF position. Wait two minutes after the engine has stopped, and if no warning message is displayed, then turn the master disconnect switch and starter disconnect switch to the OFF position.

Battery electrolyte contains sulfuric acid and can quickly burn the skin and eat holes in clothing. If electrolyte comes in contact with skin, immediately flush the area with water.

Battery acid can cause blindness if splashed into the eyes. Always wear safety glasses or goggles when working with batteries. If acid gets into the eyes, flush them immediately with large quantities of water and see a doctor immediately.

If acid is accidentally ingested, drink a large quantity of water, milk, beaten eggs or vegetable oil. Call a doctor or poison prevention center immediately.

When working with batteries, obey the following guidelines:

- Batteries generate hydrogen gas. Hydrogen gas is very explosive, and is easily ignited with a small spark or flame.
- Before working with batteries, stop the engine and turn the key switch to the OFF position. Wait two minutes after the engine has stopped. If no warning message is displayed, then turn the battery disconnect switches to the OFF position.
- Avoid short-circuiting the battery terminals through accidental contact with metallic objects, such as tools, across the terminals.
- When removing or installing a battery, positively identify the positive (+) terminal and negative (-) terminal and use precautions not to short circuit between the terminals.
- This truck is equipped with a master disconnect switch on the battery ground circuit. When disconnecting battery cables, always move the master disconnect switch to the OFF position. Disconnect the positive (+) battery cables first, then disconnect the negative (-) battery cables.

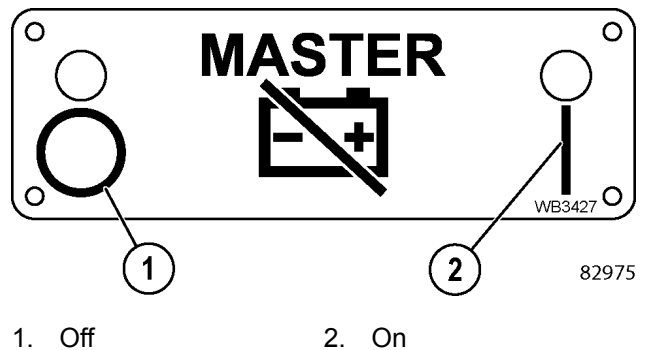

**Figure 3-5 MASTER DISCONNECT SWITCH**

**NOTE:** If the master disconnect switch is OFF, and a wrench on the negative (-) terminal touches the battery box frame, a spark will occur if any electrical component on the truck was left in the ON position.

- When connecting battery cables, always move the master disconnect switch to the OFF position. Connect the negative (-) cables first, then the positive cables (+) last.
- Tighten battery terminals securely. Loose terminals can generate sparks and could lead to an explosion.
- Tighten battery caps securely.

## Jump Starting With Booster Cables

### ⚠ CAUTION

- Always wear safety glasses or goggles when starting the machine with booster cables. DO NOT allow the two machines to touch while jump starting with another machine.

When jump starting the machine with booster cables, obey the following guidelines:

1. Ensure the parking brake is applied on both machines. The engine on the good machine must be operating.
2. Ensure the size of the booster cables and clips are suitable for the battery size. Inspect the cables and clips for any damage or corrosion.
3. Ensure the key switch and the master battery disconnect switch on the disabled machine are in the OFF position.
4. Connect the batteries in parallel: positive to positive and negative to negative.
5. Connect the positive (24VDC +) cable from the good machine to the (24VDC +) on the disabled machine first.
6. Then connect the ground cable from the negative (-) battery terminal on the good machine to the frame of the disabled machine, as far away as possible from the batteries. This will prevent a spark from possibly starting a battery fire.
7. Move the master battery disconnect switch to the ON position. Allow time for the batteries to charge.
8. If starting with a booster cable, perform the operation with two people. One person must be in the cab of the disabled machine, the other person must be working with the jumper cables.
9. If the batteries are low, DO NOT attempt to start the machine with only one set of jumper cables installed. Install the second set of jumper cables in the same way as already described.
10. Attempt to start the disabled machine.
11. For booster cable removal, disconnect the ground or negative (-) cable first, then the (24VDC +) cable last.

**NOTE:** If any tool touches between the positive (+) terminal and the chassis, it will cause sparks. Always use caution when using tools near the batteries.

## Jump Starting With Receptacles

### ⚠ CAUTION

- Always wear safety glasses or goggles when starting the machine with booster cables. DO NOT allow the two machines to touch while jump starting with another machine.

When jump starting the machine with receptacles, obey the following guidelines:

1. Ensure the parking brake is applied on both machines. The engine on the good machine must be operating.
2. Inspect the cables and connectors for any damage or corrosion.
3. Ensure the key switch and master battery disconnect switch on the disabled machine are in the OFF position.
4. Connect the jumper cable to the receptacle on the good machine to the receptacle on the disabled machine.
5. Allow time for the batteries to charge.

**NOTE:** The batteries will charge even with the master battery disconnect switch in the OFF position.

6. If starting with a booster cable, perform the operation with two people. One person must be in the cab of the disabled machine, the other person must be working with the jumper cables.
7. If the batteries are low, DO NOT attempt to start the machine with only one set of jumper cables installed. Install the second set of jumper cables in the same way as already described.
8. Turn the master battery disconnect switch to the ON position and attempt to start the disabled machine.
9. For booster cable removal, disconnect the cables from each machine.

**NOTE:** If any tool touches between the positive (+) terminal and the chassis, it will cause sparks. Always use caution when using tools near the batteries.

## WHEN REPAIRS ARE NECESSARY E.9-0000051280

### Observe The Following Precautions

#### **⚠ WARNING**

- Any operating fluid, such as hydraulic oil or brake fluid escaping under pressure, can have sufficient force to enter a person's body by penetrating the skin. Serious injury and possibly death may result if proper medical treatment by a physician familiar with this injury is not received immediately.

#### **⚠ WARNING**

- **DO NOT stand in front of a rim and locking ring when inflating a tire mounted on the machine. Observers must not be permitted in the area.**
- **DO NOT weld or heat the rim assembly with the tire mounted on the rim. Resulting gases inside the tire may ignite, causing explosion of the tire and rim.**

- Only qualified maintenance personnel who understand the systems being repaired must attempt repairs.
- Many components on the Komatsu truck are large and heavy. Ensure that lifting equipment - hoists, slings, chains, lifting eyes - are of adequate capacity to handle the lift.
- DO NOT stand under a suspended load. DO NOT work under raised body unless body safety cables, props, or pins are in place to hold the body in up position.
- DO NOT repair or service the truck while the engine is running, except when adjustments can only be made under such conditions. Keep a safe distance from moving parts.
- When servicing any air conditioning system with refrigerant, wear a face shield and cold resistant gloves for protection against freezing. Ensure all current regulations for handling and recycling refrigerants are followed.

- Follow package directions carefully when using cleaning solvents.
- If an auxiliary battery assist is needed, refer to Jump Starting with Booster Cables or Jump Starting with Receptacles earlier in this section.
- Before performing any welding on the truck, always turn the battery disconnect switches to the OFF position and disconnect the alternator positive cable. Failure to do so may seriously damage the battery and electrical equipment. It is not necessary to disconnect or remove any control circuit cards on electric drive dump trucks or any of the Alarm Indicating Device (AID) circuit control cards.

Always fasten the welding machine ground (-) lead to the piece being welded; the grounding clamp must be attached as near as possible to the weld area. Never allow welding current to pass through ball bearings, roller bearings, suspensions, or hydraulic cylinders. Always avoid laying welding cables over or near the vehicle electrical harnesses. Welding voltage could be induced into the electrical harness and cause damage to components.

- If a truck is to be towed for any reason, use a rigid tow bar. Check the truck cab for decals for special towing precautions. (Refer to [TOWING, page 5-25.](#))
- Drain, clean and ventilate fuel tanks and/or hydraulic tanks before making any welding repairs.
- Relieve pressure in lines or hoses before making any disconnects.
- After adjustments or repairs, replace all shields, screens and clamps.
- Working near tires can be dangerous. Use extreme caution when working around tires.
- Only a qualified operator or experienced maintenance personnel who are also qualified in operation can move the truck under its own power in the repair facility or during road testing after repairs are complete.



**SPECIAL PRECAUTIONS** F.11-0000051279**Preliminary Procedures Before Welding or Performing Maintenance****⚠ DANGER**

- Before opening any cabinets or touching a grid element or a power cable, the engine must be shutdown and the red drive system warning lights must not be illuminated.

Prior to welding and/or repairing, maintenance personnel must attempt to notify a Komatsu service representative. Only qualified personnel, specifically trained for servicing the AC drive system, must perform this service.

**Engine Shutdown Procedure Before Welding or Performing Maintenance**

Normal operation of the drive system at shutdown will leave the system safe to maintain. However, in the event of a system failure, performing the following procedure prior to any maintenance activities will ensure that no hazardous voltages are present in the AC drive system.

1. Before shutting down the engine, verify there are no warning messages being displayed on the instrument panel.
2. If any drive system warning messages are displayed on the status indicator panel, DO NOT attempt to open any cabinets, disconnect any cables, or reach inside the retarder grid cabinet without a trained drive system technician present - even if engine is off.
3. If there are no drive system warning messages, refer to [Safe Parking Of The Machine, page 3-8](#) for parking instructions.
4. After the engine has been off for at least five minutes, inspect the link voltage lights on the exterior of the main control cabinet. If all lights are off, the retard grids, wheel motors, alternator, and related power cables are safe to work on.
5. Locate the GF cut-out switch in the front access panel on the left side of the main control cabinet. Place the switch in the CUTOUT position. This will prevent the alternator from re-energizing and creating system voltage until the switch is returned to the previous position.
6. Ensure both battery disconnect switches are in the OFF position. Verify that the battery disconnects are functioning.

**NOTE:** If the red lights on the exterior of the control cabinet and/or the back wall of the center console continue to be illuminated after the above procedure, a fault has occurred. Leave all cabinet doors in place; DO NOT touch the retard grid elements; DO NOT disconnect any power cables, or use them as hand or foot holds.

**⚠ WARNING**

- Notify your Komatsu service representative, immediately. Only qualified personnel, specifically trained for servicing the A-C drive system, must perform this service.

7. Replace all covers and doors and place the GF cutout switch and battery disconnect switches in their original positions. Reconnect all harnesses prior to starting the truck.

8. Leave the drive system in the rest mode until the truck is to be moved.

**Before welding on the machine, obey the following guidelines:**

- Before doing any welding on the truck, always disconnect the battery charging alternator lead wire.
- DO NOT weld on the rear of the control cabinet. The metal panels on the back of the cabinet are part of capacitors and cannot be heated.
- DO NOT weld on the retard grid exhaust louvers - they are made of stainless steel. Some power cable panels throughout the truck are also made of aluminum or stainless steel. They must be repaired with the same material or the power cables may be damaged.
- Power cables must be cleated in wood or other non-ferrous materials. DO NOT repair cable cleats by encircling the power cables with metal clamps or hardware. Always inspect power cable insulation prior to servicing the cables and prior to returning the truck to service. Discard cables with broken insulation.
- Power cables and wiring harnesses must be protected from weld spatter and heat.
- Always fasten the welding machine ground (-) lead to the piece being welded; the grounding clamp must be attached as near as possible to the weld area.
- Always avoid laying welding cables over or near the vehicle electrical harnesses. Welding voltage could be induced into the electrical harness and cause damage to components.

- Never allow welding current to pass through ball bearings, roller bearings, suspensions, or hydraulic cylinders.

### **Discharging Control Cabinet Capacitors**

The control cabinet is equipped with two capacitor charge lights, one on the exterior of the cabinet and one in the interior. The capacitor charge lights, when off, indicate to service personnel that the drive system is safe to work on. Certain drive system failures,

however, can result in a condition where one or more capacitors can remain in a charged state even though the capacitor charge lights are off.

Because a danger can still exist with the capacitor charge lights off, refer to the shop manual "Manual Discharge of Capacitors" before servicing the drive system. Adhere to the proper procedures for disabling the drive system. Only authorized service personnel are allowed to service the drive system.

# **WARNING AND CAUTIONS**

**GENERAL INFORMATION** C.3-0000051318

The following pages give an explanation of the warning, caution, and service instruction plates and decals attached to the truck. The plates and decals listed here are typical of this Komatsu model, but

**PIN PLATE** E.2-0000051328

A product identification plate is located on the frame in front of the right side front wheel and shows the truck model number, maximum GVW and Product Identification Number (PIN).

**NOTE:** This product identification plate may vary depending on engine options.

The PIN consists of 19 total characters. The first and last characters are tamper preventative symbols (\*). The remaining 17 alpha/numeric characters are used to identify 5 characteristics of the machine. The 5 characteristics are detailed below.

**WMC** - Character positions 1, 2 and 3 identify the Worldwide Manufacturer Code (WMC). The WMC designates the manufacturer of the product. Komatsu brand products are identified with the letters KMT.

**MDS** - Character positions 4, 5, 6, 7 and 8 identify the Machine Descriptor Section (MDS). The MDS code identifies general information regarding machine specifications. The MDS is a code for the machine type and model.

**CL** - Character position 9 identifies the Check Letter (CL). The CL is used to verify the accuracy of the individual PIN.

**FC** - Character positions 10 and 11 identify the Factory Code (FC). The FC identifies the Komatsu factory in charge of claims for the product. The FC for electric drive trucks is 61.

**SN** - Character positions 12, 13, 14, 15, 16, and 17 identify the Serial Number (SN). The SN is a unique sequential number.

because of customer options, individual trucks may have plates and decals that are different from those shown here.

The plates and decals must be kept clean and legible. If any decal or plate becomes illegible or damaged, it must be replaced with a new one.

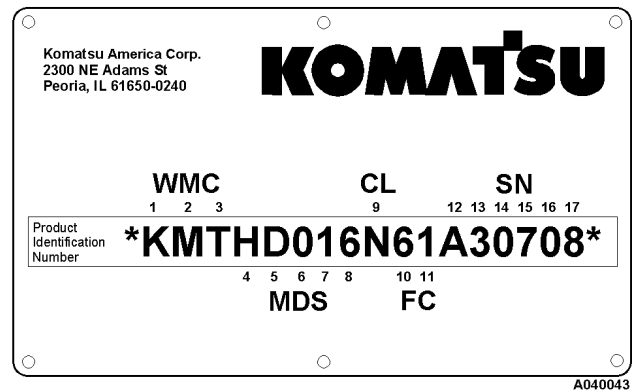
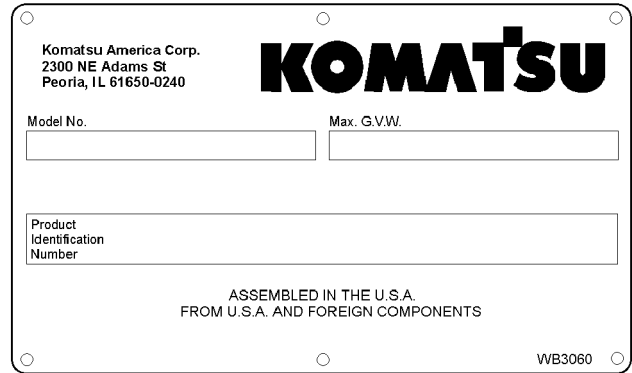

**GRADE SPEED CHART .**

A grade/speed retard chart is located on the left front post of the operator's cab and provides the recommended maximum speeds to be used when descending various grades with a loaded truck. Always refer to the decal in operator's cab. This decal may change with optional truck equipment such as wheel motor drive train ratios, retarder grids, tire sizes, etc.

CAUTION

DO NOT DESCEND GRADES AT SPEEDS GREATER THAN LISTED WHEN VEHICLE IS LOADED AT MAX. G.V.W. 1,100,000 LB. (498,957 kg) & 53/80 R 63 TIRES.

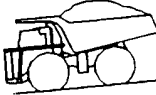
	EFFECTIVE GRADE	SPEED (CONTINUOUS)	SPEED (SHORT TERM)
	%	MPH(KM/H)	MPH(KM/H)
	12	15(24)	19(31)
_____	10	11(18)	23(37)
_____	8	14(23)	29(47)
_____	6	19(31)	36(58)
_____	4	29(47)	36(58)

THE ACTUAL GRADE CAPABILITY WILL VARY DEPENDING ON OUTSIDE TEMPERATURE, SYSTEM TEMPERATURE, ROLLING RESISTANCE, LOAD, AND TIRE SIZE. THE ABOVE IS BASED ON 32° C (90°F) OUTSIDE TEMPERATURE AND ASSUMES THAT ROAD AND VISIBILITY CONDITIONS PERMIT THE USE OF ALL AVAILABLE RETARDING TORQUE WITHOUT SKIDDING. FOR ADDITIONAL BRAKING AND RETARD INFORMATION, SEE OPERATION MANUAL.

ACTUAL GRADE, NOT INCLUDING ROLLING RESISTANCE.

WB2751

**MACHINE SAFETY** c.3-0000051326

Warning plates are mounted on the frame in front of, and to the rear, of both front tires. All personnel are warned that the clearances change when the truck is steered and could cause serious injury.

WARNING

STAY CLEAR. CLEARANCE REDUCED WHEN MACHINE IS STEERED. MOVING COMPONENTS MAY CAUSE CRUSHING.

WB2448

Warning plates are attached to both the hydraulic tank and fuel tank to alert technicians not to work on the truck with the body in the raised position unless the body-up retention device (cable/sling) is in position.



A caution decal is also attached to the door of the rear hatch cover to alert personnel that hot exhaust air is present and may cause injury.

This caution decal is also placed around the retarding grid cabinet.

This information decal is placed on the outside of the door panel on the control cabinet wall that faces the right side of the operator cab.

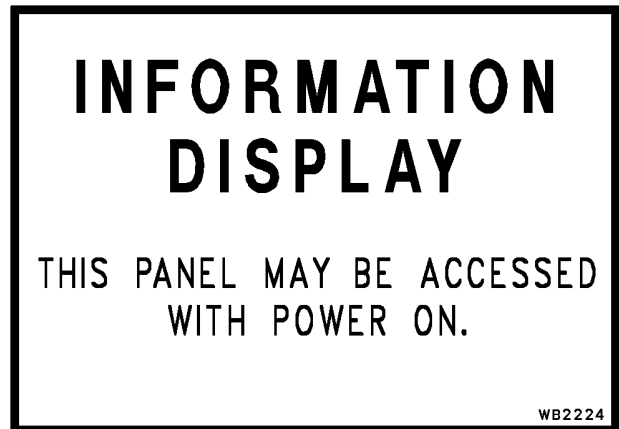

This decal is located by the emergency ladder on both sides of the truck.



This decal is located in the cab to the left of the intake vacuum gauges. Wireless signals from the truck's KOMTRAX Plus system can interfere with other wireless signals in the area. This interference can cause a malfunction in a blast zone resulting in an unintended detonation. Know the locations of blast zones in the area and keep a safe distance to avoid unintentional blasts. Operating frequency of KOMTRAX Plus is 148 MHz to 150 MHz.

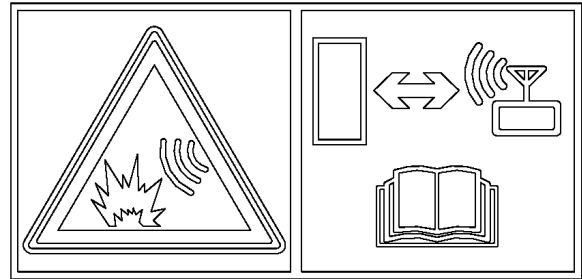

09845 - 00480

**KEY SWITCH E.2-0000051325**

A warning decal is located below the key switch, to the right of the steering column on the instrument panel. The warning stresses the importance of reading the operator's manual before operation.



**OIL FILL AND CHECK c.3-0000051324**

A plate on the side of the hydraulic tank furnishes instructions for filling the hydraulic tank.

Keep the system open to the atmosphere only as long as absolutely necessary to lessen the chances of system contamination. Service the tank with clean Type C-4 hydraulic oil. All oil being put into the hydraulic tank must be filtered using filters rated at three microns.

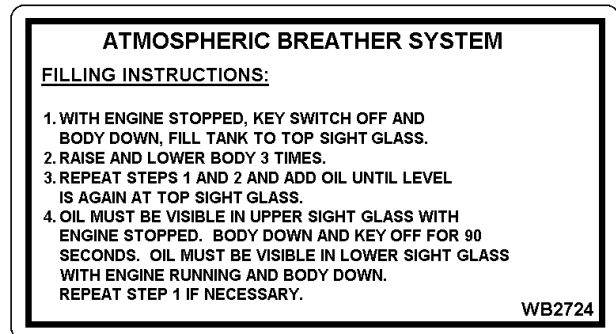

A caution decal is attached below the hydraulic tank oil level sight gauge. Check level with body down, engine stopped, and key switch OFF. Add oil per filling instructions, if oil level is below top of sight glass.



A wheel motor oil level decal is attached to the gear cover on both electric wheel motors. This decal stresses the fact that the truck must be on a level surface and parked for 20 minutes prior to checking the oil level. This is necessary in order to get an accurate reading.

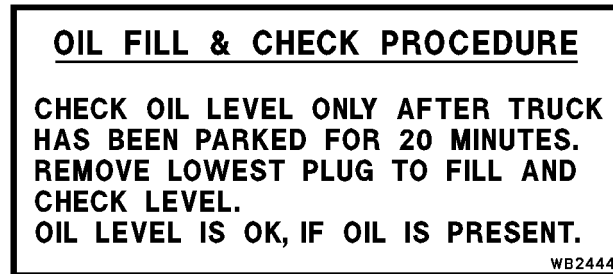

**HIGH PRESSURES** F.9-0000051323

A warning plate is mounted on top of the radiator surge tank cover near the radiator cap. The engine cooling system is pressurized. **Always turn the key switch OFF and allow the engine to cool before removing the radiator cap.** Unless the pressure is first released, removing the radiator cap after the engine has been operating for a time will result in the hot coolant being expelled from the radiator. **Serious scalding and burning may result.**

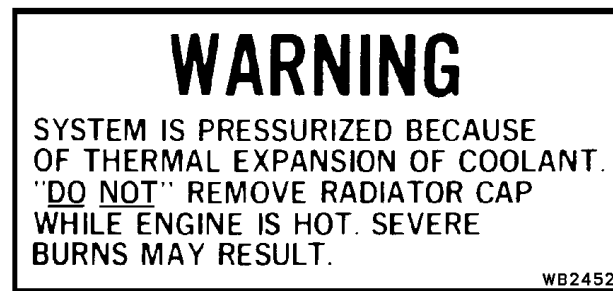

These danger plates are mounted on the outside of each frame rail by the steering accumulators and the brake accumulators. These danger plates alert technicians to read the warning labels attached to the side of each of the accumulators (see below) prior to releasing internal nitrogen pressure or disconnecting any hydraulic lines or hardware. There are similar decals mounted on top of each of the accumulators (both steering and brake) with the same danger message.





Warning decals are applied to the inside of the brake system cabinet behind the operator cab. These decals remind servicing technicians to close the accumulator drain valves after they have been opened to bleed brake pressure. It further warns not to over-tighten the drain valves to prevent damage to the valve seat(s).



This warning plate is located on the inside and outside of the brake system cabinet doors. This warning plate alerts the technician to stop the engine, turn the key switch OFF, and open the drain valves on all three accumulators to bleed the hydraulic system pressure before disconnecting a brake line.

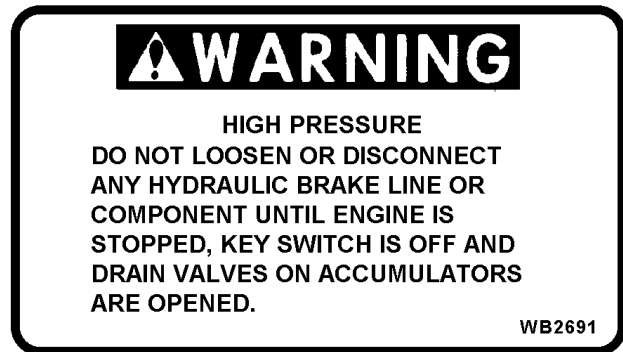

This danger plate is attached to all four suspensions. The plate contains instructions for releasing internal pressure before disconnecting any hardware. Serious injury can occur if these directions are not followed.

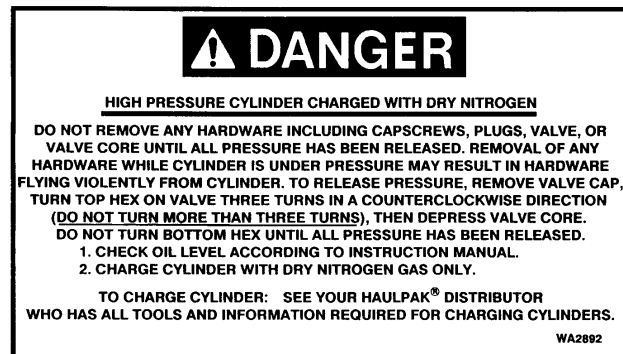

A warning plate is attached to the hydraulic tank to inform technicians that high pressure hydraulic oil is present during operation. When it is necessary to open the hydraulic system, ensure the engine is stopped and key switch is OFF to bleed down hydraulic pressure. There is always a chance of residual pressure being present. Open fittings slowly to allow all pressure to bleed off before removing any connections.

**⚠ WARNING**

- **Any operating fluid, such as hydraulic oil or brake fluid escaping under pressure, can have sufficient force to enter a person's body by penetrating the skin. Serious injury and possibly death may result if proper medical treatment by a physician familiar with this injury is not received immediately.**

This warning decal is located below the battery disconnect switches and on the front of the battery box to warn personnel not to disconnect the batteries during the first 90 seconds after turning the key switch off.

Turn the key switch to the OFF position and wait for the engine to stop. After the engine has stopped, wait two minutes, and if no warning message is displayed, then turn the battery disconnect switches to the OFF position.

The first 90 seconds after the key switch is turned off is the bleddown process. Turning the battery disconnect switches off within 90 seconds could interrupt the bleddown process and leave stored energy in the accumulator. Wait two minutes after the engine has stopped, then observe for bleddown malfunction warning message on the instrument panel. If warning is being displayed, notify maintenance immediately. Turning the battery disconnect switches to the OFF position sooner than two minutes could mask a problem that was detected during the bleddown process.

This decal is placed on both front wheel hubs to warn about hot oil inside the wheel hubs. Remove the oil level plug carefully to avoid injury.

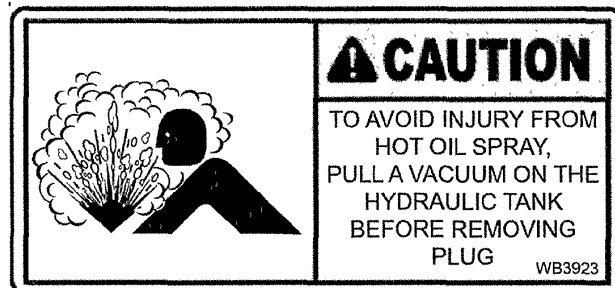
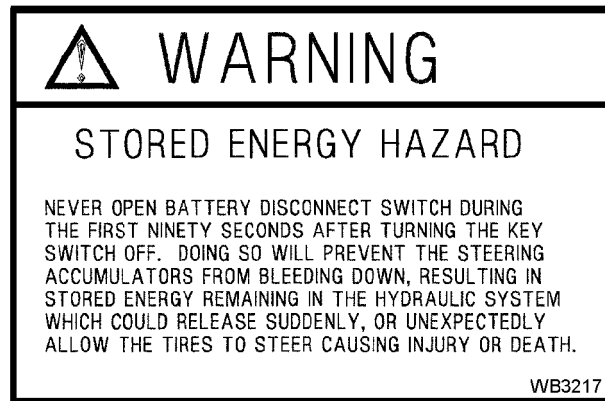

**BATTERY AND ISOLATION BOX** D.4-0000051322

This plate is placed on isolation box cover and the battery box cover to indicate that the battery system (24VDC) is a negative (-) ground system.

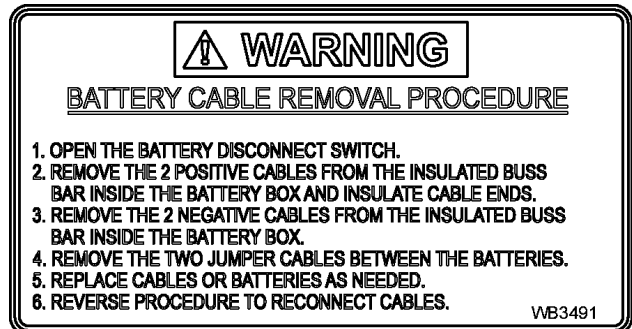

This decal is placed on the cover for the ground level engine shutdown switch to indicate where the emergency shutdown control is located. The shutdown switch is mounted above the isolation box.



This decal is located below the engine shutdown switch. It is used for emergency shutdown only. Push the button in to stop the engine.

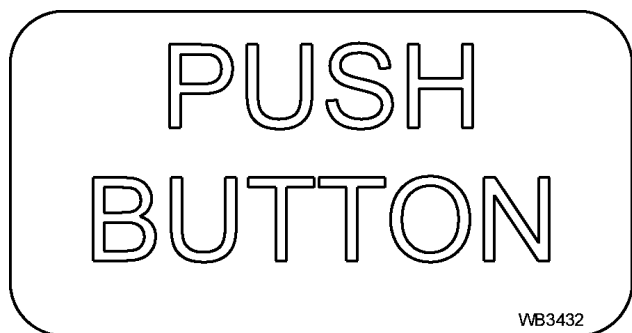

This decal is located on the isolation box. The isolation box contains the disconnect switches that can be used to isolate the cranking motor, battery and propulsion system circuits.



These plates are located above the battery disconnect switches on the isolation box to indicate the OFF and ON positions of the switches.

The master switch will disconnect the batteries from the entire electrical system.

The cranking motor switch will disconnect the power supply to the two cranking motors. This will prevent the truck from starting, but will allow for diagnostic testing of the electrical system if the master switch is still ON.

- Storing the machine for more than one month
- Replacing electrical system components
- Performing welding maintenance
- Handling batteries, or starting with booster cables
- Replacing fuses or fusible links

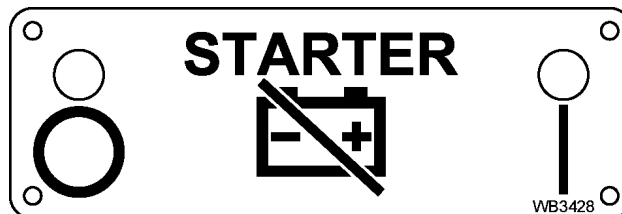
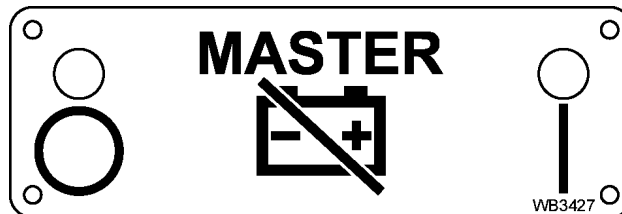

This plate is located above the propel lockout lever on the isolation box to indicate the OFF and ON positions of the lever. When this lever is placed in the OFF position, the truck's AC electric drive system is locked out and the truck will not propel. When the lever is placed in the ON position, the truck's AC electric drive system will function and the truck can be driven.

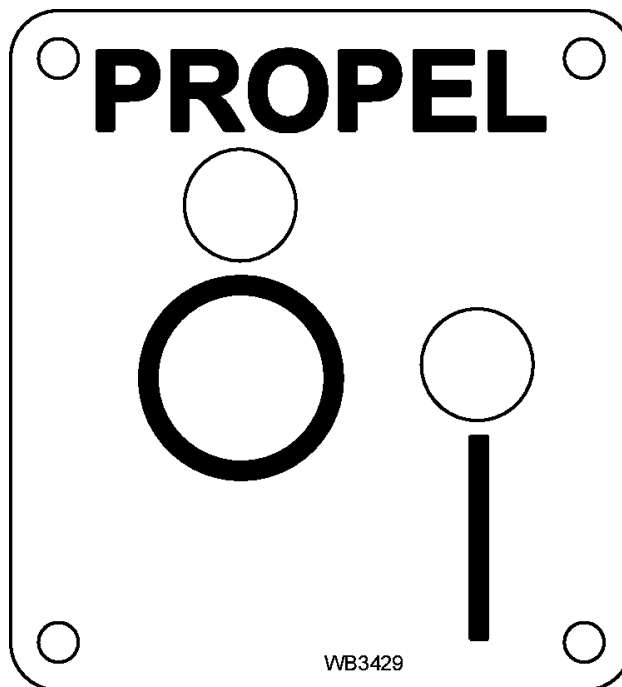

Attached to the exterior of both battery compartments is a danger plate. This plate stresses the need to keep from making any sparks near the battery. When another battery or 24VDC power source is used for auxiliary power, all switches must be OFF prior to making any connections. When connecting auxiliary power cables, positively maintain correct polarity. Connect the positive (+) posts together and then connect the negative (-) lead of the auxiliary power cable to a good frame ground. **DO NOT connect to the negative posts of the truck battery or a ground near the battery box.** This hookup completes the circuit but minimizes danger of sparks near the batteries.

Sulfuric acid is corrosive and toxic. Use proper safety gear, goggles, rubber gloves and rubber apron when handling and servicing batteries. Get proper medical help immediately, if required.

**HIGH VOLTAGE** E.9-0000051321

A high voltage danger plate is attached to the door of the rear hatch cover. High voltage may be present!

Only authorized personnel can access this rear housing.

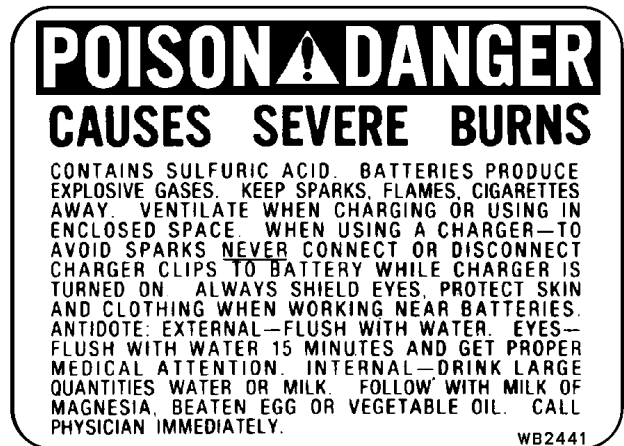



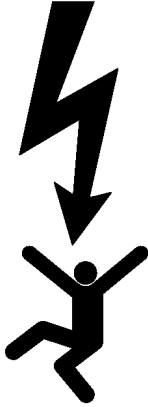

These warning plates are mounted on all of the AC drive control housings and cabinets.

High voltage may be present, with or without, the engine running.

Only authorized personnel can access these cabinets.

	<h2>DANGER</h2>
	<h3>HIGH VOLTAGE HAZARD</h3> <p>Access by Authorized Personnel Only                  High Voltage may cause Serious Injury or Death                  High Voltage may still be present even if Engine and Capacitor Charge Light are both off</p> <p>Complete all of these steps before accessing any High Voltage area:</p> <p>1st Complete the Electrical System Isolation Procedure as instructed in the Shop Manual.</p> <p>2nd Confirm that Capacitor Charge Light is not illuminated.</p> <p style="text-align: center;">AND</p> <p>3rd Confirm that each Capacitor has been fully discharged by using an electric meter rated for at least 2000 VDC. If the electric meter indicates that any voltage remains present, discharge the capacitors as instructed in the Shop Manual.</p> <p style="text-align: right;">WB3777</p>

	<h2>DANGER</h2>
	<h3>HIGH VOLTAGE HAZARD</h3> <p>Access by Authorized Personnel Only                  High Voltage may cause Serious Injury or Death                  High Voltage may still be present even if Engine and Capacitor Charge Light are both off</p> <p>Complete all of these steps before accessing any High Voltage Area</p> <p>1st. With engine running and drive system in ready mode, check if both Capacitor Charge Lights are on. If they are off, then do not proceed and troubleshoot high voltage system using the capacitor discharge system procedure as instructed in the Operation and Maintenance Manual. If they are on, then proceed to step 2.</p> <p>2nd. Turn engine off. Check if both Capacitor Charge Lights turn off within 15 sec. If they do not turn off, then do not proceed and troubleshoot high voltage system using the capacitor discharge system procedure as instructed in the Operation and Maintenance Manual. If they turn off then proceed with step 3.</p> <p>3rd. Complete the Electrical System Isolation Procedure as instructed in the Operation and Maintenance Manual.</p> <p>4th. If the lights are on when the engine is running and they turn off when engine is turned off, then check voltage in RP Contactor Box or findings by a 600 V meter. If no voltage is indicated, then proceed with maintenance. If voltage is indicated, then troubleshoot electrical system using the capacitor discharge system procedure as indicated in the Operation and Maintenance Manual.</p> <p style="text-align: right;">SSB-93-00410</p>

	 <h2>DANGER</h2> <p>High Voltage may still be present even if Engine and Capacitor Charge Light are both off</p> <p style="text-align: right;">WB3876</p>
-------------------------------------------------------------------------------------	-----------------------------------------------------------------------------------------------------------------------------------------------------------------------------------------------------------------------------------------------

This decal is placed near two different indicator lights:

- On the front of the control box which is mounted on the right side of the main control cabinet.
- On the outside of the left control cabinet wall that faces the right side of the operator cab.

This decal is located on the front of the contactor box and on the inside of the left control cabinet door.

**NOTE:** *When any of these indicator lights are on, high voltage is present throughout the propulsion and retarding system. Extreme care must be exercised!*

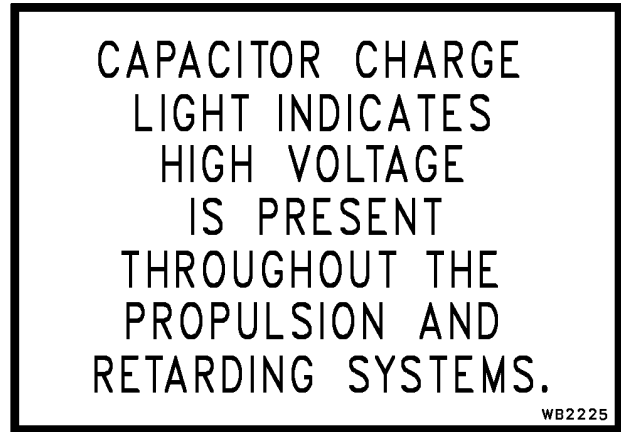

**WELDING E.7-0000051320**

This caution decal is on the front of the battery box to alert servicing technicians that before doing any welding on the truck, always disconnect the battery charging alternator lead wire before making any welding repairs.

Turn the key switch to the OFF position and wait for the engine to stop. After the engine has stopped, wait two minutes, and if no warning message is displayed, then turn the battery disconnect switches to the OFF position. Then disconnect the battery charging alternator lead wire.

**NOTE:** *Always fasten the welding machine ground (-) lead to the piece being welded; grounding clamp must be attached as near as possible to the weld area.*

Never allow welding current to pass through ball bearings, roller bearings, suspensions, or hydraulic cylinders. Always avoid laying welding cables over or near the vehicle electrical harnesses. Welding voltage could be induced into the electrical harness and possibly cause damage to components.

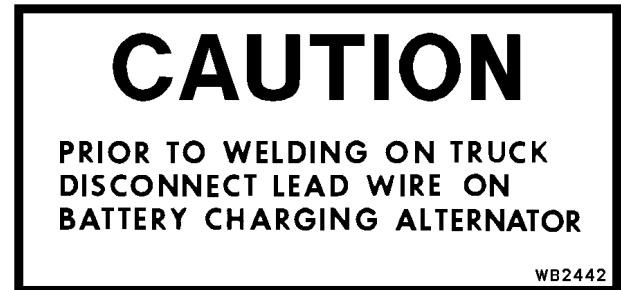

**LIFTING POINTS** E.12-0000051319

This page illustrates a variety of decals which are mounted on deck mounted cabinets, housings, and structures which must be lifted in a specific manner, and from specific points, in order to safely move or lift any of these structures.

If any of these decals are damaged or defaced, so that it is no longer legible, it must be replaced immediately.

**NOTE:** Maintenance personnel must follow these lifting instructions.

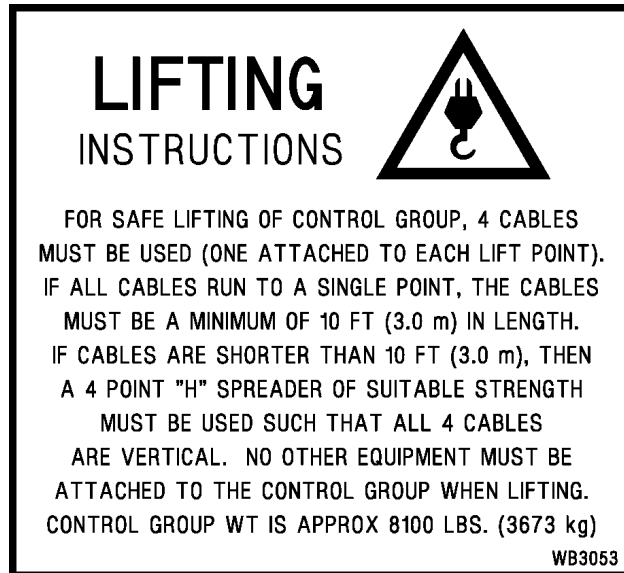
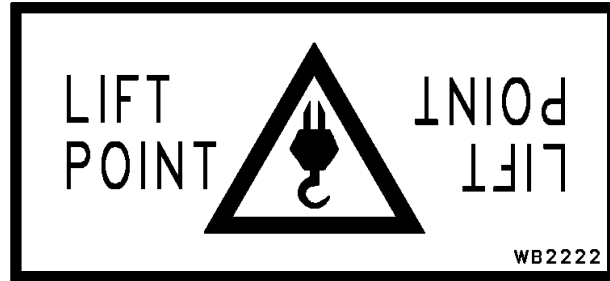



**LIFTING  
INSTRUCTIONS**



**FOR SAFE LIFTING OF GRID BOX, 4 CABLES  
MUST BE USED (ONE ATTACHED TO EACH LIFT POINT).  
ALL CABLES MUST RUN TO A SINGLE POINT. ALL  
CABLES MUST BE EQUAL, AND BE BETWEEN 7.5 (2.3)  
AND 15 FEET (4.6 m) IN LENGTH. NO OTHER EQUIPMENT  
MUST BE ATTACHED TO THE GRID BOX WHEN LIFTING.  
GRID BOX WT IS APPROX 5900 LBS. (2676 kg)**

WB2226

**EMERGENCY DUMPING** E.2-0000051378

A decal plate located on the frame near the left hoist cylinder provides the operator or technician with the hook-up procedure for dumping a loaded, disabled truck. The use of a functional truck for hydraulic power is required.

Refer to the shop manual for additional instructions for using this procedure.

**EMERGENCY DUMP PROCEDURE**

- 1. CONNECT A HYDRAULIC POWER SUPPLY CAPABLE OF 2500 PSI (17.2 MPa) WHICH HAS A RESERVE CAPACITY EXCEEDING 80 GAL. (303 l) TO THE QUICK DISCONNECTS ON L.H. HOIST CYLINDER.**
- 2. PLACE HOIST VALVE IN HOLD POSITION.**
- 3. DUMP LOAD AND LOWER BODY USING CONTROL VALVE ON HYDRAULIC POWER SUPPLY UNIT.**

WB2246

**AUTOMATIC LUBRICATION**

**FILL** D.3-0000051377

This decal is located on the automatic lubrication reservoir informing the technician that the cover must never be removed for filling purposes as there is potential for dirt or debris entering the system. Always fill the grease reservoir through the coupling provided where the grease passes through a filter before entering the reservoir.



**WARNING**

**DO NOT REMOVE COVER**

**FOR FILLING - PRESSURE  
FILL THRU FILTER**

WB2763

**ROPS/FOPS** C.4-0000051375

A plate attached to the right rear corner of the cab states the Rollover Protective Structure (ROPS) and Falling Object Protective Structure (FOPS) meet various SAE performance requirements.

**NOTE:** DO NOT make modifications to this structure, or attempt to repair damage without written approval from Komatsu. Unauthorized repairs will void certification.

<p>MACHINE MODEL <input type="text"/></p> <p>ROPS/FOPS NO. <input type="text"/></p> <p><b>AS INSTALLED BY THE MANUFACTURER ON THIS DUMPER HAVING WEIGHT WITHOUT BODY LESS THAN <input type="text"/> kg. THIS ROLLOVER PROTECTIVE STRUCTURE AND FALLING OBJECT PROTECTIVE STRUCTURE MEETS THE PERFORMANCE REQUIREMENTS OF ISO3449:2005(E) AND ISO3471:2008(E).</b></p> <p>Komatsu America Corporation 2300 NE Adams St. Peoria, IL 61650-0240 U.S.A.</p>	<p style="text-align: center;"><b>WARNING</b></p> <p>THE PROTECTION OFFERED MAY BE IMPAIRED IF SUBJECTED TO ANY MODIFICATIONS OR DAMAGE. TO MAINTAIN MANUFACTURERS CERTIFICATION: ANY REPAIR OR ALTERATION ON THIS STRUCTURE, INCLUDING INSTALLATION OF A NON-STANDARD SEAT, OR RELOCATION OF SEAT, MUST HAVE WRITTEN APPROVAL.</p>
-----------------------------------------------------------------------------------------------------------------------------------------------------------------------------------------------------------------------------------------------------------------------------------------------------------------------------------------------------------------------------------------------------------------------------------------------------------------	-------------------------------------------------------------------------------------------------------------------------------------------------------------------------------------------------------------------------------------------------------------------------------------------------------------------------------------

**TOWING** E.5-0000051374

A decal plate is located on the frame near the hydraulic tank. It provides the operator or technician with the hydraulic hook-up procedure before towing a disabled truck, by using a functional truck for hydraulic power. Refer to the [TOWING PROCEDURE](#), page 5-25 in this manual for additional instructions on towing.

**WARNING**

**EMERGENCY TOWING PROCEDURE**

1. ENGINE MUST BE STOPPED AND ACCUMULATOR(S) DISCHARGED.
2. EXTERNAL SUPPLY MUST BE ABLE TO MAINTAIN 3000 PSI AND HAVE A MIN. CAPACITY OF 20 GAL.
3. CONNECT EXTERNAL SUPPLY TO THE 'QD' SUPPLY AND 'QD' RETURN PORTS ON THE BLEEDOWN MANIFOLD.
4. CHECK OPERATION OF STEERING AND BRAKES.
5. PROCEED WITH TOWING OPERATION.

WB2443

**LUBRICATION CHART** E.6-0000051373

The lubrication chart is mounted on the left hand side of the radiator grille structure. Refer to the lube chart in the lubrication and service section later in this manual for more complete lubrication instructions.

**LUBRICATION CHART**

LUBRICATION SPECIFICATIONS

SW#	DESCRIPTION	PTS	LUBE	10 HR	90 HR	100 HR	250 HR	500 HR	1000 HR	2000 HR	2500 HR
1	CRANKCASE OIL LEVEL	1	A	CHECK							
2	ENGINE LUBE OIL FILTERS	1	A	CHECK							
3	FUEL FILTER										
4	FUEL REGULATOR (DAVCO)										
5	FUEL TANK	1									
6	DE PRE-FILTER BLOWER	1	D								
7	FUEL TANK BREATHER	1	B	CHECK							
8	HYDRAULIC OIL LEVEL	1	B	CHECK							
9	HYDRAULIC STRAINER	2									
10	HYDRAULIC TANK BREATHER	2									
11	HYDRAULIC FILTERS	3									
12	MOTORIZED WHEEL OIL LEVEL	2	C								
13	HYD. PUMP DRIVE SHAFT	2	D								
14	CHASSIS LUBE LEVEL	1	D								
15	SEAT SLIDES & STEER SHAFT	4	D								
16	WHEEL MOTOR BLOWER	2	D								
17	FRONT WHEEL BEARINGS ***	2	E								
18	FRONT PUMP	1	D								
18	MAGNETIC PLUG	2									
18	FRONT WHL COVER ****	2									

SEE ENGINE MANUAL

630E, 730E, 830E, & 930E

\* 1000 HR INTERVAL CAN BE EXTENDED TO 2500 HR PROVIDED OIL SAMPLING AND ANALYSIS IS CONDUCTED EVERY 250 HR.  
 \*\* ONE TIME CHANGE AT 50, 100 AND 250 HR.  
 \*\*\* NOT APPLICABLE FOR 930E.  
 \*\*\*\* APPLICABLE FOR 930E ONLY.

WB2790

# OPERATING INSTRUCTIONS

## **WARNING**

**Read and follow all safety precautions. Failure to do so may result in serious injury or death.**

---

This safety section also contains precautions for optional equipment and attachments.

## PREPARING FOR OPERATION C.16-0000060900

The safest trucks are those which have been properly prepared for operation. At the beginning of each shift, a careful check of the truck must be made by the operator before starting the engine.

### Safety Is Thinking Ahead

Prevention is the best safety program. Prevent a potential accident by knowing the employer's safety requirements, all necessary job site regulations, as well as use and care of the safety equipment on the truck. Only qualified operators or technicians can operate or maintain a Komatsu truck.

Safe practices start before the operator gets to the equipment!

- Wear the proper clothing. Loose fitting clothing, unbuttoned sleeves and jackets, jewelry, etc., can catch on a protrusion and cause a potential hazard.
- Always use the personal safety equipment provided for the operator such as hard hats, safety shoes, safety glasses or goggles. There are some conditions when protective hearing devices must also be worn for operator safety.
- When walking to and from the truck, maintain a safe distance from all machines, even if the operator is visible.

### Walk Around Inspection

At the beginning of each shift, a careful walk around inspection of the truck must be performed before the operator attempts engine start-up. A walk around

inspection is a systematic ground level inspection of the truck and its components to ensure that the truck is safe to operate before entering the operator's cab.

Start at the left front corner of the truck (Figure 5-1 [WALK AROUND INSPECTION, page 5-3](#)), and move in a counter-clockwise direction. Move front-to-rear, across the rear, and continuing forward up the opposite side of the truck to the original starting point.

If these steps are performed in sequence, and are repeated from the same point and in the same direction before every shift, many potential problems may be avoided, or scheduled for maintenance. Unscheduled downtime and loss of production can be reduced as a result.

Local work practices may prevent an operator from performing all tasks suggested here. To the extent permitted, the operator must follow this or a similar routine.

### DANGER

- **High voltage may be present on this truck! DO NOT open any electrical cabinet doors on the truck while the engine is operating! Never climb on any power cables or use power cables for handholds or footholds, unless the engine has been shut off and the system has been verified as at rest!**

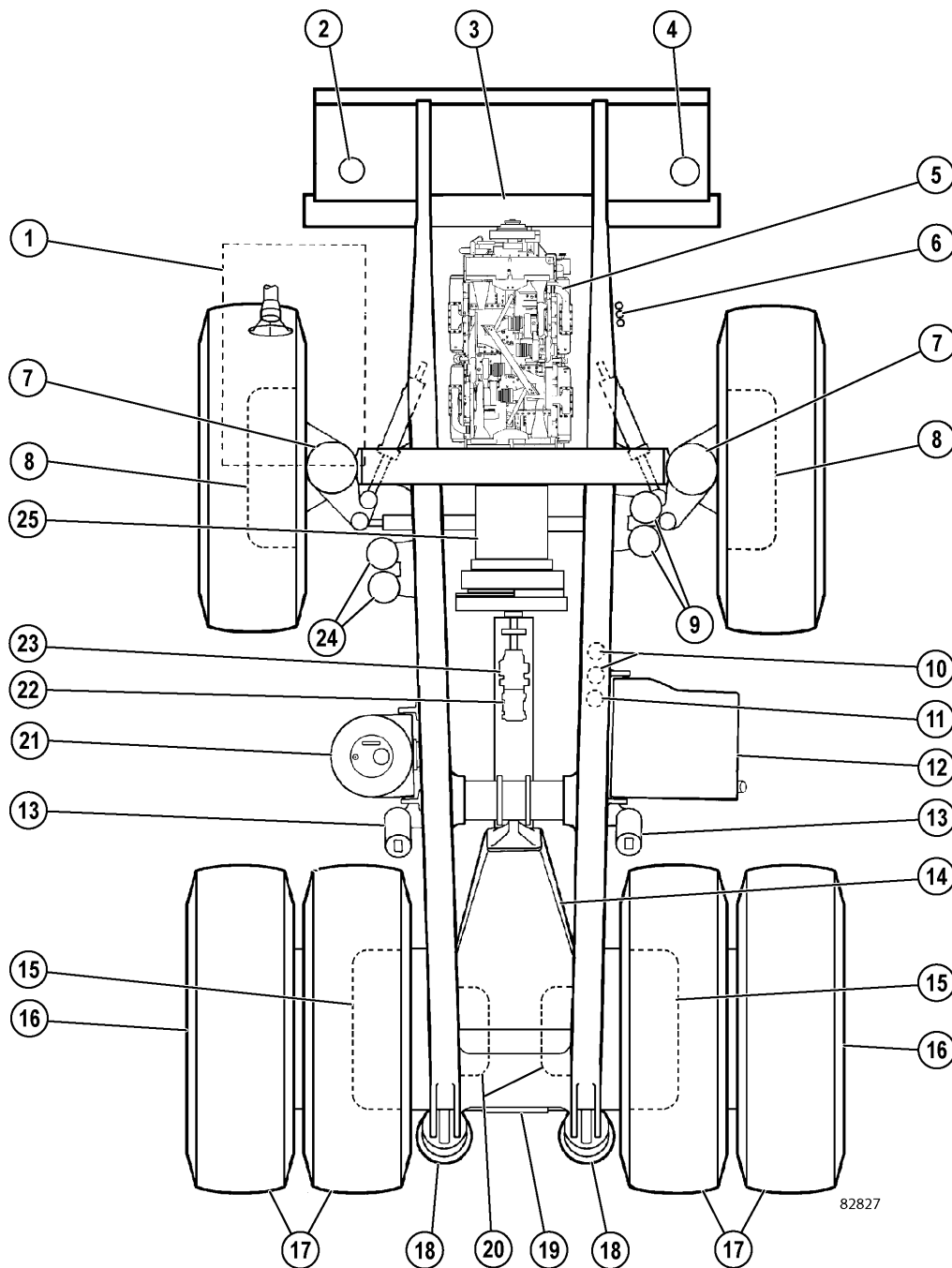

82827

- |                       |                              |                           |
|-----------------------|------------------------------|---------------------------|
| 1. Operator Cab       | 10. Hoist Filters            | 18. Rear Suspension       |
| 2. Auto Lubrication   | 11. Steering Filter          | 19. Rear Axle Hatch       |
| 3. Radiator           | 12. Fuel Tank                | 20. AC Electric Motor     |
| 4. Reserve Oil System | 13. Hoist Cylinder           | 21. Hydraulic Tank        |
| 5. Engine             | 14. Rear Axle Housing        | 22. Steering Pump         |
| 6. Fuel Filters       | 15. Wet Disc Brake           | 23. Hoist Pump            |
| 7. Suspension         | 16. Wheel Motor Transmission | 24. Steering Accumulators |
| 8. Wet Disc Brake     | 17. Rear Tires               | 25. Alternator            |
| 9. Brake Accumulators |                              |                           |

**Figure 5-1 WALK AROUND INSPECTION**

1. Start at left front of the truck. While performing the walk around inspection, visually inspect

all lights and safety equipment for external damage from rocks or misuse. Ensure lenses

- are clean and unbroken. Make sure that the battery box covers are in place and secure.
2. Inspect auto lube system. Refer to [AUTOMATIC LUBRICATION SYSTEM, page 5-43](#), for specific details concerning the auto lube system.
  3. Move in front of the left front tire. Inspect the hub and brake assemblies for leaks and any abnormal conditions.
  4. Check that all suspension attaching hardware is secure and inspect the mounting key area for evidence of wear. Check that the suspension rod extension is correct, and that there are no leaks. Ensure the suspension protective boot is in good condition.
  5. Inspect the anchor end of the steering cylinder for proper greasing and all parts are secure.
  6. With the engine stopped, check the engine oil level. To obtain an accurate measurement, remove the dipstick and wipe it off. Then reinsert the dipstick and remove it again to check the oil level. Use the service light if necessary.
  7. Inspect air conditioner belts for obvious wear. Check the security and condition of the fan guard. When leaving this point, turn off the service light, if used.
  8. Move outside of the front wheel. Ensure that all of the mounting nuts/studs are in place and tight. Check the tires for cuts, damage, or bubbles. Check for evidence of incorrect tire inflation.
  9. Move in behind the front wheel. Ensure that the steering cylinder is properly greased and the mounting hardware is tight. Check the suspension mounting hardware and suspension extension. Ensure that the suspension protective boot is in good condition. Inspect the hub and brakes for any unusual conditions. Check the entire area for leaks.
  10. Inspect the sight glass on hydraulic tank. With the engine stopped and the body down, the hydraulic oil level must be visible in the center of the upper sight glass.
  11. If equipped, verify all hydraulic tank shut off valves are locked in their fully open positions.
  12. Move around the hydraulic tank and in front of the rear dual tires. Inspect hoist cylinder for any damage and leaks. Inspect both upper and lower hoist cylinder pins for integrity and for proper greasing.
  13. Look under the lower edge of the chassis to ensure the flexible duct that carries the air from the blower to the final drive housing is in good condition with no holes or breakage. Also, look up at the main hydraulic pumps to see that there is no leakage or any other unusual condition with the pumps or the pump drive shafts.
  14. Move around the left side dual tires. Ensure that all wheel nuts/studs are in place and tight. Inspect the wheel for any oil that would indicate brake leakage or wheel motor leakage.
  15. Check the dual tires for cuts, damage or bubbles. Verify that inflation appears to be correct. If the truck has been operating on a flat tire, the tire must be cool before moving the truck inside a building. Check for any rocks that might be lodged between the dual tires.
  16. Inspect the left rear suspension for damage and for correct rod extension. Check for leaks. Ensure that the covers over the chrome piston rod are in good condition. Inspect for proper greasing.
  17. Open the rear hatch cover. Inspect for leaks around the parking brakes. Ensure the cooling air exhaust ductwork is intact and there are no obstructions.
  18. While standing in front of the rear hatch, look up to see that rear lights are in good condition, along with the back-up horns. Look up at the anti-sway bar to see that it is getting proper greasing. Also look at both body hinge pins for greasing and any abnormal condition. Check the hoist limit switch and clear any mud/debris.
  19. Perform the same inspection on the right rear suspension as done on the left.
  20. Move around the right dual tires. Inspect between the tires for rocks. Inspect the tires for cuts or damage, and for correct inflation.
  21. Ensure that all wheel nuts/studs are in place and tight. Inspect the wheel for any oil that would indicate brake leakage or wheel motor leakage.
  22. Move in front of the right dual tires and inspect hoist cylinder in the same manner as the left side. Check integrity and condition of the body-up limit switch. Remove any mud/dirt accumulation from the switch.
  23. Move around the fuel tank. Inspect the mounting hardware for the fuel tank at the

upper saddles and at the lower back side of the tank. Check the hoist filters for leaks.

24. Move in behind the right front wheel. Ensure that the steering cylinder is properly greased and the mounting hardware is secure. Check the suspension mounting hardware and suspension extension. Ensure that the suspension protective boot is in good condition. Inspect the hub and brakes for any unusual conditions. Check the entire area for leaks.
25. Move outside of the front wheel. Ensure that all of the mounting nuts/studs are in place and tight. Check the tires for cuts, damage, or bubbles. Check for evidence of incorrect tire inflation.
26. Move in behind the front of the right front wheel, check the hub and brakes for leaks and any unusual condition. Inspect the steering cylinder for secureness and for proper greasing. Inspect the engine compartment for any leaks and unusual conditions. Inspect the fan guard and belts. Check for any rags or debris behind the radiator.
27. Move around to the right front of the truck. If equipped, check the oil level in the reserve tank.
28. While in front of the radiator, inspect for any debris in the radiator and remove. Check for any coolant leaks. Inspect headlights and fog lights.
29. Before climbing the ladder to first level, ensure that the ground level engine shutdown switch is ON. If equipped, inspect the fire control actuator. Ensure that the safety pin and the plastic tie that prevents accidental actuation are in place and in good condition. Ensure that the battery disconnect switches are activated.
30. Always use handrails and the ladder when mounting or dismounting the truck. Clean the ladder and steps and hand rails of any foreign material, such as ice, snow, oil or mud.
31. Use the stairs and handrails while climbing from the first level to the cab deck.

### WARNING

- **Always mount and dismount ladders facing the truck. Never attempt to mount or dismount while the truck is in motion.**

32. If equipped with a retractable ladder system:

- a. Visually inspect the ladder for mechanical damage. If movement is impaired in any way, the assembly must be repaired.
  - b. Visually inspect for cleanliness. Ensure the ladder is dry and free from grease and oil.
  - c. Ensure correct oil level is maintained in the reservoir.
  - d. Raise and lower the ladder. Check for loose parts or any adverse noise conditions.
  - e. Ensure the movement alarm and both UP and DOWN LEDs operate correctly.
  - f. Check for any change in equipment appearance, especially that which will affect ladder system stability.
33. Use the coolant level sight gauge to check the coolant level in the radiator. If it is necessary to remove the radiator cap, ensure that the engine is off, then relieve the coolant pressure by *slowly* removing the radiator cap.

### WARNING

- **If the engine has been running, allow the coolant to cool before removing the fill cap or draining the radiator. Serious burns may result if skin comes in contact with hot coolant.**

34. Inspect the covers over the retarding grids and ensure they are secure. Inspect the main air inlet to ensure it is clear. Ensure all cabinet door latches are secure.
35. Move to the back of the cab. Open the doors to the brake cabinet and inspect for leaks.
36. Clean the cab windows and mirrors. Clean out the cab floor as necessary. Ensure steering wheel, controls and pedals are free of any oil, grease or mud.
37. Stow personal gear in the cab in a manner that does not interfere with truck operation. Dirt or trash buildup, specifically in the operator's cab, must be cleaned. DO NOT carry tools or supplies in the cab of the truck or on the decks.
38. Adjust the seat and the steering wheel for use.
39. Read and understand the description of all operator controls. Become familiar with all control locations and functions before operating the truck.
40. If equipped, raise the retractable ladder using the in cab control panel.

## RETRACTABLE LADDER SYSTEM (If Equipped) E.3-0000051316

### GENERAL INFORMATION

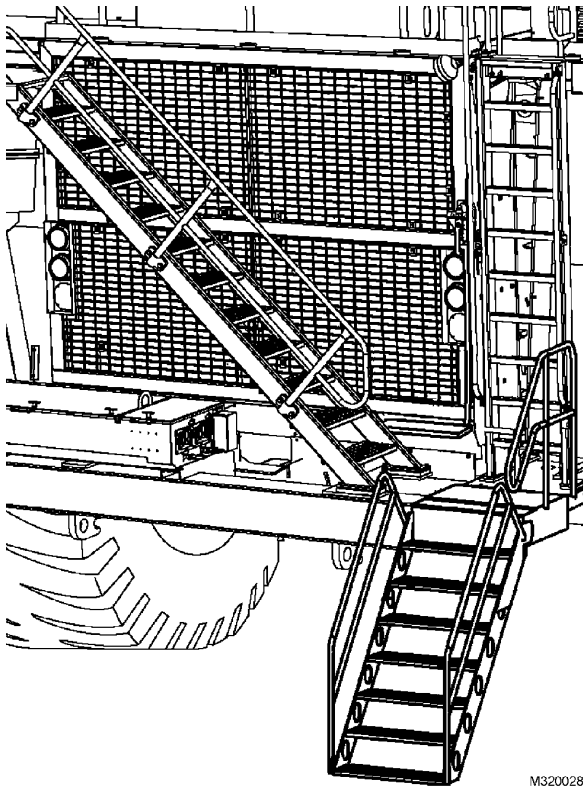

**Figure 5-2 RETRACTABLE LADDER SYSTEM**

The following safety procedures, at a minimum, must be followed to ensure safe operation and use of the Retractable Ladder System (RLS).

1. DO NOT run or jump on the ladder.
2. DO NOT overload the ladder. Use the ladder one person at a time.
3. Hold onto the handrail when using the ladder.
4. Face the ladder when ascending or descending.
5. DO NOT attempt to ride on the ladder while it is being raised or lowered or while the truck is in motion.
6. Visually check the ladder before use to ensure the unit has not been damaged.
7. Ensure the ladder is in the fully down position before boarding.
8. Keep hands and fingers away from pinch points while the ladder is in motion.

9. Check to ensure no personnel are on or in the immediate vicinity of the ladder while it is in motion.
10. The ladder must be kept clean and free of moisture, grease and oil.
11. When in the truck's cab, always use the in-cab control panel to raise the ladder.
12. Report defects to maintenance personnel immediately.

### LADDER SYSTEM DESCRIPTION

The RLS is an electro-hydraulic ladder powered by the truck's 24VDC electrical system. The RLS provides a safe means to mount and dismount the truck under normal and emergency conditions. The RLS consists of two main control components, the in-cab control panel and the power pack that operates the ladder.

- The in-cab control panel is a microprocessor that controls, monitors, stores and reports ladder system operational data.
- The electro-hydraulic power pack is in a ground level stainless steel cabinet. It houses the main control hydraulics and electrical components that lower and raise the ladder.

The RLS also contains wiring harnesses, hydraulic hoses and an emergency down valve.

### LADDER SYSTEM OPERATION

During normal operation, a person can lower or raise the RLS by using the following components:

- In-cab control panel
- Emergency down valve

**NOTE:** The master disconnect switch located in the isolation box and the isolation switch in the power pack must both be in the ON position for the RLS to operate.

As an added safety measure, the RLS uses a parking brake interlock that requires the parking brake to be set before the ladder can be operated under normal conditions. The RLS will automatically raise the ladder if the operator moves the directional control lever out of PARK and fails to press the [UP] button on the in-cab control panel before attempting to drive the truck.



**In-Cab Control Panel**

**⚠ CAUTION**

- **When in the operator’s cab, always use the [UP] button on the control panel to raise the ladder instead of moving the directional control lever out of PARK. The automatic operation of the ladder when the parking brake is released is an emergency feature only. DO NOT move the directional control lever out of PARK to raise the ladder as part of normal operation.**

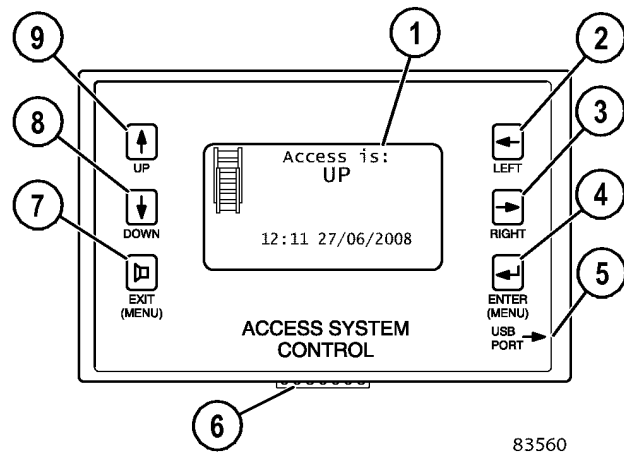

- |                   |                        |
|-------------------|------------------------|
| 1. Display Screen | 6. 15-Pin Harness Plug |
| 2. [LEFT] Button  | 7. [EXIT] Button       |
| 3. [RIGHT] Button | 8. [DOWN] Button       |
| 4. [ENTER] Button | 9. [UP] Button         |
| 5. USB Port       |                        |

**Figure 5-3 IN-CAB CONTROL PANEL**

The in-cab control panel is located on the left side of the dash and contains a microprocessor that controls, displays, monitors, stores, and reports ladder system operational data. The in-cab control panel provides real time position of the ladder to the operator.

The in-cab control panel features a digital display screen, command buttons ([UP], [DOWN], [ENTER], [EXIT], [LEFT], [RIGHT]) for operating the ladder and navigating through the various menu display screens, a USB key port and RS 232 port for downloading ladder system operational data to a laptop computer for troubleshooting. Refer to Figure 5-3 IN-CAB CONTROL PANEL, page 5-7.

While the ladder is in motion, the direction (up or down) can be changed by pressing the opposite direction ([UP] or [DOWN]) button on the control panel.

If the IN CAB LOCKOUT message is displayed on the control panel screen, then the RLS can only be operated from the ground level control box mounted next to the battery isolation box. All other control panel functionality is still available including fault indication and audible alarms.

**Digital Display Screen**

In-cab control panel display screen (1, Figure 5-3 IN-CAB CONTROL PANEL, page 5-7) provides the user with system status, error/fault messages, and a visual indicator of the ladder’s position (lowered, raised, and in motion).

**Command Buttons**

[LEFT] button (2) is for scrolling left when entering a password.

[RIGHT] button (3) is for scrolling right when entering a password.

[ENTER] button (4) is a multi-function button used for ladder system alarm acknowledgement and menu access when in Display Mode. This button is also used to confirm or accept changes shown on the display screen. Press this button to confirm or accept changes listed on the display screen.

[EXIT] button (7) is a multi-function button used for ladder system alarm acknowledgement and menu access when in Display Mode. This button is also used to exit from the menu screens. Press this button to exit from menu screens.

[DOWN] button (8) is a dual function control that is used to lower the ladder during normal operation and scroll through the menu displays. Pressing this button and holding it briefly will cause the ladder to lower. Pressing and releasing this button one time will scroll down one line of menu display, and holding it will result in continuous menu scrolling.

[UP] button (9) is a dual function control that is used to raise the ladder during normal operation and scroll through the menu displays. Pressing this button and holding it briefly will cause the ladder to raise. Pressing and releasing this button one time will scroll up one line of menu display, and holding it will result in continuous menu scrolling.

**Raising the Ladder**

The ladder will typically be in the lowered position on a stationary truck. The in-cab control panel will indicate that the access is DOWN, as shown here:

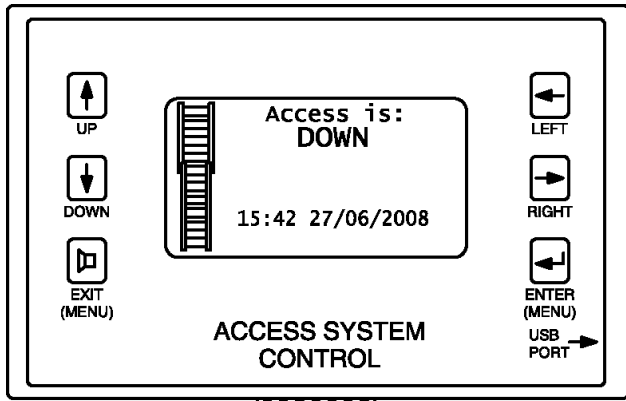

M320011

To raise the ladder, press and hold (temporarily) the [UP] button located on the in-cab control panel. The illustrated ladder on the screen will animate and begin to rise to the UP position and the UP arrow (on the control panel button) will flash. When the ladder is completely raised, the [UP] button will remain illuminated continuously.

When the ladder has reached its raised travel position and strikes the limit switch, the control panel will indicate that the access is UP, as shown here:

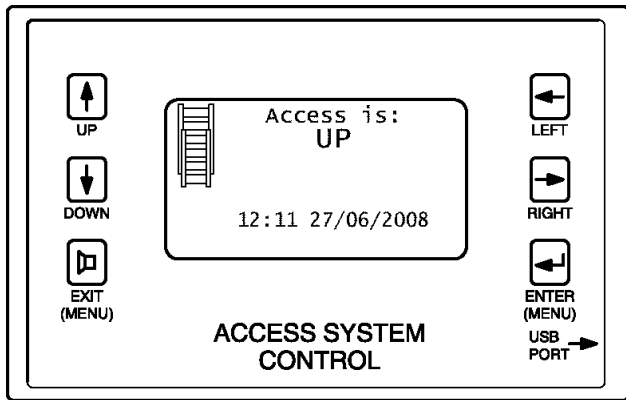

M320002

The RLS power pack will continue to operate for three more seconds to charge hydraulic accumulator. During this time, the UP arrow will continue to flash until the cycle is complete.

The RLS uses a limit switch to monitor ladder travel to the UP position. If the ladder fails to strike the limit switch or the limit switch fails to close, a fault alarm will activate after a short delay and the in-cab control panel will display this message, as shown here:

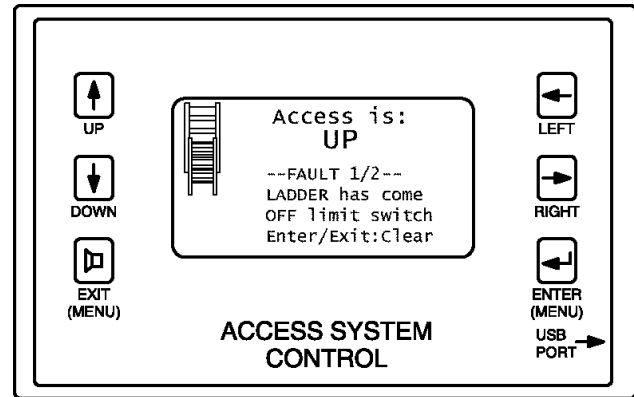

M320003

**NOTE:** The fault alarm must be acknowledged by pressing the [EXIT] or [ENTER] buttons on the control panel. Once the alarm has been acknowledged, the fault message will be replaced by a FAULT IN SYSTEM message. A defective limit switch will prevent normal RLS operation and must be corrected immediately.

**Lowering the Ladder**

**NOTE:** The directional control lever must be in PARK before the ladder can be lowered.

To lower the ladder, press and hold (temporarily) the [DOWN] button located on the in-cab control panel. The illustrated ladder on the screen will animate and begin to lower to the DOWN position and the [DOWN] button will flash.

When the ladder has reached its lowered travel position, the control panel will indicate that the access is DOWN, as shown here:

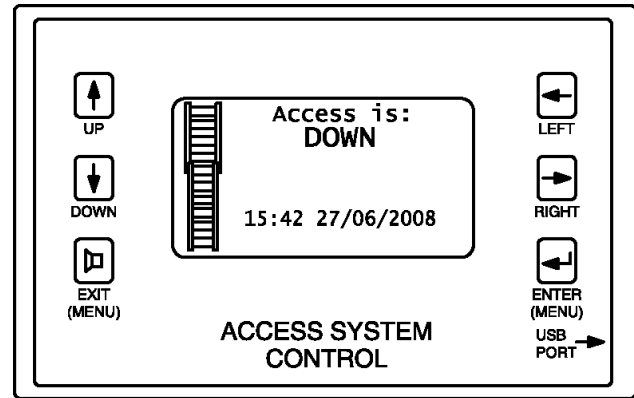

M320011

When the ladder is completely lowered, the [DOWN] button will remain illuminated continuously.

## Ground Level Control Box

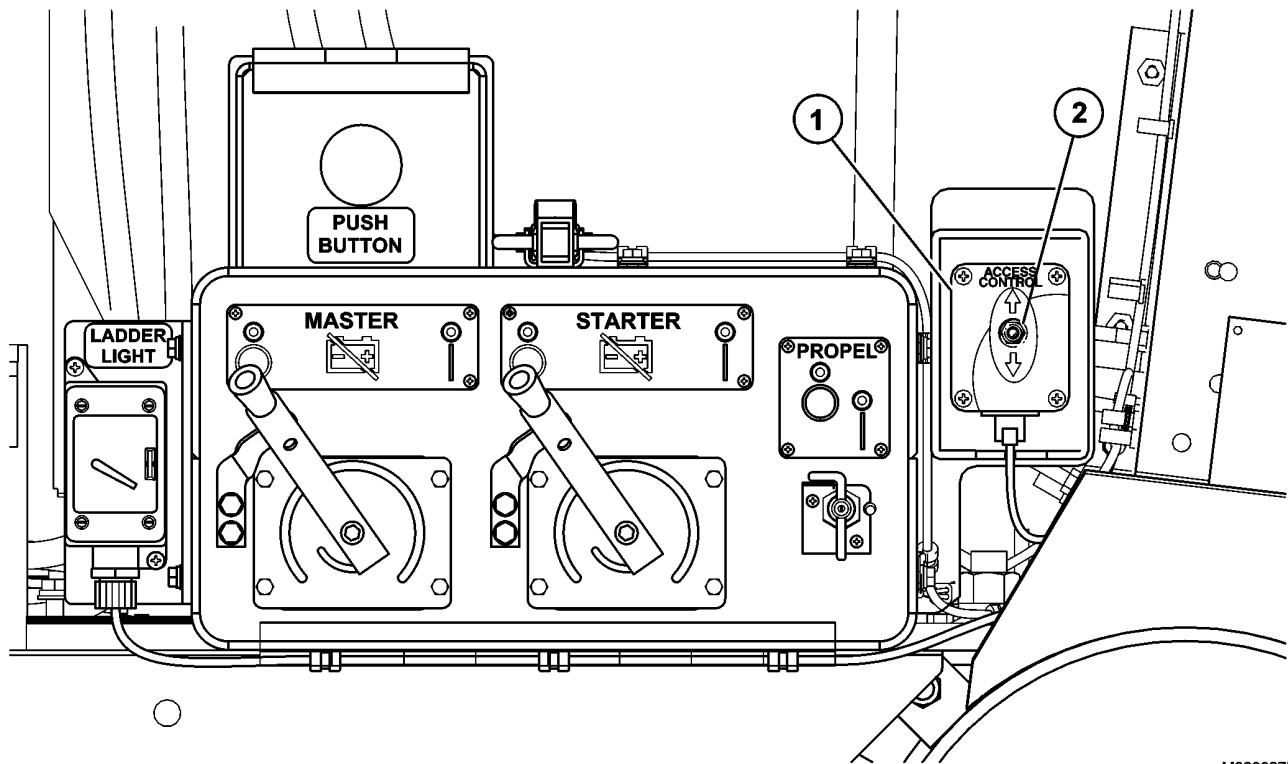

M320027R1

1. Ground Level Control Box

2. Toggle Switch

**Figure 5-4 GROUND LEVEL CONTROL BOX**

Ground level control box (1, Figure 5-4 GROUND LEVEL CONTROL BOX, page 5-9) is located next to the battery isolation box and contains toggle switch (2) that lowers and raises the ladder.

**NOTE:** The parking brake must be applied before the ladder can be lowered. If toggle switch (2) is held in either position for more than ten seconds, a fault will be activated and will need to be acknowledged by pressing either the [EXIT] or [ENTER] buttons located on the in-cab control panel.

**Raising the Ladder**

To raise the ladder, push toggle switch (2) to the LADDER UP position and release. Ladder operation via this switch is the same as using the in-cab control panel. Any ladder movement will be shown on the in-cab control panel.

**Lowering the Ladder**

To lower the ladder, push toggle switch (2) to the LADDER DOWN position and release. Ladder operation via this switch is the same as using the in-cab control panel. Any ladder movement will be shown on the in-cab control panel.

## Emergency Down Valve

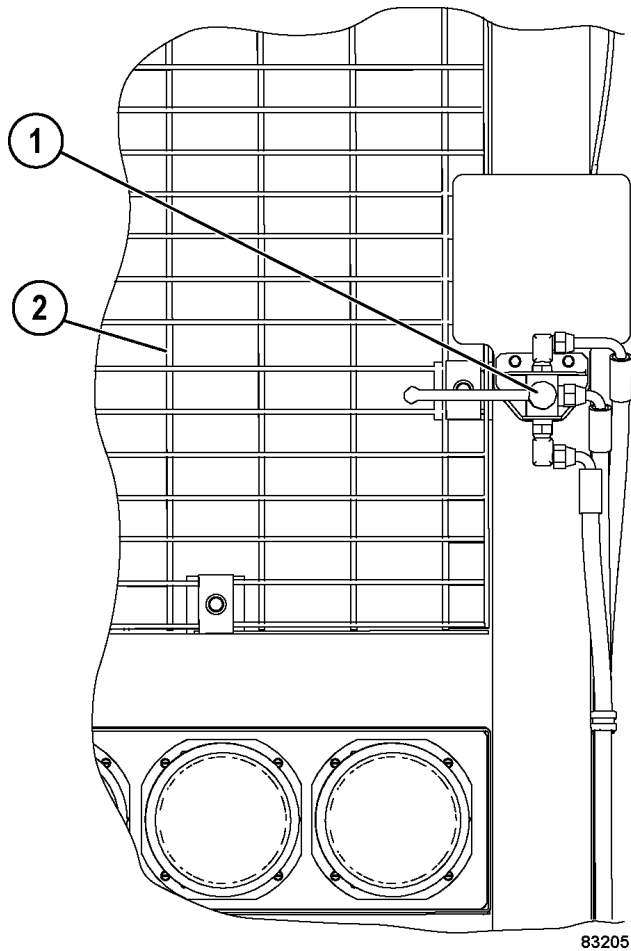

1. Emergency Down Valve
2. Grille

Figure 5-5 EMERGENCY DOWN VALVE

In an emergency, the RLS ladder can be lowered by using the emergency down valve (1, Figure 5-5 EMERGENCY DOWN VALVE, page 5-10) mounted on the frame above the left hand side headlight assembly. The emergency down valve relieves ladder system hydraulic pressure and allows the ladder to smoothly lower to the ground.

To lower the ladder, rotate the handle on the emergency down valve clockwise. The ladder will lower smoothly until it reaches the ground.

To reset the ladder, rotate the handle counterclockwise to its original position and, with power restored to the power pack, press the [UP] button to raise the ladder.

**NOTE:** The handle on the emergency down valve must be in the original position before re-activating the ladder.

**PRE-SHIFT BRAKE TEST** B.5-0000051681

**NOTE:** *Komatsu recommends that operators perform static brake tests to verify that the braking systems are adequate at the beginning of each shift before operating the truck.*

The static brake test allows the operator to check the service brake, parking brake and the dynamic retarder. The purpose of these tests is to verify the functionality of the service brake, parking brake and retarder systems at the time they are tested.

After performing each test, it is the operator's responsibility to determine if the truck passed each test and if the truck is safe for operation.

The order of performing the brake tests, (service brake, parking brake or retard system) does not matter. Each brake test is a separate test, where one brake system or all three can be tested at any time.

**⚠ WARNING**

- **If the truck fails any brake test, notify maintenance personnel immediately. Do not resume operation unless the truck passes all brake tests.**

**OPERATION**

The static brake test utilizes a momentary switch and a check light located on the dash panel.

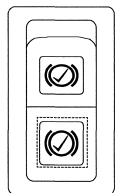

The brake test switch is used to initiate a brake test. Press on the momentary switch to enter the brake test mode. If certain conditions are met, the operator can enter a brake test sequence.

The amber light in the top of the switch is used to indicate when the truck is in brake test mode, and is referred to as the brake check light. When illuminated, a brake test is ready. When flashing, the brake test is at the validation point, or the retard system test is finished.

The operator can choose which brake test to perform, and will set the truck controls based on the settings in Table 1. The drive system will detect the position of the directional control lever, and will prepare for the appropriate test. The operator will then press the brake test switch.

If the brake check light is illuminated solid after pressing the brake test switch, the system is in brake test mode and is ready for the chosen test to be

initiated by the operator. After testing, the operator will then determine if the truck passed the brake tests, and if it is safe for operation.

If the brake check light does not illuminate immediately after pressing the brake test switch, there is most likely a problem with the setup. Refer to the setup conditions and take action to prepare the truck for a brake test.

If there is a problem with the truck setup, the DID panel will display the problem.

For example if the engine is off:

- ERROR: Entering Brake Test, Engine Not Running

If the Truck is loaded:

- ERROR Entering Brake Test, Truck is Not Empty

If all of the conditions are correct, except the brakes are not set correctly, an error message will be displayed. For example, if the service brake and parking brake are both applied together:

- ERROR Entering Brake Test, Set Brakes for Test

Test Type	Wheel Brake Lock	Service Brake Pedal	Directional Control Lever
Service Brake	Off	Fully Applied	Neutral
Parking Brake	Off	Released	Park
Retard Test	Off	Released	Park

**NOTE:** *The drive system will not enter any brake test if the truck is loaded.*

Before performing any brake test, the following conditions must be met:

- Dump body is empty.
- Truck located outside on a flat area, where truck movement is allowed.

**⚠ WARNING**

- **Ensure the area around the truck is free of personnel and objects. Some truck movement could occur during brake testing.**
- **The drive system is unable to determine if the truck is on a hill or in a parking ditch. Testing during these conditions will affect test results.**

Before performing any brake test, the truck must be in the following state:

- Engine at (low idle)
- Drive system ready (Ready Mode)
- Dump body down
- Can not be in LIMP mode.
- Zero ground speed

### Service Brake Test

#### WARNING

- **If the truck fails any brake test, notify maintenance personnel immediately. Do not resume operation unless the truck passes all brake tests.**

To perform the service brake test, obey the following guidelines:

1. Firmly depress the service brake pedal.
2. Place the directional control lever in the NEUTRAL position. Ensure the wheel brake lock switch is OFF.
3. Press the brake test switch and wait for the brake check light to be on solid.
4. Fully depress the service brake pedal. Ensure full brake application is reached. Failure to reach full brake application will affect the service brake test results.

The DID panel will display:

“Service Brake Test READY, Press Accel Pedal to Start”

5. With the service brake pedal still fully applied, fully depress the accelerator pedal. The drive system controller will enter propel mode and generate torque up to the service brake limit. Maintain full service brake pressure during the test.

The DID panel will display:

“Service Brake Test ACTIVE, Check Truck Movement when Light Flashes”

**NOTE:** *The drive system can only detect if the service brakes are applied. It can not detect the percentage of application. It is up to the operator to press hard enough on the service brake pedal to achieve a full brake application.*

6. Once torque has reached the limit for the service brake test, the brake check light will

begin to flash. This is the indication for the operator to make a determination as to the status of the service brake system.

- If the truck did not move, the service brake system passed the test.
  - If the truck moved during the test, the service brake system failed the test.
7. Release the accelerator pedal and the torque will be reduced, the test will stop and the brake check light will turn off.
  8. Place the directional control lever in the PARK position. Release the service brake pedal.
  9. If the truck failed the service brake test, notify maintenance personnel immediately.

**NOTE:** *If the operator partially or fully releases the accelerator pedal during the test, torque will be reduced and the brake check light will go back on solid when torque falls below the test set point. The operator can re-apply the accelerator pedal to increase torque and the brake check light will again flash when the torque is at the test limit.*

If the test exits abnormally, or if the operator simply does not press the accelerator pedal far enough to achieve the torque level for the service brake test, the DID panel will display:

“Brake Test ERROR, Test did NOT complete”

### Parking Brake Test

#### WARNING

- **If the truck fails any brake test, notify maintenance personnel immediately. Do not resume operation unless the truck passes all brake tests.**

To perform the parking brake test, obey the following guidelines:

1. Place the directional control lever in the PARK position.
2. Press the brake test switch and wait for the brake check light to be on solid.

The DID panel will display:

“Parking Brake or Retard Test READY, Press Accelerator or Retard Pedal to Start”

3. Fully depress the accelerator pedal. The drive system controller will enter propel mode and generate torque up to the park brake limit.

The DID panel will display:

“Park Brake Test ACTIVE, Check Truck Movement when Light Flashes”

4. Once the torque has reached the limit for the parking brake test, the brake check light will begin to flash. This is the indication for the operator to make a determination as to the status of the parking brake system.
  - If the truck did not move, the park brake system passed the test.
  - If the truck moved during the test, the park brake test has failed. Release the accelerator pedal. If the truck starts to roll, apply the service brakes to hold the truck stationary. Notify maintenance personnel immediately.
5. When the operator releases the accelerator pedal, torque will be reduced. The test will stop and the brake check light will turn off.

### Retard System Test

#### WARNING

- **If the truck fails any brake test, notify maintenance personnel immediately. Do not resume operation unless the truck passes all brake tests.**

To perform the retard system test, obey the following guidelines:

1. Place the directional control lever in the PARK position.
2. Press the brake test switch and wait for the brake check light to be on solid.

The DID panel will display:

“Parking Brake or Retard Test READY, Press Accel or Retard Pedal to Start”

3. Fully depress the retard pedal. The drive system controller will ramp up the engine speed, close RP1, close RP2, close RP3

(if present), turn on the choppers, and test the retarding system. The system will verify current flow through each grid leg and the grid blower motor.

4. The DID panel will display the current status of the test.

“Retard System Test ACTIVE, RP1, RP2, RP3, CHOP” (Elements are added as the test progresses.)

Upon successful completion of the test, the light will flash for 10 seconds indicating a successful test. The DID panel will display:

“Retard System Test PASSED”

“Retard System Test FAILED or Incomplete”

**NOTE:** *If the brake check light never flashes, but turns off, the test has failed.*

5. When the operator releases the retard pedal, the test will stop and the brake check light will turn off.
6. If the retard system failed the test, notify maintenance personnel immediately. Do not resume operation unless the truck passes all brake tests.

### Brake Test Exit Criteria

Conditions which may interrupt a brake test, including the following:

- Any of the setup conditions becoming false
- Drive system fault which restricts the LINK or Propel mode
- Truck Speed greater than 3.2 kph (2.0 mph)
- Drive system at torque level for more than 30 seconds
- Brake test requested, but not initiated by the operator within 60 seconds after pressing the brake test switch

**TRUCK OPERATION** C.3-0000051314**ENGINE START-UP SAFETY** C.13-0000051311**⚠ DANGER**

- **Never attempt to start the engine by shorting across the cranking motor terminals. This may cause a fire, or serious injury or death to anyone in the machine's path.**

**NOTE:** Start the engine from the operator's seat only.

Always obey the following guidelines when starting the engine:

1. Ensure all personnel are clear of the truck before starting the engine. Always sound the horn as a warning before actuating any operational controls. If the truck is in an enclosure, ensure there is adequate ventilation before start-up. Exhaust fumes are dangerous!
2. The directional control lever must be in the PARK position before starting.

**NOTE:** The park brake will always be applied whenever the directional control lever is in the park position and the truck is moving slower than 0.5 mph.

3. Move the rest switch to the ON position to put the drive system in rest mode of operation. Refer to the Instrument Panel section for information about the rest switch.
4. If the truck is equipped with auxiliary cold weather heater system(s), DO NOT attempt to start the engine while the heaters are in operation. **Damage to coolant heaters will result!**
5. The key switch is a four position (ACC, OFF, RUN, START) switch. The ACC position is not currently used. When the switch is rotated one position clockwise, it is in the RUN position and all electrical circuits (except START) are activated. Turn key switch to the RUN (not START) position. Verify that all indicator lights and gauges are functioning.
6. With the directional control lever in PARK, and after the message "System Initializing" is displayed on the dash, rotate the key switch fully clockwise to the START position, and hold this position until the engine starts (see NOTE below). The START position is spring-loaded and will return to RUN when the key is released.

**NOTE:** This truck is equipped with an engine prelube system. With this feature, a noticeable time delay may occur (while engine lube oil passages are being filled and pressurized) before engine cranking will begin.

7. After the engine has started, place the rest switch in the OFF position to enable the drive system.

**NOTE:** The electric cranking motors have a 30 second time limit. If the 30 second limit is reached, cranking will be prohibited for two minutes. After two minutes, cranking will be allowed. If the 30 second limit is reached seven consecutive times, the key switch must be turned to the OFF position. This will allow the interface module to power down and reset, which requires seven minutes to complete.

**After Engine Has Started**

1. Become thoroughly familiar with steering and emergency controls. After the engine has been started, DO NOT accelerate engine speed or drive truck until low pressure and warning systems are normal, and the coolant temperature is at least 71° C (160° F).
2. With the service brakes applied, move the directional control to the NEUTRAL position, then apply the wheel brake lock. Release the service brakes. Test the truck steering in extreme right and left directions. If the steering system is not operating properly, shut the engine off immediately. Determine the steering system problem and have it repaired before resuming operation.
3. Operate each of the truck's brake circuits at least twice prior to operating and moving the truck. These circuits include individual activation from the operator's cab of the service brake, parking brake, and wheel brake lock. With the engine running and with the hydraulic circuit fully charged, activate each circuit individually.

To operate each brake circuit, perform the following:

- a. Park the truck on level ground.
- b. To operate the park brake, place the directional control lever in the PARK position.
- c. To operate the wheel brake lock, apply the service brake and move directional control lever to neutral. Release service brakes, and apply wheel brake lock. Turn the wheel brake lock OFF, then back ON again.



- d. Release wheel brake lock and apply service brakes several times.
  - e. With service brakes applied, move directional control lever to PARK.
4. If any application or release of any brake circuit appears sluggish or improper, or if warning alarms are activated on application or release, shut the engine off and notify maintenance personnel. DO NOT operate the truck until the brake circuit in question is fully operational.
  5. Check the gauges, check for warning messages and instruments before moving the truck to ensure proper system operation and proper instrument functioning. Pay special attention to braking and steering circuit hydraulic warning messages. If any warning messages are displayed, shut off the engine immediately and determine the cause.
  6. Ensure the headlights, work lights and taillights are in proper working order. Good visibility may prevent an accident. Check operation of the windshield wipers.
- Always look to the rear before reversing the truck. Watch for and obey the ground spotter's hand signals before traveling in reverse. Sound the horn (three blasts). The spotter will have a clear view of the total area at the rear of the truck.
  - Operate the truck only while properly seated with seat belt fastened. Keep hands and feet inside the cab compartment while the truck is in operation.
  - Check gauges and instruments frequently during operation for proper readings.
  - Observe all regulations pertaining to the job site's traffic patterns. Be alert to any unusual traffic patterns. Obey the spotter's signals.
  - Match the truck speed to haul road conditions and slow the truck in congested areas. Keep a firm grip on the steering wheel at all times.
  - DO NOT allow the engine to run at idle for extended periods of time.
  - Check the brake lock performance periodically to ensure safe loading and dumping.

### **⚠ WARNING**

## MACHINE OPERATION SAFETY PRECAUTIONS H.27-0000051309

After the truck engine is started and all systems are functioning properly, the operator must follow all local safety rules to ensure safe machine operation.

### **⚠ WARNING**

- **If the red warning light is illuminated and any warning messages are displayed, or if any gauge reads in the red area during truck operation, a malfunction is indicated. Stop the truck as soon as safety permits, and stop the engine. Have the problem corrected before resuming truck operation.**

### **⚠ WARNING**

- **The truck is equipped with traction control (often referred to as "slip/slide" control). If this function becomes inoperative, operating the truck with stalled or free spinning wheel motors may cause serious damage to wheel motors! If the truck does not begin to move within ten seconds after depressing the throttle pedal (directional control lever in a drive position), release the throttle pedal and allow wheels to regain traction before accelerating again.**

- **DO NOT use the brake lock for parking. When the engine is turned off, hydraulic pressure will bleed down, allowing the brakes to release!**

- Proceed slowly on rough terrain to avoid deep ruts or large obstacles. Avoid traveling close to soft edges and near the edges of a fill area.
- Truck operation requires a concentrated effort by the driver. Avoid distractions of any kind while operating the truck.

## Machine Operation on the Haul Road

While traveling on the haul road, obey the following guidelines:

- Always stay alert. If unfamiliar with the haul road, drive with extreme caution. Cab doors must remain closed at all times if the truck is in motion or unattended.
- Obey all road signs. Keep the truck under control at all times. Govern truck speed by the road conditions, weather and visibility. Report poor haul road conditions immediately. Muddy or icy roads, pot holes or other obstructions can present hazards.
- Initial propulsion with a loaded truck must begin from a level surface whenever possible. At times, starting on a hill or grade cannot be avoided. Refer

to [Starting on a Grade With a Loaded Truck](#), page 5-16 later in this chapter.

- Before traveling in reverse, give a back-up signal of three blasts with the horn and wait until the area is clear. Before starting forward, signal with two blasts with the horn and wait until the area is clear. These signals must be given each time the truck is moved forward or backward.
- Use extreme caution when approaching a haul road intersection. Maintain a safe distance from oncoming vehicles.
- Maintain a safe distance when following another vehicle. Never approach another vehicle from the rear, in the same lane, closer than 15 m (50 ft). When driving on a down grade, this distance must not be less than 30 m (100 ft).
- If the warning light on the dash panel illuminates and a warning message is displayed on the dash panel during operation, steer the truck immediately to a safe area away from other traffic, if possible, and stop the truck.
- DO NOT stop or park on a haul road unless unavoidable. If the truck must be stopped on a haul road, park in a safe place, move the directional control lever to PARK, and shut the engine off before leaving the cab. Block the wheels securely and notify maintenance personnel for assistance.
- While driving on a slope, maintain a speed that will ensure safe driving and provide effective retarding under all conditions. Refer to [DYNAMIC RETARDING](#), page 6-4. Refer to the grade/speed retard chart in the operator's cab to determine maximum safe truck speeds for descending various grades with a loaded truck.
- When operating the truck in darkness, or when visibility is poor, DO NOT move the truck unless all headlights, clearance lights, and tail lights are on. DO NOT back the truck if the back-up alarm or lights are inoperative. Always dim the headlights when approaching oncoming vehicles.
- Check the tires for proper inflation during each shift. If the truck has been operating on a flat or under-inflated tire, the truck must remain outside of any buildings until the tire cools.

## Starting on a Grade With a Loaded Truck

Initial propulsion with a loaded truck must begin from a level surface whenever possible. There are circumstances when starting on a hill or grade cannot be avoided. In these instances use the following procedure:

1. Fully depress the service brake pedal to hold the truck on the grade. DO NOT use the retarder lever.
2. With the service brakes fully applied, move the directional control lever to a drive position (FORWARD/REVERSE) and increase engine rpm with the throttle pedal.
3. As engine rpm approaches maximum, and when propulsion effort is felt working against the brakes, release the brakes and allow truck movement. Ensure the service brake pedal is completely released. As truck speed increases above 5-8 kph (3-5 mph) the system will drop propulsion if the retarder is still applied.

**NOTE:** *Releasing and reapplying dynamic retarding during a hill start will result in loss of propulsion.*

## Retarding on a Grade

The grade/speed retard chart provides the recommended maximum retarding limits for descending grades with a fully loaded truck.

The decal in the truck may differ from the decal shown here due to optional truck equipment such as wheel motor drive train ratios, retarder grids, tire sizes, etc. Always refer to the decal in the operator's cab and follow the recommendations for truck operation.

The operator must reference this chart before descending any grade with a loaded truck. Proper use of dynamic retarding will maintain a safe speed.

Two speed lists are provided, one for *continuous* retarding, and the second for *short term* retarding. Both lists are matched to the truck at maximum Gross Vehicle Weight (GVW). The two ratings are guidelines for proper usage of the retard function on downhill grades.

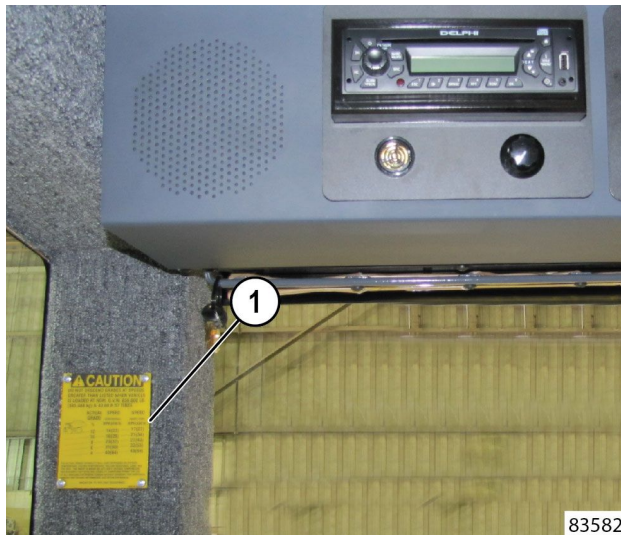

1. Grade Speed Chart

### Figure 5-6 GRADE SPEED CHART LOCATION

The “short term” numbers listed on the chart indicate the combination of speeds and grades which the vehicle can safely negotiate for a short duration before system components reach the maximum allowable temperature during retarding. These speeds are faster than the “continuous” values, reflecting the thermal capacity of various system components. System components can accept heating at a higher-than-continuous rate for a short period of time. Beyond this short duration of time, the system would become overheated.

If the vehicle is operated at “short term” grade and speed limits for a period of time, it is possible to exceed the thermal capacity of the drive system components. The drive system controller will then gradually reduce the retarding effort from “short term” to “continuous”. A warning buzzer will sound alerting the operator 15 seconds before the reduction in retarding performance will take place and the need for a reduction in speed. A warning message will also be displayed on the instrument panel to reduce truck speed. The operator must control the speed of the truck in accordance to the “continuous” speeds on the grade/speed chart. The operator must use the service brakes to quickly slow the truck to the maximum “continuous” retarding limits (or less) based on the grade the truck is currently on.

## ⚠ CAUTION

- **DO NOT** lightly apply the service brakes when attempting to slow the truck on a downhill grade. Overheating of the brakes will result. Fully apply the brakes, within safe limits for road conditions, in order to quickly slow the truck to maximum “continuous” retarding limits or less.

The “short term” rating will successfully accommodate most downhill loaded hauls. If actual time on the grade exceeds the allowable limits, the grade will need to be negotiated at the “continuous” speed.

The “continuous” numbers on the chart indicate the combination of speeds and grades which the vehicle can safely negotiate for unlimited time or distance during retarding.

DO NOT exceed these recommended maximum speeds when descending grades with a loaded truck.

## Passing

- DO NOT pass another truck on a hill or on a blind curve.
- Before passing, ensure the road ahead is clear. If a disabled truck is blocking your lane, slow down and pass with extreme caution.
- Use only the areas designated for passing.

## Loading

To load the truck, perform the following:

1. Approach the loading area with caution. Remain at a safe distance while the truck ahead is being loaded.
2. DO NOT drive over unprotected power cables.
3. When approaching or leaving a loading area, watch for other vehicles and for personnel working in the area.
4. When pulling in under a loader or shovel, follow the spotter’s or the shovel operator’s signals. The truck operator may speed up loading by observing the location and loading cycle of the truck being loaded ahead, and then following a similar pattern.
5. During loading, the operator must stay in the truck cab with the engine running. Place the directional control lever in NEUTRAL and apply the brake lock.
6. When loaded, pull away from the shovel as quickly as possible with extreme caution.

## Overload Speed Limit Function

**NOTE:** This feature can be enabled or disabled at the discretion of site management. The setting for payload trigger and speed limits are also adjustable by local site preference.

The overload speed limit function limits the speed of the truck if a payload limit setting has been exceeded. The overload signal becomes true (24 volts) when the PLMIII early estimate of payload exceeds the preset payload ton threshold.

The PLMIII early estimate of payload calculation occurs after 12 seconds of travel above 5 kph (3 mph) after being loaded. Once the overload signal becomes true, it stays true until the payload is dumped.

By default, the overload speed limit is disabled (option 0 in the configuration file). The configuration file can be set to:

Option 1 - Overload speed limit is imposed.  
or

Option 2 - No propel restriction is imposed and logged. The truck cannot move under its own power when the overload signal becomes true.

The overload speed limit can be adjusted by modifying the configuration file. Use the Payload Service Software Lite Version (available for download at [www.KomatsuAmerica.net](http://www.KomatsuAmerica.net)) to set the overload threshold.

When option 1 is selected, and the overload signal is true, tractive effort is reduced to attempt to respect the speed limit setting. The retard effort will not be engaged to lower the speed of the truck. Once the truck speed matches that of the overload speed limit setting, limited propel efforts and retarding efforts will be used as necessary. This feature maintains the truck speed at the maximum of the overload speed limit setting.

## Dumping

### ⚠ WARNING

- **DO NOT move the truck with the dump body raised except for emergency purposes only. Failure to lower the body before moving the truck may cause damage to the hoist cylinders, frame and/or body hinge pins.**

### ⚠ WARNING

- **The dumping of very large rocks (10% of payload, or greater) or sticky material (loads that do not flow freely from the body) may allow the material to move too fast and cause the body to move RAPIDLY and SUDDENLY. This sudden movement may jolt the truck violently and cause possible injury to the operator, and/or damage to the hoist cylinders, frame, and/or body hinge pins. If it is necessary to dump this kind of material, slowly accelerate engine rpm while raising the body. When the material starts to move, release the hoist lever to the HOLD position. If the material does not continue moving and clear the body, repeat this procedure until the material has been dumped.**

Perform the following when raising the dump body:



1. Approach the dump area with extreme caution. Ensure the area is clear of persons and obstructions, including overhead utility lines. Obey signals as directed by the spotter, if present.
2. Avoid unstable areas. Keep a safe distance from the edge of the dump area. Position the truck on a solid, level surface before dumping.
3. Carefully maneuver the truck into the dump position. When backing the truck into the dump position, use only the brake pedal to stop and hold the truck. DO NOT rely on the brake lock to stop the truck. This control is not modulated and applies the rear service brakes only.
4. When the truck is stopped and in dump position, apply the brake lock and move the directional control lever to the NEUTRAL position.
5. Pull the hoist lever to the rear (to RAISE position) to actuate the hoist circuit. (Releasing the lever anywhere during the raise cycle will hold the body at that position.)

### ⚠ DANGER

- **As the body raises, the truck center of gravity will move. The truck must be on level surface to prevent tipping/rolling!**

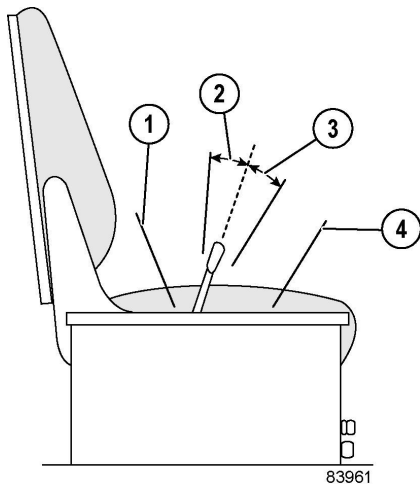

- |          |          |
|----------|----------|
| 1. Raise | 3. Float |
| 2. Hold  | 4. Lower |

**Figure 5-7 DUMP BODY CONTROLS**

6. Raise the engine rpm to accelerate the hoist speed.
7. Reduce the engine rpm as the last stage of the hoist cylinder begins to extend. Keep the engine speed at low idle as the last stage reaches half-extension.
8. Release the hoist lever as the last stage of the hoist cylinder reaches full extension.

**NOTE:** If the directional control lever is in REVERSE when the dump body is raised, reverse propel is inhibited. To deactivate, lower the dump body and move the directional control lever out of REVERSE.

**Lowering the Dump Body (When Dumping on Flat Ground)**

**⚠ WARNING**

- **DO NOT** move the truck with the dump body raised except for emergency purposes only. Failure to lower the body before moving the truck may cause damage to the hoist cylinders, frame and/or body hinge pins.

Perform the following when lowering the dump body:



It is very likely when dumping on flat ground that the dumped material will build up enough to prevent the body from lowering.



In this case, the truck will have to be driven forward a short distance (just enough to clear the material) before the body can be lowered.

1. Shift the directional control lever to FORWARD, release the brake lock, depress the override button and drive just far enough forward for the body to clear the material. Stop, shift the directional control lever to NEUTRAL, and apply the brake lock.
2. Move the hoist lever forward to the LOWER position and release. Releasing the lever places the hoist control valve in the FLOAT position, allowing the body to return to the frame.

If dumped material builds up at the rear of the body and the body cannot be lowered, then perform the following steps:

- a. Move the hoist lever back to the RAISE position to fully raise the dump body. Then release the lever so it returns to the HOLD position.
- b. Move the directional control lever to FORWARD, release the brake lock, depress the override button, and drive forward to clear the material.
- c. Stop, move the directional control lever to NEUTRAL, apply the brake lock, and lower the body.

**NOTE:** When an attempt to lower the body is unsuccessful because of material obstruction, raise the body back up. This will help to prevent the body from suddenly dropping when pulling away from the obstruction.

**⚠ CAUTION**

- **Do not** move the truck with the dump body raised except in an emergency. Failure to lower body before moving truck may cause damage to the hoist cylinders, frame and/or body hinge pins.

3. With the body returned to the frame, move the directional control lever to FORWARD, release the brake lock, and carefully leave the dump area.

**Lowering the Dump Body (When Dumping Over a Berm Or Into a Crusher)**

Perform the following when lowering the dump body:



1. Move the hoist lever to the LOWER position and release. Releasing the lever places the hoist control valve in the FLOAT position, allowing the body to return to the frame.

**NOTE:** If dumped material builds up at the rear of the body and the body cannot be lowered, perform Steps a and b below:

- a. Move the hoist lever back to the RAISE position to fully raise the dump body. Release the hoist lever to return it to the HOLD position.

**NOTE:** DO NOT drive forward if the tail of the body will not clear the crusher wall in the fully raised position.

- b. Move the directional control lever to FORWARD, release the brake lock. Depress the override button and drive forward to clear the material. Stop, shift the directional control lever to NEUTRAL, apply the brake lock and lower the body again.

**NOTE:** When an attempt to lower the body is unsuccessful because of material obstruction, raise the body back up. This will help to prevent the body from suddenly dropping when pulling away from the obstruction.

2. With the body returned to the frame, move the directional control lever to FORWARD, release the brake lock, and carefully leave the dump area.

## SUDDEN LOSS OF ENGINE POWER F.6-0000051428

If the engine suddenly stops, there is enough hydraulic pressure stored in the brake and steering accumulators to allow the operation of the steering and brake functions. However, this oil supply is limited so it is important to stop the truck as quickly and safely as possible after the loss of engine power.

If the brake supply pressure drops to a pre-determined level, the red warning light will illuminate and a buzzer will sound. If the brake pressure continues to decrease, the auto-apply feature will activate and the service brakes will apply automatically to stop the truck.

**NOTE:** Dynamic retarding will not be available. DO NOT use the service brakes for continuous retarding purposes.

When loss of engine power occurs, perform the following:

1. Bring the truck to a safe stop as quickly as possible by using the foot pedal to apply the service brakes. If possible, safely steer the truck to the side of the road while braking.
2. As soon as the truck has stopped moving, park the truck.
3. Slowly release the service brakes to check the capacity of the parking brake. If the parking brake can not hold the truck stationary, apply the service brakes and hold them ON. DO NOT turn the key switch OFF, and DO NOT release the service brakes.
4. Notify maintenance personnel immediately.
5. If the truck is on level ground, or if the parking brake can hold the truck stationary and the truck is in a stable condition, it is then OK to turn the key switch OFF.
6. If safe to do so, have maintenance personnel place wheel chocks or other mechanisms in front or behind the wheels to reduce the risk of the truck rolling.
7. If traffic is heavy near the disabled machine, mark the truck with warning flags during daylight hours or use flares at night. Adhere to local regulations.

## EMERGENCY STEERING SYSTEM F.6-0000051427

### Operation

This truck is equipped with an emergency steering system. This system is a backup in the event of loss of oil supply to the main steering system. The emergency steering system was designed to meet or exceed SAE J1511 and ISO 5010 standards.

If the red warning light and alarm are activated, a failure in the hydraulic oil supply to the steering and brake system exists. When the alarm is activated, typically there is enough hydraulic pressure stored in the brake and steering accumulators to allow brief operation of the steering and brake functions. However, this oil supply is limited. Therefore, it is important to stop the truck as quickly and safely as possible after the alarm is first activated.

If the oil pressure continues to decrease, the brake auto-apply feature will activate the service brakes to stop the truck.

## Pre-Operation Testing

**NOTE:** *Komatsu recommends that operators perform this test to verify that the steering accumulator precharge pressure is adequate at the beginning of each shift before operating the truck.*

### **WARNING**

- **Ensure no one is near the front tires during this test. All personnel are warned that clearances change when the steering wheel is turned and this could cause serious injury.**

This test can only be performed with an empty truck.

1. Park the empty truck on flat, level ground. Lower the dump body onto the frame and stop the engine. Ensure the key switch is in the OFF position.
2. Wait at least 90 seconds to verify that all hydraulic pressure has been relieved from the steering accumulators. Turn the steering wheel from stop to stop. If the front wheels do not move, there is no hydraulic pressure.
3. Check the hydraulic tank oil level. The oil level must be visible in the center of the upper sight glass and must not cover the entire upper sight glass. Add oil if necessary. DO NOT overfill.
4. Turn the key switch to the ON position, but DO NOT start the engine.
  - If any warning messages are displayed immediately notify maintenance personnel. DO NOT operate the truck until the problem is corrected.
5. Start the engine and allow the steering accumulators to fully charge. Turn the steering wheel so that the front wheels are straight.
6. Check the hydraulic tank oil level while the engine is on.
  - If the oil level is visible in center of the lower sight glass and does not cover the entire lower sight glass, the steering accumulators are adequately charged. Proceed to Step 7.
  - If the oil level is below the lower sight glass, the steering accumulators are not adequately charged. Stop the engine and turn the key switch to the OFF position. Immediately notify maintenance personnel. DO NOT operate the truck until the problem is corrected.
7. Shut the engine off by using the engine stop button located on the center console. Leave

the key switch in the ON position. This allows the steering accumulators to retain their hydraulic charge.

- If the warning light and buzzer do activate, turn the key switch OFF and notify maintenance personnel. DO NOT operate the truck until the problem is corrected.
  - If the steering accumulators are adequately charged, the warning light and buzzer will not activate. Continue to the next step.
8. If the front wheels cannot be turned fully to the left and right, or if the warning light and buzzer do not activate, immediately notify maintenance personnel. DO NOT operate the truck until the problem is corrected.

If the truck passes this test, the emergency steering system is functioning properly.

## Additional Guidelines

- When the truck body is raised, DO NOT allow anyone below it unless the body-up retaining cable is in place.
- DO NOT use the fire extinguisher for any purpose other than putting out a fire! If an extinguisher is discharged, report the occurrence so the used unit can be refilled or replaced.
- DO NOT allow unauthorized personnel to ride in the truck. DO NOT allow anyone to ride on the ladder or outside of the truck cab. Passengers must be belted into the passenger seat during travel.
- DO NOT leave the truck unattended while the engine is running. Move the directional control lever to PARK, then shut the engine off before getting out of the cab.

## FUEL DEPLETION D.3-0000051426

### **CAUTION**

- **Operating the truck to fuel depletion forces the injector train into a no-follow condition. No fuel flow between the plungers may cause damage to the injectors and the overhead due to adhesive wear, resulting in costly repairs and unnecessary downtime.**

### **WARNING**

- **Allowing the Komatsu truck to operate until fuel depletion can lead to unsafe operating conditions possibly resulting in an uncontrollable vehicle and/or personal injury.**



DO NOT allow the fuel tank to become empty. The high pressure injection (HPI) fuel system uses fuel to adjust fuel delivery timing. Metered fuel is also used to lubricate the injector plunger and barrel. The maximum demand for metered fuel is required during high speed / low load conditions.

## SAFE PARKING PROCEDURES F.6-0000051425

Ensure the truck body is empty. Completely lower the dump body. If the machine must be parked on a slope, follow local regulations to secure the truck to prevent the machine from moving.

Refer to the following procedure to park the machine:

1. Move the directional control lever to PARK (this will apply the parking brake). DO NOT apply the wheel brake lock.
2. Turn the key switch to the OFF position and wait for the engine to stop. This could take up to three minutes for a hot engine to cool down. After the engine has stopped, wait two minutes before exiting the cab. If any warning messages are displayed, or the warning buzzer is sounding, DO NOT leave the cab. Notify maintenance personnel immediately.
3. When exiting the machine, always lock compartments, and take the keys with you to prevent entry from unauthorized persons.
4. Place wheel chocks around the wheels to prevent the truck from rolling.

**NOTE:** If the engine is running, and the truck is stationary and no brakes are applied, the red warning light will illuminate and the warning buzzer will sound. The operator must apply one of the following braking systems: the service brakes, the wheel brake lock or the parking brake to prevent truck roll away and to silence the alarms.

## NORMAL ENGINE SHUTDOWN PROCEDURE G.12-0000051424

1. Park on a level surface, free of overhead power lines or other objects that could prevent raising the dump body. Reduce engine speed to idle and place the directional control lever in PARK. This will apply the parking brake. DO NOT apply the wheel brake lock.

Ensure the parking brake indicator light is illuminated.

**NOTE:** If the truck starts to roll, apply the service brakes and notify maintenance personnel immediately.

2. Place the rest switch in the ON position to put the AC drive system in rest mode. Ensure the no propel indicator light is illuminated.
3. Turn the key switch counterclockwise to the OFF position to stop the engine.

**NOTE:** There is also an engine stop switch located at ground level at the right or left front corner of the truck. When this switch is activated, the engine will stop immediately, with no cooling off time.

The engine may continue to run for up to three minutes after the key switch is turned OFF, if the parking brake has been set. The engine may stop before three minutes has elapsed if the engine coolant is not too hot, and the engine speed and fuel delivery have been low for a period of time before the key switch was placed in the OFF position. The engine shutdown delay indicator light will be illuminated during the shutdown sequence.

**NOTE:** When the key switch is turned OFF, the parking brake will automatically be set, even if it was not set already by the operator. The wheel brake lock will be disabled, even if it was set by the operator.

4. With the key switch OFF and engine stopped, wait at least two minutes. If any warning messages are displayed, notify maintenance personnel immediately.
5. Ensure the steering circuit is completely bled down by turning the steering wheel back and forth several times. No front wheel movement will occur when hydraulic pressure is relieved. If the front tires continue to steer after the engine is stopped, notify maintenance personnel.
6. Verify both link voltage lights on the electrical cabinet are off. Notify maintenance personnel if the lights remain illuminated longer than five minutes after the engine has been stopped.
7. If equipped, lower the retractable ladder.
8. Close and lock all windows. Remove the key from the key switch and lock the cab to prevent possible unauthorized truck operation. Properly dismount the truck. Put wheel chocks in place.

**NOTE:** If the engine must be shut down immediately, stop the truck, shift the directional control lever to PARK, turn the key switch OFF, then pull up on the engine stop switch located in the operator cab center console. Push the switch back down to enable engine operation.



## DISABLED TRUCK CONNECTORS

C.3-0000051229

### GENERAL INFORMATION B.3-0000051423

Refer to the Shop Manual for repair and troubleshooting procedures for the hoist system components and steering system components. Refer to the Shop Manual for repair and troubleshooting procedures for the hydraulic brake system components.

### HOIST SYSTEM C.3-0000051421

Sometimes it is necessary to dump a load from the body of a truck when the hoist system is inoperable. To use this feature, two hoses (supply and return) must be connected to a hydraulic source (such as an operational truck or an auxiliary power unit).

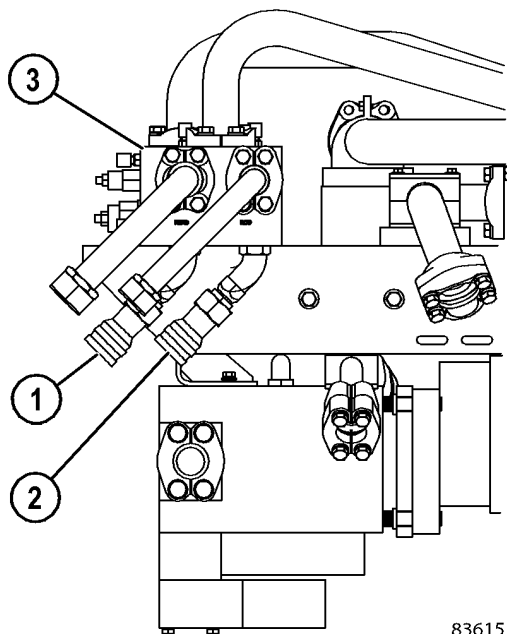

83615

1. Power Up Quick Disconnect
2. Power Down Quick Disconnect
3. Over Center Valve

#### Figure 5-8 HOIST CONNECTIONS

**NOTE:** The matching quick disconnect coupling for items (1 & 2) is PB4684.

Quick disconnect fittings (1) and (2, Figure 5-8 HOIST CONNECTIONS, page 5-23) are provided on the over center valve to allow operation of the hoist circuit for temporary truck operation if the hoist pump, hoist valve or other hoist system component is not operational. This will allow maintenance personnel to raise the truck body to dump the load before moving the disabled truck.

Figure 5-8 HOIST CONNECTIONS, page 5-23 shows a typical hookup from an operational truck. The disabled truck may be another of the same model, or a different Komatsu electric drive truck model.

The hoist circuit relief valves are adjusted to 17 240 kPa (2,500 psi).

### Hookup

Ensure there is an adequate, clear area to dump the loaded truck. When the operational truck is in position, stop the engine and wait two minutes to allow the hydraulic system to bleed down. Ensure hydraulic pressure has bled off before connecting hoses.

Obey the following guidelines when hooking up the disabled truck to the operational truck.

1. With the operational truck parked as close as possible to the disabled truck, attach a hose from power up quick disconnect (1) of the operational truck to power down quick disconnect (2) of the disabled truck. (Hose must be rated to withstand 17 237 kPa (2,500 psi) or greater pressure.

**NOTE:** The power down circuit will use a smaller diameter hose (tube) than the power up circuit.

2. Connect another hose from power down quick disconnect (2) of the operational truck to power up quick disconnect (1) of the disabled truck.

**NOTE:** If both trucks are the same model, the hoses will be installed at the quick disconnects but will be crossed when connected.

### Dumping Procedure

To raise the body, perform the following:

1. On the disabled truck, move the hoist control lever to power up and then release it to place the hoist pilot valve in the HOLD position (leave in this position during entire procedure).
2. Start the engine on the good truck, place the hoist control in the power down position and increase engine rpm to high idle to dump the disabled truck. If the body of the disabled truck fails to raise, increase the operational truck's power down relief pressure as follows:
  - a. Stop the engine and wait two minutes to allow the hydraulic system pressure to bleed down.

- b. Remove the cap from the hoist pilot valve relief valve located in the hydraulics components cabinet behind the cab. While counting the number of turns, slowly screw the relief valve adjustment screw clockwise until it bottoms.

To lower the body, perform the following:

1. Place the hoist lever of the good truck in FLOAT to lower the body. If necessary, momentarily place the hoist control in POWER UP until the body is able to descend in FLOAT. Do not accelerate the engine.
2. After body is lowered, stop the engine and wait two minutes to allow the hydraulic system to bleed down. Then disconnect the hoses.
3. Reduce power down relief valve pressure to normal on the good truck by turning the adjustment counterclockwise the same number of turns as required in step 2b of the body dumping procedure.
4. Check power down relief pressure using instructions in the shop manual.
5. Check hydraulic tank oil level.

**TOWING** E.3-0000051288**⚠ WARNING**

- Before towing a truck, many factors must be carefully considered. Serious personal injury and/or significant property damage may result if important safety practices, procedures and preparation for moving heavy equipment are not observed.

A disabled machine may be towed after the following precautions have been taken.

- Do not exceed 8 kph (5 mph) while towing.
- DO NOT tow with a cable. Use a solid tow bar. Use a towing device with ample strength for the weight of this truck.
- Never tow a truck on a slope.
- Inspect towing components, such as tow bars and couplings, for any signs of damage. Never use damaged or worn components to tow a disabled vehicle.
- Keep a safe distance from the trucks and towing apparatus while towing a vehicle.
- When connecting a truck that is to be towed, do not allow anyone to go between the tow vehicle and the disabled vehicle.
- Set the coupling of the truck being towed in a straight line with the towing portion of the tow truck and secure it in position.
- An operator must remain in the cab of the towed vehicle at all times during the towing procedure.

**SPECIAL WIRING HARNESS** E.1-0000051420

Before towing, a special wiring harness must be made in order to release the parking brake. The harness will require approximately 9 meters (30 ft) of #14 wire, one ON/OFF switch (capable of carrying 2 amps of current) and two ring terminals.

Refer to Figure 5-9 PARKING BRAKE HARNESS CONNECTION DIAGRAM, page 5-25 for a diagram of the special wiring harness circuit.

- Using a ring terminal, one end of the harness must connect to 24VDC terminal (1, Figure 5-9 PARKING BRAKE HARNESS CONNECTION DIAGRAM, page 5-25) in the auxiliary control cabinet to supply 24V to the parking brake solenoid.
- Switch (2) must be connected to the other end of the harness so the operator can use the switch while seated in the cab.

- The harness must be fitted with connector (4) to allow it to be plugged into parking brake solenoid (3) inside the brake cabinet. Ground wire (5) leading from this connector must be long enough to connect to a ground block using the second ring terminal.

Connector (4) consists of:

- one housing (PB8538)
- two sockets (08191-05430)
- one wedge (PB8540)

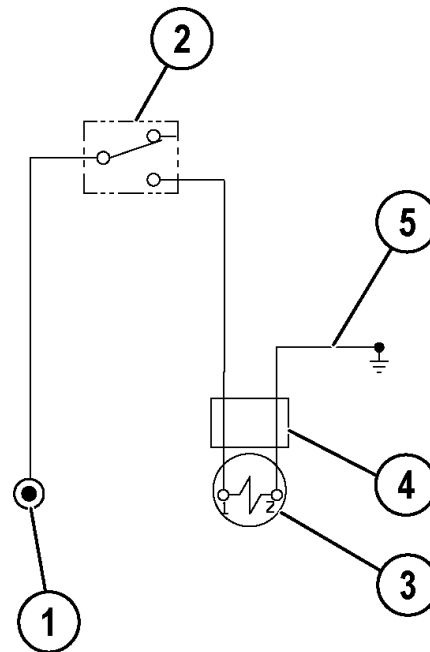

82834

- |                               |                |
|-------------------------------|----------------|
| 1. 24VDC Connection (Bus Bar) | 4. Connector   |
| 2. Switch (ON/OFF)            | 5. Ground Wire |
| 3. Park Brake Solenoid        |                |

**Figure 5-9 PARKING BRAKE HARNESS CONNECTION DIAGRAM****TOWING PROCEDURE** C.11-0000060791

1. Turn off the engine.
2. Block the wheels on the disabled truck to prevent movement while preparing the truck for towing and while attaching the tow bar.
3. Ensure that the towing vehicle has adequate capacity to both move and stop the towed truck under all conditions.
4. Ensure that the tow bar has adequate strength (approximately 1.5 times the empty vehicle weight of truck being towed). Install tow bar between the two vehicles.
5. If necessary, install quick disconnect fittings to the bleeddown manifold to allow the hydraulic

system to be operational. Install hydraulic connections for steering/braking between the tow vehicle and the disabled vehicle. An auxiliary power unit can also be used.

6. If the truck is loaded, dump the entire load. Never pull or tow a loaded truck. Refer to "Disabled Truck Dumping Procedure".
7. When ready to tow the disabled truck, remove the blocking from the wheels.
8. Tow the disabled truck. Sudden movement may cause tow bar failure. Smooth, gradual truck movement is preferred. Do not exceed 8 kph (5 mph) while towing.

**NOTE:** Minimize the tow angle at all times. Never exceed 30 degrees. The towed truck must be steered in the direction of the tow bar.

9. Block the wheels on the towing vehicle and on the disabled truck to prevent roll-away.
10. Turn off the engine in the towing vehicle.
11. If installed, disconnect the hydraulic hoses at the quick disconnect fittings on the bleeddown manifold.
12. Disconnect the tow bar.

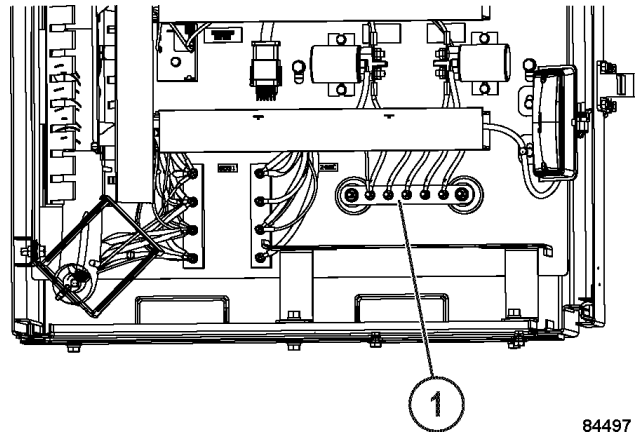

84497

1. 24VDC Bus Bar

**Figure 5-10 AUXILIARY CONTROL CABINET**

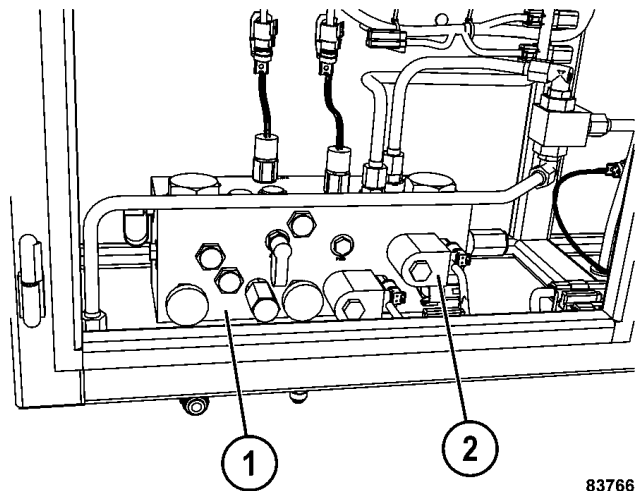

83766

1. Brake Manifold      2. Parking Brake Solenoid

**Figure 5-11 BRAKE CABINET**

## PAYLOAD METER III SYSTEM

D.3-0000051313

### GENERAL INFORMATION

D.3-0000051419

Payload Meter III (PLMIII) measures, displays and records the weight of material being carried by an off-highway truck. The system generally consists of a payload meter, a gauge display, deck-mounted lights, a scoreboard (optional), and sensors.

### Data Summary

5208 haul cycles can be stored in memory. The following information is recorded for each haul cycle:

- Payload
- Operator ID number (0000-9999)
- Distance traveled loaded and empty
- The amount of time spent empty run/stop, loading, loaded run/stop, and dumping
- Maximum speed loaded and empty with time of day
- Average speed loaded and empty
- Empty carry-back load
- Haul-cycle, loading, dumping start time of day
- Peak positive and peak negative frame torque with time of day
- Peak sprung load with time of day
- Tire ton-mph for each front and average per rear tires

The payload meter stores lifetime data that cannot be erased. This data includes:

- Top 5 maximum payloads and time stamps
- Top 5 positive and negative frame torque and time stamps
- Top 5 maximum speeds and time stamps

### Data Gathering

Software is available to download, store and view payload and fault information on the Komatsu website. The PC software will download an entire truck fleet into a database file. Users can query the database by date, time, truck type and truck number to produce reports, graphs and export the data.

It is important that each payload meter be configured for each truck using the PC software. The information for frame serial number and truck number is used by

the database program to organize the payload data. In addition, the payload meter must be configured to make calculations for the proper truck model. Improper configuration can lead to data loss and inaccurate payload calculations.

### COMPONENT DESCRIPTION

D.9-0000051437

#### Operator Display

The speedometer/digital display is used to display payload information. The top display is used for speed and can display metric (km/h) or English (mph) units. See [DIGITAL DISPLAY OPERATION, page 6-24](#) for instructions on setting the displayed units.

#### Operator Switches

In addition to toggling through warning screens and various truck information, the operator switches can be used to set, view and clear the total load counter and total ton counter of the payload meter. It is also used to enter the operator ID number (0-9999) and view the suspension pressures and inclinometer.

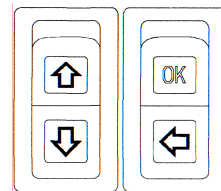

The operator switches are two-way momentary switches located on the lower left hand dash panel. The arrow positions are used to step through the different displays. The OK position is used to set the operator ID or clear the load and total ton counters. Normally, the inputs from the switches to the payload meter are open circuit.

#### Brake Lock Switch

The brake lock is used to lock the rear brakes on the truck. Locking the rear brakes is necessary for the accurate calculation of swing loads during the loading process. Without the brake lock applied, the payload meter will not calculate swing loads. Without the brake lock, the payload meter will assume that the truck was loaded using a continuous loader and the system will flag the haul cycle record. All other functions will be normal regardless of brake lock usage.

## Payload Meter Module

The payload meter module is housed in a black aluminum housing. There is a small window on the face of the module. Status and active alarm codes can be viewed through the window. During normal operation, a two-digit display flashes 0 back and forth. Active fault codes will be displayed for two seconds. These codes are typically viewed using a laptop computer connected to the serial communications port or the diagnostic port next to the DID panel.

## Communications Ports

The payload meter has two RS232 serial communications ports and two CAN ports. Connections for the two serial ports are available inside the payload meter junction box. The two CAN ports are for electronics systems.

Serial port #1 is used to connect to a laptop computer. A laptop computer can also be connected to the payload meter diagnostic port located at the rear of the cab. The display gauge will remain blank when the PC is using the serial port. This port initially operates with serial settings at 9600,8,N,1. These settings change automatically to increase the communications rate when a PC is using the port. This serial port uses a 3-wire hardware connection.

Serial port #2 is used to communicate to other on-board electronics like Modular Mining's Dispatch® system or the scoreboard. This port uses a 3-wire hardware connection. Connections to this serial port must be approved by Komatsu. Several protocol options are available and detailed technical information is available depending on licensing.

## Load Lights

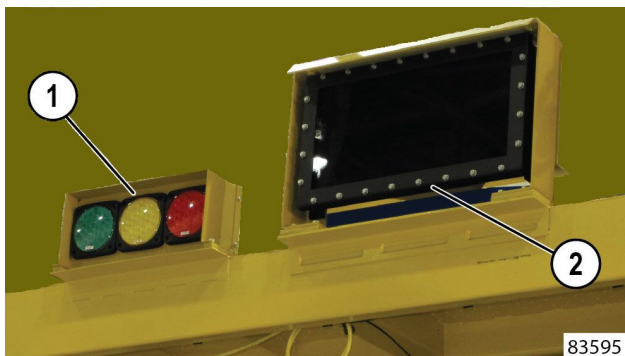

1. Load Lights
2. Payload Meter Score Board (Optional)

### Figure 5-12 SCORE BOARD AND LOAD LIGHTS

A flashing green light indicates the next swingload will make the measured load greater than 50% of rated load. A solid green light indicates that the current load is greater than 50% of rated capacity.

A flashing amber light indicates the next swingload will make the measured load greater than 90% of rated load. A solid amber light indicates that the current load is greater than 90% of rated capacity.

A flashing red light indicates the next swingload will make the measured load greater than 105% of rated load. A solid red light indicates that the current load is greater than 105% of rated capacity.

PLMIII uses load lights to indicate to the shovel operator the approximate weight of the material in the truck. The load lights are illuminated only when the brake lock is applied. The optimal loading target is a solid green and amber lights with a flashing red light. This indicates that the load is between 90% and 105% of rated load for the truck and the next swingload will load the truck over 105%.

## OPERATOR'S DISPLAY AND SWITCH B.9-0000051711

### Reading the Load Display

The lower display on the speedometer/digital display is used for payload information. Use the operator switches to scroll to the "PAYLOAD DATA" main level screen, then through the following payload meter information displays:

- Operator ID
- Total Shift Tons
- Shift Load Counter
- Suspension Pressures and Inclinometer

The display holds the operator ID and total shift tons information until the OK position of the operator switch is pressed. The suspension pressures, inclinometer, and payload displays are based on current sensor inputs.

### Setting the Operator ID

The current operator ID number is recorded with each haul cycle. The number can be between 0 and 9999.

To set the operator ID, use the arrow positions of the operator switches to scroll to the "PAYLOAD DATA" main level screen. Refer to [DIGITAL DISPLAY OPERATION, page 6-24](#) and follow the flow chart substituting your operator ID for the one in the example.

If no buttons are pressed for 30 seconds, the display will return to normal operation. The number being entered will be lost and the operator ID returns to the previous number.



## Load and Ton Counter

PLMIII allows the truck operator to monitor and track the total tons hauled and the number of haul cycles during the shift. This display can be cleared at the beginning of each shift to allow the operator to record how many loads and tons have been hauled during the shift.

The total ton counter records the number of tons hauled since the last time it was cleared. This display is in 100's of tons. For example, if the display shows **432**, the total tons is 43,200. This display can be cleared at the beginning of each shift to allow the operator to record how many tons have been hauled. The units are selected using the PC software.

The total load counter records the number of loads hauled since the last time it was cleared. This display can be cleared at the beginning of each shift to allow the operator to record how many loads have been hauled. Clearing the total ton counter or total load counter clears both records.

To clear the total ton and total load counter, perform the following:

1. Using the operator switches, scroll through the displays until the "Payload Data" screen.
2. Once in the "Payload Data" screen, scroll until you reach the "Load and Ton Counter" screen.
3. Press "OK" to clear the counter. Refer to [DIGITAL DISPLAY OPERATION, page 6-24](#).

## Viewing Live Sensor Data

The display can be used to quickly show the current readings from the four suspension pressure sensors and the inclinometer. This can be used during regularly scheduled service periods to check the state of the suspensions. These displays are live and will update as the values change. The live displays cannot be cleared and the OK position of the operator switch will have no effect.

The units for the display are controlled by the configuration of the payload meter. If the payload meter is set to display metric units, the pressures will be displayed in tenths of kg/cm<sup>2</sup>. For example, if the display shows **202** the actual value is 20.2 kg/cm<sup>2</sup>. If the payload meter is set to display short tons, the pressures will be displayed in psi (lbs/in<sup>2</sup>). Multiply by 14.2 to convert kg/cm<sup>2</sup> to psi. (example – 1kg/cm<sup>2</sup> x 14.2 = 14.2 psi). There is no way to detect the units setting for the gauge without the PC software.

The inclinometer displays whole degrees of incline. Positive incline is truck nose up. The gauge will quickly display the type of information shown every

10 seconds. For example, if the left-front pressure is being displayed, **LF Pres** = will flash on the display every minute.

- Left Front Pressure - To display the pressure in the left-front suspension, press and release the OK position of the operator switch until **LF Pres** is displayed.
- Right Front Pressure - To display the pressure in the right-front suspension, press and release the OK position of the operator switch until **rF Pres** is displayed.
- Left Rear Pressure - To display the pressure in the left-rear suspension, press and release the OK position of the operator switch until **Lr Pres** is displayed.
- Right Rear Pressure - To display the pressure in the right-rear suspension, press and release the OK position of the operator switch until **rr Pres** is displayed.
- Inclinometer - To display the truck incline, press and release the OK position of the operator switch until **Incline** is displayed.

## Other Display Messages

On startup of the payload meter system, the operator display will scroll the truck type that the PLMIII is configured for. For example, on a 960E, the gauge will scroll, **960E**.

If the PLMIII encounters memory problems, it will display **ErBB**, where 88 is the specific memory error. In this very rare circumstance, the system should be turned off for 30 seconds and restarted.

## HAUL CYCLE WARNING

**FLAGS** D.2-0000051435

### Haul Cycle Data

All data is calculated and stored in metric units within the payload meter. The data is downloaded and stored in metric units within the database on the PC. The analysis program converts units for displays, graphs and reports.

The units noted in the Table 1 are the actual units stored in the data file. The value for the haul cycle start time is the number of seconds since January 1, 1970 to the start of the haul cycle. All other event times are referenced in seconds since the haul cycle start time. The PC download and analysis program converts these numbers into dates and times for graphs and reports.

The following information is recorded for each haul cycle:

<b>Table 1: HAUL CYCLE DATA</b>		
<b>Data</b>	<b>Unit</b>	<b>Remark</b>
Truck #	alpha-numeric	Up to 22 characters can be stored in this field to identify the truck. Typically this field will be just the truck number.
Haul Cycle Start Date/Time	seconds	Number of seconds from 1/1/70 to the start of the haul cycle, haul cycle starts when the meter transitions from dumping to empty state after the previous haul cycle, download program converts seconds into date and time for display
Payload	tons	Stored as metric, download program allows for conversion to short or long tons.
Number of Swing loads	number	The number of swing loads detected by the payload meter
Operator ID	number	This is a 4 digit number that can be entered by the operator at the start of the shift.
Warning Flags	alpha	Each letter represents a particular warning message about the haul cycle.
Carry-back load	tons	The difference between the latest empty tare and the clean truck tare
Payload (net)	tons	Final payload calculation (excludes carry-back)
Payload (gross)	tons	Final payload calculation (includes carry-back)
Quick payload estimate (net)	tons	Calculated about 160 m (525 ft) away from the shovel
Payload estimate at shovel (net)	tons	This calculation is based on last swing load
Empty Haul Time	seconds	Number of seconds in the tare_zone and empty states with the truck moving
Empty Stop Time	seconds	Number of seconds in the tare_zone and empty states with the truck stopped
Loading Time	seconds	Number of seconds in the loading state
Loaded Haul Time	seconds	Number of seconds in the maneuvering, final_zone and loaded states with the truck moving
Loading Stop Time	seconds	Number of seconds in the maneuvering, final_zone and loaded states with the truck stopped
Dumping Time	seconds	Number of seconds in the dumping state
Loading Start Time	seconds	Number of seconds from the start of the haul cycle to when the meter transitions from empty to loading state
Dump Start Time	seconds	Number of seconds from the start of the haul cycle to the time when the meter switches from loaded to dumping state
Loaded Haul Distance	m	Distance traveled while loaded
Empty Haul Distance	m	Distance traveled while empty
Loaded Max Speed	km/h	Maximum speed recorded while the truck is loaded



<b>Table 1: HAUL CYCLE DATA</b>		
<b>Data</b>	<b>Unit</b>	<b>Remark</b>
Loaded Max Speed Time	seconds	Number of seconds from the start of the haul cycle to the time when the max speed occurred
Empty Max Speed	km/h	Maximum speed recorded while the truck is empty
Empty Max Speed Time	seconds	Number of seconds from the start of the haul cycle to the time when the max speed occurred
Peak Positive Frame Torque	ton-meter	Positive frame torque is measured as the frame twists in the clockwise direction as viewed from the operator's seat.
Peak Frame Torque Time	seconds	Number of seconds from the start of the haul cycle to the peak torque, download program converts to time for display
Peak Negative Frame Torque	ton-meter	Negative frame torque is measured as the frame twists in the counter-clockwise direction as viewed from the operator's seat.
Peak Frame Torque Time	seconds	Number of seconds from the start of the haul cycle to the peak torque, download program converts to time for display
Peak Sprung Load	tons	Peak dynamic load calculation
Peak Sprung Load Time	seconds	Number of seconds from the start of the haul cycle to the peak instantaneous load calculation
Front left tire ton km/h	t-km/h	Tire ton-km/h for haul cycle
Front right tire ton km/h	t-km/h	Tire ton-km/h for haul cycle
Average rear tire ton km/h	t-km/h	Tire ton-km/h for haul cycle
Truck Frame Serial Number	alpha	The truck serial number from the nameplate on the truck frame
Reserved 1–10	number	These values are internal calculations used in the continued development of the PLMIII system and should be ignored

### Haul Cycle Warning Flags

The payload meter expects haul cycles to progress in a particular way. When something unexpected takes place, the system records a warning flag. Several events within the haul cycle can cause a warning flag to be generated. Each one indicates an unusual occurrence during the haul cycle. They do not necessarily indicate a problem with the payload meter or payload calculation.

#### Continuous Loading

This message indicates the truck is loaded over 50% full without the payload meter sensing swingloads. This indicates that a continuous loading operation was used to load the truck. It may also indicate that the payload meter did not receive the brake lock input while the truck was being loaded. There

may be a problem with the wiring or the brake lock was not used. The payload meter will not measure swingloads unless the brake lock is used during the loading process.

#### Loading to Dumping Transition

This message indicates the payload meter senses a body up input during the loading process. This message is usually accompanied by a "no\_final\_load" flag.

#### No Final Load

This message indicates the payload meter is unable to determine the final payload in the truck. Typically, this means that the payload meter switched from a loaded state to the dumping state before the load could be accurately measured.

**Maneuvering to Dumping Transition**

This message indicates the payload meter senses a body-up input during the maneuvering or repositioning process indicating that the operator has dumped the load. It may also be generated if the body-up signal is not properly reaching the payload meter and the weight in the truck falls dramatically while the truck is maneuvering or repositioning.

**Average Load or Tare Used**

This message indicates that the recorded payload may not be as accurate as a typical final load calculation. Typically, this is recorded when loading begins before an accurate tare is calculated or the load is dumped before the load can be accurately measured.

**Final Zone to Dumping Transition**

This message indicates the payload meter senses a body-up while it is calculating the final payload indicating that the operator has dumped the load. It may also be generated if the body-up signal is not properly reaching the payload meter and the weight in the truck falls dramatically while the truck is calculating the final payload.

**False Body Up**

This message indicates that the body was raised during the haul cycle without the load being dumped. The body-up signal indicated that the truck was dumping, but the weight of the truck did not fall below 20% of the rated load.

**Body Up Signal Failed**

This message indicates that the load was dumped without a body-up signal being received by the payload meter. The weight of the truck fell below 20%, but the payload meter did not receive a body-up signal from the sensor.

**New Tare Not Calculated**

This message indicates the payload meter was not able to accurately calculate a new empty sprung weight for the truck to use as the tare value for the haul cycle. The tare value from the last haul cycle was used to calculate payload.

**Incomplete Haul Cycle**

This message indicates the payload meter did not have proper data to start the haul cycle after powering up. When the PLMIII powers off, it records the data from the haul cycle in progress into memory. This flag indicates that this data was not recorded the last time the payload meter was shut down. This can happen when the main battery disconnect is used to shut the truck down instead of the key switch. A haul cycle with this warning flag should not be considered accurate.

Haul cycles with this warning are displayed in red on the Payload Summary window and are not included in the summary statistics for reports or display.

**Haul Cycle Too Long**

This message indicates indicates that the haul cycle took longer than 18.2 hours to complete. The times stored for particular events may not be accurate. This does not affect the payload calculation.

**Sensor Input Error**

This message indicates an alarm was set for one of the critical sensor inputs during the haul cycle. Critical sensors are the four pressure sensors, the speed sensors, and the inclinometer. Any flat suspension or machine speed alarms will set this flag as well. Without these inputs, the payload meter cannot calculate payload. A haul cycle with this warning flag should not be considered accurate. Haul cycles with this warning are displayed in red on the Payload Summary window and are not included in the summary statistics for reports or display.

**False Swingload**

This message indicates the payload meter detected a swingload, but less than 20% load was measured on the truck after it had driven 160 meters from the loading site. When this condition occurred, the payload meter considered the swingload to be "false" and returned to the "tare\_zone" state. All distance and speed statistical calculations that occurred during the "false swingload" are recorded as part of the EMPTY statistics.

**PC SOFTWARE OVERVIEW** D.3-0000051434

The PC software contains the following basic functions:

- Configure the PLMIII system on the truck.
- Troubleshoot and check the PLMIII system.
- Download data from the PLMIII system.
- Analyze data from the payload systems.

Configuration, troubleshooting and downloading require a serial connection to the payload meter on the truck. Analysis can be done at any time without a connection to the payload meter.

Payload data is downloaded from several trucks into one database on the PC. The database can be queried to look at the entire fleet, one truck or truck model. The data can be graphed, reported, imported or exported. The export feature can take payload data and save it in a format that spreadsheet programs like Microsoft™ Excel® or word processing programs can easily import.

PLMIII needs to be configured for operation when it is first installed on the truck. This process requires several steps and uses a laptop computer to make the necessary settings. The setup procedure can be broken down into several steps:

- Connecting the laptop to the PLMIII system
- Starting communications
- Setting the time & date
- Setting the truck type
- Setting the truck ID
- Setting the speedometer/display gauge units

The Payload Meter III software is available on the Komatsu extranet. This software is compatible with any 32 or 64 bit version of Microsoft™ Windows®.

**SYSTEM CONFIGURATION E.2-0000051433**

**Connecting to the Payload Meter**

The PDM software allows users to download and configure the system.

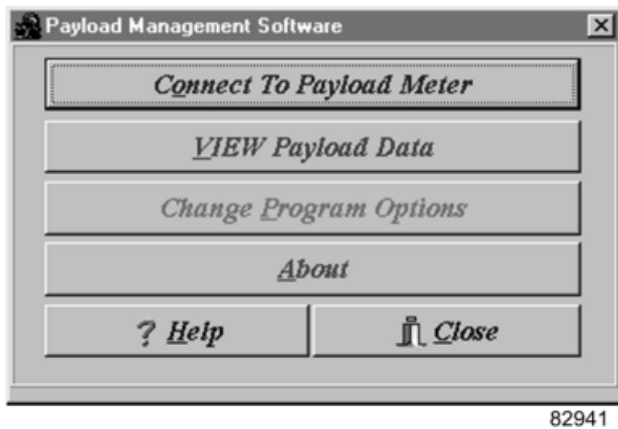

82941

Before connecting to the payload meter, select "Change Program Options" and confirm that the program has selected the correct laptop serial port. Most laptops use Comm 1 for serial communications. The units displayed for reports and graphs by the PC software can be set on this form. Click "Done" to return to the main menu.



82940

From the main menu, click the "Connect to Payload Meter" button. The PC will try to connect to the payload meter and request basic information from the system. In the event of communications trouble, the PC will try 3 times to connect before timing-out. This may take several seconds.

Communications to the PLMIII requires a laptop computer running the PDM software. The software connects to the payload meter through the meter's serial port #1. This is the same port used by the speedometer/display gauge. When the laptop is using the serial port, the lower display on the operator gauge on the dashboard will be blank. This does not affect the operation of the speedometer.

Connect a laptop to the system using the EF9160 or PC2525 communications harness. The download connector is typically located on the housing mounted in the cab to the back wall. The PLMIII system uses the same connection as the Payload Meter II system.

**Displayed Payload Units**

The following options are available for the display of units in the PC software, reports, and graphs:

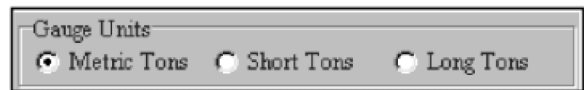

82959

*Short Tons:* Payload is displayed in short tons, distances and speeds will be displayed in Miles

*Metric Tons:* Payload is displayed in metric tons, distances and speeds are displayed in Kilometers

*Long Tons:* Payload is displayed in long tons, distances and speeds are displayed in Miles

### Connection Menu



The connection screen displays the following basic system information to the user:

- Frame S/N should agree with the truck serial number from the serial plate located on the truck frame.
- Truck Number is an ID number assigned to the truck by the mine.
- The Payload Meter Date / Time values come from the payload meter at the moment of connection.
- Number of Haul Cycle Records is the number of haul cycles stored in memory and available for download.
- Number of Active Alarms shows how many alarms are currently active in the system at the time of connection. If there are active alarms, the "Display Active Alarms" button is available.
- Number of Inactive Alarms shows how many alarms have been recorded in memory and are available for download.
- PLM Software Version displays the current version of software in the payload meter.

The information on the connection menu comes from the configuration of the payload system on the truck.

There are also many configuration and download options available from this screen. The Connection Menu is updated only when the connection is first made. It does not refresh automatically. To view changes made while connected, the user must close the window and reconnect to the payload meter.

The connection menu is displayed after a serial connection has been established and the PC software has connected to the payload meter.

### Configure the Payload Meter

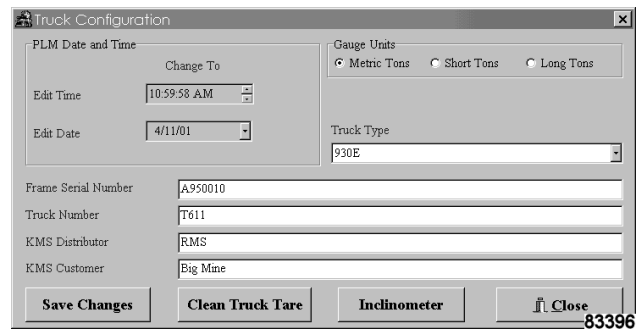

Configuration of the payload meter requires a serial connection to the PLMIII system. Clicking the "Configure Payload Meter" button will bring up the Truck Configuration screen and menu. This screen displays the latest configuration information stored on the payload meter.

When changes are made to the configuration, the "Save Changes" button must be pressed to save the changes into the payload meter. To confirm the changes, exit to the main menu and re-connect to the payload meter.

### Setting the Date and Time

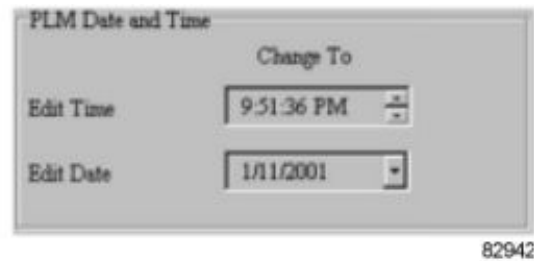

The time shown on the form is the time transmitted from the payload when the connection was first established.



The date and time are maintained by a capacitor when the power is removed from the payload meter. The capacitor will maintain the date and time settings for approximately 30 days. After this time, it is possible for the payload meter to lose the date and time setting. It is recommended that the system be powered every 20 days to maintain the date and time. If the date and time is lost, simply reset the information using this procedure. It takes approximately 90 minutes to recharge the capacitor.

Changing the date and time will affect the haul cycle in progress and may produce unexpected results in the statistical information for that one haul cycle.

**NOTE:** If the truck is equipped with KOMTRAX Plus, do not set the time or date in the PLM III controller. The PLM III clock is synchronized by the KOMTRAX Plus controller clock.

To change the time:

1. Click on the digit that needs to be changed.
2. Use the up/down arrows to change or type in the correct value.
3. Press the "Save Changes" button to save the new time in the payload meter.

To change the date:

1. Click on the digit that needs to be changed.
2. Type in the correct value or use the pull-down calendar to select a date.
3. Press the "Save Changes" button to save the new time in the payload meter.

**Setting the Truck Type and Serial Number**



82958

- From the Truck Configuration screen, use the pull-down menu to select the truck type that the payload meter is installed on.
- Press the "Save Changes" button to program the change into the meter.

Frame Serial Number	A950010
Truck Number	T3444
KMS Distributor	RMS
KMS Customer	Pit Mine <b>83397</b>

The frame serial number is located on the plate mounted to the truck frame. The plate is outboard on the lower right rail facing the right front tire. It is very important to enter the correct frame serial number. This number is one of the key fields used within the haul cycle database. The field will hold 20 alpha-numeric characters.

**NOTE:** The "A" located at the beginning of a machine's serial number must be entered into the "Frame Serial Number" field in order to retrieve payload information from the machine.

- On the Truck Configuration screen, enter the truck frame serial number in the appropriate field.

- Press the "Save Changes" button to program the change into the payload meter.

**Setting the Gauge Display Units**

The payload meter speedometer / display gauge displays the speed on the upper display. The units for the speed display are selected using a jumper on the rear of the case.

The payload units on the lower display can be changed from metric to short tons or long tons using the Truck Configuration screen. This selection also switches between metric (kg/cm<sup>2</sup>) and psi (lbs/in<sup>2</sup>) for the live display of pressure on the gauge.

To set the gauge display units, perform the following:

1. From the Truck Configuration screen, select the payload units to be used on the lower display of the speedometer/display gauge.
2. Press the "Save Changes" button to program the change into the payload meter.

**Setting the Carryback Alarm Threshold**

The payload meter measures empty sprung weight as the truck is driving from the dump to the loading site. Because the payload meter also stores the sprung weight of the truck when the "Clean Truck Tare" was configured, the empty carryback weight is calculated and stored for each haulcycle.

Enabling the Carryback Alarm will cause the payload meter to generate an alarm if the measured carryback exceeds the specified threshold for two consecutive haulcycles. If a carryback alarm occurs, the operator payload gauge will indicate the alarm by displaying "-Cb-" while the truck is empty. The gauge will return to normal operation when a swingload is detected, and remain in normal operation until the truck becomes empty again.

**NOTE:** Some earlier versions of payload meter software may not support the Carryback Alarm feature. In this case, the option will show as disabled on the Truck Configuration menu. Please contact your distributor for a information about upgrading the payload meter software.

**Setting the Truck Number**

Most mining operations assign a number to each piece of equipment for quick identification. This number or name can be entered in the Truck Number field. It is very important to enter a unique truck number for each truck using the PLMIII system. This number is one of the key fields used within the haul cycle database. The field will hold 20 alpha-numeric characters.

To set the truck number, perform the following:

1. On the Truck Configuration screen, enter the truck number in the appropriate field.
2. Press the "Save Changes" button to program the change into the payload meter.

### Setting the Komatsu Distributor

This field in the haul cycle record can hold the name of the Komatsu distributor that helped install the system. Komatsu also assigns a distributor number to each distributor. This number is used on all warranty claims. This Komatsu distributor number can also be put into this field. The field will hold 20 alpha-numeric characters.

To set the Komatsu distributor, perform the following:

1. On the Truck Configuration screen, enter the distributor name or number in the appropriate field.
2. Press the "Save Changes" button to program the change into the payload meter.

### Setting the Komatsu Customer

This field in the haul cycle record can hold the name of the mine or operation where the truck is in service. Komatsu also assigns a customer number to each customer. This number is used on all warranty claims. This Komatsu customer number can also be put into this field. The field will hold 20 alpha-numeric characters.

To set the Komatsu customer, perform the following:

1. On the Truck Configuration screen, enter the customer name or number in the appropriate field.
2. Press the "Save Changes" button to program the change into the payload meter.

### Clean Truck Tare Calibration

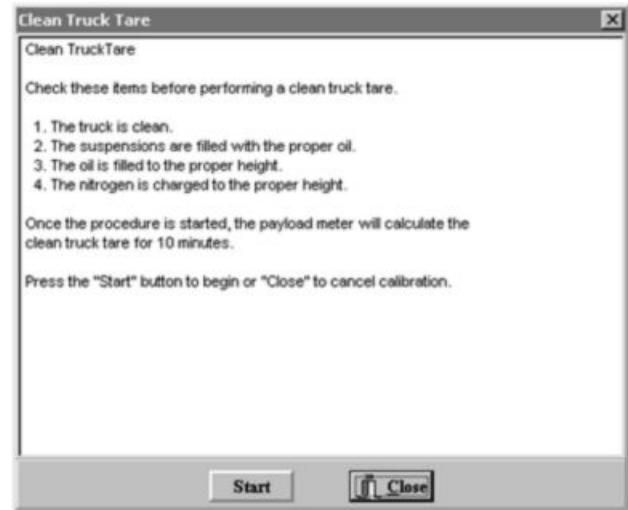

82944

The payload meter uses the clean truck tare value to calculate carry-back load for each haul cycle. The carry-back stored in the haul cycle record is the new empty tare minus the clean truck tare.

This procedure should be performed after service to the suspensions or when significant changes are made to the sprung weight of the truck. Before performing this procedure, make sure that the suspensions are properly filled with oil and charged. It is critical to the payload measurement that the proper oil height and gas pressure be used.

Once the clean tare process is started, the payload meter will begin to calculate the clean empty sprung weight of the truck. This calculation continues while the truck drives to the next loading site. Once the procedure is started, there is no reason to continue to monitor the process with the PC. The truck does not need to be moving to start this procedure.

To calibrate the clean truck tare, perform the following:

1. Clean all debris from the truck and dump body.
2. Ensure that there are no faults recorded in the system and all sensors are reading correctly.
3. Use the PDM software to connect to the payload meter. From the Truck Configuration screen, select "Clean Truck Tare".
4. Follow the on-screen instructions.

**NOTE:** The truck must be driven continuously for ten minutes above minimum speed of 5 Km/hr. The PLM module does not calibrate while the machine is stopped.

**NOTE:** Drive on actual haul roads during calibration. Inaccurate payload readings may result.

**NOTE:** DO NOT use the wheel brake lock during calibration. Inaccurate payload readings may result.

- Once the calibration is complete, confirm that the PLM module states "Empty" in the Haul Cycle State parameter. If the calibration is not complete or has failed, the Haul Cycle State parameter will state "Tare Zone".

### Inclinometer Calibration

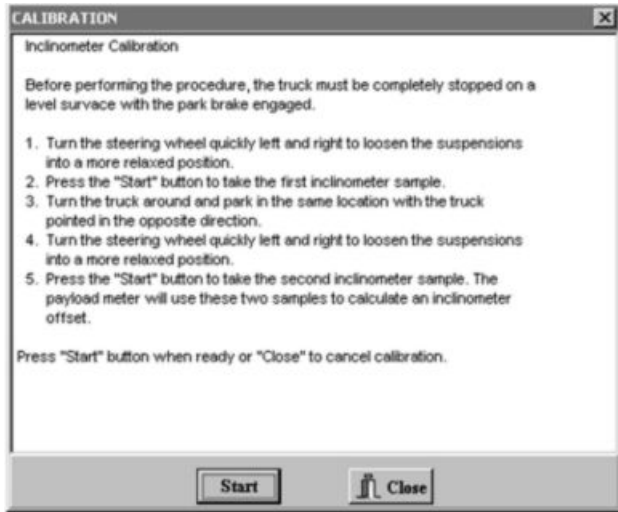

82945

The inclinometer calibration procedure is designed to compensate for variations in the mounting attitude of the inclinometer. The inclinometer input is critical to the payload calculation.

This procedure should be performed on relatively flat ground. Often the maintenance area is an ideal location for this procedure.

To calibrate the inclinometer, perform the following:

- After cleaning debris from the truck and checking to see that the suspensions are properly serviced, use the PLMIII software to connect to the payload meter.
- From the "Truck Configuration" screen, select "Inclinometer".
- With the truck stopped and the park brake on, press the "Start" button. Pressing the "Start" button instructs the payload meter to sample the inclinometer once.
- Turn the truck around. Drive the truck around and park in the exact same spot as before, facing the other direction.
- With the truck stopped and the brake lock on, press the "Start" button. This instructs the payload meter to sample the inclinometer

again. The payload meter will average the two samples to determine the average offset.

- Be sure to follow the screen instructions.

### DOWNLOADING PAYLOAD DATA D.3-0000051432

PLMIII records many types of data. The PLMIII PC software is designed to download the data from a whole truck fleet. Instead of creating one data file for each truck, the PC software combines all the data from many trucks into one database on the hard drive of the computer. The software then allows users to query the database to create custom reports and graphs. Data for individual trucks or groups of trucks can be easily analyzed. This same data can be exported for use in other software applications like word processors and spreadsheet applications.

As the database grows, performance of the PC software for analysis will slow down. It may be helpful to periodically export data. For example, query the database to show the oldest quarter, month, or half year and print out a summary report. Then export the data to a compressed format and save the file in a secure location. Once the data is exported, delete the entire query results from the database. If necessary, the data can easily be imported back into the main database for analysis at a future date. Removing this older data will improve performance.



82939

The PC software downloads the data from the payload meter into a database. The data from all the trucks is added to the same database. Downloading the payload meter can take several minutes.

To move the data to another computer, a query must be run to isolate the particular data for export. Do not press the operator switch on the dashboard while downloading.

To download the payload meter, perform the following:

- Connect to the payload meter and start the PC software.

- From the main menu, select "Connect to Payload Meter". The PC will request the latest status information from the payload meter. The number of haul cycles and alarms will be displayed.

- Select the "Begin Download" button. The PC will request the payload and alarm data from the payload meter and save it into the database. This may take several minutes. A progress bar at the bottom will show the approximate time left.

**UPLOADING DATA** D.3-0000051431

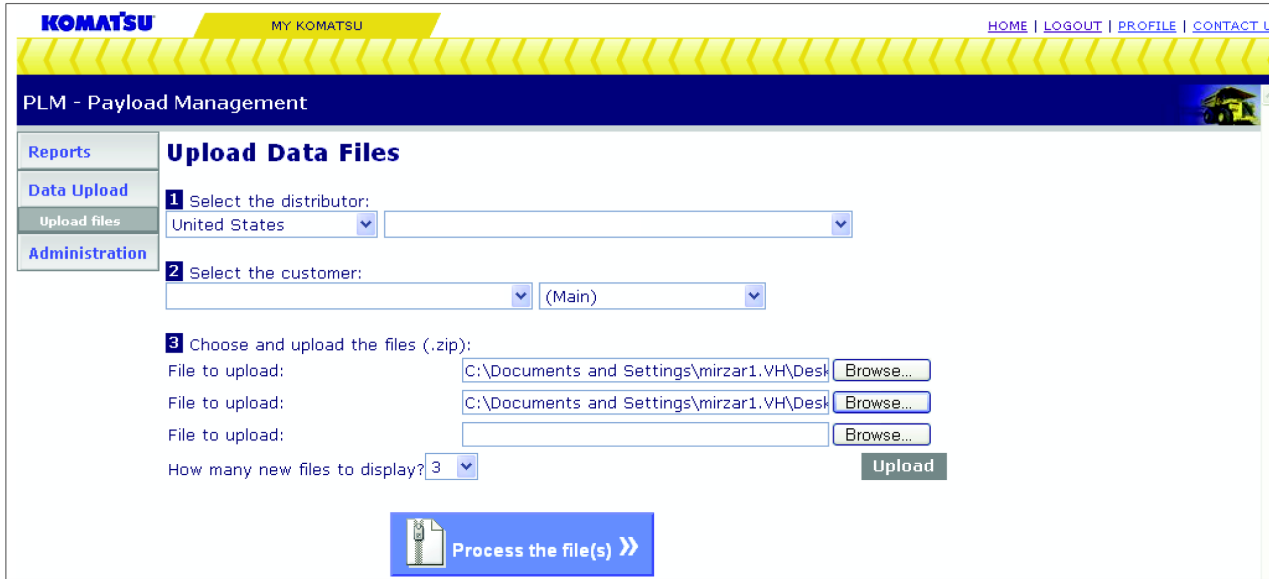

83575

**Figure 5-13 UPLOADING DATA**

The Payload Meter (PLM) application uses data that has been uploaded and stored on the server. The reports generated by the application are in PDF (Adobe) format. CSV files are also available for special analysis. The upload feature allows you to send the PLM data stored on your computer to the server.

To access the PLM application, perform the following:

- Open the internet browser and go to <https://www.mykomatsu.com>. User id and password is required. If you need access, either contact your administrator or click "Register Now".
- Once logged in, there will be "Go To" links for the applications that you have access to. Click "Go to PLM" to access the PLM application.

**NOTE:** If no link exists, please send an email to: [servicesystems@komatsuna.com](mailto:servicesystems@komatsuna.com). Please include your company and contact information.

To upload PLM information to the server, perform the following:

**NOTE:** Data must be exported as a "Compressed File" (.zip) from the Payload Data Manager software. If the file is in the incorrect format, an error will be displayed when trying to upload.

- Once logged in and at the "Payload Management" screen, click "Data Upload", on the left side of the screen, and enter the specific information about the location, distributor, and customer.
- Click the "Browse" button to locate the file desired for uploading. Multiple files can be submitted at once by clicking a new "Browse" button for each file.

**NOTE:** An uploaded file can either contain data for a group of trucks or an individual truck. The application will automatically sort the machines.

- When all the files have been selected, click the "Upload" button. The time it takes to complete the upload will depend on the number and size of the file(s) submitted.
- Once the uploading is finished, click "Process the files(s)".



- When the files are finished processing, a report will be generated that will display graphs corresponding to what months were included within the PLM data for each truck.

**NOTE:** If you receive a "Mismatch" error, it means that a specific truck was not registered on the system beforehand. Please send an email to [servicesystems@komatsuna.com](mailto:servicesystems@komatsuna.com) to register the machine. Be sure to include the truck serial number and ownership information.

**DATA ANALYSIS E.3-0000051430**

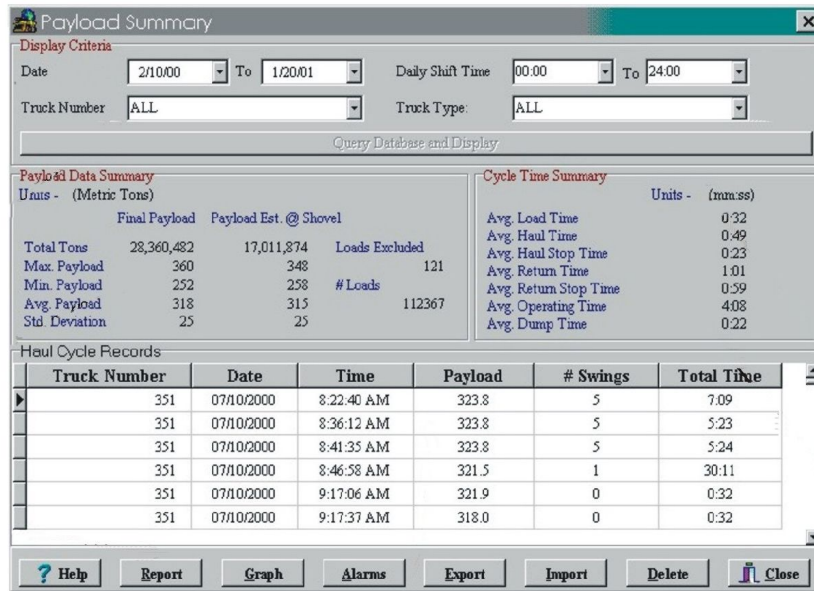

83584

Payload data can be uploaded to "www.MyKomatsu.com" where a payload management report can be generated to analyze payload data. The data analysis tools allow the user to monitor the performance of the payload systems across the fleet. Analysis begins when the "View Payload Data" button is pressed. This starts an "all trucks, all dates, all times" query of the database and displays the results in the Payload Summary Form.

The user can change the query by changing the dates, times, or trucks to include in the query for display.

Haul cycles in the data grid box at the bottom can be double-clicked to display the detailed results of that haul.

**Creating a Query**

The program defaults to show all trucks, all types, all dates and all times for the initial query. The display can be narrowed by selecting which trucks or types to view and for what dates and times. It is important to carefully select the query data and press the "Query Database & Display" button before printing a report.

Choosing one particular truck number will limit the data in the displays, summaries and reports to the one selected truck. To create reports for truck number 374, select 374 from the pull-down menu and hit the "Query Database and Display" button.

The truck type is the size of the truck from the family of Komatsu trucks. This allows the user to quickly view results from different types of trucks on the property. For example, a separate report can be generated for 830E and 930E trucks.

The default query starts in 1995 and runs through the current date on the PC. To narrow the range to a specific date, change the "From" and "To" dates.

The time range sorts the times of the day for valid dates. Changing the time range to 6:00AM to 6:00PM will limit the payloads displayed to the loads that occurred between those times for each day of the date range. Times are entered in 24:00 format.

**Payload Detail Screen**

The payload detail screen gives the details for any individual haul cycle. From the payload summary screen, double-click on any haul cycle to display the detail.



### Creating Reports

Reports can be generated and viewed on the screen or printed. These reports are generated from the query displayed on the Payload Summary Screen.

It is important to carefully select the query data and press the "Query Database & Display" button before printing a report.

**NOTE:** Some haul cycles may contain the Sensor Input warning flag. This indicates that one of the four pressure sensors or inclinometer was not functioning properly during the haul cycle. Haul cycles with this warning are displayed in red on the Payload Summary window and are not included in the summary statistics for reports or display.

### Summary - one page report

A summary of the queried data can be printed onto 1 page. The cycle data is summarized onto one sheet. Displayed is the speeds, cycle times, load statistics, frame and tire data.

### Detailed - multi-page report

The detail report starts with the summary report and follows with pages of data for each haul cycle. The detailed report prints date, time, payload, cycle times, and cycle distances, speeds and the number of swing loads.

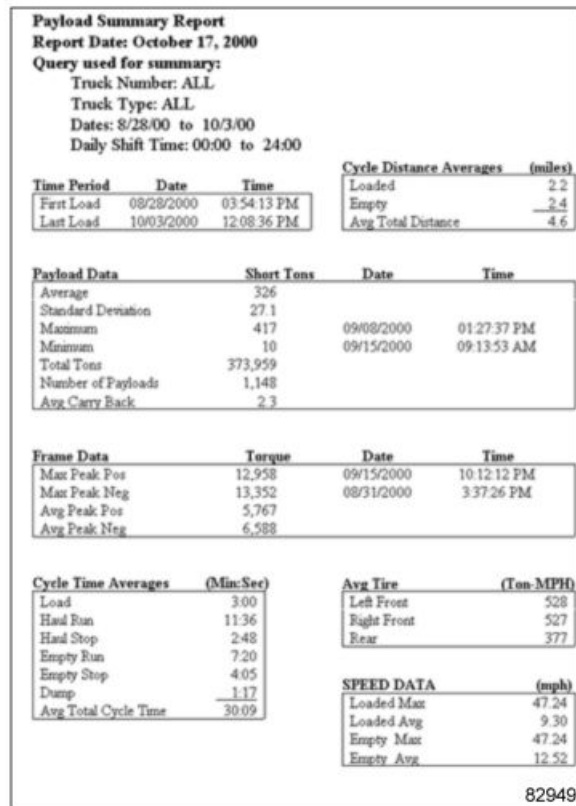

### Creating Graphs

The PLMIII software can generate graphs that quickly summarize payload data. These graphs can be customized for printing. Just like the reports, the graphs are generated from the query displayed on the payload summary screen.

It is important to carefully select the query data and press the "Query Database & Display" button before creating a graph.

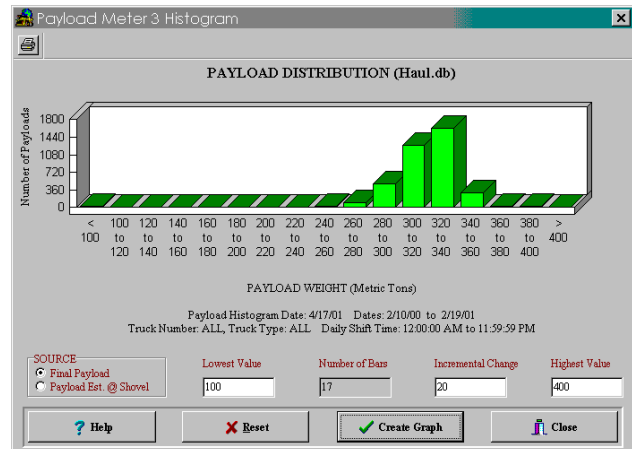

1. From the Payload Summary Screen select the "Graph" button at the bottom.

2. Enter the lowest value. This will be the lowest payload on the graph. Any payloads less than this value will be summed in the first bar.
3. Enter the highest value. This will be the highest value on the graph. Payloads over this value will be summed in the last bar.
4. Enter the incremental change. This will determine the number of bars and the distance between them. The program limits the number of bars to 20. This allows graphs to fit on the screen and print onto 1 page.
5. Press the "Graph" button. The graph will be displayed based on the query settings from the Payload Summary screen. The graph can be customized and printed.

## Exporting Data

### CSV Export

CSV stands for Comma Separated Value. This is an ASCII text file format that allows spreadsheet applications like Excel and Lotus 123 to import data easily. To export the data into a csv file, press the "Export" button at the bottom of the payload summary screen and select "To CSV". The program will request a filename and location for the file.

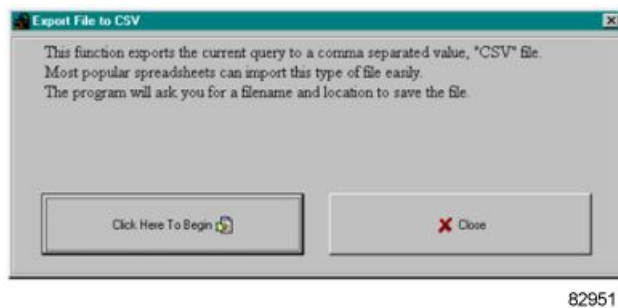

To export data in CSV format:

1. Confirm that the data displayed is the query data that needs to be exported.
2. From the payload summary screen, press the "Export" button and select "To CSV".
3. The program will ask for a filename and location.

### ZIP Export

This export function allows the data from one laptop to be transferred to another computer. This can be useful when a service laptop is used to download multiple machines and transfer the data to a central computer for analysis. This can also be used to copy haul data from a particular truck onto a diskette for analysis.

The file format is a compressed binary form of the displayed query. The file can only be imported by another computer running the PDM software.

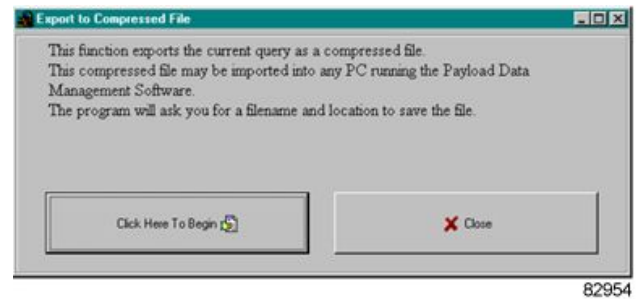

To export data in ZIP format:

1. Confirm that the data displayed is the query data that needs to be exported.
2. From the payload summary screen, press the "Export" button and select "To ZIP".
3. The program will ask for a filename and location.

## Importing Data

This import function allows the data from one laptop to be transferred to another computer. This can be useful when a service laptop is used to download multiple machines and transfer the data to a central computer for analysis. This can also be used to copy haul data from a particular truck from a diskette into a database for analysis.

To import data, press the "Import" button at the bottom of the payload summary screen. The program will ask for a zip file to import, locate the file and press open. The program will only import zip files created by another computer running the PDM Software.

## Deleting Haul Cycle Records

To delete haul cycle records from the main database, press the "Delete" button at the bottom of the payload summary screen. The program will display a summary of the records from the displayed query. To delete a record, select one at a time and press the "Delete" button. It is recommended that records be exported to a zip file for archival purposes before deletion. Multiple records may be selected by holding down the Shift key. Pressing the "Delete All" button will select all the records from the current query and delete them.

**NOTE:** *There is no recovery for records that have been deleted from the main database. It is highly recommended that all records be exported and archived in a compressed file format for future reference before being deleted.*

Truck Number	Date	Time	Payload	# Swings	Total Time
374	08/28/2000	3:54:13 PM	346.7	7	39:11
374	08/28/2000	5:18:14 PM	301.5	6	27:52
374	08/28/2000	5:46:04 PM	300.0	6	25:48
374	08/28/2000	6:11:30 PM	330.5	4	37:51
374	08/28/2000	6:49:37 PM	343.7	4	46:58
374	08/28/2000	7:36:31 PM	379.9	5	37:10
374	08/28/2000	8:13:37 PM	351.6	4	36:50
374	08/28/2000	8:50:22 PM	356.3	4	35:41
374	08/28/2000	9:25:59 PM	369.6	5	34:36
374	08/28/2000	10:00:31 PM	362.6	5	36:18
374	08/28/2000	10:56:44 PM	340.5	7	26:00
374	08/28/2000	11:02:42 PM	330.9	4	36:01
374	08/28/2000	11:38:40 PM	316.5	5	32:26
374	08/29/2000	12:56:37 AM	319.7	5	43:42
374	08/29/2000	1:40:16 AM	301.6	4	27:54

82955

### Deleting Alarm Records

To delete alarm records from the main database, press the “Delete” button at the bottom of the alarm display screen. The program will display a summary of the alarms from the query. To delete an alarm, select one at a time and press the "Delete" button. It is recommended that the query data be exported to a zip file for archival purposes before deletion. Multiple records may be selected by holding down the Shift key. Pressing the “Delete All” button will select all the alarms from the current query and delete them.

**NOTE:** *There is no recovery for alarms that have been deleted from the main database. It is highly recommended that all records be exported and archived in a compressed file format for future reference before being deleted.*

### Viewing Alarms

From the Payload Summary screen, click the “Alarms” button to display the alarm screen. The alarms are sorted by the query settings from the payload Summary screen. Alarms can be displayed as active or inactive.

Truck Number	Type	Set Date	Set Time	Description	Cleared Date	Cleared Time
374	13	8/31/00	2:34:48 AM	ALARM BODY UP SWITCH	8/31/00	2:34:52 AM
374	13	9/1/00	2:36:57 PM	ALARM BODY UP SWITCH	9/1/00	2:37:01 PM
374	13	9/1/00	2:45:22 PM	ALARM BODY UP SWITCH	9/1/00	2:45:26 PM
374	13	9/1/00	9:19:43 PM	ALARM BODY UP SWITCH	9/1/00	9:19:48 PM
374	13	9/30/00	2:42:05 AM	ALARM BODY UP SWITCH	9/30/00	2:42:10 AM

82946

### Patent Acknowledgment

Portions of Payload Meter III measuring systems are manufactured under license from L.G. Hagenbuch, holder of U.S. Patent numbers 5,416,706; 5,528,499; 5,631,832; 5,631,835; 5,644,489; 5,650,928; 5,650,930; 5,742,914

**AUTOMATIC LUBRICATION SYSTEM** C.3-0000051429

**GENERAL INFORMATION** D.3-0000051468

The automatic lubrication system is a pressurized lubricant delivery system which delivers a controlled amount of lubricant to designated lube points. The system is controlled by an electronic timer which signals a solenoid valve to operate a hydraulic motor powered grease pump. Hydraulic oil for pump operation is supplied by the truck steering circuit.

A 24VDC solenoid mounted on the manifold turns the pump on and off. The pump is driven by the rotary motion of the hydraulic motor, which is then converted to reciprocating motion through an eccentric crank mechanism. The pump is a positive displacement, double-acting type as grease output occurs on both the up and the down stroke.

**COMPONENT DESCRIPTION** E.12-0000051467

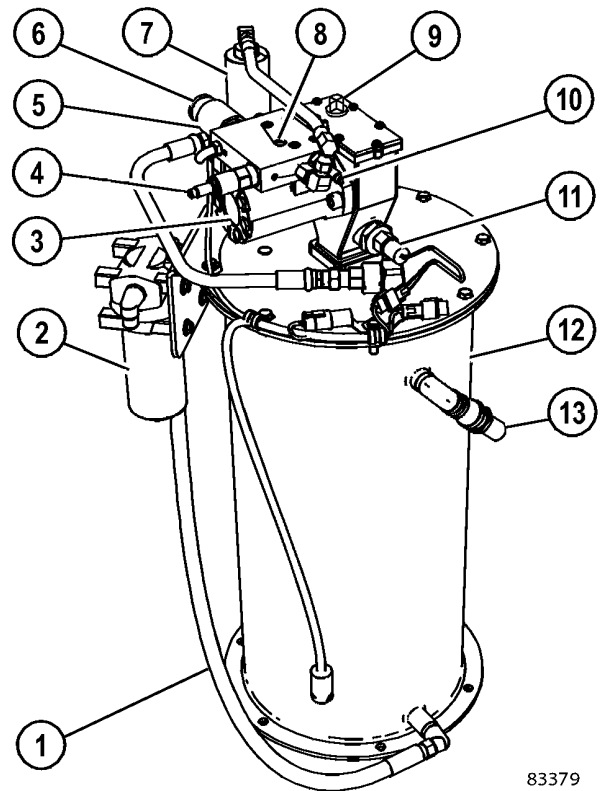

- |                                      |                             |
|--------------------------------------|-----------------------------|
| 1. Hose From Filter                  | 8. Pipe Plug                |
| 2. Filter                            | 9. Dipstick                 |
| 3. Hydraulic Motor and Pump Assembly | 10. Flow Control Valve      |
| 4. Pressure Reducing Valve           | 11. Pressure Cut Off Switch |
| 5. Solenoid Valve                    | 12. Grease Reservoir        |
| 6. Override Switch                   | 13. Vent Hose               |
| 7. Vent Valve                        |                             |

**Figure 5-14 PUMP & RESERVOIR COMPONENTS**



**⚠ WARNING**

- Over-pressurizing the system, modifying parts, using incompatible chemicals and fluids, or using worn or damaged parts may result in equipment damage and/or serious personal injury.
- This equipment generates very high grease pressure. Extreme caution must be used when operating this equipment. Pressurized fluid leaking from loose or ruptured components can result in fluid being injected into the skin and body causing serious injury and possibly the need for amputation. Adequate protection is recommended to prevent splashing of material onto skin or into the eyes.
- If any fluid appears to penetrate the skin, get emergency medical care immediately! Do not treat as a simple cut. Tell attending physician exactly what fluid was injected.

filters the grease prior to refilling the reservoir. Bypass indicator (1) alerts service personnel when the filter requires replacement.

**Hydraulic Motor and Pump**

Rotary hydraulic motor and pump is a fully hydraulically operated grease pump. An integrated pump control manifold is incorporated with the motor to control input flow and pressure.

The pump housing must be filled to the proper level with SAE 10W-30 motor oil. Use dipstick (9, Figure 5-14 PUMP & RESERVOIR COMPONENTS, page 5-43) to check the oil level at 1,000 hour intervals. If necessary, add oil to the correct level that is marked on the dipstick.

High pressure hydraulic fluid from the truck steering system is reduced by the pressure reducing valve located on the manifold on top of the pump motor. This pressure can be read if pipe plug (8) is removed, and a gauge is installed on the manifold.

**⚠ WARNING**

- Hydraulic oil supply inlet pressure must not exceed 24 132 kPa (3,500 psi). Exceeding the rated pressure may result in damage to the system components and personal injury.

**Filter**

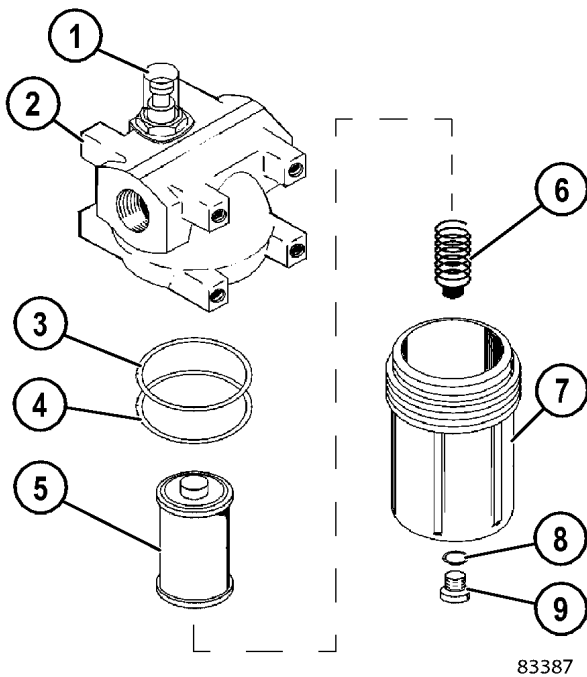

- |                     |           |
|---------------------|-----------|
| 1. Bypass Indicator | 6. Spring |
| 2. Housing          | 7. Bowl   |
| 3. O-Ring           | 8. O-Ring |
| 4. Backup Ring      | 9. Plug   |
| 5. Filter Element   |           |

**Figure 5-15 FILTER ASSEMBLY**

Filter element (5) must be replaced if bypass indicator (1) shows excessive element restriction. The filter assembly is mounted on the grease reservoir and

**Grease Reservoir**

Reservoir (12) has an approximate capacity of 41 kg (90 lbs.) of grease. When the grease supply is replenished by filling the system at the service center, the grease is passed through the filter to remove contaminants before it flows into the reservoir.

**Pressure Reducing Valve**

Pressure reducing valve (4), located on the manifold, reduces the hydraulic supply pressure (from the truck steering circuit) to a suitable operating pressure for the hydraulic motor used to drive the lubricant pump.

**NOTE:** The pressure reducing valve has been factory adjusted and the setting should not be disturbed unless grease output pressure is outside the recommendations.

A pressure gauge can be installed where pipe plug (8) is located. The pressure gauge will indicate hydraulic oil pressure to the inlet of the hydraulic motor. Normal pressure is 2241 - 2413 kPa (325 - 350 psi).

**Flow Control Valve**

Flow control valve (10), mounted on the manifold, controls the amount of oil flow to the hydraulic motor.

**NOTE:** *The flow control valve has been factory adjusted and the setting should not be disturbed.*

### **Solenoid Valve**

Solenoid valve (5), when energized, allows oil to flow to the hydraulic motor.

### **Vent Valve**

With vent valve (7) closed, the pump continues to operate until maximum grease pressure is achieved. As this occurs, the vent valve opens and allows the grease pressure to drop to zero, so the injectors can recharge for their next output cycle.

### **Interface Module**

The interface module provides a 24 VDC timed-interval signal to energize the solenoid valve, providing oil flow to operate the grease pump motor. This interface module is mounted in the auxiliary control cabinet.

### **Pressure Cut Off Switch**

Pressure cut off switch (11) is a normally open switch set at 20 684 kPa (3,000 psi). This switch de-energizes the pump solenoid relay if the grease line pressure reaches the switch pressure setting, turning off the motor and pump.

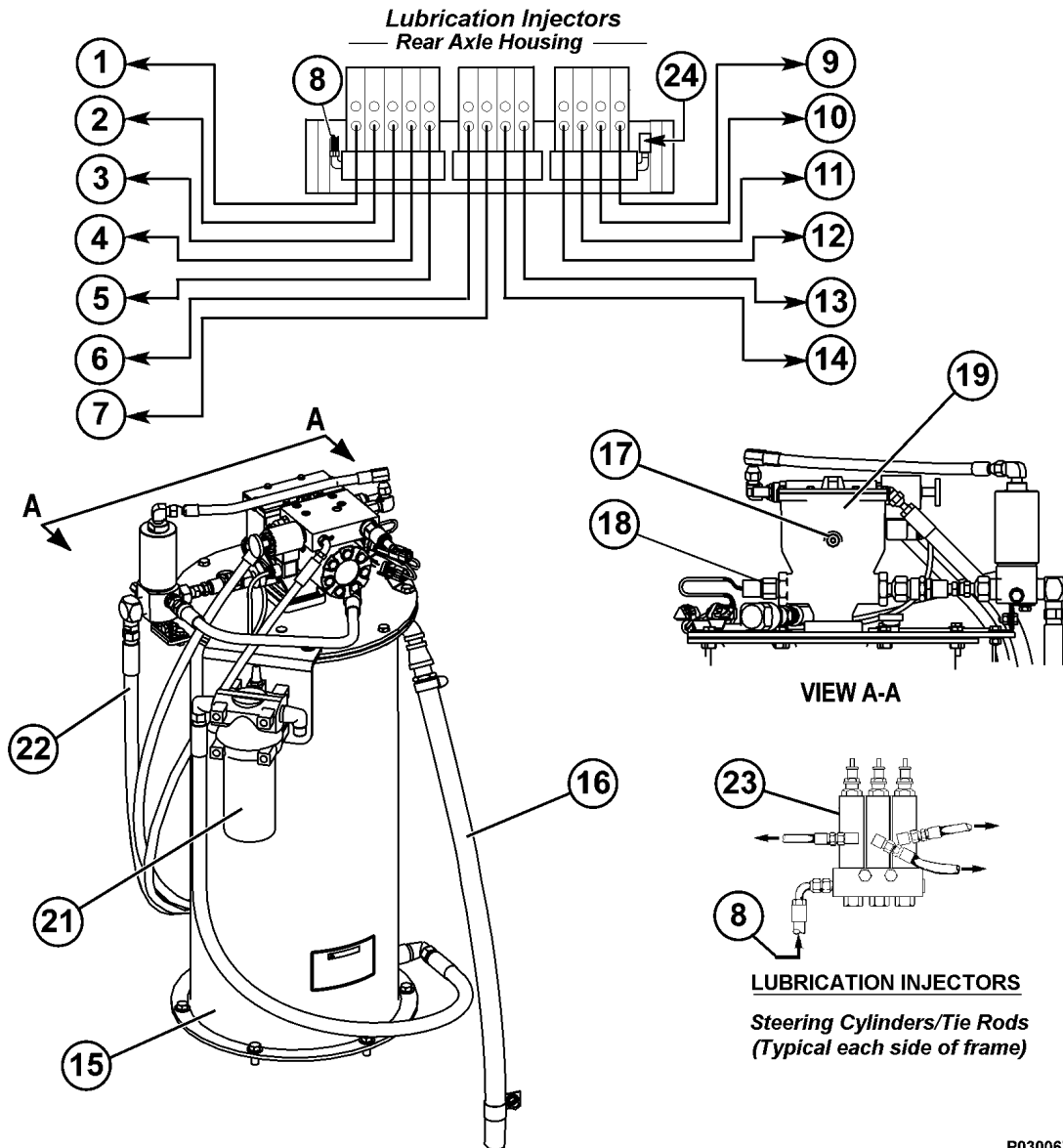

P030067

- |                                        |                                         |                                                   |
|----------------------------------------|-----------------------------------------|---------------------------------------------------|
| 1. L.H. Suspension, Bottom Bearing     | 9. R.H. Suspension, Bottom Bearing      | 17. Pipe Plug (Oil Level)                         |
| 2. L.H. Hoist Cylinder, Bottom Bearing | 10. R.H. Hoist Cylinder, Bottom Bearing | 18. Pressure Switch, N.O.- 20 685 kPa (3,000 psi) |
| 3. L.H. Anti-Sway Bar Bearing          | 11. Rear Axle Pivot Pin                 | 19. Grease Pump                                   |
| 4. L.H. Suspension, Top Bearing        | 12. R.H. Anti-Sway Bar Bearing          | 20. Vent Valve                                    |
| 5. L.H. Body Pivot Pin                 | 13. R.H. Suspension, Top Bearing        | 21. Filter                                        |
| 6. L.H. Hoist Cylinder, Top Bearing    | 14. R.H. Body Pivot Pin                 | 22. Grease Supply to Injectors                    |
| 7. R.H. Hoist Cylinder, Top Bearing    | 15. Grease Reservoir                    | 23. Injectors                                     |
| 8. Grease Supply From Pump             | 16. Vent Hose                           | 24. Pressure Switch, N.O.- 13 790 kPa (2,000 psi) |

**Figure 5-16 LUBRICATION INJECTORS**

**Injectors**

Each injector delivers a controlled amount of pressurized lubricant to a designated lube point. Refer to [Figure 5-16 LUBRICATION INJECTORS, page 5-46](#).



## Grease Pressure Failure Switch

Pressure switch (18) is a normally open switch set at 13 790 kPa (2,000 psi). If the appropriate grease pressure is not achieved during the normal pump cycle, the warning system will be activated, illuminating the warning lamp in the overhead display to notify the operator a problem exists in the lube system.

## Relief Valve (unloader valve)

There is a relief valve that protects the pump from high pressures. The relief valve is set at 27 580 kPa (4,000 psi).

## SYSTEM OPERATION A.4-0000053765

During truck operation, the lubrication cycle logic (in the interface module) will energize the system at a preset time interval. The interface module provides a path to ground to energize the pump solenoid valve allowing hydraulic oil provided by the steering pump circuit to flow to the pump motor and initiate a pumping cycle.

The hydraulic oil from the steering circuit is directed through the pressure reducing valve and the flow control valve before entering the motor. Pump pressure can be read on optional pressure gauge mounted on the manifold. With oil flowing into the hydraulic motor, the grease pump will operate, pumping grease from the reservoir to the injectors, through a check valve, and to the vent valve. During this period, the injectors will meter the appropriate amount of grease to each lubrication point.

**NOTE:** Each lube injector services only one grease point. In case of pump malfunction, each injector is equipped with a covered grease fitting to allow the use of external lubricating equipment.

When grease pressure reaches the setting of pressure switch, the switch contacts will close and energize the relay. Energizing this relay removes power from the hydraulic motor/pump solenoid and the pump will stop. The relay will remain energized until the interface module completes its 120 second ON cycle.

After the pump solenoid valve is de-energized, hydraulic pressure in the manifold drops and the vent valve will open releasing grease pressure in the lines to the injector banks. When this occurs, the injectors are then able to recharge for the next lubrication cycle.

**NOTE:** The system will remain at rest until the next lubrication cycle turns on and initiates a new grease cycle. During the normal lubrication cycle, if grease pressure fails to reach 13 790 kPa (2,000 psi) at the pressure switch located on the rear axle housing, a repair indicator light will illuminate on the monitor display panel. In addition, fault A190 "Auto Lube Fault" will be shown in the repair fault menu.

## Filling The Reservoir

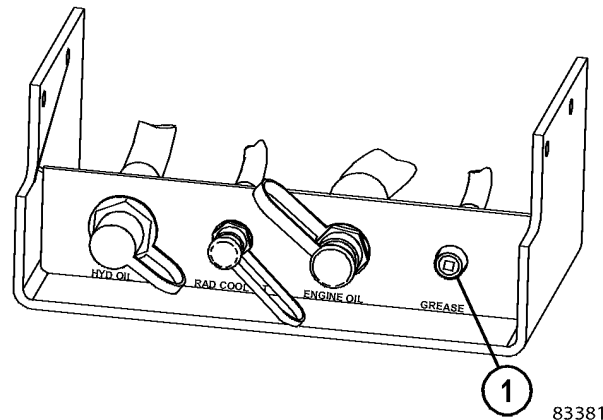

1. Automatic Lubrication Fill Connector

### Figure 5-17 SERVICE CENTER

The grease reservoir has an approximate capacity of 41 kg (90 lb) of grease. When the grease supply is replenished by filling the system at the service center, the grease is passed through the filter to remove contaminants before it flows into the reservoir.

To fill the automatic lubrication system reservoir, perform the following:

1. Connect an external grease supply to grease connector (1) of the service center.
2. Remove the vent hose from the reservoir.
3. Pump grease into the reservoir, from the service center, until grease is seen through the vent hose port. Once grease is present, stop filling.
4. Disconnect external grease supply from the service center and reconnect the vent hose to the reservoir.

### Lubricant Required For Automatic Lubrication System

Grease requirements will depend on ambient temperatures encountered during truck operation:

- Above 32°C (90°F) - Use NLGI No. 2 multipurpose grease (MPG).

- -32° to 32°C (-25° to 90°F) - Use NLGI No. 1 multipurpose grease (MPG).
- Below -32°C (-25°F) - Refer to local supplier for extreme cold weather lubricant requirements.

**Priming The Automatic Lubrication System**

The system must be full of grease and free of air pockets to function properly. After maintenance, if primary or secondary lubrication lines were replaced, it will be necessary to prime the system to eject all entrapped air.

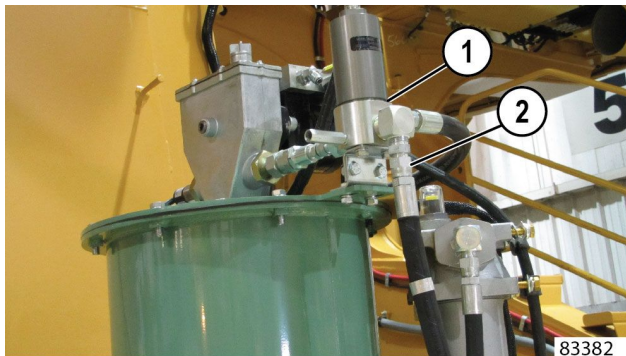

1. Vent Valve
2. Main Supply Line

**Figure 5-18 AUTO LUBE MAIN SUPPLY LINE**

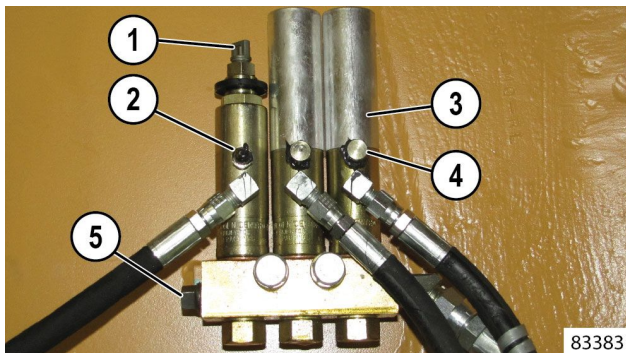

1. Injector Indicator
2. Injector Grease Zerk
3. Injector Cover
4. Injector Grease Zerk Cap
5. Injector Manifold Plug

**Figure 5-19 INJECTOR MANIFOLD**

To prime the main supply lines, perform the following:

1. Fill lube reservoir with lubricant, if necessary.
2. Remove injector manifold plug (5, Figure 5-19 INJECTOR MANIFOLD, page 5-48) from injector manifold. Always start with the injector manifold closest to the pump. The last grease line to be purged should be the main grease line to the rear axle (longest grease line).

3. Disconnect main supply line (2, Figure 5-18 AUTO LUBE MAIN SUPPLY LINE, page 5-48) from vent valve (1). Connect an external grease supply to main supply line (2).
4. Pump grease in main supply line (2) until grease appears at the injector manifold plug.
5. Re-install the injector manifold plug. Repeat for remaining injector groups.

After all main supply lines are purged of air, the injector circuits must now be primed.

To prime the secondary supply lines, perform the following:

1. If necessary, disconnect an injector grease line from the component that particular injector supplies grease to.
2. Remove injector grease zerk cap (4) from each injector and connect an external grease supply to injector grease zerk (2) on the injector.
3. Pump grease into the injector until grease appears at the far end of the individual grease line or the joint being greased.
4. Reconnect injector grease line to the component, remove the external grease supply, and reinstall injector grease zerk cap.
5. Repeat steps 1 through 4 until all secondary supply lines have been primed.
6. After all grease lines are primed, use the override switch to cycle the automatic lubrication pump a few times to lube the components.

**PREVENTIVE MAINTENANCE PROCEDURES E.7-0000051465**

Use the following maintenance procedures to ensure proper system operation.

**Daily Lubrication System Inspection**

1. Check the grease reservoir level after each shift of operation. Grease usage should be consistent from day-to-day operations. Lack of lubricant usage would indicate an inoperative system. Excessive usage would indicate a broken supply line.
2. Check filter bypass indicator when filling reservoir. Replace element if bypassing.
3. Check all grease hoses from the injectors to the lubrication points.
  - a. Repair or replace all damaged feed line hoses.

- b. Ensure that all air is purged and all new feed line hoses are filled with grease before returning the truck to service.
4. Inspect the key lubrication points for a bead of lubricant around seal. If a lubrication point appears dry, troubleshoot and repair problem.

## 250 Hour Inspection

1. Check all grease hoses from the injectors to the lubrication points.
  - a. Repair or replace all worn or broken hoses.
  - b. Ensure that all air is purged and all new feed line hoses are filled with grease before returning the truck to service.
2. Check all grease supply line hoses from the pump to the injectors.
  - a. Repair or replace all worn / broken supply lines.
  - b. Ensure that all air is purged and all new supply line hoses are filled with grease before returning the truck to service.
3. Check the grease reservoir level.
  - a. Fill the reservoir if the grease level is low. Check the filter bypass indicator when filling the reservoir. Replace the element if bypassing.
  - b. Check the reservoir for contaminants. Clean the reservoir, if required.
  - c. Ensure that all filler plugs, covers and breather vents on the reservoir are intact and free of contaminants.
4. Inspect all bearing points for a bead of lubricant around the bearing seal.

It is good practice to manually lube each bearing point at the grease fitting provided on each Injector. This will indicate if there are any frozen or plugged bearings, and it will help flush the bearings of contaminants.

5. System Checkout
  - a. Remove all injector cover caps to allow visual inspection of the injector cycle indicator pins during system operation.
  - b. Start truck engine.
  - c. Actuate lube system override switch. The hydraulic motor and grease pump should operate.

- d. With the grease under pressure, check each injector assembly. The cycle indicator pin should be retracted inside the injector body.
- e. When the system is at 16 203 - 17 237 kPa (2,350 - 2,500 psi), the pump should shut off and the pressure in the system should drop to zero, venting back to the grease reservoir.
- f. After the system has vented, check the injector indicator pins. All of the pins should be visible. Replace or repair any defective injectors.
- g. Install all injector cover caps.
- h. Initiate one or more lubrication cycles to check the system operation.

**NOTE:** Turning the key switch to the ON position will not initiate a lube cycle. To initiate a lube cycle while the truck is stationary, select manual lube using the dash display panel, or use the switch on the lubrication pump. The system should build 13 790 kPa (2,000 psi) at the rear axle during normal pump cycle.

- i. If the system is working properly, the machine is ready for operation.
- j. If the system is malfunctioning, immediately report problem to maintenance personnel.

## 1000 Hour Inspection

1. Using the dipstick, check the pump housing oil level. If necessary, refill with SAE 10W-30 motor oil.

## SYSTEM CHECKOUT C.9-0000051738

### General Checks

To check system operation, proceed as follows:

1. Remove the dust covers from the injectors.
2. Start the engine.
3. Actuate the manual override button at the pump assembly and observe pin movement at each injector.
4. Check for pump, hose or injector damage or leakage with the system under pressure.
5. After checking system, stop the engine. Observing normal precautions regarding high voltage present in the propulsion system before attempting to repair lube system.
6. Re-install the injector dust covers.

### Lubrication Cycle Operation

The time between lube events is determined by the setting selected in the dash panel. Refer to Figure 5-20 LUBRICATION MENU, page 5-50 for lubrication menu screens. With the key switch ON, scroll through the display menu screens and select either 8, 15, 24 or 30 minutes between lube cycles. The default setting is 15 minutes.

**NOTE:** Turning the key switch to the ON position will not initiate a lube cycle. To initiate a lube cycle while the truck is stationary, select manual lube using the dash display panel, or use the switch on the lubrication pump. The truck must be moving before the lube system will initiate lube cycles based on the time interval selected.

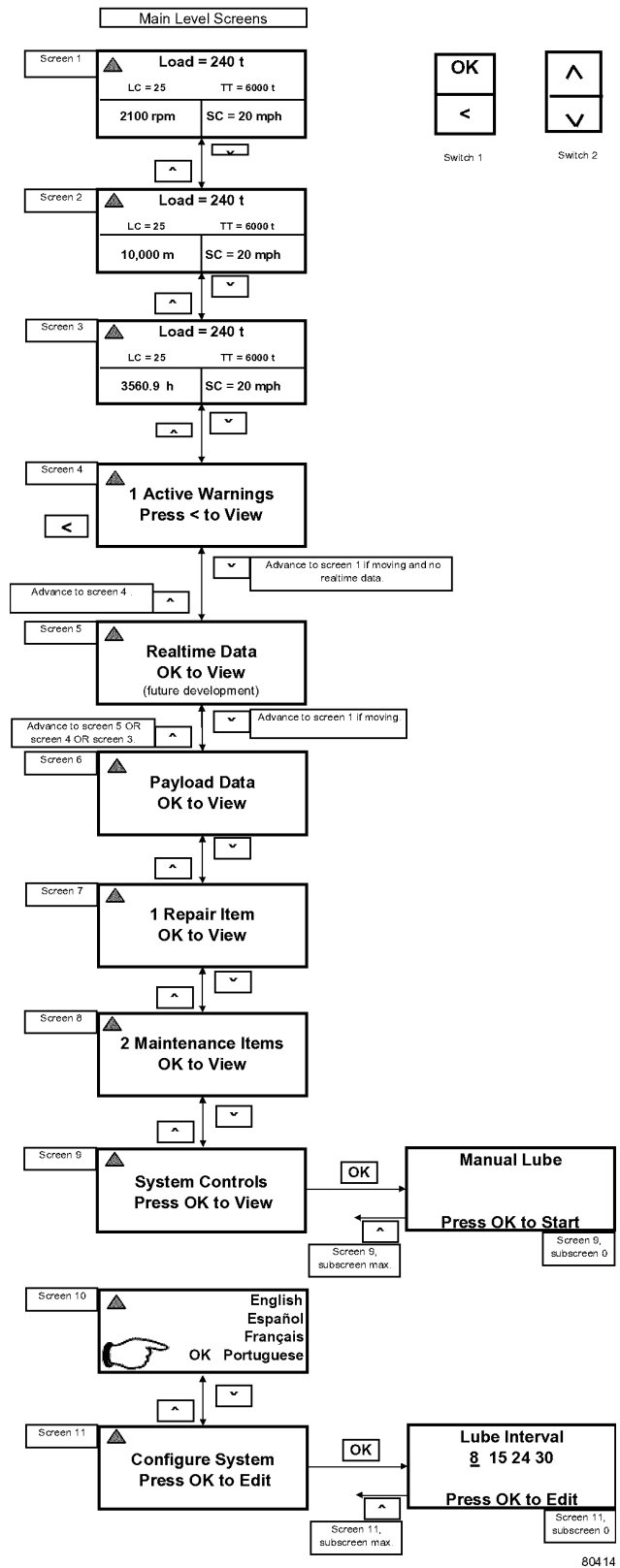

Figure 5-20 LUBRICATION MENU

## RESERVE ENGINE OIL SYSTEM

F.2-0000051462

The reserve oil tank for the engine is designed to add more oil capacity to the engine and to make less frequent servicing of the engine oil. The circulation of oil between the engine sump and reserve tank increases the total volume of working oil. This dilutes the effects of contamination and loss of additives and maintains the oil quality over longer periods.

### Operation

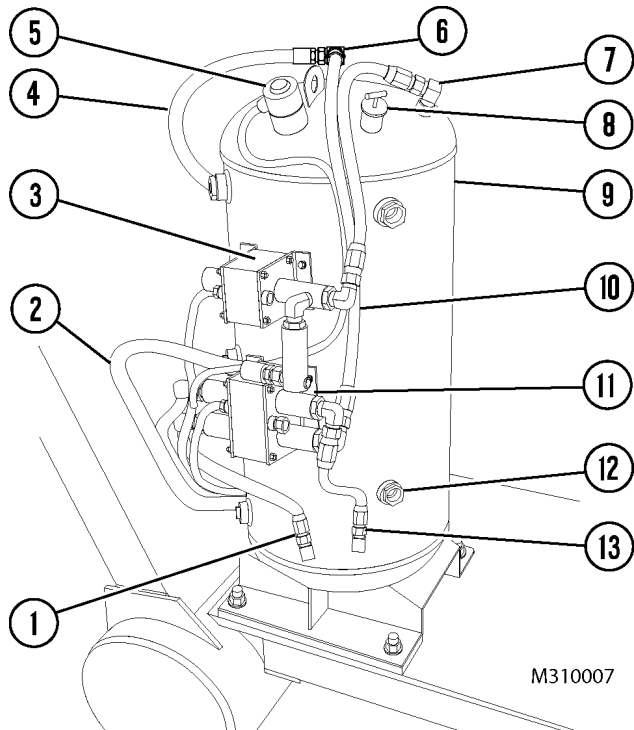

- |                     |                      |
|---------------------|----------------------|
| 1. Oil Suction      | 8. Fill Cap          |
| 2. Oil Tank Fill    | 9. Reserve Oil Tank  |
| 3. Fill Valve       | 10. Engine Fill Line |
| 4. Engine Fill Line | 11. Pump Unit        |
| 5. Oil Level Sensor | 12. Sight Gauge      |
| 6. Air Valve        | 13. Tank Return Line |
| 7. Tank Fill Line   |                      |

### Figure 5-21 RESERVE ENGINE OIL SYSTEM

Engine oil is circulated between the engine sump and the reserve tank by two electrically driven pumps within a single pumping unit (11, [5-21 RESERVE ENGINE OIL SYSTEM, page 5-51](#)). The pump unit is mounted on the side of the reserve tank, and is equipped with an LED monitor light on one side.

Pump 1 (in the pump unit) draws oil from the engine sump at a preset control point determined by the height of the suction tube. Oil above this point is withdrawn and transferred to reserve tank (9). This lowers the level in the engine sump until air is drawn.

Air reaching the pumping unit activates pump 2 (in the pump unit) which returns oil from the reserve tank and raises the engine sump level until air is no longer drawn by pump 1. Pump 2 then turns off. The running level is continuously adjusted at the control point by alternation between withdrawal and return of oil at the sump.

### LED Monitor Light

The following light indications should be used to understand pump operation.

- Steady - Pump 1 is withdrawing oil from the engine sump and bringing down the oil level.
- Regular Pulsing - Pump 2 is returning oil to the engine sump and raising the oil level.
- Irregular Pulsing - Oil is on the correct operating level.

### Changing Oil

Obey the following guidelines when changing the oil.

1. Drain both the engine sump and the reserve tank. Refill both the engine and reserve tank with new oil to proper levels.
2. Change engine and reserve tank filters as required.
3. Start the engine and check for proper operation.

**NOTE:** DO NOT use the oil in the reserve tank to fill the engine sump. Both must be at proper level before starting the engine.

4. The engine oil level must be checked with the engine dipstick at every shift change. If the oil level in the engine is incorrect, check for proper operation of the reserve engine oil system.
5. The oil level in the reserve tank must also be checked at every shift change. Use dipstick on fill cap (8) to check oil level. If necessary, add oil to the reserve tank by using the quick fill system utilizing tank fill valve (3). For filling instructions, refer to [Lubrication and Service-RESERVE ENGINE OIL SERVICE, page 7-4](#) in this manual.

Oil must always be visible in lower sight gauge (12). If the tank is equipped with three sight gauges, oil must always be visible in the middle sight gauge.



# **OPERATOR CAB AND CONTROLS**

**CAB INTERIOR** A.3-0000070600

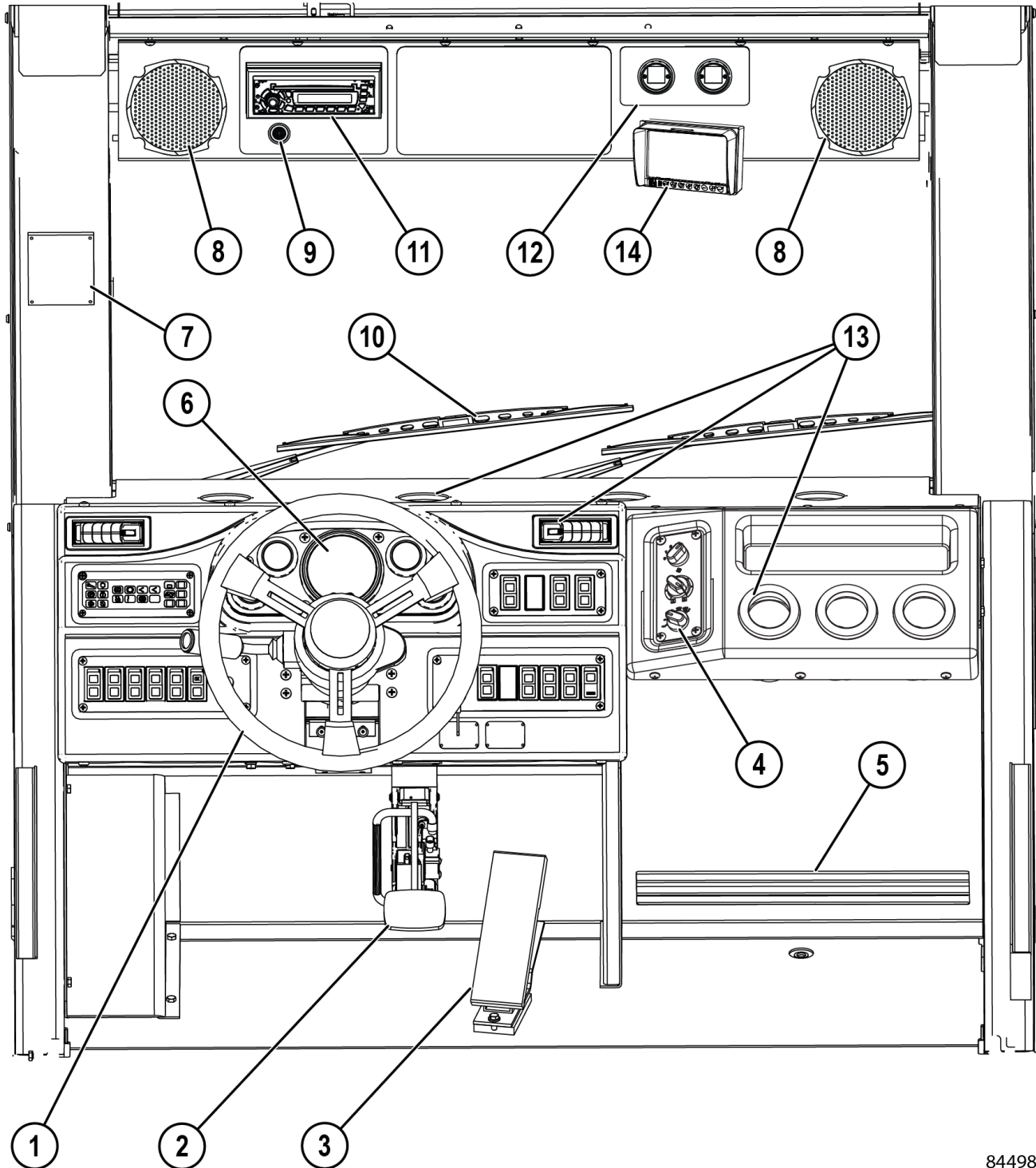

84498

- |                                    |                             |                                  |
|------------------------------------|-----------------------------|----------------------------------|
| 1. Steering Wheel                  | 6. Instrument Panel         | 11. AM/FM Radio / CD Player      |
| 2. Service Brake/Retard Pedal      | 7. Grade/Speed Retard Chart | 12. Air Cleaner Vacuum Gauges    |
| 3. Throttle/Accelerator Pedal      | 8. Radio Speakers           | 13. Heater/Air Conditioner Vents |
| 4. Heater/Air Conditioner Controls | 9. Warning Alarm Buzzer     | 14. Camera Monitor (Optional)    |
| 5. Recirculation Filter            | 10. Windshield Wipers       |                                  |

**Figure 6-1 CAB INTERIOR - OPERATOR VIEW**



# STEERING WHEEL AND CONTROLS

E.5-0000051460

Steering wheel (1, Figure 6-2 STEERING WHEEL & CONTROLS, page 6-3) can be telescoped "in" and "out" and the tilt angle can be adjusted to provide a comfortable steering wheel position for most operators.

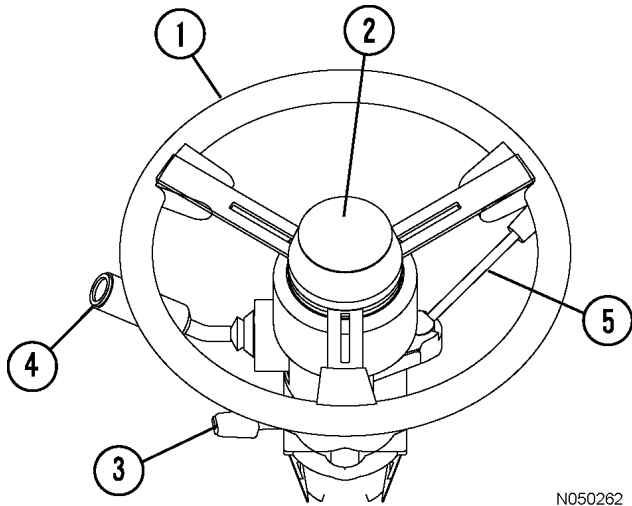

N050262

- 1. Steering Wheel
- 2. Horn Button
- 3. Tilt/Telescope Lever
- 4. Multi-Function Turn Signal Switch
- 5. Retarder Lever

Figure 6-2 STEERING WHEEL & CONTROLS

## Horn Button

Horn (2) is actuated by pushing the button in the center of the steering wheel. Ensure that the horn operates before moving the truck. Observe all local safety rules regarding the use of the horn as a warning signal device before starting the engine and moving the vehicle.

## Tilt / Telescope Lever

The steering column can be telescoped or the wheel tilted with lever (3).

Adjust the tilt of the steering wheel by pulling the lever toward the steering wheel and moving the wheel to the desired angle. Releasing the lever will lock the wheel in the desired location.

Adjust the telescope function by pushing the lever forward to unlock. After positioning as desired, release the lever to the lock position.

## Multi-Function Turn Signal Switch

Multi-function turn signal switch (4) is used to activate the turn signal lights, the windshield wipers, and to select either high or low beam headlights.



N050186

## Turn Signal Operation

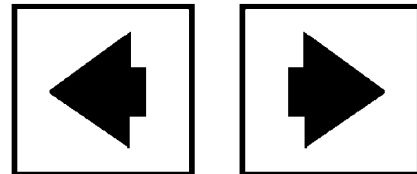

83632

Move the lever upward to signal a right turn. Move the lever downward to signal a left turn. An indicator in the top, center of the instrument panel will illuminate to indicate turn direction selected. Refer to Instrument Panel and Indicator Lights in this section.

**NOTE:** If the truck is not equipped with a self-canceling turn signal, the turn signal will not automatically cancel after the turn has been completed.





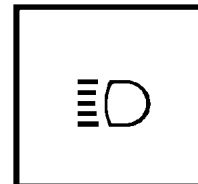

## High Beam Headlight Operation

Pulling the lever inward (toward the rear of the cab) changes the headlights to high beam. When the high beams are selected, the indicator in the top center of the instrument panel will illuminate.



Moving the switch back to the original position will return the headlights to low beam.

## Windshield Wiper Operation

	Windshield Wipers OFF
	Intermittent - Long Delay
	Intermittent - Medium Delay
	Intermittent - Short Delay
	Low Speed
	High Speed
	Depressing the button at the end of the lever will activate the windshield washer.

## PEDALS AND RETARDER LEVER B.5-0000060899

### DYNAMIC RETARDING

Dynamic retarding is a braking torque (not a brake) produced through electrical generation by the wheelmotors when the truck motion (momentum) is the propelling force.

For normal truck operation, dynamic retarding must be used to slow and control truck speed.

Dynamic retarding is available in FORWARD/REVERSE at all truck speeds above 0 kph/mph; however, as the truck speed slows below 5 kph (3 mph), the available retarding force may not be effective. Use the service brakes to bring the truck to a complete stop.

Dynamic retarding will not hold a stationary truck on an incline. Use the parking brake or wheel brake lock for this purpose.

Dynamic retarding is available in NEUTRAL only when truck speed is above 5 kph (3 mph).

When dynamic retarding is in operation, engine rpm will automatically go to an advance retard speed setting. This rpm will vary depending on temperature of several electrical system components.

Dynamic retarding will be applied automatically if the speed of the truck obtains the maximum speed setting programmed in the control system software.

When dynamic retarding is activated, an indicator light will illuminate. The grade/speed retard chart must always be used to determine safe downhill speeds. Refer to the grade speed chart in the cab.

### RETARDER LEVER

Retarder lever (5, Figure [STEERING WHEEL AND CONTROLS, page 6-3](#)) mounted on the right side of the steering column can be used to modulate retarding effort. The lever will command the full range of retarding and will remain at a fixed position when released.

- When the lever is rotated to full “up” (counterclockwise) position, it is in the OFF/no retard position. An adjustable detent holds the lever in the OFF position. Refer to the shop manual for adjustment procedures.
- When the lever is rotated to full “down” (clockwise) position, it is in the full ON/retard position.
- For long downhill hauls, the lever may be positioned to provide desired retarding effort, and it will remain where it is positioned.

**NOTE:** The retarder lever must be rotated back to the OFF position before the truck will resume the propel mode of operation.

The lever and foot-operated retarder/service brake pedal can be used simultaneously or independently. The Propulsion System Controller (PSC) will determine which device is requesting the most retarding effort and apply that amount.

### BRAKE/RETARDER PEDAL

Brake/retarder pedal (2, Figure [6-1 CAB INTERIOR - OPERATOR VIEW, page 6-2](#)) is a single, foot-operated pedal that controls both retarding and service brake functions. The first portion of pedal travel commands retarding effort through a rotary potentiometer. The second portion of pedal travel modulates service brake pressure directly through a hydraulic valve. Thus, the operator must first apply, and maintain, full dynamic retarding in order to apply the service brakes. Releasing the pedal returns brake and retarder to the OFF position.

When the pedal is partially depressed, the dynamic retarding is actuated. As the pedal is further depressed, to where dynamic retarding is fully applied; the service brakes (while maintaining full retarding) are actuated through a hydraulic valve which modulates pressure to the service brakes. **Completely depressing the pedal causes full application of both dynamic retarding and the service brakes.** Indicator light (15, Figure [6-11 STATUS INDICATOR LIGHTS, page 6-21](#)) will illuminate, and an increase in pedal resistance will be felt when the service brakes are applied.

For normal truck operation, dynamic retarding (lever or foot-operated pedal) should be used to slow and control the speed of the truck.

Service brakes should be applied only when dynamic retarding requires additional braking force to slow the truck speed quickly or when bringing the truck to a complete stop.

### ACCELERATOR PEDAL

Accelerator pedal (3, Figure [6-1 CAB INTERIOR - OPERATOR VIEW, page 6-2](#)) is a foot-operated pedal which allows the operator to control engine rpm depending on pedal depression.

It is used by the operator to request torque from the motors when in forward or reverse. In this mode, the propulsion system controller commands the correct engine speed for the power required. In NEUTRAL, this pedal controls engine speed directly.

## OVERHEAD PANEL AND DISPLAYS

D.16-0000054540

The items listed below are located on the overhead panel. Refer to Figure 6-1 CAB INTERIOR - OPERATOR VIEW, page 6-2 for the location of each item. A brief description of each component is documented below.

### RADIO SPEAKERS

Radio speakers for the AM/FM Radio / CD Player are located at the far left and right of the overhead panel.

### WARNING ALARM BUZZER

Warning alarm buzzer will sound when activated by any one of several truck functions. Refer to INSTRUMENT PANEL , page 6-16 in this section for a detailed description of functions and indicators that will activate this alarm.

### CAB RADIO

This panel will normally contain AM/FM Radio/CD Player. Refer to RADIO OPERATION, page 9-2 for a more complete description of the radio and its

functions. Individual customers may use this area for other purposes, such as a two-way communications radio.

### AIR CLEANER VACUUM GAUGES

Air cleaner vacuum gauges provide a continuous reading of the maximum air cleaner restriction reached during operation. The air cleaner(s) must be serviced when the gauge(s) shows the maximum recommended restriction of 635 mm (25 in.) of H<sub>2</sub>O vacuum.

**NOTE:** After service, push the reset button on face of gauge to allow the gauge to return to zero.

### CAMERA MONITOR (OPTIONAL)

The camera monitor displays the images from one of four different cameras. Three cameras are mounted on the front of the truck (left corner, center, right corner) and one camera facing rearward. Once the truck speed reaches 16 km/h (10 mph), the camera monitor will go dark automatically. Once truck speed is reduced to less than 16 km/h 10 mph for more than 30 seconds, it will display camera images again.

**CENTER CONSOLE** D.28-000051505

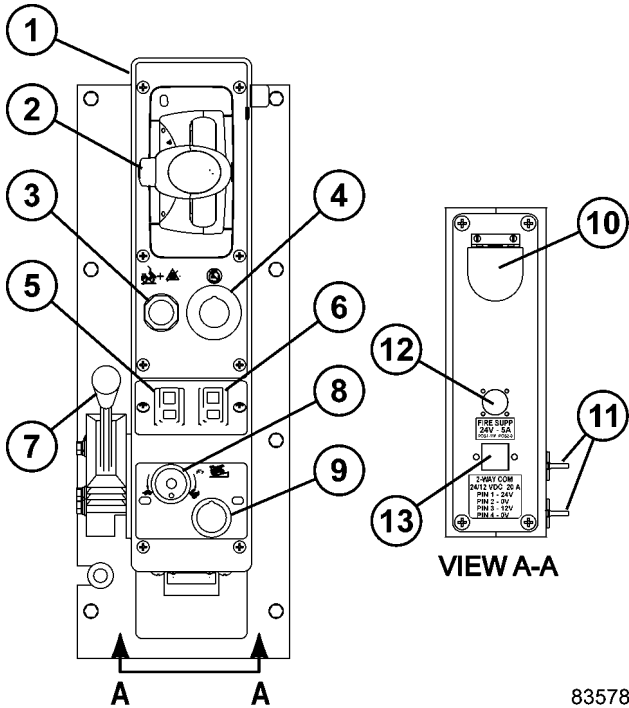

- |                                |                                     |
|--------------------------------|-------------------------------------|
| 1. Center Console              | 8. Retarder Speed Control Dial      |
| 2. Directional Control Lever   | 9. Retarder Speed Control Switch    |
| 3. Override/Fault Reset Switch | 10. Data Store Button               |
| 4. Engine Stop Switch          | 11. 12V Auxiliary Power Outlets     |
| 5. L.H. Window Control Switch  | 12. Fire Suppression Control Outlet |
| 6. R.H. Window Control Switch  | 13. Communication Radio Outlet      |
| 7. Hoist Control Lever         |                                     |

**Figure 6-3 CENTER CONSOLE**

**DIRECTIONAL CONTROL LEVER**

Directional control lever (2, Figure **CENTER CONSOLE**) is mounted on a console to the right of the operator's seat. It is a four position lever that controls the park, reverse, neutral, and forward motion of the truck. Before moving the directional control lever, apply the service brakes to completely stop the truck. Depress the button on the side to release the detent lock, then move the control lever to the desired position. When the control lever is in the center N position, it is in NEUTRAL. When the control lever is in the P position, it is in PARK, and the parking brake will be applied. The parking brake is spring applied and hydraulically released. It is designed to hold the truck stationary when the engine is off and the key switch is turned OFF. The truck must be completely stopped before moving the control lever to PARK, or

damage may occur to the park brake. When the key switch is ON, and the control lever is in PARK, the parking brake indicator light will be illuminated.

**NOTE:** The directional control lever must be in PARK to start the engine. DO NOT move the directional control lever to the PARK position at the shovel or dump.

Select FORWARD drive by moving the control lever to the F position.

Select REVERSE drive by moving the control lever to the R position. DO NOT allow the control lever to travel too far and go into the PARK position when REVERSE is desired.

**NOTE:** The truck must be completely stopped before the control lever is moved to a drive position or into PARK. A drive system fault will be recorded if the control lever is placed into the PARK position while the truck is still moving.

**OVERRIDE/FAULT RESET SWITCH**

Override/fault reset switch (3) is spring-loaded to the OFF position. When pushed in and held, this switch may be used for several functions.

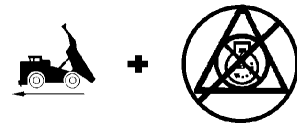

1. This switch permits the operator to override the body-up limit switch and move the truck forward when the directional control lever is in FORWARD, the dump body is raised, and the brakes are released.
2. The push button deactivates the retard pedal function when truck speed is below 5 kph (3 mph).
3. The override switch is also used to reset an electric system fault when the truck is stopped.

**ENGINE STOP SWITCH**

Engine stop switch (4) is used to stop the engine. Pull the switch up to stop the engine. Push the switch back down to enable engine operation.



Use this switch to stop the engine if the key switch fails to operate, or to stop the engine without turning off the 24 VDC electrical circuits.

A ground level engine stop switch is also located at the right or left front corner of the truck, depending on ladder access.

**WINDOW CONTROL SWITCHES**

The window control switch controls the operation of the window. The switch is spring-loaded to the OFF position.

- Pushing the front of the switch raises the cab window.
- Pushing the rear of the switch lowers the window.

**HOIST CONTROL LEVER**

Hoist control lever (7) is a four position hand-operated lever located between the operator seat and the center console (see illustration below).

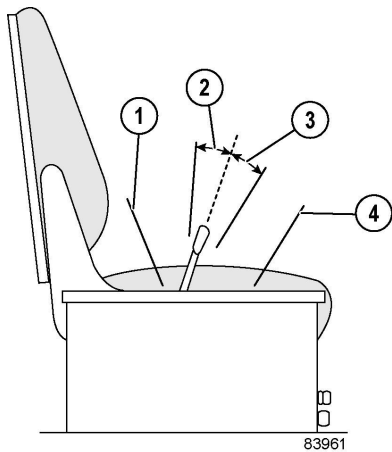

- |          |          |
|----------|----------|
| 1. Raise | 3. Float |
| 2. Hold  | 4. Lower |

**Raising The Dump Body**

1. Pull the lever to the rear to actuate hoist circuit. (Releasing the lever anywhere during “hoist up” will place the body in HOLD at that position.)
2. Raise engine rpm to increase hoist speed.
3. Reduce engine rpm as the last stage of the hoist cylinders begin to extend and then let the engine go to low idle as the last stage reaches half-extension.
4. Release hoist lever as the last stage reaches full extension.
5. After material being dumped clears the body, lower the body to frame.

Refer to [Dumping, page 5-18](#) for more complete details concerning this control

**Lowering The Dump Body**

Move hoist lever forward to DOWN position and release. Releasing the lever places hoist control valve in the FLOAT position allowing the body to return to frame.

**RETARD SPEED CONTROL (RSC) ADJUST DIAL**

The retard speed setting will be displayed to the operator on the digital display in the instrument panel.

When the dial is rotated counterclockwise toward this symbol, the truck will descend a grade at lower speeds.

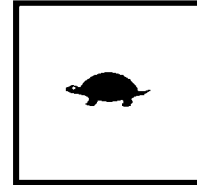

When the dial is rotated clockwise toward this symbol, the truck speed will increase.

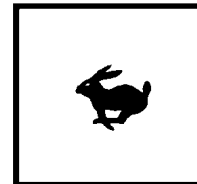

Always refer to the Grade/Speed Chart in the operator's cab and follow the recommendations for truck operation. DO NOT exceed these recommended MAXIMUM speeds when descending grades with a loaded truck.

Throttle pedal position will override RSC setting. If operator depresses throttle pedal to increase truck speed, dynamic retarding will not come on unless truck over speed setting is reached or the brake/retarder pedal (or retarder lever) is used. When throttle pedal is released and RSC switch is on, dynamic retarding will come on at, or above, the RSC dialed speed and will adjust truck speed to, and maintain, the dialed speed. The dialed speed will be displayed on the digital display in the instrument panel.

To adjust RSC control, pull switch (9) ON and start with dial (8) rotated toward fastest speed while driving truck at desired maximum speed. Relax throttle pedal to let truck coast and turn RSC adjusting dial slowly counterclockwise until dynamic retarding is activated. Dynamic retarding will now be activated automatically anytime the “set” speed is reached, the RSC switch is on, and throttle pedal is released.

With RSC switch on and dial adjusted, the system will function as follows: As truck speed increases to the “set” speed and throttle pedal released, dynamic retarding will apply. As truck speed tries to increase, the amount of retarding effort will automatically adjust to keep the selected speed. When truck speed decreases, the retarding effort is reduced to maintain the selected speed. If truck speed continues to decrease to approximately 5 kph (3 mph) below “set” speed, dynamic retarding will turn off automatically. If truck speed must be reduced further, the operator can turn the adjust dial to a new setting or depress the brake/retarder pedal (or use the retarder lever).

If the operator depresses the brake/retarder pedal or uses the retarder lever and the retard effort called for is greater than that from the automatic system, the brake/retarder pedal or retarder lever will override RSC.

**RETARD SPEED CONTROL (RSC) SWITCH**

Retard speed control (RSC) switch (9) turns the system on and off. Push the knob in for OFF and pull the knob out to turn the system ON.

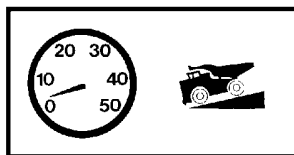

**DATA STORE BUTTON**

Data store button (10) is for use by qualified maintenance personnel to record in memory a snapshot of the AC drive system.

**12V AUXILIARY POWER OUTLETS**

Outlets (11) can be used to provide 12VDC power for tools and accessories.

**FIRE SUPPRESSION CONTROL OUTLET**

Outlet (12) can be used to provide power for an optional fire suppression control system with the key switch ON.

**COMMUNICATION RADIO OUTLET**

Outlet (13) can be used to provide power for an optional 2-way communication radio with the key switch ON.



**DIAGNOSTIC PORTS** B.4-0000051438

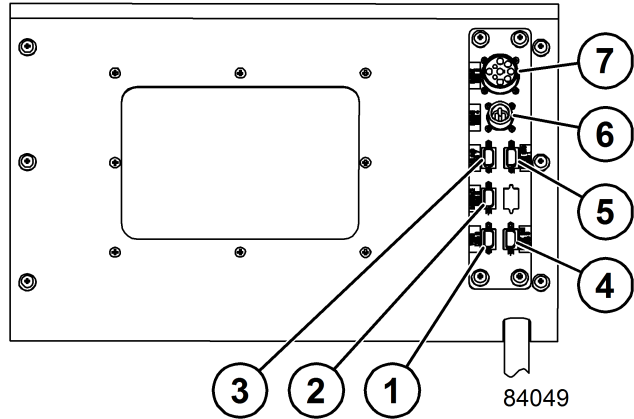

- |                                      |                                     |
|--------------------------------------|-------------------------------------|
| 1. KOMTRAX Plus Diagnostic Port      | 5. DSC Diagnostic Port              |
| 2. Interface Module Diagnostic Port  | 6. Engine Diagnostic Port (CENSE)   |
| 3. Payload Meter Diagnostic Port     | 7. Engine Diagnostic Port (QUANTUM) |
| 4. Drive System / MM Diagnostic Port |                                     |

**Figure 6-4 DIAGNOSTIC PORTS**

The diagnostic ports shown in Figure 6-4 [DIAGNOSTIC PORTS, page 6-9](#) are located on the back wall of the cab next to the D.I.D. Panel.

**KOMTRAX Plus**

KOMTRAX Plus diagnostic port (1) is used to download truck operation data from the KOMTRAX Plus controller.

**INTERFACE MODULE (IM)**

Interface module (IM) diagnostic port (2) is used to connect the interface module to a computer for installing software.

**PAYLOAD METER**

Payload Meter diagnostic port (3) is used to download data from the payload meter system. Refer to [PAYLOAD METER III SYSTEM, page 5-27](#) for a more complete description of the payload meter and its functions.

**DRIVE SYSTEM OR MODULAR MINING**

Drive system controller (DSC) or Modular Mining diagnostic port (4) is used to access diagnostic information for the Drive System Controller (DSC) or for Modular Mining controller.

**DRIVE SYSTEM CONTROLLER (DSC)**

Drive system controller (DSC) diagnostic port (5) is used to access diagnostic information for the Drive System Controller (DSC).

**ENGINE (CENSE)**

Engine diagnostic port (CENSE) (6) is a three pin connector used to access diagnostic information for the engine monitoring system.

**ENGINE (QUANTUM)**

Engine diagnostic port (QUANTUM) (7) is a nine pin connector used to access diagnostic information for the engine control system.

**OPERATOR SEAT  
(Standard) F.3-0000051504**

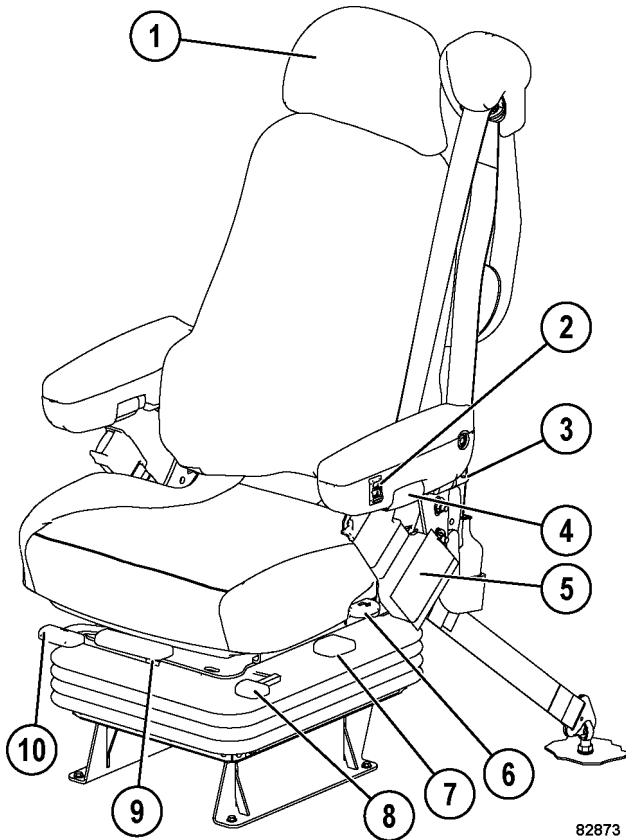

- |                       |                              |
|-----------------------|------------------------------|
| 1. Headrest           | 6. Backrest Recline          |
| 2. Seat Height Switch | 7. Seat Cushion Fore and Aft |
| 3. Lumbar Support     | 8. Suspension Dampener       |
| 4. Armrest Tilt       | 9. Seat Tilt                 |
| 5. Seat Belt          | 10. Fore and Aft             |

**Figure 6-5 OPERATOR SEAT CONTROLS**

The operator seat provides a fully adjustable cushioned ride for driver comfort and easy operation.

**SEAT BELTS**

- On both driver and passenger seats, check the seat belt fabric, buckle, all belt retractors and hardware for damage or wear. Replace any worn or damaged parts immediately.
- Even if there are no signs of damage, replace both driver and passenger seat belts 5 years after seat belt manufacture, or every 3 years after start of use, whichever comes first. The passenger seat belt date of manufacture label is sewn into the seat belt near the buckle. The driver seat belt date of manufacture label is sewn into the shoulder harness belt, near the retractor end.

**ADJUSTMENT**

The following adjustments must be made while sitting in the seat. Refer to Figure 6-5 OPERATOR SEAT CONTROLS, page 6-10.

- **Headrest** - Move headrest (1) up or down to the desired position. It can also be tilted forward by pulling on the top of the headrest. There are four positions. Pulling the headrest completely forward will release the ratchet mechanism and return the headrest to the furthest back position.
  - **Seat Height** - Push and hold seat height switch (2) to adjust the height of the seat. Release the switch when the desired height is reached. Optimum ride height is obtained when the suspension is at the middle of its stroke. To properly adjust, raise the seat to its highest level. Then, lower the seat approximately 51 mm (2 in.) to the middle of the suspension stroke.
  - **Lumbar Support** - Move lumbar support (3) to adjust the lumbar support to the desired position.
  - **Armrest Tilt** - Rotate armrest tilt (4) until the armrest is in desired position.
  - **Seat Belt** - The operator must always have seat belt (5) buckled and properly adjusted whenever the truck is being operated.
  - **Backrest Recline** - Lift backrest recline (6) to select the desired backrest recline. Release the handle to set the position.
  - **Fore/Aft Location of Seat Cushion (if equipped)** - Lift and hold fore/aft (7) and move the seat cushion to a comfortable position. Release the lever to lock the position adjustment.
  - **Suspension Dampener** - Adjust suspension dampener (8) to obtain the desired stiffness of the adjustable shock absorber. Move the lever upward to stiffen the absorbency of the shock. Move the lever downward to soften the ride. Five detented settings are available.
- NOTE:** This seat contains a fixed rate shock absorber in addition to the adjustable shock absorber that is controlled by the suspension dampener.
- **Seat Cushion Tilt (if equipped)** - Lift and hold lever (9) and tilt the seat cushion to a comfortable position. Release the lever to lock the position adjustment.
  - **Fore/Aft Location of Seat** - Lift and hold lever (10) and move the seat to a comfortable height. Release the lever to lock the fore/aft location.



***NOTE:** The seat compressor must be allowed to cool down for ten minutes for every one minute of continuous operation. The compressor must not be operated continuously for more than three minutes.*

## PASSENGER SEAT (Standard) D.3-0000051503

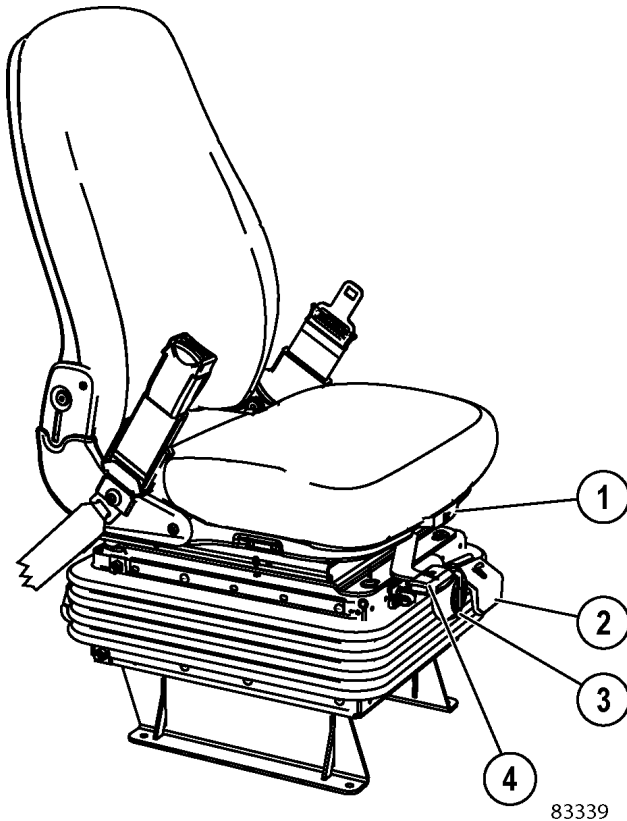

- |                              |                      |
|------------------------------|----------------------|
| 1. Seat Cushion Fore and Aft | 3. Weight Adjustment |
| 2. Seat Height               | 4. Fore and Aft      |

### Figure 6-6 PASSENGER SEAT CONTROLS

The passenger seat provides a fully adjustable cushioned ride for driver comfort and easy operation.

## SEAT BELTS

- On both driver and passenger seats, check the seat belt fabric, buckle, all belt retractors and hardware for damage or wear. Replace any worn or damaged parts immediately.
- Even if there are no signs of damage, replace both driver and passenger seat belts 5 years after seat belt manufacture, or every 3 years after start of use, whichever comes first. The passenger seat belt date of manufacture label is sewn into the seat belt near the buckle. The driver seat belt date of manufacture label is sewn into the shoulder harness belt, near the retractor end.

## ADJUSTMENT

The following adjustments must be made while sitting in the seat. Refer to Figure 6-6 PASSENGER SEAT CONTROLS, page 6-12.

- **Fore/Aft Location of Seat Cushion (if equipped)** - Lift and hold fore/aft lever (1) and move the seat cushion to a comfortable position. Release the lever to lock the position adjustment.
- **Seat Height** - Pull up on seat height (2), then adjust the height of the seat. When the desired height is reached, release the lever.
- **Weight Adjustment**- Rotate weight adjustment (3) until the weight indicator next to the knob is pointing to the weight of the person that will be riding in the seat. This will provide the most comfortable ride setting
- **Fore/Aft Location of Seat** - Lift and hold fore/aft lever (4) and move the seat to a comfortable height. Release the lever to lock the fore/aft location.

**OPERATOR SEAT (Optional)** D.3-0000053881

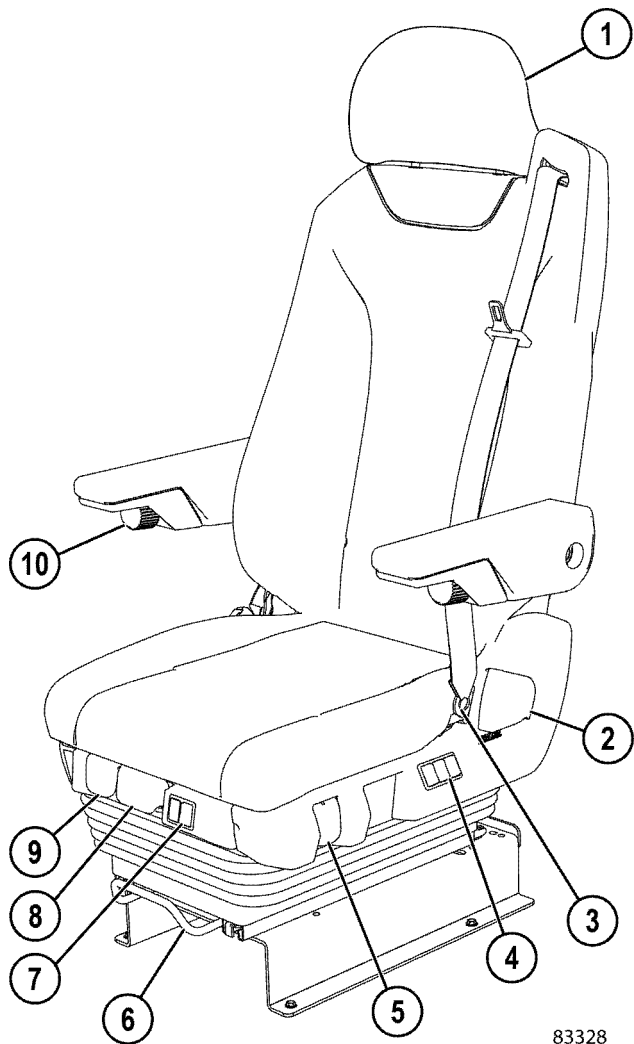

83328

- |                        |                              |
|------------------------|------------------------------|
| 1. Headrest            | 6. Fore and Aft              |
| 2. Backrest Angle      | 7. Seat Height               |
| 3. Seat Belt           | 8. Seat Cushion Fore and Aft |
| 4. Lumbar Support      | 9. Seat Tilt                 |
| 5. Suspension Dampener | 10. Armrest Tilt             |

**Figure 6-7 OPERATOR SEAT CONTROLS**

The operator seat provides a fully adjustable cushioned ride for driver comfort and easy operation.

**SEAT BELTS**

On both driver and passenger seats, check the seat belt fabric, buckle, all belt retractors and hardware for damage or wear. Replace any worn or damaged parts immediately.

Even if there are no signs of damage, replace both driver and passenger seat belts 5 years after seat belt manufacture, or every 3 years after start of use,

whichever comes first. The passenger seat belt date of manufacture label is sewn into the seat belt near the buckle. The driver seat belt date of manufacture label is sewn into the shoulder harness belt, near the retractor end.

**ADJUSTMENT**

The following adjustments must be made while sitting in the seat. Refer to Figure 6-7 OPERATOR SEAT CONTROLS, page 6-13.

- Headrest:** (1) will move up, down, fore or aft by moving headrest to desired position.
- Backrest Angle:** Lift backrest adjustment handle (2) to release and select the backrest angle. Release the control handle to set.
- Seat Belt:** The operator must have seat belt (3) buckled in place and properly adjusted whenever vehicle is in motion.
- Air Lumbar Support:** Each rocker switch (4) controls an air pillow. One switch controls the lower air pillow and the other switch controls the upper air pillow. To inflate, press on top of the rocker switch and hold for desired support, then release. To deflate, press on the bottom of the rocker switch and hold for desired support, then release. Adjust each pillow for desired support.
- Suspension Dampener:** Press rocker switch (5) on top to increase ride firmness. Press on lower part of rocker switch to decrease ride firmness.
- Fore/Aft Location of Seat:** Lift fore and aft lever (6) and hold. Bend knees to move seat to a comfortable position. Release the control lever to lock the adjustment.
- Seat Height:** Press rocker switch (7) on top to increase ride height. Press on lower part of rocker switch to decrease ride height.
- Fore/Aft Location of Seat Cushion -** Lift and hold lever (8) and move the seat cushion to a comfortable position. Release the lever to lock the position adjustment.
- Seat Tilt:** Lift seat slope lever (9) and hold to adjust the slope of the seat. Release the lever to lock the adjustment.
- Armrests:** Rotate adjusting knob (10) until the armrest is in the desired position.

## PASSENGER SEAT (Optional) A.10-0000054284

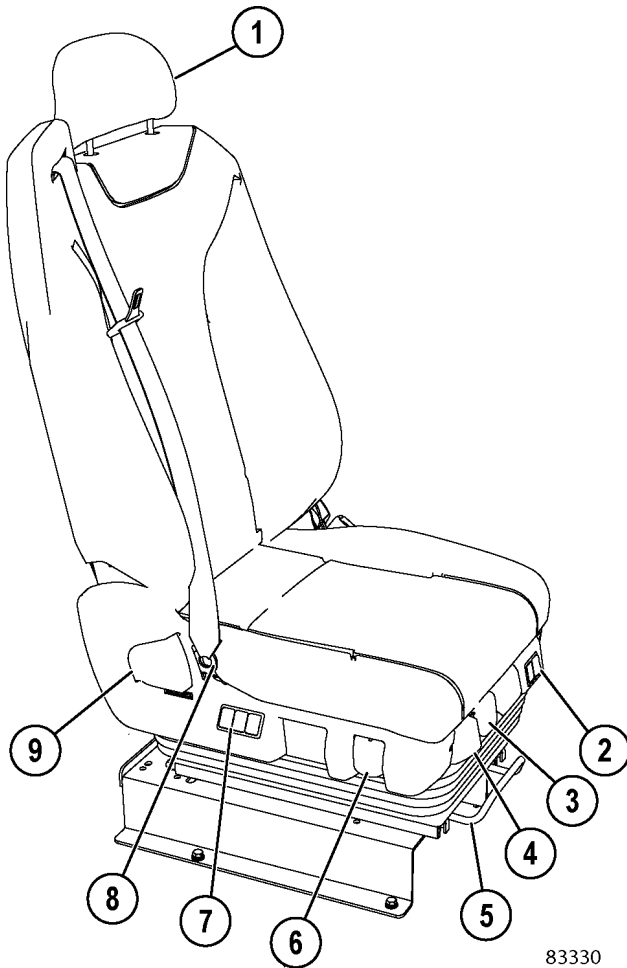

83330

- |                              |                        |
|------------------------------|------------------------|
| 1. Headrest                  | 6. Suspension Dampener |
| 2. Seat Height               | 7. Lumbar Support      |
| 3. Seat Cushion Fore and Aft | 8. Seat Belt           |
| 4. Seat Tilt                 | 9. Backrest Angle      |
| 5. Fore and Aft              |                        |

**Figure 6-8 PASSENGER SEAT CONTROLS**

The passenger seat provides a fully adjustable cushioned ride for passenger comfort and easy operation.

### SEAT BELTS

On both driver and passenger seats, check the seat belt fabric, buckle, all belt retractors and hardware for damage or wear. Replace any worn or damaged parts immediately.

Even if there are no signs of damage, replace both driver and passenger seat belts 5 years after seat belt manufacture, or every 3 years after start of use,

whichever comes first. The passenger seat belt date of manufacture label is sewn into the seat belt near the buckle. The driver seat belt date of manufacture label is sewn into the shoulder harness belt, near the retractor end.

### ADJUSTMENT

The following adjustments must be made while sitting in the seat. Refer to Figure 6-8 PASSENGER SEAT CONTROLS, page 6-14.

- Headrest:** (1) will move up, down, fore or aft by moving headrest to desired position.
- Seat Height:** Press rocker switch (2) on top to increase ride height. Press on lower part of rocker switch to decrease ride height.
- Fore/Aft Location of Seat Cushion:** Lift and hold lever (3) and move the seat cushion to a comfortable position. Release the lever to lock the position adjustment.
- Seat Tilt:** Lift seat slope lever (4) and hold to adjust the slope of the seat. Release the lever to lock the adjustment.
- Fore/Aft Location of Seat:** Lift fore and aft lever (5) and hold. Bend knees to move seat to a comfortable position. Release the control lever to lock the adjustment.
- Suspension Dampener:** Press rocker switch (6) on top to increase ride firmness. Press on lower part of rocker switch to decrease ride firmness.
- Air Lumbar Support:** Each rocker switch (7) controls an air pillow. One switch controls the lower air pillow and the other switch controls the upper air pillow. To inflate, press on top of the rocker switch and hold for desired support, then release. To deflate, press on the bottom of the rocker switch and hold for desired support, then release. Adjust each pillow for desired support.
- Seat Belt:** The operator must have seat belt (8) buckled in place and properly adjusted whenever vehicle is in motion.
- Backrest Angle:** Lift backrest adjustment handle (9) to release and select the backrest angle. Release the control handle to set.

# HEATER / AIR CONDITIONER CONTROLS

E.4-0000051502

The heater/air conditioner compartment contains heater/air conditioner controls and some of the heater/air conditioner components, such as the blower motor assembly and the heater coil. Optimum cab air climate can be selected by using the following controls in various combinations.

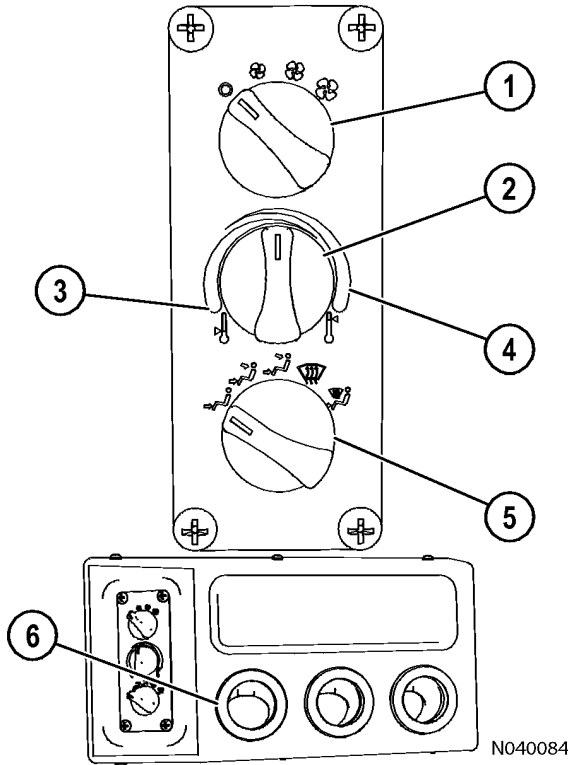

- 1. Fan Speed Control Knob
- 2. Temperature Control Knob
- 3. Blue Zone
- 4. Red Zone
- 5. Air Flow Directional Knob
- 6. Heater/Air Conditioner Vents

Figure 6-9 A/C & HEATER CONTROLS

## Fan Speed Control Knob

Fan speed control knob (1, Figure 6-9 A/C & HEATER CONTROLS, page 6-15) is provided to control the cab air fan motor. The fan motor is a 3-speed motor (low, medium and high). Speeds are selected by

rotating the control knob clockwise to the desired position. OFF is in the full counter-clockwise position. The control knob must be switched ON for the air conditioner to function.

## Temperature Control Knob

Temperature control knob (2) allows the operator to select a comfortable air temperature.

The control knob determines the operation of the air conditioning and heater modes.

Rotating the control knob counter-clockwise (blue zone 3) will cause the A/C compressor to operate and result in cooler air temperatures. Full counter-clockwise position is the coldest air setting.

Rotating the control knob clockwise (red zone 4) will affect coolant flow through the heater core and result in warmer air temperatures. The full clockwise position is the warmest heater setting.

## Air Flow Directional Knob

Air flow directional knob (5) controls the direction of airflow as follows:

	Provides airflow to floor vents, only.
	Provides airflow to upper vents and floor vents.
	(Blue Icon) Provides dehumidified air to upper vents and floor vents.
	Defrost - Provides dehumidified air to the windshield.
	Defrost - Provides dehumidified air to the windshield as well as to floor vents.

## Heater/Air Conditioner Vents

Heater/air conditioner vents (6) may be rotated 360°. There are three vents in the heater/air conditioner compartment, four vents across the top of the instrument panel, and one vent each in the RH and LH instrument panels. There are also an additional four vents under the instrument panel. Air flow through the vents is controlled by manually opening, closing or turning the louvers.

## INSTRUMENT PANEL B.8-000051679

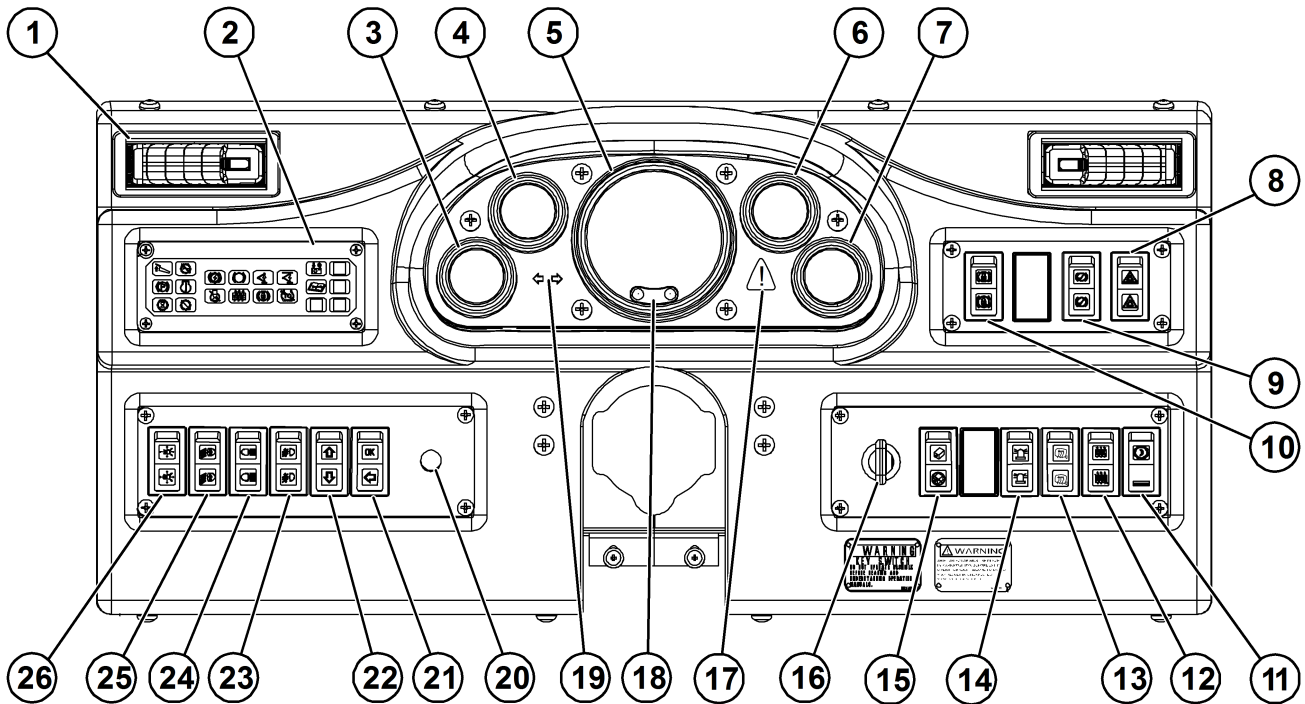

84048

- |                                    |                                         |
|------------------------------------|-----------------------------------------|
| 1. Heater/Air Conditioner Vents    | 14. Rotating Beacon                     |
| 2. Status Indicator Light Panel    | 15. Camera System (Optional)            |
| 3. Hydraulic Oil Temperature Gauge | 16. Key Switch                          |
| 4. Coolant Temperature Gauge       | 17. Warning Light                       |
| 5. Speedometer/Digital Display     | 18. Digital Display Contrast Buttons    |
| 6. Fuel Level Gauge                | 19. Turn Signal Indicators              |
| 7. Drive System Temperature Gauge  | 20. Panel Lights Dimmer Switch          |
| 8. Hazard Light Switch             | 21. Mode Switch #1                      |
| 9. Brake Test Switch               | 22. Mode Switch #2                      |
| 10. Wheel Brake Lock Switch        | 23. Fog Light Switch                    |
| 11. AC Drive System Rest Switch    | 24. Backup Light Switch                 |
| 12. Engine Warm Up Switch          | 25. Ladder Light Switch                 |
| 13. Heated Mirrors                 | 26. Headlight/Panel Illumination Switch |

Figure 6-10 PANEL GAUGES, INDICATORS, AND CONTROLS

**CONTROL SYMBOLS**

The operator must understand the function and operation of each instrument and control. Many control functions are identified with international symbols that the operator must learn to recognize immediately. This knowledge is essential for proper and safe operation.

Items that are marked optional do not apply to every truck.

The following symbols are general indicators and may appear in multiple locations and combinations on the instrument panel.

Most switches have two LED lights inside them, one amber and one green in color. The amber is located in the top portion of the switch and indicates that function has been activated. The green LED is located in the lower portion of the switch and indicates that function has not been activated.

- To activate a function, push on the top portion of the switch. At this time, the amber LED will be illuminated, and the green LED will be OFF.
- To de-activate a function, push on the lower portion of the switch. At this time, the green LED will be illuminated, and the amber LED will be OFF.

**NOTE:** The green LED light in the hazard light switch, head light switch and the ladder light switch will be illuminated when battery power is connected to the truck. The LED lights in the other switches will illuminate when the key switch is turned to the ON position.

This symbol when it appears on an indicator or control identifies that this indicator or control is NOT used.

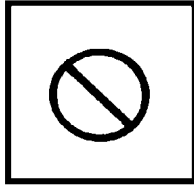

This symbol identifies a rotary control or switch. Rotate the knob clockwise or counterclockwise for functions.

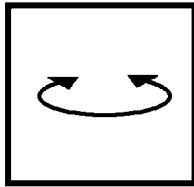

This symbol identifies a switch used to test or check a function. Press the switch on the side near the symbol to perform the test.

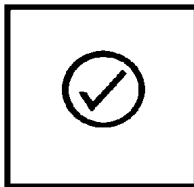

**Cab/Air Conditioner Vents**

Cab/air vents (1, Figure 6-10 PANEL GAUGES, INDICATORS, AND CONTROLS, page 6-16) may be directed by the operator to provide the most comfortable cabin air flow.

**Status Indicator Light Panel**

**Hydraulic Oil Temperature Gauge**

**⚠ WARNING**

- If temperature gauge does not move into the green range after a few minutes, and the red overhead indicator light does not go out, stop the engine and notify maintenance personnel immediately.

Hydraulic oil temperature gauge (3) indicates the oil temperature in the hydraulic tank. There are two colored bands: green and red.

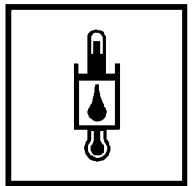

Green indicates normal operation. As the needle approaches the red zone, minimum engine idle speed will increase to help cool the oil. Red indicates high

oil temperature in the hydraulic tank. Continued operation could damage components in the hydraulic system. If this occurs, the operator should safely stop the truck, move directional control lever to PARK and operate the engine at 1200 - 1500 rpm to reduce system temperature.

**Coolant Temperature Gauge**

Coolant temperature gauge (4) indicates the temperature of the coolant in the engine cooling system.

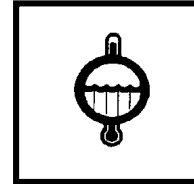

The temperature range after engine warm-up and a truck operating under normal conditions should be 85° to 97°C (185° to 207°F).

**Speedometer/Digital Display**

Speedometer/digital display (5) displays the following information:

- The analog speedometer indicates the truck speed in miles per hour (mph) or in kilometers per hour (kph).
- The digital display shows payload meter information.
- The digital display also shows warning messages and fault codes indicating abnormal operating conditions and critical problems. See DIGITAL DISPLAY OPERATION, page 6-24 for more information.

**Fuel Level Gauge**

Fuel level gauge (6) indicates how much diesel fuel is in the fuel tank. When there is only 10% of total fuel tank capacity remaining, the amber low fuel level indicator on the gauge will illuminate.

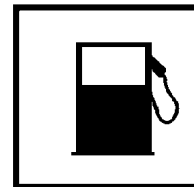

**Drive System Temperature Gauge**

Drive system temperature gauge (7) indicates the status of the highest measured temperature range in the drive system.

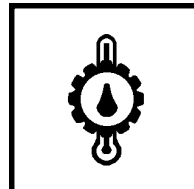



### Hazard Warning Light Switch

Hazard warning light switch (8) flashes all the turn signal lights. Pressing the top side of the rocker switch activates these lights.

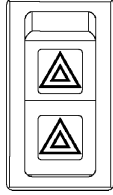

When these lights are on, a red LED light will be illuminated inside the switch. Pressing on the lower side of the rocker switch turns these lights off, and a green LED light will be illuminated.

### Pre-Shift Brake Test Switch

Pre-shift brake test switch (9) is used to initiate a brake test. Press on the momentary switch to enter the brake test mode. If certain conditions are met, the operator can enter a brake test sequence.

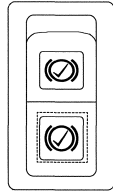

The amber light in the top of the switch is used to indicate when the truck is in brake test mode, and is referred to as the brake check light. When illuminated, a brake test is ready. When flashing, the brake test is at the validation point, or the retard system test is finished.

### Wheel Brake Lock Control Switch

Wheel brake lock switch (10) should be used with engine running for dumping and loading operations only. The brake lock switch actuates the hydraulic brake system which locks the rear wheel service brakes only.

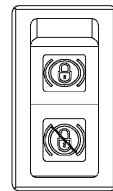

When pulling into shovel or dump area, stop the truck using the foot-operated service brake pedal. When truck is completely stopped and in loading position, move the directional control lever to NETURAL, then apply the brake lock by pressing the top of the rocker switch. To release the brake, press the bottom of the rocker switch.

**NOTE:** The wheel brake lock will not function if the directional control lever is in the PARK position.

### ⚠ WARNING

- **DO NOT** use this switch to stop the truck unless the foot-operated treadle valve is inoperative. Use of this switch applies rear service brakes at a reduced, unmodulated pressure. **DO NOT** use the brake lock for parking. With the engine stopped, hydraulic pressure will bleed down, allowing the brakes to release.

Use at shovel and dump only to hold the truck in position.

**NOTE:** The wheel brake lock will not apply when the directional control lever is placed in the PARK position, or when the key switch is OFF, or when the engine is not running.

### Rest Switch

Rest switch (11) is a rocker switch with a locking device. A safety tab on the switch must be pushed to unlock the switch before the top of the switch can be depressed to activate the rest mode.

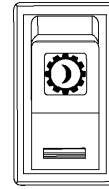

When activated, an internal amber lamp will illuminate. The switch should be activated to deenergize the AC drive system whenever the engine is to be shutdown or parked for a length of time with the engine running.

The directional control lever must be in PARK or NEUTRAL and the vehicle not moving to enable this function. This will allow the engine to continue running while the AC drive system is de-energized.

### ⚠ WARNING

- **Activation of the rest switch alone DOES NOT completely ensure that the drive system is safe to work on. Refer to the Safety chapter for more information on servicing an AC drive. Check all "link-on", or "link energized", indicator lights to verify the AC drive system is de-energized before performing any maintenance on the drive system. DO NOT activate the rest switch while the truck is moving! The truck may unintentionally enter the "rest" mode after stopping.**



**Engine Warm Up**

Engine warm up switch (12) is a rocker switch. When in the ON position, this feature is used to keep the engine warm in cold conditions because it puts a small amount of load on the engine.

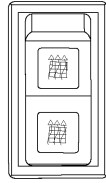

This energy is created by passing a load through one bank of the grid resistors in the retarding grid.

**Key Switch**



Key switch (16) is a four-position (ACC, OFF, RUN, START) switch. The ACC position is not currently used.

**Starting**

When the switch is rotated one position clockwise, it is in the RUN position and all electrical circuits except START are activated.

1. With the selector switch in PARK, rotate key switch fully clockwise to the START position, and hold this position until the engine starts. The START position is spring-loaded to return to RUN when the key is released. If the engine is equipped with a prelube system, a noticeable delay will occur before engine cranking begins.
2. After engine has started, place rest switch (4) in the OFF position, which will de-activate the rest mode of operation. Refer to the discussion of rest switch later in this chapter.

**NOTE:** The electric cranking motors have a 30 second time limit. If the 30 second limit is reached, cranking will be prohibited for two minutes. After two minutes, cranking will be allowed. If the 30 second limit is reached seven consecutive times, the key switch must be turned to the OFF position. This will allow the interface module to power down and reset, which requires seven minutes to complete.

**Warning Light**

Red warning light (17) will come on to indicate that a truck function requires immediate action by the operator. Safely stop the truck and notify maintenance personnel. A warning message will appear on the digital display.



**Digital Display Contrast Buttons**

Cold ambient operating temperatures may affect the contrast of the digital display. If necessary, use buttons (18) to increase or decrease the contrast of the digital display to make it easier to read.

**Turn Signal Indicators**

Indicators (19) illuminate to indicate that the right or left turn signals are operating when the turn signal lever on the steering column is moved upward or downward. Moving the lever to its center position will turn the indicator off.

**Panel Light Dimmer**

Panel illumination light dimmer switch (20) is a rheostat which allows the operator to vary the brightness of the instruments and panel lights.

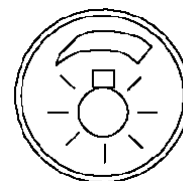

- Rotating the knob to the full clockwise position turns the panel lights on to the brightest condition.
- Rotating the knob counterclockwise continually dims the lights until OFF position is reached at full counterclockwise rotation.

**Mode Switches**

Mode switches (21) and (22) are two-way momentary rocker switches. The

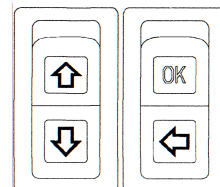

arrows are used to toggle through the different options and messages on the digital display. The OK position is used to acknowledge and clear warnings and faults and set certain Payload Meter III settings.

Refer to [DIGITAL DISPLAY OPERATION](#), page 6-24 for more information about using the digital display.

### Fog Light Switch

Pressing the top of fog light switch (23) turns the lights on. Pressing the bottom of the switch turns the lights off.

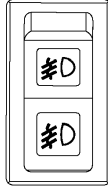

### Backup Light Switch

Backup light switch (24) allows the backup lights to be turned on for added visibility and safety when the directional control lever is not in the REVERSE position.

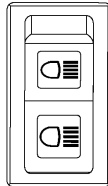

### Ladder Light Switch

Ladder light switch (25) turns the ladder lights and deck lights on or off after or before using ladder.



Pressing the top of the rocker switch turns the lights on. Pressing the bottom of the switch turns the lights off. Another switch is mounted at the front left of truck near the base of ladder.

### Headlight/Panel Illumination Light Switch

The instrument panel lights, clearance lights, and the headlights are controlled by this three-position rocker type switch (26).

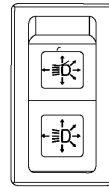

OFF is selected by pressing the bottom of the switch. Press the top of the switch until it reaches the first position to select the panel lights, clearance lights and tail lights only. Press the top of the switch again until it reaches the second position to select headlights, panel lights, clearance lights and tail lights.

**STATUS INDICATOR LIGHT PANEL** B.18-0000053883

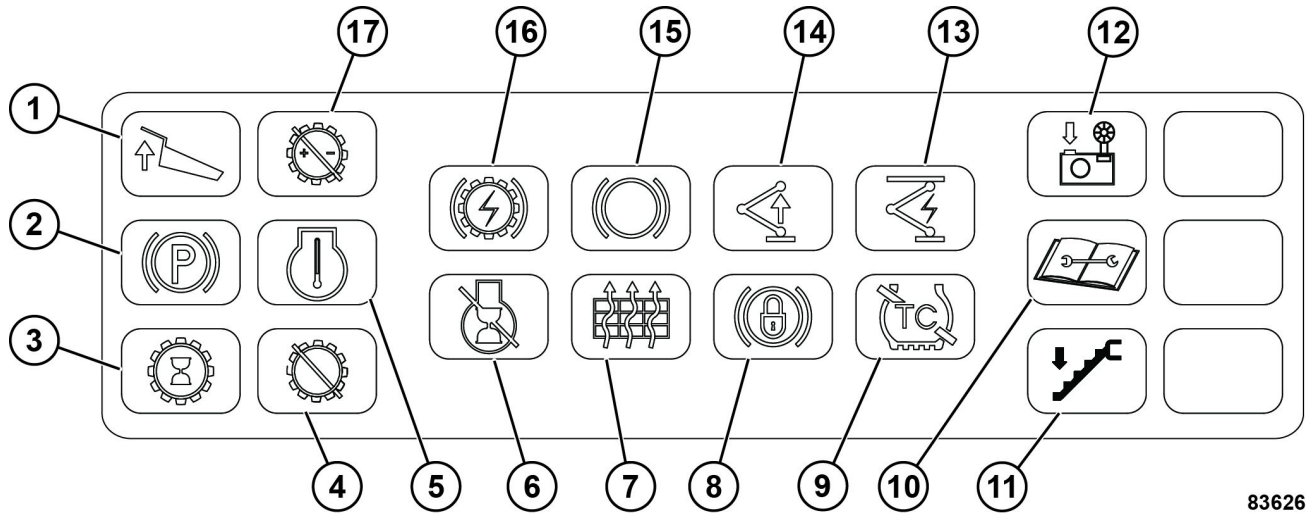

83626

- |                                |                                 |                          |
|--------------------------------|---------------------------------|--------------------------|
| 1. Body Up                     | 7. Not used in this application | 13. Pantograph Energized |
| 2. Parking Brake               | 8. Wheel Brake Lock             | 14. Pantograph Up        |
| 3. Propulsion System Not Ready | 9. Traction Control             | 15. Service Brake        |
| 4. No Propel                   | 10. Repair Monitor              | 16. Dynamic Retarding    |
| 5. Engine Warming              | 11. Retractable Ladder Down     | 17. No DC Link Voltage   |
| 6. Engine Shutdown Delay       | 12. Snapshot In Progress        |                          |

**Figure 6-11 STATUS INDICATOR LIGHTS**

**STATUS INDICATOR LIGHT SYMBOLS** B.2-0000053882

When illuminated, these amber (yellow) status lights alert the operator that the indicated truck function requires some precaution. Refer to the following descriptions for explanations of the symbols.

**Body Up**

The body up indicator will illuminate when the body is not completely down on the frame. The truck must not be driven until body is down and the light is off.

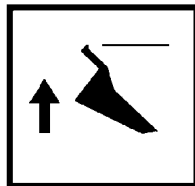

**Parking Brake**

The parking brake indicator will illuminate when the parking brake is applied. The parking brake is applied by placing the directional control lever in the PARK position.



If the directional control lever is in the PARK position and the interface module (IM) detects any parking brake abnormalities, this light will not illuminate. The red warning light on the dash will flash, the warning buzzer will sound intermittently and an error code will be displayed. If the red warning light and buzzer are active, the operator must not leave the cab. Notify maintenance personnel immediately.

**Propel System Not Ready**

Propulsion system not ready indicator will illuminate during start-up much like the hour glass icon on a computer screen.

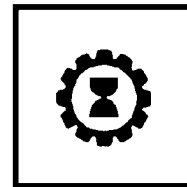

This light indicates the computer is in the process of performing the self-diagnostics and set-up functions at start-up. Propulsion will not be available at this time.

**No Propel**

The no propel indicator will illuminate when the rest switch is placed in the ON position. It will also illuminate when a fault has occurred which has eliminated the propulsion capability. If this condition occurs, the operator must safely stop the truck, move directional control lever to PARK, shut down the engine, and notify maintenance personnel immediately.

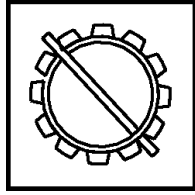

**Wheel Brake Lock**

The wheel brake lock indicator will illuminate when the wheel brake lock is on.



**Traction Control**

The traction control indicator light, often referred to as the Slip Slide indicator light, will only turn on if there is a problem detected in the system.

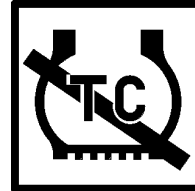

**Engine Warm Up**

Engine warm up indicator will illuminate when the engine warming switch is turned on.

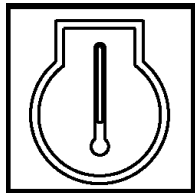

**Repair Monitor**

The repair monitor indicator will illuminate if a "repair" fault is detected, which must be corrected after the operator's shift is done.

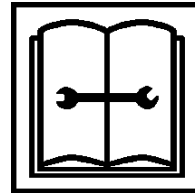

**Engine Shutdown Delay**

When the key switch has been turned OFF, and certain conditions have been met, this indicator light will illuminate to indicate that the shutdown timing sequence has started. The engine could operate for up to three minutes.



**Retractable Ladder Down**

The retractable ladder down indicator will illuminate when the power ladder is not in the full up position. The indicator will flash if the park brake is released without the ladder in the full up position.

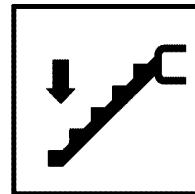

- If the directional control lever is moved out of PARK, the engine will stop immediately.
- If the key switch is turned back ON, the engine stop sequence will be terminated, and the engine will remain running.

**Snapshot In Progress**

The indicator will illuminate when the KOMTRAX Plus system is in the process of recording a "snapshot" of certain vehicle conditions.



**Retarding Grid Drier**

This indicator light is not used in this application.

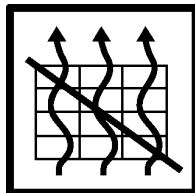

**Pantograph Energized**

This indicator light is not used in this application.

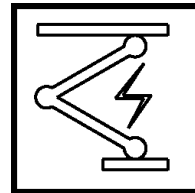

**Pantograph Up**

This indicator light is not used in this application.

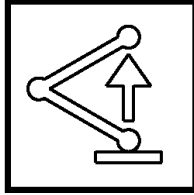

**Service Brake**

The service brake indicator will illuminate when the service brake pedal is applied.

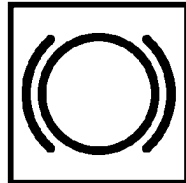

**Dynamic Retarding**

The dynamic retarding indicator will illuminate whenever the retarder pedal is operated, or the automatic overspeed retarding circuit is energized. It indicates that the dynamic retarding function of the truck is being used.

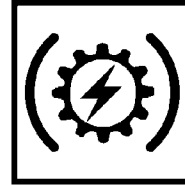

**No DC Link Voltage**

The no DC link voltage indicator will illuminate when the rest switch in ON, or whenever the DC link in the control cabinet is not providing voltage to the propulsion system.

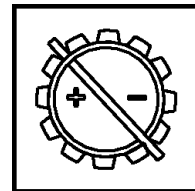

# DIGITAL DISPLAY OPERATION

C.3-0000051680

## Toggleing Through Main Level Screens

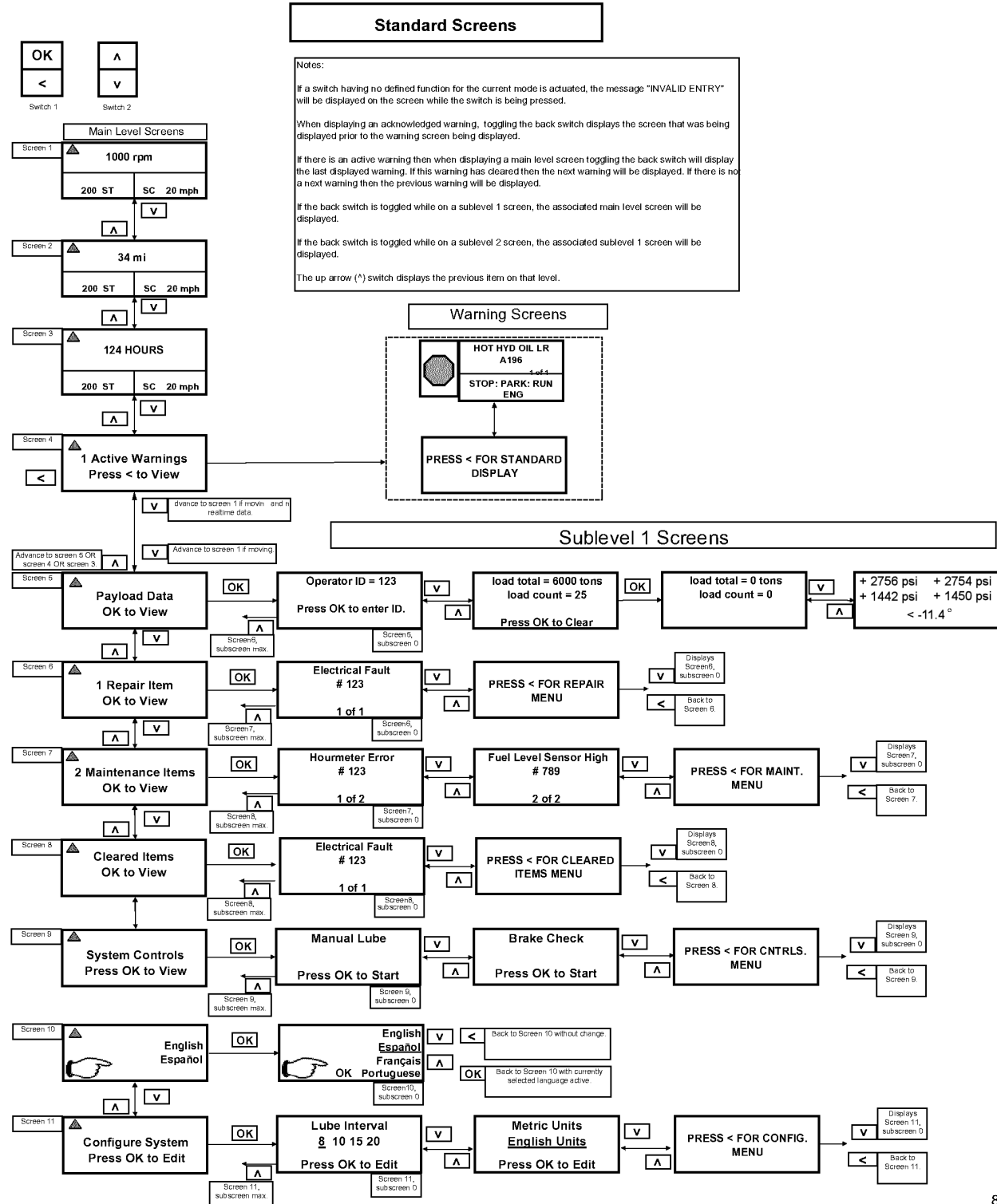

83442

Toggle Through Warning Screens

Warning Screens

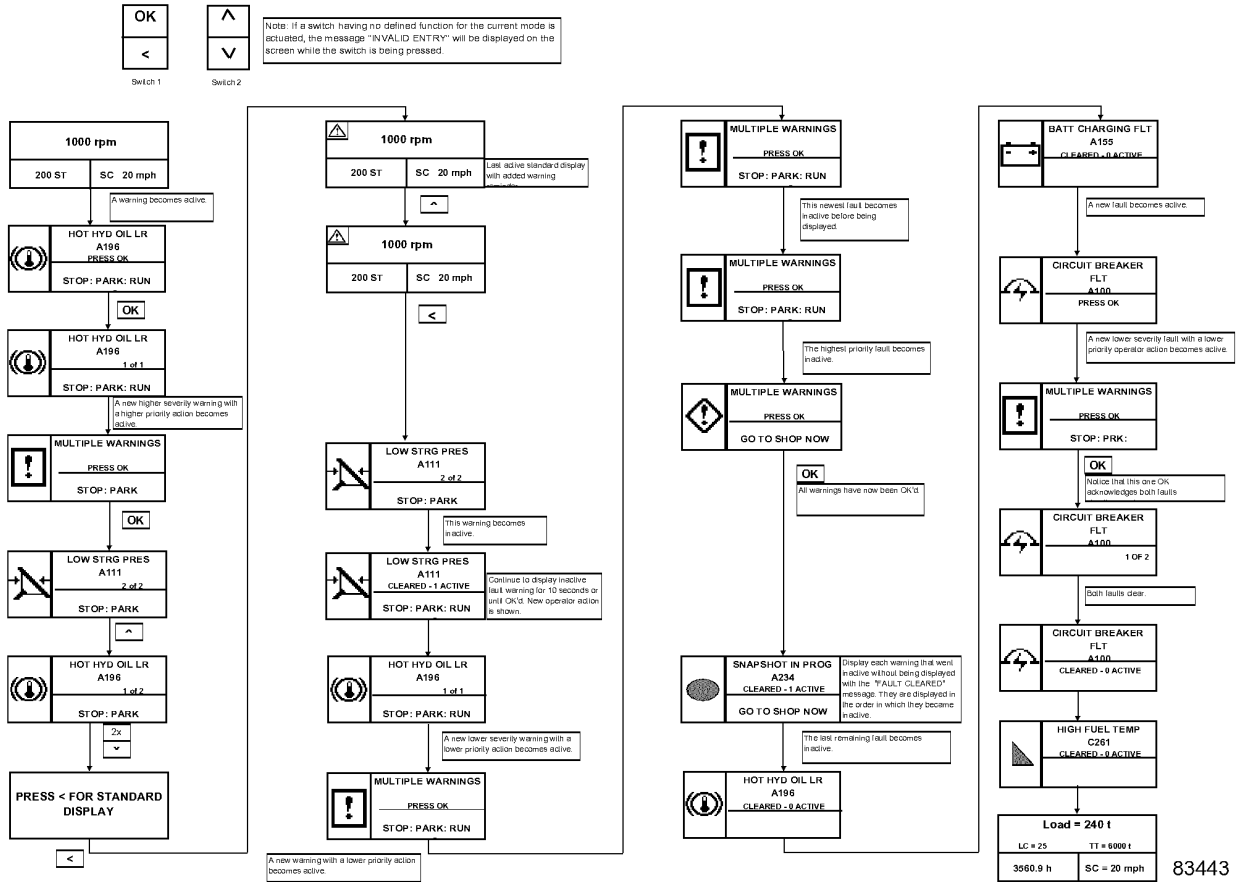

83443

### Entering Payload Meter Data

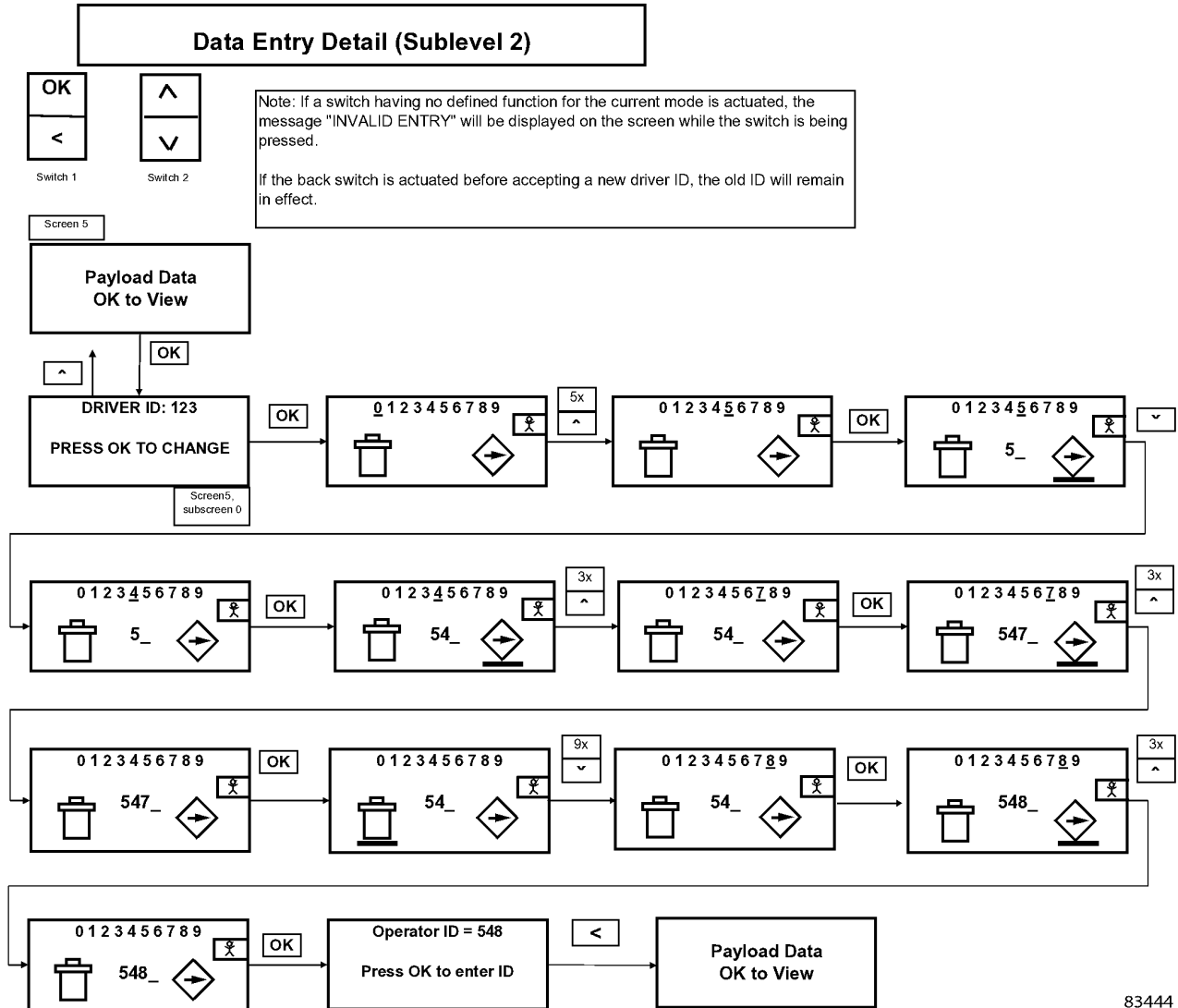

83444



**KOMTRAX Plus** C.3-0000051569**KOMTRAX Plus OPERATION** B.8-0000051740**Basic Precautions**

- When using this truck, there is no particular need to operate the KOMTRAX Plus system.
- Never disassemble, repair, or modify the KOMTRAX Plus system. This may cause failure or fire on the machine or this system.
- Do not touch the system when operating the machine.
- Do not pull on the wiring harnesses, connectors, or sensors of this system. This may cause short circuits or disconnections that lead to failure or fire on the machine or this system.
- Do not get water, dirt or oil on the system controllers.
- If there is any abnormality with the KOMTRAX Plus system, please consult the servicing Komatsu distributor.

**⚠ CAUTION**

- **DO NOT disassemble, repair, or modify the KOMTRAX Plus system without proper authorization. Changes to the system may cause machine failures and fire. DO NOT touch the KOMTRAX Plus system components during machine operation. DO NOT pull on KOMTRAX Plus system wiring harnesses, connectors, or sensors. This may cause short circuits or open circuits and lead to machine failure or fire. DO NOT allow water, dirt, or oil onto system components. The ORBCOMM satellite requires the installation of a pole and antenna, adding to the overall height of the machine. The height increase is 410 mm (16.2 in.). With the guard installed, the overall height increases another 260 mm (10.2 in.). Use caution when operating in areas with height restrictions.**

**⚠ DANGER**

- **Anyone with a pacemaker must remain a minimum of 22 cm (9 in.) from the communications antenna. Radio waves from the antenna can interfere with pacemaker operation.**

**⚠ CAUTION**

- **The KOMTRAX Plus system uses wireless components that transmit via radio waves. It is necessary to conform to local laws when using this system. Proper operation of the system is dependent on good reception. Operating in tunnels, mountain ranges and covered areas may prevent communication of the system. Contact your Komatsu distributor before selling or exporting a truck equipped with KOMTRAX Plus. It may be necessary to remove the system before transfer of ownership. Contact your Komatsu distributor before installing equipment that may interfere with the KOMTRAX Plus system. Komatsu is not responsible for any failures that result from neglecting KOMTRAX Plus system precautions and instructions.**

This system uses KOMTRAX Plus controller (2, Figure 6-13 [KOMTRAX Plus COMPONENT LOCATION, page 6-28](#)) to gather data about the operation of the truck from sensors and other controllers installed on the truck. The data stored in the KOMTRAX Plus controller is collected by a laptop personal computer (PC) or transmitted directly by communications satellite (utilizing the Orbcomm controller). This data is then compiled at the Komatsu computer server. Based on this information, the servicing Komatsu distributor will suggest improvements and provide information aimed at reducing machine repair costs and downtime.

When the data-store button (1, Figure 6-12 [CENTER CONSOLE, REAR VIEW, page 6-28](#)) is pressed on the back side of the center console, it will store a “snapshot” of the Statex III drive system. It will also trigger the KOMTRAX Plus system to store a “snapshot” of the truck operating system. A light on the controller will stay illuminated while the KOMTRAX Plus system is recording the “snapshot”, which lasts for 7.5 minutes.

The KOMTRAX Plus system is turned on by the truck key switch. Immediately after receiving 24V power from the key switch, the KOMTRAX Plus controller begins the power-up initialization sequence. This sequence takes about three seconds, during which time the red LED digits display a circular sequence of flashing LED segments.

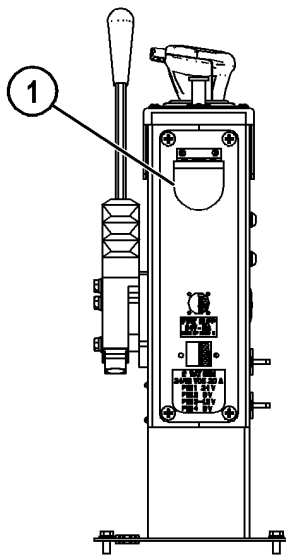

83627

1. Data Store Button

### Figure 6-12 CENTER CONSOLE, REAR VIEW

During normal truck operation, the red LED digits on the KOMTRAX Plus controller will count from 00-99 continuously.

When the key switch is turned OFF, the KOMTRAX Plus controller will remain on while it finishes processing internal data and saves the recent data into permanent memory. When the data has been safely stored, the two digit LED display will turn OFF. This process could take up to three minutes to complete.

### **⚠ WARNING**

- If 24V power is disconnected (using the battery disconnect switches) from the KOMTRAX Plus controller before it has completed its shut down procedure, the KOMTRAX Plus controller will lose all data gathered since the key switch was last turned ON. DO NOT disconnect battery power until the KOMTRAX Plus controller has completed the shut down procedure and has turned the LED digits off.

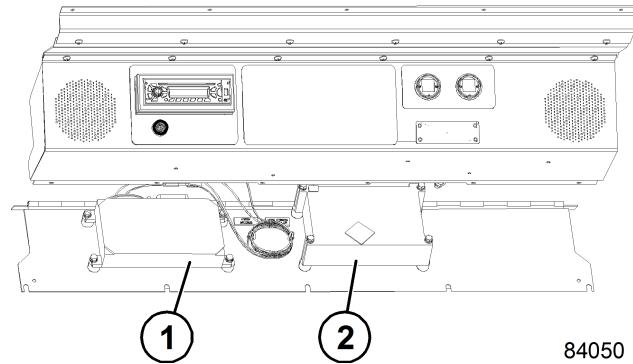

84050

1. Orbcomm Controller
2. KOMTRAX Plus Controller

### Figure 6-13 KOMTRAX Plus COMPONENT LOCATION

#### Interface Module

Interface module (1, Figure 6-14 KOMTRAX Plus COMPONENT LOCATION, page 6-29) receives data from the sensors installed on the truck and sends this information to the KOMTRAX Plus controller. There is a small green LED light on the face of the interface module controller. With the key switch ON, the light must be blinking. If the light is continuously illuminated, there is a problem in the controller.

When a new interface module controller is installed on the truck, new software has to be installed inside the controller. IM-Diag connector (1, Figure 6-15 DIAGNOSTIC PORTS (D.I.D. PANEL AT REAR OF CAB), page 6-29) is used to connect the interface module to a laptop PC for installing software.

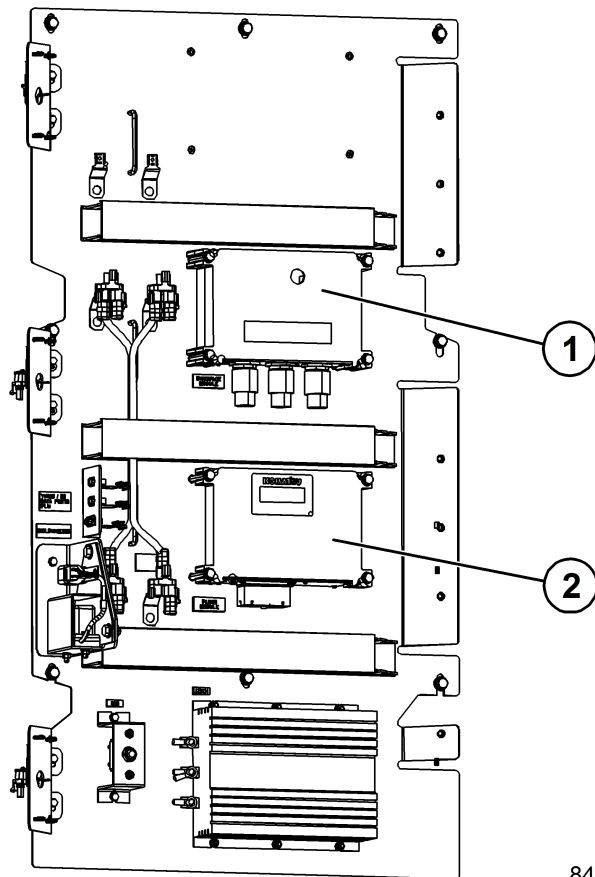

1. Interface Module      2. PLMIII Controller

**Figure 6-14 KOMTRAX Plus COMPONENT LOCATION**

**DOWNLOADING KOMTRAX Plus DATA** D.10-0000051588

**GENERAL INFORMATION**

Downloading data requires a laptop PC running Windows 95/98/2000/ME/XP/Vista/7 operating systems, the *VHMS Technical Analysis Toolbox* software, and a serial cable to connect the PC to the KOMTRAX Plus controller. Refer to the *VHMS Technical Analysis Tool Box* instruction manual for additional information about using this software. When a download to a laptop PC is performed, certain files are generated to store data. KOMTRAX Plus diagnostic port (2, [Figure 6-15 DIAGNOSTIC PORTS \(D.I.D. PANEL AT REAR OF CAB\)](#), page 6-29), located on the D.I.D. panel at the rear of the operator cab, is used to download data from the controller.

**KOMTRAX Plus DOWNLOADING PROCEDURE**

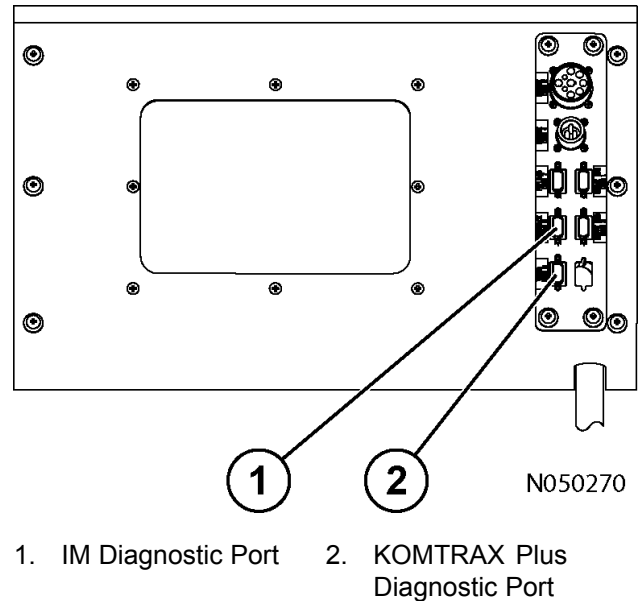

1. IM Diagnostic Port      2. KOMTRAX Plus Diagnostic Port

**Figure 6-15 DIAGNOSTIC PORTS (D.I.D. PANEL AT REAR OF CAB)**

**NOTE:** Always verify the full download has completed before disconnecting the PC from the machine.

1. Turn the key switch to the OFF position to stop the engine.
2. Turn the key switch to the ON position, but DO NOT start the engine.
3. Allow the KOMTRAX Plus controller to start up. This will take about one minute. Verify the red LED display starts counting up.
4. Attach the KOMTRAX Plus serial cable to KOMTRAX Plus diagnostic port (2), and the other end to the PC's serial port.
5. Double-click on the *VHMS Technical Analysis Tool Box* icon on the PC's desktop.
6. Enter the appropriate User Name and Password and click the [OK] button.
7. Double-click on the [Download] icon.
8. Select the COM port in the Port No. drop-down box and click the [Connection] button.
9. Verify that the date and time is correct for current local date and time. Also verify that the displayed service meter hours are equal to the value entered previously.
10. If this is the first time this PC has connected to the machine, you will need to download its definition file by clicking the [OK] button.

11. Verify that a manual snapshot (MFAO) has been recorded. The display will show an item named "Snapshot" with the code MFAO and text "Manual Trigger".
12. On the Download screen, click the [Select All] button. All items will become checked.
13. Click the [Download] button. The download may take one to ten minutes. Generally, if there are several snapshots in the download items, the download will take longer.
14. Click the [OK] button to complete the download.
15. Verify that the "Download Completed" message is displayed. Click on [Exit].
16. Select the [Machine History] option from the list on the left side of the screen.
17. Verify that the key ON/OFF and engine ON/OFF records are recorded correctly.
18. Exit any open windows on the PC.
19. Verify a full download has been taken. Refer to Location of Downloaded Files on Computer for more detailed instructions.
20. Disconnect the KOMTRAX Plus cable from the PC and from the machine.
21. Turn the key switch to OFF.

### Location of Downloaded Files

When a download using VHMS Technical Analysis *Tool Box* is performed, several files are downloaded onto the computer. They are organized in a specific way so that they can be used by VHMS Technical *Analysis Tool Box* at a later time. This structure is created automatically when the computer is used to perform the download from the KOMTRAX Plus controller. The situation may arise where the files need to be sent to someone, or someone gives these files to you.

1. Open Windows Explorer by right-clicking on the start button and choosing Explore.
2. In the left frame, the computer's file structure will be displayed. The right frame will show the details for the folder that is highlighted in the left frame.
3. In the left frame, navigate to the download files.

The basic path is as follows:

- Desktop
- My Computer
- Local Disk (C:)

- VHMS\_Data
- Model
- Serial Number
- Date
- Check Number

**NOTE:** The date folder is named in the format "YYYYMMDD".

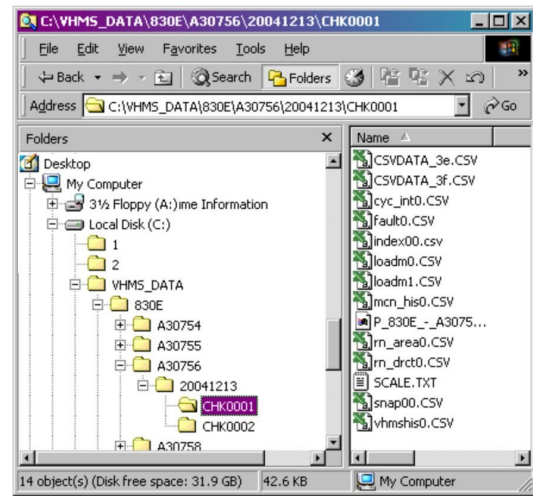

D120064

**Figure 6-16 FILE LOCATION**

The screenshot shows the location of where the KOMTRAX Plus download files reside on a computer. The Check Number folder is named in the format CHK000#. Each time a download is taken, it is placed in one of these folders. The first download will be in the CHK0001 folder. If a second download is taken on the same day, will be in the CHK0002 folder, etc.

Once the appropriate folder is selected, the contents will be shown in the right frame. These files can then be e-mailed or copied to a disk.

If someone provides KOMTRAX Plus download files through e-mail or on a disk, the same folder organization must be created in order to view them in *VHMS Technical Analysis Tool Box*.

### UPLOADING KOMTRAX Plus DATA D.3-0000051586

After downloading, the KOMTRAX Plus data resides on the PC that performed the download. In order to make this data available to others, it must be sent to an online database named WebCARE. Once the data has been uploaded (ftp'd) to WebCARE, it is accessible to anyone with an internet connection and an ID and password.

VHMS Technical Analysis Tool Box is used to perform the ftp upload. Perform an ftp upload as soon as the person who performed the download can obtain an internet connection. All downloads must be uploaded to WebCARE.

1. Double-click on the VHMS technical analysis tool box icon on the PC's desktop.
2. Enter the appropriate user name and password and click the [OK] button.

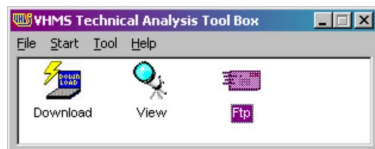

D120046

3. Double click the [FTP] icon.
4. At the ftp Client Login window, enter the ftp User ID and Password.
  - a. User ID = komatsu
  - b. Password = vhms
5. The target directory must be set to the PC's hard drive (usually drive C:\).
  - a. Double-click the VHMS\_Data folder to drop down the model folders.
  - b. Double-click the appropriate model folder to drop down the serial number folders.
  - c. Double-click the appropriate serial number folder to drop down the date folders.
  - d. Double-click the appropriate date folder to drop down the check number folders.

- e. Double-click the appropriate check number folder to display its contents in the files window.

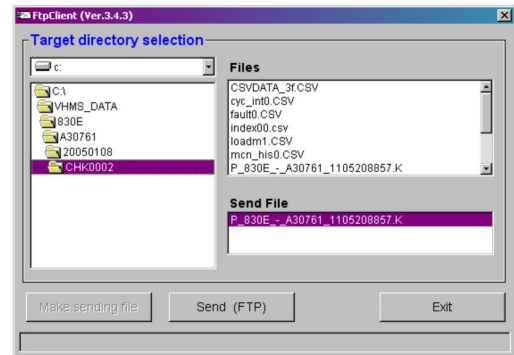

D120047

6. Some models will automatically create a sending file during the download process. Others need to have the sending file created at this time. A sending file is just a compressed version of all the other downloaded files. If there is already a sending file in the Send File window, you do not need to perform this step. If there is not a sending file in the Send File window, click the [Make Sending File] button.

**NOTE:** The compressed sending file will look similar to this file name, and will always end with a ".K".  
 P\_830E\_-\_A30761\_1105208857.K

7. After selecting the correct file to send, click the [Send (FTP)] button.
8. Click the [Yes] button to verify that you want to upload the data to WebCARE.

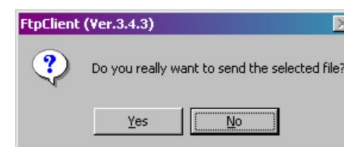

D120048

9. If the sending file was uploaded successfully, the file will appear in the OK window. If the sending file was not uploaded successfully, the file will appear in the "NG" (No Good) window. Ensure the PC has an internet connection.



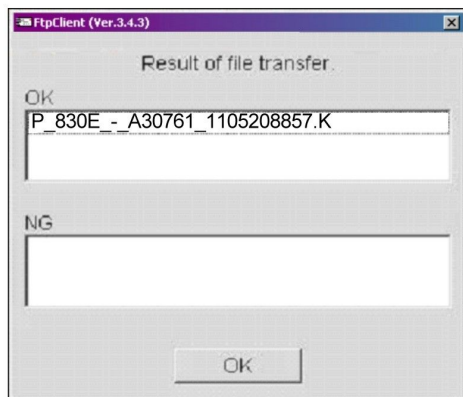

D120049

10. Click the [OK] button, then the [Exit] button. Close all other open windows.

## ORBCOMM B.3-0000051739

### **⚠ DANGER**

- **ORBCOMM is a two-way radio communication device. Wireless signals from the system can interfere with other wireless signals in the area. This interference can cause a malfunction in a blast zone resulting in an unintended detonation. Know the locations of blast zones in the area and keep a safe distance to avoid unintentional blasts. If the machine is operating within a distance of 12m (40 ft) of a blast zone, disconnect the ORBCOMM harness. Failure to do so could result in serious injury or death. This warning does not supersede requirements or regulations of the area or country where this machine is in operation. The following specifications are provided to ensure compliance with all of the applicable requirements or regulations: Transmit power: 5-10 Watts Operating Frequency Range: 148 - 150 MHz**

The Orbcmm controller transmits data through antenna (1, Figure 6-17 ORBCOMM ANTENNA, page 6-32) mounted on top of the cab. The antenna coaxial cable is routed through the inside of the cab to protect it from damage. If the antenna or coaxial cable is damaged, replace the parts.

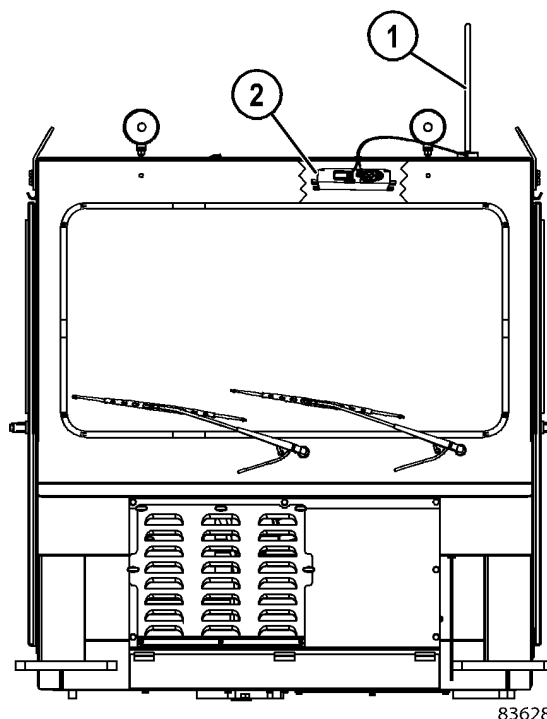

83628

1. Orbcmm Antenna
2. Orbcmm Controller

Figure 6-17 ORBCOMM ANTENNA

## KOMATSU WIRELESS BRIDGE (Optional) E.2-0000051584

### General Information

The Komatsu wireless bridge allows for the transfer of information from the KOMTRAX Plus controller to a laptop computer with wireless network capabilities. The information that is downloaded through the KWB (Komatsu wireless bridge) is the same information that is gathered during a manual download from the KOMTRAX Plus system. Downloads can be performed with the laptop computer located on or near a stationary truck, or the computer can be located close to a path of moving trucks. Total download time is approximately 10 seconds. If only a portion of the data is downloaded while the truck is passing by a laptop computer, the remaining information will be downloaded the next time a data download occurs. The wireless bridge transmits data using an antenna mounted on top of the auxiliary control cabinet.

### Communication Setup

A computer running a Microsoft™ operating system (with a wireless network adaptor) is required to download data from the KWB. The individual steps required are different depending upon the computer operating system and each computer's specific wireless adaptor. Please refer to the computer and/or adaptor manuals for further details.

1. Ensure that the KWB:
  - Shows power and function (LEDs illuminated)
  - Has not been previously setup
  - Is within range of the computer
2. Use the computer to scan for any available wireless networks. The computer should find a network with "KWB\_SETUP" as its SSID (SSID = Service Set Identifier). If this SSID is present the KWB is transmitting correctly. Switch to the KWB\_SETUP network.

If the KWB\_SETUP SSID is not detected, verify all connections to the KWB. If all connections are correct, the KWB will need to be reset. Reset the KWB by pushing the reset button (2, [6-18 RESET LOCATION, page 6-35](#)) next to the connector plug.

KOMATSU WIRELESS BRIDGE LIGHTS	
Name	Description
CONN	Reserved for future use.
LINK	When ON, the KWB is operational. When OFF, the KWB may not be set for Ad-Hoc, or it may be damaged. An ON condition is not an indication that the antenna or antenna cable is in good condition or that the antenna is connected.
CFG	When ON, the KWB has an IP address. When OFF, the KWB may be configured for DHCP (DHCP should not be selected for ad-hoc mode).
POST	When ON, the KWB is receiving power and is operational. When OFF, the KWB may not be powered or it may be defective.

**NOTE:** A KWB\_SETUP SSID could be transmitted by another laptop computer and not by the desired KWB. Power down any other wireless sources with an SSID of KWB\_SETUP.

### Switching to the KWB\_SETUP Network

The computer should be on the same network as the KWB. It will be necessary to "create a profile" for the new network. Check the wireless adaptor's manual for details.

1. Configure the new profile as follows:
  - Set the profile name to KWB\_SETUP.
  - Set the SSID to KWB\_SETUP.
  - Select the wireless network type as "ad hoc".
  - In the security settings, select "no encryption" or a similar setting.
  - Select channel 11 (most adaptors will automatically select a channel).
2. Some wireless adaptor software allows the setting of a static IP address and subnet mask for each profile. If this option is available, complete the following steps:
  - Set the IP address to 192.168.0.xxx, where xxx is any number between 1 and 255. 123 is recommended if only one computer will be used to interact with the KWB. If multiple computers are used, each must be set to a different IP address.
  - Set the subnet mask to 255.255.0.0. If asked for a default gate-way, this may be assigned the same IP address as the computer.

### Setting the Computer Subnet Mask and IP Address

If the adaptor software does not allow for setting an IP address, then this must be done manually. This prepares the computer to communicate with the KWB and to interact with the automatic download software.

The Windows TCP/IP settings must be modified for the correct subnet mask and an adequate IP address. The steps to reach the point where the TCP/IP settings can be modified vary according to the operating system and are described below. The actual steps for making the changes to the settings are described for the following operating systems.

#### Windows 2000®

- Click on the start menu, select settings and then "Network and Dial-up Connections".
- Right click on the wireless network adaptor and select "properties". Skip instructions for other Operating Systems.

#### Windows XP®

- Click on the start menu, right click on “My Networks” and select “Properties”. A window with all available networks will be shown.
- Right click on the wireless network and select “Properties”. Skip instructions for other Operating Systems.

#### Windows Vista®

- Click on the Windows menu, right click on “Network” then select “Properties”. A window will open with the option “Manage network connections” as one of the options on the left side. Select that option.
- A new window showing all available networks will open. Right click on the wireless network to be used to connect to the KWB and select “Properties”. Vista will inquire if this was an intentional selection; select “Continue”. Skip instructions for other Operating Systems.

#### Windows 7®

- Click on the Windows start menu, click on “Control Panel” then select “Network and Internet”. A window will open with the option “Network and Sharing Center” . Select that option.
- A new window showing all available networks will open. Right click on the wireless network to be used to connect to the KWB and select “Properties”.
  1. Once the window with the list of available protocols is shown, the TCP/IP should then be selected. Click on “Properties” and bring up a window for setting the IP address and the subnet mask (alternatively, double click on TCP/IP). Before making any changes, write down the current settings. These settings will be needed to restore the original computer settings if needed.
  2. Select “Use the following IP address”, then set the IP address to 192.168.0.xxx, where xxx represents any number between 1 and 255. 123 is generally used. However, no two computers should use the same IP address). The subnet mask should now be set to 255.255.0.0. If a gateway address is requested, this is set to the same as the IP address.

**NOTE:** *The previous steps are not necessary if the software that comes with the computer/adaptor allows an IP address and mask to be assigned to each profile. This is done automatically by selecting the profile. It may be necessary to repeat these steps to restore the computer settings when connecting to another network.*

## Setting Up the KWB

The KWB is preset from the factory. It is recommended that the SSID be changed at setup to establish a unique identity from other KWBs. No previously installed KWBs should show up as KWB\_SETUP.

Changing the network channel may be necessary. For example, if another network in the vicinity uses channel 11 for transmission, the KWB may interfere with this network.

If the information downloaded from the KOMTRAX Plus controller is considered sensitive and private, then the KWB data should be encrypted.

Once the computer has been setup correctly the KWB may be setup using a web browser as follows:

1. On the KWB, label locate the IP address.
2. Type the KWB IP address into the address bar of a web browser (just the numbers and the periods).
3. When prompted to enter a User Name and Password, enter “dpac” for both.
4. The initial screen that is displayed will show the current status of the KWB. Select “Network” from the top right corner.
5. Change the SSID to any name. (for example, “KOMTRAX controller”). The SSID is used to separate networks. If one computer will be used to download data from excavators, one from haul trucks, and one from dozers, then the KWB that will be installed on these machines could have their SSID set to “KOMTRAX\_dig”, “KOMTRAX\_haul”, and “KOMTRAX\_push” respectively. This would make excavators and haul trucks invisible to the computer setup to download data from dozers. All KWBs that are to be in the same network should be set to the same SSID.

If the default channel (11) is used by another network in the vicinity, change the channel. It is preferable to assign channels that are at least three channels apart.

## Adding Encryption

It is recommended that encryption be added for data security. To encrypt the network, perform the following:

1. On “Wireless Security Mode”, select WEP128. In “WEP key 1”, using only numbers and the letters from “A” to “F” input a 26 character long passkey, for example “0123456789ABCDEF0123456789” (a more



complex combination should be used). All KWBs that are to be in the same network should have the same WEP key, SSID, and be on the same channel.

2. Keep a record of the key.

**NOTE:** If a more secure encryption method is desired, consult a network professional to setup WPA encryption.

3. If the "DHCP Client Name" is blank, input the KWB IP address in this field before pressing the "Save" button at the bottom of the page. No further network settings are required.
4. Once the KWB is reset, all the settings will be applied. Reset the KWB when prompted or, if you prefer to review the settings, click on "Networks" and, when reviewing is complete, click on "Reset". Both of these options are in the blue bar under "KWB-1".

### Final Computer Settings

Once the KWB SSID is changed, the KWB is no longer in the KWB\_SETUP network. In order to establish communications with the KWB, the computer must be setup to have the same settings as the KWB. Follow the steps outlined in "Communication Setup", but use the new settings to create a different network profile. Once all setting are complete, typing the KWB IP address in the browser's address bar should open the KWB settings page. This confirms that the KWB and the computer are on the same network.

Once the steps described above have been performed, the computer will have two network profiles in the program that manages the network adaptor. The KWB\_SETUP profile should remain in the list in order to setup other KWBs in the future. The other profile will be the one used to communicate with the existing KWB. For both networks, the computer IP address can remain the same. If the computer is also used to connect to the internet, select "obtain IP address automatically" when connecting to the internet.

### Downloading Data

To obtain the software for downloading data from the KOMTRAX Plus controller, go to the Komatsu Extranet (<https://www.komatsuamerica.net>) and perform the following:

1. Select KOMTRAX / VHMS / PLM.
2. Select VHMS / PLM, then select SOFTWARE.
3. Select KWB - Komatsu Wireless Bridge (Wireless Download Software). Load and

install the software. The icon "VHMS Controller Auto Download Tool" will be created during the download process.

Running the software for the first time will offer the opportunity to choose a login name and password; "user" should be used for "User Name" and "1" for "Password". This may change this the next time the software is run. Clicking "OK" will start the download tool. If any KWBs are within range and are connected to the KOMTRAX Plus controller, the tool will automatically download all the data from each KOMTRAX Plus controller.

The auto-download software will not download from KOMTRAX Plus controllers that have not had the vehicle data setup (this is a consideration only when replacing a KOMTRAX Plus Controller or installing a KOMTRAX Plus Controller for the first time nor will any KWB that is not connected to a KOMTRAX Plus controller show up in the list of available download sources. Once the data from one vehicle has been downloaded, the tool will not perform another download for that vehicle until 20 hours have passed.

It is possible to force a download by right clicking on a vehicle in "View". Vehicles in "View" are shown in the top list; vehicles that have been previously in "View" are shown in the lower list.

### Resetting the KWB

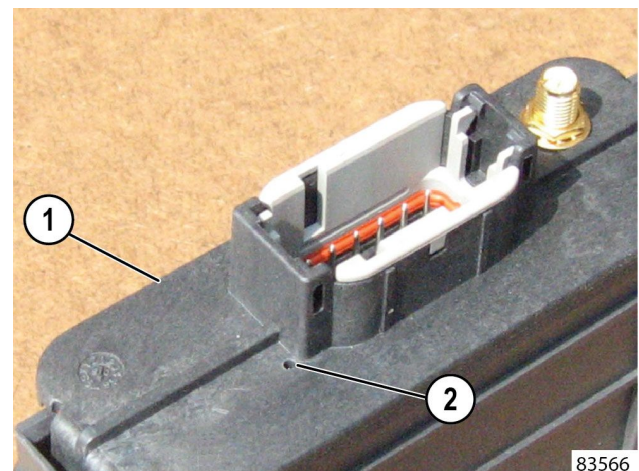

1. Komatsu Wireless Bridge
2. Reset Button

**Figure 6-18 RESET LOCATION**

It may be necessary to reset the KWB. For example, if the WEP key was incorrectly typed when setting up the KWB, it will not be possible to connect to that KWB without the correct key.

1. Remove the power by turning OFF the key or by disconnecting the harness from the KWB.

2. Lightly insert, press and hold a paperclip into the hole on the connector face. To prevent damage to the internal switch do not use sharp objects.
3. Restore power to the KWB while keeping the reset switch depressed. The LEDs should begin to flash. The KWB is now reset.
4. Switch to the KWB\_SETUP SSID network. The IP address after a reset will be 192.168.1.0.
5. When setting the KWB, the IP address must be changed from the reset IP address. Use the address on the KWB label.

**NOTE:** After a reset, the KWB will revert to the KWB\_SETUP SSID.

**FUSES AND CIRCUIT BREAKERS** E.8-0000051583

**VEHICLE ELECTRICAL CENTER**

89 A.2-0000070603

Vehicle Electrical Center 89 is located inside the auxiliary control cabinet.

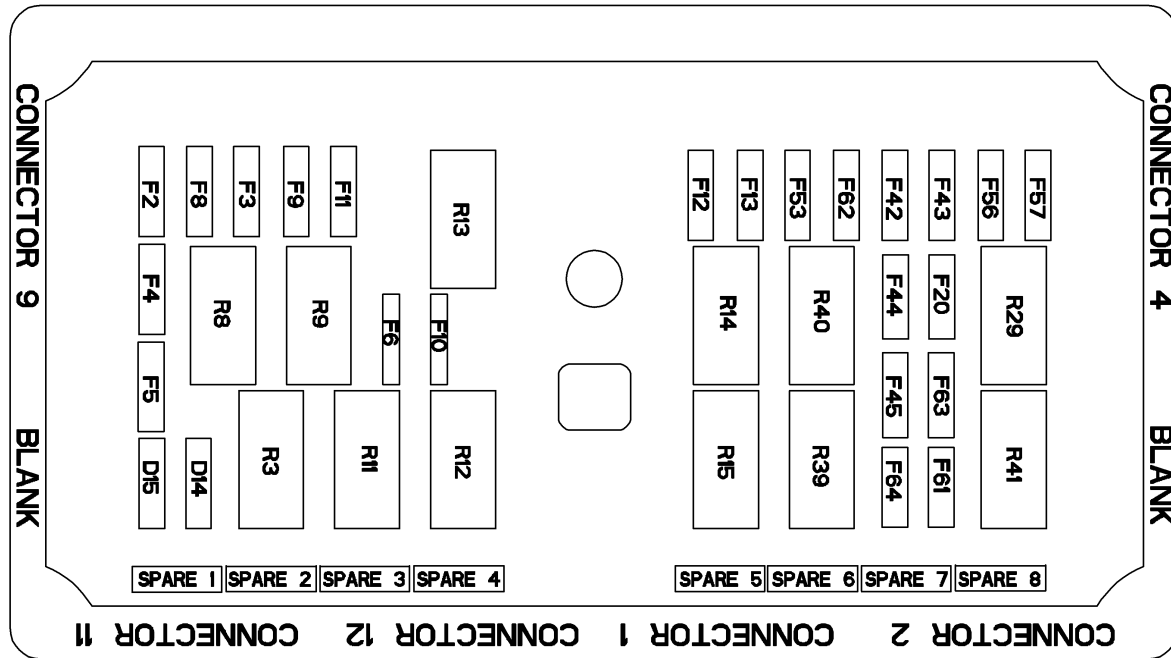

84052

Figure 6-19 VEHICLE ELECTRICAL CENTER 89

VEHICLE ELECTRICAL CENTER 89		
LOCATION	AMPS	DEVICE(S) PROTECTED
F2	25	Back-Up Lamps
F3	15	Back-Up Horn
F4	15	Left Low Beam Headlights
F5	15	Right Low Beam Headlights
F6	25	High Beam Headlights
F8	15	Marker & Tail Lights
F9	10	Brake Light
F10	20	Ladder Lights
F11	15	Turn Signal Hazard
F12	10	Steering Bleed Down
F13	10	Retard Lamps
F20	10	Auto Lube
F42	5	IM & Fuel Sensor
F43	1	Direction Selector Switch

VEHICLE ELECTRICAL CENTER 89		
LOCATION	AMPS	DEVICE(S) PROTECTED
F44	5	Display Mode Switch, Camera Switch and Switch LED Lights
F45	15	GE Drive Control & Feedback
F53	20	Heated Mirror
F56	10	Operator Seat
F57	10	Pre-Shift Brake Test
F61	1	Left Rear Wheel Speed
F62	15	Fog Lamp
F63	15	Seat Belt Alarm
F64	5	Headlight Switch
SP1	1	Spare
SP2	1	Spare
SP3	1	Spare
SP4	5	Spare
SP5	10	Spare
SP6	15	Spare
SP7	20	Spare
SP8	25	Spare
D14	3	Back-Up Diode 1
D15	3	Back-Up Diode 2
R3		Back-Up Horn Micro Relay
R8		Marker & Tail Light Micro Relay
R9		Brake Light Micro Relay
R11		Left Turn Micro Relay
R12		Right Turn Micro Relay
R13		Turn Signal Hazard Flasher Relay
R14		Steering Bleed Down Micro Relay
R15		Retard Lamps Micro Relay
R29		Auto Lube Micro Relay
R39		Heated Mirror Micro Relay
R40		Fog Lamp Micro Relay
R41		Seat Belt Alarm Micro Relay

**VEHICLE ELECTRICAL CENTER**

90 A.2-0000070602

Vehicle Electrical Center 90 is located inside the auxiliary control cabinet.

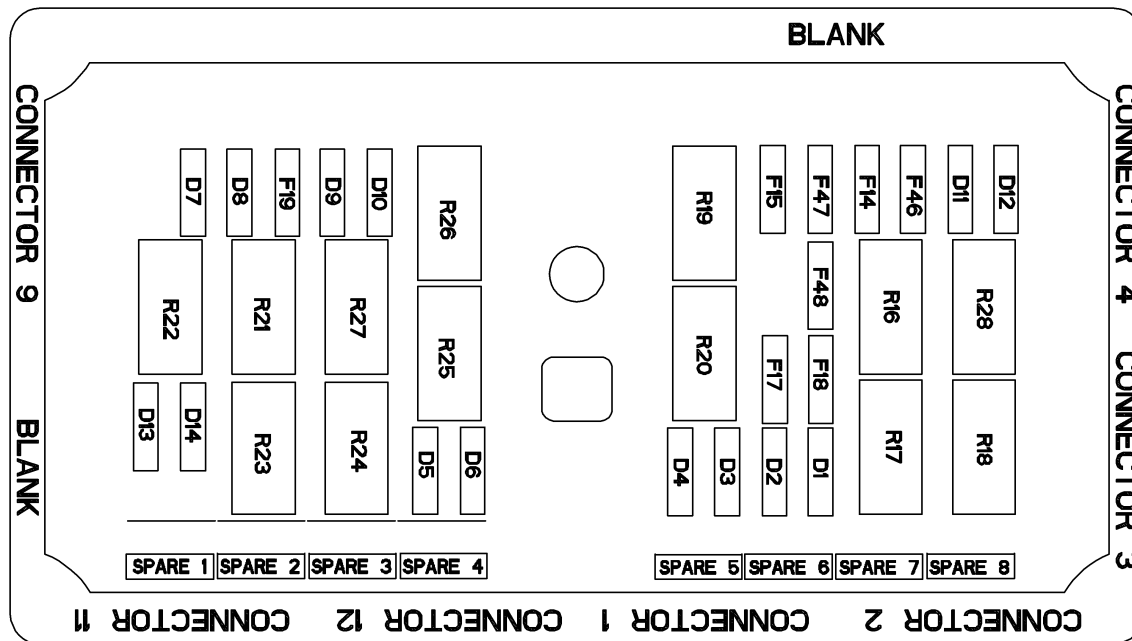

84053

Figure 6-20 VEHICLE ELECTRICAL CENTER 90

VEHICLE ELECTRICAL CENTER 90		
LOCATION	AMPS	DEVICE(S) PROTECTED
F14	5	Payload Lamps
F15	5	Park Brake Status
F17	5	Payload Meter
F18	15	Ground Level Shutdown Switch
F19	10	Park Brake Control
F46	5	Payload Meter Key Switch Power
F47	5	KOMTRAX Plus Key Switch Power
F48	5	Modular Mining Conn Key Switch Power
SP1	1	Spare
SP2	1	Spare
SP3	1	Spare
SP4	5	Spare
SP5	10	Spare
SP6	15	Spare

VEHICLE ELECTRICAL CENTER 90		
LOCATION	AMPS	DEVICE(S) PROTECTED
SP7	20	Spare
SP8	25	Spare
D1	3	Key Switch Run Diode
D2	3	Shift Selector Reverse Diode
D3	3	Shift Selector Neutral Diode
D4	3	Shift Selector Forward Diode
D5	3	Park Brake Diode
D6	3	Truck Moving Diode
D7	3	Brake Lock Diode
D8	3	Park Brake Latch Diode
D9	3	GE True Forward Signal Diode
D10	3	GE True Reverse Signal Diode
D11	3	GE Propel System At Rest Diode
D12	3	GE Propel System Not Ready Diode
D13	3	Forward, Neutral, Reverse Signal Diode
D14	3	Engine Running Diode
R16		Payload Red Lamp Relay
R17		Payload Amber Lamp Relay
R18		Payload Green Lamp Relay
R19		Engine Interlock Relay
R20		Timed Engine Shutdown Relay
R21		Engine Running Relay
R22		Park Brake Request Relay
R23		Park Brake Release Relay
R24		Park Brake Switch Relay
R25		Truck Moving Relay
R26		Park Brake Latch Relay
R27		GE Interface Relay
R28		Park Brake Status Relay

**VEHICLE ELECTRICAL CENTER**

91 A.2-000070601

Vehicle Electrical Center 91 is located inside the auxiliary control cabinet.

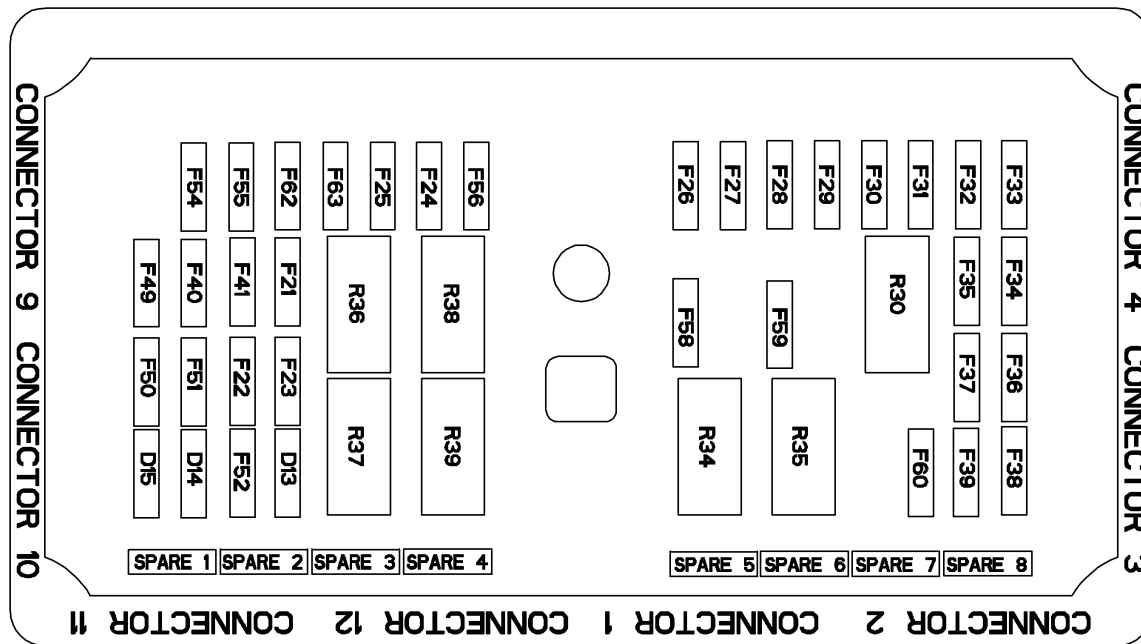

84054

Figure 6-21 VEHICLE ELECTRICAL CENTER 91

VEHICLE ELECTRICAL CENTER 91		
LOCATION	AMPS	DEVICE(S) PROTECTED
F21	10	Ether Start
F22	20	Op-Cab Communication Radio 12V
F23	10	Entertainment Radio 12V
F24	10	A/C Compressor
F25	10	Shutter Control
F26	15	Electronic Gauge Display Un-Switched
F27	10	IM Un-Switched # 1
F28	10	IM Un-Switched # 2
F29	10	KOMTRAX Plus & Orbcomm
F30	20	Modular Mining Un-Switched
F31	15	Engine Oil Reserve Pump Motor
F32	15	Engine Oil Reserve Controller
F33	15	Vehicle Horn / Service Lamps
F34	15	Engine Service Lamps / Hydraulic Mod Lamp
F35	15	Ladder & Hazard Lamp Control Switch
F36	20	Engine Un-Switched Power Fuse #1
F37	20	Engine Un-Switched Power Fuse #2

VEHICLE ELECTRICAL CENTER 91		
LOCATION	AMPS	DEVICE(S) PROTECTED
F38	20	Engine Un-Switched Power Fuse #3
F39	20	Engine Un-Switched Power Fuse #4
F40	20	Op-Cab Communication Radio 24V
F41	5	Op-Cab Fire Suppression
F49	15	Operator Cab HVAC Key Switch
F50	10	Windshield Wipers
F51	10	Hoist Limit Switch
F52	5	Turn Signal Switch
F54	5	Electronic Gauge Display Key Switch
F55	5	Aux Box Dome Lamps
F56	20	Electric Window - Left
F58	1	Right Front Wheel Speed
F59	1	Left Front Wheel Speed
F60	1	Left Rear Wheel Speed
F62	20	Electric Window - Right
F63	20	Auxiliary Power Port 12V
SP1	5	Spare
SP2	5	Spare
SP3	10	Spare
SP4	10	Spare
SP5	10	Spare
SP6	15	Spare
SP7	15	Spare
SP8	15	Spare
D13	3	Turn Signal Switch Diode
D14	3	Key Switch Power Or Diode
D15	3	GE Control Power Or Diode
R30		Starter Enable Relay
R34		GE Payload 70% Signal Relay
R35		GE Payload 100% Signal Relay
R36		Ether Start Relay
R37		Entertainment Radio Relay



<b>VEHICLE ELECTRICAL CENTER 91</b>		
<b>LOCATION</b>	<b>AMPS</b>	<b>DEVICE(S) PROTECTED</b>
R38		A/C Compressor Relay
R39		Shutter Control Relay

**CIRCUIT BREAKERS** C.3-0000051607

<b>CIRCUIT BREAKERS</b>				
	<b>AMPS</b>	<b>DEVICES(S) PROTECTED</b>	<b>CIRCUIT</b>	<b>LOCATION</b>
CB60	50	12VDC Power Supply	11B5	Auxiliary Control Cabinet



# LUBRICATION AND SERVICE

## **WARNING**

**Read and follow all safety precautions. Failure to do so may result in serious injury or death.**

---

This safety section also contains precautions for optional equipment and attachments.

**GENERAL INFORMATION** E.7-0000051606

Recommended preventive maintenance will contribute to the long life and dependability of the truck and its components. The use of proper lubricants and the performance of checks and adjustments at the recommended intervals is most important.

Refer to [LUBRICATION CHART, page 7-9](#) for lubricant requirements. For detailed service requirements for specific components, refer to the service manual section for that component.

Refer to the manufacturer's service manual when servicing any components of the drive system.

Refer to the engine manufacturer's service manual when servicing the engine or any of its components.

The service intervals presented here are in hours of operation. These intervals are recommended in lieu of an oil analysis program which may determine different intervals. However, if the truck is being operated under extreme conditions, some or all, of the intervals may need to be shortened and the service performed more frequently.

This truck is equipped with an automatic lubrication system. The initial setup for this system provides for nominal amounts of lubricant to be delivered to each serviced point. The lubrication injectors can be adjusted to vary the amount of lubricant delivered. In addition, the timer for lubrication intervals is normally adjustable. Refer to [AUTOMATIC LUBRICATION SYSTEM, page 5-43](#) for adjustments to these devices.

<b>Service Capacities</b>		
<b>System</b>	<b>Liters</b>	<b>U.S. Gallons</b>
Crankcase (including 4 oil filters) (Komatsu SSDA16V160 Engines)	280	74
Cooling System (Komatsu SSDA16V160 Engine)	594	157
Hydraulic System (Refer to <a href="#">HYDRAULIC SYSTEM SERVICE, page 7-2</a> )	1325	350

<b>Service Capacities</b>		
<b>System</b>	<b>Liters</b>	<b>U.S. Gallons</b>
Wheel Motors (each side)	95	25
Fuel Tank (Diesel Fuel Only)	4542	1200

**HYDRAULIC SYSTEM SERVICE** c.7-0000051605

**Hydraulic Tank**

There are two sight gauges on the side of the hydraulic tank. With the engine stopped, key switch OFF, hydraulic system bled down and body down, oil should be visible in the top sight gauge. If hydraulic oil is not visible in the top sight gauge, follow Adding Oil instructions below.

**Adding Oil**

Keep the system open to the atmosphere only as long as absolutely necessary to lessen the chances of system contamination.

Service the tank with clean Type C-4 hydraulic oil only. All oil being put into the hydraulic tank must be filtered through filters rated at three microns.

1. Ensure that the engine is stopped, key switch is OFF, hydraulic accumulators depressurized, and body is down.
2. Remove fill cap (2, Figure [7-1 HYDRAULIC TANK SERVICE, page 7-3](#)) and add hydraulic oil until the oil level is visible in the center of the top sight gauge.
3. Install the fill cap.
4. Start the engine. Raise and lower the dump body three times.
5. Check the hydraulic oil level again with the engine stopped, key switch OFF, hydraulic accumulators depressurized, and body down.
6. Repeat steps 1 - 5 until the oil level is maintained in the center of the top sight gauge.

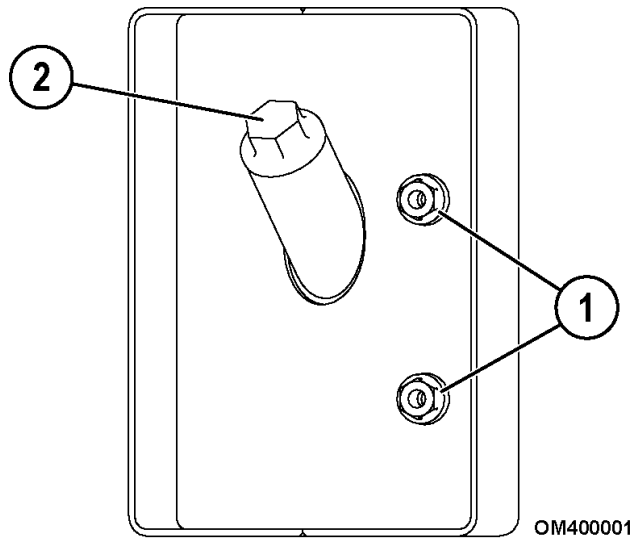

1. Sight Gauges      2. Fill Cap

**Figure 7-1 HYDRAULIC TANK SERVICE**



1. Hydraulic Tank Breathers

**Figure 7-2 HYDRAULIC TANK BREATHERS**

Hydraulic tank breathers (1, Figure 7-2 HYDRAULIC TANK BREATHERS, page 7-3) need to be replaced every 500 hours.

**Hydraulic Filters**

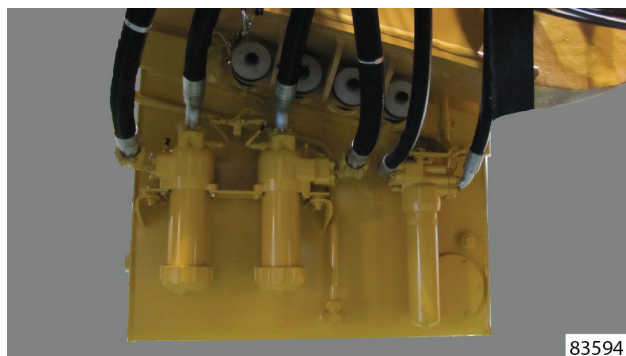

**Figure 7-3 HYDRAULIC FILTERS**

Replace filter elements after the initial 50, 100, and 250 hours of operation; then at each 500 hours of operation thereafter. Check oil level. Add oil as necessary. (Lube Key "B").

**Hydraulic Pump Drive Shaft**

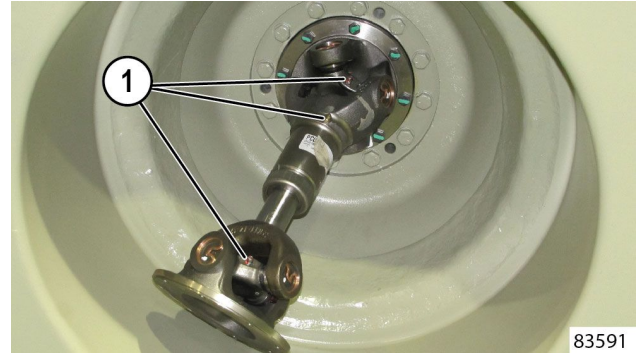

1. Drive Shaft Grease Fittings

**Figure 7-4 DRIVE SHAFT LUBRICATION POINTS**

Add one or two applications of grease to each drive shaft grease fitting (1, Figure 7-4 DRIVE SHAFT LUBRICATION POINTS, page 7-3). Non - moly grease only. Check that each bearing of the U-joint assembly is receiving grease. Replace bearings if any wear is detected.

**WHEEL MOTOR SERVICE C.3-0000051604**

Due to differences in gear ratio and component evolution/design, wheel motor service intervals may be unit number and/or mine specific. Because of the wide variety of factors involved, it is necessary to consult your area Komatsu representative for all wheel motor service intervals and instructions. General intervals for oil service and sampling are listed in the interval charts.

**COOLANT LEVEL SERVICE H.8-0000051603**

Inspect the coolant sight gauge. If coolant cannot be seen in the sight gauge, it is necessary to add coolant to the system before truck operation. Refer to the procedure below for the proper filling instructions.

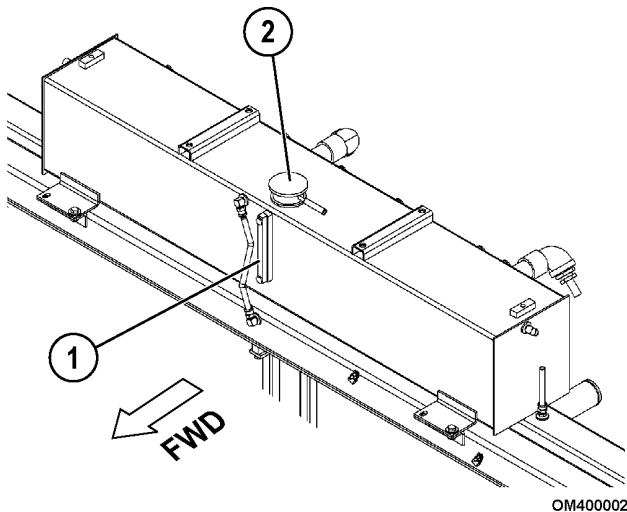

1. Sight Gauge                      2. Radiator Cap

### Radiator Filling Procedure

#### **⚠ WARNING**

- The cooling system is pressurized due to thermal expansion of coolant. **DO NOT remove the radiator cap while the engine and coolant are hot. Severe burns may result.**

1. With the engine and coolant at ambient temperature, remove the radiator cap.

**NOTE:** If coolant is added using the quick fill service center, the radiator cap **MUST** be removed prior to adding coolant.

2. Fill the radiator with the proper coolant mixture (as specified by the engine manufacturer) until coolant is visible in the sight gauge.
3. Install the radiator cap.
4. Operate the engine for five minutes. Check the coolant level.
5. If coolant is not visible in the sight gauge, repeat Steps 1 through 4. Any excess coolant will be discharged through the vent hose after the engine reaches normal operating temperature.

Engine coolant must always be visible in the sight gauge before truck operation.

### Coolant Specifications

For ambient temperatures of  $-32^{\circ}\text{C}$  ( $-25^{\circ}\text{F}$ ) and above, use a standard 50/50 anti-freeze-to-water mixture.

For arctic climates with ambient temperatures between  $-32^{\circ}\text{C}$  ( $-25^{\circ}\text{F}$ ) and  $-54^{\circ}\text{C}$  ( $-65^{\circ}\text{F}$ ), use a 60/40 anti-freeze-to-water mixture.

**NOTE:** Do not use propylene glycol coolant in arctic climates. Only use ethylene glycol coolants.

### Unacceptable Practices

- Use of high-silicate anti-freeze.
- Under concentration or over concentration of Extended Service Additive (SCA).
- Use of anti-freezes/coolants that are not fully formulated for extended service intervals.
- Use of sealing additives (stop-leak) in the cooling system.
- Use of soluble oils in the cooling system.
- Use of poor-quality water. See the engine manufacturer's specifications for water quality requirements.
- Use of anti-freeze, Extended Service Additive (SCA) or coolant filter(s) that do not meet the engine manufacturer's specifications.
- Use of Treated Water coolant.
- Use of coolants with less than 40 percent antifreeze.

### RESERVE ENGINE OIL SERVICE G.2-0000051463

The reserve oil tank for the engine is designed to add more oil capacity to the engine to reduce the frequent servicing of the engine oil. The engine oil level must still be checked every shift using the dipstick. If engine oil level is not correct, check for proper operation of the reserve oil system. Never add oil to the engine unless it has been drained.

If the engine oil has been drained from the oil pan, the new oil must be added to the engine oil pan before starting. **DO NOT** use the oil in the reserve tank to fill an empty engine with oil. After an oil change, both the engine and reserve tank must be full of oil before starting the engine.

With the engine running, check the operation of the red LED light on the pump.

- **Continuously on** - Pump 1 is withdrawing oil from the engine sump and bringing down the oil level.
- **Regular pulsing** - Pump 2 is returning oil to the engine sump and raising the oil level.
- **Irregular pulsing** - Oil is at the correct running level.

Oil should always be visible in the bottom sight gauge. If not, add oil to the reserve oil tank until oil is visible in the top sight gauge.

- Never add oil to the engine unless it has been completely drained.
- If the engine oil has been drained from the oil pan, new oil must be added to the oil pan. **Do not use the oil in the reserve oil tank to fill an empty engine oil pan.**

After an oil change, both the engine and reserve oil tank must be full of oil before starting the engine.

### Reserve Oil Tank Filling Procedure (Remote Fill)

1. Connect the pressure supply hose from the new oil supply to the quick coupler on the truck. Open the valve on the supply hose to apply pressure.
2. Pull out on switch (2, [7-5 CONTROL PANEL](#), [page 7-5](#)) to turn the system on.
3. Push start switch (3). The VALVE OPEN light (5) should illuminate and the filling process will begin.
4. When tank is full, the VALVE OPEN light will turn off and FULL light (4) will illuminate.
5. Close the oil supply valve in the fill hose.
6. Press and hold start switch (3) for a couple of seconds.
7. Disconnect the new oil supply hose.
8. Push switch (2) in to turn system power OFF.

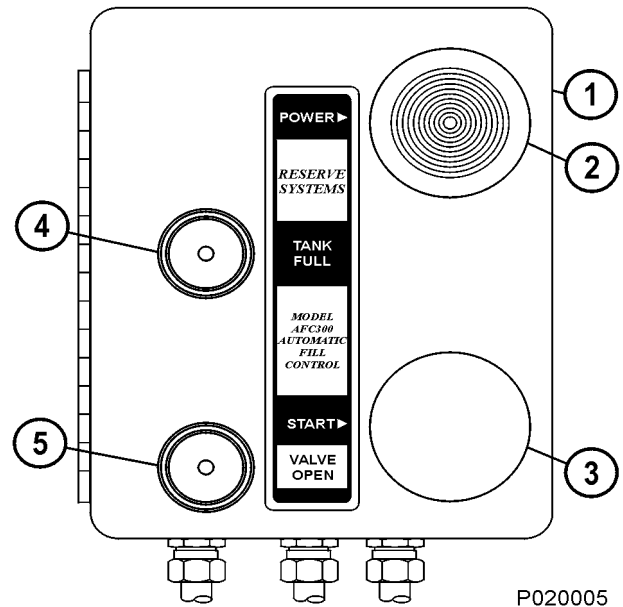

- |                       |                       |
|-----------------------|-----------------------|
| 1. Remote Control Box | 4. "FULL" Light       |
| 2. System Switch      | 5. "VALVE OPEN" Light |
| 3. Start Switch       |                       |

**Figure 7-5 CONTROL PANEL**

### Inline Screen

There is an inline screen located at the inlet of the fill valve. This screen does not require periodic maintenance, but it can be cleaned by removing the screen and back flushing.

### CAB AIR FILTER SERVICE C.3-0000051602

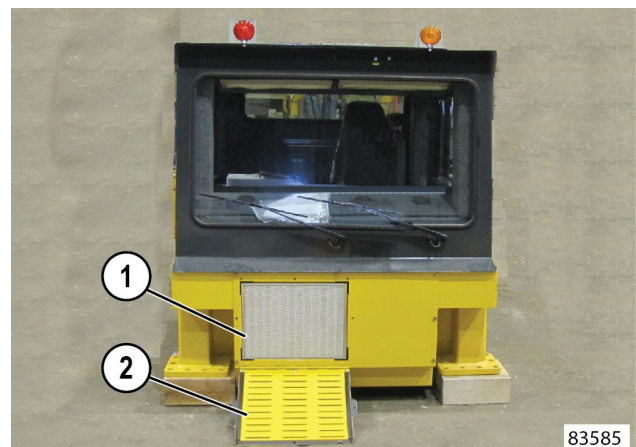

- |                       |                 |
|-----------------------|-----------------|
| 1. Cab Filter Element | 2. Filter Cover |
|-----------------------|-----------------|

**Figure 7-6 CAB AIR FILTER LOCATION**



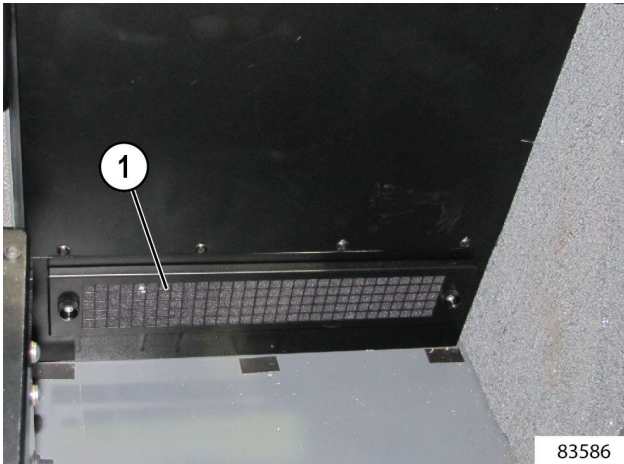

1. HVAC Recirculation Filter Element

**Figure 7-7 HVAC RECIRCULATION FILTER LOCATION**

1. Clean both filter elements (1, Figure 7-6 CAB AIR FILTER LOCATION, page 7-5 and 7-7 HVAC RECIRCULATION FILTER LOCATION, page 7-6) with mild soap and water.
2. Rinse completely clean and air dry with a maximum of 275 kPa (40 psi).
3. Reinstall the filters.

**FUEL SYSTEM SERVICE** G.15-0000051601

**Fuel Tank Cleaning**

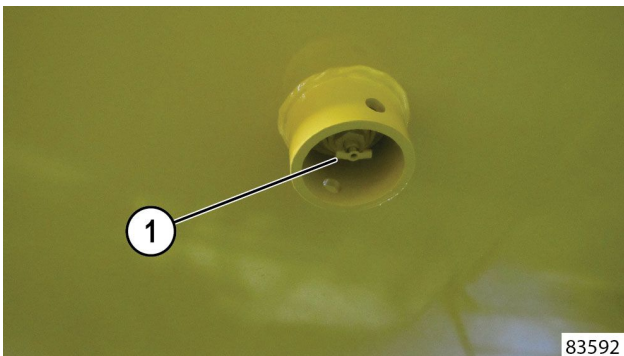

1. Fuel Tank Drain

**Figure 7-8 FUEL TANK**

Open fuel tank drain (1, Figure 7-8 FUEL TANK, page 7-6) to drain water and sediment from the fuel tank. The fuel tank is provided with a drain and a cleaning port in the side that allows steam or solvent to be utilized in cleaning tanks that have accumulated foreign material.

It is not necessary to remove the tank from the truck for cleaning of sediment, however rust and scale on the walls and baffles may require complete tank removal. Prior to a cleaning procedure of this type, all vents, fuel

gauge, and hose connections should be removed and temporarily sealed. After all scale, rust, and foreign material has been removed, the temporary plugs can be removed. A small amount of light oil must be sprayed into the tank to prevent rust if the tank is to remain out of service. All openings should be sealed for rust prevention.

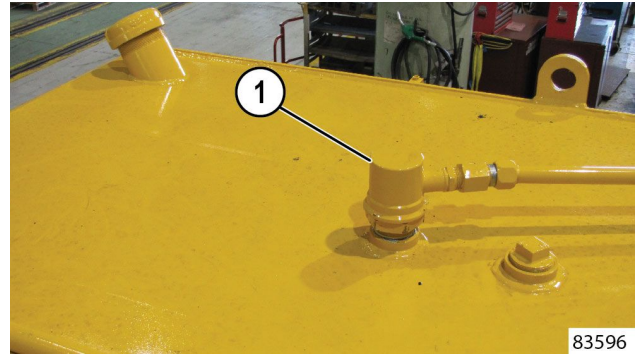

1. Fuel Tank Breather

**Figure 7-9 FUEL TANK BREATHER**

Remove breather (1, Figure 7-9 FUEL TANK BREATHER, page 7-6) and clean in solvent. Dry with pressurized air and reinstall.

**Fuel Filter Service**

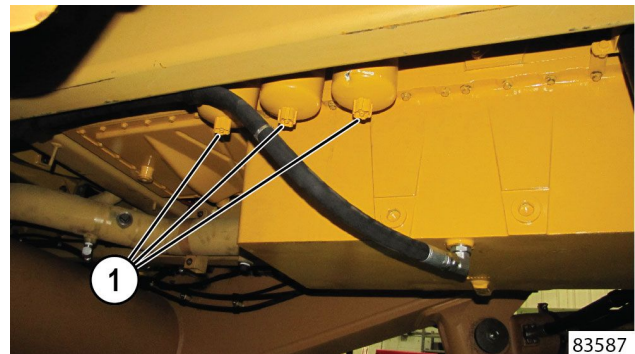

1. Water Drain Valves

**Figure 7-10 WATER SEPARATOR DRAIN**



1. Water Drain Valves

**Figure 7-11 WATER SEPARATOR DRAIN (TIER 2 OR TIER 4 ONLY)**



Open water drain valves (1, Figure 7-10 WATER SEPARATOR DRAIN, page 7-6) to remove water from the fuel/water separators daily.

## INTAKE AIR CLEANER SERVICE

E.3-0000051600

### CAUTION

- The engine must be turned off before servicing the air cleaner assemblies or opening the engine air intake system. Never start the engine with the filter elements removed. Serious engine damage can result.

During operation or after the engine has been turned off, observe the air filter restriction gauges mounted on the overhead panel in the cab. When a gauge shows maximum restriction, filter service is required.

To service the intake air cleaner system, perform the following:

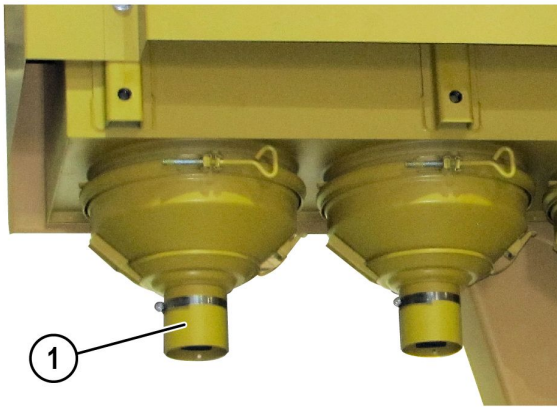

83589

- Dust Cup

### Figure 7-12 DUST CUP LOCATION

- Inspect and empty dust cups (1, Figure 7-12 DUST CUP LOCATION, page 7-7). Never allow the dust level to build up to the tube (precleaner) chamber.

**NOTE:** On dust cups with the Vacuator™ valve, dust cup service is minimal; just check the valve to see that it is not inverted, damaged or plugged. If it is damaged, replace it immediately.

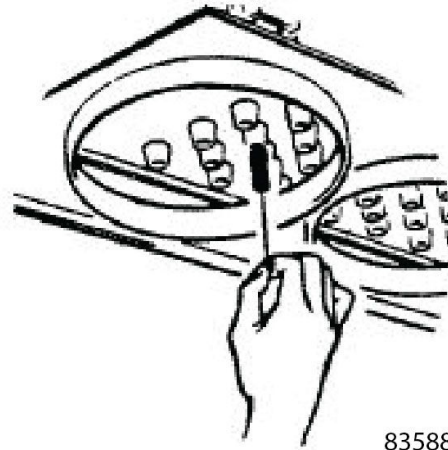

83588

- Check tubes for plugging. Generally tubes are self cleaning. Under special circumstances plugging can occur. If tubes carry light dust, remove it with a stiff brush. If heavy plugging with fibrous material occurs, remove the section and clean it with compressed air or water no hotter than 72° C (160° F).

**NOTE:** Never clean Donalson™ tubes with compressed air unless both the primary and safety filters are installed in the air cleaner.

- Change the filter. If the new filter is not to be installed immediately, be sure to cover the inlet to prevent contamination.

**NOTE:** Before installing the new filter, inspect it for shipping damage and gasket integrity. If there is damage, DO NOT install the filter.

- Check all engine intake air plumbing, hoses and clamps. All connections must be air tight to prevent dirt from entering. If there are holes or damage, replace immediately.

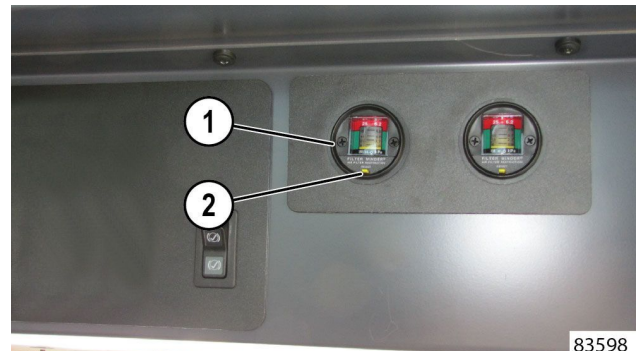

83598

- Filter Vacuum Gauge
- Reset Button

### Figure 7-13 VACUUM GAUGES

- After the filters have been serviced, reset air cleaner vacuum gauges (1, Figure 7-13

VACUUM GAUGES, page 7-7) in the cab by pressing reset button (2) on the face of the gauge. Refer to the Shop Manual, for more detailed instructions about the intake air cleaner system.

**QUICK FILL SERVICE CENTER** E.3-0000051637

The service center can be located on either side of the machine and is used to fill system fluids. The table shows the maximum recommended fill pressures for the service center.

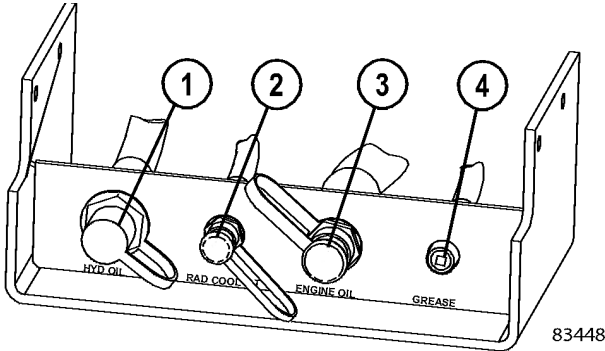

- 1. Hydraulic Oil
- 2. Radiator Coolant
- 3. Engine Oil
- 4. Grease

Figure 7-14 SERVICE CENTER

MAXIMUM FILL PRESSURES		
Fill System	kPa	psi
Engine Crankcase	345	50
Reserve Tank	862	125
Hydraulic Tank	345	50
Coolant	345	50
Grease	10 342	1,500
Fuel	103	15

**TIE ROD INSPECTION AND TORQUE PROCEDURE** A.7-0000061684

1. When inspecting this area or making adjustments, turn off the engine and make sure that the key switch is in the OFF position.
2. After the engine has been turned off, allow at least 90 seconds for the accumulators to bleed down.
3. Turn the steering wheel to the left and to the right to ensure that the steering accumulator pressure has been bled down.

4. Block the front and back of the rear wheels.
5. For the four cap screw clamp style tie rod assembly tighten locknuts (4, Figure 7-15 FOUR CAP SCREW CLAMP STYLE TIE ROD ASSEMBLY, page 7-8) to .

**NOTE:** Ensure that cap screws (5) are parallel to the ground as shown, the gap between clamps (3) is aligned with the slot in tie rod structure (1) and the anti-rotation retainer is on the bottom of the rod end.

**NOTE:** Some slight movement of the capscrew heads may be observed during the first couple of checks due to torque tolerance.

6. Reapply torque to each cap screw until the specified torque is maintained.
  7. Apply an upwards force to each end of the tie rod assembly near rod end threads. Look for lateral movement between the tie rod ends and tie rod structure.
- If lateral movement is detected, visually inspect the internal and external threads on both ends. Replace parts that have damaged threads. Use new cap screws and locknuts where thread damage to the tie rod end and tie rod structure is observed.
8. Ensure that sufficient grease is being supplied by the auto lube system to the spherical bearings of the tie rod and steering cylinders.

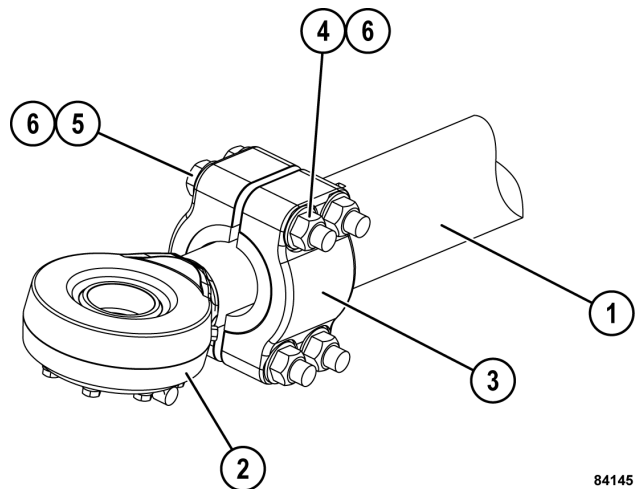

- 1. Tie Rod
- 2. Rod End Threads
- 3. Clamp
- 4. Locknut
- 5. Cap Screw
- 6. Flat Washer

Figure 7-15 FOUR CAP SCREW CLAMP STYLE TIE ROD ASSEMBLY

LUBRICATION CHART C.3-0000051317

# LUBRICATION CHART

LUBRICATION SPECIFICATIONS

LUBE KEY	TYPE LUBRICANT	LUBE KEY									
		PTS	10 HR	50 HR	100 HR	250 HR	500 HR	1000 HR	2000 HR	2500 HR	
A	ENGINE OIL	SEE ENGINE MANUAL									
B	HYDRAULIC OIL	SAE 10W C-4 ..... AUXILIARY HEATERS REQUIRED BELOW -10°F (-23°C)									
C	HEAVY-DUTY SYNTHETIC GEAR OIL	..... SEE DRIVE SYSTEM MANUAL									
D	MULTI-PURPOSE EXTREME PRESSURE GREASE	..... NLGI NO.2 (5% MIN. MOLY-DISULFIDE)									
E	MULTI-PURPOSE GEAR OIL	..... SAE 80W-90									
SYM	DESCRIPTION	PTS	10 HR	50 HR	100 HR	250 HR	500 HR	1000 HR	2000 HR	2500 HR	
1	CRANKCASE OIL LEVEL	1	A	CHECK							
2	ENGINE LUBE OIL FILTERS										
3	FUEL FILTER										
4	FUEL SEPARATOR (DAVCO)										
5	FUEL TANK	1									
6	GE PREFILTER BLOWER	1	D								
7	FUEL TANK BREATHER	1									
8	HYDRAULIC OIL LEVEL	1	B	CHECK				CLEAN			
9	HYDRAULIC STRAINER	2						*CHANGE			
10	HYDRAULIC TANK BREATHER	2						CLEAN			
11	HYDRAULIC FILTERS	3		**	**	**	**	CHANGE			
12	MOTORIZED WHEEL OIL LEVEL	2	C					CHANGE			
13	HYD. PUMP DRIVE SHAFT	2	D					SEE DRIVE SYSTEM MANUAL			
14	CHASSIS LUBE LEVEL	1	D					GREASE			
15	SEAT SLIDES & STEER SHAFT	4	D					GREASE			
16	WHEEL MOTOR BLOWER	2	D					GREASE			
17	FRONT WHEEL BEARINGS ***	2	E					GREASE			
18	FRONT TRUNION	1	D					CHECK			
19	MAGNETIC PLUG	2						CHECK			
	FRONT WHL COVER ****	2						CHECK			

SEE ENGINE MANUAL

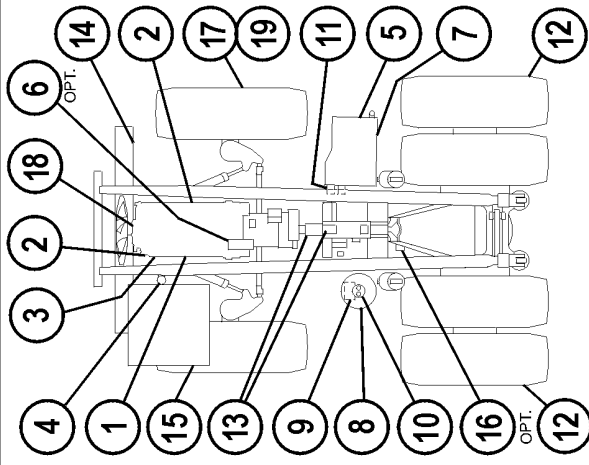

630E, 730E, 830E, & 930E

WB2790

\* 1000 HR INTERVAL CAN BE EXTENDED TO 2500 HR PROVIDED OIL SAMPLING AND ANALYSIS IS CONDUCTED EVERY 250 HR.  
 \*\* ONE-TIME CHANGE AT 50, 100 AND 250 HR.  
 \*\*\* NOT APPLICABLE FOR 930E  
 \*\*\*\* APPLICABLE FOR 930E ONLY

## EVERY 10 HOUR (DAILY) MAINTENANCE D.10-0000051636

EVERY 10 HOUR (DAILY) MAINTENANCE	
Item	Task
MACHINE	Inspect the entire machine for leaks, worn parts, and damage. Repair as necessary.
ENGINE	<ul style="list-style-type: none"> <li>• Check the oil level. To obtain an accurate measurement, remove the dipstick and wipe it off. Then reinsert the dipstick and remove it again to check the oil level. Refer to the engine manual for oil recommendations. (Lube Key "A").</li> <li>• Check the oil level in the reserve tank. The oil level must be visible in the lower sight gauge. If it is not, add oil to the reserve tank using the reserve oil tank filling procedure. Also, with the engine running, check the operation of the LED monitor light. Refer to <a href="#">RESERVE ENGINE OIL SYSTEM, page 5-51</a>.</li> <li>• Check the coolant level. Fill the radiator with the proper mixture as shown in <a href="#">COOLANT LEVEL SERVICE, page 7-3</a>. Refer to the engine manual for proper coolant additives.</li> <li>• Check for abnormal noises and fluid leaks.</li> <li>• Check the turbocharger for leaks, vibration or unusual noise.</li> <li>• Check alternator and fan belt condition and alignment.</li> <li>• Check all mounting hardware, joints, and connections. Ensure no air leaks exist and all hardware is properly tightened.</li> <li>• Inspect the exhaust piping for integrity.</li> <li>• Check the operating indicator for the eliminator filter.</li> </ul>
HYDRAULIC TANK	Check the oil level in the tank, add oil if necessary. Refer to <a href="#">HYDRAULIC SYSTEM SERVICE, page 7-2</a> . Oil should be visible in the top sight glass. - DO NOT overfill. (Lube Key "B").
DRIVE SYSTEM COOLING AIR	Inspect ductwork from the blower to the rear drive case. Ensure that ductwork is secure, free of damage, and unrestricted.
INTAKE AIR CLEANERS	<ul style="list-style-type: none"> <li>• Check the air cleaner vacuum gauges in the operator cab. The air cleaner(s) must be serviced if the gauge(s) shows a restriction of 25 in. of water (625 mm of water) vacuum.</li> <li>• Check intake piping for leaks.</li> </ul> <p>Refer to <a href="#">INTAKE AIR CLEANER SERVICE, page 7-7</a> for servicing the intake air cleaner system.</p>
CAB AIR FILTERS	Clean the cab air filters every 250 hours. In extremely dusty conditions, service as frequently as required. Refer to <a href="#">CAB AIR FILTER SERVICE, page 7-5</a> .
FUEL FILTERS (Water Separators)	Drain water from the bottom drain valve on each fuel separator. Refer to <a href="#">FUEL SYSTEM SERVICE, page 7-6</a> .
RETRACTABLE LADDER SYSTEM (If Equipped)	<ul style="list-style-type: none"> <li>• Operate the ladder. Check for loose parts and adverse noise conditions.</li> <li>• Check the oil level for the ladder system. Oil level should be 8 L (2 gal).</li> </ul>

EVERY 10 HOUR (DAILY) MAINTENANCE	
Item	Task
AUTOMATIC LUBE SYSTEM	<ul style="list-style-type: none"> <li>• Check the grease reservoir; fill as required. (Lube Key "D").</li> <li>• When filling the reservoir, check the grease filter indicator. Clean or replace the grease filter if the indicator detects a problem.</li> <li>• Inspect the system and check for proper operation. Ensure the following important areas are receiving grease. (Lube Key "D").</li> <li>• Steering Linkage</li> <li>• Final Drive Pivot Pin</li> <li>• Rear Suspension Pin Joints - Upper &amp; Lower</li> <li>• Body Hinge Pins - Both Sides</li> <li>• Hoist Cylinders Pins - Upper &amp; Lower</li> <li>• Anti-sway Bar - Both Ends</li> </ul>
PRE-SHIFT BRAKE TEST	<ul style="list-style-type: none"> <li>• See <a href="#">PRE-SHIFT BRAKE TEST</a> to perform the pre-shift brake test.</li> </ul>
WHEELS AND TIRES	<ul style="list-style-type: none"> <li>• Inspect tires for proper inflation and wear.</li> <li>• Check for embedded debris in tread and remove.</li> <li>• Inspect for damaged, loose, or missing wheel mounting nuts and studs.</li> </ul>
WASHER FLUID	Check the level of washer fluid in the bottle behind the cab. Fill as needed.
FUEL TANK	<ul style="list-style-type: none"> <li>• Check the quick fill fuel receivers for excessive wear, leaks and mud buildup.</li> <li>• Check the vent on the back of the fuel tank at the bottom for mud buildup or any other obstructions. Clean if necessary. See <a href="#">EVERY 1000 HOURS LUBRICATION AND MAINTENANCE, page 7-18</a> for cleaning instructions.</li> </ul>

**INITIAL 50 HOUR LUBRICATION  
AND MAINTENANCE  
INSPECTION** B.3-0000060941

*NOTE: These checks are required only after the initial 50 hours of operation, such as the commissioning of a new truck, or after a new or rebuilt component installation.*

INITIAL 50 HOUR SERVICE INSPECTION	
Item	Task
HYDRAULIC SYSTEM FILTERS	Replace filter elements only after the initial 50, 100 and 250 hours of operation; then at each 500 hours of operation thereafter.
FUEL FILTERS	Replace the fuel filters. Refer to the engine operation and maintenance manual for filter replacement instructions.
WHEELS	Check to ensure the wheel nut torque on all wheels is <b>746 N·m (550 ft lb)</b> .

LUBRICATION AND SERVICE

**INITIAL 100 HOUR LUBRICATION  
AND MAINTENANCE  
INSPECTION** E.3-0000051634

*NOTE: These checks are required only after the initial 100 hours of operation (such as: the commissioning of a new truck, or after a new or rebuilt component installation).*

INITIAL 100 HOUR LUBRICATION AND MAINTENANCE INSPECTION	
Item	Task
HYDRAULIC SYSTEM FILTERS	Replace filter elements only after the initial 100 and 250 hours of operation; then at each 500 hours of operation thereafter.

**EVERY 250 HOUR LUBRICATION  
AND MAINTENANCE** E.14-0000051633

**NOTE:** The 10 hour lubrication and maintenance checks must also be performed at this time. "Lube Key" references are to the lubrication chart.

EVERY 250 HOUR LUBRICATION AND MAINTENANCE	
Item	Task
ENGINE	<ul style="list-style-type: none"> <li>• Change the engine oil. (Lube Key "A").</li> <li>• Replace engine oil filters.</li> <li>• Check belt tension and the condition of each accessory belt. Refer to the engine Operation &amp; Maintenance manual for specific adjustment instructions.</li> </ul> <p><b>NOTE:</b> If the engine is equipped with the Centinel™ oil system and/or the Eliminator™ filter system, engine oil and filter change intervals are extended beyond 250 hours. Take an engine oil sample for analysis.</p> <p>Refer to the engine Operation &amp; Maintenance manual for complete specifications regarding engine lube oil specifications.</p>
COOLING SYSTEM	<ul style="list-style-type: none"> <li>• Check for proper coolant mixture. Add coolant as required.</li> <li>• Change coolant filters.</li> <li>• Check cooling system hoses for damage and signs of deterioration.</li> <li>• Check the torque on the cooling fan mounting cap screws: <b>237 N·m (175 ft lb)</b>.</li> </ul> <p>Refer to the engine maintenance manual for coolant filter replacement instructions and proper coolant mixture instructions.</p>
FUEL SYSTEM	<ul style="list-style-type: none"> <li>• Change the fuel filters (fuel separators). Refer to the engine Operation &amp; Maintenance manual for specific filter replacement instructions.</li> <li>• Drain water and sediment from the fuel tank. Refer to <a href="#">FUEL SYSTEM SERVICE, page 7-6</a> for detailed instructions.</li> </ul>
AIR INTAKE PIPING	Check all mounting hardware, joints and connections. Ensure that there are no air leaks and all hardware is properly tightened.
HYDRAULIC SYSTEM	<ul style="list-style-type: none"> <li>• Add one or two applications of grease to each grease fitting on the pump drive shaft. Non - moly grease only.</li> <li>• Replace filter elements after the initial 250 hours of operation; then at each 500 hours of operation thereafter. Refer to (Lube Key "B").</li> </ul> <p>Refer to <a href="#">HYDRAULIC SYSTEM SERVICE, page 7-2</a> for detailed instructions.</p>
STEERING LINKAGE	<ul style="list-style-type: none"> <li>• Check the torque on the pin retaining nuts located on the steering linkage - <b>1017 N·m (750 ft lb)</b>.</li> </ul>
REAR WHEEL MOUNTING	Use a flashlight and a mirror on a long rod to inspect all inner and outer wheel mounting nuts and studs. Check for loose, damaged or missing hardware.



<b>EVERY 250 HOUR LUBRICATION AND MAINTENANCE</b>	
<b>Item</b>	<b>Task</b>
CAB AIR FILTER	Under normal operating conditions, clean every 250 hours. In extremely dusty conditions, service as frequently as required. Refer to <a href="#">CAB AIR FILTER SERVICE, page 7-5</a> for detailed instructions.
FRONT WHEEL HUB	Remove the magnetic plugs from the front wheel hub covers and check for debris. Clean the plugs and perform any necessary repairs.
WHEEL MOTOR OIL SAMPLING	Take an oil sample of the wheel motor oil. Refer to the shop manual for oil sampling instructions.
BATTERIES	Check the electrolyte level and add water if necessary.
BODY-UP & HOIST LIMIT SWITCHES	<ul style="list-style-type: none"> <li>• Check operation of the switches.</li> <li>• Clean the sensing areas of any dirt accumulation and inspect the wiring for any signs of damage.</li> </ul>
AC DRIVE BELT	Check the belt for wear or damage.
AUTOMATIC LUBE SYSTEM	<ul style="list-style-type: none"> <li>• Check all grease hoses from the injectors to the lubrication points.</li> <li>• Check all grease supply line hoses from the pump to the injectors.</li> <li>• Check the grease reservoir level.</li> <li>• Inspect all bearing points for a bead of lubricant around the bearing seal.</li> <li>• Perform system checkout. Refer to the Shop Manual for detailed instructions.</li> </ul>
RETRACTABLE LADDER SYSTEM (If Equipped)	<p>Check the ladder system for:</p> <ul style="list-style-type: none"> <li>• Loose or missing hardware.</li> <li>• Bent or misaligned structures.</li> <li>• Foreign materials such as dirt, mud, etc., that could affect proper operation of ladder.</li> <li>• Damaged wiring and harnesses.</li> <li>• Power pack box free of moisture and is properly sealed.</li> <li>• System voltage of 21VDC (off) to 30VDC max (operating).</li> <li>• Adverse noise conditions.</li> <li>• Proper movement in a vertical plane (viewed from front of ladder); the ladder must move up and down central to the actuator box.</li> <li>• Range of functions, including remote switches and park-brake interlock.</li> </ul>
DUMP BODY PADS	Check the pads, shims and mounting hardware for wear and proper tightening.

**EVERY 500 HOUR LUBRICATION  
AND MAINTENANCE** D.14-0000051632

*NOTE: Maintenance requirements for every 10 & 250 hour Lubrication and Maintenance Checks must also be performed at this time. "Lube Key" references are to the lubrication chart.*

INITIAL 500 HOUR MAINTENANCE (Includes after rebuild)	
Item	Task
WHEEL MOTOR	Change or filter the gear case oil.

EVERY 500 HOUR LUBRICATION AND MAINTENANCE	
Item	Task
WHEEL MOTOR	<ul style="list-style-type: none"> <li>• Check the gear case oil level.</li> <li>• Replace the wheel motor breather elements.</li> <li>• Remove and clean the gear case magnetic plugs.</li> <li>• Take gear case oil sample. (Refer to the Shop Manual for oil sample instructions.)</li> <li>• Based on oil sample results, refer to the GE Planned Maintenance Schedule to determine if the gear case oil is satisfactory, needs filtered or if an oil change is required.</li> </ul>
HYDRAULIC SYSTEM	<ul style="list-style-type: none"> <li>• Replace the high pressure filter elements. Check the oil level. Add oil as necessary. (Lube Key "B").</li> <li>• Replace the breather elements. Refer to <a href="#">HYDRAULIC SYSTEM SERVICE, page 7-2</a> for detailed instructions.</li> </ul>
HYDRAIR® SUSPENSION	Check for proper piston extension (front and rear). Refer to the Shop Manual for more information on proper suspension extension and maintenance procedures.
THROTTLE AND BRAKE PEDAL	Lubricate the treadle roller and hinge pins with lubricating oil. Lift the boot from the mounting plate and apply a few drops of lubricating oil between the mounting plate and the plunger.
HOIST ACTUATOR LINKAGE	Check operation. Clean, lubricate, and adjust as necessary.
ACCUMULATOR PRECHARGE	Check all steering and brake accumulator pre-charge pressures. Refer to the Shop Manual for details.
HVAC	<ul style="list-style-type: none"> <li>• Clean the air conditioner recirculation filter.</li> <li>• Ensure the air conditioner cab drains are clear of any obstructions.</li> <li>• Wash the air conditioner condenser with a low pressure hose. Check for any obstructions to airflow, clean as required.</li> </ul>
COOLING SYSTEM	Wash the radiator fins with a low pressure hose. Check for any obstructions to airflow, clean as required.
FUEL SYSTEM	Wash the fuel cooler (if equipped), located on the front RH side of the radiator, with a low pressure hose. Check for any obstructions to airflow, clean as required.
PARKING BRAKE	Refer to the Shop Manual for the recommended inspections.

<b>EVERY 500 HOUR LUBRICATION AND MAINTENANCE</b>	
<b>Item</b>	<b>Task</b>
FRAME AND AXLE BOX INSPECTION	Wash the truck, clean all of the weld joints, and visually inspect the entire frame and axle box for cracking or damage.
RESERVE ENGINE OIL SYSTEM (If Equipped)	<ul style="list-style-type: none"> <li>• Check the battery, oil pressure switch, junction boxes, remote control fill box and the circuit breaker connections for tightness, corrosion and physical damage.</li> <li>• Examine all electrical cables over their entire length for possible damage.</li> <li>• Examine all hoses, including those on the reserve tank and the ones leading to and from the engine. Check for leaks, cracks or other damage. Check all fittings for tightness, leakage or damage.</li> </ul>
KOMTRAX Plus DATA DOWNLOAD	Using a laptop PC with the <i>VHMS Technical Analysis Tool Box</i> program, perform a data download from the KOMTRAX Plus controller. Send the data to WebCARE using the FTP feature. Refer to <a href="#">DOWNLOADING KOMTRAX Plus DATA, page 6-29</a> for more detailed instructions.
TIE ROD	Refer to <a href="#">TIE ROD INSPECTION AND TORQUE PROCEDURE, page 7-8</a> .
CONTROL CABINET	<ul style="list-style-type: none"> <li>• Vacuum the dust and debris from inside the control cabinet.</li> <li>• Do not use compressed air. Compressed air causes dust particles and contaminants to be blown across the surface of the electrical cards, eroding the varnish and driving the particles into the electrical and mechanical components of the system.</li> <li>• Wear the appropriate Personal Protective Equipment (PPE). A clean, soft-bristle brush can be used in areas such as the ST transformer coils, if needed.</li> </ul>

**EVERY 1000 HOURS LUBRICATION  
AND MAINTENANCE** F.10-0000051631

**NOTE:** Maintenance for every 10, 250, & 500 hour Lubrication and Maintenance Checks must also be performed at this time. "Lube Key" references are to the lubrication chart.

EVERY 1000 HOURS LUBRICATION AND MAINTENANCE	
Item	Task
HYDRAULIC SYSTEM	Drain the hydraulic tank and clean the inlet strainer. Refill the tank with new oil. (Lube Key "B").  <b>NOTE:</b> Oil change interval can be extended to 2,500 hours if oil is sampled at every 250 hour intervals and no abnormalities are detected.
COOLING SYSTEM	Clean the cooling system with a quality cleaning agent. Flush the system with water. Refill the system with anti-freeze and water solution. Check the <a href="#">Coolant Specifications, page 7-4</a> in this chapter.
FUEL SYSTEM	Service the fuel tank breather. Refer to <a href="#">FUEL SYSTEM SERVICE, page 7-6</a> for more detailed instructions.
OPERATOR'S SEAT	Apply grease to the slide rails. (Lube Key "D").
AUTOMATIC BRAKE APPLICATION	Ensure the brakes are automatically applied when brake pressure decreases below the specified limit. Refer to the Shop Manual for more details.
AUTOMATIC LUBE SYSTEM	Check pump housing oil level using dipstick on top of the pump unit. If necessary, add SAE 10W-30 motor oil.
ELIMINATOR FILTER (If Equipped)	Clean and check centrifuge. Refer to engine manufacturer's Operation & Maintenance Manual. (Service interval is dependent on duty cycle, oil quality, etc.)
BRAKE DISC	Use the front and rear brake wear indicators included in the truck's tool group to check for brake disc wear. Refer to the shop manual for instructions.

## EVERY 5000 HOUR MAINTENANCE E.16-0000051629

EVERY 5000 HOUR MAINTENANCE	
Item	Task
AIR CLEANERS	Visually inspect the Vacuator™ valve to make sure it is not inverted or damaged. Refer to <a href="#">INTAKE AIR CLEANER SERVICE, page 7-7</a> for detailed instructions.
RETRACTABLE LADDER SYSTEM (If Equipped)	<ul style="list-style-type: none"> <li>• Drain, flush and re-fill the hydraulic oil reservoir.</li> <li>• Replace oil filter screen.</li> </ul>
STEERING WHEEL RETAINER NUT	Check that the torque on the steering wheel retainer nut is <b>81 ± 7 N·m (60 ± 5 ft lb)</b> . If tightening is necessary, add Loctite® Threadlocker Blue 242 to the nut, then use a torque wrench to tighten the nut to <b>81 ± 7 N·m (60 ± 5 ft lb)</b> .



# **SPECIFICATIONS**

## MAJOR COMPONENT DESCRIPTION

C.3-0000051647

### Truck and Engine B.2-0000060881

The 930E-4 dump truck is an off-highway, rear dump truck with AC electric drive. The gross vehicle weight is 498 960 kg (1,100,000 lbs). The engine is a Komatsu SSDA16V160 rated at 2 014 kW (2,700 HP).

### Traction Alternator D.7-0000051645

The diesel engine drives an in-line alternator at engine speed. The alternator produces AC current which is rectified to DC within the main control cabinet.

Cooling air for the control / power group and wheel motors, as well as the alternator itself, is provided by a fan mounted on the alternator shaft.

### Main Control Cabinet A.2-0000060880

Each phase module contains paired positive and negative semiconductor switches referred to as insulated gate bipolar transistors (IGBT). The IGBTs cycle on and off at varying frequencies to create an AC power signal from the DC supply.

The AC power signal produced by each inverter is a variable-voltage, variable-frequency (VVVF) signal. Frequency and voltage are changed to suit the operating conditions.

### AC Induction Traction Motorized Wheels C.3-0000051644

The alternator output supplies electrical energy to the two wheel motors attached to the rear axle housing. The motorized wheels use three-phase AC induction motors with full-wave AC power.

The two wheel motors convert electrical energy back to mechanical energy through built-in gear trains within the wheel motor assembly. The direction of the wheel motors is controlled by a forward or reverse hand selector switch located on the center console.

### Suspension D.3-0000051643

Hydrair II® suspension cylinders located at each wheel provide a smooth and comfortable ride for the operator and dampens shock loads to the chassis during loading and operation.

## Operator's Cab D.7-0000051642

The operator cab has been engineered for operator comfort and to allow for efficient and safe operation of the truck. The cab provides wide visibility, with an integral 4-post ROPS/FOPS structure, and an advanced analog operator environment. It includes a tinted safety-glass windshield and power-operated side windows, a deluxe interior with a fully adjustable seat with lumbar support, a fully adjustable tilt/telescope steering wheel, controls mounted within easy reach of the operator, and an analog instrument panel which provides the operator with all instruments and gauges which are necessary to control and/or monitor the truck's operating systems.

### Power Steering C.3-0000051641

The truck is equipped with a full time power steering system which provides positive steering control with minimum operator effort. The system includes nitrogen-charged accumulators which automatically provide emergency power if the steering hydraulic pressure is reduced below an established minimum.

### Dynamic Retarding Grid E.5-0000051640

The dynamic retarding grid is used to slow the truck during normal operation or control speed coming down a grade. The dynamic retarding ability of the electric system is controlled by the operator through the activation of the retarder pedal (or by operating a lever on the steering column) in the operator's cab and by setting the speed control. Dynamic Retarding is automatically activated if the truck speed goes to a preset overspeed setting.

### Brake System B.5-0000060879

Service brakes at each wheel are oil-cooled multiple disc brakes applied by an all-hydraulic actuation system. Depressing the brake pedal actuates both front and rear brakes after first applying the retarder. All wheel brakes will be applied automatically if the brake system pressure decreases below a preset minimum.

The parking brake is a dry disc type, mounted inboard on each rear wheel motor, and is spring-applied and hydraulically-released with wheel speed application protection (will not apply with truck moving).



**SPECIFICATIONS** D.3-0000051658

**Engine** B.2-0000060878

**Komatsu SSDA16V160**

No. of Cylinders.....	16
Operating Cycle.....	4-Stroke
Rated Brake HP.....	2 014 kW (2,700 HP) @ 1900 RPM
Flywheel HP .....	1 902 kW (2,550 HP) @ 1900 RPM
Weight* (Wet) .....	9 608 kg (21,182 lb)

*\*Weight does not include Radiator, Sub-frame, or Alternator.*

**AC Electric Drive System** B.2-0000060877

(AC/DC Current)

Alternator .....	General Electric GTA - 41
Dual Impeller, In-Line Blower.....	340 m <sup>3</sup> / min (12,000 cfm)
Motorized Wheels.....	GDY106 AC Induction Traction Motors
Standard Gear Ratio* .....	32.62:1
Maximum Speed.....	64.5 km/h (40 mph)

*\*Wheel motor application depends upon GVW, haul road grade and length, rolling resistance, and other parameters. Komatsu and GE must analyze each job condition to ensure proper application.*

**Dynamic Retarding** B.2-0000060891

Electric Dynamic Retarding .....	Standard
Maximum Rating.....	4 026 kW (5,400 HP)
Continuous* .....	2 460 kW (3,300 HP)

*\*Continuously rated high-density blown grids with retard at engine idle and retard in reverse propulsion.*

**Battery Electric System** F.5-0000051654

Batteries .....	4 x 8D 1450 CCA, 12 volt, in series/parallel, bumper mounted with disconnect switch
Alternator .....	24 Volt, 250 Ampere Output
Lighting.....	24 Volt
Cranking Motors (2).....	24 Volt

**Service Capacities** B.4-0000060890

Crankcase (including lube oil filters).....	280 L / 74 gal
Fuel.....	4 542 L / 1,200 gal
Hydraulic System.....	1 325 L / 350 gal

**Hydraulic Systems** B.6-0000060889

Hoist and Brake Cooling Pump .....	Tandem Gear
Rating .....	931 L/min (246 gpm) @ 1900 RPM and 17 237 kPa (2,500 psi)
Steering/Brake Pump .....	Pressure Compensated Piston
Rating .....	246 L/min (65 gpm) @ 1900 RPM and 18 961 kPa (2,750 psi)
Relief Pressure-Hoist.....	17 237 kPa (2,500 psi)
Relief Pressure-Steering/Brake .....	27 579 kPa (4,000 psi)
Hoist Cylinders (2).....	3-Stage Hydraulic
Tank (Vertical/Cylindrical) .....	Non-Pressurized
Tank Capacity .....	947 liters (250 gallons)
Filtration.....	In-line replaceable elements
Suction.....	Single, Full Flow, 100 Mesh
Hoist and Steering Filters (Dual In-Line, High Pressure).....	Beta <sub>12</sub> Rating =200

**Service Brakes B.5-0000060895**

Hydraulic actuated, oil-cooled multiple discs on each wheel with slip/slide control.

Total Friction Area / Brake .....	97 019 cm <sup>2</sup> (15,038 in <sup>2</sup> )
Maximum Apply Pressure.....	17 238 kPa (2,500 psi)

**Steering B.5-0000060901**

Twin hydraulic cylinders with accumulator assist to provide constant rate steering. Emergency power steering automatically provided by accumulators.

Turning Circle (SAE).....	29.7 m (97 ft. 7 in.)
---------------------------	-----------------------

**Standard Dump Body Capacities and Dimensions A.3-0000060897**

**Capacity**

Heaped @ 2:1 (SAE).....	211 m <sup>3</sup> (276 yd <sup>3</sup> )
Struck .....	171 m <sup>3</sup> (224 yd <sup>3</sup> )
Width (Inside) .....	8.15 m (26 ft. 9 in.)
Depth.....	3.2 m (10 ft. 7 in.)
Loading Height .....	7.06 m (23 ft. 2 in.)
Dumping Angle.....	45°

*NOTE: Optional capacity dump bodies are available.*

**Tires A.2-0000060898**

Radial Tires (standard).....	53/80 R63
Rock Service, Deep Tread .....	Tubeless
Rims, standard 5 piece.....	Rated to 827 kPa (120 psi)

**Weight Distribution B.2-0000060896**

**Empty Vehicle**

Front Axle (49.3%).....	103 301 kg (227,738 lb)
Rear Axle (50.7%) .....	107 518 kg (237,034 lb)
Total (with 50% Fuel).....	210 819 kg (464,772 lb)
Standard Komatsu Body.....	30 362 kg (66,936 lb)
Standard Tire Weight.....	26 127 kg (57,600 lb)

**Loaded Vehicle**

Front Axle (33.0%).....	165 554 kg (364,980 lb)
Rear Axle (67.0%) .....	336 124 kg (741,020 lb)
Total.....	501 678 kg (1,106,000 lb)

Nominal Payload* .....	290 859 kg (641,228 lb)
------------------------	-------------------------

\*Nominal payload is defined by Komatsu America Corporation's payload policy documentation. In general, the nominal payload must be adjusted for the specific vehicle configuration and site application. The figures above are provided for basic product description purposes. Please contact your Komatsu distributor for specific application requirements.

**Overall Truck Dimensions B.8-0000060851**

(Empty With Standard Body)

Length .....	15.6 m (51 ft. 2 in.)
Width .....	8.69 m (28 ft. 6 in.)
Height with Canopy .....	7.37 m (24 ft. 2 in.)
Height with Dump Body Up .....	14.02 m (46 ft. 0 in.)

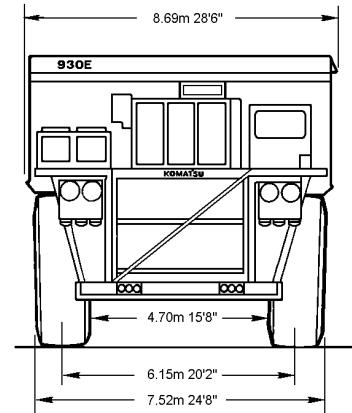
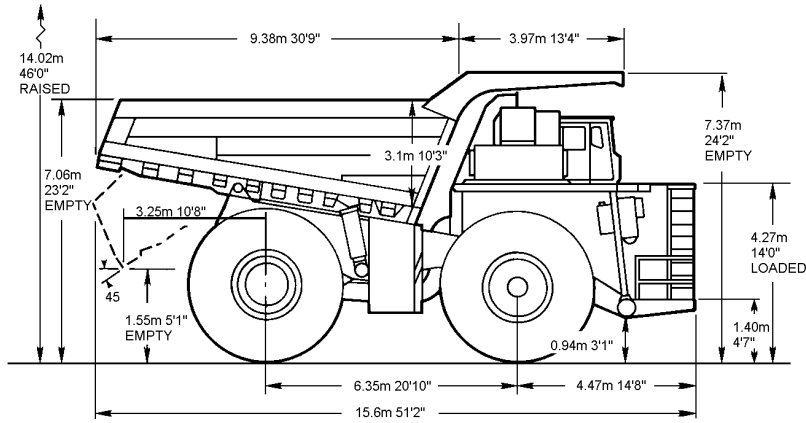

All Dimensions with 171/211 m<sup>3</sup> 224/276 yd<sup>3</sup> Body

BODIES	Struck		2:1 Heap		Loading Height	
	M <sup>3</sup>	Yd <sup>3</sup>	M <sup>3</sup>	Yd <sup>3</sup>	M	Feet
Standard	171	224	211	276	7.06	23'2"

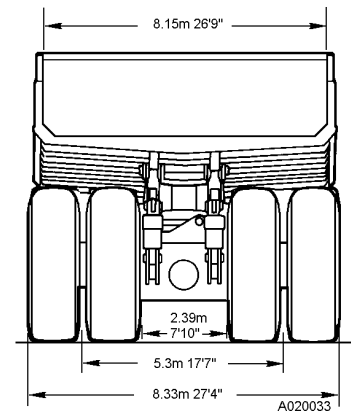



# RADIO

**RADIO OPERATION** E.2-0000051508

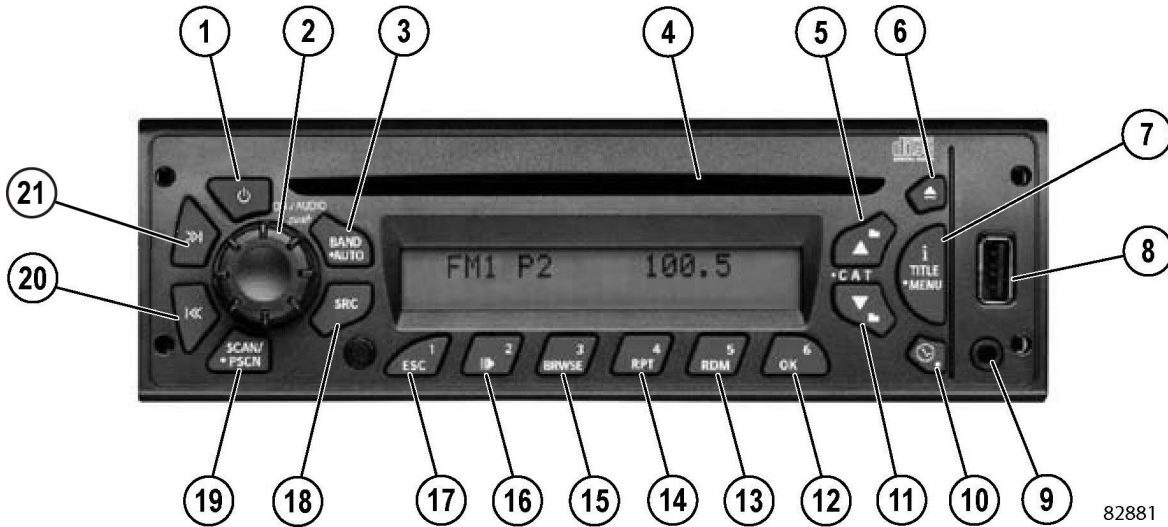

- |                                                                                                                                                                                                                                                                                                                                                                                                                                                                                                                                                                                                                     |                                                                                                                                                                                                                                                                                                                                                                                                                                                                                                                                                                                                                                                                                           |
|---------------------------------------------------------------------------------------------------------------------------------------------------------------------------------------------------------------------------------------------------------------------------------------------------------------------------------------------------------------------------------------------------------------------------------------------------------------------------------------------------------------------------------------------------------------------------------------------------------------------|-------------------------------------------------------------------------------------------------------------------------------------------------------------------------------------------------------------------------------------------------------------------------------------------------------------------------------------------------------------------------------------------------------------------------------------------------------------------------------------------------------------------------------------------------------------------------------------------------------------------------------------------------------------------------------------------|
| <ol style="list-style-type: none"> <li>1. Turns the radio on or off</li> <li>2. Power/volume/receiver settings</li> <li>3. Switches bands, stores stations to presets</li> <li>4. Place CDs into radio</li> <li>5. Switches to next available radio station or changes folder on CD/MP3 or USB</li> <li>6. Ejects CD from radio</li> <li>7. Displays information/title of current song</li> <li>8. Input port for memory devices</li> <li>9. Input port for external audio devices</li> <li>10. Displays alarm set time</li> <li>11. Switches to previous radio station, or changes folder on CD/MP3/USB</li> </ol> | <ol style="list-style-type: none"> <li>12. Enables selection on a menu</li> <li>13. Plays CD tracks and MP3/WMA files and folders randomly</li> <li>14. Repeats the same CD track or WMA file/folder until cancelled</li> <li>15. Allows access into iPod menu</li> <li>16. Pauses or plays CDs, MP3 files and iPod</li> <li>17. Exits when in a menu or backs one submenu</li> <li>18. Switches to CD/MP3/USB/iPod/Aux mode</li> <li>19. Scans all stations and presets in current band CD/MP3/WMA/ files and folders</li> <li>20. Switch to previous available radio station/CD track/MP3/WMA file</li> <li>21. Switch to next available radio station/CD track/MP3/WMA file</li> </ol> |
|---------------------------------------------------------------------------------------------------------------------------------------------------------------------------------------------------------------------------------------------------------------------------------------------------------------------------------------------------------------------------------------------------------------------------------------------------------------------------------------------------------------------------------------------------------------------------------------------------------------------|-------------------------------------------------------------------------------------------------------------------------------------------------------------------------------------------------------------------------------------------------------------------------------------------------------------------------------------------------------------------------------------------------------------------------------------------------------------------------------------------------------------------------------------------------------------------------------------------------------------------------------------------------------------------------------------------|

Push Buttons 12-17 - Pre-set stations/controls CD/MP3/WMA/USB/iPOD functions

**Figure 9-1 AM/FM RADIO / CD PLAYER**

**GENERAL RADIO RECEIVER FUNCTIONS**

The receiver is equipped with:

- An AM band with 6 AM presets
- Two FM bands for a total 12 FM presets
- One Weatherband with 6 WX presets
- USB port to access additional music files
- Auxiliary port to access additional music files

**Turning On the Power**

With the key switch ON, the receiver can be turned on and off by pressing button (1, Figure 70-1). Pressing ON/AUDIO (2) knob also activates the radio.

**One-Hour Timer**

With the key switch OFF, pressing button (1) or ON/AUDIO (2) knob will turn on the receiver and activate the receiver's one-hour timer. The receiver will turn off after one hour. Pressing button (1) or ON/AUDIO (2) knob again reactivates the one-hour timer.

**Finding a Station**

**BAND/AUTO:** Press this button to switch between FM1, FM2, AM and WX.

**TUNE:** To tune the radio manually, press the up/down button once to tune to the next higher or lower station, one frequency at a time.

**SEEK:** Press button (20) or (21) once to tune to the next available station. The SEEK mode ends once it reaches a tunable station.

If either button (20) or (21) is pushed while the radio is finding a station, the tuner will stop at the frequency tuned at the time the button was pressed.

If SEEK does not find a tunable station, it displays NO STATION FOUND. The radio remembers the station that was tuned when SEEK was initiated and goes back to that frequency if SEEK is cancelled. The audio mutes during the SEEK UP/DOWN process.

To cancel SEEK, perform one of the following:

- Switch modes including: power off, ignition off, switch to CD, Radio, MP3, WMA, USB, AUX or iPod
- Change bands
- Press SCAN/PSCAN button
- Press any preset button
- Disconnect battery
- Press and hold SCAN/PSCAN button
- Press and hold BAND/AUTO button

**AUTO STORE:** AUTO STORE temporarily stores the 6 strongest stations onto pushbuttons 1-6. Press and hold the BAND/AUTO button for more than 2 seconds. A beep will sound and AUTO STORE will appear on the display until all of the presets have been saved in the band. AS will be displayed while AUTO STORE is active. Pressing BAND/AUTO will not affect the other bands. For example: if BAND/AUTO is pressed while listening to FM1, the presets on AM, FM2, and WX will not change. Pressing and holding BAND/AUTO again will cancel AUTO STORE, and the original presets will be restored.

**SCAN:** Press SCAN/PSCAN and release to scan all stations on the band that are being used. When a strong enough frequency is found, the radio will play for 8 seconds before continuing to scan. To end the scan, press SCAN/PSCAN again. The radio will beep and display SCAN plus the frequency.

**PSCAN:** Press and hold SCAN/PSCAN for more than 2 seconds to scan the presets on the band being used. When a strong enough frequency is found, the radio will play that station for 8 seconds and then continue scanning. The display will show PSCN, the frequency, preset number and the current band. Preset scan will continue until the SCAN/PSCAN button is pressed again.

## Setting the Presets

The six numbered buttons allows six favorite presets to be stored per band and easily return to them with the touch of a button. To set the presets, perform the following:

1. Turn the receiver on.
2. Select the band.
3. Tune to the desired station.
4. Press and hold one of the 6 numbered buttons for more than 2 seconds to store the selected station. During the 2-second set time, the radio will be muted and the preset number will be displayed. When the preset station has been set, a beep will sound, then the audio and selected preset number will return.
5. Repeat steps 1-4 for each button.

Pressing a preset button in the future will tune the radio to the station previously set on the band currently in use.

## Adjusting the Receiver Audio Settings

To adjust the bass, middle, treble, fade, balance and auto EQ, press and release the ON/AUDIO knob. Each time the knob is pressed, the radio will advance to the next setting and BASS, MIDDLE, TREBLE, FADE, BALANCE or AUTO EQ will appear on the display.

**BASS:** Rotate the ON/AUDIO knob clockwise to increase the bass and counterclockwise to decrease it. The display will show BASS and its level from -6 to +6.

**MIDDLE:** Rotate the ON/AUDIO knob clockwise to increase the middle sound and counterclockwise to decrease it. The display will show MIDDLE and its level from -6 to +6.

**TREBLE:** Rotate the ON/AUDIO knob clockwise to increase the treble sound and counterclockwise to decrease it. The display will show TREBLE and its level from -6 to +6.

**FADE:** Rotate the ON/AUDIO knob clockwise to move the sound to the front speakers and counterclockwise to move the sound to the rear speakers. The display will show FADE and the fade level from R15 to F15. Fade is not available in 2-speaker mode.

**BALANCE:** Rotate the ON/AUDIO knob clockwise to move the sound to the right speakers and counterclockwise to move it to the left speakers. The display will show BALANCE and the balance level from L15 to R15.

**AUTO EQ:** Rotate the ON/AUDIO knob clockwise and counterclockwise to cycle through auto EQ options from 1 to 7.

Options are:

1. Pop
2. Rock
3. Country
4. News
5. Jazz
6. Classical
7. Manual

To select the desired option, press the ON/AUDIO knob again.

**NOTE:** *Three audio configurations can be set (AUX and the rest of the sources).*

## Display

The receiver will display the time of day when it is off. Momentarily pressing “i Title/Menu” (7) button when the receiver is on allows the user to toggle between displays (such as the information on the current song playing) depending on the mode the radio is in.

When using an external device connected through the auxiliary inputs, pressing the “i Title/Menu” button will have no effect.

When a device is connected via the aux input, the radio will display FRONT AUX as long as it is kept in this mode. If AUX is selected by pressing the SRC button and no device is connected, the radio will select the rear auxiliary input, and display REAR AUX as long as it is kept in this mode.

## Adjusting the Receiver Menu Settings

To adjust the settings for the Clock, Alarm, Advanced (Speakers, Seek Sensitivity & Dimming), Hands Free, RDS (Europe only), and USB, press and hold “i Title/Menu” button until a beep is heard. Rotate the ON/AUDIO knob clockwise and counterclockwise to cycle through options available, or use the up and down buttons until the desired feature appears on the display. After reaching the desired feature, press the OK button to select. The ESC button will return back to previous options or exit menu options.

**ADVANCED:** Rotate the ON/AUDIO knob or press up/down button to select one of the following options:

- Speakers
- Seek Sensitivity (available only in Tuner mode)
- Dimming

**SPEAKERS:** Rotate the ON/AUDIO knob in either direction to toggle from 2- speaker to 4-speaker functionality. When 2-speaker functionality is chosen, only front speakers are used.

**SEEK SENSITIVITY:** Rotate the ON/AUDIO knob clockwise to increase the seek sensitivity and counterclockwise to decrease it. The display will show SEEK SENSITIV and the seek level from -2 to +2.

**DIMMING:** Rotate the ON/AUDIO knob clockwise to increase the brightness of the display and counterclockwise to decrease the brightness. The display will show DIMMING and the dim level from 0 to 30.

**RDS:** Press the OK button to select, and the radio will let you choose between AF and TRAFFIC. Press the OK button to turn each selection ON and OFF. (This option is available in Europe only).

**USB:** Press the OK button to select, and the radio will display PLAYLIST MODE. Rotate the ON/AUDIO knob in either direction to toggle from ON to OFF.

## Front Auxiliary Mode

In front auxiliary mode, an external device such as an iPod or MP3 player can be used via the auxiliary input jack on the front of the receiver. To use an external device, connect the device via the auxiliary input jack.

Front auxiliary mode will not be available if no device is connected to the auxiliary input jack on the front of the receiver.

## Rear Auxiliary Mode

In rear auxiliary mode, the radio can play an external device that is connected via the auxiliary input radio lines. To enable rear auxiliary mode, press the SRC button until the display shows REAR AUX.



**CLOCK** D.3-0000051664**Clock/Alarm Button**

In any mode, pressing the clock/alarm button, the display will show the time for 3 seconds. If you press and hold the clock/alarm button, the display will show the alarm set time for 3 seconds and a beep will be heard.

**Setting the Clock**

The clock can function in a 12-hour or 24-hour mode. The 12-hour mode distinguishes between AM and PM. The 24-hour mode operates as military time.

Perform the following steps to set the clock:

1. Turn the key switch on.
2. Press and hold the "i Title/Menu" button for more than 2 seconds until the menu appears. This indicates the radio is in the menu mode.
3. Press OK button to enter to the clock submenu.
4. Turn the ON/AUDIO knob or press the up/down buttons to change to SET TIME. Press the OK button to enter set mode.
5. Turn the ON/AUDIO knob or press the up/down buttons to change between 12-hour or 24-hour format. Press the OK button to select one.
6. The display changes to clock configuration, causing the hour digits to flash. Rotate the ON/AUDIO knob or press the up/down buttons to change the hour. Rotating the knob clockwise or pressing the up button will increase the hour. Rotating counterclockwise or pressing the down button will decrease the hour.
7. Press the OK button causing the minute digits to flash. Rotate the ON/AUDIO knob or press the up/down buttons to change the minutes. Rotating the knob clockwise or pressing the up button will increase the minutes; rotating counterclockwise or pressing the down button will decrease the minutes.

At any point in the time set process, not pressing a button or rotating the knob within 8 seconds will cancel time set mode, return the radio to normal operation and keep the setting changes have been made. Pressing the power or band buttons sets the clock at the time you have selected. The clock is displayed when the key switch is ON and the radio is off. With radio and key switch OFF, the display is blank.

**Setting the Alarm**

The alarm activates the radio at a set time. Pressing the CLOCK/ALARM button for more than 2 seconds will display the alarm set time for 3 seconds.

Perform the following steps to set the alarm:

1. With the radio on, press and hold the "i Title/Menu" button for more than 2 seconds until the menu appears. This indicates the radio is in the menu mode.
2. Rotate the ON/AUDIO knob or press the up/down buttons to change to SET ALARM. Press the OK button to enter the alarm submenu.
3. Press the OK button to turn the alarm on or off. The alarm icon will turn on when enabling the alarm. Rotate the ON/AUDIO knob or press up/down buttons to change to SET TIME and press the OK button. The hour digits for the alarm time will begin to flash. The format will be the same as set for the clock (12- or 24-hour mode).
4. Rotate the ON/AUDIO knob or press the up/down buttons to change the hour. Rotating the knob clockwise or pressing up button will increase the hour, rotating counterclockwise or pressing the down button will decrease the hour.
5. Press the OK button, which causes the minute digits to flash. Rotate the ON/AUDIO knob or press the up/down buttons to change the minutes. Rotating the knob clockwise or pressing up button will increase the minutes. Rotating counterclockwise or pressing the down button will decrease the minutes.
6. Press the OK button to set the alarm time. Then select between SET MUS (Music) or SET TONE. Press the OK button to select.

**NOTE:** If SET TONE is selected, the alarm will sound a medium priority tone for 2 minutes before changing to a constant high priority tone.

If SET MUS is selected, the alarm sound will be whatever was playing when the radio was turned OFF. For example, if the radio was set to FM, the alarm sound will be the FM station that was last tuned to. If that station is no longer available, the alarm will sound a medium priority tone for 2 minutes before changing to a high priority tone. If the AUX input, a CD or other media was playing and there is no longer an AUX input or CD available, the alarm will turn the radio on instead.

7. Press the OK button again to set the volume of the alarm tone or music.

When the OK button is pressed, VOLUME will appear and the radio will play the actual volume of the tone or music, whichever one was selected. To increase the volume, rotate the ON/AUDIO knob clockwise. To decrease the volume, rotate the ON/AUDIO knob counterclockwise.

8. Press the OK button again to finish and return the display to normal operation. The alarm icon will appear on the display to indicate that the alarm is active.

**NOTE:** *If no buttons were pressed (or any button or knob rotated for 8 seconds during the alarm set process), the alarm clock setup will be cancelled and the radio will return to normal operation, keeping whatever setting changes have been made.*

## Turning the Alarm Off

When the alarm is triggered, press and hold the CLOCK/ALARM button until the alarm icon on the display disappears.

If the alarm is not turned off, it will automatically shut off after 63 minutes. The radio will return to the mode (on or off) it was in before the alarm went off.

## Activating Snooze

To use SNOOZE, press any button for less than 2 seconds when the alarm sounds. SNOOZE will appear for 3 seconds and the alarm will be postponed for 9 minutes. If any buttons are pressed during these 3 seconds, the radio will return to the mode it was in before the alarm sounded.

## CD PLAYER E.3-0000051663

### Playing a Compact Disc

The integrated CD player plays full size CDs, MP3 and WMA discs.

Perform the following steps to play a compact disc:

1. Turn the key switch and radio on.
2. Insert a disc partway into the slot, label-side up. The player will automatically pull the disc in once it has been partially inserted. CD READING and the CD icon will appear on the display followed by the track number and elapsed time. Then, the disc will begin to play.
3. If currently listening to FM/AM/WX radio, press the SRC button to play a CD that has been loaded into the player. If no CD has been loaded, the option will not be available and the radio will access the next available source. If no sources are available, the radio will remain on REAR AUX. If a CD has been loaded, the CD icon remains on until the CD has been ejected. CD READING will appear followed by the track number and the elapsed time.

If a CD is ejected and not removed within 15 seconds, the CD will reload but will not start playing until the SRC button is pressed.

### Playing an MP3 DISC

The MP3 player will play files recorded on a CD-R up to 700 MB or on a USB stick of up to 1 GB. Files can be recorded at a variable bit rate or the following fixed-bit rates: 32 kpbs, 40 kpbs, 64 kpbs, 80 kpbs, 96 kpbs, 112 kpbs, 128 kpbs, 160 kpbs, 192 kpbs, 224 kpbs, 256 kpbs, and 320 kpbs. Both single and multi-session discs will play. Song title, artist name and album are available when discs are recorded using ID3 tags, versions 1 and 2.

Files supported on USB sticks: MP1, MP2, MP3 (VBR), WMA (ver 9 and VBR) and ACC (MPEG4 and M4A).

The MP3 player is able to read and play a maximum of 50 folders and playlists. Long files, folders or a combination can reduce the number of files and folders that can be played. If a large number of files or folders are to be played, minimize the length of the files and folders. The MP3/WMA recorded files without file folders can also be played. The system can support up to 11 levels of folder nesting. If a disc contains more than 50 folders or 11 folder levels, the player will only allow access and navigate the maximum number and will ignore additional items.

### CD Mode Displays

When using the CD player, press the "i Title/Menu" button to toggle between different display views:

- Artist Name
- Song Name
- Album Name

CD information, including disc and track title, is shown when a track starts to play. If there is more information than can appear on the display at one time, the display will advance every 2 seconds until all of the information has appeared.

**NOTE:** When an audio CD is inserted into the CD player, the receiver will display CD READING until the first track is played. Then the track number, time elapsed and CD will appear.

If the RPT button is pressed, the radio will display the RPT icon. If it is pressed again, the display will delete the RPT icon.

If the RDM button is pressed, the radio will display the RDM icon. If it is pressed again, the display will delete the RDM icon.

If the PAUSE/PLAY button is pressed, the radio will display PAUSE. If pressed again, it will go back to the previous display and continue playing the CD.

### Button Functions

**SEEK:** Press button (21) for less than 2 seconds to forward to the next track. Press and hold the button to fast forward. When the button is released, the track will continue to play.

**SEEK:** Press button (20) for less than 2 seconds to go to the beginning of the current track. If pressed within the first 10 seconds of the track, the radio goes to the previous track. Press the button again within the first second to go to the beginning of the previous track. Press and hold the button to fast reverse. When the button is released, the disc will begin to play.

**2/PAUSE/PLAY:** Press the PAUSE/PLAY button to pause a CD. PAUSE will be displayed and the audio will be muted. Press PAUSE/PLAY again to resume playing.

**4/RPT:** Press the RPT button to repeat the track being played. When "Track Repeat" is on, the RPT icon will be on, and the track that is playing will be repeated until the RPT button is pressed again.

**5/RDM:** Press the RDM button to activate random track selection. RDM icon on the display indicates that tracks on the loaded disc will be played randomly until the RDM button is pushed again.

**TRACK SCAN:** Press SCAN/PSCAN for less than 2 seconds to scan the tracks on a disc. After playing 8 seconds of the current track, the radio will go to the next track. When all tracks on the disc have been scanned, the SCAN ends and playback begins with the first track in the SCAN. Press SCAN again to deactivate.

**EJECT:** Press button (6) to eject a CD.

## MP3 PLAYER D.3-0000051662

### Playing MP3 Files

Insert a USB stick fully into the slot. USB READING will appear on the display, and the USB will begin playing.

The type of file, elapsed time and the track number will be displayed. Play begins from the first track and continues sequentially through all tracks. After playing the last track of the last folder, play continues at the first track of the first folder or root directory.

**Root Directory:** The root directory is treated as a folder. If the root directory has compressed audio files, the directory is displayed as ROOT. All files contained directly under the root directory are accessed prior to any root directory folders.

**Empty Directory or Folder:** If there is a root directory or folder in the file structure that contains empty folders/subfolders, play advances to the next folder in the file structure that contains compressed audio files. The empty folder will not be displayed or numbered.

**No Folder:** When a disc contains only compressed files, the files are located under the root folder. The next and previous folder functions have no function on a CD recorded without folders. When displaying the name of the folder, the radio displays ROOT.

**File Name Display:** A song title is displayed when contained in the ID3 tag. Titles longer than 8 characters scroll at a rate of 8 characters every 2 seconds until the entire name is shown.

### MP3 Mode Displays

When playing MP3 or WMA files, press the "i Title/Menu" button to toggle between different display views:

- Track Number
- Artist Name
- Song Name
- Album Name
- Folder/PLST Name

Information, including track title and artist name, is shown when a track starts to play. If no information is available then the radio will show blank fields. If there is more information than can appear on the display at one time, the display will advance every 2 seconds until all of the information has been displayed.

**NOTE:** When a USB stick or an iPod is connected into the USB connector, it will display USB READING or iPod READING until the first track is played. The file type and elapsed time will appear next. Then the track/file number, artist, song, album & folder/playlist name will appear on the second row display.

If button (5) or (6) are pressed, the radio will display the folder and track number, then it will begin showing the track/file number, artist, song, album & folder/playlist name on the second row display before returning to the default display.

If RPT is pressed once, REPEAT TRACK will appear and the RPT icon will turn on. Then the display returns to its default, current track playing. In iPod mode, the display will read REPEAT ONE TRACK.

If RPT is pressed a second time, REPEAT FOLDER/PLST will appear and the RPT icon will remain turned on. Then the display returns to its default. In iPod mode, the display will read REPEAT ALL TRACKS.

If RPT is pressed a third time, REPEAT OFF will appear and the RPT icon will turn off. Then the display returns to its default.

If RDM is pressed once, RANDOM FOLDER/PLST will appear and the RDM icon will turn on. Then the display returns to its default. In iPod mode, the display will read SHUFFLE TRACKS.

If RDM is pressed a second time, RANDOM USB will appear and the RDM icon will remain turned on. Then the display returns to its default. In iPod mode, the display will read SHUFFLE ALBUMS.

If RDM is pressed a third time, RANDOM OFF will appear and the RDM icon will turn off. Then the display returns to its default. In iPod mode, the display will read SHUFFLE OFF.

If the PAUSE/PLAY button is pressed, the radio will display PAUSE (if RPT or RDM are currently selected the icon will remain on). If pressed again, it will go back to the previous display and continue playing the CD/USB/iPod.

When a USB stick is connected and DEVICE NOT SUPPORTED appears on the display, the USB stick is not supported by the receiver and a different USB stick will have to be used.

### Button Functions

**SEEK:** Press button (21) for less than 2 seconds to forward to the next track. Press and hold the button to fast forward. When the button is released, the track will continue to play.

**SEEK:** Press button (20) for less than 2 seconds to go to the beginning of the current track. If pressed within the first 10 seconds of the track, the radio goes to the previous track. Press the button again within the first second to go to the beginning of previous track. Press and hold the button to fast reverse. When the button is released, the track will continue to play.

**2/PAUSE/PLAY:** Press the PAUSE/PLAY button to pause a track. PAUSE will be displayed and the audio will be muted. Press PAUSE/PLAY again to resume playing the track.

**4/RPT:** Press the RPT button once to repeat the current file. The RPT icon and REPEAT TRACK will appear on the display. The same file will continue to play until the RPT button is pressed again. If RPT is pressed a second time REPEAT FOLDER/PLST will appear on the display and the RPT icon will remain turned on. The same folder/playlist will continue to play until the RPT button is pressed again. If RPT is pressed a third time, REPEAT OFF will appear on the display. The function will be off and the RPT icon will turn off. Then the display returns to its default.

**5/RDM:** Pressing the RDM button activates random folder/playlist. The RDM icon on the display indicates that this feature is on. To cancel RANDOM FOLDER/PLAYLIST or RANDOM ALL, press the RDM button again to reach RANDOM OFF.

**RANDOM FOLDER/PLAYLIST:** Press the RDM button once to play MP3 files within a folder/playlist randomly.

**RANDOM ALL:** Press the RDM button a second time to play MP3 files on a media device randomly.

**FOLDER SCAN:** Press the SCAN/PSCAN button for less than 2 seconds to scan files within a folder. After playing 5 seconds of the first MP3 file in the current folder, the radio will go to the next file. When all of the files within the folder have been scanned, normal play resumes with the first file scanned.

**SCAN FOLDERS:** Press the SCAN/PSCAN button for more than 2 seconds to scan all the folders on a device. When all folders have been scanned, normal play resumes with the MP3 file that was scanned first.

Press button (11) for less than 2 seconds while playing an MP3 file to find the previous folder on the disc.

**HOME JUMP:** Press button (11) for more than 2 seconds while playing an MP3 file to start playback at the first file in the first folder.

Press button (5) for less than 2 seconds while playing an MP3 file to find the next folder on the disc.

**END JUMP:** Press button (5) for more than 2 seconds while playing an MP3 file to start playback at the first file in the last folder.

**EJECT:** Press button (6) to eject a disc.

To remove a USB device simply pull the device out of the USB port. The radio will return to its previous mode/source.

**iPod®** D.3-0000051661**Playing an iPod®**

**NOTE:** The radio is capable of controlling and playing music from some models of iPods. It is recommend not connecting the 3G iPhone or iPod Touch to the radio.

Insert the iPod® USB cable connector to the radio USB connector (the other end connected to your iPod). iPod READING will appear on the display. Insert the 3.5mm audio cable connector to the radio aux input jack connector (the other end connected to your iPod 3.5mm audio jack connector). If the audio cable is not connected the radio will display FRONT AUX JACK UNPLUGGED. After all the connections have been made and the radio has finished reading the iPod, the iPod will begin playing. The elapsed time and the track number will be displayed. Play begins from current track played on iPod and continues sequentially through all tracks from the iPod's last selected mode. After playing the last track of the iPod's last selected mode, play stops and the radio will display the iPod Menu.

**iPod® Mode Displays**

When playing ipod® files, press the "i Title/Menu" button to toggle between different display views:

- Track Number
- Artist Name
- Song Name
- Album Name
- Folder/PLST Name

Information, including track title and artist name, is shown when a track starts to play. If no information is available then the radio will show blank fields. If there is more information than can appear on the display at one time, the display will advance every 2 seconds until all of the information has been displayed.

**NOTE:** When a USB stick or an iPod is connected into the USB connector, it will display USB READING or iPod READING until the first track is played. The file type and elapsed time will appear next. Then the track/file number, artist, song, album & folder/playlist name will appear on the second row display.

If button (5) or (6) are pressed, the radio will display the folder and track number, then it will begin showing the track/file number, artist, song, album & folder/playlist name on the second row display before returning to the default display.

If RPT is pressed once, REPEAT TRACK will appear and the RPT icon will turn on. Then the display returns to its default, current track playing. In iPod mode, the display will read REPEAT ONE TRACK.

If RPT is pressed a second time, REPEAT FOLDER/PLST will appear and the RPT icon will remain turned on. Then the display returns to its default. In iPod mode, the display will read REPEAT ALL TRACKS.

If RPT is pressed a third time, REPEAT OFF will appear and the RPT icon will turn off. Then the display returns to its default.

If RDM is pressed once, RANDOM FOLDER/PLST will appear and the RDM icon will turn on. Then the display returns to its default. In iPod mode, the display will read SHUFFLE TRACKS.

If RDM is pressed a second time, RANDOM USB will appear and the RDM icon will remain turned on. Then the display returns to its default. In iPod mode, the display will read SHUFFLE ALBUMS.

If RDM is pressed a third time, RANDOM OFF will appear and the RDM icon will turn off. Then the display returns to its default. In iPod mode, the display will read SHUFFLE OFF.

If the PAUSE/PLAY button is pressed, the radio will display PAUSE (if RPT or RDM are currently selected the icon will remain on). If pressed again, it will go back to the previous display and continue playing the CD/USB/iPod.

When a USB stick is connected and DEVICE NOT SUPPORTED appears on the display, the USB stick is not supported by the receiver and a different USB stick will have to be used.

**Button Functions**

**SEEK:** Press buttons (20) or (21) for less than 2 seconds to forward to the next track. Press and hold the same button to fast forward. When the button is released, the track will continue to play.

**SEEK:** Press buttons (20) or (21) for less than 2 seconds to go to the beginning of the current track. If pressed within the first 10 seconds of the track, the radio goes to the previous track. Press the button again within the first second to go to the beginning of previous track. Press and hold the same button to fast reverse. When the button is released, the track will continue to play.

**1/ESC:** Press the ESC button to exit or go back to previous menu when in a menu.

**2/PAUSE/PLAY:** Press the PAUSE/PLAY button to pause a track. PAUSE will be displayed and the audio will be muted. Press PAUSE/PLAY again to resume playing the track.

**3/BRWSE:** Press the BRWSE button to enter to the iPod menu. In the iPod menu you will be able to scroll and select with the ON/AUDIO knob. Turn to the right to increase, left to decrease and press knob to confirm selection (only on iPod menu).

**4/RPT:** Press the RPT button once to repeat the current track. RPT icon & REPEAT ONE TRACK will appear on the display. The same file will continue to play until the RPT button is pressed again. If RPT is pressed a second time REPEAT ALL TRACKS will appear on the display and the RPT icon will remain turned on. The same folder/playlist (iPod last

selected mode) will continue to play until the RPT button is pressed again. If RPT is pressed a third time, REPEAT OFF will appear on the display. The function will be off and the RPT icon will turn off. Then the display returns to its default.

**5/RDM:** Pressing the RDM button activates the shuffle feature. RDM icon on the display indicates that this feature is on. To cancel SHUFFLE TRACKS or SHUFFLE ALBUMS, press the RDM button again to reach SHUFFLE OFF.

**6/OK:** Press the OK button when on a menu to confirm the selection.

To remove the iPod USB cable connector, simply pull the device out of the USB port. The radio will return to the previous mode/source.



**WEATHERBAND (USA Only)** D.3-0000051660

NOAA Weather Radio is a service of the U.S. National Weather Service. It provides continuous broadcasts of the latest weather information directly from the National Weather Service. Taped weather messages are repeated every four to six minutes and are revised every one to three hours or more frequently if needed. Most stations operate 24 hours a day.

The local weather can be found on one of 7 stations. When in Weatherband mode, the display will show WX and the channel number. The channel can be changed using the SEEK / buttons; the up/down buttons can also be preset to the push buttons.

The frequencies associated with each channel are as follows:

1. 162.400 Mhz
2. 162.425 Mhz
3. 162.450 Mhz
4. 162.475 Mhz
5. 162.500 Mhz
6. 162.525 Mhz
7. 162.550 Mhz

The National Weather Service operates approximately 372 stations. Nearly 90 percent of the nation's population is within listening range of an NOAA Weather Radio broadcast.

## TROUBLESHOOTING E.3-0000051659

The following error messages may appear while playing a CD, MP3 disc/USB, iPod:

**NO CD:** No CD has been loaded in the player

**NO PLAYABLE DISC:** No playable files on media – Change media

**NO MUSIC FILES:** No playable files on media – Load music files to media

**FRONT AUX UNPLUGGED:** No front aux connected while iPod connected – Connect front aux cable

**IPOD NOT SUPPORTED:** Connected iPod not supported by receiver – Disconnect iPod

**DEVICE NOT SUPPORTED:** Connected device not supported by receiver – Disconnect device

**NOTE:** *Sound quality, skipping, difficulty in finding tracks, and/or difficulty in loading or ejecting a CD-R may be affected by a CD-R's quality, the method of recording, the quality of the music that has been recorded or the way the CD-R has been handled. If these problems occur, try playing a CD that is good to see if the error corrects itself. If an error occurs repeatedly or if an error cannot be corrected, contact an authorized Delphi dealer. If the radio displays an error message, write it down and provide it to the Delphi dealer when reporting the problem.*

### Tips About the Audio System

Hearing damage from loud noise is almost undetectable until it is too late. Your hearing can adapt to high volumes of sound. Sound that seems

normal can be loud and harmful to your hearing. Take precautions by adjusting your receiver's volume to a safe sound level before your hearing adapts to it.

To help avoid hearing loss:

- Adjust the volume control to the lowest setting.
- Increase the volume slowly until you hear comfortably and clearly.

### Understanding Radio Reception

**FM STEREO:** FM stereo will give better sound than AM, but FM signals will only reach between 10 and 40 miles (16-65 km). Tall buildings or hills can interfere with FM signals, causing the sound to come and go.

**AM:** The range for most AM stations is greater than FM, especially at night.

The longer range, however, can cause stations to interfere with each other. AM can pick up noise from things like storms and power lines. Try reducing the treble to reduce this noise if you experience it.

### Care of the Compact Discs

Handle discs carefully. Store them in their original or other protective cases and away from direct sunlight and dust. If the surface of a disc is soiled, dampen a clean, soft cloth in a mild, neutral detergent solution. Clean the disc, wiping from the center to the edge.

Never touch the signal surface when handling discs. Pick up discs by grasping the outer edges or the edge of the hole and the outer edge.

Do not attach a label or tape or write on the surface of a disc.