

Operation & Maintenance Manual

PC5500-6

HYDRAULIC MINING SHOVEL

SERIAL NUMBER 15045 and up

This material is proprietary to Komatsu Mining Germany GmbH and is not to be reproduced, used, or disclosed except in accordance with written authorization from Komatsu Mining Germany GmbH. It is our policy to improve our products whenever it is possible and practical to do so. We reserve the right to make changes or add improvements at any time without incurring any obligation to install such changes on products sold previously.

Due to this continuous program of research and development, periodic revisions may be made to this publication. It is recommended that customer contact their distributor for information on the latest revision.

August 2006

Copyright 2006

KOMATSU
MINING GERMANY

1. INTRODUCTION

1.1 CONTENTS OF THE BINDER

Assembled in this file are the Operation-, Lubrication- and Maintenance Manuals for your KOMATSU Hydraulic Mining Shovel.

1.2 DIVISION OF THE BINDER

Part 1:

Operation Manual

Part 2:

Lubrication- and Maintenance Manual

Part 3:

Depending on the volume of Part 3 a second Binder "Volume 2" is being delivered with the Shovel. This Binder contains the General Assembly Procedure Manual for the Shovel, Specification Booklet, Service Literature for the Power Unit (Diesel Engine or Electric Motor) and for Special Equipment. The Electrical- and Hydraulic Diagrams are attached in the pocket of the front cover.

Refer to the "TABLE OF CONTENTS VOLUME 2 BINDER" for details.

Read the Manuals before You Start the Engines.

Before operating the machine, familiarize yourself with its instruments and controls.

Observe the instructions in these manuals for:

- your Personal SAFETY
- Operating SAFETY, and
- READY and EFFICIENT PERFORMANCE of your KOMATSU Hydraulic Mining Shovel.

Periodic preventive inspections and maintenance are the surest means of keeping the machine in proper working order. Prompt detection and correction of minor irregularities, and immediate replacement of worn out or broken parts will prevent failures and avoid expenses.

Replace damaged graphics and symbols.

Observe safety precautions to prevent injury and damage.

If you have any questions concerning this literature please contact

Komatsu Mining Germany GmbH

Service Information
Department 8151.40
P.O. Box 18 03 61
D - 40570 Düsseldorf
GERMANY

1.3 DESIGNATED USE OF THE SHOVEL

This machine has been manufactured in accordance with advanced and up-to-date technology standards including recognized safety rules. Nevertheless, its use may constitute a risk to life and limb of the user or of third parties, or cause damage to the machine and to other material property.

The machine must only be used in technically perfect condition in accordance with its designated use and the instructions set out in the operation manual. Only trained safety-conscious operators who are fully aware of the risks involved should operate the machine. Any functional disorders, especially those affecting the safety of the machine, should, therefore, be rectified immediately.

The hydraulic Shovel is designed exclusively for excavating, i.e. excavation of bulk material and natural soil structure (e.g. earth, clay, sand and stones ashore and off-shore). Observe local and national safety regulations. Special conditions at the worksite require additional safe working precautions, follow your company's safety instructions. Short traveling distances for changing the working site are considered as part of the designated use of the Shovel.

Using the Shovel for purposes other than those mentioned above (such as object handling and use as a transport vehicle) is considered contrary to its designated use. The manufacturer/supplier cannot be held liable for any damage resulting from such use. The risk of such misuse lies entirely with the user.

 **WARNING**

Special use of the Shovel beyond its designated use, e.g. object handling operations, require written agreement from the manufacturer and retrofitment of the Shovel with respective safety related equipment before such special applications are permitted.

1.4 DELIVERY OF THE SHOVEL

The Shovel is being delivered disassembled into its main components.

For assembling the Shovel refer to the separate Manual "Assembly Procedure" in Volume 2 Binder.

⚠ WARNING

Personnel entrusted with work on the machine must have read the Assembly Manual, the Operation,- Lubrication- and Maintenance Manual and in particular the section on safety before beginning work. Reading the instructions after work has begun is too late.

If there are any questions concerning the assembling procedure, contact your local Service Center.

Prior to first operation, inspect the Shovel thoroughly with the Service Engineer responsible for the erection of the machine. Check all fluid levels according to the Lubrication and Maintenance Schedule.

Damages and defects caused by incorrect operation and maintenance are not covered by the manufacturers guarantee.

NOTICE

If the Shovel is equipped with a fire suppression system, make sure that the system is ready for operation.

SPARE PARTS

For your spare part orders refer to the Parts Catalogue.

In order to keep your Shovel in first-class operating condition use only genuine spare and wear parts.

The use of any part other than the genuine part releases the KOMATSU MINING GERMANY GmbH from any guarantee.

SERVICE

For all questions related to your Shovel please contact your local Service Center.

In all your written or phoned inquiries please indicate the model and serial number of your Shovel.

1.5 EXPLANATION OF ABBREVIATIONS

ABB.	Definition
A	Ampere
AC	Alternating Current
API	American Petroleum Institute
cSt	Centistoke
°C	Degree Celsius
CENTRY	Engine Electronic Control System
CLS	Central Lubrication System
DC	Direct Current
DIN	German Institute for Standardization
EBL	Electronic Bucket Levelling System
ECM	Electronic Control Module (Engine)
ECS	Electronic Control and Monitoring System
FGPS	Front Guard Protective Structure
FOPS	Falling-Object Protective Structure
GL	Gear Lubricant
h	hours of operation
HPF	High Pressure Filter (Hydraulic Oil)
HT	High Tension
LED	Light Emitting Diode
LT	Low Tension
MPG	Multi-Purpose Grease
N	Newton
Nm	Newton meter
PLC	Programmable Logic Controller
PM	Planned Maintenance
ppm	parts per million
PTO	Power Take-Off (Pump Distributor Gear)
SLS	Swing circle pinion Lubrication System
V	Volt
1/min	Revolutions Per Minute (RPM)

1.6 TABLE OF CONTENTS

1. INTRODUCTION	3
1.1 CONTENTS OF THE BINDER	4
1.2 DIVISION OF THE BINDER	5
1.3 DESIGNATED USE OF THE SHOVEL	6
1.4 DELIVERY OF THE SHOVEL	7
1.5 EXPLANATION OF ABBREVIATIONS	8
1.6 TABLE OF CONTENTS	9
2. SAFETY	15
2.1 SAFETY INSTRUCTIONS	16
2.1.1 WARNINGS AND SYMBOLS	16
2.1.2 BASIC OPERATION AND DESIGNATED USE OF THE HYDRAULIC SHOVEL	16
2.1.3 ORGANIZATIONAL MEASURES	17
2.1.4 SELECTION AND QUALIFICATION OF PERSONNEL - BASIC RESPONSIBILITIES	19
2.1.5 SAFETY INSTRUCTIONS GOVERNING SPECIFIC OPERATIONAL PHASES	20
2.1.6 WARNING OF SPECIAL DANGERS	23
2.1.7 TRANSPORTING AND TOWING -RECOMMISSIONING	25
2.1.8 SPECIAL SAFETY EQUIPMENT	25
2.1.9 SAFETY HARNESS IN CONFORMITY WITH EN 361 (EUROPEAN STANDARD)	29
3. OPERATION	37
3.1 FOREWORD	38
3.2 CONSTRUCTION OF THE SHOVEL	39
3.2.1 OVERALL VIEW	39
3.2.2 UNDERCARRIAGE AND SUPERSTRUCTURE	40
3.2.3 HYDRAULICALLY OPERATED ACCESS LADDER	46
3.2.4 EMERGENCY ESCAPE LADDER	50
3.2.5 EMERGENCY ENGINE SHUTDOWN FROM GROUND MAN OR OPERATOR WARNING SYSTEM	52
3.2.6 OPERATOR'S CAB WITH INTEGRATED FALLING OBJECT PROTECTIVE STRUCTURE (FOPS)	54
3.2.7 ENGINE OIL MANAGEMENT SYSTEM	64
3.3 OPERATOR'S CAB - CONTROLS	72
3.3.1 CONTROLS WITH BACKHOE ATTACHMENT	72
3.3.2 CONTROLS WITH BOTTOM DUMP BUCKET ATTACHMENT	76

3.3.3	OPERATOR'S CONSOLE	81
3.3.4	INTERFACE PANEL FOR DIAGNOSTICS	89
3.3.5	CONTROL MODULE FOR AUXILIARY CAB HEATER	91
3.4	ELECTRONIC MONITORING AND CONTROL SYSTEM ECS	92
3.4.1	INTRODUCTION	93
3.4.2	OPERATING THE ELECTRONIC MONITORING SYSTEM	101
3.4.3	AUTOMATIC DISPLAY OF MESSAGES	105
3.4.4	MENU CONTROL AND SERVICE FUNCTIONS	129
3.4.5	MENU CONTROL LIST	154
3.4.6	FAULT AND INFORMATION MESSAGE LIST	172
3.5	OPERATING THE HEATER, VENTILATION AND AIR CONDITIONING	198
3.5.1	AUXILIARY HEATER FOR OPERATOR'S CAB	201
3.6	MACHINERY HOUSE	202
3.6.1	EMERGENCY ENGINE SHUTDOWN SWITCHES	203
3.6.2	SAFETY SWITCH FOR MAINTENANCE	205
3.6.3	CONTROL AND FILTER PANEL OF REAR- AND FRONT POWER UNIT	207
3.7	ELECTRICAL EQUIPMENT IN CAB BASE	208
3.7.1	STANDARD COMPONENTS IN CAB BASE	209
3.7.2	SWITCH BOARD (X2) IN CAB BASE	211
3.7.3	COMPONENTS OF ELECTRICAL PREHEATING SYSTEM IN CAB BASE	219
3.8	PREHEATING SYSTEMS FOR OIL, COOLANT AND BATTERIES	222
3.9	CHECKS BEFORE STARTING THE ENGINES	228
3.10	STARTING THE ENGINES	234
3.10.1	STARTING PROCEDURE	237
3.11	MOVING THE SHOVEL	245
3.11.1	TRAVEL CONTROL WITH FOOT PEDALS	245
3.11.2	TRAVELLING INSTRUCTIONS	248
3.12	SLEWING AND BRAKING THE SUPERSTRUCTURE	249
3.12.1	SLEWING THE SUPERSTRUCTURE	249
3.13	WORKING WITH THE ATTACHMENT	252
3.13.1	MACHINES EQUIPPED WITH "EURO" CONTROL SYSTEM	252
3.13.2	MACHINES EQUIPPED WITH "KMG" CONTROL SYSTEM	253
3.13.3	BOTTOM DUMP BUCKET	254
3.13.4	DROP BALL OPERATION	255
3.13.5	COMBINED OPERATION CYCLES	258
3.14	WORKING INSTRUCTIONS	260
3.14.1	STABILITY OF THE SHOVEL	260
3.14.2	SHOVEL OPERATION	260

3.15	PARKING THE SHOVEL	263
3.16	STOPPING THE ENGINES	264
3.16.1	RELIEVE PRESSURE IN THE HYDRAULIC SYSTEM	267
3.17	OPERATION OF THE LUBRICATION SYSTEM	268
3.17.1	CENTRAL LUBRICATION SYSTEM -CLS- FOR SUPERSTRUCTURE AND ATTACHMENT 268	
3.17.2	SWING CIRCLE PINION LUBRICATION SYSTEM "SLS"	270
3.18	FIRE DETECTION AND SUPPRESSION SYSTEM	272
3.18.1	HIGH LEVEL ALARM "FIRE"	275
3.18.2	ENGINE SHUT-DOWN THROUGH FUEL SHUT-OFF SOLENOID VALVE	275
3.18.3	ACTUATION MODES OF THE FIRE SUPPRESSION SYSTEM	275
3.18.4	INDICATION OF OPERATIONAL MODES AT CONTROL MODULE, AFTER AUTOMATIC ACTUATION OF THE FIRE SUPPRESSION SYSTEM	277
3.18.5	LOCATION OF THE EXTINGUISHING AGENT TANK ASSEMBLIES AND EXPELLANT GAS CARTRIDGES ON POWER HOUSE ROOF	279
3.19	TRANSFER PUMP FOR HYDRAULIC OIL	280
3.19.1	OPERATING THE TRANSFER PUMP	281
3.19.2	FUNCTIONS OF THE TRANSFER PUMP	283
3.20	CENTRAL REFILLING SYSTEM	286
3.20.1	SYSTEMS CONNECTED TO THE REFILLING SYSTEM	287
3.20.2	OPERATING THE HYDRAULIC SERVICE ARM	289
3.20.3	RECEIVER PANEL WITH MONITOR BOX	291
3.20.4	REFILLABLE GREASE CONTAINERS OF THE AUTOMATIC LUBRICATION SYSTEMS ... 297	
3.21	WORK ON THE LOADER ATTACHMENT	298
3.22	TRANSPORTATION AND LIFTING OF THE SHOVEL	299
3.22.1	DISASSEMBLING OF THE SHOVEL	299
3.22.2	TRANSPORTATION AND LIFTING	299
3.23	RETRIEVAL PROCEDURE	300
3.24	SHOVEL STORAGE	301
3.24.1	PREPARING FOR STORAGE	301
3.24.2	ONE MONTH REPETITIVE SERVICE PERIOD	302
3.24.3	SIX MONTH REPETITIVE SERVICE PERIOD	302
3.24.4	PREPARING FOR OPERATION	303
3.25	TROUBLE SHOOTING	304
3.25.1	ENGINE	304
3.25.2	HYDRAULIC SYSTEM	305
3.25.3	FINAL DRIVES AND SWING GEAR	306
3.25.4	CRAWLER TRACKS	306

4.	MAINTENANCE	307
4.1	FOREWORD	308
4.2	PRECAUTIONS FOR MAINTENANCE	309
4.3	FUEL AND LUBRICANTS	311
4.4	FILLING CAPACITIES	313
4.5	STANDARD TORQUE LIST	314
4.6	LUBRICATION AND MAINTENANCE SCHEDULE	315
4.6.1	INITIAL SERVICING	315
4.6.2	PERIODIC SERVICING INTERVALS	315
4.6.3	PERIODIC SERVICING SCHEDULE	316
4.6.4	EXTENDED SERVICE INTERVALS FOR ENGINES WITH ENGINE OIL MANAGEMENT SYSTEM	323
4.6.5	RESETTING THE ENGINE OIL BURNING SYSTEM CENTINEL	325
4.6.6	MAINTENANCE OF THE ENGINES	327
4.6.7	ENGINE FUEL FILTER LOCATIONS	329
4.7	WHEN NECESSARY	330
4.7.1	ENGINE AIR CLEANER MAINTENANCE	331
4.7.2	SWING CIRCLE TOOTHING LUBRICATION	335
4.7.3	AUTOMATIC LUBRICATION SYSTEMS FILL GREASE CONTAINERS	337
4.7.4	TRACK ROLLERS AND GUIDE WHEELS - REPLACE FLOATING SEALS	341
4.7.5	COLD STARTING AID, REPLACE FLUID CYLINDER	343
4.8	EVERY 10 OPERATING HOURS OR DAILY	344
4.8.1	WALK - AROUND INSPECTION	345
4.8.2	AIR CLEANER - CLEAN PRE-CLEANER	353
4.8.3	RADIATORS - CHECK COOLANT LEVEL	355
4.8.4	TRACK GROUPS - CLEAN	355
4.9	EVERY 50 OPERATING HOURS OR WEEKLY	356
4.9.1	SWING GEARS AND MOTOR ADAPTER HOUSINGS - CHECK OIL LEVELS	357
4.9.2	TRAVEL GEARS, MOTOR ADAPTER HOUSINGS AND FINAL DRIVES CHECK OIL LEVELS	361
4.9.3	PTO's (PUMP DISTRIBUTOR GEARS) AND OIL RESERVOIR - CHECK OIL LEVEL ...	367
4.9.4	HYDRAULIC ACCESS LADDER - CHECK SAFETY SENSOR	371
4.9.5	HYDRAULIC OIL COOLERS - INSPECT AND CLEAN IF NECESSARY	373
4.10	EVERY 250 OPERATING HOURS OR MONTHLY	374
4.10.1	AIR CONDITIONING COMPRESSOR - CHECK DRIVE BELT TENSION	375
4.10.2	SIGNAL HORN COMPRESSOR - LUBRICATE	377
4.10.3	HYDRAULIC OIL COOLER FAN BEARINGS - CHECK FOR LEAKAGE AND CLEAN BREATHER FILTER	377
4.10.4	RADIATOR FAN BEARINGS - CHECK FOR LEAKAGE AND CLEAN BREATHER FILTER	377
4.10.5	AUTOMATIC LUBRICATION SYSTEMS - CLEAN IN-LINE GREASE FILTER AND CHECK BREATHER FILTER	379

4.10.6	CAB AIR CLEANER - CLEAN OR REPLACE FILTER ELEMENT	381
4.10.7	AIR CONDITIONING FOR OPERATOR'S CAB - CHECK REFRIGERANT LEVEL	383
4.10.8	WINDSHIELD WASHER SYSTEM - CHECK FLUID LEVEL	385
4.11	EVERY 500 OPERATING HOURS OR QUARTERLY	386
4.11.1	BATTERIES - CHECK FLUID LEVEL	387
4.11.2	FLEXIBLE DRIVE COUPLINGS - CHECK OIL LEVEL	389
4.11.3	FUEL TANK - DRAIN CONDENSATION	391
4.11.4	CRAWLER TRACK - INSPECTION	393
4.11.5	GROUND CABLES OF ENGINE AND ALTERNATOR - CHECK FOR CORRECT CONNECTION	399
4.11.6	GROUND CABLE OF OPERATOR'S CAB - CHECK FOR CORRECT CONNECTION ...	401
4.12	EVERY 1000 OPERATING HOURS OR EVERY 6 MONTH	402
4.12.1	HIGH STRENGTH BOLT CONNECTIONS - CHECK TORQUE LOAD	403
4.12.2	HYDRAULIC SYSTEM - FILTER SERVICE	461
4.12.3	PTO'S (PUMP DISTRIBUTOR GEARS), SWING GEARS AND TRAVEL GEARS - OIL SAMPLE ANALYSIS	475
4.12.4	SIGNAL HORN COMPRESSOR - CLEAN AND LUBRICATE	477
4.12.5	HYDRAULIC TRACK TENSIONING SYSTEM - CHECK PRESSURE ACCUMULATORS ...	479
4.12.6	WATER FILTER - REPLACE FILTER CARTRIDGE	481
4.12.7	HYDRAULIC OIL COOLER - INSPECT AND LUBRICATE DOOR HINGES	483
4.12.8	MACHINERY HOUSE DOORS - INSPECT AND LUBRICATE DOOR HINGES	485
4.13	EVERY 2000 OPERATING HOURS OR YEARLY	486
4.13.1	HYDRAULIC SYSTEM - CHANGE OIL, REPLACE SUCTION STRAINERS AND PULSATION DAMPER	487
4.13.2	EMERGENCY ESCAPE LADDER - INSPECTION	499
4.14	EVERY 3000 OPERATING HOURS HOWEVER AT LEAST ONCE A YEAR	500
4.14.1	SWING GEARS AND MOTOR ADAPTER HOUSING - CHANGE OIL	501
4.14.2	TRAVEL GEARS, MOTOR ADAPTER HOUSINGS AND FINAL DRIVES CHANGE OIL	509
4.14.3	PTO (PUMP DISTRIBUTOR GEAR) - CHANGE OIL	513
4.15	FIRE PREVENTION	516
4.16	WELD REPAIRS	518
4.16.1	PROTECTIVE MEASURES BEFORE STARTING WELD REPAIRS ON THE UNDERCARRIAGE	521
4.16.2	PROTECTIVE MEASURES BEFORE STARTING WELD REPAIRS ON THE LOADER ATTACHMENT	523
4.16.3	PROTECTIVE MEASURES BEFORE STARTING WELD REPAIRS ON THE SUPERSTRUCTURE	525
4.16.4	AFTER FINISHING THE REPAIR WELDINGS ON THE SUPERSTRUCTURE	527

2. SAFETY

2.1 SAFETY INSTRUCTIONS

2.1.1 WARNINGS AND SYMBOLS

The following signs and designations are used in the manual to designate in-structions of particular importance.

⚠ WARNING

Refers to orders and prohibitions designed to prevent injury or extensive damage.

⚠ CAUTION

Refers to special information and/or orders and prohibitions directed towards preventing damage.

NOTICE

Refers to special information on how to use the machine most efficiently.

2.1.2 BASIC OPERATION AND DESIGNATED USE OF THE HYDRAULIC SHOVEL

Refer to "DESIGNATED USE OF THE SHOVEL" on page 6 for details.

⚠ WARNING

The use of the Shovel for object handling operations without the respective safety related equipment is not allowed.

2.1.3 ORGANIZATIONAL MEASURES

- The Operation,- Lubrication and Maintenance Manual must always be at hand at the place of use of the machine, e. g. by stowing them in the box provided for such purpose.
- In addition to the Operation,- Lubrication and Maintenance Manual, observe and instruct the user in all other generally applicable legal and other mandatory regulations relevant to accident prevention and environmental protection.
These compulsory regulations may also deal with the handling of hazardous substances, issuing and/or wearing of personal protective equipment, or traffic regulations.
- The Operation,- Lubrication and Maintenance Manual must be supplemented by instructions covering the duties involved in supervising and notifying special organizational features, such as job organization, working sequences or the personnel entrusted with the work.
- Personnel entrusted with work on the machine must have read the Operation,- Lubrication and Maintenance Manual and in particular the chapter on safety before beginning work. Reading the instructions after work has begun is too late. This applies especially to persons working only occasionally on the machine, e. g. during setting up or maintenance.
- Check - at least from time to time - whether the personnel is carrying out the work in compliance with the Operation,- Lubrication and Maintenance Manual and paying attention to risks and safety factors.
- For reasons of security, long hair must be tied back or otherwise secured, garments must be close-fitting and no jewellery - such as rings - may be worn. Injury may result from being caught up in the machinery or from rings catching on moving parts.
- Use protective equipment wherever required by the circumstances or by law.
- Observe all safety instructions and warnings attached to the machine.
- See to it that safety instructions and warnings attached to the machine are always complete and perfectly legible.
- In the event of safety-relevant modifications or changes in the behaviour of the machine during operation, stop the machine immediately and report the malfunction to the competent authority/person.
- Never make any modifications, additions or conversions which might affect safety without the supplier's approval. This also applies to the installation and adjustment of safety devices and valves as well as to welding work on load-bearing elements.
- Spare parts must comply with the technical requirements specified by the manufacturer. Spare parts from original equipment manufacturers can be relied to do so.

- Replace hydraulic hoses within stipulated and appropriate intervals even if no safety-relevant defects have been detected.
- Adhere to prescribed intervals or those specified in the Operation,- Lubrication and Maintenance Manual for routine checks and inspections.
- For the execution of maintenance work, tools and workshop equipment adapted to the task on hand are absolutely indispensable.
- The personnel must be familiar with the location and operation of fire extinguishers.
- Observe all fire-warning and fire-fighting procedures.

2.1.4 SELECTION AND QUALIFICATION OF PERSONNEL - BASIC RESPONSIBILITIES

- Any work on and with the machine must be executed by reliable personnel only. Statutory minimum age limits must be observed.
- Employ only trained or instructed staff and set out clearly the individual responsibilities of the personnel for operation, set-up, maintenance and repair.
- Make sure that only authorized personnel works on or with the machine.
- Define the machine operator's responsibilities - also with regard to observing traffic regulations - giving the operator the authority to refuse instructions by third parties that are contrary to safety.
- Do not allow persons to be trained or instructed or persons taking part in a general training course to work on or with the machine without being permanently supervised by an experienced person.
- Work on the electrical system and equipment of the machine must be carried out only by a skilled electrician or by instructed persons under the supervision and guidance of a skilled electrician and in accordance with electrical engineering rules and regulations.
- Work on chassis, brake and steering systems must be performed by skilled personnel only which has been specially trained for such work.
- Work on the hydraulic system must be carried out only by personnel with special knowledge and experience of hydraulic equipment.

2.1.5 SAFETY INSTRUCTIONS GOVERNING SPECIFIC OPERATIONAL PHASES

STANDARD OPERATION

- Avoid any operational mode that might be prejudicial to safety.
- Before beginning work, familiarize yourself with the surroundings and circumstances of the site, such as obstacles in the working and travelling area, the soil bearing capacity and any barriers separating the construction site from public roads.
- Take the necessary precautions to ensure that the machine is used only when in a safe and reliable state.
Operate the machine only if all protective and safety-oriented devices, such as re-movable safety devices, emergency shut-off equipment, sound-proofing elements and exhausters, are in place and fully functional.
- Check the machine at least once per working shift for obvious damage and defects. Report any changes (incl. changes in the machine's working behaviour) to the competent organization/person immediately. If necessary, stop the machine immediately and lock it.
- In the event of malfunctions, stop the machine immediately and lock it. Have any defects rectified immediately.
- Start the machine from the driver's seat only.
- During start-up and shut-down procedures always watch the indicators in accordance with the Operation,- Lubrication and Maintenance Manual.
- Before starting up or setting the machine in motion, make sure that nobody is at risk.
- Before starting work or travelling with the machine, check that the braking, steering, signalling and lighting systems are fully functional.
- Before setting the machine in motion always check that the accessories have been safely stowed away.
- When travelling on public roads, ways and places always observe the valid traffic regulations and, if necessary, make sure beforehand that the machine is in a condition compatible with these regulations.
- In conditions of poor visibility and after dark always switch on the lighting system.
- Persons accompanying the driver must be seated on the passenger seat provided for this purpose.
- When crossing underpasses, bridges and tunnels or when passing under overhead lines always make sure that there is sufficient clearance.

- Always keep at a distance from the edges of building pits and slopes.
- Avoid any operation that might be a risk to machine stability.
- Never travel across slopes; always keep the working equipment and the load close to the ground, especially when travelling downhill.
- On sloping terrain always adapt your travelling speed to the prevailing ground conditions. Never change to a lower gear on a slope but always before reaching it.
- Before leaving the driver's seat always secure the machine against inadvertent movement and unauthorized use.

SPECIAL WORK IN CONJUNCTION WITH UTILIZATION OF THE MACHINE AND MAINTENANCE AND REPAIRS DURING OPERATION; DISPOSAL OF PARTS AND CONSUMABLES

- Observe the adjusting, maintenance and inspection activities and intervals set out in the Operation,- Lubrication and Maintenance Manual, including information on the replacement of parts and equipment. These activities may be executed by skilled personnel only.
- Brief operating personnel before beginning special operations and maintenance work, and appoint a person to supervise the activities.
- In any work concerning the operation, conversion or adjustment of the machine and its safety-oriented devices or any work related to maintenance, inspection and repair, always observe the start-up and shut-down procedures set out in the Operation,- Lubrication and Maintenance Manual and the information on maintenance work.
- Ensure that the maintenance area is adequately secured.
- If the machine is completely shut down for maintenance and repair work, it must be secured against inadvertent starting by:
 - locking the principal control elements and removing the ignition key and/or
 - attaching a warning sign to the main switch
- Carry out maintenance and repair work only if the machine is positioned on stable and level ground and has been secured against inadvertent movement and buckling.
- To avoid the risk of accidents, individual parts and large assemblies being moved for replacement purposes should be carefully attached to lifting tackle and secured. Use only suitable and technically perfect lifting gear and suspension systems with adequate lifting capacity. Never work or stand under suspended loads.

-
- The fastening of loads and the instructing of crane operators should be entrusted to experienced persons only. The marshaller giving the instructions must be within sight or sound of the operator.
 - For carrying out overhead assembly work always use specially designed or otherwise safety-oriented ladders and working platforms. Never use machine parts as a climbing aid. Wear a safety harness when carrying out maintenance work at greater heights.
Keep all handles, steps, handrails, platforms, landings and ladders free from dirt, snow and ice.
 - Clean the machine, especially connections and threaded unions, of any traces of oil, fuel or preservatives before carrying out maintenance/repair. Never use aggressive detergents. Use lint-free cleaning rags.
 - Before cleaning the machine with water, steam jet (high-pressure cleaning) or detergents, cover or tape up all openings which - for safety and functional reasons - must be protected against water, steam or detergent penetration. Special care must be taken with electric motors and switchgear cabinets.
 - Ensure during cleaning of the machine that the temperature sensors of the fire-warning and fire-fighting systems do not come into contact with hot cleaning agents as this might activate the fire-fighting system.
 - After cleaning, remove all covers and tapes applied for that purpose.
 - After cleaning, examine all fuel, lubricant, and hydraulic fluid lines for leaks, loose connections, chafe marks and damage. Any defects found must be rectified without delay.
 - Always tighten any screwed connections that have been loosened during maintenance and repair.
 - Any safety devices removed for set-up, maintenance or repair purposes must be refitted and checked immediately upon completion of the maintenance and repair work.
 - Ensure that all consumables and replaced parts are disposed of safely and with minimum environmental impact.

2.1.6 WARNING OF SPECIAL DANGERS

ELECTRIC ENERGY

- Use only original fuses and circuit breakers with the specified current rating. Switch off the machine immediately if trouble occurs in the electrical system.
- When working with the machine, maintain a safe distance from overhead electric lines. If work is to be carried out close to overhead lines, the working equipment must be kept well away from them. Caution, danger! Check out the prescribed safety distances.
- If your machine comes into contact with a live wire
 - do not leave the machine
 - drive the machine out of the hazard zone
 - warn others against approaching and touching the machine
 - have the live wire de-energized
 - do not leave the machine until the damaged line has been safely de-energized.
- Work on the electrical system or equipment may only be carried out by a skilled electrician himself or by specially instructed personnel under the control and supervision of such electrician and in accordance with the applicable electrical engineering rules.
- If provided for in the regulations, the power supply to parts of machine, on which inspection, maintenance and repair work is to be carried out must be cut off.
Before starting any work, check the de-energized parts for the presence of power and ground or short-circuit them in addition to insulating adjacent live parts and elements.
- The electrical equipment of the machine is to be inspected and checked at regular intervals. Defects such as loose connections or scorched cables must be rectified immediately.
- Necessary work on live parts and elements must be carried out only in the presence of a second person who can cut off the power supply in case of danger by actuating the emergency shut-off or main power switch. Secure the working area with a red-and-white safety chain and a warning sign. Use insulated tools only.
- Before starting work on high-voltage assemblies and after cutting out the power supply, the feeder cable must be grounded and components such as capacitors short-circuited with a grounding rod.

GAS, DUST, STEAM AND SMOKE

- Operate internal combustion engines and fuel operated heating systems only on adequately ventilated premises. Before starting the machine on enclosed premises, make sure that there is sufficient ventilation.
Observe the regulations in force at the respective site.
- Carry out welding, flame-cutting and grinding work on the machine only if this has been expressly authorized, as there may be a risk of explosion and fire. Special care must be taken before welding, flame-cutting and grinding operations are carried out on the counterweight. The filling of the counterweight chambers can create explosive gases which will accumulate in the chambers of the counterweight. These gases must be expelled before welding, flame-cutting and grinding operations are carried out on the counterweight. Danger of explosion. Follow the instructions given in PARTS & SERVICE NEWS No. AH04518 for expelling the gases from the counterweight chambers.
- Before carrying out welding, flame-cutting and grinding operations, clean the machine and its surroundings from dust and other inflammable substances and make sure that the premises are adequately ventilated (risk of explosion).

HYDRAULIC AND PNEUMATIC EQUIPMENT

- Work on hydraulic equipment may be carried out only by persons having special knowledge and experience in hydraulic systems.
- Check all lines, hoses and screwed connections regularly for leaks and obvious damage. Repair damage immediately. Splashed oil may cause injury and fire.
- Depressurize all system sections and pressure pipes (hydraulic system, compressed-air system) to be removed in accordance with the specific instructions for the unit concerned before carrying out any repair work.
- Hydraulic and compressed-air lines must be laid and fitted properly. Ensure that no connections are interchanged. The fittings, lengths and quality of the hoses must comply with the technical requirements.

NOISE

- During operation, all sound baffles must be closed. Always wear the prescribed ear protectors.

OIL, GREASE AND OTHER CHEMICAL SUBSTANCES

- When handling oil, grease and other chemical substances, observe the product-related safety regulations. Be careful when handling hot consumables (risk of burning or scalding).

2.1.7 TRANSPORTING AND TOWING -RECOMMISSIONING

- The machine must be towed, loaded and transported only in accordance with the Operation,- Lubrication and Maintenance Manual.
- For towing the machine observe the prescribed transport position, admissible speed and itinerary.
- Use only appropriate means of transport and lifting gear of adequate capacity.
- The recommissioning procedure must be strictly in accordance with the Operation,- Lubrication and Maintenance Manual.

2.1.8 SPECIAL SAFETY EQUIPMENT

SAFETY HARNESS IN CONFORMITY WITH EN 361 (EUROPEAN STANDARD)

The safety harness should only be used together with connectors according to EN 354, and fall arrest according to EN 355, or fall protection devices according to EN 360.

Refer to page page 29 in this section for more information.

FALLING-OBJECT PROTECTIVE STRUCTURE "FOPS" FOR OPERATOR'S CAB.

The Shovel must be equipped with a falling object protective structure "FOPS" if it is used for applications where there is a risk of falling material.
The "FOPS" structure shall comply with EN 474.

FRONT GUARD PROTECTIVE STRUCTURE "FGPS" FOR OPERATOR'S CAB

The Shovel must be equipped with a front guard protective structure "FGPS" if it is used for applications where there is a risk of hitting objects from the front.

OBJECT HANDLING

Object handling operations are not allowed. If the Shovel is used for object handling applications it must be equipped with the respective safety devices.

LIGHTING

The Shovel must only be operated when the operator has sufficient visibility in relation to the work area.

Disturbing shady areas or dazzling effects must be avoided.

If necessary, the Shovel must be retrofitted with lighting equipment (working lights) in order to ensure sufficient visibility conditions.

WARNING BEACON

The Shovel can be retrofitted with a warning beacon which is fitted on the cab roof by means of a magnetic bracket.

NOTICE

The above-mentioned special safety devices can be ordered as accessories together with the Shovel.

They are also available as a field package for installation through our service organization.

This page left intentionally blank

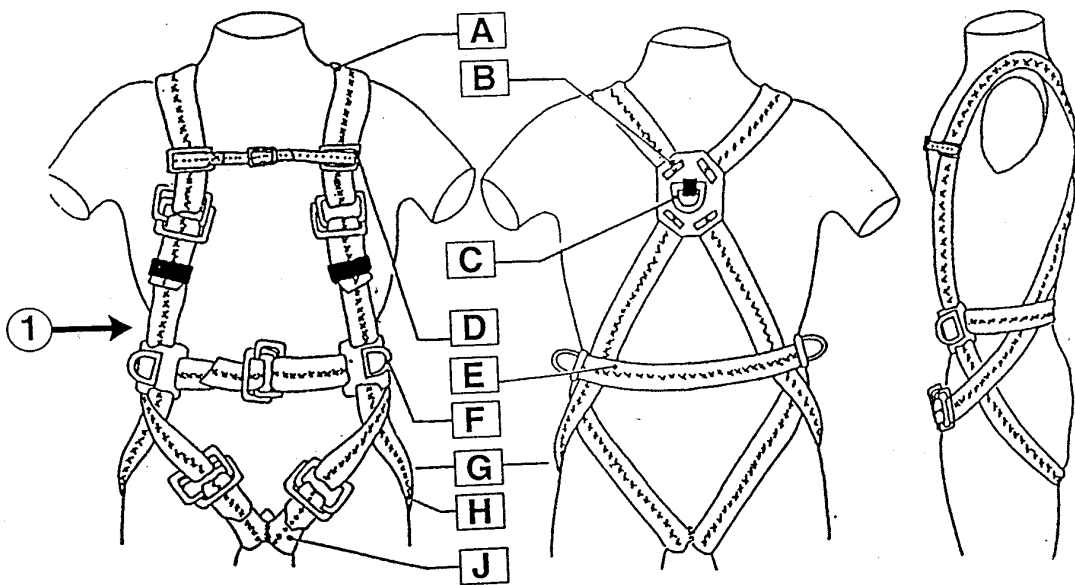
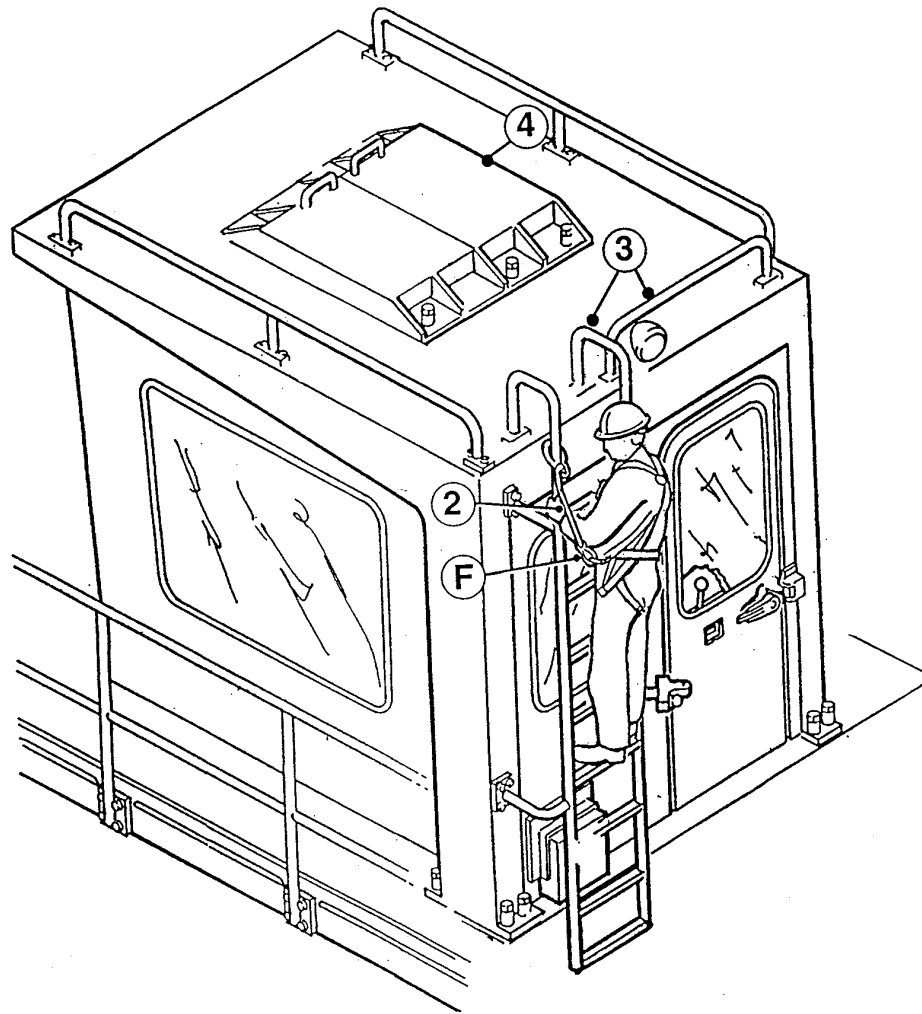

Z 20885

2.1.9 SAFETY HARNESS IN CONFORMITY WITH EN 361 (EUROPEAN STANDARD)

⚠ WARNING

Always use the Safety Harness (1) in conjunction with strap type Fall Absorber (2), illust. (Z 20885) before mounting onto the loader attachment or other unsecured places of the Shovel.

NOTICE

- The Safety Harness is located in the Cabinet of the Operator's Cab.
- The illustration (Z 20885) shows a typical use of the safety harness in connection with the strap type fall absorber.

Legend for illustration Z 20885

- (1) Safety Harness according to EN 361
- (2) Strap-Type Fall Absorber according to DIN EN 355
- (3) Ladder to cab roof and railings (attachment points)
- (4) Protection hoods for roof mounted air conditioning, if so equipped
- (A) Shoulder Strap
- (B) Back Plate
- (C) Catching Hook
- (D) Shoulder-Strap Fixing
- (E) Belly Strap
- (F) Holding Hook
- (G) Hold-Back Hook
- (H) Pelvis Strap
- (J) Leg Strap

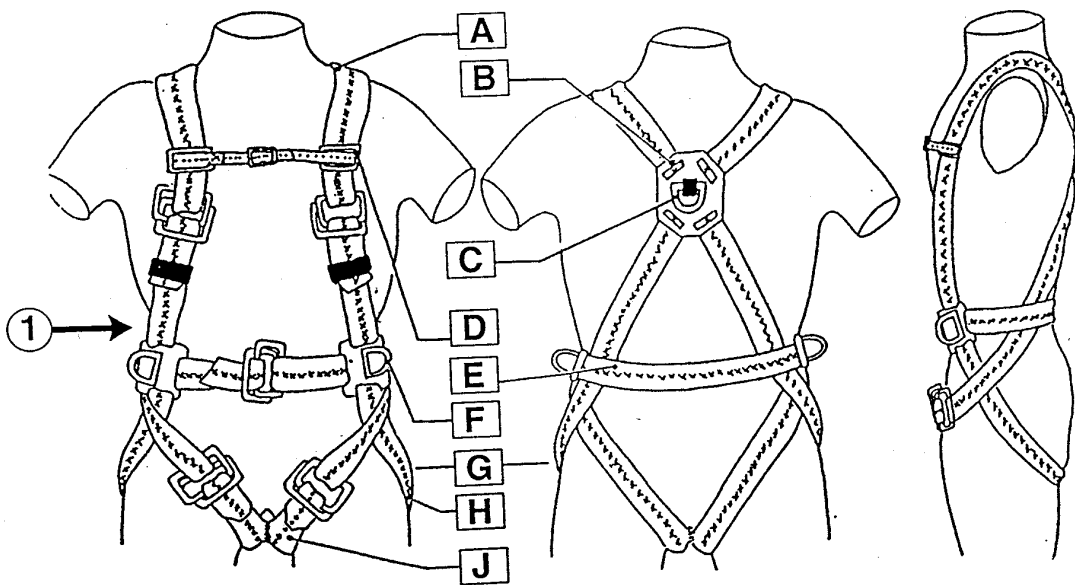
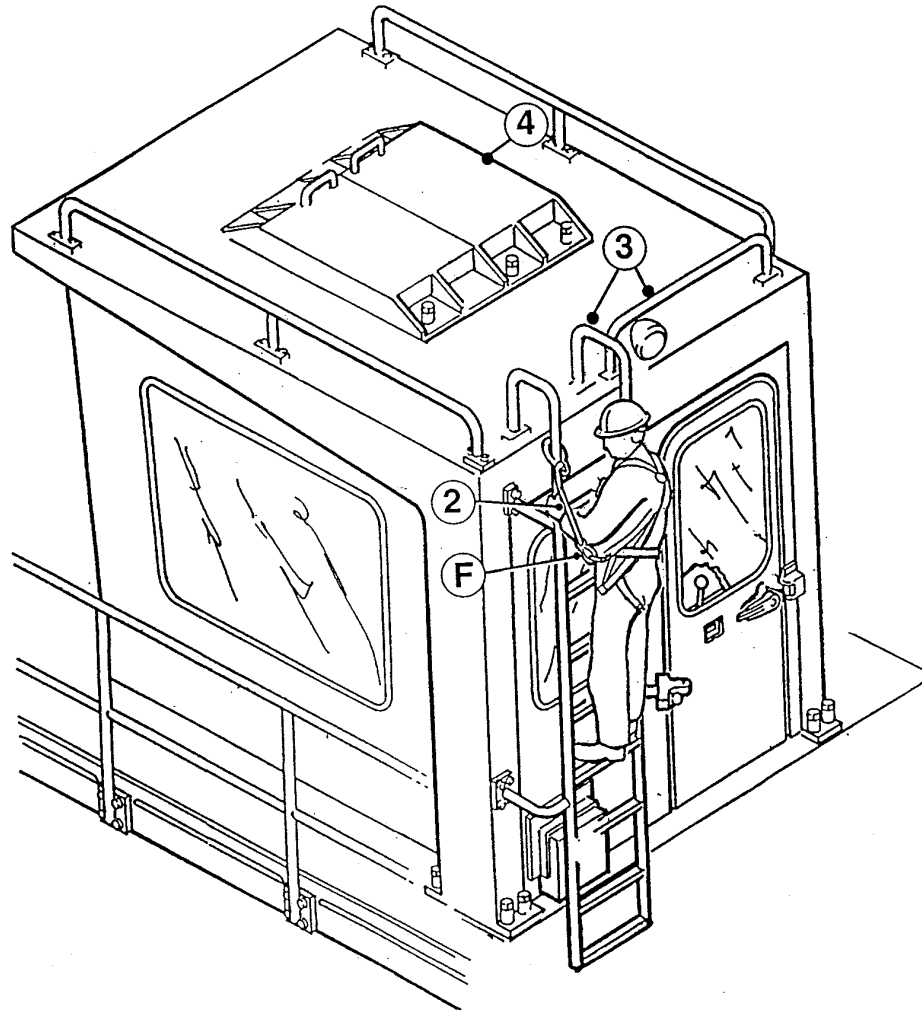

Z 20885

INSTRUCTIONS FOR USE

Open the lock, lift the harness by the catch hook (C), the blue straps (leg straps J) are below. The harness is being put on just like a jacket. Pull the belly strap (E) through the lock, as shown on the illustration, and secure it.

By closing the breast strap, you avoid the shoulder straps to side-slip. Bring the leg straps (J) around the legs to the front, pull them in, as shown in the illustration, and tighten them. Adapt the harness to body form, seeing to perfect fit, in particular that the catching hook (C) be in the center of the back.

The safety harness should belong to its wearer personally.

The safety harness should only be used together with connectors acc. to EN 354, and fall arrest acc. to EN 355, or fall protection devices acc. to EN 360.

The attachment point for the safety harness should be above the wearer, and the carrying capacity of the attachment point should be sufficient to correspond with the minimum carrying capacity acc. to EN 795.

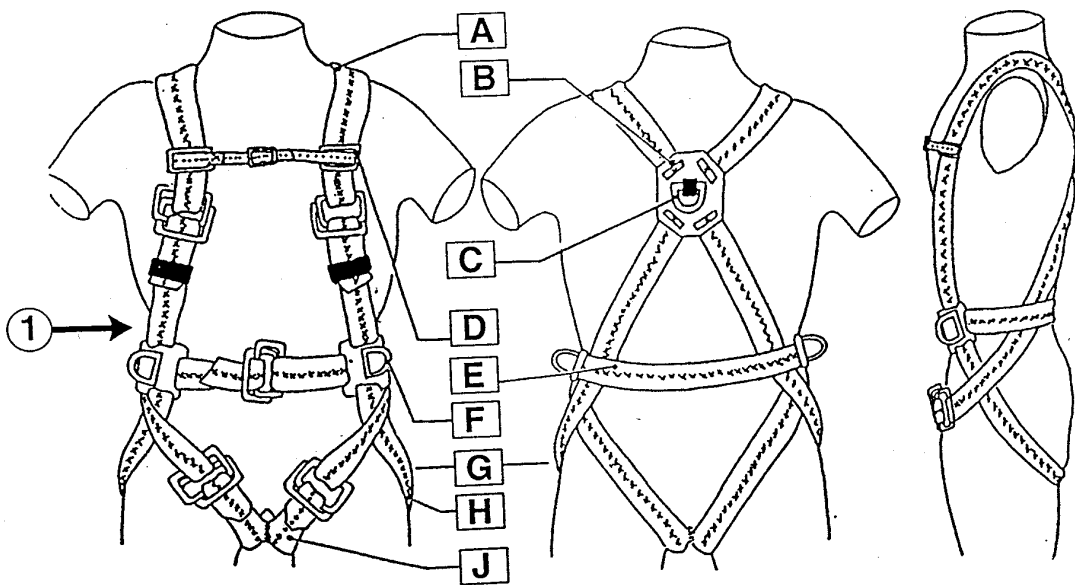
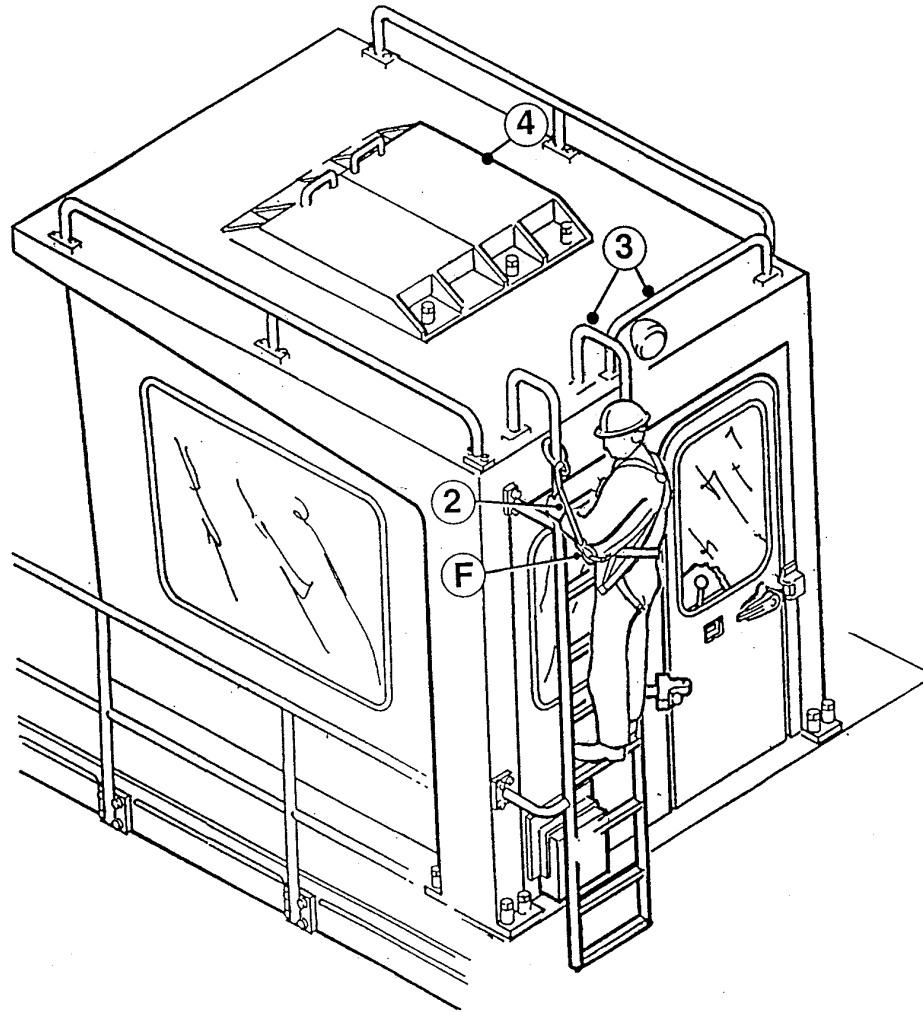

Z 20885

PRIOR TO USING THE HARNESS (1), THE WEARER SHALL

- Carry out a visual check of the system or component; correct functioning and perfect working order have to be assured.
- Make sure that the recommendations for use with other components of the system be observed in conformity with the instructions for use.

The system or component must no longer be used, if there are any doubts in respect

of its safe condition. The equipment has to be inspected by the manufacturer or by a qualified person.

It is essential for safety reasons that a fall protection system or system component

which has already been subjected to fall be removed from service and sent back to the manufacturer or an authorized qualified repair shop for maintenance and renewed testing.

Fall protection systems have to be treated with care and to be kept clean and ready for use. It has to be warned against bringing the systems into contact with acids or other caustic liquids and gases, oils, detergents, or sharp-edged objects.

Should the harness have become wet during use or cleaning, do not dry near a fire or other sources of heat, but rather in a natural way in not too warm rooms. Keep the harness freely suspended or loosely rolled up.

When using the fall protection systems, the pertaining safety regulations in force and the "Rules for Use of Personal Fall Arrest Systems" have to be observed for protection against danger.

At least every 12 months, the safety harness and its components have to be inspected by a competent person authorized by the manufacturer and maintained, if the manufacturer considers it necessary.

RECOMMENDATIONS FOR USE OF THE HOLDING HOOKS AND HOLD-BACK HOOKS OF THE SAFETY HARNESS (1),

During the holding function, the connectors may only be placed around a mast or other construction between the two holding hooks, so that free fall is limited to max.0.5 m.

It should be strictly seen to it that the connector be not slung around constructions with too small diameter or sharp edges.

With the lateral holding hooks, work may only be carried out on horizontal or almost horizontal surfaces (roofs). The connectors have to be adjusted in such a way that the area, where danger of falling down prevails, cannot be reached.

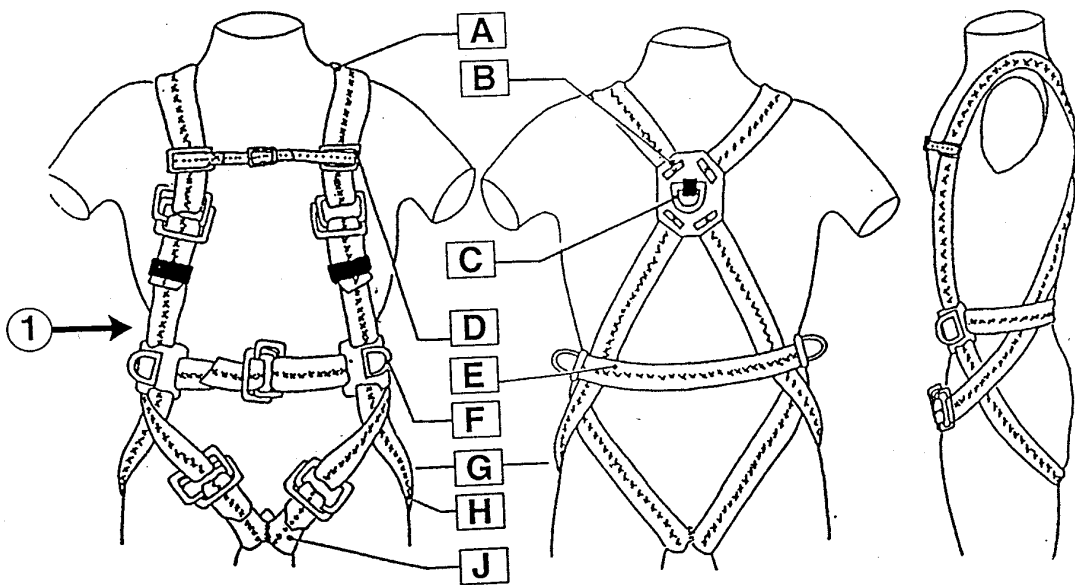
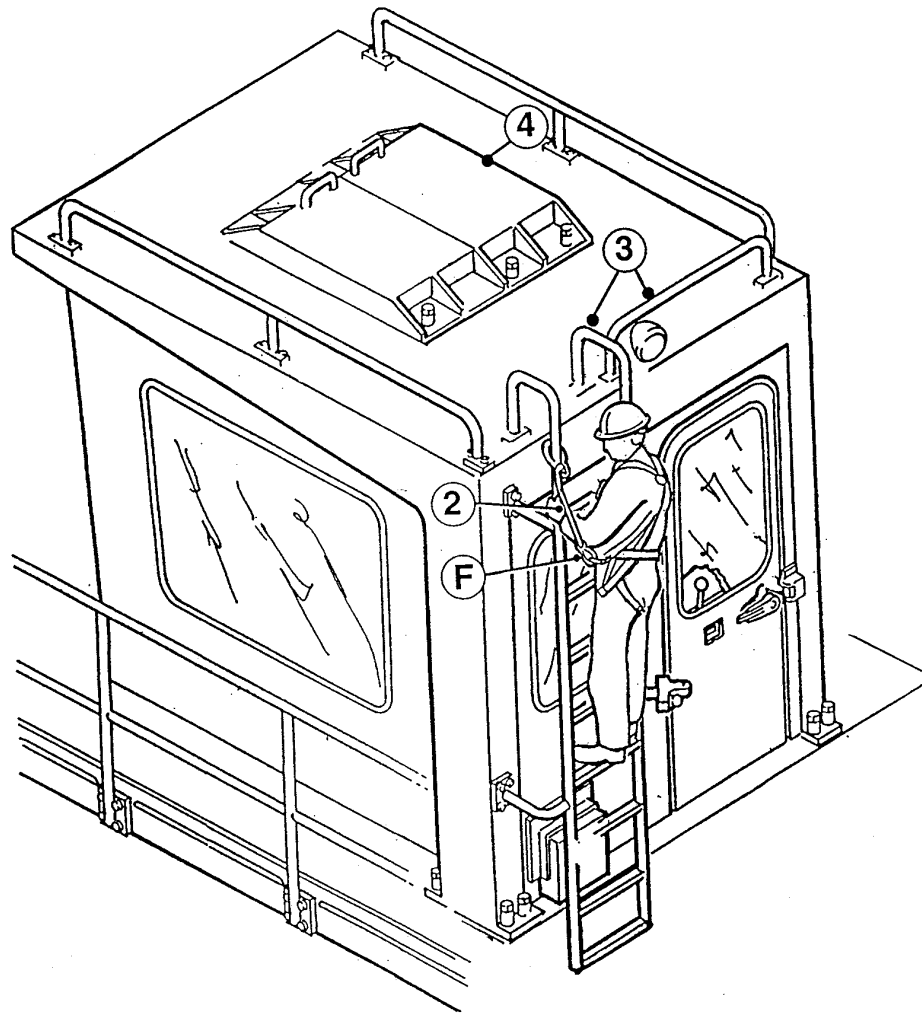

Z 20885

INSTRUCTIONS FOR USE

Strap-Type Fall Absorber acc. to DIN EN 355 (Type E.K.N.-BFD)

Use

Within a fall-arrest system, the strap-type fall absorber (2) has to be used in conjunction with a safety harness (1) acc. to DIN EN 361. The maximum length including the safety rope must not exceed 2.0 m. For longer ropes, a rope-shortening device has to be applied in addition.

Fix the rope to the attachment point and attach the strap-type fall absorber to the catching hook in the back of the safety harness. The attachment point should be above the wearer and its minimum carrying capacity should be 10 KN, acc. to DIN EN 795.

The strap-type fall absorber and the safety rope must not be damaged, e.g. never pull

them over sharp edges nor get them burnt by welding sparks.

Storing and maintenance

The strap-type fall absorber has to be kept dry in an airy and shady room. It must not be exposed to acids, caustic chemicals, nor to an aggressive atmosphere, and contact with oils has to be avoided. If the strap-type fall absorber is dirty, it may be cleaned with a little water and a light-duty detergent. Dry it in a shady place (nowhere near fire or other sources of heat). Protect it from sharp-edged objects.

Inspection

Prior to use, all parts have to be inspected for safe condition and damages. At least once a year, the strap-type fall absorber has to be tested by a competent person. A damaged or used strap-type fall absorber has to be removed from service immediately. The strap-type fall absorber must not be changed in any way. Repair work has to be done by the

3. OPERATION

3.1 FOREWORD

This Operation Manual contains the instructions for correct operation of your KOMATSU Mining Shovel. It should always be ready for use in the Operator's cab.

▲ WARNING

The information in this manual does not replace any safety rules or laws used in your area.

Special safety regulations are given in the rules for the prevention of accidents. It is your responsibility to observe these rules.

Carefully read the Safety Instructions → See "SAFETY" on page 15.

Before operating the machine, familiarize yourself with its instruments and controls.

Observe the instructions in this manual for:

- your Personal SAFETY
- Operating SAFETY, and
- READY and EFFICIENT PERFORMANCE of your KOMATSU Mining Shovel.

▲ WARNING

Improper operation of this machine can cause injury or death.

NOTICE

Optional equipment and accessories are available. Disregard the instructions for equipment not on your Shovel.

3.2 CONSTRUCTION OF THE SHOVEL

3.2.1 OVERALL VIEW

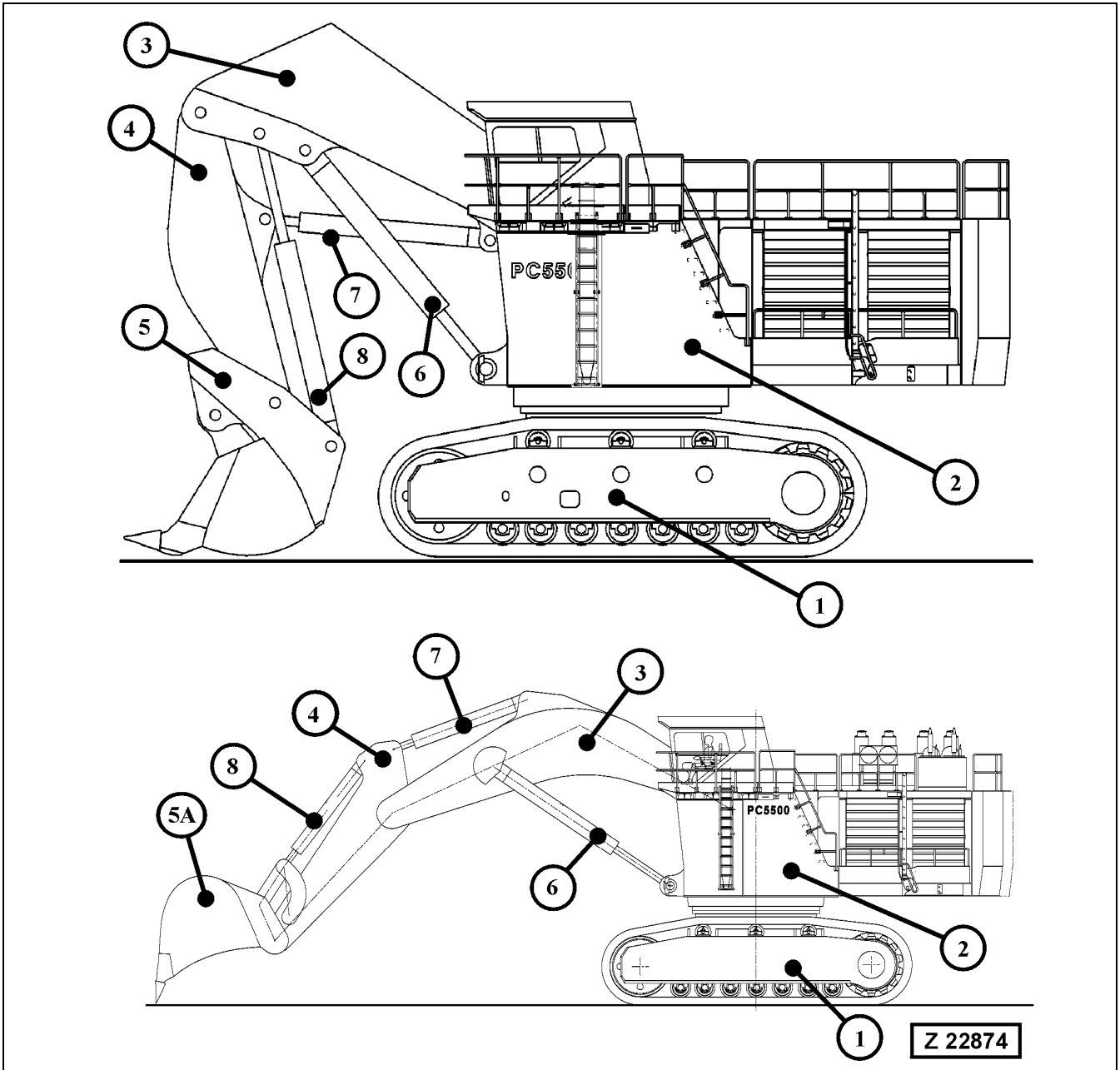

Legend for illustration Z22874

- | | | | |
|-----|--------------------|------|------------------|
| (1) | Undercarriage | (5A) | Backhoe bucket |
| (2) | Superstructure | (6) | Boom cylinders |
| (3) | Boom | (7) | Stick cylinders |
| (4) | Stick | (8) | Bucket cylinders |
| (5) | Bottom dump bucket | | |

3.2.2 UNDERCARRIAGE AND SUPERSTRUCTURE

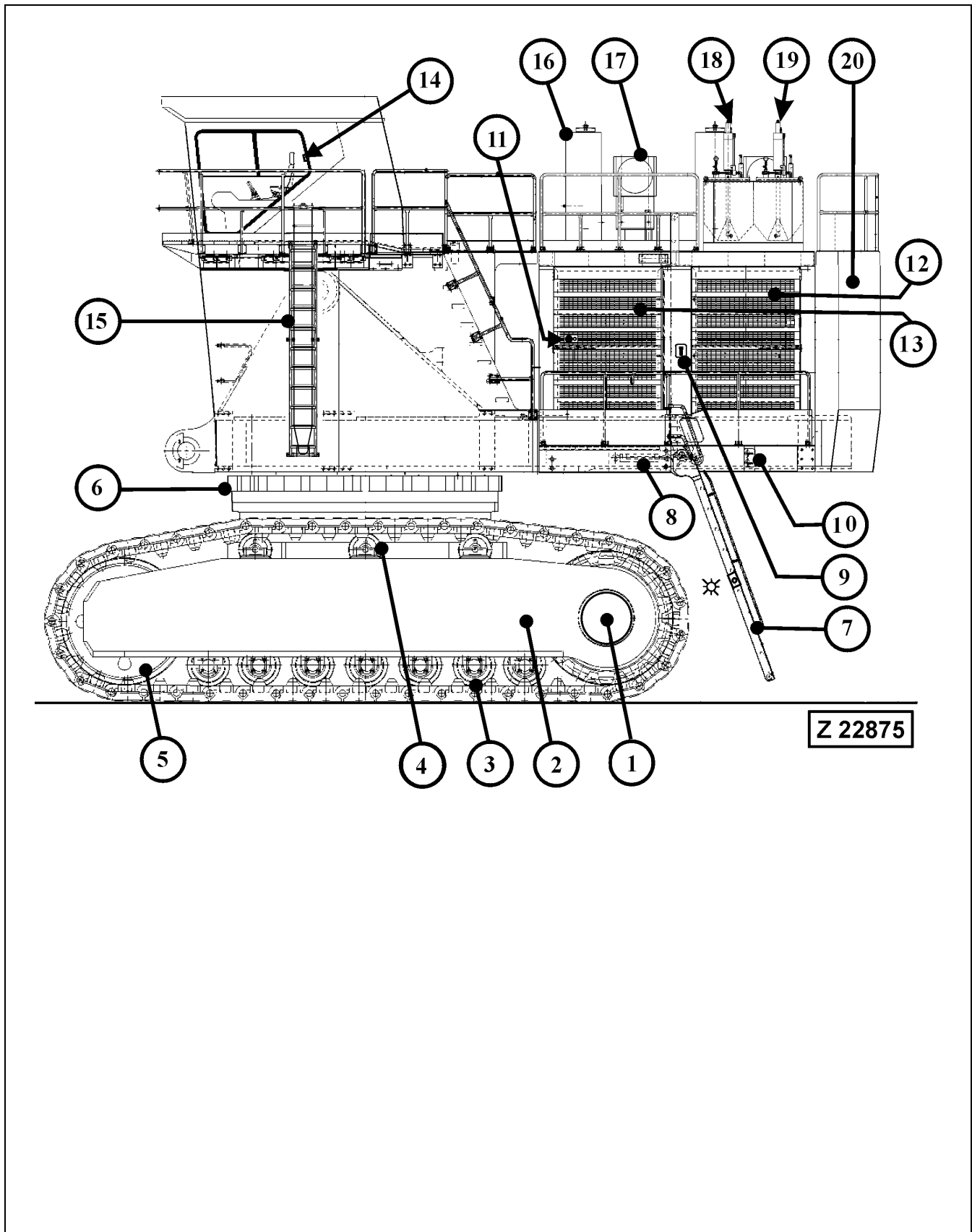

Legend for illustration Z22875

- (1) Final drive, hub type travel gear
- (2) Crawler carrier
- (3) Track roller
- (4) Carrier roller
- (5) Guide wheel
- (6) Swing circle guard
- (7) Hydraulically operated access ladder, see page 46 for more information
- (8) Hydraulic cylinder for access ladder
- (9) Control switch for access ladder
- (10) Battery main switches
- (11) Emergency engine shut down switch and manual actuator switch for the fire suppression system, if so equipped.

CAUTION

Never stop the engines from a full load except in case of emergency. If a hot engine is shut down without previous idling period of three to five minutes, the temperature in certain engine parts rising sharply after the cooling system ceases to function. The resulting thermal stress, especially in the turbochargers, may cause serious damage.

- (12) Radiator of rear engine, designation number 1
- (13) Radiator of front engine, designation number 2
- (14) Sliding window of operator's cab, see page 54 for more information
- (15) Emergency escape ladder
- (16) Exhaust muffler
- (17) Engine air cleaners
- (18) Hydraulically driven grease pump of the Swing circle pinion Lubrication System (SLS)
- (19) Hydraulically driven grease pump of the Central Lubrication System (CLS)
- (20) Counterweight

WARNING

The chambers of the counterweight are filled with a mixture of concrete, granulated ore and steel pellets. This mixture can create explosive gases which will accumulate in the chambers of the counterweight. Before any welding, flame-cutting, grinding or drilling procedures are carried out on the counterweight it is vital to expel these gases from the counterweight chambers. Failure to properly expel the gases from the counterweight chambers can result in an explosion with serious personal injury or death. Follow the instructions given in PARTS & SERVICE NEWS No. AH04518 for expelling the gases from the counterweight chambers.

SUPERSTRUCTURE - TOP VIEW

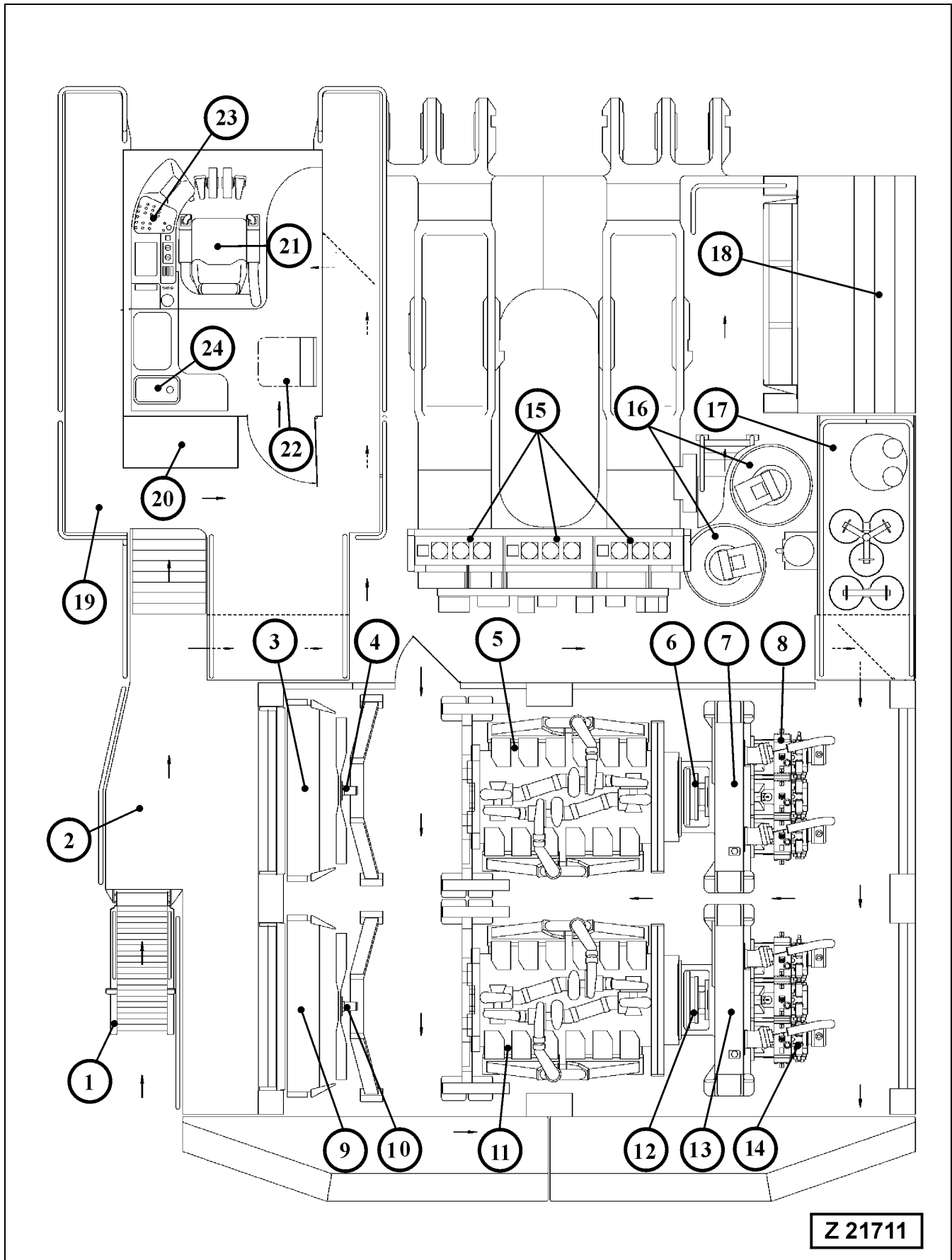

Legend for illustration Z21711

- (1) Hydraulically operated access ladder, see page 46 for more information
- (2) Lower deck
- (3) Coolant radiator for front engine number 2
- (4) Hydraulic motor for radiator fan drive
- (5) Front Diesel engine, designated as engine number 2
- (6) Flexible coupling, oil filled
- (7) Front PTO (pump distributor gear)
- (8) Main hydraulic pumps
- (9) Coolant radiator for rear engine number 1
- (10) Hydraulic motor for radiator fan drive
- (11) Rear Diesel engine, designated as engine number 1
- (12) Flexible coupling, oil filled
- (13) Rear PTO (pump distributor gear)
- (14) Main hydraulic pumps
- (15) Control valves with high pressure in-line filters
- (16) Swing gear
- (17) Main hydraulic oil tank
- (18) Hydraulic oil coolers
- (19) Upper deck
- (20) Air conditioner unit for Operator's cab
- (21) Operator's seat, see page 61 for more information
- (22) Co-driver's seat, see page 62 for more information
- (23) Instrument panel, see page 81 for more information
- (24) Hand wash sink, see page 59 for more information

MACHINERY HOUSE

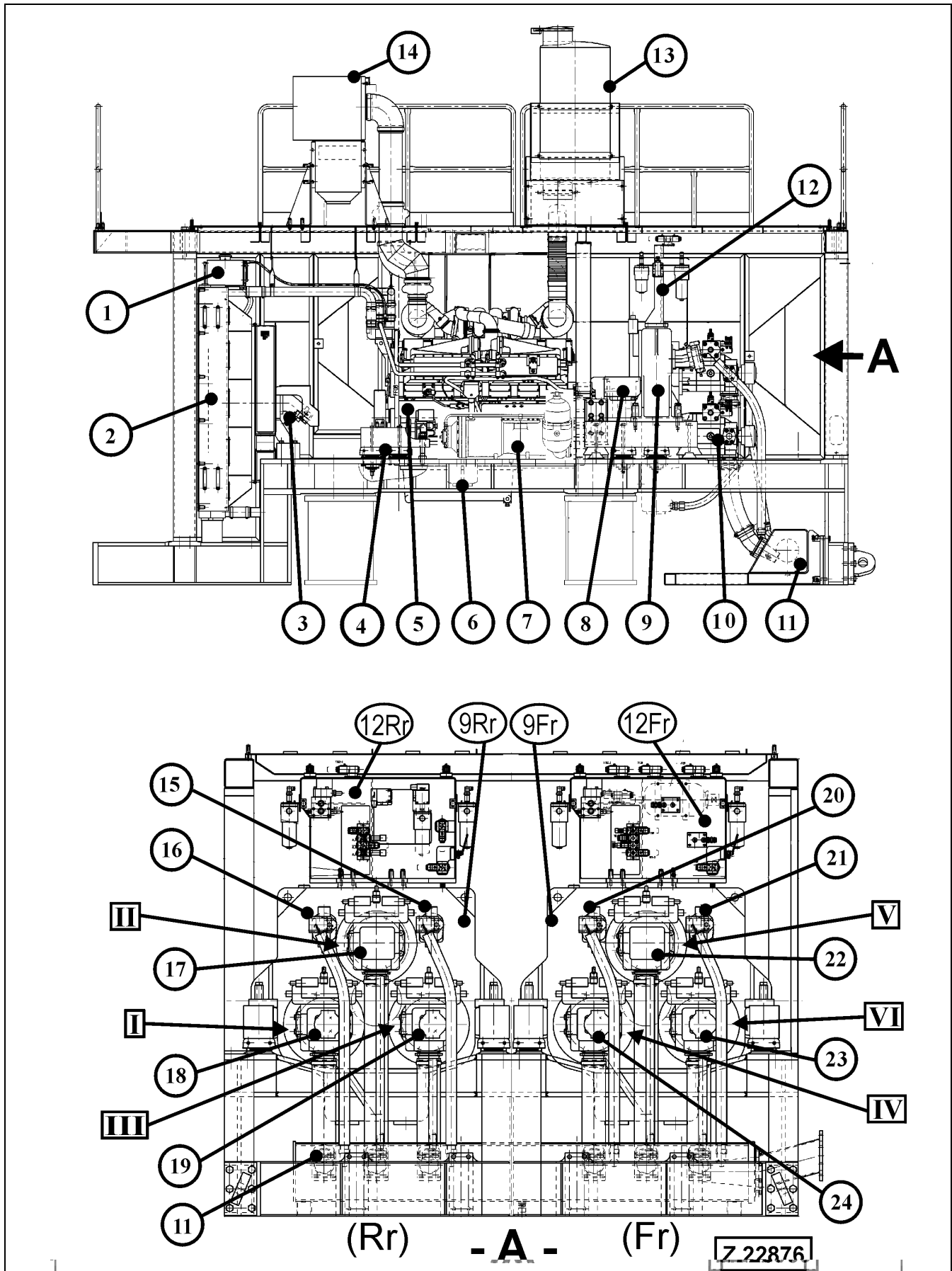

Legend for illustration Z22876**REMARK**

The upper part of the illustration shows the rear power unit, viewed from counterweight side.

The lower part, view "A" shows the pump compartment of the Rear power unit (Rr), engine number 1, and the pump compartment of the Front power unit (Fr), engine number 2.

- (1) Expansion tank for radiator
- (2) Coolant radiator
- (3) Hydraulic motor for radiator fan drive
- (4) Engine mounts
- (5) Diesel engine, refer to the separate Operation and Maintenance Manual, filed in volume 2 binder, for all operation and maintenance instructions.
- (6) Fuel filters
- (7) Eliminator engine oil filtration system, refer to the separate Service Bulletin "Eliminator Filter" filed in volume 2 binder for all operation and maintenance instructions.
- (8) Cover for flexible coupling
- (9) PTO, pump distributor gear
(Rr) Rear PTO
(Fr) Front PTO
- (10) Main hydraulic pumps (I - VI)
- (11) Suction oil reservoir
- (12) Control and filter panel
(Rr) Rear Control and filter panel
(Fr) Front Control and filter panel
- (13) Exhaust muffler
- (14) Engine air cleaner
- (15) Hydraulic pump for hydraulic oil cooler fan drive
- (16) Hydraulic pump for radiator fan drive of engine 1
- (17) Circulating pump for hydraulic oil cooling circuit
- (18) Pump for PTO gear 1 lubrication
- (19) Pump for pilot pressure circuit
- (20) Hydraulic pump for radiator fan drive of engine 2
- (21) Hydraulic pump for hydraulic oil cooler fan drive
- (22) Circulating pump for hydraulic oil cooling circuit
- (23) Pump for pilot pressure circuit
- (24) Pump for PTO gear 2 lubrication

3.2.3 HYDRAULICALLY OPERATED ACCESS LADDER

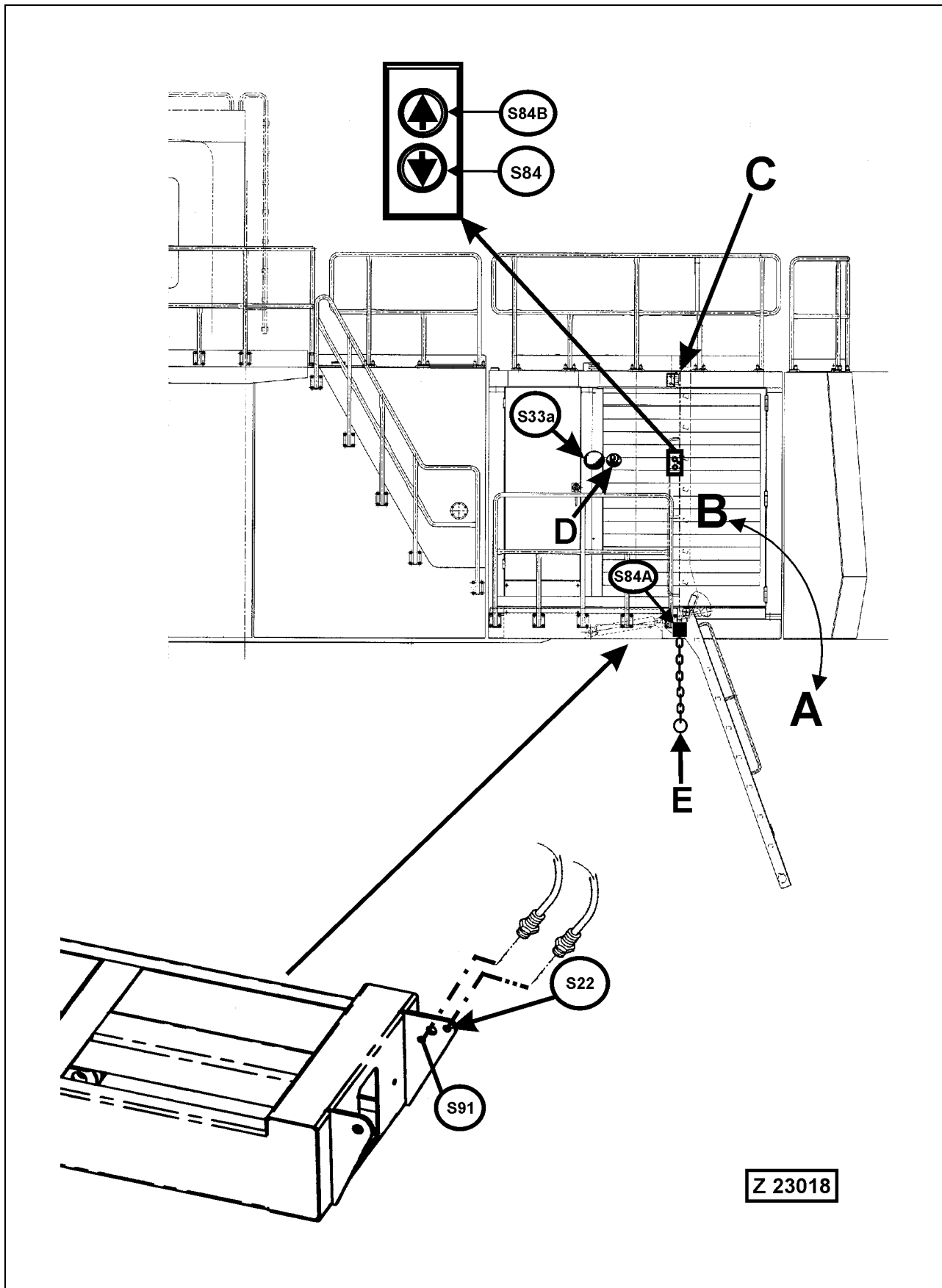

Legend for illustration Z 23018

- (A) Access ladder in lowered position
- (B) Access ladder in upper position (Working position)
- (C) Stop bar
- (D) Manual actuator for fire suppression system (if so equipped)
- (E) Pull chain for emergency lowering of the access ladder

⚠ CAUTION

Use this chain only in emergency cases, when the Operator does not respond to other communication signals.

- (S84) Ladder control switch for lowering the ladder
- (S84B) Ladder control switch for lifting the ladder
- (S84A) Safety switch for emergency lowering of the access ladder. When the chain (E) is being pulled down with the engine running, the pilot control system is made inoperative, preventing further movements of the Shovel.
- (S22) Safety sensor, located on ladder pivot bracket
Function of sensor (S22): Cut out of the pilot control system and actuation of the hydraulic swing brake with the ladder in lowered position.
- (S91) Monitor and control sensor
Function of sensor (S91):
This sensor monitors the ladder position and controls the moving speed of the ladder. In case the sensor (S22) fails to function properly, the sensor (S91) prevents unintended movement of the ladder.
- (S33A) Emergency shutdown switch for both engines

Operating the hydraulic Access Ladder

⚠ WARNING

- **Make sure the moving range of the ladder is clear of all persons before raising the ladder. Stop raising the ladder by releasing the control switch (S84B) if there are any obstacles within the moving range of the ladder.**
 - **Mount the ladder only in completely lowered position. Entering the ladder in any other position can result in serious injury or death.**
 - **DO NOT lift persons with the hydraulic access ladder. Death or serious injury can result.**
 - **DO NOT lift objects (tools) with the hydraulic access ladder.**
-
-

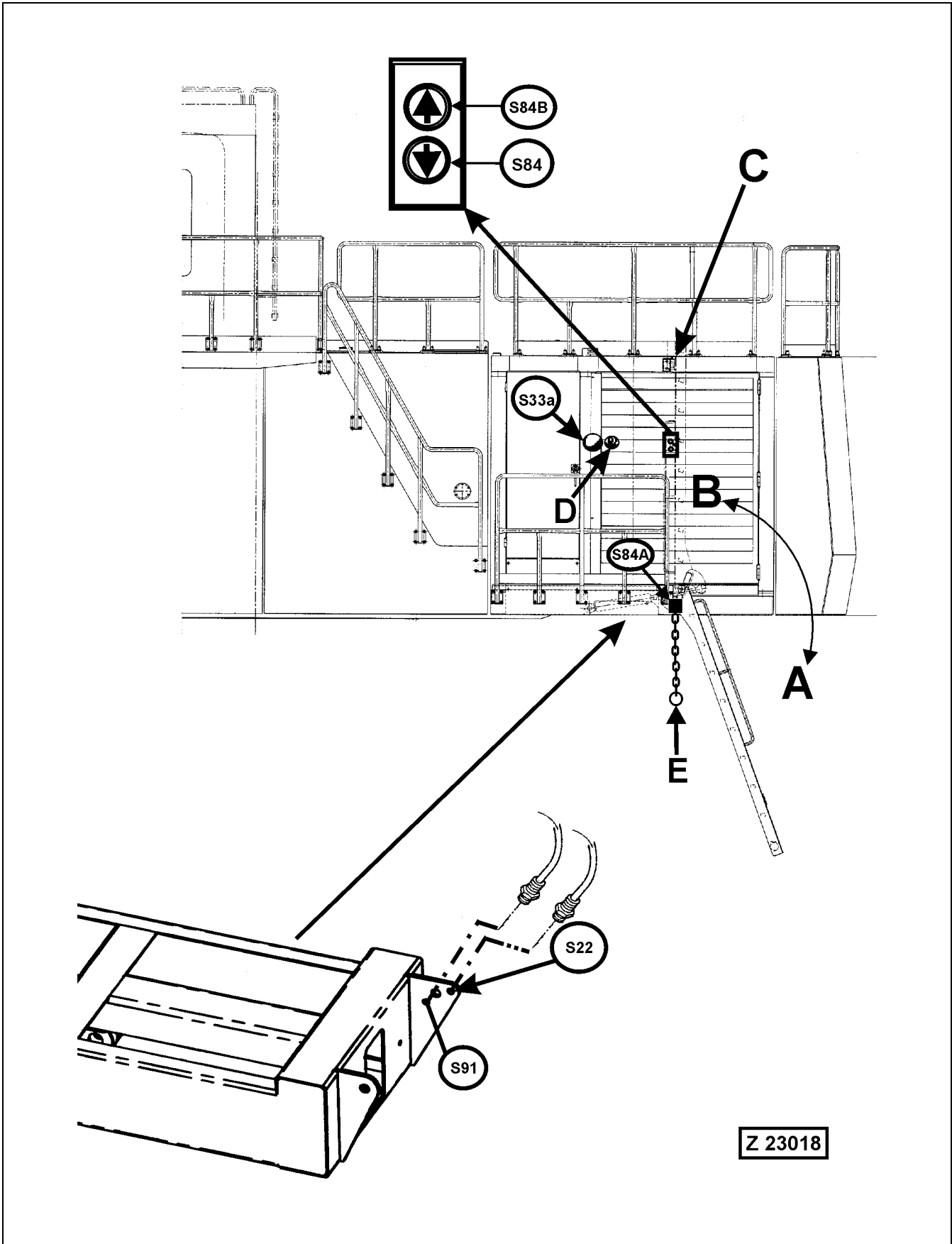

Operating the hydraulic Access Ladder, illust. (Z 23018)**Raise the ladder**

Enter the Shovel with ladder in fully lowered position (A).

Start the engine.

For starting procedure → See "STARTING THE ENGINES" on page 234.

Go back to the ladder control switch (S84B).

Raise the ladder by pressing button (84B) until the ladder contacts the stop bar (C) in position (B).

Lowering the ladder

Stop the engine.

For stopping procedure → See "STOPPING THE ENGINES" on page 264.

Lower the ladder by pressing push button (S84). If necessary, slightly push the ladder until it starts moving down by its own weight.

▲ WARNING

- **Make sure the moving range of the ladder is clear of all persons before lowering the ladder.**
 - **Enter the ladder only after the ladder is in fully lowered position (A).**
-
-

NOTICE

Check safety sensor of access ladder for correct function after every 50 operating hours or once a week. Refer to Maintenance Section 4, for checking procedure.

3.2.4 EMERGENCY ESCAPE LADDER

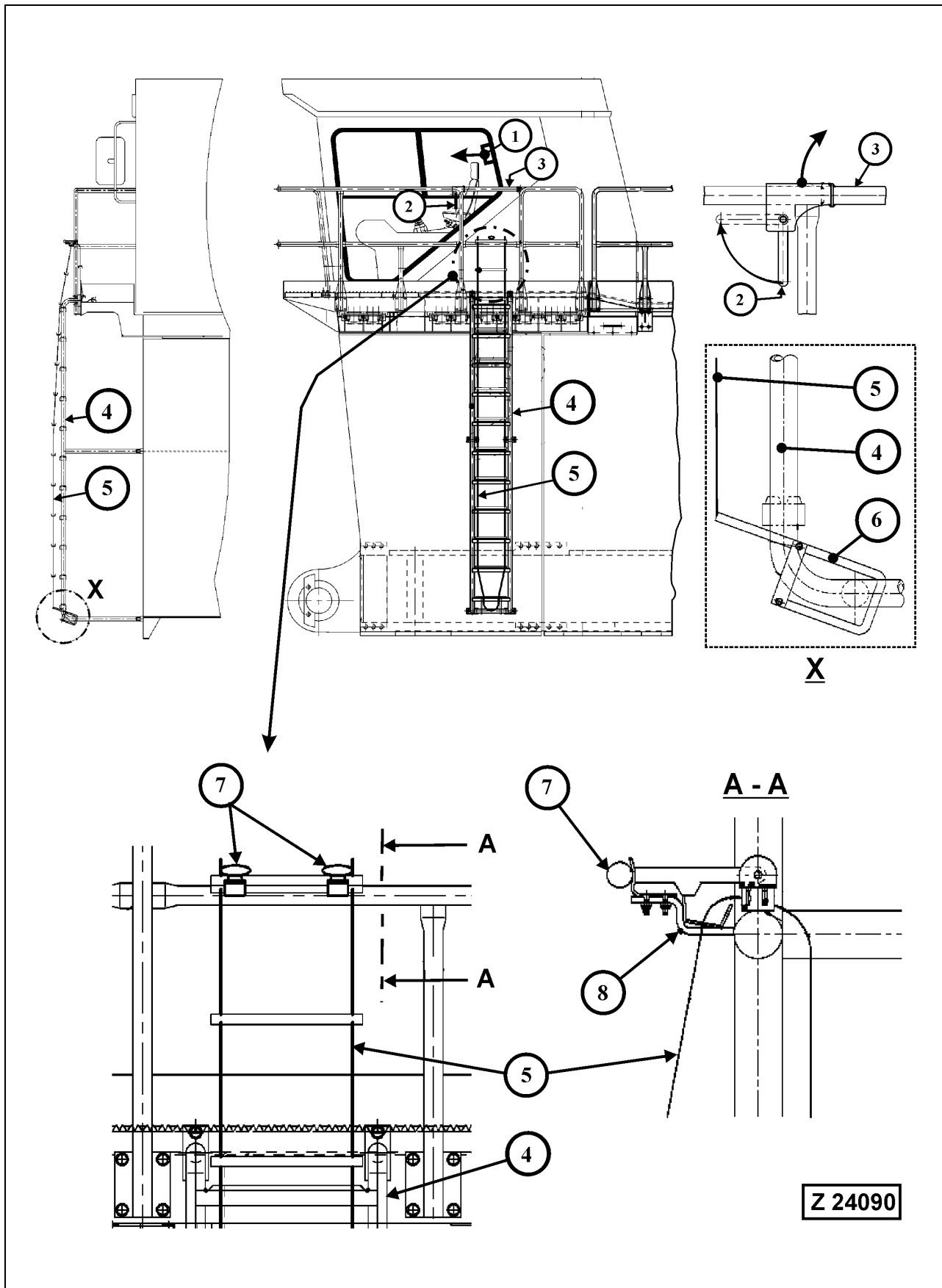

Legend for illust. Z24090

- (1) Sliding window, serves also for emergency exit
- REMARK**
- If the operator's cab is equipped with external metal sun visors, disengage the four catches and push out the sun visor panel.
- (2) Release lever for hinged railing bar (3)
 - (3) Hinged railing bar
 - (4) Rigidly mounted emergency escape ladder. The rigidly mounted emergency escape ladder with rope ladder extension provides the means to go down to the ground.
 - (5) Rope ladder. The upper end of the rope ladder is fixed onto the lower rung of the rigid escape ladder (4) by means of the fasteners (6), see detail (X). The lower end of the rope ladder is fixed on brackets (8) and secured with rubber fasteners (7), see section (A-A).
 - (6) Hooks for fastening the rope ladder onto the rigid ladder (4)
 - (7) Rubber fasteners for rope ladder in lifted position
 - (8) Bracket for rope ladder in lifted position. The lower rung of the rope ladder is hooked up into the brackets (8)

Using the emergency escape ladder

In case of emergency with normal walkways obstructed use escape ladder (4) and (5) for leaving the machine. Proceed as follows:

1. Move up lever (2) and pull out.
2. Open the hinged railing bar (3).
3. Unhook fasteners (7) and take out rope ladder rung from brackets (8).
4. Let the rope ladder fall down to the ground. The upper end of the rope ladder is fixed onto the lower rung of the rigid ladder (4).
5. Use the rigid ladder (4) and then the rope ladder (5) for leaving the shovel.

3.2.5 EMERGENCY ENGINE SHUTDOWN FROM GROUND MAN OR OPERATOR WARNING SYSTEM

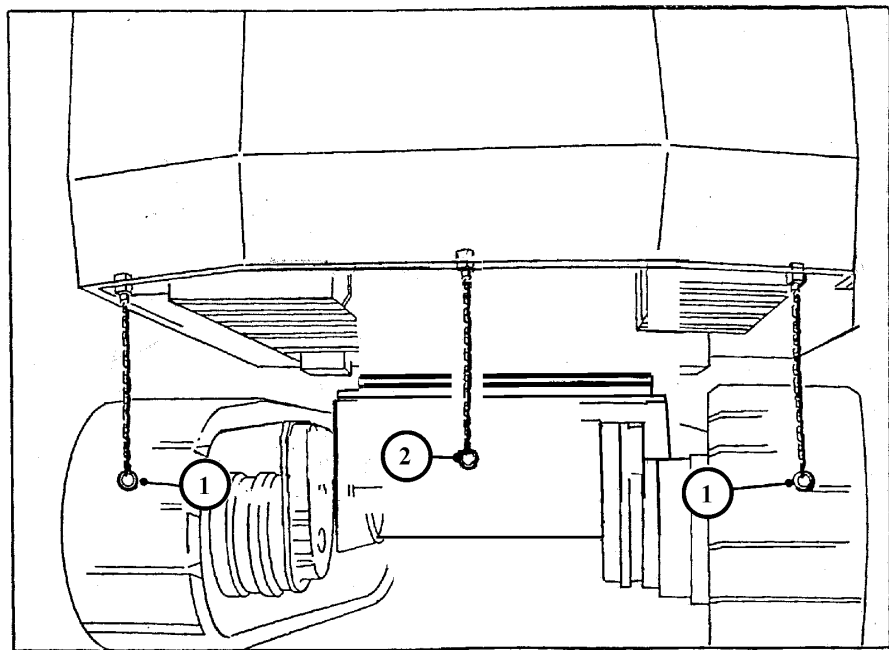
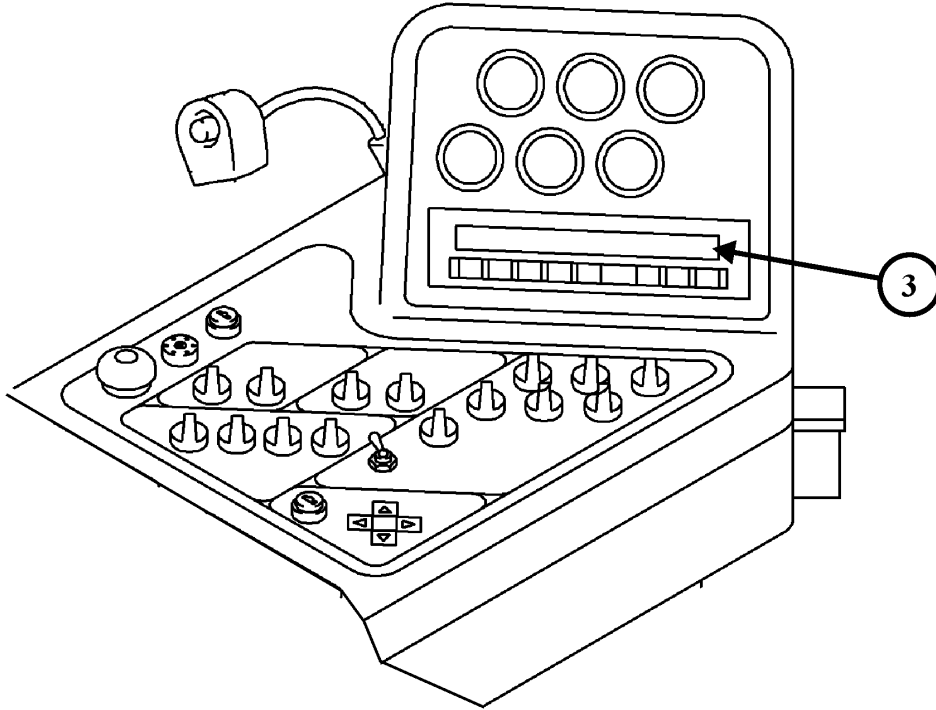

7225409

Emergency Engine Shutdown System actuated from Ground Man (Special Equipment)

Legend for illust. Z25499

- (1) Actuating chains for emergency shut down of both engines. To stop the engines, pull down one of the chains (1).
- (2) Actuating chain for hydraulically operated service arm.
- (3) ECS display on the instrument panel in the Operator's cab. When one of the chains (1) is being pulled down from ground man, both engines will be stopped and the following message will be displayed on the ECS screen (3):
Engine shut down has been actuated from ground man.

CAUTION

Never stop the engines from a full load except in case of emergency.

If a hot engine is shut down without previous idling period of three to five minutes, the temperature in certain engine parts rising sharply after the cooling system ceases to function. The resulting thermal stress, especially in the turbochargers, may cause serious damage.

Operator Warning System (Special Equipment)

This system is used to inform the Operator that someone wants to enter the Shovel or to draw the Operator's attention to special circumstances requiring his action.

Legend for illust. (Z25499):

- (1) Actuating chains for pull switches of the Operator warning system
- (2) Actuating chain for hydraulically operated service arm.
- (3) ECS display on the instrument panel in the Operator's cab. When one of the chains (1) is being pulled down the following message will be displayed on the ECS screen (3):
Warning: Pull switch from ground man actuated.

As soon as a chain (1) is being pulled down, the above message will be displayed informing the Operator that someone wants his attention. In such a case, the Operator should stop work until he has received the ground man's request.

3.2.6 OPERATOR'S CAB WITH INTEGRATED FALLING OBJECT PROTECTIVE STRUCTURE (FOPS)

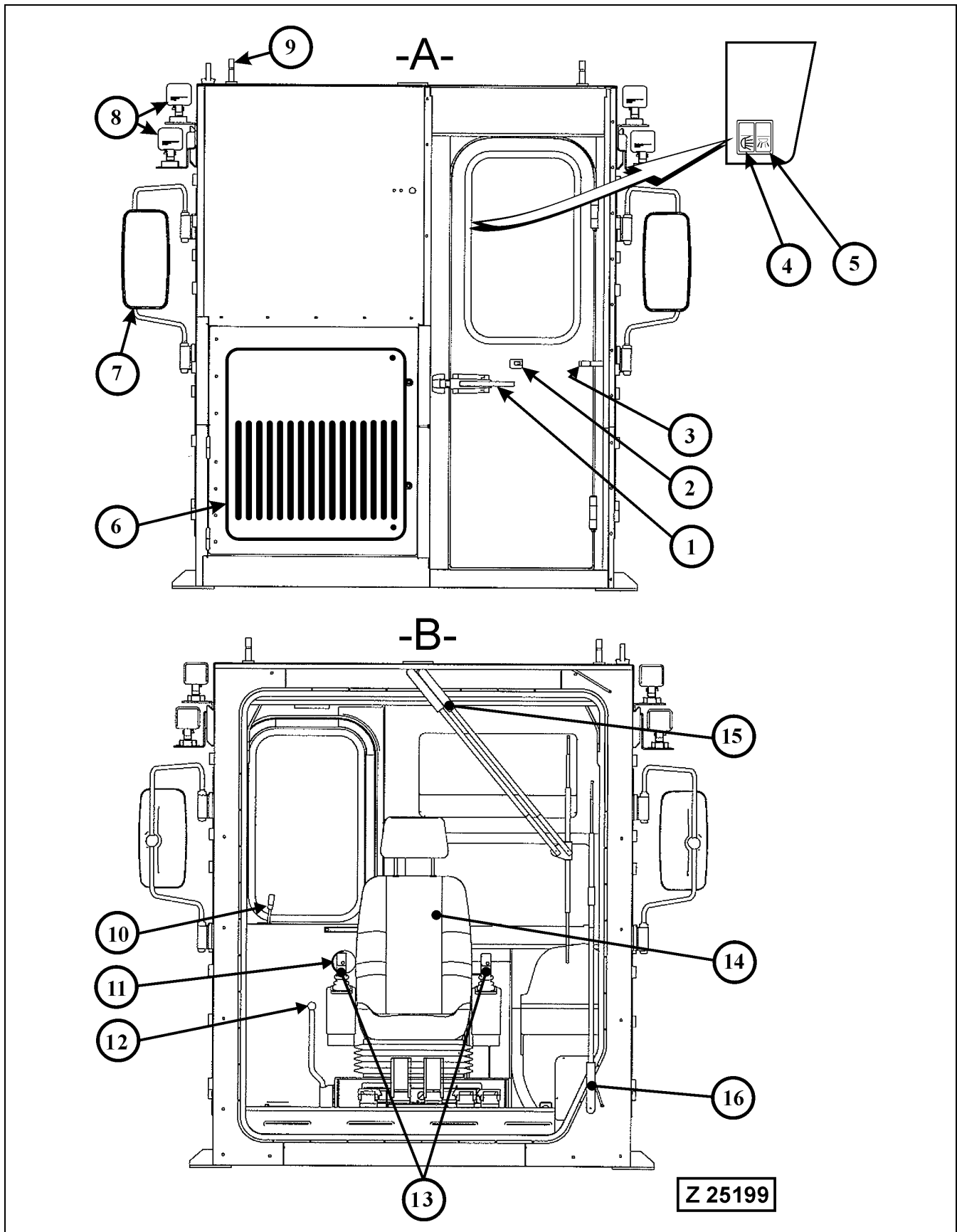

Legend for illust. Z 25199**NOTICE**

The Operator's cab is equipped with an integrated Falling Object Protective Structure (FOPS) that meets the requirements of ISO 3449. Any modifications on the steel structure of the cab are inadmissible. Repairs on the FOPS must only be carried out by specialists having the authorization for repair work on Falling Object Protective Structures and in accordance with the manufacturer's repair instructions.

A Rear View of Operator's Cab

- (1) Door handle
- (2) Door latch (with door fully opened)
- (3) Door locking pin, engages into latch (2) when the cab door is fully opened.
- (4) Light switch for access area lighting
- (5) Light switch for interior cab lighting
- (6) Air conditioner door
- (7) Outside Mirrors with integrated heaters, both mirrors are adjusted electrically via a control switch on the instrument panel. Refer to page 83 for more information.
- (8) Main Working Lights
- (9) Adapter for Warning Beacon

B Front View of Operator's Cab

- (10) Release lever for door lock (2 - 3)
- (11) Door opener push button
- (12) Safety lock lever, see page 57 for more information
- (13) Control levers for working attachment, see page 72 for more information.
- (14) Operator's Seat, refer to page page 61 for more information.
- (15) Upper windshield wiper
- (16) Lower windshield wiper

CAUTION

Make sure the cab door is always closed when working with the Shovel.

Lock the door in open position by engaging latch (2) into locking pin (3).

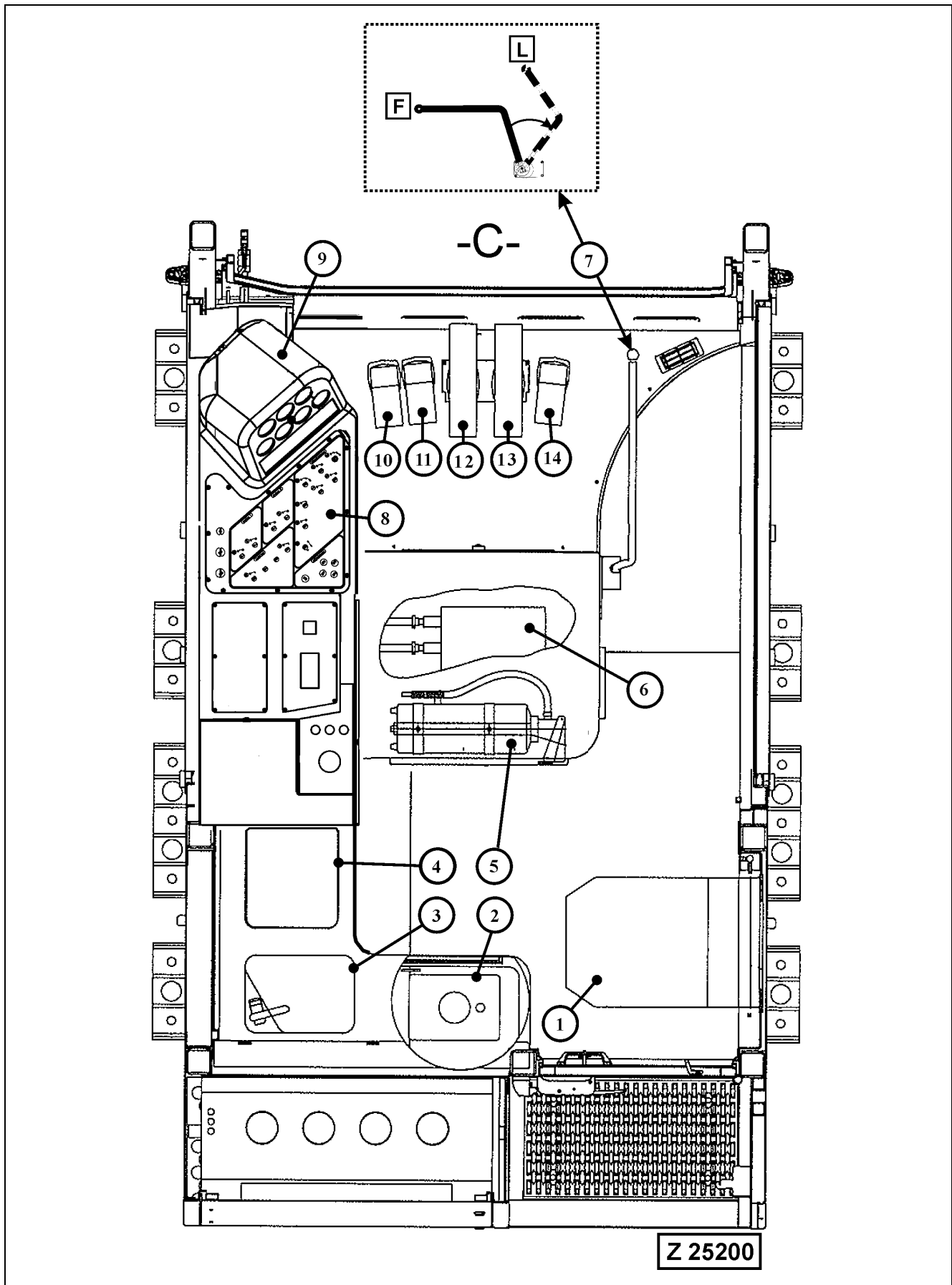

Legend for illustration Z25200**C Top View of Operator's Cab**

- (1) Co-driver's seat, refer to page 62 for more information
- (2) Windshield washer reservoir, refer to page 59 for more information.
- (3) Washbasin with water tap
- (4) Refrigerator box
- (5) Portable fire extinguisher located behind the Operator's seat. Make sure the fire extinguisher is always charged and ready for use.
- (6) Heater unit located in the seat base
- (7) Safety lock lever.
 - This lever locks the controls for working equipment, swing and travel drive when placed in the fully rear position (L).
 - Start the engine with lock lever in LOCKED position (L). Thereafter set the lock lever to free position (F) in order to enable operation of the hydraulic control system.

▲ WARNING

Before leaving the operator's cab set the safety lock lever to LOCK position (L). If the controls are not locked, and they are touched inadvertently, this may lead to a serious accident.

- (8) Instrument panel, see page 83 for more information.
- (9) Analog gauges and ECS display, see page 83 for more information.
- (10) Pedal for closing the bottom dump bucket (Face shovel only)
- (11) Pedal for opening the bottom dump bucket (Face shovel only)
- (12) Travel control pedal, left track forward - reverse
- (13) Travel control pedal, right track forward - reverse
- (14) Swing brake pedal

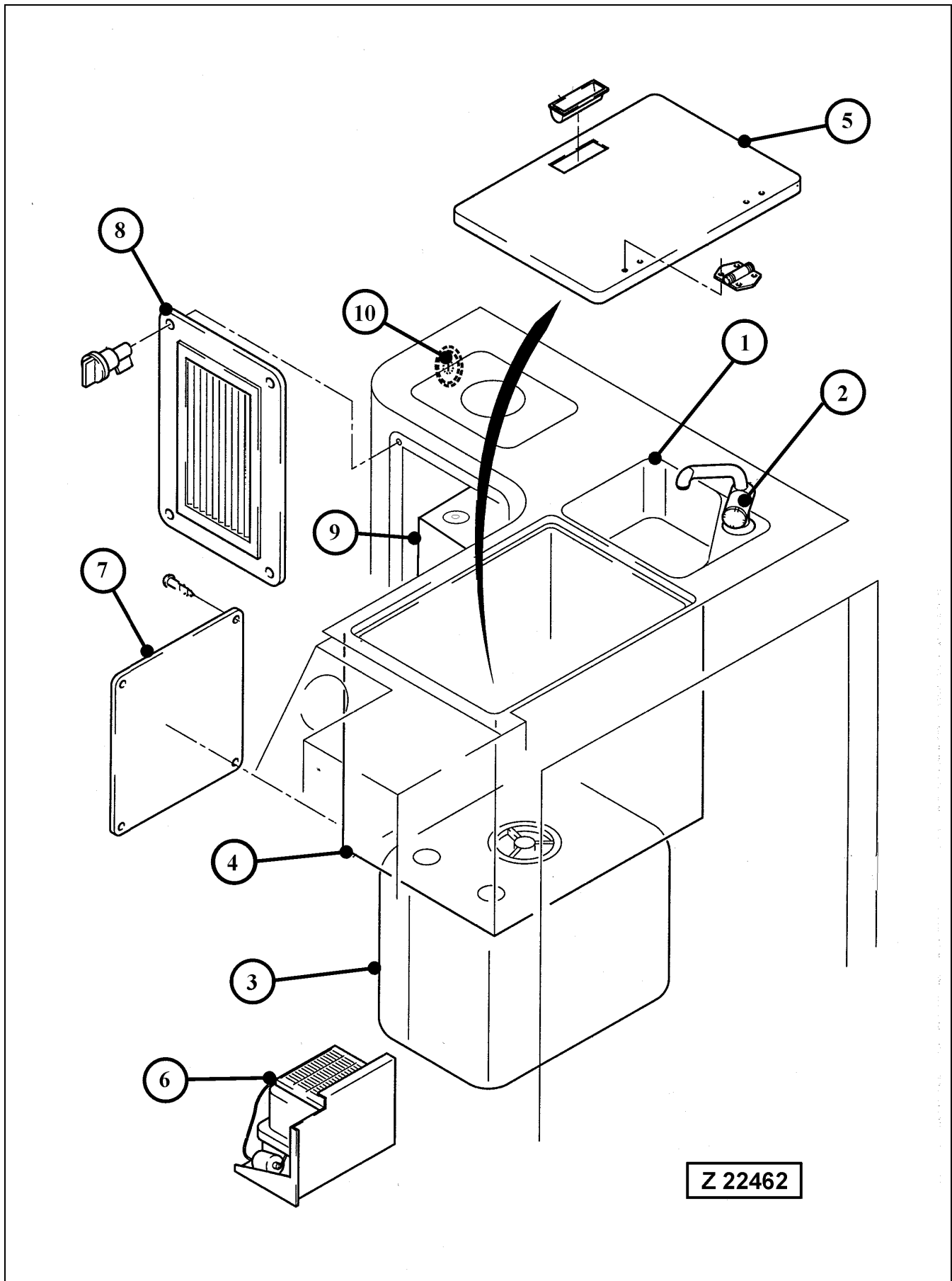

Operator's Cab - Hand Wash Sink and Refrigerator Box

Legend for illust. Z 21589

- (1) Hand wash sink
- (2) Water-tap

 **WARNING**

**No drinking water.
Use for hand washing only**

- (3) Water tank for hand wash sink. The capacity of the water tank is 50 liters. The tank can be filled through the filler opening (10) or via the adapter on the service arm. Refer to page 286 for more information.
- (4) Refrigerator box
- (5) Refrigerator box cover
- (6) Refrigerator unit
- (7) Access cover for water tank (3) and refrigerator unit (6)
- (8) Access cover for windshield washer reservoir
- (9) Windshield washer reservoir. The water reservoir is accessible after removing the cover (8). The reservoir has a capacity of 7 liters.
- (10) Filler cap lockable. To fill the water tank (3) unlock cap (10) using the key provided and remove. Be sure to lock the cap after filling the water tank.

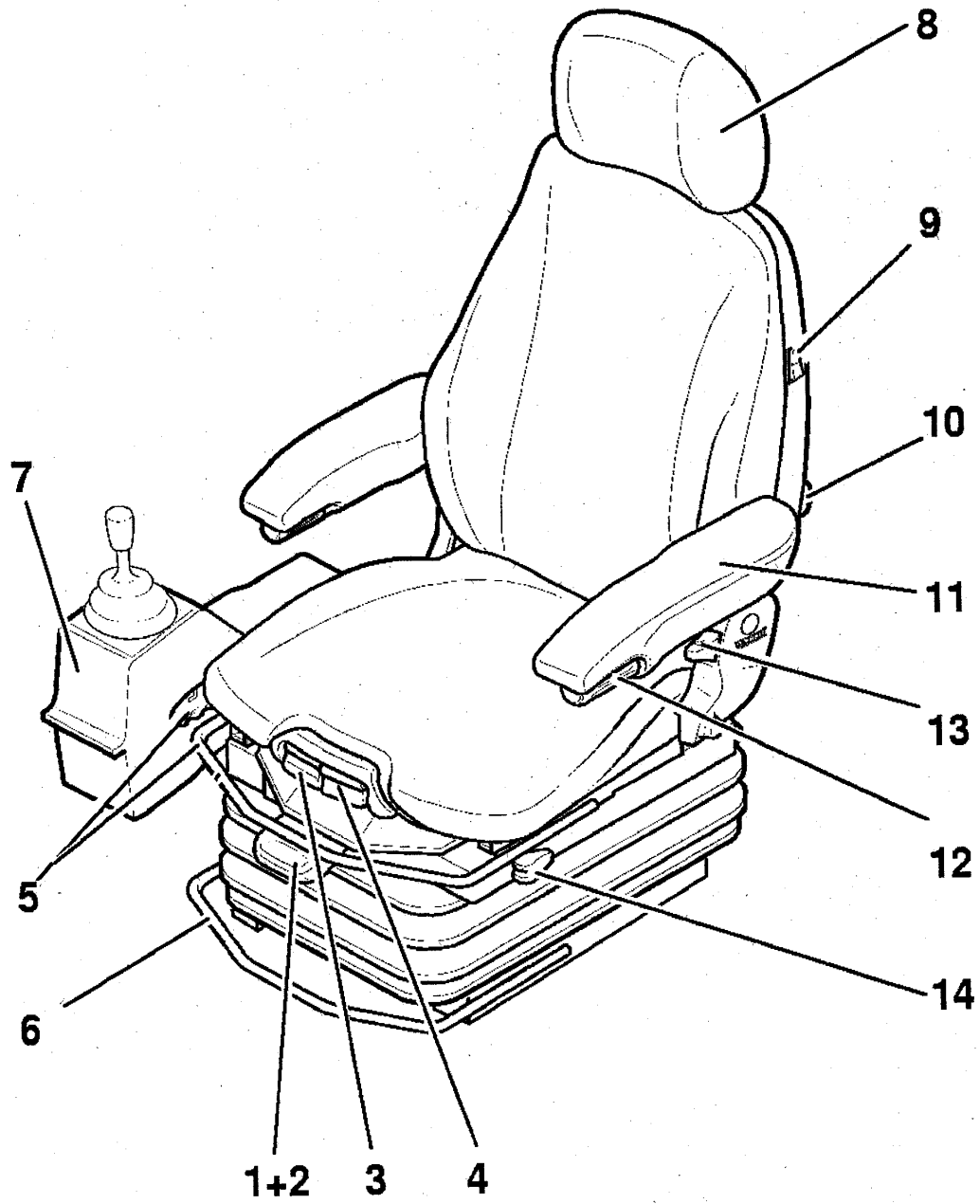

Z 21420

Operator's Seat Adjustment

Before operating the Shovel adjust the seat and mirrors for Operators maximum comfort, visibility, and complete control of the Shovel.

Legend for illust. (Z 21420):

- (1) Seat suspension adjustment (firm to soft ride)
 - (2) Height adjustment
 - (3) Seat depth adjustment
 - (4) Seat cushion tilt adjustment
 - (5) Fore/aft adjustment
 - (6) Not used on this model
 - (7) Control lever carrier
 - (8) Headrest (optional)
 - (9) Seat heater switch (optional)
 - (10) Lumbar support adjustment
 - (11) Armrest, foldable
 - (12) Armrest adjustment
 - (13) Backrest adjustment
 - (14) Fore/aft isolator
- Seat belt (not shown)

⚠ WARNING

- **Use seat belt in accordance with the local safety regulations and laws.**
 - **Check condition and fastening of the seat belt. Replace any worn or damaged part of the seat belt system.**
 - **To ensure proper functioning of the seat belt replace the seat belt and securing parts after every three years.**
-
-

For more Information, refer to the separate Operating Instruction Manual "AIR SUSPENSION SEAT" in volume 2 binder.

Co-driver's Seat

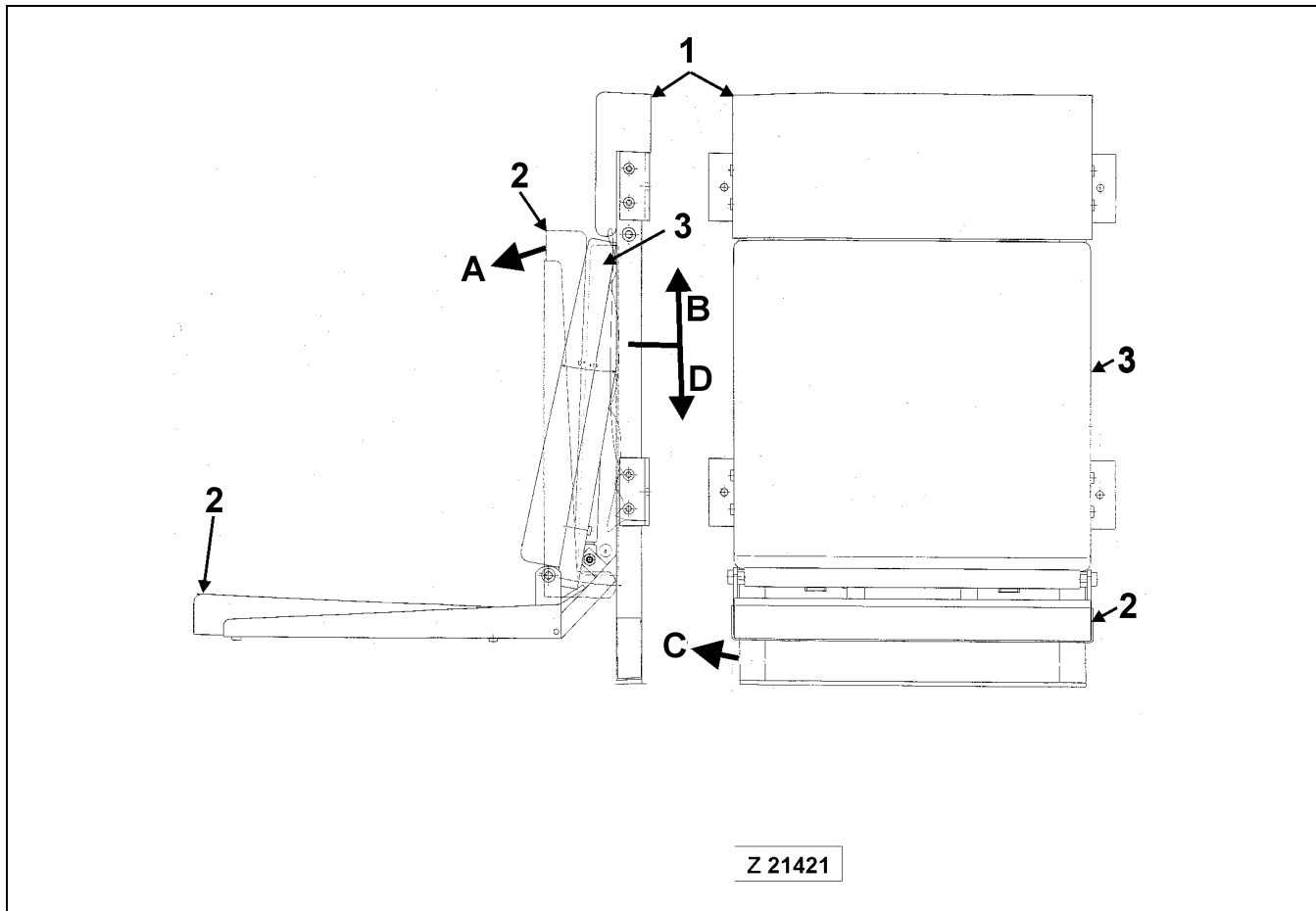

Legend for illust. Z 21421

- (1) Seat suspension frame (3) Back rest
 (2) Folding seat

Adjust Seat Position

A - Fold down seat to sitting position. The seat will automatically move up when released.

B - To swing the seat out, towards the front, first lift seat suspension frame (1) and then swing seat to the front; facing the wind-shield.

C - Swing seat to stop position.

D - With the seat in its final stop position lower seat suspension frame (1). The seat suspension frame (1) must engage into stop blocks mounted in the seat carrier.

REMARK

Be sure to secure the seat in its home position and swung out position by lowering suspension frame (1) into the stop blocks of the seat carrier.

This page left intentionally blank

3.2.7 ENGINE OIL MANAGEMENT SYSTEM

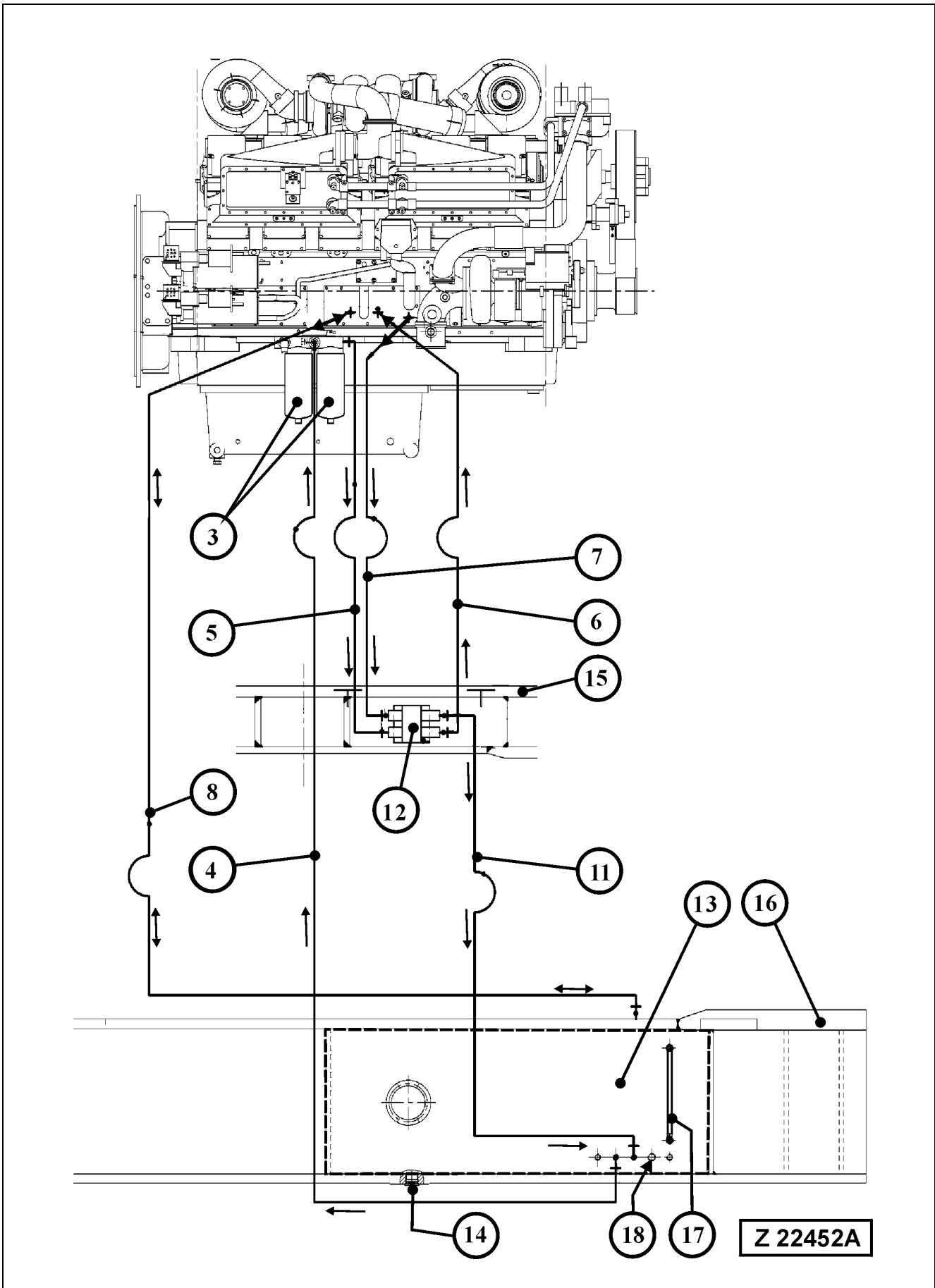

Engine Oil Management System

The engine oil management system of each engine combines the automatic engine oil supply system "**Reserve**" and the oil burning system "**Centinel**" in connection with the "**Eliminator**" oil filtration system.

Reserve System Oil Flow Schematic, illust. Z 22452A. Front engine -2- shown. Rear engine -1- is connected to the reserve tank in the LH side member of the main frame

- (3) Oil filters for the engine oil reserve system
- (4) Suction line from reserve tank
- (5) Suction line to pumping unit
- (6) Supply line from pumping unit to crankcase
- (7) Withdrawal oil line from engine oil pan to pump
- (8) Ventilation line for reserve tank
- (11) Oil feed-back line to reserve tank
- (12) Pumping unit, located in the cross member opposite of the oil filters (3). The pump unit works automatically as soon as the engine speed is above 300 RPM. The pump unit consists of a pumping element for feeding oil from tank (13) into the engine oil pan. The second pumping element withdraws oil from the engine oil pan and feeds it back into the reserve tank when the oil level in the oil pan exceeds the maximum running oil level. The combined operation of the pumping elements maintains an optimal oil level in the engine oil pan. Oil drawn off by the Centinel burn system is also replaced through the supply system "Reserve".
- (13) Reserve oil tank. The reserve oil tank for the rear engine -1- is an integrated part of the LH main frame side member. The reserve oil tank for the front engine -2- is an integrated part of the RH main frame side member.
- (14) Drain plug
- (15) Machinery house frame cross member
- (16) RH side member of main frame
- (17) Oil level sight gauge
- (18) Connector for refilling line from swing down service arm

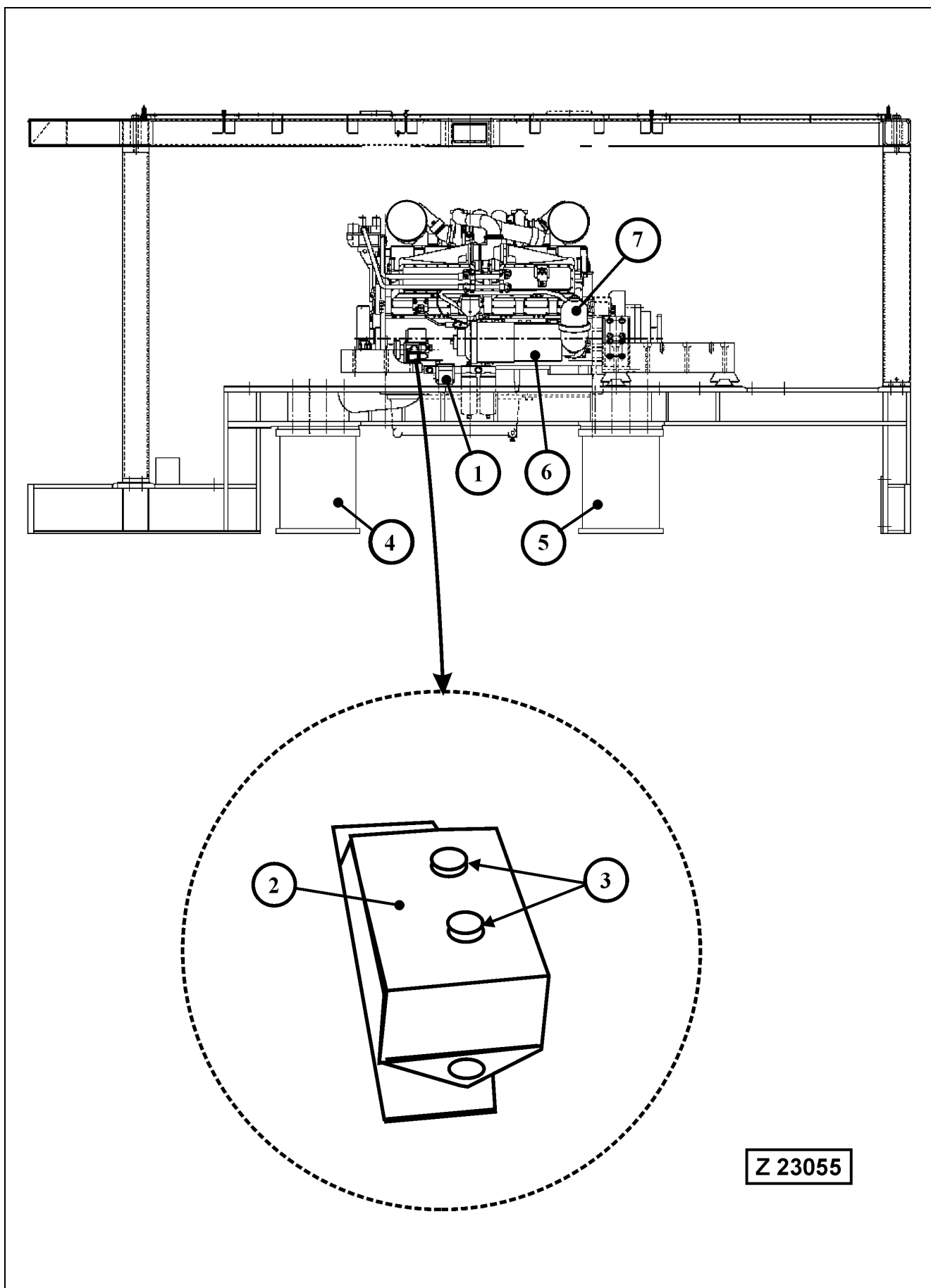

Centinel Diagnostic Lamps

Legend for illust. (Z 23055)

Engine viewed from counterweight side

- (1) Centinel oil control valve (one on each engine)
- (2) Centinel monitor box (one on each engine)
- (3) Centinel diagnostic lamps
- (4) Left engine oil reserve tank for rear engine 1
- (5) Right engine oil reserve tank for front engine 2
- (6) Eliminator engine oil filter
- (7) Centrifugal separator

Check Centinel Diagnostic Lamps for faults

The Centinel system of each engine is monitored by two diagnostic lamps (3). The green lamp indicates the Centinel system has power and is operating. The red lamp indicates that a system parameter is not within specification. Check the diagnostic lamps at regular intervals. If the red lamp is illuminated, stop the engines and turn key switch to OFF position. Turn key switch to ON position. To prevent starting of the engine, remove plug from pre-lube time relay 3D30-1 for rear engine 1 and/or 3D30-2 for front engine 2. Turn starter switch of the concerned engine and release. Look at the red lamp, it should start flashing a three-digit code. This code will be associated with a fault code. The codes are read as follows:

1. If the red lamp flashes three times, the first digit is "3", the number of flashes will indicate the first digit of the code.
2. There will be a pause.
3. If the red lamp flashes four times, the second digit of the fault code will be "4", the number of flashes will indicate the second digit of the code.
4. There will be another pause.
5. If the red lamp flashes two times, the third digit of the fault code is "2", the number of flashes will indicate the third digit of the code.
6. In this example, the code is 3-4-2. Fault code 342 is a Centinel Control Module Calibration fault.

At this point, there will be a longer pause before the fault code will be flashed again. This process will occur four times. After the fourth time, the fault lamp will stay red if the fault is still active. To read the code again, turn the key switch to OFF position and back to ON position. Turn starter switch of the concerned engine and release. Once the correct fault code is identified, refer to the Master Repair Manual CENTINEL filed in volume 2 binder for fault code explanation, and inform your Komatsu Service Organization about the trouble condition.

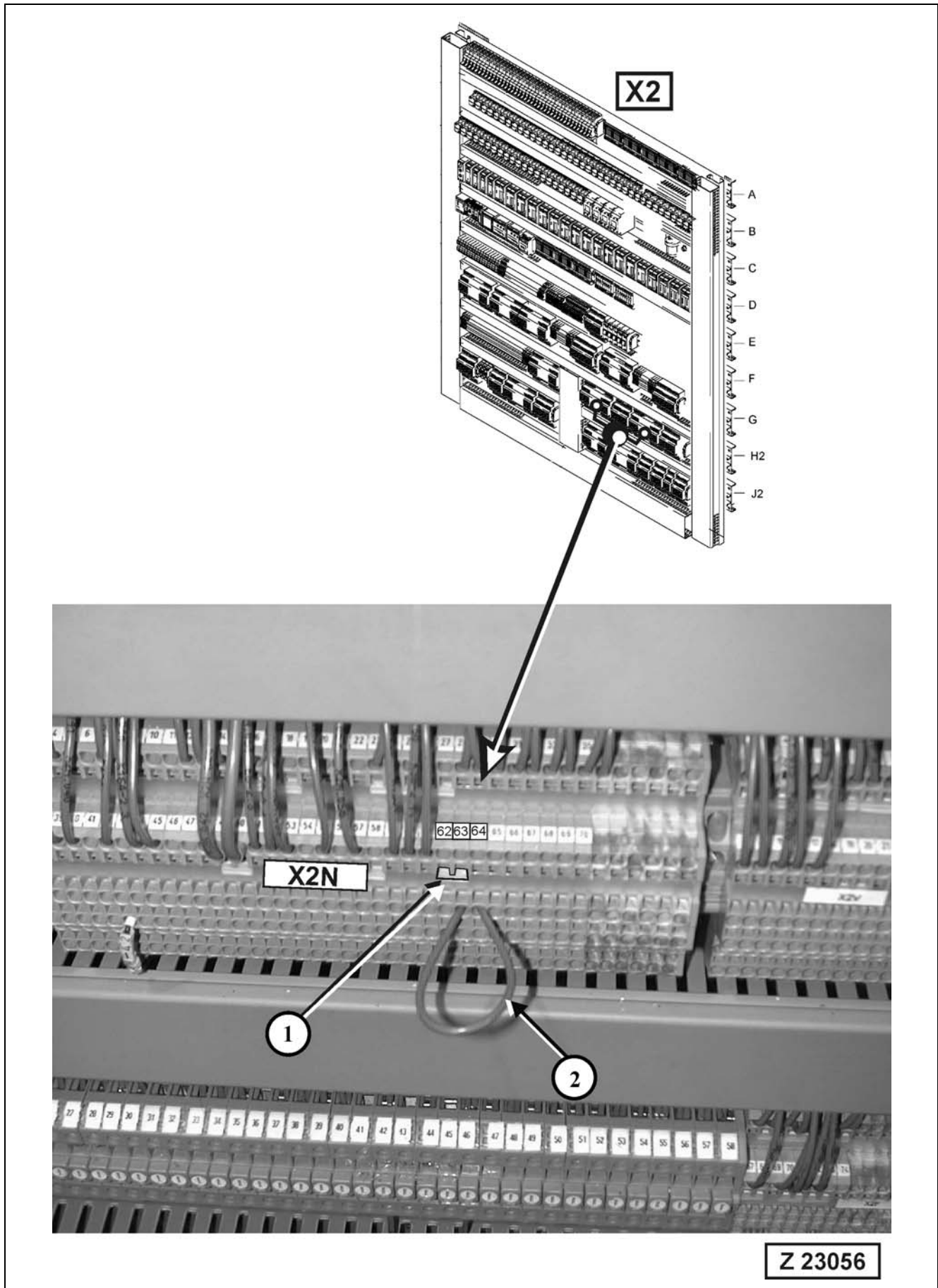

Clearing Active Faults and Reset the Centinel System to Operational Condition

Legend for illust. (Z 23056)

The illustration shows the terminal configuration on the (X2) switch board for the FRONT ENGINE 2

- (1) Calibration Plug for Engine Oil Quality
- (2) Bridge wire for resetting the Centinel system to operational condition

Resetting of the Centinel system is necessary:

- After every engine oil change.
- Whenever the engine oil reserve tank has been allowed to run empty.
- After repairs on the Centinel system.

Proceed as follows:

1. Turn key switch to ON position. To prevent starting of the engine, remove plug from pre-lube time relay 3D30-1 for rear engine 1 and/or 3D30-2 for front engine 2. Turn starter switch of the concerned engine and release.
2. For resetting the Centinel system of the FRONT ENGINE 2, bridge the contacts no. 63 and 64 at the terminal block (X2N) by inserting bridge wire (2). Remove the bridge wire (2).
3. For resetting the Centinel system of the REAR ENGINE 1, bridge the contacts no. 61 and 62 at the terminal block (X2M) by inserting bridge wire (2). Remove the bridge wire (2). For additional information refer also to the electrical diagram, page CENTINEL CONTROL MODULE.

Check the Centinel System for proper Operation

1. Install plug to pre-lube time relay 3D30-1 for rear engine 1 and/or plug to pre-lube time relay 3D30-2 for front engine 2.
2. Start the engine(s). Look at the indicator lights (3) on monitor box (2), see page 67 for more information. The green light must be illuminated with the engine running.

Calibration Plug for Engine Oil Quality

Ex works the calibration plug (1) is installed for Centinel operation with Mineral engine oil. When changing the engine oil quality from Mineral oil to Synthetic oil, the calibration plug (1) must be replaced accordingly. For FRONT ENGINE 2, remove calibration plug (1) from contacts 62/63 at the terminal block (X2N) and insert to contacts 63/64. For REAR ENGINE 1, remove calibration plug from contacts 60/61 at the terminal block (X2M) and insert to contacts 61/62. Be sure to re-position the calibration plug when changing back to Mineral engine oil. Use only engine oils as specified in the Engine Operation and Maintenance Manual.

Oil Burning System "Centinel" combined with Oil Supply System "Reserve"

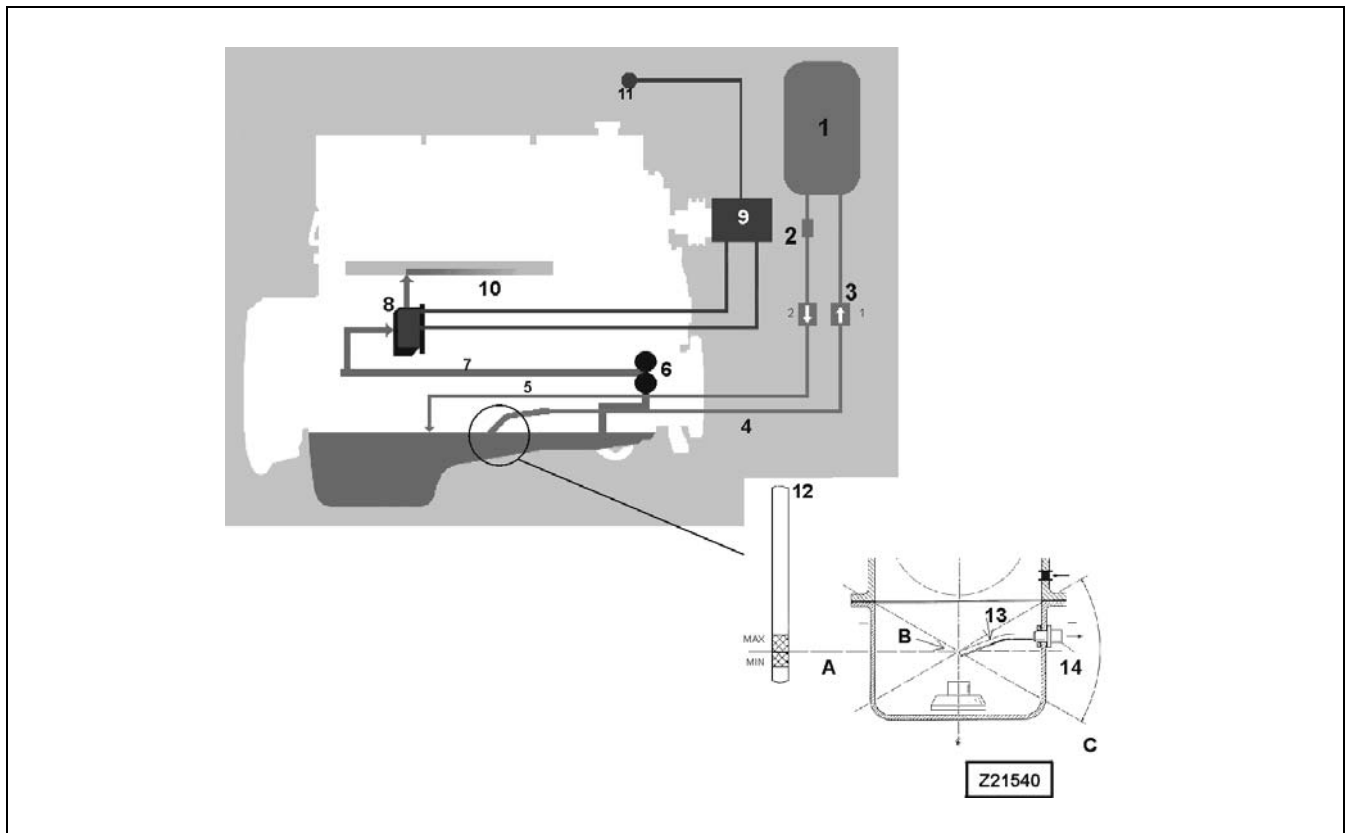

Legend for illust. Z 21473 (schematic illustration)

- | | |
|-------------------------------------|--|
| (1) Engine oil reserve tank | (10) Fuel/lube oil blend return to fuel tank |
| (2) Oil filters | (11) System function indicator LED's |
| (3) Pump unit | (12) Oil level gauge |
| (4) Suction oil to reserve tank | (13) Oil withdrawal tube |
| (5) Supply oil from tank to oil pan | (14) Withdrawal adapter plate |
| (6) Engine oil pump | (A) Oil level with engine running |
| (7) Main oil rifle | (B) Control point for filling / withdrawal |
| (8) Oil control valve | (C) Roll or tilt oil level |
| (9) Centinel Control Module (CCM) | |

Brief description of system function

The combined "Centinel - Reserve" system is a continuous oil replacement system of electromechanical design and can extend oil change intervals through continuous oil exchange. This is accomplished by injecting engine oil at a controlled rate, proportional to fuel consumed, into the fuel system for consumption. Make-up oil is introduced into the engine by the oil supply system "Reserve", maintaining an optimal engine oil level.

Eliminator Engine Oil Filtration System

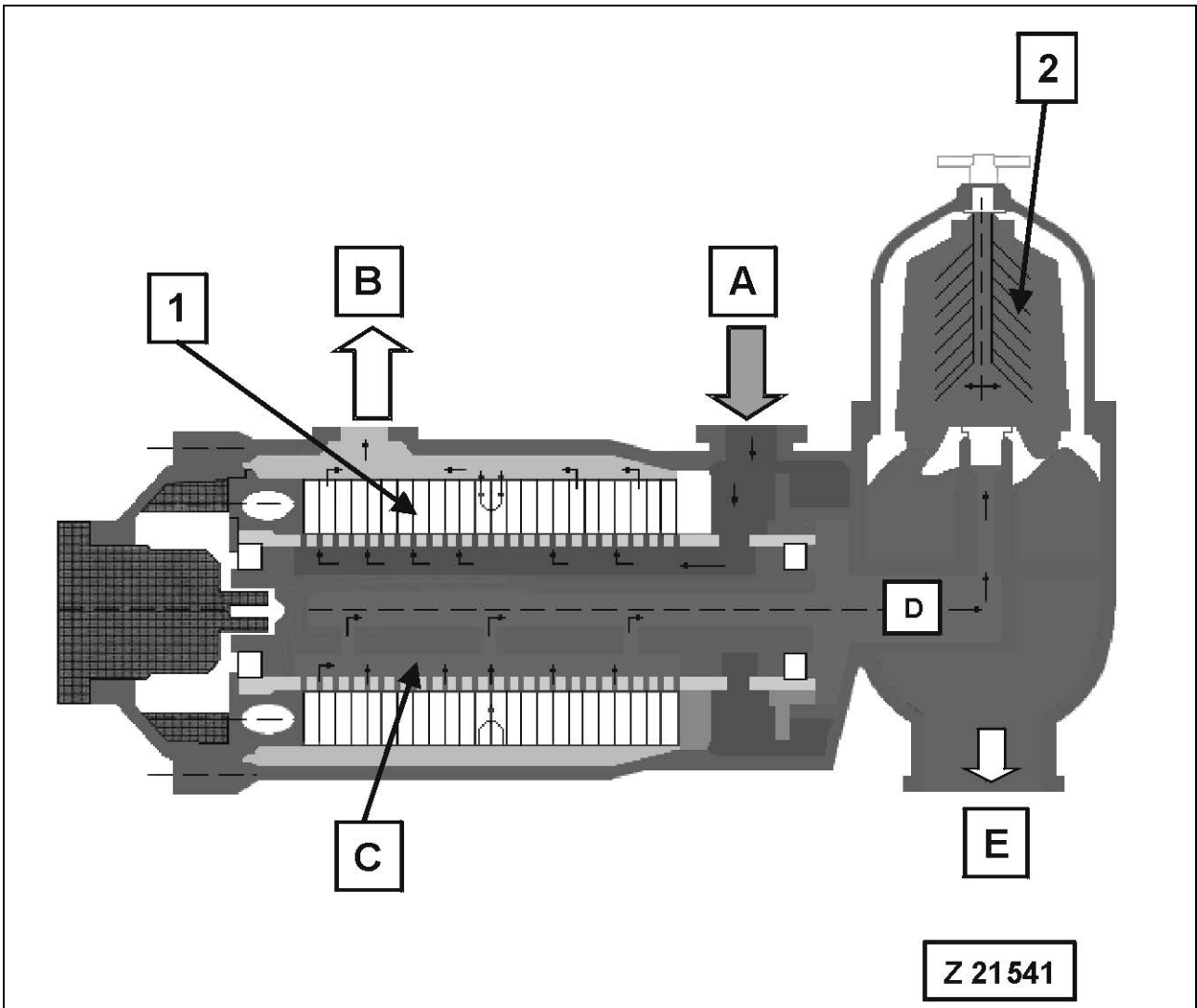

Legend for illust. Z 21541 (schematic illustration)

- | | | | |
|-----|--|-----|--|
| (A) | Oil inlet from engine (100%) | (E) | Oil flow to engine oil pan (5%) |
| (B) | Oil outlet to engine (95%) | (1) | Stainless steel filter removes particles as small as 20 µm |
| (C) | Backflush oil (5%) for cleaning the filter | (2) | Centrifugal separator removes particles up to a size of 2 µm |
| (D) | Oil flow to centrifuge (5%) | | |

3.3 OPERATOR'S CAB - CONTROLS

3.3.1 CONTROLS WITH BACKHOE ATTACHMENT

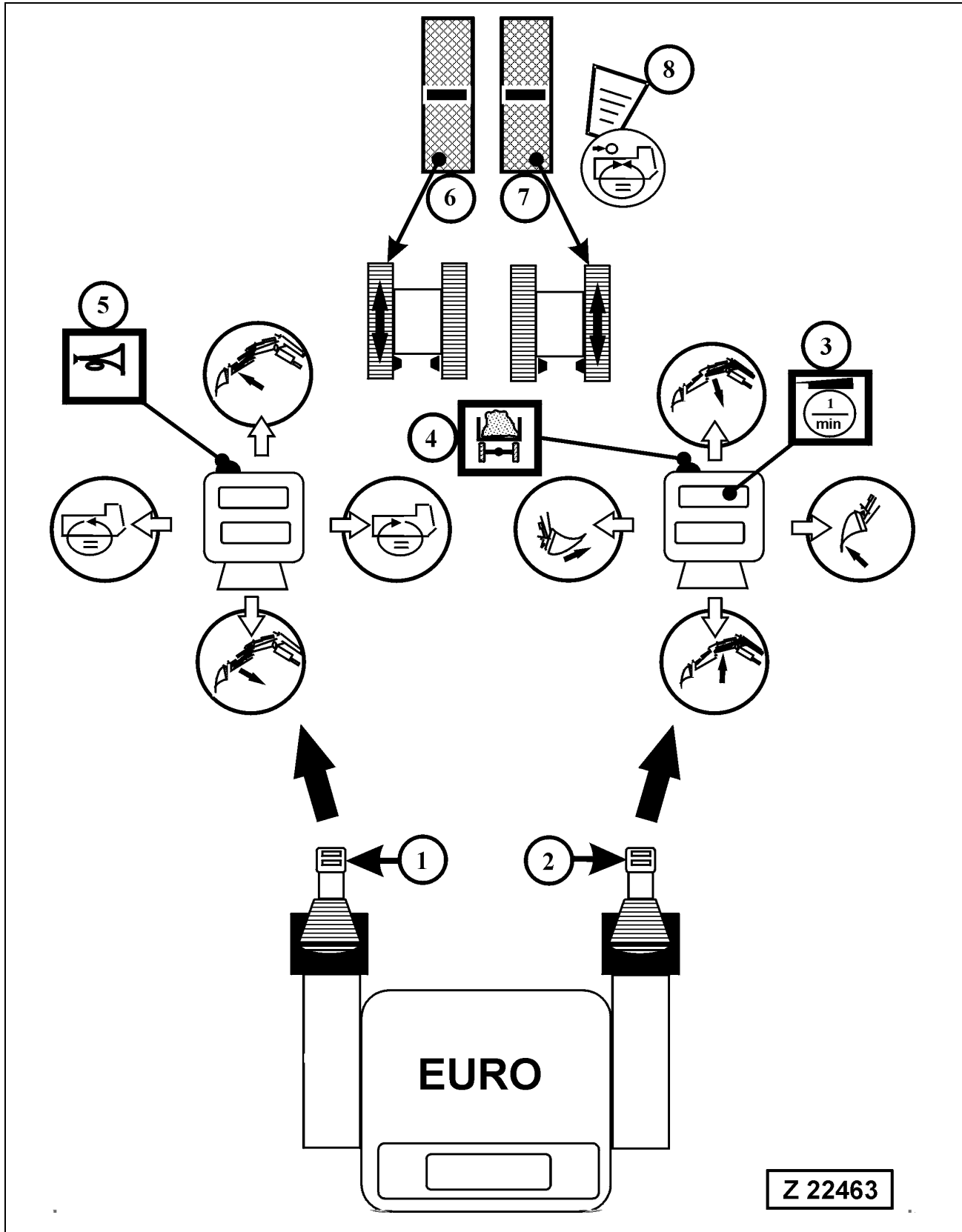

Hydraulic Control System

There are two control patterns of levers (1 and 2) available:

- "EURO" control pattern and
- "KMG" (Komatsu Mining Germany) control pattern

Your Shovel is equipped with the **EURO** control pattern for levers (1 and 2).

For more information → See "WORKING WITH THE ATTACHMENT" on page 252.

WARNING

- **Wrong operation of the controls can cause mechanical break-down, property damage, injury or death.**
 - **Observe the Safety Instructions → See "SAFETY" on page 15.**
 - **Before starting the engine / motor, make sure you know the location and function of each control.**
 - **Always sit in the Operator's seat when operating this machine.**
-
-

Safety Circuit for Controls

(Pilot control system cut-out and actuation of hydraulic swing parking brake)

This system is controlled through the Operator's seat, the hydraulic access ladder and the service arm of the refilling system, if so equipped. It prevents movements of the Shovel and its attachment as long as the Operator is not sitting in his seat and/or the access ladder is in the lowered position or when the service arm of the central refilling system is in its lowered position.

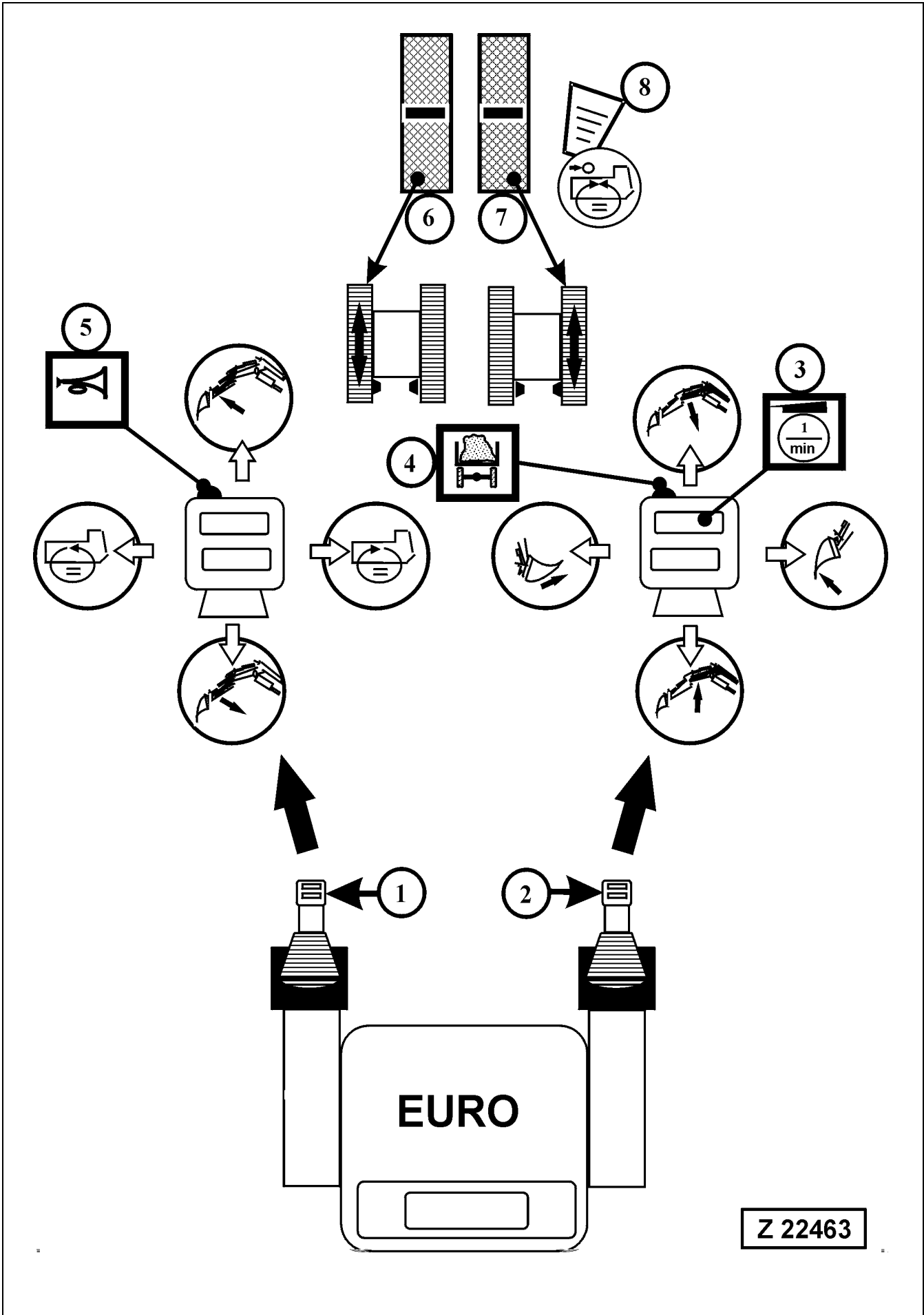

EURO Control Pattern

Legend for illustration (Z 22463)

- (1) Control lever for stick and swing machinery
- (2) Control lever for boom and bucket
- (3) Toggle switch for engine speed selection
Low idle – High idle
- (4) Push button for Truck counter.
For counting loaded trucks press this button. The total number of trucks loaded is shown on the ECS display, refer to page 92 for more information.
- (5) Signal horn button
- (6) Travel control pedal, left track forward - reverse
- (7) Travel control pedal, right track forward - reverse
- (8) Swing brake pedal

For more information → See "WORKING WITH THE ATTACHMENT" on page 252.

3.3.2 CONTROLS WITH BOTTOM DUMP BUCKET ATTACHMENT

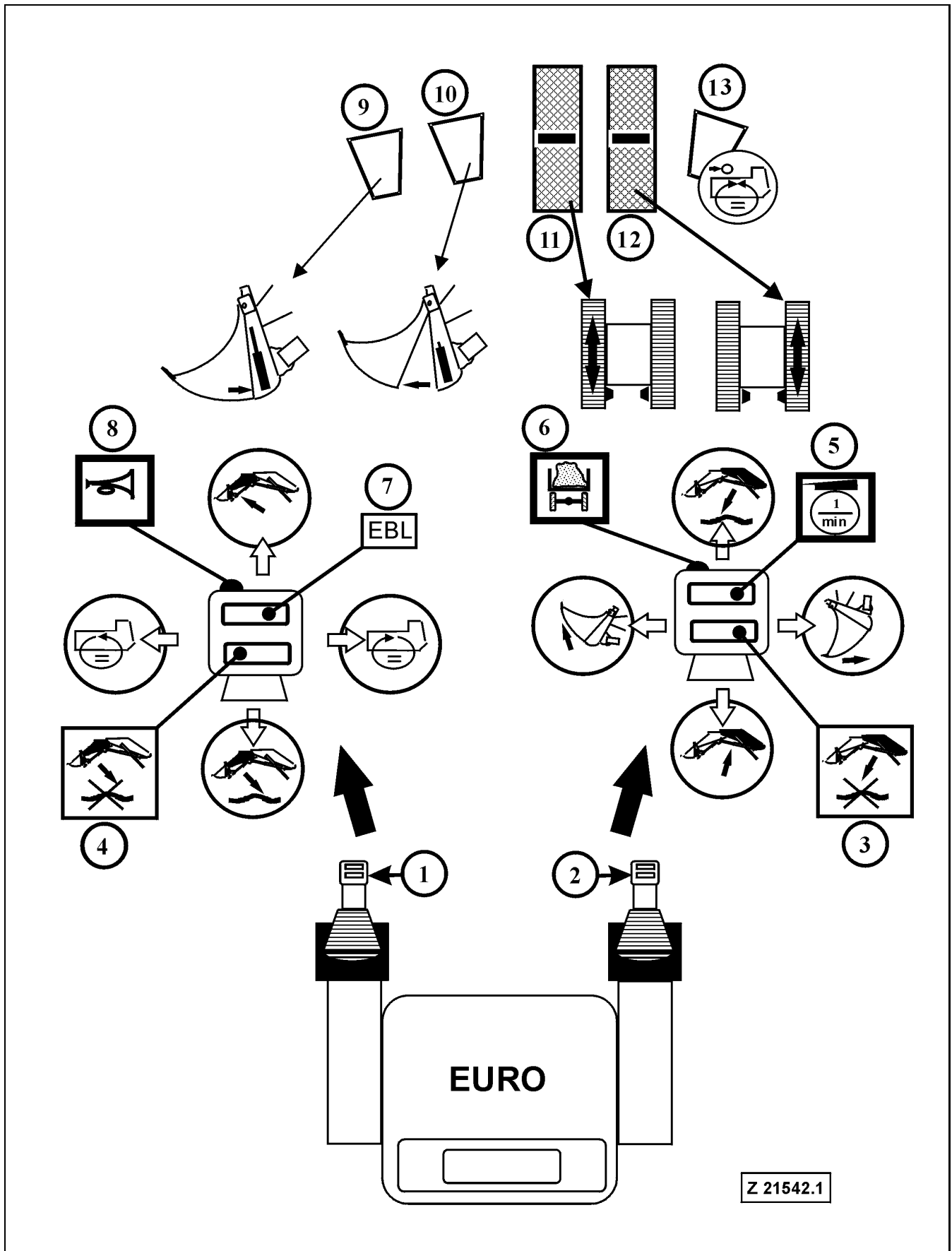

Hydraulic Control System

There are two control patterns of levers (1 and 2) available:

- "EURO" control pattern and
- "KMG" (Komatsu Mining Germany) control pattern

Your Shovel is equipped with the **EURO** control pattern for levers (1 and 2).

For more information → See "WORKING WITH THE ATTACHMENT" on page 252.

WARNING

- Wrong operation of the controls can cause mechanical break-down, property damage, injury or death.
 - Observe the Safety Instructions → See "SAFETY" on page 15.
 - Before starting the engine / motor, make sure you know the location and function of each control.
 - Always sit in the Operator's seat when operating this machine.
-
-

Safety Circuit for Controls

(Pilot control system cut-out and actuation of hydraulic swing parking brake)

This system is controlled through the Operator's seat, the hydraulic access ladder and the service arm of the refilling system, if so equipped. It prevents movements of the Shovel and its attachment as long as the Operator is not sitting in his seat and/or the access ladder is in the lowered position or when the service arm of the central refilling system is in its lowered position.

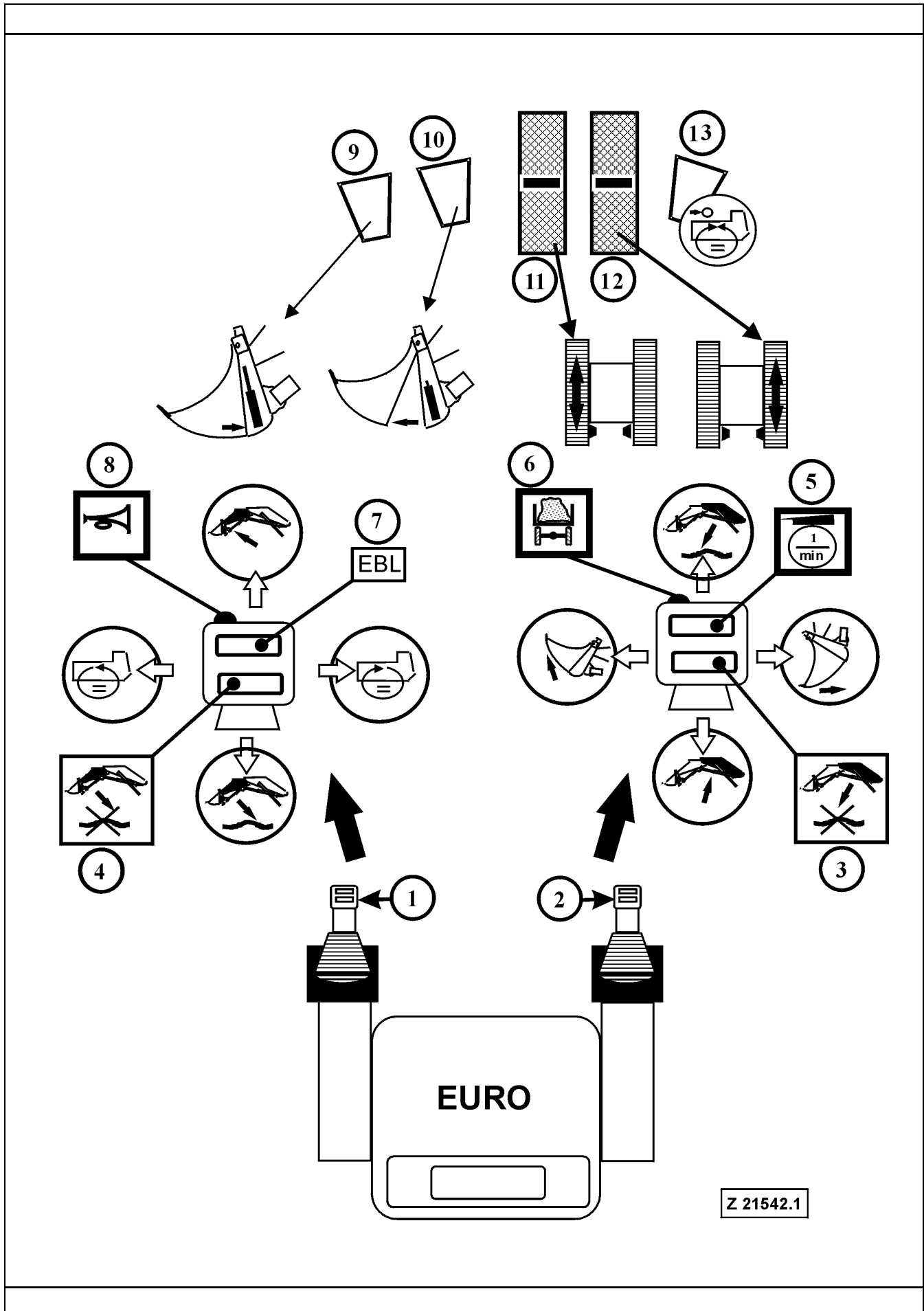

EURO Control Pattern

Legend for illustration (Z 21542.1)

- (1) Control lever for stick and swing machinery
- (2) Control lever for boom and bucket
- (3) Push button for deactivation of boom float position
- (4) Push button for deactivation of stick float position
- (5) Toggle switch for engine speed selection
Low idle – High idle
- (6) Push button for Truck counter.
For counting loaded trucks press this button. The total number of trucks loaded is shown on the ECS display, refer to page 92 for more information.
- (7) Toggle switch for the Electronic Bucket Levelling system "EBL" (If so equipped). This system prevents material from spilling over at the rear bucket wall by stopping the Roll Back motion of the bucket automatically in a predetermined position. The "EBL" system is switched ON and OFF with the toggle switch (7). The ECS text display informs the Operator about the operating condition of the "EBL" system.
- (8) Signal horn button
- (9) Pedal for closing the bottom dump bucket
- (10) Pedal for opening the bottom dump bucket
- (11) Travel control pedal, left track forward - reverse
- (12) Travel control pedal, right track forward - reverse
- (13) Swing brake pedal

Automatic Float Position for Boom and Stick

The Shovel operates automatically with the float position for boom and stick activated.

That means the lowering movement of boom and stick is always done in the float position. To deactivate the float position, press button (3) for boom and/or (4) for stick, and keep depressed as long as the float position shall be deactivated. When releasing the buttons the float position is activated again.

For more information → See "WORKING WITH THE ATTACHMENT" on page 252.

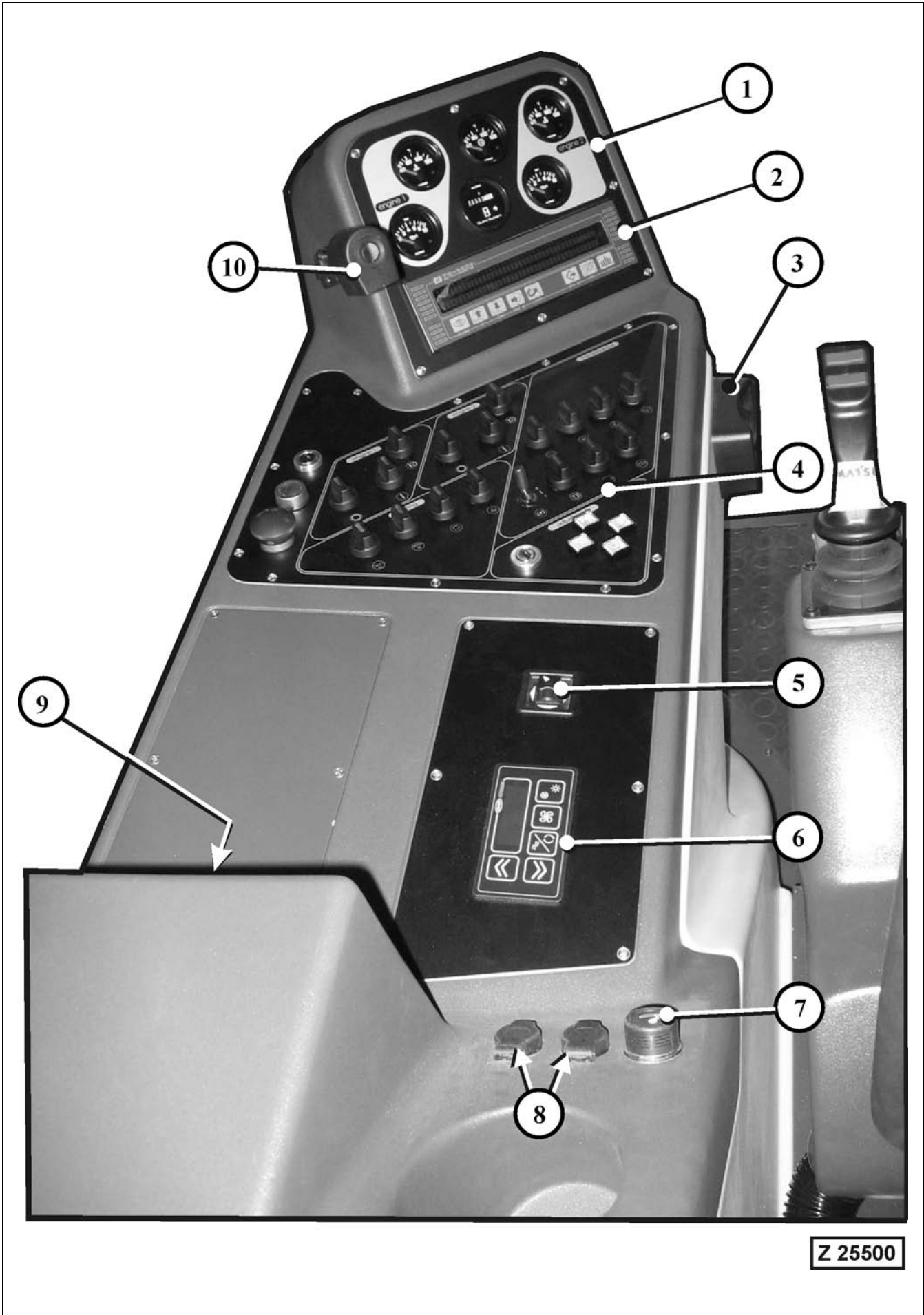

3.3.3 OPERATOR'S CONSOLE

Legend for illustration Z25500

- (1) Analog gauges, see page 83 for more information
- (2) Text display with key board of the Electronic Control and Monitoring System (ECS). Refer to page 92 for more information.
- (3) Ashtray
- (4) Switch board, see page 83 for more information
- (5) Switch for adjustment of left and right cab mirror
- (6) Control unit for air conditioning and heating, see page 198 for more information
- (7) Cigarette lighter
- (8) Plug sockets 24V DC
- (9) Radio
- (10) Switch board lighting with flexible arm

 **CAUTION**

Make sure the cab door is always closed when working with the Shovel.

Secure the door in open position with the locking device provided.

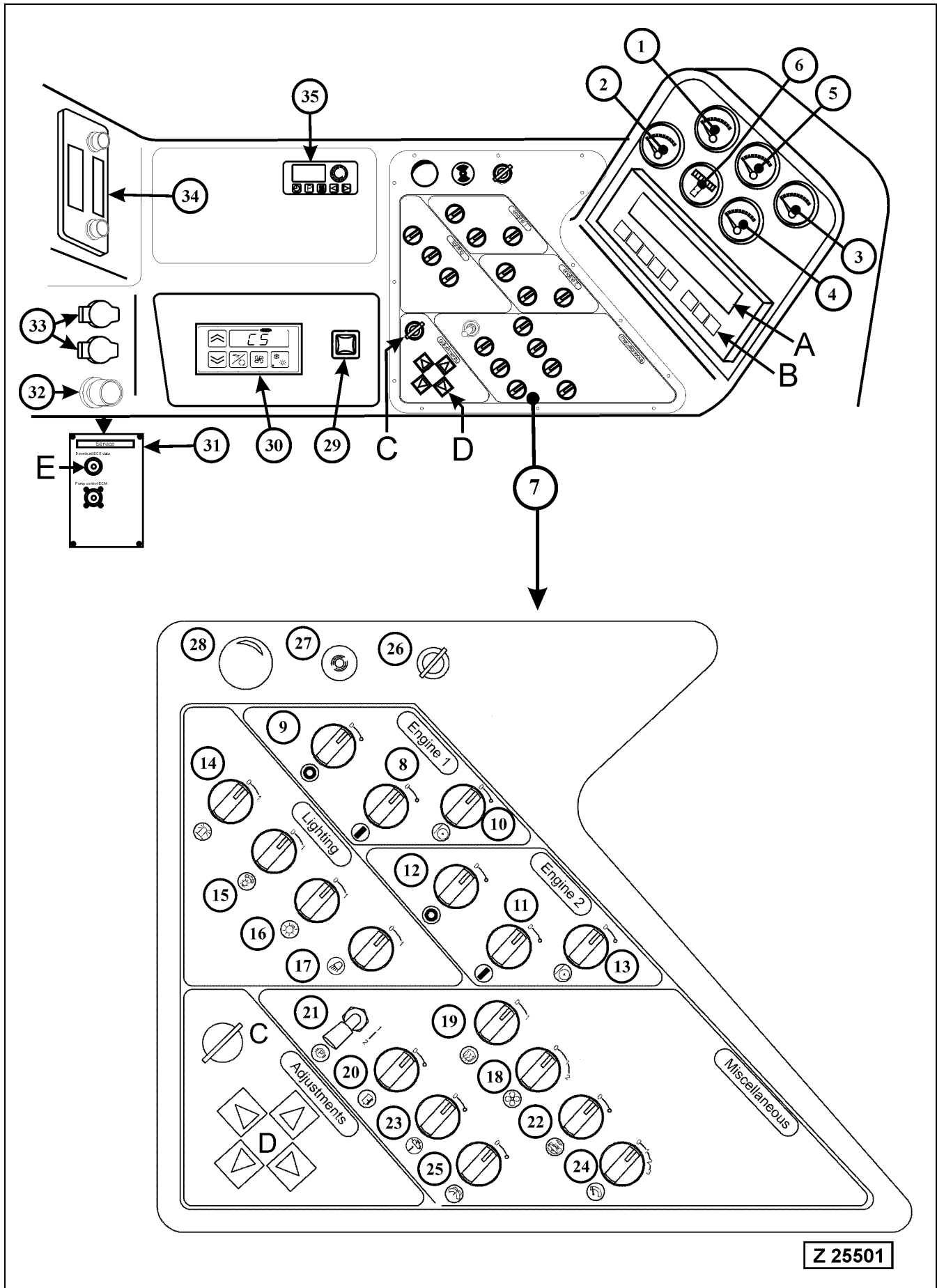

Control Panel

Legend for illust. Z25501

NOTICE

The items (A, B, C, D and E) are part of the Electronic Monitoring and Control System, refer to page 92 for more information.

- (A) The screen (A) displays the condition of the machine, the maintenance status, and messages for the operator and service man.
 - (B) Keyboard with 8 keys, used to switch the screen and for input of data
 - (C) Key operated switch for enabling access to the Shovel Component levels and for input of operational data.
 - (D) Switch group with four switches for menu control of the Service functions and for the Shovel Components (On screen display).
 - (E) Serial interface (X27) for download of ECS memory data
- (1) Engine coolant temperature gauge for rear engine 1
 - (2) Engine oil pressure gauge for rear engine 1
 - (3) Engine coolant temperature gauge for front engine 2
 - (4) Engine oil pressure gauge for front engine 2
 - (5) Hydraulic oil temperature gauge
 - (6) Operating hour meter
 - (7) Switch board
 - (8) Rotary switch -Rear Engine 1 START-
 - (9) Rotary switch -Rear Engine 1 STOP-
 - (10) Rotary switch -Rear Engine 1 Start Pilot- cold starting aid
 - (11) Rotary switch -Front Engine 2 START-
 - (12) Rotary switch -Front Engine 2 STOP-
 - (13) Rotary switch -Front Engine 2 Start Pilot- cold starting aid
 - (14) Switch, warning beacon on cab roof
 - (15) Switch, dashboard illumination
 - (16) Switch, interior illumination
 - (17) Switch, main working lights

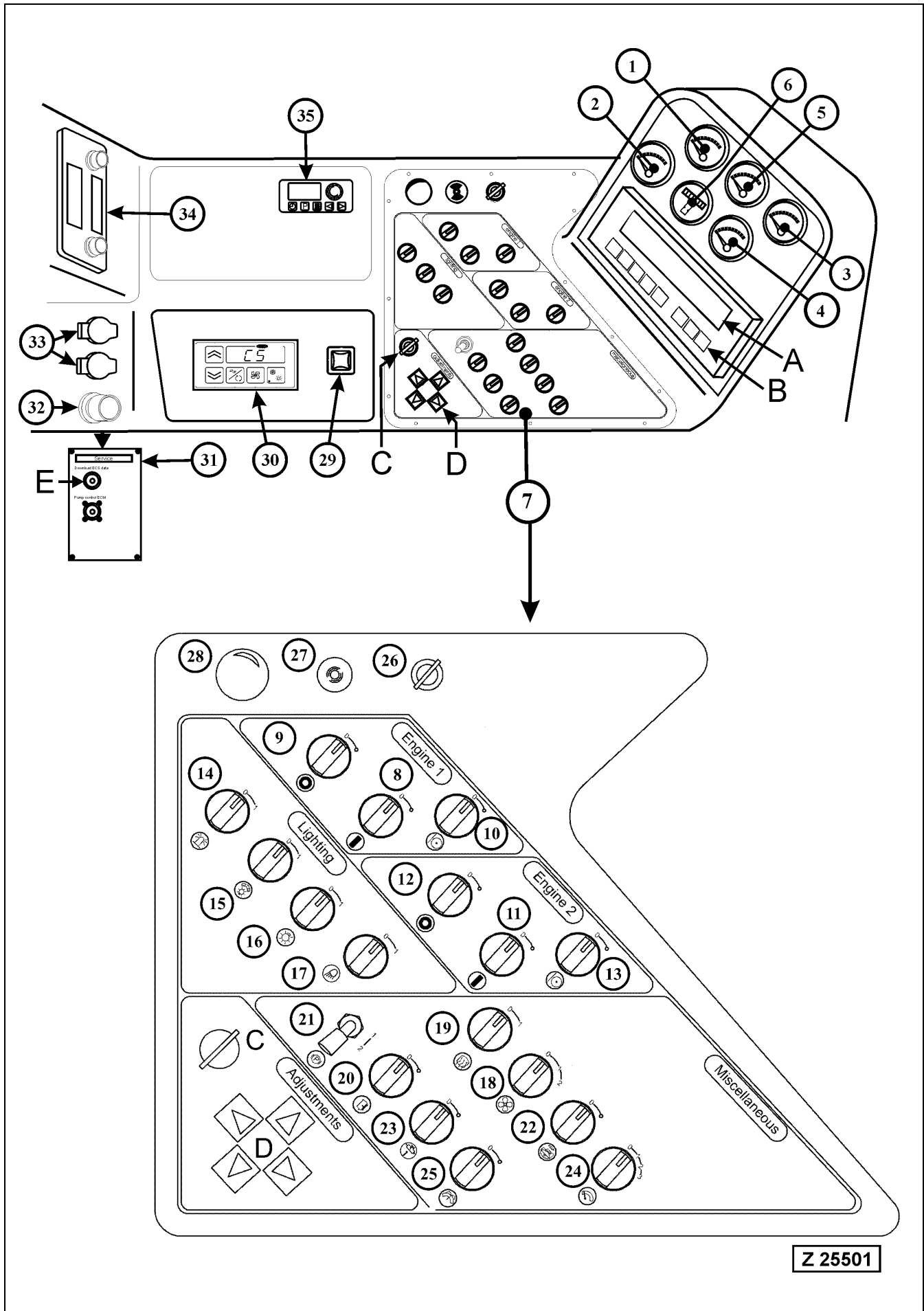

Switch Board

Legend for illust. Z25501

- (18) Switch, cab ventilation blower. Blower runs with low speed, even with switch in -0- position. (Cab pressurizing prevents ingress of dust).
- (19) Switch, mirror heating
- (20) Enable switch for hydraulic service arm operation. Set this switch to ON position before lowering the service arm. With this switch in ON position, the pilot control system is made inoperative and the hydraulic swing brake is applied. After completion of replenishment procedure, swing back the service arm to its home position and set switch (26) to OFF position.
- (21) Toggle switch, swing parking brake
 - 0 - Parking brake released - UP
 - 1 - Parking brake applied - DOWN.

CAUTION

The parking brake should only be applied with superstructure at complete standstill, except in case of emergency. Refer to page 250 for more information.

- (22) Switch, manual actuation of swing ring gear pinion lubrication system
- (23) Switch, manual actuation of central lubrication system
- (24) Switch for upper and lower windshield wiper
 - 0 - Off
 - 1 - Interval stage
 - 2 - Slow stage
 - 3 - Fast stage
- (25) Switch, windshield washer
- (26) Key operated main switch
- (27) Acoustic warning signal

This signal sounds for approximately 1 second when a fault message appears on the ECS screen.

CAUTION

In case of too low hydraulic oil level this signal sounds continuously. Shut down the Shovel, locate and correct the cause immediately. Fill up hydraulic oil to the correct level. For the correct checking procedure → See "CHECKS BEFORE STARTING THE ENGINES" on page 228.

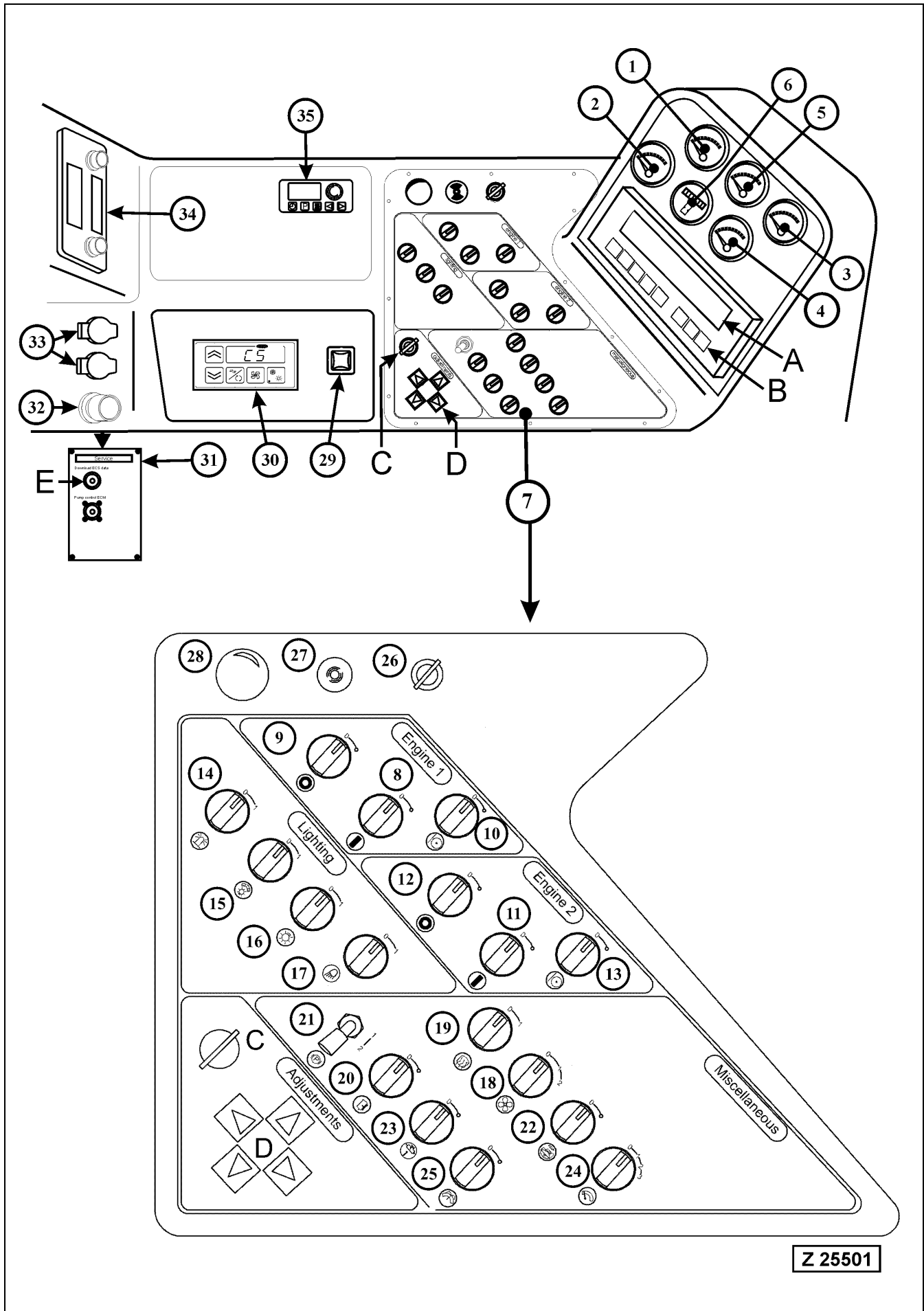

Switch Board (continued)

Legend for illust. Z25501

- (28) Strike button, emergency shut down of both engines and pilot control system cut out.

 **WARNING**

In case of emergency push in this button to stop the Diesel engines and to cut out the pilot control circuit. DO NOT use for normal stopping procedure.

- For releasing the switch, turn and pull-up the strike button.
- (29) Switch, RH and LH mirror adjustment
- (30) Control unit for air conditioning and heating, see page 198 for more information.
- (31) Interface panel for download of ECS data and for electronic tool connection to the pump control system MC7
- (32) Cigarette lighter
- (33) Plug sockets 24V DC
- (34) Radio
- (35) Control module for the auxiliary cab heater HYDRONIC 10, special equipment. If so equipped, see page 89 for more information.

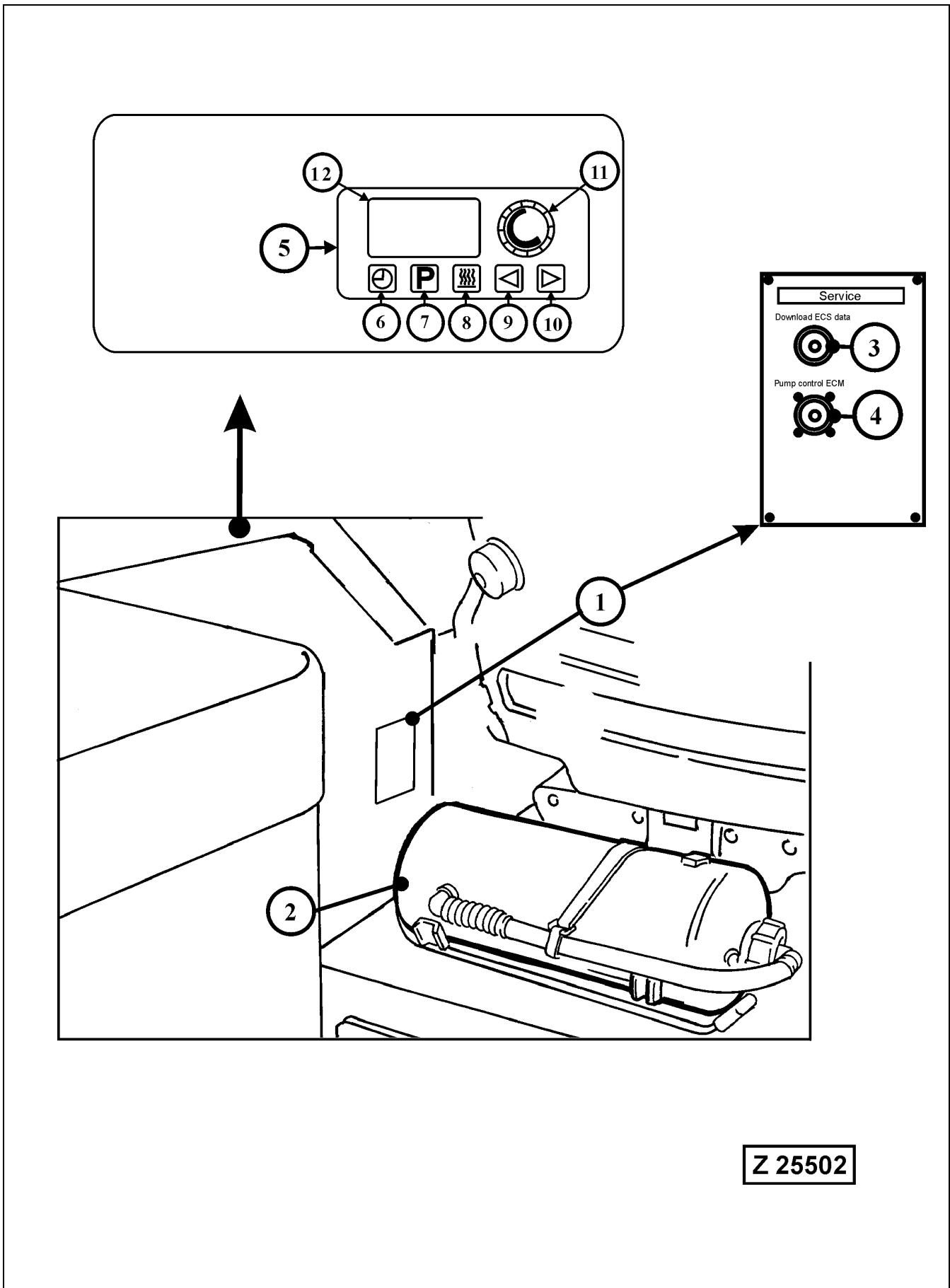

Z 25502

3.3.4 INTERFACE PANEL FOR DIAGNOSTICS

Legend for illust. Z25502

- (1) Interface panel
- (2) Portable fire extinguisher. Observe the local Fire Prevention Regulations in regard to number, size and location of portable fire extinguishers. Make sure the fire extinguisher is always charged and ready for use.
- (3) Adapter (X27) for download of ECS data
- (4) Adapter (X13) for connecting an electronic tool to the ECM of the pump control system MC7

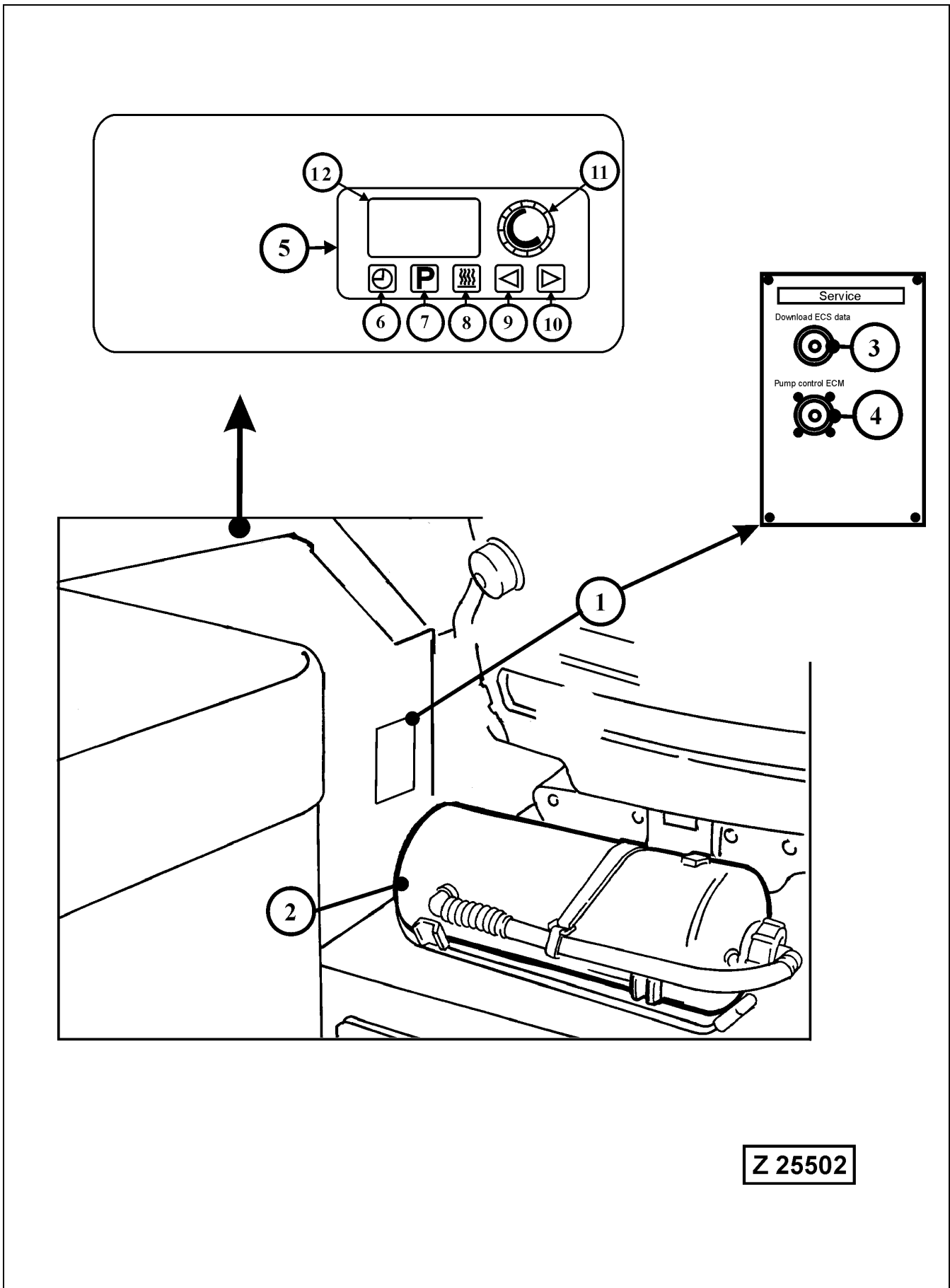

Z 25502

3.3.5 CONTROL MODULE FOR AUXILIARY CAB HEATER

Special Equipment

Legend for illust. Z25502

- (5) Control module for the engine independent auxiliary cab heater.
This module is used for switching ON and OFF the auxiliary cab heater during operation of the shovel with the Diesel engines running, and for pre-selection of heater start times and duration of heating periods. For detailed setting instructions of the control module refer to the separate operating instruction sheet in volume 2 binder.
- (6) Button for actual time indication
- (7) Button for preselection of heating time
- (8) Button for heating indication
- (9) Button for settings backwards
- (10) Button for settings forward
- (11) Not used
- (12) Display shows the operating condition of the auxiliary cab heater

3.4 ELECTRONIC MONITORING AND CONTROL SYSTEM ECS

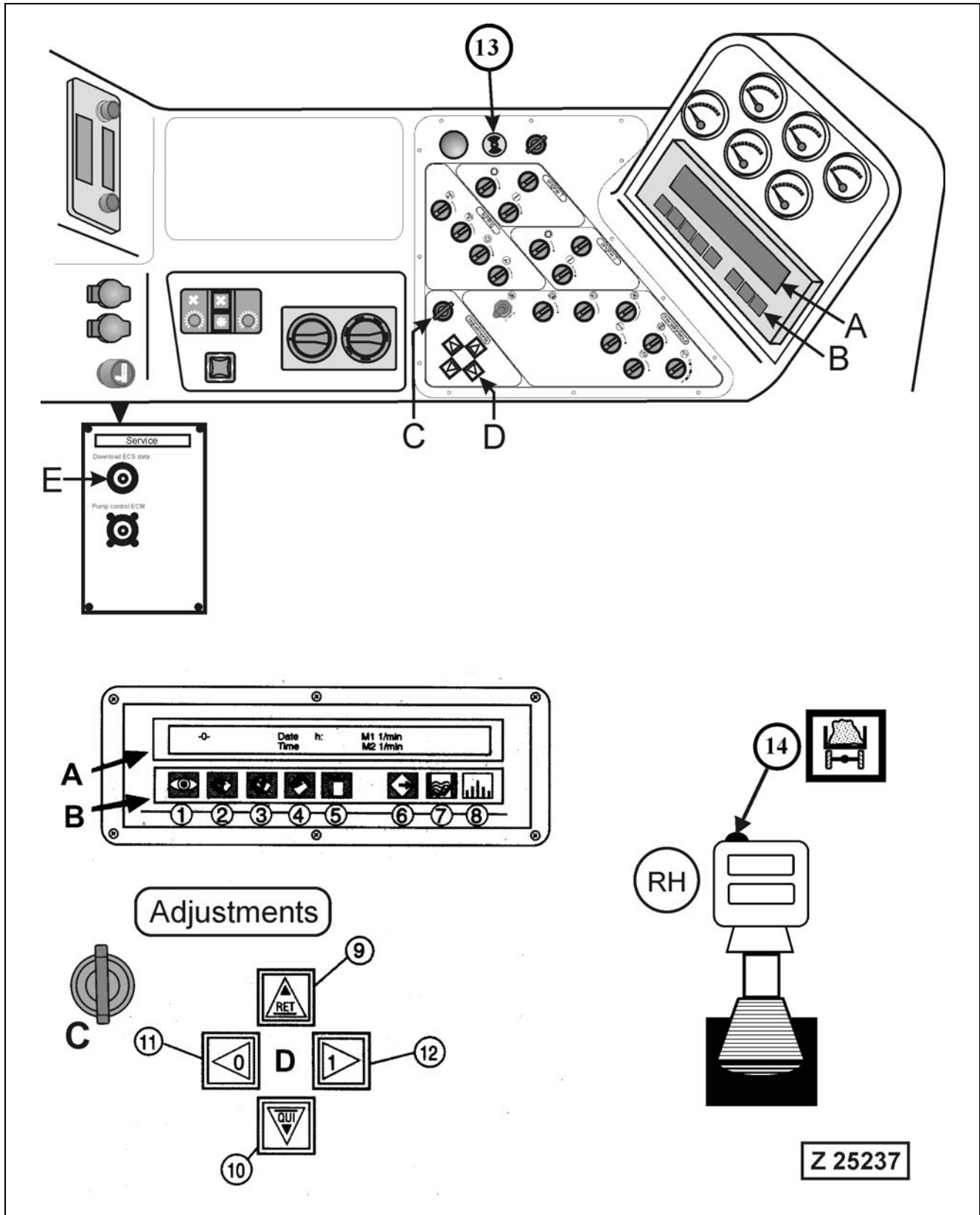

3.4.1 INTRODUCTION

The Electronic Monitoring and Control System ECS incorporates the following two main functional groups:

1. TEXT DISPLAY (A) with INTEGRATED KEY BOARD (B), illustration Z25237
2. SERVICE FUNCTIONS operated with KEY GROUP (D) and KEY SWITCH (C)

1. TEXT DISPLAY and KEY BOARD

1.1 Text Display (A)

Plain text display for continuous monitoring of all Shovel functions and operating conditions.

Also included are the periodic servicing intervals which will be displayed according to the operating hours of the Shovel.

1.2 Integrated Key Board (B) of the Text Display for the following functions:

Call up messages

Change of value settings

Call up contents of Protocol and Statistics memory

Print out of Protocol and Statistics contents

Refer to page 99 for detailed description of the key functions.

2. SERVICE FUNCTIONS operated with KEY GROUP (D) and KEY SWITCH (C), illustration Z25237

Display/Deletion of Truck Counter Reading.

Display of Central Lubrication System cycle counter reading

Display of Swing ring gear Lubrication System cycle counter reading

Display of Service section

Selection of displayed language.

Power Checks.

Display of Maintenance Intervals.

Acknowledgement of carried out Maintenance

Settings of ECS operational data.

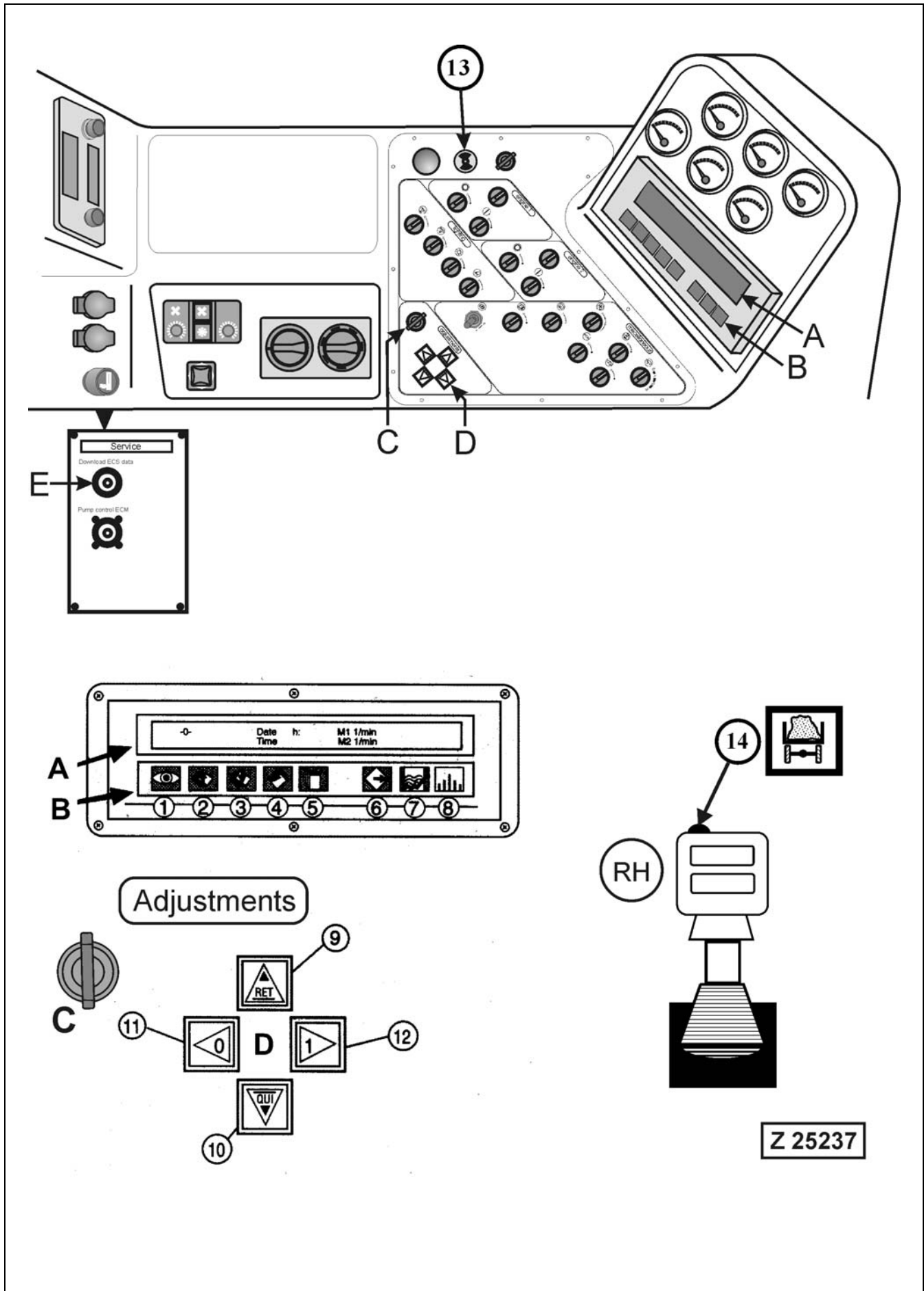

SERVICE FUNCTIONS operated with KEY GROUP (D) and KEY SWITCH (C), illustration Z25237, continued**Display of "INPUTS-OUTPUTS".**

This section is basically used for Testing procedures through authorized service staff and therefore locked during normal operation by the software program. Access to this section can be obtained in the Service section "INPUTS-OUTPUTS ON/OFF" through actuation of key switch (C).

Messages ON/OFF

The creation of Messages can be switched off, when for example, tests in the INPUT / OUTPUT levels are carried out with the ECS control functions operative (engines running) and test conditioned messages shall not be displayed (stored), i.e. Protocol and Statistics memory will not be filled with messages caused by testing operations.

Evaluation ON/OFF.

When commissioning or servicing the Shovel the data evaluation in the respective service function can be switched off with key switch (C). This prevents an overwriting of the selected function (Standard display, Inputs-Outputs or Service) by occurring messages, caused by repairs on the ECS system.

⚠ CAUTION

The function EVALUATION must only be switched OFF through authorized Service Staff. The instructions in the ECS Service Manual have to be observed. With the Evaluation switched OFF all monitoring and control functions of the ECS are inoperative.

Refer to Section "SERVICE FUNCTIONS" and "MENU CONTROL" on page 129 for more information.

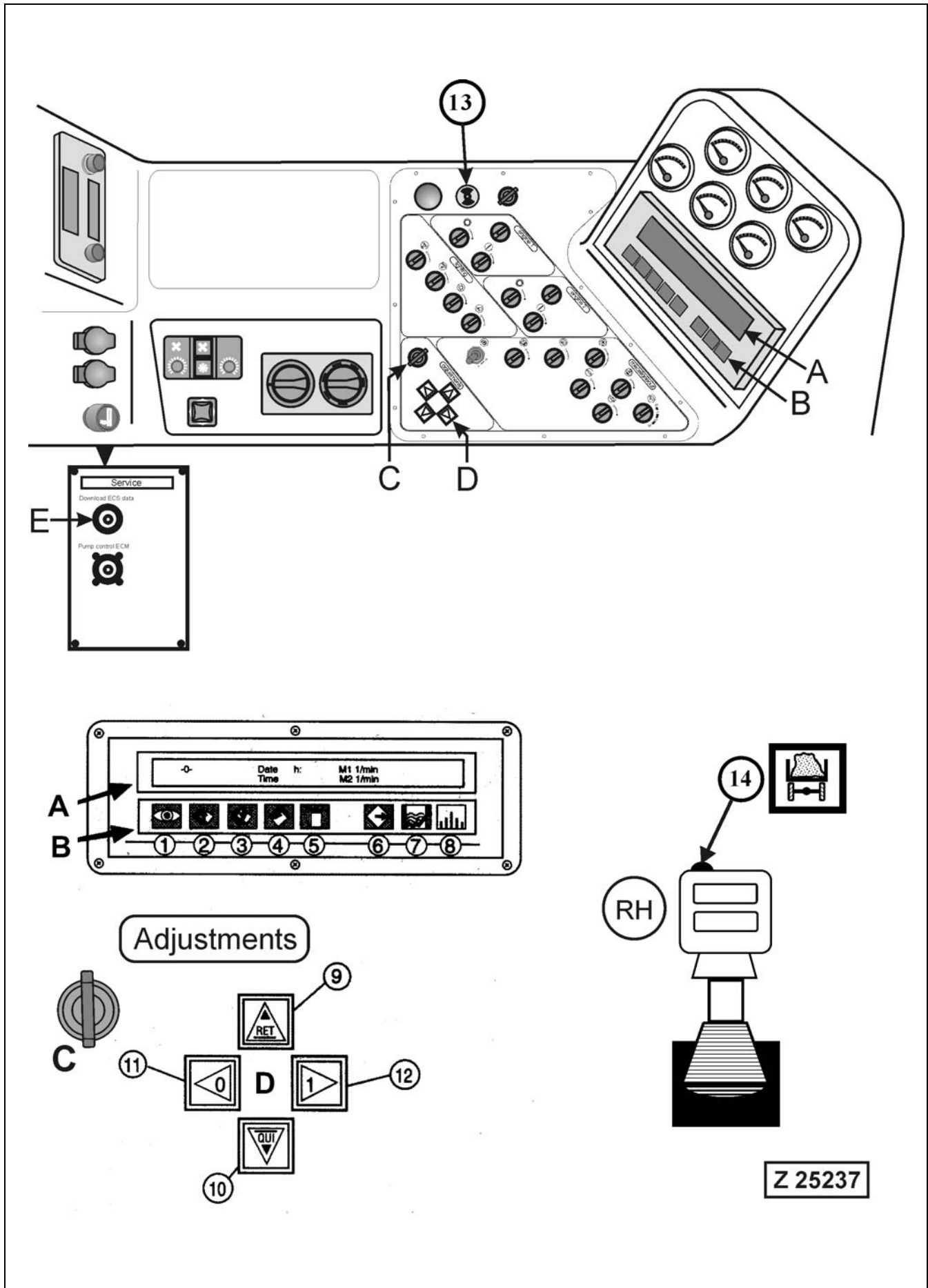

Legend for illust. Z25237

- (A) Display with basic information
- (B) Key board with 8 keys. For the function of the keys refer to page 99.
- (C) Key operated switch for enabling access to the INPUT-OUTPUT levels and input of operational data.
- (D) Key section with 4 keys for menu control of Service Functions and for INPUT-OUTPUT functions (On Screen Display).
- (9) RETURN Key, this key is used for returning to previous level of INPUT-OUTPUT or Service Functions.
- (10) QUI Key, this key is used for access to the next lower level of INPUT-OUTPUT or Service Functions and going back to the Standard Display from a displayed current message.
- (11) "0" Key, this key is used for selection of horizontal menu items within a main section of the inputs-outputs or service levels (LH direction).
- (12) "1" Key, same function as key (11) but in RH direction. Refer to page 131 Menu Control, for more information about the key section (D).
- (13) Acoustic warning signal (Buzzer)
 - This signal is heard for approximately 1 second when a fault message appears on screen (B).
 - Continuous sound when the hydraulic oil level is too low.



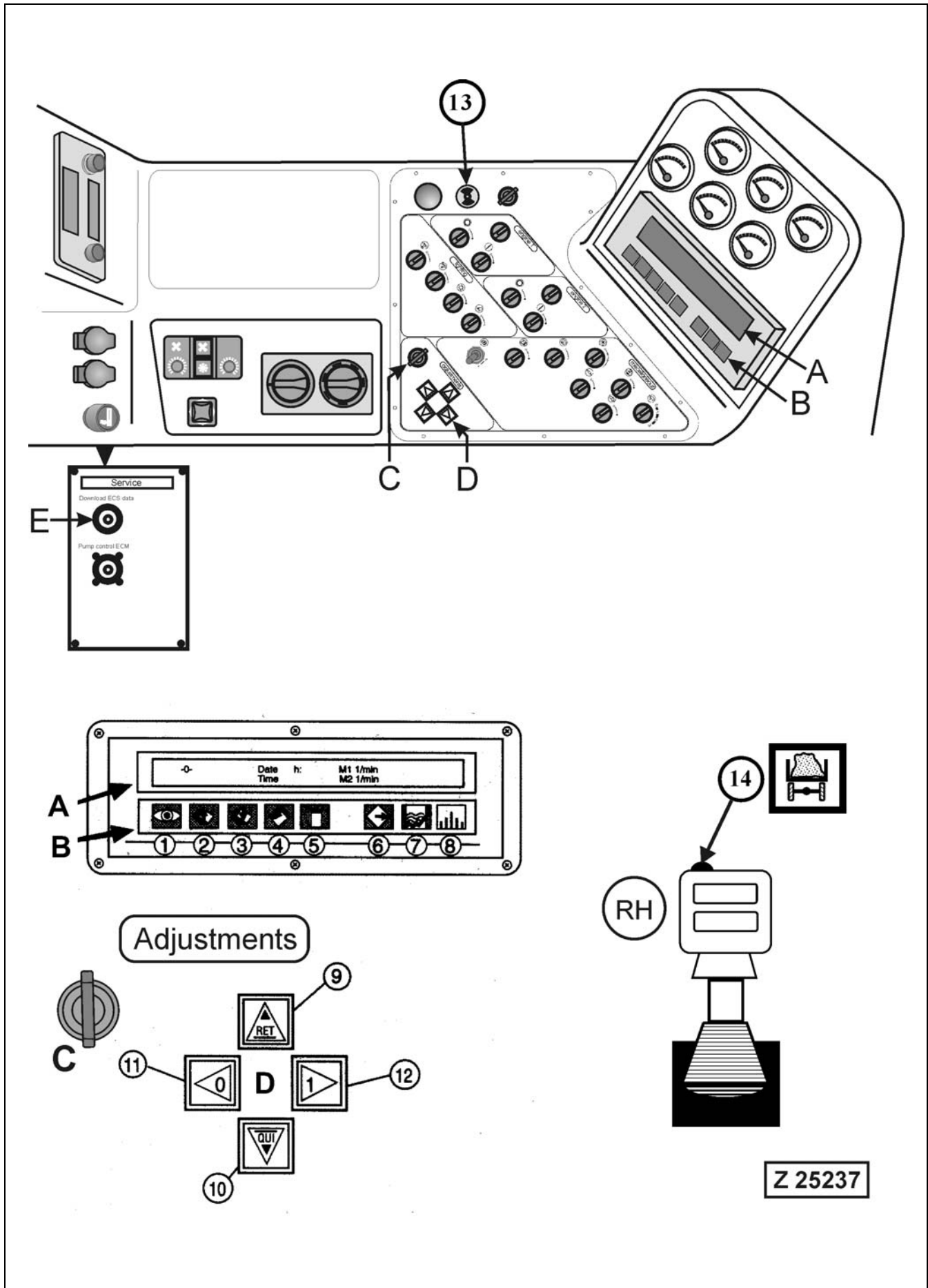

CAUTION

In case of too low hydraulic oil level this signal sounds continuously. Shut down the Shovel, locate and correct the cause immediately. Fill up hydraulic oil to the correct level.

- (14) Switch for truck counter on RH control lever. The loaded trucks can be counted by actuating this switch. The total number of trucks loaded will then be displayed on screen (A) for five seconds.
- (E) Plug socket for connecting remote printer or other data downloading equipment.
For printing out the contents of the **Statistics** memory, press key (8) and key (6). For printing out the contents of the **Protocol** memory, press keys (7, 6 and 3). Keep key (3) depressed until all messages are selected and then press key (6) two times. Refer also to page 121 for more detailed information.

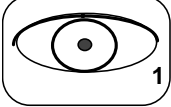

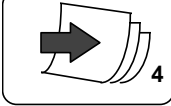
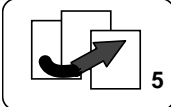
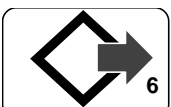
Function of the keys (1 to 8) of Keyboard (B):

 <p>MESSAGE</p>	<ul style="list-style-type: none"> • Text display of that page, which was selected from the Text store, Record memory or Statistics memory. • Shifting to the mode "leaf through" of current messages. • Acknowledgement of changed settings.
 <p>UP</p>	<ul style="list-style-type: none"> • Calls up the next text lines or the next pages (in the text mode). • Change of settings (figures)
 <p>DOWN</p>	<ul style="list-style-type: none"> • Calls up the preceding text lines or preceding pages (in the text mode). • Change of settings (figures)
 <p>PAGE NO</p>	<ul style="list-style-type: none"> • Display of a desired message • Moves the cursor • Change-over to the text mode
 <p>SYSTEM</p>	<ul style="list-style-type: none"> • Return to the basic display (basic information or last indicated message) from record memory, statistics memory or text store.
 <p>DATA OUT</p>	<p>Print out of:</p> <ul style="list-style-type: none"> • Contents of record memory • Contents of statistics memory • Acknowledgement of changed settings
 <p>PRO</p>	<ul style="list-style-type: none"> • Display of the record memory
 <p>STA</p>	<ul style="list-style-type: none"> • Display of the statistics memory

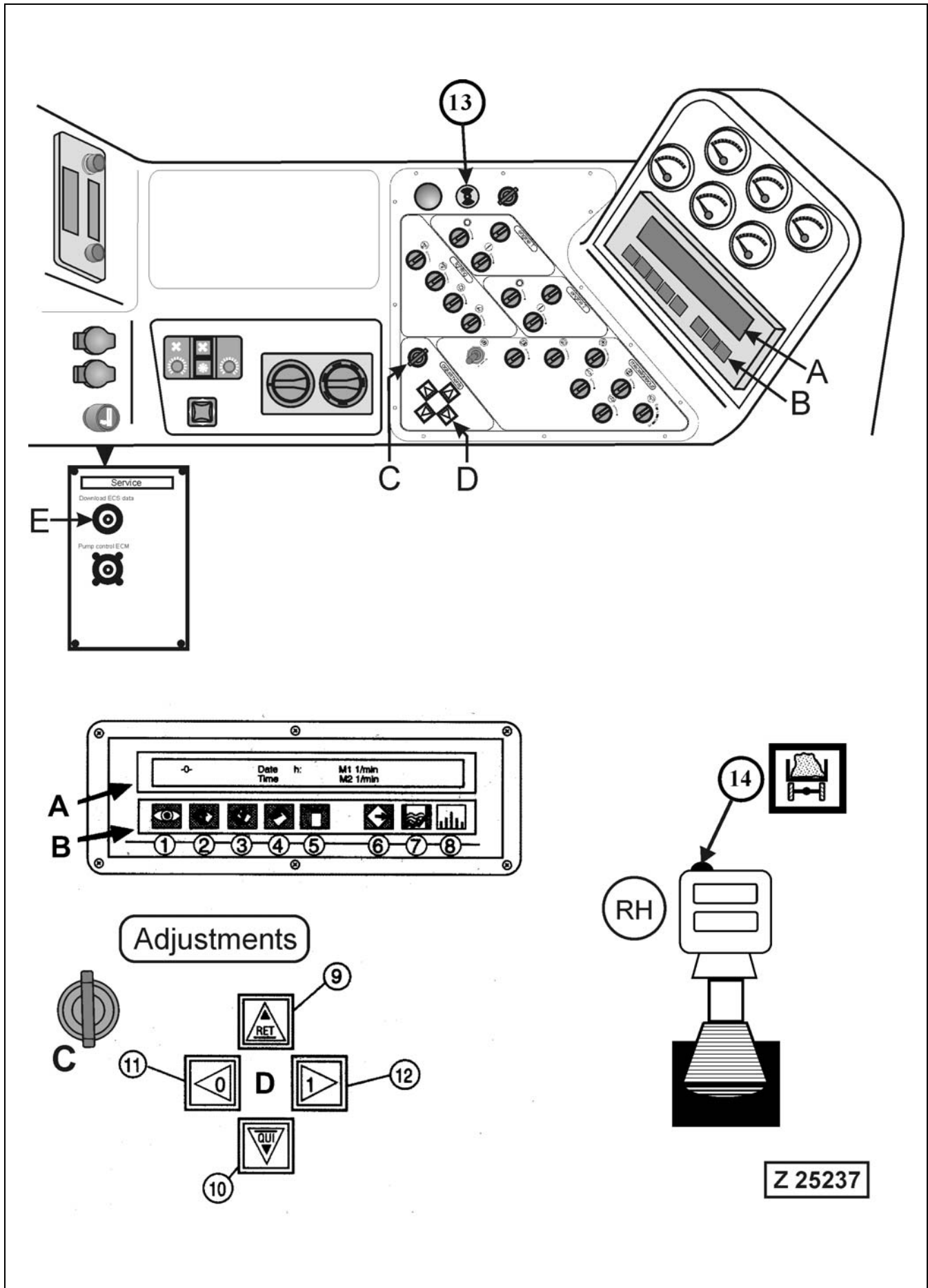

3.4.2 OPERATING THE ELECTRONIC MONITORING SYSTEM

1.0 TEXT DISPLAY (A) with integrated KEY BOARD (B)

illust. Z25237

After switching on the Shovel's key operated main switch, the following introductory messages will be displayed on screen (A):

1st. # Please be Safety Conscious when working!

This message will be displayed for approximately 10 seconds.

2nd. |QUI| Did you check the Operating Safety of the Shovel?

Press the "QUI" key (10) to acknowledge this message.

3rd. |QUI| Did you do Maintenance according to the Service Literature?

Press the "QUI" key (10) to acknowledge this message. Thereafter the basic ECS display normally automatically appears on the screen (A) if no information - or fault messages are present. Present information - or fault messages overwrite the introductory messages no. 2 and 3.

-0-	Date	h:	M1 *1) 1/min:
	Time		M2 *2) 1/min:

*1) **M1** = Short form for Rear Engine on counterweight side designated as Engine 1.

*2) **M2** = Short form for Front Engine on Operator's cab side designated as Engine 2.

All messages related to one of the two engines, their connected cooling systems and pump distributor gears are identified by the figure 1 or 2.

Example of an engine related message:

Fault No. 560:
(563)

\$h:	Shut down of engine 1: oil pressure at low idle too low
------	---

Help:

Message through sensor B1-1.

This message applies to the **rear engine** on counterweight side "**Engine 1**".

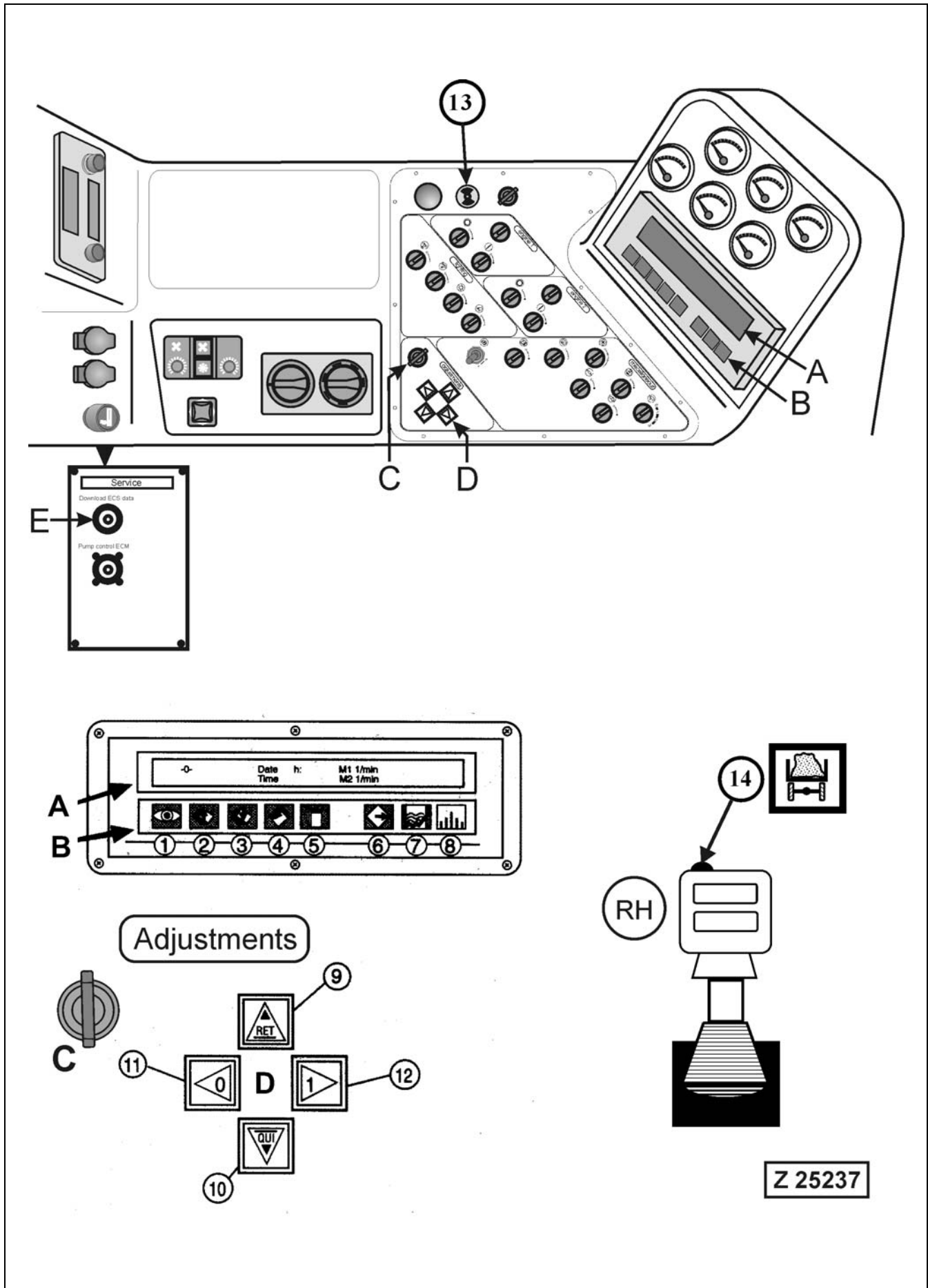

Basic Display

The basic display in system level -0- is for general information during operation and shows the Date, the Time of Day, the Operating Hours (h) and the speed of engine 1 (M1) and engine 2 (M2). Within Level -0- further operating data can be called up by pressing key (12).

Call up further Operating Data in System Level -0-:

The following data can be called up by pressing key (12), illust. Z25237

-0- PTO Gear oil temperature M1	Nominal < °C)	Actual: °C
-0- PTO Gear oil temperature M2	Nominal < °C)	Actual: °C
-0- Hydraulic oil temperature	Nominal < °C)	Actual: °C
Fuel level		: %
-0- Boardnet voltage	Nominal >22 V	Actual: V
Charging current	Nominal 4-100 A	Actual: A
-0- Ambient temperature		: °C

REMARK

The maximum permissible temperature of the PTO gear oil and of the hydraulic oil depends on the viscosity of the oil used. The following table shows the maximum permissible temperature of the respective oil viscosity.

PTO Gear Oil

Viscosity class according to ISO	T 32	CLP 150
maximum permissible temperature °C:	< 60	< 95

Hydraulic Oil

Viscosity class according to ISO	VG 22	VG 32	VG 46	VG 68	VG 100	SHELL SL0851
maximum permissible temperature °C:	< 58	< 69	< 79	< 85	< 85	< 85 *1) < 81 *2)

*1) Temperature value for new oil (freshly filled in).

*2) Temperature value for used oil. This temperature value has to be adjusted when the viscosity of the hydraulic oil has decreased by 10 to 12 percent compared with new oil. The determination of the hydraulic oil viscosity should be carried out in the course of the regular oil analysis procedure.

The input (setting) of the viscosity class has to be done in main group Service *SETTINGS*.

For more information refer to page 135.

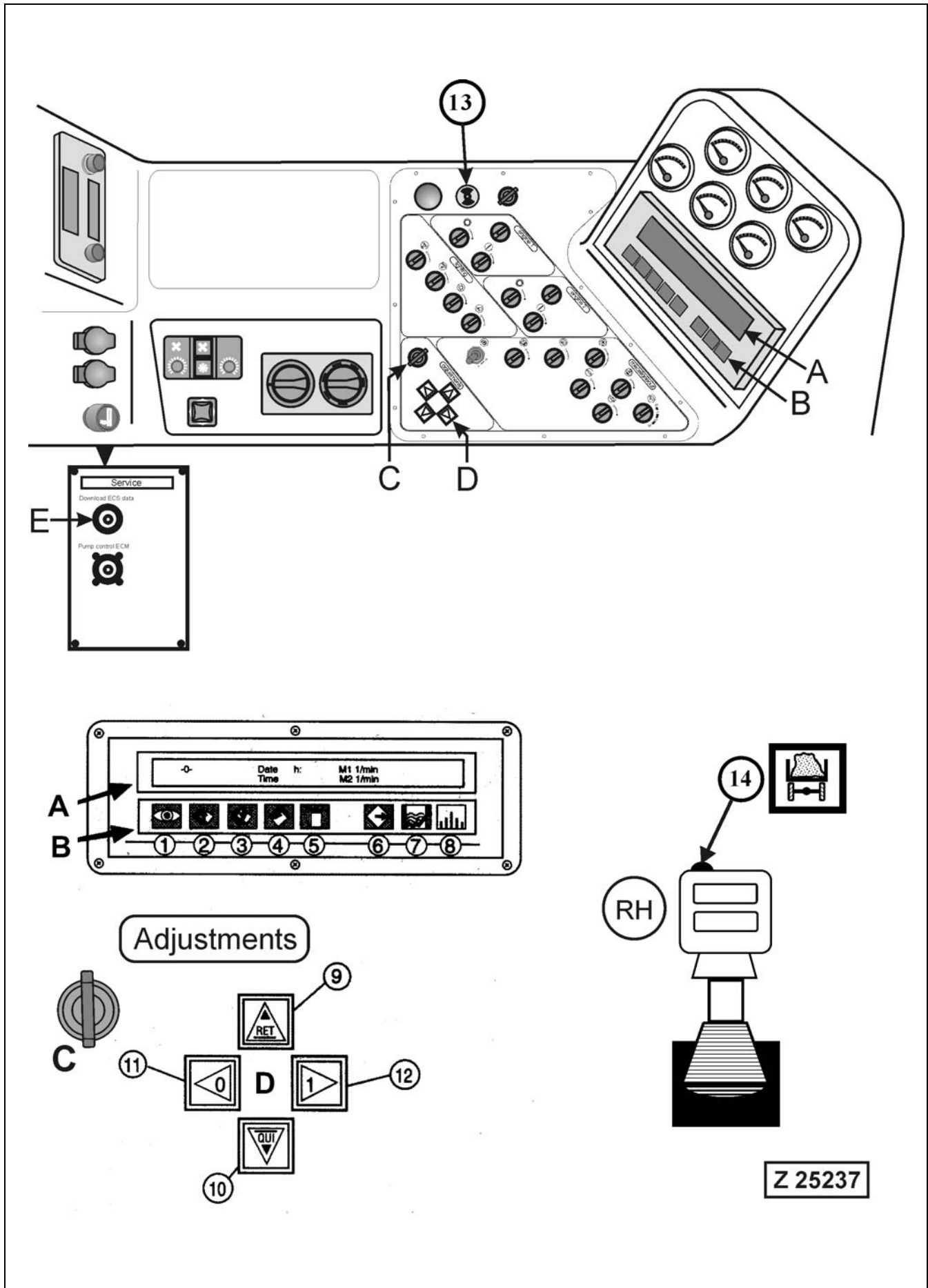

3.4.3 AUTOMATIC DISPLAY OF MESSAGES

The messages of the ECS system are divided into three main categories as follows:

Category I:

Information messages indicating an operating condition, e.g. "# swing Parking Brake Applied" or a present maintenance interval message.

How to act:

- These information messages are self-explanatory.
- Press the "RET" key (9) twice for returning to basic display.

Category II:

Fault messages without automatic shut-down of the unit. These messages indicating a deviation from normal operating condition.

How to act:

- Immediate shut-down of the unit is not necessary.
- Inform the responsible Service Staff about the fault message.
- Press the "RET" key (9) twice for returning to basic display.

Category III:

Fault messages resulting in an automatic shut-down of the unit. These messages indicating a serious failure.

How to act:

- Press the "RET" key (9) twice for returning to basic display.
- Re-start of the unit can be tried. If the fault still exists, the unit will not start or automatic shut-down will happen again.

Emergency By-pass switch for the ECS- Shut-down Function.

The unit is equipped with an Emergency By-pass Switch for the ECS-system. This switch is located on the "X2" switch board in the cab base compartment and marked with "S27". The location of the switch is shown on page 211. If an automatic shut-down of the Shovel happens, with a dangerous situation for man or machine, which needs the Shovel to be operable to overcome the dangerous situation, actuate this switch to override the shut-down function of the system and to enable a restart of the engines.

As soon as the immediate situation of danger is over, shut down the unit. Correct the fault that caused the shut down and re-set the Emergency By-pass switch.

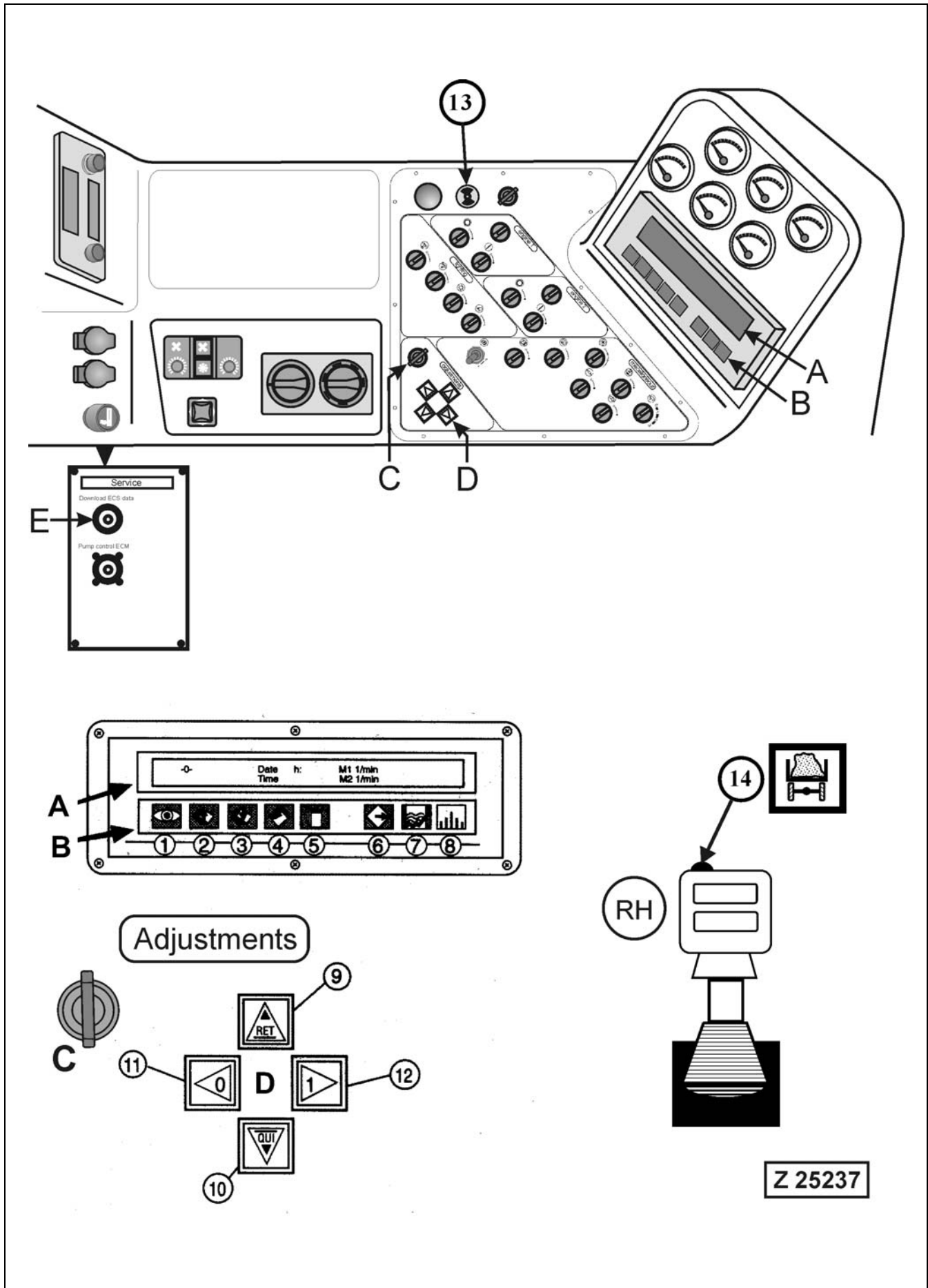

Automatic Display of Messages

If a fault or an information condition occurs during operation, the basic display is automatically replaced by a message in text. If a further condition occurs, another message is displayed so that the operator is always shown the latest message.

The message text provides the operator with an explanation of the condition in standard texts.

When a fault message is displayed, further "HELP" information relating to the fault message can be obtained by pressing the "DOWN" key (3), illust. Z25237. All fault and information messages are listed in section "Message Texts". Each message is related to a page. These MESSAGE PAGES are numbered and can be called up individually. When a fault message is displayed the number of operating hours is displayed and stored at the same time. Fault and information messages are held as long as their cause is existent

Maintenance Schedule

In accordance with the operating hours of the Shovel, the initial and periodic maintenance intervals are automatically displayed.

Example:

After the first 250 operating hours of the Shovel the following message will be displayed:

Initial 250 h Maintenance
Perform initial 250 h Maintenance.

Perform maintenance according to the Maintenance section.

Acknowledgement of performed maintenance.

The acknowledgement of performed maintenance is obtained in the main group "Service" under menu item "Maintenance" refer to Menu Control Chart -VI- on page 149.

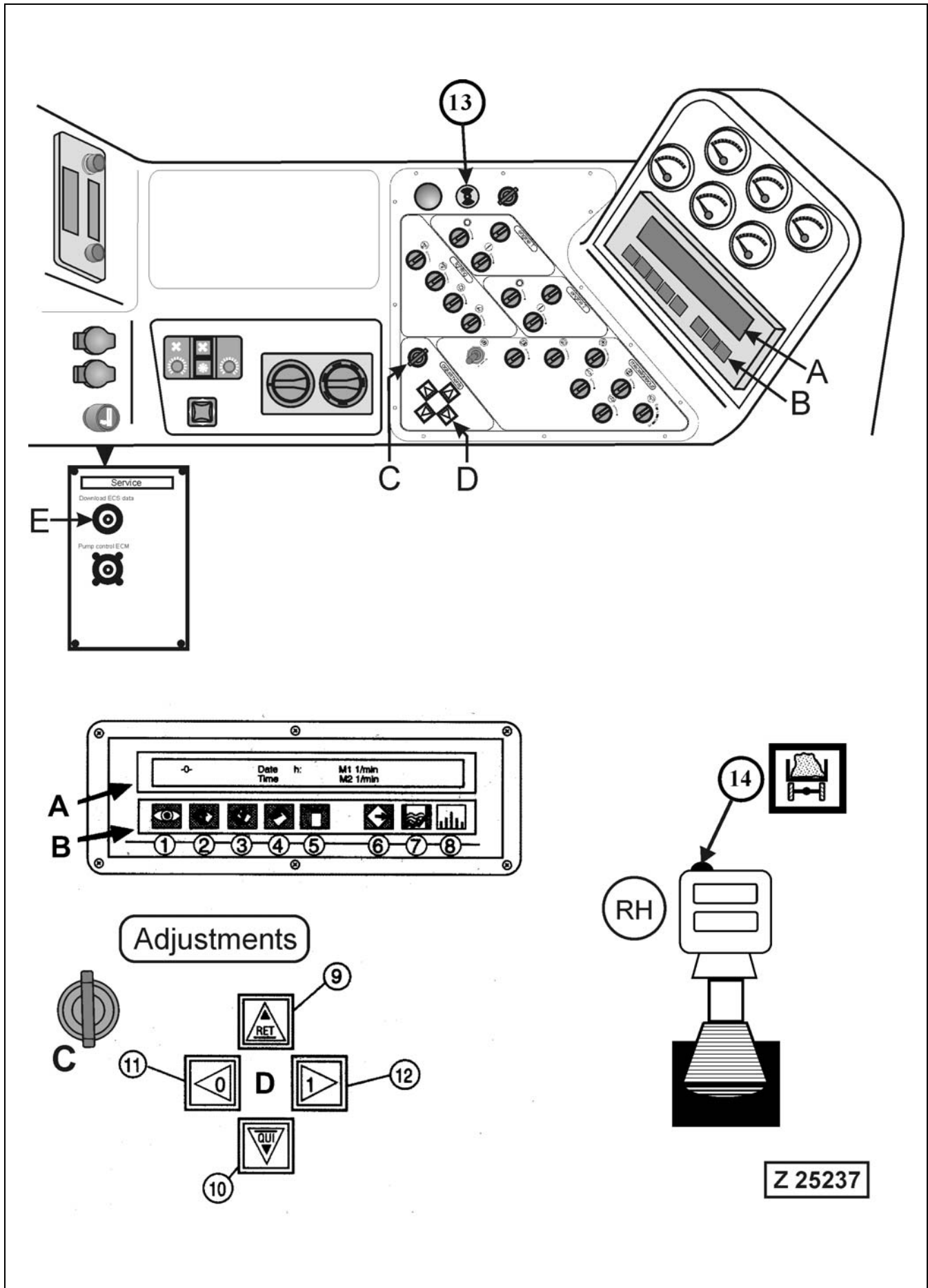

Message Classification

All messages filed in the text store of the text display are listed in Section "Table of messages" on page 172 in sequence of their page numbers and are divided into the following 4 groups:

Group 1

Fault Messages of message text pages number 500 - 739.
When a fault message of this group is displayed, the warning buzzer (13), illust. Z25237 will sound for 1 second, simultaneously an automatic engine speed reduction to low idle, or an automatic shut-down of the Shovel will happen. These messages are recorded in the protocol memory and in the statistics memory for later evaluation.

Group 2

Fault Messages of message text pages number 740 - 1309.
When a fault message of this group is displayed, the warning buzzer (13) will sound for 1 second, no shut down of the Shovel. These messages are recorded in the protocol memory and in the statistics memory for later evaluation.

Group 3

Acknowledgement messages of performed maintenance of message text pages number 1310 - 1319.
The acknowledgement messages serve only for protocollation of the acknowledgement of performed maintenance. They are recorded in the protocol memory and in the statistics memory for later evaluation.

Group 4

Information Messages of message text pages number 1320 - 1535.
Information messages are identified by the sign (#) in the upper LH corner of the screen (A). These messages are for information only and are not recorded.

REMARK

The message pages no. 1 - 499 contain the text of the MENU CONTROL (Service function) of the ECS-system.

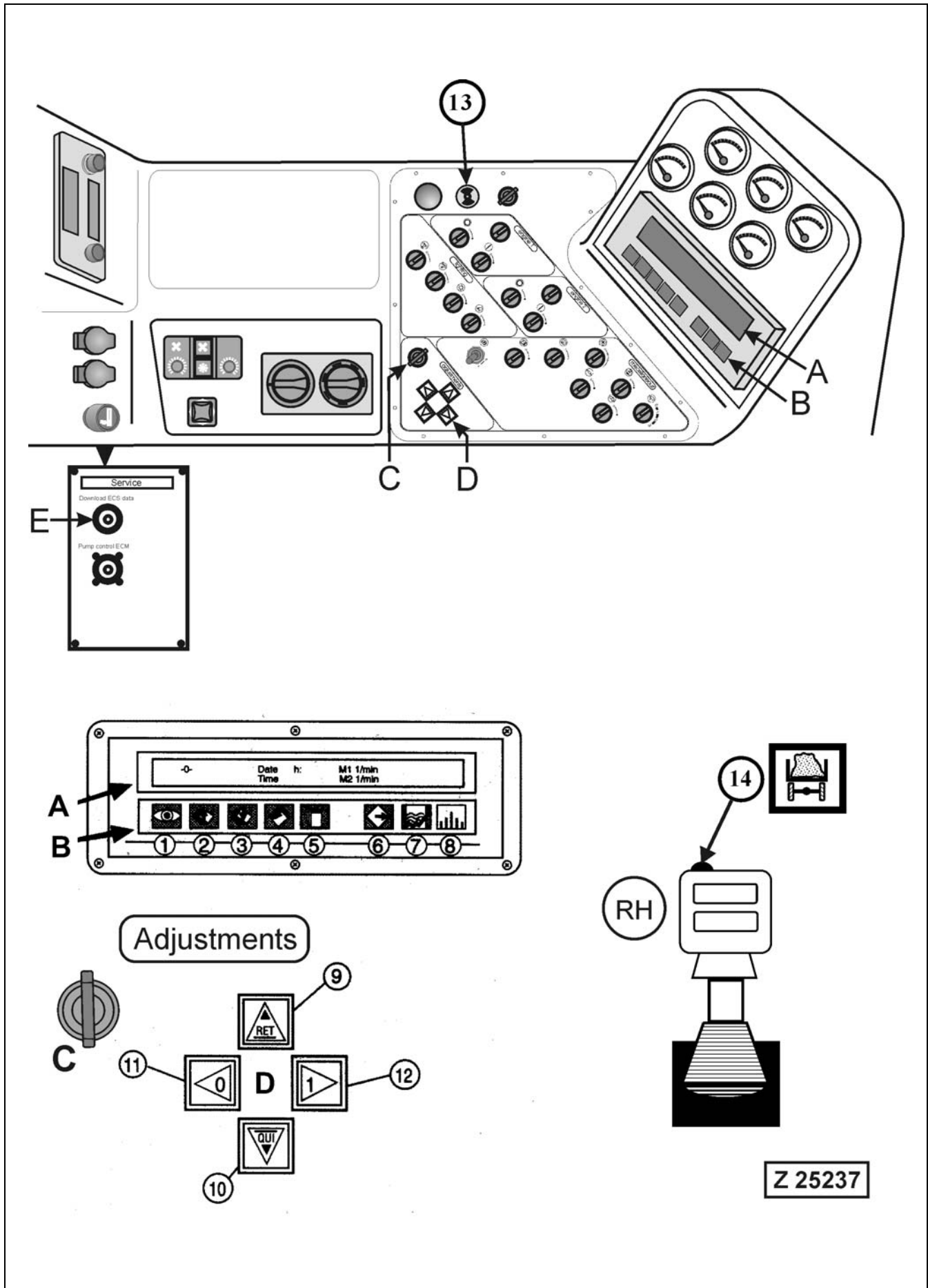

Emergency Indication of Operating Conditions.

The ECS system is equipped with an emergency indication. In case the text display (A) fails to work, it indicates faults in important operating systems of the Shovel. The indication is effected by means of LED's at the **Programmable Logic Controller "PLC"** installed in the cab base. Refer to page 208 for the location of the **"PLC"**.

The following faults are indicated:

Fault:	LED No.:
The ECS system is by-passed (By-pass switch S27 actuated)	H30
Start of engine 1 and/or engine 2 blocked, resp. engine shifted to low idle speed by one or more of the six high pressure filters. NOTICE The LED "H31" monitors all six high pressure filters. Refer to page 217 for description of the diagnostic codes flashed out by LED "H31".	H31
Coolant pressure	H33
Coolant temperature	H34
Engine oil pressure	H36
Start of both engines blocked, resp. engine shut down, due to closed main shut-off (gate) valve hydraulic tank	H37
Faulty monitor channel for hydraulic oil temperature	H38
Too low hydraulic oil level! Stop the engines	H39
Faulty monitor channel engine speed	H112
Emergency shut down switch actuated	H116
Engine shutdown from ground man (if so equipped)	H135

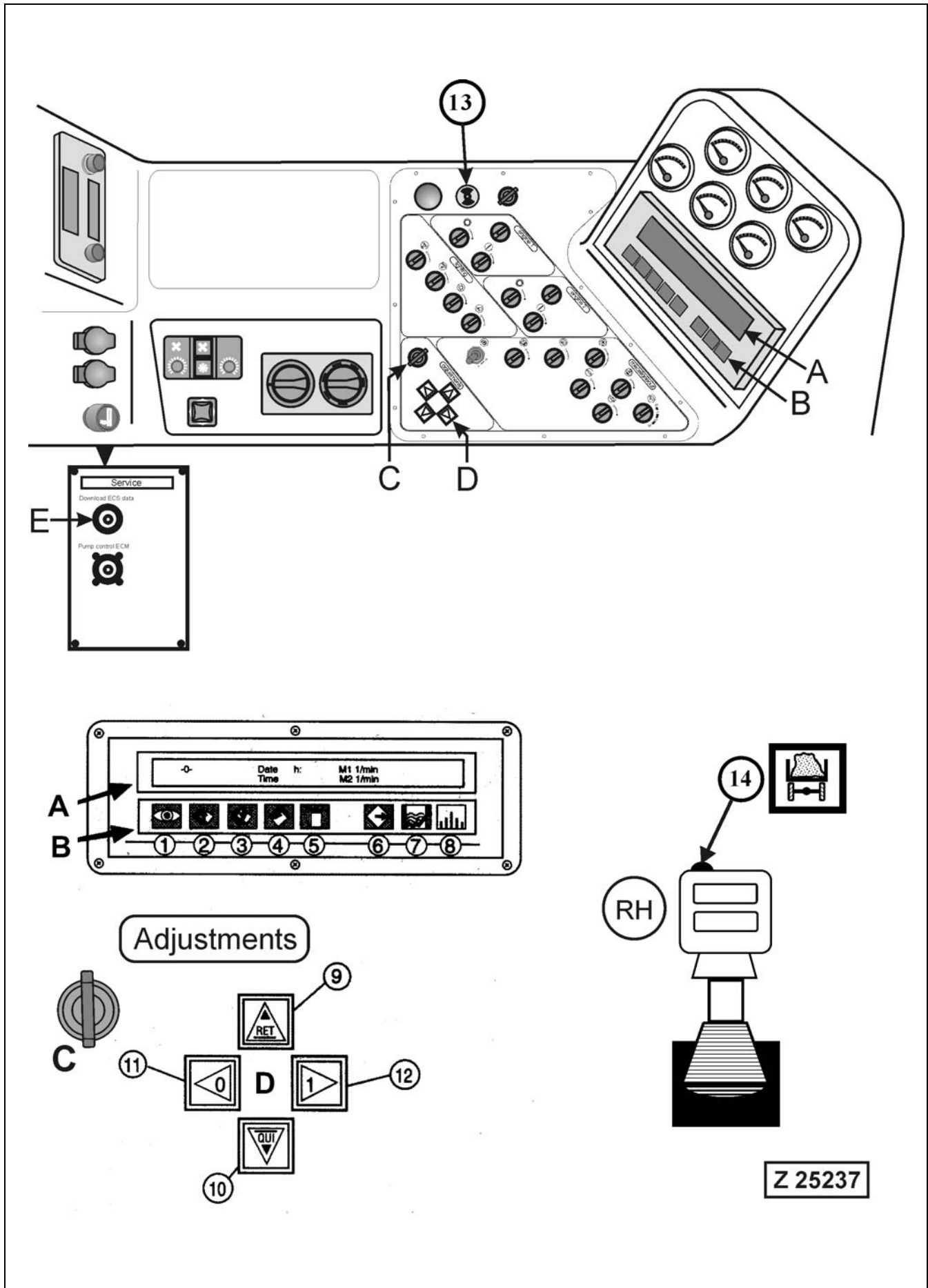

TEXT DISPLAY (A), illust. Z25237

Several messages are present at the same time:
The last input message is displayed. The number of all current messages is indicated by a flashing number in the second text line.

Example: Fault message No. 596:

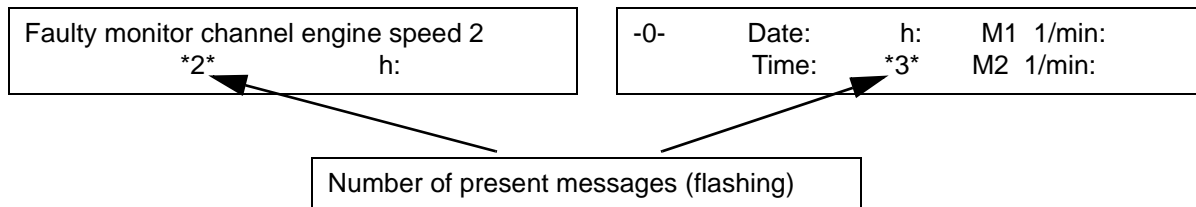

These present messages can be called up with key (1) (MESSAGE). Press key 2 (UP) or 3 (DOWN) for the display of the present messages.

Call up of "HELP" Information (HELP Texts) to a displayed message.

If additional "HELP" information (HELP Texts) to a displayed fault message are desired, press key (4) to enter the Text mode. Then press key (3), to display the "HELP" text.

Example fault message 596:

Fault No. 596:	Faulty monitor channel engine speed 2
Help:	The frequency converter E8.2 for engine speed 2 shows inadmissible values - Check frequency converter E8.2 and pick-up B64.2

Messages and Help texts are displayed each time in two text lines. The two next text lines can be called up by pressing key (3) "DOWN".

The fault messages including the Help text consist of maximum 8 text lines. For return to the fault message press key (2) "UP" until the message is displayed again.

Resetting Fault Messages of the Lubrication Systems after Repairs which have been carried out with the Engine(s) running or with the Engine(s) OFF and Main Switch Key in ON position. After repairs under the above conditions it is necessary to reset the control circuit of the concerned lubrication system by actuating the rotary switch on the instrument panel for a full lube cycle. If this manually actuated lube cycle is not being carried out, the fault message "LUBE SYSTEM FAILURE" will remain on the ECS display. Resetting of the lube system control circuit can also be done by shutting down the engine(s) and switching OFF the main switch key.

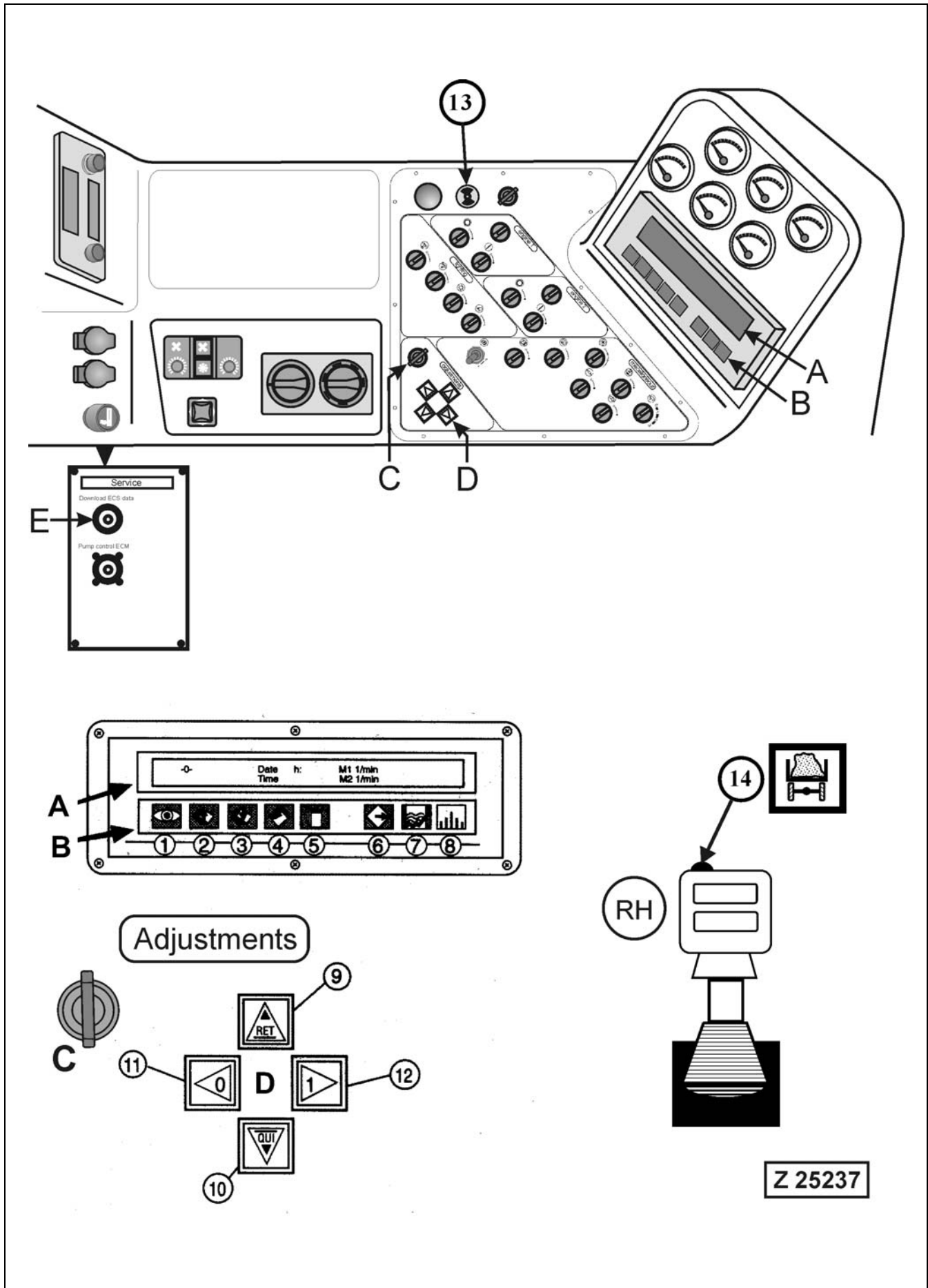

Display of message pages without present message.

If there is a statistics print out and the individual Nos. of the message pages cannot be adjoined to the message text, the message text can be called up as follows.

Starting from basic display (Message 2)

-0-	Date	h:	M1 *1) 1/min:
	Time		M1 *2) 1/min:

Message 500 shall be displayed.

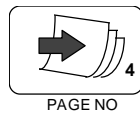

Press, a page no appears.

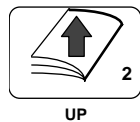

Press, until page 500 appears

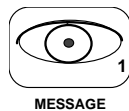

Press, to display text of message 500

Display:

Fault No. 500 :

Start blocked because of main Shut-OFF (gate) valve	h:
---	----

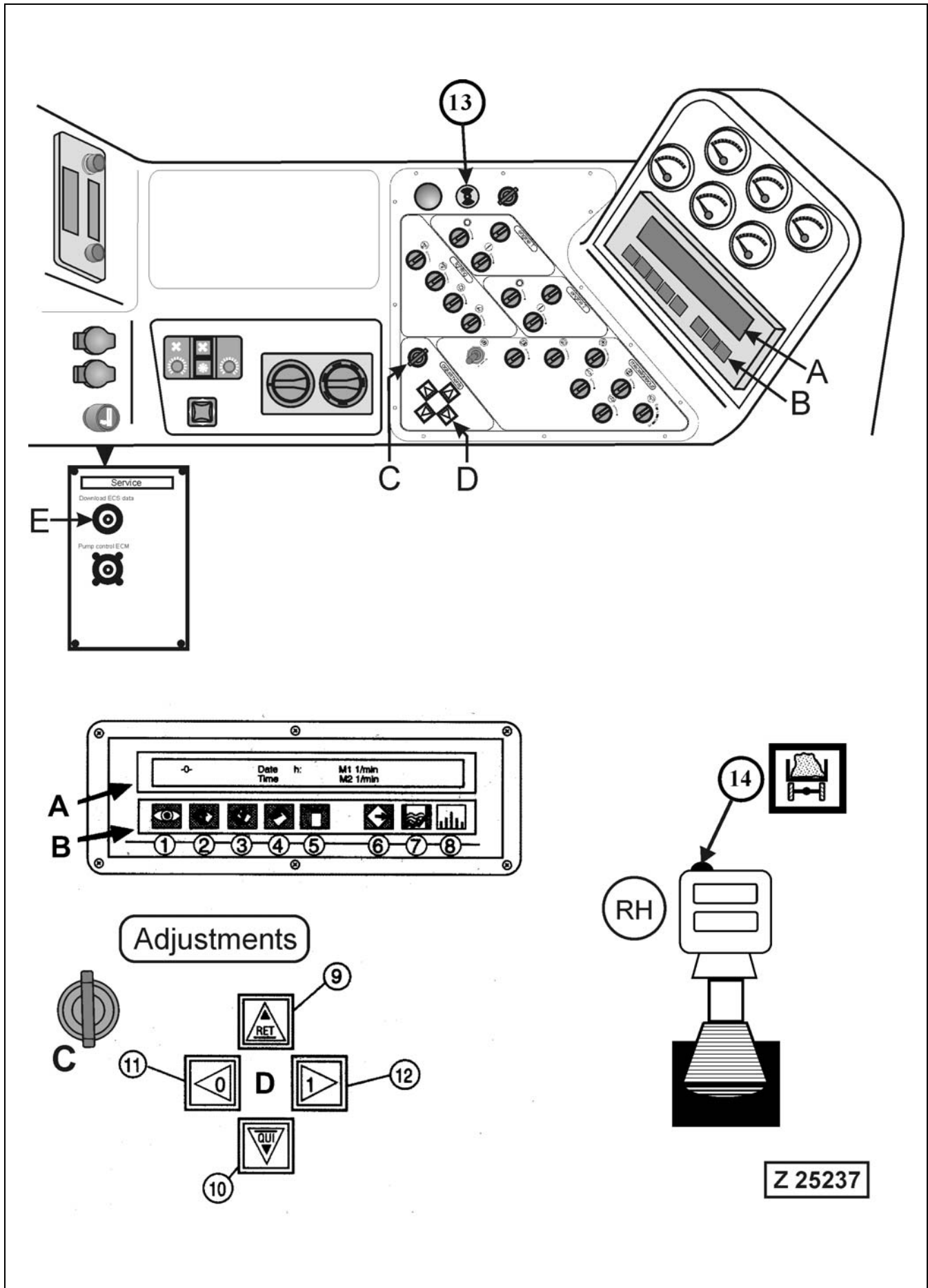

Display the Contents of Record (PROTOCOL) Memory, illust. Z25237



Press to display Protocol memory.

Last entry of the protocol memory will be displayed first. Higher numbers indicating older entries.

Fault message going

Display:

PROTOCOL entry no: 1 status : going
message : 716 date 15.07.06 at 15:27:32

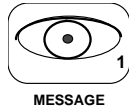

Press to display message 716.

Example for other entries (e.g. Message No. 980)



Press until the desired message **no. 980** appears.

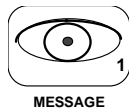

Press to display message 980.

Display: Fault Message No. 980:

\$h Swing gear house brake off

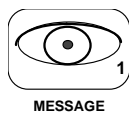

or

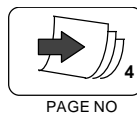

Press to return to the last message text.

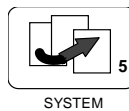

Press to return to the basic display (Standard display) or to the last current message

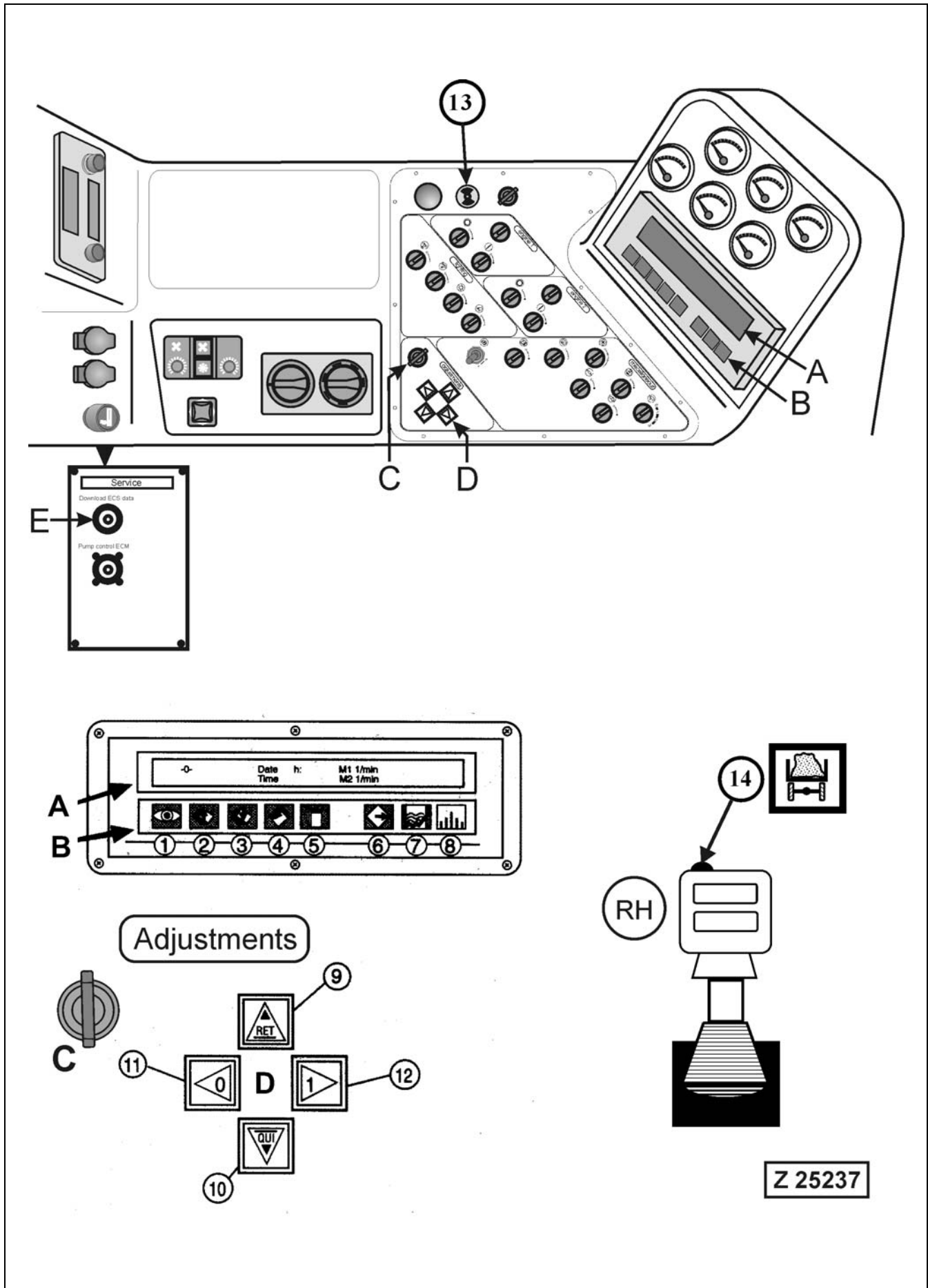

**Display the Contents of Statistics Memory,
illust. Z25237**

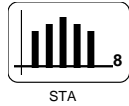

Press to display statistics memory.

Display:

STATISTICS	Appeared:	4 = 80.0%
Error :	644 Elapsed :	00:02:40 = 100.0%

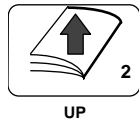

or

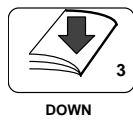

Press to leaf through all recorded messages.

Example:

Indication in percent how often the fault has occurred in relation to the total number of faults = 100%

STATISTICS	Appeared:	1 = 20.0%
Error :	500 Elapsed :	00:03:40 = 74.5%

Message page
500

Duration of
the fault

Fault portion in percent
of the total error time

Print out Contents of Statistics Memory:

-0-	Date	h:	M1 *1) 1/min:
	Time		M1 *2) 1/min:

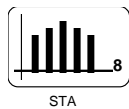

The complete statistics are now being printed out.

Display:

***** STATISTICS PRINTOUT *****
Printing statistics table, please wait....

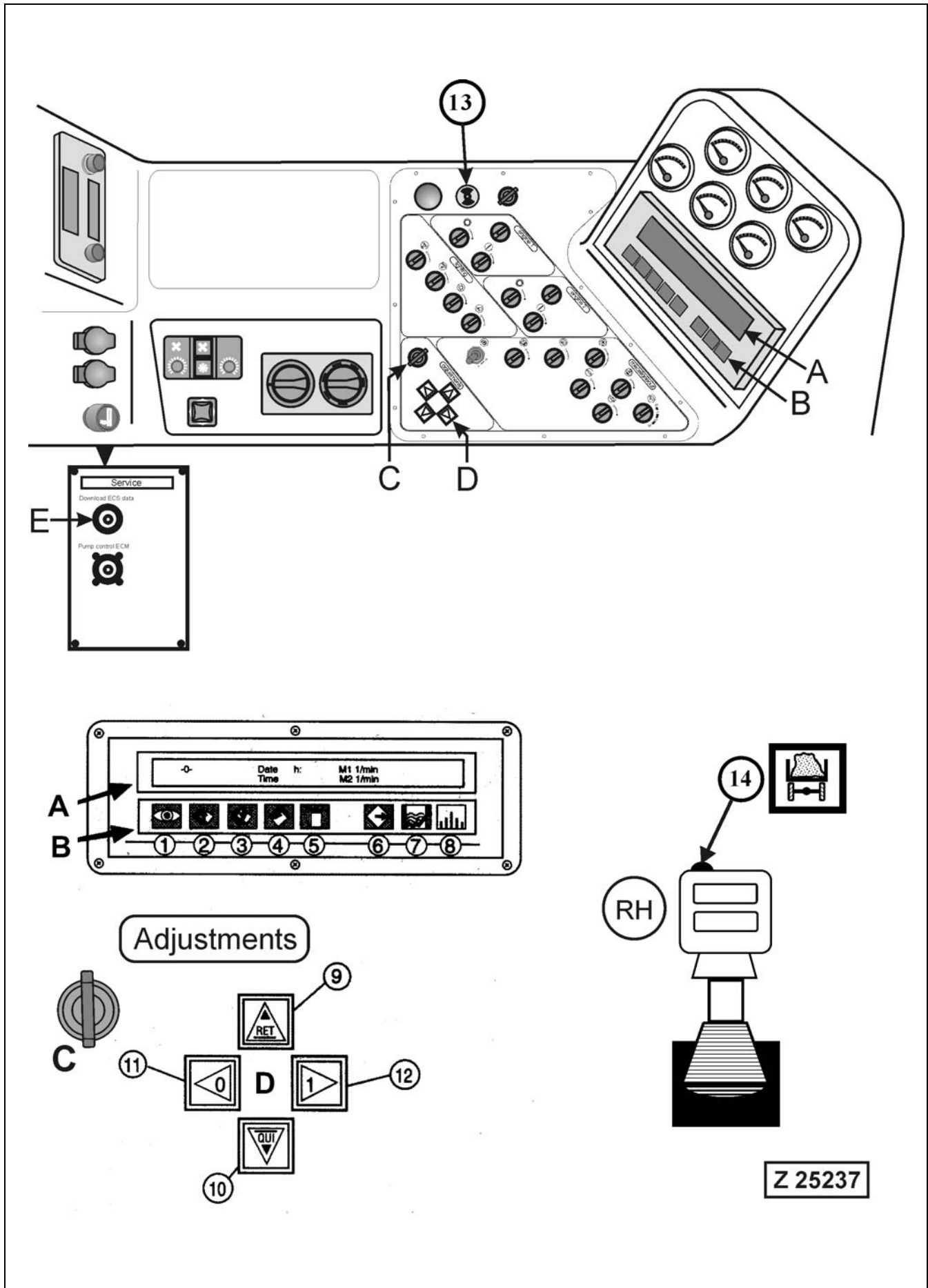

How to print out Contents of Record (PROTOCOL) Memory:

Print out the *complete* Contents of Record (PROTOCOL) Memory

Display:

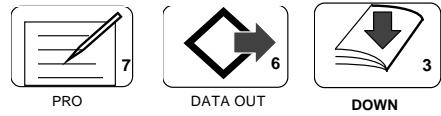

Press until the maximum amount of entries (**39**) is reached

Print from the last	>	1< PRO entries
page no all * PRO has		39 entries *P*

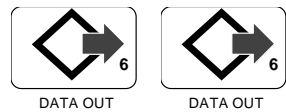

The complete PROTOCOL is now being printed out.

Distinctive marks for "OLD" and "NEW" entries:

New entries, not yet displayed / called up / printed or downloaded are marked with *P*.

After being displayed / called up / printed or downloaded the marking will change to -P-.

Print out the *last* Entries of the Record (PROTOCOL) Memory

1st. Possibility - The last (X) Entries under consideration of all Messages

(X) = desired number of the last entries e.g. **10** (the last 10 entries of 39 total entries)

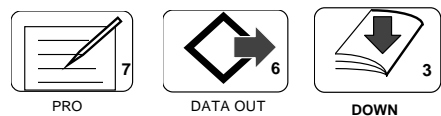

Press until the desired nos. of entries are reached, e.g. 10.

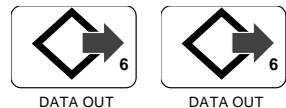

The record memory with the last 10 entries is now being printed out.

Print from the last	>	10<PRO entries
page no all * PRO has		39 entries *P*

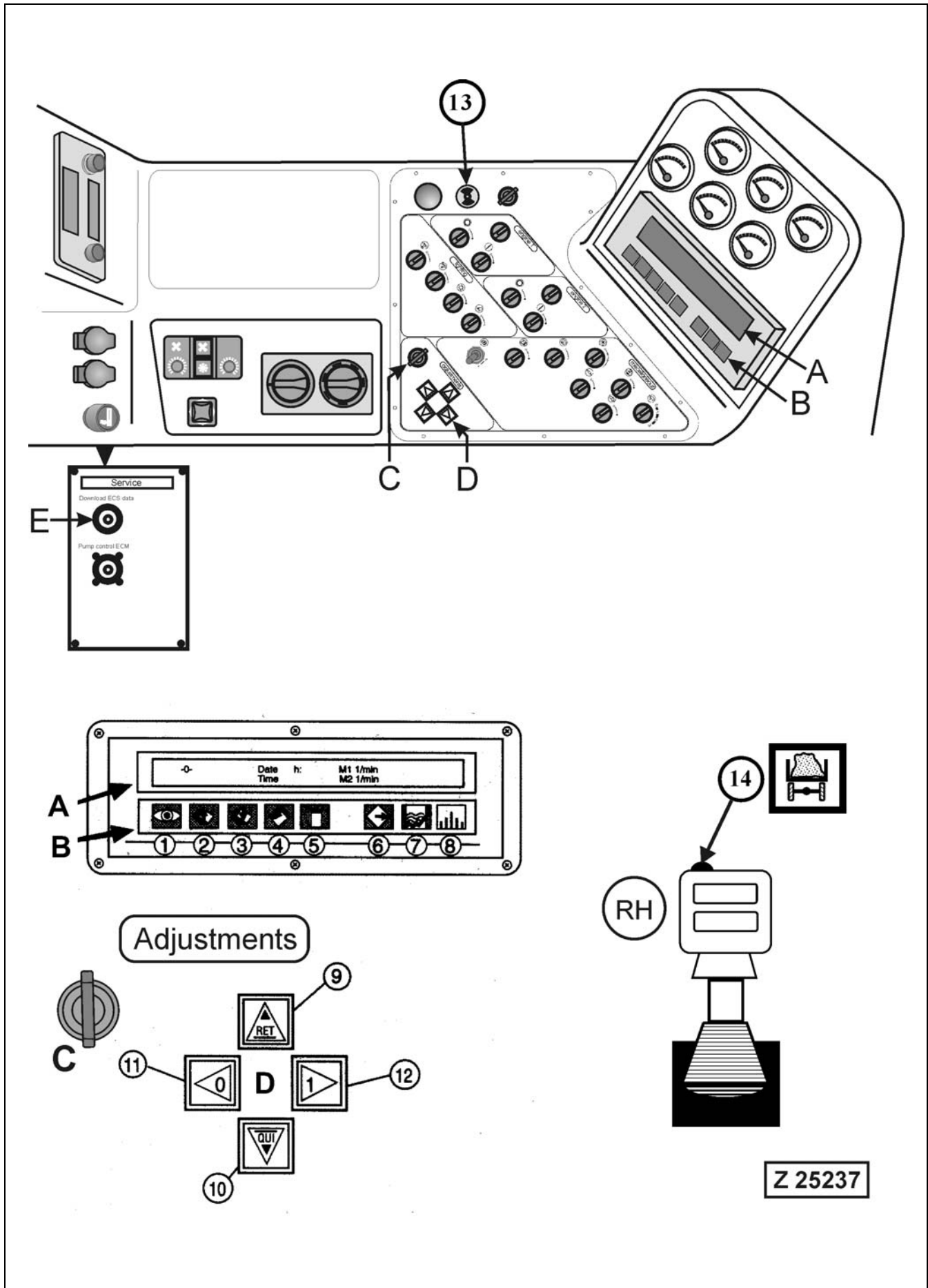

2nd. Possibility - The last (X) Entries of a certain Message

(X) = desired number of the last entries e.g. **10**.

This print shows, whether the desired message appeared within the last 10 entries.



Press until the desired nos. of entries are reached, e.g. 10.

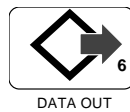

The position of the brackets > < is now being changed from the entries to the message texts.

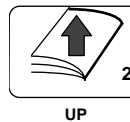

Select message (page) e.g. 524.

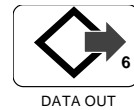

The records of message 524 of the last 10 entries are printed out..

Print from the last	10 PRO entries
page no > 524<	PRO has 39 entries *P*

Explanation of the statistics print-out

You receive for example the following print-out:

Column	1	2	3	4	5
Good	0	=	0.0 %	02:00:00	= 33.3%
524:	1	=	14.3 %	01:00:00	= 25.0%
578:	1	=	14.3 %	01:00:00	= 25.0%
590:	3	=	42.6 %	02:30:00	= 62.5%
608	2	=	28.6 %	01:00:00	= 25.0%
Err.:	7	=	100 %	04:00:00	= 66.6%

Column 1:

Good: Time with no faults, number of faults = 0

Err : Time, where faults have occurred, number of faults = 7

The numbers 524, 578, etc. indicate the message page number in the text store.

Column 2:

The number indicates, how often the fault has occurred, for example the fault of page no. 590 has occurred 3 times. In line "Err" (Error) the number of faults is summed up, the result is 7.

Column 3:

Here is indicated in percent, how often the fault has occurred applying to the total number of faults (7 = 100 %).

Column 4:

The time indicates, how long the fault has been present. If a fault has occurred more than one time, the sum of time will be indicated here.

Column 5:

The duration of the fault applying to the total time with faults (Err), = 4:00:00 (4 hours). This number results in the temporal overlapping of the faults. If you sum up the times, you receive 5:30:00. Good and Err apply to the sum of Good and Err, respectively. Refer to the diagram on next page for more information.

Time Diagram of Statistics Print

The diagram below shows an example, how the time without faults (Good) and the time with faults (Err) could be distributed within the total operating time of the ECS.

E: Total operating time of the ECS

524/578/590/608: Total time of a message

Err: Total time of all messages

Good: Total time without messages

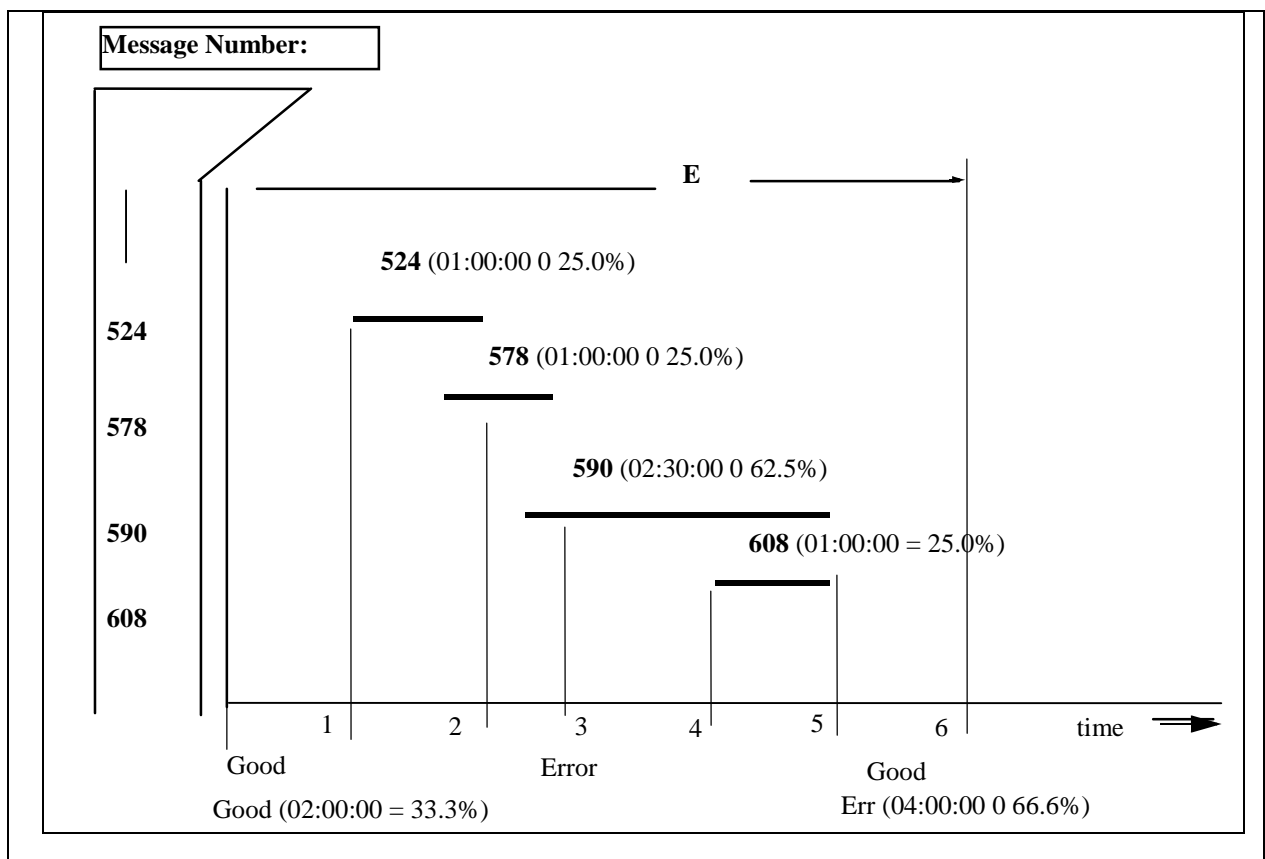

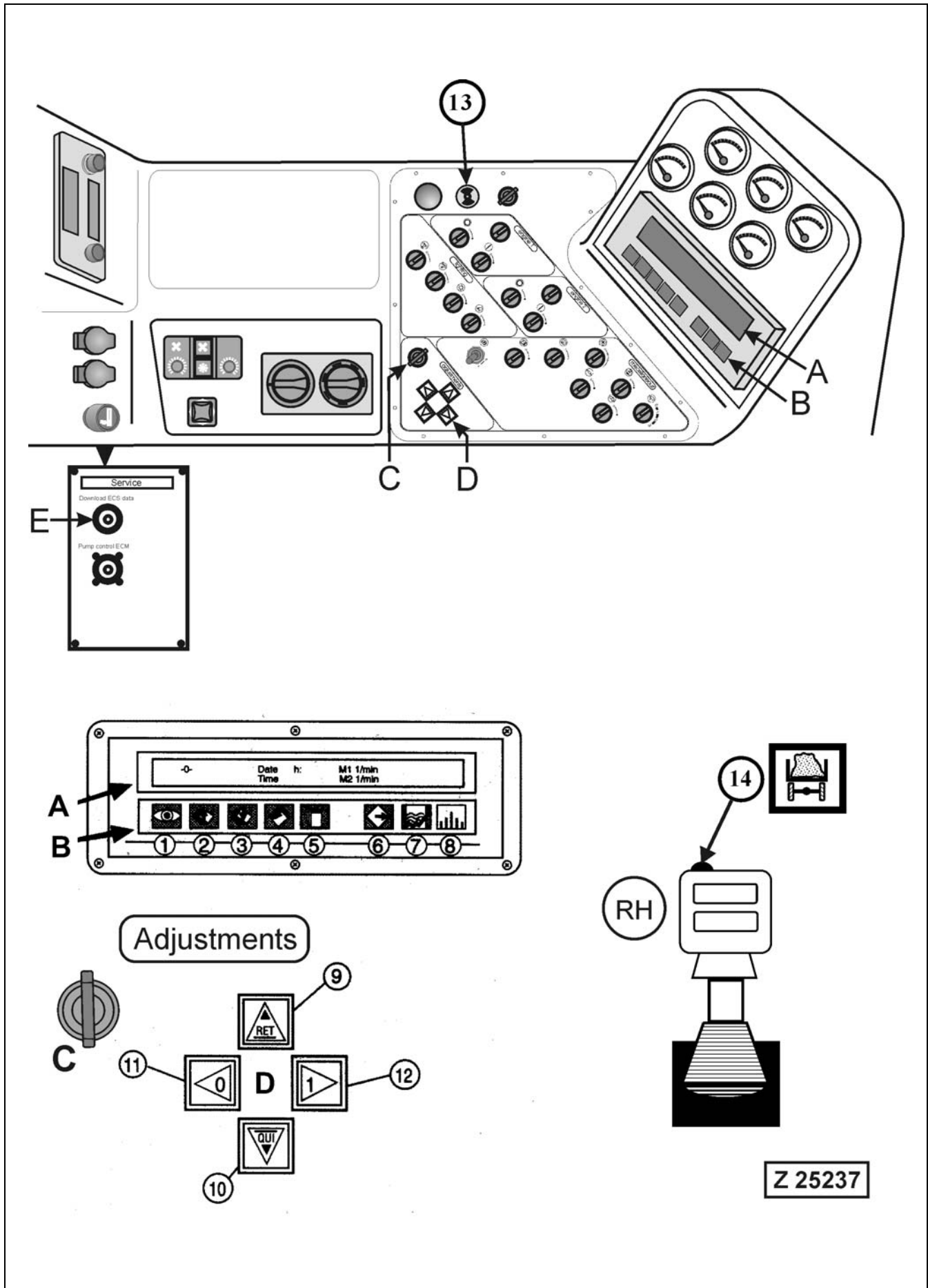

Return to SYSTEM level:

Display of the Last Message Received or Menu
(Standard Display)

Operation of the keyboard (B) has no influence to the recording of input messages. For example, if the record memory is called up via keyboard (B), the ECS switches back to SYSTEM level after a period of 20 seconds when no further key is actuated within this period. For immediate return to SYSTEM level (message display or menu) press key 5 (SYSTEM).

Setting of Screen Brightness

Increase brightness: Press keys (5 and 2) simultaneously.

Decrease brightness: Press keys (5 and 3) simultaneously.

Ex works the display is adjusted to maximum brightness (basic setting). Any change of the screen brightness via keyboard (B) will be kept until the system is switched off. When the system is switched on again, the maximum brightness of screen (A) will be restored automatically (basic setting).

System Languages

The text of the messages and of the menu control of the ECS-System is available in 2 languages and can be selected in the main group SERVICE with the menu control.

Refer to the section "SERVICE FUNCTIONS AND MENU CONTROL" for further information.

Message Numbers and Message PAGE Numbers

Each message of the two available system languages is related to a message page. The **message number** and the **message PAGE number** are identical for the **first language**, e.g. English. The **message PAGE numbers** of the second language have always a higher number (offset), although the **message number** itself remains the same.

If, for example, the **message number. 500**

(\$h: Start blocked because of main Shut-Off (gate) valve)

is displayed in the English (first) language, the applying **message PAGE number is also 500**. In the second language e.g. German the message page number is 503. The message number displayed on the screen never changes, only the related message page number in the second language changes. If the contents of the protocol memory are printed out in the second language, only the message page numbers of the second language are shown on the print. Depending on the type of the message, the **message PAGE number** of the second language will be **higher** than the **message number** by the following numbers (offsets):

Message number range **500-1309**: message pages with **3** numbers offset

Message number range **1310-1349**: message pages with **1** number offset

Message number range **1350-1439**: message pages with **2** numbers offset

Message number range **1440-1515**: message pages with **5** numbers offset

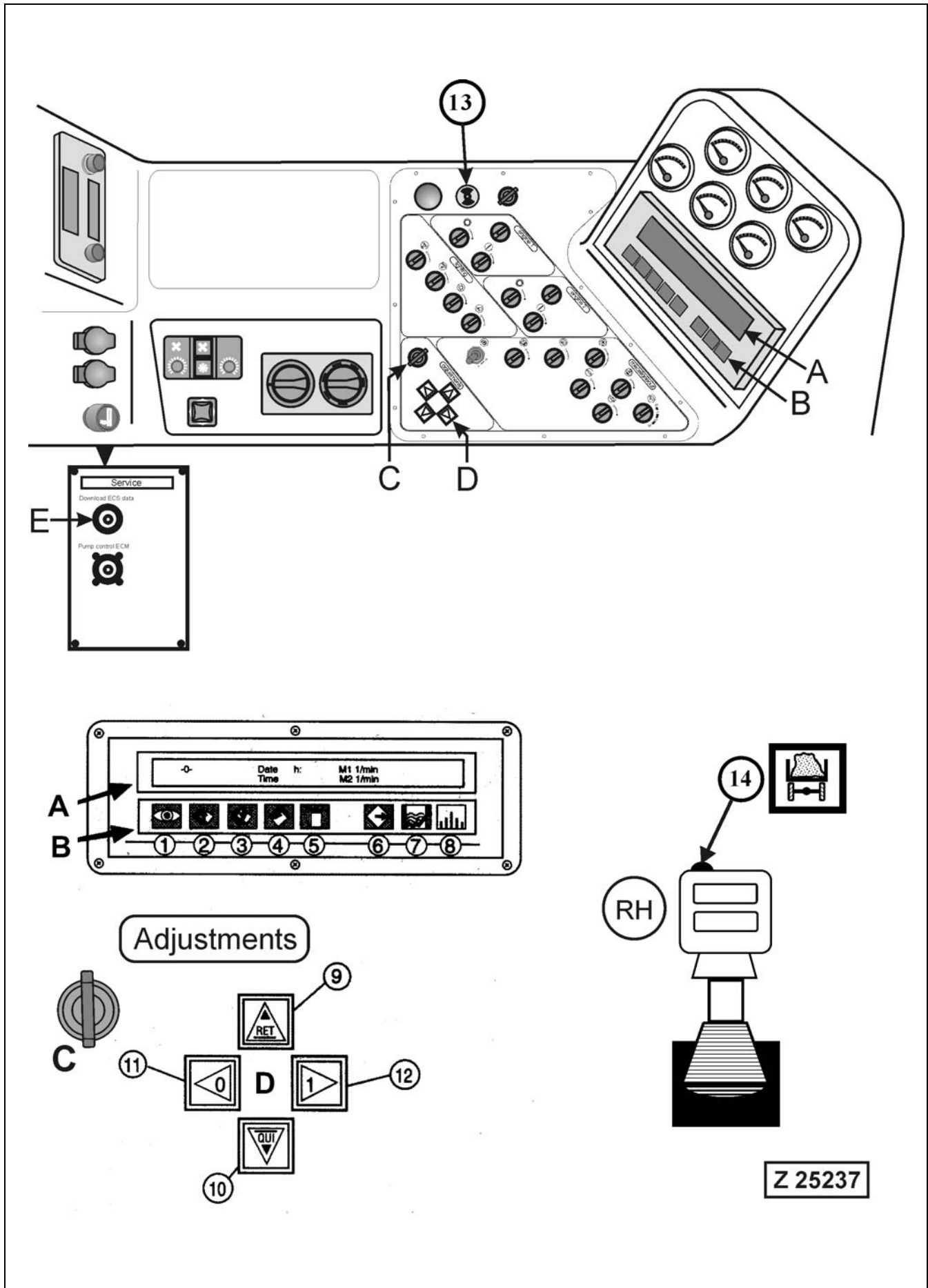

3.4.4 MENU CONTROL AND SERVICE FUNCTIONS

Menu Control operated with Key Switch (C) and Key Group (D),
illust. Z25237

The menu controls are structured hierarchically. The highest-level menu is designated "LEVEL 0" and is accessed by depressing the "RET" key (9). All lower-level menus have consecutively higher numbers up to "LEVEL 5", see Menu Control Charts I - VI on the following pages and are accessed by depressing the "QUI" key (10). In menu levels (1 and 2), the menu options (main groups) can be selected horizontally, without having to return to the higher menu level. In menu levels (3 and 4), the menu options (sub groups) are horizontally only accessible within their main groups.

When entering a menu level, always the L.H. main- or sub group will be displayed first. By pressing key (12), all other main groups in the selected level in the R.H. direction can be called up. For returning to the starting group (main or sub group) press key (11).

The Menu Control Charts on the following pages show the structure and contents of each system level. The interconnection of the main groups through all system levels is also shown.

Menu Control with Key Switch (C) and Key Group (D)

Legend for illust. Z25237

- (C) Key operated switch for enabling setting of operational Data in main group **SERVICE** and for access to the **INPUT-OUTPUT** levels.
- (D) Key group with 4 keys for **menu control** of Service Functions and INPUTS-OUTPUTS.
- (9) Return Key - function:
Return to previous level of INPUTS-OUTPUTS or Service function.
- (10) QUI Key - functions:
Used for access to the lower level.
Acknowledgement of carried out Maintenance
Calling up of current Truck counter reading and lubrication system cycle counter readings
Acknowledgement of inputs and setting of new oil viscosity
- (11) "0" Key - functions:
Selection of horizontal menu items within the respective service or INPUT-OUTPUT level in the L.H. direction
Selection of the oil viscosity for hydraulic system or PTO gear
Change of condition of outputs (0-1).
- (12) "1" Key - function:
Same function as key (11), but in the R.H. selection direction.

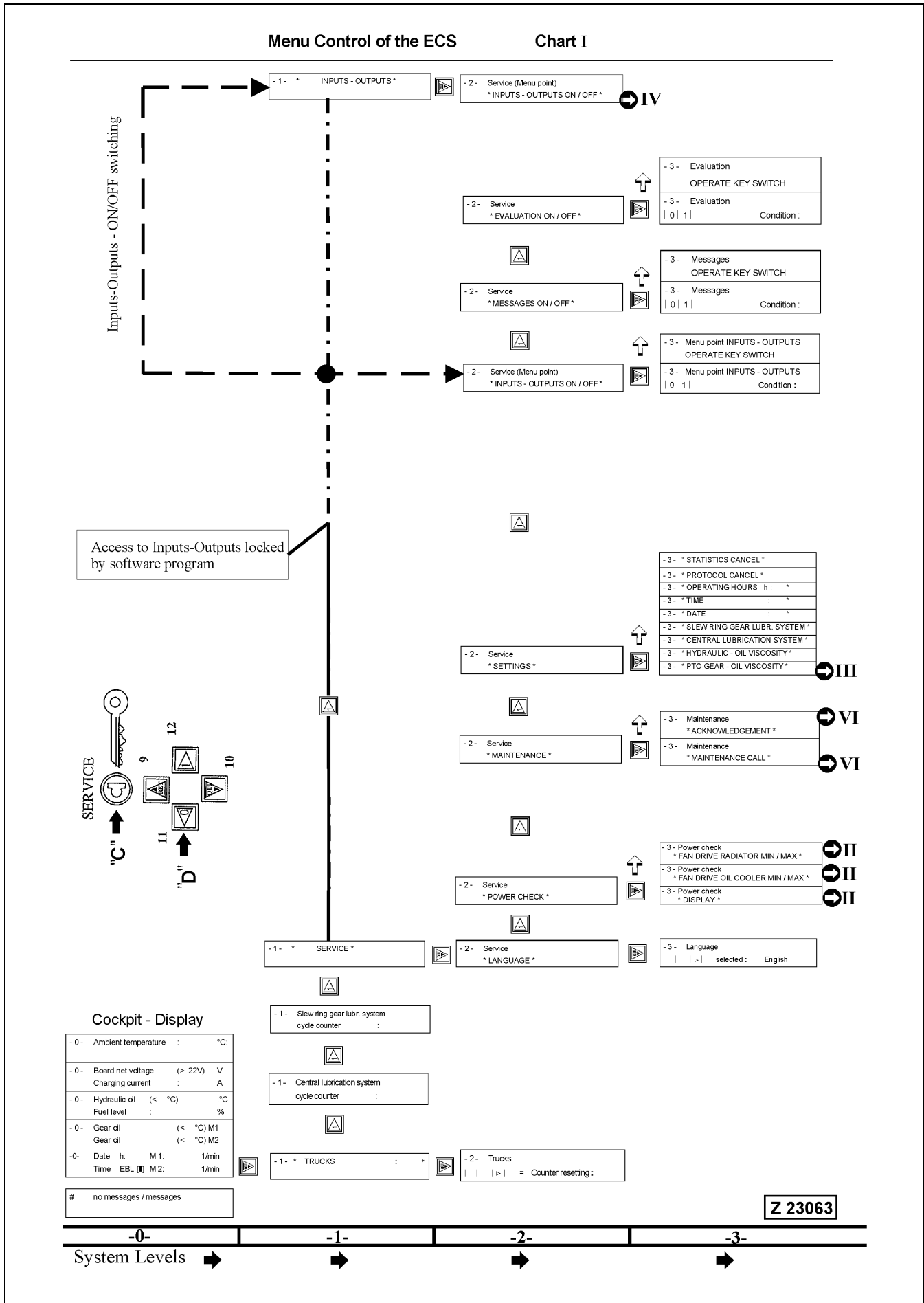

Menu Control with Key Switch (C) and Key Group (D)**Display of Menu Options, see Menu Control Chart I (Z23063)**

EXAMPLE: Display of **TRUCK COUNTER READING**, starting from basic display on level -0-

Proceed as follows:

1. Press the "QUI" key (10), the menu level -1- with the current truck counter reading appears on the display.
2. If you want to reset the counter, press the "QUI" key (10) again. Menu level -2- appears on display. Use key (12) for setting the counter to zero.
3. Press "RET" key (9) twice for return to the standard display, level -0-.

EXAMPLE: Display of **LUBRICATION SYSTEMS CYCLE COUNTER READINGS**, starting from basic display on level -0-

Proceed as follows:

1. Press the "QUI" key (10), the menu level -1- with the starting item truck counter reading appears on the display.
2. Press key (12) once the Central lubrication system cycle counter reading appears on display. By pressing key (12) again the swing ring gear cycle counter reading is displayed.
3. For returning to the standard display level -0- press "RET" key (9).

REMARK

Changing of the lubrication cycle counter settings can be carried out in the main group SERVICE under the section *SETTINGS*, see also menu control chart III.

EXAMPLE: Display of **Service *POWER CHECK*** starting from basic display on level -0-

1. Press the "QUI" key (10), the menu level -1- with the starting item truck counter reading appears on the display.
2. Press key (12) three times the menu item *SERVICE* appears on the display.
3. Press the "QUI" key (10), Service *LANGUAGE* appears.
4. Press key (12) once the menu item Service *POWER CHECK* appears on the display.
5. Press the "QUI" key (10), the menu level -3- with the starting item Power check *DISPLAY* appears on the screen.

Continue according to description on next page, menu control chart II.

Menu Control of the ECS Chart II

Service / Power Check

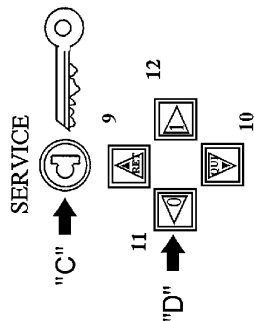
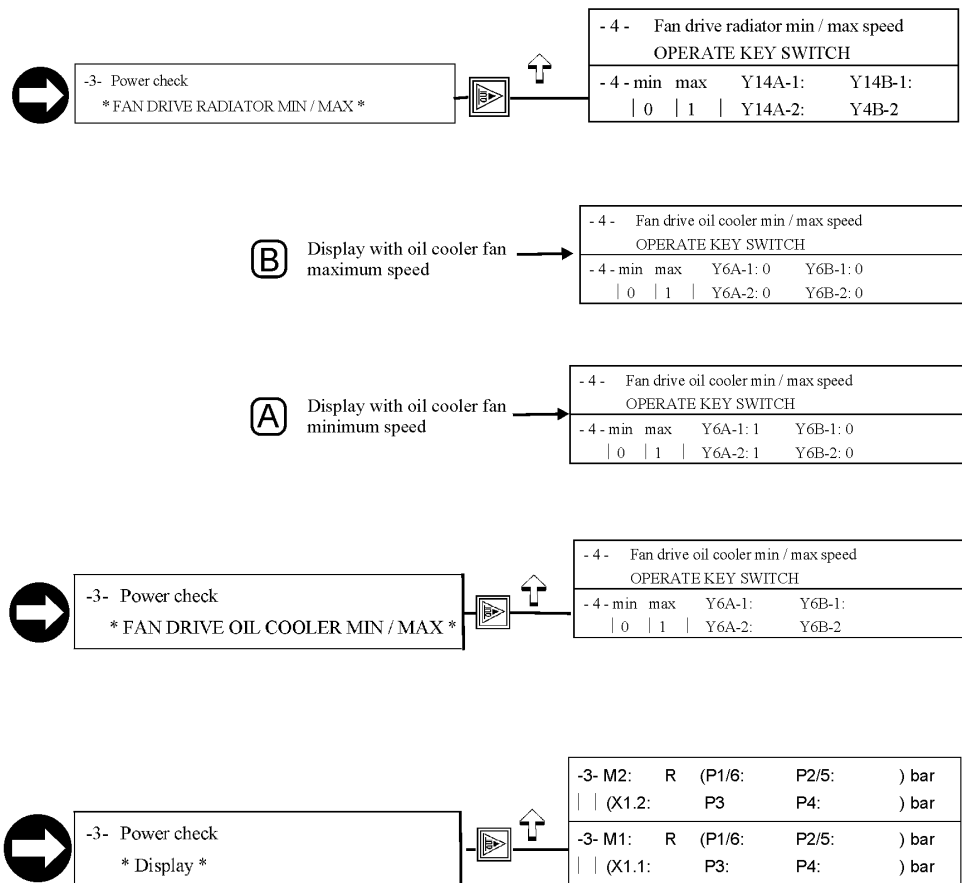

Z 23064

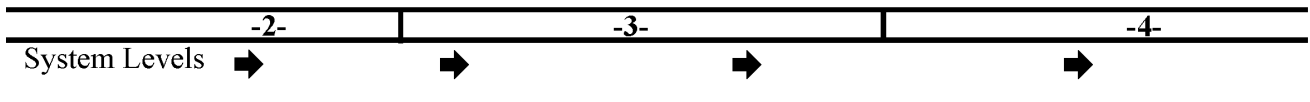

Display of Service *POWER CHECK* continued, see menu control chart II, illustration (Z 23064)

6. Press key (10) for display of the present system pressures in level 4.
7. For returning to the standard display level -0- press "RET" key (9) four times.

Adjust hydraulic oil cooler fan speed

Within the menu point ***POWER CHECK*** the fan speed of the hydraulic oil coolers can be set to minimum or maximum speed as follows:

1. Select menu point Power Check ***FAN DRIVE OIL COOLER MIN / MAX*** in level 3, see chart II.
2. Press key (10), the present speed condition of the cooler fans appears on the display in level 4.
3. To change the fan speed insert service key (C) and select with keys (11 and 12) the condition for minimum speed as shown in display (A) or for maximum speed as shown in display (B).
4. For display of the system pressures with the adjusted fan speed press key (9) the menu point Power Check ***FAN DRIVE OIL COOLER MIN / MAX*** in level 3 appears on the screen.
5. Select menu point Power Check ***DISPLAY*** with key (11) then press key (10) the current system pressures are now displayed in level 4.

Adjust radiator fan speed

Start from menu point Power Check ***FAN DRIVE RADIATOR MIN / MAX*** in level 3 and then use the same procedure as for oil cooler fan speed adjustment.

Reset hydraulic oil cooler fan speed and/or radiator fan speed to normal condition

For resetting the fan speed to normal condition (Evaluation ON) switch off key (C) or go back to menu point ***SERVICE*** in level 1 by pressing the RET key (9) three times.

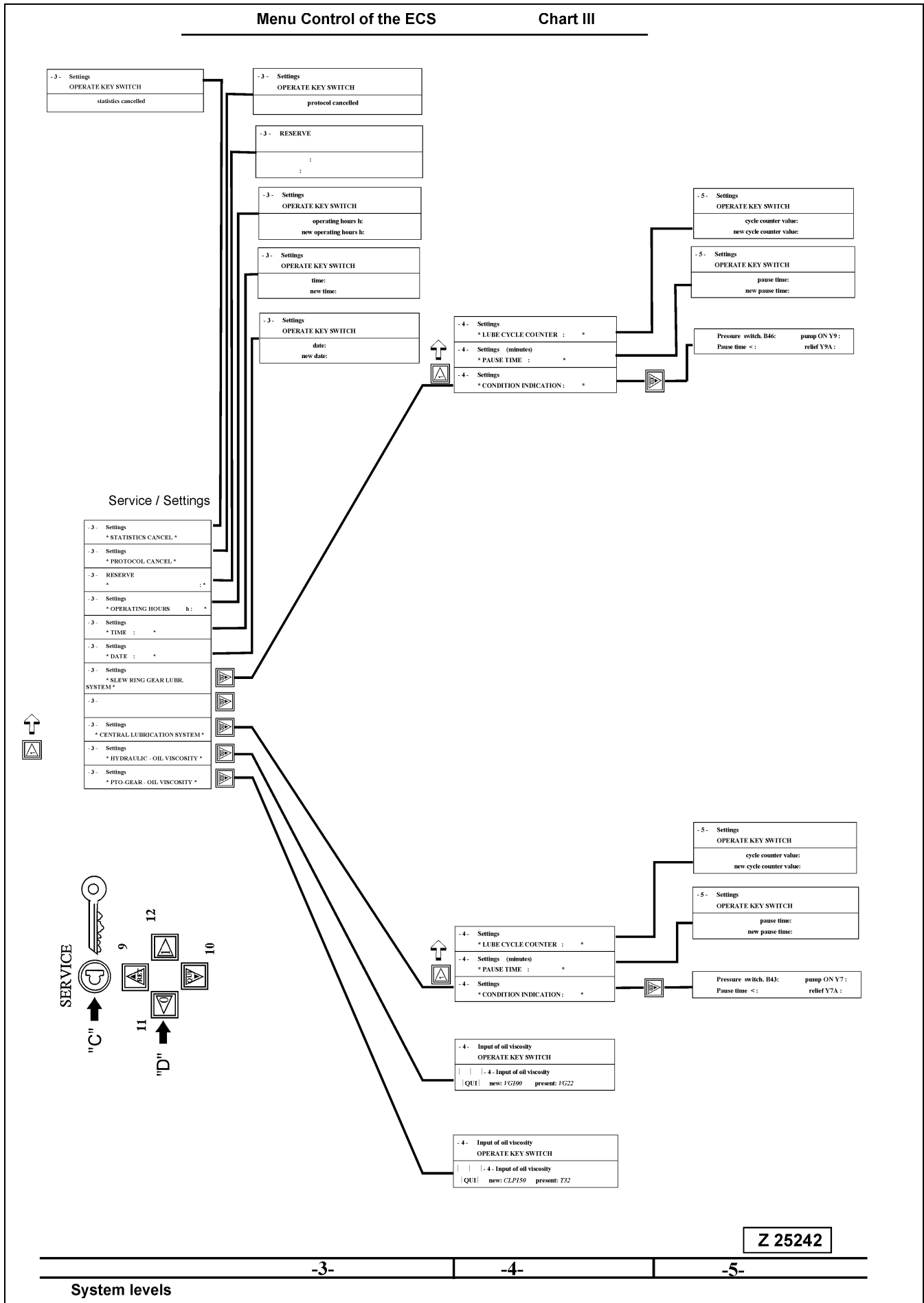

Z 25242

-3-

-4-

-5-

Menu Control with Key Switch (C) and Key Group (D)

Setting of Operational Data, menu item Service *SETTINGS*

Example: Changing the pause time of the Central Lubrication System (on machines with factory installed lube systems only). Starting from the menu level -1-, *SERVICE* see menu control charts I and III (Z25242).

Proceed as follows:

1. Select menu level -1- by pressing "QUI" key (10) the starting menu item *Truck counter reading:* appears on the display, see chart I.
Press key (12) three times, the main group *SERVICE* is displayed. Press key (10), level -2- with menu item *LANGUAGE* appears on the display.
2. Press key (12) three times, the menu point *SETTINGS* appears on the display.
3. Press key (10), *PTO GEAR-OIL VISCOSITY* in level 3, see chart III appears on the display.
4. Press key (12) two times, the item *CENTRAL LUBRICATION SYSTEM* is displayed.
5. Press key (10), level 4 with the starting menu item *CONDITION INDICATION* appears on the display.
6. Press key (12) once, the display changes to menu item *PAUSE TIME* with the information of the present *PAUSE TIME (e.g.) 01:00* appears on the display.
7. Press key (10) again, the display changes to level 5 with the information "Settings OPERATE KEY SWITCH".
8. Operate key switch (C), now the "pause time: 01:00"
"new pause time: 01:00 "
is displayed.
9. Use key (4) of the Text display keyboard to position the cursor below the numerical value that shall be changed.
10. Use key (2 and/or 3) "UP/DOWN" of the Text display keyboard for changing the numerical value.
11. Acknowledge the new setting by pressing key (1). The information on the display changes over to the introductory message page -0- or if a message is present to the respective message page.

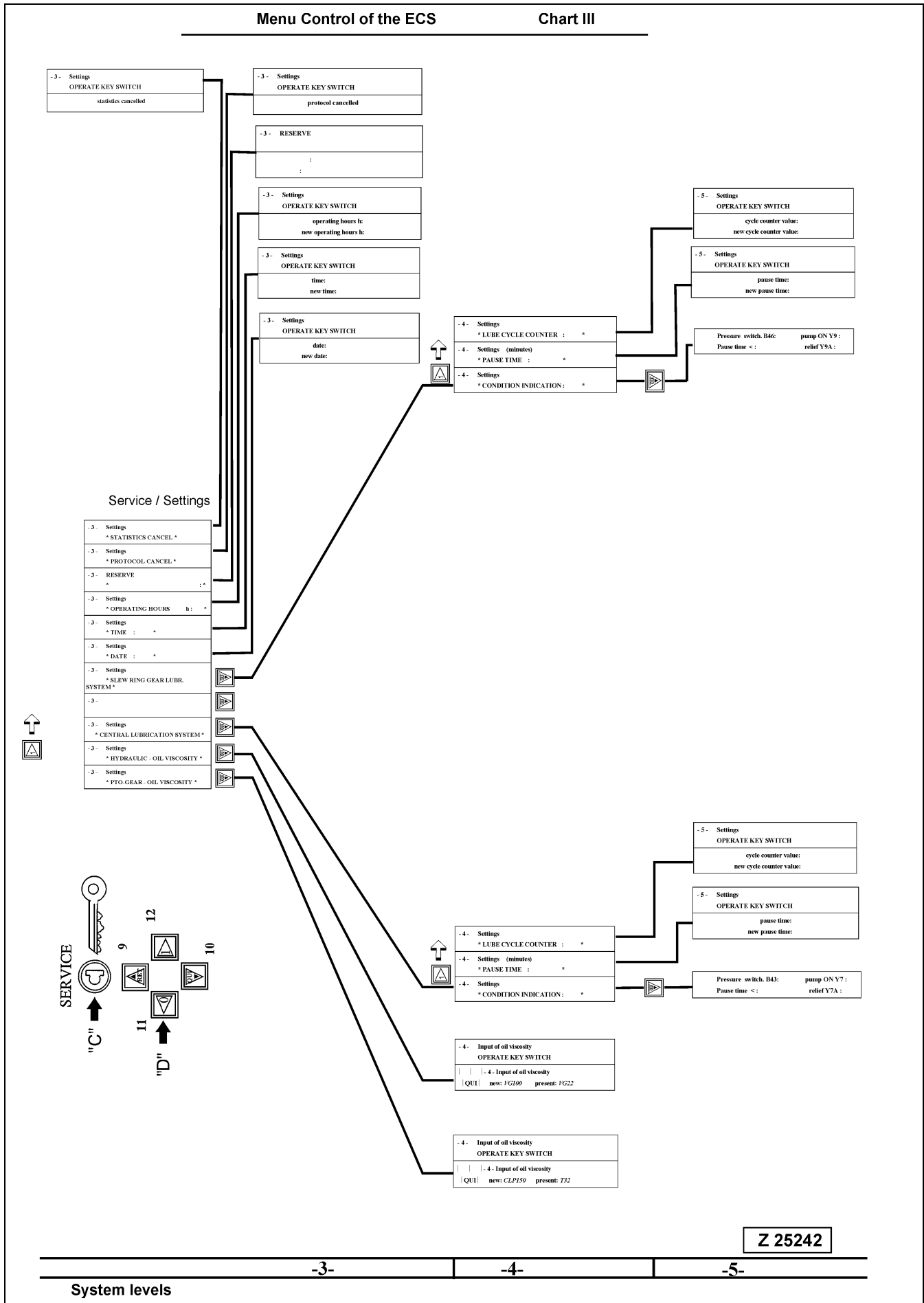

Menu Control with Key Switch (C) and Key Group (D)

Manual actuation Mode of the Lubrication Systems with Service Key

The manual actuation mode is useful for testing the electrical and hydraulic functions of the lubrication systems. The pause time is reduced to 30 seconds and the holding time to 15 seconds permitting rapid sequences of lubrication cycles. Both lubrication systems can be set to the manual actuation mode.

⚠ CAUTION

In the manual actuation mode all monitoring functions of the system are made inoperative and, because of the very short pause and holding times grease will not reach all the lubrication points.

Carry out manual lubrication by using the service key

1. Insert key into service switch (C) and set to operating position.
2. Actuate the rotary switch on the instrument panel of that lubrication system which has to be tested. The message # SERVICE appears on the display. Up to ten repeated actuation of the switch are possible. The lubrication cycles are counted and displayed in the cycle counter window.
3. After finishing the manual lubrication remove service key (C). The system returns to the normal timer settings.

Menu Control of the ECS

Chart III

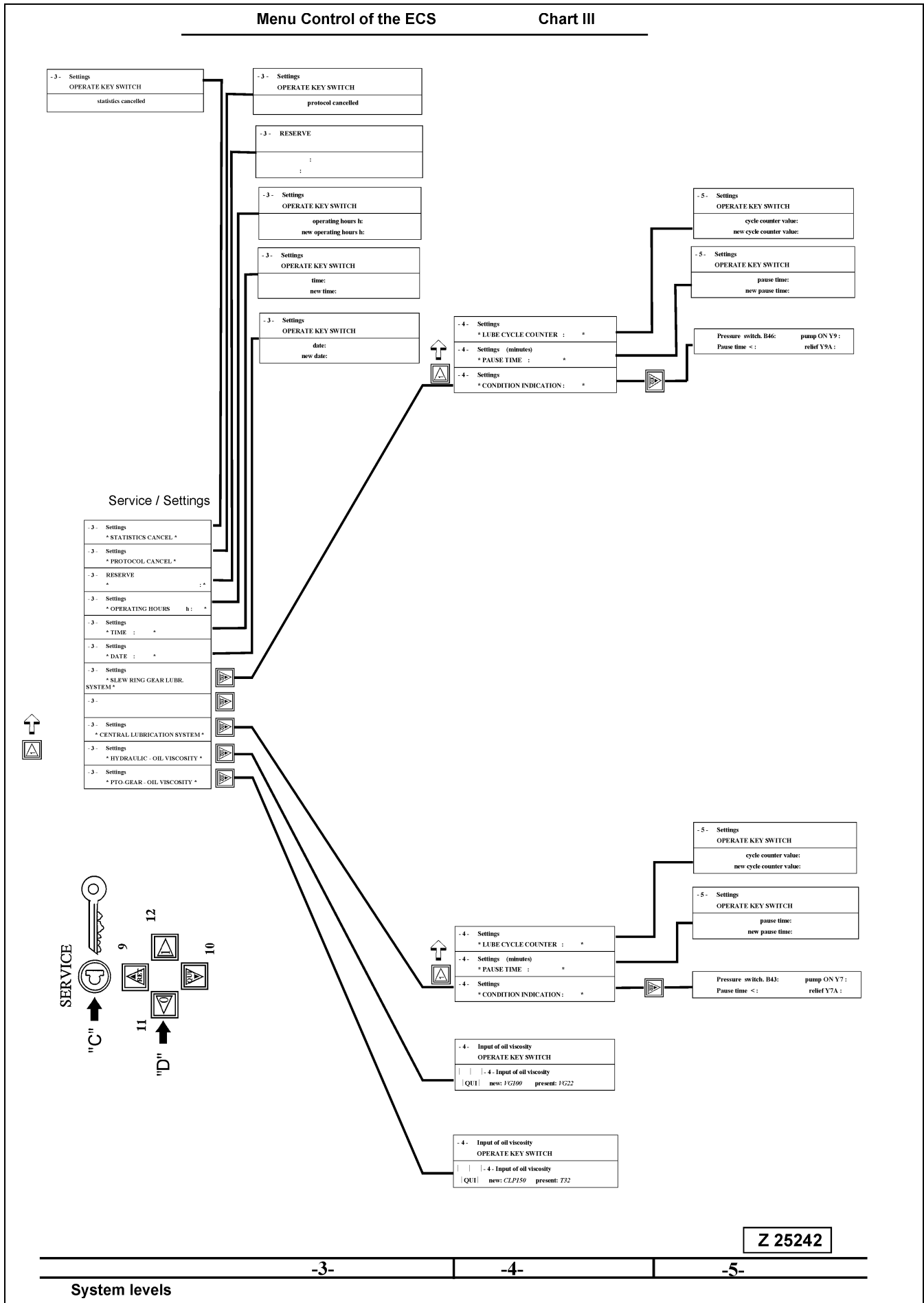

Menu Control with Key Switch (C) and Key Group (D)

Setting of Operational Data, menu item Service *SETTINGS*

Example: Changing the hydraulic oil viscosity grade

When changing the hydraulic oil, the viscosity grade of the new oil has to be entered in the appropriate "Service/Settings" group, if the viscosity of the new oil is different from that of the drained oil.

REMARK

The procedure up to the menu item *PTO GEAR-OIL VISCOSITY* is described on page 135 Changing pause time of the Central Lubrication System; item 1. to 3.

Starting from menu item *PTO GEAR-OIL VISCOSITY* in level -3- proceed as follows, see Menu Control Chart III.

1. Press key (12), the item *HYDRAULIC-OIL VISCOSITY* is displayed.
2. Press key (10), level -4- Input of viscosity with the information of the present oil viscosity grade appears on the display.
3. Press key (10) once more, the information "OPERATE KEY SWITCH" appears on the display.
4. Operate key switch (C).
5. "Input of oil viscosity" appears on the display. Under **present:** the used oil viscosity grade is indicated. Under **new:** all the viscosity grades available in the system are offered for selection. The example on Chart III shows changing the viscosity grade from **VG 22** to **VG 100**.
6. Press key (12) until in the field **new: VG 100** appears.
7. Press key (10), to acknowledge the new viscosity grade. On the display the information in the field **present:** changes to **VG 100**.

The procedure input of a new hydraulic oil viscosity grade is now finished. For returning to the standard display on level -0- press the key "RET" (9) four times.

REMARK

When a battery voltage fault has occurred, the operational data (oil viscosities, timer settings etc.) stored in the Programmable Logic Controller (PLC) can be lost and must be re-entered after the correct battery voltage has been re-established.

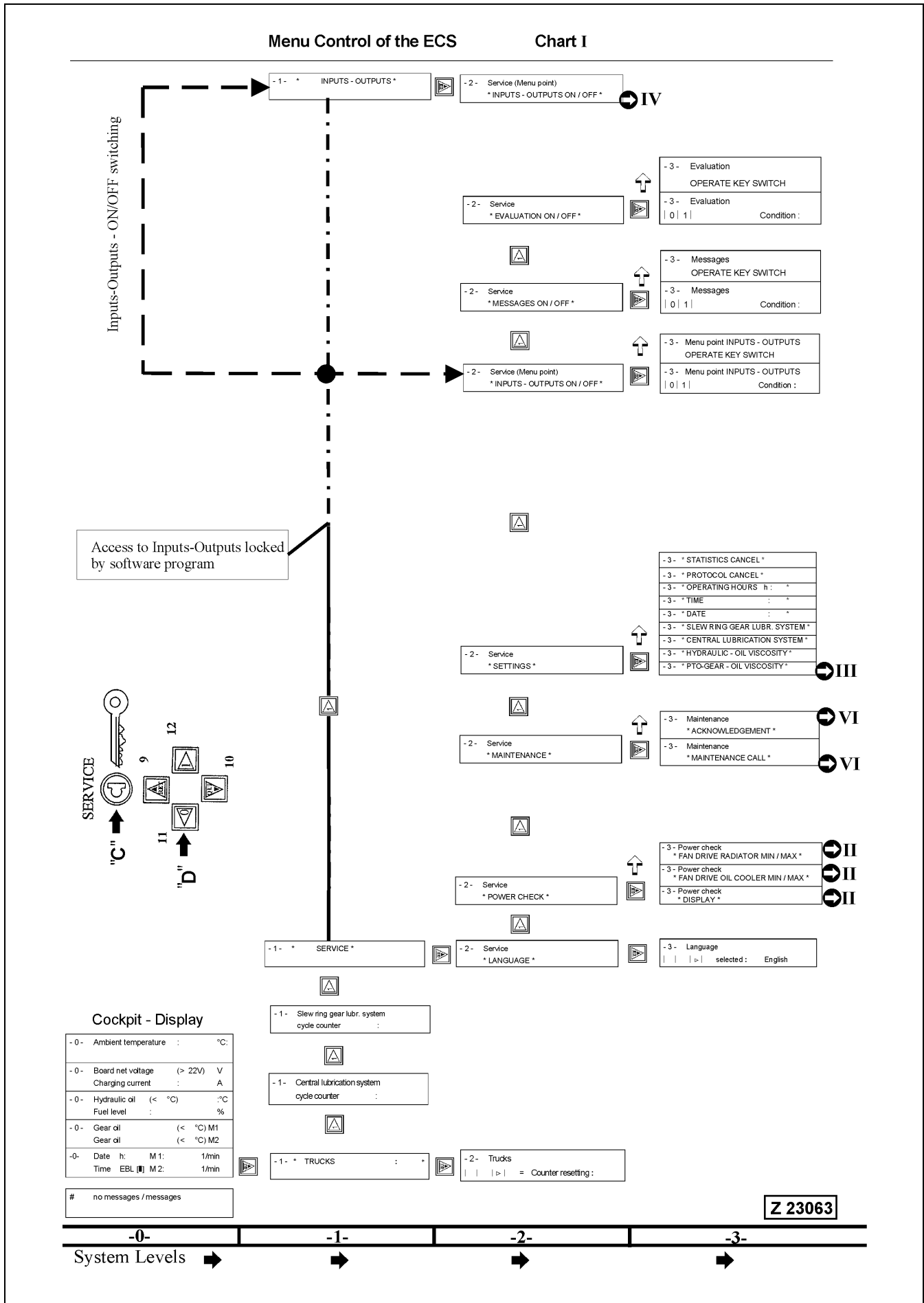

Z 23063

-0-

System Levels →

-1-

→

-2-

→

-3-

→

Menu Control with Key Switch (C) and Key Group (D)

Display of Menu Options

Example: Display of **INPUTS-OUTPUTS**, starting from basic display on level -0-, see Menu Control Charts I and IV (Z 23066).

The main group ***INPUTS-OUTPUTS*** is basically used for Testing procedures through authorized service staff and therefore locked during normal operation. Access to the ***INPUTS-OUTPUTS*** can be obtained in the main group ***SERVICE*** as described below.

Proceed as follows:

1. Press the "QUI" key (10), the menu level -1- ***TRUCKS*** appears on the display, see Chart I.
2. Press key (12) three times, the main group ***SERVICE*** appears on display.
3. Press key (10), the menu level -2- with the starting group ***Language*** appears on the display.
4. Press key (12) four times, the group ***INPUTS-OUTPUTS ON/OFF*** appears on the display.
5. Press key (10), the menu level -3- with Menu item **INPUTS-OUTPUTS Condition: 0 (OFF)** is displayed.
6. Press key (12), ***OPERATE KEY SWITCH*** appears on the display.
7. Operate key switch (C) "Condition: 0 (OFF)" appears on the display.
8. Press key (12) to change the condition from "0" to "1 (**ON**)" Now access to main group ***INPUTS-OUTPUTS*** is possible.
9. Press the "RET" key (9) two times for returning to the menu level -1-. The main group ***SERVICE*** appears on the display.
10. Press key (12), for display of the main group **"INPUTS-OUTPUTS"**.
All menu levels and items within the main group **INPUTS-OUTPUTS** are now accessible by means of key group (D), refer to menu control charts on the following pages.

Menu Control of the ECS Chart IV

NOTE:
 The designation codes of the units listed in the DIGITAL and ANALOG INPUTS table are of exemplary nature only. The unit designation and their sequence within the system levels may vary according to the implemented software. For the applying unit designations and their sequence within the system levels, refer to the separate Menu Control List in this section.

Inputs - Outputs / DIGITAL INPUTS

8S31 (E12.8):	I	8S34 (E13.5):
8S44 (E13.2):	I	8S46 (E13.3):
8S24 (E12.4):	I	8S26 (E12.5):
8S27 (E12.6):	I	8S28 (E12.7):
8S7/8S8 (E12.2):	I	8S23 (E12.3):
8K89 (E8.7):	I	8K200 (E12.1):
8K74a (E8.3):	I	8K83 (E8.4):
8K84 (E8.5):	I	8K88 (E8.6):
8E31 (E7.7):	I	8F12 (E7.8):
8K70 (E8.1):	I	8K71 (E8.8):
8D32/8K125 (E7.5):	I	8E30 (E7.6):
8B97.2 (E7.3):	I	8B343 (E7.4):
8B46 (E11.7):	I	8B48 (E11.8):
8B50 (E7.1):	I	8B97.1 (E7.2):
8B28.2 (E11.5):	I	8B43 (E11.6):
8B27.2 (E11.3):	I	8B28.1 (E11.4):
8B26 (E11.1):	I	8B27.1 (E11.2):
8B23.1 (E6.5):	I	8B23.2 (E6.6):
8B24 (E6.7):	I	8B25 (E6.8):
8B16 (E6.1):	I	8B17.1 (E6.2):
8B17.2 (E6.3):	I	8B22 (E6.4):
8B9 (E5.5):	I	8B10 (E5.6):
8B11 (E5.7):	I	8B12 (E5.8):
8B5 (E5.1):	I	8B6 (E5.2):
8B7 (E5.3):	I	8B8 (E5.4):
5K1 (E10.5):	I	6B1 (E10.6):
6B2 (E10.7):	I	8B4 (E10.8):
5K1 (E10.5):	I	6B1 (E10.6):
6B2 (E10.7):	I	8B4 (E10.8):
1U1 (E10.1):	I	4F17 (E10.3):
4F18 (E10.4):	I	4Q1 (E10.2):
1S2.2 (E4.5):	I	1S3.1 (E4.6):
1S3.2 (E4.7):	I	1S5 (E4.8):
1K27 (E4.1):	I	1K30 (E4.2):
1S1 (E4.3):	I	1S2.1 (E4.4):
1K14.2 (E3.5):	I	1K15 (E3.6):
1K17 (E3.7):	I	1K18 (E3.8):
1K8.2 (E3.1):	I	1K10 (E3.2):
1K12 (E3.3):	I	1K14.1 (E3.4):
1K5.2 (E9.5):	I	1K6.1 (E9.6):
1K6.2 (E9.7):	I	1K8.1 (E9.8):
1K3.1 (E9.1):	I	1K3.2 (E9.2):
1K4 (E9.3):	I	1K5.1 (E9.4):
OS15 (E2.5):	I	1K1 (E2.6):
1K2.1 (E2.7):	I	1K2.2 (E2.8):
OS6 (E2.1):	I	OS7 (E2.2):
OS8 (E2.3.6):	I	OS12 (E2.4):

Inputs - Outputs / ANALOG INPUTS

E7	Charging current (EVB.3):	A
B108	CLS Grease level (EVM5.1):	%
B109	SLS Grease level (EVM5.2):	%
B90	Ambient temp. (EV2.2):	°C
B87C	Pump 3 (EVM4.3):	bar
B87D	Pump 4 (EVM4.4):	bar
B87A	Pump 1/6 (EVM4.1):	bar
B87B	Pump 2/5 (EVM4.2):	bar
B86	X2-Pressure (EVM3.3):	bar
B85-2	X1.2-Pressure (EVM3.2):	bar
B85-1	X1.1-Pressure (EVM3.1):	bar
B63	Fuel level (EVB.2):	%
B49.2	PTO - gear oil temperature M2 (EVM.4):	°C
B49.1	PTO - gear oil temperature M1 (EVM.3):	°C
B15	Hydraulic oil temperature (EVM.1):	°C
B14.2	Coolant temperature M2 (EVM.2):	°C
B14.1	Coolant temperature M1 (EVM.1):	°C

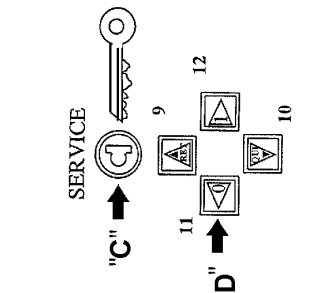
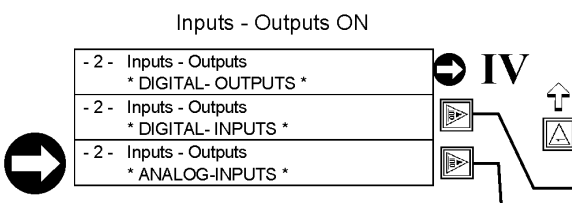

Z 23066

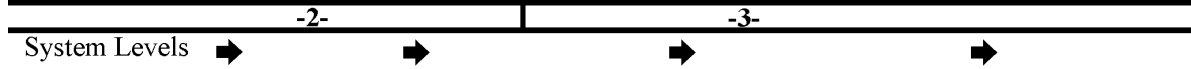

Menu Control with Key Switch (C) and Key Group (D).

Display of INPUTS-OUTPUTS

Example: Display of menu items in the group ***ANALOG-INPUTS***, starting from menu level -2-, see Menu Control Chart IV (Z23066).

The following menu items shall be displayed:

- Hydraulic oil temperature
- Grease barrel filling level of Central Lubrication System.

Proceed as follows:

1. Starting from display level -2- Inputs-Outputs ***ANALOG-INPUTS***; see chart IV.
2. Press key (10), the starting menu item "Coolant temperature M1" in level -3- is displayed.
3. Press key (12) two times, on the display appears the menu item >Hydraulic oil temperature< with the input designation (EW2.1): e.g. 72°C (present oil temperature). The oil temperature sender unit with the designation "**B15**" is also shown on the display.
4. For display of the grease barrel filling level of Central Lubrication System, press key (12) eight times, on the display appears the item >CLS Grease level< .
5. For returning to the basic display press "RET" key (9) three times.

Example: Display of menu items in the group ***DIGITAL-INPUTS***, starting from menu level -2-, ***ANALOG-INPUTS** see Menu Control Chart IV.

The following menu items shall be displayed:

- Condition of differential pressure switch "B7.1" of High Pressure Filter # 3.
- Condition of differential pressure switch "B22" of the pump regulation oil filter

Proceed as follows:

1. Starting from level-2- ***ANALOG-INPUTS*** press key (12) once, the display changes to ***DIGITAL-INPUTS***:

(continued)

Menu Control of the ECS Chart IV

NOTE:
 The designation codes of the units listed in the DIGITAL and ANALOG INPUTS table are of exemplary nature only. The unit designation and their sequence within the system levels may vary according to the implemented software. For the applying unit designations and their sequence within the system levels, refer to the separate Menu Control List in this section.

Inputs - Outputs / DIGITAL INPUTS

8S31 (E12.8):	I	8S34 (E13.5):
8S44 (E13.2):	I	8S46 (E13.3):
8S24 (E12.4):	I	8S26 (E12.5):
8S27 (E12.6):	I	8S28 (E12.7):
8S7/8S8 (E12.2):	I	8S23 (E12.3):
8K89 (E8.7):	I	8K200 (E12.1):
8K74a (E8.3):	I	8K83 (E8.4):
8K84 (E8.5):	I	8K88 (E8.6):
8E31 (E7.7):	I	8F12 (E7.8):
8K70 (E8.1):	I	8K71 (E8.8):
8D32/8K125 (E7.5):	I	8E30 (E7.6):
8B97.2 (E7.3):	I	8B343 (E7.4):
8B46 (E11.7):	I	8B48 (E11.8):
8B50 (E7.1):	I	8B97.1 (E7.2):
8B28.2 (E11.5):	I	8B43 (E11.6):
8B27.2 (E11.3):	I	8B28.1 (E11.4):
8B26 (E11.1):	I	8B27.1 (E11.2):
8B23.1 (E6.5):	I	8B23.2 (E6.6):
8B24 (E6.7):	I	8B25 (E6.8):
8B16 (E6.1):	I	8B17.1 (E6.2):
8B17.2 (E6.3):	I	8B22 (E6.4):
8B9 (E5.5):	I	8B10 (E5.6):
8B11 (E5.7):	I	8B12 (E5.8):
8B5 (E5.1):	I	8B6 (E5.2):
8B7 (E5.3):	I	8B8 (E5.4):
5K1 (E10.5):	I	6B1 (E10.6):
6B2 (E10.7):	I	8B4 (E10.8):
5K1 (E10.5):	I	6B1 (E10.6):
6B2 (E10.7):	I	8B4 (E10.8):
1U1 (E10.1):	I	4F17 (E10.3):
4F18 (E10.4):	I	4Q1 (E10.2):
1S2.2 (E4.5):	I	1S3.1 (E4.6):
1S3.2 (E4.7):	I	1S5 (E4.8):
1K27 (E4.1):	I	1K30 (E4.2):
1S1 (E4.3):	I	1S2.1 (E4.4):
1K14.2 (E3.5):	I	1K15 (E3.6):
1K17 (E3.7):	I	1K18 (E3.8):
1K8.2 (E3.1):	I	1K10 (E3.2):
1K12 (E3.3):	I	1K14.1 (E3.4):
1K5.2 (E9.5):	I	1K6.1 (E9.6):
1K6.2 (E9.7):	I	1K8.1 (E9.8):
1K3.1 (E9.1):	I	1K3.2 (E9.2):
1K4 (E9.3):	I	1K5.1 (E9.4):
OS15 (E2.5):	I	1K1 (E2.6):
1K2.1 (E2.7):	I	1K2.2 (E2.8):
OS6 (E2.1):	I	OS7 (E2.2):
OS8 (E2.3.6):	I	OS12 (E2.4):

Inputs - Outputs / ANALOG INPUTS

E7	Charging current (EV8.3):	A
B108	CLS Grease level (EVM5.1):	%
B109	SLS Grease level (EVM5.2):	%
B90	Ambient temp. (EV2.2):	°C
B87C	Pump 3 (EVM4.3):	bar
B87D	Pump 4 (EVM4.4):	bar
B87A	Pump 1/6 (EVM4.1):	bar
B87B	Pump 2/5 (EVM4.2):	bar
B86	X2-Pressure (EVM3.3):	bar
B85-2	X1.2-Pressure (EVM3.2):	bar
B85-1	X1.1-Pressure (EVM3.1):	bar
B63	Fuel level (EV8.2):	%
B49.2	PTO - gear oil temperature M2 (EVM.4):	°C
B49.1	PTO - gear oil temperature M1 (EVM.3):	°C
B15	Hydraulic oil temperature (EVM2.1):	°C
B14.2	Coolant temperature M2 (EVM.2):	°C
B14.1	Coolant temperature M1 (EVM.1):	°C

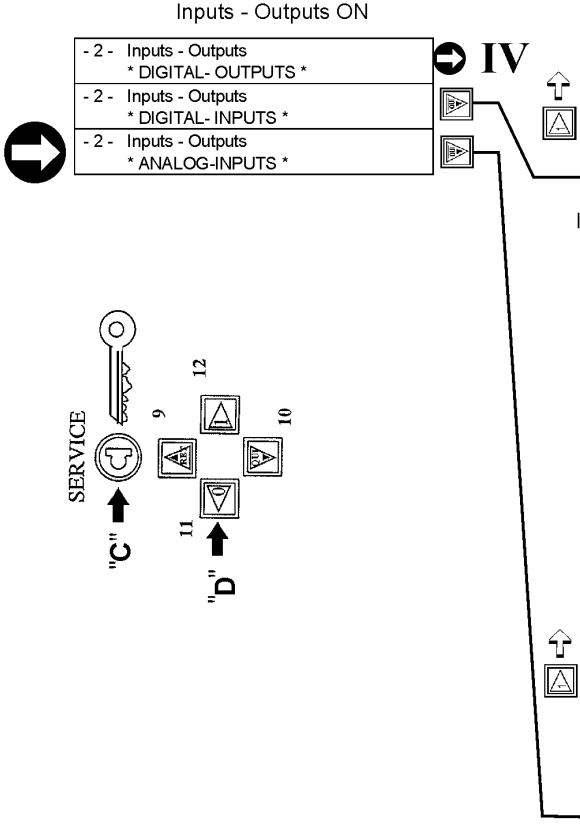

Z 23066

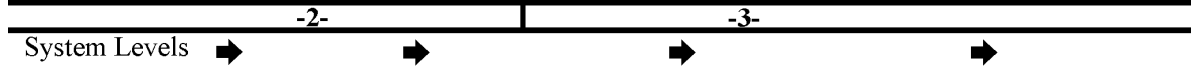

Menu Control with Key Switch (C) and Key Group (D).

Display of DIGITAL-INPUTS (continued)

2. Press "QUI" key (10) the starting menu item "B1-1 (E11.5):" in level -3- appears on the display.
3. Press key (12) once for display of the Condition (**0 or 1**) of differential pressure switch "B7-1" of High Pressure Filter # 3. The following display appears on the screen:

B5-2 (E9.4):	1	B6-1 (E9.2):	1
B6-2 (E9.5):	1	B7-1 (E9.3):	1 *

*) In order to know whether the displayed condition **1** is correct or not correct, it is necessary to check the condition on hand of the Electrical Diagram and in connection with the ECS Service Manual. Depending on the operating status of the machine the displayed conditions can be **1 or 0**.

For quick reference of the unit codes (B7-1, B26 etc.) and their related connections within the ECS System, refer to the "Inputs and Outputs List" which is part of the Electrical Diagram.

4. For displaying the condition (0 or 1) of pressure switch "B22" for pump regulation oil filter, press key (12) three times. The following display appears on the screen:

B21-1 (E4.5):	0	B21-2 (E4.6):	0
B22 (E4.7):	0 *	B24 (E4.3):	0

*) See explanation above.

5. By pressing key (12) all further items of the DIGITAL-INPUTS group can be called up. For going in the opposite direction of the menu items use key (11).
6. For returning to the basic display press "RET" key (9) three times.

Menu Control of the ECS Chart V

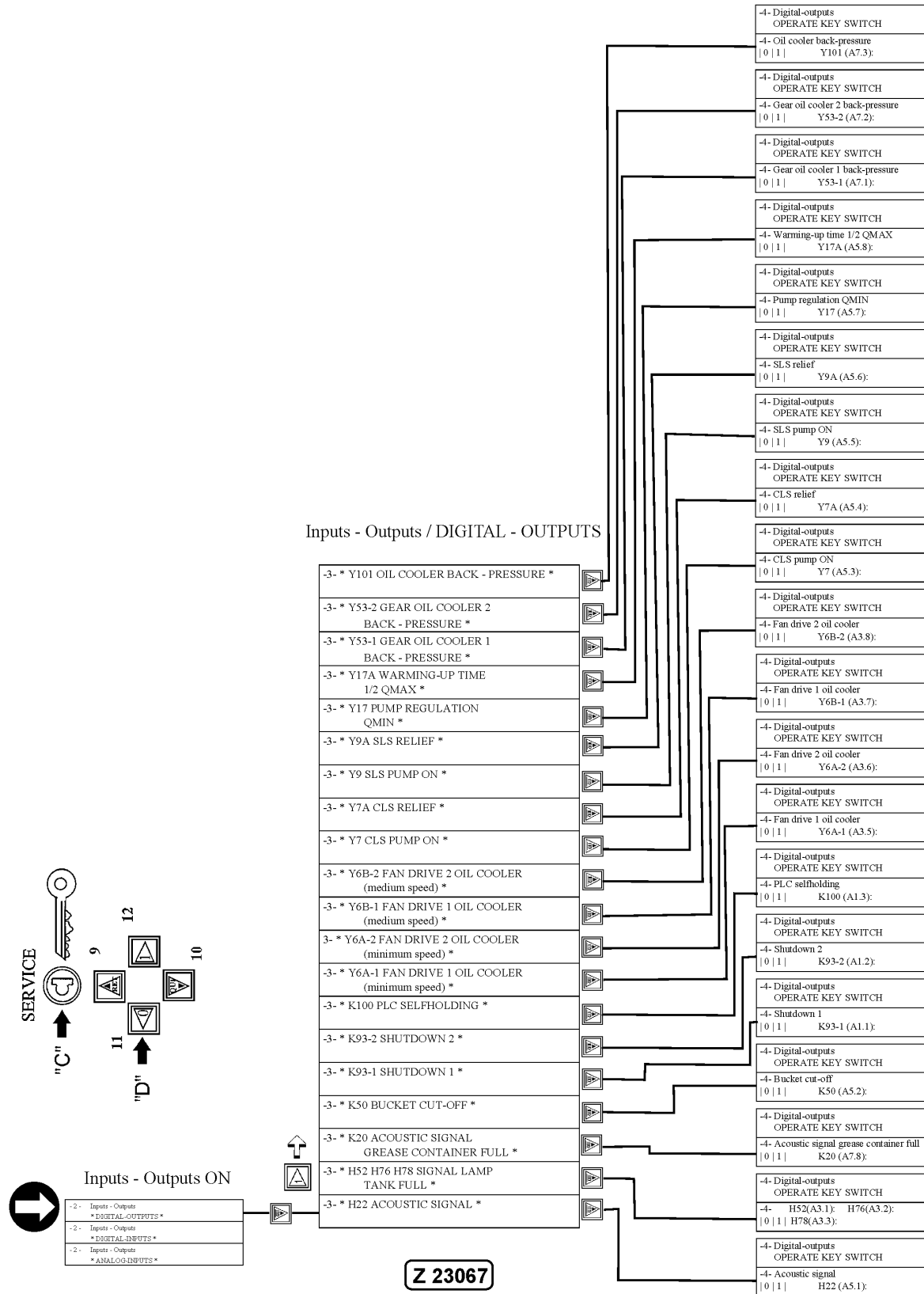

Menu Control with Switch (C) and Key Group (D).

Display of DIGITAL-OUTPUTS

Example: You want to display the condition of the **Central Lubrication System** (solenoid valve Y7 / Y7A) in the group ***DIGITAL-OUTPUTS***, starting from menu level -2-, see Control Chart V.

Proceed as follows:

1. Starting from level -2- ***ANALOG-INPUTS*** press key (12) twice, the display changes to ***DIGITAL-OUTPUTS***:
2. Press "QUI" key (10) the starting menu item "H22 ACOUSTIC SIGNAL" in level -3- appears on the display, see chart V.
3. Press key (12) until the menu item ***CLS PUMP ON Y7*** is displayed.
4. Press key (10). Depending on the Operating Condition of the Central Lubrication System one of the three following displays (A, B or C) in level -4- appears on the screen:

A – Display with Central Lubrication Pump ON (lubrication cycle)

```
-4-   CLS pump ON  Y7 (A15.1):  1
| 0 | 1 | CLS relief   Y7A (A15.2):  1
```

B – Display with Central Lubrication Pump OFF and pressure relief valve closed

```
-4-   CLS pump OFF Y7 (A15.1):  0
| 0 | 1 | CLS relief Y7A (A15.2):  1*)
```

C – Display with Central Lubrication Pump OFF and pressure relief valve open

```
-4-   CLS pump OFF Y7 (A15.1):  0
| 0 | 1 | CLS relief Y7A (A15.2):  0**)
```

*) Pressure holding time of active.

**) Pressure holding time elapsed.

5. For display of further solenoid valve or relay settings go back to level -3- by pressing "RET" key (9).
6. Use key (12 or 11) to select those items you want to be displayed.
7. Press key (10) for display of settings in level -4-.
8. For returning to the basic display in level -0- press key (9) four times.

▲ CAUTION

DO NOT change any settings in the INPUT-OUTPUT groups before having the permission of authorized Service Staff.

Menu Control of the ECS Chart VI

Service MAINTENANCE

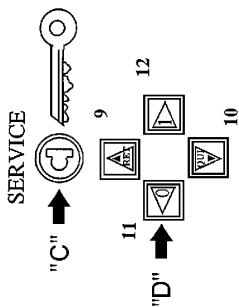
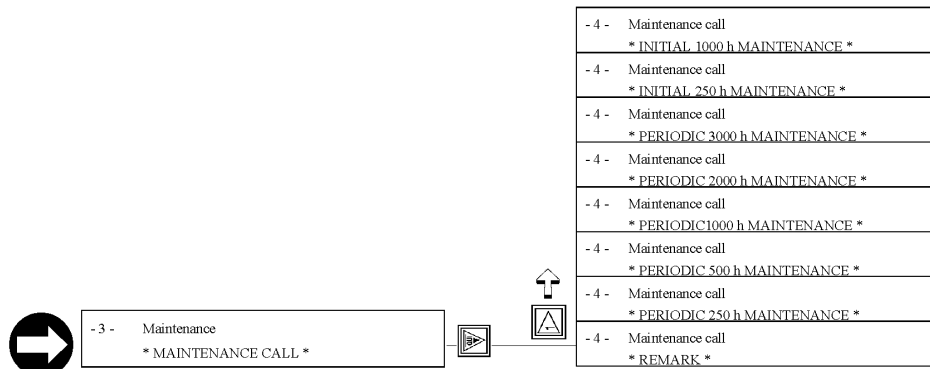
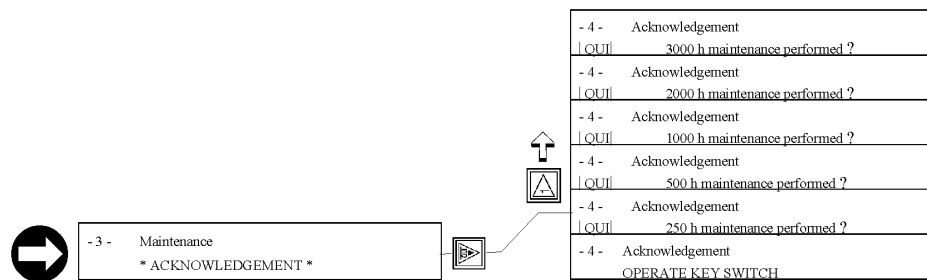

Z 23068

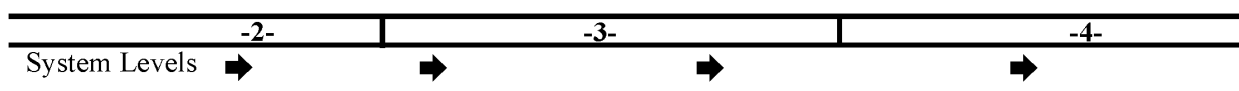

Menu Control with Switch (C) and Key Group (D).

Acknowledgement of carried out Maintenance according to displayed MAINTENANCE CALL, see Menu Control Chart I and VI.

Example:

The Maintenance call ***INITIAL 250h MAINTENANCE*** is displayed. Inform the Service Staff for performing the initial 250h maintenance according to the Maintenance Section. Press key (9) four times for returning to the basic display. After the initial 250h maintenance has been carried out, acknowledge the MAINTENANCE CALL as follows:

1. Select menu item Maintenance ***ACKNOWLEDGEMENT*** level -3-; see Menu Control Chart I and VI.
2. Press key (10), the menu item "Acknowledgement 250h maintenance performed ?" is displayed, see Menu Control Chart VI, level -4-.
3. Press "QUI" (10), the menu item "Acknowledgement OPERATE KEY SWITCH" appears on the display.
4. Operate key switch (C), the menu item "Acknowledgement 250h maintenance performed ?" is displayed.
5. Press "QUI" (10) to acknowledge the performed maintenance.
6. Press key (9) four times for returning to the basic display.

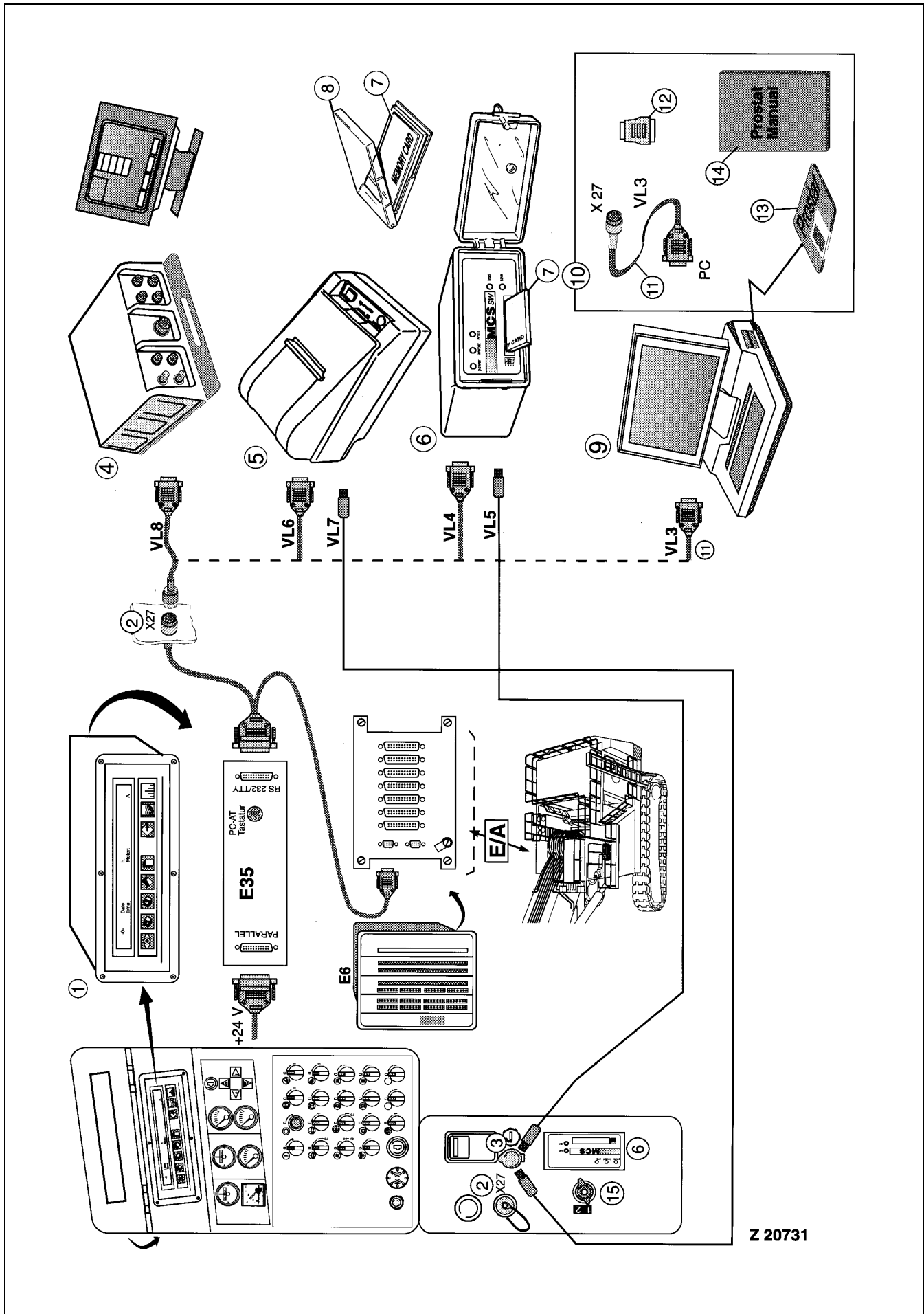

Data Transfer from Protocol and Statistics Memory to various Downloading Equipment

The illustration (Z 20731) shows typical arrangement of several downloading equipment connected to the text display interface plug socket (X27).

Legend for illust. (Z 20731)

- (1) Text display unit on instrument panel (E35)
- (2) Plug socket (serial interface X27) for connecting data transfer cable to units (4, 5, 6 or 9)
- (3) Plug socket for connecting current supply cable to units (5 or 6)
- (4) MODULAR MINING field computer system "MMS"
- (5) Printer
- (6) Memory Card System "MCS". As a special equipment, this system can also be installed in the instrument panel ex works.
- (7) Memory card
- (8) Protective box for memory card
- (9) Laptop or PC
- (10) Soft- and hardware package for PROSTAT operation program
- (11) Data transfer cable (VL3)
- (12) Adapter for 25 pin interface on PC or laptop
- (13) 3,5" disk PROSTAT software
- (14) Instruction manual PROSTAT (PARTS & SERVICE NEWS No. AH02512)
- (15) Change-over switch for connecting the internal output channel to plug socket (2) or to the onboard MCS system (6) if so equipped
- (E6) Programmable Logic Controller "PLC"
- (VL4) Data transfer cable to Memory card system (6)
- (VL5) Current supply cable to Memory Card System (6)
- (VL6) Data transfer cable to printer (5)
- (VL7) Current supply cable to printer (5)
- (VL8) Data transfer cable to field computer system (4)

REMARK

The downloading units shown in illust. (Z 20731) are special equipment.
More information to these units on request.

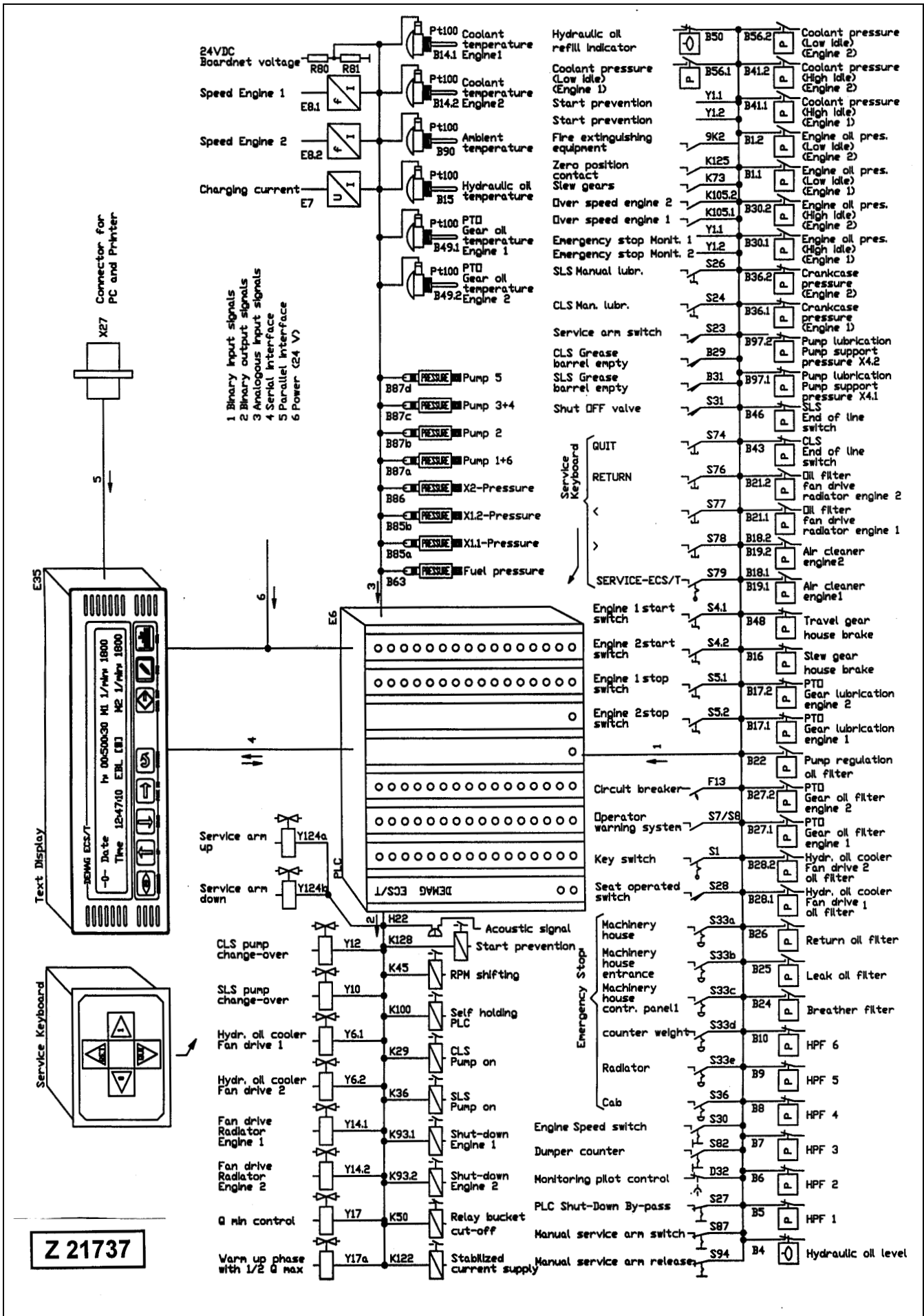

Graphical Diagram

see illustration Z21737

This illustration shows the components and the signal flow of a typical ECS-System for Shovels powered by two Diesel engines.

Overall View of Menu Control

All items of the Menu Control are listed up on page 154 in sequence of their Menu Levels.

Overall View of Fault Messages and Information Messages

All fault messages and information messages are listed up on page 172 in sequence of their message page Numbers.

3.4.5 MENU CONTROL LIST

Level 0: Cockpit - Display

no messages / messages

-0- Date h: M1 *1) 1/min: Time EBL M2 *2) 1/min:
- 0 - Gear oil (< °C) M1 : °C - 0 - Gear oil (< °C) M2 : °C
- 0 - Hydraulic oil (< °C) : °C Fuel level : %
- 0 - Boardnet voltage (>22V) : V Charging current : A
- 0 - Ambient temperature : °C : V

Level 1:

- 1 - * TRUCKS : *
- 1 - Central lubrication system cycle counter value : manual release :
- 1 - Swing ring gear lube system cycle counter value : manual release :
- 1 - * SERVICE *
- 1 - * INPUTS - OUTPUTS *

Level 2: TRUCKS

- 2 - Trucks = Counter resetting :

Level 2: Service

- 2 - Service * LANGUAGE *
- 2 - Service * POWER CHECK *
- 2 - Service * MAINTENANCE *
- 2 - Service * SETTINGS *
- 2 - Service (Menu item) * INPUTS - OUTPUTS ON / OFF *
- 2 - Service * MESSAGES ON / OFF *
- 2 - Service * EVALUATION ON / OFF *

Level 3: Service / LANGUAGE

- 3 - Language selected : English
--

Level 3: Service / POWER CHECK

- 3 - Power check * DISPLAY *
- 3 - Power check * FAN DRIVE OIL COOLER MIN / MAX *
- 3 - Power check * FAN DRIVE RADIATOR MIN / MAX *

Level 4: Service / Power check / DISPLAY

- 4 - (P1/6: P2/5: P3:) bar M1: R (X1.1: P4:) bar
- 4 - (P1/6: P2/5: P3:) bar M2: R (X1.2: P4:) bar

Level 4: Service / Power check / FAN DRIVE OIL COOLER, minimum / maximum speed

- 4 - Fan drive oil cooler min / max OPERATE KEY SWITCH
- 4 - min / max Y6A-1: Y6B-1: 0 1 Y6A-2: Y6B-2:

Level 4: Service / Power check / FAN DRIVE RADIATOR, minimum / maximum speed

- 4 - Fan drive radiator min / max OPERATE KEY SWITCH
- 4 - min / max Y14A-1: Y14B-1: 0 1 Y14A-2: Y14B-2:

Level 3: Service / MAINTENANCE

- 3 - Maintenance * MAINTENANCE CALL *
- 3 - Maintenance * ACKNOWLEDGEMENT *

Level 4: Service / Maintenance / MAINTENANCE CALL

- 4 - Maintenance call * REMARK *
- 4 - Maintenance call * PERIODIC 250 h MAINTENANCE *
- 4 - Maintenance call * PERIODIC 500 h MAINTENANCE *
- 4 - Maintenance call * PERIODIC 1000 h MAINTENANCE *
- 4 - Maintenance call * PERIODIC 2000 h MAINTENANCE *
- 4 - Maintenance call * PERIODIC 3000 h MAINTENANCE *
- 4 - Maintenance call * INITIAL 250 h MAINTENANCE *
- 4 - Maintenance call * INITIAL 1000 h MAINTENANCE *

Level 4: Service / Maintenance / ACKNOWLEDGEMENT

- 4 - Acknowledgement OPERATE KEY SWITCH
- 4 - Acknowledgement QUI 250 h maintenance performed ?
- 4 - Acknowledgement QUI 500 h maintenance performed ?
- 4 - Acknowledgement QUI 1000 h maintenance performed ?
- 4 - Acknowledgement QUI 2000 h maintenance performed ?
- 4 - Acknowledgement QUI 3000 h maintenance performed ?

Level 3: Service / SETTINGS

- 3 - Settings * PTO-GEAR - OIL VISCOSITY *
- 3 - Settings * HYDRAULIC - OIL VISCOSITY *
- 3 - Settings * CENTRAL LUBRICATION SYSTEM *
- 3 - Settings * SWING RING GEAR LUBE SYSTEM *
- 3 - Settings * DATE : *
- 3 - Settings * TIME : *
- 3 - Settings * OPERATING HOURS h : *
- 3 - Settings * PROTOCOL CANCEL *
- 3 - Settings * STATISTICS CANCEL *

Level 4: Service / Settings / PTO-GEAR - OIL VISCOSITY

- 4 - Input of oil viscosity OPERATE KEY SWITCH
- 4 - Input of oil viscosity QUI new: present:

Level 4: Service / Settings / HYDRAULIC - OIL VISCOSITY

- 4 - Input of oil viscosity OPERATE KEY SWITCH
- 4 - Input of oil viscosity QUI new: present:

Level 4: Service / Settings / CENTRAL LUBRICATION SYSTEM (CLS)

- 4 - Settings * CONDITION INDICATION *
--

- 4 - Settings (minutes) * PAUSE TIME : *
--

- 4 - Settings * LUBE CYCLE COUNTER : *
--

Level 5: Service / Settings / CLS / CONDITION INDICATION

Pressure switch B43: pump ON Y7 : Pause time < : relief Y7A
--

Level 5: Service / Settings / CLS / PAUSE TIME

- 5 - Settings OPERATE KEY SWITCH

pause time: new pause time:

Level 5: Service / Settings / CLS / LUBE CYCLE COUNTER

- 5 - Settings OPERATE KEY SWITCH

cycle counter value: new cycle counter value:
--

Level 4: Service / Settings / SWING RING GEAR LUBE SYSTEM (SLS)

- 4 - Settings * CONDITION INDICATION *
- 4 - Settings (minutes) * PAUSE TIME : *
- 4 - Settings * LUBE CYCLE COUNTER : *

Level 5: Service / Settings / SLS / CONDITION INDICATION

Pressure switch B46 : pump ON Y9 : Pause time < : relief Y9A

Level 5: Service / Settings / SLS / PAUSE TIME

- 5 - Settings OPERATE KEY SWITCH
pause time: new pause time:

Level 5: Service / Settings / SLS / LUBE CYCLE COUNTER

- 5 - Settings OPERATE KEY SWITCH
cycle counter value: new cycle counter value:

Level 3: Service / Settings / DATE

- 3 - Settings OPERATE KEY SWITCH
date: new date:

Level 3: Service / Settings / TIME

- 3 - Settings OPERATE KEY SWITCH
time: new time:

Level 3: Service / Settings / OPERATING HOURS

- 3 - Settings OPERATE KEY SWITCH
operating hours h: new operating hours h:

Level 3: Service / Settings / PROTOCOL

- 3 - Settings OPERATE KEY SWITCH
protocol cancelled:

Level 3: Service / Settings / STATISTICS

- 3 - Settings OPERATE KEY SWITCH
statistics cancelled

Level 3: Service / (Menu item) INPUTS - OUTPUTS ON / OFF

- 3 - Menu item INPUTS - OUTPUTS OPERATE KEY SWITCH
- 3 - Menu item INPUTS - OUTPUTS 0 1 Condition :

Level 3: Service / MESSAGES ON / OFF

- 3 - Messages OPERATE KEY SWITCH
- 3 - Messages 0 1 Condition :

Level 3: Service / EVALUATION ON / OFF

- 3 - Evaluation OPERATE KEY SWITCH
- 3 - Evaluation 0 1 Condition :

Level 2: Inputs - Outputs

- 2 - Inputs - Outputs * ANALOG-INPUTS *
- 2 - Inputs - Outputs * DIGITAL-INPUTS *
- 2 - Inputs - Outputs * DIGITAL-OUTPUTS *

Level 3: Inputs - Outputs / ANALOG-INPUTS

B14-1 Coolant temperature M1 (EW1.1): °C
B14-2 Coolant temperature M2 (EW1.2): °C
B15 Hydraulic oil temperature (EW2.1): °C
B49-1 PTO - gear oil temperature M1 (EW1.3): °C
B49-2 PTO - gear oil temperature M2 (EW1.4): °C
B63 Fuel level (EW3.2): % B85-1 X1.1-Pressure (EW13.1): bar
B85-2 X1.2-Pressure (EW13.2): bar B86 X2 -Pressure (EW13.3): bar
B87a Pump 1/6 (EW14.1): bar B87b Pump 2/5 (EW14.2): bar
B87c Pump 3 (EW14.3): bar B87d Pump 4 (EW14.4): bar
B90 Ambient temperature (EW2.2): °C
B108 CLS grease level (EW15.1): % B109 SLS grease level (EW15.2): %
E7 Charging current (EW3.3): A
E8-1 Engine speed M1(EW15.3): 1/min E8-2 Engine speed M2(EW15.4): 1/min
R80/R81 Boardnet voltage (EW3.4): V

Level 3: Inputs - Outputs / DIGITAL-INPUTS

B1-1 (E11.5): B4 (E9.8):	B1-2 (E11.6): B5-1 (E9.1):
B5-2 (E9.4): B6-2 (E9.5):	B6-1 (E9.2): B7-1 (E9.3):
B7-2 (E9.6): B17-1 (E3.1):	B16 (E3.3): B17-2 (E3.2):
B18-1/B19-1 (E4.1):	B18-2/B19-2 (E4.2):
B21-1 (E4.5): B22 (E4.7):	B21-2 (E4.6): B24 (E4.3):
B25 (E4.8): B27-1(E10.2):	B26 (E10.1): B27-2 (E10.3):
B28-1(E10.4): B30-1(E11.3):	B28-2 (E10.5): B30-2 (E11.4):
B36-1 (E7.1): B41-1(E11.7):	B36-2 (E7.2): B41-2 (E11.8):
B42 (cool) (E13.1):	B42 (warm) (E13.2):
B43 (E5.2): B48 (E3.4):	B46 (E5.5): B50 (E5.7):
B56-1 (E7.3):	B56-2 (E7.4)
B97-1 (E10.7):	B97-2(E10.8):
B102-1 (E13.3):	B102-2 (E13.4):
B103-1 (E13.5):	B103-2 (E13.6):
B108B (E3.6): B109B (E7.7):	B108C (E3.7): B109C (E7.8):
B165 (E14.1):	D32/K125 (E8.3):
D33-1(E14.2): E32 (E14.4):	D33-2 (E14.3): F13 (E5.8):

Level 3: Inputs - Outputs / DIGITAL-INPUTS

K73 (E8.5): K125 (E8.4):	K83 (E8.6): S1 (E8.1):
S4.1 (E2.1): S5.1 (E2.3):	S4.2 (E2.2): S5.2 (E2.4):
S7 (E14.5):	S10 (E8.8):
S11.1 (E8.7): S11.3 (E13.8):	S11.2 (E13.7):
S23 (E2.7): S24 (E5.3):	S26 (E5.6):
S27 (E8.2):	S28 (K119) (E2.6):
S30 (E2.5): S33a (E6.4):	S31 (E9.7): S33b (E6.5):
S33c (E6.6): S36 (E6.3):	S33d (E6.7): S43 (E14.6):
S58 (E14.7):	S82 (E1.6):
S85 (E1.8): S87 (E2.8):	S86 (E1.7): S94 (E7.5):
S155 Qmax (E6.2): 9K1 (E3.8):	S155 Qmin (E6.1):

Level 3: Inputs - Outputs / DIGITAL-OUTPUTS

-3- * H22 ACOUSTIC SIGNAL *
-3- * H52 H76 H78 H139 SIGNAL LAMP TANK FULL *
-3- * H142-1 H142-2 SIGNAL LAMP TANK FULL *
-3- * K20 ACOUSTIC SIGNAL GREASE BARREL FULL *
-3- * K45 RELAY ENGINE SPEED SHIFTING *
-3- * K50 RELAY BUCKET CUT-OFF *
-3- * K93-1 RELAY SHUTDOWN 1 *
-3- * K93-2 RELAY SHUTDOWN 2 *
-3- * K100 RELAY PLC SELFHOLDING *

Level 3: Inputs - Outputs / DIGITAL-OUTPUTS

-3- * K122 RELAY STAB. CURRENT SUPPLY *
-3- * K164-1 RELAY ENGINE OIL TANK 1 EMPTY *
-3- * K164-2 RELAY ENGINE OIL TANK 2 EMPTY *
-3- * K197 LOWER WINDSCREEN WIPER SLOW *
-3- * K198 LOWER WINDSCREEN WIPER FAST *
-3- * K199 UPPER WINDSCREEN WIPER SLOW *
-3- * K200 UPPER WINDSCREEN WIPER FAST *
-3- * Y6a-1 VALVE FAN DRIVE 1 OIL COOLER (minimum speed)*
-3- * Y6a-2 VALVE FAN DRIVE 2 OIL COOLER (minimum speed)*
-3- * Y6b-1 VALVE FAN DRIVE 1 OIL COOLER (medium speed) *
-3- * Y6b-2 VALVE FAN DRIVE 2 OIL COOLER (medium speed) *
-3- * Y7 VALVE CLS PUMP ON * * Y7a VALVE CLS RELIEF *
-3- * Y9 VALVE SLS PUMP ON * * Y9a VALVE SLS RELIEF *
-3- * Y14a-1 VALVE FAN DRIVE 1 RADIATOR (minimum speed) *
-3- * Y14a-2 VALVE FAN DRIVE 2 RADIATOR (minimum speed) *
-3- * Y14b-1 VALVE FAN DRIVE 1 RADIATOR (medium speed) *
-3- * Y14b-2 VALVE FAN DRIVE 2 RADIATOR (medium speed) *
-3- * Y17 VALVE PUMP REGULATION QMIN *
-3- * Y17a VALVE WARMING-UP TIME 1/2 QMAX *
-3- * Y53-1 Y53-2 GEAR OIL COOLER 1 / 2 BACK - PRESSURE *
-3- * Y101 VALVE OIL COOLER BACK - PRESSURE *
-3- * Y124a VALVE SERVICE ARM LIFT *
-3- * Y124b VALVE SERVICE ARM LOWER *

**Level 4: Inputs - Outputs / DIGITAL-OUTPUTS
/ H22 ACOUSTIC SIGNAL**

-4- Output signals OPERATE KEY SWITCH
-4- Acoustic signal 0 1 H22 (A5.1):

**Level 4: Inputs - Outputs / DIGITAL-OUTPUTS
/ H52 H76 H78 H139 SIGNAL LAMP TANK FULL**

-4- Output signals OPERATE KEY SWITCH
-4- H52 (A7.1): H76 (A7.2): 0 1 H78 (A7.3): H139 (A7.4):

**Level 4: Inputs - Outputs / DIGITAL-OUTPUTS
/ H142-1 H142-2 SIGNAL LAMP TANK FULL**

-4- Output signals OPERATE KEY SWITCH
-4- H142-1 (A7.5): H142-2 (A7.6): 0 1

**Level 4: Inputs - Outputs / DIGITAL-OUTPUTS
/ H142-1 H142-2 SIGNAL LAMP TANK FULL**

-4- Output signals OPERATE KEY SWITCH
-4- Acoustic signal grease barrel full 0 1 K20 (A5.3) :

**Level 4: Inputs - Outputs / DIGITAL-OUTPUTS
/ K45 RELAY ENGINE SPEED SHIFTING**

-4- Output signals OPERATE KEY SWITCH
-4- Relay engine speed shifting 0 1 K45 (A1.3):

**Level 4: Inputs - Outputs / DIGITAL-OUTPUTS
/ K50 RELAY BUCKET CUT-OFF**

-4- Output signals OPERATE KEY SWITCH
-4- Relay bucket cut-off 0 1 K50 (A1.5):

**Level 4: Inputs - Outputs / DIGITAL-OUTPUTS
/ K93-1 RELAY SHUTDOWN 1**

-4- Output signals OPERATE KEY SWITCH
-4- Relay shutdown 1 0 1 K93-1 (A1.1):

**Level 4: Inputs - Outputs / DIGITAL-OUTPUTS
/ K93-2 RELAY SHUTDOWN 2**

-4- Output signals OPERATE KEY SWITCH
-4- Relay shutdown 2 0 1 K93-2 (A1.2):

**Level 4: Inputs - Outputs / DIGITAL-OUTPUTS
/ K100 PLC SELFHOLDING**

-4- Output signals OPERATE KEY SWITCH
-4- Relay PLC selfholding 0 1 K100 (A5.2):

**Level 4: Inputs - Outputs / DIGITAL-OUTPUTS
/ K122 RELAY STAB. CURRENT SUPPLY**

-4- Output signals OPERATE KEY SWITCH
-4- Relay stab. current supply 0 1 K122 (A1.7):

**Level 4: Inputs - Outputs / DIGITAL-OUTPUTS
/ K164-1 RELAY ENGINE OIL TANK 1 EMPTY**

-4- Output signals OPERATE KEY SWITCH
-4- Relay engine oil tank 1 empty 0 1 K164-1 (A7.7):

**Level 4: Inputs - Outputs / DIGITAL-OUTPUTS
/ K164-2 RELAY ENGINE OIL TANK 2 EMPTY**

-4- Output signals OPERATE KEY SWITCH
-4- Relay engine oil tank 2 empty 0 1 K164-2 (A7.8):

**Level 4: Inputs - Outputs / DIGITAL-OUTPUTS
/ K197 RELAY LOWER WINDSCREEN WIPER SLOW**

-4- Output signals OPERATE KEY SWITCH
-4- Relay Lower windscreen wiper slow 0 1 K197 (A13.5):

**Level 4: Inputs - Outputs / DIGITAL-OUTPUTS
/ K198 RELAY LOWER WINDSCREEN WIPER FAST**

-4- Output signals OPERATE KEY SWITCH
-4- Relay Lower windscreen wiper fast 0 1 K198 (A13.8):

**Level 4: Inputs - Outputs / DIGITAL-OUTPUTS
/ K199 RELAY UPPER WINDSCREEN WIPER SLOW**

-4- Output signals OPERATE KEY SWITCH
-4- Relay Upper windscreen wiper slow 0 1 K197 (A13.5):

**Level 4: Inputs - Outputs / DIGITAL-OUTPUTS
/ K200 RELAY UPPER WINDSCREEN WIPER FAST**

-4- Output signals OPERATE KEY SWITCH
-4- Relay Upper windscreen wiper fast 0 1 K197 (A13.5):

Level 4: Inputs - Outputs / DIGITAL-OUTPUTS
/ Y6a-1 VALVE FAN DRIVE 1 OIL COOLER
(minimum speed)

-4- Output signals OPERATE KEY SWITCH
-4- Valve fan drive 1 oil cooler 0 1 Y6a-1 (A3.1):

Level 4: Inputs - Outputs / DIGITAL-OUTPUTS
/ Y6a-2 VALVE FAN DRIVE 2 OIL COOLER
(minimum speed)

-4- Output signals OPERATE KEY SWITCH
-4- Valve fan drive 2 oil cooler 0 1 Y6a-2 (A3.2):

Level 4: Inputs - Outputs / DIGITAL-OUTPUTS
/ Y6b-1 VALVE FAN DRIVE 1 OIL COOLER
(medium speed)

-4- Output signals OPERATE KEY SWITCH
-4- Valve fan drive 1 oil cooler 0 1 Y6b-1 (A3.3):

Level 4: Inputs - Outputs / DIGITAL-OUTPUTS
/ Y6b-2 VALVE FAN DRIVE 2 OIL COOLER
(medium speed)

-4- Output signals OPERATE KEY SWITCH
-4- Valve fan drive 2 oil cooler 0 1 Y6b-2 (A3.4):

Level 4: Inputs - Outputs / DIGITAL-OUTPUTS
/ Y7 VALVE CLS PUMP ON / Y7a VALVE CLS RELIEF

-4- Output signals OPERATE KEY SWITCH
-4- CLS pump ON Y7 (A15.1): 0 1 CLS relief Y7a (A15.2):

Level 4: Inputs - Outputs / DIGITAL-OUTPUTS
/ Y9 VALVE SLS PUMP ON / Y9a VALVE SLS RELIEF

-4- Output signals OPERATE KEY SWITCH
-4- SLS pump ON Y9 (A5.8): 0 1 SLS relief Y9a (A13.2):

Level 4: Inputs - Outputs / DIGITAL-OUTPUTS
/ Y14a-1 VALVE FAN DRIVE 1 RADIATOR
(minimum speed)

-4- Output signals OPERATE KEY SWITCH
-4- Valve fan drive 1 radiator 0 1 Y14a-1 (A3.5):

Level 4: Inputs - Outputs / DIGITAL-OUTPUTS
/ Y14a-2 VALVE FAN DRIVE 2 RADIATOR
(minimum speed)

-4- Output signals OPERATE KEY SWITCH
-4- Valve fan drive 2 radiator 0 1 Y14a-2 (A3.6):

Level 4: Inputs - Outputs / DIGITAL-OUTPUTS
/ Y14b-1 VALVE FAN DRIVE 1 RADIATOR
(medium speed)

-4- Output signals OPERATE KEY SWITCH
-4- Valve fan drive 1 radiator 0 1 Y14b-1 (A3.7):

Level 4: Inputs - Outputs / DIGITAL-OUTPUTS
/ Y14b-2 VALVE FAN DRIVE 2 RADIATOR
(medium speed)

-4- Output signals OPERATE KEY SWITCH
-4- Valve fan drive 2 radiator 0 1 Y14b-2 (A3.8):

Level 4: Inputs - Outputs / DIGITAL-OUTPUTS
/ Y17 VALVE PUMP REGULATION QMIN

-4- Output signals OPERATE KEY SWITCH
-4- Valve pump regulation Qmin 0 1 Qmin Y17 (A1.4):

Level 4: Inputs - Outputs / DIGITAL-OUTPUTS
/ Y17a VALVE WARMING-UP TIME 1/2 QMAX

-4- Output signals OPERATE KEY SWITCH
-4- Valve warming-up time 0 1 1/2 Qmax Y17a (A1.6):

Level 4: Inputs - Outputs / DIGITAL-OUTPUTS
/ Y53-1 Y53-2 GEAR OIL COOLER 1 / 2
BACK - PRESSURE

-4- Output signals OPERATE KEY SWITCH
-4- Cooler 1 Y53-1 (A13.3): 0 1 Cooler 2 Y53-2 (A13.4):

Level 4: Inputs - Outputs / DIGITAL-OUTPUTS
/ Y101 VALVE OIL COOLER BACK-PRESSURE

-4- Output signals OPERATE KEY SWITCH
-4- Valve oil cooler back-pressure 0 1 Y101 (A5.4):

Level 4: Inputs - Outputs / DIGITAL-OUTPUTS
/ Y124a VALVE SERVICE ARM LIFT

-4- Output signals OPERATE KEY SWITCH
-4- Valve service arm lift 0 1 Y124a (A5.5):

Level 4: Inputs - Outputs / DIGITAL-OUTPUTS
/ Y124b VALVE SERVICE ARM LOWER

-4- Output signals OPERATE KEY SWITCH
-4- Valve service arm lower 0 1 Y124b (A5.6):

3.4.6 FAULT AND INFORMATION MESSAGE LIST

The messages are divided into four groups as follows:

<p>Group 1</p>	<p>The fault messages of group 1 will be stored and result in:</p> <ul style="list-style-type: none"> ● Start blocked condition or ● Automatic engine speed reduction to low idle or ● Automatic shutdown of the Shovel or ● Attention of Service Staff required. <p>Message page numbers of start blocked condition:</p> <ul style="list-style-type: none"> ● 500, 506, 536, 542, 578, 596, 608, 620, 626, 638, 644, 650, 656, 704 and 728. <p>Message page numbers of automatic engine speed reduction to low idle:</p> <ul style="list-style-type: none"> ● 524, 602, 614, 662, 668, 674, 680 and 686. <p>Message page numbers of shutdown conditions:</p> <ul style="list-style-type: none"> ● 548, 560, 590, 632 and 716. 	<p>Message Text Pages: 500 - 739</p>
<p>Group 2</p>	<p>The fault messages of group 2 will be stored. The following messages will result in automatic engine speed reduction to low idle:</p> <ul style="list-style-type: none"> ● 1286, 1292, 1298 and 1304. 	<p>Message Text Pages: 740 - 1309</p>
<p>Group 3</p>	<p>The fault messages of group 3 will be stored.</p>	<p>Message Text Pages: 1310 - 1319</p>
<p>Group 4</p>	<p>The fault messages of group 4 will not be stored.</p>	<p>Message Text Pages: 1320 - 1535</p>

Explanation of Control Signs shown at the beginning of the first text line:

<p>\$:</p>	<p>The Dollar sign serves as a reference signal for on-line data transfer on machines using the Modular Mining Dispatch System "MMS".</p>
<p># :</p>	<p>Message will not be stored.</p>
<p>? :</p>	<p>Recording of this message in the protocol memory is accomplished with "COMING" registration only.</p>

Fault and Information Message List

GROUP 1 Fault Message Texts of message pages No. 500 - 739

Fault No. 500:
(503) *1)

\$h: Start blocked through main Shut-Off (gate) valve

Help:

Limit switch S31 not closed.
- Check for broken cables to switch S31.

Fault No. 506:
(509)

\$h: Start of engine 1 blocked by high pressure filter 1

Help:

Differential pressure switch B5-1 not closed.
- Check cables to differential pressure switch B5-1.

Fault No. 512:
(515)

\$h:

Help:

Fault No. 518:
(521)

Help:

Fault No. 524:
(527)

\$h: *High pressure filter 1 restricted. Stop the engine 1*
Action required No Shutdown

Help:

Differential pressure switch B5-1 not closed
- Clean or replace filter element.
- Check pump

Fault No. 530:
(533)

\$h:

Help:

*1) Numbers in brackets are the message page numbers of the second language.

Fault No. 536:
(539)

\$h: Faulty monitor channel oil pressure of engine 1 at high idle (with engine running, message no. 1286 displayed)

Help:

Sensor B30-1 shows inadmissible values
- Check sensor and cables.

Fault No. 542:
(545)

\$h: Faulty monitor channel engine speed 1

Help:

Frequency converter E8-1 for speed of engine 1 shows inadmissible values
- Check frequency converter E8-1 and pick-up B64-1

Fault No. 548:
(551)

\$h: Engines switched OFF due to closed main Shut-Off (gate) valve

Help:

Main Shut-Off (gate) valve not fully open.
Open the valve.

Fault No. 554:
(557)

\$h:

Help:

Fault No. 560:
(563)

\$h: Shut down of engine 1: oil pressure at low idle too low

Help:

Message through Sensor B1-1.

Fault No. 566:
(569)

\$h:

Help:

Fault No. 572:
(575)

\$h:

Help:

Fault No. 578:
(581)

\$h: Faulty monitor channel for coolant temperature of engine 1 (no shutdown, with engine running, message no. 614 displayed)

Help:

Sensor B14-1 shows inadmissible values.
- Check sensor and cables.

Fault No. 584: (587)	\$h:
Help:	
Fault No. 590: (593)	\$h: Shutdown: Hydraulic oil level too low
Help:	- Fill up hydraulic oil. - Check level sensor B4 and B50.
Fault No. 596: (599)	\$h: Faulty monitor channel engine speed 2
Help:	Frequency converter E8-2 for speed of engine 2 shows inadmissible values - Check frequency converter E8-2 and pick-up B64-2
Fault No. 602: (605)	\$h: Engine 2 shifted to low idle. Too high coolant temperature (no shutdown)
Help:	Message through sensor B14-2. - Let the engine cool down at low idle speed.
Fault No. 608: (611)	\$h: Faulty monitor channel for oil pressure of engine 1 at low idle (with engine running, message no. 560 displayed)
Help:	Sensor B1-1 shows inadmissible values - Check sensor and cables.
Fault No. 614: (617)	\$h: Engine 1 shifted to low idle due to too high coolant temperature
Help:	Message through sensor B14-1. - Let the engine cool down at low idle speed.
Fault No. 620: (623)	\$h: Faulty monitor channel for coolant temperature of engine 2
Help:	Sensor B14-2 shows inadmissible values - Check sensor and cables.

Fault No. 626: (629)	\$h: Start of engine 1 blocked by high pressure filter 2
Help:	Differential pressure switch B6-1 not closed. - Check cables to differential pressure switch B6-1.
Fault No. 632: (635)	\$h: Fire in the power house (Shutdown)
Help:	Fire suppression system 9K1 actuated. - Inform the fire brigade. - Evacuate endangered Persons. - Fight the fire and recharge the system
Fault No. 638: (641)	\$h: Start of engine 1 blocked by high pressure filter 3
Help:	Differential pressure switch B7-1 not closed. - Check cables to differential pressure switch B7-1.
Fault No. 644: (647)	\$h: Start of engine 2 blocked by high pressure filter 4
Help:	Differential pressure switch B5-2 not closed . - Check cables to differential pressure switch B5-2 .
Fault No. 650: (653)	\$h: Start of engine 2 blocked by high pressure filter 5
Help:	Differential pressure switch B6-2 not closed. - Check cables to differential pressure switch B6-2.
Fault No. 656: (659)	\$h: Start of engine 2 blocked by high pressure filter 6
Help:	Differential pressure switch B7-2 not closed. - Check cables to differential pressure switch B7-2.
Fault No. 662: (665)	\$h: High pressure filter 2 restricted. Stop the engine 1
Help:	Differential pressure switch B6-1 not closed . - Clean or replace filter element. - Check pump

Fault No. 668:
(671)

\$h: High pressure filter 3 restricted. Stop the engine 1

Help:

Differential pressure switch B7-1 not closed.
- Clean or replace filter element.
- Check pump

Fault No. 674:
(677)

\$h: High pressure filter 4 restricted. Stop the engine 2

Help:

Differential pressure switch B5-2 not closed.
- Clean or replace filter element.
- Check pump

Fault No. 680:
(683)

\$h: High pressure filter 5 restricted. Stop the engine 2

Help:

Differential pressure switch B6-2 not closed.
- Clean or replace filter element.
- Check pump.

Fault No. 686:
(689)

\$h: High pressure filter 6 restricted. Stop the engine 2

Help:

Differential pressure switch B7-2 not closed.
- Clean or replace filter element.
- Check pump.

Fault No. 692:
(695)

\$h: Short circuit at PLC output group
A1.X A3.X A5.X A7.X A13.X

Help:

- MK-LED indicates the output group.
- Check cables at the output group.

Fault No. 698:
(701)

\$h:

Help:

Fault No. 704:
(707)

\$h: Faulty monitor channel for oil pressure of engine 2
at high idle (with engine running, message no. 1298 displayed)

Help:

Sensor B30-2 shows inadmissible values
- Check sensor and cables.

Fault No. 710:
(713)

\$h:

Help:

Fault No. 716:
(719)

\$h: Shut down of engine 2: oil pressure at low idle too low

Help:

Message through Sensor B1-2.

Fault No. 722:
(725)

\$h:

Help:

Fault No. 728:
(731)

\$h: Faulty monitor channel for oil pressure of engine 2 at low idle (with engine running, message no. 716 displayed)

Help:

Sensor B1-2 shows inadmissible values
- Check sensor and cables.

Fault No. 734:
(737)

\$h:

Help:

GROUP 2 Fault Message Texts of message pages No. 740 - 1309 will be stored

Fault No. 740:
(743)

\$h: Faulty pressure switch for strainer oil cooler

Help:

Closed contact of pressure switch B165 for return oil strainer with switched off engine.
- Check pressure switch and cables.

Fault No. 746:
(749)

\$h: Strainer oil cooler restricted

Help:

Replace strainer.

Fault No. 752:
(755)

\$h: Faulty monitor channel for pump #1/6 pressure

Help:

Pressure pick up B87A for the pump #1/6 pressure shows inadmissible values.
- Check sensor and cables.

Fault No. 758:
(761)

\$h: Faulty monitor channel for pump #2/5 pressure

Help:

Pressure pick up B87B for the pump #2/5 pressure shows inadmissible values.
- Check sensor and cables.

Fault No. 764
(767)

\$h: Faulty monitor channel for pump #3 pressure

Help:

Pressure pick up B87C for the pump #3 pressure shows inadmissible values.
- Check sensor and cables.

Fault No. 770:
(773)

\$h: Faulty monitor channel for pump #4 pressure

Help:

Pressure pick up B87D for the pump #4 pressure shows inadmissible values.
- Check sensor and cables.

Fault No. 776:
(779)

\$h: Shutdown through emergency stop switch S33A

Help:

Emergency stop switch S33A at radiator door actuated.
- Find cause

Fault No. 782:
(785)

\$h: Shutdown through emergency stop switch S33B

Help:

Emergency stop switch S33B at control valves actuated.
- Find cause

Fault No. 788:
(791)

\$h: Shutdown through emergency stop switch S33D.

Help:

Emergency stop switch S33D at counterweight actuated.
- Find cause

Fault No. 794:
(797)

\$h: Coolant temperature of engine 1 too high.
Main pumps shifted to half power

Help:

Message through sensor B14-1
The engine operates with reduced load for a cooling down period.

Fault No. 800:
(803)

\$h: Faulty pressure switch for gear oil filter of
PTO gear 1

Help:

Closed contact of pressure switch B27-1 for PTO-gear
lubrication filter 1 with switched off engine.
- Check pressure switch and cables.

Fault No. 806:
(809)

\$h: Faulty pressure switch for pump regulation oil filter

Help:

Closed contact of pressure switch B22 for pump regulation
filter with switched off Engine.
- Check pressure switch and cables.

Fault No. 812:
(815)

\$h: Faulty pressure switch for oil tank breather filter

Help:

Closed contact of pressure switch B24 for oil tank breather
filter with switched off Engine.
- Check pressure switch and cables.

Fault No. 818:
(821)

\$h: Faulty pressure switch for return oil filter

Help:

Closed contact of pressure switch B26 for return oil filter
with switched off Engine.
- Check pressure switch and cables.

Fault No. 824: (827)	\$h: Faulty pressure switch for leak oil filter
Help:	Closed contact of pressure switch B25 for leak oil filter with switched off Engine. - Check pressure switch and cables.
Fault No. 830: (833)	\$h: No 24 V voltage at circuit breaker F13
Help:	No 24 V behind circuit breaker F13. - Check circuit breaker F13. - Check current supply to circuit breaker.
Fault No. 836 (839)	\$h: Faulty pressure switch of fan drive oil filter for oil cooler 1
Help:	Closed contact of pressure switch B28-1 for oil cooler fan drive filter with switched off engine. - Check pressure switch and cables.
Fault No. 842: (845)	\$h: Hydraulic oil far below operating temperature. Wait for warm-up phase!
Help:	The machine was taken into operation although the start viscosity was not attained. - Preheat hydraulic oil !
Fault No. 848: (851)	\$h: Faulty monitor channel for hydraulic oil temperature
Help:	Sensor B15 shows inadmissible values. - Check sensor and cables.
Fault No. 854: (857)	\$h: PTO-gear 1 oil filter restricted
Help:	- Replace filter element.
Fault No. 860: (863)	\$h: Pump regulation oil filter restricted
Help:	- Replace filter element.
Fault No. 866: (869)	\$h: Oil tank breather filter restricted
Help:	- Replace filter element.

Fault No. 872:
(875)

\$h: Return oil filter restricted

Help:

- Replace filter elements.

Fault No. 878:
(881)

\$h: Leak oil filter restricted

Help:

- Replace filter element.

Fault No. 884:
(887)

\$h: Faulty monitor channel for charge- /discharge current.

Help:

The monitor channel for charge-/discharge current shows inadmissible values.
- Check frequency converter E7 and shunt R3.

Fault No. 890:
(893)

\$h: Fan drive oil filter oil cooler 1 restricted

Help:

- Replace filter element.

Fault No. 896:
(899)

\$h: Battery charging circuit failure

Help:

The ECS detects a battery charging current with the machine turned off.
- Check battery charging circuit for separate feeding.

Fault No. 902:
(905)

\$h: Load of the batteries too high

Help:

Too much current is being taken from the batteries.
- Check board net for short circuit.
- Switch off unnecessary consumers.

Fault No. 908:
(911)

\$h: Batteries are not being charged

Help:

- Check charging circuit for broken cables.
- Switch off unnecessary consumers.

Fault No. 914:
(917)

\$h: Battery charging current too high

Help:

- Check boardnet for short circuit.
- Check generator and batteries.

Fault No. 920:
(923) \$h: Faulty monitor channel for oil temperature of PTO gear 2

Help: Temperature sensor B49-2 for PTO gear oil shows inadmissible values.
- Check sensor and cables.

Fault No. 926:
(929) \$h: Oil temperature of PTO gear 2 too high

Help: - Check gear oil cooling circuit.
- Clean gear oil cooler.

Fault No. 932:
(935) \$h: Faulty monitor channel for fuel level

Help: Pressure transducer B63 for fuel level shows inadmissible values.
- Check monitor channel and transducer.

Fault No. 938:
(941) \$h: Hydraulic oil temperature too high.
Bucket motion switched off.

Help: Cool off the oil by moving attachment w/o load.
- Check hydraulic oil cooling system.
- Clean oil cooler.

Fault No. 944:
(947) \$h: Faulty monitor channel for oil temperature of PTO gear 1

Help: Temperature sensor B49-1 for PTO gear oil shows inadmissible values.
- Check sensor and cables.

Fault No. 950:
(953) \$h: Oil temperature of PTO gear 1 too high

Help: - Check gear oil cooling circuit.
- Clean gear oil cooler.

Fault No. 956:
(959) \$h: Faulty monitor channel for ambient temperature

Help: Temperature sensor B90 for ambient temperature shows inadmissible values.
- Check sensor and cables.

Fault No. 962: (965)	\$h: Control pressure X1-1 for the main pumps too high
Help:	<ul style="list-style-type: none"> - Check / adjust electronic pump regulation. - Check / adjust pressure reduction valve.
Fault No. 968: (971)	\$h: Pilot pressure X2 too low.
Help:	- Check / adjust pressure relief valve.
Fault No. 974: (977)	\$h: Pilot pressure X2 too high
Help:	- Check / adjust pressure relief valve.
Fault No. 980: (983)	\$h: Swing gear house brake OFF
Help:	<ul style="list-style-type: none"> - Check solenoid valve Y5. - Check pressure switch B16.
Fault No. 986 (989)	\$h: Travel gear house brake OFF
Help:	<ul style="list-style-type: none"> - Check solenoid valve Y16. - Check pressure switch B48.
Fault No. 992: (995)	\$h: Travel gear house brake ON
Help:	<ul style="list-style-type: none"> - Check solenoid valve Y16. - Check pressure switch B48.
Fault No. 998: (1001)	\$h: Faulty monitor channel for onboard mains tension
Help:	<p>The mains tension is beyond the permissible limits.</p> <ul style="list-style-type: none"> - Check monitor channel.
Fault No. 1004: (1007)	\$h: Board net voltage too high
Help:	- Check generator and regulator.

Fault No. 1010: (1013)	<p>\$h: Board net voltage too low</p>
Help:	<ul style="list-style-type: none"> - Check batteries - Check generator.
Fault No. 1016: (1019)	<p>\$h: Faulty monitor channel for X1-2-pressure</p>
Help:	<p>Pressure pick up B85-2 for the X1-2-pressure shows inadmissible values.</p> <ul style="list-style-type: none"> - Check sensor and cables.
Fault No. 1022: (1025)	<p>\$h: Control pressure X1-2 for the main pumps too high</p>
Help:	<ul style="list-style-type: none"> - Check / adjust electronic pump regulation. - Check / adjust pressure reduction valve.
Fault No. 1028: (1031)	<p>\$h: Central lube system grease container empty</p>
Help:	<p>The message sensor B108 grease container empty has responded.</p> <ul style="list-style-type: none"> - Replace or fill grease container.
Fault No. 1034: (1037)	<p>\$h: Central lube system failure</p>
Help:	<p>Lube cycle is not performed at the given time.</p> <ul style="list-style-type: none"> - Check lube system for defects. - Check lube times.
Fault No. 1040: (1043)	<p>\$h: Central lube system failure</p>
Help:	<p>The lube lines are not relieved at the given time.</p> <ul style="list-style-type: none"> - Check valve Y7 and pressure switch B43. - Check lube times and injectors.
Fault No. 1046: (1049)	<p>\$h: Swing ring gear lube system grease container empty</p>
Help:	<p>The message sensor B109 grease container empty has responded.</p> <ul style="list-style-type: none"> - Replace or fill grease container.

Fault No. 1052:
(1055)

\$h: Swing ring gear lube system failure

Help:

Lube cycle is not performed at the given time.
- Check lube system for defects.
- Check lube times.

Fault No. 1058:
(1061)

\$h: Swing ring gear lube system failure

Help:

The lube lines are not relieved at the given time.
- Check valve Y9 and pressure switch B46.
- Check lube times and injectors.

Fault No. 1064:
(1067)

\$h: Faulty pressure switch of gear oil filter for PTO gear 2

Help:

Closed contact of pressure switch B27-2 for PTO-gear lubrication filter 2 with switched OFF engine.
- Check pressure switch and connected cables.

Fault No. 1070:
(1073)

\$h: Faulty pressure switch of fan drive oil filter for oil cooler 2

Help:

Closed contact of pressure switch B28-2 for cooler fan drive filter with switched OFF engine.
- Check pressure switch and connected cables.

Fault No. 1076:
(1079)

\$h: Faulty pressure switch of fan drive oil filter for coolant radiator 1

Help:

Closed contact of pressure switch B21-1 for radiator fan drive filter with switched OFF engine.
- Check pressure switch and connected cables.

Fault No. 1082:
(1085)

\$h: Faulty pressure switch of fan drive oil filter for coolant radiator 2

Help:

Closed contact of pressure switch B21-2 for radiator fan drive filter with switched OFF engine.
- Check pressure switch and connected cables.

Fault No. 1088:
(1091)

\$h: The ECS is by-passed

Help:

- Reset by-pass switch S27.
- Remove bridge wires.

Fault No. 1094: (1097)	\$h: PTO gear 2 oil filter restricted
Help:	- Replace filter element.
Fault No. 1100: (1103)	\$h: Fan drive oil filter for oil cooler 2 restricted
Help:	- Replace filter element.
Fault No. 1106: (1109)	\$h: Fan drive oil filter for coolant radiator 1 restricted
Help:	- Replace filter element.
Fault No. 1112: (1115)	\$h: Fan drive oil filter for coolant radiator 2 restricted
Help:	- Replace filter element.
Fault No. 1118: (1121)	\$h: Electric pilot control system failure
Help:	<p>Pilot control amplifiers energized with control levers in neutral position. DANGER of phantom movements! - Check safety relay D32 and K125.</p>
Fault No. 1124: (1127)	\$h: Faulty pressure switch for lubrication of PTO gear 1
Help:	<p>Open contact of pressure switch B17-1 for PTO-gear 1 lubrication with switched OFF engine. - Check pressure switch and connected cables.</p>
Fault No. 1130: (1133)	\$h: Faulty pressure switch for lubrication of PTO gear 2
Help:	<p>Open contact of pressure switch B17-2 for PTO-gear 2 lubrication with switched OFF engine. - Check pressure switch and connected cables.</p>
Fault No. 1136: (1139)	\$h: Lubrication system failure of PTO gear 1
Help:	<p>Oil pressure for lubrication of PTO gear 1 insufficient - Check lubrication oil pump and connected lines.</p>

Fault No. 1142:
(1145)

\$h: Lubrication system failure of PTO gear 2

Help:

Oil pressure for lubrication of PTO gear 2 insufficient.
- Check lubrication oil pump and connected lines.

Fault No. 1148:
(1151)

\$h: Pump back-up pressure X4-1 failure

Help:

Back-up pressure for pumps on engine 1 insufficient
- Check valve Y102-1.

Fault No. 1154:
(1157)

\$h: Pump back-up pressure X4-2 failure

Help:

Back-up pressure for pumps on engine 2 insufficient.
- Check valve Y102-2.

Fault No. 1160:
(1163)

\$h: Faulty pressure switch for pump
back-up pressure X4

Help:

One of the pressure switches B97 for X4 back-up pressure
is open with switched off engine.
- Check pressure switches B97-1 & B97-2.

Fault No. 1166:
(1169)

\$h: Air cleaner of engine 1 restricted

Help:

- Clean or replace filter elements.

Fault No. 1172:
(1175)

\$h: Air cleaner of engine 2 restricted

Help:

- Clean or replace filter elements

Fault No. 1178:
(1181)

\$h: Faulty pressure switch for air cleaner of
engine 1

Help:

The pressure switch is closed with the engine switched off.
- Check pressure switches B18-1 & B19-1

Fault No. 1184:
(1187)

\$h: Faulty pressure switch for air cleaner of
engine 2

Help:

The pressure switch is closed with switched off
engine.
- Check pressure switches B18-2 & B19-2

Fault No. 1190: (1193)	\$h: Faulty monitor channel for X1-1-pressure
Help:	Pressure pick up B85-1 for the X1-1-pressure shows inadmissible values. - Check sensor and cables.
Fault No. 1196: (1199)	\$h: Faulty monitor channel for X2-pressure
Help:	Pressure pick up B86 for the X2-pressure shows inadmissible values. - Check sensor and cables.
Fault No. 1202: (1205)	\$h: Coolant temperature of engine 2 too high. Pumps at half power
Help:	Message through sensor B14-2. The engine operates with reduced load for a cooling down period.
Fault No. 1208: (1211)	\$h: Engine control module 1 reports light failure.
Help:	Report through engine control module 1 - Check ECM and cables.
Fault No. 1214: (1217)	\$h: Engine control module 2 reports light failure.
Help:	Report through engine control module 2 - Check ECM and cables.
Fault No. 1220: (1223)	\$h: Engine control module 1 reports serious failure.
Help:	Report through engine control module 1 - Repair soon.
Fault No. 1226: (1229)	\$h: Engine control module 2 reports serious failure.
Help:	Report through engine control module 2 - Repair soon.

Fault No. 1232: (1235)	\$h: Shutdown through emergency stop switch S36.
Help:	Emergency stop switch S36 in the cab actuated. - Find cause
Fault No. 1238: (1241)	\$h: Shutdown through maintenance safety switch S58.
Help:	Maintenance safety switch S58 in machinery house actuated. - Find cause
Fault No. 1244: (1247)	\$h: Faulty monitor channel for level central lube system.
Help:	Level sensor B108 shows inadmissible values. - Check monitor channel and sensor.
Fault No. 1250: (1253)	\$h: Acoustic warning signal due to lubrication system failure
Help:	Automatic lubrication suspended for 4 hours. - Perform manually actuated lubrication. - Repair lubrication system.
Fault No. 1256: (1259)	\$h: Faulty switch hydraulic oil level or lack of hydraulic oil
Help:	Stop the engines. - Check level sensor B4 and B50. - Check hydraulic oil level.
Fault No. 1262: (1265)	\$h: Lack of hydraulic oil ! Fill up hydraulic oil !
Help:	Hydraulic oil level too low. - Fill up hydraulic oil.
Fault No. 1268: (1271)	\$h: Faulty monitor channel for level swing ring gear-lube system.
Help:	Level sensor B109 shows inadmissible values. - Check monitor channel and sensor.

Fault No. 1274:
(1277)

\$h: Problems pump control.

Help:

Problem in the pump control.
- If the fault further exist, inform service.

Fault No. 1280:
(1283)

\$h: Shutdown through emergency stop switch S33C.

Help:

Emergency stop S33C in pump compartment actuated.
- Find cause

Fault No. 1286:
(1289)

\$h: Engine 1 shifted to low idle. Oil pressure too low.

Help:

Message through sensor B30-1.

Fault No. 1292:
(1295)

\$h: Engine 1 shifted to low idle. Coolant pressure too low.

Help:

Message through sensor B41-1.

Fault No. 1298:
(1301)

\$h: Engine 2 shifted to low idle. Oil pressure too low.

Help:

Message through sensor B30-2.

Fault No. 1304:
(1307)

\$h: Engine 2 shifted to low idle. Coolant pressure too low.

Help:

Message through sensor B41-2.

**GROUP 3 Information Message Texts of message pages No.
1310 - 1319 will be stored**

Information No. 1310: (1311)

Information No. 1312: (1313)

Information No. 1314: (1315)

Information No. 1316: (1317)

Information No. 1318: (1319)

GROUP 4**Information Message Texts of message pages No. 1320 - 1535 will not be stored**Information No. 1320:
(1321)# Hydraulic oil not at operating temp. !
Operate with reduced power !Information No. 1322:
(1323)

Swing gear house brake ON

Information No. 1324:
(1325)? Engine 2 start h:
(This message will be stored).Information No. 1326:
(1327)? Engine 2 stop h:
(This message will be stored).Information No. 1328:
(1329)# No clearance for starting, shift
engines to low idle speed.Information No. 1330:
(1331)# Starter motor not engaged, engine
already running.Information No. 1332:
(1333)

Evaluation switched off.

Information No. 1334:
(1335)? Engine 1 start h:
(This message will be stored).Information No. 1336:
(1337)? Engine 1 stop h:
(This message will be stored).Information No. 1338:
(1339)

Fill up fuel tank

Information No. 1340:
(1341)

Actuate engine speed selector switch

Information No. 1342:
(1343)# Engine shutdown has been actuated from
ground man

Information No. 1344: (1345)	# Messages switched OFF
Information No. 1346: (1347)	#
Information No. 1348: (1349)	# Trucks : @ C05
Information No. 1350: (1352)	# Pilot control switched OFF. Safety lever in locked position or ladder end switch closed or service arm switch closed.
Information No. 1354: (1356)	# Pilot control switched OFF. Service arm actuated.
Information No. 1358: (1360)	# Emergency shut-down switch S33D at the counter weight was actuated. Unlock before restarting.
Information No. 1362: (1364)	# Emergency shut-down switch S33B at the main control valves was actuated. Unlock before restarting.
Information No. 1366: (1368)	# Emergency shut-down switch S36 in the cab was actuated. Unlock before restarting.
Information No. 1370: (1372)	# Maintenance safety switch S58 in the power house was actuated. Unlock before restarting.
Information No. 1374: (1376)	# Operator warning system actuated from ground man.
Information No. 1378: (1380)	# Swing ring gear lube system grease container on reserve. Replace or fill grease container.

Information No. 1382:
(1384)

Central lube system grease container on reserve.
Replace or fill grease container.

Information No. 1386:
(1388)

Hydraulic oil below operating temperature!
Pre-heat hydraulic oil or warm up at low idle speed and reduced power.

Information No. 1390:
(1392)

Emergency shut-down switch S33A at the radiator door was actuated.
Unlock before restarting.

Information No. 1394:
(1396)

Emergency shut-down switch S33C in the pump compartment was actuated.
Unlock before restarting.

Information No. 1398:
(1400)

Engine 1 reserve oil tank empty.
- Fill tank before next shift.

Information No. 1402:
(1404)

Engine 2 reserve oil tank empty.
- Fill tank before next shift.

Information No. 1406:
(1408)

Central lubrication system
- manual release.

Information No. 1410:
(1412)

Switch off wiper and remove lower wiper
Push -QUI- button.

Information No. 1414:
(1416)

Swing ring gear lubrication system
- manual release.

Information No. 1418:
(1420)

Faulty switch S85 - only upper wiper
- Check switch S85

Information No. 1422:
(1424)

Faulty switch S86 - switch off wiper.
- Check switch S86 - push (QUI) button

Information No. 1426:
(1428)

SERVICE: Central lubrication system.

Information No. 1434:
(1436)

SERVICE: Swing ring gear lubrication system.

Information No. 1440:
(1445)

Remark to Maintenance calls.
The maintenance calls integrated in the ECS system are to be performed according to the maintenance section in the operation and maintenance manual.
The routine visual checks, lubrication work and engine maintenance are not called up. Please pay attention to the Service Literature.

Information No. 1450:
(1455)

Initial 250 h Maintenance
Perform initial 250 h Maintenance.

Information No. 1460:
(1465)

Initial 1000 h Maintenance
Perform initial 1000 h Maintenance.
Perform also the 250 h/ 500 h Maintenance.

Information No. 1470:
(1475)

Periodic 250 h Maintenance
Perform periodic 250 h Maintenance

Information No. 1480:
(1485)

Periodic 500 h Maintenance
Perform periodic 500 h Maintenance.
Perform also the 250 h Maintenance.

Information No. 1490:
(1495)

Periodic 1000 h Maintenance
Perform periodic 1000 h Maintenance.
Perform also the 250 h/ 500 h Maintenance.

Information No. 1500:
(1505)

Periodic 2000 h Maintenance
Perform periodic 2000 h Maintenance.
Perform also the 250 h/ 500 h/ 1000 h Maintenance.

Information No. 1510:
(1515)

Periodic 3000 h Maintenance
Perform periodic 3000 h Maintenance.
Perform also the 250 h/ 500 h/ 1000 h Maintenance.

3.5 OPERATING THE HEATER, VENTILATION AND AIR CONDITIONING

Digital Display

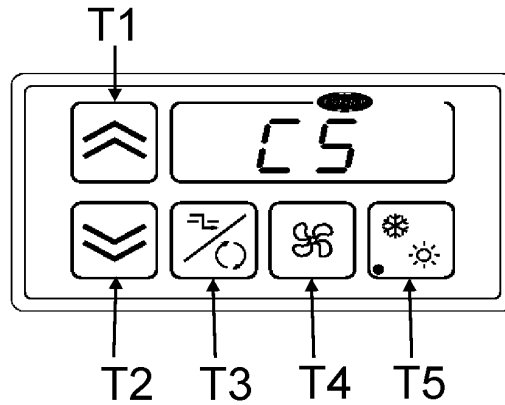

Function of Keys when “Engine On” and Controller Active

Key T1: Plus Key

increases interior temperature setpoint by 1 degree per stroke or increases manual blower speed, depending on displayed mode

Key T2: Minus Key

decreases interior temperature setpoint by 1 degree per stroke or decreases manual blower speed, depending on displayed mode

Key T3: Recirculating Air/Fresh Air

switches from Recirculating Air to Fresh Air and vice versa

Key T4: Blower Control

switches on the manual blower control. Press Plus/Minus Key to select the following speeds: 1^{*)}-2-3-4-5
 1^{*)} to 5: adjusts the blowers to speeds 20%, 40%, 60%, 80%, 100%.
 Off^{*)}: Switches off the blowers or switches to automatic.
 Automatic: The blowers are controlled automatically based on the interior temperature.

Key T5: Automatic Climate Control

Switches on the automatic temperature control

Key T2+T3: Temperature Indication

shows the inside temperature for 10 seconds, if pressed a second time show the outside temperature for 10 seconds (optional)

Key T3+T5: Reheat (optional)

starts Reheat mode for 3 minutes (duration adjustable)

Key T3+T4: Controller Off

switches off all control functions and the display.

^{*)} The following blower steps are disabled when the automatic climate control is on:

2-, 3-step blower: Off
 continuously adjustable blower: Off, 1

Ac1

Air Flow Control

- For defrosting the windshield close the slide in the seat base. The whole air flow is now directed to the windshield.
- To direct the air flow to your feet, open the slide in the seat base.

Luminous Indication

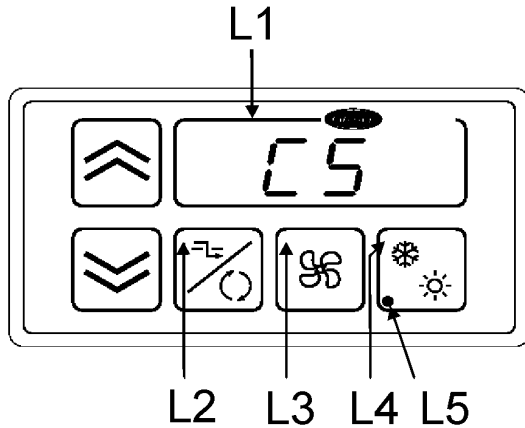

Function of Indication when "Engine On" and Controller Active

- LED Field L1: Standard indication is the setpoint temperature
- LED L2: Fresh air operation (green)
- LED L3: Manual blower control "ON" (green)
- LED L4: Cooling/Heating mode (green)
- LED L5: Malfunction cooling unit (red)

Operating Instructions



When the engine is running, press any key to activate the Air Conditioning Control Unit. All previously set functions are reactivated.

Display

When the unit is ON, the display shows the interior setpoint temperature. When selecting individual functions, the display shows the corresponding information for a short period of time. The display is dark when engine or control unit are OFF.

Interior Temperature Control

When the unit is on, select Automatic Climate Control  to start interior temperature control.

Press the Plus  or Minus  keys to set the required interior temperature.



The temperature can be adjusted between 18° und 28°C.

When outside temperatures are below 2°C (adjustable parameter), the cooling function remains disabled.

Ventilation



When the unit is operating in Automatic Climate Control mode, the blower speed is controlled based on the room temperature.

However, the blowers may be switched to manual mode of operation by pressing the blower key.

Press the Plus  or Minus  keys to define one of 5 different blower steps. The blowers can not be switched OFF when Automatic Climate Control  is ON.



When Automatic Climate Control is OFF, the blowers stop when the manual blower control is turned to zero.

Reheat (optional)

The Reheat mode is used to remove air humidity and to help defogging up the windshields. Press  and  at the same time to activate Reheat. Heating and cooling will be energized on for 3 minutes (adjustable parameter). In addition, the blowers are switched to maximum speed and the fresh air flap is closed. At the end of the pre-set duration time, the functions return to the previously selected settings.

Reheat mode is disabled with outside temperatures below 2°C (adjustable parameter) or when the sensor is not installed or has a failure.

Temperature Indication

Press  and  at the same time to display the inside temperature, e.g. "i 22" for 10 seconds.

Optional, the outside temperature, e.g. "o 19", may be displayed when pressing the keys a second time.

A sensor malfunction is displayed by "i - -" or "o - -".

Ac2

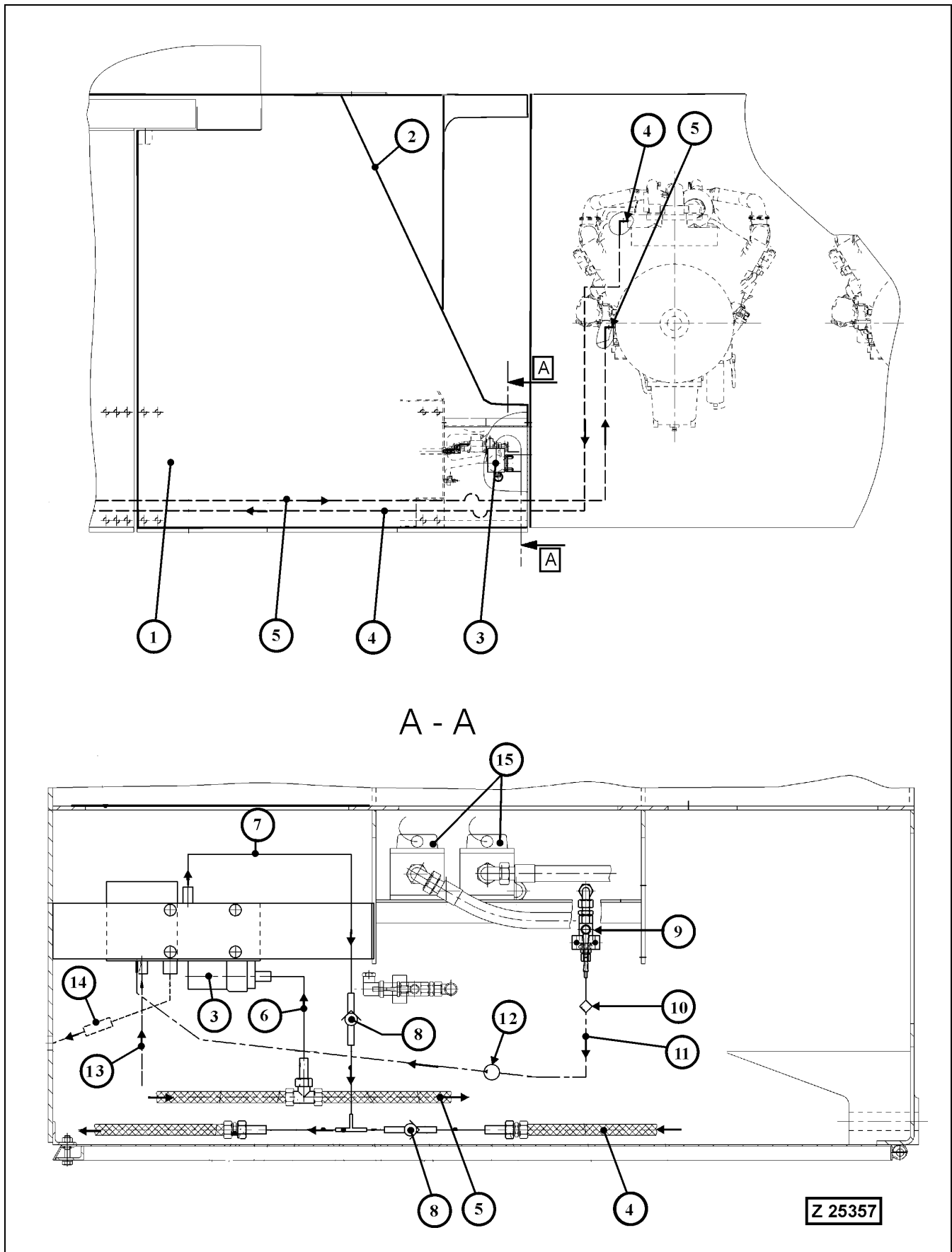

3.5.1 AUXILIARY HEATER FOR OPERATOR'S CAB

Special Equipment

REMARK

The auxiliary cab heater is located in the compartment below the stair to the operator's cab. View A-A shows the arrangement of components and the flow of water, fuel and air.

Legend for illustration Z25357

- (1) Fuel tank
- (2) Stair to operator's cab
- (3) Heater unit HYDRONIC 10, refer to the separate operation manual HYDRONIC 10 for all operating and maintenance instructions. The manual is filed in volume 2 binder.
- (4) Water supply line from engine to cab heater
- (5) Water return line
- (6) Water line to auxiliary heater
- (7) Hot water line from auxiliary heater to cab heater
- (8) Check valve
- (9) Fuel shut off-cock for fuel supply to heater (3)
- (10) Fuel strainer
- (11) Fuel supply line
- (12) Fuel dosing pump
- (13) Combustion air intake line
- (14) Exhaust muffler
- (15) Fuel shut-off solenoid valves

Operation

To activate the heater (3), open fuel shut off-cock (9). Select the desired heating stage with the control module (5) shown on page 91.

REMARK

During the warm season the fuel shut-off cock (9) should be closed.

3.6 MACHINERY HOUSE

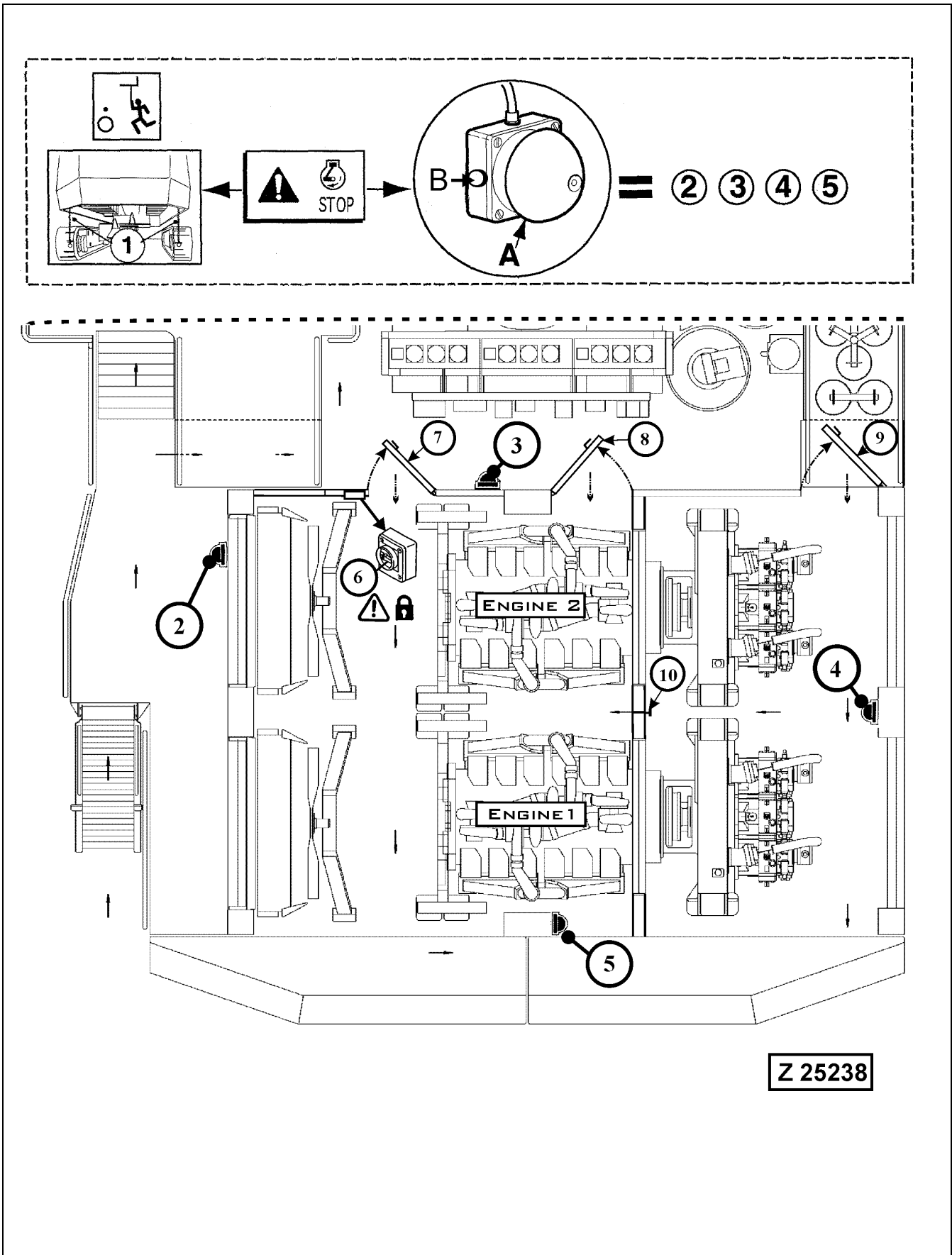

3.6.1 EMERGENCY ENGINE SHUTDOWN SWITCHES

Legend for illustration Z25238

- (1) Pulling chains for emergency shut down from ground man (special equipment). When one of the chains (1) is being pulled down for emergency shut down of both engines, the Operator will be informed by the following message, displayed on the ECS screen:
" # Engine shut down has been actuated from ground man"
- (2) Emergency engine shutdown switch (S33A) on radiator door
- (3) Emergency engine shutdown switch (S33B) at the main control valves
- (4) Emergency engine shutdown switch (S33C) in pump compartment on center post
- (5) Emergency engine shutdown switch (S33D) at the counterweight
- (A) Push button of emergency shutdown switches (2, 3, 4 and 5) for stopping the engines
- (B) Release button for emergency shut down switch (if so equipped)

⚠ WARNING

- **In case of emergency push in the button (A) to stop the engines.**
 - **Never stop the engines from a full load except in case of emergency. If a hot engine is shut down without previous idling period of three to five minutes, the temperature in certain engine parts rising sharply after the cooling system ceases to function. The resulting thermal stress, especially in the turbochargers, may cause serious damage.**
-
-

NOTICE

- **For restarting, first push in release button (B). On switches without button (B) pull out button (A) and then start the engines in the normal way at control panel in the operator's cab. The engines can not be started with button (A) in depressed position.**
- **When one of the Shutdown switches (2 - 5) is activated, the ECS display informs the Operator by a corresponding message.**

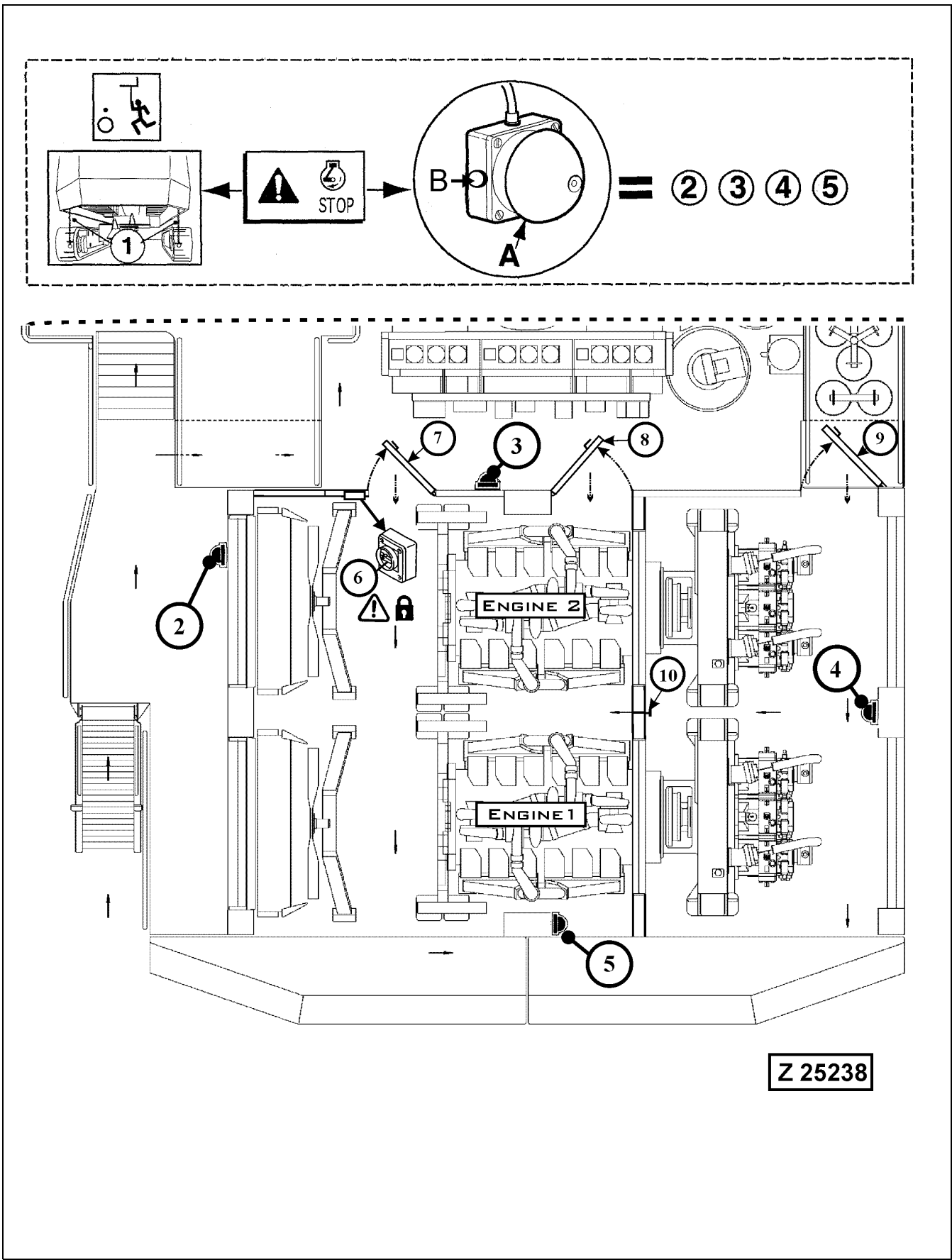

Z 25238

3.6.2 SAFETY SWITCH FOR MAINTENANCE

Legend for illustration Z25238

- (6) Maintenance safety switch for start prevention of the engines

CAUTION

Before beginning any maintenance operations set the safety switch (6) to "0" position to prevent starting of the engines during maintenance. Secure this position by inserting a padlock into the holes of the safety switch. Up to three padlocks can be attached.

Machinery house doors

- (7) Front door
- (8) Access door to the oil level gauge of the front engine
- (9) Access door to the pump compartment
- (10) Center floor door

NOTICE

Make sure that all machinery house doors are securely closed before starting the engines.

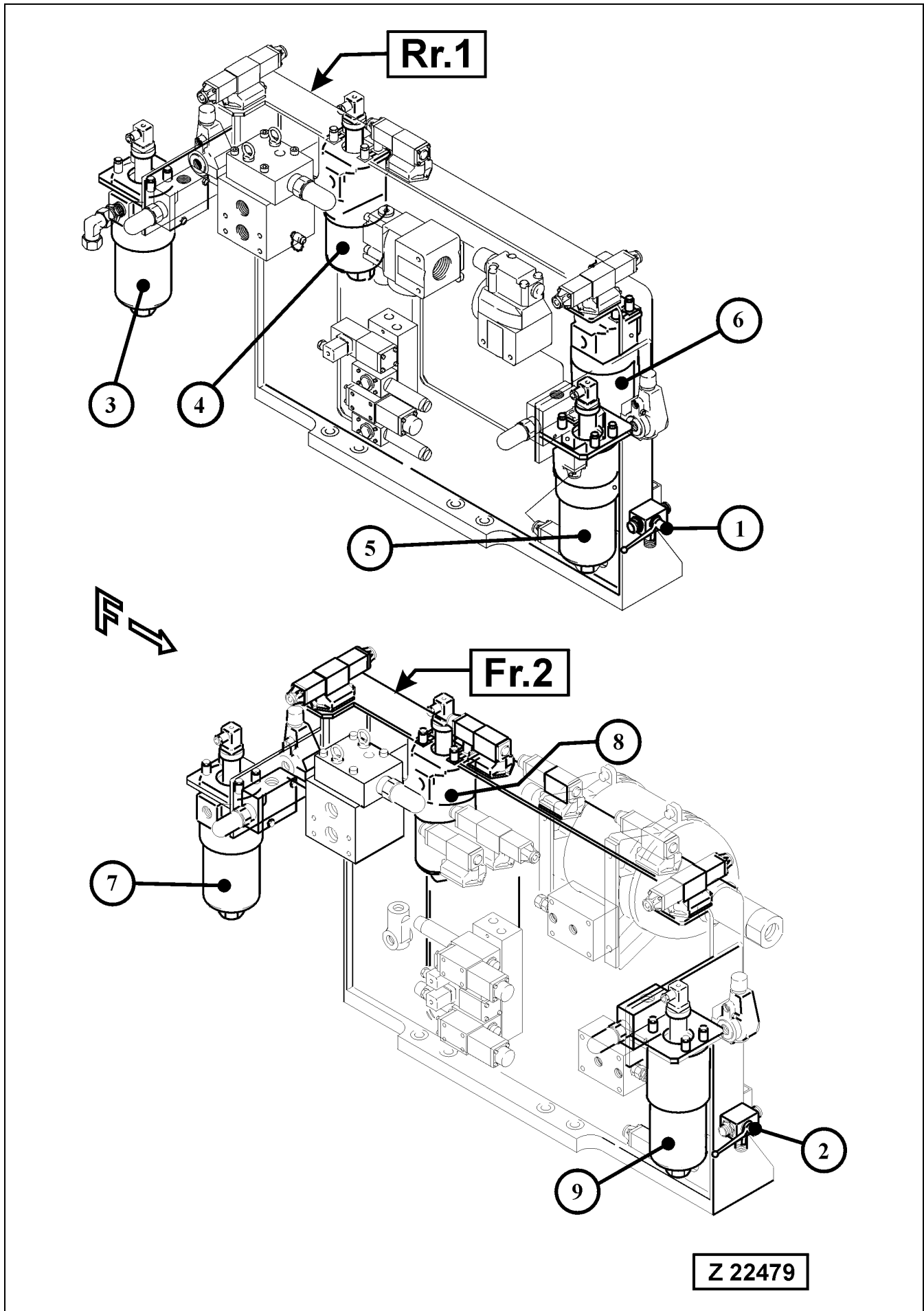

3.6.3 CONTROL AND FILTER PANEL OF REAR- AND FRONT POWER UNIT

Legend for illustration Z22479

- (Rr.1) Control and filter panel of rear power unit, engine 1
- (Fr.2) Control and filter panel of front power unit, engine 2
- (1) Change over valve for operation mode of pump control system for rear power unit, engine 1.
- (2) Change over valve for operation mode of pump control system for front power unit, engine 2.
- (3) Pressure oil filter for fan drive hydraulic motor of coolant radiator for rear engine "1". Filter restriction monitored by differential pressure switch B21-1.
- (4) Pressure oil filter for pump distributor gear PTO "1" lubricating oil. Filter restriction monitored by differential pressure switch B27-1.
- (5) Pressure oil filter for fan drive motor of hydraulic oil cooler "1". Filter restriction monitored by differential pressure switch B28-1.
- (6) Pressure oil filter for pilot- and pump control oil circuit. Filter restriction monitored by differential pressure switch B22.
- (7) Pressure oil filter for fan drive hydraulic motor of coolant radiator for front engine "2". Filter restriction monitored by differential pressure switch B21-2.
- (8) Pressure oil filter for pump distributor gear PTO "2" lubricating oil. Filter restriction monitored by differential pressure switch B27-2.
- (9) Pressure oil filter for fan drive motor of hydraulic oil cooler "2". Filter restriction monitored by differential pressure switch B28-2.

Operation Modes of Pump Regulation System

The standard operation mode of the pump control system is the Electronic Operation Mode.

For testing purposes the pump control system can be changed to the hydraulic operation mode. In case of a failure in the electronic control system the hydraulic operation mode can be used to continue operation.

The lever positions for electronic and hydraulic operation mode are marked with corresponding symbols at levers (1) and (2).

3.7 ELECTRICAL EQUIPMENT IN CAB BASE

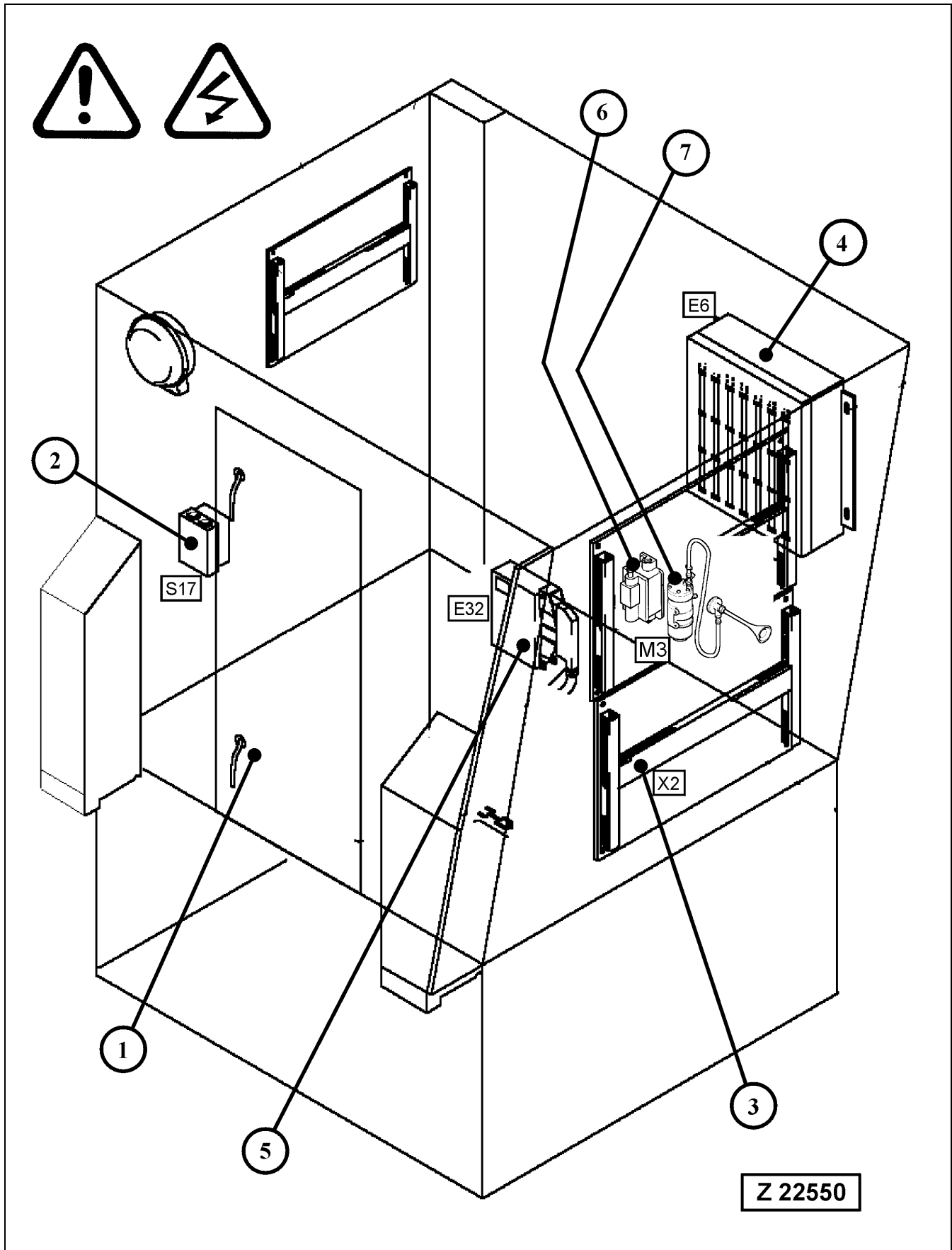

3.7.1 STANDARD COMPONENTS IN CAB BASE

REMARK

On shovels equipped with electrical pre-heating systems there are additional components in the cab base. Refer to page 219 for more information.

⚠ WARNING

- **The cab base may contain high tension electrical appliances. Access to the cab base for authorized service staff only.**
 - **All cables of the 24V DC board net are of blue color. All other cable colors indicating a higher voltage. DO NOT touch these cables and their terminals and connected components. Always contact authorized electricians having the permission to work on medium and high voltage systems.**
-

Legend for illustration Z 22550

- (1) Cab base door. Keep the door locked, access for authorized service staff only.
- (2) Light switch
- (3) Mounting location of main switch board "X2". See page 211 for more information.
- (4) Programmable Logic Controller (PLC) of the ECS system. See page 215 for more information.
- (5) Electronic control module (ECM) of the pump control system MC7
- (6) Pressure switch DPST of the FIRE DETECTION, ACTUATION AND SUPPRESSION SYSTEM. Refer to page 272 for more information.
- (7) Signal horn compressor with signal horn

Electronic Pump Control Module (5)

The data link adapter for connecting an electronic tool to the control module (5) is located in the Operator's cab on the Operator's console.

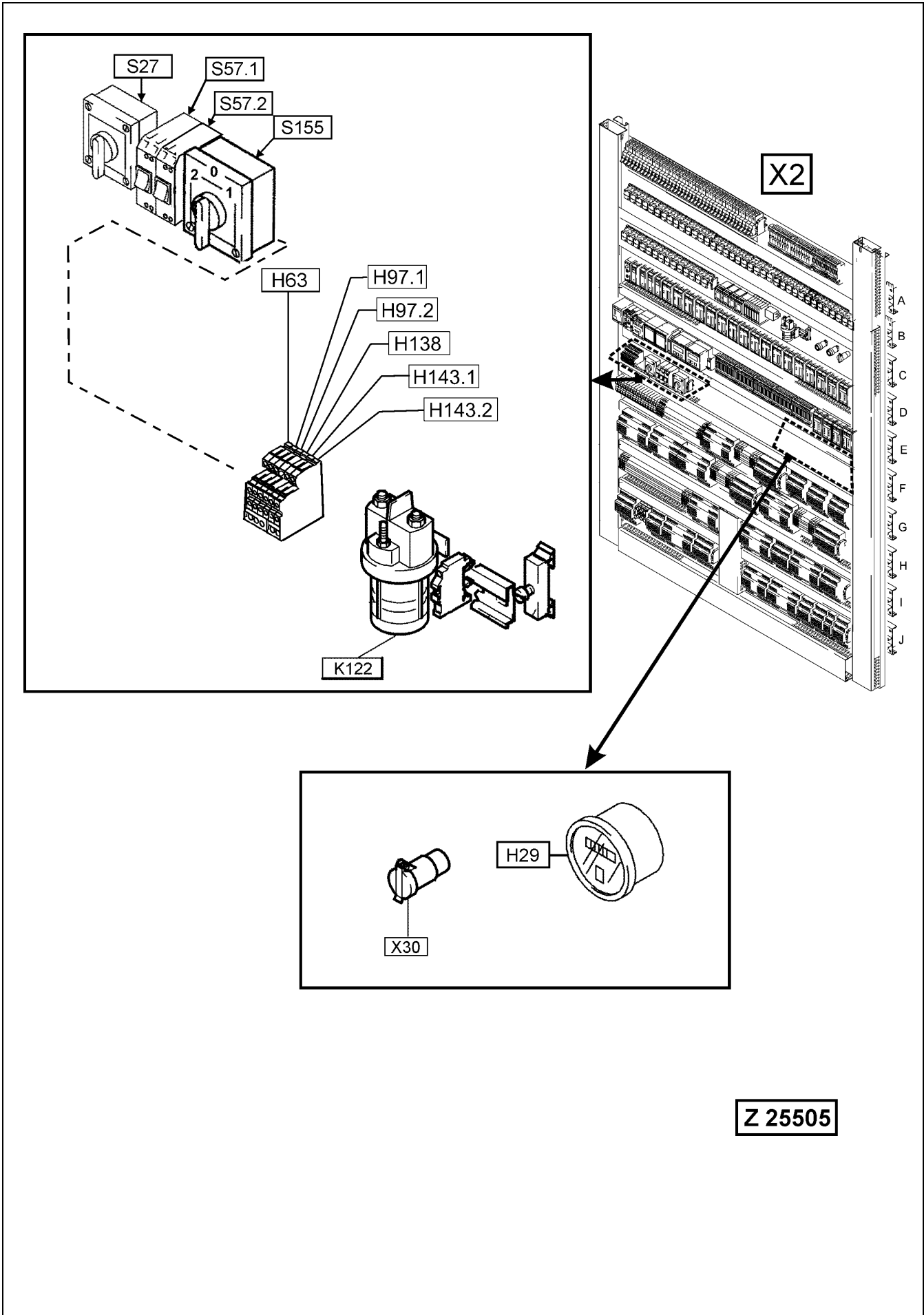

3.7.2 SWITCH BOARD (X2) IN CAB BASE

Legend for illustration Z25505

- (S27) Emergency By-pass switch for the shutdown function of the PLC (E6). If an automatic shutdown is initiated by Shovel systems, with a dangerous situation for man or machine, which needs the Shovel to be operable to over-come the dangerous situation, actuate this switch to override the shutdown function of the system and to enable a restart of the Diesel engine.

NOTICE

This switch can not override engine initiated shutdowns.

CAUTION

As soon as the immediate situation of danger is over, shutdown the unit. Correct the fault that caused the shut down and re-set the Emergency By-pass switch (S27).

- (S57.1) Diagnostic switch for flashing out fault codes via lamp (H97.1) of the Centry system for engine 1.
- (S57.2) Diagnostic switch for flashing out fault codes via lamp (H97.2) of the Centry system for engine 2.
- (H97.1) Fault lamp for flashing out diagnostic fault codes of the Centry system for engine 1.
- (H97.2) Fault lamp for flashing out diagnostic fault codes of the Centry system for engine 2.

Diagnostic Fault Codes of the Engine Centry System

The fault lamps (H97.1 and H97.2) will light for about 2 seconds after main key switch-on and then go out when no faults are being detected. When a fault condition exist, the fault lamp will turn "ON" for warning faults, and "ON FLASHING" for more severe faults that can affect engine operation and need immediate attention. To determine an active fault, shut off the engine and turn main key switch to "ON" position (engine not running). Press diagnostic switch (S57.1 or S57.2) for 1 to 2 seconds and then release. If the corresponding fault lamp illuminates while the diagnostic switch is held depressed, there is an active fault or faults. Active faults MUST be corrected as soon as possible.

For more information, refer to the separate Operation and Maintenance Manual CENTRY, filed in volume 2 binder.

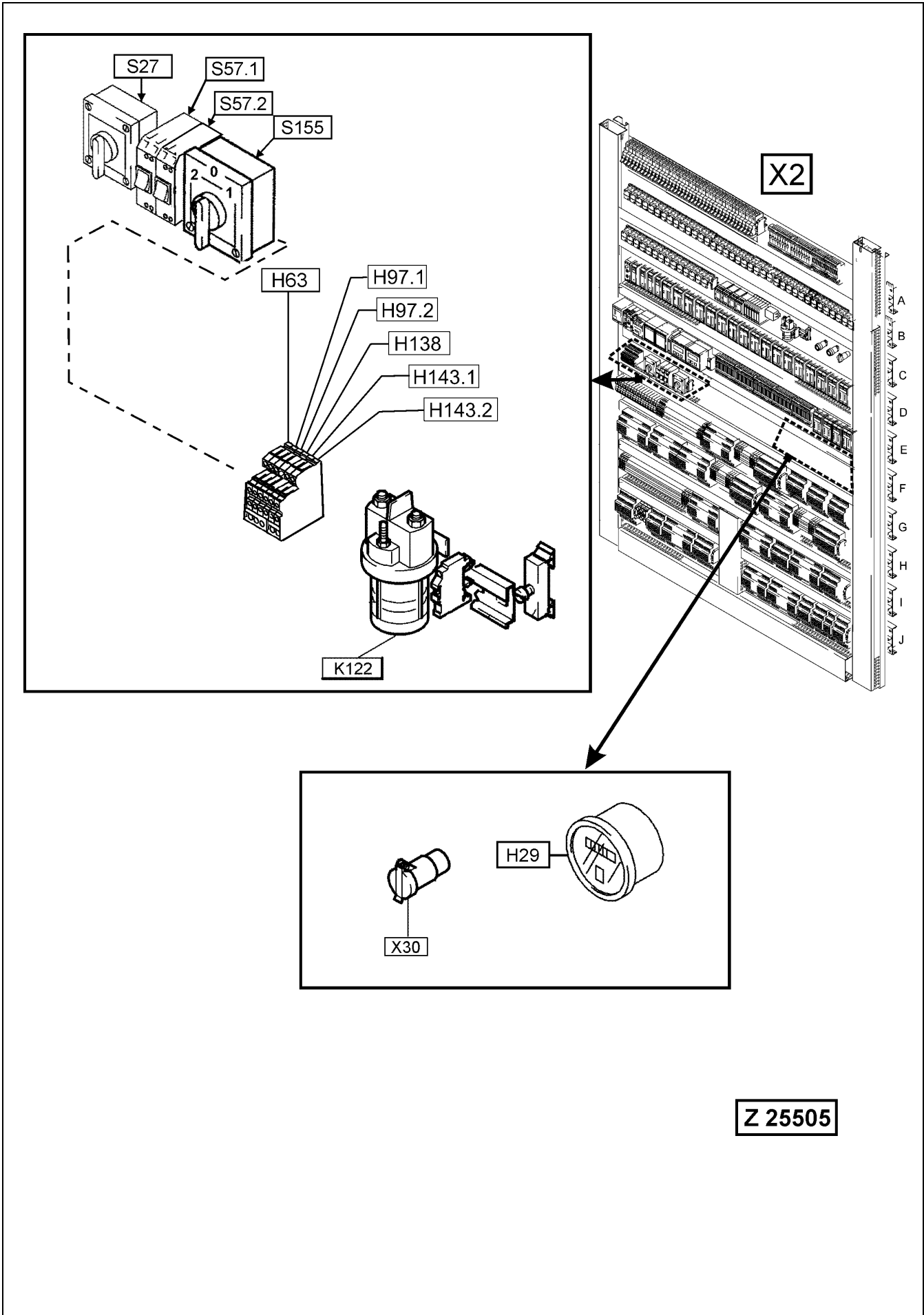

Switch Board "X2" in Cab Base (continued)

Service Switch for "QMIN" and "QMAX" Control of the Main Hydraulic Pumps (S155), illustration Z25505

CAUTION

The Service switch "S155" is used for testing and adjustment procedures of the hydraulic system and should only be operated through authorized service personnel

(S155) Service switch for Qmin/Qmax position of main hydraulic pumps.

Switch positions:

- 0 - Normal operating position
- 1 - Qmax position: The main pumps remain in maximum delivery position.
- 2 - Qmin position: The main pumps remain in Qmin position i.e. minimum oil delivery to the hydraulic system.

NOTICE

Make sure that the switch (S155) is set to "0" position as soon as the testing and adjusting procedures of the hydraulic system are finished.

Indicator Lights (H63), (H138), (H143.1) and (H143.2)

- (H63) Electronic pump control module (E32) active and program information.
- (H138) This light pulses if there is a failure in the electronic pump control module (E32)
- (H143.1 for rear engine 1)
(H143.2 for front engine 2)
- Monitoring light of the automatic engine oil supply system "Reserve"
- Steady light: oil is pumped from engine oil pan to reserve oil tank.
 - Regular blinking: oil is pumped from reserve oil tank to engine oil pan.
 - Irregular blinking: oil is pumped in both directions, oil level in engine oil pan is correct.

REMARK

If the indicator lights (H143.1 and H143.2) are off with the engines running, there is a failure in the reserve systems. Have the reserve systems checked and repaired through authorized service personnel.

(H29) Hour meter for drive operation

X30 Plug socket 24V DC

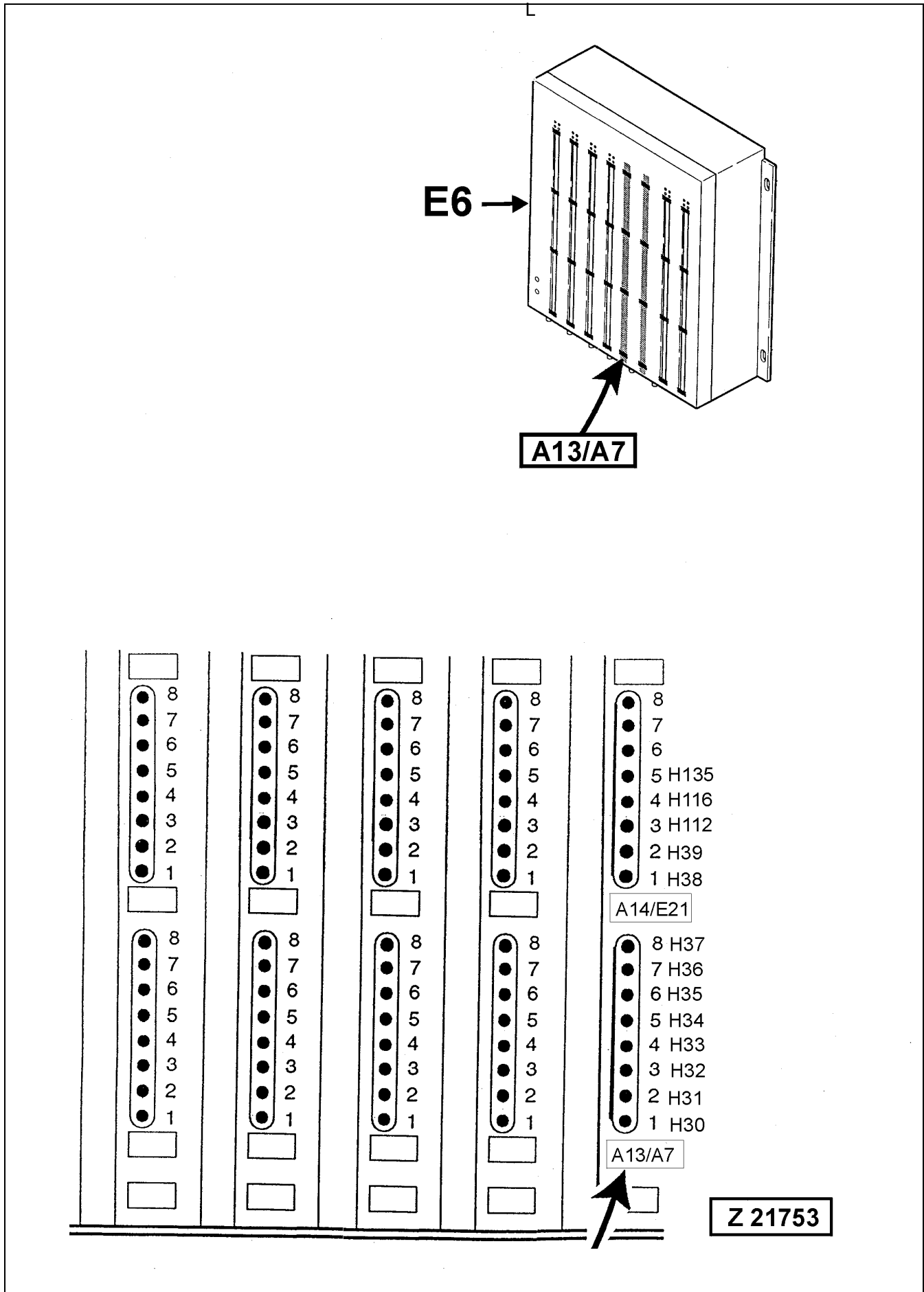

Emergency Indication of Operating Conditions

The ECS system is equipped with an emergency indication via LED's on the Programmable Logic Controller "PLC" (E6), illust. Z21753.

In case of a malfunction of the text display in the operator's cab, the LED's in the fifth column (A13/A7) of the "PLC" indicating failures in vital operating systems of the Shovel.

The following faults are indicated:

Fault:	LED No.:
The ECS system is by-passed (By-pass switch S27 actuated)	H30
Start of engine 1 and/or engine 2 blocked, resp. engine shifted to low idle speed by one or more of the six high pressure filters.	H31
NOTICE The LED "H31" monitors all six high pressure. Refer to page 217 for description of the diagnostic codes flashed out by LED "H31".	
	H32 *)
Coolant pressure	H33
Coolant temperature	H34
	H35 *)
Engine oil pressure	H36
Start of both engines blocked, resp. engine shut down, due to closed main shut-off (gate) valve hydraulic tank	H37
Faulty monitor channel for hydraulic oil temperature	H38
Too low hydraulic oil level! Stop the engines	H39
Faulty monitor channel engine speed	H112
Emergency shut down switch actuated	H116
Engine shutdown from ground man (if so equipped)	H135

*) These LED's are not used.

REMARK

The location of the numbered LED's on the PLC may differ from that shown in the illustration.

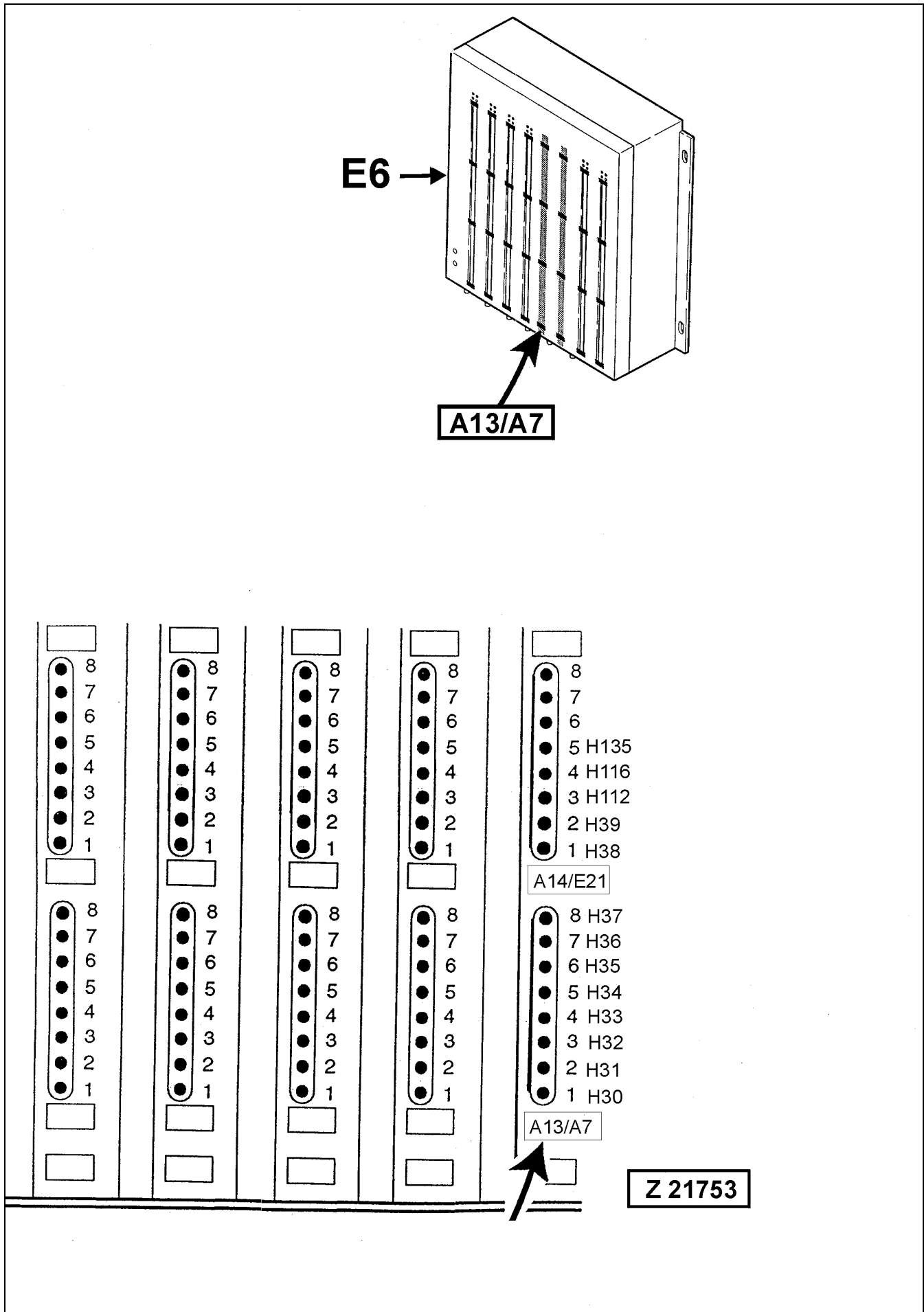

High Pressure Filter "HPF" Identification Codes of LED H31

The LED "H31", illust. Z 21753, monitors all six high pressure filters. If a failure condition of a high pressure filter occurs, the LED "H31" will begin flashing out a diagnostic code for identification of the concerned filter. If more than one filter send a failure signal at the same time, the LED will always show the diagnostic code of that filter with the lowest number.

High Pressure Filter "HPF" number:

Code HPF #1	1	1	1	1																
Code HPF #2	0.5s	2s	1	2	1	2	1	2												
Code HPF #3	0.5s	0.5s	0.5s	2s	1	2	3	1	2	3	1									
Code HPF #4	0.5s	0.5s	0.5s	0.5s	0.5s	2s	1	2	3	4	1	2	3	4						
Code HPF #5	0.5s	0.5s	0.5s	0.5s	0.5s	0.5s	0.5s	2s	1	2	3	4	1	2	3	4				
Code HPF #6	0.5s	0.5s	0.5s	0.5s	0.5s	0.5s	0.5s	0.5s	0.5s	2s	1	2	3	1	2	3				
	0.5s	0.5s	0.5s	0.5s	0.5s	0.5s	0.5s	0.5s	0.5s	0.5s	2s									

**Example:
Identification Code for High Pressure Filter #4 :**

When the differential pressure switch of high pressure filter #4 sends the signal "Filter restricted", the LED H31 will flash four times at regular intervals of 0.5 seconds and then after two seconds pause time will start again flashing four times at regular intervals of 0.5 seconds and so on.

The number of the four 0.5 seconds interval flashing groups corresponds to the number of the high pressure filters.

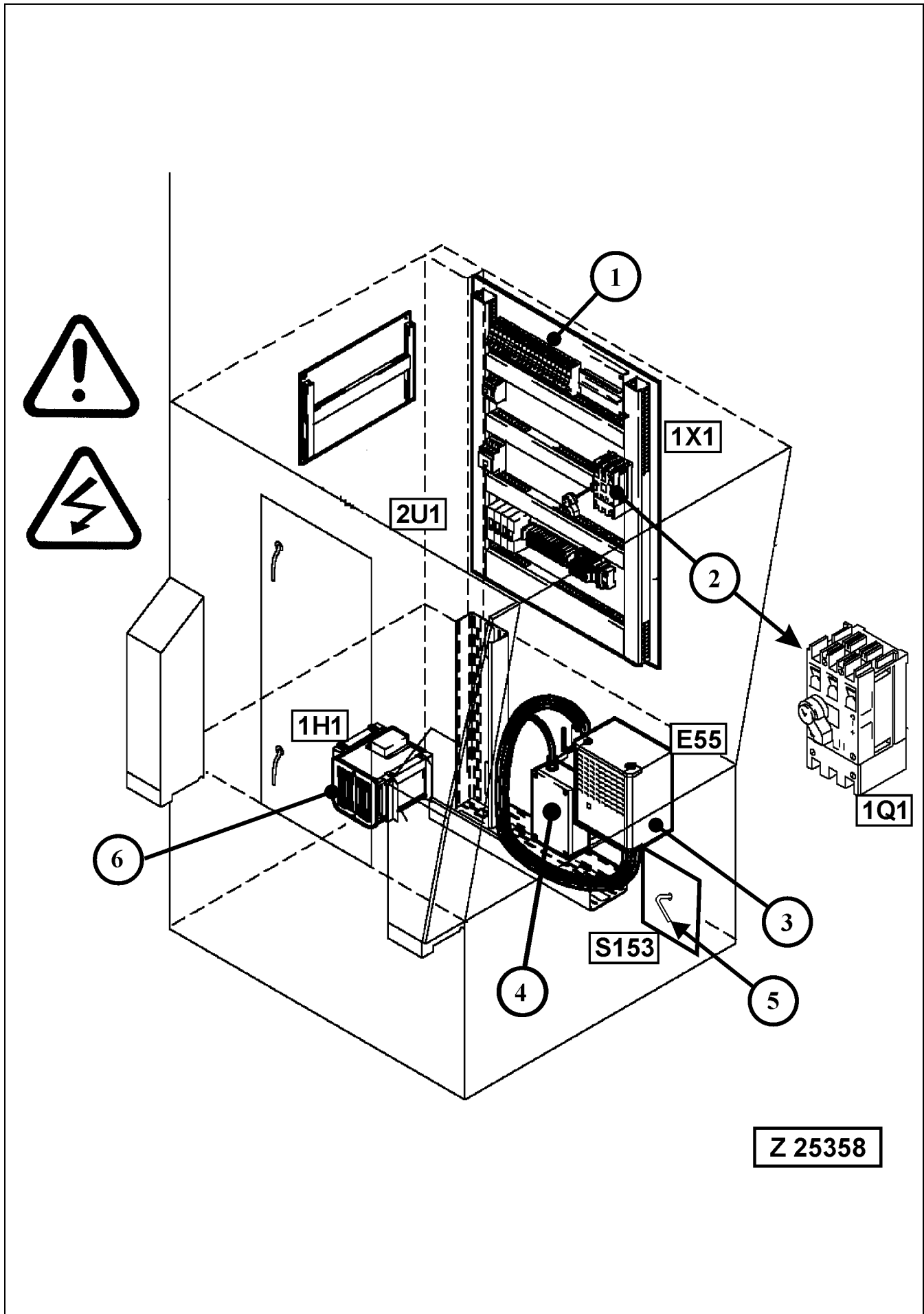

3.7.3 COMPONENTS OF ELECTRICAL PREHEATING SYSTEM IN CAB BASE

⚠ WARNING

**The cab base contains high voltage electrical appliances.
Access to the cab base for authorized service staff only.**

General

The preheating system is a special equipment and can be installed in the factory or locally at site. Power supply to the preheating system is provided by an external power source.

The following systems are equipped with heaters:

- Engine cooling system
- Engine lubricating system
- Hydraulic system (main and suction oil reservoir)
- PTO's (pump distributor gears)
- Storage batteries

REMARK

The auxiliary heater unit in the cab base (6), illust. Z25358 and the battery charger (3) are also connected to the external power supply.

Legend for illustration Z25358

- (1) Main switch board (1X1) for the preheating systems, located in the cab base
- (2) Main switch (1Q1) for all system heaters
- (3) Battery charger (E55)
- (4) Fuse box with circuit breaker F76 - 125A for battery charger
- (5) Key switch (S153) for battery charger (3)
- (6) Heater unit for cab base

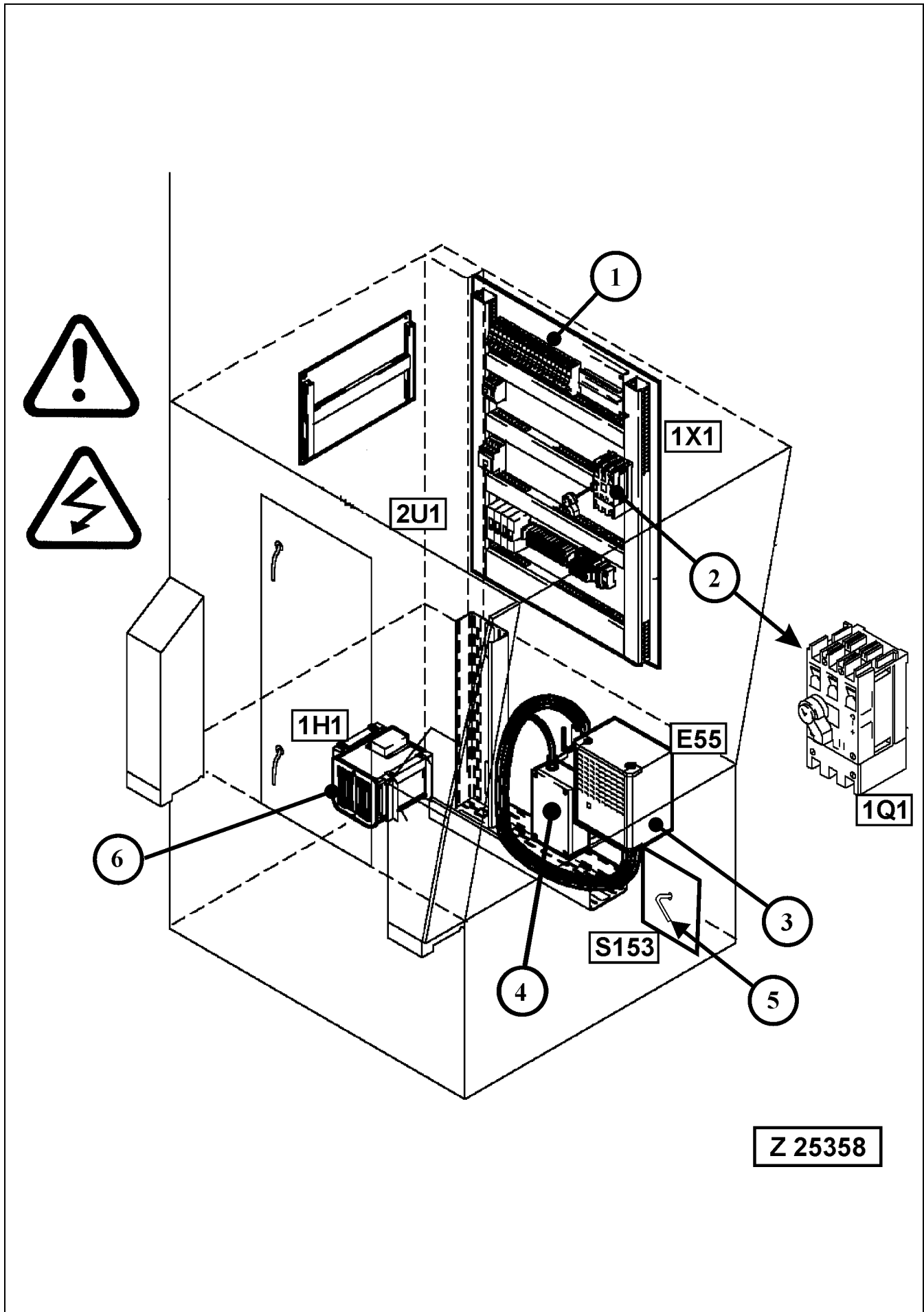

Components of Electrical Preheating System in Cab Base (continued)

⚠ WARNING

Be sure to switch off main switch (2), illust. Z25358 and to shut down the generator set or to disconnect the power supply cable from external power source before working on any part of the heating system.

Operating the Preheating System

Use the preheating system during stand-still periods e.g. over night and low ambient temperatures.

The heating system should be energized as soon as the engines are shut down. This allows the heating system to maintain the desired temperature with the use of minimum power.

The preheating systems for hydraulic oil and engine coolant are equipped with additional control boxes with separate ON/OFF switches. See following pages for more information.

Battery Charger (3)

Power supply to the battery charger is provided by the generator set or an external power source connected to the 1X2 plug socket at the cab stairway. The batteries of the shovel are charged by the battery charger (3). The battery charger is switched ON and OFF with main switch (5) and the switch on the front panel of the battery charger. For operating instructions refer to the separate Users Manual "MASTERVOLT" battery charger filed in volume 2 binder.

3.8 PREHEATING SYSTEMS FOR OIL, COOLANT AND BATTERIES

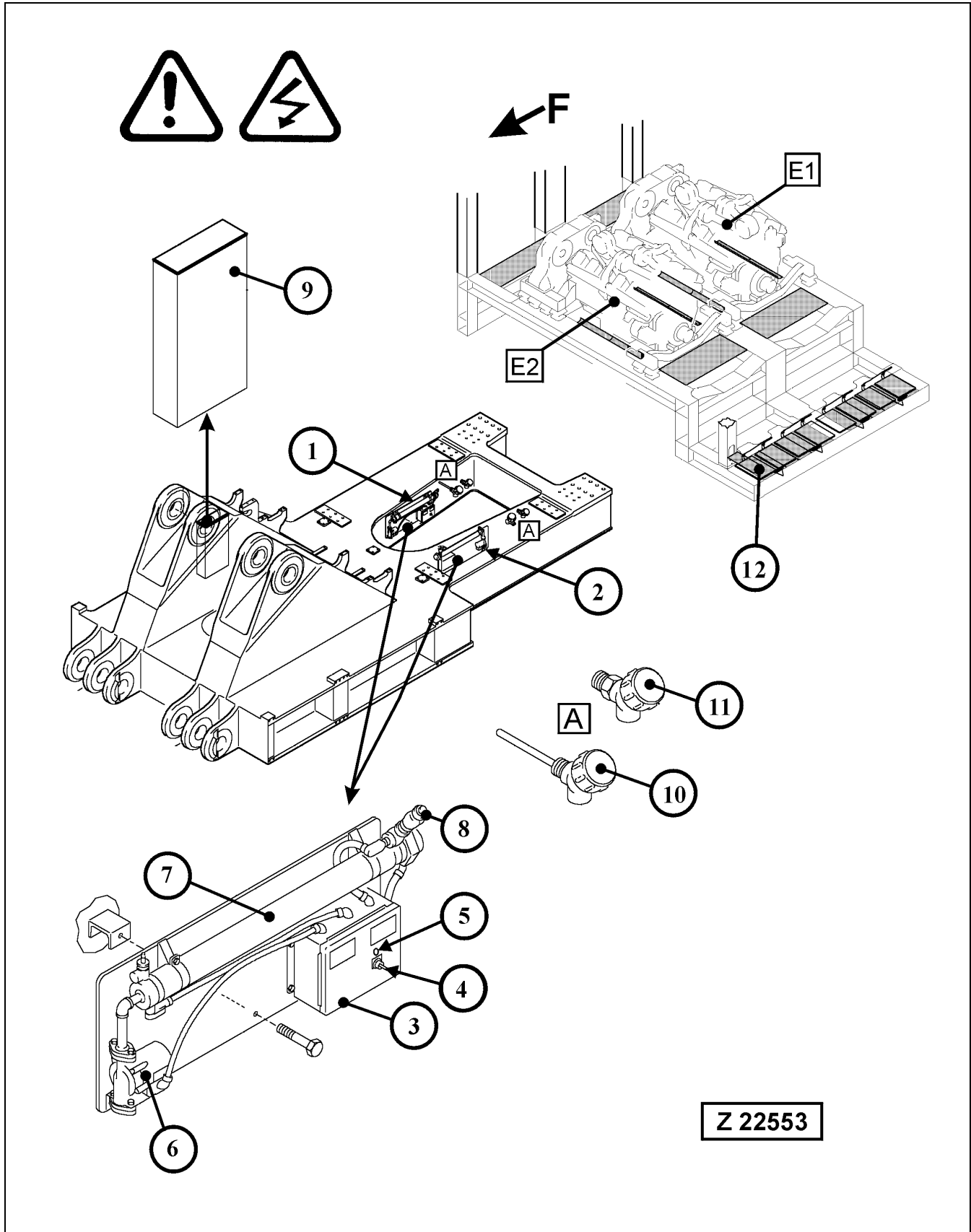

Engine Coolant and Engine Oil Reserve Tank Heatings

Legend for illustration Z 22553

- (1) Coolant heating for engine, vertically mounted on inside of counter-weight.
- (2) Control box for coolant heating
- (3) Switch, coolant heater ON/OFF.
- (4) Indicator light, coolant heating ON,
- (5) Water pump with motor
- (6) Coolant heating element and tank
- (7) Battery heater plates

To activate the coolant heating, set main switch (1Q1) on the switch board in cab base to ON position. The coolant heating can then be switched on with switch (4) on the control panel. The lamp (5) illuminates with coolant heating ON.

Before starting the shovel engines, switch OFF the coolant heaters.

REMARK

For more information about the coolant heating system, refer to the operation manual "Coolant Heating System" filed in volume 2 binder.

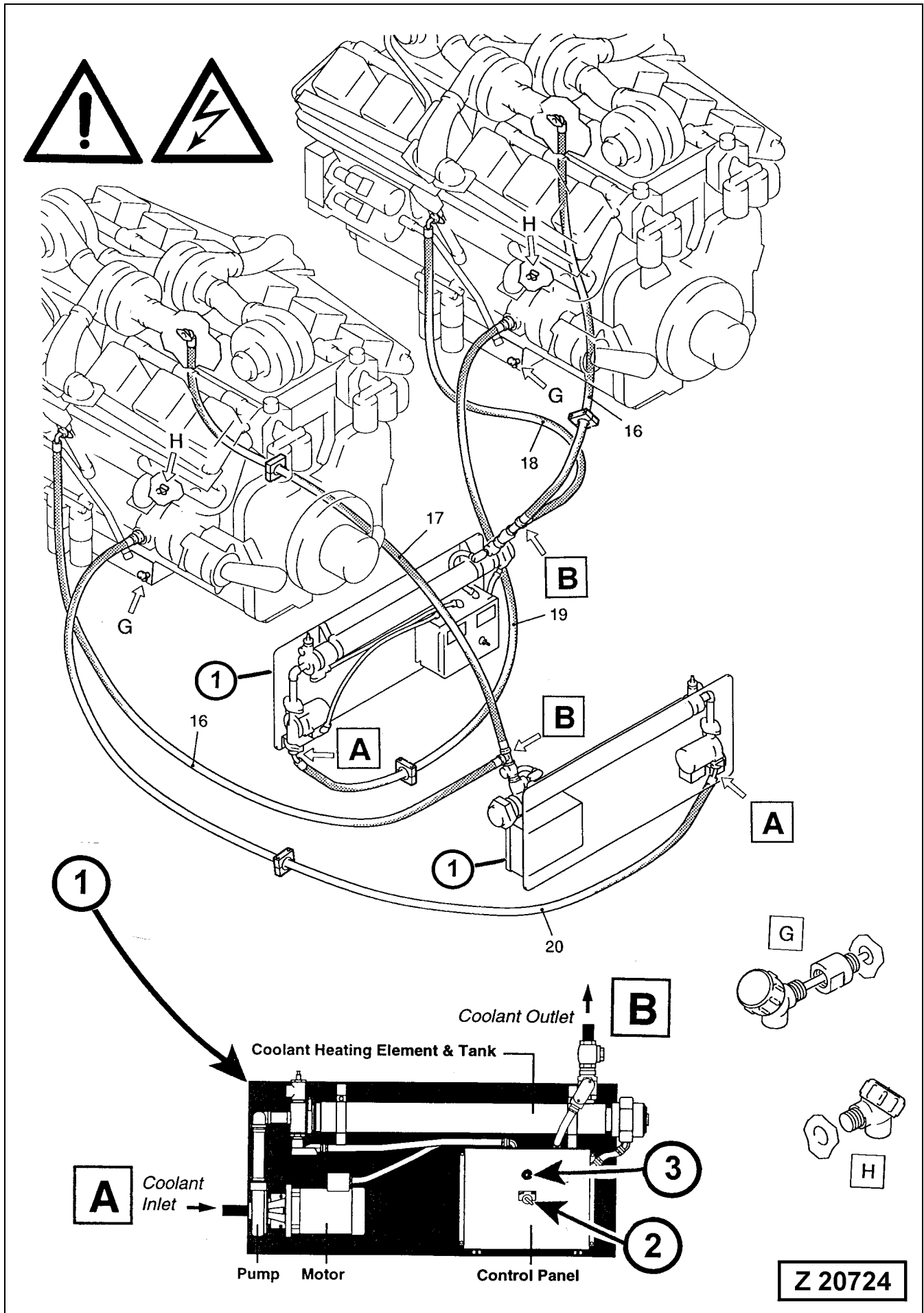

Engine Coolant and Engine Oil Heatings

Legend for illustration Z 21724

- (1) Coolant heating systems, installed on RH and LH side member of the main frame.
- (2) Switch, coolant heater ON/OFF.
- (3) Indicator light, coolant heating ON,
- (16) Coolant hoses, preheated coolant to the engine.
- (17) Coolant hose, preheated coolant to the engine.
- (18) Coolant hose, preheated coolant to the engine.
- (19) Coolant hose from engine to coolant heater
- (20) Coolant hose from engine to coolant heater
- (A) Coolant inlet
- (B) Coolant outlet
- (G) Engine oil heaters installed in the engine oil pan
- (H) Thermostats for engine oil heaters installed in the engine oil pan

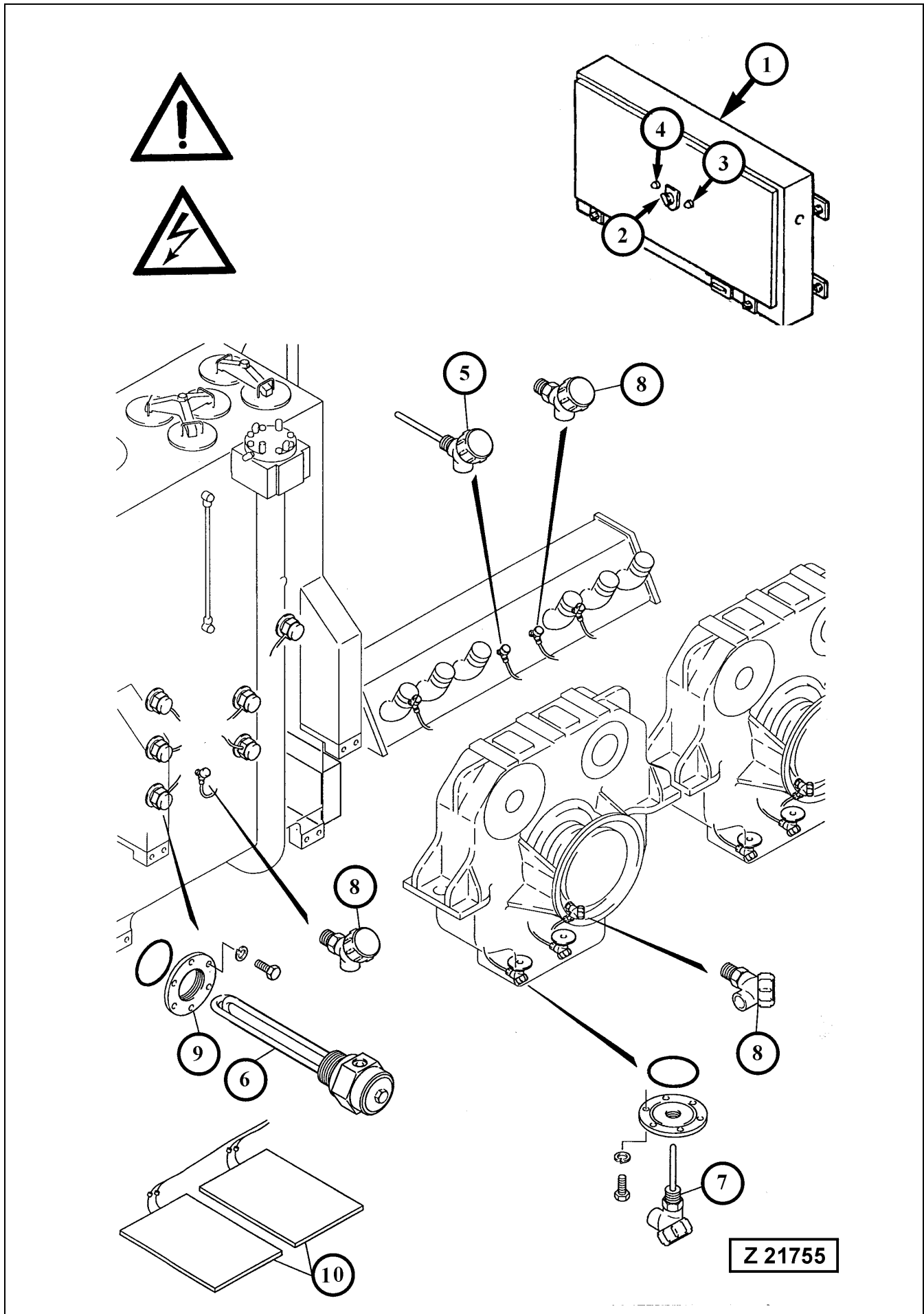

Hydraulic Oil and PTO Gear Oil Heatings

Junction Box for Hydraulic Oil Heating and Location of Heaters and Thermostats, illustration Z 21755

- (1) Junction box for hydraulic oil heating
- (2) Switch, hydraulic oil heating ON/OFF.
- (3) Warning light, heating system failure,
- (4) Indicator light, hydraulic oil heating ON.
- (5) Immersion heaters installed in the suction oil reservoir
- (6) Immersion heaters installed in the main oil reservoir
- (7) Immersion heaters installed in the PTO's (pump distributor gears)
- (8) Thermostats installed in the main oil reservoir, suction oil reservoir and in the PTO's (pump distributor gears)
- (9) Adapter flange for heater element
- (10) Heater plates for batteries

3.9 CHECKS BEFORE STARTING THE ENGINES

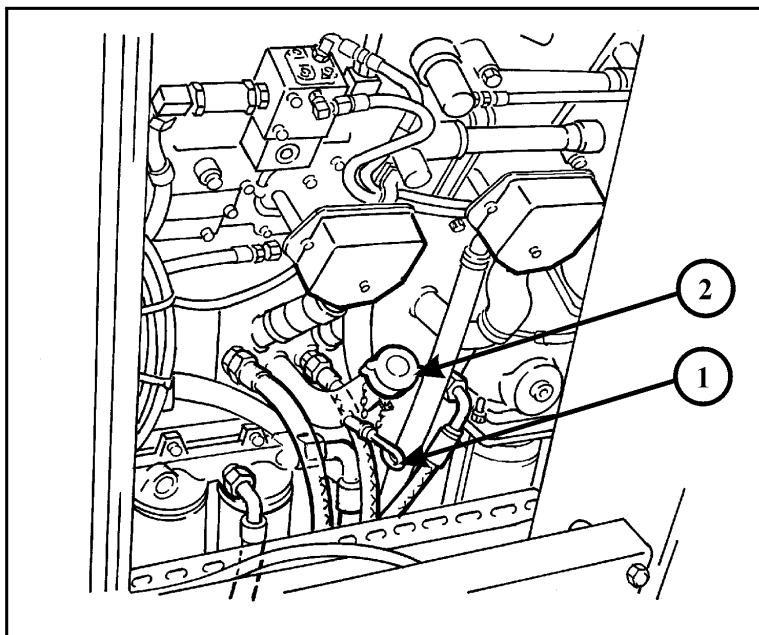
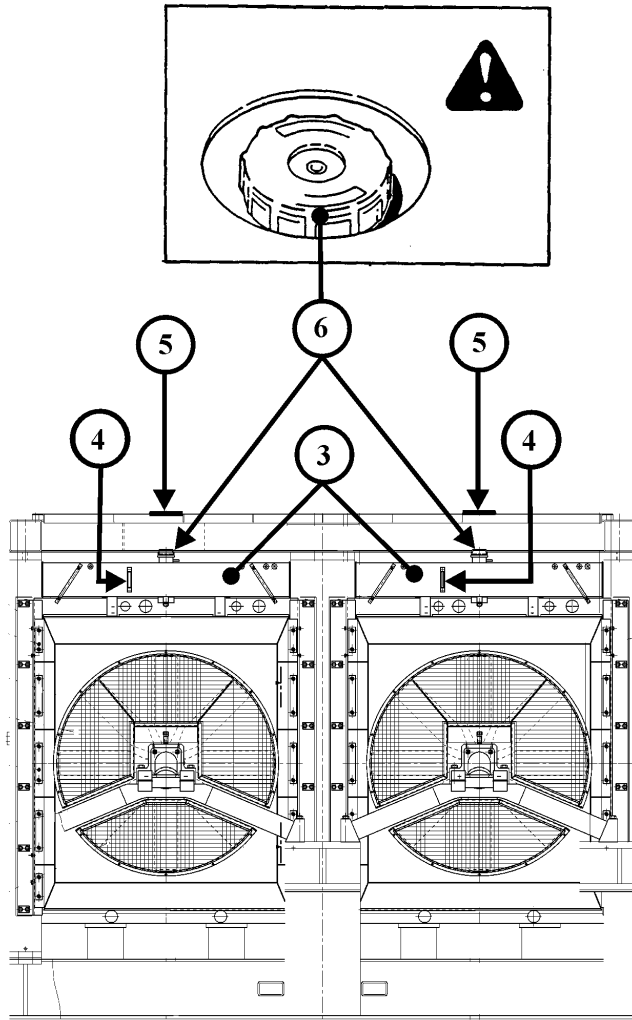

Z 22468

CAUTION

Before starting the Engines, make sure that no one will be endangered when starting the Engines.

CHECK THE FOLLOWING ITEMS

Legend for illustration Z 22468

- (1) Engine oil pan dipstick oil level gauge
- (2) Oil filler tube for engine oil pan
- (3) Coolant expansion tank of front and rear engine radiators
- (4) Coolant level sight gauge on front and rear coolant expansion tanks
- (5) Cover plates on power house roof above front and rear radiator pressure caps
- (6) Radiator pressure caps

Walk-around Inspection

Make a "Walk-around" inspection of the Shovel. Refer to page 349 in the Maintenance Section for the daily inspection items.

Engine oil level of Front and Rear Engine

Check oil level with Shovel standing on level ground. Check oil level in engine oil pan with the dipstick oil gauge (1). For accurate readings, the oil level should not be checked until the oil has settled into the oil pan after the engine has been shut down (about 5 minutes).

REMARK

The oil level in the engine oil pan can vary between the MIN and MAX marking on gauge (1) depending on the operating condition of the reserve system when the engine was stopped.

With sufficient oil in the reserve tank and with the reserve system in proper working order, there is no need to fill the engine oil pan even with the oil level at the MIN mark on gauge (1). If the oil level is below the MIN marking on the gauge, corrective action must be taken. Fill the reserve tank and check the reserve system. The function of each reserve system is monitored by an indicator light located on the "X2" switch board in the cab base. See section "SWITCH BOARD (X2) IN CAB BASE" for more information.

Check the oil level in both engine oil reserve tanks, see page 326 for more information.

Be sure to fill the corresponding reserve tank of rear engine -1- or the reserve tank of front engine -2- when the information message **"Engine oil reserve tank 1 (or 2) empty"** is being displayed on the ECS screen in the operator's cab.

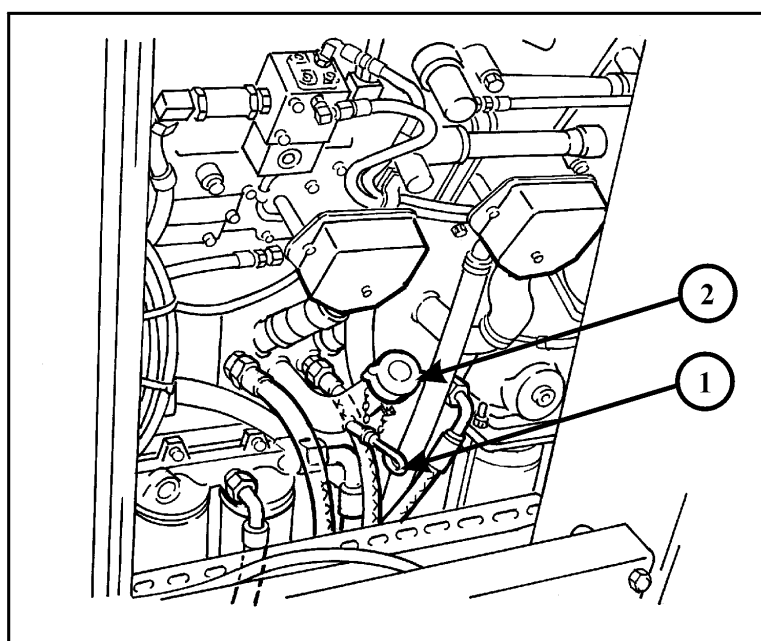
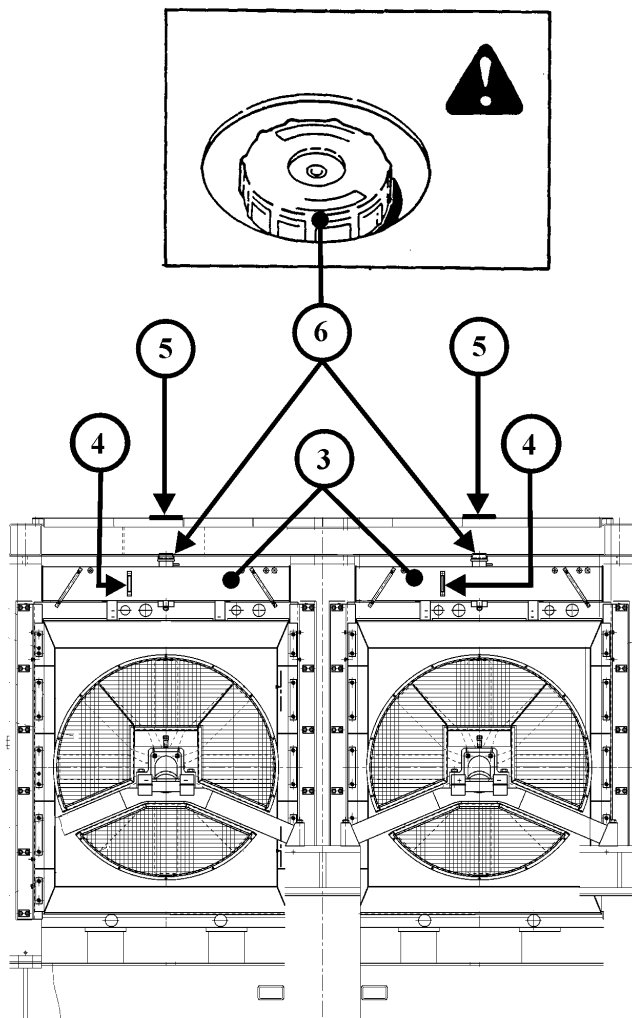

Z 22468

Coolant Level

⚠ WARNING

DO NOT remove the radiator pressure cap (6), illust. Z22468 from a hot engine. Wait until the temperature is below 50°C before removing the pressure cap (6). Failure to do so can result in personal injury from heated coolant spray or steam. Press the red button on the radiator pressure cap to allow the pressure to escape. Turn the radiator cap slowly counter-clockwise to the safety stop, then continue to turn until cap is free to be removed.

The coolant level should be in the upper field of the sight gauges (4). If necessary add coolant via the swing down service arm to the MAX marking on the sight gauge. Refer to section "CENTRAL REFILLING SYSTEM" on page 286 for more information.

REMARK

Refer to the Engine Manual for the correct coolant composition and filling procedure.

Fill Engine Fuel Tank

⚠ WARNING

Engine fuel is flammable and can cause a fire or an explosion. Do not fill the fuel tank or service the fuel system near an open flame, welding, burning cigar or cigarettes, etc.

Fill the fuel tank at the end of the of the shift to prevent condensation from forming. Fill the fuel tank via the swing down service arm. Refer to section "CENTRAL REFILLING SYSTEM" on page 286 for more information. Observe the fuel specifications in the engine operation and maintenance manual.

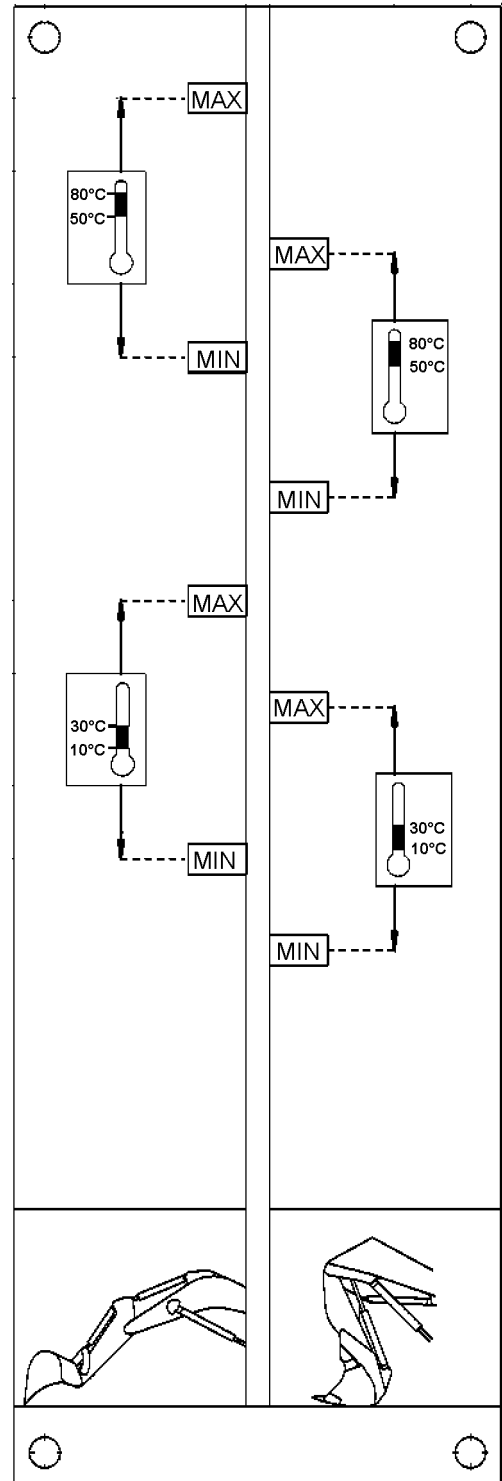
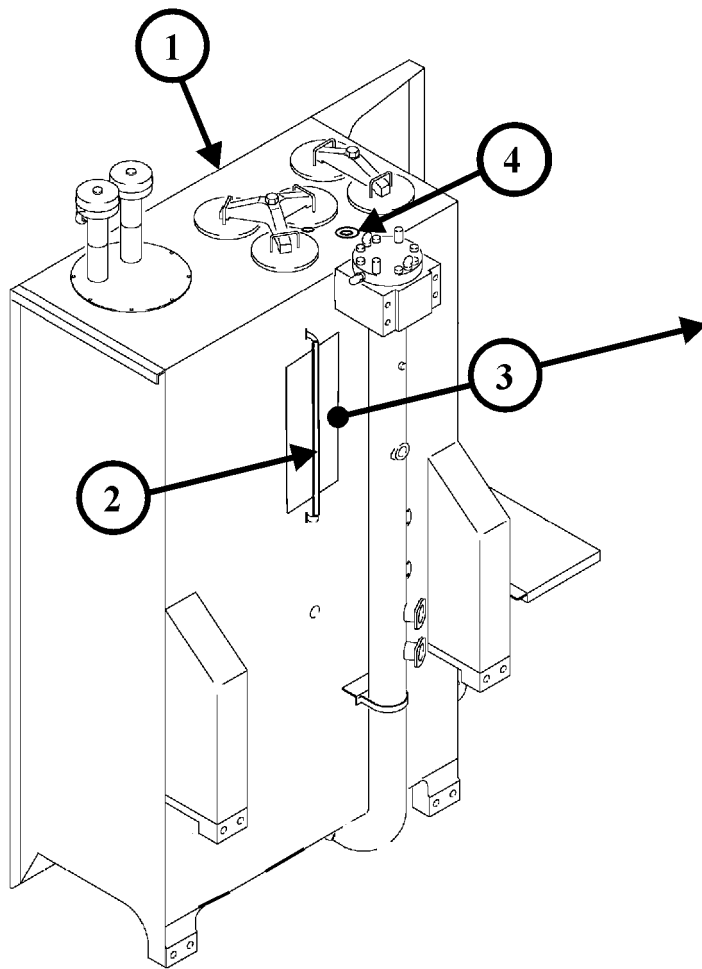

Z 22878

HYDRAULIC SYSTEM - CHECK OIL LEVEL

General Information

The hydraulic oil level in the main oil reservoir fluctuates depending on the oil temperature and the position of the loader attachment (hydraulic cylinders retracted / extended).

Legend for illustration Z22878

- (1) Main hydraulic oil reservoir
- (2) Hydraulic oil level sight gauge
- (3) Oil level plate
- (4) Oil filler plug

For checking the oil level lower the attachment (backhoe or bottom dump bucket) onto the ground in a position as shown in the illustration Z22878.

Depending on type of attachment and the present oil temperature, select the applying oil level range on plate (3). Be sure to use the correct marking on oil level plate (3).

Add hydraulic oil as necessary.

Machinery House Doors

Make sure that all machinery house doors are securely closed before starting the engines.

OPERATOR'S SEAT ADJUSTMENT

Before operating the Shovel adjust the seat and mirrors for Operators maximum comfort, visibility, and complete control of the Shovel.

 **CAUTION**

Use seat belt in accordance with the local safety regulations and laws.

3.10 STARTING THE ENGINES

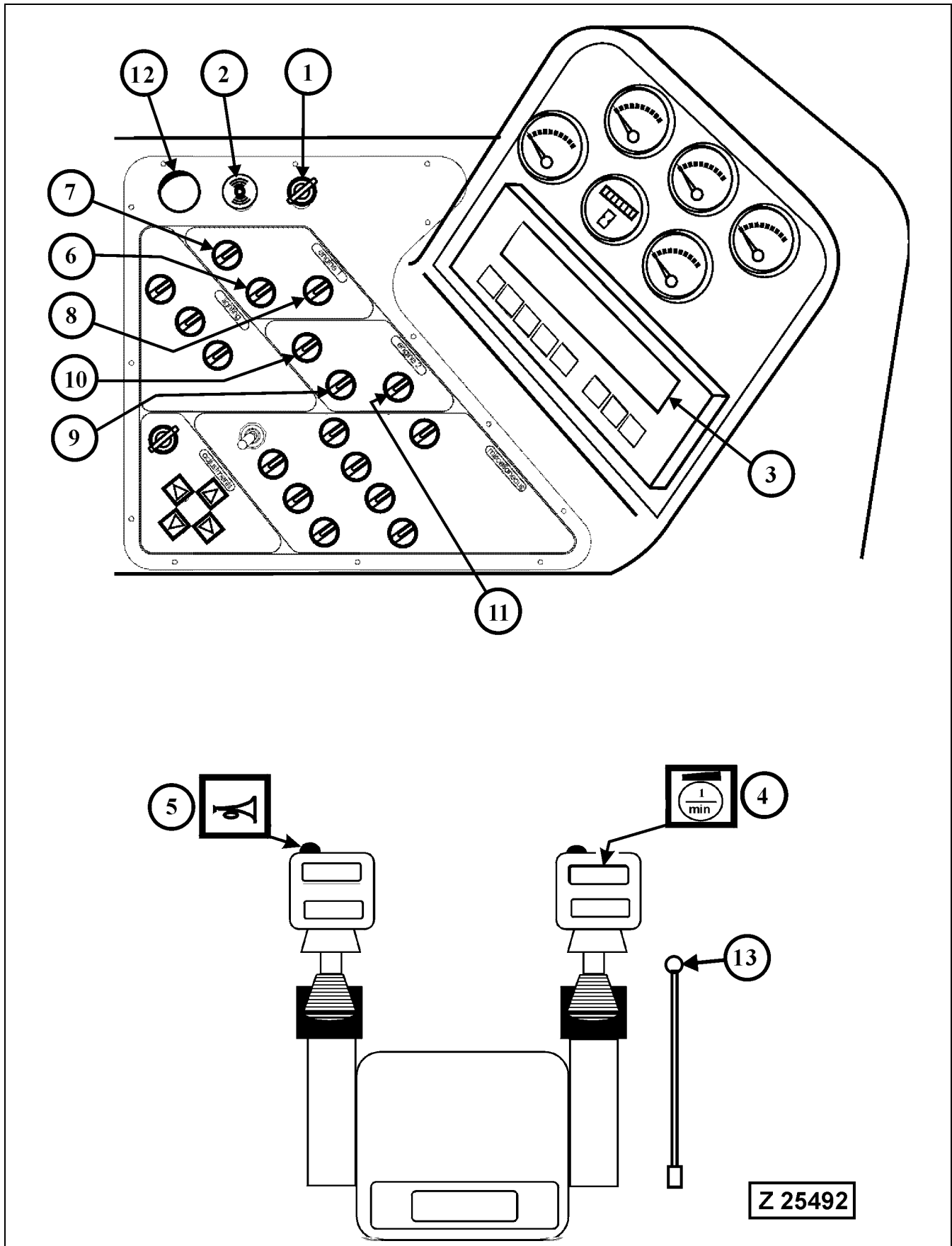

NOTICE

- Before starting read the Engine Operation Manual. Observe the instructions for starting the Engines.

⚠ WARNING

- After repairs on the Diesel engines or starter motors, make sure that the ground cables are correctly connected before starting the engines. Loose or missing ground cables can cause fire, serious injury or death.
 - Start the engines from the operator's seat only. Never attempt to start the engines by shorting across starter terminals. This can cause fire, serious injury or death.
 - Before each starting make sure that all controls are in neutral position.
 - Be sure to sound the signal horn before starting to make your intention clear.
-
-

⚠ CAUTION

Before starting the engines and again before starting work, pay attention to the hydraulic oil temperature. Refer to paragraph "Hydraulic Oil Warm-up" in this section.

Legend for illustration Z25492

- (1) Key operated main switch
- (2) Acoustic warning signal
- (3) ECS text display
- (4) Engine speed selector switch
 - Low idle - High idle
- (5) Signal horn button
- (6) Rotary switch - rear engine 1 start
- (7) Rotary switch - rear engine 1 stop
- (8) Rotary switch - rear engine 1 start pilot, cold starting aid
- (9) Rotary switch - front engine 2 start
- (10) Rotary switch - front engine 2 stop
- (11) Rotary switch - front engine 2 start pilot, cold starting aid
- (12) Strike button - emergency engine shutdown and cut out of pilot control system
- (13) Safety lock lever

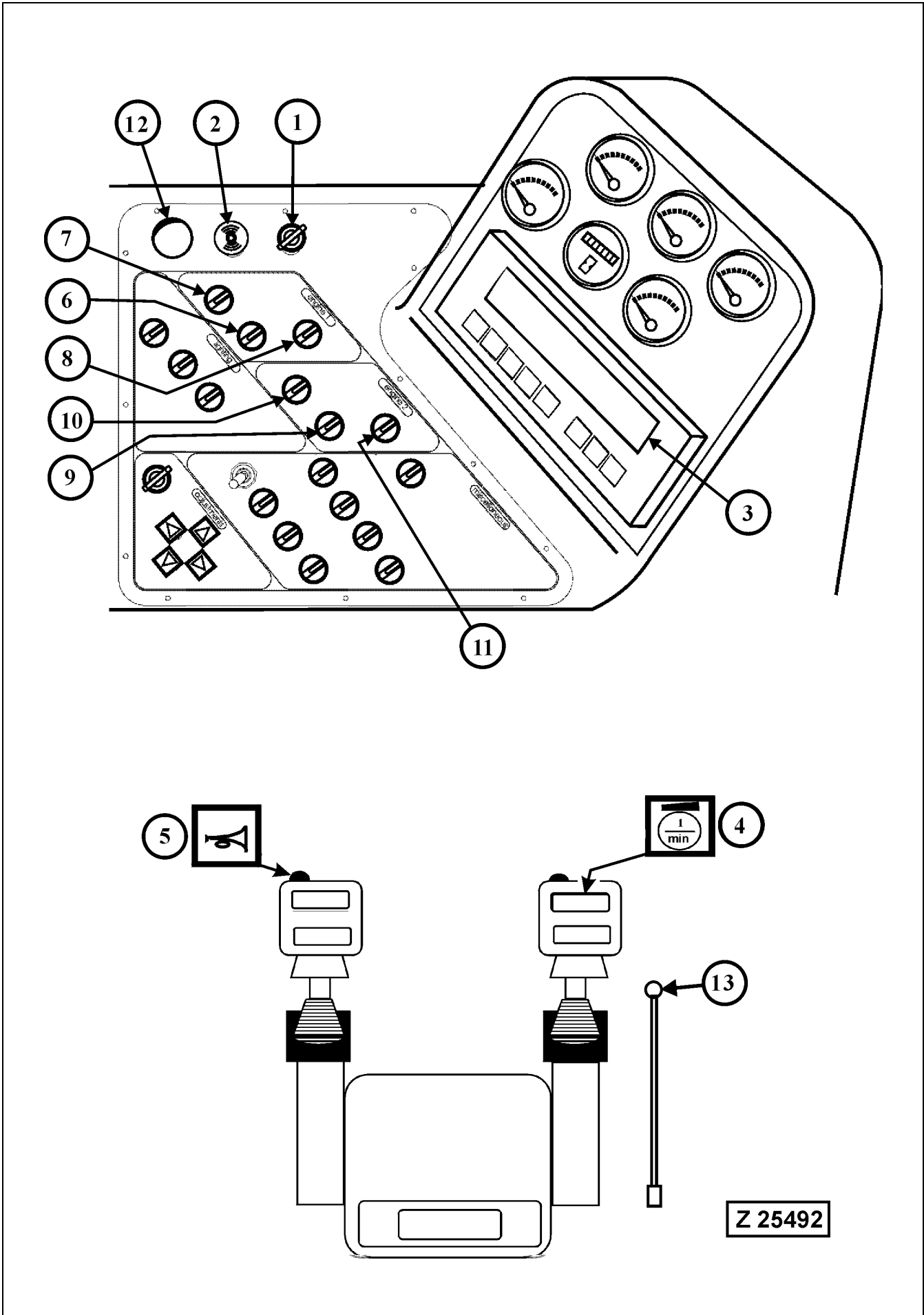

3.10.1 STARTING PROCEDURE

REMARK

Start the engines one after another, e.g. first rear engine (1) then front engine (2). Both engines are started in the same way.

1. Insert battery main switch keys and turn to operating position.

REMARK

Start the engines with the safety lock lever (13), illustration Z25492 in the fully rear LOCKED position. When the engines are running move the safety lock lever fully to the front in FREE position.

2. Insert key into the switch (1) and turn to operating position. The warning buzzer (2) must give an acoustic test signal. If the buzzer fails to function, corrective action must be taken.
3. Observe ECS display (3). Normally the basic display appears on screen (3). If a FAULT message or INFORMATION item is displayed, proceed according to section "ELECTRONIC MONITORING AND CONTROL SYSTEM ECS" on page 92.
4. Set toggle switch (4) to low idle speed position.
5. Sound the signal horn (5).
6. Start the engines by turning starter switches (6 and 9).

REMARK

Each engine is equipped with a prelubrication system which is activated by the starter switch (6/9). Turning and holding the switch in the start position sends current to the prelubrication starter solenoid which then prelubricates the engine. This solenoid timer prevents current from flowing to the conventional starting motor until 17 kPa (2.5 psi) oil pressure has been achieved in the cam oil rifle. After a subsequent 3 second delay, current is then directed to the starting motors for cranking the engine.

7. Cold Weather Starting

To facilitate starting at low outside temperatures (below 0° C) and with the engines cold, use the cold starting aid. Take into account, that the prelubrication period will be longer at low ambient temperatures. Inject starting fluid only after the prelubrication period is finished and the engine starts to crank. Engage the starter and while cranking, apply metered amounts of starting fluid using switch (8/11) until the engine idles smoothly.

 **CAUTION**

Use the cold starting aid only during starting and with the engines cold.

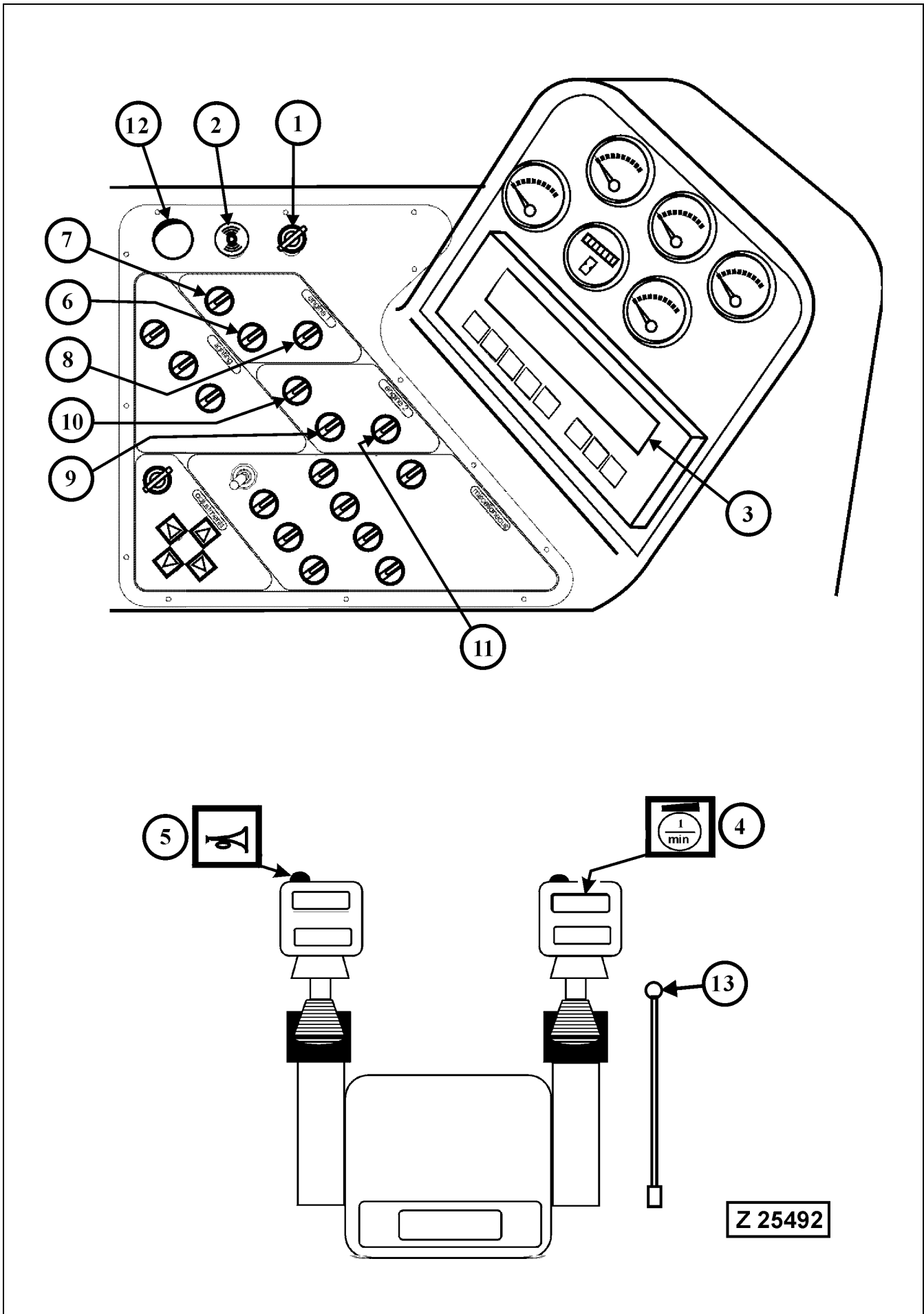

REMARK

Never operate the starter longer than 30 seconds at a time in order to avoid damage. If the engine does not start within the first 30 seconds, wait 2 minutes before cranking again.

8. As soon as the engines are running, check display (3) for messages.

After starting observe the following:

The ECS System monitors the Shovel's functions and provides information about the appropriate operational data.

If a FAULT message is displayed on screen (3), the acoustic warning signal (2) will sound simultaneously for approximately 1 second. In such a case proceed according to the instructions of the ECS system on page 92.

Warning buzzer (2) will sound continuously when the hydraulic oil level is too low. In this case, stop the engines, locate and correct the cause immediately. Fill up hydraulic oil to the correct level.

9. Idle the engines 3 to 5 minutes to attain a minimum coolant temperature of 60°C before operating with a load.
10. After warming up of the engines, the speed can be increased by setting switch (4) to high idle speed position.

NOTICE

DO NOT idle the engines for excessively long periods. Long periods of idling, more than 10 minutes, can damage the engine because combustion chamber temperature drop so low the fuel will not burn completely. This will cause carbon to clog the injector spray holes and piston rings and can cause the valves to stick.

REMARK

If one engine fails to work during operation, the shovel can be operated with the second engine as an emergency measure, e.g. for moving the shovel out of a danger area.

Automatic Engine Shut-Down System (Safety Chain)

The engine(s) will be stopped or shifted to low idle speed automatically if a serious trouble condition occurs. The operator will be informed about the trouble condition by a corresponding message displayed on screen (3).

CAUTION

Never let the engines run with disconnected batteries. This may cause alternator damage.

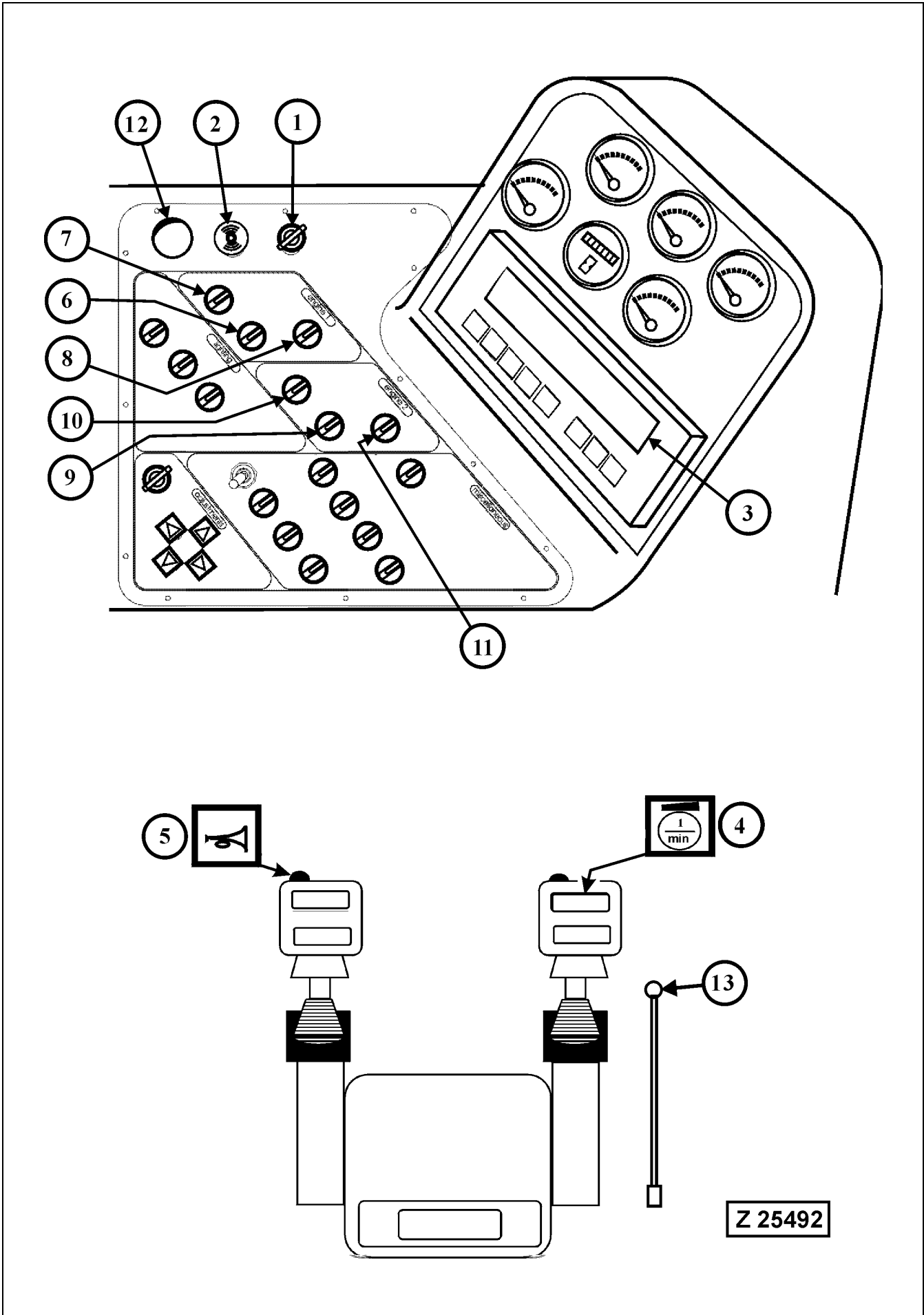

Emergency By-pass Switch for the ECS- Shut-down Function.

The unit is equipped with an Emergency By-pass Switch for the ECS-system.

This switch is located on the "X2" switch board in the cab base compartment and marked with "**S27**".

If an automatic shut-down of the Shovel happens, with a dangerous situation for man or machine, which needs the Shovel to be operable to overcome the dangerous situation, actuate this switch to override the shut-down function of the system and to enable a restart of the engines.

NOTICE

This switch can not override engine initiated shutdowns.

⚠ CAUTION

As soon as the immediate situation of danger is over, shut down the unit. Correct the fault that caused the shut down and re-set the Emergency By-pass switch.

REMARK

When a battery voltage fault has occurred, the operational data (oil viscosities, timer settings etc.) stored in the Programmable Logic Controller (PLC) can be lost and must be re-entered after the correct battery voltage has been re-established.

Hydraulic oil warm-up

- On machines without hydraulic oil pre-heating system:
DO NOT start the engines if the ambient temperature (oil temperature) is below the starting temperature shown in column "1" of the hydraulic oil viscosity chart on page 244 in this section.
- On machines with hydraulic oil pre-heating system:
Before starting the engine, warm-up the hydraulic oil to the starting temperature shown in column "1" of the hydraulic oil viscosity chart.

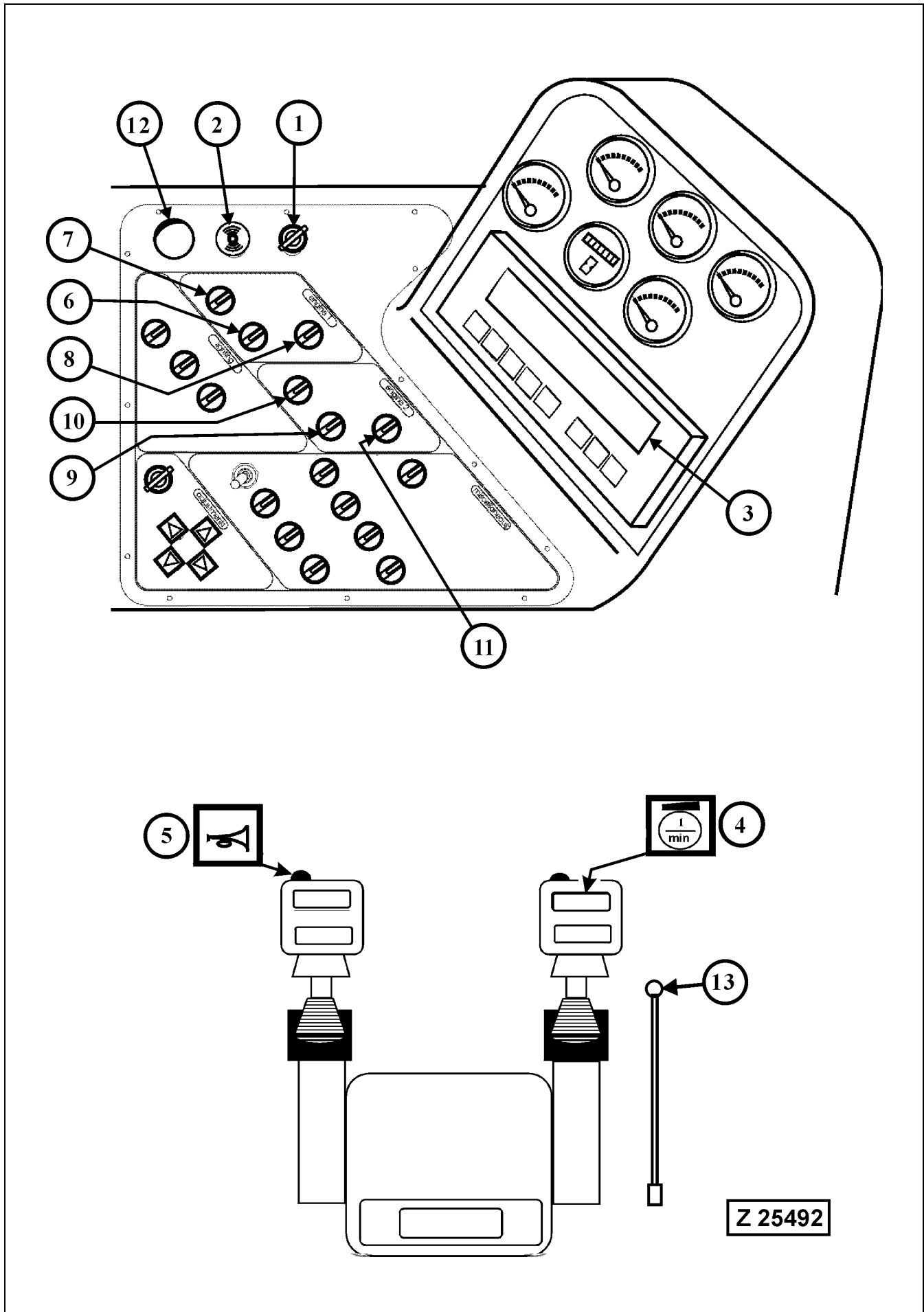

Messages displayed with hydraulic oil too cold:

Fault

Hydraulic oil far below operating temp. Wait for warm-up phase!
--

Help:

The machine was taken into operation although the start viscosity was not attained.
- Preheat hydraulic oil!

Information

Hydraulic oil not at operating temp.! Operate with reduced power! (Main pump delivery 50% of total capacity)
--

The Shovel is equipped with a "½ **Qmax control circuit for cold oil**" which limits the main pumps oil delivery to approximately 50% of the total capacity as long as the oil temperature has not reached the minimum operating temperature shown in column "2" of the Viscosity and Temperature Chart on page 244.

The pumps will move to maximum delivery position and the message will disappear, as soon as the minimum operating temperature of the hydraulic oil is obtained.

Information

Hydraulic oil below operating temperature! Pre-heat hydraulic oil or warm up at low idle speed and reduced power.
--

During the warm-up period, complete several operating cycles of all hydraulic movements without load. Avoid operation against limit stops. (high pressure build up).

Work can be started when the minimum operating temperature shown in column "2" of the viscosity chart is obtained.

Hydraulic Oil Viscosity and Temperature Chart

Rated viscosity at 40° C of hydraulic oil grade:	Starting temperature (max. 1000 cSt) -1-	Operating range (100 - 10 cSt) -2-
ISO VG	°C	°C
SL 0851 *1)	- 32	10 - 85
SL 0851 *2)	- 34	5 - 81
HLP 22	-20	8 - 55
HLP 32	-14	16 - 70
HLP 46	-6	25 - 80
HLP 68	0	32 - 85
HLP 100	+5	39 - 85

*1) Temperature values for new oil (freshly filled in).

*2) Temperature values for used oil. This temperature value has to be adjusted when the viscosity of the hydraulic oil has decreased by 10 to 12 percent compared with new oil. The determination of the hydraulic oil viscosity should be carried out in the course of the regular oil analysis procedure.

REMARK

The starting and operating temperatures in the above chart depend on the hydraulic oil viscosity grade used in the system. See decal in the operator's cab for viscosity grade of the factory oil filling.

For example:

Hydraulic system filled with **VG 22** viscosity grade oil.

- Lowest permissible starting temperature (ambient temperature):
-20° C, see column "1"
- Operating temperature:
min. + 8° C
max. + 55° C, see column "2"

3.11 MOVING THE SHOVEL

3.11.1 TRAVEL CONTROL WITH FOOT PEDALS

NOTICE

Travelling directions with cab in normal working and travel position i.e. cab above idler wheel. Counter weight above drive sprockets.

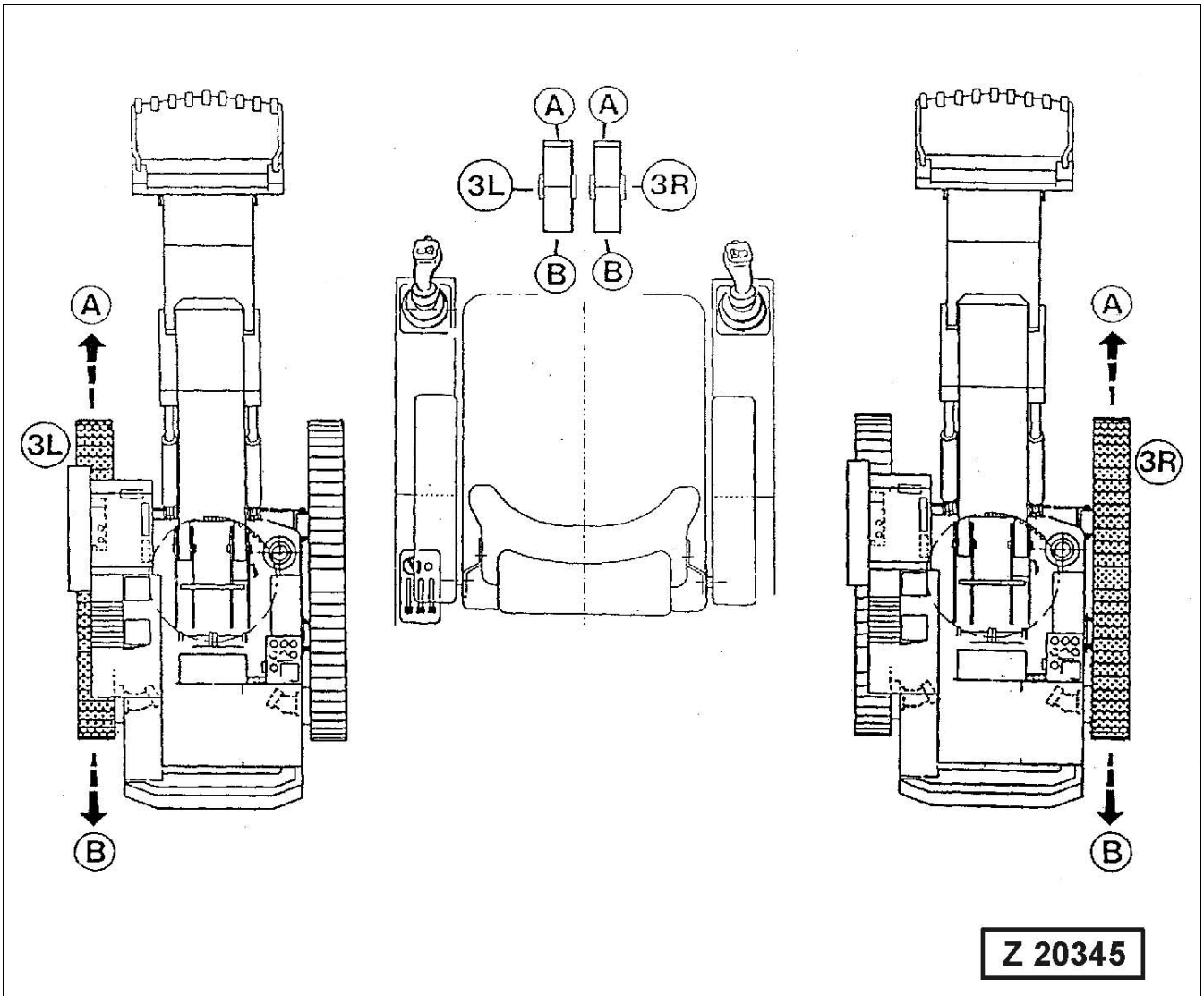

Legend for illustration Z 20345

- (3L) Left pedal, inside
- A Left track forward
- B Left track reverse

- (3R) Right pedal, inside
- A Right track forward
- B Right track reverse

WARNING

Be sure to sound the signal horn before starting to drive to make your intention clear.

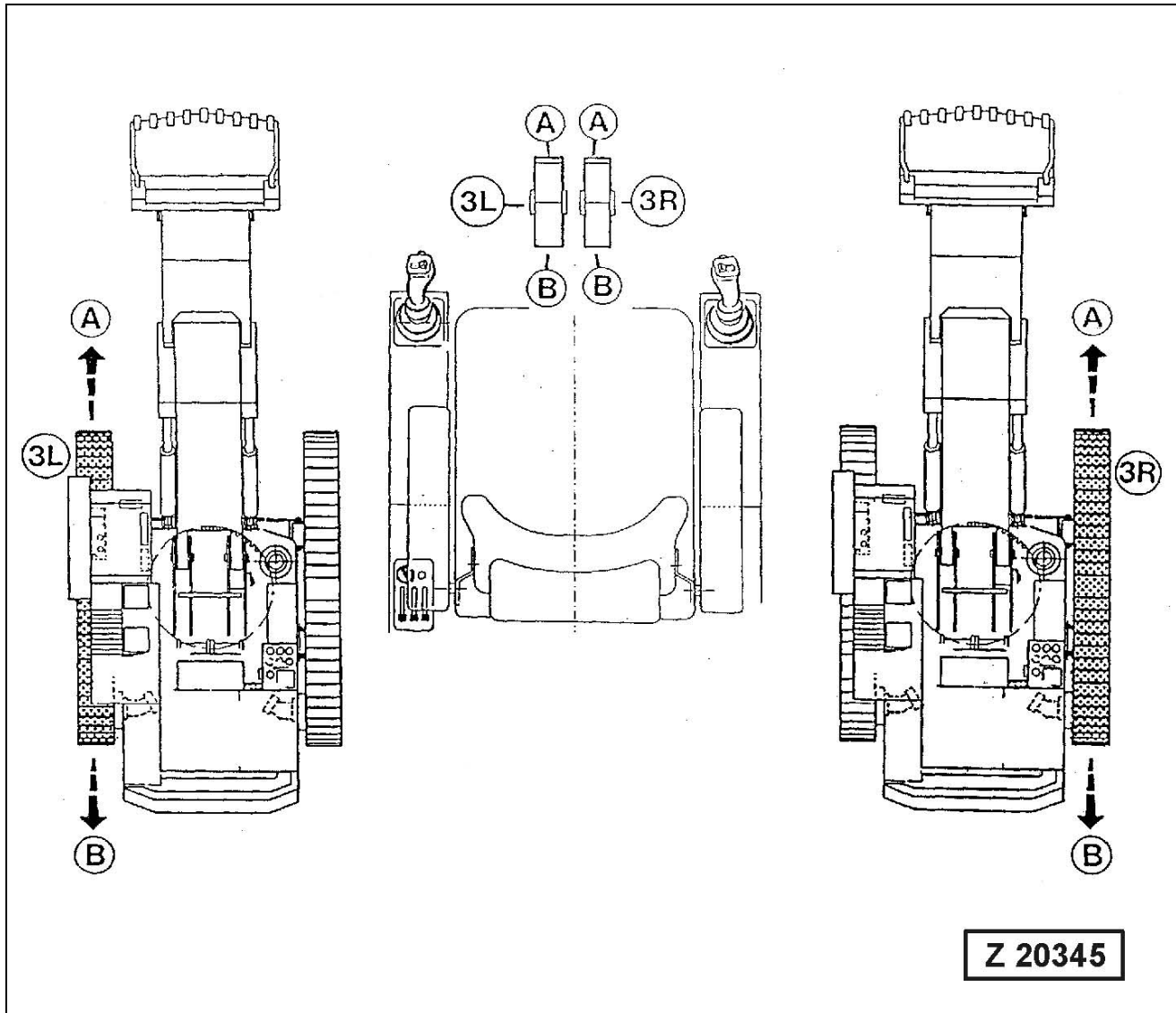

Regulate travel speed by depressing the pedals more or less. Apply swing circle brake as necessary.

On machines with two-speed range travel drive, select normal or fast speed range according to ground conditions.

For braking the machine release pedals (3L and 3R)

DO NOT reduce engine speed for braking, otherwise travel motors and gears could be damaged.

⚠ WARNING

- Travelling on a grade requires special care. Plan your work so that the Shovel travels up- and downhill parallel to the grade. The superstructure must be parallel with the undercarriage and the working attachment must face to the front in travel direction. The travel gears must be at the rear in the direction of travel.
 - **DO NOT** use the **FAST TRAVEL SPEED RANGE** when travelling on a grade.
 - For maximum stability carry the bucket as close to ground level as possible. Operate the travel control pedals sensitively. Avoid jerky acceleration and deceleration of travel motions. Travel speed must be conform to the ground conditions.
-

NOTICE**Two Speed Range Travel Drive**

If the Shovel is equipped with a Two Speed Range travel drive, always use the low speed range when travelling on a slope.

Never go downhill with fast speed range engaged.

The low travel speed range must also be used during cornering.

PARKING BRAKE

The Shovel is equipped with spring loaded disk type parking brakes. These brakes engaging and releasing automatically. They are arranged between the hydraulic motors and travel gears. When the motor/engine is running the parking brakes are automatically released by pilot oil pressure. With the motor/engine at standstill the parking brakes are engaged.

TRAVEL ALARM / BACK-UP ALARM

(Special equipment)

The Shovel can be equipped with one of the above alarm systems. The back-up alarm will sound at reverse travel. The travel alarm will sound at forward and reverse travel.

3.11.2 TRAVELLING INSTRUCTIONS

- Never travel the Shovel without first making certain that no one will be endangered.
- Be sure to sound the signal horn before starting to drive to make your intention clear.
- Before travelling long distances swing the superstructure parallel to the undercarriage and apply the swing brake.
- When travelling over inclines and gradients raise the working attachment only to such a height, that the bucket has sufficient ground clearance.
- Do not travel crossways to slope.
- Whenever possible operate the Shovel with the sprockets to the rear in the direction of travel.
- On steep terrain make sure that the final drives are at the rear in relation to travel direction.
- Before travelling over a bridge find out whether its bearing capacity is sufficient for the operating weight of the Shovel.
- Check for sufficient clearance and use a spotter.
- Pay attention to high voltage lines. On rough terrain observe movement of the boom.
- Travel speed must conform to local conditions so that the Shovel can be stopped at any time.
- Change travelling direction only after the machine is stopped.
- In order to avoid damage to track rollers and links, never turn the undercarriage over ditches and troughs.
- When working attachment is removed, the reduced stability of the Shovel has to be considered during travelling or slewing and when basic boom is operated. The stability can be improved, when the final drives are positioned opposite to counterweight.
- Observe permissible tilt angle of the Diesel engine when travelling uphill or downhill (superstructure must be in line with the undercarriage). Refer to Engine Operation Manual for the respective data.

3.12 SLEWING AND BRAKING THE SUPERSTRUCTURE

3.12.1 SLEWING THE SUPERSTRUCTURE

MACHINES WITH "EURO" CONTROL

Legend for illustration Z25222

"L" CCW- Lever (1) to the left "L"

"N" Neutral position

"R" CW- Lever (1) to the right "R"

WARNING

- Be sure everyone is in the clear before slewing the superstructure.
- Never swing or position the attachment or load over persons or vehicle cabs.
- Never allow anyone to walk or work under the Shovel or load while the Shovel is operating.

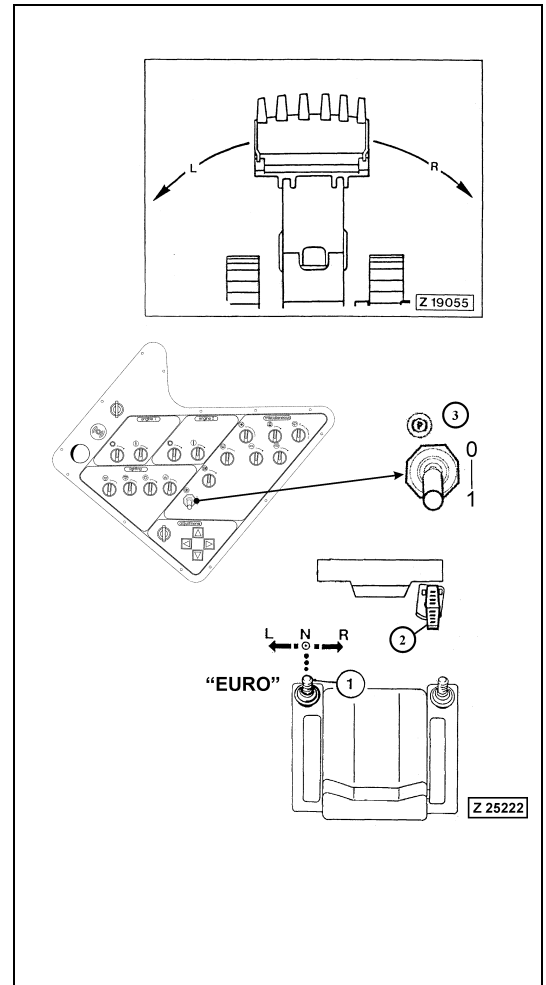

MACHINES WITH "KMG" CONTROL

Legend for illustration Z25221

- "L" CCW- Lever (2) to the left "L"
- "N" Neutral position
- "R" CW- Lever (2) to the right "R"

WARNING

- Be sure everyone is in the clear before slewing the superstructure.
- Never swing or position the attachment or load over persons or vehicle cabs.
- Never allow anyone to walk or work under the Shovel or load while the Shovel is operating.

BRAKING THE SUPERSTRUCTURE

Braking of the superstructure from a slewing movement is carried out first by returning the control lever (1) or (2), illustration Z25223 to the neutral position (N). This procedure can be shortened by depressing the swing brake pedal (3).

Swing Parking Brake

The parking brake for the swing gears is a spring loaded disk type brake. This brake is switched ON and OFF with toggle switch (4).

NOTICE

The swing parking brake must only be applied with the Superstructure at complete standstill. Applying the parking brake with superstructure still slewing may result in severe damage to the brake.

WARNING

- Use the swing parking brake only in an emergency situation for stopping the rotating superstructure.
- If the parking brake has been used for emergency stopping, it is necessary to shut down the Excavator and to have the parking brake of each swing gear inspected and repaired if necessary. Contact your Komatsu dealer for support.

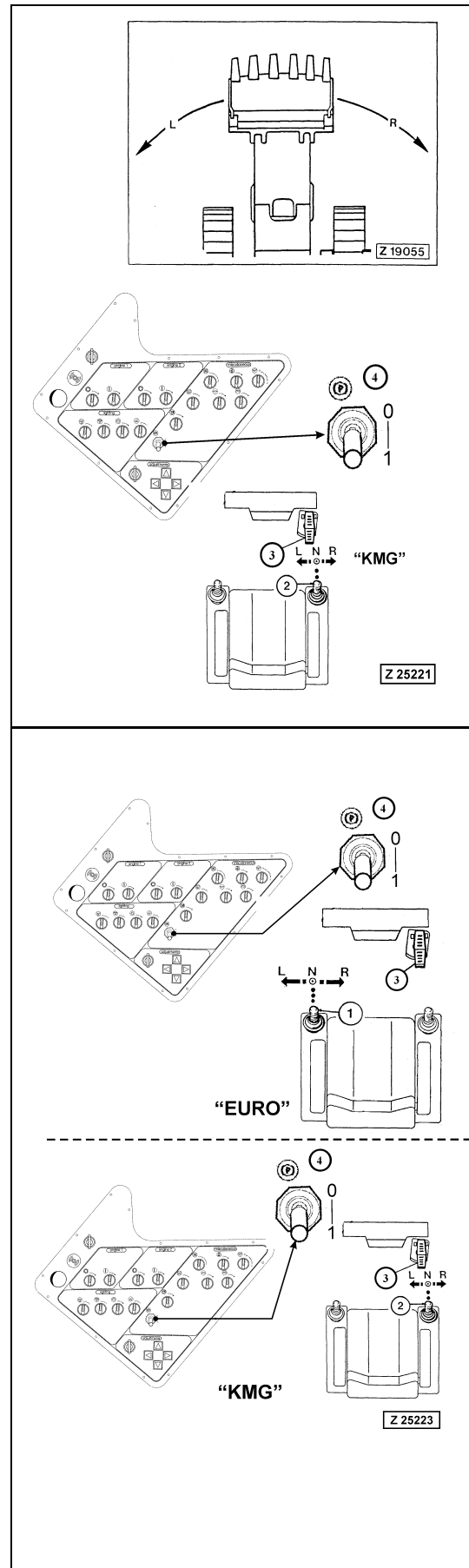

Switch Positions, illustration Z25223

- "0" Parking brake OFF
- "1" Parking brake ON

Applying the Parking Brake

Pull out toggle switch (4) against spring force and move down to position "1".

Releasing the Parking Brake

Move up toggle switch (4) to position "0". In this position the switch is automatically pulled down by spring force.

NOTICE

Be sure to release the parking brake before slewing the superstructure.

Hydraulic Swing Brake actuated by hydraulic access Ladder and Service Arm of Central Refilling System

The hydraulic swing brake will be applied automatically when the access ladder and/or the service arm of the central refilling system is not in its completely lifted position.

Important Instructions for Slewing the Superstructure

⚠ WARNING

- **DO NOT** swing over persons or over the unprotected cab of a truck.
 - **DO NOT** level the ground in front of the Shovel by turning superstructure back and forth.
 - **Never** swing against the wall of a pit. First raise the attachment out of the pit and then start rotating the superstructure.
 - **Start digging** only after finishing the slewing operation.
-

3.13 WORKING WITH THE ATTACHMENT

3.13.1 MACHINES EQUIPPED WITH "EURO" CONTROL SYSTEM

NOTICE

The illustrations show a typical construction of control stand and working attachment. However, the shown operation - and working movements apply to this machine.

BACKHOE

- | | |
|---------------------|----------------------------------|
| LH control lever(1) | RH control lever (2) |
| E Extending stick | A Lowering boom |
| F Retracting stick | B Lifting boom |
| | C Filling bucket (roll back) |
| | D Emptying bucket (roll forward) |

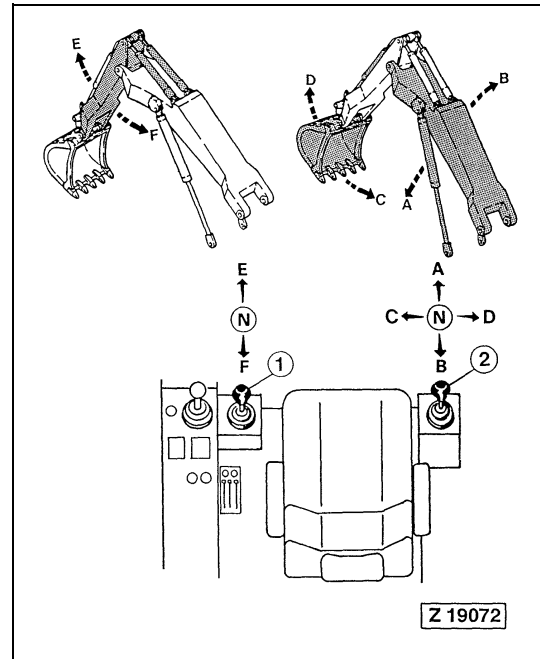

FACE SHOVEL

- | | |
|----------------------|---------------------------------|
| LH control lever (1) | RH control lever (2) |
| E Extending stick | A Lowering boom |
| F Retracting stick | B Lifting boom |
| | C Filling bucket (roll forward) |
| | D Emptying bucket (roll back) |

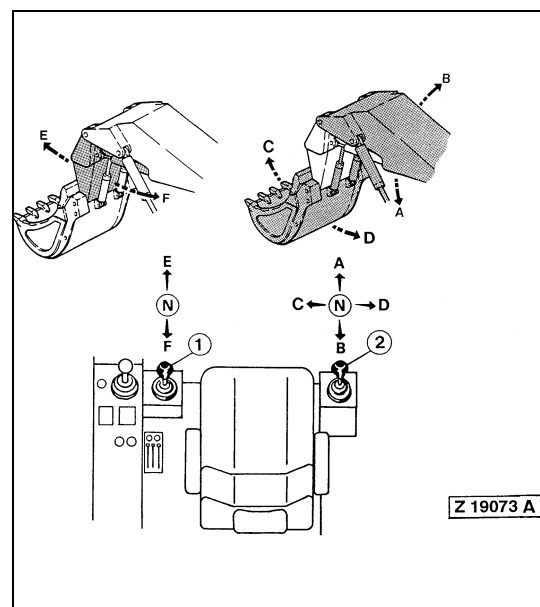

NOTICE

The raised working attachment can also be lowered with the ENGINE at standstill. If, for example, the engine stalls with the working attachment in a raised position, lowering of the working attachment is possible by moving control lever (2) to position (A). The necessary oil pressure for shifting the spools of the main control valves is provided by a pressure accumulator in the pilot oil circuit. After stopping the engine, relieve the pressure in the hydraulic system.

For more information → See "STOPPING THE ENGINES" on page 264.

3.13.2 MACHINES EQUIPPED WITH "KMG" CONTROL SYSTEM

NOTICE

The illustrations show a typical construction of control stand and working attachment.

However, the shown operation - and working movements apply to this machine.

BACKHOE

- | | |
|-------------------------------------|------------------------|
| L.H. control lever (1) | R.H. control lever (2) |
| A Lowering boom | E Extending stick |
| B Lifting boom | F Retracting stick |
| C Filling bucket
(roll back) | |
| D Emptying bucket
(roll forward) | |

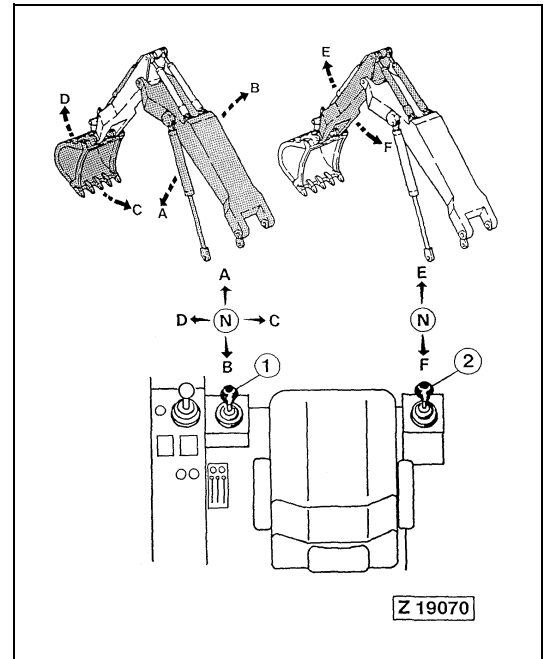

FACE SHOVEL

- | | |
|------------------------------------|------------------------|
| L.H. control lever (1) | R.H. control lever (2) |
| A Lowering boom | E Extending stick |
| B Lifting boom | F Retracting stick |
| C Emptying bucket
(roll back) | |
| D Filling bucket
(roll forward) | |

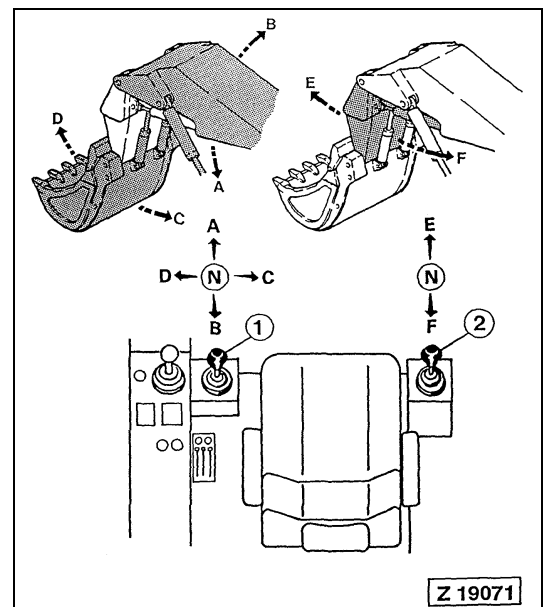

NOTICE

The raised working attachment can also be lowered with the engine at standstill. If, for example, the engine stalls with the working attachment in a raised position, lowering of the working attachment is possible by moving control lever (1) to position (A). The necessary oil pressure for shifting the spools of the main control valves is provided by a pressure accumulator in the pilot oil circuit. After stopping the engine, relieve the pressure in the hydraulic system.

For more information → See "STOPPING THE ENGINES" on page 264.

3.13.3 BOTTOM DUMP BUCKET

NOTICE

The illustration shows a typical construction of control stand and working attachment. However, the shown operation- and working movements apply to this machine.

OPERATING THE BUCKET CLAM

- G Closing the bottom dump bucket:
Depress LH pedal (4)
- H Opening the bottom dump bucket:
Depress RH pedal (5)

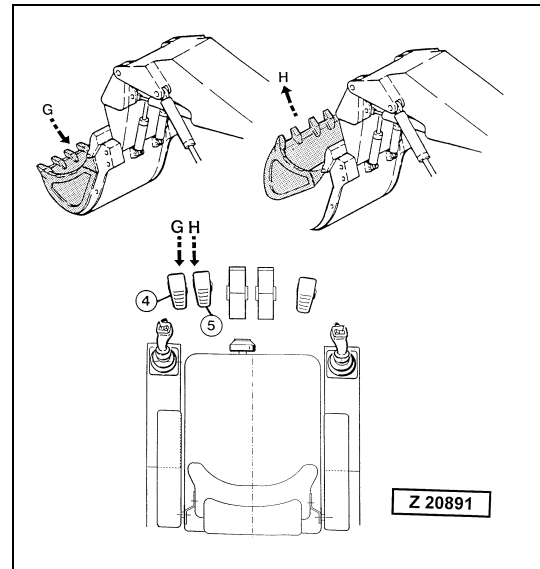

CAUTION

As soon as the bucket is completely closed, release pedal (4). Otherwise the pressure relief valve of the bucket closing circuit will open resulting in unnecessary loading of the hydraulic system.

CAUTION

DO NOT use the bucket clam for loosening or removing anchored rocks or other solid objects (illust. Z 19984 and Z 19985), since such operations may result in severe damage to the clam pivot bearings.

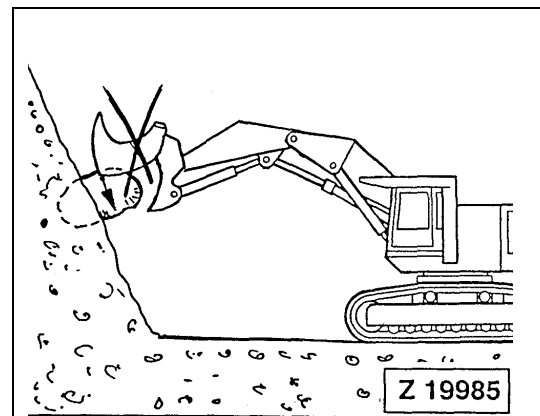
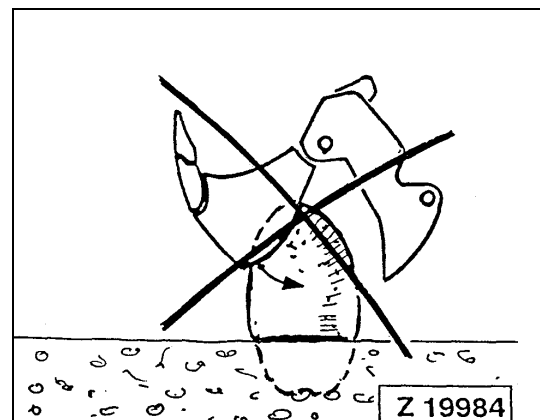

3.13.4 DROP BALL OPERATION

⚠ WARNING

- Make sure all safety devices are correctly installed on your machine.
- Always walk-around and look for hazards before you operate your machine in the work area.
- Consult the supervisor of the job site for instructions concerning safe operation in the work area.
- Know the rules for movement of people and machines on the job site. Follow the instructions of the supervisor.
- Before starting drop ball operation, clear area of other persons and sound the signal horn. Stop drop ball operation when other persons approaching to the work area.
- The drop ball must never be placed loosely in the bucket. Always pick-up the drop ball at its greatest circumference, see detail (A) in the illustration number (6).
- When lifting the drop ball, make sure the back wall of the bucket remains in a vertical position, see detail (B) in illustration no. (7). The ball drop height is reached, when the bucket is on a level with the cab roof.
- With the drop ball lifted, never tilt back the bucket beyond the vertical position (B), otherwise the drop ball could roll over and fall on the Shovel.
- Before leaving the Shovel locate the drop ball on a safe place. DO NOT leave the drop ball in the bucket.

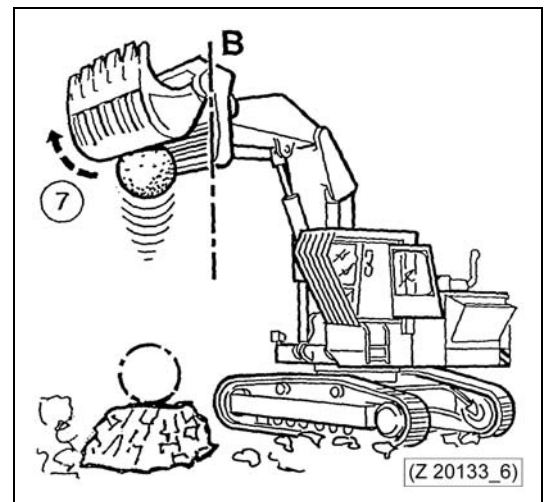
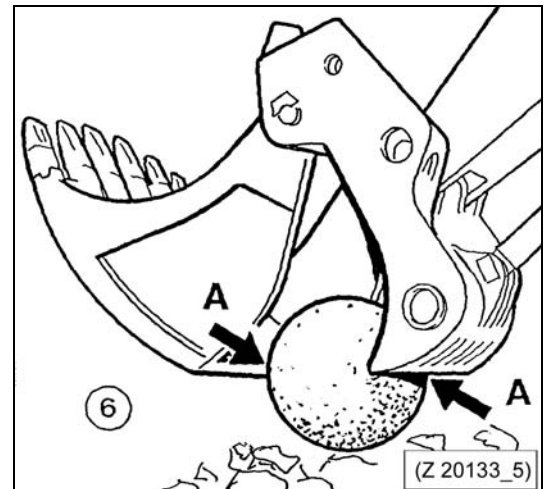

SAFETY DEVICES (SPECIAL EQUIPMENT)

Legend for illustration Z 20133_1

- (1) Front splinter guard for operator's cab
- (2) Protection screen for lubrication system, swing gear and working lights (if so equipped)
- (3) Cylinder piston rod guard
- (4) Swing ring guard
- (5) Reinforcement ledges on bucket wall and clam edges

NOTICE

More information regarding safety devices for drop ball operation on request.

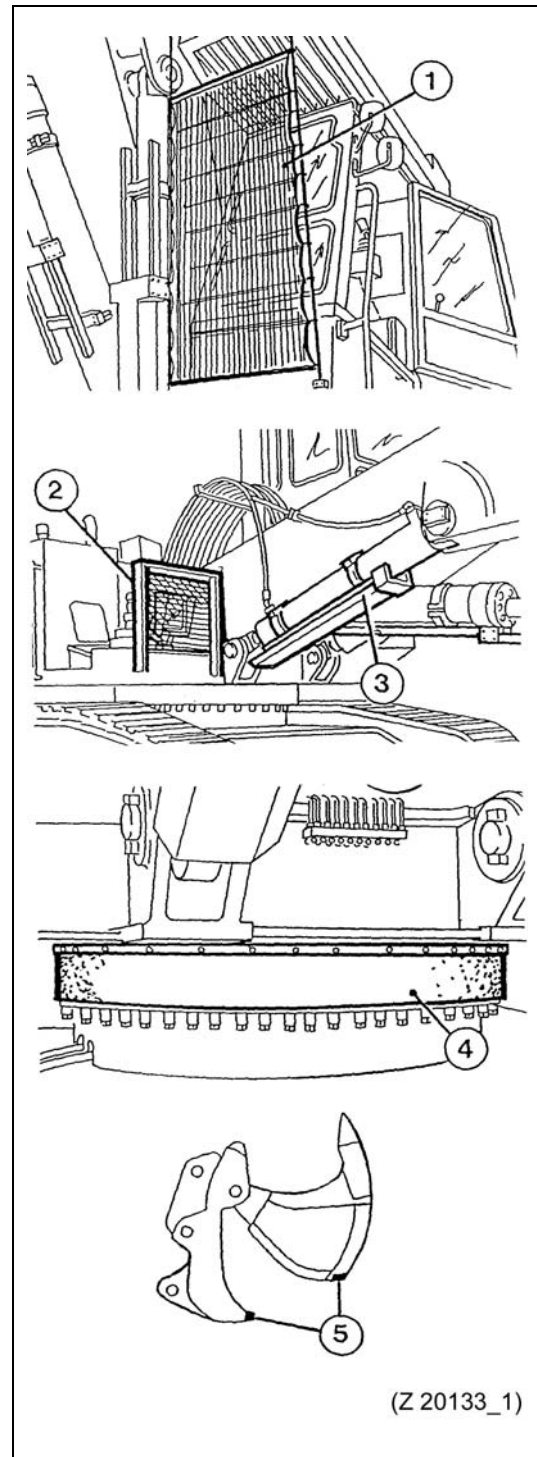

Legend for illustration Z 20133_5

- (6) Pick-up position of the drop ball
 A - Greatest circumference of the drop ball

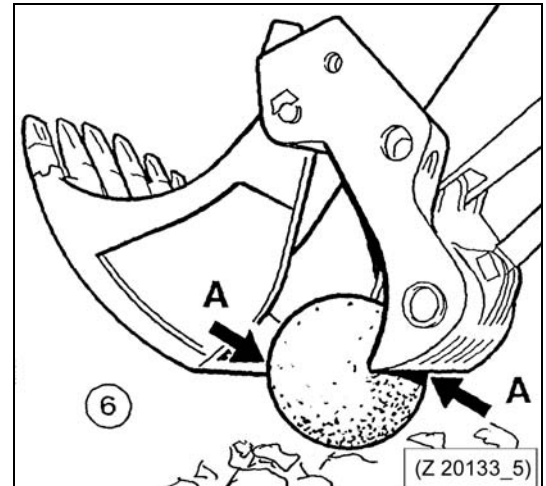
**Legend for illustration Z 20133_6**

- (7) Drop height, level with cab roof
 B - Back wall of the bucket in vertical position

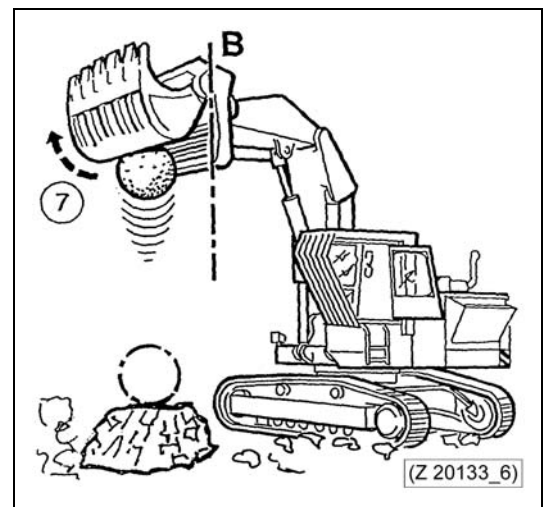
**WORKING HINTS**

Place the rock to be crushed on a solid and level ground with the impact surface in a horizontal position.

If so equipped lift up the cab front guard (1). The roof mounted beacon will then automatically switched on for warning other persons.

Change the impact surface of the rock by 90°, if after two to three drops the rock is not being crushed.

3.13.5 COMBINED OPERATION CYCLES

With each of the control levers, two operation cycles can be initiated simultaneously. In order to obtain efficient operation, always select intermediate control lever positions in relation to work load.

NOTICE

The illustration shows a typical Shovel.

The movements shown in the illustration are controlled:

- at KMG control system with L.H. lever
- at EURO control system with R.H. lever

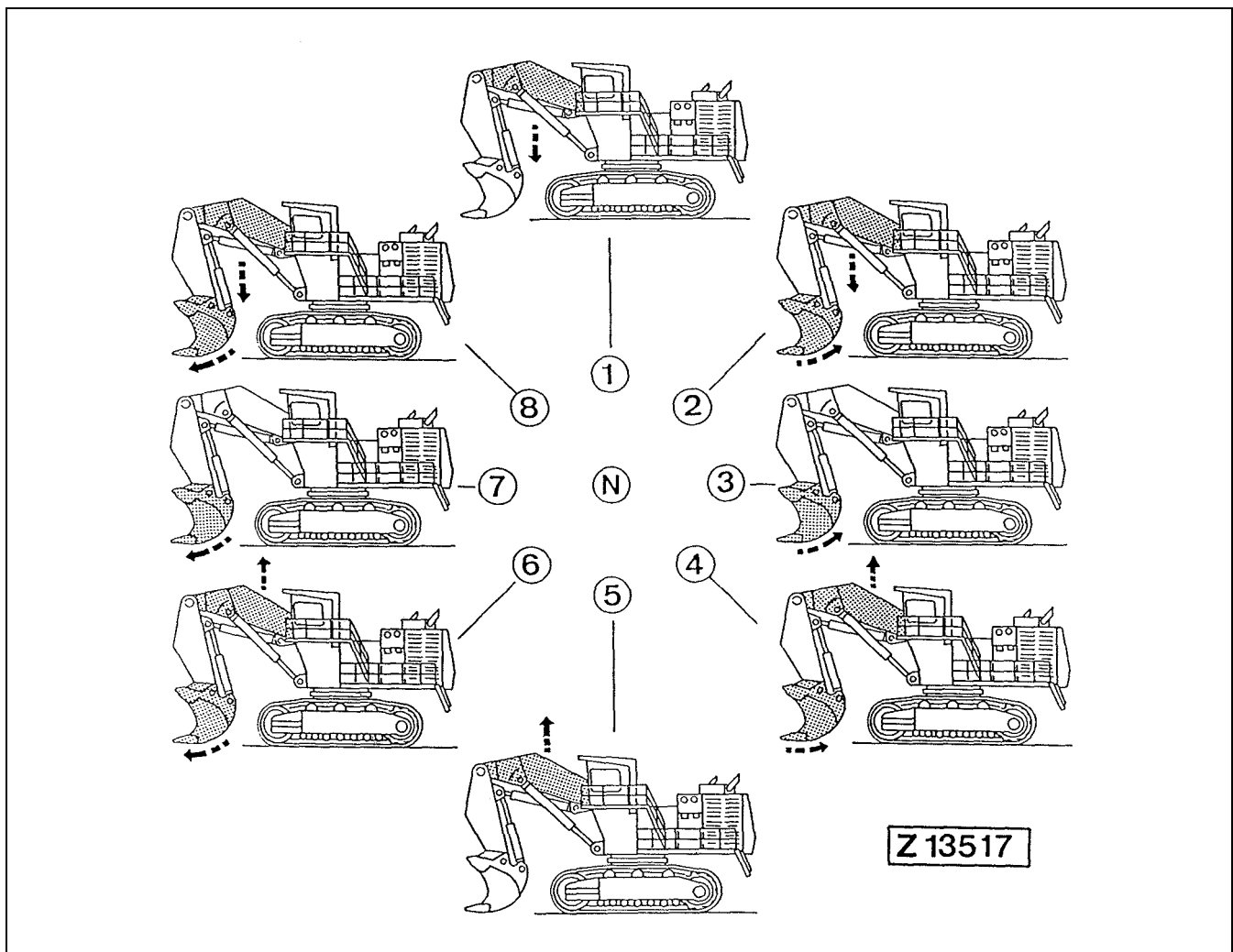

Legend for illustration Z 13517

- | | |
|---------------------------------------|--------------------------------------|
| (N) Neutral position | (5) Raising boom |
| (1) Lowering boom | (6) Raising boom and filling bucket |
| (2) Lowering boom and emptying bucket | (7) Filling bucket |
| (3) Emptying bucket | (8) Lowering boom and filling bucket |
| (4) Raising boom and emptying bucket | |

NOTICE

The illustration shows a typical Shovel.

The movements shown in the illustration are controlled:

- at KMG control system with R.H. lever
- at EURO control system with L.H. lever

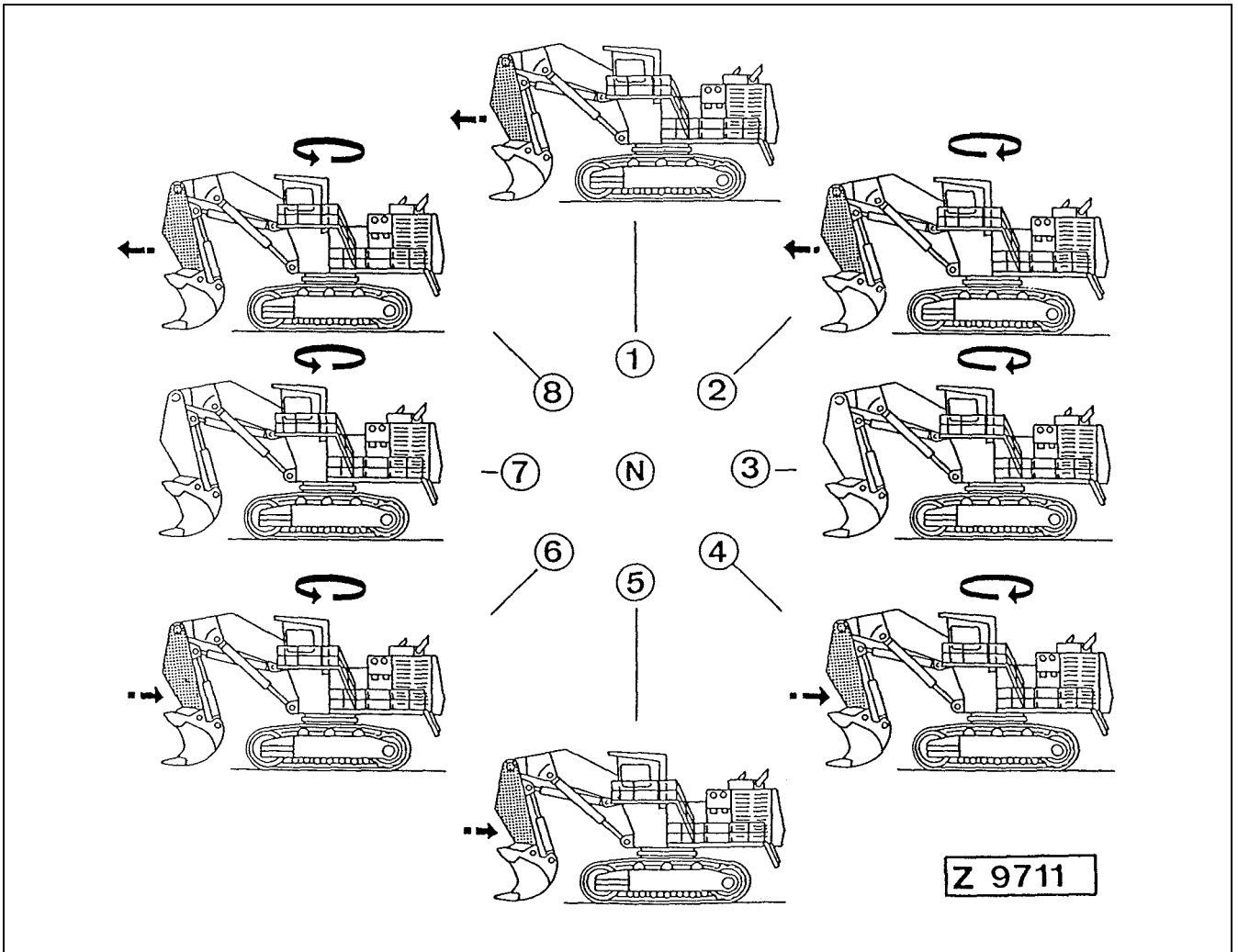

Legend for illustration Z 9711)

- | | | | |
|-----|---|-----|--|
| (N) | Neutral position | (5) | Retracting stick |
| (1) | Extending stick (away from machine) | (6) | Retracting stick and slewing to the left |
| (2) | Extending stick and slewing to the right | (7) | Slewing to the left |
| (3) | Slewing to the right | (8) | Extending stick and slewing to the left |
| (4) | Retracting stick (towards machine) and slewing to the right | | |

3.14 WORKING INSTRUCTIONS

3.14.1 STABILITY OF THE SHOVEL



WARNING

Before beginning work prepare a suitable Shovel base, to ensure adequate stability for safe working of the Shovel.

The stability of the Shovel is determined according to DIN 24087, and is based on a level ground.

The Shovel must therefore be operated in such away, that its stability is always ensured and the danger of tipping over is avoided.

When slewing the superstructure take in account, that the stability of the Shovel is being reduced when the superstructure (bucket) is turning in a transverse direction to the undercarriage.

Avoid working with the crawler tracks across the slope, as this reduces stability and increases the tendency for the Shovel to slide or to tip over.

In the following a few Examples of Operating and Working Conditions which can reduce the Stability of the Shovel:

- Overloading of the Shovel (Bucket overfilled).
- Ground conditions such as loose sand or wet soil (possibility of a cave-in).
- Jerky acceleration or deceleration of working- and travel motions.
- Operating on a slope.

3.14.2 SHOVEL OPERATION

- When working with the loader attachment, switch-off the fast speed range (if equipped).
- Do not operate control levers jerkily.
- Do not work below overhanging rocks or earth masses.
- Always keep a safe distance to the edge of an excavation where bank cave-ins are possible.
- Operation on a grade requires special care. Plan your work so that the Shovel travels uphill and downhill parallel to the grade. Bear in mind, that the Shovel's stability is reduced when operating on a slope.
- Always keep the Shovel under control.
- Know the Shovel's limits - and do not exceed them.

CAUTION

DO NOT "Sweep" with the loader attachment, illust. (Z 10369), as this may result in severe damage on swing gear components.

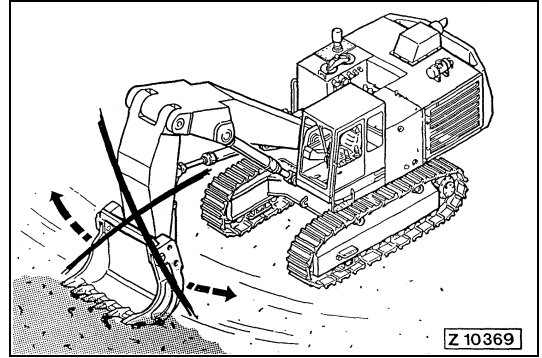

CAUTION

DO NOT use the bucket clam for loosening or removing anchored rocks or other solid objects (illust. Z 19984 and Z 19985), since such operations may result in severe damage to the clam pivot bearings.

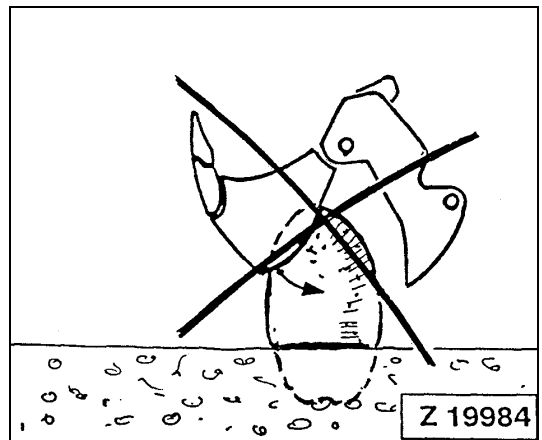
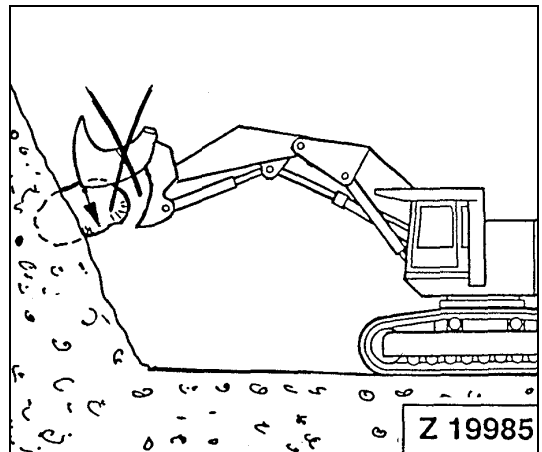

- When working with the bucket in the longitudinal direction, the final drives should be in the rear position illust. (Z 0144), for the following reasons:
 - The travel motors and travel gears are protected from falling rocks etc.
 - When the Shovel is operated on muddy ground and the tracks are covered with mud, the sprocket runs on a clean track when backing up.

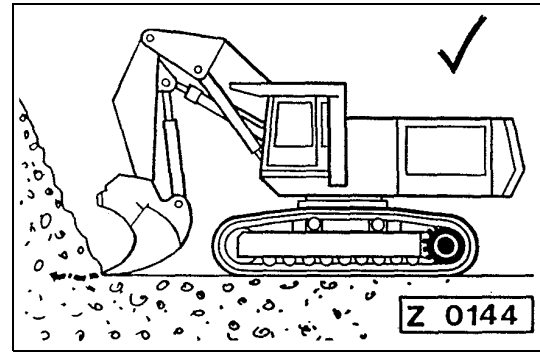

- When working with the loader in a cross direction to the track group, be sure that the track is not raised off the ground, illust. (Z 20978). This can cause the track to set-off from the rollers when it is lowered down on the ground. Also the flanges of the track rollers and the track shoes can be bent by the excessive load.

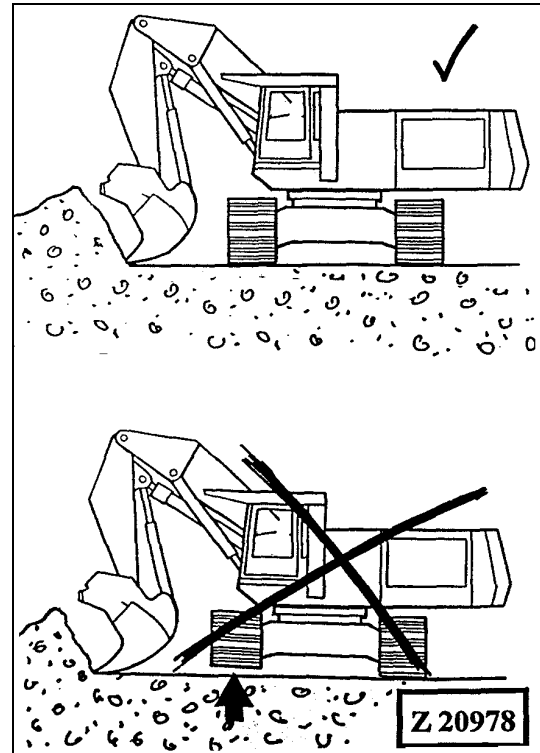

- **Loading Trucks:**
 Position the truck as closely as possible to the Shovel.
 Do not swing the attachment over unprotected driver cabs.
 Swing the attachment at a sufficient height over the loading platform
 Distribute material evenly on loading platform.
 Do not overload the truck.
- Remove sticky material from the bucket.
- Always keep the Shovel as close as possible to the work area. Short boom trips - high efficiency.
- When turning into a pit, the rotating motion must not be stopped by the walls of the pit.
- Only a bucket with a complete set of teeth and cutting edges in good condition ensures efficient performance.
- Loosen hard material and rocks with the bucket, not with the stick crowding thrust.
- Correct bucket size and properly adjusted equipment prevents overloading and ensures maximum operating efficiency of the Shovel.

3.15 PARKING THE SHOVEL

Park the machine at a safe place on level and solid ground.

- Lower the working attachment onto the ground in a position as shown on the oil level plate at the hydraulic oil reservoir.
- Stop the engines and relieve the pressure in the hydraulic system, see page 267 for more information.
- Move the safety lock lever fully to the rear in locked position.

WARNING

DO NOT leave the Operator's Cab when the engines are running.

- Be sure to lock the operator's cab door before leaving the Shovel.
- If the Shovel has to be parked on steep terrain, the track groups must be secured with wedges.
- Before leaving the Shovel make sure that the parked machine does not impair local requirements, have consideration for other mining traffic.

CLEANING THE TRACK GROUPS

Under working conditions with excessive material build up on the crawler components, cleaning of the crawlers is very important to prevent damage.

Material build up on guide wheels, drive sprockets and tracks can lead to over tensioning of the tracks, resulting in severe damage to these components.

If there is danger of frost, the tracks must also be cleaned.

NOTICE

Use a suitable cleaning device for removing dirt, mud and debris from the tracks, rollers, guide wheels and sprockets.

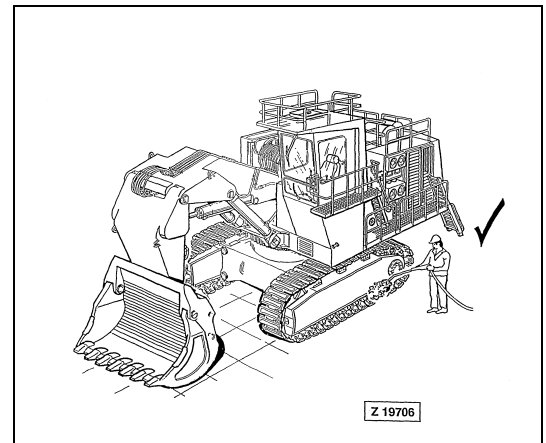

3.16 STOPPING THE ENGINES

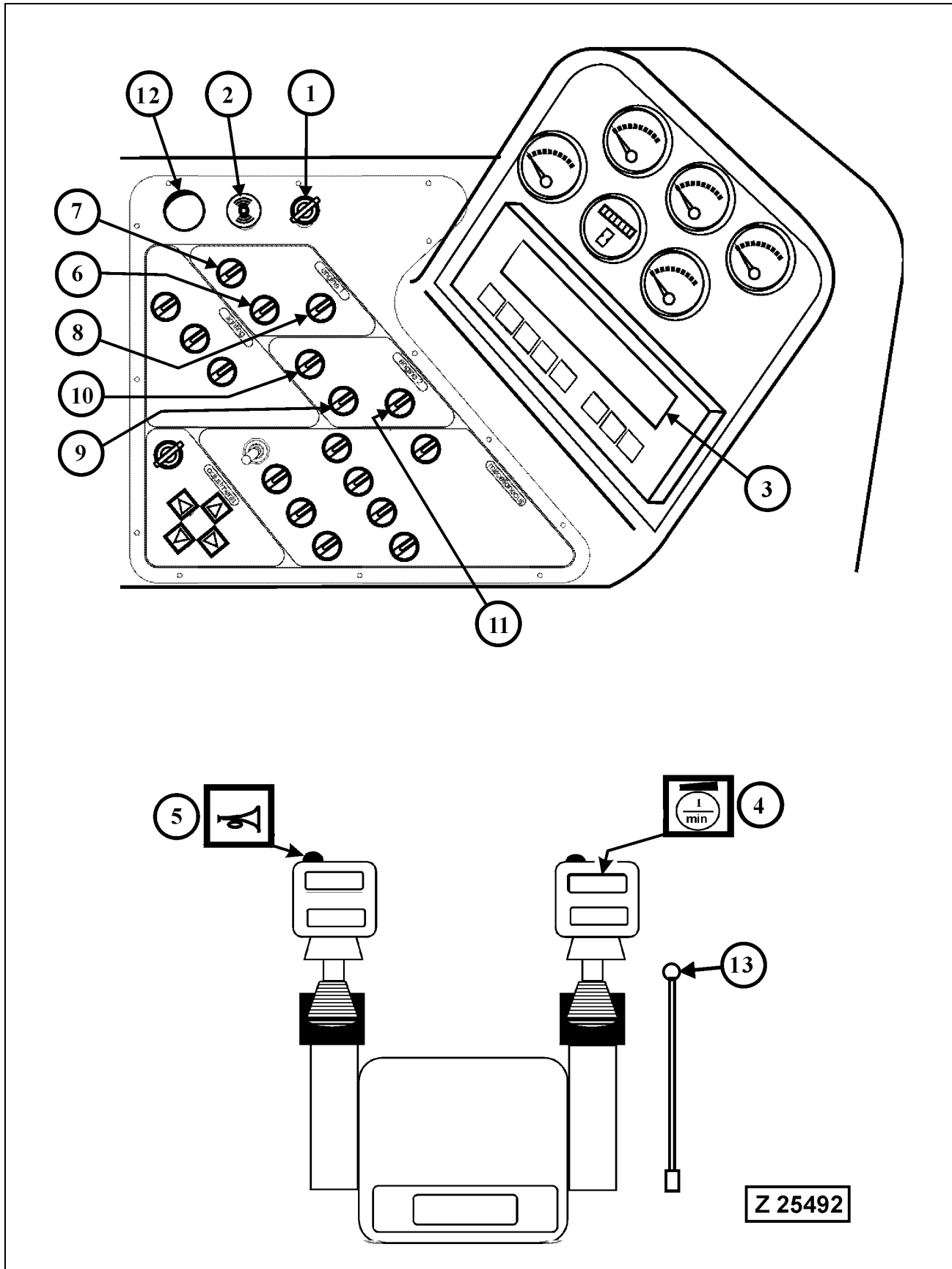

⚠ CAUTION

Never stop the engines from full load except in case of emergency.

Before shutting down run the engines at idling speed for approximately 5 minutes. This cooling down period prevents heat accumulation and thermal stress, especially in the turbochargers.

⚠ CAUTION

For EMERGENCY SHUTDOWN of the Engine, use STRIKE BUTTON (12).

Additional emergency shut-down switches are located on the power house. For more information → See "MACHINERY HOUSE" on page 202.

Stopping procedure, see illustration Z25492.

1. Park the Shovel at a safe place on level and solid ground.

For more information → See "PARKING THE SHOVEL" on page 263.

2. Deposit the working attachment onto the ground, proceed as follows:
 - **A - Backhoe Attachment**
Lower the backhoe attachment fully extended onto the ground in a position as shown on the oil level plate.
 - **B - Bottom Dump Bucket Attachment**
Lower the bottom dump bucket attachment onto the ground in a position as shown on the oil level plate.

The positions A or B are necessary to prevent unintentional movement of the working attachment when the pressure in the hydraulic system is relieved and for correct checking of the hydraulic oil level.

3. Move all controls into neutral position.
4. Set toggle switch (4) to low idle speed position. Let the engines idle for about five minutes without load.
5. Turn switches (7 and 10) clockwise to stop position. After the engines have come to standstill, relieve the pressure in the hydraulic system.

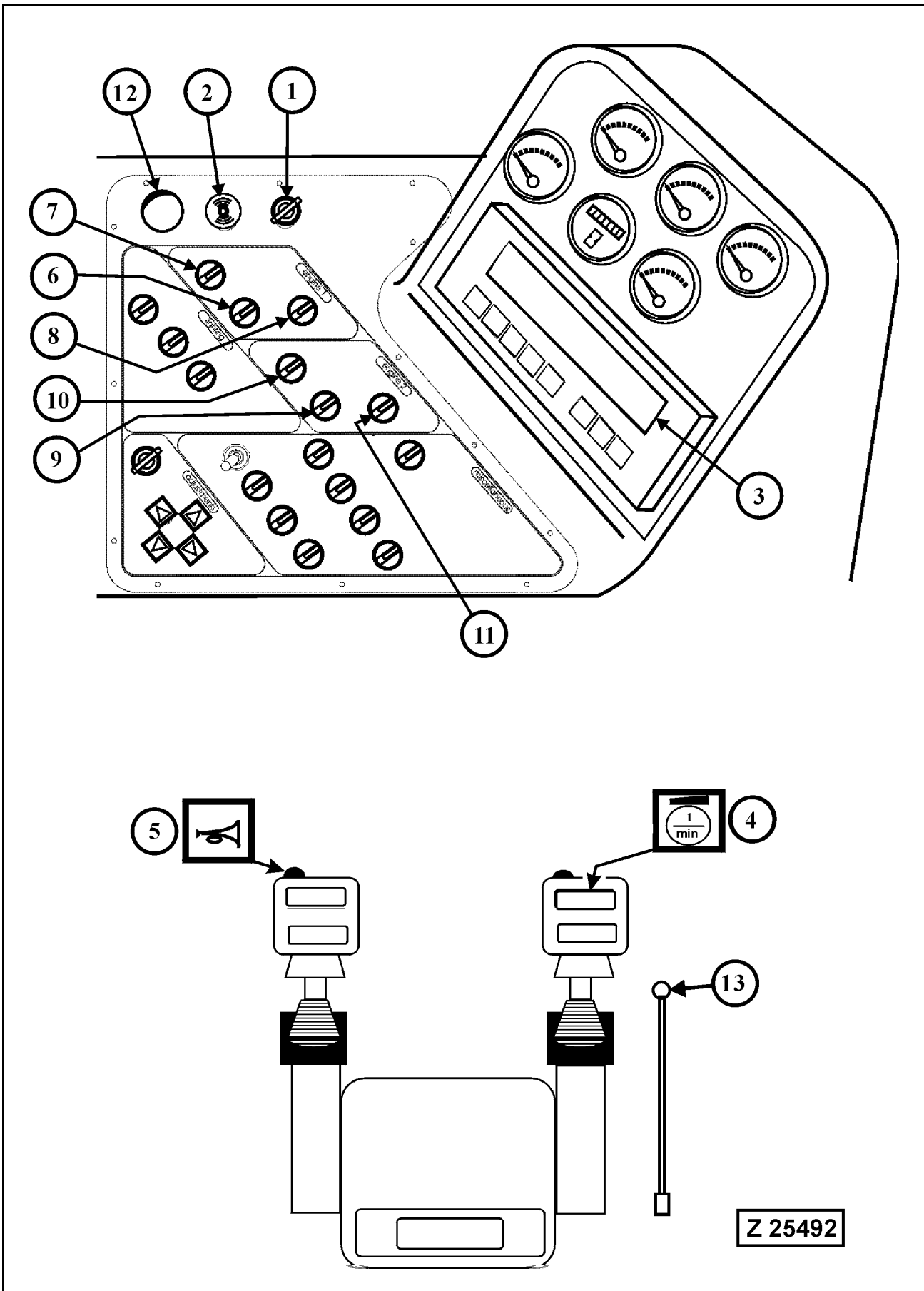

Z 25492

3.16.1 RELIEVE PRESSURE IN THE HYDRAULIC SYSTEM

▲ WARNING

With the engines at standstill and main switch (1) in ON position, move all controls for working attachment and crawlers several times through all shift positions to relieve the pressure in the hydraulic system. The necessary oil pressure for shifting the spools of the main control valves is provided by a pressure accumulator in the pilot oil circuit.

NOTICE

The pressure accumulator in the pilot oil circuit serves also for lowering a raised working attachment to the ground with the engines at standstill. If, for example, the engines stall with the working attachment in a raised position, lowering of the working attachment is possible by operating the respective control lever.

6. Set main switch key (1) to "0" position and remove.
7. Set safety lock lever (13) fully to the rear in LOCKED position.
8. Switch off the battery main switches and remove keys.

3.17 OPERATION OF THE LUBRICATION SYSTEM

3.17.1 CENTRAL LUBRICATION SYSTEM -CLS- FOR SUPERSTRUCTURE AND ATTACHMENT

The central lubrication system works automatically as soon as the engine is running.

The ECS System monitors the function of the central lubrication system. Trouble conditions of the lubrication system are indicated through fault messages on display (A).

Legend for illustration Z25503

- (1) Switch, manual actuation of central lubrication system
- (2) Switch, manual actuation of swing ring gear pinion lubrication system
- (3) Key operated service switch
- (A) ECS display

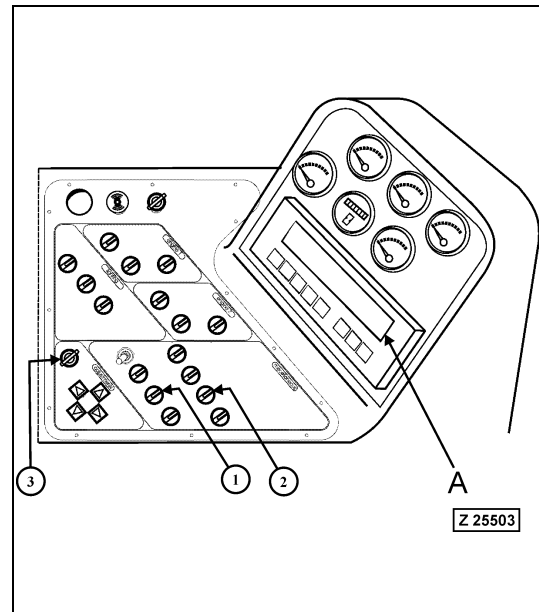

Manual actuation of the central lubrication system

Manual actuation of the central lubrication system overrides the adjusted pause time (factory setting 60 minutes). The lubrication cycle starts after a pressure build up time of 1 to 2 minutes. Thereafter the monitoring time of 10 minutes starts. The complete lubrication cycle takes approximately 12 minutes. After this period the lubrication cycle counter adds one lubrication cycle to the memory. For display of the cycle counter reading use the menu control of the ECS system, see page 129 for more information.

REMARK

The start of a manually actuated lubrication cycle can be delayed by up to 10 minutes if the system is in the monitoring time period of a previous automatic lubrication cycle.

CAUTION

If the central lubrication system fails to work for a period of four hours automatic bucket motion cut off can happen depending on the installed ECS soft ware. Repair the system as soon as possible.

ADJUSTMENTS OF THE CENTRAL LUBRICATION SYSTEM

Manual actuation Mode of the Lubrication System with Service Key

The manual actuation in the Service mode is useful for testing the electrical and hydraulic functions of the of the lubrication system. The pause time is reduced to 30 seconds and the holding time to 15 seconds permitting rapid sequences of lubrication cycles. Both lubrication systems can be set to the manual actuation mode.

CAUTION

In the manual actuation mode all monitoring functions of the system are made inoperative and, because of the very short pause and holding times, grease will not reach to all lubrication points.

Carry out manual lubrication by using the service key

1. Insert key into service switch (3) and set to operating position.
2. Actuate the rotary switch (1) on the instrument panel. The message # SERVICE appears on the display. Up to ten repeated actuation of the switch are possible. The lubrication cycles are counted and displayed in the cycle counter window.
3. After finishing the manual lubrication remove service key. The system returns to the normal timer settings.

Adjustments of the Central Lubrication System

The following adjustments can be made with the menu control of the ECS system:

Level 4: Service / Settings

- 4 - Settings * CONDITION INDICATION *
- 4 - Settings (minutes) * PAUSE TIME : *
- 4 - Settings * LUBE CYCLE COUNTER : *

Refer to section "ELECTRONIC MONITORING AND CONTROL SYSTEM ECS" for description of adjustment procedure.

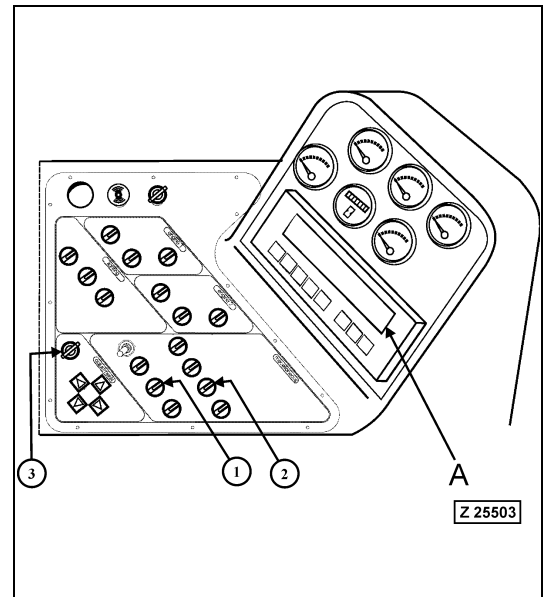

3.17.2 SWING CIRCLE PINION LUBRICATION SYSTEM "SLS"

This system works automatically as soon as the engine is running. The ECS System monitors the function of the swing circle lubrication system. Trouble conditions of the lubrication system are indicated through fault messages on ECS display (A).

Legend for illustration Z25503

- (1) Switch, manual actuation of central lubrication system
- (2) Switch, manual actuation of swing ring gear pinion lubrication system
- (3) Key operated service switch
- (A) ECS display

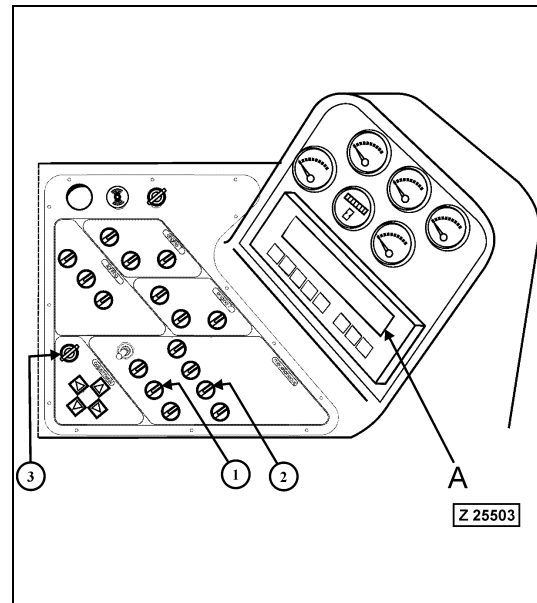

Manual actuation of the swing circle lubrication system

Manual actuation of the lubrication system overrides the adjusted pause time (factory setting 15 minutes). The lubrication cycle starts after a pressure build up time of 1 to 2 minutes. Thereafter the monitoring time of 10 minutes starts. The complete lubrication cycle takes approximately 12 minutes. However, since the swing circle lubrication system works only during slewing of the superstructure also the monitoring time elapses only during the slewing movement. This is the reason why the total monitoring time usually lasts longer than the adjusted 10 minutes. After elapsing of the monitoring time the lubrication cycle counter adds one lubrication cycle to the memory. For display of the cycle counter reading use the menu control of the ECS system, see page 129 for more information.

REMARK

The start of a manually actuated lubrication cycle can be delayed by up to 10 minutes if the system is in the monitoring time period of a previous automatic lubrication cycle.

CAUTION

If the swing circle lubrication system fails to work for a period of four hours automatic bucket motion cut off can happen depending on the installed ECS soft ware. Repair the system as soon as possible.

SWING CIRCLE LUBRICATION SYSTEM "SLS"

Manual actuation Mode of the Lubrication System with Service Key

The manual actuation in the Service mode is useful for testing the electrical and hydraulic functions of the lubrication system. The pause time is reduced to 30 seconds and the holding time to 15 seconds permitting rapid sequences of lubrication cycles.

CAUTION

In the manual actuation mode all monitoring functions of the system are made inoperative and, because of the very short pause and holding times grease will not reach to all lubrication points.

Carry out manual lubrication by using the service key

REMARK

The swing ring lubrication system works only during slewing of the superstructure.

1. Insert key into service switch (3) and set to operating position.
2. Actuate the rotary switch (2) of the swing ring gear lubrication system. The message # SERVICE appears on the display. Up to ten repeated actuation of the switch are possible. The lubrication cycles are counted and displayed in the cycle counter window.
3. After finishing the manual lubrication remove service key. The system returns to the normal timer settings.

ADJUSTMENTS OF THE SWING CIRCLE LUBRICATION SYSTEM

The following adjustments can be made in the service menu of the ECS system:

Level 4: Service Menu / Settings

- 4 - Settings * CONDITION INDICATION *
- 4 - Settings (minutes) * PAUSE TIME : *
- 4 - Settings * LUBE CYCLE COUNTER : *

Refer to section "ELECTRONIC MONITORING AND CONTROL SYSTEM ECS" for description of adjustment procedure.

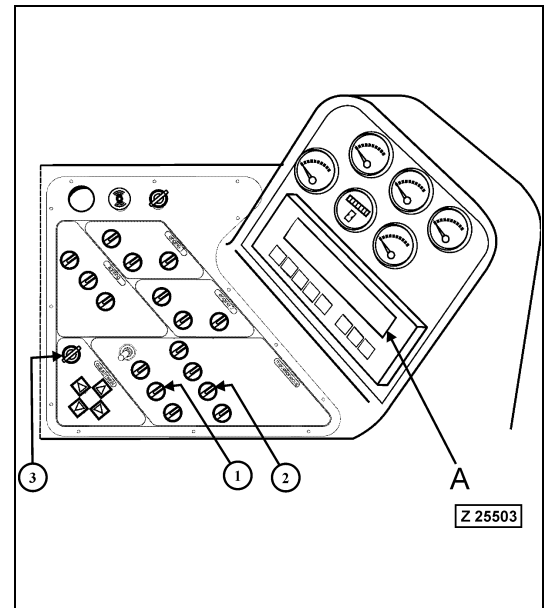

3.18 FIRE DETECTION AND SUPPRESSION SYSTEM

(Special Equipment)

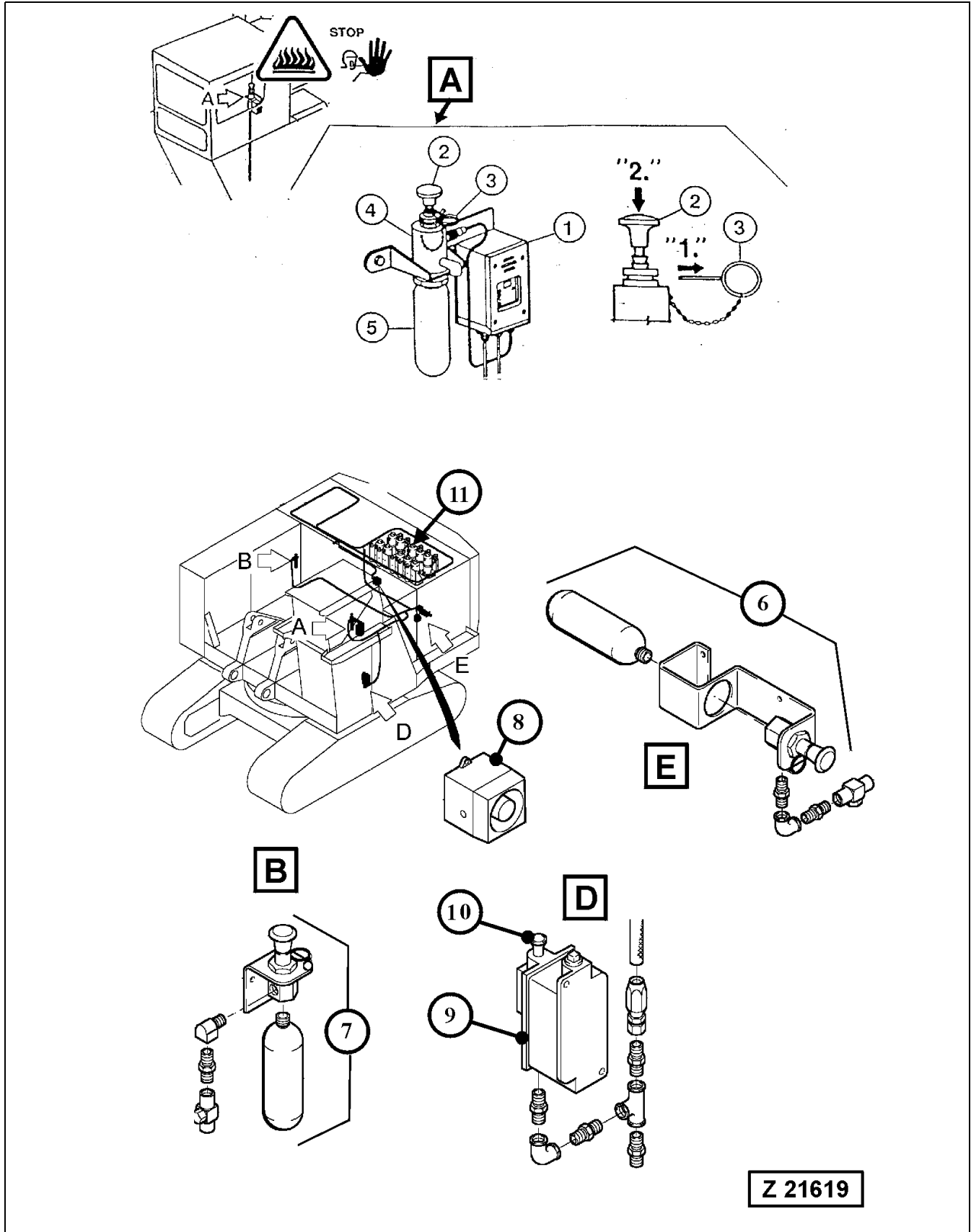

FIRE DETECTION AND SUPPRESSION SYSTEM

⚠ WARNING

Before operating the Shovel make sure the Fire Detection, Actuation and Suppression system is operative.

Carry out inspection and maintenance according to the separate manuals "Fire Detection and Actuation System" and "Fire Suppression System" in Volume 2 Binder.

⚠ CAUTION

This section covers only such information necessary for the operator to understand operation of the fire detection and actuation system.

All other information i.e. placing the system in service, daily inspection, functional tests, maintenance and trouble shooting are contained in the separate manuals.

Legend for illustration Z 21619

- (A) Control module with manual/automatic actuator in the Operator's cab
- (1) Control module, refer to the separate Manual "CHECKFIRE SC ELECTRIC DETECTION AND ACTUATION SYSTEM" for all information concerning - Operational Modes, Daily Inspection, Maintenance and System Conditions -.
- (2) Strike button, manual actuation
- (3) Ring pin
- (4) Manual / automatic actuator
- (5) LT-5-R cartridge
- (6) Manual actuator switch at the radiator door
- (7) Manual actuator switch at the rear power house door
- (8) High level alarm on operator's cab
- (9) Pressure switch - DPST located in the cab base. This switch shuts off the engine immediately when the fire detection system has a fire detected. The reset plunger (10) moves out into its upper position. When the fire suppression system has been recharged, push in the reset plunger.
- (10) Reset plunger, be sure to push in this plunger as soon as the fire suppression system has been recharged after actuation of the system.
- (11) Fire extinguishing tanks on power house roof

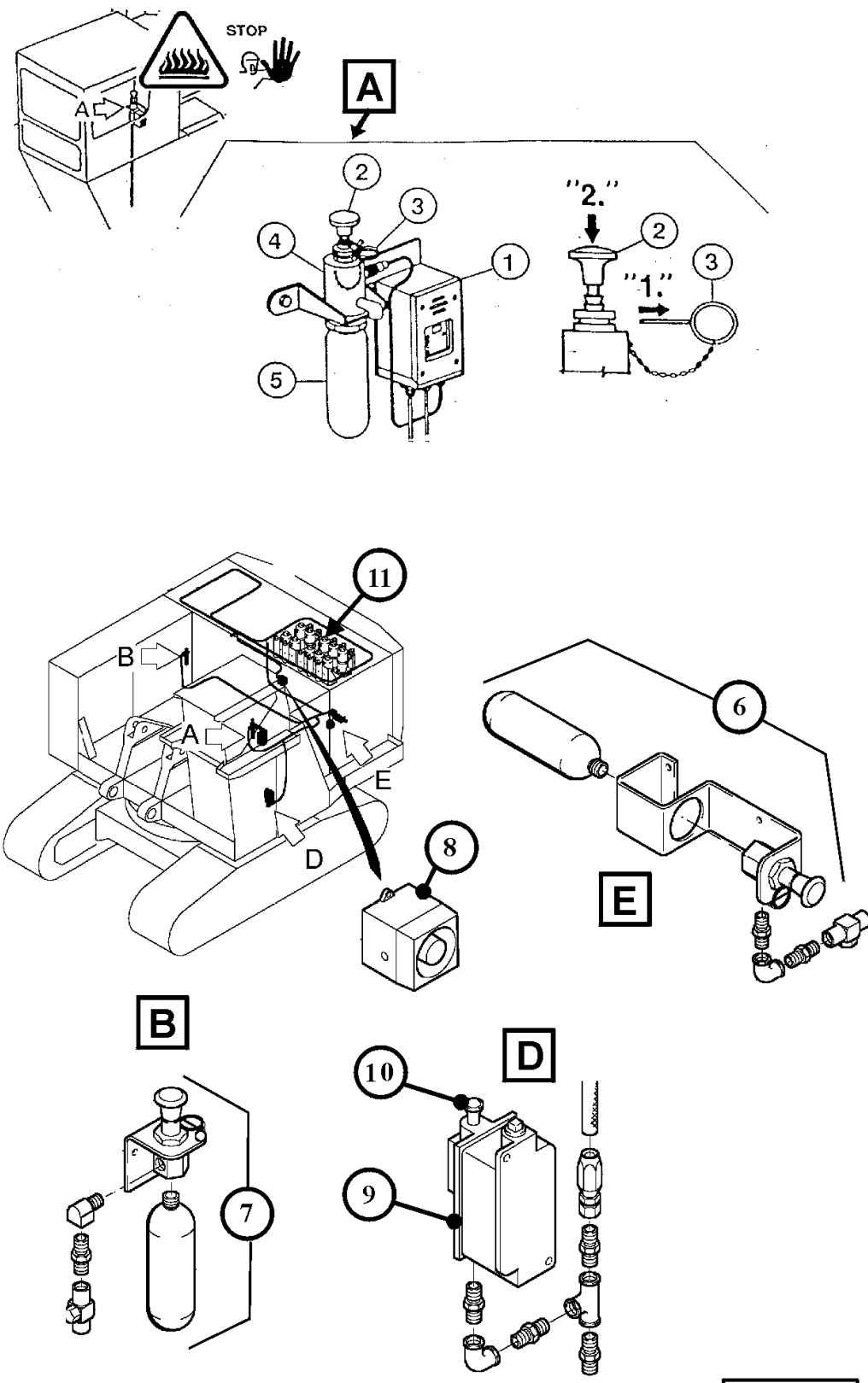

Z 21619

3.18.1 HIGH LEVEL ALARM "FIRE"

The high level alarm (8), illust. Z 21619 will sound approximately 15 seconds before discharge of the fire suppression system in case of automatic actuation of the system. Act according to the circumstances and the applying safety regulations. Evacuate area to lessen risk of injury from flames.

3.18.2 ENGINE SHUT-DOWN THROUGH FUEL SHUT-OFF SOLENOID VALVE

The fuel shut-off solenoid valve for the engine is actuated through pressure switch (9), illust. Z 21619.

When the fire detection system detects a fire, the valve will be closed shutting-off fuel supply to the engine (Shut-down of the engine).

3.18.3 ACTUATION MODES OF THE FIRE SUPPRESSION SYSTEM

MANUAL ACTUATION

Via strike button (2) in operator's cab or strike button of switches (6) on radiator door and (7) at the rear power house door.

▲ WARNING

Manual actuation will result in immediate system discharge which may obscure vision. Make certain the Shovel is stopped safely before manually actuating the system. Manual actuation will bypass all auxiliary shutdown and alarm functions.

NOTICE

For manual actuation via switches (4, 6 or 7), pull ring (3) and strike button (2).

AUTOMATIC ACTUATION

Via detection wires routed through the engine - and hydraulic pump compartments.

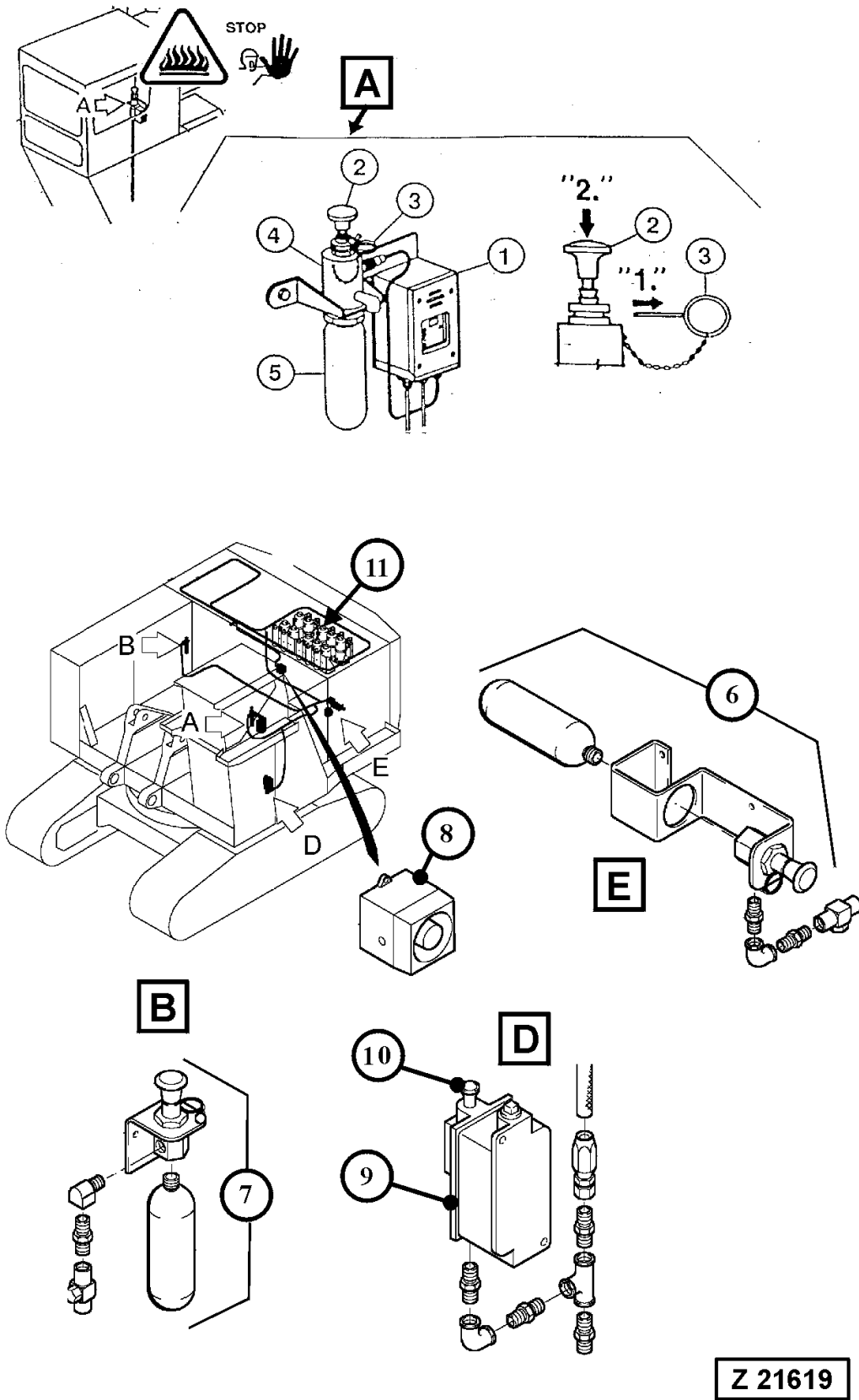

3.18.4 INDICATION OF OPERATIONAL MODES AT CONTROL MODULE, AFTER AUTOMATIC ACTUATION OF THE FIRE SUPPRESSION SYSTEM

Alarm to Shutdown Period - The RED alarm LED and the audio alarm will pulse at a rate of 2 times per second.

Shutdown to Discharge Period - The RED alarm LED and the audio alarm pulses "on" four times per second.

Timer Setting (factory adjustment)

- Alarm to Shutdown: 5 seconds
- Shutdown to Discharge: 10 seconds

▲ WARNING

In Case of Fire

- Act according to the circumstances and the applying safety regulations.
 - Evacuate area to lessen risk of injury from flames, heat, hazardous vapours, explosions, or other hazards that may be created.
 - Evacuate endangered Persons.
 - Inform the fire brigade.
 - Fight the fire.
-
-

▲ CAUTION

For continued protection, the Detection and Actuation System and the Fire Suppression System must be recharged through authorized Service Personnel immediately after operation.

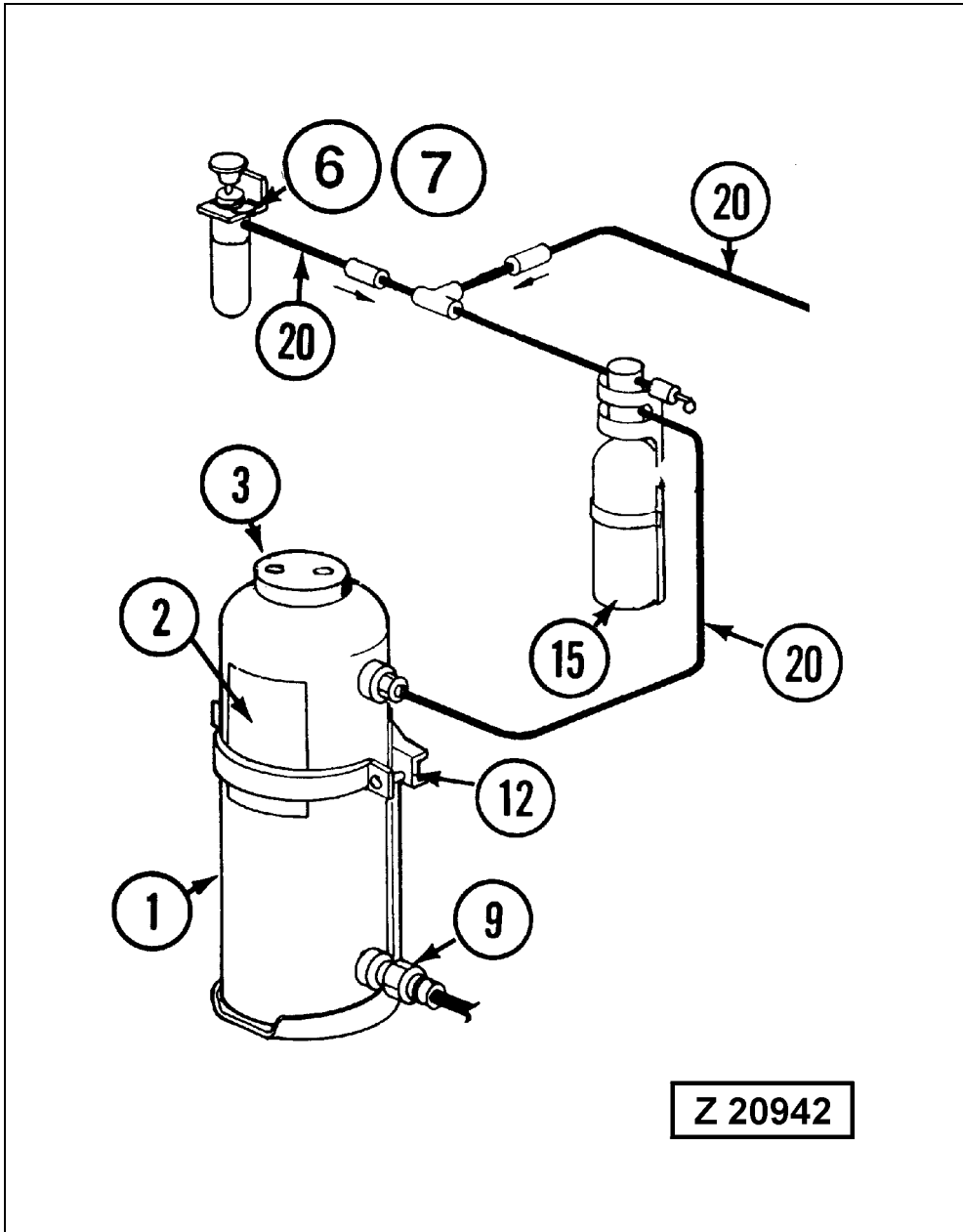

3.18.5 LOCATION OF THE EXTINGUISHING AGENT TANK ASSEMBLIES AND EXPELLANT GAS CARTRIDGES ON POWER HOUSE ROOF

REMARK

All fourteen extinguishing agent tank assemblies with their expellant gas cartridges are located on the rear railing of the power house roof.

Legend for illustration Z 20942

- (1) Extinguishing agent tank assembly
- (2) Name plate
- (3) Fill cap
- (6) Manual actuator switch at the radiator door
- (7) Manual actuator switch at the rear power house entrance
- (9) Extinguishing agent outlet to nozzle
- (12) Mounting clamp
- (15) Expellant gas cartridge
- (20) Pneumatic actuation line

REMARK

Check Extinguishing agent tank assemblies (1) and Expellant gas cartridges (15) for good condition and proper mounting.

Check filling level of Extinguishing agent tank assemblies (1) according to the instructions in the separate Inspection and Maintenance manual "A-101 VEHICLE FIRE SUPPRESSION SYSTEM".

When checking the filling level, make sure the extinguishing powder is not compacted. Stir up the extinguishing powder with a suitable stick until it is in a free flowing condition.

3.19 TRANSFER PUMP FOR HYDRAULIC OIL

(SPECIAL EQUIPMENT)

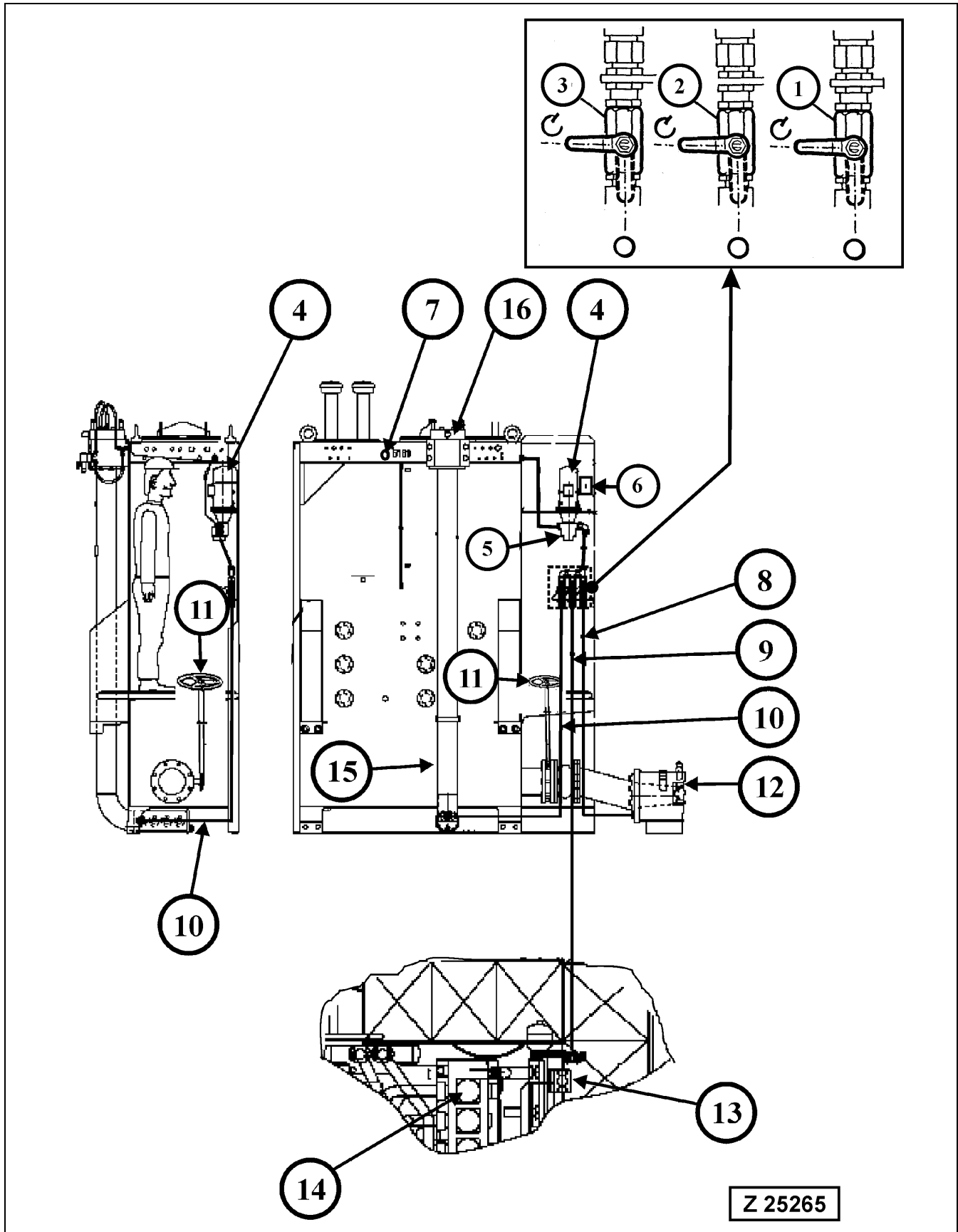

3.19.1 OPERATING THE TRANSFER PUMP

Legend for illust. Z25265

REMARK

The illustration shows the transfer pump arrangement viewed from center of the platform.

- (1) Cock for suction oil reservoir (12)
- (2) Cock for return oil collector pipe (13)
- (3) Cock for back-pressure valve pipe (15)
 - C - Closed
 - O - Open
- (4) Electric motor of the transfer pump
- (5) Transfer pump
- (6) Operating switch (S35) for transfer pump (4)
- (8) Suction line to suction oil reservoir (12)
- (9) Suction line to return oil collector pipe (13)
- (10) Suction line to back-pressure valve pipe (15)
- (11) Hand wheel of main shut-off valve between suction oil reservoir and main oil reservoir
 - To OPEN the valve turn hand wheel (11) CCW to the stop.
 - To CLOSE the valve turn hand wheel (11) CW to the stop.

A proximity switch located on the gearbox of the shut-off valve monitors the valve position. With the valve not fully open a corresponding message will be displayed on the ECS screen in the Operator's cab.

CAUTION

Before starting the engines make sure the shut-off valve is completely open by turning hand wheel (11) fully to the left (CCW).

- (12) Suction oil reservoir
- (13) Return oil collector pipe in front of main control valves
- (14) Main control valves
- (15) Back-pressure valve pipe
- (16) Back-pressure valve

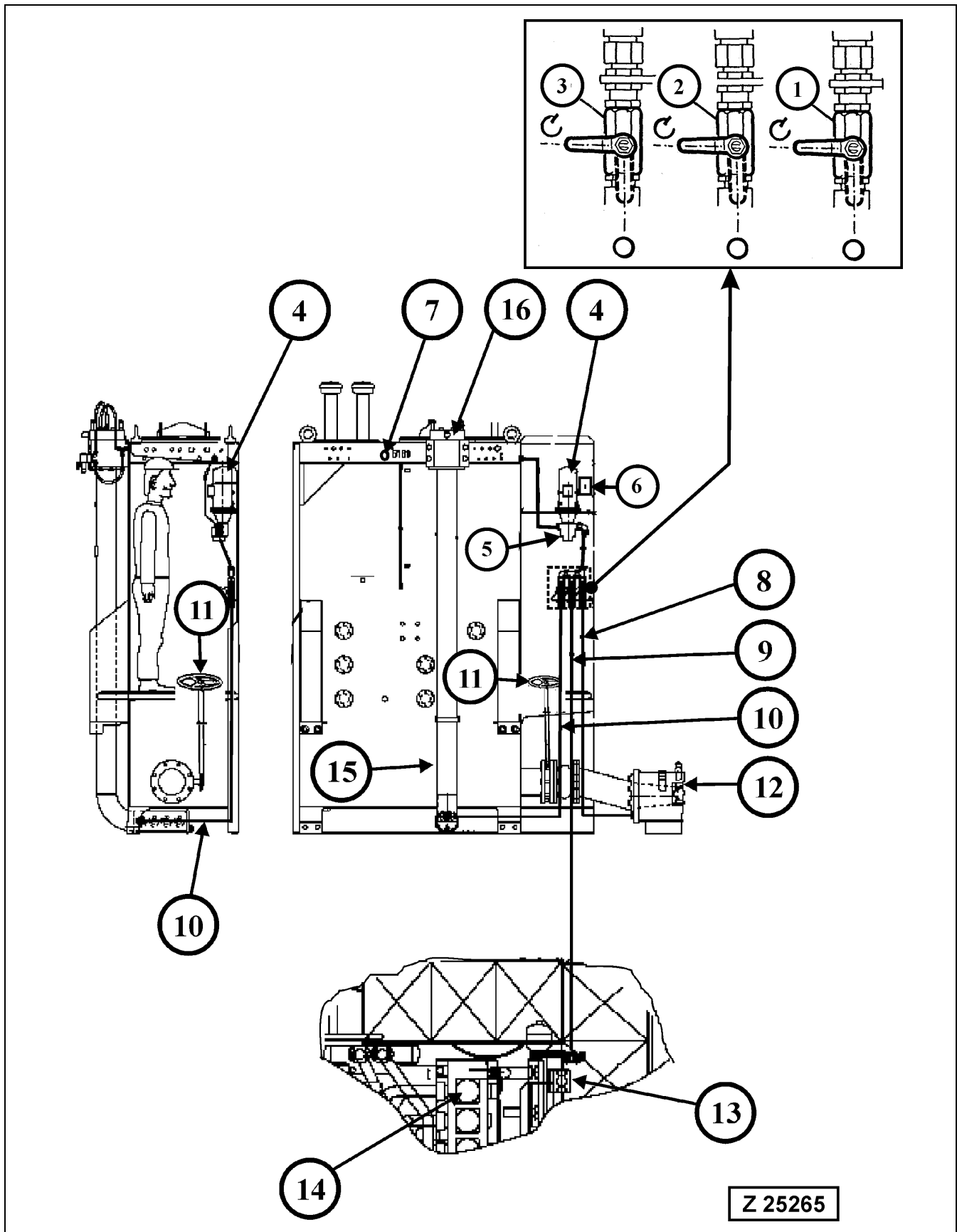

3.19.2 FUNCTIONS OF THE TRANSFER PUMP

A - Transfusing oil from the suction oil reservoir (12), illustration Z25265 into the main oil reservoir. Necessary for evacuation of the suction oil reservoir, when changing the hydraulic oil (main oil reservoir will be evacuated via service arm connector, see page 286 for details). Before servicing the main hydraulic pumps it is advisable to empty the suction oil reservoir partially.

B - Transfusing oil from return oil collector pipe (13) and back-pressure valve pipe (15) into main oil reservoir. Necessary when changing the hydraulic oil and prior to servicing the high pressure filters or the main control valves (oil return system).

CAUTION

Before operating the transfer pump, lower the attachment to the ground with the stick fully retracted and the bucket fully rolled back. Shut down the engines.

NOTICE

During normal operation the valves (1, 2 and 3) must be in closed position -C-.

A - Pumping the oil from the Suction Oil Reservoir (12) into the Main Oil Reservoir

1. Close main valve (11).
2. Aerate the return oil filter chamber by opening the filler plug on top of the main reservoir.
3. Open cock (1), position -O-.

REMARK

In order to prevent build-up of a vacuum in the suction system, open the vent plugs on the suction port of each main hydraulic pump.

4. Switch on pump (4) with switch (6).
When changing the hydraulic oil, be sure to evacuate the main oil reservoir via the service arm connector simultaneously with the transfusion procedure. Otherwise overfilling of the main oil reservoir. Observe oil level at sight gauge.
5. When the suction oil reservoir is empty or after completion of the maintenance job switch off transfer pump (4) with switch (6). Close cock (1), position -C- and open main valve (11).
6. With the main shut-off valve (11) open, the suction oil reservoir will be filled with oil from the main oil reservoir. Let the vent plugs on the main pump suction ports open to allow the air to escape from the suction oil reservoir and hoses.

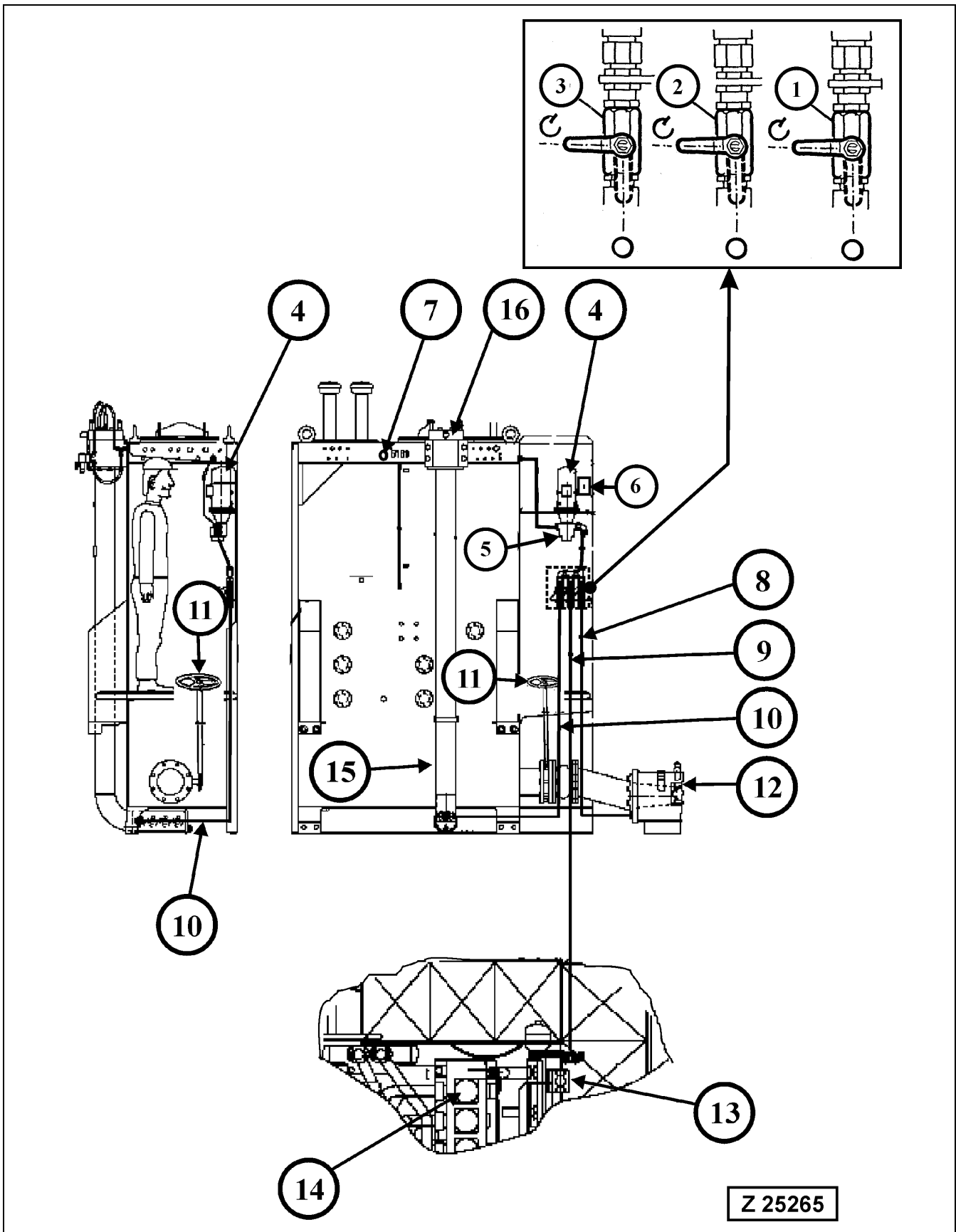

A - Pumping the oil from the Suction Oil Reservoir (12) into the Main Oil Reservoir (continued)

7. The suction oil reservoir and the suction hoses are filled, when bubble free oil flows out at the vent plug openings on each main pump. Install vent plugs and tighten securely.
8. Check oil level in all main pump housings and vent the hydraulic pumps according to page 497 in the Maintenance Section 4.
9. Check oil level in the main reservoir. Fill up with new hydraulic oil as necessary and install filler plug.
10. Start the engines and run without load to allow trapped air to be removed from the hydraulic system.

CAUTION

DO NOT start the engines when the suction oil reservoir is empty.

B - Pumping the Oil from the Return Oil Collector Pipe (13) and back-pressure valve pipe (15) into the Main Reservoir

1. To empty the collector pipe (13), open cock (2).
2. Aerate the return oil filter chamber by opening the filler plug on top of the main reservoir.
3. Switch on pump with switch (6).
4. Observe oil level sight gauge at the main oil reservoir. As soon as the oil level remains constant the return oil collector pipe is empty. Now switch off the transfer pump (4) and close cock (2).
5. To empty the back-pressure valve pipe (15), open cock (3).
6. Switch on pump with switch (6).
7. Observe oil level sight gauge at the main oil reservoir. As soon as the oil level remains constant the back-pressure valve pipe is empty. Now switch off the transfer pump (4) and close cock (3).
8. Install filler plug on top of the main oil reservoir.

CAUTION

DO NOT start the engines during servicing.

3.20 CENTRAL REFILLING SYSTEM

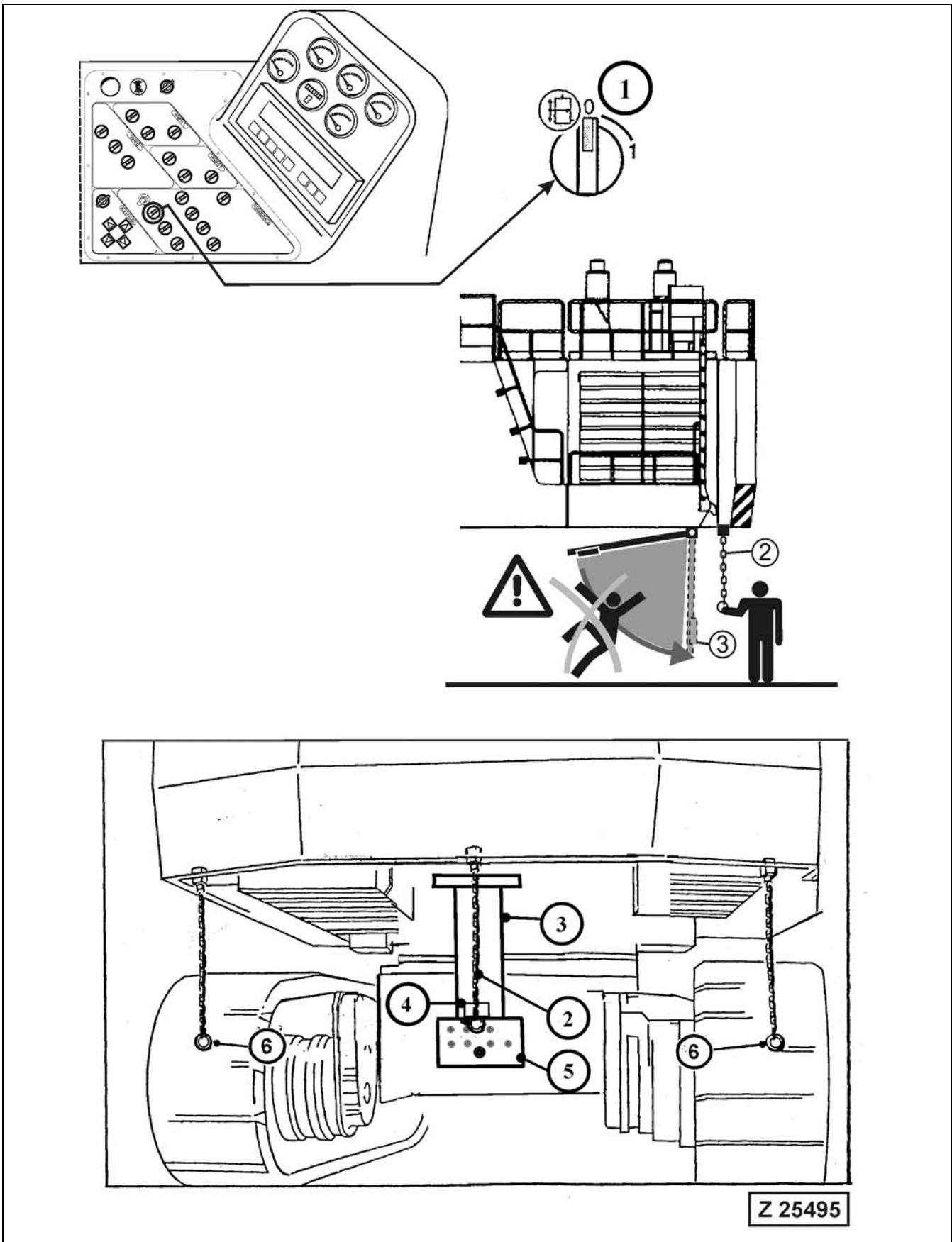

3.20.1 SYSTEMS CONNECTED TO THE REFILLING SYSTEM

The following systems are connected to the receiver panel (5) of service arm (3), illust. (Z25495):

- Fuel Tank
- Water Tank for Hand Wash Sink in the Operator's Cab
- Front and Rear Engine Oil Pan
- Front and Rear Engine Oil Reserve Tank
- Front and Rear Engine Coolant Radiator
- Main Hydraulic Oil Reservoir
- Central Lubrication System (CLS)
- Swing circle pinion Lubrication System (SLS)

Legend for illustration Z25495

- (1) Enabling switch for hydraulic service arm operation
- (2) Actuating chain for lowering and lifting of hydraulic service arm (3)
- (3) Service arm, hydraulically operated
- (4) Monitoring and control box
- (5) Receiver panel
- (6) Actuating chains for Operator Warning System or Emergency Shutdown of the Engines (if so equipped).

Operation of the hydraulic Service Arm

⚠ WARNING

- **Never enter, or allow anyone else to enter the moving range of the service arm (3). Death or serious injury can result.**
 - **DO NOT loosen any connections on the hydraulic circuit of the service arm. The circuit is under pressure. Lower the service arm completely before carry out any work on the hydraulic circuit.**
-
-

REMARK

With Enabling switch (1) in ON position "1" and/or Service Arm (3) not in fully lifted home position, the pilot control system is inoperative i.e. no Shovel movement possible.

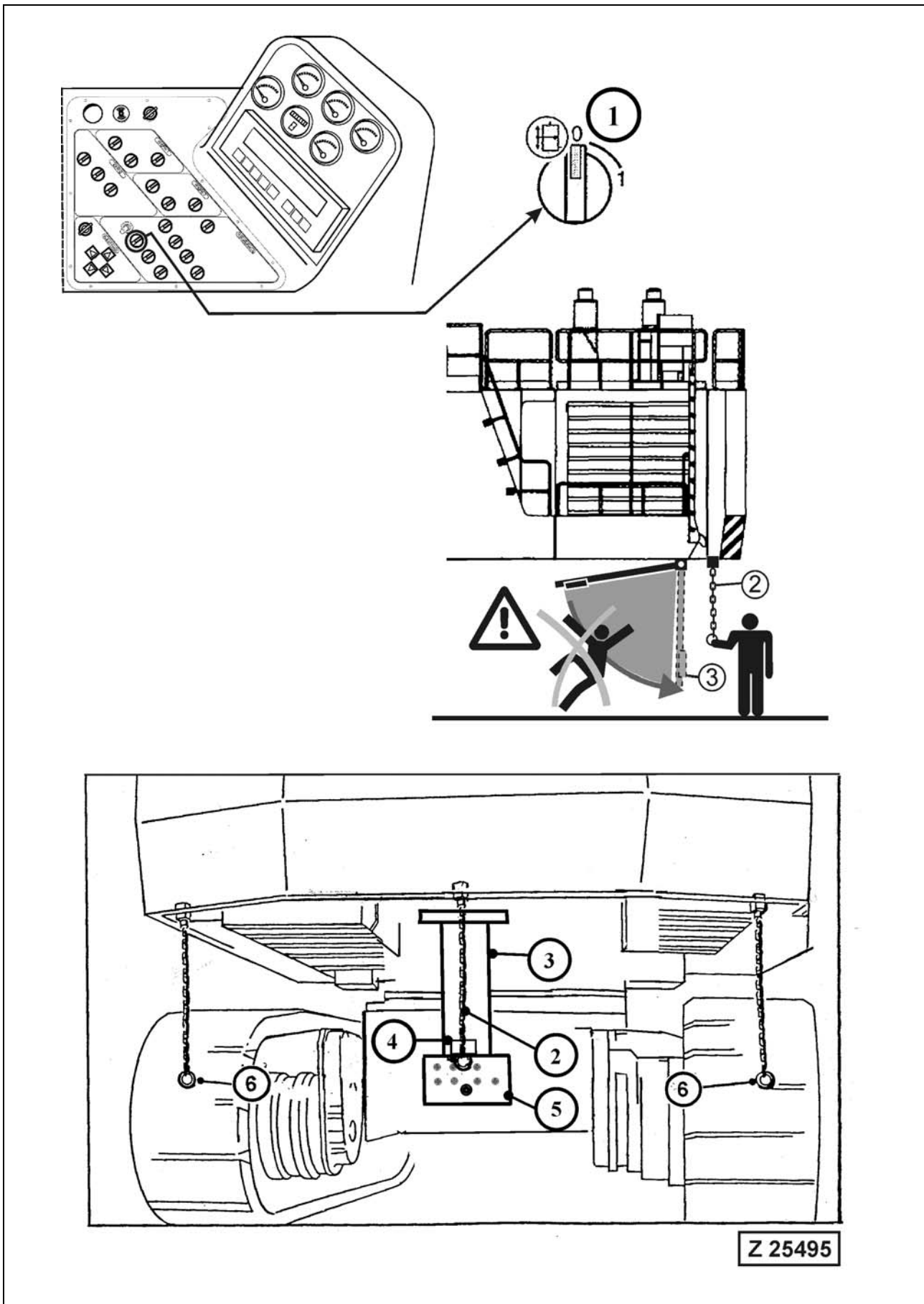

3.20.2 OPERATING THE HYDRAULIC SERVICE ARM

A - Diesel Engines OFF

The Service Arm can only be lowered.

Proceed as follows:

1. Turn main key switch to ON position.
2. Turn enabling switch (1), illust. (Z25495) to ON position "1".
3. For lowering the Service Arm (3) pull down chain (2).
4. Release chain (2) when arm (3) is in fully lowered position.

REMARK

To stop lowering movement of the Service Arm in any position release chain (2).

5. Before leaving the Shovel turn enabling switch (1) to OFF position "0" and remove the main switch key.

B - Diesel Engines running

Control the Service Arm as follows:

1. Turn enabling switch (1), illust. (Z25495) to ON position "1".
2. To lower the service arm (3) pull chain (2) and hold until the service arm is in fully lowered position. For reversing moving direction of service arm release the chain (2) to stop service arm movement and then pull chain (2) again.
3. To lift the service arm pull chain (2) and hold until the service arm is completely lifted into its home position.

NOTICE

Be sure the Service Arm is completely lifted to its home position otherwise the proximity sensor in the guide frame of the service arm will not release the pilot control system.

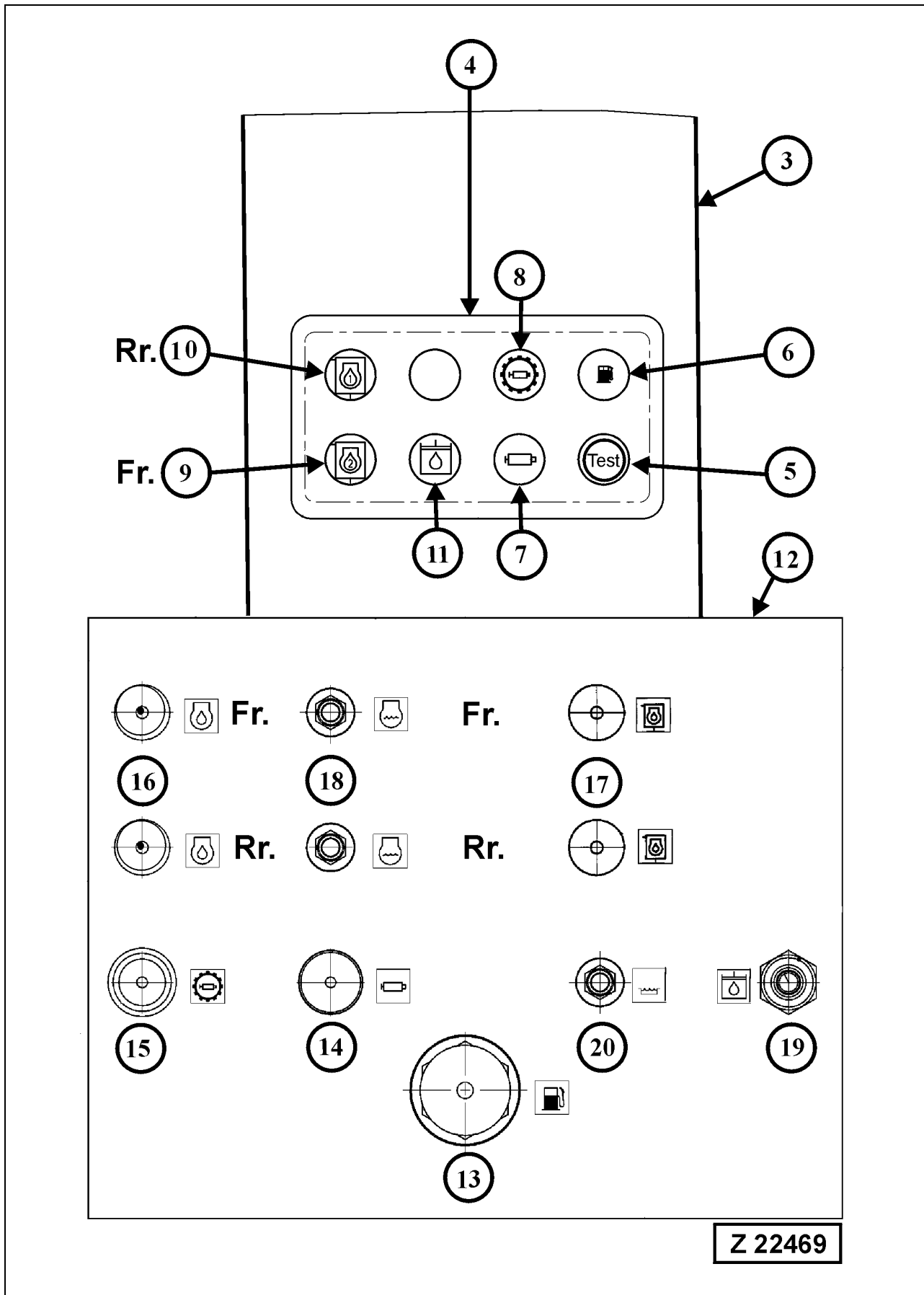

3.20.3 RECEIVER PANEL WITH MONITOR BOX

Legend for illustration Z 22469:

3	Service arm, hydraulically operated
4	Monitoring and control box
5	Push button for testing lamps (6, 7, 8, 9, 10 and 11). Push the button, all lamps must light up. If a lamp does not light up, corrective action must be taken.
6	Indicator lamp, fuel tank full. (H139)
7	Indicator lamp, grease container of Central lubrication System FULL. (H76)
8	Indicator lamp, grease container of Swing circle pinion Lubrication System FULL. (H78)
9	Indicator lamp, engine oil reserve tank for Front engine 2 FULL. (H142-2)
10	Indicator lamp, engine oil reserve tank for Rear engine 1 FULL. (H142-1)
11	Indicator lamp, main hydraulic oil reservoir FULL. Recheck hydraulic oil level at the sight gauge before operating the machine. (H52)
12	Receiver panel
13	Fuel filling adapter, observe lamp (6). REMARK The fuel nozzle cut-out pressure should be adjusted to 0,38 bar. If this pressure is too low for filling the fuel tank up to the correct level, gradually increase the cut-out pressure until the pressure is sufficient for filling up to the correct level The maximum flow rate should not exceed 680 liter per minute.
14	Adapter for filling the grease container of the Central Lubrication System (CLS). Before filling the grease container make sure the grease filter in the filling line is not obstructed. Observe lamp (7).
15	Adapter for filling the grease container of the Swing circle pinion Lubrication System (SLS). Before filling the grease container make sure the grease filter in the filling line is not obstructed. Observe lamp (8).
16	(Fr.) Front engine, (Rr.) Rear engine. Oil evacuation and filling adapter connected to the engine oil pan. Monitor oil level at level gauge.

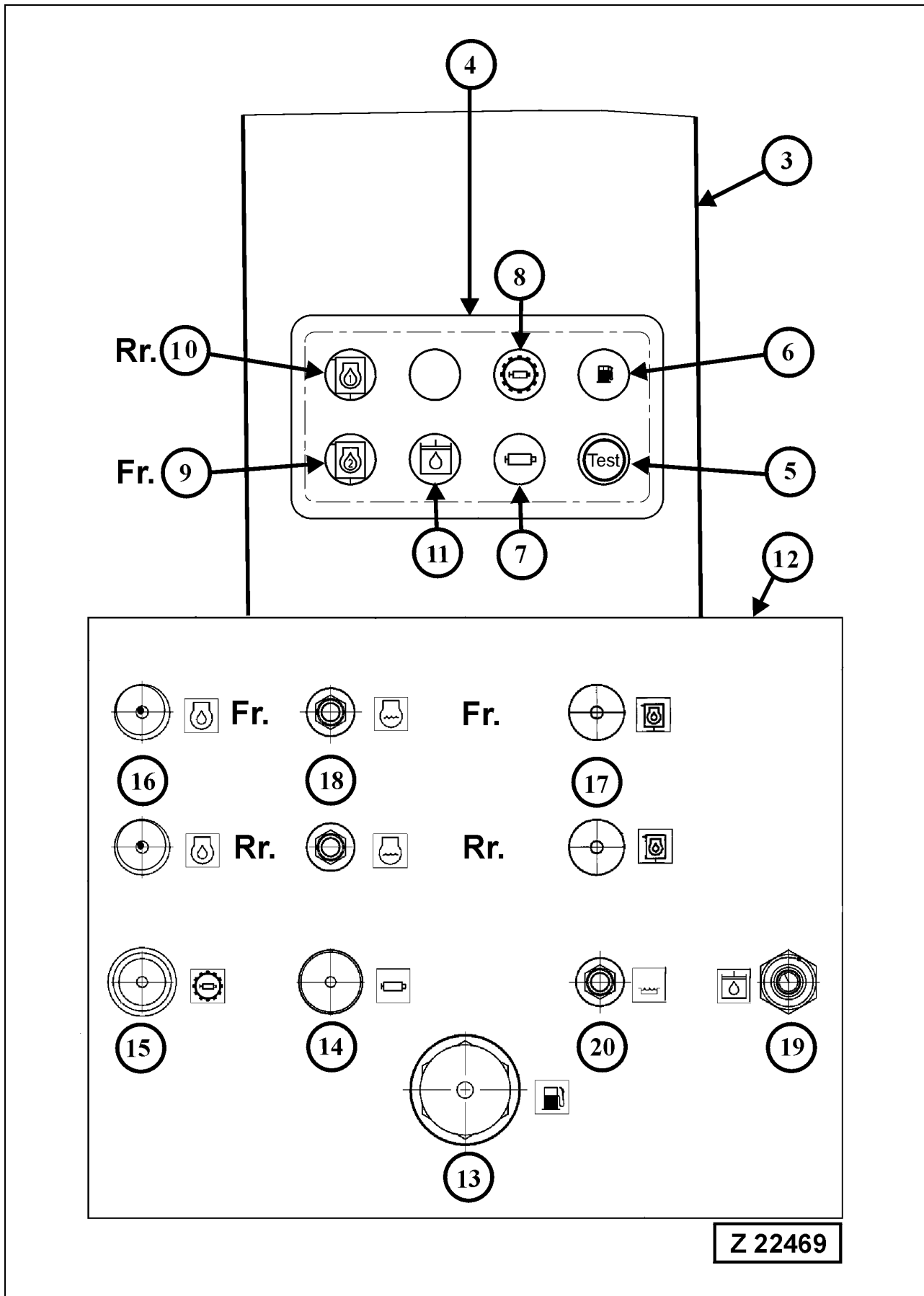

Z 22469

Legend for illustration Z 22469

17	Engine oil evacuation and filling adapters of the reserve tanks for Front engine (Fr.) and Rear engine (Rr.). Observe the corresponding indicator lamp (9) and (10).
18	(Fr.) Front engine, (Rr.) Rear engine. Radiator coolant draining and filling adapter. Monitor coolant level at radiator filler neck.
<p>NOTICE</p> <p>The two-loop type cooling system of each engine is equipped with two radiators. One radiator for the engine crankcase and cylinder heads and one radiator for the low temperature aftercooler (LTA) system. The radiators are connected with a pipe on the bottom side. This pipe contains a check valve which allows coolant flow from rear radiator to the front LTA radiator only. For draining the coolant from the front mounted LTA radiator, it is necessary to open the shut-off cock in the draining/filling hose line just below the radiators. Refer to the engine Operation and Maintenance Manual in volume 2 binder for the maintenance instructions of the cooling system.</p> <p style="text-align: center;">CAUTION</p> <p>Be sure to close the shut-off cock on the bottom side of the radiators as soon as the maintenance of the cooling system is finished.</p>	
19	Adapter for evacuation and filling of the main hydraulic oil reservoir. After the oil is completely evacuated, drain the oil from suction oil reservoir, collector pipe and back-pressure valve pipe. Refer to maintenance section, item hydraulic oil change for draining procedure. Open the shut-off valve between main oil reservoir and suction oil reservoir. Fill the hydraulic reservoir and observe indicator lamp (11).

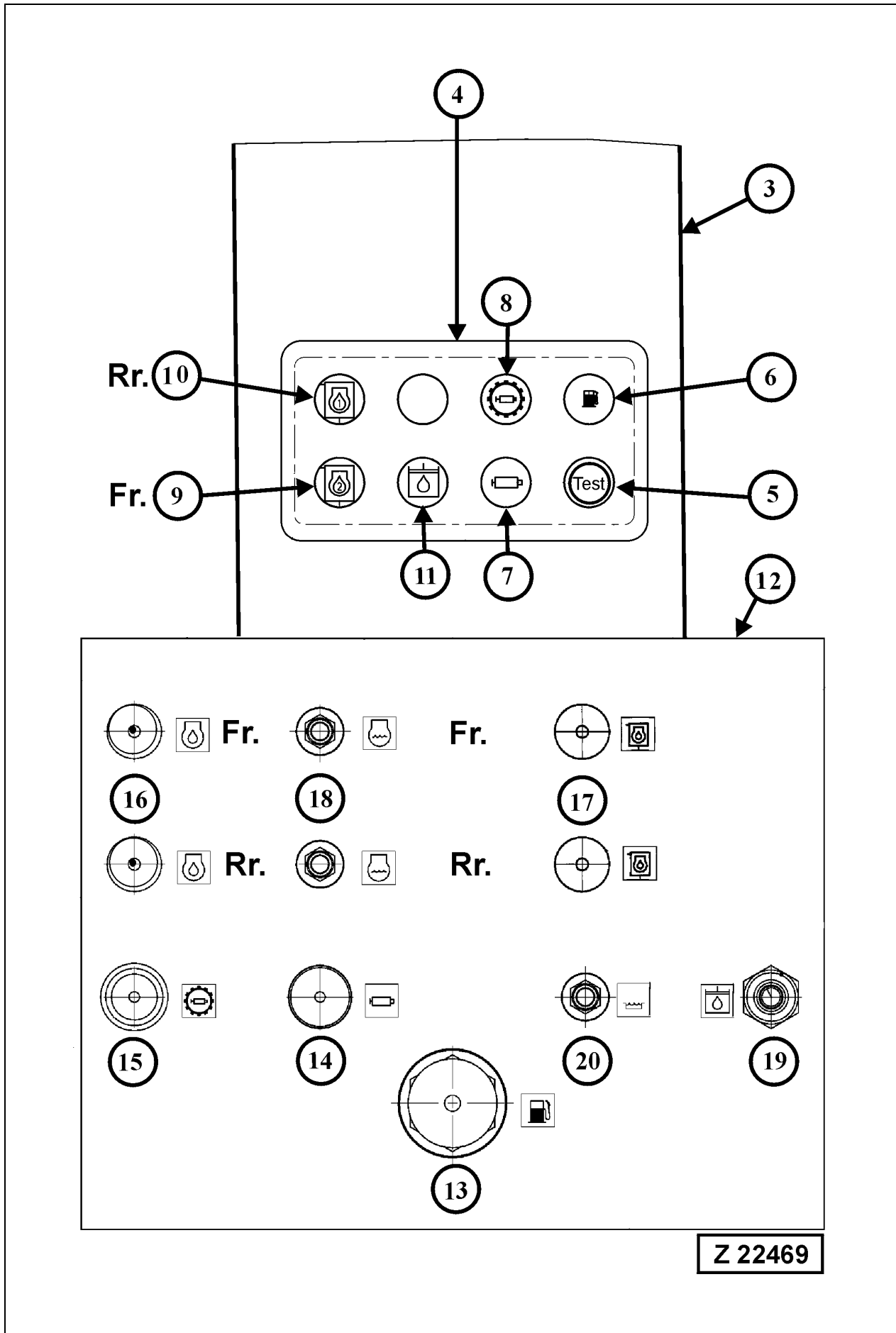

Z 22469

RECEIVER PANEL WITH MONITOR BOX

Legend for illust. Z 22469

20	Adapter for filling the water tank in the Operator's cab. The water tank has a capacity of 50 liters. The filling line of the water tank is equipped with a drain cock. Before filling the water tank, drain the old water by opening this drain cock. Close the drain cock and fill in 50 liters of clear water. The tank can also be filled through a filler opening in the Operator's cab.
----	---

NOTICE

If freezing temperatures are expected, drain the water from the filling line by opening the drain cock. Switch on the engine-independent auxiliary cab heater during standstill periods to prevent freezing of the water in the cab water tank.

⚠ WARNING

- **DO NOT drink the water from the water-tap in the Operator's cab.**
- **Use for hand washing only.**

REMARK

The overflow line of the hand wash sink and water tank must not be obstructed. The overflow line is routed inside the cab base through a hole in the base floor to the outside. Excess water will flow through this line to the outside just below the cab base.

Refilling Procedure:

REMARK

Refer to Maintenance section 4, for the correct lubricant specifications and filling capacities.

For Engine Lubricants and Coolants refer to the separate Engine Operation & Maintenance Manual in volume 2 Binder.

1. Connect supply lines to the respective adapters.
2. Monitor the respective fluid/lubricant level at the indicator lights (6, 7, 8, 9, 10 and 11).
3. After finishing the refilling operation, cover the adapters with the protection caps provided and swing back hydraulic service arm (3) to its home position.

⚠ CAUTION

Recheck fluid levels before operating the machine.

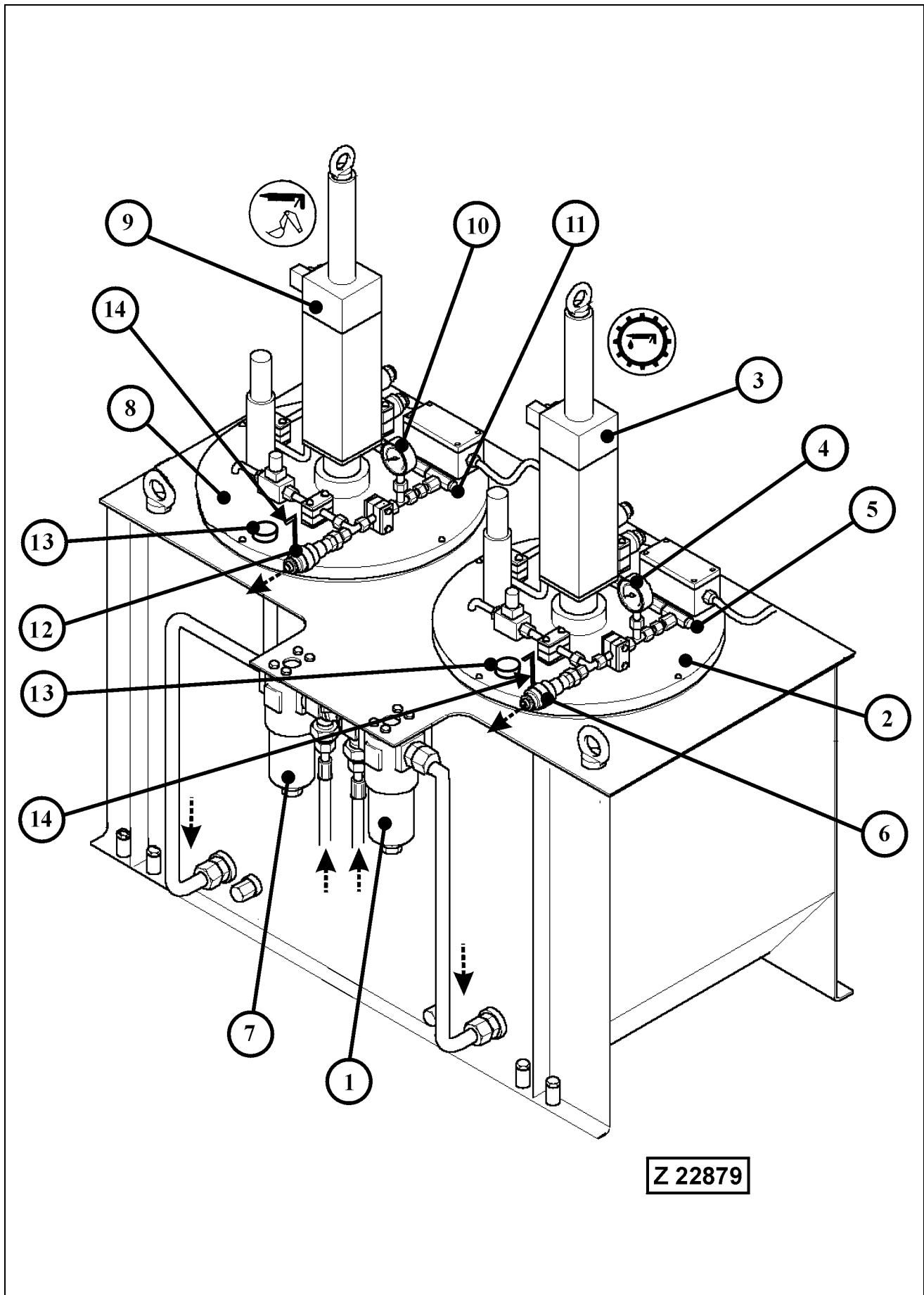

3.20.4 REFILLABLE GREASE CONTAINERS OF THE AUTOMATIC LUBRICATION SYSTEMS

Legend for illustration Z22879

- (1) Grease filter for swing circle pinion lubrication system. Before filling the grease container make sure the filter is not obstructed. Service the filter element according to the instructions in the maintenance section 4, item no. 4.8.
- (2) Grease container of the swing circle pinion lubrication system
- (3) Hydraulically driven grease pump
- (4) Grease pressure gauge
- (5) In-line grease filter
- (6) Quick disconnect coupling
- (7) Grease filter for central lubrication system. Before filling the grease container make sure the filter is not obstructed. Service the filter element according to the instructions in the maintenance section 4, item no. 4.8.
- (8) Grease container of the central lubrication system
- (9) Hydraulically driven grease pump
- (10) Grease pressure gauge
- (11) In-line grease filter
- (12) Quick disconnect coupling
- (13) Breather filters
- (14) Grease level gauge for manual checking of the grease level

Refill the respective grease container, when the Fault message "Central lube system grease container on reserve" or "Swing circle lube system grease container on reserve" is being displayed on the ECS monitor.

▲ CAUTION

The central lubrication system and the swing circle pinion lubrication system have to be filled with different types of grease. Select the correct greases according to the Lubricant Charts in volume 2 binder.

As soon as a grease container is filled up to the correct level the corresponding indicator lamp (7 or 8), illust. (Z 22469) lights up and the signal horn sounds. In order to ensure proper operation of the lubrication systems carry out the periodic maintenance of the grease filters (1 and 7), illust. (Z22879). Refer to maintenance section 4, item no. 4.8. Periodic inspection of the grease pumps (3 and 9) at least once a year is advisable. After finishing the refilling operation, cover the adapters with the protection caps provided. Carry out a test-run of the lubrication systems by actuating the switches on the instrument panel.

3.21 WORK ON THE LOADER ATTACHMENT

WARNING

- **Work on the loader attachment must be carried out only by personnel with special knowledge of the Shovel. Improper working on the attachment can cause severe accidents with personal injury.**
 - **If you are not sure how to carry out the work on the attachment contact your local Komatsu Service Station for support.**
-

OBSERVE THE FOLLOWING INSTRUCTIONS

- Wear safety clothing, goggles, respirator and other safety devices, whenever working conditions make this necessary.
- Provide hoists of sufficient capacity to lift heavy units. Refer to the separate "Assembly Procedure Manual" filed in volume 2 binder for more information.
- Before working on the loader attachment lower it to the ground, stop the engine and cycle all hydraulic control levers to relieve all pressure before disconnecting hydraulic lines.

For more information → See "STOPPING THE ENGINES" on page 264

- Lifting gear, tools and other suspension systems must be in good condition and of sufficient lifting capacity.
- Be sure hydraulic cylinders and attachment components are properly supported from hoist and securely fastened before removing supporting pins.
- Floors must be clean and dry. After draining operations be sure all spillage is cleaned up.

3.22 TRANSPORTATION AND LIFTING OF THE SHOVEL

WARNING

Before Disassembling, Lifting or Transporting this Shovel contact your local Komatsu Service Station for all the necessary instructions for safe and economic disassembling, lifting and transportation procedures of your Shovel.

3.22.1 DISASSEMBLING OF THE SHOVEL

The Shovel is being transported disassembled into its main components.

WARNING

Disassembling of the Shovel must be carried out only by personnel with special knowledge of the Shovel. Improper disassembling procedures can cause severe accidents with personal injury.

The sequence of disassembly can be derived from the Assembly Procedure Manual in volume 2 Binder. Disassembling is basically the reverse order of the assembling procedure.

3.22.2 TRANSPORTATION AND LIFTING

The transport dimensions and weights of the Shovel's components are listed in the separate Assembly Procedure Manual filed in volume 2 binder.

Observe the operating permits of the low loader used for transportation. They contain the permissible load, loading width and height.

WARNING

- **Observe the federal, state and local laws and regulations for transportation of heavy units. Know the safety rules and laws before you transport this Shovel.**
 - **Make sure the low loader and the components of the Shovel are equipped with the correct safety devices.**
 - **Secure the Shovel and all components transported on the low loader against movement.**
-
-

3.23 RETRIEVAL PROCEDURE

⚠ WARNING

- Before starting retrieval measures, inform the responsible safety department.
 - Check whether fuel or oil has flown out.
 - Observe the local fire prevention- and safety regulations.
-

⚠ CAUTION

Contact your local Komatsu service station for all the necessary instructions for safe and economic retrieval procedures of your Shovel

NOTICE

Select the sequence of retrieval steps with regard to the stability of the Shovel. It must be prevented that the removal of main components impairs the stability of the Shovel

GENERAL

The "Assembly Procedure Manual" in volume 2 binder contains information for lifting the main components of the Shovel.

Provide adequate crane and lifting gear with sufficient lifting capacity.

3.24 SHOVEL STORAGE

GENERAL

Storage periods up to 30 days require no special preservation when the unit is stored in a protected place. When the Shovel is placed in storage for 30 days or more follow the procedure below.

NOTICE

The description below includes special equipment which may not be installed in your machine.

3.24.1 PREPARING FOR STORAGE

1. Clean the Shovel thoroughly, lubricate all points according to the lubrication chart. Move the machine to a protected place or cover the Shovel with a tarpaulin. Retract all hydraulic cylinders as far as possible. Cover the protruding piston rods with grease.
2. Refer to Engine Operation and Maintenance Manual for Engine storage procedure.
3. Fill up cooling system with anti-freeze and coolant. Observe instructions in the Engine Manual.
4. Service the engine air cleaner.
5. Drain condensation from fuel tank and fill the fuel tank with a mixture of 90% Diesel fuel and 10% protection oil, e.g. Shell Ensis 20.
6. Seal the engine air intake, exhaust outlet, electrical components, fuel tank ventilation and breather on the hydraulic oil reservoir to prevent dirt and moisture from entering.
7. Remove the batteries and store them in a cool, dry place (0 to 10° C) to minimize self discharge. Be sure the batteries are fully charged. Never allow batteries to run down below $\frac{3}{4}$ full charge.
8. Loosen all drive belts.
9. Repaint areas that have paint damage with a good quality paint. Grease all machined unpainted surfaces with good quality grease to prevent rust.
10. Drain condensation from hydraulic oil reservoir. If necessary, add hydraulic oil.
11. Attach a tag to the instrument panel to indicate what work has been done.

3.24.2 ONE MONTH REPETITIVE SERVICE PERIOD

1. Service the engine according to the engine manual.
2. Check coolant level and cooling systems for leakage.
3. Check all oil levels according to the lubrication chart.
4. Drain condensation from fuel tank and hydraulic oil reservoir.
5. Operate air conditioning for approx. ½ hour.

3.24.3 SIX MONTH REPETITIVE SERVICE PERIOD

1. Perform steps 1 through 4 of the one month repetitive service period.
2. Lubricate the Shovel according to lubrication chart (manual lubrication only).
3. Completely fill the fuel tank.
4. Check hydraulic system and all gear boxes for leakage. If necessary - fill up the units with the specified lubricant. Repaint surfaces that have paint damage.
5. Prepare the engine for operation according to the engine manual. Tighten all drive belts. Install fully charged batteries. Make sure the alternator is correctly connected.
6. Remove coverings from engine air intake, exhaust outlet, electrical components, fuel tank ventilation and breathers on the hydraulic reservoir.
7. Start the engine and run at low idle a few minutes to allow distribution of lubricating oil. DO NOT increase engine speed until normal oil pressure and temperature are reached.
8. Operate heater unit and air conditioning.
9. Operate the central lubricating system and swing ring gear lubrication system. Check the lubrication results at the respective lubrication points.
10. Carry out several complete working cycles with the loader attachment.
11. Stop the engine, observe the cooling down period. Install all coverings which have been removed according to step 6. Service the engine according to the engine manual. Lubricate all machined surfaces. Remove Batteries and store as described under "Preparing for Storage". Loosen all drive belts. Fill up the fuel tank.

3.24.4 PREPARING FOR OPERATION

1. Remove grease from all machined unpainted surfaces (piston rods).
2. Install fully charged batteries.
3. Remove all coverings.
4. Fill up fuel tank with an approved Diesel fuel.
5. Check cooling system for leaks, loose connections and coolant level. Check mixture ratio of antifreeze, refer to the engine manual for details.
6. Service the engine according to the engine manual. Tighten all drive belts. Make sure the alternator is correctly connected.
7. Carry out the maintenance according to the lubrication and maintenance manual of the Shovel.
8. Start the engine and run at low idle speed until the normal oil pressure and temperature are reached. DO NOT place the Shovel under load before the normal values are indicated.
9. If the engine is misfiring or loss of power is evident, check the fuel system for restriction or loose parts.
10. Carry out several complete working cycles. Check the function of special equipments (central lubricating system, swing circle pinion lubricating system, fire detection and suppression system etc.).

3.25 TROUBLE SHOOTING

GENERAL

The following charts list a number of the most common problems encountered in operation. Some of the faults may be due to careless handling or operation, improper maintenance or the use of lubricating oils other than specified. The "Probable Cause" column is formulated in such a way as to imply the answer to particular failure. For repairs requiring expert knowledge and tools, consult authorized service personnel.

3.25.1 ENGINE

Problem	Probable cause
Engine will not start	<ul style="list-style-type: none"> ● Fuel tank empty or filter clogged ● Fuel supply system air-bound or clogged ● Fuel filters not sealed properly ● Engine speed control system defective ● Cold starting aid, fluid container empty
Uneven engine operation	<ul style="list-style-type: none"> ● Fuel filters clogged ● Air in fuel system ● Engine speed governor defective
Engine overheats	<ul style="list-style-type: none"> ● Coolant supply insufficient ● Fan belt slipping ● Coolant passages in cooling system clogged with dirt or scale ● Radiator air passages clogged with dirt ● Exhaust pipe or muffler restricted ● Thermostat defective
Engine does not develop full power	<ul style="list-style-type: none"> ● Air cleaner clogged ● Fuel filters clogged ● Exhaust pipe or muffler restricted ● Engine speed control system incorrectly adjusted ● Valve (s) faulty ● Fuel lines restricted ● Turbocharger faulty, or inoperative
Loss of oil pressure	<ul style="list-style-type: none"> ● Oil filter (s) clogged ● Low oil level ● Poor quality oil ● Oil pressure switch defective ● Oil pump filter screen clogged ● Dirt in regulating valve ● Crankshaft, connecting rod or camshaft bearing (s) worn excessively.

NOTICE

Refer to the engine manual for more detailed information.

3.25.2 HYDRAULIC SYSTEM

Problem	Probable cause
Poor hydraulic system performance	<ul style="list-style-type: none"> ● Hydraulic oil not at operating temperature. ● Engine speed too low. ● Reservoir low on oil ● Restrictions in lines ● Cooling circuit, pump control system and/or pilot control circuit defective. ● Internal leakage (control blocks, valves or power units.) ● Pressure lines twisted or kinked ● Spool not in full stroke. ● Relief valve defective, or out of adjustment. ● Worn cylinders. ● Defective hydraulic pump.
Excessive oil temperature	<ul style="list-style-type: none"> ● Low oil level ● Incorrect viscosity or type of oil ● Hydr. oil cooler clogged with dirt. ● Oil cooler fan defective or wrong speed. ● Cooling circuit defective ● Pump control system defective ● Spool not in full stroke. ● Internal leakage (control blocks, valves or power units) ● Worn pump components ● Job conditions (high temperature of materials being handled)
Jerky motion of power cylinders	<ul style="list-style-type: none"> ● Piston rod bent ● Piston sticking ● Inside diameter of cylinder tube partially increased or scored ● Air in control circuit ● Oil too cold ● Valve spool sticking, centering springs defective ● Pump and/or engine control system defective ● Valve of power circuit defective
Noise when slewing	<ul style="list-style-type: none"> ● Inssufficient lubrication of swing ring gear and/or slewing connection. ● Slewing connection mounting bolts loose ● Drive pinion worn ● Swing gear bearings worn ● Sun gear or planetary pinions worn ● High pressure circuit valves defective ● Anti-cavitation valves sticking
Excessive oil foaming	<ul style="list-style-type: none"> ● Air in hydraulic system ● Poor quality oil ● Excessive by-passing of oil over relief valves ● Pressure hoses badly twisted or kinked ● Restricted oil flow due to foreign matter ● Breather on the reservoir clogged. ● Relief valve improperly adjusted

3.25.3 FINAL DRIVES AND SWING GEAR

Noisy operation	<ul style="list-style-type: none"> ● Incorrect lubricant or oil level too low ● Bearings scored or damaged. ● Sun gear teeth excessively worn or damaged ● Bearings of planetary pinions worn
-----------------	---

3.25.4 CRAWLER TRACKS

Excessive track wear	<ul style="list-style-type: none"> ● Wrong track tension ● Track roller loose or out of alignment ● Track shoes loose ● Track links stuck ● Worn drive sprocket
Excessive wear on drive sprocket	<ul style="list-style-type: none"> ● Wrong track tension ● Track links (pins/bores) Excessively worn ● Sprocket, rollers and guide wheel out of alignment

4. MAINTENANCE

4.1 FOREWORD

This section contains instructions for the correct care and maintenance of your machine.

NOTICE

Since this section covers also special equipment and accessories, you may find illustrations and descriptions which do not apply to your machine.

DEFINITIONS

Service point

Unit or system where the prescribed maintenance work has to be performed (e.g. engine, hydraulic, PTO etc.).

Service intervals

Number of operating hours after which the maintenance work has to be performed (e.g. "Every 10 Operating Hours", at 10, 20, 30 etc.; "Every 250 Operating Hours", at 250, 500, 750 etc.).

GENERAL RECOMMENDATIONS

Thoroughly clean all grease fittings, caps and plugs before lubricating.

Seals must be replaced when oil drain plugs and oil level plugs have been opened.

Fill-up fuel tank at the end of the shift to prevent condensation of moisture.

It is recommended to carry-out oil change in assemblies when they are still at operating temperature to speed up draining.



WARNING

Avoid direct contact of hot oil with your skin. Hot oil can cause personal injury.

4.2 PRECAUTIONS FOR MAINTENANCE

- Before starting any lubrication or maintenance work read the Fundamental Safety Instructions on page 15.
- Park the Excavator at a safe place on level ground. Proceed according to the instructions on page 263 "Parking the Excavator". Lower the attachment flat onto the ground. Move all control levers to neutral position.
- Stop the engine and move all control levers through their shift positions to relieve the pressure in the hydraulic system. Refer to page 264 "Stopping the Engine" for detailed description of the stopping procedure.
- Before any maintenance work is started, set the maintenance safety switch to 0 position. Refer to page 205 for location of the maintenance safety switch. In the 0 position the engines can not be started. Secure this position by inserting a padlock into the holes of the switch. Up to three padlocks can be attached to the holes provided.
- A warning plate "CAUTION MACHINE MAINTENANCE" must be fixed in the Operator's cab before any lubrication or maintenance work is started.

NOTICE

Some checks and adjustments can only be done with the engine running. For such jobs two men are necessary. Thereby, the controls must not be left unattended, while the other man carries out checks and adjustments.

The man in the operator's seat must keep constant visual contact with the other one and they must agree on suitable communication signals before they start their work.

- Block the machine to prevent machine movement
- Always use safety devices to block hydraulic cylinders. Never rely on the machine hydraulic system to hold when working on the loader attachment. A hydraulic line or cylinder could fail or someone could accidentally strike the control levers causing the loader to fall.
- Relieve all pressure in the hydraulic system before servicing the hydraulic system.
- Oily cloth and inflammable material must be removed from the machine. Clean the excavator before starting maintenance work.
- Switch-off battery main switch and remove key, before working on the electrical system.
- Wear safety clothing, goggles, respirator and other safety devices, whenever working conditions make this necessary. Observe the local safety rules.
- Never allow unauthorized persons access to the machine during lubrication and maintenance work.

- After servicing, remove oily cloth, inflammable material and all tools from the machine.
- Clean the Excavator with a steam jet, especially after servicing fuel system, engine and hydraulic system.

NOTICE

- **For cleaning the Excavator and its components use only fresh water with a salt content of less than 0.05%.**
- **For cleaning the headlights, DO NOT use steam jet, high pressure cleaning device or strong water jet.**
- **Be sure to reinstall safety devices, guards or shields after adjusting and/or servicing the machine.**

4.3 FLUIDS AND LUBRICANTS

4.3.1 LUBRICANTS FOR OPERATION IN COLD AND ARCTIC CLIMATES

Lubrication Point	Lubricant	Ambient Temperature °C
Hydraulic System (pre-heated)	Shell Tellus Arctic Oil 32 NG	- 50 to + 35
Travel Gears	Shell Omala HD 220	All seasons
Final Drives	Shell Omala HD 220	All seasons
Swing Gears	Shell Omala HD 220	All seasons
Pump Distributor Gears (pre-heated)	Shell Transaxle Oil 75W-90 Tranself Synthese FE 75W-90	All seasons - 45 to + 35
Brake housings and Motor adapter housings of Gears	Shell Tellus Arctic Oil 32 NG	All seasons
Fan Bearing Housings of Hydraulic Oil Coolers	Shell Omala HD 220	All seasons
Track Rollers, Carrier Rollers and Idler Wheels	Shell Omala HD 220	All seasons
Central Lubrication System	Fuchs Stabyl L-TS MO Shell Darina XL 102 Moly Fuchs Urethyn HGO	- 10 to + 35 - 30 to + 35 - 50 to - 10
Swing Circle Lubrication System	Shell Malleus GL 400 Shell Malleus GL 25 Fuchs Urethyn HGO	- 10 to + 35 - 20 to 0 - 50 to - 10
Refrigerant Lubricant	Shell Clavus Oil R 68	- 50 to + 35
Refrigerant	Shell R 134 a	- 50 to + 35

Grease for the bearings of the main drive Electric Motors

- Mobilith SHC 100 or
- Esso Unirex S2

4.3.2 FLUIDS AND LUBRICANTS FOR MODERATE AND HOT CLIMATES

Point of Lubrication	Lubricant	Ambient Temperature °C	Viscosity Grades		Quality Grades DIN/API
Motors	Refer to page 312 and to the motor maintenance manual for specifications.				
Hydraulic System	Hydraulic oil "HLP or "HLPD" with ZINC anti-wear additives *1)	- 20 to + 11	22	-	DIN 51524 T.2 and T.3-HLP
		-14 to + 21	32	or 32 - 68	
		- 6 to + 31	46		
		0 to + 40	68		
		+ 5 to + 48	100	-	
Travel gears, Final drives and Swing gears	Hydraulic oil "HLP"	- 40 to + 10	HLP T32		DIN 51524. T.2 and T.3- HLP
	Gear oil "CLP" *2)	-15 to + 50	CLP 220		DIN 51517 3 - CLP
Brake housings and Motor adapter housings of Travel Gears	Engine oil	all	SAE 10		DIN 51524T.2 and T.3- HLP
	or Hydraulic oil		HLP 22 or HLP 32		
PTO's (Pump distributor gears) and pump drive shaft housings	Hydraulic oil "HLP"	- 40 to + 10	HLP T32		DIN 51524. T.2 and T.3- HLP
	Gear oil "CLP" *2)	-15 to + 50	CLP 150		DIN 51517 3 - CLP
Fan bearing housings of Hydraulic oil coolers	Gear oil "CLP"	all	CLP 150		DIN 51517 3 - CLP

NOTICE

- *1) **DO NOT mix ZINC-FREE Hydraulic oils with Hydraulic oils containing Zinc. DO NOT mix Mineral Hydraulic oils with Synthetic Hydraulic oils. Mixing of the above oils, will reduce anti wear properties and oxidation stability of the oil. Quick plugging of the oil filters in the hydraulic system will occur.**
- *2) **Refer to the chart "Gear Oils" filed in volume 2 binder for the released gear oil qualities and viscosity grades.**

REMARK

The lubricating instructions in this book refer to the recommended grade specifications. Damages caused by using lubricants other than specified are not covered by the manufacturer's warranty.

Point of Lubrication	Lubricant	Ambient Temperature °C	Viscosity Grades	Quality Grades
				DIN/API
Grease Fittings (manual lubrication)	Multi-Purpose Grease "MPG"	Refer to the Lubricant Chart in volume 2 binder for the recommended Multi-Purpose Greases. The part numbers of recommended Multi-Purpose Greases are listed in the Parts Catalog.		
Central Lubrication System				
Swing Circle Teeth (manual lubrication)	Adhesive Lubricant	Refer to PARTS & SERVICE NEWS, Bulletin No. AH00519 in volume 2 binder for the recommended Adhesive Lubricants. The part numbers of the recommended Adhesive Lubricants are listed in the Parts Catalog.		
Swing Circle Pinion Lubrication System				
Track rollers, Carrier rollers and Idler wheels	Gear oil "CLP"	all	CLP 220	DIN 51517 3 CLP
Air conditioning system	Refrigerant		R 134a	
Refrigerant compressor	Special oil See Note below.		REMARK The Air Conditioning is prepared for Refrigerant "R134a" only. Observe Notice below.	

NOTICE

The Air Conditioning must be filled with refrigerant "R134a" through authorized Service Specialists only. DO NOT use refrigerant "R12", otherwise serious damage on system components could occur. The lubrication oil for the refrigerant compressor must be compatible with "R134a" refrigerant.

Main Drive Electric Motor – Bearing Lubrication

(Excerpt of the Motor Maintenance Manual)

**Explanation of Abbreviations: D-end bearing = Drive end
N-end bearing = Non-drive end**

8 MAINTENANCE OF THE MACHINE

8.1 Bearings and lubrication

8.1.1 Antifriction bearings

Bearing solutions

The bearing constructions for different bearing solutions are shown in appendices 2-6. Deep groove ball bearings both in the D-end the N-end is the standard solution. When great radial forces appear, for example in belt drives, a cylindrical roller bearing can be fitted in the D-end. The complete bearing types are stamped on the rating plate.

The bearing in the D-end is axially fixed for horizontal machines when ball bearings are used in both ends. This means that the thermal growth will happen towards the N-end.

The bearing in the N-end is axially fixed for horizontal machines, when a cylindrical roller bearing is used in the D-end. In this case the thermal growth will happen towards the D-end. This should be considered when adjusting the coupling.

The bearing in the N-end is axially fixed downwards for vertical machines. In this case the thermal growth will happen in the D-end. This should be considered when adjusting the coupling and moving the machine.

Lubrication

The lubricating system of the machine is shown in appendices 2-5. Grease is injected to the inner side of the bearing through the grease passage. After filling the free space in the bearing, excessive grease will be discharged out from the bearing passing the grease valve. The excessive grease comes out through the opening in the bottom of the bearing construction.

The machines are equipped with a greasing nipple in both ends for lubricating the bearings. The grease nipples are located on side of the machine in both ends. The amount of grease and the interval of greasing are stamped on the relubrication plate. These can also be read from tables 3 and 4.

Table 3. Relubrication intervals and amount of grease for horizontally mounted machines.

Bearing type	Amount of grease [g]	Lubrication intervals in running hours at different speeds [rpm]					
		3600	3000	1800-1500	1200-1000	900-750	600-500
6317	35	800	2200	8800	8800	8800	8800
6319	45	400	1600	6600	8800	8800	8800
6322	60			6600	8800	8800	8800
6324	70			4400	8800	8800	8800
6326	80			4400	8800	8800	8800
*) 6330	100			1000	6600	8800	8800
NU317	35	400	1100	4400	8800	8800	8800
NU319	45			3300	6600	8800	8800
NU322	60			3300	6600	8800	8800
NU324	70			2200	6600	8800	8800
NU326	80			2200	6600	8800	8800
NU330	100			2200	3300	6600	8800

*) D-end and N-end bearing

Main Drive Electric Motor – Bearing Lubrication

(Excerpt of the Motor Maintenance Manual, for more information refer to Motor Manual)

Table 5. Recommended standard lubricants.

Manufacturer	Quality	Thickener	Base oil	Temperature range [°C]	Kinematic viscosity of base oil [mm ² /s, cSt at 40°C]	Kinematic viscosity of base oil [mm ² /s, cSt at 100°C]	Consistency [NLGI scale]
ESSO	UNIREX N2	Li	Mineral	-30 to +165	115	12.2	2
ESSO	UNIREX N3	Li	Mineral	-30 to +165	115	12.2	3
ESSO	BEACON 2	Li	Mineral	-40 to +120	100	9.5	2
SKF	LGMT 2	Li	Mineral	-30 to +120	92	9.6	2
MOBIL OIL	Mobilux 2	Li	Mineral	-30 to +120	100	10.0	2
SHELL	Alvania Grease G2	Li/Ca	Mineral	-25 to +140	100	11	2
SHELL	Alvania Grease G3	Li/Ca	Mineral	-20 to +150	100	11	2
TEBOIL	Multi-Purpose Grease	Li	Mineral	-30 to +110	110	10.5	2
BP	Energrease LS 2	Li	Mineral	-30 to +110	92	9.5	2
STATOIL	Uniway Li 42	Li	Mineral	-30 to +120	100	12.0	2

Note! AMA machines are lubricated in the factory with ESSO UNIREX N2, if nothing else is specified.

Table 6. Recommended high temperature greases.

Manufacturer	Quality	Thickener	Base oil	Temperature range [°C]	Kinematic viscosity of base oil [mm ² /s, cSt at 40°C]	Kinematic viscosity of base oil [mm ² /s, cSt at 100°C]	Consistency [NLGI scale]
ESSO	UNIREX N3	Li-comp.	Mineral	-30 to +165	115	12.2	3
SKF	LGHT 3	Li-comp.	Mineral	-30 to +150	110	13.0	3
MOBIL OIL	Mobiltemp SHC 100	Inorga.	Synthetic	-40 to +200	100	12.5	2
SHELL	Syntix 100	Li-comp.	Synthetic	-40 to +150	100	21.0	2
TEBOIL	Syntex Grease	Li-comp.	Synthetic	-40 to +140	150	20.0	2
STATOIL	Uniway LIX 42 PA	Li-comp.	Polyalfa	-35 to +150	100	18.0	2
CHEVRON	SRI 2	Polyr.	Mineral	-30 to +150	115	14.0	2
NESTE	Rasva 606	Li-comp.	Synthetic	-40 to +150	150	20.0	2

Mixing properties

It is important to consider the miscibility of greases if it is necessary to change from one grease to another. If incompatible greases are mixed, the consistency can change dramatically and the maximum operating temperature of the grease mix can be so low compared to the original grease, that bearing damage cannot be ruled out.

Greases having the same thickener and similar base oils can generally be mixed without any detrimental consequences, e.g. a lithium base grease can be mixed with another

lithium base grease. Calcium and lithium base greases are generally miscible with each other but not with sodium base greases. However, mixtures of compatible greases may have a consistency which is less than either of the component greases, although the lubricating properties are not necessarily impaired.

Control of the bearings when running

One way of detecting bearing damages is to measure the shock pulse generated by impacts as damaged surfaces are overrolled. Measuring devices for this kind of measuring

4.4 FILLING CAPACITIES

Unit or System	Liter (approx.)	Unit or System	Liter (approx.)
Cooling System		Swing Gears made by L&S , each:	42.0
Front Engine	360.0	Motor Adapter Housings	0.6
Rear Engine	360.0	Swing Gears made by Siebenhaar , each:	60.0
Engine Oil		Motor Adapter Housings	*2)
Front Engine Oil Pan	190.0	Brake Housings	*2)
Front Engine Reserve Tank (Refill)	580.0 (425.0)	Travel Gears, each	155.0
Rear Engine Oil Pan	190.0	Motor Adapter Housings, each	2.0
Rear Engine Reserve Tank (Refill)	580.0 (425.0)	REMARK The travel gear brakes are dry type multiple disk brakes. DO NOT fill the housings with oil.	
Fuel Tank	10800.0	Final drive housings, each	165.0
Hydraulic Oil Reservoir	3600.0 *1)	Guide Wheels, each	3.2
Total Hydraulic System	6600.0	Support Rollers, each	7.0
Pump Distributor Gears, each	95.0	Track Rollers, each	2,7
Oil Collector Reservoir, Auxiliary Hydraulic Pumps	1.0	Water tank for hand wash sink in Operator's cab	50.0
Main Hydraulic Pumps, Drive Shaft Housing	1.5	Water reservoir for windshield washer	7.0
Flexible Drive Couplings between Engine and Pump Distributor Gear, each	1.45		

***1)** Oil change quantity including suction oil tank and return oil collector pipes approximately 4450 liter with loader attachment in oil level checking position, see oil level plate on the main hydraulic oil reservoir.

***2)** Fill up to level gauge marking.

REMARK

Capacities listed above are approximate values. For proper checking use level plugs, dipsticks, and inspection openings provided for this purpose. Prior to commissioning check the fluid levels in all units and systems listed above.

4.5 STANDARD TORQUE LIST

Bolt dia.	Wrench size [mm]	Tightening torque		
		Nm		
		lbs.ft.		
		Quality grades		
		8.8	10.9	12.9
M 10	17	43	63	73
		32	47	54
M 12	19	74	108	127
		54.6	80	94
M 14	22	118	173	202
		87	128	149
M 16	24	179	265	310
		132	196	229
M 18	27	255	360	425
		188	265	313
M20	30	360	510	600
		265	376	443
M 22	32	485	690	810
		358	509	597
M 24	36	620	880	1030
		457	649	760
M 27	41	920	1310	1530
		679	966	1128
M 30	46	1250	1770	2080
		922	1305	1534
M 33	50	1690	2400	2800
		1246	1770	2065
M 36	55	2170	3100	3600
		1600	2286	2655
M 39	60	2800	4000	4700
		2065	2950	3466

Insert all bolts lubricated with MPG, KP2K

4.6 LUBRICATION AND MAINTENANCE SCHEDULE

4.6.1 INITIAL SERVICING

AFTER THE FIRST 250 OPERATING HOURS

Change oil in Swing gears, Travel gears and PTO's (pump distributor gears). Thereafter every 3000 hours, but at least once a year. An oil sample analysis should be made every 1000 operating hours.

Hydraulic system: Replace return oil filter elements and leakage oil filter element. Inspect return oil strainers. Thereafter every 1000 hours.

AFTER THE FIRST 250 AND 1000 OPERATING HOURS

Check tightening torque of high strength bolt connections. Thereafter every 1000 hours.

NOTICE

- **The mounting bolts of the left and right crawler carrier to the undercarriage carbody have to be retightened only after the first 1000 operating hours, see page 449 for retightening procedure.**
- **The swing circle connection bolts need only to be checked after the first 1000 operating hours in accordance with PARTS&SERVICE NEWS No. AH00511 filed in volume 2 binder.**

NOTICE

The above initial service is of vital importance for proper operation and long service life of the machine.

4.6.2 PERIODIC SERVICING INTERVALS

All following intervals of time between services are based on average operating conditions. Under unusually severe conditions of operation, reduce the interval of time between services.

NOTICE

The periodic servicing intervals are also displayed on the ECS screen.

Carry out the maintenance work of indicated service intervals according to this maintenance section.

4.6.3 PERIODIC SERVICING SCHEDULE

Service Intervals	Service Point	Service	See
When necessary	Engine Air Cleaners	Maintenance	page 335
	Swing circle toothing	Immediately apply grease if bare spots are visible	page 339
	Automatic lubrication systems	Fill grease containers Clean or replace filter elements	page 341
	Track rollers	If leakage occurs replace	page 345
	Carrier rollers	floating seals and fill with GL	
	Guide wheels	ISO VG CLP 220	
	Cold starting aid	Replace fluid cartridges	page 347
Every 10 operating hours or daily	Excavator	Walk-around inspection	page 349
	Working attachment	Check grease injectors of automatic lubrication system. Check for proper lubrication.	page 351
	Swing circle	Check grease injectors of automatic lubrication system. Check for proper lubrication.	page 355
	Air cleaners	Clean pre-cleaner	page 357
	Radiators	Check coolant level	page 359
	Track groups	Clean, esp. in winter	page 359
	Engines	Check oil level	(1)
	Fire detection and actuation system	Inspection	(2)
Every 50 operating hours or weekly	Swing gears and Motor adapter housings	Check oil levels	page 361
	Travel gears, Motor adapter housings and Final drives	Check oil levels	page 365
	PTO's (Pump distributor gears)	Check oil level	page 371
	Hydraulic access ladder	Check safety sensor	page 375
	Hydraulic oil cooler and radiator	Check and clean as necessary	page 377

- (1) Perform maintenance according to separate Engine Operation and Maintenance Manual filed in volume 2 binder.
- (2) Perform inspections according to the separate Manual "FIRE DETECTION AND ACTUATION SYSTEM" filed in volume 2 binder.

Service Intervals	Service Point	Service	See
Every 250 operating hours or monthly	Refrigerant compressor	Check drive belt tension	page 379
	Signal horn compressor	Lubricate	page 381
	Oil cooler fan bearings and Radiator fan bearing	Check for leakages and clean breather filters	page 381
	Automatic lube systems	Clean in-line grease screens and breather filters	page 383
	Cab air cleaner	Clean or replace filter element	page 385
	Air conditioning for Operator's cab	Inspection	page 387
	Windshield washer reservoir	Check fluid level	page 389
	Engine	Maintenance	(1)
	Fire suppression system	Inspection	(2)
	Eliminator filter	Maintenance check	(4)
Every 500 operating hours or quarterly	Batteries	Check fluid level	page 391
	Flexible Couplings	Check oil level	page 393
	Fuel tank	Drain condensation	page 395
	Crawler tracks	Inspection	page 397
	Engine and alternator ground cables	Check for correct connection	page 403
	Cab ground cable	Check for correct connection	page 405
	Fire detection and actuation system	Maintenance	(2)

- (1) Perform maintenance according to separate Engine Operation an Maintenance Manual filed in volume 2 binder.
- (2) Perform inspections according to the separate Manuals "FIRE DETECTION AND ACTUATION SYSTEM" and "FIRE SUPPRESSION SYSTEM" filed in volume 2 binder.
- (3) Perform inspections according to the separate Manual "OPERATING INSTRUCTIONS AC" filed in volume 2 binder.
- (4) Perform maintenance according to separate Service Bulletin "Eliminator Filter" filed in volume 2 binder.

CAUTION

Carry out initial service according to item 4.6.1.

Service Intervals	Service Point	Service	See
Every 1000 operating hours or every 6 months	High strength bolt connections	Check for correct tightening torque and security	page 407
	Hydraulic system	- Replace return and pressure filter elements - Clean or replace high pressure filter elements - Replace breather filter elements - Drain sediments	page 465
	PTO's (Pump distributor gears) Swing gears and Travel gears	Oil sample analysis	page 479
	Signal horn compressor	Clean and lubricate	page 481
	Hydraulic track tensioning system	Check pressure accumulators	page 483
	Water filter for hand wash sink in Operator's cab	Replace carbon filter cartridge	page 485
	Hydraulic oil cooler doors and machinery house doors	Inspect and lubricate door hinges	page 487
	Engine	Maintenance	(1)
	Fire suppression system	Maintenance	(2)
	Air conditioning	Inspect the complete system	(3)

- (1) Perform maintenance according to separate Engine Operation an Maintenance Manual filed in volume 2 binder.
- (2) Perform inspections according to the separate Manual "FIRE SUPPRESSION SYSTEM" filed in volume 2 binder.
- (3) Perform inspections according to the separate Manual "OPERATING INSTRUCTIONS AC" filed in volume 2 binder.

CAUTION

Carry out initial service according to item 4.6.1.

Service Intervals	Service Point	Service	See
Every 2000 operating hours or yearly.	Hydraulic system	- Change oil (*) - Replace suction strainers (*) - Replace pulsation damper	page 491
	Emergency escape ladder	Inspect	page 503
	Fire detection and actuation system	Maintenance	(3)
Every 3000 operating hours however at least once a year.	Swing gears and Motor adapter housings	Change oil	page 505
	Travel gears, Motor adapter housings and Final drives	Change oil	page 513
	PTO's (Pump distributor gears)	Change oil	page 517
	Engine	Maintenance	(1)

(*) The hydraulic oil change intervals can be extended for a further time period, when an oil sample analysis shows a positive result. When extending the oil change interval, it is necessary to carry out an oil sample analysis after every 1000 operating hours. However, it is recommended to change the hydraulic oil and the suction strainers after 6000 operating hours at the latest.

REMARK

The pulsation damper of the hydraulic oil cooler circuit must be replaced after every 2000 operating hours.

- (1) Perform maintenance according to separate Engine Operation and Maintenance Manual filed in volume 2 binder.
- (3) Perform inspections according to the separate Manual FIRE SUPPRESSION SYSTEM filed in volume 2 binder.

NOTICE

The Lubrication oil Pumps for Pump Distributor Gear Lubrication should be replaced with new pumps after every 5000 OPERATING HOURS.

Lubrication Chart

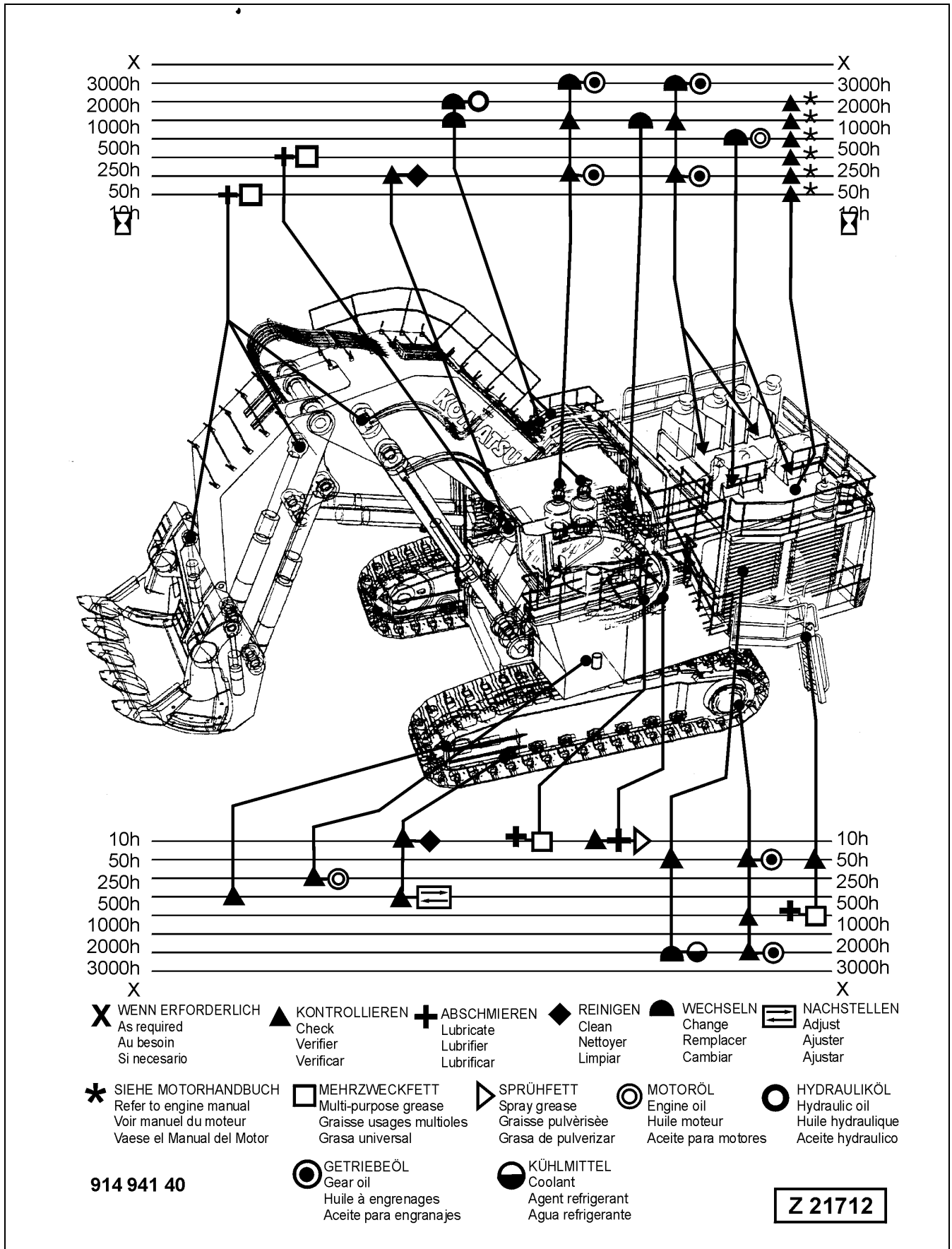

REPLACEMENT OF HYDRAULIC HOSE LINES

Hydraulic Hose lines are subjected to natural aging. Hence, their usable lifetime is limited to maximum 6 years.

CAUTION

The maximum permissible storage time of hydraulic hose lines is 2 years. This storage period is part of the usable lifetime and must be considered when a new hose line is being installed. If, for example, a hose line with a one year storage time shall be installed, the remaining service life of the hose line is 5 years. The production year and the ordering number of the hydraulic hose lines is stamped on the hose fittings.

All hydraulic hose lines of the Excavator have to be replaced after every 6 years at the latest, even if there are no visible damages.

WARNING

Repairs on hydraulic hoses and hose lines are not allowed. Use ONLY GENUINE KMG Replacement Hydraulic Hose Lines.

INSPECTION OF HYDRAULIC HOSE LINES

Inspect all hoses, hose lines and fittings periodically. Check for leaks and damages. Replace damaged parts without delay. Hydraulic fluid escaping under pressure can cause serious injuries and fire break out.

Some examples of faults on hydraulic hoses requiring replacement of the concerned part:

- Damages on the outer layer (e.g. chafed spots, cuts or scratches).
- Brittle top layers. Flaws on the hose material
- Distortion of the hose line (strong deviation from the original shape) under pressurized and pressureless conditions or when bent, e.g. disintegration of hose layers or blistering.
- Leaks
- Detachment of hose and fitting. Damaged hose fitting

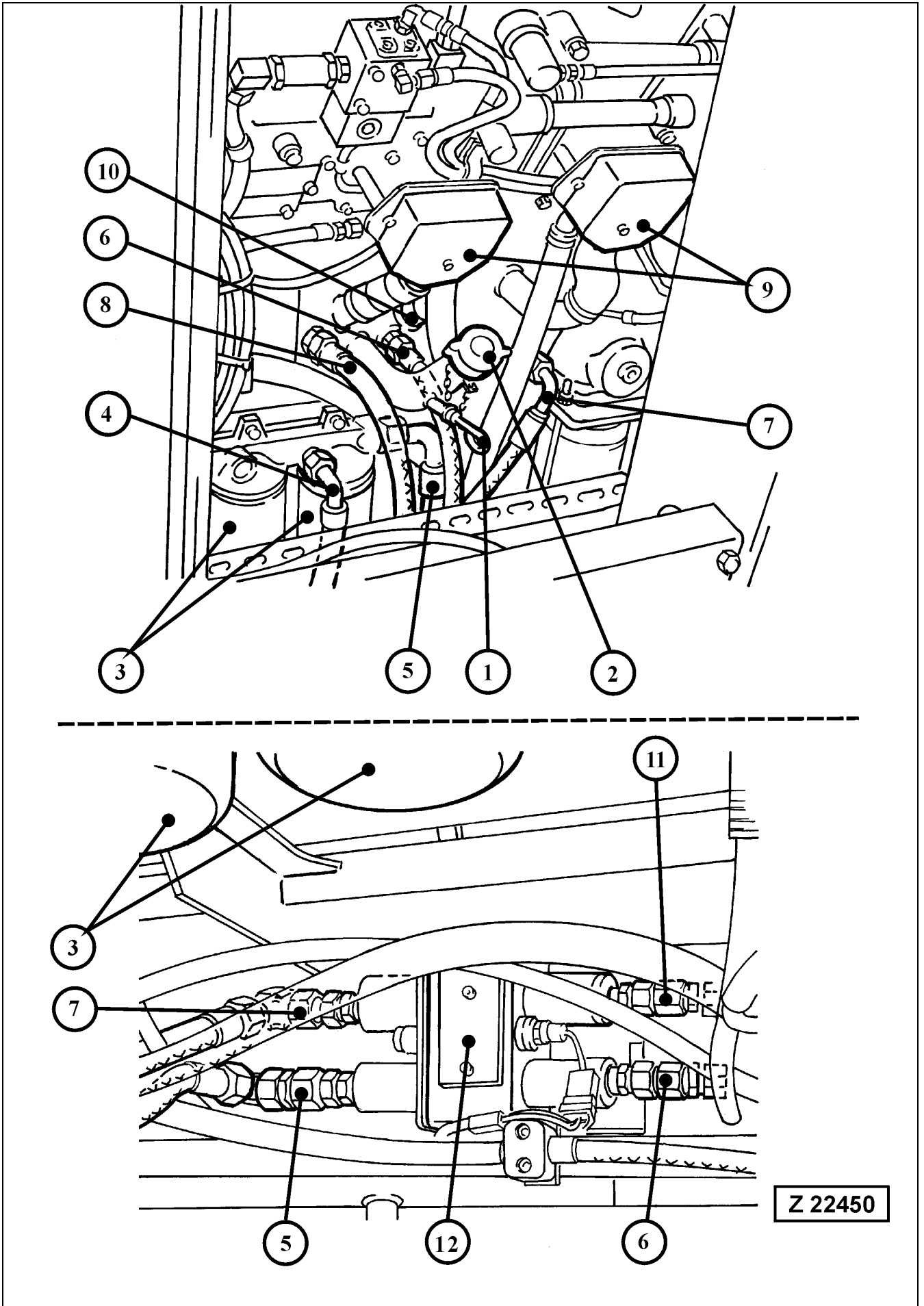

4.6.4 EXTENDED SERVICE INTERVALS FOR ENGINES WITH ENGINE OIL MANAGEMENT SYSTEM

REMARK

The engine oil management system of each engine combines the automatic engine oil supply system "**Reserve**" and the oil burning system "**Centinel**" in connection with the "**Eliminator**" oil filtration system.

Legend for illustration Z 22450

- (1) Engine oil level gauge
- (2) Oil filler tube
- (3) Oil filters for the engine oil reserve system
- (4) Suction line from reserve tank
- (5) Suction line to pumping unit
- (6) Supply line from pumping unit to crankcase
- (7) Withdrawal oil line from engine oil pan to pump
- (8) Ventilation line for reserve tank
- (9) Breather filters
- (10) Plug
- (11) Oil feed-back line to reserve tank
- (12) Pumping unit, located in the cross member opposite of the oil filters (3).

Servicing Intervals

- **Every 10 operating hours**

Check oil level in both engine oil pans with Excavator standing on level ground, using oil level gauge (1). Check also oil level in both reserve tanks, see illust. Z 22452A.

REMARK

The oil level in the engine oil pan can vary between the MIN and MAX marking on gauge (1) depending on the operating condition of the reserve system when the engine was stopped. With sufficient oil in the reserve tank and with the reserve system in proper working order, there is no need to fill the engine oil pan even with the oil level at the MIN mark on gauge (1). If the oil level is below the MIN marking on the gauge, corrective action must be taken. Fill the reserve tank and check the reserve system. The function of pumping unit (12) is monitored by an indicator light located on the "X2" switch board in the cab base. See section "SWITCH BOARD (X2) IN CAB BASE" for more information.

Be sure to fill the corresponding reserve tank of rear engine -1- or the reserve tank of front engine -2- when the information message "**Engine oil reserve tank 1 (or 2) empty**" is being displayed on the ECS screen in the operator's cab.

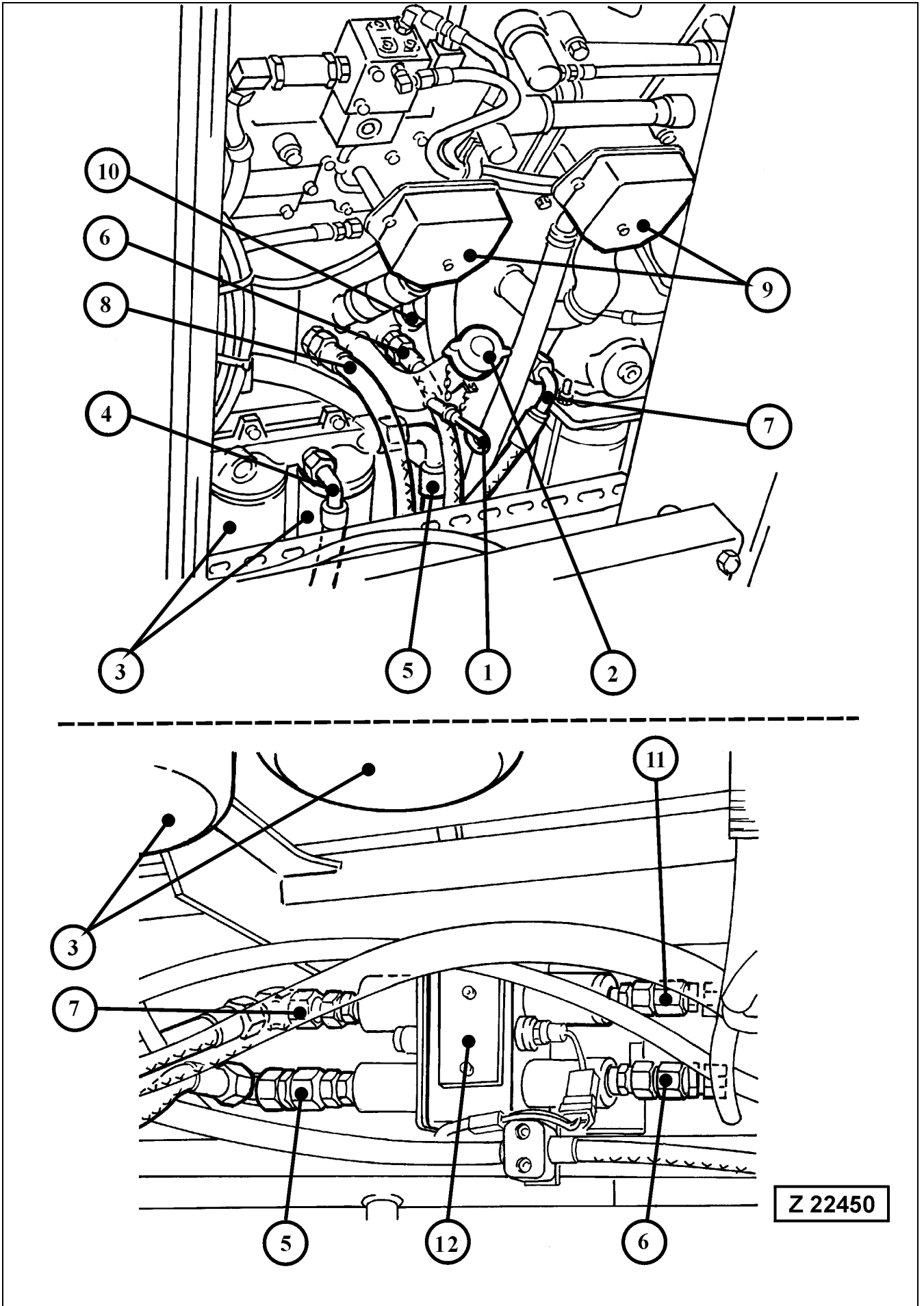

Extended Service Intervals for Engines with Engine Oil Management System

- **Every 500 operating hours**

The contents of each engine oil reserve tank is sufficient for approximately 500 hours of operation. The oil level in the reserve tanks is also monitored by the ECS system. Be sure to fill the corresponding reserve tank for rear engine -1- or front engine -2- when the information message **"Engine oil reserve tank 1 (or 2) empty"** is being displayed on the ECS screen.

Fill the reserve tanks via the swing down service arm.

Use engine oil according to the specifications in the Engine Operation and Maintenance Manual.

Change both oil filter cartridges (3) of the reserve system.

- **Every 4000 operating hours**

Change engine oil. Drain the oil from both engine oil pans and from both engine oil reserve tanks. See illustration Z22452A on page page 330 for location of the drain plugs on the reserve tanks. It is recommended to change the oil when the oil level in the reserve tanks is near the minimum level.

NOTICE

After the engine oil has been drained from both engine oil pans and from both reserve tanks, fill both engine oil pans and both reserve tanks via the swing down service arm.

See section "Central Refilling System" on page 286 for more information.

DO NOT use the oil in the reserve tanks to fill the engine oil pans after an oil change.

Refer also to the Engine Operation and Maintenance Manual for oil change procedure and oil specifications.

4.6.5 RESETTING THE ENGINE OIL BURNING SYSTEM CENTINEL

Resetting of the Centinel system is necessary in the following cases:

- After every engine oil change.
- Whenever the engine oil reserve tank has been allowed to run empty.
- After repairs on the Centinel system.
- When changing the engine oil quality from Mineral oil to Synthetic oil and vice versa.

For resetting procedure refer to page 69 in section 3.2

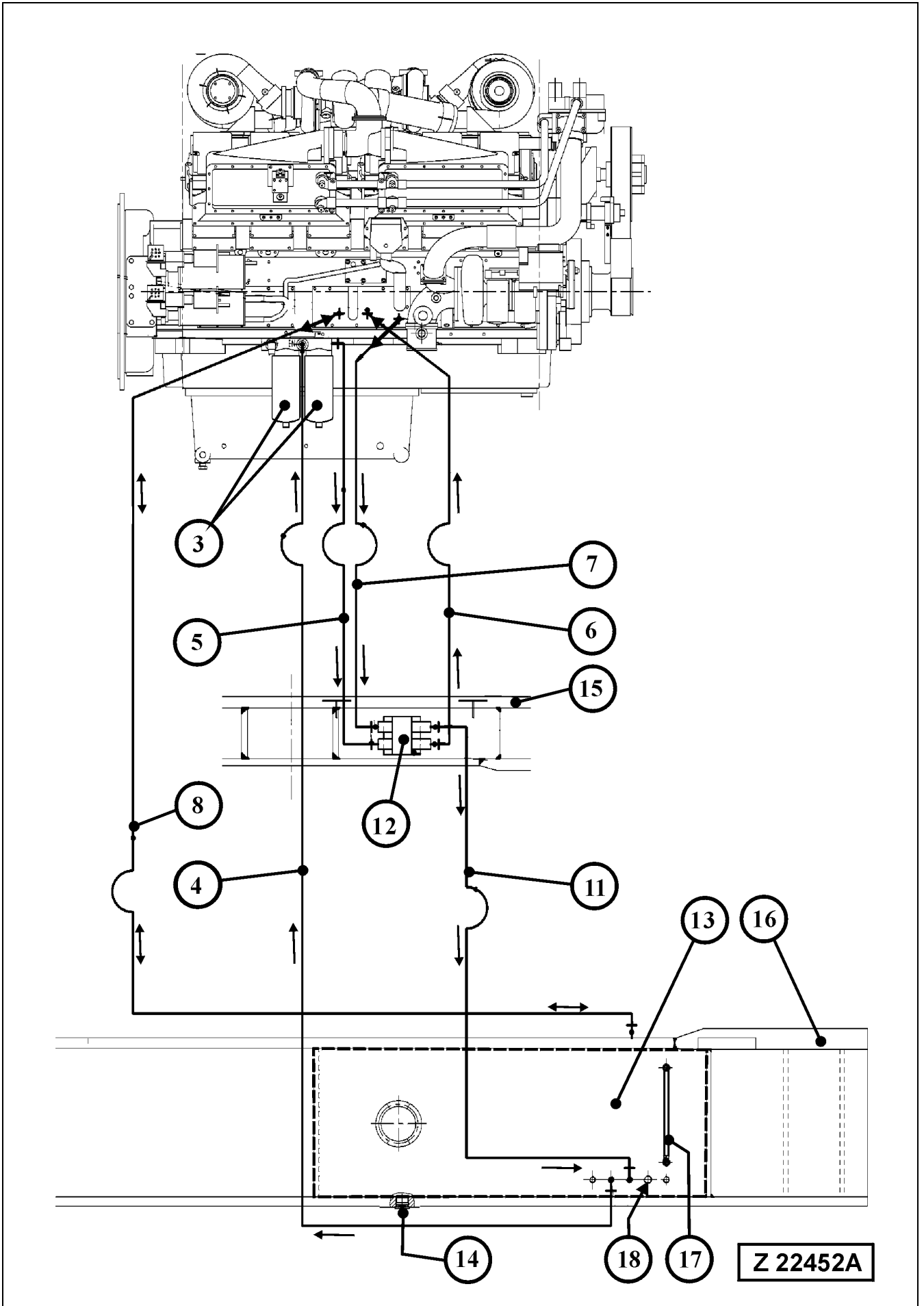

Extended Service Intervals for Engines with Engine Oil Management System

Reserve System Oil Flow Schematic, illust. Z 22452A.
Front engine -2- shown. Rear engine -1- is connected to the reserve tank in the LH side member of the main frame

- (3) Oil filters for the engine oil reserve system
- (4) Suction line from reserve tank
- (5) Suction line to pumping unit
- (6) Supply line from pumping unit to crankcase
- (7) Withdrawal oil line from engine oil pan to pump
- (8) Ventilation line for reserve tank
- (11) Oil feed-back line to reserve tank
- (12) Pumping unit, located in the cross member opposite of the oil filters (3). The pump unit works automatically as soon as the engine speed is above 300 RPM. The pump unit consists of a pumping element for feeding oil from tank (13) into the engine oil pan. The second pumping element withdraws oil from the engine oil pan and feeds it back into the reserve tank when the oil level in the oil pan exceeds the maximum running oil level. The combined operation of the pumping elements maintains an optimal oil level in the engine oil pan. Oil drawn off by the Centinel burn system is also replaced through the supply system "Reserve".
- (13) Reserve oil tank. The reserve oil tank for the rear engine -1- is an integrated part of the LH main frame side member. The reserve oil tank for the front engine -2- is an integrated part of the RH main frame side member.
- (14) Drain plug
- (15) Machinery house frame cross member
- (16) RH side member of main frame
- (17) Oil level sight gauge. Be sure to add engine oil via the swing down service arm before the oil level is at the MIN marking on the sight gauge.
- (18) Connector for refilling line from swing down service arm

4.6.6 MAINTENANCE OF THE ENGINES

All maintenance has to be carried out in accordance with the separate Engine Operation and Maintenance Manual.

REMARK

Service the Eliminator Oil Filter according to the separate Service Bulletin "**Eliminator Filter**" filed in volume 2 Binder.

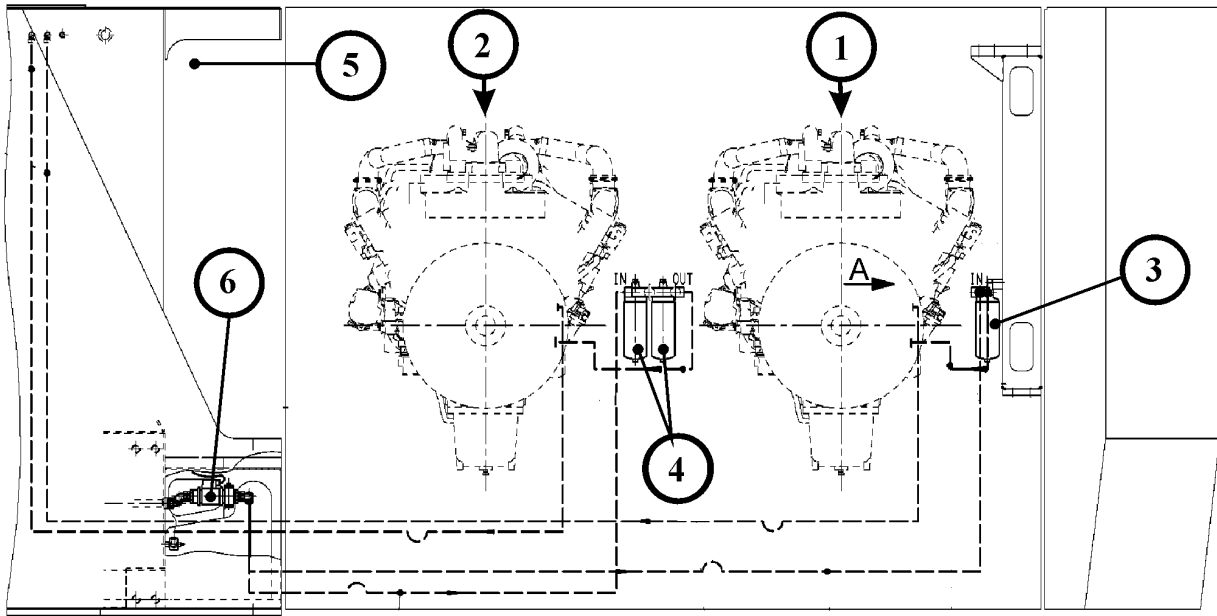

View A →

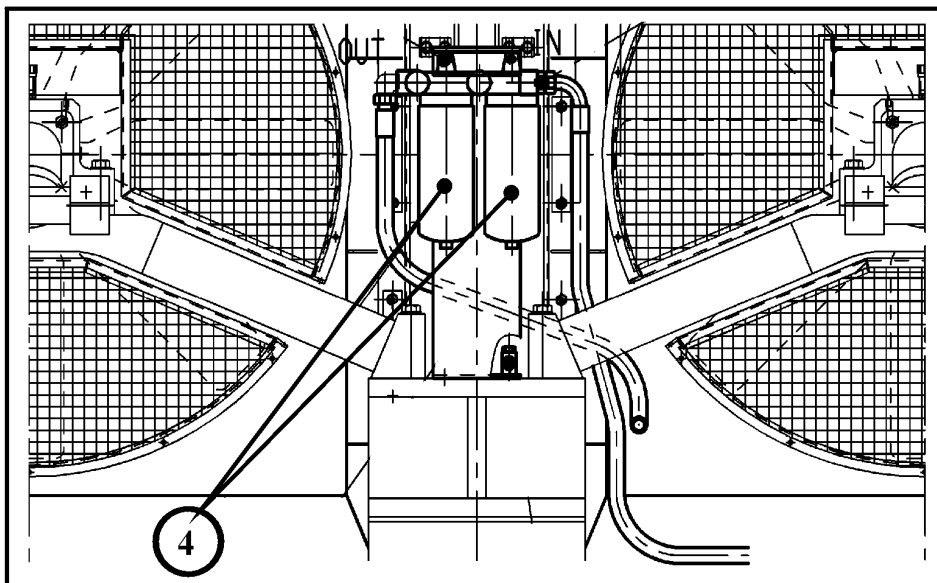
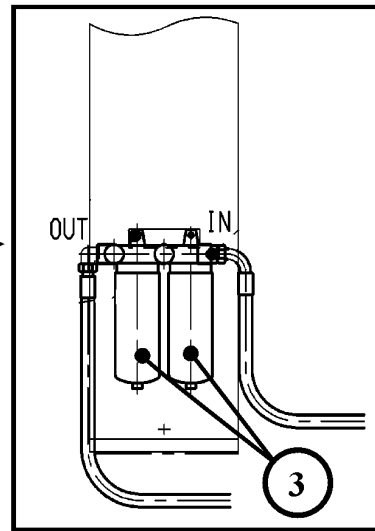

Z 22880

4.6.7 ENGINE FUEL FILTER LOCATIONS

REMARK

The fuel filters for engine 1 and 2 are relocated as shown in illustration Z22880 for better accessibility.

Legend for illustration Z 22880

- (1) Rear engine 1
- (2) Front engine 2
- (3) Fuel filters for rear engine 1 mounted on rear machinery house post
- (4) Fuel filters for front engine 2 mounted on center radiator post
- (5) Fuel tank
- (6) Fuel shut-off solenoid valves

NOTICE

Carry out fuel filter maintenance according to the instructions in the separate Engine Operation and Maintenance Manual filed in volume 2 binder.

4.7 WHEN NECESSARY

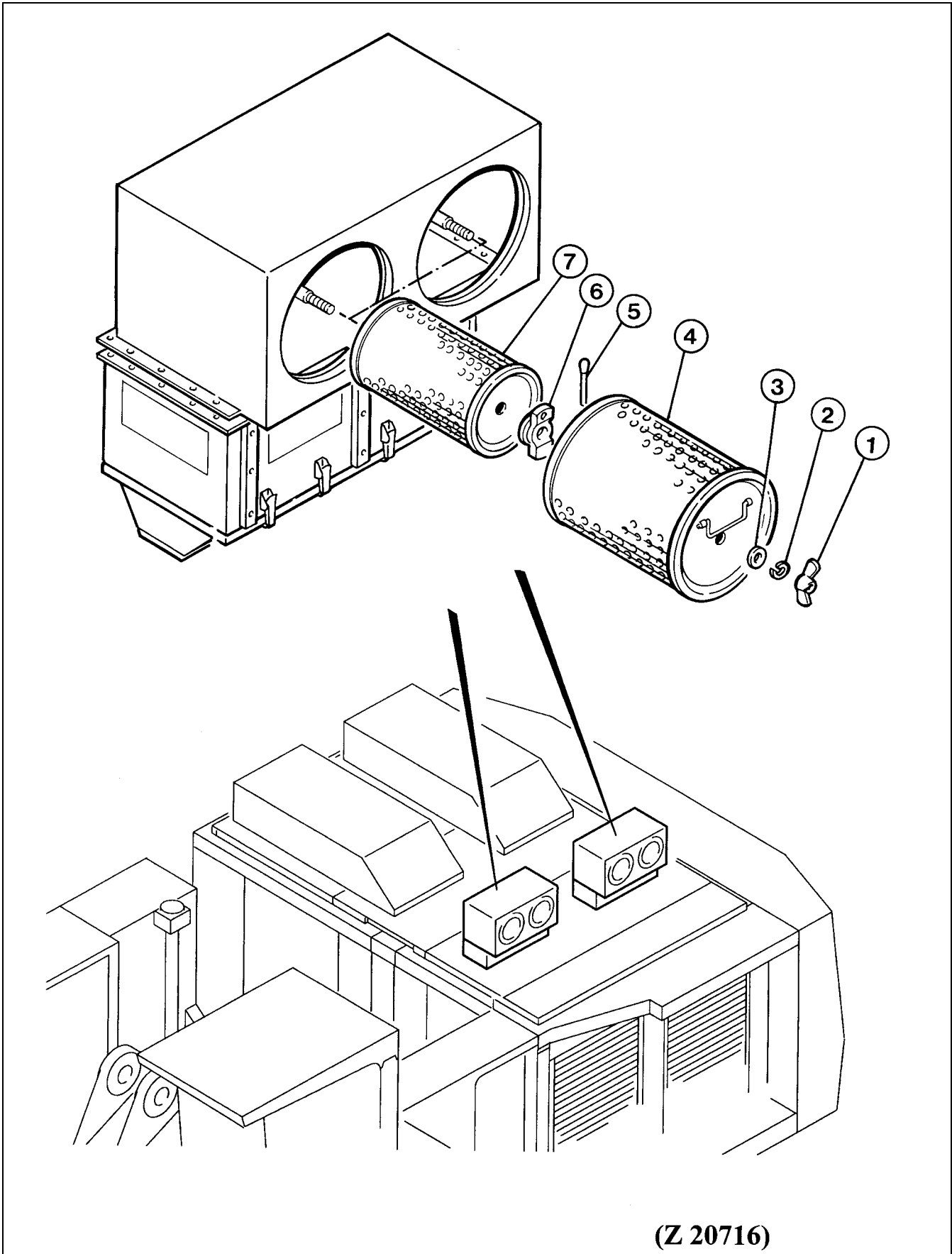

(Z 20716)

4.7.1 ENGINE AIR CLEANER MAINTENANCE

NOTICE

Before servicing the filter elements clean dust cups of the pre-cleaners.

Servicing the main filter elements, illust. Z 20716:

 CAUTION

Never service air cleaner while engine is running.
Clean main filter elements as soon as the fault message "Air cleaner element restricted" is displayed on the ECS screen.
Replace elements after 6 cleanings or annually, whichever occurs first.

1. Remove elements in sequence of reference numbers (1 to 4).
2. Clean and check respectively. replace main filter element.
Wipe out filter housing with a clean cloth.
3. Element cleaning methods:
Clean main element by one of the following methods.
Compressed air or washing:
Compressed air is recommended when element will be re-used immediately because a washed element must be dried before re-use.

Compressed air:

Direct air through element in the direction opposite to normal air flow through the element. Move nozzle up and down while rotating element. Keep nozzle at least one inch from pleated paper. Maximum air pressure to prevent damage of element is 100 P.S.I. (6 bar).

Washing:

1. Soak element 15 minutes or more in cleaning solution. See package for full instructions.
2. Rinse until water is clear maximum water pressure 40 P.S.I. (2.5 bar).
3. Air-dry or use warm flowing air, max. 160° F (+70° C). Do not use compressed air or light bulbs.

REMARK

Before installing main elements (4) check service indicator (6) of safety element (7). If a red signal is shown, replace safety element (7). Clean indicator (6) then suck on the outer side of the indicator to reset signal to green indication.

4. Install main filter elements (4).

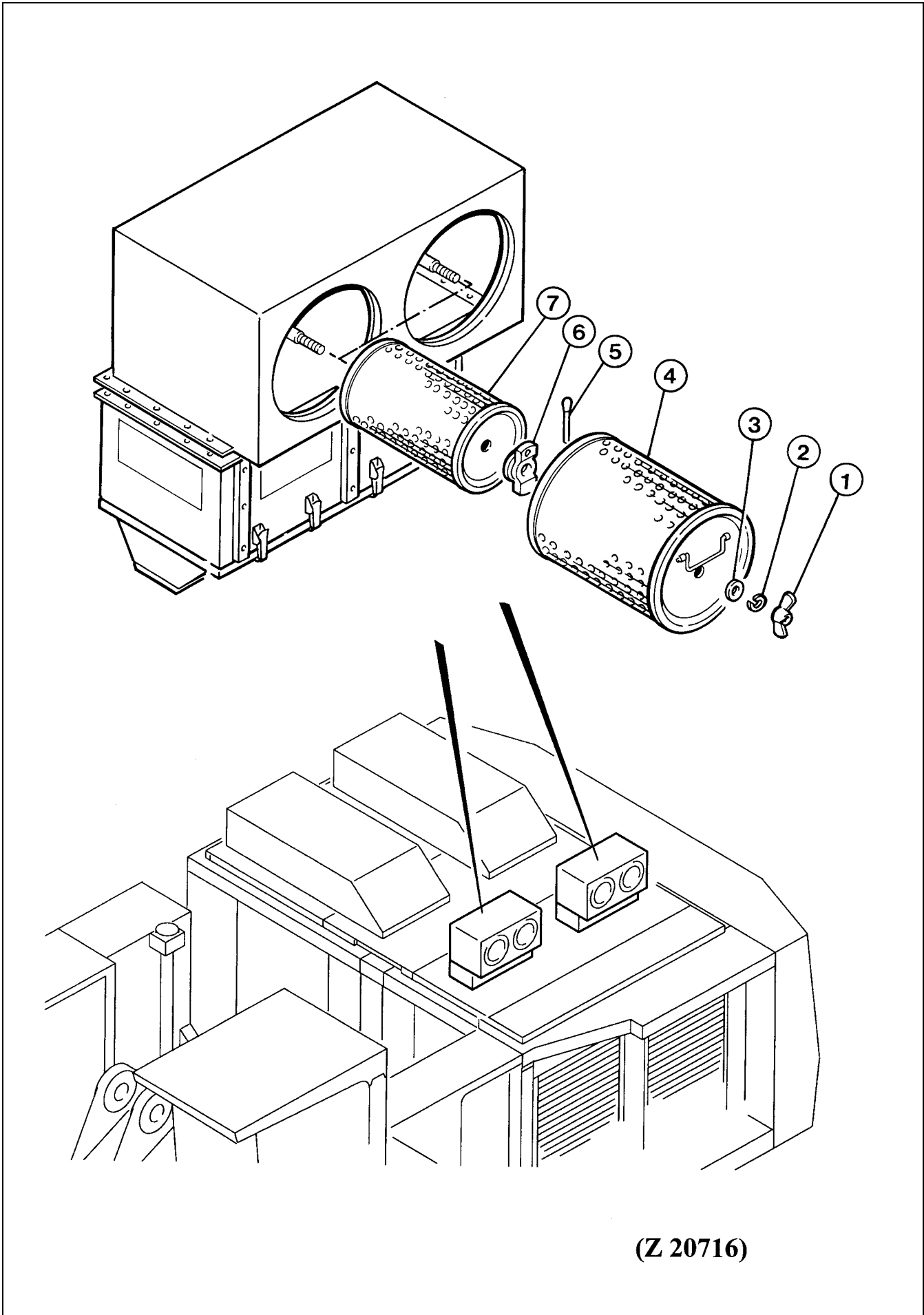

(Z 20716)

Air Cleaner Maintenance, illustration Z 20716

NOTICE

- If the fault message "Air cleaner element restricted" is again displayed on the ECS screen after installation of a new main filter element the safety-filter element has also to be replaced.
- If faulty service or a defect has been detected while servicing the main filter element also the safety filter element has to be replaced.
- After having the main filter element cleaned three-times or replaced also the safety filter element has to be replaced.

Replacing the safety filter element (7):

1. Remove element in sequence of ref. no. (1 to 7).
2. Cover air intake opening.
3. Install new safety filter element (7).

 **WARNING**

The safety filter element may not be cleaned and re-used

4. Remove cover from air intake opening.
5. Install safety and main filter element, take care service indicator (6) is correctly secured by cotter pin (5).

General Service Tips

The air cleaners should be inspected periodically to maintain maximum engine protection and maximum service life. These inspections should include the following points.

1. Inspect the air transfer duct between the air cleaner and the engine to be sure all clamps are tight, all flange joints are tight, and there are no cracks in the ducting.
2. Air cleaner mounting bolts and clamps must be tight to hold the air cleaner securely.
3. Check the dust cup to make sure it is sealing 360° around the air cleaner body.
4. Automatic dust unloader valve (if so equipped) must be in place, not inverted or damaged, and free from obstruction.

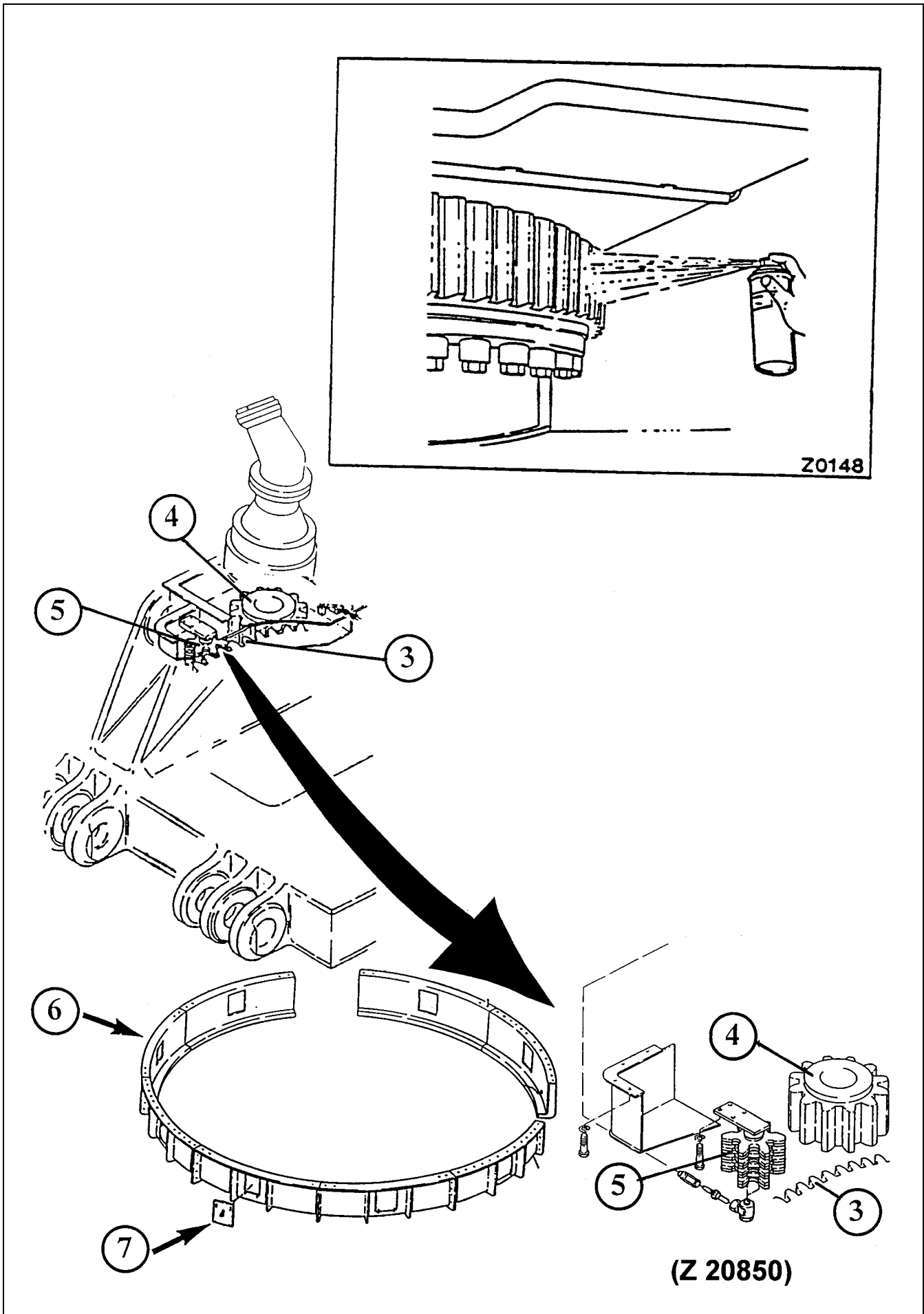

4.7.2 SWING CIRCLE TOOTHING LUBRICATION

See illustration Z 20850

All teeth of the ring gear (3) must be completely covered with grease.

If teeth are not completely covered with grease, they have to be lubricated immediately with special adhesive spray grease, illust. (Z 0148) or spread type adhesive grease as specified in the Parts Catalog. The spread type grease can be applied, for example, with a brush.

Observe the instructions on the grease container for correct use of the lubricant.

NOTICE

- **If the machine is equipped with gear ring guard (6), remove covers (7) for swing circle teeth inspection.**
- **If the automatic lubrication system of the swing circle-teeth, is out of function for more than one shift, lubricate manually (using spray grease) and remove the lube pinion (5), to prevent serious damages.**
- **In order to ensure proper adherence of the lubricant, clean and dry the ring gear prior lubrication. In most cases it is sufficient to rotate the superstructure several times for removing moisture from the gear teeth.**
- **Make sure that the multi-purpose grease of the swing circle bearing does not come in contact with the teeth of the swing circle because this will diminish lubrication capability of the swing circle teeth lubricant. If necessary remove excessive multi-purpose grease from the swing circle above the dust seal ring.**

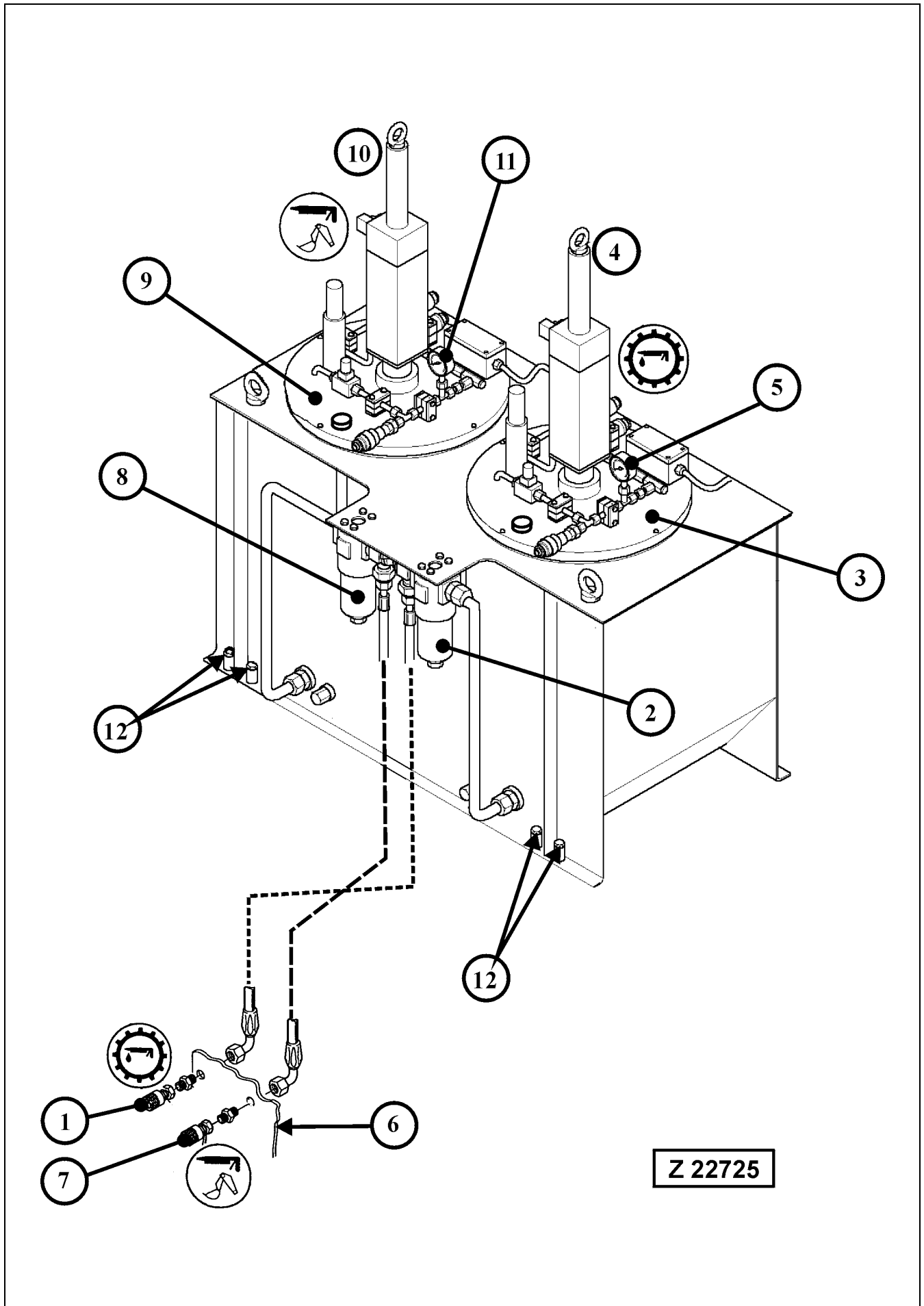

4.7.3 AUTOMATIC LUBRICATION SYSTEMS FILL GREASE CONTAINERS

Fill the grease containers of the Central Lubrication System and Swing circle pinion Lubrication System when the corresponding message "grease container on reserve" is displayed on the ECS screen. Make sure the grease filters in the filling lines are not obstructed. If necessary service the Grease Filters.

Legend for illustration Z 22725

- (1) Coupling on swing down service arm for filling the grease container (3) of the Swing circle gear Lubrication System "SLS"
 - (2) Grease filter for Swing circle gear Lubrication System "SLS" grease container.
Before filling the grease container make sure the filter is not obstructed.
Service the filter element according to instructions on page 343.
 - (3) Grease container of the Swing circle gear Lubrication System "SLS"
 - (4) Hydraulic motor with pump unit
 - (5) Grease pressure gauge for "SLS"
 - (6) Receiver panel on swing down service arm
 - (7) Coupling on swing down service arm for filling the grease container (9) of the Central Lubrication System "CLS"
 - (8) Grease filter for Central Lubrication System "CLS" grease container.
Before filling the grease container make sure the filter is not obstructed.
Service the filter element according to instructions on page 343.
 - (9) Grease container of the Central Lubrication System "CLS"
 - (10) Hydraulic motor with pump unit
 - (11) Grease pressure gauge for "CLS"
 - (12) Mounting bolts of the grease container housing
- Fill the grease containers according to the instructions on page 286.

REMARK

Check mounting bolts (12) on front and rear side of the grease container housing for correct tightening torque.

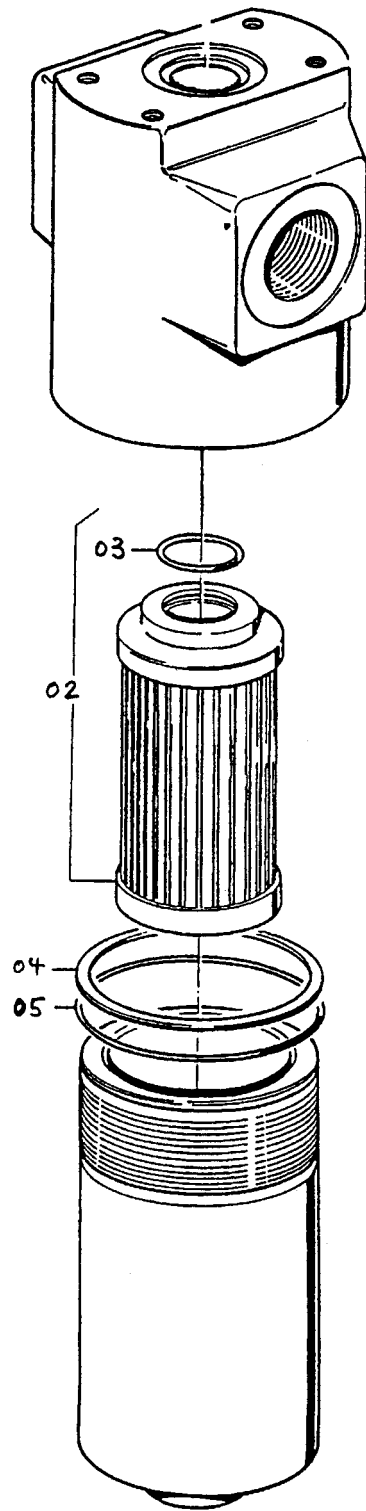

(Z 20718)

Service the Grease Filters for Refillable Grease Containers of the Central Lubrication System and Swing circle pinion Lubrication System, illustration Z 20718

1. Screw off filter case.
2. Remove element assy. (02) and clean. Take care not to contaminate the "Clean" inside of the element when flushing.

NOTICE

Carefully inspect elements for damage. Always install new elements if ruptures or other damages are found.

3. Inspect O-rings (03 and 05) and back-up ring (04). Replace if necessary.
4. Fill filter case half way up with the specified grease.
5. Installation sequence vice versa. Take care for proper position of filter element (02).

NOTICE

Replace element (02) after three cleanings or after every 5000 operating hours, whichever occurs first.

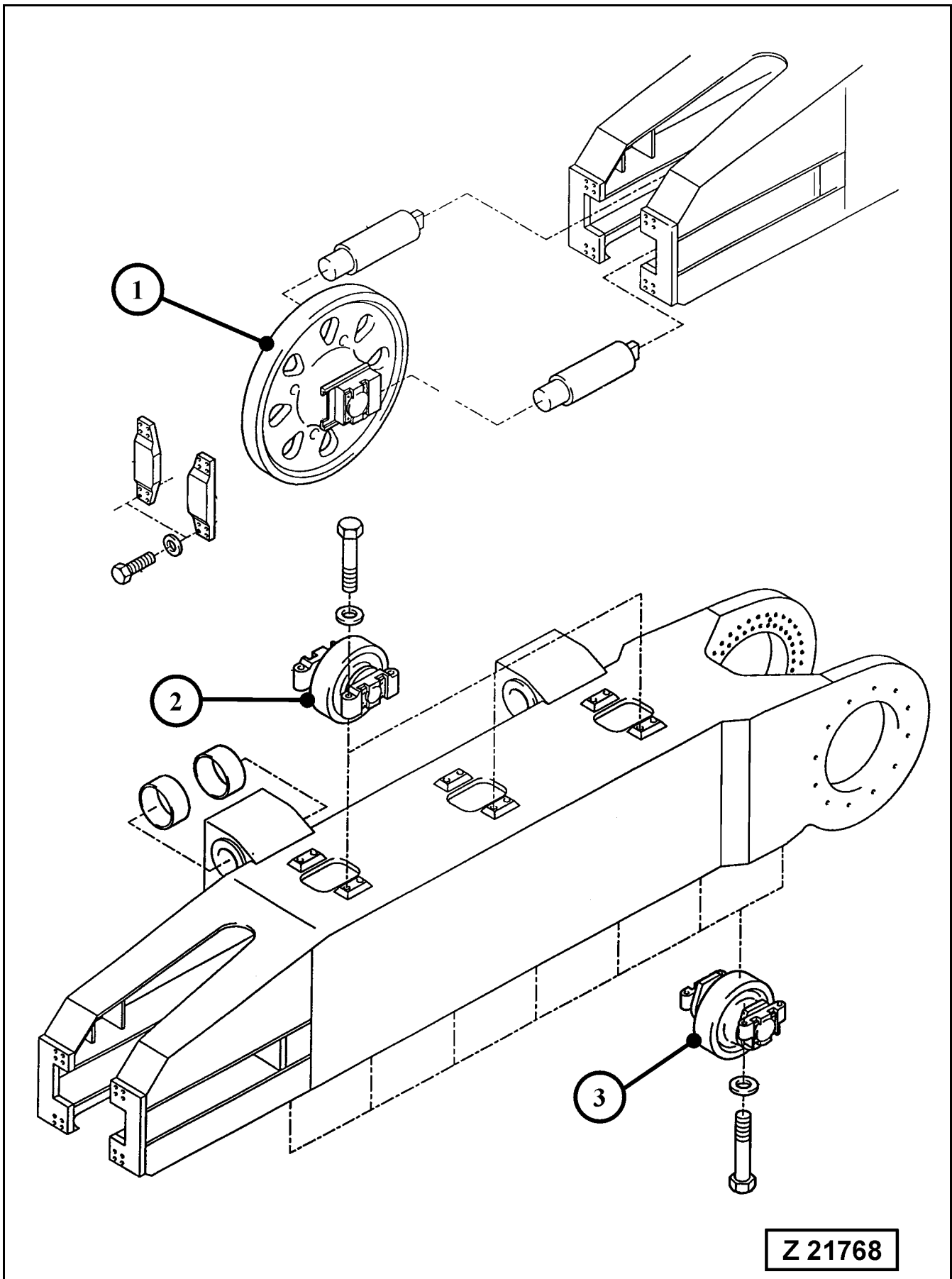

4.7.4 TRACK ROLLERS AND GUIDE WHEELS - REPLACE FLOATING SEALS

Legend for illustration Z 21768

- (1) Guide wheel, if leakage occurs. replace floating seal.
Refer to repair manual for replacement procedure.
- (2) Carrier roller, if leakage occurs. replace floating seal.
Refer to repair manual for replacement procedure.
- (3) Track roller, if leakage occurs. replace floating seal.
Refer to repair manual for replacement procedure.

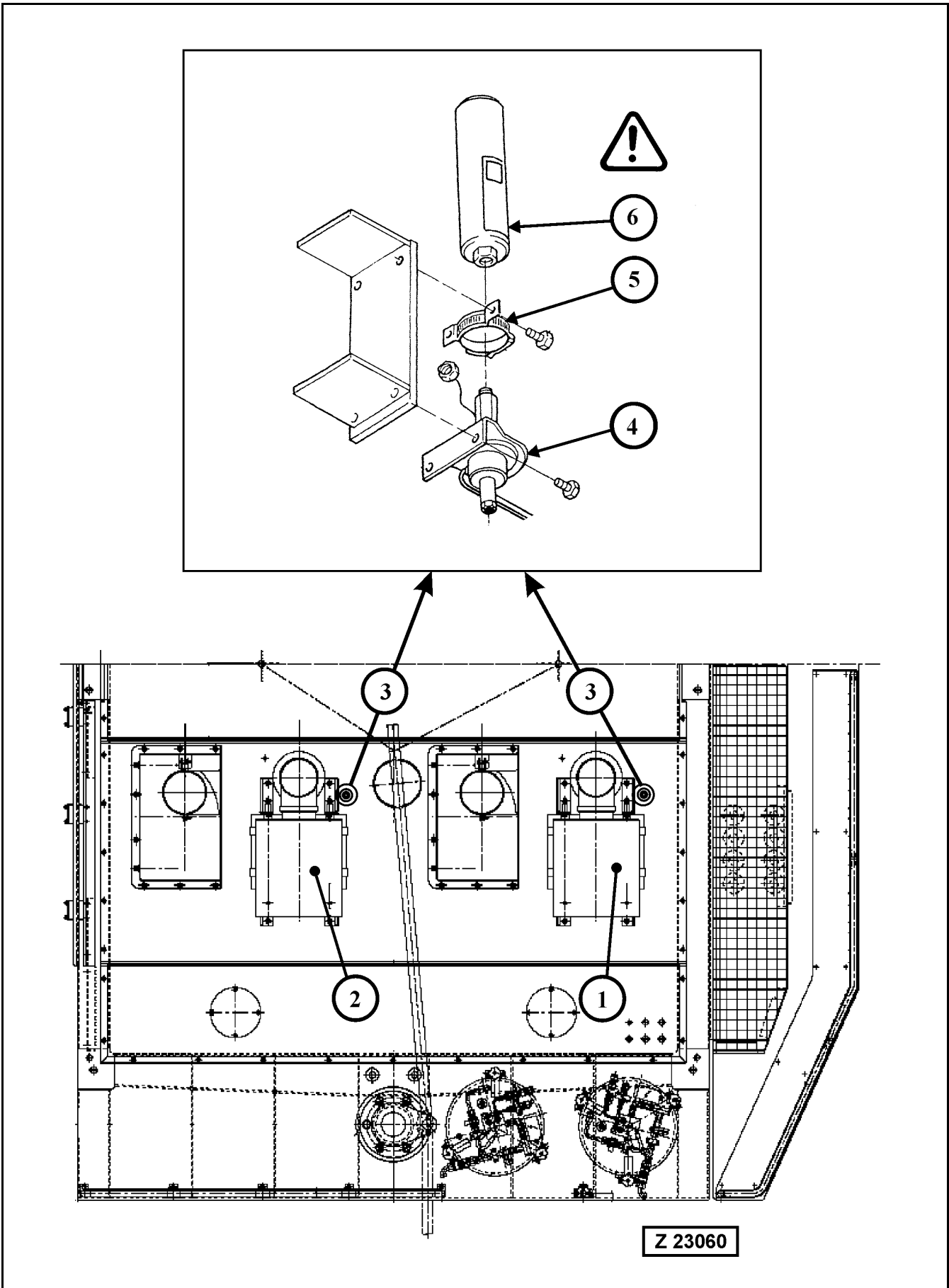

4.7.5 COLD STARTING AID, REPLACE FLUID CYLINDER

Legend for illustration Z 23060

- (1) Air cleaner for rear engine 1
- (2) Air cleaner for front engine 2
- (3) Cold starting aid mounted on the air cleaner carrier
- (4) Electrically operated valve
- (5) Mounting clamp
- (6) Cold start fluid cylinder

▲ WARNING

- **Starting fluid is poisonous and flammable**
 - **Do not store replacement cylinders in living areas**
 - **Do not smoke while changing cylinders**
 - **Use only in well ventilated areas**
 - **Use with care to avoid fires**
 - **Avoid breathing of vapors or repeated contact with skin**
 - **Do not puncture or burn cylinders**
 - **Discard cylinders in a safe place**
 - **Keep fluid container away from heat, sparks, open flame, or open sunlight. It may explode**
 - **Observe instructions on the container**
 - **Do not store or use at temperatures above 93° C (200° F)**
-
-

4.8 EVERY 10 OPERATING HOURS OR DAILY

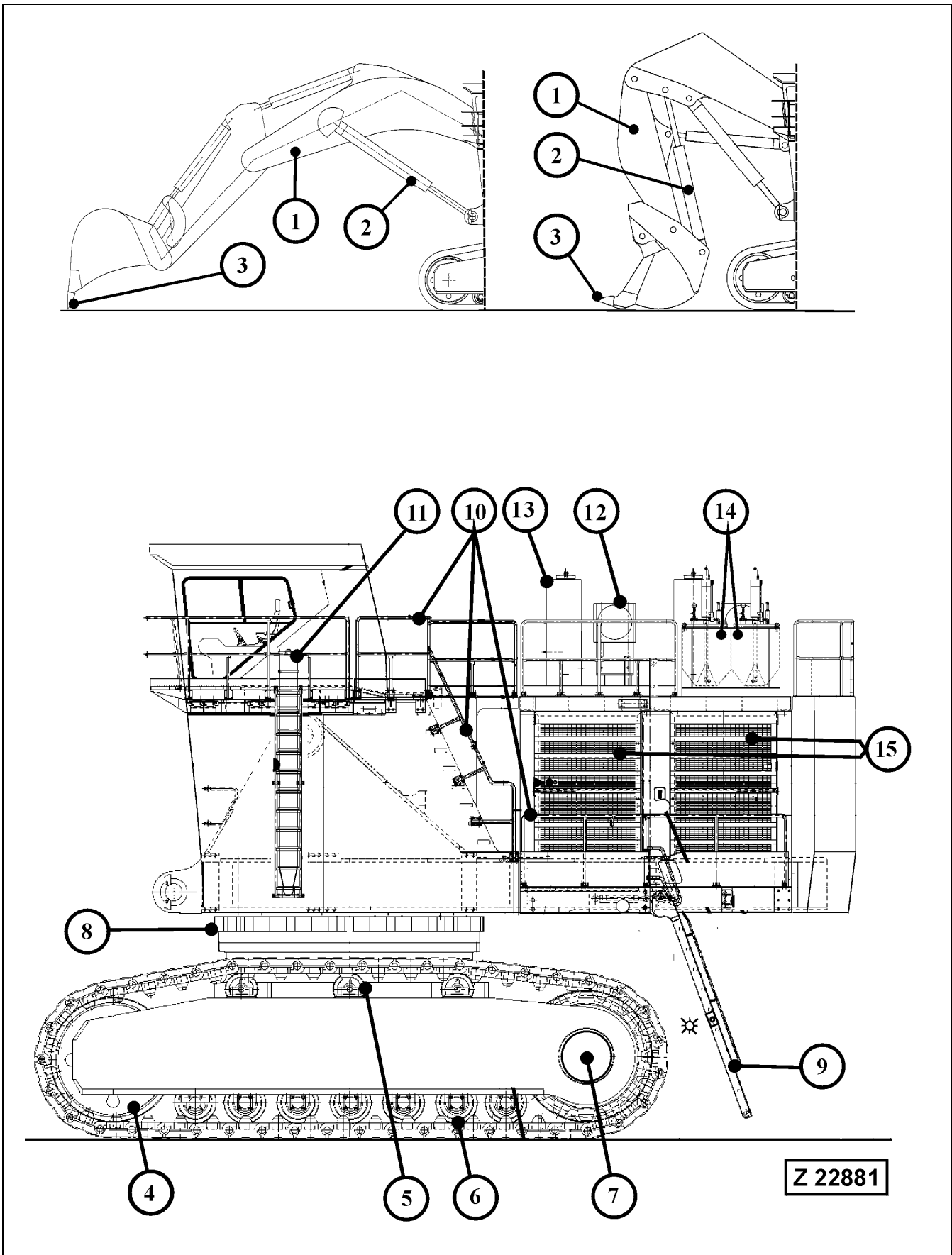

4.8.1 WALK - AROUND INSPECTION

WARNING

Before carry out any maintenance on this machine, make sure the mounting ladder, handrails and walkways are properly installed and in good condition. Keep the ladder, steps, handrails and walkways free of mud, oil and grease.

Always use the ladder, handrails and steps to get on or off the machine. Jumping on or off the machine can cause an injury.

Legend for illustration Z22881

- (1) Working attachment. Check overall condition. Inspect for loose or missing securing parts.
- (2) Hydraulic cylinders. Check cylinders, hydraulic lines and connections for leakage and damage.
- (3) Check bucket teeth for proper mounting. Inspect for loose or missing securing parts. Check condition of the loader bucket. Both loader bucket versions, bottom dump bucket and back-hoe bucket are equipped with wear protection packages as specified in the contract. These wear packages protect the base body of the bucket from premature wear and tear. Therefore it is important to check the condition of the wear protection elements regularly. Worn or damaged protection elements should be replaced at an early stage in order to prevent damage to the base body of the bucket.
In case the bucket base is already weakened, reconditioning measures will be necessary. Contact your Komatsu dealer for support.
- (4) Check guide wheels for leakage.
- (5) Check carrier rollers for leakage.
- (6) Check track rollers for leakage.
- (7) Check travel gears for leakage
- (8) Check swing circle tothing for adequate lubrication.
- (9) Check condition, fastening and security of access ladders.
- (10) Check condition, fastening and security of all walk-ways, steps, railings and hand rails.
- (11) Check condition, fastening and security of emergency escape ladder
- (12) Check condition and fastening of engine air cleaners
- (13) Check condition and fastening of exhaust mufflers
- (14) Check condition and fastening of automatic lubrication system grease container
- (15) Make a visual inspection of the engine room. Check engine oil level and coolant level.

NOTICE

If any damages, failures or wrong condition, have been found during the inspection, corrective action must be taken.

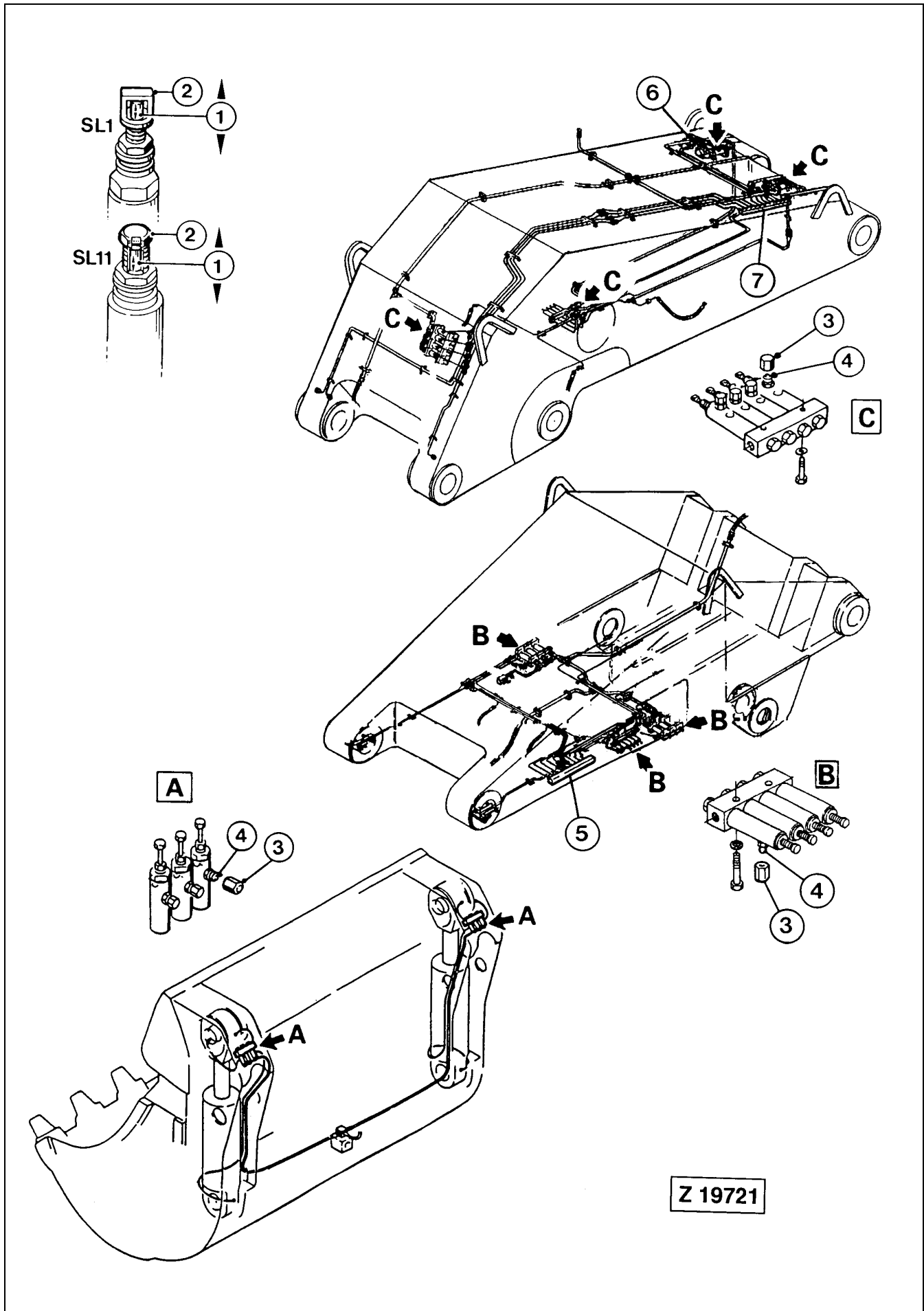

WORKING ATTACHMENT - CHECK GREASE INJECTORS FOR PROPER OPERATION

NOTICE

There are two types of grease injectors installed "SL1" and "SL11" injectors, see illust. (Z 19721).

Legend for illustration Z 19721

- A Injectors on bucket
- B Injectors on stick
- C Injectors on boom
- (1) Indicator stem for visual indication of injector operation
- (2) Output adjusting screw
- (3) Protection cap
- (4) Grease fitting
- (5) Distributor ledge, stick
- (6) Boom
- (7) Distributor ledge, boom

Check operation of all grease injectors (A, B and C) by visually watching the cycle indicator stem (1) while operating the central lubrication system manually. Stem (1) must move in and out once a complete lubrication cycle.

If a cycle indicator (1) does not move during a lubrication cycle, grease supply to the lubrication point of the concerned injector is interrupted.

Refer to paragraph "CORRECTIVE ACTIONS" in this section and to the separate manual "Lubrication Systems" in volume 2 binder for corrective action.

Carry out same checks on the injectors for slewing connection.

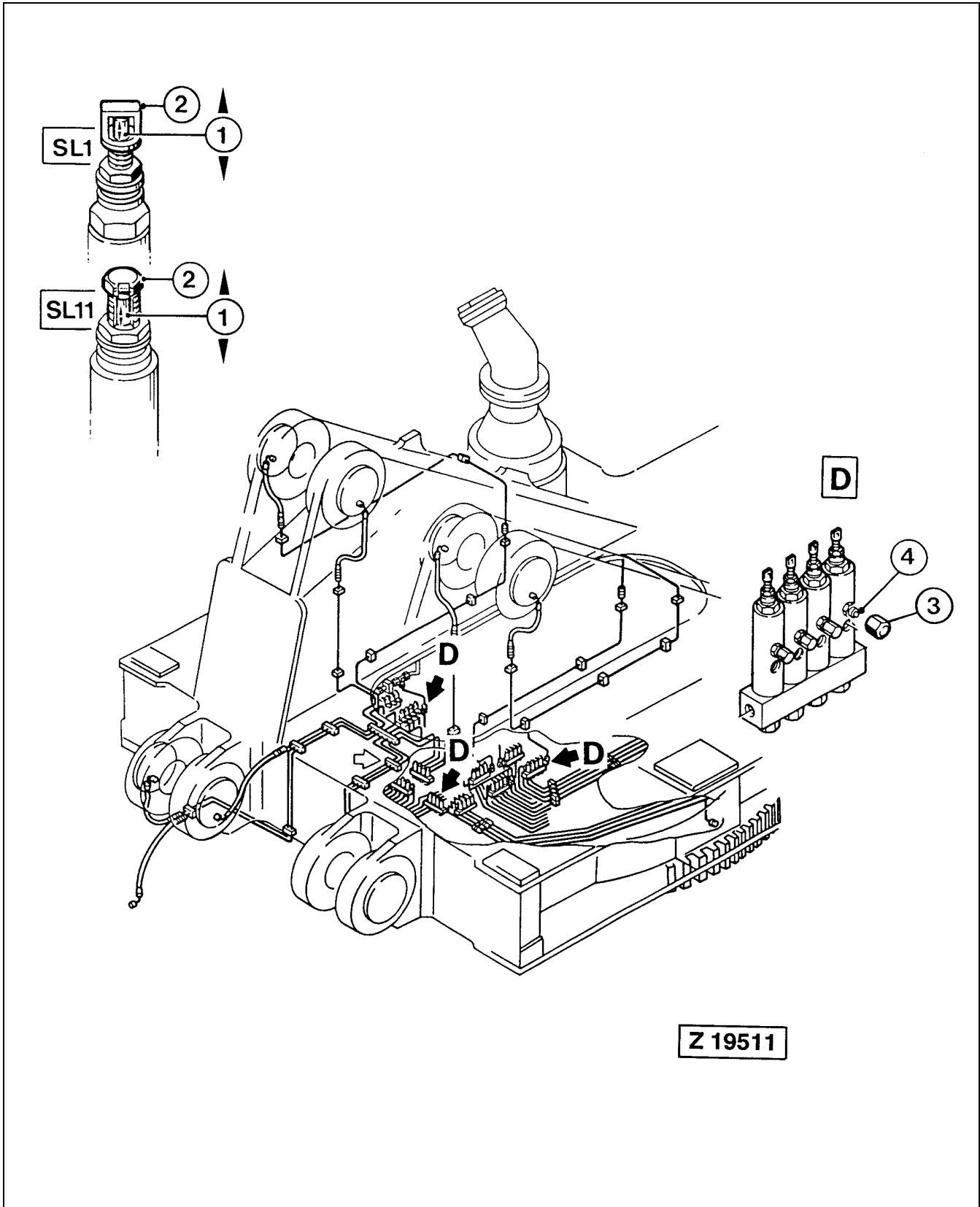

CHECK GREASE INJECTORS

Legend for illustration Z 19511

- (D) Injectors on slewing connection
- (1) Indicator stem for visual indication of injector operation
- (2) Output adjusting screw
- (3) Protection cap
- (4) Grease fitting

Check operation of all grease injectors (D) by visually watching the cycle indicator stem (1) while operating the central lubrication system manually. Stem (1) must move in and out once a complete lubrication cycle.

If a cycle indicator (1) does not move during a lubrication cycle, grease supply to the lubrication point of the concerned injector is interrupted, proceed according to paragraph CORRECTIVE ACTIONS.

NOTICE

If the failure is caused through a defective central lubrication system, manually lubricate at grease fittings (4) after removal of caps (3).

CORRECTIVE ACTIONS

1. Check to make sure grease supply through inlet line is provided.
2. Disconnect the outlet line of the respective injector.
3. Operate the central lubrication system manually.
 - A -
If now the injector works, i.e. cycle indicator stem (1) moves in and out the disconnected line or the grease passage at the lubrication point is damaged or blocked by foreign matter. Repair as necessary.
 - B -
If the injector does not work, i.e. cycle indicator stem (1) stationary, replace the respective injector.
4. Operate the central lubrication system and re-check operation of the grease injectors.

REMARK

If the failure is caused through a defective central lubrication system, manually lubricate at grease fittings (4) after removal of caps (3).

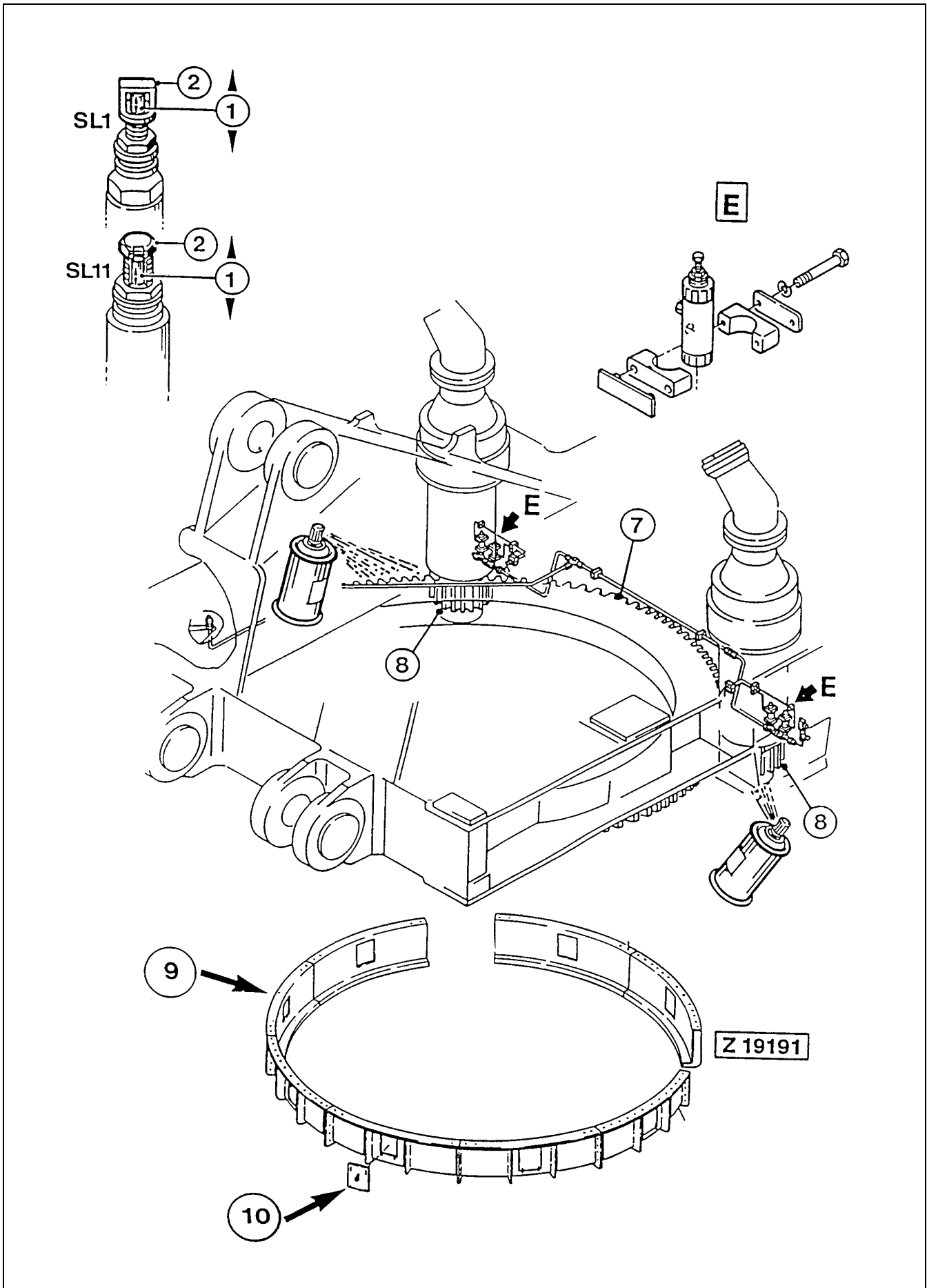

SWING CIRCLE - CHECK GREASE INJECTORS

Legend for illustration Z 19191

- E - Injectors for swing circle teeth lubrication
- (1) Indicator stem for visual indication of injector operation
- (2) Output adjusting screw
- (7) Slew gear ring
- (8) Slew gear ring
- (9) Slew gear ring guard (if so equipped)
- (10) Inspection covers for slew gear ring

Check operation of injectors "E".
If necessary lubricate manually, using spray grease.

REMARK

If the machine is equipped with gear ring guard (9), remove covers (10) for gear ring inspection.

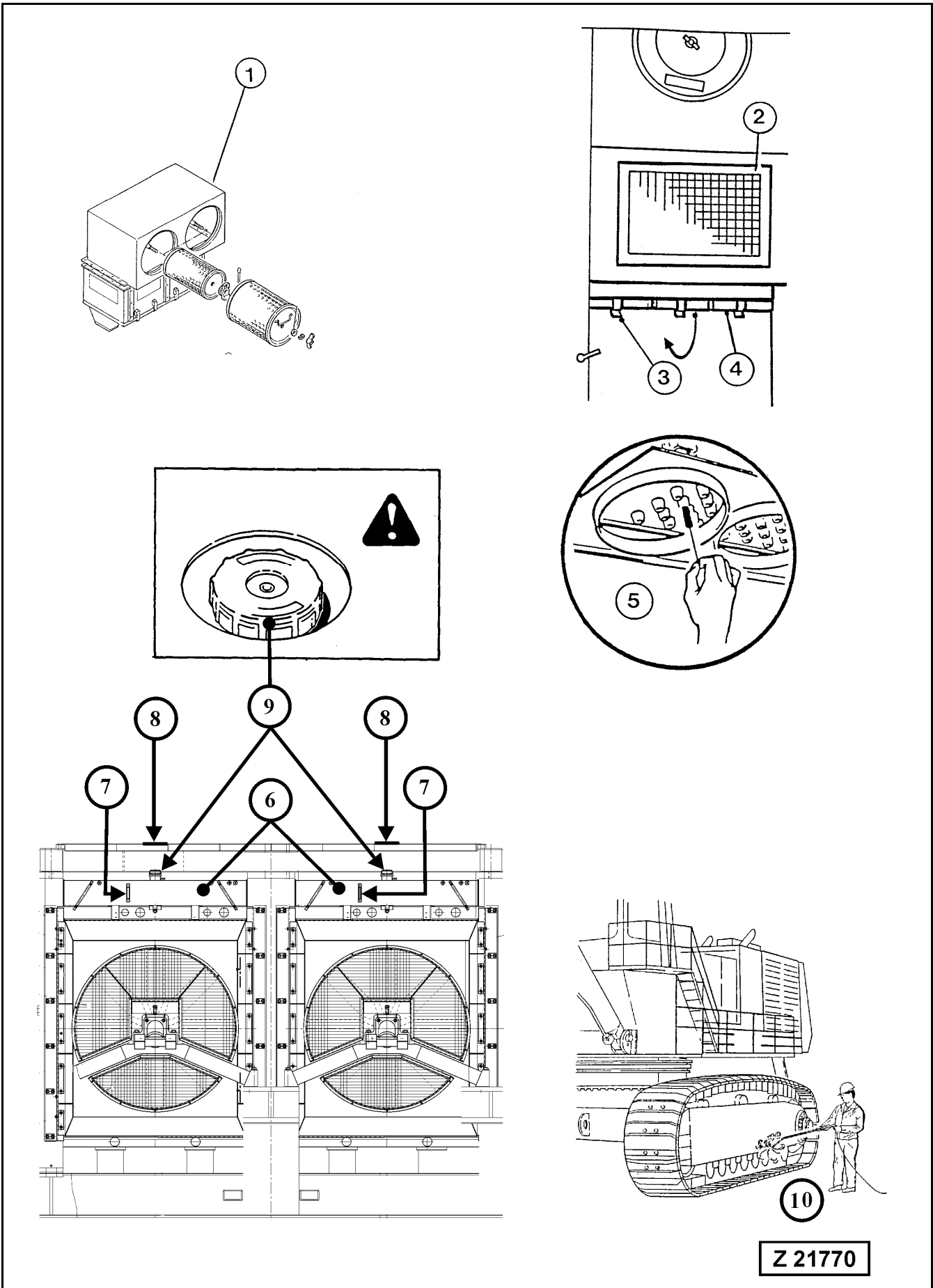

Z 21770

4.8.2 AIR CLEANER - CLEAN PRE-CLEANER

Clean dust cups of pre-cleaners

Legend for illust. Z 21770:

- (1) Roof mounted air cleaner units
- (2) Air intake screen
- (3) Clamps
- (4) Dust cups
- (5) Jet tubes

1. Provide suitable container for collecting the dust before opening the dust cups (4).
2. Loosen the clamps and swing down dust cups (4).
3. Remove dust from pre-cleaner dust cups.
4. Check condition of the dust cup gaskets and replace if necessary.
5. Swing back dust cups (4) to closed position and secure with the clamps provided.
6. Check air cleaner mounting parts for tight fit and security.

NOTICE

When operating the machine under very dusty conditions, check pre-cleaner jet tubes (5) for plugging. Dust plugging of tubes can be removed with a stiff fiber brush.

Never clean tubes with compressed air unless both the primary and safety elements are installed in the air cleaner. Do not steam-clean tubes.

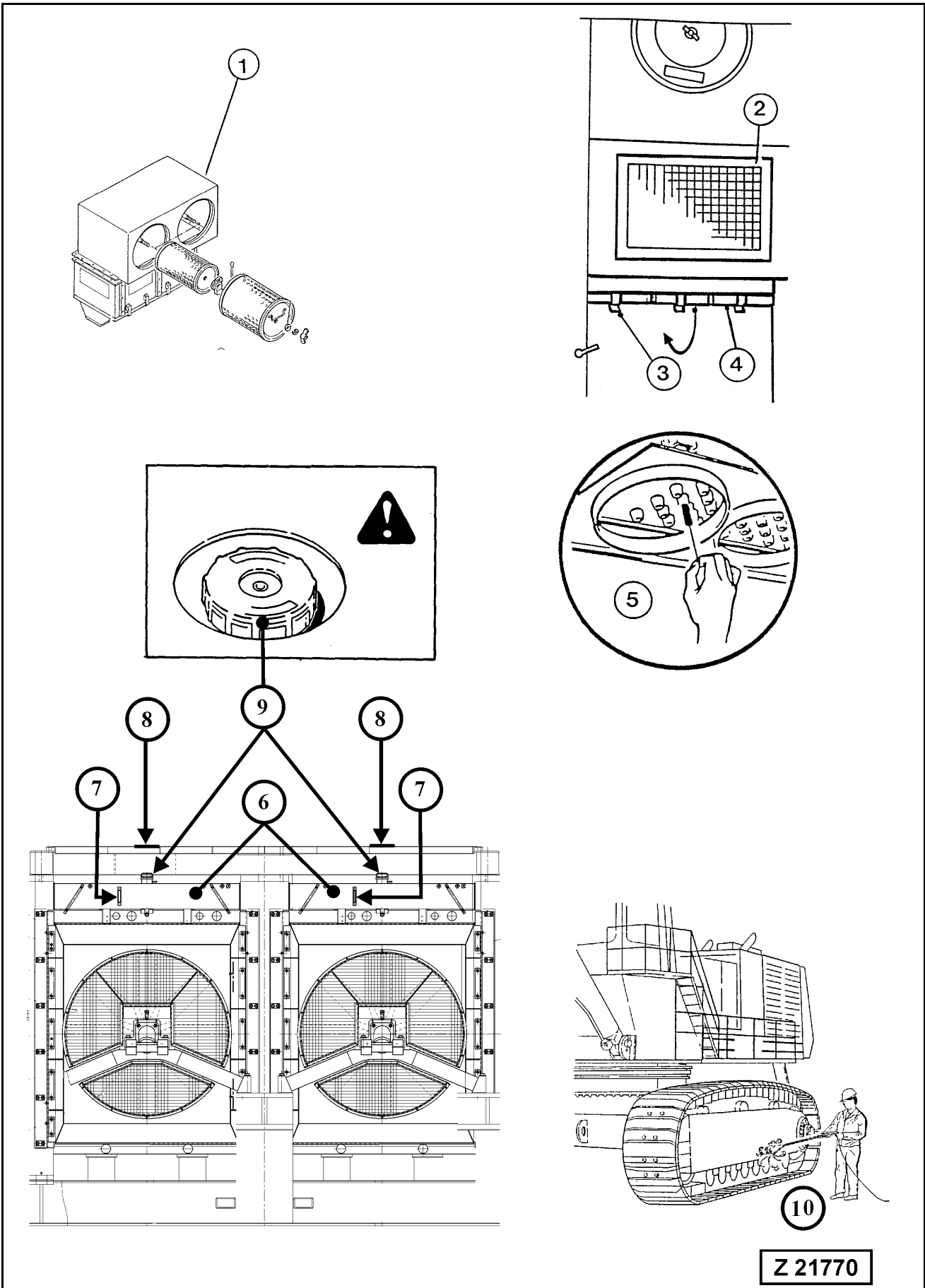

4.8.3 RADIATORS - CHECK COOLANT LEVEL

Legend for illustration Z 21770

- (6) Coolant expansion tank of front and rear engine radiators
- (7) Coolant level sight gauge on front and rear coolant expansion tanks
- (8) Cover plates on power house roof above front and rear radiator pressure caps
- (9) Radiator pressure caps

▲ WARNING

DO NOT remove the radiator pressure cap (9), illust. Z21770 from a hot engine. Wait until the temperature is below 50°C before removing the pressure cap (9). Failure to do so can result in personal injury from heated coolant spray or steam. Press the red button on the radiator pressure cap to allow the pressure to escape. Turn the radiator cap slowly counter-clockwise to the safety stop, then continue to turn until cap is free to be removed.

The coolant level should be in the upper field of the sight gauges (7). If necessary add coolant.

REMARK

Refer to the Engine Operation and Maintenance Manual for the correct coolant composition.

4.8.4 TRACK GROUPS - CLEAN

See (10), illustration Z 21770.

Clean track groups especially during the cold season.

4.9 EVERY 50 OPERATING HOURS OR WEEKLY

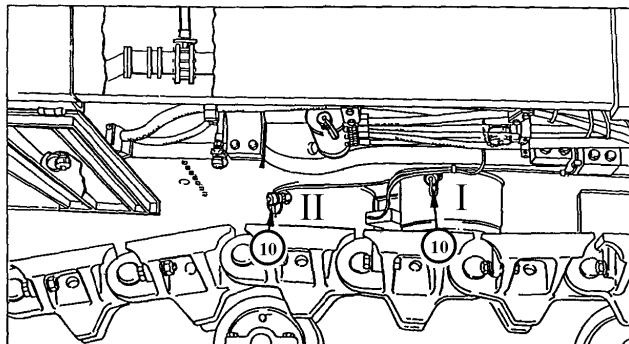
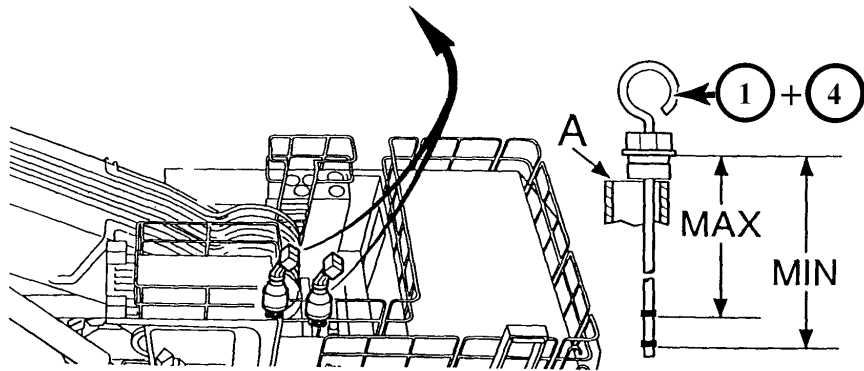
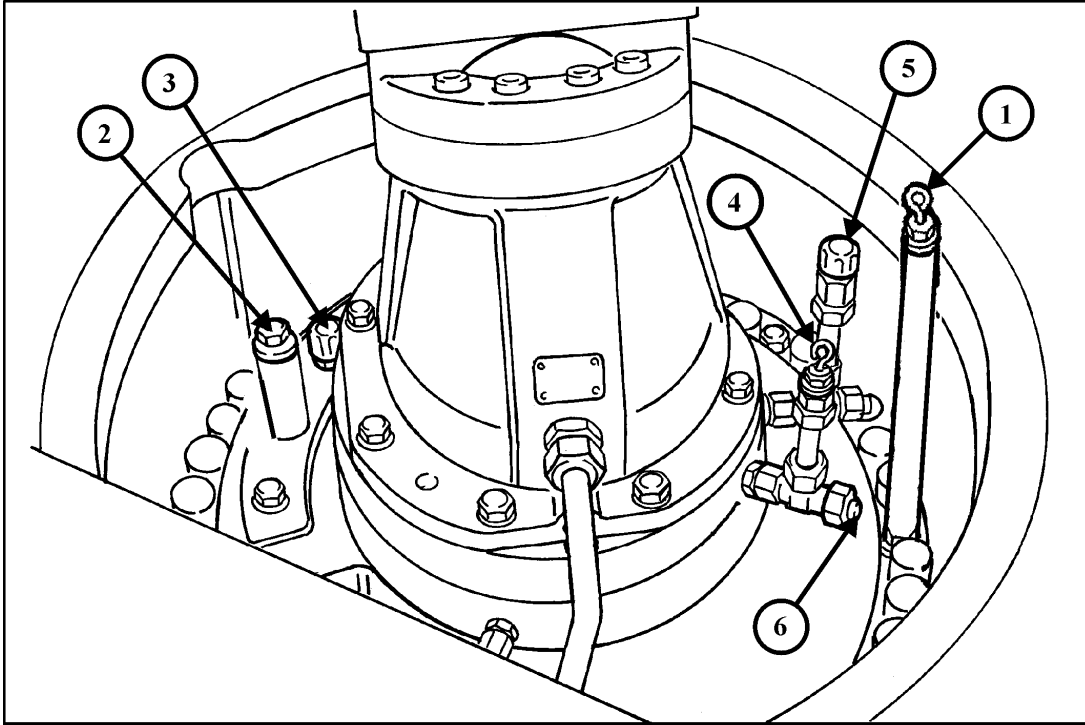

Z 22882

4.9.1 SWING GEARS AND MOTOR ADAPTER HOUSINGS - CHECK OIL LEVELS

REMARK

The machine can be equipped either with a swing gear of manufacturer "L&S" or of manufacturer "Siebenhaar". Refer to the data plate on each swing gear housing to find out the manufacturer of the swing gear.

Swing Gear manufactured by "L&S"

I Front Swing gear

II Rear Swing gear

Legend for illustration Z22882

Swing gears

- (A) Position of oil level gauge for checking the oil levels
- (1) Oil level gauge
- (2) Oil filler plug
- (3) Breather filter
- (10) Drain coupling or evacuation nozzles for Wiggins system

Motor Adapter Housing

- (4) Oil level gauge and filler opening. This opening can also be used for connecting a suction pump when changing the oil.
- (5) Breather filter
- (6) Oil drain plug

CHECK SWING GEAR OIL LEVEL

Remove oil level gauge (1), illustration Z22882 and wipe it clean. Insert the gauge but DO NOT screw in, see detail "A". Remove the gauge. The oil level should be at the upper mark of gauge (1). If necessary add the specified gear oil through filler opening (2). Remove breather filter (3). Blow out with compressed air from inside to outside and reinstall.

CHECK MOTOR ADAPTER HOUSING OIL LEVEL

Remove oil level gauge (4) and wipe it clean. Insert the gauge but DO NOT screw in, see detail "A". Remove the gauge. The oil level should be at the upper mark of gauge (4). If necessary add the specified oil through filler opening (4). Remove breather filter (5). Blow out with compressed air from inside to outside and reinstall.

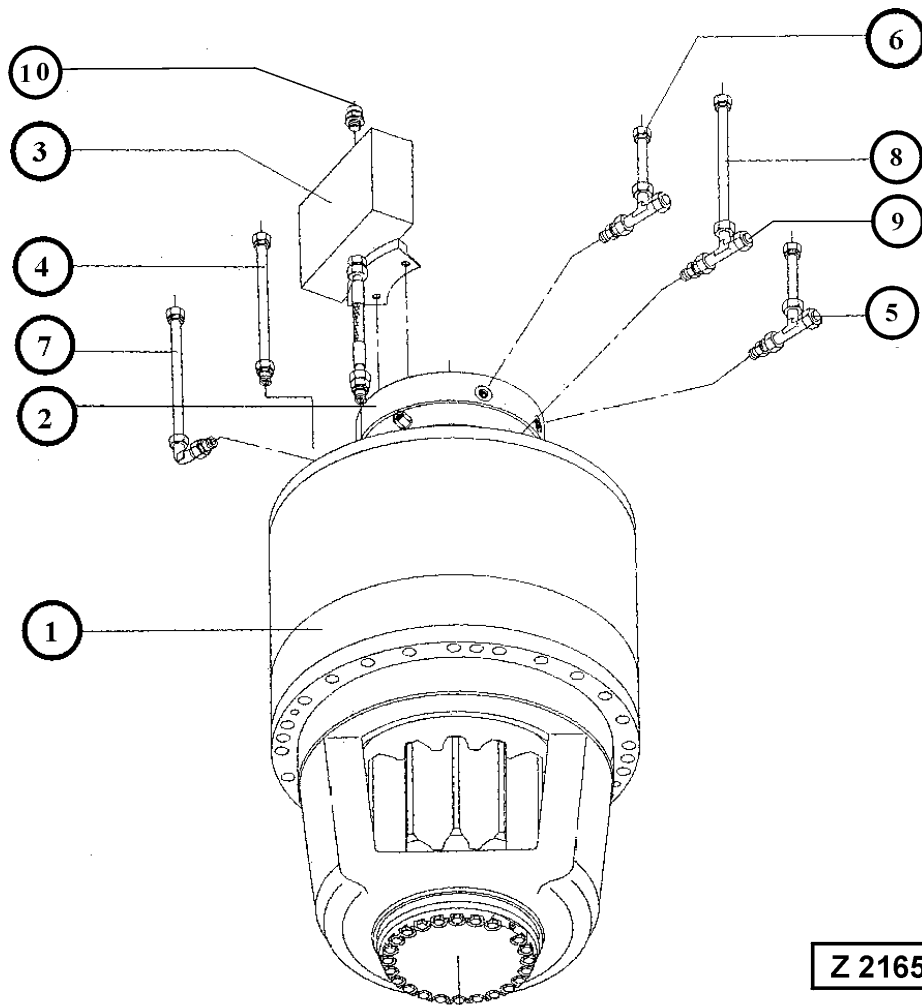
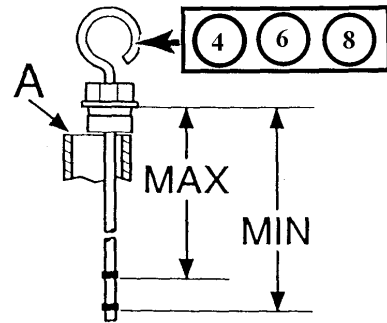
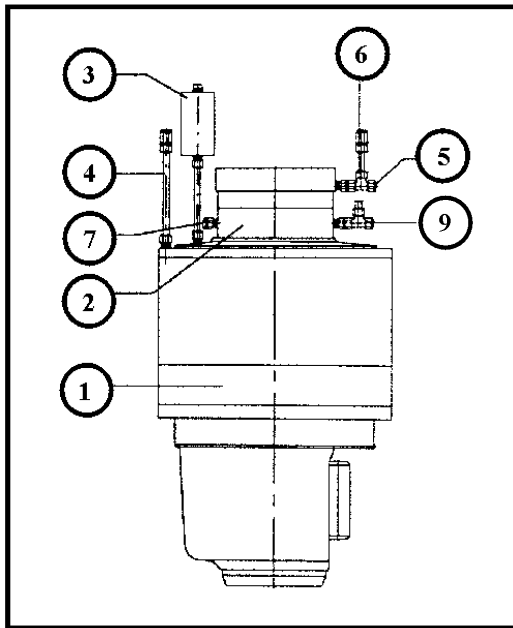

Z 21656

Swing gear manufactured by "Siebenhaar"

Legend for illustration Z 21656

- (A) Position of oil level gauge for checking the oil levels
- (1) Swing gear
- (2) Brake housing
- (3) Compensator oil tank for swing gear
- (4) Oil level gauge for swing gear
- (5) Oil drain plug for motor adapter housing
- (6) Oil level gauge for motor adapter housing
- (7) Breather filter for brake housing
- (8) Oil level gauge for brake housing
- (9) Oil drain plug for brake housing
- (10) Breather filter

CHECK SWING GEAR OIL LEVEL

Remove oil level gauge (4) and wipe it clean. Insert the gauge but DO NOT screw in, see detail "A". Remove the gauge. The oil level should be at the upper mark of gauge (4). If necessary add the specified gear oil through filler pipe. Remove breather filter (10). Blow out with compressed air from inside to outside and reinstall.

CHECK BRAKE HOUSING OIL LEVEL

Remove oil level gauge (8) and wipe it clean. Insert the gauge but DO NOT screw in, see detail "A". Remove the gauge. The oil level should be at the upper mark of gauge (8).
If necessary add engine oil SAE 10 or hydraulic oil HLP 22 or HLP 32 through filler opening.
Remove breather filter from pipe (7). Blow out with compressed air from inside to outside and reinstall.

CHECK MOTOR ADAPTER HOUSING OIL LEVEL

Remove oil level gauge (6) and wipe it clean. Insert the gauge but DO NOT screw in, see detail "A". Remove the gauge. The oil level should be at the upper mark of gauge (6). If necessary add engine oil SAE 10 or hydraulic oil HLP 22 or HLP 32 through filler opening.

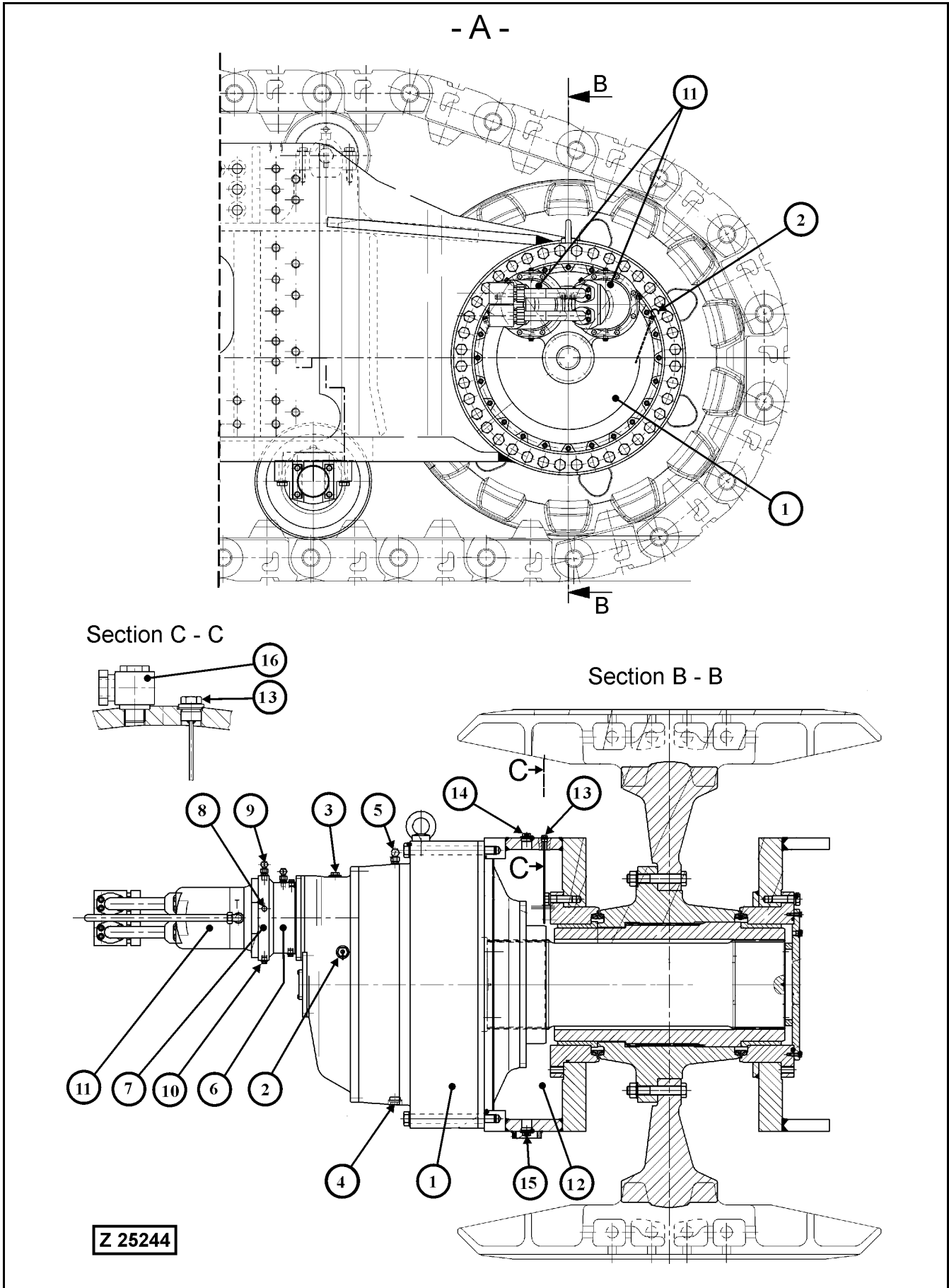

4.9.2 TRAVEL GEARS, MOTOR ADAPTER HOUSINGS AND FINAL DRIVES CHECK OIL LEVELS

Legend for illustration Z25244

- A - View of the RH Final drive. The configuration of the LH Final drive is the same.

(1) Travel gear

(2) Oil level gauge

(3) Oil filler plug

(4) Oil drain plug

(5) Connector for breather filter line. The breather filter is located inside the center frame, see illustration Z25243 on page 369.

(6) Travel brake housing

REMARK

The travel gear brakes are dry type multiple disk brakes. DO NOT fill the housings with oil.

(7) Motor adapter housing

(8) Oil level plug

(9) Connector for breather filter line, the breather filter is located inside the center frame, see illustration Z25243 on page 369. The port of connector (9) is also used as oil filler opening.

(10) Oil drain plug

(11) Hydraulic motors

(12) Final drive housing contains the lubricating oil for sprocket bearing lubrication.

(13) Oil level gauge

(14) Oil filler plug

(15) Oil drain plug

(16) Connector for breather filter line, the breather filter is located inside the center frame, see illustration Z25243 on page 369.

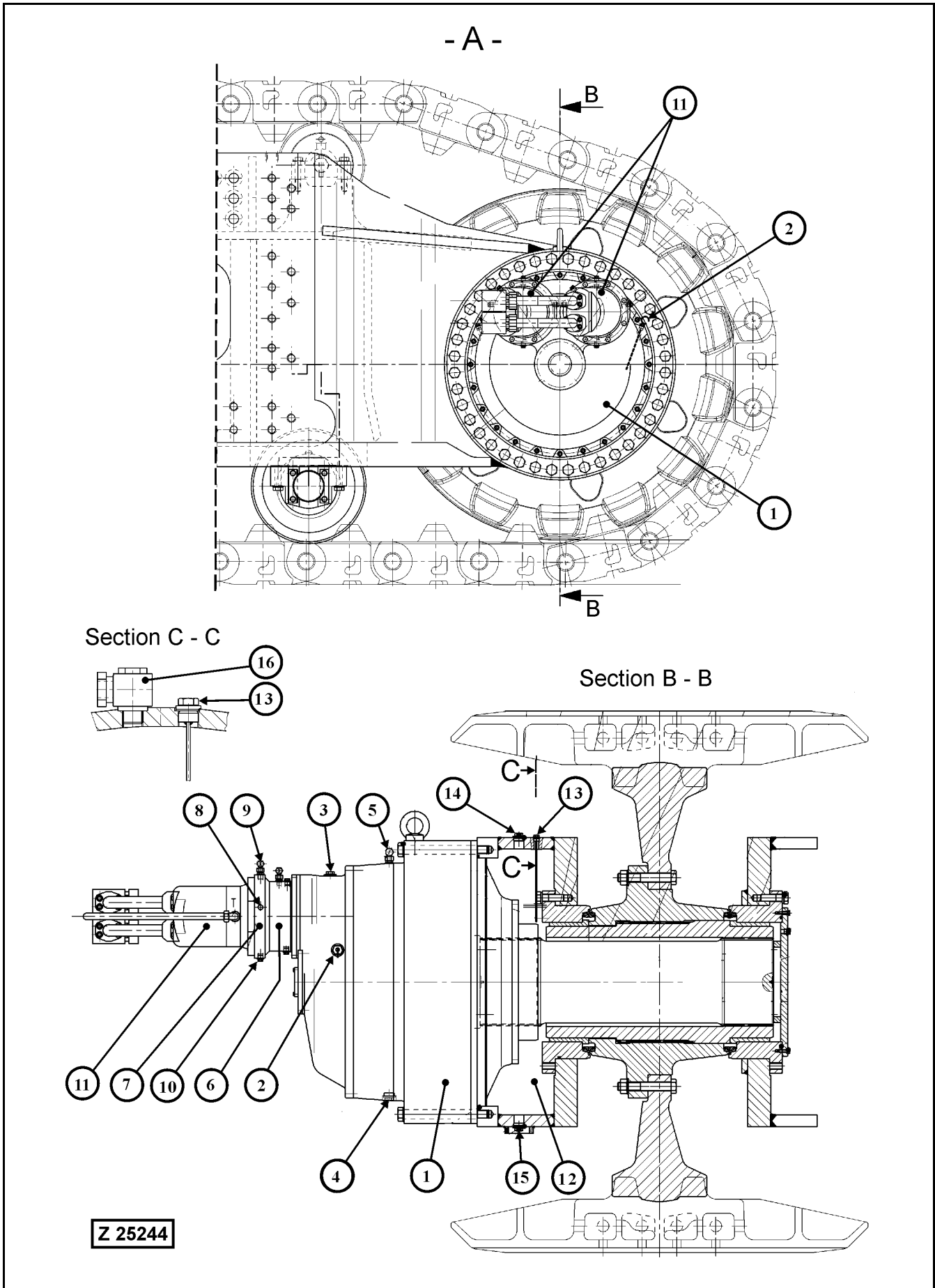

TRAVEL GEAR BOX - CHECK OIL LEVEL

Illustration Z25244:

Remove oil level gauge (2) and wipe it clean. Screw in the gauge and remove again. Oil level should be at the upper mark of gauge (2). If necessary add oil through filler opening (3). Insert gauge (2) and filler plug (3) and tighten securely. Check breather filter (18), illustration Z25243 on page 369 for restriction. If necessary, remove breather filters, blow out with compressed air from inside to outside and reinstall.

MOTOR ADAPTER HOUSINGS - CHECK OIL LEVEL

Check oil level by removing oil level plugs (8).

Oil level should be at lower edge of openings (8). If necessary, remove connector (9) for breather filter line and add oil through filler opening. Install level plugs (8) and screw in breather filter line connectors (9).

Check breather filter (19), illustration Z25243 on page 369 for restriction. If necessary, remove breather filters, blow out with compressed air from inside to outside and reinstall.

FINAL DRIVE HOUSING - CHECK OIL LEVEL

Remove oil level gauge (13) and wipe it clean. Screw in the gauge and remove again. Oil level should be at the upper mark of gauge (13). If necessary add oil through filler opening (14). Insert gauge (13) and filler plug (14) and tighten securely. Check breather filter (20), illustration Z25243 on page 369 for restriction. If necessary, remove breather filters, blow out with compressed air from inside to outside and reinstall.

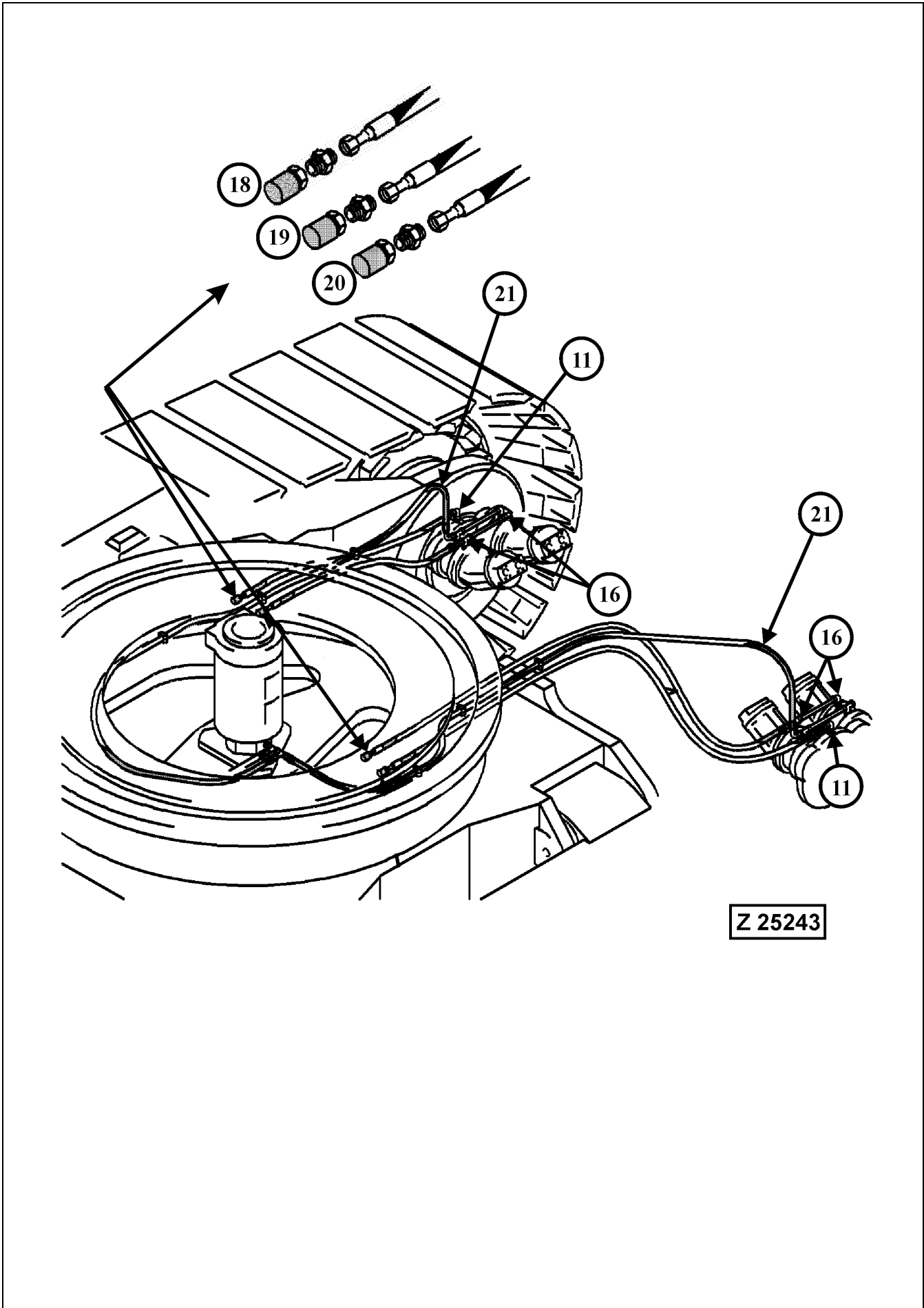

Z 25243

TRAVEL GEARS, MOTOR ADAPTER HOUSINGS AND FINAL DRIVES - CHECK BREATHER FILTERS

Legend for illustration Z25243

- (11) Connector on travel gear box for breather filter (18)
- (16) Connectors on motor adapter housing for breather filter (19)
- (18) Breather filters for travel gears
- (19) Breather filters for motor adapter housings
- (20) Breather filters for final drives
- (21) Pilot oil pressure hydraulic lines for releasing the parking brakes

Check the six breather filters(18, 19 and 20), located inside the center frame, for restriction. If necessary, remove breather filters, blow out with compressed air from inside to outside and reinstall.

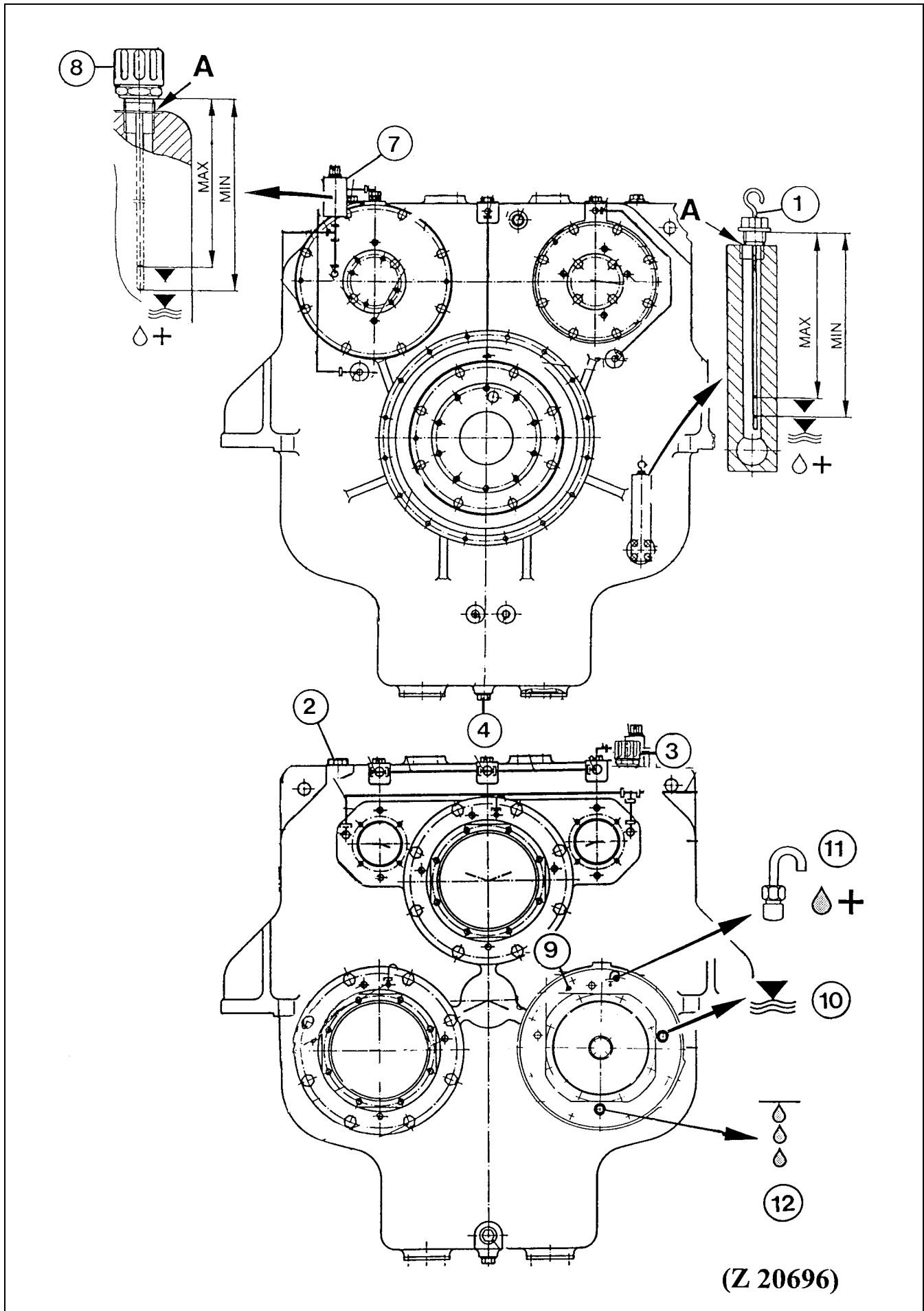

4.9.3 PTO's (PUMP DISTRIBUTOR GEARS) AND OIL RESERVOIR - CHECK OIL LEVEL

Legend for illustration Z 20696

- (1) Oil level gauge
- (2) Oil filler plug
- (3) Breather filter
- (4) Oil drain plug
- (7) Oil collector reservoir for adapter housings of hydraulic pumps for fan drives
- (8) Breather filter with oil level gauge
- (9) Adapter housings for main hydraulic pumps
- (10) Oil level plugs
- (11) Oil filler plug with breather pipe
- (12) Oil drain plug

PUMP DISTRIBUTOR GEARS, CHECK OIL LEVEL:

NOTICE

Checking of the oil level in both PTO gears must be carried out at the scheduled intervals, also on excavators equipped with an oil loss sensor. This sensor does not monitor the oil level but shuts down the excavator in case of a massive oil loss.

1. Unscrew level gauge (1) and wipe it clean.
2. Insert gauge (1), but DO NOT screw in, see detail (A).
3. Remove level gauge and read the oil level. The oil level should be between the "MIN" and "MAX" mark. If necessary, add oil through filler opening (2) up to the "MAX" mark on gauge (1).

REMARK

If the oil level is above the "MAX" mark, drain the oil down until the oil level is at the "MAX" mark. Too much oil in the pump distributor gear will cause aeration of the oil.

4. Insert gauge (1) and tighten securely. Remove breather filter (3). Blow out with compressed air from inside to outside and reinstall.

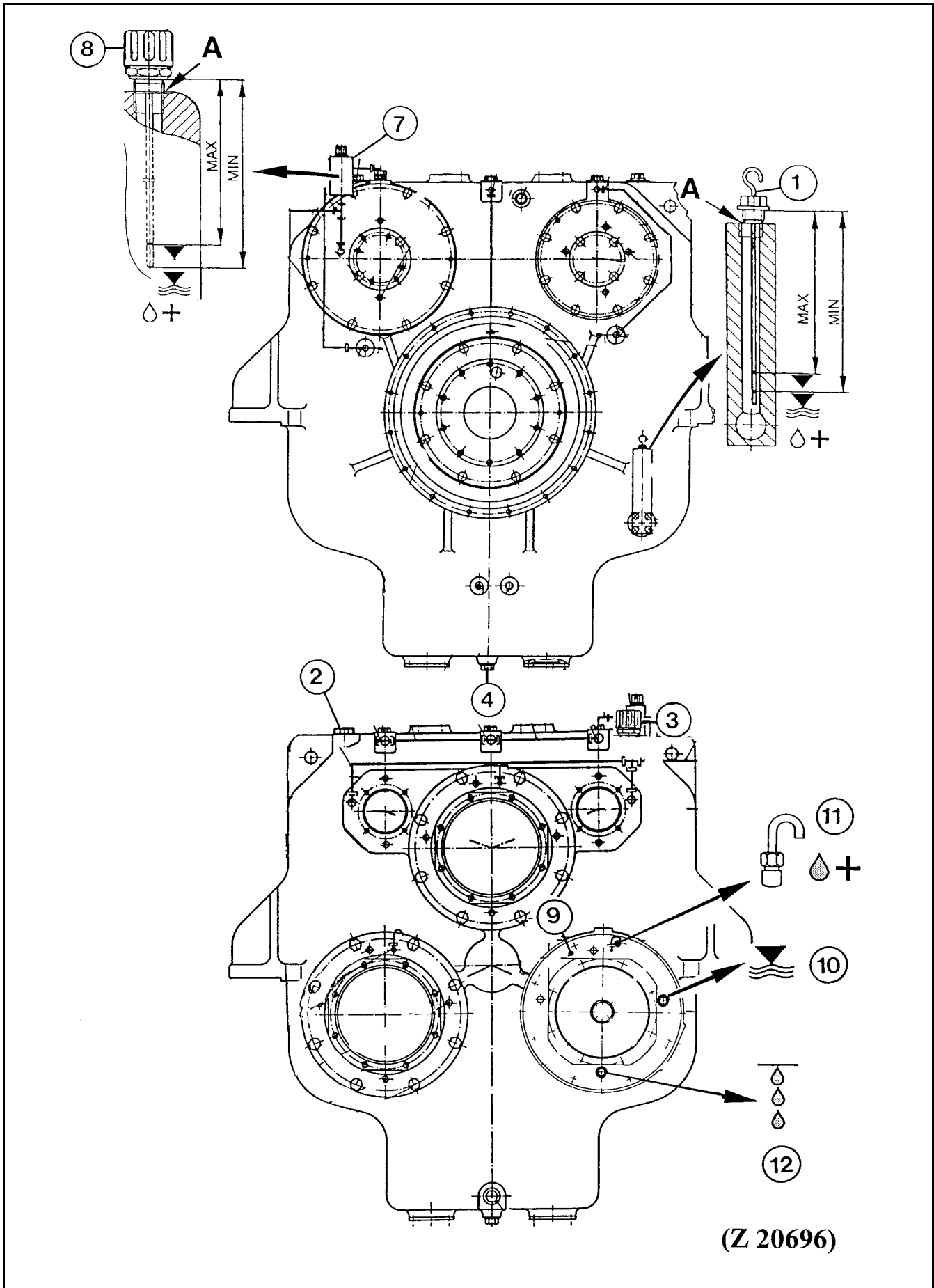

OIL COLLECTOR RESERVOIR - CHECK OIL LEVEL.

1. Unscrew level gauge (8), illustration Z 20696 and wipe it clean.
2. Insert gauge (8), but DO NOT screw in, see detail (A).
3. Remove level gauge and read the oil level.
The oil level should be between the "MIN" and "MAX" mark.
If necessary, add oil through filler opening (A) up to the "MAX" mark on gauge (8).
4. Blow out breather filter with compressed air from inside to outside. Insert gauge (8) and tighten securely.

NOTICE

If oil starts dropping out at breather (8), check oil seal of pump drive shaft for damage.

Main Hydraulic Pumps - Check Oil Level in Drive Shaft Housings

The Oil level should be at the lower edge of level plug opening (10). If necessary remove filler plug with breather pipe (11) and add Gear Oil through the filler opening up to the level opening (10).

Re-install plugs (10 and 11) and tighten securely.

If pump removal becomes necessary, drain the drive shaft housing oil by removing drain plug (12). Be sure to fill the drive shaft housing up to the filler opening (10) after mounting of the pump.

NOTICE

If oil starts dropping out at one of the breather pipes (11), the oil seal ring of the respective pump drive shaft must be checked and replaced if necessary.

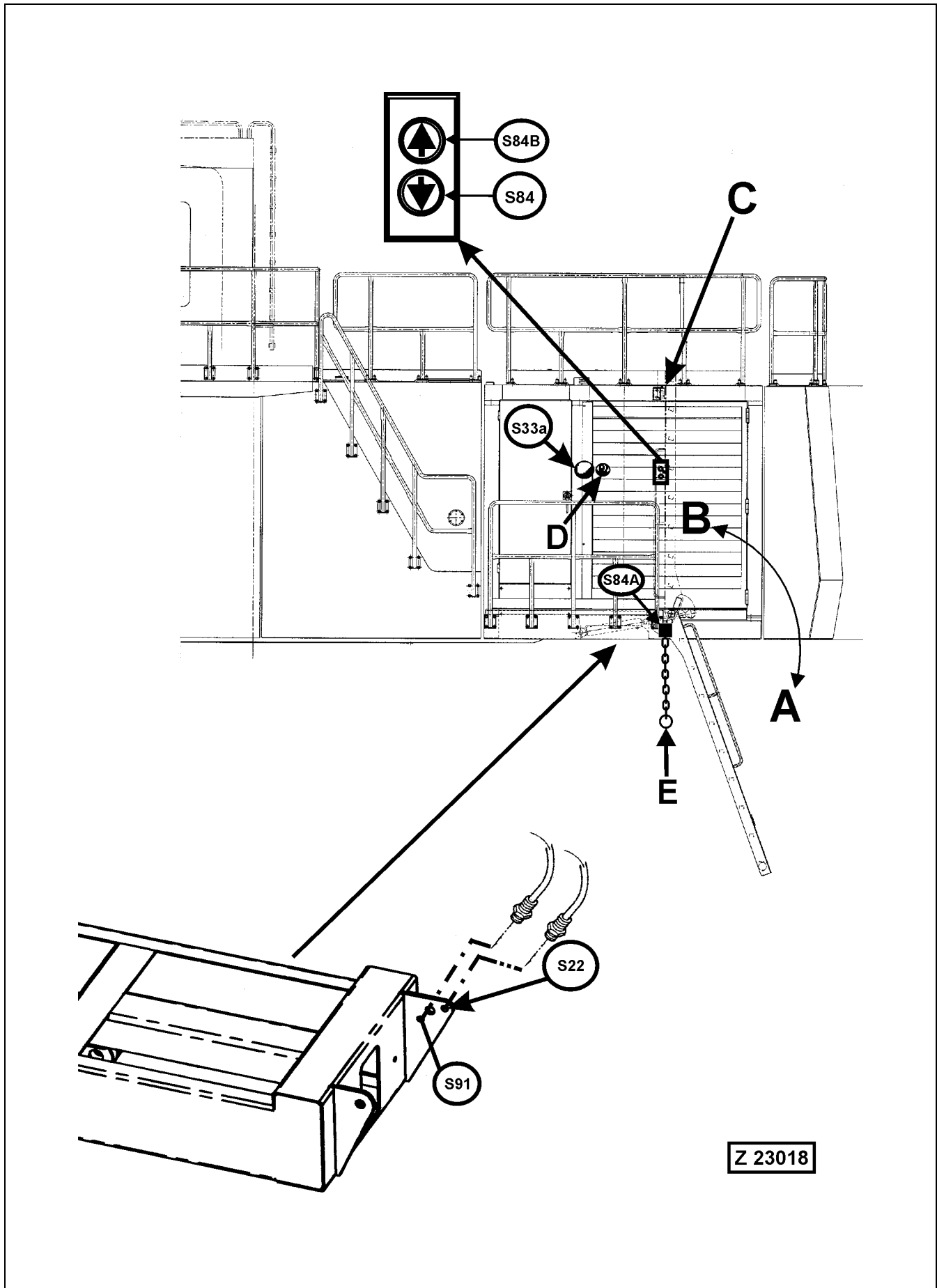

4.9.4 HYDRAULIC ACCESS LADDER - CHECK SAFETY SENSOR

Legend for illustration Z 23018

- (A) Access ladder in lowered position
- (B) Access ladder in upper position (Working position)
- (C) Stop bar
- (D) Manual actuator for fire suppression system (if so equipped)
- (E) Pull chain for emergency lowering of the access ladder

⚠ CAUTION

Use this chain only in emergency cases, when the Operator does not respond to other communication signals.

- (S84) Ladder control switch for lowering the ladder
- (S84B) Ladder control switch for lifting the ladder
- (S84A) Safety switch for emergency lowering of the access ladder. When the chain (E) is being pulled down with the engine running, the pilot control system is made inoperative, preventing further movements of the Shovel.
- (S22) Safety sensor, located on ladder pivot bracket
Function of sensor (S22): Cut out of the pilot control system and actuation of the hydraulic swing brake with the ladder in lowered position.
- (S91) Monitor and control sensor
Function of sensor (S91):
This sensor monitors the ladder position and controls the moving speed of the ladder. In case the sensor (S22) fails to function properly, the sensor (S91) prevents unintended movement of the ladder.
- (S33A) Emergency shutdown switch for both engines

Check Safety Sensor (S22) as follows:

With the ladder completely lowered (position A) start the engine.
Hold an iron part (screw driver) in front of sensor (S22).
The ladder must not start to move.
If the ladder starts to move, immediately remove the iron part from the sensor.

⚠ WARNING

- Inform the Service Staff about the malfunction of the ladder sensor.
- DO NOT operate the Excavator before the failure has been eliminated and the sensors function properly.

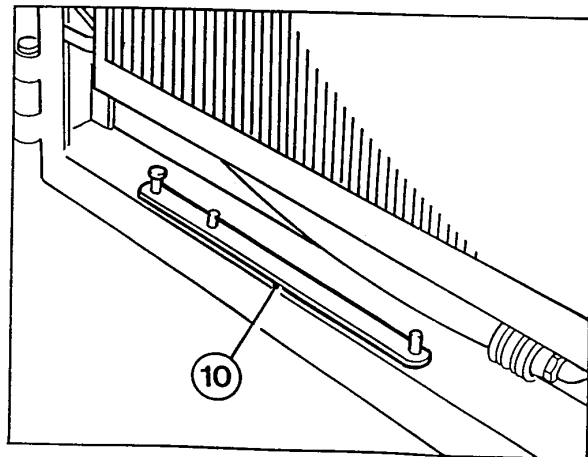
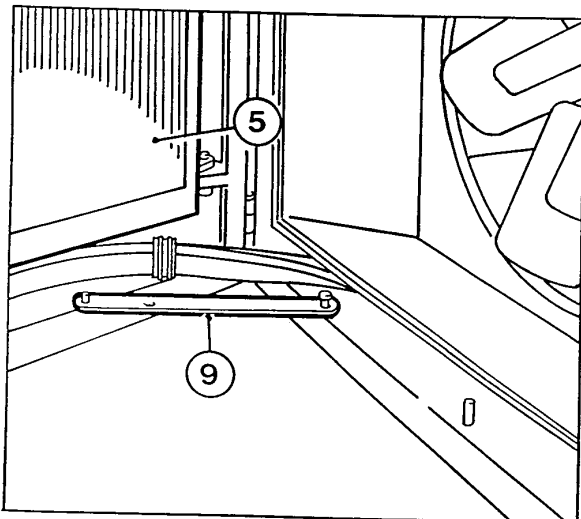
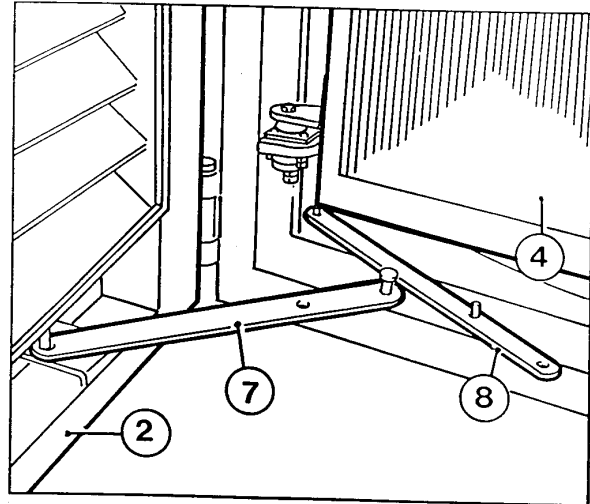
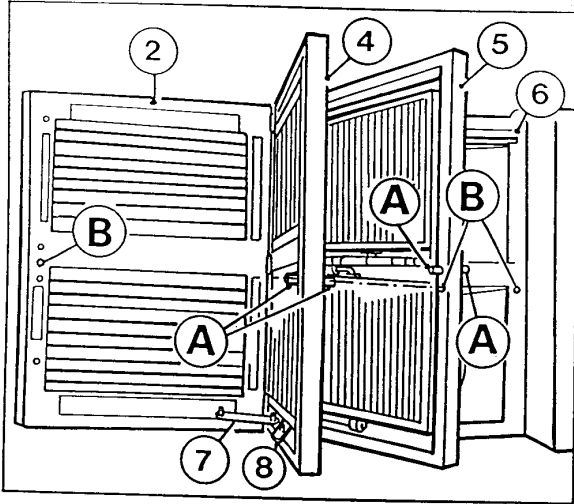
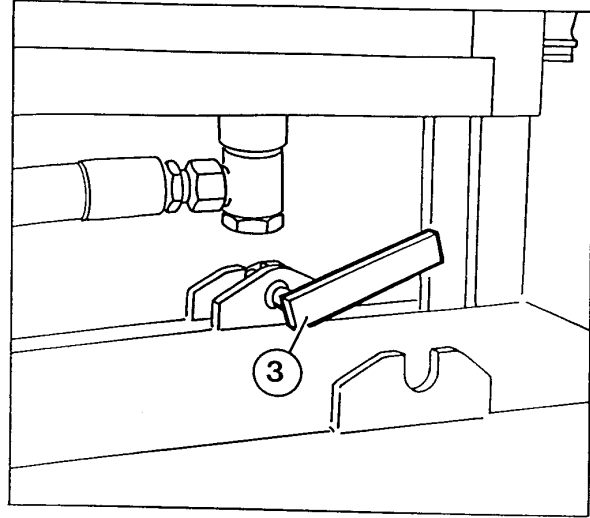
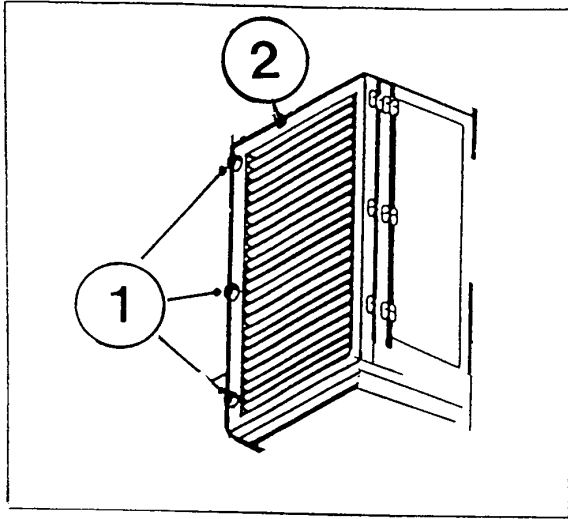

(Z 20369)

4.9.5 HYDRAULIC OIL COOLERS - INSPECT AND CLEAN IF NECESSARY

See illustration Z 20369

WARNING

- Provide adequate working platform for safe access to the hydraulic oil coolers.
 - Before removing mounting bolts (1) of the hydraulic oil cooler door (2) check to make sure that all door hinges are in good condition and properly fastened on their carrier frames. If cracks are found at the welded joints of the hinges, **DO NOT** remove mounting bolts (1) otherwise the cooler door may become detached and fall off. Danger of accidents. Have the damage repaired as soon as possible.
-
-

1. Loosen mounting bolts (1).
2. Open door (2).

REMARK

Details (A and B) i show LH hinge mounted oil coolers. The description below applies also to RH mounted oil coolers.

3. Loosen fasteners (3) and swing out oil coolers (4 and 5).
4. Secure door (2) and oil coolers (4 and 5) with locking bars (7, 8 and 9).
5. Clean the oil coolers with compressed air. Direct the air flow from inside to outside.
6. After cleaning, bring back the oil coolers to their home position.

PROCEED AS FOLLOWS

- Disengage locking bars (7, 8 and 9) and bring them in storage position (10).
- Swing back inner cooler (5). Take care guide pin (A) fits into hole (B) of main frame (6). Secure cooler (5) with fastener (3).
- Swing back outer cooler (4); observe (A - B) and secure with fastener (3).
- Close door (2); observe (B - A). Install mounting bolts (1) and tighten securely.

NOTICE

When cleaning the oil coolers, inspect also laying and fastening of the hydraulic oil lines.

4.10 EVERY 250 OPERATING HOURS OR MONTHLY

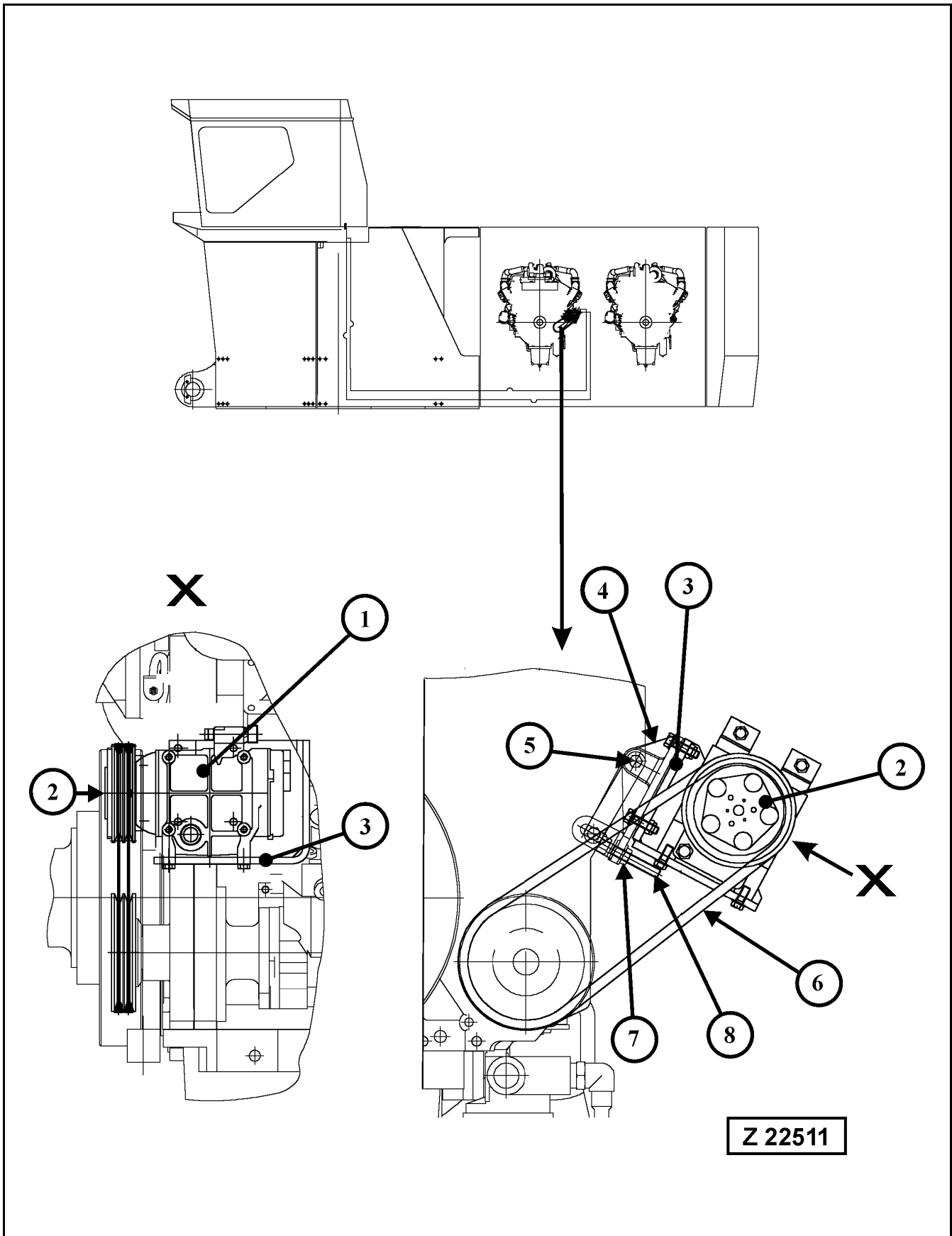

4.10.1 AIR CONDITIONING COMPRESSOR - CHECK DRIVE BELT TENSION

WARNING

Be sure to set the maintenance safety switch to 0 position before to start the checking procedure. Refer to page 205 for the location of the maintenance safety switch. In the 0 position the engines can not be started. Secure this position by inserting a padlock into the holes of the switch. Up to three padlocks can be attached to the holes provided.

Legend for illustration Z 22511

- (1) Refrigerant compressor
- (2) Electromagnetic clutch
- (3) Compressor carrier
- (4) Swivel bracket
- (5) Pivot bolt, loosen for adjusting belt tension
- (6) Drive belts
- (7) Lock nut
- (8) Adjusting bolt for belt tension

Check tension of each belt

The tension is correct if the belt can be depressed with 110 N (25 lb.) force approximately 15 to 20 mm midway between the belt pulleys.

Excessive belt tension causes undue wear on the bearings. After a new belt has been in use for approximately 20 minutes, check the tension and adjust again if necessary.

NOTICE

Always replace the belts in complete sets.

Adjust belt tension

1. Loosen pivot bolt (5)
2. Loosen lock nut (7)
3. Turn adjusting bolt (8) until correct belt deflection is obtained.
Tighten lock nut (7)
4. Tighten pivot bolt (5) and check the belt adjustment.

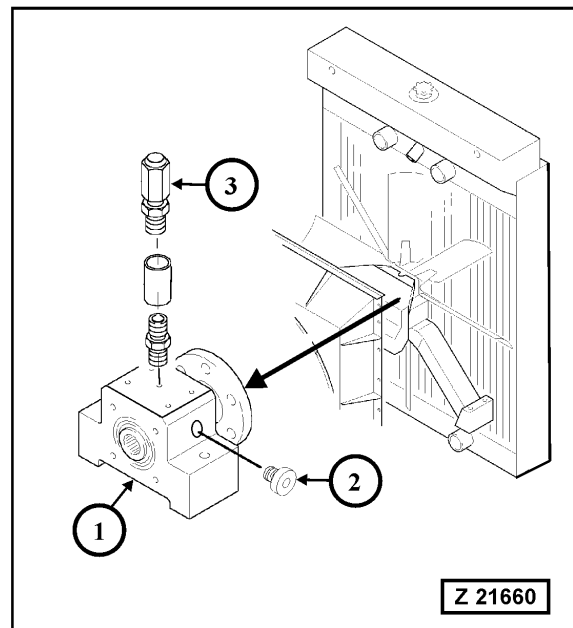
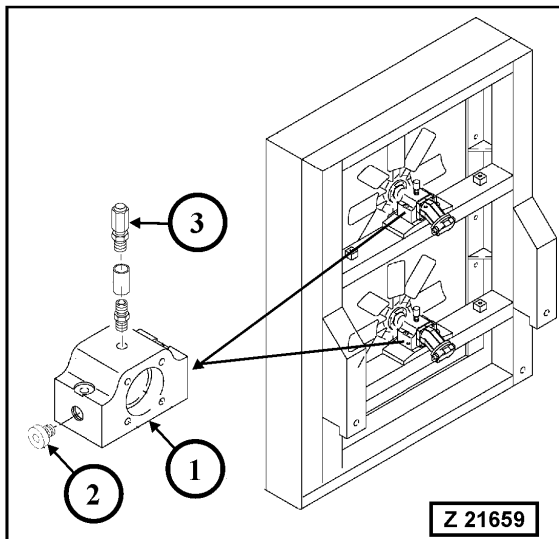
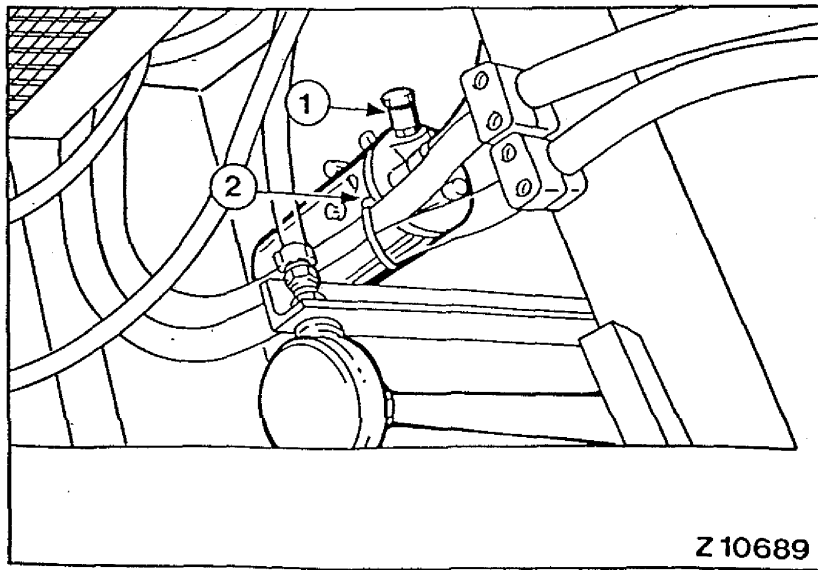

4.10.2 SIGNAL HORN COMPRESSOR - LUBRICATE

See illustration Z 10689

The compressor (2) is located in the cab base.

Fill several drops of thin oil into the lubricator (1).

The oil must be free from resin and acid and must have the lowest solidifying-point possible (below - 40° C).

REMARK

If the Excavator is equipped with a second signal horn there is also a second compressor which has to be lubricated in the same way as the first one.

4.10.3 HYDRAULIC OIL COOLER FAN BEARINGS - CHECK FOR LEAKAGE AND CLEAN BREATHER FILTER

See illustration Z 21659

Check housing (1) for leakage. If leakage is found, check the oil level in the bearing housing. Remove oil level plug (2). The oil level should be at lower edge of the opening. If necessary add oil through the breather filter adapter pipe. Clean breather filter (3) with compressed air from inside to outside and install plug (2) and breather filter (3). Oil loss of the bearing housing indicates worn or damaged seal rings. To prevent damage to the fan bearings, install new seal rings.

4.10.4 RADIATOR FAN BEARINGS - CHECK FOR LEAKAGE AND CLEAN BREATHER FILTER

See illustration Z 21660

Check housing (1) for leakage. If leakage is found, check the oil level in the bearing housing. Remove oil level plug (2). The oil level should be at lower edge of the opening. If necessary add oil through the breather filter adapter pipe. Clean breather filter (3) with compressed air from inside to outside and install plug (2) and breather filter (3). Oil loss of the bearing housing indicates worn or damaged seal rings. To prevent damage to the fan bearings, install new seal rings.

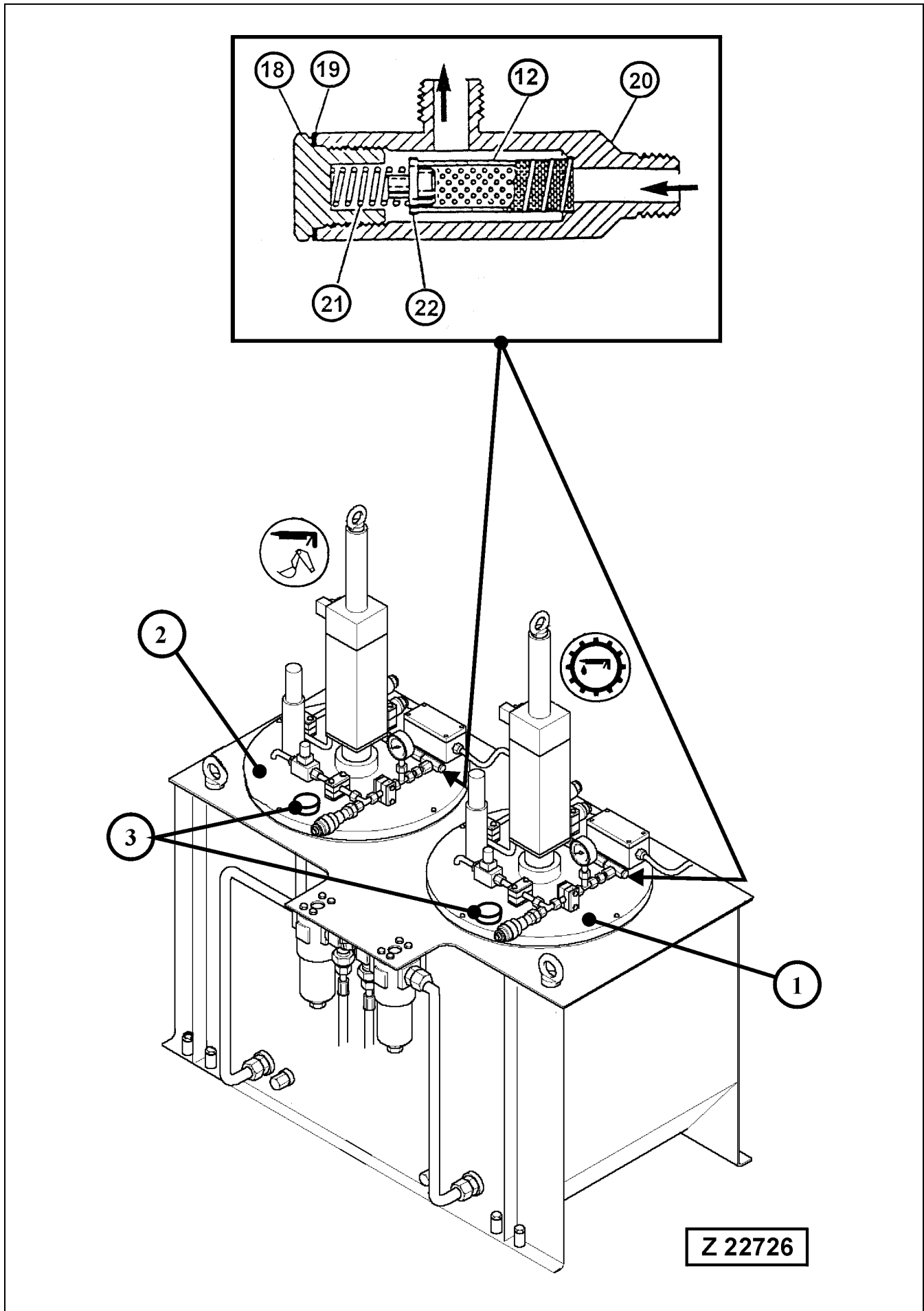

Z 22726

4.10.5 AUTOMATIC LUBRICATION SYSTEMS - CLEAN IN-LINE GREASE FILTER AND CHECK BREATHER FILTER

Legend for illustration Z 22726

- (1) Grease container of swing circle pinion lubrication system
- (2) Grease container of central lubrication system
- (3) Breather filters

Components of In-Line-Grease-Filter:

- (12) Filter element
- (18) Plug screw
- (19) Packing ring
- (20) Filter housing
- (21) Spring
- (22) Spring guide

WARNING

Before servicing stop the engine/motor and remove ignition key in order to prevent operation of the system. Be sure to vent system pressure before removing plug (18).

A blocked filter can disintegrate under pressure and damage the automatic lube system.

Service the in-line grease filter

1. Unscrew plug (18), illustration Z 22726, using 36 mm width wrench and remove packing ring (19).
2. Take out spring (21), spring guide (22) and element (12). Clean all parts and inspect for damage. Replace as necessary.
3. Assemble all parts according to the illustration. Make sure all sealing surfaces are clean. Take care for proper position of spring guide (22). Install plug screw (18) with new packing ring (19) and tighten with a wrench.

Check breather filter

Check condition and fastening of breather filters (3). If necessary clean the breather filter with compressed air. For removal of the breather filter it is necessary to lift off the container cover. Make sure the breather filter mounting nut inside the cover is securely tightend before lowering the cover onto the container.

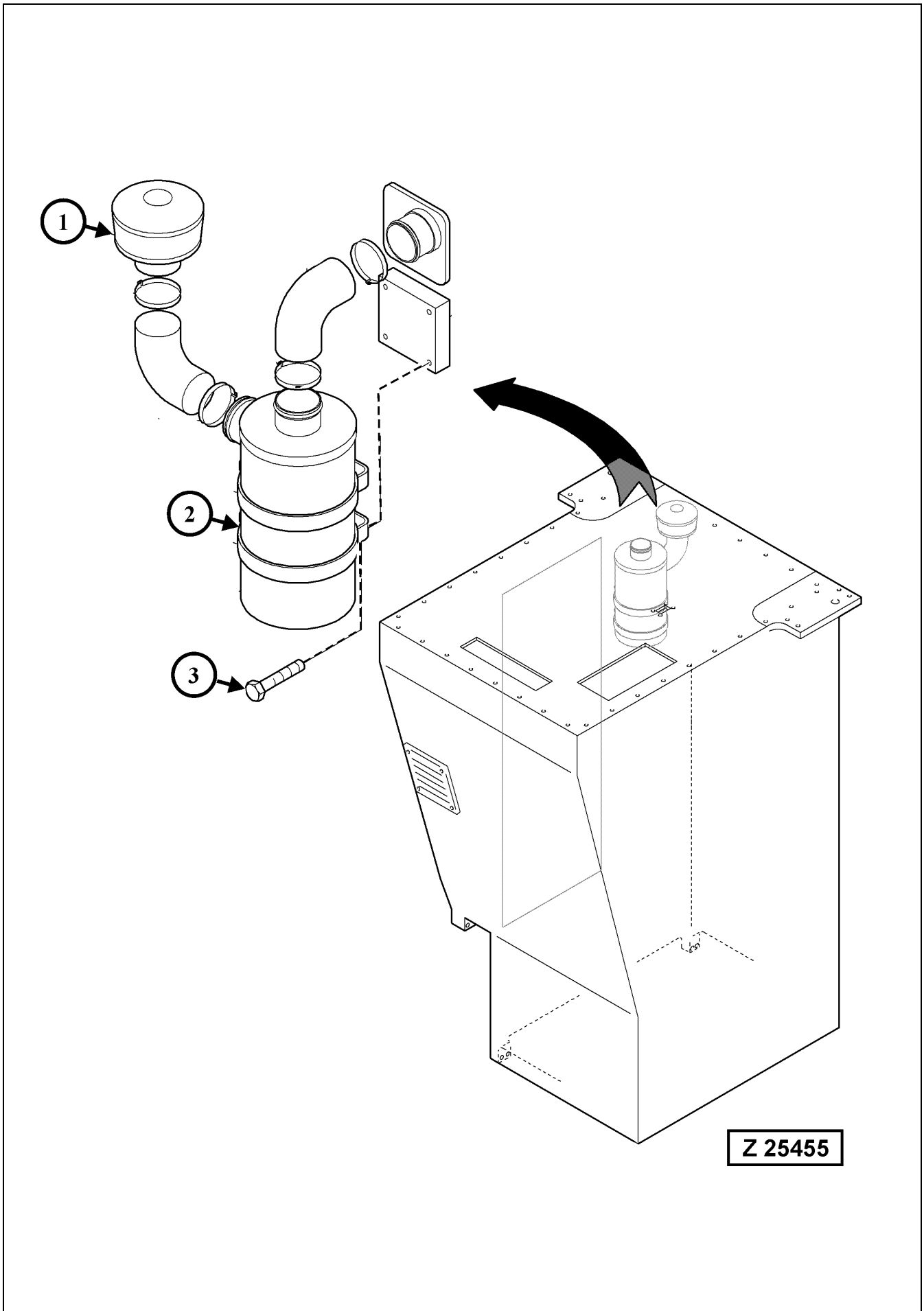

4.10.6 CAB AIR CLEANER - CLEAN OR REPLACE FILTER ELEMENT

Legend for illustration Z25455

- (1) Pre-cleaner
- (2) Air cleaner housing located on cab base
- (3) Air cleaner mounting bolts

Clean pre-cleaner dust bowl

1. Check the dust level in bowl (1), if the level is near the Max. marking remove and clean the dust bowl.
2. Install dust bowl and cover.
3. Check condition of the hose and hose clamps and replace if necessary.

REMARK

When operating the machine under very dusty conditions, check pre-cleaner in shorter intervals.

Clean and inspect main filter element

1. Remove element from housing (2).
2. Clean and check resp. replace filter element. Wipe out filter housing with a clean cloth.
3. Element cleaning methods:
Clean main element by one of the following methods. Compressed air or washing. Compressed air is recommended when element will be re-used immediately because a washed element must be dried before re-use.

Compressed air:

Direct air through element in the direction opposite to normal air flow through the element. Move nozzle up and down while rotating element. Keep nozzle at least one inch from pleated paper. Maximum air pressure to prevent damage of element is 100 P.S.I. (6 bar).

Washing:

Soak element 15 minutes or more in cleaning solution. See package for full instructions. Rinse until water is clear maximum water pressure 40 P.S.I. (2,5 bar). Air-dry or use warm flowing air, max. 160° F (+70° C). Do not use compressed air or light bulbs.

Replace element after 6 cleaning or annually, whichever occurs first.

4. Install filter element and bottom cover. Make sure all connections are correctly fitted and tight.

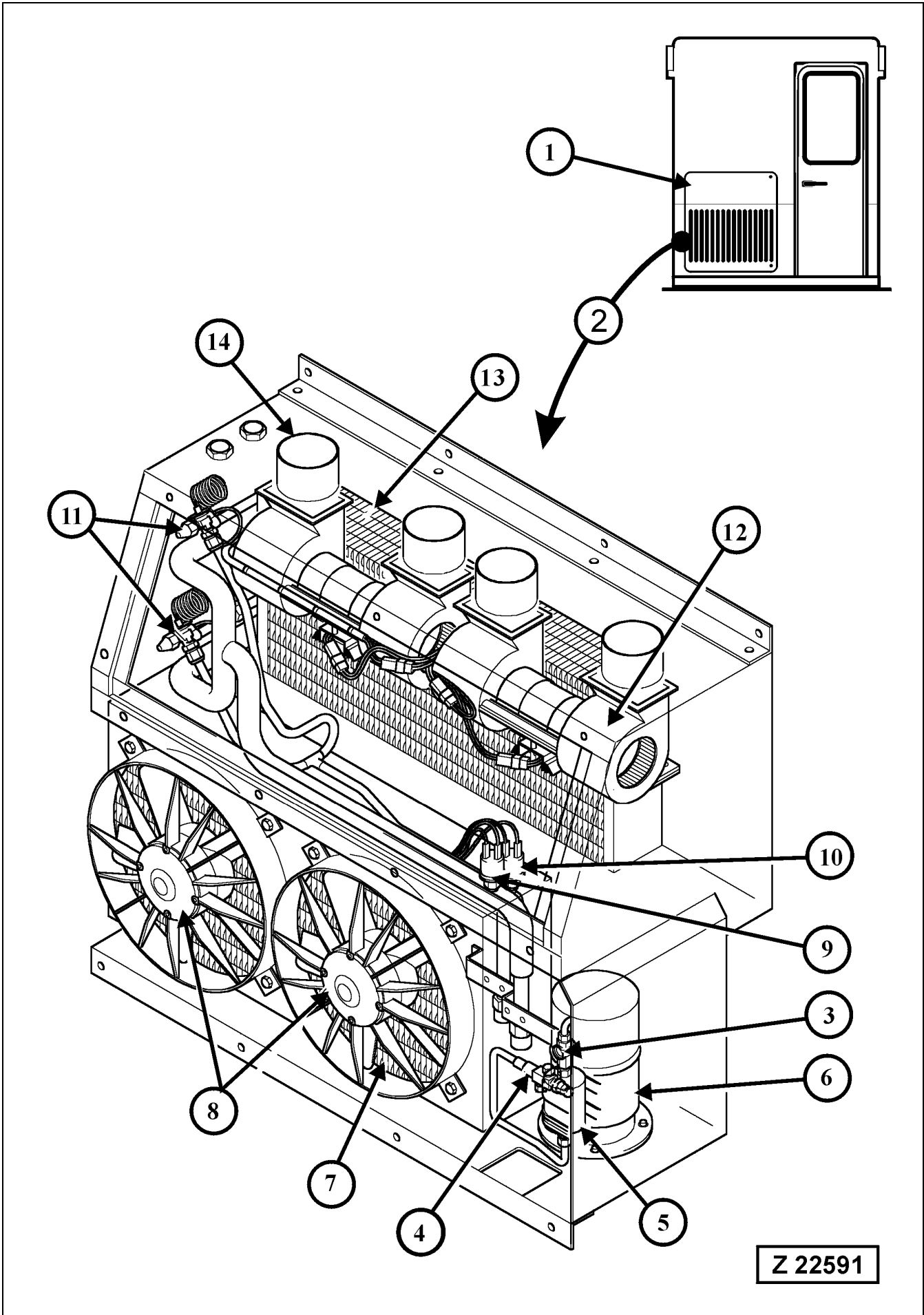

Z 22591

4.10.7 AIR CONDITIONING FOR OPERATOR'S CAB - CHECK REFRIGERANT LEVEL

Legend for illustration Z 22591

- (1) Air conditioner door with filter mat
- (2) Air conditioner unit
- (3) Sight glass for checking refrigerant filling
- (4) Shut-off valve on dryer cartridge
- (5) Dryer cartridge
- (6) Refrigerant collector reservoir
- (7) Condenser
- (8) Condenser blower
- (9) Low pressure switch
- (10) High pressure switch
- (11) Expansion valves
- (12) Evaporator blower
- (13) Evaporator
- (14) Cool air outlets

Checking the refrigerant level:

Switch on air conditioning equipment and run at maximum capacity for approx. 5 minutes.

Observe inspection glass (3). A refrigerant flow loaded with bubbles or foam indicates a lack of refrigerant. In this case well equipped refrigeration specialists must check the circuit for tightness and must add the missing quantity or refrigerant. If more than 200 grams per year are lost, the oil level of the refrigerant compressor must also be checked. This is a special procedure and must be carried out by refrigeration specialists only. Isolated small bubbles in the inspection glass may be neglected.

Even with an absolutely tight equipment a certain amount of refrigerant is lost through the walls of the hoses.

Therefore a small annual replenishment of the refrigerant quantity is normal.

The dryer cartridge (5) must be replaced after every 1000 operating hours or once a year by refrigeration specialists.

Clean the filter mats of condenser (7) and evaporator (13).

REMARK

Servicing of the air conditioning systems is restricted to workshops especially equipped for this purpose. Refer to the separate booklet "AIR CONDITIONING" in Service Literature Binder – Volume 2 for more information.

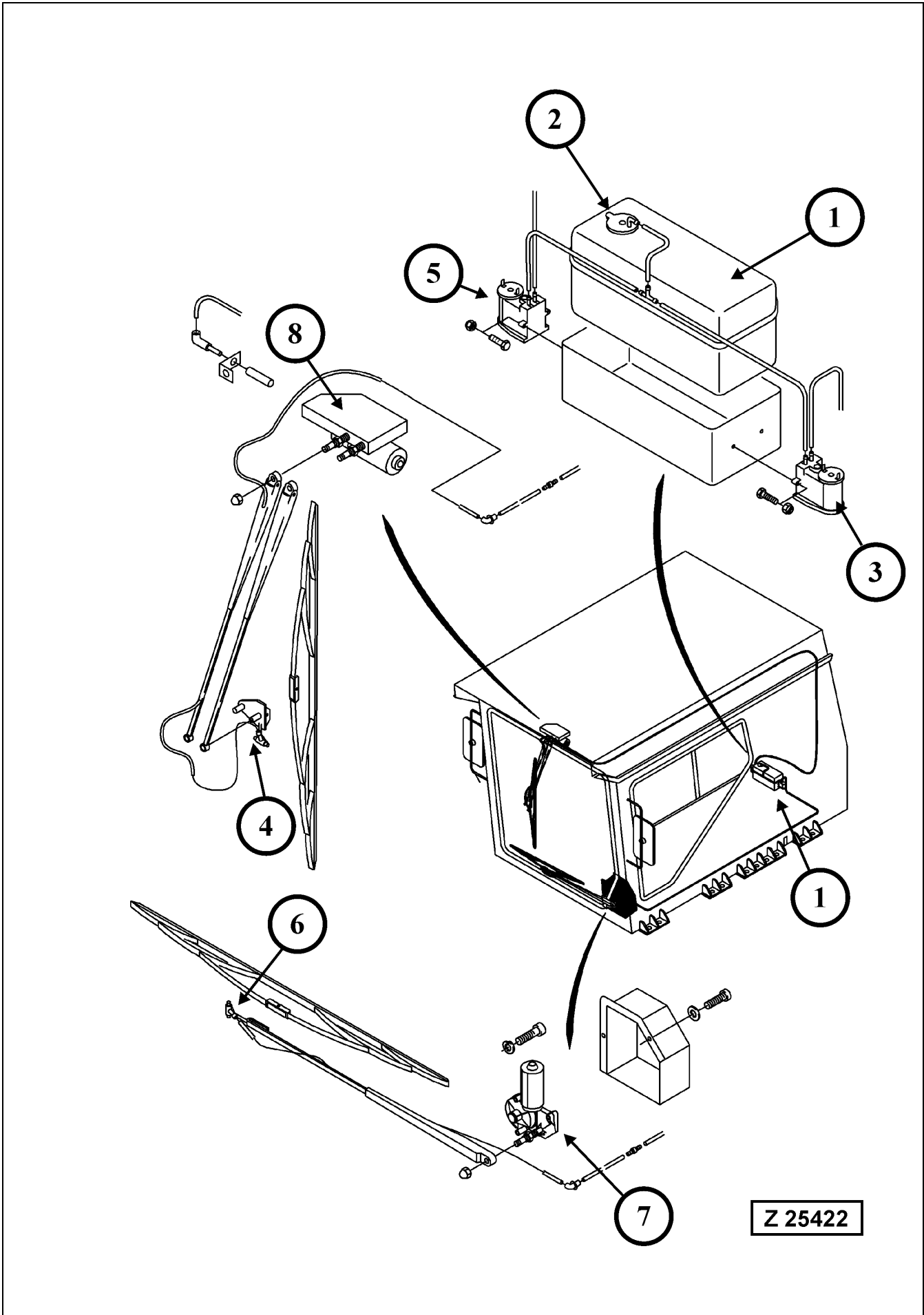

4.10.8 WINDSHIELD WASHER SYSTEM - CHECK FLUID LEVEL

Legend for illustration Z 25422

- (1) Water reservoir for windshield washer
- (2) Filler cap with suction line
- (3) Water pump for windshield washer
- (4) Upper washer nozzle for windshield
- (5) Water pump for windshield washer
- (6) Lower washer nozzle for windshield
- (7) Wiper motor for lower windshield wiper
- (8) Wiper motor for upper windshield wiper

Fill the water reservoir (1) with clear water, add anti-freeze and cleaning agent as necessary. Filling capacity of the water reservoir is 7 liters.

Check washer and wiper system for tightness and carry out a functional test of both systems.

4.11 EVERY 500 OPERATING HOURS OR QUARTERLY

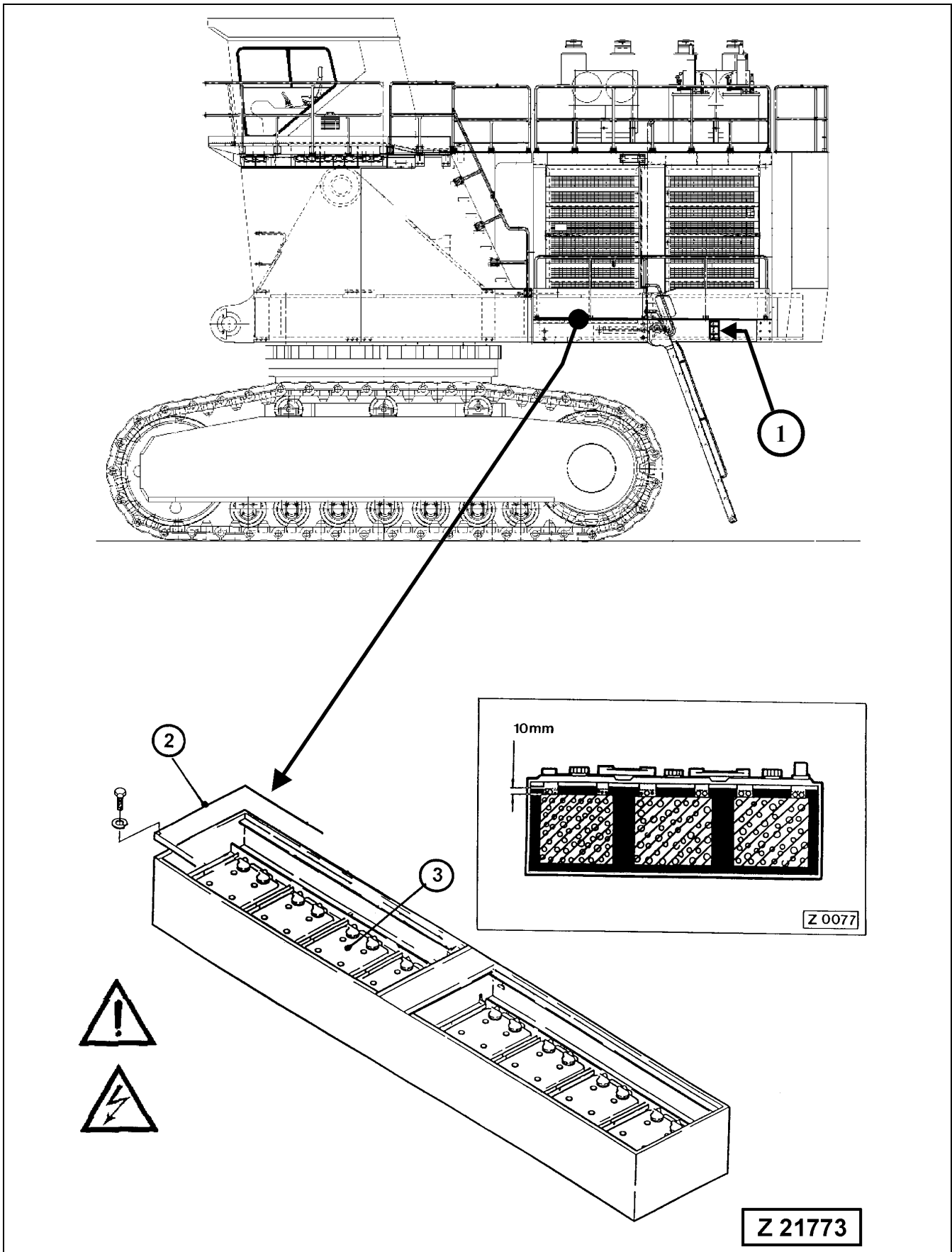

4.11.1 BATTERIES - CHECK FLUID LEVEL

See illustration Z 21773

⚠ WARNING

- Batteries give off highly inflammable gas! Never allow sparks or open flame near the batteries!
 - Avoid spilling any electrolyte on hands or clothing. Repair or replace all broken wires immediately. All terminals must be clean and securely fastened; never paint connections.
 - DO NOT short across or ground any terminals of the batteries.
-

Check electrolyte level:

NOTICE

The batteries are located below the walkway floor in two separate boxes. To get access to the batteries remove floor plate fastening bolts and open the hinged floor plates. Secure the open floor plates against falling down with the safety chains provided.

1. Remove the two battery main switch keys (1).
2. Open floor plates (2).
3. Check electrolyte level of batteries (3) see illustr. (Z 0077).
4. If necessary remove filler and breather caps and top up with clean distilled water.
5. See that contact surfaces of battery terminals are bright. Clean if necessary and apply some vaseline to the terminal posts.

⚠ WARNING

- Care must be taken that the batteries are not overfilled as the electrolyte will expand and overflow when the temperature rises.
 - On removal always disconnect the ground (-) cables first. When re-installing the batteries connect the positive (+) cables first.
-

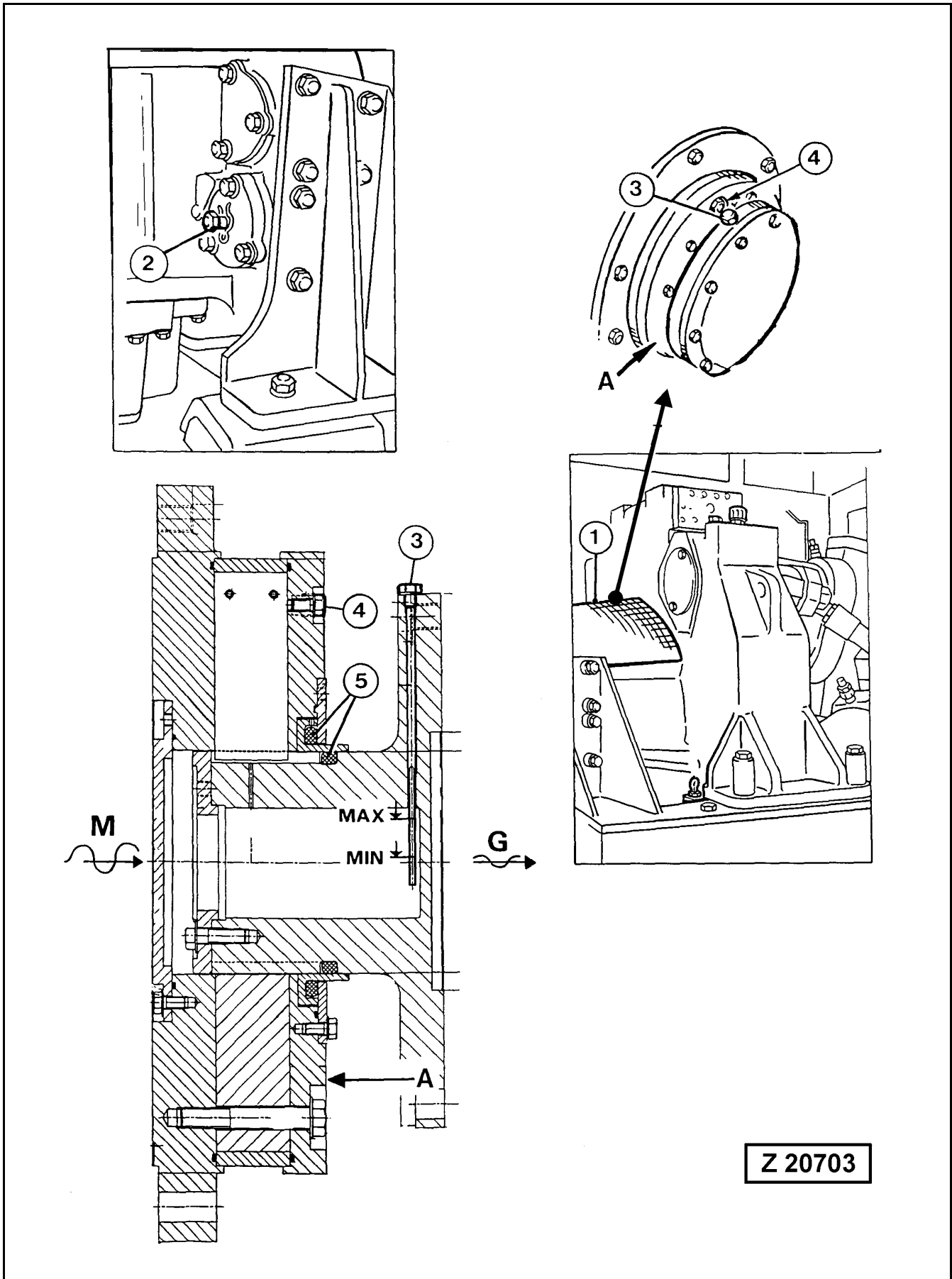

4.11.2 FLEXIBLE DRIVE COUPLINGS - CHECK OIL LEVEL

See illustration Z 20703

NOTICE

The Engines must be out of operation for approximately 30 minutes before checking the oil level. This period is necessary for settling of the oil in the lower part of the coupling housing.

1. Remove guard (1).
2. Turn flexible coupling by using barring device (2) to bring oil level gauge (3) in its uppermost (12 o'clock) position.

REMARK

To use the barring device, remove the clip and push the device shaft toward the flywheel. The barring device must be rotated counterclockwise to turn the flywheel (flexible coupling) in the direction of normal rotation.

3. Unscrew gauge (3), wipe it clean and insert into the gauge opening.
DO NOT screw in. Pull out gauge (3) and read the oil level.
4. If necessary add oil through gauge opening to bring the oil level up to the "MAX" mark on gauge (3). To speed-up the filling procedure, remove bleeder screw (4) and warm up the oil to approximately +30°C.
5. Insert gauge (3) with packing ring and bleeder screw (4) with packing ring and tighten securely.
6. Check area (A) for leakage. If oil leakage is found (radial traces of oil), O-rings (5) must be checked for damage and replaced if necessary.
7. Install guard (1).
8. Repeat checking procedure on the flexible coupling of the second engine.

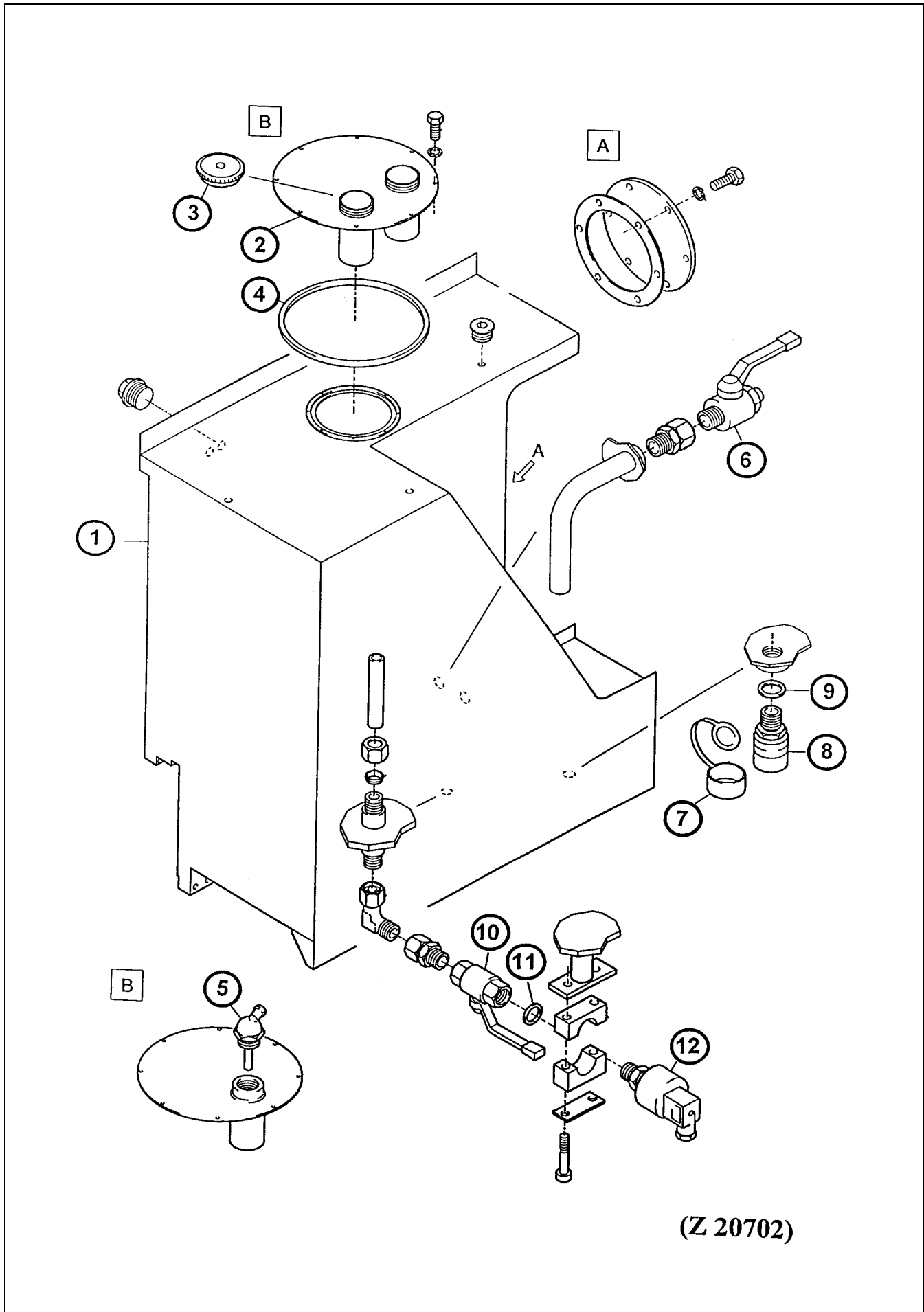

(Z 20702)

4.11.3 FUEL TANK - DRAIN CONDENSATION

Legend for illustration Z 20702

- (1) Fuel tank
- (2) Cover
- (3) Filler cap
- (4) Seal ring
- (5) Fuel tank breather valve on machines with refilling system
- (6) Main fuel shut-off cock
- (7) Protection cap for drain coupling (8)
- (8) Drain coupling
- (9) Seal ring
- (10) Shut-off cock for pressure transducer (12). Close this cock when replacing the pressure transducer (12).
- (11) Seal ring
- (12) Pressure transducer for level indication

▲ WARNING

DO NOT smoke or use an open flame when working around inflammable fuels.

Drain Water and Sediments from Fuel Tank.

Open the hinged cover below the fuel tank.
Attach drain hose and open drain coupling (8). Collect outflowing sediments in a suitable container.

Servicing the Fuel System.

When servicing the fuel system close fuel shut-off cock (6).

NOTICE

On machines equipped with a Fire Detection and Suppression System, a solenoid valve is installed in place of the shut-off cock (6).

After finishing the service, open cock (6) and vent the fuel system according to the engine maintenance manual. Check to make sure all fuel lines and connections are in good condition. Check the complete fuel system for leaks.

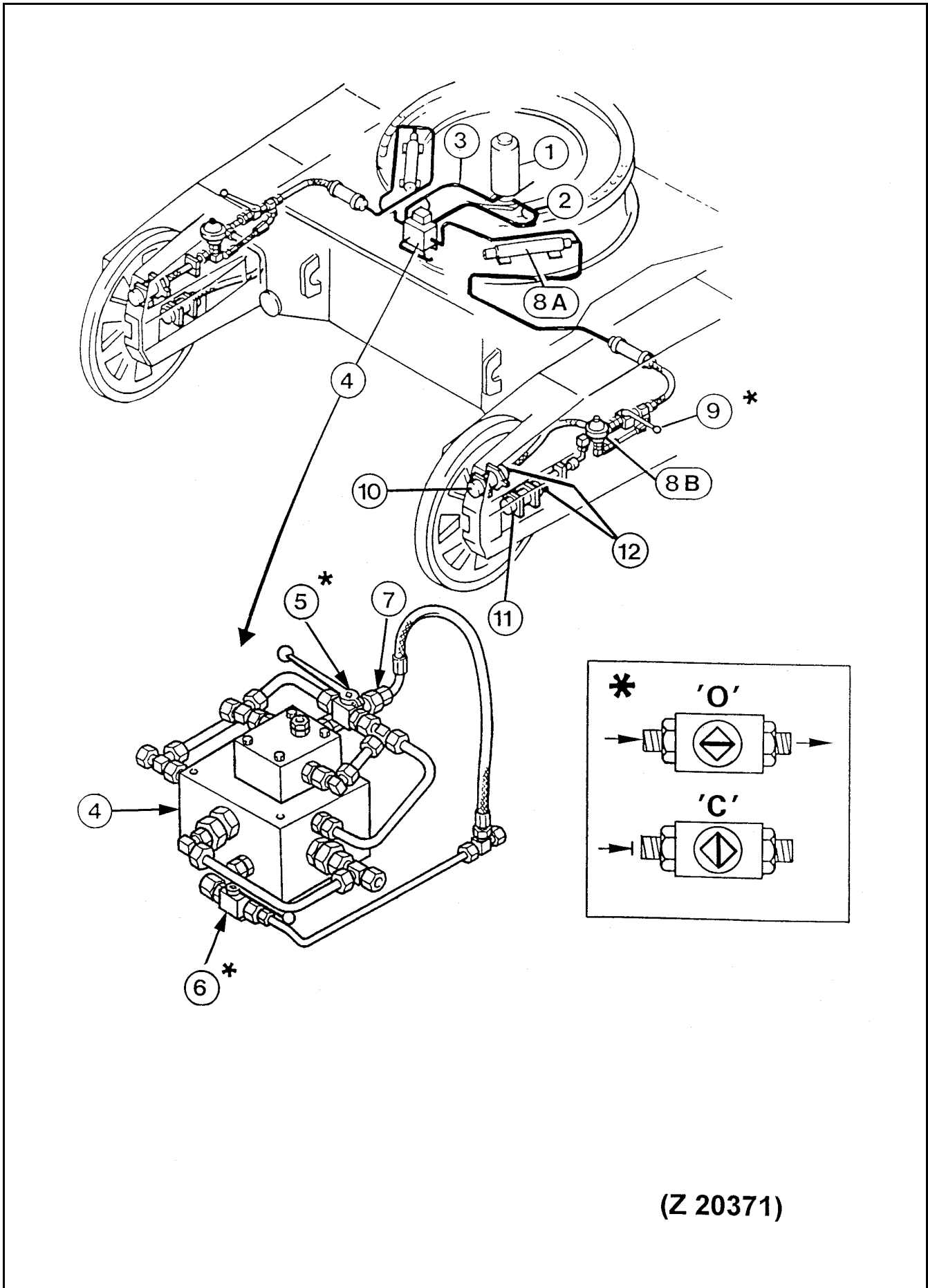

(Z 20371)

4.11.4 CRAWLER TRACK - INSPECTION

CHECK ADJUSTING RANGE OF GUIDE WHEELS

(Track retensioning range)

GENERAL

The hydraulic track tensioning system, illust. Z 20371 maintains automatically the correct track tension. The pilot pressure oil of the travel brake release circuit is used, to pressurize the four adjusting cylinders (10) and (11). The resulting force moves the guide wheels toward the front, until the correct track tension is obtained. External forces acting upon the guide wheels are absorbed through the pressure accumulators (8A) and (8B).

Legend for illust. Z 20371:

- (1) Rotary distributor
- (2) Supply line, pilot pressure from travel brake release circuit
- (3) Return oil line (leakage oil)
- (4) Valve block
- (5) Pressure relief cock for hydraulic track tensioning system.
"C" - Closed (Normal working position)
"O" - Open
- (6) Shut-off cock in supply line (if so equipped)
"O" - Open (Normal working position)
"C" - Closed
- (7) Two stage pilot pressure operated relief valve
- (8A) Pressure accumulator, high pressure (150 bar)
- (8B) Pressure accumulator, low pressure (31 bar)
- (9) Shutoff cocks, RH & LH
"O" - Open (Normal working position)
"C" - Closed
- (10) Track adjusting cylinders, inner
- (11) Track adjusting cylinders, outer
- (12) Test connectors and vent valves

WARNING

Before working on the hydraulic track tensioning system, relieve all pressure in the system by opening cock (5), position 'O'. After finishing the service work close the pressure relief cock (5), position 'C'.

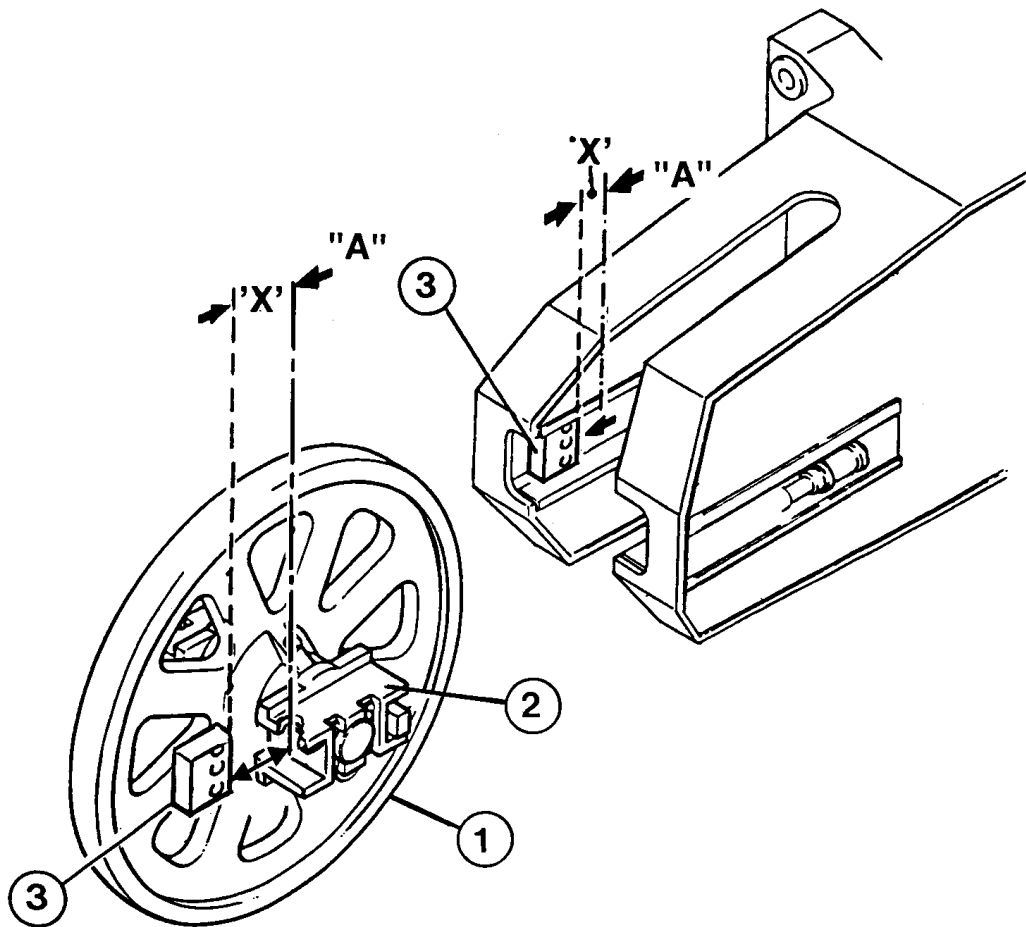
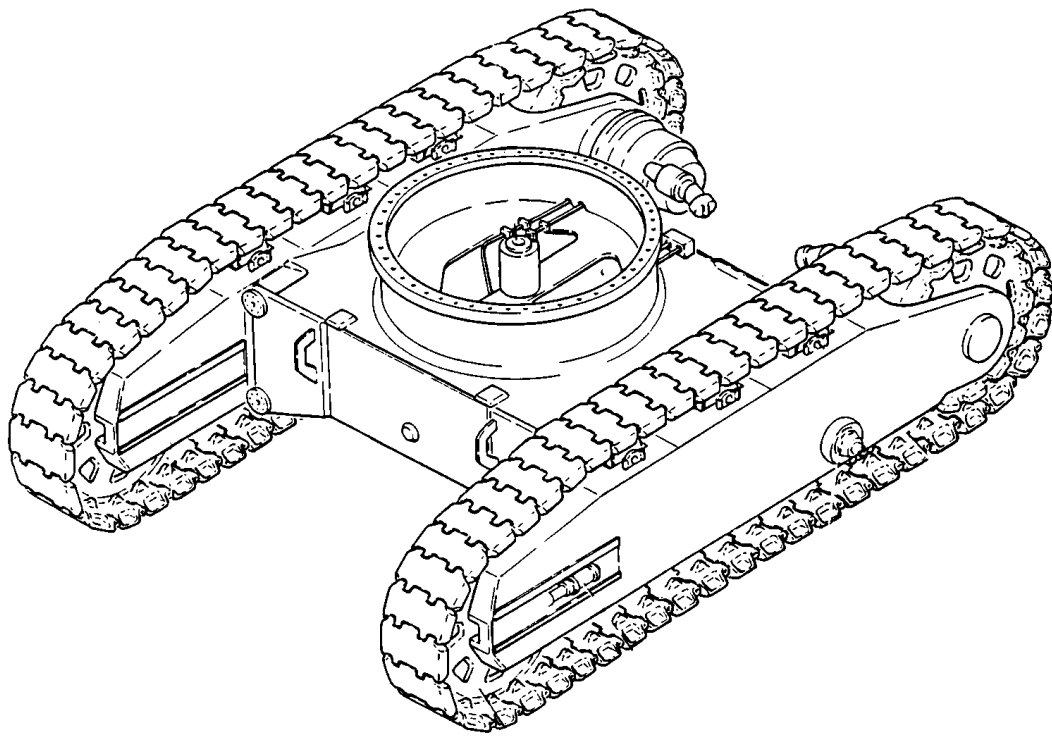

Z 20015

CHECK ADJUSTING RANGE FOR GUIDE WHEELS

Legend for illustration Z 20015

- (1) Guide wheel
- (2) Slide block
- (3) Stop plate

“X” Adjusting range for track tension

The adjusting range for track tension is the distance “X” between guide wheel slide block (2) and stop plate (3). Depending on lengthening of the track the slide block (2) may come in contact with stop plate (3). In such a case, it must be ensured that the track does not become too loose. Depending on track condition, the removal of one track pad will restore the adjusting range “X”. If necessary contact our Service Department for more information.

⚠ WARNING

Before working on the track adjusting system, relieve all pressure in the system by opening the pressure relief cock (5), see illust. Z 20371 on previous page.

NOTICE

- If removal of a track pad becomes necessary, it must be done on both tracks in order to maintain the same length of both tracks.
- During operation, the pressure relief cock (5) must always be in CLOSED position. Open cock (5) for pressure relieve prior servicing any part of the system, e.g. removal of a track pad.

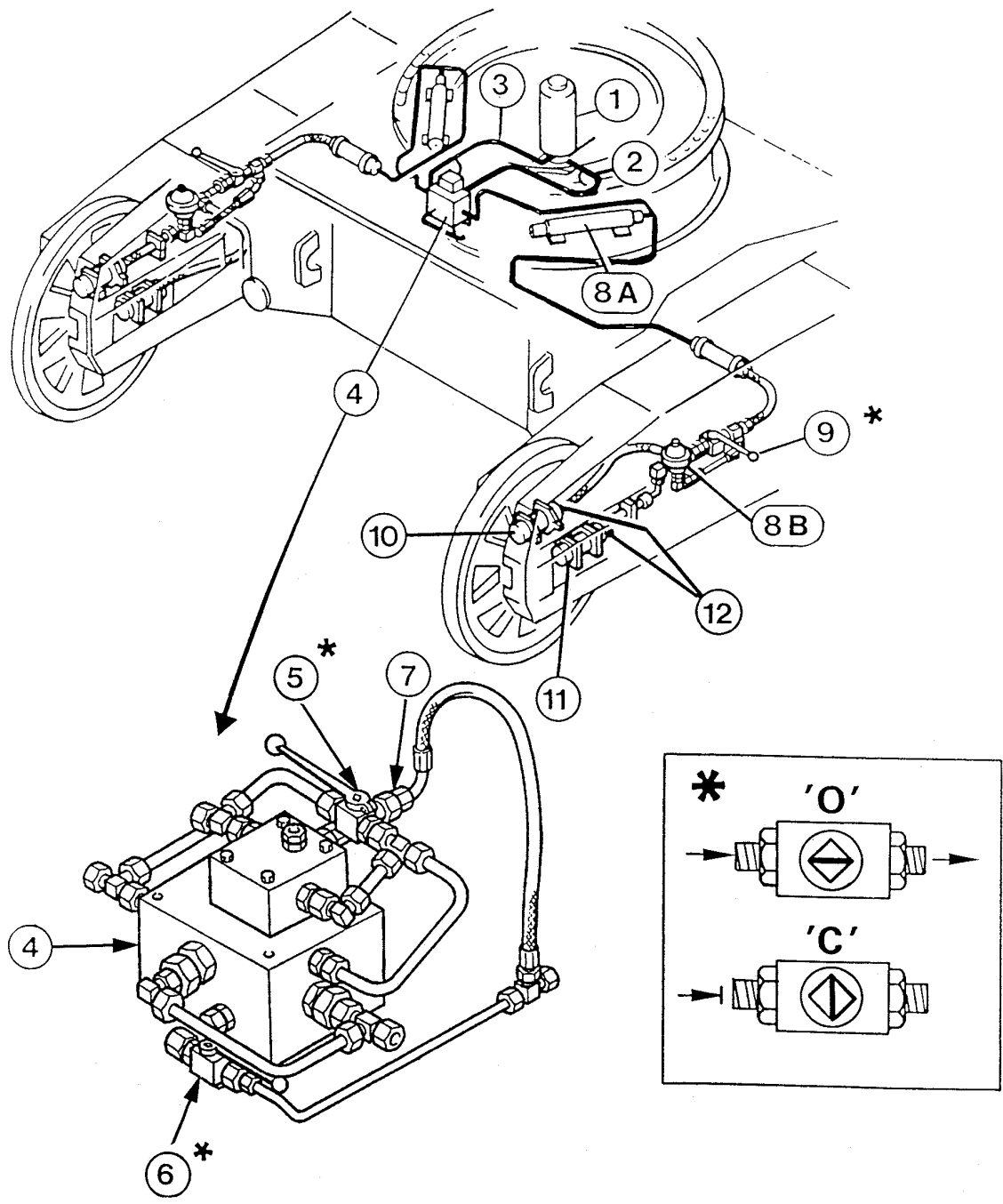

(Z 20371)

CHECK ADJUSTING RANGE FOR GUIDE WHEELS

NOTICE

The cocks (9), illust. Z 20371 must always be in OPEN position. Close only in such cases, when the adjusting cylinders (10 and 11) must remain under pressure while servicing other components of the system.

Bleeding the System

1. Make sure pressure relief cock (5) illust. Z 20371 is in closed position "C"; and shutoff cocks (6 and 9) are in open position "O".
2. Start the engine/motor.
3. Slowly open vent valves (12) on all four adjusting cylinders until bubble free oil flows out. Close the vent valves (12).
4. Move the machine forward and reverse to distribute tension.
5. Check adjusting range "X" according to Illust. (Z 20015) on previous page.
6. Check the complete system for leakages.

NOTICE

Further track group inspection and wear measurement procedures should be carried out according to Parts and Service News Bulletin No. AH02521 filed in volume 2 binder.

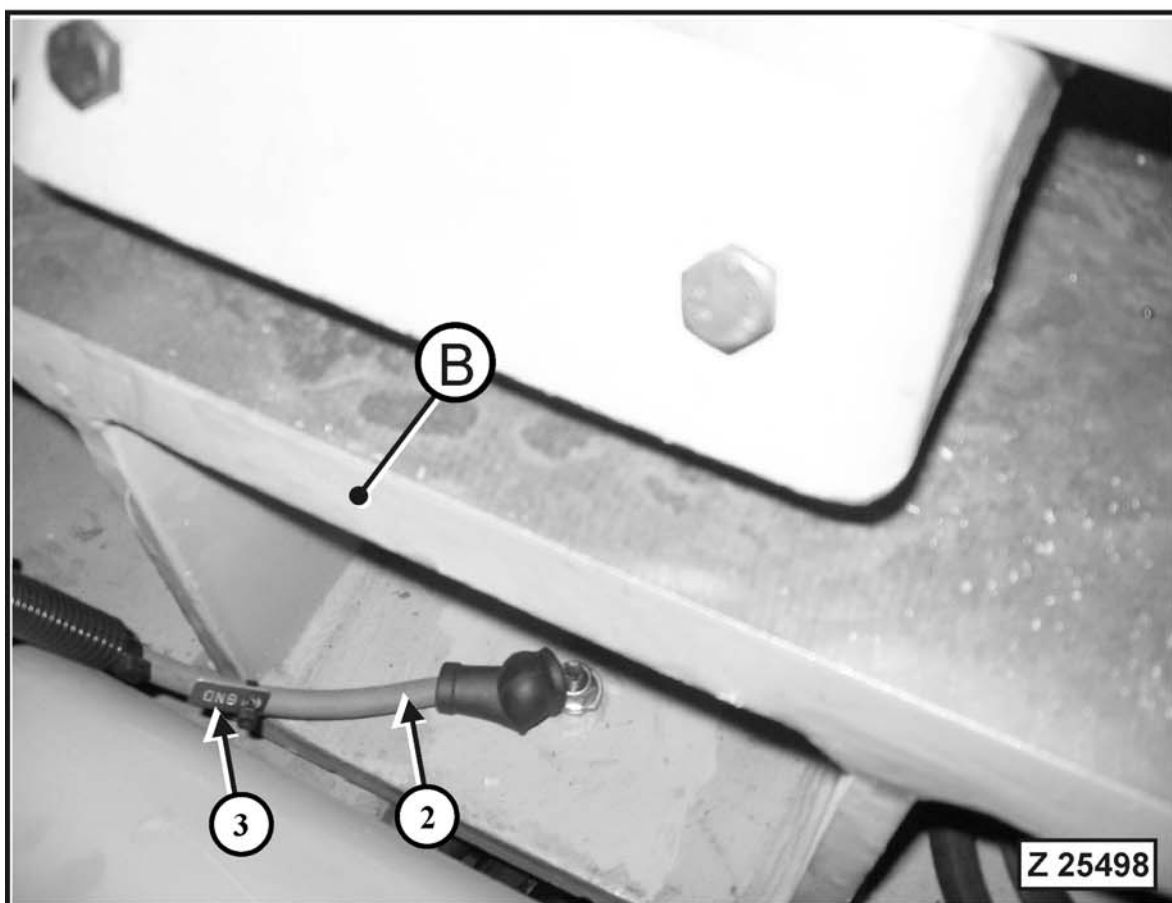
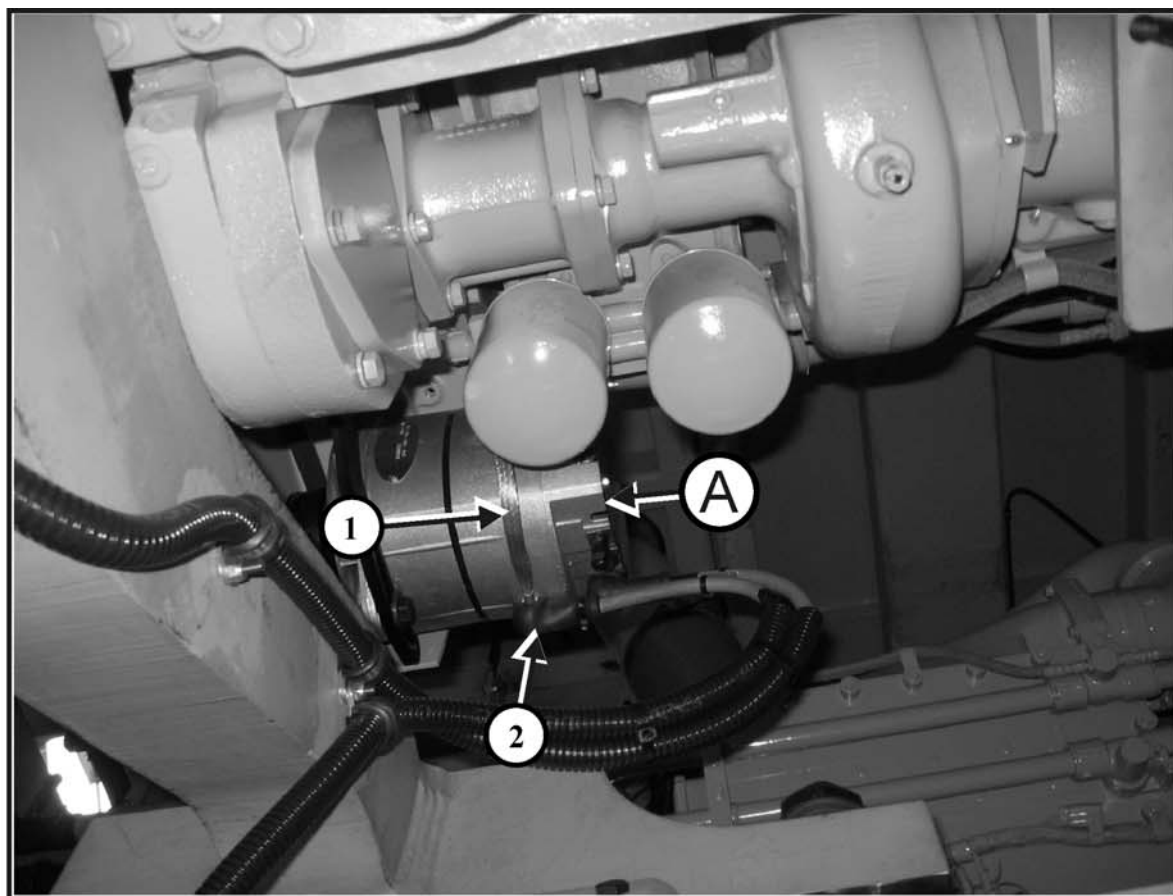

4.11.5 GROUND CABLES OF ENGINE AND ALTERNATOR - CHECK FOR CORRECT CONNECTION

Legend for illustration Z25498

- (A) Alternator seen from below
- (B) RH member of engine carrier frame
- (1) Ground strap from engine to the ground terminal of alternator (A)
- (2) Ground cable from alternator (A) to RH member of engine carrier frame (B)
- (3) Identification plate (GND) for ground cables

Check ground cables

1. Remove both battery main switch keys.
2. Check ground strap (1) and ground cable (2) on both engines for good condition and secure fastening.

▲ WARNING

- **Be sure to replace a worn or damaged cable or fastening part without delay.**
 - **Loose or missing ground cables can cause fire, serious injury or death.**
-
-

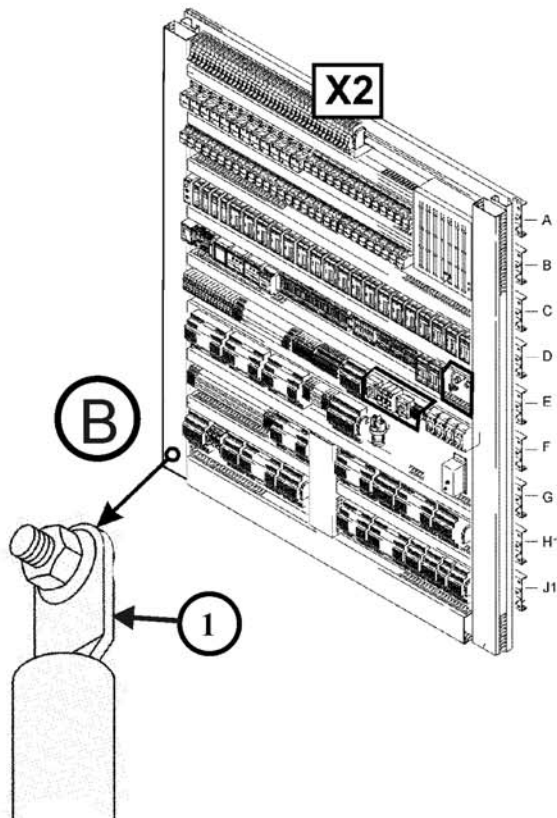
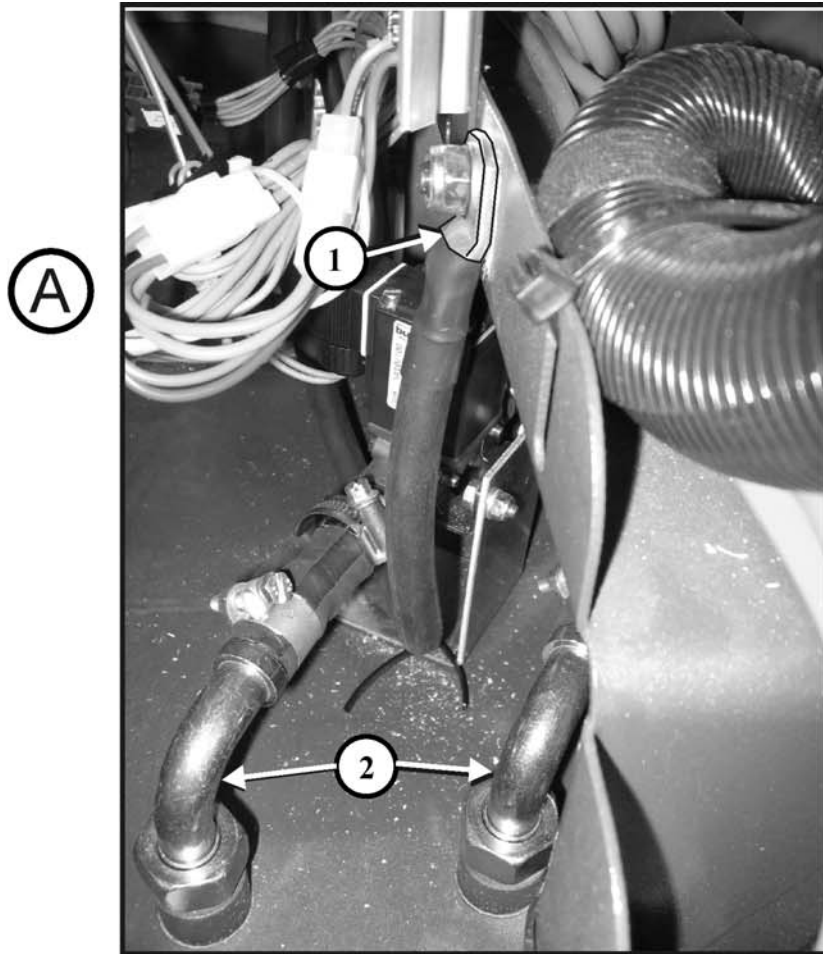

Z 25520

4.11.6 GROUND CABLE OF OPERATOR'S CAB - CHECK FOR CORRECT CONNECTION

Legend for illustration Z25520

- (A) Ground cable fixing point inside the operator's console
- (B) Ground cable fixing point in the cab base on the lower left mounting bolt of the (X2) switch board
- (1) Ground cable from operator's console to the lower left mounting bolt of the (X2) switch board
- (2) Cab heater water lines

Check ground cable

1. Remove both battery main switch keys.
2. Open the dashboard of the operator's console and secure with the prop rod provided.
3. Check cable (1), view (A) for good condition and secure fastening.
4. Close the dashboard and secure with the clamps provided.
5. Check cable (1) in the cab base, view (B) for good condition and secure fastening on the lower left mounting bolt of the (X2) switch board.

⚠ WARNING

- **Be sure to replace a worn or damaged cable or fastening part without delay.**
 - **Loose or missing ground cables can cause fire, serious injury or death.**
-

4.12 EVERY 1000 OPERATING HOURS OR EVERY 6 MONTH

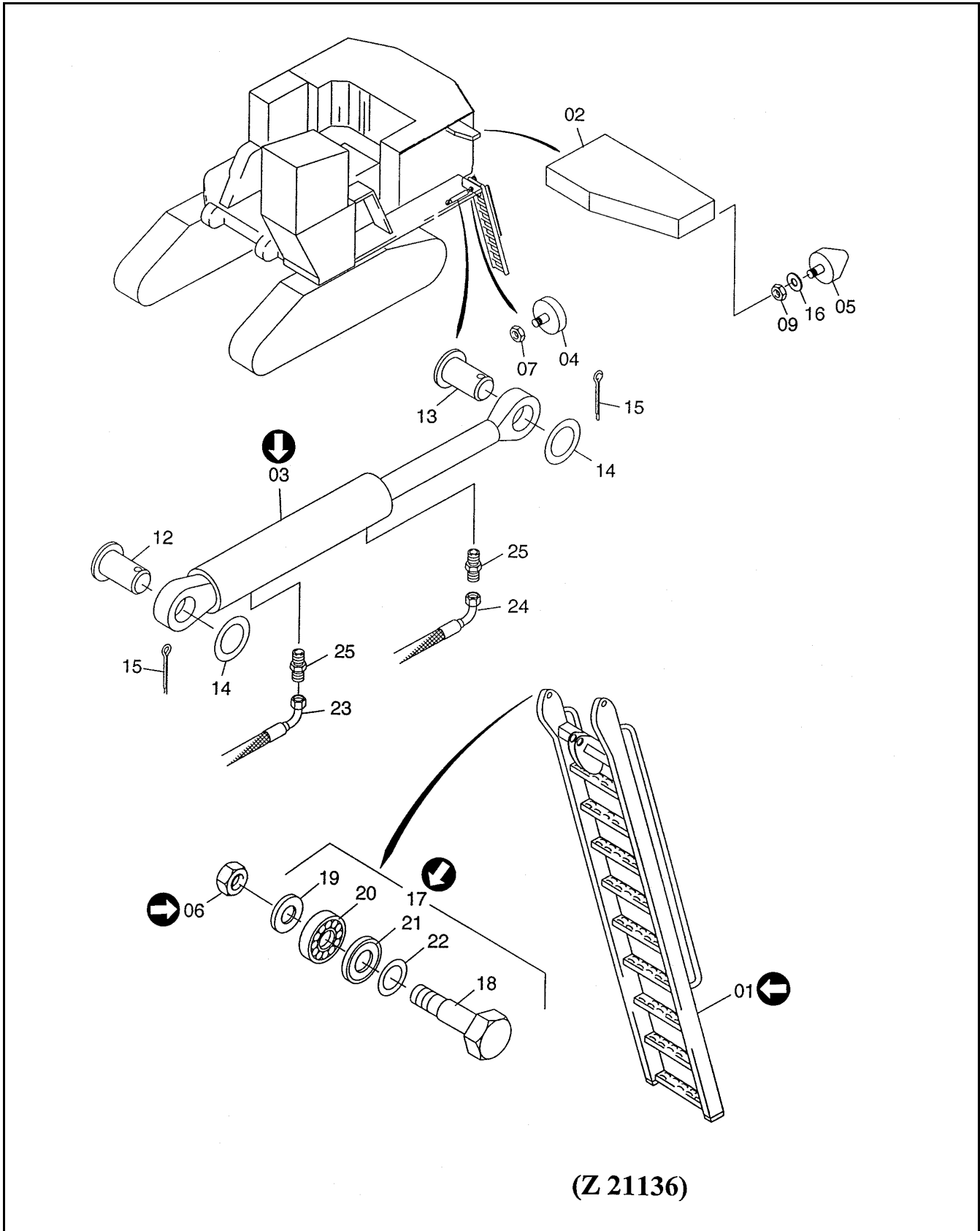

4.12.1 HIGH STRENGTH BOLT CONNECTIONS - CHECK TORQUE LOAD

Check high-strength bolt connections and securing elements for damage and looseness. If any damages, failures or wrong condition are found, corrective action must be taken.

NOTICE

- **If the torque load is not stated otherwise refer to standard torque chart for torque data.**
- **Bolts inserted with Multi-Purpose Grease MPG, KP2K on thread and head.**

REMARK

When selecting the tightening torque observe quality grade and bolt size

Hydraulic Access Ladder, illust. Z 21136

- (01) Hinged ladder
- (03) Ladder lifting cylinder
- (06) Self locking nut
- (17) Ladder bearing assembly

Check condition and fastening of hinged ladder (01), bearing assembly (17) and hydraulic cylinder (03).

Make sure the self locking nuts (06) are correctly tightened and have not lost their clamping torque.

Tightening Torque of Self Locking Nuts (06):

- New nut: 1000 Nm
- Used nut: 800 Nm

Clamping Torque of Self Locking Nuts (06):

- New nut: 200 Nm
- Used nut: 20 Nm minimum

If the clamping torque is less than 20 Nm, use a new self locking nut.

Lubricate both eyes of hydraulic cylinder (03). Make sure both pivot pins (12 and 13) are properly secured with cotter pins (15). Check hydraulic lines (23 and 24) for leakage and damage. Replace as necessary.

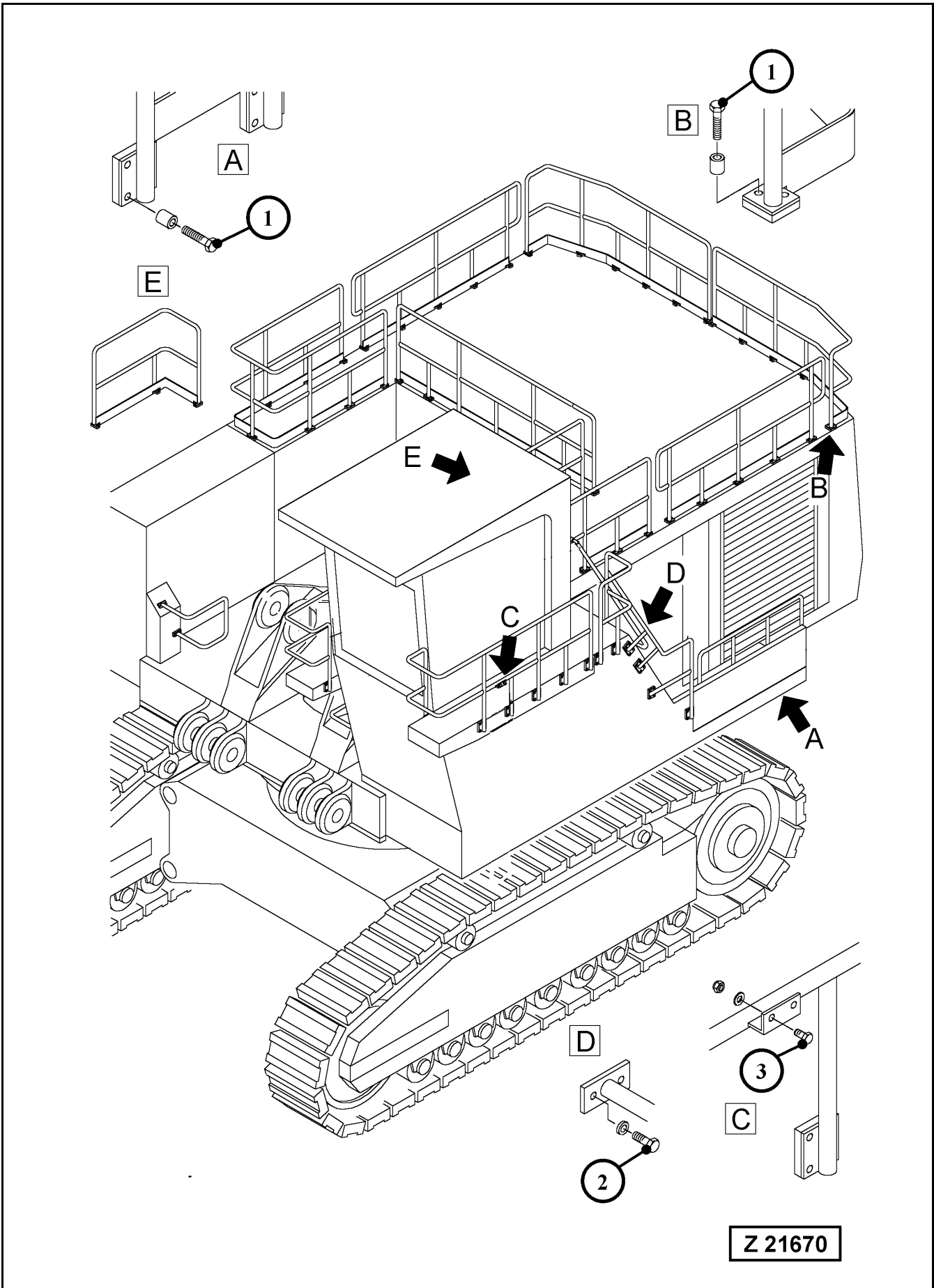

High-Strength Bolt Connections (continued)

Check fastening and condition of railings (A, B, C, D and E),
illust. Z 21670

Reference No.:	Bolt size mm	Grade	SW * mm	Tightening torque Nm
(1)	M12	8.8	19	74
(2)	M12	8.8	19	74
(3)	M10	8.8	17	43

* SW = Wrench size

NOTICE

Detail (C) shows the bracket for attaching the emergency escape ladder (storage position).

- Re-tighten mounting bolts to their correct torque and replace missing or damaged bolts.

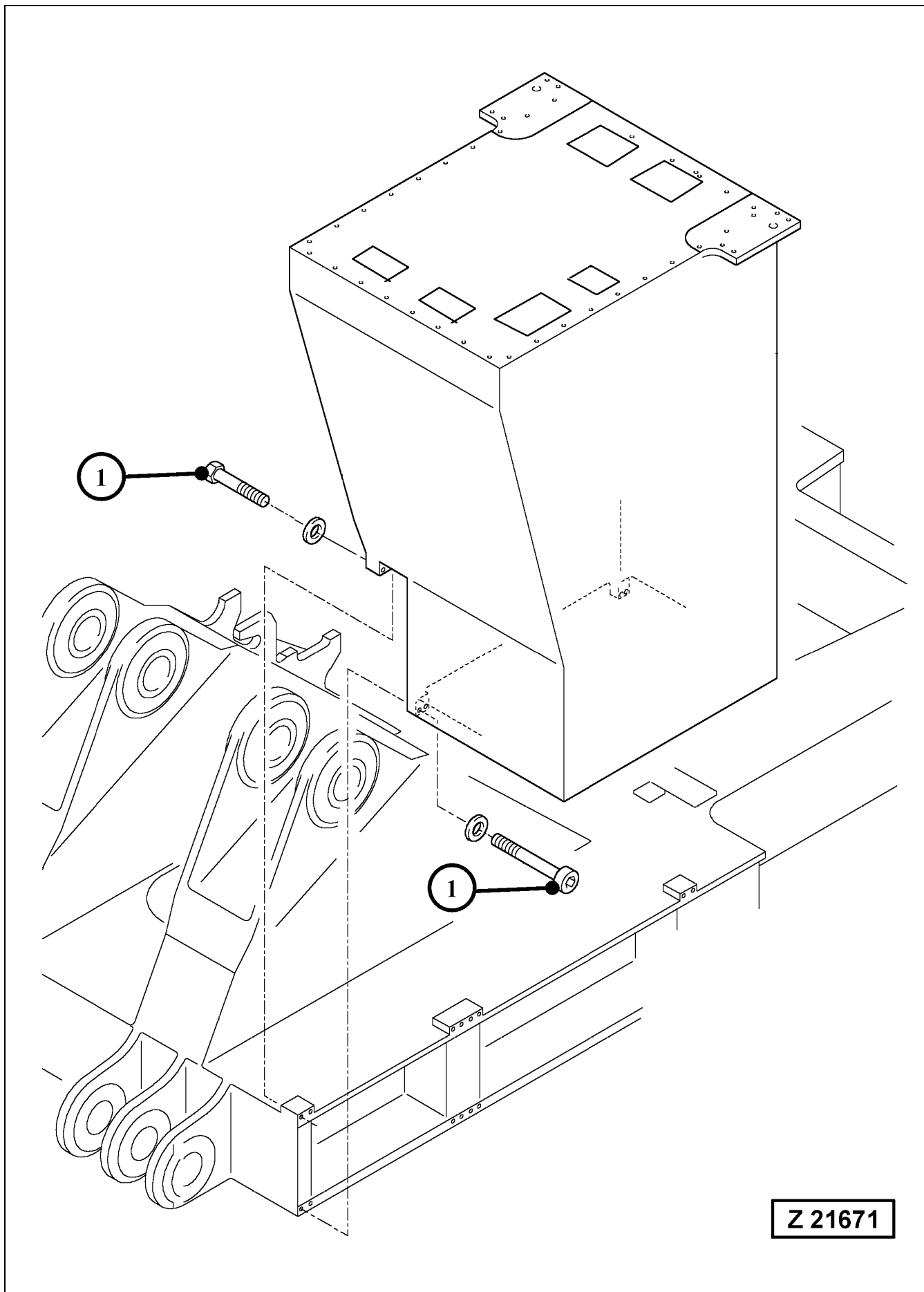

Z 21671

High-Strength Bolt Connections (continued)**Check fastening and condition of cab base, illust. Z 21671**

Reference No.:	Bolt size mm	Grade	SW * mm	Tightening torque Nm	Qty.
(1)	M36	10.9	55	3100	8

* SW = Wrench size*

- Re-tighten mounting bolts to their correct torque and replace missing or damaged bolts.

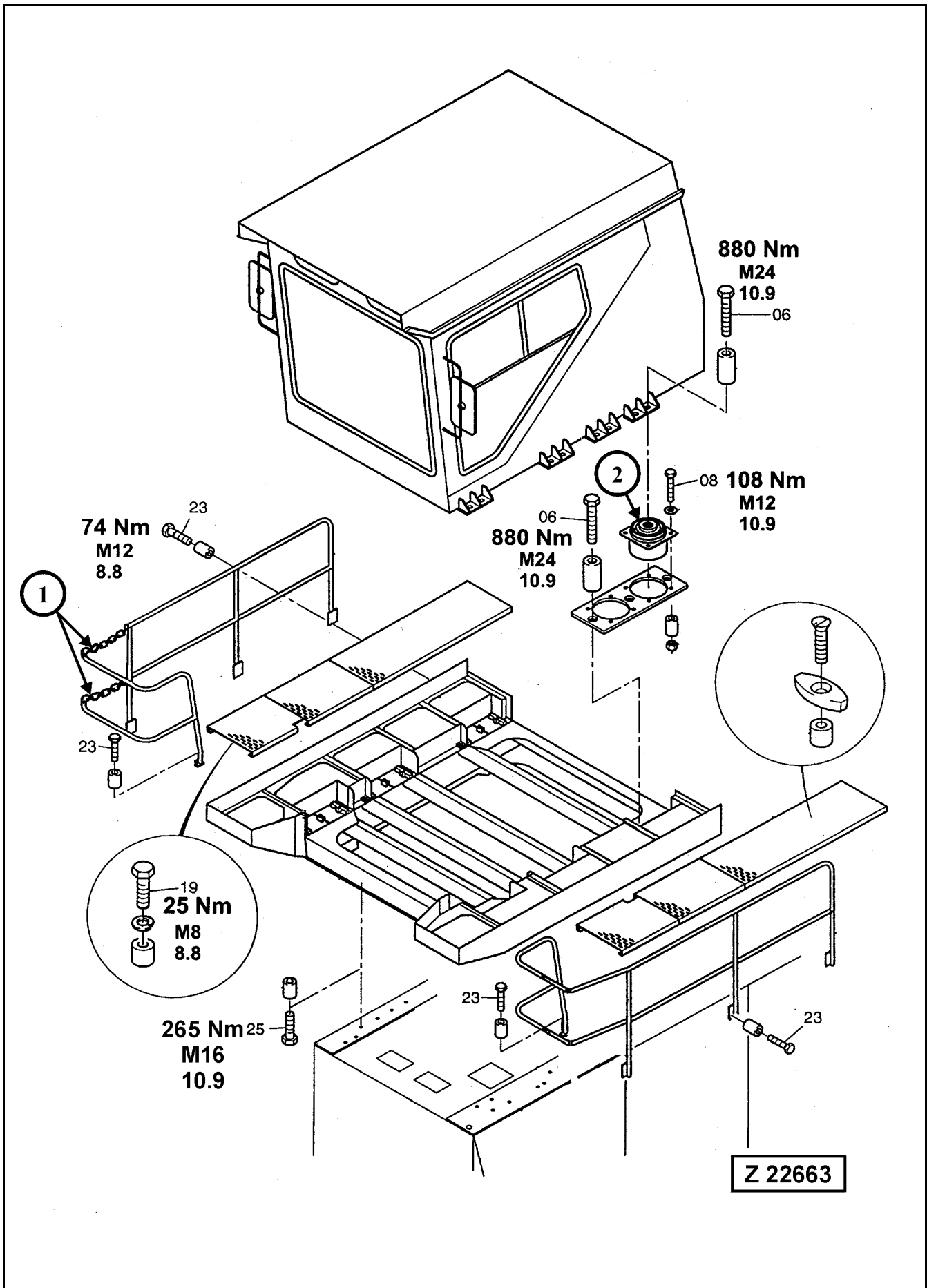

High-Strength Bolt Connections (continued)**Check mounting of Operator's cab, illust. Z 22663**

- Check tightening torque of mounting bolts as indicated in the illustration.
- Check condition and fastening of chains (1).
- Check the silicone oil filled viscous mounts (2) for leakage and signs of fatigue.

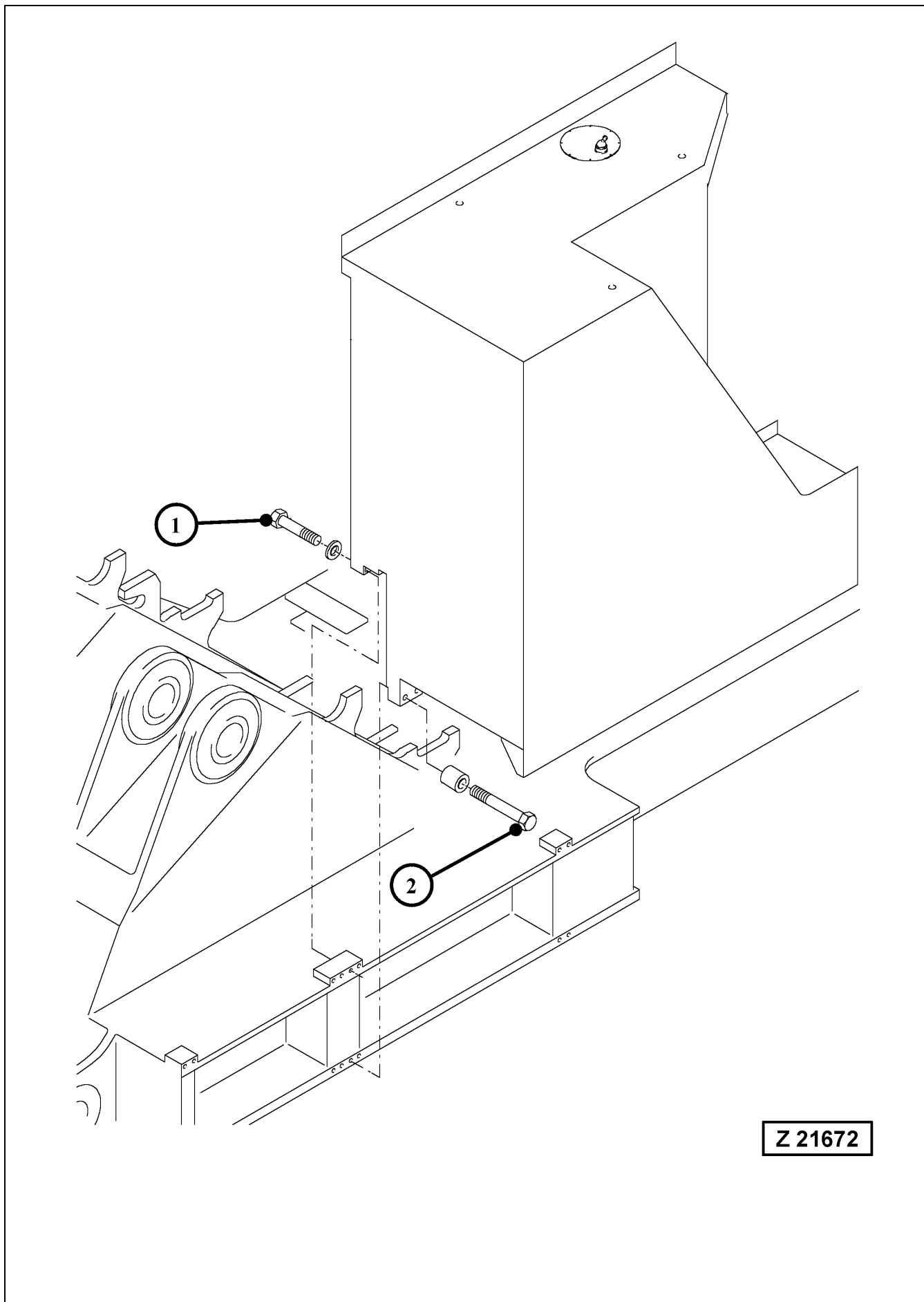

High-Strength Bolt Connections (continued)

Check fastening and condition of fuel tank, illust. Z 21672

Reference No.:	Bolt size mm	Grade	SW * mm	Tightening torque Nm	Qty.
(1)	M30	10.9	46	1770	4
(2)	M30	10.9	46	1770	4

* SW = Wrench size* SW = Wrench size

- Re-tighten mounting bolts to their correct torque and replace missing or damaged bolts.

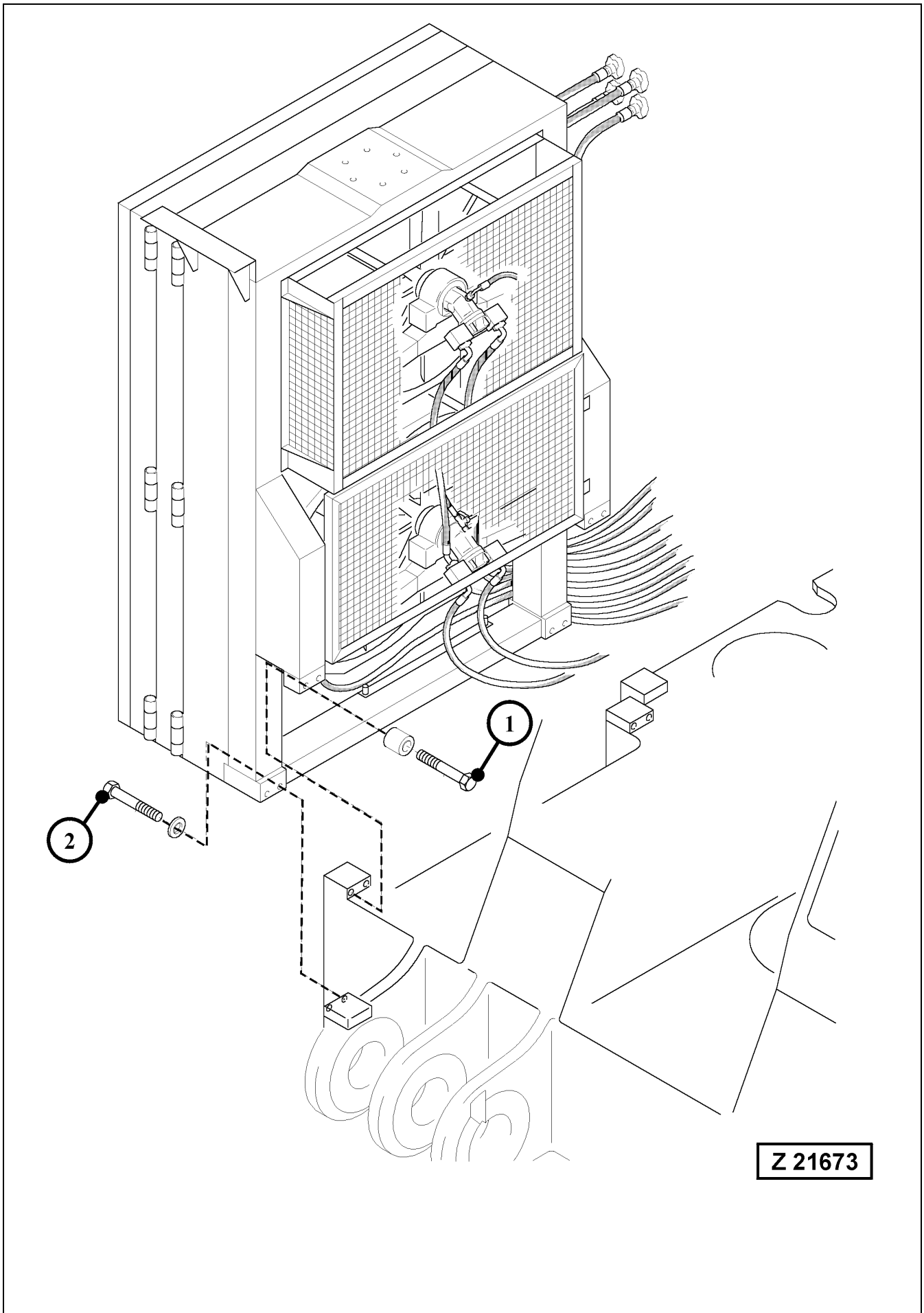

High-Strength Bolt Connections (continued)

Check fastening and condition of hydraulic oil cooler,
illust. Z 21673

Reference No.:	Bolt size mm	Grade	SW * mm	Tightening torque Nm	Qty.
(1)	M30	10.9	46	1770	4
(2)	M30	10.9	46	1770	4

* SW = Wrench size

- Re-tighten mounting bolts to their correct torque and replace missing or damaged bolts.

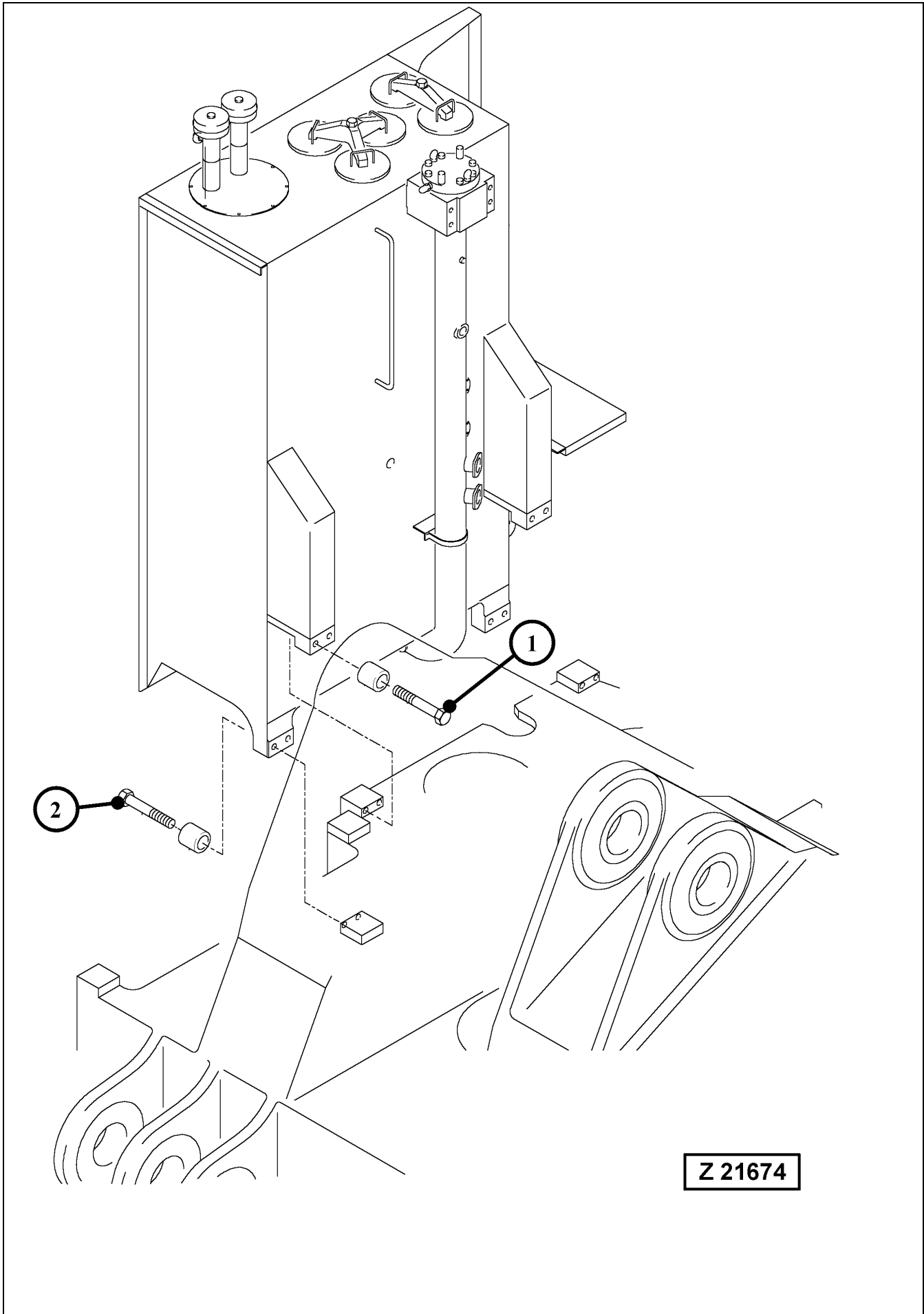

Z 21674

High-Strength Bolt Connections (continued)

Check fastening and condition of hydraulic oil tank,
illust. Z 21674

Reference No.:	Bolt size mm	Grade	SW * mm	Tightening torque Nm	Qty.
(1)	M30	10.9	46	1770	4
(2)	M30	10.9	46	1770	4

* SW = Wrench size

- Re-tighten mounting bolts to their correct torque and replace missing or damaged bolts.

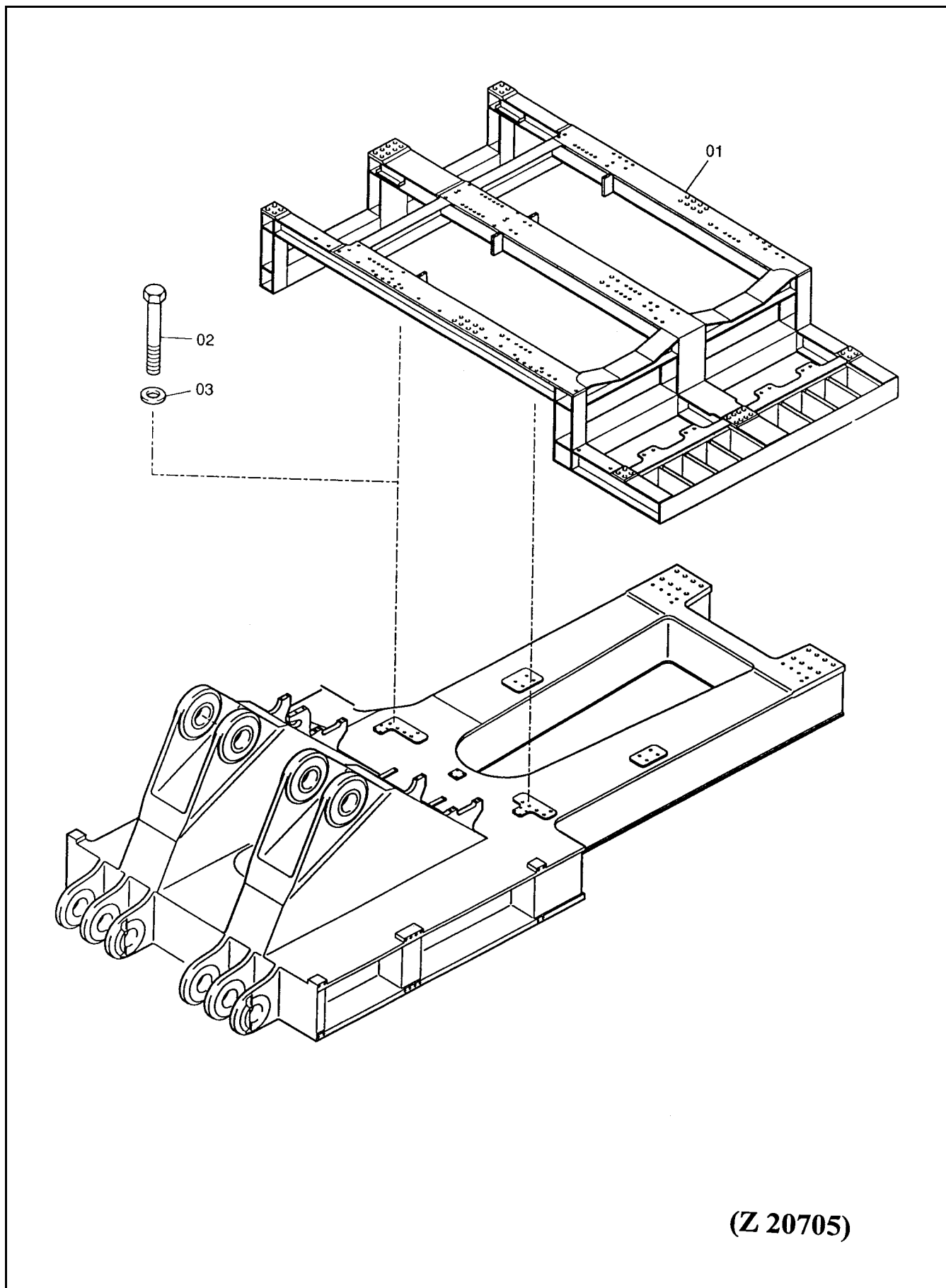

High-Strength Bolt Connections (continued)

Check fastening of power house frame (01) to superstructure main frame, illust. Z 20705

Reference No.:	Bolt size mm	Grade	SW * mm	Tightening torque Nm	Qty.
(02)	M30	10.9	46	1770	28
(03)				Washer	28

* SW = Wrench size

- Re-tighten mounting bolts to their correct torque and replace missing or damaged bolts.

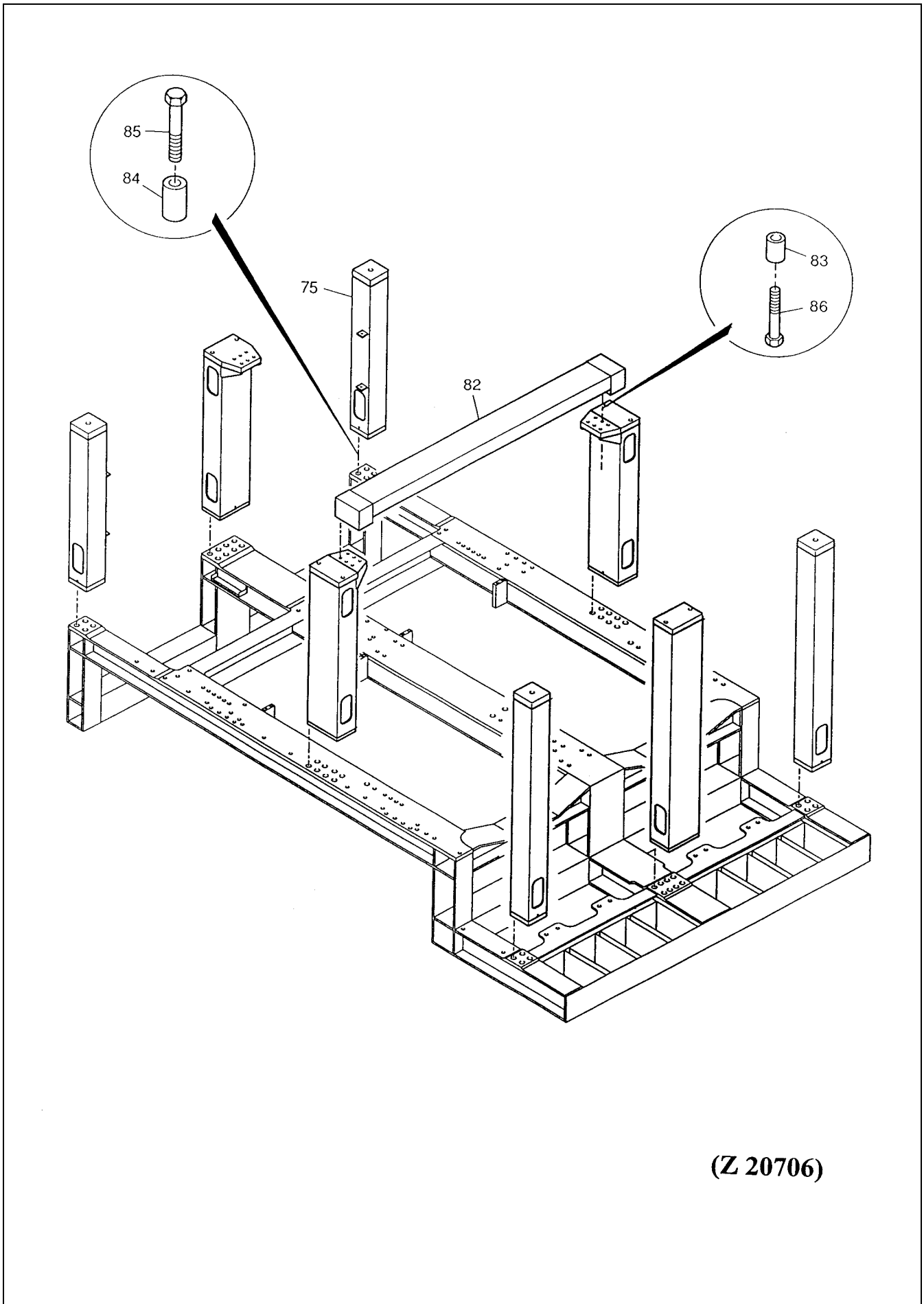

(Z 20706)

High-Strength Bolt Connections (continued)

Check fastening and condition of the eight power house posts (75) and transverse carrier (82), illust. Z 20706

Reference No.:	Bolt size mm	Grade	SW * mm	Tightening torque Nm	Qty.
(85)	M30	10.9	46	1770	48
(86)	M24	10.9	36	880	12

* SW = Wrench size

- Re-tighten mounting bolts to their correct torque and replace missing or damaged bolts.

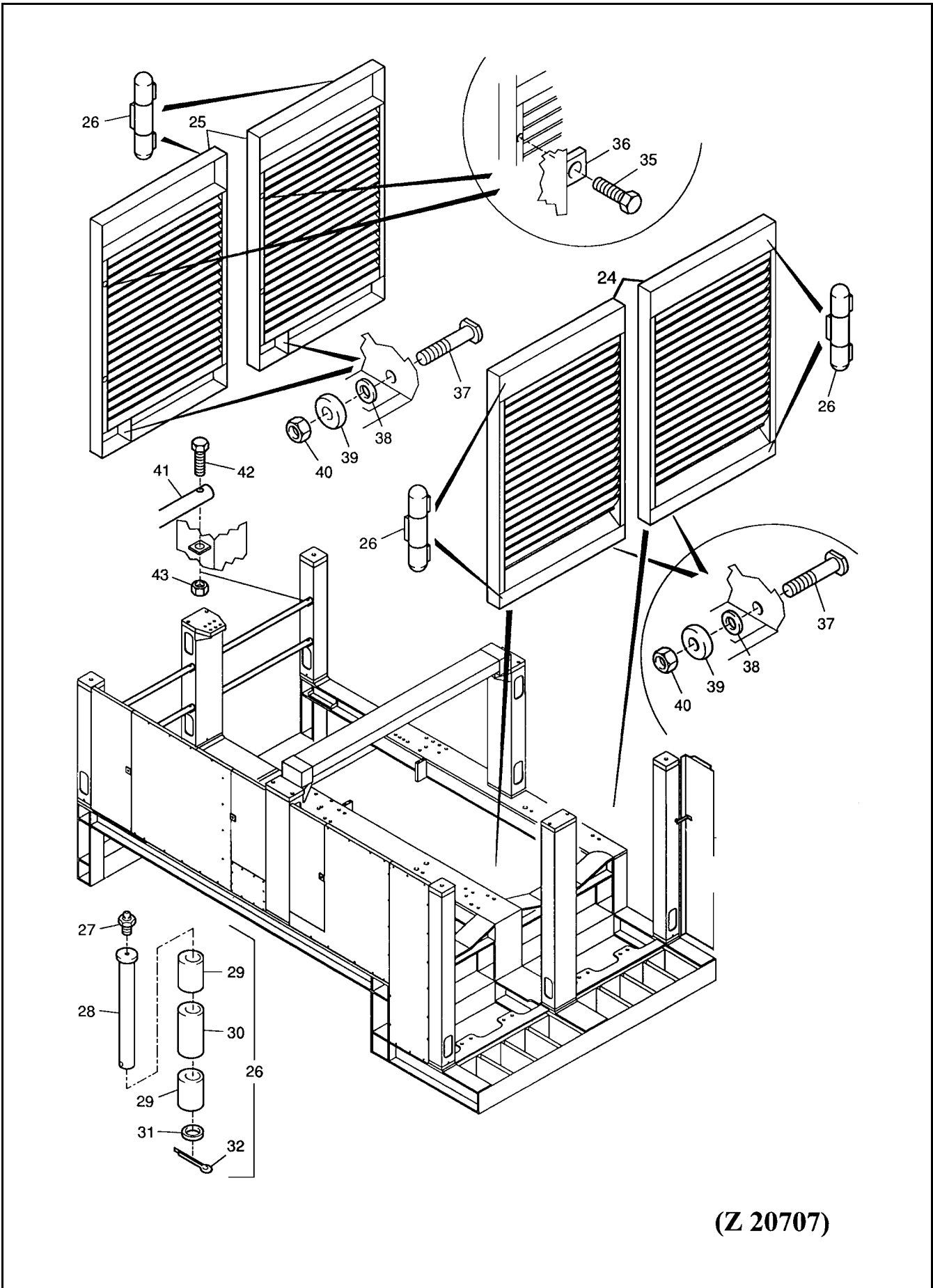

(Z 20707)

High-Strength Bolt Connections (continued)

Power House Doors, illust. Z 20707

- Check fastening and condition of power house doors (24 - 25) and door hinges (26).
- Check fastening and condition of safety rods (41).
- Check upper pump compartment door locks (35 - 36) for correct mounting.
- Check lower pump compartment door locks and radiator door locks (37 - 40) for correct mounting.
- Lubricate door hinges (26) at grease fittings (27).

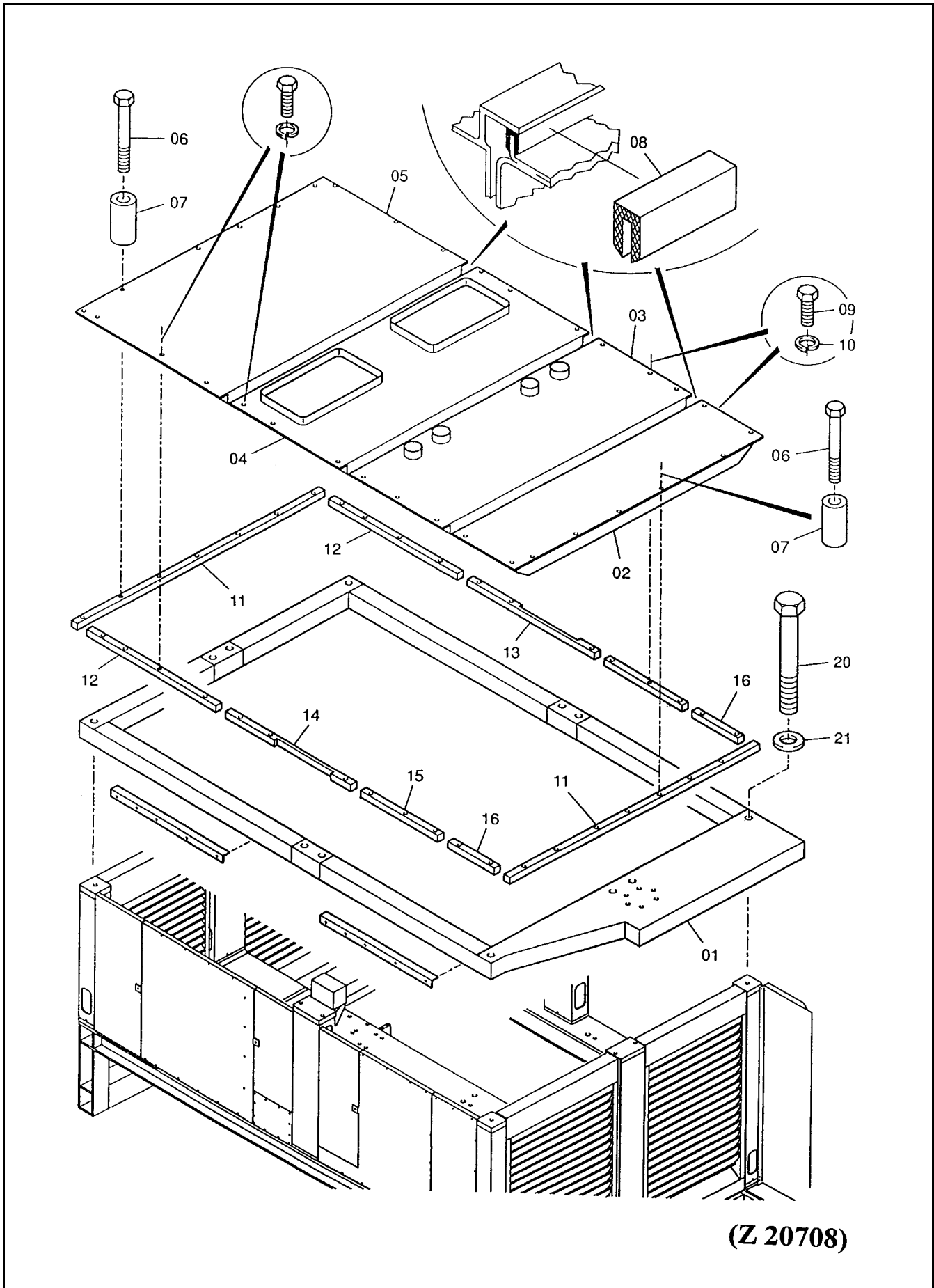

Power house Roof, illust. Z 20708

- Check fastening and condition of power house roof segments (02 - 05).
- Check sealing elements (08) between roof segments for correct seat and good condition.
- Check sealing elements (11 - 16) between roof segments and roof frame (01) for correct seat and good condition.

Reference No.:	Bolt size mm	Grade	SW * mm	Tightening torque Nm	Qty.
(06)	M12	10.9	19	108	50
(20)	M36	10.9	55	3100	12

* SW = Wrench size

- Re-tighten mounting bolts to their correct torque and replace missing or damaged bolts.

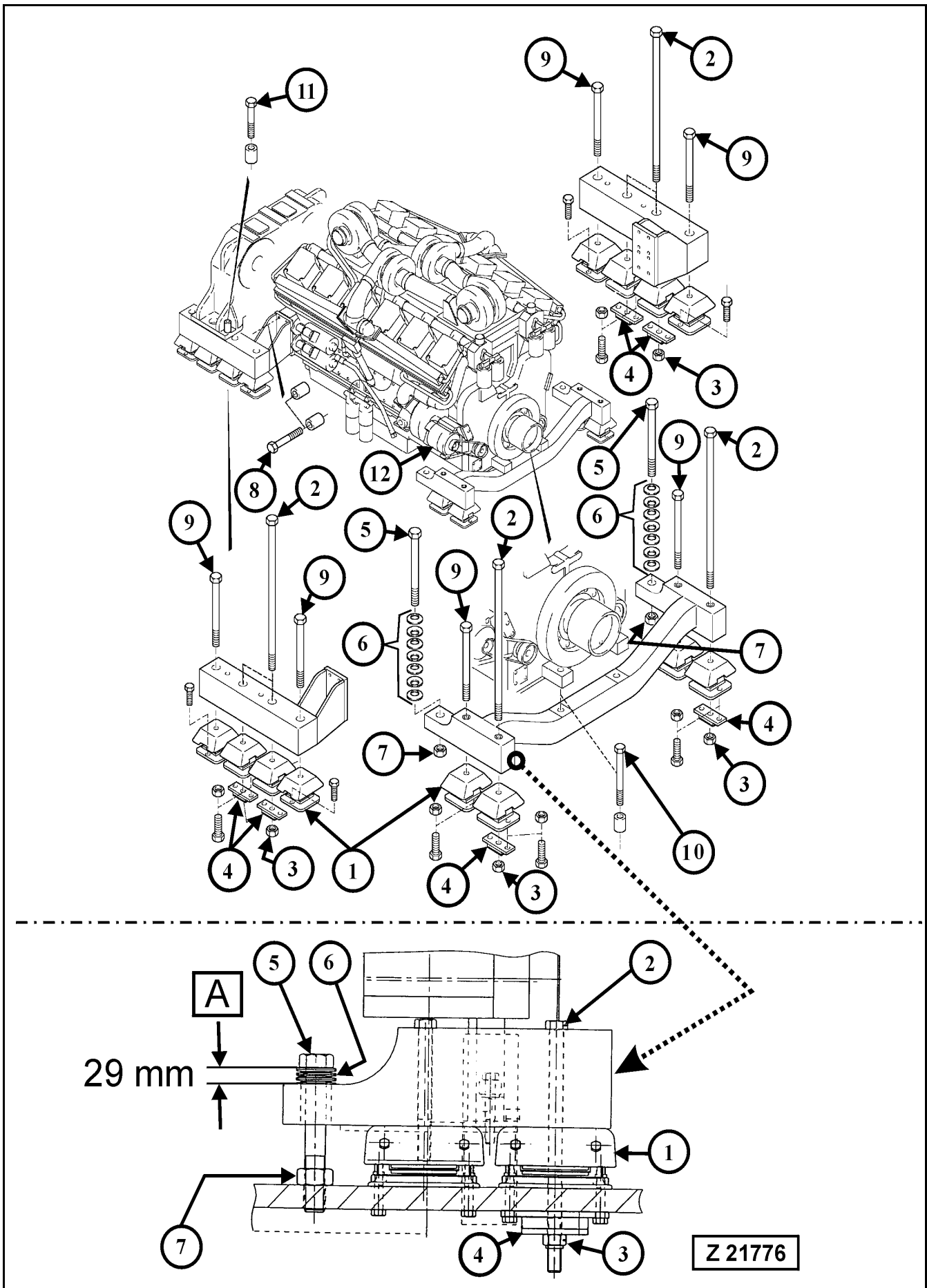

High-Strength Bolt Connections (continued)

Check mounting and security of Diesel engines and pump distributor gears, illust. Z 21776

Legend for illustration Z 21776:

Reference No.:	Bolt size mm	Grade	SW * mm	Tightening torque Nm	Qty. both power units
(1) Flexible bearings					24
(2) Tie bolts	M24	10.9	36	snugly	12
(3) Self locking nuts	M24	8.0	36	snugly	12
(4) Rubber bounded metal bars					12
(5) Stop bolts	M36	10.9	55	to distance "A"	4
(6) Cup springs					28
(7) Lock nuts	M36	10.0	55		4
(8) Engine mounting bolts, rear	3/4 - 10	UNC		400	32
(9) Bolts	M24	10.9	36	880	12
(10) Engine mounting bolts, front	M18	10.9	27	360	4
(11) PTO mounting bolts	M30	10.9	46	1770	8
(12) Generator				Check condition and fastening	2

- * SW = Wrench size

REMARK

Refer to page 431 for checking procedure of engine mounting.

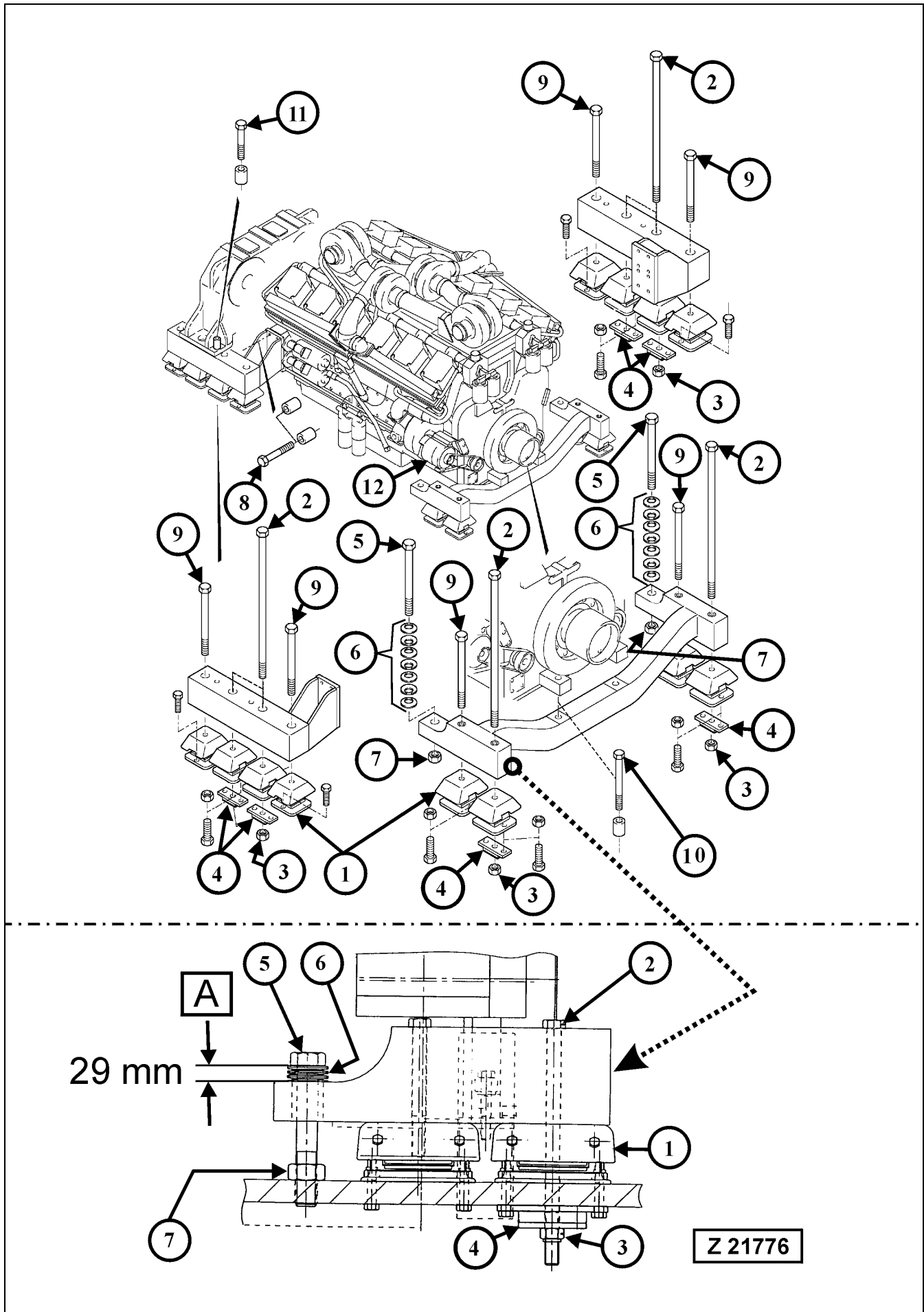

High-Strength Bolt Connections (continued)

Check mounting and security of each Diesel engine and pump distributor gear, illust. Z 21776

- Check all flexible bearings (1) for engine and pump distributor gear.
 - Check the flexible bearings for damage and signs of fatigue. Make sure that there is no contact between the upper and lower metal brackets of the flexible bearings (1). Replace the bearings if necessary.
After new flexible bearings have been installed, check distance (A) on both torque supports.

NOTICE

All flexible bearings (1) and all rubber-bounded metal bars (4) should be replaced during engine overhaul.

- Check distance (A) between torque support and stop bolt (5).
 - With setting of the flexible engine bearings (1) the distance (A) increases and must be adjusted. To do this, loosen lock nut (7) and tighten stop bolt (5) until the correct distance (A) is obtained. Tighten lock nut (7) and recheck distance (A).
If new flexible engine bearings (1) have been installed, replace also cup springs (6) and adjust distance (A) to 29 mm.
- Check tie bolts (2) on front and rear carrier units for looseness.
 - Check to make sure that the self locking retainer nuts (3) are tight and that there is no gap between nut and rubber-bounded metal bar (4).
If necessary retighten retainer nuts (3) snugly.
Check rubber-bounded metal bars (4) for signs of fatigue and damage.
Replace as necessary.

NOTICE

- **Check all bolt connections for correct tightening torque.**

Check condition of engine carrier and brackets. If any damages, failures or wrong condition are found, corrective action must be taken.

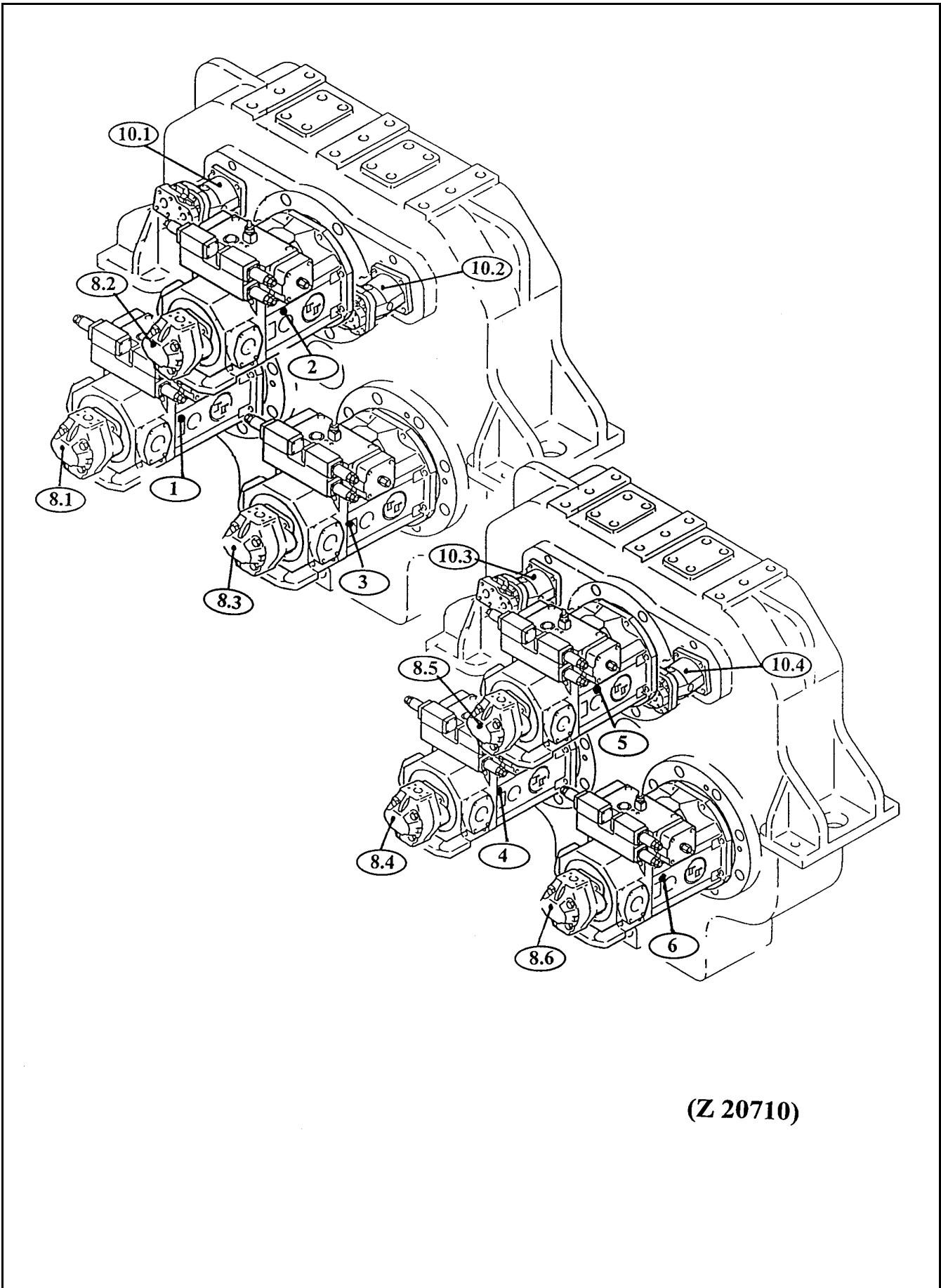

(Z 20710)

High-Strength Bolt Connections (continued)

- Check fastening and condition of main hydraulic pumps (1-6), illust. Z 20710.
Mounting bolt size: M20, Grade 8.8, tightening torque 360 Nm.
- Check fastening and condition of auxiliary pumps (8.1 - 8.6) and secondary hydraulic pumps (10.1 - 10.4).
Mounting bolt size: M12, Grade 8.8, tightening torque 74 Nm.

Pump Description:

- | | |
|-------------|--|
| (1-6) | Main hydraulic pumps, swash plate type for all working and travelling motions. |
| (8.1-8.6) | Gear type pumps. |
| (10.1-10.4) | Axial piston pumps. |

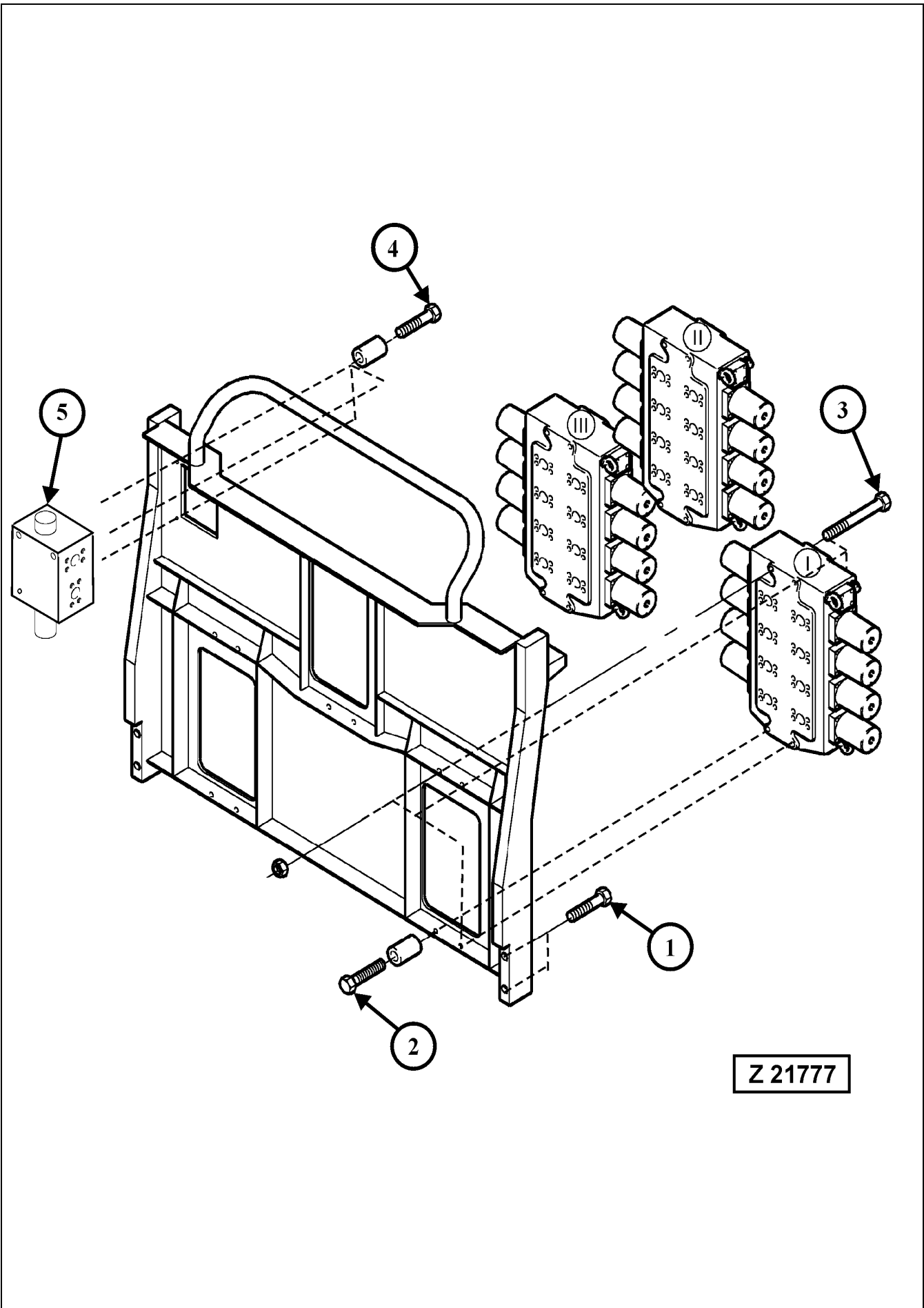

High-Strength Bolt Connections (continued)

Check fastening and condition of control valve carrier, main control valves (I, II and III) and swing control valve (5), illust. Z 21777

Reference No.:	Bolt size mm	Grade	SW * mm	Tightening torque Nm	Qty.
(1)	M24	10.9	36	880	4
(2)	M20	10.9	30	510	3
(3)	M20	10.9	30	510	9
(4)	M16	10.9	24	265	3
(5) Swing control valve					

* SW = Wrench size

- Re-tighten mounting bolts to their correct torque and replace missing or damaged bolts.

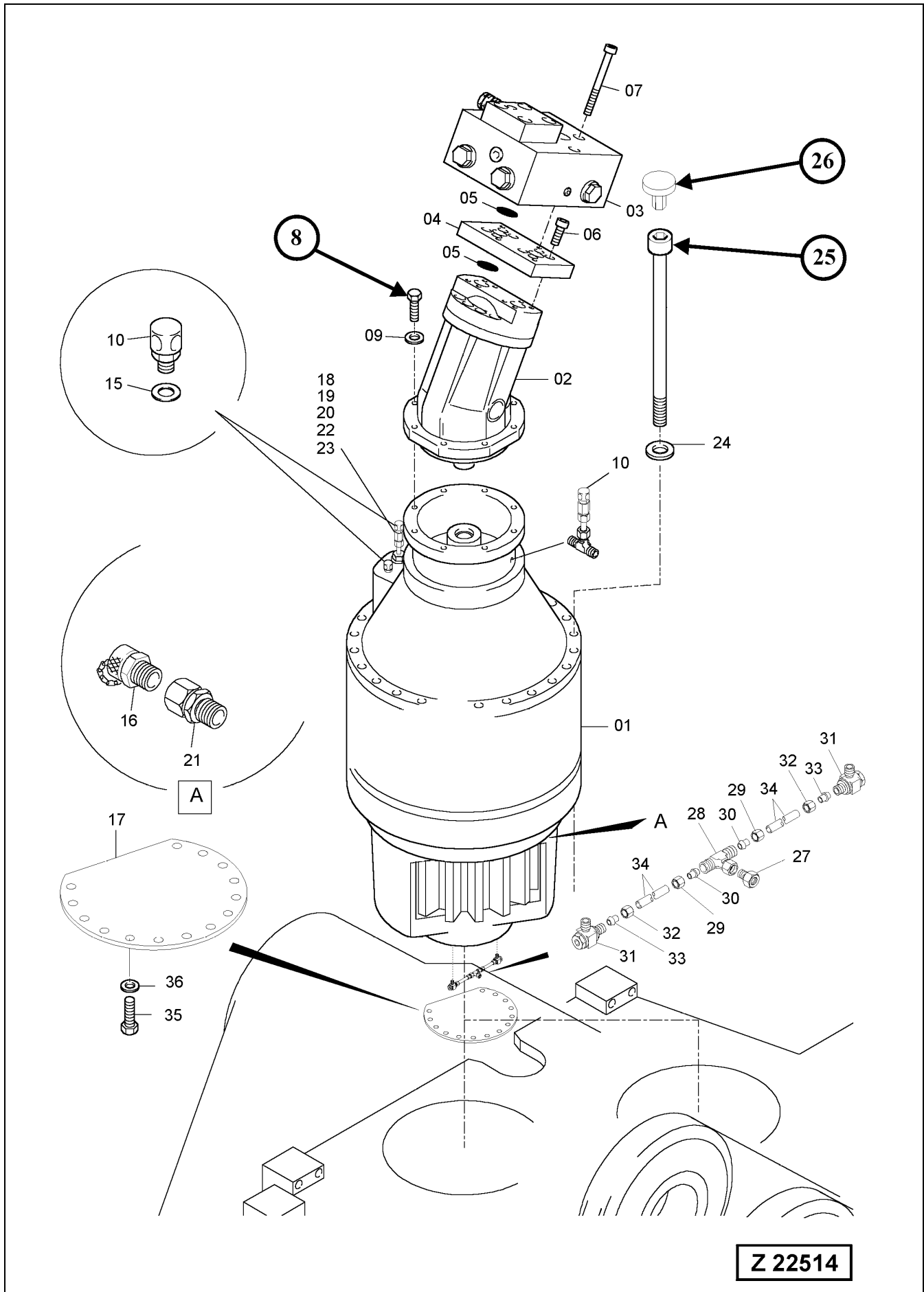

High-Strength Bolt Connections (continued)

Check condition and fastening of both swing gears (01) and swing motors (02), illust. Z 22514

Reference No.:	Bolt size mm	Grade	SW * mm	Tightening torque Nm	Qty.
(8)	M 16	10.9	24	265	16
(25)	M 24	12.9	19	1030	34

* SW = Wrench size

- Re-tighten mounting bolts to their correct torque and replace missing or damaged bolts.

REMARK

After checking and retightening of swing gear mounting bolts (25), attach protection caps (26) onto the bolt heads.

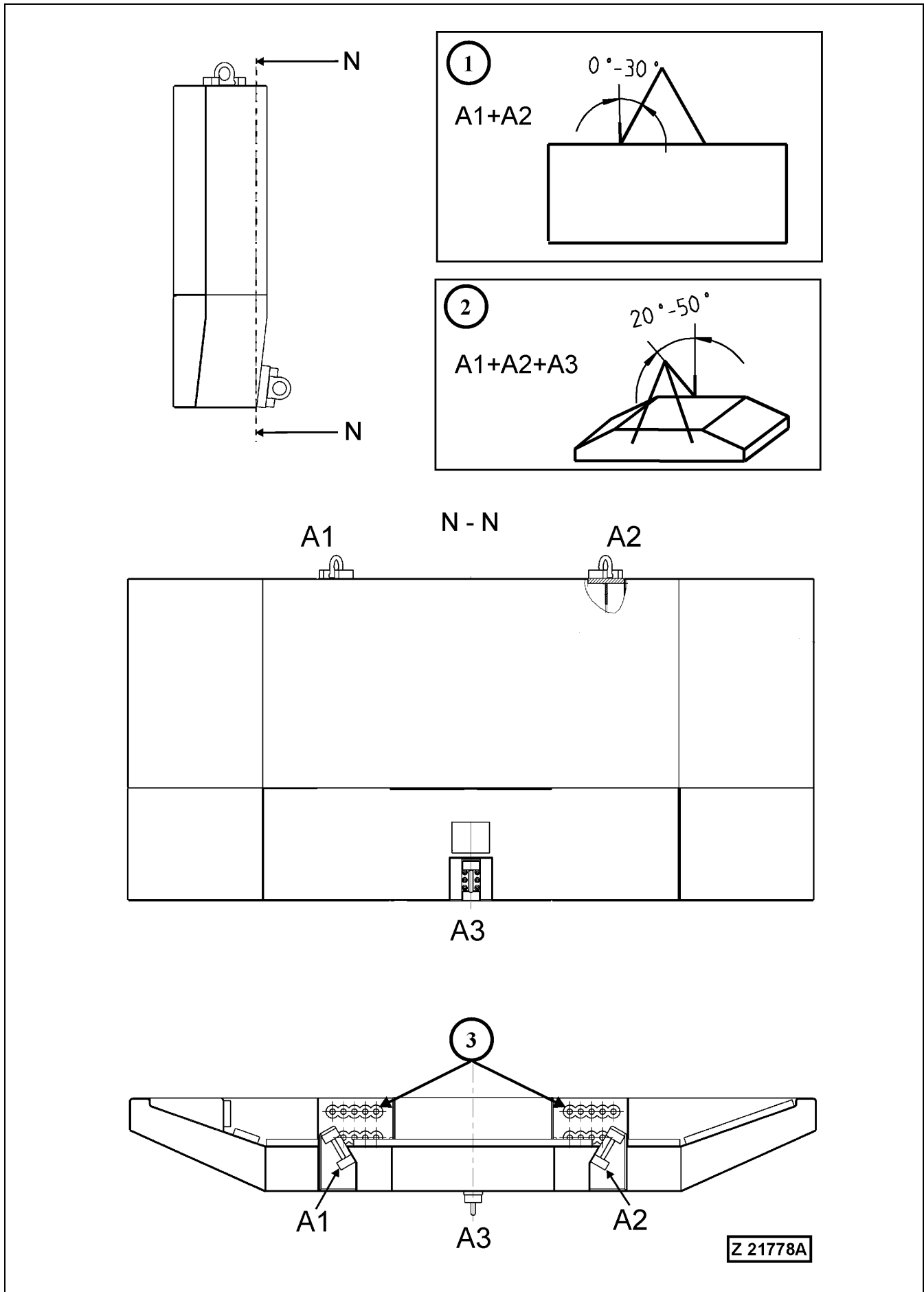

High-Strength Bolt Connections (continued)

Check tightening torque of the counterweight mounting bolts, illustration Z 21778A

Reference No.:	Bolt size mm	Grade	SW * mm	Tightening torque Nm	Qty.
(3) Mounting bolts	M48	10.9	75	7500	20

* SW = Wrench size

- Re-tighten mounting bolts to their correct torque and replace missing or damaged bolts.

Guideline for transportation and lifting of the counterweight illustration Z 21778A

- (1) A1 and A2 fastening points for vertical transport and for raising up of the counterweight with two symmetrical ropes
- (2) A1, A2 and A3 fastening points for horizontal transport and for loading of the counterweight with three symmetrical ropes

⚠ WARNING

The chambers of the counterweight are filled with a mixture of concrete, granulated ore and steel pellets. This mixture can create explosive gases which will accumulate in the chambers of the counterweight. Before any welding, flame-cutting, grinding or drilling procedures are carried out on the counterweight it is vital to expel these gases from the counterweight chambers. Failure to properly expel the gases from the counterweight chambers can result in an explosion with serious personal injury or death.

Follow the instructions given in PARTS & SERVICE NEWS No. AH04518 for expelling the gases from the counterweight chambers.

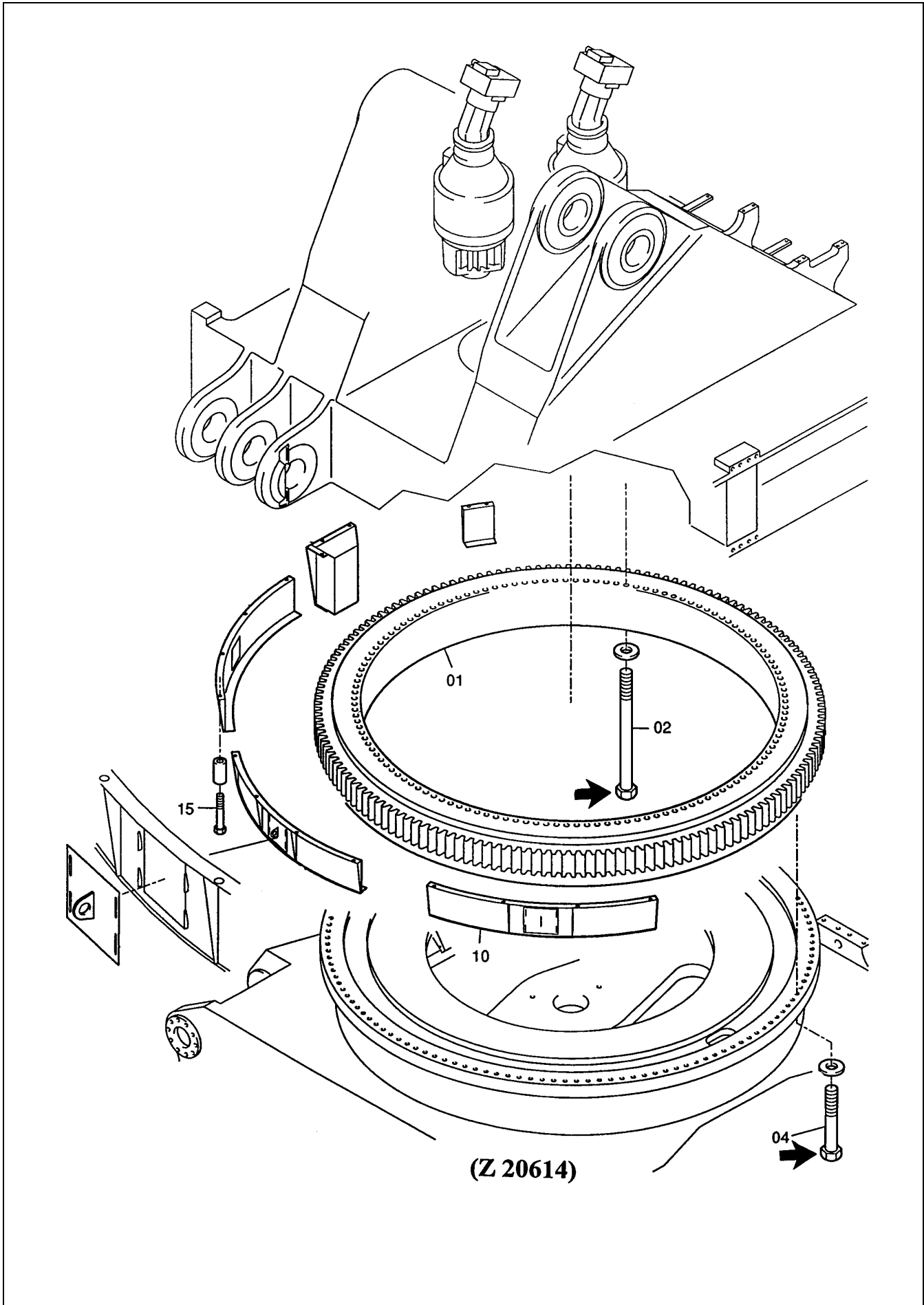

High-Strength Bolt Connections (continued)

Swing circle, illust. Z 20614

Check tightening torque of inner and outer mounting bolts (02 and 04) according to PARTS & SERVICE NEWS, No. AH00511.

NOTICE

Checking/retightening of swing circle mounting bolts is only necessary after the first 1000 operating hours.

Check condition and fastening of swing circle guard (10) and bolts (15).

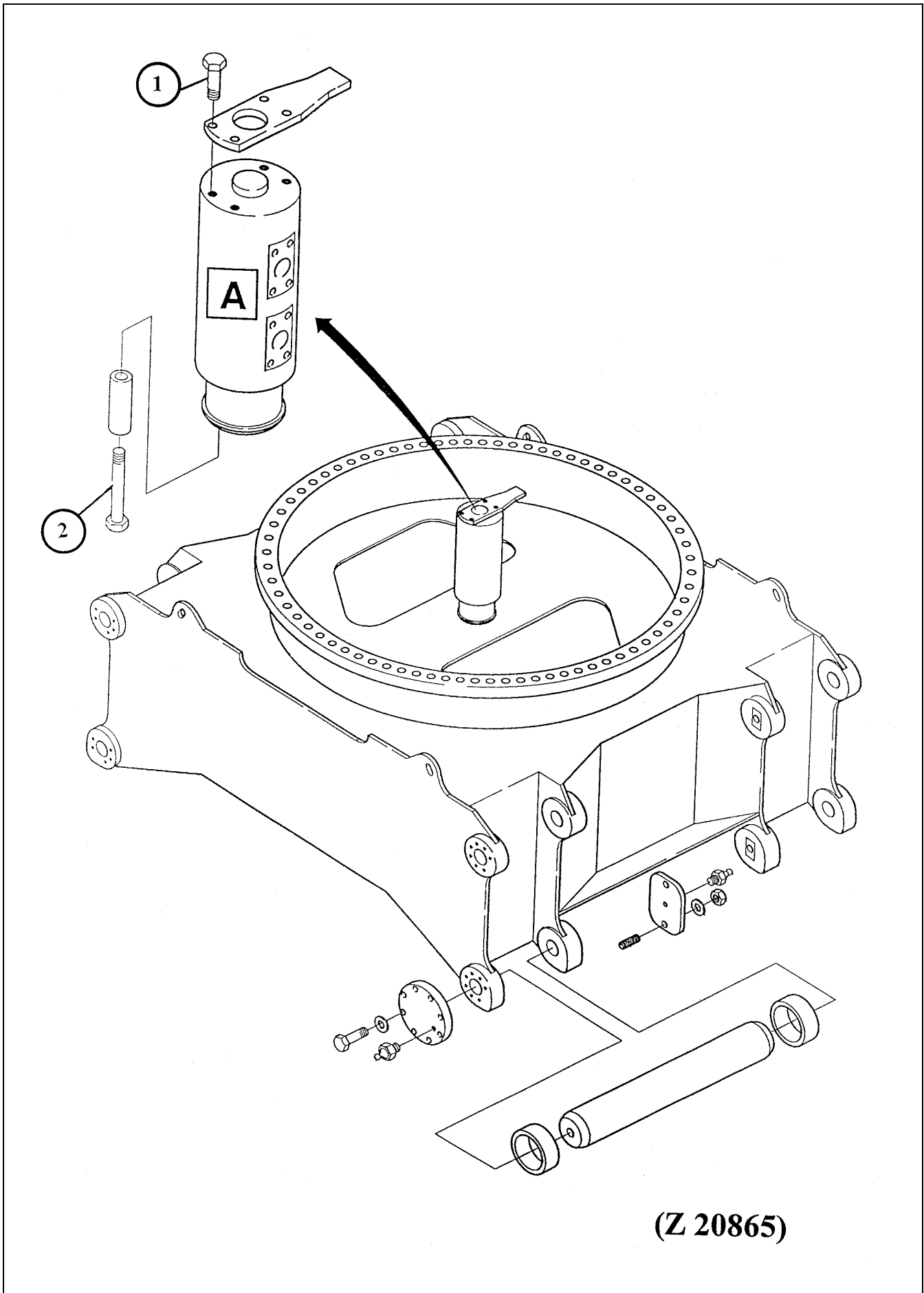

(Z 20865)

High-Strength Bolt Connections (continued)

**Check condition and fastening of swivel joint (A),
illust. Z 20865**

Reference No.:	Bolt size mm	Grade	SW * mm	Tightening torque Nm	Qty.
(1)	M 16	10.9	24	265	4
(2)	M 16	10.9	24	265	8

* SW = Wrench size

- Re-tighten mounting bolts to their correct torque and replace missing or damaged bolts.

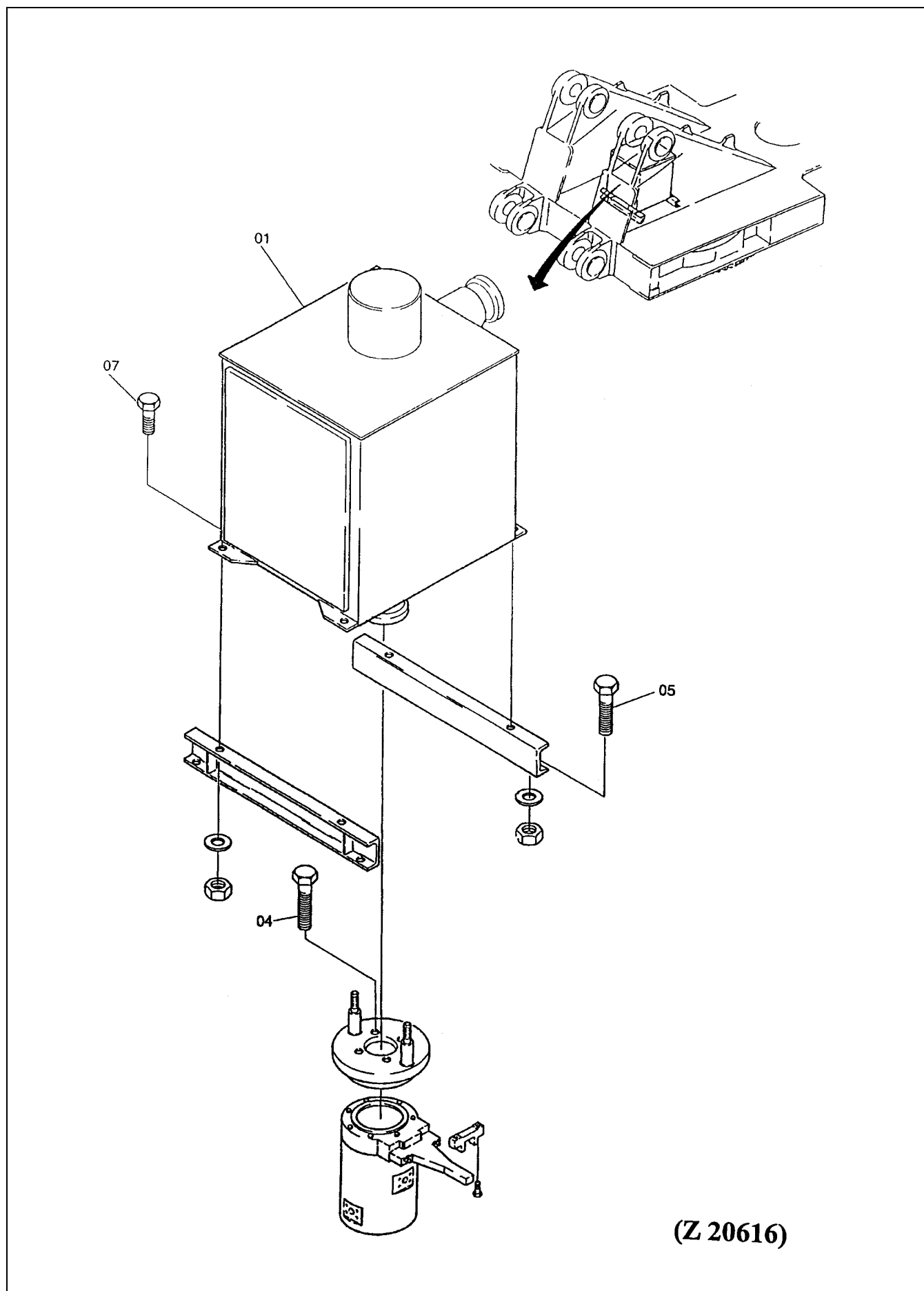

High-Strength Bolt Connections (continued)

Excavators with Electric Prime Mover

Check condition and fastening of slip ring unit (01),
illust. Z 20616

Reference No.:	Bolt size mm	Grade	SW * mm	Tightening torque Nm	Qty.
((04)	M16	10.9	24	265	4
(05)	M16	8.8	24	180	4
(07)	M16	8.8	24	180	4

* = Wrench size

- Re-tighten mounting bolts to their correct torque and replace missing or damaged bolts.

- A -

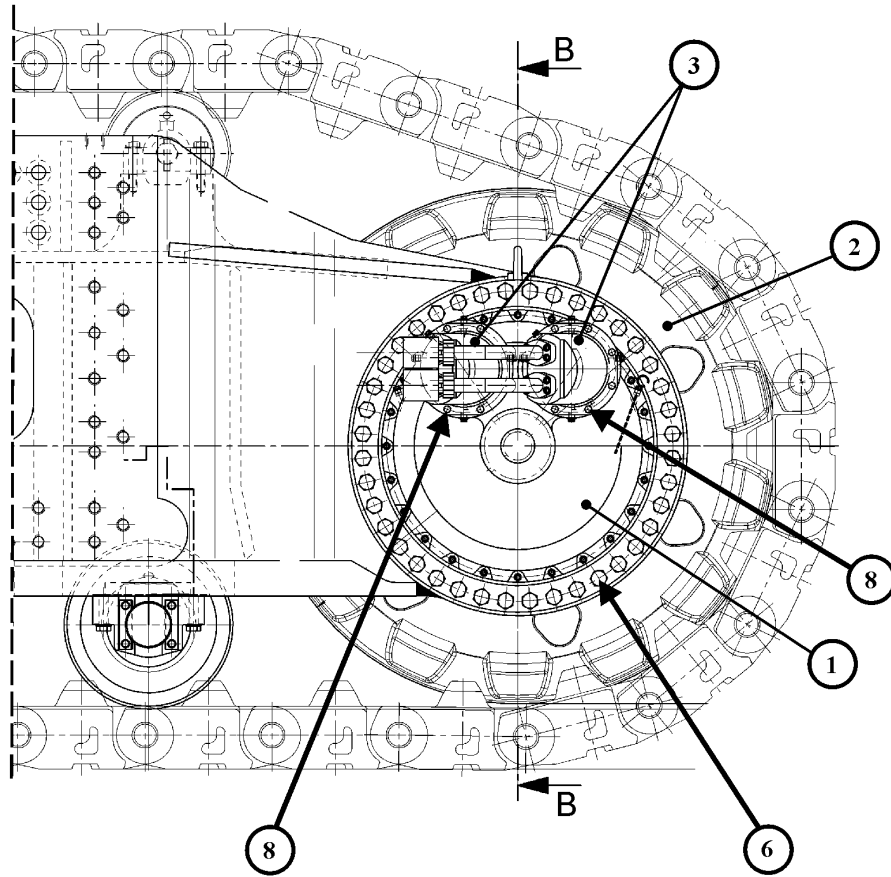

Section B - B

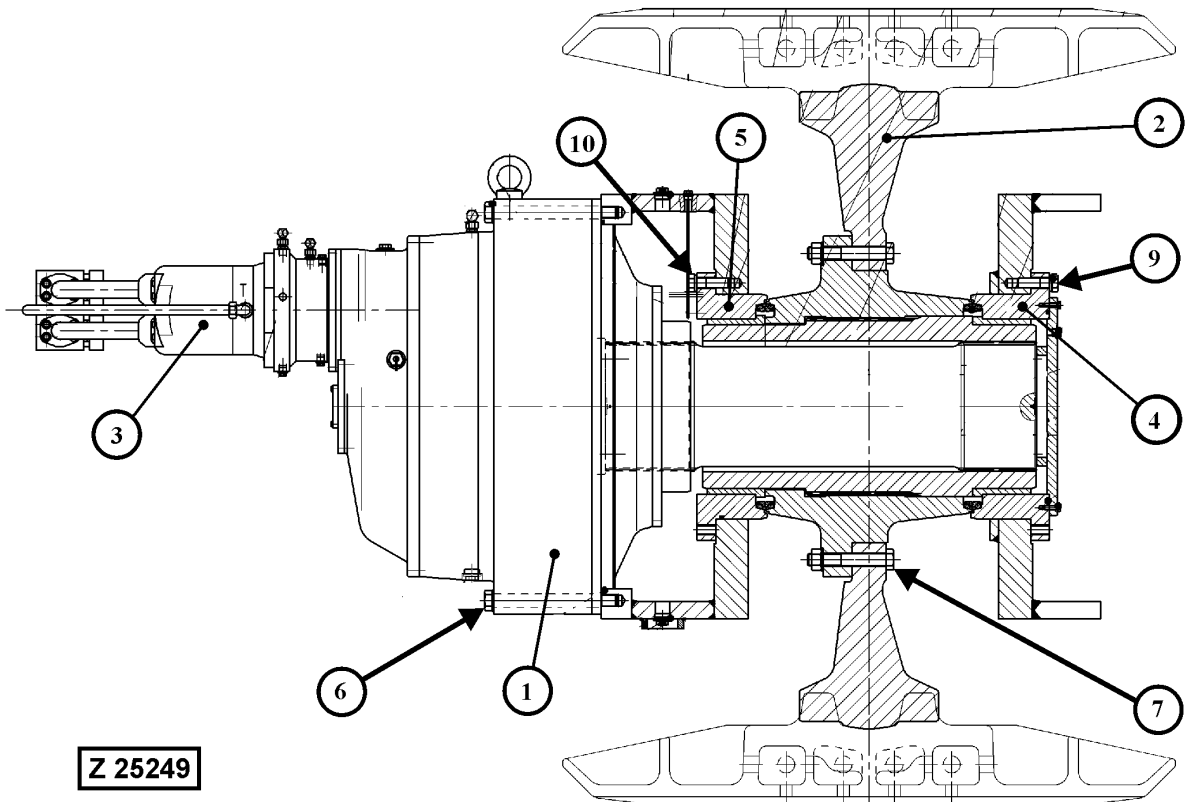

Z 25249

High-Strength Bolt Connections (continued)

Check condition and fastening of travel gears, sprockets and travel motors

Legend for illustration Z 25249

- A - View of the RH Final drive. The configuration of the LH Final drive is the same.
- (1) Travel gear
- (2) Sprocket
- (3) Travel motors
- (4) Outer sprocket bearing
- (5) Inner sprocket bearing
- (6) Mounting bolts for travel gear to crawler carrier
- (7) Mounting bolts for sprocket to hub
- (8) Mounting bolts for travel motors
- (9) Mounting bolts for outer bearing to crawler carrier
- (10) Mounting bolts for inner bearing to crawler carrier

Reference No.:	Bolt size mm	Grade	SW *1) mm	Tightening torque Nm	Qty. *2)
(6)	M36	10.9	55	3100	80
(7)	M36	10.9	55	3100	72
(8)	M16	10.9	24	265	32
(9)	M30	10.9	46	1770	24
(10)	M30	10.9	46	1770	24

*1) SW = Wrench size

*2) Quantity for both final drives

- Re-tighten mounting bolts to their correct torque and replace missing or damaged bolts.

NOTICE

If the outer bolts (9) have been found loose, it is necessary to check also the inner bolts (10) for looseness.

For this purpose the travel gear assy has to be removed.

Contact your Komatsu Dealer for support.

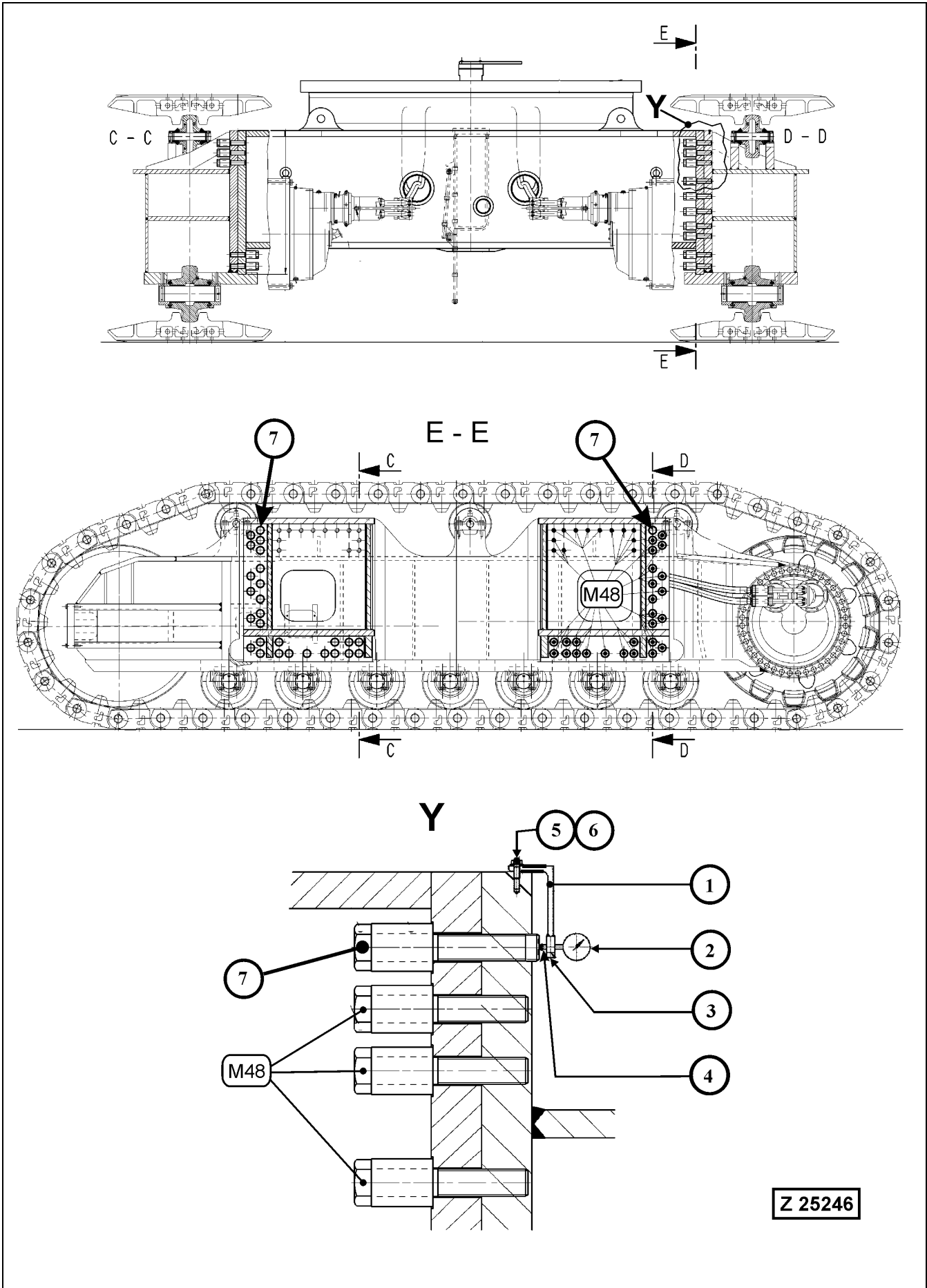

High-Strength Bolt Connections (continued)

Retightening procedure of the crawler carrier mounting bolts

REMARK

The required tightening torque for the mounting bolts of the crawler carriers has been determined and applied during the assembling procedure of the excavator at the mine site. This procedure has to be repeated one time after the first 1000 operating hours through your Komatsu dealer.

General

The required tightening torque for all mounting bolts (M48), illustration Z25246 has to be determined with the four measuring bolts (7), which dimension is analogous to the mounting bolts.

The required axial tensioning force of the bolts (M48) is determined by means of the elongation of the bolts.

For determination of the tightening torque, two especially prepared measuring bolts (7) are installed on each crawler carrier. The measuring bolts can be identified by the centering dot at the bolt head and the milled area at the shaft end.

Necessary equipment for the retightening procedure:

- Measuring device (1 - 6) delivered with the new machine, see table below.
- Special hydraulic torque wrench, see illustration Z24072 on page 453. This tool will be provided by your Komatsu dealer.

Measuring Device PN 92847640

Position	Part name	Part No.	Qty.
1	Angle bar	928 475 40	1
2	Dial gauge	092 706 40	1
3	Screw M5x16	502 515 98	1
4	Feeler	477 172 40	1
5	Bolt M10x25	307 777 99	2
6	Washer	517 122 98	2
7	Measuring bolts (installed)	913 613 40	4

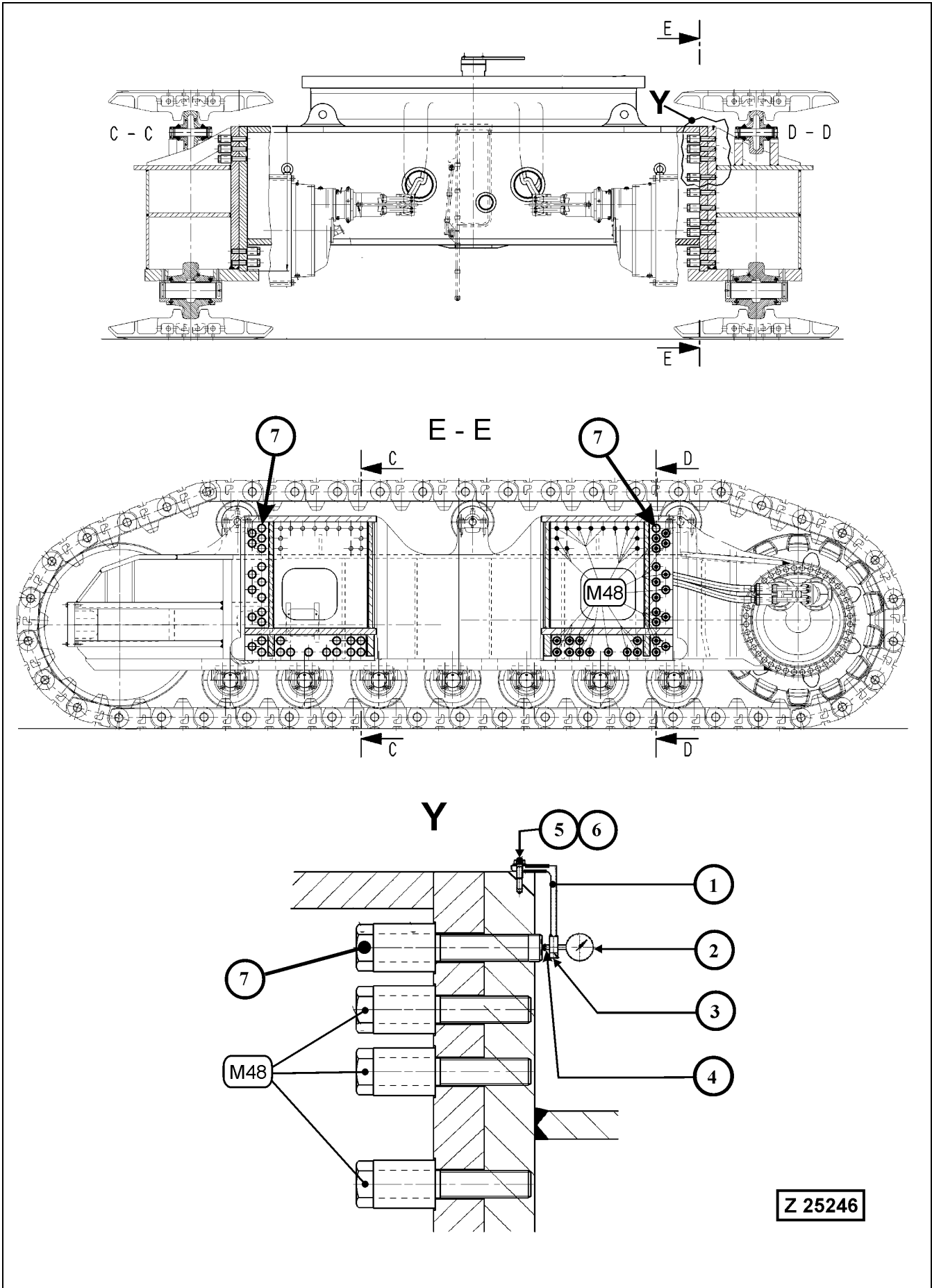

Z 25246

High-Strength Bolt Connections (continued)

Procedure for determination of the tightening torque for the crawler carrier mounting bolts after the first 1000 operating hours, see illustration Z25246

1. Loosen the two measuring bolts (7) at the left crawler carrier and the two measuring bolts at the right crawler carrier.
Do not lubricate the measuring bolts.
2. Tighten the four measuring bolts (7) with 150 Nm.
3. Attach the measuring device (1 - 6).
4. Set the dial gauge (2) to the zero position.
5. Attach the special hydraulic torque wrench (1), see illustration Z24072 on next page to the measuring bolt (7).
6. Increase the pressure at the hydraulic torque wrench until a torque of 2100 Nm is reached and tighten the measuring bolt.
7. Record the pressure and the change of the bolt length in a table.
8. Increase the pressure further by steps of 10 bar until the required elongation of 0.93 mm of the measuring bolts (7) is reached.
9. Record the corresponding hydraulic pressures in a table.
10. Repeat this procedure on all four measuring bolts (7).
11. Add the 4 determined hydraulic pressures and then divide by 4 to obtain an average value.
12. Now loosen only one of the mounting bolts (M48) and tighten up to the determined average pressure.

CAUTION

DO NOT loosen more than one bolt at the same time.
DO NOT lubricate the bolts (M48).

13. Repeat this procedure step by step at all of the 156 mounting bolts (M48) .

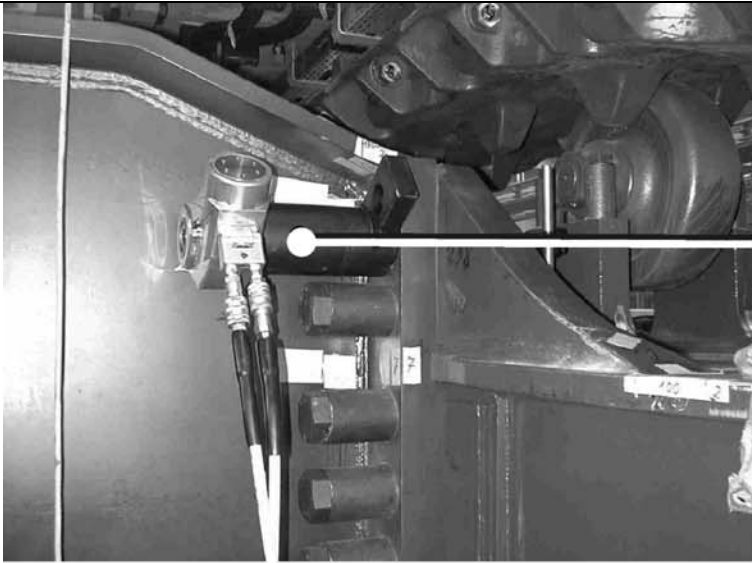

1

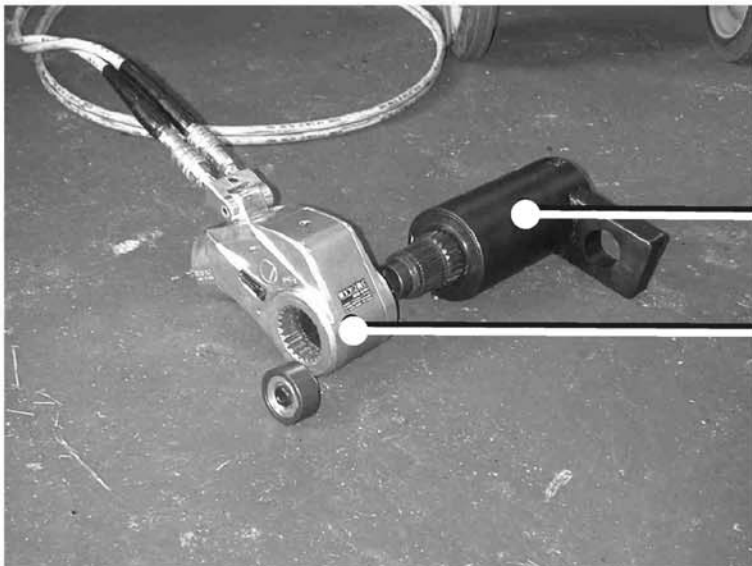

2

3



4

Z 24072

High-Strength Bolt Connections (continued)

Special hydraulic torque wrench

Legend for illustration Z24072:

- (1) Application of the hydraulic torque wrench
- (2) Special wrench socket with supporting bar (P/N 793 376 73)
- (3) Hydraulic wrench (P/N 793 374 73)
- (4) Electro-hydraulic pump set (P/N 793 375 73)

The equipment shown in illustration Z24072 will be provided by your Komatsu dealer.

Location of the four measuring bolts (7), illustration Z25247

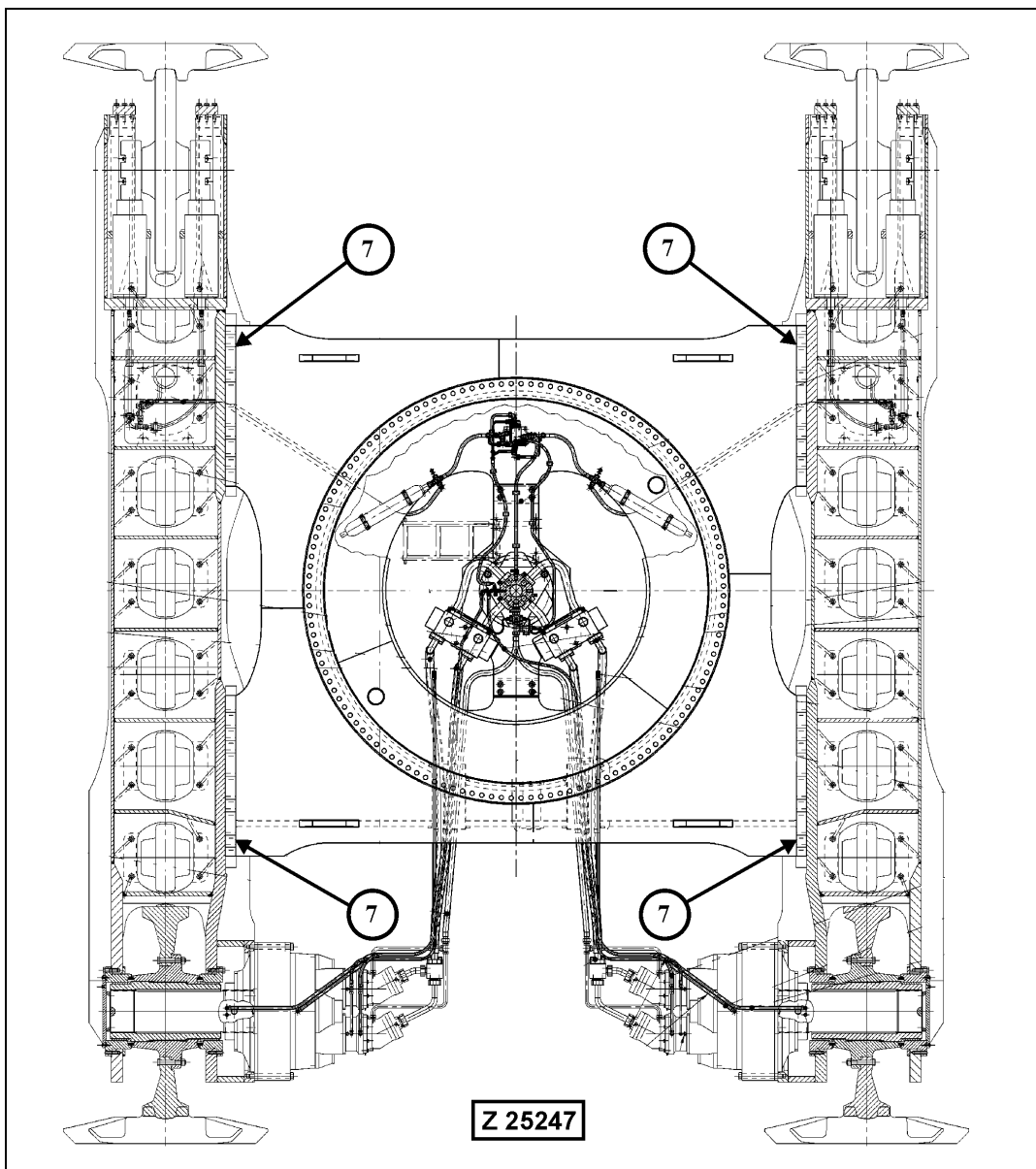

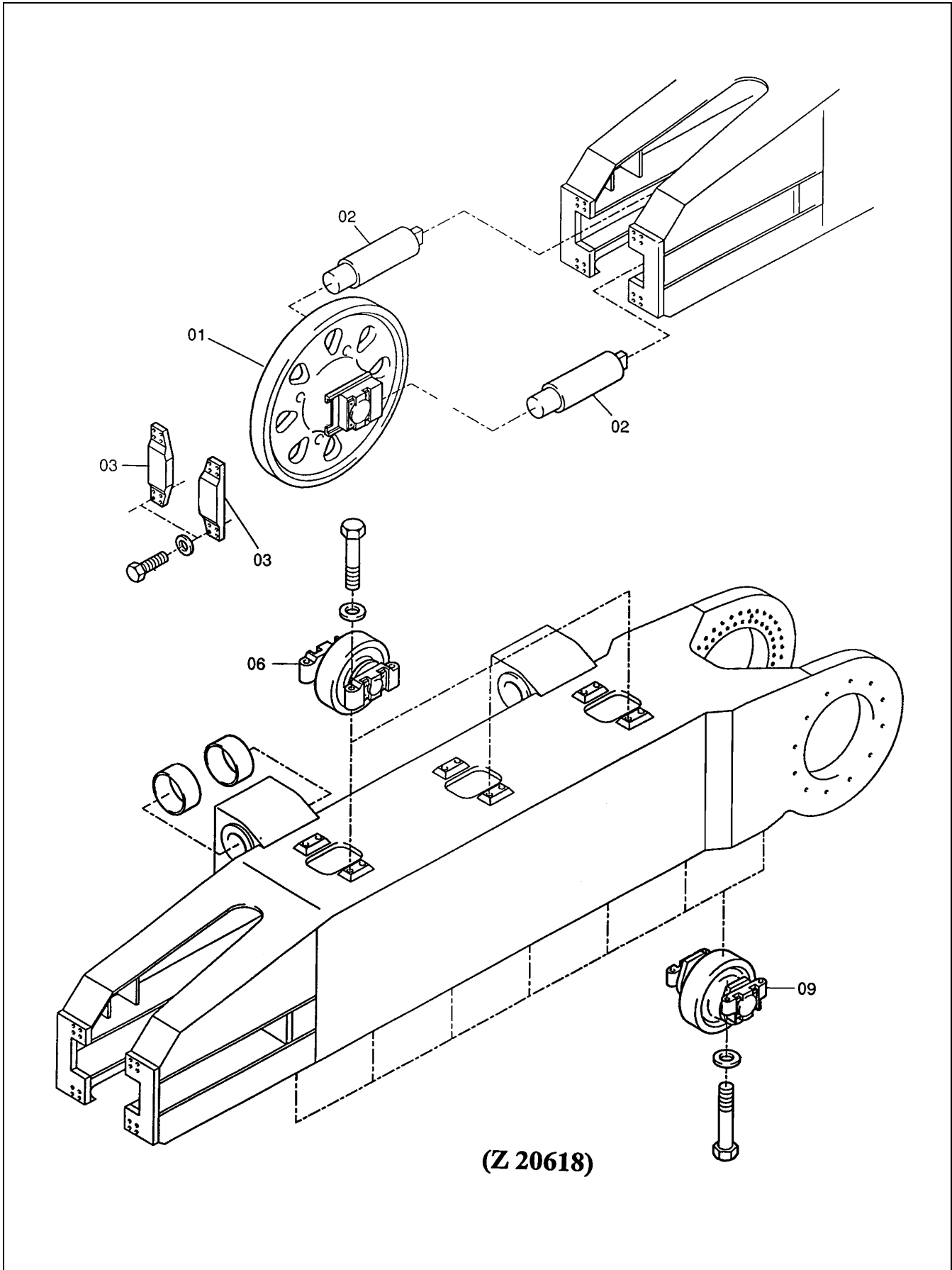

High-Strength Bolt Connections (continued)

Crawler Carrier

Check condition and fastening of guide wheels (01), stop plates (03) and rollers (06 and 09), illust. Z 20618.

Legend for illust. Z 20618:

- (01) Guide wheel
- (02) hydraulic track tensioning cylinders
- (03) Stop plates for guide wheel sliding blocks
- (06) Support rollers
- (09) Bottom rollers

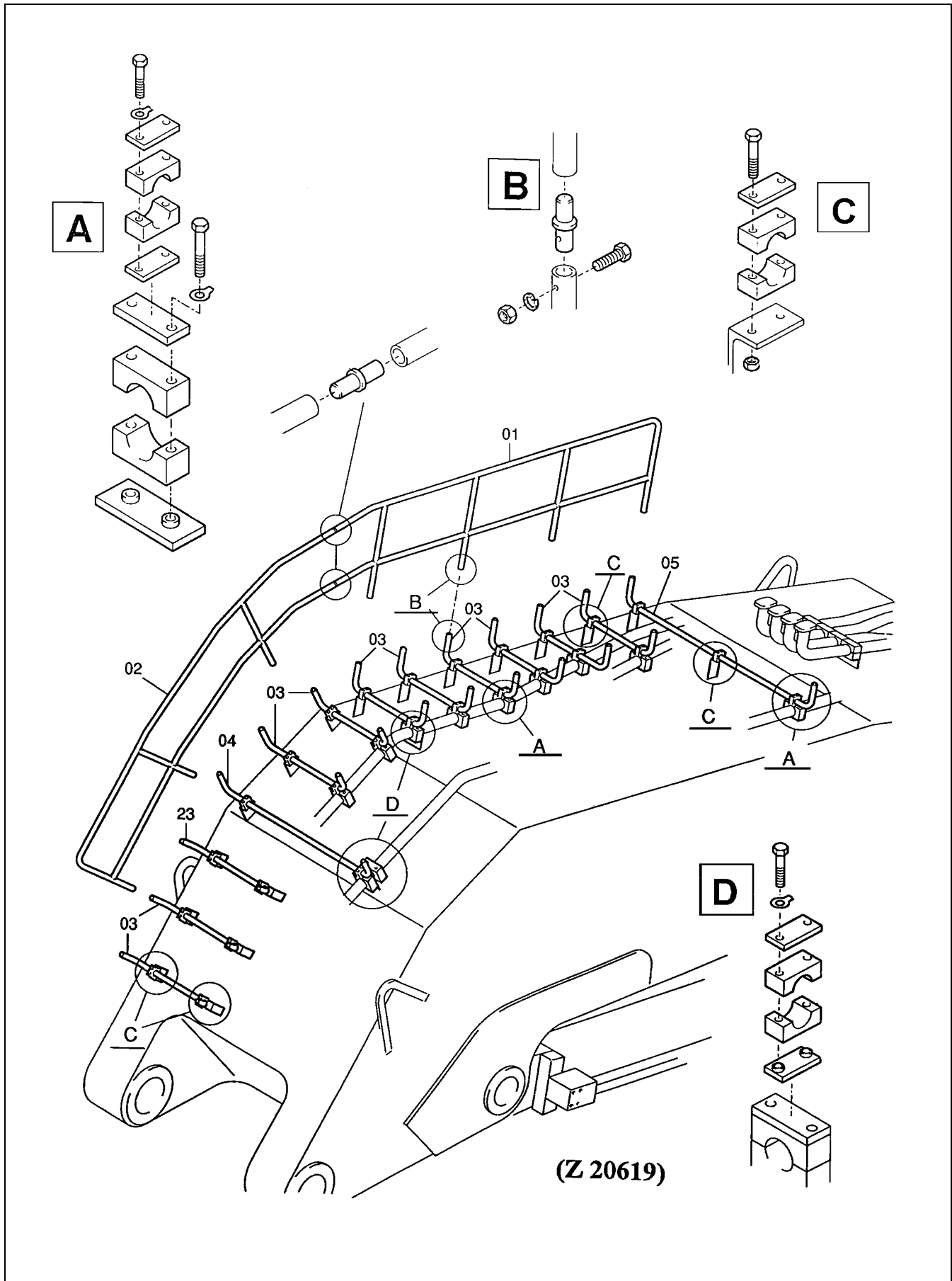

High-Strength Bolt Connections (continued)

Check condition and fastening of railings (01/02) and of steps (03, 04, 05 and 23).

See details (A - D) for mounting parts arrangement.

Legend for illust. Z 20619

- (A) Mounting assembly for steps (03) to steel pipe, version I
- (B) Mounting assembly for railing posts to steps (03)
- (C) Mounting assembly for steps (03) to boom welded brackets
- (D) Mounting assembly for steps (03) to steel pipe, version II

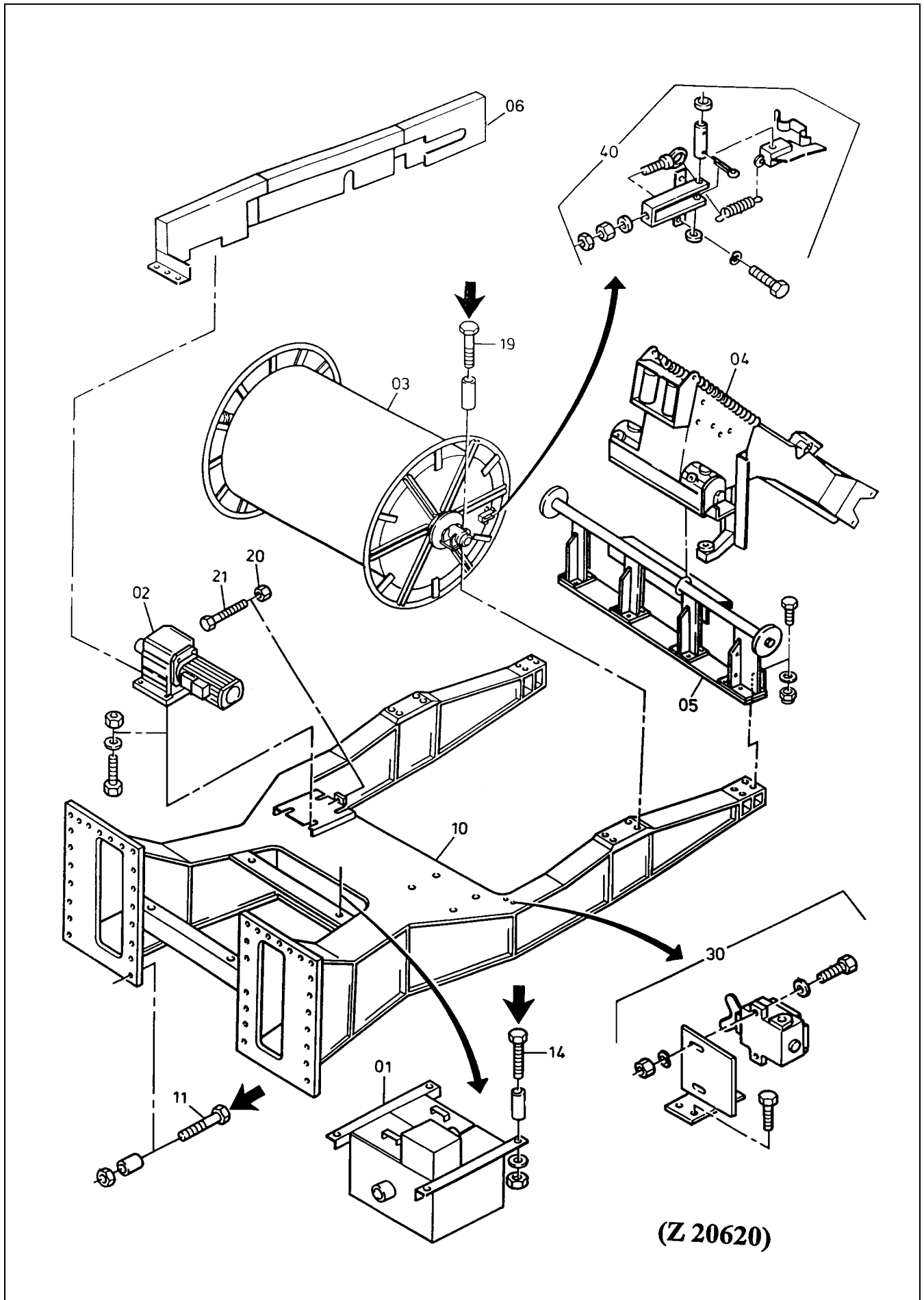

High-Strength Bolt Connections (continued)

Cable Drum for Excavators with Electric Prime Mover

- Check condition and fastening of parts (01 - 06) and (10, 30 and 40), illust. Z 20620

Legend for illust. Z 20620

- (01) Junction box
- (02) Brake motor
- (03) Drum body
- (04) Cable guide rocker arm
- (05) Sliding frame
- (06) Drive chain guard
- (10) Cable drum carrier frame
- (11) Mounting bolts frame (10) to undercarriage center section
- (14) Mounting bolts junction box (01) to frame (10)
- (19) Mounting bolts drum (03) to frame (10)
- (20) Lock nut
- (21) Adjusting screw for drive chain tension
- (30) Limit switch, cable end
- (40) Actuator lever for limit switch (30)

Reference No.:	Bolt size mm	Grade	SW * mm	Tightening torque Nm	Qty.
(11)	M20	10.9	30	510	40
(14)	M20	10.9	30	510	4
(19)	M16	10.9	24	265	4

* SW Wrench size

For more information concerning cable drum maintenance refer to the separate booklet CABLE DRUM in volume 2 binder.

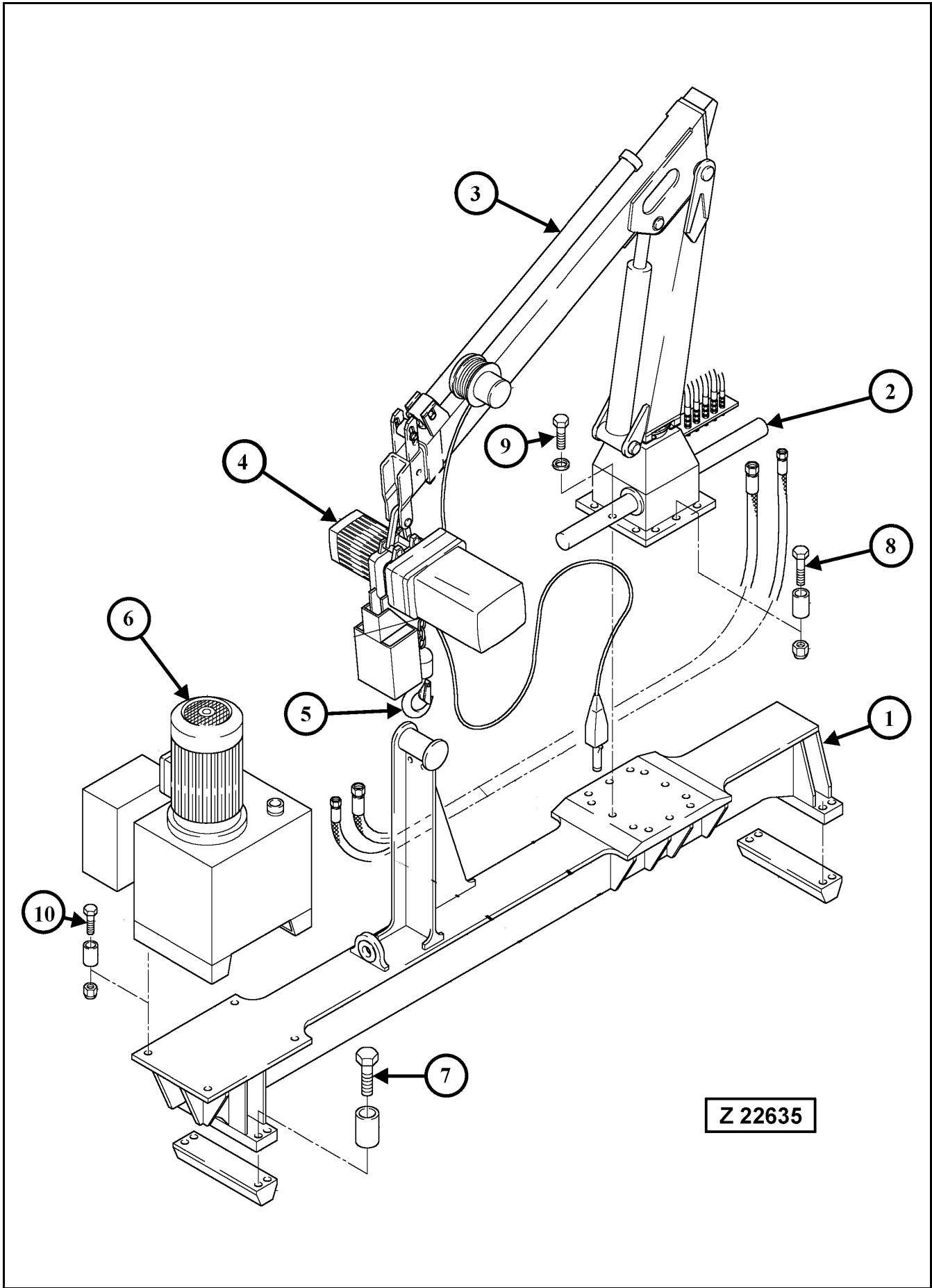

High-Strength Bolt Connections (continued)

Roof-mounted service crane

Check condition and fastening of crane base and crane

Legend for illust. Z 22635

- (1) Crane base
- (2) Slew crane
- (3) Outrigger
- (4) Electric chain hoist or hydraulic rope winch
- (5) Safety hook
- (6) Electric -hydraulic power unit

Reference No.:	Bolt size mm	Grade	SW * mm	Tightening torque Nm	Qty.
(7)	M24	10.9	36	880	8
(8)	M20	10.9	30	510	10
(9)	M20	10.9	30	510	2
(10)	M12	8.8	19	74	16

* SW Wrench size

- Re-tighten loose mounting bolts and replace missing bolts.
- Replace self locking nuts which have lost their clamping torque.

REMARK

For more information concerning crane maintenance refer to the separate Instruction Manual "MKG CRANE HMK 60 Ta1" filed in volume 2 binder.

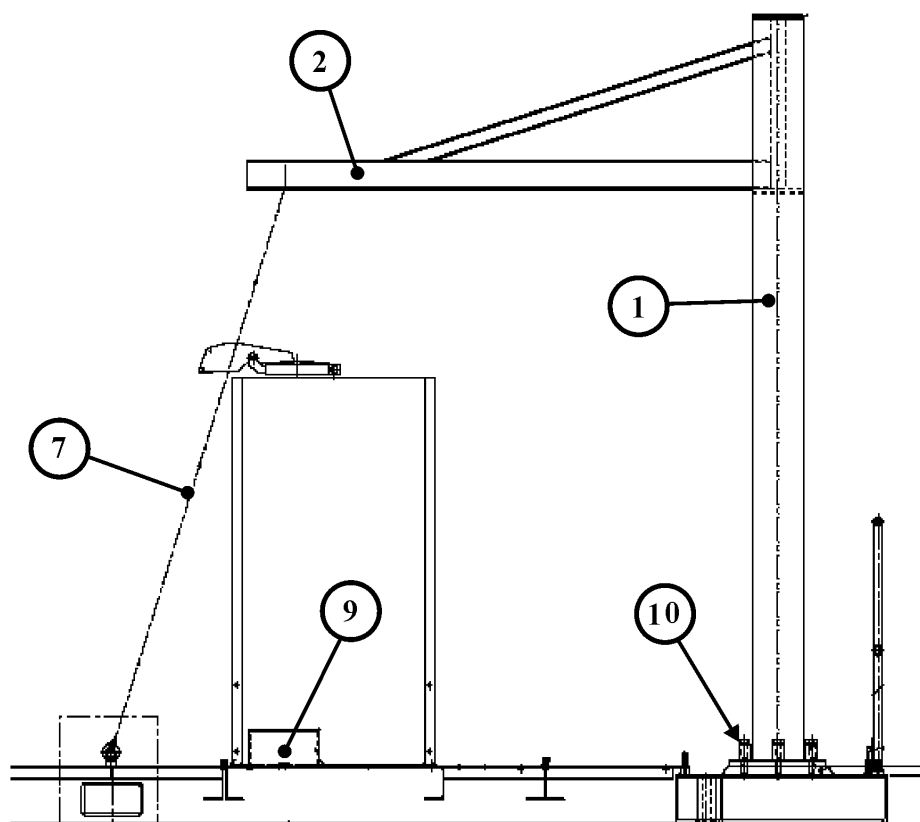

View X

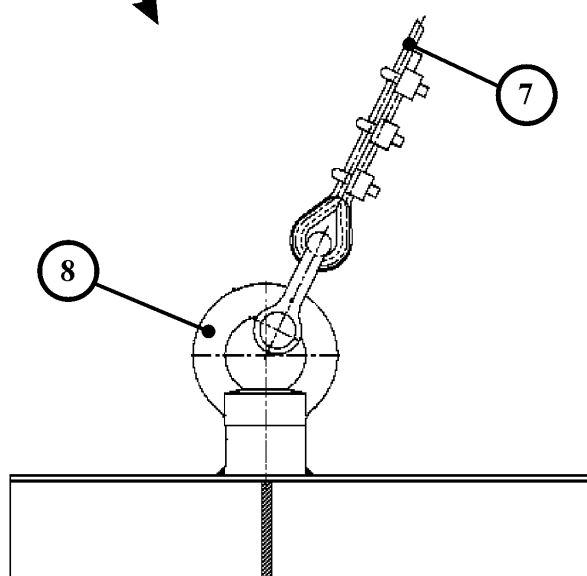

Z 23054

High-Strength Bolt Connections (continued)

Roof-mounted crane for grease barrel replacement Check condition and fastening of the crane

Legend for illustration Z 23054

- | | |
|----|--|
| 1 | Crane post |
| 2 | Outrigger |
| 7 | Ropes for securing the outrigger (2) in home position |
| 8 | Ring for fastening the wire ropes (7). |
| 9 | Storage box for hoist chain |
| 10 | Crane mounting bolts, M27 quality grade 8.8. Tightening torque 920 Nm. |

Be sure to check security and tightening torque of the crane mounting bolts (10) after the first 100 operating hours and thereafter every 1000 operating hours. Check condition of fastening ropes (7) and ring (8).

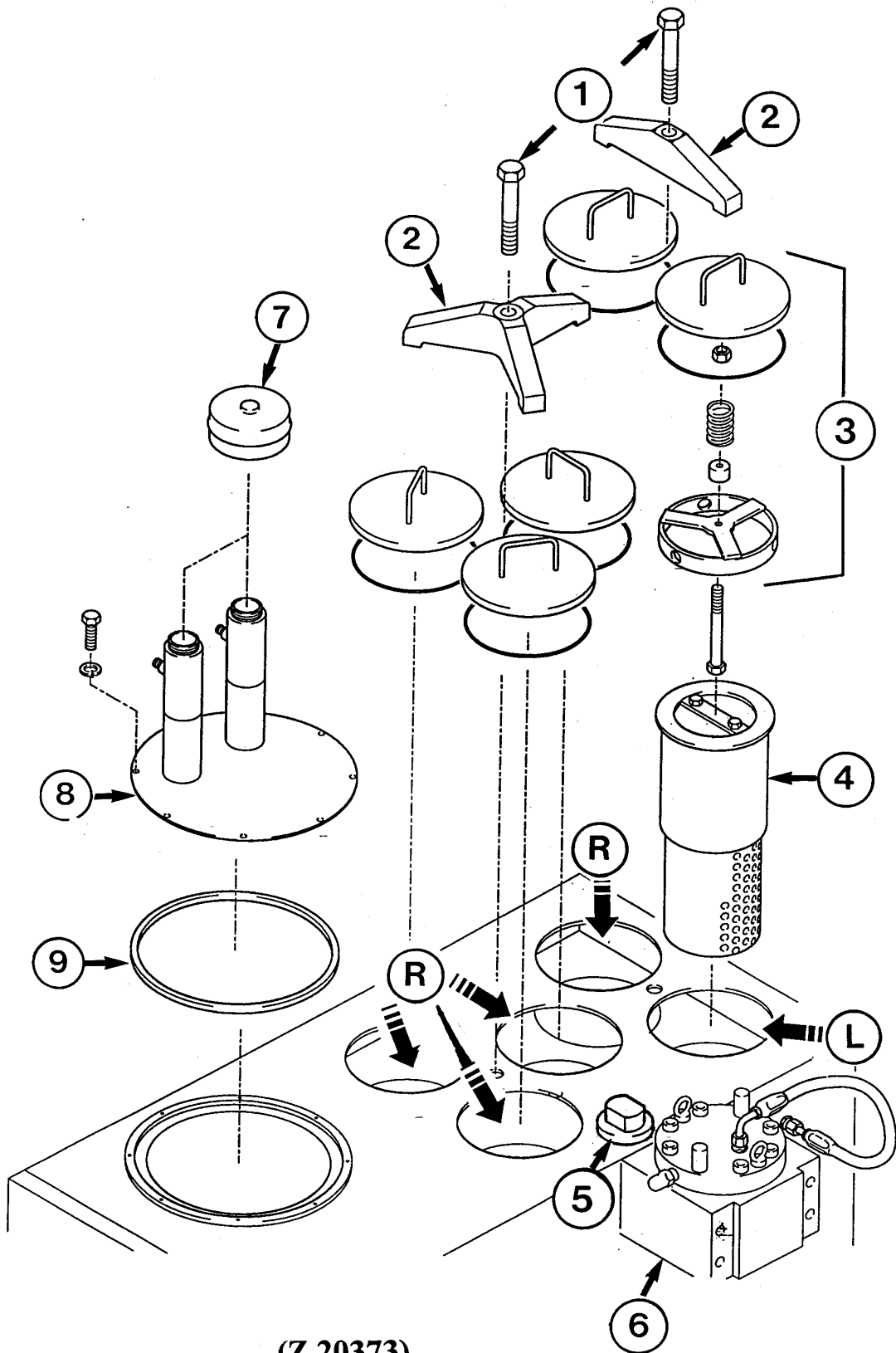

(Z 20373)

4.12.2 HYDRAULIC SYSTEM - FILTER SERVICE

Legend for illust. Z 20373

R	Return of filter location
L	Leakage oil filter location
(1)	Mounting bolt
(2)	Filter cover retainer
(3)	Filter cover assy
(4)	Return- and leakage filter unit
(5)	Oil filler plug
(6)	Back-pressure valve
(7)	Breather filter
(8)	Cover
(9)	Gasket

NOTICE

The description of the hydraulic filters appears in the following sequence:

- Return- and Leakage oil filters, see page 467
- Breather filter, see page 469
- High pressure filters, see page 471
- Pressure filters on central control and filter frame, see page 475

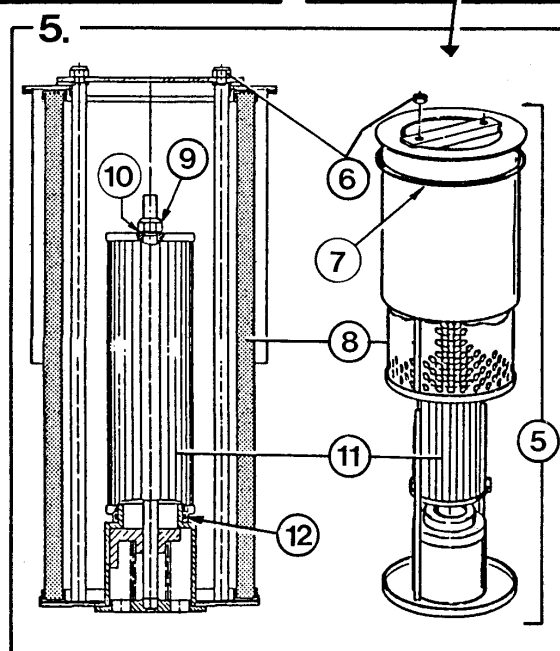
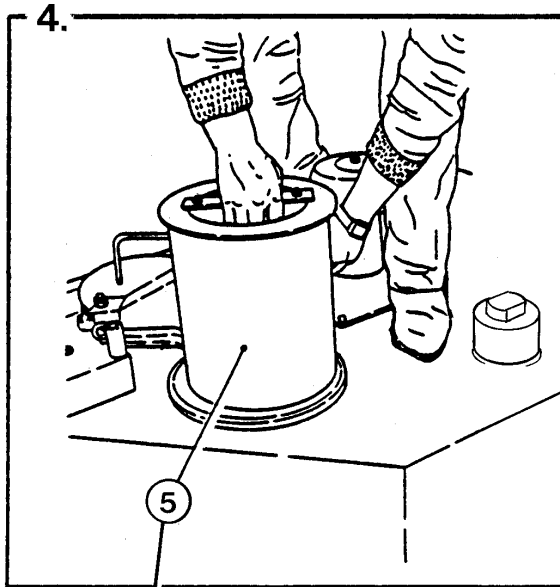
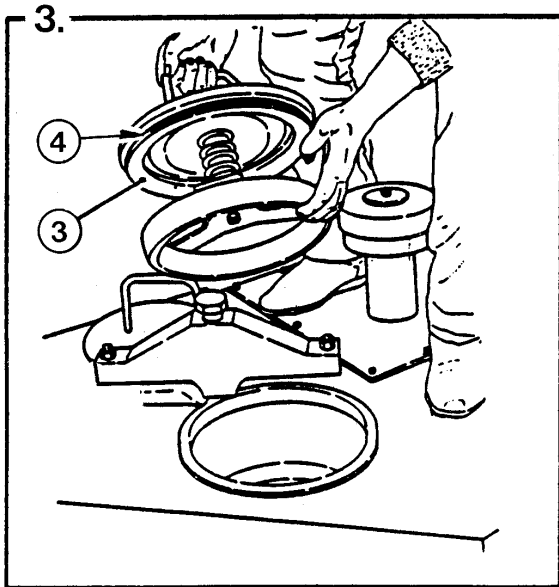
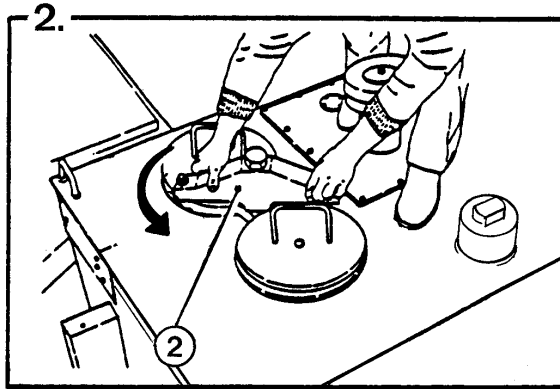
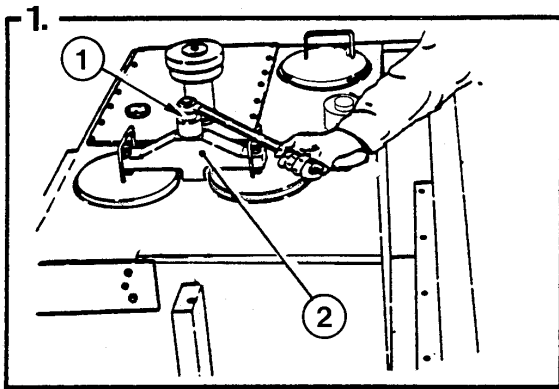

Z 19336

FILTER SERVICE

- Replace return oil filter elements
- Replace leakage oil filter element
- Check filter screens

Follow the steps shown in illust. Z 19336:

1. Loosen bolt (1).
2. Turn retainer (2).
3. Remove cover assy (3). Inspect O-ring (4) and replace if necessary.
4. Lift out element assy (5).
5. Disassemble filter assy (5) in sequence of ref. nos. (6 to 12)
6. Discard element (8)
7. Inspect screen (11) and clean if necessary.

NOTICE

Take care not to contaminate the clean inside of the screen when flushing.

8. Inspect screen (11) and O-ring (12) for damage replace if necessary.
Install screen (11) use new sealing washer (10) and self locking nut (9).
9. Reassemble filter assy (5) with new element (8) according to step 5.
Use new self locking nuts (6).
10. Install filter assy use new gasket (7).
Torque bolt (1) to 850 Nm.

NOTICE

- **After each repair of the hydraulic system the elements (8) should be replaced after about 50 operating hours.**
- **The filter elements must also be replaced when the fault message "Filter restriction" is displayd on the ECS screen.**
- **Replace screens (11) every 5000 operating hours at the latest.**

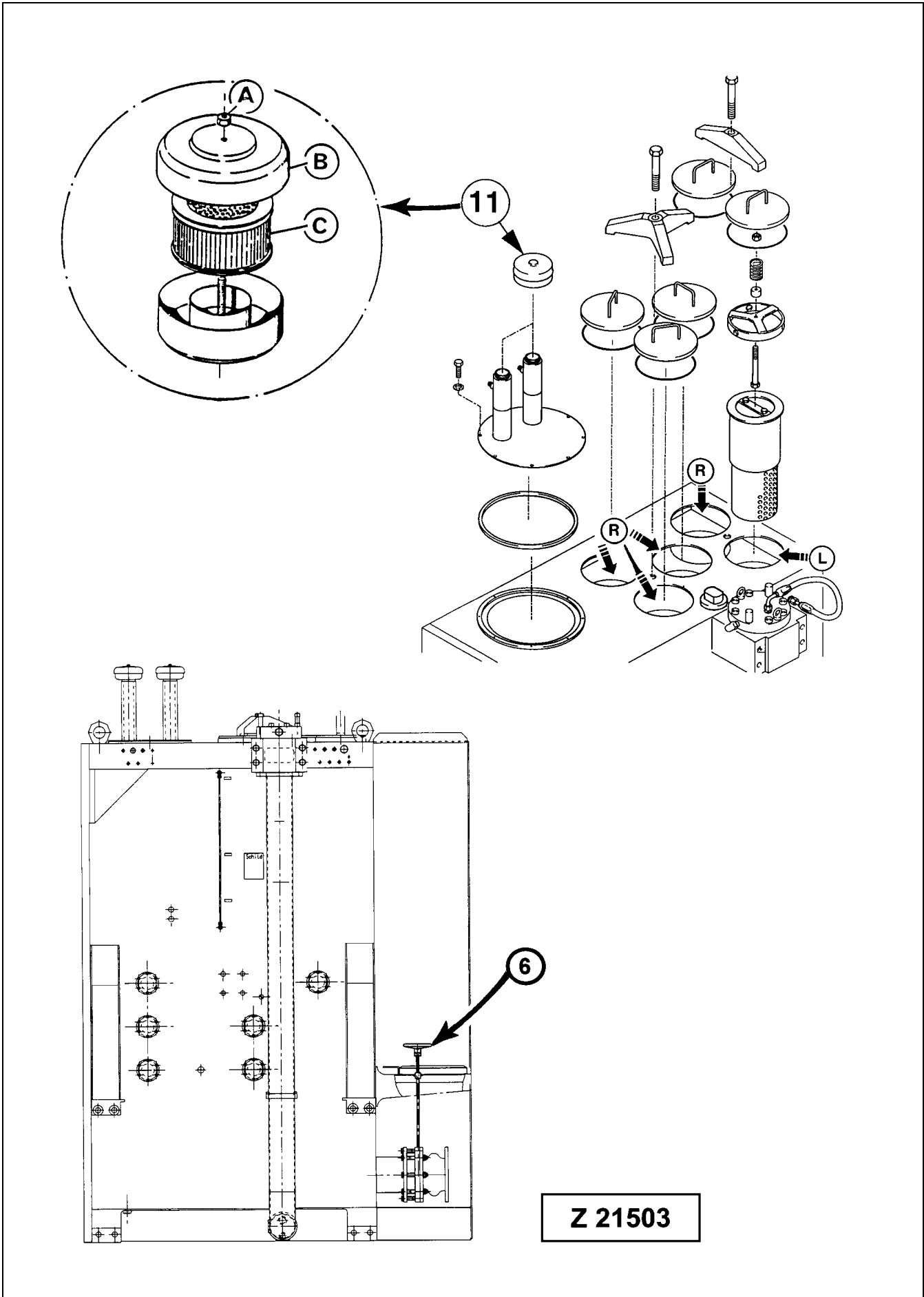

FILTER SERVICE

- Replace breather filter element
- Drain water and sediments from hydraulic oil tank

Legend for illust. Z 21503

- (6) Hand wheel of main shut-off valve located between suction oil reservoir and main oil reservoir
- To OPEN the valve, turn hand wheel (6) CCW to the stop
 - To CLOSE the valve, turn hand wheel CW to the stop

A proximity switch located on the gearbox of the shut-off valve monitors the valve position. With the valve not fully open, a corresponding message will be displayed on the ECS screen in the Operator's cab.

REMARK

Before starting the engine, make sure the shut-off valve is completely open by turning hand wheel (6) fully to the left (CCW).

- (11) Breather filter

Replace Element (C) of Breather Filter (11).

1. Remove nut (A).
2. Remove cover (B).
3. Remove filter element (C).
4. Insert new filter element and reassemble the breather filter (11).

Drain Water and Sediments

Drain water and sediments with machine standing on level ground and when machine was out of operation for some time.

Refer to Operation section page 286 for evacuation procedure.

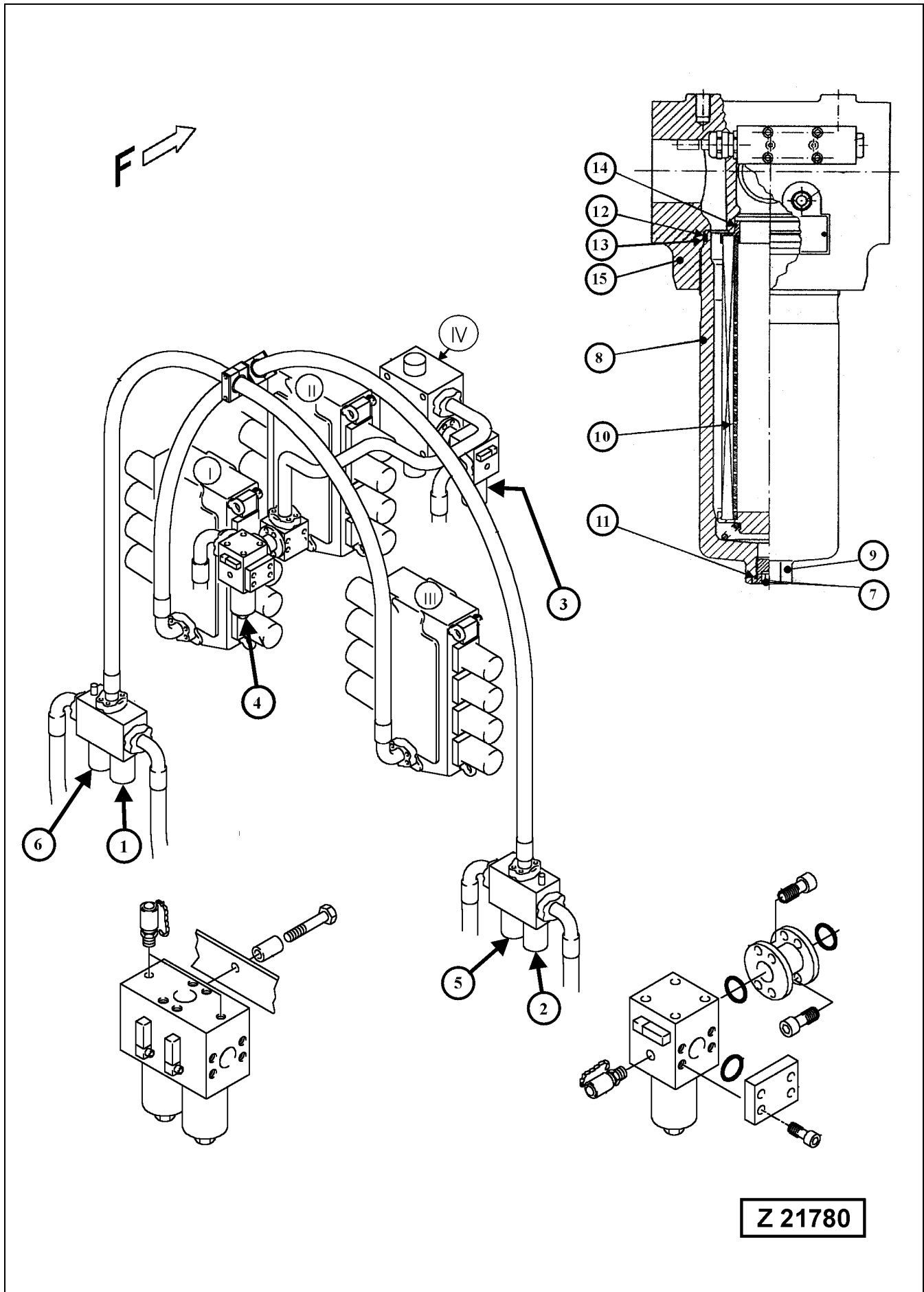

FILTER SERVICE

High Pressure Filters "HPF", illustration Z 21780

NOTICE

- The filter reference numbers (1 - 6) correspond to the numbering of the main pumps.
- If, for example, the fault message "High pressure filter #5 restricted" is being displayed on the ECS screen, the filter number (5) in the illustration has to be serviced. The engine will be shifted automatically to low idle speed. Stop work and inform Service staff about the fault message.

Legend for illustration Z 21780

- (1) HPF for pump 1
- (2) HPF for pump 2
- (3) HPF for pump 3
- (4) HPF for pump 4
- (5) HPF for pump 5
- (6) HPF for pump 6
- (7) Drain plug
- (8) Filter case
- (9) Hexagon
- (10) Filter element
- (11) Packing ring
- (12) O-ring
- (13) Back-up ring
- (14) O-ring
- (15) Filter header

Clean or replace high pressure filter elements:

1. Place working attachment on the ground and shut-off the engines.
Relieve pressure in the hydraulic system with several movements of the control levers.
2. Place a suitable container below the filter in order to collect outflowing oil.
3. Remove plug (7) and drain the oil.
4. Screw off filter case (8).

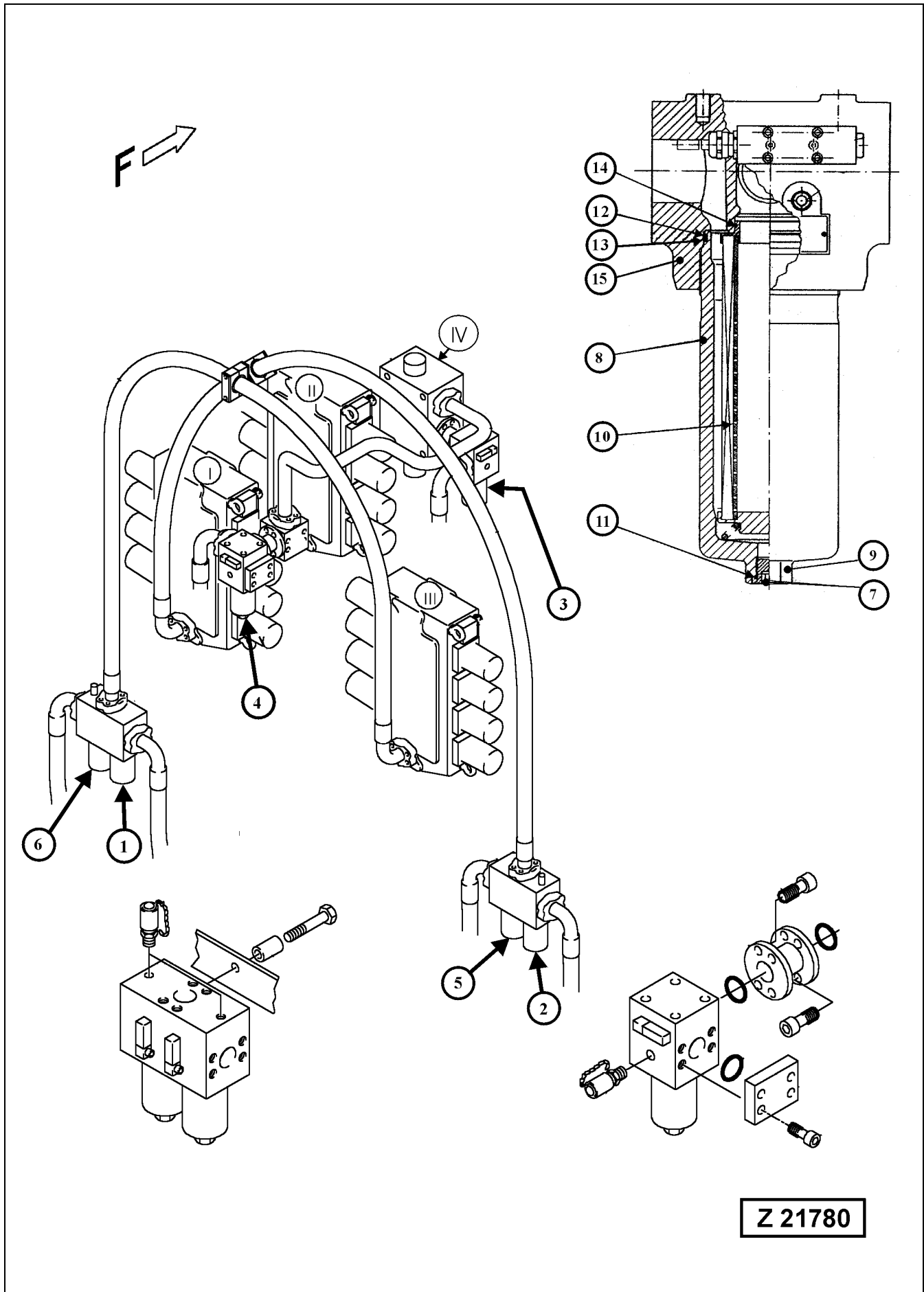

FILTER SERVICE

High Pressure Filters "HPF", illustration Z 21780

NOTICE

Carefully inspect elements for damage. Always install new elements if ruptures or other damages are found.

5. Remove element (10) and clean. Take care not to contaminate the "Clean" inside of the element when flushing.
6. Inspect O-rings (12 and 14) and back-up ring (13). Replace if necessary.
7. Install drain plug (7) with new packing ring (11). Fill filter case (8) half way up with clean hydraulic oil and re-assemble the filter. Make sure element (10) is properly seated in the filter head.
8. After short operating period check filter units for leakage.

⚠ CAUTION

In case filter element (10) is soiled by metal chips, examine hydraulic pump for damages. Install new element (10).

NOTICE

If after cleaning of the filter element, the message "High pressure filter restricted" is displayed again, replace the filter element.

Replace elements (10) after three cleanings or after every 5000 operating hours, whichever occurs first.

After pump repairs all high pressure filter elements must be replaced.

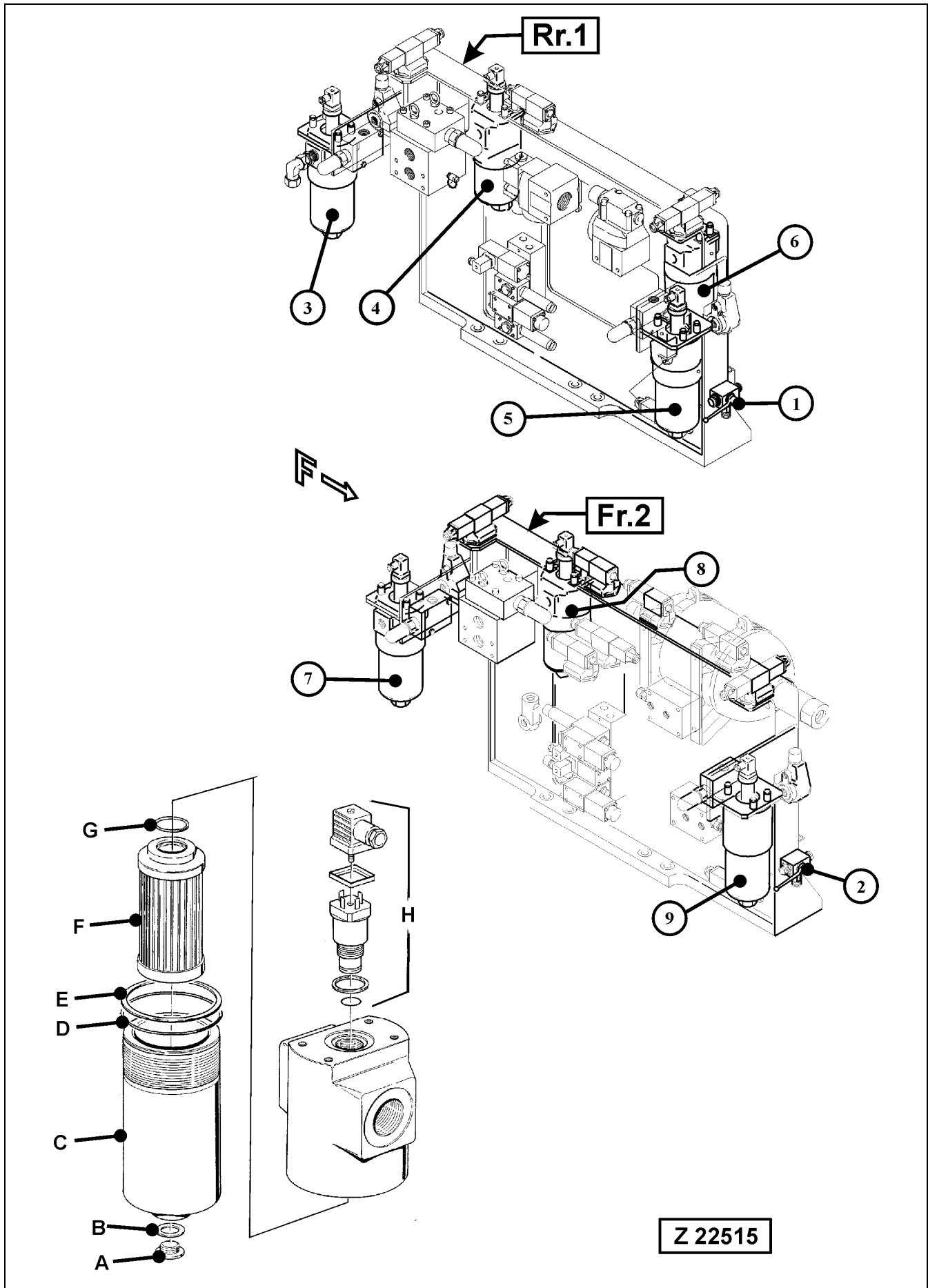

FILTER SERVICE

Replace filter elements of the hydraulic oil pressure filters

NOTICE

When a fault message "Pressure Filter restricted" is displayed, stop work and replace element of the corresponding pressure filter.

Legend for illust. Z 22515

- (Rr.1) Control and filter panel of rear power unit, engine 1
- (Fr.2) Control and filter panel of front power unit, engine 2
- (1) Change over valve for operation mode of pump control system for rear power unit, engine 1.
- (2) Change over valve for operation mode of pump control system for front power unit, engine 2.
- (3) Pressure oil filter for fan drive hydraulic motor of coolant radiator for rear engine "1". Filter restriction monitored by differential pressure switch B21-1.
- (4) Pressure oil filter for pump distributor gear PTO "1" lubricating oil. Filter restriction monitored by differential pressure switch B27-1.
- (5) Pressure oil filter for fan drive motor of hydraulic oil cooler "1". Filter restriction monitored by differential pressure switch B28-1.
- (6) Pressure oil filter for pilot- and pump control oil circuit. Filter restriction monitored by differential pressure switch B22.
- (7) Pressure oil filter for fan drive hydraulic motor of coolant radiator for front engine "2". Filter restriction monitored by differential pressure switch B21-2.
- (8) Pressure oil filter for pump distributor gear PTO "2" lubricating oil. Filter restriction monitored by differential pressure switch B27-2.
- (9) Pressure oil filter for fan drive motor of hydraulic oil cooler "2". Filter restriction monitored by differential pressure switch B28-2.

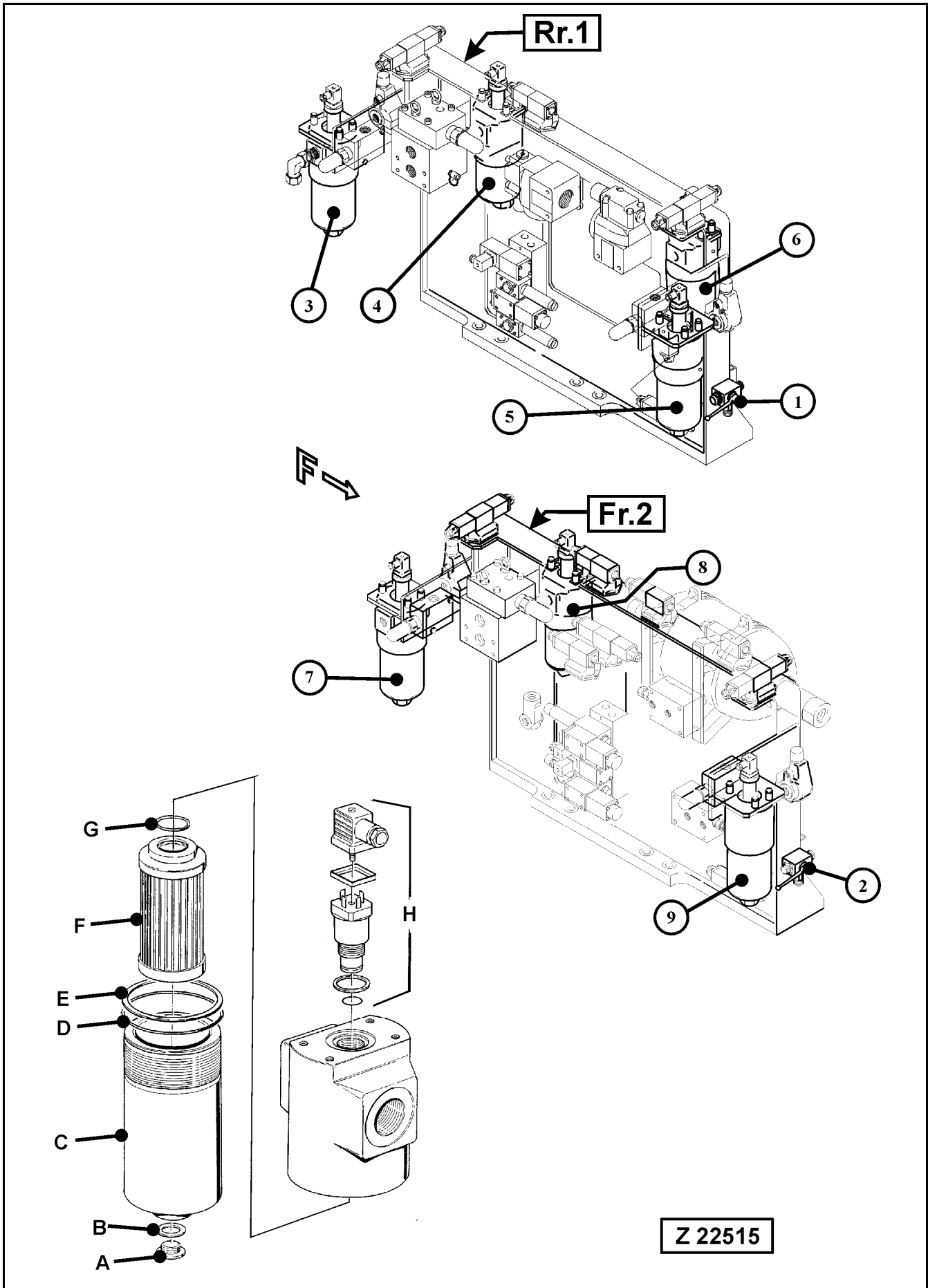

FILTER SERVICE

Replace pressure filter elements, illust. Z 22515, as follows:

1. Place working equipment on the ground and shut-off the engines.
Relieve pressure in the hydraulic system according to page 264 in the operation section.
2. Place a suitable container below the filter in order to collect outflowing oil.
3. Remove plug (A) and drain the oil.
4. Unscrew case (C) of the respective filter and clean the filter case.
5. Discard element (F) with O-ring (G).
6. Inspect O-ring (D) and back-up ring (E), replace if necessary.
7. Install drain plug (A) with new packing ring (B).
8. Lubricate the thread at the filter head and at filter case (C) with multi-purpose grease K2K.
9. Insert a new element (F) with new O-ring (G).
10. Fill the case (C) half way up with clean hydraulic oil.
11. Screw the case (C) into the head and tighten.
12. After short operating period check filter for leakage.
13. Check restriction indicator (H) for proper mounting and good condition.

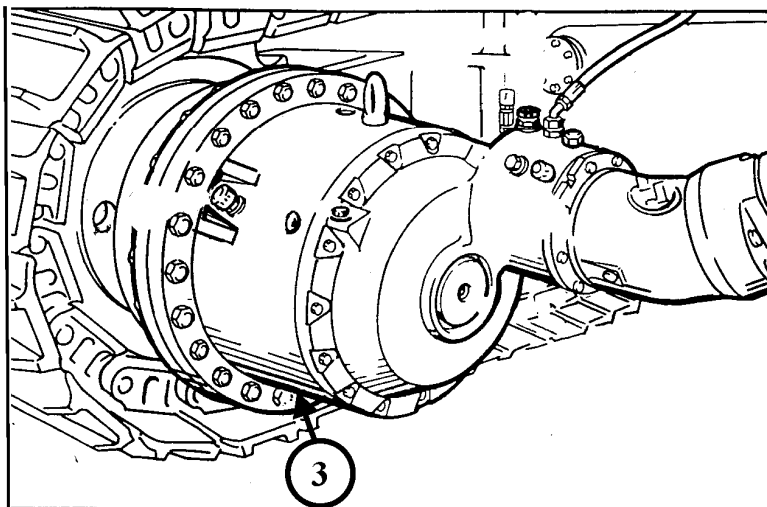
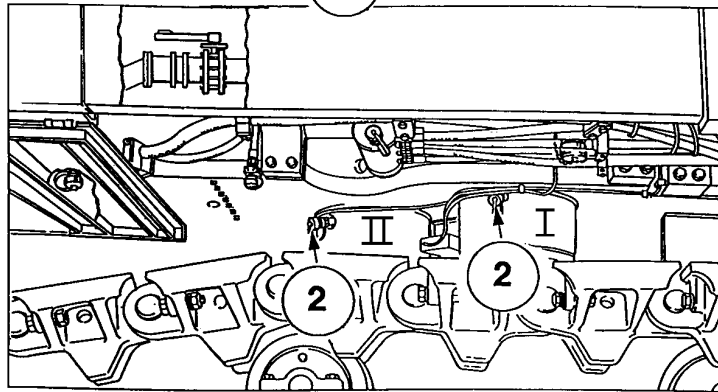
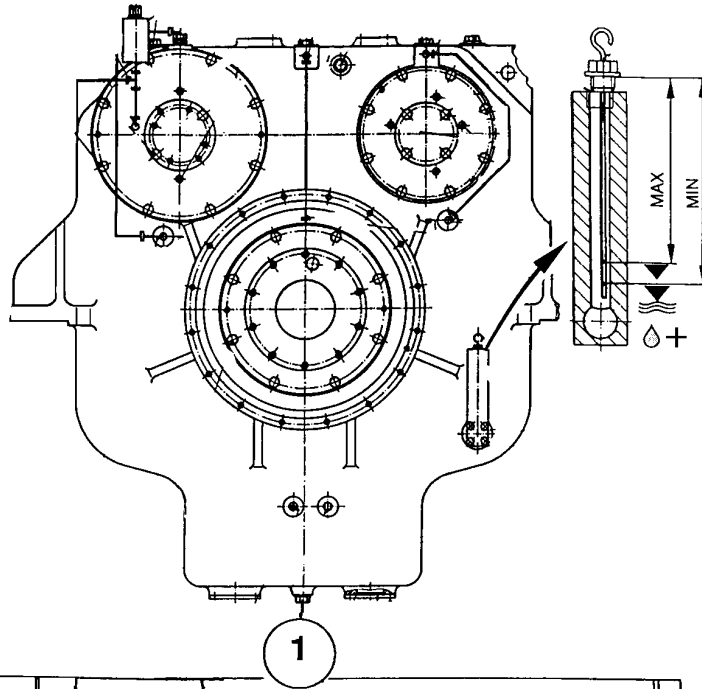

Z 25250

4.12.3 PTO'S (PUMP DISTRIBUTOR GEARS), SWING GEARS AND TRAVEL GEARS - OIL SAMPLE ANALYSIS

The oil sample analysis gives information about the grade of contamination and aging of the gear oils. Refer to the tables below for limits of contamination.

Oil drain plugs, illustration Z25250

- (1) PTO (Pump distributor gears)
- (2) Swing gears (I and II)
- (3) Travel gears

PTO (PUMP DISTRIBUTOR GEAR)

(Oil contamination)

Element		Normal	Increased		Critical
Iron	<	100 ppm	100 - 300 ppm	>	300 ppm
Copper	<	10 ppm	10 - 20 ppm	>	20 ppm
Chromium	<	5 ppm	5 - 15 ppm	>	15 ppm
Silicon	<	40 ppm	40 - 60 ppm	>	60 ppm

SWING GEARS AND TRAVEL GEARS

(Oil contamination)

Element		Normal	Increased		Critical
Iron	<	400 ppm	400 - 700 ppm	>	700 ppm
Copper	<	25 ppm	25 - 60 ppm	>	60 ppm
Chromium	<	5 ppm	5 - 15 ppm	>	15 ppm
Silicon	<	40 ppm	40 - 60 ppm	>	60 ppm

NOTICE

If the grade of contamination approaches to the “critical” values in the above tables, change the gear oil. However, the regular oil changes must be carried out every 3000 operating hours or once a year, whichever occurs first.

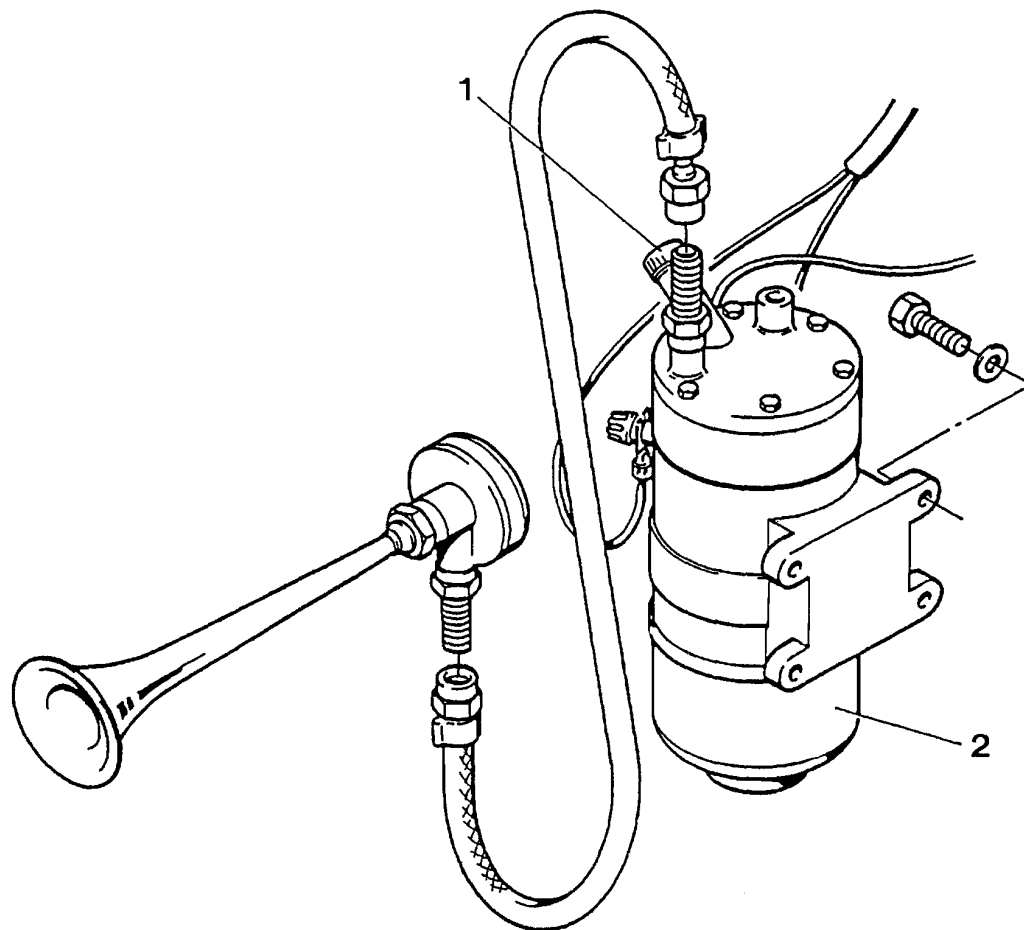

Z9543

4.12.4 SIGNAL HORN COMPRESSOR - CLEAN AND LUBRICATE

See illustration Z 9543

Unscrew collector protection cap (2).

Unscrew ball bearing cover and fill it half way up with grease.

If the fins of the collector are very strongly blackened or coated with verdigris, clean them with emery cloth.

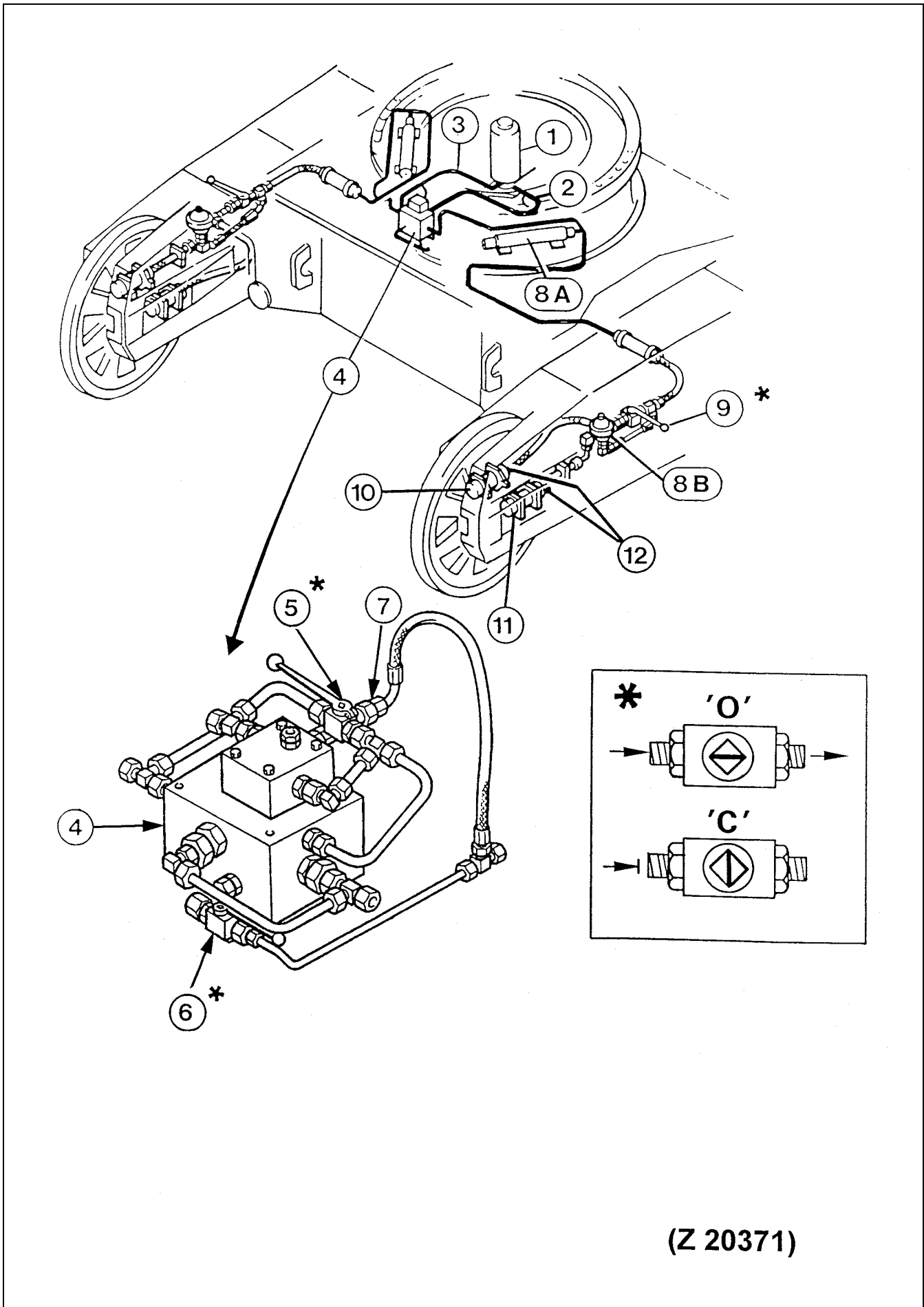

(Z 20371)

4.12.5 HYDRAULIC TRACK TENSIONING SYSTEM - CHECK PRESSURE ACCUMULATORS

WARNING

Before working on any part of the hydraulic track tensioning system relieve all pressure in the system by opening pressure relief cock (5), illustration Z 20371.

NOTICE

For checking the charging pressure a special testing and filling device must be used. This device can be ordered from your Komatsu Dealer.

The testing and filling procedure of the pressure accumulators has to be carried out in accordance with Service Bulletin No. AH01531.

Legend for illust. Z 20371:

- (1) Rotary distributor
- (2) Supply line, pilot pressure from travel brake release circuit
- (3) Return oil line (leakage oil)
- (4) Valve block
- (5) Pressure relief cock for hydraulic track tensioning system.
 "C" - Closed (Normal working position)
 "O" - Open
- (6) Shut-off cock in supply line
 "O" - Open (Normal working position)
 "C" - Closed
- (7) Two stage pilot pressure operated relief valve
- (8A) Pressure accumulator, high pressure (150 bar)
- (8B) Pressure accumulator, low pressure (31 bar)
- (9) Shutoff cocks, RH & LH
 "O" - Open (Normal working position)
 "C" - Closed
- (10) Track adjusting cylinders, inner
- (11) Track adjusting cylinders, outer
- (12) Test connectors and vent valves

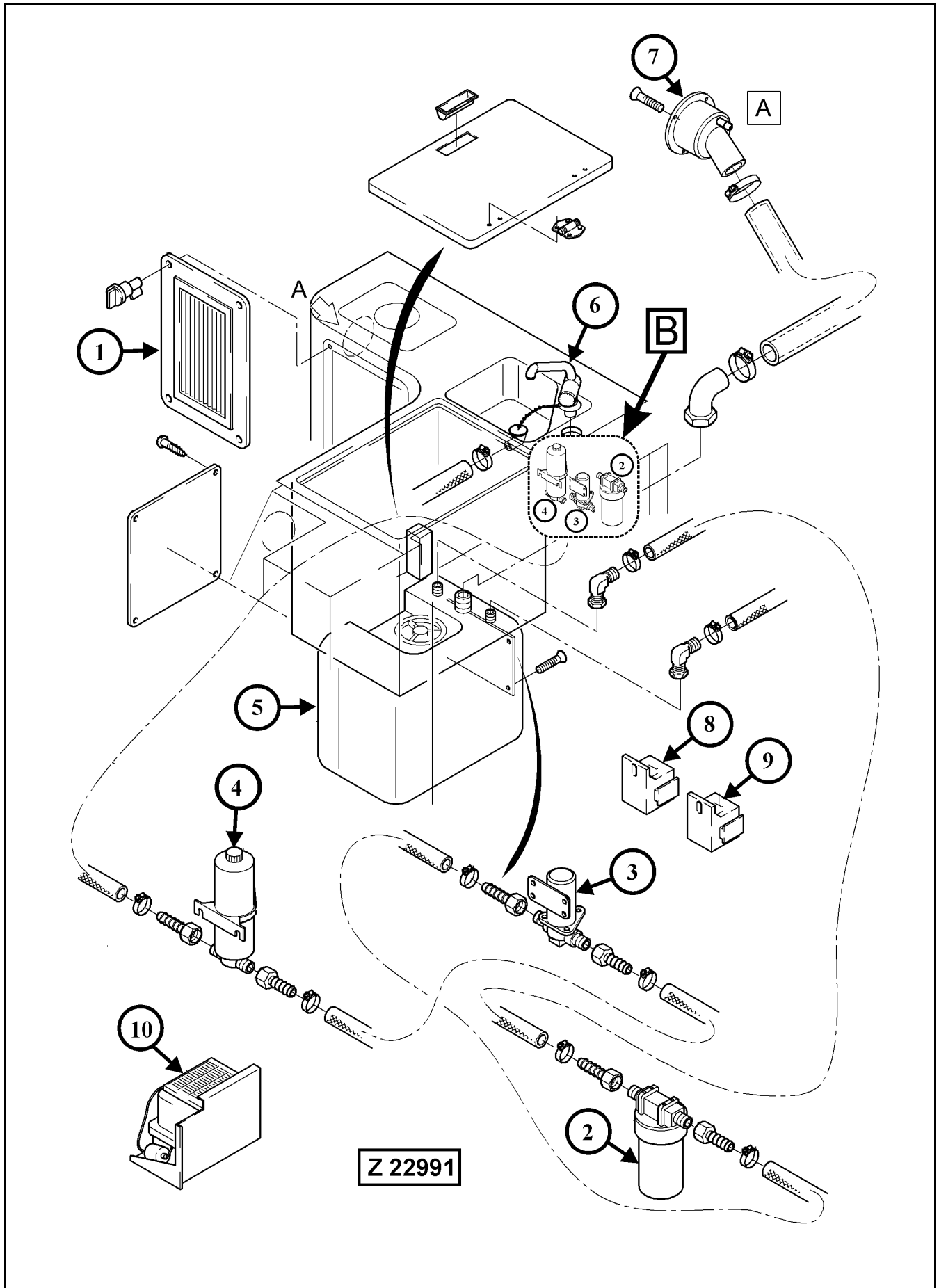

4.12.6 WATER FILTER - REPLACE FILTER CARTRIDGE

Legend for illust. Z22991

- (A) Location of filler neck for water tank (5)
- (B) Location of water filter (2), pump (3) and pressure compensation tank (4).
- (1) Access cover for water filter compartment
- (2) Water filter
- (3) Water pump
- (4) Pressure compensation tank
- (5) Water tank
- (6) Water tap
- (7) Filler neck for water tank
- (8) Relay
- (9) Circuit breaker 7,5 A
- (10) Refrigerator

Replace filter cartridge of water filter (2) as follows:

1. Open water tap (6) and drain all water from tank (5). Remove access cover (1). Depress red pressure relief button on filter header (if so equipped) to relieve pressure.
2. Unscrew bottom of housing. Remove large O-ring, wipe clean of lubricant and set aside. Remove used cartridge and discard. Rinse out bottom of housing and fill about 1/3 full with water. Add 2 tablespoons of bleach and scrub cap and bottom of housing with nonabrasive cloth. Rinse thoroughly.
3. Lubricate O-ring with clean petroleum jelly (Vaseline). Place O-ring back into groove and smooth into place with finger. Insert new cartridge over stand pipe in bottom of housing. Cartridges with tapered ends need to be specifically installed with the tapered end toward the threads of the housing.
4. Screw bottom of housing onto cap and hand tighten. DO NOT over-tighten. Make sure cap standpipe slips into cartridge. Fill water tank (5) with 50 liters of clear water. Depress pressure relief button (if so equipped) to release trapped air.
5. Open water tap (6) and flush the new filter cartridge for a minimum of 5 minutes. The water must be completely clear before closing the tap.

⚠ WARNING

DO NOT drink the water of the cab water system. The cab water system is not constructed as a drinking water system.

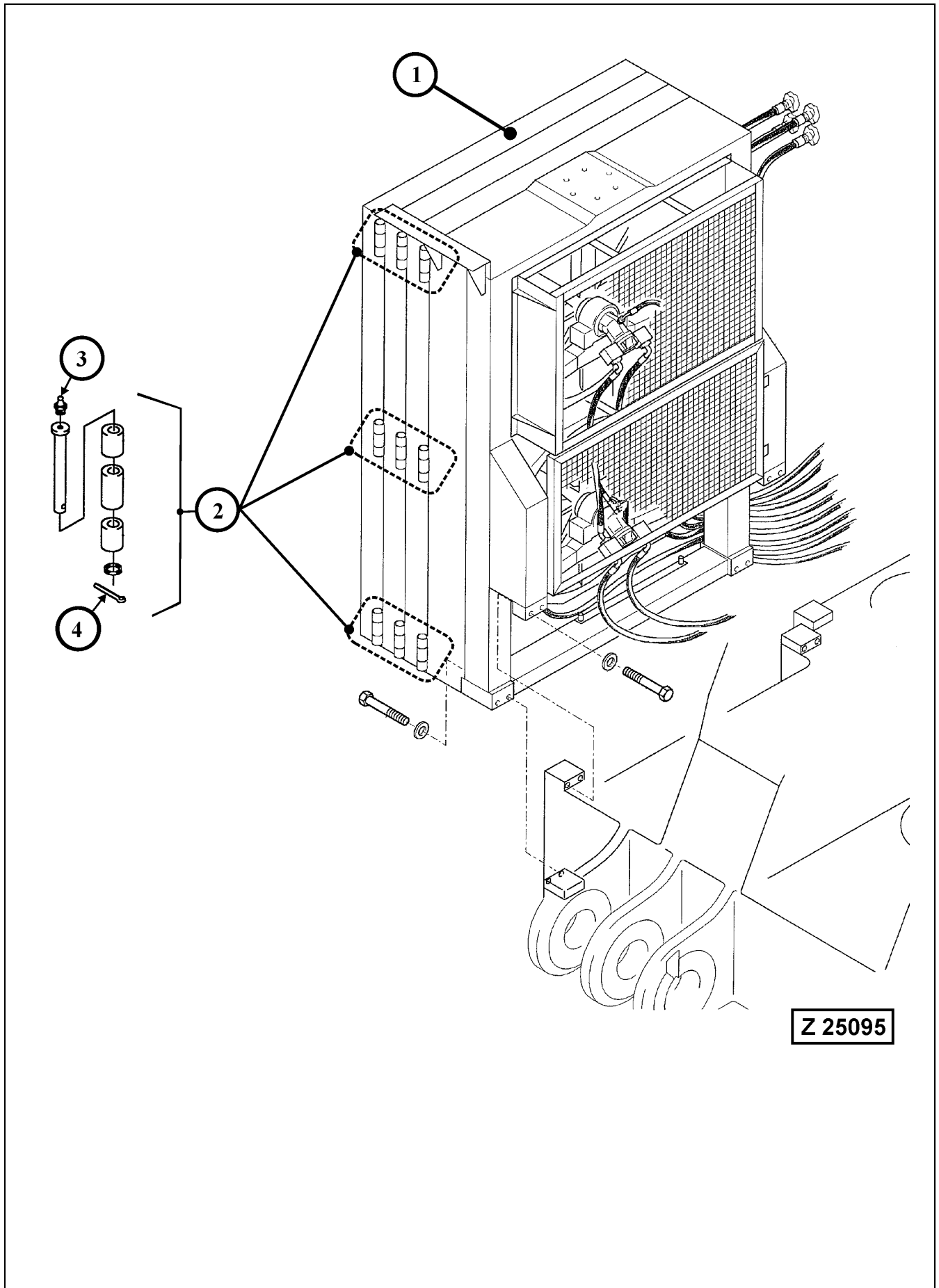

4.12.7 HYDRAULIC OIL COOLER - INSPECT AND LUBRICATE DOOR HINGES

⚠ WARNING

- Provide adequate working platform for safe access to the hydraulic oil cooler.
 - Check all door hinges (2) for good condition and proper fastening to their carrier frames. If cracks or distortion at the weld area of the hinges are found corrective action must be taken. **DO NOT** try to open the cooler doors before the damage has been repaired otherwise the cooler door may become detached and fall off. Danger of accidents.
-

Legend for illust. Z25095

- (1) Hydraulic oil cooler
- (2) Cooler hinges
- (3) Grease fitting
- (4) Cotter pin

- Lubricate all cooler hinges (2) at grease fittings (3).
- Check to make sure that the hinge pins are properly secured with cotter pins (4).

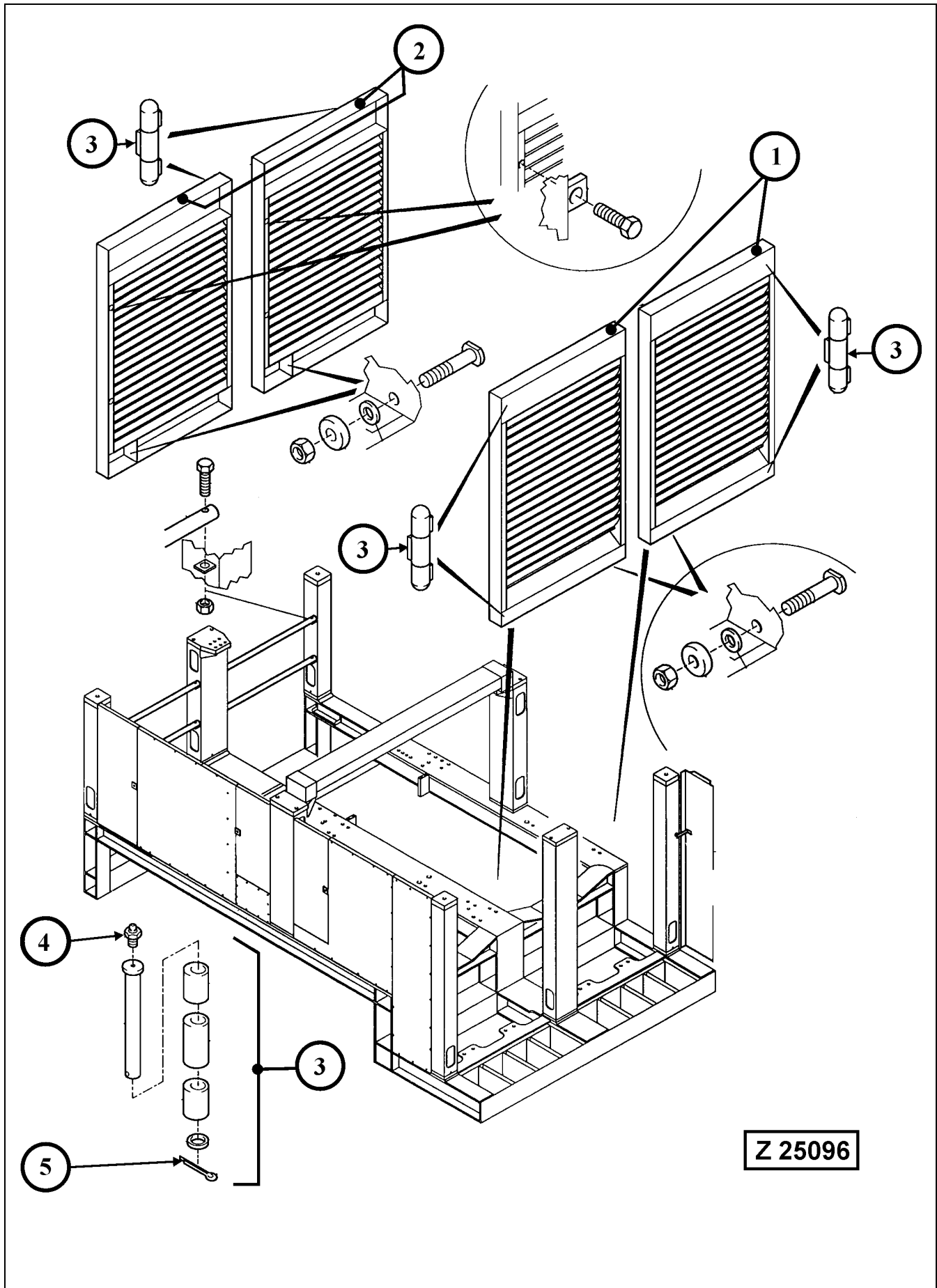

4.12.8 MACHINERY HOUSE DOORS - INSPECT AND LUBRICATE DOOR HINGES

 **WARNING**

- Provide adequate working platform for safe access to the rear machinery house doors (2).
 - Check all door hinges (3) for good condition and proper fastening to their carrier frames. If cracks or distortion at the weld area of the hinges are found corrective action must be taken.
-
-

Legend for illust. Z25096

- (1) Radiator doors (on Diesel engine powered shovels only)
 - (2) Rear doors of machinery house
 - (3) Door hinges
 - (4) Grease fitting
 - (5) Cotter pin
- Lubricate all door hinges (3) at grease fittings (4).
 - Check to make sure that the hinge pins are properly secured with cotter pins (5).

4.13 EVERY 2000 OPERATING HOURS OR YEARLY

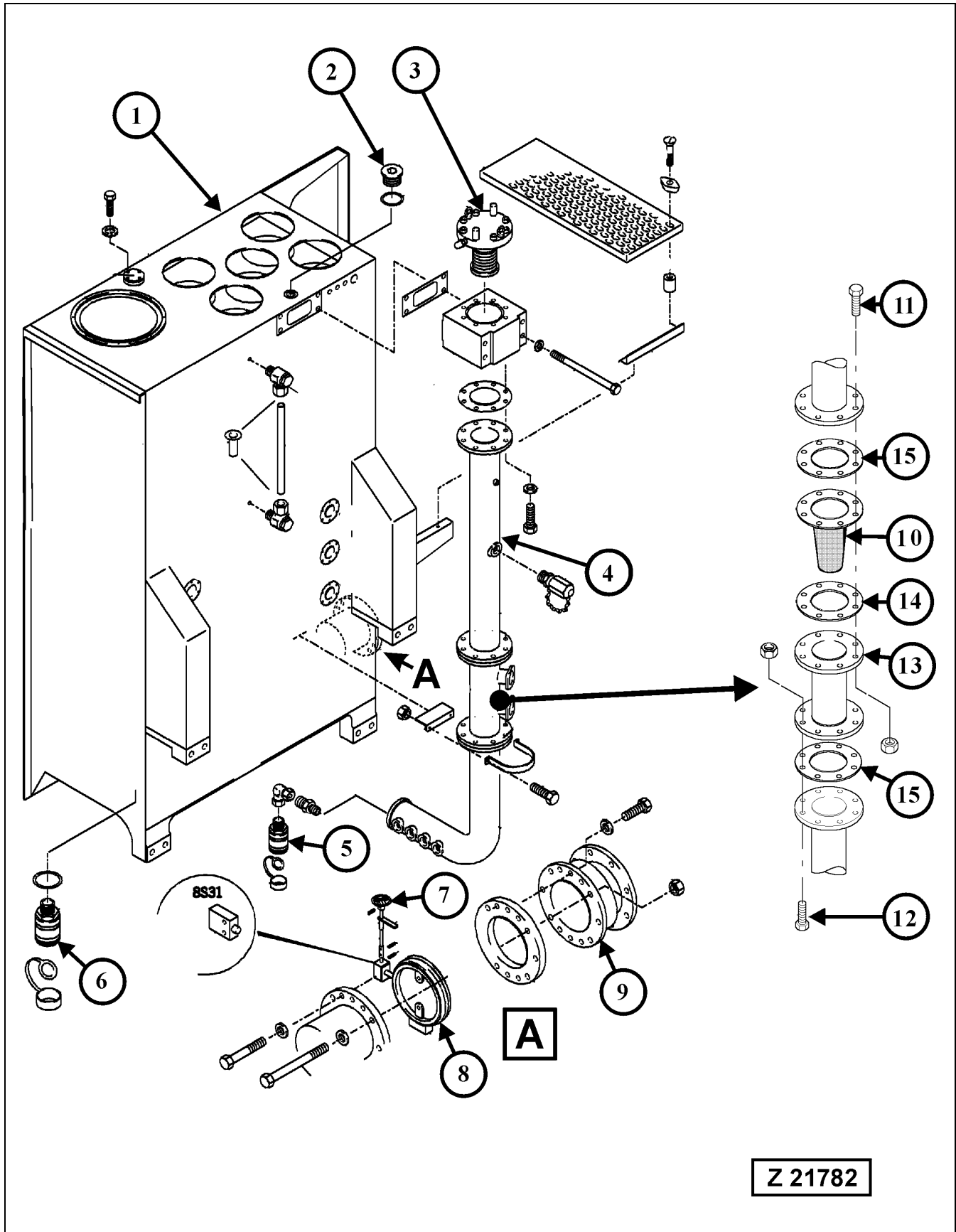

4.13.1 HYDRAULIC SYSTEM - CHANGE OIL, REPLACE SUCTION STRAINERS AND PULSATION DAMPER

NOTICE

The hydraulic oil change intervals can be extended for a further time period, when an oil sample analysis shows a positive result. When extending the oil change interval, it is necessary to carry out an oil sample analysis after every 1000 operating hours.

However, it is recommended to change the hydraulic oil and the suction strainers after 6000 operating hours at the latest. The pulsation damper must be replaced after every 2000 operating hours.

Legend for illust. Z 21782

- (1) Main oil reservoir
- (2) Oil filler plug
- (3) Back-pressure valve
- (4) Return oil collector pipe
- (5) Drain coupling for collector pipe
- (6) Drain coupling for main oil reservoir
- (7) Hand wheel of main shut-off valve
- (8) Main shut-off valve
- (9) Compensator between main oil reservoir and suction oil reservoir. Check condition and tightness of compensator and connected parts.
- (10) Return oil strainer
- (11) Bolt
- (12) Bolt
- (13) Intermediate pipe
- (14) Gasket
- (15) Gaskets

Evacuate main hydraulic oil reservoir according to section Central Refilling System on page 286.

Attach drain hose (part of tool set) to coupling (5) and drain oil from return oil collector pipe (4). Drain also the oil from return oil manifold, see illustration Z 21785 and from suction oil reservoir, see illustration Z 21787.

REMARK

Replace return oil strainer (10), illustration Z 21782 after major repairs on the hydraulic system and after every 6000 operating hours. Use new gaskets (14 and 15).

With hydraulic oil reservoir empty, service the return oil filters and inspect the reservoir for sediments. Clean the reservoir if necessary.

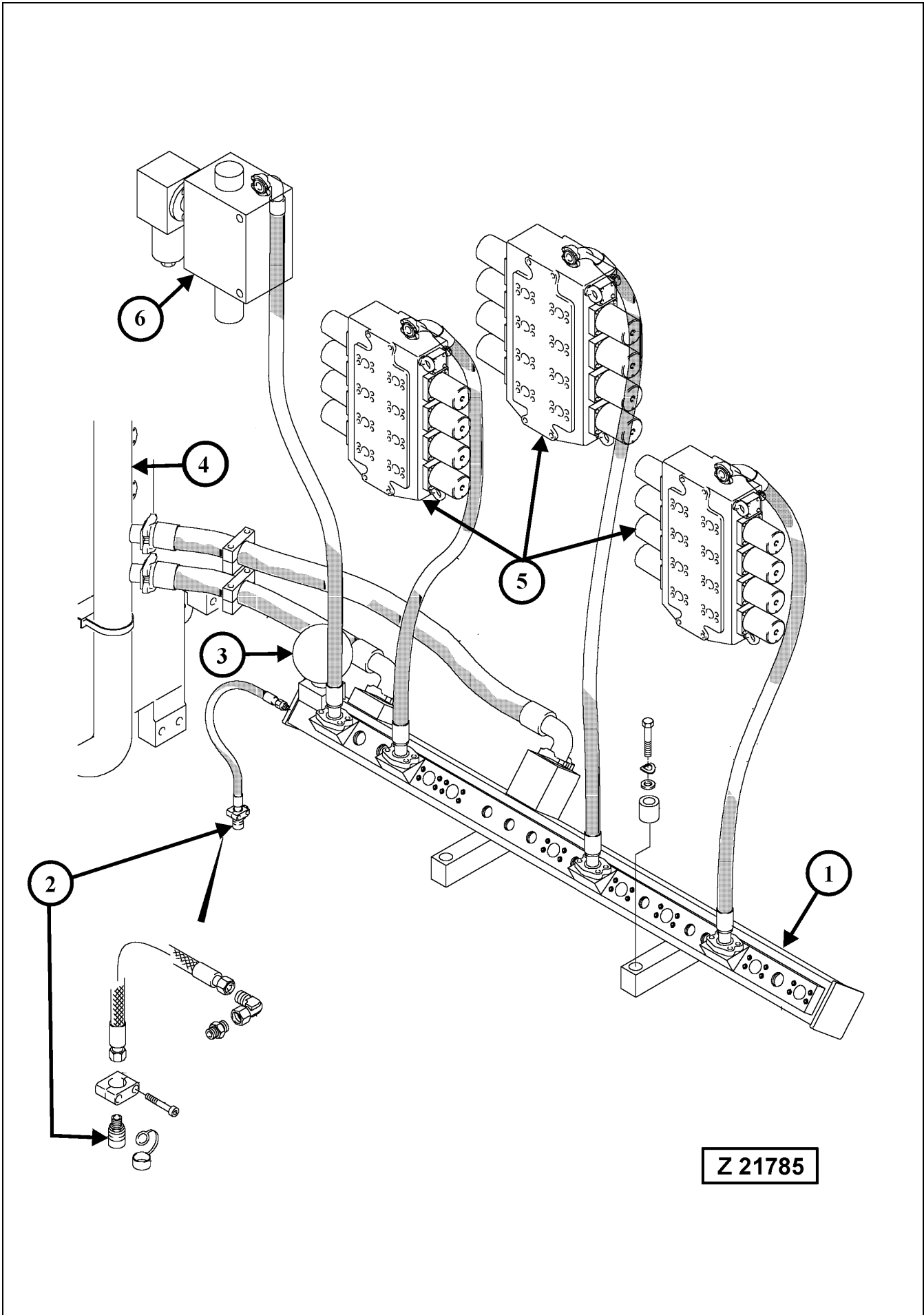

HYDRAULIC SYSTEM - CHANGE OIL, REPLACE SUCTION STRAINERS AND PULSATION DAMPER

Legend for illust. Z 21785

- (1) Return oil collector manifold
- (2) Drain coupling
- (3) Pulsation damper
- (4) Return oil collector pipe
- (5) Main control valves
- (6) Swing control valve

NOTICE

Attach drain hose (part of tool set) to coupling (2) and drain oil from return oil collector manifold (1). Remove pulsation damper (3) and install new pulsation damper with new O-ring.

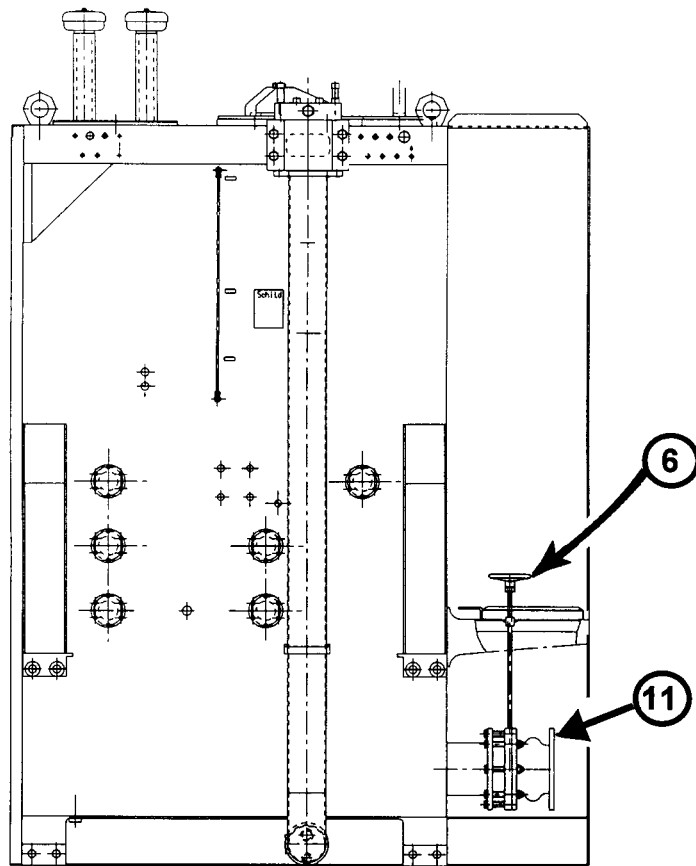
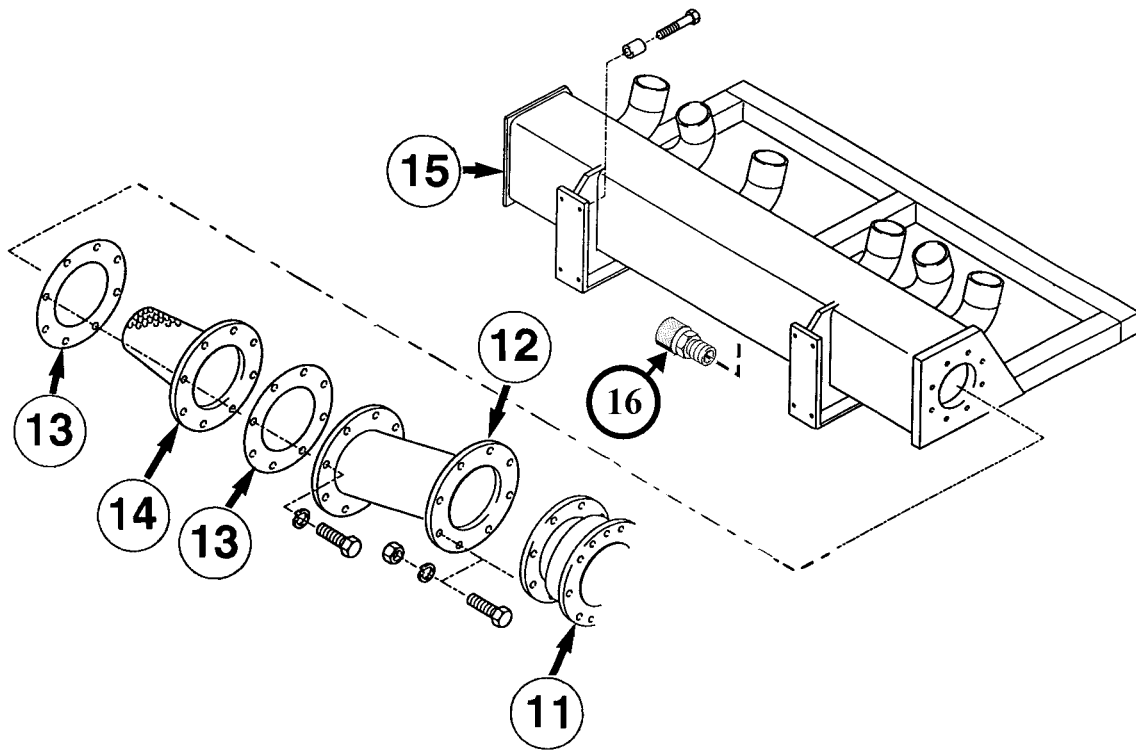

Z 21787

HYDRAULIC SYSTEM - CHANGE OIL, REPLACE SUCTION STRAINERS AND PULSATION DAMPER

Legend for illust. Z 21787

- (6) Hand wheel of main shut off valve between main oil reservoir and suction oil reservoir
- To open the valve, turn hand wheel (6) CCW to the stop
 - To close the valve, turn hand wheel (6) CW to the stop

NOTICE

Before starting the engines, make sure the shut off valve is completely open by turning the hand wheel (6) fully to the left (CCW).

- (11) Compensator
(12) Intermediate pipe
(13) Gaskets
(14) Suction oil strainer
(15) Suction oil reservoir
(16) Drain coupling

Attach drain hose (part of tool set) to coupling (16) and drain oil from suction oil reservoir. Remove intermediate pipe (12) and strainer (14). Install new strainer (14) with new gaskets (13).

REMARK

There are six further strainers installed in the suction oil reservoir (15). Refer to page 497 for replacement instructions.

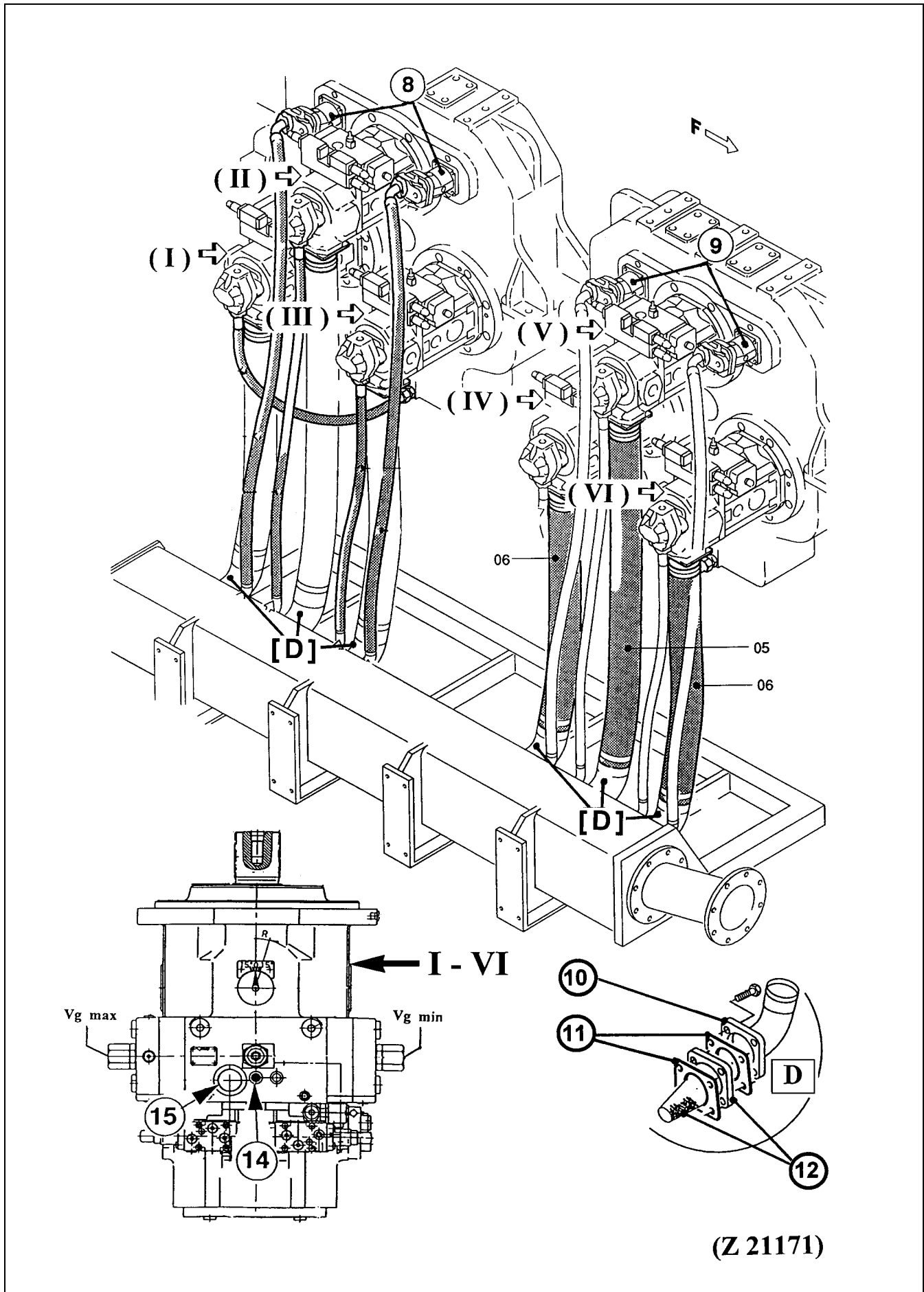

(Z 21171)

HYDRAULIC SYSTEM - CHANGE OIL, REPLACE SUCTION STRAINERS AND PULSATION DAMPER

Legend for illust. Z 21171

(I-VI)	Main Hydraulic pumps
(D)	Location of the suction strainers for the six main pumps
(05-06)	Main pump suction lines
(8)	Secondary hydraulic pumps on PTO gear 1
(9)	Secondary hydraulic pumps on PTO gear 2
(10)	Suction hose elbow
(11)	Gaskets
(12)	Suction strainer for the six main pumps
(14)	Plug
(15)	Port of leakage oil return line, use this port as Oil level and filler opening for the main pump housing

Replace Suction Strainer of Main Pumps

1. Remove elbows (10), of all six main pump suction hoses (D), from suction oil reservoir.
2. Remove gaskets (11) and strainer (12) and discard.
3. Insert new strainer (12) with new gaskets (11) and mount suction hose elbow (10) onto the suction oil reservoir.
4. Check to make sure that the hose clamps of suction hoses (D) are in good condition and properly fitted.

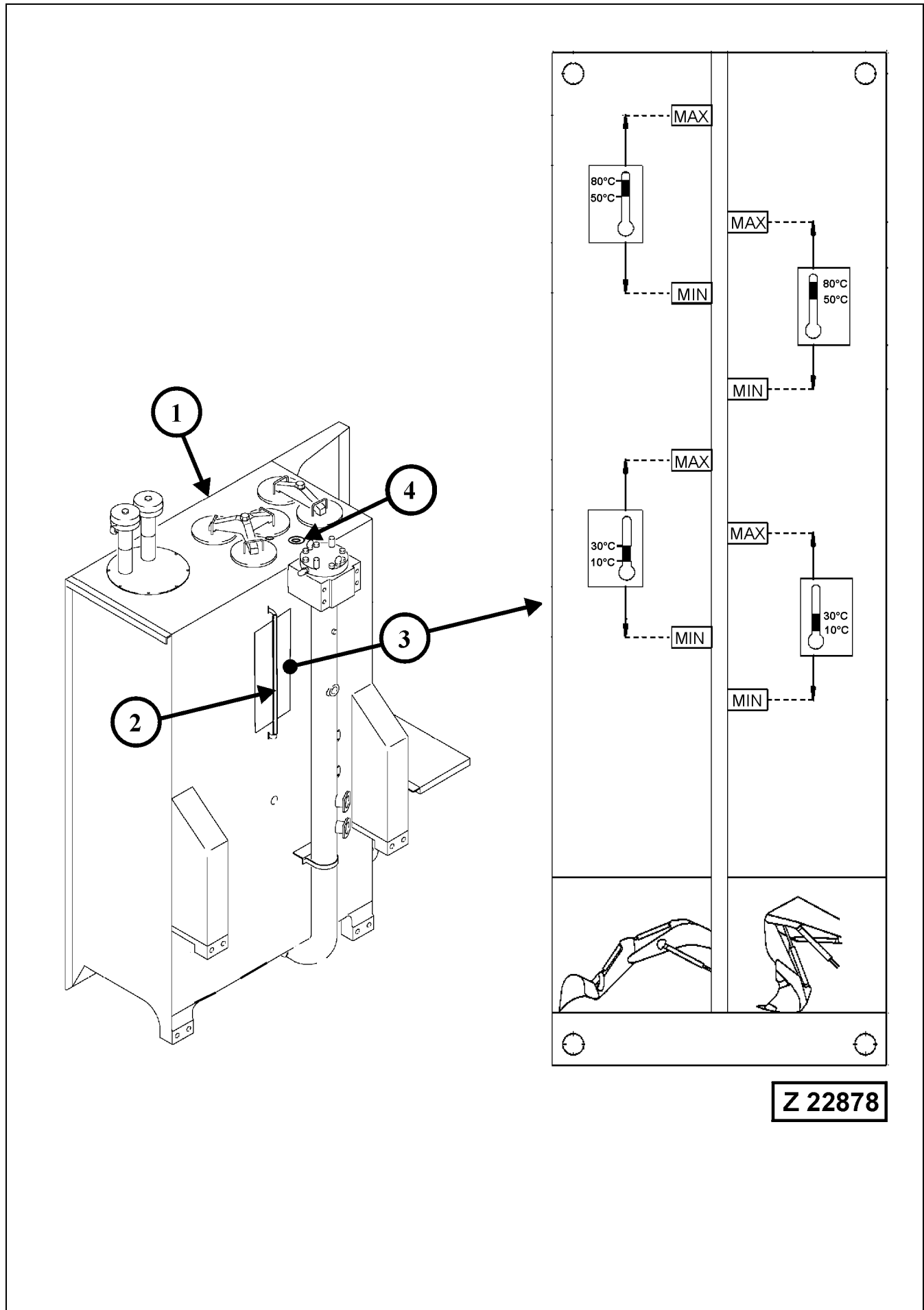

HYDRAULIC SYSTEM - CHANGE OIL, REPLACE SUCTION STRAINERS AND PULSATION DAMPER

FILLING THE HYDRAULIC SYSTEM

1. Make sure main shut-off valve is in open position and all connections are securely tightened.

REMARK

Select hydraulic oil viscosity grade according to ambient temperatures.

If the new hydraulic oil has a different viscosity grade compared with the drained oil it is necessary to enter the new viscosity grade into the appropriate "**Excavator Components**" group of the ECS Menu Control.

2. On machines equipped with Central Refilling System fill main hydraulic oil reservoir according to section "Central Refilling System" on page 286.
On machine without central refilling system fill main oil reservoir through opening (4), illustration Z22878. Depending on type of attachment and the present oil temperature, select the applying oil level range on plate (3). Be sure to use the correct marking on oil level plate (3).

Legend for illustration Z22878

- | | |
|-----|---------------------------------|
| (1) | Main hydraulic oil reservoir |
| (2) | Hydraulic oil level sight gauge |
| (3) | Oil level plate |
| (4) | Oil filler plug |

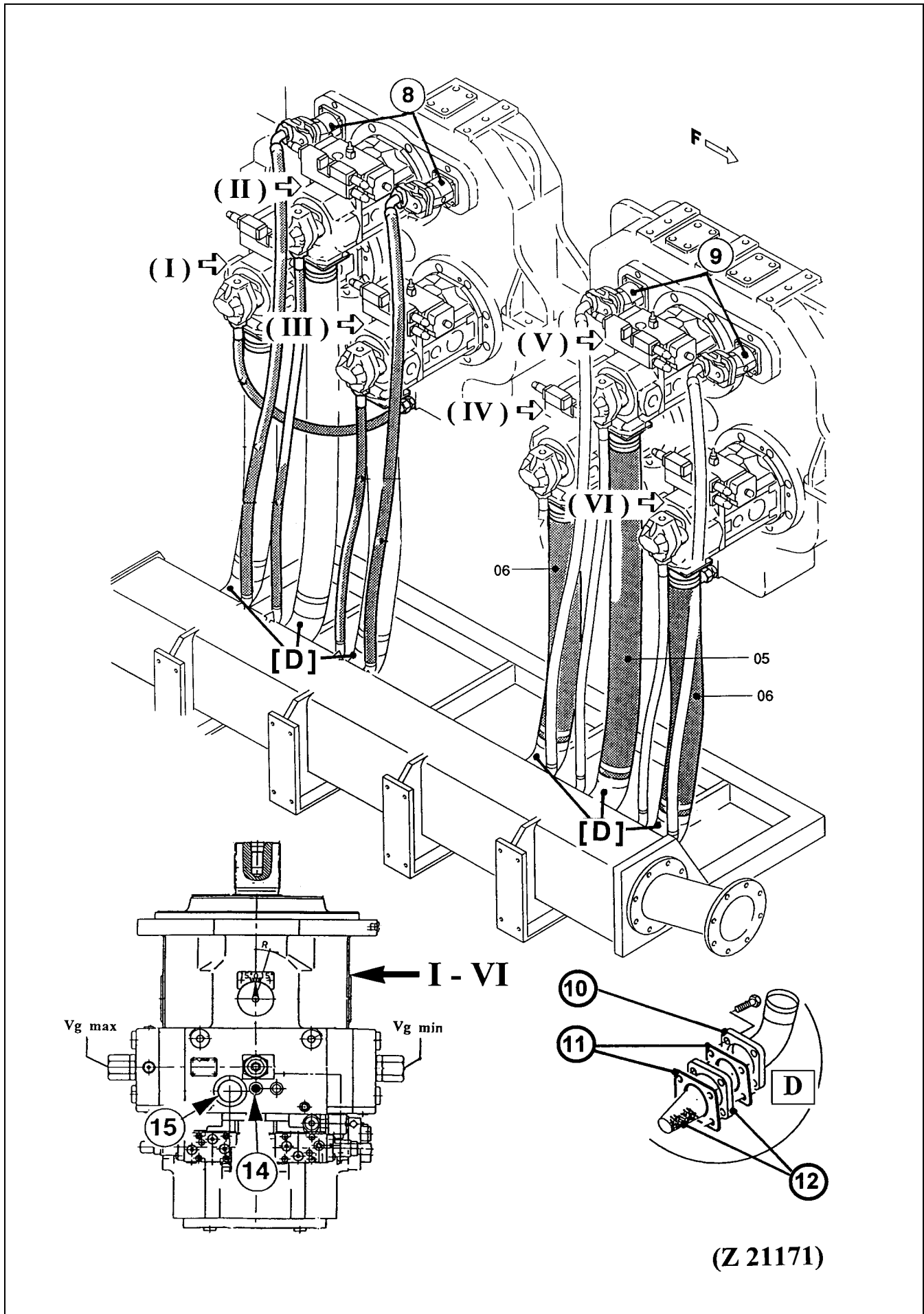

HYDRAULIC SYSTEM - CHANGE OIL, REPLACE SUCTION STRAINERS AND PULSATION DAMPER

Vent Hydraulic pumps

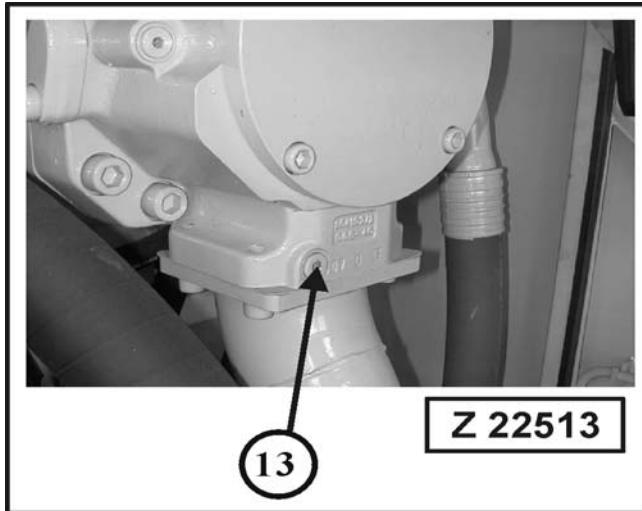

1. Open vent plug (13), illust. Z 22513 on the pump suction port of all six main pumps.
2. As soon as bubble free oil flows out, tighten the vent plug (13).
3. Open vent screw on secondary pumps (8 and 9), illustration Z 21171. Close vent screw as soon as bubble free oil flows out.
4. Open vent plug (13) on the pump suction port of the piggy-back gear pumps and wait until bubble free oil flows out then tighten the vent plugs (13).
5. Check hydraulic oil level and the whole hydraulic system for leakage.

Check the Oil level in all six Main Pump Housings (I - VI), illust. 21171:

1. Remove leakage oil return line from port (15). The oil level in the pump housing should reach the lower edge of port (15).
2. If necessary add hydraulic oil up to the lower edge of the filler opening.
3. Connect leakage oil return line to port (15).

NOTICE

Make sure the main pump housings are correctly filled, otherwise the pump drive shaft bearings could be damaged due to lack of lubrication.

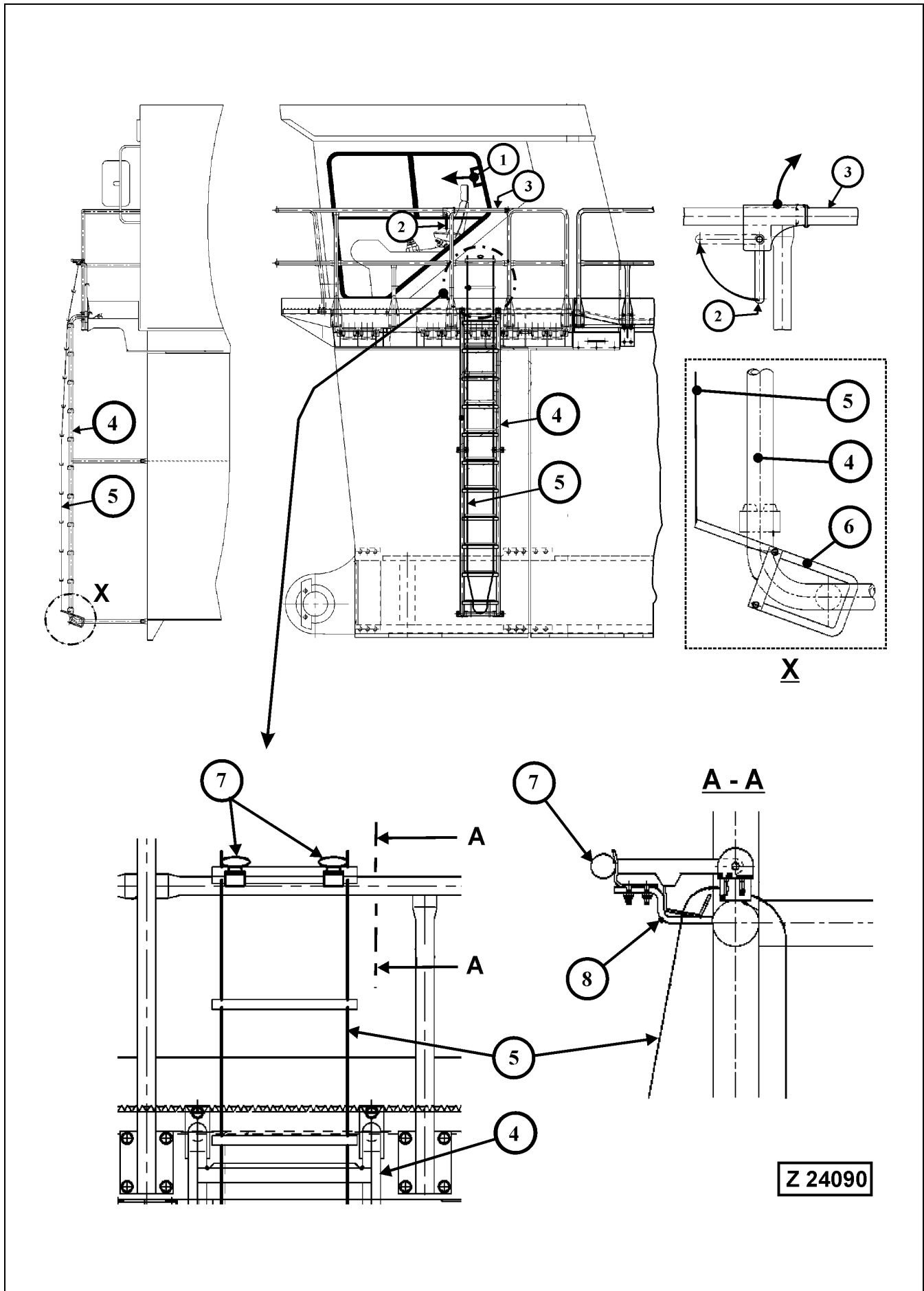

4.13.2 EMERGENCY ESCAPE LADDER - INSPECTION

Legend for illust. Z24090

- (1) Sliding window, serves also for emergency exit
 - (2) Release lever for hinged railing bar (3)
 - (3) Hinged railing bar
 - (4) Rigidly mounted emergency escape ladder
 - (5) Rope ladder. The upper end of the rope ladder is fixed onto the lower rung of the rigid escape ladder (4) by means of the fasteners (6), see detail (X). The lower end of the rope ladder is fixed on brackets (8) and secured with rubber fasteners (7), see section (A-A).
 - (6) Hooks for fastening the rope ladder onto the rigid ladder (4)
 - (7) Rubber fasteners for rope ladder in lifted position
 - (8) Bracket for rope ladder in lifted position. The lower rung of the rope ladder is hooked up into the brackets (8)
- Check rigidly mounted emergency escape ladder (4) for good condition and proper fastening.
 - Check rope ladder (5) for good condition and proper fastening.

If any damage or bad condition is found replace the concerned parts without delay.

4.14 EVERY 3000 OPERATING HOURS HOWEVER AT LEAST ONCE A YEAR

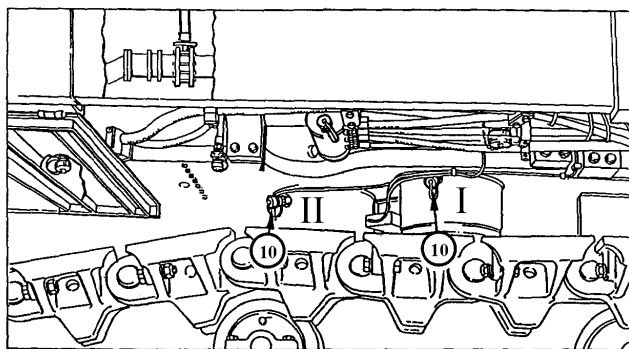
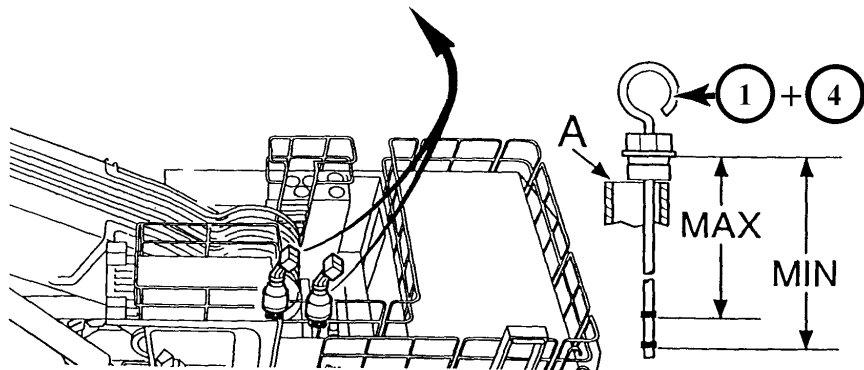
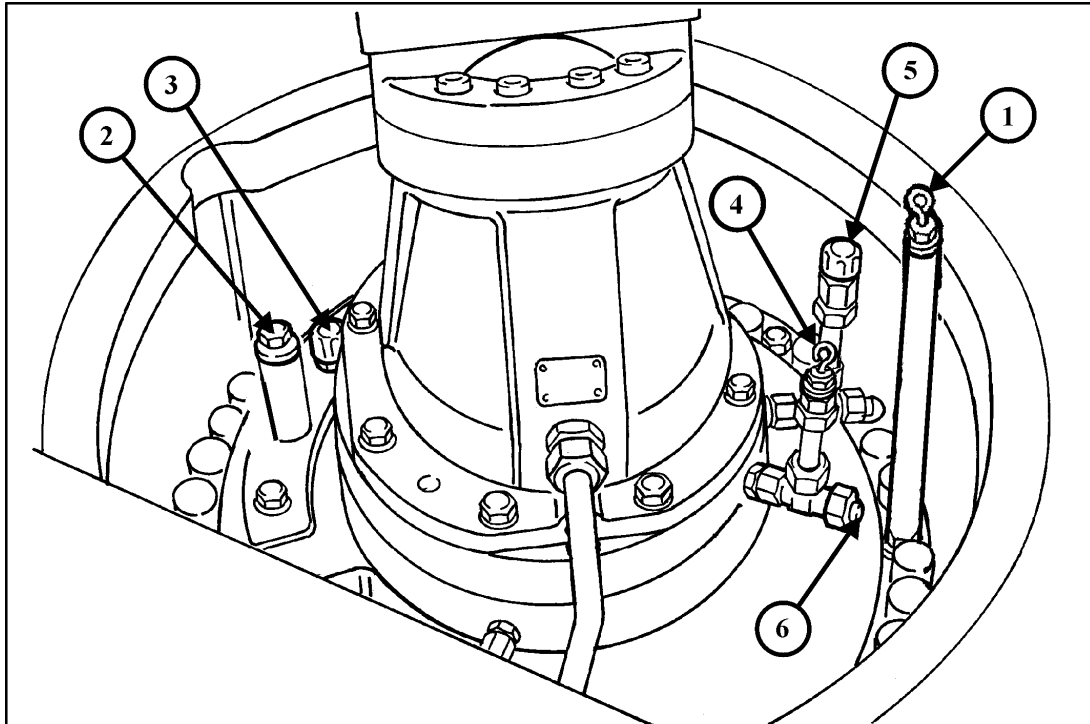

Z 22882

4.14.1 SWING GEARS AND MOTOR ADAPTER HOUSING - CHANGE OIL

REMARK

The machine can be equipped either with a swing gear of manufacturer "L&S" or of manufacturer "Siebenhaar". Refer to the data plate on each swing gear housing to find out the manufacturer of the swing gear.

Swing gear manufactured by "L&S"

Legend for illustration Z22882

Swing gears

- (A) Position of oil level gauge for checking the oil levels
- (1) Oil level gauge
- (2) Oil filler plug
- (3) Breather filter
- (10) Drain couplings or evacuation nozzles for Wiggins system

Motor Adapter Housing

- (4) Oil level gauge and filler opening. This opening can also be used for connecting a suction pump when changing the oil.
- (5) Breather filter
- (6) Oil drain plug

Swing Gears, change oil:

1. Use adequate working platform for draining the oil. Place receptacles of sufficient capacity (approx. 100 liter) below drain couplings (10). Attach drain hose (part of tool set) to drain coupling (10). Remove parts (1, 2 and 3) to speed up draining. On swing gears with evacuation nozzle (10), use the Wiggins system for changing the oil.
2. Clean breather filter (3) with compressed air from inside to outside and re-install.
3. After the oil is completely drained, flush the gear with the regular gear oil.
4. Remove drain hose from coupling (10) and attach the protection cap onto the drain coupling.
5. Fill gear housing through filler opening (2) up to the "MAX" mark on level gauge (1) with fresh oil and re-install plug (2).

NOTICE

For checking the oil level insert the level gauge (1) but DO NOT screw in, see detail (A).

6. After short operating period check oil level and housings for leaks.

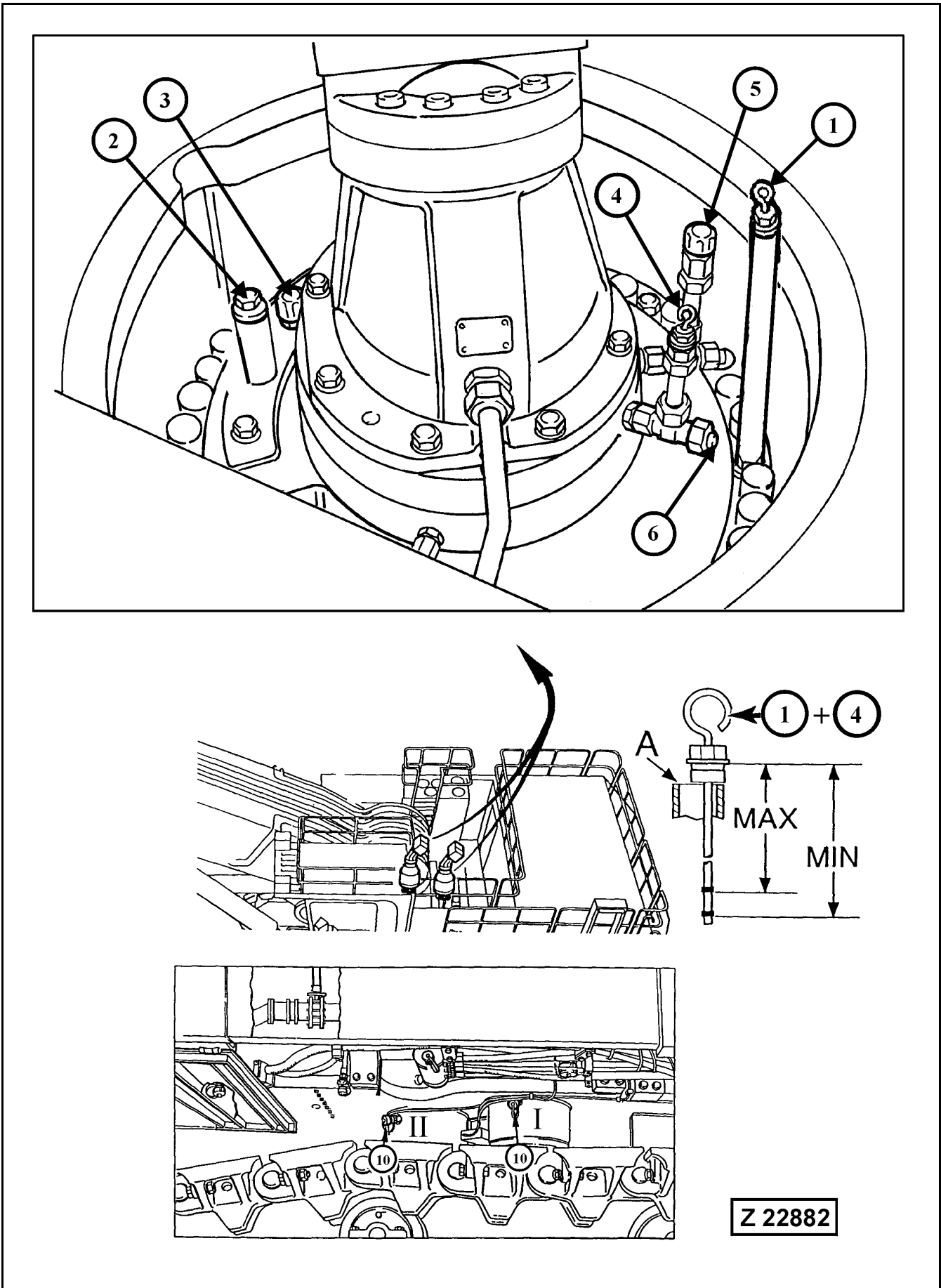

Motor Adapter Housing, Change Oil:

1. Remove level gauge (4) and breather filter (5). Insert the hose of a suction pump into the gauge pipe (4) until the hose end just touches the bottom of the T-union. Place the oil outlet hose of the suction pump into a receptacle. Switch on the pump and completely suck off the oil from the motor housing. If a suction pump is not available, place a receptacle below drain plug (6).
Remove plug (6) and drain the oil completely.
2. Clean breather filter (5) with compressed air from inside to outside and re-install.
3. If removed, install drain plug (6) and fill-up gear oil through filler opening (4), up to the "MAX" mark on level gauge (4) and install the level gauge.
4. After short operating period check oil level and housing for leaks.

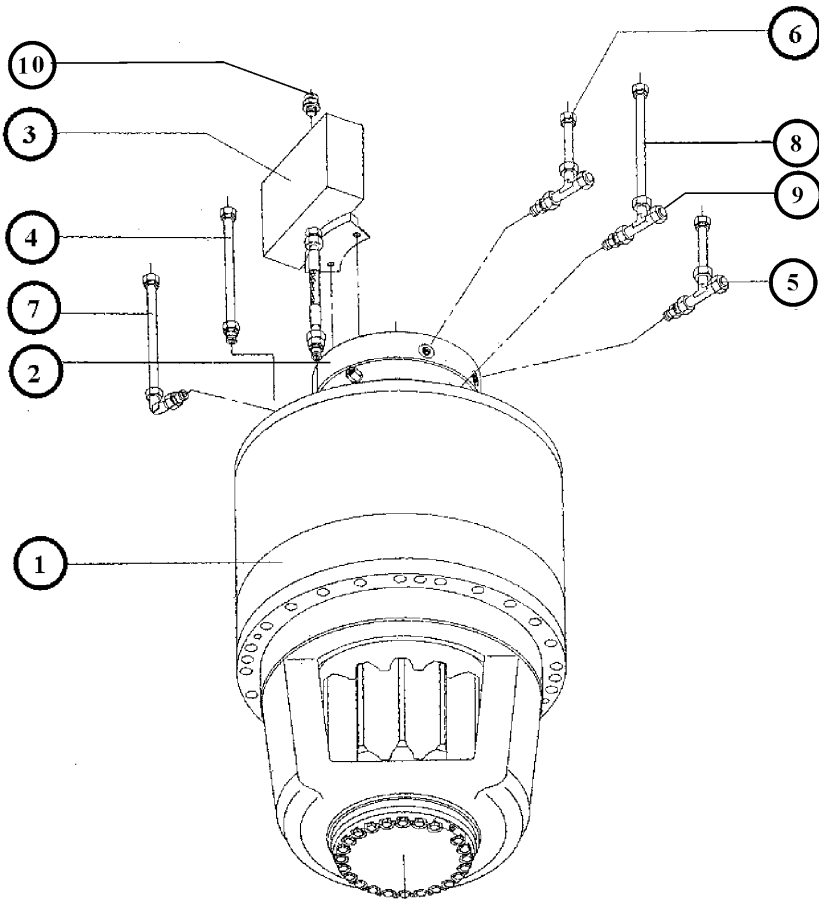
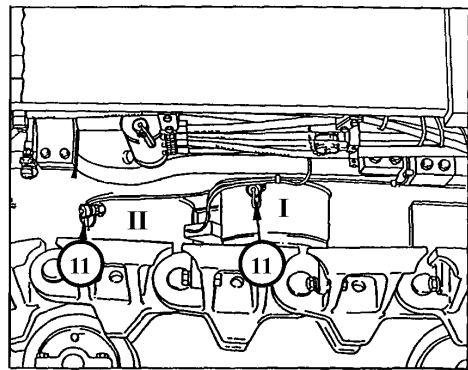
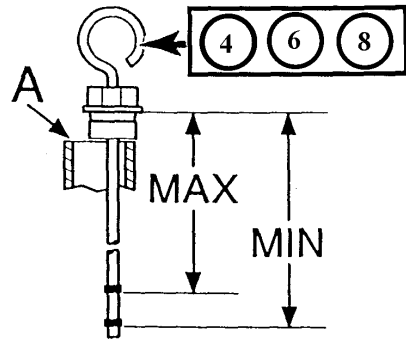
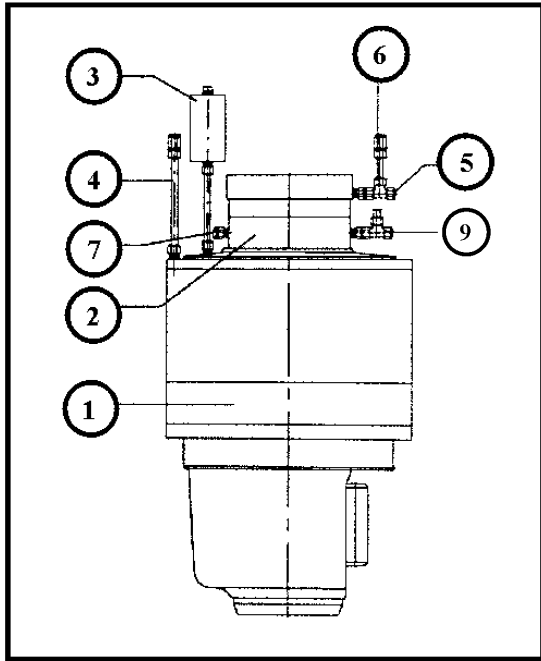

Z 24091

SWING GEAR MANUFACTURED BY "SIEBENHAAR"

Legend for illustration Z24091

- (A) Position of oil level gauge for checking the oil levels
- (1) Swing gear (RH and LH)
- (2) Brake housing
- (3) Compensator oil tank for swing gear
- (4) Oil level gauge for swing gear
- (5) Oil drain plug for motor adapter housing
- (6) Oil level gauge for motor adapter housing
- (7) Breather filter for brake housing
- (8) Oil level gauge for brake housing
- (9) Oil drain plug for brake housing
- (10) Breather filter
- (11) Drain coupling or evacuation nozzle for Wiggins system

SWING GEAR - CHANGE OIL (SIEBENHAAR)

1. Use adequate working platform for draining the oil. Place receptacles of sufficient capacity (approx. 100 liter) below each drain coupling (11). Attach drain hose (part of tool set) to drain coupling (11). Remove parts (4 and 10) to speed up draining.
2. Clean breather filter (10) with compressed air from inside to outside and re-install.
3. After the oil is completely drained, flush the gear with the regular gear oil.
4. Remove drain hose from coupling (11) and attach the protection cap onto the drain coupling.
5. Fill gear housing through filler opening up to the "MAX" mark on level gauge (4) with fresh gear oil and re-install oil filler plug.

NOTICE

For checking the oil level insert the level gauge (4) but DO NOT screw in, see detail (A).

6. After short operating period check oil level and housings for leaks.

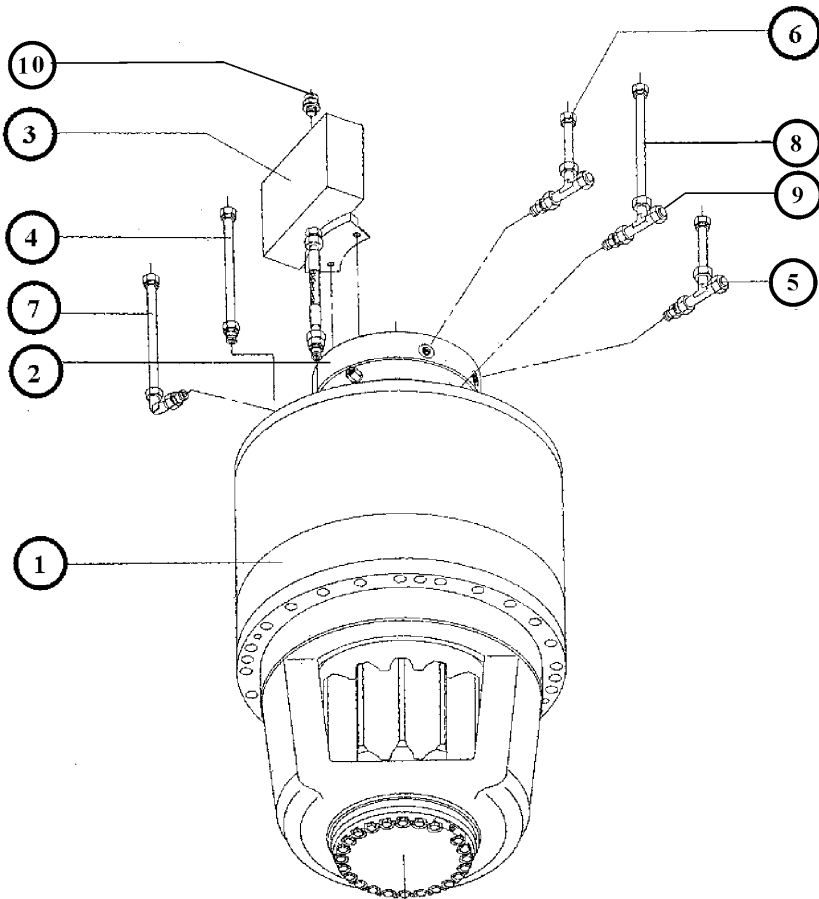
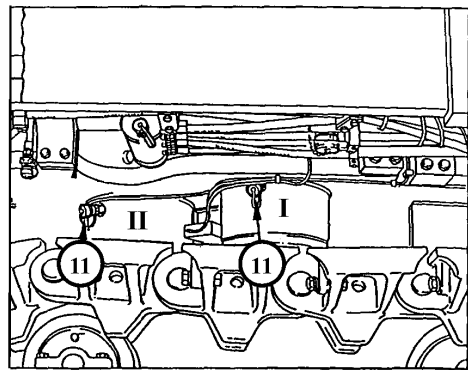
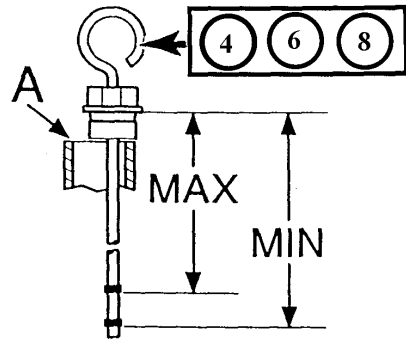
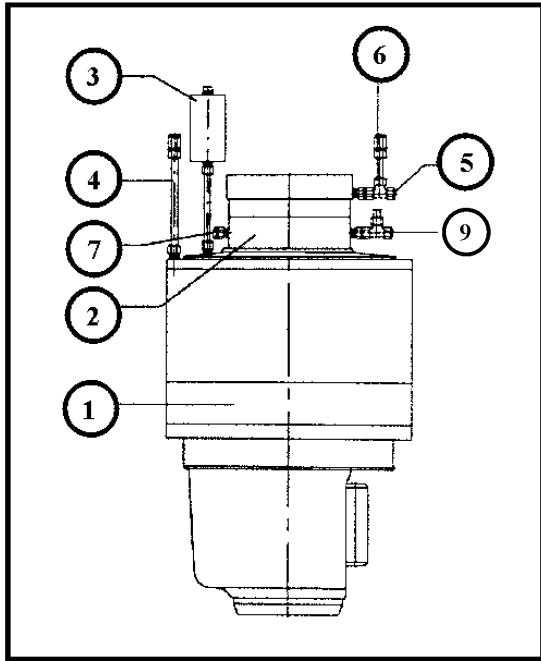

Z 24091

Brake Housing - Change Oil (Siebenhaar)

1. Remove level gauge (8), illustration Z24091, drain plug (9) and breather filter (7). Drain the oil into a receptacle of approx. 5 liter capacity.
2. Clean breather filter (7) with compressed air from inside to outside and re-install.
3. Install drain plug (9) and fill-up engine oil SAE 10 or hydraulic oil HLP 22 or HLP 32 through filler opening up to the "MAX" mark on level gauge (8) and install the level gauge.
4. After short operating period check oil level and housing for leaks.

NOTICE

Be sure to fill the brake housing and motor adapter housing with engine oil or hydraulic oil as specified on page 311.

Motor Adapter Housing - Change Oil

1. Remove level gauge (6) and drain plug (5). Drain the oil into a receptacle of approx. 5 liter capacity.
2. Install drain plug (5) and fill-up engine oil SAE 10 or hydraulic oil HLP 22 or HLP 32 through filler opening up to the "MAX" mark on level gauge (6) and install the level gauge.
3. After short operating period check oil level and housing for leaks.

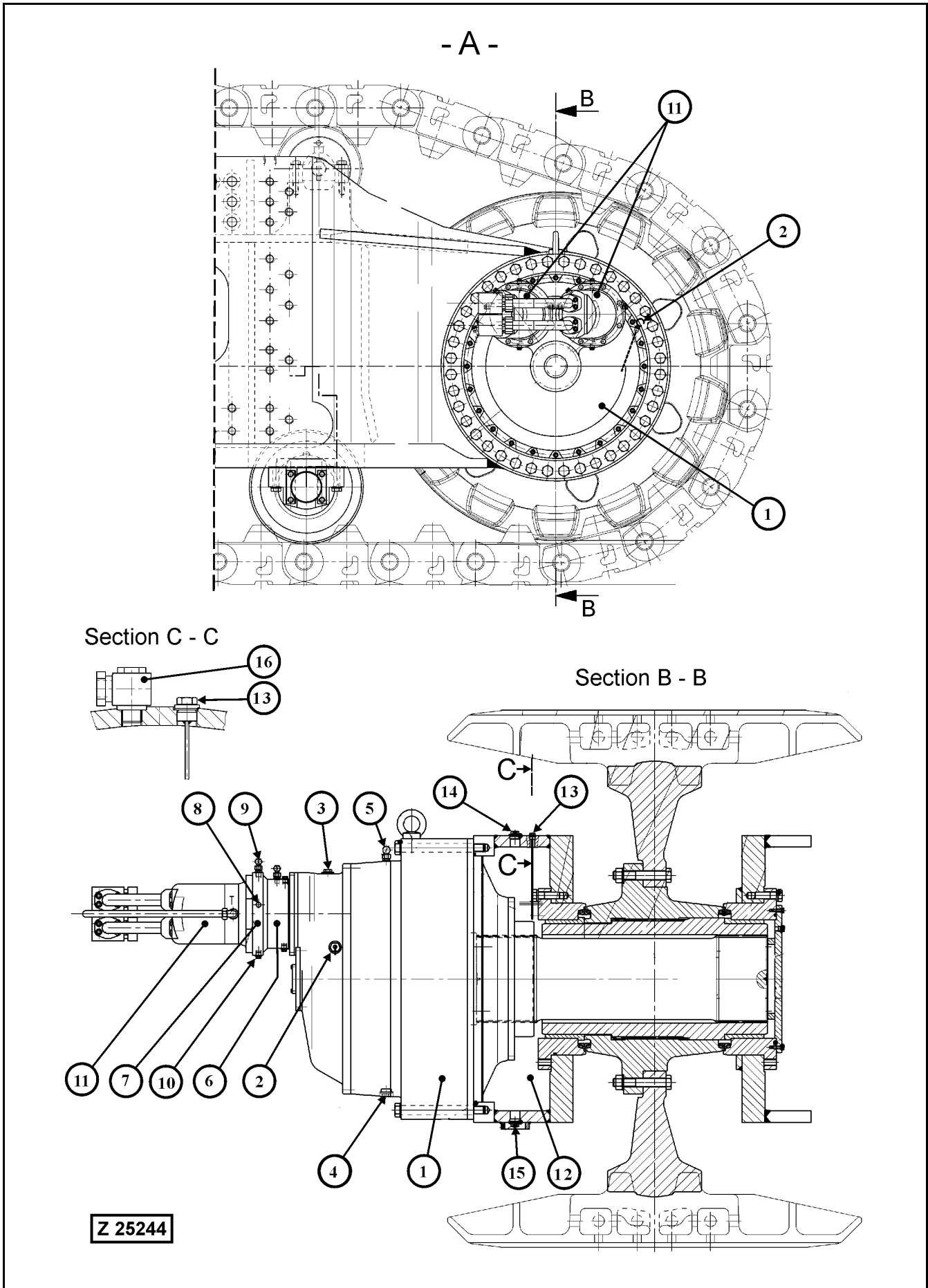

4.14.2 TRAVEL GEARS, MOTOR ADAPTER HOUSINGS AND FINAL DRIVES CHANGE OIL

Legend for illustration Z25244

- A - View of the RH Final drive. The configuration of the LH Final drive is the same.

(1) Travel gear

(2) Oil level gauge

(3) Oil filler plug

(4) Oil drain plug

(5) Connector for breather filter line. The breather filter is located inside the center frame, see illustration Z25243 on page 369.

(6) Travel brake housing

REMARK

The travel gear brakes are dry type multiple disk brakes. DO NOT fill the housings with oil.

(7) Motor adapter housing

(8) Oil level plug

(9) Connector for breather filter line, the breather filter is located inside the center frame, see illustration Z25243 on page 369. The port of connector (9) is also used as oil filler opening.

(10) Oil drain plug

(11) Hydraulic motors

(12) Final drive housing contains the lubricating oil for sprocket bearing lubrication.

(13) Oil level gauge

(14) Oil filler plug

(15) Oil drain plug

(16) Connector for breather filter line, the breather filter is located inside the center frame, see illustration Z25243 on page 369.

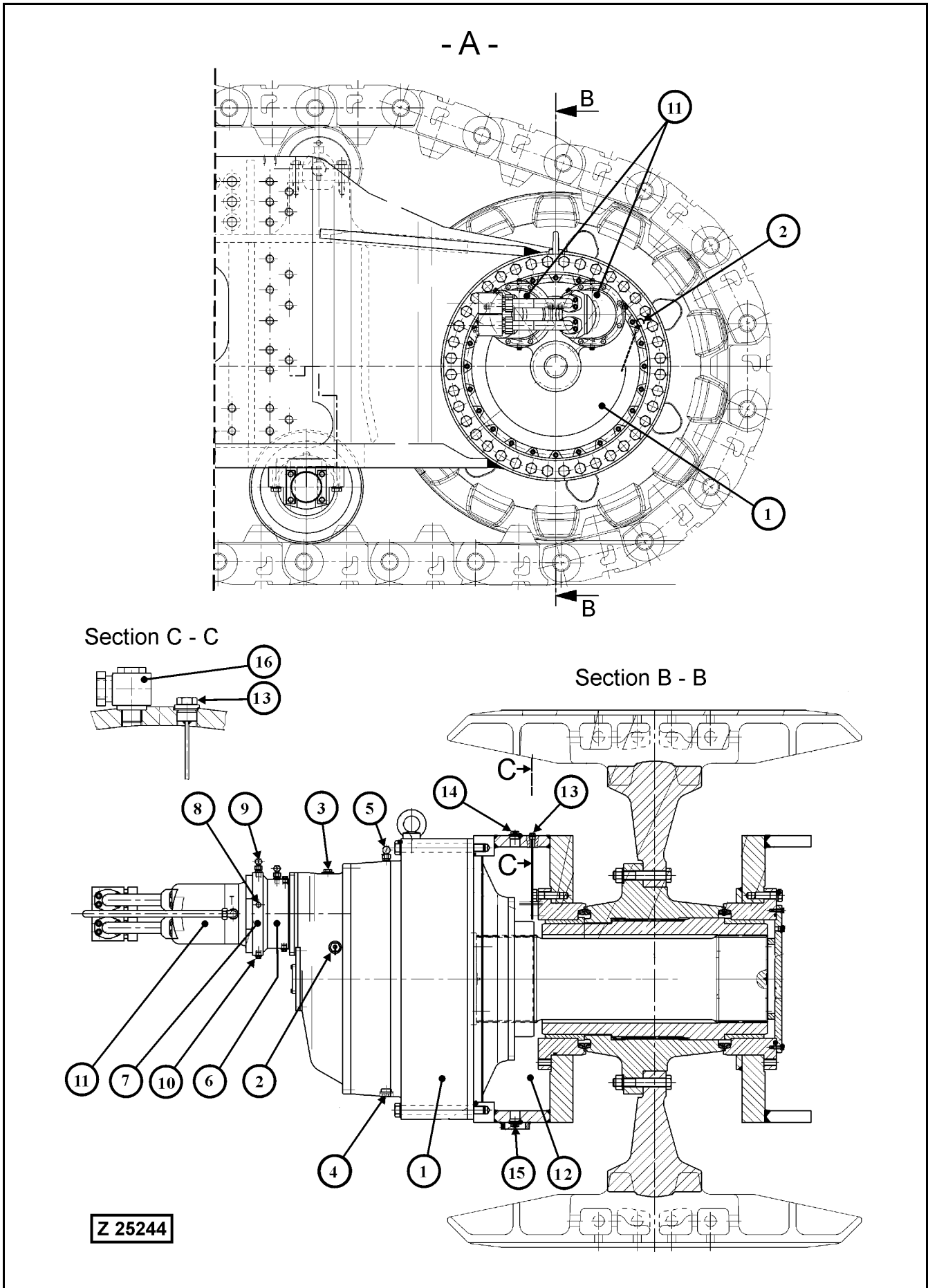

TRAVEL GEARS - CHANGE OIL

Illustration Z25244:

REMARK

The breather filters for the travel gears are mounted inside the center frame and connected with extension hoses.

1. Remove drain plugs (4), filler plug (3) and oil level gauge (2). Check breather filter, mounted inside center frame, and clean as necessary.
2. After the oil is completely drained, flush the gear with the regular gear oil and reinstall drain plugs (4).
3. Fill the gear with fresh oil through filler opening (3) up to the Max mark on oil level gauge (2).
4. Install filler plug (3) and gauge (2).
5. After short operating period check gears for leakage.

MOTOR ADAPTER HOUSINGS - CHANGE OIL

1. Remove parts (8, 9 and 10) and drain the oil completely.
2. Check breather filter, mounted inside center frame, and clean as necessary.
3. Install drain plug (10) and fill-up oil to level opening (8). Reconnect breather filter hose line to filler opening (9).

FINAL DRIVE HOUSINGS - CHANGE OIL

1. Remove drain plug (15), filler plug (14) and oil level gauge (13) and drain the lubricating oil.
2. Check breather filter mounted inside center frame, and clean as necessary.
3. After the oil is completely drained, install the cleaned drain plug (15) and tighten securely.
4. Fill in new oil up to the "MAX" marking on oil level gauge (13).
5. Clean filler plug (14) and reinstall.
6. Insert oil level gauge (13) and tighten securely.
7. After short operating period check oil level and gear for leakage.

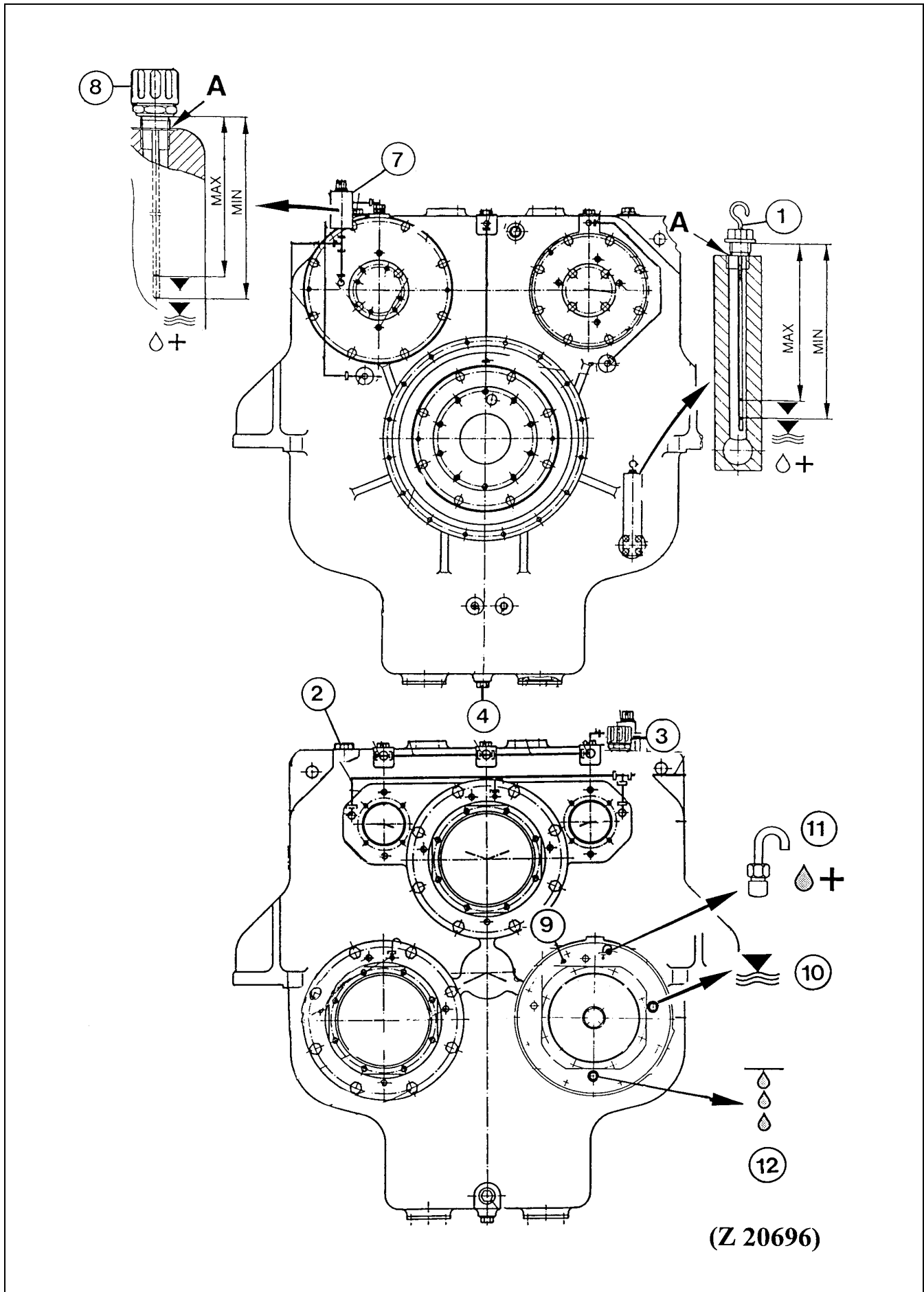

(Z 20696)

4.14.3 PTO (PUMP DISTRIBUTOR GEAR) - CHANGE OIL

Legend for illustration Z 20696

- (1) Oil level gauge
- (2) Oil filler plug
- (3) Breather filter
- (4) Oil drain plug
- (7) Oil collector reservoir for adapter housings of hydraulic pumps for fan drives of radiator and hydraulic oil coolers
- (8) Breather filter with oil level gauge
- (9) Adapter housings for main hydraulic pumps
- (10) Oil level plug
- (11) Oil filler plug with breather pipe
- (12) Oil drain plug

Gear Oil Viscosity

Select gear oil viscosity grade according to ambient temperatures.

If the new gear oil has a different viscosity grade compared with the drained oil it is necessary to enter the new viscosity grade into the appropriate "**Excavator Components**" group.

Refer to page 92 for the INPUT procedure of the oil viscosity.

NOTICE

Before opening the access covers from below the pump distributor gears provide an adequate working platform with sufficient space for the oil collecting container (approx. 200 liters for both gears).

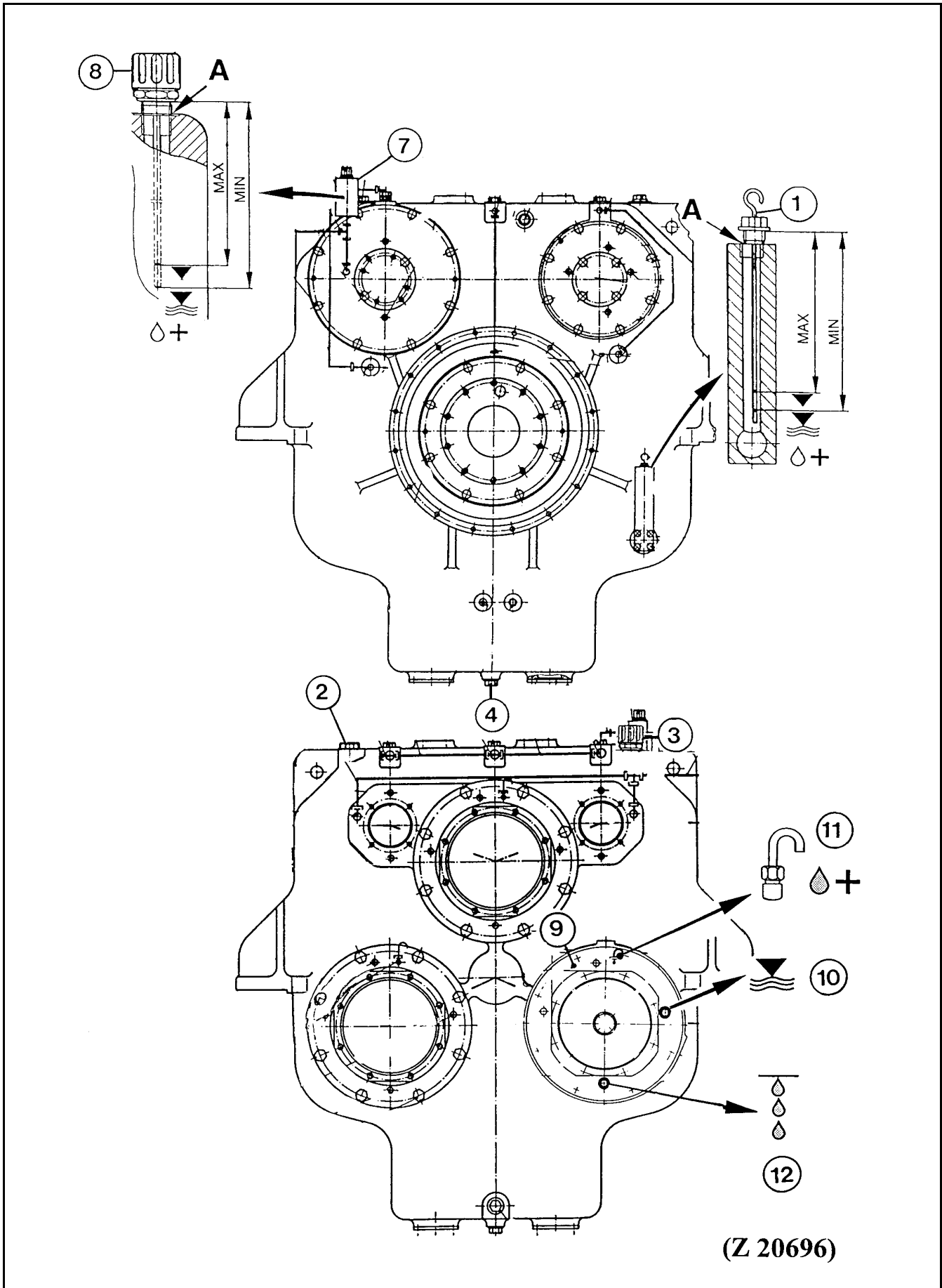

Change the Oil

1. Remove drain plug (4).
2. Remove gauge (1) and filler plug (2).
3. Remove breather filter (3), blow out with compressed air from inside to outside and re-install.
4. After the oil is completely drained, flush the gear with the regular gear oil and reinstall drain plug (4).
5. Fill in new oil through opening (2) up to the "MAX" mark on gauge (1). If the machine is equipped with a central refilling system, proceed according to page 286.
6. Re-install parts (1 and 2).
7. After short operating period, check oil level and housing for leakage.

NOTICE

If the oil level is above the "MAX" mark, drain the oil down until the oil level is at the "MAX" mark. Too much oil in the pump distributor gear will cause aeration of the oil.

4.15 FIRE PREVENTION

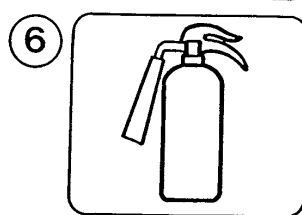
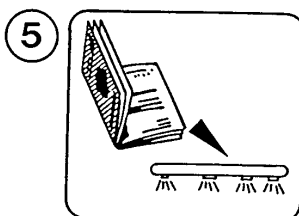
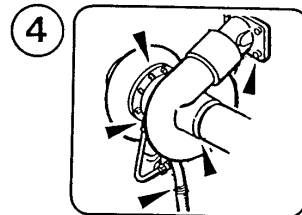
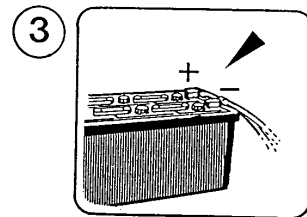
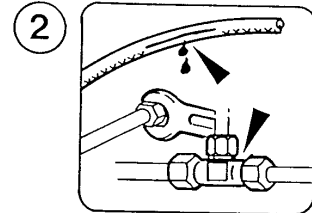
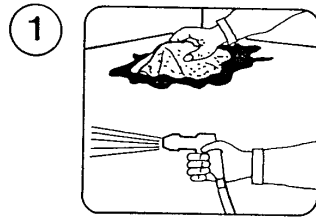

Z 19360

PRECAUTIONS

See illustration Z 19360

In order to prevent risks of possible fire break out observe the following items:

1. Keep the excavator clean, especially from inflammable materials.
Clean the excavator after servicing the hydraulic system, engine and fuel system by means of a steam jet.
2. Clean engine compartment, hydraulic pump compartment and service platform of the superstructure.
Thereafter check fuel lines, engine oil lines and hydraulic oil lines for leakage, loose fastenings and damage.
If any leakage, damage or loose fastening is found, corrective action must be taken immediately.
3. Check all electrical cables, terminals and connections for loose fastenings, damage and wear.
Replace or repair defective or worn parts without delay.
4. Check the turbocharger for correct mounting and tight exhaust, intake and lube oil connections.
Carry out all necessary repairs without delay.
5. **On machines equipped with a fire detection, actuation and suppression system:**
Refer to the manufacturers service manuals filed in Service Literature Binder Volume 2 for correct maintenance and inspection of the systems.
When checking the filling level of the dry chemical tanks, make sure that the extinguishing powder (Ansul FORAY dry chemical agent) is not compacted.
Stir up the extinguishing powder with a suitable stick until it is in a free flowing condition.

NOTICE

When cleaning the power house take care the heat detection sensors do not come in contact with hot steam or other hot agent. Otherwise the fire suppression system may be triggered.

6. Make sure fire extinguishers are charged and ready for use.

NOTICE

**After cleaning lubricate all lubrication points by means of central lube system or manually.
Lubricate swing circle gear after drying by means of the automatic lube system or manually.**

4.16 WELD REPAIRS

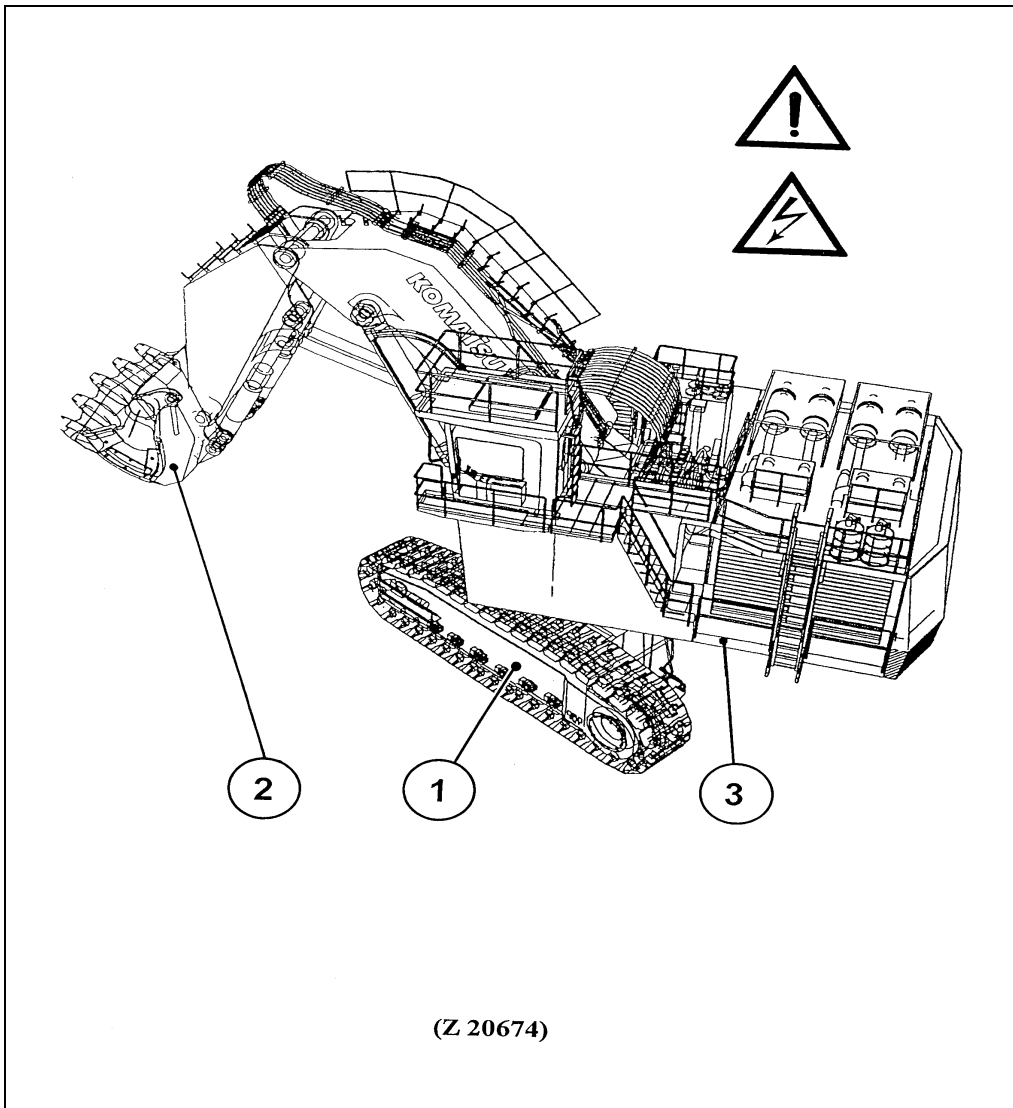

CAUTION

Before carry out weld repairs, contact our Service Department EXCAVATORS in order to avoid improper welding procedures. Weld repairs can cause severe damage to an entire structure if performed incorrectly. If cracks are found in the steel construction of your excavator, please inform our Service Department as soon as possible. Attach suitable information material (photos, catalog drawings etc.) showing the location and nature of the crack.

GENERAL INFORMATION

Welding operations can cause damage to electronic components. (Computers, Control Units, Sensors etc.), in case the welding current goes through these units. Therefore protective measures are necessary before any weld repair is started.

GENERAL PROTECTIVE MEASURES

- A. Observe the prevailing safety and fire prevention regulations.

Before any weld repair is started, a survey should be made of the area and all safety considerations satisfied such as fuel tanks, oil lines, electrical cables and synthetic materials.

- B. Attach the welding ground directly to the part that is being repaired. Do not allow welding current to go through bearings. Welding current could arc the bearings, resulting in severe damage to the bearing.

WELD REPAIRS ON MAJOR COMPONENTS OF THE EXCAVATOR

COUNTERWEIGHT

⚠ WARNING

The chambers of the counterweight are filled with a mixture of concrete, granulated ore and steel pellets. This mixture can create explosive gases which will accumulate in the chambers of the counterweight. Before any welding, flame-cutting, grinding or drilling procedures are carried out on the counterweight it is vital to expel these gases from the counterweight chambers. Failure to properly expel the gases from the counterweight chambers can result in an explosion with serious personal injury or death.

Follow the instructions given in **PARTS & SERVICE NEWS No. AH04518** for expelling the gases from the counterweight chambers.

Legend for illustration Z 20674

- (1) Undercarriage, refer to page 525 for protective measures.
- (2) Loader attachment, refer to page 527 for protective measures.
- (3) Superstructure, refer to page 529 for protective measures.

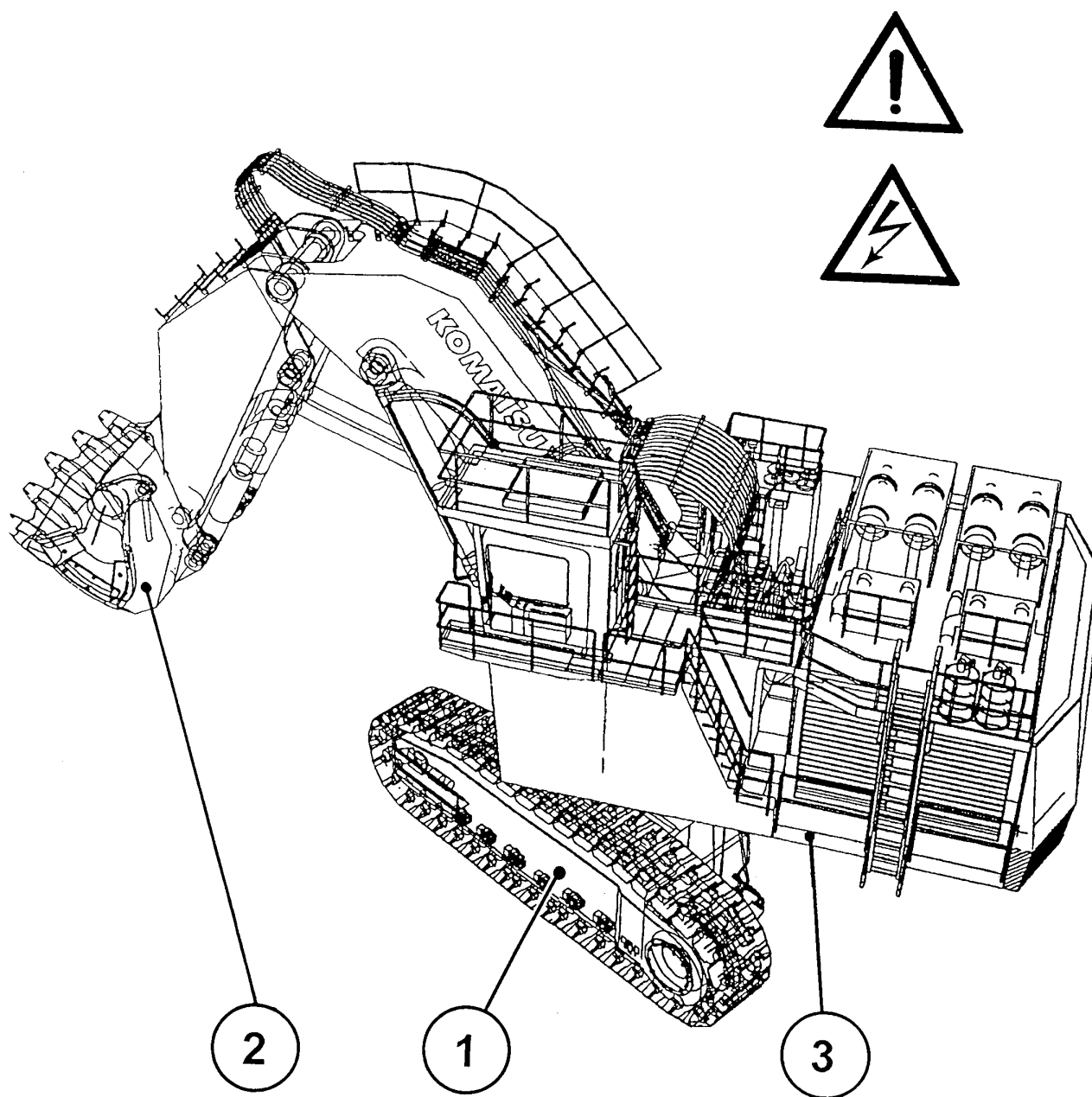

(Z 20674)

4.16.1 PROTECTIVE MEASURES BEFORE STARTING WELD REPAIRS ON THE UNDERCARRIAGE

See illustration Z 20674

On standard Excavators there are no special protective measures necessary.

However, the general protective measures (A and B) must be observed.

On Excavators with a power unit (generator set) mounted to the undercarriage, all electrical connections between the Excavator and the power unit have to be disconnected.

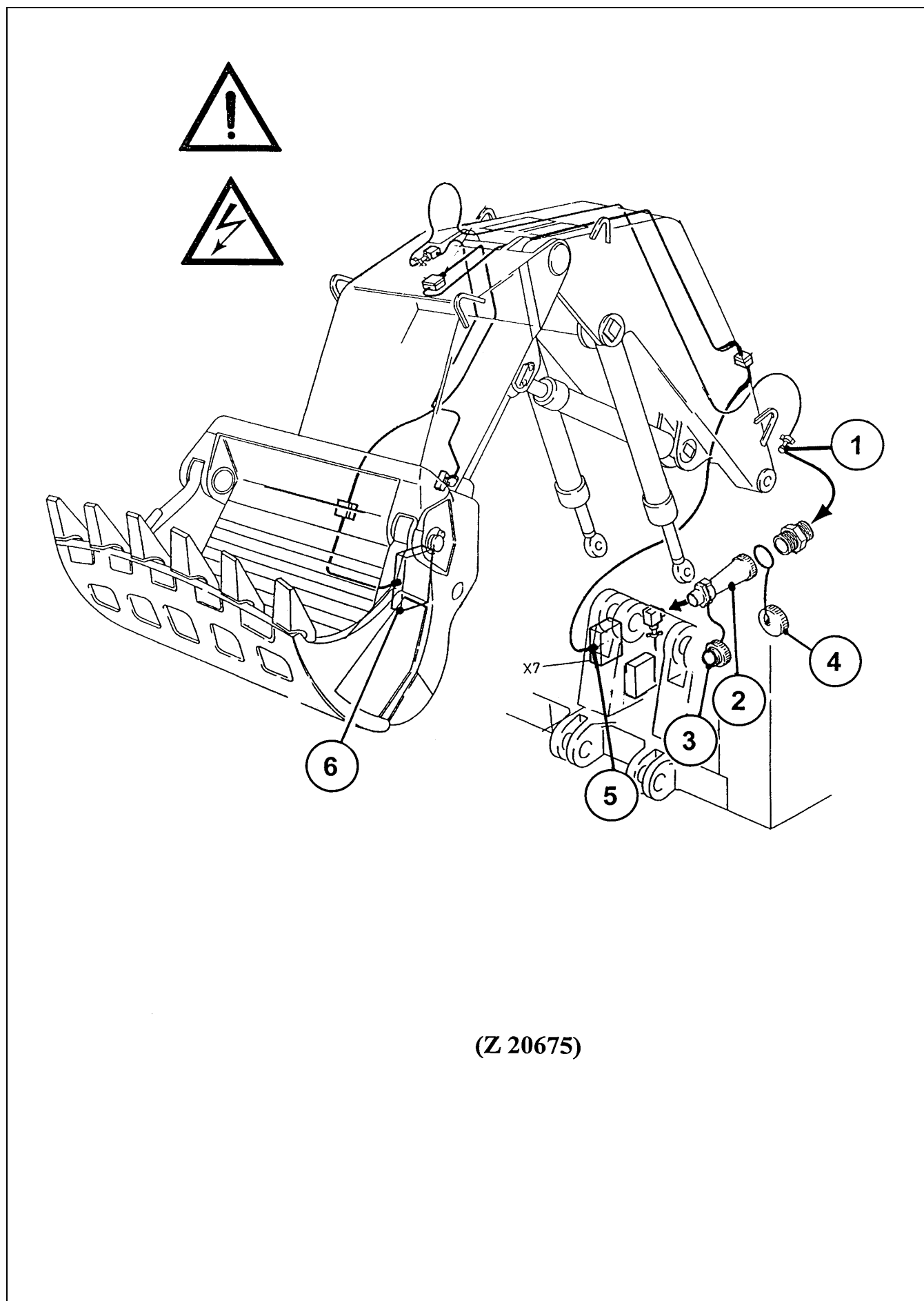

(Z 20675)

4.16.2 PROTECTIVE MEASURES BEFORE STARTING WELD REPAIRS ON THE LOADER ATTACHMENT

Legend for illustration Z 20675

- (1) Electrical cable connector of the end-line pressure switch for the central lubrication system
- (2) Plug socket
- (3) Protection cap for (2)
- (4) Protection cap for (1)
- (5) Switch box of the electronic bucket levelling system "EBL", (Special Equipment)
- (6) Bucket position detector box for the "EBL" system (Special Equipment)

NOTICE

If weld repairs have to be carried out on the Loader Attachment (Bucket, Stick and/or Boom) disconnect the end line pressure switch cable connector (1) from socket (2) and close the openings with caps (3 and 4).

If the Excavator is equipped with an electronic Bucket Levelling System, disconnect also the cable connector on switch box (5).

Be sure to disconnect electrical connections of working lights and other electrical equipment mounted on the loader attachment.

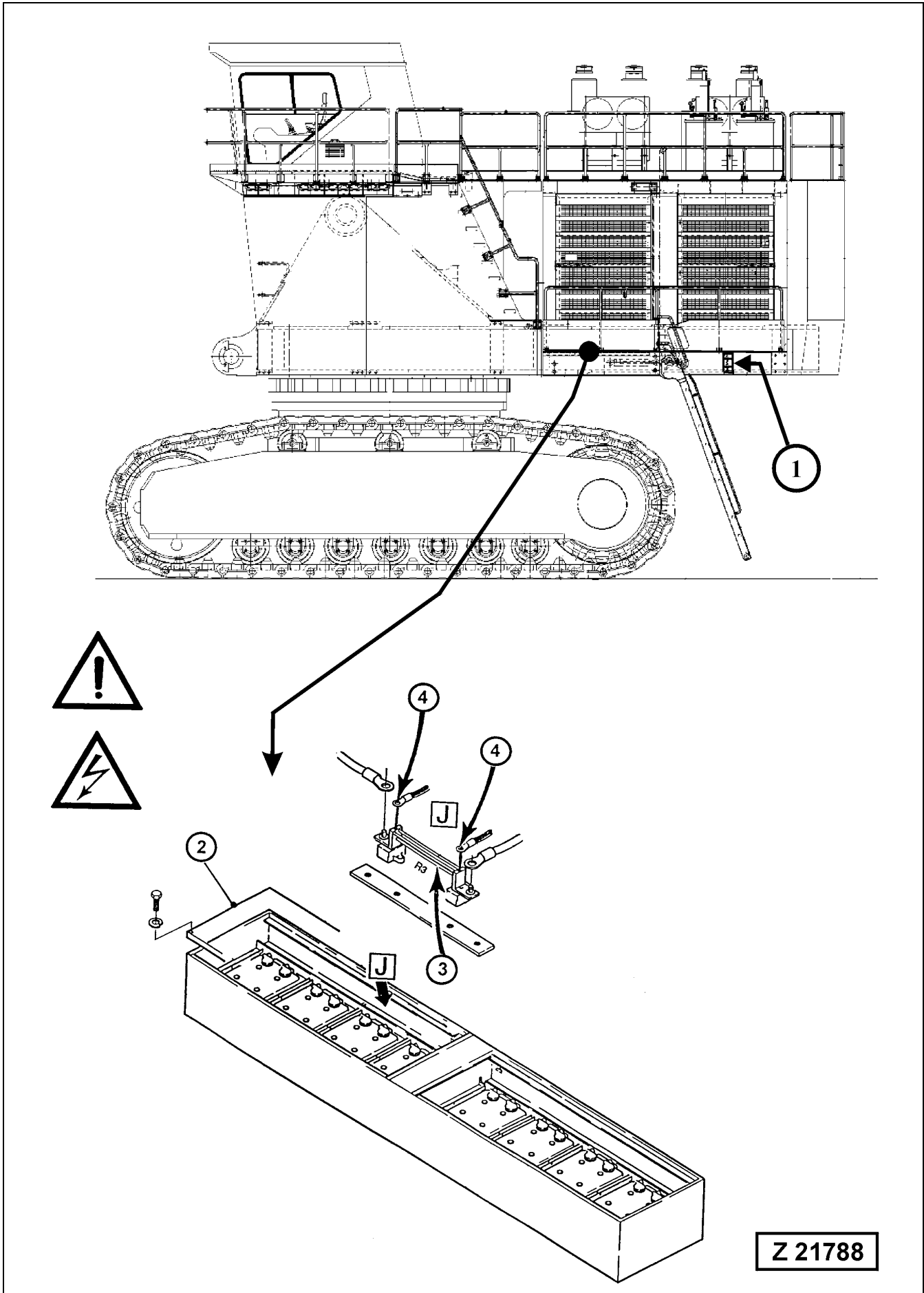

4.16.3 PROTECTIVE MEASURES BEFORE STARTING WELD REPAIRS ON THE SUPERSTRUCTURE

Legend for illustration Z 21788

- (1) Battery main switch keys
- (2) Battery box cover underneath the cat walk
- (3) Battery current sensor (auxiliary resistor)
- (4) Cables for transmitting the battery charging current to the DC converter (E7)
- (J) Location of battery current sensor (auxiliary resistor) (3)

Observe sequence of steps:

1. Remove keys (1) of the two battery main switches.
2. Open the battery box cover (2) and secure in open position with the safety chains provided.
3. Disconnect both cables (4) from auxiliary resistor (3).

▲ WARNING

Batteries give off highly inflammable gas! Never allow sparks or open flame near the batteries! Avoid spilling any electrolyte on hands or clothing. repair or replace all broken wires immediately. All terminals must be clean and securely fastened; never paint connections.

DO NOT short across or ground any terminals of the batteries.

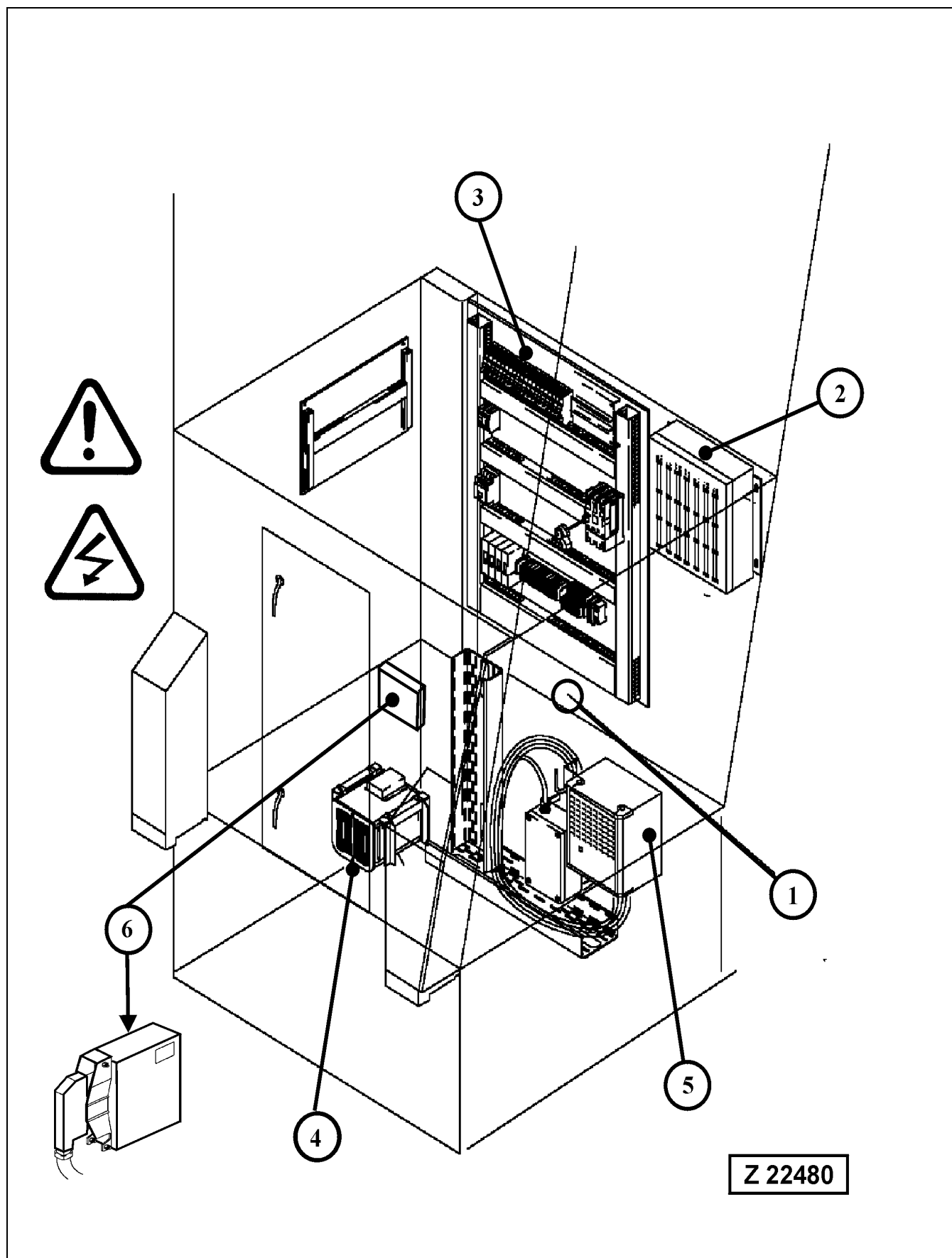

Electrical Units in Cab Base, illustration Z 22480

1. Switch off all circuit breakers on switch board "X2".
2. Disconnect all plugs on the programmable logic controller (2).
3. Remove the wiring harness connector from electronic pump control module (6).
4. Switch off all circuit breakers on switch board (3) for preheating systems.

REMARK

Be sure to isolate Electronic Components of Special Equipment.

Engine Electronics

Disconnect the two Deutsch connectors (C5 and C6), illustration Z 22516. The connectors are located on the LH engine side near the flywheel housing.

For more information refer to the Operation and Maintenance Manual CENTRY System, filed in Volume 2 Binder.

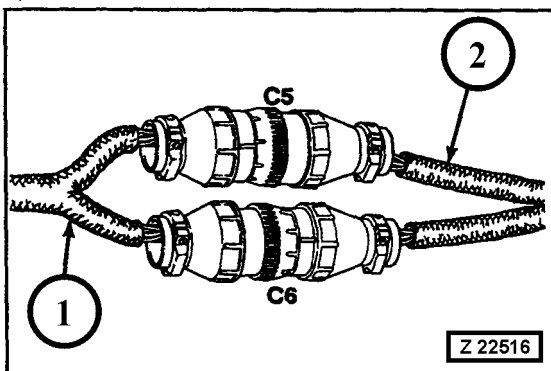

- (1) - Engine harness
(2) - Shovel harness

4.16.4 AFTER FINISHING THE REPAIR WELDINGS ON THE SUPERSTRUCTURE

After finishing the weld repairs connect all cable connectors which have been disconnected. When connecting the two Deutsch connectors (C5 and C6), make sure you hear a click.

When all electrical connections are established insert the battery main switch keys.

1. INTRODUCTION	3
1.1 CONTENTS OF THE BINDER	4
1.2 DIVISION OF THE BINDER	5
1.3 DESIGNATED USE OF THE SHOVEL	6
1.4 DELIVERY OF THE SHOVEL	7
1.5 EXPLANATION OF ABBREVIATIONS	8
1.6 TABLE OF CONTENTS	9
2. SAFETY	15
2.1 SAFETY INSTRUCTIONS	16
2.1.1 WARNINGS AND SYMBOLS	16
2.1.2 BASIC OPERATION AND DESIGNATED USE OF THE HYDRAULIC SHOVEL	16
2.1.3 ORGANIZATIONAL MEASURES	17
2.1.4 SELECTION AND QUALIFICATION OF PERSONNEL - BASIC RESPONSIBILITIES	19
2.1.5 SAFETY INSTRUCTIONS GOVERNING SPECIFIC OPERATIONAL PHASES	20
2.1.6 WARNING OF SPECIAL DANGERS	23
2.1.7 TRANSPORTING AND TOWING -RECOMMISSIONING	25
2.1.8 SPECIAL SAFETY EQUIPMENT	25
2.1.9 SAFETY HARNESS IN CONFORMITY WITH EN 361 (EUROPEAN STANDARD)	29
3. OPERATION	37
3.1 FOREWORD	38
3.2 CONSTRUCTION OF THE SHOVEL	39
3.2.1 OVERALL VIEW	39
3.2.2 UNDERCARRIAGE AND SUPERSTRUCTURE	40
3.2.3 HYDRAULICALLY OPERATED ACCESS LADDER	46
3.2.4 EMERGENCY ESCAPE LADDER	50
3.2.5 EMERGENCY ENGINE SHUTDOWN FROM GROUND MAN OR OPERATOR WARNING SYSTEM	52
3.2.6 OPERATOR'S CAB WITH INTEGRATED FALLING OBJECT PROTECTIVE STRUCTURE (FOPS)	54
3.2.7 ENGINE OIL MANAGEMENT SYSTEM	64
3.3 OPERATOR'S CAB - CONTROLS	72
3.3.1 CONTROLS WITH BACKHOE ATTACHMENT	72
3.3.2 CONTROLS WITH BOTTOM DUMP BUCKET ATTACHMENT	76
3.3.3 OPERATOR'S CONSOLE	81
3.3.4 INTERFACE PANEL FOR DIAGNOSTICS	89
3.3.5 CONTROL MODULE FOR AUXILIARY CAB HEATER	91

3.4	ELECTRONIC MONITORING AND CONTROL SYSTEM ECS	92
3.4.1	INTRODUCTION	93
3.4.2	OPERATING THE ELECTRONIC MONITORING SYSTEM	101
3.4.3	AUTOMATIC DISPLAY OF MESSAGES	105
3.4.4	MENU CONTROL AND SERVICE FUNCTIONS	129
3.4.5	MENU CONTROL LIST	154
3.4.6	FAULT AND INFORMATION MESSAGE LIST	172
3.5	OPERATING THE HEATER, VENTILATION AND AIR CONDITIONING	198
3.5.1	AUXILIARY HEATER FOR OPERATOR'S CAB	201
3.6	MACHINERY HOUSE	202
3.6.1	EMERGENCY ENGINE SHUTDOWN SWITCHES	203
3.6.2	SAFETY SWITCH FOR MAINTENANCE	205
3.6.3	CONTROL AND FILTER PANEL OF REAR- AND FRONT POWER UNIT	207
3.7	ELECTRICAL EQUIPMENT IN CAB BASE	208
3.7.1	STANDARD COMPONENTS IN CAB BASE	209
3.7.2	SWITCH BOARD (X2) IN CAB BASE	211
3.7.3	COMPONENTS OF ELECTRICAL PREHEATING SYSTEM IN CAB BASE	219
3.8	PREHEATING SYSTEMS FOR OIL, COOLANT AND BATTERIES	222
3.9	CHECKS BEFORE STARTING THE ENGINES	228
3.10	STARTING THE ENGINES	234
3.10.1	STARTING PROCEDURE	237
3.11	MOVING THE SHOVEL	245
3.11.1	TRAVEL CONTROL WITH FOOT PEDALS	245
3.11.2	TRAVELLING INSTRUCTIONS	248
3.12	SLEWING AND BRAKING THE SUPERSTRUCTURE	249
3.12.1	SLEWING THE SUPERSTRUCTURE	249
3.13	WORKING WITH THE ATTACHMENT	252
3.13.1	MACHINES EQUIPPED WITH "EURO" CONTROL SYSTEM	252
3.13.2	MACHINES EQUIPPED WITH "KMG" CONTROL SYSTEM	253
3.13.3	BOTTOM DUMP BUCKET	254
3.13.4	DROP BALL OPERATION	255
3.13.5	COMBINED OPERATION CYCLES	258
3.14	WORKING INSTRUCTIONS	260
3.14.1	STABILITY OF THE SHOVEL	260
3.14.2	SHOVEL OPERATION	260
3.15	PARKING THE SHOVEL	263
3.16	STOPPING THE ENGINES	264
3.16.1	RELIEVE PRESSURE IN THE HYDRAULIC SYSTEM	267

3.17	OPERATION OF THE LUBRICATION SYSTEM	268
3.17.1	CENTRAL LUBRICATION SYSTEM -CLS- FOR SUPERSTRUCTURE AND ATTACHMENT 268	
3.17.2	SWING CIRCLE PINION LUBRICATION SYSTEM "SLS"	270
3.18	FIRE DETECTION AND SUPPRESSION SYSTEM	272
3.18.1	HIGH LEVEL ALARM "FIRE"	275
3.18.2	ENGINE SHUT-DOWN THROUGH FUEL SHUT-OFF SOLENOID VALVE	275
3.18.3	ACTUATION MODES OF THE FIRE SUPPRESSION SYSTEM	275
3.18.4	INDICATION OF OPERATIONAL MODES AT CONTROL MODULE, AFTER AUTOMATIC ACTUATION OF THE FIRE SUPPRESSION SYSTEM	277
3.18.5	LOCATION OF THE EXTINGUISHING AGENT TANK ASSEMBLIES AND EXPELLANT GAS CARTRIDGES ON POWER HOUSE ROOF	279
3.19	TRANSFER PUMP FOR HYDRAULIC OIL	280
3.19.1	OPERATING THE TRANSFER PUMP	281
3.19.2	FUNCTIONS OF THE TRANSFER PUMP	283
3.20	CENTRAL REFILLING SYSTEM	286
3.20.1	SYSTEMS CONNECTED TO THE REFILLING SYSTEM	287
3.20.2	OPERATING THE HYDRAULIC SERVICE ARM	289
3.20.3	RECEIVER PANEL WITH MONITOR BOX	291
3.20.4	REFILLABLE GREASE CONTAINERS OF THE AUTOMATIC LUBRICATION SYSTEMS ... 297	
3.21	WORK ON THE LOADER ATTACHMENT	298
3.22	TRANSPORTATION AND LIFTING OF THE SHOVEL	299
3.22.1	DISASSEMBLING OF THE SHOVEL	299
3.22.2	TRANSPORTATION AND LIFTING	299
3.23	RETRIEVAL PROCEDURE	300
3.24	SHOVEL STORAGE	301
3.24.1	PREPARING FOR STORAGE	301
3.24.2	ONE MONTH REPETITIVE SERVICE PERIOD	302
3.24.3	SIX MONTH REPETITIVE SERVICE PERIOD	302
3.24.4	PREPARING FOR OPERATION	303
3.25	TROUBLE SHOOTING	304
3.25.1	ENGINE	304
3.25.2	HYDRAULIC SYSTEM	305
3.25.3	FINAL DRIVES AND SWING GEAR	306
3.25.4	CRAWLER TRACKS	306
4.	MAINTENANCE	307

4.1	FOREWORD	308
4.2	PRECAUTIONS FOR MAINTENANCE	309
4.3	FLUIDS AND LUBRICANTS	311
4.3.1	LUBRICANTS FOR OPERATION IN COLD AND ARCTIC CLIMATES	311
4.3.2	FLUIDS AND LUBRICANTS FOR MODERATE AND HOT CLIMATES	312
4.4	FILLING CAPACITIES	316
4.5	STANDARD TORQUE LIST	317
4.6	LUBRICATION AND MAINTENANCE SCHEDULE	318
4.6.1	INITIAL SERVICING	318
4.6.2	PERIODIC SERVICING INTERVALS	318
4.6.3	PERIODIC SERVICING SCHEDULE	319
4.6.4	EXTENDED SERVICE INTERVALS FOR ENGINES WITH ENGINE OIL MANAGEMENT SYSTEM	326
4.6.5	RESETTING THE ENGINE OIL BURNING SYSTEM CENTINEL	328
4.6.6	MAINTENANCE OF THE ENGINES	331
4.6.7	ENGINE FUEL FILTER LOCATIONS	333
4.7	WHEN NECESSARY	334
4.7.1	ENGINE AIR CLEANER MAINTENANCE	335
4.7.2	SWING CIRCLE TOOTHING LUBRICATION	339
4.7.3	AUTOMATIC LUBRICATION SYSTEMS FILL GREASE CONTAINERS	341
4.7.4	TRACK ROLLERS AND GUIDE WHEELS - REPLACE FLOATING SEALS	345
4.7.5	COLD STARTING AID, REPLACE FLUID CYLINDER	347
4.8	EVERY 10 OPERATING HOURS OR DAILY	348
4.8.1	WALK - AROUND INSPECTION	349
4.8.2	AIR CLEANER - CLEAN PRE-CLEANER	357
4.8.3	RADIATORS - CHECK COOLANT LEVEL	359
4.8.4	TRACK GROUPS - CLEAN	359
4.9	EVERY 50 OPERATING HOURS OR WEEKLY	360
4.9.1	SWING GEARS AND MOTOR ADAPTER HOUSINGS - CHECK OIL LEVELS	361
4.9.2	TRAVEL GEARS, MOTOR ADAPTER HOUSINGS AND FINAL DRIVES CHECK OIL LEVELS	365
4.9.3	PTO's (PUMP DISTRIBUTOR GEARS) AND OIL RESERVOIR - CHECK OIL LEVEL ...	371
4.9.4	HYDRAULIC ACCESS LADDER - CHECK SAFETY SENSOR	375
4.9.5	HYDRAULIC OIL COOLERS - INSPECT AND CLEAN IF NECESSARY	377
4.10	EVERY 250 OPERATING HOURS OR MONTHLY	378
4.10.1	AIR CONDITIONING COMPRESSOR - CHECK DRIVE BELT TENSION	379
4.10.2	SIGNAL HORN COMPRESSOR - LUBRICATE	381
4.10.3	HYDRAULIC OIL COOLER FAN BEARINGS - CHECK FOR LEAKAGE AND CLEAN BREATHER FILTER	381
4.10.4	RADIATOR FAN BEARINGS - CHECK FOR LEAKAGE AND CLEAN BREATHER FILTER	381
4.10.5	AUTOMATIC LUBRICATION SYSTEMS - CLEAN IN-LINE GREASE FILTER AND CHECK	

	BREATHER FILTER	383
4.10.6	CAB AIR CLEANER - CLEAN OR REPLACE FILTER ELEMENT	385
4.10.7	AIR CONDITIONING FOR OPERATOR'S CAB - CHECK REFRIGERANT LEVEL	387
4.10.8	WINDSHIELD WASHER SYSTEM - CHECK FLUID LEVEL	389
4.11	EVERY 500 OPERATING HOURS OR QUARTERLY	390
4.11.1	BATTERIES - CHECK FLUID LEVEL	391
4.11.2	FLEXIBLE DRIVE COUPLINGS - CHECK OIL LEVEL	393
4.11.3	FUEL TANK - DRAIN CONDENSATION	395
4.11.4	CRAWLER TRACK - INSPECTION	397
4.11.5	GROUND CABLES OF ENGINE AND ALTERNATOR - CHECK FOR CORRECT CONNECTION	403
4.11.6	GROUND CABLE OF OPERATOR'S CAB - CHECK FOR CORRECT CONNECTION ...	405
4.12	EVERY 1000 OPERATING HOURS OR EVERY 6 MONTH	406
4.12.1	HIGH STRENGTH BOLT CONNECTIONS - CHECK TORQUE LOAD	407
4.12.2	HYDRAULIC SYSTEM - FILTER SERVICE	465
4.12.3	PTO'S (PUMP DISTRIBUTOR GEARS), SWING GEARS AND TRAVEL GEARS - OIL SAMPLE ANALYSIS	479
4.12.4	SIGNAL HORN COMPRESSOR - CLEAN AND LUBRICATE	481
4.12.5	HYDRAULIC TRACK TENSIONING SYSTEM - CHECK PRESSURE ACCUMULATORS ...	483
4.12.6	WATER FILTER - REPLACE FILTER CARTRIDGE	485
4.12.7	HYDRAULIC OIL COOLER - INSPECT AND LUBRICATE DOOR HINGES	487
4.12.8	MACHINERY HOUSE DOORS - INSPECT AND LUBRICATE DOOR HINGES	489
4.13	EVERY 2000 OPERATING HOURS OR YEARLY	490
4.13.1	HYDRAULIC SYSTEM - CHANGE OIL, REPLACE SUCTION STRAINERS AND PULSATION DAMPER	491
4.13.2	EMERGENCY ESCAPE LADDER - INSPECTION	503
4.14	EVERY 3000 OPERATING HOURS HOWEVER AT LEAST ONCE A YEAR	504
4.14.1	SWING GEARS AND MOTOR ADAPTER HOUSING - CHANGE OIL	505
4.14.2	TRAVEL GEARS, MOTOR ADAPTER HOUSINGS AND FINAL DRIVES CHANGE OIL	513
4.14.3	PTO (PUMP DISTRIBUTOR GEAR) - CHANGE OIL	517
4.15	FIRE PREVENTION	520
4.16	WELD REPAIRS	522
4.16.1	PROTECTIVE MEASURES BEFORE STARTING WELD REPAIRS ON THE UNDERCARRIAGE	525
4.16.2	PROTECTIVE MEASURES BEFORE STARTING WELD REPAIRS ON THE LOADER ATTACHMENT	527
4.16.3	PROTECTIVE MEASURES BEFORE STARTING WELD REPAIRS ON THE SUPERSTRUCTURE	529
4.16.4	AFTER FINISHING THE REPAIR WELDINGS ON THE SUPERSTRUCTURE	531