

Operation & Maintenance Manual

PC58UU-3

HYDRAULIC EXCAVATOR

SERIAL NUMBERS PC58UU - 20001 and up

This material is proprietary to Komatsu Utility Division and is not to be reproduced, used, or disclosed except in accordance with written authorization from Komatsu America International Company.

It is our policy to improve our products whenever it is possible and practical to do so. We reserve the right to make changes or improvements at any time without incurring any obligation to install such changes on products sold previously.

Due to this continuous program of research and development, revisions may be made to this publication. It is recommended that customers contact their distributor for information on the latest revision.

Copyright 2001 Komatsu
DataKom Publishing Corporation

December 2001

FOREWORD

CALIFORNIA

Proposition 65 Warning

Diesel engine exhaust and some of its constituents are known to the State of California to cause cancer, birth defects, and other reproductive harm.

CALIFORNIA

Proposition 65 Warning

Battery posts, terminals and related accessories contain lead and lead compounds, chemicals known to the State of California to cause cancer and birth defects or other reproductive harm.

Wash hands after handling.

FOREWORD

This manual provides rules and guidelines which will help you use this machine safely and effectively. The precautions in this manual must be followed at all times when performing operation and maintenance. Most accidents are caused by the failure to follow fundamental safety rules for the operation and maintenance of machines. Accidents can be prevented by knowing beforehand conditions that may cause hazard when performing operation and maintenance.

WARNING

Operators and maintenance personnel must always do as follows before beginning operation or maintenance.

- Always be sure to read and understand this manual thoroughly before performing operation and maintenance.
- Read the safety messages given in this manual and the safety labels affixed to the machine thoroughly and be sure that you understand them fully.

Keep this manual at the storage location for the Operation and Maintenance Manual given below, and have all personnel read it periodically.

If this manual has been lost or has become dirty and cannot be read, request a replacement manual immediately from Komatsu or your Komatsu distributor.

If you sell the machine, be sure to give this manual to the new owners together with the machine.

Komatsu delivers machines that comply with all applicable regulations and standards of the country to which it has been shipped. If this machine has been purchased in another country or purchased from someone in another country, it may lack certain safety devices and specifications that are necessary for use in your country. If there is any question about whether your product complies with the applicable standards and regulations of your country, consult Komatsu or your Komatsu distributor before operating the machine.

Storage location for the Operation and Maintenance Manual:
Pocket at rear of operator's seat

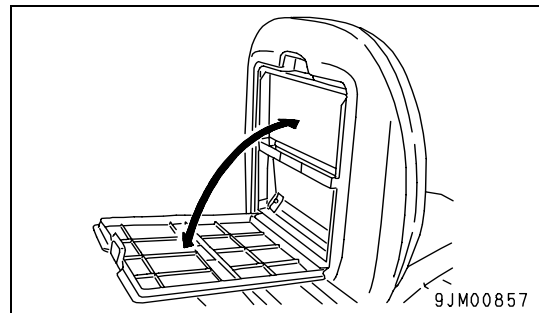

EMISSION CONTROL WARRANTY

EMISSION CONTROL WARRANTY STATEMENT (APPLIES TO CANADA ONLY)

1. Products Warranted

Komatsu America International Company, Komatsu Mining Systems Inc. and Komatsu Utility Corporation (collectively "Komatsu") produce and/or market products under brand names of Komatsu, Dresser, Dressta, Haulpak and Galion. This emissions warranty applies to new engines bearing the Komatsu name installed in these products and used in Canada in machines designed for industrial off-highway use. This warranty applies only to these engines produced on or after January 1, 2000. This warranty will be administered by Komatsu distribution in Canada.

2. Coverage

Komatsu warrants to the ultimate purchaser and each subsequent purchaser that the engine is designed, built and equipped so as to conform, at the time of sale by Komatsu, with all U.S. Federal emission regulations applicable at the time of manufacture and that it is free from defects in workmanship or material which would cause it not to meet these regulations within five years or 3,000 hours of operation, whichever occurs first, as measured from the date of delivery of the engine to the ultimate purchaser.

3. Limitations

Failures, other than those resulting from defects in materials or workmanship, are not covered by this warranty. Komatsu is not responsible for failures or damage resulting from what Komatsu determines to be abuse or neglect, including, but not limited to: operation without adequate coolant or lubricants; over fueling; over speeding; lack of maintenance of lubricating, cooling or intake systems; improper storage, starting, warm-up, run-in or shutdown practices; unauthorized modifications of the engine. Komatsu is also not responsible for failures caused by incorrect fuel or by water, dirt or other contaminants in the fuel. Komatsu is not responsible for non-engine repairs, "downtime" expense, related damage, fines, all business costs or other losses resulting from a warrantable failure.

KOMATSU IS NOT RESPONSIBLE FOR INCIDENTAL OR CONSEQUENTIAL DAMAGES.

This warranty, together with the express commercial warranties, are the sole warranties of Komatsu. **THERE ARE NO OTHER WARRANTIES, EXPRESS OR IMPLIED, OR OF MERCHANTABILITY OR FITNESS FOR A PARTICULAR PURPOSE.**

GARANTIE SUR LE CONTRÔLE DES ÉMISSIONS

ÉNONCÉ DE GARANTIE SUR LE CONTRÔLE DES ÉMISSIONS (APPLICABLE AU CANADA SEULEMENT):

1. Produits garantis:

Komatsu America International Company, Komatsu Mining Systems Inc. et Komatsu Utility Corporation (collectivement Komatsu) produisent et/ou font la mise en marché de produits portant les noms de marque Komatsu, Dresser, Dressta, Haulpak et Galion. Cette garantie sur les émissions s'applique à tous les nouveaux moteurs portant le nom Komatsu, installés dans ces produits et utilisés au Canada dans des machines conçues pour utilisation industrielle non-routière. Cette garantie s'applique seulement sur les moteurs produits à partir du 1er Janvier 2000. Cette garantie sera administrée par la distribution de Komatsu au Canada.

2. Couverture:

Komatsu garantit à l'acheteur ultime et chaque acheteur subséquent que le moteur est conçu, construit et équipé en toute conformité, au moment de la vente par Komatsu, avec toutes les Réglementations fédérales américaines sur les émissions applicables au moment de la fabrication et qu'il est exempt de défauts de construction ou de matériaux qui auraient pour effet de contrevenir à ces réglementations en dedans de 5 ans ou 3000 heures d'opération, mesuré à partir de la date de livraison du moteur au client ultime.

3. Limitations:

Les bris, autres que ceux résultant de défauts de matériaux ou de construction, ne sont pas couverts par cette Garantie. Komatsu n'est pas responsable pour bris ou dommages résultant de ce que Komatsu détermine comme étant de l'abus ou négligence, incluant mais ne se limitant pas à: l'opération sans lubrifiants ou agent refroidissants adéquats; la suralimentation d'essence; la survitesse; le manque d'entretien des systèmes de lubrification, de refroidissement ou d'entrée; de pratiques non-propices d'entreposage, de mise en marche, de réchauffement, de conditionnement ou d'arrêt; les modifications non-autorisées du moteur. De plus, Komatsu n'est pas responsable de bris causés par de l'essence inadéquate ou de l'eau, des saletés ou autres contaminants dans l'essence. Komatsu n'est pas responsable des réparations non-relées au moteur, des dépenses encourues suite aux temps d'arrêts, des dommages relatifs, amendes, et de tout autre coût d'affaires ou autres pertes résultant d'un bris couvert par la garantie.

KOMATSU N'EST PAS RESPONSABLE DES INCIDENTS OU DOMMAGES CONSÉQUENTS.

Cette garantie, ainsi que les garanties expresses commerciales, sont les seules garanties de Komatsu. **IL N'Y A AUCUNE AUTRE GARANTIE, EXPRESSE OU SOUS-ENTENDUE, MARCHANDABLE OU PROPICE A UNE UTILISATION PARTICULIÈRE.**

INFORMATION IMPORTANTE SUR LE MOTEUR
 CE MOTEUR EST CONFORME AUX NORMES AMÉRICAINES DE L'EPA (ANNÉE DU MODÈLE) ET DE LA CALIFORNIE POUR LES MOTEURS LARGES NON-ROUTIERS À IGNITION PAR COMPRESSION. CE MOTEUR EST CERTIFIÉ POUR OPERATION À ESSENCE DIESEL.

AVERTISSEMENT
 DES BLESSURES PEUVENT RÉSULTER ET LA GARANTIE S'ANNULER SI LES RPM DU TAUX D'ESSENCE OU L'ALTITUDE EXCÈDENT LES VALEURS MAXIMALES PUBLIÉES POUR CE MODÈLE ET SON APPLICATION.

IMPORTANT ENGINE INFORMATION
 THIS ENGINE CONFORMS TO YYYY MODEL YEAR U.S. EPA REGULATION AND THE CALIFORNIA REGULATIONS LARGE NON ROAD COMPRESSION IGNITION ENGINES. THIS ENGINE IS CERTIFIED TO OPERATE ON DIESEL FUEL.

WARNING
 INJURY MAY RESULT AND WARRANTY IS VOIDED IF FUEL RATE RPM OR ALTITUDES EXCEED PUBLISHED MAXIMUM VALUES FOR THIS MODEL AND APPLICATION.

| | |
|---------------------------------|---|
| ENGINE MODEL | SERIAL NO. |
| ENGINE FAMILY | DISPLACEMENT LITERS |
| EXHAUST EMISSION CONTROL SYSTEM | FIRING ORDER 1-3-3-6-2-4 |
| ADV. LOAD OUTPUT Kw (HP) | RPM |
| VALVE LASH COLD (mm) | EX. FUEL RATE AT ADV. mm ³ /STROKE |
| IDLE SPEED | RPM FAMILY EMISSION LIMIT |
| INITIAL INJECTION TIMING | DEG. BTDC DATE OF MANUFACTURE |
| KOMATSU LTD. MADE IN JAPAN | |

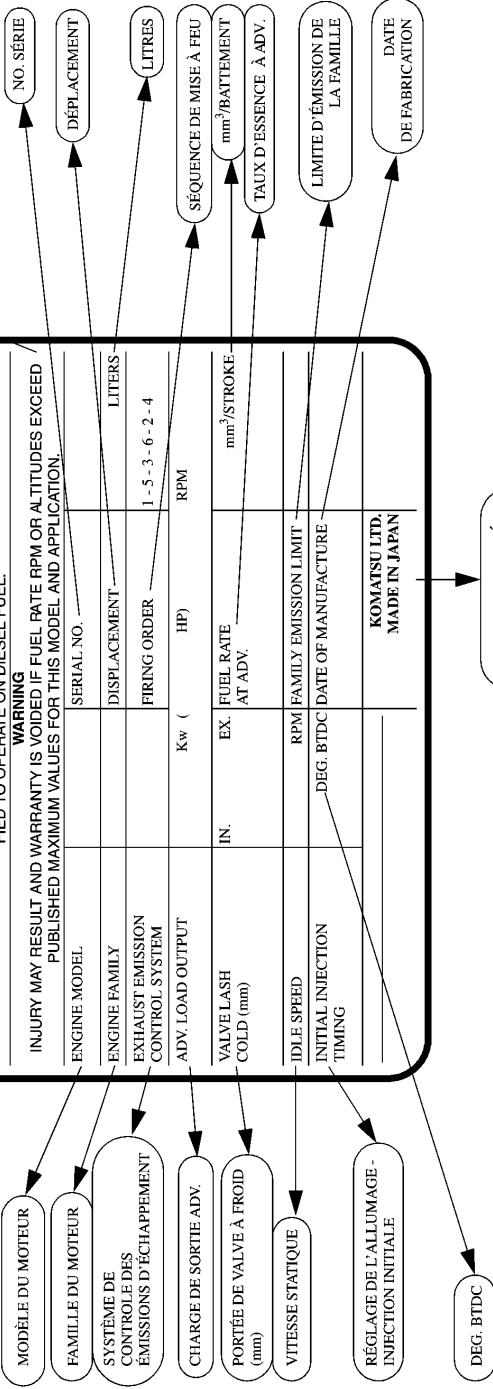

KOMATSU LTD.
 FABRIQUÉ AU JAPON

ENGINE DATAPLATE - ENGLISH / FRENCH

SAFETY INFORMATION

To enable you to use this machine safely, safety precautions and labels are given in this manual and affixed to the machine to give explanations of situations involving potential hazards and of the methods of avoiding such situations.

Signal words

The following signal words are used to inform you that there is a potential hazardous situation that may lead to personal injury or damage.

In this manual and on machine labels, the following signal words are used to express the potential level of hazard.



Indicates an imminently hazardous situation which, if not avoided, will result in death or serious injury. This signal word is to be limited to most extreme situations.



Indicates a potentially hazardous situation which, if not avoided, could result in death or serious injury.



Indicates a potentially hazardous situation which, if not avoided, may result in minor or moderate injury. It may also be used to alert against unsafe practices.

Example of safety message using signal word



**When standing up from the operator's seat, always place the safety lock lever in the LOCK position.
If you accidentally touch the levers when they are not locked, this may cause a serious injury or damage.**

Other signal words

In addition to the above, the following signal words are used to indicate precautions that should be followed to protect the machine or to give information that is are useful to know.

NOTICE

This word is used for precautions that must be taken to avoid actions which could shorten the life of the machine.

REMARKS

This word is used for information that is useful to know.

- Safety labels

Safety labels are affixed to the machine to inform the operator or maintenance worker on the spot when carrying out operation or maintenance of the machine that may involve hazard.

This machine uses "Safety labels using words" and "Safety labels using pictograms" to indicate safety procedures.

Example of safety label using words

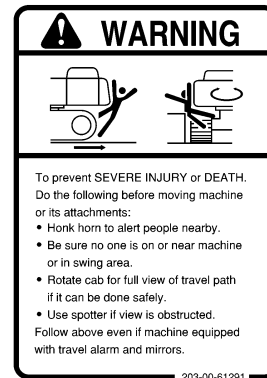

Part No.

Safety labels using pictogram

Safety pictograms use a picture to express a level of hazardous condition equivalent to the signal word. These safety pictograms use pictures in order to let the operator or maintenance worker understand the level and type of hazardous condition at all times.

Safety pictograms show the type of hazardous condition at the top or left side, and the method of avoiding the hazardous condition at the bottom or right side. In addition, the type of hazardous condition is displayed inside a triangle and the method of avoiding the hazardous condition is shown inside a circle.



Part No.

Komatsu cannot predict every circumstance that might involve a potential hazard in operation and maintenance. Therefore, the safety messages in this manual and on the machine may not include all possible safety precautions.

If any procedures or actions not specifically recommended or allowed in this manual are used, it is your responsibility to take the necessary steps to ensure safety.

In no event should you engage in prohibited uses or actions described in this manual.

The explanations, values, and illustrations in this manual were prepared based on the latest information available at that time. Continuing improvements in the design of this machine can lead to changes in detail which may not be reflected in this manual. Consult Komatsu or your Komatsu distributor for the latest available information of your machine or for questions regarding information in this manual.

The numbers in circles in the illustrations correspond to the numbers in () in the text. (For example: → (1))

INTRODUCTION

This Komatsu machine is designed to be used mainly for the following work:

- Digging work
- Leveling work
- Ditching work
- Loading work
- Demolition work

See the section "RECOMMENDED APPLICATIONS (3-68)" for further details.

DIRECTIONS OF MACHINE

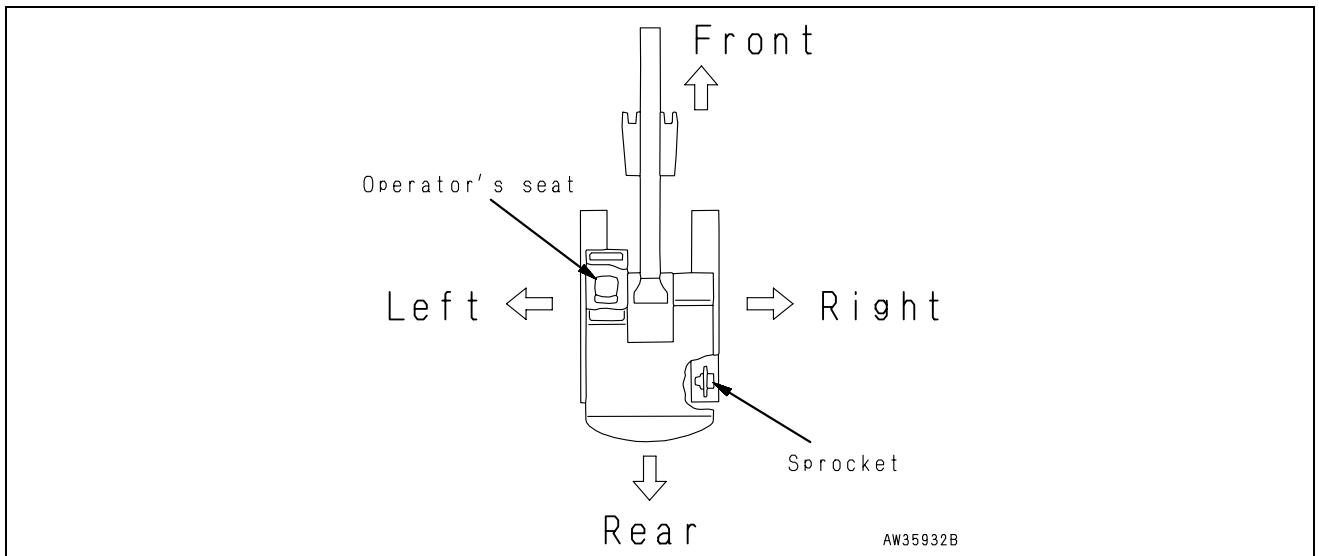

In this manual, the terms front, rear, left, and right refer to the travel direction as seen from the operator's cab when the operator's cab is facing the front and the sprocket is at the rear of the machine.

PRODUCT INFORMATION

When requesting service or ordering replacement parts, please inform your Komatsu distributor of the following items.

MACHINE SERIAL NUMBER PLATE AND ITS LOCATION

This is located at the front right lower part of the operator's cab or canopy.

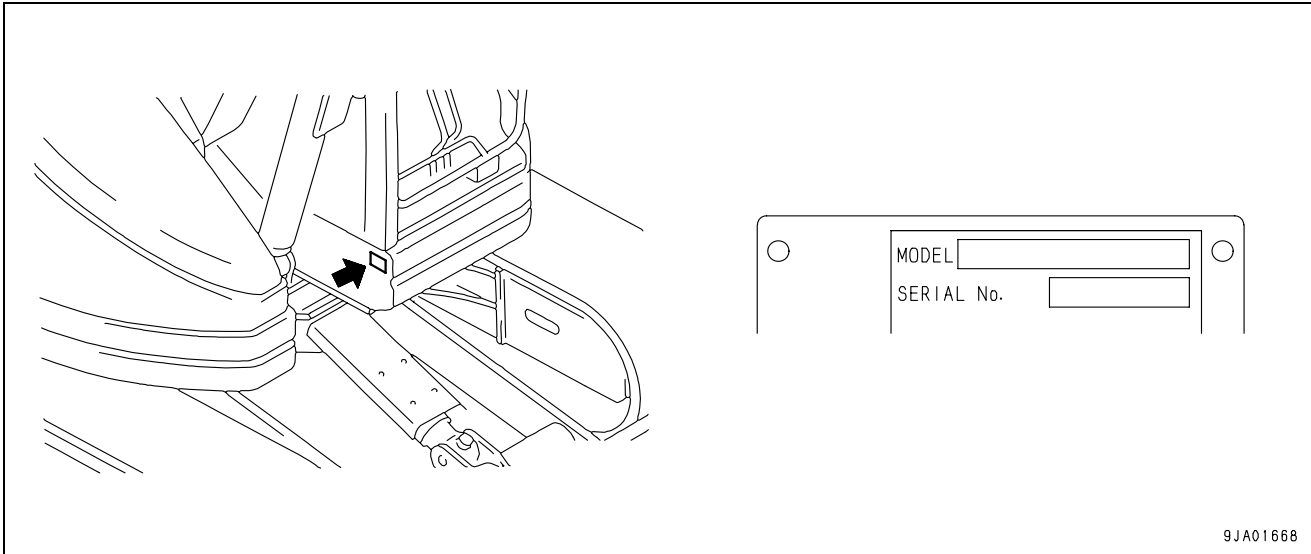

ENGINE SERIAL NUMBER PLATE AND ITS LOCATION

This is stuck to the air cleaner bracket.

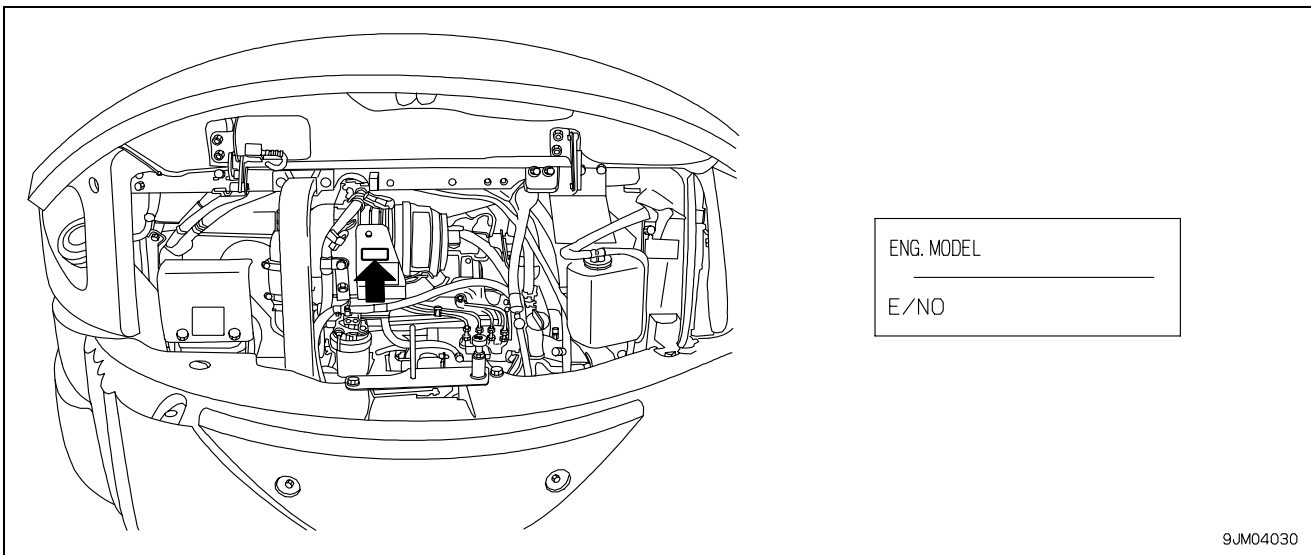

EMISSION CONTROL INFORMATION LABEL AND ITS LOCATION

This is stuck to the air cleaner.

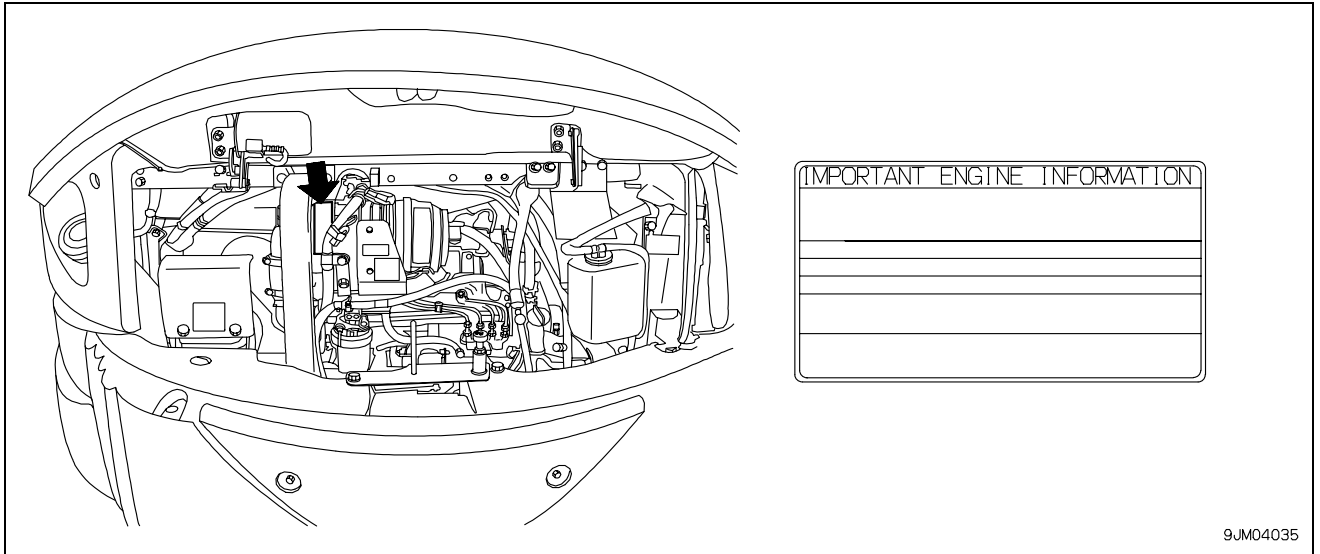

EPA: Environmental Protection Agency, U.S.A.

SERVICE METER LOCATION

On top of the machine monitor

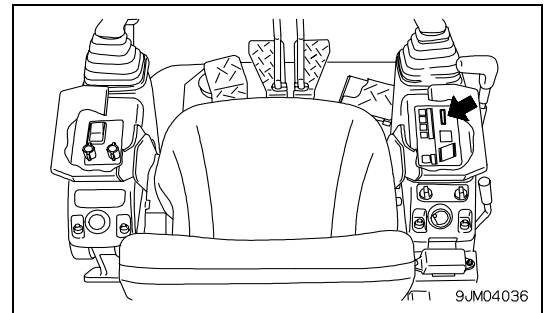

YOUR MACHINE SERIAL NUMBERS AND DISTRIBUTOR

| | |
|--------------------|--|
| Machine serial No. | |
| Engine serial No. | |
| Distributor name | |
| Address | |
| | |
| Service Personal | |
| Phone/Fax | |

CONTENTS

FOREWORD

| | |
|---|-----|
| FOREWORD | 1-2 |
| SAFETY INFORMATION | 1-5 |
| INTRODUCTION | 1-7 |
| DIRECTIONS OF MACHINE | 1-7 |
| PRODUCT INFORMATION | 1-8 |
| MACHINE SERIAL NUMBER PLATE AND ITS LOCATION | 1-8 |
| ENGINE SERIAL NUMBER PLATE AND ITS LOCATION | 1-8 |
| EMISSION CONTROL INFORMATION LABEL AND ITS LOCATION | 1-9 |
| SERVICE METER LOCATION | 1-9 |
| YOUR MACHINE SERIAL NUMBERS AND DISTRIBUTOR | 1-9 |

SAFETY

| | |
|--|------|
| SAFETY INFORMATION | 2-2 |
| WARNING LABELS AND PICTOGRAMS | 2-4 |
| WARNING LABELS AND PICTOGRAMS - LOCATION | 2-5 |
| WARNING LABELS AND PICTOGRAMS - ACTUAL | 2-6 |
| SAFETY INFORMATION | 2-13 |
| SAFETY MACHINE OPERATION | 2-21 |
| STARTING ENGINE | 2-21 |
| OPERATION | 2-22 |
| TRANSPORTATION | 2-28 |
| BATTERY | 2-29 |
| TOWING | 2-31 |
| LIFTING OBJECTS WITH BUCKET | 2-32 |
| SAFETY MAINTENANCE INFORMATION | 2-33 |

OPERATION

| | |
|------------------------------------|-----|
| MACHINE VIEW ILLUSTRATIONS | 3-2 |
| OVERALL MACHINE VIEW | 3-2 |
| CONTROLS AND GAUGES | 3-3 |
| DETAILED CONTROLS AND GAUGES | 3-4 |
| MONITORING SYSTEM | 3-4 |

| | |
|--|-------------|
| Caution Monitors..... | 3-5 |
| Emergency Monitors..... | 3-6 |
| Meter Display Portion | 3-7 |
| Electronic Control System | 3-9 |
| SWITCHES | 3-11 |
| CONTROL LEVERS AND PEDALS | 3-14 |
| WINDSHIELD | 3-18 |
| SLIDING DOOR..... | 3-22 |
| REAR WINDOW | 3-23 |
| SIDE WINDOW..... | 3-24 |
| EMERGENCY ESCAPE HAMMER | 3-24 |
| CAP WITH LOCK..... | 3-25 |
| ENGINE HOOD | 3-26 |
| MUD COVER..... | 3-27 |
| FUSE | 3-28 |
| BLOCK FUSE | 3-28 |
| AUXILIARY ELECTRIC POWER..... | 3-29 |
| OPERATION MANUAL STORAGE | 3-29 |
| TOOL BOX..... | 3-30 |
| GREASE PUMP HOLDER..... | 3-30 |
| ASHTRAY | 3-30 |
| MACHINE OPERATIONS AND CONTROLS..... | 3-31 |
| BEFORE STARTING ENGINE | 3-31 |
| Walk-Around Checks | 3-31 |
| Checks Before Starting..... | 3-33 |
| Adjustment..... | 3-39 |
| Seat Belt | 3-40 |
| Operations Before Starting Engine | 3-41 |
| STARTING ENGINE | 3-43 |
| Normal Starting..... | 3-43 |
| Starting Engine In Cold Weather | 3-45 |
| AFTER STARTING ENGINE | 3-47 |
| Breaking-In The New Machine | 3-47 |
| Warming-Up Operation..... | 3-48 |
| STOPPING THE ENGINE | 3-51 |
| CHECK AFTER SHUTTING OFF ENGINE | 3-51 |
| MACHINE OPERATION | 3-52 |
| Preparations For Moving The Machine Off..... | 3-52 |
| Moving Machine Forward | 3-53 |
| Moving Machine Backward..... | 3-54 |
| Stopping Machine | 3-55 |
| STEERING THE MACHINE..... | 3-56 |
| Steering | 3-56 |
| SWINGING | 3-58 |
| WORK EQUIPMENT CONTROLS AND OPERATIONS | 3-59 |
| PROHIBITED OPERATIONS | 3-61 |
| GENERAL OPERATION INFORMATION | 3-62 |

CONTENTS

| | |
|--|-------------|
| TRAVELING ON SLOPES | 3-65 |
| ESCAPE FROM MUD | 3-67 |
| Stuck One Side Of Track | 3-67 |
| Stuck Both Sides Of Tracks | 3-67 |
| RECOMMENDED APPLICATIONS | 3-68 |
| Backhoe Work | 3-68 |
| Ditching Work | 3-68 |
| Loading Work..... | 3-68 |
| Refill And Finishing Work..... | 3-69 |
| Side Ditching Work | 3-69 |
| Operations In Confined Spaces..... | 3-69 |
| BUCKET REPLACEMENT | 3-70 |
| PARKING MACHINE | 3-71 |
| MACHINE INSPECTION AFTER DAILY WORK | 3-72 |
| LOCKING..... | 3-72 |
| ELECTRONIC CONTROL SYSTEM HANDLING..... | 3-73 |
| Interference Prevention Device (Between Bucket And Cab, Canopy)..... | 3-74 |
| Handling Automatic Control Device | 3-76 |
| ROAD LINERS AND RUBBER SHOES | 3-80 |
| Road Liners And Rubber Shoes Information | 3-80 |
| Warranty For Road Liners And Rubber Shoes | 3-80 |
| Using Road Liners And Rubber Shoes | 3-81 |
| Long Life Operations | 3-81 |
| TRANSPORTATION | 3-85 |
| TRANSPORTATION PROCEDURE..... | 3-85 |
| LOADING AND UNLOADING WITH TRAILER | 3-85 |
| Loading | 3-86 |
| Securing Machine | 3-87 |
| Unloading..... | 3-88 |
| LIFTING MACHINE..... | 3-89 |
| COLD WEATHER OPERATION | 3-91 |
| COLD WEATHER OPERATION INFORMATION..... | 3-91 |
| Fuel And Lubricants | 3-91 |
| Cooling System Coolant | 3-91 |
| Battery | 3-92 |
| CAB HEATER IN COLD WEATHER | 3-92 |
| AFTER DAILY WORK COMPLETION | 3-93 |
| AFTER COLD WEATHER SEASON | 3-93 |
| LONG TERM STORAGE | 3-94 |
| BEFORE STORAGE..... | 3-94 |
| DURING STORAGE | 3-94 |
| AFTER STORAGE..... | 3-94 |
| TROUBLES AND ACTIONS | 3-95 |
| RUNNING OUT OF FUEL | 3-95 |
| PHENOMENA THAT ARE NOT FAILURES..... | 3-95 |

| | |
|---|-------|
| TOWING THE MACHINE | 3-98 |
| SEVERE JOB CONDITION | 3-98 |
| DISCHARGED BATTERY | 3-99 |
| Battery Removal And Installation..... | 3-99 |
| Battery Charges..... | 3-100 |
| Starting Engine With Booster Cables | 3-101 |
| OTHER TROUBLE | 3-103 |
| Electrical System | 3-103 |
| Chassis..... | 3-103 |
| Engine..... | 3-104 |
| Electronic Control System | 3-105 |

MAINTENANCE

| | |
|---|------|
| MAINTENANCE INFORMATION | 4-2 |
| LUBRICANTS, COOLANT AND FILTERS | 4-4 |
| HANDLING OIL, FUEL, COOLANT, AND PERFORMING OIL CLINIC | 4-4 |
| Oil | 4-4 |
| Fuel..... | 4-4 |
| Cooling System Coolant | 4-4 |
| Grease..... | 4-5 |
| Carrying out KOWA (Komatsu Oil Wear Analysis) | 4-5 |
| Oil And Fuel Storage | 4-6 |
| Filters | 4-6 |
| ELECTRICAL SYSTEM MAINTENANCE..... | 4-6 |
| WEAR PARTS | 4-7 |
| WEAR PARTS LIST..... | 4-7 |
| LUBRICANTS, FUEL AND COOLANT SPECIFICATIONS | 4-8 |
| PROPER SELECTION | 4-8 |
| TIGHTENING TORQUE SPECIFICATIONS | 4-11 |
| TIGHTENING TORQUE LIST..... | 4-11 |
| SAFETY CRITICAL PARTS | 4-12 |
| SAFETY CRITICAL PARTS LIST | 4-12 |
| MAINTENANCE SCHEDULE | 4-13 |
| MAINTENANCE SCHEDULE CHART | 4-13 |
| MAINTENANCE INTERVAL FOR HYDRAULIC BREAKER..... | 4-14 |
| MAINTENANCE PROCEDURE | 4-15 |
| INITIAL 250 HOURS MAINTENANCE (ONLY AFTER THE FIRST 250 HOURS)..... | 4-15 |
| WHEN REQUIRED | 4-16 |
| Air Cleaner Element - Check/Clean/Replace..... | 4-16 |
| Cooling System Coolant - Clean/Change..... | 4-21 |

CONTENTS

| | |
|---|------|
| Water Separator Element - Clean..... | 4-24 |
| Fuel Tank - Drain | 4-24 |
| Fuel Tank - Clean | 4-25 |
| Track Shoe Bolts - Check/Tighten | 4-26 |
| Track Tension - Check/Adjust..... | 4-27 |
| Road Liners or Rubber Shoes - Check..... | 4-28 |
| Rubber Shoe Tension - Check/Adjust | 4-30 |
| Road Liners - Replace | 4-31 |
| Rubber Shoes - Replace | 4-31 |
| Road Liners or Steel Shoes to Rubber Shoes - Change | 4-34 |
| Bucket Teeth - Check/Replace | 4-35 |
| Windshield Washer Fluid Level - Check/Add..... | 4-38 |
| Cab Slide Door Rail And Roller - Check/Clean/Lubricate..... | 4-39 |
| Hydraulic System - Bleed Air | 4-40 |
| CHECK BEFORE STARTING | 4-42 |
| EVERY 100 HOURS MAINTENANCE..... | 4-43 |
| Lubricating | 4-43 |
| EVERY 250 HOURS MAINTENANCE..... | 4-44 |
| Engine Crankcase Oil - Change | 4-44 |
| Hydraulic Oil Filter Element - Replace..... | 4-45 |
| Cooling Fan Belt Tension - Inspect/Adjust..... | 4-46 |
| Battery Electrolyte Level - Check..... | 4-48 |
| EVERY 500 HOURS MAINTENANCE..... | 4-50 |
| Engine Crankcase Oil Filter Cartridge - Replace..... | 4-50 |
| Fuel Filter Element - Replace | 4-51 |
| Final Drive Case Oil Level - Check/Add | 4-52 |
| Lubricating | 4-53 |
| Radiator Fins, Oil cooler fins - Clean/Check..... | 4-55 |
| EVERY 1000 HOURS MAINTENANCE..... | 4-56 |
| Final Drive Case Oil - Change | 4-56 |
| Engine Valve Clearance - Check/Adjust..... | 4-56 |
| EVERY 2000 HOURS MAINTENANCE..... | 4-57 |
| Hydraulic Oil and Strainer - Change/Clean..... | 4-57 |
| | 4-58 |
| | 4-58 |
| | 4-58 |
| Alternator and Starting Motor - Inspect..... | 4-58 |

SPECIFICATIONS

| | |
|----------------------|-----|
| SPECIFICATIONS | 5-2 |
|----------------------|-----|

ATTACHMENTS AND OPTIONS

| | |
|--|-----|
| ATTACHMENTS AND OPTIONS - GENERAL INFORAMTION..... | 6-2 |
|--|-----|

| | |
|--|-------------|
| SAFETY FIRST..... | 6-2 |
| ATTACHMENT INSTALLATION..... | 6-3 |
| BUCKET WITH HOOK..... | 6-4 |
| HOOK CONDITION | 6-4 |
| PROHIBITED OPERATIONS | 6-4 |
| AIR CONDITIONER..... | 6-5 |
| CONTROL PANEL AND COMPONENTS | 6-5 |
| AIR CONDITIONER CONTROLS..... | 6-7 |
| AIR CONDITIONER MAINTENANCE..... | 6-8 |
| When Required..... | 6-8 |
| Every 250 Hours Maintenance | 6-9 |
| Every 500 Hours Maintenance | 6-10 |
| DEFROSTER CONTROLS..... | 6-12 |
| CONTROL PANEL..... | 6-12 |
| MACHINE READY FOR ATTACHMENT | 6-14 |
| LOCATIONS | 6-14 |
| HYDRAULIC CIRCUIT..... | 6-16 |
| Hydraulic Circuit Connection | 6-16 |
| ATTACHMENT OPERATIONS..... | 6-17 |
| When Using Breaker..... | 6-17 |
| When Using General Attachment | 6-18 |
| LONG TERM STORAGE | 6-19 |
| X WEIGHT (ADDITIONAL COUNTERWEIGHT) REMOVAL AND INSTALLATION METHOD..... | 6-20 |
| CHANGING MACHINE CONTROL PATTERN (IF PATTERN CHANGE VALVE EQUIPPED) | 6-22 |
| CONTROL PATTERN CHANGE PROCEDURE | 6-22 |
| MACHINE CONTROL PATTERNS..... | 6-23 |
| ATTACHMENT GUIDE..... | 6-24 |
| ATTACHMENT COMBINATIONS..... | 6-24 |
| RECOMMENDED ATTACHMENT OPERATIONS | 6-25 |
| HYDRAULIC BREAKER..... | 6-25 |

INDEX

SAFETY

WARNING

Please read and make sure that you fully understand the precautions described in this manual and the safety labels on the machine. When operating or servicing the machine, always follow these precautions strictly.

SAFETY INFORMATION

| | |
|---|------|
| WARNING LABELS AND PICTOGRAMS | 2-4 |
| WARNING LABELS AND PICTOGRAMS - LOCATION | 2-5 |
| WARNING LABELS AND PICTOGRAMS - ACTUAL | 2-6 |
| | |
| SAFETY INFORMATION | |
| Safety rules | 2-13 |
| If abnormalities are found | 2-13 |
| Working wear and personal protective items | 2-13 |
| Fire extinguisher and first aid kit | 2-13 |
| Safety equipment | 2-13 |
| Keep machine clean | 2-14 |
| Keep operator's compartment clean | 2-14 |
| Leaving operator's seat with lock | 2-14 |
| Handrails and steps | 2-15 |
| Mounting and dismounting | 2-15 |
| No persons on attachments | 2-15 |
| Crushing or cutting prevention | 2-15 |
| Burn prevention | 2-16 |
| Fire prevention and explosion prevention | 2-16 |
| Action if fire occurs | 2-17 |
| Windshield Washer Fluid | 2-17 |
| Falling objects, flying objects and intruding objects prevention | 2-17 |
| Attachment installation | 2-17 |
| Attachment combinations | 2-17 |
| Windows | 2-18 |
| Protection Against Falls In An Operation In Front Of The Operator's Seat (Canopy Specification) | 2-18 |
| Unauthorized modifications | 2-18 |
| Safety at jobsite | 2-18 |
| Working on loose ground | 2-18 |
| Distance to high voltage cables | 2-18 |
| Ensure good visibility | 2-19 |
| Ventilation for enclosed area | 2-19 |
| Signalman's signal and signs | 2-19 |
| Emergency exit from operator's cab | 2-19 |
| Asbestos dust hazard prevention | 2-20 |
| | |
| SAFETY MACHINE OPERATION | 2-21 |
| STARTING ENGINE | 2-21 |
| Checks before starting engine | 2-21 |
| Safety rules for starting engine | 2-21 |
| Starting engine in cold weather | 2-21 |
| OPERATION | 2-22 |
| Checks before operation | 2-22 |
| Safety rules for changing machine directions | 2-22 |
| Safety rules for traveling | 2-23 |
| Traveling on slopes | 2-24 |
| Operations on slopes | 2-25 |
| Prohibited operations | 2-25 |
| Operations on snow | 2-27 |
| Parking machine | 2-27 |
| TRANSPORTATION | 2-28 |
| Loading and unloading | 2-28 |
| Shipping the machine | 2-28 |
| BATTERY | 2-29 |
| Battery hazard prevention | 2-29 |
| Starting engine with booster cables | 2-30 |
| TOWING | 2-31 |
| Safety rules for towing | 2-31 |

| | |
|--|------|
| LIFTING OBJECTS WITH BUCKET | 2-32 |
| Safety rules for lifting objects | 2-32 |
| SAFETY MAINTENANCE INFORMATION | 2-33 |
| Warning Tag | 2-33 |
| Keep Work Place Clean and Tidy | 2-33 |
| Appoint Leader when Working with Others | 2-33 |
| Stop Engine Before Carrying Out Maintenance | 2-33 |
| Two Workers for Maintenance when Engine is Running | 2-34 |
| Proper Tools | 2-34 |
| Personnel | 2-34 |
| Attachments | 2-35 |
| Work Under the Machine | 2-35 |
| Noise | 2-35 |
| When Using Hammer | 2-35 |
| Welding Works | 2-35 |
| Removing Battery Terminals | 2-35 |
| Safety First when Using High-pressure Grease to Adjust Track Tension | 2-36 |
| Do Not Disassemble Recoil Springs | 2-36 |
| Safety Rules for High-pressure Oil | 2-36 |
| Safety Handling High-pressure Hoses | 2-36 |
| Waste Materials | 2-37 |
| Air Conditioner Maintenance | 2-37 |
| Compressed Air | 2-37 |
| Periodic Replacement of Safety Critical Parts | 2-37 |

WARNING LABELS AND PICTOGRAMS

The following warning signs and safety labels are used on this machine.

- Be sure that you fully understand the correct position and content of labels.
- To ensure that the content of labels can be read properly. Be sure that they are in the correct place and always keep them clean. When cleaning them, do not use organic solvents or gasoline, there may cause the labels to peel off.
- There are also other labels in addition to the warning signs and safety labels. Handle those labels in the same way.
- If the labels are damaged, lost, or cannot be read properly, replace them with new ones. For details of the part numbers for the labels, see this manual or the actual label, and place an order with your Komatsu distributor.

WARNING LABELS AND PICTOGRAMS - LOCATION

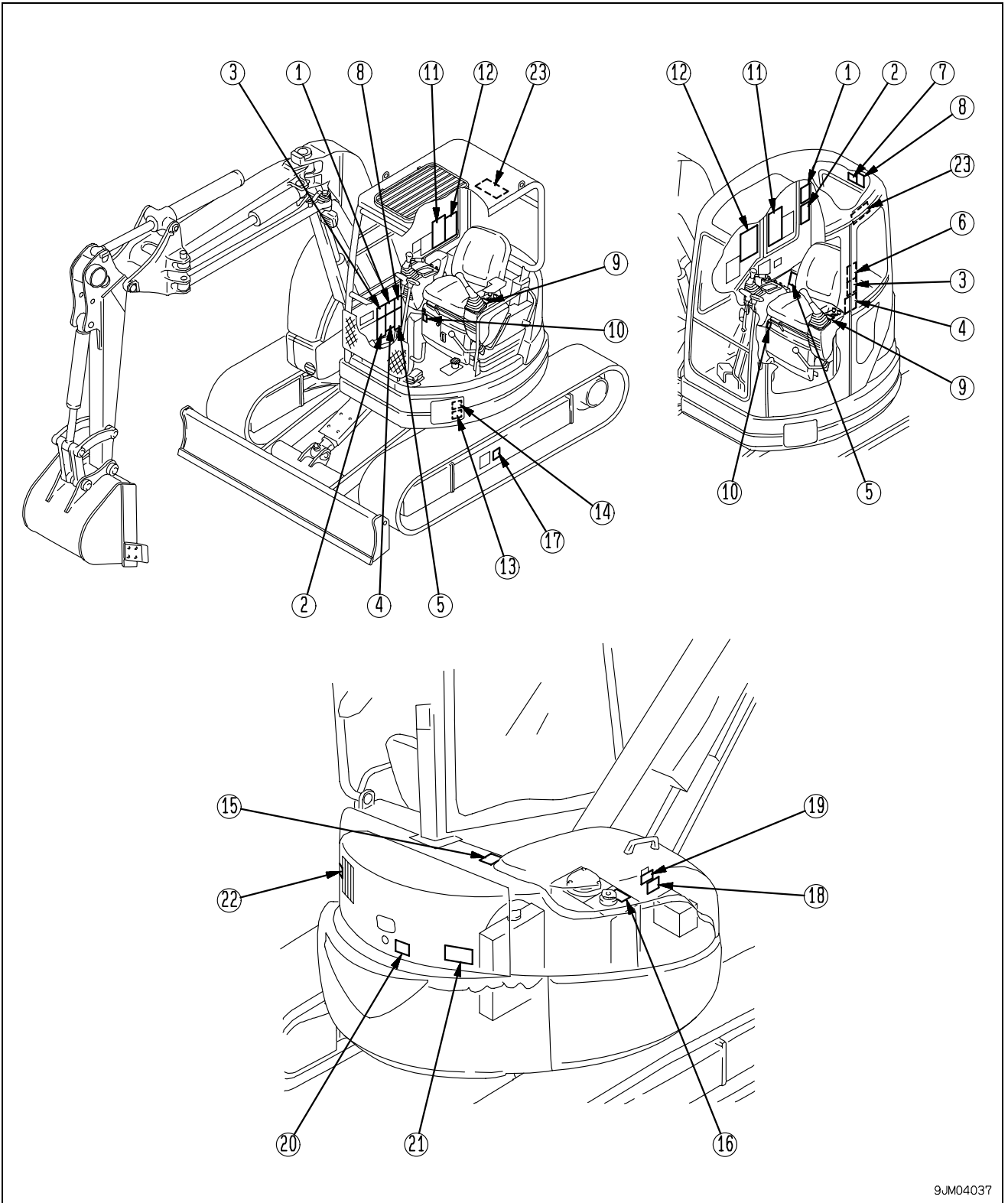

9JM04037

WARNING LABELS AND PICTOGRAMS - ACTUAL

(1) Precautions for operation, inspection and maintenance (09651-03001)

(2) Precautions before operation (09802-03000)

⚠ WARNING

Improper operation and maintenance can cause serious injury or death.

Read manual and labels before operation and maintenance. Follow instructions and warnings in manual and in labels on machine.

Keep manual in machine cab near operator.
Contact Komatsu distributor for a replacement manual.

09651-03001

⚠ WARNING

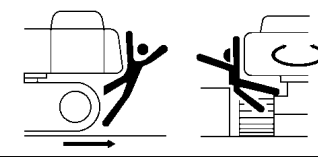

To prevent SEVERE INJURY or DEATH, do the following before moving machine or its attachments:

- Honk horn to alert people nearby.
- Be sure no one is on or near machine or in swing area.
- Rotate cab for full view of travel path if it can be done safely.
- Use spotter if view is obstructed.

Follow above even if machine is equipped with travel alarm and mirrors.

09802-03000

(3) Warning for leaving operator's seat (09654-03001)

(4) Warnings for high voltage (09801-03001)

⚠ WARNING

To avoid hitting unlocked operation levers, lower equipment to ground and move SAFETY LOCK LEVER (located near seat) to LOCK position before dtanding up from operator's seat.

Sudden and unwanted machine movement can cause serious injury or death.

09654-03001

⚠ DANGER



Hazardous voltage hazard. Seriou injury or death can occur it machine of attachments are not kept safe distance away from electric lines.

| VOLTAGE | | SAFE DISTANCE |
|----------------------|-----------|---------------|
| LOW VOLTAGE | 100V 200V | 2m |
| | 6 600V | 2m |
| | 22 000V | 3m |
| SPECIAL HIGH VOLTAGE | 66 000V | 4m |
| | 154 000V | 5m |
| | 187 000V | 6m |
| | 275 000V | 7m |
| | 500 000V | 11m |

09801-03001

(5) Precautions for operating pattern
Standard machine (09822-03000)



WARNING

In order to prevent an accident resulting in injury or death caused by error-operation, confirm the machine motion and indicated operating pattern, when operating machines. Pay attention to the circumference and operate slowly when confirming the machine motion.

ISO pattern

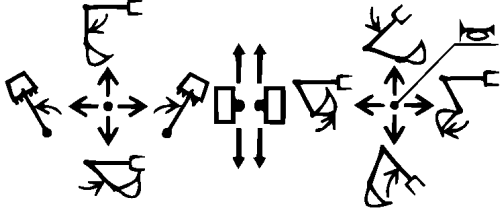

09822-03000

(6) Machine equipped with operating pattern selector valve (22M-98-11160)



WARNING

This machine is equipped with a control pattern selector valve. To prevent personal injury caused by mistaken operation, always check that the movement of the machine matches the pattern shown on the control pattern card before starting operations.

- When checking the movement of the machine, check that the surrounding area is safe and operate the machine slowly.
- If the movement does not match the control pattern card, replace the card with the card showing the correct control pattern.

Always do as follows when changing the control pattern.

- Lower the work equipment to the ground, stop the engine, and set the safety lock lever to the LOCK position. Then change the control pattern.

22M-98-11160

(7) Precautions for opening the window (09839-03000)



WARNING

To open or close the front or ceiling window, never stand up from the operator's seat before throwing the safety lock lever to the LOCK position. Inadvertently touching any of the working equipment control levers might cause the machine to start moving all of a sudden, probably resulting in a serious injury.

09839-03000

(8) Precautions for storage (09803-03000)



WARNING

When raising window, lock it in place with lock pins on both sides.

Falling window can cause injury.

09803-03000

(9) Precautions for broken or dislodged window (20U-98-21910)

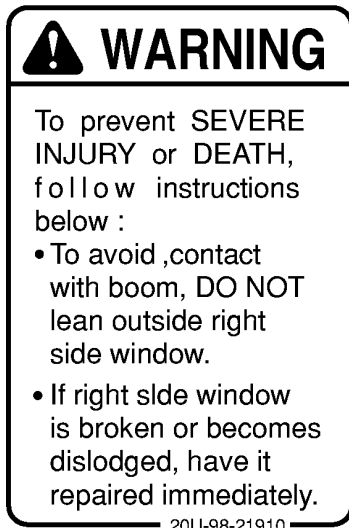

(10) The safety lock is operated with the lock lever (22L-98-18240)



(11) Cautions for emergency work equipment actuation switch (21W-98-21521)

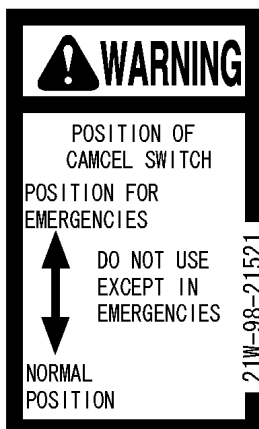

(12) Cautions for handling interference prevention device (21W-98-21420)

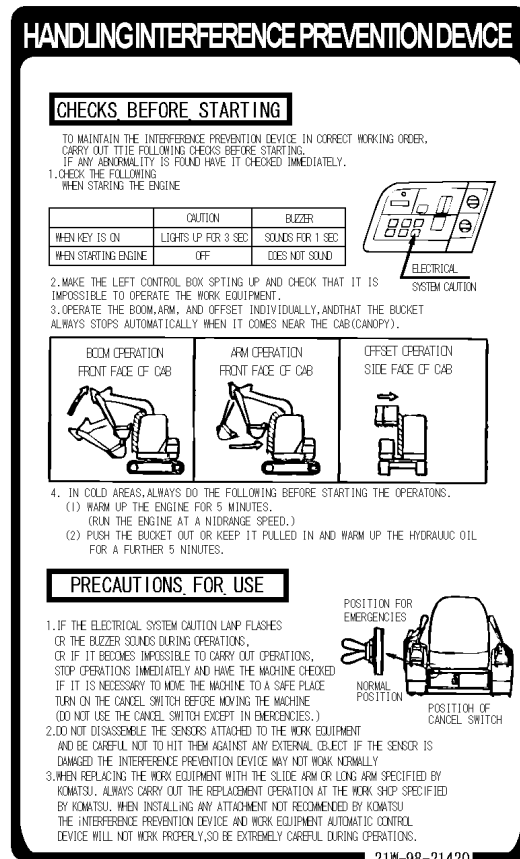

(13) Handling automatic control system for work equipment (20U-98-41640)

(14) Precautions when switching operating pattern (22M-98-11180)
(For machines equipped with operating pattern selector valve)

HANDLING AUTOMATIC CONTROL SYSTEM FOR WORK EQUIPMENT

THIS MACHINE IS EQUIPPED WITH THE FOLLOWING AUTOMATIC CONTROL DEVICES TO ALLOW THE MACHINE TO CARRY OUT OPERATIONS SUCH AS SIDE DITCHING WITH INCREASED EFFICIENCY. FOR DETAILS, SEE THE OPERATION AND MAINTENANCE MANUAL.

1. DEPTH DISPLAY (DEPTH FROM GROUND LEVEL)
THIS IS ALWAYS DISPLAYED DURING OPERATIONS.

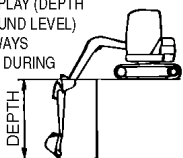

2. DEPTH SET 0 MODE: (DEPTH FROM STANDARD SURFACE)
STANDARD SURFACE

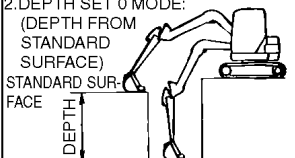

3. HEIGHT MODE: THIS SETS THE AMOUNT THAT THE BOOM IS RAISED.

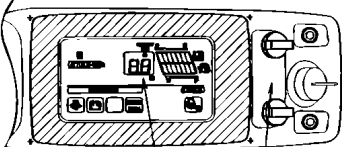
METHOD OF SETTING

- (1) SET THE MODE SELECTOR SWITCH TO THE DESIRED MODE.
- (2) SET THE WORK EQUIPMENT TO THE DESIRED POSITION.
- (3) TURN THE SET SWITCH TO THE SET POSITION.
THE BUZZER WILL SOUND TWICE AND THE INDICATOR OF THE SELECTED MENU WILL LIGHT UP.
- (4) TO CANCEL THE SETTING, TURN THE SET SWITCH TO THE CLEAR POSITION.

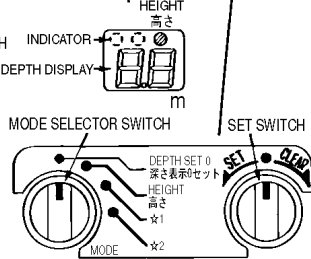

※ IT IS POSSIBLE TO SET TWO OR MORE MODES AT THE SAME TIME.
※ WHEN THE ENGINE IS STOPPED, ALL THE SETTINGS WILL BE CANCELED.

20U-98-41640

⚠ WARNING

- When changing the control pattern, set the machine in the parking condition, stop the engine, and set the safety lock lever to the LOCK position.
- Align the control pattern selector lever to the specified position. (Check the detent.)
- After changing the control pattern, do not forget to exchange the control pattern card and display the new control pattern card inside the operator's cab.

22M-98-11180

(15) Precautions for avoiding falling down (20U-98-41690)



(16) Precautions for high-temperature cooling water (09668-03001)



(17) Precautions for high-temperature hydraulic oil (09653-03001)



(18) Precautions for checking and adjusting track tension (09657-03003)



(19) Precautions for handling electrical wires (09808-03000)

| |
|--|
|  WARNING |
| <p>Improper use of booster cables and battery cables can cause an explosion resulting in serious injury or death.</p> <ul style="list-style-type: none"> • Follow instructions in manual when using booster cable and battery cables. |
| <p>09808-03000</p> |

(20) Precautions when handling battery (09664-30082)

| |
|---|
|  WARNING |
| <p>EXPLOSIVE GASES Cigarettes, flames or sparks could cause battery to explode. Always shield eyes and face from battery. DO not charge or use booster cables or adjust post connections without proper instruction and training. KEEP VENT CAPS TIGHT AND LEVEL</p> <p>POISON causes severe burns Contains sulfuric acid. Avoid contact with skin, eyes or clothing. In event of accident flush with water and call a physician immediately. KEEP OUT OF REACH OF CHILDREN</p> |
| <p>09664-30082</p> |

(21) Precautions for opening engine hood (09667-03001)

| |
|--|
|  CAUTION |
| <p>While engine is running:</p> <ol style="list-style-type: none"> 1. Do not open cover. 2. Keep away from fan and fan-belt. |
| <p>09667-03001</p> |

(22) It is prohibited to enter the range of swing (20M-98-73130)

| |
|--|
|  DANGER |
| <p><i>KEEP OUT OF TURNING AREA</i></p> |

(23) Precautions for high temperature parts (09817-K064B)
 CAB specification

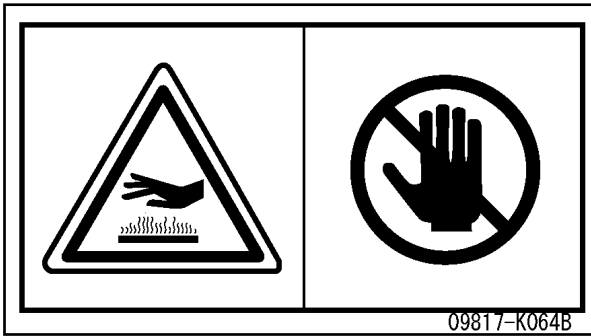

Sign indicates a burn hazard from touching heated parts, such as engine, motor, or muffler during or right after operation.

Never touch when hot.

(24) Precautions when handling TOPS (09620-30205)

TIP-OVER PROTECTIVE STRUCTURE (TOPS)
 THE TIP-OVER PROTECTIVE STRUCTURE OF THIS MACHINE COMPLIES WITH THE FOLLOWING STANDARDS.
 INTERNATIONAL STANDARD:ISO/DIS12117

KOMATSU

MODEL MACHINE MODEL SERIAL NO. MAX MASS

⚠ WARNING

- **Altering TOPS may weaken it. Consult Komatsu Distributor before altering.**
- **TOPS may provide less protection if it has been structurally damaged or involved in roll-over.**
- **Always wear seat belt when moving.**

Komatsu Ltd. Japan 2-3-6 Akasaka, Minato-ku, Tokyo, Japan 09620-30205

SAFETY INFORMATION

Safety Rules

- Only trained and authorized personnel can operate and maintain the machine.
- Follow all safety rules, precautions and instructions when operating or performing maintenance on the machine.
- If you are under the influence of alcohol or medication, your ability to safely operate or repair your machine may be severely impaired putting yourself and everyone else on your jobsite in danger.
- When working with another operator or with a person on worksite traffic duty, be sure that all personnel understand all hand signals that are to be used.

If Abnormalities are Found

If you find any abnormality in the machine during operation or maintenance (noise, vibration, smell, incorrect gauges, smoke, oil leakage, etc., or any abnormal display on the warning devices or monitor), report to the person in charge and have the necessary action taken. Do not operate the machine until the abnormality has been corrected.

Working Wear and Personal Protective Items

- Do not wear loose clothing and accessories. There is a hazard. They may catch on control levers or other protruding parts.
- If you have long hair and it hangs out from your hard hat, there is a hazard that it may get caught up in the machine. Tie your hair up and be careful not to let it get caught.
- Always wear a hard hat and safety shoes. If the nature of the work requires it, wear safety glasses, mask, gloves, ear plugs, and safety belt when operating or maintaining the machine.
- Check that all protective equipment functions properly before using it.

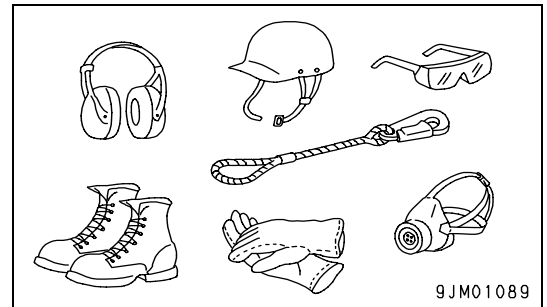

Fire Extinguisher and First Aid Kit

Always follow the precautions below to prepare for action if any injury or fire should occur.

- Be sure that fire extinguishers have been provided and read the labels to ensure that you know how to use them in emergencies.
- Carry out periodic inspection and maintenance to ensure that the fire extinguisher can always be used.
- Provide a first aid kit at the storage point. Carry out periodic checks and add to the contents if necessary.

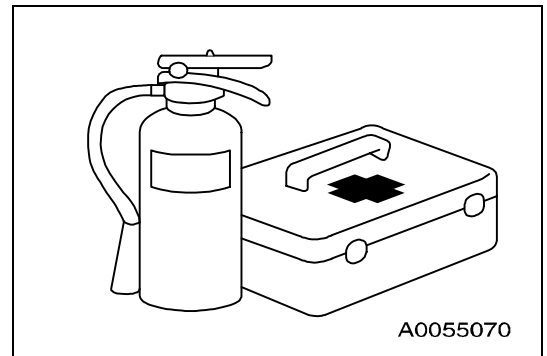

Safety Equipment

- Be sure that all guards and covers are in their proper position. Have guards and covers repaired immediately if they are damaged.
- Understand the method of use of safety features and use them properly.
- Never remove any safety features. Always keep them in good operating condition.

Keep Machine Clean

- If water gets into the electrical system, there is a danger that it will cause malfunctions or faulty operation. Do not use water or steam to wash the electrical system (sensors, connectors).
- If inspection and maintenance is carried out when the machine is still dirty with mud or oil, there is a hazard that you will slip and fall, or that dirt or mud will get into your eyes. Always keep the machine clean.

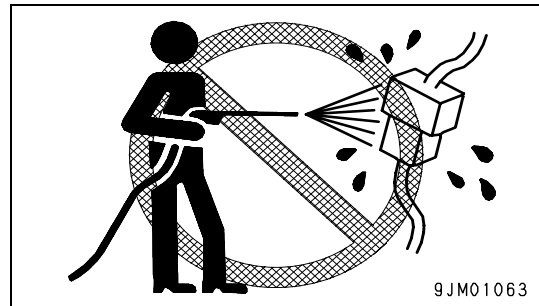

Keep Operator's Compartment Clean

- When entering the operator's compartment, always remove all mud and oil from the soles of your shoes. If you operate the pedal with mud or oil affixed to your shoes, your foot may slip and this may cause a serious accident.
- Do not leave parts or tools lying around the operator's compartment.
- Do not stick suction pads to the window glass. Suction pads act as a lens and may cause fire.
- Do not use cellular telephones inside the operator's compartment when driving or operating the machine.
- Never bring any dangerous objects such as flammable or explosive items into the operator's cab.

Leaving Operator's Seat with Lock

- Before standing up from the operator's seat (such as when opening or closing the front window, installing or removing the bottom window, or adjusting the operator's seat), always lower the work equipment completely to the ground, set safety lock lever (1) securely to the LOCK position, then stop the engine. If you accidentally touch the levers when they are not locked, there is a hazard that the machine may suddenly move and cause serious injury or property damage.
- When leaving the machine, always lower the work equipment completely to the ground, set safety lock lever (1) securely to the LOCK position, then stop the engine. Use the key to lock all the equipment. Always remove the key, take it with you, and keep it in the specified place.

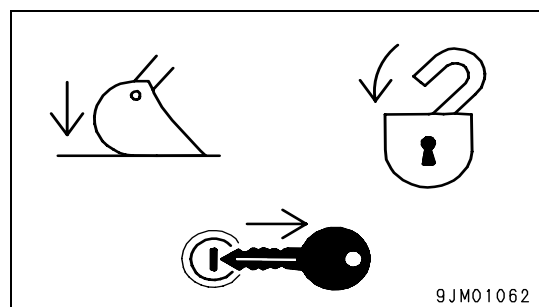
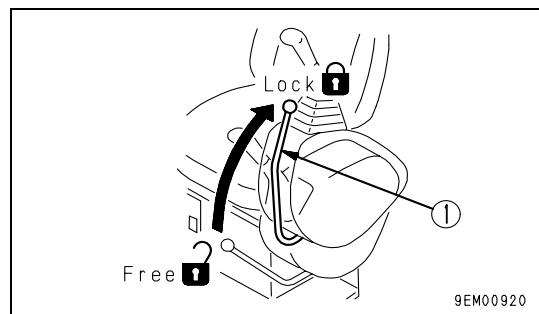

Handrails and Steps

To prevent personal injury caused by slipping or falling off the machine, always do as follows.

- Use the handrails and steps marked by arrows in the diagram on the right when getting on or off the machine.

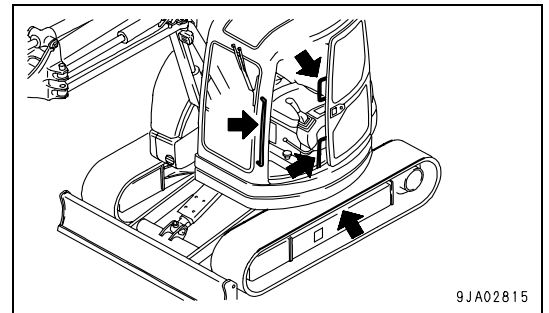
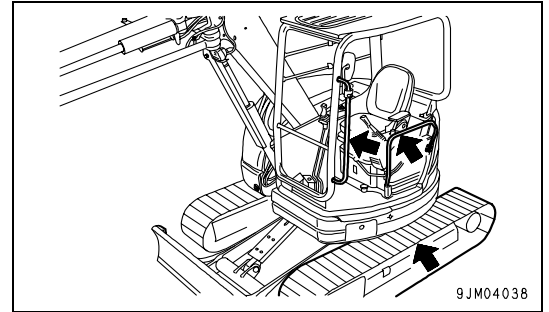

- To ensure safety, always face the machine and maintain three-point contact (both feet and one hand, or both hands and one foot) with the handrails and steps (including the track shoe) to ensure that you support yourself.
- Do not grip the control levers when getting on or off the machine.
- Never climb on the engine hood or covers where there are no non-slip pads.
- Before getting on or off the machine, check the handrails and steps (including the track shoe). If there is any oil, grease, or mud on the handrails or steps (including the track shoe), wipe it off immediately. Always keep these parts clean. Repair any damage and tighten any loose bolts.
- Do not get on or off the machine while holding tools in your hand.

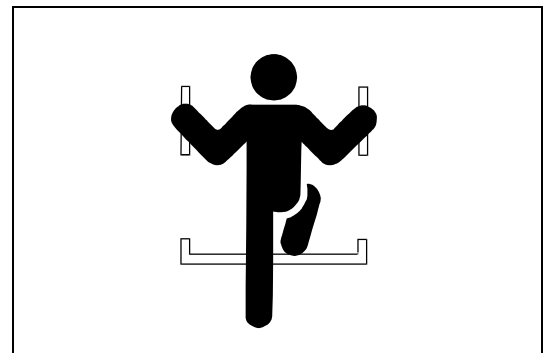

Mounting and Dismounting

- Never jump on or off the machine. Never get on or off a moving machine.
- If the machine starts to move when there is no operator on the machine, do not jump on to the machine and try to stop it.

No Persons on Attachments

Never let anyone ride on the bucket, grapple, clam-shell, or other attachments. There is a hazard of falling and suffering serious injury.

Do Not Get Caught In Articulated Portion

The clearance around the work equipment will change according to the movement of the link. If you get caught, this may lead to serious personal injury. Do not allow anyone to approach any rotating or telescoping part.

Burn Prevention

Hot coolant

- To prevent burns from hot water or steam spurting out when checking or draining the coolant, wait for the water to cool to a temperature where it is possible to touch the radiator cap by hand. Even when the coolant has cooled down, loosen the cap slowly to relieve any pressure inside the radiator before removing the cap.

Hot oil

- To prevent burns from hot oil spurting out when checking or draining the oil, wait for the oil to cool to a temperature where it is possible to touch the cap or plug by hand before starting the operation. Even when the oil has cooled down, loosen the cap or plug slowly to relieve any internal pressure before removing the cap or plug.

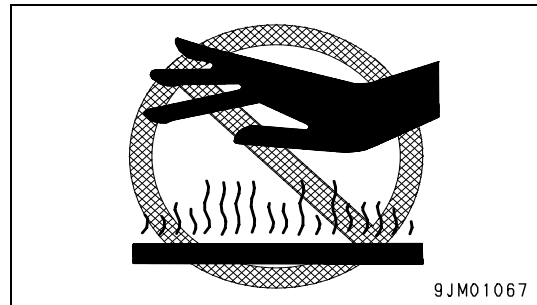
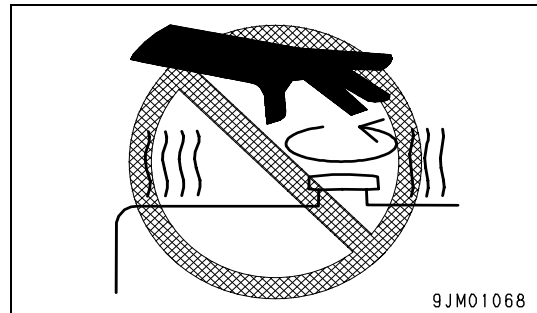

Fire Prevention and Explosion Prevention

- Fire caused by fuel or oil

Fuel, oil, antifreeze, and window washer liquid are particularly flammable and can be hazardous. To prevent fire, always observe the following:

- Do not smoke or use any flame near fuel or oil.
- Stop the engine before refueling.
- Do not leave the machine while adding fuel or oil.
- Tighten all fuel and oil caps securely.
- Do not spill fuel on overheated surfaces or on parts of the electrical system.
- Use well-ventilated areas for adding or storing oil and fuel.
- Keep oil and fuel in the determined place and do not allow unauthorized persons to enter.
- After adding fuel or oil, wipe up any spilled fuel or oil.
- When carrying out grinding or welding work on the chassis, move any flammable materials to a safe place before starting.
- When washing parts with oil, use a non-flammable oil. Diesel oil and gasoline may catch fire, so do not use them.
- Put greasy rags and other flammable materials into a safe container to maintain safety at the work place.
- Do not weld or use a cutting torch to cut any pipes or tubes that contain flammable liquids.

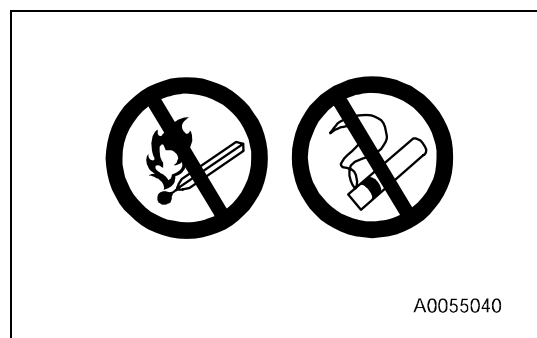
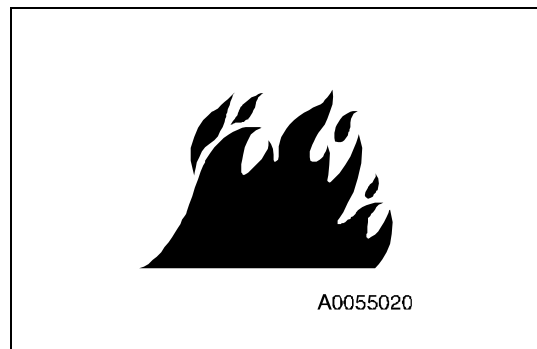

- Fire caused by accumulation of flammable material.

Remove any dry leaves, chips, pieces of paper, dust, or any other flammable materials accumulated or affixed around the engine, exhaust manifold, muffler, or battery, or inside or under the covers.

- Fire coming from electric wiring

Short circuits in the electrical system can cause fire.

- Always keep electric wiring connections clean and securely tightened.
- Check the wiring every day for looseness or damage. Tighten any loose connectors or wiring clamps. Repair or replace any damaged wiring.

- Fire coming from hydraulic line
Check that all the hose and tube clamps, guards, and cushions are securely fixed in position. If they are loose, they may vibrate during operation and rub against other parts. This may lead to damage to the hoses, and cause high-pressure oil to spurt out, leading to fire damage or serious injury.
- Explosion caused by lighting equipment
 - When checking fuel, oil, battery electrolyte, window washer fluid, or coolant, always use lighting with anti-explosion specifications. If such lighting equipment is not used, there is danger of explosion that may cause serious injury.
 - When taking the electrical power for the lighting from the machine itself, follow the instructions in this manual.

Action If Fire Occurs

If a fire occurs, escape from the machine as follows.

- Turn the start switch OFF to stop the engine.
- Use the handrails and steps to get off the machine.

Windshield Washer Fluid

Use an ethyl alcohol base washer liquid. Methyl alcohol base washer liquid may irritate your eyes, so do not use it.

Falling Objects, Flying Objects and Intruding Objects Prevention

On jobsites where there is a hazard that falling objects, flying objects, or intruding objects may hit or enter the operator's cab, consider the operating conditions and install the necessary guards to protect the operator.

- When carrying out demolition or breaker operations, install a front guard and use a laminated coating sheet on the front glass.
- When working in mines or quarries where there is a hazard of falling rock, install FOPS (Falling Objects Protective Structure) install a front guard, and use a laminated coating sheet on the front glass.
- When carrying out the above operations, always close the front window. In addition, always ensure that bystanders are a safe distance away and are not in hazard from falling or flying objects.
- The above recommendations assume that the conditions are for standard operations, but it may be necessary to add additional guards according to the operating conditions on the jobsite. Always contact your Komatsu distributor for advice.

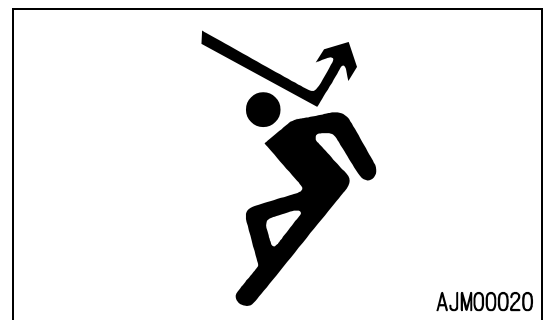
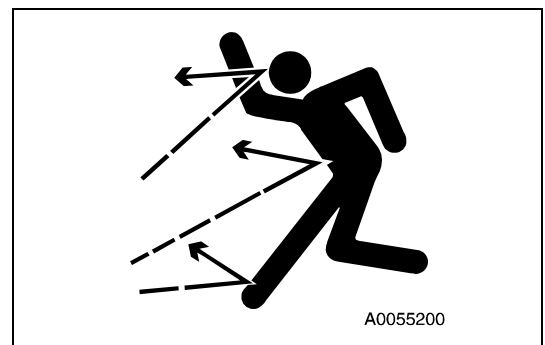

Attachment Installation

- When installing optional parts or attachments, there may be problems with safety or legal restrictions. Therefore, contact your Komatsu distributor for advice.
- Any injuries, accidents, or product failures resulting from the use of unauthorized attachments or parts will not be the responsibility of Komatsu.
- When installing and using optional attachments, read the instruction manual for the attachment, and the general information related to attachments in this manual.

Attachment Combinations

Depending on the type or combination of work equipment, there is a hazard that the work equipment may hit the cab or other parts of the machine. Before using unfamiliar work equipment, check if there is any hazard of interference, and operate with caution.

Windows

If the window on the work equipment side is broken, there is a hazard that work equipment may contact the operator's body directly. Stop operation immediately and replace the window.

Protection Against Falling Objects While Operating In Front Of The Operator's Seat (Canopy Specification)

When digging or loading in front of the operator's seat, do not place a foot or any other part of your body past the front guard. The work equipment or falling objects may hit you.

Unauthorized Modifications

Any modification made without authorization from Komatsu can create hazards. Before making a modification, consult your Komatsu distributor.

- Komatsu will not be responsible for any injuries, accidents, or product failures resulting from modifications made without authorization from Komatsu.

Safety at Jobsite

Before starting operations, thoroughly check the area for any unusual conditions that could be dangerous.

- When carrying out operations near combustible materials such as thatched roofs, dry leaves or dry grass, there is a hazard of fire, so be careful when operating.
- Check the terrain and condition of the ground at the worksite, and determine the safest method of operation. Do not carry out operations at places where there is a hazard of landslides or falling rocks.
- If water lines, gas lines, or high-voltage electrical lines may be buried under the worksite, contact each utility and identify their locations. Be careful not to sever or damage any of these lines.
- Take action to prevent unauthorized people from approaching the jobsite.

When working on public roads, position flagmen and erect barriers to ensure the safety of passing traffic and pedestrians.

- When traveling or operating in shallow water or on soft ground, check the shape and condition of the bedrock, and the depth and speed of flow of the water before starting operations.

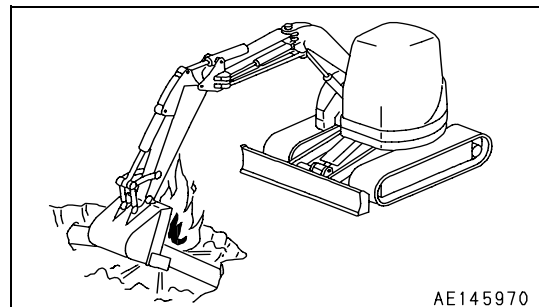

Working on Loose Ground

- Avoid traveling or operating your machine too close to the edge of cliffs, overhangs, and deep ditches. The ground may be weak in such areas. If the ground should collapse under the weight or vibration of the machine, there is a hazard that the machine may fall or tip over. Remember that the soil after heavy rain or blasting or after earthquakes is weak in these areas.
- When working on embankments or near excavated ditches, there is a hazard that the weight and vibration of the machine will cause the soil to collapse. Before starting operations, take steps to ensure that the ground is safe and to prevent the machine from rolling over or falling.

Distance to High Voltage Cables

Do not travel or operate the machine near electric cables. There is a hazard of electric shock, which may cause serious injury or property damage. On jobsites where the machine may go close to electric cables, always do as follows.

- Before starting work near electric cables, inform the local power company of the work to be performed, and ask them to take the necessary action.

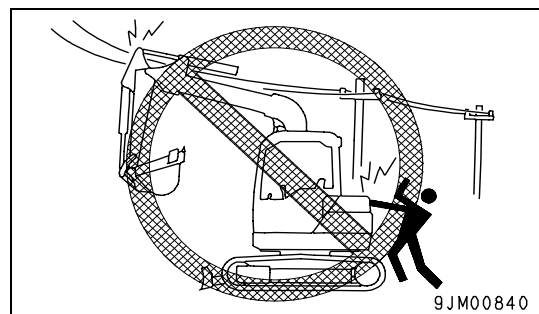

- Even going close to high-voltage cables can cause electric shock, which may cause serious burns or even death. Always maintain a safe distance (see the table on the right) between the machine and the electric cable. Check with the local power company about safe operating procedure before starting operations.
- To prepare for any possible emergencies, wear rubber shoes and gloves. Lay a rubber sheet on top of the seat, and be careful not to touch the chassis with any exposed part of your body.
- Use a signalman to give warning if the machine approaches too close to the electric cables.
- When carrying out operations near high voltage cables, do not let anyone come close to the machine.
- If the machine should come too close or touch the electric cable, to prevent electric shock, the operator should not leave the operator's compartment until it has been confirmed that the electricity has been shut off. Also, do not let anyone come close to the machine.

| | Voltage of Cables | Safety Distance |
|--------------------|-------------------|-------------------|
| Low Voltage | 100 V - 200 V | Over 2 m (7ft) |
| | 6,600 V | Over 2 m (7ft) |
| Extra-high Voltage | 22,000 V | Over 3 m (10 ft) |
| | 66,000 V | Over 4 m (14 ft) |
| | 154,000 V | Over 5 m (17 ft) |
| | 187,000 V | Over 6 m (20 ft) |
| | 275,000 V | Over 7 m (23 ft) |
| | 500,000 V | Over 11 m (36 ft) |

Ensure Good Visibility

Check for any persons or obstacles in the area around the machine and check the conditions of the jobsite to ensure that operations and travel can be carried out safely. Always do as follows.

- When working in dark places, turn on the working lamp and front lamps installed on the machine, and set up additional lighting in the work area if necessary.
- Stop operations if the visibility is poor, such as in mist, snow, rain, or dust.

Ventilation for Enclosed Area

Exhaust fumes from the engine can kill.

- If it is necessary to start the engine within an enclosed area, or when handling fuel, flushing oil, or paint, open the doors and windows to ensure that adequate ventilation is provided to prevent gas poisoning.

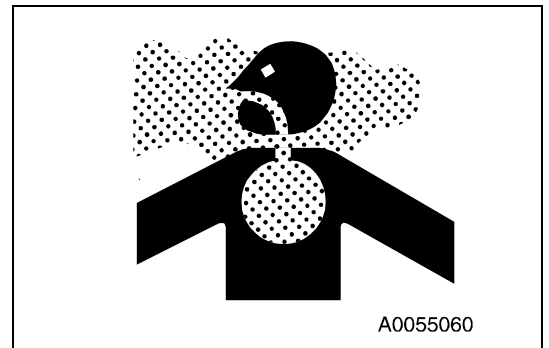

Signalman's Signal and Signs

- Set up signs to inform of road shoulders and soft ground. If the visibility is not good, position a signalman if necessary. Operators should pay careful attention to the signs and follow the instructions from the signalman.
- Only one signalman should give signals.
- Make sure that all workers understand the meaning of all signals and signs before starting work.

Emergency Exit from Operator's Cab

If for any reason it becomes impossible to open the cab door, use the hammer supplied to break the window and use it as an emergency escape.

For details, see "EMERGENCY ESCAPE HAMMER (3-24)" in this manual.

- When escaping, remove all the pieces of glass from the window frame first and be careful not to cut yourself on the glass. Be careful also not to slip on the broken pieces of glass on the ground.

Asbestos Dust Hazard Prevention

Asbestos dust in the air can cause lung cancer if it is inhaled. There is danger of inhaling asbestos when working on jobsites handling demolition work or work handling industrial waste. Always observe the following.

- Spray water to keep down the dust when cleaning. Do not use compressed air for cleaning.
- If there is danger that there may be asbestos dust in the air, always operate the machine from an upwind position. All workers should use an approved respirator.
- Do not allow other persons to approach during the operation.
- Always observe the rules and regulations for the work site and environmental standards.

This machine does not use asbestos, but there is a danger that imitation parts may contain asbestos, so always use genuine Komatsu parts.

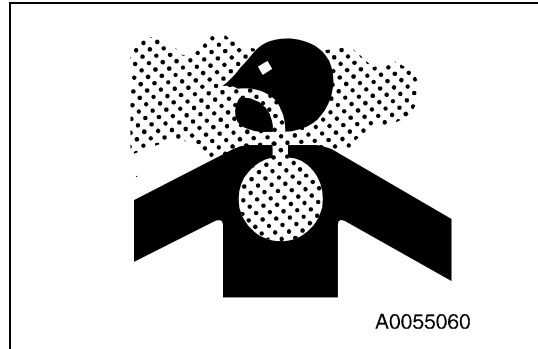

SAFETY MACHINE OPERATION

STARTING ENGINE

If there is a warning tag hanging from the work equipment control lever, do not start the engine or touch the levers .

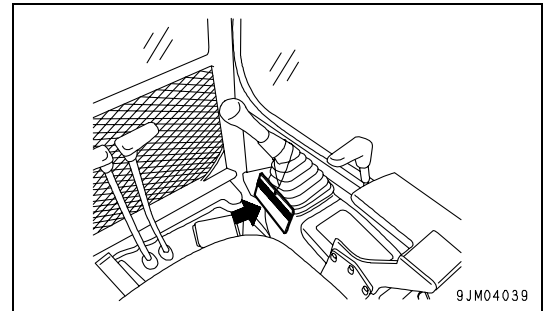

Checks Before Starting Engine

Carry out the following checks before starting the engine at the beginning of the day's work.

- Remove all dirt from the surface of the window glass to ensure a good view.
- Remove all dirt from the surface of the lens of the working lamps, and check that they light up correctly.
- Check the coolant level, fuel level, and oil level in engine oil pan, check for clogging of the air cleaner, and check for damage to the electric wiring.
- Adjust the operator's seat to a position where it is easy to carry out operations, and check that there is no damage or wear to the seat belt or mounting clamps.
- Check that the gauges work properly, check the angle of the lights and working lamps, and check that the control levers are all at the neutral position.
- Before starting the engine, make sure that the safety lock lever is in the LOCK position.
- Adjust the mirror to a position which gives a good view to the rear from the operator's seat. When adjusting, see "Rearview Mirrors (3-39)".
- Check that there are no persons or obstacles above, below, or in the area around the machine.

Safety Rules for Starting Engine

- When starting the engine, sound the horn as a warning.
- Start and operate the machine only while seated.
- Do not allow anyone apart from the operator to ride on the machine.
- Do not short circuit the starting motor circuit to start the engine. It is not only dangerous, but will also cause damage to the equipment.

Starting Engine in Cold Weather

- Carry out the warming-up operation thoroughly. If the machine is not thoroughly warmed up before the control levers are operated, the reaction of the machine will be slow, and this may lead to unexpected accidents.
- If the battery electrolyte is frozen, do not charge the battery or start the engine with a different power source. There is a hazard that this will ignite the battery. Before charging or starting the engine with a different power source, melt the battery electrolyte and check for frost and leakage of battery electrolyte before starting.

OPERATION

Checks Before Operation

When carrying out the checks, move the machine to a wide area where there are no obstructions, and operate slowly. Do not allow anyone near the machine.

- Fit the seat belt (if equipped) securely.
- Check that the movement of the machine matches the display on the control pattern card. If it does not match, replace it immediately with the correct control pattern card.
- Check the operation of the work equipment, travel system and swing system.
- Check for any abnormality in the sound of the machine, vibration, heat, smell, or gauges; check also that there is no leakage of oil or fuel.
- If any abnormality is found, carry out repairs immediately.

Safety Rules for Changing Machine Directions

- Position the upper structure so that the sprocket is at the rear of the operator's cab before traveling.
If the sprocket is at the front of the operator's cab, the direction of operations is reversed (for example, forward becomes reverse, and left becomes right).
- Before travelling, check again that there is no one in the surrounding area, and that there are no obstacles.
- Before travelling, sound the horn to warn people in the area.
- Always operate the machine only when seated.
- Do not allow anyone apart from the operator to ride on the machine.
- Always lock the door and windows of the operator's compartment in position (open or closed).
On jobsites where there is a hazard of flying objects or of objects entering the operator's compartment, check that the door and windows are securely closed.

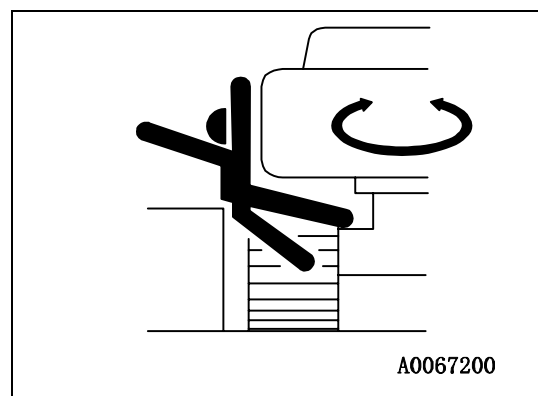
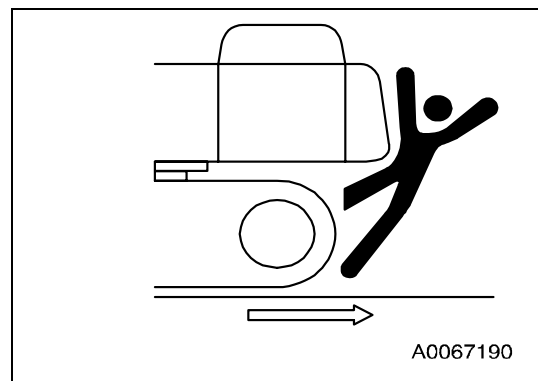
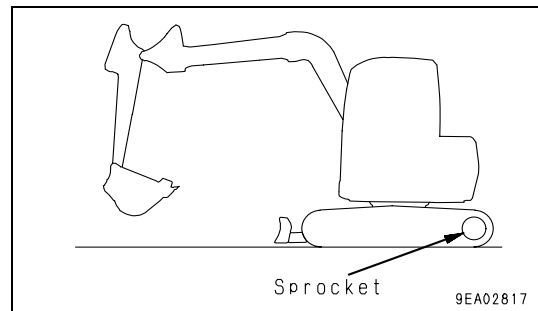

Safety Rules for Traveling

- It is dangerous to drive too fast, or to start suddenly, stop suddenly, or to turn sharply.
- When traveling on level ground, keep the work equipment at a height of 40 to 50 cm (1.6 to 2.0 in) from the ground.
- When traveling on rough ground, travel at low speed and do not operate the steering suddenly. There is danger that the machine may turn over. The work equipment may hit the ground surface and cause the machine to lose its balance, or may damage the machine or structures in the area.

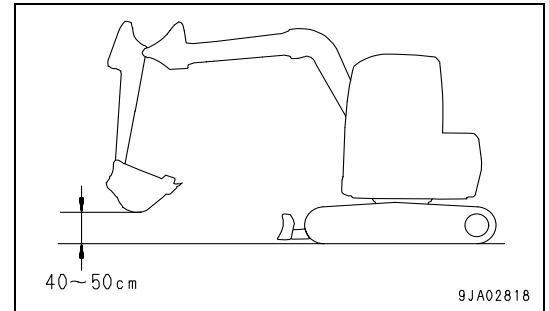

- Avoid traveling over obstacles when possible. If the machine has to travel over an obstacle, keep the work equipment close to the ground and travel at low speed. Never travel over obstacles which make the machine tilt strongly to one side.
- When traveling or carrying out operations, always keep a safe distance from people, structures, or other machines to avoid coming into contact with them.
- When passing over bridges or structures, check first that the structure is strong enough to support the weight of the machine. When traveling on public roads, check first with the relevant authorities and follow their instructions.
- When operating in tunnels, under bridges, under electric wires, or other places where the height is limited, operate slowly and be extremely careful not to let the work equipment hit anything.

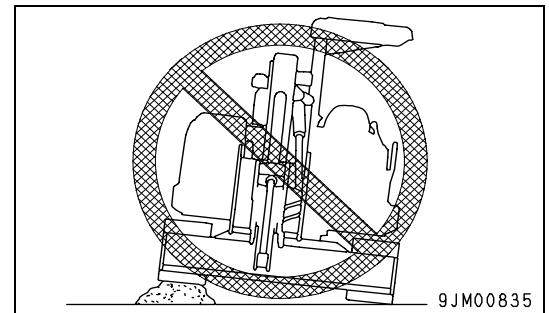

Traveling on Slopes

To prevent the machine from tipping over or slipping to the side, always do as follows.

- Keep the work equipment approx. 20 to 30 cm (8 to 12 in) above the ground. In case of emergency, lower the work equipment to the ground immediately to help stop the machine.
- When travel up slopes, set the operator's cab facing uphill, when travel down slopes, set the operator's cab facing downhill. Always check the firmness of the ground under the front of the machine when traveling.

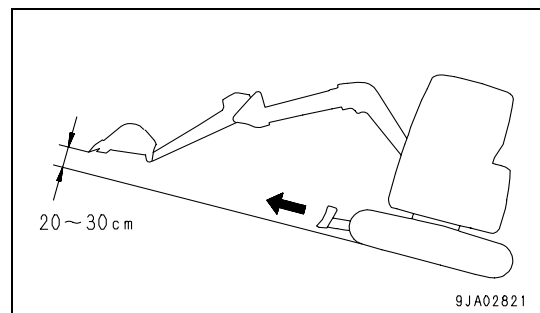
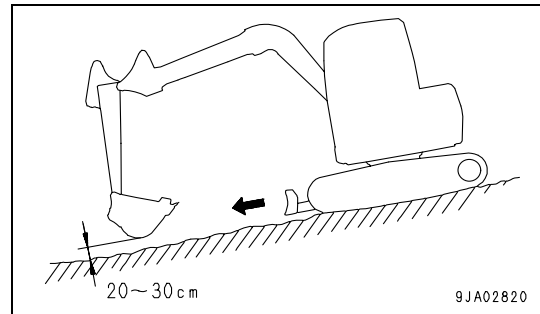
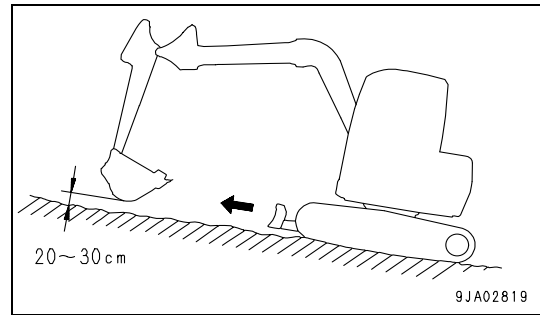

- When traveling up a steep slope, extend the work equipment to the front to improve the balance, keep the work equipment approximately 20 to 30cm (8 to 12 in) above the ground, and travel at low speed.

- When traveling downhill, lower the engine speed, keep the travel lever close to the neutral position, and travel at low speed.
- Always travel straight up or down a slope. Traveling at an angle or across the slope is extremely dangerous.
- Do not turn on slopes or travel across slopes. Always go down to a flat place to change the position of the machine, then travel on to the slope again.
- Travel on grass, fallen leaves, or wet steel plates with low speed. Even with slight slopes there is a hazard that the machine may slip.
- If the engine stops when the machine is traveling on a slope, move the control levers immediately to the neutral position and start the engine again.

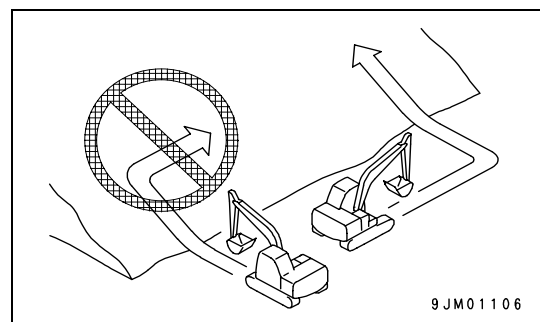

Operations on Slopes

- When working on slopes, there is a hazard that the machine may lose its balance and turn over when the swing or work equipment are operated. This may lead to serious injury or property damage, so always provide a stable place when carrying out these operations, and operate carefully.
- Do not swing the work equipment from the uphill side to the downhill side when the bucket is loaded. This operation is dangerous, and may cause the machine to tip over.
- If the machine has to be used on a slope, pile the soil to make a platform that will keep the machine as horizontal as possible.

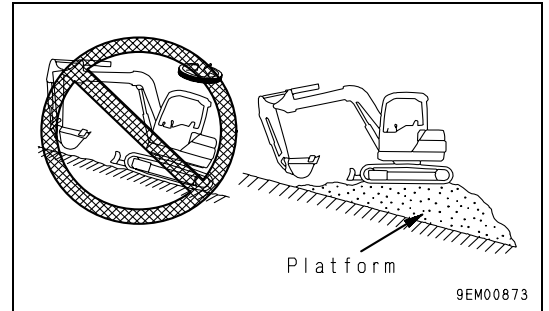

Prohibited Operations

- Never dig the work face under an overhang. There is a hazard that rocks may fall or that the overhang may collapse and fall on top of the machine.

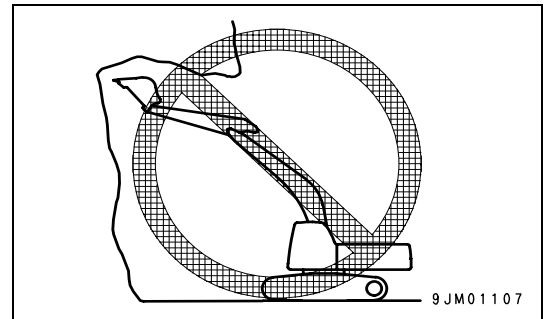

- Do not excavate too deeply under the front of the machine. The ground under the machine may collapse and cause the machine to fall.

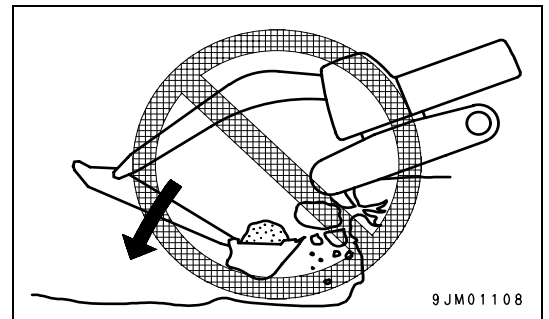

- To make it easier to escape if there is any problem, set the tracks at right angles to the road shoulder or cliff with the sprocket at the rear when carrying out operations.

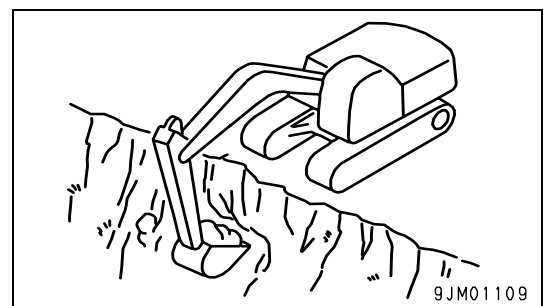

- Do not carry out demolition work under the machine. There is a hazard that the machine may become unstable and tip over.
- When working on or from the top of buildings or other structures, check the strength and the structure before starting operations. There is a hazard of the building collapsing and causing serious injury or damage.

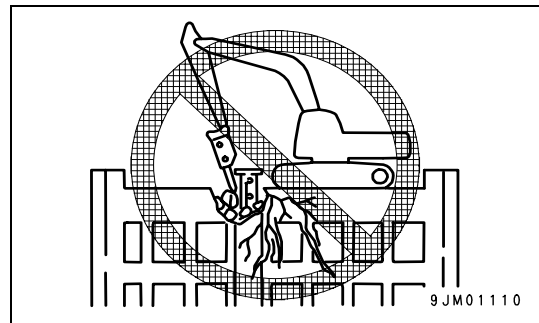

- When carrying out demolition work, do not carry out demolition above your head. There is a hazard of broken parts falling or of the building collapsing and causing serious injury or property damage.

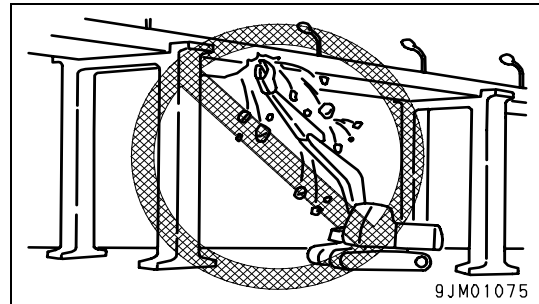

- Do not use the impact force of the work equipment for breaking work. There is a hazard of personal injury or property damage being caused by flying pieces of broken material or damage to the work equipment.
- Generally speaking, the machine is more liable to overturn when the work equipment is at the side than when it is at the front or rear.

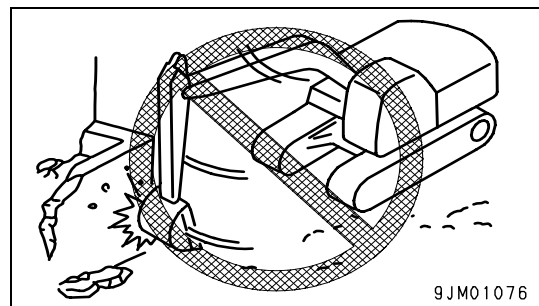

- When using a breaker or other heavy work equipment, there is a hazard of the machine losing its balance and tipping over. When operating on flat ground as well as on slopes.
 - Do not suddenly lower, swing, or stop the work equipment.
 - Do not suddenly extend or retract the boom cylinder. There is a hazard that impact will cause the machine to tip over.
- Do not pass the bucket over any worker's head or over the operator's cab of the truck or hauling machine. The load may fall or the bucket may come into contact and cause serious personal injury or property damage.

Operations on Snow

- Snow-covered or frozen surfaces are slippery, so be extremely careful when traveling or operating the machine, and do not operate the levers suddenly. Even a slight slope may cause the machine to slip, so be particularly careful when working on slopes.
- With frozen ground surfaces, the ground becomes soft when the temperature rises, and this may cause the machine to tip over.
- If the machine enters deep snow, there is a hazard that it may tip over or become buried in the snow. Be careful not to leave the road shoulder or to get trapped in a snow drift.
- When clearing snow, the road shoulder and objects placed beside the road are buried in the snow and cannot be seen. There is a hazard of the machine tipping over or hitting covered objects, so always carry out operations carefully.

Parking Machine

- Park the machine on firm, level ground.
- Select a place where there is no hazard of falling rocks or landslides, or of flooding if the land is low.
- Lower the work equipment completely to the ground.

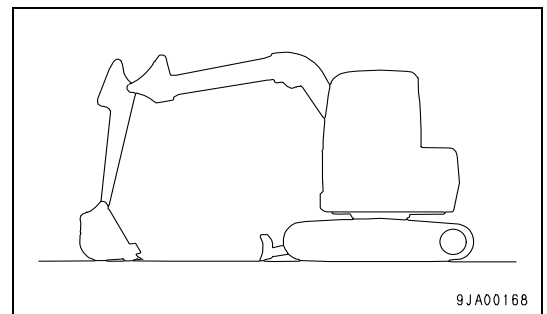

- When leaving the machine, set safety lock lever (1) to the LOCK position, then stop the engine.
- Always close the operator's cab door, and use the key to lock all the equipment in order to prevent any unauthorized person from moving the machine. Always remove the key, take it with you, and leave it in the specified place.
- If it is necessary to park the machine on a slope, always do as follows.
 - Set the bucket on the downhill side, then dig it into the ground.
 - Put blocks under the tracks to prevent the machine from moving.

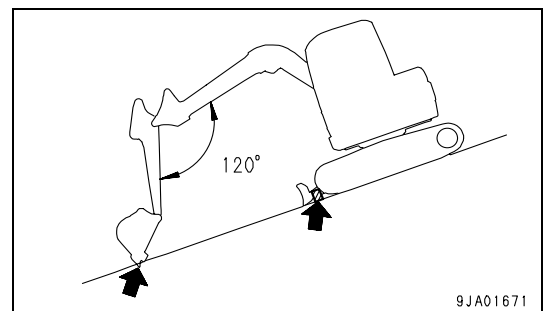
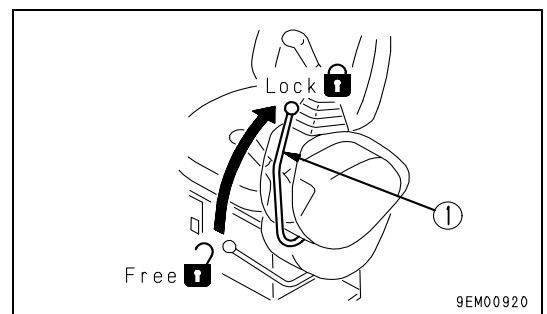

TRANSPORTATION

Loading and Unloading

When loading or unloading the machine, mistaken operation may bring the hazard of the machine tipping over or falling, so particular care is necessary. Always do as follows.

- Perform loading and unloading on firm, level ground only. Maintain a safe distance from the edge of the road or cliff.
- Never use the work equipment to load or unload the machine. There is danger that the machine may fall or tip over.
- Always use ramps of adequate strength. Be sure that the ramps are wide, long, and thick enough to provide a safe loading slope. Take suitable steps to prevent the ramps from moving out of position or coming off.
- Be sure the ramp surface is clean and free of grease, oil, ice and loose materials. Remove dirt from machine-tracks. On a rainy day, in particular, take extremely careful since the ramp surface is slippery.
- Run the engine at low speed and travel slowly.
- When on the ramps, do not touch any other parts.
- Never correct your steering on the ramps. If necessary, drive off the ramps, correct the direction, then enter the ramps again.
- The center of gravity of the machine will change suddenly at the joint between the ramps and the track or trailer, and there is danger of the machine losing its balance. Travel slowly over this point.
- When loading or unloading to an embankment or platform, make sure that it has suitable width, strength, and grade.
- When swinging the upper structure on the trailer, the trailer is unstable, so pull in the work equipment and swing slowly. And turn swing lock switch ON to apply swing lock after loading machine.
- For machines equipped with a cab, always lock the door securely after boarding the machine. Otherwise, the door may suddenly open during shipping.
Refer to "TRANSPORTATION (3-85)".

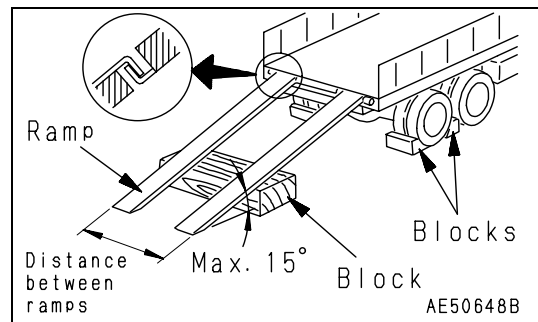

Shipping the Machine

When shipping the machine on a trailer, do as follows.

- The weight, transportation height, and overall length of the machine differ according to the work equipment, so be sure to confirm the dimensions.
- When passing over bridges or structures on private land, check first that the structure is strong enough to support the weight of the machine. When traveling on public roads, check first with the relevant authorities and follow their instructions.
- For details of the shipping procedure, see "TRANSPORTATION (3-85)" in the OPERATION section.

BATTERY

Battery Hazard Prevention

Battery electrolyte contains sulfuric acid, and batteries generate flammable hydrogen gas, which may explode. Mistaken handling can lead to serious injury or fire. For this reason, always observe the following precautions.

- Do not use or charge the battery if the battery electrolyte level is below the LOWER LEVEL line. This may cause an explosion. Always check the battery electrolyte level periodically and add distilled water to bring the electrolyte level to the UPPER LEVEL line.
- When working with batteries, always wear safety glasses and rubber gloves.
- Never smoke or use any flame near the battery.

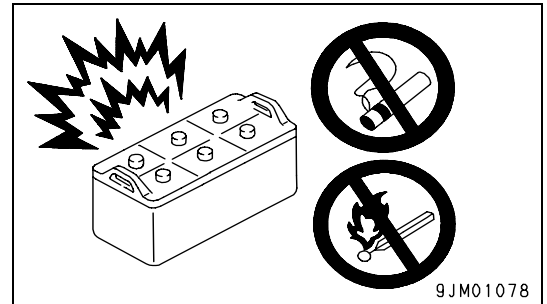

- If you spill acid on your clothes or skin, immediately flush the area with large amount of water.
- If acid gets into your eyes, flush them immediately with large amount of water and seek medical attention.

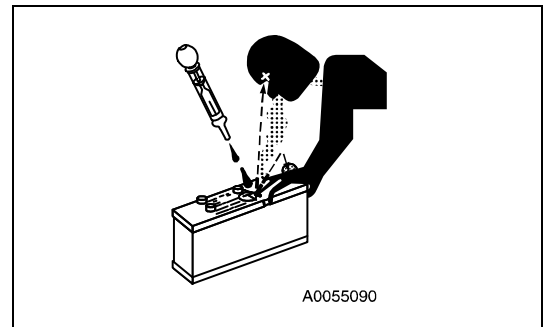

- Before working with batteries, turn the starting switch to the OFF position.

As there is a hazard that sparks will be generated, always do as follows.

- Do not let tools or other metal objects make any contact between the battery terminals. Do not leave tools or other metal objects lying around near the battery.
- Always disconnect the negative (-) terminal (ground side) first when removing the battery; when installing the battery, connect the positive (+) terminal first, and connect the ground last. Tighten the battery terminals securely.
- Flammable hydrogen gas is generated when the battery is charged, so remove the battery from the chassis, take it to a well-ventilated place, and remove the battery caps before charging it.
- Tighten the battery caps securely.
- Install the battery securely to the determined place.

Starting Engine with Booster Cables

If any mistake is made in the method of connecting the booster cables, it may cause the battery to explode, so always do as follows.

- When starting with a booster cable, carry out the starting operation with two workers (one worker sitting in the operator's seat and the other working with the battery).
- When starting from another machine, do not allow the two machines to touch.
- When connecting the booster cables, turn the starting switch OFF for both the normal machine and problem machine. There is a hazard that the machine will move when the power is connected.
- Be sure to connect the positive (+) cable first when installing the booster cables. Disconnect the negative (-) cable (ground side) first when removing them.
- When removing the booster cables, be careful not to let the booster cable clips touch each other or to let the clips touch the machine.
- Always wear safety goggles and rubber gloves when starting the engine with booster cables.
- When connecting a normal machine to a problem machine with booster cables, always use a normal machine with the same battery voltage as the problem machine.
- For details of the starting procedure when using booster cables, see "Starting Engine With Booster Cables (3-101)" in the OPERATION section.

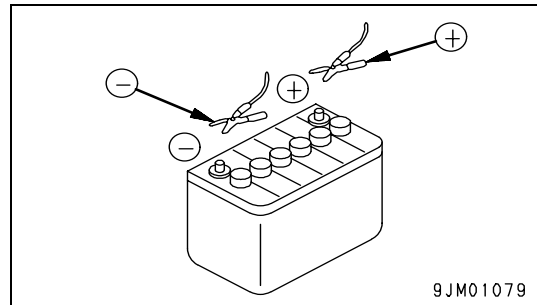
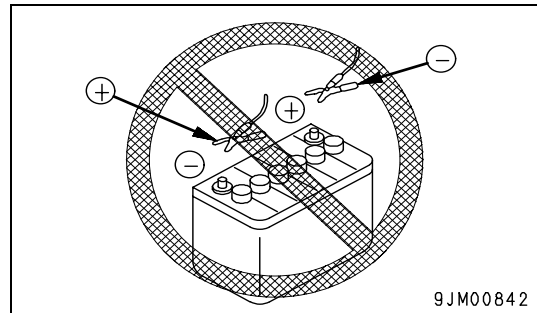

TOWING

Safety Rules for Towing

Serious injury or death could result if a disabled machine is towed incorrectly or if there is a mistake in the selection or inspection of the wire rope.

For towing, see "TOWING THE MACHINE (3-98)".

- Always wear leather gloves when handling wire rope.
- Fix the wire rope to the track frame.
- During the towing operation, never stand between the towing machine and the machine being towed.
- Never tow a machine on a slope.

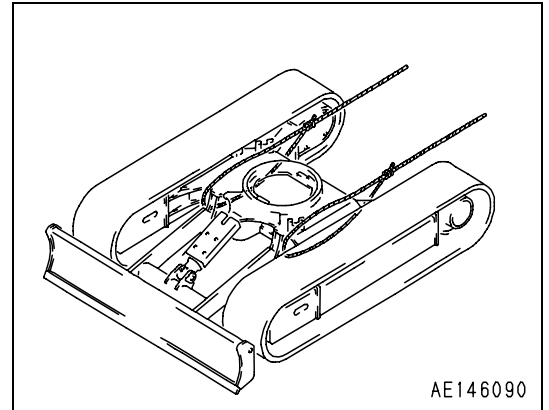

- Never use a wire rope which has cut strands (A), reduced diameter (B), or kinks (C). There is danger that the rope may break during the towing operation.

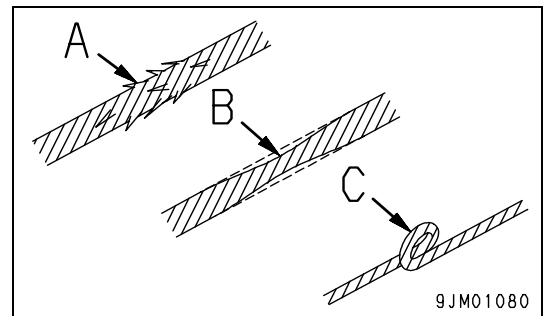

LIFTING OBJECTS WITH BUCKET

Safety Rules for Lifting Objects

- Do not carry out lifting work on slopes, soft ground, or other places where the machine is not stable.
- Use wire rope that conforms to the specified standard.
- Do not exceed the specified lifting load.
For details of the maximum lifting load permitted for this machine, see "BUCKET WITH HOOK (6-4)".
- It is dangerous if the load hits any worker or structure. Always check carefully that the surrounding area is safe before swinging or turning the machine.
- Do not start, swing, or stop the machine suddenly. There is a hazard that the lifted load will swing.
- Do not pull the load to the side or in towards the machine.
- Do not leave the operator's seat when there is a raised load.

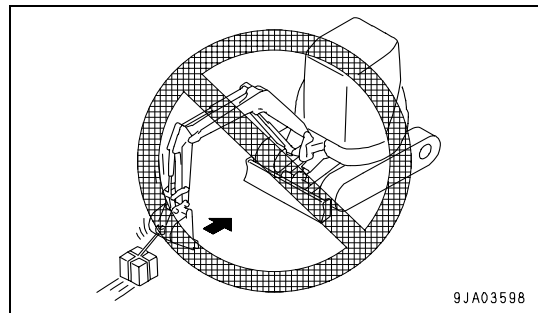
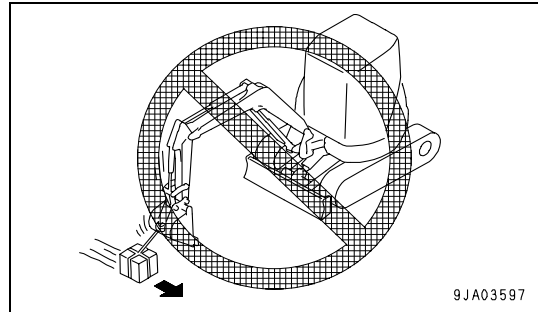

SAFETY MAINTENANCE INFORMATION

Warning Tag

- Always attach the "DO NOT OPERATE" warning tag to the work equipment control lever in the operator's cab to alert others that you are performing service or maintenance on the machine. Attach additional warning tags around the machine if necessary.
Warning tag Part No. 09963-03001
Keep this warning tag in the tool box while it is not used. If there is not the tool box, keep the tag in the operation manual pocket.
- If others start the engine, or touch or operate the work equipment control lever while you are performing service or maintenance, you could suffer serious injury or property damage.

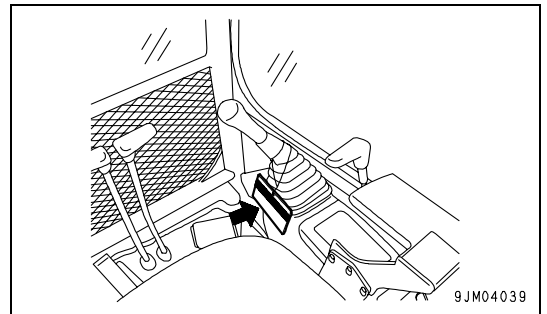

Keep Work Place Clean and Tidy

Do not leave hammers or other tools lying around in the work place. Wipe up all grease, oil, or other substances that will cause you to slip. Always keep the work place clean and tidy to enable you to carry out operations safely. If the work place is not kept clean and tidy, there is the danger that you will trip, slip, or fall over and injure yourself.

Appoint Leader when Working with Others

When repairing the machine or when removing and installing the work equipment, appoint a leader and follow his instructions during the operation.

When working with others, misunderstandings between workers can lead to serious accidents.

Stop Engine Before Carrying Out Maintenance

- Stop the machine on firm, level ground.
- Select a place where there is no hazard of falling rocks or landslides, or of flooding if the land is low.
- Lower the work equipment completely to the ground and stop the engine.

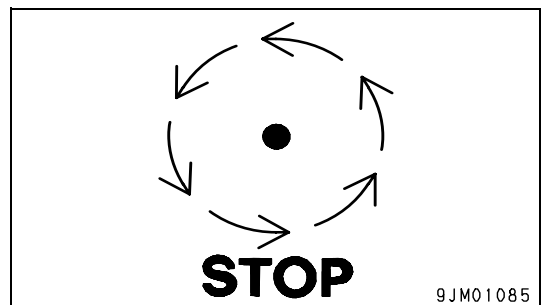

- Set safety lock lever (1) to the LOCK position.

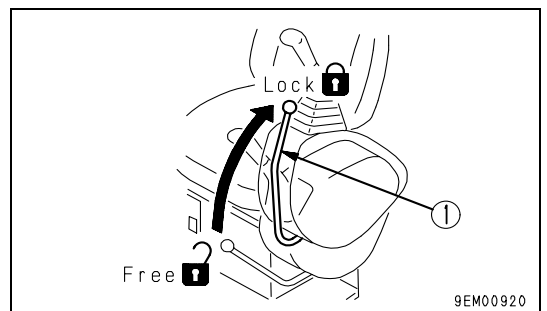

- Put blocks under the track to prevent the machine from moving.

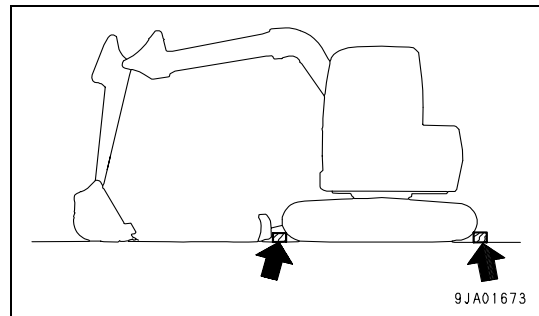

Two Workers for Maintenance when Engine is Running

To prevent injury, do not carry out maintenance with the engine running. If maintenance must be carried out with the engine running, carry out the operation with at least two workers and do as follows.

- One worker must always sit in the operator's seat and be ready to stop the engine at any time. All workers must maintain contact with the other workers.

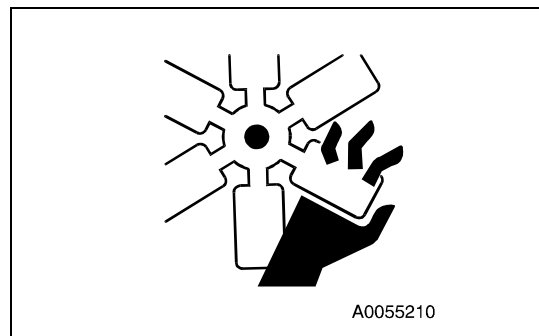

- Set safety lock lever (1) to the LOCK position.
- When carrying out operations near the fan, fan belt, or other rotating parts, there is a hazard of being caught in the parts, so be extremely careful.
- Do not touch any control levers. If any control lever must be operated, give a signal to the other workers to warn them to move to a safe place.
- Never drop or insert tools or other objects into the fan or fan belt. Parts may break or be sent flying.

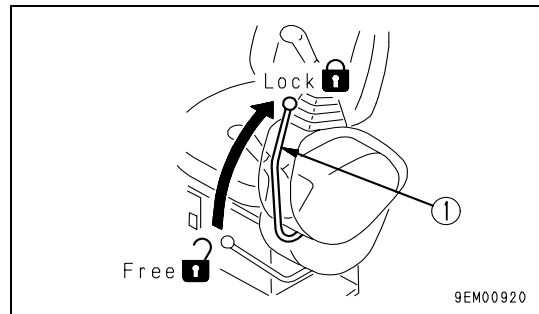

Proper Tools

Use only tools suited to the task and be sure to use the tools correctly. Using damaged, low quality, faulty, makeshift tools or improper use of the tools could cause serious personal injury.

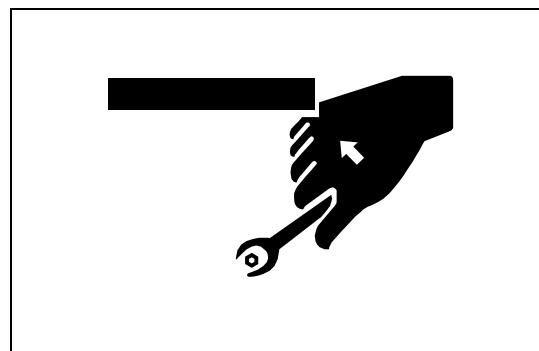

Personnel

Only authorized personnel can service and repair the machine. Do not allow unauthorized personnel into the area. If necessary, employ an observer.

Attachments

- Appoint a leader before starting removal or installation operations for attachments.
- Place attachments that have been removed from the machine in a stable condition so that they do not fall. And take steps to prevent unauthorized persons from entering the storage area.

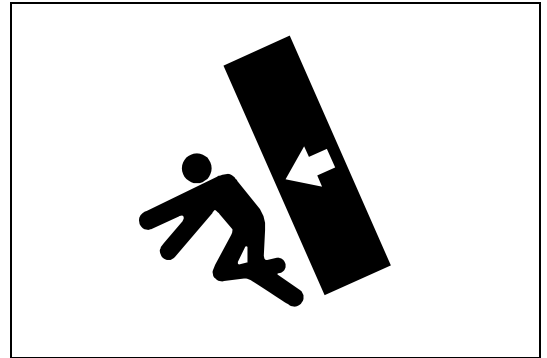

Work Under the Machine

- If it is necessary to go under the work equipment or the machine to carry out service and maintenance, support the work equipment and machine securely with blocks and stands strong enough to support the weight of the work equipment and machine.
- It is extremely dangerous to work under the machine if the track shoes are off the ground and the machine is supported only by the work equipment. If the control levers are touched by mistake, or there is a hazard to the hydraulics, the work equipment or the machine may suddenly descend. This is extremely dangerous. Never work under the machine if the machine is not properly supported by blocks or stands.



Noise

If the noise from the machine is too loud, it may cause temporary or permanent hearing problems. When carrying out maintenance of the engine and you are exposed to noise for long periods of time, wear ear covers or ear plugs while working.

When Using Hammer

When using a hammer, pins may fly out or metal particles may be scattered. This may lead to serious injury. Always do as follows.

- If hard metal parts such as pins, bucket teeth, cutting edges, or bearings are hit with a hammer, there is a hazard that pieces might be scattered and cause injury. Always wear safety goggles and gloves.
- When hitting pins or bucket teeth, there is a hazard that broken pieces might be sent flying and injure people in the surrounding area. Always check that there is no one in the surrounding area.
- If pins are hit with strong force, there is a hazard that the pin may fly out and injure people in the surrounding area.

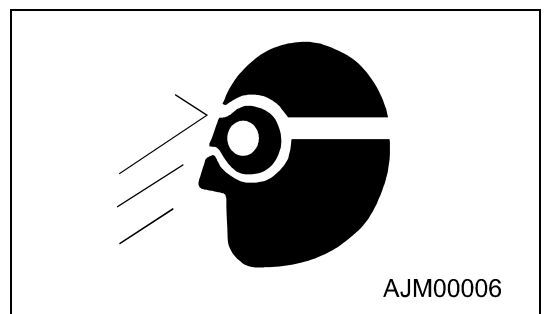

Welding Works

Welding operations must always be carried out by a qualified welder and in a place equipped with a proper equipment. There is a hazard of fire or electrocution when carrying out welding, so never allow any unqualified personnel to carry out welding.

Removing Battery Terminals

When repairing the electrical system or when carrying out electrical welding, disconnect the negative (-) terminal of the battery to prevent the flow of current.

Safety First when Using High-pressure Grease to Adjust Track Tension

- Grease is pumped into the track tension adjustment system under high pressure.
If the specified procedure for maintenance is not followed when making adjustment, grease drain plug (1) may fly out and cause serious injury or property damage.
- When loosening grease drain plug (1) to loosen the track tension, never loosen it more than one turn. Loosen the grease drain plug slowly.
- Never put your face, hands, feet, or any other part of your body close to grease drain plug (1).

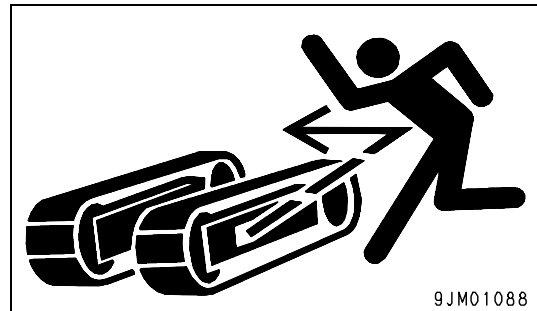
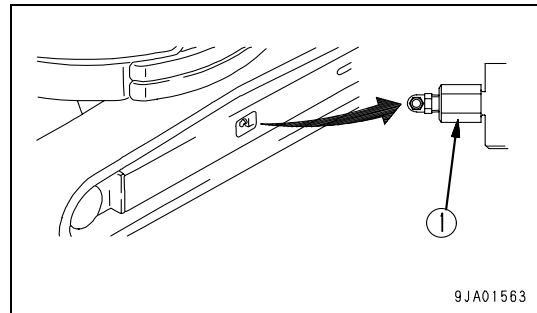

Do Not Disassemble Recoil Springs

The recoil spring assembly is used to reduce the impact on the idler. It contains a spring under high pressure, so if it is disassembled by mistake, the spring will fly out and cause serious injury or even death. Never disassemble the recoil spring.

Safety Rules for High-pressure Oil

The hydraulic system is always under internal pressure. When inspecting or replacing piping or hoses, always check that the pressure in the hydraulic circuit has been released. If the circuit is still under pressure, it will lead to serious injury or property damage, so always do as follows.

- Always release the pressure before starting any inspection or replacement operation.
- If there is any leakage from the piping or hoses, the surrounding area will be wet, so check for cracks in the piping and hoses and for swelling in the hoses.
When carry out inspection, wear safety glasses and leather gloves.
- There is a hazard that high-pressure oil leaking from small holes may penetrate your skin or cause blindness if it contacts your eyes directly. If you are hit by a jet of high-pressure oil and suffer injury to your skin or eyes, wash the place with clean water, and consult a doctor immediately for medical attention.

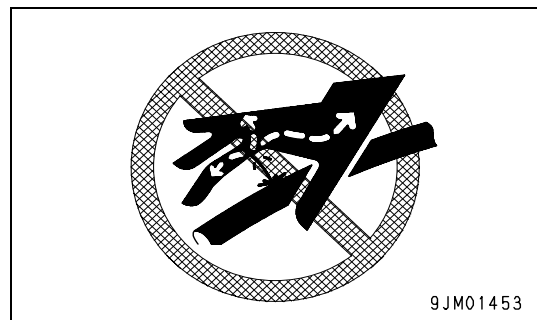

Safety Handling High-pressure Hoses

- If oil or fuel leaks from high-pressure hoses, it may cause fire or defective operation, which may lead to serious injury or property damage. If any loose bolts are found, stop work and tighten to the specified torque. If any damaged hoses are found, stop operations immediately and contact your Komatsu distributor.

Replace the hose if any of the following problems are found.

- Damaged or leaking hydraulic fitting.
- Frayed or cut covering or exposed reinforcement layer of wire.
- Covering swollen in places.
- Twisted or crushed movable portion.
- Foreign material embedded in covering.

Waste Materials

To prevent pollution, pay careful attention to the method of disposing of waste materials.

- Always put oil drained from your machine in containers. Never drain oil directly onto the ground or dump into the sewage system, rivers, the sea, or lakes.
- Obey appropriate laws and regulations when disposing of harmful objects such as oil, fuel, coolant, solvent, filters, and batteries.

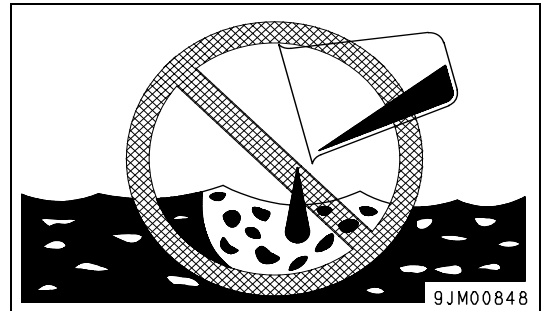

Air Conditioner Maintenance

If air conditioner refrigerant gets into your eyes, it may cause blindness; if it touches your skin, it may cause frost-bite. Never touch refrigerant.

Compressed Air

- When carrying out cleaning with compressed air, there is a hazard of serious injury or property damage caused by flying particles.
- When using compressed air to clean elements or the radiator, always wear safety goggles, dust mask, gloves, and other protective equipment.

Periodic Replacement of Safety Critical Parts

- In order for the machine to be operated safely for a long time, it is necessary to add oil and to carry out service and maintenance at periodic intervals. In order to further increase safety, components with a strong relationship to safety, such as hoses and seat belts, must be replaced at periodic intervals.

Replacement of safety critical parts: See "SAFETY CRITICAL PARTS (4-12)".

- The material of these components naturally changes over time, and repeated use causes deterioration, wear, and fatigue. As a result, there is a hazard that these components may fail and cause serious injury or property damage. It is difficult to judge the remaining life of these components from external inspection or the feeling when operating, so always replace them at the specified interval.
- Replace or repair safety critical parts if any defect is found, even when they have not reached the time specified interval.

OPERATION

 **WARNING**

Please read and make sure that you understand the SAFETY section before reading this section.

MACHINE VIEW ILLUSTRATIONS

OVERALL MACHINE VIEW

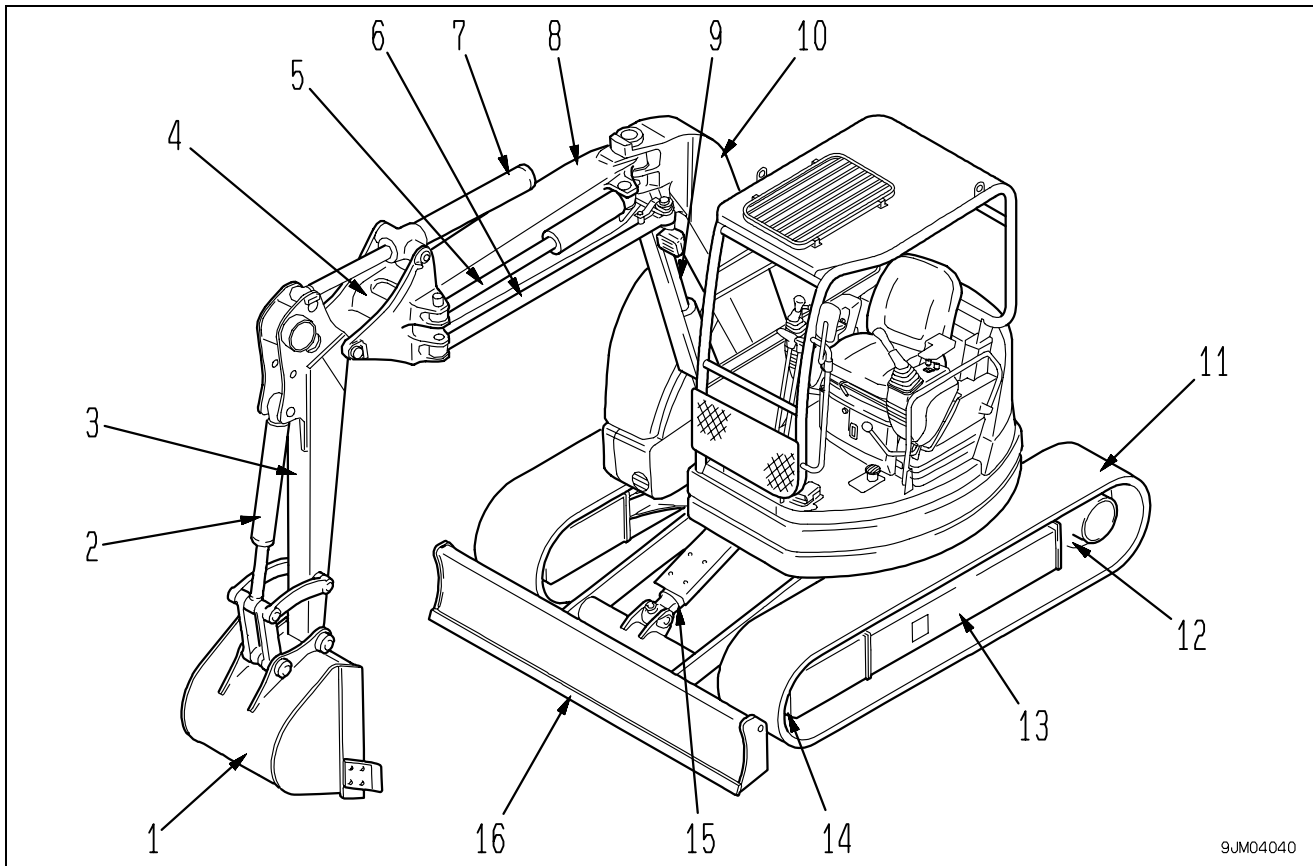

9JM04040

- | | |
|---------------------|---------------------|
| (1) Bucket | (9) Boom cylinder |
| (2) Bucket cylinder | (10) First boom |
| (3) Arm | (11) Track shoe |
| (4) Third bracket | (12) Sprocket |
| (5) Offset cylinder | (13) Track frame |
| (6) Sub-link | (14) Idler |
| (7) Arm cylinder | (15) Blade cylinder |
| (8) Second boom | (16) Blade |

CONTROLS AND GAUGES

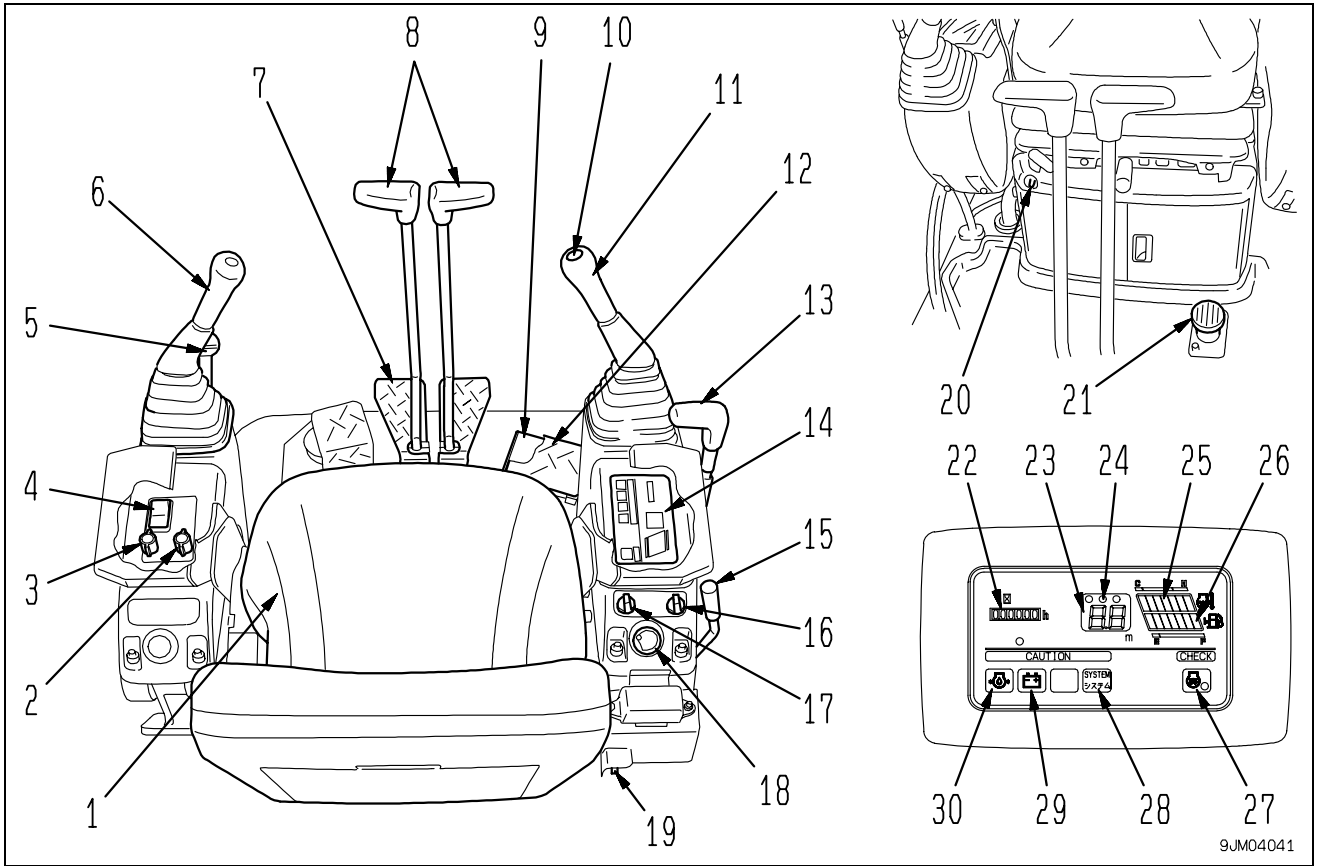

- | | |
|---|--|
| (1) Operator's seat | (16) Setting switch |
| (2) Heater switch | (17) Mode selector switch |
| (3) Lamp switch | (18) Starting switch |
| (4) Wiper switch | (19) Emergency pump drive switch |
| (5) Safety lock lever | (20) Emergency work equipment actuation switch |
| (6) Left work equipment control lever | (21) Traveling accelerator pedal |
| (7) Travel pedal | (22) Service meter |
| (8) Travel lever | (23) Depth display |
| (9) Pedal lock | (24) Mode indicator |
| (10) Horn button | (25) Engine coolant temperature gauge |
| (11) Right work equipment control lever | (26) Fuel gauge |
| (12) Boom offset control pedal | (27) Engine pre-heating monitor |
| (13) Blade control lever | (28) Electric system monitor |
| (14) Monitor panel | (29) Charge level monitor |
| (15) Fuel control lever | (30) Engine oil pressure monitor |

DETAILED CONTROLS AND GAUGES

The following is an explanation of the devices needed for operating the machine.
To carry out suitable operations correctly and safely, it is important to understand fully the methods of operating the equipment and the meanings of the displays.

MONITORING SYSTEM

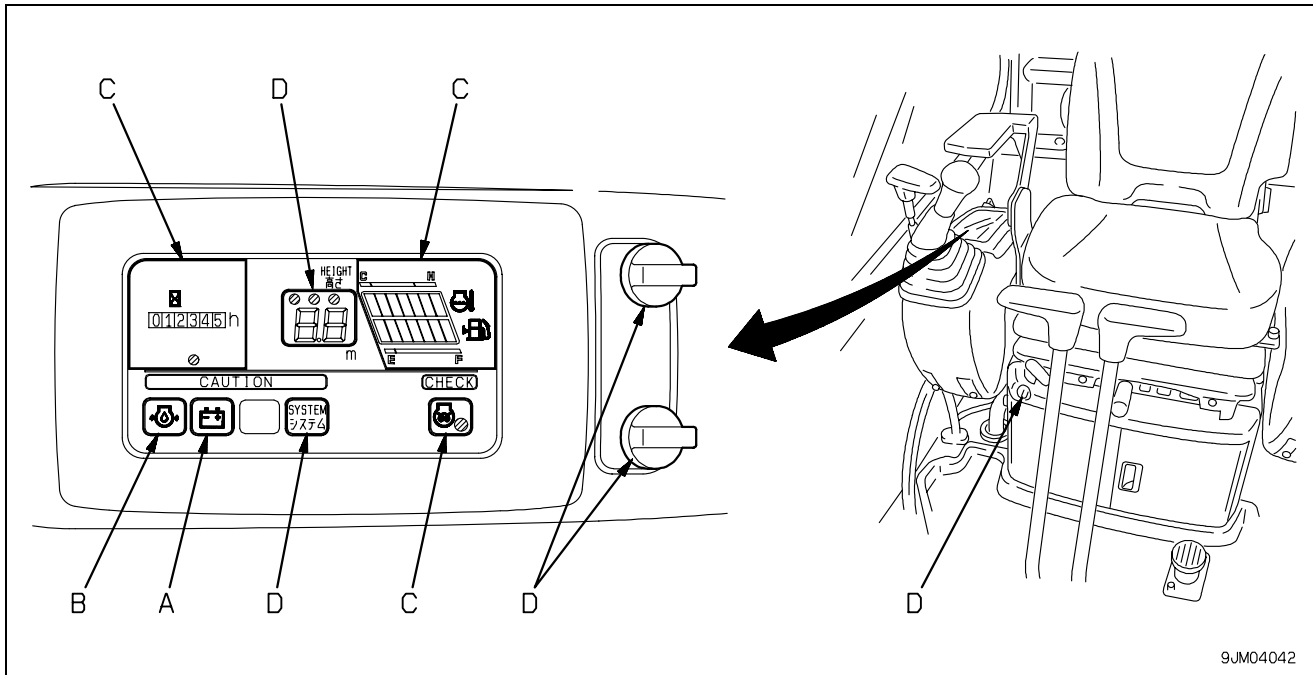

9JM04042

A: Caution monitors
B: Emergency monitors

C: Meter display portion
D: Electronic control system

Caution Monitors

⚠ CAUTION

If the caution monitor lamp lights up, repair the problem as soon as possible.

These are items that must be watched carefully when the engine is running. If any abnormality occurs, the monitor displays the item that should be corrected as soon as possible. If there is any abnormality, the monitor for the location of the abnormality flashes.

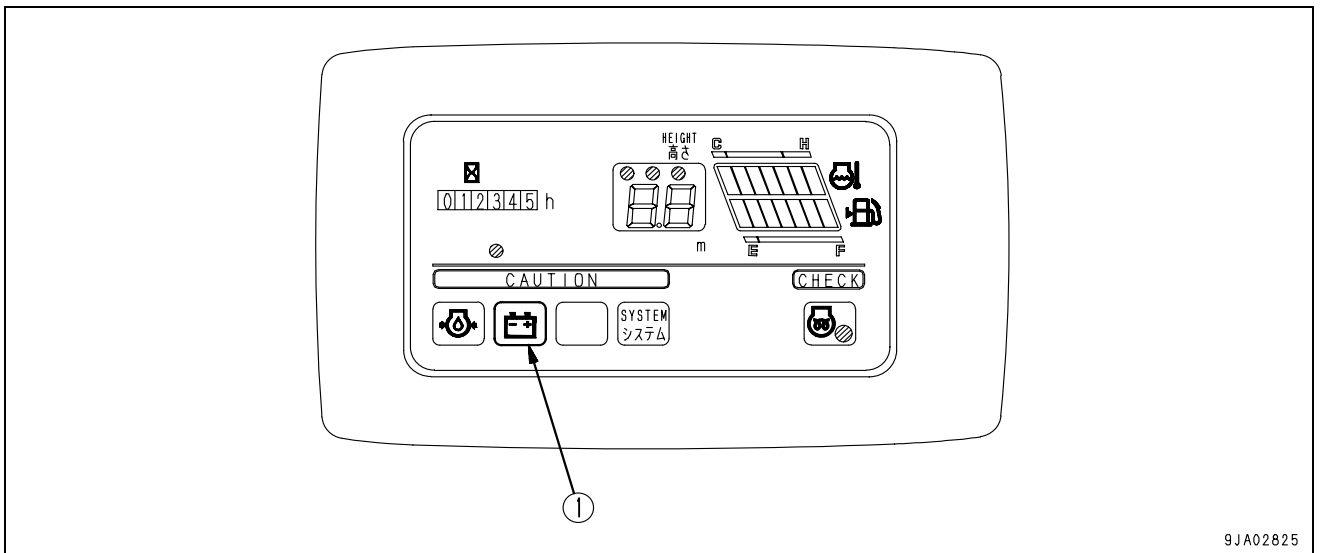

(1) Charge level monitor

Charge Level Monitor

This monitor (1) indicates an abnormality in the charging system while the engine is running. If the charging is not being carried out properly when the engine is running, the lamp lights up and the buzzer sounds.

REMARK

- This lamp will light up if the starting switch is turned ON when the engine is stopped, but this does not indicate any abnormality.
- When the engine is started or stopped with the starting switch at the ON position, the lamp may light up and the buzzer may sound momentarily, but this does not indicate any abnormality.

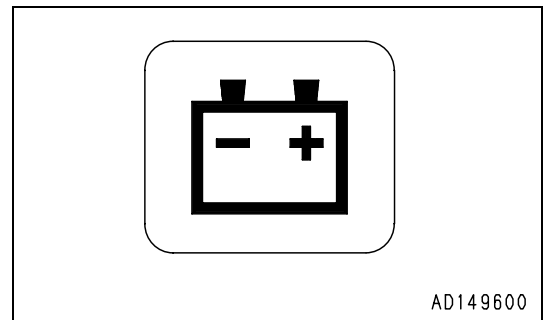

Emergency Monitors

CAUTION

If any monitor lamp lights up, stop the engine or run it at low idling, and take the following action.

These are items that should be watched when the engine is running. If any abnormality occurs, the monitor for the problem point lights up and the buzzer sounds. Take action immediately.

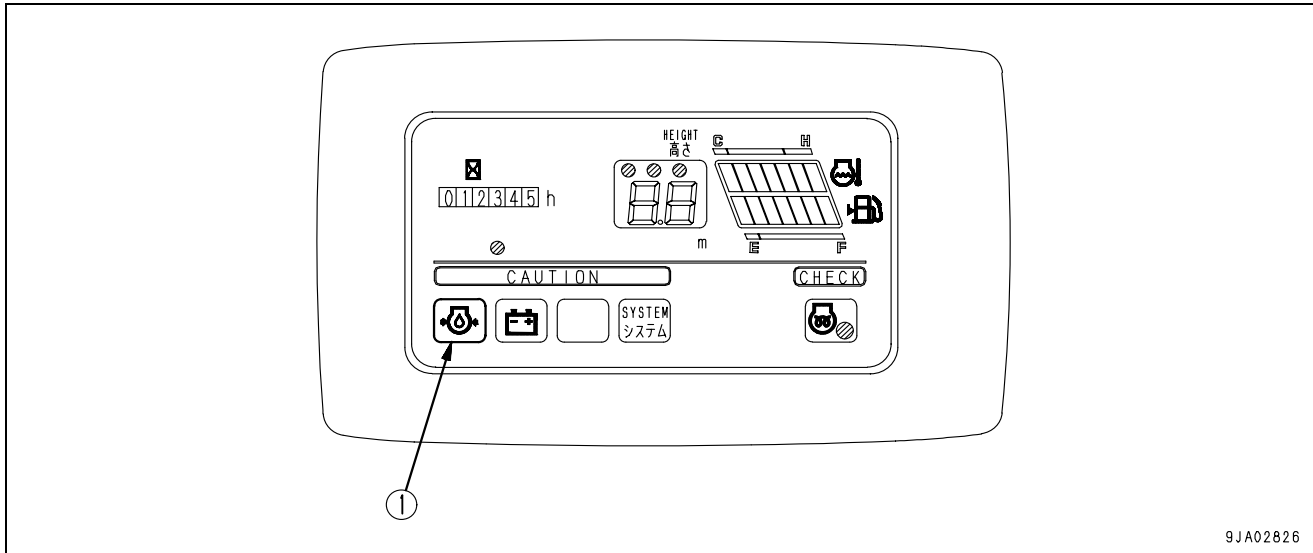

(1) Engine Oil Pressure Monitor

Engine Oil Pressure Monitor

If the engine lubricating oil pressure goes below the normal value, this monitor when lights up and the buzzer sounds. If the lamp lights up, stop the engine, and check the lubricating system and oil level in the oil pan.

REMARK

- This lamp will light up if the starting switch is turned ON when the engine is stopped, but this does not indicate any abnormality.
- When the engine is started or stopped with the starting switch at the ON position, the lamp may light up and the buzzer may sound momentarily, but this does not indicate any abnormality.

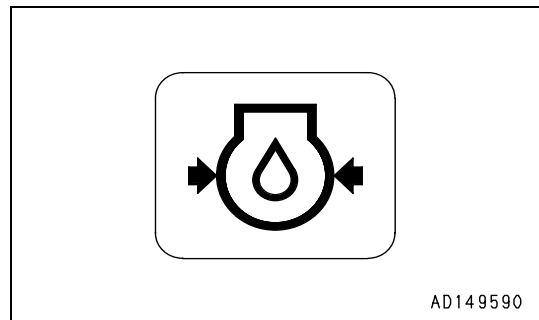

AD149590

Meter Display Portion

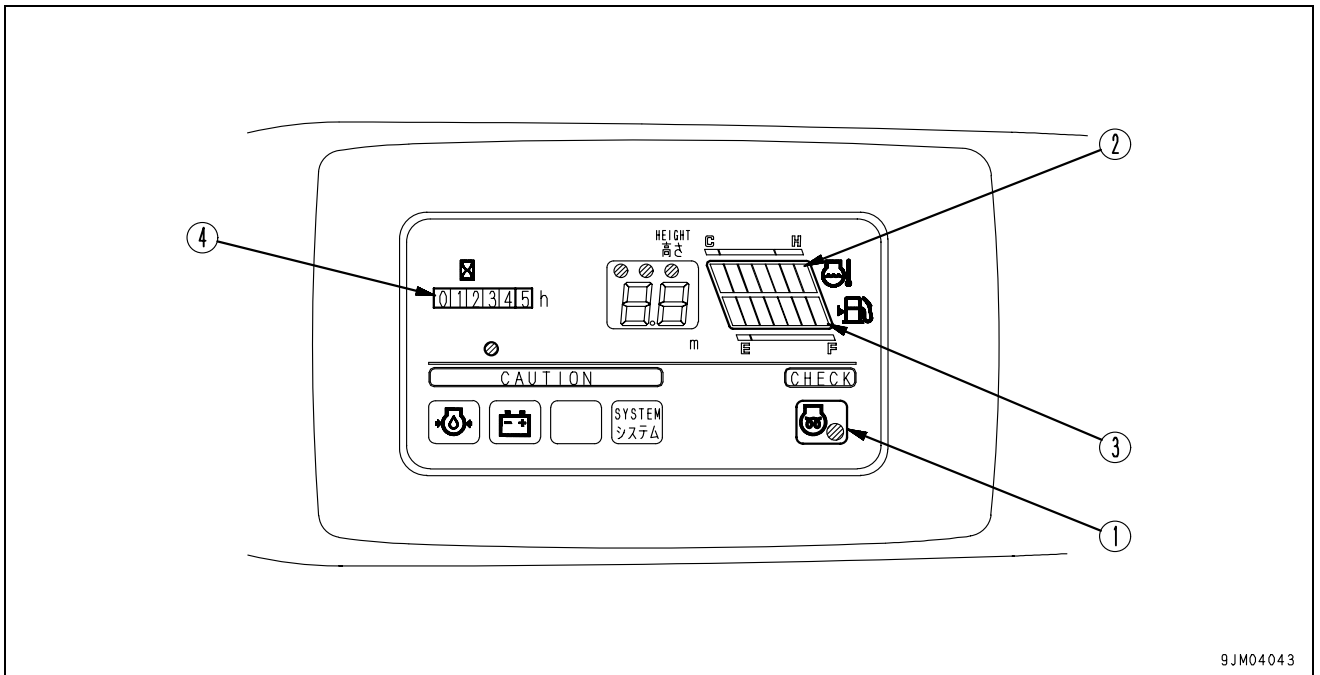

9JM04043

Pilot Display

(1) Engine Pre-heating Monitor

Meter

(2) Engine Coolant Temperature Gauge

(3) Fuel Gauge

(4) Service Meter

Pilot Display

When the starting switch is ON, the pilot display lights up when the display items are functioning.

Engine Pre-heating Monitor

This monitor lamp (1) indicates the pre-heating time required when starting the engine at an ambient temperature below 0°C (32°F).

The monitor lamp lights when the starting switch is turned to the HEAT position and goes off after about 18 seconds to show that the pre-heating is completed.

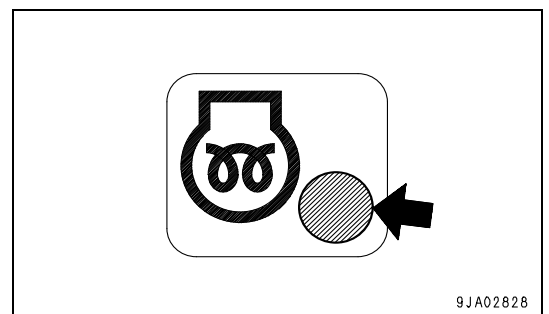

9JA02828

Gauges and Meter

Engine Coolant Temperature Gauge

This meter (2) shows the engine cooling water temperature. During normal operation, the lamp should light up in the green range (A).

If the lamp in the red range (B) lights up during operation, run the engine at low idling and wait for the temperature to go down to the green range (A).

After starting the engine, warm up it until the green range lights up.

REMARK

Only segment (C) flashes, and the alarm buzzer sounds at the same time.

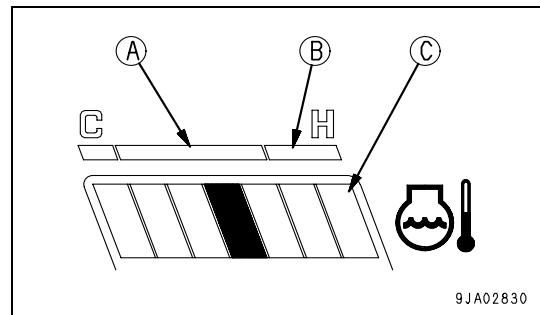

Fuel Gauge

This meter (3) shows the fuel level in the fuel tank.

During normal operation, the lamp should light up in the green range (A).

If the lamp is in the red range (B), it flashes during operation indicating that there is less than 19 liters (5.02 US gal) of fuel remaining. Check and add fuel.

The correct level may not be displayed for a short time after the starting switch is turned to the ON position. This is normal.

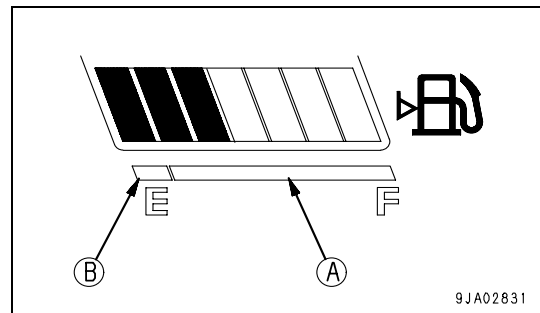

Service Meter

This meter (4) shows the total operation hours of the machine.

Set the periodic maintenance intervals using this display.

The service meter advances while the engine is running - even if the machine is not traveling.

While the engine is running, operation display (A) at the top inside of the meter will light to show that the meter is advancing.

The meter will advance by 1 for each 1/10 hour of operation regardless of the engine speed.

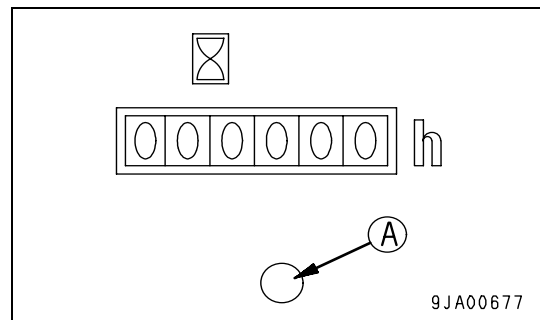

Electronic Control System

The electrical system displays the cab/canopy and bucket interference prevention system and the automatic work equipment control system as well set their operating conditions.

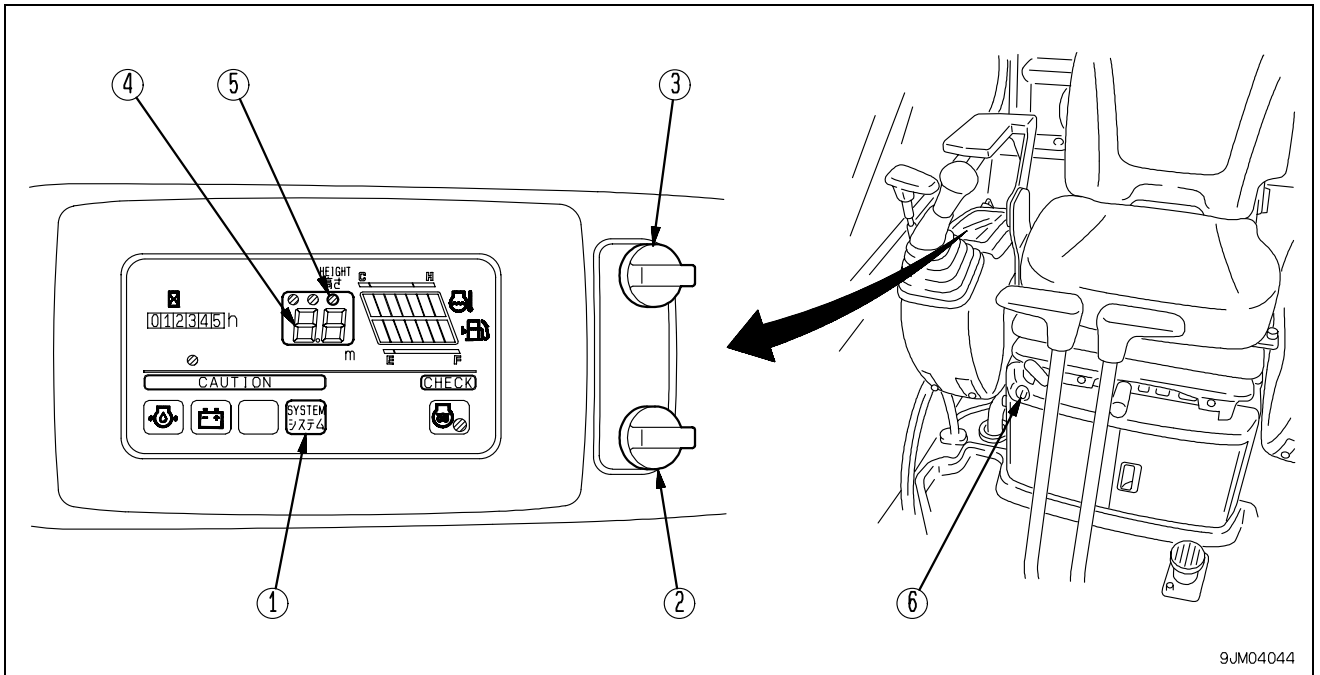

- (1) Electronic control system monitor
- (2) Mode selector switch
- (3) Setting switch

- (4) Depth display
- (5) Height mode pilot lamp
- (6) Emergency work equipment actuation switch

Electronic Control System Monitor

This monitor (1) flashes or lights a warning lamp, and sounds a warning buzzer, whenever an abnormality occurs in the electronic control system (i.e. cab/canopy and bucket interference prevention system or automatic work equipment control system). If a warning is activated, stop the engine. The fault is shown in the depth display by way of an error code No. Start checking and refer to the instructions in "Electronic Control System (3-105)" in this manual.

The warning lamp may light up or the warning buzzer may sound momentarily with the engine starting switch in the ON position, when starting or stopping the engine. This is no normal.

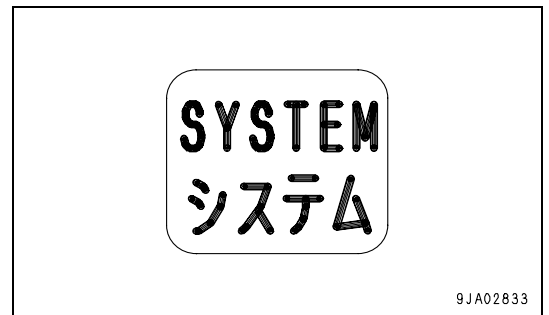

Mode Selector Switch

This switch (2) is used to select the depth display 0 set mode or height mode.

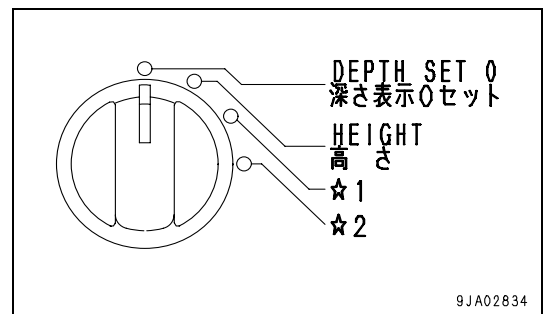

Setting Switch

This switch (3) is used to set or clear the mode selected by the mode selector switch.

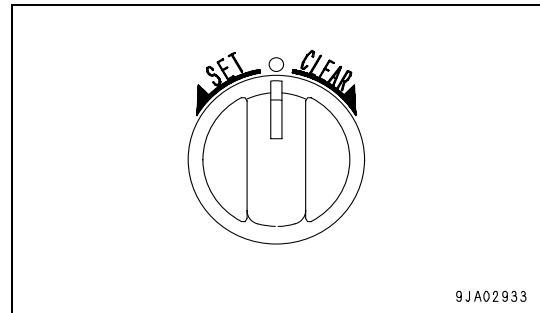

9JA02933

Depth Display

This monitor (4) shows the depth of the bucket from the ground level.

When the bucket is above the ground level, UP is always displayed. If a height lower than the ground surface is set as the standard surface (when in the depth display 0 set mode), the depth from the standard surface is displayed.

When some abnormality occurs in the electrical system, the location of that abnormality is indicated with a two-digit figure.

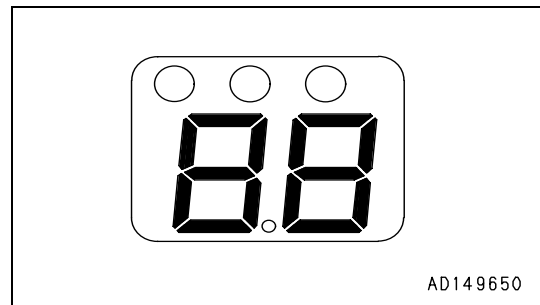

AD149650

Height Mode Pilot Lamp

This pilot lamp (5) lights when the raising distance of the boom is set.

It lights up when the mode selector switch is set to HEIGHT, and shows that the boom raising distance is set.

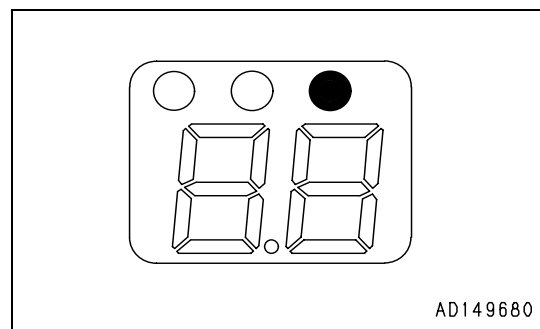

AD149680

Emergency Work Equipment Actuation Switch

⚠ WARNING

Do not operate the machine for work with this switch in the ON position. The electrical system will not work and therefore, the work equipment will not stop. There is also danger that the work equipment may interfere with other parts of the machine.

Use this switch (6) only in an emergency. Such as; the work equipment has stopped due to some abnormality in the electrical system and it has to be operated out of safety consideration.

- (a) POSITION FOR EMERGENCIES: Pull it up to this position in emergency.
- (b) NORMAL POSITION: Keep it in this position normally.

When the switch is held at "POSITION FOR EMERGENCIES" and released, it automatically returns to "NORMAL POSITION".

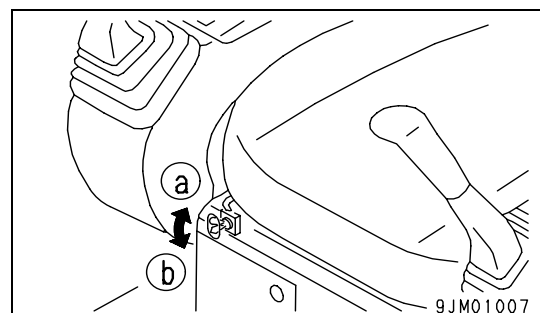

9JM01007

SWITCHES

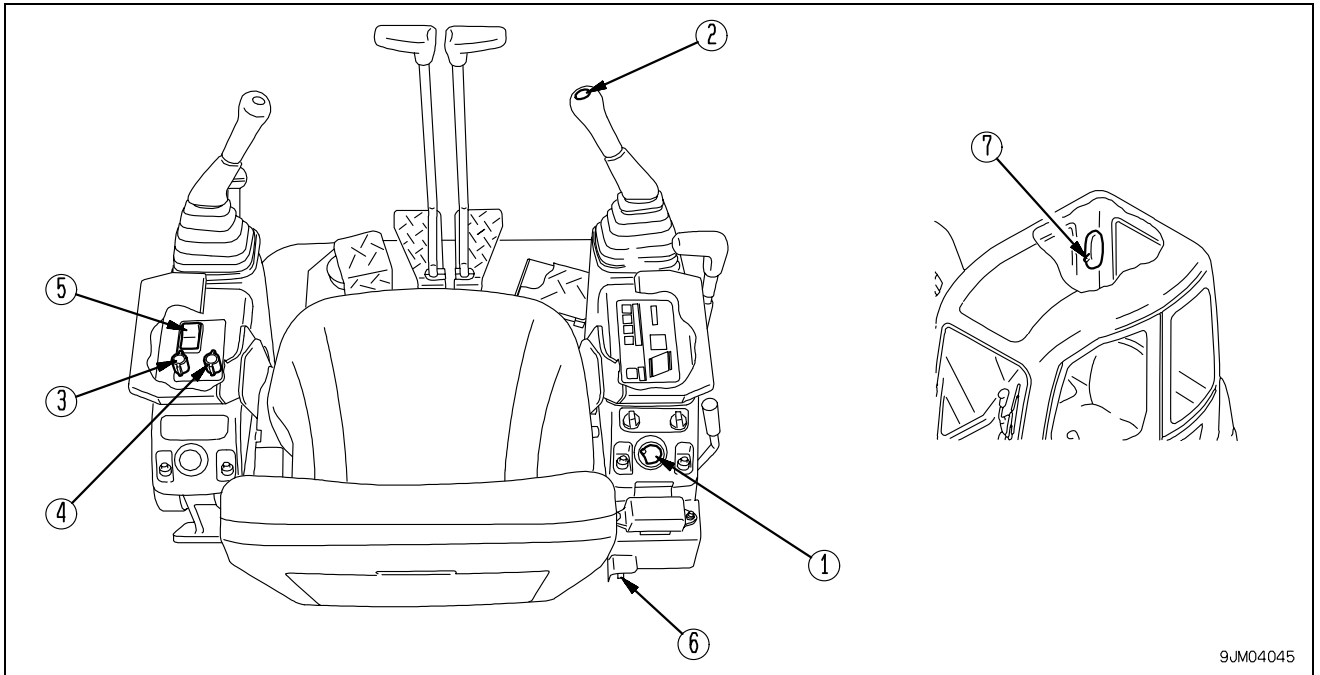

9JM04045

- (1) Starting switch
- (2) Horn button
- (3) Lamp switch
- (4) Car heater switch (Cab specified)
- (5) Wiper switch (Cab specified)
- (6) Emergency pump drive switch
- (7) Room lamp switch (Cab specified)

Starting Switch

This switch (1) is used to start or stop the engine.

OFF position

In this position the engine starting switch can be pushed in or pulled out. When the switch is turned to this position, power supply to the electrical system is terminated, thereby stopping the engine.

ON position

Electric current flows in the charging and lamp circuits. Keep the starting switch key at the ON position while the engine is running.

START position

This is the engine-start position. Keep the key at this position during cranking. Immediately after starting the engine, release the key. It will automatically return to the ON position.

HEAT (preheat) position

When starting the engine in cold weather, turn the key to this position. When the key is set to the HEAT position, the preheating monitor lights up. Keep the key at this position until the preheating monitor goes out.

When the preheating monitor goes out, release the key.

When the key is released, it will return to the OFF position, so turn it immediately to START and start the engine.

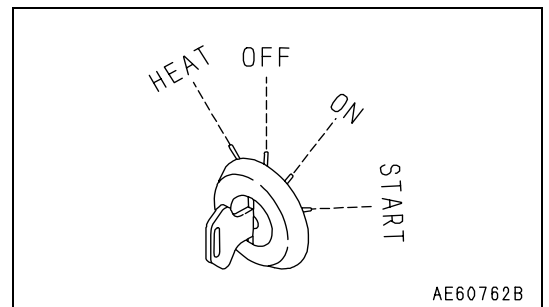

AE60762B

REMARK

The engine will not start, if the safety lock lever is not in the LOCK position. First make sure that the safety lock lever is in the LOCK position, and then turn the engine starting switch.

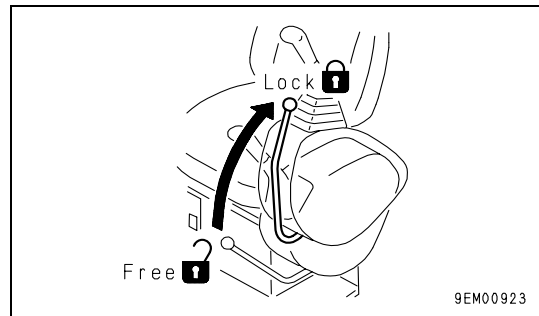

Horn Switch

When the button (2) at the tip of the right work equipment control lever is pressed, the horn will sound.

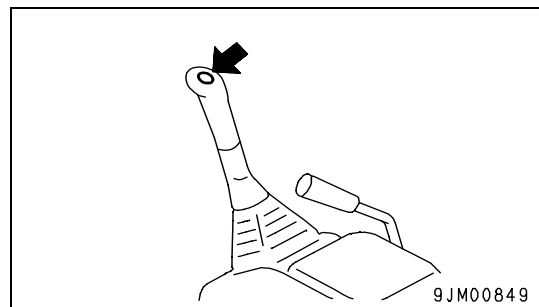

Lamp Switch

This switch (3) lights up the working lamps and panel lamp.

- Position 1: Panel lamp lights up
- Position 2: Panel and working lamps light up.
- OFF position: Lamps goes off.

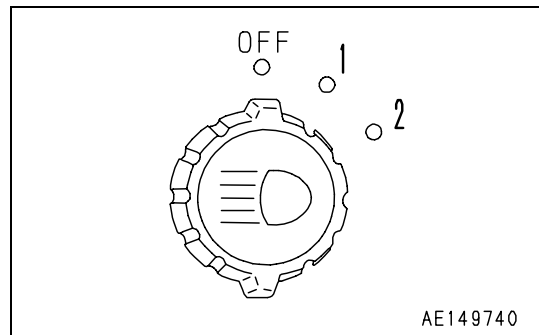

Cab Heater Switch

(Machine equipped with cab)

This switch (4) is used to heat the operator's compartment. The flow rate of the hot air can be set to two levels.

- H position: Strong
- L position: Weak

Hot water from the engine is used for heating. Heating is possible when the engine cooling water is hot.

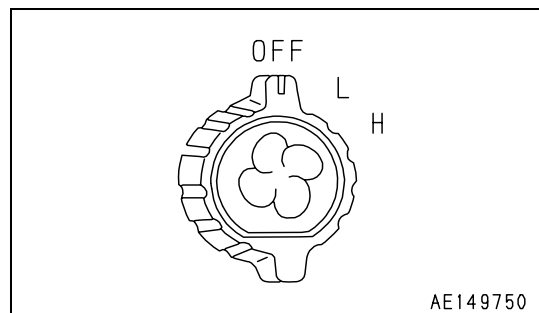

Windshield Wiper Switch

(Machine equipped with cab)

This switch (5) actuates the front window wiper.

- (a) OFF: The wiper stops.
- (b) ON: The wiper moves continuously.
- (c) The wiper moves continuously and window washer fluid is sprayed out. When the switch is released, it return to (b).
- (d) Window washer fluid is sprayed out. When the switch is released, it return to (a).

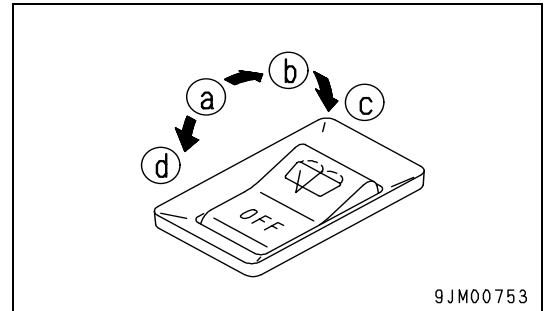

REMARK

- Do not keep the switch pressed at the washer spray position for more than 10 seconds continuously.
- Do not press the switch to the washer spray position if the washer fluid container is empty.

Pump Drive Emergency Switch

NOTICE

The emergency pump driving switch is provided to make it possible to carry out work for a short time when there is a failure in pump control system. It is necessary to repair the abnormal location as soon as possible.

This switch (6) is provided to enable an operator to temporarily continue with work in an emergency, i.e. something unusual occurs in the controller, which makes the hydraulic pump inoperable.

- (a) EMERGENCY: Pull up the switch to this position.
- (b) NORMAL: Hold the switch in this position normally

When the switch is held in "EMERGENCY" and released, it automatically returns to "NORMAL".

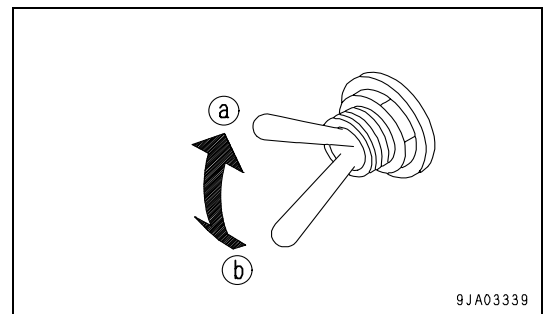

Room Lamp Switch

(Machine equipped with cab)

This switch (7) is used to turn on the cab lamp.

- ON position: lights up
- OFF position: goes off

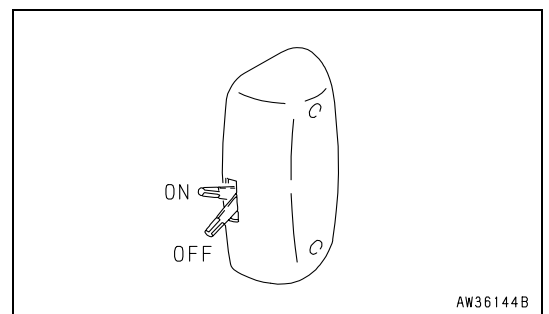

CONTROL LEVERS AND PEDALS

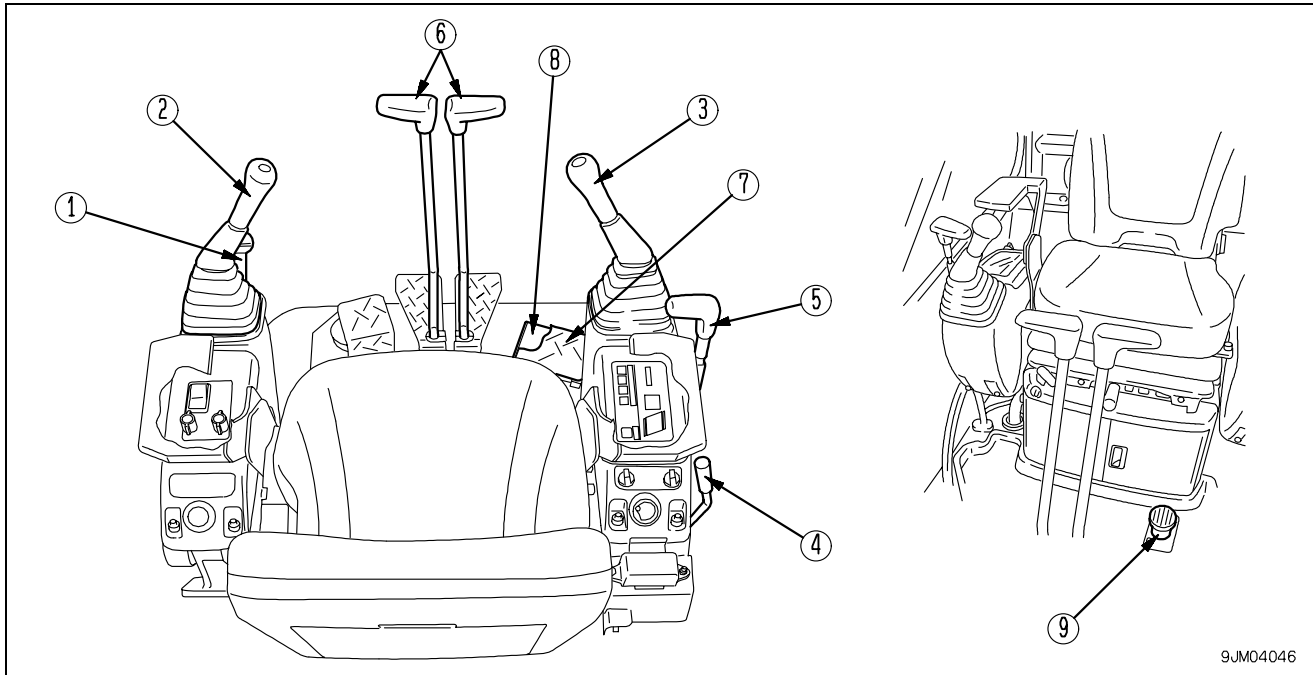

9JM04046

- (1) Safety lock lever
- (2) Left work equipment control lever
- (3) Right work equipment control lever
- (4) Fuel control lever
- (5) Blade control lever
- (6) Travel levers (machines with travel pedal)
- (7) Pedal lock (for boom offset control pedal)
- (8) Boom offset control pedal
- (9) Travel accelerator pedal

Safety Lock Lever

⚠ WARNING

- When leaving the operator's cab, be sure to move the safety lock lever to the LOCK position. If the safety lock lever is not in the LOCK position and a control lever is touched accidentally, an accident, which may cause serious bodily injury, can occur.
- If the safety lock lever is not secured in the LOCK position, this may result in serious bodily injury. Check that the lever is in the illustrated (locked) position.
- Even if the safety lever is moved to the LOCK position, blade operation is not locked.
- Be careful not to accidentally touch the work equipment control lever while pulling up the safety lock lever.
- Be careful not to accidentally touch the work equipment control lever while pushing down the safety lock lever.

This lever (1) is a device with which to lock the operations of the work equipment, swing, travel and any attachment(s). When pulled up, it locks them.
 This safety lock lever is hydraulically actuated. When it is in the LOCK position, the work equipment control lever and travel control lever are still movable, but none of the work equipment, swing and travel motors work.

REMARK
 The engine will not start, if the safety lock lever is not in the LOCK position. First make sure that the safety lock lever is in the LOCK position, and then turn the engine starting switch.

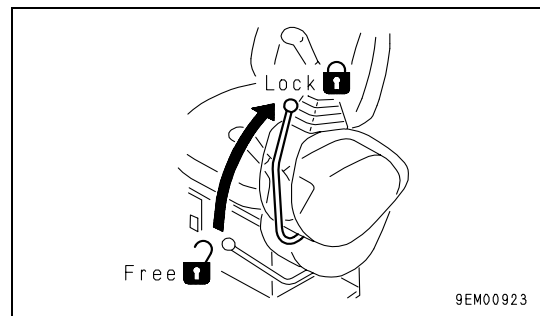

9EM00923

Work Equipment Control Lever

⚠ WARNING

- The operating pattern is set to the standard operating pattern (ISO pattern).
- When changing the operating pattern, please contact your Komatsu distributor.
- The method of using operating patterns other than the ISO pattern is given in the ATTACHMENT AND OPTIONS section. Always read and understand the contents before operating the machine.
- When changing the operating pattern, change the operating plate at the same time to the operating plate that matches the movement of the machine.
- The place to attach the operating plate is on the right side of the operator's cab.

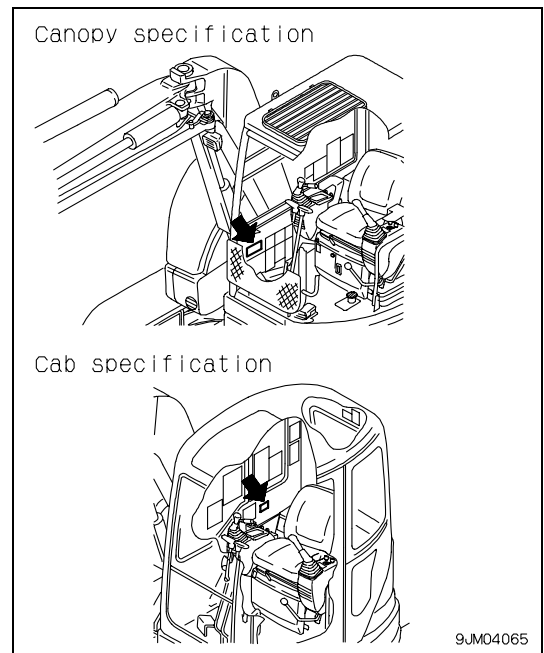

This Left work equipment control lever (2) is used to operate the arm and upper structure.

Arm operation Swing operation

- (a) Swing to right
- (b) Swing to left
- (c) Arm IN
- (d) Arm OUT

N (Neutral): The upper structure and arm are held in position and do not move.

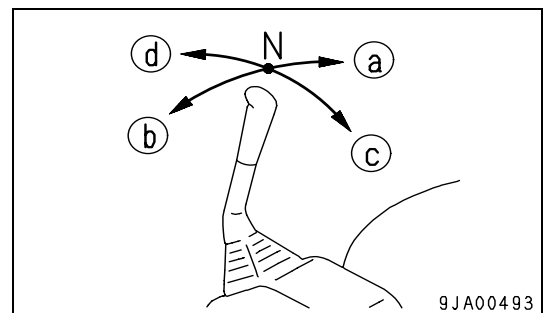

This Right work equipment control lever(3) is used to operate the arm and upper structure.

Boom operation Bucket operation

- (e) RAISE
- (f) LOWER
- (g) DUMP
- (h) CURL

N (Neutral): The boom and bucket are held in position and do not move.

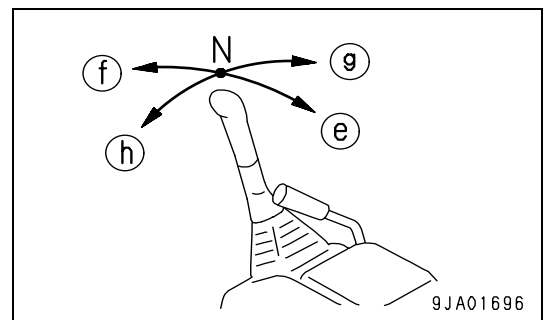

Fuel Control Lever

This lever (4) is used to control the engine speed and output.

- (a) Low idling: Push the lever fully.
- (b) High idling: Pull the lever fully.

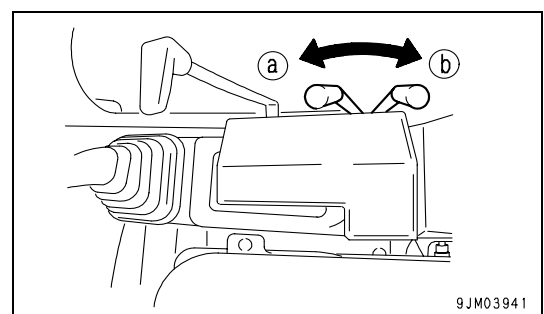

Blade Control Lever

NOTICE

- This lever is not locked even when the safety lock lever is at the LOCK position, so when not operating the blade, be careful not to touch this lever.
- When operations using the blade are continued for more than one hour, pay careful attention to the rise in the water temperature.

This lever (5) is used to control the blade.

- (a) Lower
- (b) Raise

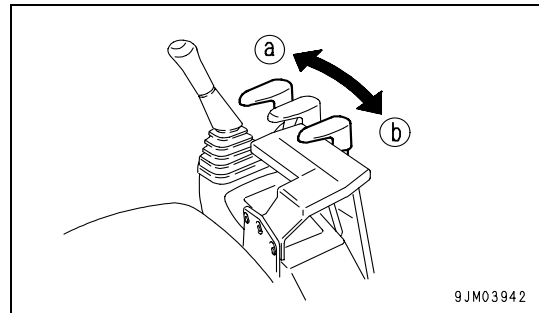

9JM03942

Travel Levers

! WARNING

- Do not put your foot on the pedal unless the machine is traveling. If you leave your foot on the pedal and press it by mistake, the machine will move suddenly. This may lead to a serious accident. Do not rest a foot on the pedal except when traveling or steering the machine using the pedal.
- If the track frame is facing the rear, the direction of travel operations will be reversed.

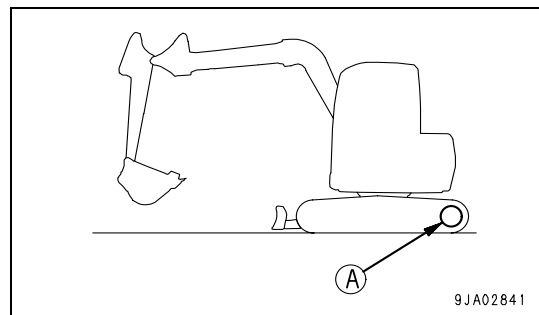

9JA02841

When operating the travel levers, check if the track frame is facing the front or the rear.

- (If sprocket (A) is at the rear, the track frame is facing the front.)
- Be careful when traveling or steering the machine using the pedal.

This lever (6) is used to change the direction of travel.

(): This indicates operation of the pedal.

(a) FORWARD: This lever is pushed forward
(The pedal is angled forward)

(b) REVERSE: The lever is pulled back
(The pedal is angled back)

N (Neutral): The machine stops

REMARK

If the lever is shifted to the advance or reverse position from the neutral position, the alarm sounds to warn that the machine is starting to advance.

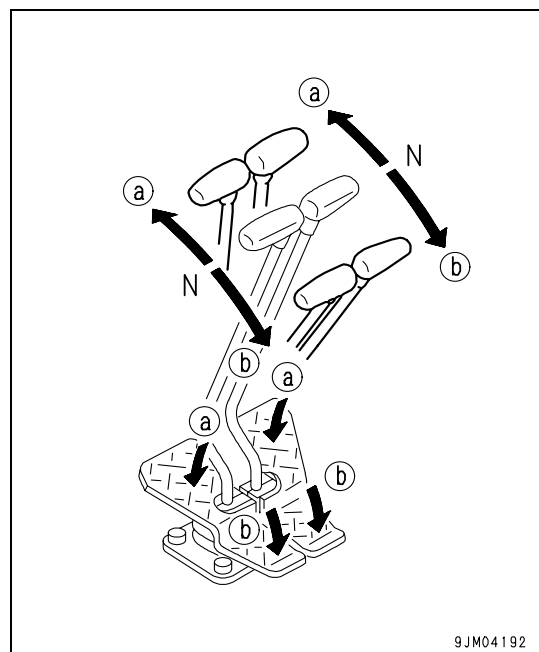

9JM04192

Pedal Lock

(for boom offset control pedal)

! WARNING

When not operating the boom offset, always keep it locked with the pedal lock. If the control pedal is not locked and it is touched by mistake, it may lead to a serious accident.

This device (7) locks the boom offset control pedal. The pedal is locked, when it is capped with the plate.

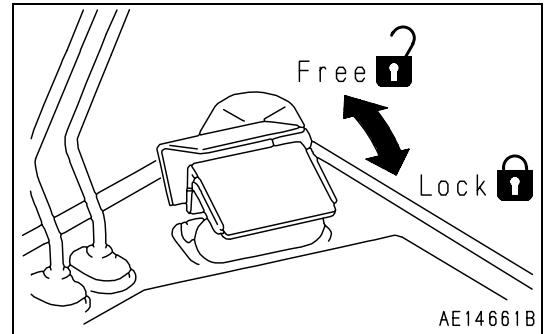

Boom Offset Control Pedal

This pedal (8) is to control the boom offset.

(a) Right offset

(b) Left offset

N (NEUTRAL): The offset boom is at standstill and held in that position.

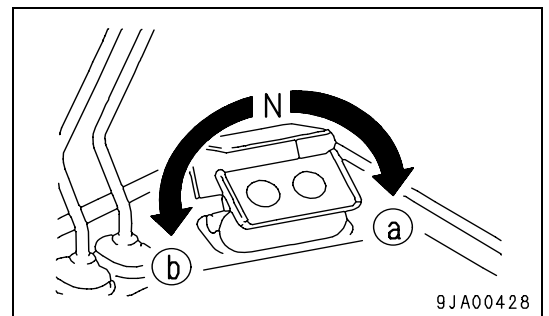

Traveling Accelerator Pedal

If the pedal (9) is depressed, the machine speed will increase.

For details of the travel speed values, see "SPECIFICATIONS (5-2)".

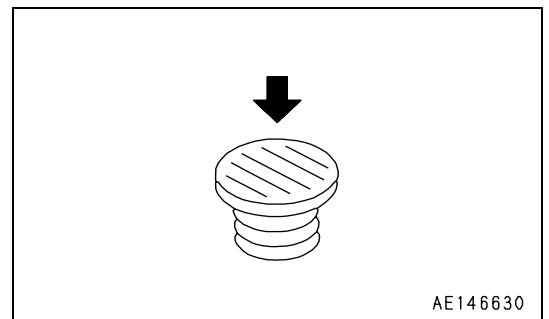

WINDSHIELD

(Machine equipped with cab)

WARNING

- When opening or closing the front window, bottom window, or door always set the safety lock lever to the lock position.
- If the control levers are not locked and they are touched by accident, this may lead to a serious accident.
- When opening the front window, hold the grip securely with both hands, pull up, and do not let go until the automatic lock catch is locked.
- When the front window is open, there is danger that it will fall, so always lock it with left and right lock pins (A).
- When closing the front window, the window will move quicker under its own weight. Hold the grips securely with both hands when closing it.

It is possible to stow (pull up) the front window in the roof of the operator's compartment.

Opening

1. Stop the machine on level ground, lower the work equipment completely to the ground, then stop the engine.
2. Set the safety lock lever securely to the LOCK position.

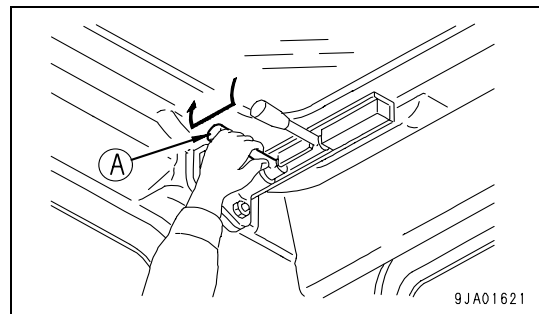
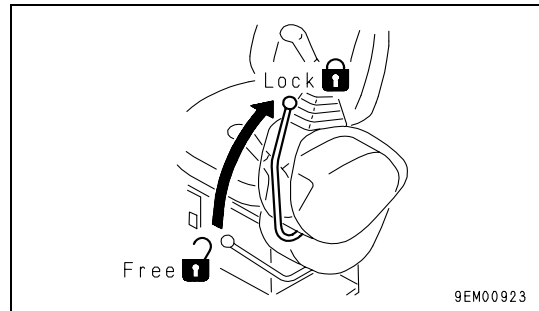

3. Pull lock pins (A) at the top left and right sides of the front window to the inside to release the lock.

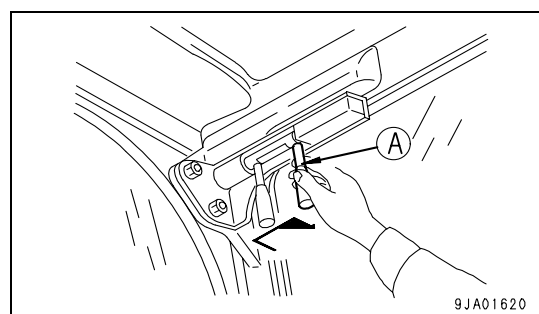
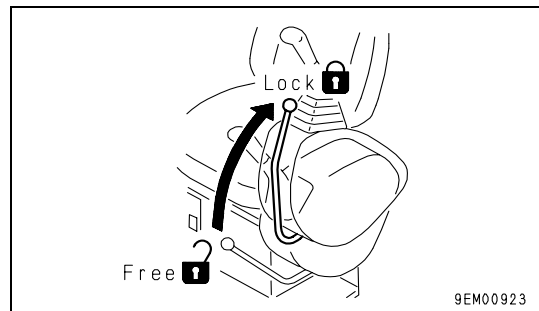

OPERATION

DETAILED CONTROLS AND GAUGES

4. Hold the top grip with your right hand, pull it to the front to remove the top of the front window from the frame, then set it on the rail of the top roller.

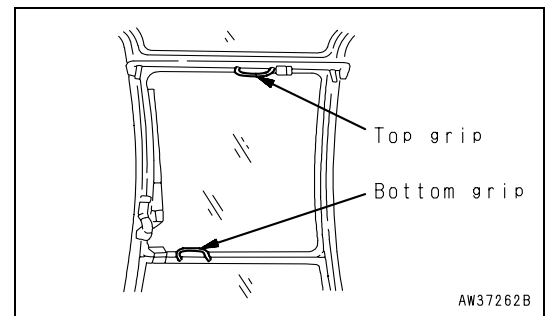

5. From the inside of the operator's cab, hold the bottom grip with the left hand and the top grip with right hand, pull up the upper windshield, and push it in fully until it is locked by catch (C).

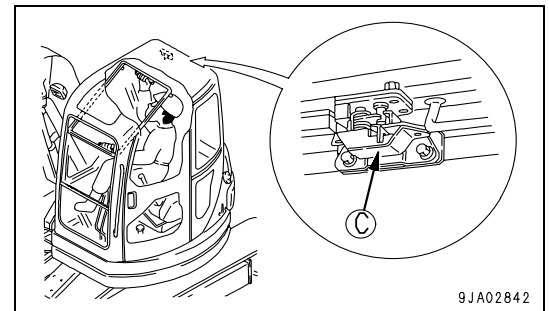

6. Lock securely with lock pins (A) at the left and right sides.

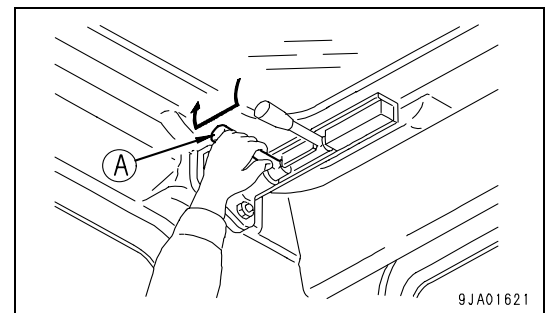

Closing

1. Stop the machine on level ground, lower the work equipment completely to the ground, then stop the engine.
2. Set the safety lock lever securely to the LOCK position.

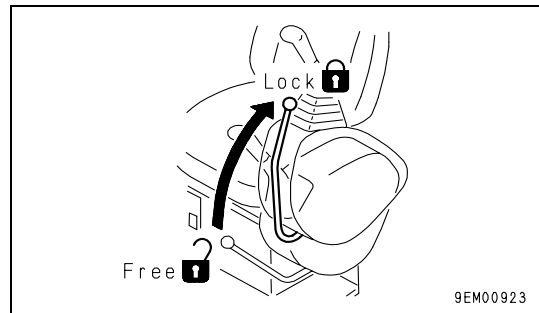

3. Release the lock pin (A).

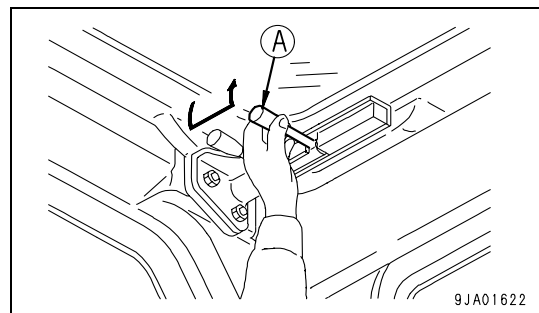

4. Hold the grip at the bottom of the front window with your left hand and the grip at the top with your right hand, release the lock of catch (C) with your right thumb, then pull the top grip to the front and lower the front window slowly. When releasing the lock of catch (C), move release lever (D) in the direction of the arrow to release the lock.

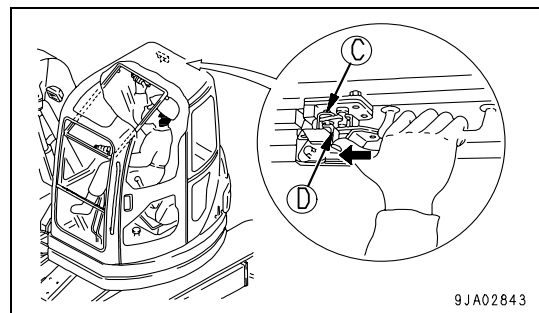

5. When the bottom of the window reaches the top of the bottom window, push the top of the window to the front, and insert left and right lock pins (A) securely in the holes to apply the lock.

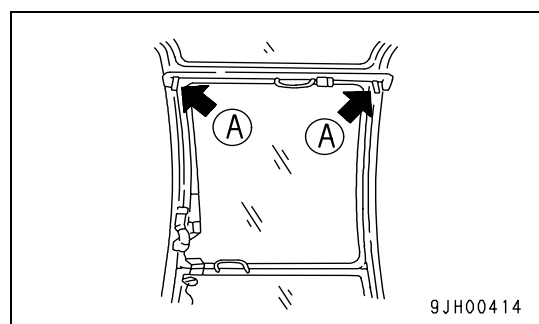

Removing Lower Windshield

1. With the front window open, remove lock pins (E), and the bottom part of the front window can be removed.

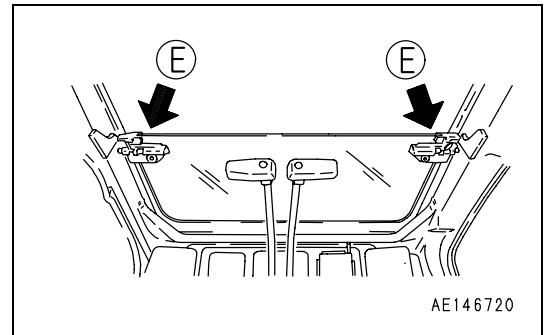

2. Store the removed bottom part of the front window at the rear of the operator's cab and lock with lock pins (E).

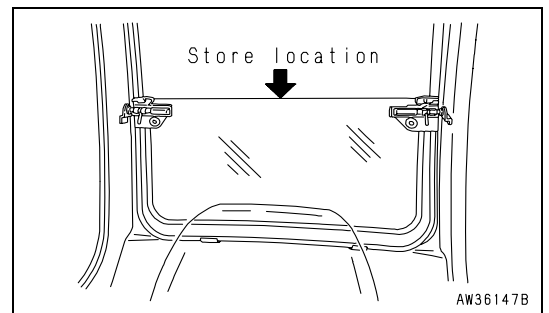

SLIDING DOOR

(Machine equipped with cab)

CAUTION

- Be sure to check that the sliding door is locked in position both when it is open and when it is closed.
- Always stop the machine on level ground when opening or closing the door.
- If the door is opened or closed on a slope, there is danger that the operating effort will suddenly change. Do not open or close the door on slopes.
- When opening or closing the door, always use door handle (1) and knob (2).
- Be careful not to get your hands caught between the front pillar or center pillar.
- If there is anyone inside the cab, call out to that person before opening or closing the door.
- When the sliding door is opened wide, the far end of the door overruns the machine's turning radius. Make sure that the door does not hit objects in the turning radius.

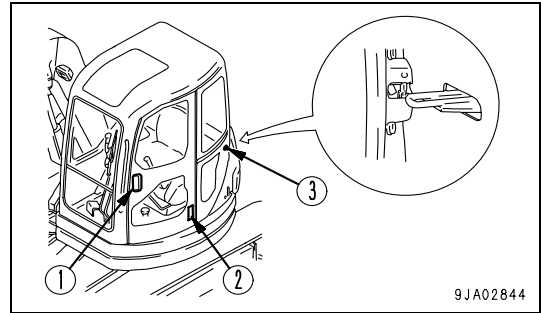

NOTICE

Foreign objects stuck in the door slide can cause a failure in the door when it is opened and closed. Periodically check and remove any foreign objects.

Door Lock

When closing the door, pull the handle back to remove lock (3), then pull the door to the front.

REAR WINDOW

(Machine equipped with cab)

⚠ WARNING

When the rear window is removed, the glass will drop, so carry out the operation with two workers: one worker removes the bolts and the other worker supports the glass.

It is possible to remove the rear window.
Remove the rear window as follows.

1. Remove 3 bolts (1) at the top from inside the cab. When the bolts are removed, spacer (2) and button (3) will drop, so one worker should stand outside the cab to catch the spacer and button before they fall.
 2. Remove 4 bolts (4) at two places in the center from the inside of the cab.
 3. Remove three bolts (5) at the bottom from outside the cab. When bolts (5) are removed, the glass will drop, so one worker should support the glass securely.
 4. Rotate the glass approx. 30° when removing it.
 5. After removing the parts, put them in a bag and store them in a safe place to prevent them from becoming lost.
- Install the rear window exactly, in reverse order of removal.
 - Check the rear window after installation to make sure that there is no clearance in the window.

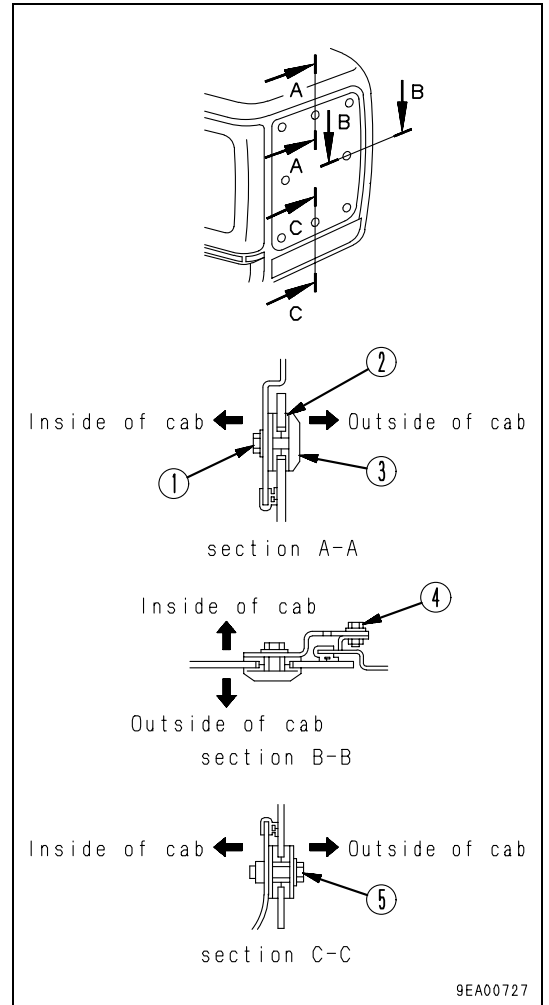

SIDE WINDOW

(Machine equipped with cab)

CAUTION

- Do not take off guard (1).
- When the side window is open, do not stick a hand out.

The side window can be opened and closed.
Lock the side window firmly with lever lock (2).

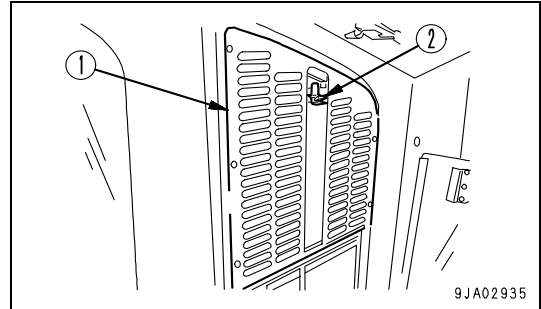

EMERGENCY ESCAPE HAMMER

(Machine equipped with cab)

NOTICE

When escaping, remove the broken pieces of the glass from the sash so that you will not cut yourself with them. Take care not to slip on the broken and scattered pieces.

In case it becomes impossible to open the door, a hammer (1) to be used for escape from the cab is installed.

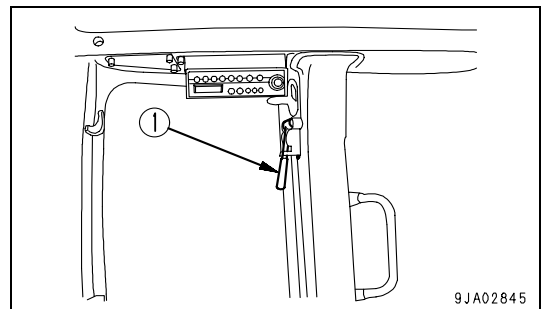

When escaping, break the window glass with hammer (1).

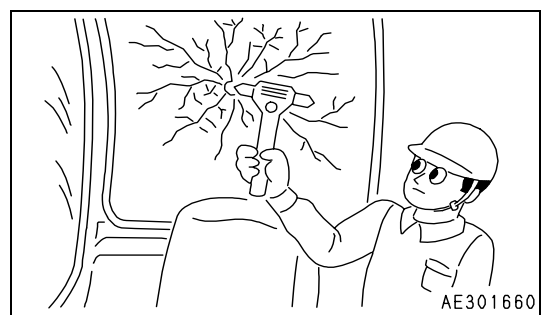

CAP WITH LOCK

Use the starting key to open and close the locks on the caps and covers.

For details of the locations of the caps and covers with locks, see "LOCKING (3-72)".

Insert the key as far as it will go to the shoulder. If the key is turned before it is inserted all the way, it may break.

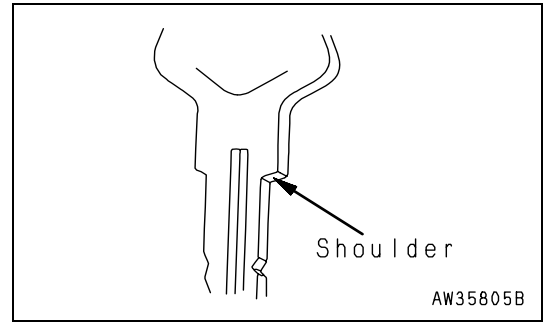

Opening and Closing Caps with Lock

Opening the Cap

1. Insert the key into the key slot.
2. Turn the key clockwise, align the key slot with the match mark on the cap, then open the cap.

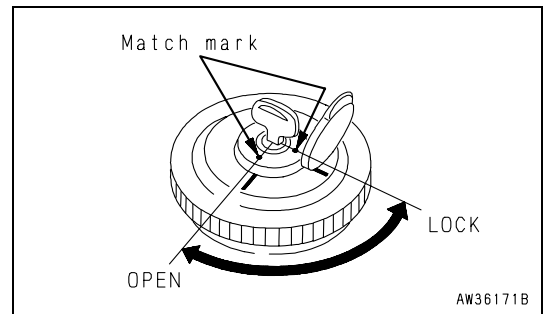

Locking the Cap

1. Turn the cap until tight, then insert the key into the key slot.
2. Turn the key counterclockwise and take the key out.

Opening and Closing Covers with Lock

Opening the Cover

1. Insert the key into the key slot.
2. Turn the key counterclockwise and open the cover by pulling the cover grip.

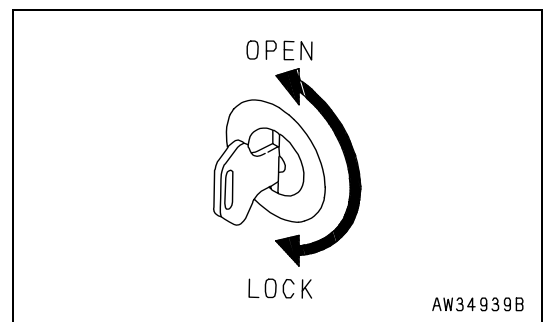

Locking the Cover

1. Close the cover and insert the key into the key slot.
2. Turn the key clockwise and take the key out.

ENGINE HOOD

WARNING

- An engine exhaust pipe runs through part (1) under the label. This part (1) is hot, while the engine is running or immediately after it is shut off and can cause a burn if touched. Be careful not to touch it.
- When performing inspection or maintenance in the engine compartment, pull the engine hood completely open and latch it.

NOTICE

Always keep the hood locked except when opening it. Check the direction of the key slot in the opening knob to check that it is locked.

1. Release lock (2) of the engine hood. (For details see "Opening and Closing Covers with Lock (3-25)".)
2. Push engine hood opening knob (2) and open hood (3).

3. Push engine hood (3) fully open. Then stopper (4) automatically clicks in and latches the engine hood (3).
4. When closing engine hood (3), pull stopper (4) supporting the hood, then let down the hood gently and press it down for locking.

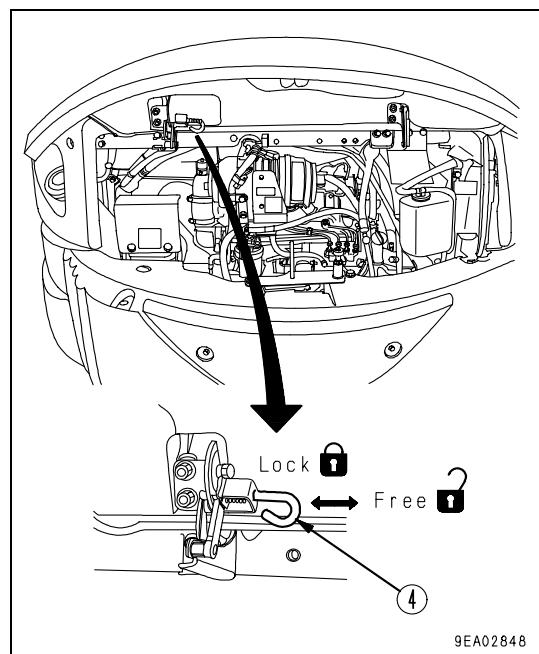
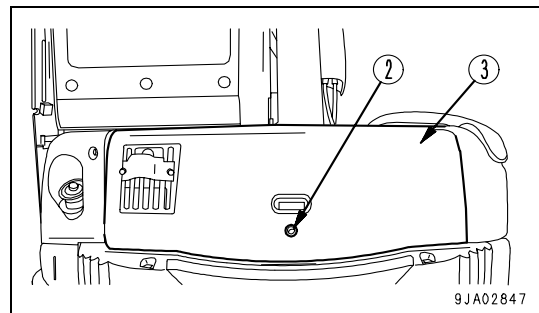
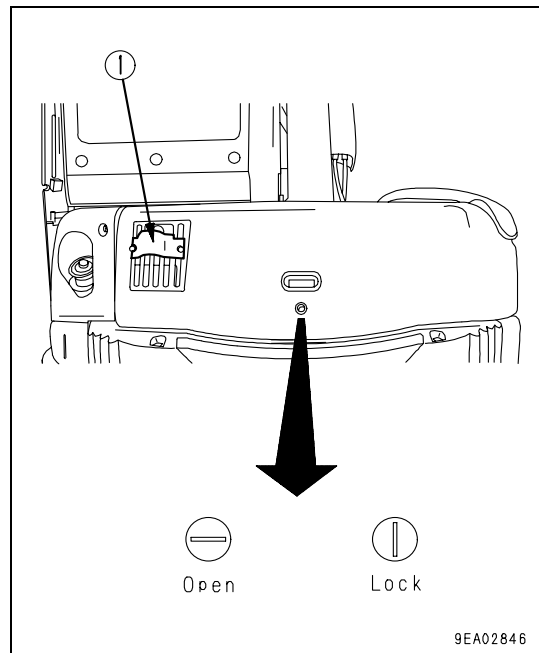

MUD COVER

 **WARNING**

When carrying out inspection or maintenance inside the cover, open the cover and be sure to fix it securely in position with the stopper.

NOTICE

Always keep the hood locked except when opening it. Check the direction of the key slot in the opening knob to check that it is locked.

1. Release lock (1) of the mud cover. (For details see "Opening and Closing Covers with Lock (3-25).")
2. Push mud cover opening knob (1) and open cover (2).

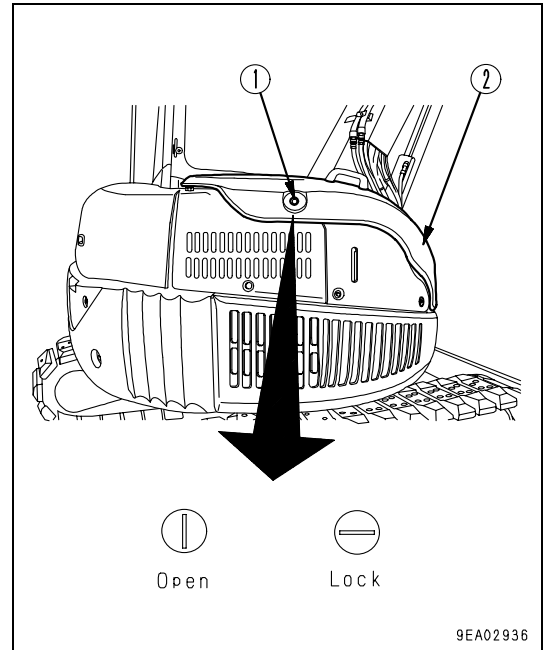

3. After opening the cover (2), use cover support lever (3) to secure the cover in position.
4. When closing cover (2), remove cover support lever (3), fit it securely in the lever lock, then lower the cover slowly and push it down to lock it.

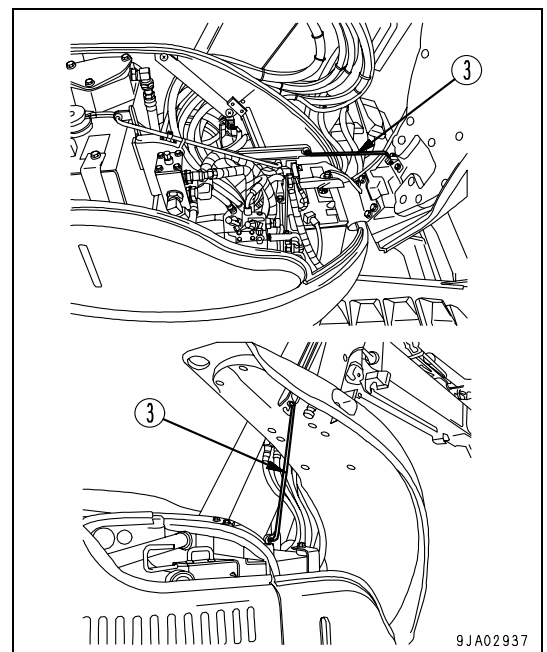

FUSE

NOTICE

Before replacing a fuse, be sure to turn off the starting switch.

The fuses protect the electrical equipment and wiring from burning out.

If the fuse becomes corroded, or white powder can be seen, or the fuse is loose in the fuse holder, replace the fuse.

Replace the fuse with another of the same capacity.

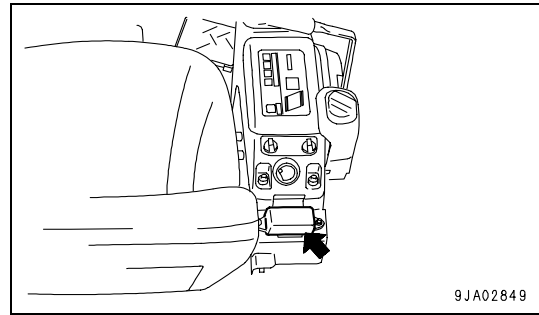

Fuse Capacities and Circuit Names

| No. | Fuse capacity | Name of circuit |
|-----|---------------|--|
| (1) | 30A | Engine stop solenoid valve, timer |
| (2) | 20A | Horn, working lamp, caution buzzer |
| (3) | 20A | PPC lock solenoid valve, emergency circuit, governor motor |
| (4) | 25A | Alternator, safety relay, cab harness, fuel pump |
| (5) | 20A | Controller, monitor panel, reset terminal |

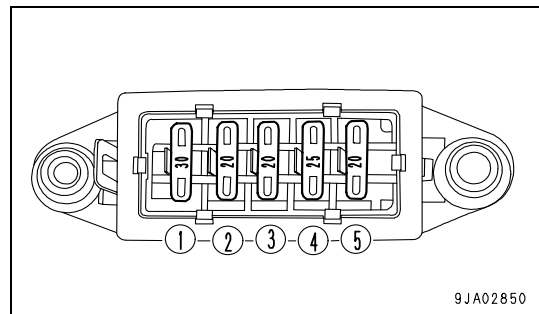

BLOCK FUSE

If the starting motor does not rotate even when the starting switch is turned to the ON position, block fuse (1) is probably blown, so open the cover on the right side of the machine and check or replace.

REMARK

A block fuse is a large fuse wire installed to the circuit where a large-capacity current is flowing. It acts in the same way as a normal fuse to protect the electrical equipment and wiring from burning out under abnormal current.

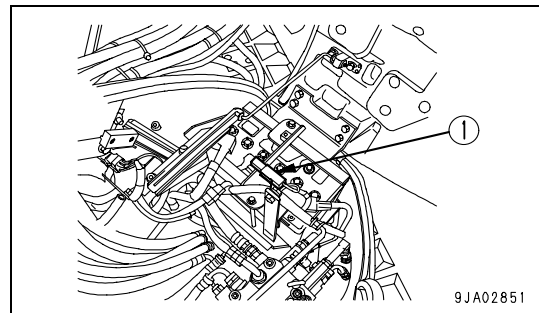

AUXILIARY ELECTRIC POWER

NOTICE

When installing electrical equipment not supplied by Komatsu, use 12V equipment with a maximum of rating of 180W (equivalent to 15A). If equipment is to be installed with a capacity greater than this, please contact your Komatsu distributor.

A 2-terminal connector is provided beneath the operator's seat on the right side as a power source for optional electrical equipment. Use this power source for electrical equipment other than those of Komatsu make.

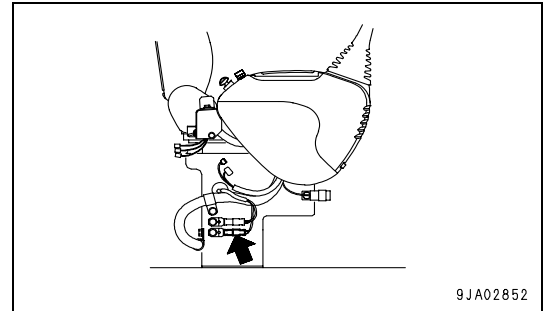

The connector types are shown in the table below.

| | M type housing (2-terminal) | | Terminal |
|------------------|-----------------------------|-------------|---------------|
| | Body | Rear holder | M. AVS0.85 `2 |
| Komatsu part No. | 08056-00211 | 08056-00230 | 08056-00051 |

OPERATION MANUAL STORAGE

There is a box provided in the rear of the operator's seat to keep the Operation and Maintenance Manual. Keep the operation manual in this box so that you can read it when you need it.

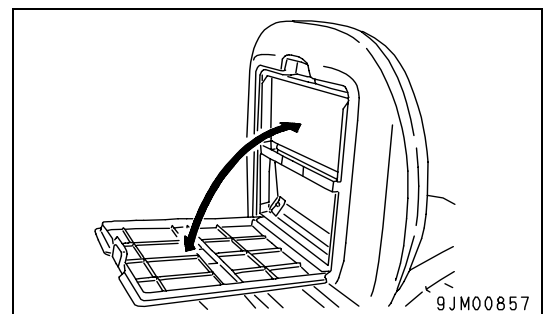

TOOL BOX

NOTICE

Except when opening the cover for some reason, always keep the cover locked.

Store the tools in this box.

For canopy specification and operator's cab + heater specifications

A toolbox is provided beneath the operator's seat.

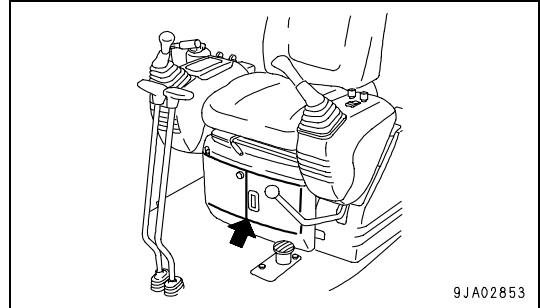

9JA02853

For operator's cab + air conditioner specifications

A toolbox is provided inside a plate at a lower part on the left side of the operator's cab.

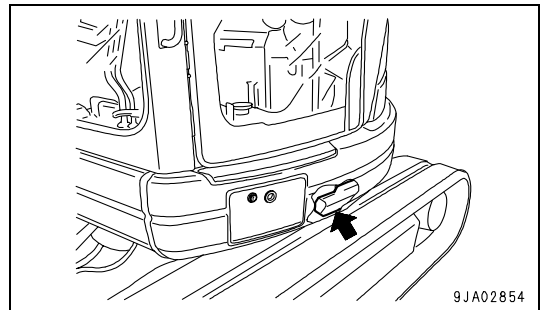

9JA02854

GREASE PUMP HOLDER

The holder is at the hydraulic tank side. When not using the grease gun, store it in the holder.

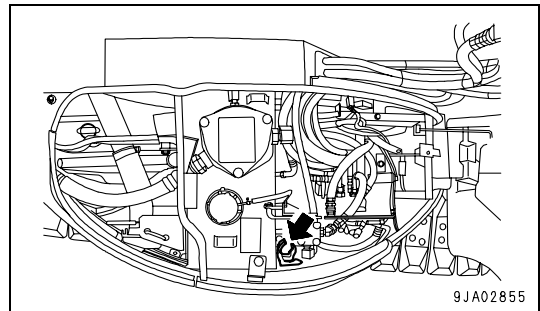

9JA02855

ASHTRAY

(Machine equipped with cab)

This is on the right side of the operator's seat.

Always make sure that you extinguish the cigarette before closing the lid.

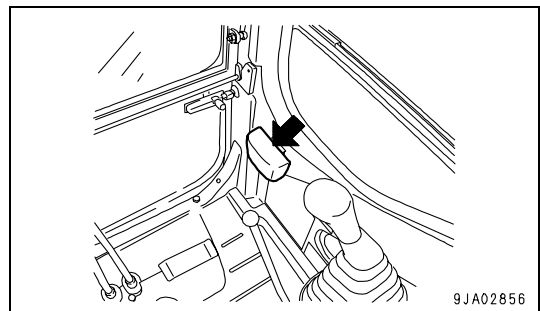

9JA02856

MACHINE OPERATIONS AND CONTROLS

BEFORE STARTING ENGINE

Walk-Around Checks

Before starting the engine, look around the machine and under the machine to check for loose nuts or bolts, or leakage of oil, fuel, or coolant, and check the condition of the work equipment and hydraulic system. Check also for loose wiring, play, and accumulation of dust at places which reach high temperatures.

WARNING

Remove any flammable materials from around the battery or engine muffler or other high temperature engine parts. Leakage of fuel or oil will cause the machine to catch fire. Check carefully, and be sure to repair any abnormalities, or please contact your Komatsu distributor.

If the machine is at an angle, make it horizontal before checking.

Always check the items in this section before starting the engine each day.

1. Check sensors for damage
Check the sensors for damage. If any abnormality is found, please contact your Komatsu distributor for service or repair.
2. Check for damage, wear, play in work equipment, cylinders, linkage, hoses
Check that there are no cracks, excessive wear, or play in the work equipment, cylinders, linkage, or hoses. If any abnormality is found, repair it.
3. Remove dirt and dust from around engine, battery, and radiator
Check that there is no dirt or dust accumulated around the engine or radiator. Check also that there is no flammable material (dry leaves, twigs, etc.) accumulated around the engine muffler or high temperature parts of the engine, or around the battery. Remove all dirt, dust, and flammable materials.
4. Remove debris piled between boom and engine cover
The clearance between the boom and the engine cover is a spot where dust and debris easily piles up. Be sure to remove it whenever it has piled up. If the boom is operated with debris piled up, the hydraulic hoses or the engine cover may be damaged.
5. Check for leakage of water or oil around engine
Check that there is no leakage of oil from the engine or leakage of water from the cooling system. If any abnormality is found, repair it.
6. Check for oil leakage from hydraulic equipment, hydraulic tank, hoses, joints
Check that there is no oil leakage. If any abnormality is found, repair the place where the oil is leaking.
7. Check the undercarriage (track, sprocket, idler, guard) for damage, wear, loose bolts, or leakage of oil from rollers.
If any abnormality is found, repair it.
8. Check for abnormality in handrails, steps, loose bolts.
If any abnormality is found, repair it. Tighten any loose bolts.
9. Check for abnormality in gauges, monitor, loose bolts.
Check that there is no abnormality in the gauges and monitor in the operator's cab. If any abnormality is found, replace the parts. Clean off any dirt on the surface.

10. Check for damage or displaced window

Check that there is no damage or displacement of the window. If any damage is found, replace with a new part. If the window comes out of position or breaks during operations, do not continue operations. Stop immediately and repair the window.

11. Checking and cleaning rear view mirror

Check the rear view mirror for any abnormality, and replace it with a new one if it is damaged. Keep the mirror surface clean and adjust the angle so that the lower, rear part of the machine (a portion whose view is blocked by the engine hood) can be seen from the operator's seat.

12. Seat belt and mounting clamps

Check that there is no abnormality in the seat belt or mounting clamps. If there is any damage, replace with new parts.

13. Check bucket with hook (if equipped) for damage.

Check that there is no damage to the hook, guide, or hook mount. If any abnormality is found, please contact your Komatsu distributor for repair.

Checks Before Starting

Always carry out the items of the checks in this section before starting the engine each day.

Cooling System Coolant Level - Check/Add

WARNING

- Do not open the radiator cap unless necessary. When checking the coolant, always wait for the engine to cool down and check the sub tank.
- Immediately after the engine is stopped, the coolant is at a high temperature and the radiator is under high internal pressure. If the cap is removed to check the coolant level in this condition, there is a hazard of burns. Wait for the temperature to go down, then turn the cap slowly to release the pressure before removing it.

1. Open the engine hood and check that the cooling water level is between the FULL and LOW marks on radiator reserve tank (1) (Shown in the diagram on the right). If the water level is low, add clean and soft water through the water filler of reserve tank (1) to the FULL level.
2. After adding water, tighten the cap securely.
3. If the sub tank is empty, there is probably leakage of water. After inspecting, repair any abnormality immediately. If there is no abnormality, check the water level in the radiator. If the water level is low, add water to the radiator, then fill the reserve tank(1).

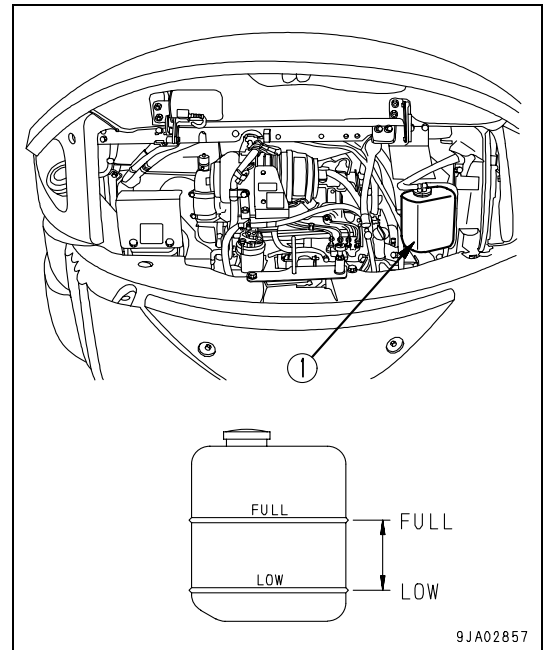

Engine Crankcase Oil Level - Check/Add

⚠ WARNING

The parts and oil are at high temperature immediately after the engine is stopped, and may cause serious burns. Wait for the temperature to go down before starting the operation.

1. Open engine hood.
2. Remove dipstick (G) and wipe the oil off with a cloth.
3. Insert dipstick(G) fully in the oil filler pipe, then take it out again.

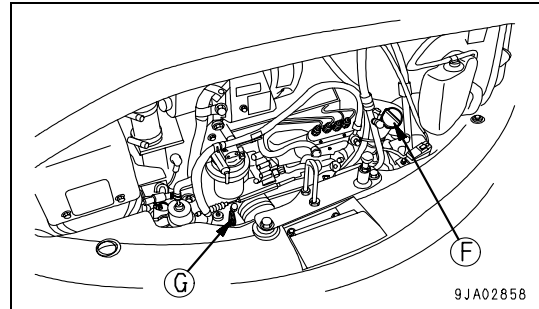

4. The oil level should be between the H and L marks on dipstick (G).
If the oil level is below the L mark, add engine oil through oil filler (F).

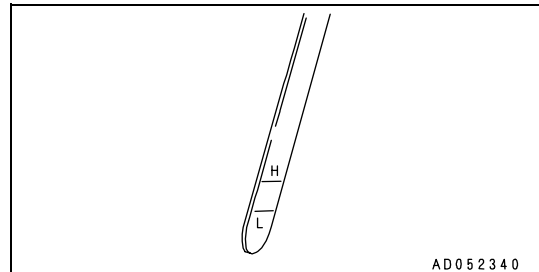

5. If the oil is above the H mark, drain the excess engine oil from drain plug (P), and check the oil level again.
6. If the oil level is correct, tighten the oil filler cap securely and close the engine hood.

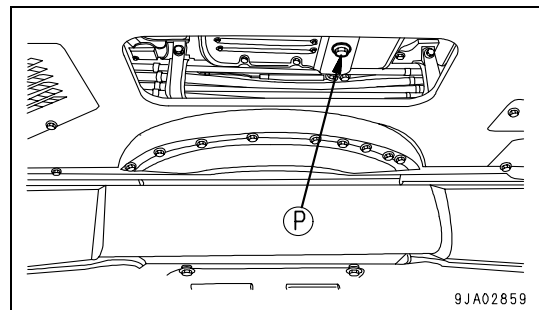
**REMARK**

- If the machine is at an angle, make it horizontal before checking.
- When checking the oil level after the engine has been operated, wait for at least 15 minutes after stopping the engine before checking.

Fuel Level - Check/Refill

⚠ WARNING

When adding fuel, never spill the fuel or let it overflow. It will cause fire. If any fuel has spilled, wipe it up completely. If fuel has spilled over soil or sand, remove that soil or sand. Fuel is highly flammable and dangerous. Never bring flames near fuel.

1. Insert the key in starting switch (1), and turn in to the ON position to light up the monitor.

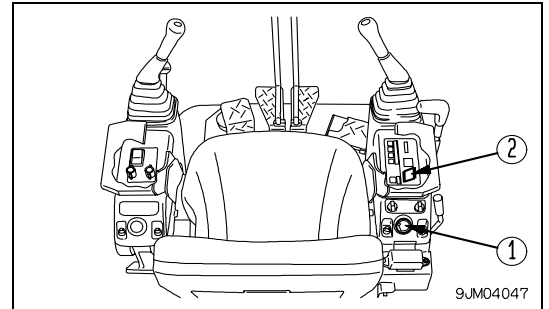

2. Check the remaining fuel level with fuel gauge (2). If the fuel level is low, watch sight gauge (G), and add fuel through fuel filler port (F).
Fuel tank capacity: 80 liters (21.14 US gal)
3. After adding fuel, tighten the cap securely.

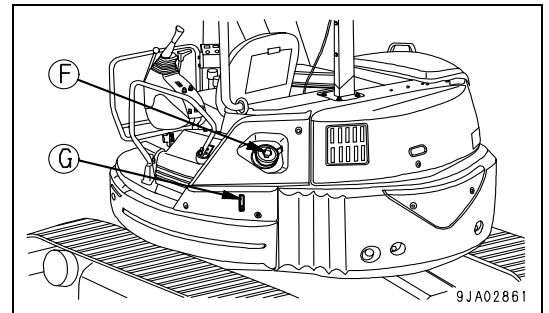

NOTICE
If breather hole (3) in the cab is clogged, the pressure in the tank will drop and fuel may not flow. Clean the hole from time to time and check that breather hole (3) is not clogged.

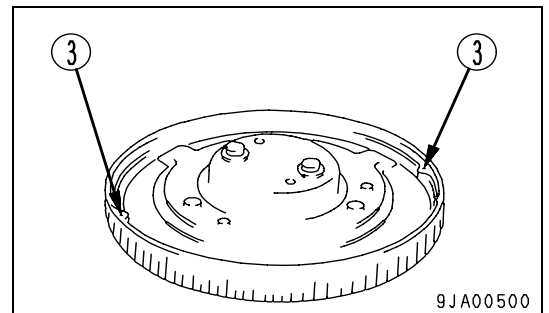

Hydraulic Oil Level - Check/Add

⚠ WARNING

- The parts and oil are at high temperature after the engine is stopped, and may cause burns. Wait for the temperature to go down before starting the work.
- When removing the oil filler cap, turn it slowly to release the internal pressure, then remove it.

1. If the work equipment is not in the condition shown in the diagram on the right, start the engine, run the engine at low speed, retract the arm and bucket cylinder rods fully, then lower the boom, set the bucket teeth in contact with the ground, and stop the engine.

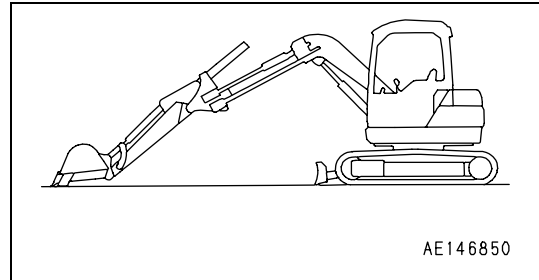

2. Confirm that the oil level is between the H and L marks of sight gauge (G).

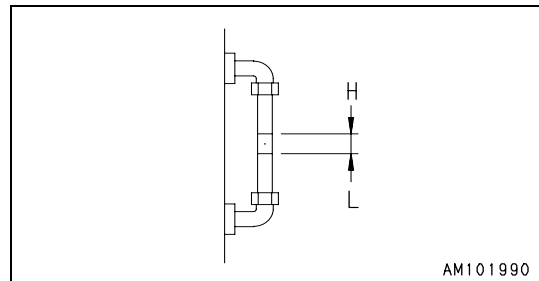

NOTICE

Do not add oil above the H line. This will damage the hydraulic circuit or cause the oil to spurt out.

If oil has been filled exceeding the H level, swing the upper structure until drain plug (P) beneath the hydraulic tank comes between the right and left track shoes and stop the engine. Wait for the oil to cool down sufficiently, then remove cover (1) and drain the excess oil through drain plug (P).

3. If it is below the L level, open the mud cover and add through filler port (F).

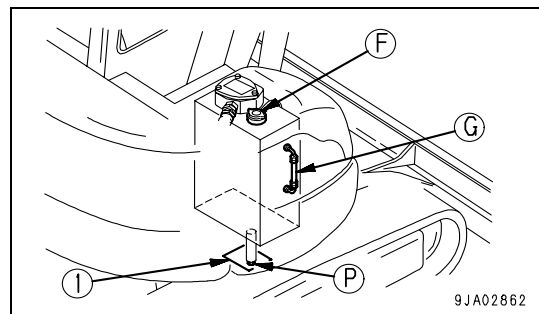

REMARK

The oil level will vary depending upon the oil temperature. Accordingly, use the following as the guide:

- Before operation: around L level
- (Oil temperature 10 to 30°C (50 to 86°F))
- Normal operation: around H level
- (Oil temperature 50 to 80°C (122 to 176°F))

4. Extend the boom, arm, and bucket cylinder fully as shown in the diagram on the right, remove the oil filler cap, then install the cap and pressurize the inside of the tank.

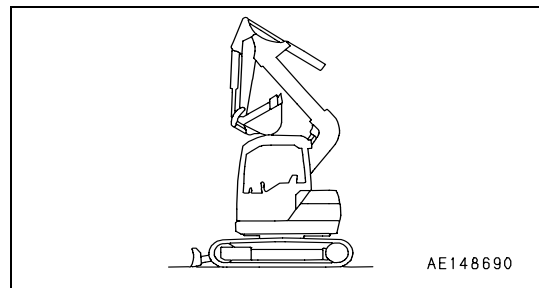

NOTICE

Be sure to pressurize the hydraulic tank. If it is not pressurized, the pump will suck in air, and this will adversely affect the equipment.

Air Cleaner Dust Indicator - Check

1. Open the engine hood and check that the red piston is not showing in dust indicator (1).
2. If the red piston has appeared, clean or replace the element immediately.

For details of the method of cleaning the element, see "Air Cleaner Element - Check/Clean/Replace (4-16)".

3. After checking, cleaning, and replacing, press the knob of dust indicator (1) to return the red piston to its original position.

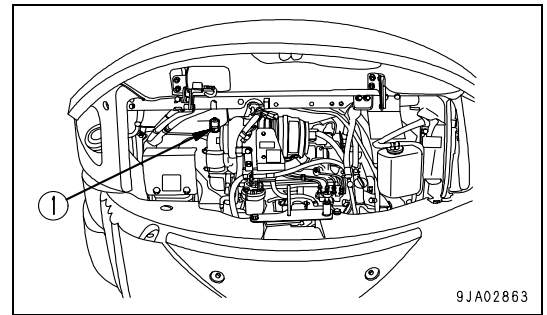

9JA02863

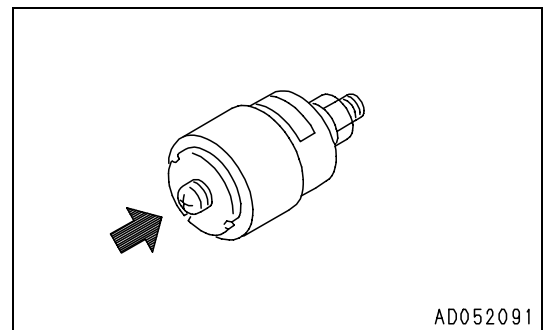

AD052091

Water Separator - Check

If red ring (5) of water separator is at the bottom of element cup (4), there is no water.

If red ring (5) is floating, there is water up to the bottom of the ring, so drain the water as follows.

- Prepare the filter wrench for fuel filter.
1. Open inspection cover (1) on the left side of the machine and set handle (2) of the filter inside to the CLOSED position (a).
 2. Using the filter wrench, loosen ring (3), then remove element cup (4) and throw out the water inside it.
 3. Fill element cup (4) with fuel, install it to the filter holder, then tighten ring (3).
 4. Set handle (2) to the OPEN position (b).
 5. Drain any water or sediment from the fuel tank. For details, see "Fuel Tank - Drain (4-24)".

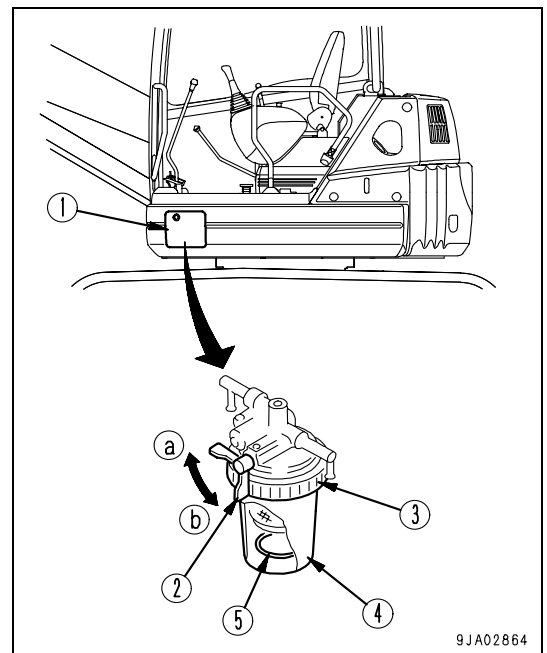

9JA02864

Electric Wiring - Inspect

⚠ WARNING

- If the fuses frequently blow or if there are traces of short circuits on the electrical wiring, locate the cause immediately and carry out repairs, or contact your Komatsu distributor for repairs.
- Keep the top surface of the battery clean and check the breather hole in the battery cap. If it is clogged with dirt or dust, wash the battery cap to clean the breather hole.

Check that there is no damage to the fuses and that a fuse of the correct capacity is being used. Check that there are no disconnections or traces of short circuits on the electrical wiring, and no damage to the covering. Check also that there are no loose terminals.

Be particularly careful to check the wiring of the battery, starting motor, and alternator.

Always check also that there is no flammable material accumulated around the engine. Remove any such flammable material.

Please contact your Komatsu distributor for advice on investigation and correction of the cause.

Horn Function - Check

1. Turn the starting switch to the ON position.

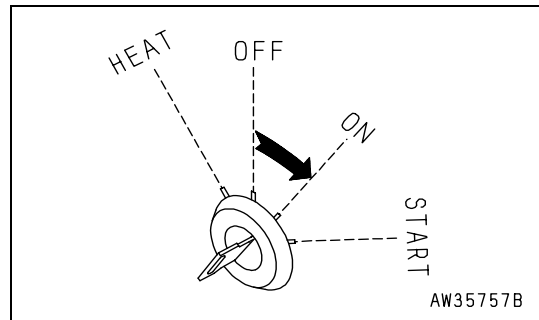

2. Confirm that the horn sounds immediately when the horn button is pressed.
If the horn does not sound, please contact your Komatsu distributor for repair.

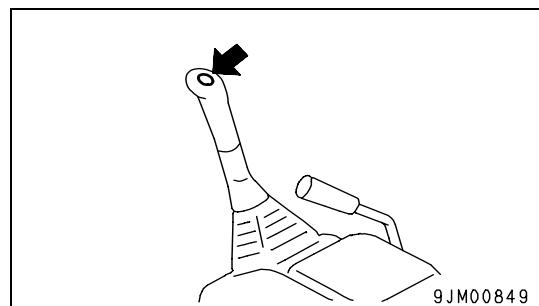

Adjustment

 **WARNING**

- Adjust the seat position before starting operations or after changing the operator.
- Adjust the seat so that the control levers and switches can be operated freely and easily with the operator back against the backrest.

Seat Adjustment**(A) Fore-and-aft adjustment**

The seat can move forward and backward.

Move lever (1) to the upper, set the operator's seat at the desired position, then release the lever.

Fore-and-aft adjustment: 80 mm (3.2 in) (5 stages)

Adjust the position of the operator's seat to match the operation. For example, when carrying out deep digging operations, slide the seat to the front to improve the view below the front of the machine.

(B) Adjusting reclining

Pull up lever (2) and set the seat back to a position which is comfortable for operation, then release the lever.

Sit with your back against the seat back when adjusting. If your back is not touching the seat back, the seat back may suddenly move forward.

(C) Adjusting suspension

Pull lever (2) up, then move it to the left to make the suspension harder or move it to the right to make the suspension softer. Adjust the lever position to match the weight of the operator and provide the optimum suspension.

Suspension adjustment: 5 stages 50kg to 120kg (110 lb to 265 lb)

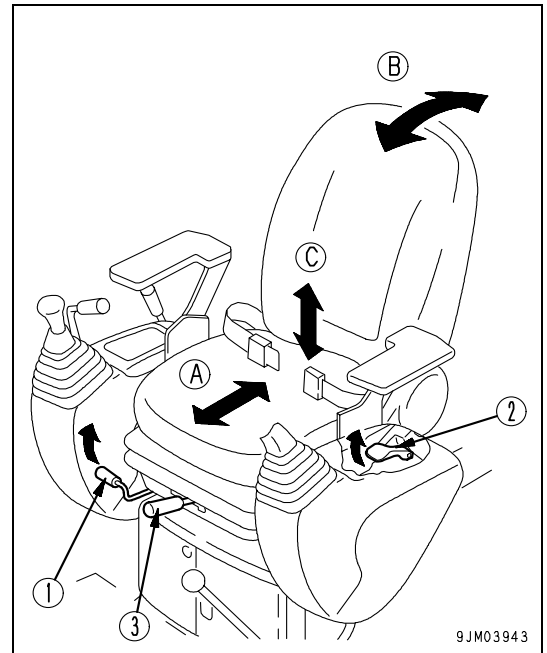
**Rearview Mirrors**

Adjust the angle of the mirrors so that the area to the bottom rear of the operator's seat (the area hidden by the engine hood) can be seen clearly.

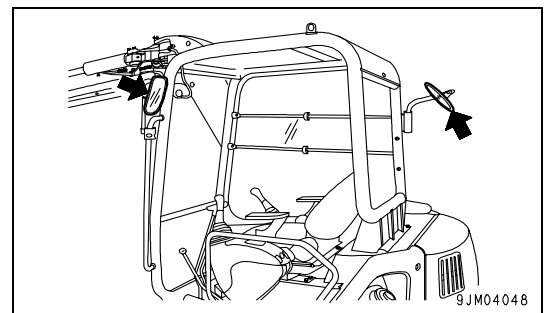

Seat Belt

WARNING

- Before fastening the seat belt, check that there is no abnormality in the securing brackets or belt. If there is any wear or damage, replace.
- Even if there appears to be no abnormality in the seat belt, replace the seat belt once every 3 years. The date of manufacture is woven on the reverse side of the belt.
- Adjust and fasten the seat belt before operating the machine.
- Always use the seat belt when operating the machine.
- Do not use the seat belt with either half of the belt twisted.

Check that the bolts of the clamp securing the belt to the chassis are not loose. Tighten them if they are loose. The tightening torque for the mounting bolt is $24.5 \pm 4.9\text{N}\cdot\text{m}$ ($2.5 \pm 0.5\text{kgf}\cdot\text{m}$, $18.1 \pm 3.6\text{lbft}$).

If the belt surface is scratched or frayed or if the fittings are broken or deformed, replace the seat belt unit.

Fastening and Removing

1. Adjust the seat so that the operator still feels that there is sufficient knee room when fully depressing the pedal while seated, with the operator's back against the backrest.
2. After adjusting the seat position, sit in the seat. Grip buckle (1) and tongue (2) in each hand and insert tongue (2) into buckle (1). Confirm by pulling the belt that the tongue is securely locked to the buckle.
3. When removing the belt, raise the tip of buckle (1) lever to release it.

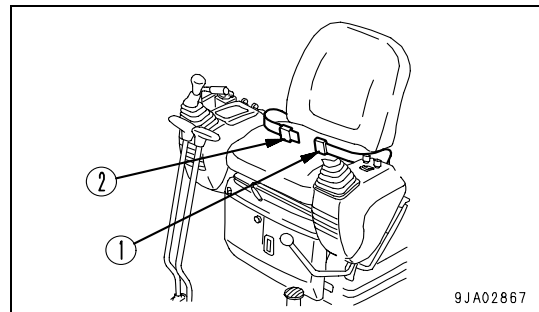

Fasten belt along your body without kinking it. Adjust the lengths of the belt on the tongue sides.

Seat Belt Adjustment

Shortening

Pull the free end of the belt on either the buckle body or tongue side.

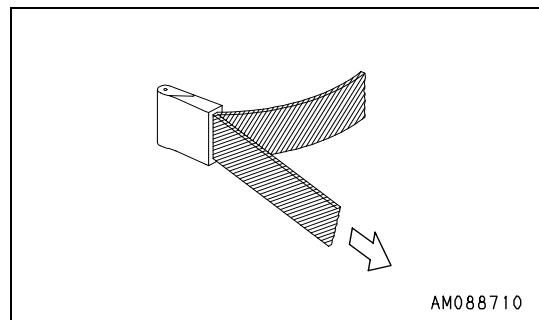

Lengthening

Pull the belt while holding it at a right angle to the buckle or tongue.

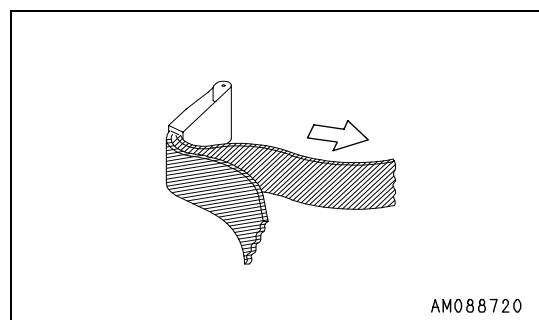

Operations Before Starting Engine

⚠ WARNING

Before standing up from the operator's seat, always set the safety lock lever to the LOCK position, regardless of whether the engine is running or stopped.

1. Check the safety lock lever (1) is at the LOCK position.

REMARK

The engine will not start if the safety lock lever is not in the LOCK position.

2. Check the position of each levers.

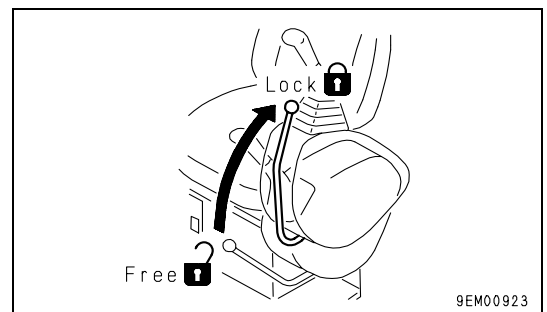
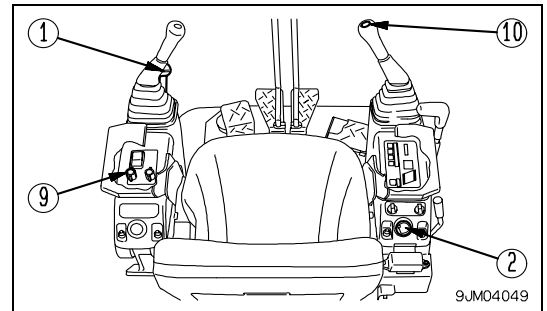

3. Insert the key in starting switch (2), turn the key to the ON position, then carry out the following checks.

- 1) The buzzer will sound for approx. 1 second, and the following monitors and gauges will light up for approx. 3 seconds.

- Engine pre-heating monitor (3)
- Charge level monitor (4)
- Engine oil pressure monitor (5)
- Electronic control system monitor (6)
- Engine coolant temperature gauge (7)
- Fuel gauge (8)

If the monitors or gauges do not light up or the buzzer does not sound, there is probably a blown bulb or disconnection, so please contact your Komatsu distributor for repair.

After approx. 3 seconds, the following gauges will remain on and the other monitors will go out.

- Charge level monitor (4)
- Engine oil pressure monitor (5)
- Engine coolant temperature gauge (7)
- Fuel gauge (8)

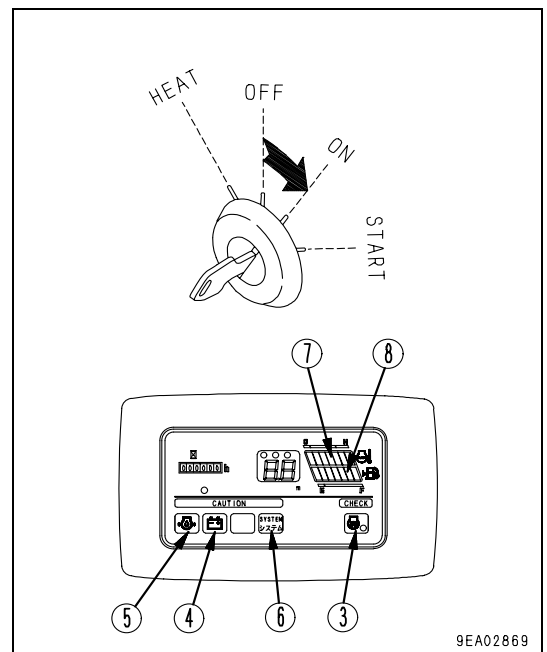

- 2) Turn lamp switch (9) to the working lamps on position.
If it does not light up, there is probably a blown bulb or disconnection, so please contact your Komatsu distributor for repair.

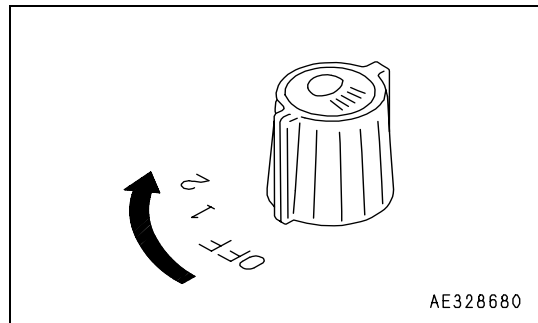

- 3) Press horn switch (10) to confirm that the horn will sound.

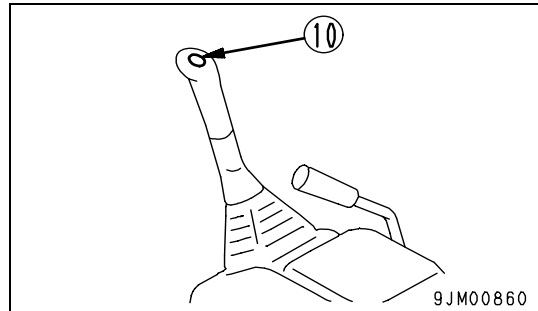

STARTING ENGINE

Normal Starting

 **WARNING**

- Check that there are no persons or obstacles in the surrounding area, then sound the horn and start the engine.
- Exhaust gas is toxic. When starting the engine in confined spaces, be particularly careful to ensure good ventilation.

NOTICE

Do not keep the starting motor rotating continuously for more than 20 seconds.

If the engine will not start, wait for at least 30 seconds before trying to start the engine again.

1. Check the safety lock lever (1) is at the LOCK position. If the safety lock lever is in the FREE position, the engine will not start.

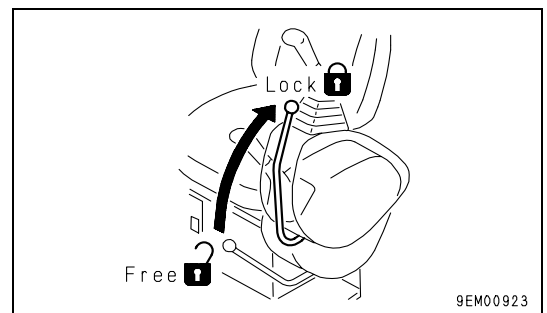
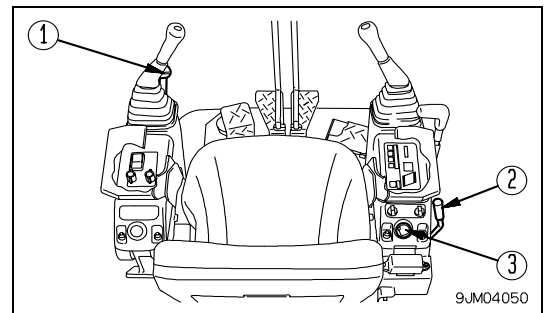

2. Before starting the engine, check that fuel control lever (2) is at the LOW IDLING position.
3. Pull fuel control lever (1) to the center position between LOW IDLING and HIGH IDLING.

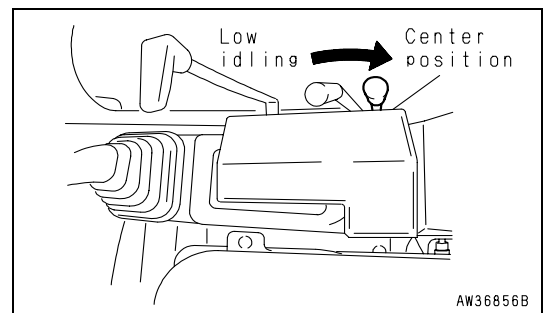

- Turn the key in starting switch (3) to the START position.
The engine will start.

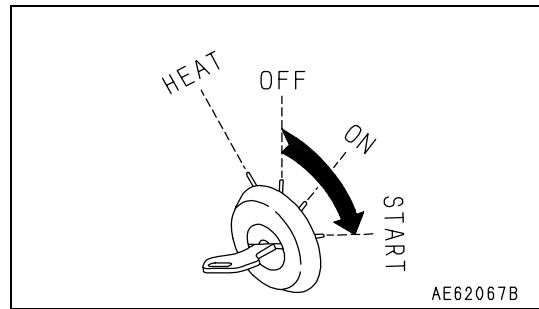

- When the engine starts, release the key in the starting switch (3). The key will return automatically to the ON position.

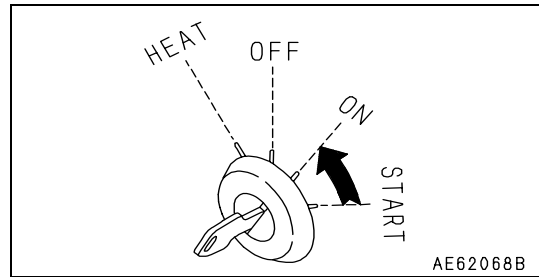

Starting Engine In Cold Weather

⚠ WARNING

- Check that there are no persons or obstacles in the surrounding area, then sound the horn and start the engine.
- Never use starting aid fluids as they may cause explosions.

NOTICE

Do not keep the starting motor running for more than 20 seconds continuously.
 If the engine does not start, wait for about 30 seconds and being with the step 4. again.

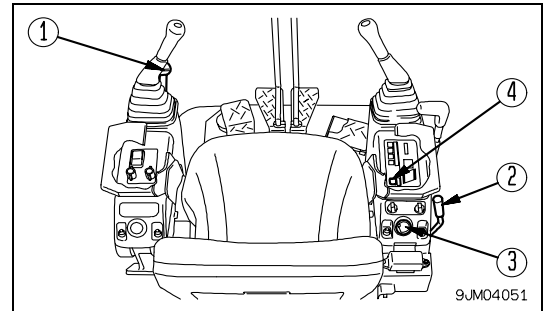

When starting in low temperatures, do as follows.

1. Check the safety lock lever (1) is at the LOCK position. If the safety lock lever is in the FREE position, the engine will not start.

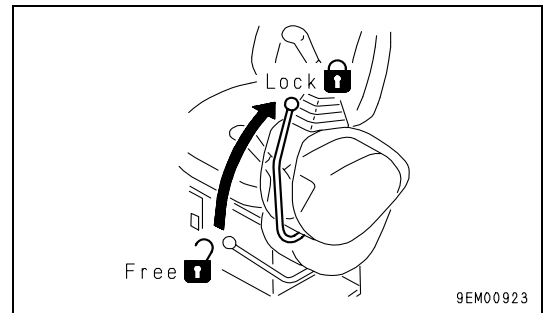

2. Before starting the engine, check that fuel control lever (2) is at the LOW IDLING position.
3. Pull fuel control lever (1) to the HIGH IDLING position.

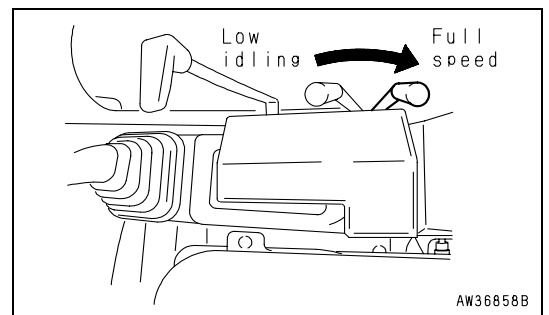

4. Hold the key in starting switch (3) at the HEAT position, and check that pre-heating monitor (4) lights up. After about 18 seconds, pre-heating monitor (4) will go off to indicate that pre-heating is finished.

REMARK

The monitor and gauge also light up when the key is at the HEAT position, but this does not indicate any abnormality.

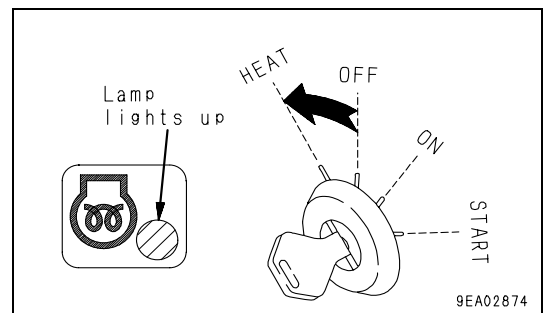

- 5. When pre-heating monitor (4) goes off, turn the key in starting switch (3) to the START position to start the engine.

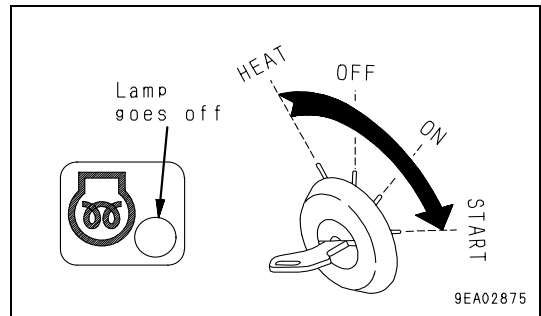

- 6. When the engine starts, release the key in the starting switch (3). The key will return automatically to the ON position.

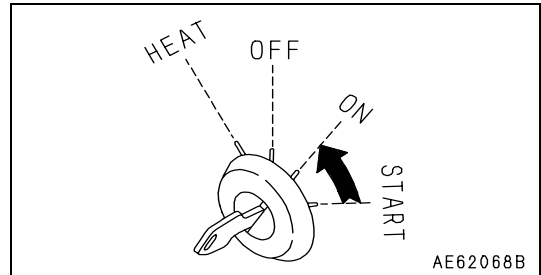

- 7. Return fuel control lever (2) to a position midway between the low idling and full speed positions.

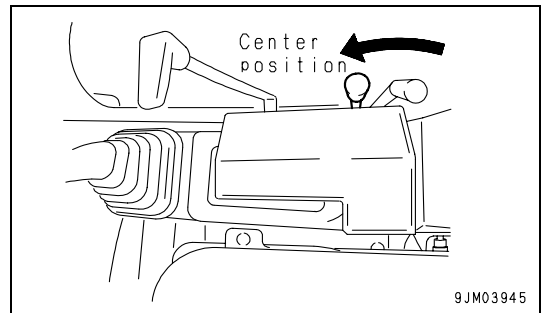

AFTER STARTING ENGINE

WARNING

- Emergency stop
- If there has been any abnormal action or trouble, turn the starting switch key to the OFF position.
- If the work equipment is operated without warming the machine up sufficiently, the response of the work equipment to the movement of the control lever will be slow, and the work equipment may not move as the operator desires. Always warm up the machine. Particularly in cold areas, make sure to completely warm up the machine.
- For operation patterns other than the standard one (ISO pattern), refer to the chapter of ATTACHMENTS AND OPTIONS in this manual.

Breaking-In The New Machine

CAUTION

Your Komatsu machine has been thoroughly adjusted and tested before shipment. However, operating the machine under severe conditions at the beginning can adversely affect the performance and shorten the machine life.

Be sure to breaking-in the machine for the initial 100 hours (as indicated by the service meter).

During breaking-in operations, follow the precautions described in this manual.

- Idle the engine for 5 minutes after starting it up.
- Avoid operation with heavy loads or at high speeds.
- Avoid sudden starts, sudden acceleration, sudden steering and sudden stops except in cases of emergency.

Warming-Up Operation

WARNING

- Be sure to warm up the engine after the engine is started in a cold temperature. Otherwise, the automatic stop position in the interference prevention device will likely shift.
- When checking the interference prevention device while in motion, operate the control levers slowly.

NOTICE

- When the hydraulic oil is at a low temperature, do not carry out operations or move the lever suddenly. Always carry out the warming-up operation. This will help to extend the machine life.
- Do not suddenly accelerate the engine before the warming-up operation is completed.
- Do not run the engine at low idling or high idling continuously for more than 20 minutes. (Oil down) If it is necessary to run the engine at idling, apply a load from time to time or run the engine at a mid-range speed.

After starting the engine, do not immediately start operations. First, carry out the following operations and checks.

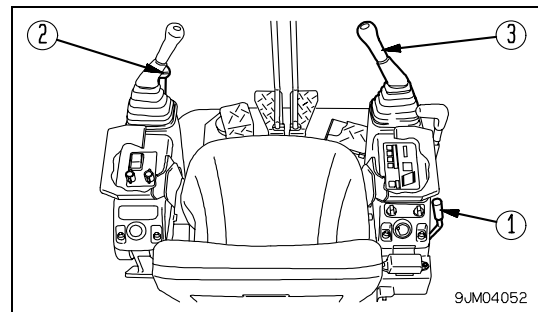

1. Pull fuel control lever (1) to the center position between LOW IDLING and HIGH IDLING and run the engine at medium speed for about 10 minutes with no load.

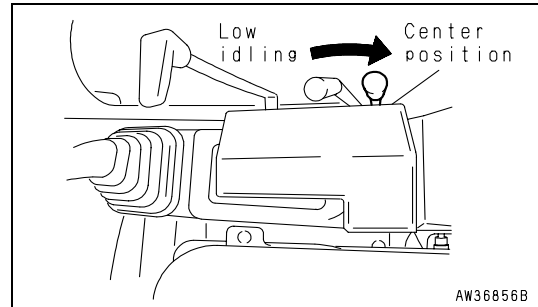

REMARK

When the ambient temperature is below 0°C (32°F), keep the fuel control lever close to the 1/4 position when warming up the engine.

2. Set safety lock lever (2) to the FREE position, and raise the bucket from the ground.

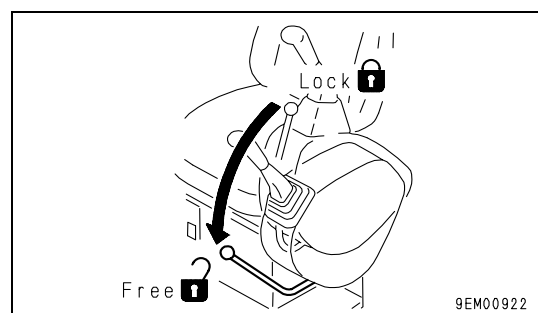

- Operate right work equipment control lever (3) slowly, pull the bucket into the stop position, and hold it there for 5 minutes.

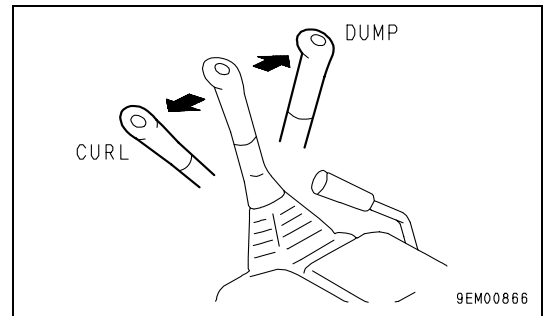

- After warming up the engine, check that each gauge and monitor lamp indicates the following. If there is any abnormality, carry out maintenance and repair.

- Engine coolant temperature gauge (4): Inside green range
- Fuel gauge (5): Inside green range
- Engine oil pressure gauge (6): OFF
- Charge level monitor (7): OFF
- Electronic control system monitor (9): OFF

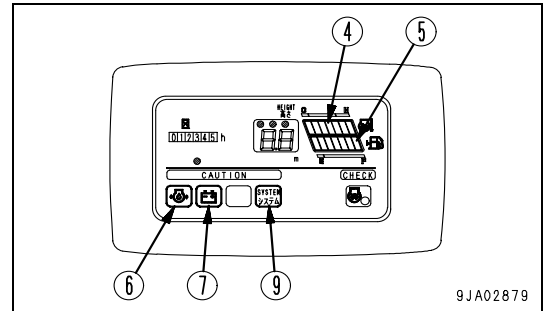

- Check that there is no abnormal exhaust gas color, noise, or vibration. If any abnormality is found, contact your Komatsu distributor.
- Set lock lever (2) to the LOCK position and check that it is impossible to operate the swing and work equipment with the left and right work equipment control levers.

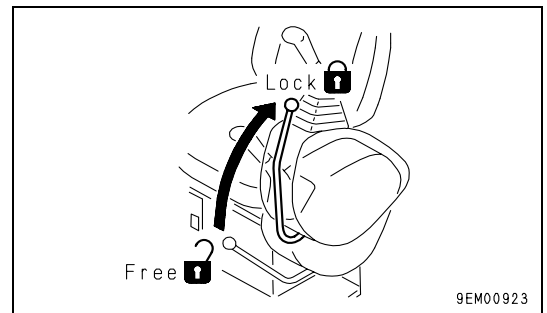

- Set safety lock lever (2) to the FREE position and inspect the following interference protection action.

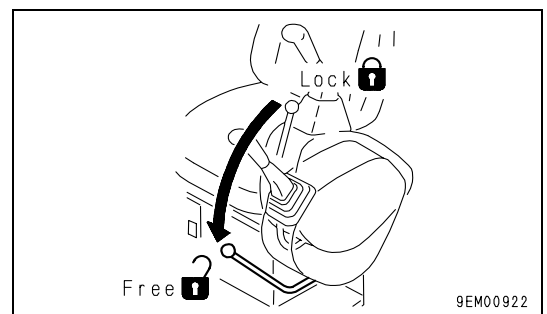

- Set the work equipment to the maximum left offset posture shown in the diagram on the right, then raise the boom and check that it stops automatically when it comes close to the operator's compartment. When it stops, lower the boom and cancel the automatic stop.

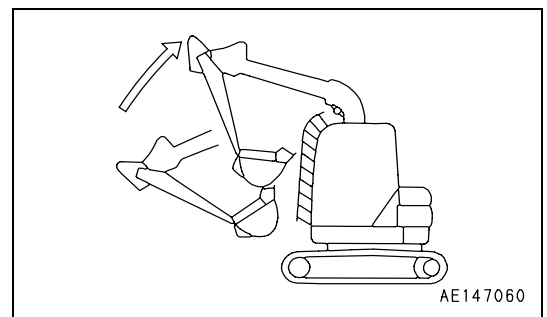

- Set the work equipment to the maximum left offset posture shown in the diagram on the right, then pull in the arm and check that it stops automatically when it comes close to the operator's compartment. When it stops, move the arm out and cancel the automatic stop.

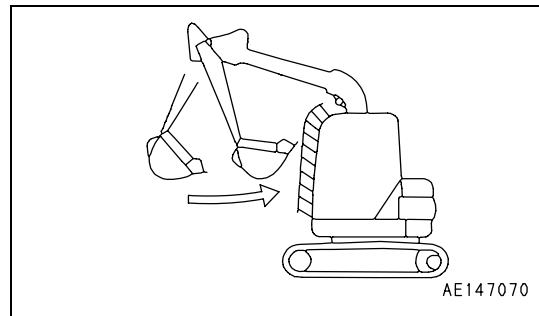

- Set the work equipment in the posture shown in the diagram on the right, operate the left offset and check that it stops automatically when it comes close to the operator's compartment. When it stops, lower the boom and cancel the automatic stop.

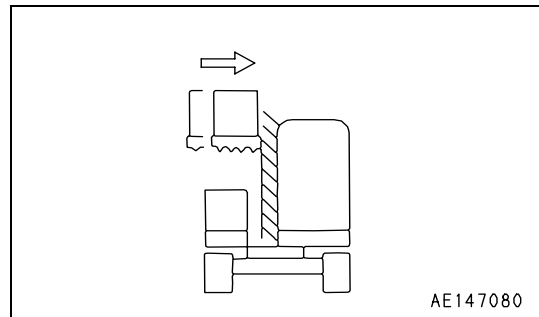

If any abnormality is found during the inspection, use the procedure in Item 3 to warm up the hydraulic oil. Then, carry out the inspection again.

If there is still an abnormality, move the machine to a safe place, stop the engine, and contact your Komatsu distributor for inspection and repair.

STOPPING THE ENGINE

NOTICE

If the engine is abruptly stopped before it has cooled down, engine life may be greatly shortened. Consequently, do not abruptly stop the engine apart from an emergency.

In particular, if the engine has overheated, do not abruptly stop it but run it at medium speed to allow it to cool gradually, then stop it.

1. Run the engine at low idling for about 5 minutes to cool down gradually.

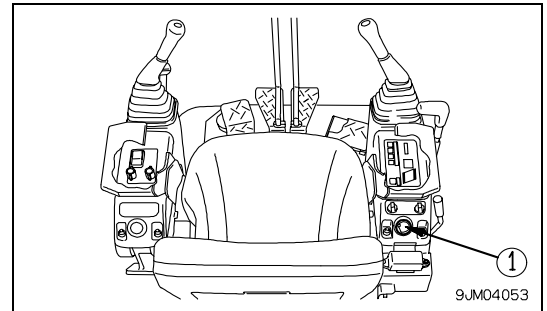

2. Turn the key of starting switch (1) to the OFF position to stop the engine.
3. Remove the key from starting switch (1).

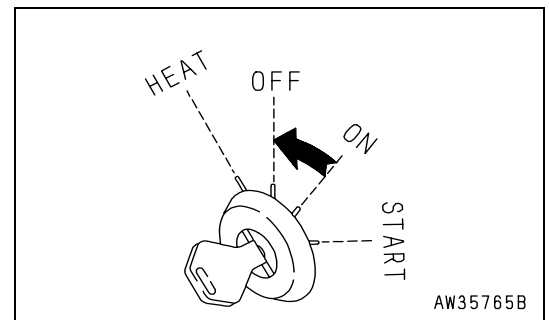

CHECK AFTER SHUTTING OFF ENGINE

1. Walk around the machine and check the work equipment, machine exterior, and undercarriage, and check also for leakage of oil or water. If any abnormalities are found, repair them.
2. Fill the fuel tank.
3. Check the engine compartment for paper and debris. Clean out any paper and debris to avoid a fire hazard.
4. Remove any mud affixed to the undercarriage.

MACHINE OPERATION

⚠ WARNING

- Before operating the travel levers, check the direction of the track frame. If the sprocket is at the front, the operation of the travel levers is reversed.
- When moving off, check that the area around the machine is safe, and sound the horn before moving.
- Clear all personnel from the machine and the area.
- Clear all obstacles from the path of the machine.
- Check that the travel alarm works properly.

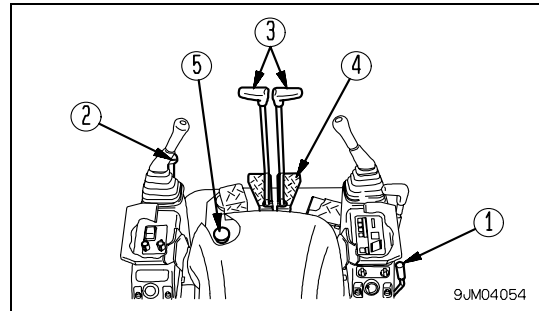
**Preparations For Moving The Machine Off**

1. Pull fuel control lever (1) towards the high idling position to increase the engine speed.

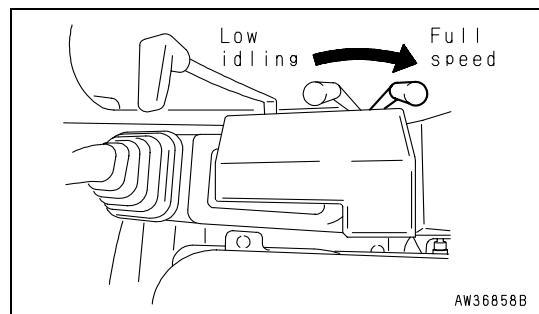

Moving Machine Forward

1. Set safety lock lever (2) to the FREE position, then raise the work equipment 40 to 50 cm (1.6 to 2.0 in) from the ground.

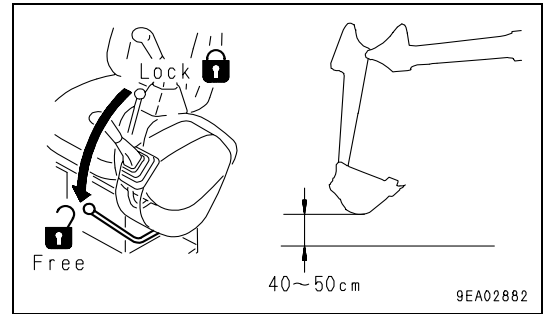

2. Raise the blade.

3. Operate right and left travel control levers (3) or right and left travel pedals (4) in the following manner.

- When sprocket (A) is situated at the rear of the machine; Start the machine either by pushing lever (3) forward slowly or by stepping on the front part of pedal (4) slowly.

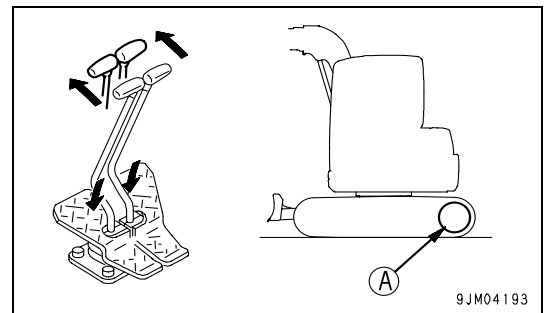

- When sprocket is situated at the front of the machine; Start the machine either by pulling lever (3) back slowly or by stepping on the rear part of pedal (4) slowly.

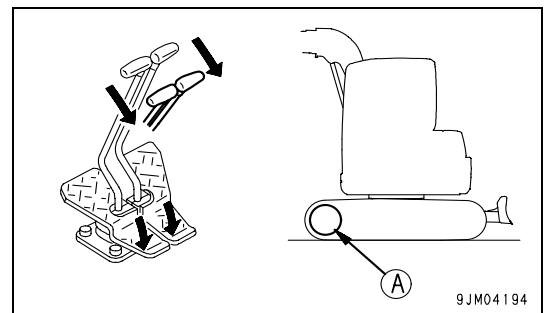

4. When travel accelerator pedal (5) is depressed, the speed will increase.
For details on speed, see "SPECIFICATIONS (5-2)".

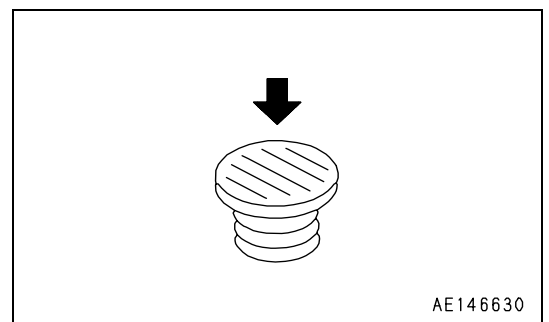

Check that the travel alarm sounds.

If the travel alarm does not sound, please contact your Komatsu distributor for repairs.

Moving Machine Backward

1. Set safety lock lever (2) to the FREE position, then raise the work equipment 40 to 50 cm (1.6 to 2.0 in) from the ground.

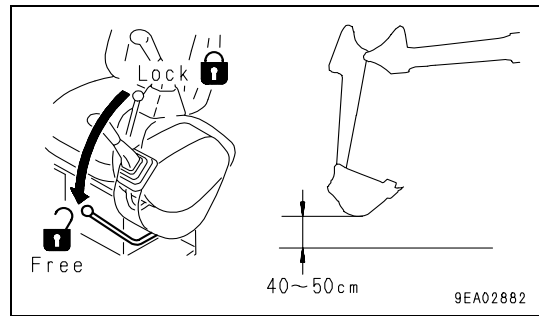

2. Raise the blade.

3. Operate right and left travel control levers (3) or right and left travel pedals (4) in the following manner.

- When sprocket is situated at the rear of the machine; Start the machine either by pulling lever (3) back slowly or by stepping on the rear part of pedal (4) slowly.

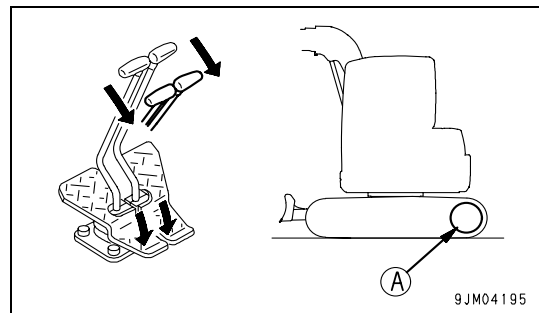

- When sprocket (A) is situated at the front of the machine; Start the machine either by pushing lever (3) forward slowly or by stepping on the front part of pedal (4) slowly.

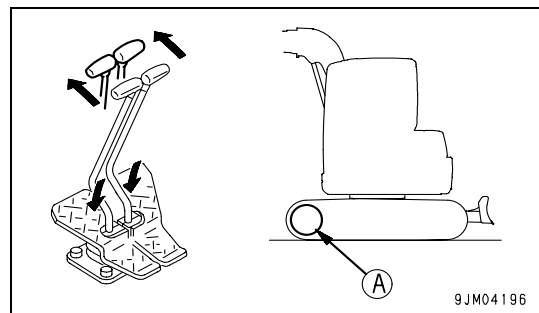

4. When travel accelerator pedal (5) is depressed, the speed will increase.
For details on speed, see "SPECIFICATIONS (5-2)".

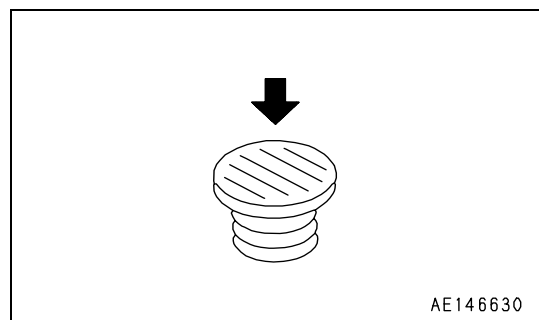

Check that the travel alarm sounds.

If the travel alarm does not sound, please contact your Komatsu distributor for repairs.

Stopping Machine

⚠ WARNING

Avoid stopping suddenly. Give yourself ample room when stopping.

Put the left and right travel levers (1) in the neutral position, then stop the machine.

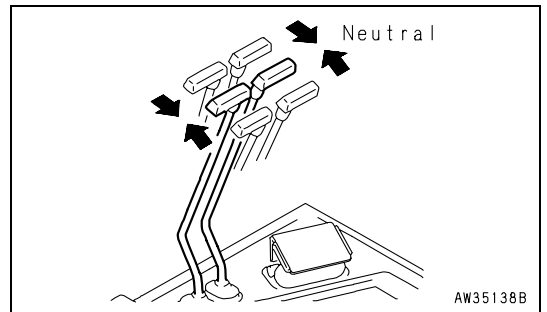
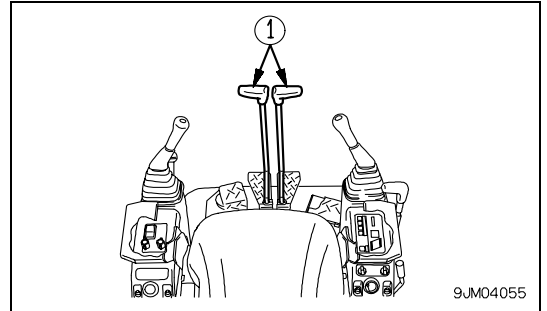

STEERING THE MACHINE

Steering

⚠ WARNING

Before operating the travel levers, check the position of the sprocket. If the sprocket is at the front, the operation of the travel levers is reversed.

Use the travel levers to change direction. Avoid sudden changes of direction as far as possible. In particular, when carrying out counter-rotation (spin turn), stop the machine first before turning. Operate two travel levers (1) as follows.

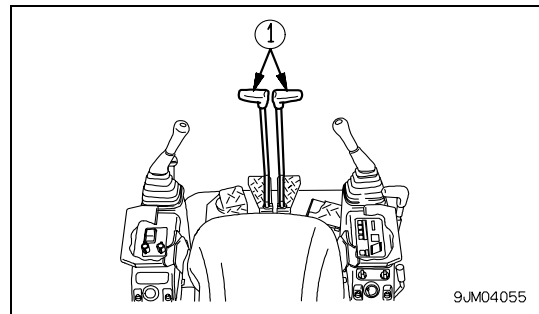

Steering the Machine when Stopped

When turning to the left: Push the right travel lever forward to turn to the left when traveling forward; and pull it back to turn left when traveling in reverse.

REMARK
When turning to the right, operate the left travel lever in the same way.

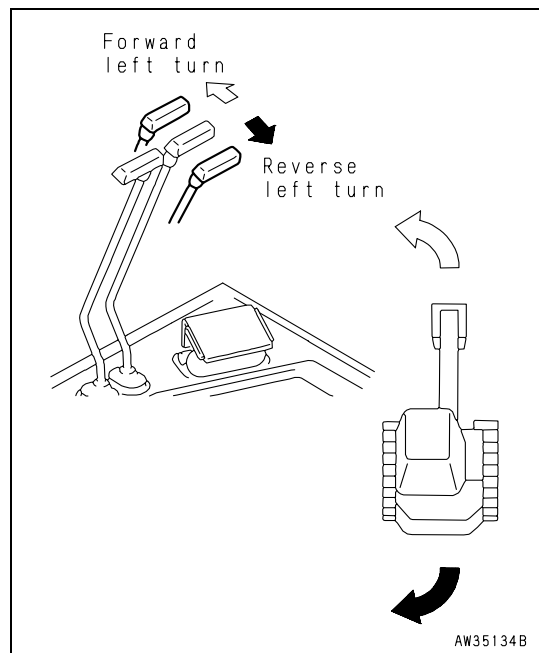

Steering when Traveling

When turning to the left:

If the left travel lever is returned to the neutral position, the machine will turn to the left.

REMARK

When turning to the right, operate the right travel lever in the same way.

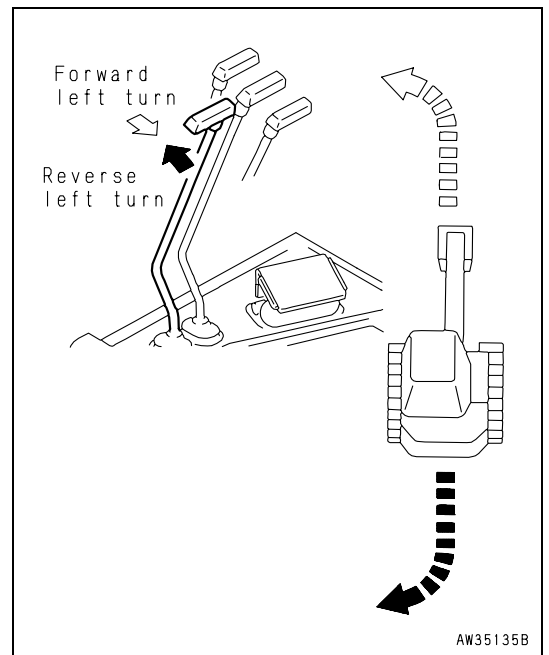

Counter-rotation Turn (Spin Turn)

When using counter-rotation (spin turn) to turn left, pull the left travel lever back and push the right travel lever forward.

REMARK

When using counter-rotation to turn right, pull the right travel lever back and push the left travel lever forward.

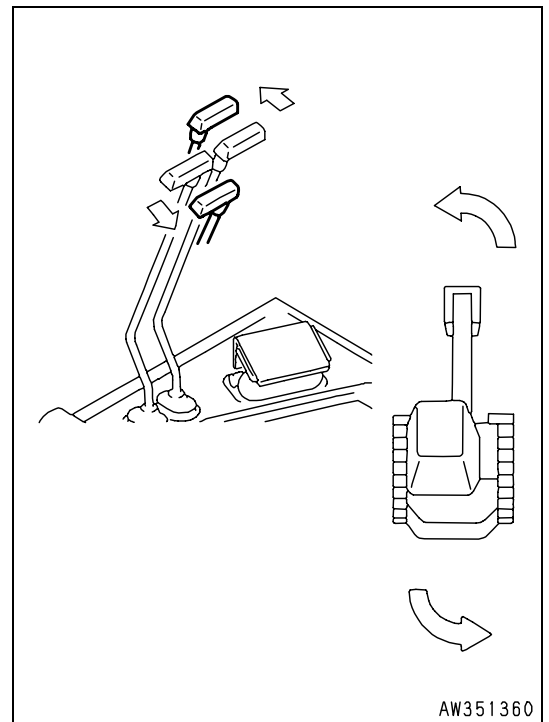

SWINGING

WARNING

When operating the swing, check that the area around the machine is safe.

1. Operate left work equipment control lever (1) to swing the upper structure.
2. When not using the swing, set left work equipment control lever (1) to the N position.
The swing holding brake will be applied.

REMARK

- When using the swing on a slope, run the engine at low idling and operate the swing lever extremely slowly.
- Be particularly careful to avoid sudden movement when the bucket is loaded.
- When the bucket is loaded and the left work equipment control lever is operated, the swing holding brake is released, so the upper structure may swing momentarily, but this is not an abnormality.

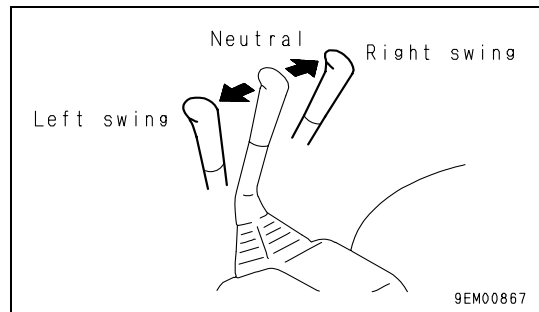
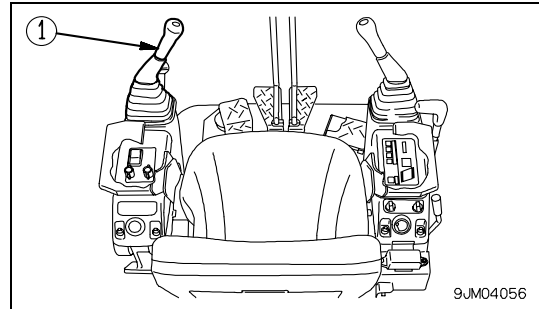

CAUTION

With a machine equipped with an operator's cab, a within-track-shoe swing cannot be attained because the cab exceeds the shoe width. In a swing, take care that the cab or cab door are not be damaged.

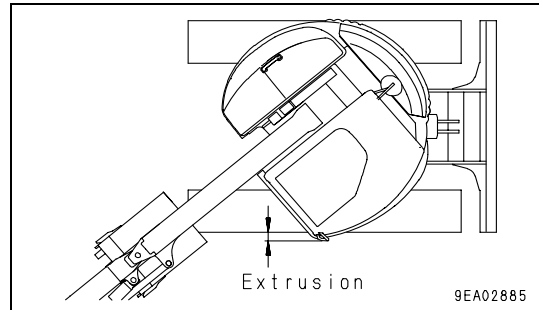

WORK EQUIPMENT CONTROLS AND OPERATIONS

⚠ WARNING

- For operation patterns other than the standard one (ISO pattern), refer to the chapter of ATTACHMENTS AND OPTIONS in this manual.
- If the work equipment control lever is operated quickly, the work equipment will move quickly; and if it is operated slowly, the work equipment will move slowly.

Use the control levers to operate the work equipment.

Note that when the levers are released, they return to the HOLD position and the work equipment is held in that position.

- **Arm control**
Move the left work equipment control lever to the front or rear to operate the arm.

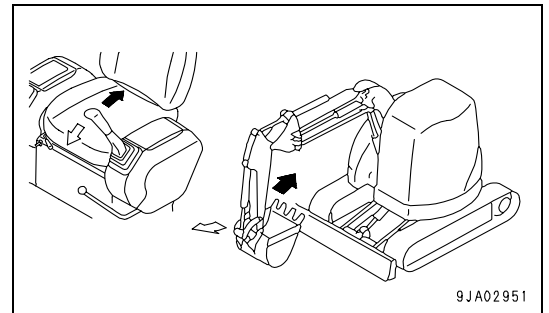

- **Swing control**
Move the left work equipment control lever to the left or right to swing the upper structure.

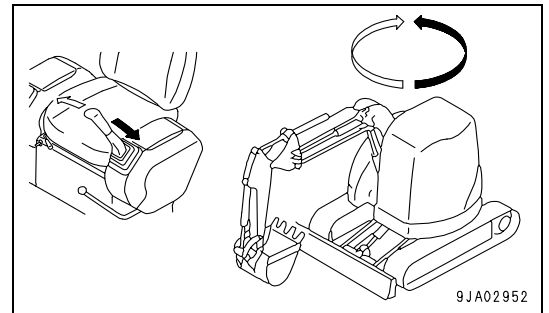

- **Boom control**
Move the right work equipment control lever to the front or rear to operate the boom.

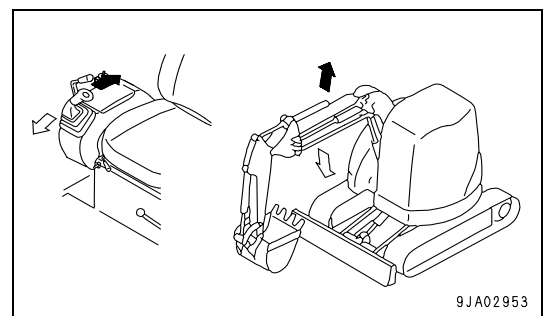

- **Bucket control**
Move the right work equipment control lever to the left or right to operate the bucket.

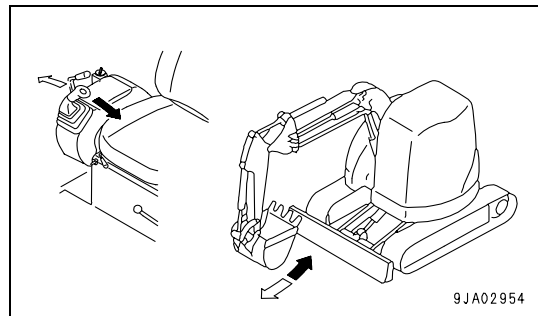

- **Boom offset operation**
Boom offset operations can be carried out with the boom offset control pedal.

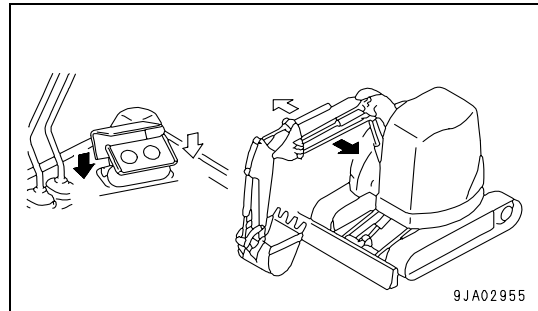

- **Blade control**
Move the lever on the right side of the operator's seat to the front or rear to operate the blade.

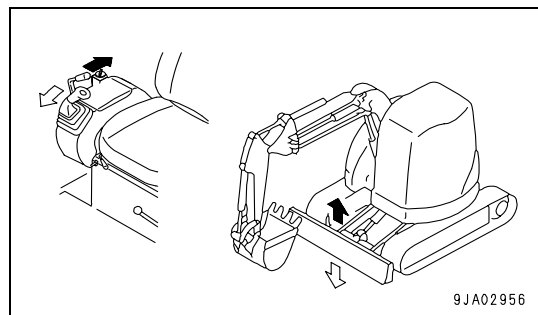

PROHIBITED OPERATIONS

⚠ WARNING

If it is necessary to operate the work equipment control lever when the machine is traveling, stop the travel and operate the control lever.

Operations Using Swing Force

Do not use the swing force to compact soil or break objects. This is not only dangerous, but will also markedly reduce the life of the machine.

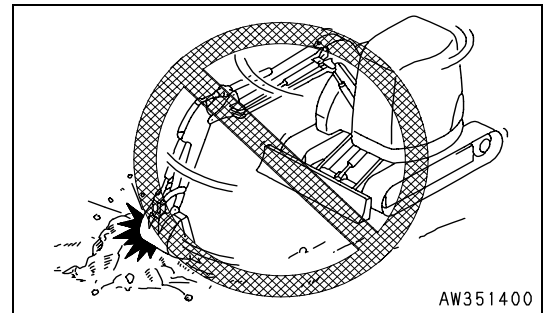

Operations Using Travel Force

Do not dig the bucket into the ground and use the travel force to carry out excavation. This will damage the machine or work equipment.

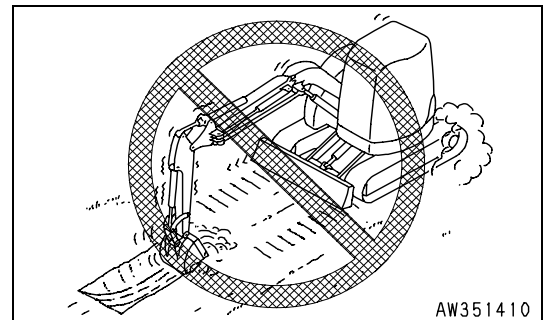

Operations Using Hydraulic Cylinder Stroke Ends

If the cylinder is used when the cylinder rod has been operated to the end of its stroke during operations, external force will cause impact to the work equipment, and this will damage the hydraulic cylinders. Avoid carrying out operations with the hydraulic cylinder fully retracted or fully extended.

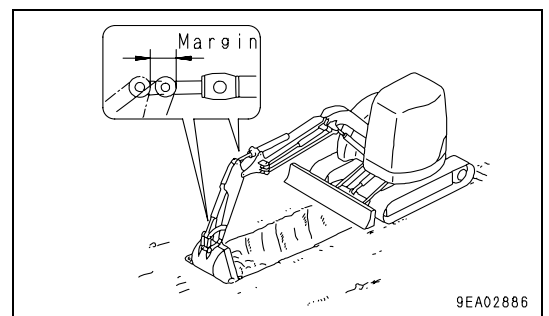

Operations Using Bucket Dropping Force

Do not use the dropping force of the machine for digging, or use the dropping force of the bucket as a pickax, breaker, or pile driver.

This will markedly reduce the life of the machine.

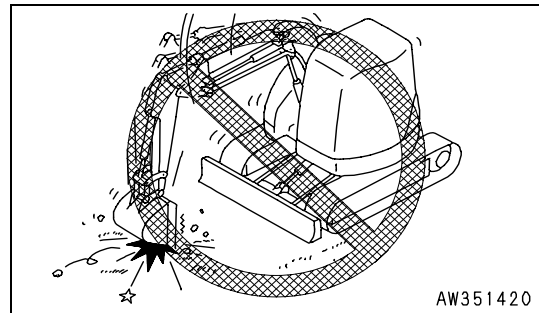

Operations Using Machine Dropping Force

Do not use the dropping force of the machine for digging.

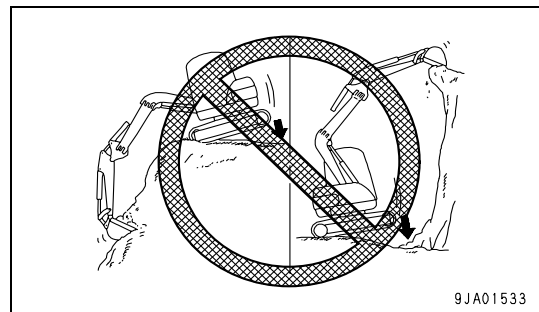

Support Blade on Both Sides

When using the blade as an outrigger, never support the machine with only one end of the blade.

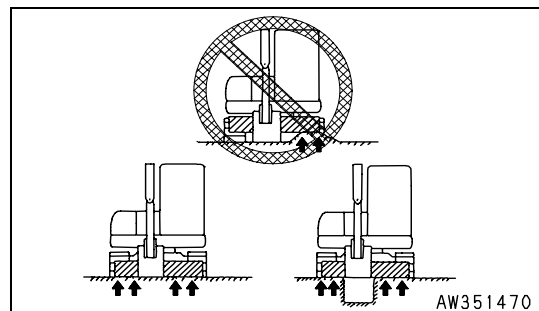

GENERAL OPERATION INFORMATION

Traveling

Traveling over boulders, tree stumps, or other obstacles will cause a big shock to the chassis (and in particular to the tracks), and this will cause damage to the machine. For this reason, always remove any obstacles or travel around them, or take other steps to avoid traveling over such obstacles as far as possible.

If there is no way to avoid traveling over an obstacle, reduce the travel speed, keep the work equipment close to the ground, and try to travel so that the center of the track passes over the obstacle.

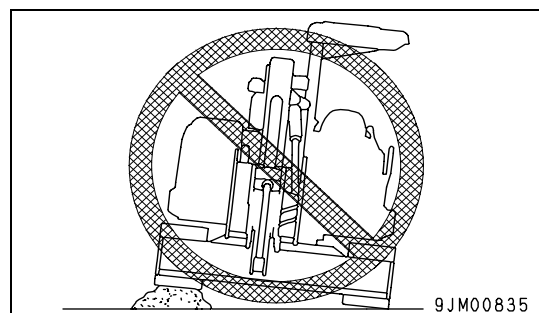

Folding In Work Equipment

When folding in the work equipment to the travel or transportation posture, be careful not to let the bucket hit the blade.

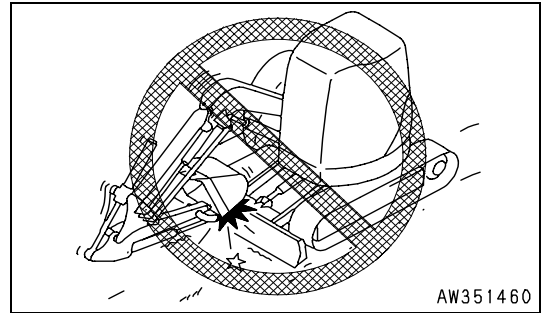

Avoid Hitting Blade

Be careful not to hit the blade against rocks or boulders. This will cause premature damage to the blade or cylinders.

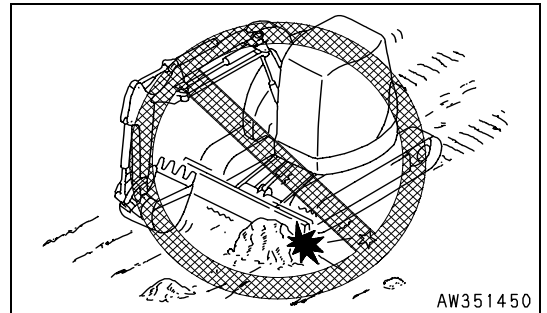

Blade During Backhoe Operations

When carrying out deep digging operations with the blade at the front, be careful not to let the boom cylinder hit the blade. Always position the blade at the back unless it is needed at the front.

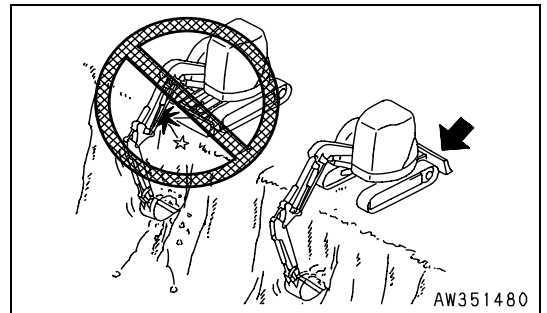

Permissible Water Depth

⚠ CAUTION

When driving the machine out of water, if the angle of the machine exceeds 15°, the rear of the upper structure will go under water, and water will be thrown up by the radiator fan. This may cause the fan to break. Be extremely careful when driving the machine out of water.

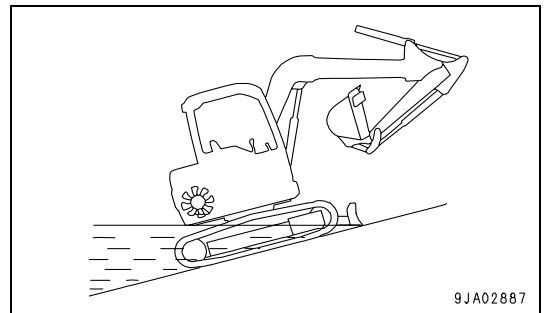

Do not immerse the machine in water by more than the permissible depth (under center of carrier roller (1)).

In addition, for parts that have been immersed in water for a long time, pump in grease until the old grease comes out from the bearings. (Around the bucket pins)

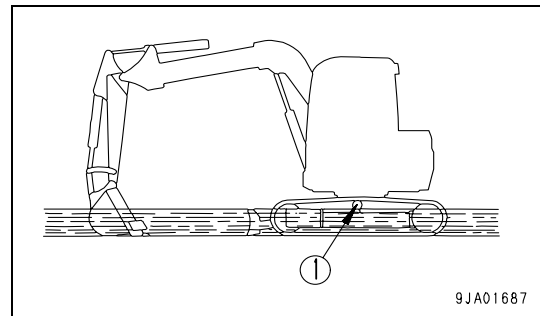

Digging Hard Rocky Ground

It is better to excavate hard rocky ground after breaking it up by some other means. This will not only reduce damage to the machine but make for better economy.

Avoid Interference Between Arm Cylinder And Obstacles

When the arm is operated, the position of the rear tip of the arm cylinder changes. Be careful not to get the wiring caught or hit anything in the surrounding area.

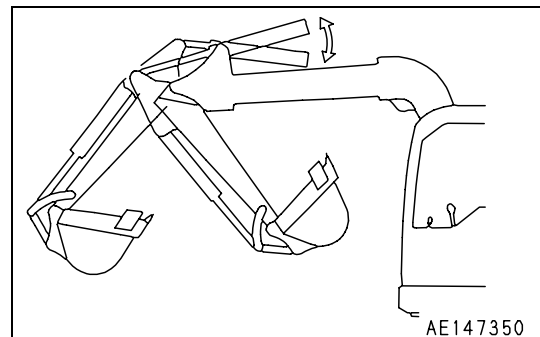

Attention To Boom And Obstacles When Machine Takes Posture For Min. Turning Radius

When the boom is extended to the maximum, the back of the boom gets close to the turning radius at the rear of machine. Take good care so that the boom will not hit objects in the surroundings.

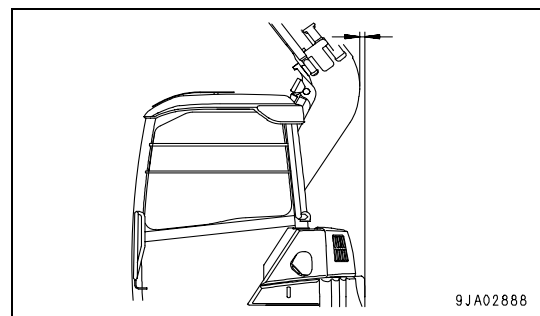

Protection Of Sensors From Obstacles

Be careful not to hit interference prevention sensors or sensor levers with other objects (logs, ditches, steel sheets, etc.).

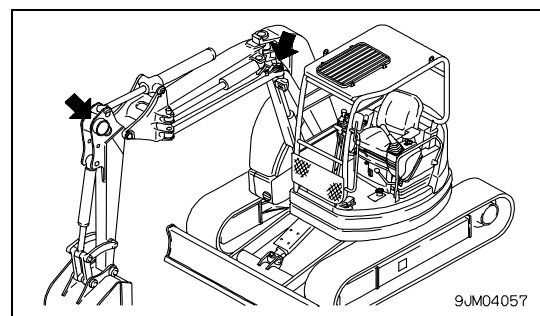

TRAVELING ON SLOPES

⚠ WARNING

When traveling, raise the bucket approx. 20 to 30 cm (8 to 12 in) from the ground.

Do not travel downhill in reverse.

- When traveling over ridges or other obstacles, keep the work equipment close to the ground and travel slowly.
- Never turn on slopes or travel across slopes.
- Always go down to a flat place to perform these operations. It may be longer, but it will ensure safety.
- Always operate or travel in such a way that it is possible to stop safely at any time if the machine slips or becomes unstable.
- Turning or operating the work equipment when working on slopes may cause the machine to lose its balance and turn over, so avoid such operations.

It is particularly dangerous to swing downhill when the bucket is loaded.

- If such operations have to be carried out, pile soil to make a platform on the slope so that the machine can be kept horizontal when operating.
- Do not travel up or down steep slopes. There is danger that the machine may turn over.
- When traveling uphill, if the shoes slip or it is impossible to travel uphill using only the force of the tracks, do not use the pulling force of the arm to help the machine travel uphill. There is danger that the machine may turn over.

1. When traveling down steep hills, use the travel lever and fuel control lever to keep the travel speed low. When traveling down a steep hill of more than 15°, set the work equipment to the posture shown in the diagram on the right, and lower the engine speed.

REMARK

Travel down fills with the sprocket (1) side down. If the machine travels down with the sprocket (1) side up, the track tends to become loose, and that can cause skipping pitches.

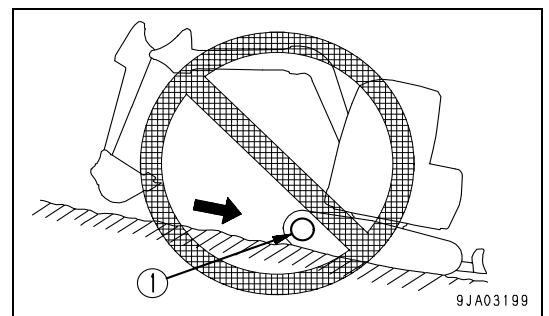
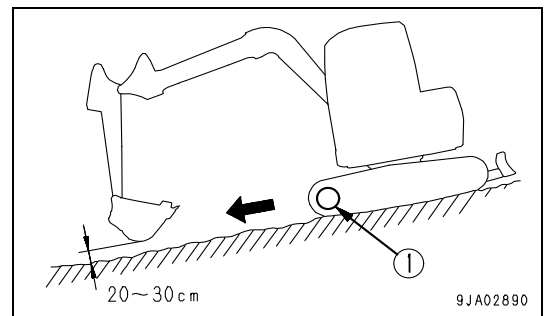
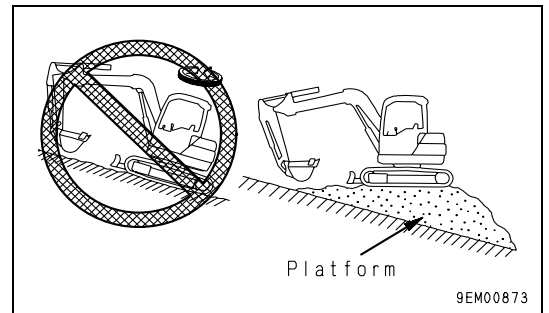
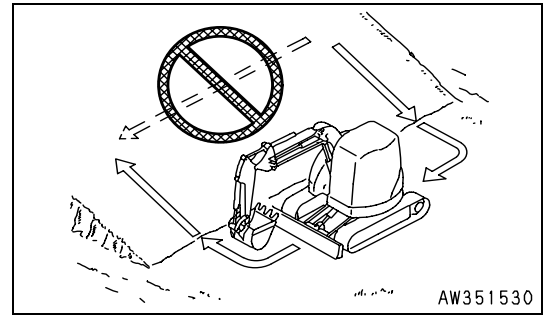

- When traveling up a steep hill of more than 15", set the work equipment to the posture shown in the diagram on the right.

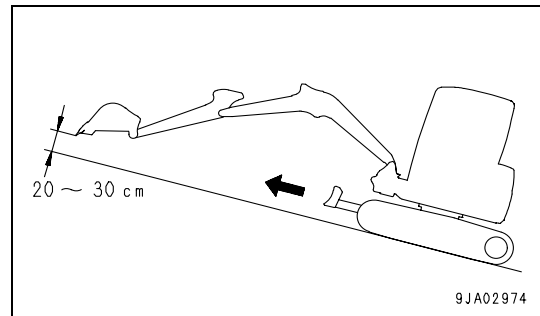

Traveling Downhill

To brake the machine during downhill runs, put the travel lever in the neutral position. This will cause the brake to be automatically applied.

Engine Stopped on Slope

If the engine stops when traveling uphill, move the travel levers to the neutral position, stop the machine, then start the engine again.

Cab Doors on Slope

- Do not open or close the sliding door (cab specifications) on slopes when traveling or operating. The operating effort may change suddenly. Always keep the sliding door locked.
- Be extremely careful when opening or closing the sliding doors (cab specifications) when the machine is stopped on a slope. There is danger that the weight of the door may cause it to open or close suddenly.

ESCAPE FROM MUD

Always operate carefully to avoid getting affixed in mud. If the machine does get affixed in mud, do as follows to get the machine out.

Stuck One Side Of Track

NOTICE

When using the boom or arm to raise the machine, always have the bottom of the bucket in contact with the ground. (Never push with the teeth.) The angle between the boom and arm should be 90° to 110°.

When only one side is affixed in mud, use the bucket to raise the track, then lay boards or logs and drive the machine out.

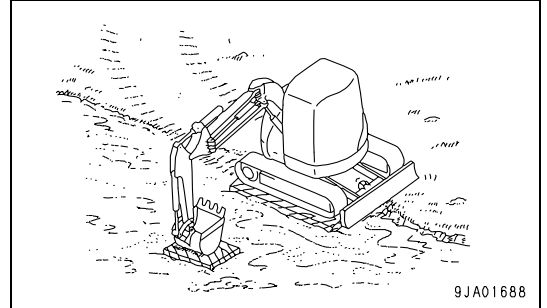

Stuck Both Sides Of Tracks

If the track on both sides are in mud and the machine slips and cannot move, use the procedure given above to lay logs or timber. dig the bucket into the ground at the front, operate the arm in the same way as when digging, and set the travel lever to FORWARD to pull the machine out.

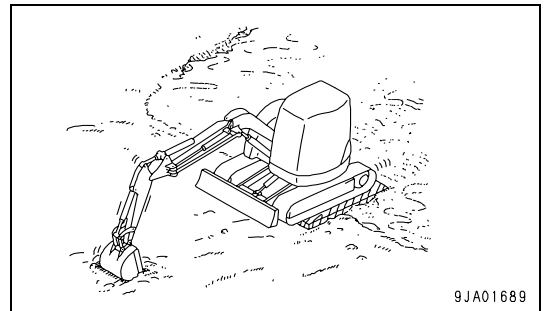

RECOMMENDED APPLICATIONS

In addition to the following, it is possible to further increase the range of applications by using various attachments.

Backhoe Work

A backhoe is suitable for excavating at a position lower than the machine.

When the condition of the machine is as shown in the diagram at right, each cylinder's maximum pushing excavation force is obtained when the bucket cylinder and link, arm cylinder and arm are at 90° .

When excavating, use this angle effectively to optimize your work efficiency.

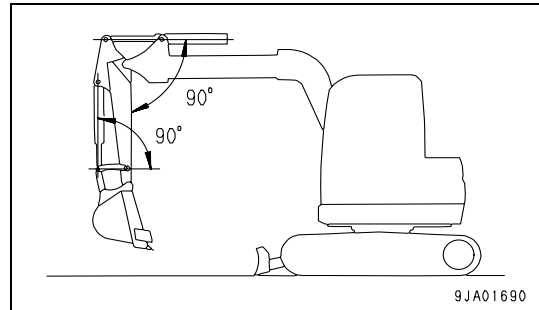

The range for excavating with the arm is from a 45° angle away from the machine to a 30° angle toward the machine.

There may be some differences depending on the digging depth, not try to keep within the above range rather than operating to the end of the cylinder stroke.

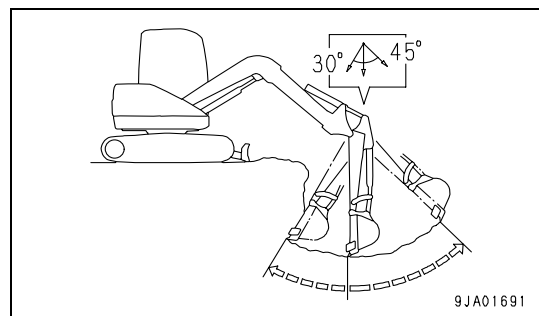

Ditching Work

Ditching work can be performed efficiently by attaching a bucket which matches the digging operation and then setting the tracks parallel to the line of the ditch to be excavated.

To excavate a wide ditch, first dig both sides and then finally remove the center portion.

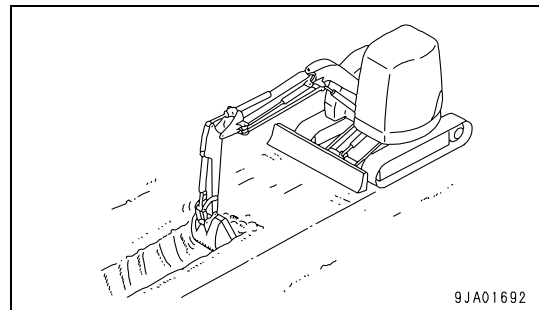

Loading Work

In places where the swing angle is small, work efficiency can be enhanced by locating the dump truck in a place easily visible to the operator.

Loading dump trucks is easier and the loading capacity is greater if the hydraulic excavator loads from the rear of the dump truck rather than from the side.

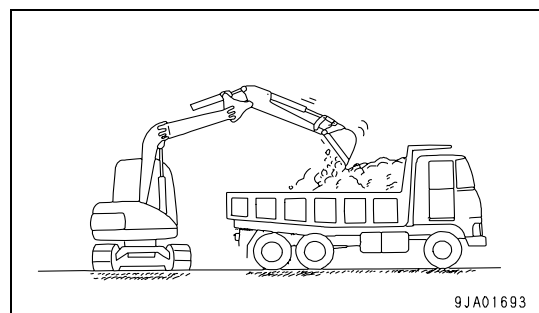

Refill And Finishing Work

When refilling after excavation and when smoothing the ground surface, use the blade.

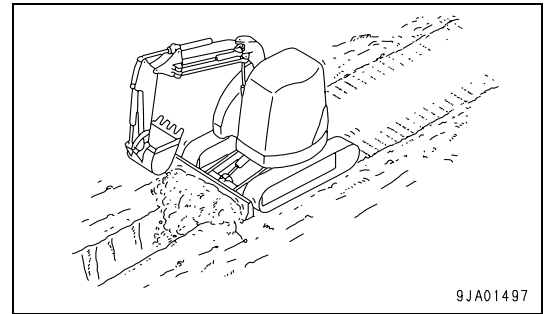

Side Ditching Work

When the boom offset is used, it is possible to carry out side ditching work in confined spaces without swinging the upper works.

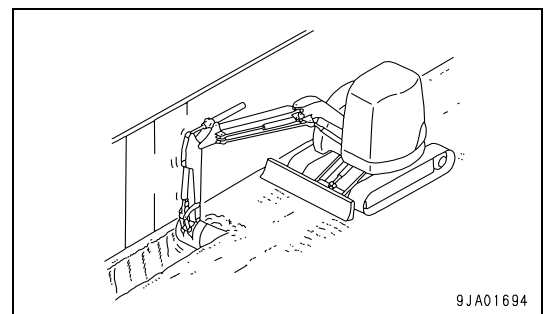

Operations In Confined Spaces

When operating in a confined space, set the work equipment in the posture in the diagram on the right. This will allow the machine to swing freely in any area where it is possible for the tracks to enter.

Minimum swing posture

1. Offset the boom to the right.
2. Extend the arm cylinder and bucket cylinder fully, and fold the work equipment.
3. Extend the boom cylinder fully.
4. Offset the boom to the left and move to a point just before the interference prevention device is actuated.

CAUTION

With a machine equipped with an operator's cab, a within-track shoe swing cannot be attained even if it takes a posture for the min. turning radius, as the cab exceeds the shoe width.

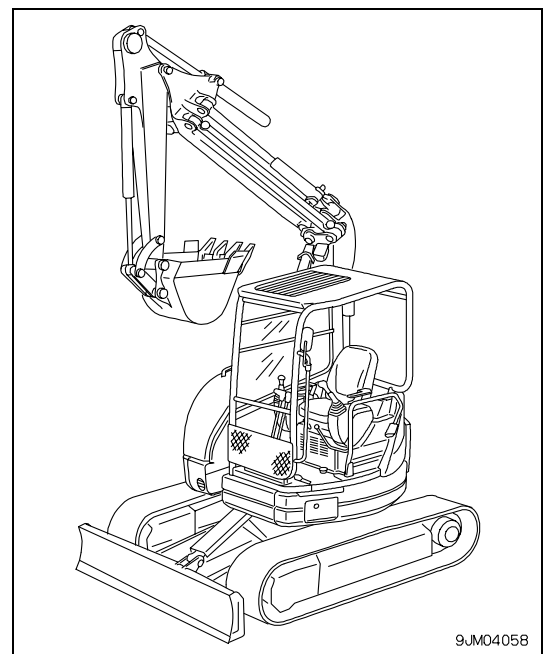

BUCKET REPLACEMENT

WARNING

- When pins are knocked in with a hammer, pieces of metal may fly and cause serious injury.
- When carrying out this operation, always wear goggles, hard hat, gloves, and other protective equipment.
- When the bucket is removed, place it in a stable condition.
- If pins are hit with a strong force, there is a hazard that the pin may fly out and injure people in the surrounding area. Make sure that there is no one in the surrounding area before starting the operation.
- When removing the pins, do not stand behind the bucket. In addition, be extremely careful not to insert your foot from the side when working.
- When removing or inserting pins, be extremely careful not to get your fingers caught.
- Never insert your fingers into the pin holes when aligning the holes.

Stop the machine on a firm, flat surface. When performing joint work, make clear signals to each other and work carefully for safety's sake.

1. Place the bucket in contact with a flat surface.

REMARK

When removing the pins, place the bucket so that it is in light contact with the ground.

If the bucket is lowered strongly to the ground, the resistance will be increased and it will be difficult to remove the pins.

NOTICE

After removing the pins, make sure that mud or sand does not get on them. Dust seals are fitted at both ends of the bushings, so be careful not to damage them.

2. Remove the stopper bolts and nuts, then remove pins (A) and (B), and remove the bucket.
3. Align the arm with hole (1) and the link with hole (2), then coat pins (A) and (B) with grease and install them.

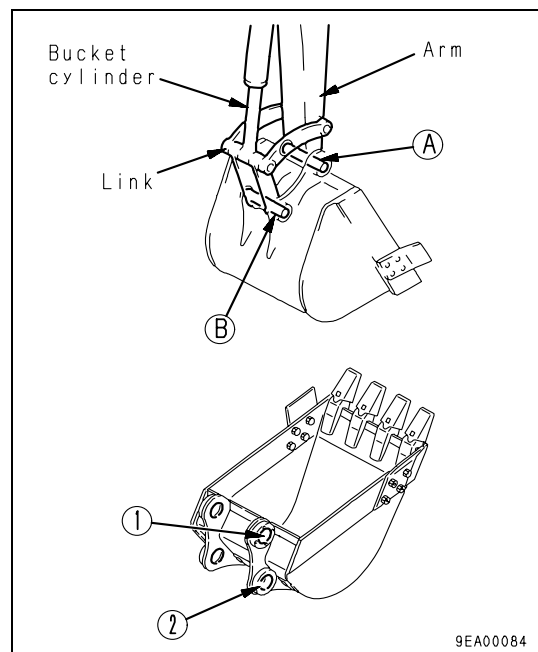

REMARK

When installing the bucket, the O-rings are easily damaged, so fit the O-rings on the boss of the arm end as shown in the diagram. When knocking the pin, move the O-ring down to the regular groove.

4. Install the stopper bolts and nuts for each pin, then grease the pin.

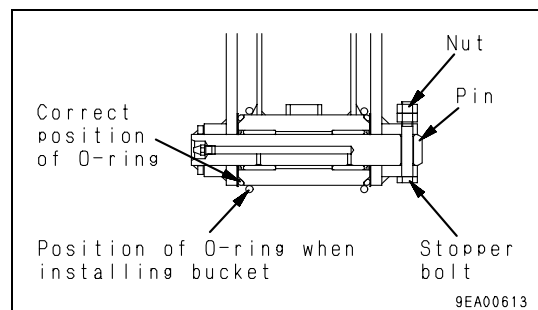

PARKING MACHINE

⚠ WARNING

- Park the machine on the firm, level ground. Avoid parking the machine on slopes.
- If it is unavoidably necessary to park the machine on a slope, put blocks under the tracks and dig the work equipment into the ground surface to stop the machine from moving.
- If the control levers are touched by accident, the work equipment or machine may move suddenly, and this may lead to a serious accident. Before standing up from the operator's seat, always set the safety lock lever securely to the LOCK position.
- Set the blade on the downhill side and lower it to the ground.

1. Stop the machine. For details, see "Stopping Machine (3-55)".
2. Set fuel control lever (1) to the low idling position to lower the engine speed.

3. Lower the bucket horizontally until the bottom touches the ground.
4. Lower the blade to the ground.

5. Set safety lock lever (2) in the LOCK position.

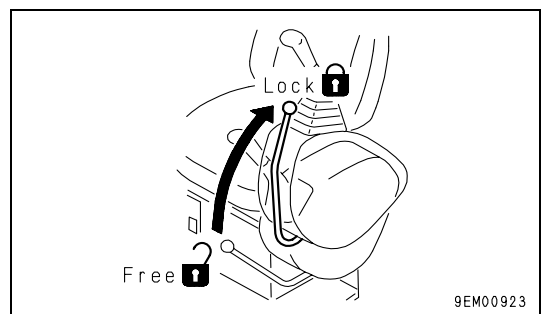
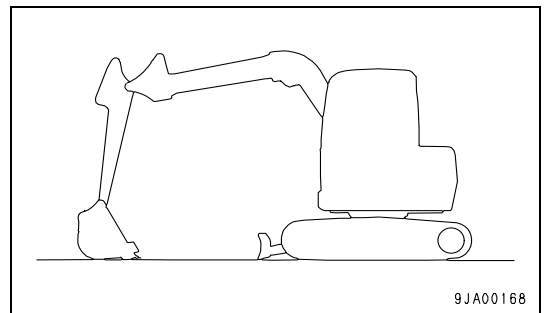
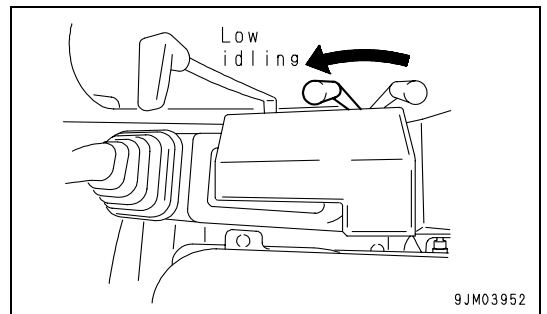
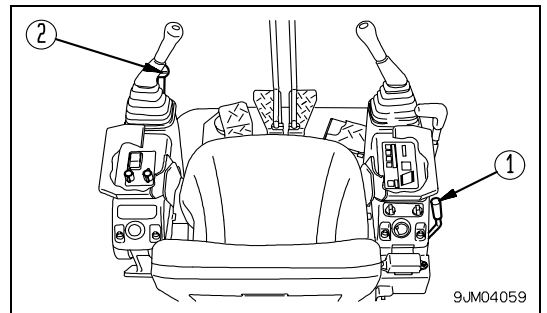
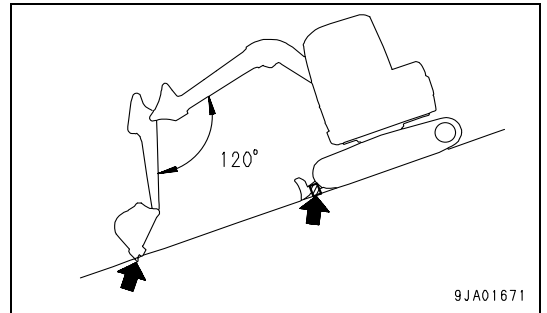

MACHINE INSPECTION AFTER DAILY WORK

Check the engine water temperature (1), engine oil pressure (2), and fuel level (3) on the machine monitor.

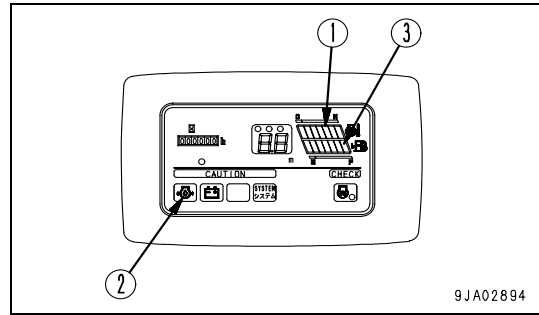

LOCKING

Always lock the following places.

- (1) Fuel tank filler port
 - (2) Engine hood
 - (3) Mud cover
 - (4) Tool box cover (canopy specified)
 - (5) Tool box cover (machine equipped with air conditioner)
 - (6) Door of operator's cab (cab specified)
- Always remember to close the window.

REMARK

Use the starting switch key to open and close all these places.

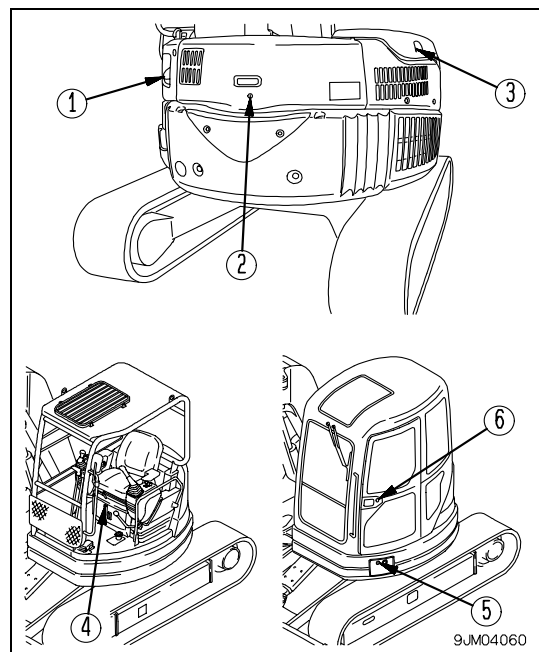

ELECTRONIC CONTROL SYSTEM HANDLING

⚠ WARNING

- Never remove, install, or disassemble and repair any sensor. This will cause mistaken actuation of the interference prevention device.
- Always contact your Komatsu distributor for repairs.
- If any sensor is hit or any external damage is found, check the actuation condition of the automatic stop.
- If any abnormality is found, please contact your Komatsu distributor.
- Never do any work in which the sensors go below water.
- If any sensor should be immersed in water, check the actuation condition of the automatic stop.
- When washing the machine, do not spray water directly onto the electrical parts or the wiring connectors.
- The auto-stop cancel switch must only be used for moving the machine to a safe place when there is an abnormality in the electronic control system. It must not be used for any other reason.
- When changing to the long arm, multi-changer arm or A lock specified by Komatsu, ask your Komatsu distributor to change the attachment.
- If the attachment is changed from the standard work equipment, the electronic control system will not work normally. If the work equipment is replaced by an attachment made by another company, please consult your Komatsu distributor first.

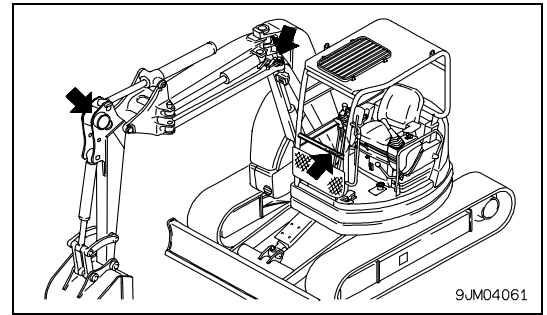
**NOTICE**

- If an abnormality occurs in the electronic control system, the controller will carry out self diagnosis. Electrical system monitor (1) on the monitor panel will flash, the buzzer will sound, and the error code will be displayed on the depth display (2).
- For details of the correct action to carry out, see "Machine Monitoring System (3-105)".
- Depending on the location of the failure of the electronic control system the controller may not carry out self diagnosis, and it may become impossible to operate the work equipment. If this happens, move the machine to a safe place, and contact your Komatsu distributor for inspection.
- Before using the electronic control system, always carry out the checks before starting and after starting.
- In cold areas, carry out thorough warming up before using the machine. If the hydraulic oil temperature is low, the automatic stop may be out of position.

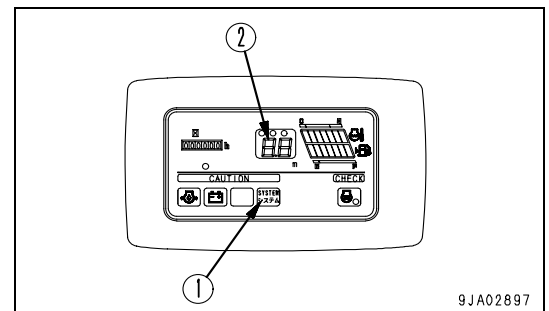

The electronic control system is an automatic control system for the work equipment and a device to prevent interference between the bucket and cab, or canopy.

To ensure that this device works properly, always keep to the following points.

Interference Prevention Device (Between Bucket And Cab, Canopy)

⚠ WARNING

This device is a preventive device intended only for unexpected cases, so it is dangerous to rely on it completely during operations. Always make sure that the work equipment does not come close to the cab during operations.

During left offset, if the arm and boom are pulled in too far, or during right offset, if the arm and boom are pulled in and it is attempted to offset to the left, this device will warn that the bucket will hit the cab or canopy, and will automatically stop the work equipment.

Operation Of Interference Prevention Device

Reduced Speed Range (Front To Rear Direction Only)

If the work equipment is operated so that it comes close to the operator's compartment, when the bucket enters area A in the diagram on the right, the work equipment speed will drop. This is to prevent the load in the bucket from being spilled when the work equipment is stopped.

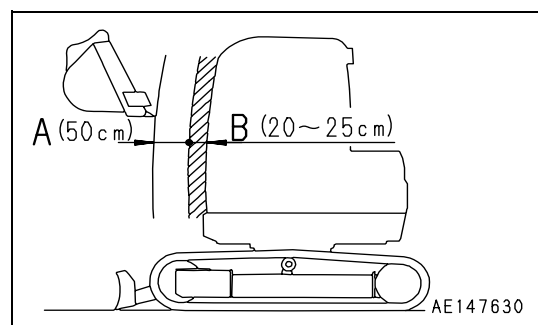

Automatic Stop

If the bucket continues to come close and enters area B in the diagram on the right, the work equipment will automatically stop.

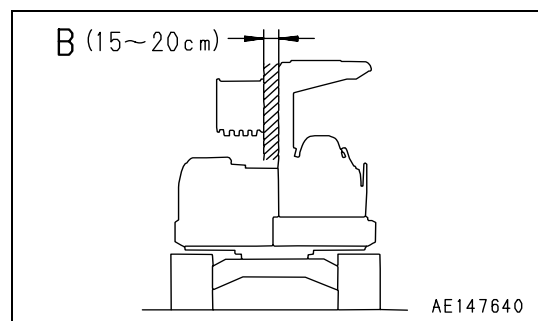

Emergency Stop

If for any reason the work equipment is not automatically stopped in area B above, all operations (boom, arm, bucket, swing) will stop when it enters area C in the diagram on the right.

When this happens, error code "61" is displayed on the depth display on the monitor panel, and self diagnosis is carried out. If the cancel switch is operated and the bucket is moved to the front or the right, the self diagnosis is canceled and it becomes possible to carry out normal operations.

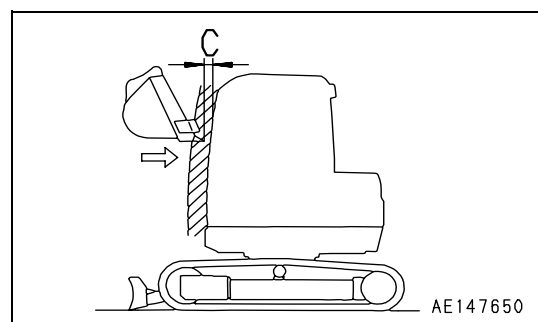

Operation When There Is Automatic Stop

⚠ WARNING

After using the cancel switch to cancel the automatic stop, never try to raise the boom, pull in the arm, or operate the left offset.

After automatic stop, it is impossible to raise the boom, pull in the arm, or operate the left offset. Move the work equipment to the front or to the right to move it away from the operator's compartment, then carry out normal operations.

REMARK

- After automatic stop, even if the work equipment is moved 5 to 10 cm (2.0 to 4.0 in) to the front or right, it is impossible to raise the boom, pull in the arm, or operate the left offset, but this does not indicate a failure.
- After automatic stop, if the work equipment is moved forward approx. 50 cm (20 in) and the boom is raised or the arm is pulled in, the movement will be slow (if the engine is running at low idling, it may even be impossible to raise the boom or pull the arm in), so move the work equipment more than 50 cm (20 in) before carrying out operations again.
- When the machine is not being used, lower the work equipment to the ground.
- If there is hydraulic drift and the bucket enters the emergency stop range, the work equipment will not move when the engine is started again.
- Do not use the left offset when transporting the machine.
- If there is hydraulic drift and the bucket enters the emergency stop range, the work equipment will not move when the engine is started again.

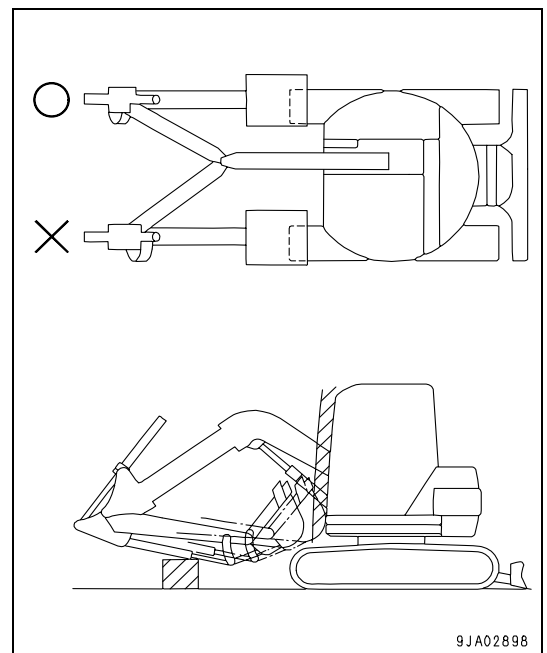
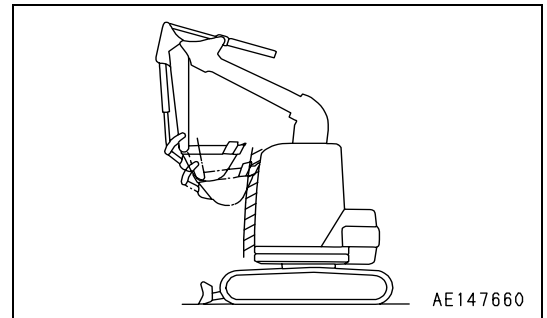

Handling Automatic Control Device

Depth display: This displays the depth from the ground surface.

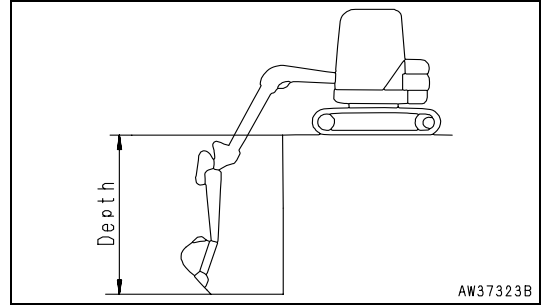

Depth display 0 set mode: This displays the depth from the standard surface.

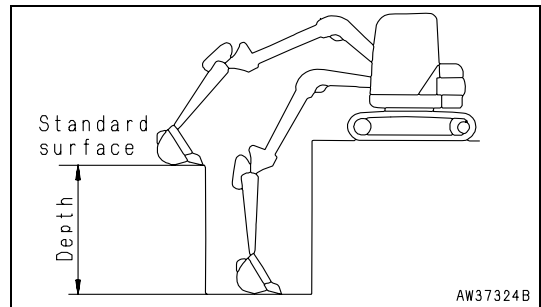

Height mode: This sets the amount the boom can be raised.

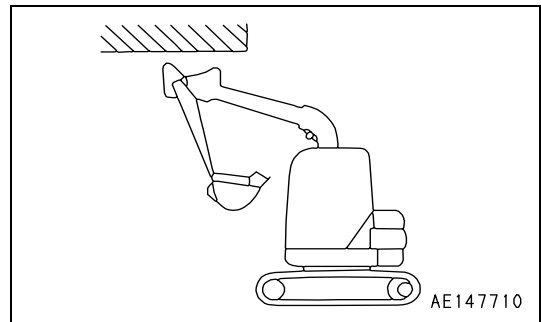

It is possible to set either the depth display or depth display 0 set mode together with height mode, so use these settings to match the operation.

Depth Display (Depth From Ground Surface)

When the engine is started and the switch is ON, the depth display will always indicate the depth from the ground surface unless depth display 0 set mode is being used. If work equipment is above ground level, UP is displayed.

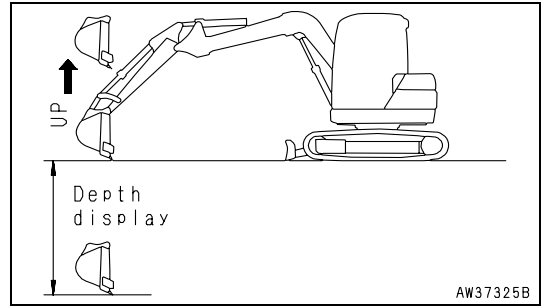

REMARK

This display assumes that the bucket is pointing down, so if the bucket is in the condition shown in the diagram on the right, the actual depth may be different from the display depth.

When measuring the depth, always set the machine horizontally.

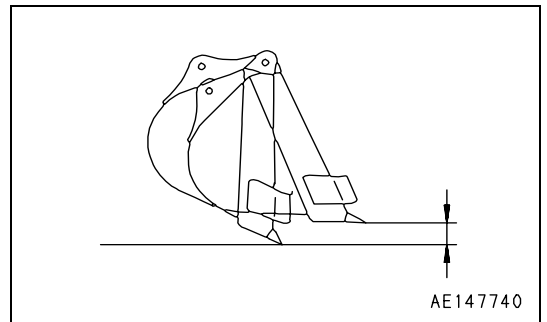

Setting Depth Display 0 Set Mode (Depth From Standard Surface)

This displays the desired standard surface as 0.0 m (0.0 in), and displays the depth of the bucket from this surface.

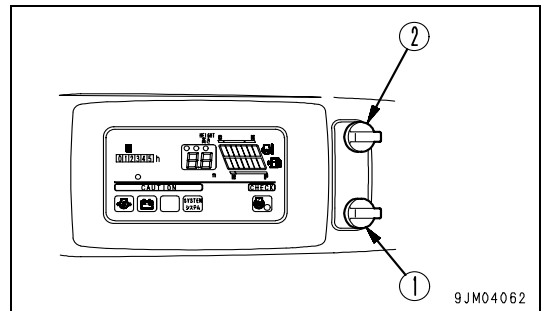

1. Turn mode selector switch (1) to the depth display 0 set mode position.

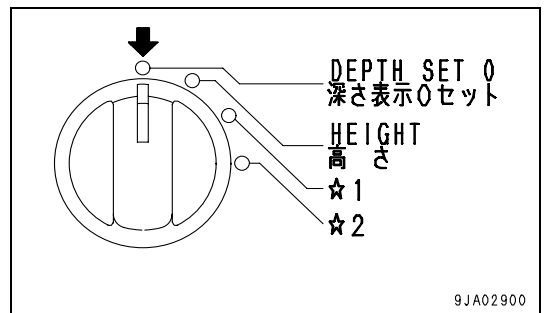

2. Set the machine horizontally, and align the bucket with the position to use as the standard surface. When aligning, the way in which the bucket is placed becomes the standard for the depth display.

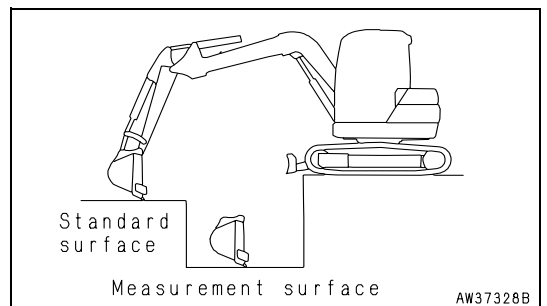

- Turn setting switch (2) to the SET position. The depth display will become 0.0 m.

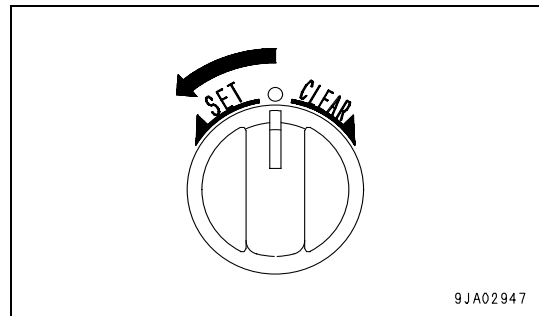

- Move the bucket to the point that is to be measured (measurement surface).

- To return the setting so that it measures the depth from the ground surface, turn mode selector switch (1) to the depth display 0 set mode position, then turn setting switch (2) to the CLEAR position. The display will return to the depth display measured from the ground surface.

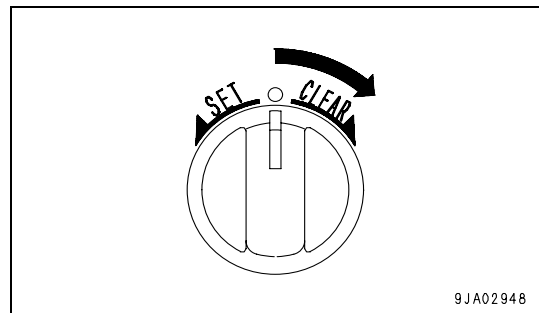

REMARK

- When carrying out the measurement, place the bucket in the same posture at the measurement point as it was at the standard surface.
- If the starting switch is turned OFF in the mode set condition, the mode set condition is canceled.

Setting Height Mode

When the boom is raised to the desired set height, it will automatically stop.

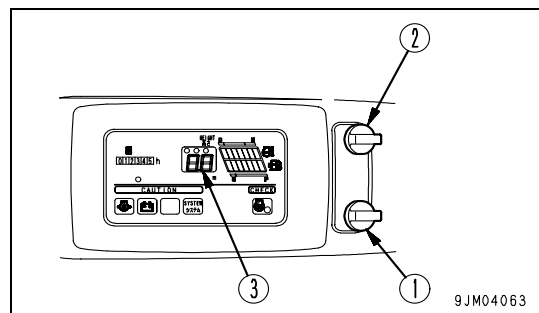

- Turn mode selector switch (1) to the height mode position.

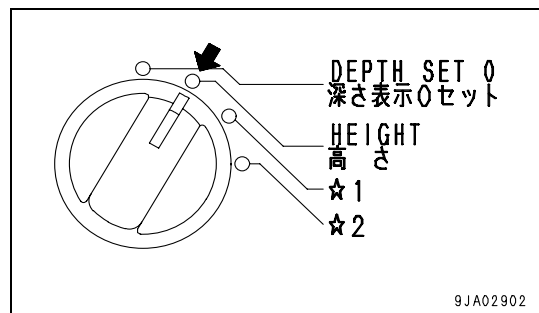

2. Raise the boom to the position to be set.
3. Turn setting switch (2) to the SET position. The buzzer will sound twice and indicator (3) will light up.

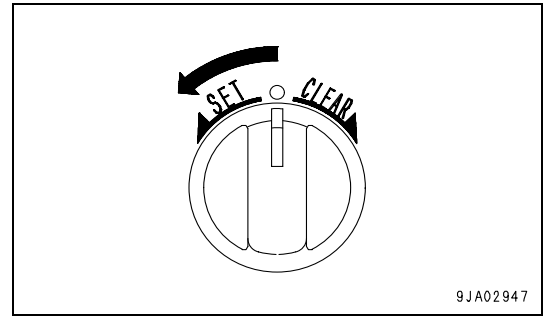

4. If the boom is lowered, then raised again, it will stop at the set point.

NOTICE

The HEIGHT mode sets the amount of boom RAISE. If the height is set with the arm and bucket curled as illustrated at right, it will likely be lower than when the arm and the bucket are extended. Hence take care in the latter case so that the bucket or arm will not hit an object in the surroundings.

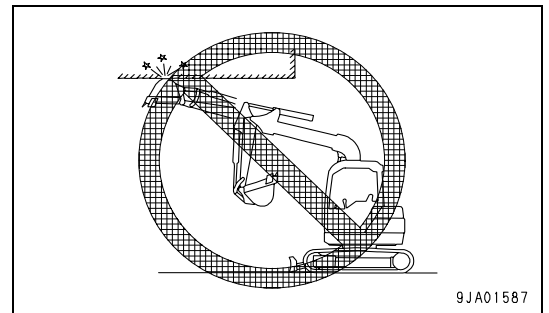

5. When canceling the height mode, turn mode selector switch (1) to the height mode position, then turn setting switch (2) to the CLEAR position. Indicator (3) will go out.

REMARK

When the mode is set, if the starting switch is turned OFF, the mode setting is canceled.

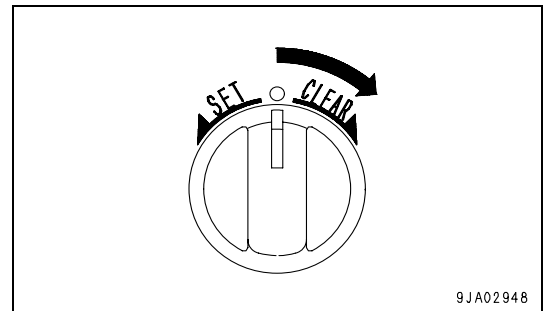

ROAD LINERS AND RUBBER SHOES

(Machine equipped with road liner or rubber shoe)

Road Liners And Rubber Shoes Information

Road liners and rubber shoes have excellent properties that are not found in steel shoes. However, if they are used in the same way as steel shoes, full use cannot be made of their advantages.

Be sure to operate without straining the road liners and rubber shoes in a way that matched the conditions of the jobsite and the nature of the work.

Comparison Of Road Liners, Rubber Shoes and Steel shoes

| | Road liner | Rubber shoe | Steel shoe |
|-------------------------------|------------|-------------|------------|
| Little vibration | Excellent | Excellent | Average |
| Smooth travel (No creaks) | Good | Excellent | Good |
| Little noise | Excellent | Excellent | Average |
| No damage of paved surface | Excellent | Excellent | Average |
| Easy to handle | Average | Excellent | Average |
| Easily damaged | Good | Average | Excellent |
| Strong drawbar pull | Excellent | Excellent | Excellent |

Considering the properties of the material used, road liners and rubber shoes offer various advantages. However, their weak point is lack of strength. Therefore, it is important to understand the advantages of road liners and rubber shoes, and to follow the precautions regarding handling and prohibited work. This will extend the life of the road liners and rubber shoes and will enable the machine to display the advantages of road liners and rubber shoes to the maximum. Before using road liners and rubber shoes, always read "Using Road Liners And Rubber Shoes (3-81)".

Warranty For Road Liners And Rubber Shoes

It is important to inspect and maintain the tracks at the correct tension. Furthermore, these shoes must not be used near objects where they are likely to suffer damage, such as the corners of steel plates, U-shaped ditch liners, blocks, on crushed rock or the sharp edges of rocks, iron beams, or scrap iron.

Any damage resulting from the customer's mistaken use of the machine shall not be included in the scope of the warranty.

Using Road Liners And Rubber Shoes

Prohibited Works

Do not carry out the following types of work.

- Carrying out operations and steering on crushed rock, extremely rough hard rock, steel beams, scrap iron, or near the edges of steel plates will cause damage to the road liners and rubber shoes.
- In places such as river beds where there are large numbers of large and small boulders, the stones may get caught and damage the road liners and rubber shoes or make the shoes come off. If dozing operations are carried out when the shoes are slipping, this will reduce the life of the road liners and rubber shoes.
- Be careful not to get oil, fuel, or chemical solvent on the road liners and rubber shoes. If such a substance should get on the shoes, remove it immediately. Furthermore, do not travel on road surfaces where oil has collected.
- When putting the machine into long-term storage (3 months or more), store the machine indoors where it is protected from direct sunlight or rain.
- Do not use the machine in high-temperature areas, such as areas where there is burning wood, steel plates that have been left under the hot sun, or places where asphalt has been laid.
- Do not move the machine with the crawler on one side raised using the work equipment. This will cause damage to the rubber shoes and may cause the rubber shoes to come off.
- When the rubber parts of the road liner are so worn or broken that the head of the mounting bolts are scratched, replace the shoe immediately. If the bolt heads are broken, the bolt cannot be removed.
- When installing road liners, always install them to all links on both sides. If they are installed to only one part of the links, their durability will be greatly reduced.

Long Life Operations

Be careful of the following points when carrying out work.

- Avoid carrying out counter rotation turns on concrete surfaces. There is danger that the concrete surface will scrape off the rubber from the shoe.
- Avoid making sudden changes in direction. This may cause premature wear or damage to the road liners and rubber shoes.
- Avoid operating the steering when traveling over places where there is a big difference in height. When traveling over obstacles or places where there is a difference in height, drive the machine at right angles to the obstacle to prevent the shoes from coming off.
- If the machine has been raised using the bucket, lower it slowly.
- Avoid doing work with materials that produce oil when crushed (soya beans, corn, or remains of vegetables squeezed for oil); or wash the machine after use.
- Avoid handling materials that will attack the adhesion of the steel core, such as salt, ammonium sulfate, potassium chloride, potassium sulfate, or calcium super phosphate; or wash the machine after use.
- The adhesion of the core will be attacked by salt, so avoid using the machine in coastal areas.
- When handling salt, sugar, wheat, or soybeans, if there is any deep cut in the road liners and rubber shoes, these substances may get into the lugs or cut portion of the rubber. Always repair the rubber before use.
- Do not carry out work that involves scraping against walls or concrete embankments.
- Road liners and rubber shoes slip extremely easily on snow or frozen roads. Be careful not to slip when traveling or working on slopes.
- The properties of road liners and rubber shoes change when working in extremely cold places. This will reduce the life of the road liners and rubber shoes.
- Because of the properties of rubber, use the road liners and rubber shoes within a range of -25°C to $+65^{\circ}\text{C}$ (-13°F to $+149^{\circ}\text{F}$).
- When carrying out bucket operations, be careful not to damage the road liners and rubber shoes with the bucket.
- Always maintain the rubber shoes at the proper tension to prevent them from coming off. If the tension is low, the rubber shoes will come off under the following conditions. Even if the tension is correct, be extremely careful when carrying out operations.

1. Avoid operating the steering when traveling over curbs, rocks, or places where there is a big difference in height (more than approx. 20 cm (8 in)). When traveling over such objects, always travel at right angles to the object.

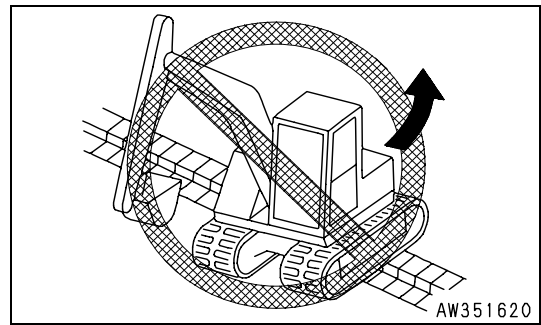

2. When traveling in reverse up a slope, do not turn when moving from flat ground onto the slope. If it is necessary to turn on slopes, be sure to turn gradually.

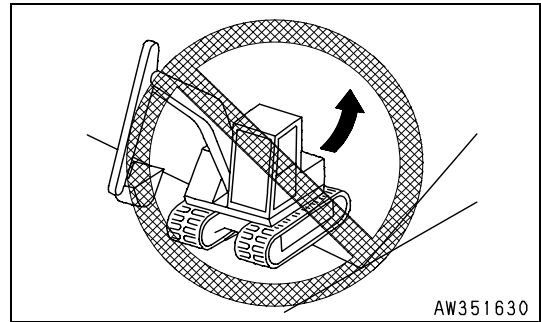

3. Avoid traveling along the edge of slopes or on rough ground with the track on one side raised (with the machine tilting at an angle of more than approx. 10°) and with the track on the other side on flat ground. To avoid damage to the road liners and rubber shoes, travel with the tracks on both sides on flat ground.

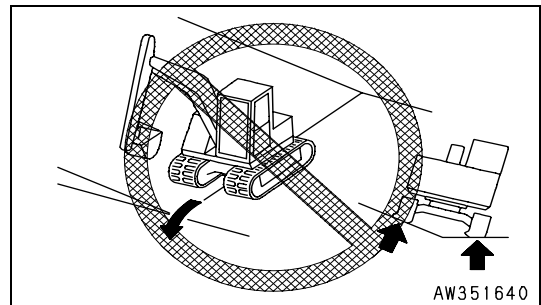

4. If the machine is operated as explained in 1 to 3 above, the rubber shoes is slackened. Do not steer the machine in the positions shown in the figure.

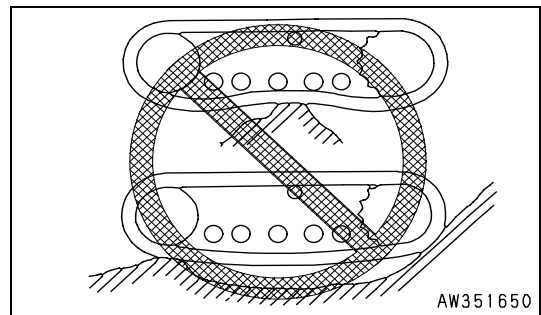

OPERATION

Mechanism of rubber shoe coming off track

1) When traveling over an obstacle, a gap is formed between the track roller and the rubber shoe. In this condition, the rubber shoe may come off.

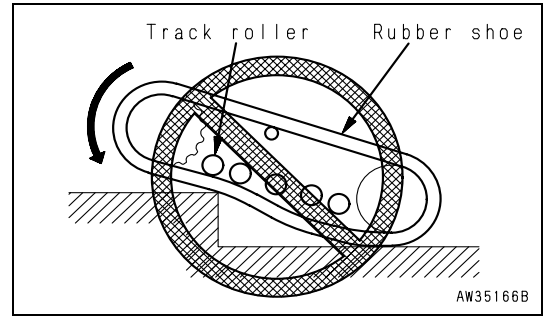

2) Furthermore, if the machine travels in reverse, a gap is formed between the track roller, idler, and rubber shoe.

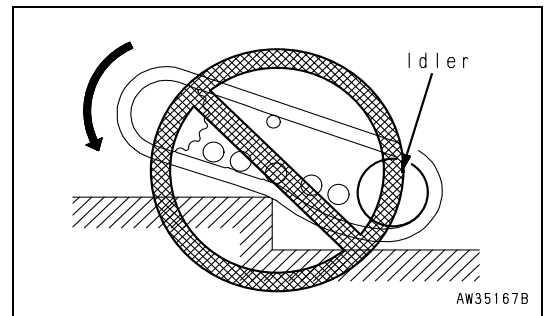

- When turning in a condition where the rubber shoe cannot move to the side because of the object it is passing over, or because of some other object.
- When the rubber shoe has moved out of alignment and the idler or track roller are not aligned with the core.

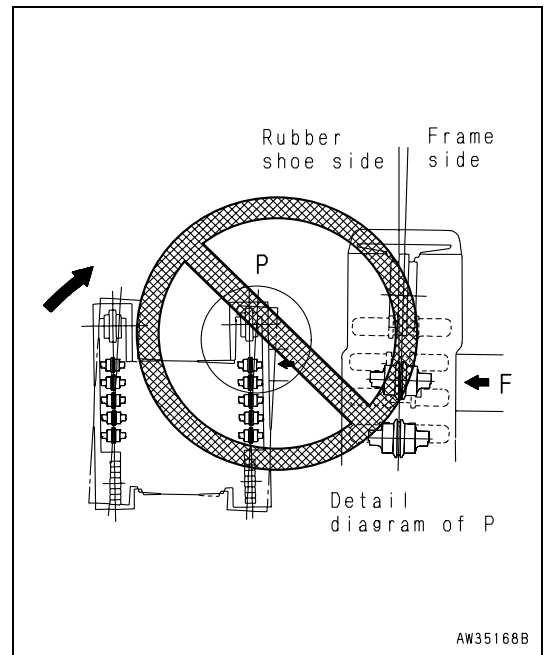

- If the machine travels in reverse in this condition, the rubber shoe will come off.

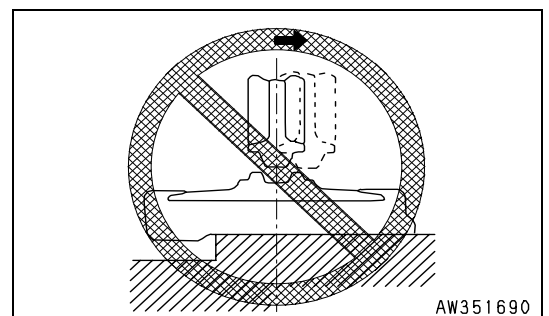

- If the machine is turned in this condition, the rubber shoe will come off.

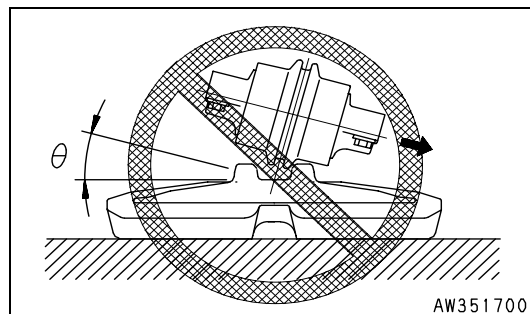

TRANSPORTATION

When transporting the machine, observe all related laws and regulations, and be careful to assure safety.

TRANSPORTATION PROCEDURE

As a basic rule, transport the machine by trailer.

Select the trailer to match the weight and dimensions given in "SPECIFICATIONS (5-2)".

Note that the value for the weight and transportation dimensions given in SPECIFICATIONS may differ according to the type of shoe or type of arm or other attachments.

LOADING AND UNLOADING WITH TRAILER

WARNING

- When loading or unloading, always drive at low speed and do not operate the travel boost pedal.
- When loading or unloading, run the engine at low speed and operate slowly.
- When loading or unloading the machine, park the trailer on a flat firm roadbed.
- Keep a fairly long distance between the road shoulder and the machine.
- Use ramps with ample width, length, thickness, and strength and install them at a maximum slope of 15°.
- When using piled soil, compact the piled soil fully and prevent the slope face from collapsing.
- Remove the mud from the undercarriage to prevent the machine from slipping to the side on the ramps.
- Remove any water, snow, grease, oil, or other substances stuck to the ramps.
- Never change the direction of travel when on the ramps. There is danger that the machine may tip over.
- If it is necessary to change direction, drive off the ramps to the ground or back onto the platform, correct the direction, then drive onto the ramps again.
- It is dangerous to use the work equipment for the loading or unloading operation.
- Never operate any lever other than the travel lever on the ramps.
- The center of gravity of the machine will change suddenly at the joint between the ramps and the truck or trailer, and there is a hazard of the machine losing its balance. Travel slowly over this point.
- When swinging the upper structure on the trailer or truck, the machine is unstable, so pull in the work equipment and swing slowly.
- On machines with a cab, always check that the sliding door is locked in position, both when it is open and when it is closed. If the door is open or closed on the ramps or on the platform of the trailer, there is danger that the operating effort will suddenly changed. Do not open or close the door on the ramps or on trailer platforms.

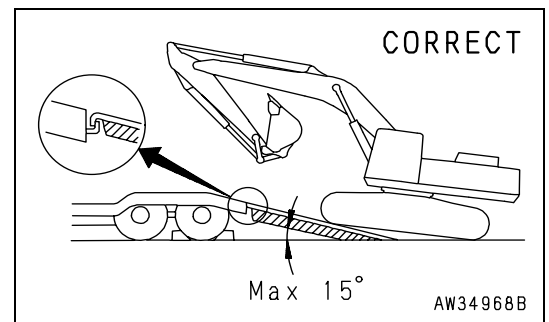
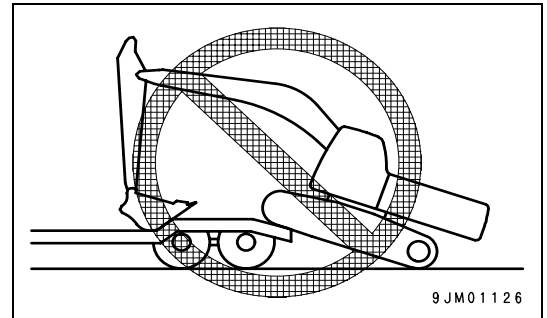

When loading or unloading, always use ramps or a platform and carry out the operation as follows.

Loading

1. Perform loading and unloading on firm, level ground only.
Maintain a safe distance from the edge of a road.
2. Properly apply the brakes on the trailer and put blocks under the tires to ensure that the trailer does not move.
Then fix the ramps in line with the center of the trailer and the machine.
Be sure that the two sides are on the same level.
Make the slope of the ramps a maximum of 15°.
Set the distance between the ramps to match the center of the tracks.

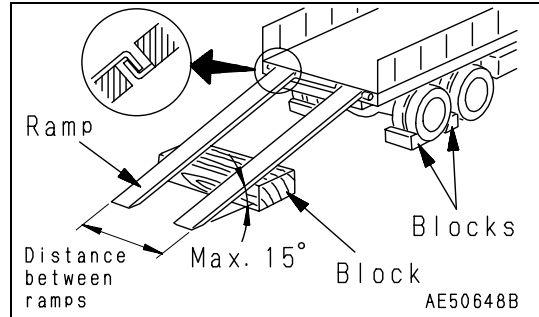

3. Run the engine at low speed.

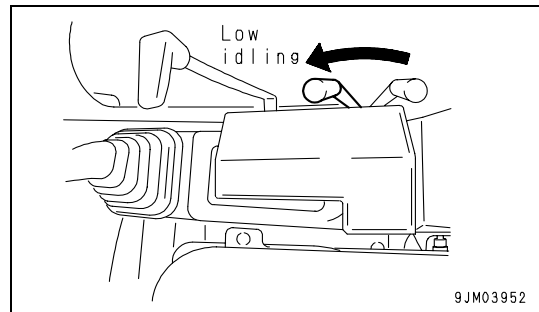

4. When loading, set the work equipment at the front and the blade at the rear, with the undercarriage and upper structure set parallel.
5. Align the direction of travel with the ramps and travel slowly.
Lower the work equipment as far as possible without causing interference.
When on the ramps, operate only the travel lever. Do not operate any other lever or pedal.

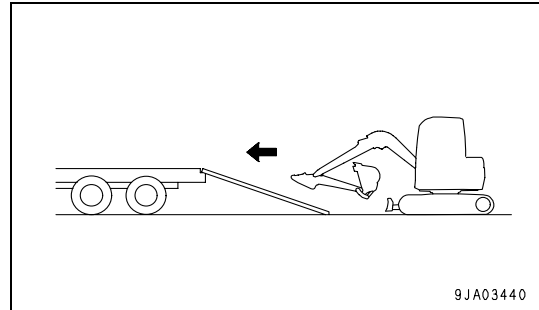

6. Do not operate the accelerator pedal.

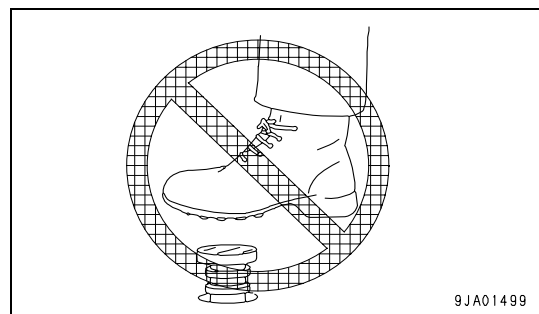

7. Stop the machine at the specified place, then swing the upper structure slowly 180°.
8. Stop the machine at the specified position on the trailer.

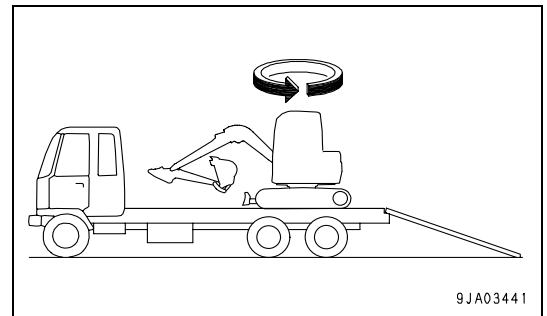

Securing Machine

After placing the machine on the specified position of the trailer, secure it according to the following procedure.

NOTICE

To prevent damage to the bucket cylinder during transportation, fit a wooden block at one end of the bucket cylinder to prevent it from touching the floor.

1. Lower the blade.
2. Extend the bucket and arm cylinders fully, then lower the boom slowly.
3. Stop the engine, then remove the key from the starting switch.
4. Lock each control lever with the safety lock lever securely.

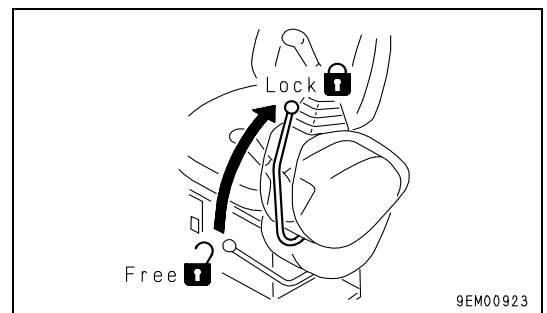
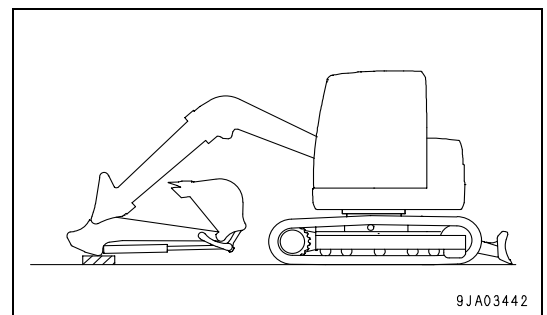

5. Lock the sliding door (cab specification) and covers with locks.
6. Put blocks under both ends of the tracks to prevent the machine from moving during transportation, and tie the machine down securely with chains or wire rope of suitable strength.
Be particularly careful to fix the machine in position securely so that it does not slip to the side.

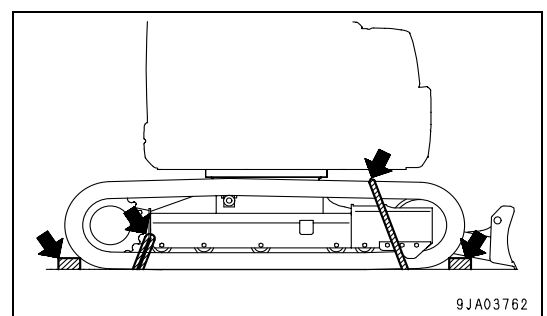

Unloading

1. Perform loading and unloading on firm, level ground only. Maintain a safe distance from the edge of a road.
2. Properly apply the brakes on the trailer and put blocks under the tires to ensure that the trailer does not move. Then fix the ramps in line with the center of the trailer and the machine.
 Be sure that the two sides are on the same level.
 Make the slope of the ramps a maximum of 15°.
 Set the distance between the ramps to match the center of the tracks.
3. Remove the chains or wire rope holding the machine.
4. Start the engine.
 Warm the engine up fully.
5. Set the safety lock lever to the FREE position.

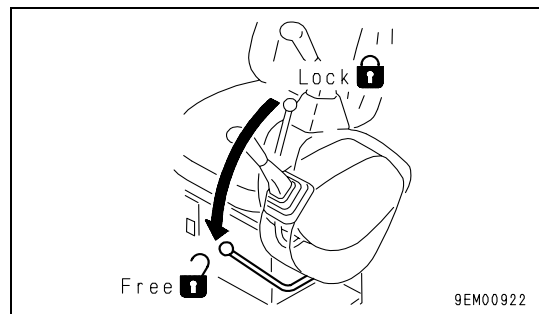
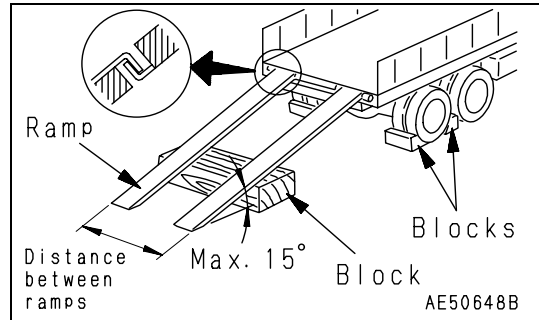

6. Run the engine at low speed.
7. Raise the blade.

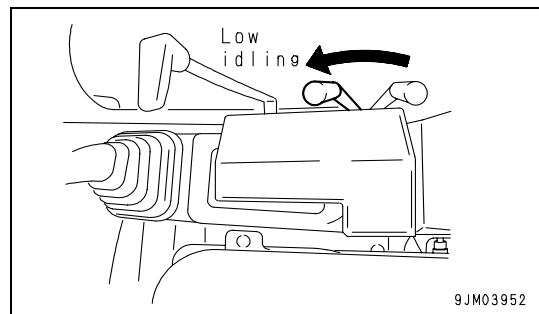

8. Raise the work equipment, align the direction of travel with the ramp, and travel slowly.
 Lower the work equipment as far as possible without causing interference.
 When on the ramps, operate only the travel lever. Do not operate any other lever or pedal.

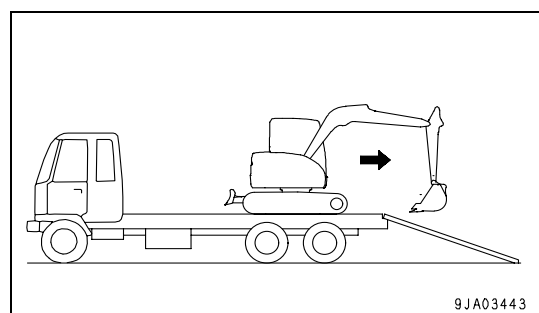

9. Do not the operate the accelerator pedal.

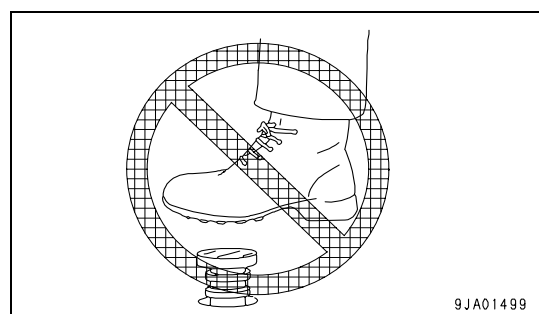

LIFTING MACHINE

 **WARNING**

- Never raise the machine with any worker on it.
- Always make sure that the cable used for lifting the machine is of ample strength for the weight of the machine.
- Never try to lift the machine in any posture other than the posture given in the procedure below.
- There is a hazard that the machine may lose its balance.
- Never lift the machine with the upper structure swung to the side. Swing the work equipment so that it is at the sprocket end and set the undercarriage and upper structure parallel before lifting.
- When lifting, keep the machine horizontal.
- Never go under the machine when it is raised.

NOTICE

- For the details on the machine weight, see the section of "SPECIFICATIONS (5-2)".
- The lifting procedure applies to machines with standard specifications.
- The method of lifting differs according to the attachments and options actually installed. In such cases, please contact your Komatsu distributor for information.

When lifting the machine, carry out the operation on flat ground as follows.

1. Start the engine, then swing the upper structure so that the work equipment is at sprocket (1) end with the track frame and upper structure set parallel.
2. If the boom is offset to either side of right and left, use the offset pedal to make the boom straight and then move the pedal lock to the LOCK position.
3. Extend the bucket cylinder and arm cylinder fully, then lower the work equipment to the ground as shown in the diagram on the right using the boom cylinder.
4. Lower the blade to the ground.
5. Operate the safety lock lever to the LOCK position.

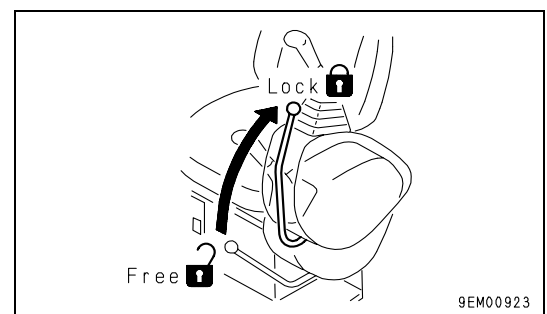
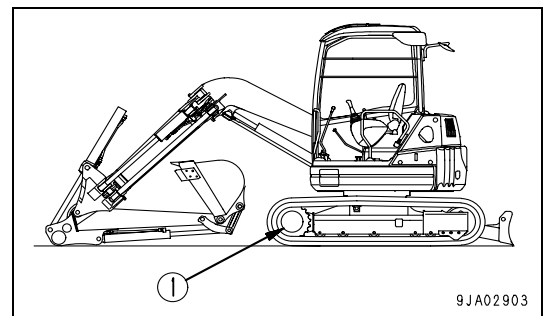

6. Stop the engine, check that there is nothing around the operator's compartment, then get off the machine.
For cab specification machines, close the cab door and front glass securely.
7. Run a cable between the 1st and 2nd track rollers at the machine front and between the sprocket and the track roller at the rear.

NOTICE

Do not attempt to lift up the machine by hanging a cable to the bracket that is provided for fastening the machine in transportation. Such a practice will damage the machine.

8. Hook the cable to a sling.
9. Set the lifting angle of the cable to 30° to 40° , then lift the machine slowly.
10. After the machine comes off the ground, check carefully that the machine is balanced, then lift slowly.

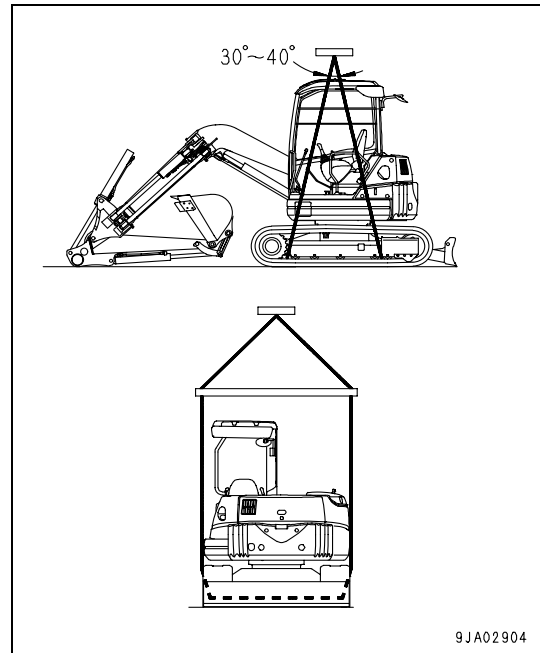

COLD WEATHER OPERATION

COLD WEATHER OPERATION INFORMATION

If the temperature becomes low, it becomes difficult to start the engine, and the coolant may freeze, so do as follows.

Fuel And Lubricants

Change to fuel and oil with low viscosity for all components. For details of the specified viscosity, see "LUBRICANTS, FUEL AND COOLANT SPECIFICATIONS (4-8)".

Cooling System Coolant

WARNING

- Antifreeze is toxic. Be careful not to get it into your eyes or on your skin. If it should get into your eyes or on your skin, wash it off with large quantities of fresh water and see a doctor at once.
- Antifreeze is toxic. Be extremely careful when handling it. When replacing coolant containing antifreeze or when handling coolant when repairing the radiator, contact your Komatsu distributor or ask your local antifreeze dealer. Be careful not to let the water flow into drainage ditches or spray on to the ground surface.
- Antifreeze is flammable, so do not bring any flame close. Do not smoke when handling antifreeze.

NOTICE

- Never use methanol, ethanol, or propanol-based antifreeze.
- Never use any water-leakage prevention agent or any antifreeze containing such an agent.
- Do not mix different types of antifreeze.

For details of the antifreeze mixture when changing the coolant, see "Cooling System Coolant - Clean/Change (4-21)".

Use a Permanent Antifreeze (ethylene glycol mixed with corrosion inhibitor, antifoam agent, etc.) meeting the standard requirements as shown below. With permanent antifreeze, no change of coolant is required for a year. If it is doubtful that an available antifreeze meets the standard requirements, ask the supplier of that antifreeze for information.

Standard requirements for permanent antifreeze

- SAE J1034
- FEDERAL STANDARD O-A-548D

REMARK

In areas where permanent antifreeze is not available, it is possible to use antifreeze whose main component is ethylene glycol and does not contain any corrosion inhibitor. (Such antifreeze can be used for the winter season only.) However, in such a case, the cooling water must be changed twice a year (spring and fall), so use permanent antifreeze as far as possible.

Battery

WARNING

- The battery generates flammable gas, so do not bring fire or sparks near the battery.
- Battery electrolyte is dangerous. If it gets in your eyes or on your skin, wash it off with large amounts of water, and consult a doctor.
- Battery electrolyte dissolves paint. If it gets on to the bodywork, wash it off immediately with water.
- If the battery electrolyte is frozen, do not charge the battery or start the engine with a different power source. There is danger that the battery may explode.

When the ambient temperature drops, the capacity of the battery will also drop. If the battery charge ratio is low, the battery electrolyte may freeze. Maintain the battery charge as close as possible to 100%, and insulate it against cold temperature so that the machine can be started easily the next morning.

REMARK

Measure the specific gravity and calculate the rate of charge from the following conversion table.

| Temperature (°C) \ Charging Rate (%) | 20 | 0 | -10 | -20 |
|--------------------------------------|------|------|------|------|
| 100 | 1.28 | 1.29 | 1.30 | 1.31 |
| 90 | 1.26 | 1.27 | 1.28 | 1.29 |
| 80 | 1.24 | 1.25 | 1.26 | 1.27 |
| 75 | 1.23 | 1.24 | 1.25 | 1.26 |

- As the battery capacity drops markedly in low temperatures, cover the battery or remove it from the machine, keep it in a warm place, and install it again the next morning.
- If the electrolyte level is low, add distilled water in the morning before beginning work. Do not add the water after the day's work so as to prevent fluid in the battery from freezing in the night.

CAB HEATER IN COLD WEATHER

(Machine equipped with cab)

If the ambient temperature drops, use the operator's cab heater.

When using the heater, turn valve (1) on the water manifold counterclockwise to open it.

When leaving the heater unused for a long time, turn valve (1) clockwise to close it.

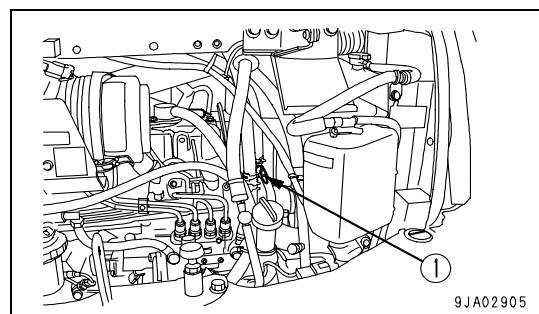

AFTER DAILY WORK COMPLETION**⚠ WARNING**

- Performing idle-running of the tracks is dangerous, so stay well away from the tracks.
- After completion of operations, fill the fuel tank to prevent the formation of water caused by condensation of moisture in the empty space in the tank when the temperature goes down.

To prevent mud, water, or the undercarriage from freezing and making it impossible for the machine to move on the following morning, always observe the following precautions.

- Mud and water on the machine body should be completely removed. This is to prevent damage to the seal caused by mud or dirt getting inside the seal with frozen drops of water.
- Park the machine on hard, dry ground.

If this is impossible, park the machine on wooden boards.

The boards help protect the tracks from being frozen in soil and the machine can start next morning.

- Open the drain valve and drain any water collected in the fuel system to prevent it from freezing.
 - After operation in water or mud, remove water from undercarriage as described below to extend undercarriage service life.
1. Swing 90° with engine at low idling and bring the work equipment to the side of the track.
 2. Jack up the machine until the track is raised slightly from the ground. Rotate the track under no load. Repeat this procedure on both the left and right sides.

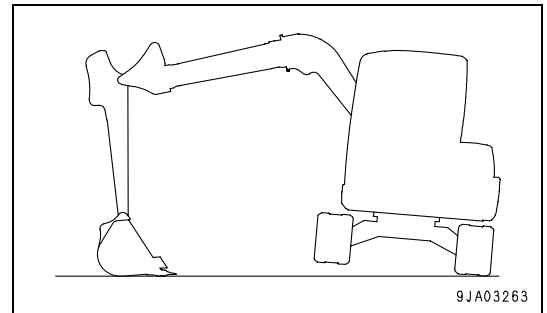
**AFTER COLD WEATHER SEASON**

When season changes and the weather becomes warmer, do as follows.

- Replace the fuel and oil for all parts with oil of the viscosity specified.
For details, see "LUBRICANTS, FUEL AND COOLANT SPECIFICATIONS (4-8)".
- If for any reason permanent antifreeze cannot be used, and an ethyl glycol base antifreeze (winter, one season type) is used instead, or if no antifreeze is used, drain the cooling system completely, then clean out the inside of the cooling system thoroughly, and fill with fresh soft water.

LONG TERM STORAGE

BEFORE STORAGE

NOTICE

To protect the cylinder piston rod when the machine is not being used, set the work equipment in the posture shown in the diagram.

(This prevents rusting of the cylinder rod.)

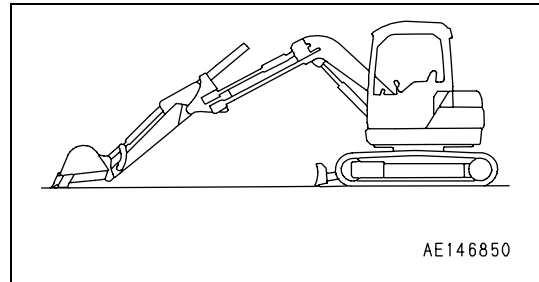

When putting the machine in storage for a long time, do as follows.

- Clean and wash all parts, then store the machine indoors. If the machine has to be stored outdoors, select level ground and cover the machine with a sheet.
- Completely fill the fuel tank, lubricate and change the oil before storage.
- Apply a thin coat of grease to the metal surface of the hydraulic piston rods.
- Disconnect the negative terminals of the battery and cover it or remove it from the machine and store it separately.
- Komatsu genuine Super Coolant (AF-ACL) is added to the cooling water, so there is no need to change the density for temperatures above -10°C (14°F).
If the temperature goes below -10°C (14°F), adjust the density. For details, see "Cooling System Coolant - Clean/Change (4-21)".
- Lock each control lever and pedal with the lock lever and pedal lock.
- Set the stop valve to the "lock" position on machines ready for attachments. Install the blind plugs to the elbows.
- Set the selector valve on the machines which can install attachments to the "Crusher or general attachment" position.

DURING STORAGE

WARNING

If it is unavoidably necessary to carry out the rust-preventive operation while the machine is indoors, open the doors and windows to improve ventilation and prevent gas poisoning.

Operate the engine and move the machine for a short distance once a month so that a new film of oil will be coated over movable parts and component surfaces. At the same time, also charge the battery.

- For machines equipped with an air conditioner, run the air conditioner.
- Rotate the tracks.

AFTER STORAGE

NOTICE

If the machine is to be used when the monthly rust prevention operation has not been carried out, please contact your Komatsu distributor.

When using the machine after long-term storage, do as follows before using it.

- Wipe off the grease from the hydraulic cylinder rods.
- Add oil and grease to all places.
- When a machine is stored for a long period, moisture in the air will get into the oil. Check the oil before and after starting the engine. If there is water in the oil, change the oil.
- A plastic fuel tank is used, so never use trichloroethylene when washing it. Washing in trichloroethylene will reduce the strength of the fuel tank.

TROUBLES AND ACTIONS

RUNNING OUT OF FUEL

When starting after running out of fuel, fill with fuel and bleed the air from the fuel system before starting.
For details of bleeding the air, see "Air Bleeding (4-51)".

PHENOMENA THAT ARE NOT FAILURES

Note that the following phenomena are not failures:

- When the arm control lever is operated to the IN position and the work equipment is lowered under no load from a high position, the arm speed will drop momentarily when the arm is more or less at the vertical position.
- When the bucket control lever is operated to the CURL position and the work equipment is lowered under no load from a high position, the bucket speed will drop momentarily when the bucket teeth are more or less at the horizontal position.
- When starting or stopping the swing, noise will be emitted from the brake valve.
- When going down a steep slope at low speed, a noise will be emitted from the travel motor brake valve.

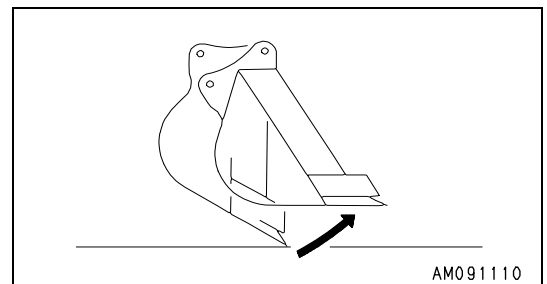
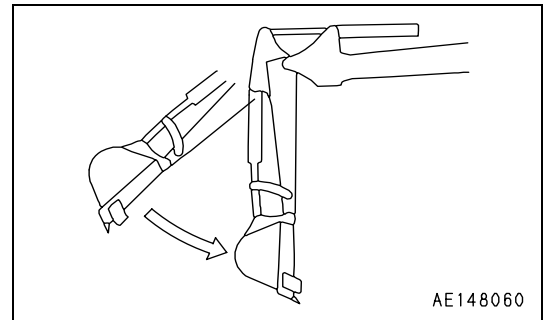

Phenomena That Are Not Failures On The electronic Control System

- After automatic stop, even when the work equipment has been moved 5 - 10 cm (2 - 4 in) to the front or right, it is impossible to raise the boom, pull the arm in, or operate the left offset.

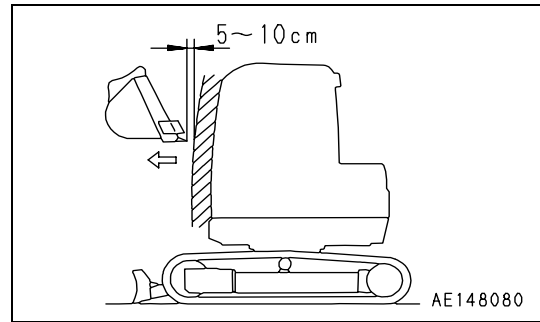

- After automatic stop, when the work equipment has been moved 50 cm (19.7 in) to the front, the speed of the work equipment is slow when the boom is raised or the arm is pulled in.
(If the engine is running at low idle, it may even be impossible to raise the boom or pull the arm in.)

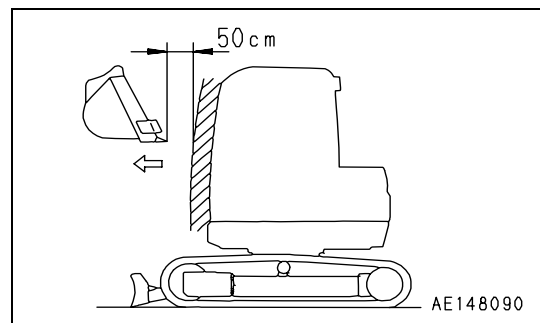

- After automatic stop when the boom is offset to the left, if the work equipment is moved to the front to escape from the condition, and is then returned to the original position, it automatically stops on the way. (If it is offset 5 cm (2 in) to the right, it can be returned to the original posture.)

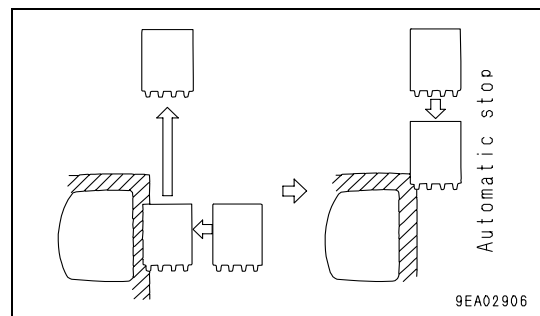

- After automatic stop, when the cancel switch is turned on and the work equipment is moved closer to the operator's compartment, the controller carries out self diagnosis and it becomes impossible to operate the swing or any of the work equipment. (Error code 61 is displayed. For details, see "Electronic Control System (3-105)".)

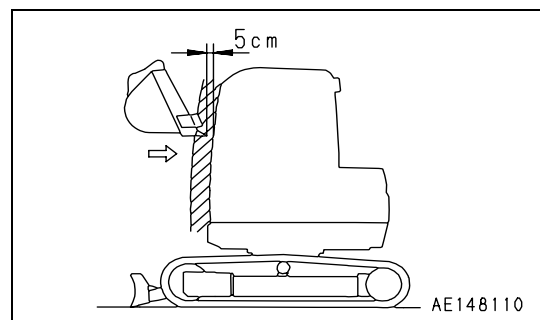

- When the work equipment angle sensor has been removed and installed again, the automatic stop position will change.

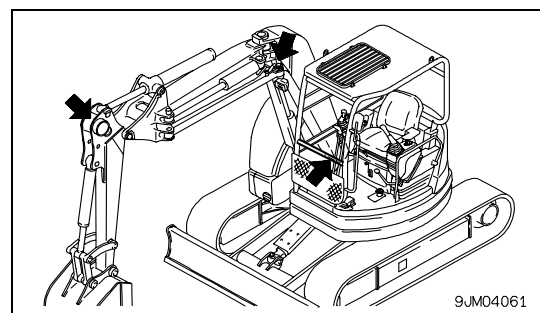

- When the cutting edge of the bucket is lowered to the ground surface, the depth display does not become 0.0 m (0.0 in).

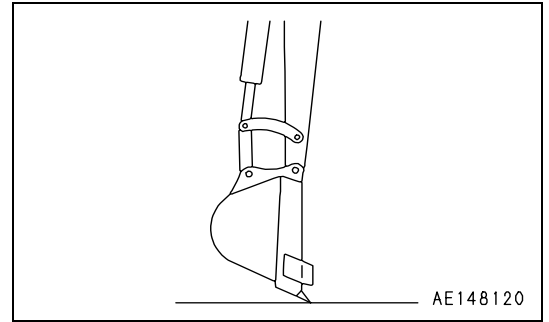

- The depth display changes according to the position of the bucket.

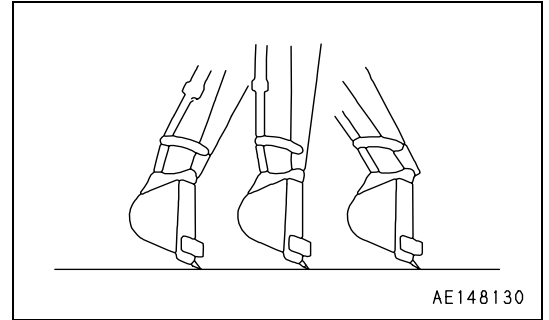

- The boom stops before the point set for the depth mode. (This happens particularly when the boom is lowered slowly.)
- In cold weather, the stop position changes when the interference prevention device and automatic control device are actuated. (This returns to normal when the hydraulic oil is warmed up.)

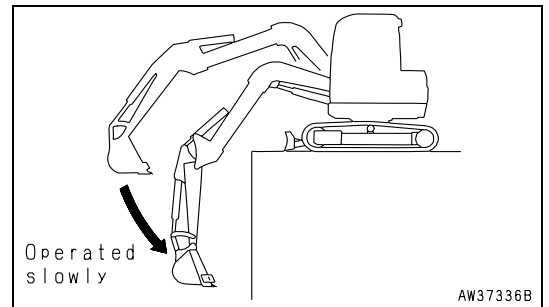

TOWING THE MACHINE

⚠ WARNING

- When towing the machine, use a wire rope that has ample strength for the weight of the machine that is being towed.
- Do not apply a sudden load to the wire rope.

If the machine sinks in mud and cannot get out under its own power, or if the drawbar pull of the excavator is being used to tow a heavy object, use a wire rope as shown in the diagram on the right.

Places pieces of wood between the wire ropes and the body to prevent the wire ropes from damaging the body.

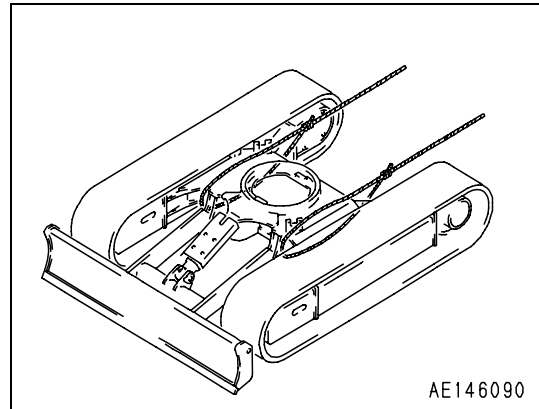

SEVERE JOB CONDITION

⚠ WARNING

Never carry out any operation where the sensor goes under water.

If the sensor should go under water, check the actuation of the automatic stop.

If there is any abnormality, please contact your Komatsu distributor for repairs.

- When digging in water, if the water gets on to the work equipment mounting pins, add grease to bucket links (A), (B), (C), (D) and (E) for each operation.
- When carrying out heavy duty digging and deep digging operations, add grease to bucket links (A), (B), (C), (D) and (E) (total: 5 points) before each operation. After greasing, operate the bucket several times, then add grease again.

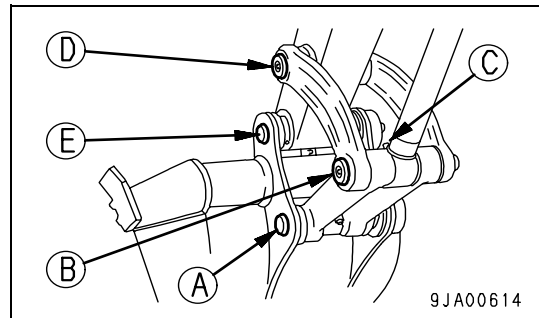

DISCHARGED BATTERY

⚠ WARNING

- When checking or handling the battery, stop the engine and turn the starting switch key to the OFF position.
- The battery generates hydrogen gas, so there is a hazard of explosion. Do not bring lighted cigarettes near the battery, or do anything that will cause sparks.
- Battery electrolyte is dilute sulfuric acid, and it will attack your clothes and skin. If it gets on your clothes or on your skin, wash it immediately off with large amounts of water. If it gets in your eyes, wash it out with fresh water, and consult a doctor.
- When handling batteries, always wear protective goggles and rubber gloves.
- When removing the battery, first disconnect the cable from the ground (normally the negative (-) terminal). When installing, install the positive (+) terminal first.
- If a tool touches the positive terminal and the chassis, there is danger that it will cause a spark, so be extremely careful.
- If the terminals are loose, there is danger that the defective contact may generate sparks that will cause an explosion.
- When removing or installing the terminals, check which is the positive (+) terminal and which is the negative (-) terminal.
- Green rust around the terminals is a cause of self-discharge of the battery. Polish the terminals with sandpaper. After removing the rust, coat the terminals thinly with grease before installing.

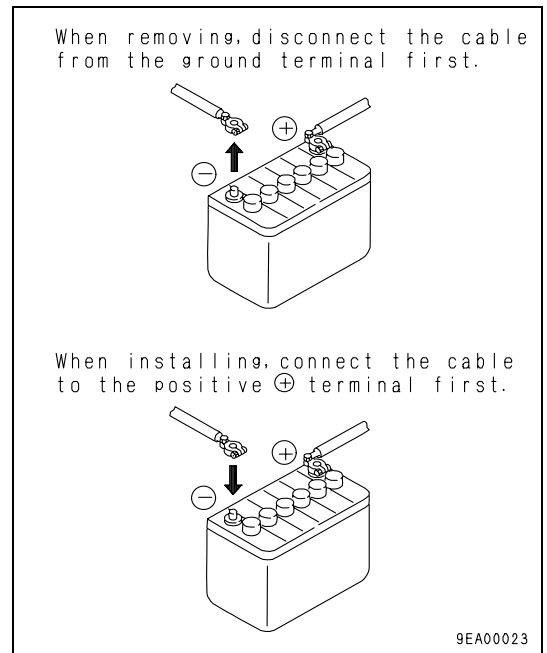
**Battery Removal And Installation****NOTICE**

After securing the battery, check that it does not move. If it moves, tighten it again securely.

- Before removing the battery, remove the ground cable (normally connected to the negative(-) terminal).
If any tool touches between the positive terminal and the chassis, there is a hazard of sparks being generated.
- When installing the battery, connected the ground cable last.
- When replacing the battery, fasten the battery securely with battery clamp (1).
Tightening torque for mounting bolt (2):
4.90 to 5.88 N·m (0.5 to 0.6 kgf·m, 3.6 to 4.3 lbft)

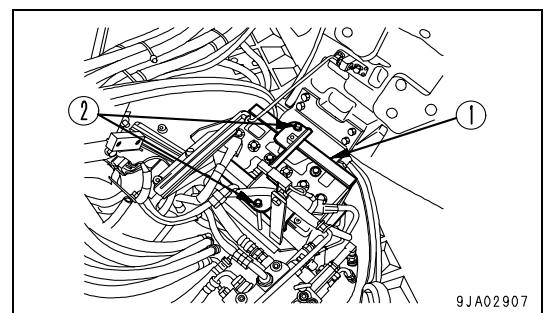

Battery Charges

When charging the battery, if the battery is not handled correctly, there is a hazard that the battery may explode. Always follow the instructions of "DISCHARGED BATTERY (3-99)" and the instruction manual accompanying the charger, and do as follows.

- Set the voltage of the charger to match the voltage of the battery to be charged. If the voltage is not selected correctly, the charger may overheat and cause an explosion.
- Connect the positive (+) charger clip of the charger to the positive (+) terminal of the battery, then connect the negative (-) charger clip of the charger to the negative (-) terminal of the battery. Be sure to fix the clips securely.
- Set the charging current to 1/10 of the value of the rated battery capacity; when carrying out rapid charging, set it to less than the rated battery capacity.
If the charger current is too high, the electrolyte will leak or dry up, and this may cause the battery to catch fire and explode.
- If the battery electrolyte is frozen, do not charge the battery or start the engine with a different power source. There is a hazard that this will ignite the battery electrolyte and cause the battery to explode.
- Do not use or charge the battery if the battery electrolyte level is below the LOWER LEVEL line. This may cause an explosion. Always check the battery electrolyte level periodically and add distilled water to bring the electrolyte level to the UPPER LEVEL line.

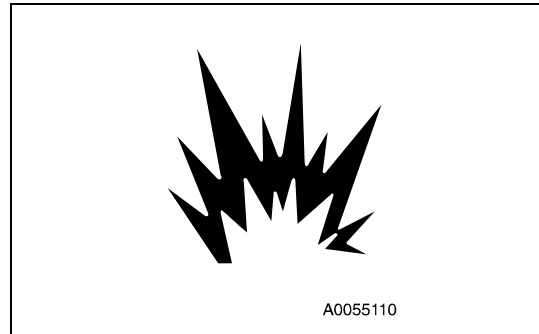

Starting Engine With Booster Cables

When starting the engine with a booster cable, do as follows:

Connecting and Disconnecting Booster Cables

⚠ WARNING

- When connecting the cables, never contact the positive (+) and negative (-) terminals.
- When starting the engine with a booster cable, always wear safety glasses.
- Be careful not to let the normal machine and problem machine contact each other. This prevents sparks from generating near the battery which could ignite the hydrogen gas given off by the battery. If hydrogen gas explodes, it could cause serious injury.
- Make sure you do not make a mistake in connecting the booster cables. Make the final connection to the frame, be aware that sparks might be generated when this is done, so connect to a place as far as possible from the battery. (However, avoid connecting the cable to the work equipment, as conduction is poor.)
- Use care when removing the cables from the machine that has been started. To avoid hydrogen explosion, do not allow the cable ends to contact each other or the machine.

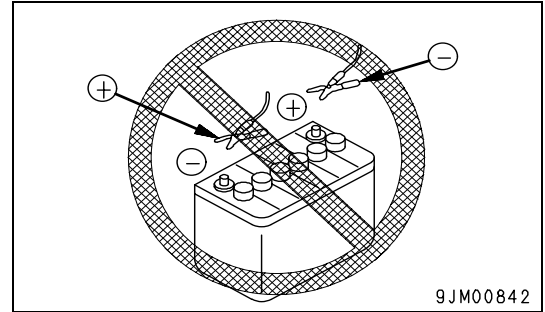

NOTICE

- The size of the booster cable and clip should be suitable for the battery size.
- Use the same capacity battery for both the normal machine and the problem machine.
- The starting system for this machine uses 12V. For the normal machine, select a machine which also uses 12V.
- Make sure that the cables and clips are firmly connected.
- Connect securely with the clips.
- Check that the safety lock levers and parking brake levers of both machines are in the LOCK position.
- Check that each lever is in the NEUTRAL position.

Booster Cable Connection

Keep the starting switch of the normal machine and problem machine are both at the OFF position.

Connect the booster cable as follows, in the order of the numbers marked in the diagram.

1. Connect one clip of booster cable (A) to the positive (+) terminal of the problem machine.
2. Connect the other clip of booster cable (A) to the positive (+) terminal of the normal machine.
3. Connect one clip of booster cable (B) to the negative (-) terminal of the normal machine.
4. Connect the other clip of booster cable (B) to the engine block of the problem machine.

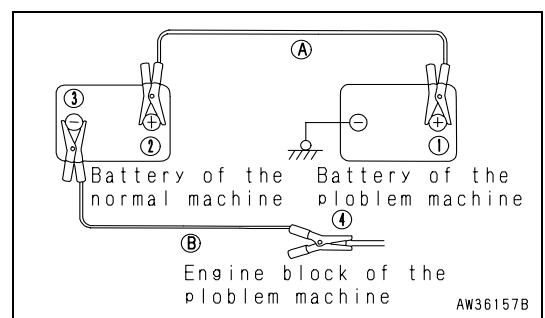

Starting the Engine

 **CAUTION**

Always check that the safety lock lever is set to the LOCK position, regardless of whether the machine is working normally or has failed. Check also that all the control levers are at the HOLD or neutral position.

1. Make sure the clips are firmly connected to the battery terminals.
2. Start the engine of the normal machine and keep it to run at high idling speed.
3. Turn the starting switch of the problem machine to the START position and start the engine.
If the engine doesn't start at first, try again after 30 seconds or so.

Booster Cable Disconnection

After the engine has started, disconnect the booster cables in the reverse of the order in which they were connected.

1. Remove one clip of booster cable (B) from the engine block of the problem machine.
2. Remove the other clip of booster cable (B) from the negative (-) terminal of the normal machine.
3. Remove one clip of booster cable (A) from the positive (+) terminal of the normal machine.
4. Remove the other clip of booster cable (A) from the positive (+) terminal of the problem machine.

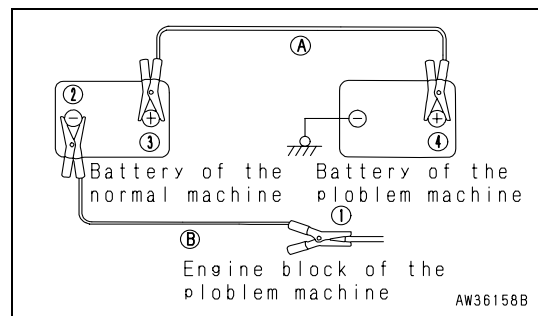

OTHER TROUBLE

Electrical System

- (): Always contact your Komatsu distributor when dealing with these items.
- In cases of abnormalities or causes which are not listed below, please contact your Komatsu distributor for repairs.

| Problem | Main causes | Remedy |
|--|---|--|
| Lamp dose not glow brightly even when the engine runs at high speed | • Defective wirinG | (• Check, repair loose terminals, disconnections) |
| Lamp flickers while engine is running | • Defective adjustment of fan belt tension • Blown fuse | • Adjust fan belt tension For details, see EVERY 250 HOURS SERVIC • Replace |
| Charge level monitor dose not go out even when engine is running | • Defective alternator • Defective wiring | (• Replace) (• Check, repair) |
| Abnormal noise is generated from alternator | • Defective alternator | (• Replace) |
| Starting motor dose not turn when starting switch is turned to ON | • Defective wiring • Insufficient battery charge • Blown fuse | (• Check, repair) • Charge • Replace |
| Starting motor pinion repeatedly moves in and out (makes rattling sound) | • Insufficient battery charge | • Charge |
| Starting motor turns engine sluggishly | • Insufficient battery charge • Defective starting motor | • Charge (• Replace) |
| Starting motor disengages before engine starts | • Defective wiring • Insufficient battery charge | (• Check, repair) • Charge |
| Pre-heating monitor dose not lights | • Defective wiring • Defective monitor | (• Check, repair) (• Replace) |
| Oil pressure monitor dose not light up when engine is stopped (starting switch at ON position) | • Defective monitor • Defective oil pressure switch | (• Replace) (• Replace) |

Chassis

- In cases of abnormalities or causes which are not listed below, please contact your Komatsu distributor for repairs.

| Problem | Main causes | Remedy |
|---|--|---|
| Speed of travel, swing, boom, arm, bucket is slow | • Lack of hydraulic oil | • Add oil to specified level, see CHECK BEFORE STARTING |
| Pump generates abnormal noise | • Clogged element in hydraulic tank strainer | • Clean, see EVERY 2000 HOURS SERVICE |
| Excessive rise in hydraulic oil temperature | • Lack of hydraulic oil • Loose fan belt | • Add oil to specified level, see CHECK BEFORE STARTING • Adjust fan belt tension, EVERY 250 HOURS SERVICE |
| Track comes off | • Track too loose | • Adjust track tension, see WHEN REQUIRED |
| Abnormal wear of sprocket | | |

Engine

- (): Always contact your Komatsu distributor when dealing with these items.
- In cases of abnormalities or causes which are not listed below, please contact your Komatsu distributor for repairs.

| Problem | Main causes | Remedy |
|---|---|---|
| Engine oil pressure monitor lights up | <ul style="list-style-type: none"> Oil level low in oil pan (sucking air in) Clogged oil filter cartridge Defective tightening of oil pipe, pipe joint, oil leakage from damaged point Defective engine oil pressure sensor | <ul style="list-style-type: none"> Add oil to specified level, see CHECK BEFORE STARTING Replace cartridge, see EVERY 500 HOURS SERVICE (• Check, repair) (• Replace sensor) |
| Steam spurts out from top of radiator (pressure valve) | <ul style="list-style-type: none"> Cooling water level low, leakage of water Loose fan belt Dirt or scale accumulated in cooling system Clogged radiator fins or damaged fins Defective thermostat Loose radiator filler cap (high altitude operations) Defective water level sensor | <ul style="list-style-type: none"> Check, add water, repair, see CHECK BEFORE STARTING Adjust fan belt tension, see EVERY 250 HOURS SERVICE Change coolant, flush inside of cooling system, see WHEN REQUIRED Clean or repair, see EVERY 500 HOURS SERVICE (• Replace thermostat) Tightening cap or replace packing (• Replace sensor) |
| Red range of engine water temperature gauge lights up | <ul style="list-style-type: none"> Clogged radiator fins or damaged fins Defective thermostat Loose radiator filler cap (high altitude operations) Defective water level sensor | <ul style="list-style-type: none"> Clean or repair, see EVERY 500 HOURS SERVICE (• Replace thermostat) Tightening cap or replace packing (• Replace sensor) |
| White range of engine water temperature gauge is lights up even after operating for long time | <ul style="list-style-type: none"> Defective thermostat | <ul style="list-style-type: none"> (• Replace thermostat) |
| Engine dose not start when starting motor is turned | <ul style="list-style-type: none"> Lack of fuel Air in fuel system Water in fuel system Defective fuel injection pump or defective nozzle Starting motor cranks engine sluggishly Preheating monitor dose not light up Defective compression Defective valve clearance | <ul style="list-style-type: none"> Add fuel, see CHECK BEFORE STARTING Repair place where air is sucked in, see EVERY 500 HOURS SERVICE Drain water. For details, see WHEN REQUIRED and CHECK BEFORE STARTING (• Replace pump or nozzle) See ELECTRICAL SYSTEM See ELECTRICAL SYSTEM (• Adjust valve clearance) |
| Exhaust gas is while or blue | <ul style="list-style-type: none"> Too mach oil in oil pan Improper fuel | <ul style="list-style-type: none"> Set oil to specified level, see CHECK BEFORE STARTING Change to specified fuel |
| Exhaust gas sometimes becomes black | <ul style="list-style-type: none"> Clogged air cleaner element Defective nozzle Defective compression | <ul style="list-style-type: none"> Clean or replace, see WHEN REQUIRED (• Replace nozzle) (• See "Defective compression") |
| Combustion noise occasionally make breathing sound | <ul style="list-style-type: none"> Defective nozzle | <ul style="list-style-type: none"> (• Replace nozzle) |
| Abnormal noise generated (combustion or mechanical) | <ul style="list-style-type: none"> Low grade fuel being used Overheating Damage inside muffler Excessive valve clearance | <ul style="list-style-type: none"> Change to specified fuel See "Red range of engine water temperature gauge lights up" Replace muffler (• Adjust valve clearance) |

Electronic Control System

If any error code is displayed on the depth display portion (1) of the monitor panel, follow the procedure given in the table below for the action to take after self diagnosis.

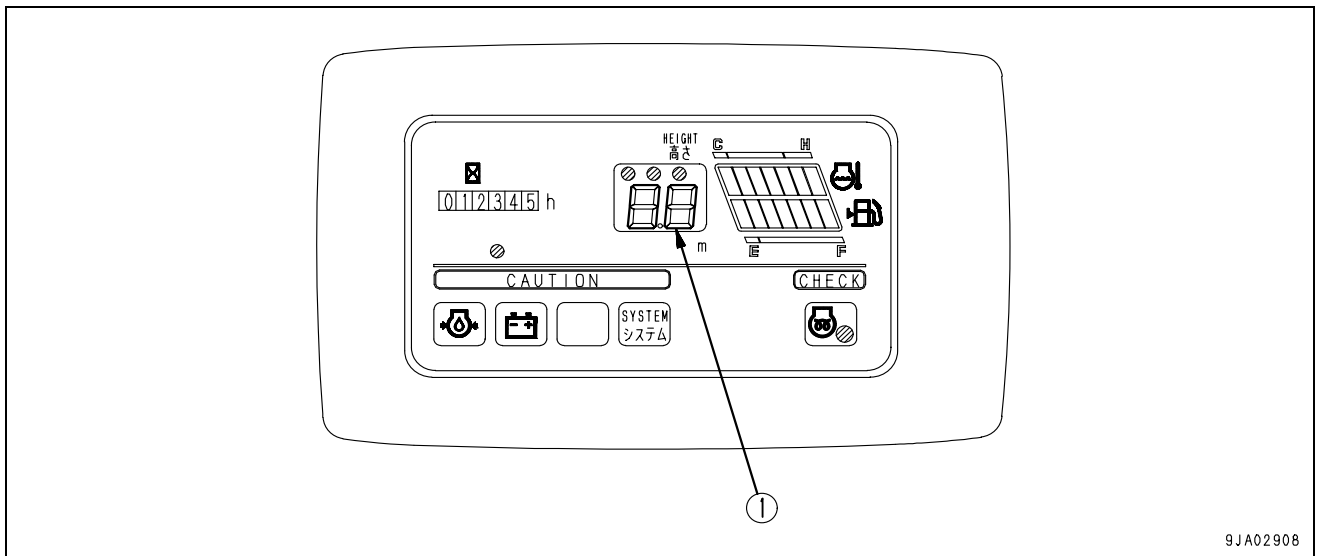

9JA02908

Machine Monitoring System

| Error code | Machine condition | Probable causes | Action |
|--|--|---|---|
| 21 | Automatic stop distance is too far | Abnormality in model selector signal | Operation can still be carried out, but have the machine checked immediately |
| 22 | Automatic stop distance is too far | Abnormality in work equipment selector signal | |
| 31 | Boom RAISE, arm IN, offset left cannot be carried out | Abnormality in boom angle sensor | Use the emergency work equipment actuation switch to move the machine to a safe place, then have the machine checked immediately. |
| 32 | Boom RAISE, arm IN, offset left cannot be carried out | Abnormality in arm angle sensor | |
| 34 | Boom RAISE, arm IN, offset left cannot be carried out | Abnormality in offset angle sensor | |
| 41 | Impossible to carry out any operation of work equipment, impossible to operate swing | Abnormality in basic pressure lock solenoid valve | Use the emergency work equipment actuation switch to move the machine to a safe place, then have the machine checked immediately. Depending on location of failure, it may be impossible to carry out operations even when the emergency work equipment actuation switch is turned ON, so in such cases, have the machine checked immediately. |
| 42 | Boom RAISE, arm IN, offset left cannot be carried out | Abnormality in offset solenoid valve | |
| 44 | Boom RAISE, arm IN, offset left cannot be carried out | Abnormality in boom LOWER solenoid valve | |
| 51 | Boom RAISE, arm IN, offset left cannot be carried out | Abnormality in boom RAISE solenoid valve | |
| 52 | Boom RAISE, arm IN, offset left cannot be carried out | Abnormality in arm IN solenoid valve | |
| 61 | Impossible to carry out any operation of work equipment, impossible to operate swing | Abnormality in automatic stop position | If the emergency work equipment actuation switch is used to move bucket to the front or to the right, the self diagnosis is canceled and it becomes possible to operate the machine again, but have the machine checked immediately. |
| No error code is displayed, but it is impossible to carry out any work equipment operation or swing operation. | | | Have the machine checked immediately. |

MAINTENANCE

 **WARNING**

Please read and make sure that you understand the SAFETY section before reading this section.

MAINTENANCE INFORMATION

Do not carry out any inspection and maintenance operation that is not found in this manual.

Service Meter Reading

Check the service meter reading every day to see if the time has come for any necessary maintenance to be carried out.

Komatsu Genuine Replacement Parts

Use Komatsu genuine parts specified in the Parts Book as replacement parts.

Komatsu Genuine Lubricants

Use Komatsu genuine oils and grease. Choose oils and grease with proper viscosities specified for ambient temperature.

Windshield Washer Fluid

Use automobile window washer fluid, and be careful not to let any dirt get into it.

Fresh and Clean Lubricants

Use clean oil and grease. Also, keep the containers of the oil and grease clean. Keep foreign materials away from oil and grease.

Check Drained Oil and Used Filter

After oil is changed or filters are replaced, check the old oil and filters for metal particles and foreign materials. If large quantities of metal particles or foreign materials are found, always report to the person in charge, and carry out suitable action.

Fuel Strainer

Do not remove the strainer from the filler port when adding fuel.

Welding Instructions

- Turn off the engine starting switch.
- Do not apply more than 200V continuously.
- Connect grounding cable within 1m (3.3 ft) from the area to be welded. If grounding cable is connected near instruments, connectors, etc., the instruments may have troubles.
- Avoid seals or bearings from being between the area to be welded and the position of grounding point.
- Do not use the area around the work equipment pins or the hydraulic cylinders as the grounding point.

Do Not Drop Things Inside Machine

- When opening inspection windows or the oil filler port of the tank to carry out inspection, be careful not to drop nuts, bolts, or tools inside the machine.
If such things are dropped inside the machine, it will cause damage and malfunction of the machine, and will lead to failure. If you drop anything inside the machine, always remove it immediately.
- Do not put unnecessary things in your pockets. Carry only things which are necessary for inspection.

Dusty Jobsite

When working at dusty worksites, do as follows:

- Inspect the dust indicator frequently to see if the air cleaner is dirty or clogged.
- Clean the radiator core frequently to avoid clogging.
- Clean and replace the fuel filter frequently.
- Clean electrical components, especially the starting motor and alternator, to avoid accumulation of dust.
- When inspecting or changing the oil, move the machine to a place that is free of dust to prevent dirt from getting into the oil.

Avoid Mixing Lubricants

Never mix different kinds of oil. If a different type of oil has to be added, drain the old oil and replace all the oil with the new type of oil.

Locking the Inspection Covers

Lock inspection cover in position securely with a lock bar. If inspection or maintenance is carried out with the inspection cover open and not locked in position, there is a hazard that it may be suddenly blown shut by the wind and cause injury to the worker.

Hydraulic System - Air Bleeding

When hydraulic equipment has been repaired or replaced, or the hydraulic piping has been removed and installed again, the air must be bled from the circuit. For details, see "Hydraulic System - Bleed Air (4-40)".

Hydraulic Hose Installation

- When removing parts at locations where there are O-rings or gasket seals, clean the mounting surface, and replace with new parts.
When doing this, be careful not to forget to assemble the O-rings and gaskets.
- When installing the hoses, do not twist them or bend them into loops with a small radius.
This will cause damage to the hose and markedly reduce its service life.

Checks After Inspection and Maintenance Works

If you forget to carry out the checks after inspection and maintenance, unexpected problems may occur, and this may lead to serious injury or property damage. Always do as follows.

- Checks after operation (with engine stopped)
 - Have any inspection and maintenance points been forgotten?
 - Have all inspection and maintenance items been carried out correctly?
 - Have any tools or parts been dropped inside the machine? It is particularly dangerous if parts are dropped inside machine and get caught in the lever linkage mechanism.
 - Is there any leakage of water or oil? Have all the bolts been tightened?
- Checks when operating engine
 - For details of the checks when operating the engine, see "Two Workers for Maintenance when Engine is Running (2-34)" and pay careful attention to safety.
 - Are the inspection and maintenance items working properly?
 - Is there any leakage of oil when the engine speed is raised and load is applied to the oil pressure?

LUBRICANTS, COOLANT AND FILTERS

HANDLING OIL, FUEL, COOLANT, AND PERFORMING OIL CLINIC

Oil

- Oil is used in the engine and work equipment under extremely severe conditions (high temperature, high pressure), and is deteriorates with use.
Always use oil that matches the grade and temperature for use given in the Operation and Maintenance Manual.
Even if the oil is not dirty, always change the oil after the specified interval.
- Oil corresponds to blood in the human body, so always be careful when handling it to prevent any impurities (water, metal particles, dirt, etc.) from getting in.
The majority of problems with machine are caused by the entry of such impurities.
Take particular care not to let any impurities get in when storing or adding oil.
- Never mix oils of different grades or brands.
- Always add the specified amount of oil.
Having too much oil or too little oil are both causes of problems.
- If the oil in the work equipment is not clear, there is probably water or air getting into the circuit. In such cases, please contact your Komatsu distributor.
- When changing the oil, always replace the related filters at the same time.
- We recommend you have an analysis made of the oil periodically to check the condition of the machine. For those who wish to use this service, please contact your Komatsu distributor.

Fuel

- The fuel pump is a precision instrument, and if fuel containing water or dirt is used, it cannot work properly.
- Be extremely careful not to let impurities get in when storing or adding fuel.
- Always use the fuel specified in the Operation and Maintenance Manual.
Fuel may congeal depending on the temperature when it is used (particularly in low temperatures below -15°C (5°F)). It is necessary to change to the fuel that is suitable for the temperature.
- To prevent the moisture in the air from condensing and forming water inside the fuel tank, always fill the fuel tank after completing the day's work.
- Before starting the engine, or when 10 minutes have passed after adding fuel, drain the sediment and water from the fuel tank.
- If the engine runs out of fuel, or if the filters have been replaced, it is necessary to bleed the air from the circuit.
- If there is any foreign material in the fuel tank, wash the tank and fuel system.

Cooling System Coolant

- River water contains large amounts of calcium and other impurities, so if it is used, scale will stick to the engine and radiator, and this will cause defective heat exchange and overheating.
Do not use water that is not suitable for drinking.
- When using anti-freeze, always observe the precautions given in the Operation and Maintenance Manual.
- Komatsu machines are supplied with Komatsu original anti-freeze in the coolant when the machine is shipped. This anti-freeze is effective in preventing corrosion of the cooling system.
The anti-freeze can be used continuously for two years or 4000 hours. Therefore, it can be used as it is even in hot areas.
- Anti-freeze is flammable, so be extremely careful not to expose it to flame or fire.
- The proportion of anti-freeze to water differs according to the ambient temperature.
For details of the mixing proportions, see "Cooling System Coolant - Clean/Change (4-21)".
- If the engine overheats, wait for the engine to cool before adding coolant.
- If the coolant level is low, it will cause overheating and will also cause problems with corrosion from the air in the coolant.

Grease

- Grease is used to prevent twisting and noise at the joints.
- The nipples not included in the MAINTENANCE section are nipples used when overhauling, so they do not need grease.

If any part becomes stiff or generates noise after being used for a long time, grease it.

- Always wipe off all of the old grease that is pushed out when greasing.
Be particularly careful to wipe off the old grease in places where sand or dirt sticking in the grease would cause wear of the rotating parts.

Carrying out KOWA (Komatsu Oil Wear Analysis)

KOWA (Komatsu Oil Wear Analysis) is a maintenance service that makes it possible to prevent machine failures and down-time. With KOWA, the oil is periodically sampled and analyzed. This enables early detection of wear of the machine drive parts and other abnormalities.

Periodic use of KOWA makes the following possible:

- It enables the accurate understanding of the machine condition by utilizing our long experience and accumulated data base.
- The report on the result of analysis and recommendation will be delivered to the customer soon at low cost (only the actual expenses will be charged). Use of this service is strongly recommended.

KOWA analysis items

- Analysis of metal wear particles.
This uses the latest ICP (Inductively Coupled Plasma) analyzer to measure the density of metal wear particles in the oil.

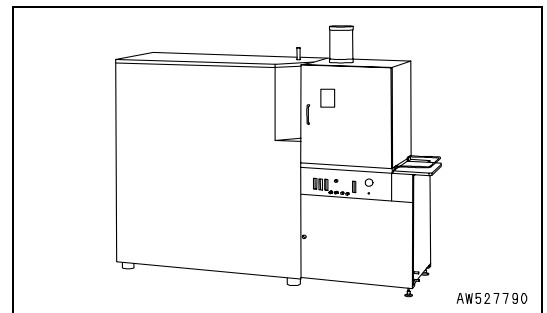

- This uses a PQI (Particle Quantifier Index) measurer to measure the quantity of large iron particles (larger than 5 microns) in the oil, which enables the early detection of defect.

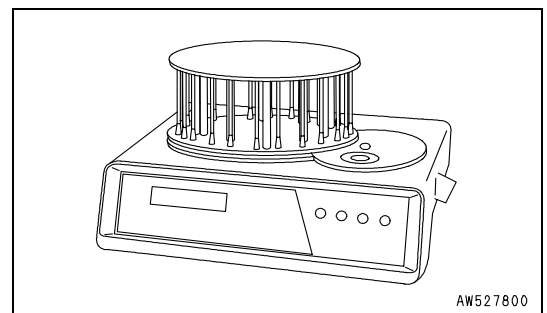

- Others
Measurements are made of items such as the ratio of water in oil or fuel in the oil, and the dynamic viscosity.

Oil sampling

- Sampling interval
250 hours: Engine
500 hours: Other components
- Precautions when sampling
 - Make sure that the oil is well mixed before sampling.
 - Carry out sampling regularly at fixed intervals.
 - Do not carry out sampling on rainy or windy days when water or dust can get into the oil.

For further details of KOWA, please contact your Komatsu distributor.

Oil And Fuel Storage

- Keep indoors to prevent any water, dirt, or other impurities from getting in.
- When keeping drum cans for a long period, put the drum on its side so that the filler port of the drum can is at the side. (To prevent moisture from being sucked in)
If drum cans have to be stored outside, cover them with a waterproof sheet or take other measures to protect them.
- To prevent any change in quality during long-term storage, be sure to use in the order of first in - first out (use the oldest oil or fuel first).

Filters

- Filters are extremely important safety parts. They prevent impurities in the fuel and air circuits from entering important equipment and causing problems.
Replace all filters periodically. For details, see the Operation and Maintenance Manual.
However, when working in severe conditions, replace the filters at shorter intervals according to the oil and fuel (sulfur content) being used.
- Never try to clean the filters (cartridge type) and use them again. Always replace with new filters.
- When replacing oil filters, check if any metal particles are affixed to the old filter. If any metal particles are found, please contact your Komatsu distributor.
- Do not open packs of spare filters until just before they are to be used.
- Always use Komatsu genuine filters.

ELECTRICAL SYSTEM MAINTENANCE

- It is extremely dangerous if the electrical equipment becomes wet or the covering of the wiring is damaged. This will cause electrical leakage and may lead to malfunction of the machine. Do not wash the inside of the operator's cab with water. When washing the machine, be careful not to let water get into the electrical components.
- Service relating to the electric system is check of fan belt tension, check of damage or wear in the fan belt and check of battery fluid level.
- Never install any electric components other than there specified by Komatsu.
- External electrical interference may cause malfunction of the control system controller, so before installing a radio receiver or other wireless equipment, please contact your Komatsu distributor.
- When working at the seashore, carefully clean the electric system to prevent corrosion.
- When installing electrical equipment, connect it to the special power source connector.
Do not connect the optional power source to the fuse, starting switch, or battery relay.

WEAR PARTS

Replace filter elements, bucket teeth, and other wear parts at the specified interval or before they reach the wear limit.

Replacing wear parts correctly ensures more economical use of the machine.

When replacing parts, always use high-quality Komatsu genuine parts.

When ordering parts, the parts differ according to the serial number of the machine, so please inform your Komatsu distributor of the machine serial number.

WEAR PARTS LIST

The parts in parentheses are to be replaced at the same time.

| Item | Part No. | Part name | Q'ty | Replacement frequency |
|--------------------------------|--|--|----------------------|-------------------------|
| Hydraulic oil filter | 07063-01054 (07000-02135) | Element (O-ring) | 1 (1) | Every 250 hours service |
| Engine oil filter | YM129150-35151 | Cartridge | 1 | Every 500 hours service |
| Fuel filter | YM129100-55650 (YM24311-000160) (YM24321-000650) | Element (O-ring) (O-ring) | 1 (1) (1) | Every 500 hours service |
| Air cleaner | YM119808-12520 | Element | 1 | - |
| Standard bucket (Vertical pin) | 20U-70-23340 (20U-70-23360) (20U-70-23350) | Tooth (Pin) (Lock) | 4 (4) (4) | - |
| | 20U-70-13241 20U-70-13251 (20U-70-13270) (203-32-51220) | Cutter (left) Cutter (right) (Bolt) (Nut) | 1 1 (8) (8) | - |
| Blade | 20T-71-81120 | Edge (welding) | 1 | - |

LUBRICANTS, FUEL AND COOLANT SPECIFICATIONS

PROPER SELECTION

| RESERVOIR | KIND OF FLUID | AMBIENT TEMPERATURE | | | | | | | | | |
|------------------|---------------|---------------------|-----------|-----------|---------|------------|----------------|----------|-----------|---------------|--|
| | | -22 -30 | -4 -20 | 14 -10 | 32 0 | 50 10 | 68 20 | 86 30 | 104 40 | 122°F 50°C | |
| Engine oil pan | Engine oil | | | | | | SAE 30 | | | | |
| | | | | | | SAE 10W | | | | | |
| | | | | | | SAE 10W-30 | | | | | |
| | | | | | | SAE 15W-40 | | | | | |
| Final drive case | | | | | | | SAE 30 | | | | |
| Hydraulic system | | | | | | | SAE 10W | | | | |
| | | | | | | | SAE 10W-30 | | | | |
| | | | | | | | SAE 15W-40 | | | | |
| Fuel tank | | Diesel fuel | | | | | ASTM D975 No.2 | | | | |
| | | | | | | | | | | | |
| Grease fitting | Grease | | | | | | | | | | |
| Cooling system | Water | | | | | | | | | | |

*1: ASTM D975 No. 1

| | | Engine oil pan | Final drive case (each) | Hydraulic system | Fuel tank | Cooling system |
|--------------------|--------|----------------|-------------------------|------------------|-----------|----------------|
| Specified capacity | Liter | 9.1 | 1.0 | 64 | 80 | 6.5 |
| | US gal | 2.40 | 0.26 | 16.91 | 21.14 | 1.27 |
| Refill capacity | Liter | 8.7 | 1.0 | 38 | - | - |
| | US gal | 2.30 | 0.26 | 10.04 | - | - |

REMARK

- When fuel sulfur content is less than 0.5%, change oil in the oil pan according to periodic maintenance hours described in this manual.
- Change oil according to the following table if fuel sulphur content is above 0.5%.
- When starting the engine with an atmospheric temperature of lower than 0°C (32°F), be sure to use engine oil of SAE10W, SAE10W-30 and SAE15W-40, even though the atmospheric temperature goes up to 10°C (50°F) more or less during the day.
- Use API classification CD as engine oil and if API classification CC is used, reduce the engine oil change interval to half.
- There is no problem if single grade oil is mixed with multigrade oil (SAE10W-30, 15W-40), but be sure to add single grade oil that matches the temperature range in the table.
- We recommend Komatsu genuine oil which has been specifically formulated and approved for use in engine and hydraulic work equipment applications.

Specified capacity: Total amount of oil including oil for components and oil in piping.

Refill capacity: Amount of oil needed to refill system during normal inspection and maintenance.

ASTM: American Society of Testing and Material

SAE: Society of Automotive Engineers

API: American Petroleum Institute

| Fuel sulfur content | Charge interval of oil in engine oil pan |
|---------------------|--|
| 0.5 to 1.0% | 1/2 of regular interval |
| Above 1.0% | 1/4 of regular interval |

| No. | Supplier | Engine Oil [CD or CE] SAE10W, 30, 40 10W30, 15W40 (The 15W40 oil marked * is CE.) | Gear Oil [GL-4 or GL-5] SAE80, 90, 140 | Grease [Lithium-Base] NLGI No.2 | Anti-freeze Coolant [Ethylene Glycol Base] Permanent Type |
|-----|----------|--|--|---|---|
| 1 | KOMATSU | EO10-CD EO30-CD EO10-30CD EO15-40CD | GO90 GO140 | G2-LI G2-LI-S | AF-ACL AF-PTL AF-PT (Winter, one season type) |
| 2 | AGIP | Diesel sigma S super diesel multigrade *Sigma turbo | Rotra MP | GR MU/EP | - |
| 3 | AMOCO | *Amoco 300 | Multi-purpose gear oil | PYKON premium grease | - |
| 4 | ARCO | *Arcofleet S3 plus | Arco HD gear oil | Litholine HEP 2 Arco EP moly D | - |
| 5 | BP | Vanellus C3 | Gear oil EP Hypogear EP | Energrease LS-EP2 | Antifreeze |
| 6 | CALTEX | *RPM delo 400 RPM delo 450 | Universal thuban Universal thuban EP | Marfak all purpose 2 Ultra-duty grease 2 | AF engine coolant |
| 7 | CASTROL | *Turbomax *RX super CRD | EP EPX Hypoy Hypoy B Hypoy C | MS3 Spheerol EPL2 | Anti-freeze |
| 8 | CHEVRON | *Delo 400 | Universal gear | Ultra-duty grease 2 | - |

| No. | Supplier | Engine Oil [CD or CE] SAE10W, 30, 40 10W30, 15W40 (The 15W40 oil marked * is CE.) | Gear Oil [GL-4 or GL-5] SAE80, 90, 140 | Grease [Lithium-Base] NLGI No.2 | Anti-freeze Coolant [Ethylene Glycol Base] Permanent Type |
|-----|-----------------|---|--|---|---|
| 9 | CONOCO | *Fleet motor oil | Universal gear lubricant | Super-sta grease | - |
| 10 | ELF | Multiperformance 3C Performance 3C | - | Tranself EP Tranself EP type 2 | Glacelf |
| 11 | EXXON (ESSO) | Essolube D3 *Essolube XD-3 *Essolube XD-3 Extra *Esso heavy duty Exxon heavy duty | Gear oil GP Gear oil GX | Beacon EP2 | All season coolant |
| 12 | GULF | Super duty motor oil *Super duty plus | Multi-purpose gear lubricant | Gulfcrown EP2 Gulfcrown EP special | Antifreeze and coolant |
| 13 | MOBIL | Delvac 1300 *Delvac super 10W-30, 15W-40 | Mobilube GX Mobilube HD | Mobilux EP2 Mobilgrease 77 Mobilgrease special | - |
| 14 | PENNZOIL | *Supreme duty fleet motor oil | Multi-purpose 4092 Multi-purpose 4140 | Multi-purpose white grease 705 707L White-bearing grease | Anti-freeze and summer coolant |
| 15 | PETROFINE | FINA kappa TD | FINA potonic N FINA potonic NE | FINA marson EPL2 | FINA tamidor |
| 16 | SHELL | Rimura X | Spirax EP Spirax heavy duty | Albania EP grease | - |
| 17 | SUN | - | Sunoco GL5 gear oil | Sunoco ultra prestige 2EP Sun prestige 742 | Sunoco antifreeze and summer coolant |
| 18 | TEXACO | *Ursa super plus Ursa premium | Multigear | Multifak EP2 Starplex 2 | Coda 2055 startex antifreeze coolant |
| 19 | TOTAL | Rubia S *Rubia X | Total EP Total Transmission TM | Multis EP2 | Antigal/antifreeze |
| 20 | UNION | *Guardol | MP gear lube LS | Unoba EP | - |
| 21 | VEEDOL | *Turbostar *Diesel star MDC | Multigear Multigear B Multigear C | - | Antifreeze |

TIGHTENING TORQUE SPECIFICATIONS

TIGHTENING TORQUE LIST



If nuts, bolts, or other parts are not tightened to the specified torque, it will cause looseness or damage to the tightened parts, and this will cause failure of the machine or problems with operation. Always pay careful attention when tightening parts.

Unless otherwise specified, tighten the metric nuts and bolts to the torque shown in the table below. The tightening torque is determined by the width across the flats of the nut and bolt. If it is necessary to replace any nut or bolt, always use a Komatsu genuine part of the same size as the part that was replaced.

| Thread diameter of bolt (a)(mm) | Width across flats (b)(mm) | Tightening torque | | | | | |
|---------------------------------|----------------------------|-------------------|-------|--------|---------------|-------------|---------------|
| | | Target value | | | Service limit | | |
| | | N·m | kgf·m | lbft | N·m | kgf·m | lbft |
| 6 | 10 | 13.2 | 1.35 | 9.8 | 11.8-14.7 | 1.2-1.5 | 8.7-10.8 |
| 8 | 13 | 31 | 3.2 | 23.1 | 27-34 | 2.8-3.5 | 20.3-25.3 |
| 10 | 17 | 66 | 6.7 | 48.5 | 59-74 | 6.0-7.5 | 43.4-54.2 |
| 12 | 19 | 113 | 11.5 | 83.2 | 98-123 | 10.0-12.5 | 72.3-90.4 |
| 14 | 22 | 177 | 18 | 130.2 | 157-196 | 16.0-20.0 | 115.7-144.7 |
| 16 | 24 | 279 | 28.5 | 206.1 | 245-309 | 25.0-31.5 | 180.8-227.8 |
| 18 | 27 | 382 | 39 | 282.1 | 343-425 | 35.0-43.5 | 253.2-314.6 |
| 20 | 30 | 549 | 56 | 405.0 | 490-608 | 50.0-62.0 | 361.7-448.4 |
| 22 | 32 | 745 | 76 | 549.7 | 662-829 | 67.5-84.5 | 488.2-611.2 |
| 24 | 36 | 927 | 94.5 | 683.5 | 824-1030 | 84.0-105.0 | 607.6-759.5 |
| 27 | 41 | 1320 | 135.0 | 976.5 | 1180-1470 | 120.0-150.0 | 868.0-1085.0 |
| 30 | 46 | 1720 | 175.0 | 1265.8 | 1520-1910 | 155.0-195.0 | 1121.1-1410.4 |
| 33 | 50 | 2210 | 225.0 | 1627.4 | 1960-2450 | 200.0-25.0 | 1446.6-1808.3 |
| 36 | 55 | 2750 | 280.0 | 2025.2 | 2450-3040 | 250.0-310.0 | 1808.3-2242.2 |
| 39 | 60 | 3280 | 335.0 | 2423.1 | 2890-3630 | 295.0-370.0 | 2133.7-2676.2 |

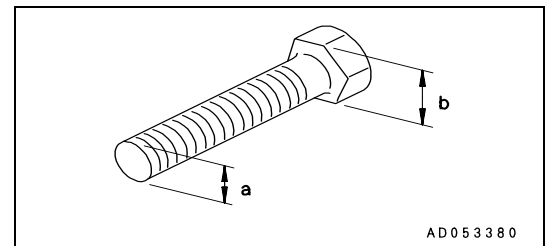

Use the following table for Hydraulic Hose.

| Hose nominal number | Width across flat (b)(mm) | Tightening torque | | | | | |
|---------------------|---------------------------|-------------------|-------|-------|---------------|-------------|---------------|
| | | Target value | | | Service limit | | |
| | | N·m | kgf·m | lbft | N·m | kgf·m | lbft |
| 02 | 19 | 44 | 4.5 | 32.5 | 35 - 63 | 3.5 - 6.5 | 25.3 - 47.0 |
| 03 | 22 | 74 | 7.5 | 54.2 | 54 - 93 | 5.5 - 9.5 | 39.8 - 68.7 |
| | 24 | 78 | 8.0 | 57.9 | 59 - 98 | 6.0 - 10.0 | 43.4 - 72.3 |
| 04 | 27 | 103 | 10.5 | 75.9 | 84 - 132 | 8.5 - 13.5 | 61.5 - 97.6 |
| 05 | 32 | 157 | 16.0 | 115.7 | 128 - 186 | 13.0 - 19.0 | 94.0 - 137.4 |
| 06 | 36 | 216 | 22.0 | 159.1 | 177 - 245 | 18.0 - 25.0 | 130.2 - 180.8 |

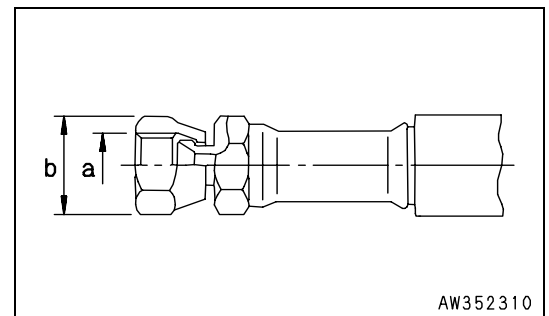

SAFETY CRITICAL PARTS

To ensure safety at all times when operating or driving the machine, the user of the machine must always carry out periodic maintenance. In addition, to further improve safety, the parts in the safety-critical parts list on the next page must also be replaced at the specified interval. These parts are particularly closely connected to safety and fire prevention, so please contact your Komatsu distributor to have them replaced.

With these parts, the material changes as time passes, or they easily wear out or deteriorate. However, it is difficult to judge the condition of the parts simply by periodic maintenance, so they should always be replaced after a fixed time has passed, regardless of their condition. This is necessary to ensure that they always maintain their function completely.

However, if these parts show any abnormality before the replacement interval has passed, they should be repaired or replaced immediately.

If the hose clamps show any deterioration, such as deformation or cracking, replace the clamps at the same time as the hoses.

In addition, carry out the checks for the hydraulic hoses other than periodic replacement parts. If any abnormality is found, tighten the clamps or replace the parts.

When replacing the hoses, always replace the O-rings, gaskets, and other such parts at the same time.

Ask your Komatsu distributor to replace the critical parts.

SAFETY CRITICAL PARTS LIST

| No. | Safety critical parts for periodic replacement | Q'ty | Replacement interval |
|-----|--|------|---|
| 1 | Fuel hose (fuel tank - feed pump pre-filter) | 1 | Every 2 years or 4000 hours, whichever comes sooner |
| 2 | Fuel hose (feed pump pre-filter - feed pump) | 1 | |
| 3 | Fuel hose (feed pump - fuel filter) | 1 | |
| 4 | Fuel hose (fuel filter - injection pump) | 1 | |
| 5 | Fuel hose (fuel filter - fuel tank) | 1 | |
| 6 | Spill hose (fuel filter - injection pump) | 1 | |
| 7 | Spill hose (between nozzles) | 2 | |
| 8 | Spill hose (nozzle - injection pump) | 1 | |
| 9 | Spill cap | 1 | |
| 10 | Hydraulic hose (main pump suction) | 2 | |
| 11 | Hydraulic hose (main pump delivery) | 4 | |
| 12 | Hydraulic hose (boom cylinder) | 2 | |
| 13 | Hydraulic hose (arm cylinder) | 4 | |
| 14 | Hydraulic hose (bucket cylinder) | 4 | |
| 15 | Hydraulic hose (offset cylinder) | 4 | |
| 16 | Seat belt (if equipped) | 1 | Every 3 years |

MAINTENANCE SCHEDULE

If the machine is equipped with a hydraulic breaker, the maintenance schedule for some parts will be different. For details, see "MAINTENANCE INTERVAL FOR HYDRAULIC BREAKER (4-14)" to confirm the correct maintenance schedule when carrying out maintenance.

MAINTENANCE SCHEDULE CHART

Initial 250 Hours Maintenance (Only after the first 250 hours)

| | |
|---|------|
| Engine Crankcase Oil Filter Cartridge - Replace | 4-50 |
| Fuel Filter Element - Replace..... | 4-51 |

When Required

| | |
|--|------|
| Air Cleaner Element - Check/Clean/Replace | 4-16 |
| Cooling System Coolant - Clean/Change | 4-21 |
| Clean Water Separator Element | 4-24 |
| Fuel Tank - Drain | 4-24 |
| Fuel Tank - Clean..... | 4-25 |
| Track Shoe Bolts - Check/Tighten | 4-26 |
| Track Tension - Check/Adjust..... | 4-27 |
| Road Liners and Rubber Shoes - Check | 4-28 |
| Rubber Shoe Tension - Check/Adjust..... | 4-30 |
| Road Liners - Replace | 4-31 |
| Rubber Shoes - Replace..... | 4-31 |
| Road Liners or Steel Shoes to Rubber shoes - Change | 4-34 |
| Bucket Teeth - Check/Replace | 4-35 |
| Windshield Washer Fluid Level - Check/Add | 4-38 |
| Cab Slide Door Rail and Rooler - Check/Clean/Lubricate | 4-39 |
| Hydraulic System - Bleed Air | 4-40 |

Checks Before Starting

Every 100 Hours Maintenance

| | |
|------------------|------|
| Lubricating..... | 4-43 |
|------------------|------|

Every 250 Hours Maintenance

| | |
|--|------|
| Engine Crankcase Oil - Change..... | 4-44 |
| Hydraulic Oil Filter Element - Replace | 4-45 |
| Cooling Fan Belt Tension - Inspect/Adjust..... | 4-46 |
| Battery Electrolyte Level - Check..... | 4-48 |

Every 500 Hours Maintenance

| | |
|---|------|
| Engine Crankcase Oil Filter Cartridge - Replace | 4-50 |
| Fuel Filter Element - Replace..... | 4-51 |
| Final Drive Case Oil Level - Check/Add..... | 4-52 |
| Lubricating..... | 4-53 |
| Radiator Fins, Oil Cooler Fins - Clean/Check | 4-55 |

Every 1000 Hours Maintenance

| | |
|--|------|
| Final Drive Case Oil - Change | 4-56 |
| Engine valve clearance - Check/Adjust..... | 4-56 |

Every 2000 Hours Maintenance

| | |
|---|------|
| Hydraulic Oil and Strainer - Change/Clean | 4-57 |
| Alternator and Starting Motor - Inspect | 4-58 |

MAINTENANCE INTERVAL FOR HYDRAULIC BREAKER

For machine equipped with a hydraulic breaker, the hydraulic oil deteriorates faster than for normal bucket digging operations, so set the maintenance intervals as follows.

- Replace hydraulic filter element
On a new machine, replace the element after the first 100 to 150 hours, then carry out further replacement of the element according to the table on the right.
- Change oil in hydraulic tank
Change the oil according to the table on the right.

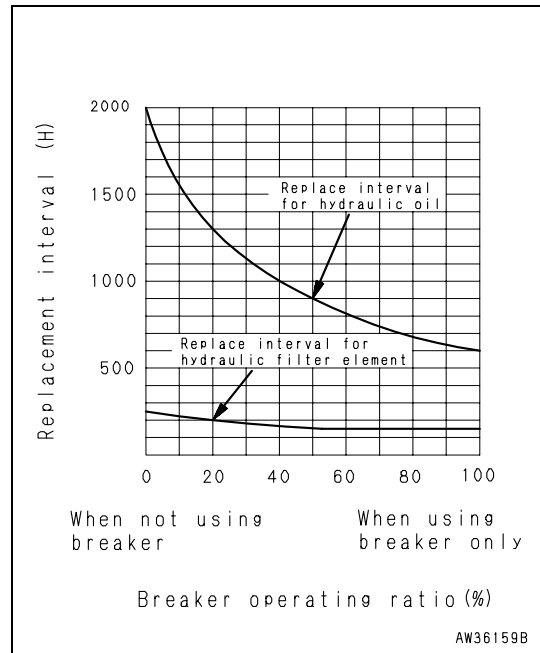

MAINTENANCE PROCEDURE

INITIAL 250 HOURS MAINTENANCE (ONLY AFTER THE FIRST 250 HOURS)

Carry out the following maintenance only after the first 250 hours.

- Engine Oil Filter Cartridge - Replace
- Fuel Filter Element - Replace

For details of the method of maintaining, see EVERY 500 HOURS MAINTENANCE.

WHEN REQUIRED

Air Cleaner Element - Check/Clean/Replace

WARNING

- If inspection, cleaning, or maintenance is carried out with the engine running, dirt will get into the engine and the engine will suffer damage. Always stop the engine before carrying out these operations.
- When using compressed air, there is danger that dirt may be blown around and cause serious injury.
- Always use safety glasses, dust mask, and other protective equipment.

Machines Equipped With Single Element

Checking

Whenever the red piston in dust indicator (1) appears, clean the air cleaner element.

NOTICE

Do not clean the air cleaner element before the red piston in dust indicator (1) appears.

If the air cleaner element is cleaned frequently before the red piston in the dust indicator appears, the air cleaner cannot provide the proper performance and the cleaning efficiency is lowered.

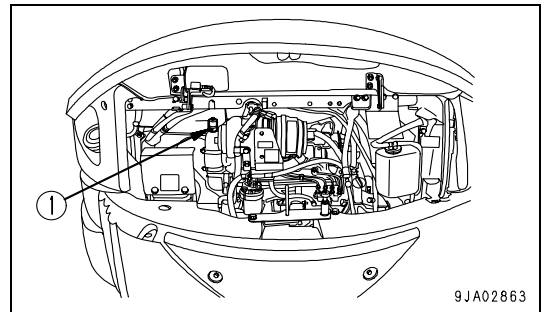

Cleaning or replacing element

1. Open the engine hood, remove clip (2), then remove cover (3).

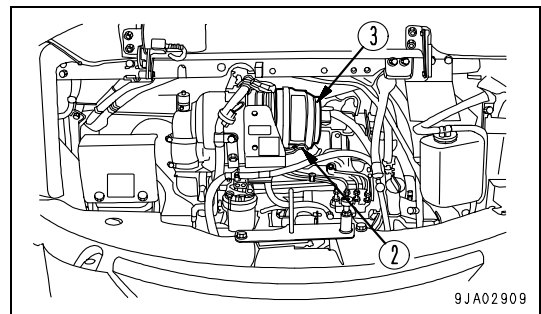

2. Take out element (4) and cover the air connector at the end of the air cleaner body with a clean cloth or tape.
3. Clean the interior of the air cleaner body, cover (3) and evacuator valve (5).

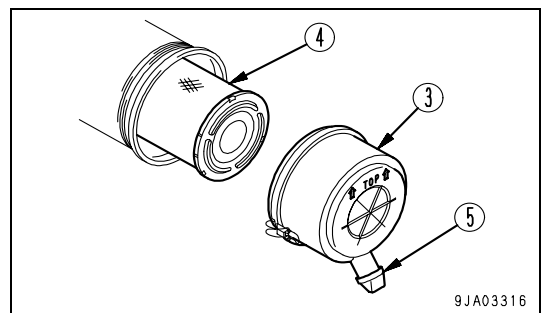

4. Direct dry compressed air (Max. 0.69 MPa (7 kgf/cm² ,99.4 psi)) from the inside of the outer element along its folds. Then below with air along the folds from the outside, and finally blow again from the inside.
 - 1) Replace the element which has been cleaned 5 times repeatedly or used throughout a year.
 - 2) Replace element when the dust indicator red piston appears soon after installing the cleaned element even though it has not been cleaned 6 times.

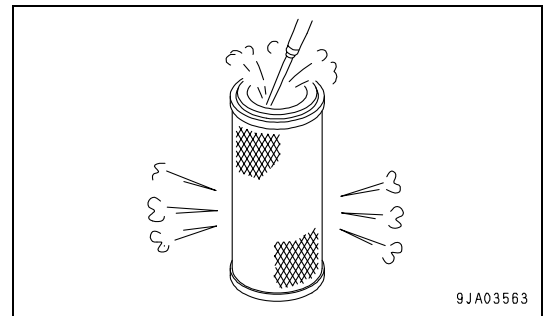

5. If small holes or thinner parts are found on the element when it is checked by shining a light through it after cleaning, replace the element.

NOTICE

When cleaning the element, do not hit or beat it against anything.

Do not use an element whose folds, gasket or seal are damaged.

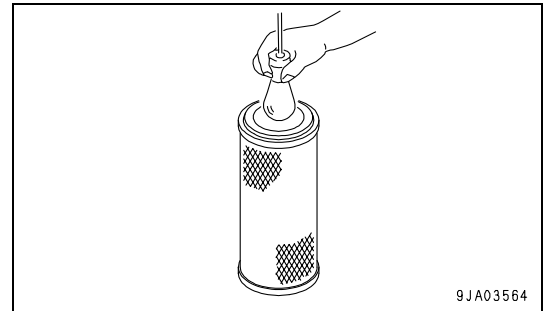

6. Remove the cloth or adhesive tape used to cover the air connector inside the air cleaner body.
7. Install cleaned element (4) or a new element.
8. Set the arrow mark on cover (3) at the top, install to the air cleaner body, then secure with clip (2).

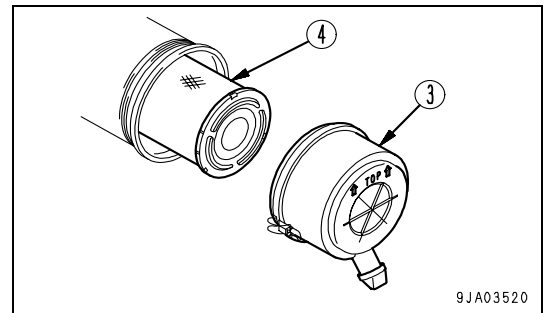

9. Press the button of dust indicator (1) to return the red piston to its original position.

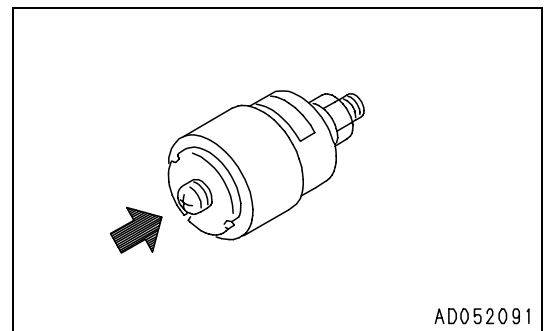

Machines Equipped With Double Element

Checking

Whenever the red piston in dust indicator (1) appears, clean the air cleaner element.

NOTICE

Do not clean the air cleaner element before the dust indicator becomes red.

If the element is cleaned frequently before the dust indicator becomes red, the performance of the air cleaner is not used perfectly and the cleaning effect is lowered. In addition, dust sticking to the element falls into the inner element each time the element is cleaned.

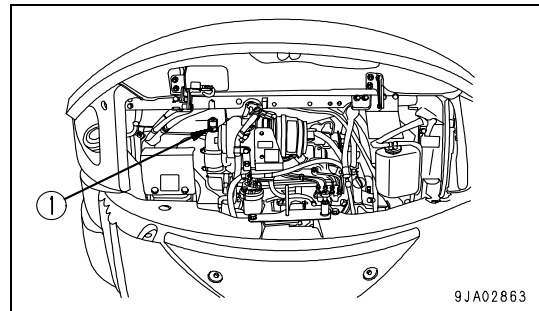

Cleaning outer element

1. Open the engine hood, remove clip (2), then remove cover (3).

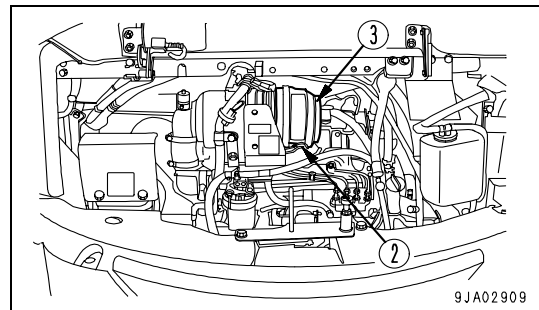

NOTICE

Never remove inner element (5). If it is removed, dust will enter and cause an engine trouble.

2. Remove outer element(4).
3. Take out element (4) and cover the air connector at the end of the air cleaner body with a clean cloth or tape.
4. Clean the interior of the air cleaner body, cover (3) and evacuator valve (6).

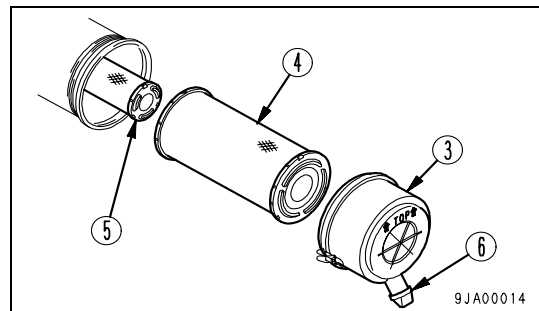

NOTICE

The inner element must not be cleaned and used again. When replacing the outer element, replace the inner element at the same time.

5. Direct dry compressed air (Max. 0.69 MPa (7 kgf/cm² ,99.4 psi)) from the inside of the outer element along its folds. Then below with air along the folds from the outside, and finally blow again from the inside.

- 1) Replace the element which has been cleaned 5 times repeatedly or used throughout a year.
- 2) Replace element when the dust indicator red piston appears soon after installing the cleaned element even though it has not been cleaned 6 times.

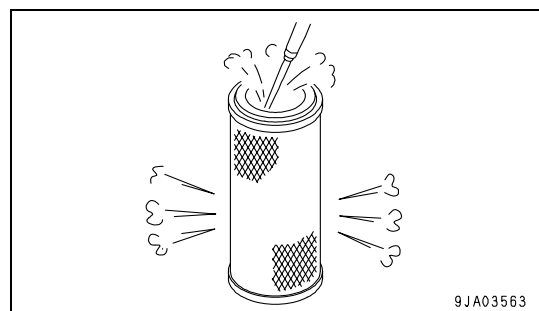

6. If small holes or thinner parts are found on the element when it is checked by shining a light through it after cleaning, replace the element.

NOTICE

When cleaning the element, do not hit or beat it against anything.

Do not use an element whose folds, gasket or seal are damaged.

7. Set the cleaned outer element (4) in position.
8. Set the arrow mark on cover (3) at the top, install to the air cleaner body, then secure with clip (2).

9. Press the button of dust indicator (1) to return the red piston to its original position.

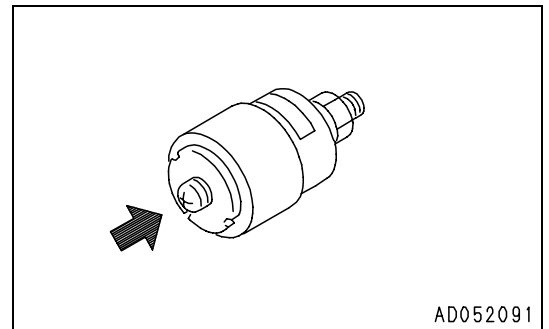
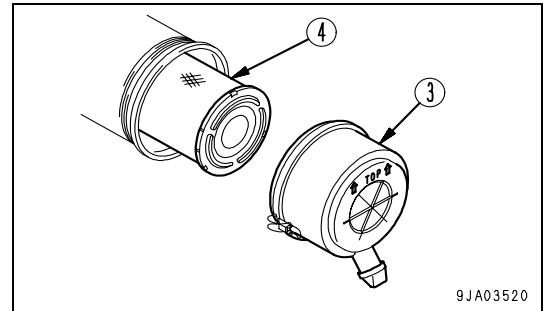
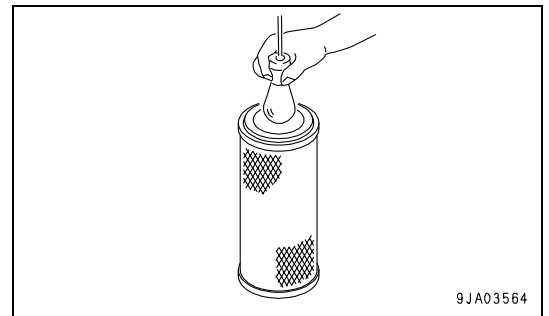

Replacing element

1. Open the engine hood, remove clip (2), then remove cover (3).
2. Remove outer element(4).
Do not remove inner element(5) at this time, however.
3. Clean the interior of the air cleaner body, cover (3) and evacuator valve (6).
4. Remove inner element(5), then install a new inner element immediately.
5. Set the new outer element (4) in position.
6. Set the arrow mark on cover (3) at the top, install to the air cleaner body, then secure with clip (2).
7. Return the red piston in the dust indicator(1) to its original position.

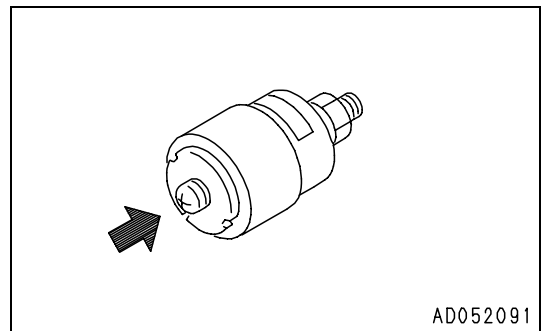
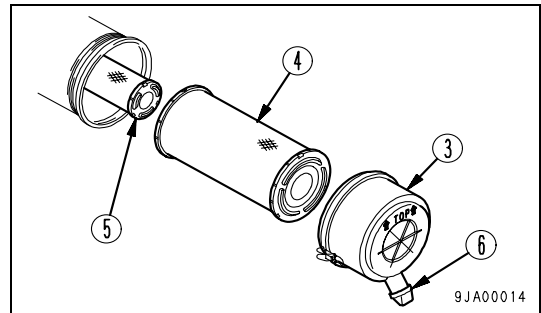
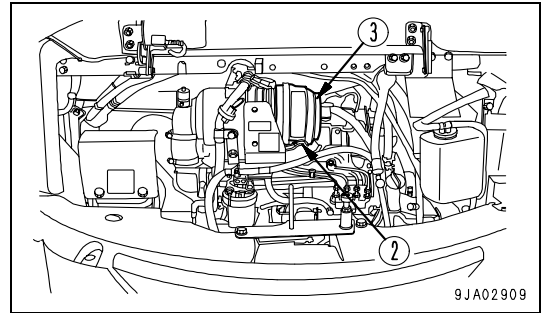

Cooling System Coolant - Clean/Change

⚠ WARNING

- **Immediately** after the engine is stopped, the coolant is at a high temperature and the radiator is under high internal pressure. If the cap is removed to drain the coolant in this condition, there is a hazard of burns. Wait for the temperature to go down, then turn the cap slowly to release the pressure before removing it.
- **Cleaning is carried out with the engine running. When standing up or leaving the operator's seat, set the safety lock lever to the LOCK position.**
- **For details of starting the engine, see "BEFORE STARTING ENGINE (3-31)" and "STARTING ENGINE (3-43)" in the OPERATION section.**
- **The engine is operated when washing, so it is dangerous if the machine moves when you are standing behind it. Never stand behind the machine when the engine is running.**

Clean the inside of the cooling system, change the coolant and replace the corrosion resistor agent KI according to the table below.

| Kind of coolant | Cleaning inside of cooling system and changing coolant | Adding corrosion resistor agent KI |
|--|--|--|
| Permanent type antifreeze (All season type) | Every year (autumn) or every 2000 hours whichever comes first | Every 1000 hours and when cleaning the inside of the cooling system and when changing coolant. |
| Non permanent type antifreeze containing ethylene glycol (winter, one season type) | Every 6 months (spring, autumn) (Drain antifreeze in spring, add antifreeze in autumn) | |
| When not using antifreeze | Every 6 months or every 1000 hours whichever comes first | |

Stop the machine on level ground when cleaning or changing the coolant.

Use a permanent type of antifreeze.

If, for some reason, it is impossible to use permanent type antifreeze, use an antifreeze containing ethylene glycol. Super Coolant (AF-ACL) has an anti-corrosion effect as well as an antifreeze effect.

The ratio of antifreeze to water depends on the ambient temperature, but to obtain the corrosion resistance effect, a minimum ratio of 30% by volume is necessary.

In areas where the water is hard, always add Komatsu genuine corrosion resistor agent KI. One packet of corrosion resistor agent contains 100 g (0.22 lb). The standard density of the mixture should be 7 g/liter (0.065 oz./US gal).

When deciding the ratio of antifreeze to water, check the lowest temperature in the past, and decide from the mixing rate table given below.

It is actually better to estimate a temperature about 10°C (50°F) lower when deciding the mixing rate.

Mixing rate of water and antifreeze

| Min. atmospheric temperature | °C | Above -10 | -15 | -20 | -25 |
|------------------------------|--------|-----------|------|------|------|
| | °F | Above 14 | 5 | -4 | -13 |
| Amount of antifreeze | Liter | 1.9 | 2.3 | 2.7 | 3.0 |
| | US gal | 0.50 | 0.61 | 0.71 | 0.79 |
| Amount of water | Liter | 4.6 | 4.2 | 3.8 | 3.5 |
| | US gal | 1.22 | 1.11 | 1.00 | 0.92 |

⚠ WARNING

Antifreeze is flammable, so keep it away from flame.

Antifreeze is toxic. When removing the drain plug, be careful not to get water containing antifreeze on you. If it gets in your eyes, flush your eyes with large quantities of fresh water and see a doctor at once.

Use city water for the cooling water.

If river water, well water or other such water supply must be used, contact your Komatsu distributor.

We recommend use of an antifreeze density gauge to control the mixing proportions.

- Prepare a container to catch drained coolant: 6.5 liters (1.72 US gal) capacity.
- Prepare a water inlet hose.

1. Open the cover at the right side of the machine.
2. Check that the cooling water temperature has gone down enough to make it possible to touch the radiator cap surface by hand, then turn radiator cap (1) slowly until it contacts the stopper to release the pressure.
3. Following this, push radiator cap (1), turn it until it contacts the stopper, then remove it.

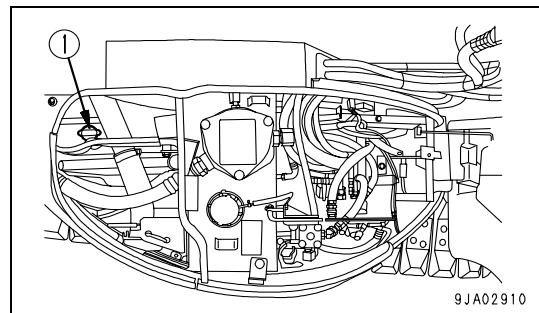

4. Remove cover (2) at the rear right under the machine.
5. Set container to catch the coolant under drain valve (3) and drain plug of cylinder block.
6. Open drain valve (3) to drain the water. Remove drain plug to drain the water.
7. After you drain the water, close drain valve (3), install the drain plug, and add water. When the radiator is full, start the engine and run it at low idle to raise the water temperature above 90°C (194°F) and run the engine for approx. 10 minutes.

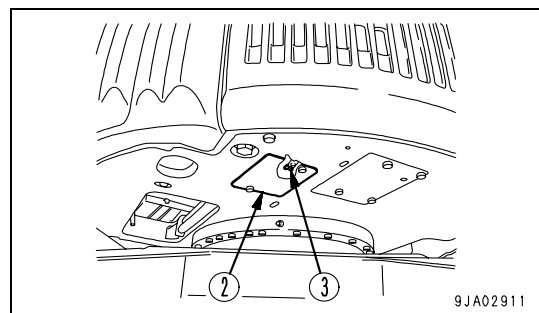

8. Stop the engine, then open drain valve (3) and remove the drain plug to drain the water.
9. After draining the water, clean the radiator with detergent. For the cleaning method, follow the instruction of detergent.
10. Close drain valve (3), wrap the drain plug with sealing tape, then close it.
11. Decide the proportions of antifreeze and water according to the table for the mixing rate of water and antifreeze.
12. After the engine warming up, check that each gauge and caution lamp are in normal condition. If any abnormality is found, carry out adjustment or repairs. Operate the machine under a light load until the engine water temperature gauge (2) points to the white range (monitor panel spec.) or the green range (gauge panel spec.). To remove the air in the cooling water, run the engine for 5 minutes at low idling, then for another 5 minutes at high idling. (While doing this, leave the radiator cap removed)

13. Drain the cooling water inside sub-tank (4), clean the inside of the sub-tank, then fill again with cooling water to a point midway between the FULL and LOW marks.
14. Stop the engine. About 3 minutes later, supply city water up to the water filler, then close radiator cap.

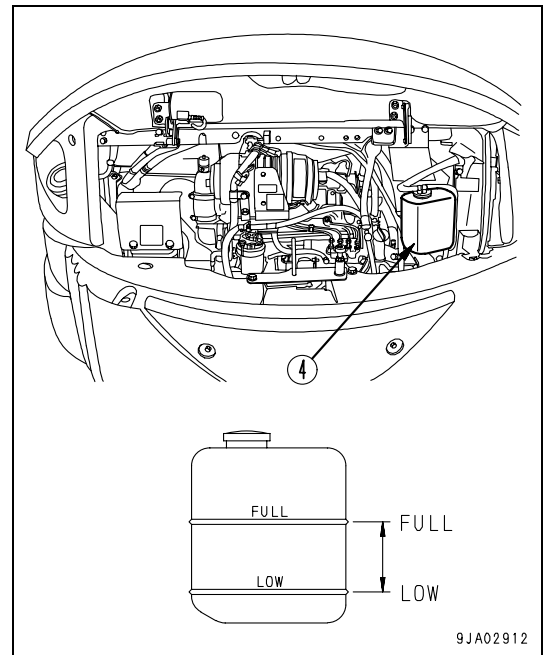

Water Separator Element - Clean

⚠ WARNING

Do not bring any fire or flame close.

- Prepare the filter wrench for fuel filter.
1. Open inspection cover (1) on the left side of the machine and set handle (2) of the filter inside to the CLOSED position (a).
 2. Using a filter wrench, loosen ring (3), then remove element cup (4) and take out element (5). Be careful not to lose red ring (6) inside the case.
 3. Wash element cup (4) and element (5) in diesel oil or flushing oil.
 4. After washing, install element (5).
 5. Insert a red ring (6) into element cover (4), fill with fuel, install to the filter holder, then tighten ring (3).
 6. Set handle (2) to the OPEN position (b).
 7. After completing the washing of the water separator, bleed the air.
For details of the method for bleeding the air, see Air Bleeding (4-51)

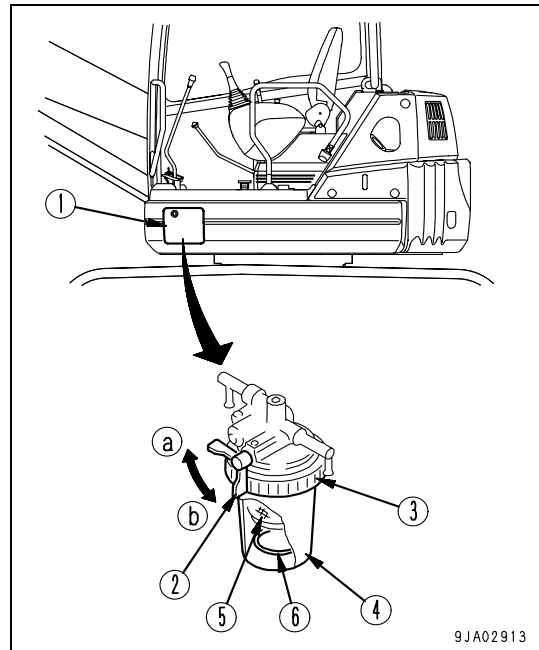

Fuel Tank - Drain

Carry out this procedure before operating the machine.

- Prepare a container to catch the fuel that is drained.
1. Swing the upper structure so that inspection cover (1) is between the tracks.
 2. Open the inspection cover.

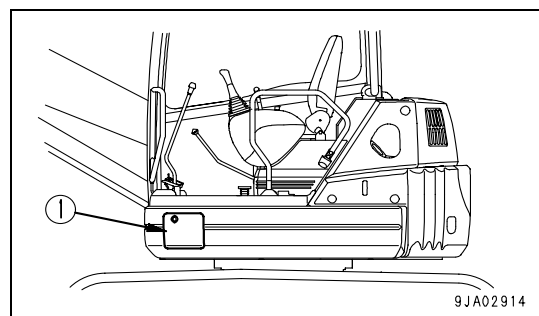

3. Open drain valve (2) and drain the sediment and water accumulated at the bottom together with the fuel. When doing this, be careful not to get fuel on yourself.
4. When only clean fuel comes out, close drain valve (2).
5. Close the inspection cover.

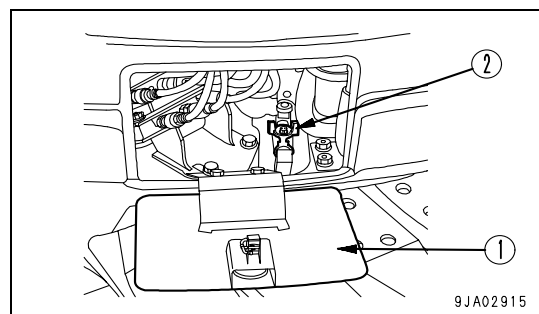

Fuel Tank - Clean

NOTICE

- **Never use trichlene for washing the inside of the tank. Use diesel fuel only.**
- **Carry out this procedure before operating the machine as a daily maintenance.**

1. Drain fuel from the fuel tank, refer to the procedures 1 through 3 in the section "Fuel Tank - Drain (4-24)" in this manual.
2. Remove floor mat.
3. Remove cover (1).

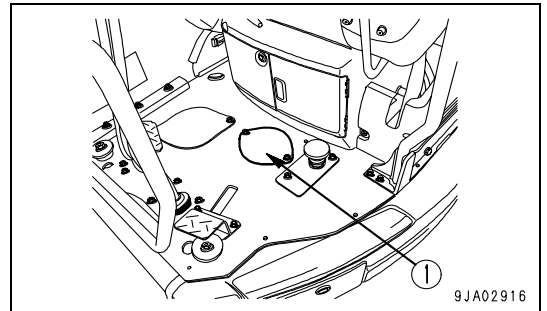

4. Remove fuel sensor (2).
5. Wash inside of the tank.

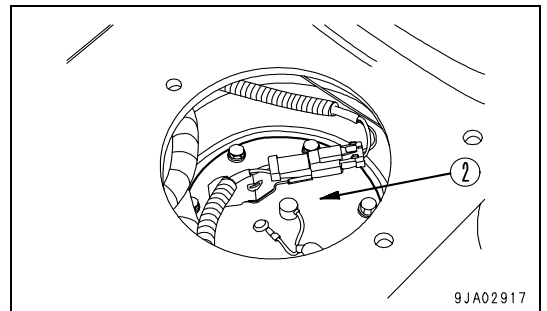

6. After washing the tank, tighten drain valve (3) and install fuel sensor (2), cover (1) and floor mat.

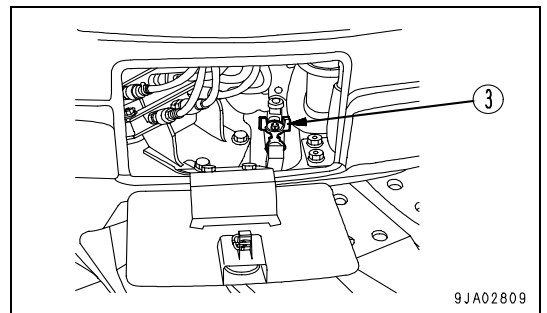

Track Shoe Bolts - Check/Tighten

(Machine equipped with road liner, Steel shoe)

If the machine is used with track shoe bolts (1) loose, they will break, so tighten any loose bolts immediately

Method for further tightening of road liner

After tightening to a torque of 137 ± 19.6 N·m (14 ± 2 kgf·m, 101.3 ± 14.5 lbft), check that the nut and shoe are in tight contact with the link mating surface.

Method for further tightening of steel shoe

1. First tighten to a torque of 137 ± 19.6 N·m (14 ± 2 kgf·m, 101.3 ± 14.5 lbft) then check that the nut and shoe are in close contact with the link contact surface.
2. After checking, tighten a further $90^\circ \pm 10^\circ$.

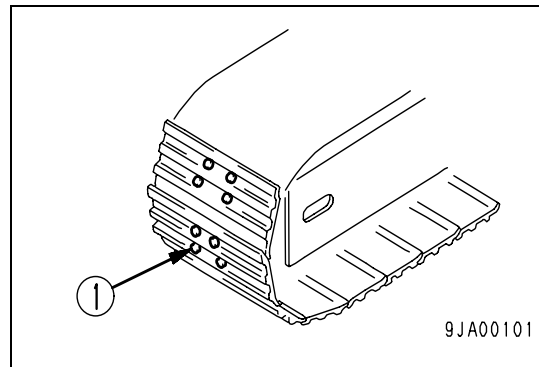
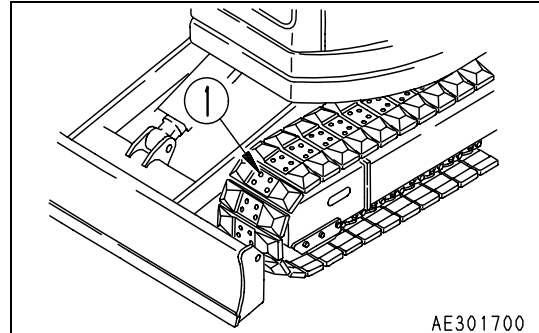

Order for tightening

Tighten the bolts in the order shown in the diagram on the right. After tightening, check that the nut and shoe are in close contact with the link mating surface.

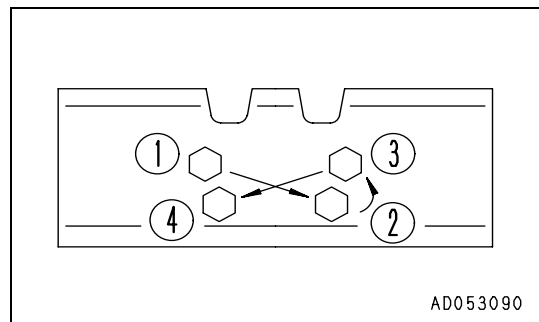
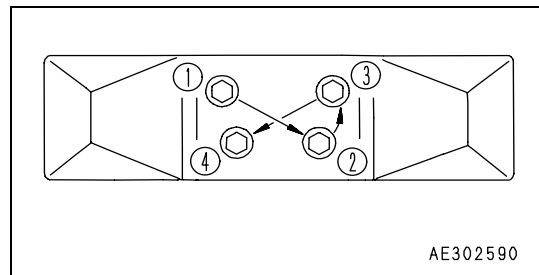

Track Tension - Check/Adjust

(Machine equipped with road liner, Steel shoe)

The wear of the pins and bushings on the undercarriage will vary with the working conditions and type of soil, so inspect the track tension frequently in order to maintain the standard tension.

Stop the machine on firm, horizontal ground when carrying out the inspection and maintenance.

Checking

1. Run the engine at low idling, move the machine forward a distance equal to the length of track on ground, then stop the machine.
2. Choose wooden block (3) that will reach from idler (1) to carrier roller (2), then place it on top of the track.
3. Measure the maximum deflection between the top surface of the track and the bottom surface of the wooden block.
 - Standard deflection
Deflection "a" should be 10 to 30 mm (0.4 to 1.2in).

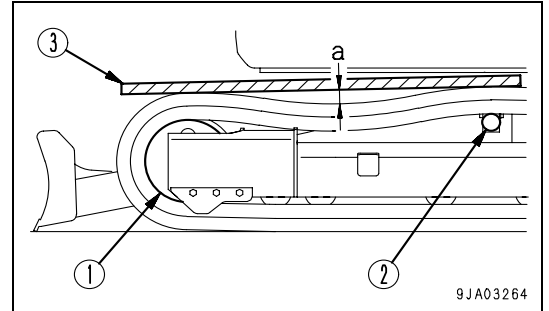

If the track tension is not at the standard value, adjust it in the following manner.

Adjustment

⚠ WARNING

There is danger of plug (1) flying out under the high internal pressure of the grease. Never loosen plug (1) more than 1 turn.

Never loosen any part other than plug (1). Never put your face in the mounting direction of plug (1).

If the track tension cannot be loosened with the procedure given here, please contact your Komatsu distributor.

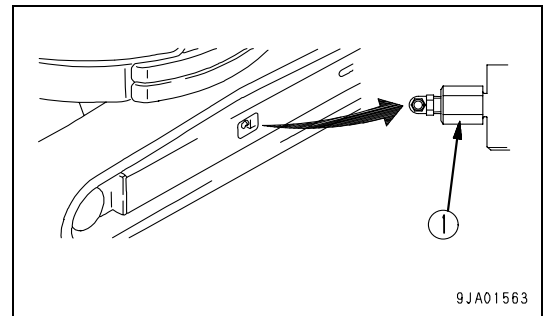

Increasing Track Tension

Prepare a grease gun.

1. Pump in grease through grease fitting (2) with a grease pump.
2. To check that the track tension is correct, run the engine at low idling, move the machine forward a distance equal to the length of track on ground, then stop the machine.
3. Check the track tension again, and if the tension is not correct, adjust it again.

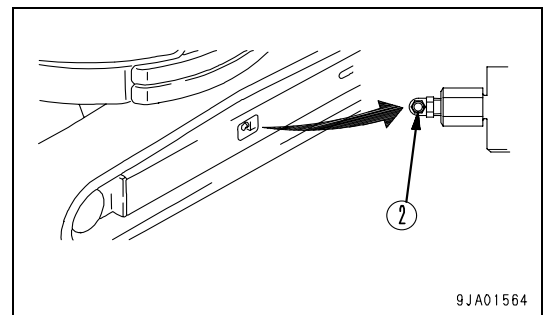

4. Continue to pump in grease until dimension S becomes zero (0). If the tension is still loose, the pin and bushing are excessively worn, so they must be either turned or replaced. Please contact your Komatsu distributor for repairs.

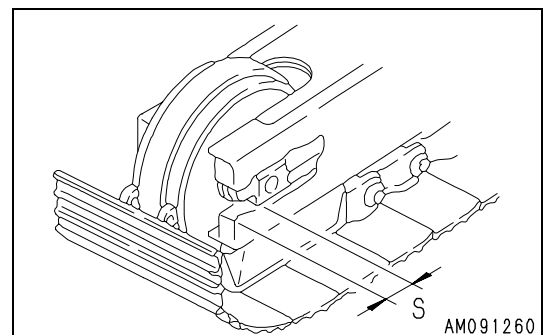

Loosening Track Tension

⚠ WARNING

It is extremely dangerous to release the grease by any method except the procedure given below. If the track tension is not relieved by this procedure, please contact your Komatsu distributor for repairs.

1. Loosen plug (1) gradually to release the grease.
2. When loosening plug (1), turn it a maximum of one turn.
3. If the grease does not come out smoothly, move the machine forwards and backwards a short distance.
4. Tighten plug (1).
5. To check that the track tension is correct, run the engine at low idling, move the machine forward a distance equal to the length of track on ground, then stop the machine.
6. Check the track tension again, and if the tension is not correct, adjust it again.

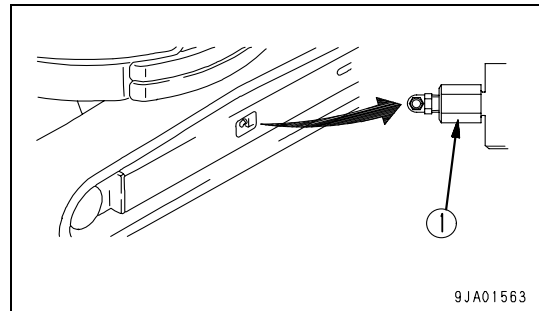

Road Liners or Rubber Shoes - Check

(Machine equipped with road liner or rubber shoe)

If the road liners and rubber shoes are in the following condition, they must be repaired or replaced, so please contact your Komatsu distributor for repairs or replacement.

Lug Height

- If lug height "a" is reduced by wear, the drawbar pull will drop.
If "a" is less than 5mm (0.2 in), replace with a new part.

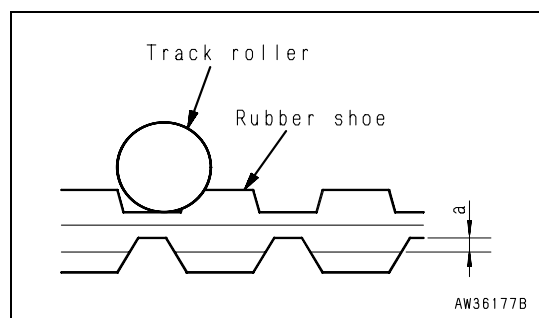
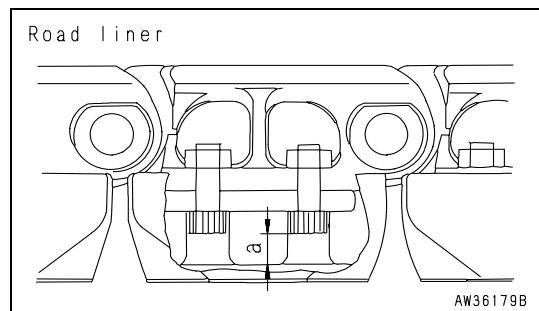

- If the lug wears and the steel cord inside the shoe is exposed for two links or more, replace with a new part.
(Machine equipped with rubber shoes)

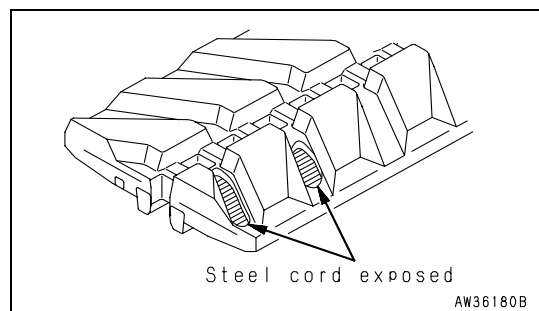

Rubber Shoe Steel Cord Cuts

If more than half of the steel cord layer on one side is cut, replace with a new part.

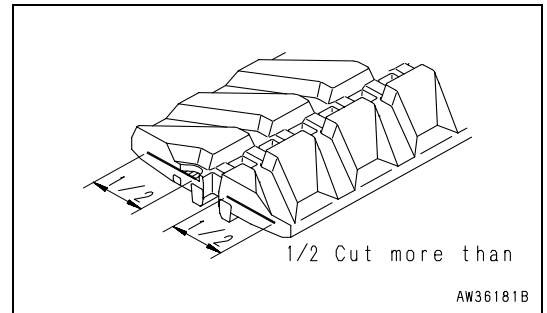

Rubber Shoe Core Separations

If the rubber core has separated at one place or more, replace with a new part.

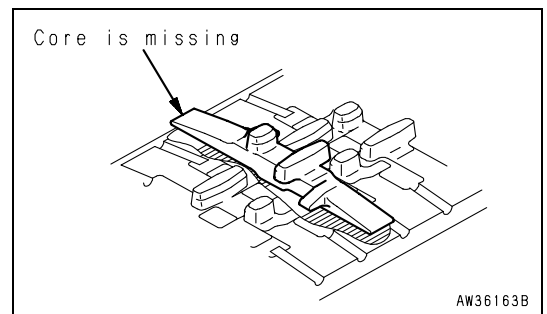

Rubber Shoe Tension

If the rubber shoe is still slack even when grease is pumped in, replace with a new part or replace the seal inside the cylinder.

If the track tension can only be increased to a level where the rubber shoe may come off, there may be not only elongation of the rubber shoe but also damage to the grease cylinder.

Rubber Shoe Cracks

If the cracks between the rubber shoe lugs increase to a size of approx. 60mm (2.36 in) the rubber shoe must be repaired. Even if the crack is small and short, if the steel cord can be seen inside, carry out repairs immediately.

If the length is less than 30mm (1.18 in) or the depth of the crack is less than 10mm (0.39 in), there is no particular need to carry out repairs.

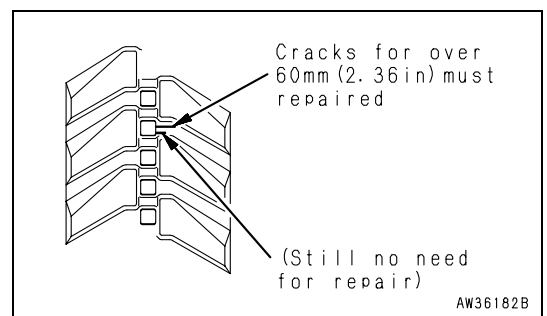

When making a judgement whether to replace, repair, or continue using the road liner and rubber shoe, please contact your Komatsu distributor.

Rubber Shoe Tension - Check/Adjust

(Machine equipped with rubber shoes)

The wear of the rubber shoe will vary with the work conditions and type of soil, so inspect the wear and track tension whenever necessary. Stop the machine on firm, horizontal ground when carrying out the inspection and maintenance.

In particular, on new machines or after new tracks have been installed and the tension has been set to the specified value, the track tension will become loose in the first 5 to 30 hours when the machine has been used for a certain amount of repeated

travel. If the track tension is adjusted frequently until the initial loosening no longer occurs, this will prevent the shoes from coming off due to insufficient track tension.

If operations are carried out when the rubber shoe is loose, the track will come off and it will cause premature wear of the core.

Checking

1. Run the engine at low idling, move the machine forward a distance equal to the length of track on ground, then stop the machine.
2. Choose wooden block (3) that will reach from idler (1) to carrier roller (2), then place it on top of the track.
3. Measure the maximum deflection between the top surface of the rubber shoe and the bottom surface of the wooden block.
 - Standard deflection
Deflection "a" should be 1 to 3 m (3 ft 3 in to 9 ft 10 in).

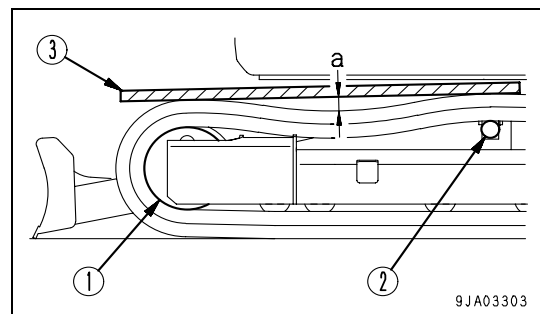

If the track tension is not at the standard value, adjust it in the following manner.

Adjustment

⚠ WARNING

There is danger of the plug flying out under the high internal pressure of the grease. When loosening plug (1), never loosen it more than one turn.

Never loosen any part other than plug (1). Never put your face in line with the mount of plug (1).

If the Rubber shoe tension is not relieved by this procedure, please contact your Komatsu distributor.

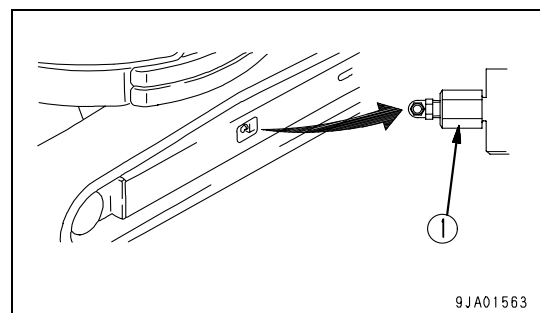

Increasing Track Tension

NOTICE

The standard value is low, so be careful not to tighten the rubber shoe too much.

Prepare a grease gun.

1. Pump in grease through grease fitting (2) with a grease pump.
2. To check that the track tension is correct, run the engine at low idling, move the machine forward a distance equal to the length of track on ground, then stop the machine.
3. Check the rubber shoe tension again, and if the tension is not correct, adjust it again.
4. If the tension is still low after supplied grease, the rubber shoe needs to be replaced or the seal in the cylinder needs to be replaced. Ask your Komatsu distributor for replacement.

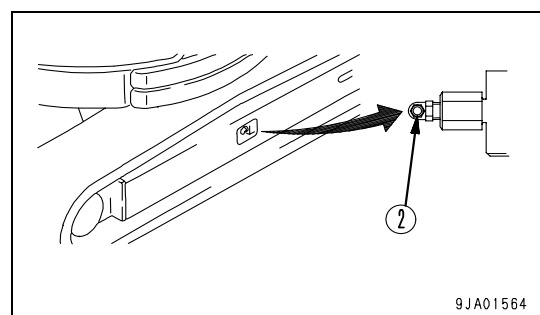

Loosening Track Tension

⚠ WARNING

It is extremely dangerous to release the grease by any method except the procedure given below. If the track tension is not relieved by this procedure, please contact your Komatsu distributor.

1. Loosen plug (1) gradually to release the grease.
2. When loosening plug (1), turn it a maximum of one turn.
3. If the grease does not come out smoothly, move the machine forwards and backwards a short distance.
4. Tighten plug (1).
5. To check that the track tension is correct, run the engine at low idling, move the machine forward a distance equal to the length of track on ground, then stop the machine.
6. Check the rubber shoe tension again, and if the tension is not correct, adjust it again.

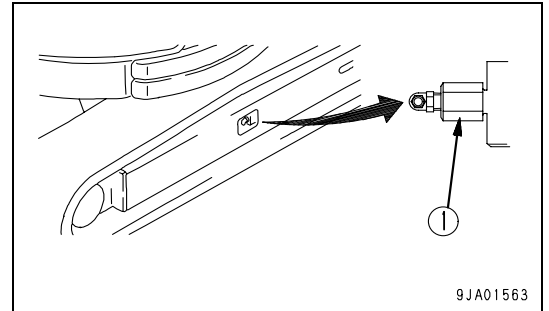

Road Liners - Replace

(Machine equipped with road liner)

- When replacing all the road liner for the machine, please contact your Komatsu distributor to have the replacement carried out.
- When replacing only part of the road liner, use the special road liner removal tool. Please order the tool from your Komatsu distributor.

Rubber Shoes - Replace

(Machine equipped with rubber shoes)

⚠ WARNING

- Carry out this operation with two workers. The operator must move the machine in accordance with the signals from the other worker.
- The rubber shoes are replaced with the machine raised, so it is extremely dangerous if the machine is lowered by mistake during the replacement operation. During the replacement operation, never move the rubber shoe track except the rubber shoe track to be replaced.
- In addition, never go under or put any part of your body under the rubber shoe or track frame during the replacement operation.
- To check that the track tension is correct, run the engine at low idling, move the machine forward a distance equal to the length of track on ground, then stop the machine.

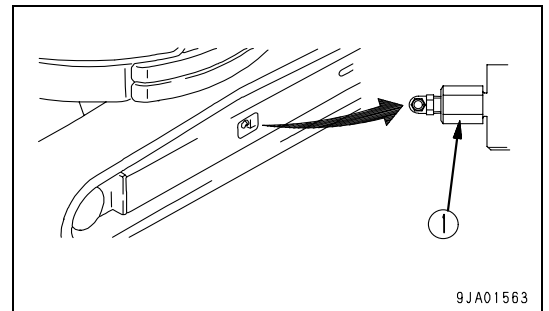

NOTICE

It is possible to change from the rubber shoe to the road liner and steel shoe. However, it is necessary to remove the idler guard and to carry out adjustment, so always contact your Komatsu distributor to have the replacement carried out.

- Prepare a grease gun.
- Prepare a steel pipe

Rubber Shoes Removal

⚠ WARNING

- It is extremely dangerous to release the grease by any method except the procedure given below.
- If the rubber shoe tension is not relieved by this procedure, please contact your Komatsu distributor for repairs.
- Check that all the grease has been released before rotating the sprocket to remove the rubber shoe.

1. Raise the chassis with the boom and arm.
When doing this, operate the levers slowly.

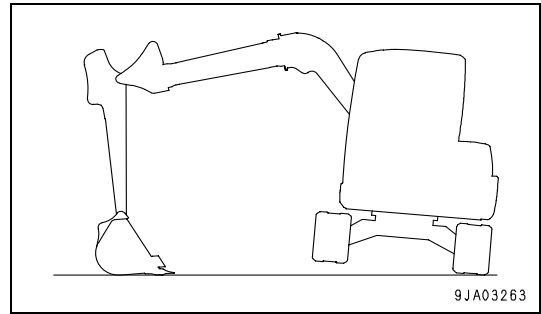

2. Loosen plug (1) gradually to release the grease.
3. When loosening plug (1), turn it a maximum of one turn.

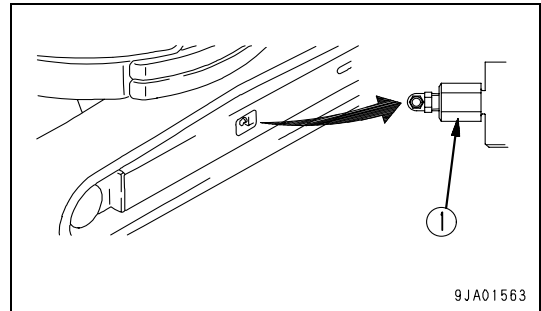

4. Fit the steel pipes inside the rubber shoe, rotate the sprocket in reverse, so that the steel pipes make the rubber shoe come up from the idler, then to the side to remove.

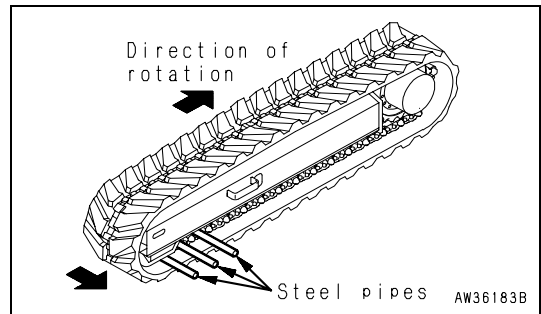

Rubber Shoes Installation

1. Raise the chassis with the boom and arm.
When doing this, operate the levers slowly.

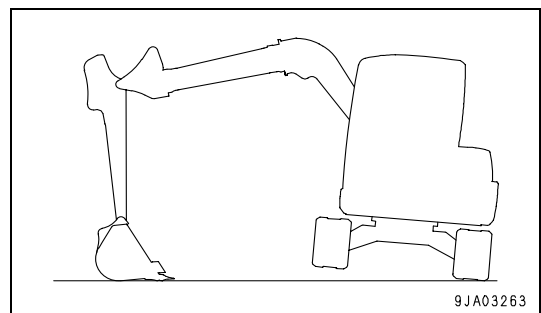

2. Mesh the rubber shoe with the sprocket and fit it over the idler.
3. Rotate the sprocket in reverse, then push in the rubber shoe and stop the rotation.

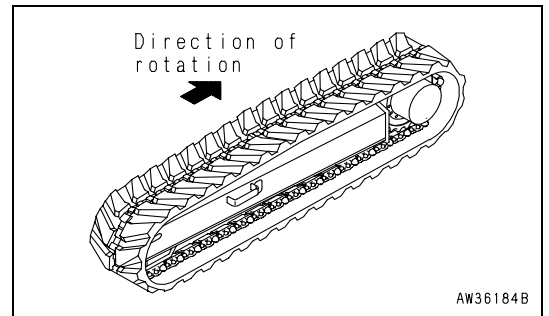

4. Fit a steel pipe in the rubber shoe, then rotate the sprocket again and fit the rubber shoe securely on the idler.

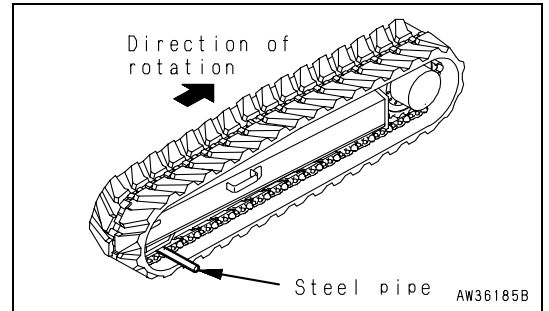

5. Stop the rotation, and check that the rubber shoe is securely fitted to the sprocket and idler.

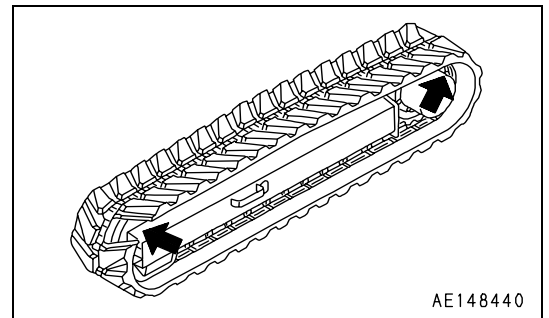

6. Adjust the tension of the rubber shoe.
For details, see "Rubber Shoe Tension - Check/Adjust (4-30)".
7. Check that the track tension is correct and that the rubber shoe is correctly meshed on the sprocket and idler, then lower the machine to the ground.

Road Liners or Steel Shoes to Rubber Shoes - Change

WARNING

When changing from the steel shoe or road liner to the rubber shoe, or when changing from the rubber shoe to the steel shoe or road liner, it is necessary to remove and adjust the idler cushion, so contact your Komatsu distributor to have the change carried out.

Changing from Road Liners or Steel Shoes to Rubber Shoes

1. Remove idler guard mounting bolts (1), then remove idler guard (2).
2. Remove the steel shoe or road liner and install the rubber shoe.

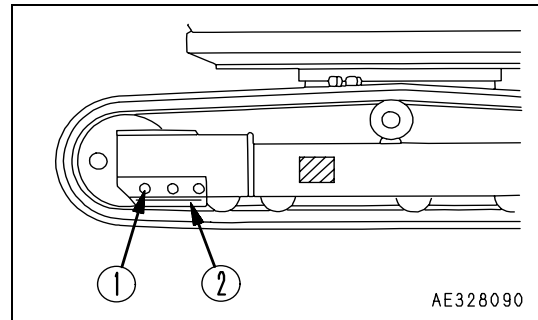

Changing from Rubber Shoes to Road Liners or Steel Shoes

1. Remove the rubber shoe and install the steel shoe or road liner.
2. Install idler guard (2) with idler guard mounting bolts (1).

Bucket Teeth - Check/Replace

⚠ WARNING

- It is dangerous if the work equipment moves by mistake when the teeth are being replaced.
- Set the work equipment in a stable condition, then stop the engine and set the safety lock lever securely to the LOCK position.
- If the pin is knocked out with strong force, there is a hazard that the pin may fly out. Check that there is no one in the surrounding area.
- There is a hazard that pieces will fly during the replacement operation, so always wear safety glasses, gloves, and other protective equipment.

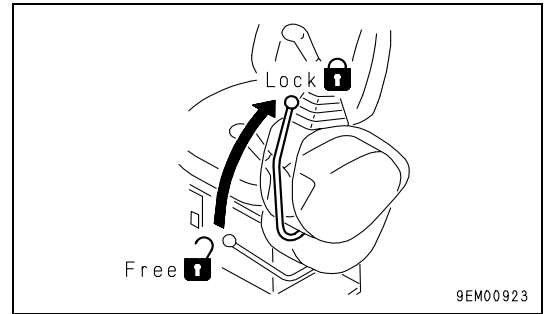

Replace the bucket teeth before the adapter starts to wear.

1. To make it possible to knock out the pin of tooth (1), set the bottom surface of the bucket on a block, check that the work equipment is in a stable condition, then set the safety lock lever to the LOCK position. Set so that the bottom face of the bucket is horizontal.

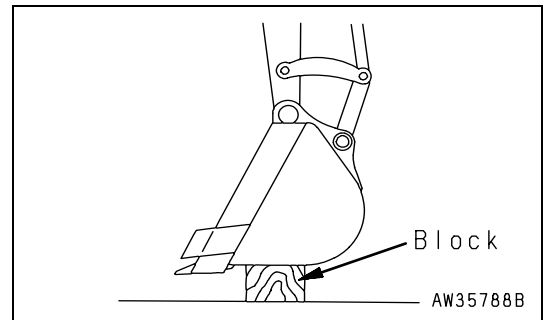

2. Use a hammer and drift to knock out lock pin (2). (If the drift is set against rubber pin lock (3) when it is hit, the rubber pin lock may break. Set it against the back of the pin.)
3. After removing lock pin (2) and rubber pin lock (3), check them.

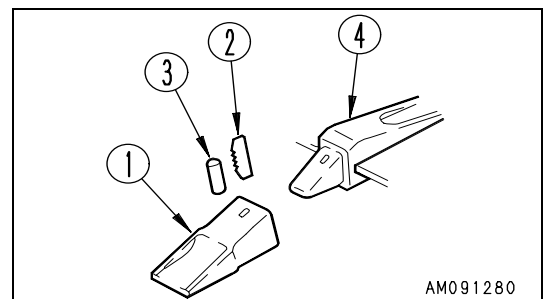

If lock pins and rubber pin locks with the following defects are used, the teeth may come off the bucket. Replace them with new ones.

- The lock pin is too short.

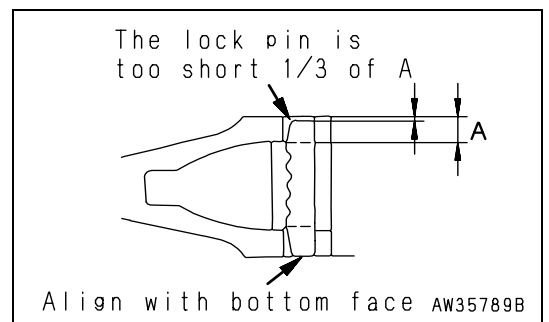

- The rubber of the rubber pin lock is torn, and the steel balls may come out.

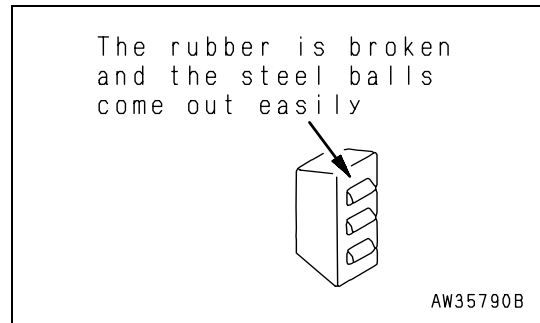

- The steel balls are buried when they are pressed by hand.

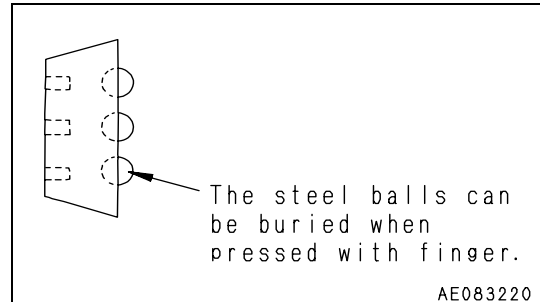

4. Clean the surface of adapter (4) and remove the soil with a knife.
5. Use your hand or a hammer to push rubber pin lock (3) into the hole of the adapter.
When doing this, be careful that the rubber pin lock does not fly out from the adapter surface.

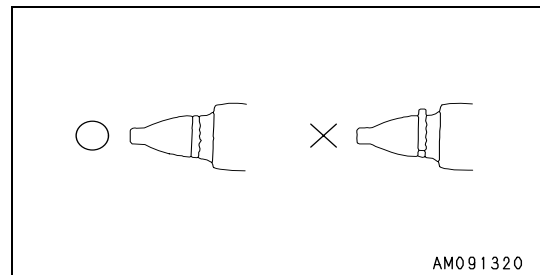

6. Clean the inside of teeth (1), then install it to adapter (4). If there is mud affixed to it or if there are protrusions, the teeth will not enter the adapter properly, and there will not be proper contact at the mating portion.
7. Fit teeth (1) to adapter (4), and confirm that when the pointer is pressed strongly, the rear face of the hole for the pin of the teeth is at the same level as the rear face of the hole for the pin of the adapter.
If the rear face of the hole for the pin of teeth (1) is protruding to the front from the rear face of the pin hole for adapter (4), do not try to knock the pin in.
There is something preventing teeth (1) from entering adapter (4) fully, so remove the obstruction. When teeth (1) enters adapter (4) fully, knock in lock pin (2).

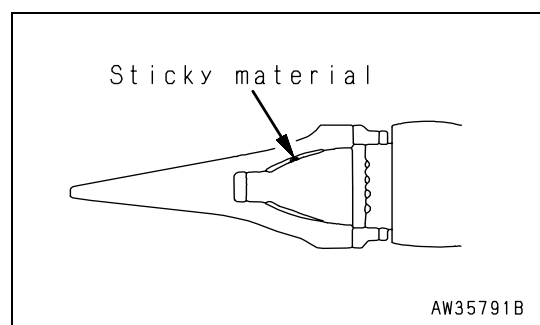

8. Insert lock pin (2) in the hole of the teeth and hit it until its top is the same level as the surface of teeth (1).
9. After replacing a bucket tooth, always check the following.
 - 1) After the lock pin has been knocked in completely, check that it is secured by the point and surface.
 - 2) Lightly hit lock pin (2) in the reverse direction from which it was hit in.

- 3) Lightly hit the tip of the point from above and below, and hit its sides from right and left.
- 4) Confirm that rubber pin lock (3) and lock pin (2) are set as shown in the figure.

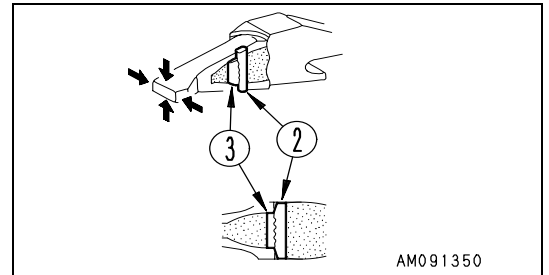
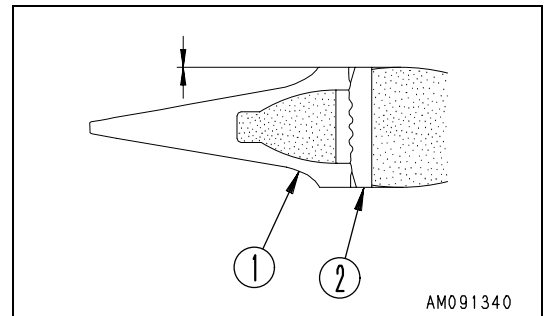

The life of the teeth can be lengthened and the frequency of its replacement can be reduced by turning it upside down so that it will wear evenly. Replace the rubber pin lock and locking pin at the same time as replacing the teeth. This makes it possible to prevent the teeth from falling out.

Windshield Washer Fluid Level - Check/Add

(Machine equipped with cab)

If there is air in the window washer fluid, check the level of the fluid in window washer tank. Add automobile window washer fluid if necessary.

When adding fluid, be careful not to let any dust get in.

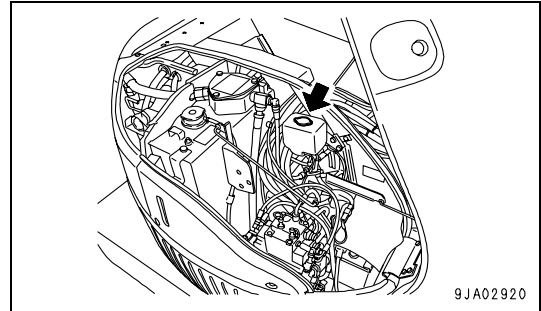

Washer Fluid Dilution Ratio

The proportion differs according to the ambient temperature, so dilute the washer fluid with water to the following proportions before adding.

| Area, season | Proportions | Freezing temperature |
|-------------------------------|------------------------------|----------------------|
| Normal | Washer fluid 1/3: water 2/3 | -10°C (14°F) |
| Winter in cold area | Washer fluid 1/2 : water 1/2 | -20°C (-4°F) |
| Winter in extremely cold area | Pure washer fluid | -30°C (-22°F) |

There are two types of solutions, depending upon the freezing temperature:

-10°C (14°F) (general use) and -30°C (-22°F) (cold area use), so select according to the area and season.

Cab Slide Door Rail And Roller - Check/Clean/Lubricate

(Machine equipped with cab)

Checking

When opening or closing the slide door, if it is clogged with mud and does not move freely, clean and supply grease to roller (2) and rail (1) of the slide door.

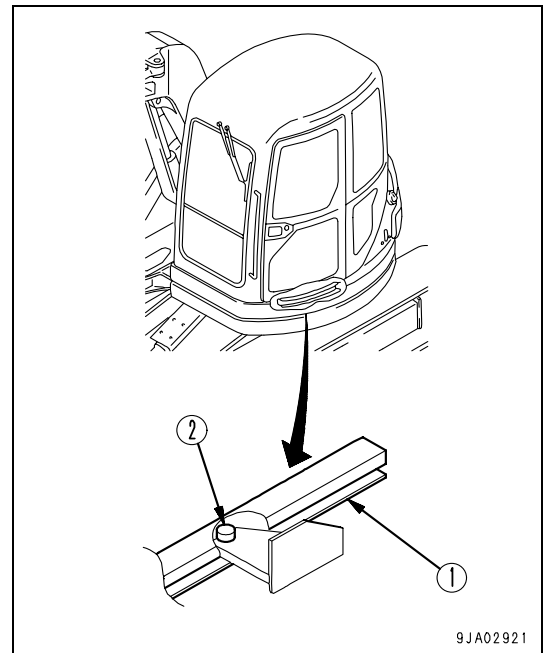

Cleaning

1. Open and close the door, and use a brush to remove any dirt from rail (1).
2. Use a cloth to wipe off any dirt from rail (1).

Greasing

NOTICE

Do not use high-viscosity oil for the lubricant.

1. Spray rail (1) and roller (2) thoroughly with lubricant.
2. After spraying with lubricant, slide the door and check that the door opens and closes smoothly.
If the movement is not smooth, contact your Komatsu distributor for repair.

Hydraulic System - Bleed Air

NOTICE

If the pump is operated without filling the pump case with hydraulic oil, there is danger that the pump may be prematurely damaged. Be sure to bleed the air completely.

1. Bleeding air from piston pump
 - 1) Remove the oil filler cap from the hydraulic oil tank.
 - 2) Open cover (1) at left side of machine.

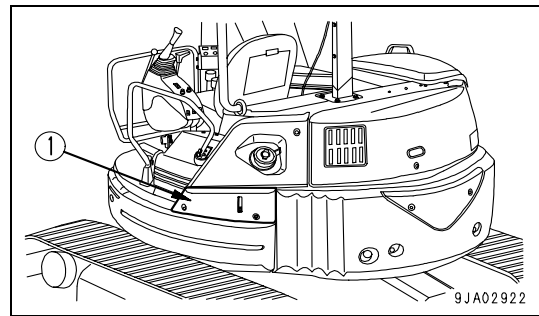

- 3) Loosen air bleeder (2) and confirm that oil oozes through it (the all air has been bled.)
- 4) After bleeding air, tighten the air bleeder.
Tightening torque:
8.83 ± 0.98 N·m (0.9 ± 0.1 kgf·m, 6.5 ± 0.7 lbft)
- 5) Tighten the oil filler cap of the hydraulic oil tank.

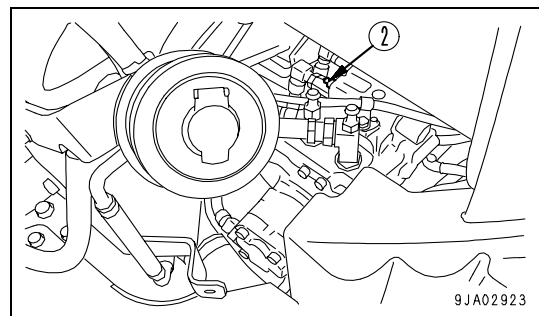

NOTICE

Be sure to pressurize the hydraulic tank. If it is not pressurized, the pump will suck in air, and this will adversely affect the equipment.

- 6) Extend the boom, arm, and bucket cylinder fully as shown in the diagram on the right. Remove the oil filler cap, then install the cap and pressurize the inside of the tank.
- 7) After bleeding air from the hydraulic tank, check the oil level. Refer to section "Hydraulic Oil Level - Check/Add (3-36)" in this manual.

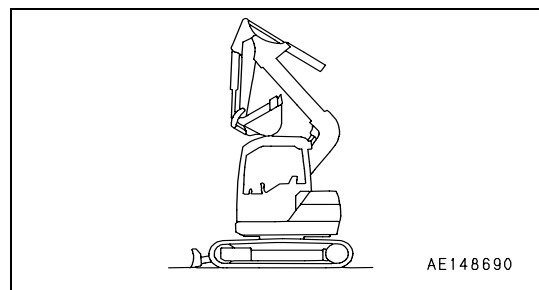

NOTICE

If the engine is run immediately at high speed or the cylinder is operated to the end of its stroke, the air inside the cylinder may cause damage to the piston packing.

2. Start the engine. For details, see "STARTING ENGINE (3-43)".
Run the engine at low idling for 10 minutes, then do as follows.
3. Bleeding air from cylinders
 - 1) Run the engine at low idling, and extend and retract each cylinder 4 to 5 times. Do not operate the cylinder to the end of its stroke. (Stop at a point approx. 100 mm (4 in) before the end of the stroke.)
 - 2) Next, operate each cylinder 3 to 4 times to the end of its stroke.
 - 3) Finally, operate each cylinder 4 to 5 times to the end of its stroke to completely remove the air.

NOTICE

- **If the method of bleeding the air from the attachment itself is specified by the manufacturer, bleed the air according to the specified procedure.**
 - **After completing the air bleeding operation, stop the engine, and leave the machine for 5 minutes before starting operations. This will remove the air bubbles in the oil inside the hydraulic cylinders.**
 - **Check that there is no leakage of oil and wipe off any oil that has been spilled.**
4. Bleeding air from attachment (when installed)
If a breaker or other attachment has been installed, run the engine at low idling and operate the attachment pedal repeatedly (approx. 10 times) until the air has been bled from the attachment circuit.

CHECK BEFORE STARTING

For details of the following items, see "Checks Before Starting (3-33)" in the OPERATION section.

- Cooling System Coolant Level - Check/Add
- Engine Crankcase Oil Level - Check/Add
- Fuel Level - Check/Refill
- Hydraulic Oil Level - Check/Add
- Air Cleaner Dust Indicator - Check
- Water Separator - Check
- Electric Wiring - Inspect
- Horn Function - Check

EVERY 100 HOURS MAINTENANCE

Lubricating

⚠ WARNING

Do not swing the upper structure while greasing the swing pinion.

NOTICE

- **For the first 100 hours on new machines where the parts are settling in, carry out greasing every ten hours.**
- **After digging operations under water, be sure to grease the pins which were submerged.**

- Prepare a grease gun.

1. Using a grease pump, pump grease in through the grease fittings shown by arrows.
2. After greasing, wipe off any old grease that was pushed out.

(1) Swing circle (1 point)

(2) Swing pinion (1 point)

When lubricating the swing pinion, turn the chassis little by little and apply grease through the grease fitting.

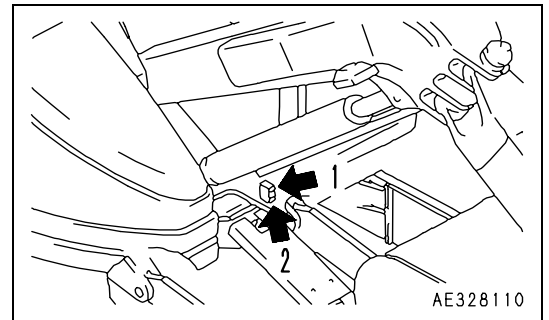

EVERY 250 HOURS MAINTENANCE

Engine Crankcase Oil - Change

WARNING

The parts and oil are at high temperature immediately after the engine is stopped, and may cause serious burns. Wait for the temperature to go down before starting the operation.

- Refill capacity: 8.7 liters (2.30 US gal)
1. Set a container to catch the oil immediately under the drain plug (P) at the bottom of the machine.
 2. Remove drain plug (P) slowly to avoid getting oil on yourself, and drain the oil.
 3. Check the drained oil, and if there are excessive metal particles or foreign material, please contact your Komatsu distributor.
 4. Install drain plug (P).
-
5. Add engine oil through oil filler (F) up to between the H and L level on dipstick (G).
 6. Run the engine at idle for a while, then stop the engine and confirm that the oil level is between the H and L lines according to "Engine Crankcase Oil Level - Check/Add (3-34)".

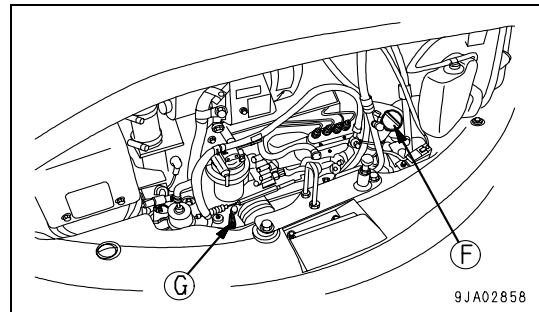
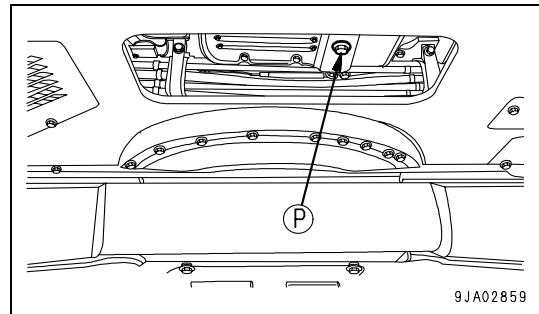

Hydraulic Oil Filter Element - Replace

WARNING

- The parts and oil are at high temperature after the engine is stopped, and may cause burns. Wait for the temperature to go down before starting the work.
- When removing the oil filler cap, turn it slowly to release the internal pressure, then remove it.

NOTICE

If the machine is equipped with a hydraulic breaker, the hydraulic oil will deteriorate much faster than during normal bucket operations. For details, see "MAINTENANCE INTERVAL FOR HYDRAULIC BREAKER (4-14)" when carrying out maintenance.

1. Open the cover at the right side of the machine.
2. Remove the cap from oil filler (F), and release the internal pressure.
3. Loosen 3 bolts, then remove cover (1). When doing this, the cover may fly out under the force of spring (2), so hold the cover down when removing the bolts.
4. After removing spring (2) and valve (3), take out element (4).
5. Clean the removed parts in diesel oil.
6. Install the new element where the old element (4) was installed.

Check the O-ring fitted to cover (1). If it is scratched or damaged, replace it with a new O-ring.

7. Set valve (3) and spring (2) on top of the element.
8. Set cover (1) in position, push it down by hand, and install the cover with the mounting bolts.
9. Extend the boom, arm, and bucket cylinder fully as shown in the diagram on the right, remove the oil filler cap, then install the cap and pressurize the inside of the tank.
10. Close mud cover at the right side of the machine.

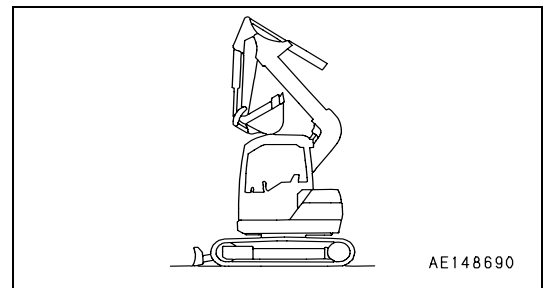
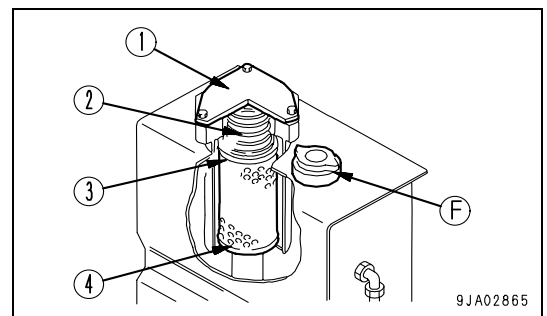

Cooling Fan Belt Tension - Inspect/Adjust

Inspection

1. Remove cover (1).

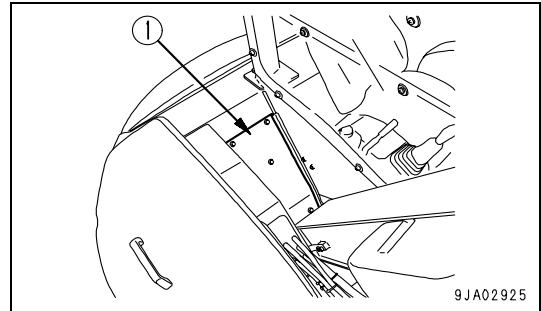

The belt should deflect approx. 5 to 6 mm(0.197 to 0.236 in) when pressed with "a" finger force of approx. 58.8 N (6 kgf) at a point midway between the alternator pulley and fan pulley.

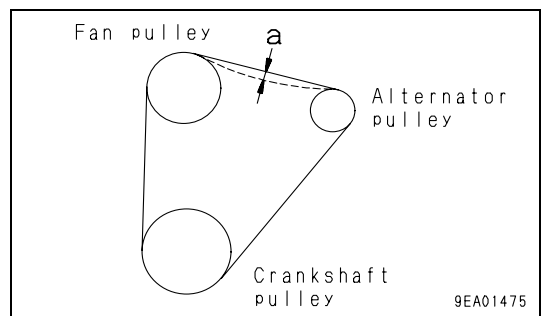
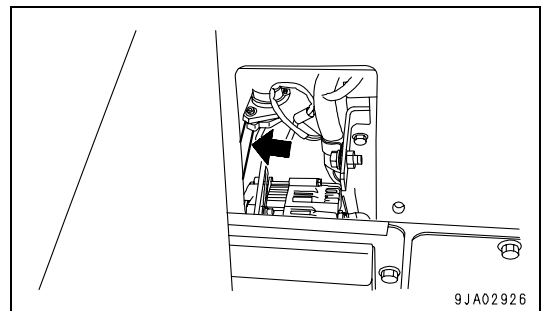

Adjustment

- Prepare a pinch bar.
 - Prepare a wooden block.
1. Retract the boom cylinder to the maximum end as illustrated at right.

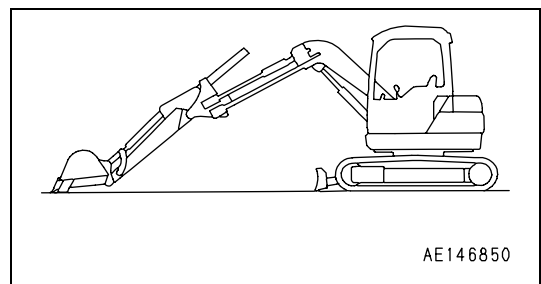

2. Remove cover (1).

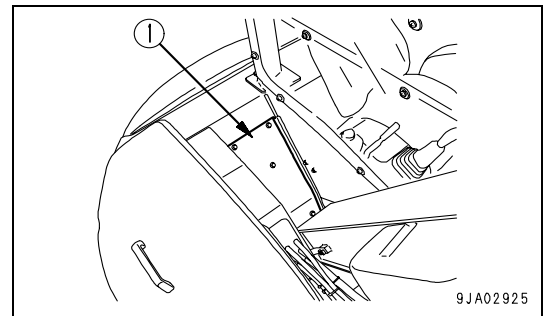

3. Remove cover (2).

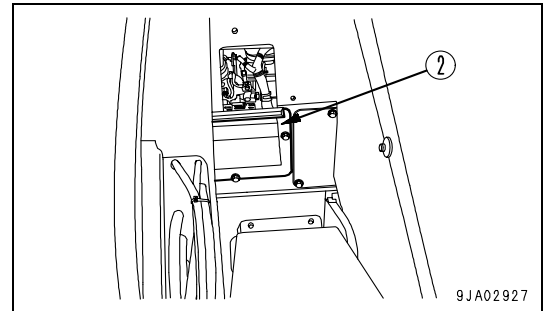

4. Insert a bar between alternator (3) and the cylinder block to fix alternator (3) in position. When fixing alternator (3) in position, insert a wooden block between the bar and alternator (1) to prevent any damage to the alternator.
5. Loosen alternator fixing bolt (4) and adjust bolt (5).
6. Using a bar, move alternator (3) towards the front of the machine to adjust the belt tension so that the deflection is approx. 5 to 6 mm (0.197 to 0.236 in) (approx. 58.5 N (6 kgf)), then tighten adjustment bolt (5).
7. Tighten mounting bolt (4).

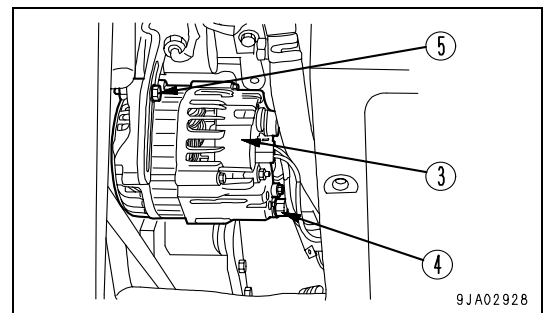

NOTICE

- Check each pulley for damage, wear of the V-groove, and wear of the V-belt. In particular, be sure to check that the V-belt is not touching the bottom of the V-groove.
- If the belt is stretched and there is no allowance for adjustment, or if it is cut or cracked, please contact your Komatsu distributor for replacement.

8. Install cover (2) and cover (1).

Battery Electrolyte Level - Check

Carry out this check before operating the machine.

⚠ WARNING

- Do not use the battery if the battery electrolyte level is below the LOWER LEVEL line. This will accelerate deterioration of the inside of the battery and reduce the service life of the battery. In addition, it may also cause an explosion.
- The battery generates flammable gas and there is danger of explosion, so do not bring fire or sparks near the battery.
- Battery electrolyte is dangerous. If it gets in your eyes or on your skin, wash it off with large amount of water and consult a doctor.
- When adding distilled water to the battery, do not allow the battery electrolyte to go above the UPPER LEVEL line. If the electrolyte level is too high, it may leak and cause damage to the paint surface or corrode other parts.

NOTICE

When adding distilled water in cold weather, add it before starting operations in the morning to prevent the electrolyte from freezing.

Inspect the battery electrolyte level at least once a month and follow the basic safety procedures given below.

When Checking Electrolyte Level from side of Battery

If it is possible to check the electrolyte level from the side of the battery, check as follows.

1. Open the cover at the right side of the machine.
2. Use a wet cloth to clean the area around the electrolyte level lines and check that the electrolyte level is between the UPPER LEVEL (U.L) and LOWER LEVEL (L.L) lines. If the battery is wiped with a dry cloth, static electricity may cause a fire or explosion.

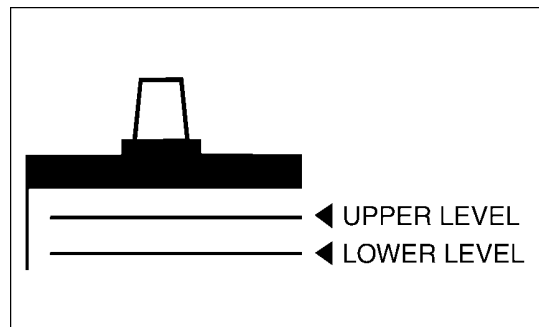

3. If the electrolyte level is below the midway point between the U.L and L.L lines, remove cap (1) and add distilled water to the U.L line.
4. After adding distilled water, tighten cap (1) securely.

REMARK

If distilled water is added to above the U.L line, use a pipette to lower the level to the U.L line. Neutralize the removed fluid with baking soda (sodium bicarbonate), then flush it away with a large amount of water or consult your Komatsu distributor or battery maker.

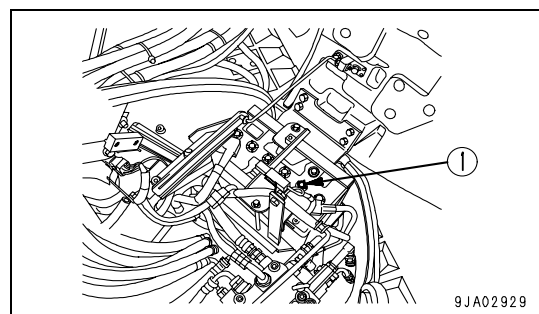

9JA02929

When It is Impossible to Check Electrolyte Level from Side of Battery

If it is impossible to check the electrolyte level from the side of the battery, or there is no display of the UPPER LEVEL line on the side of the battery, check as follows.

1. Open the cover at the right side of the machine.
2. Remove cap (1) at the top of the battery, look through the water filler port, and check the electrolyte surface. If the electrolyte does not reach the sleeve, add distilled water so that the level reaches the bottom of the sleeve (UPPER LEVEL line) without fail.

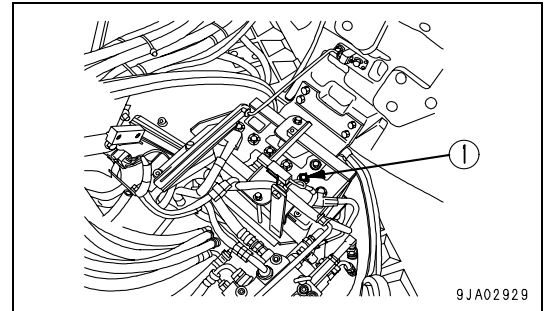

Use the diagram below for reference, and check if the electrolyte reaches the bottom of the sleeve.

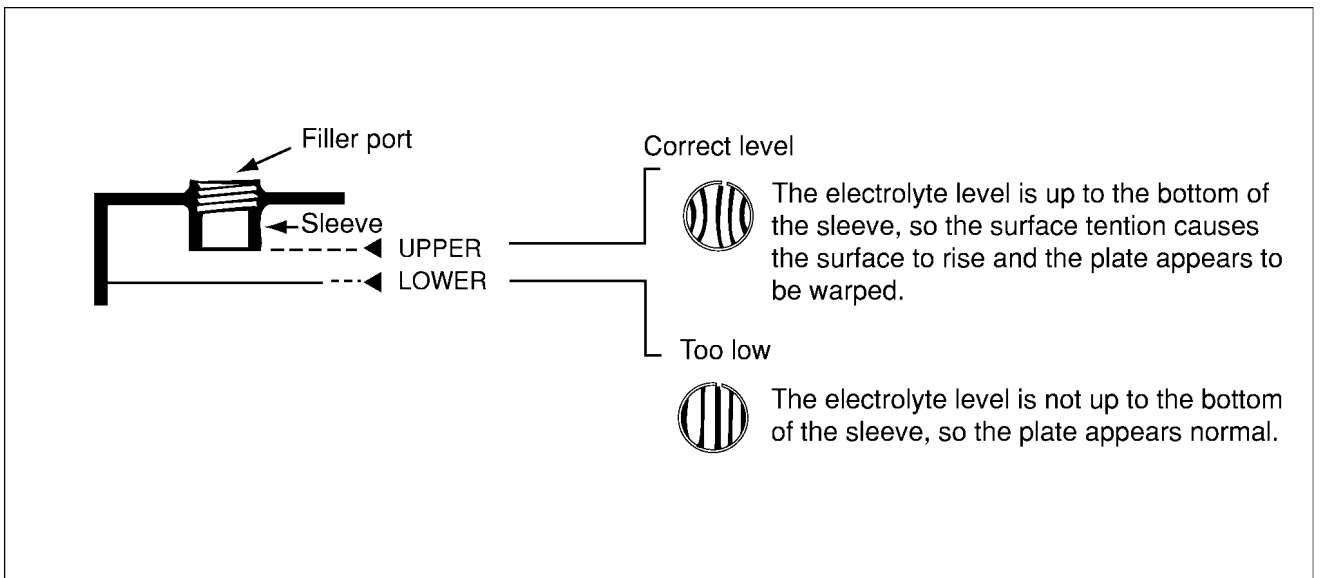

3. After adding distilled water, tighten cap (1) securely.

REMARK

If distilled water is added to above the bottom of the sleeve, use a pipette to lower the level to the bottom of the sleeve. Neutralize the removed fluid with baking soda (sodium bicarbonate), then flush it away with a large amount of water or consult your Komatsu distributor or battery maker.

When It is Possible to Use Indicator to Check Electrolyte Level

If it is possible to use an indicator to check the electrolyte level, follow the instructions given.

EVERY 500 HOURS MAINTENANCE

Maintenance for every 100 and 250 hours should be carried out at the same time.

Engine Crankcase Oil Filter Cartridge - Replace

WARNING

The parts and oil are at high temperature immediately after the engine is stopped, and may cause serious burns. Wait for the temperature to go down before starting the operation.

- Change oil in engine oil pan should be carried out at the same time.
- Filter wrench

1. Set the fuel control lever at low idling to stop the engine.

REMARK

The reason for setting the fuel control dial at low idling is to provide room for the filter wrench to grip due to the slackening of the fuel cable above the engine oil filter.

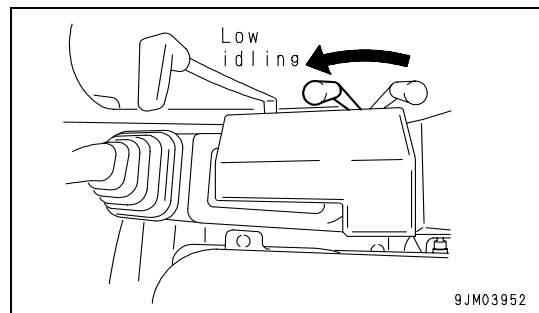

2. Drain the engine oil. For details, see "Engine Crankcase Oil - Change (4-44)".
3. Using a filter wrench, turn filter cartridge (1) counterclockwise to remove it.
4. Clean the filter holder, coat the steel surface of the new filter cartridge with clean engine oil (or coat it thinly with grease), then install it.

REMARK

Confirm that no remnants of old packing still adhere to the filter holder as this may result in oil leakage. Check that there is no old packing affixed to the filter holder. If there is any old packing affixed to the filter, it will cause leakage of oil.

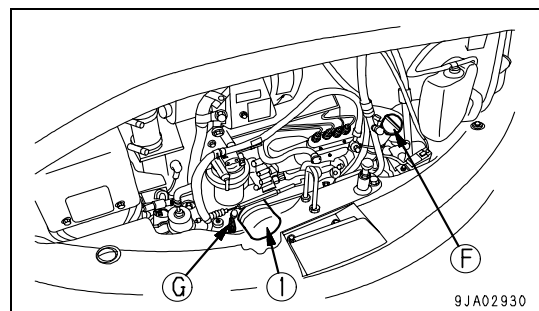

5. When installing; tighten until the packing surface contacts the seal surface of the filter holder, then tighten it up 1/2 to 3/4 of a turn.
6. After replacing the filter cartridge, add engine oil through oil filler port (F) so that the oil level is between the H and L marks on dipstick (G).
7. Run the engine at idle for a while, then stop the engine and confirm that the oil level is between the H and L lines according to "Engine Crankcase Oil Level - Check/Add (3-34)".

Fuel Filter Element - Replace

⚠ WARNING

- Engine is at high temperature immediately after the machine has been operated. Wait for engine to cool down before replacing the filter.
- Do not bring fire or sparks near the fuel.

- Prepare a filter wrench for fuel filter element.
 - Prepare a container to catch the oil.
1. Place a container under the filter element to catch the oil.
 2. Close valve (1) at the top of the filter.
 3. Using a filter wrench, loosen ring (2), then remove element cup (3) and take out element (4).
 4. Wash element cup (3) in diesel oil or in a cleaning oil and install a new element.
 5. Fill the element cup with fuel, then install filter holder. When replacing a fuel filter element, replace the filter O-ring at the same time.
 6. Open valve (1) at the top of the filter.

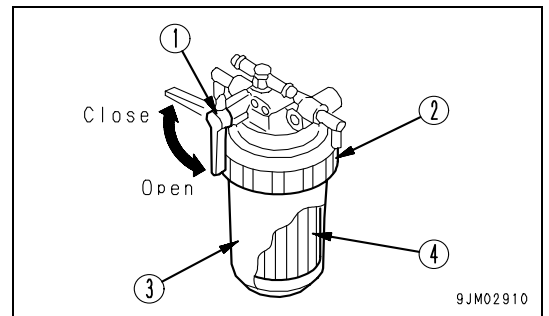
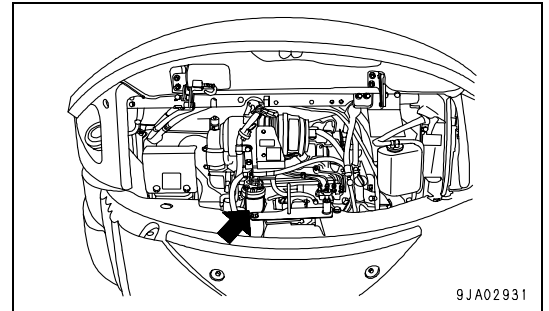

7. Set fuel control lever to the low idling position.
8. After replacing the fuel filter element, bleed the air. For details of the procedure, see "Air Bleeding (4-51)".

Air Bleeding

1. Fill the fuel tank with fuel.
2. Turn and keep the starting switch key to the ON position for 15 to 20 seconds. Air is automatically bled by the automatic air bleeding device.

NOTICE

After running the starting motor once, wait at least 30 seconds before running it again.

REMARK

When the machine has run out of fuel, carry out the same procedure and crank the engine for 15 - 20 seconds. Repeat this operation 2 - 3 times to bleed the air.

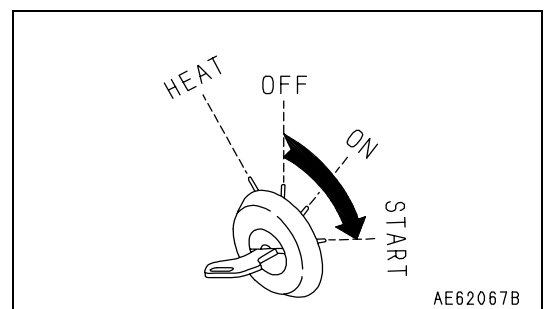

Final Drive Case Oil Level - Check/Add

WARNING

- The oil is at high temperature immediately after the machine has been operated. Wait for the oil to cool down before starting the operation.
- If there is still pressure remaining inside the case, the oil or plug may fly out.
- Loosen the plug slowly to release the pressure.

- Prepare a container to catch drained oil.
- Prepare a hexagon wrench.

1. Turn the sprocket so that plug (P) is at the bottom.
2. Set the container to catch oil under plug (P).
3. Remove plug (G) with a hexagonal wrench. Oil level should be near the bottom of the plug hole (G).
4. If the oil is insufficient, remove plug (F) with a hexagonal wrench, then add oil through plug (F), until oil flows out of level plug hole (G).
5. After checking the oil level, install plugs (F) and (G).

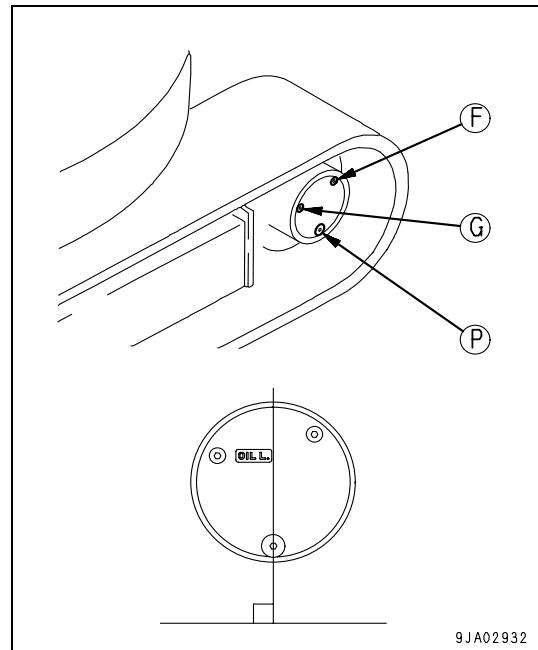

9JA02932

Lubricating

NOTICE

- For the first 100 hours on new machines where the parts are settling in, carry out greasing every ten hours.
- After digging operations under water, be sure to grease the pins which were submerged.

- Prepare a grease gun.
1. Set the machine to the greasing posture shown on the right diagram, lower the work equipment to the ground, then stop the engine.
 2. Using a grease pump, pump grease in through the grease fittings shown by arrows.
 3. After greasing, wipe off any old grease that was pushed out.

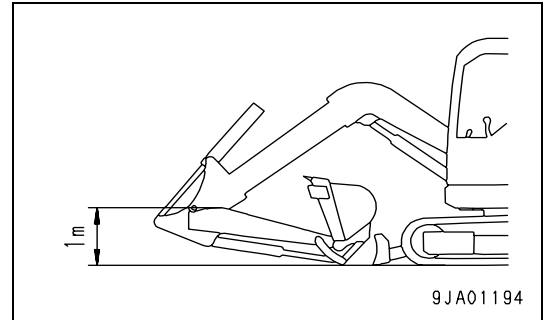

- (1) Blade cylinder foot pin (1 place)
- (2) Blade cylinder rod end pin (1 point)
- (3) Blade foot pin (2 points)

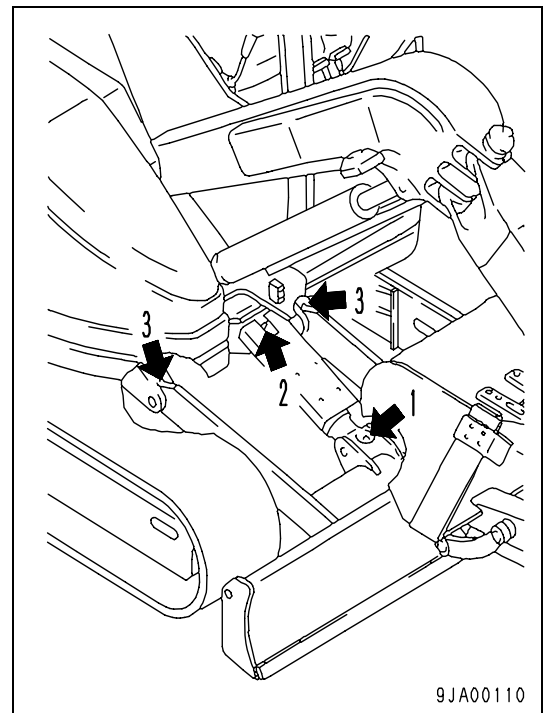

- (4) First boom foot pin (2 points)
- (5) First boom cylinder foot pin (1 point)
- (6) First boom cylinder rod end pin (1 point)
- (7) First boom-Second boom coupling pin (1 point)

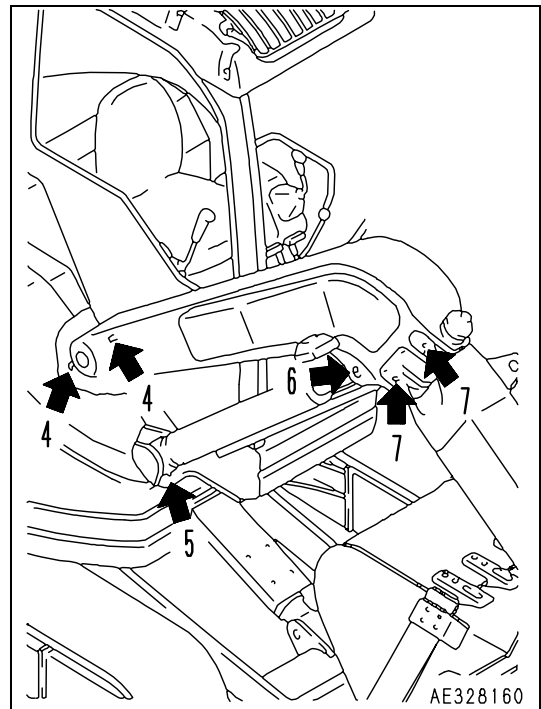

- (8) Offset cylinder foot pin (1 point)
- (9) Offset cylinder rod end pin (1 point)
- (10) Sub-link coupling pin (2 points)

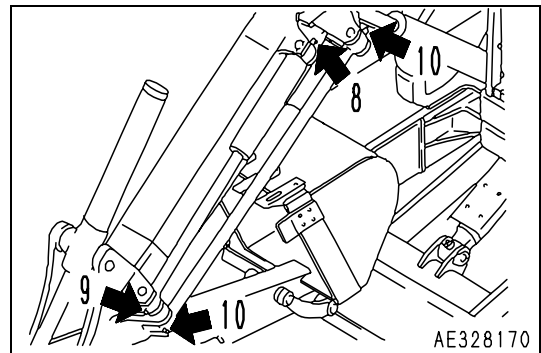

- (11) Second boom-Third bracket coupling pin (2 points)
- (12) Arm cylinder foot pin (2 places)
- (13) Arm cylinder rod end pin (1 place)
- (14) Third bracket-Arm coupling pin (1 place)
- (15) Bucket cylinder foot pin (1 place)

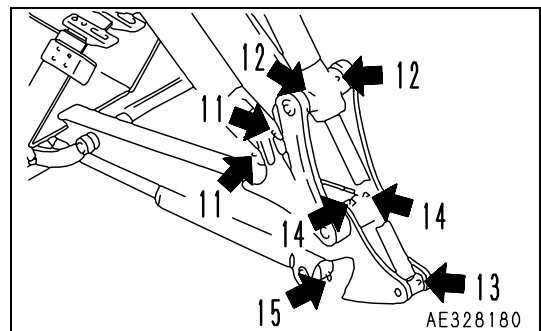

- (16) Bucket cylinder rod end pin (1 place)
- (17) Arm-Link coupling pin (1 place)
- (18) Link coupling pin (1 place)
- (19) Bucket-Link coupling pin (1 place)
- (20) Arm-Bucket coupling pin (1 place)

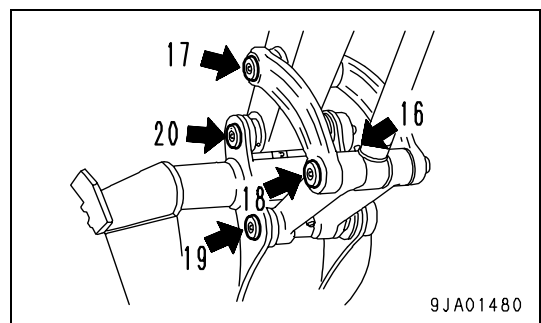

Radiator Fins, Oil cooler fins - Clean/Check

⚠ WARNING

If compressed air, high-pressure water, or steam hit your body directly, or they cause dirt or dust to be blown up, there is a hazard of serious injury. Always use safety glasses, dust mask, or other protective equipment.

NOTICE

When using compressed air, keep the air nozzle at a distance to prevent damage to the fins. Especially for the aftercooler, blow the air from 300 mm (11.8 in) or more, and at a 45 degree angle.

To prevent damage to the fins, apply compressed air from an appropriate distance. Damaged fins may cause water leakage or overheating. On dusty sites, check the fins daily, regardless of the maintenance interval.

1. Open the engine hood and cover.
2. Remove bolt (1).
3. Open cover (2) and fix it with the stopper.

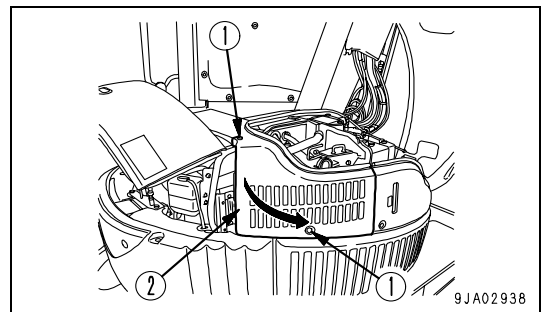

4. Remove bolt (3), then loosen bolt (4).
5. Pull oil cooler (5) toward yourself to widen the distance between the oil cooler and the radiator fins.

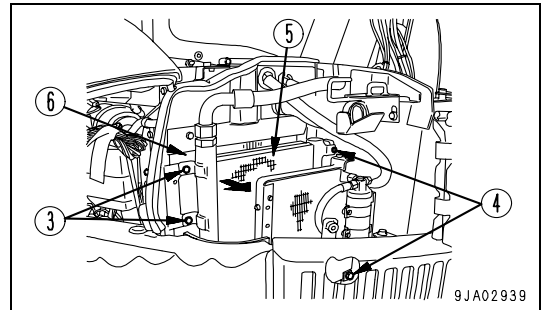

6. Use compressed air to clean the mud, dust, and leaves from the radiator fins (6), and oil cooler fins (5). Steam or water may be used instead of compressed air.

EVERY 1000 HOURS MAINTENANCE

Maintenance for every 100, 250 and 500 hours should be carried out at the same time.

Final Drive Case Oil - Change

⚠ WARNING

- The oil is at high temperature immediately after the machine has been operated. Wait for the oil to cool down before starting the operation.
- If there is still pressure remaining inside the case, the oil or plug may fly out.
- Loosen the plug slowly to release the pressure.

- Refill capacity (each): 1.0 liter (0.26 US gal)
 - Prepare a hexagon wrench
1. Turn the sprocket so that plug (P) is at the bottom.
 2. Set the container to catch oil under plug (P).
 3. Remove plugs (P), (G) and (F) with hexagonal wrench to drain the oil.
 4. Tighten plug (P).
 5. Add oil through the hole of plug (F) up to the refill level.
 6. After the oil flows out of the hole plug (G), install plugs (G) and (F).

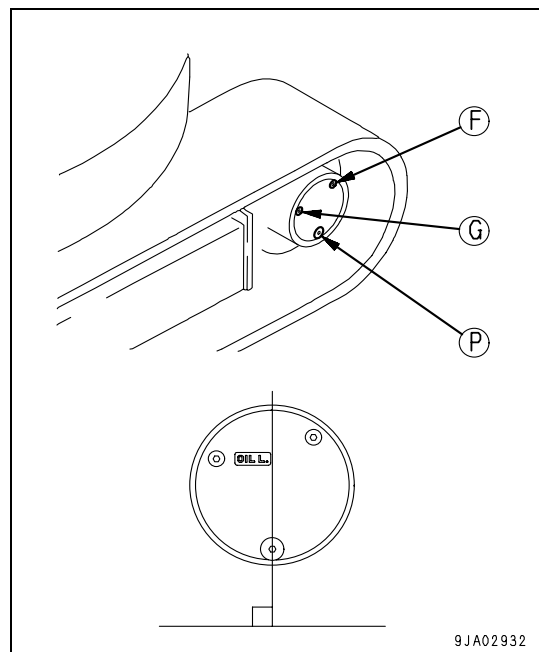

Engine Valve Clearance - Check/Adjust

As special tool is required for removing and adjusting the parts, you shall request Komatsu distributor for service.

EVERY 2000 HOURS MAINTENANCE

Maintenance for every 100, 250, 500 and 1000 hours should be carried out at the same time.

Hydraulic Oil and Strainer - Change/Clean

⚠ WARNING

- The parts and oil are at high temperature after the engine is stopped, and may cause burns. Wait for the temperature to go down before starting the work.
- When removing the oil filler cap, turn it slowly to release the internal pressure, then remove it.

- Refill capacity: 38 liters (10.04 US gal)
- Prepare a handle (for the socket wrench).

1. Swing the upper structure so that the drain plug under the hydraulic tank will be between both tracks.
2. Retract the arm and bucket cylinders, then lower the boom and put the teeth in contact with the ground.
3. Lower the blade to the ground.

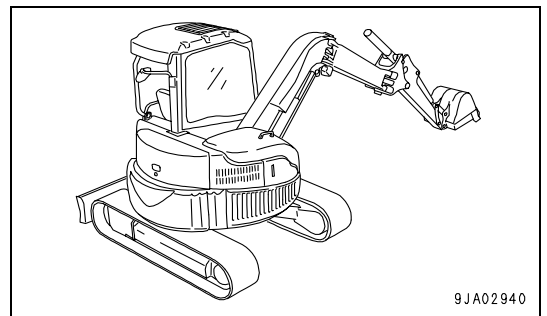

4. Set the safety lock lever to the LOCK position and stop the engine.

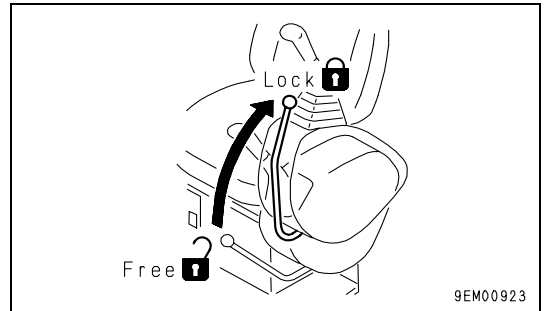

5. Open mud cover, then remove the cap of oil filler (F) to release the internal pressure.
6. Set a container under the drain plug (P) on the underside of the machine body. Remove the drain plug (P) to drain oil. Check the O-rings fitted to plug (P). If they have any flaw, replace them. After draining the oil, tighten drain plug (P).

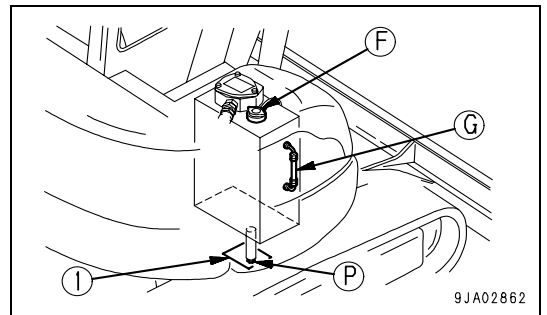

Take care not to get oil on yourself when you remove drain plug (P).

7. Loosen hose clamp (2) and remove hose (3), then loosen bolt (4) and take out strainer (5).
8. Remove any dirt stuck to strainer (5), then wash it in clean diesel fuel or flushing oil. If strainer (5) is damaged, replace it with a new part.
9. Secure strainer (5) in position with bolt (4), then install hose (3) and secure it with hose clamp (2).
10. Add the specified amount of new and clean engine oil (for hydraulic system) through oil filler port (F). Check that the oil level is between H and L on the sight gauge.

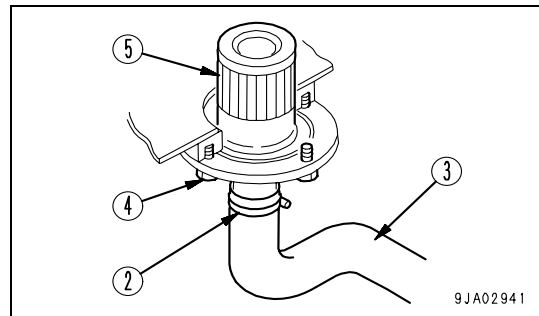

11. Extend the boom, arm, and bucket cylinder fully as shown in the diagram on the right, remove the oil filler cap, then install the cap and pressurize the inside of the tank.

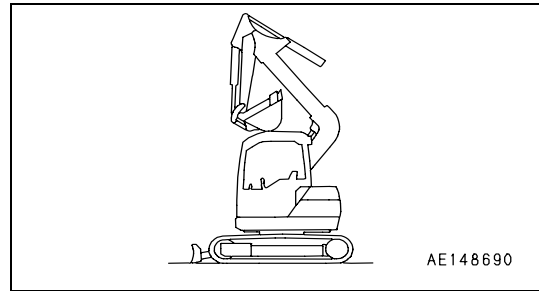

NOTICE

Be sure to pressurize the hydraulic tank. If it is not pressurized, the pump will suck in air, and this will adversely affect the equipment.

12. After replacing the oil, set each control lever to the neutral position and run the engine idle at a low speed for 2 to 3 minutes, then start the normal work.

Alternator and Starting Motor - Inspect

The brush may be worn or the bearing may have run out of grease. Contact your Komatsu distributor for inspection or repair.

If the engine is started frequently, carry out inspection every 1000 hours.

SPECIFICATIONS

SPECIFICATIONS

| Item | | Unit | Road liner specified | Rubber shoe specified | Steel shoe specified |
|-------------------------|---------------------------|-----------------------------------|-------------------------------|-----------------------|----------------------|
| Operating weight | Canopy specified | kg (lb) | 5,330 (11,753) | 5,230 (11,532) | 5,280 (11,624) |
| | Cab specified | kg (lb) | 5,390 (11,885) | 5,290 (11,664) | 5340 (11,775) |
| Bucket capacity | | m ³ (yd ³) | 0.22 (0.29) | | |
| Name of engine | | - | Komatsu 4D88E-3 Diesel engine | | |
| Engine horsepower | | kW (HP)/rpm | 29.4 (39)/2,400 | | |
| A | Overall length | mm (ft in) | 5,335 (17'6") | | |
| B | Overall height | mm (ft in) | 2,625 (8'7") | 2,610 (8'7") | 2,605 (8'7") |
| | | mm (ft in) | 2,625 (8'7") | 2,610 (8'7") | 2,605 (8'7") |
| C | Overall width | mm (ft in) | 2,000 (6'7") | | |
| D | Track width | mm (ft in) | 400 (1'4") | | |
| E | Radius of upper structure | mm (ft in) | 1,035 (3'5") | | |
| F | Length of track | mm (ft in) | 2,470 (8'1") | 2,460 (8'1") | 2,430 (7'12") |
| G | Tumbler center distance | mm (ft in) | 1,910 (6'3") | 1,940 (6'4") | 1,910 (6'3") |
| Min. ground clearance | | mm (ft in) | 335 (1'1") | 320 (1'1") | 315 (1'0") |
| Travel speed (Low/High) | | km/h (MPH) | 2.5 (1.6)/4.2 (2.6) | 2.7 (1.7)/4.5 (2.8) | 2.5 (1.6)/4.2 (2.6) |
| Swing speed | | rpm | 10.0 | | |

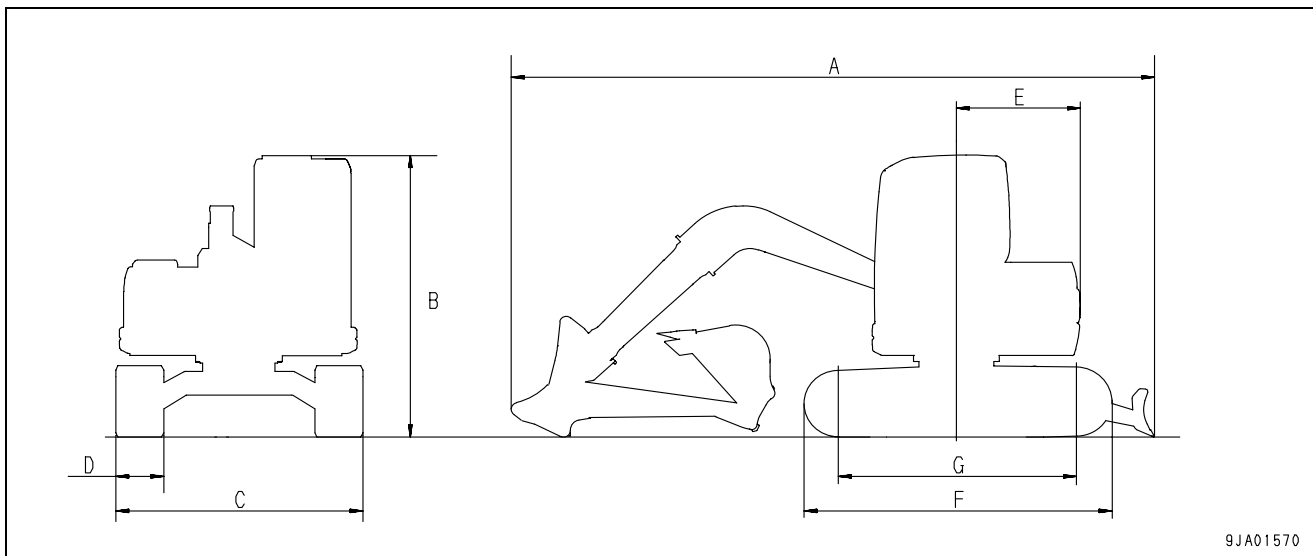

9JA01570

| | Working ranges | Unit | PC58UU-3 |
|---|----------------------------|------------|---------------|
| A | Max. digging reach | mm (ft in) | 5,660 (18'7") |
| B | Max. digging depth | mm (ft in) | 4,000 (13'1") |
| C | Max. digging height | mm (ft in) | 6,330 (20'9") |
| D | Max. vertical wall depth | mm (ft in) | 2,900 (9'6") |
| E | Max. dumping height | mm (ft in) | 4,600 (15'1") |
| F | Min. front swing radius | mm (ft in) | 1,060 (3'6") |
| G | Max. reach at ground level | mm (ft in) | 5,565 (18'3") |
| H | Max. blade lifting height | mm (ft in) | 400 (1'4") |
| I | Max. Blade lowering depth | mm (ft in) | 270 (0'11") |

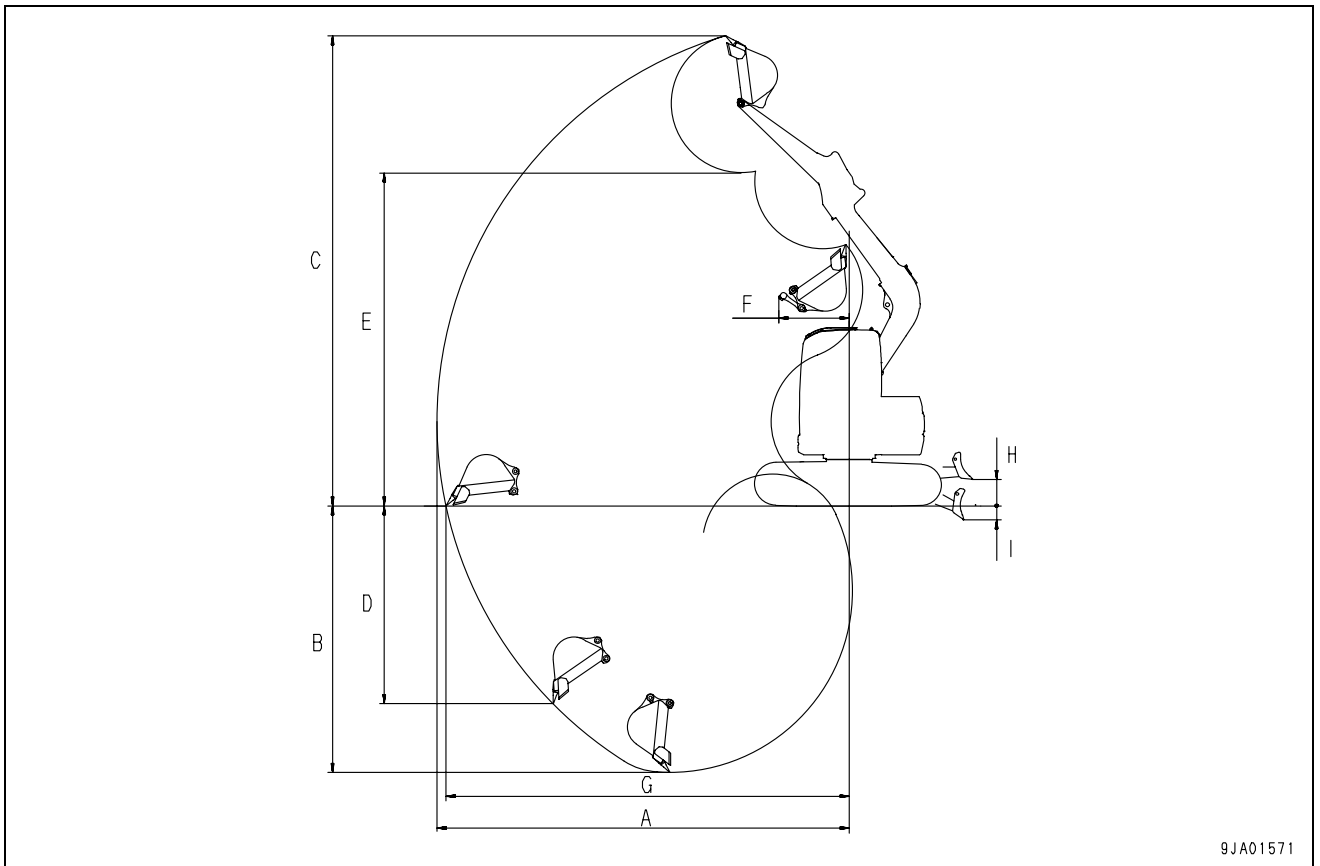

ATTACHMENTS AND OPTIONS

 **WARNING**

Please read and make sure that you understand the SAFETY section before reading this section.

ATTACHMENTS AND OPTIONS - GENERAL INFORMATION

SAFETY FIRST

If attachments or options other than those authorized by Komatsu are installed, this will not only affect the life of the machine, but will also cause problems with safety.

When installing attachments not listed in this Operation and Maintenance Manual, contact your Komatsu distributor first.

If you do not contact Komatsu, we cannot accept any responsibility for any accidents or failures.

WARNING

General precautions

- Read the instruction manual for the attachment thoroughly, and do not use this attachment unless you are sure that you have understood the guides completely.
- If you lose the instruction manual, always ask the manufacturer or your Komatsu distributors for a new copy.
- Depending on the attachment, install the necessary front guard to the machine.
- Depending on the attachment, the impact noise may make it difficult for fellow workers to transmit instructions for the operation. Before starting operation, decide a leader and determine the signals to be used.
- Do not carry out swinging operations to the side with a heavy load on the attachment. This is particularly dangerous on slopes.
- Comparing with a machine equipped with a bucket, a machine equipped with a breaker has a heavy load at the front of the work equipment and is unstable. To avoid a hazard of tipping over, do not carry out operations with the attachment swung to the side.
- When an attachment is installed, the swing range and center of gravity of the machine are different, and the machine may move in an unexpected way. Be sure that you understand the condition of the machine properly.
- Before starting operations, set up a fence around the machine to prevent people from entering.
- Never operate the machine when there are people near the machine.
- To prevent serious accidents caused by misoperation, do not put your foot on the pedal except when operating the pedal.

Precautions for removal and installation operations

When removing or installing the attachments, obey the following precautions and take care to ensure safety during the operation.

- Carry out the removal and installation operation on a flat, firm ground surface.
- When the operation is carried out by two or more workers, determine the signals and follow these during the operation.
- When carrying heavy objects (more than 25kg or 55 lb), use a crane.
- When removing heavy parts, always support the part before removing it.
- When lifting such as heavy parts with a crane, always pay careful attention to the position of the center of gravity.
- It is dangerous to carry out operations with the load kept suspended. Always set the load on a stand, and check that it is safe.
- When removing or installing attachments, make sure that it is in a stable condition and will not fall over.
- Never go under a load suspended from a crane.
- Always stand in a position that is safe even if the load should fall.

NOTICE

Qualifications are required to operate a crane. Never allow the crane to be operated by an unqualified person.

For details of removal and installation operations, contact your Komatsu distributor.

ATTACHMENT INSTALLATION

⚠ WARNING

Long work equipment or heavy work equipment causes the machine to have poor stability. There is danger of the machine losing its balance and tipping over when traveling down steep hills or when swinging on slopes. Never do any of the following. They are extremely dangerous.

- Traveling downhill with the work equipment raised
- Traveling across slopes
- Swinging upper structure on slopes
- If heavy-load work equipment is installed, there will be excessive overrun when swinging (the distance from operating to stop the swing to the point where the swing stops completely), so there is danger of mistaking the distance and hitting other objects.

Allow a margin to the stopping point when operating.

- In addition, the hydraulic drift (the gradual downward movement caused by the weight of the work equipment when the work equipment is stopped in a raised condition) will also increase.
- If the correct procedure is not used when installing the boom and arm, it may lead to serious damage. Please consult your Komatsu distributor.
- When long work equipment is installed, the working range will suddenly become larger, so there is danger of mistaking the distance and hitting other objects. Allow an ample margin between the work equipment and surrounding obstacles when operating.

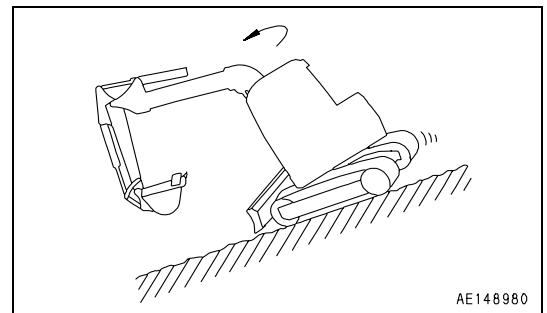
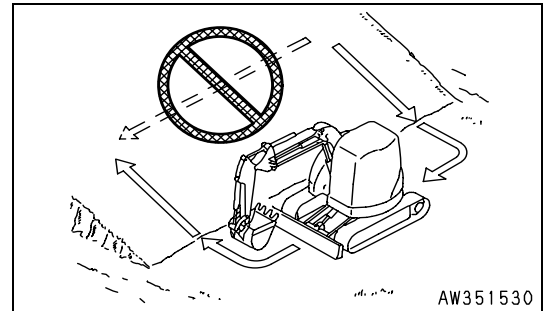
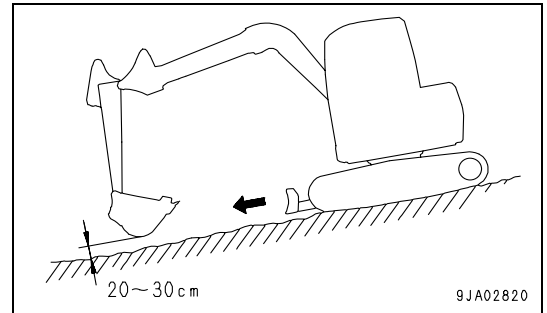

BUCKET WITH HOOK

HOOK CONDITION

Check that there is no damage to the hook, stopper, or hook mount. If there is any abnormality, contact your Komatsu distributor.

PROHIBITED OPERATIONS

Operations with Care

- When carrying out lifting operations, reduce the engine speed and operate slowly.
- Depending on the operating posture, there is danger that the wire or ring may come off the hook. To prevent this, pay careful attention to the angle of the hook.
- Never steer the machine while lifting a load.
- If the bucket with hook is turned and used for operations, it will hit the arm during dumping operations, so be careful when using it.
- If you are planning to install a hook, contact your Komatsu distributor.

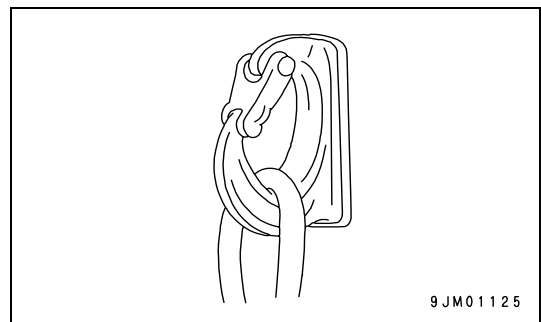
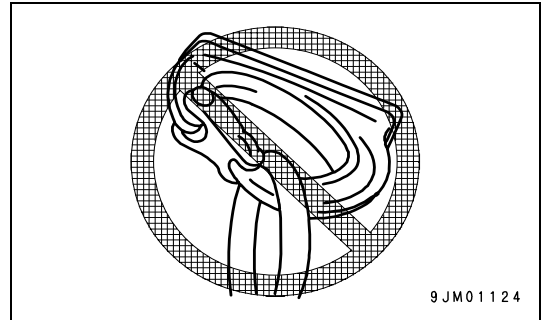

AIR CONDITIONER

CONTROL PANEL AND COMPONENTS

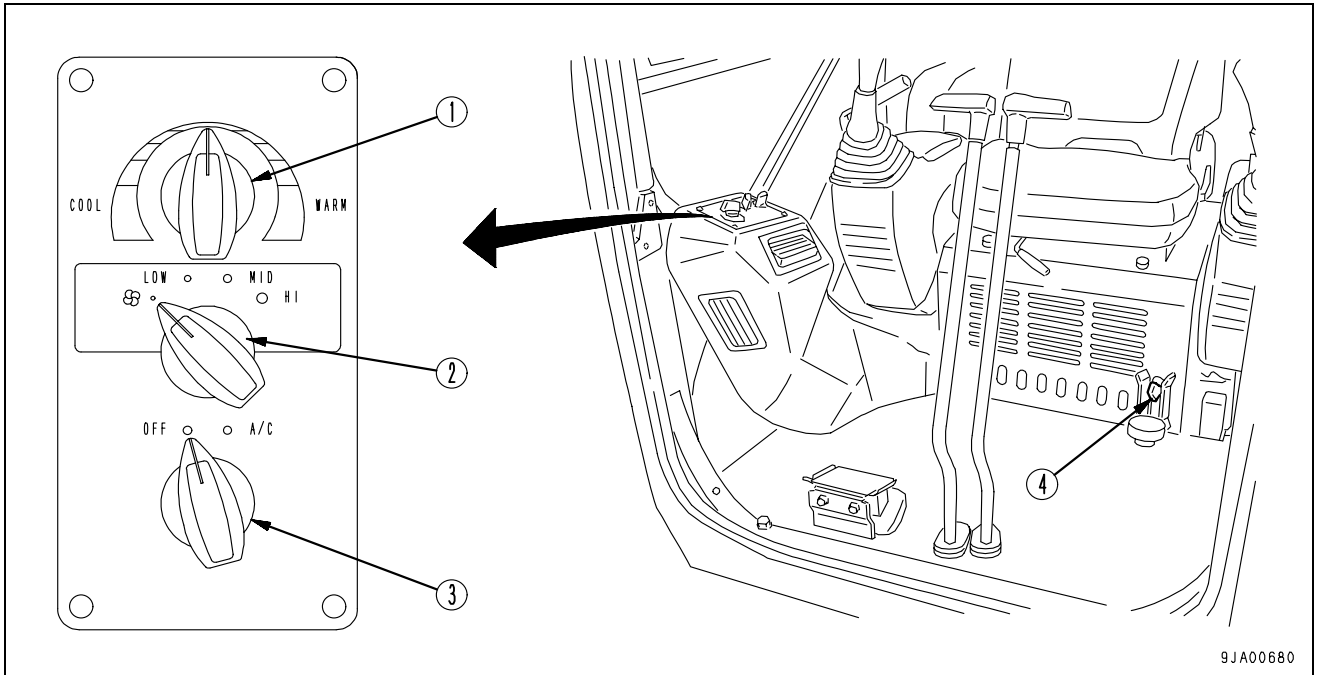

- (1) Temperature control switch
- (2) Air flow selector switch

- (3) Air conditioner switch
- (4) Air outlet selector lever

Temperature Control Switch

This switch (1) continuously adjusts the temperature between high and low.

The more the switch is turned to the left, the lower the temperature becomes; the more the switch is turned to the right, the higher the temperature becomes.

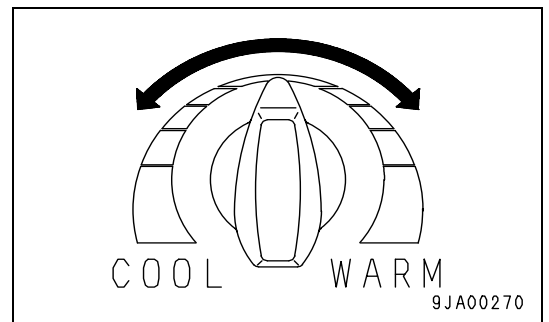

Air Flow Selector Switch

This switch (2) adjusts air flow in three steps.

- Position (a): OFF
- Position (b): Low
- Position (c): Intermediate
- Position (d): High

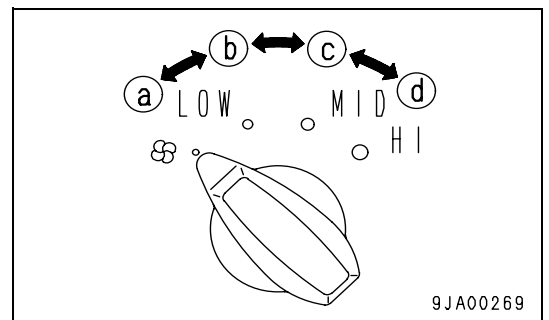

Air Conditioner Switch

This switch (3) functions as an ON/OFF switch for the air-conditioning system.

A/C: ON
 OFF: STOP

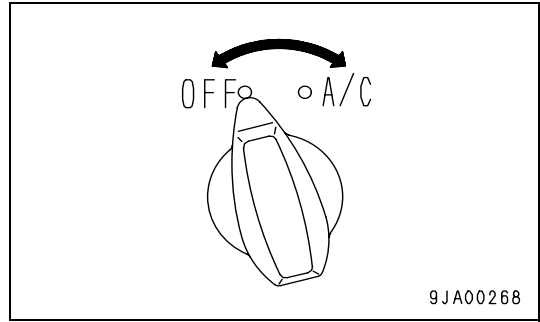

Air Outlet Selector Lever

Use lever (4) to select the air outlet to match the purpose of use.

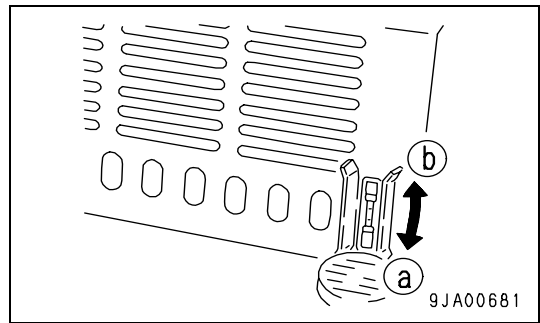

- Position (a): Sends air to operator's feet

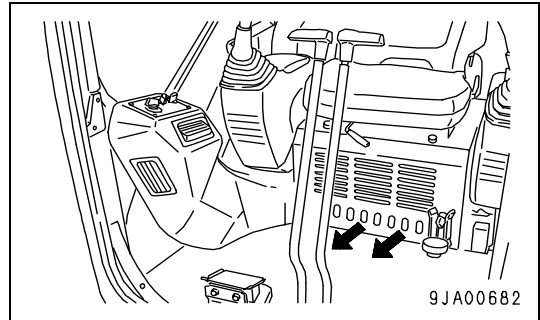

- Position (b): Sends air to upper part of operator's body.

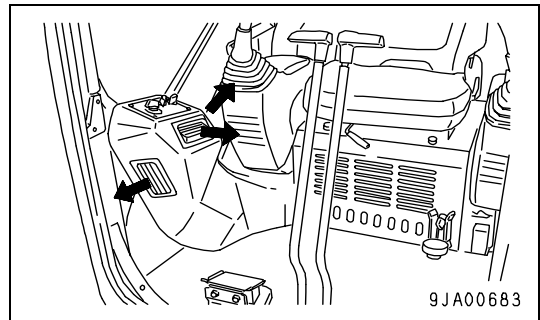

AIR CONDITIONER CONTROLS

Cooling

- If you smoke when the cooler is on, the smoke may start to hurt your eyes. Use both ventilation and cooling for a short time to remove the smoke.
- When running the air conditioner for a long time, use ventilation and cooling together once an hour.

Cooling with Care

- When the cooler is on, set the temperature so that it feels slightly cool when entering the cab (5 to 6°C (41 to 42.8°F) lower than the outside temperature). This temperature difference is considered to be the most suitable for your health. Adjust the temperature properly.

AIR CONDITIONER MAINTENANCE

When Required

Refrigerant (Gas) Level - Check

⚠ WARNING

If the refrigerant used in the cooler gets into your eyes or on your hands, it may cause loss of sight or frostbite. Do not touch the refrigerant. Never loosen any part of the refrigerant circuit. Do not bring any flame close to any point where the refrigerant gas is leaking.

If there is a lack of refrigerant (gas), the cooling performance will be poor. When operating the cooler at high speed with the engine at full throttle, use the receiver sight glass (inspection window) to check the condition of the refrigerant gas (Freon R134a) flowing in the refrigerant circuit.

- No bubbles in refrigerant flow: Suitable
- Some bubbles in flow (bubbles pass continuously): Lack of refrigerant
- Colorless, transparent: No refrigerant

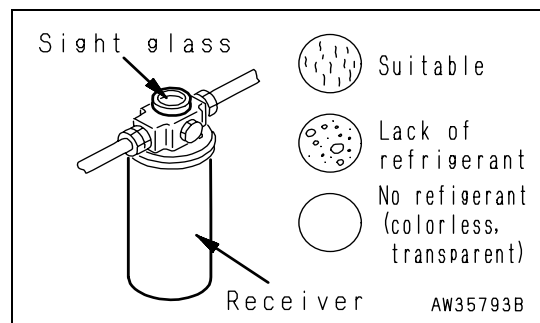

REMARK

When there are bubbles, the refrigerant gas level is low, so contact your refrigerant dealer to have refrigerant added. If the air conditioner is run with the refrigerant gas level low, it will cause damage to the compressor.

Off Season Checks

Even during the off-season, run the compressor at low speed for 3 to 5 minutes once a month to prevent the loss of the oil film at the lubricated parts of the compressor.

Inspection and Maintenance Items

| Check, maintenance items | Content of check, maintenance | Guideline for maintenance interval |
|--------------------------|--|------------------------------------|
| Refrigerant (gas) | Charge amount | Twice a year (spring, autumn) |
| Condenser | Clogged fins | Every 500 hours |
| Compressor | Operating condition | Every 4000 hours |
| V-belt | Damage, tension | Every 250 hours |
| Blower motor, fan | Operating condition (does it make abnormal noise?) | When required |
| Control mechanism | Operating condition (does it function normally?) | When required |
| Piping mounts | Mounting condition, looseness at tightening or connecting portions, leakage of gas, damage | When required |

Every 250 Hours Maintenance

Air Conditioner Compressor Belt Tension - Inspect/Adjust

Inspection

The belt should deflect 5 to 6 mm (0.197 to 0.236 in) when pressed with a finger force of approx. 58.8 N (6 kgf, 13 lb) at a point midway between the idle pulley and compressor pulley.

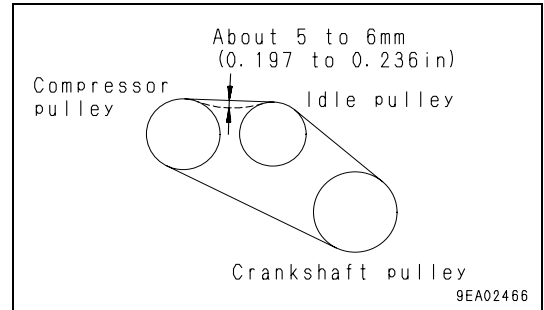

Adjustment

Adjust the belt tension with adjustment nut (2) of idle pulley (1).

1. Open the engine hood and loosen nut (3).
2. Adjust with adjustment nut (2) so that the deflection of the belt is 5 to 6 mm (0.197 to 0.236 in) (approx. 58.8 N (6 kgf, 13 lb)).
3. Tighten nut (3) to hold idle pulley in position.
4. Check for damage to the pulleys, and wear of the V-groove and V-belt. Be particularly careful to check that the V-belt is not in contact with the bottom of the V-groove.
5. Replace the belt if it has stretched, leaving no allowance for adjustment, or if it is cut or cracked.
6. When the new V-belt is installed, readjust it after the first hour of operation.

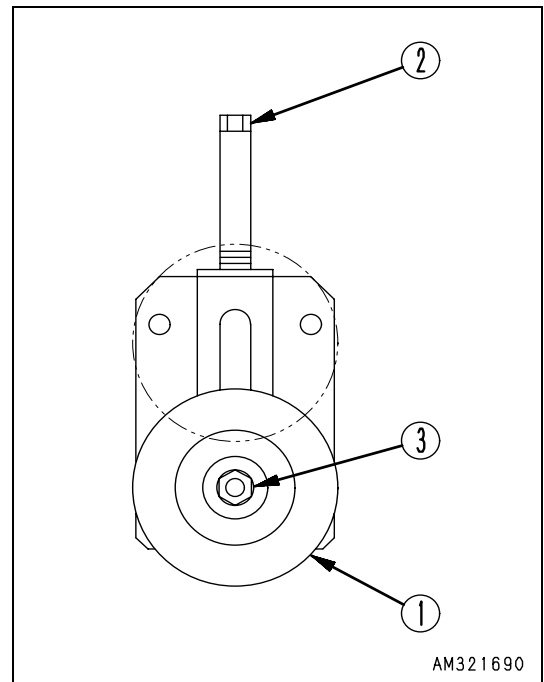

Every 500 Hours Maintenance

Air Conditioner Condenser - Clean

WARNING

If compressed air, high-pressure water, or steam hit your body directly, or they cause dirt or dust to be blown up, there is a hazard of serious injury. Always use safety glasses, dust mask, or other protective equipment.

NOTICE

When using compressed air, keep the air nozzle at a distance to prevent damage to the fins. Especially for the aftercooler, blow the air from 300mm (11.8 in) or more, and at a 45 degree angle.

To prevent damage to the fins, apply compressed air from an appropriate distance. Damaged fins may cause water leakage or overheating. On dusty sites, check the fins daily, regardless of the maintenance interval.

1. Open the engine hood and cover.
2. Remove bolt (1).
3. Open cover (2) and fix it with the stopper.

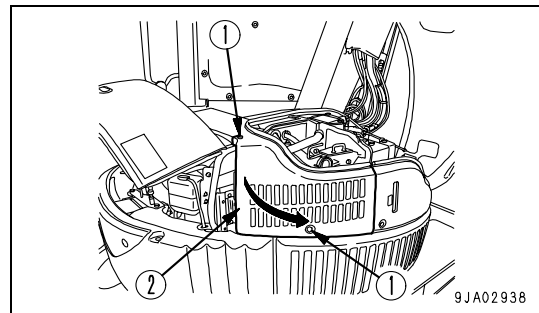

4. Blow off mud, dust or leaves clogging the condenser fins using compressed air.
Steam or water may be used instead of compressed air.
5. Check the rubber hose. Replace with a new one if the hose is found to have cracks or to be hardened by ageing.
Further, check hose clamps for looseness.

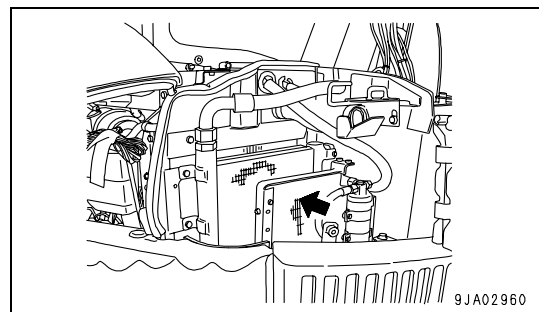

Air Conditioner Air Filter - Clean

1. Remove trim (1) and pull out filter (2).
2. Clean filter (2) with compressed air. If there is oil stuck to the filter or it is extremely dirty, wash it in a neutral agent. After washing, dry it thoroughly before using it again. If the dirt clogging the filter cannot be removed by blowing it with air or washing it in water, replace the filter with a new part.
3. Insert filter (2) and attach trim (1).

NOTICE

As a guideline, the filters should be cleaned every 500 hours, but on dusty jobsites, clean the filters more frequently.

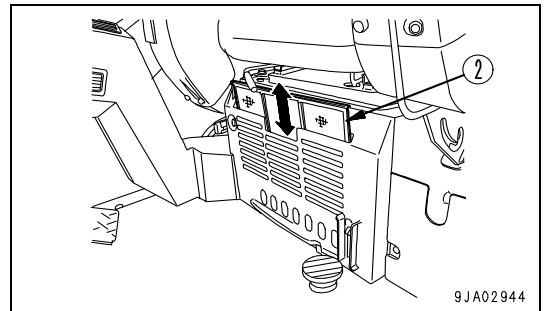
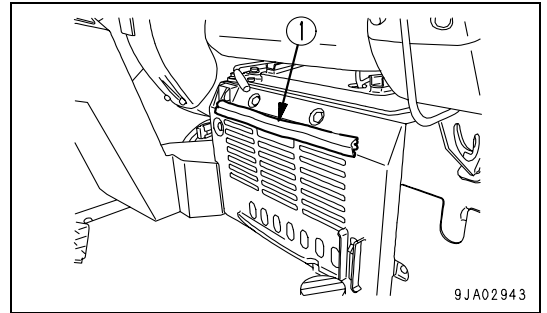

DEFROSTER CONTROLS

CONTROL PANEL

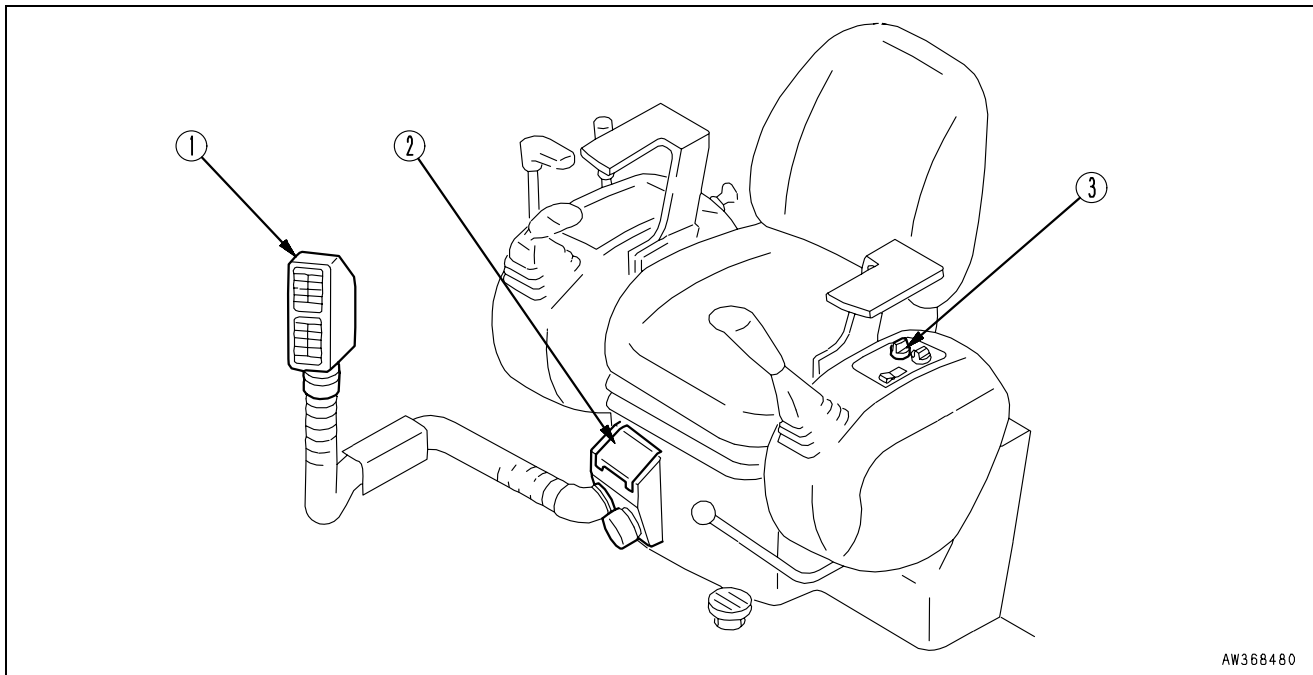

AW368480

- (1) Hot air vent (window side)
- (2) Hot air vent (foot)

- (3) Wind volume selector switch

Hot Air Vent

This equipment (1) is used to remove the mist from the window. It is possible to change the direction of the vent by adjusting with knob (A).

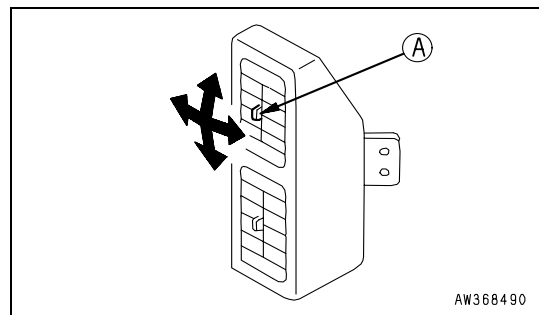

AW368490

Foot Vent

When cover (B) of this equipment (2) is opened, hot air will flow to the operator's feet.

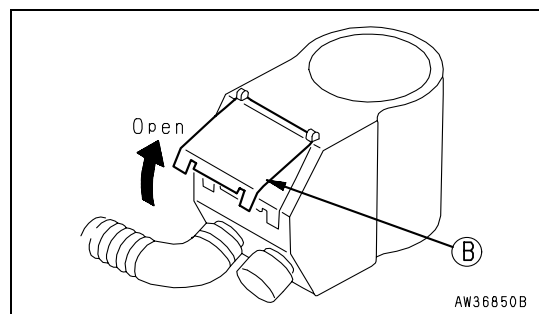

AW36850B

Wind Volume Selector Switch

This switch (3) can be used to adjust the flow of hot air to 2 levels.

H position: High

L position: Low

The air is heated by the hot water from the engine, so it can be used when the engine cooling water is warmed up.

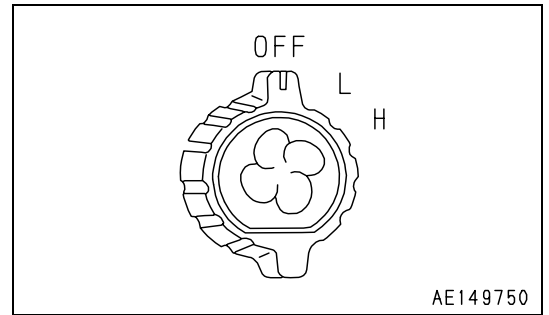

MACHINE READY FOR ATTACHMENT

LOCATIONS

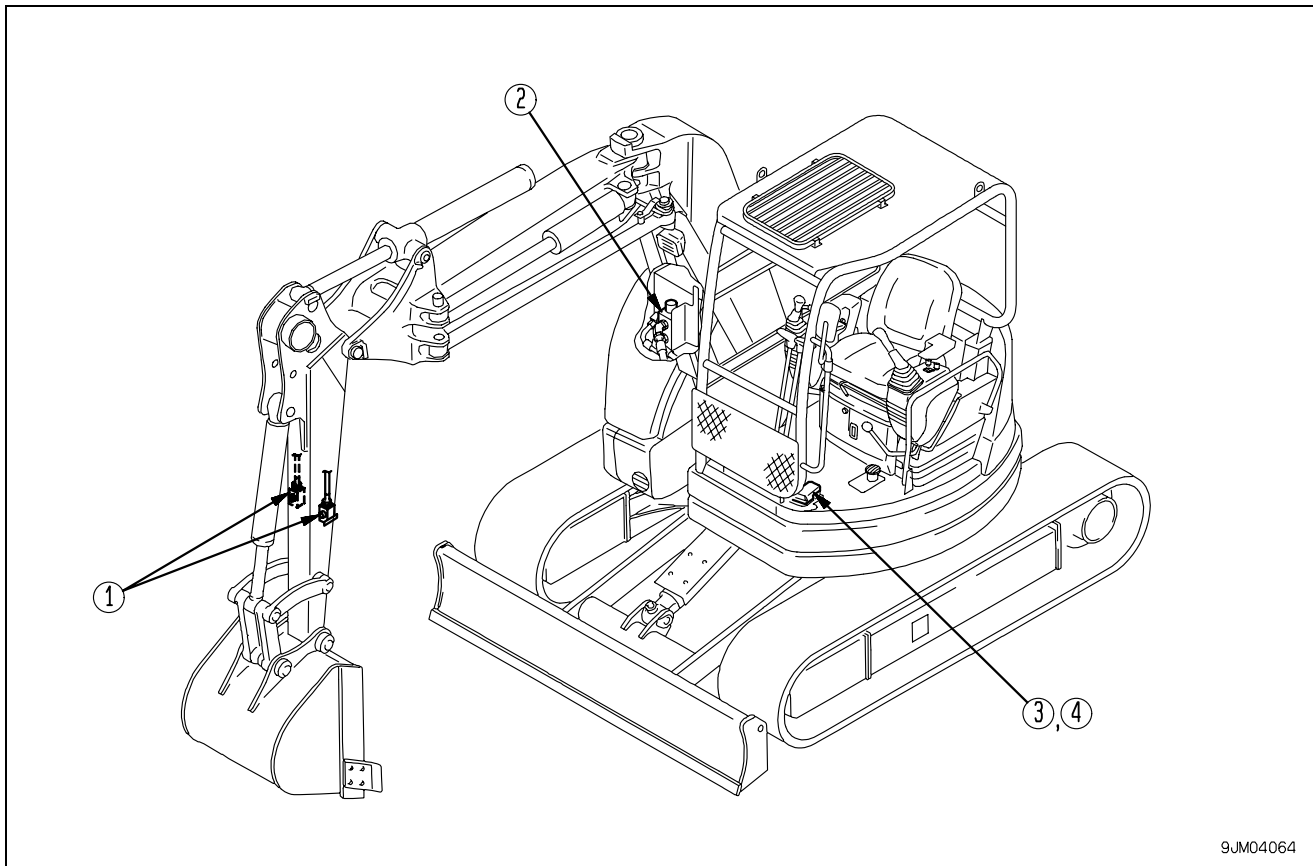

9JM04064

- (1) Stop valve
- (2) Selector valve

- (3) Attachment control pedal
- (4) Pedal lock (for attachment control pedal)

Stop Valve

This valve (1) stop the flow of the hydraulic oil.

direction of slit at hexagonal portion

Position (a): Hydraulic oil stops.

Position (b): Hydraulic oil flows.

When removing or installing attachments, set this valve to the position (a).

Rotate the hexagonal portion to the point where it is stopped by the stopper.

Width across flats of hexagonal portion: 19 mm (0.7 in)

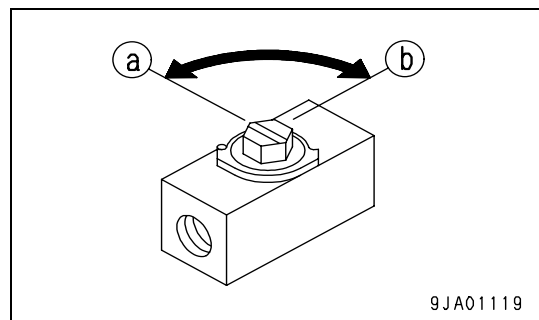

9JA01119

Selector Valve

This valve (2) switches the flow of hydraulic oil.

Position (a): When using breaker

Rotate to the left to the point where it is stopped by the stopper.

Position (b): When using general attachment

Rotate to the right to the point where it is stopped by the stopper.

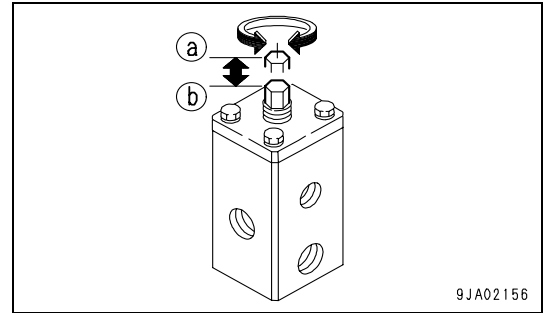

Attachment Control Pedal

This pedal (3) is used to operate the attachment.

Top of pedal depressed: Oil flows to right side of arm (hydraulic tank side).

Bottom of pedal depressed: Oil flows to left side of arm (operator's seat side).

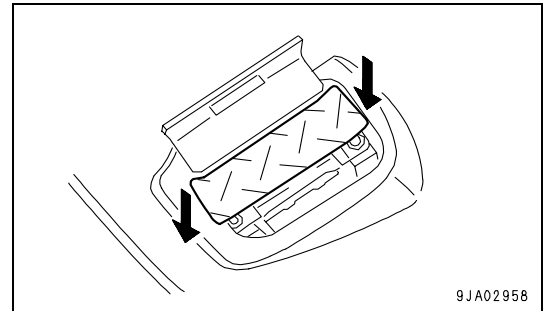

Pedal lock

(for attachment control pedal)

WARNING

When attachment operation is not required, lock the attachment control pedal with the pedal lock. If the attachment control pedal is accidentally pressed while it is not locked, a serious accident may occur.

This plate (4) is a device to lock the attachment control pedal. When the pedal is covered by the plate, it is locked.

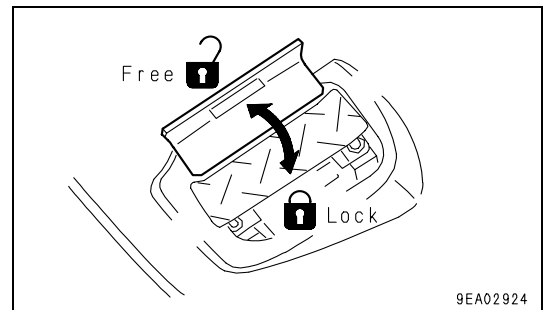

HYDRAULIC CIRCUIT

Hydraulic Circuit Connection

NOTICE

The pressure in the attachment hydraulic circuit on this machine is set at 20.6 MPa (210 kgf/cm², 2982 PSI), so check the ability of the attachment to withstand the pressure before installing it.

When connecting the attachment, connect the hydraulic circuit as follows.

1. Check that the stop valve is at the LOCK position, then remove the plug.
Be careful not to lose or damage any part that is removed.

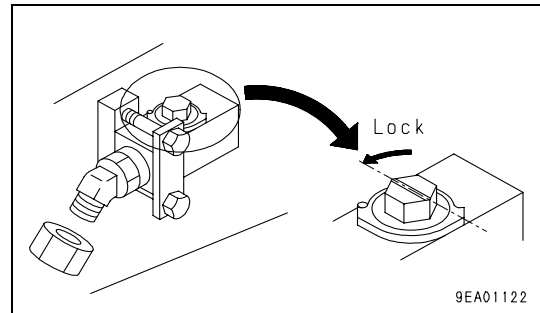

2. Connect the piping for the attachment provided by the attachment maker.
The thread size of the elbow installed to the stop valve is PF1/2.

REMARK

If the elbow thread size does not match, please contact your Komatsu distributor.

3. After connecting the piping, bleed the air from the circuit.
 - 1) Start the engine and run it at low idling for 10 minutes. For details, see "STARTING ENGINE (3-43)". Then carry out the following operation.
 - 2) Run the engine at low idling until the air in the attachment circuit is completely removed, then operate the attachment pedal repeatedly (approx. 10 times) to bleed the air.

NOTICE

If the attachment maker specifies an air bleeding procedure for the attachment itself, follow the specified procedure to bleed the air.

- 3) After completing the bleeding of the air, stop the engine, and wait for at least 5 minutes before starting operations. This will release the bubbles in the oil inside the tank.
- 4) Check that there is no oil leakage, and wipe off any oil that has been spilled.

ATTACHMENT OPERATIONS

NOTICE

If the pedal is operated when a breaker or general attachment is not installed, it will cause overheating or other problems.

Operate the attachment as follows.

When Using Breaker

Depress the bottom of the pedal to operate the breaker.

REMARK

If it is necessary to adjust the oil flow, please ask your Komatsu distributor to carry out the adjustment.

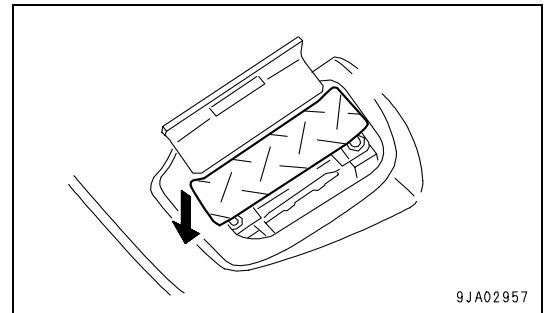

Precautions When Using

- Check that the stopper valve is in the FREE position.

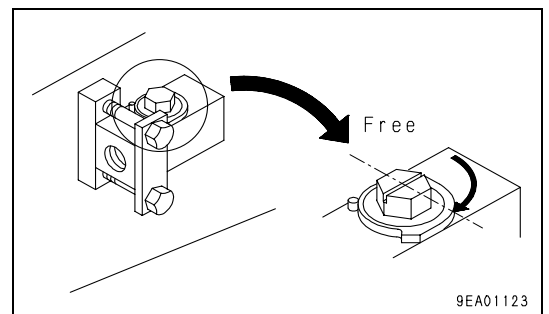

- Check that the selector valve is in the position for using the breaker.

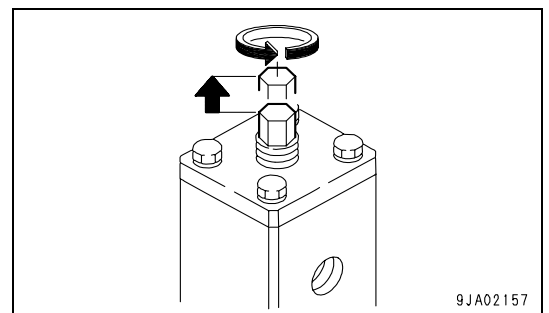

- For details of other precautions when handling the breaker, read and use correctly the instruction manual provided by the breaker manufacturer.

When Using General Attachment

When the pedal is depressed, the attachment is actuated.

REMARK

If it is necessary to adjust the oil flow, please ask your Komatsu distributor to carry out the adjustment.

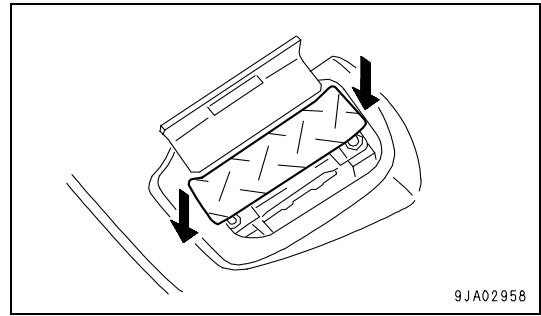

Precautions When Using

- Check that the stopper valve is in the FREE position.

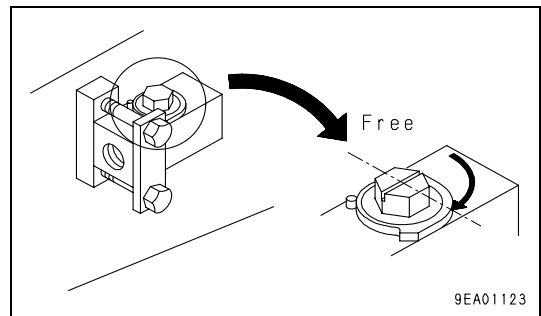

- Check that the selector valve is in the position for general attachments.

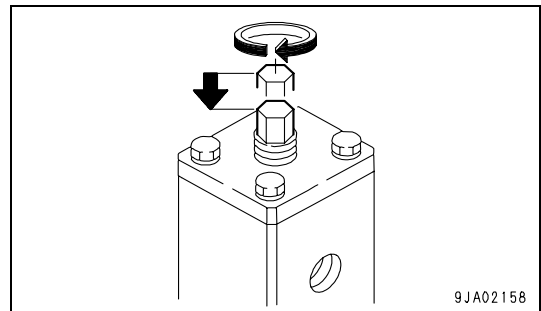

- For details of other precautions when handling the attachment, read and use correctly the instruction manual provided by the attachment manufacturer.

LONG TERM STORAGE

If the machine is not to be used for a long time, do as follows.

- Set the stop valve in the LOCK condition.
- Install a blind plug to the elbow installed to the stop valve.
- Set the selector valve to the position for general attachment.
- Set the lock plate to the LOCK position to make it impossible to depress the pedal.

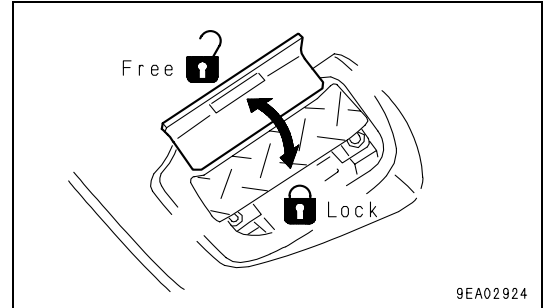

X WEIGHT (ADDITIONAL COUNTERWEIGHT) REMOVAL AND INSTALLATION METHOD

Weight Installation and Removal Method

⚠ WARNING

- For lifting this machine, use a wire rope with sufficient strength to withstand the machine weight.
- Do not attempt to lift the machine in a posture other than that explained below. Otherwise there is the danger that the lifted machine may become unbalanced in the air.
- Lift the machine keeping it level.

1. Remove the nameplate at the rear of the machine.

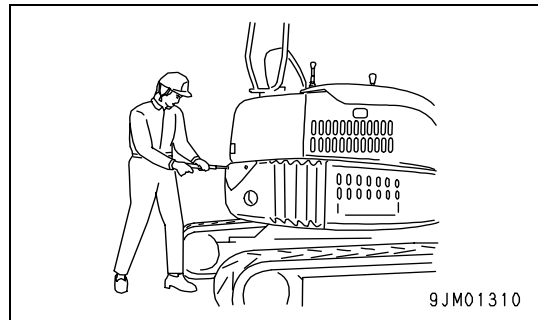

2. Lift up the X weight (additional counterweight) with a crane and install it behind the standard counterweight.

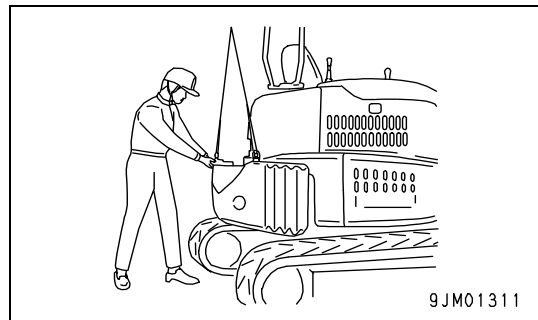

REMARK

The appropriate length of the wire rope is indicated below.

(A) Wire rope: Total length 800 mm (31.5 in)
Rope diameter: 9 mm (0.4 in)

(B) Eyebolt

X Weight (additional counterweight) weight: 170 kg (375 lb)

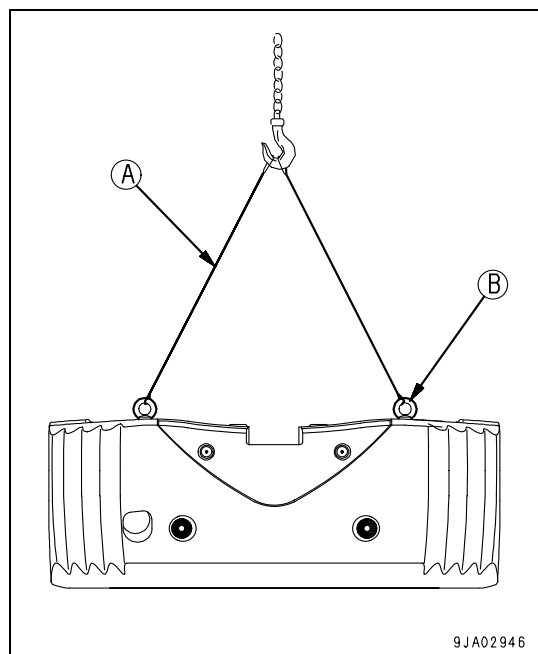

ATTACHMENTS AND OPTIONS

X WEIGHT (ADDITIONAL COUNTERWEIGHT) REMOVAL AND IN-

3. Tighten X Weight (additional counterweight) securing bolts (1).

M20 bolt x 2 pcs.

Tightening torque: 549 ± 58.8 N·m
(56 ± 6 kgf·m, 405 ± 43.4 lbft)

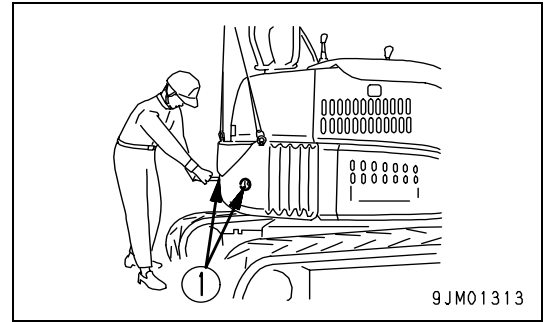

4. Disconnect the wire rope from the crane.
5. Open the engine cover and tighten additional counterweight hook securing bolts (2).

M12 bolt x 2 pcs.

Tightening torque: 113 ± 9.81 N·m
(11.5 ± 1 kgf·m, 83.2 ± 7.2 lbft)

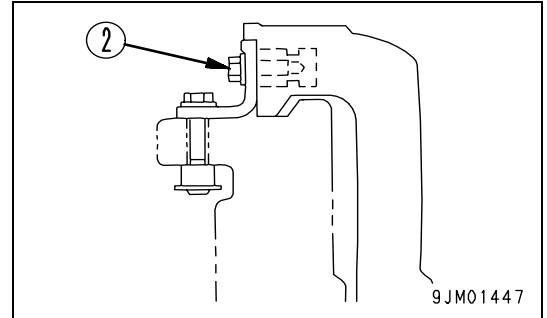

6. Install the nameplate, which was removed earlier, in the following manner.
 - 1) Put a rubber washer beneath the nameplate.
 - 2) After confirming that the collar has thrust through the rubber washer, tighten the screws.

NOTICE

As the screws are tightened, if the washer becomes misaligned or the nameplate is dislocated, the nameplate may be broken. Be careful to avoid such misalignment or dislocation.

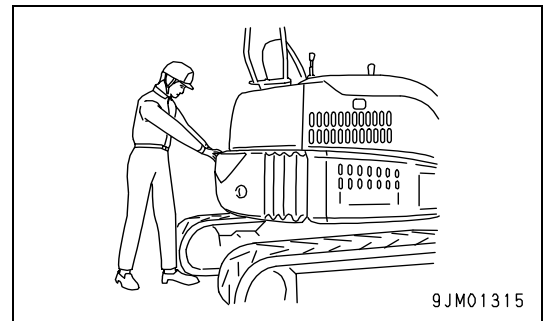

7. After the additional counterweight has been properly mounted, install an extension exhaust pipe in the following manner.

(Canopy specification)

- 1) Connect the extension exhaust pipe (1) to the existing exhaust pipe so that it clears the additional counterweight.
- 2) Tighten clamp (2).

REMARK

When removing or installing the extension exhaust pipe, put the removed exhaust pipe in the toolbox stored beneath the operator's seat.

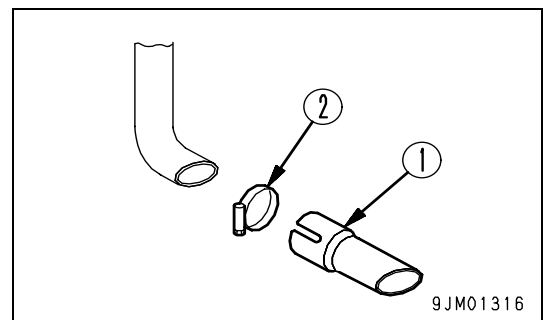

CHANGING MACHINE CONTROL PATTERN (IF PATTERN CHANGE VALVE EQUIPPED)

⚠ WARNING

- When changing the operating pattern of the machine, set the machine in the parking posture, stop the engine, check that the safety lock lever is at the LOCK position, then change the operating pattern.
- To prevent personal injury caused by mistaken operation, test operate the machine and check that the display on the operating pattern card is the same as the movement of the machine.
- If it is not the same, replace the operating pattern card immediately with the card that matches the operating pattern.
- When checking the movement of the machine, check carefully that the surrounding area is safe, and operate slowly.

CONTROL PATTERN CHANGE PROCEDURE

1. After setting the machine in the parking posture, set the safety lock lever to the LOCK position, then stop the engine.
2. Open the inspection cover on the left side of the machine.
The selector valve is inside.

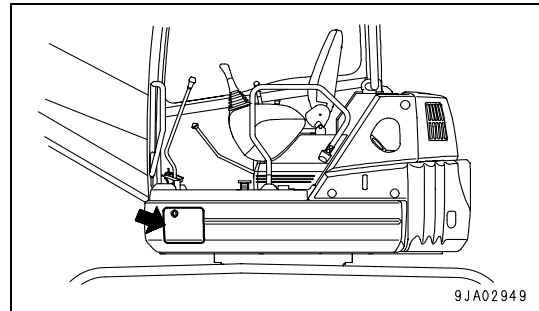

3. Follow the steps explained below, when switching the patterns.
 - 1) Loosen wing nut (1).
 - 2) Select a new operation pattern with a notch on lever (2) and then move lever (2) downward so that the notch will match the dark triangular mark (▲) on the valve.
 - 3) After the switching, tighten wing nut (1).

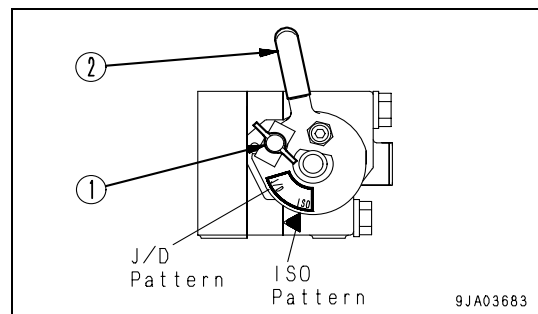

4. Change to an operating pattern card (insert it in the holder) that matches the selected operating pattern.
5. Start the engine, set the safety lock lever to the FREE position, operate the work equipment levers slowly, and check that the operating pattern has changed.

MACHINE CONTROL PATTERNS

WARNING

After changing the operating pattern, always change the operating pattern card in the operator's compartment.

- ISO pattern

- J/D pattern

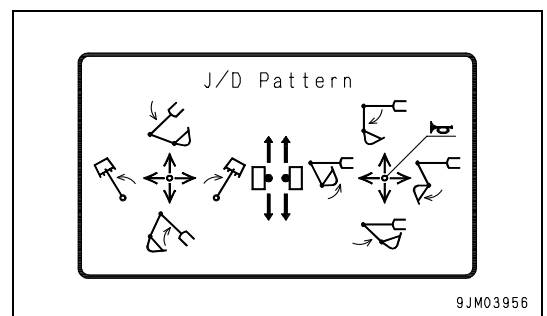
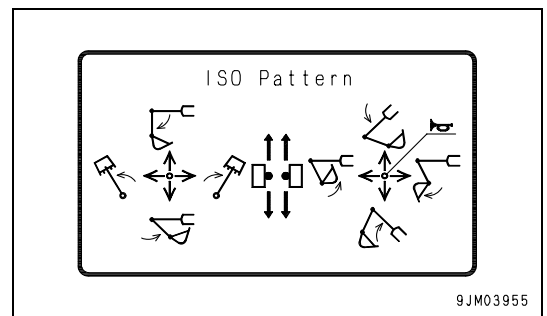
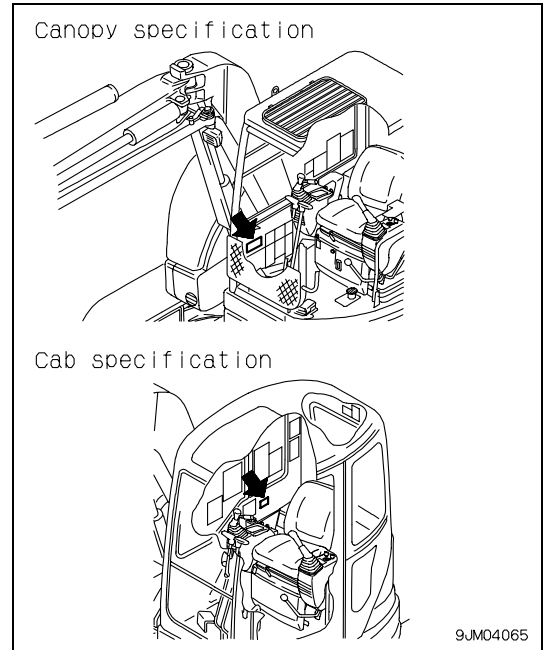

ATTACHMENT GUIDE

WARNING

- Please read the instruction manual for the attachment and the sections of this manual related to attachments and options.
- When installing any attachment or option, there may be problems with safety, so please contact your Komatsu distributor before installing.
- Installing attachments or options without consulting your Komatsu distributor may not only cause problems with safety, but may also have an adverse effect on the operation of the machine and the life of the equipment.
- Any injuries, accidents, or damage resulting from the use of unauthorized attachments or options will not be the responsibility of Komatsu.

ATTACHMENT COMBINATIONS

WARNING

Depending on the type or combination of work equipment, there is danger that the work equipment may hit the cab or machine body.

When using unfamiliar work equipment for the first time, check before starting if there is any danger of interference, and operate with caution.

This table lists the combination of bucket which can be installed to the standard arm and long arm.

○: Can be used

△: Can be used only for light duty work

×: Cannot be used

NOTICE

- When the long arm is equipped, if the bucket is pulled in to the machine body, the arm interferes with the body. Operate the long arm carefully.
- When the boom is fully lowered during oblique digging, the boom interferes with the undercarriage. Operate the boom carefully.

Categories of use

For general digging: Digging or loading sand, gravel, clay etc.

For light duty digging: Digging or loading dry, uncaked earth and sand, mud etc.

For loading work: Loading dry, loose earth and sand

| Name | Capacity m ³ (yd ³) | Outside width (bucket body) mm (in) | Outside width (side cutter) mm (in) | Use | Standard arm | Long arm |
|-----------------|---|---|---|-----------------|-----------------|----------|
| Narrow bucket | 0.06 (0.08) | 300 (11.8) | 370 (14.6) | Narrow digging | ○ | ○ |
| Narrow bucket | 0.13 (0.17) | 410 (16.2) | 480 (18.9) | Narrow digging | ○ | ○ |
| Narrow bucket | 0.16 (0.21) | 560 (22.1) | 650 (25.6) | Narrow digging | ○ | ○ |
| Standard bucket | 0.22 (0.29) | 610 (24.0) | 680 (26.8) | General digging | ○ | × |

RECOMMENDED ATTACHMENT OPERATIONS

This section describes the necessary precautions to be observed when operating a hydraulic excavator equipped with an attachment.

NOTICE

Select the attachment most suited to the machine body.

- The machine models to which attachments can be mounted vary. For selection of attachment and machine model, consult your Komatsu distributor.

HYDRAULIC BREAKER

Main Applications

- Crushed rock
- Demolition work
- Road construction

This attachment can be used for a wide range of work including demolition of buildings, breaking up of road surfaces, tunnel work, breaking up slag, rock crushing, and breaking operations in quarries.

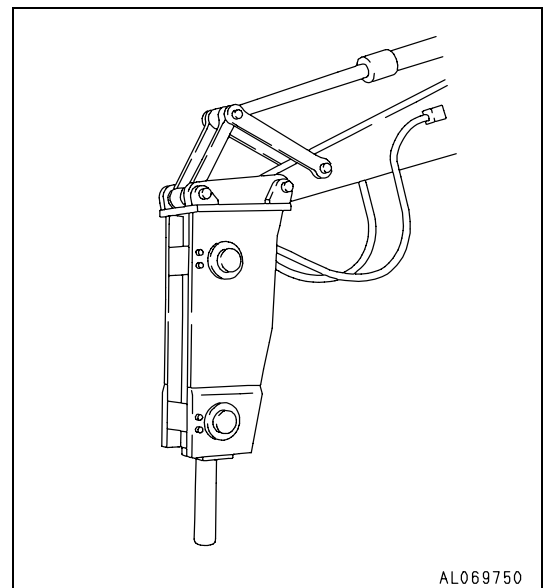

Keep the chisel pushed perpendicularly against the impact surface when carrying out breaking operations.

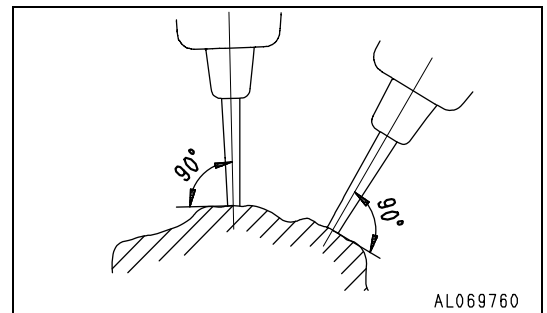

When applying impact, push the chisel against the impact surface and operate so that the chassis rises approx. 5 cm (2 in) off the ground. Do not let the machine come further off the ground than this amount.

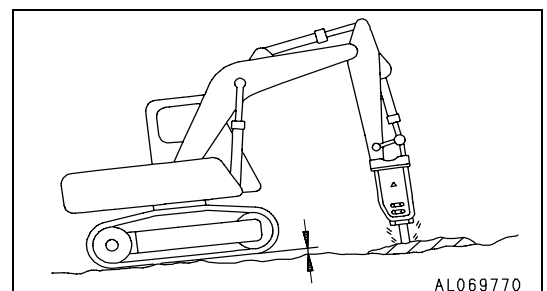

When applying continuous impact to the same impact surface, if the chisel does not penetrate or break the surface within 1 minute, change the point of impact and carry out breaking operations closer to the edge.

The direction of penetration of the chisel and the direction of the breaker body will gradually move out of line with each other, so always adjust the bucket cylinder to keep them aligned.

Always keep the chisel pressed against the impact surface properly to prevent using the impact force when there is no resistance.

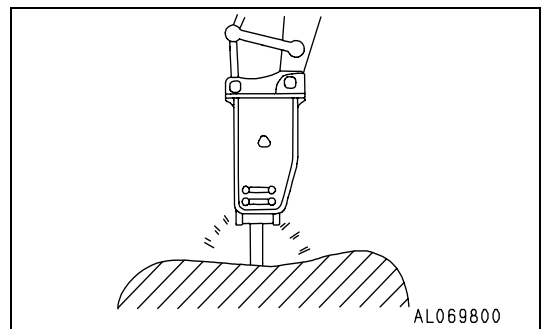
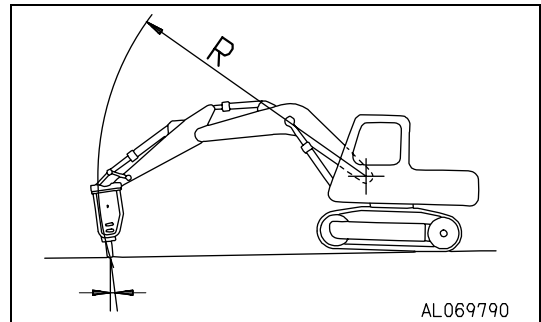
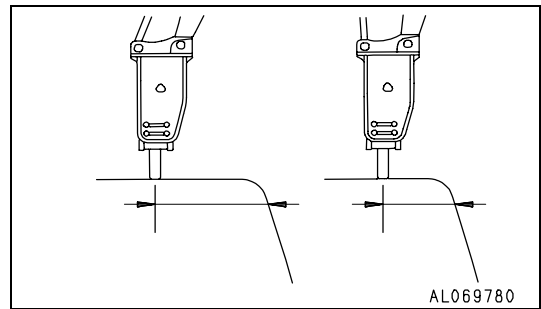

Prohibited Works

To ensure that the machine has a long life, and to ensure that operations are carried out in safety, do not operate the machine in any of the following ways.

- Do not operate all cylinders to the end of their strokes. Always leave approx. 5cm (2 in) to spare.

Using the mount to gather in pieces of rock

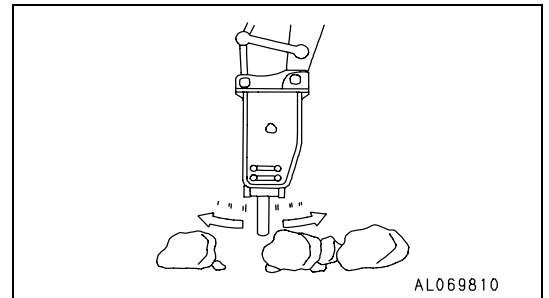

Operations using the swing force

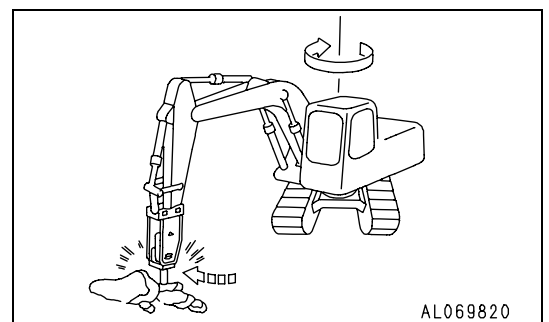

Moving the chisel while carrying out impacting operations

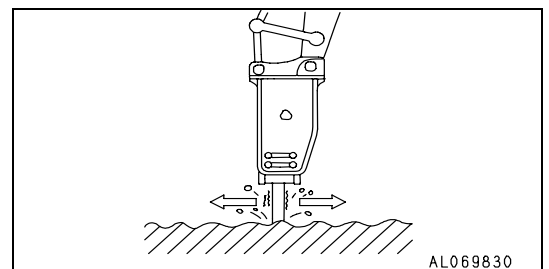

Holding the chisel horizontal or pointed up when carrying out impacting operations

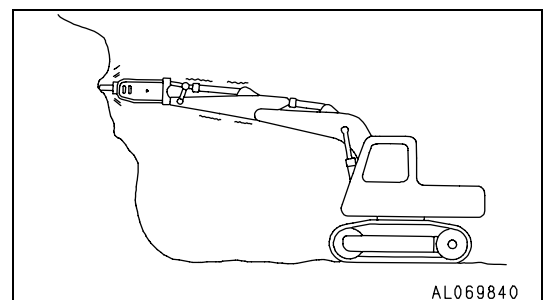

Twisting the chisel when it has penetrated the rock

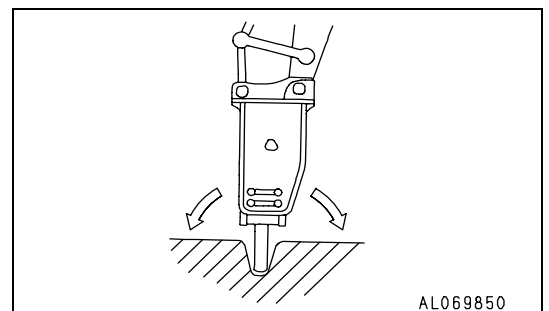

Pecking operations

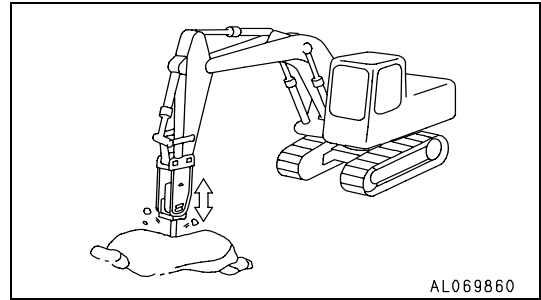

Extending the bucket cylinder fully and thrusting to raise the machine off the ground

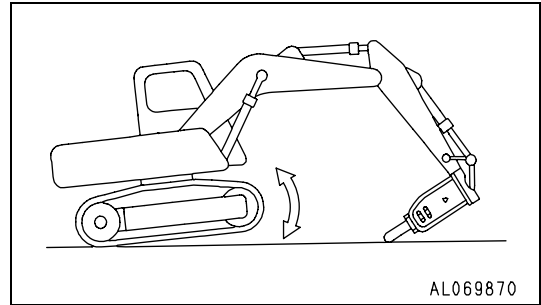

Greasing

Supply grease in the correct position.

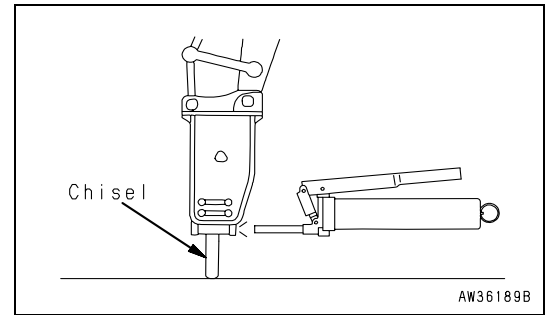

NOTICE

If grease is supplied in an incorrect position, the breaker is filled with more grease than necessary. As a result, soil and sand will enter the hydraulic circuit and can damage the hydraulic devices while the breaker is used. Accordingly, be sure to supply grease in the correct position.

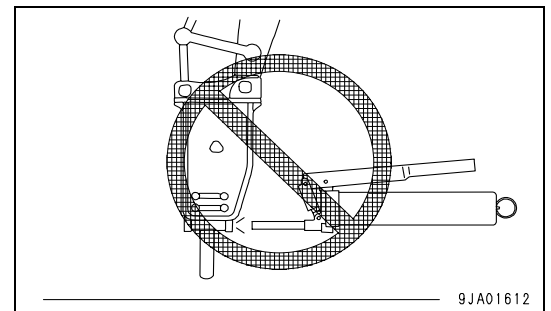
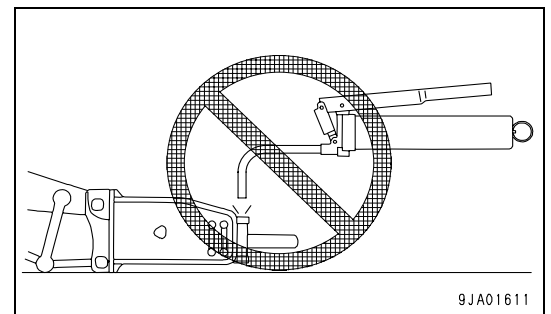

INDEX

<A>

| | |
|--|------|
| Air Conditioner | 6-5 |
| Air Conditioner Controls | 6-7 |
| Air Conditioner Maintenance | 6-8 |
| Control Panel And Components | 6-5 |
| Ashtray | 3-30 |
| Attachment Guide | 6-24 |
| Attachment Combinations | 6-24 |
| Attachments And Options - General Information .. | 6-2 |
| Attachment Installation | 6-3 |
| Safety First | 6-2 |
| Auxiliary Electric Power | 3-29 |

| | |
|-----------------------------|------|
| Block Fuse | 3-28 |
| Bucket Replacement | 3-70 |
| Bucket With Hook | 6-4 |
| Hook Condition | 6-4 |
| Prohibited Operations | 6-4 |

<C>

| | |
|--|------|
| Cap With Lock | 3-25 |
| Changing Machine Control Pattern (If Pattern Change Valve Equipped) | 6-22 |
| Control Pattern Change Procedure | 6-22 |
| Machine Control Patterns | 6-23 |
| Cold Weather Operation | 3-91 |
| After Cold Weather Season | 3-93 |
| After Daily Work Completion | 3-93 |
| Cab heater in cold weather | 3-92 |
| Cold Weather Operation Information | 3-91 |
| Control Levers And Pedals | 3-14 |
| Controls And Gauges | 3-3 |

<D>

| | |
|------------------------------------|------|
| Defroster Controls | 6-12 |
| Control Panel | 6-12 |
| Detailed Controls And Gauges | 3-4 |
| Direction Of Machine | 1-7 |

<E>

| | |
|--|------|
| Electric System Maintenance | 4-6 |
| Electronic Control System Handling | 3-73 |
| Emergency Escape Hammer | 3-24 |
| Emission Control Information Label and Its Location . 1-9 | |
| Engine After Starting | 3-47 |
| Engine Before Starting | 3-31 |
| Engine Hood | 3-26 |
| Engine Serial No. Plate And Its Location | 1-8 |
| Engine, Check After Shut Off | 3-51 |
| Engine, Starting | 3-43 |

| | |
|----------------------------|------|
| Engine, Stopping The | 3-51 |
| Escape From Mud | 3-67 |

<F>

| | |
|---------------|------|
| Forword | 1-2 |
| Fuse | 3-28 |

<G>

| | |
|-------------------------------------|------|
| General Operation Information | 3-62 |
| Grease Pump Holder | 3-30 |

<H>

| | |
|---|--|
| Handling Oil, Fuel, Coolant, And Performing Oil Clinic 4-4 | |
|---|--|

<I>

| | |
|--------------------|-----|
| Introduction | 1-7 |
|--------------------|-----|

<L>

| | |
|---|------|
| Locking | 3-72 |
| Long term storage | 3-94 |
| After Storage | 3-94 |
| Before Storage | 3-94 |
| During Storage | 3-94 |
| Lubricants, Coolant And Filters | 4-4 |
| Lubricants, Fuel And Coolant Specifications | 4-8 |
| Proper Selection | 4-8 |

<M>

| | |
|---|------|
| Machine Inspection After Daily Work | 3-72 |
| Machine Operation | 3-52 |
| Machine Operations And Controls | 3-31 |
| Machine Ready For Attachment | 6-14 |
| Attachment Operations | 6-17 |
| Hydraulic Circuit | 6-16 |
| Locations | 6-14 |
| Long term storage | 6-19 |
| Machine Serial No. Plate And Its Location | 1-8 |
| Machine View Illustrations | 3-2 |
| Machine, Steering The | 3-56 |
| Maintenance Information | 4-2 |
| Maintenance Procedure | 4-15 |
| Check before starting | 4-42 |
| Every 100 hours | 4-43 |
| Every 250 hours | 4-44 |
| Every 500 hours | 4-50 |
| Every 1000 hours | 4-56 |
| Every 2000 hours | 4-57 |
| Initial 250 hours (First 0250 hours only) | 4-15 |
| When required | 4-16 |

Maintenance Schedule4-13
 Maintenance Interval For Hydraulic Breaker ..4-14
 Maintenance Schedule Chart4-13
 Monitoring System3-4
 Mud Cover3-27

<O>

Road Liners and Rubber Shoes3-80
 Operation Manual Storage3-29
 Overall Machine View3-2

<P>

Parking Machine3-71
 Product Information1-8
 Prohibited Operations3-61

<R>

Rear Window3-23
 Recommended Applications3-68
 Recommended Attachment Operations6-25
 Hydraulic Breaker6-25

<S>

Safety Critical Parts4-12
 Safety Critical Parts List4-12
 Safety Information1-5, 2-2, 2-13
 Safety Machine Operation2-21
 Battery2-29
 Lifting Objects With Bucket2-32
 Operation2-22
 Starting Engine2-21
 Towing2-31
 Transportation2-28
 Safety Maintenance Information2-33
 Service Meter Location1-9
 Side Window3-24
 Sliding Door3-22
 Specifications5-2
 Swinging3-58
 Switches3-11

<T>

Tightening Torque Specifications4-11
 Tightening Torque List4-11
 Tool Box3-30
 Transportation3-85
 Lifting Machine3-89
 Loading And Unloading With Trailer3-85
 Transportation Procedure3-85
 Traveling On Slopes3-65
 Troubles And Actions3-95
 Battery, Discharged3-99
 Other Trouble3-103
 Phenomena that are not failures3-95
 Running Out Of Fuel3-95

Severe Job Condition3-98
 Towing The Machine3-98

<W>

Warning Labels And Pictograms2-4
 Warning Labels And Pictograms - Actual2-6
 Warning Labels And Pictograms - Location2-5
 Wear Parts4-7
 Wear Parts List4-7
 Windshield3-18
 Work Equipment Controls And Operations3-59

<X>

X Weight (Additional Counterweight) Removal and
 Installation Method6-20

<Y>

Your Machine Serial Numbers And Distributor1-9

PC58UU-3 HYDRAULIC EXCAVATOR

Form No. SEAM040500T

©2001 KOMATSU

All Right Reserved

Printed in Japan 09-01
