

# Operation & Maintenance Manual

SEAM002410T

## PC200,200LC-6 PC210,210LC-6 MIGHTY PC220,220LC-6 PC230,230LC-6 MIGHTY HYDRAULIC EXCAVATOR

SERIAL NUMBERS PC200,200LC-102229  
PC210,210LC-31425 and up  
PC220,220LC-53562  
PC230,230LC-10247

### WARNING

Unsafe use of this machine may cause serious injury or death. Operators and maintenance personnel must read this manual before operating or maintaining this machine. This manual should be kept near the machine for reference and periodically reviewed by all personnel who will come into contact with it.

### NOTICE

Komatsu has Operation & Maintenance Manuals written in some other languages. If a foreign language manual is necessary, contact your local distributor for availability.

# KOMATSU

# 1. FOREWORD

---

This manual provides rules and guidelines which will help you use this machine safely and effectively. Keep this manual handy and have all personnel read it periodically. If this manual has been lost or has become dirty and can not be read, request a replacement manual from Komatsu or your Komatsu distributor.

If you sell the machine, be sure to give this manual to the new owners.

Continuing improvements in the design of this machine can lead to changes in detail which may not be reflected in this manual. Consult Komatsu or your Komatsu distributor for the latest available information of your machine or for questions regarding information in this manual.

This manual may contain attachments and optional equipment that are not available in your area. Consult Komatsu or your Komatsu distributor for those items you may require.

## WARNING

- **Improper operation and maintenance of this machine can be hazardous and could result in serious injury or death.**
- **Operators and maintenance personnel should read this manual thoroughly before beginning operation or maintenance.**  
Keep this manual in the luggage box to the rear of the operator's seat, and have all personnel involved in working on the machine read the manual periodically.
- **Some actions involved in operation and maintenance of the machine can cause a serious accident, if they are not done in a manner described in this manual.**
- **The procedures and precautions given in this manual apply only to intended uses of the machine. If you use your machine for any unintended uses that are not specifically prohibited, you must be sure that it is safe for you and others. In no event should you or others engage in prohibited uses or actions as described in this manual.**
- **Komatsu delivers machines that comply with all applicable regulations and standards of the country to which it has been shipped. If this machine has been purchased in another country or purchased from someone in another country, it may lack certain safety devices and specifications that are necessary for use in your country. If there is any question about whether your product complies with the applicable standards and regulations of your country, consult Komatsu or your Komatsu distributor before operating the machine.**
- **The description of safety is given in SAFETY INFORMATION on page 0-4 and in SAFETY from page 1-1.**

### **CALIFORNIA**

#### **Proposition 65 Warning**

Diesel engine exhaust and some of its constituents are known to the State of California to cause cancer, birth defects, and other reproductive harm.

### **CALIFORNIA**

#### **Proposition 65 Warning**

Battery posts, terminals and related accessories contain lead and lead compounds, chemicals known to the State of California to cause cancer and birth defects or other reproductive harm.

**Wash hands after handling.**

## EMISSION CONTROL WARRANTY

### EMISSION CONTROL WARRANTY STATEMENT (APPLIES TO CANADA ONLY)

#### 1. Products Warranted

Komatsu America International Company, Komatsu Mining Systems Inc. and Komatsu Utility Corporation (collectively "Komatsu") produce and/or market products under brand names of Komatsu, Dresser, Dressta, Haulpak and Galion. This emissions warranty applies to new engines bearing the Komatsu name installed in these products and used in Canada in machines designed for industrial off-highway use. This warranty applies only to these engines produced on or after January 1, 2000. This warranty will be administered by Komatsu distribution in Canada.

#### 2. Coverage

Komatsu warrants to the ultimate purchaser and each subsequent purchaser that the engine is designed, built and equipped so as to conform, at the time of sale by Komatsu, with all U.S. Federal emission regulations applicable at the time of manufacture and that it is free from defects in workmanship or material which would cause it not to meet these regulations within five years or 3,000 hours of operation, whichever occurs first, as measured from the date of delivery of the engine to the ultimate purchaser.

#### 3. Limitations

Failures, other than those resulting from defects in materials or workmanship, are not covered by this warranty. Komatsu is not responsible for failures or damage resulting from what Komatsu determines to be abuse or neglect, including, but not limited to: operation without adequate coolant or lubricants; over fueling; over speeding; lack of maintenance of lubricating, cooling or intake systems; improper storage, starting, warm-up, run-in or shutdown practices; unauthorized modifications of the engine. Komatsu is also not responsible for failures caused by incorrect fuel or by water, dirt or other contaminants in the fuel. Komatsu is not responsible for non-engine repairs, "downtime" expense, related damage, fines, all business costs or other losses resulting from a warrantable failure.

### KOMATSU IS NOT RESPONSIBLE FOR INCIDENTAL OR CONSEQUENTIAL DAMAGES.

This warranty, together with the express commercial warranties, are the sole warranties of Komatsu. **THERE ARE NO OTHER WARRANTIES, EXPRESS OR IMPLIED, OR OF MERCHANTABILITY OR FITNESS FOR A PARTICULAR PURPOSE.**

## GARANTIE SUR LE CONTRÔLE DES ÉMISSIONS

### ÉNONCÉ DE GARANTIE SUR LE CONTRÔLE DES ÉMISSIONS (APPLICABLE AU CANADA SEULEMENT):

#### 1. Produits garantis:

Komatsu America International Company, Komatsu Mining Systems Inc. et Komatsu Utility Corporation (collectivement Komatsu) produisent et/ou font la mise en marché de produits portant les noms de marque Komatsu, Dresser, Dressta, Haulpak et Galion. Cette garantie sur les émissions s'applique à tous les nouveaux moteurs portant le nom Komatsu, installés dans ces produits et utilisés au Canada dans des machines conçues pour utilisation industrielle non-routière. Cette garantie s'applique seulement sur les moteurs produits à partir du 1er Janvier 2000. Cette garantie sera administrée par la distribution de Komatsu au Canada.

#### 2. Couverture:

Komatsu garantit à l'acheteur ultime et chaque acheteur subséquent que le moteur est conçu, construit et équipé en toute conformité, au moment de la vente par Komatsu, avec toutes les Réglementations fédérales américaines sur les émissions applicables au moment de la fabrication et qu'il est exempt de défauts de construction ou de matériaux qui auraient pour effet de contrevenir à ces réglementations en dedans de 5 ans ou 3000 heures d'opération, mesuré à partir de la date de livraison du moteur au client ultime.

#### 3. Limitations:

Les bris, autres que ceux résultant de défauts de matériaux ou de construction, ne sont pas couverts par cette Garantie. Komatsu n'est pas responsable pour bris ou dommages résultant de ce que Komatsu détermine comme étant de l'abus ou négligence, incluant mais ne se limitant pas à: l'opération sans lubrifiants ou agent refroidissants adéquats; la suralimentation d'essence; la survitesse; le manque d'entretien des systèmes de lubrification, de refroidissement ou d'entrée; de pratiques non-propices d'entreposage, de mise en marche, de réchauffement, de conditionnement ou d'arrêt; les modifications non-autorisées du moteur. De plus, Komatsu n'est pas responsable de bris causés par de l'essence inadéquate ou de l'eau, des saletés ou autres contaminants dans l'essence. Komatsu n'est pas responsable des réparations non-relées au moteur, des dépenses encourues suite aux temps d'arrêts, des dommages relatifs, amendes, et de tout autre coût d'affaires ou autres pertes résultant d'un bris couvert par la garantie.

### KOMATSU N'EST PAS RESPONSABLE DES INCIDENTS OU DOMMAGES CONSÉQUENTS.

Cette garantie, ainsi que les garanties expresses commerciales, sont les seules garanties de Komatsu. **IL N'Y A AUCUNE AUTRE GARANTIE, EXPRESSE OU SOUS-ENTENDUE, MARCHANDABLE OU PROPICE A UNE UTILISATION PARTICULIÈRE.**

**INFORMATION IMPORTANTE SUR LE MOTEUR**  
 CE MOTEUR EST CONFORME AUX NORMES AMÉRICAINES DE L'EPA (ANNÉE DU MODÈLE) ET DE LA CALIFORNIE POUR LES MOTEURS LARGES NON-ROUTIERS À IGNITION PAR COMPRESSION. CE MOTEUR EST CERTIFIÉ POUR OPERATION À ESSENCE DIESEL.

**AVERTISSEMENT**  
 DES BLESSURES PEUVENT RESULTER ET LA GARANTIE S'ANNULER SI LES RPM DU TAUX D'ESSENCE OU L'ALTITUDE EXCÈDENT LES VALEURS MAXIMALES PUBLIÉES POUR CE MODÈLE ET SON APPLICATION.

**IMPORTANT ENGINE INFORMATION**

THIS ENGINE CONFORMS TO YYYY MODEL YEAR U.S. EPA REGULATION AND THE CALIFORNIA REGULATIONS LARGE NON ROAD COMPRESSION IGNITION ENGINES. THIS ENGINE IS CERTIFIED TO OPERATE ON DIESEL FUEL.

<b>WARNING</b>	
INJURY MAY RESULT AND WARRANTY IS VOIDED IF FUEL RATE RPM OR ALTITUDES EXCEED PUBLISHED MAXIMUM VALUES FOR THIS MODEL AND APPLICATION.	
ENGINE MODEL	SERIAL NO.
ENGINE FAMILY	DISPLACEMENT
EXHAUST EMISSION CONTROL SYSTEM	LITERS
ADV. LOAD OUTPUT	FIRING ORDER
	1 - 5 - 3 - 6 - 2 - 4
	RPM
VALVE LASH COLD (mm)	EX. FUEL RATE AT ADV.
	Kw ( HP)
	mm <sup>3</sup> /STROKE
IDLE SPEED	FAMILY EMISSION LIMIT
INITIAL INJECTION TIMING	DEG. BTDC
	RPM
	TAUX D'ESSENCE À ADV.
	LIMITÉ D'ÉMISSION DE LA FAMILLE
	DATE DE FABRICATION
	KOMATSU LTD. MADE IN JAPAN

MODÈLE DU MOTEUR

FAMILLE DU MOTEUR

SYSTÈME DE CONTRÔLE DES ÉMISSIONS D'ÉCHAPPEMENT

CHARGE DE SORTIE ADV.

PORTÉE DE VALVE À FROID (mm)

VITESSE STATIQUE

RÉGLAGE DE L'ALLUMAGE - INJECTION INITIALE

DEG. BTDC

NO. SÉRIE

DÉPLACEMENT

LITRES

SÉQUENCE DE MISE À FEU

mm<sup>3</sup>/BATTEMENT

TAUX D'ESSENCE À ADV.

LIMITÉ D'ÉMISSION DE LA FAMILLE

DATE DE FABRICATION

KOMATSU LTD.  
 FABRIQUÉ AU JAPON



**ENGINE DATAPLATE - ENGLISH / FRENCH**

## 2. SAFETY INFORMATION

---

Most accidents are caused by the failure to follow fundamental safety rules for the operation and maintenance of machines. To avoid accidents, read, understand and follow all precautions and warnings in this manual and on the machine before performing operation and maintenance.

To identify safety messages in this manual and on machine labels, the following signal words are used.

-  **DANGER** – This word is used on safety messages and safety labels where there is a high probability of serious injury or death if the hazard is not avoided. These safety messages or labels usually describe precautions that must be taken to avoid the hazard. Failure to avoid this hazard may also result in serious damage to the machine.
  
-  **WARNING** – This word is used on safety messages and safety labels where there is a potentially dangerous situation which could result in serious injury or death if the hazard is not avoided. These safety messages or labels usually describe precautions that must be taken to avoid the hazard. Failure to avoid this hazard may also result in serious damage to the machine.
  
-  **CAUTION** – This word is used on safety messages and safety labels for hazards which could result in minor or moderate injury if the hazard is not avoided. This word might also be word for hazards where the only result could be damage to the machine.
  
- NOTICE** – This word is used for precautions that must be taken to avoid actions which could shorten the life of the machine.

Safety precautions are described in SAFETY from page 1-1.

Komatsu cannot predict every circumstance that might involve a potential hazard in operation and maintenance. Therefore the safety messages in this manual and on the machine may not include all possible safety precautions. If any procedures or actions not specifically recommended or allowed in this manual are used, you must be sure that you and others can do such procedures and actions safely and without damaging the machine. If you are unsure about the safety of some procedures, contact Komatsu distributor.

## 3. INTRODUCTION

---

### 3.1 INTENDED USE

This Komatsu HYDRAULIC EXCAVATOR is designed to be used mainly for the following work:

- Digging work
- Smoothing work
- Ditching work
- Loading work

See the section "12.15 WORK POSSIBLE USING HYDRAULIC EXCAVATOR" for further details.

### 3.2 FEATURES

- This Komatsu HYDRAULIC EXCAVATOR is equipped with various controls based on an advanced electronics system.
  - The monitor panel greatly facilitates daily maintenance and self-diagnosis.
  - Working mode, travel speed, and active mode are selectable.
  - Digging and lifting force can be increased by light-touch control.  
(For details, see operation section.)
- Adjustable wrist control levers make operations smooth and easy.
- Air-conditioned operator's cab assures comfortable operation.
- Low noise level and smart urban-style design and coloring.
- Superb operating performance provided by powerful engine and high-performance hydraulic pumps.
- Low fuel consumption controlled by an electronic control system provides an environment-friendly machine.

### 3.3 BREAKING IN THE MACHINE

Your Komatsu machine has been thoroughly adjusted and tested before shipment. However, operating the machine under severe conditions at the beginning can adversely affect the performance and shorten the machine life.

Be sure to break in the machine for the initial 100 hours (as indicated by the service meter.)

During breaking in:

- Idle the engine for 5 minutes after starting it up.
- Avoid operation with heavy loads or at high speeds.
- Avoid sudden starts, sudden acceleration, sudden steering and sudden stops except in cases of emergency.

The precautions given in this manual for operating, maintenance, and safety procedures are only those that apply when this product is used for the specified purpose. If the machine is used for a purpose that is not listed in this manual, Komatsu cannot bear any responsibility for safety. All consideration of safety in such operations is the responsibility of the user.

Operations that are prohibited in this manual must never be carried out under any circumstances.

## 4. LOCATION OF PLATES, TABLE TO ENTER SERIAL NO. AND DISTRIBUTOR

---

### 4.1 MACHINE SERIAL NO. PLATE POSITION

On the front bottom right of the operator's cab

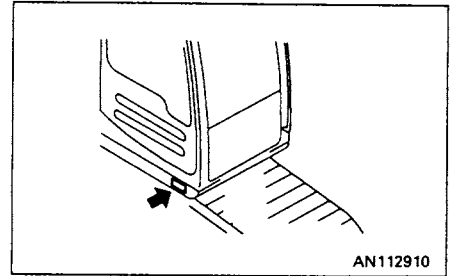

### 4.2 ENGINE SERIAL NO. PLATE POSITION

On the upper side of the engine cylinder head cover

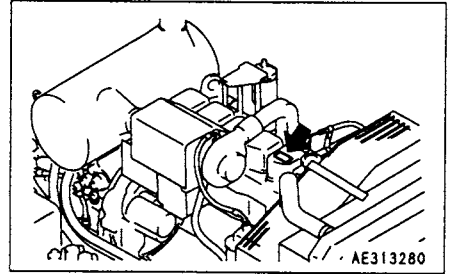

### 4.3 TABLE TO ENTER SERIAL NO. AND DISTRIBUTOR

Machine serial No.:	
Engine serial No.:	
Distributor name:	
Address:	Phone:
Service personnel for your machine:	

REMARKS

## 5. CONTENTS

---

1. Foreword .....	0- 1
2. Safety information .....	0- 4
3. Introduction .....	0- 5
4. Location of plates, table to enter serial No. and distributor .....	0- 6

### SAFETY

6. General precautions .....	1- 2
7. Precautions during operation .....	1- 9
7.1 Before starting engine .....	1- 9
7.2 After starting engine .....	1-11
7.3 Transportation .....	1-18
7.4 Battery .....	1-19
7.5 Towing .....	1-21
7.6 Lifting operations .....	1-21
8. Precautions for maintenance .....	1-22
8.1 Before carrying out maintenance .....	1-22
8.2 During maintenance .....	1-26
9. Position for attaching safety labels .....	1-32

### OPERATION

10. General view .....	2- 2
10.1 General view of machine .....	2- 2
10.2 General view of controls and gauges .....	2- 3
11. Explanation of components .....	2- 4
11.1 Machine monitor .....	2- 4
11.2 Switches .....	2-15
11.3 Control levers, pedals .....	2-19
11.4 Ceiling window .....	2-24
11.5 Front window .....	2-25
11.6 Door lock .....	2-27
11.7 Cap, cover with lock .....	2-28
11.8 Hot/Cool box .....	2-29
11.9 Luggage box .....	2-29
11.10 Ashtray .....	2-29
11.11 Air conditioner .....	2-30
11.12 Car radio .....	2-33
11.13 Fuse .....	2-38
11.14 Fusible link .....	2-39
11.15 Controllers .....	2-39
11.16 Tool box .....	2-39
11.17 Grease pump holder .....	2-39
11.18 Handling accumulator .....	2-40



<b>12. Operation</b> .....	2- 42
12.1 Check before starting engine .....	2- 42
12.2 Starting engine .....	2- 52
12.3 Operations and checks after starting engine .....	2- 55
12.4 Moving machine off .....	2- 61
12.5 Steering machine .....	2- 64
12.6 Stopping machine .....	2- 66
12.7 Swinging .....	2- 67
12.8 Operation of work equipment .....	2- 68
12.9 Handling active mode .....	2- 69
12.10 Working mode selection .....	2- 71
12.11 Prohibitions for operation .....	2- 73
12.12 Precautions for operation .....	2- 75
12.13 Precautions when traveling up or down hills .....	2- 76
12.14 How to escape from mud .....	2- 78
12.15 Work possible using hydraulic excavator .....	2- 79
12.16 Replacement and inversion of bucket .....	2- 80
12.17 Parking machine .....	2- 82
12.18 Check after finishing work .....	2- 83
12.19 Stopping engine .....	2- 84
12.20 Check after stopping engine .....	2- 85
12.21 Locking .....	2- 85
<b>13. Transportation</b> .....	2- 86
13.1 Loading, unloading work .....	2- 86
13.2 Precautions for loading .....	2- 88
13.3 Precautions for transportation .....	2- 89
<b>14. Cold weather operation</b> .....	2- 90
14.1 Precautions for low temperature .....	2- 90
14.2 Precautions after completion of work .....	2- 92
14.3 After cold weather .....	2- 92
<b>15. Long-term storage</b> .....	2- 93
15.1 Before storage .....	2- 93
15.2 During storage .....	2- 94
15.3 After storage .....	2- 94
15.4 Starting machine after long-term storage .....	2- 94
<b>16. Troubleshooting</b> .....	2- 95
16.1 Phenomena that are not failures .....	2- 95
16.2 Method of towing machine .....	2- 95
16.3 Using method for light-weight towing hole .....	2- 95
16.4 Precautions on particular jobsites .....	2- 96
16.5 If battery is discharged .....	2- 96
16.6 Other trouble .....	2-100

## MAINTENANCE

<b>17. Guides to maintenance</b> .....	3- 2
<b>18. Outlines of service</b> .....	3- 5
18.1 Outline of oil, fuel, coolant .....	3- 5
18.2 Outline of electric system .....	3- 8
18.3 Outline of hydraulic system .....	3- 9
<b>19. Wear parts list</b> .....	3-10
<b>20. Use of fuel, coolant and lubricants according to ambient temperature</b> .....	3-12
<b>21. Standard tightening torques for bolts and nuts</b> .....	3-16
21.1 Introduction of necessary tools .....	3-16
21.2 Torque list.....	3-17
<b>22. Periodic replacement of safety critical parts</b> .....	3-18
<b>23. Maintenance schedule chart</b> .....	3-22
23.1 Maintenance schedule chart .....	3-22
23.2 Maintenance interval when using hydraulic breaker.....	3-24
<b>24. Service Procedure</b> .....	3-25
24.1 Initial 250 hours service .....	3-25
24.2 When required .....	3-26
24.3 Check before starting .....	3-44
24.4 Every 100 hours service .....	3-49
24.5 Every 250 hours service .....	3-52
24.6 Every 500 hours service .....	3-58
24.7 Every 1000 hours service .....	3-63
24.8 Every 2000 hours service .....	3-66
24.9 Every 4000 hours service .....	3-69
24.10 Every 5000 hours service .....	3-70

## SPECIFICATIONS

<b>25. Specifications</b> .....	4- 2
---------------------------------	------

## OPTIONS, ATTACHMENTS

<b>26. General precautions</b> .....	5- 2
26.1 Precautions related to safety .....	5- 2
26.2 Precautions when installing attachments .....	5- 3
<b>27. Handling bucket with hook</b> .....	5- 4
27.1 Checking for damage to bucket with hook.....	5- 4
27.2 Prohibited operations .....	5- 4
27.3 Precautions during operations .....	5- 4
<b>28. Using seat belt</b> .....	5- 5
28.1 Seat belt.....	5- 5
<b>29. Handling car heater</b> .....	5- 7
29.1 Explanation of components .....	5- 7
29.2 Preparing car heater .....	5- 8
<b>30. Machines ready for attachments</b> .....	5- 9
30.1 Explanation of components .....	5- 9
30.2 hydraulic circuit.....	5-11
30.3 Attachment mounting/dismounting procedure .....	5-13
30.4 Operation .....	5-15
30.5 Long-term storage .....	5-16
30.6 Specifications .....	5-16
<b>31. Introduction of attachments</b> .....	5-17
31.1 Specification, use .....	5-17
31.2 Attachment installation combination table .....	5-19
31.3 Selection of track shoes .....	5-22
31.4 Selection of bucket teeth .....	5-23
31.5 Handling rubber pad shoe .....	5-24
31.6 Handling trapezoidal bucket .....	5-26
31.7 Handling extension arm .....	5-27
31.8 Handling clamshell bucket.....	5-28
31.9 Handling variable 2-piece boom, rotating arm .....	5-29
<b>32. Extending machine service life</b> .....	5-38
32.1 Hydraulic breaker .....	5-38
32.2 Power ripper .....	5-42
32.3 Fork grab.....	5-43
32.4 Grapple bucket .....	5-44
32.5 Scrap grapple .....	5-45
32.6 Crusher & cutter .....	5-46
32.7 Hydraulic pile driver .....	5-47
32.8 Hydraulic excavator with multi-purpose crane .....	5-48

# SAFETY



## WARNING

**Read and follow all safety precautions. Failure to do so may result in serious injury or death.**

This safety section also contains precautions for optional equipment and attachments.

## 6. GENERAL PRECAUTIONS

**⚠ WARNING:** For reasons of safety, always follow these safety precautions.

### SAFETY RULES

- Only trained and authorized personnel can operate and maintain the machine.
- Follow all safety rules, precautions and instructions when operating or performing maintenance on the machine.
- Do not operate the machine if you are not feeling well, or if you are taking medicine which will make you sleepy, or if you have been drinking. Operating in such a condition will adversely affect your judgement and may lead to an accident.
- When working with another operator or with a person on worksite traffic duty, be sure that all personnel understand all hand signals that are to be used.
- Always follow all rules related to safety.

### SAFETY FEATURES

- Be sure that all guards and covers are in their proper position. Have guards and covers repaired if damaged.
- Use safety features such as safety lock levers ① and the seat belt properly.
- Never remove any safety features. Always keep them in good operating condition.  
**Safety lock lever** → See "12.17 PARKING MACHINE".  
**Seat belt** → See "28. USING SEAT BELT".
- Improper use of safety features could result in serious bodily injury or death.

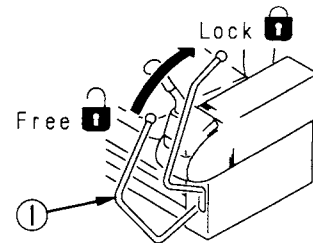

### CLOTHING AND PERSONAL PROTECTIVE ITEMS

- Avoid loose clothing, jewelry, and loose long hair. They can catch on controls or in moving parts and cause serious injury or death.
- Also, do not wear oily clothes, because they are flammable.
- Wear a hard hat, safety glasses, safety shoes, mask or gloves when operating or maintaining the machine. Always wear safety goggles, hard hat and heavy gloves if your job involves scattering metal chips or minute materials particularly when driving pins with a hammer and when cleaning the air cleaner element with compressed air. Check also that there is no one near the machine.
- Check that all protective equipment functions properly before using.

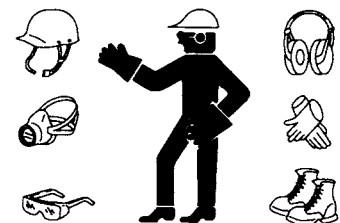

### UNAUTHORIZED MODIFICATION

Any modification made without authorization from Komatsu can create hazards. Before making a modification, consult your Komatsu distributor. Komatsu will not be responsible for any injury or damage caused by any unauthorized modification.

**ALWAYS APPLY LOCK WHEN LEAVING OPERATOR'S SEAT**

- When standing up from the operator's seat, always place the safety lock levers ① securely in the LOCK position. If you accidentally touch the levers when they are not locked, the work equipment may suddenly move and cause serious injury or damage.
- When leaving the machine, lower the blade and ripper completely to the ground, set the safety lock levers ① to the LOCK position, then stop the engine. Use the key to lock all the equipment. Always remove the key and take it with you.

**Work equipment posture → See "12.17 PARKING MACHINE".**

**Locking → See "12.21 LOCKING"**

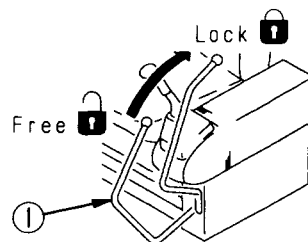

**MOUNTING AND DISMOUNTING**

- Never jump on or off the machine. Never get on or off a moving machine.
- When getting on or off the machine, always face the machine and use the handrails and steps.
- Never hold any control levers or lock levers when getting on or off the machine.
- To ensure safety, always maintain three-point contact (both feet and one hand, or both hands and one foot) with the handrails and steps to ensure that you support yourself.
- If there is any oil, grease, or mud on the handrails or steps, wipe it off immediately. Always keep these parts clean. Repair any damage and tighten any loose bolts.
- When getting on or off the machine, or when moving along the top of the track, if you hold the handrail inside the door when moving on top of the track shoe, and the door lock is not locked securely, the door may move and cause you to fall.

Always lock the door securely.

**Method of locking door → See "11.6 DOOR LOCK".**

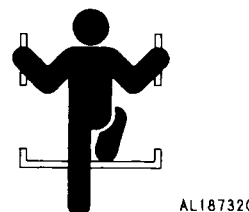
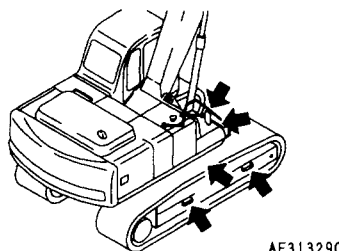
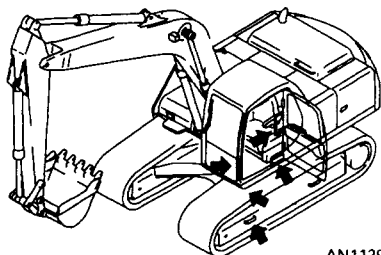

### FIRE PREVENTION FOR FUEL AND OIL

Fuel, oil, and antifreeze can be ignited by a flame. Fuel is particularly flammable and can be hazardous.

Always observe the following:

- Keep any flame or lighted cigarette away from flammable fluids.
- Stop the engine and do not smoke when refueling.
- Tighten all fuel and oil caps securely.
- Use well-ventilated areas for adding or storing oil and fuel.
- Keep oil and fuel in the determined place and do not allow unauthorized persons to enter.



A0055020

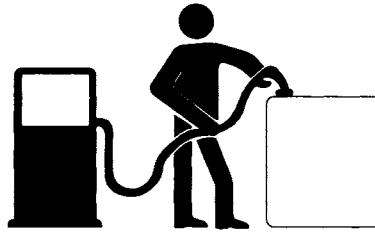

A0055030



A0055040

### PRECAUTIONS WHEN HANDLING AT HIGH TEMPERATURE

- Immediately after operations are stopped, the engine oil and hydraulic oil are at high temperature and are still under pressure. Attempting to remove the cap, drain the oil or water, or replace the filters may lead to serious burns. Always wait for the temperature to go down, and follow the specified procedures when carrying out these operations.
- To prevent hot water from spurting out, stop the engine, wait for the water to cool, then loosen the cap slowly to relieve the pressure before removing the cap.  
(When checking if the water temperature has gone down, put your hand near the front face of the radiator and check the air temperature. Be careful not to touch the radiator.)
- To prevent hot oil from spurting out, stop the engine, wait for the oil to cool, then loosen the cap slowly to relieve the pressure before removing the cap.  
(When checking if the oil temperature has gone down, put your hand near the front face of the hydraulic tank and check the air temperature. Be careful not to touch the hydraulic tank.)



A0055050

### ASBESTOS DUST HAZARD PREVENTION

Asbestos dust can be hazardous to your health if it is inhaled.

Komatsu does not use asbestos in its products, but if you handle materials containing asbestos fibers, follow the guidelines given below:

- Never use compressed air for cleaning.
- Use water to keep down the dust when cleaning.
- If there is danger that there may be asbestos dust in the air, operate the machine from an upwind position whenever possible.
- Use an approved respirator if necessary.

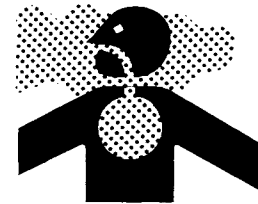

A0055060

### CRUSHING OR CUTTING PREVENTION

Do not enter, or put your hand or arm or any other part of your body between movable parts such as the work equipment and cylinders, or between the machine and work equipment.

If the work equipment is operated, the clearance will change and this may lead to serious damage or personal injury.

If it is necessary to go between movable parts, always lock the levers and be sure that the work equipment cannot move. For details, see "8. PRECAUTIONS FOR MAINTENANCE".



A0066090

### FIRE EXTINGUISHER AND FIRST AID KIT

Always follow the precautions below to prepare for action if any injury or fire should occur.

- Be sure that fire extinguishers have been provided and read the labels to ensure that you know how to use them.
- Provide a first aid kit at the storage point. Carry out periodic checks and add to the contents if necessary.
- Know what to do in the event of a fire or injury.
- Decide the phone numbers of persons (doctor, ambulance, fire station, etc.) to contact in case of an emergency. Post these contact numbers in specified places and make sure that all personnel know the numbers and correct contact procedures.

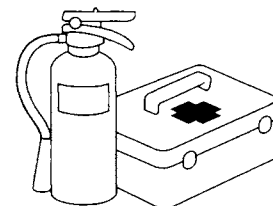

A0055070



**PROTECTION AGAINST FALLING OR FLYING OBJECTS**

If there is any danger of falling or flying objects hitting the operator, install protective guards in place to protect the operator as required for each particular situation.

- For work with breakers, install a front guard on the windshield. Also, place a laminate coating sheet over the windshield.
- For demolition or shear work, install a front guard on the windshield and a top guard on the cab. Also, place a laminate coating sheet over the windshield.
- For work in mines, tunnel or other places where there is danger of falling rocks, put FOPS (falling object protective structure) in place. Also, place a laminate coating sheet over the windshield.

The above comments are made with regards to typical working conditions. By all means you should put on other guards if required by conditions at your particular site. For details of safety guards, please contact your Komatsu distributor.

Also, even for other types of work, if there is any danger of getting hit by falling or flying objects, or of objects entering the operator's cab, select and install a guard that matches the working conditions.

Be sure to close the front window before commencing work.

When carrying out the above operations, make sure to keep all persons other than the operator outside the range of falling or flying objects. Be particularly sure to maintain a proper distance when carrying out shear operations.

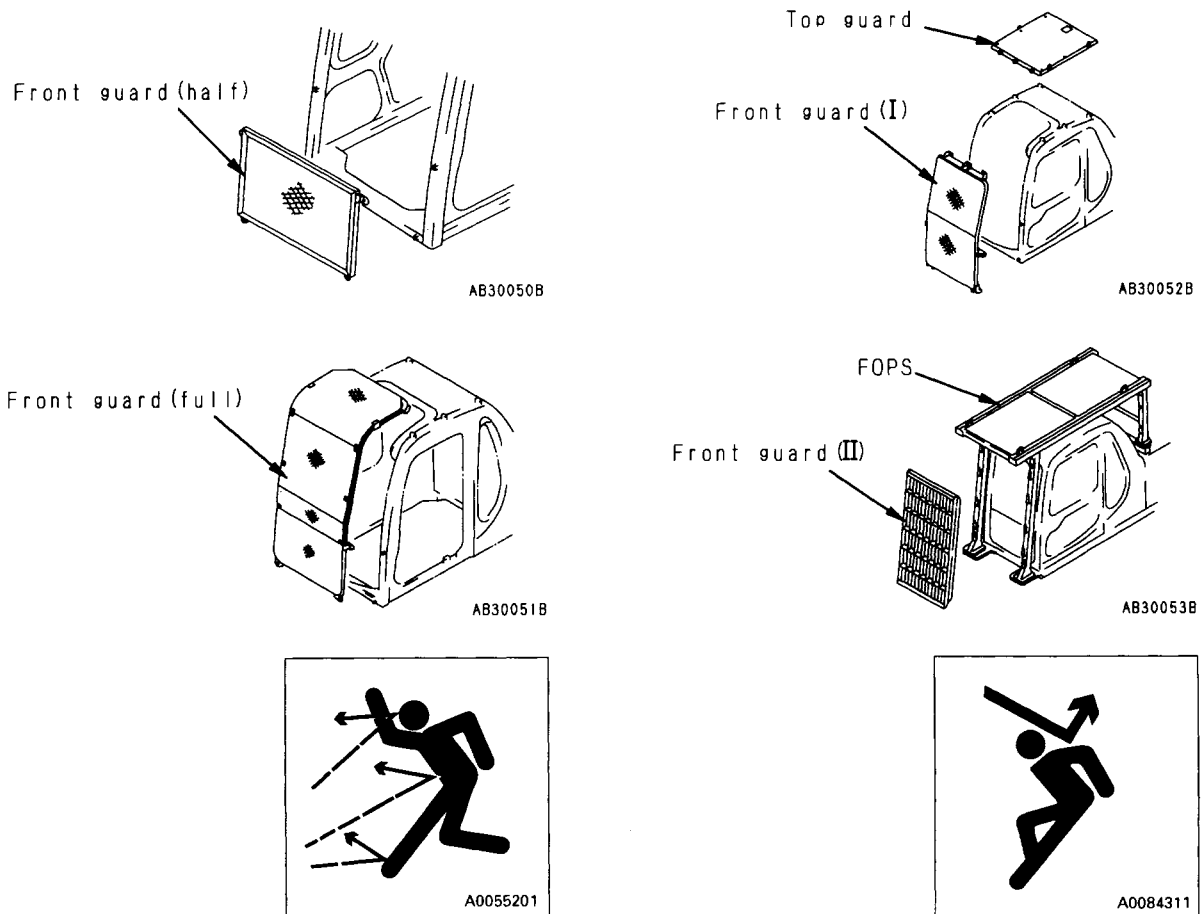

### PRECAUTIONS FOR ATTACHMENTS

- When installing and using an optional attachment, read the instruction manual for the attachment and the information related to attachments in this manual.
- Do not use attachments that are not authorized by Komatsu or your Komatsu distributor. Use of unauthorized attachments could create a safety problem and adversely affect the proper operation and useful life of the machine.
- Any injuries, accidents, product failures resulting from the use of unauthorized attachments will not be the responsibility of Komatsu.

### MACHINES WITH ACCUMULATOR

On machines equipped with an accumulator, for a short time after the engine is stopped, the work equipment will lower under its own weight when the work equipment control lever is shifted to LOWER. After the engine is stopped, set the safety lock lever ① to the lock position and also lock the attachment pedal with the lock pin.

When releasing the pressure inside the work equipment circuit on machines equipped with an accumulator, follow the procedure given in the inspection and maintenance section.

**Method of releasing pressure → See "11.18 HANDLING ACCUMULATOR".**

The accumulator is filled with high-pressure nitrogen gas, and it is extremely dangerous if it is handled in the wrong way. Always observe the following precautions.

- Never make any hole in the accumulator or expose it to flame or fire.
- Do not weld any boss to the accumulator.
- When carrying out disassembly or maintenance of the accumulator, or when disposing of the accumulator, it is necessary to release the gas from the accumulator. A special air bleed valve is necessary for this operation, so please contact your Komatsu distributor.

**Gas in accumulator → See "11.18 HANDLING ACCUMULATOR".**

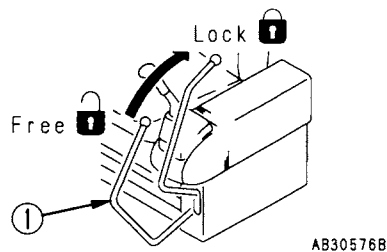

### VENTILATION FOR ENCLOSED AREAS

Exhaust fumes from the engine can kill.

- If it is necessary to start the engine within an enclosed area, or you handle fuel, flushing oil, or paint, open the doors and windows to ensure that you provide adequate ventilation to prevent gas poisoning.
- If opening the doors and windows still does not provide adequate ventilation, set up fans.

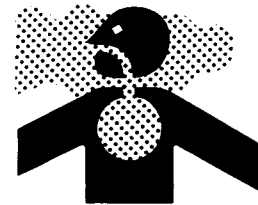

A0055060

### PRECAUTIONS WITH CAB GLASS

If by mistake the cab glass on the work equipment side should crack, there is danger of direct contact between the operator's body and the work equipment. This is extremely dangerous. If the glass is cracked, stop operations immediately and replace the glass.

### EMERGENCY EXIT FROM OPERATOR'S CAB

- If it should become impossible to open the cab door, open the rear window and use it as an emergency escape.
- Remove the rear window as follows.
  1. Pull ring ① and completely remove seal ② from the window frame rubber.
  2. Push the corner of the rear window glass strongly to push it out and make it possible to remove.
- Remove the rear window only when it is being used as an emergency escape.

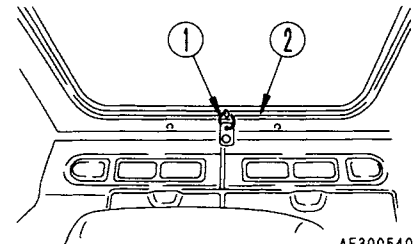

AE300540

## 7. PRECAUTIONS DURING OPERATION

**⚠ WARNING:** Failure to follow these safety precautions may lead to a serious accident.

### 7.1 BEFORE STARTING ENGINE

#### SAFETY AT WORKSITE

- Before starting operations, thoroughly check the area for any unusual conditions that could be dangerous.
- Check the terrain and condition of the ground at the worksite, and determine the best and safest method of operation.
- Make the ground surface as hard and horizontal as possible before carrying out operations. If the jobsite is dusty, spray water before starting operations.
- If you need to operate on a road, protect pedestrians and cars by designating a person for worksite traffic duty or by installing fences and putting up No Entry signs around the worksite.
- If water lines, gas lines, or high-voltage electrical lines may be buried under the worksite, contact each utility and identify their locations. Be careful not to sever or damage any of these lines.
- Check the ground condition and the depth and flow of water before operating in water or crossing a river. NEVER be in water which is in excess of the permissible water depth.

**Permissible water depth →**

**See "12.12 PRECAUTIONS FOR OPERATION".**

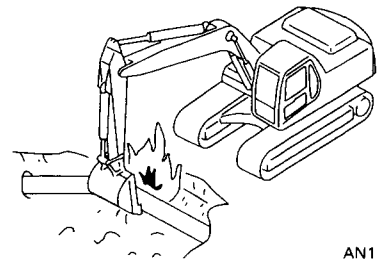

AN112960

#### CHECKS BEFORE STARTING ENGINE

Carry out the following checks before starting the engine at the beginning of the days work. Failure to carry out these checks may lead to serious injury or damage.

- Completely remove all flammable materials accumulated around the engine and battery, return all fuel containers to their proper place, remove all parts and tools from the operator's compartment, and remove any dirt from the mirrors, handrails, and steps.  
**Walk-around checks → See "12.1.1 WALK-AROUND CHECK".**
- Check the coolant level, fuel level, and oil level in the hydraulic tank, check for clogging of the air cleaner, and check the electric wiring.  
**Checks before starting → See "12.1.2 CHECK BEFORE STARTING".**
- Adjust the operator's seat to a position where it is easy to carry out operations, and check for wear or damage to the seat belt and seat belt mounting equipment.  
**Adjusting operator's seat → See "12.1.3 ADJUSTING SEAT POSITION".**  
**Seat belt → See "28. USING SEAT BELT".**
- Check that the gauges work properly, and check that the control levers are all at the NEUTRAL position.  
**Method of checking operation of gauges →**  
**See "12.1.4 OPERATIONS AND CHECKS BEFORE STARTING ENGINE".**
- Clean all dirt off the surface of the mirrors, window glass, and lights to ensure good visibility.
- Adjust the mirrors so that they give the optimum view from the operator's seat.  
**When adjusting → See "12.1 CHECK BEFORE STARTING ENGINE".**
- If any of the mirrors are broken, replace them with new ones.
- When removing and installing the mirrors for replacement or transportation, see "13.3 PRECAUTIONS FOR TRANSPORTATION".

If the above inspections show any abnormality, carry out repairs immediately.



A0055020

**WHEN STARTING ENGINE**

- Walk around your machine again just before mounting it, and check for people and objects that might be in the way.
- Never start the engine if a warning tag has been attached to the work equipment control lever.
- When starting the engine, sound the horn as an alert.
- Start and operate the machine only while seated.
- An additional worker may ride in the machine only when sitting in the passenger seat. Do not allow anyone to ride on the machine body.
- Do not short circuit the starting motor circuit to start the engine. It is not only dangerous, but will also cause damage to the equipment.

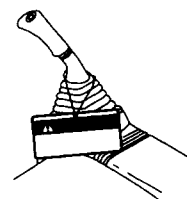
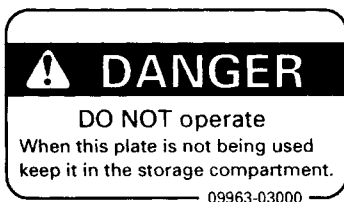

AE305910

**⚠ WARNING:** Failure to follow these safety precautions may lead to a serious accident.

## 7. PRECAUTIONS DURING OPERATION

### 7.2 AFTER STARTING ENGINE

#### CHECKS AFTER STARTING ENGINE

Failure to carry out the checks properly after starting the engine will lead to delays in discovery of abnormalities, and this may lead to serious injury or damage to the machine.

When carrying out the checks, use a wide area where there are no obstructions. Do not allow anyone near the machine.

- Check the operation of the gauges and equipment, and check the operation of the blade, ripper, brakes, travel system, and steering system.
- Checks for any abnormality in the sound of the machine, vibration, heat, smell, or gauges; check also that there is no leakage of air, oil, or fuel.
- If any abnormality is found, carry out repairs immediately.  
If the machine is used when it is not in proper condition, it may lead to serious injury or damage to the machine.

#### PRECAUTIONS WHEN STARTING OFF

Check the direction of the track frame before operating the travel lever.

- When the sprocket is at the front, the operation of the travel lever is reversed, so operate the machine carefully.

**Method of steering machine → See "12.4 MOVING MACHINE OFF".**

Before moving the machine off, check again that there are no persons or obstacles in the surrounding area.

- When moving the machine off, sound the horn to warn people in the surrounding area.
- Always sit in the operator's seat when driving the machine.
- Fasten your seat belt securely.
- The operator must not let any other person sit anywhere except in the assistant's seat.
- Check that the travel alarm (option) works properly.
- Always close the door of the operator's cab and check that the door is locked in position securely.

Travel in reverse direction

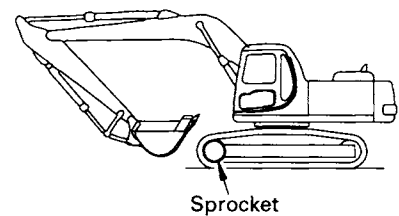

Sprocket

AN112970

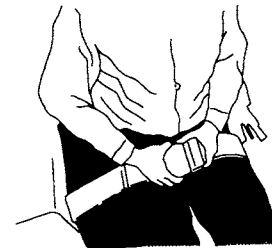

AE305800

#### CHECK WHEN CHANGING DIRECTION

To prevent serious injury or death, always do the following before moving the machine or doing the leveling work.

- Before changing between forward and reverse, reduce speed and stop the machine.
  - Before operating the machine, sound the horn to warn people in the area.
  - Check that there is no one near the machine. Be particularly careful to check behind the machine.
  - When operating in areas that may be hazardous or have poor visibility, designate a person to direct worksite traffic.
  - Ensure that no unauthorized person can come within the direction of turning or direction of travel.
- Always be sure to carry out the above precautions even when the machine is equipped with a backup alarm and mirrors.

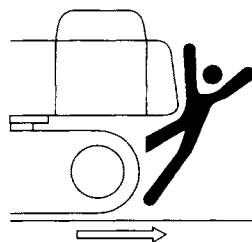

A0067190

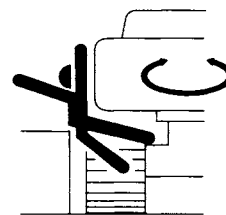

A0067200

### PRECAUTIONS WHEN TRAVELING

- Never turn the key in the starting switch to the OFF position when traveling. It is dangerous if the engine stops when the machine is traveling, because it becomes impossible to operate the steering.
- It is dangerous to look around you when operating. Always concentrate on your work.
- It is dangerous to drive too fast, or to start suddenly, stop suddenly, turn sharply, or zigzag.
- If you find any abnormality in the machine during operation (noise, vibration, smell, incorrect gauges, air leakage, oil leakage, etc.), move the machine immediately to a safe place and look for the cause.
- Set the work equipment to a height of 40 – 50 cm (16 – 20 in) from the ground level and travel on level ground.
- When traveling, do not operate the work equipment control levers. If the work equipment control levers have to be operated, never operate them suddenly.
- Do not operate the steering suddenly. The work equipment may hit the ground surface and cause the machine to lose its balance, or may damage the machine or structures in the area.
- When traveling on rough ground, travel at low speed, and avoid sudden changes in direction.
- Avoid traveling over obstacles as far as possible. If the machine has to travel over an obstacle, keep the work equipment as close to the ground as possible and travel at low speed. Never travel over obstacles which make the machine tilt strongly ( $10^\circ$  or more).
- When traveling or carrying out operations, always keep your distance from other machines or structures to avoid coming into contact with them.
- NEVER be in water which is in excess of the permissible water depth.  
**Permissible water depth → See "12.12 PRECAUTIONS FOR OPERATION".**
- When passing over bridges or structures on private land, check first that the structure is strong enough to support the mass of the machine. When traveling on public roads, check first with the relevant authorities and follow their instructions.

Travel posture

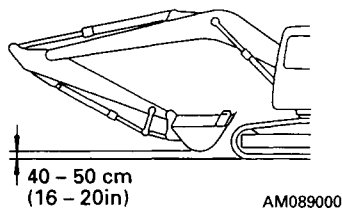

INCORRECT

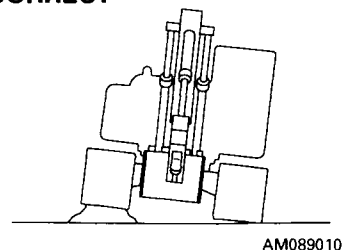

**⚠ WARNING:** Failure to follow these safety precautions may lead to a serious accident.

## 7. PRECAUTIONS DURING OPERATION

### TRAVELING ON SLOPES

- Traveling on slopes could result in the machine tipping over or slipping to the side.
- When traveling on slopes, keep the blade approximately 20 – 30 cm (8 – 12 in) above the ground. In case of emergency, quickly lower the bucket to the ground to help the machine to stop.
- Do not turn on slopes or travel across slopes. Always go down to a flat place to perform these operations.

**Method of traveling on slopes → See "12.13 PRECAUTIONS WHEN TRAVELING UP OR DOWN HILLS".**

- Do not travel on grass, fallen leaves, or wet steel plates. Even slight slopes may cause the machine to slip to the side, so travel at low speed and make sure that the machine is always traveling directly up or down the slope.
- If the engine stops on a slope, place the travel lever at the neutral position and lower the bucket to the ground. Do not operate the steering. There is danger that the machine will turn under its own weight.

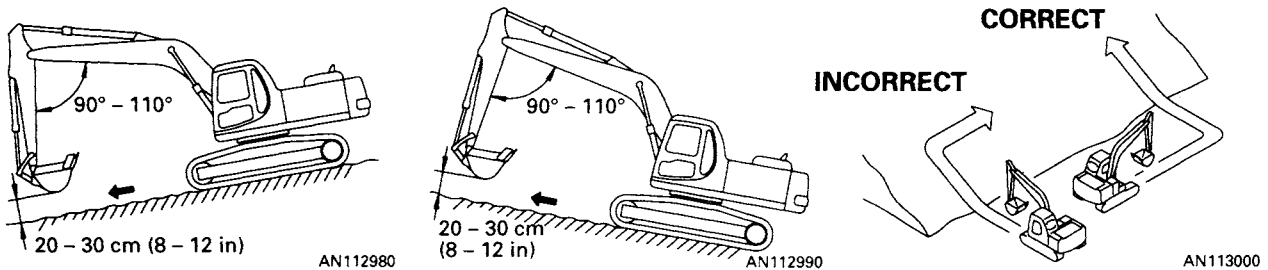

### PROHIBITED OPERATIONS

- Do not dig the work face under an overhang. This may cause the overhang to collapse and fall on top of the machine.
- Do not carry out deep digging under the front of the machine. The ground under the machine may collapse and cause the machine to fall. Take emergencies into consideration and set with the travel motor at the rear and the track (undercarriage) at right angles to the road shoulder before digging to enable the machine to move back quickly. If the ground under the machine collapses and there is no time to drive in reverse, do not suddenly raise the arm and boom. In some cases, it may in fact be safer to lower the arm and boom.
- Do not swing the work equipment to the side when it is carrying a heavy load. The stability to the side is less than the stability to the front, so there is danger that the machine may turn over.
- Limits on use

To prevent accidents caused by breakage of the work equipment or tipping over of the machine under excessive load, do not use the machine in excess of its capacity. Always be sure to keep within the maximum specified load and safe angle determined for the structure.

**INCORRECT**

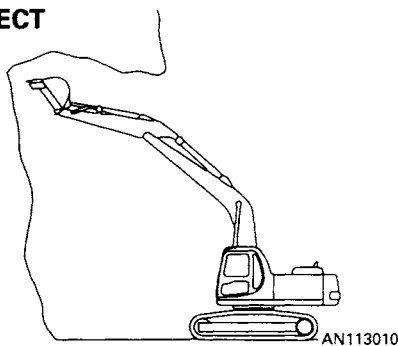

**INCORRECT**

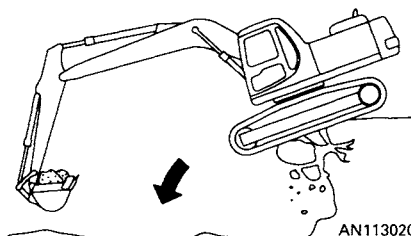



**PRECAUTIONS WHEN OPERATING**

- Be careful not to approach too close to the edge of cliffs.
- Carry out only work that is specified as the purpose of the machine.  
Carrying out other operations will cause breakdowns.  
**Specified operations → See “12.15 WORK POSSIBLE USING HYDRAULIC EXCAVATOR”.**
- Do the following to ensure good visibility.
  - When operating in dark places, turn on the working lamps and front lamps, and install lighting at the jobsite if necessary.
  - Do not carry out operations in fog, mist, snow, or heavy rain, or other conditions where the visibility is poor. Wait for the weather to clear so that visibility is sufficient to carry out work.
- Always do as follows to prevent the work equipment from hitting other objects.
  - When operating in tunnels, under bridges, under electric wires, or other places where the height is limited, be extremely careful not to let the bucket, boom, or arm hit anything.
  - To prevent accidents caused by hitting other objects, always operate the machine at a speed which is safe for operation, particularly in confined spaces, indoors, and in places where there are other machines.
  - Never pass the bucket over the head of any worker or over the operator’s cab on a dump truck.

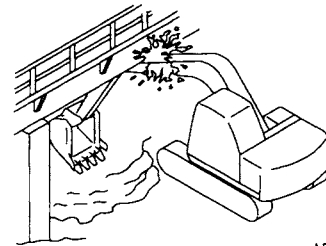

AE305810

**DO NOT GO CLOSE TO HIGH-VOLTAGE CABLES**

- Do not let the machine touch overhead electric cables. Even going close to high-voltage cables can cause electric shock. Always maintain the safe distance given below between the machine and the electric cable.
- To prevent accidents, always do as follows.
  - On jobsites where there is danger that the machine may touch the electric cables, consult the electricity company before starting operations to check that the actions determined by the relevant laws and regulations have been taken.
  - Wear rubber shoes and gloves. Lay a rubber sheet on top of the operator's seat, and be careful not to touch the chassis with any exposed part of your body.
  - Use a signalman to give warning if the machine approaches too close to the electric cables.
  - If the work equipment should touch the electric cable, the operator should not leave the operator's compartment.
  - When carrying out operations near high voltage cables, do not let anyone come close to the machine.
  - Check with the electricity company about the voltage of the cables before starting operations.

	Voltage	Min. safety distance
Low voltage	100 - 200 V	2 m
	6,600 V	2 m
Very high voltage	22,000 V	3 m
	66,000 V	4 m
	154,000 V	5 m
	187,000 V	6 m
	275,000 V	7 m
	500,000 V	11 m

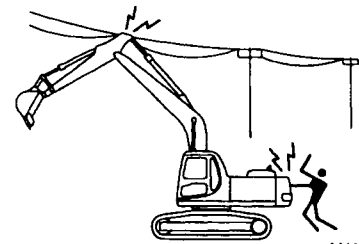

AN113030

**OPERATE CAREFULLY ON SNOW**

- When working on snow or icy roads, even a slight slope may cause the machine to slip to the side, so always travel at low speed and avoid sudden starting, stopping, or turning. There is danger of slipping particularly on uphill or downhill slopes.
- With frozen road surfaces, the ground becomes soft when the temperature rises, so the travel conditions become unstable. In such cases be extremely careful when traveling.
- When there has been heavy snow, the road shoulder and objects placed beside the road are buried in the snow and cannot be seen, so always carry out operations carefully.  
When traveling on snow-covered slopes, never apply the brakes suddenly. Reduce the speed and use the engine as a brake while applying the foot brake intermittently (depress the brake intermittently several times). If necessary, lower the bucket to the ground to stop the machine.
- The load varies greatly according to the characteristics of the snow, so adjust the load accordingly and be careful not to let the machine slip.

**WORKING ON LOOSE GROUND**

- Do not operate the machine on soft ground. It is difficult to get the machine out again.
- Avoid operating your machine too close to the edge of cliffs, overhangs, and deep ditches. If these areas collapse under the mass or vibration of your machine, it could fall or tip over and this could result in serious injury or death. Remember that the soil after heavy rain, blasting, or earthquakes is weakened in these areas.
- Earth laid on the ground and the soil near ditches is loose. It can collapse under the mass or vibration of your machine and cause your machine to tip over.
- Install the head guard (FOPS) when working in areas where there is danger of falling stones.
- Install the ROPS and wear the seat belt when working in areas where there is danger of falling rocks or of the machine turning over.

**PRECAUTIONS WHEN WORKING ON SLOPES**

- When working on slopes, there is danger that the machine may lose its balance and turn over when the swing or work equipment are operated. Always carry out these operations carefully.
- Do not swing the work equipment from the uphill side to the downhill side when the bucket is loaded. This operation is dangerous.
- If the machine has to be used on a slope, pile the soil to make a platform that will keep the machine as horizontal as possible.

**Piled soil on slope → See "12.13 PRECAUTIONS WHEN TRAVELING UP OR DOWN HILLS".**

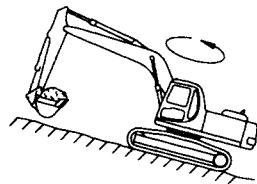
**INCORRECT**

AN113040

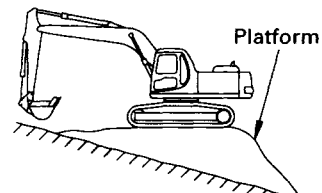
**CORRECT**

AN113050

**⚠ WARNING:** Failure to follow these safety precautions may lead to a serious accident.

## 7. PRECAUTIONS DURING OPERATION

### PARKING MACHINE

- Park the machine on level ground where there is no danger of falling rocks or landslides, or of flooding if the land is low, and lower the work equipment to the ground.
- If it is necessary to park the machine on a slope, set blocks under the tracks to prevent the machine from moving, then dig the work equipment into the ground.
- After stopping the engine, operate the right work equipment control lever several times to the RAISE and LOWER positions to release the remaining pressure in the hydraulic circuit.
- When parking on public roads, provide fences, signs, flags, or lights, and put up any other necessary signs to ensure that passing traffic can see the machine clearly, and park the machine so that the machine, flags, and fences do not obstruct traffic.

**Parking procedure → See "12.17 PARKING MACHINE".**

- When leaving the machine, set the safety lock lever ① to the LOCK position, stop the engine, and use the key to lock all the equipment. Always remove the key and take it with you.

**Work equipment posture → See "12.17 PARKING MACHINE".**

**Locks → See "12.21 LOCKING".**

- Always close the door of the operator's compartment.

#### CORRECT

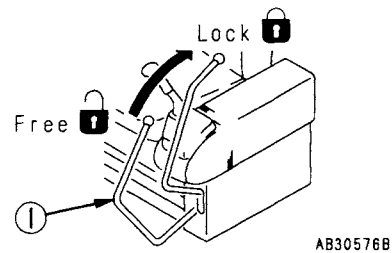
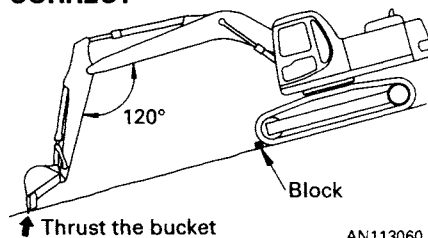

### PRECAUTIONS IN COLD AREAS

- After completing operations, remove all water, snow, or mud stuck to the wiring harness, connector ①, switches, or sensors, and cover these parts. If the water freezes, it will cause malfunctions of the machine when it is next used, which may lead to unexpected accidents.
- Carry out the warming-up operation thoroughly. If the machine is not thoroughly warmed up before the control levers are operated, the reaction of the machine will be slow, and this may lead to unexpected accidents.
- Operate the control levers to relieve the hydraulic pressure (raise to above the set pressure for the hydraulic circuit and release the oil to the hydraulic tank) to warm up the oil in the hydraulic circuit. This ensures good response from the machine and prevents malfunctions.
- If the battery electrolyte is frozen, do not charge the battery or start the engine with a different power source. There is danger that this will ignite the battery. When charging or starting the engine with a different power source, melt the battery electrolyte and check for leakage of battery electrolyte before starting.

**Battery charge rate → See "14. COLD WEATHER OPERATION".**

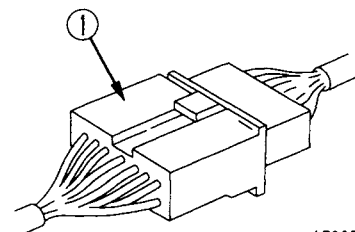

## 7.3 TRANSPORTATION

### PRECAUTIONS FOR TRANSPORTATION

- When transporting the machine, follow the relevant rules and regulations, and take steps to ensure safety.
- When selecting the transportation route, take into consideration the maximum width, height, and weight of the machine when loaded on the trailer.
- When passing over bridges or structures on private land, check first that the structure is strong enough to support the weight of the machine. When traveling on public roads, check first with the relevant authorities and follow their instructions.
- For machines equipped with a cab, always lock the door securely.

## 7.4 BATTERY

### BATTERY HAZARD PREVENTION

Battery electrolyte contains sulphuric acid, and batteries generate hydrogen gas, so mistaken handling can lead to serious injury or fire. For this reason, always observe the following precautions.

- Never bring any lighted cigarette or flame near the battery.
- When working with batteries, ALWAYS wear safety glasses and rubber gloves.
- If you spill acid on your clothes or skin, immediately flush the area with large amounts of water.
- Battery acid could cause blindness if splashed into the eyes. If acid gets into your eyes, flush them immediately with large quantities of water and see a doctor at once.
- If you accidentally drink electrolyte, drink a large quantity of water or milk, beaten egg or vegetable oil. Call a doctor or poison prevention center immediately.
- Before working with batteries, stop the engine and turn the starting switch to the OFF position.
- Avoid short-circuiting the battery terminals (between the positive ⊕ terminal and negative ⊖ terminal) through accidental contact with metal objects, such as tools.
- When installing the battery, connect the positive ⊕ terminal first, and when removing the battery, disconnect the negative ⊖ terminal (ground side) first.
- When removing or installing, check which is the positive ⊕ terminal and negative ⊖ terminal, and tighten the nuts securely.  
If the battery electrolyte is near the LOWER LEVEL, add distilled water. Do not add distilled water above the UPPER LEVEL.
- When cleaning the top surface of the battery, wipe it with a damp cloth. Never use gasoline, thinner, or any other organic solvent or cleaning agent.
- Tighten the battery caps securely.
- If the battery electrolyte is frozen, do not charge the battery or start the engine with a different power source. There is danger that this will ignite the battery.  
When charging or starting the engine with a different power source, melt the battery electrolyte and check for leakage of battery electrolyte before starting.
- Always remove the battery from the chassis before charging it.

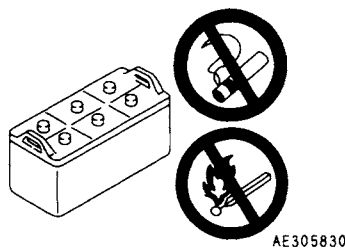
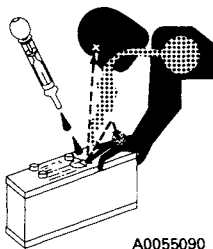

### STARTING WITH BOOSTER CABLES

If any mistake is made in the method of connecting the booster cables, it may cause a fire, so always do as follows.

- Carry out the starting operation with two workers (with one worker sitting in the operator's seat).
- When starting from another machine, do not allow the two machines to touch.
- When connecting the booster cables, turn the starting switch OFF for both the normal machine and problem machine.
- Be sure to connect the positive  $\oplus$  cable first when installing the booster cables. Disconnect the ground or negative  $\ominus$  cable first when removing them.
- The final ground connection is the connection of the ground to the engine block of the problem machine. However, this will cause sparks, so be sure to connect it as far as possible from the battery.

**Starting procedure when using booster cables → See "16.5 IF BATTERY IS DISCHARGED".**

- When removing the booster cables, be careful not to let the booster cable clips touch each other or to let the clips touch the machine.

**INCORRECT**

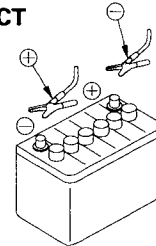

A0067320

### CHARGING BATTERY

If the battery is handled incorrectly when it is being charged, there is danger that the battery may explode, so follow the instructions in HANDLING BATTERY and in the instruction manual for the charger, and always observe the following precautions.

- Carry out the charging in a well-ventilated place, and remove the battery caps. This disperses the hydrogen gas and prevents explosion.
- Set the voltage on the charger to match the voltage on the battery to be charged. If the voltage setting is wrong, it will cause the charger to overheat and catch fire, and this may lead to an explosion.

Connect the positive  $\oplus$  charging clip of the charger to the positive  $\oplus$  terminal of the battery, then connect the negative  $\ominus$  charging clip to the negative  $\ominus$  terminal of the battery. Be sure to tighten both terminals securely.

- If the battery charge is less than 1/10 of the rated charge, and high speed charging is carried out, set to a value below the rated capacity of the battery.

If there is an excessive flow of charging current, it may cause leakage or evaporation of the electrolyte, which may catch fire and explode.

**INCORRECT**

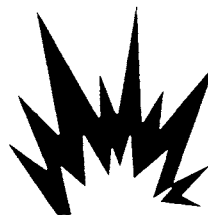

A0055110

## 7.5 TOWING

### WHEN TOWING

- Injury or death could result if a disabled machine is towed incorrectly or if there is a mistake in the selection of the wire rope, so always do as follows.
- Do not tow in a different way from the method given in the section "16.2 METHOD OF TOWING MACHINE".
- Always wear leather gloves when handling wire rope.
- When carrying out the preparation for towing with another worker, agree on signals before starting the operation.
- If the engine on the problem machine will not start or there is a failure in the brake system, please contact your Komatsu distributor for repairs.
- It is dangerous to tow a machine on a slope, so choose a place where there is a gradual slope. If there is no place with a gradual slope, carry out work to make the slope as small as possible.
- If a problem machine is towed by another machine, ALWAYS use a wire rope with a sufficient towing capacity for the weight of the problem machine.
- Do not use a wire rope which has cut strands (A), kinks (B), or reduced diameter (C).

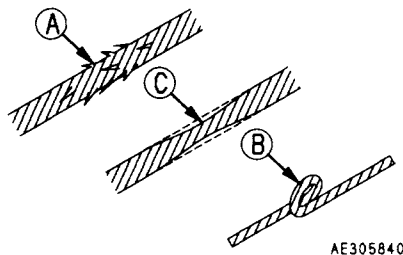

CORRECT

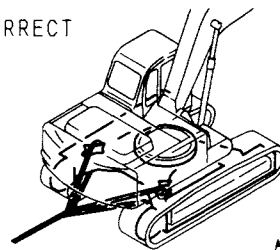

## 7.6 LIFTING OPERATIONS

### PROHIBITIONS FOR LIFTING OPERATIONS

Do not use the work equipment to carry out lifting operations. In particular, do not do the following.

- Do not weld a hook to the bucket to lift a load.
- Do not fit a wire rope to the bucket teeth to lift a load.
- Do not wind a wire rope directly around the boom or arm to lift a load.



## 8. PRECAUTIONS FOR MAINTENANCE

**⚠ WARNING:** For reasons of safety, always follow these safety precautions.

### 8.1 BEFORE CARRYING OUT MAINTENANCE

#### NOTIFICATION OF FAILURE

Carrying out maintenance not described in the Komatsu operation and maintenance manual may lead to unexpected failures.

Please contact your Komatsu distributor for repairs.

#### WARNING TAG

- ALWAYS attach the "DO NOT OPERATE" warning tag to the work equipment control lever in the operator's cab to alert others that you are working on the machine. Attach additional warning tags around the machine if necessary.
- If others start the engine, or touch or operate the work equipment control lever while you are performing service or maintenance, you could suffer serious injury or death.

Warning tag Part No. 09963-03000

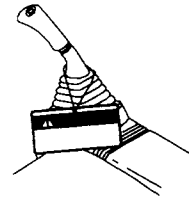
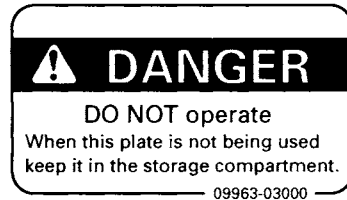

AE305910

#### CLEAN BEFORE INSPECTION AND MAINTENANCE

- Clean the machine before carrying out inspection and maintenance. This will ensure that dirt does not get into the machine and will also ensure that maintenance can be carried out safely.
- If inspection and maintenance are carried out with the machine still dirty, it will be difficult to find the location of problems, and there is also the danger that you will get dirty or mud in your eyes, and that you will slip and injure yourself.
- When washing the machine, always do as follows.
  - Wear non-slip shoes to prevent yourself from slipping on the wet surface.
  - When using high-pressure steam to wash the machine, always wear protective clothing. This will protect you from being hit by high-pressure water, and cutting your skin or getting mud or dust into your eyes.
  - Do not spray water directly on to the electrical system (sensors, connectors) ①. If water gets into the electrical system, there is danger that it will cause defective operation and malfunction.

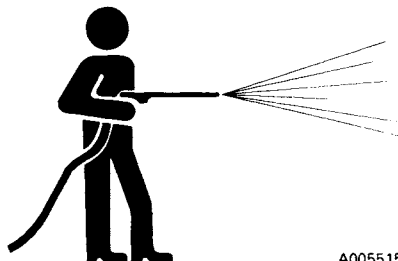

A0055150

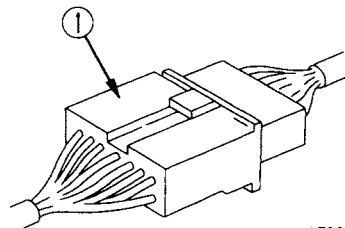

AE305820

### KEEP WORK PLACE CLEAN AND TIDY

Do not leave hammers or other tools lying around in the work place. Wipe up all grease, oil, or other substances that will cause you to slip. Always keep the work place clean and tidy to enable you to carry out operations safely.

If the work place is not kept clean and tidy, there is danger that you will trip, slip, or fall over and injure yourself.

### APPOINT LEADER WHEN WORKING WITH OTHERS

When repairing the machine or when removing and installing the work equipment, appoint a leader and follow his instructions during the operation.

When working with others, misunderstandings between workers can lead to serious accidents.

### RADIATOR WATER LEVEL

- When inspecting the radiator water level, stop the engine, and wait for the engine and radiator to cool down. Check the water level in the sub-tank. Under normal conditions, do not open the radiator cap.
- If there is no sub-tank, or the radiator cap must be removed, always do as follows.
- Wait for the radiator water temperature to go down before checking the water level. (When checking if the water temperature has gone down, put your hand near the engine or radiator and check the air temperature. Be careful not to touch the radiator or engine.)
- Release the internal pressure before removing the radiator cap, and remove the radiator cap slowly.



A0055050

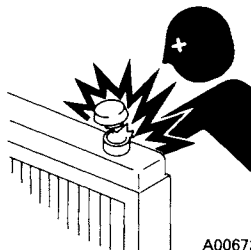

A0067380

### STOP ENGINE BEFORE CARRYING OUT INSPECTION AND MAINTENANCE

- When carrying out inspection and maintenance, park the machine on level ground where there is no danger of falling rocks or land slides, or of flooding if the land is low, then lower the work equipment to the ground and stop the engine.
- Operate the right work equipment control lever several times to the RAISE and LOWER positions to release the remaining pressure in the hydraulic circuit, then set safety lock lever ① to the LOCK position.
- Put blocks under the track to prevent the machine from moving.
- The worker carrying out the maintenance should be extremely careful not to touch or get caught in the moving parts.

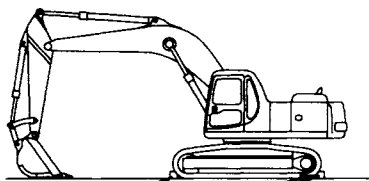

Block

A031404B

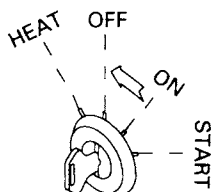

AM089160

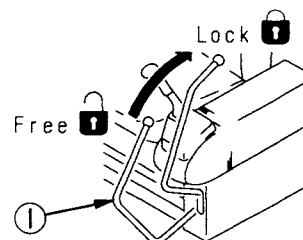

AB30576B

**SAFETY DEVICES FOR WORK EQUIPMENT**

When carrying out inspection and maintenance with the work equipment raised, fit stand ② securely to the boom to prevent the work equipment from coming down.  
Place the work equipment control levers at HOLD, and set safety lock lever ① to the LOCK position.

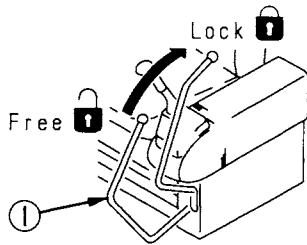

AB30576B



A0055140

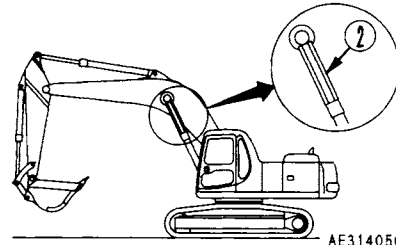

AE314050

**PROPER TOOLS**

Use only tools suited to the task. Using damaged, low quality, faulty, or makeshift tools could cause personal injury.

Broken pieces of chisels or hammers could fly into your eyes and blind you.

**Tools → See "21.1 INTRODUCTION OF NECESSARY TOOLS".**



A0055120

**PERIODIC REPLACEMENT OF SAFETY CRITICAL PARTS**

Hoses and other parts of the fuel, hydraulic, and brake system are critical parts for ensuring safety, so they must be replaced periodically.

Replacement of safety critical parts requires skill, so please ask your Komatsu distributor to carry out replacement.

- Replace these components periodically with new ones, regardless of whether or not they appear to be defective.

These components deteriorate over time, and can cause fire because of oil leakage or failure in the work equipment system.

- Replace or repair any such components if any defect is found, even though they have not reached the time specified.

**Replacement of safety critical parts →**

**See "22. PERIODIC REPLACEMENT OF SAFETY CRITICAL PARTS".**

### USE OF LIGHTING

- When checking fuel, oil, or battery electrolyte, always use lighting with anti-explosion specifications. If such lighting equipment is not used, there is danger of explosion.
- If work is carried out in dark places without installing lighting, there is danger of injury, so always install proper lighting.
- Even if it is dark, do not use a lighter or flame instead of lighting. There is danger of starting a fire, and if the battery gas ignites, it may cause an explosion.
- When using the machine as the power supply for the lighting, follow the instructions in this Operation and Maintenance Manual.

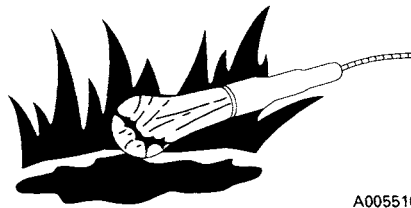

A0055160

### PREVENTION OF FIRE

There is danger of the fuel and battery gas catching fire during maintenance, so always follow the precautions below when carrying out maintenance.

- Store fuel, oil, grease, and other flammable materials away from flame.
- Use non-flammable materials as the flushing oil for cleaning parts. Do not use diesel oil or gasoline. There is danger that they will catch fire.
- Never smoke when carrying out inspection or maintenance. Always smoke in the prescribed place.
- When checking fuel, oil, or battery electrolyte, always use lighting with anti-explosion specifications. Never use lighters or matches as lighting.
- When carrying out grinding or welding operations on the chassis, remove any flammable materials to a safe place.
- Be sure that a fire extinguisher is present at the inspection and maintenance point.



A0055020

## 8.2 DURING MAINTENANCE

### PERSONNEL

Only authorized personnel can service and repair the machine. Do not allow unauthorized personnel into the area. If necessary, employ an observer.  
Extra precaution should be used when grinding, welding, and using a sledge-hammer.

### ATTACHMENTS

- Appoint a leader before starting removal or installation operations for attachments.
- Do not allow anyone other than the workers close to the machine or attachment.
- Place attachments that have been removed from the machine in a safe place so that they do not fall. Put a fence around the attachments, and set up No Entry signs to prevent unauthorized persons from coming close.



A0055130

### WORK UNDER THE MACHINE

- Stop the machine on firm, level ground, and always lower all work equipment to the ground before performing service or repairs under the machine.
- Always block the track shoes securely.
- It is extremely dangerous to work under the machine if the track shoes are off the ground and the machine is supported only by the work equipment. Never work under the machine if the machine is poorly supported.



A0055140

### WORK ON TOP OF MACHINE

- When carrying out maintenance on top of the machine, make sure that the footholds are clean and free of obstructions, and follow the precautions below to prevent yourself from falling.
  - Do not spill oil or grease.
  - Do not leave tools lying around.
  - Mind your step when you are walking.
- Never jump down from the machine. When getting on or off the machine, always use the steps and handrails, and maintain three-point contact (both feet and one hand or both hands and one foot) at all times.
- Use protective equipment if necessary.



A0305870

**⚠ WARNING:** Failure to follow these safety precautions may lead to a serious accident.

## 8. PRECAUTIONS FOR MAINTENANCE

### LOCKING INSPECTION COVERS

When carrying out maintenance with the inspection cover open, lock it securely with a lock bar. If maintenance is carried out with the inspection cover open and not locked in position, it may close suddenly if knocked or blown by the wind, and may cause injury to the operator.

### MAINTENANCE WITH ENGINE RUNNING

To prevent injury, do not carry out maintenance with the engine running. If maintenance must be carried out with the engine running, carry out the operation with at least two workers and do as follows.

- One worker must always sit in the operator's seat and be ready to stop the engine at any time. All workers must maintain contact with the other workers.
- When carrying out operations near rotating parts, there is danger of being caught in the parts, so be extremely careful.
- When cleaning inside the radiator, set safety lock lever ① to the LOCK position to prevent the work equipment from moving.
- Do not touch any control levers. If any control lever must be operated, always give a signal to the other workers to warn them to move to a safe place.
- Never touch the fan blade or fan belt with any tool or any part of your body. There is danger of serious injury.

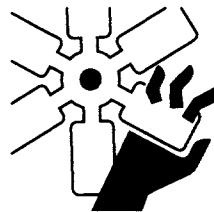

A0055210

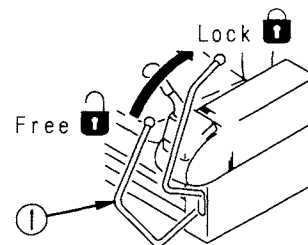

AB30576B

### DO NOT DROP TOOLS OR PARTS INSIDE MACHINE

- When opening the inspection window or tank oil filler to carry out inspection, be careful not to drop any nuts, bolts, or tools inside the machine. If such parts are dropped into the machine, it will cause breakage of the machine, mistaken operation, and other failures. If you drop any part into the machine, always be sure to remove it from the machine.
- When carrying out inspection, do not carry any unnecessary tools or parts in your pocket.

### PRECAUTIONS WHEN USING HAMMER

When using a hammer, always wear safety glasses, safety helmet, and other protective clothing, and put a brass bar between the hammer and the part being hammered. If hard metal parts such as pins, edges, teeth, or bearings are hit with a hammer, there is danger that broken pieces might fly into your eyes and cause injury.

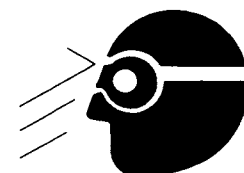

AE305880

### REPAIR WELDING

Welding operations must always be carried out by a qualified welder and in a place equipped with a proper equipment. Gas is generated, and there is danger of fire or electrocution when carrying out welding, so never allow any unqualified personnel to carry out welding.

The qualified welder must follow the precautions given below.

- Disconnect the battery terminals to prevent explosion of the battery.
- Remove the paint from the place being welded to prevent gas from being generated.
- If hydraulic equipment or piping, or places close to these are heated, flammable vapor or spray will be generated, and there is danger of this catching fire, so avoid applying heat to such places.
- If heat is applied directly to rubber hoses or piping under pressure, they may suddenly burst, so cover them with fireproof sheeting.
- Always wear protective clothing.
- Ensure that there is good ventilation.
- Clear up any flammable materials, and make sure that there is a fire extinguisher at the workplace.

### PRECAUTIONS WITH BATTERY

When repairing the electrical system or when carrying out electrical welding, remove the negative ⊖ terminal of the battery to stop the flow of current.

**Handling battery → See "16.5 IF BATTERY IS DISCHARGED".**

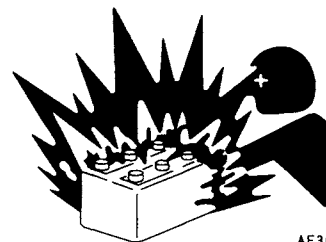

AE305890

### WHEN ABNORMALITY IS LOCATED

- If any abnormality is found during inspection, always carry out repairs. In particular, if the machine is used when there is any abnormality in the brakes or work equipment systems, it may lead to serious accident.
- Depending on the type of failure, please contact your Komatsu distributor for repairs.

### RULES TO FOLLOW WHEN ADDING FUEL OR OIL

If any flame is brought close to fuel or oil, there is danger that it will catch fire, so always follow the precautions below.

- Stop the engine when adding fuel or oil.
- Do not smoke.
- Spilled fuel and oil may cause you to slip, so always wipe it up immediately.
- Always tighten the cap of the fuel and oil fillers securely.
- Always add fuel and oil in a well-ventilated place.



A0055020



A0055030



A0055040

**⚠ WARNING:** Failure to follow these safety precautions may lead to a serious accident.

### PRECAUTIONS WHEN USING HIGH-PRESSURE GREASE TO ADJUST TRACK TENSION

- Grease is pumped into the track tension adjustment system under high pressure. If the specified procedure for maintenance is not followed when making adjustment, valve ① may fly out and cause damage or personal injury.
- When loosening grease drain valve ①, never loosen it more than one turn.
- Never put your face, hands, feet, or any other part of your body directly in front of any grease drain valve.

**Adjusting track tension → See "24.2 WHEN REQUIRED".**

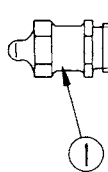
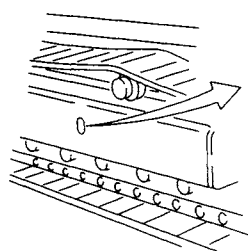

AB307180

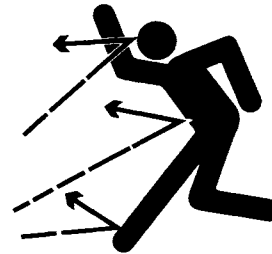

A0055200

### HANDLING HIGH-PRESSURE HOSES

- If oil or fuel leaks from high-pressure hoses, it may cause fire or defective operation, which may lead to personal injury or damage. If any damaged hoses or loose bolts are found, stop work and contact your Komatsu distributor for repairs.
- Replacing high-pressure hoses requires a high level of skill, and the torque is determined according to the type of hose and size, so please do not carry out replacement yourself. Ask your Komatsu distributor to carry out replacement.

### PRECAUTIONS WITH HIGH-PRESSURE OIL

When inspecting or replacing high-pressure piping or hoses, always check that the pressure in the hydraulic circuit has been released. If the circuit is still under pressure, it will lead to serious injury or damage, so always do as follows.

- For details of the method of releasing the pressure, see **"8.1 BEFORE CARRYING OUT MAINTENANCE, STOP ENGINE BEFORE CARRYING OUT INSPECTION AND MAINTENANCE"**. Never carry out inspection or replacement before releasing the pressure completely.
- Wear safety glasses and leather gloves.
- If there is any leakage from the piping or hoses, the piping, hoses, and the surrounding area will be wet, so check for cracks in the piping and hoses and for swelling in the hoses. If it is difficult to locate the leakage, always please contact your Komatsu distributor for repairs.
- If you are hit by a jet of high-pressure oil, consult a doctor immediately for medical attention.

**INCORRECT**



A0055180

**CORRECT**

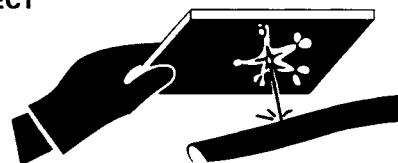

A0055190



**PRECAUTIONS WHEN CARRYING OUT MAINTENANCE AT HIGH TEMPERATURE**

Immediately after stopping operations, the engine coolant, oil at all parts, the exhaust manifold, and the muffler are at high temperature.

In this condition, if the cap is removed, or the oil is drained, or the filters are replaced, this may result in burns or other injury. Wait for the temperature to go down, then carry out the inspection and maintenance in accordance with the procedures given in this manual.

**Cleaning inside of cooling system → See "24.2 WHEN REQUIRED".**

**Checking coolant level, oil level in hydraulic tank → see "24.3 CHECK BEFORE STARTING".**

**Checking lubricating oil level, adding oil → see "24.3-7 PERIODIC MAINTENANCE".**

**Changing oil, replacing filters → see "24.5-10 PERIODIC MAINTENANCE".**

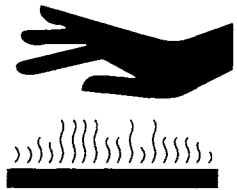

A0055050

**CHECKS AFTER INSPECTION AND MAINTENANCE**

Failure to carry out inspection and maintenance fully, or failure to check the function of various maintenance locations may cause unexpected problems and may even lead to personal injury or damage, so always do as follows.

- Checks when engine is stopped
  - Have all the inspection and maintenance locations been checked?
  - Have all the inspection and maintenance items been carried out correctly?
  - Have any tools or parts dropped inside the machine? It is particularly dangerous if they get caught in the lever linkage.
  - Has water and oil leakage been repaired? Have bolts been tightened?
- Checks when engine is running
 

For details of checks when the engine is running, see **"8.2 DURING MAINTENANCE, MAINTENANCE WITH ENGINE RUNNING"**, and be extremely careful to ensure safety.
- Do the inspection and maintenance locations work normally?
- Is there any oil leakage when the engine speed is raised and load is applied to the hydraulic system?

**WASTE MATERIALS**

To prevent pollution, particularly in places where people or animals are living, always follow the procedures given below.

- Never dump waste oil in a sewer system, rivers, etc.
- Always put oil drained from your machine in containers. Never drain oil directly onto the ground.
- Obey appropriate laws and regulations when disposing of harmful objects such as oil, fuel, coolant, solvent, filters, and batteries.

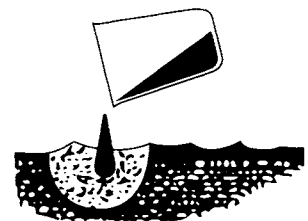
**INCORRECT**

A0055220

**⚠ WARNING:** Failure to follow these safety precautions may lead to a serious accident.

#### **MAINTENANCE OF AIR CONDITIONER**

If the air conditioner refrigerant gets into your eyes or touches your skin, it may cause blindness or frostbite.

- When repairing or inspecting the air conditioner, be sure to handle the refrigerant gas according to regulations of your country.
- When handling the refrigerant, follow the precautions given on the container.
- To prevent the refrigerant from leaking into the atmosphere, use a recovery recycling system.
- Never touch the refrigerant.

## 9. POSITION FOR ATTACHING SAFETY LABELS

Always keep these labels clean. If they are lost or damaged, attach them again or replace them with a new label.

There are other labels in addition to the safety labels listed as follows, so handle them in the same way.

Safety labels may be available in languages other than English. To find out what labels are available, contact your Komatsu distributor.

### POSITION FOR ATTACHING SAFETY LABELS

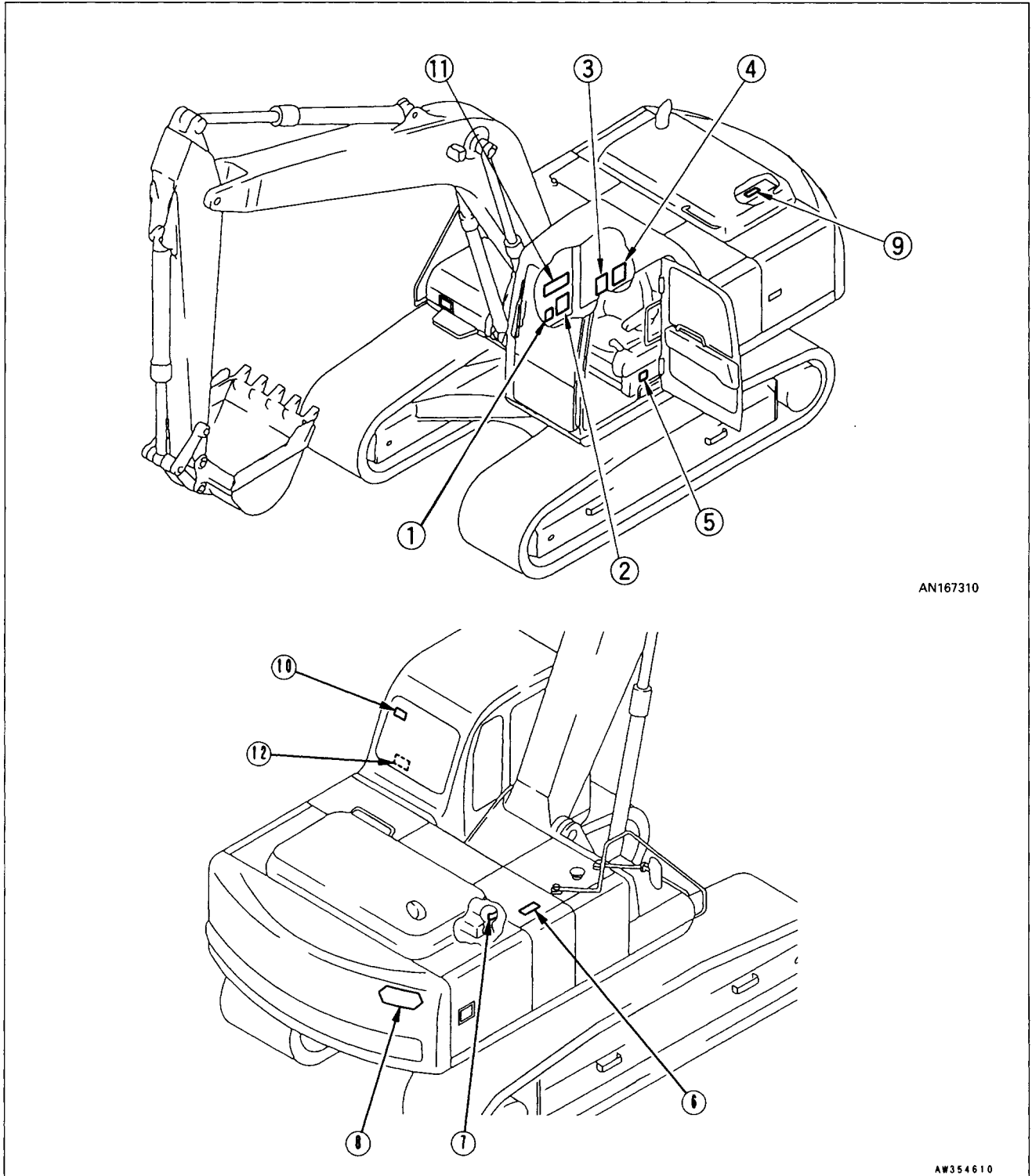

1. Warnings for leaving operator's seat (203-00-61270)

**⚠ WARNING**

To avoid hitting unlocked operation levers, lower equipment to ground and move SAFETY LOCK LEVER (located near seat) to LOCK position before standing up from operator's seat.

Sudden and unwanted machine movement can cause serious injury or death.

203-00-61270

3. Warnings for operation, inspection and maintenance (14X-98-11580)

**⚠ WARNING**

Improper operation and maintenance can cause serious injury or death.

Read manual and labels before operation and maintenance.  
Follow instructions and warnings in manual and in labels on machine.

Keep manual in machine cab near operator.  
Contact Komatsu distributor for a replacement manual.

14X-98-11580

2. Warnings before operating machine (203-00-61291)

**⚠ WARNING**

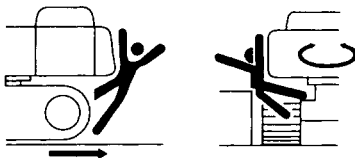

To prevent SEVERE INJURY or DEATH. Do the following before moving machine or its attachments:

- Honk horn to alert people nearby.
- Be sure no one is on or near machine or in swing area.
- Rotate cab for full view of travel path if it can be done safely.
- Use spotter if view is obstructed.

Follow above even if machine equipped with travel alarm and mirrors.

203-00-61291

4. Warnings for high voltage (203-00-61310)

**⚠ DANGER**



Hazardous voltage hazard. Serious injury or death can occur if machine or attachments are not kept safe distance away from electric lines.

Line voltage	Safe Disatnce
6.6 kv	At least 10 ft (3 m)
66.0 kv	At least 16 ft (5 m)
275.0 kv	At least 33 ft (10 m)

203-00-61310

9. POSITION FOR ATTACHING SAFETY LABELS

---

5. Warnings when adjusting track tension (14X-98-11551)

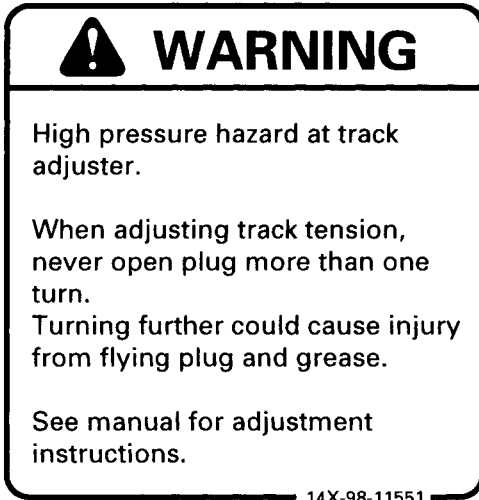

7. Warnings for handling accumulator (14X-98-11390)

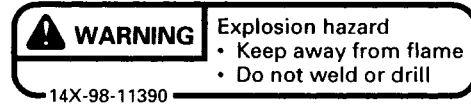

6. Warnings for hot oil (203-00-61260)



8. Keep off swing area (20Y-00-21270)



9. Warnings for hot water (14X-98-11531)

**! WARNING**

Hot water hazard.

To prevent hot water from spurting out:

- Turn engine off.
- Allow water to cool.
- Slowly loosen cap to relieve pressure before removing.

14X-98-11531

10. Warnings when opening front window (203-00-61280)

**! WARNING**

When raising window, lock it in place with lock pins on both sides.

Falling window can cause injury.

203-00-61280

11. Warnings when equipped with variable 2-piece boom (option), rotating arm (option) (20Y-966-1141)

**! WARNING**

IF THE BUCKET IS OPERATED IN A CERTAIN WAY, IT COMES IN CONTACT WITH THE MACHINE BODY (OPERATOR'S CAB, UPPER BOOM CYLINDER AND UNDER CARRIAGE). WHEN OPERATING THE WORK EQUIPMENT, TAKE SUFFICIENT CARE NOT TO BRING BUCKET IN CONTACT WITH THE MACHINE BODY. DO NOT RISK SERIOUS BODILY INJURY, DEATH OR DAMAGE TO MACHINE.

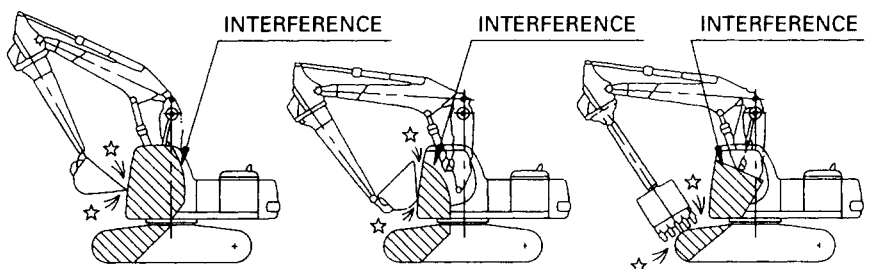

WHEN WORKING AFTER INSTALLING A 0.7m<sup>3</sup> BUCKET OPERATE CAREFULLY BY ENSURING THE BODY'S STABILITY.

20Y-966-1141

9. POSITION FOR ATTACHING SAFETY LABELS

---

12. Explanation of escape method in emergency  
(20Y-00-22880)

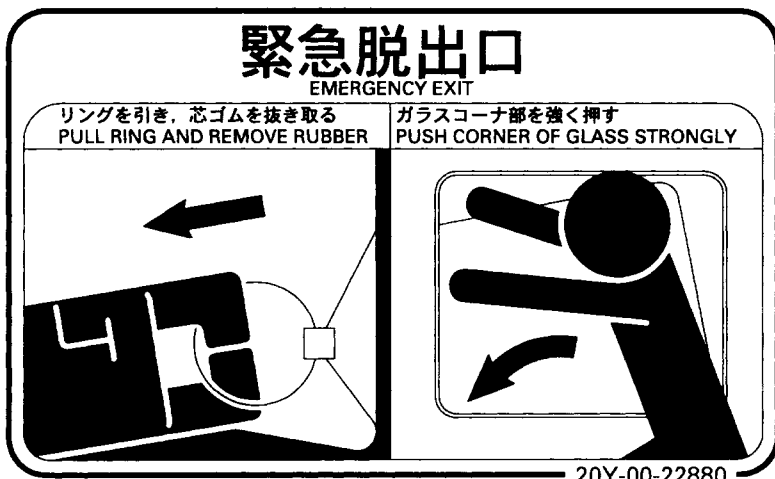

# **OPERATION**



# 10. GENERAL VIEW

## 10.1 GENERAL VIEW OF MACHINE

If directions are indicated in this section, they refer to the directions shown by the arrows in the diagram below.

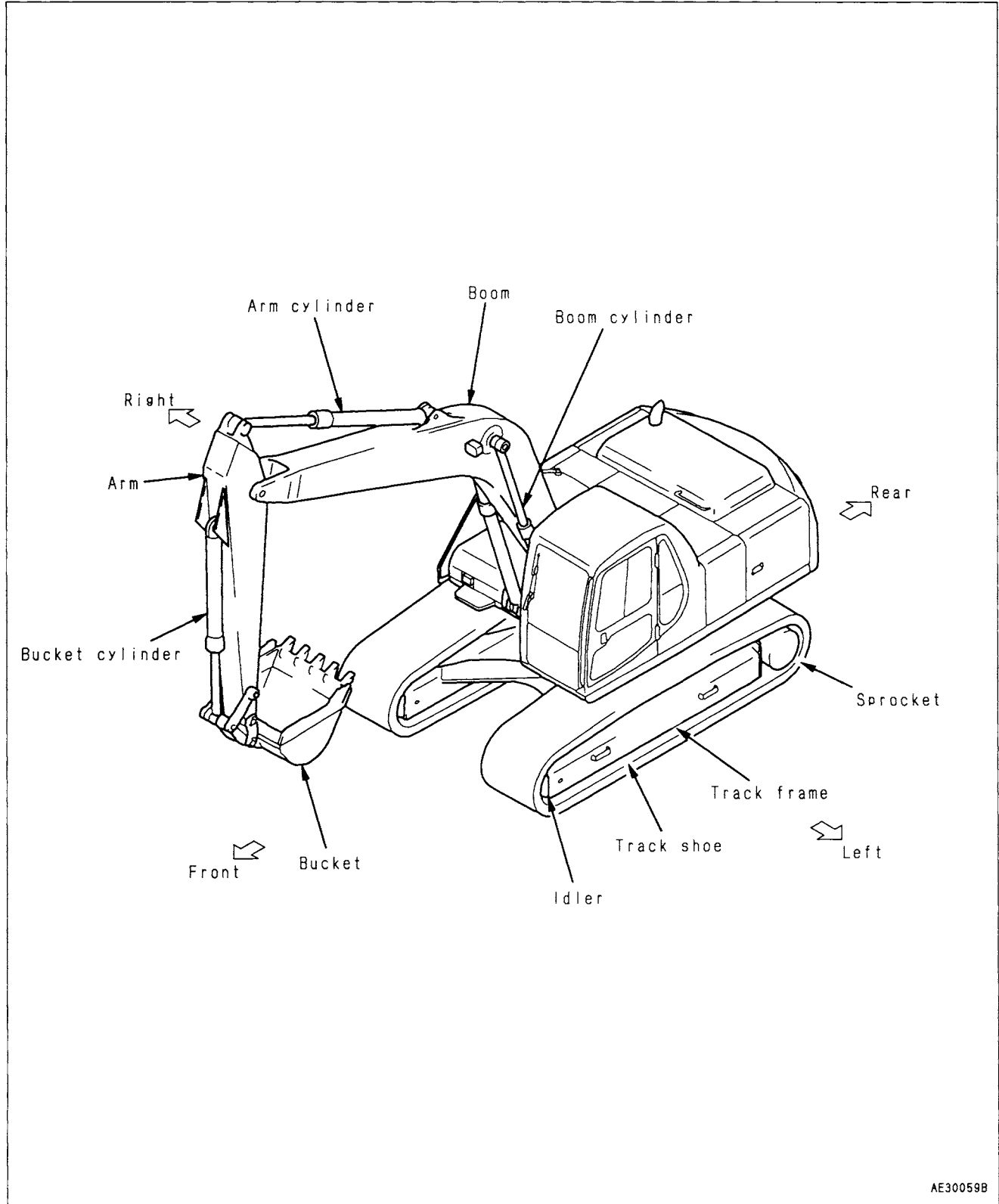

10.2 GENERAL VIEW OF CONTROLS AND GAUGES

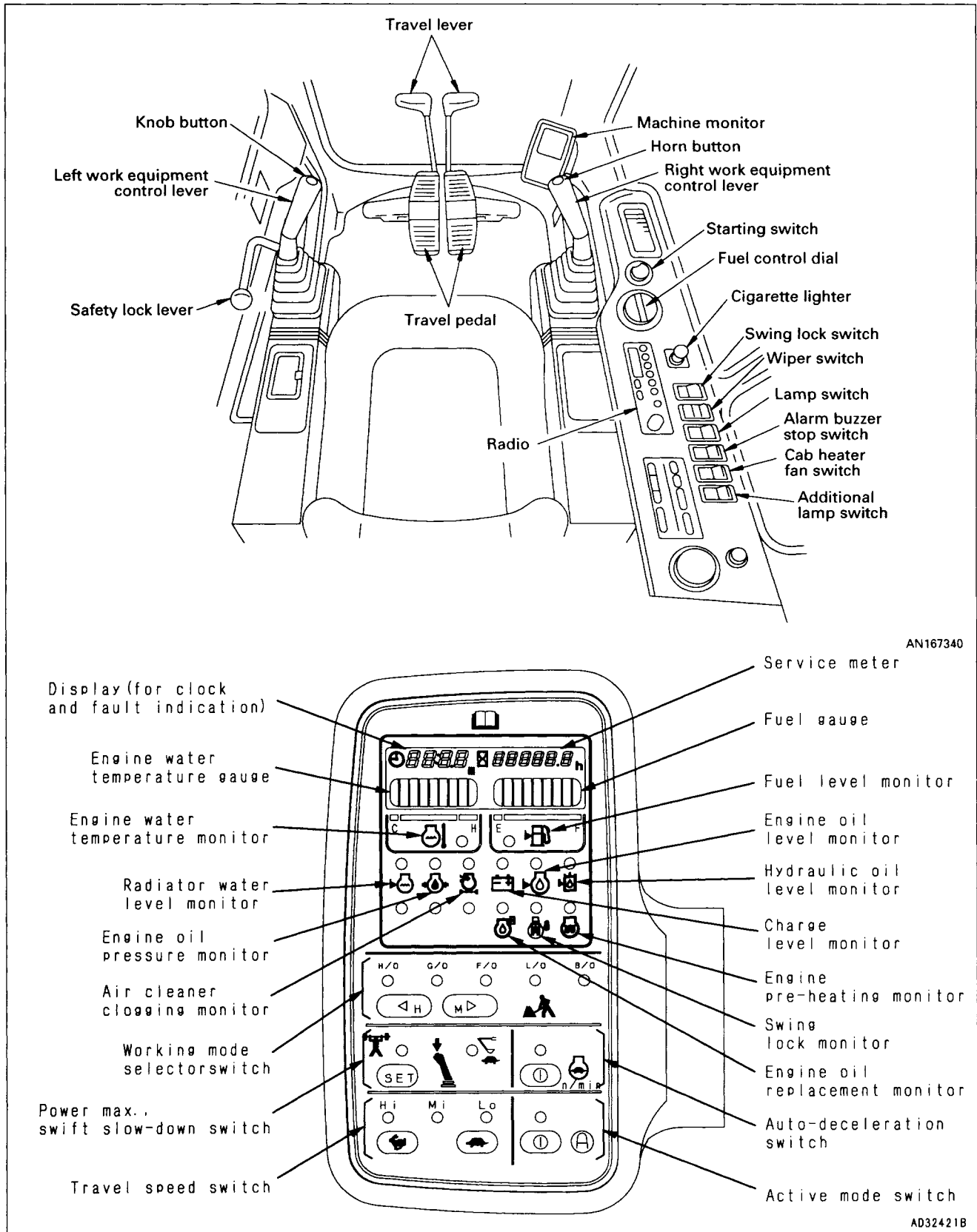

# 11. EXPLANATION OF COMPONENTS

The following is an explanation of the devices needed for operating the machine.

To carry out suitable operations correctly and safely, it is important to understand fully the methods of operating the equipment and the meanings of the displays.

## 11.1 MACHINE MONITOR

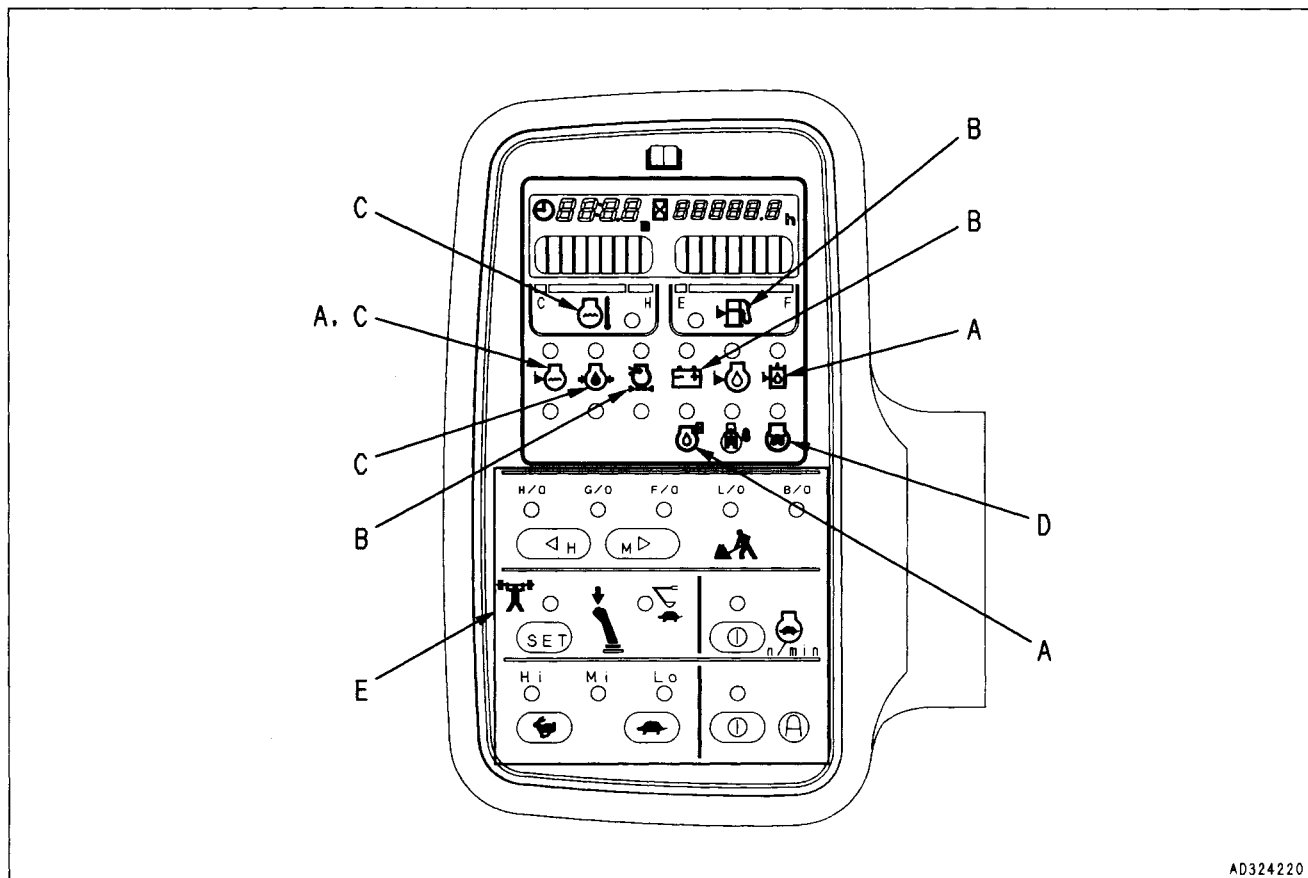

A0324220

### A. BASIC CHECK ITEMS (11.1.1)

This displays the basic items that should be checked before starting the engine.

If there is any abnormality, the appropriate monitor lamp will flash.

### NOTICE

When carrying out checks before starting, do not simply rely on the monitor. Always refer to the periodic maintenance items or "12. OPERATION" to carry out the checks.

**B. CAUTION ITEMS (11.1.2)** **CAUTION**

**If these monitor items flash, check and repair the appropriate location as soon as possible.**

These are items which need to be observed while the engine is running. If any abnormality occurs, items which need to be repaired as soon as possible are displayed.

If there is any abnormality, the appropriate monitor lamp will flash to indicate the location of the abnormality.

**C. EMERGENCY STOP ITEMS (11.1.3)** **CAUTION**

**If these monitor items flash, stop operations immediately, then check and repair the appropriate location.**

These are items which need to be observed while the engine is running. If any abnormality occurs, items which need to be repaired immediately are displayed.

If there is any abnormality, the appropriate monitor lamp will flash to indicate the location of the abnormality and the buzzer will sound.

**D. METER DISPLAY PORTION (11.1.4)**

This portion consists of pre-heating monitor, swing lock monitor, engine water temperature gauge, fuel gauge, service meter and display.

**E. SWITCHES (11.1.5)**

The switches are used for setting clock time and for selecting working mode and travel speed.

## 11. EXPLANATION OF COMPONENTS

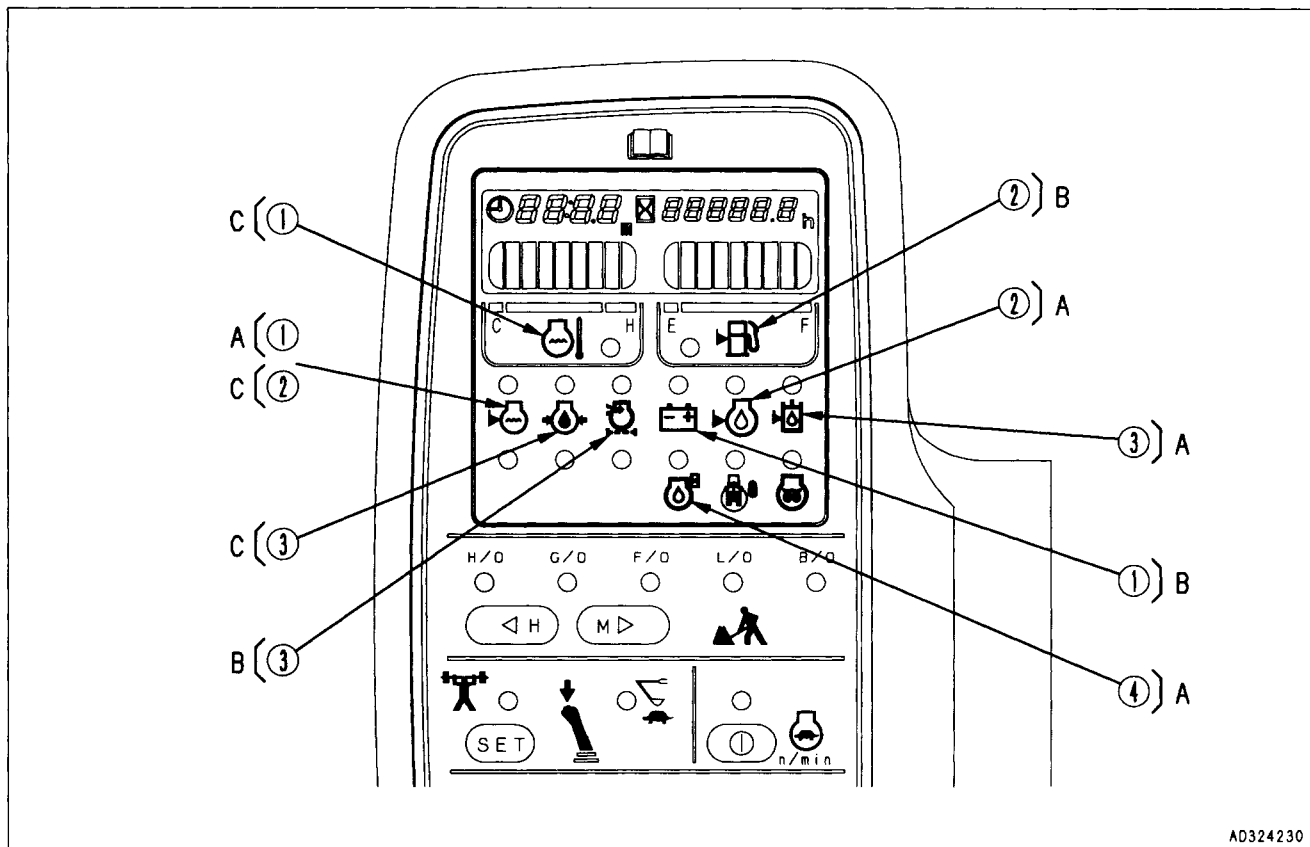

A0324230

### 11.1.1 A: BASIC CHECK ITEMS

#### NOTICE

Do not rely on the "BASIC CHECK ITEMS" only for the check before starting

Always refer to the periodic maintenance items or "12. OPERATION" to carry out the checks.

#### 1. RADIATOR WATER LEVEL

This warns that the radiator cooling water level is too low. If the monitor lamp flashes, check the cooling water level in the radiator and reserve-tank, and add water.

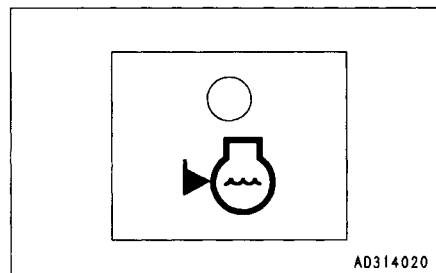

A0314020

#### 2. ENGINE OIL LEVEL

This warns that the oil level in the engine oil pan is too low. If the monitor lamp flashes, check the oil level in the engine oil pan, and add oil.

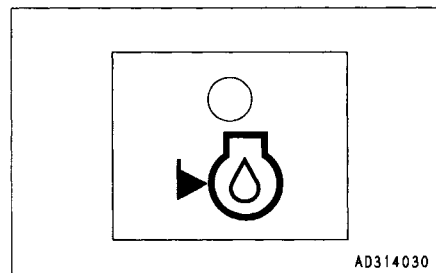

A0314030

**3. HYDRAULIC OIL LEVEL**

This warns that the hydraulic oil level is too low.  
If the monitor lamp flashes, check the hydraulic oil level, and add oil.

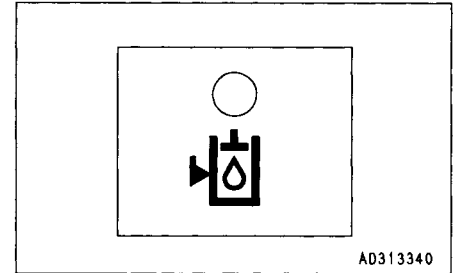
**4. REPLACEMENT OF ENGINE OIL (For only set machines)**

If the set time (125, 250, 500H) passes after the engine oil is replaced, this lamp lights up. At this time, replace the engine oil.

If you want to change the set time for replacement of oil, consult your Komatsu distributor.

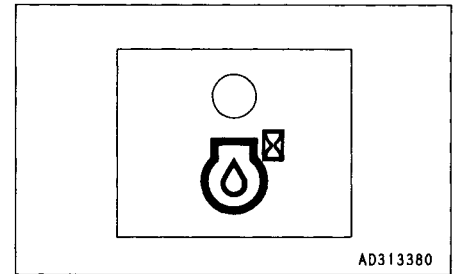
**11.1.2 B: CAUTION ITEMS****CAUTION**

If the caution monitor lamp flashes, repair the problem as soon as possible.

**1. CHARGE LEVEL**

This monitor indicates an abnormality in the charging system while the engine is running.

If the monitor lamp flashes, check the V-belt tension. If any abnormality is found, see "16.6 OTHER TROUBLE".

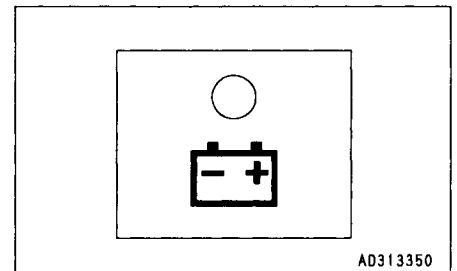
**REMARK**

While the starting switch is ON, the lamp will remain lit and will go off once the engine is started.

**2. FUEL LEVEL**

If the fuel drops below 45 liters (11.9 US gal, 9.9 UK gal), the lamp will flash. Top up the fuel before this.

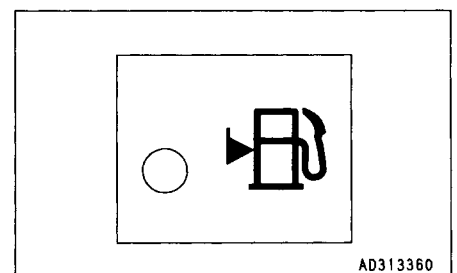

### 3. AIR CLEANER CLOGGING

This warns that the air cleaner is clogged.  
If the monitor lamp flashes, stop the engine, then inspect and clean the air cleaner.

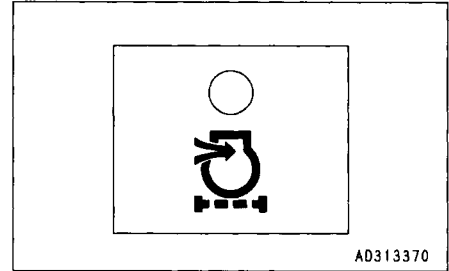

### 11.1.3 C: EMERGENCY STOP ITEMS

#### ⚠ CAUTION

If any monitor lamp flashes, stop the engine or run it at low idling, and take the following action.

#### 1. ENGINE WATER TEMPERATURE

If the temperature of the engine cooling water becomes abnormally high, the monitor lamp flashes, and the overheat prevention system is automatically actuated to reduce the engine speed.

Stop operations and run the engine at low idling until the engine water temperature gauge enters the green range.

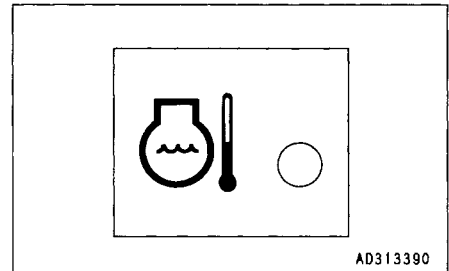

#### 2. RADIATOR WATER LEVEL

If the radiator water level drops, the monitor lamp flashes. Stop the engine, check the radiator water level, and add water if necessary.

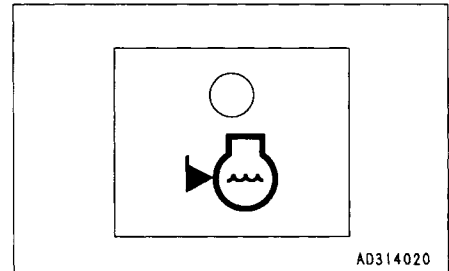

#### 3. ENGINE OIL PRESSURE

If the engine oil pressure drops below the normal pressure, the monitor lamp flashes. At this item, stop the engine and inspect it according to "16.6 OTHER TROUBLE."

#### REMARK

While the starting switch is ON, the lamp remains lit and goes off once the engine is started. When the engine starts, the buzzer may sound for a short time, however, this does not indicate a fault.

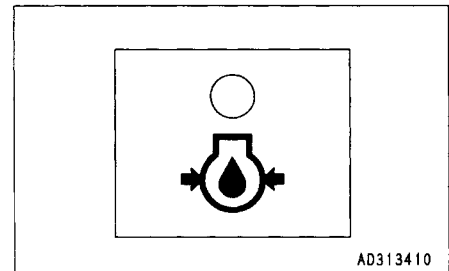

11.1.4 D: METER DISPLAY PORTION

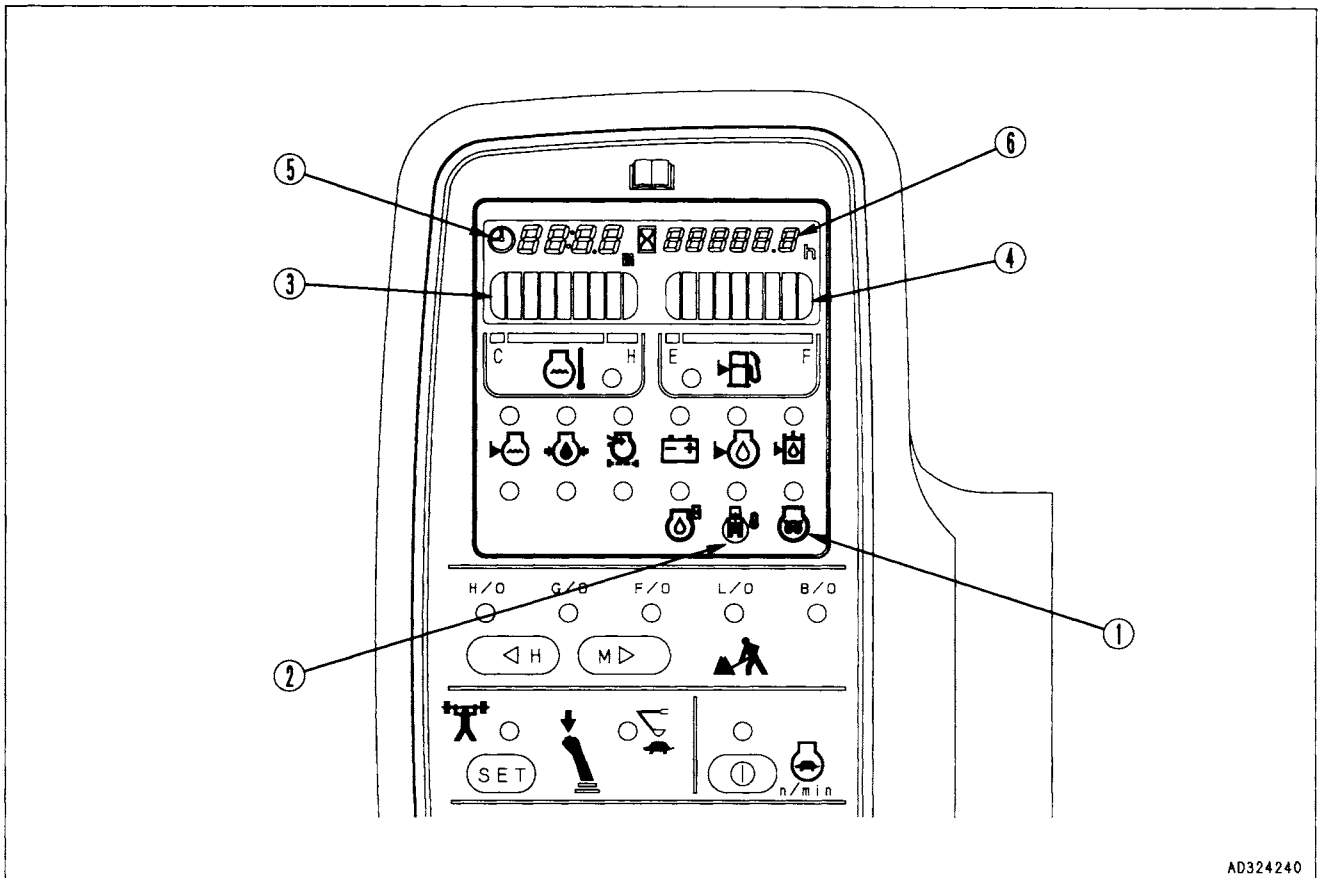

AD324240

**PILOT DISPLAY**

When the starting switch is ON, the pilot display lights up when the display items are functioning.

**1. ENGINE PRE-HEATING MONITOR**

This monitor lamp indicates the pre-heating time required when starting the engine at an ambient temperature below 0°C.

The monitor lamp lights when the starting switch is turned to HEAT position and flashes after about 30 seconds to show that the pre-heating is completed. (The monitor lamp will go off after about 10 seconds.)

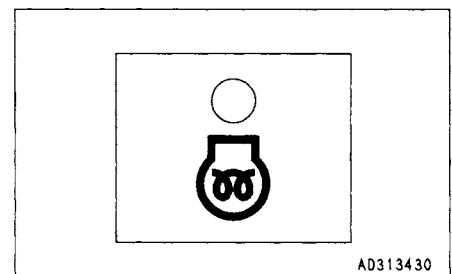

AD313430

**2. SWING LOCK MONITOR**

This informs the operator that the swing lock is being actuated.

Actuated: Lights up

When the swing lock switch is turned ON (ACTUATED), the monitor lamp lights up.

When the swing lock override switch is turned on, this monitor lamp flashes.

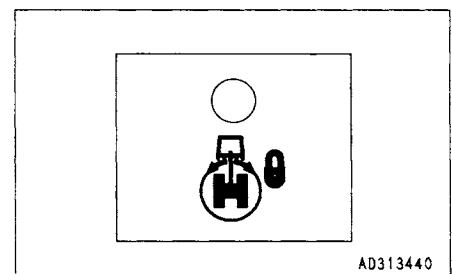

AD313440

**REMARK**

A disc brake is installed in the swing motor to mechanically stop motor rotation.

The brake is always applied while the swing lock is actuated.



**METERS**

**3. ENGINE WATER TEMPERATURE GAUGE**

This gauge indicates the engine cooling water temperature. If the temperature is normal during operation, the green range will light up. If the red range lights up during operation, the overheat prevention system will be actuated.

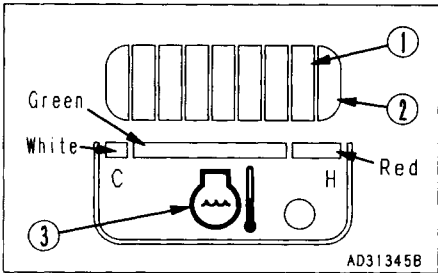

The overheat prevention system acts as follows.

When red range ① lights up:

Engine water temperature monitor ③ flashes.

When red range ② lights up:

Engine speed is lowered further to low idling, engine water temperature monitor ③ flashes, and alarm buzzer sounds at the same time.

The overheat prevention system is actuated until the temperature enters the green range.

When red range ② lights, if the engine water temperature is reduced and the fuel control dial is turned to the low idling position, the display will be canceled.

**4. FUEL GAUGE**

This gauge indicates the amount of fuel in the fuel tank. If the fuel level is normal during operation, the green range will light up.

If only the red range lights up during operation, there is less than 25 liters (6.6 US gal, 5.5 UK gal) of fuel remaining in the tank, so check and add fuel.

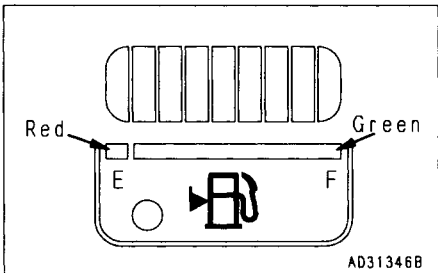

After the starting switch is turned ON, the correct level may not be displayed for a moment, but this does not indicate any abnormality.

When stopping the engine, turn the starting switch ON and check that the monitor lamps on items A, B, C and D and the meters light up.

**5. DISPLAY**

When the starting switch is ON, the time and service meter reading is displayed if the condition is normal. If the condition is abnormal, the content of the failure is displayed. When setting the time, the ⊕ symbol flashes.

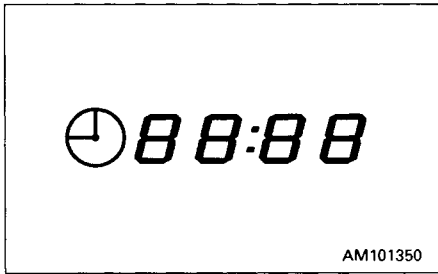

**Manual setting**

1. When the time is displayed, depress clock switch ① for 2.5 sec or more.
2. "⊕" flashes.
3. Pressing H switch ② increases hours and pressing M switch ③ increases minutes. If switch ② or ③ is pressed for 2.5 seconds or more, hours or minutes increase continuously.
4. When the correct time is reached, press clock switch ①. This completes clock setting.

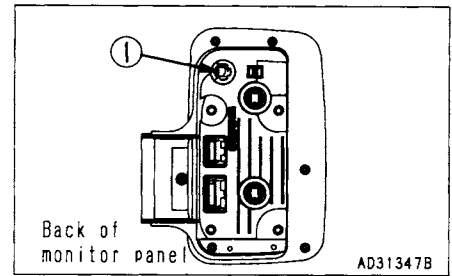

**Correct time setting**

1. When the time is displayed, depress the clock switch for 2.5 sec or more.
2. "⊕" flashes.
3. When SET switch ④ is pressed, the hour is rounded off for 0 to 14 minutes and rounded up for 45 to 59 minutes.  
 [Examples] 10:14 becomes 10:00 (rounded off)  
 10:45 becomes 11:00 (rounded up)  
 When SET switch ④ is pressed at the time signal or standard clock, the correct time is obtained.
4. When the correct time is reached, press clock switch ①. This completes clock setting.

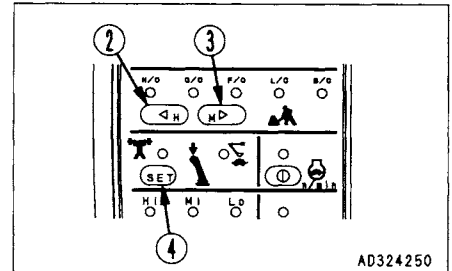

If the machine has a fault, error information appears while the starting switch is ON. The monitor flashes and displays all error informations sequentially.

Monitor indications	Error mode
E02	PC-EPC valve system error
E03	Swing brake system error
E05	Governor system error
CALL	Non-operating error

If any of these monitors flashes, see "16.6.4 ELECTRONIC CONTROL SYSTEM".

**6. SERVICE METER**

This meter shows the total operation hours of the machine. Set the periodic maintenance intervals using this display. The service meter advances while the engine is running - even if the machine is not traveling.

The meter will advance by 1 for each hour of operation regardless of the engine speed.

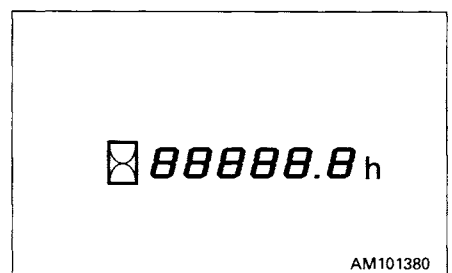

11.1.5 E: SWITCHES

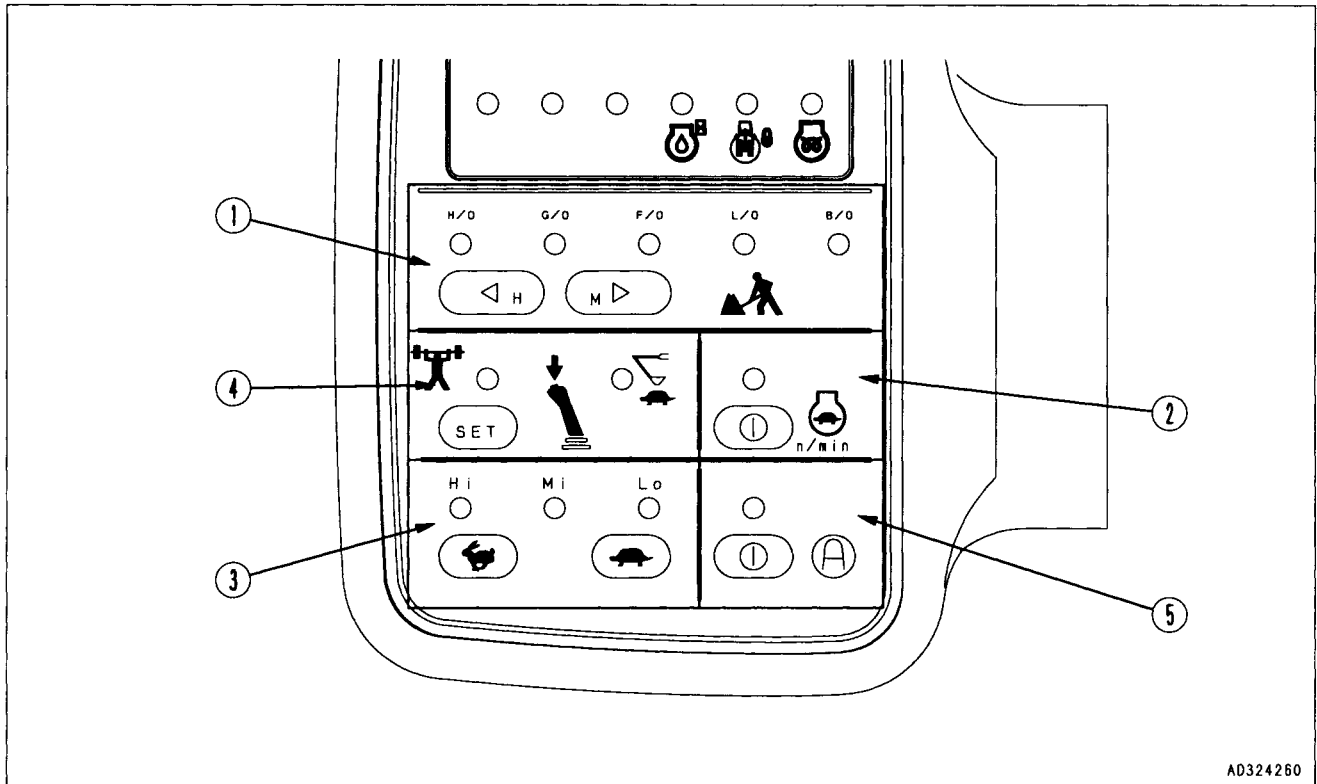

AD324260

1. WORKING MODE SELECTOR SWITCH (Basic switch)

This switch is used to set the movement or power for the work equipment. By selecting the mode to match the working conditions, it is possible to carry out operations more easily.

H.O. (heavy-duty operation mode) lights up:

This is used for heavy-duty work.

G.O. (general operation mode) lights up:

This is used for ordinary work.

F.O. (finishing operation mode) lights up:

This is used for leveling or grading work.

L.O. (lifting operation mode) lights up:

This is used for fine control operations.

B.O. (breaker operation mode) lights up:

This is used for breaker work.

- When starting the engine, G.O. (general operation) mode is automatically selected. Each time the switch is pressed, the mode selection changes.
- If you want to set the H.O. (heavy-duty operation) mode automatically when starting engine, consult your Komatsu distributor.

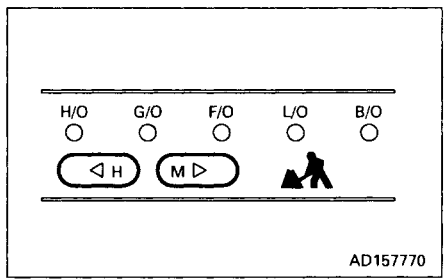

AD157770

NOTICE

When the breaker is used, never select the H.O. (heavy-duty operation) mode.

REMARK

H switch is also used for setting "hours" in the clock and M switch for setting "minutes". See "11.1.4-5. DISPLAY".

## 2. AUTO-DECELERATION SWITCH (Selection switch)

This switch acts to activate the function that automatically lowers the engine speed and reduces fuel consumption when the control lever is at neutral.

Lamp lights up: Auto-deceleration is actuated.  
Lamp goes out: Auto-deceleration is canceled.

Each time the switch is pressed, the auto-deceleration is actuated or canceled.

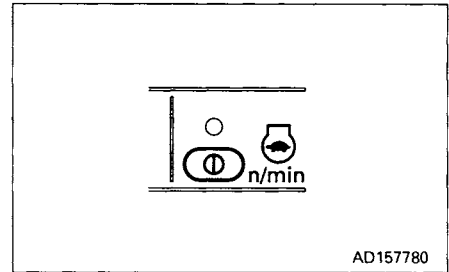

## 3. TRAVEL SPEED SWITCH

### **WARNING**

If the Hi-Lo switch is operated when the machine is traveling, the machine may deviate even when traveling in a straight line. To prevent this, always stop the machine before operating the travel speed switch.

This is used to select the three travel speeds.

Lo lights up: Low speed travel  
Mi lights up: Mid range speed travel  
Hi lights up: High speed travel

When the engine is started, the travel speed is automatically set to Lo.

When traveling in Hi or Mi, the travel speed is automatically switched to low speed travel (Lo) to match the travel surface on soft ground or when traveling uphill, so there is no need to operate this switch. The monitor indication keeps lamp Hi or Mi lighted.

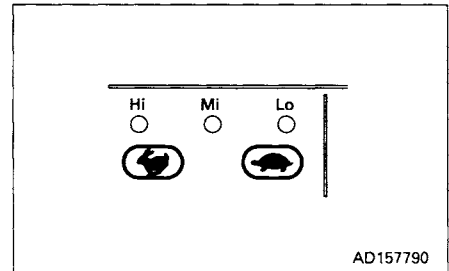

## 11. EXPLANATION OF COMPONENTS

### 4. POWER MAX./SWIFT SLOW-DOWN SWITCH

During operations, the digging power can be increased and the speed reduced by a one-touch operation of the knob button (single click while pushing).

Power max. (power up) lights up:

When the working mode is heavy-duty and general operation mode only, the power can be increased while the knob button is being pressed. Even if the knob button continues to be pressed, the increase in power finishes after approx. 8.5 sec.

Swift slow-down (speed down) lights up:

When the working mode is heavy-duty operation and general operation mode only, the speed can be reduced while the knob button is being pressed.

When the engine is started, the power max. lamp lights up. Each time the SET switch is pressed, the mode is switched.

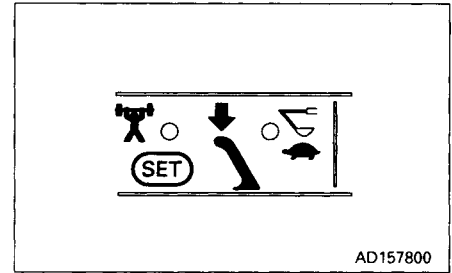

### 5. ACTIVE MODE SWITCH (SELECTOR SWITCH)

The active mode is effective for quick leveling operations or deep digging and loading operations.

Lamp lights up: Active mode is actuated.

Lamp goes out: Active mode is cancelled.

The lamp is off when the engine is started.

If it is turned lamp (lights up), it is possible to enter the active mode from any working mode.

Even when it is turned lamp (lights up), the working mode display does not change. When the lamp goes out, the system returns to the original working mode.

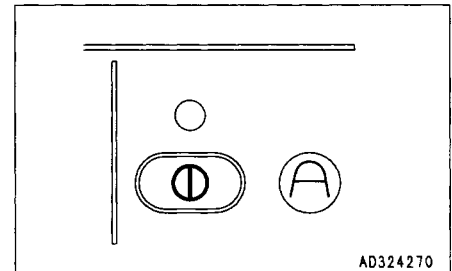

## 11.2 SWITCHES

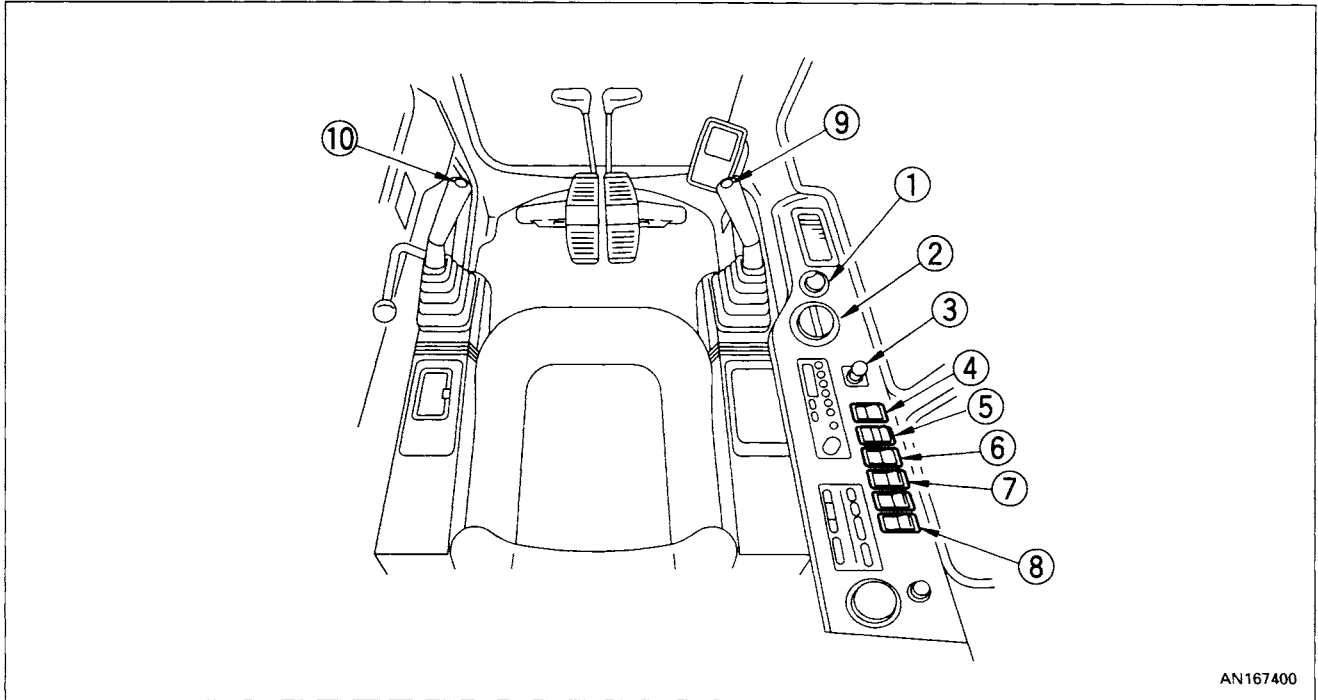

AN167400

### 1. STARTING SWITCH

This switch is used to start or stop the engine.

#### OFF position

The key can be inserted or withdrawn. Except for the cab lamp and clock, the switches for the electric system are all turned off and the engine is stopped.

#### ON position

Electric current flows in the charging and lamp circuits.

Keep the starting switch key at the ON position while the engine is running.

#### START position

This is the engine-start position. Keep the key at this position during cranking. Immediately after starting the engine, release the key which will automatically return to the ON position.

#### HEAT (preheat) position

When starting the engine in winter, set the key to this position. When the key is set to the HEAT position, the pre-heating monitor lights up. Keep the key at this position until the monitor lamp goes off. Immediately after the pre-heating monitor goes off, release the key. The key automatically returns to the OFF position. Then, start the engine by turning the key to the START position.

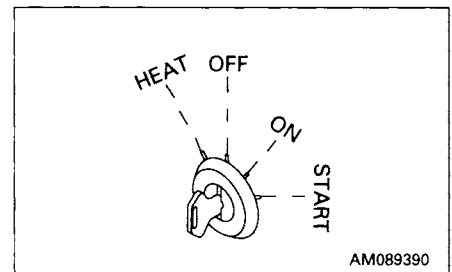

AM089390

## 11. EXPLANATION OF COMPONENTS

### 2. FUEL CONTROL DIAL (WITH AUTO-DECELERATION MECHANISM)

This adjusts the engine speed and output.

- ① Low idling (MIN): Turned fully to the left
- ② Full speed (MAX): Turned fully to the right

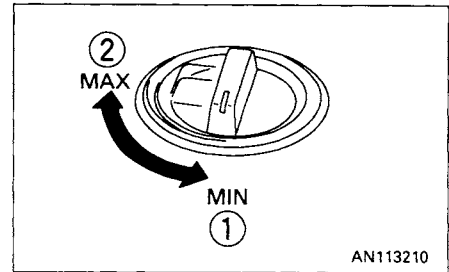

### 3. CIGARETTE LIGHTER

This is used to light cigarettes. To use, push the lighter in. After a few seconds it will spring back.

Pull out the lighter and light your cigarette.

By removing the cigarette lighter, the socket is available as a power source for the yellow flashing lamp. Max. current is 3.5 A (85 W).

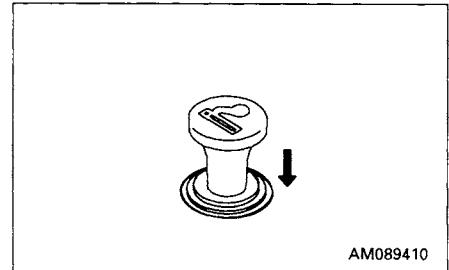

### 4. SWING LOCK SWITCH

#### WARNING

- When the machine is traveling under its own power, or when the swing is not being operated, always set the switch to the ON (ACTUATED) position.
- On a slope, the work equipment may swing to the down side even if the swing lock switch is located at the ON position. Be careful concerning this point.

This switch is used to lock the upper structure so that it cannot swing.

ON position (actuated):

The swing lock is always applied, and the upper structure will not swing even if the swing is operated. In this condition, the swing lock lamp lights up.

OFF position (canceled):

The swing lock is applied only when all work equipment control levers are at neutral; when any work equipment control lever is operated, it is canceled.

The swing lock is actuated approx. 4 seconds after all work equipment control lever is placed in neutral.

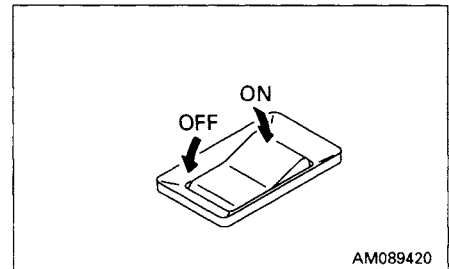

### 5. WIPER SWITCH

This switch actuates the front window wiper.

- ① OFF: The wiper stops.
- ② ON: The wiper moves continuously.
- ③ Window washer fluid is sprayed out: When the switch is released, it returns to ②.
- ④ ON: The wiper moves intermittently.
- ⑤ Window washer fluid is sprayed out: When the switch is released, it returns to ④.

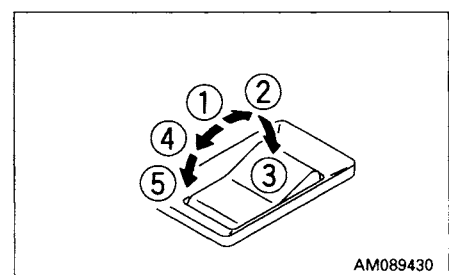

**6. LAMP SWITCH**

This switch turns on the head lamp, working lamp and monitor illumination.

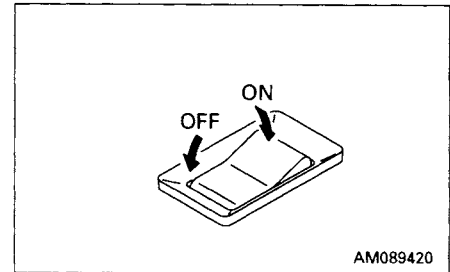

**7. ALARM BUZZER STOP SWITCH**

This is used to stop the alarm buzzer when it has sounded to warn of some abnormality in the EMERGENCY STOP ITEMS while the engine is running.

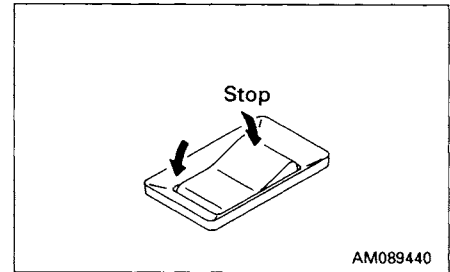

**8. ADDITIONAL LAMP SWITCH**

This switch is provided to turn on an additional lamp on the cab front top. Setting to OFF turns the switch off.

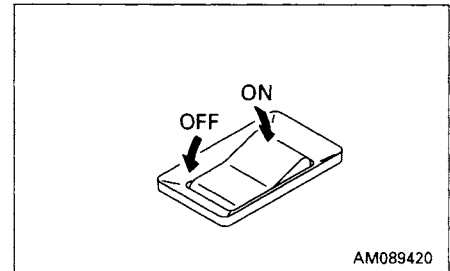

**9. HORN BUTTON**

When the button at the tip of the right work equipment control lever is pressed, the horn will sound.

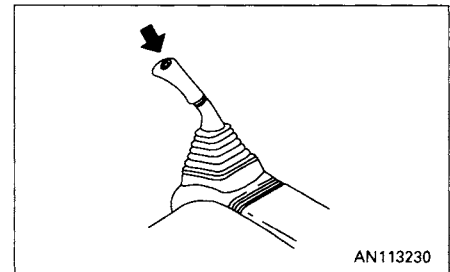

**10. KNOB BUTTON**

The button at the tip of the left work equipment control lever is used to actuate the power max./swift slow-down functions. Press the button once (single click) and keep it depressed. In the heavy-duty and general operation modes, the power max. function actuates for max. 8.5 seconds and the swift slow-down function actuates while the button is depressed.

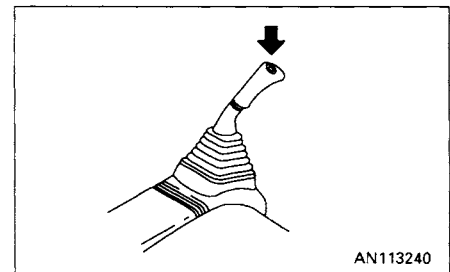



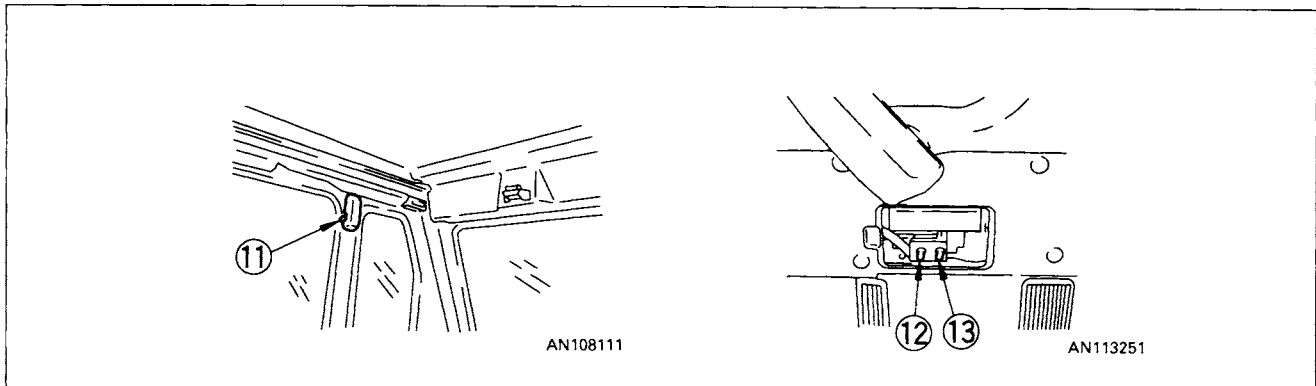

**11. CAB LAMP SWITCH**

This lights up the cab lamp.

ON position: Lights up

The cab lamp can be turned on even when the starting switch is at the OFF position, so be careful not to leave it on by mistake.

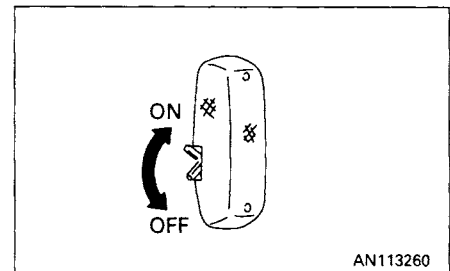

**12. PUMP CONTROL OVERRIDE SWITCH**

When normal: Switch is down

When abnormal: When the monitor display shows E02 (TVC valve system error), it is possible to carry out operation when this switch is moved up.

The pump control override switch is designed to allow operations to be carried out for a short period when there is an abnormality in the pump control system (TVC valve system error). The abnormality must be repaired immediately.

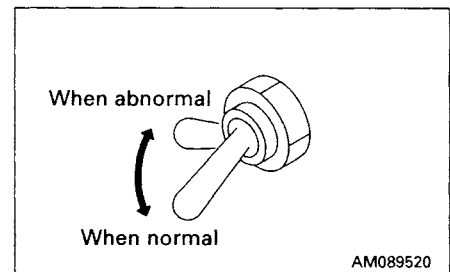

**13. SWING LOCK OVERRIDE SWITCH**

When normal: Switch is down

When abnormal: When the monitor display shows E03 (Swing brake system error), the brake is canceled and it becomes possible to swing the upper structure when this switch is moved up, so normal operations can be carried out. However, the swing brake remains canceled.

The swing lock override switch is designed to allow operations to be carried out for a short period when there is an abnormality in the swing brake electrical system (Swing brake system error). The abnormality must be repaired immediately.

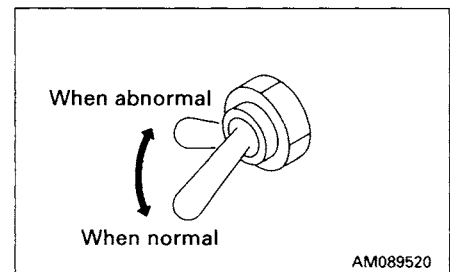

### 11.3 CONTROL LEVERS, PEDALS

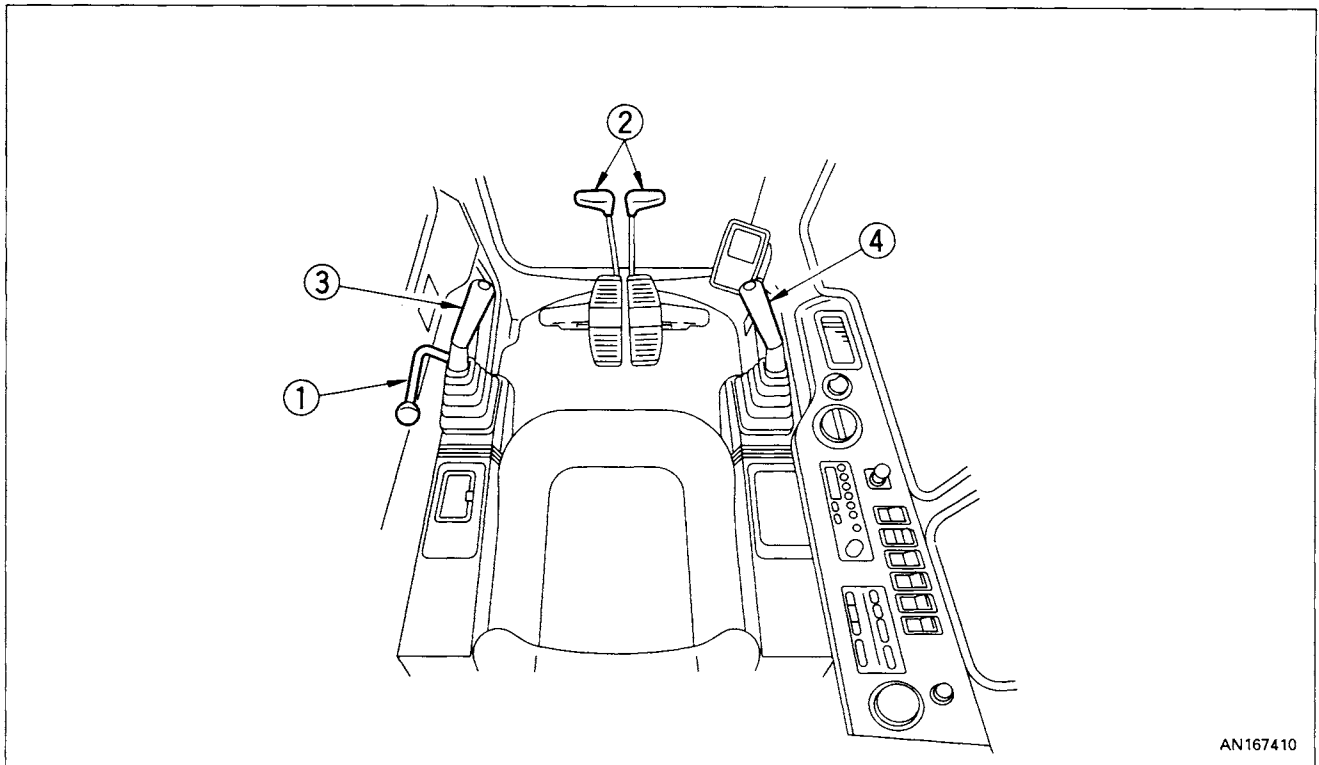

AN167410

#### 1. SAFETY LOCK LEVER

#### **⚠ WARNING**

- When leaving the operator's compartment, set the safety lock lever securely to the LOCK position. If the control levers are not locked, and they are touched by mistake, this may lead to a serious accident.

If the safety lock lever is not placed securely in the LOCK position, the control levers may not be properly locked. Check that the situation is as shown in the diagram.

- When the safety lock lever is raised, take care not to touch the work equipment control lever. If the safety lock lever is not properly locked at the upper position, the work equipment and swing will move, creating a potentially dangerous situation.
- When the safety lock lever is lowered, take care not to touch the work equipment control lever.

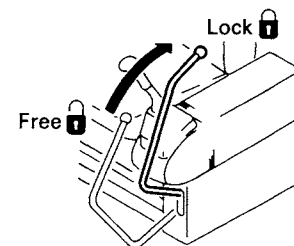

AN112930

## 11. EXPLANATION OF COMPONENTS

This lever locks the work equipment, swing, travel and attachment controls.

This lock lever is a hydraulic lock, so even if it is in the lock position, the work equipment control lever and travel lever will move, but the work equipment, travel motor, and swing motor will not work.

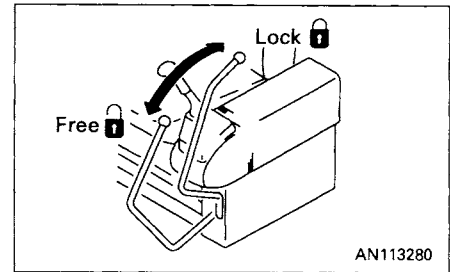

## 2. TRAVEL LEVERS (WITH PEDAL, AUTO-DECELERATION MECHANISM)

### WARNING

- Do not put your foot on the pedal unless the machine is traveling. If you leave your foot on the pedal and press it by mistake, the machine will move suddenly, and this may lead to a serious accident.
- With the track frame facing to the rear, the machine will move in the reverse direction by forward traveling and in the forward direction by reverse traveling. When the travel lever is used, check to see if the track frame is facing forward or backward. (If the sprocket is located to the rear, the track frame is facing forward.)

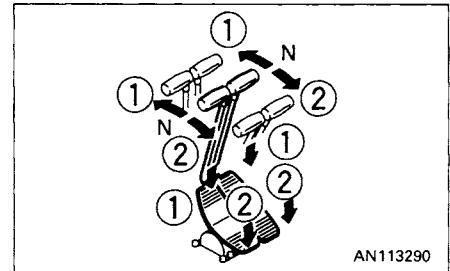

- ① FORWARD:  
The lever is pushed forward  
(The pedal is angled forward)
- ② REVERSE:  
The lever is pulled back  
(The pedal is angled back)
- N (Neutral): The machine stops

( ): This indicates operation of the pedal.

### REMARK

#### Machines equipped with travel alarm

If the lever is shifted to the advance or reverse position from the neutral position, the alarm sounds to warn that the machine is starting to advance.

### 3. LEFT WORK EQUIPMENT CONTROL LEVER (with auto-deceleration device)

**⚠ WARNING**

If any lever is operated when in the deceleration range, the engine speed will suddenly increase, so be careful when operating the levers.

This lever is used to operate the arm and upper structure.

Arm operation

Ⓐ Arm OUT

Ⓑ Arm IN

N (Neutral)

Swing operation

Ⓒ Swing to right

Ⓓ Swing to left

When the lever in this position, the upper structure and the arm will be retained in the position in which they stop.

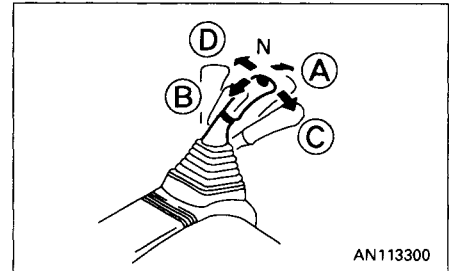

### 4. RIGHT WORK EQUIPMENT CONTROL LEVER (with auto-deceleration device)

**⚠ WARNING**

If any lever is operated when in the deceleration range, the engine speed will suddenly increase, so be careful when operating the levers.

This lever is used to operate the boom and bucket.

Boom operation

① RAISE

② LOWER

N (Neutral)

Bucket operation

③ DUMP

④ CURL

When the lever in this position, the boom and the bucket will be retained in the position in which they stop.

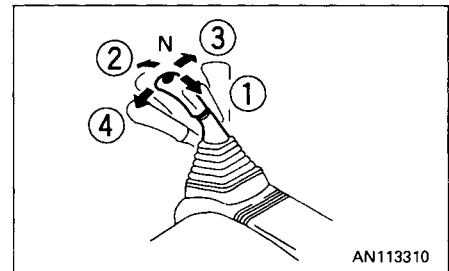

For levers 2, 3 and 4, the engine speed changes as follows because of the auto-deceleration mechanism.

- When the travel lever and work equipment control levers are at neutral, even if the fuel control dial is above the mid-range position, the engine speed will drop to a mid-range speed. If any of the levers are operated, the engine speed will rise to the speed set by the fuel control dial.
- If all control levers are set to neutral, the engine speed will drop by approx. 100 rpm, and after approx. 4 seconds, the engine speed will drop to the deceleration speed (approx. 1400 rpm).

## 11. EXPLANATION OF COMPONENTS

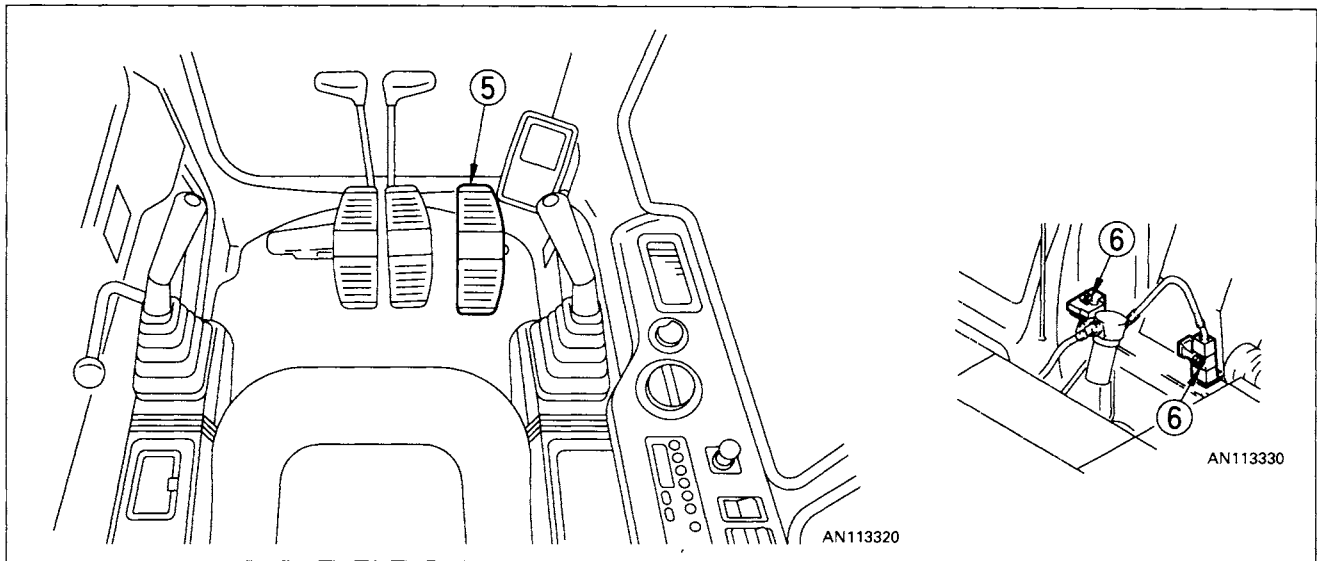

### 5. ATTACHMENT CONTROL PEDAL

#### WARNING

Do not put your foot on the pedal except when operating the pedal. If resting your foot on the pedal during operations, and it is depressed by accident, the attachment may move suddenly and cause serious damage or injury.

#### When breaker is installed

- When the front part of the pedal is depressed, the breaker is actuated.
- The lock pin actuates locking at ①. Position ② is the pedal half stroke position and position ③ is the pedal full stroke position.
- Set the working mode to the breaker (B.O) and use the lock pin at the position ③.

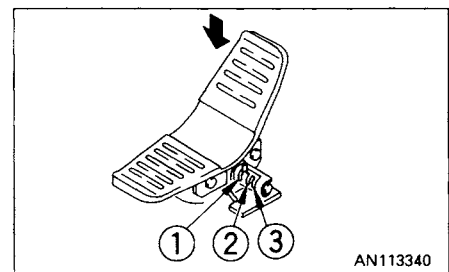

#### When general attachment is installed

- When the pedal is depressed, the attachment is actuated.
- The lock pin actuates locking at ①. Position ② is the pedal half stroke position and position ③ is the pedal full stroke position.

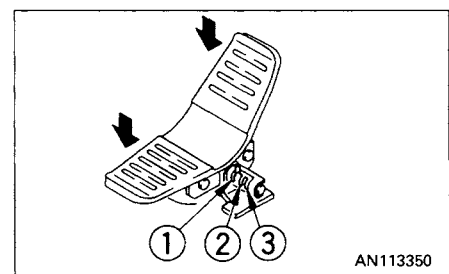

**HYDRAULIC OIL FLOW**

When the front part of the pedal is depressed, the hydraulic oil flows into the left-hand work equipment piping, and, when the rear part of the pedal is depressed, the oil flows into the right-hand work equipment piping. (When equipped with breaker, depress only the front part of the pedal.)

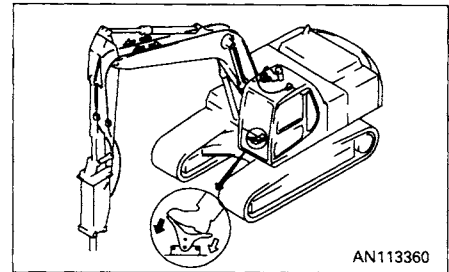





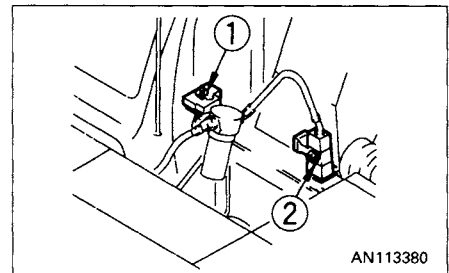
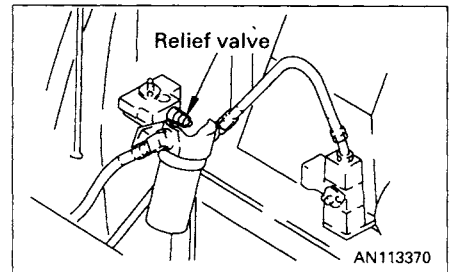

**6. SELECTOR VALVES FOR BREAKER AND GENERAL ATTACHMENT (crusher etc.)**

**⚠ WARNING**  
**Do not touch the relief valve.**

When using the breaker and general attachment (crusher etc.), turn the rotors of 3-way valves ① and ② to change them over according to the following illustration. (The arrow marks indicating the port direction are stamped on the 3-way valve heads.)



Attachments	Left 3-way valve ①	Right 3-way valve ②
Breaker etc.	Forward direction of machine 	Upper direction of machine 
Crusher etc.	Forward direction of machine 	Upper direction of machine 
When not use	Forward direction of machine 	Upper direction of machine 

**NOTICE**

Perform work only after the engine is stopped and the work equipment and machine body are in a stable posture on the ground.

**REMARK**

For details, see "30. MACHINES READY FOR ATTACHMENTS".

## 11.4 CEILING WINDOW

### WARNING

When leaving the operator's compartment, set the safety lock lever securely to the LOCK position. If the control levers are not locked, and they are touched by mistake, this may lead to a serious accident.

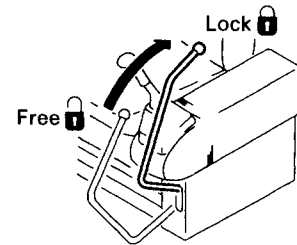

AN112930

### When opening

1. Lock the safety lock lever securely.
2. Check for any ceiling window movement by pulling lock ② located on both sides, then push up and open the ceiling window grasping grip ①.

### When closing

Close the ceiling window grasping grip ① and lock it with lock ②. If the lock cannot be applied, open and close the ceiling window again.

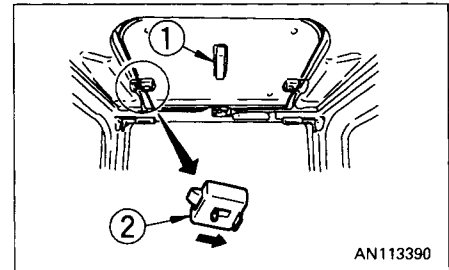

AN113390

## 11.5 FRONT WINDOW

### WARNING

When opening the front window, always hold the grip firmly with both hands and pull up. If you use only one hand, your hand may slip and get caught.

It is possible to store (pull up) the front window (top) in the roof of the operator's compartment.

### When opening

### WARNING

When the front window is open, there is danger that it will fall, so always lock it with left and right lock pins (A).

1. Place the work equipment on flat ground and stop the engine.
2. Securely lock the safety lock lever.

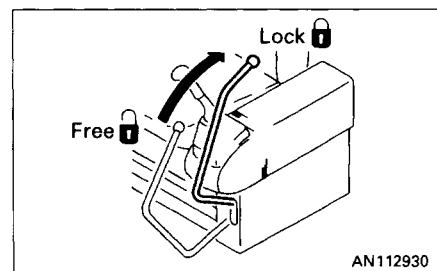
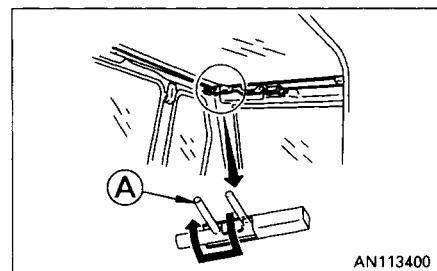

3. Confirm that the wiper is stored inside the right frame.

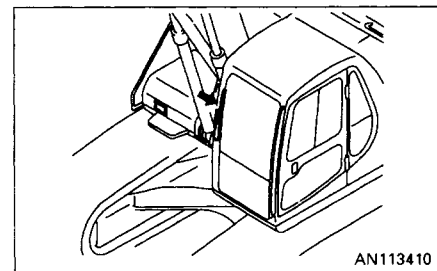

4. Pull lock pins (A) at the top left and right sides of the front window to the inside to release the lock.

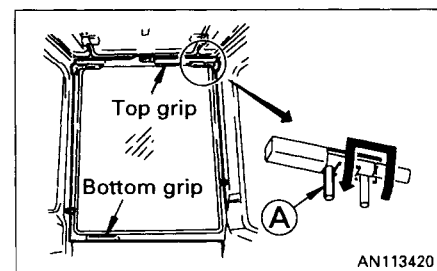



## 11. EXPLANATION OF COMPONENTS

- From the inside of the operator's cab, hold the bottom grip with the left hand and the top grip with the right hand, pull up the window, and push it in fully until it is locked by catch ③.

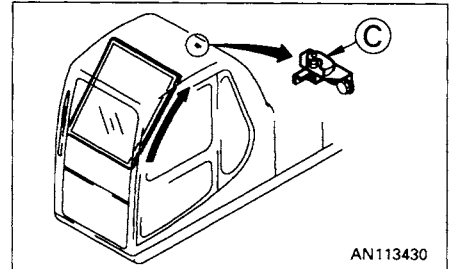

- Lock with lock pins ① on the left and right sides.

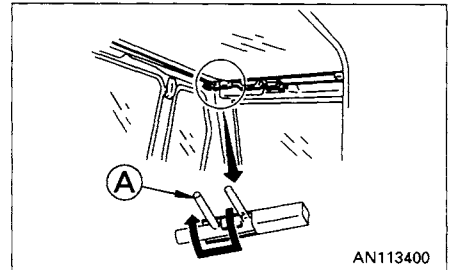

### When closing

#### WARNING

When closing the window, lower it slowly and be careful not to get your hand caught.

- Place the work equipment on a flat ground and stop the engine.
- Securely lock the safety lock lever.

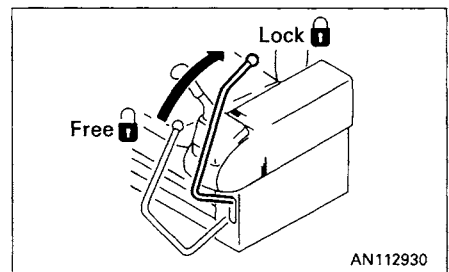

- Release the lock pin ①.

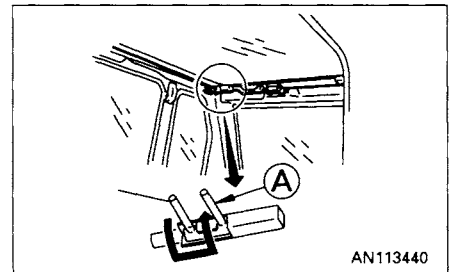

- Hold the grip at the bottom of the front window with your left hand and the grip at the top with your right hand, release the lock of catch ③ with your right thumb, then pull the top grip slowly and lower the front window. When releasing the lock of catch ③, push release lever ④ in the direction of the arrow to release the lock.

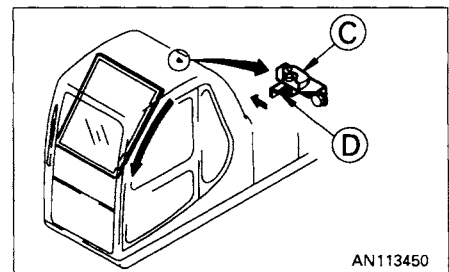

5. Lock securely with lock pins ① at the left and right sides.

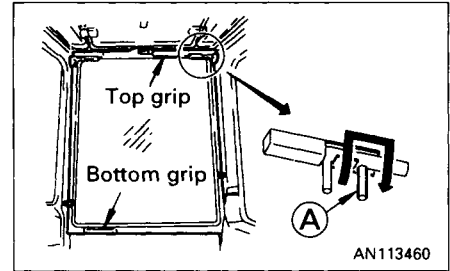

**Removing front window (bottom)**

With the front window open, remove lock pins ②, and the bottom part of the front window can be removed.

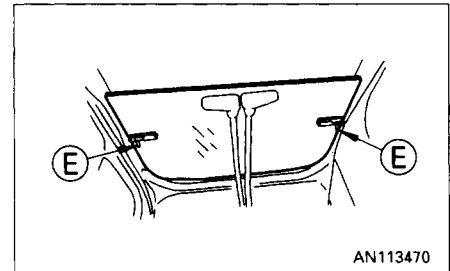

Store the removed bottom part of the front window at the rear of the operator's cab and lock with lock pins ③.

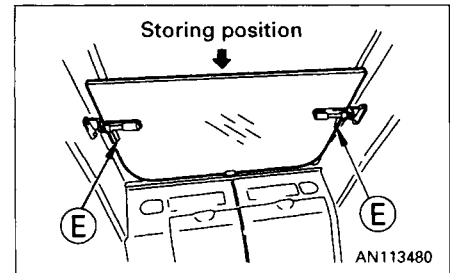

**11.6 DOOR LOCK**

Use the door lock to fix the door in position after opening it.

1. The door will become fixed in place when it is pressed against catch ①.
2. To release the lock, press knob ② down at the left side of the operator's seat to release the catch.  
When fixing the door, fix it firmly to the catch.

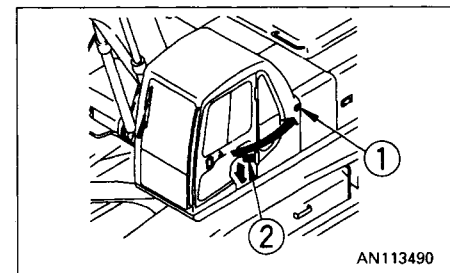

## 11.7 CAP, COVER WITH LOCK

The fuel filler, operator's cab, engine hood, tool box cover, pump room door (right side of the machine body) and battery room door (left side of the machine body) are fitted with locks.

Use the starting key to lock or unlock these places.

Insert the key as far as it will go. If the key is turned before it is inserted all the way, it may break.

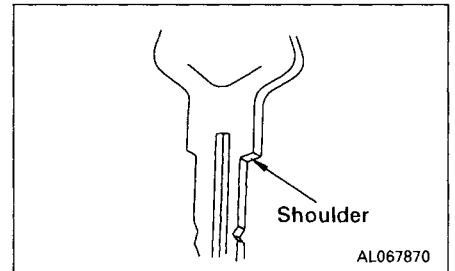

### 11.7.1 METHOD OF OPENING AND CLOSING CAP WITH LOCK

#### To open the cap

1. Insert the key into the key slot.
2. Turn the key clockwise (but, for the B type, turn counterclockwise), align the key slot with the match mark on the cap, then open the cap.

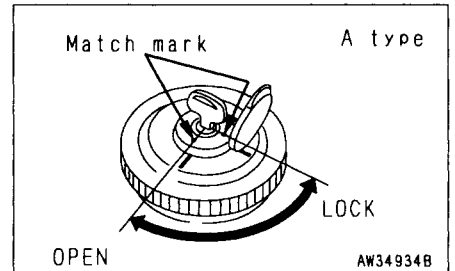

#### To lock the cap

1. Turn the cap into place and insert the key into the key slot.
2. Turn the key counterclockwise (but, for the B type, turn clockwise) and take the key out.

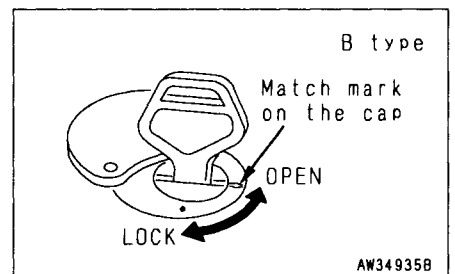

### 11.7.2 METHOD OF OPENING AND CLOSING COVER WITH LOCK

#### To open the cover (locked cover)

1. Insert the key into the key slot.
2. Turn the key counterclockwise and open the cover by pulling the cover grip.

#### To lock the cover

1. Close the cover and insert the key into the key slot.
2. Turn the key clockwise and take the key out.

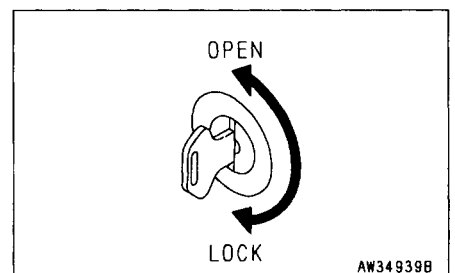

### 11.8 HOT/COOL BOX

This box is located at the right rear of the operator's seat. In interlock with the air conditioner, it warms the box during heating and chills it during cooling.

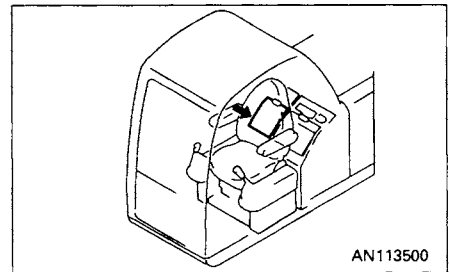

### 11.9 LUGGAGE BOX

This box is located on the left rear of the operator's seat. Always keep the operation & maintenance manual in this box for easy reading access.

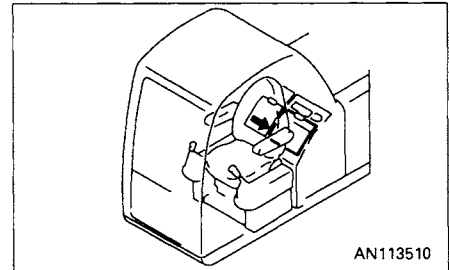

### 11.10 ASHTRAY

This is on the left side of the operator's seat. Always make sure that you extinguish the cigarette before closing the lid.

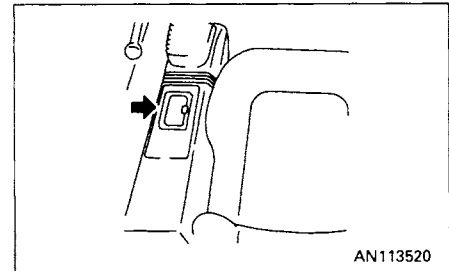

11. EXPLANATION OF COMPONENTS

11.11 AIR CONDITIONER  
 11.11.1 VIEW OF CONTROL PANEL

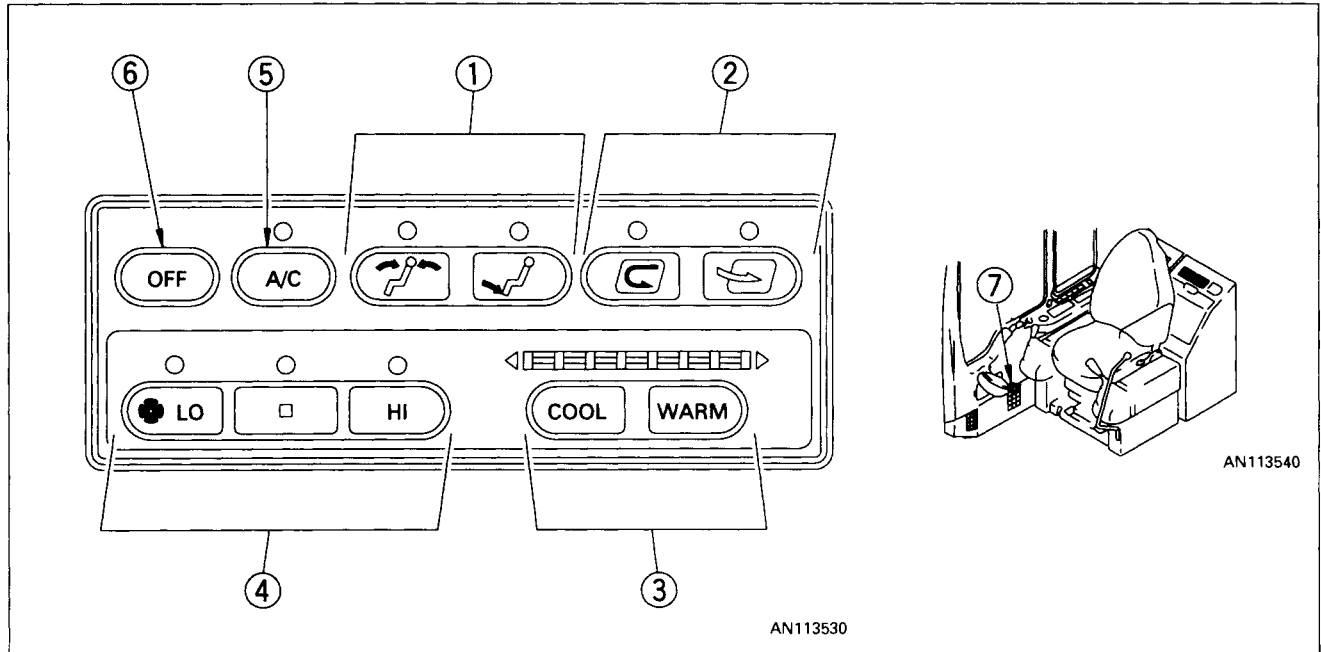

When a function is activated, the related indicator lamp lights up.

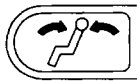
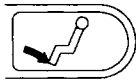
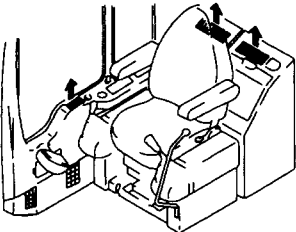
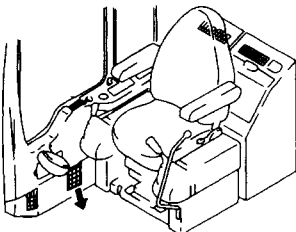

1. Air outlet selector switch

The operator can select a suitable outlet as required.

Purpose	Sending air to upper area of operator's seat	Sending air to lower area of operator's seat
Switch	 AN113550	 AN113560
Air outlets	 AN113570	 AN113580



**2. External/internal air changeover switch**

Changes between internal air circulation and external air intake.

Purpose	Internal air circulation This is used when wishing to quickly cool or warm the cab or when the air inside the cab is stale.	External air intake This is used for fresh air intake or to remove condensation on windows.
Switch	 AN113590	 AN113600



**3. Temperature control switch**

This switch continuously adjusts the temperature between high and low.

Purpose	To low temperature	To high temperature
Switch	 AN113610	 AN113620
	 AN113630 Blue range indicates low temperature and red range high temperature. The range is divided into seven steps, each of which is continuously adjustable.	

**4. Air flow selector switch**

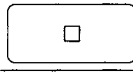
This switch adjusts air flow in three steps.

Purpose	To "Low"	To "intermediate"	To "High"
Switch	 AN113640	 AN113650	 AN113660

## 11. EXPLANATION OF COMPONENTS

### 5. Air conditioner switch

This switch functions as an ON/OFF switch for the air-conditioning system.

### 6. OFF switch

This switch is used to stop the fan function.

### 7. Defroster selector lever

This lever is used to remove condensation on the front window during winter or the rainy season.

Selector lever forward: defrosts

Selector lever backward: warms operator's feet

Defroster is available when air outlet indicates .

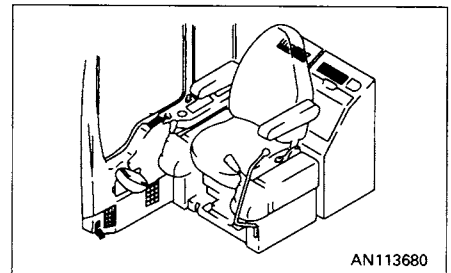
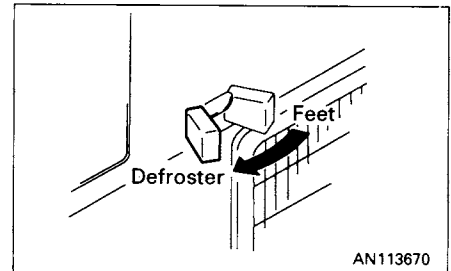

### 11.11.2 PRECAUTIONS WHEN USING AIR CONDITIONER

#### During cooling, ventilate the air from time to time

- If operator is smoking during cooling, eyes may occasionally smart. In this case, temporarily change the switch to ventilation/cooling to exhaust the smoke.
- When cooling for a long time period, select ventilation/cooling once an hour.

#### Avoiding excessive cooling

- If the operator feels somewhat cool when entering a cooled cab, the temperature (temperature difference between external temperature is 5 to 6°C (9 to 11°F) is at the optimum level from a health viewpoint. Adjust the cooling temperature carefully.

### 11.11.3 CHECK, MAINTAIN MACHINE EQUIPPED WITH AIR CONDITIONER

When carrying out inspection and maintenance of a machine equipped with air conditioner, see "23.1 MAINTENANCE SCHEDULE CHART".

## 11.12 CAR RADIO

### 11.12.1 EXPLANATION OF COMPONENTS

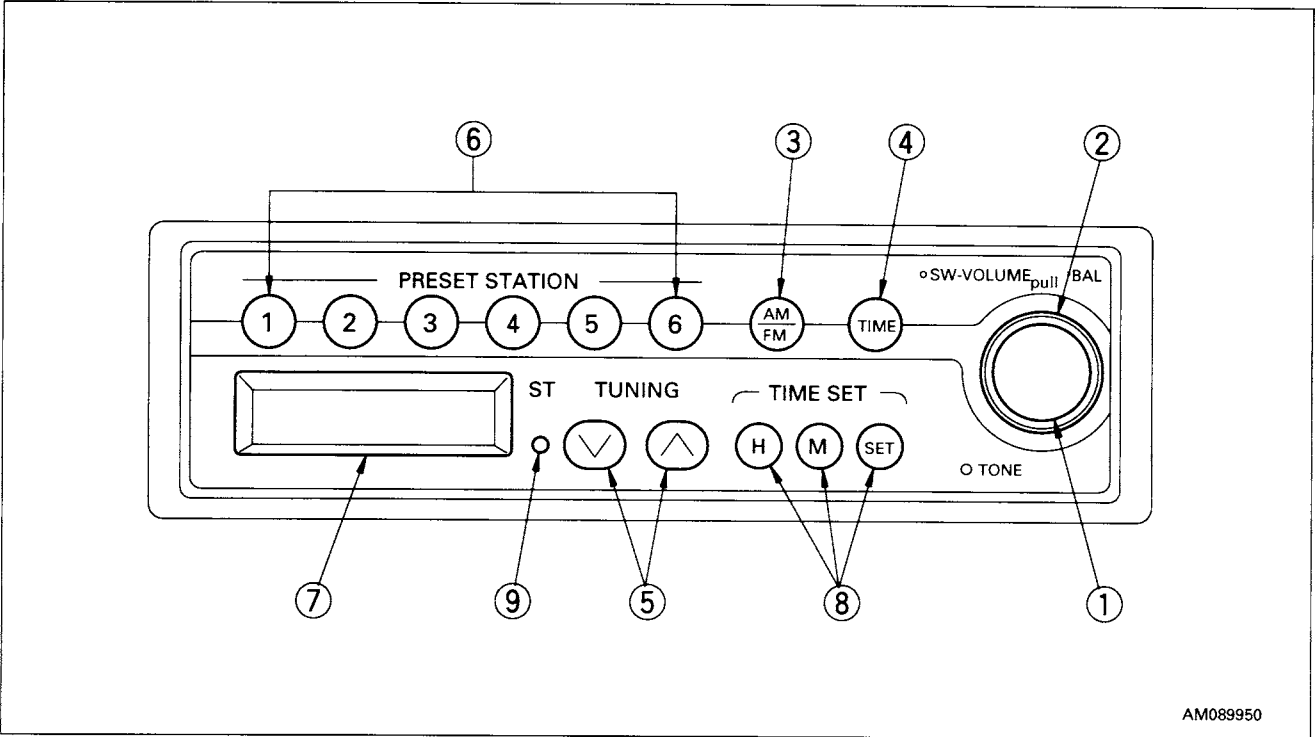

#### 1. POWER SWITCH/VOLUME CONTROL KNOB (SW-VOLUME) BALANCE (Pull BAL)

Press this knob to turn the power for the radio on. The frequency is displayed on display ⑦. Press again to turn the power off.

Turn the knob to adjust the volume as follows.

Turn CLOCKWISE to INCREASE volume

Turn COUNTERCLOCKWISE to REDUCE volume

If the knob is pulled until it locks, it can be turned to the left or right to adjust the balance of the left and right speakers.

Turn CLOCKWISE to increase volume from RIGHT speaker

Turn COUNTERCLOCKWISE to increase volume from LEFT speaker

After adjusting the left and right balance, press lightly to return the knob to its original position. (If it is left pulled out, the overall volume cannot be adjusted.)

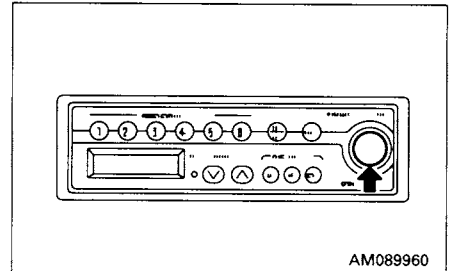

#### 2. TONE CONTROL KNOB

Turn the knob to adjust the tone as follows.

Turn CLOCKWISE to emphasize the high sounds

Turn COUNTERCLOCKWISE to suppress the high sounds

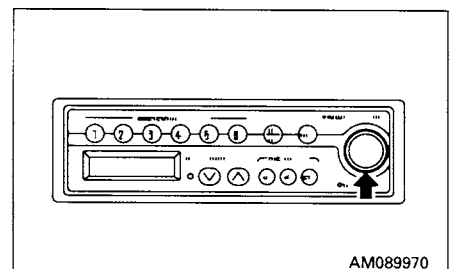



## 11. EXPLANATION OF COMPONENTS

### 3. FM/AM SELECTOR BUTTON (AM/FM)

Press this button and select the desired band.

Each time the button is pressed, it switches AM → FM → AM ...

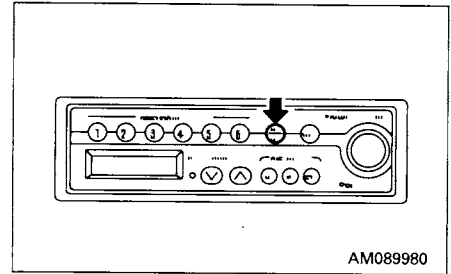

### 4. DISPLAY SELECTOR BUTTON (TIME)

This equipment gives priority to the frequency display. If the button is pressed when the frequency is displayed, display will give the present time for 5 seconds. After 5 seconds pass, the display will automatically return to the frequency display. If any button other than TIME SET (H, M, SET) is pressed within the 5 seconds, the display will return to the frequency display.

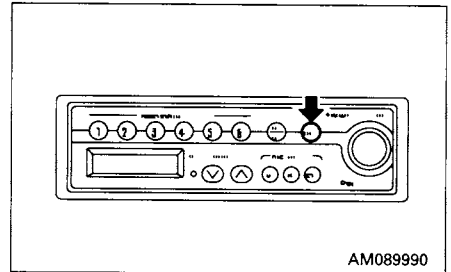

### 5. TUNING BUTTONS (TUNING) MANUAL TUNING (MANUAL)

Use the buttons to change the frequency.

Up button (^): Each time the button is pressed, the frequency will go up in steps (FM: 0.1 MHz, AM: 9 kHz).

Down button (v): Each time the button is pressed, the frequency will go down in steps (FM: 0.1 MHz, AM: 9 kHz).

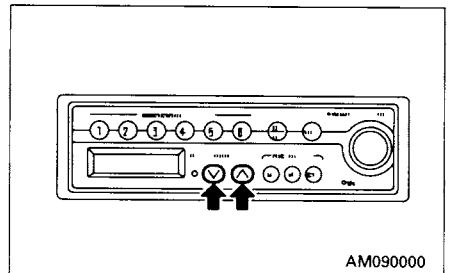

### 6. PRESET BUTTONS (1, 2, 3, 4, 5, 6) (PRESET STATION)

If these buttons are set to the frequency of the desired broadcasting station, the station can be selected at a touch.

For details of the method of presetting, see "11.12.2 METHOD OF OPERATION".

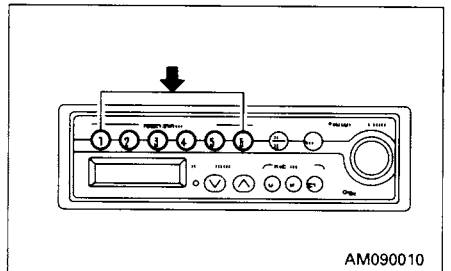

### 7. DISPLAY

The reception band, frequency, preset number, and time are displayed.

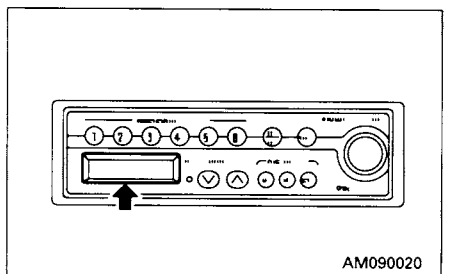

### 8. TIME CORRECTION BUTTON

This is used to correct the time.

H : Hour

M : Minute

SET : Sets to start of hour (00 minutes)

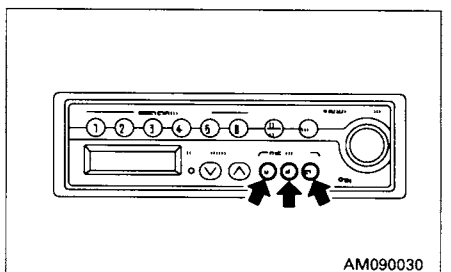

## 9. STEREO INDICATOR (ST)

This lamp lights up when a stereo broadcasting is picked up when receiving an FM broadcasting station.

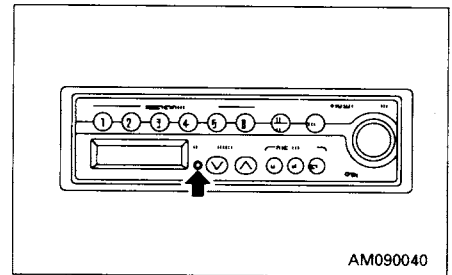

### 11.12.2 METHOD OF OPERATION METHOD OF SETTING PRESET BUTTONS

1. Press power switch ① and display the frequency on display ⑦.
2. Turn the tuning button (manual, auto) to adjust to the desired frequency.
3. Select a preset button to use for recording the frequency setting, and keep that button pressed for at least 1.5 seconds. The sound will disappear, but when the setting is recorded, the sound will appear and the preset number will appear on display ⑦ to show that the station has been preset.

After completion of presetting, press preset button ⑥, and release it within approx. 1.5 seconds. The setting will change to the frequency of the broadcasting station recorded for that button. One AM station and one FM station can be recorded for each preset button.

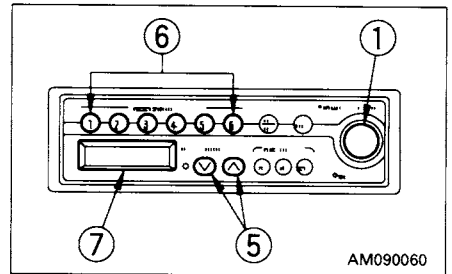

### MANUAL TUNING

Press tuning button ⑤ and set to the desired frequency.

Each time the button is pressed, the frequency will move up or down in steps of 9 kHz (AM) or 0.1 MHz (FM).

- ∇ button: Move to a higher frequency station
- ∧ button: Move to a lower frequency station

- If the frequency reaches the top or bottom limit, it will automatically change as follows: top limit → bottom limit, or bottom limit → top limit

### AUTOMATIC TUNING

Keep tuning button ⑤ pressed for at least 0.5 seconds. When a broadcasting station is picked up, it will automatically stop. To search for the next station, press tuning button ⑤ again for at least 0.5 seconds.

- ∇ button: Move to a higher frequency station
- ∧ button: Move to a lower frequency station

- If tuning button ⑤ is pressed during auto tuning, the auto tuning will be canceled and the frequency at the point where it is canceled will be picked up.

**SETTING CORRECT TIME**

1. Press display selector button ④ to display the time.  
After 5 seconds, the display will return to the frequency display and the time cannot be corrected. If this happens, press display selector button ④ again.
2. Press time adjustment button ⑧ and adjust the hour and minute.  
H button: Adjusts hour (advances one hour each time it is pressed)  
M button: Adjusts minute (advances one minute each time it is pressed)  
If the H or M button are kept pressed, the time will advance continuously until the button is released.  
SET button: Sets to start of hour (when it is pressed, the minute returns to 00)  
If the minute display is between 0 and 29, and the SET button is pressed, the minute reading will return to 00. If it is pressed when the minute display is between 30 and 59, the minute display will return to 00 and the hour will advance by 1.  
Example 10:29 → 10:00  
10:30 → 11:00  
Press the H, M, and SET buttons to set to the correct time.

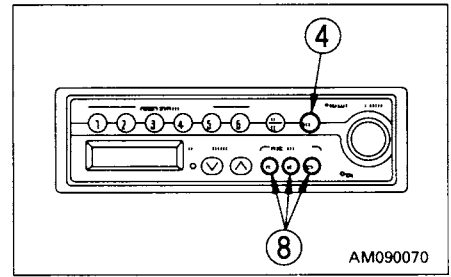

**ANTENNA**

In areas where the reception is weak or there is interference, extend the antenna. If the radio is set to a station with strong radio waves, retract the antenna to set to a weaker input.

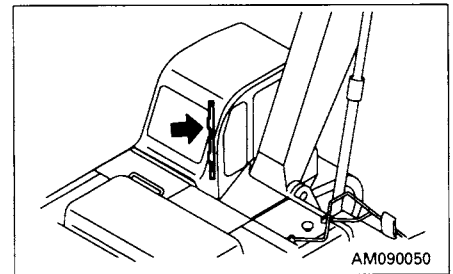

**NOTICE**

**Always retract the antenna before transporting the machine or driving the machine into a work shop or garage.**

### 11.12.3 PRECAUTIONS WHEN USING

- To ensure safety, always keep the sound to a level where it is possible to hear outside sounds during operation.
- If water gets into the speaker case or car radio (auto tuning), it may lead to an unexpected failure, so be careful not to get water on the equipment.
- Do not wipe the scales or buttons with benzene, thinner, or any other solvent. Wipe with a soft dry cloth. Use a cloth soaked in alcohol if the equipment is extremely dirty.
- When the battery is replaced, the settings for the preset buttons are all cleared, so set again.

### 11.12.4 SPECIFICATIONS

Tuning method	: PLL synthesizer method
Reception frequency	: AM 522 kHz – 1629 kHz (in 9 kHz steps) FM 76.0 MHz – 90.0 MHz (in 0.1 MHz steps)
Actual max. sensitivity:	AM 30 dB FM 15 dB
Actual max. output	: 10 W x 2
Current consumption	: Max. 2 A
External dimensions	: Width 184 mm, Height 56 mm Depth 116 mm
Weight	: 0.65 kg

## 11. EXPLANATION OF COMPONENTS

### 11.13 FUSE

#### NOTICE

**Before replacing a fuse, be sure to turn off the starting switch.**

The fuses protect the electrical equipment and wiring from burning out.

If the fuse becomes corroded, or white powder can be seen, or the fuse is loose in the fuse holder, replace the fuse.

Replace a fuse with another of the same capacity.

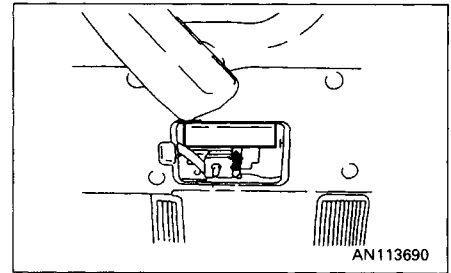

#### Fuse capacity and name of circuit

No.	Fuse capacity	Name of circuit
①	10 A	Governor controller
②	10 A	Solenoid valve
③	20 A	Air conditioner (motor)
④	10 A	Right head lamp, Working lamp
⑤	10 A	Radio, Cigarette lighter, Air conditioner panel, Heater, Window washer, Left knob button
⑥	10 A	Horn
⑦	15 A	Wiper controller
⑧	15 A	Head lamp, Rear working lamp
⑨	10 A	Travel alarm
⑩	10 A	Key switch signal
⑪	10 A	Spare
⑫	10 A	Spare
⑬	10 A	Alarm buzzer, Monitor
⑭	10 A	Battery relay, Ribbon heater, Start signal
⑮	10 A	Cab lamp, Radio (back-up)
⑯	10 A	Spare fuse
⑰	10 A	Spare fuse
⑱	15 A	Spare fuse
⑲	20 A	Spare fuse

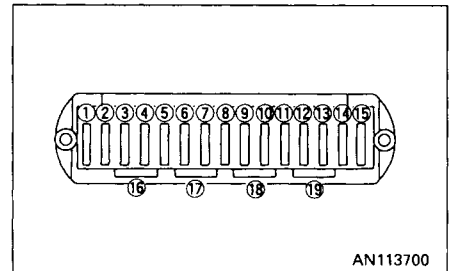

### 11.14 FUSIBLE LINK

If the starting motor will not rotate when the starting switch is turned ON, a possible cause is disconnection of wire-type fusible link ①. Open the battery box cover on the right side of the machine body to inspect the fusible link and, if necessary, replace it.

#### REMARK

A fusible link refers to the large-sized fuse wiring installed in the high current flow portion of the circuit to protect electrical components and wiring from burning, similarly to an ordinary fuse.

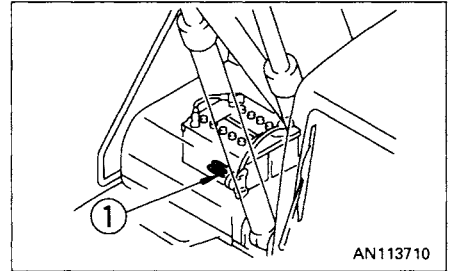

### 11.15 CONTROLLERS

Governor pump controller is provided.

#### NOTICE

- Never splash or spill water, mud or drink over the controllers as this may cause a fault.
- If a fault occurs in the controller, do not attempt repair, but consult your Komatsu distributor.

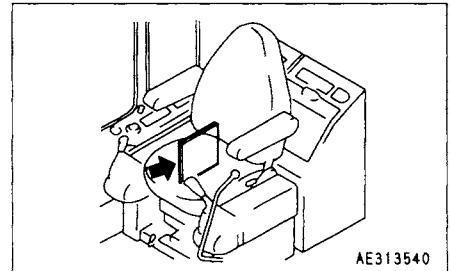

### 11.16 TOOL BOX

This is used for keeping the tools.

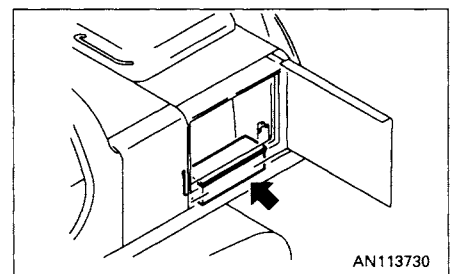

### 11.17 GREASE PUMP HOLDER

This is inside the left rear door of the machine.  
Fit the grease pump to the holder when it is not being used.

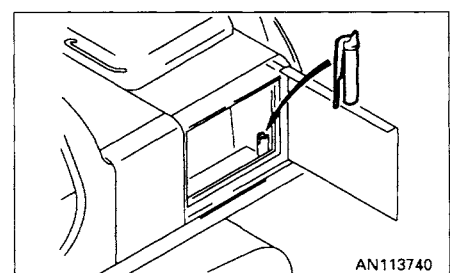

## 11.18 HANDLING ACCUMULATOR

**⚠ WARNING**

On machines equipped with an accumulator, for a short time after the engine is stopped, if the work equipment control lever is moved to the LOWER position, the work equipment will move down under its own weight.

After stopping the engine, always place the safety lock lever in the LOCK position and lock the attachment control pedal with the lock pin.

The accumulator is filled with high-pressure nitrogen gas, and it is extremely dangerous if it is handled in the wrong way. Always observe the following precautions.

- Never make any hole in the accumulator or expose it to flame or fire.
- Do not weld any boss to the accumulator.
- When disposing of the accumulator, it is necessary to release the gas from the accumulator, so please contact your Komatsu distributor.

This machine is equipped with the accumulator in the control circuit. The accumulator is a device to store the pressure in the control circuit, and when it is installed, the control circuit can be operated for a short time even after the engine is stopped. Therefore, if the control lever is moved in the direction to lower the work equipment, it is possible for the work equipment to move under its own weight.

The accumulator is installed to the position shown in the diagram on the right.

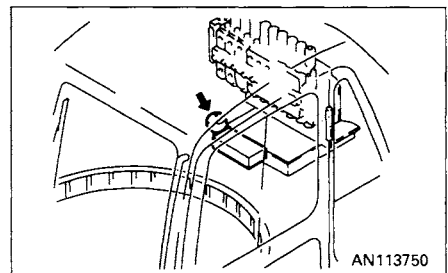

**11.18.1 METHOD OF RELEASING PRESSURE IN  
CONTROL CIRCUIT ON MACHINE  
EQUIPPED WITH ACCUMULATOR**

1. Place the work equipment on the ground. Close the crusher attachment jaws, etc.
2. Stop the engine.
3. Move the safety lock lever to the free position. Move the work equipment control lever and the attachment control pedal to full stroke back and forth, right and left so as to release the pressure in the control circuit.
4. Move the safety lock lever to the lock position. Lock the control lever and attachment control pedal. The pressure, however, will not be completely released, so when the accumulator is removed in the control circuit, gradually loosen the screws. Never stand in the oil ejection direction.



## 12. OPERATION

### 12.1 CHECK BEFORE STARTING ENGINE

#### 12.1.1 WALK-AROUND CHECK

**⚠ WARNING**

- Leakage of oil or fuel, or accumulation of flammable material around high temperature parts, such as the engine muffler or turbocharger, may cause fire. Check carefully, and if any abnormality is found, repair it or contact your Komatsu distributor.

Before starting the engine, look around the machine and under the machine to check for loose nut or bolts, or leakage of oil, fuel, or coolant, and check the condition of the work equipment and hydraulic system. Check also for loose wiring, play, and collection of dust at places which reach high temperatures.

Always carry out the items in this section before starting the engine each day.

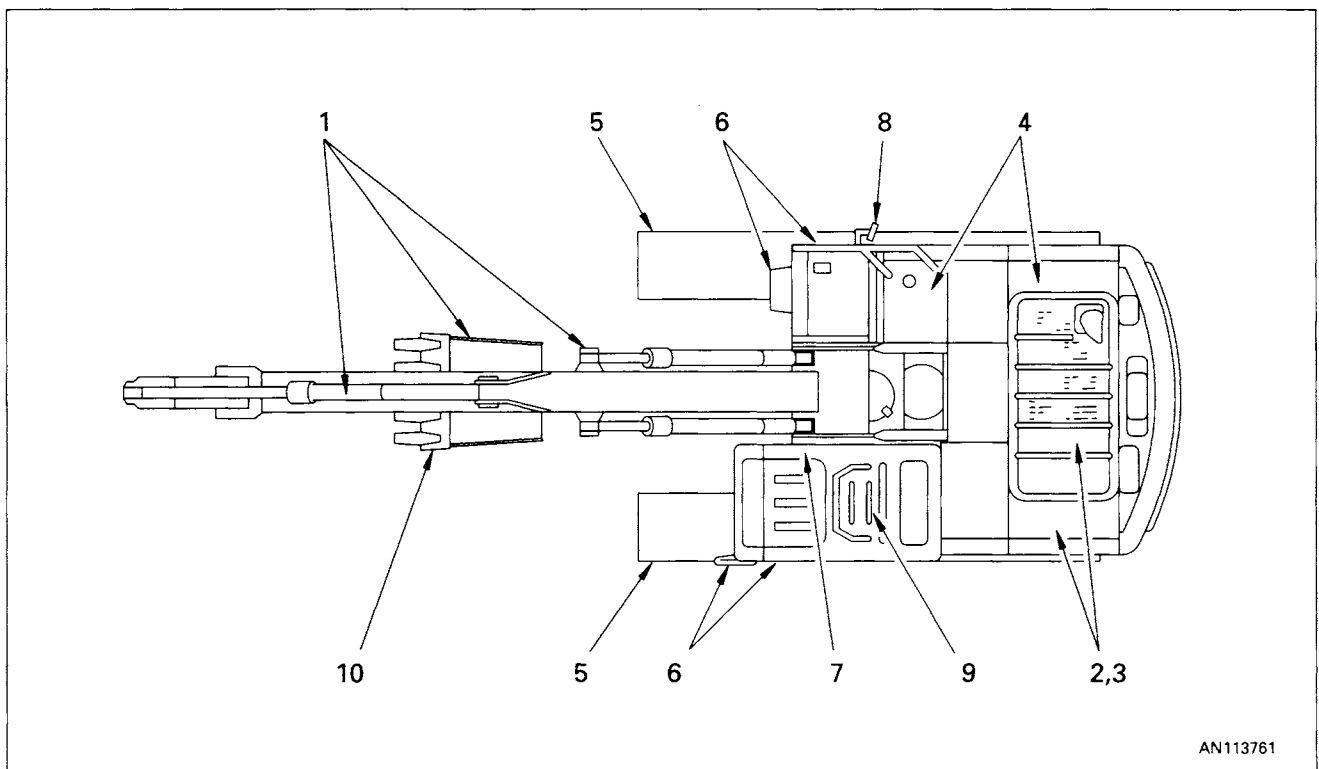

AN113761

#### 1. Check for damage, wear, play in work equipment, cylinders, linkage, hoses

Check that there are no cracks, excessive wear, or play in the work equipment, cylinders, linkage, or hoses. If any abnormality is found, repair it.

- 2. Remove dirt and dust from around engine, battery, radiator**  
Check if there is any dirt or dust accumulated around the engine or radiator. Check also if there is any flammable material (dead leaves, twigs, grass, etc.) accumulated around the battery or high temperature engine parts, such as the engine muffler or turbocharger. Remove all such dirt or flammable material.
- 3. Check for leakage of water or oil around engine**  
Check that there is no leakage of oil from the engine or leakage of water from the cooling system. If any abnormality is found, repair it.
- 4. Check for oil leakage from hydraulic equipment, hydraulic tank, hoses, joints**  
Check that there is no oil leakage. If any abnormality is found, repair the place where the oil is leaking.
- 5. Check the undercarriage (track, sprocket, idler, guard) for damage, wear, loose bolts, or leakage of oil from rollers**
- 6. Check for damage to handrail, loose bolts**  
Repair any damage and tighten any loose.
- 7. Check for damage to gauges, monitor, loose bolts**  
Check that there is no damage to the gauges and monitor in the operator's cab. If any abnormality is found, replace the parts. Clean off any dirt on the surface.
- 8. Clean rear view mirror, check for damage**  
Check that there is no damage to the rear view mirror. If it is damaged, replace it with a new mirror. Clean the surface of the mirror and adjust the angle so that the view to the rear can be seen from the operator's seat.
- 9. Seat belt and mounting clamps**  
Check that there is no abnormality in the seat belt or mounting clamps. If there is any damage, replace with new parts.
- 10. Check bucket with hook for damage.**  
Check the hook, catcher and hook foot for damage. If damage is found, contact your Komatsu distributor for repair.

## 12. OPERATION

### 12.1.2 CHECK BEFORE STARTING

Always carry out the items in this section before starting the engine each day.

#### CHECK COOLANT LEVEL, ADD WATER

##### WARNING

Do not open the radiator cap unless necessary. When checking the coolant, always check the radiator reserve tank when the engine is cold.

1. Open the rear door on the left side of the machine and check that the cooling water level is between the FULL and LOW marks on radiator reserve tank ① (shown in the diagram on the right). If the water level is low, add water through the water filler of reserve tank ① to the FULL level.
2. After adding water, tighten the cap securely.
3. If the reserve tank becomes empty, first inspect for water leaks and then fill the radiator and the reserve tank with water.

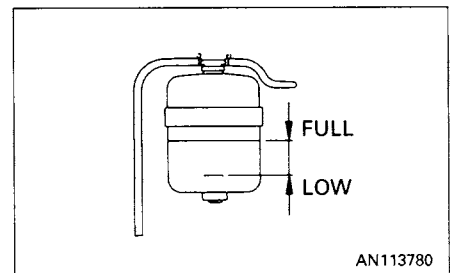
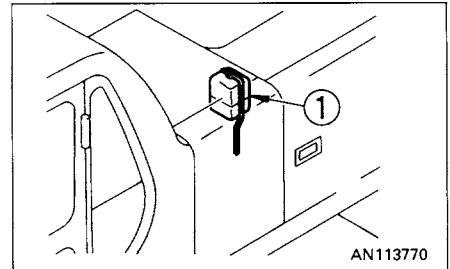

#### CHECK OIL LEVEL IN ENGINE OIL PAN, ADD OIL

1. Open the engine hood.
2. Remove dipstick ⑥ and wipe the oil off with a cloth.
3. Insert dipstick ⑥ fully in the oil filler pipe, then take it out again.

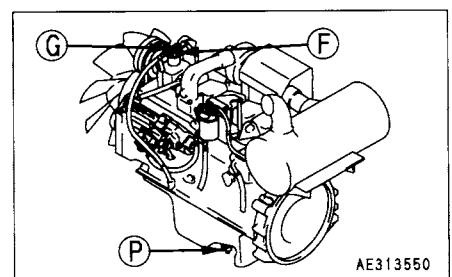

4. The oil level should be between the H and L marks on dipstick ⑥.  
If the oil level is below the L mark, add engine oil through oil filler ⑦.

#### NOTICE

For details of the oil to use, see "20. USE OF FUEL, COOLANT AND LUBRICANTS ACCORDING TO AMBIENT TEMPERATURE".

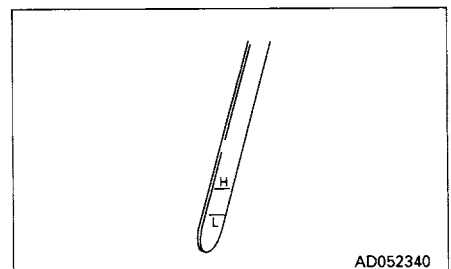

5. If the oil is above the H mark, drain the excess engine oil from drain valve (P), and check the oil level again.
6. If the oil level is correct, tighten the oil filler cap securely and close the engine hood.

**REMARK**

When checking the oil level after the engine has been operated, wait for at least 15 minutes after stopping the engine before checking.

If the machine is at an angle, make it horizontal before checking.

**CHECK FUEL LEVEL, ADD FUEL****⚠ WARNING**

When adding fuel, never let the fuel overflow. This may cause a fire. If spilling fuel, thoroughly clean up any spillage.

1. Open fuel filler cap (F) of the fuel tank.
2. When fuel filler cap (F) is opened, float gauge (G) will rise according to the fuel level.  
Check that the fuel tank is full. Check by looking into the tank and by using float gauge (G).
3. If the tank is not full, add fuel through the fuel filler until float gauge (G) rises to the maximum position.
  - Fuel tank capacity: 340 ℓ (89.8 US gal, 74.8 UK gal)
  - Position of tip of float gauge (G) when tank is full: Approx. 130 mm (5.1 in) from top surface of fuel tank

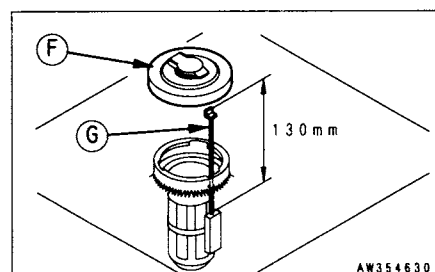
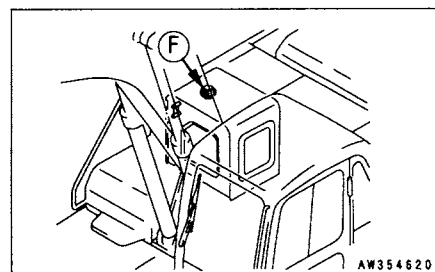
**NOTICE**

For details of the fuel to use, see "20. USE OF FUEL, COOLANT AND LUBRICANTS ACCORDING TO AMBIENT TEMPERATURE".

4. After adding fuel, push float gauge (G) straight down with fuel filler cap (F). Be careful not to get float gauge (G) caught in the tab (2) of fuel filler cap (F), and tighten fuel filler cap (F) securely.

**REMARK**

If breather hole (1) on the cap is clogged, the pressure in the tank will drop and fuel will not flow.

Clean the hole from time to time.

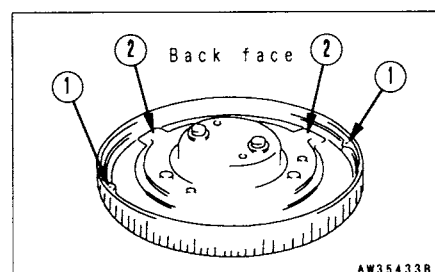

**CHECK OIL LEVEL IN HYDRAULIC TANK, ADD OIL**

**⚠ WARNING**

- When removing the oil filler cap, oil may spurt out, so turn the cap slowly to release the internal pressure before removing the cap.
- If oil has been added to above the H mark, stop the engine and wait for the hydraulic oil to cool down, then drain the excess oil from the drain plug (P).

1. If the work equipment is not in the condition shown in the diagram on the right, start the engine, run the engine at low speed, retract the arm and bucket cylinders, then lower the boom, set the bucket teeth in contact with the ground, and stop the engine.
2. Within 15 seconds after stopping the engine, move each control lever (for work equipment and travel) to the full stroke in all directions to release the internal pressure.
3. Check sight gauge (G). The oil level is normal if between the H and L marks.

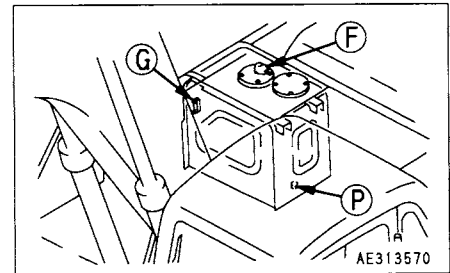
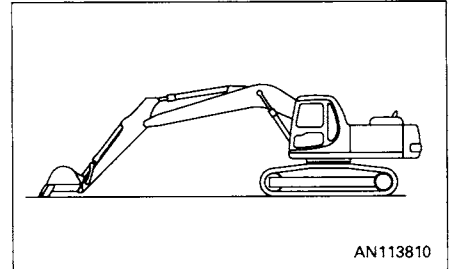

**NOTICE**

Do not add oil if the level is above the H line. This will damage the hydraulic equipment and cause the oil to spurt out.

4. If the level is below the L mark, add oil through oil filler (F).

**NOTICE**

For details of the oil to use, see "20. USE OF FUEL, COOLANT AND LUBRICANTS ACCORDING TO AMBIENT TEMPERATURE".

**REMARK**

The oil level will vary depending upon the oil temperature. Accordingly, use the following as a guide:

- Before operation: around L level (Oil temperature 10 to 30°C (50 to 86°F))
- Normal operation: around H level (Oil temperature 50 to 80°C (122 to 176°F))

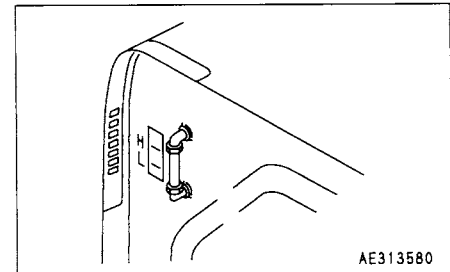

**CHECK AIR CLEANER FOR CLOGGING**

1. Confirm that the air cleaner clogging monitor does not flash.
2. If it flashes, immediately clean or replace the element.

For details of the method of cleaning the element, see "24.2.1 CHECK, CLEAN AND REPLACE AIR CLEANER ELEMENT".

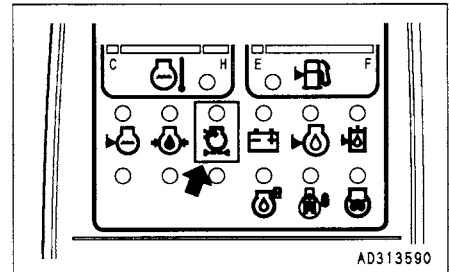
**CHECK ELECTRIC WIRINGS****⚠ WARNING**

**If fuses are frequently blown or if there are traces of short circuit on the electrical wiring, locate the cause and carry out repair.**

Check for damage of the fuse and any sign of disconnection or short circuit in the electric wiring. Check also for loose terminals and tighten any loose parts. Check the following points carefully.

- Battery
- Starting motor
- Alternator

Please contact your Komatsu distributor for investigation and correction of the cause.

**⚠ WARNING**

**Accumulation of flammable material (dead leaves, twigs, grass, etc.) around the battery may cause fire, so always check and remove such material.**

When carrying out walk-around checks or checks before starting, always check if there is any accumulation of flammable material around the battery, and remove such flammable material.

**LUBRICATE CLAMSHELL BUCKET**

- Prepare a grease pump.
1. Place the work equipment in a stable posture on the ground, then stop the engine.
  2. Using a grease pump, pump in grease through the grease fittings shown by arrows.
  3. After greasing, wipe off any old grease that was pushed out.

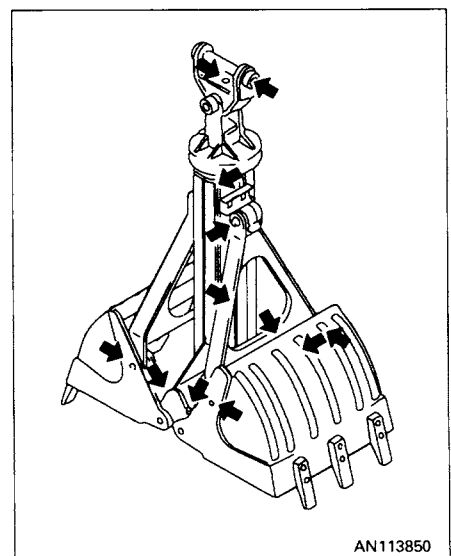

**CHECK FOR WATER AND SEDIMENT IN WATER SEPARATOR, DRAIN WATER**

The water separator separates water mixed in the fuel. If float ② is at or above red line ①, drain the water according to the following procedure:

1. Loosen drain plug ③ and drain the accumulated water until the float reaches the bottom.
2. Tighten drain plug ③.
3. If the air is sucked into fuel line when draining and water, be sure to bleed air in the same manner as for the fuel filter. See "24.6 EVERY 500 HOURS SERVICE".

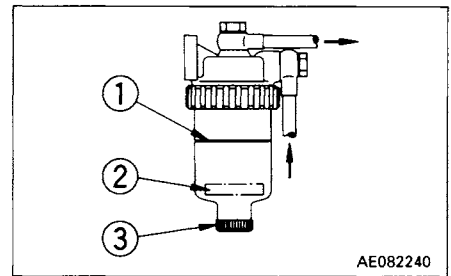

AE082240

**12.1.3 ADJUSTING SEAT POSITION**

**⚠ WARNING**

- Adjust the seat position at the beginning of each shift or when operators change.
- Adjust the seat so that the travel pedal can be depressed all the way with the operator's back against the backrest.

**OPERATOR'S SEAT**

**Ⓐ Fore-and-aft adjustment of seat**

Pull lever ① up. After the seat is set to the desired position, release the lever.

Adjustable distance: 100 mm (3.9 in) in 10 steps

**Ⓑ Adjustment of reclining seat**

**NOTICE**

The amount of reclining for the seat is greatest when the seat is moved forward, and becomes smaller as the seat is moved to the rear. For this reason, when moving the seat to the rear, set the seat back to the upright position.

Pull lever ② up. After the seat back is set to the optimum position for easy operation, release the lever.

Sit with your back against the seat back when adjusting. If your back is not touching the seat back, the seat back may suddenly move forward.

**Ⓒ Adjusting seat tilt**

**1. Forward tilt (↕)**

Push lever ③ down and adjust the angle at the front of the seat. (4 stages)

1. To raise the angle at the front of the seat, keep the lever pushed down and apply your weight to the rear of the seat.
2. To lower the angle at the front of the seat, keep the lever pushed down and apply your weight to the front of the seat.

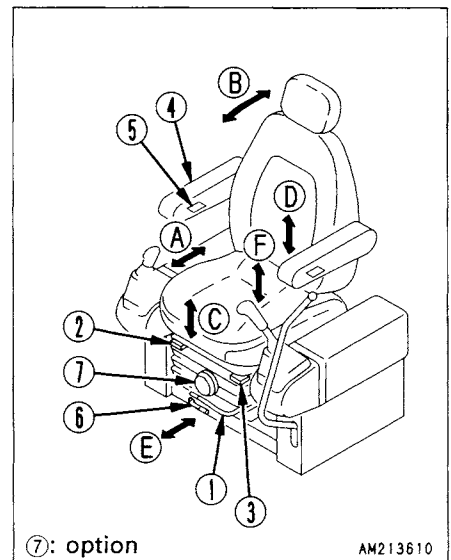

⑦: option

AM213610

## 2. Rear tilt ( )

Pull lever ③ up and adjust the angle at the rear of the seat. (4 stages)

1. To raise the angle at the rear of the seat, keep the lever pulled up and stand up slightly to remove your weight from the seat.
  2. To lower the angle at the rear of the seat, keep the lever pulled up and apply your weight to the rear of the seat.
- Amount of tilt: Up 13°, down 13°

## 3. Seat height adjustment

By a combination of steps 1 and 2, the seat can be moved up and down. After the desired height is set by forward/backward tilting, bring the seat to the horizontal position by reverse-tilting and fix it. Adjustable height: 60 mm (2.4 in)

### ④ Adjusting armrest angle

Armrest ④ can be made to spring up by hand to an angle of approx. 90°.

In addition, by turning the bottom ⑤ of the armrest by hand it is possible to make fine vertical adjustments of the armrest angle. Armrest adjustment angle: 25°

### REMARK

If the back seat is tilted back and forth without raising armrest ④, it will spring up automatically.

### ⑥ Fore-and-aft adjustment of whole seat

After lever ⑥ is pulled up and the seat is set to the desired position, release the lever. In this case the operator's seat, left and right levers and safety lock lever will slide together. Adjustable fore-and-aft movement: 120 mm (4.7 in)

### ⑦ Suspension adjustment

When knob ⑦ is turned clockwise, the suspension becomes harder and when turned counterclockwise, softer. Adjust the dial so that the suspension best matching the operator's weight is selected.

### REMARK

To obtain the optimum adjustment, turn the knob so that the indicator of the weight display (kg) in the transparent portion of knob ⑦ is the same as the operator's weight.

## ADJUSTMENT OF MONITOR PANEL ANGLE

Turn the monitor panel so that the operator can view the monitor with ease. When adjusting the angle, the panel should be set to the desired position using both hands. The panel is automatically locked at that position.

Amount of adjustment: 30° (stepless)

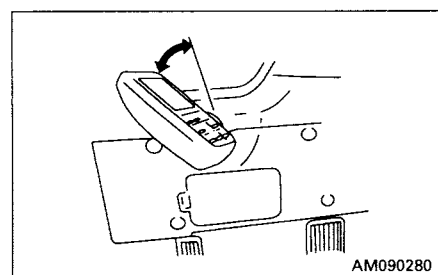



**ADJUSTMENT OF MIRRORS**

- Loosen nut ① and bolt ② of the mirror and adjust the mirror so that it gives the optimum view from the operator's seat.
- Adjust the mirror mount so that any person on the left and right side at the rear of the machine (or any object approx. 1 m (39.4 in) high and 30 cm (11.8 in) in diameter) is clearly visible.
- Install so that the mounting position of the mirror is the dimensions shown in the chart. The field of visibility is given in the chart below for reference.

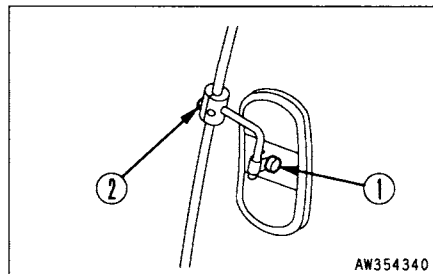

	Mounting position	Field of visibility	
	X	Y (right)	Z (left)
PC200,200LC-6	50 mm (2.0 in)	1500 mm (59 in)	1830 mm (72 in)
PC210,210LC-6			
PC220,220LC-6			
PC230,230LC-6			

Mirror A:  
Hatched area ① (opposite side from ②) to be visible

Mirror B:  
Hatched area ③ to be visible

Mirror C:  
Hatched area ④ (option) to be visible

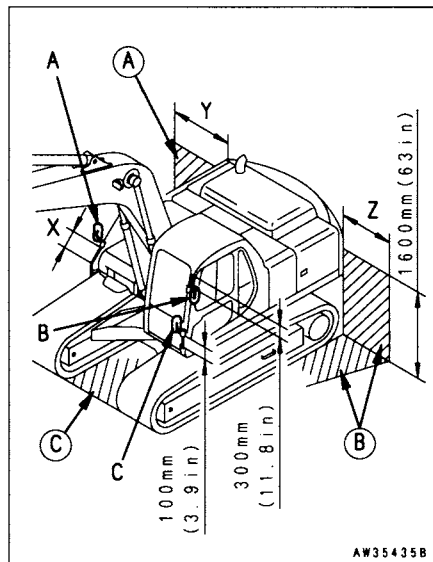

### 12.1.4 OPERATIONS AND CHECKS BEFORE STARTING ENGINE

#### **WARNING**

If the control lever is touched by accident, the work equipment or the machine may move suddenly. When leaving the operator's compartment, always set the safety lock lever securely to the LOCK position.

1. Check that safety lock lever ① is at the LOCK position.

2. Check the position of each lever.

Set the control lever to the neutral position.

When starting the engine, never touch the knob button.

3. Insert the key in starting switch ②, turn the key to the ON position, then carry out the following checks.

(1) The buzzer will sound for approx. 1 sec, and the following monitors and gauges will light up for approx. 3 sec.

- Radiator water level monitor ③
- Engine oil level monitor ④
- Hydraulic oil level monitor ⑤
- Charge level monitor ⑥
- Fuel level monitor ⑦
- Engine water temperature monitor ⑧
- Engine oil pressure monitor ⑨
- Engine water temperature gauge ⑩
- Fuel gauge ⑪
- Engine pre-heating monitor ⑫
- Air cleaner clogging monitor ⑬
- Swing lock monitor ⑭
- Engine oil replacement monitor ⑮

If the monitors or gauges do not light up or the buzzer does not sound, there is probably a broken bulb or disconnection in the monitor wiring, so contact your Komatsu distributor for repairs.

After approx. 3 sec, the following gauges will remain on and the other monitors will go out.

- Engine water temperature gauge ⑩
- Fuel gauge ⑪

(2) Press lamp switch ⑯ to turn on the head lamps.

If the lamps do not light up, there is probably a broken bulb or disconnection in the wiring, so contact your Komatsu distributor for repairs.

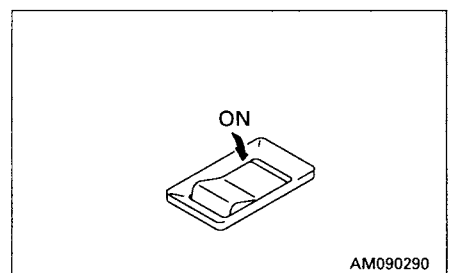
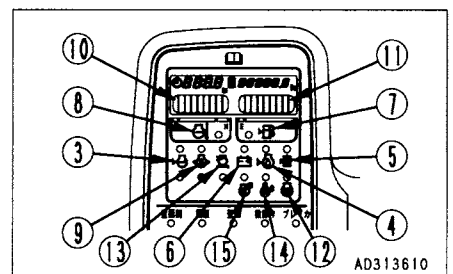
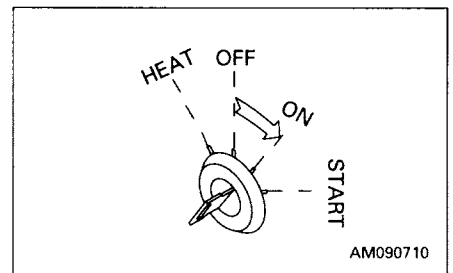
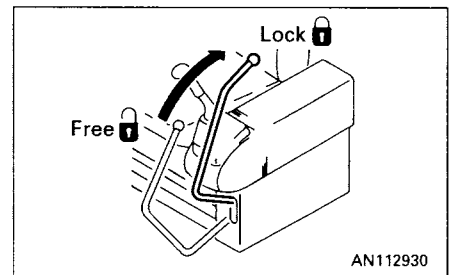
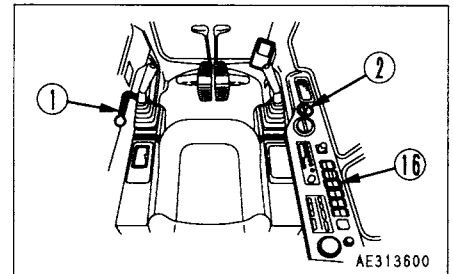

## 12.2 STARTING ENGINE

### 12.2.1 NORMAL STARTING

**⚠ WARNING**

Check that there are no persons or obstacles in the surrounding area, then sound the horn and start the engine.

**NOTICE**

Do not keep the starting motor rotating continuously for more than 20 seconds.

If the engine will not start, wait for at least 2 minutes before trying to start the engine again.

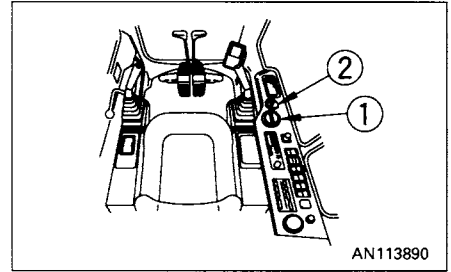

1. Set fuel control dial ① at the low idling (MIN) position.

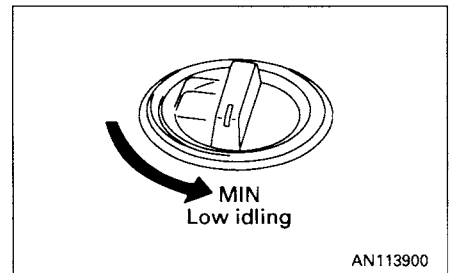

2. Turn the key in starting switch ② to the START position. The engine will start.

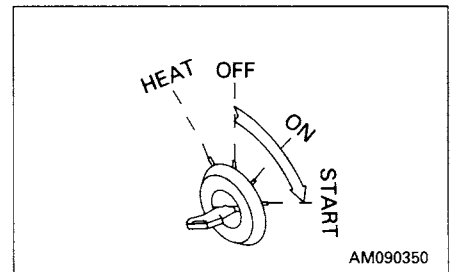

3. When the engine starts, release the key in starting switch ②. The key will return automatically to the ON position.

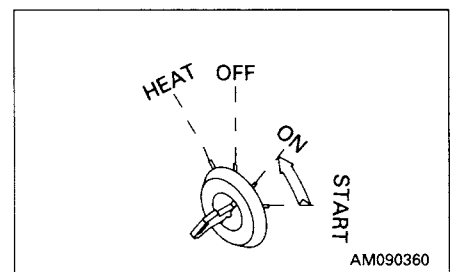

## 12.2.2 STARTING IN COLD WEATHER

### ⚠ WARNING

- Check that there are no persons or obstacles in the surrounding area, then sound the horn and start the engine.
- Never use starting aid fluids as they may cause explosions.

### NOTICE

Do not keep the starting motor rotating continuously for more than 20 seconds.

If the engine fails to start, repeat from step 2 and after waiting for about 2 minutes.

When starting in low temperatures, do as follows.

1. Set fuel control dial ① at the low idling (MIN) position.

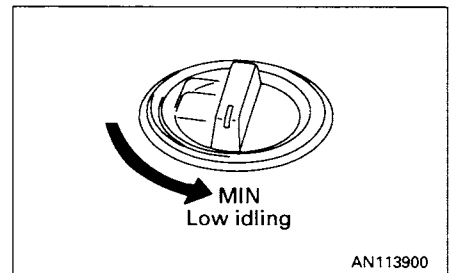
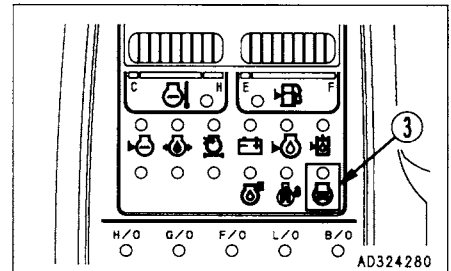
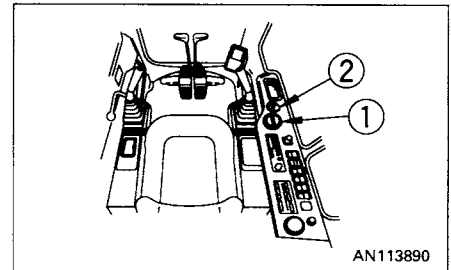

2. Hold the key in starting switch ② at the HEAT position, and check that preheating monitor ③ lights up. After about 30 seconds, preheating monitor lamp ③ will flash for about 10 seconds to indicate that preheating is finished.

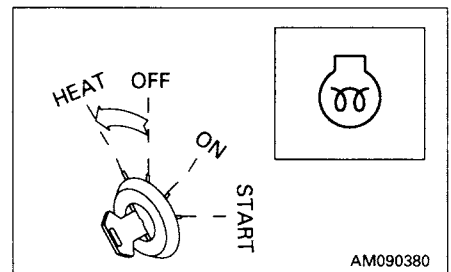

### REMARK

The monitor and gauge also light up when the key is at the HEAT position, but this does not indicate any abnormality.

## 12. OPERATION

3. When preheating monitor ③ flashes, turn the key in starting switch ② to the START position to start the engine.

Ambient temperature	Preheating time
Above 0°C	-
0°C to -10°C	20 seconds
-10°C to -20°C	30 seconds

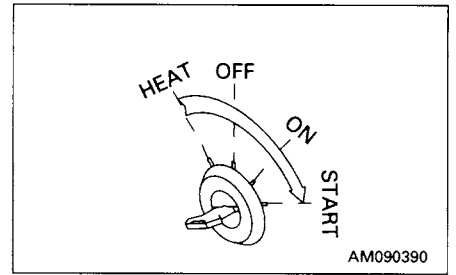

4. When the engine starts, release the key in starting switch ②. The key will return automatically to the ON position.

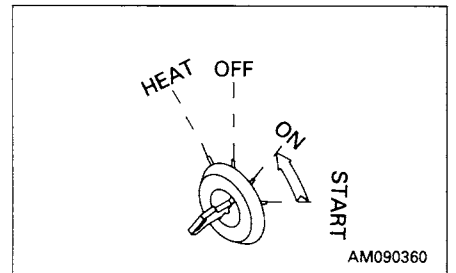

## 12.3 OPERATIONS AND CHECKS AFTER STARTING ENGINE

### ⚠ WARNING

- **Emergency stop**  
If there has been any abnormal actuation or trouble, turn the starting switch key to the OFF position.
- **If the work equipment is operated without warming the machine up sufficiently, the response of the work equipment to the movement of the control lever will be slow, and the work equipment may not move as the operator desires, so always carry out the warming-up operation. Particularly in cold areas, be sure to carry out the warming-up operation fully.**

### 12.3.1 WHEN NORMAL

#### NOTICE

- **When the hydraulic oil is at a low temperature, do not carry out operations or move the levers suddenly. Always carry out the warming-up operation. This will help to extend the machine life.**
- **Do not suddenly accelerate the engine before the warming-up operation is completed.**  
**Do not run the engine at low idling or high idling continuously for more than 20 minutes. This will cause leakage of oil from the turbocharger oil supply piping. If it is necessary to run the engine at idling, apply a load from time to time or run the engine at a mid-range speed.**

After starting the engine, do not immediately start operations. First, carry out the following operations and checks.

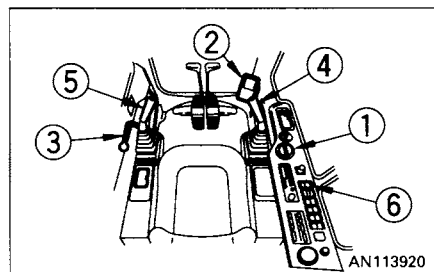

1. Turn fuel control dial ① to the center position between LOW IDLING (MIN) and HIGH IDLING (MAX) and run the engine at medium speed for about 5 minutes with no load.

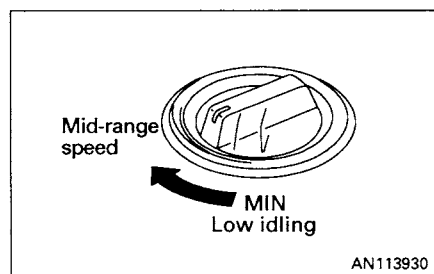

2. While running the engine at medium speed, press working mode switch ② until the heavy-duty operation mode lamp is turned on.

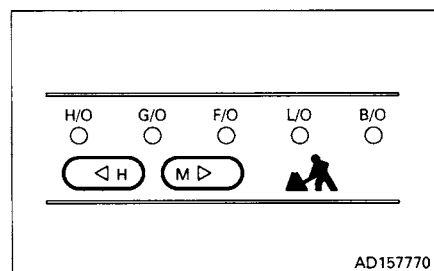

## 12. OPERATION

3. Set the safety lock lever ③ to the FREE position, and raise the bucket from the ground.

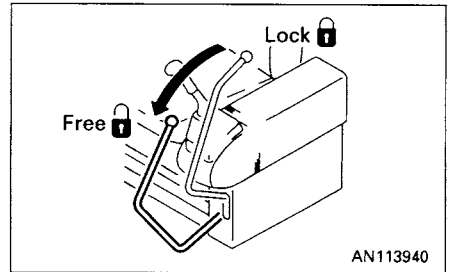

4. Operate bucket control lever ④ and arm control lever ⑤ slowly to move the bucket cylinder and arm cylinder to the end of the stroke.

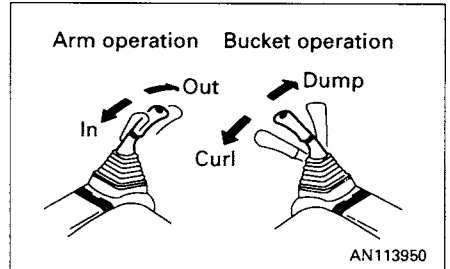

5. Carry out bucket and arm operation for 5 minutes at full stroke, alternating between bucket operation and arm operation at 30 second intervals.  
If the swing lock switch ⑥ is set to the ON (actuated) position and swing control lever ⑤ is operated at full stroke, oil temperature-rise can be increased earlier.

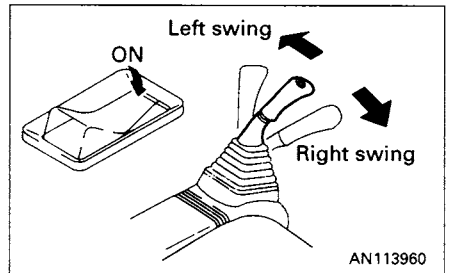

### NOTICE

When the work equipment is retracted, take care that it does not interfere with the machine body or ground.

6. After carrying out the warming-up operation, check that each gauge and monitor lamp is in the following condition.
- Engine water temperature gauge ⑦: Inside green range
  - Fuel gauge ⑧: Inside green range
  - Engine water temperature monitor ⑨: OUT
  - Radiator water level monitor ⑩: OUT
  - Engine oil pressure monitor ⑪: OUT
  - Charge level monitor ⑫: OUT
  - Fuel level monitor ⑬: OUT
  - Air cleaner clogging monitor ⑭: OUT
  - Engine pre-heating monitor ⑮: OUT
  - Engine oil level monitor ⑯: OUT
  - Hydraulic oil level monitor ⑰: OUT
  - Engine oil replacement monitor ⑱: OUT

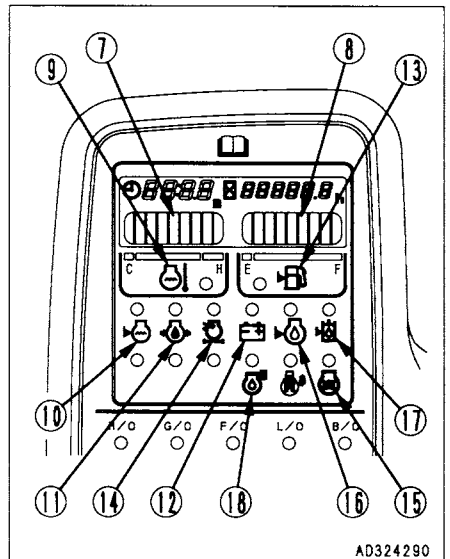

7. Check that there is no abnormal exhaust gas color, noise, or vibration. If any abnormality is found, repair it.

8. Press working mode switch ② on the monitor panel until the lamp of the mode to be used lights up.

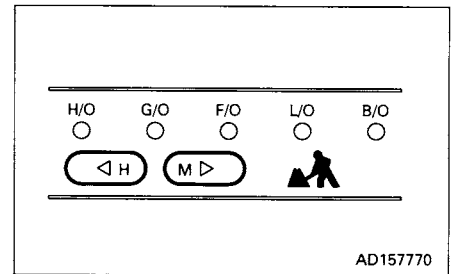

### 12.3.2 IN COLD AREAS (AUTOMATIC WARMING-UP OPERATION)

When starting the engine in cold areas, carry out the automatic warming-up operation after starting the engine.

When the engine is started, if the engine water temperature is low (below 30°C), the warming-up operation is carried out automatically.

The automatic warming-up operation is canceled if the engine water temperature reaches the specified temperature (30°C) or if the warming-up operation is continued for 10 minutes. If the engine water temperature or hydraulic oil temperature are low after the automatic warming-up operation, warm the engine up further as follows.

#### NOTICE

- When the hydraulic oil is at a low temperature, do not carry out operations or move the levers suddenly. Always carry out the warming-up operation. This will help to extend the machine life.
- Do not suddenly accelerate the engine before the warming-up operation is completed.  
Do not run the engine at low idling or high idling continuously for more than 20 minutes. This will cause leakage of oil from the turbocharger oil supply piping. If it is necessary to run the engine at idling, apply a load from time to time or run the engine at a mid-range speed.

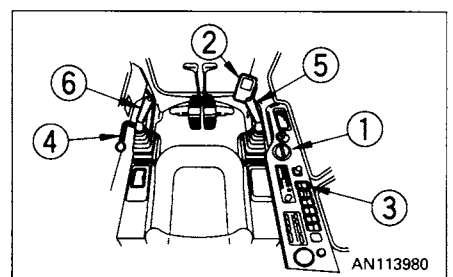

1. Set fuel control dial ① to the low idling (MIN) position and run the engine for about 5 minutes without load.

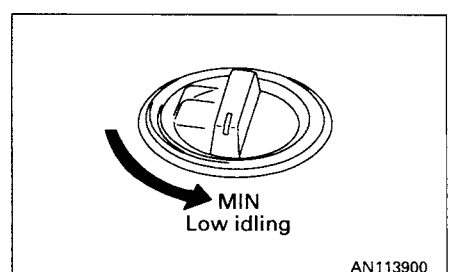



## 12. OPERATION

2. Press working mode switch ② on the monitor panel until the H.O (heavy-duty operation) mode lamp lights up.

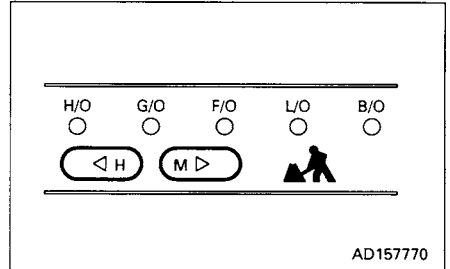

3. Turn fuel control dial ① to the mid-range speed position.

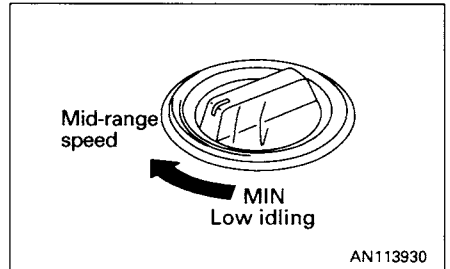

4. Set safety lock lever ④ to the FREE position and raise the bucket from the ground.

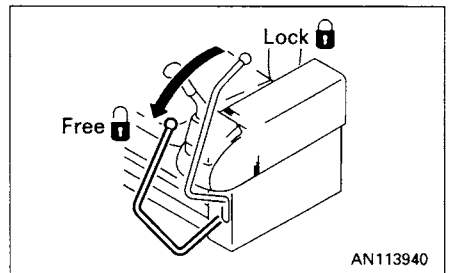

5. Operate bucket control lever ⑤ and arm control lever ⑥ slowly to move the bucket cylinder and arm cylinder to the end of their stroke.

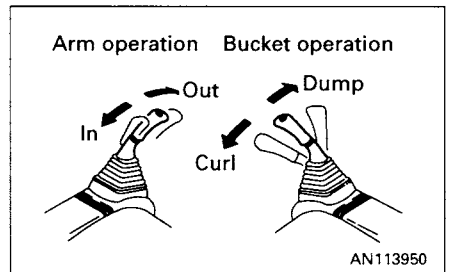

6. Operate the bucket for 30 seconds and the arm for 30 seconds in turn fully for 5 minutes.

### REMARK

Turn swing lock switch ③ ON (ACTUATED) and operate the lever to make the oil temperature rise more quickly.

### NOTICE

When the work equipment is retracted, take care that it does not interfere with the machine body or ground.

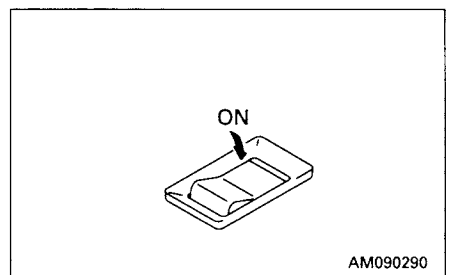

7. Turn fuel control dial ① to the full speed (MAX) position and carry out the operation in Step 6 for 3 – 5 minutes.
8. Repeat the following operation 3 – 5 times and operate slowly.
- Boom operation            RAISE ↔ LOWER
  - Arm operation            IN ↔ OUT
  - Bucket operation        CURL ↔ DUMP
  - Swing operation        LEFT ↔ RIGHT
  - Travel (Lo) operation    FORWARD ↔ REVERSE

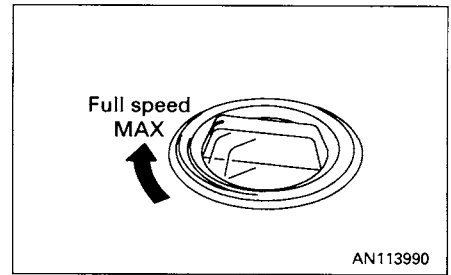

#### REMARK

In the above operation is not carried out, there may be a delay in response when starting or stopping each actuator, so continue the operation until it becomes normal.

9. Use working mode switch ② on the monitor panel to select the working mode to be used.

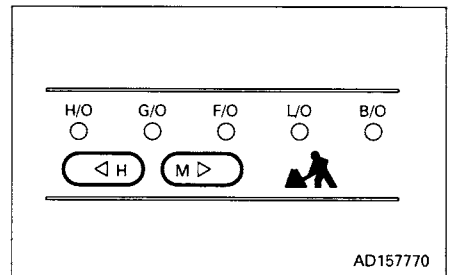

**NOTICE**

**Canceling automatic warming-up operation**

If it becomes necessary in an emergency to lower the engine speed to low idling, cancel the automatic warming-up operation as follows.

1. Turn fuel control dial ① to the full speed (MAX) position and hold it for 3 seconds.

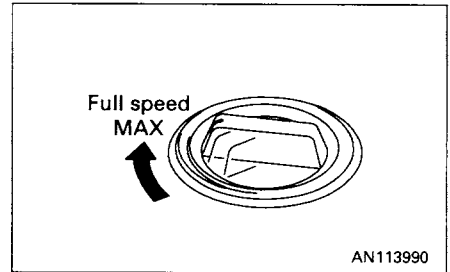

2. When fuel control dial ① is returned to the low idling (MIN) position, the engine speed will drop.

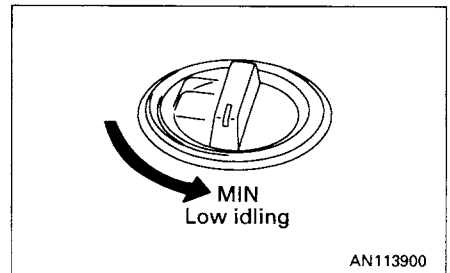

## 12.4 MOVING MACHINE OFF

### 12.4.1 MOVING MACHINE FORWARD

#### WARNING

- Before operating the travel levers, check the direction of the track frame. If the sprocket is at the front, the operation of the travel levers is reversed.
- When moving off, check that the area around the machine is safe, and sound the horn before moving.
- Clear all personnel from the machine and the area.
- Clear all obstacles from the path of the machine.
- If the lever is moved inside the deceleration range, engine speed will rise suddenly. Operate the levers carefully.

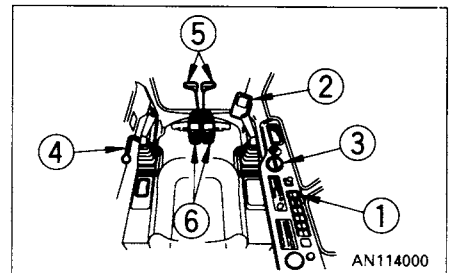

1. Set swing lock switch ① to the ON (actuated) position and confirm that swing lock monitor lamp ② lights up.

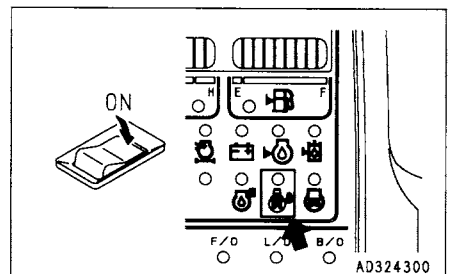

2. Turn fuel control dial ③ towards the full speed position to increase the engine speed.

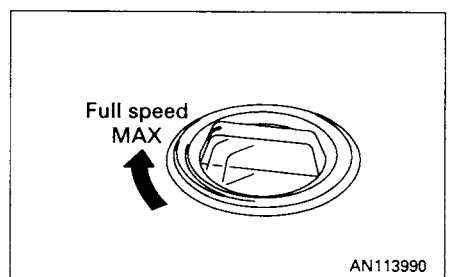

3. Set safety lock lever ④ in the FREE position, fold the work equipment, and raise it 40 – 50 cm (16 to 20 in) from the ground.

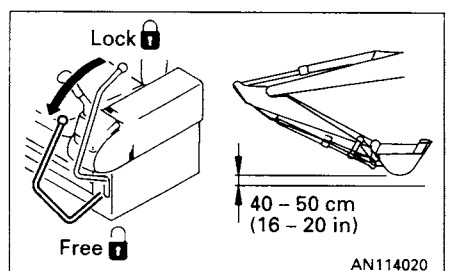

## 12. OPERATION

4. Operate right and left travel levers ⑤ or right and left travel pedals ⑥ as follows.

- **When the sprocket is at the rear of the machine**  
Push levers ⑤ forward slowly or depress the front part of pedals ⑥ slowly to move the machine off.

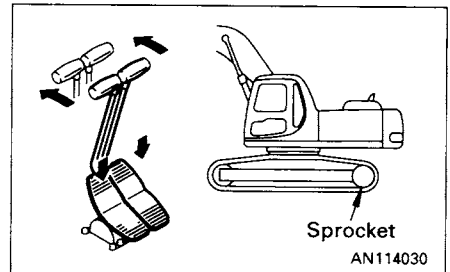

- **When the sprocket is at the front of the machine**  
Pull levers ⑤ backward slowly or depress the rear part of pedals ⑥ slowly to move the machine off.

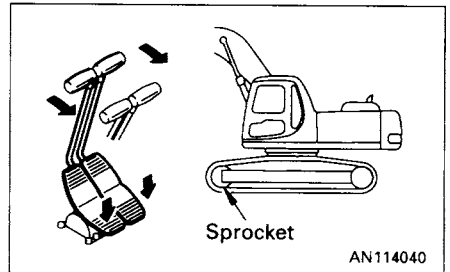

### REMARK

Each time the travel levers are operated on machines equipped with the travel alarm, the alarm sounds to warn people in the machine vicinity.

### 12.4.2 MOVING MACHINE BACKWARD

#### ⚠ WARNING

- Before operating the travel levers, check the direction of the track frame. If the sprocket is at the front, the operation of the travel levers is reversed.
- When moving off, check that the area around the machine is safe, and sound the horn before moving.
- Clear all personnel from the machine and the area.
- Clear all obstacles from the path of the machine.
- Use extreme care when reversing the machine. Note there is an blind spot behind the machine.
- If the lever is moved inside the deceleration range, engine speed will suddenly rise. Operate the levers carefully.

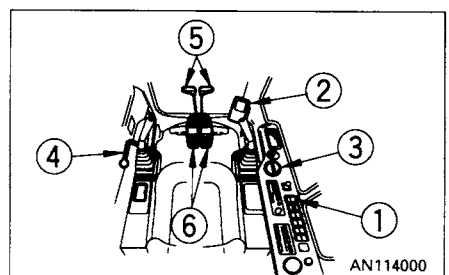

1. Set swing lock switch ① to the ON (actuated) position and confirm that swing lock monitor lamp ② lights up.

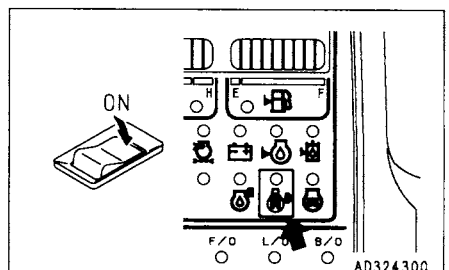

2. Turn fuel control dial ③ towards the full speed (MAX) position to increase the engine speed.

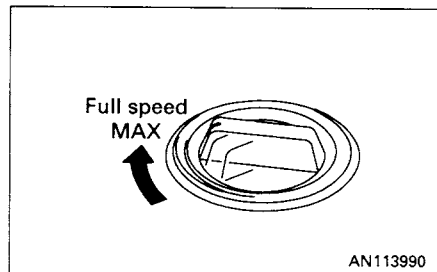

3. Set safety lock lever ④ in the FREE position, fold the work equipment, and raise it 40 – 50 cm (16 to 20 in) from the ground.

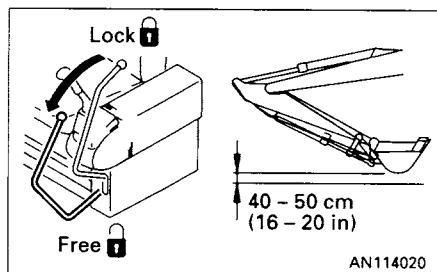

4. Operate right and left travel levers ⑤ or right and left travel pedals ⑥ as follows.

- **When the sprocket is at the rear of the machine**  
Pull levers ⑤ backward slowly or depress the rear part of pedals ⑥ to move the machine off.

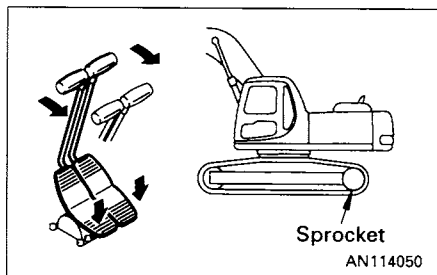

- **When the sprocket is at the front of the machine**  
Push levers ⑤ forward slowly or depress the front part of pedals ⑥ to move the machine off.

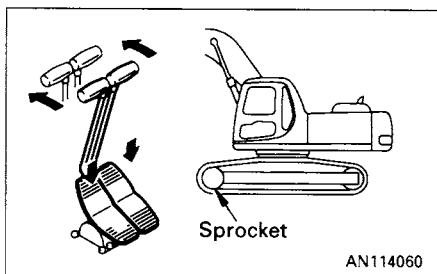

## 12.5 STEERING MACHINE

### 12.5.1 STEERING (CHANGING DIRECTION)

**⚠ WARNING**

Before operating the travel levers, check the position of the sprocket. If the sprocket is at the front, the operation of the travel levers is reversed.

Use the travel levers to change direction.

Avoid sudden changes of direction as far as possible. In particular, when carrying out counter-rotation (spin turn), stop the machine first before turning.

Operate two travel levers ① as follows.

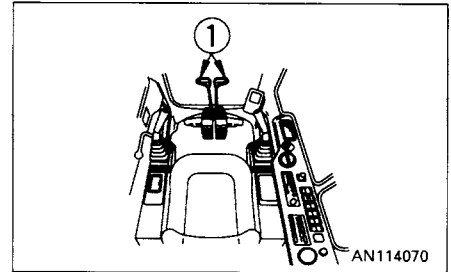

#### Changing direction of machine when stopped

When turning to the left:

Push the right travel lever forward to travel left when traveling forward; and pull it back to turn left when traveling in reverse.

**REMARK**

When turning to the right, operate the left travel lever in the same way.

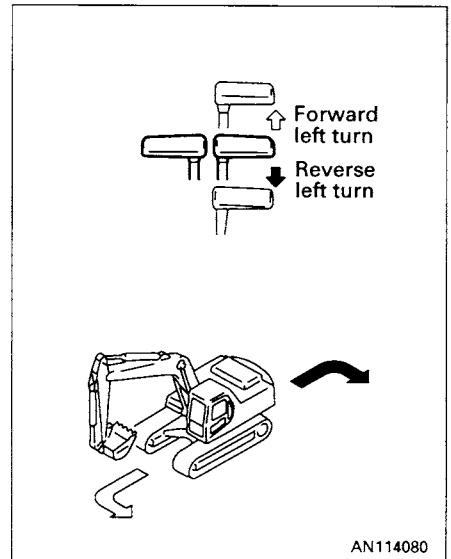

#### Steering when traveling (left and right travel levers both operated in same direction)

When turning to the left:

If the left travel lever is returned to the neutral position, the machine will turn to the left.

**REMARK**

When turning to the right, operate the right travel lever in the same way.

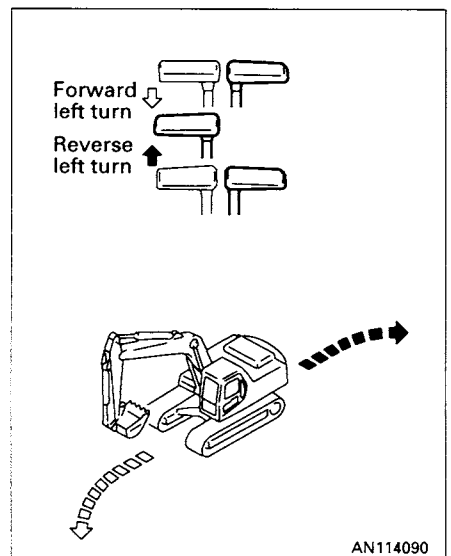

**When making counter-rotation turn (spin turn)**

When turning left using counter-rotation, pull the left travel lever back and push the right travel lever forward.

**REMARK**

When turning right using counter-rotation, pull the right travel lever back and push the left travel lever forward.

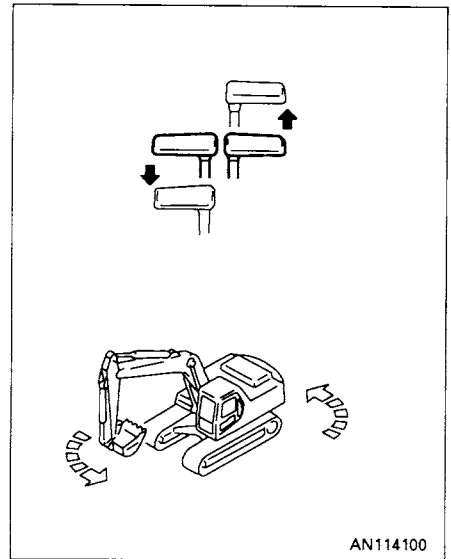



## 12.6 STOPPING MACHINE

### WARNING

- Avoid stopping suddenly. Give yourself ample room when stopping.
- When stopping the machine, select flat hard ground and avoid dangerous places. If it is unavoidably necessary to park the machine on a slope, insert blocks underneath the track shoes. As an additional safety measure, thrust the bucket into the ground.
- If the control lever is touched by accident, the work equipment or the machine may move suddenly, and this may lead to a serious accident. Before leaving the operator's compartment, always set the safety lock lever securely to the LOCK position.

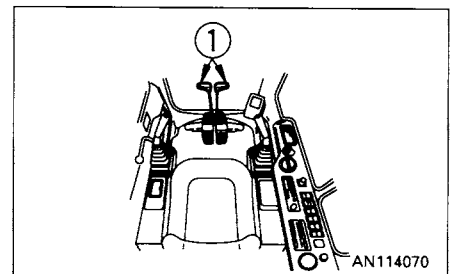
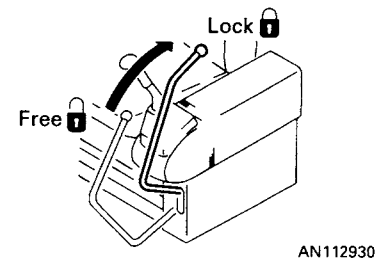
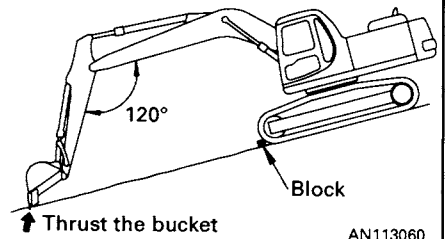

1. Put the left and right travel levers ① in the neutral position, then stop the machine.

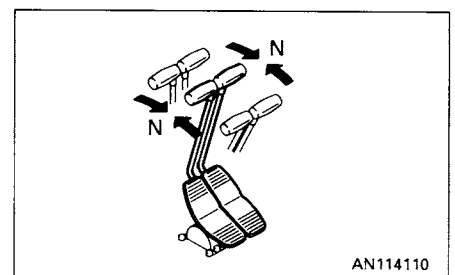

## 12.7 SWINGING

### WARNING

When operating the swing, check that the area around the machine is safe.

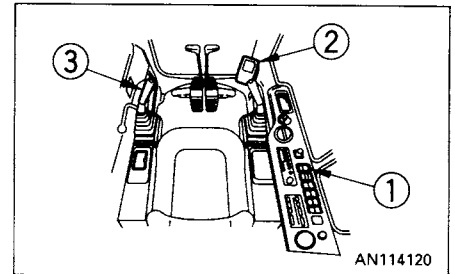

1. Before operating the swing, turn swing lock switch ① OFF (CANCELED).

### NOTICE

Check that swing lock monitor ② goes out at the same time.

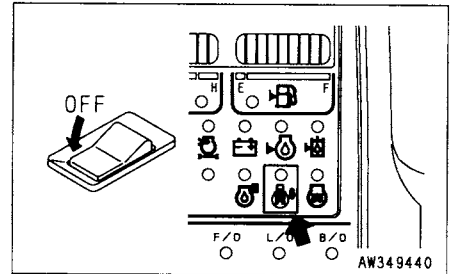

2. Operate left work equipment control lever ③ to swing the upper structure.

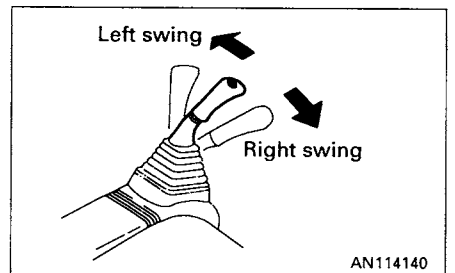

3. When not operating the swing, turn swing lock switch ① ON (ACTUATED).

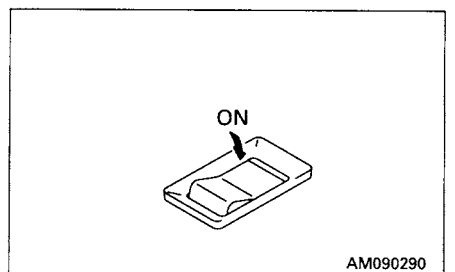

## 12.8 OPERATION OF WORK EQUIPMENT

### WARNING

If any lever is operated when in the deceleration range, the engine speed will suddenly increase, so be careful when operating the levers.

The work equipment is operated by the left and right work equipment control levers. The left work equipment control lever operates the arm and swing, and the right work equipment control lever operates the boom and bucket.

The movements of the lever and work equipment are as shown in the diagrams on the right. When the levers are released, they automatically return to the neutral position and the work equipment is held in place.

- If the work equipment control lever is returned to the neutral position when the machine is stopped, even if the fuel control dial is set to FULL, the auto-deceleration mechanism will act to reduce the engine speed to a mid-range speed.

### REMARK

If the levers are operated within 15 seconds after stopping the engine, it is possible to lower the work equipment to the ground. In addition, the levers can also be operated to release any remaining pressure inside the hydraulic cylinder circuit and to lower the boom after loading the machine on a trailer.

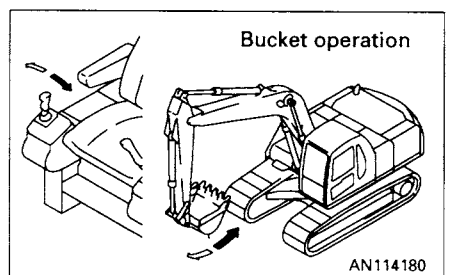
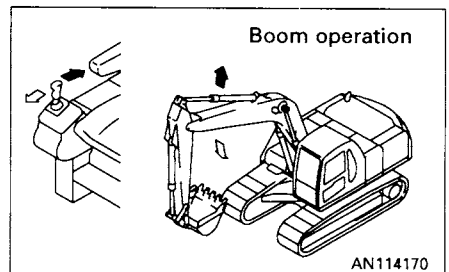
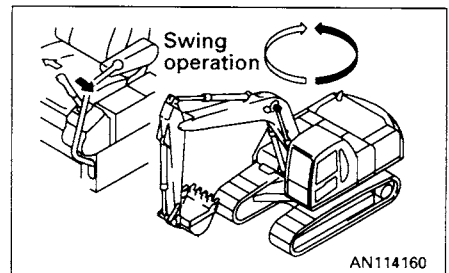
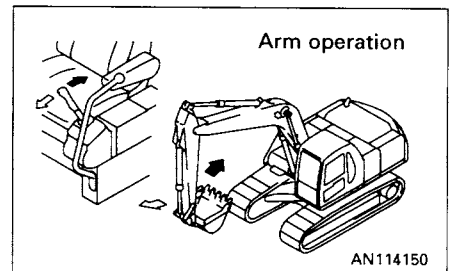

## 12.9 HANDLING ACTIVE MODE

Make full use of the active mode to match the purpose and conditions of the operation in order to carry out operations effectively and efficiently.

The active mode selector switch can be turned ON (lights up) in order to provide quick leveling operations and effective deep digging and loading operations.

ON lights up: Active mode ON

ON goes out: Active mode cancelled

The ON lamp is off when the engine is started.

If it is turned ON (lights up), it is possible to enter the active mode from any working mode.

Even when it is turned ON (lights up), the working mode display does not change. When the lamp goes out, the system returns to the original working mode.

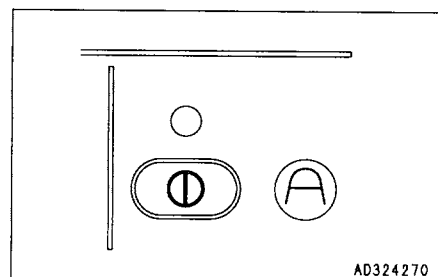

Mode	Effective operation	Advantages for operation
Active mode	Digging and loading	The boom lowering speed is increased and the amount of lift of the work equipment when raising the boom and swinging is increased, so the cycle time for deep digging operations is reduced.
	Leveling	By increasing the arm IN speed and the pump response, the speed of rough leveling (light loads) is increased.

### NOTICE

**There is danger that the hydraulic equipment may be broken if breaker operations are carried out in the active mode, so never use the active mode for breaker operations.**

### REMARK

- Use the active mode with the fuel control dial turned to the MAX position. If it is not at the MAX position, it will be impossible to achieve a suitable increase in the work equipment speed.
- Active power-up function  
When finishing ground quickly with heavy loads or digging deep and loading, use the active power-up function according to the following procedures.

## 12. OPERATION

1. Turn on the active mode selector switch (lights up).
2. While in this condition, press and hold the knob switch of the left-hand work equipment lever once (single click).
3. Since the machine returns to the normal active mode in 8.5 sec after the switch is pressed, use the active power-up mode effectively for heavy and quick work.

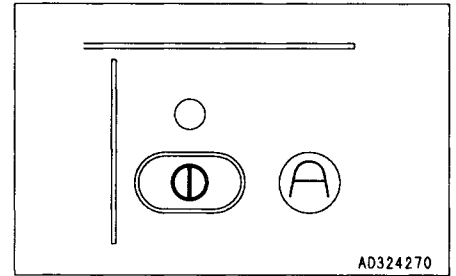

Mode	Suitable work	Advantages on work
Active power-up function	Digging and loading (Heavy load)	Since engine speed is increased, cycle time of deep scraping work is shortened.
	Rock raising (Heavy load)	Since digging force of arm and bucket is increased, working speed is increased.
	Finishing operation (Heavy load)	Since engine speed is increased, rough scraping speed is increased.

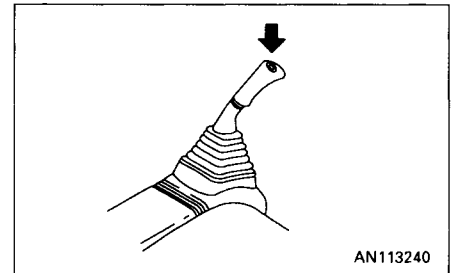

## 12.10 WORKING MODE SELECTION

### WORKING MODE

The mode selector switches can be used to switch the mode to match the conditions and purpose of work, thereby enabling efficient operation.

Use the following procedures to make the most effective use of each mode.

- When the starting switch is turned ON, the working mode is set to general operation mode (G.O.), so normal work can be carried out without needing to set the mode.
- If you want to change the initial position of the working mode that is set when the starting switch is turned ON, consult your Komatsu distributor.

Set the most effective mode according to the type of work using working mode selector switch.

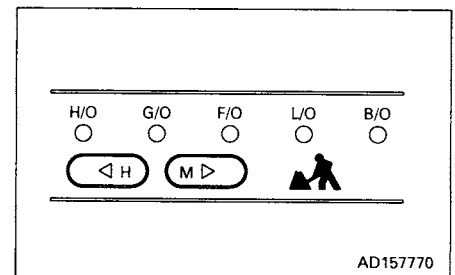

Working mode	Applicable work	Power max. (power up)		Swift slow-down (speed down)	
		Power	Set pressure	Speed	Set pressure
Heavy-duty operation mode (H.O)	Large amount of digging and loading in a short time	5% up	9% up	40% down	9% up
General operation mode (G.O)	Normal digging and loading operation	23% up	9% up	30% down	9% up
Finishing operation mode (F.O)	Finishing, leveling and general hauling operation	-		-	
Lifting operation mode (L.O)	Positioning etc.	-		-	
Breaker operation mode (B.O)	Breaker operation	-		-	

### NOTICE

**Never carry out breaker operation in heavy-duty operation mode (H.O.) or active mode as this may result in breakage of hydraulic equipment.**

**POWER MAX./SWIFT SLOW-DOWN**

During operation, power up/speed down of work equipment can be performed by one-touch. Use this function effectively in combination with working mode.

1. When starting switch is turned ON, the power up lamp turns on. When SET switch is pressed once, the speed down lamp turns on and the power up lamp goes out, and when pressed again, the opposite occurs.

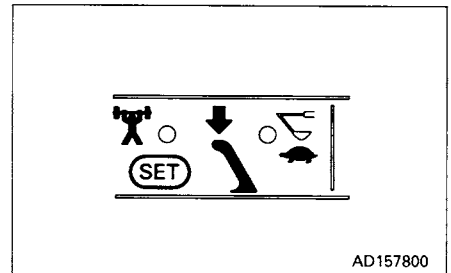
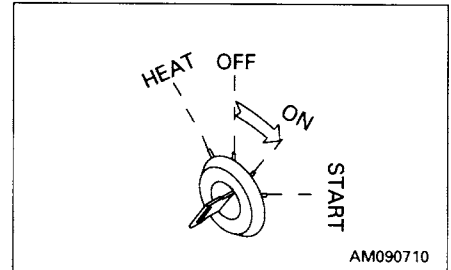

2. When the left knob button is given a single click (keep depressed after initially pressing) power keeps increasing while depressed. However, power up automatically completes after 8.5 seconds.

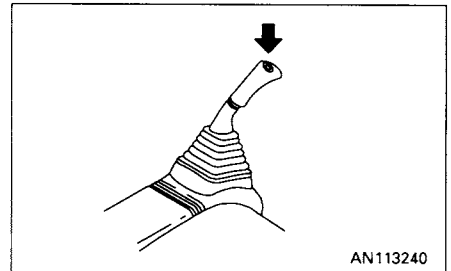

## 12.11 PROHIBITIONS FOR OPERATION

### WARNING

- If it is necessary to operate the work equipment control lever when the machine is traveling, stop the machine before operating the work equipment control lever.
- If the lever is moved inside the deceleration range, engine speed will suddenly rise. Operate the levers carefully.
- Never operate the machine on a rock bed (hard or soft rock).

#### Prohibited operations using swing force

Do not use the swing force to compact soil or break earth mounds or walls.

When swinging, do not dig the bucket teeth into the soil. These operations will damage the work equipment.

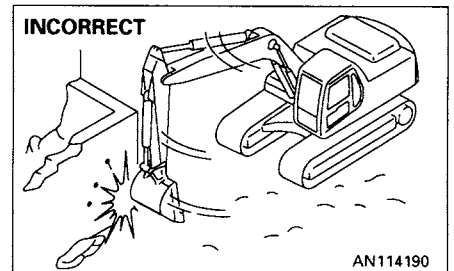

#### Prohibited operations using travel force

Do not leave the bucket dug into the ground and use the travel force to excavate. This will bring excessive force to bear on the machine and the work equipment.

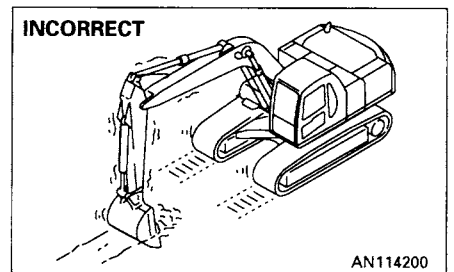

#### Precautions when operating hydraulic cylinders to end of stroke

If the cylinder is operated to the end of its stroke during operations, force will be brought to bear on the stopper inside the cylinder, and this will reduce the life of the machine. To prevent this, always leave a small safety margin when operating the cylinders.

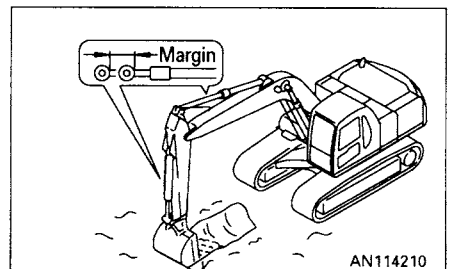

#### Prohibited operations using dropping force of bucket

Do not use the dropping force of the bucket as a pickaxe, breaker, or pile driver. This will bring excessive force to bear on the rear of the machine, and will not only damage the machine, but is also dangerous.

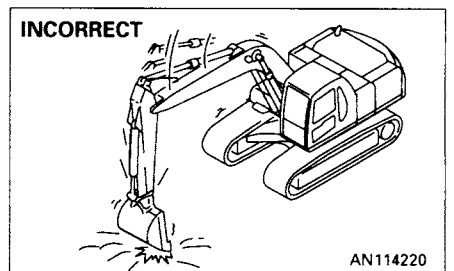



**Prohibited operations using dropping force of machine**

Do not use the dropping force of the machine for digging.

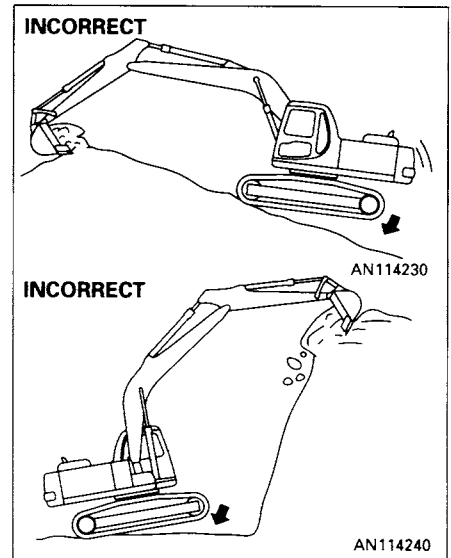

**Digging rocky ground**

It is better to excavate hard rocky ground after breaking it up by some other means. This will not only reduce damage to the machine but make for better economy.

**Sudden lever shifting during Hi-speed travel prohibited**

- ① Never carry out sudden lever shifting as this may cause sudden starting.
- ② Avoid sudden lever shifting from forward to reverse (or vice versa).
- ③ Avoid sudden lever shifting change such as sudden stopping from near top speed (lever release operation).

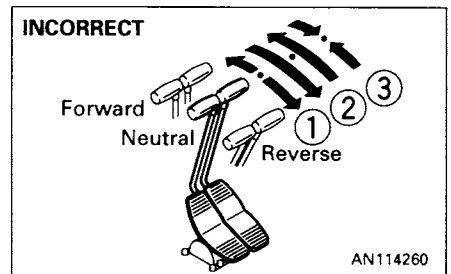

## 12.12 PRECAUTIONS FOR OPERATION

### PRECAUTIONS WHEN TRAVELING

When traveling over obstacles such as boulders or tree stumps, the machine (in particular, the undercarriage) is subjected to a large shock, so reduce the travel speed and travel over the obstacle at the center of the tracks. As far as possible, remove such obstacles or avoid traveling over them.

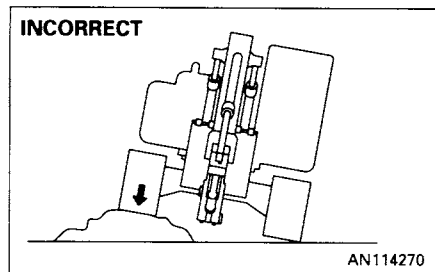

### PRECAUTIONS AT HI-SPEED TRAVEL

On uneven roadbeds such as rock beds or uneven roads with large locks, travel at Mi or Lo speed. When Hi-speed traveling, set the idler in the forward direction.

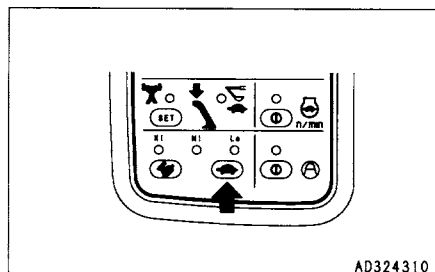

### PERMISSIBLE WATER DEPTH NOTICE

When driving the machine out of water, if the angle of the machine exceeds 15°, the rear of the upper structure will go under water, and water will be thrown up by the radiator fan. This may cause the fan to break.

**Be extremely careful when driving the machine out of water.**

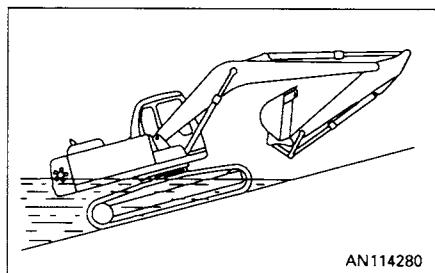

Do not immerse the machine in water by more than the permissible depth (under center of carrier roller ①).

In addition, for parts that have been immersed in water for a long time, pump in grease until the old grease comes out from the bearings. (Around the bucket pins)

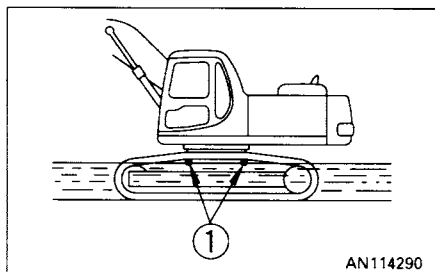

### 12.13 PRECAUTIONS WHEN TRAVELING UP OR DOWN HILLS

**WARNING**

- When traveling, raise the bucket approx. 20 – 30 cm (8 – 12 in) from the ground. Do not travel downhill in reverse.
- When traveling over ridges or other obstacles, keep the work equipment close to the ground and travel slowly.
- It is dangerous to turn on slopes or to travel across slopes. Always go down to a flat place to perform these operations. It may be longer, but it will ensure safety.
- If the machine starts to slide or loses stability, lower the bucket immediately and brake the machine.
- Turning or operating the work equipment when working on slopes may cause the machine to lose its balance and turn over, so avoid such operations. It is particularly dangerous to swing downhill when the bucket is loaded. If such operations have to be carried out, pile soil to make platform on the slope so that the machine can be kept horizontal when operating.
- Do not travel on slopes of over 30° as there is danger that the machine may overturn.

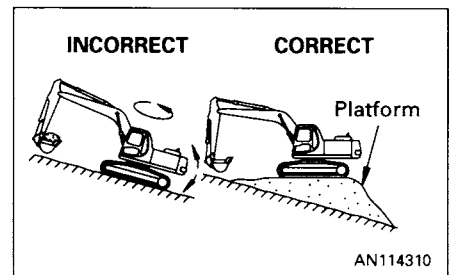
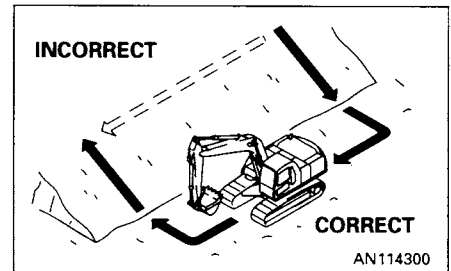

- 1) When traveling down steep hills, use the travel lever and fuel control lever to keep the travel speed low. When traveling down slopes of more than 15°, set the work equipment in the posture shown in the figure on the right, and lower the engine speed.

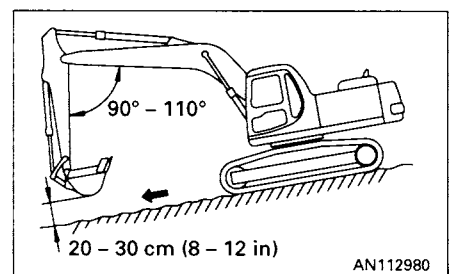

- 2) When traveling up a steep hill of more than 15°, set the work equipment in the posture shown in the diagram on the right.

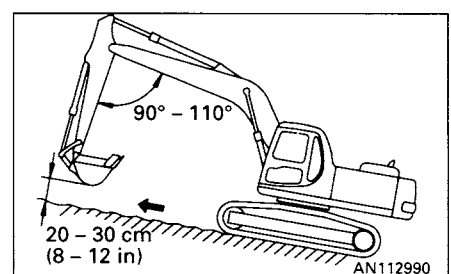

**Braking when traveling downhill**

To brake the machine during downhill runs, put the travel lever in the neutral position. This will cause the brake to be automatically applied.

**If shoes slip**

When traveling uphill, if the shoes slip or it is impossible to travel uphill using the force of the track only, it is possible to use the pulling force of the arm to help the machine travel uphill.

**If engine stops**

If the engine stops when traveling uphill, move the travel levers to the neutral position, lower the bucket to the ground, stop the machine, then start the engine again.

**Precautions on slopes**

- If the engine stops when the machine is on a slope, never use the left work equipment control lever to carry out swing operations. The upper structure will swing under its own weight.
- Do not open or close the door on the cab if the machine is on a slope. This may cause a sudden change in the operating force. Always keep the door locked.

### 12.14 HOW TO ESCAPE FROM MUD

Always operate carefully to avoid getting stuck in mud. If the machine does get stuck in mud, use the following procedures to get the machine out.

#### 12.14.1 WHEN ONE SIDE IS STUCK

When only one side is stuck in mud, use the bucket to raise the track, then lay boards or logs and drive the machine out. If necessary, put a board under the bucket also.

#### NOTICE

When using the boom or arm to raise the machine, always have the bottom of the bucket in contact with the ground. (Never push with the teeth). The angle between the boom and arm should be 90° to 110°.

The same applies when using the inverting bucket.

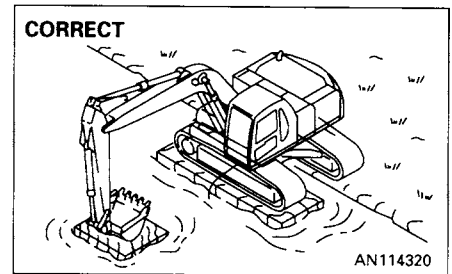

#### 12.14.2 WHEN BOTH SIDES ARE STUCK

When the tracks on both sides are stuck in mud and the machine will not move, lay boards as explained above, and dig the bucket into the ground in front. Then pull in the arm as in normal digging operations and put the travel levers in the FORWARD position to pull the machine out.

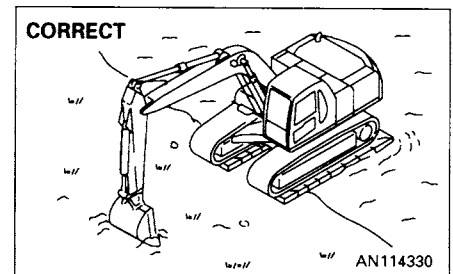

## 12.15 WORK POSSIBLE USING HYDRAULIC EXCAVATOR

In addition to the following, it is possible to further increase the range of applications by using various attachments.

### 12.15.1 BACKHOE WORK

When condition of the machine is as shown in the diagram at right, each cylinders maximum pushing excavation force is obtained when the bucket cylinder and link, arm cylinder and arm are at 90°.

When excavating, use this angle effectively to optimize your work efficiency.

The range for excavating with the arm is from a 45° angle away from the machine to a 30° toward the machine.

There may be some differences depending on the excavation depth, but try to use within the above range rather than going all the way to the extreme end of the cylinder stroke.

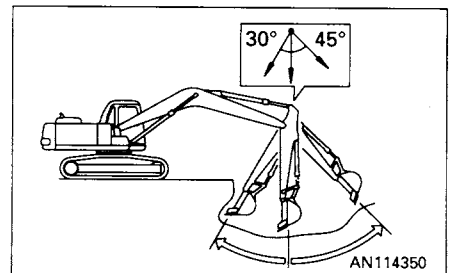
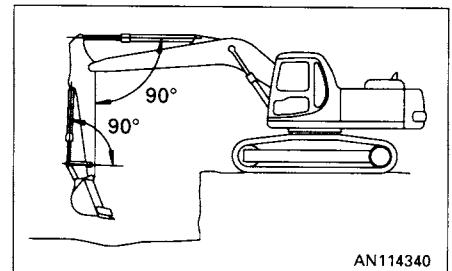

### 12.15.2 SHOVEL WORK

A shovel is suitable for excavating at a position higher than the machine. Shovel work is performed by attaching the bucket in the reverse direction.

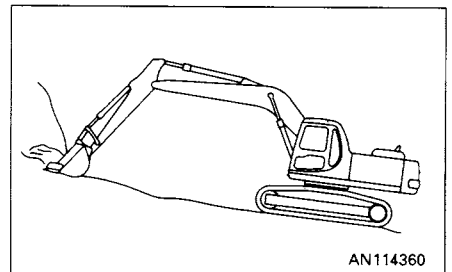

### 12.15.3 DITCHING WORK

Ditching work can be performed efficiently by attaching a bucket to match the width of the ditch and then setting the tracks parallel to the line of the ditch to be excavated.

To excavate a wide ditch, first dig out both sides and then finally remove the center portion.

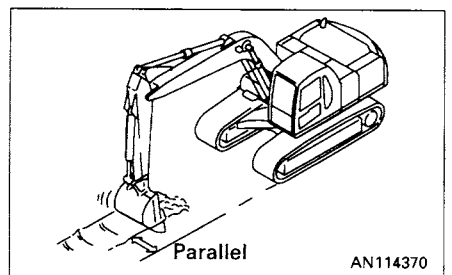

### 12.15.4 LOADING WORK

In places where the swing angle is small, work efficiency can be enhanced by locating the dump truck in a place easily visible to the operator.

Loading is easier and capacity greater if you begin from the front of the dump truck body than if loading is done from the side.

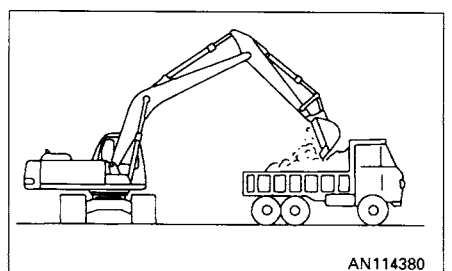

## 12.16 REPLACEMENT AND INVERSION OF BUCKET

### ⚠ WARNING

- When knocking the pin in with a hammer, metal particles may fly and cause serious injury, particularly if they get into your eyes. When carrying out this operation, always wear goggles, helmet, gloves, and other protective equipment.
- When the bucket is removed, place it in a stable condition.

Stop the machine on a firm, flat surface. When performing joint work, make clear signals to each other and work carefully for safety's sake.

### 12.16.1 REPLACEMENT

1. Place the bucket in contact with a flat surface.

#### REMARK

When removing the pins, place the bucket so that it is in light contact with the ground.

If the bucket is lowered strongly to the ground, the resistance will be increased and it will be difficult to remove the pins.

2. Remove the stopper bolts and nuts, then remove pins (A) and (B), and remove the bucket.

#### NOTICE

After removing the pins, make sure that they do not become contaminated with sand or mud and that the seals of bushing on both sides do not become damaged.

3. Align the arm with holes (1) and the link with holes (2), then coat with grease and install pins (A) and (B).

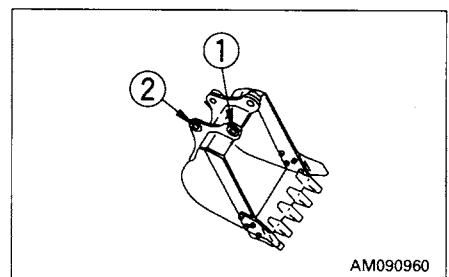
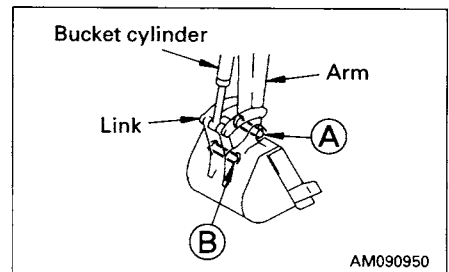

#### REMARK

When installing the bucket, the O-rings are easily damaged, so fit the O-rings on the boss of the arm end as shown in the diagram. When knocking the pin, move the O-ring down to the regular groove.

4. Install the stopper bolts and nuts for each pin, then grease the pin.

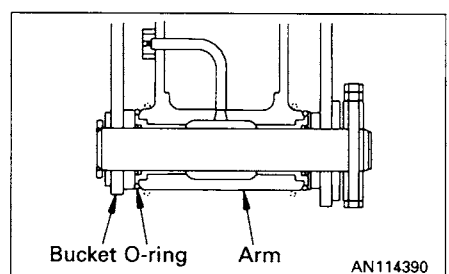

**12.16.2 INVERSION**

1. Place the bucket in contact with a flat surface.

**REMARK**

When removing the pins, place the bucket so that it is in light contact with the ground.

If the bucket is lowered strongly to the ground, the resistance will be increased and it will be difficult to remove the pins.

2. Remove the stopper bolts and nuts, then remove pins (A) and (B), and remove the bucket.

**NOTICE**

After removing the pins, make sure that they do not become contaminated with sand or mud and that the seals of bushing on both sides do not become damaged.

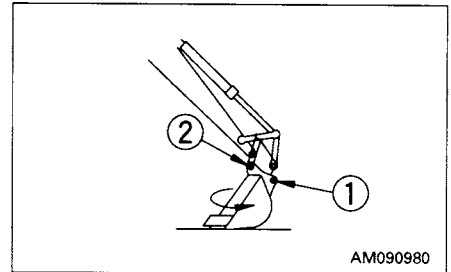
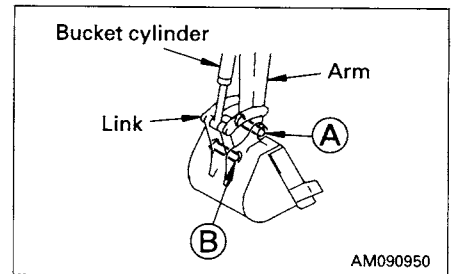

3. Install the bucket inversely.  
After the bucket is inverted, correct the inclination and direction of the retaining pin holes (1) and (2) and stabilize the bucket securely.
4. Align the arm with holes (1) and the link with holes (2), then coat with grease and install pins (A) and (B).

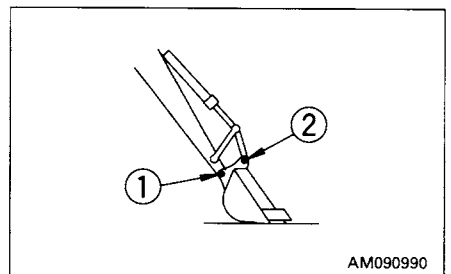
**REMARK**

Install the O-rings into retaining hole (1) of the arm and bucket.

When installing the bucket, the O-rings are easily damaged, so fit the O-rings on the boss of the arm end as shown in the diagram. When knocking the pin, move the O-ring down to the regular groove.

5. Install the stopper bolts and nuts for each pin, then grease the pin.

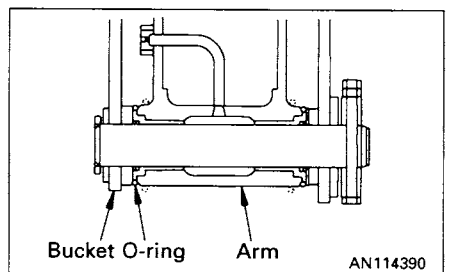



## 12.17 PARKING MACHINE

### WARNING

- Avoid stopping suddenly. Give yourself ample room when stopping.
- When stopping the machine, select flat hard ground and avoid dangerous places. If it is unavoidably necessary to park the machine on a slope, insert blocks underneath the track shoes. As an additional safety measure, thrust the bucket into the ground.
- If the control lever is touched by accident, the work equipment or the machine may move suddenly, and this may lead to a serious accident. Before leaving the operator's compartment, always set the safety lock lever securely to LOCK position.

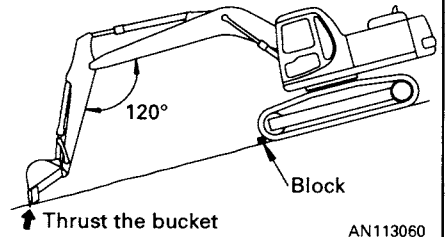

AN113060

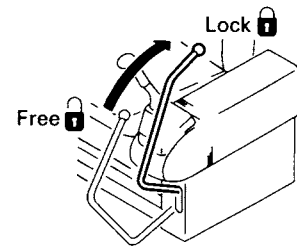

AN112930

1. Put left and right travel levers ① in the neutral position. The machine stops.

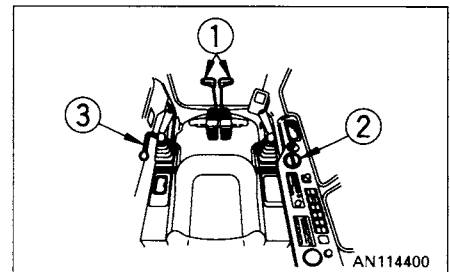

AN114400

2. Turn fuel control dial ② to lower the engine speed to low idling.

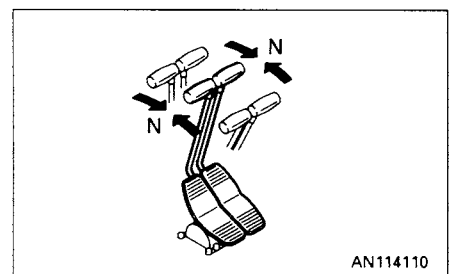

AN114110

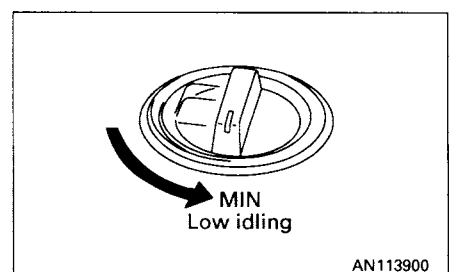

AN113900

3. Lower the bucket horizontally until the bottom touches the ground.

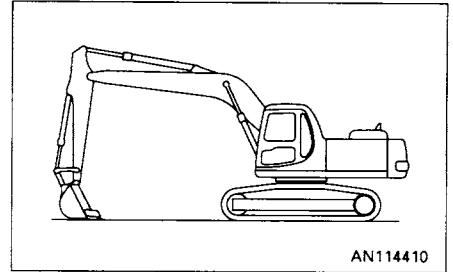

4. Set safety lock lever ③ in the LOCK position.

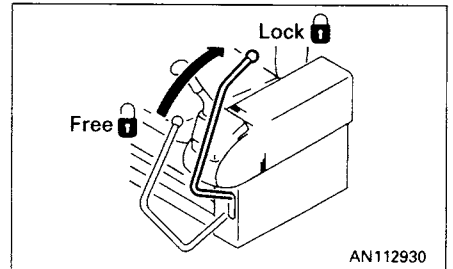

## 12.18 CHECK AFTER FINISHING WORK

Check the engine water temperature, engine oil pressure and fuel level on the monitor.

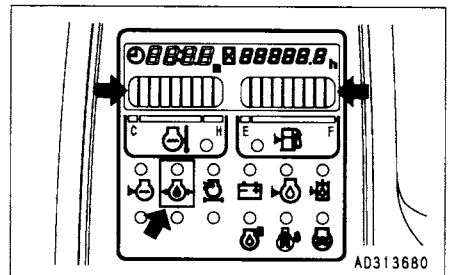

## 12.19 STOPPING ENGINE

### NOTICE

If the engine is abruptly stopped before it has cooled down, engine life may be greatly shortened. Consequently, do not abruptly stop the engine apart from an emergency.

In particular, if the engine has overheated, do not abruptly stop it but run it at medium speed to allow it to cool gradually, then stop it.

1. Run the engine at low idling speed for about 5 minutes to allow it go gradually cool down.

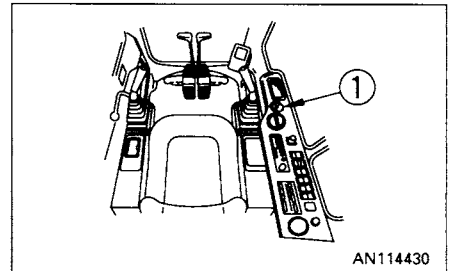

2. Turn the key in starting switch ① to the OFF position and stop the engine.
3. Remove the key from starting switch ①.

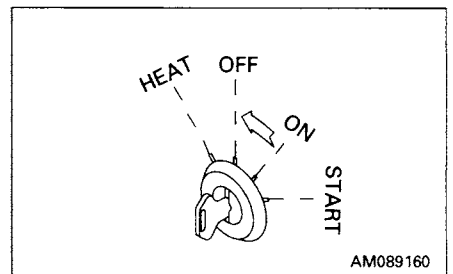

## 12.20 CHECK AFTER STOPPING ENGINE

1. Walk around the machine and check the work equipment, paint-work, and undercarriage, and check also for leakage of oil or water. If any abnormalities are found, repair them.
2. Fill the fuel tank.
3. Check the engine compartment for paper and debris. Clean out any paper and debris to avoid a fire hazard.
4. Remove any mud stuck to the undercarriage.

## 12.21 LOCKING

Always lock the following places.

- ① Door of operator's cab  
Always remember to close the window.
- ② Fuel tank filler port
- ③ Engine hood
- ④ Battery box cover
- ⑤ Left side door of the machine
- ⑥ Right side door of the machine
- ⑦ Hydraulic tank filler port

### REMARK

Use the starting switch key to open and close all these places.

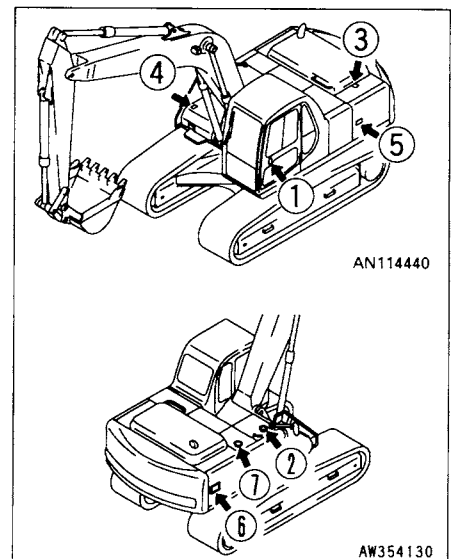

## 13. TRANSPORTATION

When transporting the machine, observe all related laws and regulations, and be careful to assure safety.

### 13.1 LOADING, UNLOADING WORK

#### WARNING

- Loading or unloading the machine can be a dangerous operation, so be particularly careful.  
When loading or unloading the machine, run the engine at low idling and travel at low speed.
- Make sure the ramp has sufficient width, length and thickness to enable the machine to be safely loaded and unloaded. If the ramp sags appreciably, reinforce it with blocks, etc.
- When loading and unloading the machine, park the trailer on a flat firm roadbed. Keep a fairly long distance between the road shoulder and the machine.
- Remove the mud from the undercarriage to prevent the machine from slipping to the side on slopes. Be sure the ramp surface is clean and free of grease, oil, ice and loose materials.
- Never change the direction of travel when on the ramps. If it is necessary to change direction, drive off the ramps and correct the direction, then drive on to the ramps again.
- When turning the machine on the trailer, the machine's footing is unstable, so carry out the operation slowly.
- Always check that the door on the cab is locked, regardless of whether it is open or closed.  
Do not open or close the door on ramps or on a platform. This may cause a sudden change in the operating force.
- When loading or unloading the machine with the automatic warming-up operation mode, if the automatic warming-up is released, the speed may change suddenly. Avoid loading or unloading during automatic warming-up operation.

When loading or unloading, always use ramps or a platform and carry out the operations as follows.

1. Properly apply the brakes on the trailer and insert blocks beneath the tires to ensure that it does not move. Then fix the ramps in line with the centers of the trailer and the machine. Be sure that the two sides are at the same level as one another.

Make the angle of the ramps a maximum of 15°.

Set the distance between the ramps to match the center of the tracks.

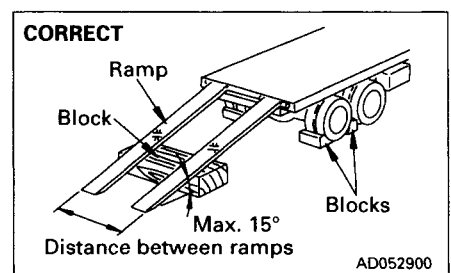

2. Set the travel speed switch to the Lo position.

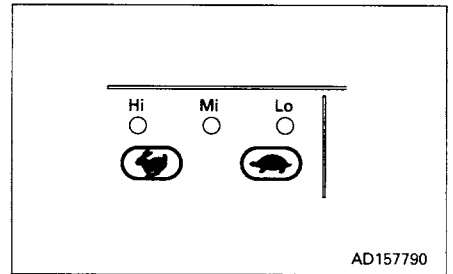

3. Turn the auto-deceleration switch OFF, and return the fuel control dial to reduce the engine speed.

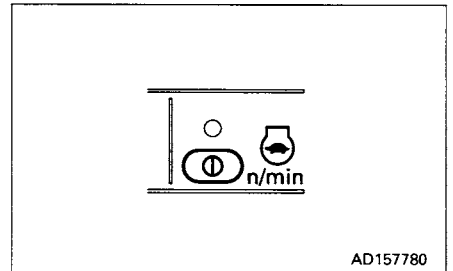

4. Turn the swing lock switch ON to apply the swing lock.
5. Set in the direction of the ramps, lower the work equipment as far as possible without letting it hit the trailer, then travel slowly to load or unload the machine.

When on the ramps, do not operate any lever other than the travel lever.

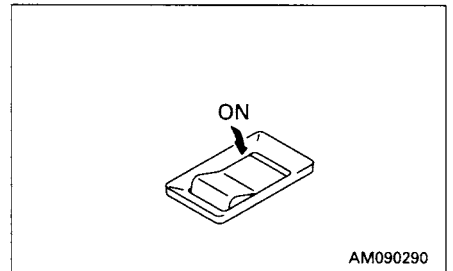

6. Load the machine correctly in the specified position on the trailer.

#### REMARK

When the work equipment is installed, load the machine from the front; when the work equipment is not installed, load the machine from the rear.

## 13.2 PRECAUTIONS FOR LOADING

**WARNING**

When loading the machine, park the trailer on a flat firm roadbed. Keep a fairly long distance between the road shoulder and the machine.

After loading to the specified position, secure the machine as follows.

1. Fully extend the bucket cylinder and arm cylinder, then slowly lower the boom.
2. Stop the engine and remove the key from the starting switch.
3. Lock all the control levers securely with the safety lock lever.
4. When transporting the machine, place rectangular timber underneath the front and rear track shoes to prevent the machine from moving about. Also, hold it down with chains or rope. Be particularly careful to ensure that the machine does not slip sideways.

**NOTICE**

When transporting the machine, place rectangular timber under one end of the bucket cylinder to prevent it touching the ground, thereby saving it from possible damage.

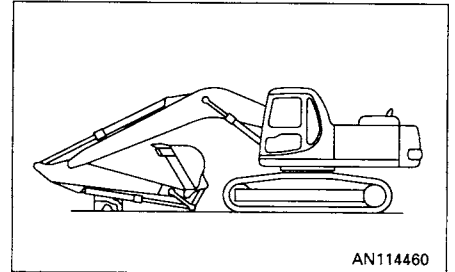

AN114460

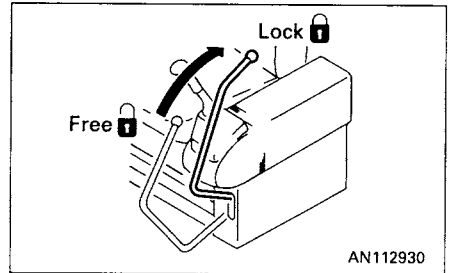

AN112930

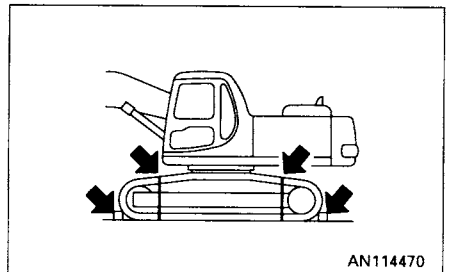

AN114470

### 13.3 PRECAUTIONS FOR TRANSPORTATION

 **WARNING**

- **Determine the route for transporting the machine by taking into account the width, height and weight of the machine.**
- **Always check that the door on the cab is closed and locked before transporting the machine.**

**NOTICE**

**Always retract the car radio antenna.**

Obey all state and local laws governing the weight, width and length of a load. Observe all regulations governing wide loads.



# 14. COLD WEATHER OPERATION

---

## 14.1 PRECAUTIONS FOR LOW TEMPERATURE

If the temperature becomes low, it becomes difficult to start the engine, and the coolant may freeze, so do as follows.

### 14.1.1 FUEL AND LUBRICANTS

Change to fuel and oil with low viscosity for all components. For details of the specified viscosity, see "20. USE OF FUEL, COOLANT AND LUBRICANTS ACCORDING TO AMBIENT TEMPERATURE".

### 14.1.2 COOLANT

 **WARNING**

**Keep antifreeze fluid away from an open flame. Never smoke when using antifreeze.**

#### NOTICE

- **Never use methanol, ethanol or propanol based antifreeze.**
- **Absolutely avoid using any water leak preventing agent irrespective of whether it is used independently or mixed with an antifreeze.**
- **Do not mix one antifreeze with a different brand.**

For details of the antifreeze mixture when changing the coolant, see "24.2 WHEN REQUIRED".

Use a Permanent Antifreeze (ethylene glycol mixed with corrosion inhibitor, antifoam agent, etc.) meeting the standard requirements as shown below. With permanent antifreeze, no change of coolant is required for a year. If it is doubtful that an available antifreeze meets the standard requirements, ask the supplier of that antifreeze for information.

Standard requirements for permanent antifreeze

- SAE ..... J1034
- FEDERAL STANDARD ..... O-A-548D

#### REMARK

Where no permanent antifreeze is available, an ethylene glycol antifreeze without corrosion inhibitor may be used only for the cold season. In this case, clean the cooling system twice a year (in spring and autumn). When refilling the cooling system, add antifreeze in autumn, but do not add any in spring.

### 14.1.3 BATTERY

**⚠ WARNING**

- To avoid gas explosions, do not bring fire or sparks near the battery.
- Battery electrolyte is dangerous. If it gets in your eyes or on your skin, wash it off with large amounts of water, and consult a doctor.

When the ambient temperature drops, the capacity of the battery will also drop. If the battery charge ratio is low, the battery electrolyte may freeze. Maintain the battery charge as close as possible to 100%, and insulate it against cold temperature so that the machine can be started easily the next morning.

**REMARK**

Measure the specific gravity and calculate the rate of charge from the following conversion table.

Rate of charge	Temp. of fluid	20°C	0°C	-10°C	-20°C
	100%	1.28	1.29	1.30	1.31
90%	1.26	1.27	1.28	1.29	
80%	1.24	1.25	1.26	1.27	
75%	1.23	1.24	1.25	1.26	

## 14.2 PRECAUTIONS AFTER COMPLETION OF WORK

To prevent mud, water, or the undercarriage from freezing and making it impossible for the machine to move on the following morning, always observe the following precautions.

- Mud and water on the machine body should be completely removed. This is to prevent damage to the seal caused by mud or dirt getting inside the seal with frozen drops of water.
- Park the machine on hard, dry ground. If this is impossible, park the machine on wooden boards. The boards help protect the tracks from being frozen in soil and the machine can start next morning.
- Open the drain valve and drain any water collected in the fuel system to prevent it from freezing.
- After operation in water or mud, remove water from undercarriage as described below, to extend undercarriage service life.

**⚠ WARNING**

**Performing idle-running of tracks is potentially dangerous so stay well away from tracks at this time.**

1. Swing by 90° with engine at low idle and bring work equipment beside track.
  2. Slightly float track by slowly pushing the ground and cause track to idle-run. Perform this for the opposite track, too.
- As the battery capacity drops markedly in low temperatures, cover the battery or remove it from the machine, keep it in a warm place, and install it again the next morning.
  - If electrolyte level is found low, add distilled water in the morning before beginning work. Do not add the water after the day's work so as to prevent fluid in the battery from freezing in the night.

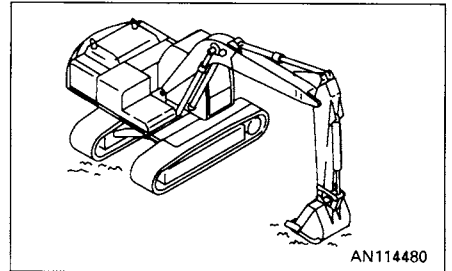

## 14.3 AFTER COLD WEATHER

When season changes and the weather becomes warmer, do as follows.

- Replace the fuel and oil for all parts with oil of the viscosity specified.

### NOTICE

**For details, see "20. USE OF FUEL, COOLANT AND LUBRICANTS ACCORDING TO AMBIENT TEMPERATURE".**

- If for any reason permanent antifreeze cannot be used, and an ethyl glycol base antifreeze (winter, one season type) is used instead, or if no antifreeze is used, drain the cooling system completely, then clean out the inside of the cooling system thoroughly, and fill with fresh water.

# 15. LONG-TERM STORAGE

---

## 15.1 BEFORE STORAGE

### NOTICE

To protect the cylinder rod when the machine is not being used, set the work equipment in the posture shown in the diagram. (This prevents rusting of the cylinder rod)

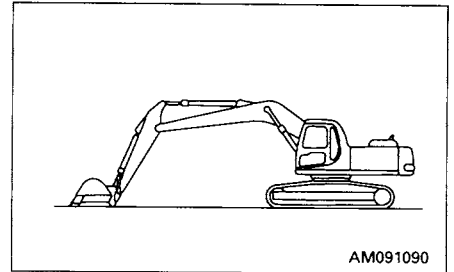

When putting the machine in storage for a long time, do as follows.

- Wash and clean each part, then store the machine indoors. If you must keep the machine outdoors, place it on a level place where it will not be subjects to floods and other natural disasters, and keep it covered.
- Completely fill the fuel tank, lubricate and change the oil before storage.
- Apply a thin coat of grease to metal surface of the hydraulic piston rods.
- Disconnect the negative terminals of the battery and cover it, or remove it from the machine and store it separately.
- If the ambient temperature is expected to drop below 0°C, always add antifreeze to the cooling water.
- Lock each control lever and pedal with the lock lever and pedal lock.
- Set the stop valve to the “lock” position on machines ready for attachments. Install the blind plugs to the elbows.
- Set the selector valve to the “When not use” position on machines ready for attachments.

## 15.2 DURING STORAGE

 **WARNING**

**If it is unavoidably necessary to carry out the rustpreventive operation while the machine is indoors, open the doors and windows to improve ventilation and prevent gas poisoning.**

Operate the engine and move the machine for a short distance once a month so that a new film of oil will be coated over movable parts and component surfaces. At the same time, also charge the battery.

Also carry out cooler operation in the case of machines equipped with an air conditioner.

## 15.3 AFTER STORAGE

### NOTICE

**If the machine is stored without carrying out the monthly rust prevention operation, request your Komatsu distributor for service.**

Carry out the following procedure when taking the machine out of long-term storage.

- Wipe off the grease from the hydraulic cylinder rods.
- Add oil and grease to all places.

## 15.4 STARTING MACHINE AFTER LONG-TERM STORAGE

When starting the machine after a long-term storage, first cancel the automatic warming-up function as follows.

1. Turn the starting switch key to the ON position.
2. Turn the fuel control dial from the low idling (MIN) position to the full (MAX) position, hold it there for 3 seconds, then return it to the low idling (MIN) position and start the engine.

## 16. TROUBLESHOOTING

### 16.1 PHENOMENA THAT ARE NOT FAILURES

Note that the following phenomena are not failures:

1. When the arm is pulled in, the speed of movement will drop momentarily when the arm is more or less vertical.
2. The arm speed will drop momentarily when the bucket teeth are more or less horizontal.
3. When starting or stopping the swing, noise will be emitted from the brake valve.
4. When going down a steep slope at low speed, a noise will be emitted from the travel motor.

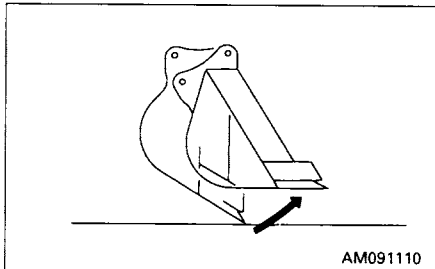
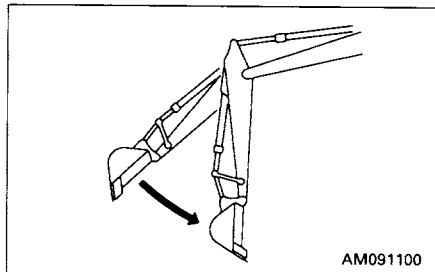

### 16.2 METHOD OF TOWING MACHINE

**⚠ WARNING**

When towing the machine, use a wire rope that has ample strength for the weight of the machine that is being towed.

If the machine sinks in mud and cannot get out under its own power, or if the drawbar pull of the excavator is being used to tow a heavy object, use a wire rope as shown in the diagram on the right. Place pieces of wood between wire ropes and body to prevent damage to ropes and body.

At this time, never use the hole for light-weight towing.

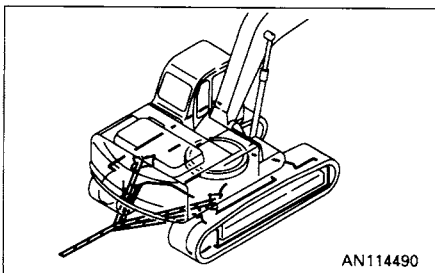

### 16.3 USING METHOD FOR LIGHT-WEIGHT TOWING HOLE

**⚠ WARNING**

- The shackle must always be used.
- Hold the rope level and direct it straight to the track frame.
- Move the machine slowly in the Lo mode.

The track frame has been opened with a hole to pass the shackle for towing light objects.

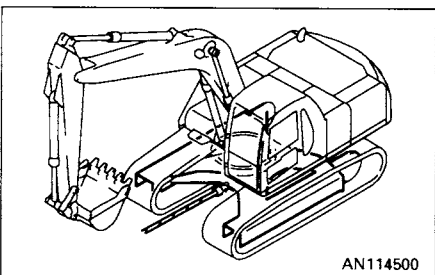

## 16.4 PRECAUTIONS ON PARTICULAR JOBSITES

1. When carrying out digging operations in water, if the work equipment mounting pin goes into the water, carry out greasing every time the operation is carried out.
2. For heavy-duty operations and deep digging, carry out greasing of the work equipment mounting pins every time before operation.

After greasing, operate the boom, arm and bucket several times, then grease again.

## 16.5 IF BATTERY IS DISCHARGED

### WARNING

- When checking or handling the battery, stop the engine and turn the starting switch key to the OFF position before starting.
- The battery generates hydrogen gas, so there is danger of explosion. Do not bring lighted cigarettes near the battery, or do anything that will cause sparks.
- Battery electrolyte is dilute sulphuric acid, and it will attack your clothes and skin. If it gets on your clothes or on your skin, wash it immediately off with large amounts of water. If it gets in your eyes, wash it out with fresh water, and consult a doctor.
- When handling battery, always wear protective goggles.
- When removing the battery, first disconnect the cable from the ground (normally, from the negative  $\ominus$  terminal). When installing, install the positive  $\oplus$  terminal first. If a tool touches the cable connecting the positive terminal and the chassis, there is danger that it will cause sparks.
- If the terminals are loose, there is danger that the defective contact may generate sparks that will cause an explosion. When installing the terminals, install them tightly.
- When removing or installing, check which is the positive  $\oplus$  terminal and negative  $\ominus$  terminal.

When removing, disconnect the cable from the ground terminal first

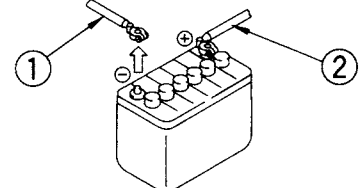

When installing, connect the cable to the positive  $\oplus$  terminal first.

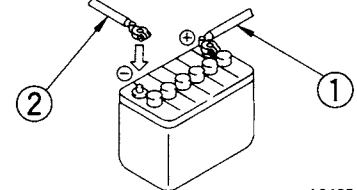

A0135160

### 16.5.1 REMOVAL AND INSTALLATION OF BATTERY

- When removing the battery, remove the cable from the ground side first (normally the negative  $\ominus$  terminal).  
If any tool contacts between the positive  $\oplus$  terminal and the chassis, a spark will be caused. This is dangerous.
- When installing, connect the ground cable last.
- Tightening torque for battery holder: 9.8 – 14.7 Nm (1.0 – 1.5 kgfm, 7.2 – 10.9 lbft)

### 16.5.2 STARTING ENGINE WITH BOOSTER CABLE

When starting the engine with a booster cable, do as follows:

#### Precautions when connecting and disconnecting booster cable

#### WARNING

- When connecting the cables, never contact the positive  $\oplus$  and negative  $\ominus$  terminals.
- When starting the engine with a booster cable, always wear safety glasses.
- Be careful not to let the normal machine and problem machine contact each other. This prevents sparks from generating near the battery which could ignite the hydrogen gas given off by the battery. If hydrogen gas explodes, it could cause serious injury.
- Make sure that there is no mistake in the booster cable connections. The final connection is to the revolving frame, but sparks will be generated when this is done, so connect to a place as far as possible from the battery. (However, avoid connecting the cable to the work equipment, as conduction is poor.)
- Use care when removing the cables from the machine that has been started. Do not allow the cable ends to contact each other or the machine, to avoid hydrogen explosion.

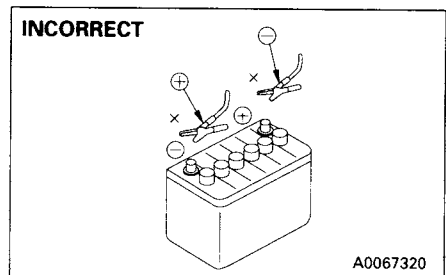

#### NOTICE

- The size of the booster cable and clip should be suitable for the battery size.
- The battery of the normal machine must be the same capacity as that of the engine to be started.
- Check the cables and clips for damage or corrosion.
- Make sure that the cables and clips are firmly connected.



**Connecting the booster cables**

Keep the starting switch at the OFF position.

Connect the booster cable as follows, in the order of the numbers marked in the diagram.

1. Make sure that the starting switches of the normal machine and problem machine are both at the OFF position.
2. Connect one clip of booster cable (A) to the positive (+) terminal of the problem machine.
3. Connect the other clip of booster cable (A) to the positive (+) terminal of the normal machine.
4. Connect one clip of booster cable (B) to the negative (-) terminal of the normal machine.
5. Connect the other clip of booster cable (B) to the engine block of the problem machine.

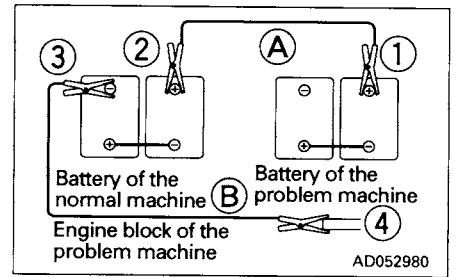

**Starting the engine**

1. Make sure the clips are firmly connected to the battery terminals.
2. Start the engine of the normal machine and keep it to run at high idling speed.
3. Turn the starting switch of the problem machine to the START position and start the engine. If the engine doesn't start at first, try again after 2 minutes or so.

**Disconnecting the booster cables**

After the engine has started, disconnect the booster cables in the reverse of the order in which they were connected.

1. Remove one clip of booster cable (B) from the engine block of the problem machine.
2. Remove the other clip of booster cable (B) from the negative  $\ominus$  terminal of the normal machine.
3. Remove one clip of booster cable (A) from the positive  $\oplus$  terminal of the normal machine.
4. Remove the other clip of booster cable (A) from the positive  $\oplus$  terminal of the problem machine.

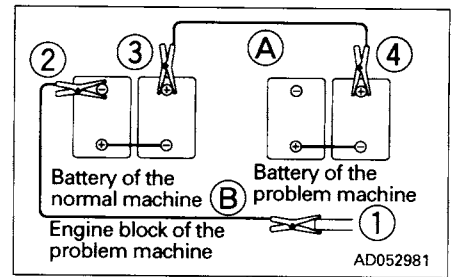

## 16.6 OTHER TROUBLE

### 16.6.1 ELECTRICAL SYSTEM

- ( ): Always contact your Komatsu distributor when dealing with these items.
- In cases of abnormalities or causes which are not listed below, please contact your Komatsu distributor for repairs.

Problem	Main causes	Remedy
Lamp does not glow brightly even when the engine runs at high speed	<ul style="list-style-type: none"> <li>● Defective wiring</li> <li>● Defective adjustment of alternator belt tension</li> </ul>	(● Check, repair loose terminals, disconnections)
Lamp flickers while engine is running		<ul style="list-style-type: none"> <li>● Check, repair alternator belt tension</li> </ul> For details, see EVERY 1000 HOURS SERVICE
Charge level monitor does not go out even when engine is running	<ul style="list-style-type: none"> <li>● Defective alternator</li> <li>● Defective wiring</li> </ul>	<ul style="list-style-type: none"> <li>(● Replace)</li> <li>(● Check, repair)</li> </ul>
Abnormal noise is generated from alternator	<ul style="list-style-type: none"> <li>● Defective alternator</li> </ul>	(● Replace)
Starting motor does not turn when starting switch is turned to ON	<ul style="list-style-type: none"> <li>● Defective wiring</li> <li>● Insufficient battery charge</li> </ul>	<ul style="list-style-type: none"> <li>(● Check, repair)</li> <li>● Charge</li> </ul>
Pinion of starting motor keeps going in and out	<ul style="list-style-type: none"> <li>● Insufficient battery charge</li> </ul>	● Charge
Starting motor turns engine sluggishly	<ul style="list-style-type: none"> <li>● Insufficient battery charge</li> <li>● Defective starting motor</li> </ul>	<ul style="list-style-type: none"> <li>● Charge</li> <li>(● Replace)</li> </ul>
Starting motor disengages before engine starts	<ul style="list-style-type: none"> <li>● Defective wiring</li> <li>● Insufficient battery charge</li> </ul>	<ul style="list-style-type: none"> <li>(● Check, repair)</li> <li>● Charge</li> </ul>
Pre-heating monitor does not light	<ul style="list-style-type: none"> <li>● Defective wiring</li> <li>● Defective heater relay</li> <li>● Defective monitor</li> </ul>	<ul style="list-style-type: none"> <li>(● Check, repair)</li> <li>(● Replace)</li> <li>(● Replace)</li> </ul>
Oil pressure monitor does not light up when engine is stopped (starting switch at ON position)	<ul style="list-style-type: none"> <li>● Defective monitor</li> <li>● Defective caution lamp switch</li> </ul>	<ul style="list-style-type: none"> <li>(● Replace)</li> <li>(● Replace)</li> </ul>
Outside of electrical heater is not warm when touched by hand	<ul style="list-style-type: none"> <li>● Defective wiring</li> <li>● Disconnection in electric heater</li> <li>● Defective operation of heater relay switch</li> </ul>	<ul style="list-style-type: none"> <li>(● Check, repair)</li> <li>(● Replace)</li> <li>(● Replace)</li> </ul>

**16.6.2 CHASSIS**

- ( ): Always contact your Komatsu distributor when dealing with these items.
- In cases of abnormalities or causes which are not listed below, please contact your Komatsu distributor for repairs.

<b>Problem</b>	<b>Main causes</b>	<b>Remedy</b>
Speed of travel, swing, boom, arm, bucket is slow	<ul style="list-style-type: none"> <li>● Lack of hydraulic oil</li> </ul>	<ul style="list-style-type: none"> <li>● Add oil to specified level, see CHECK BEFORE STARTING</li> </ul>
Pump generates abnormal noise	<ul style="list-style-type: none"> <li>● Clogged element in hydraulic tank strainer</li> </ul>	<ul style="list-style-type: none"> <li>● Clean, see EVERY 2000 HOURS SERVICE</li> </ul>
Excessive rise in hydraulic oil temperature	<ul style="list-style-type: none"> <li>● Loose fan belt</li> <li>● Dirty oil cooler</li> <li>● Lack of hydraulic oil</li> </ul>	<ul style="list-style-type: none"> <li>● Adjust fan belt tension, see EVERY 250 HOURS SERVICE</li> <li>● Clean, see EVERY 500 HOURS SERVICE</li> <li>● Add oil to specified level, see CHECK BEFORE STARTING</li> </ul>
Track comes off	<ul style="list-style-type: none"> <li>● Track too loose</li> </ul>	<ul style="list-style-type: none"> <li>● Adjust track tension, see WHEN REQUIRED</li> </ul>
Abnormal wear of sprocket		
Bucket rises slowly, does not rise	<ul style="list-style-type: none"> <li>● Lack of hydraulic oil</li> </ul>	<ul style="list-style-type: none"> <li>● Add oil to specified level, see CHECK BEFORE STARTING</li> </ul>

**16.6.3 ENGINE**

- ( ): Always contact your Komatsu distributor when dealing with these items.
- In cases of abnormalities or causes which are not listed below, please contact your Komatsu distributor for repairs.

Problem	Main causes	Remedy
Engine oil pressure monitor lights up	<ul style="list-style-type: none"> <li>● Engine oil pan oil level is low (sucking in air)</li> <li>● Clogged oil filter cartridge</li> <li>● Defective tightening of oil pipe joint, oil leakage from damaged part</li> <li>● Defective engine oil pressure sensor</li> </ul>	<ul style="list-style-type: none"> <li>● Add oil to specified level, see CHECK BEFORE STARTING</li> <li>● Replace cartridge, see EVERY 250 HOURS SERVICE</li> <li>(● Check, repair)</li> <li>(● Replace sensor)</li> </ul>
Steam is emitted from top part of radiator (pressure valve)	<ul style="list-style-type: none"> <li>● Cooling water level low, water leakage</li> <li>● Loosen fan belt</li> <li>● Dirt or scale accumulated in cooling system</li> </ul>	<ul style="list-style-type: none"> <li>● Add cooling water, repair, see CHECK BEFORE STARTING</li> <li>● Adjust fan belt tension, see EVERY 250 HOURS SERVICE</li> <li>● Change cooling water, clean inside of cooling system, see WHEN REQUIRED</li> </ul>
Radiator water level monitor lights up	<ul style="list-style-type: none"> <li>● Clogged radiator fin or damaged fin</li> <li>● Defective thermostat</li> <li>● Loose radiator filler cap (high altitude operation)</li> <li>● Defective water level sensor</li> </ul>	<ul style="list-style-type: none"> <li>● Clean or repair, see EVERY 500 HOURS SERVICE</li> <li>(● Replace thermostat)</li> <li>● Tighten cap or replace packing</li> <li>(● Replace sensor)</li> </ul>
Engine does not start when starting motor is turned	<ul style="list-style-type: none"> <li>● Lack of fuel</li> <li>● Air in fuel system</li> <li>● Defective fuel injection pump or nozzle</li> <li>● Starting motor cranks engine sluggishly</li> <li>● Preheating monitor does not light up</li> <li>● Defective compression                             <ul style="list-style-type: none"> <li>○ Defective valve clearance</li> </ul> </li> </ul>	<ul style="list-style-type: none"> <li>● Add fuel, see CHECK BEFORE STARTING</li> <li>● Repair place where air is sucked in, see EVERY 500 HOURS SERVICE</li> <li>(● Replace pump or nozzle)</li> <li>— See ELECTRICAL SYSTEM</li> <li>(○ Adjust valve clearance)</li> </ul>

**ENGINE (cont'd) (16.6.3)**

<b>Problem</b>	<b>Main causes</b>	<b>Remedy</b>
Exhaust gas is white or blue	<ul style="list-style-type: none"> <li>● Too much oil in oil pan</li> <li>● Improper fuel</li> </ul>	<ul style="list-style-type: none"> <li>● Add oil to specified level, see CHECK BEFORE STARTING</li> <li>● Change to specified fuel</li> </ul>
Exhaust gas occasionally turns black	<ul style="list-style-type: none"> <li>● Clogged air cleaner element</li> <li>● Defective nozzle</li> <li>● Defective compression</li> <li>● Defective turbocharger</li> </ul>	<ul style="list-style-type: none"> <li>● Clean or replace, see WHEN REQUIRED</li> <li>(● Replace nozzle)</li> <li>(● See defective compression above)</li> <li>● Clean or replace turbocharger</li> </ul>
Combustion noise occasionally makes breathing sound	<ul style="list-style-type: none"> <li>● Defective nozzle</li> </ul>	<ul style="list-style-type: none"> <li>(● Replace nozzle)</li> </ul>
Abnormal noise generated (combustion or mechanical)	<ul style="list-style-type: none"> <li>● Low grade fuel being used</li> <li>● Overheating</li> <li>● Damage inside muffler</li> <li>● Excessive valve clearance</li> </ul>	<ul style="list-style-type: none"> <li>● Change to specified fuel</li> <li>● Refer to "Radiator water level monitor lights up" as above</li> <li>(● Replace muffler)</li> <li>(● Adjust valve clearance)</li> </ul>

**16.6.4 ELECTRONIC CONTROL SYSTEM**

If an error code appears on the machine monitor display (normally displays TIME), follow the countermeasure table as shown below in the self-diagnosis.

**Machine monitor trouble display**

Monitor display	Error mode	Countermeasure
E02	PC-EPC valve system error	If the pump override switch is set to the ON position, operation can be carried out. However, immediately have the TVC valve system inspected by your Komatsu distributor. (※)
E03	Swing brake system error	Turn the swing prolix switch ON to cancel the brake. When applying the swing brake, operate the swing lock switch manually. Depending on the cause of the failure, it may be impossible to release the brake. In any case, have the system inspected immediately by your Komatsu distributor. (※)
E05	Governor system error	Governor will not execute the control function. Manually operate the governor-lever. To fix the governor lever at the full stroke position, use the retaining bolt holes on bracket. In this case, immediately have the governor system inspected by your Komatsu distributor.
CALL	Error indicating that operation cannot be continued	Place the machine in a safe posture, then have it inspected immediately by your Komatsu distributor.
In the case where the monitor will not display error codes and work equipment operation and swing operation cannot be carried out.		Have the machine inspected immediately by your Komatsu distributor.

(※) For detail of operating the pump override switch and the swing override switch, refer to "11.2 SWITCHES".

# **MAINTENANCE**



## **17. GUIDES TO MAINTENANCE**

---

Do not carry out any inspection and maintenance operation that is not given in this manual. Perform maintenance work on hard, flat ground.

**Check service meter:**

Check the service meter reading every day to see if the time has come for any necessary maintenance to be carried out.

**Komatsu genuine replacement parts:**

Use Komatsu genuine parts specified in the Parts Book as replacement parts.

**Komatsu genuine oils:**

Use Komatsu genuine oils and grease. Choose oils and grease with proper viscosities specified for ambient temperature.

**Always use clean washer fluid:**

Use automobile window washer fluid and be careful not to let any dirt get into it.

**Always use clean oil and grease:**

Use clean oil and grease. Also, keep containers of the oil and grease clean. Keep foreign materials away from oil and grease.

**Keeping the machine clean:**

Always keep the machine clean. This makes it easier to find parts causing problems. Keep in particular grease fittings, breathers and oil level gauges clean and avoid foreign matters from getting in them.

**Be careful of hot water and oil:**

Draining hot oils and coolants and removing their filters immediately after the engine stops are hazardous. Allow the engine to cool.

If the oil has to be drained when it is cold, warm up the oil to a suitable temperature (approx. 20 – 40°C) before draining it.

**Checking foreign materials in drained oil and on filter:**

After oil is changed or filters are replaced, check the oil and filters for metallic particles and foreign materials. If large quantities of metallic particles or foreign materials are found, consult your Komatsu distributor.

**Fuel strainer:**

If your machine is equipped with a fuel strainer, do not remove it while fueling.

**Oil change:**

Check or change oils in the places where dust is scarce to keep foreign materials away from oils.

**Warning tag:**

Attach the warning tag to the starting switch or other appropriate control lever to avoid someone who is not aware of the circumstances from starting the engine.

**Obey precautions:**

During the operation, always obey the precautions on the safety label attached to the machine.

**Welding instructions:**

- Turn off the engine starting switch.
- Do not apply more than 200 V continuously.
- Connect grounding the cable within 1 m from the area to be welded.
- Avoid seals or bearings from being between the area to be welded and the position of grounding point.
- Do not use the area around the work equipment pins or the hydraulic cylinders as the grounding point.

**Fire prevention:**

Use nonflammable cleaner or light oil for cleaning parts. Keep flame or cigarette light away from light oil.

**Clamp faces:**

When O-rings or gaskets are removed, clean the clamp faces and replace the O-rings and gaskets with new ones. Be sure to fit O-rings and gaskets when assembling.

**Objects in your pockets:**

Keep your pockets free of loose objects which can fall out and drop into the machinery; especially when you work on the machinery while bending over it.

**Checking undercarriage:**

When working in rocky areas, check for damage to the undercarriage and for looseness, flaws, wear and damage in bolts and nuts. Loosen the track tension a little when working in such areas.

**Precautions when washing machine:**

- Never spray steam or water directly on the connectors and mechatronics parts.
- Do not allow water to get on the monitors and controllers inside the operator's cab.
- Never spray water at high pressure directly at the radiator or oil cooler when washing the machine.

**Pre-and post-work checks:**

Before starting work in mud, rain, snow or at seashore, check plugs and valves for tightness.

Wash the machine immediately after the work to protect components from rusting.

Lubricate components more frequently than usual. Be sure to lubricate work equipment pins daily if they are submerged in water.

**Dusty worksites:**

When working at dusty worksites, do as follows:

- Inspect the air cleaner clogging monitor to see whether the air cleaner is blocked up.
- Clean the radiator core frequently to avoid clogging.
- Clean and replace the fuel filter frequently.
- Clean electrical components, especially the starting motor and alternator, to avoid accumulation of dust.

**Avoid mixing oils:**

Never mix oils of different brands. If you have only oil which is a different brand from the one that is used in the machine, do not add it but replace all the oil.

## 18. OUTLINES OF SERVICE

---

- Use Komatsu genuine parts for replacement.
- When changing or adding oil, do not use a different type of oil.
- Unless otherwise specified, the oil and coolant used at the time of shipment from the factory are as shown in the table below.

Item	Kind of fluid
Engine oil pan	SAE 15W-40 API classification CD
Swing machinery case Final drive case Damper case	SAE 30 API classification CD
Hydraulic tank	SAE 10W API classification CD
Fuel tank	ASTM D975 No. 2 (However, ASTM D975 No. 1 is used for the winter season (October to March))
Radiator	Komatsu Super Coolant (AF-ACL) 41% added to water

### 18.1 OUTLINE OF OIL, FUEL, COOLANT

#### 18.1.1 OIL

- Oil is used in the engine and work equipment under extremely severe conditions (high temperature, high pressure), and it deteriorates with use.  
Always use oil that matches the grade and temperature for use given in the Operation and Maintenance Manual. Even if the oil is not dirty, always replace the oil after the specified interval.
- Oil corresponds to blood in the human body, so always be careful when handling it to prevent any impurities (water, metal particles, dirt, etc.) from getting in.  
The majority of problems with machine are caused by the entry of such impurities.  
Take particular care not to let any impurities get in when storing or adding oil.
- Never mix oils of different grades or brands.
- Always add the specified amount of oil.  
Having too much oil or too little oil are both causes of problems.
- If the oil in the work equipment is not clear, there is probably water or air getting into the circuit.  
In such cases, please contact your Komatsu distributor.
- When changing the oil, always replace the related filters at the same time.
- We recommend you to have an analysis made of the oil periodically to check the condition of the machine. For those who wish to use this service, please contact your Komatsu distributor.

### 18.1.2 FUEL

- The fuel pump is a precision instrument, and if fuel containing water or dirt is used, it cannot work properly.
- Be extremely careful not to let impurities get in when storing or adding fuel.
- Always use the fuel specified in the Operation and Maintenance Manual.  
Fuel may congeal depending on the temperature when it is used (particularly in low temperature below-15°C), so it is necessary to change to a fuel that matches the temperature.
- To prevent the moisture in the air from condensing and forming water inside the fuel tank, always fill the fuel tank after completing the day's work.
- Before starting the engine, or when 10 minutes have passed after adding fuel, drain the sediment and water from the fuel tank.
- If the engine runs out of fuel, or if the filters have been replaced, it is necessary to bleed the air from the circuit.

### 18.1.3 COOLANT

- River water contains large amounts of calcium and other impurities, so if it is used, scale will stick to the engine and radiator, and this will cause defective heat exchange and overheating.  
Do not use water that is not suitable for drinking.
- When using anti-freeze, always observe the precautions given in the Operation and Maintenance Manual.
- Komatsu machines are supplied with Komatsu original anti-freeze in the coolant when the machine is shipped.  
This anti-freeze is effective in preventing corrosion of the cooling system.  
The anti-freeze can be used continuously for two years or 4000 hours. Therefore, it can be used as it is even in hot areas.
- Anti-freeze is inflammable, so be extremely careful not to expose it to flame or fire.
- The proportion of anti-freeze to water differs according to the ambient temperature.  
For details of the mixing proportions, see 24.2.2 CLEAN INSIDE OF COOLING SYSTEM.
- If the engine overheats, wait for the engine to cool before adding coolant.
- If the coolant level is low, it will cause overheating and will also cause problems with corrosion from the air in the coolant.

**18.1.4 GREASE**

- Grease is used to prevent twisting and noise at the joints.
- The nipples not included in the maintenance section are nipples for overhaul, so they do not need grease.  
If any part becomes stiff after being used for long time, add grease.
- Always wipe off all of the old grease that is pushed out when greasing. Be particularly careful to wipe off the old grease in places. Where sand or dirt sticking in the grease would cause wear of the rotating parts.

**18.1.5 STORING OIL AND FUEL**

- Keep indoors to prevent any water, dirt, or other impurities from getting in.
- When keeping drum cans for a long period, put the drum on its side so that the filler port of the drum can is at the side. (To prevent moisture from being sucked in)  
If drum cans have to be stored outside, cover them with a waterproof sheet or take other measures to protect them.
- To prevent any change in quality during long-term storage, be sure to use in the order of first in - first out (use the oldest oil or fuel first).

**18.1.6 FILTERS**

- Filters are extremely important safety parts. They prevent impurities in the fuel and air circuits from entering important equipment and causing problems.  
Replace all filters periodically. For details, see the Operation and Maintenance Manual.  
However, when working in severe conditions, it is necessary to consider replacing the filters at shorter intervals according to the oil and fuel (sulfur content) being used.
- Never try to clean the filters (cartridge type) and use them again. Always replace with new filters.
- When replacing oil filters, check if any metal particles are stuck to the old filter. If any metal particles are found, please contact your Komatsu distributor.
- Do not open packs of spare filters until just before they are to be used.
- Always use Komatsu genuine filters.

## 18.2 OUTLINE OF ELECTRIC SYSTEM

- If the wiring gets wet or the insulation is damaged, the electric system leaks and this could result in hazardous malfunction of the machine.
- Services relating to the electric system are (1) check of fan belt tension, (2) check of damage or wear in the fan belt and (3) check of battery fluid level.
- Never remove or disassemble any electric components installed in the machine.
- Never install any electric components other than these specified by Komatsu.
- Be careful to keep the electric system free of water when washing the machine or when it rains.
- Since the controller for the control system may cause malfunction due to external wave interference, before installing a radio receiver and a walkie-talkie or citizen band, consult your Komatsu distributor.
- When working on the seashore, carefully clean the electric system to prevent corrosion.
- When installing a car cooler or any other electrical equipment, connect it to an independent power source connector. The optional power source must never be connected to the fuse, starting switch, or battery relay.

### 18.3 OUTLINE OF HYDRAULIC SYSTEM

- During operation and immediately after operation is ended, the temperature of the hydraulic system still remains high.  
In addition, high hydraulic pressure is applied to the system. Take care when inspecting and maintaining the hydraulic system.
  - Stop the machine on level ground, lower the bucket to the ground, then set so that there is no pressure applied to the cylinder circuit.
  - Always stop the engine.
  - Immediately after operations, the hydraulic oil and lubricating oil are at high temperature and high pressure, so wait for the oil temperature to go down before starting maintenance.  
Even when the temperature goes down, the circuit may still be under internal pressure, so when loosening the plug or screw, or the hose joint, do not stand in front of the part. Loosen it slowly to release the internal pressure before removing it.
  - When carrying out inspection or maintenance of the hydraulic circuit, always bleed the air from the hydraulic tank to remove the internal pressure.
- Periodic maintenance includes the inspection of the hydraulic oil level, replacement of the filter and refilling of hydraulic oil.
- When the high pressure hose, etc. is removed, check the O-ring for damage. If necessary, replace it.
- After the hydraulic filter element and strainer are cleaned or replaced, or after the hydraulic system is repaired or replaced or the hydraulic piping is removed, bleed air from the hydraulic circuit.
- The accumulator is charged with high-pressure nitrogen gas. Incorrect handling may be dangerous. For the handling procedure, see "11.18 Handling accumulator".



## 19. WEAR PARTS LIST

Wear parts such as the filter element, bucket tooth, etc. are to be replaced at the time of periodic maintenance or before their abrasion limits.

The wear parts should be changed correctly in order to use the machine economically.

For part change, Komatsu genuine parts of excellent quality should be used.

When ordering parts, please check the part number in the parts book.

The parts in parentheses are to be replaced at the same time.

Item	Part No.	Part Name	Q'ty	Replacement frequency
Engine oil filter	6735-51-5140	Cartridge	1	Every 250 hours service
Hydraulic oil filter	20Y-60-21510 (07000-05180)	Element (O-ring)	1 (1)	Every 500 hours service
Fuel filter	6732-71-6111	Cartridge	1	Every 500 hours service
Additional fuel filter (option)	600-311-9121	Cartridge	1	Every 500 hours service
Hydraulic tank breather	20Y-60-21410	Element	1	Every 500 hours service
Air cleaner	600-181-6740	Double element	1	—
Additional filter for breaker	20Y-970-1820 (07000-12115)	Element (O-ring)	1 (1)	—
Electrical intake air heater	6732-11-4810	Gasket	2	—
Corrosion resistor (option)	600-411-1151	Cartridge (400 g)	1	When change the coolant
Corrosion resistor (option)	600-411-1191	Cartridge (200 g)	1	Every 1000 hours service

If optional oil filter cartridge, replace the cartridge at every 500 hours service.

Item	Part No.	Part Name	Q'ty	Replacement frequency
Engine oil filter	6736-51-5141	Cartridge	1	Every 500 hours service

Item	Part No.	Part Name	Q'ty	Replacement frequency
Bucket (PC200, 210)	205-70-74272 (205-70-74281) (205-70-74291)	Vertical pin type Tooth (Pin) (Lock)	5 (5) (5)	—
	205-70-19570 (09244-02496)	Horizontal pin type Tooth (Pin)	5 (5)	
	205-70-74180 205-70-74190 (176-32-11210) (01803-02430)	Cutter (left) Cutter (right) (Bolt) (Nut)	1 1 (8) (8)	
Bucket (PC220, 230)	206-70-54221 (207-70-34221) (205-70-74291)	Vertical pin type Tooth (Pin) (Lock)	4 (4) (4)	—
	206-70-48610 (09244-02516)	Horizontal pin type Tooth (Pin)	4 (4)	
	205-70-74180 205-70-74190 (176-32-11210) (01803-02430)	Cutter (left) Cutter (right) (Bolt) (Nut)	1 1 (8) (8)	

## 20. USE OF FUEL, COOLANT AND LUBRICANTS ACCORDING TO AMBIENT TEMPERATURE

### PROPER SELECTION OF FUEL, COOLANT AND LUBRICANTS

RESERVOIR	KIND OF FLUID	AMBIENT TEMPERATURE										CAPACITY	
		-40	-22	-4	14	32	50	68	86	104	122°F	Specified	Refill
		-40	-30	-20	-10	0	10	20	30	40	50°C		
Engine oil pan	Engine oil	SAE 15W-40										26.3 ℓ 6.95 US gal 5.79 UK gal	24.0 ℓ 6.34 US gal 5.28 UK gal
		SAE 10W-30											
		SAE 30W											
		SAE 10W											
		Synthetic SAE 5W-30											
Swing machinery case	Engine oil											5.5 ℓ 1.45 US gal 1.21 UK gal	5.5 ℓ 1.45 US gal 1.21 UK gal
Final drive case (each)		SAE 30										4.4 ℓ 1.16 US gal 0.97 UK gal	4.2 ℓ 1.11 US gal 0.92 UK gal
Damper case												0.75 ℓ 0.20 US gal 0.17 UK gal	—
Hydraulic system		SAE 10W										(PC200, 210) 239 ℓ 63.1 US gal 52.6 UK gal	166 ℓ 43.8 US gal 36.5 UK gal
	SAE 10W-30										(PC220, 230) 246 ℓ		
	SAE 15W-40										64.9 US gal 54.1 UK gal		
Fuel tank	Diesel fuel	ASTM D975 No.2										340 ℓ 89.8 US gal 74.8 UK gal	—
		※											
Cooling system	Water	Add antifreeze										(PC200, 210) 22.2 ℓ 5.87 US gal 4.88 UK gal	—
												(PC220, 230) 23.3 ℓ 6.16 US gal 5.13 UK gal	

※ ASTM D975 No.1

**REMARK**

- When fuel sulphur content is less than 0.5%, change oil in the oil pan every periodic maintenance hours described in this manual.  
Change oil according to the following table if fuel sulphur content is above 0.5%.

Fuel sulphur content	Change interval of oil in engine oil pan
0.5 to 1.0%	1/2 of regular interval
Above 1.0%	1/4 of regular interval

- When starting the engine in an atmospheric temperature of lower than 0°C, be sure to use engine oil of SAE10W, SAE10W-30 and SAE15W-40, even though an atmospheric temperature goes up to 10°C more or less in the day time.
- Use API classification CD, CE or CF-4 as engine oil and if API classification CC, reduce the engine oil change interval to half.
- If equipped with optional oil filter cartridge, use API classification CE, CF-4, CG, CH as engine oil.
- There is no problem if single grade oil is mixed with multigrade oil (SAE10W-30, 15W-40), but be sure to add single grade oil that matches the temperature in the table.
- We recommend Komatsu genuine oil which has been specifically formulated and approved for use in engine and hydraulic work equipment applications.

Specified capacity: Total amount of oil including oil for components and oil in piping.

Refill capacity: Amount of oil needed to refill system during normal inspection and maintenance.

ASTM: American Society of Testing and Material

SAE: Society of Automotive Engineers

API: American Petroleum Institute

20. USE OF FUEL, COOLANT AND LUBRICANTS ACCORDING TO AMBIENT TEMPERATURE

No.	Supplier	Engine Oil [CD, CE or CF-4] SAE10W, 30, 40 10W30, 15W40 (The 15W40 oil marked * is CE.)	Gear Oil [GL-4 or GL-5] SAE80, 90, 140	Grease [Lithium-Base] NLGI No. 2	Anti-freeze Coolant [Ethylene Glycol Base] Permanent Type
1	KOMATSU	EO10-CD EO30-CD EO10-30CD EO15-40CD	GO90 GO140	G2-LI G2-LI-S	AF-ACL AF-PTL AF-PT (Winter, one season type)
2	AGIP	Diesel sigma S Super dieselmulti- grade *Sigma turbo	Rotra MP	GR MU/EP	-
3	AMOCO	*Amoco 300	Multi-purpose gear oil	RYKON premium grease	-
4	ARCO	*Arcofleet S3 plus	Arco HD gear oil	Litholine HEP 2 Arco EP moly D	-
5	BP	Vanellus C3	Gear oil EP Hypogear EP	Energrease LS-EP2	Antifreeze
6	CALTEX	*RPM delo 400 RPM delo 450	Universal thuban Universal thuban EP	Marfak all purpose 2 Ultra-duty grease 2	AF engine coolant
7	CASTROL	*Turbomax *RX super CRD	EP EPX Hypoy Hypoy B Hypoy C	MS3 Spheerol EPL2	Anti-freeze
8	CHEVRON	*Delo 400	Universal gear	Ultra-duty grease 2	-
9	CONOCO	*Fleet motor oil	Universal gear lubricant	Super-sta grease	-
10	ELF	Multiperformance 3C Performance 3C	-	Tranself EP Tranself EP type 2	Glacelf
11	EXXON (ESSO)	Essolube D3 *Essolube XD-3 *Essolube XD-3 Extra *Esso heavy duty Exxon heavy duty	Gear oil GP Gear oil GX	Beacon EP2	All season coolant
12	GULF	Super duty motor oil *Super duty plus	Multi-purpose gear lubricant	Gulfcrown EP2 Gulfcrown EP special	Antifreeze and coolant
13	MOBIL	Delvac 1300 *Delvac super 10W-30, 15W-40	Mobilube GX Mobilube HD	Mobilux EP2 Mobilgrease 77 Mobilgrease special	-

20. USE OF FUEL, COOLANT AND LUBRICANTS ACCORDING TO AMBIENT TEMPERATURE

No.	Supplier	Engine Oil [CD, CE or CF-4] SAE10W, 30, 40 10W30, 15W40 (The 15W40 oil marked * is CE.)	Gear Oil [GL-4 or GL-5] SAE80, 90, 140	Grease [Lithium-Base] NLGI No. 2	Anti-freeze Coolant [Ethylene Glycol Base] Permanent Type
14	PENNZOIL	*Supreme duty fleet motor oil	Multi-purpose 4092 Multi-purpose 4140	Multi-purpose white grease 705 707L White – bearing grease	Anti-freeze and summer coolant
15	PETROFINA	FINA kappa TD	FINA potonic N FINA potonic NE	FINA marson EPL2	FINA tamidor
16	SHELL	Rimula X	Spirax EP Spirax heavy duty	Alvania EP grease	-
17	SUN	-	Sunoco GL5 gear oil	Sunoco ultra prestige 2EP Sun prestige 742	Sunoco antifreeze and summer coolant
18	TEXACO	*Ursa super plus Ursa premium	Multigear	Multifak EP2 Starplex 2	Code 2055 startex antifreeze coolant
19	TOTAL	Rubia S *Rubia X	Total EP Total transmission TM	Multis EP2	Antigel/antifreeze
20	UNION	*Guardol	MP gear lube LS	Unoba EP	-
21	VEEDOL	*Turbostar *Diesel star MDC	Multigear Multigear B Multigear C	-	Antifreeze

# 21. STANDARD TIGHTENING TORQUES FOR BOLTS AND NUTS

## 21.1 INTRODUCTION OF NECESSARY TOOLS

The following tools are needed when carrying out maintenance.

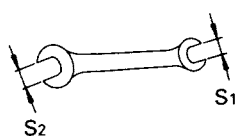
No.	Name of tool	Part No.	Remarks
1	Wrench	09002-01417 09002-03032	Applicable width across flats ( $S_1$ - $S_2$ ) 14mm - 17mm 30mm - 32mm  AD053370
2	Screwdriver	09033-00190	Interchangeable flat-head and cross-head type
3	Socket wrench set	20Y-98-21130	Applicable width across flats 12 mm, 14 mm, 17 mm, 19 mm, 22 mm, 24 mm, 30 mm Extension, Handle (large), Handle (small)
4	Hexagon wrench	09007-00836	Applicable width across flats 8 mm
5	Filter wrench	09019-08035	
6	Grease pump	07950-10450	For greasing work
7	Nozzle	07951-11400	
8	Grease cartridge	07950-90403	(Lithium base grease, 400 g)
9	Hammer	09039-00150	
10	Pinch bar	09055-10390	

If any of the above tools are broken, please order them from your Komatsu distributor.

## 21.2 TORQUE LIST

Unless otherwise specified, tighten the metric bolts and nuts to the torque shown in the table.

The tightening torque is determined by the width across the flats (b) of the nut and bolt.

If it is necessary to replace any nut or bolt, always use a Komatsu genuine part of the same size as the part that was replaced.

Nm (newton meter):  $1\text{Nm} \cong 0.1 \text{kgm}$   
 $\cong 0.74 \text{lbft}$

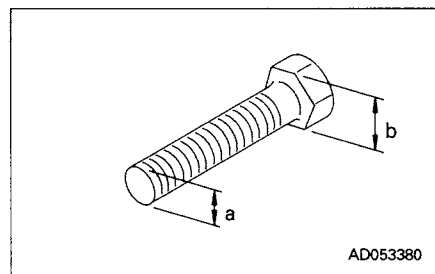

Thread diameter of bolt (mm) (a)	Width across flat (mm) (b)	AD054300		
		Nm	kgm	lbft
6	10	13.2 ± 1.4	1.35 ± 0.15	9.73 ± 1.03
8	13	31.4 ± 2.9	3.2 ± 0.3	23.2 ± 2.1
10	17	65.7 ± 6.8	6.7 ± 0.7	48.5 ± 5.0
12	19	112 ± 9.8	11.5 ± 1.0	82.6 ± 7.2
14	22	177 ± 19	18.0 ± 2.0	131 ± 14
16	24	279 ± 29	28.5 ± 3	206 ± 21
18	27	383 ± 39	39 ± 3	282 ± 29
20	30	549 ± 58	56 ± 6	405 ± 43
22	32	745 ± 78	76 ± 8	549 ± 58
24	36	927 ± 98	94.5 ± 10	684 ± 72
27	41	1320 ± 140	135 ± 15	973 ± 100
30	46	1720 ± 190	175 ± 20	1270 ± 140
33	50	2210 ± 240	225 ± 25	1630 ± 180
36	55	2750 ± 290	280 ± 30	2030 ± 210
39	60	3280 ± 340	335 ± 35	2420 ± 250

### NOTICE

When tightening panels or other parts having tightening fixtures made of plastic, be careful not to use excessive tightening torque: doing so will damage the plastic parts.



## **22. PERIODIC REPLACEMENT OF SAFETY CRITICAL PARTS**

To ensure safety at all times when operating or driving the machine, the user of the machine must always carry out periodic maintenance. In addition, to further improve safety, the user should also carry out periodic replacement of the parts given in the table. These parts are particularly closely connected to safety and fire prevention.

With these parts, the material changes as time passed, or they easily wear or deteriorate. However, it is difficult to judge the condition of the parts simply by periodic maintenance, so they should always be replaced after a fixed time has passed, regardless of their condition. This is necessary to ensure that they always maintain their function completely.

However, if these parts show any abnormality before the replacement interval has passed, they should be repaired or replaced immediately.

If the hose clamps show any deterioration, such as deformation or cracking, replace the clamps at the same as the hoses.

When replacing the hoses, always replace the O-rings, gaskets, and other such parts at the same time.

Ask your Komatsu distributor to replace the safety critical parts.

**SAFETY CRITICAL PARTS**

No.	Safety critical parts for periodic replacement	Q'ty	Replacement interval
1	Fuel hose (Fuel tank – Connector)	1	Every 2 years or 4000 hours, whichever comes sooner
2	Fuel hose (Connector – Fuel injection pump)	1	
3	Fuel return hose (Fuel injection pump – Fuel tank)	1	
4	Fuel return hose (Fuel filter – Connector)	1	
5	Fuel return hose (Connector – Fuel tank)	1	
6	Turbocharger lubricating oil hose	1	
7	Pump outlet hose (Pump – Control valve)	2	
8	Work equipment hose (Boom cylinder inlet)	4	
9	Work equipment hose (Bucket cylinder line – Boom foot section)	2	
10	Work equipment hose (Bucket cylinder inlet)	2	
11	Work equipment hose (Arm cylinder line – Boom foot section)	2	
12	Work equipment hose (Arm cylinder inlet)	2	
13	Additional attachment line hose (Boom foot section)	2	
14	Additional attachment line hose (Boom top section)	2	
15	Swing line hose (Swing motor inlet)	2	
16	Main suction hose	1	
17	Heater hose	2	
18	Water separator case, O-ring, plug	1	
19	Seat belt	1	Replace every 3 years

22. PERIODIC REPLACEMENT OF SAFETY CRITICAL PARTS

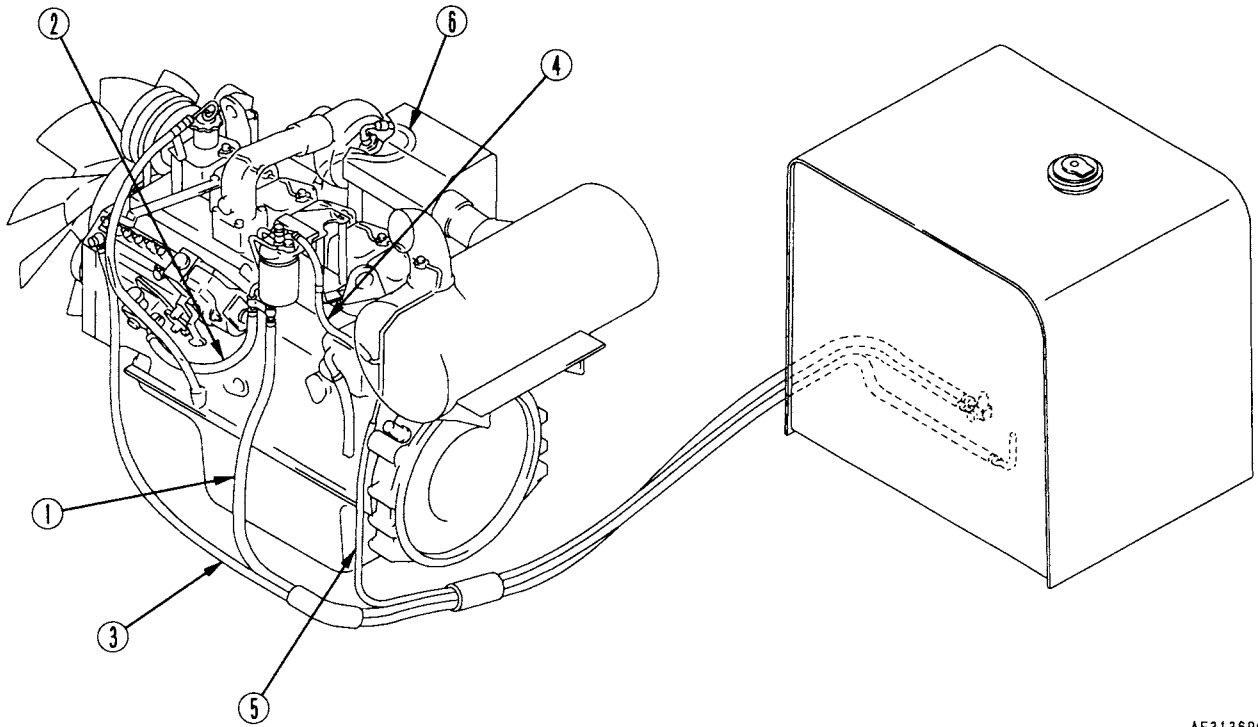

AE313690

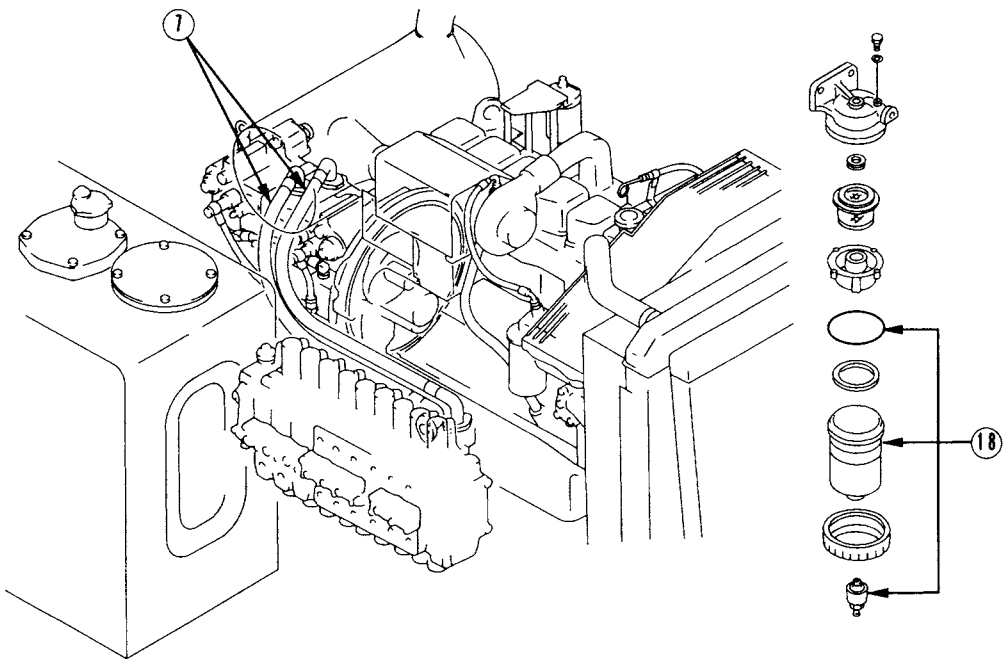

AW354640

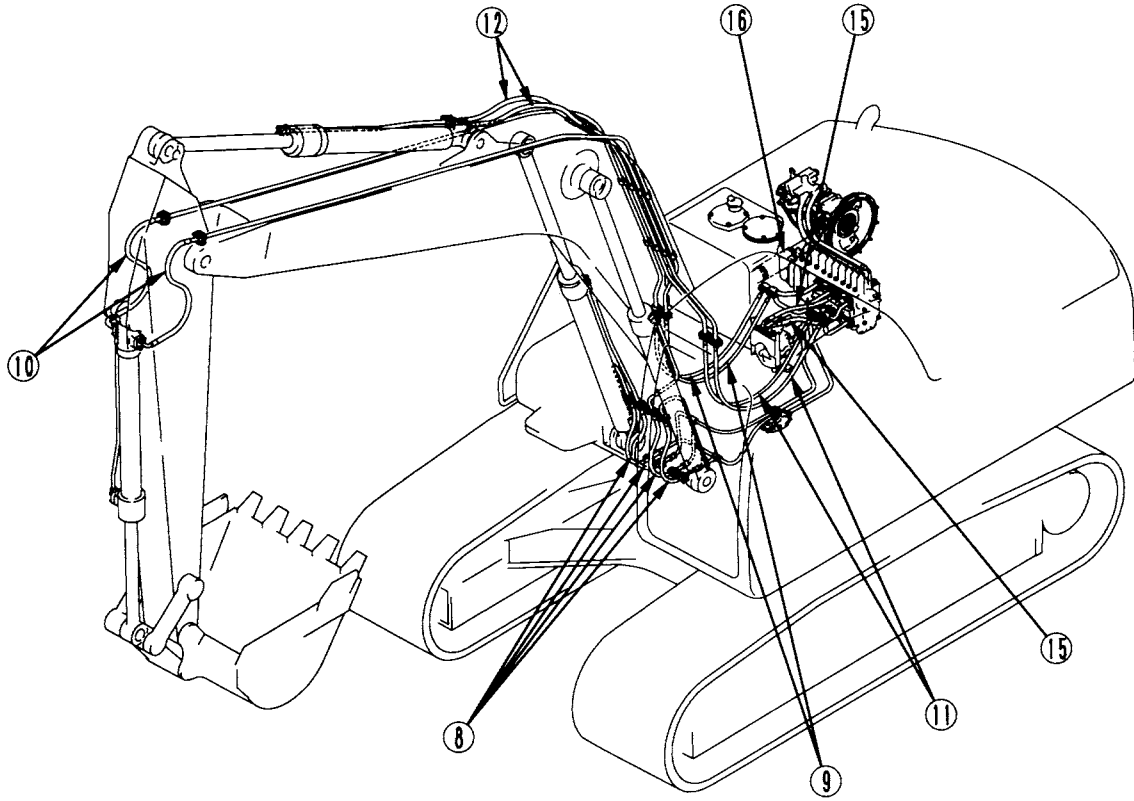

AE313710

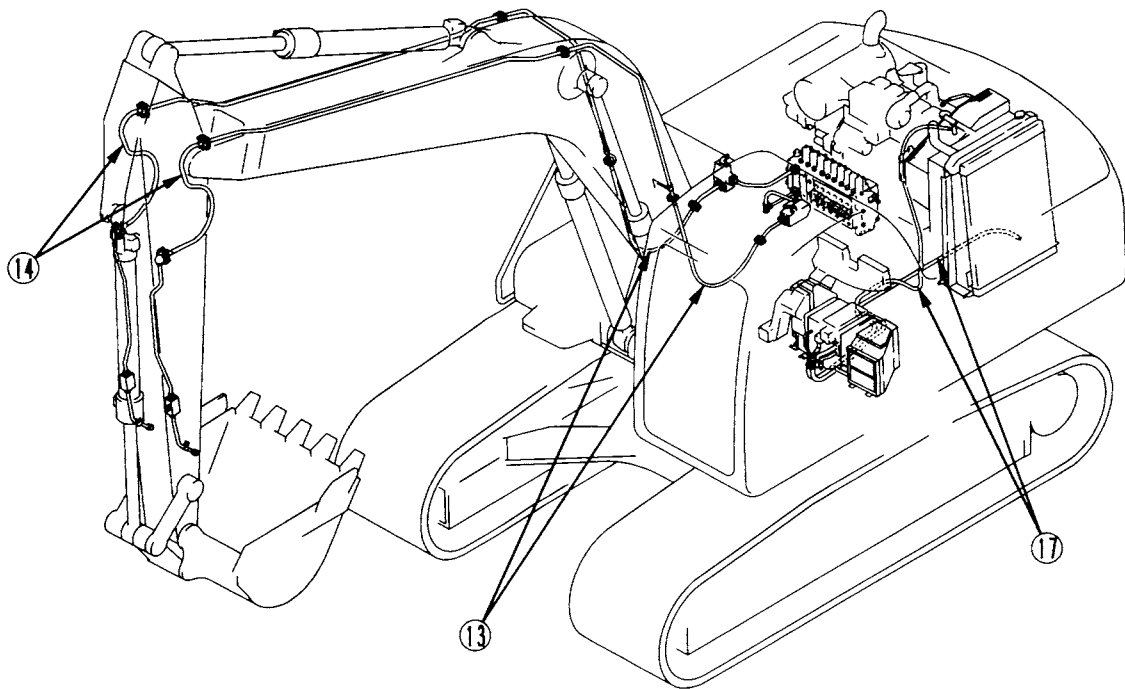

AE313720

## 23. MAINTENANCE SCHEDULE CHART

---

### 23.1 MAINTENANCE SCHEDULE CHART

SERVICE ITEM	PAGE
<b>INITIAL 250 HOURS SERVICE (only after the first 250 hours)</b>	
Replace fuel filter cartridge and additional fuel filter cartridge (option)	3-58
Check engine valve clearance, adjust	3-67
Change oil in engine oil pan, replace engine oil filter cartridge (only for machine equipped with optional filter cartridge)	3-54
<b>WHEN REQUIRED</b>	
Check, clean and replace air cleaner element	3-26
Clean inside of cooling system	3-28
Check and tighten track shoe bolts	3-32
Check and adjust track tension	3-33
Check electrical intake air heater	3-35
Replace bucket teeth (vertical pin type)	3-36
Replace bucket teeth (horizontal pin type)	3-39
Adjust bucket clearance	3-40
Check window washer fluid level, add fluid	3-41
Check and adjust air conditioner	3-42
Replace additional breaker filter element	3-43
<b>CHECK BEFORE STARTING</b>	
Check coolant level, add water	3-44
Check oil level in engine oil pan, add oil	3-44
Check fuel level, add fuel	3-45
Check oil level in hydraulic tank, add oil	3-46
Check air cleaner for clogging	3-47
Check electric wirings	3-47
Lubricate clamshell bucket (12 points)	3-48
Check for water and sediment in water separator, drain water (option)	3-48
<b>EVERY 100 HOURS SERVICE</b>	
Lubricating	3-49
● Boom cylinder foot pin (2 points)	3-49
● Boom foot pin (2 points)	3-49
● Boom cylinder rod end (2 points)	3-49

SERVICE ITEM	PAGE
Lubricating	3-49
● Arm cylinder foot pin (1 point)	3-49
● Boom-arm coupling pin (1 point)	3-50
● Arm cylinder rod end (1 point)	3-50
● Bucket cylinder foot pin (1 point)	3-50
● Arm-link coupling pin (1 point)	3-50
● Arm-bucket coupling pin (1 point)	3-50
● Link coupling pin (2 points)	3-50
● Bucket cylinder rod end (1 point)	3-50
● Bucket-link coupling pin (1 point)	3-50
Check oil level in swing machinery case, add oil	3-50
Drain water and sediment from fuel tank	3-51
<b>EVERY 250 HOURS SERVICE</b>	
Check oil level in final drive case, add oil	3-52
Check level of battery electrolyte	3-53
Change oil in engine oil pan, replace engine oil filter cartridge	3-54
Lubricate swing circle (2 points)	3-55
Check fan belt tension, adjust	3-56
Check air conditioner compressor belt tension, adjust	3-57
<b>EVERY 500 HOURS SERVICE</b>	
Replace fuel filter cartridge and additional fuel filter cartridge (option)	3-58
Check swing pinion grease level, add grease	3-59
Clean and inspect radiator fins, oil cooler fins and condenser fins (only for machines equipped with air conditioner)	3-60
Clean internal and external air filters of air conditioner system (only for machines equipped with air conditioner)	3-61
Replace hydraulic tank breather element	3-61
Replace hydraulic filter element	3-62
Change oil in engine oil pan, replace engine oil filter cartridge (only for machine equipped with optional filter cartridge)	3-54

## 23. MAINTENANCE SCHEDULE CHART

SERVICE ITEM	PAGE
<b>EVERY 1000 HOURS SERVICE</b>	
Change oil in swing machinery case	3-63
Check oil level in damper case, add oil	3-64
Check all tightening parts of turbocharger	3-64
Check play of turbocharger rotor	3-64
Check alternator belt tension and replacce alternator belt	3-65
Replace corrosion resistor cartridge	3-65
<b>EVERY 2000 HOURS SERVICE</b>	
Change oil in final drive case	3-66
Clean hydraulic tank strainer	3-67
Clean, check turbocharger	3-67
Check alternator, starting motor	3-67
Check engine valve clearance, adjust	3-67
Check vibration damper	3-68
<b>EVERY 4000 HOURS SERVICE</b>	
Check water pump	3-69
<b>EVERY 5000 HOURS SERVICE</b>	
Change oil in hydraulic tank	3-70

### 23.2 MAINTENANCE INTERVAL WHEN USING HYDRAULIC BREAKER

For machines equipped with a hydraulic breaker, the hydraulic oil deteriorates faster than for normal bucket digging operations, so set the maintenance intervals as follows.

- Replacing hydraulic element  
On new machines, replace the element after the first 100 to 150 hours, then carry out further replacement of the element according to the table on the right.
- Changing oil in hydraulic tank  
Change the oil according to the table on the right.
- Replacing additional filter element for breaker  
Use a guideline of 250 hours for use of the breaker (operating ratio for the breaker: 50 % or more), and replace the element according to the table on the right.

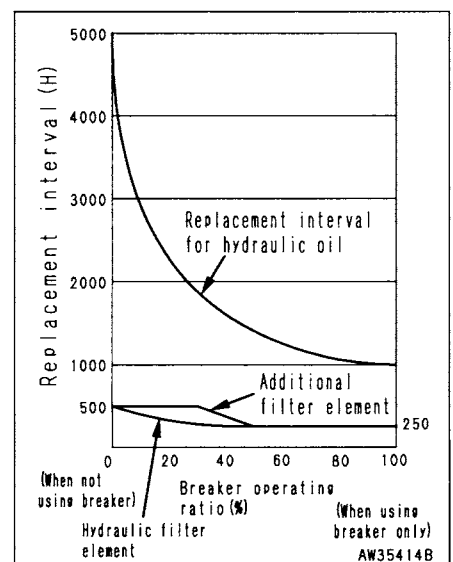

## **24. SERVICE PROCEDURE**

---

### **24.1 INITIAL 250 HOURS SERVICE**

Carry out the following maintenance only after the first 250 hours.

- **REPLACE FUEL FILTER CARTRIDGE AND ADDITIONAL FUEL FILTER CARTRIDGE (OPTION)**
- **CHECK ENGINE VALVE CLEARANCE, ADJUST**
- **CHANGE OIL IN ENGINE OIL PAN, REPLACE ENGINE OIL FILTER CARTRIDGE (ONLY FOR MACHINE EQUIPPED WITH OPTIONAL FILTER CARTRIDGE)**

For details of the method of replacing or maintaining, see the section on EVERY 500 HOURS and 2000 HOURS SERVICE.



## 24.2 WHEN REQUIRED

### 24.2.1 CHECK, CLEAN AND REPLACE AIR CLEANER ELEMENT

**⚠ WARNING**

- Never clean or replace the air cleaner element with the engine running.
- When using pressure air to clean the element wear safety glasses or goggles to protect the eyes.

#### Checking

If air cleaner clogging monitor ① flashes, clean the air cleaner element.

#### NOTICE

Do not clean the element before the air cleaner clogging monitor on the monitor panel flashes. If the element is cleaned frequently before the clogging monitor flashes, the air cleaner cannot display its full ability, and the cleaning efficiency will be lowered.

In addition, if the element is cleaned more frequently, the dust sticking to the element will drop into the inner element more frequently.

#### Cleaning or replacing outer element

1. Open the front door on the left side of the machine, remove wing nut ② and take out element ③.  
To prevent entry of dirt and dust, cover the air connector side of the rear end of the air cleaner with a clean cloth and adhesive tape.
2. Clean the air cleaner body interior and the cover.
3. Direct dry compressed air (less than 700 kPa (7 kg/cm<sup>2</sup>, 100 psi)) to element ③ from inside along its folds, then direct it from outside along its folds and again from inside.
  - 1) Remove one seal from the outer element whenever the outer element has been cleaned.
  - 2) Replace the outer element which has been cleaned 6 times repeatedly or used throughout a year. Replace the inner element at the same time.
  - 3) Replace both inner and outer elements when the monitor lamp ① flashes soon after installing the cleaned outer element even though it has not been cleaned 6 times.
  - 4) Check inner element mounting nuts for looseness and, if necessary, retighten.

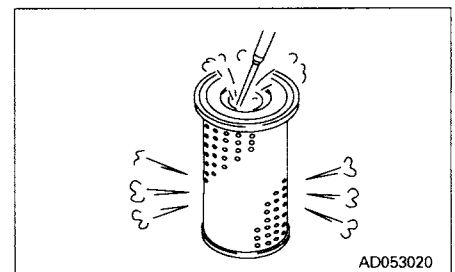
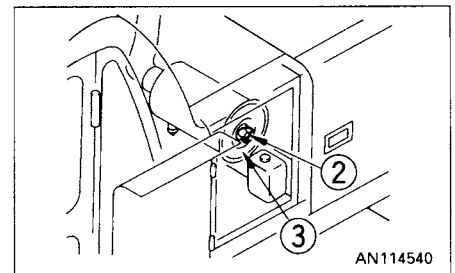
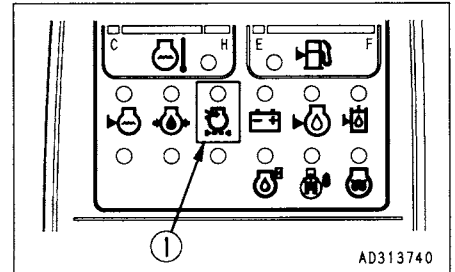

4. If small holes or thinner parts are found on the element when it is checked with an electric bulb after cleaning replace the element.

**NOTICE**

**Do not use an element whose folds or gasket or seal are damaged.**

**When cleaning the element, do not hit it or beat it against something.**

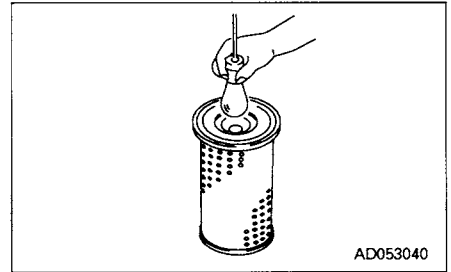

5. Remove the cloth and tape used for cover in Step 1.
6. Install the cleaned element and fix it with the wing nut.
7. Replace seal washer ④ or wing nut ② with new parts if they are broken.
8. Remove evacuator valve ⑤ and clean with compressed air. After cleaning, install it.

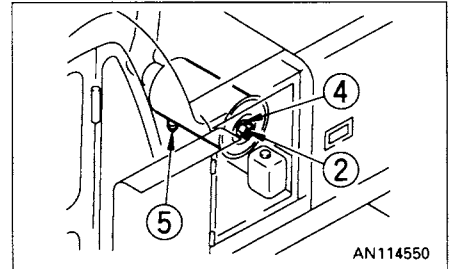
**Replacing inner element**

1. First remove the outer element, and then remove the inner element.
2. To prevent dust from getting in, use a clean cloth or tape to cover the air connector (outlet side).
3. Clean the air cleaner body interior, then remove the cover installed in Step 2.
4. Fit a new inner element to the connector and tighten it with nuts. Do not clean and reinstall a inner element.
5. Install the outer element and fix it with the wing nut.

**24.2.2 CLEAN INSIDE OF COOLING SYSTEM**

**⚠ WARNING**

- **Soon after the engine has been stopped, the coolant is hot and can cause personal injury. Allow the engine to cool before draining water.**
- **Since cleaning is performed while the engine is running, it is very dangerous to enter the rear side of the machine as the machine may suddenly start moving. If the under cover is left removed, it may interfere with the fan. While the engine is running, never enter the rear side of the machine.**
- **Never remove the radiator cap when the engine is at operating temperature. At operating temperature, the coolant is under pressure. Steam blowing up from the radiator could cause personal injury. Allow the engine to cool until the radiator filler cap is cool enough to touch with your hand. Remove the filler cap slowly to allow pressure to be relieved.**

- Clean the inside of the cooling system change the coolant and replace the corrosion resistor (option) according to the table below.

Kind of coolant	Cleaning inside of cooling system and changing coolant	Replacing corrosion resistor (option)
Permanent type antifreeze (All season type)	Every year (autumn) or every 2000 hours whichever comes first	Every 1000 hours and when cleaning the inside of the cooling system and when changing coolant
Non permanent type antifreeze containing ethylene glycol (Winter, one season type)	Every 6 months (spring, autumn) (Drain antifreeze in spring, add antifreeze in autumn)	
When not using antifreeze	Every 6 months or every 1000 hours whichever comes first	

- Stop the machine on level ground when cleaning or changing the coolant.
- Use a permanent type of antifreeze.  
If, for some reason, it is impossible to use permanent type antifreeze, use an antifreeze containing ethylene glycol.

- When deciding the ratio of antifreeze to water, check the lowest temperature in the past, and decide from the mixing rate table given below.

It is actually better to estimate a temperature about 10°C lower when deciding the mixing rate.

### Mixing rate of water and antifreeze

PC200, 210

Min. atmospheric temperature	°C	-5	-10	-15	-20	-25	-30
	°F	23	14	5	-4	-13	-22
Amount of antifreeze	ℓ	5.1	6.7	8.0	9.1	10.2	11.1
	US gal	1.35	1.77	2.11	2.40	2.69	2.93
	UK gal	1.12	1.47	1.76	2.00	2.24	2.44
Amount of water	ℓ	17.1	15.5	14.2	13.1	12.0	11.1
	US gal	4.52	4.10	3.75	3.96	3.17	2.93
	UK gal	3.76	3.41	3.12	2.88	2.64	2.44

PC220, 230

Min. atmospheric temperature	°C	-5	-10	-15	-20	-25	-30
	°F	23	14	5	-4	-13	-22
Amount of antifreeze	ℓ	5.4	7.0	8.4	9.6	10.7	11.65
	US gal	1.43	1.85	2.22	2.54	2.83	3.08
	UK gal	1.19	1.54	1.85	2.11	2.35	2.56
Amount of water	ℓ	17.9	16.3	14.9	13.7	12.6	11.65
	US gal	4.73	4.31	3.94	3.62	3.33	3.08
	UK gal	3.94	3.59	3.28	3.01	2.77	2.56

#### WARNING

**Antifreeze is flammable, so keep it away from any flame.**

- Use city water for the cooling water.  
If river water, well water or other such water supply must be used, contact your Komatsu distributor.
- We recommend use of an antifreeze density gauge to control the mixing proportions.

#### WARNING

**When removing drain plug, avoid pouring coolant on yourself.**

## 24. SERVICE PROCEDURE

- Prepare a container to catch drained coolant: Min 23.3 ℓ (6.16 US gal, 5.13 UK gal) capacity.

1. If a corrosion resistor cartridge is installed, close valves ①.
2. Turn radiator cap ② slowly to release the internal pressure.
3. Pushing radiator cap ②, turn it slowly to remove it.
4. Remove the undercover, then set a container to catch the coolant under drain valve ③ and drain plug ④. Open drain valve ③ at the bottom of the radiator to drain the water. Remove drain plug ④ in the cylinder block when draining the water.
5. After draining the water, close drain valve ③ and drain plug ④, and fill with city water.
6. Open drain valve ③ and drain plug ④, run the engine at low idling, and flush water through the system for 10 minutes.

When doing this, adjust the speed of filling and draining the water so that the radiator is always full.

While flushing water through the system, watch carefully that the water inlet hose does not come out of the radiator water filler.

7. After flushing, stop the engine, open drain valve ③ and drain plug ④, then close it again after all the water has drained out.
8. After draining the water, clean with a flushing agent.  
We recommend use of a Komatsu genuine cleaning agent. For details of the cleaning method, see the instructions given with the cleaning agent.
9. After cleaning, open drain valve ③ and drain plug ④ to drain all the cooling water, then close them and fill slowly with clean water.
10. When the water comes up to near the water filler port, open drain valve ③ and drain plug ④, run the engine at low idling, and continue to run water through the system until clean colorless water comes out.

When doing this, adjust the speed of filling and draining the water so that the radiator is always full.

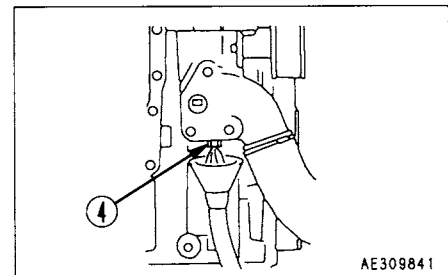
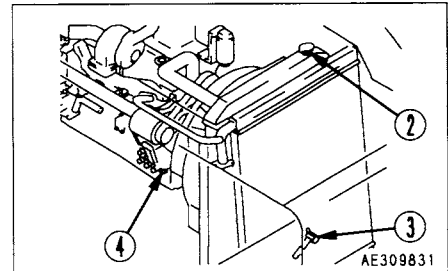
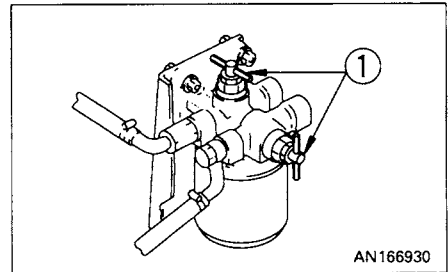

11. When the water is completely clean, stop the engine, close drain valve ③, wrap the drain plug with seal tape, then close drain plug ④.
12. Replace the corrosion resistor cartridge and open valves ①.  
For details of replacement of the corrosion resistor, see "24.7 EVERY 1000 HOURS SERVICE".
13. Install the undercover.
14. Add cooling water until it overflows from the water filler.
15. To remove the air in the cooling water, run for five minutes at low idling, then for another five minutes at high idling.  
When doing this, leave radiator cap ② off.
16. After draining off the cooling water of reserve tank ⑤, clean the inside of the reserve tank and refill the water between FULL and LOW level.
17. Stop the engine, wait for about three minutes, add cooling water up to near the radiator water filler port, then tighten cap ②.

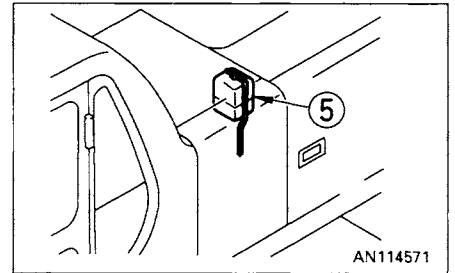

### 24.2.3 CHECK AND TIGHTEN TRACK SHOE BOLTS

If the machine is used with track shoe bolts ① loose, they will break, so tighten any loose bolts immediately.

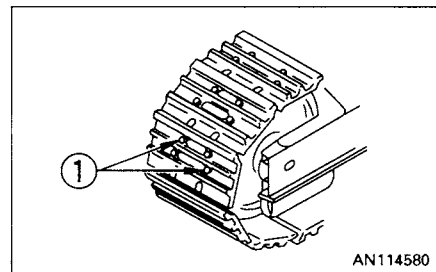

#### Method for tightening

- 1 First tighten to a tightening torque of  $490 \pm 50$  Nm ( $50 \pm 5$  kgm,  $360 \pm 36$  lbft) then check that the nut and shoe are in close contact with the link contact surface.
- 2 After checking, tighten a further  $120^\circ \pm 10^\circ$ .

#### Order for tightening

Tighten the bolts in the order shown in the diagram on the right. After tightening, check that the nut and shoe are in close contact with the link mating surface.

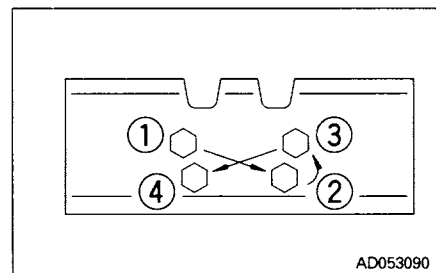

### 24.2.4 CHECK AND ADJUST TRACK TENSION

#### WARNING

Carry out this operation with two workers. The operator must move the machine in accordance with the signals from the other worker. The track tension is checked with the chassis raised, so it is extremely dangerous if the machine is lowered by mistake during the inspection. Never move the machine while anyone is carrying out measurements.

The wear of pins and bushings on the undercarriage will vary with the working conditions and soil properties. It is thus necessary to continually inspect the track tension so as to maintain the standard tension.

Carry out the check and adjustment under the same conditions as when operating (on jobsites where the track becomes clogged with mud, measure with the track clogged with mud).

#### Inspection

1. Raise the chassis with the boom and arm.  
When doing this, operate the levers slowly.
2. Measure the clearance between the bottom of the track frame and the top of the track shoe at a position that is safe even if the chassis should come down.

Standard clearance:  $303 \pm 20$  mm ( $11.9 \pm 0.8$  in)

#### Places to measure

- PC200, 210 : 4th track roller from sprocket  
 PC200LC, 210LC : 5th track roller from sprocket  
 PC220, 230 : Between 4th and 5th track roller from sprocket  
 PC220LC, 230LC : Between 5th and 6th track roller from sprocket

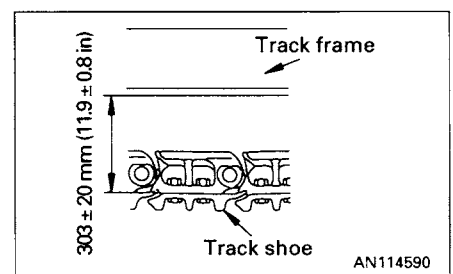
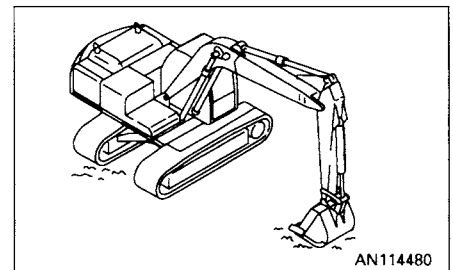



If the track tension is not at the standard value, adjust it in the following manner.

**Adjustment**

**⚠ WARNING**

Grease inside the adjusting mechanism is under high pressure. Grease coming from plug ① under pressure can penetrate the body causing injury or death. For this reason, do not loosen plug ① more than one turn. Do not loosen any part other than plug ①. Furthermore, do not bring your face in front of the plug ①. If the track tension is not relieved by this procedure, please contact your Komatsu distributor.

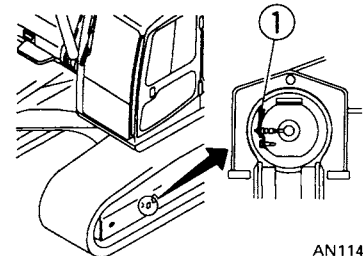

AN114600

**When increasing tension**

Prepare a grease gun.

1. Pump in grease through grease fitting ② with a grease gun.
2. To check that the tension is correct, move the machine slowly forward (7 – 8 m).
3. Check the track tension again, and if the tension is not correct, adjust it again.
4. Continue to pump in grease until S becomes 0 mm. If the tension is still loose, the pin and bushing are excessively worn, so they must be either turned or replaced. Please contact your Komatsu distributor.

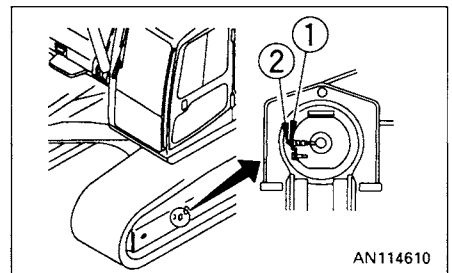

AN114610

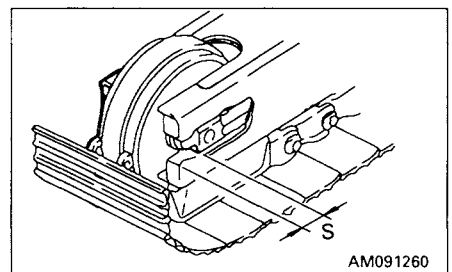

AM091260

**When loosening tension****⚠ WARNING**

It is extremely dangerous to release the grease by any method except the procedure given below. If the track tension is not relieved by this procedure, please contact your Komatsu distributor.

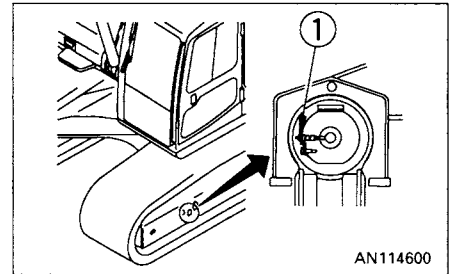

1. Loosen plug ① gradually to release the grease.
2. Turn plug ① a maximum of one turn.
3. If the grease does not come out smoothly, move the machine backwards and forwards a short distance.
4. Tighten plug ①.
5. To check that the tension is correct, move the machine slowly forward (7 – 8 m).
6. Check the track tension again, and if the tension is not correct, adjust it again.

**24.2.5 CHECK ELECTRICAL INTAKE AIR HEATER**

Before the start of the cold season (once a year), contact your Komatsu distributor to have the electrical intake air heater repaired or checked for dirt or disconnections.

### 24.2.6 REPLACE BUCKET TEETH (VERTICAL PIN TYPE)

Replace the point before the adapter starts to wear.

#### ⚠ WARNING

It is dangerous if the work equipment moves by mistake when the teeth are being replaced. Set the work equipment in a stable condition, then stop the engine and apply the locks securely to the levers.

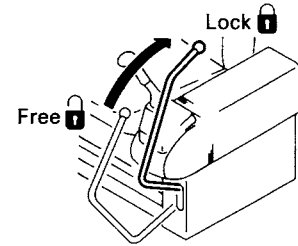

AN112930

1. Place a block under the bucket bottom to allow the pin of tooth ① to be knocked out with a hammer. Carry out full stroke operation of the control levers within 15 seconds after stopping the engine. After confirming that the work equipment is in a stable condition, lock the safety lock lever. Set so that the bottom face of the bucket is horizontal.
2. Use a hammer and drift to knock out lock pin ② (If the drift is set against rubber pin lock ③ when it is hit, the rubber pin lock may break. Set it against the back of the pin.)
3. After removing lock pin ② and rubber pin lock ③, check them.

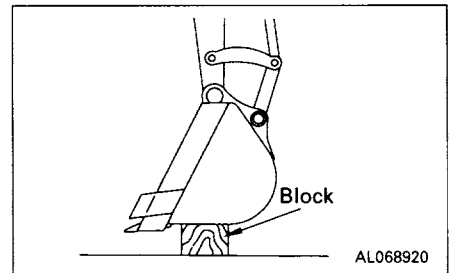

AL068920

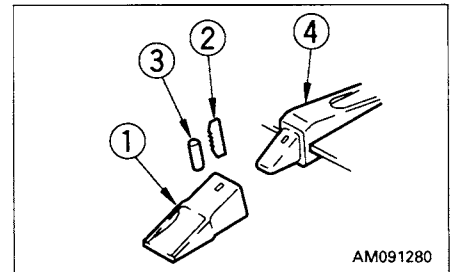

AM091280

If lock pins and rubber pin locks with the following defects are used, the point may come off the bucket. Replace them with new ones.

- The lock pin is too short.

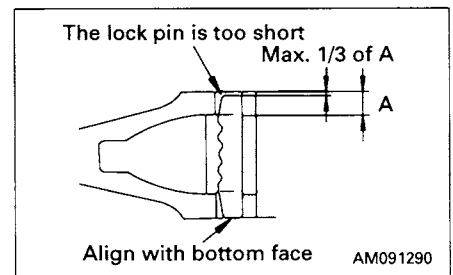

AM091290

- The rubber of the rubber pin lock is torn, and the steel balls may come out.

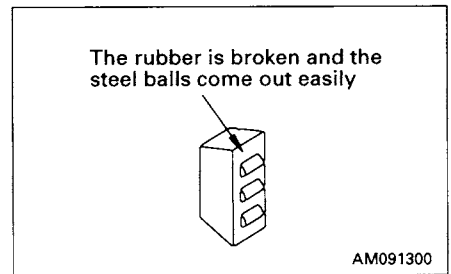

- The steel balls are buried when they are pressed by hand.

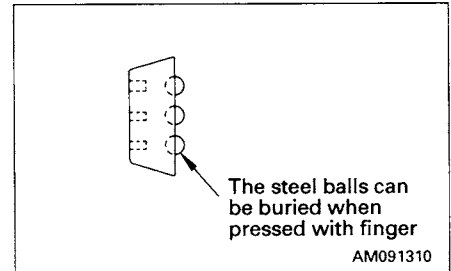

4. Clean the surface of adapter ④ and remove the soil from it with a knife.

5. Use your hand or a hammer to push rubber pin lock ③ into the hole of the adapter. When doing this, be careful that the rubber pin lock does not fly out from the adapter surface.

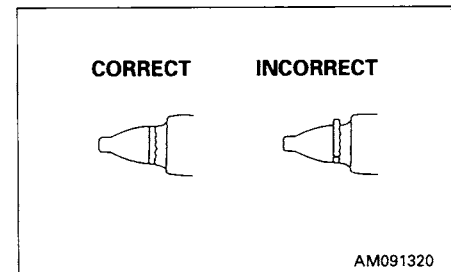

6. Clean the inside of point ①, then install it to adapter ④. If there is mud stuck to it or if there are protrusions, the point will not enter the adapter properly, and there will not be proper contact at the mating portion.

7. Fit point ① to adapter ④, and confirm that when the pointer is pressed strongly, the rear face of the hole for the pin of the point is at the same level as the rear face of the hole for the pin of the adapter.

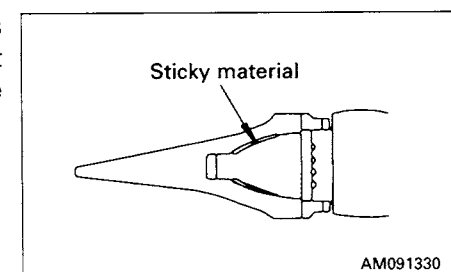

If the rear face of the hole for the pin of point ① is protruding to the front from the rear face of the pin hole for adapter ④, do not try to knock the pin in. There is something preventing point ① from entering adapter ④ fully, so remove the obstruction. When point ① enters adapter ④ fully, knock in lock pin ②.

8. Insert lock pin ② in the hole of the point and hit it until its top is the same level as the surface of point ①.
9. After replacing a bucket tooth, always check the following.
  - 1) After the lock pin has been knocked in completely, check that it is being secured by the point and surface.
  - 2) Lightly hit lock pin ② in the reverse direction from which it was hit in.
  - 3) Lightly hit the tip of the point from above and below, and hit its sides from right and left.

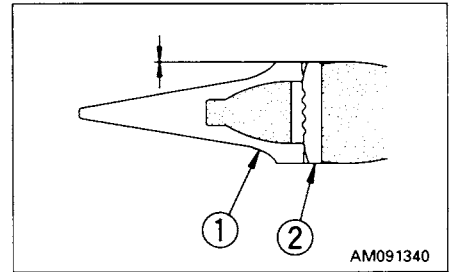

- 4) Confirm that rubber pin lock ③ and lock pin ② are set as shown in the figure.

The life of the point can be lengthened and the frequency of its replacement can be reduced by turning it upside down so that it will wear evenly.

Replace the rubber pin and locking pin with new pins at the same time as replacing the point to prevent the point from falling.

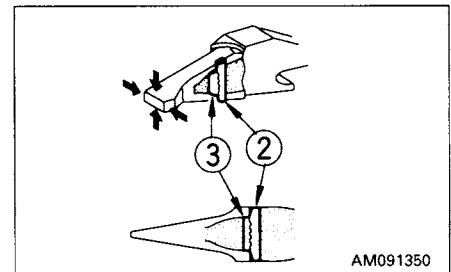

### 24.2.7 REPLACE BUCKET TEETH (HORIZONTAL PIN TYPE)

Replace the teeth before the wear reaches the adapter.

#### WARNING

It is dangerous if the work equipment moves by mistake when the teeth are being replaced. Set the work equipment in a stable condition, then stop the engine and apply the locks securely to the levers.

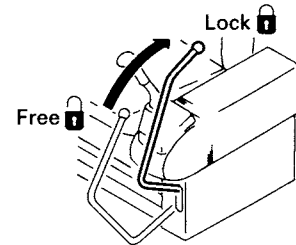

AN112930

1. Place a block under the bucket bottom so that the pin ① of tooth can be knocked out with a hammer. Carry out full stroke operation of the control levers within 15 seconds after the engine has stopped. After confirming that the work equipment is in a stable condition, lock the safety lock lever. Set so that the bottom face of the bucket is horizontal.

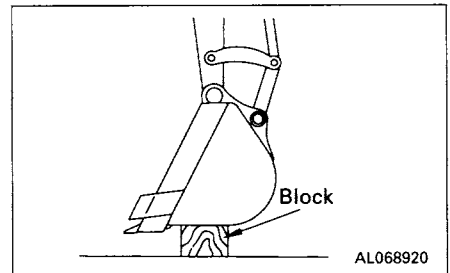

AL068920

2. Place a bar on the pin head and strike the bar with a hammer to knock out pin ①. Remove tooth ②.

#### REMARK

Use a round bar with a smaller diameter than that of the pin.

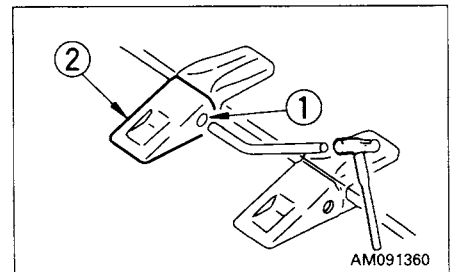

AM091360

3. Clean the mounting face. Fit a new tooth ② in the adapter, push in pin ① partially by hand, then lock it with a hammer to install the tooth to the bucket.

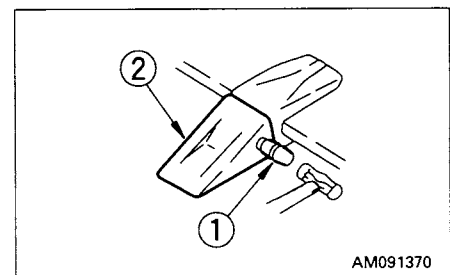

AM091370

### 24.2.8 ADJUST BUCKET CLEARANCE

**⚠ WARNING**

It is dangerous if the work equipment moves by mistake when the clearance is being adjusted. Set the work equipment in a stable condition, then stop the engine and lock the lever securely.

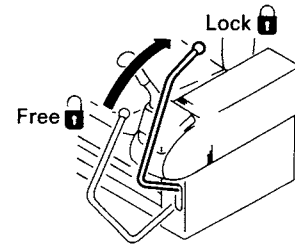

AN112930

1. Set the work equipment to the position shown in the diagram at right, stop the engine and set the lock lever to the locked position.
2. Shift O-ring ① of the linkage and measure the amount of play (a).  
Measurement is easier if you move the bucket to one side or the other so all the play can be measured in one place. (In the diagram this is on the left-hand side)  
Use a gap (clearance) gauge for easy and accurate measurement.
3. Loosen the four plate fixing bolts of ② and loosen plate ③. Because it uses split shims, you can carry out the operation without removing the bolts entirely.
4. Remove shim ④ corresponding to the amount of play (a) measured above.

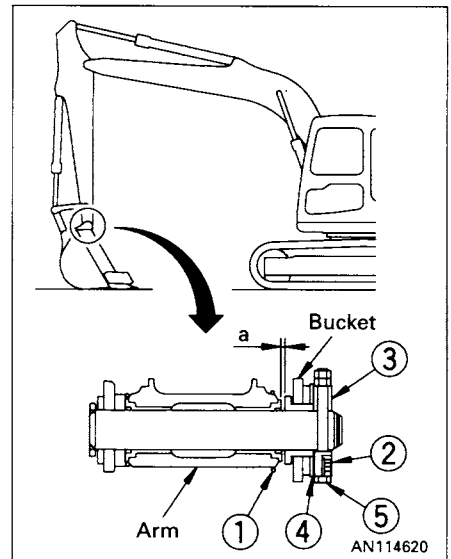

AN114620

[Example]

In the case of play of 3 mm, remove two 1.0 mm shims and one 0.5 mm shim. Play becomes 0.5 mm. For shim (4), two types of 1.0 mm and 0.5 mm are used.

When play a is smaller than one shim, do not carry out any maintenance.

5. Tighten the four bolts ②.  
If the bolts ② are too stiff to tighten, pull out pin stopper bolt ⑤ for easier tightening.

### 24.2.9 CHECK WINDOW WASHER FLUID LEVEL, ADD FLUID

If air is ejected with the window washer fluid, check the fluid level in window washer tank ①. If showing under the level, fill with automobile window washer fluid.

When adding fluid, be careful not to let dirt or dust get in.

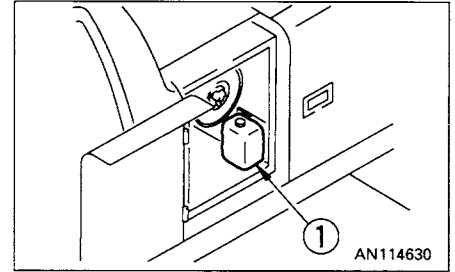

- Mixture ratio of pure washer fluid and water  
Since the ratio should be varied depending on atmospheric temperature, replenish washer fluid at the following mixture ratio, taking temperature into account.

Operation area and season	Mixture ratio	Freezing temperature
Normal	Pure washer fluid 1/3: water 2/3	- 10°C (14°F)
Winter in cold region	Pure washer fluid 1/2: water 1/2	- 20°C (- 4°F)
Winter in extremely cold region	Pure washer fluid	- 30°C (- 22°F)

Pure washer fluid comes in two types: for -10°C (14°F) (for general use) and for -30°C (-22°F) (cold regions).  
Use pure washer fluid according to operation area and season.



**24.2.10 CHECK AND ADJUST AIR CONDITIONER**

**CHECK LEVEL OF REFRIGERANT (GAS)**

**⚠ WARNING**

- When repairing or inspecting the air conditioner, be sure to handle the refrigerant gas according to regulations of your country.
- If the liquid gets into your eyes or on your hands, it may cause loss of sight or frostbite, so never loosen any part of the refrigerant circuit.

If there is a lack of refrigerant (Freon 134a), the cooling performance will be poor.

When operating the cooler at high speed, there should be no bubbles in the sight glass (inspection window) mounted on the condenser unit receiver.

- No bubbles in refrigerant flow: Correct
- Bubbles in refrigerant flow (bubbles continuously pass through): Refrigerant level low
- Colorless, transparent: No refrigerant

**REMARK**

When there are bubbles, the refrigerant gas level is low, so contact your refrigerant dealer to have refrigerant added. If the air conditioner is run with the refrigerant gas level low, it will cause damage to the compressor.

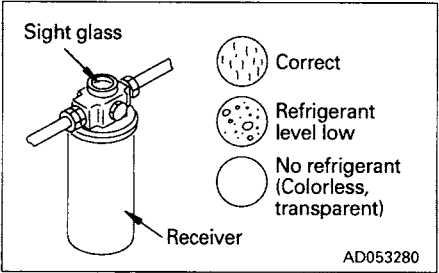
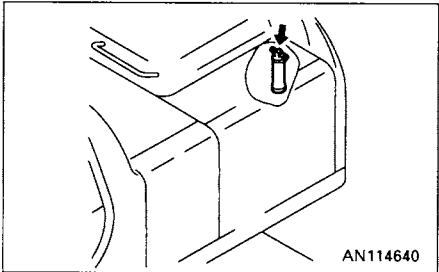

**Check in off-season**

When not being used for a long period, operate the cooler for 3 to 5 minutes once a month to supply lubricant to each component of the compressor.

**Inspection and maintenance items list for cooler**

Inspection and maintenance items	Contents	Maintenance interval
Refrigerant (gas)	Filling quantity	Twice a year; spring and autumn
Condenser	Clogging of fin	Every 500 hours
Compressor	Function	Every 4000 hours
V belt	Damage and tension	Every 250 hours
Blower motor and fan	Function (Check for abnormal sound)	When required
Control mechanism	Function (Check for normal function)	When required
Piping for connection	Installation condition looseness of tightening connection portions gas leakage, damage	When required

### 24.2.11 REPLACE ADDITIONAL BREAKER FILTER ELEMENT

#### ⚠ WARNING

Immediately after operating the engine, all parts still retain high temperature. Never replace the filter in such condition. Replace it only after each part has sufficiently cooled.

- Prepare a container for draining off oil.
1. Place the container under the filter element.
  2. Turn filter case ① counterclockwise to remove it. Remove element ② from the case.
  3. Unscrew plug ③ from filter case ①.
  4. Clean the removed parts. Mount a new element ② and O-ring ④.
  5. After the case reaches the filter holder, additionally tighten the case by more than a 1/2 turn.

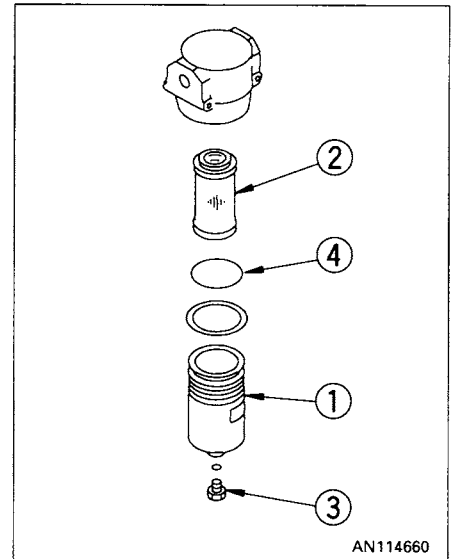
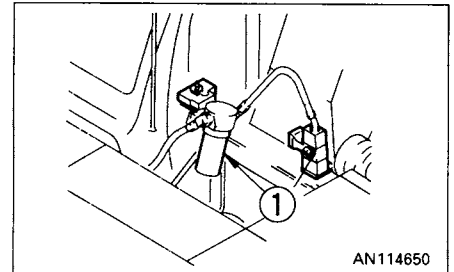

#### NOTICE

- When the breaker is used, replace the element every approx. 250 hours (when operating ratio is more than 50%), referring to the chart at the right.
- If the machine is equipped with the hydraulic breaker, be sure to install an additional filter to the return circuit.

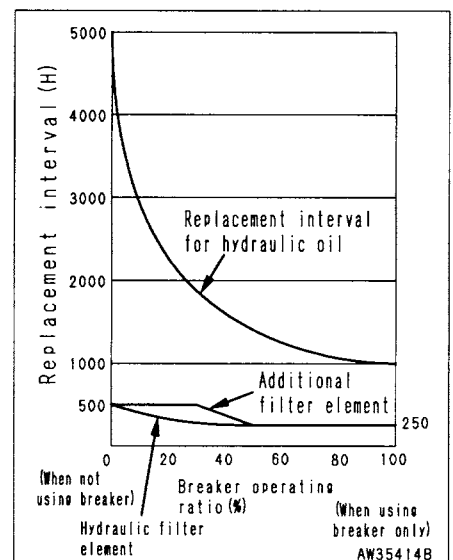

## 24.3 CHECK BEFORE STARTING

### 24.3.1 CHECK COOLANT LEVEL, ADD WATER

**⚠ WARNING**

**Do not open the radiator cap unless necessary. When checking the coolant, always check the radiator reserve tank when the engine is cold.**

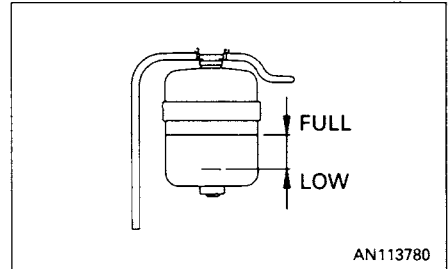
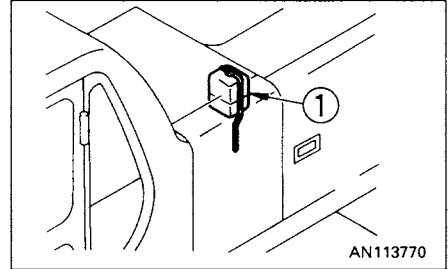

1. Open the rear door on the left side of the machine and check that the cooling water level is between the FULL and LOW marks on radiator reserve tank ① (shown in the diagram on the right). If the water level is low, add water through the water filler of reserve tank ① to the FULL level.
2. After adding water, tighten the cap securely.
3. If the reserve becomes empty, first inspect for water leaks and then fill the radiator and the reserve tank with water.

### 24.3.2 CHECK OIL LEVEL IN ENGINE OIL PAN, ADD OIL

1. Open the engine hood.
2. Remove dipstick ⑥ and wipe the oil off with a cloth.
3. Insert dipstick ⑥ fully in the oil filler pipe, then take it out again.
4. The oil level should be between the H and L marks on dipstick ⑥.  
If the oil level is below the L mark, add engine oil through oil filler ⑦.

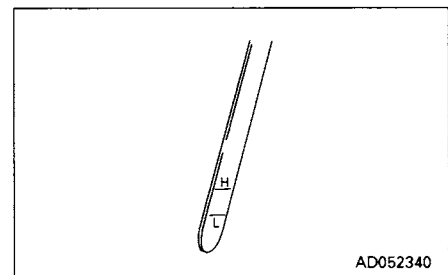
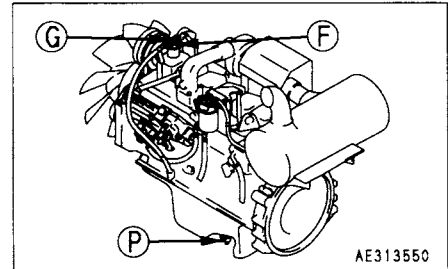

**NOTICE**

**For details of the oil to use, see "20. USE OF FUEL, COOLANT AND LUBRICANTS ACCORDING TO AMBIENT TEMPERATURE".**

5. If the oil is above the H mark, drain the excess engine oil from drain valve ⑧, and check the oil level again.
6. If the oil level is correct, tighten the oil filler cap securely and close the engine hood.

**REMARK**

When checking the oil level after the engine has been operated, for at least 15 minutes after stopping the engine before checking. If the machine is at an angle, make it horizontal before checking.

### 24.3.3 CHECK FUEL LEVEL, ADD FUEL

#### **⚠ WARNING**

When adding fuel, never let the fuel overflow. This may cause a fire. If spilling fuel, thoroughly clean up any spillage.

1. Open fuel filler cap ① of the fuel tank.
2. When fuel filler cap ① is opened, float gauge ② will rise according to the fuel level.  
Check that the fuel tank is full. Check by looking into the tank and by using float gauge ②.
3. If the tank is not full, add fuel through the fuel filler until float gauge ② rises to the maximum position.
  - Fuel tank capacity: 340 l (89.8 US gal, 74.8 UK gal)
  - Position of tip of float gauge ② when tank is full: Approx. 130 mm (5.1 in) from top surface of fuel tank

#### **NOTICE**

For details of the fuel to use, see "20. USE OF FUEL, COOLANT AND LUBRICANTS ACCORDING TO AMBIENT TEMPERATURE".

4. After adding fuel, push float gauge ② straight down with fuel filler cap ①. Be careful not to get float gauge ② caught in the tab ③ of fuel filler cap ①, and tighten fuel filler cap ① securely.

#### **REMARK**

If breather hole ④ on the cap is clogged, the pressure in the tank will drop and fuel will not flow.

Clean the hole from time to time.

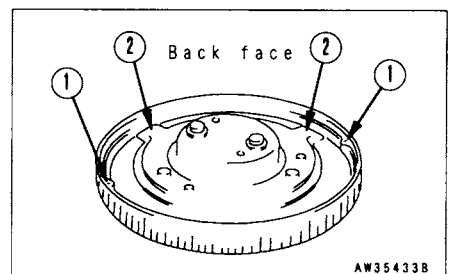
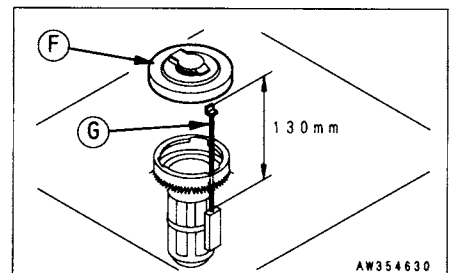
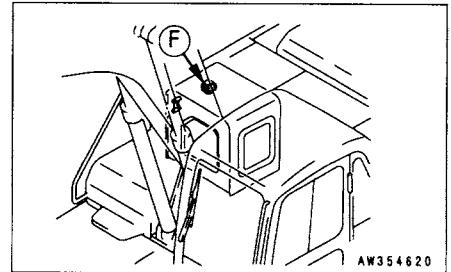

**24.3.4 CHECK OIL LEVEL IN HYDRAULIC TANK, ADD OIL**

**⚠ WARNING**

- When removing the oil filler cap, oil may spurt out, so turn the cap slowly to release the internal pressure before removing the cap.
- If oil has been added to above the H mark, stop the engine and wait for the hydraulic oil to cool down, then drain the excess oil from drain plug (P).

1. If the work equipment is not in the condition shown in the diagram on the right, start the engine run the engine at low speed, retract the arm and bucket cylinders, then lower the boom, set the bucket teeth in contact with the ground, and stop the engine.
2. Within 15 seconds after stopping the engine, move each control lever (work equipment and travel) to full stroke in all directions to release the internal pressure.
3. Check sight gauge (G). The oil level is normal if between the H and L marks.

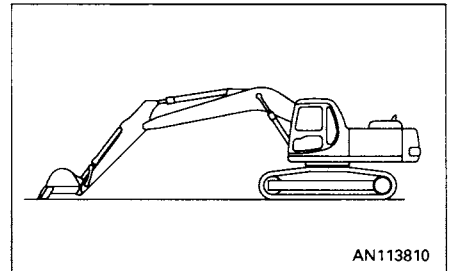

AN113810

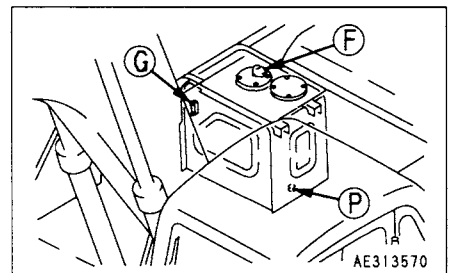

AE313570

**NOTICE**

**Do not add oil if the level is above the H line. This will damage the hydraulic equipment and cause the oil to spurt out.**

4. If the level is below the L mark, add oil through oil filler (F).

**NOTICE**

**For details of the oil to use, see "20. USE OF FUEL, COOLANT AND LUBRICANTS ACCORDING TO AMBIENT TEMPERATURE".**

**REMARK**

The oil level will vary depending upon the oil temperature. Accordingly, use the following as a guide:

- Before operation: around L level (Oil temperature 10 to 30°C (50 to 86°F))
- Normal operation: around H level (Oil temperature 50 to 80°C (122 to 176°F))

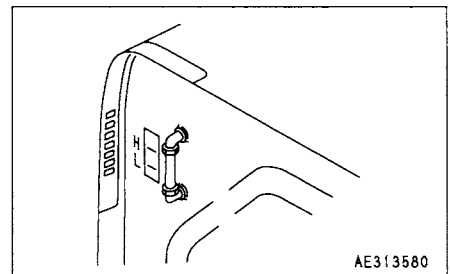

AE313580

### 24.3.5 CHECK AIR CLEANER FOR CLOGGING

1. Confirm that the air cleaner clogging monitor does not flash.
2. If it flashes, immediately clean or replace the element.

For details of the method of cleaning the element, see "24.2.1 CHECK, CLEAN AND REPLACE AIR CLEANER ELEMENT".

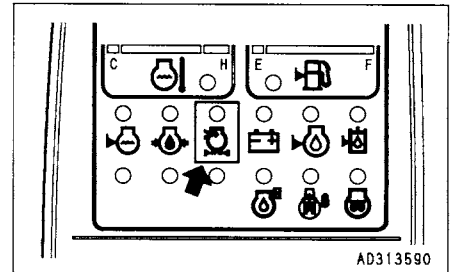

### 24.3.6 CHECK ELECTRIC WIRINGS

#### **WARNING**

**If the fuse blows frequently, or there are traces of shortcircuiting in the electric wiring, always locate and repair the cause.**

Check for damage of the fuse and any sign of disconnection or short circuit in the electric wiring. Check also for loose terminals and tighten any loose parts. Check the following points carefully.

- Battery
- Starting motor
- Alternator

Please contact your Komatsu distributor for investigation and correction of the cause.

#### **WARNING**

**Accumulation of flammable material (dead leaves, twigs, grass, etc.) around the battery may cause fire, so always check and remove such material.**

When carrying out walk-around checks or checks before starting, always check if there is any accumulation of flammable material around the battery, and remove such flammable material.

**24.3.7 LUBRICATE CLAMSHELL BUCKET (12 POINTS)**

- Prepare a grease pump.
1. Place the work equipment on the ground in a stable posture and stop the engine.
  2. Using a grease gun, pump in grease through the grease fittings (12 points) shown by arrows.
  3. After greasing, wipe off any old grease that was pushed out.

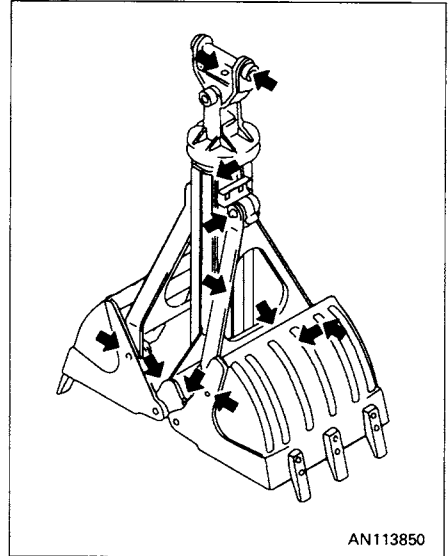

**24.3.8 CHECK FOR WATER AND SEDIMENT IN WATER SEPARATOR, DRAIN WATER (OPTION)**

The water separator separates water mixed in the fuel. If float ② is at or above red line ①, drain the water according to the following procedure:

1. Loosen drain plug ③ and drain the accumulated water until the float reaches the bottom.
2. Tighten drain plug ③.
3. If the air is sucked into fuel line when draining and water, be sure to bleed air in the same manner as for the fuel filter. See "24.6 EVERY 500 HOURS SERVICE".

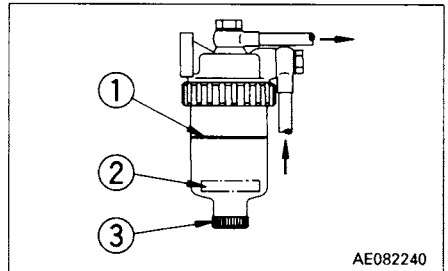

## 24.4 EVERY 100 HOURS SERVICE

### 24.4.1 LUBRICATING

#### NOTICE

- If any abnormal noise is generated from any greasing point, carry out greasing regardless of the greasing interval.
- Carry out greasing of greasing points 1 – 7 every 10 hours for the first 100 hours on a new machine.

1. Set the work equipment in the greasing posture below, then lower the work equipment to the ground and stop the engine.
2. Using a grease pump, pump in grease through the grease fittings shown by arrows.
3. After greasing, wipe off any old grease that was pushed out.

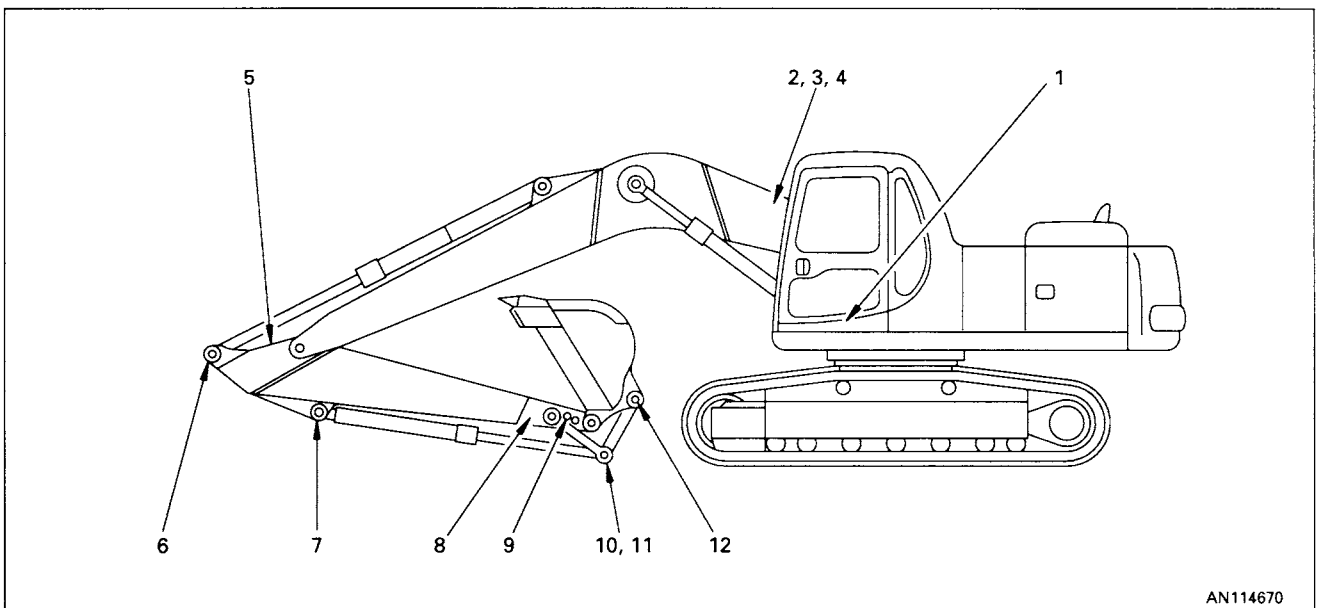

AN114670

1. Boom cylinder foot pin (2 points)

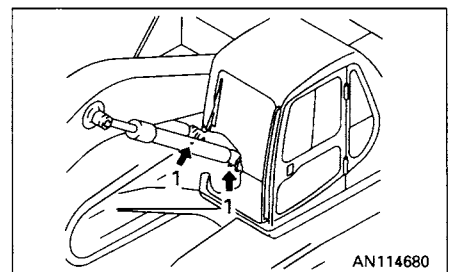

AN114680

2. Boom foot pin (2 points)
3. Boom cylinder rod end (2 points)
4. Arm cylinder foot pin (1 point)

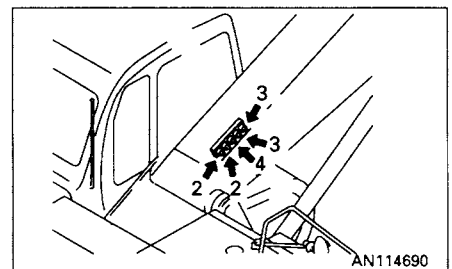

AN114690



## 24. SERVICE PROCEDURE

5. Boom-Arm coupling pin (1point)
6. Arm cylinder rod end (1 point)
7. Bucket cylinder foot pin (1 point)

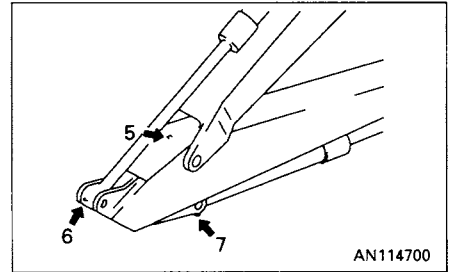

8. Arm-Link coupling pin (1 point)
9. Arm-Bucket coupling pin (1 point)

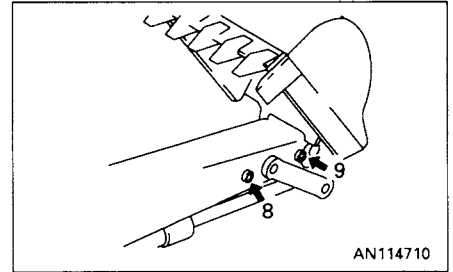

10. Link coupling pin (2 points)
11. Bucket cylinder rod end (1 point)
12. Bucket-Link coupling pin (1 point)

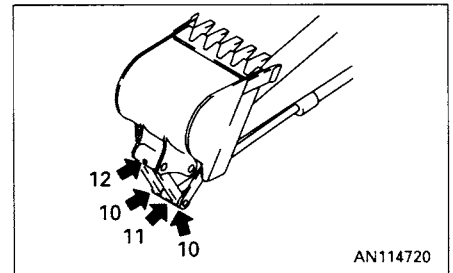

### 24.4.2 CHECK OIL LEVEL IN SWING MACHINERY CASE, ADD OIL

#### WARNING

The oil is at high temperature immediately after the machine has been operated. Wait for the oil to cool down before carrying out this check.

1. Remove dipstick **G** and wipe the oil from the dipstick with a cloth.
2. Insert dipstick **G** fully in the guide.
3. When dipstick **G** is pulled out, if the oil level is between the H and L marks of the gauge, oil level is proper.

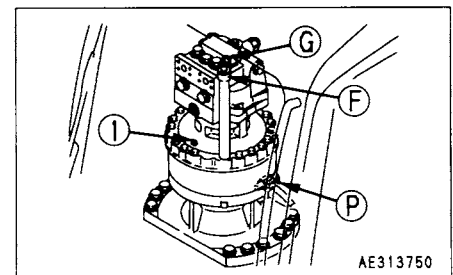

4. If the oil does not reach the L mark on dipstick ④, add engine oil through dipstick insertion hole ⑤. When refilling, remove bleeding plug ①.

**NOTICE**

For details of the oil to use, see "20. USE OF FUEL, COOLANT AND LUBRICANTS ACCORDING TO AMBIENT TEMPERATURE".

5. If the oil level exceeds the H mark on the dipstick, loosen drain valve ⑥ to drain the excess oil.
6. After checking oil level or adding oil, insert the dipstick into the hole and install air bleeding plug ①.

**24.4.3 DRAIN WATER AND SEDIMENT FROM FUEL TANK**

1. Carry out this procedure before operating the machine.
2. Prepare a container to catch the fuel that is drained.
3. Open valve ① at the bottom of the tank and drain the sediment and water that has accumulated at the bottom together with fuel. When doing this, be careful not to get fuel on yourself.
4. When only clean fuel comes out, close drain valve ①.

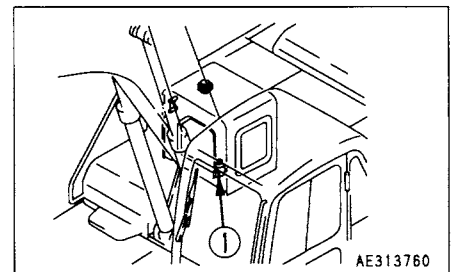
**NOTICE**

Never use trichlene for washing the inside of the tank.

## 24.5 EVERY 250 HOURS SERVICE

### 24.5.1 CHECK OIL LEVEL IN FINAL DRIVE CASE, ADD OIL

**⚠ WARNING**

- The oil is at high temperature immediately after the machine has been operated. Wait for the oil to cool down before starting the operation.
- If there is still pressure remaining inside the case, the oil or plug may fly out.  
Loosen the plug slowly to release the pressure.

- Prepare a handle.
1. Set the TOP mark at the top, with the TOP mark and plug ① perpendicular to the ground surface.
  2. Remove plug ② using the handle. When the oil level reaches a point 10 mm below the bottom of the plug hole, the correct amount of oil has been added.
  3. If the oil level is too low, install plug ②, operate the travel levers, and drive forward or in reverse to rotate the sprocket one turn. Then repeat Step 2 to check again.
  4. If the oil level is still too low, add engine oil through the hole in plug ② until the oil overflows.

**NOTICE**

For details of the oil to use, see "20. USE OF FUEL, COOLANT AND LUBRICANTS ACCORDING TO AMBIENT TEMPERATURE".

5. After checking, install plug ②.

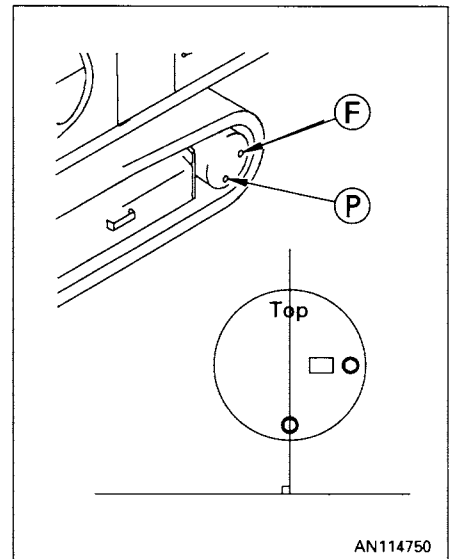

### 24.5.2 CHECK LEVEL OF BATTERY ELECTROLYTE

**⚠ WARNING**

- To avoid gas explosions, do not bring fire or sparks near the battery.
- Battery electrolyte is dangerous. If it gets in your eyes or on your skin, wash it off with large amounts of water, and consult a doctor.

Carry out this check before operating the machine.

1. Open the battery box cover on the right side of the machine.
2. Remove cap ①, and check that the battery electrolyte is up to the UPPER LEVEL line. If the level is low, add distilled water to the UPPER LEVEL line.  
Do not add water above the UPPER LEVEL line. This may cause leakage of the electrolyte, which may cause fire.

If the battery electrolyte is spilled, have dilute sulphuric acid added.

3. Clean the air hole in the battery cap, then tighten the cap securely.

When adding distilled water in cold weather, add it before starting operations in the morning to prevent the electrolyte from freezing.

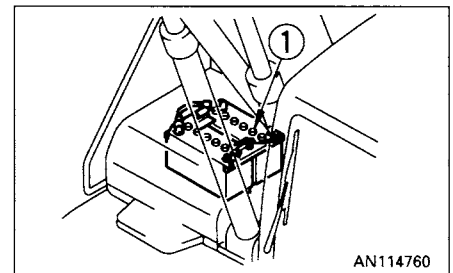

### 24.5.3 CHANGE OIL IN ENGINE OIL PAN, REPLACE ENGINE OIL FILTER CARTRIDGE

**⚠ WARNING**

The oil is at high temperature after the engine has been operated, so never change the oil immediately after finishing operations. Wait for the oil to cool down before changing it.

Prepare the following

- Container to catch drained oil: Min 24 ℓ capacity
- Refill capacity: 24 ℓ (6.34 US gal, 5.28 UK gal)
- Filter wrench

1. Place a drain container under drain cock ① located on the bottom of the machine.
2. Loosen drain cock ① slowly to avoid getting oil on yourself, and drain the oil.
3. Check the drained oil, and if there are excessive metal particles or foreign material, please contact your Komatsu distributor.
4. Install drain cock ①.
5. Open the engine hood. Using the filter wrench from the upper side of the engine, turn filter cartridge ② counterclockwise to remove it.  
In particular, if this operation is carried out immediately after stopping the engine, a large amount of oil will come out, so wait for 10 minutes before starting the operation.
6. Clean the filter holder, coat the packing surface of a new filter cartridge with engine oil (or coat it thinly with grease), then install it to the filter holder.

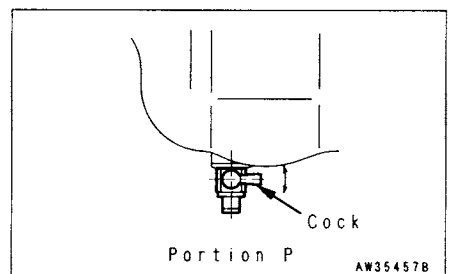
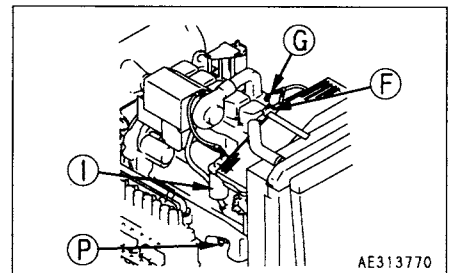

**REMARK**

Confirm that no remnants of old packing still adhere to the filter holder as this may result in oil leakage.

7. When installing, tighten until the packing surface contacts the seal surface of the filter holder, then tighten it up 3/4 of a turn.

8. After replacing the filter cartridge, add engine oil through oil filler ⑤ until the oil level is between the H and L marks on dipstick ⑥.

**NOTICE**

For details of the oil to use, see "20. USE OF FUEL, COOLANT AND LUBRICANTS ACCORDING TO AMBIENT TEMPERATURE".

9. Run the engine at idling for a short time, then stop the engine, and check that the oil level is between the H and L marks on the dipstick. For details, see "24.3 CHECK BEFORE STARTING".

**NOTICE**

- Even if the machine has not been operated for 250 hours, the oil and filter cartridge must be replaced when the machine has been operated for 6 months.  
In the same way, even if the machine has not been operated for 6 months, the oil and filter cartridge must be replaced when the machine has been operated for 250 hours.
- If optional oil filter cartridge, replace the cartridge at every 500 hours service.

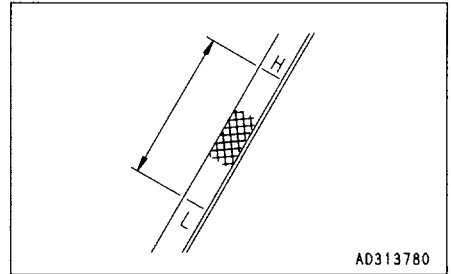
**24.5.4 LUBRICATE SWING CIRCLE (2 POINTS)**

1. Lower the work equipment to the ground.
2. Using a grease gun, pump in grease through the grease fittings shown by arrows.
3. After greasing, wipe off all the old grease that was pushed out.

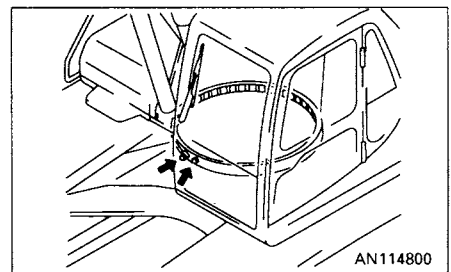

### 24.5.5 CHECK FAN BELT TENSION, ADJUST

#### Checking

The belt should normally deflect by about 5 – 6 mm (0.20 – 0.24 in) when pressed with the finger (with a force of approx. 6 kg (13 lb) at a point midway between the fan pulley and tension pulley.

#### Adjusting

1. Loosen bolts and nuts ① and ②.
2. Loosen locknut ⑤ and use adjustment bolt ③ to move tension pulley ④ to adjust the belt tension so that the deflection is approx. 5 – 6 mm (0.20 – 0.24 in) when pushed at portion A (with a force of approx. 6 kg (13 lb)).
3. Tighten the lock nuts ⑤, bolts ① and nuts ② to fix tension pulley ④ in position.
4. Check each pulley for damage, wear of the V-groove, and wear of the V-belt. In particular, be sure to check that the V-belt is not touching the bottom of the V-groove.
5. Replace 2 belts if it has stretched, leaving no allowance for adjustment, or if there is a cut or crack on belt.
6. When the new belt is set, readjust it after operation for an hour.

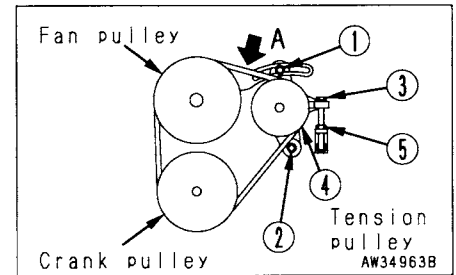

### 24.5.6 CHECK AIR CONDITIONER COMPRESSOR BELT TENTION, ADJUST

#### Checking

The belt should normally deflect by about 5 – 8 mm (0.20 – 0.31 in) when pressed with the finger (with a force of approx. 6kg (13 lb)) at a point midway between the drive pulley and compressor pulley.

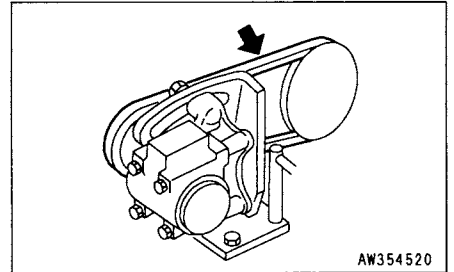

#### Adjusting

1. Insert a tension adjusting bar wrapped with cloth or another cushioning material between brackets ③ and ④.
2. Loosen bolts ① and ②.
3. Move bracket ④ with the tension adjusting bar so that the deflection of the belt will be 5 – 8 mm (0.20 – 0.31 in).
4. Tighten bolts ① and ② to secure bracket ④. Then, take out the tension adjusting bar.
5. Check each pulley for damage, wear of the V-groove, and wear of the V-belt. In particular, be sure to check that the V-belt is not touching the bottom of the V-groove.
6. Replace belt if it has stretched, leaving no allowance for adjustment, or if there is a cut or crack on belt.
7. When the new belt is set, readjust it after operation for an hour.

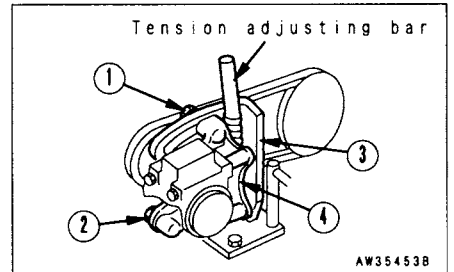



## 24.6 EVERY 500 HOURS SERVICE

Maintenance for every 100 and 250 hours should be carried out at the same time.

### 24.6.1 REPLACE FUEL FILTER CARTRIDGE AND ADDITIONAL FUEL FILTER CARTRIDGE (OPTION)

**⚠ WARNING**

- Engine is at high temperature immediately after the machine has been operated. Wait for engine to cool down before replacing the filter.
- Do not bring fire or sparks near the fuel.

Prepare a filter wrench and a container to catch the fuel.

1. Set the container to catch the fuel under the filter cartridge.
2. Using a filter wrench, turn filter cartridge ① and ④ counterclockwise to remove it.
3. Clean the filter holder, fill a new filter cartridge ① with clean fuel, coat the packing surface with engine oil, then install it to the filter holder.
4. When installing, tighten until the packing surface contacts the seal surface of the filter holder, then tighten it up 1/2 of a turn.
5. Clean the additional filter holder, fill a new additional filter cartridge ④ with clean fuel, coat the packing surface with engine oil, then install it to the filter holder.
6. When installing, tighten until the packing surface contacts the seal surface of the additional filter holder, then tighten it up 2/3 of a turn.

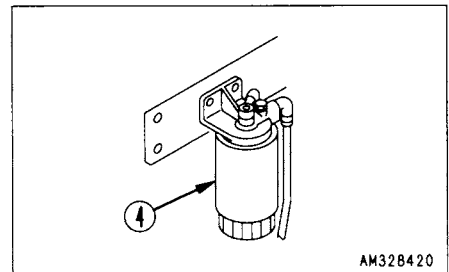
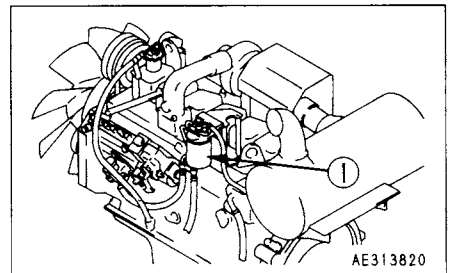

If the filter cartridge is tightened too far, the packing will be damaged and this will lead to leakage of fuel. If the filter cartridge is too loose, fuel will also leak from the packing, so always tighten to the correct amount.

7. After replacing the fuel filter cartridge, bleed the air. Bleed the air according to the following procedures.

● **Normal air bleeding procedure**

- (1) Add fuel to the fuel tank until full (to FULL mark on the fuel gauge).
- (2) After replacing filter cartridge ①, loosen joint bolt ③.
- (3) Loosen the knob of feed pump ②, and move it up and down about 50 – 60 times to cause fuel to overflow until bubbles do not come out from the joint bolt any more.
- (4) Tighten joint bolt ③.

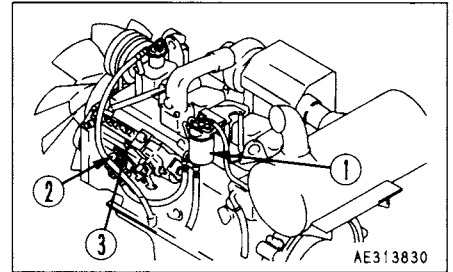

**NOTICE**

**Do not rotate the starting motor continuously for more than 20 seconds. Wait for 1 – 2 minutes before rotating again.**

**REMARK**

When the engine stops because of running out of fuel, also operate the feed pump according to the above procedure to bleed air.

**24.6.2 CHECK SWING PINION GREASE LEVEL, ADD GREASE**

Prepare a scale.

1. Remove bolts ① (2 bolts) on the top of the revolving frame and remove cover ②.
2. Insert a scale into the grease and check that the height of the grease in the portion where the pinion passes is at least 28 mm (1.1 in). Add more grease if necessary.
3. Check if the grease is milky white. If it is milky white, it is necessary to change the grease. Please contact your Komatsu distributor.

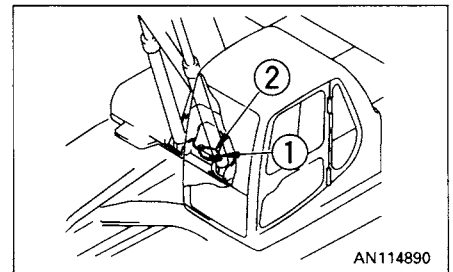

The total amount of grease is 21 ℓ (18.9 kg) (5.5 US gal, 4.6 UK gal [41.7 lb]).

4. Install cover ② with bolts ①.

### 24.6.3 CLEAN AND INSPECT RADIATOR FINS, OIL COOLER FINS AND CONDENSER FINS (ONLY FOR MACHINES EQUIPPED WITH AIR CONDITIONER)

**⚠ WARNING**

If compressed air, steam, or water hit your body directly, there is danger of injury. Always wear protective glasses, mask, and safety shoes.

1. Open the engine hood and rear door on the left side of the machine. Loosen 4 bolts ① and remove the radiator front cover.
2. When cleaning radiator fins, remove the four bolts ② fixing the oil cooler to the radiator. Tilt the oil cooler outward, then clean the radiator fins.
3. Blow off mud, dust or leaves clogging the radiator fins and oil cooler fins using compressed air.  
At the same time, clean the net in front of the oil cooler.  
Clean the condenser fins on machines equipped with the air conditioner.  
Steam or water may be used instead of compressed air.  
After cleaning, fix the oil cooler with bolts ② and install the cover with bolt ①.
4. Check the rubber hose. Replace with a new one if the hose is found to have cracks or to be hardened by ageing.  
Further, check hose clamps for looseness.

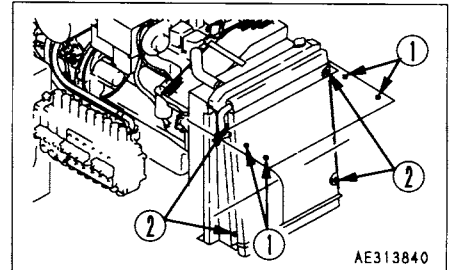

#### NOTICE

To prevent damage to the fins, apply compressed air from an appropriate distance. Damaged fins may cause water leakage or overheating. In a dusty site, check the fins daily, irrespective of the maintenance interval.

### 24.6.4 CLEAN INTERNAL AND EXTERNAL AIR FILTERS OF AIR CONDITIONER SYSTEM (ONLY FOR MACHINES EQUIPPED WITH AIR CONDITIONER)

1. Remove 4 bolts on the upper side of the luggage box and remove bracket ①.
2. Remove 2 bolts on the lower side of the luggage box and lift box ② to remove it.
3. Remove stopper ③ and open covers ④ and ⑤. Remove internal air filter ⑥ and external air filter ⑦ by lifting them up.
4. Clean filters ⑥ and ⑦ using compressed air. If the filters are stained by oil or are very dirty, wash them with neutral detergent. After washing, dry them thoroughly, then reinstall them.

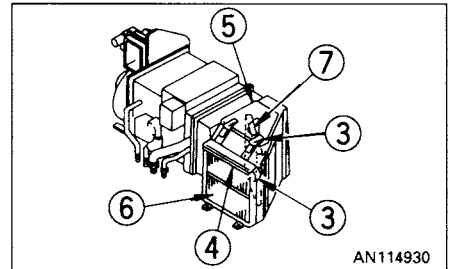
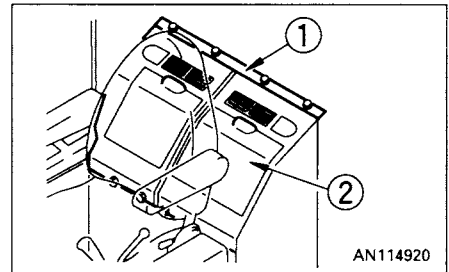

If a clogged filter cannot be cleaned with air or water, replace it with a new one.

#### NOTICE

The normal cleaning interval is 500 hours. However, if the filters are used at a dusty site, shorten this interval.

### 24.6.5 REPLACE HYDRAULIC TANK BREATHER ELEMENT

#### ⚠ WARNING

Wait for the oil to cool down before replacing the breather element. When removing the oil filler cap, turn it slowly to release the internal pressure, then remove it carefully.

1. Remove the cap of oil filler ①.
2. Replace element ① inside the cap with a new one.

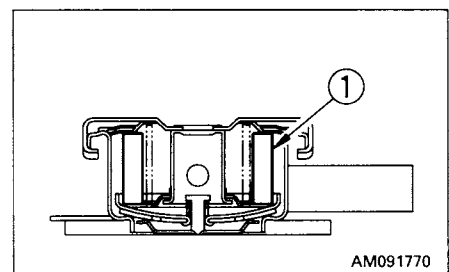
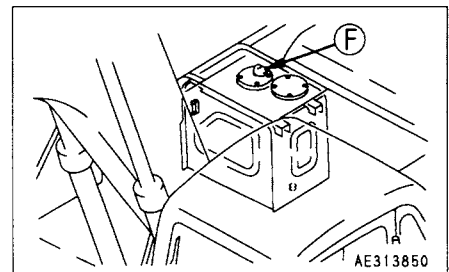

### 24.6.6 REPLACE HYDRAULIC FILTER ELEMENT

**⚠ WARNING**

**When removing the oil filler cap, turn it slowly to release the internal pressure before removing it.**

1. Remove the cap from oil filler (F), and release the internal pressure.
2. Loosen 4 bolts, then remove cover (1).  
When doing this, the cover may fly out under the force of spring (2), so hold the cover down when removing the bolts.
3. After removing spring (2) and valve (3), take out element (4).
4. Clean the removed parts in diesel oil.
5. Install a new element in the place where old element (4) was installed.
6. Set valve (3) and spring (2) on top of the element.
7. Set cover (1) in position, push it down by hand, and install the cover with the mousing bolts.
8. Screw in the oil filler cap and install the cover.
9. To bleed the air, start the engine according to "12.2 STARTING ENGINE" and run the engine at low idling for 10 minutes.
10. Stop the engine.

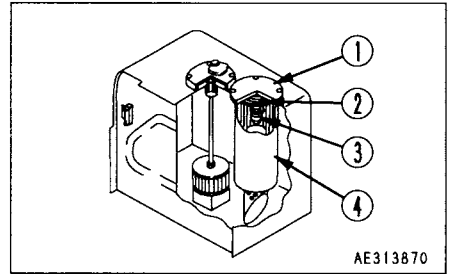
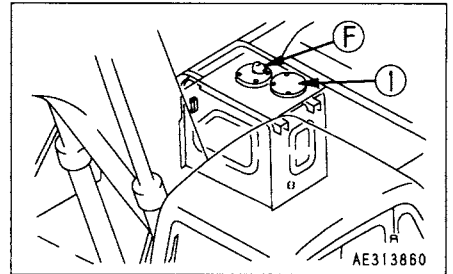

**REMARK**

Operate the machine after halting for more than 5 minutes to eliminate bubbles in the oil inside the tank.

11. Check for oil leakage and wipe off any spilled oil.

When the hydraulic breaker is installed, the hydraulic oil deteriorates earlier than in normal bucket digging work. The first element replacement should be at 100 to 150 hours for new machines. Thereafter, replace the element according to the table on the right.

Replace the additional filter element for the breaker every approx. 250 hours (when breaker operating ratio is more than 50%) according to the table on the right. (See "24.2.11 REPLACE ADDITIONAL BREAKER FILTER ELEMENT".)

**NOTICE**

- If the machine is equipped with the hydraulic breaker, be sure to install an additional filter to the return circuit.
- When it is obliged to use the breaker horizontally in a tunnel, etc., check the hydraulic oil periodically by OIL CLINIC to prepare and to carry out the oil replacement program matched to the jobsite.

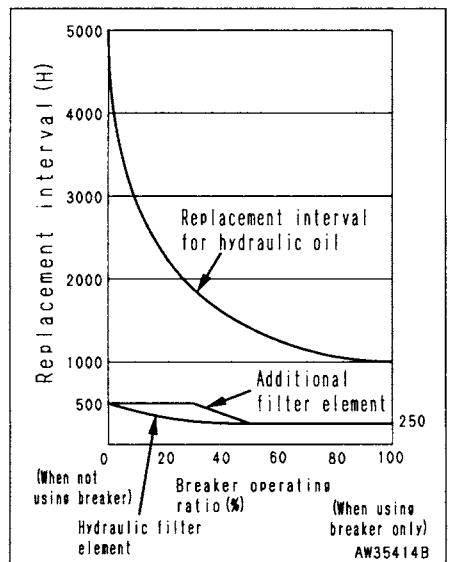

## 24.7 EVERY 1000 HOURS SERVICE

Maintenance for every 100, 250 and 500 hours should be carried out at the same time.

### 24.7.1 CHANGE OIL IN SWING MACHINERY CASE

#### **⚠ WARNING**

The oil is at high temperature immediately after the machine has been operated. Wait for the oil to cool down before carrying out maintenance.

- Container to catch drained oil: Min. 5.5 ℓ capacity
- Refill capacity: 5.5 ℓ (1.45 US gal, 1.21 UK gal)

1. Set an oil container under drain valve (P) under the machine body.
2. Loosen drain valve (P) under the body, drain the oil, then tighten the drain valve again.
3. Remove dipstick (G) and bleeding plug (I).  
Add the specified amount of engine oil through gauge hole (F).

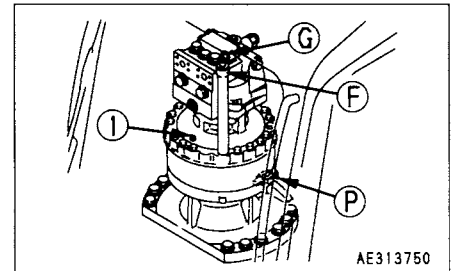

#### **NOTICE**

For details of the oil to use, see "20. USE OF FUEL, COOLANT AND LUBRICANTS ACCORDING TO AMBIENT TEMPERATURE".

4. After refilling, install bleeding plug (I).
5. Wipe off oil on the dipstick with a cloth.
6. Insert dipstick (G) into the gauge pipe thoroughly and then pull out it again.
7. When the oil level is between the H and L marks, on dipstick (G), it is normal. If the oil does not reach the L mark, add more oil through oil filler (F).
8. If the oil level exceeds the H mark, drain the excess engine oil from drain valve (P), and check the oil level again.

### 24.7.2 CHECK OIL LEVEL IN DAMPER CASE, ADD OIL

**⚠ WARNING**

The oil is at high temperature immediately after the machine has been operated. Wait for the oil to cool down before carrying out maintenance.

**NOTICE**

Park the machine on flat ground and stop the engine. After waiting for more than 30 minutes after stopping the engine, check the oil level.

1. Open the door on the right side of the machine.
2. Remove plug ⑥ and check the oil level. If the oil is up to near the bottom of the plug hole, it is normal.  
If insufficient, remove plug ⑦ and add oil through the hole of plug ⑦ up to the bottom of the plug ⑥ hole.

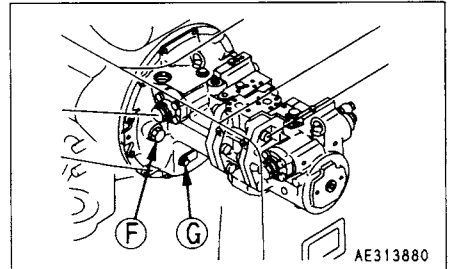

**NOTICE**

For details of the oil to use, see "20. USE OF FUEL, COOLANT AND LUBRICANTS ACCORDING TO AMBIENT TEMPERATURE".

**NOTICE**

If excess oil is supplied, drain it to the specified amount to avoid overheating.

3. Install plugs ⑥ and ⑦.
4. Close the door.

### 24.7.3 CHECK ALL TIGHTENING PARTS OF TURBOCHARGER

Contact your Komatsu distributor to have the tightening portions checked.

### 24.7.4 CHECK PLAY OF TURBOCHARGER ROTOR

Ask Komatsu distributor to check the play of the turbocharger rotor.

### 24.7.5 CHECK ALTERNATOR BELT TENSION AND REPLACE ALTERNATOR BELT

Special tools are required for inspection and replacement of the alternator belt. Contact your Komatsu distributors for inspection and replacement.

#### REMARK

Since the auto-tensioner alternator belt is installed, its tension does not need to be adjusted.

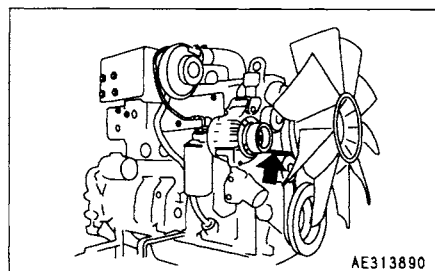

### 24.7.6 REPLACE CORROSION RESISTOR CARTRIDGE

#### ⚠ WARNING

If the engine has been operated, all parts will be at a high temperature, so never try to replace the cartridge immediately after stopping the engine.  
Always wait for the engine and other parts to cool down.

Prepare the following.

- Container to catch drained coolant
- Filter wrench

1. Close valves ①.
2. Set a container to catch the coolant under the cartridge.
3. Using a filter wrench, remove cartridge ②.
4. Clean the filter holder, coat the packing surface and thread of the new cartridge with engine oil, then install it to the filter holder.
5. When installing, tighten until the packing surface contacts the seal surface of the filter holder, then tighten it up 2/3 of a turn. If the filter cartridge is tightened too far, the packing will be damaged and this will lead to leakage of coolant. If the filter cartridge is too loose, coolant will also leak from the packing, so always tighten to the correct amount.
6. Open valves ①.
7. After replacing the cartridge, start the engine and check for any leakage of water from the filter seal surface. If there is any water leakage, check if the cartridge is tightened properly.

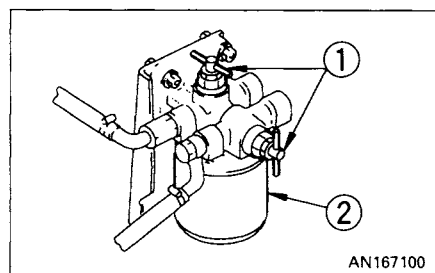



## 24.8 EVERY 2000 HOURS SERVICE

Maintenance for every 100, 250, 500 and 1000 hours should be carried out at the same time.

### 24.8.1 CHANGE OIL IN FINAL DRIVE CASE

#### **⚠ WARNING**

- The oil is at high temperature immediately after the machine has been operated. Wait for the oil to cool down before carrying out maintenance.
- If there is still pressure remaining inside the case, the oil or plug may fly out.  
Loosen the plug slowly to release the pressure.

Prepare the following.

- Container to catch drained oil: Min. 4.2 ℓ capacity
  - Refill capacity: 4.2 ℓ (1.11 US gal, 0.92 UK gal)
  - Handle
1. Set the TOP mark at the top, with the TOP mark and plug ① perpendicular to the ground surface.
  2. Set a container under plug ① to catch the oil.
  3. Remove plugs ① and ② with the handle and drain the oil.

#### **REMARK**

Check the O-rings in the plugs for damage. If necessary, replace with new ones.

4. Screw in plug ①.
5. Add engine oil through the hole of plug ②.

#### **NOTICE**

For details of the oil to use, see "20. USE OF FUEL, COOLANT AND LUBRICANTS ACCORDING TO AMBIENT TEMPERATURE".

6. When the oil overflows from the hole of plug ②, install plug ②.  
Tightening torque of plugs ① and ②:  $70 \pm 10$  Nm ( $7 \pm 1$  kgm,  $50 \pm 7$  lbft)

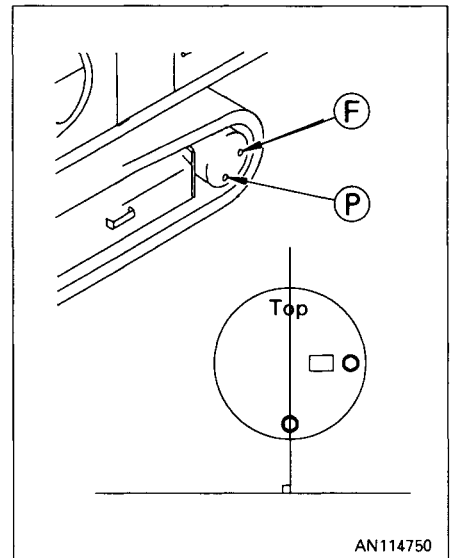

### 24.8.2 CLEAN HYDRAULIC TANK STRAINER

#### **⚠ WARNING**

The oil is at high temperature immediately after the machine has been operated. Wait for the oil to cool down before cleaning the strainer. When removing the oil filler cap, turn it slowly to release the internal pressure, then remove it carefully.

1. Loosen 4 bolts, then remove cover ①.  
When doing this, the cover may fly out under the force of spring ②, so push the cover down when removing the bolts.
2. Pull up the top of rod ③, and remove spring ② and strainer ④.
3. Remove the dirt stuck to strainer ④, then wash it in clean diesel oil or flushing oil.  
If strainer ④ is damaged, replace it with a new one.
4. Refit strainer ④ by inserting it into tank projecting part ⑤.
5. Install cover ① with bolts.

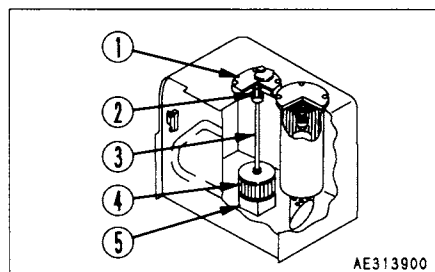

### 24.8.3 CLEAN, CHECK TURBOCHARGER

Contact your Komatsu distributor for cleaning or inspection.

### 24.8.4 CHECK ALTERNATOR, STARTING MOTOR

The brush may be worn, or the bearing may have run out of grease, so contact your Komatsu distributor for inspection or repair. If the engine is started frequently, carry out inspection every 1000 hours.

### 24.8.5 CHECK ENGINE VALVE CLEARANCE, ADJUST

As special tool is required for removing and adjusting the parts, you shall request Komatsu distributor for service.

### 24.8.6 CHECK VIBRATION DAMPER

Since special tools are required for inspection and replacement of the vibration damper, contact your Komatsu distributor in the following case.

Match marks ① are stamped on the damp hub and inertia member so that deviation from each other can be checked. If they are deviated from each other by 1.6 mm (0.06 in) or more, or if there is a dent ② below the bearing metal of the damper 3.2 mm (0.13 in) or more, ask for replacement of the parts.

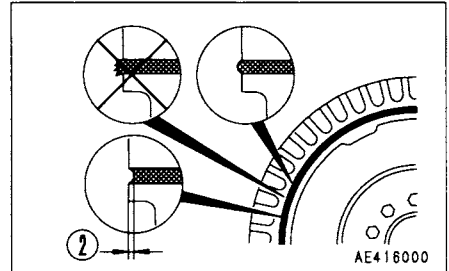
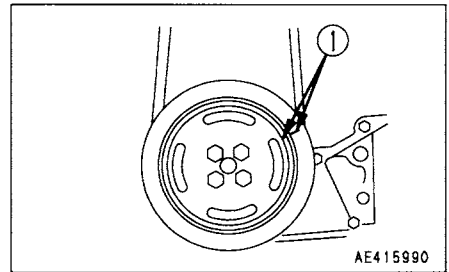

## 24.9 EVERY 4000 HOURS SERVICE

Maintenance for every 100, 250, 500, 1000 and 2000 hours should be carried out at the same time.

### 24.9.1 CHECK WATER PUMP

Since the pulley may have play, oil may leak, water may leak and the drain hole may be clogged, contact your Komatsu distributor for inspection, overhaul or replacement.

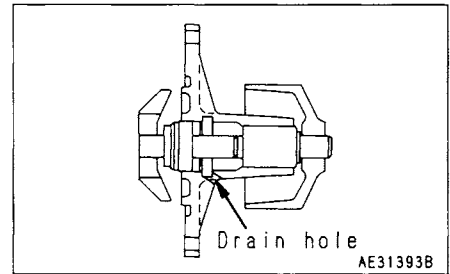

## 24.10 EVERY 5000 HOURS SERVICE

Maintenance for every 100, 250, 500 and 1000 hours should be carried out at the same time.

### 24.10.1 CHANGE OIL IN HYDRAULIC TANK

**WARNING**

The oil is at high temperature immediately after the machine has been operated. Wait for the oil to cool down before changing the oil. When removing the oil filler cap, turn it slowly to release the internal pressure, then remove it carefully.

Prepare the following.

- Container to catch drained oil: min. 166 l capacity
- Refill, capacity: 166 l (43.8 US gal, 36.5 UK gal)
- Prepare a handle for the socket wrench set.

1. Swing the upper structure so that the drain plug under the hydraulic tank comes at the middle of the left or right track.
2. Retract the arm and bucket cylinders to the stroke end, then lower the boom and put the bucket teeth in contact with the ground.
3. Lock the safety lock lever and stop the engine.
4. Remove the cap of oil filler (F) over the hydraulic tank.
5. Set the oil container under the drain plug under the machine. Using the handle, remove drain plug (P) and drain the oil. Check the O-ring installed to plug (P), and if it is damaged, replace the O-ring. After draining the oil, tighten drain plug (P). Tightening torque:  $69 \pm 10$  Nm ( $7 \pm 1$  kgm,  $51 \pm 7$  lbft).

When removing drain plug (P), be careful not to get oil on yourself.

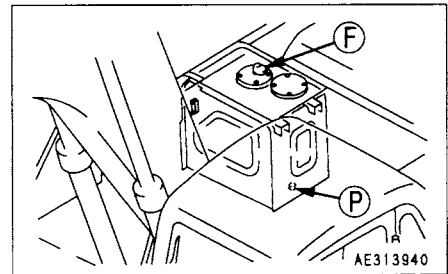
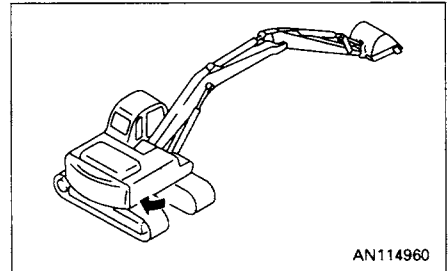

6. Add the specified amount of engine oil through oil filler port (F).  
Check that the oil level is between H and L on the sight gauge.

#### NOTICE

- For details of the oil to use, see "20. USE OF FUEL, COOLANT AND LUBRICANTS ACCORDING TO AMBIENT TEMPERATURE".
  - If the machine is equipped with the hydraulic breaker, be sure to install an additional filter to the return circuit.
  - When the hydraulic breaker is installed, the hydraulic oil deteriorates earlier than in normal bucket digging work. Therefore, replace the hydraulic oil according to the chart at the right.
7. After replacing hydraulic oil and cleaning or replacing filter element and strainer, bleed air from the circuit according to the following procedure.

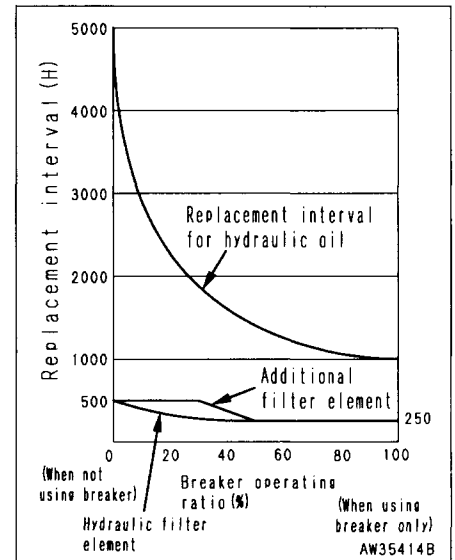

### Air bleeding procedure

Follow Steps 1 to 7 to bleed the air.

#### 1. Bleeding air from pump

1. Loosen air bleeding plug ①, and check that oil oozes out from the air bleed plug.
2. If oil does not ooze out from the plug, remove the drain hose from the pump case, and add oil through drain port ② to fill the pump case with hydraulic oil.

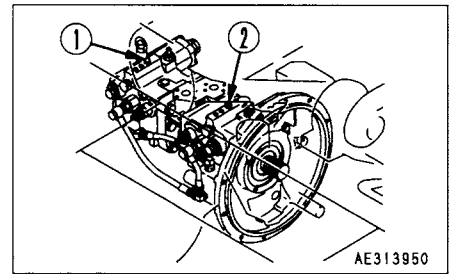

Oil will come out from the drain hose when it is removed, so secure the mouth of the hose at a place higher than the oil level inside the hydraulic tank.

3. After completion of the air bleed operation, tighten air bleeding plug ①, then install the drain hose.

### NOTICE

If the drain hose is installed first, oil will spurt out from the hole of plug ①.

If the pump is operated without filling the pump case with hydraulic oil, abnormal heat will be generated and this may lead to premature damage of the pump.

#### 2. Starting engine

Start the engine according to "12.2 STRAT ENGINE". Keep running the engine at low idling for 10 minutes, and carry out the following procedure.

#### 3. Bleeding air from cylinders

1. Run the engine at low idling, and extend and retract each cylinder 4-5 times without operating it to the end of its stroke. (Stop approx. 100 mm (4 in) before the end of the stroke)
2. Next, operate each cylinder to the end of its stroke 3-4 times.
3. After this, operate each cylinder 4-5 times to the end of its stroke to completely bleed the air.

### NOTICE

If, at first, the engine is run at high speed or the cylinder is operated to the end of its stroke, the air inside the cylinder may cause damage to the piston packing or other parts.

**4. Bleeding air from swing motor**

1. Run the engine idle at a low speed for about five minutes, then loosen drain port plug ① and confirm that oil flows out.

**NOTICE**

**When doing this, do not operate the swing.**

2. If oil does not flow out, stop the engine and fill the motor case with hydraulic oil through drain port plug ①.
3. After completion of the air bleed operation, tighten drain port plug ①.
4. Run the engine at low idling, and swing 2 or more times slowly and uniformly to the left and right.

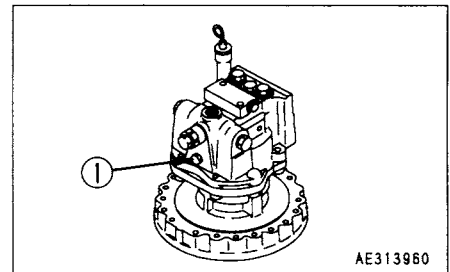
**NOTICE**

**If the air is not bled from the swing motor, the bearings of the motor may be damaged.**

**5. Bleeding air from travel motor (only after draining oil from travel motor case)**

1. Run the engine at low idling, loosen air bleeding plug ①, and if oil flows out, tighten the air bleed plug.
2. Keep the engine running at low idling, and swing the work equipment 90° to bring it to the side of the track.
3. Jack up the machine until the track is raised slightly from the ground. Rotate the track under no load for 2 minutes. Repeat this procedure on both the left and right sides, and rotate the track equally both forward and in reverse.

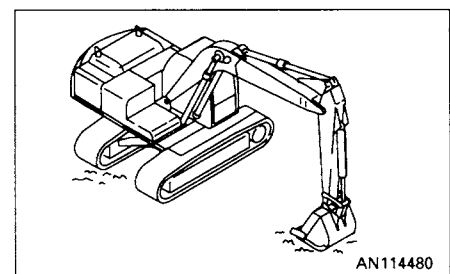
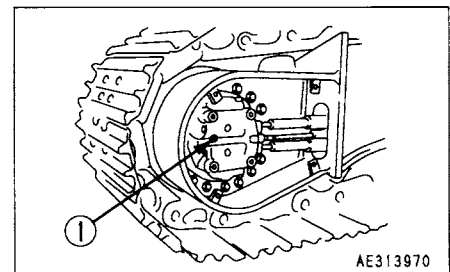



**6. Bleeding air from attachment (if installed)**

For machines equipped with attachments such as the breaker, actuate the attachment pedal about 10 times to bleed the air completely from the attachment circuit while running the engine at low idling.

**NOTICE**

**If the attachment bleeding procedure is specified by the manufacturer, bleed the attachment according to such procedure.**

**7. Operation**

1. After completion of bleeding the air, stop the engine, and wait for at least 5 minutes before starting operations. In this way, the air bubbles are removed from the oil inside the hydraulic tank.
2. Check for any leakage of oil, and wipe off any oil that has been spilled.

# **SPECIFICATIONS**

## 25. SPECIFICATIONS

### PC200, 200LC-6 PC210, 210LC-6 MIGHTY

	PC200-6	PC200LC-6	PC210-6 MIGHTY	PC210LC-6 MIGHTY
<b>WEIGHT</b>				
● Operating weight (without operator)	19100 kg (42120 lb)	20500 kg (45200 lb)	21400 kg (47190 lb)	22300 kg (49170 lb)
<b>PERFORMANCE</b>				
● Bucket capacity (standard bucket) SAE/CECE	0.8 m <sup>3</sup> (1.05 cu.yd)/0.7 m <sup>3</sup>			
● Width of opening	(Standard bucket)	1045 mm (41 in)		
	(With side cutter)	1150 mm (45 in)		
● Travel speed	Low speed	3.0 km/h (1.9 MPH)		
	Middle speed	4.1 km/h (2.5 MPH)		
	High speed	5.5 km/h (3.4 MPH)		
● Swing speed	12.4 rpm			
<b>TRACK SHOE</b>				
● Triple grouser shoe (standard)	600 mm (24 in) width	700 mm (28 in) width	600 mm (24 in) width	
<b>ENGINE</b>				
● Model	Komatsu S6D102E-1-A diesel engine			
● Flywheel horsepower	99 kW (133 HP)/2000 rpm			
● Starting motor	24 V 4.5 kW			
● Alternator	24 V 35 A			
● Battery	12 V 110 Ah x 2 pieces			

**PC200, 200LC-6**

The values given are the values for PC200-6

[     ]: Values for PC200LC-6

In cases where there are no values given in [     ], the values are the same as for PC200-6.

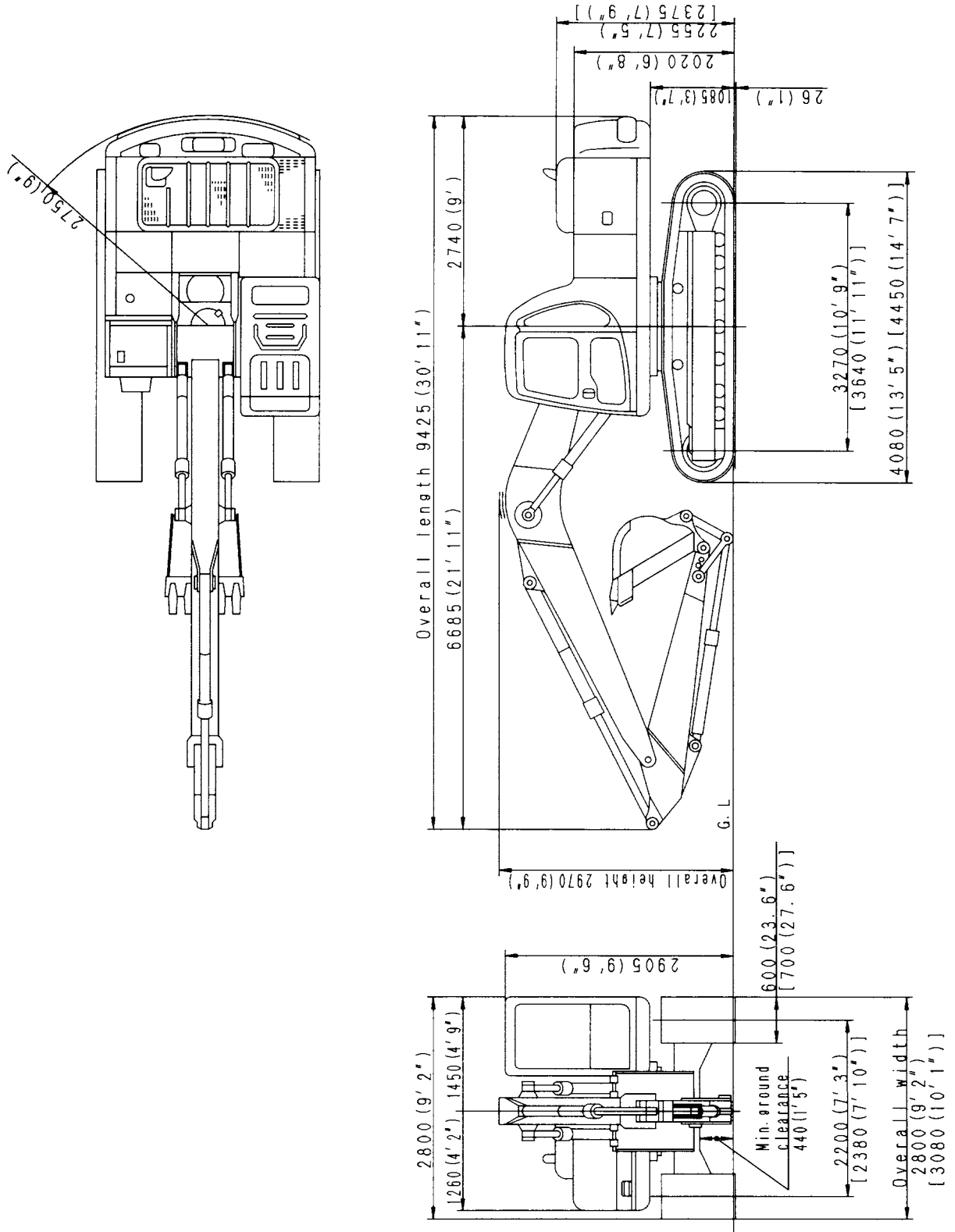

AE32433B

25. SPECIFICATIONS

**PC210, 210LC-6 MIGHTY**

The values given are the values for PC210.

[ ]: Values for PC210LC

In cases where there are no values given in [ ], the values are the same as for PC210.

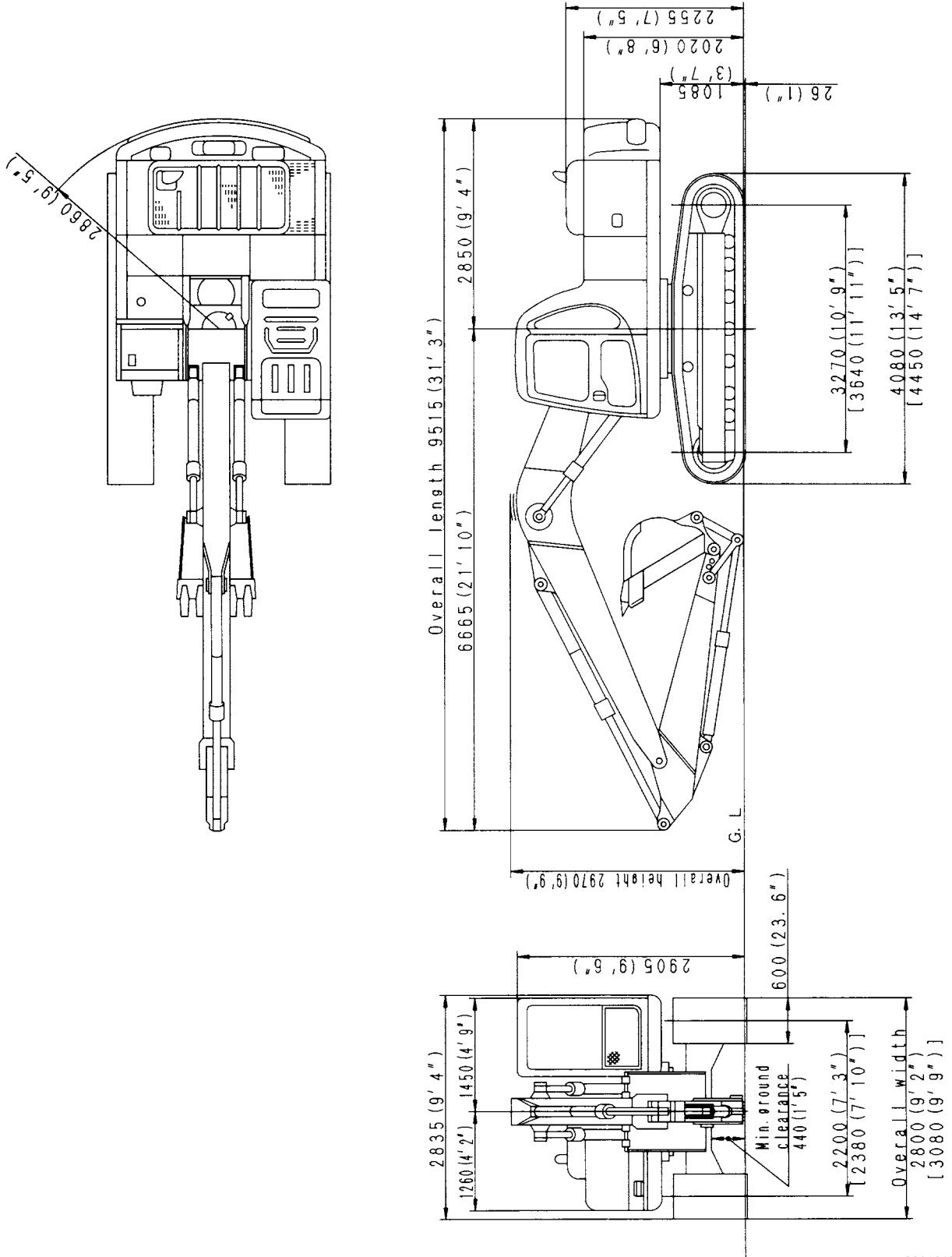

A032434B

**PC200, 200LC-6**  
**PC210, 210LC-6 MIGHTY**

1. The mark ※ indicates the dimensions for shovel operation.
2. Never allow other person than the operator to enter the swing range (Max. swing range, Max. digging radius).

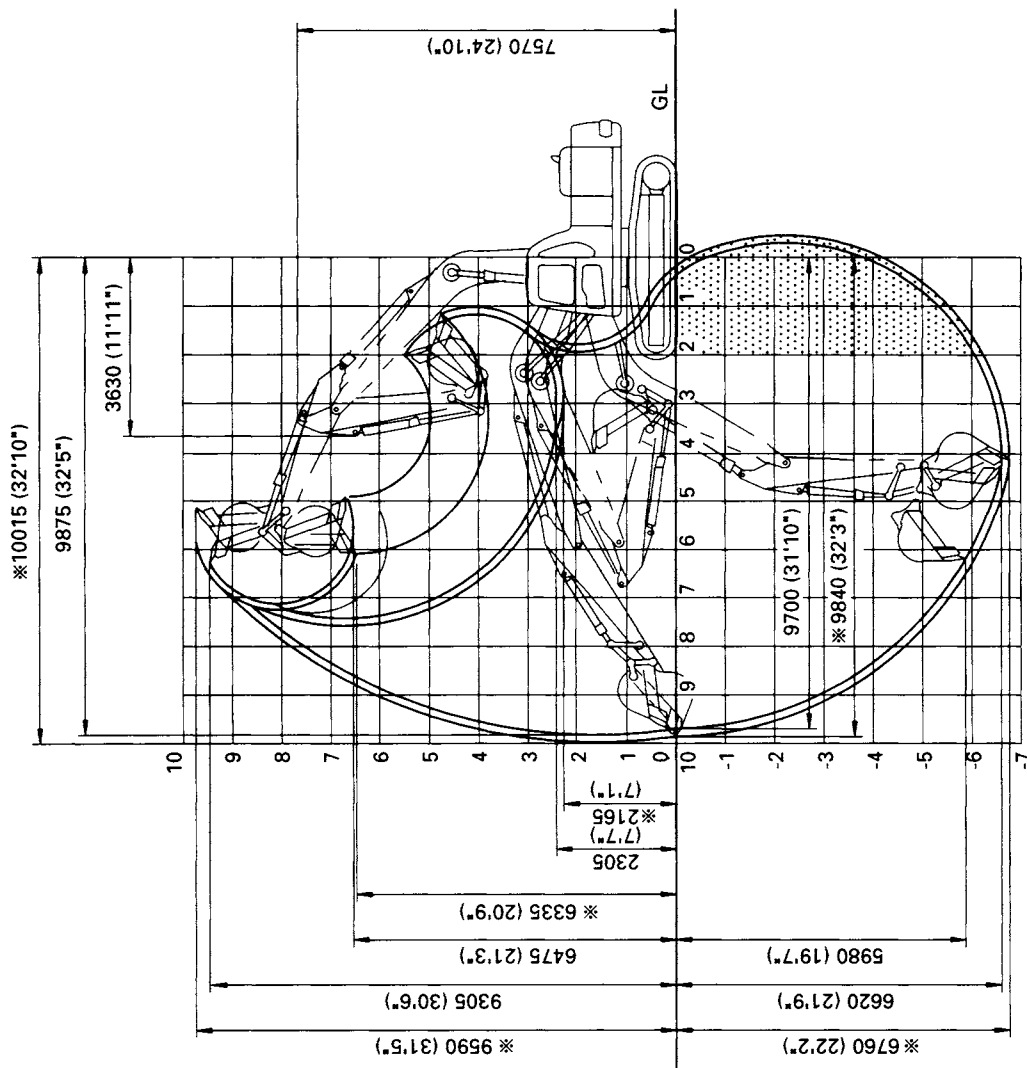

## 25. SPECIFICATIONS

### PC220, 220LC-6 PC230, 230LC-6 MIGHTY

	PC220-6	PC220LC-6	PC230-6 MIGHTY	PC230LC-6 MIGHTY
<b>WEIGHT</b>				
● Operating weight (without operator)	22100 kg (48730 lb)	23400 kg (51600 lb)	23300 kg (51380 lb)	24300 kg (53580 lb)
<b>PERFORMANCE</b>				
● Bucket capacity (standard bucket) SAE/CECE	1.0 m <sup>3</sup> (1.3 cu.yd)/0.9 m <sup>3</sup>			
● Width of opening	(Standard bucket)	1155 mm (46 in)		
	(With side cutter)	1260 mm (50 in)		
● Travel speed	Low speed	3.0 km/h (1.8 MPH)		
	Middle speed	4.1 km/h (2.5 MPH)		
	High speed	5.5 km/h (3.4 MPH)		
● Swing speed	12.4 rpm			
<b>TRACK SHOE</b>				
● Triple grouser shoe (standard)	600 mm (24 in) width	700 mm (28 in) width	600 mm (24 in) width	
<b>ENGINE</b>				
● Model	Komatsu SA6D102E-1-A diesel engine			
● Flywheel horsepower	117 kW (158 HP)/2000 rpm			
● Starting motor	24 V 4.5 kW			
● Alternator	24 V 35 A			
● Battery	12 V 110 Ah x 2 pieces			

**PC220, 220LC-6**

The values given are the values for PC220.

[     ]: Values for PC220LC

In cases where there are no values given in [     ], the values are the same as for PC220.

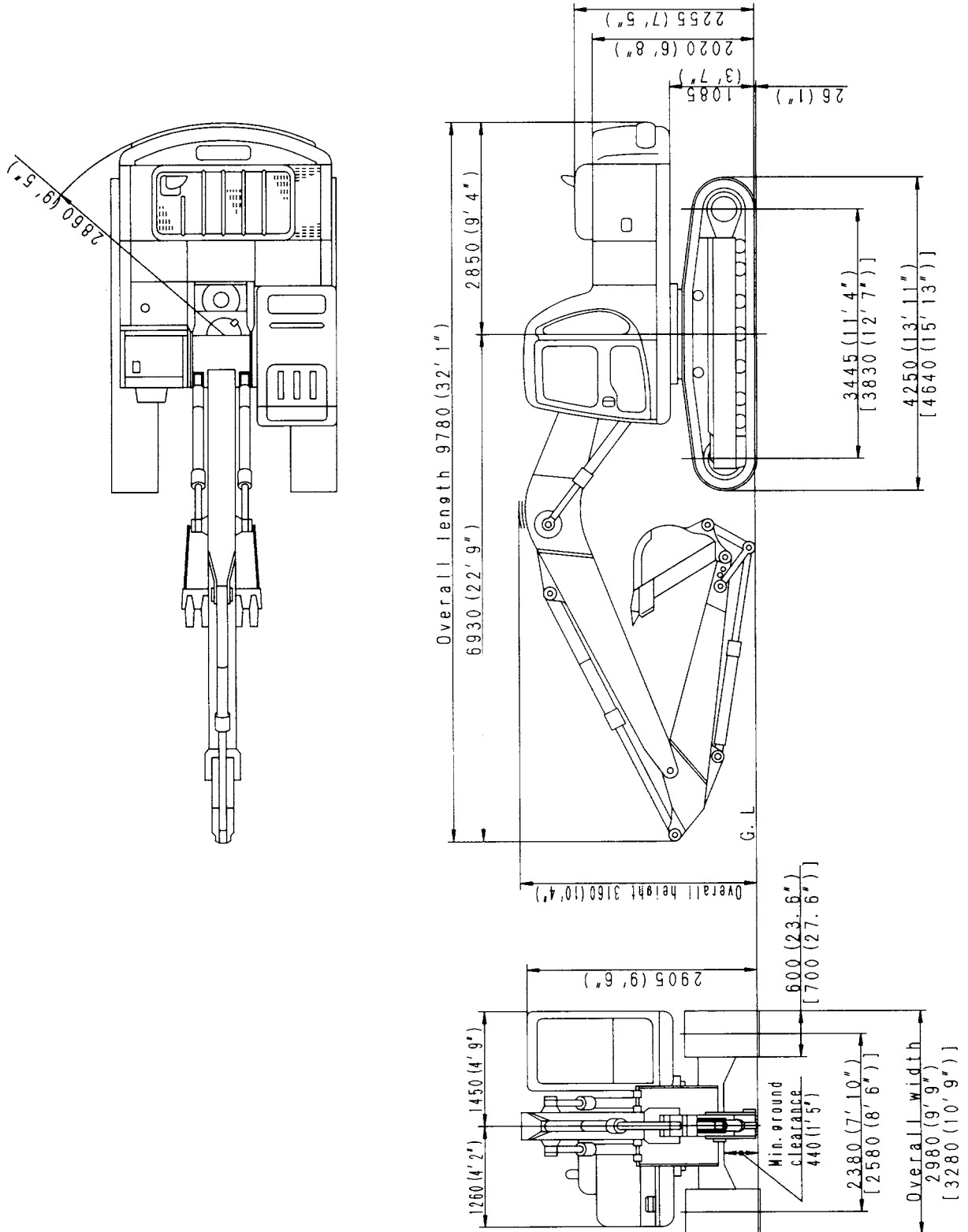



25. SPECIFICATIONS

**PC230, 230LC-6 MIGHTY**

The values given are the values for PC230.

[    ]: Values for PC230LC

In cases where there are no values given in [    ], the values are the same as for PC230.

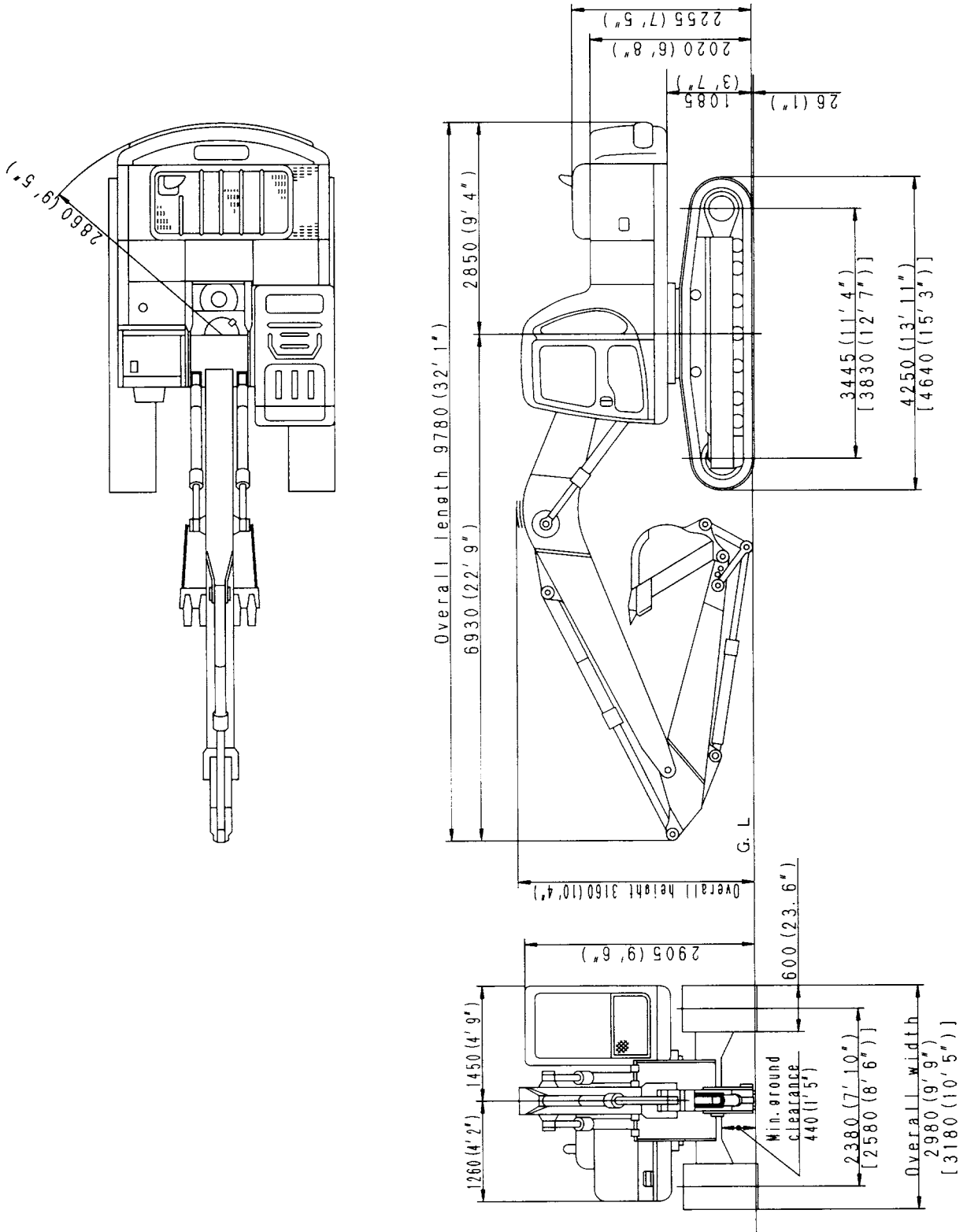

AD32436B

**PC220, 220LC-6**

**PC230, 230LC-6 MIGHTY**

1. The mark ※ indicates the dimensions for shovel operation.
2. Never allow other person than the operator to enter the swing range (Max. swing range, Max. digging radius).

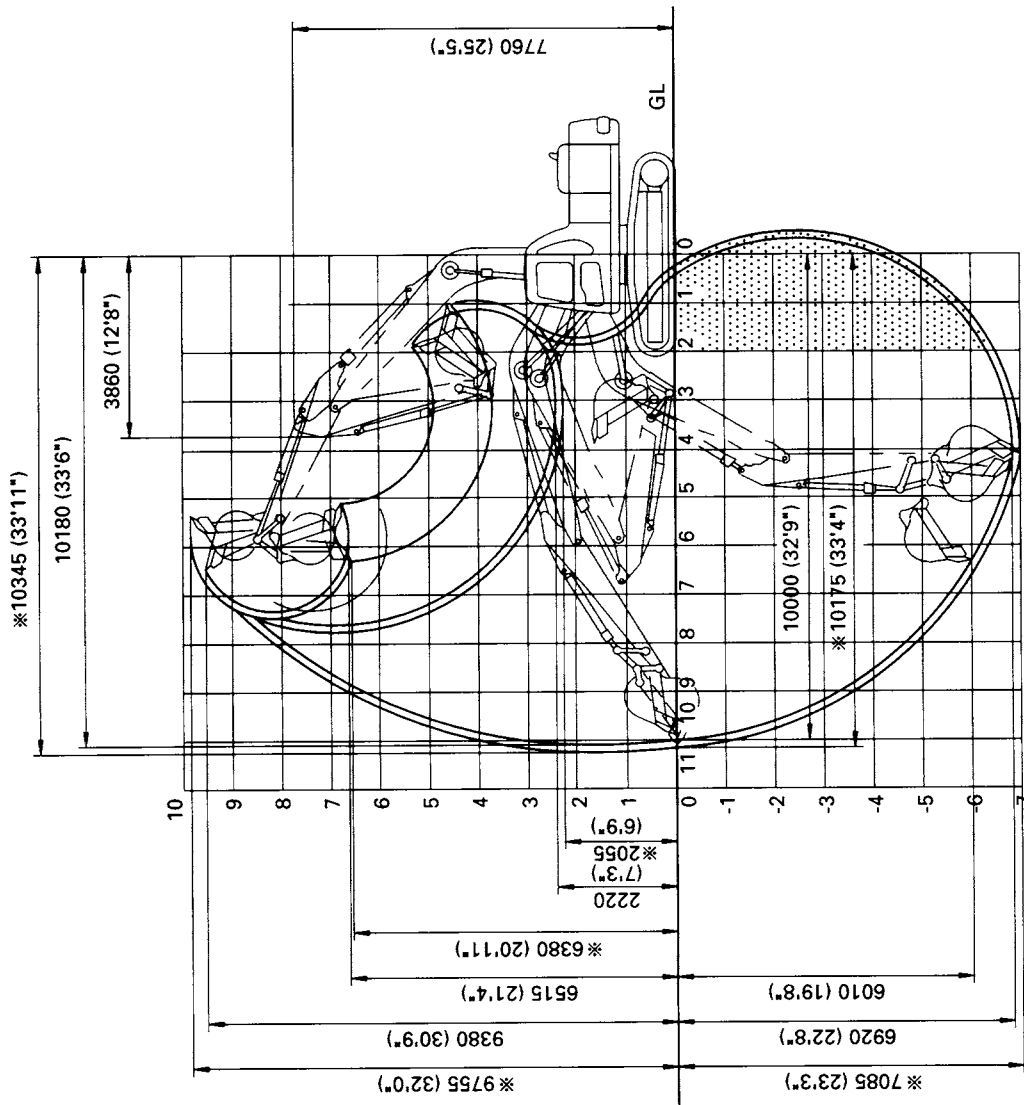

# **OPTIONS, ATTACHMENTS**

## 26. GENERAL PRECAUTIONS

---

### 26.1 PRECAUTIONS RELATED TO SAFETY

If attachments or options other than those authorized by Komatsu are installed, this will not only affect the life of the machine, but will also cause problems with safety.

When installing attachments not listed in this Operation and Maintenance Manual, please contact your Komatsu distributor first.

If you do not contact Komatsu, we cannot accept any responsibility for any accident or failure.

#### WARNING

##### **Precautions for removal and installation operations**

**When removing or installing attachments, obey the following precautions and take care to ensure safety during the operation.**

- **Carry out the removal and installation operations on a flat, firm ground surface.**
- **When the operation is carried out by two or more workers, determine signals and follow these during the operation.**
- **When carrying heavy objects (more than 25 kg (55 lb)), use a crane.**
- **When removing heavy parts, always support the part before removing it.  
When lifting such heavy parts with a crane, always pay careful attention to the position of the center of gravity.**
- **It is dangerous to carry out operations with the load kept suspended. Always set the load on a stand, and check that it is safe.**
- **When removing or installing attachments, make sure that they are in a stable condition and will not fall over.**
- **Never go under a load suspended from a crane.  
Always stand in a position that is safe even if the load should fall.**

#### **NOTICE**

**Qualifications are required to operate a crane. Never allow the crane to be operated by an unqualified person.**

**For details of the removal and installation operations, please contact your Komatsu distributor.**

## 26.2 PRECAUTIONS WHEN INSTALLING ATTACHMENTS

### ⚠ WARNING

Long work equipment reduces the stability of the chassis, so if the swing is operated on a slope, or when going down a steep hill, the machine may lose its balance and overturn. The following operations are particularly dangerous, so never operate the machine in these ways.

- Going downhill with the work equipment raised

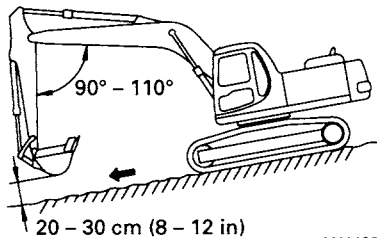

AN112980

- Traveling across slopes

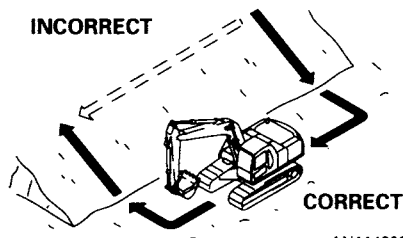

AN114300

- Swinging the upper structure on slopes

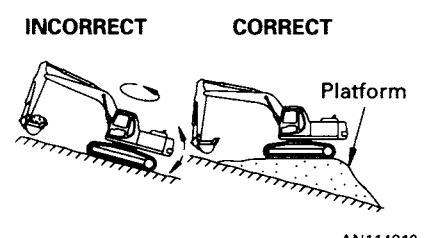

AN114310

- If heavy work equipment is installed, the overrun of the swing becomes greater (the distance from the point where the operator operates the control levers to stop the swing to the point where the upper structure stops completely), so there is danger of mistaking the distance and hitting something.  
Always operate so that there is an ample margin to the stopping point.  
Furthermore, the hydraulic drift also becomes larger (when the work equipment is stopped in mid-air, it will gradually move down under its own weight).
- Always follow the correct procedure when installing the boom and arm. If the correct procedure is not followed, this may lead to serious damage or injury, so please consult your Komatsu distributor before carrying out installation.

If long work equipment is installed, the working range will suddenly become larger, so there is danger of mistaking the distance and hitting something.

Always operate the work equipment so that there is ample space from any obstacles in the area.

## 27. HANDLING BUCKET WITH HOOK

### 27.1 CHECKING FOR DAMAGE TO BUCKET WITH HOOK

Check that there is no damage to the hook, stopper, or hook mount. If any abnormality is found, please contact your Komatsu distributor.

### 27.2 PROHIBITED OPERATIONS

The standard work equipment must not be used for lifting loads. If this machine is to be used for lifting loads, it is necessary to install the specified bucket with hook.

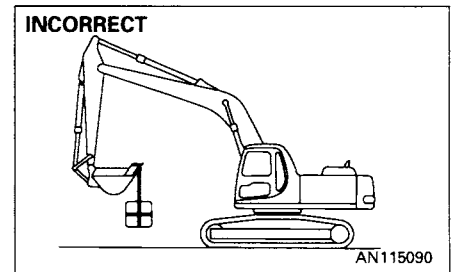

### 27.3 PRECAUTIONS DURING OPERATIONS

- When carrying out lifting operations, reduce the engine speed and use the lifting operation mode.
- Depending on the posture of the work equipment, there is danger that the wire or load may slip off the hook. Always be careful to maintain the correct hook angle to prevent this from happening.
- Never steer the machine while lifting a load.
- If the bucket with hook is turned and used for operations, it will hit the arm during dumping operations, so be careful when using it.
- Loads suspended must not exceed the limit indicated in the "LIFTING CAPACITY TABLE" stuck on the right-side lower portion of the driver's seat.
- If you wish to install a hook in the future, please contact your Komatsu distributor.

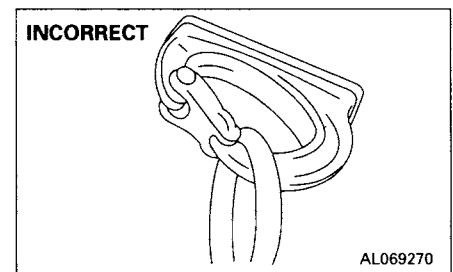
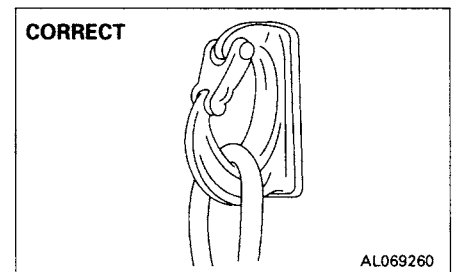

## 28. USING SEAT BELT

### 28.1 SEAT BELT

**⚠ WARNING**

- Before fastening the seat belt, inspect the securing brackets and belt for abnormal conditions. Replace any worn or damaged seat belt or the securing brackets.
- Adjust and fasten the seat belt before operating the machine.
- Always use seat belt when operating the machine.
- Do not use seat belt with either half of the belt kinked.

#### 28.1.1 FASTEN THE BELT AND REMOVE IT

1. Adjust the seat so that the operator feels comfortable while seated, with operator's back against the backrest.
2. For suspension-type seat, adjust tether belt ① after adjusting the seat position. Install the tether belt while keeping it stretched with the seat vacant. (only for suspension-type seat)
3. After adjusting the seat position, sit in the seat. Grip buckle ② and tongue ③ in each hand and insert tongue ③ into buckle ②. Confirm by pulling the belt that the tongue is securely locked to the buckle.
4. When removing the belt, raise the tip of buckle ② lever to release it.

Fasten belt along your body without kinking it. Adjust the lengths of the belt on both the buckle and the tongue sides so that the buckle is located at the mid-point of your body front.

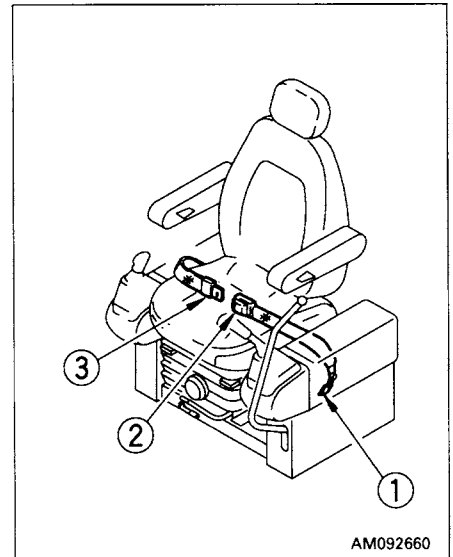

### 28.1.2 ADJUST THE BELT LENGTH

#### To shorten the belt

Pull the free end of the belt on either the buckle body or tongue side.

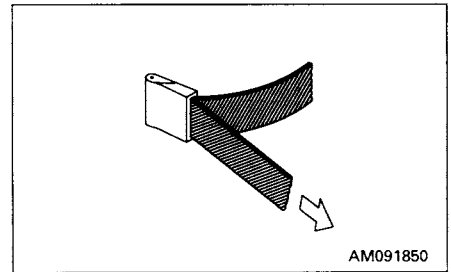

#### To lengthen the belt

Pull the belt while holding it at a right angle to buckle or tongue.

Inspect bolts and fittings on the chassis for tightness. Retighten any loose bolts to 20 to 29 Nm (2 to 3 kgm, 15 to 20 lbft) torque.

If the seat is scratched or frayed or if any of the fittings are broken or deformed from long service, replace the seat belt immediately.

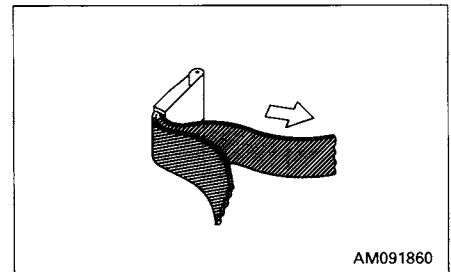



# 29. HANDLING CAR HEATER

## 29.1 EXPLANATION OF COMPONENTS

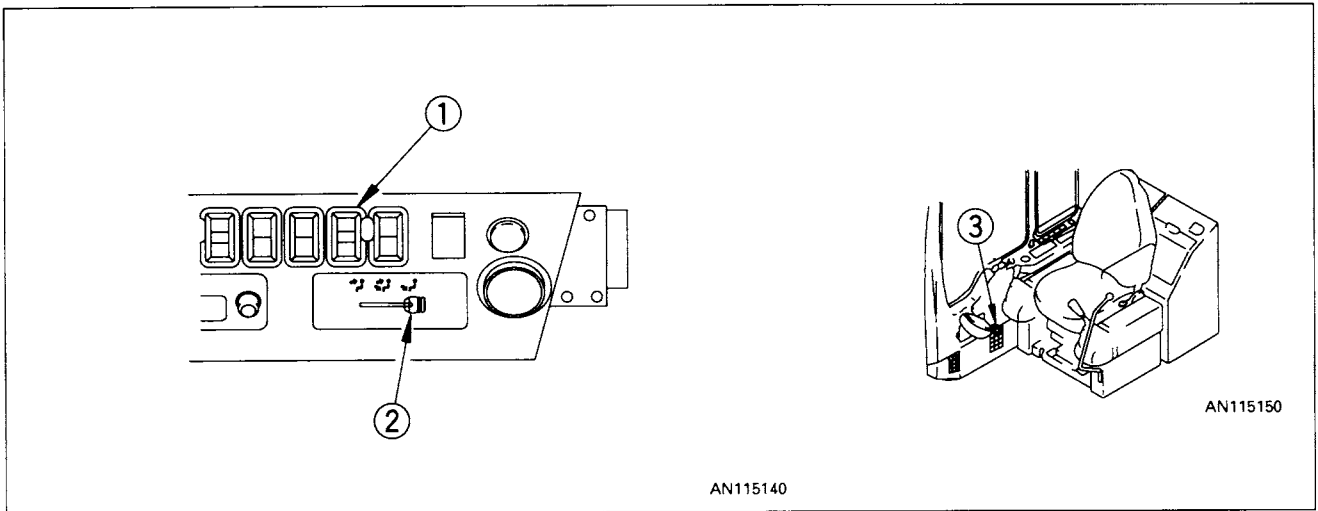

The car heater utilizes the water heated by the engine. Use the car heater when the engine coolant is warmed.

### 1. CAR HEATER FAN SWITCH

This adjusts air-flow in 2 steps.

Hi : Strong

Lo : Weak

OFF: Car heater turned off.

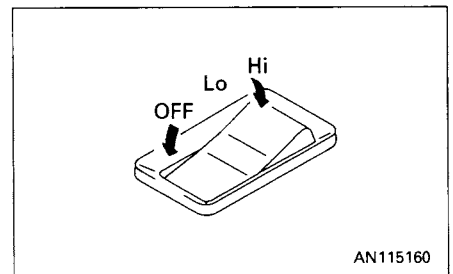

### 2. AIR OUTLET CHANGE-OVER LEVER

The air outlet is selectable according to the purpose.

Purpose	To upper portion of operator	To upper and portions of operator	To foot portion of operator
Lever position			
Air outlet	AN115170	AN115180	AN115190



## 29. HANDLING CAR HEATER

### 3. DEFROSTER CHANGE-OVER LEVER

This lever is used to eliminate condensation produced in winter or the rainy season etc.

Change-over lever forward: Defroster

Change-over lever backward: to operator's feet

Defroster is available when using the air outlet change-over lever in  or .

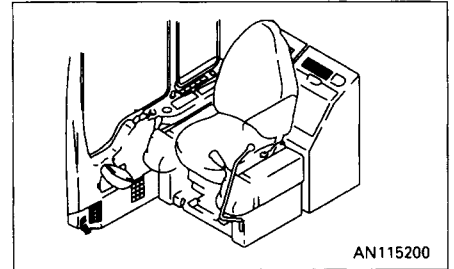
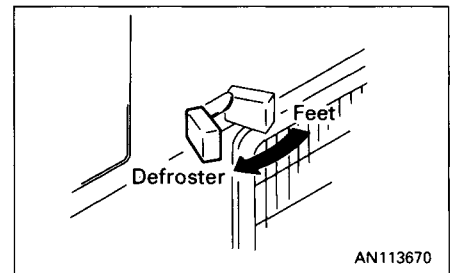

## 29.2 PREPARING CAR HEATER

If the ambient temperature drops, use the cab heater.

When using the cab heater, turn valve ① on the water pump counterclockwise to open it.

When leaving the cab heater unused for a long time, turn valve ① clockwise to close it.

### REMARK

On machines equipped with the air conditioner system, always open valve ①.

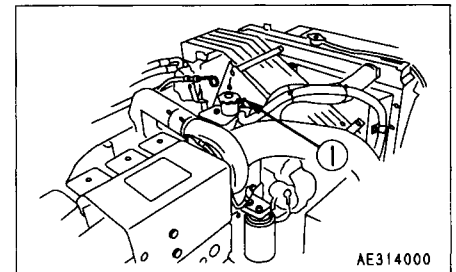

## 30. MACHINES READY FOR ATTACHMENTS

### 30.1 EXPLANATION OF COMPONENTS

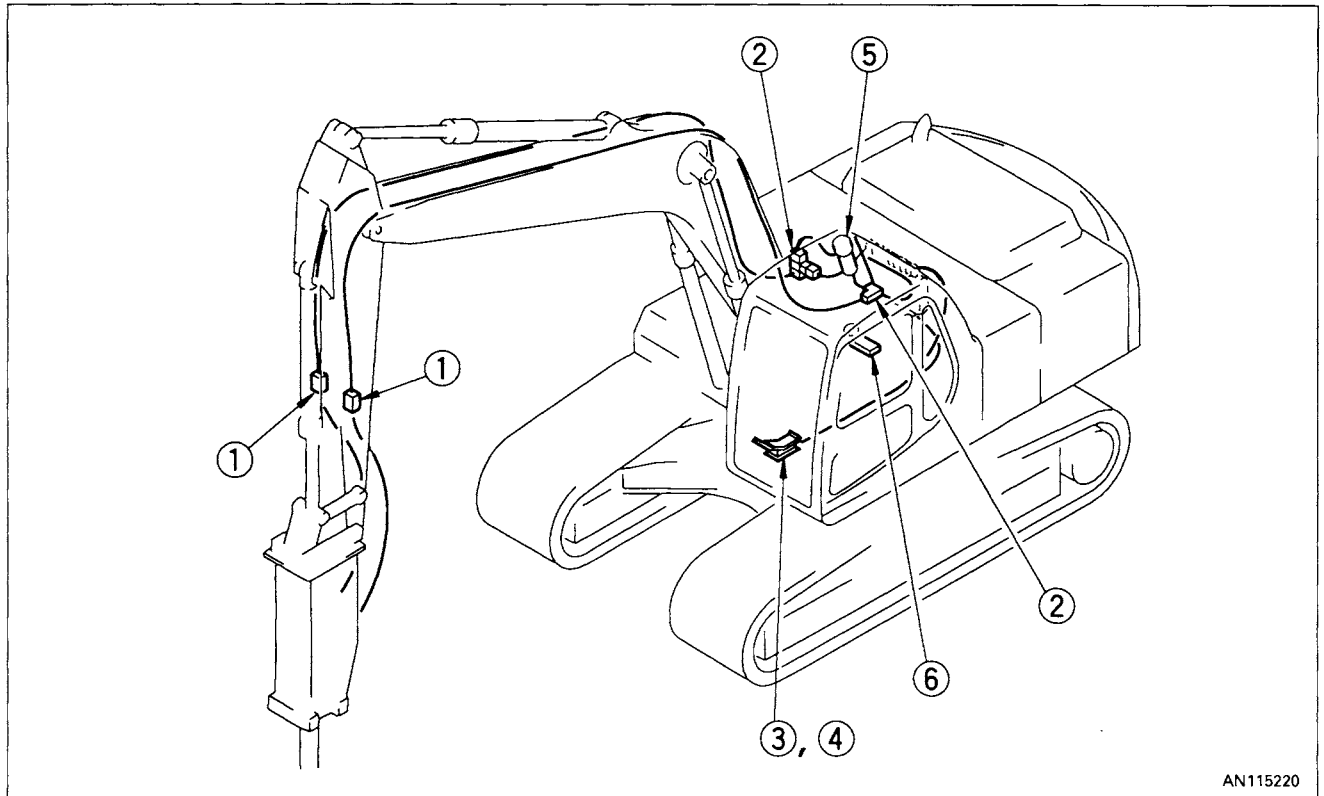

AN115220

#### 1. STOP VALVE

This valve stops the flow of the hydraulic oil.

① FREE: Hydraulic oil flows

② LOCK: Hydraulic oil stops

Set this valve to the LOCK position when removing or installing attachments.

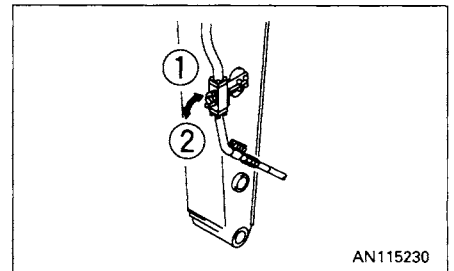

AN115230

#### 2. SELECTOR VALVE

This switches the flow of the hydraulic oil.

For attachment to be mounted and the direction of left and right 3-way valves ① and ②, see "30.2 HYDRAULIC CIRCUIT".

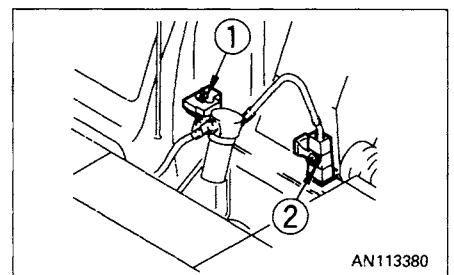

AN113380

### 3. ATTACHMENT CONTROL PANEL

This is used to operate the attachment.

When the operator depresses the pedal at the front, neutral or rear portions, the attachment moves as follows.

#### Hydraulic breaker

Pedal front ① : actuated

Pedal neutral (N) : stopped

Pedal rear ② : stopped

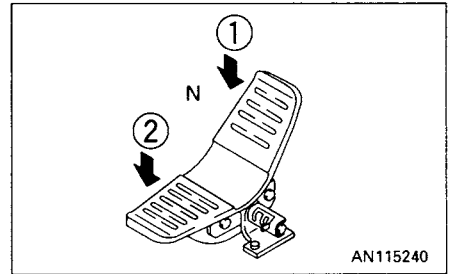

AN115240

For other attachments, confirm with the manufacturer regarding the relation between pedal operation and attachment movement when the attachment is mounted. Use the attachment only after confirming the above.

### 4. LOCK PIN

This is used to lock the control pedal.

Position ①: lock

Position ②: pedal half stroke position (flow: about 50%)

Position ③: pedal full stroke position (flow: 100%)

- When the breaker is used, select the breaker operation mode (B.O.) in the monitor and use the pedal at position ③.
- If other attachment is used at lower flow, select position ②.

Set the lock pin at the lock position when attachment is not used.

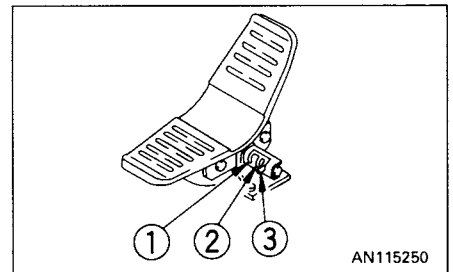

AN115250

### 5. ADDITIONAL FILTER FOR BREAKER

This filter prevents degradation of the hydraulic oil when the breaker is used.

Oil flows only when the selector valve is turned to the breaker position.

#### NOTICE

If the machine is equipped with the hydraulic breaker, be sure to install an additional filter to the return circuit.

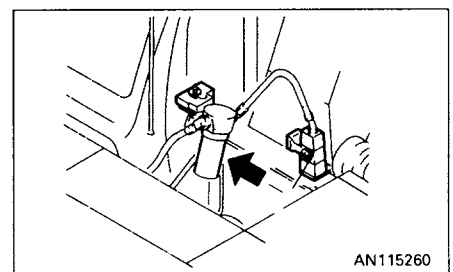

AN115260

### 6. ACCUMULATOR

#### ⚠ WARNING

The accumulator is filled with high-pressure nitrogen gas, and it is extremely dangerous if it is handled in the wrong way. For handling procedure, see "11.18 HANDLING ACCUMULATOR".

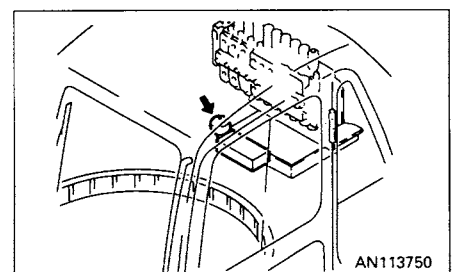

AN113750

The accumulator is provided to release the pressure remaining in the attachment circuit after stopping the engine. Normally, never touch it.

### 30.2 HYDRAULIC CIRCUIT

#### Change-over hydraulic circuit

When the machine is equipped with an attachment or a bucket, set left and right 3-way valves ① and ② as follows.

Referring to the following chart, turn the rotors of left and right 3-way valves ① and ② using a wrench to select the attachment to be mounted and the direction of both 3-way valves. (The arrows indicating the port direction are stamped on the 3-way valve heads.)

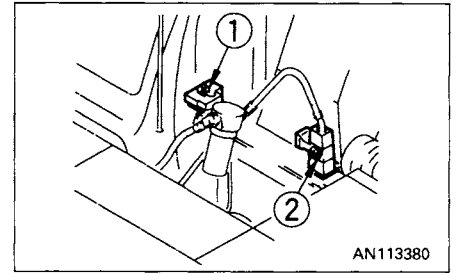

Attachment	Left 3-way valve ①	Right 3-way valve ②
Breaker etc.	Forward direction of machine 	Upper direction of machine 
Crusher etc.	Forward direction of machine 	Upper direction of machine 
When not used	Forward direction of machine 	Upper direction of machine 

#### NOTICE

- When the machine is equipped with the breaker, connect the return circuit directly to the return filter.
- The set pressure of the low pressure safety valve is set to 20600 kPa (210 kg/cm<sup>2</sup>, 2980 psi) as standard when delivered from the factory.  
If a breaker by another manufacturer is installed, adjustment is required. Consult your Komatsu distributor.

## 30. MACHINES READY FOR ATTACHMENTS

### 30.2.2 CONNECTING HYDRAULIC CIRCUIT

When connecting the attachment, connect the circuit as follows.

1. Remove blind plugs ① located on the end of the stop valve piping (2 places, left and right).  
Take care not to lose or damage the removed parts.
2. Connect attachment tubes ② supplied by the attachment manufacturer to the end from which the plug was removed in step 1.

When the machine is shipped from the factory, a 1" taper seal hose is installed to tube ③. The procedure used by the attachment manufacturer if an accumulator is added is different, so please consult your Komatsu distributor.

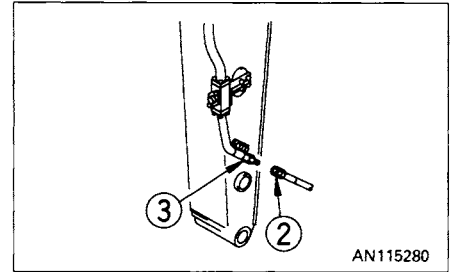
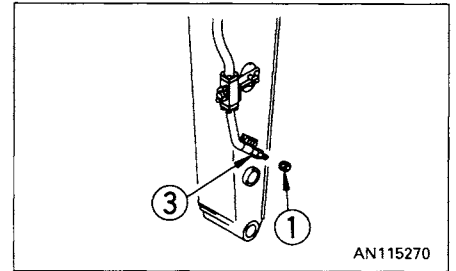

### PATH OF OIL

The direction of operation of the pedal and the path of the oil are as shown in the diagram below.

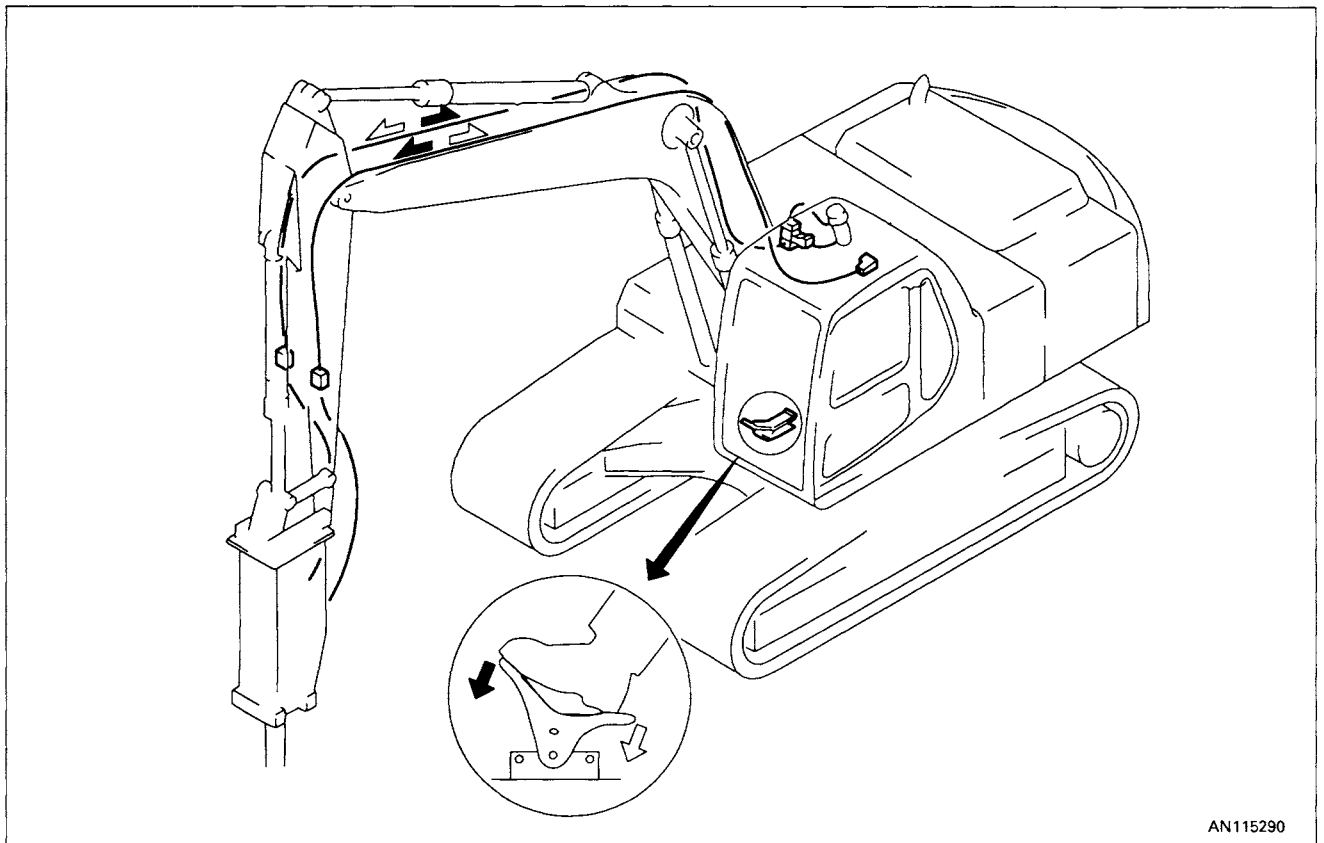

### 30.3 ATTACHMENT MOUNTING/DISMOUNTING PROCEDURE

#### DISMOUNTING PROCEDURE

1. Place the attachment on the ground and stop the engine.
2. After stopping the engine, operate each work equipment control lever and the attachment control pedal back and forth, left and right at full stroke 2 to 3 times to eliminate the internal pressure in the hydraulic circuit.
3. After confirming low oil temperature, turn the rotor of the stop valve connected to the inlet and outlet piping on the arm side face toward the lock side.
4. Remove the hoses on the attachment side. Install the blind plugs to the two outlets.

The blind plugs are used to prevent the attachment from incorrect operation caused by mixing in of foreign matter. After the plugs are correctly installed, store the attachment.

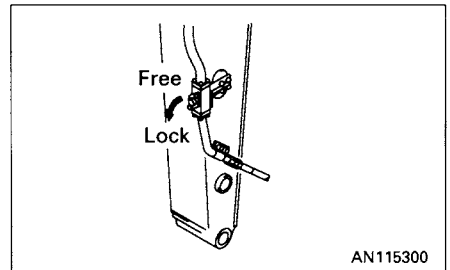

5. Dismount the attachment by removing the retaining pins (2 pins). Then, mount the bucket.

For the bucket mounting procedure, see "12.16 REPLACEMENT AND INVERSION OF BUCKET".

6. After the bucket is mounted, check the hydraulic oil level.

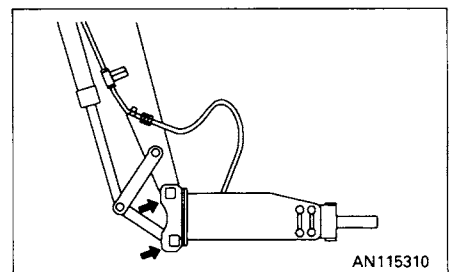

### MOUNTING PROCEDURE

1. Remove the bucket.

For bucket dismounting procedure, see "12.16 REPLACEMENT AND INVERSION OF BUCKET".

2. Place the attachment on a flat place, install pins (A) and (B) to the arm in that order.
3. After mounting the attachment, stop the engine. Operate each work equipment control lever and the attachment control pedal to full stroke back and forth, right and left to eliminate the internal pressure in the hydraulic circuit.
4. After confirming low oil temperature, remove the blind plug from the outlet and inlet port respectively.

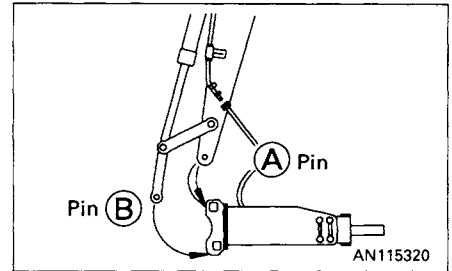

Take care that no dust, mud etc. adheres to the hose mousepiece portions.

If O-ring is damaged, replace it with a new one.

5. Turn the rotor of the stop valve connected to the inlet and outlet piping on the arm side face toward the free side.
6. Confirm that oil level in the hydraulic oil tank is correct, after mounting the attachment.

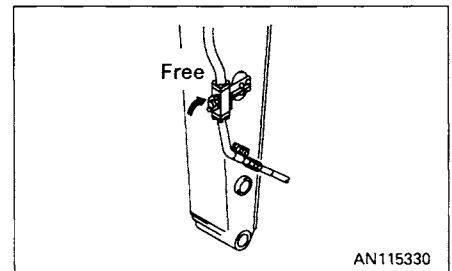



## 30.4 OPERATION

### WARNING

- If the pedal is operated inside the deceleration range, the engine speed will rise suddenly. Be careful.
- If the operator rests his foot on the attachment pedal while operating the machine, if he carelessly depresses the pedal, the attachment may move suddenly and result in serious trouble. Never place your foot on the pedal except when actually performing pedal operation.

The operation of the attachment is as follows.

### WHEN USING BREAKER

When the front portion of the pedal is depressed after the lock pin is set at the free position, the breaker is actuated. Select the working mode for breaker (B.O.).

### Precautions when using

- Check that the stop valve is at the FREE position.
- Check that the selector valve is at the position for using the breaker.

For details of the oil path, see "30.2 HYDRAULIC CIRCUIT".

- Consult with the attachment manufacturer as to whether the accumulator is required for the attachment circuit or not.
- For other precautions when using the breaker, see the instruction manual provided by the breaker manufacturer.
- When the breaker is used, the hydraulic oil degrades faster than in normal operation. Shorten the maintenance interval of the hydraulic oil and filter element.  
See "23.2 MAINTENANCE INTERVAL WHEN USING HYDRAULIC BREAKER".

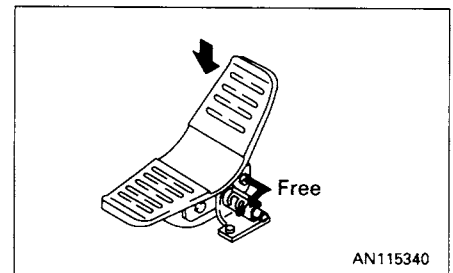

### WHEN USING GENERAL ATTACHMENT SUCH AS CRUSHER

When the lock pin is set to the free position and the pedal is depressed at the front or rear portions, the attachment is actuated.

#### Precautions when using

- Check that the stop valve is at the FREE position.
- Confirm that the selector valve is set to the position for general attachments such as the crusher.

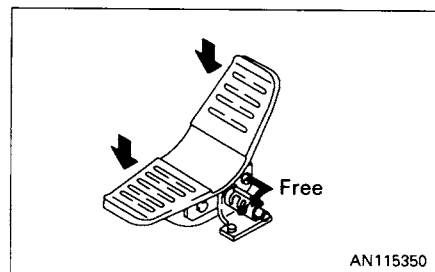

For details of the oil path, see "30.2 HYDRAULIC CIRCUIT".

- For other precautions when using the attachment, see the instruction manual provided by the attachment manufacturer.

### 30.5 LONG-TERM STORAGE

If the equipment is not to be used for a long period, do as follows.

- Set the stop valve to the LOCK position.
- Install the blind plugs and O-rings to the valves.
- Set the selector valve to the "when not use" position.
- Lock the lock pin to the lock position.

If the pedal is operated when there is no breaker or general attachment installed, it will cause overheating and other problems.

### 30.6 SPECIFICATIONS

#### Hydraulic specifications

- Max. flow when flow is joined:  
191 x 2 liter/min (50 x 2 US gal/min, 42 x 2 UK gal/min)
- Safety valve relief set pressure of service valve:  
27500 kPa (280 kg/cm<sup>2</sup>, 3980 psi)
- Safety valve cracking pressure of service valve:  
24500 kPa (250 kg/cm<sup>2</sup>, 3550 psi)
- Low pressure safety valve relief set pressure:  
20500 kPa (210 kg/cm<sup>2</sup>, 2980 psi)
- Low pressure safety valve cracking pressure:  
15200 kPa (155 kg/cm<sup>2</sup>, 2200 psi)

Other than these specifications, low pressure safety valve relief set pressure of 24500 kPa (250 kg/cm<sup>2</sup>, 3550 psi) and low pressure safety valve cracking pressure of 20100 kPa (205 kg/cm<sup>2</sup>, 2910 psi) are provided. Consult your Komatsu distributor.

# 31. INTRODUCTION OF ATTACHMENTS

## 31.1 SPECIFICATION, USE

### ● PC200, 200LC

Name	Specifications, use
Narrow bucket	Capacity SAE/CECE 0.5 m <sup>3</sup> (0.65 cu.yd)/0.45 m <sup>3</sup> Outside width 750 mm (30")
Narrow bucket	Capacity SAE/CECE 0.6 m <sup>3</sup> (0.78 cu.yd)/0.55 m <sup>3</sup> Outside width 970 mm (38")
Light duty bucket	Capacity SAE/CECE 0.9 m <sup>3</sup> (1.18 cu.yd)/0.8 m <sup>3</sup> Outside width 1200 mm (47")
Light duty bucket	Capacity SAE/CECE 1.0 m <sup>3</sup> (1.31 cu.yd)/0.9 m <sup>3</sup> Outside width 1330 mm (52")
Light duty bucket	Capacity SAE/CECE 1.17 m <sup>3</sup> (1.53 cu.yd)/1.0 m <sup>3</sup> Outside width 1450 mm (57")
Slope finishing bucket	Capacity SAE/CECE 0.40 m <sup>3</sup> (0.52 cu.yd)/0.35 m <sup>3</sup> Compacting width 2000 mm (79") Compacting area 2.00 m <sup>2</sup>
Trapezoidal bucket	Capacity SAE/CECE 0.55 m <sup>3</sup> (0.72 cu.yd)/0.5 m <sup>3</sup> Outside width 3165 mm (10'5") (45°) 3280 mm (10'9") (45°) 3310 mm (10'10") (45°)
Ripper bucket	Capacity SAE/CECE 0.61 m <sup>3</sup> (0.8 cu.yd)/0.56 m <sup>3</sup> Outside width 950 mm (37")
Clamshell bucket (Loading)	Capacity SAE/CECE 0.66 m <sup>3</sup> (0.86 cu.yd)/0.6 m <sup>3</sup> Outside width 866 mm (34") Opening width 1782 mm (70")
Ditch cleaner bucket	Capacity SAE/CECE 0.80 m <sup>3</sup> (1.05 cu.yd)/0.7 m <sup>3</sup> Outside width 1800 mm (71")
One tooth ripper bucket	Shank width 106 mm (4.2") Crushing depth 800 mm (32")

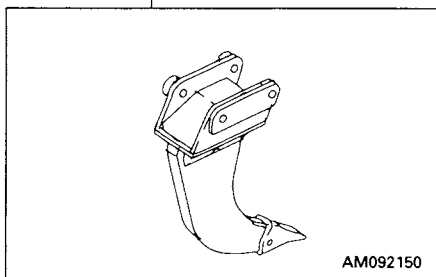

Name	Specifications, use
Three teeth ripper bucket	Shank width 90 mm (3.5") Crushing depth 640 mm (25")
Track shoes (PC200)	Triple grouser shoe width 700 mm (28") Triple grouser shoe width 800 mm (31.4") Flate shoe width 610 mm (24") Swamp shoe width 860 mm (34") Rubber shoe width 600 mm (24")
Track shoes (PC200LC)	Triple grouser shoe width 600 mm (24") Triple grouser shoe width 800 mm (31.4") Triple grouser shoe width 900 mm (35.4") Swamp shoe width 860 mm (34") Flate shoe width 610 mm (24") Rubber shoe width 600 mm (24")
Short arm	Arm length 2400 mm (7'10") Max. digging depth 6095 mm (20")
Short arm	Arm length 1800 mm (5'11") Max. digging depth 5495 mm (18")
Extension arm	Arm length 1130 mm (3'8") Max. digging depth 7750 mm (25'5")
Head guard	In place where there is danger of falling rocks, always install the head guard to protect the operator.

### ● PC210, 210LC

Name	Specifications, use
Ripper bucket	Capacity SAE/CECE 0.61 m <sup>3</sup> (0.8 cu.yd)/0.56 m <sup>3</sup> Outside width 950 mm (37")
One tooth ripper bucket	Shank width 106 mm (4.2") Crushing depth 800 mm (32")
Three teeth ripper bucket	Shank width 90 mm (3.5") Crushing depth 640 mm (25")
Track shoes	Flate shoe width 610 mm (24")

## 31. INTRODUCTION OF ATTACHMENTS

### ● PC220, 220LC

Name	Specifications, use
Narrow bucket	Capacity SAE/CECE 0.72 m <sup>3</sup> (0.94 cu.yd)/0.65 m <sup>3</sup> Outside width 900 mm (35")
Light duty bucket	Capacity SAE/CECE 1.14 m <sup>3</sup> (1.49 cu.yd)/1.0 m <sup>3</sup> Outside width 1300 mm (51")
Light duty bucket	Capacity SAE/CECE 1.26 m <sup>3</sup> (1.65 cu.yd)/1.1 m <sup>3</sup> Outside width 1400 mm (55")
Slope finishing bucket	Capacity SAE/CECE 0.40 m <sup>3</sup> (0.52 cu.yd)/0.35 m <sup>3</sup> Compacting width 2000 mm (79") Compacting area 2.00 m <sup>2</sup>
Trapezoidal bucket	Capacity SAE/CECE 0.55 m <sup>3</sup> (0.72 cu.yd)/0.5 m <sup>3</sup> Outside width 3165 mm (10'5") (45°) 3280 mm (10'9") (45°) 3310 mm (10'10") (45°)
Ripper bucket	Capacity SAE/CECE 0.61 m <sup>3</sup> (0.8 cu.yd)/0.56 m <sup>3</sup> Outside width 950 mm (37")
Clamshell bucket (Loading)	Capacity SAE/CECE 0.66 m <sup>3</sup> (0.86 cu.yd)/0.6 m <sup>3</sup> Outside width 866 mm (34") Opening width 1782 mm (70")
Ditch cleaner bucket	Capacity SAE/CECE 0.80 m <sup>3</sup> (1.05 cu.yd)/0.7 m <sup>3</sup> Outside width 1800 mm (71")
One tooth ripper bucket	Shank width 106 mm (34.2") Crushing depth 800 mm (32")

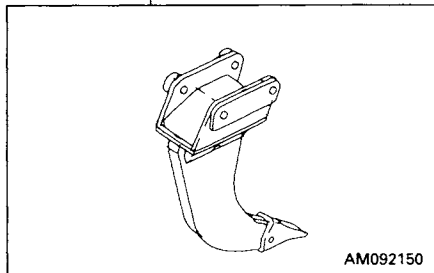

Name	Specifications, use
Three teeth ripper bucket	Shank width 90 mm (3.5") Crushing depth 640 mm (25")
Track shoes (PC220)	Triple grouser shoe width 700 mm (28") Triple grouser shoe width 800 mm (31'4") Flate shoe width 610 mm (24")
Track shoes (PC220LC)	Triple grouser shoe width 600 mm (24") Triple grouser shoe width 800 mm (31'4") Flate shoe width 610 mm (24")
Short arm	Arm length 2500 mm (8'2") Max. digging depth 6370 mm (20'11")
Short arm	Arm length 2000 mm (6'7") Max. digging depth 5870 mm (19'3")
Long arm	Arm length 3500 mm (11'6") Max. digging depth 7350 mm (24'1")
Head guard	In place where there is danger of falling rocks, always install the head guard to protect the operator.

### ● PC230, 230LC

Name	Specifications, use
Ripper bucket	Capacity SAE/CECE 0.61 m <sup>3</sup> (0.8 cu.yd)/0.56 m <sup>3</sup> Outside width 950 mm (37")
One tooth ripper bucket	Shank width 106 mm (4.2") Crushing depth 800 mm (32")
Three teeth ripper bucket	Shank width 90 mm (3.5") Crushing depth 640 mm (25")
Track shoes	Flate shoe width 610 mm (24")

- Long-life tooth, self-sharpening tooth, track frame center guard, arm hydraulic drift prevention valve, additional headlamp, rear lamp, travel alarm etc. are also provided. Please consult your Komatsu distributor.

## 31.2 ATTACHMENT INSTALLATION COMBINATION TABLE

### PC200, 200LC

This table lists the combination of attachments which can be installed to the long arm (standard), short arm and extension arm.

○ : Can be used

△ : Can be used only for light-duty work

x : Cannot be used

### NOTICE

- When the extension arm is equipped, if the bucket is drawn to the machine body, the arm interferes with the body. Operate the extension arm carefully.
- When the boom is fully lowered during oblique digging, the boom interferes with the undercarriage. Operate the boom carefully.

### Categories of use

For general digging: digging or loading sand, gravel, clay etc.

For light duty digging: digging or loading dry, uncaked earth and sand, mud etc.

For loading work: loading dry, loose earth and sand

- For digging or loading hard soil or soft rock, it is recommended that the strengthened bucket with high durability and high wear resistance be employed.

\*: Equipped with side cutter

Name of bucket	Capacity (m <sup>3</sup> ) SAE (CECE)	Outside width (mm)	Use	Standard arm (2.9 m)	Short arm (2.4 m)	Extension arm (1.1 m)	Short arm (1.8 m)
* Narrow bucket	0.50 (0.45)	750 (30")	Narrow digging	○	○	○	○
* Narrow bucket	0.60 (0.55)	970 (38")	Narrow digging	○	○	x	○
* Standard bucket	0.8 (0.7)	1150 (45")	General digging	○	○	x	○
* Light duty bucket	0.9 (0.8)	1200 (47")	Loading	△	△	x	△
Light duty bucket	1.0 (0.9)	1330 (52")	Loading	x	△	x	△
Light duty bucket	1.17 (1.0)	1450 (57")	Loading	x	△	x	△
Slope finishing bucket	0.40 (0.35)	-	Slope finishing	○	○	x	○
Trapezoidal bucket (Variable slope type)	0.55 (0.5)	-	Trapezoidal shaped ditching	○	○	x	○
Ripper bucket	0.61 (0.56)	950 (37")	Digging rocks	x	○	x	○
Clamshell bucket	0.66 (0.6)	866 (34")	Ditching, loading	○	○	x	○
Ditch cleaning bucket	0.8 (0.7)	1800 (71")	Ditching, cleaning	○	○	x	○
One tooth ripper	-	-	Digging, removing rocks	○	○	x	○
Three teeth ripper	-	-	Digging, removing rocks	○	○	x	○

## 31. INTRODUCTION OF ATTACHMENTS

### PC220, 220LC

For trimming of a slope and rolling compaction.

○ : available

△ : available only for light-duty work

x : not available

### NOTICE

- **When the boom is fully lowered during oblique digging, the boom interferes with the undercarriage. Operate the boom carefully.**

### Categories of use

For general digging: digging or loading sand, gravel, clay etc.

For light duty digging: digging or loading dry, uncaked earth and sand, mud etc.

For loading work: loading dry, loose earth and sand

- For digging or loading hard soil or soft rock, it is recommended that the strengthened bucket with high durability and high wear resistance be employed.

\*: Equipped with side cutter. \*1 is available only during loading operation.

Name of bucket	Capacity (m <sup>3</sup> ) SAE (CECE)	Outside width (mm)	Use	Standard arm (3.0 m)	Long arm (3.5 m)	Short arm (2.5 m)	Short arm (2.0 m)
* Narrow bucket	0.72 (0.65)	900 (35")	Narrow digging	○	○	○	○
* Standard bucket	1.0 (0.9)	1260 (50")	General digging	○	△ *1	○	○
* Light duty bucket	1.17 (1.0)	1300 (51")	Light duty digging	△	x	△	△
Light duty bucket	1.26 (1.1)	1400 (55")	Loading	△	x	△	△
Slope finishing bucket	0.40 (0.35)	-	For trimming of a slope and rolling compaction	○	○	○	○
Trapezoidal bucket (Variable slope type)	0.55 (0.5)	-	Trapezoidal shaped ditching	○	○	○	○
Ripper bucket	0.61 (0.56)	950 (37")	Digging rocks	○	○	○	○
Clamshell bucket	0.66 (0.6)	866 (34")	Ditching, loading	○	○	○	○
Ditch cleaning bucket	0.8 (0.7)	1800 (71")	Ditching, cleaning	○	○	○	○
One tooth ripper	-	-	Digging, removing rocks	○	x	○	○
Three teeth ripper	-	-	Digging, removing rocks	○	x	○	○

**PC210, 210 LC****NOTICE**

- **When the boom is fully lowered during oblique digging, the boom interferes with the undercarriage. Operate the boom carefully.**

\*: Equipped with side cutter

Name	Capacity (m <sup>3</sup> ) SAE (CECE)	Outside width (mm)	Use	Standard arm (2.9 m)
* Rock (standard) bucket	0.8 (0.7)	1150 (45")	General digging	o
Ripper bucket	0.61 (0.56)	950 (37")	Digging rocks	o
One tooth ripper	-	-	Digging, removing rocks	o
Three teeth ripper	-	-	Digging, removing rocks	o

**PC230, 230LC****NOTICE**

- **When the boom is fully lowered during oblique digging, the boom interferes with the undercarriage. Operate the boom carefully.**

\*: Equipped with side cutter

Name	Capacity (m <sup>3</sup> ) SAE (CECE)	Outside width (mm)	Use	Standard arm (2.9 m)
* Rock (standard) bucket	1.0 (0.9)	1260 (50")	General digging	o
Ripper bucket	0.61 (0.56)	950 (37")	Digging rocks	o
One tooth ripper	-	-	Digging, removing rocks	o
Three teeth ripper	-	-	Digging, removing rocks	o

### 31.3 SELECTION OF TRACK SHOES

Select suitable track shoes to match the operating conditions.

#### METHOD OF SELECTING SHOES

Confirm the category from the list of uses in Table 1, then use Table 2 to select the shoe.

Categories B and C are wide shoes, so there are limitations on their use. When using these shoes, check the precautions, then investigate and study fully the conditions of use to confirm that these shoes are suitable.

When selecting the shoe width, select the narrowest shoe possible that will give the required flotation and ground pressure. If a wider shoe than necessary is used, the load on the track will increase, and this will cause the shoes to bend, links to crack, pins to break, shoe bolts to come loose, and various other problems.

**Table 1**

Category	Use	Precautions when using
A	Rocky ground, riverbeds, normal soil	<ul style="list-style-type: none"> <li>On rough ground with large obstacles such as boulders or fallen trees, travel at low speed.</li> </ul>
B	Normal soil, soft ground	<ul style="list-style-type: none"> <li>These shoes cannot be used on rough ground where there are large obstacles such as boulders or fallen trees.</li> <li>Travel at Hi or Mi speed only on flat ground, and if it is impossible to avoid going over obstacles, shift down and travel at half speed in Lo.</li> </ul>
C	Extremely soft ground (swampy ground)	<ul style="list-style-type: none"> <li>Use the shoes only in places where the machine sinks and it is impossible to use A or B shoes.</li> <li>These shoes cannot be used on rough ground where there are large obstacles such as boulders or fallen trees.</li> <li>Travel at Hi or Mi speed only on flat ground, and if it is impossible to avoid going over obstacles, shift down and travel at half speed in Lo.</li> </ul>
D	Paved road surfaces	<ul style="list-style-type: none"> <li>The shoes are flat, and the gradeability is low, so use care on slopes.</li> </ul>
E	Paved road surfaces	<ul style="list-style-type: none"> <li>To protect the rubber shoes, always follow the instructions given in 31.5 HANDLING RUBBER PAD SHOE.</li> </ul>

**Table 2**

	PC200		PC200LC		PC220		PC220LC	
	Specifications	Category	Specifications	Category	Specifications	Category	Specifications	Category
Standard	600 triple grouser	A	700 triple grouser	B	600 triple grouser	A	700 triple grouser	B
Option	700 triple grouser	B	600 triple grouser	A	700 triple grouser	B	600 triple grouser	A
Option	800 triple grouser	C	800 triple grouser	C	800 triple grouser	C	800 triple grouser	C
Option	860 swamp shoe	C	900 triple grouser	C	610 flat shoe	D	610 flat shoe	D
Option	610 flat shoe	D	860 swamp shoe	C	-	-	-	-
Option	600 rubber pad shoe	E	610 flat shoe	D	-	-	-	-
Option	-	-	600 rubber pad shoe	E	-	-	-	-

	PC210		PC210LC		PC230		PC230LC	
	Specifications	Category	Specifications	Category	Specifications	Category	Specifications	Category
Standard	600 triple grouser	A	600 triple grouser	A	600 triple grouser	A	600 triple grouser	A
Option	610 flat shoe	D	610 flat shoe	D	610 flat shoe	D	610 flat shoe	D



### 31.4 SELECTION OF BUCKET TEETH

Depending on the working conditions, there is danger that the adapter and teeth may break, so select from the vertical pin teeth and horizontal pin teeth to give teeth that are suitable for the purpose.

#### METHOD OF SELECTING TEETH

##### Use of vertical pin tooth

General digging: Digging, loading normal soil, such as sand, gravel, clay  
 Light-duty digging: Digging, loading loose dry sandy soil or muddy soil  
 Loading: Loading dry loosened soil

##### Use of horizontal pin tooth

Heavy-duty digging: Compacting, digging hard soil, soil mixed with rocks, heavy-duty work such as scraping

- The heavy-duty bucket is a horizontal pin tooth type, so use it for heavy-duty digging.

The standard vertical pin and horizontal pin teeth can be used over a wide range, but we recommend the following teeth to match the operating conditions.

##### Long-life teeth

- Jobsites where wear life is demanded, such as when loading hard rocks.
- Jobsites where no penetration is needed, such as when working with crushed rock after blasting or ripping.
- Jobsites where heavy-duty operations are carried out, such as hitting or pulling up rocks with the tips of the teeth.

##### Self-sharpening teeth (horizontal pin type, vertical pin type)

- Jobsites demanding penetration such as digging and loading sandy or clayey soil.

#### Standards for selecting horizontal pin type and vertical pin type teeth

		Appropriate work site			
		Rock	Crushed stone	Clay, spread earth	Sand
Work contents	Heavy	Ground breaking excavation	Lateral pin-type teeth		Lateral pin-type teeth
	↑ ↓				Vertical pin-type teeth
		Scraping down	Lateral pin-type teeth		Lateral pin-type teeth
		Vertical pin-type teeth			
General excavation	Lateral pin-type teeth				
Vertical pin-type teeth					
Light	Loading	Lateral pin-type teeth			
		Vertical pin-type teeth			

### 31.5 HANDLING RUBBER PAD SHOE

When using rubber shoes, always obey the following precautions for handling.

#### WORKING ENVIRONMENT

- Use the rubber pad shoes mainly for work on paved road surfaces.  
If they are used on surfaces which are not paved, the rubber will be cut or damaged, so its durability will drop markedly.  
In particular, avoid the following operations.
  - Operations on broken pieces on concrete or gravel.
  - Operations on sharp protruding objects such as reinforcing iron or glass (and in particular when traveling over steel sheets driven into the ground).
  - Operations traveling over the shoulder of concrete roads, and operations on rockbed or stony river beds.
- Be careful not to let the machine slip when operating on road surfaces covered with water, ice, snow, or gravel.  
Be particularly careful when unloading the machine.
- Because of the physical properties of rubber, use the rubber pad shoe in a temperature range of  $-25^{\circ}\text{C}$  to  $65^{\circ}\text{C}$  ( $-13^{\circ}\text{F}$  to  $149^{\circ}\text{F}$ ).

#### OPERATING CONDITIONS

- Operations such as those shown in the diagram where the machine is braced when working, side ditching operations, or operations on slopes, or operations where the machine is frequently steered from side to side, there will be an excessive load on the rubber pad shoe and this will cause damage.
- If special work equipment is installed, the durability of the rubber pad shoe cannot be guaranteed.

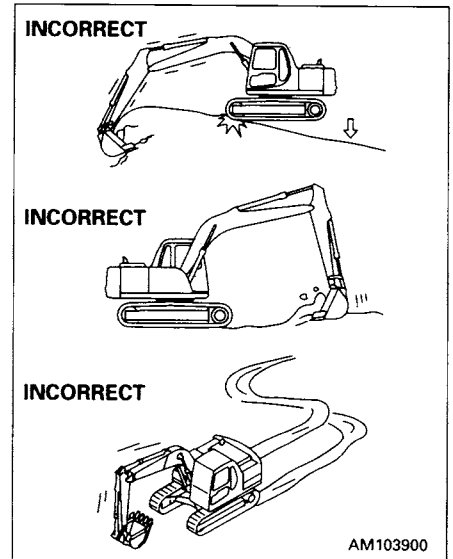

**STORAGE, MAINTENANCE**

- Be careful not to get oil or grease on the rubber. If there is any oil or grease on the rubber, wipe it off immediately.
- Install the rubber pad shoe continuously to all links. If it is not installed, it will cause excessive deformation of damage to the rubber.
- When storing the rubber pad shoe for a long time, keep it indoors out of direct sunlight or rain.

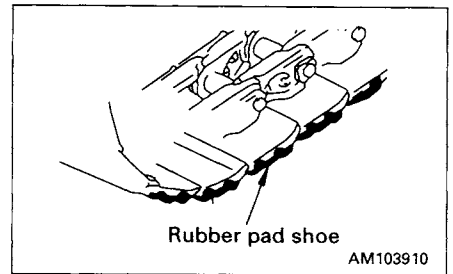

**CONDITION OF DAMAGE TO RUBBER**

- When traveling on concrete road surfaces, the rubber is transferred to the road surface, and leaves a black track.

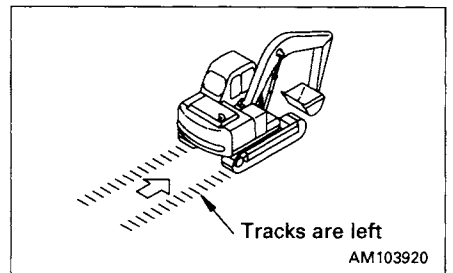

- When the shoes contact each other, dents may be formed, but the shoes can still be used.

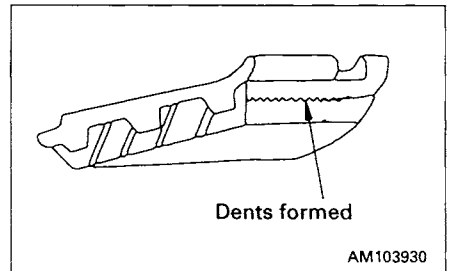

- Even if there are cuts or pieces of the rubber missing, and the shoes look in extremely bad condition, this damage does not extend immediately to the whole shoe, and it does not damage the road surface, so the shoe can be used.

### 31.6 HANDLING TRAPEZOIDAL BUCKET

This bucket is used to dig trapezoidal ditches in paddy fields, farmland etc. and it can dig 3 types of ditch gradients (45°, 40° and 38°) when a movable plate is attached.

- The mounting position of the movable plate varies depending on whether the ditch gradient is 45°, 40° or 38°.

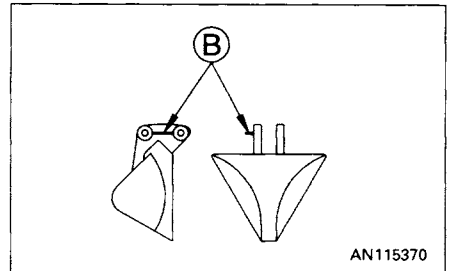
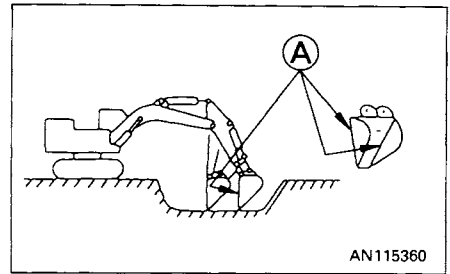

#### HOW TO PERFORM EXCAVATION

Operate the boom, the arm and the bucket to make the line **A** of the side-plate of the bucket vertical.

The guide plate **B** to check this position is installed beside the bucket pins. Accordingly, hold this plate horizontal when digging.

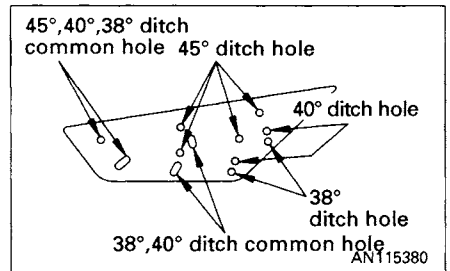

#### Ditch gradient of 45°

Attach the bucket only or the movable plate by selecting the related ditch holes. Perform digging by the above method.

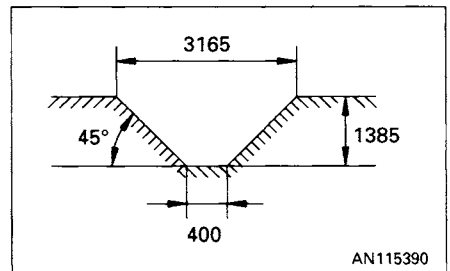

#### Ditch gradient of 40° and 38°

Attach the movable plate by selecting the related ditch holes. Perform digging according to the above method.

Even if the trapezoidal bucket is provided with the movable plate, always perform digging with the bucket side face perpendicular to the ground.

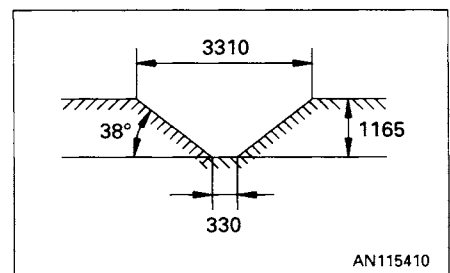
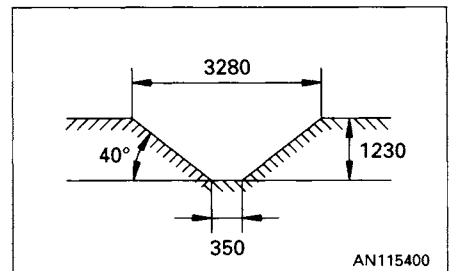

### 31.7 HANDLING EXTENSION ARM

When the extension arm is equipped, if the arm is retracted, the bucket interferes with the boom cylinder foot and the revolution frame. Be careful at operation and transportation.

- When the extension arm is equipped, use the narrow bucket (bucket width: 750 mm (30") and 560 mm (22")) without the side cutter.

Since the standard bucket causes body instability and the bucket interferes with the operator's cab when retracting the arm, do not mount the standard bucket.

- Work in hard soil or rocky terrain will shorten the life of the extension arm, the boom and the arm.  
It is better not to use the extension arm in such conditions.

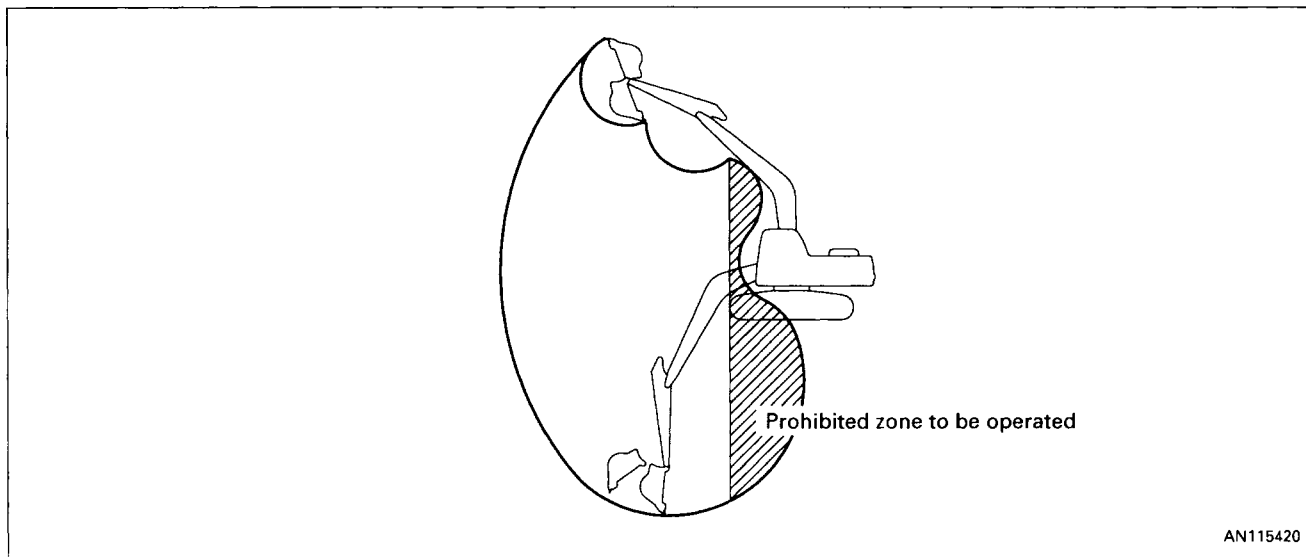

### **31.8 HANDLING CLAMSHELL BUCKET**

This bucket is used for digging and loading in side-ditches or the confined spaces.

#### **How to perform excavation**

This clamshell digs by pushing the boom against the ground. However, when perform bucket operation, perform digging while gradually raising the boom.

If the clamshell bucket rotates, relieve the bucket cylinder pressure then set the lever to the neutral position. This can temporarily stop the rotation.

#### **PRECAUTIONS WHEN USING**

- For safety, always avoid abrupt traveling, swing and stopping.
- Make the teeth of the bucket vertical in digging.
- Do not swing the bucket to crush the rock or to cut through soil.
- Do not use the bucket for hammering or pulling out piles etc.
- Before leaving the machine, open the bucket and lower it to the ground.

#### **REMARK**

Remove the bucket from the arm when transporting the machine.

**31.9 HANDLING VARIABLE 2-PIECE BOOM,  
ROTATING ARM**  
**31.9.1 EXPLANATION OF COMPONENTS**

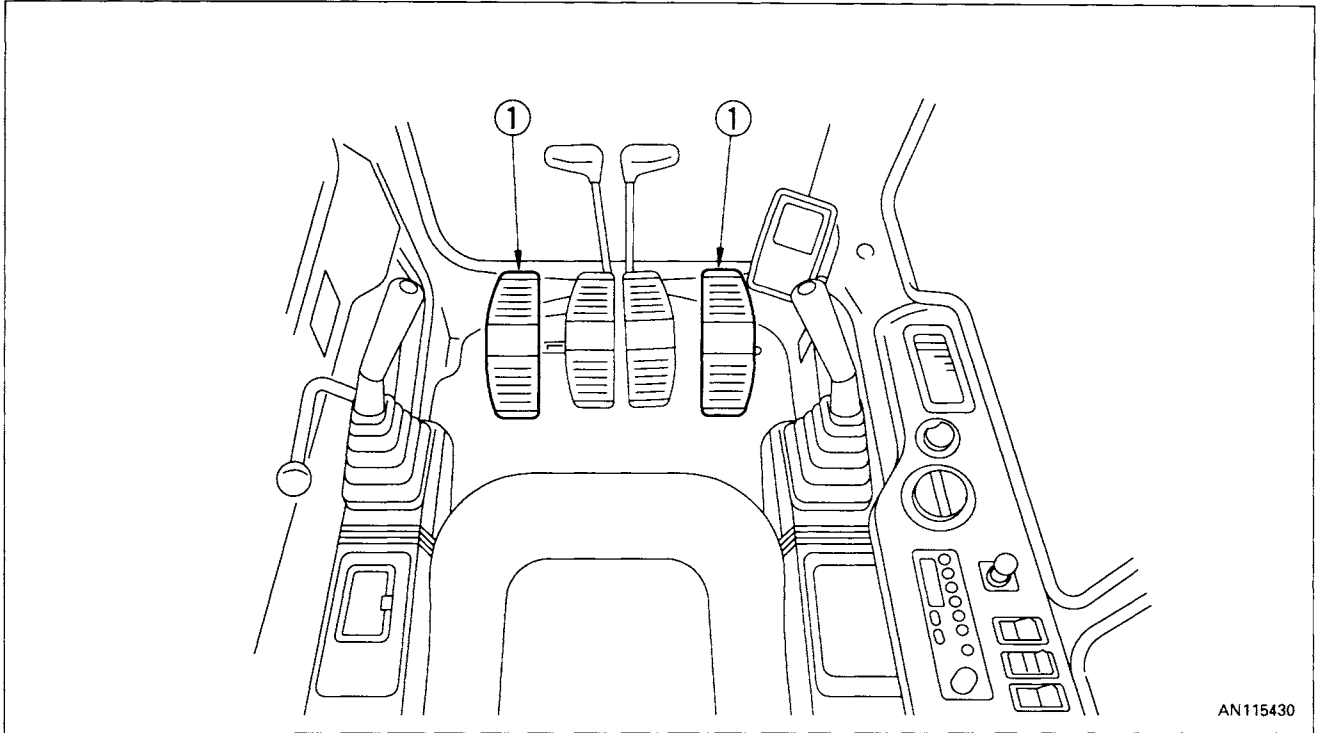

AN115430

**1. ATTACHMENT CONTROL PEDAL (OPTION)**

**⚠ WARNING**

Do not put your foot on the pedal except when operating it. If you rest your foot on the pedal during operations, and you depress the pedal by mistake, the attachment may move suddenly and cause serious damage or injury.

**When breaker is installed (right pedal)**

- When the front of the pedal is depressed, the breaker is actuated.
- The positions of the lock pin are as follows: ① lock, ② pedal half stroke position, ③ pedal full stroke position
- Set the working mode to the breaker mode and set the lock pin to position ③.

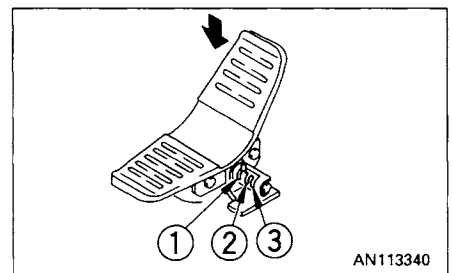

AN113340

**When general attachment is installed (right pedal)**

- When the pedal is depressed, the attachment is actuated.
- The positions of the lock pin are as follows: ① lock, ② pedal half stroke position, ③ pedal full stroke position

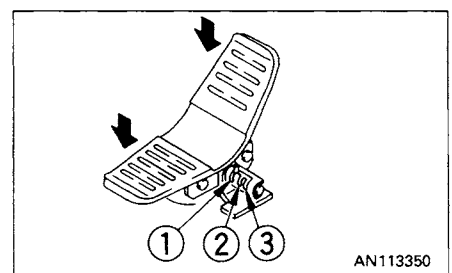

AN113350

### 31. INTRODUCTION OF ATTACHMENTS

**When variable 2-piece boom and rotating arm are installed (left and right pedals)**

- The relationship between the operation of the pedals and movement of the work equipment is as shown in the table below.

Combination			Operation of pedal, direction of operation					
2-piece boom	Rotating arm	1ATT	2-piece boom		Rotating arm		1ATT	
			RAISE	LOWER	Right rotation	Left rotation	(Bottom)	(Head)
○	—	—	Right pedal front	Right pedal rear				
—	○	—			Right pedal rear	Right pedal front		
○	—	○	Right pedal front	Right pedal rear			Left pedal front	Left pedal rear
—	○	○			Left pedal front	Left pedal rear	Right pedal front	Right pedal rear
○	○	—	Right pedal front	Right pedal rear	Left pedal front	Left pedal rear		
○	○	○	It is impossible to set up this combination					



## 31.9.2 OPERATION

**WARNING**

Be careful when operating the pedal in the deceleration range.  
The engine speed will rise suddenly.

The work equipment is operated by the left work equipment control lever, right work equipment control lever, upper boom control pedal, and arm rotation control pedal.

The left work equipment control lever operates the arm and swing, and the right work equipment control lever operates the lower boom and bucket.

The movement of the levers and work equipment are as shown in the diagrams.

When the levers are released, they return to the HOLD position and the work equipment is held in position.

- If the work equipment control levers are returned to the HOLD position when the machine is stopped, the auto-deceleration mechanism is actuated to lower the engine speed to a mid-range speed, even if the fuel control lever is at the MAX position.

**REMARK**

If the starting switch is turned ON within 15 seconds of stopping the engine, it is possible to lower the work equipment to the ground by operating the levers.

This can also be used to release the remaining pressure in the hydraulic cylinder circuit or to lower the boom after loading the machine on to a trailer.

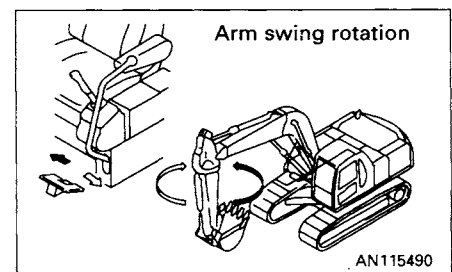
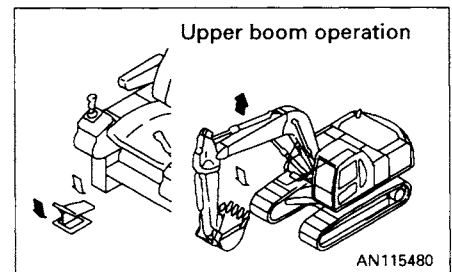
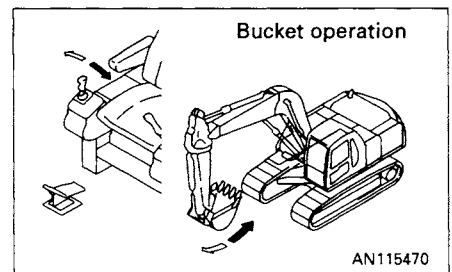
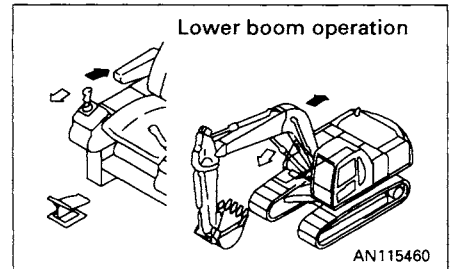
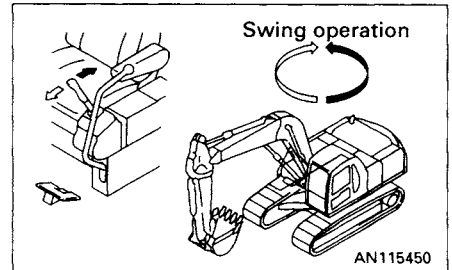
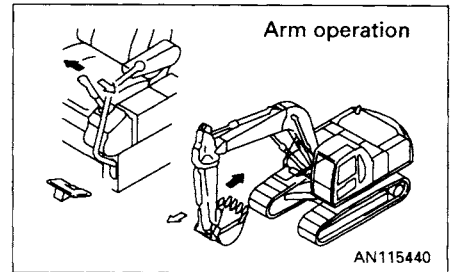

### 31.9.3 PRECAUTIONS DURING OPERATION

#### Precautions when traveling

Traveling over boulders, tree stumps, or other obstacles causes a big shock to the chassis (and in particular the tracks), and this will cause damage to the machine. For this reason, always remove any obstacles or travel around them, or take other steps to avoid traveling over such obstacles as far as possible.

If there is no way to avoid traveling over an obstacle, reduce the travel speed, lower the work equipment and keep it close to the ground, and try to travel so that the center of the tracks pass over the obstacle.

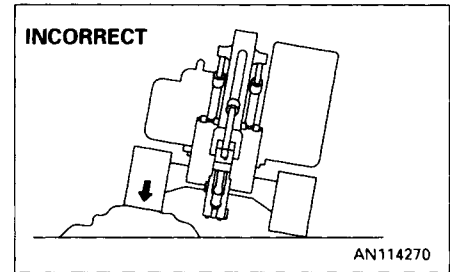

#### Precautions when traveling at high speed

When traveling on rough rocky ground or when traveling on uneven roads with many boulders, reduce speed and travel in Mi or Lo. When traveling at Hi speed, travel with the idler facing the direction of travel.

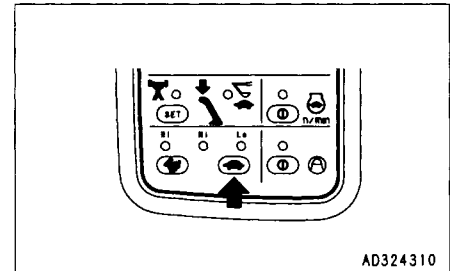

#### Permissible water depth

##### NOTICE

**Be extremely careful when driving out of water. If the angle of the slope is greater than 15°, the rear of the upper structure will go under water. If this happens, the radiator fan will throw up water, and this may cause damage to the fan.**

When operating in water, do not let the water go above the center of carrier rollers ①.

If the machine has been operated in water for a long time, pump in grease at the points which were under water until the old grease comes out from the outside of the bearing. (Be particularly careful to do this around the bucket pin.)

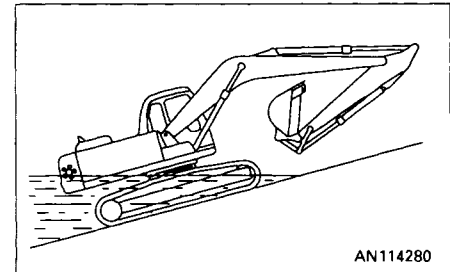

#### Precautions when operating

Depending on the way the work equipment is operated, the bucket may hit the machine body, so be extremely careful when operating.

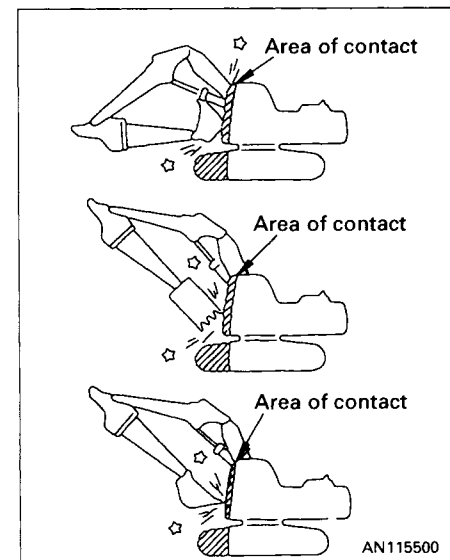
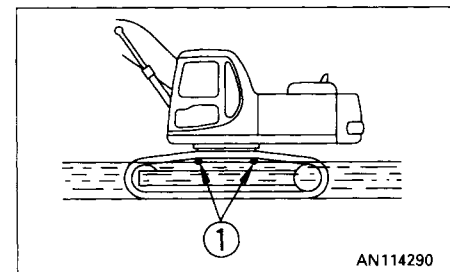

### 31.9.4 WORK POSSIBLE WITH ATTACHMENTS

#### Digging operations

These attachments are suitable for digging places lower than the position of the machine.

If the digging angle of the arm is in a range between  $30^\circ$  towards the machine and  $45^\circ$  away from the machine, the arm cylinder can be used effectively for efficient operations.

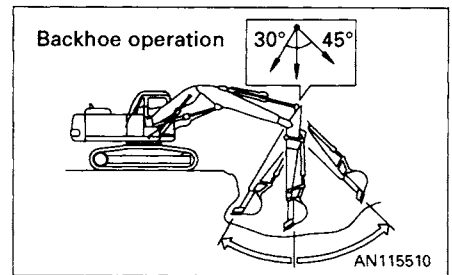

These attachments are also suitable for digging places higher than the position of the machine.

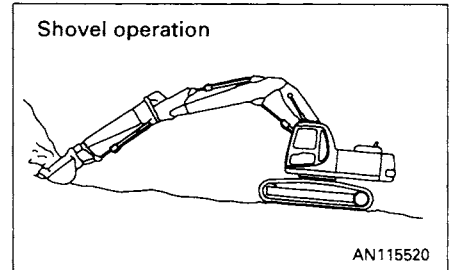

#### Digging ditches

If a suitable bucket is installed and the tracks are set parallel to the line of the ditch, the ditching operation can be carried out efficiently.

When digging wide ditches, dig both sides of the ditch first, then finally dig out the center portion.

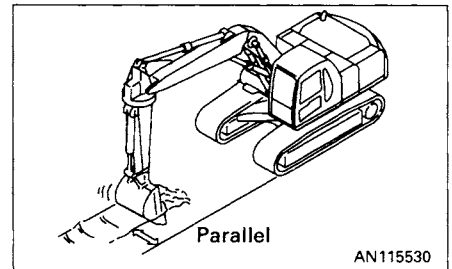

#### Loading operations

If the dump truck is positioned so that the swing angle is small, loading operations can be carried out efficiently.

When loading, if the loading is started at the front of the dump truck body, it is easier to load and more soil can be loaded than when loading from the side.

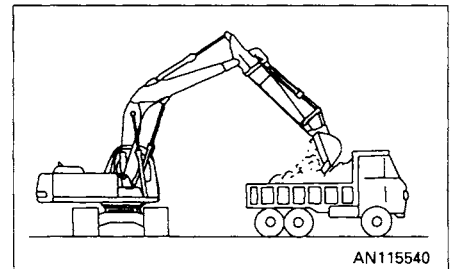

#### Digging around foundations of buildings

It is possible to dig shafts around the face of perpendicular walls and to remove soil from around sheet piles.

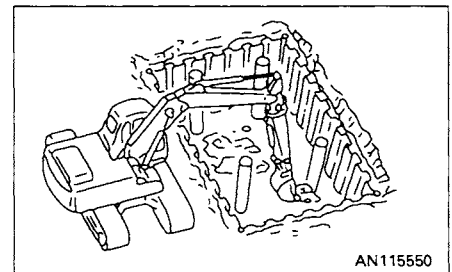

#### Side-ditching operations

Side-ditching operations can be carried out by operating the swing.

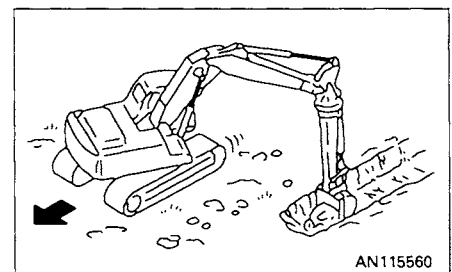

## 31. INTRODUCTION OF ATTACHMENTS

### Protective wall construction

The bucket can be reversed easily, so it is possible to carry in cobbles or fresh concrete.

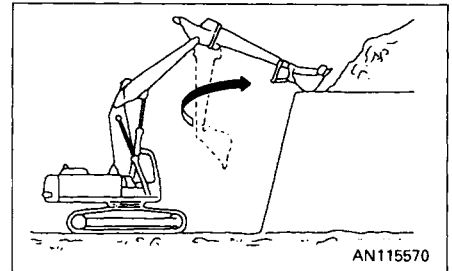

### Finishing slope faces

The boom can be retracted, so it is possible to finish long slope faces without moving the machine.

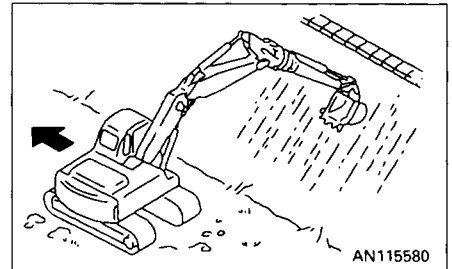

### Digging under machine

By using the 2-piece boom, it is possible to dig under the machine.

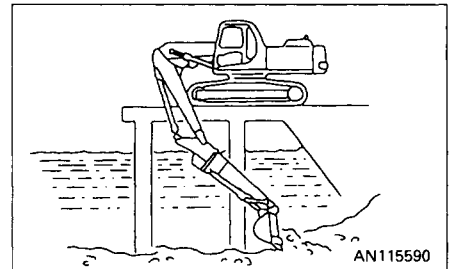

### Roadbed excavation

It is possible to excavate along the lines of joints by using the side ditching posture.

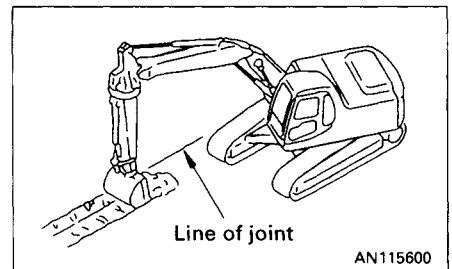

### Leveling operations

A long area of finishing can be carried out in one move.

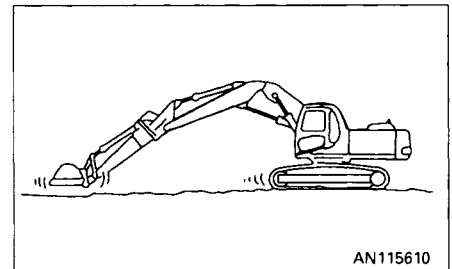

### Work on slopes

Even when working on slopes, the rotating arm can be used to carry out perpendicular digging.

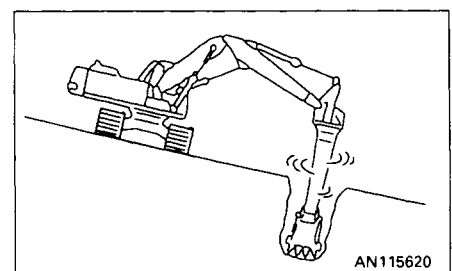

### 31.9.5 EVERY 100 HOURS SERVICE GREASING

#### NOTICE

- If any abnormal noise is generated from any greasing point, carry out greasing regardless of the greasing interval.
- Carry out greasing of greasing points 1 – 7 every 10 hours for the first 100 hours on a new machine.

1. Set the machine to the greasing posture shown below, .pa lower the work equipment to the ground, then stop the engine.
2. Using a grease gun, pump in grease through the grease fittings marked by arrows.
3. Wipe off any old grease that is pushed out.

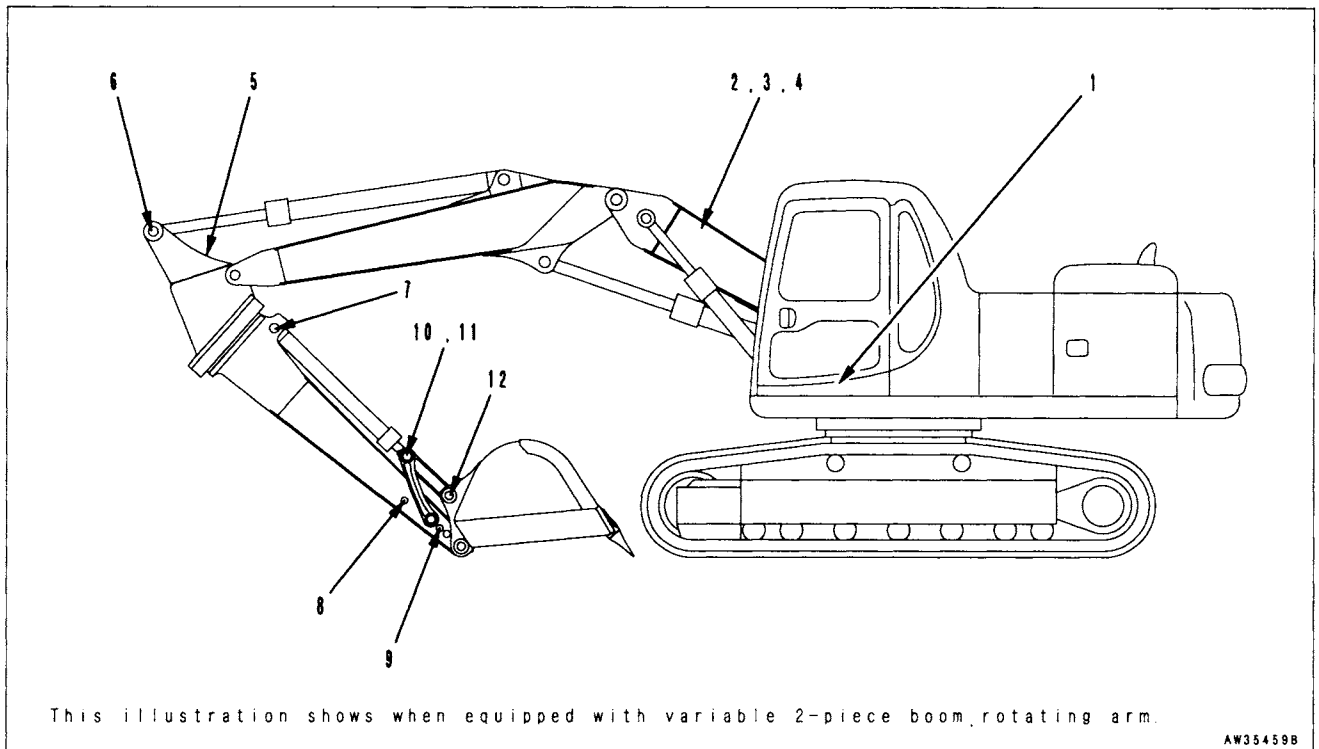

1. Lower boom cylinder foot pin (2 points)  
[When variable 2-piece boom is installed]

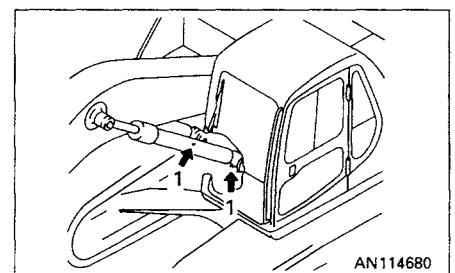

### 31. INTRODUCTION OF ATTACHMENTS

2. Lower boom foot pin (2 points)  
[When 2-piece boom is installed]
3. Lower boom cylinder rod end (2 points)  
[When variable 2-piece boom is installed]
4. Lower boom, upper boom connecting pin (1 point)  
[When variable 2-piece boom is installed]
5. Upper boom, arm connecting pin (1 point)  
[When variable 2-piece boom is installed]
6. Arm cylinder rod end (1 point)
7. Bucket cylinder foot pin (1 point)
8. Arm-link connection pin (1 point)
9. Arm-bucket connection pin (1 point)
10. Link connection pin (2 points)
11. Bucket cylinder rod end (1 point)
12. Bucket-link connection pin (1 point)
13. Upper boom cylinder rod end (1 point)  
[When variable 2-piece boom is installed]
14. Upper boom cylinder foot pin (1 point)  
[When variable 2-piece boom is installed]

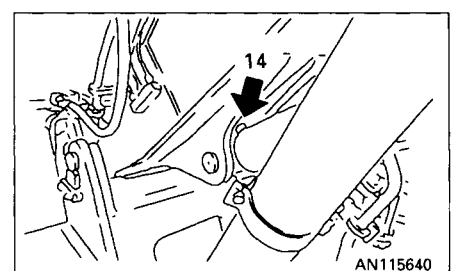
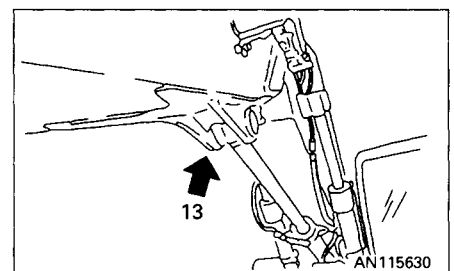
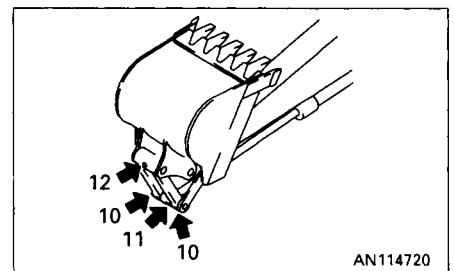
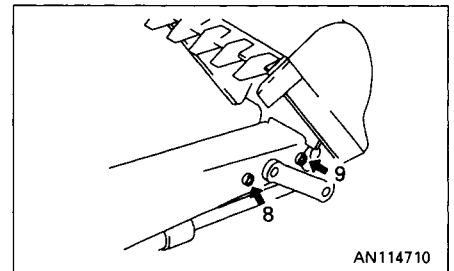
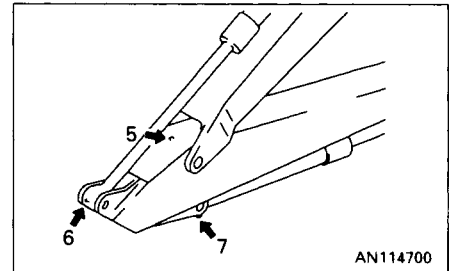
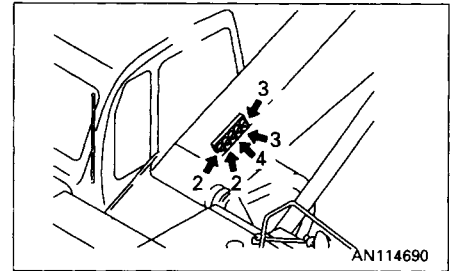

15. Check oil level in arm rotation machinery case, add oil  
[When rotating arm is installed]

1. Set the arm horizontal.
2. Remove the plug, and check that the oil is near the bottom edge of the plug hole. If the oil level is low, add gear oil (GO90, regardless of ambient temperature) through the plug hole.

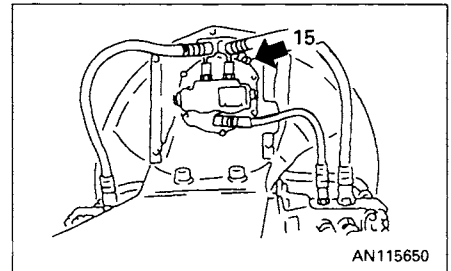

**31.9.6 EVERY 250 HOURS SERVICE**  
**GREASE ARM ROTATING CIRCLE (3 points)**  
(When rotating arm is installed)

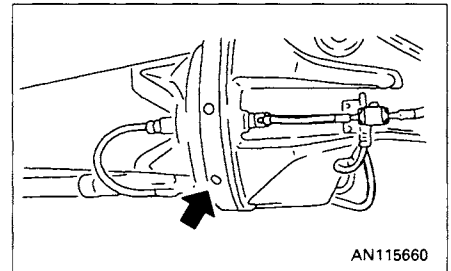

**31.9.7 EVERY 500 HOURS SERVICE**

Carry out maintenance for every 100 hours and 250 hours at the same time.

**CHECK LEVEL OF GREASE IN ARM ROTATING PINION, ADD GREASE**  
(When rotating arm is installed)

1. Remove 2 bolts ① from the top face of the arm rotating machinery case, then remove cover ②.
2. Rotate the arm slowly and add grease.

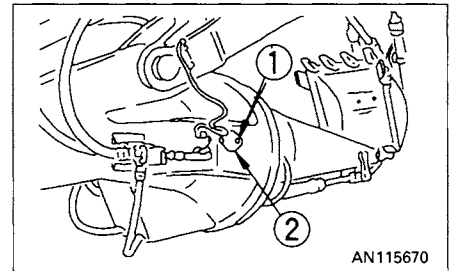

Repeat Step 2 two or three times.

**31.9.8 EVERY 1000 HOURS SERVICE**

Carry out maintenance for every 100 hours, 250 hours, and 500 hours at the same time.

**CHANGE OIL IN ARM ROTATING MACHINERY CASE**  
(When rotating arm is installed)

1. Remove plug ①, drain the oil, then tighten the plug again.
2. Add gear oil (GO90, regardless of ambient temperature) through the plug hole to the specified level.
3. After adding oil, check that the oil is at the specified level. For details, see EVERY 100 HOURS SERVICE.

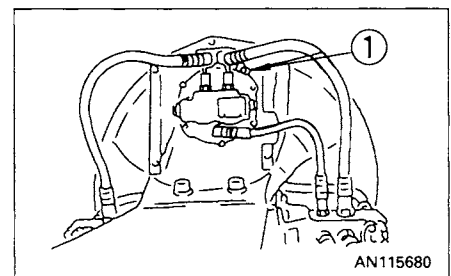

Oil refill amount: 1.6 l (0.4 US gal, 0.35 UK gal)

## 32. EXTENDING MACHINE SERVICE LIFE

This section describes the necessary precautions to be observed when operating a hydraulic excavator equipped with an attachment.

### NOTICE

Select the attachment most suited to the machine body.

- The machine models to which attachments can be mounted vary. For selection of attachment and machine model, consult your Komatsu distributor.

### 32.1 HYDRAULIC BREAKER

#### MAIN FIELDS OF APPLICATION

- Crushed rock
- Demolition work
- Road construction

This attachment can be used for a wide range of work including demolition of buildings, breaking up of road surfaces, tunnel work, breaking up slag, rock crushing, and breaking operations in quarries.

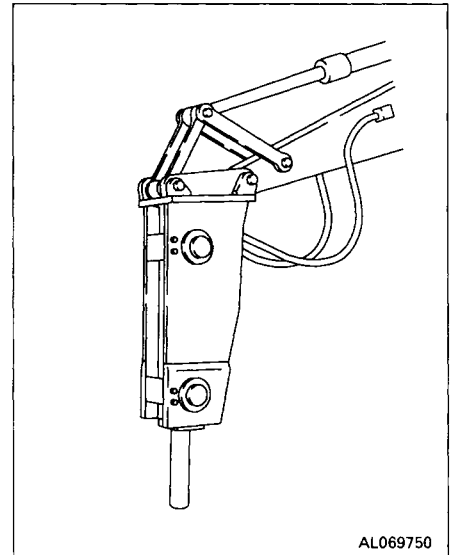

Keep the chisel pushed perpendicularly against the impact surface when carrying out breaking operations.

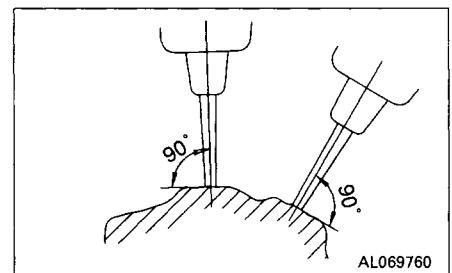

When applying impact, push the chisel against the impact surface and operate so that the chassis rises approx. 5 cm off the ground. Do not let the machine come further off the ground than is necessary.

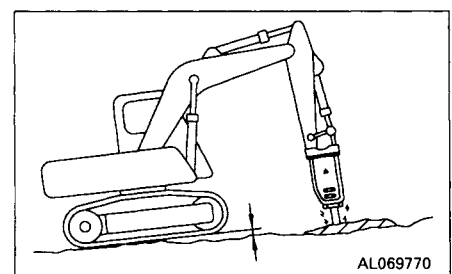



When applying continuous impact to the same impact surface, if the chisel does not penetrate or break the surface within 1 minute, change the point of impact and carry out breaking operations closer to the edge.

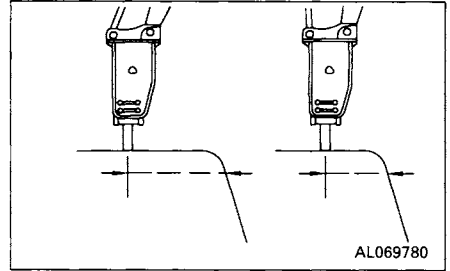

The direction of penetration of the chisel and the direction of the breaker body will gradually move out of line with each other, so always adjust the bucket cylinder to keep them aligned.

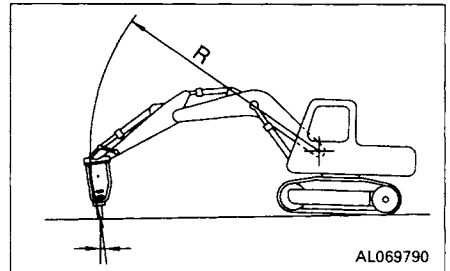

Always keep the chisel pressed against the impact surface properly to prevent using the impact force when there is no resistance.

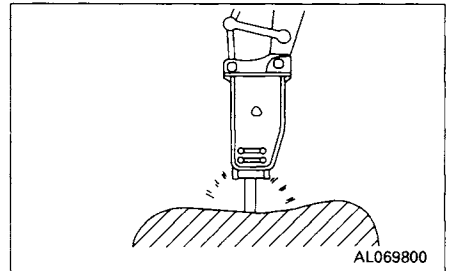

**MISTAKEN METHODS OF USE**

To ensure that the machine has a long life, and to ensure that operations are carried out in safety, do not operate the machine in any of the following ways.

- Do not operate the cylinder to the end of its stroke. Always leave approx. 5 cm (2 in) to spare.

Using the mount to gather in pieces of rock

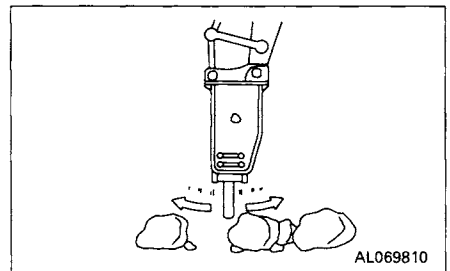

Operations using the swing force

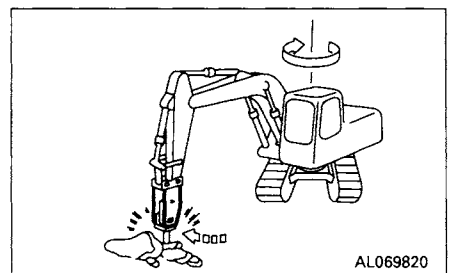

Moving the chisel while carrying out impacting operations

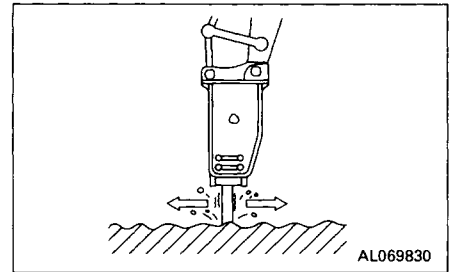

Holding the chisel horizontal or pointed up when carrying out impacting operations

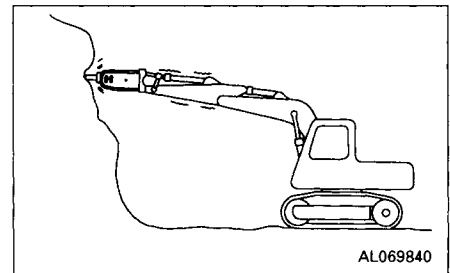

Twisting the chisel when it has penetrated the rock

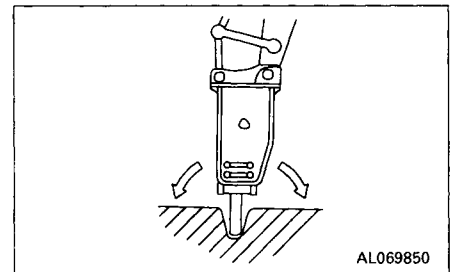

Pecking operations

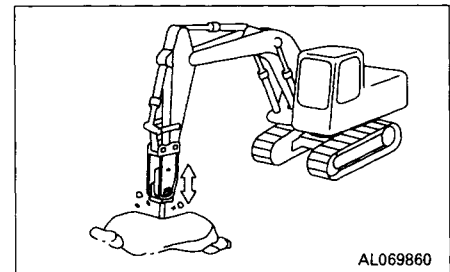

Extending the bucket cylinder fully and thrusting to raise the machine off the ground

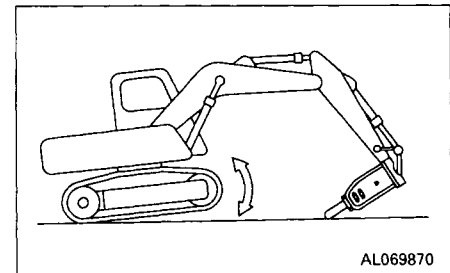

**GREASING POSITION FOR HYDRAULIC BREAKER**

Supply grease in the correct position.

**NOTICE**

If grease is supplied in an incorrect position, the breaker is filled with more grease than necessary. As a result, soil and sand will enter the hydraulic circuit and can damage the hydraulic devices while the breaker is used. Accordingly, be sure to supply grease in the correct position.

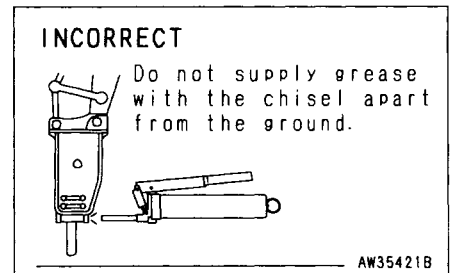
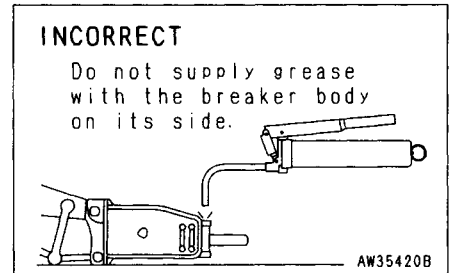
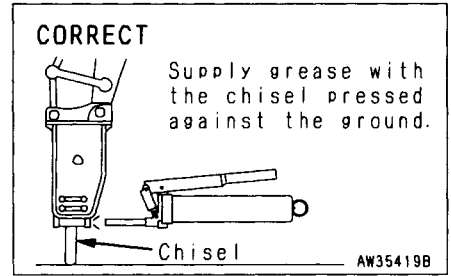

## 32.2 POWER RIPPER

### MAIN FIELDS OF APPLICATION

- Road repair work
- Demolition work

This attachment can be used for a wide range of work including peeling off and crushing pavement roads, demolishing wooden houses and buildings, and crushing foundation and roadbeds.

### MISTAKEN METHODS OF USE

To ensure that the machine has a long life, and to ensure that operations are carried out in safety, do not operate the machine in any of the following ways.

- Do not operate the cylinder to the end of its stroke.  
Always leave approx. 5 cm (2 in) to spare.

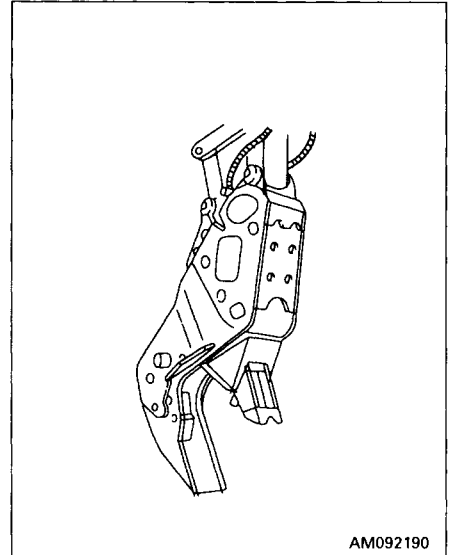

Impact operations using attachment

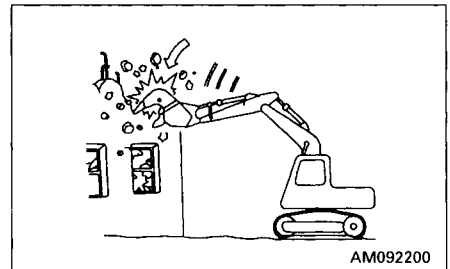

Impact operations using swing force

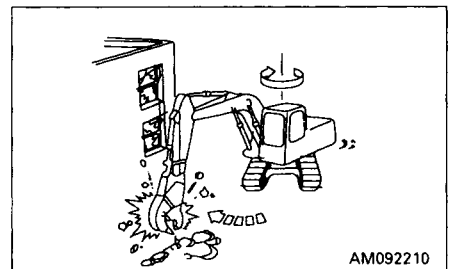

Overloading work equipment during lifting and loading operations

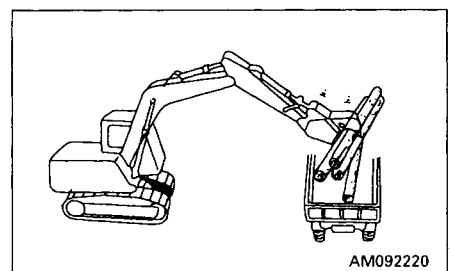

Operations using attachment to grip at an angle

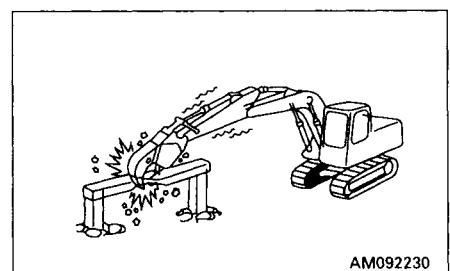

### 32.3 FORK GRAB

#### MAIN FIELDS OF APPLICATION

- Disposing of industrial waste
- Disposing of demolition waste

This can be used for a wide range of work including collecting or loading demolition waste materials and debris, timber, grass etc.

#### MISTAKEN METHODS OF USE

To ensure that the machine has a long life, and to ensure that operations are carried out in safety, do not operate the machine in any of the following ways.

- Do not operate the cylinder to the end of its stroke.  
Always leave approx. 5 cm (2 in) to spare.

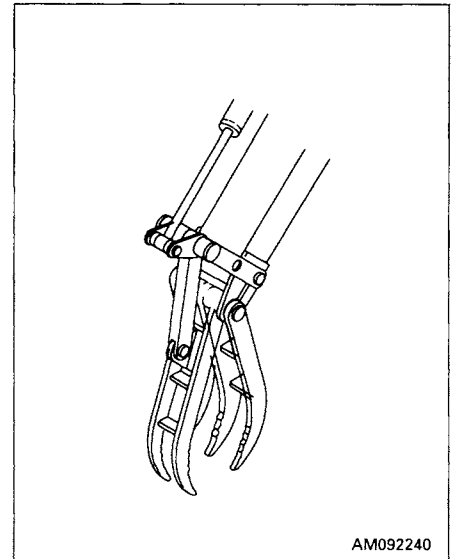

Operations using the swing force

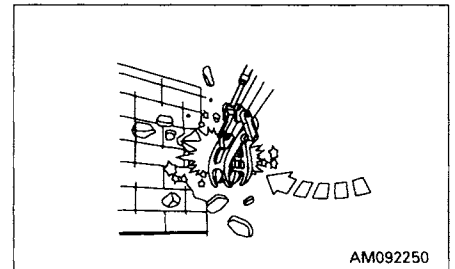

Operations using one side of work equipment

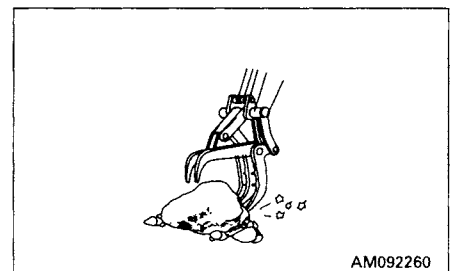

Pushing fork into ground surface to jack up and change direction of machine

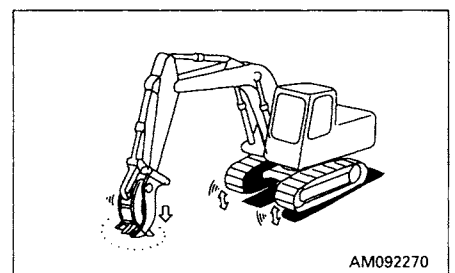

Impact operation with no load

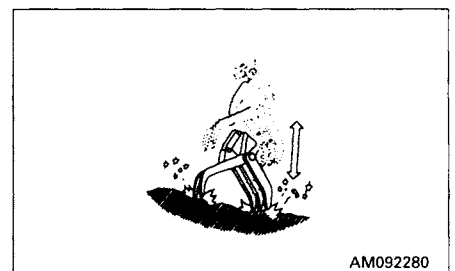

### 32.4 GRAPPLE BUCKET

#### MAIN FIELDS OF APPLICATION

- Demolition
- Disposing of industrial waste
- Forestry

This bucket is widely used for demolition including breaking-up work, grading and digging, clean-up work after natural disasters, dumping industrial waste, and forestry work, etc.

#### MISTAKEN METHODS OF USE

To ensure that the machine has a long life, and to ensure that operations are carried out in safety, do not operate the machine in any of the following ways.

- Do not operate the cylinder to the end of its stroke.  
Always leave approx. 5 cm (2 in) to spare.

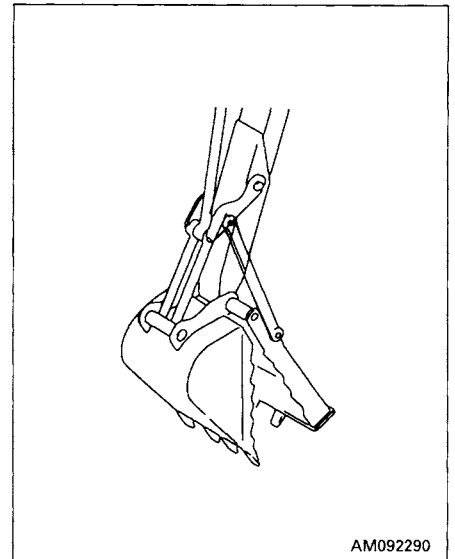

Operations using the swing force

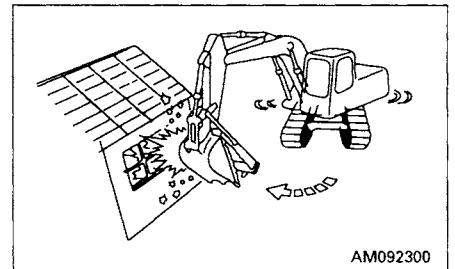

Grabbing a object using buckets on only one side

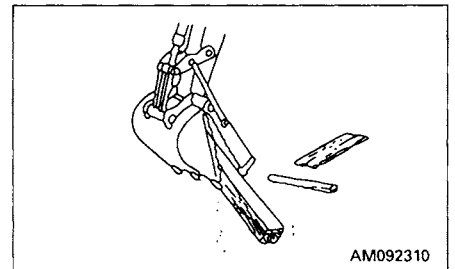

Closing the sub-bucket with the boom and arm fully extended.

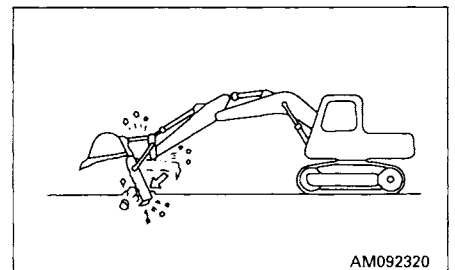

Impact operation with no load

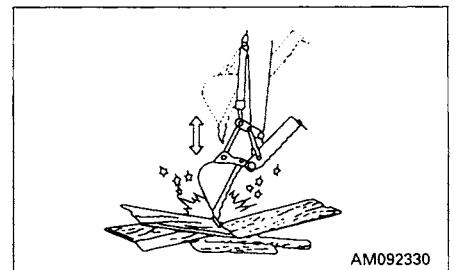

## 32.5 SCRAP GRAPPLE

### MAIN FIELDS OF APPLICATION

- Disposal of rock or debris

This attachment is mounted to the arm end and used to grasp rock, debris etc. by opening and closing the claws (3 to 5) corresponding to the extension and retraction of the hydraulic cylinder.

### MISTAKEN METHODS OF USE

To ensure that the machine has a long life, and to ensure that operations are carried out in safety, do not operate the machine in any of the following ways.

- Do not operate the cylinder to the end of its stroke.  
Always leave approx. 5 cm (2 in) to spare.

Operations using the swing force

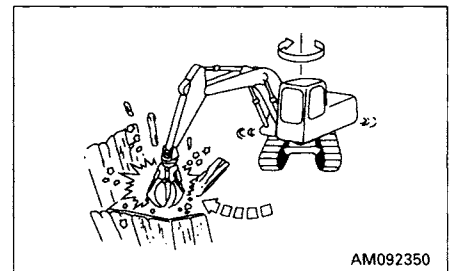
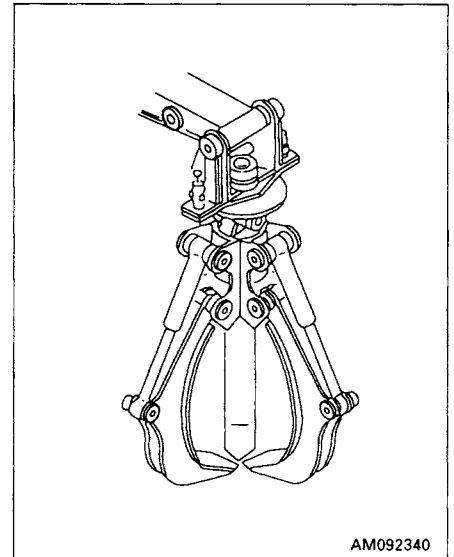

Operations using one side of work equipment

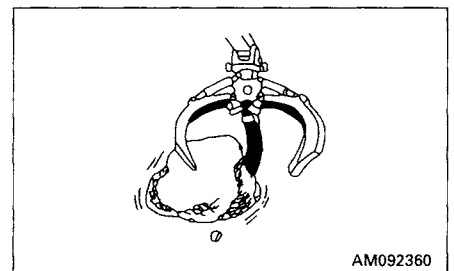

Catching and dragging with claw end

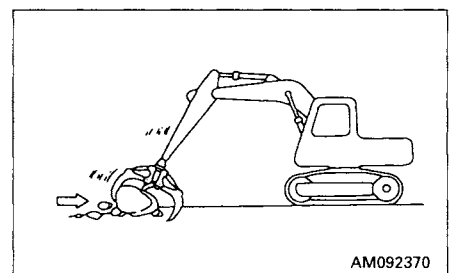

Gouging

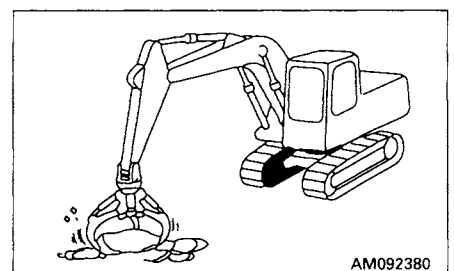

### 32.6 CRUSHER & CUTTER

#### MAIN FIELDS OF APPLICATION

- Demolition
- Road repair work

This is the optimum attachment for demolition of steel frame reinforced structures, and for crushing of concrete blocks and rock, etc. The unique blade shape provides heavy crushing power.

#### MISTAKEN METHODS OF USE

To ensure that the machine has a long life, and to ensure that operations are carried out in safety, do not operate the machine in any of the following ways.

- Do not operate the cylinder to the end of its stroke.  
Always leave approx. 5 cm (2 in) to spare.

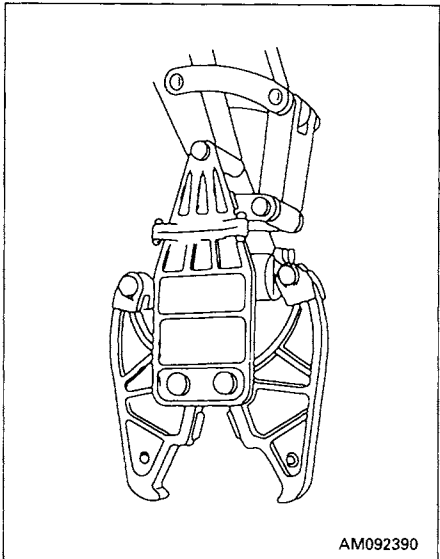

AM092390

Operations using cutting tip on one side only

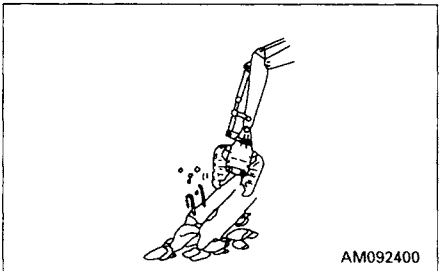

AM092400

Impact operation with no load

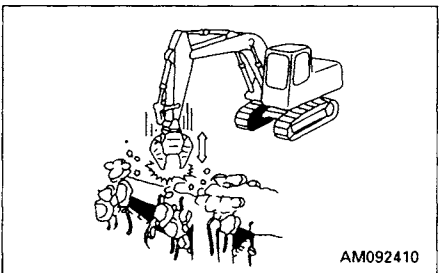

AM092410

Twisting operations at end of cylinder stroke

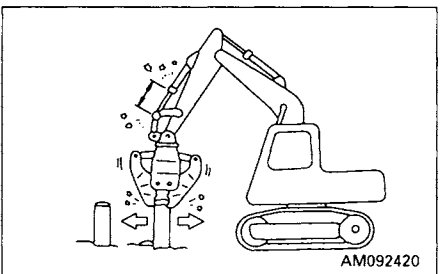

AM092420

Sudden gripping and breaking operations

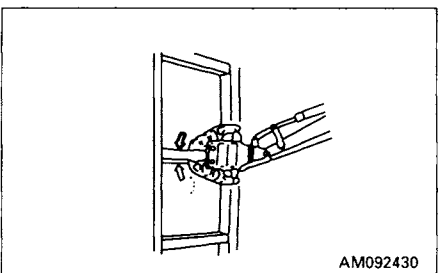

AM092430



## 32.7 HYDRAULIC PILE DRIVER

### MAIN FIELDS OF APPLICATION

- Foundation work
- River work
- Water supply and sewerage

This is a piling machine employing the hydraulic power source of the excavator. The machine features a long arm and a chuck unit movable by 360°. This facilitates operations such as driving and removing long piles, driving in piles at corners, vertical driving etc.

### MISTAKEN METHODS OF USE

To ensure that the machine has a long life, and to ensure that operations are carried out in safety, do not operate the machine in any of the following ways.

- Do not operate the cylinder to the end of its stroke.  
Always leave approx. 5 cm (2 in) to spare.

Forward or swing motion while grasping a pile

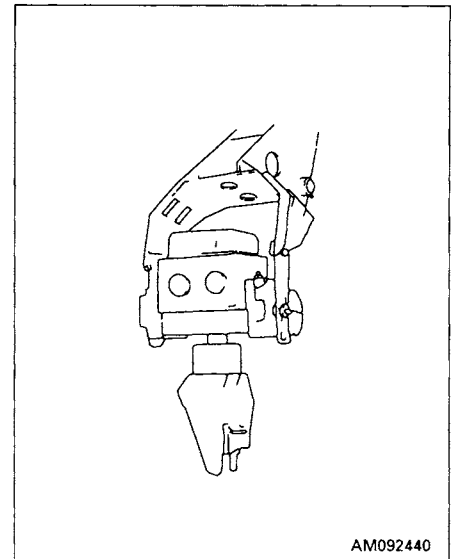

Lifting more than two piles at the same time

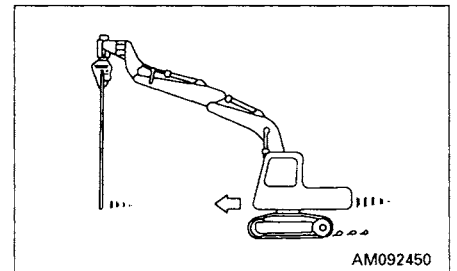

Work other than standard works

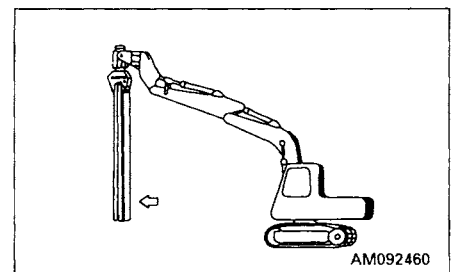

Loading or unloading a machine equipped with hydraulic pile driver

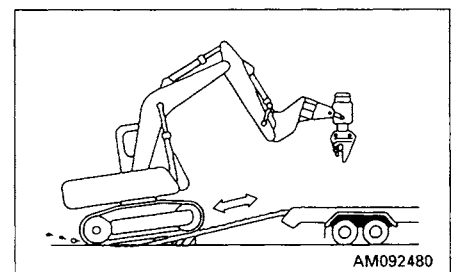
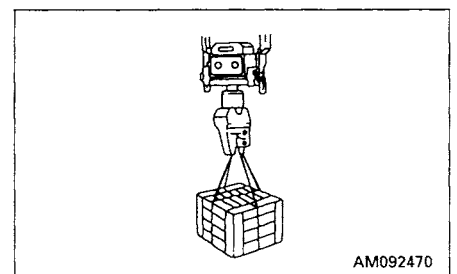

### 32.8 HYDRAULIC EXCAVATOR WITH MULTI-PURPOSE CRANE

#### MAIN FIELDS OF APPLICATION

- Site preparation
- Water supply and sewerage
- River work
- Agricultural, civil engineering work

Crane operation can be carried out without removing the bucket.

This machine is used for laying U section gutters and hume pipes for water supply and sewerage as well as river and canal work, agricultural, civil engineering work and site preparation.

#### MISTAKEN METHODS OF USE

To ensure that the machine has a long life, and to ensure that operations are carried out in safety, do not operate the machine in any of the following ways.

- Do not operate the cylinder to the end of its stroke.  
Always leave approx. 5 cm (2 in) to spare.

Abrupt lever operation

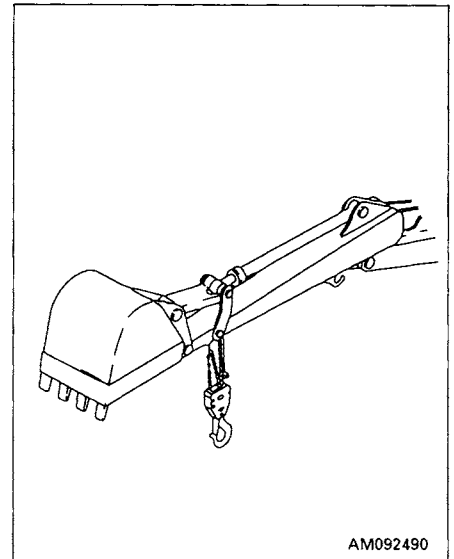

Traveling with a suspended load

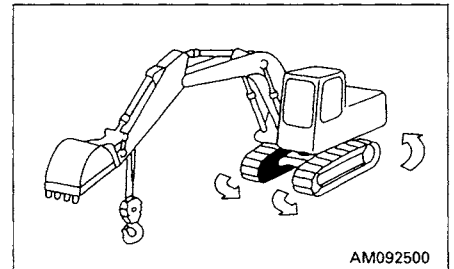

Operating other work equipment during crane operation

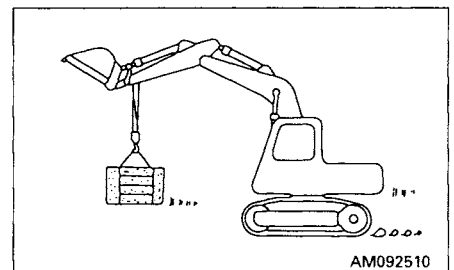

Excessive lengthening of wire rope

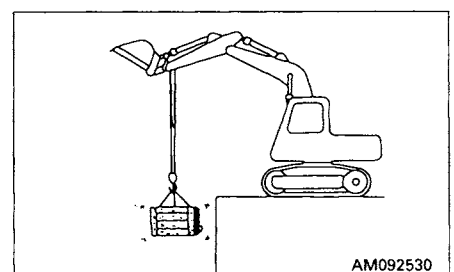
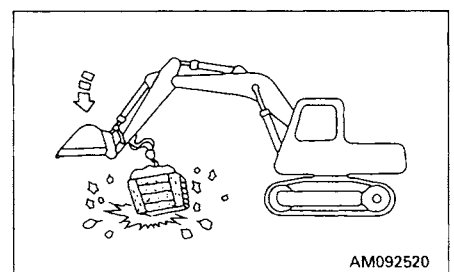

**PC200, 200LC, PC210, 210LC, PC220, 220LC, PC230, 230LC-6 MIGHTY HYDRAULIC EXCAVATOR**

---

Form No. SEAM002410T