

Operation & Maintenance Manual

GALEO

PC600-7

PC600LC-7

HYDRAULIC EXCAVATOR

SERIAL NUMBERS	PC600-7	20001 and up
	PC600LC-7	20001 and up

This material is proprietary to Komatsu America Corp. and is not to be reproduced, used, or disclosed except in accordance with written authorization from Komatsu America Corp..

It is our policy to improve our products whenever it is possible and practical to do so. We reserve the right to make changes or improvements at any time without incurring any obligation to install such changes on products sold previously.

Due to this continuous program of research and development, revisions may be made to this publication. It is recommended that customers contact their distributor for information on the latest revision.

Copyright 2006 Komatsu
Printed in U.S.A.
Komatsu America Corp.

FOREWORD

CALIFORNIA

Proposition 65 Warning

Diesel engine exhaust and some of its constituents are known to the State of California to cause cancer, birth defects, and other reproductive harm.

CALIFORNIA

Proposition 65 Warning

Battery posts, terminals and related accessories contain lead and lead compounds, chemicals known to the State of California to cause cancer and birth defects or other reproductive harm.

Wash hands after handling.

FOREWORD

This manual provides rules and guidelines which will help you use this machine safely and effectively. The precautions in this manual must be followed at all times when performing operation and maintenance. Most accidents are caused by the failure to follow fundamental safety rules for the operation and maintenance of machines. Accidents can be prevented by knowing beforehand conditions that may cause a hazard when performing operation and maintenance.

WARNING

Operators and maintenance personnel must always do as follows before beginning operation or maintenance.

Always be sure to read and understand this manual thoroughly before performing operation and maintenance.

Read the safety messages given in this manual and the safety labels affixed to the machine thoroughly and be sure that you understand them fully.

Keep this manual at the storage location for the Operation and Maintenance Manual given below, and have all personnel read it periodically.

If this manual has been lost or has become dirty and cannot be read, request a replacement manual immediately from Komatsu or your Komatsu distributor.

If you sell the machine, be sure to give this manual to the new owners together with the machine.

Komatsu delivers machines that comply with all applicable regulations and standards of the country to which it has been shipped. If this machine has been purchased in another country or purchased from someone in another country, it may lack certain safety devices and specifications that are necessary for use in your country. If there is any question about whether your product complies with the applicable standards and regulations of your country, consult Komatsu or your Komatsu distributor before operating the machine.

Storage location for the Operation and Maintenance Manual:
magazine box on the left side of the operator's seat.

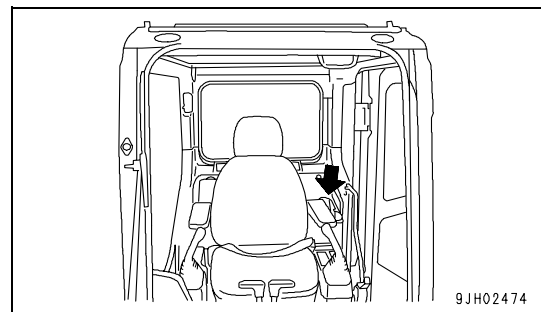

EMISSION CONTROL WARRANTY

EMISSION CONTROL WARRANTY STATEMENT (APPLIES TO CANADA ONLY)

1. Products Warranted

Komatsu America International Company, Komatsu Mining Systems Inc. and Komatsu Utility Corporation (collectively "Komatsu") produce and/or market products under brand names of Komatsu, Dresser, Dressta, Haulpak and Galion. This emissions warranty applies to new engines bearing the Komatsu name installed in these products and used in Canada in machines designed for industrial off-highway use. This warranty applies only to these engines produced on or after January 1, 2000. This warranty will be administered by Komatsu distribution in Canada.

2. Coverage

Komatsu warrants to the ultimate purchaser and each subsequent purchaser that the engine is designed, built and equipped so as to conform, at the time of sale by Komatsu, with all U.S. Federal emission regulations applicable at the time of manufacture and that it is free from defects in workmanship or material which would cause it not to meet these regulations within five years or 3,000 hours of operation, whichever occurs first, as measured from the date of delivery of the engine to the ultimate purchaser.

3. Limitations

Failures, other than those resulting from defects in materials or workmanship, are not covered by this warranty. Komatsu is not responsible for failures or damage resulting from what Komatsu determines to be abuse or neglect, including, but not limited to: operation without adequate coolant or lubricants; over fueling; over speeding; lack of maintenance of lubricating, cooling or intake systems; improper storage, starting, warm-up, run-in or shutdown practices; unauthorized modifications of the engine. Komatsu is also not responsible for failures caused by incorrect fuel or by water, dirt or other contaminants in the fuel. Komatsu is not responsible for non-engine repairs, "downtime" expense, related damage, fines, all business costs or other losses resulting from a warrantable failure.

KOMATSU IS NOT RESPONSIBLE FOR INCIDENTAL OR CONSEQUENTIAL DAMAGES.

This warranty, together with the express commercial warranties, are the sole warranties of Komatsu. **THERE ARE NO OTHER WARRANTIES, EXPRESS OR IMPLIED, OR OF MERCHANTABILITY OR FITNESS FOR A PARTICULAR PURPOSE.**

GARANTIE SUR LE CONTRÔLE DES ÉMISSIONS

ÉNONCÉ DE GARANTIE SUR LE CONTRÔLE DES ÉMISSIONS (APPLICABLE AU CANADA SEULEMENT):

1. Produits garantis:

Komatsu America International Company, Komatsu Mining Systems Inc. et Komatsu Utility Corporation (collectivement Komatsu) produisent et/ou font la mise en marché de produits portant les noms de marque Komatsu, Dresser, Dressta, Haulpak et Galion. Cette garantie sur les émissions s'applique à tous les nouveaux moteurs portant le nom Komatsu, installés dans ces produits et utilisés au Canada dans des machines conçues pour utilisation industrielle non-routière. Cette garantie s'applique seulement sur les moteurs produits à partir du 1er Janvier 2000. Cette garantie sera administrée par la distribution de Komatsu au Canada.

2. Couverture:

Komatsu garantit à l'acheteur ultime et chaque acheteur subséquent que le moteur est conçu, construit et équipé en toute conformité, au moment de la vente par Komatsu, avec toutes les Réglementations fédérales américaines sur les émissions applicables au moment de la fabrication et qu'il est exempt de défauts de construction ou de matériaux qui auraient pour effet de contrevenir à ces réglementations en dedans de 5 ans ou 3000 heures d'opération, mesuré à partir de la date de livraison du moteur au client ultime.

3. Limitations:

Les bris, autres que ceux résultant de défauts de matériaux ou de construction, ne sont pas couverts par cette Garantie. Komatsu n'est pas responsable pour bris ou dommages résultant de ce que Komatsu détermine comme étant de l'abus ou négligence, incluant mais ne se limitant pas à: l'opération sans lubrifiants ou agent refroidissants adéquats; la suralimentation d'essence; la survitesse; le manque d'entretien des systèmes de lubrification, de refroidissement ou d'entrée; de pratiques non-propices d'entreposage, de mise en marche, de réchauffement, de conditionnement ou d'arrêt; les modifications non-autorisées du moteur. De plus, Komatsu n'est pas responsable de bris causés par de l'essence inadéquate ou de l'eau, des saletés ou autres contaminants dans l'essence. Komatsu n'est pas responsable des réparations non-relées au moteur, des dépenses encourues suite aux temps d'arrêts, des dommages relatifs, amendes, et de tout autre coût d'affaires ou autres pertes résultant d'un bris couvert par la garantie.

KOMATSU N'EST PAS RESPONSABLE DES INCIDENTS OU DOMMAGES CONSÉQUENTS.

Cette garantie, ainsi que les garanties expresses commerciales, sont les seules garanties de Komatsu. **IL N'Y A AUCUNE AUTRE GARANTIE, EXPRESSE OU SOUS-ENTENDUE, MARCHANDABLE OU PROPICE A UNE UTILISATION PARTICULIÈRE.**

INFORMATION IMPORTANTE SUR LE MOTEUR
 CE MOTEUR EST CONFORME AUX NORMES AMÉRICAINES DE L'EPA (ANNÉE DU MODÈLE) ET DE LA CALIFORNIE POUR LES MOTEURS LARGES NON-ROUTIERS À IGNITION PAR COMPRESSION. CE MOTEUR EST CERTIFIÉ POUR OPERATION À ESSENCE DIESEL.

AVERTISSEMENT
 DES BLESSURES PEUVENT RÉSULTER ET LA GARANTIE S'ANNULER SI LES RPM DU TAUX D'ESSENCE OU L'ALTITUDE EXCÈDENT LES VALEURS MAXIMALES PUBLIÉES POUR CE MODÈLE ET SON APPLICATION.

IMPORTANT ENGINE INFORMATION
 THIS ENGINE CONFORMS TO YYYY MODEL YEAR U.S. EPA REGULATION AND THE CALIFORNIA REGULATIONS LARGE NON ROAD COMPRESSION IGNITION ENGINES. THIS ENGINE IS CERTIFIED TO OPERATE ON DIESEL FUEL.

WARNING
 INJURY MAY RESULT AND WARRANTY IS VOIDED IF FUEL RATE RPM OR ALTITUDES EXCEED PUBLISHED MAXIMUM VALUES FOR THIS MODEL AND APPLICATION.

ENGINE MODEL	SERIAL NO.	DISPLACEMENT	LITERS
ENGINE FAMILY	DISPLACEMENT	FIRING ORDER	1 - 3 - 6 - 2 - 4
EXHAUST EMISSION CONTROL SYSTEM	HP	ADV. LOAD OUTPUT	RPM
VALVE LASH COLD (mm)	EX. FUEL RATE AT ADV.	mm ³ /STROKE	
IDLE SPEED	RPM FAMILY EMISSION LIMIT	TAUX D'ESSENCE À ADV.	
INITIAL INJECTION TIMING	DEG. BTDC	LIMITÉ D'ÉMISSION DE LA FAMILLE	
KOMATSU LTD. MADE IN JAPAN		DATE DE FABRICATION	

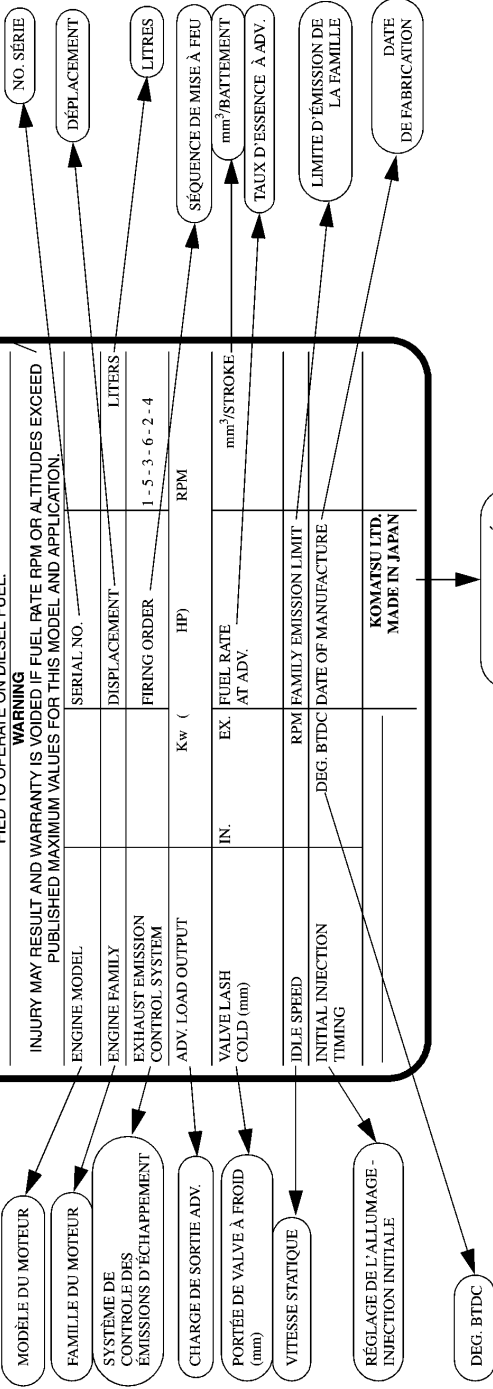

ENGINE DATAPLATE - ENGLISH / FRENCH

SAFETY INFORMATION

To enable you to use this machine safely, safety precautions and labels are given in this manual and affixed to the machine to give explanations of situations involving potential hazards and of the methods of avoiding such situations.

Signal words

The following signal words are used to inform you that there is a potential hazardous situation that may lead to personal injury or damage.

In this manual and on machine labels, the following signal words are used to express the potential level of hazard.



Indicates an imminently hazardous situation which, if not avoided, will result in death or serious injury.



Indicates a potentially hazardous situation which, if not avoided, could result in death or serious injury.



Indicates a potentially hazardous situation which, if not avoided, may result in minor or moderate injury. This word is used also to alert against unsafe practices that may cause property damage.

Example of safety message using signal word



When standing up from the operator's seat, always place the lock lever in the LOCK position.

If you accidentally touch the control levers when they are not locked, this may cause a serious injury or death.

Other signal words

In addition to the above, the following signal words are used to indicate precautions that should be followed to protect the machine or to give information that is useful to know.

NOTICE

This word is used for precautions that must be taken to avoid actions which could shorten the life of the machine.

REMARKS

This word is used for information that is useful to know.

● **Safety labels**

Safety labels are affixed to the machine to inform the operator or maintenance worker on the spot when carrying out operation or maintenance of the machine that may involve hazard.

This machine uses "Safety labels using words" and "Safety labels using pictograms" to indicate safety procedures.

Example of safety label using words

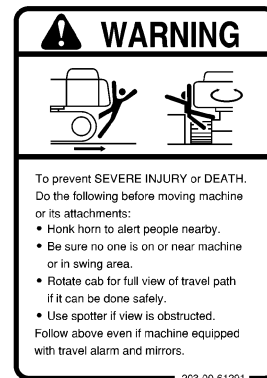

Part No.

Safety labels using pictogram

Safety pictograms use a picture to express a level of hazardous condition equivalent to the signal word. These safety pictograms use pictures in order to let the operator or maintenance worker know the level and type of hazardous condition at all times. Safety pictograms show the type of hazardous condition at the top or the left side, and the method to avoid hazardous condition at the bottom or the right side. The type of hazardous condition is also displayed inside a triangle.



Part No.

Komatsu cannot predict every circumstance that might involve a potential hazard in operation and maintenance. Therefore, the safety messages in this manual and on the machine may not include all possible safety precautions.

If any procedures or actions not specifically recommended or allowed in this manual are used, it is your responsibility to take the necessary steps to ensure safety.

In no event should you engage in prohibited uses or actions described in this manual.

The explanations, values, and illustrations in this manual were prepared based on the latest information available at that time. Continuing improvements in the design of this machine can lead to changes in detail which may not be reflected in this manual. Consult Komatsu or your Komatsu distributor for the latest available information of your machine or for questions regarding information in this manual.

The numbers in circles in the illustrations correspond to the numbers in () in the text. (For example: ① -> (1))

INTRODUCTION

This Komatsu machine is designed to be used mainly for the following work:

- Digging work
- Leveling work
- Ditching work
- Loading work
- Demolition work

See the section "RECOMMENDED APPLICATIONS (3-119)" for further details.

DIRECTIONS OF MACHINE

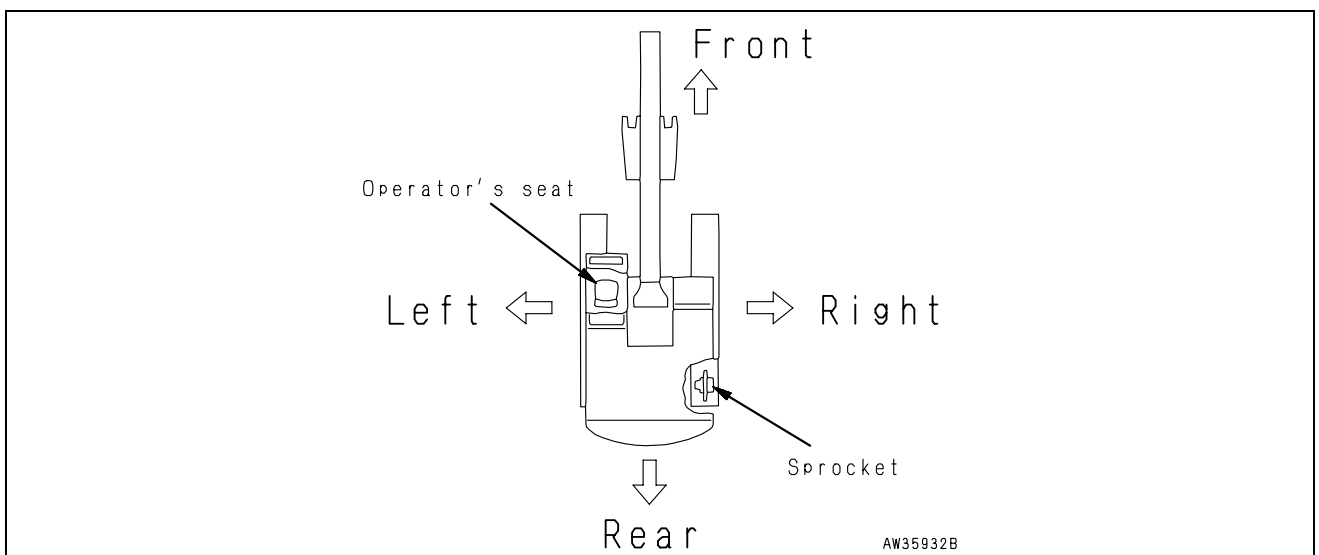

In this manual, the terms front, rear, left, and right refer to the travel direction as seen from the operator's seat when the operator's seat is facing the front and the sprocket is at the rear of the machine.

BREAKING-IN THE NEW MACHINE

NOTICE

Your Komatsu machine has been thoroughly adjusted and tested before shipment from the factory. However, operating the machine under full load before breaking the machine in can adversely affect the performance and shorten the machine life.

Be sure to break in the machine for the initial 100 hours (as indicated on the service meter).

Make sure that you fully understand the content of this manual, and pay careful attention to the following points when breaking in the machine.

- Run the engine at idling for 15 seconds after starting it. During this time, do not operate the control levers or fuel control dial.
- Idle the engine for 5 minutes after starting it up.
- Avoid operation with heavy loads or at high speeds.
- Immediately after starting the engine, avoid sudden starts, sudden acceleration, unnecessary sudden stops, and sudden changes in direction.

PRODUCT INFORMATION

When requesting service or ordering replacement parts, please inform your Komatsu distributor of the following items.

PRODUCT IDENTIFICATION NUMBER (PIN)/MACHINE SERIAL NO. PLATE

On the front bottom right of the operator's cab (side of upper frame)

The design of the nameplate differs according to the territory.

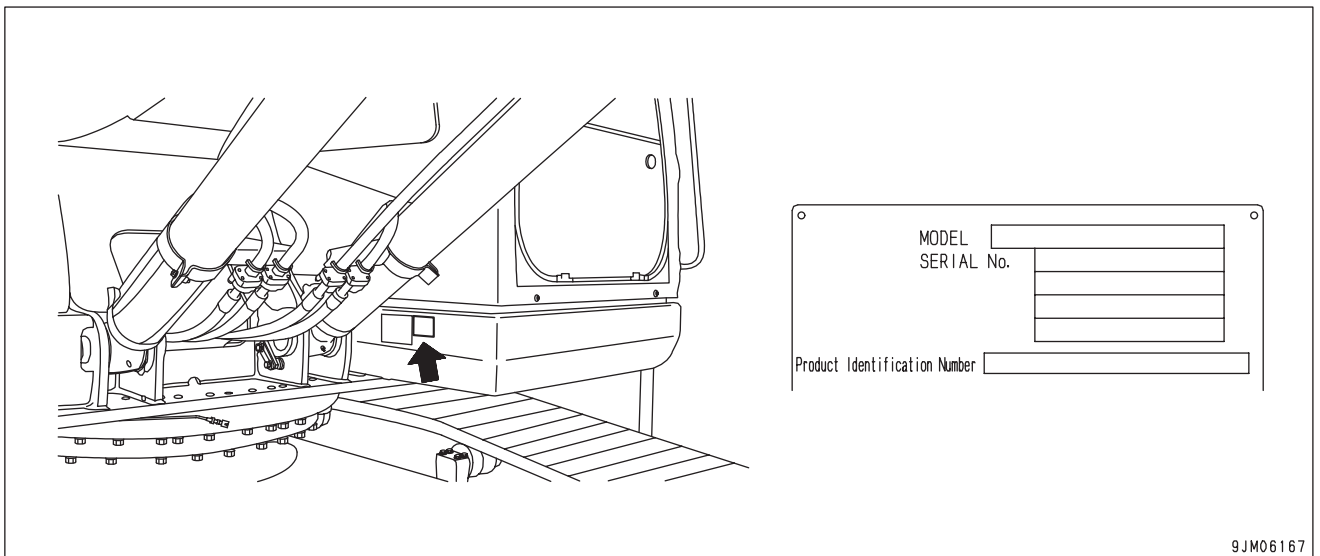

ENGINE SERIAL NUMBER PLATE AND ITS LOCATION

This is at the side of the oil cooler housing on the left side face of the engine cylinder block.

(The EPA restrictions plate is on the top surface of the intake manifold at the front of the chassis.)

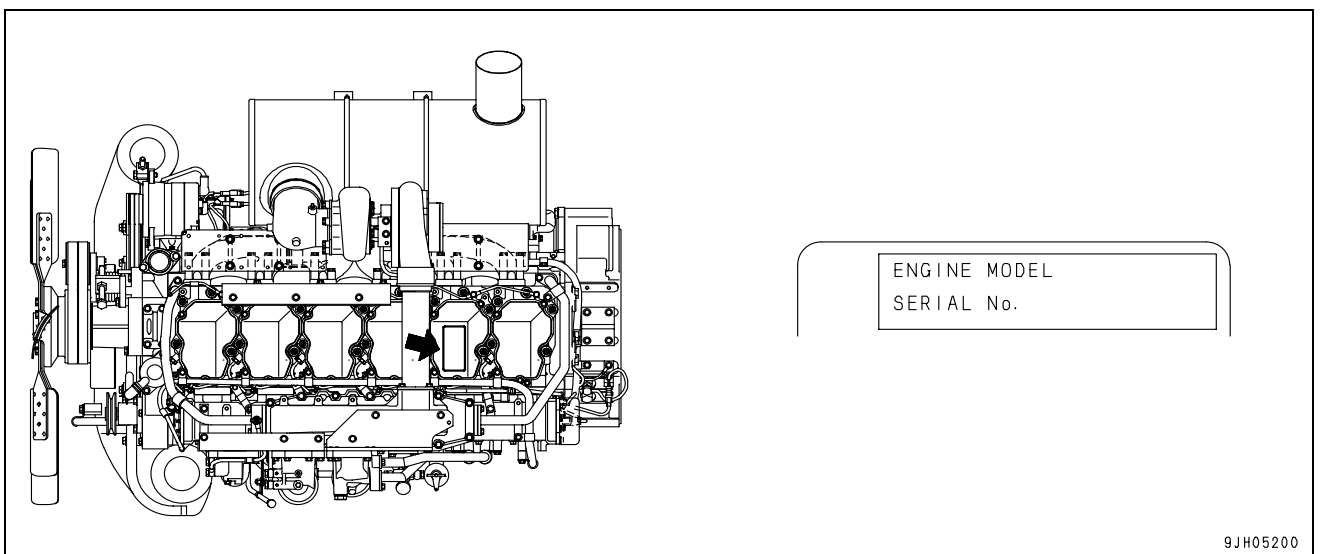

EPA: Environmental Protection Agency, U.S.A.

SERVICE METER LOCATION

On top of the machine monitor

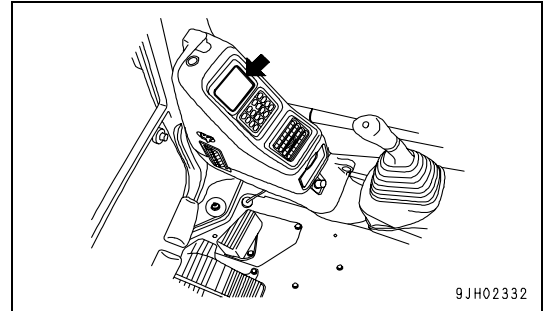

9JH02332

YOUR MACHINE SERIAL NUMBERS AND DISTRIBUTOR

Machine serial No.	
Engine serial No.	
Product identification number (PIN)	
Distributor name	
Address	-----

Service Personnel	-----
Phone/Fax	-----

CONTENTS

FOREWORD

FOREWORD	1-2
SAFETY INFORMATION	1-5
INTRODUCTION	1-7
DIRECTIONS OF MACHINE	1-7
BREAKING-IN THE NEW MACHINE	1-8
PRODUCT INFORMATION	1-9
PRODUCT IDENTIFICATION NUMBER (PIN)/MACHINE SERIAL NO. PLATE	1-9
ENGINE SERIAL NUMBER PLATE AND ITS LOCATION	1-9
SERVICE METER LOCATION	1-10
YOUR MACHINE SERIAL NUMBERS AND DISTRIBUTOR	1-10

SAFETY

SAFETY INFORMATION	2-2
SAFETY LABELS	2-4
LOCATION OF SAFETY LABELS	2-5
SAFETY LABELS	2-6
SAFETY INFORMATION	2-12
SAFETY MACHINE OPERATION	2-21
STARTING ENGINE	2-21
OPERATION	2-23
TRANSPORTATION	2-30
BATTERY	2-31
TOWING	2-33
LIFTING OBJECTS WITH BUCKET	2-34
SAFETY MAINTENANCE INFORMATION	2-35

OPERATION

MACHINE VIEW ILLUSTRATIONS	3-2
OVERALL MACHINE VIEW	3-2
CONTROLS AND GAUGES	3-3
DETAILED CONTROLS AND GAUGES	3-5
MONITORING SYSTEM	3-5

CONTENTS

Basic Operation Of Machine Monitor	3-6
Basic Check Monitors	3-8
Caution Monitors	3-10
Emergency Monitors	3-12
Meter Display Portion	3-14
Monitor Switches Portion	3-18
SWITCHES	3-27
CONTROL LEVERS AND PEDALS	3-34
SUN ROOF	3-37
Opening	3-37
Closing	3-37
WINDSHIELD	3-38
EMERGENCY EXIT FROM OPERATOR'S CAB.....	3-43
DOOR LOCK	3-43
CAP WITH LOCK.....	3-44
HOT AND COOL BOX	3-45
MAGAZINE BOX.....	3-45
ASHTRAY	3-46
AIR CONDITIONER CONTROLS	3-47
Air Conditioner Control Panel	3-47
Method Of Operation	3-52
Use Air Conditioner With Care	3-58
Inspection and maintenance of air conditioner equipped machine	3-58
Other Functions	3-59
RADIO.....	3-61
Control Panel	3-61
Controls Of Radio	3-62
Use Radio With Care	3-64
AUXILIARY ELECTRIC POWER	3-64
24V power source	3-64
12V power source	3-64
FUSE	3-65
CIRCUIT BREAKER	3-66
CONTROLLERS	3-67
TOOL BOX.....	3-67
GREASE PUMP.....	3-68
Method of Use	3-68
Precautions when Using	3-69
Supplying Grease	3-69
ACCUMULATOR	3-71
Releasing Hydraulic Pressure With Accumulator	3-72
MACHINE OPERATIONS AND CONTROLS	3-73
BEFORE STARTING ENGINE	3-73
Walk-Around Checks	3-73
Checks Before Starting	3-75
Adjustment	3-82
Seat Belt	3-85

Operations Before Starting Engine	3-86
STARTING ENGINE	3-89
Normal Starting	3-89
Starting Engine In Cold Weather	3-91
AFTER STARTING ENGINE	3-94
Warming-Up Operation	3-94
In Cold Weather Areas	3-97
STOPPING THE ENGINE	3-101
MACHINE OPERATION	3-102
Preparations For Moving The Machine	3-102
Moving Machine Forward	3-103
Moving Machine Backward	3-104
Stopping Machine	3-105
STEERING THE MACHINE	3-106
Steering	3-106
SWINGING	3-108
WORK EQUIPMENT CONTROLS AND OPERATIONS	3-109
WORKING MODE	3-111
PROHIBITED OPERATIONS	3-112
GENERAL OPERATION INFORMATION	3-114
TRAVELING ON SLOPES	3-116
ESCAPE FROM MUD	3-118
Stuck One Side Of Track	3-118
Stuck Both Sides Of Tracks	3-118
RECOMMENDED APPLICATIONS	3-119
Backhoe Work	3-119
Ditching Work	3-119
Loading Work	3-119
BUCKET REPLACEMENT	3-120
Replacement	3-120
PARKING MACHINE	3-122
CHECK AFTER SHUT OFF ENGINE	3-123
LOCKING	3-124
TRANSPORTATION	3-125
PRECAUTIONS FOR TRANSPORTATION	3-125
LIFTING MACHINE	3-125
SHIPPING MACHINE INFORMATION	3-126
TRANSPORTATION POSTURE	3-127
PROCEDURE FOR INCREASING OR REDUCING TRACK FRAME GAUGE	3-132
COLD WEATHER OPERATION	3-134
COLD WEATHER OPERATION INFORMATION	3-134
Fuel And Lubricants	3-134
AFTER DAILY WORK COMPLETION	3-136
AFTER COLD WEATHER SEASON	3-136
LONG TERM STORAGE	3-137

CONTENTS

BEFORE STORAGE.....	3-137
DURING STORAGE	3-137
AFTER STORAGE.....	3-138
STARTING MACHINE AFTER LONG-TERM STORAGE	3-138
TROUBLES AND ACTIONS	3-139
RUNNING OUT OF FUEL	3-139
PHENOMENA THAT ARE NOT FAILURES.....	3-141
TOWING THE MACHINE	3-142
SEVERE JOB CONDITION	3-142
DISCHARGED BATTERY	3-143
Battery Removal And Installation.....	3-143
Battery Charges	3-144
Starting Engine With Booster Cables	3-145
OTHER TROUBLE	3-147
Electrical System	3-147
Chassis	3-148
Engine.....	3-149
Electronic Control System	3-151
Point Of Contact To Telephone When Error Occurs	3-152
MAINTENANCE	
MAINTENANCE INFORMATION	4-2
LUBRICANTS, COOLANT AND FILTERS	4-4
HANDLING OIL, FUEL, COOLANT, AND PERFORMING OIL CLINIC.....	4-4
Oil	4-4
Fuel.....	4-4
Cooling System Coolant	4-5
Grease	4-5
Carrying out KOWA (Komatsu Oil Wear Analysis)	4-5
Oil And Fuel Storage	4-6
Filters	4-7
ELECTRIC SYSTEM MAINTENANCE	4-7
WEAR PARTS	4-8
WEAR PARTS LIST.....	4-8
LUBRICANTS, FUEL AND COOLANT SPECIFICATIONS.....	4-9
TIGHTENING TORQUE SPECIFICATIONS	4-13
TIGHTENING TORQUE LIST	4-13
SAFETY CRITICAL PARTS	4-14
SAFETY CRITICAL PARTS LIST	4-15
MAINTENANCE SCHEDULE.....	4-16
MAINTENANCE SCHEDULE CHART.....	4-16

MAINTENANCE INTERVAL FOR HYDRAULIC BREAKER.....	4-18
MAINTENANCE PROCEDURE.....	4-19
INITIAL 100 HOURS MAINTENANCE (ONLY AFTER THE FIRST 100 HOURS).....	4-19
INITIAL 500 HOURS MAINTENANCE (ONLY AFTER THE FIRST 500 HOURS).....	4-19
WHEN REQUIRED.....	4-20
CHECK, CLEAN AND REPLACE AIR CLEANER ELEMENT.....	4-20
CLEAN INSIDE OF COOLING SYSTEM.....	4-25
CHECK AND TIGHTEN TRACK SHOE BOLTS.....	4-27
CHECK AND ADJUST TRACK TENSION.....	4-28
CHECK ELECTRICAL INTAKE AIR HEATER.....	4-29
REPLACE BUCKET TEETH (HORIZONTAL PIN TYPE).....	4-30
ADJUST BUCKET CLEARANCE.....	4-31
REPLACE OF FAN BELT AND ADJUSTMENT OF AUTO TENSIONER.....	4-32
CHECK WINDOW WASHER FLUID LEVEL, ADD FLUID.....	4-32
CHECK AND ADJUST AIR CONDITIONER.....	4-33
CLEAN LINE FILTER, REMOVE DIRT.....	4-34
REPLACE BREAKER CIRCUIT ADDITIONAL OIL FILTER ELEMENT.....	4-35
CLEAN PILOT LINE FILTER, REMOVE DIRT.....	4-36
BLEEDING AIR FROM HYDRAULIC SYSTEM.....	4-37
METHOD FOR RELEASING INTERNAL PRESSURE IN HYDRAULIC CIRCUIT.....	4-40
CHECK NITROGEN GAS CHARGE PRESSURE IN ACCUMULATOR (control circuit).....	4-41
CHECK BEFORE STARTING.....	4-42
EVERY 10 HOURS MAINTENANCE.....	4-43
LUBRICATING.....	4-43
EVERY 100 HOURS MAINTENANCE.....	4-46
LUBRICATING SWING CIRCLE.....	4-46
EVERY 250 HOURS MAINTENANCE.....	4-47
CHECK OIL LEVEL IN FINAL DRIVE CASE, ADD OIL.....	4-47
CHECK LEVEL OF BATTERY ELECTROLYTE.....	4-48
CHECK, CLEAN FUEL TANK STRAINER.....	4-50
CHECK AND TIGHTEN TRACK FRAME AND AXLE CONNECTING BOLTS.....	4-50
CHECK ALTERNATOR DRIVE BELT TENSION, ADJUST.....	4-51
CHECK AIR CONDITIONER COMPRESSOR BELT TENSION, ADJUST.....	4-52
EVERY 500 HOURS MAINTENANCE.....	4-53
REPLACE FUEL FILTER CARTRIDGE.....	4-53
CHECK SWING PINION GREASE LEVEL, ADD GREASE.....	4-55
CLEAN, CHECK RADIATOR FIN, OIL COOLER FIN, FUEL COOLER FIN, CONDENSER FIN (machines equipped with air conditioner).....	4-56
CLEAN FRESH/RECIRC AIR FILTERS OF AIR CONDITIONER (ONLY FOR MACHINES EQUIPPED WITH AIR CONDITIONER).....	4-57
REPLACE BREATHER ELEMENT IN HYDRAULIC TANK.....	4-58
CLEAN STRAINER OF P.T.O LUBRICATING OIL FILTER.....	4-59
CHECK FAN BELT.....	4-59
CHANGE OIL IN ENGINE OIL PAN, REPLACE ENGINE OIL FILTER CARTRIDGE.....	4-60
EVERY 1000 HOURS MAINTENANCE.....	4-62
REPLACE HYDRAULIC OIL FILTER ELEMENT.....	4-62
CHANGE OIL IN SWING MACHINERY CASE.....	4-63

CONTENTS

CHANGE OIL IN P.T.O CASE	4-64
CHECK ALL TIGHTENING PARTS OF TURBOCHARGER	4-64
CHECK PLAY TURBOCHARGER ROTOR.....	4-64
REPLACE CORROSION RESISTOR CARTRIDGE	4-65
GREASE FAN PULLEY AND TENSION PULLEY	4-65
CHECK WELDED STRUCTURE.....	4-66
CHECK NITROGEN GAS CHARGE PRESSURE IN ACCUMULATOR (for breaker)	4-68
EVERY 2000 HOURS MAINTENANCE.....	4-69
CHANGE OIL IN FINAL DRIVE CASE	4-69
CLEAN HYDRAULIC TANK STRAINER	4-70
CLEAN ENGINE BREATHER	4-71
CLEAN, CHECK TURBOCHARGER.....	4-71
CHECK ALTERNATOR, STARTING MOTOR.....	4-71
CHECK ENGINE VALVE CLEARANCE, ADJUST	4-71
CHECK INJECTOR	4-71
EVERY 4000 HOURS MAINTENANCE.....	4-72
CHECK WATER PUMP.....	4-72
CHECK VIBRATION DAMPER	4-72
CHECK FAN PULLEY AND TENSION PULLEY	4-72
REPLACE INJECTOR ASSEMBLY.....	4-72
CHECK FOR LOOSENESS OF HIGH-PRESSURE CLAMP, HARDENING OF RUBBER.....	4-73
CHECK FOR MISSING FUEL SPRAY PREVENTION CAP, HARDENING OF RUBBER.....	4-74
EVERY 5000 HOURS MAINTENANCE.....	4-75
CHANGE OIL IN HYDRAULIC TANK.....	4-75
EVERY 8000 HOURS MAINTENANCE.....	4-77
REPLACE HIGH-PRESSURE PIPING CLAMP	4-77
REPLACE FUEL SPRAY PREVENTION CAP	4-77

SPECIFICATIONS

SPECIFICATIONS	5-2
----------------------	-----

ATTACHMENTS AND OPTIONS

GENERAL PRECAUTIONS FOR SAFETY.....	6-2
PRECAUTIONS WHEN SELECTING.....	6-2
READ THE INSTRUCTION MANUAL THOROUGHLY	6-2
PRECAUTIONS WHEN REMOVING OR INSTALLING	6-2
PRECAUTIONS WHEN USING.....	6-3
ATTACHMENT GUIDE	6-4
COMBINATIONS OF WORK EQUIPMENT.....	6-4
Working Range Diagram	6-5
TRACK SHOES SELECTION.....	6-6

SAFETY

WARNING

Please read and make sure that you fully understand the precautions described in this manual and the safety labels on the machine. When operating or servicing the machine, always follow these precautions strictly.

SAFETY INFORMATION

SAFETY LABELS.....	2-4
LOCATION OF SAFETY LABELS	2-5
SAFETY LABELS.....	2-6
SAFETY INFORMATION	2-12
Safety Rules.....	2-12
If Abnormalities are Found	2-12
Working Wear and Personal Protective Items	2-12
Fire Extinguisher and First Aid Kit.....	2-12
Safety Equipment.....	2-13
Keep Machine Clean.....	2-13
Keep Operator's Compartment Clean	2-13
Leaving Operator's Seat with Lock	2-13
Handrails and Steps.....	2-14
Mounting and Dismounting	2-15
No Persons on Attachments	2-15
Burn Prevention	2-15
Fire Prevention and Explosion Prevention.....	2-16
Action If Fire Occurs.....	2-17
Windshield Washer Fluid	2-17
Falling Objects, Flying Objects and Intruding Objects Prevention	2-17
Attachment Installation.....	2-17
Attachment Combinations	2-17
Cab Window Glasses.....	2-18
Unauthorized Modifications.....	2-18
Safety at Jobsite.....	2-18
Working on Loose Ground	2-18
Distance to High Voltage Cables	2-19
Ensure Good Visibility	2-19
Ventilation for Enclosed Area	2-19
Signalman's Signal and Signs.....	2-20
Emergency Exit from Operator's Cab	2-20
Asbestos Dust Hazard Prevention	2-20
SAFETY MACHINE OPERATION	2-21
STARTING ENGINE	2-21
Checks before starting engine	2-21
Safety rules for starting engine	2-22
Starting engine in cold weather.....	2-22
OPERATION.....	2-23
Checks before operation	2-23
Safety rules for changing machine directions	2-23
Safety rules for traveling	2-25
Traveling on slopes.....	2-25
Operations on slopes.....	2-26
Prohibited operations	2-26
Operations on snow	2-28
Parking machine	2-29
TRANSPORTATION.....	2-30
Loading and unloading.....	2-30
Shipping the machine	2-30
BATTERY.....	2-31
Battery hazard prevention.....	2-31
Starting engine with booster cables	2-32

TOWING	2-33
Safety rules for towing	2-33
LIFTING OBJECTS WITH BUCKET	2-34
Safety rules for lifting objects	2-34
SAFETY MAINTENANCE INFORMATION	2-35
Warning Tag	2-35
Keep Work Place Clean and Tidy	2-35
Appoint Leader when Working with Others	2-35
Stop Engine Before Carrying Out Maintenance	2-36
Two Workers for Maintenance when Engine is Running	2-36
Proper Tools	2-37
Accumulator	2-37
Personnel	2-37
Attachments	2-38
Work Under the Machine	2-38
Noise	2-38
When Using Hammer	2-38
Welding Works	2-38
Removing Battery Terminals	2-39
Safety First when Using High-pressure Grease to Adjust Track Tension	2-39
Do Not Disassemble Recoil Springs	2-39
Safety Rules for High-pressure Oil	2-39
Precaution for High Fuel Pressure	2-40
Safety Handling High-pressure Hoses	2-40
Precaution for High Voltage	2-40
Waste Materials	2-40
Air Conditioner Maintenance	2-40
Compressed Air	2-41
Periodic Replacement of Safety Critical Parts	2-41

SAFETY LABELS

The following warning signs and safety labels are used on this machine.

- Be sure that you fully understand the correct position and content of labels.
- To ensure that the content of labels can be read properly, be sure that they are in the correct place and always keep them clean. When cleaning them, do not use organic solvents or gasoline. These may cause the labels to peel off.
- There are also other labels in addition to the warning signs and safety labels. Handle those labels in the same way.
- If the labels are damaged, lost, or cannot be read properly, replace them with new ones. For details of the part numbers for the labels, see this manual or the actual label, and place an order with Komatsu distributor.

LOCATION OF SAFETY LABELS

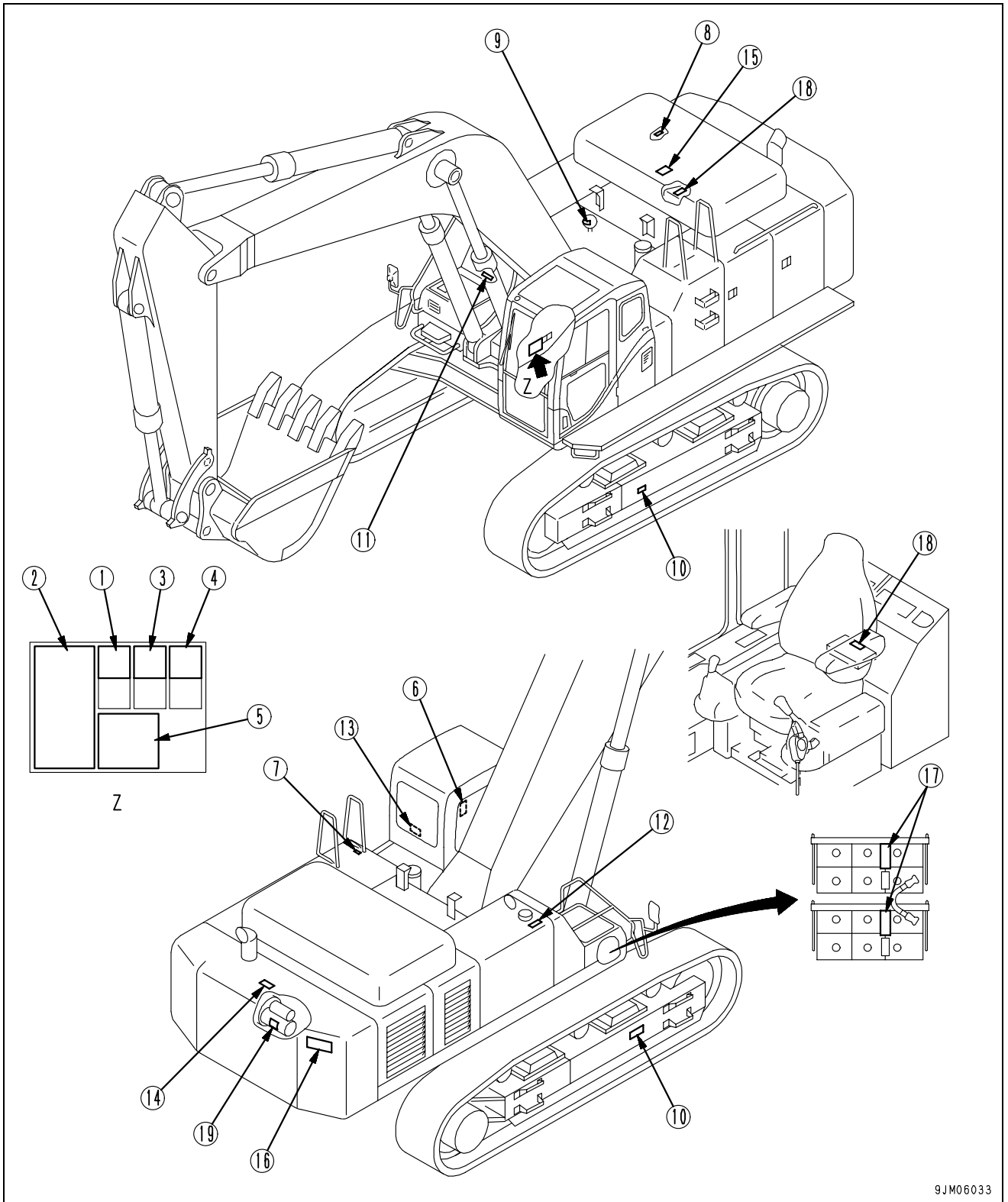

SAFETY LABELS

- (1) Precautions for operation, inspection and maintenance
(09651-03001)

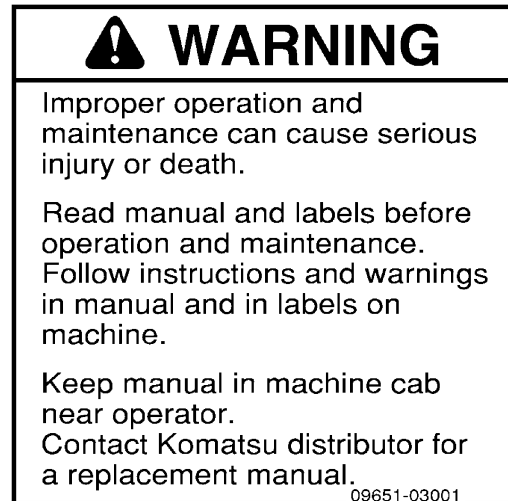

- (2) Warning before moving (09802-03000)

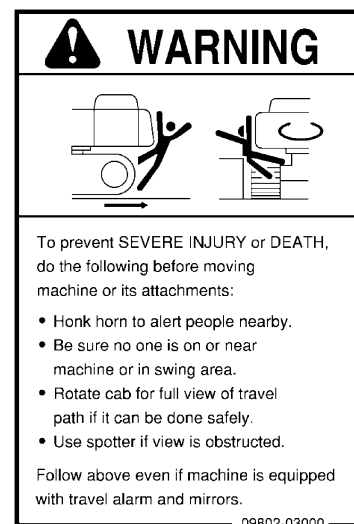

- (3) Warning when leaving operator's seat (09654-03001)



(4) Warning for electric lines (09801-03001)

⚠ DANGER



Hazardous voltage hazard.
Serious injury or death can occur if machine or attachments are not kept safe distance away from electric lines.

VOLTAGE		SAFE DISTANCE
LOW VOLTAGE	100V 200V	2m
	6,600V	2m
	22,000V	3m
SPECIAL HIGH VOLTAGE	66,000V	4m
	154,000V	5m
	187,000V	6m
	275,000V	7m
	500,000V	11m

09801-03001

(5) Warning when opening front window (09839-03000)

⚠ WARNING

To open or close the front or ceiling window, never stand up from the operator's seat before throwing the safety lock lever to the LOCK position.

Inadvertently touching any of the working equipment control levers might cause the machine to start moving all of a sudden, probably resulting in a serious injury.

09839-03000

(6) Warning when stowing front window (09803-03000)

⚠ WARNING

When raising window, lock it in place with lock pins on both sides.

Falling window can cause injury.

09803-03000

(7) Warning for hot oil (09653-03001)



(8) Warning for hot cooling water (09668-03001)



(9) Warning in handling accumulator (09659-53000)

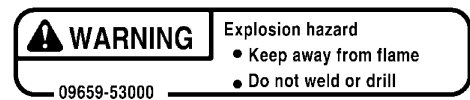

(10) Warning when adjusting track tension (09657-03003)

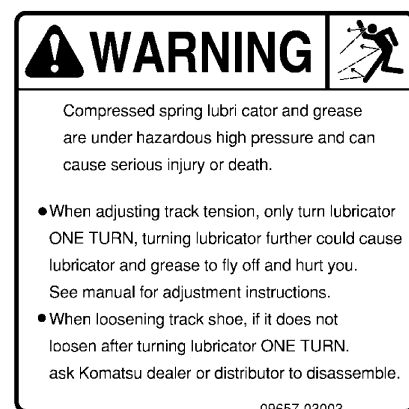

(11) Warning for improper use of cables (09808-03000)

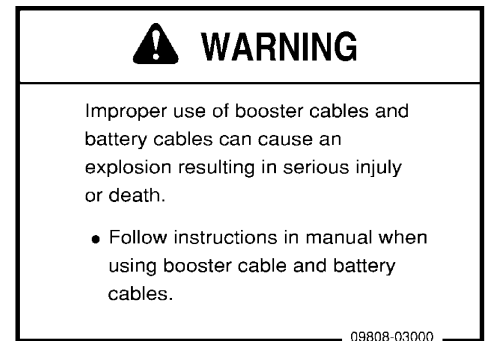

(12) Stop engine when performing inspection or maintenance (09667-03001)



(13) Emergency escape instruction (20Y-00-22880)

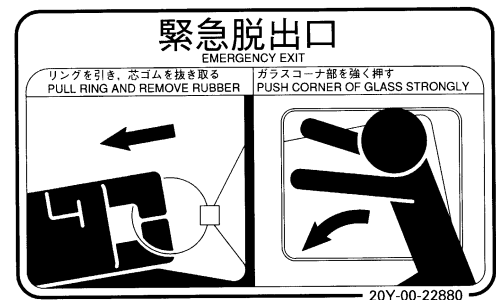

(14) Warning against falling off the edge (09805-23000)



(15) Warning against falling (09805-13000)



(16) Keep off swing area (09133-23000)



(17) Warning when handling battery (09664-30082)

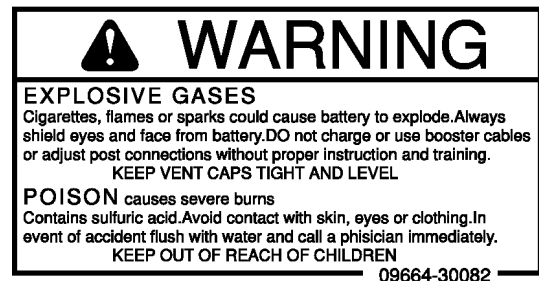

(18) Precautions for high voltage (7872-10-1600)

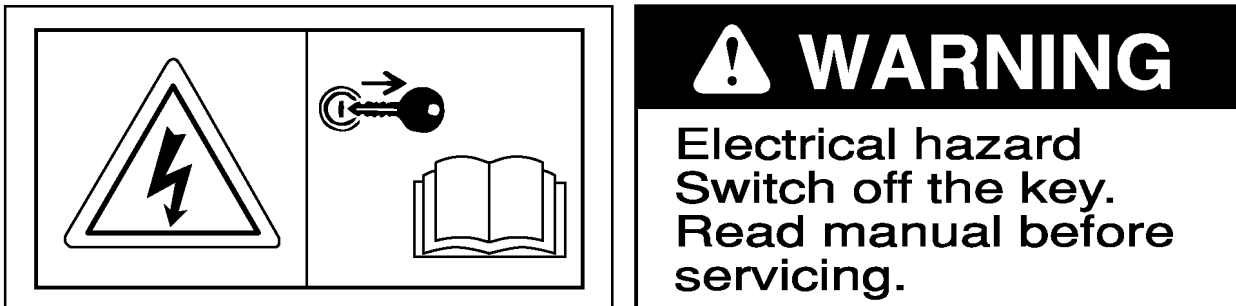

There is danger of electrocution.
 Turn the starting switch OFF before starting inspection or repairs, and read the Operation and Maintenance Manual.

(19) Jump start prohibited (09842-A0481)



Start the engine only after sitting down in the operator's seat.

Do not attempt to start the engine by short-circuiting the engine starting circuit. Such an act may cause a serious bodily injury or fire.

SAFETY INFORMATION

SAFETY RULES

- Only trained and authorized personnel can operate and maintain the machine.
- Follow all safety rules, precautions and instructions when operating or performing maintenance on the machine.
- If you are under the influence of alcohol or medication, your ability to safely operate or repair your machine may be severely impaired putting yourself and everyone else on your jobsite in danger.
- When working with another operator or with a person on worksite traffic duty, be sure that all personnel understand all hand signals that are to be used.

IF ABNORMALITIES ARE FOUND

If you find any abnormality in the machine during operation or maintenance (noise, vibration, smell, incorrect gauges, smoke, oil leakage, etc., or any abnormal display on the warning devices or monitor), report to the person in charge and have the necessary action taken. Do not operate the machine until the abnormality has been corrected.

WORKING WEAR AND PERSONAL PROTECTIVE ITEMS

- Do not wear loose clothing and accessories. There is a hazard that they may catch on control levers or other protruding parts.
- If you have long hair and it hangs out from your hard hat, there is a hazard that it may get caught up in the machine, so tie your hair up and be careful not to let it get caught.
- Always wear a hard hat and safety shoes. If the nature of the work requires it, wear safety glasses, mask, gloves, ear plugs, and safety belt when operating or maintaining the machine.
- Check that all protective equipment functions properly before using it.

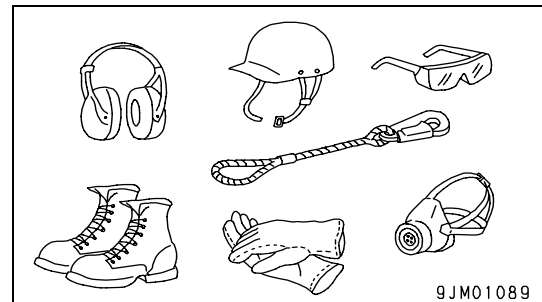

FIRE EXTINGUISHER AND FIRST AID KIT

Always follow the precautions below to prepare for action if any injury or fire should occur.

- Be sure that fire extinguishers have been provided and read the labels to ensure that you know how to use them in emergencies.
- Carry out periodic inspection and maintenance to ensure that the fire extinguisher can always be used.
- Provide a first aid kit at the storage point. Carry out periodic checks and add to the contents if necessary.

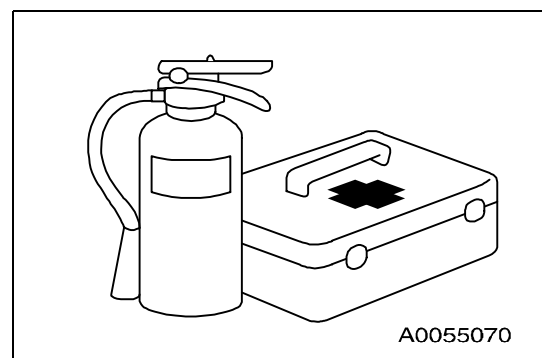

SAFETY EQUIPMENT

- Be sure that all guards and covers are in their proper position. Have guards and covers repaired immediately if they are damaged.
- Understand the method of use of safety features and use them properly.
- Never remove any safety features. Always keep them in good operating condition.

KEEP MACHINE CLEAN

- If water gets into the electrical system, there is a hazard that it will cause malfunctions or misoperation. Do not use water or steam to wash the electrical system (sensors, connectors).
- If inspection and maintenance is carried out when the machine is still dirty with mud or oil, there is a hazard that you will slip and fall, or that dirt or mud will get into your eyes. Always keep the machine clean.

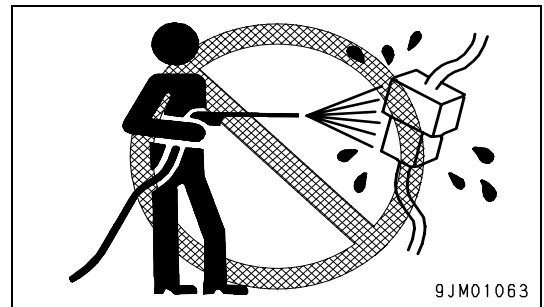

KEEP OPERATOR'S COMPARTMENT CLEAN

- When entering the operator's compartment, always remove all mud and oil from the soles of your shoes. If you operate the pedal with mud or oil affixed to your shoes, your foot may slip and this may cause a serious accident.
- Do not leave parts or tools lying around the operator's compartment.
- Do not stick suction pads to the window glass. Suction pads act as a lens and may cause fire.
- Do not use cellular telephones inside the operator's compartment when driving or operating the machine.
- Never bring any dangerous objects such as flammable or explosive items into the operator's compartment.

LEAVING OPERATOR'S SEAT WITH LOCK

- Before standing up from the operator's seat (such as when opening or closing the front window or roof window, or when removing or installing the bottom window, or when adjusting the operator's seat), lower the work equipment completely to the ground, set lock lever (1) securely to the LOCK position (L), then stop the engine. If you accidentally touch the levers when they are not locked, there is a hazard that the machine may suddenly move and cause serious injury or property damage.

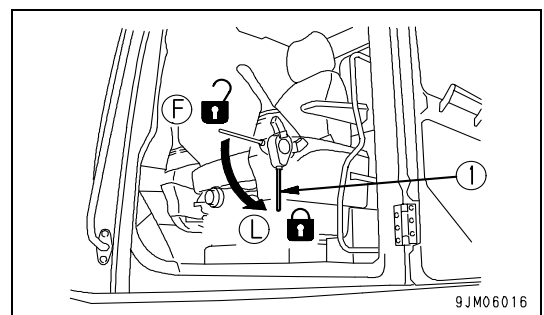

(F): Free
(L): Lock

- When leaving the machine, always lower the work equipment completely to the ground, set lock lever (1) securely to the LOCK position (L), then stop the engine. Use the key to lock all the equipment. Always remove the key, take it with you, and keep it in the specified place.

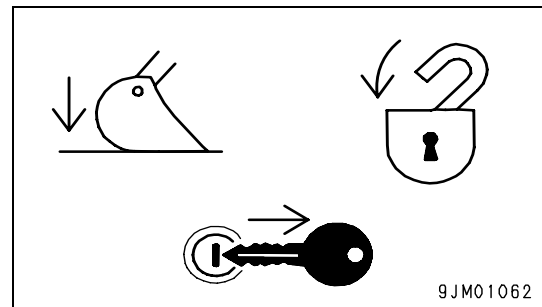

HANDRAILS AND STEPS

To prevent personal injury caused by slipping or falling off the machine, always do as follows.

- Use the handrails and steps marked by arrows in the diagram on the right when getting on or off the machine.

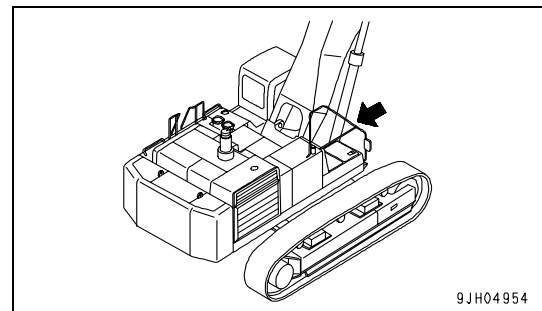
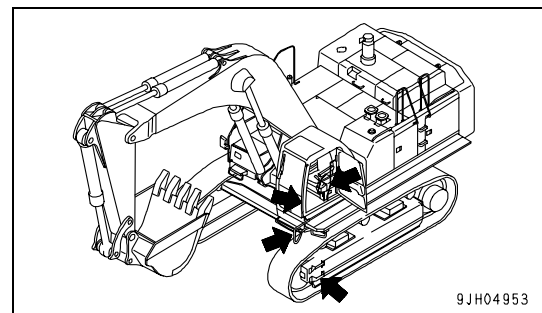

- To ensure safety, always face the machine and maintain three-point contact (both feet and one hand, or both hands and one foot) with the handrails and steps (including the track shoe) to ensure that you support yourself.
- Do not grip the control levers or lock lever when getting on or off the machine.
- Never climb on the engine hood or covers where there are no non-slip pads.
- Before getting on or off the machine, check the handrails and steps (including the track shoe). If there is any oil, grease, or mud on the handrails or steps (including the track shoe), wipe it off immediately. Always keep these parts clean. Repair any damage and tighten any loose bolts.
- Do not get on or off the machine while holding tools in your hand.

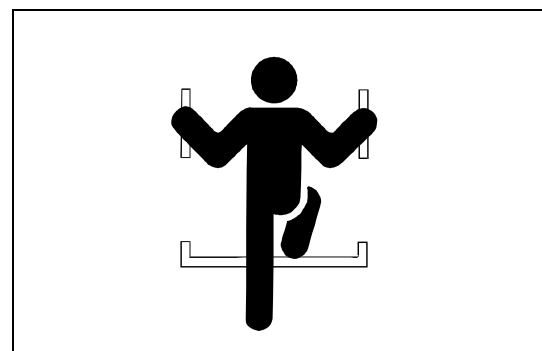

MOUNTING AND DISMOUNTING

- Never jump on or off the machine. Never get on or off a moving machine.
- If the machine starts to move when there is no operator on the machine, do not jump on to the machine and try to stop it.

NO PERSONS ON ATTACHMENTS

Never let anyone ride on the work equipment, or other attachments. There is a hazard of falling and suffering serious injury.

BURN PREVENTION**Hot coolant**

- To prevent burns from hot water or steam spurting out when checking or draining the coolant, wait for the water to cool to a temperature where it is possible to touch the radiator cap by hand before starting the operation. Even when the coolant has cooled down, loosen the cap slowly to relieve the pressure inside the radiator before removing the cap.

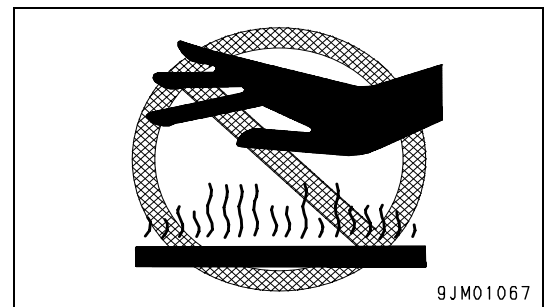
**Hot oil**

- To prevent burns from hot oil spurting out when checking or draining the oil, wait for the oil to cool to a temperature where it is possible to touch the cap or plug by hand before starting the operation. Even when the oil has cooled down, loosen the cap or plug slowly to relieve the internal pressure before removing the cap or plug.

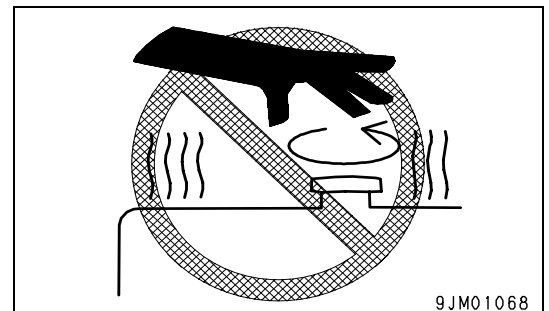

FIRE PREVENTION AND EXPLOSION PREVENTION

● Fire caused by fuel or oil

Fuel, oil, antifreeze, and window washer liquid are particularly flammable and can be hazardous. To prevent fire, always observe the following:

- Do not smoke or use any flame near fuel or oil.
- Stop the engine before refueling.
- Do not leave the machine while adding fuel or oil.
- Tighten all fuel and oil caps securely.
- Do not spill fuel on overheated surfaces or on parts of the electrical system.
- Use well-ventilated areas for adding or storing oil and fuel.
- Keep oil and fuel in the determined place and do not allow unauthorized persons to enter.
- After adding fuel or oil, wipe up any spilled fuel or oil.
- When carrying out grinding or welding work on the chassis, move any flammable materials to a safe place before starting.
- When washing parts with oil, use a non-flammable oil. Diesel oil and gasoline may catch fire, so do not use them.
- Put greasy rags and other flammable materials into a safe container to maintain safety at the work place.
- Do not weld or use a cutting torch to cut any pipes or tubes that contain flammable liquids.

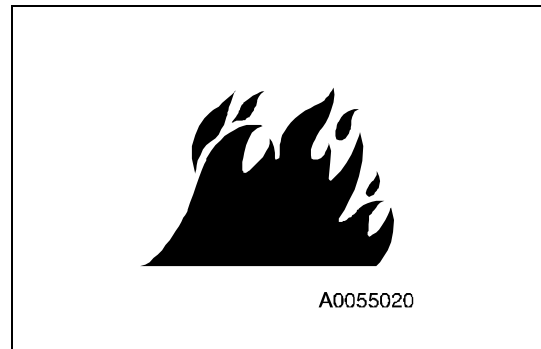

● Fire caused by accumulation of flammable material.

Remove any dry leaves, chips, pieces of paper, dust, or any other flammable materials accumulated or affixed around the engine, exhaust manifold, muffler, or battery, or inside the undercovers.

● Fire coming from electric wiring

Short circuits in the electrical system can cause fire.

- Always keep electric wiring connections clean and securely tightened.
- Check the wiring every day for looseness or damage. Tighten any loose connectors or wiring clamps. Repair or replace any damaged wiring.

● Fire coming from hydraulic line

Check that all the hose and tube clamps, guards, and cushions are securely fixed in position.

If they are loose, they may vibrate during operation and rub against other parts. This may lead to damage to the hoses, and cause high-pressure oil to spurt out, leading to fire damage or serious injury.

● Explosion caused by lighting equipment

- When checking fuel, oil, battery electrolyte, window washer fluid, or coolant, always use lighting with anti-explosion specifications. If such lighting equipment is not used, there is danger of explosion that may cause serious injury.
- When taking the electrical power for the lighting from the machine itself, follow the instructions in this manual.

ACTION IF FIRE OCCURS

If a fire occurs, escape from the machine as follows.

- Turn the start switch OFF to stop the engine.
- Use the handrails and steps to get off the machine.

WINDSHIELD WASHER FLUID

Use an ethyl alcohol base washer liquid.

Methyl alcohol base washer liquid may irritate your eyes, so do not use it.

FALLING OBJECTS, FLYING OBJECTS AND INTRUDING OBJECTS PREVENTION

On jobsites where there is a hazard that falling objects, flying objects, or intruding objects may hit or enter the operator's cab, consider the operating conditions and install the necessary guards to protect the operator.

- When carrying out demolition or breaker operations, install a front guard and use a laminated coating sheet on the front glass.
- When working in mines or quarries where there is a hazard of falling rock, install FOPS (Falling Objects Protective Structure) and a front guard, and use a laminated coating sheet on the front glass.
- When carrying out the above operations, always close the front window. In addition, always ensure that bystanders are a safe distance away and are not in hazard from falling or flying objects.
- The above recommendations assume that the conditions are for standard operations, but it may be necessary to add additional guards according to the operating conditions on the job-site. Always contact your Komatsu distributor for advice.

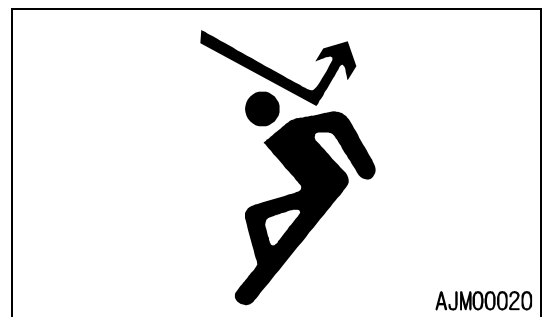
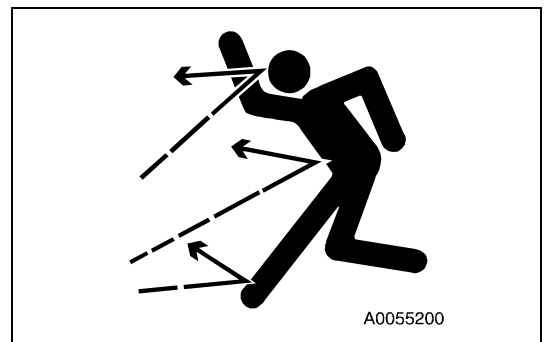

ATTACHMENT INSTALLATION

- When installing optional parts or attachments, there may be problems with safety or legal restrictions. Therefore contact your Komatsu distributor for advice.
- Any injuries, accidents, or product failures resulting from the use of unauthorized attachments or parts will not be the responsibility of Komatsu.
- When installing and using optional attachments, read the instruction manual for the attachment, and the general information related to attachments in this manual.

ATTACHMENT COMBINATIONS

Depending on the type or combination of work equipment, there is a hazard that the work equipment may hit the cab or other parts of the machine. Before using unfamiliar work equipment, check if there is any hazard of interference, and operate with caution.

CAB WINDOW GLASSES

- If the cab glass on the work equipment side is broken, there is a hazard that the work equipment may contact the operator's body directly. Stop operation immediately and replace the glass.
- The ceiling window is made of organic glass (polycarbonate), and as such it is apt to break easily when receiving damage on the surface, thereby deteriorating its protective characteristic. If there is a crack or damage caused by a fallen rock, or when any sign of them is noticed, replace it with a new window.
- If the cab door does not open for any reason, remove the glass from the rear window and use the window as an emergency escape exit.
For details, see "EMERGENCY EXIT FROM OPERATOR'S CAB (3-43)" in this manual.

UNAUTHORIZED MODIFICATIONS

Any modification made without authorization from Komatsu can create hazards. Before making a modification, consult your Komatsu distributor.

- Komatsu will not be responsible for any injuries, accidents, product failures or other property damages resulting from modifications made without authorization from Komatsu.

SAFETY AT JOBSITE

Before starting operations, thoroughly check the area for any unusual conditions that could be dangerous.

- When carrying out operations near combustible materials such as thatched roofs, dry leaves or dry grass, there is a hazard of fire, so be careful when operating.
- Check the terrain and condition of the ground at the worksite, and determine the safest method of operation. Do not carry out operations at places where there is a hazard of landslides or falling rocks.
- If water lines, gas lines, or high-voltage electrical lines may be buried under the worksite, contact each utility and identify their locations. Be careful not to sever or damage any of these lines.
- Take necessary measures to prevent any unauthorized person from entering the operating area.
- If any fire is lit near the machine, there is danger that sparks will be sucked in and cause a fire.

Be extremely careful when handling flames.

- When traveling or operating in shallow water or on soft ground, check the shape and condition of the bedrock, and the depth and speed of flow of the water before starting operations.

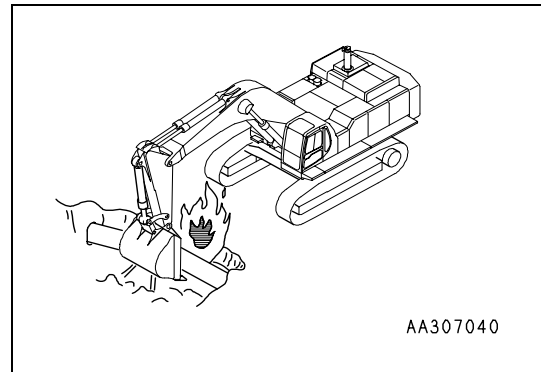

WORKING ON LOOSE GROUND

- Avoid traveling or operating your machine too close to the edge of cliffs, overhangs, and deep ditches. The ground may be weak in such areas. If the ground should collapse under the weight or vibration of the machine, there is a hazard that the machine may fall or tip over. Remember that the soil after heavy rain or blasting or after earthquakes is weak in these areas.
- When working on embankments or near excavated ditches, there is a hazard that the weight and vibration of the machine will cause the soil to collapse. Before starting operations, take steps to ensure that the ground is safe and to prevent the machine from rolling over or falling.

DISTANCE TO HIGH VOLTAGE CABLES

Do not travel or operate the machine near electric cables. There is a hazard of electric shock, which may cause serious injury or property damage. On jobsites where the machine may go close to electric cables, always do as follows.

- Before starting work near electric cables, inform the local power company of the work to be performed, and ask them to take the necessary action.
- Even going close to high-voltage cables can cause electric shock, which may cause serious burns or even death. Always maintain a safe distance (see the table on the right) between the machine and the electric cable. Check with the local power company about safe operating procedure before starting operations.
- To prepare for any possible emergencies, wear rubber shoes and gloves. Lay a rubber sheet on top of the seat, and be careful not to touch the chassis with any exposed part of your body.
- Use a signalman to give warning if the machine approaches too close to the electric cables.
- When carrying out operations near high voltage cables, do not let anyone come close to the machine.
- If the machine should come too close or touch the electric cable, to prevent electric shock, the operator should not leave the operator's compartment until it has been confirmed that the electricity has been shut off. Also, do not let anyone come close to the machine.

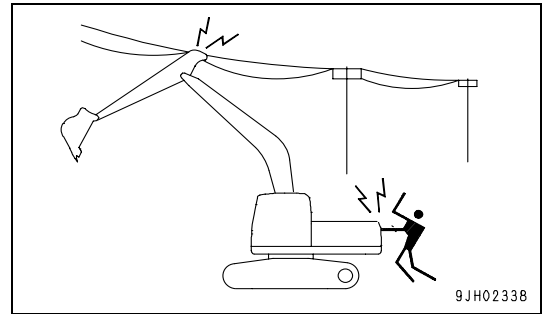

Voltage of Cables	Safety Distance
100 V - 200 V	Over 2 m (7ft)
6,600 V	Over 2 m (7ft)
22,000 V	Over 3 m (10 ft)
66,000 V	Over 4 m (14 ft)
154,000 V	Over 5 m (17 ft)
187,000 V	Over 6 m (20 ft)
275,000 V	Over 7 m (23 ft)
500,000 V	Over 11 m (36 ft)

ENSURE GOOD VISIBILITY

- Check for any persons or obstacles in the area around the machine and check the conditions of the jobsite to ensure that operations and travel can be carried out safely. Always do as follows.
 - Position a signalman if there are areas at the rear of the machine where the visibility is not good.
 - When working in dark places, turn on the working lamp and front lamps installed to the machine, and set up additional lighting in the work area if necessary.
 - Stop operations if the visibility is poor, such as in mist, snow, rain, or dust.

VENTILATION FOR ENCLOSED AREA

Exhaust fumes from the engine can kill.

- If it is necessary to start the engine within an enclosed area, or when handling fuel, flushing oil, or paint, open the doors and windows to ensure that adequate ventilation is provided to prevent gas poisoning.

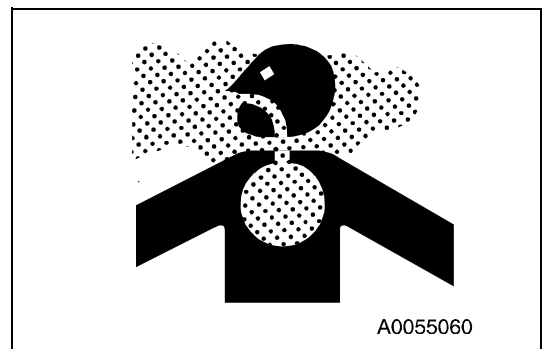

SIGNALMAN'S SIGNAL AND SIGNS

- Set up signs to inform of road shoulders and soft ground. If the visibility is not good, position a signalman if necessary. Operators should pay careful attention to the signs and follow the instructions from the signalman.
- Only one signalman should give signals.
- Make sure that all workers understand the meaning of all signals and signs before starting work.

EMERGENCY EXIT FROM OPERATOR'S CAB

If the cab door does not open for any reason, remove the glass from the rear window and use the window as an emergency escape exit.

For details, see "EMERGENCY EXIT FROM OPERATOR'S CAB (3-43)" in this manual.

ASBESTOS DUST HAZARD PREVENTION

Asbestos dust in the air can cause lung cancer if it is inhaled. There is danger of inhaling asbestos when working on jobsites handling demolition work or work handling industrial waste. Always observe the following.

- Spray water to keep down the dust when cleaning. Do not use compressed air for cleaning.
- If there is danger that there may be asbestos dust in the air, always operate the machine from an upwind position. All workers should use an approved respirator.
- Do not allow other persons to approach during the operation.
- Always observe the rules and regulations for the work site and environmental standards.

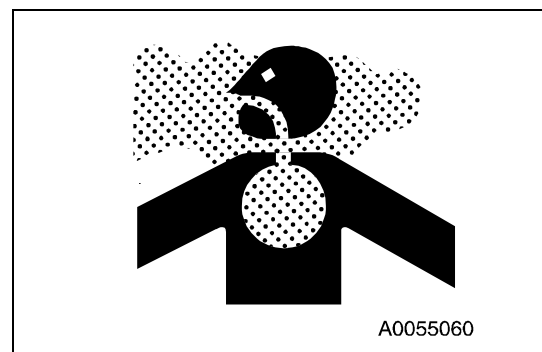

This machine does not use asbestos, but there is a danger that imitation parts may contain asbestos, so always use genuine Komatsu parts.

SAFETY MACHINE OPERATION

STARTING ENGINE

If there is a warning tag hanging from the work equipment control lever, do not start the engine or touch the levers.

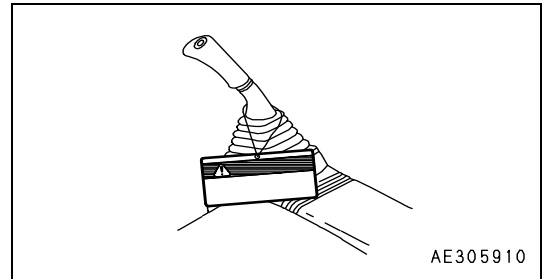

CHECKS BEFORE STARTING ENGINE

Carry out the following checks before starting the engine at the beginning of the day's work.

- Remove all dirt from the surface of the window glass to ensure a good view.
- Remove all dirt from the surface of the lens of the front lamps and working lamps, and check that they light up correctly.
- Check the coolant level, fuel level, and oil level in engine oil pan, check for clogging of the air cleaner, and check for damage to the electric wiring.
- Adjust the operator's seat to a position where it is easy to carry out operations, and check that there is no damage or wear to the seat belt or mounting clamps.
- Check that the gauges work properly, check the angle of the lights and working lamps, and check that the control levers are all at the neutral position.
- Before starting the engine, check that lock lever (1) is in LOCK position (L).
- Adjust the mirrors so that the rear of the machine can be seen clearly from the operator's seat. When adjusting, see "Rearview Mirrors (3-84)".
- Check that there are no persons or obstacles above, below, or in the area around the machine.

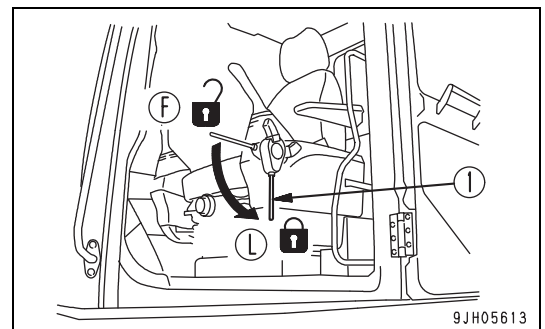

SAFETY RULES FOR STARTING ENGINE

- Start and operate the machine only while seated.
- Do not short circuit the starting motor circuit to start the engine. Short circuit can cause serious injury or fire.
- When starting the engine, sound the horn as a warning.
- Do not allow anyone apart from the operator to ride on the machine.

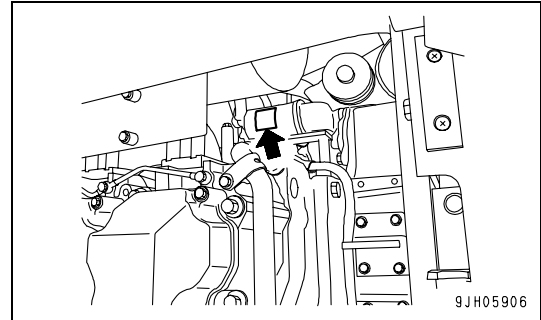
**STARTING ENGINE IN COLD WEATHER**

- Carry out the warming-up operation thoroughly. If the machine is not thoroughly warmed up before the control levers are operated, the reaction of the machine will be slow, and this may lead to unexpected accidents.
- If the battery electrolyte is frozen, do not charge the battery or start the engine with a different power source. There is a hazard that this will ignite the battery.

Before charging or starting the engine with a different power source, melt the battery electrolyte and check for frost and leakage of battery electrolyte before starting.

OPERATION

CHECKS BEFORE OPERATION

When carrying out the checks, move the machine to a wide area where there are no obstructions, and operate slowly. Do not allow anyone near the machine.

- Check that the movement of the machine matches the display on the control pattern card. If it does not match, replace it immediately with the correct control pattern card.
- Check the operation of the gauges and equipment, and check the operation of the bucket, arm, boom, travel system, swing system, and steering system.
- Check for any abnormality in the sound of the machine, vibration, heat, smell, or gauges; check also that there is no leakage of oil or fuel.
- If any abnormality is found, carry out repairs immediately.

SAFETY RULES FOR CHANGING MACHINE DIRECTIONS

- Before traveling, position the upper structure so that the sprocket (1) is at the rear of the operator's cab. If the sprocket (1) is at the front of the operator's cab, the machine makes a movement reverse to the control lever movement (for example, forward becomes reverse, and left becomes right). Be careful to avoid such a reverse movement of the machine.
- Before travelling, check again that there is no one in the surrounding area, and that there are no obstacles.
- Before travelling, sound the horn to warn people in the area.
- Always operate the machine only when seated.
- Always fasten your seat belt.

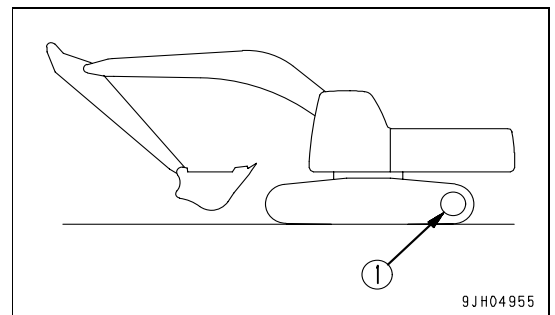

- Do not allow anyone apart from the operator to ride on the machine.
- Check that the travel alarm works properly.
- Always lock the door and windows of the operator's compartment in position (open or closed).

On jobsites where there is a hazard of flying objects or of objects entering the operator's compartment, check that the door and windows are securely closed.

- If there is an area to the rear of the machine which cannot be seen, position a signal person. Take special care not to hit other machines or people when turning or swinging the machine.

Always be sure to carry out the above precautions even when the machine is equipped with mirrors.

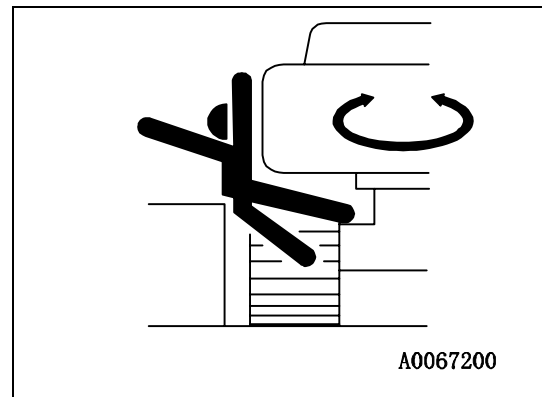
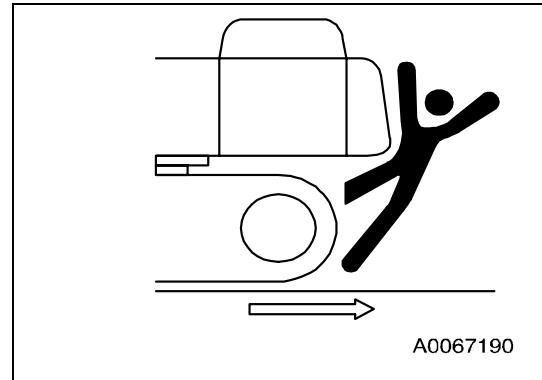

SAFETY RULES FOR TRAVELING

- When traveling on flat ground, keep the work equipment 40 to 50 cm (15.8 to 19.7 in) high above the ground.
- When traveling on rough ground, travel at low speed and do not operate the steering suddenly. There is danger that the machine may turn over. The work equipment may hit the ground surface and cause the machine to lose its balance, or may damage the machine or structures in the area.
- When traveling on rough ground or steep slopes, if the machine is equipped with auto-deceleration, always turn the auto-deceleration switch OFF (cancel).
- Avoid traveling over obstacles when possible. If the machine has to travel over an obstacle, keep the work equipment close to the ground and travel at low speed. Never travel over obstacles which make the machine tilt strongly to one side.
- When traveling or carrying out operations, always keep a safe distance from people, structures, or other machines to avoid coming into contact with them.
- When passing over bridges or structures, check first that the structure is strong enough to support the weight of the machine. When traveling on public roads, check first with the relevant authorities and follow their instructions.
- When operating in tunnels, under bridges, under electric wires, or other places where the height is limited, operate slowly and be extremely careful not to let the work equipment hit anything.

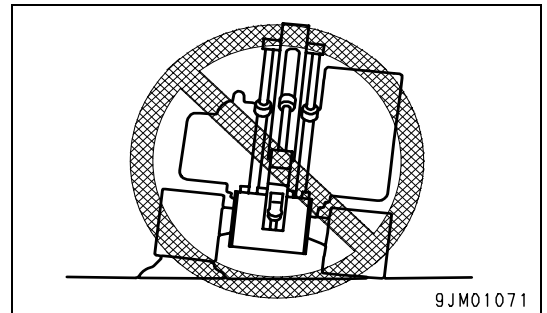
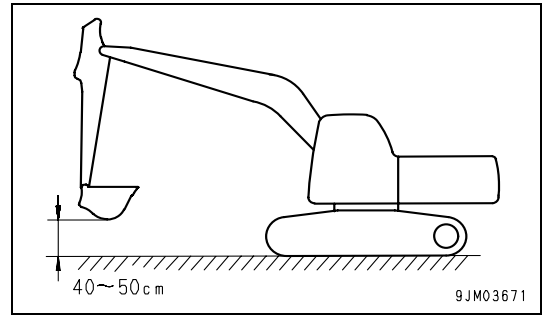

TRAVELING ON SLOPES

To prevent the machine from tipping over or slipping to the side, always do as follows.

- Keep the work equipment approx. 40 to 50 cm (15.8 to 19.7 in) above the ground. In case of emergency, lower the work equipment to the ground immediately to help stop the machine.
- When travel up slopes, set the operator's cab facing uphill, when travel down slopes, set the operator's cab facing downhill. Always check the firmness of the ground under the front of the machine when traveling.

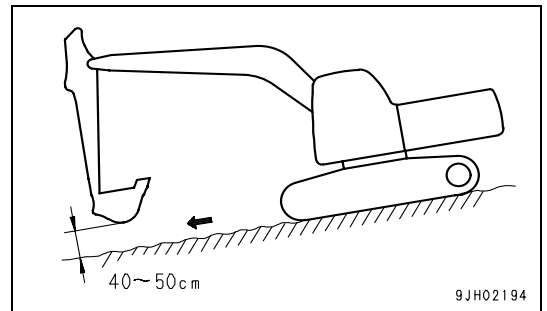
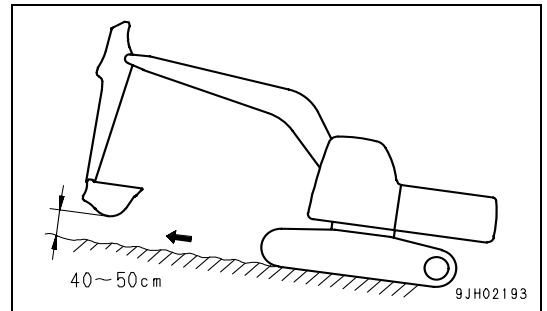

- When traveling up a steep slope, extend the work equipment to the front to improve the balance, keep the work equipment approximately 40 to 50cm (15.8 to 19.7 in) above the ground, and travel at low speed.
- When traveling downhill, lower the engine speed, keep the travel lever close to the neutral position, and travel at low speed.

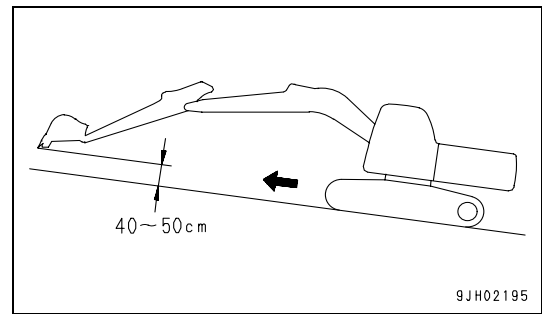

- Always travel straight up or down a slope. Traveling at an angle or across the slope is extremely dangerous.
- Do not turn on slopes or travel across slopes. Always go down to a flat place to change the position of the machine, then travel on to the slope again.
- Travel on grass, fallen leaves, or wet steel plates with low speed. Even with slight slopes there is a hazard that the machine may slip.
- If the engine stops when the machine is traveling on a slope, move the control levers immediately to the neutral position and start the engine again.

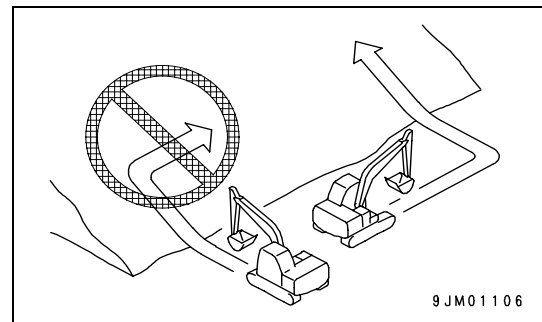

OPERATIONS ON SLOPES

- When working on slopes, there is a hazard that the machine may lose its balance and turn over when the swing or work equipment are operated. This may lead to serious injury or property damage, so always provide a stable place when carrying out these operations, and operate carefully.
- Do not swing the work equipment from the uphill side to the downhill side when the bucket is loaded. This operation is dangerous, and may cause the machine to tip over.
- If the machine has to be used on a slope, pile the soil to make a platform (A) that will keep the machine as horizontal as possible.

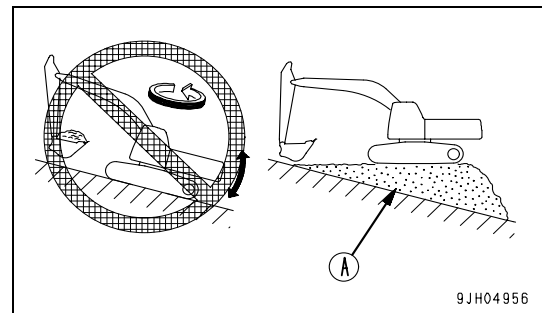

PROHIBITED OPERATIONS

- Never dig the work face under an overhang. There is a hazard that rocks may fall or that the overhang may collapse and fall on top of the machine.

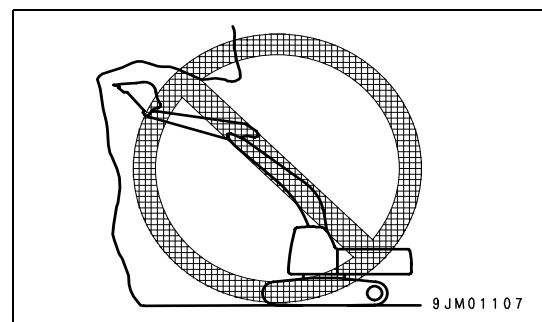

- Do not excavate too deeply under the front of the machine. The ground under the machine may collapse and cause the machine to fall.

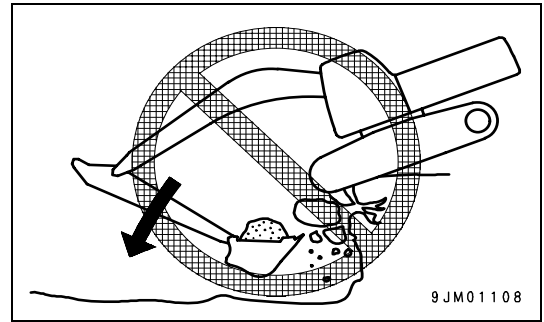

- To make it easier to escape if there is any problem, set the tracks at right angles to the road shoulder or cliff with the sprocket at the rear when carrying out operations.

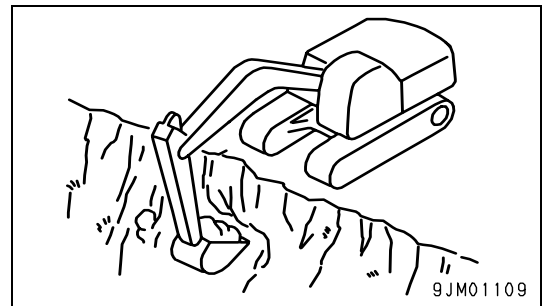

- Do not carry out demolition work under the machine. There is a hazard that the machine may become unstable and tip over.
- When working on or from the top of buildings or other structures, check the strength and the structure before starting operations. There is a hazard of the building collapsing and causing serious injury or damage.

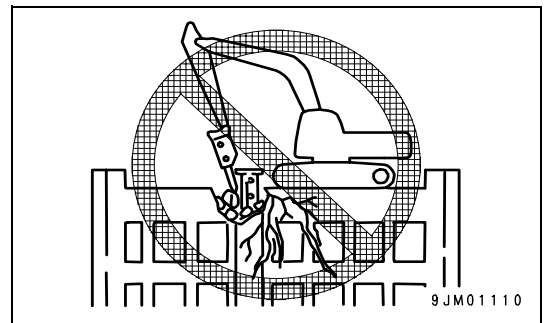

- When carrying out demolition work, do not carry out demolition above your head. There is a hazard of broken parts falling or of the building collapsing and causing serious injury or property damage.

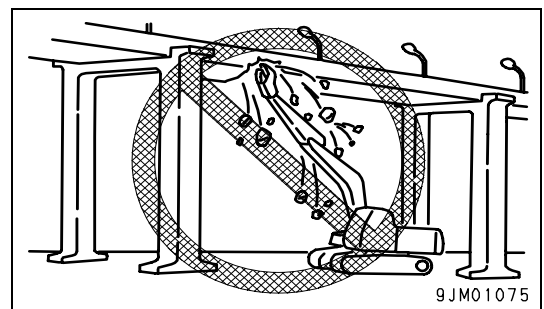

- Do not use the impact force of the work equipment for breaking work. There is a hazard of damage to the work equipment or a hazard of serious personal injury being caused by flying pieces of broken materials or the machine tipped over due to reaction from the impact.
- Generally speaking, the machine is more liable to overturn when the work equipment is at the side than when it is at the front or rear.

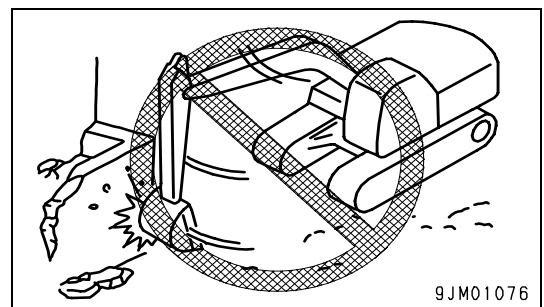

- When using a breaker or other heavy work equipment, there is a hazard of the machine losing its balance and tipping over. When operating on flat ground as well as on slopes.
 - Do not suddenly lower, swing, or stop the work equipment.
 - Do not suddenly extend or retract the boom cylinder. There is a hazard that impact will cause the machine to tip over.
- Do not pass the bucket over the head of other workers or over the operator's seat of dump trucks or other hauling equipment. The load may spill or the bucket may hit the dump truck and cause serious injury or property damage.

OPERATIONS ON SNOW

- Snow-covered or frozen surfaces are slippery, so be extremely careful when traveling or operating the machine, and do not operate the levers suddenly. Even a slight slope may cause the machine to slip, so be particularly careful when working on slopes.
- With frozen ground surfaces, the ground becomes soft when the temperature rises, and this may cause the machine to tip over.
- If the machine enters deep snow, there is a hazard that it may tip over or become buried in the snow. Be careful not to leave the road shoulder or to get trapped in a snow drift.
- When clearing snow, the road shoulder and objects placed beside the road are buried in the snow and cannot be seen. There is a hazard of the machine tipping over or hitting covered objects, so always carry out operations carefully.

PARKING MACHINE

- Park the machine on firm, level ground.
 - Select a place where there is no hazard of falling rocks or landslides, or of flooding if the land is low.
 - Lower the work equipment completely to the ground.
-
- When leaving the machine, set lock lever (1) to the LOCK position (L), then stop the engine.
 - Always close the operator's cab door, and use the key to lock all the equipment in order to prevent any unauthorized person from moving the machine. Always remove the key, take it with you, and leave it in the specified place.
 - If it is necessary to park the machine on a slope, always do as follows.
 - Set the bucket on the downhill side, then dig it into the ground.
 - Put blocks under the tracks to prevent the machine from moving.

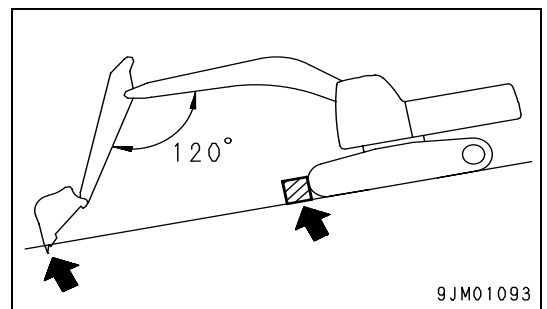
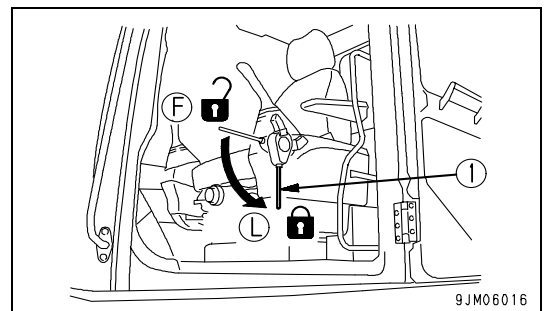
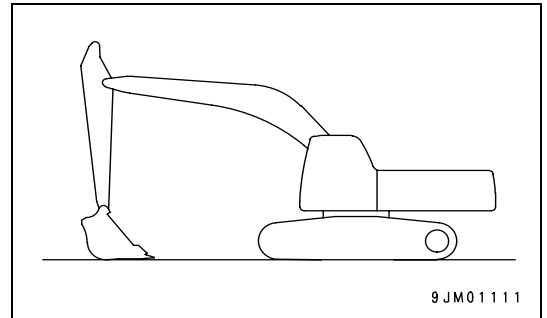

TRANSPORTATION

The machine can be divided into parts for transportation, so when transporting the machine, please contact your Komatsu distributor to have the work carried out.

LOADING AND UNLOADING

When loading or unloading the machine, mistaken operation may bring the hazard of the machine tipping over or falling, so particular care is necessary. Always do as follows.

- Perform loading and unloading on firm, level ground only. Maintain a safe distance from the edge of the road or cliff.
- Never use the work equipment to load or unload the machine. There is danger that the machine may fall or tip over.
- Always use ramps of adequate strength. Be sure that the ramps are wide, long, and thick enough to provide a safe loading slope. Take suitable steps to prevent the ramps from moving out of position or coming off.
- Be sure the ramp surface is clean and free of grease, oil, ice and loose materials. Remove dirt from machine-tracks. On a rainy day, in particular, be extremely careful since the ramp surface is slippery.
- Turn the auto-decelerator switch OFF (auto-deceleration function released).
- Run the engine at low speed and travel slowly.
- When on the ramps, do not touch any other parts.
- Never correct your steering on the ramps. If necessary, drive off the ramps, correct the direction, then enter the ramps again.
- The center of gravity of the machine will change suddenly at the joint between the ramps and the track or trailer, and there is danger of the machine losing its balance. Travel slowly over this point.
- When loading or unloading to an embankment or platform, make sure that it has suitable width, strength, and grade.
- When swinging the upper structure on the trailer, the trailer is unstable, so pull in the work equipment and swing slowly. And turn swing lock switch ON to apply swing lock after loading machine.
- For machines equipped with a cab, always lock the door after boarding the machine. If this is not done, the door may suddenly open during transportation. Refer to "TRANSPORTATION (3-125)".

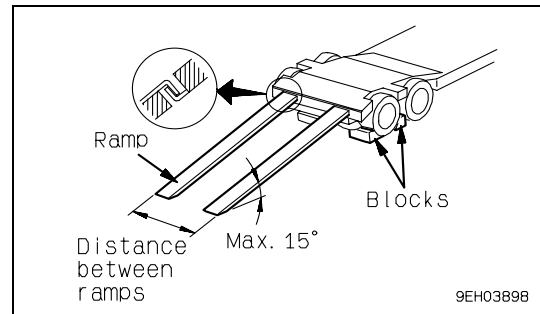

SHIPPING THE MACHINE

When shipping the machine on a trailer, do as follows.

- The weight, transportation height, and overall length of the machine differ according to the work equipment, so be sure to confirm the dimensions.
- When passing over bridges or structures on private land, check first that the structure is strong enough to support the weight of the machine. When traveling on public roads, check first with the relevant authorities and follow their instructions.
- For details of the procedure when transporting the machine, see TRANSPORTATION (3-125).

BATTERY

BATTERY HAZARD PREVENTION

Battery electrolyte contains sulphuric acid, and batteries generate flammable hydrogen gas, which may explode. Mistaken handling can lead to serious injury or fire. For this reason, always observe the following precautions.

- Do not use or charge the battery if the battery electrolyte level is below the LOWER LEVEL line. This may cause an explosion. Always check the battery electrolyte level periodically and add distilled water to bring the electrolyte level to the UPPER LEVEL line.
- When working with batteries, always wear safety glasses and rubber gloves.
- Never smoke or use any flame near the battery.

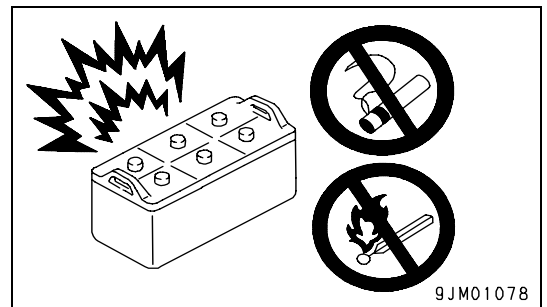

- If you spill acid on your clothes or skin, immediately flush the area with large amount of water.
- If acid gets into your eyes, flush them immediately with large amount of water and seek medical attention.

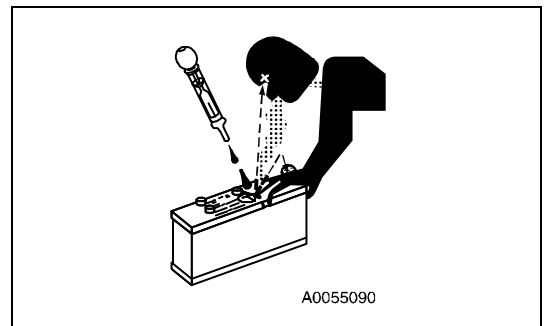

- Before working with batteries, turn the starting switch to the OFF position.

As there is a hazard that sparks will be generated, always do as follows.

- Do not let tools or other metal objects make any contact between the battery terminals. Do not leave tools or other metal objects lying around near the battery.
- Always disconnect the negative (-) terminal (ground side) first when removing the battery; when installing the battery, connect the positive (+) terminal first, and connect the ground last. Tighten the battery terminals securely.
- Flammable hydrogen gas is generated when the battery is charged, so remove the battery from the chassis, take it to a well-ventilated place, and remove the battery caps before charging it.
- Tighten the battery caps securely.
- Install the battery securely to the determined place.

STARTING ENGINE WITH BOOSTER CABLES

If any mistake is made in the method of connecting the booster cables, it may cause the battery to explode, so always do as follows.

- When starting with a booster cable, carry out the starting operation with two workers (one worker sitting in the operator's seat and the other working with the battery).
- When starting from another machine, do not allow the two machines to touch.
- When connecting the booster cables, turn the starting switch OFF for both the normal machine and problem machine. There is a hazard that the machine will move when the power is connected.
- Be sure to connect the positive (+) cable first when installing the booster cables. Disconnect the negative (-) cable (ground side) first when removing them.
- When removing the booster cables, be careful not to let the booster cable clips touch each other or to let the clips touch the machine.
- Always wear safety goggles and rubber gloves when starting the engine with booster cables.
- When connecting a normal machine to a problem machine with booster cables, always use a normal machine with the same battery voltage as the problem machine.
- For details of the starting procedure when using booster cables, see "Starting Engine With Booster Cables (3-145)" in the OPERATION section.

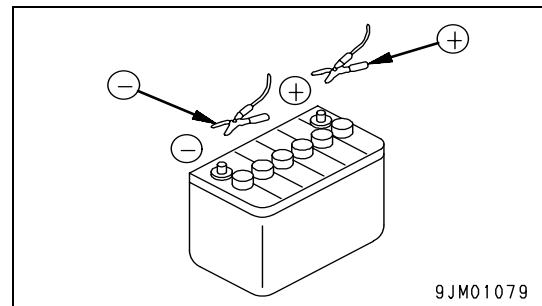
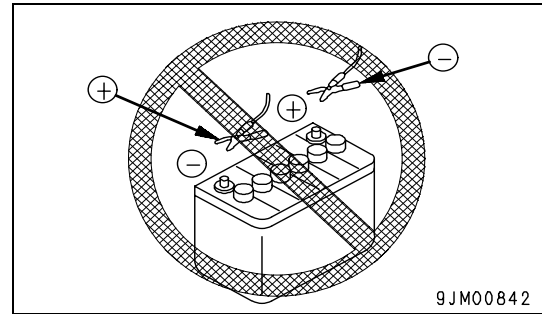

TOWING

SAFETY RULES FOR TOWING

Serious injury or death could result if a disabled machine is towed incorrectly or if there is a mistake in the selection or inspection of the wire rope.

For towing, see "TOWING THE MACHINE (3-142)".

- Always wear leather gloves when handling wire rope.
- Fix the wire rope to the track frame.
- During the towing operation, never stand between the towing machine and the machine being towed.
- Never tow a machine on a slope.

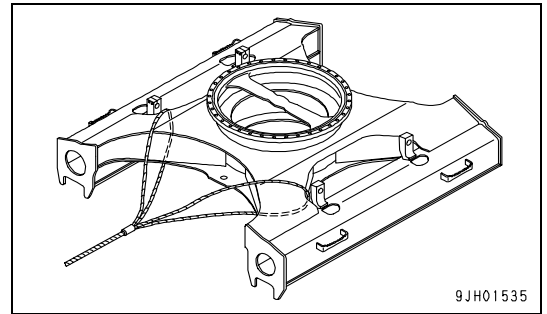
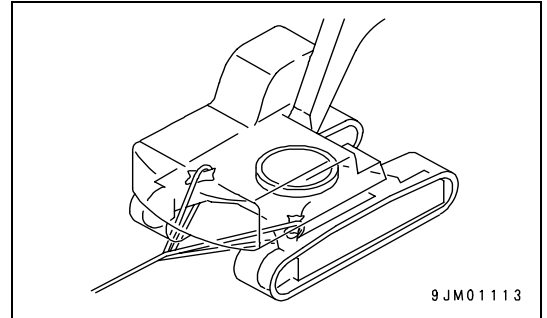

- Never use a wire rope which has cut strands (A), reduced diameter (B), or kinks (C). There is danger that the rope may break during the towing operation.

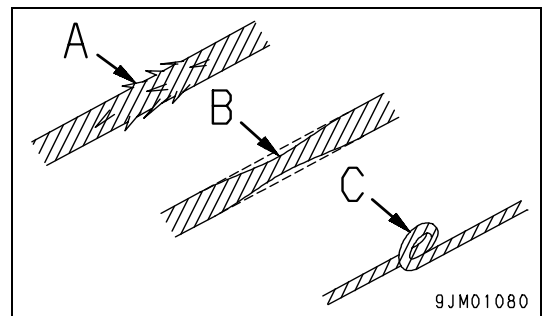

LIFTING OBJECTS WITH BUCKET

SAFETY RULES FOR LIFTING OBJECTS

- Do not carry out lifting work on slopes, soft ground, or other places where the machine is not stable.
- Use wire rope that conforms to the specified standard.
- Always observe the specified lifting load strictly.
- It is dangerous if the load hits any worker or structure. Always check carefully that the surrounding area is safe before swinging or turning the machine.
- Do not start, swing, or stop the machine suddenly. There is a hazard that the lifted load will swing.
- Do not pull the load to the side or in towards the machine.
- Do not leave the operator's seat when there is a raised load.

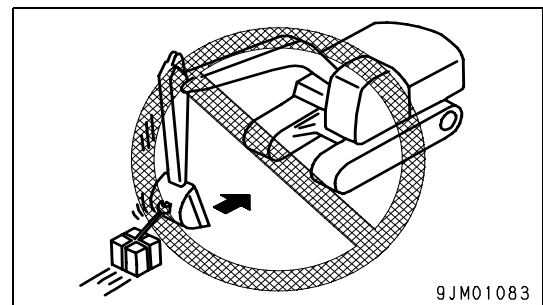
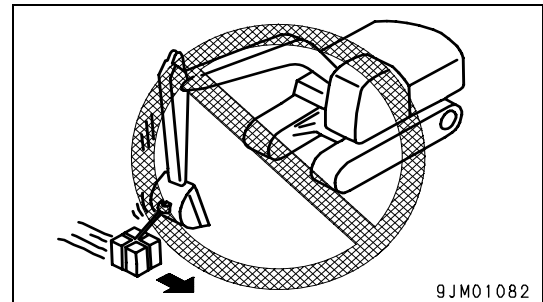

SAFETY MAINTENANCE INFORMATION

WARNING TAG

- Always attach the "DO NOT OPERATE" warning tag to the work equipment control lever in the operator's cab to alert others that you are performing service or maintenance on the machine.
Attach additional warning tags around the machine if necessary.
Warning tag Part No. 09963-03000

Keep this warning tag in the tool box while it is not used. If there is not the tool box, keep the tag in the operation manual pocket.

- If others start the engine, or touch or operate the work equipment control lever while you are performing service or maintenance, you could suffer serious injury or property damage.

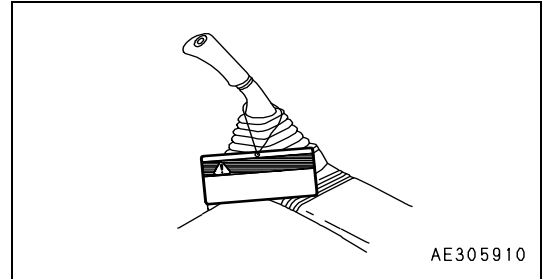

KEEP WORK PLACE CLEAN AND TIDY

- Do not leave hammers or other tools lying around in the work place. Wipe up all grease, oil, or other substances that will cause you to slip. Always keep the work place clean and tidy to enable you to carry out operations safely.
If the work place is not kept clean and tidy, there is the danger that you will trip, slip, or fall over and injure yourself.
- When cleaning the ceiling window which is made of organic glass (polycarbonate), use tap water and avoid use of organic solvents for cleaning. An organic solvent like benzene, toluene or methanol can invite a chemical reaction like dissolution and decomposition on the window glass, deteriorating polycarbonate in use.

APPOINT LEADER WHEN WORKING WITH OTHERS

- When repairing the machine or when removing and installing the work equipment, appoint a leader and follow his instructions during the operation.

STOP ENGINE BEFORE CARRYING OUT MAINTENANCE

- Stop the machine on firm, level ground.
- Select a place where there is no hazard of falling rocks or landslides, or of flooding if the land is low.
- Lower the work equipment completely to the ground and stop the engine.
- Turn the starting switch to the ON position. Operate the work equipment control lever back and forth, left and right at the full stroke 2 to 3 times to eliminate the remaining internal pressure in the hydraulic circuit, and then push down lock lever (1) to the LOCK position (L).

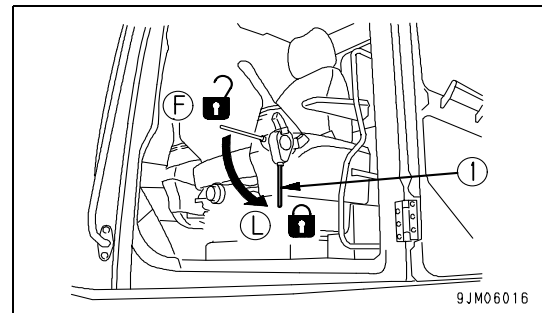
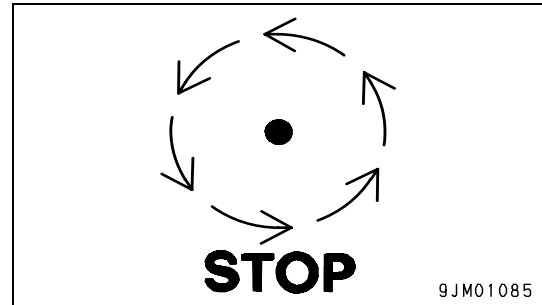

- Put blocks under the track to prevent the machine from moving.

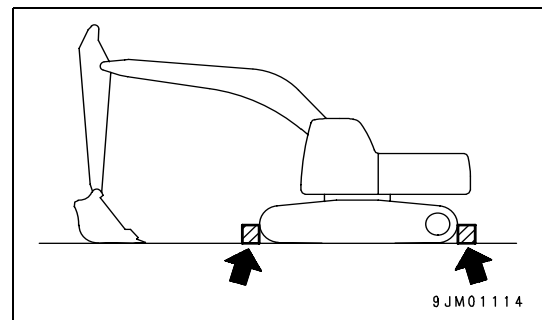
**TWO WORKERS FOR MAINTENANCE WHEN ENGINE IS RUNNING**

To prevent injury, do not carry out maintenance with the engine running. If maintenance must be carried out with the engine running, carry out the operation with at least two workers and do as follows.

- One worker must always sit in the operator's seat and be ready to stop the engine at any time. All workers must maintain contact with the other workers.

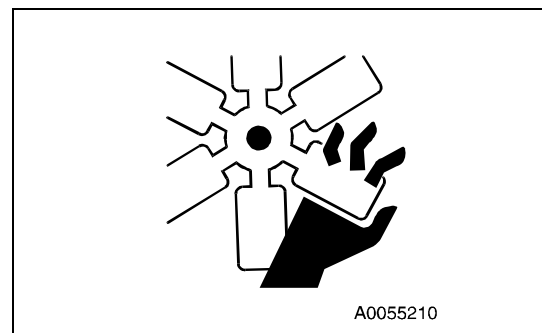

- Set lock lever (1) to the LOCK position (L).
- When carrying out operations near the fan, fan belt, or other rotating parts, there is a hazard of being caught in the parts, so be careful not to come close.
- Do not touch any control levers. If any control lever must be operated, give a signal to the other workers to warn them to move to a safe place.
- Never drop or insert tools or other objects into the fan or fan belt. Parts may break or be sent flying.

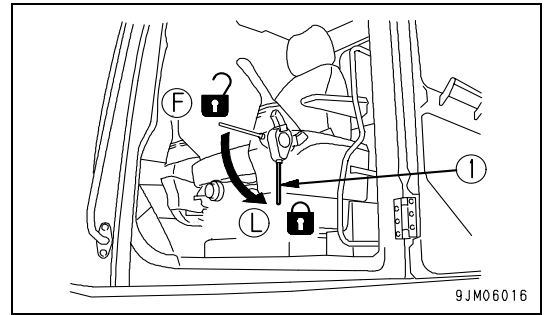

PROPER TOOLS

Use only tools suited to the task and be sure to use the tools correctly. Using damaged, low quality, faulty, makeshift tools or improper use of the tools could cause serious personal injury.

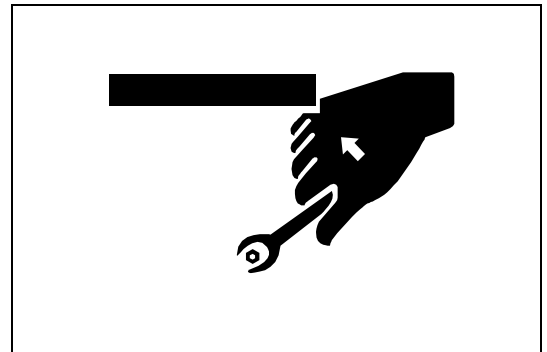

ACCUMULATOR

The accumulator is charged with high-pressure nitrogen gas. When handling the accumulator, careless procedure may cause an explosion which could lead to serious injury or property damage. For this reason, always observe the following precautions.

- Do not disassemble the accumulator.
- Do not bring it near flame or dispose of it in fire.
- Do not make holes in it, weld it, or use a cutting torch.
- Do not hit or roll the accumulator, or subject it to any impact.
- When disposing of the accumulator, the gas must be released. Please contact your Komatsu distributor to have this work performed.



PERSONNEL

Only authorized personnel can service and repair the machine. Do not allow unauthorized personnel into the area. If necessary, employ an observer.

ATTACHMENTS

- Appoint a leader before starting removal or installation operations for attachments.
- Place attachments that have been removed from the machine in a stable condition so that they do not fall. And take steps to prevent unauthorized persons from entering the storage area.

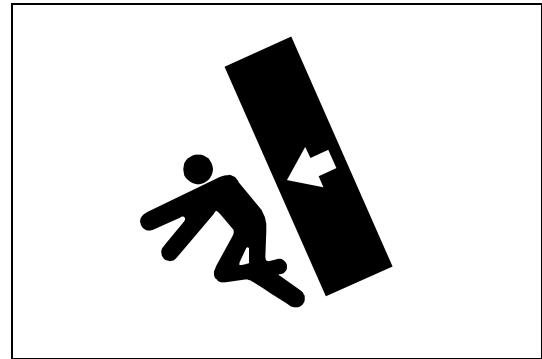

WORK UNDER THE MACHINE

- If it is necessary to go under the work equipment or the machine to carry out service and maintenance, support the work equipment and machine securely with blocks and stands strong enough to support the weight of the work equipment and machine.
- It is extremely dangerous to work under the machine if the track shoes are lifted off the ground and the machine is supported only with the work equipment. If any of the control levers is touched by accident, or there is damage occurring to the hydraulic piping, the work equipment or the machine will suddenly drop. This is extremely dangerous. Never work under the work equipment or the machine.

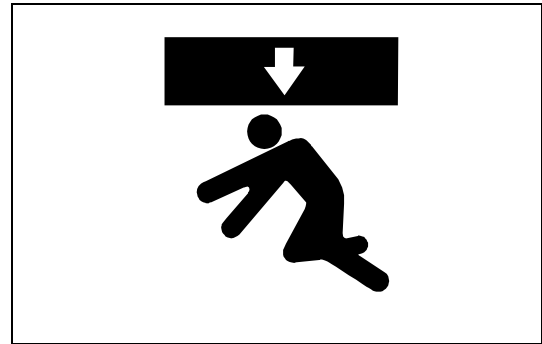

NOISE

When carrying out maintenance of the engine and you are exposed to noise for long periods of time, wear ear covers or ear plugs while working.

If the noise from the machine is too loud, it may cause temporary or permanent hearing problems.

WHEN USING HAMMER

When using a hammer, pins may fly out or metal particles may be scattered. This may lead to serious injury. Always do as follows.

- If hard metal parts such as pins, bucket teeth, cutting edges, or bearings are hit with a hammer, there is a hazard that pieces might be scattered and cause injury. Always wear safety goggles and gloves.
- When hitting pins or bucket teeth, there is a hazard that broken pieces might be sent flying and injure people in the surrounding area. Always check that there is no one in the surrounding area.
- There is a hazard that the pin hit with strong force may fly out and injure people in the surrounding area.

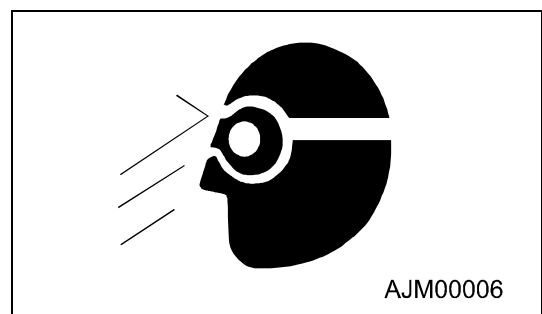

WELDING WORKS

Welding operations must always be carried out by a qualified welder and in a place equipped with proper equipment. There is a hazard of gas, fire, or electrocution when carrying out welding, so never allow any unqualified personnel to carry out welding.

REMOVING BATTERY TERMINALS

When repairing the electrical system or when carrying out electrical welding, remove the negative (-) terminal of the battery to prevent the flow of current.

SAFETY FIRST WHEN USING HIGH-PRESSURE GREASE TO ADJUST TRACK TENSION

- Grease is pumped into the track tension adjustment system under high pressure. If the specified procedure for maintenance is not followed when making adjustment, grease drain plug (1) may fly out and cause serious injury or property damage.
- When loosening grease drain plug (1) to loosen the track tension, never loosen it more than one turn. Loosen the grease drain plug slowly.
- Never put your face, hands, feet, or any other part of your body close to grease drain plug (1).

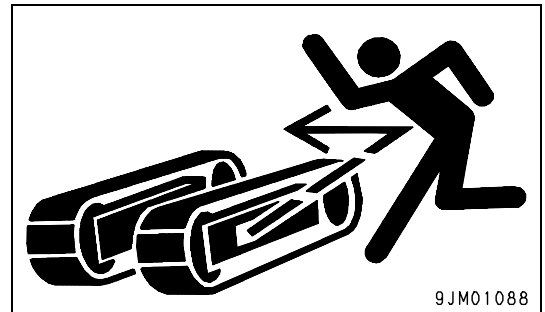
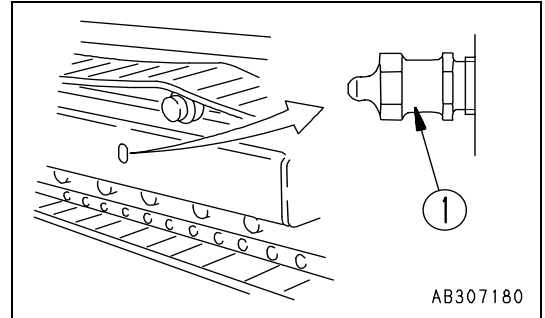

DO NOT DISASSEMBLE RECOIL SPRINGS

Never attempt to disassemble the recoils spring assembly. It contains a spring under high pressure which serves as a shock absorber for the idler. If it is disassembled by mistake, the spring will fly out and cause serious injury. When it becomes necessary to disassemble it, ask your Komatsu distributor to do the work.

SAFETY RULES FOR HIGH-PRESSURE OIL

The hydraulic system is always under internal pressure. When inspecting or replacing piping or hoses, always check that the pressure in the hydraulic circuit has been released. If the circuit is still under pressure, it will lead to serious injury, so always do as follows.

- For details of the method of releasing the pressure, see "METHOD FOR RELEASING INTERNAL PRESSURE IN HYDRAULIC CIRCUIT (4-40)". If the circuit is still under pressure, do not carry out any inspection or replacement operation.
- If there is any leakage from the piping or hoses, the surrounding area will be wet, so check for cracks in the piping and hoses and for swelling in the hoses. When carry out inspection, wear safety glasses and leather gloves.
- There is a hazard that high-pressure oil leaking from small holes may penetrate your skin or cause blindness if it contacts your eyes directly. If you are hit by a jet of high-pressure oil and suffer injury to your skin or eyes, wash the place with clean water, and consult a doctor immediately for medical attention.

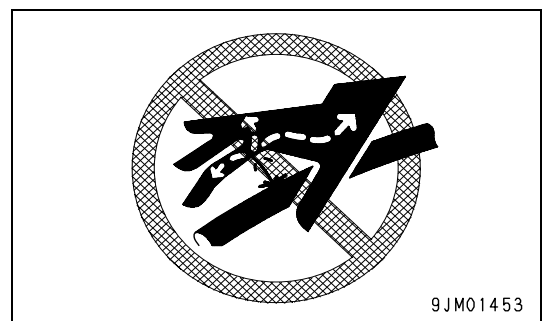

PRECAUTION FOR HIGH FUEL PRESSURE

High pressure is generated inside the engine fuel piping when the engine is running. When carrying out inspection or maintenance of the fuel piping system, wait for at least 30 seconds after stopping the engine to let the internal pressure go down before starting inspection or maintenance.

SAFETY HANDLING HIGH-PRESSURE HOSES

- If oil or fuel leaks from high-pressure hoses, it may cause fire or defective operation, which may lead to serious injury. If any loose bolts are found, stop work and tighten to the specified torque. If any damaged hoses are found, stop operations immediately and contact your Komatsu distributor.

Replace the hose if any of the following problems are found.

- Damaged or leaking hydraulic fitting.
- Frayed or cut covering or exposed reinforcement wire layer.
- Covering swollen in places.
- Twisted or crushed movable portion.
- Foreign material embedded in covering.

PRECAUTION FOR HIGH VOLTAGE

- When the engine is running and immediately after it is stopped, high voltage is generated inside the engine controller and the engine injector, and there is danger of electrocution. Never touch the inside of the controller or the engine injector portion.

If it is necessary to touch the inside of the controller or the engine injector portion, please contact your Komatsu distributor.

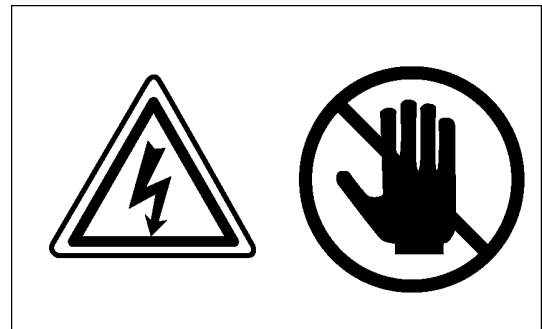

WASTE MATERIALS

To prevent pollution, pay careful attention to the method of disposing of waste materials.

- Always put oil drained from your machine in containers. Never drain oil directly onto the ground or dump into the sewage system, rivers, the sea, or lakes.
- Obey appropriate laws and regulations when disposing of harmful objects such as oil, fuel, coolant, solvent, filters, and batteries.

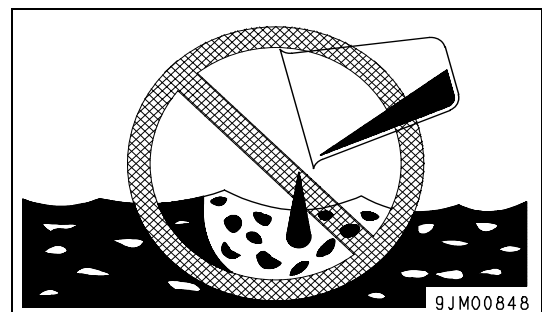

AIR CONDITIONER MAINTENANCE

If air conditioner refrigerant gets into your eyes, it may cause blindness; if it touches your skin, it may cause frostbite.

Never touch refrigerant.

COMPRESSED AIR

- When carrying out cleaning with compressed air, there is a hazard of serious injury caused by flying particles.
- When using compressed air to clean elements or the radiator, always wear safety goggles, dust mask, gloves, and other protective equipment.

PERIODIC REPLACEMENT OF SAFETY CRITICAL PARTS

- For using the machine safely for an extended period of time, replace safety-critical parts like hoses and seat belts periodically.
Replacement of safety-critical parts: See "SAFETY CRITICAL PARTS (4-14)".
- The material of these components naturally changes over time, and repeated use causes deterioration, wear, and fatigue. As a result, there is a hazard that these components may fail and cause serious injury or death. It is difficult to judge the remaining life of these components from external inspection or the feeling when operating, so always replace them at the specified interval.
- Replace or repair safety-critical parts if any defect is found, even when they have not reached the time specified interval.

OPERATION

**WARNING**

Please read and make sure that you understand the SAFETY section before reading this section.

MACHINE VIEW ILLUSTRATIONS

OVERALL MACHINE VIEW

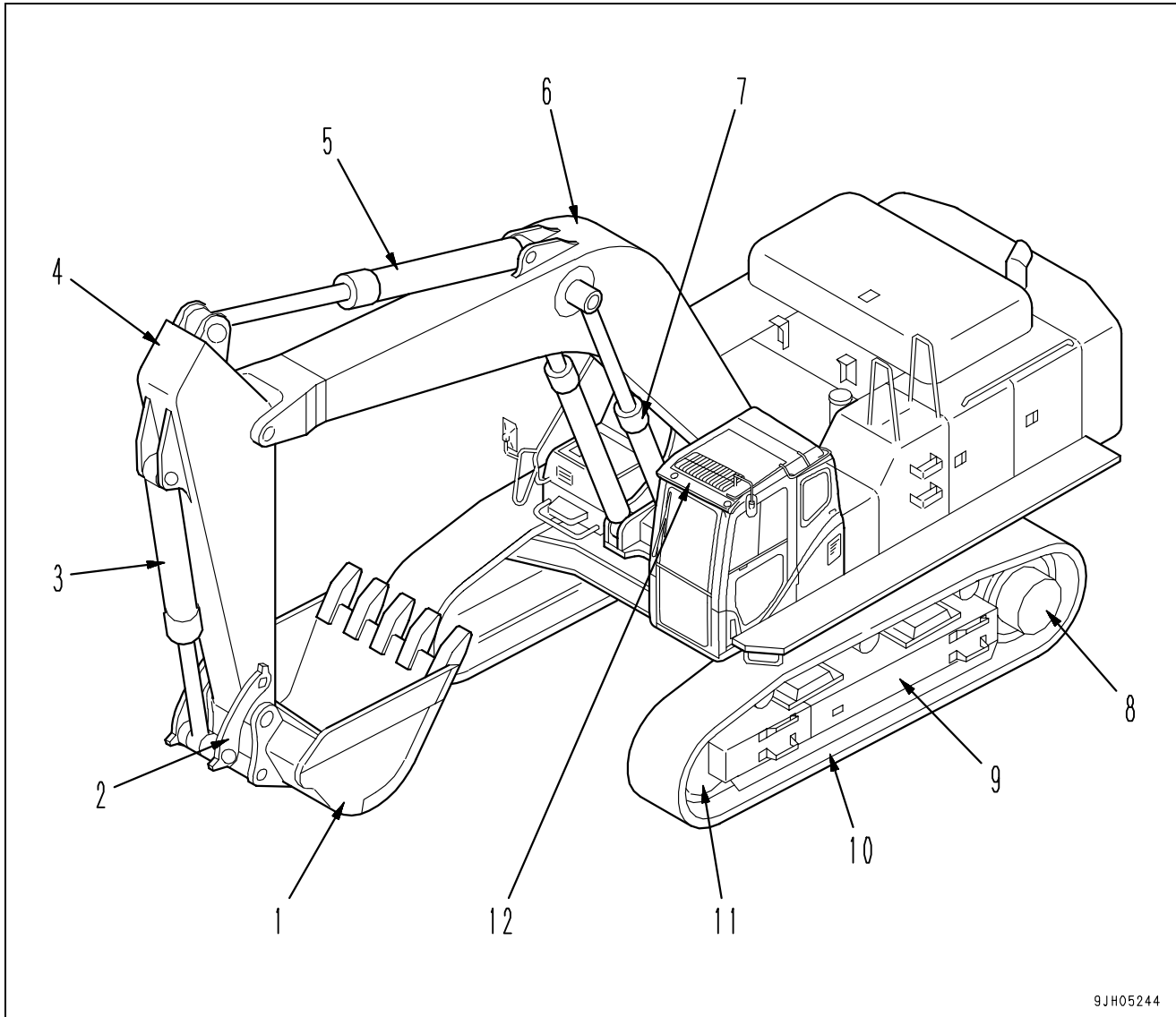

9JH05244

- | | |
|---------------------|--|
| (1) Bucket | (7) Boom cylinder |
| (2) Bucket link | (8) Sprocket |
| (3) Bucket cylinder | (9) Track frame |
| (4) Arm | (10) Track shoe |
| (5) Arm cylinder | (11) Idler |
| (6) Boom | (12) OPG (Operator Protection Guard) (if equipped) |

CONTROLS AND GAUGES

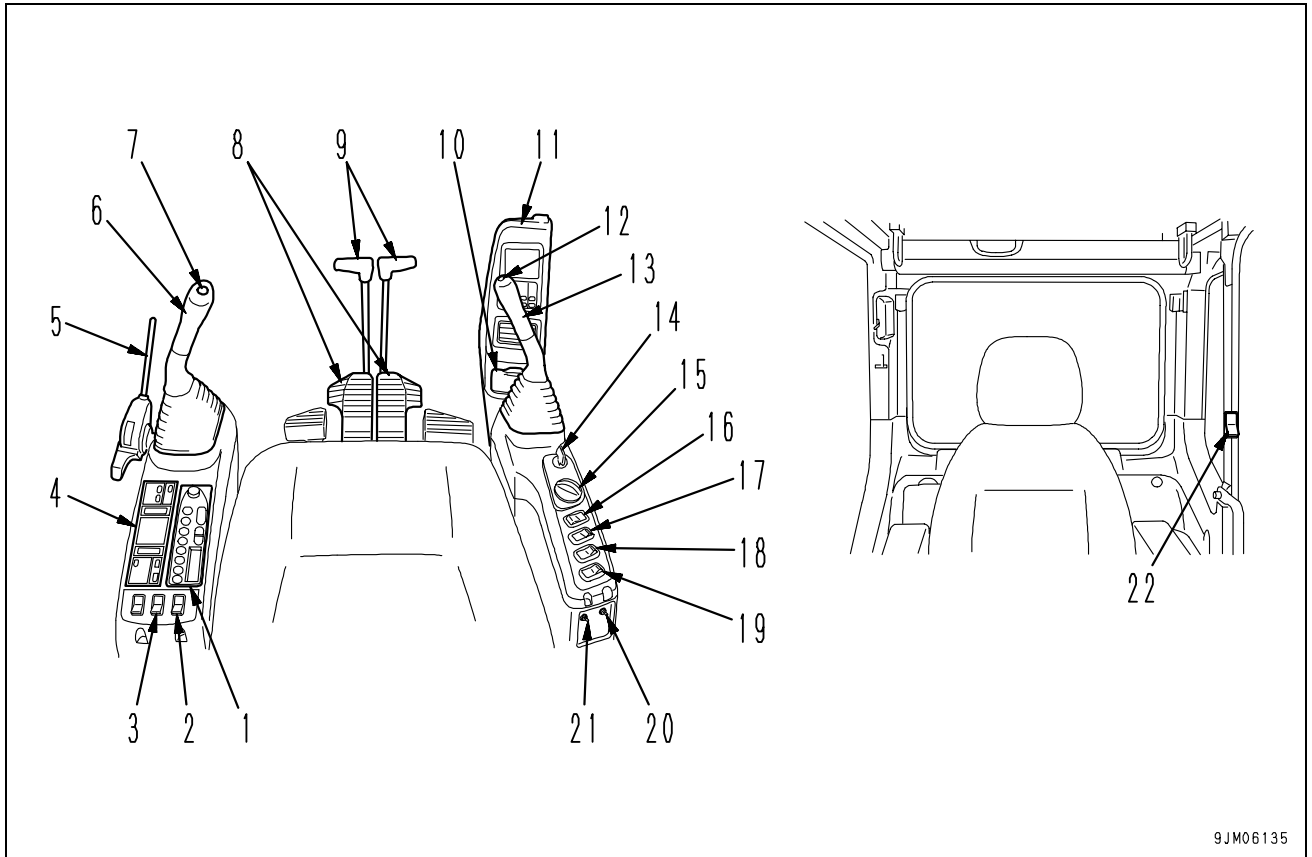

9JM06135

- | | |
|--|---|
| (1) Car radio | (11) Machine monitor |
| (2) Lower wiper switch
(machines with fixed front window cab)
or Large capacity airflow air conditioner blower
switch (If equipped) | (12) Horn switch |
| (3) Revolving warning lamp switch (option) | (13) R.H. work equipment control lever |
| (4) Air conditioner control switch | (14) Starting switch |
| (5) Lock lever | (15) Fuel control dial |
| (6) L.H. work equipment control lever | (16) Lamp switch |
| (7) One-touch power max. switch | (17) Alarm buzzer stop switch |
| (8) Travel pedals | (18) Swing lock switch |
| (9) Travel levers | (19) Machine push-up switch |
| (10) Cigarette lighter | (20) Swing holding brake release switch |
| | (21) Emergency pump drive switch |
| | (22) Step light switch |

Machine monitor

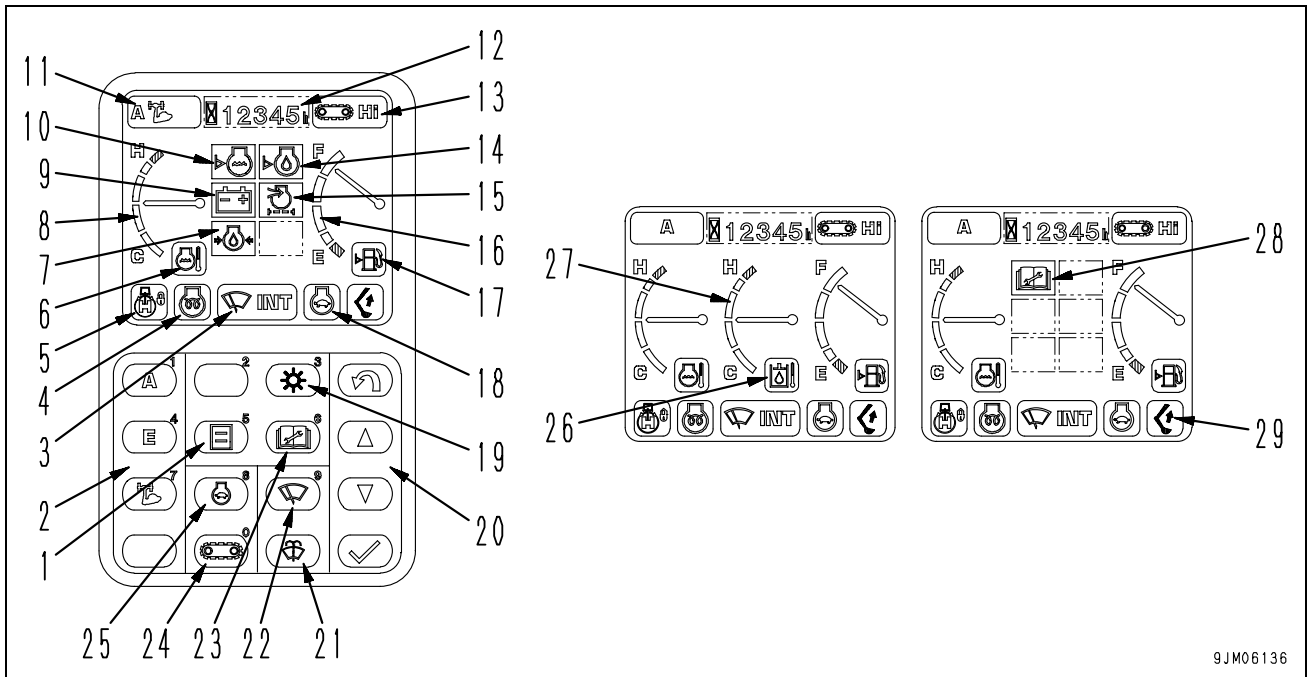

9JM06136

- | | |
|--------------------------------------|--|
| (1) No function | (16) Fuel gauge |
| (2) Working mode selector switch | (17) Fuel level monitor |
| (3) Wiper monitor | (18) Auto-deceleration switch |
| (4) Engine pre-heating monitor | (19) Display control switch |
| (5) Swing lock monitor | (20) Input control switch |
| (6) Engine water temperature monitor | (21) Window washer switch |
| (7) Engine oil pressure monitor | (22) Wiper switch |
| (8) Engine water temperature gauge | (23) Maintenance switch |
| (9) Charge level monitor | (24) Travel speed selector switch |
| (10) Radiator coolant level monitor | (25) Auto-deceleration switch |
| (11) Working mode monitor | (26) Hydraulic oil temperature monitor |
| (12) Service monitor | (27) Hydraulic oil temperature gauge |
| (13) Travel speed monitor | (28) Maintenance interval monitor |
| (14) Engine oil temperature monitor | (29) One-touch power-up monitor |
| (15) Air cleaner clogging monitor | |

DETAILED CONTROLS AND GAUGES

The following is an explanation of the devices needed for operating the machine.
 To carry out suitable operations correctly and safely, it is important to understand fully the methods of operating the equipment and the meanings of the displays.

MONITORING SYSTEM

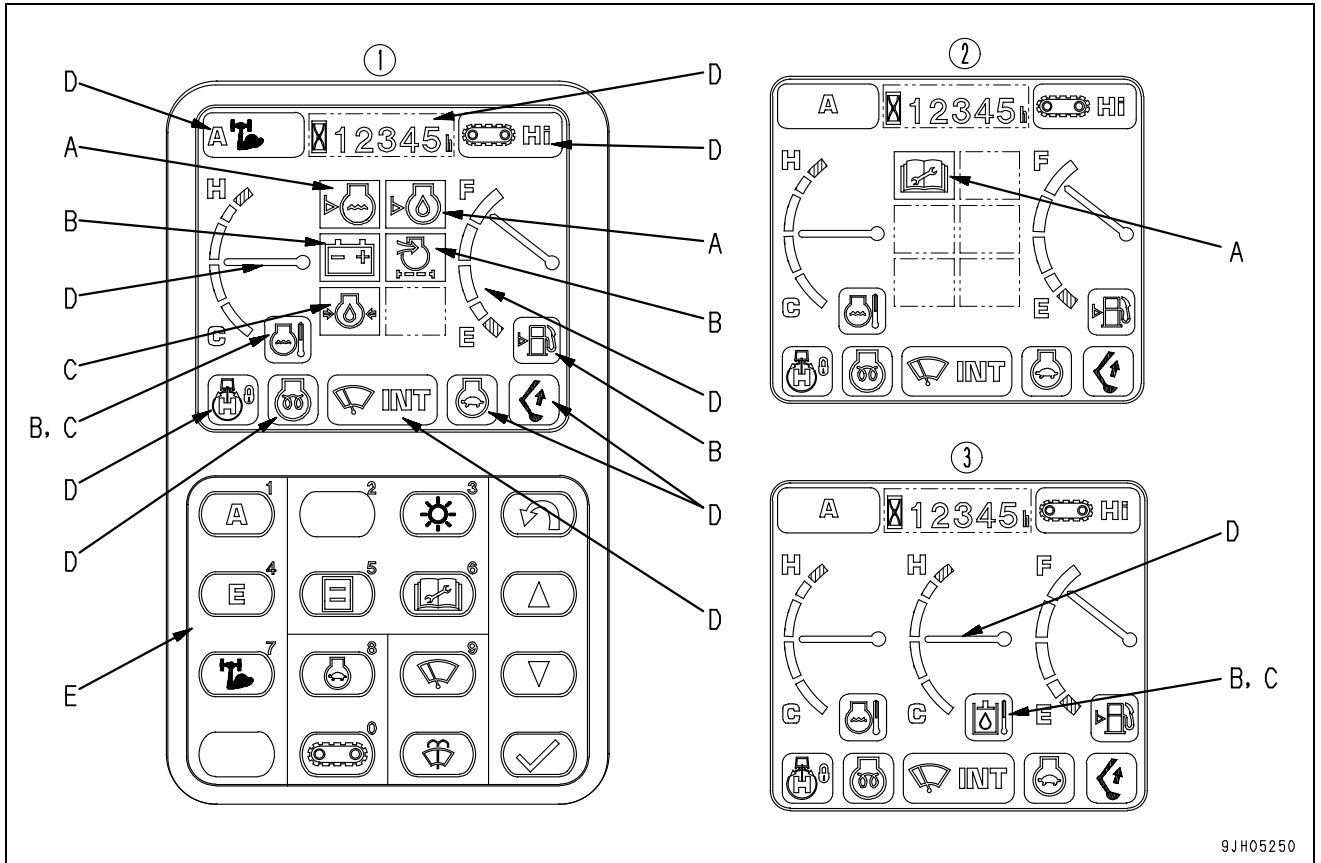

- (1) All light-up screen
- (2) Maintenance interval warning screen

- (3) Normal operation screen

- A: Basic Check Items
- B: Caution Items
- C: Emergency Stop Items

- D: Meter Display Portion
- E: Monitor Switches Portion

Basic Operation Of Machine Monitor

If There Is Abnormality When Starting Engine

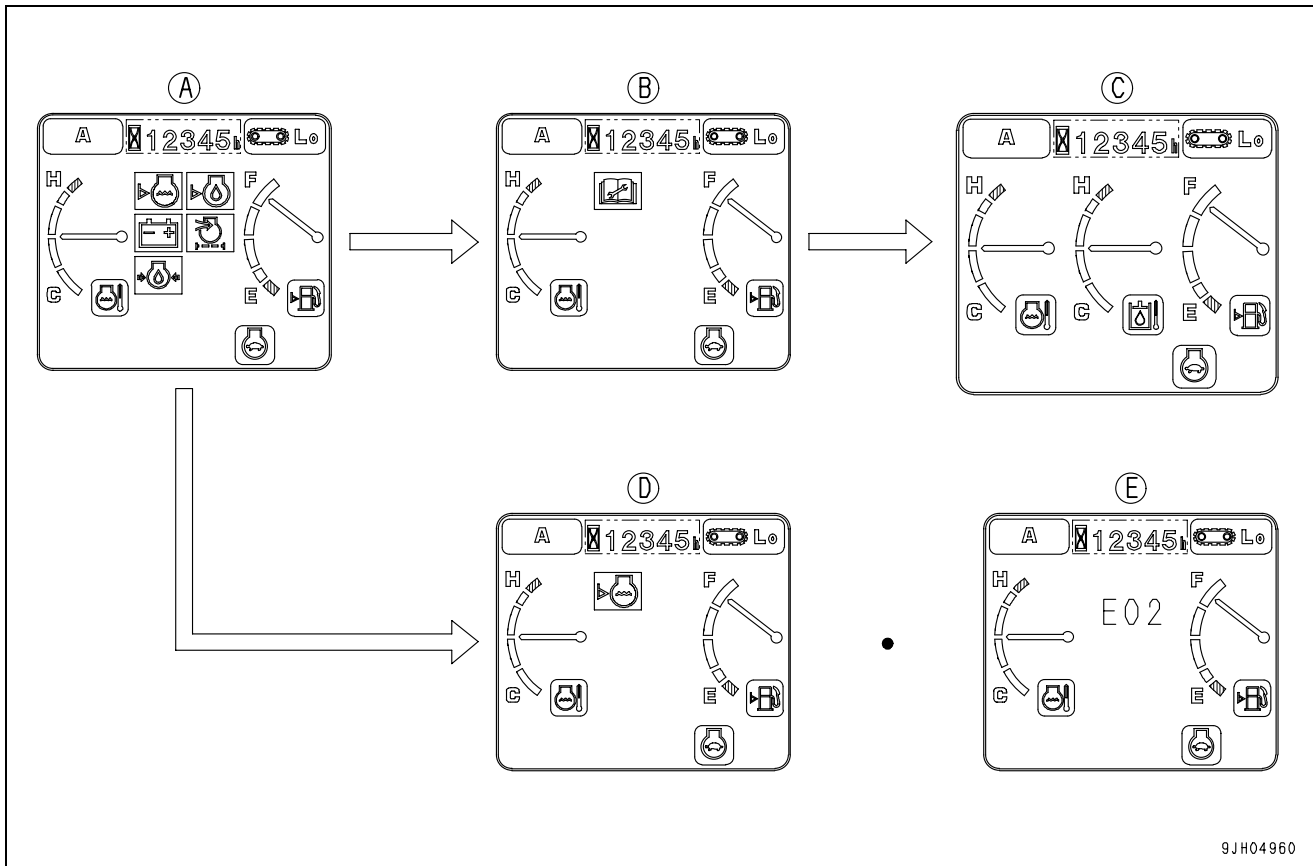

9JH04960

- If there is any abnormality when starting the engine, the check before starting screen (A) changes to the maintenance interval warning screen (B), warning screen (D), or error screen (E).
- After displaying the check before starting screen (A) for 2 seconds, the screen changes to the maintenance interval warning screen (B).
- After displaying the maintenance interval warning screen (B) for 30 seconds, the screen returns to the normal screen (C).
- After displaying the check before starting screen (A) for 2 seconds, the screen changes to the warning screen (D) or error screen (E).

If Any Abnormality Occurs During Operation

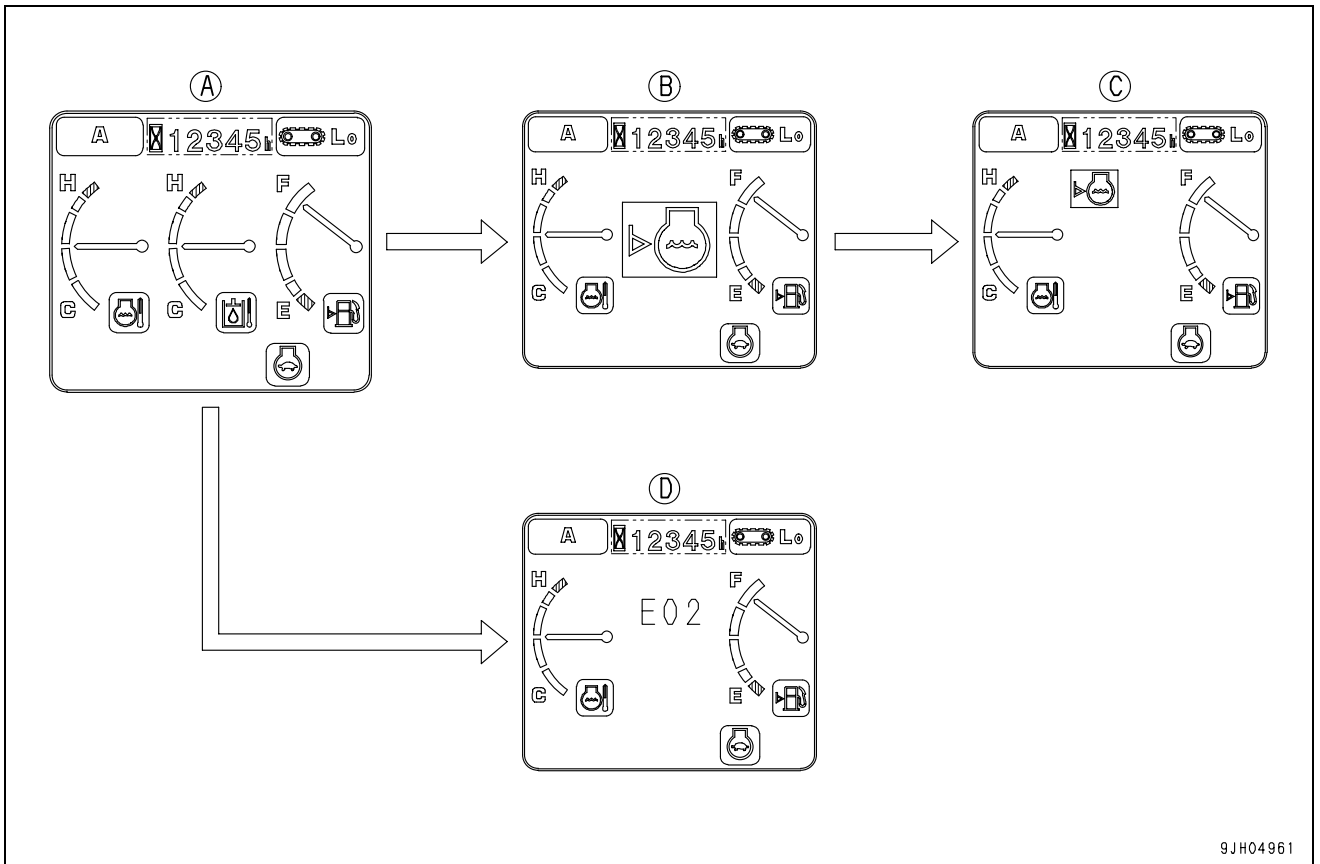

9JH04961

- If any abnormality occurs during operation, the normal operation screen (A) changes to warning screen (B) or the error screen (D).
- After displaying warning screen (B) for 2 seconds, the screen automatically changes to warning screen (C).

Basic Check Monitors

⚠ CAUTION

These monitors do not ensure that the machine is in good condition. When carrying out checks before starting (daily checks), do not simply rely on the monitors. Always get off the machine and check each item directly.

This displays the basic items among the check before starting items that must be checked before starting the engine. If there is any abnormality, the monitor for the location of the abnormality will light up.

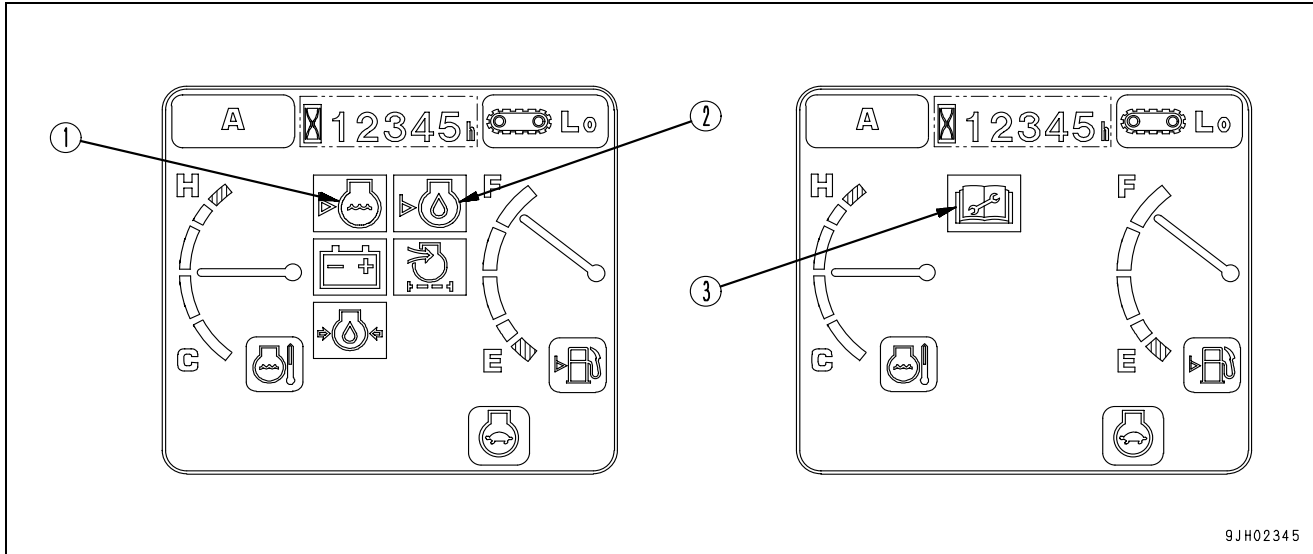

9JH02345

- A(1) Radiator coolant level monitor
- A(2) Engine oil level monitor

- A(3) Maintenance interval monitor

Radiator Coolant Level Monitor

This monitor (1) warns the operator that there has been a drop in the radiator water level.

If the radiator water level is low, the lamp lights up red, so check the water level in the radiator and the subtank, and add water.

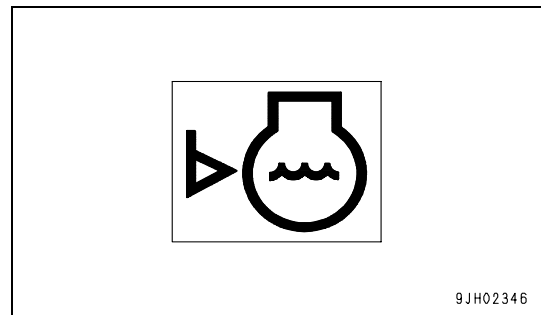

9JH02346

Engine Oil Level Monitor

This monitor (2) warns the operator that there has been a drop in the oil level in the engine oil pan.

If the oil level in the engine oil pan is low, the lamp lights up red, so check the oil level in the engine oil pan, and add oil.

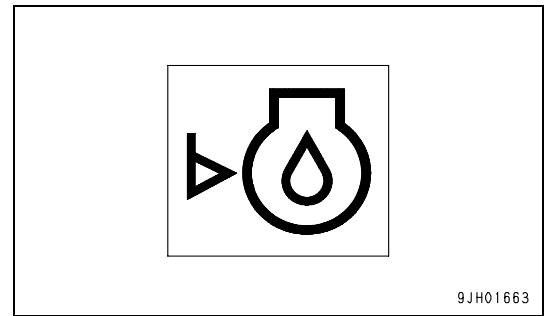

Maintenance interval Monitor

This monitor (3) lights up to warning the operator that the set time has passed since the maintenance was last carried out.

This monitor screen goes out after 30 seconds and returns to the normal operation screen.

- For details of the method of checking the maintenance interval, see "Maintenance Switch (3-22)".

If it is desired to change the setting of the maintenance interval, please consult your Komatsu distributor.

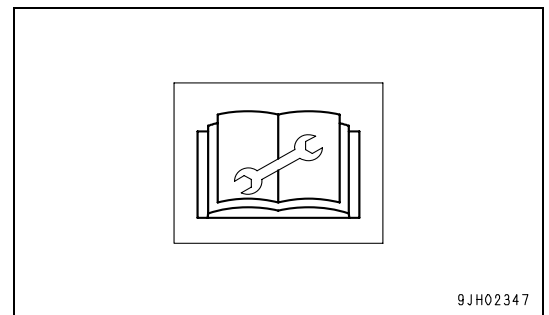

Caution Monitors

⚠ CAUTION

If the warning monitor lights up red, stop operations as soon as possible and carry out inspection and maintenance of the applicable location. If the warning is ignored, it may lead to failure.

These are items that should be observed while the engine is running. If any abnormality occurs, the screen displays the item that needs immediate action.

If there is an abnormality, the monitor for the abnormal location lights up red.

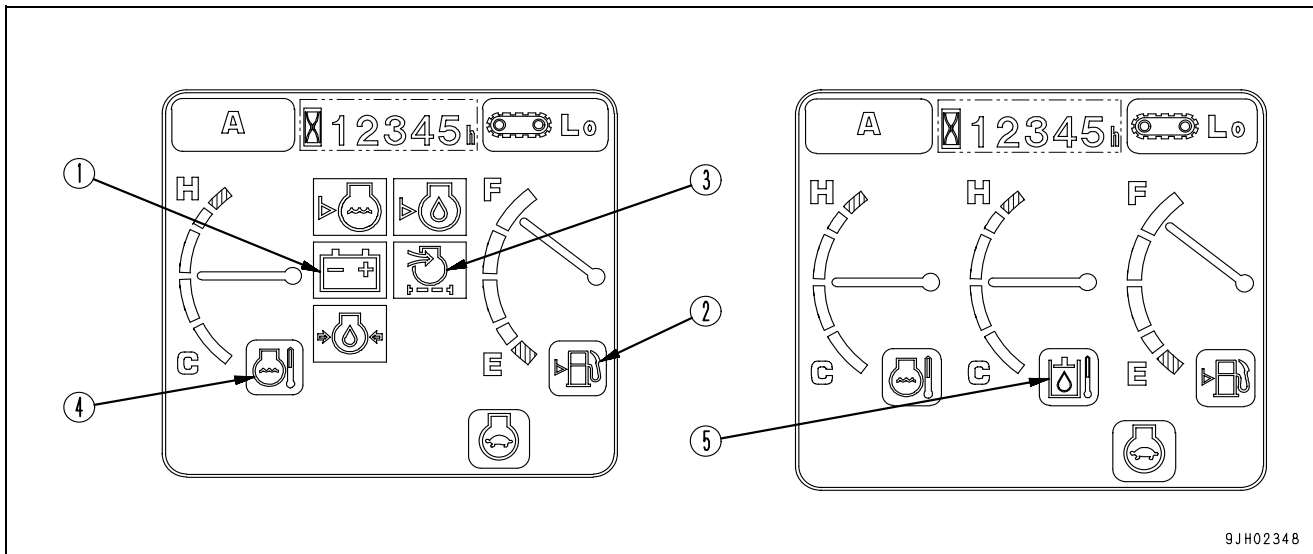

9JH02348

B(1) Charge level monitor

B(4) Engine water temperature monitor

B(2) Fuel level monitor

B(5) Hydraulic oil temperature monitor

B(3) Air cleaner clogging monitor

Charge Level Monitor

This monitor (1) warns the operator that there is an abnormality in the charging system when the engine is running.

If the battery is not being charged properly while the engine is running, it lights up red.

If it lights up red, check for looseness of the V-belt. If any abnormality is found, take the necessary action. For details, see "OTHER TROUBLE (3-147)"

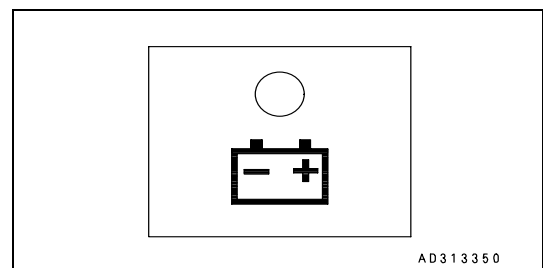

AD313350

REMARK

While the starting switch is ON, the lamp will remain lit and will go off when the engine is started.

When the engine is started or stopped with the starting switch at the ON position, the lamp may light up and the buzzer and horn may sound momentarily, but this does not indicate any abnormality.

Fuel Level Monitor

This monitor (2) lights up to warn that the operator that the level in the fuel tank is low.

If the remaining amount of fuel goes down to 101 liters (26.68 US gal), the light changes from green to red, so add fuel as soon as possible.

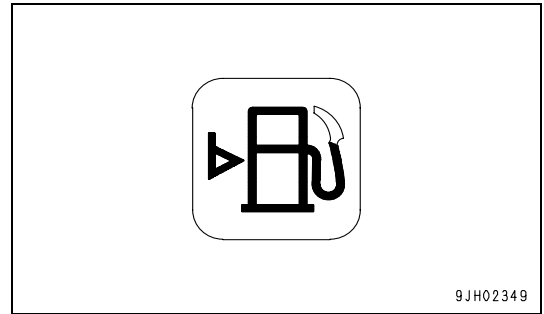

Air Cleaner Clogging Monitor

This monitor (3) warns the operator that the air cleaner is clogged.

If it lights up red, stop the engine, and check, clean, or replace the air cleaner. For details, see "CHECK, CLEAN AND REPLACE AIR CLEANER ELEMENT (4-20)".

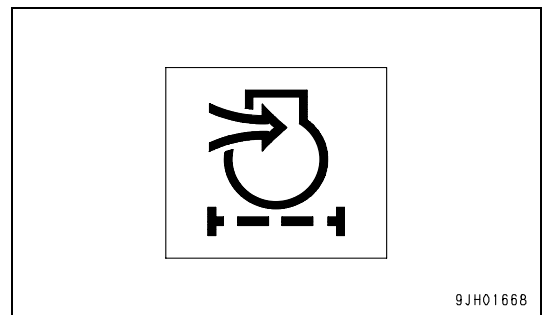

Engine Water Temperature Monitor

If this monitor (4) lights up white in low temperatures, carry out the warming-up operation. For details, see "Warming-Up Operation (3-94)".

Continue the warming-up operation until monitor (4) changes to green.

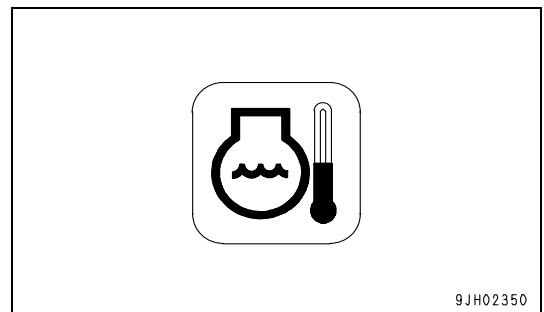

Hydraulic Oil Temperature Monitor

If this monitor (5) lights up white in low temperatures, carry out the warming-up operation. For details, see "Warming-Up Operation (3-94)".

Continue the warming-up operation until monitor (5) changes to green.

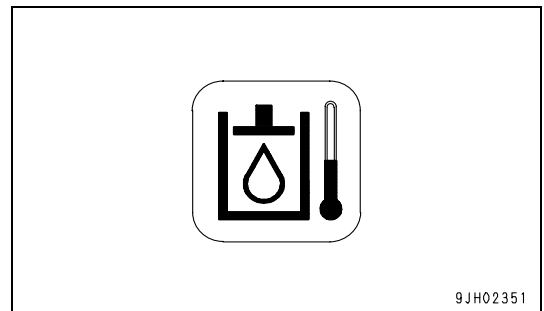

Emergency Monitors

⚠ CAUTION

If the monitor lights up red, stop the engine immediately or run it at low idling, then check the applicable location and carry out the necessary action.

These are items that should be observed while the engine is running. If there is an abnormality, the monitor for the abnormal location lights up red and the buzzer sounds, so carry out action immediately.

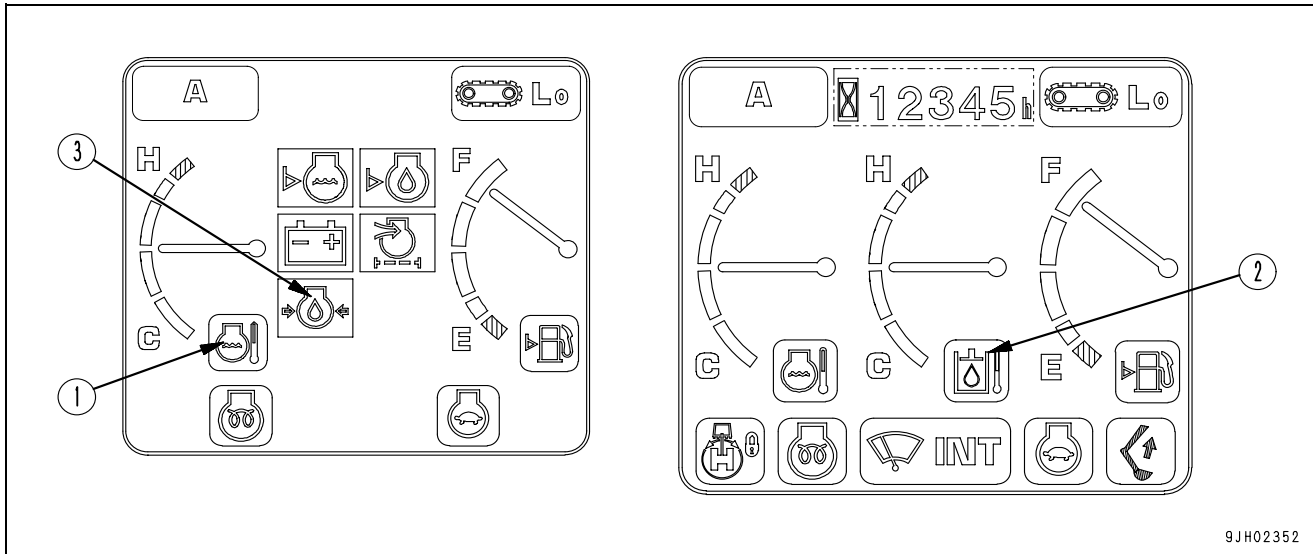

9JH02352

- (1) Engine water temperature monitor
- (2) Hydraulic oil temperature monitor
- (3) Engine oil pressure monitor

Engine Water Temperature Monitor

This monitor (1) warns the operator that the engine water temperature has risen.

If the engine water temperature becomes abnormally high, the monitor lights up red, the overheat prevention system is automatically actuated, and the engine speed goes down.

Stop operations and run the engine at low idling until monitor (1) changes to green.

Check that there is no clogging of the radiator grill or any other problem that will cause overheating.

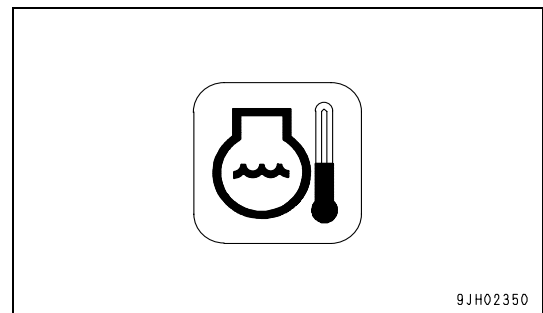

9JH02350

Hydraulic Oil Temperature Monitor

This monitor (2) warns the operator that the hydraulic oil temperature has risen. If it lights up red during operations, run the engine at low idling or stop the engine and wait until the oil temperature goes down and the monitor changes to green.

Check that there is no clogging of the radiator grill or any other problem that will cause overheating.

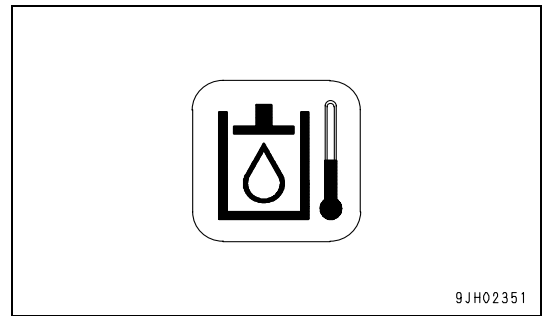

Engine Oil Pressure Monitor

This monitor (3) lights up red if the engine lubrication oil pressure goes below the normal level. If it lights up red, stop the engine, and check the lubrication system and the level of oil in the oil pan.

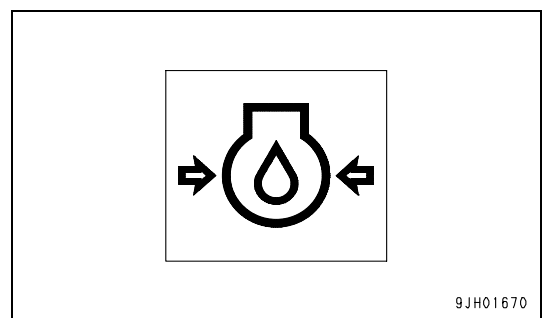

REMARK

The color when the monitor lights up for the basic check items, caution items, and emergency stop items is as follows.

Type of monitor	Color when monitor lights up		
	When normal	When abnormal	At low temperature
Radiator coolant level monitor	OFF	Red	-
Engine oil level monitor	OFF	Red	-
Maintenance interval monitor	OFF	Red	-
Charge monitor	OFF	Red	-
Fuel level monitor	Green	Red	-
Air cleaner clogging monitor	OFF	Red	-
Engine water temperature monitor	Green	Red	White
Hydraulic oil temperature monitor	Green	Red	White
Engine oil pressure monitor	OFF	Red	-

Meter Display Portion

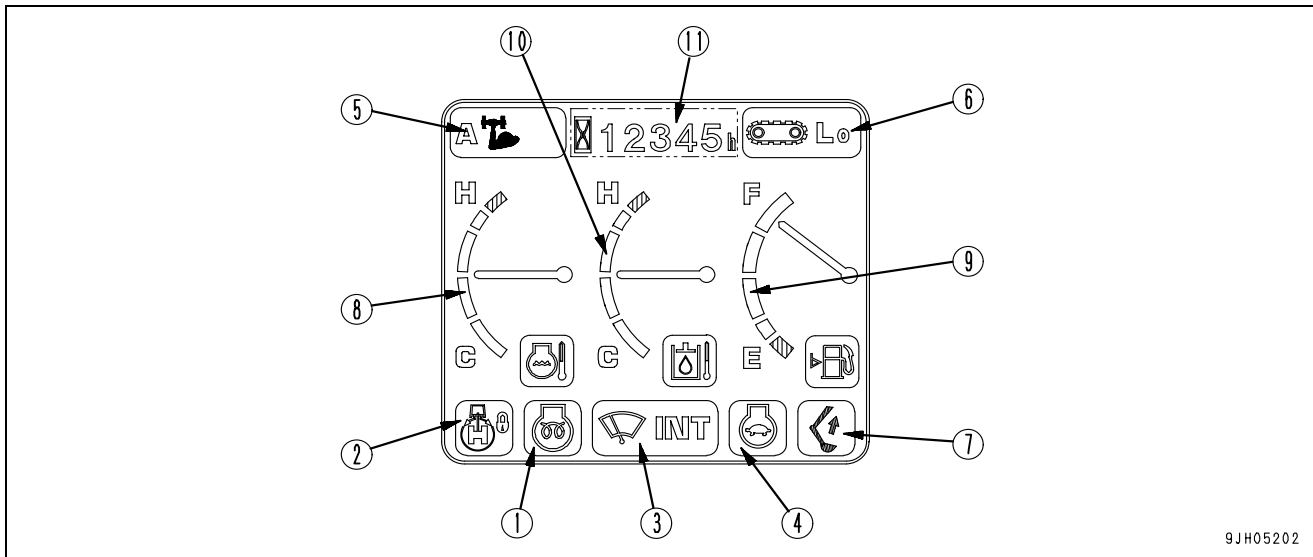

9JH05202

- D(1) Engine pre-heating monitor
- D(2) Swing lock monitor
- D(3) Wiper monitor
- D(4) Auto-deceleration monitor
- D(5) Working mode monitor
- D(6) Travel speed monitor
- D(7) One-touch power-up monitor
- D(8) Engine water temperature gauge
- D(9) Fuel gauge
- D(10) Hydraulic oil temperature gauge
- D(11) Service meter

Pilot Display

When the starting switch is ON, the pilot display lights up when the display items are functioning.

Engine Pre-heating Monitor

This monitor lamp (1) indicates the pre-heating time required when starting the engine at an ambient temperature below 0°C (32°F).

The monitor lamp lights when the starting switch is turned to HEAT position and flashes after about 30 seconds to show that the pre-heating is completed. (The monitor lamp will go off after about 10 seconds.)

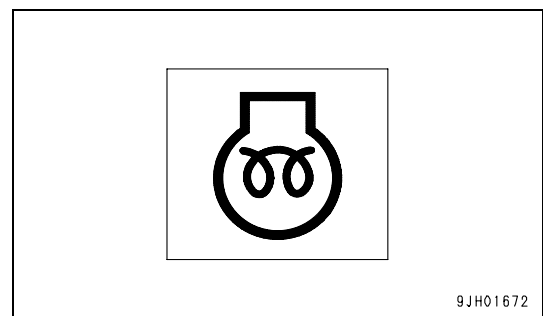

9JH01672

Swing Lock Monitor

This monitor (2) informs the operator that the swing lock is being actuated.

Actuated: Lights up

When the swing lock switch is turned ON (ACTUATED), the monitor lamp lights up.

This monitor flashes when the swing holding brake release switch is turned on.

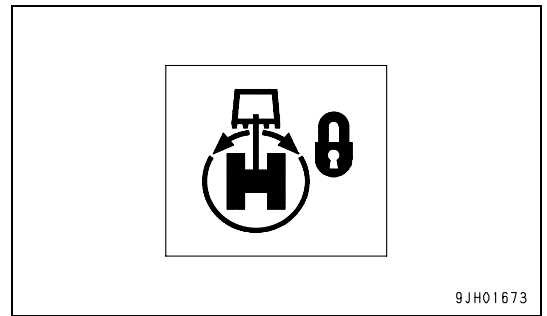

REMARK

The swing motor is equipped with a disc brake that mechanically stops the rotation. When the swing lock monitor lamp is lighted up, the brake remains applied.

Wiper Monitor

This monitor (3) indicates the operating status of the wiper.

The monitor display when the wiper switch is operated is as follows.

When ON lights up : Wiper moves continuously

When INT lights up : Wiper moves intermittently

OFF : Wiper stops

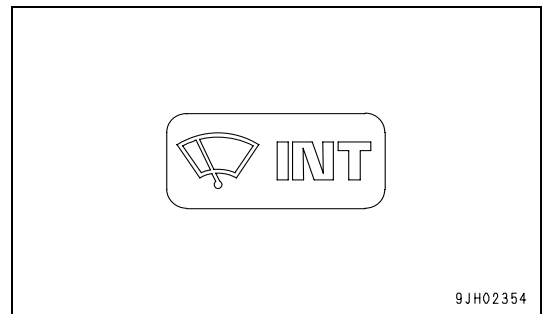

Auto-deceleration Monitor

This monitor (4) shows if the auto-deceleration function is being actuated.

The monitor display when the auto-deceleration switch is operated is as follows.

Auto-deceleration monitor ON : Auto-deceleration actuated

Auto-deceleration monitor OFF : Auto-deceleration canceled

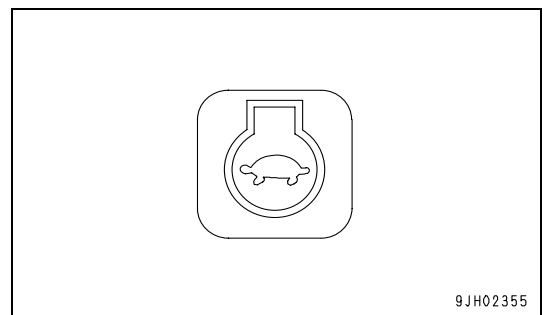

Working Mode Monitor

This monitor (5) displays the working mode setting.

The monitor display when working mode switch is operated is as follows.

A: A mode (for heavy-duty operations)

E: E mode (for operations prioritizing fuel consumption)

X: Heavy-duty lift (increase in boom lifting power when raising boom independently)

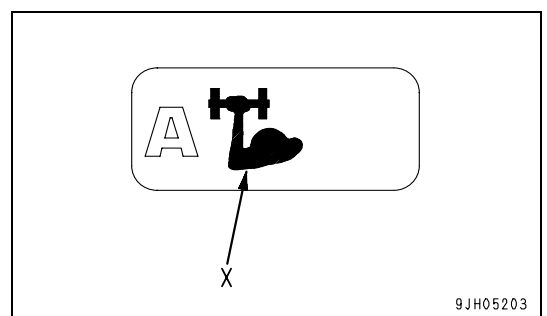

Travel Speed Monitor

This monitor (6) displays the set mode for the travel speed.

The monitor display when the travel speed selector switch is operated is as follows.

Lo : Low speed

Hi : High speed

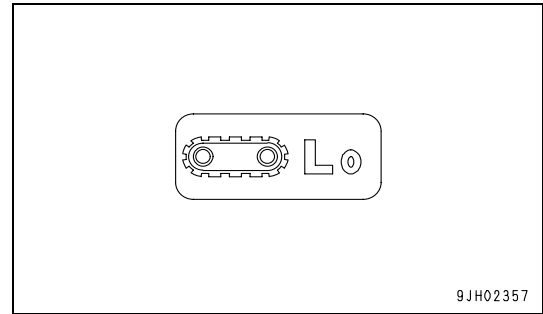

One touch power up monitor

This monitor (7) shows if the power max function is being actuated.

The monitor display when the knob switch on the left control lever is operated is as follows.

Monitor lights up: Digging power is increased while knob switch is kept pressed.

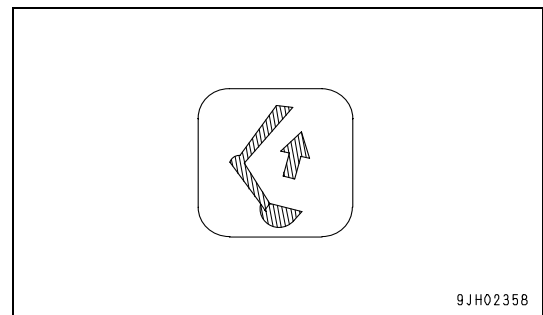

REMARK

The digging power is increased while the knob switch is being pressed only for working modes A and E. Note that even if the knob switch is kept pressed, the increase in power ends after 8.5 seconds.

Monitor goes out : Power max function stopped

Gauges and Meter

Engine Water Temperature Gauge

This gauge (8) indicates the engine cooling water temperature.

During normal operation, the indicator should be within the black range between (A) and (C). If the indicator enters the red range between (A) and (B) during operations, the overheat prevention system is actuated.

The overheat prevention system acts as follows.

Red range position (A): Engine water temperature monitor (1) lights up red

Red range position (B): Engine speed is reduced to low idling, engine water temperature monitor lamp (C) lights up red, and the alarm buzzer sounds at same time.

The overheat prevention system works until the temperature enters the black range (A) to (C).

When the engine is started, if the indicator is at position (C), engine water temperature monitor (1) lights up white.

In this case, carry out the warming-up operation. For details, see "Warming-Up Operation (3-94)".

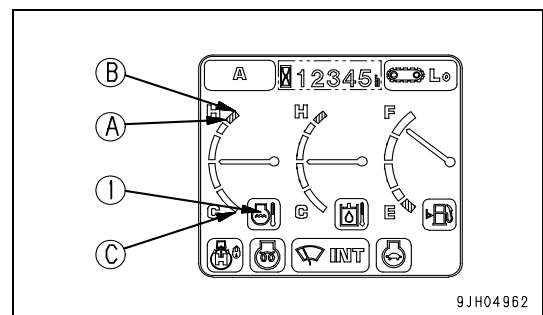

Fuel Gauge

This gauge (9) indicates the amount of fuel in the fuel tank. During operations, the indicator should be within the black range. If the indicator enters the red range (A) during operation, there is less than 101 liters (26.68 US gal) of fuel remaining in the tank; therefore check and add fuel.

REMARK

If the indicator enters red range (B), there is less than 84 liters (22.19 US gal) of fuel remaining. When the indicator is in the red range (A) to (B), fuel level monitor (1) lights up red.

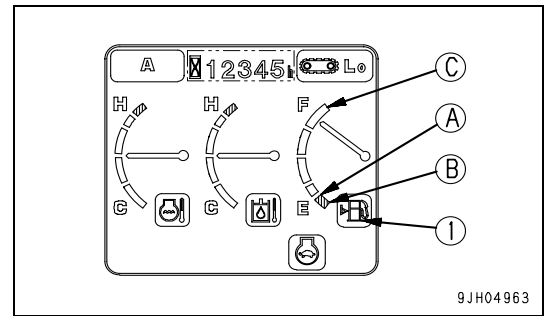

If the indicator enters the red range (A) - (B), do not carry out operations on steep slopes. There is danger of the engine stalling. The correct fuel level may not be displayed for a short time when the starting switch is turned ON, but this is not an abnormality.

Hydraulic Oil Temperature Gauge

This meter (10) displays the hydraulic oil temperature.

During normal operation, the indicator should be within the black range between (A) and (C).

If the indicator enters the red range (A) during operation, the hydraulic oil temperature has gone above 102°C (215.6°F). Stop the engine or run it at low idling and wait for the hydraulic oil temperature to go down.

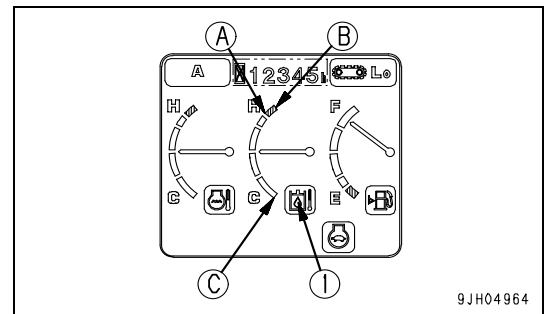

REMARK

Hydraulic oil temperature is as follows when the indicator enters the red range (A):

(A) position in the red range: 102°C (215.6°F) or over
Hydraulic oil temperature monitor will be illuminated red.

(B) position in the red range: 105°C (221°F) or over
Hydraulic oil temperature monitor will be illuminated red, and alarm buzzer will sound.

If the indicator is on (C) position when starting the engine, it means that hydraulic oil temperature is 25°C (77°F) or lower and the hydraulic oil temperature monitor (1) will be illuminated white. When this happens, refer to the section "Warming-Up Operation (3-94)" and perform warm-up operation.

Service Meter

This monitor (11) displays the total time the machine has been running.

Set the periodic maintenance interval in hours. When the starting switch is ON, the service meter advances even if the machine is not moving. The meter will advance by 1 for each hour of operation regardless of the engine speed.

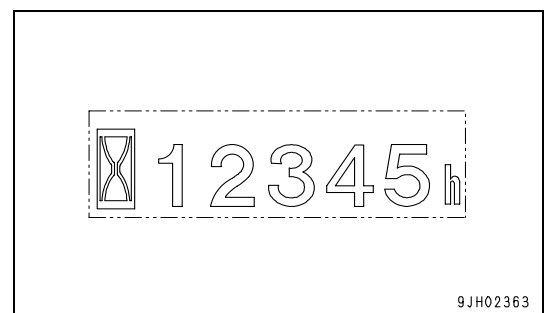

Monitor Switches Portion

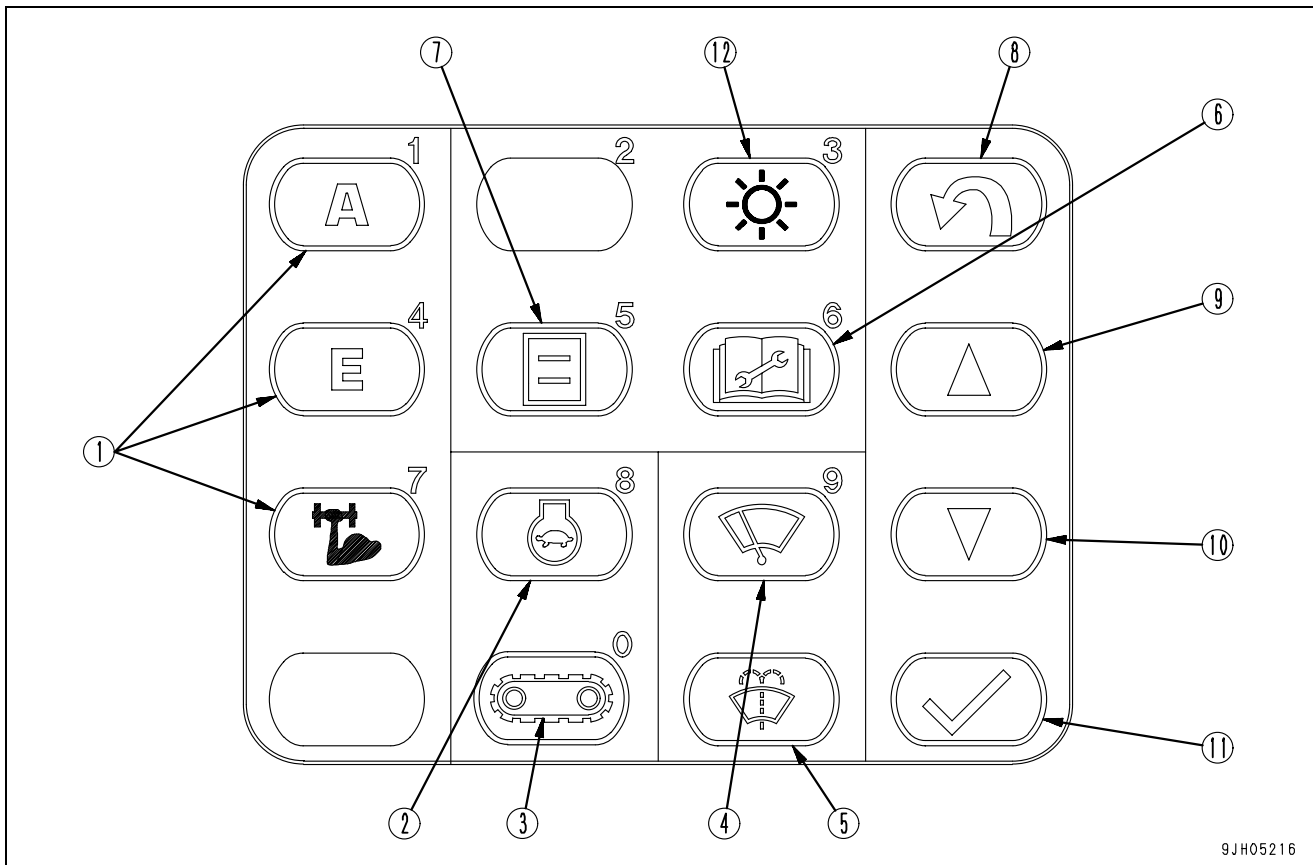

9JH05216

- | | |
|--|-------------------------------------|
| E(1) Working mode selector switches (basic switches) | E(7) No function |
| E(2) Auto-deceleration switch (selection switch) | E(8) Return switch |
| E(3) Travel speed selector switch | E(9) Up switch |
| E(4) Wiper switch | E(10) Down switch |
| E(5) Window washer switch | E(11) Input confirmation switch |
| E(6) Maintenance switch | E(12) LCD monitor adjustment switch |

Working Mode Selector Switch (Basic Switch)

This switch (1) is used to set the movement or power for the work equipment.

Operations can be carried out more easily by selecting the mode to match the type of operation.

- A mode: For heavy-duty operations
- E mode: For operations prioritizing fuel consumption
- Heavy-duty lift mode:
For operations where boom lifting power must increase when raising boom independently

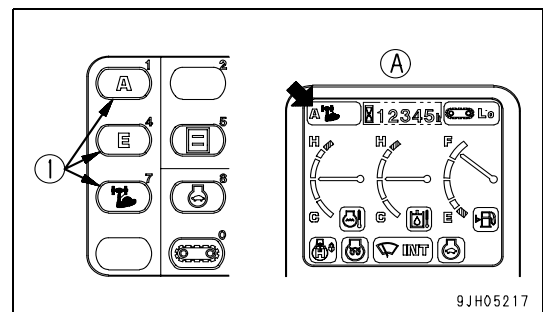

9JH05217

- When the engine is started, the working mode is set automatically to A mode. When the switch is pressed, it is possible to select the other modes. The monitor display on the monitor display portion (A) changes for each mode.
- If it is desired to have the working mode set to start automatically in E, L, or B mode (default options setting), please ask your Komatsu distributor to change the setting.

REMARK

When the mode selector switch is pressed, the mode is displayed in the center of the monitor display portion (A), and the screen returns to the normal screen after 2 seconds. (The diagram on the right is an example of the display for the E mode.)

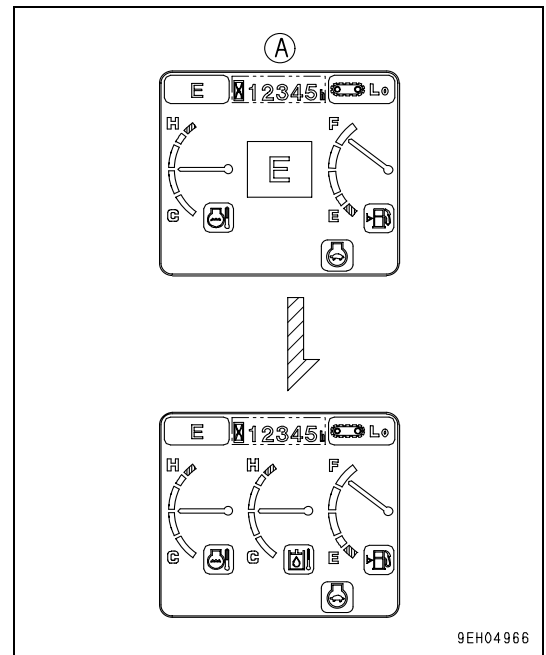

Auto-deceleration Switch (Selection Switch)

When this switch (2) is depressed, the auto-deceleration is actuated, if the control levers are in the neutral position, and the engine speed is automatically lowered to reduce fuel consumption.

Monitor display portion (A) ON : Auto-deceleration actuated
 Monitor display portion (A) OFF : Auto-deceleration canceled

Each time that the switch is pressed, the auto-deceleration switches between actuated and canceled.

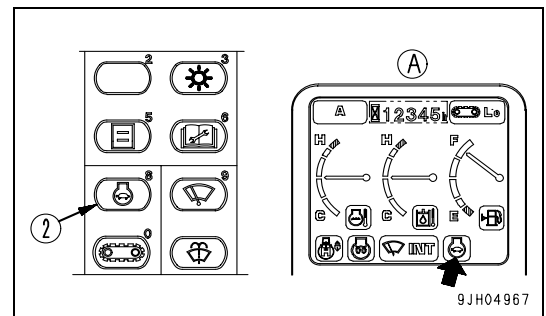

● Auto-deceleration function

When the auto-deceleration function is ON, if the work equipment levers and travel lever are returned to the N position, the engine speed will drop after approx. 4 seconds from the operating speed to the idling speed.

This makes it possible to reduce fuel consumption.

If any lever is operated when the machine is in this condition, the engine speed will return to the previous operating speed to make it possible to carry out operations.

REMARK

When the auto-deceleration switch is pressed and the auto-deceleration is actuated, the mode is displayed in the center of the monitor display portion (A), and the screen returns to the normal screen after 2 seconds.

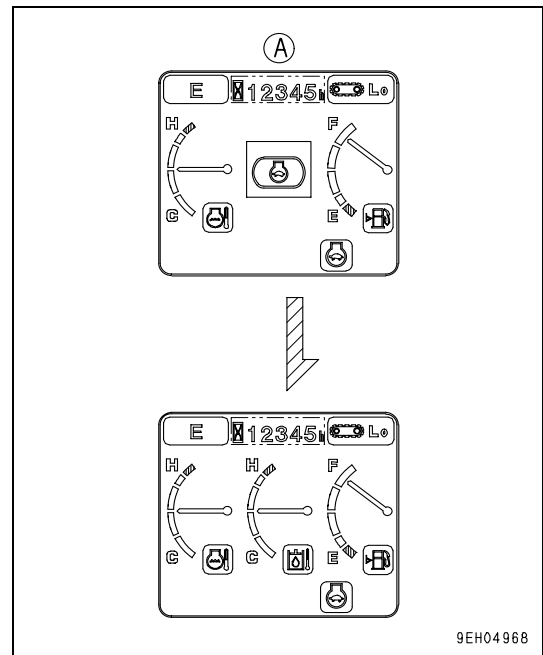

Travel Speed Selector Switch

WARNING

- When loading on or unloading from a trailer, always travel at low speed (with the travel speed selector switch put at the Lo position). Never operate the travel speed selector switch during the loading or unloading operation.
- If the travel speed is switched between Hi and Lo when the machine is traveling, the machine may deviate to one side, even when traveling in a straight line. Stop the machine before switching the travel speed.

This switch (3) is used to set the travel speed to 3 stages.

Lo lights up : Low-speed travel
 Hi lights up : Hi-speed travel

When the engine is started, the speed is automatically set to Lo.

Each time that the switch is pressed, the display changes Lo → Mi → Hi → Lo in turn.

When traveling in high speed (Hi), if travel power is needed, such as when traveling on soft ground or on slopes, the speed automatically switches to low speed (Lo), so there is no need to operate the switch. The monitor display stays at Hi.

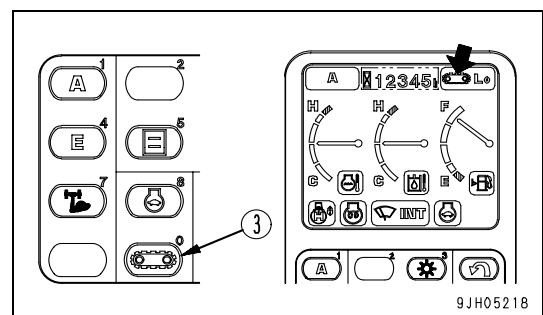

REMARK

Each time that the travel speed selector switch is operated, the mode is displayed in the center of the monitor display portion (A), and the screen returns to the normal screen after 2 seconds.

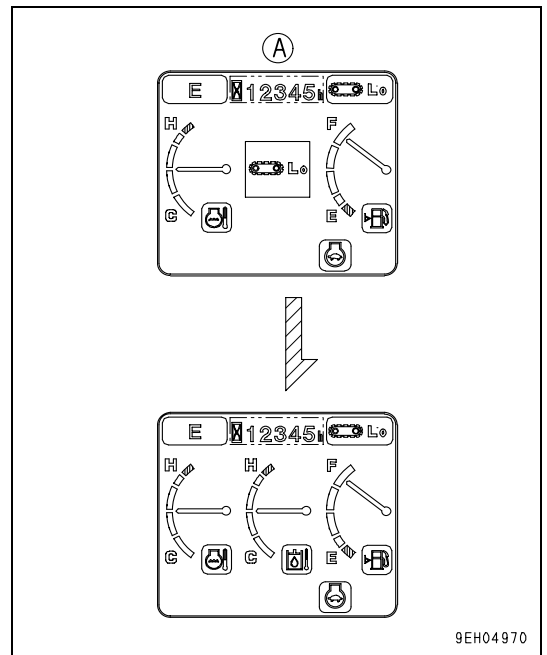

Wiper Switch

This switch (4) operates the wiper for the front glass.

Each time the switch is pressed, it changes ON → INT → stop (OFF).

Monitor display portion (A) ON lighted up: Wiper moves continuously

Monitor display portion (A) INT lighted up: Wiper moves intermittently

Monitor display portion (A) OFF : Wiper stops

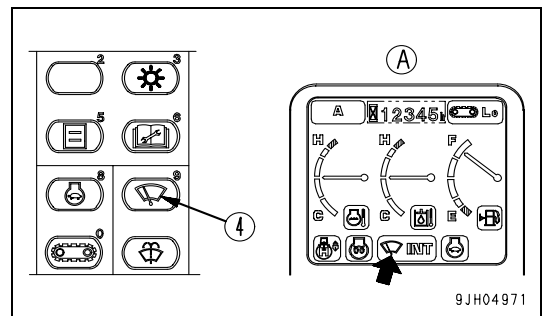

REMARK

Each time that the wiper switch is operated, the mode is displayed in the center of the monitor display portion (A). The screen returns to the normal screen after 2 seconds.

If the wiper does not work when the switch is turned ON, the wiper setting on the monitor is probably not correct, so ask your Komatsu distributor to change the setting.

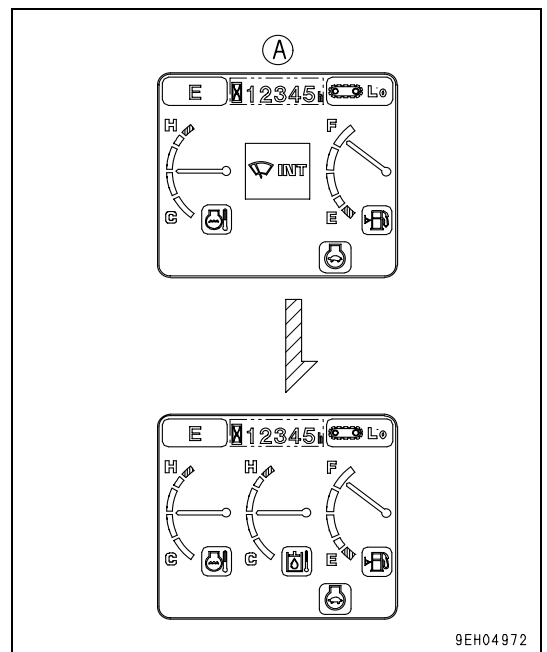

Window Washer Switch

This switch (5) is kept continuously pressed, window washer fluid is sprayed out on the front glass. When the switch is released, the spray stops.

- If switch (5) is kept pressed when the wiper is stopped, the window washer fluid will spray out, and at the same time, the wiper will be actuated continuously. When switch (5) is released, the wiper will continue to operate continuously for 2 cycles, and will then stop.
- If the wiper is moving intermittently and switch (5) is kept pressed continuously, the window washer fluid will spray out, and at the same time, the wiper will be actuated continuously. When switch (5) is released, the wiper will continue to operate continuously for 2 cycles, and will then return to intermittent operation.

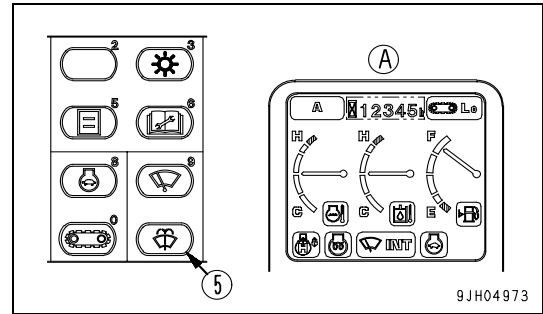

Maintenance Switch

- This switch (6) is used to check the time remaining to maintenance.

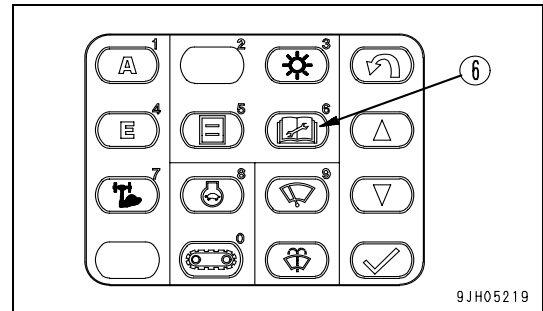

- When this switch (6) is pressed, the screen on the monitor display changes to the maintenance screen shown in the diagram on the right.

The time remaining to maintenance is indicated by the color of each monitor display. After confirming the maintenance time, carry out the maintenance.

- White display : More than 30 hours remaining to maintenance
- Yellow display : Less than 30 hours remaining to maintenance
- Red display : Maintenance time has already passed

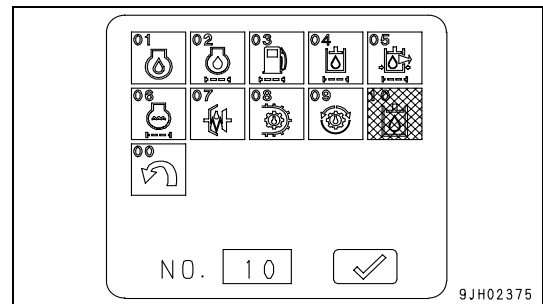

NOTICE

1. If monitor display portion (A) changes to the maintenance timing warning screen when the engine is started or when the machine is being operated, stop operations immediately. When this happens, the monitor corresponding to the maintenance time warning screen will light up red.
2. Press switch (6) to display the maintenance screen. Carry out maintenance for the location indicated by the monitor that is lighted up red.

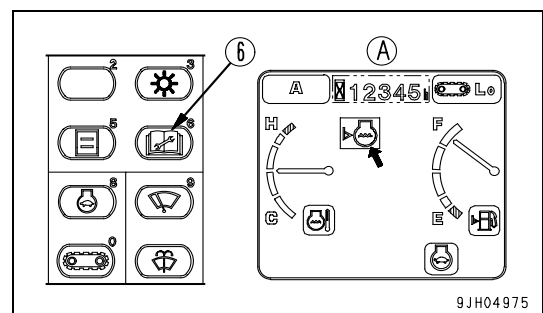

- The maintenance display items are as follows.

Monitor No.	Maintenance item	Initial setting display (H)
01	Engine oil change	500
02	Replace engine oil filter	500
03	Replace fuel filter	500
04	Replace hydraulic oil filter	1000
05	Replace hydraulic tank breather	1000
06	Replace corrosion resistor	1000
07	PTO case oil change	1000
08	Final drive case oil change	2000
09	Machinery case oil change	1000
10	Hydraulic oil change	5000

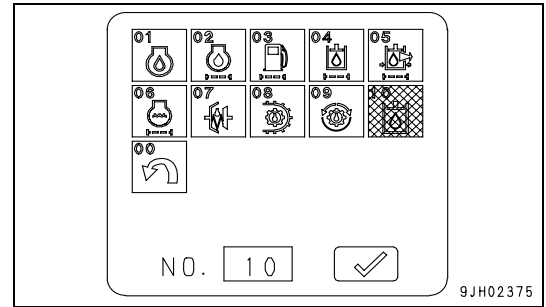

If it is desired to change the setting for the maintenance interval, please contact your Komatsu distributor.

- The method of checking the time remaining to maintenance is as follows.

1. Look at the maintenance screen, press up switch (9) or down switch (10) on the monitor switch portion, and select the item. (The color of the monitor for the selected item is inverted to black.)

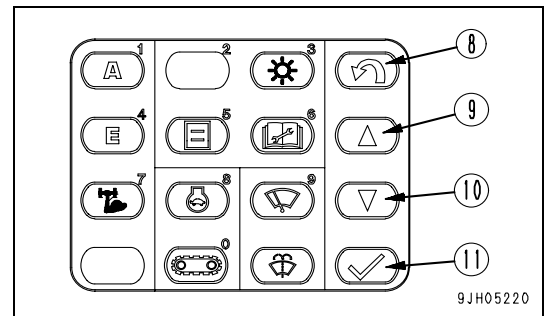

2. After selecting the monitor item, press input confirmation switch (11). The display screen will switch to the time remaining to maintenance. (Press back switch (8) to return to the previous screen.)

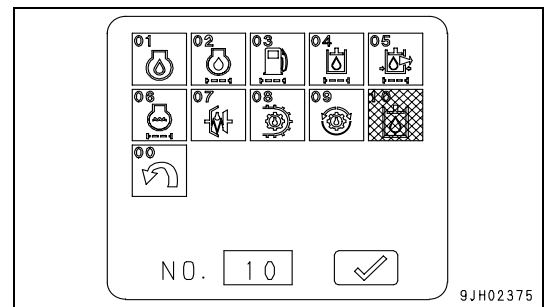

3. Check the time remaining to maintenance.

- (a) : Time remaining to maintenance
- (b) : Default setting for maintenance interval

When only checking the time remaining to maintenance, press back switch (8) twice.

The screen will return to the normal operation monitor screen.

When canceling the time remaining to maintenance and returning to the default time setting, press input confirmation switch (11). The screen will switch to the default setting screen.

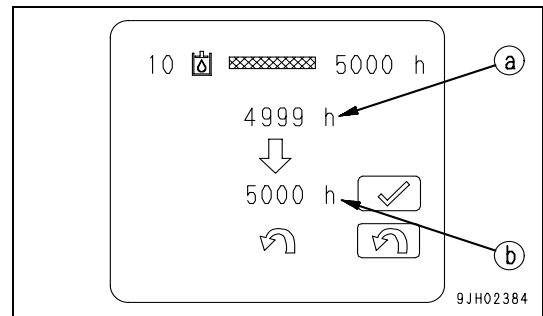

4. After checking the time on the default setting screen, press input confirmation switch (11).

The screen will return to the maintenance screen.

(Press back switch (8) to return to the previous screen.)

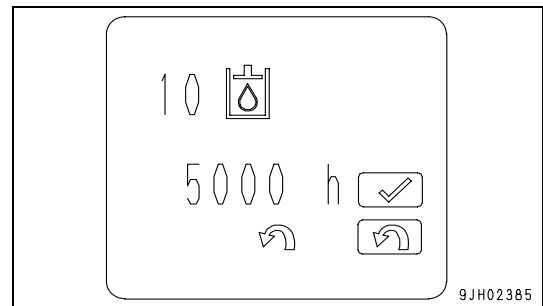

Back Switch

Press this switch (8) when in the maintenance mode, brightness/contrast adjustment mode, or select mode. The screen will return to the previous screen on the monitor display.

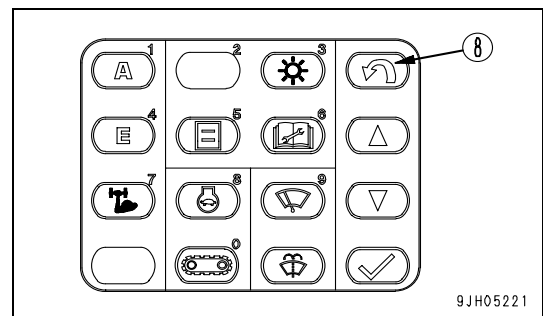

Up Switch, Down Switch

Press up switch (9) or down switch (10) when in the maintenance mode, brightness/contrast adjustment mode, or select mode to move the cursor on the monitor display (colors of selected monitor are inverted) up, down, left, or right.

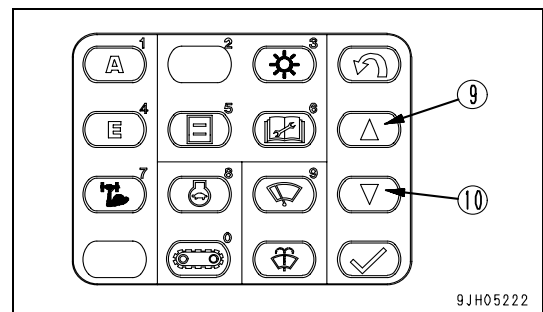

Input Confirmation Switch

Press this switch (11) to confirm the selected mode when in the maintenance mode, brightness/contrast adjustment mode, or select mode.

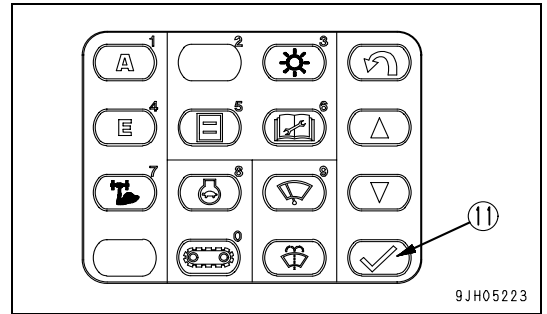

Adjusting Brightness And Contrast

Press this switch (12) to adjust the brightness and contrast of the monitor display screen.

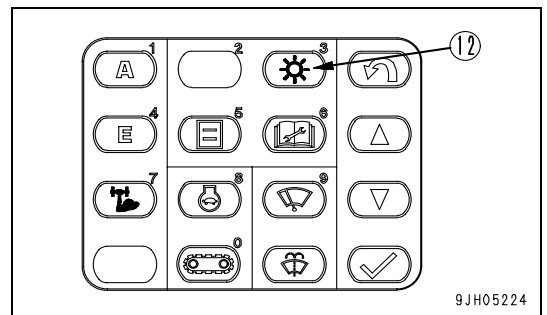

Adjusting brightness and contrast

1. When monitor adjustment switch (12) is pressed, the monitor display screen changes to the brightness/contrast screen shown in the diagram on the right.

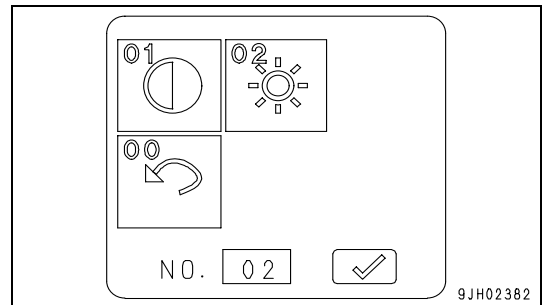

- Adjusting brightness
2. Use the brightness/contrast screen and press up switch (9) or down switch (10) to select the brightness monitor. (The selected monitor is inverted to black.)

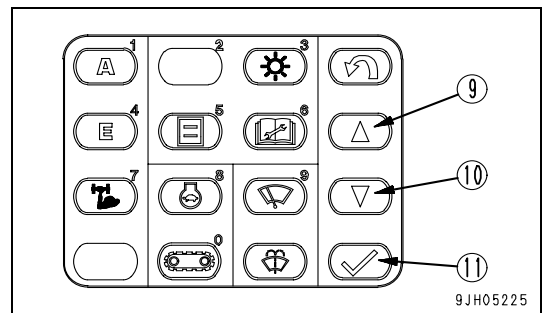

3. When the screen changes to the brightness adjustment screen, press up switch (9) or down switch (10) to adjust the brightness.
4. After completing adjustment of the brightness, press input confirmation switch (11).

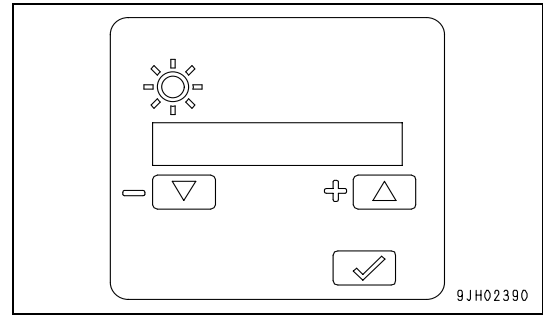

● Adjusting contrast

2. Use the brightness/contrast screen and press up switch (9) or down switch (10) to select the contrast monitor. (The selected monitor is inverted to black.)

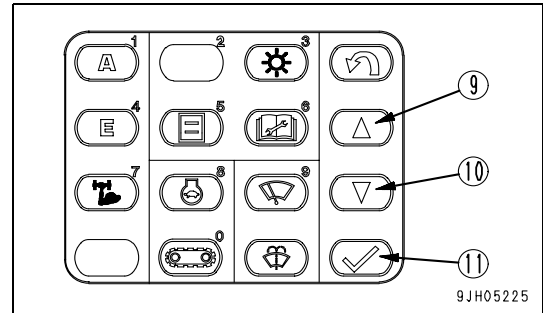

3. When the screen changes to the contrast adjustment screen, press up switch (9) or down switch (10) to adjust the contrast.
4. After completing adjustment of the contrast, press input confirmation switch (11).

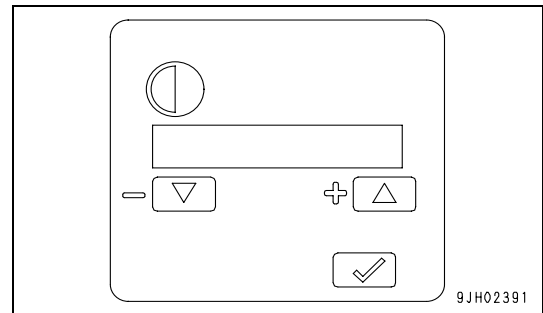

REMARK

When the machine is shipped from the factory, both the brightness and contrast are set to maximum.

SWITCHES

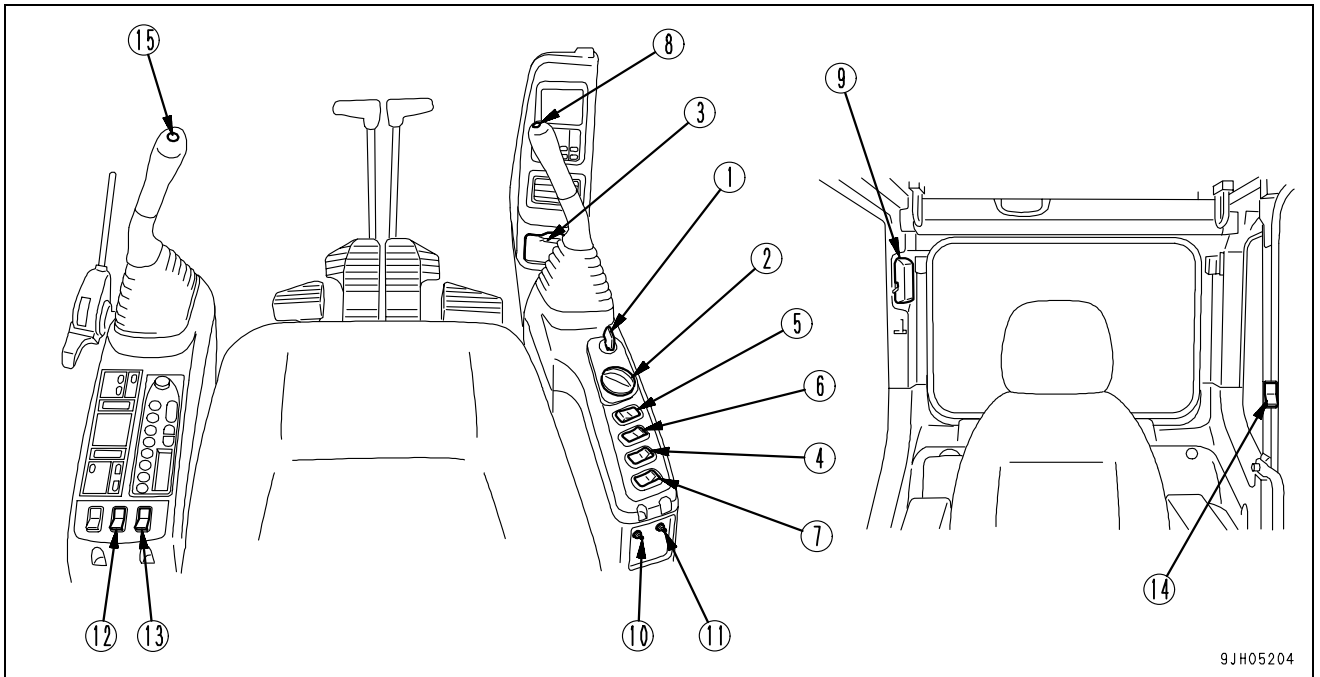

9JH05204

- (1) Starting switch
- (2) Fuel control dial
- (3) Cigarette lighter
- (4) Swing lock switch
- (5) Lamp switch
- (6) Alarm buzzer stop switch
- (7) Machine push-up switch
- (8) Horn switch
- (9) Room lamp switch
- (10) Emergency pump drive switch
- (11) Swing brake cancel switch
- (12) Revolving warning lamp switch
- (13) Lower wiper switch
(machines with fixed front window cab)
or Large capacity airflow condition blower switch
(if equipped)
- (14) Step light switch
- (15) One-touch power max. switch

Starting Switch

This switch (1) is used to start or stop the engine.

(A): OFF position

The key can be inserted or withdrawn. The switches for the electric system except the room lamp, are all turned off and the engine is stopped.

(B): ON position

Electric current flows in the charging and lamp circuits. Keep the starting switch key at the ON position while the engine is running.

(C): START position

This is the engine-start position. Keep the key at this position during cranking. Immediately after starting the engine, release the key. It will automatically return to the ON position (B).

(D): HEAT (preheat) position

When starting the engine in winter, set the key to this position. When the key is set to the HEAT position (D), the pre-heating monitor lights up. Keep the key at this position until the monitor lamp flashes. Immediately after the pre-heating monitor flashes, release the key. The key automatically returns to the OFF position (A). Then, start the engine by turning the key to the START position (C).

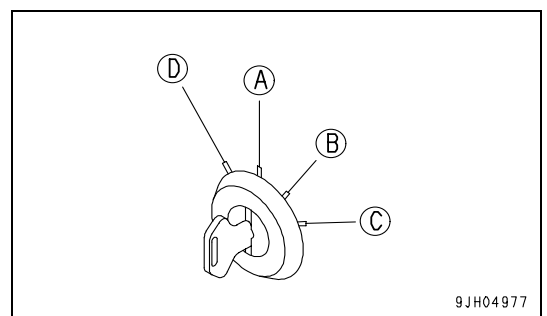

9JH04977

Fuel Control Dial

This dial (2) adjusts the engine speed and output.

- (a) Low idling (MIN): Turned fully to the left
- (b) Full speed (MAX): Turned fully to the right

REMARK

When the fuel control dial is turned, the engine speed does not change for the first few notches from MIN and the last few notches before MAX, but this does not indicate any abnormality.

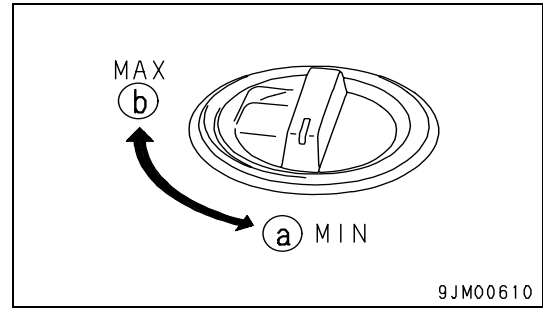

Cigarette Lighter

This switch (3) is used to light cigarettes.

To use, push the lighter in. After a few seconds it will spring back. Pull out the lighter and light your cigarette.

By removing the cigarette lighter, the socket is available as a power source for the yellow flashing lamp.

Max. current is 85 W (24V x 3.5 A).

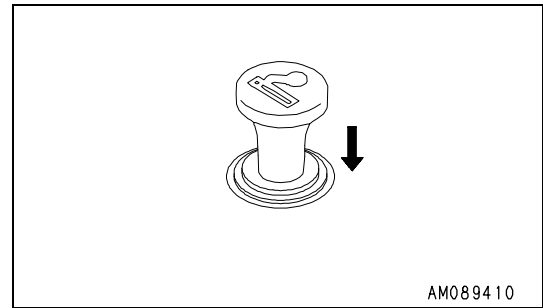

Swing Lock Switch

⚠ WARNING

- When not using the swing operation, e.g. in traveling, put the swing lock switch to the ON position (a).
- On slopes, even when the swing lock switch is at the ON position (a), the weight of the work equipment may cause the upper structure to swing if the swing control lever is operated in the downhill direction.

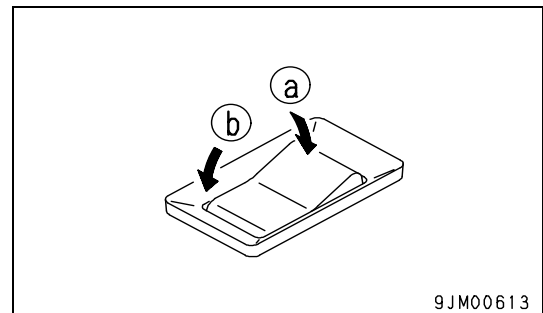

Switch (4) is used to lock the upper structure so it will not swing.

(a) ON position: The swing lock is always applied, and the upper structure will not swing even if the swing is operated. In this condition, the swing lock lamp lights up.

(b) OFF position: The swing lock is applied only when the swing control lever is in the neutral position, and released when operating the swing control lever. The swing lock is actuated in 7 seconds after putting the swing control lever in the neutral position.

Lamp Switch

This switch (5) is used to light up the front lamps, working lamp, additional lamp at the top front of the cab, rear lamp, and monitor lighting.

- (a) ON: Lamps light up
- (b) OFF: Lamps go off

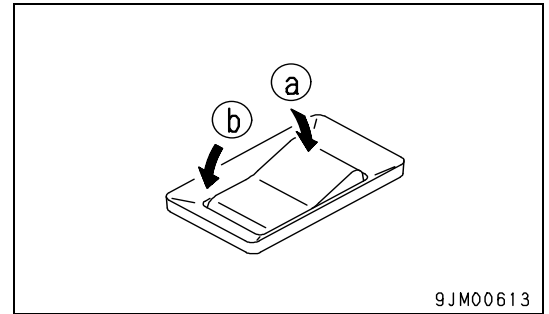

Alarm Buzzer Stop Switch

This switch (6) is used (when the engine is running) to stop the alarm buzzer when it has sounded to warn of an abnormality in a warning item.

REMARK

This switch is an automatic reset type. If the STOP position (b) is pressed, the alarm buzzer stops and the switch automatically returns to its original position.

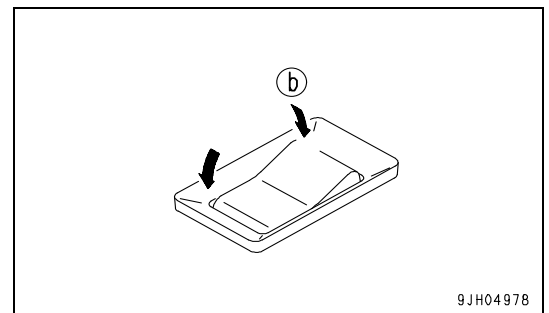

Machine Push-up Switch

⚠ WARNING

When using the boom thrust force to push up the chassis when moving down from a bench, there is danger that the machine may suddenly go down and turn over, so set to the high-pressure setting.

This switch (7) is used to switch the safety valve set pressure at the head end of the boom cylinder to two levels.

(a) Low pressure setting:

The boom thrust force is weak, so the swaying of the chassis is small during digging operations, and digging operations can be carried out smoothly.

This is used for general digging operations on normal ground, soft rock, or blasted rock.

(b) High pressure setting:

The thrusting force of the boom becomes more powerful, so it is easy to twist and swing or escape from soft ground. It is effective in carrying out digging operations using the bucket and the weight of the machine in confined areas.

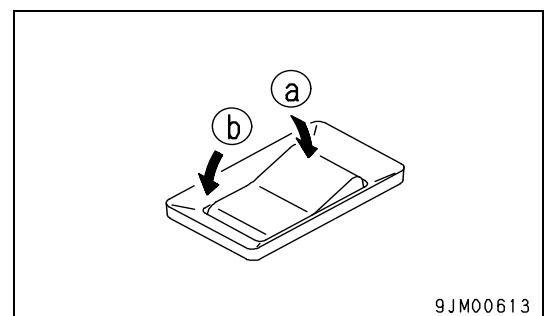

Horn Switch

When the switch (8) at the tip of the right work equipment control lever is pressed, the horn will sound.

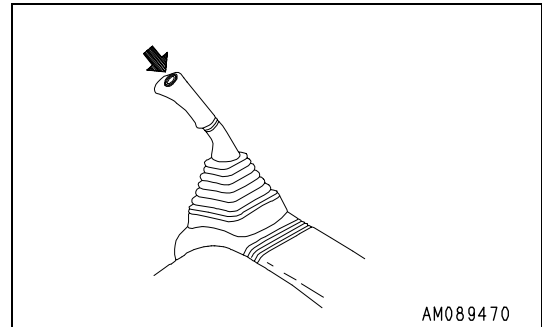

AM089470

Room Lamp Switch

NOTICE

It is possible to turn on the room lamp even when the starting switch is at the OFF position, so be careful not to forget to turn it off.

This switch (9) is used to light up the room lamp.

- (a) ON position: Lights up
- (b) OFF position: Goes out

It will also light up even when the engine is not running.

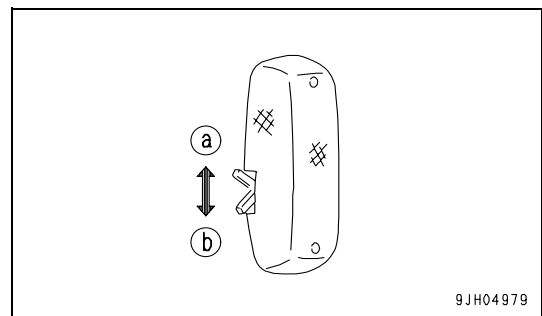

9JH04979

Pump Drive Emergency Switch

NOTICE

The emergency pump driving switch is provided to make it possible to carry out work for a short time when there is a failure in pump control system. It is necessary to repair the abnormal location as soon as possible.

This switch (10) is used to make it possible to carry out operations temporarily if any abnormality should occur in the pump control system (when the display shows E02).

- (a) When abnormal : Move switch up
- (b) When normal : Move switch down

If the display shows E02, move the switch up to make it possible to carry out work.

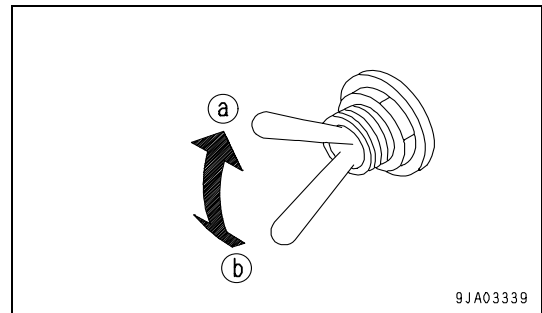

9JA03339

Swing Holding Brake Release Switch

NOTICE

This switch makes it possible to carry out swing operations for a short time even when there is an abnormality in the swing brake system. Do not use this switch except in emergencies. Repair the abnormality as soon as possible.

This switch (11) is used to make it possible to carry out operations temporarily if any abnormality should occur in the swing brake system (when the display shows E03).

- (a) Release: Position for abnormality (switch moved up)
- (b) Normal: Normal position (switch moved down)

- When the display is "E03", move this switch up to make it possible to carry out operations.
- When the switch is set to the Release (a) position, the swing lock monitor flashes.

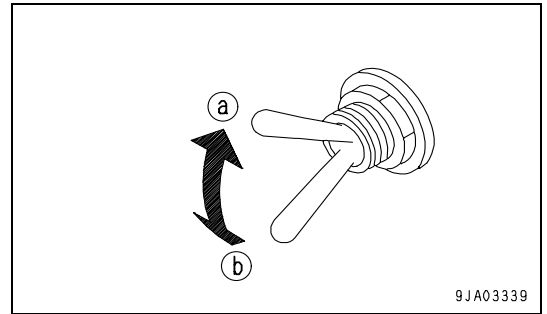

Revolving Warning Lamp Switch

(If equipped)

This switch (12) is used to light up the yellow rotating lamp on top of the cab.

- (a) ON: Lamps light up
- (b) OFF: Lamps go off

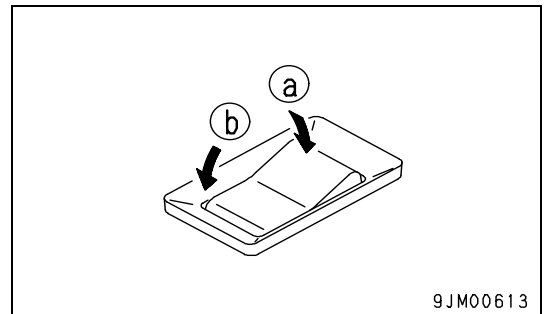

Lower Wiper Switch

(If equipped)

This switch (13) operates the lower wiper (A).

- (a) ON position: Lower wiper (A) is actuated
- (b) OFF position: Lower wiper (A) stops

If this switch is turned to the ON position at the same time as the wiper switch, the wiper and lower wiper (A) will be actuated in turn.

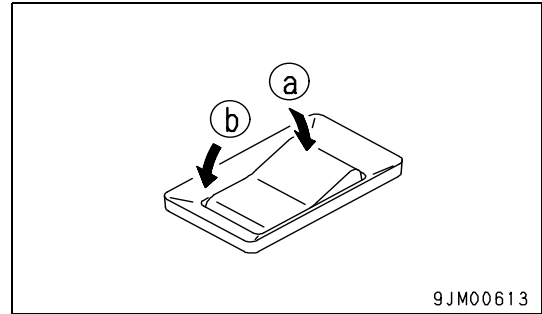

9JM00613

REMARK

If the wiper and lower wiper are being actuated at the same time, the lower wiper will not stop even when the wiper switch (monitor) is turned OFF. To stop the lower wiper, turn this switch (14) OFF.

If the wiper on the monitor is at the ON position and is operating continuously, and the lower wiper switch is turned ON, the wiper and lower wiper will be actuated in turn.

If the lower wiper switch is at the ON position and is operating continuously, and the wiper is actuated with the machine monitor, the lower wiper (both INT and ON) and wiper will be actuated in turn.

When the wiper switch (monitor) is turned ON, if the lower wiper is actuated, the wiper setting on the monitor is probably not correct, so ask your Komatsu distributor to change the setting.

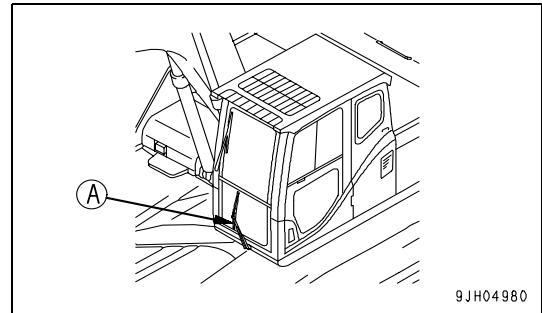

9JH04980

Large Capacity Airflow Air Conditioner Blower Switch

(If equipped)

This switch (13) operates the large-capacity airflow air conditioner blower.

- (a) ON: Large-capacity air conditioner blower is actuated
- (b) OFF: Large-capacity air conditioner blower is stopped

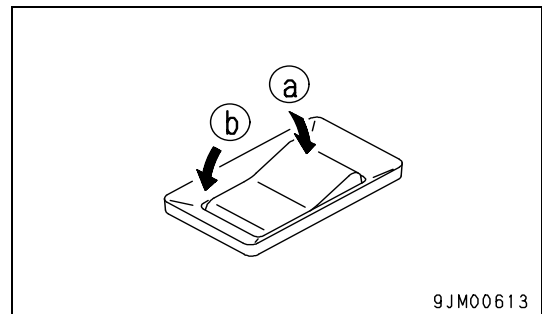

9JM00613

Step Light Switch

(If equipped)

Use this switch (14) when getting off the machine at night.

- When the switch is turned to the ON (a) position, the step light will light up for approx. 60 seconds.
- Even if the starting switch key is at the OFF position, the step light will light up for approx. 60 seconds when the switch is pressed.

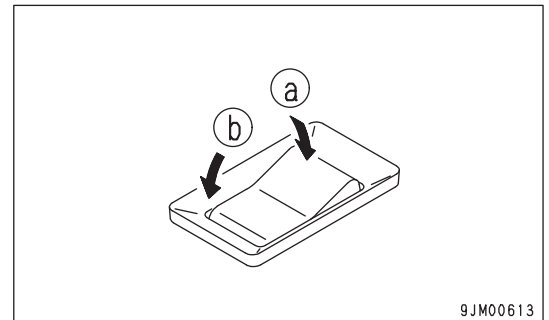
**One-Touch Power Max. Switch**

This switch (15) on the left work equipment control lever is used to actuate the power max and slow down functions.

Press once (single click) and keep the switch pressed. The one-touch power max. function is actuated for a maximum of 8.5 seconds at A and E mode.

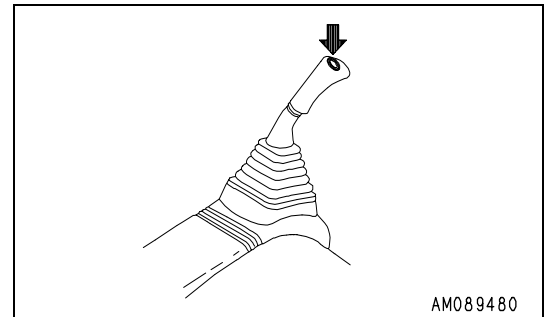

CONTROL LEVERS AND PEDALS

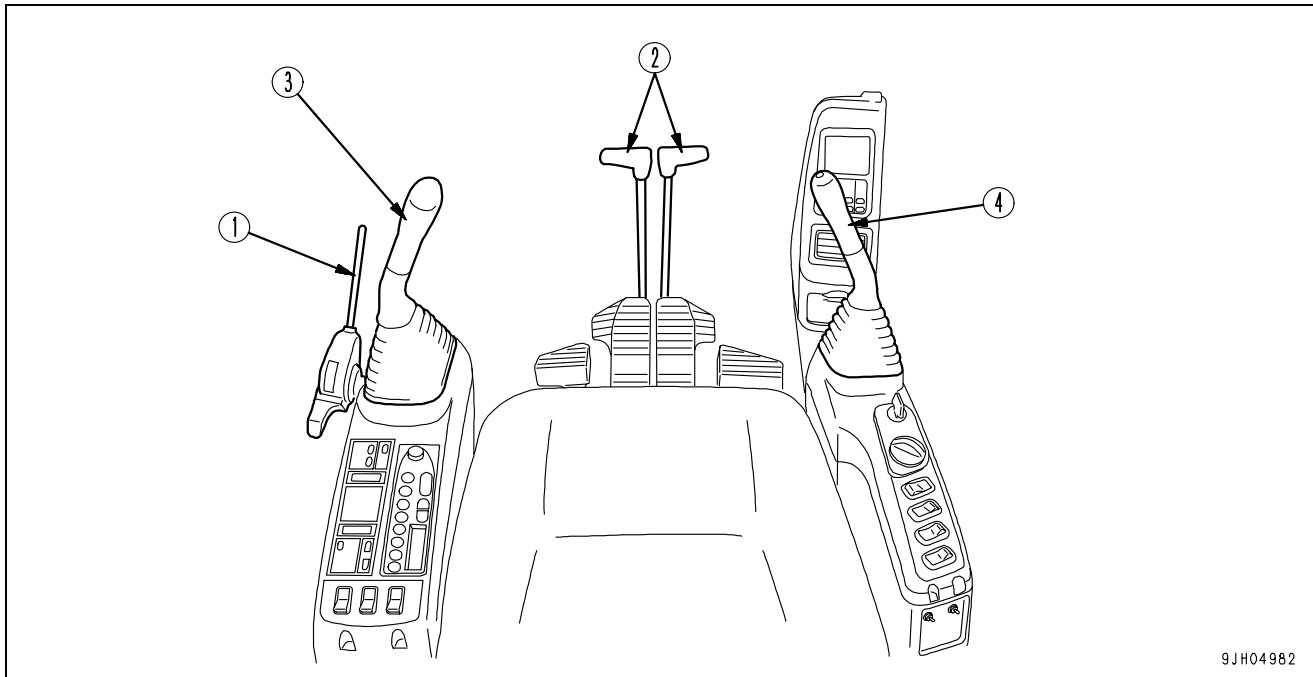

9JH04982

- (1) Lock lever
- (2) Travel lever
(with a pedal and auto-deceleration system)
- (3) Left work equipment control lever
(with Auto-deceleration System)
- (4) Right work equipment control lever
(with Auto-deceleration System)

Lock Lever

! WARNING

- When standing up from the operator's seat, push lock lever (1) down securely to set it to LOCK position (L). If lock lever (1) is not at LOCK position (L) and the control levers are touched by mistake, it may lead to serious personal injury.
- Check that lock lever (1) is placed securely at LOCK position (L).
- Be careful not to touch the work equipment control levers when pulling lock lever (1) up or pushing it down.

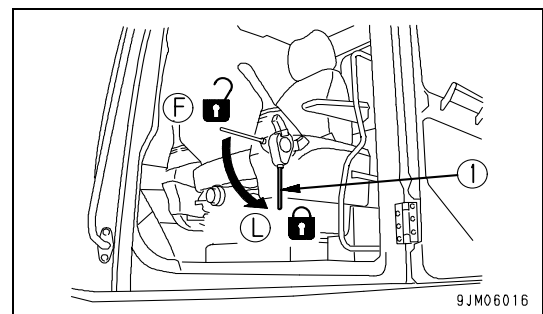

9JM06016

This lever (1) is a device to lock the work equipment, swing, travel, and attachment (if equipped) control levers.

Push lever (1) down to apply the lock.

This lock lever (1) is a hydraulic lock, so even if it is in the lock position (L), the work equipment control lever and travel lever will move, but the work equipment, travel motor, and swing motor will not work.

Travel Levers

! WARNING

- Do not rest your foot on the pedal during operations. If the pedal is depressed by mistake, the machine may suddenly move and cause a serious accident. Be extremely careful when operating the pedal for travel or steering operations. When you are not using the pedal, do not rest your foot on it.
- If the track frame is facing the rear, the direction of travel operations will be reversed when the travel lever is operated. (The machine will travel forward when operated in reverse, and in reverse when operated forward; the left and right directions will also be reversed.)
- When operating the travel levers, check if the track frame is facing the front or the rear. (If the sprocket is at the rear, the track frame is facing the front.)

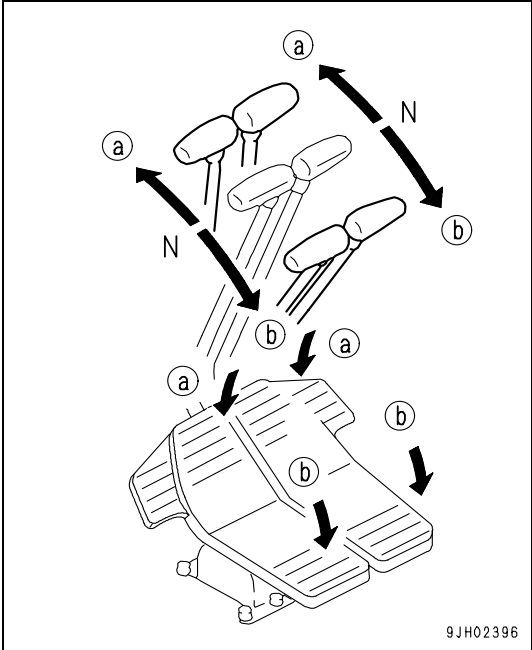

Lever (2) is used to change the direction of travel between forward and reverse. () shows the pedal operation.

(a) FORWARD: The lever is pushed forward
(The pedal is angled forward)

(b) REVERSE: The lever is pulled back
(The pedal is angled back)

N (Neutral): The machine stops

REMARK

If the travel lever is operated from the Neutral position to the FORWARD or REVERSE position, the alarm sounds to warn people in the surrounding area that the machine is about to move.

Work Equipment Control Lever

This Left work equipment control lever (3) is used to operate the arm and upper structure.

Arm operation

- (a) Arm OUT
- (b) Arm IN

Swing operation

- (c) Swing to right
- (d) Swing to left

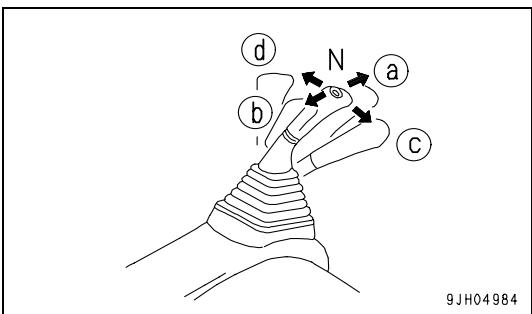

N (Neutral): The upper structure and arm are held in position and do not move.

This Right work equipment control lever(4) is used to operate the boom and bucket.

Boom operation

- (a) RAISE
- (b) LOWER

Bucket operation

- (c) DUMP
- (d) CURL

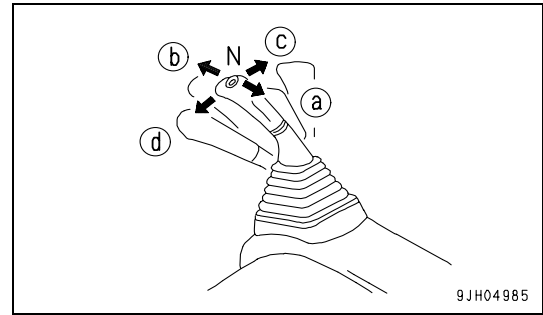

N (Neutral): The boom and bucket are held in position and do not move.

REMARK

With auto-deceleration system, the positions of all control levers (travel, work equipment, and attachment) affect the engine speed as follows:

When the travel lever and the work equipment control lever are in the neutral position, the engine will slow down to a medium speed even if the fuel control dial is above the medium speed position. When operating either of these levers, the engine speed will go up to the one adjusted by the fuel control dial.

When all the control levers are in the neutral position, the engine speed will slow down by 100 rpm and 4 seconds later, it will go down to the deceleration speed (approximately 1,400 rpm).

SUN ROOF

(PC600-7, PC600LC-7 full cab specification machine only)

WARNING

When leaving the operator's seat, set lock lever (1) securely to the LOCK position (L).

If lock lever (1) is at the FREE position (F) and the control lever is touched by mistake, this may lead to a serious accident.

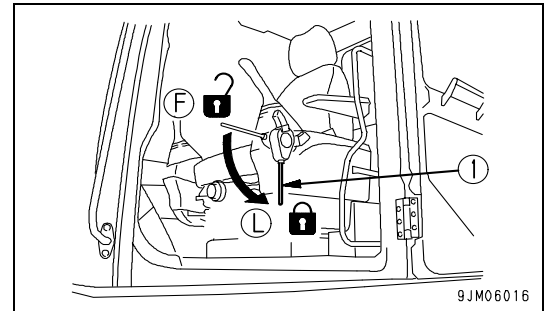

Opening

1. Set lock lever (1) securely to the LOCK position (L).
2. Check for any ceiling window movement by pulling lock knob (A) located on front side, then push up and open the ceiling window grasping grip (B).

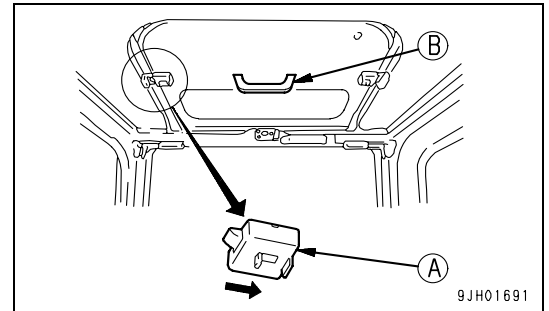

Closing

Hold grip (B), lower the ceiling window, and apply lock (A). If the lock cannot be applied, open the ceiling window, then pull it in again and apply the lock.

WINDSHIELD

(PC600-7, PC600LC-7 full cab specification machine only)

WARNING

- When opening or closing the front window, bottom window, or door, always set lock lever (1) to the LOCK position (L).
If the control levers are not locked and they are touched by accident, this may lead to a serious accident.
- When opening or closing the window at the front of the cab, stop the machine on horizontal ground, lower the work equipment completely to the ground, stop the engine, then carry out the operation.
- When opening the front window, hold the grip securely with both hands, pull up, and do not let go until the automatic lock catch is locked.
- When closing the front window, the window will move quicker under its own weight. Hold the grips securely with both hands when closing it.

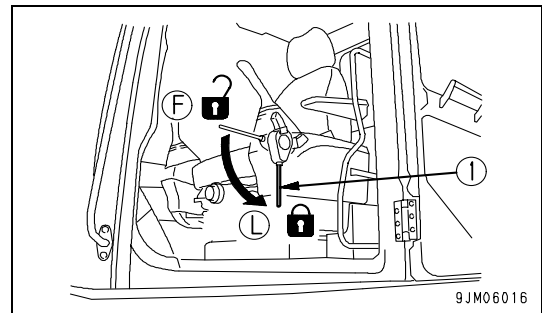

It is possible to stow (pull up) the front window in the roof of the operator's compartment.

Opening

1. Stop the machine on level ground, lower the work equipment completely to the ground, then stop the engine.
2. Set lock lever (1) securely to the LOCK position (L).

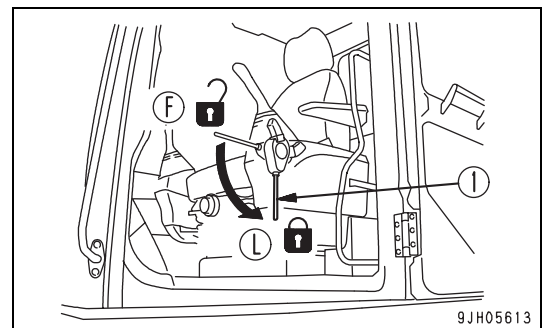

3. Check that the wiper blade is stowed in the right stay.

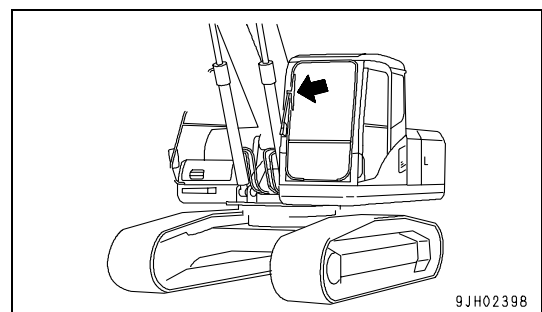

4. Grip handles (A) at the top right and left of the front window, and pull lock lever (B) toward yourself to release the lock at the top of the front window. The top of the front window will come out.

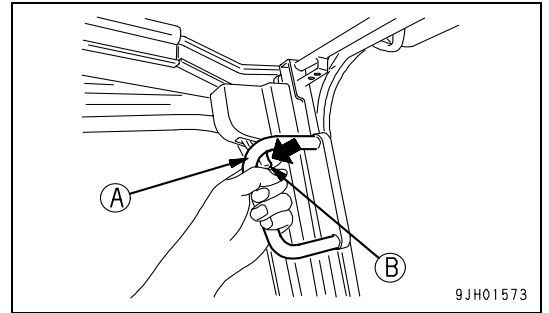
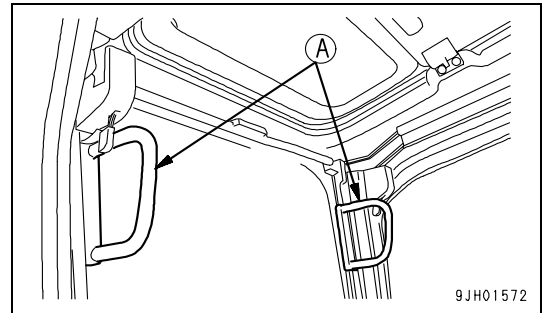

5. Hold lower knob (C) with your left hand from inside the operator's cab, and with your right hand, grip top knob (D), pull it up, and push it against lock catch (E) at the rear of the cab securely to lock the window.

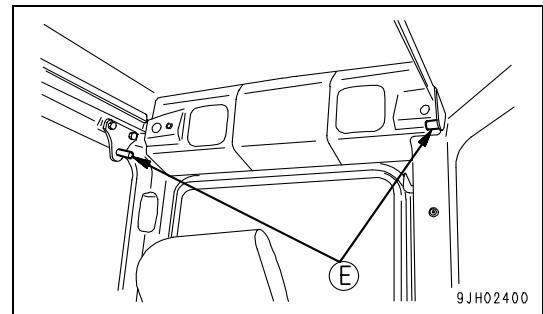
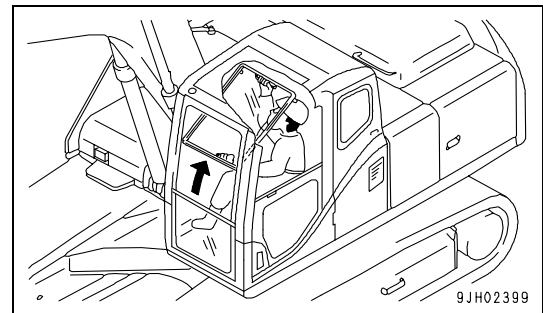
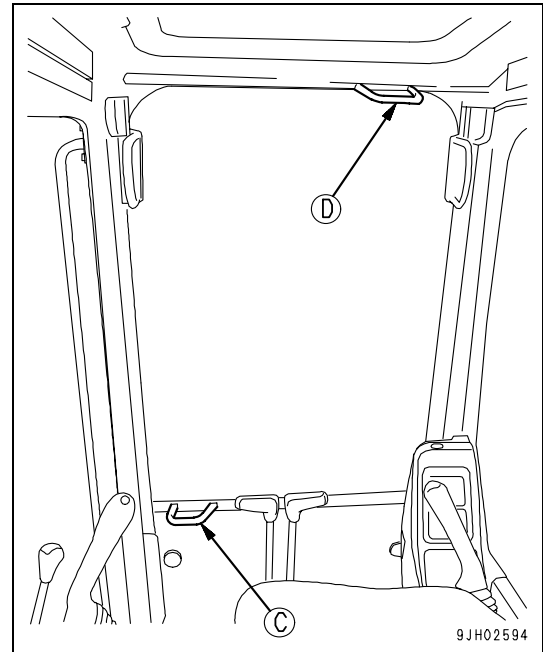

6. Check that lock lever (B) is securely at the LOCK position.
 - The lock is engaged if the arrow on lock case (F) matches the position of the arrow on lock lever (B). Check visually.
 - If the arrow on lock case (F) does not match the position of the arrow on lock lever (B), the lock is not engaged. Repeat the operation in Step 5 to engage the lock.

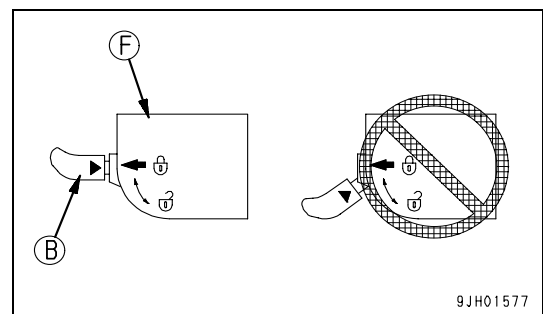

Closing

 **WARNING**

When closing the window, lower it slowly and be careful not to get your hand caught.

1. Stop the machine on level ground, lower the work equipment completely to the ground, then stop the engine.
2. Set lock lever (1) to the LOCK position (L) securely.

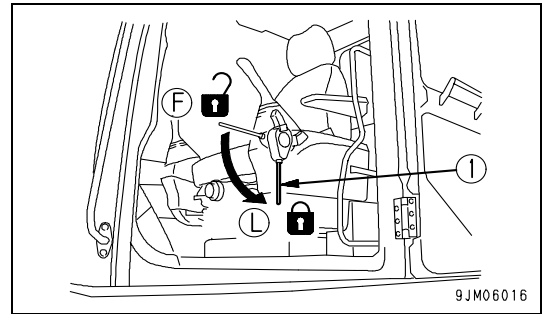

3. Grip left and right handles (A), and pull down lock lever (B) to release the lock.

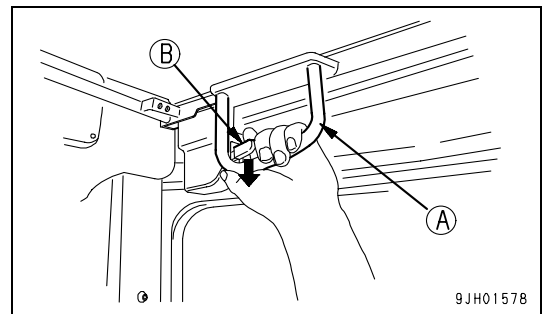

4. Grip handle (C) at the bottom of the front window with your left hand and handle (D) at the top with your right hand, push to the front, then lower slowly.

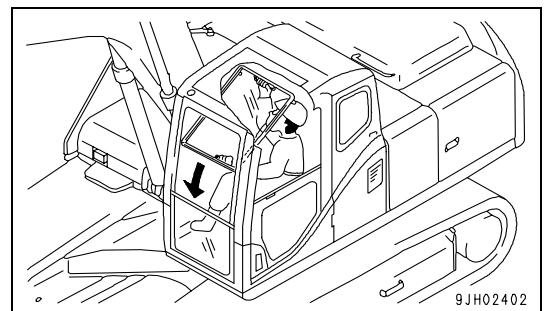
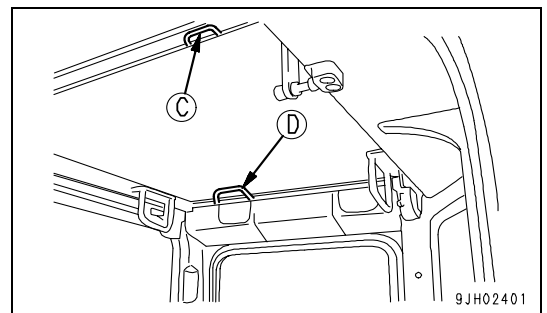

5. When the bottom of the window reaches the top of the bottom window, push the top of the window to the front to push it against left and right lock catches (G) and engage the lock.

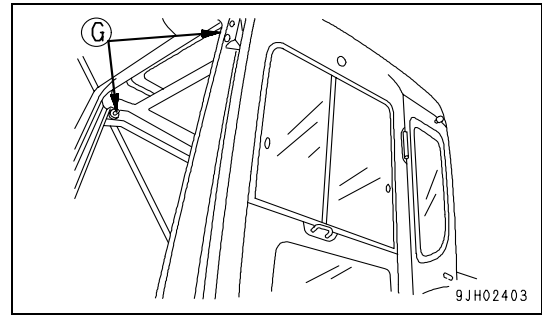

6. Check that lock lever (B) is securely at the LOCK position.
 - The lock is engaged if the arrow on lock case (F) matches the position of the arrow on lock lever (B). Check visually.
 - If the arrow on lock case (F) does not match the position of the arrow on lock lever (B), the lock is not engaged. Repeat the operation in Step 5 to engage the lock.

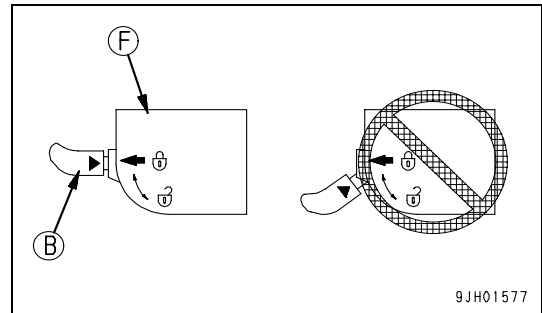

Removing Lower Windshield

1. Open the front window, then hold grip (A), pull up, and remove the bottom window.

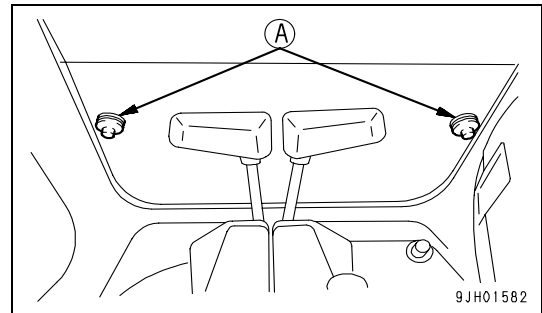

2. After removing the bottom window, store it at the rear of the operator's cab and lock it securely with left and right locks (B).
 - When removing, always hold the glass with one hand and release the lock with the other hand.

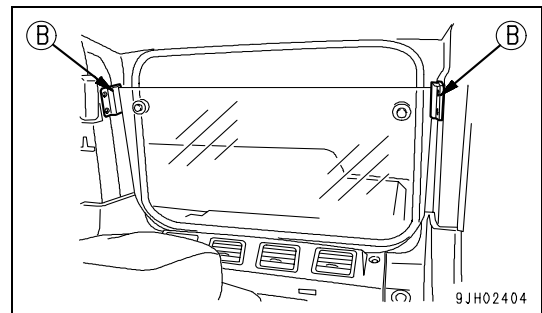

EMERGENCY EXIT FROM OPERATOR'S CAB

- If for some reason, the cab door does not open, remove the rear window and use it as an emergency escape.
- Remove the rear window as follows.
 1. Pull ring (1) and completely remove seal (2) from the rubber core.
 2. When the corner of the rear window glass is pushed strongly, it can be removed to the outside.
 - Do not remove the rear window except when using it as an emergency exit.

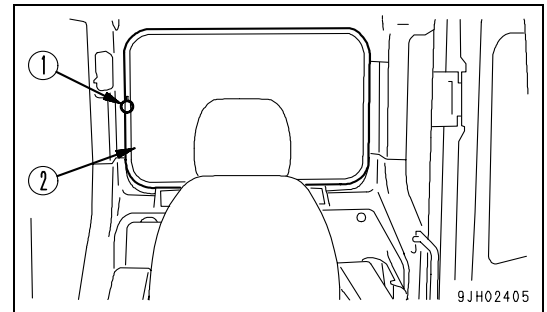

DOOR LOCK

WARNING

- Before releasing the door lock, always stop the machine on flat ground. Never release the door lock on a slope. The door may suddenly close and cause injury.
- When releasing the door lock, do not extend your body or hands outside the machine and do not put your hands on the door frame. The door may suddenly close and cause injury.

Use the door lock to fix the door in position after opening it.

1. Push the door against catch (1) to lock it in position.
2. To release the lock, press knob (2) down at the left side of the operator's seat to release the catch.
When fixing the door, fix it firmly to the catch.

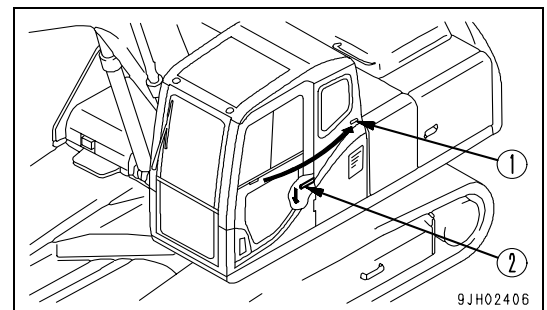

CAP WITH LOCK

Use the starting key to open and close the locks on the caps and covers.

For details of the locations of the caps and covers with locks, see "LOCKING (3-124)".

Insert the key as far as it will go to the shoulder (A). If the key is turned before it is inserted all the way, it may break.

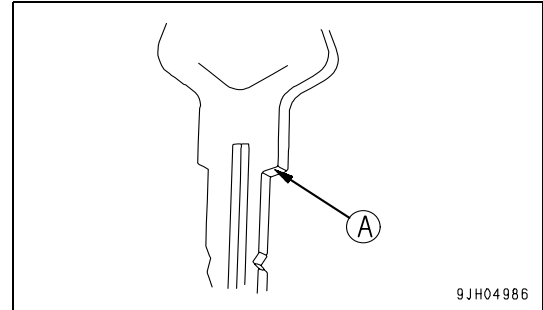

Opening and Closing Caps with Lock

Opening the Cap

1. Insert the key into the key slot.
2. Turn the starting switch key counterclockwise, align the key slot with the match mark (3) on the cap, then open the cap.
 - (1): Open
 - (2): Lock

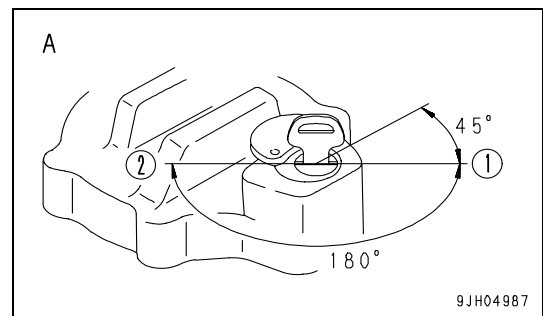

REMARK

B type is used for the fuel tank cap and hydraulic tank cap. With A type, if the cap rotates freely, it is locked. In this condition, the cap cannot be removed from the tank. Turned the starting switch key counterclockwise, align counter mark (3) on the cap with the groove of the rotor, then turn the cap slowly until a click is heard. This releases the lock and the cap can be opened.

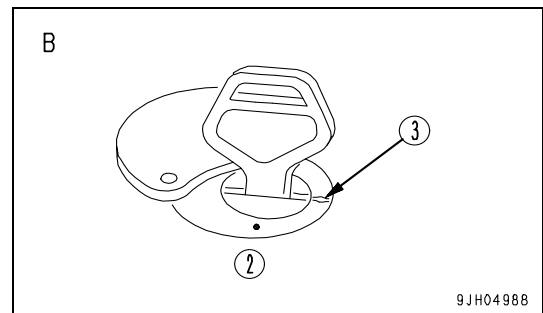

Locking the Cap

1. Turn the cap until tight, then insert the key into the key slot.
2. Turn the key counterclockwise (but, for the B type, turn clockwise) and take the key out.

Opening and Closing Cover with Lock

Opening the Cover (Locked Cover)

- 1. Insert the key into the key slot.
- 2. Turn the key counterclockwise and open the cover by pulling the cover grip.
(A): Open
(B): Lock

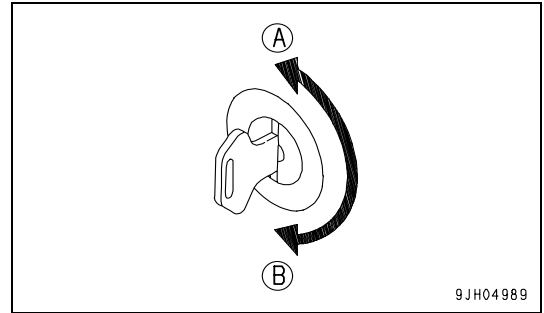

Locking the Cover

- 1. Close the cover and insert the key into the key slot.
- 2. Turn the key clockwise and take the key out.

HOT AND COOL BOX

This is on the right side at the rear of the operator's seat. It is interconnected with the air conditioner: it stays warm when the heating is used, and stays cool when the cooling is used.

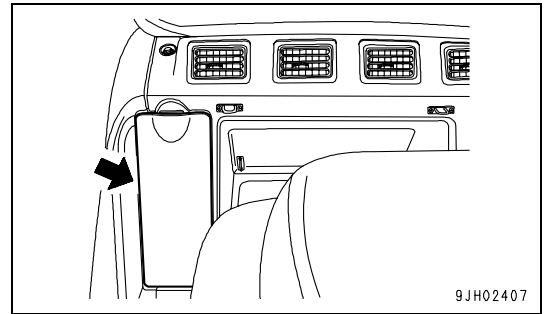

MAGAZINE BOX

(with cup holder)

This is on the left side of the operator's seat.

Keep the Operation and Maintenance Manual in this box so that it can be taken out and read whenever necessary.

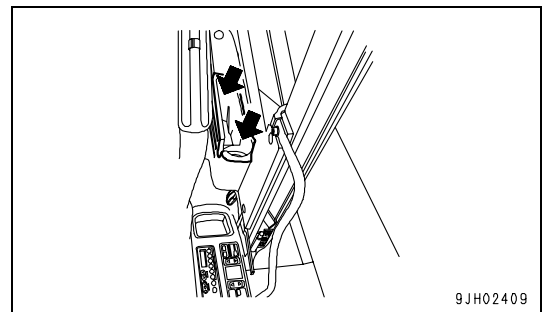

ASHTRAY

This is under the machine monitor at the front right of the operator's compartment.

Always make sure that you extinguish your cigarette, then put it in the ashtray and close the lid.

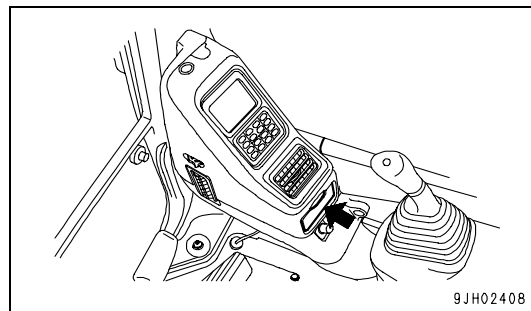

AIR CONDITIONER CONTROLS

Air Conditioner Control Panel

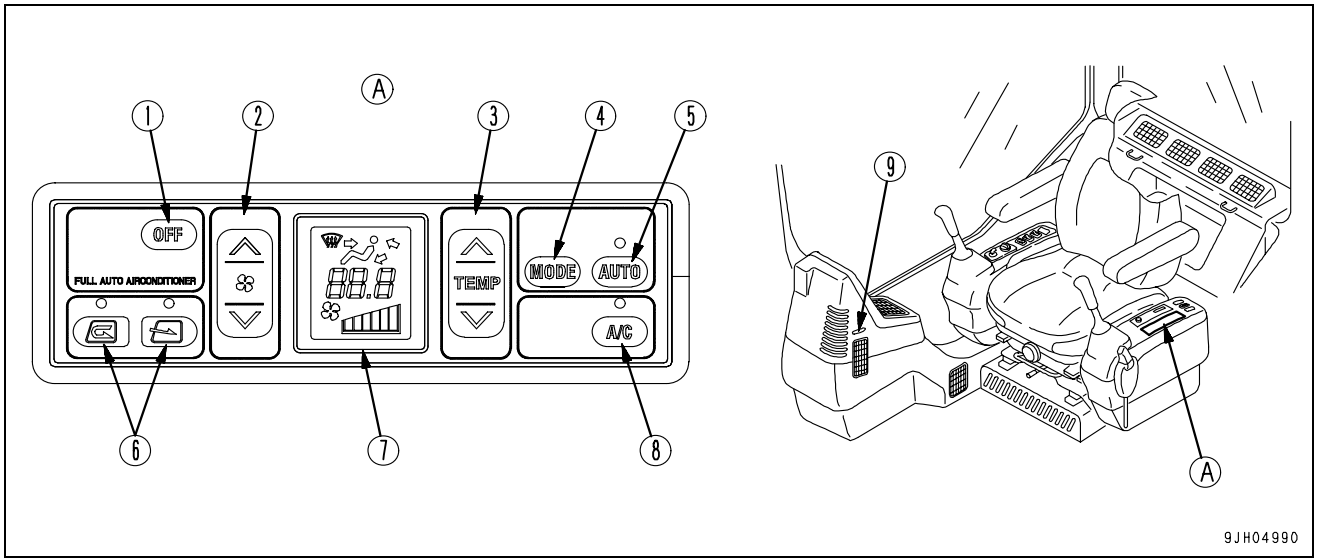

- | | |
|--------------------------------|----------------------------------|
| (1) OFF switch | (6) RECIRC/FRESH selector switch |
| (2) Fan switch | (7) Display monitor |
| (3) Temperature control switch | (8) Air conditioner switch |
| (4) Vent selector switch | (9) Defroster selector lever |
| (5) Auto switch | |

When the function of the switch is actuated, the pilot lamp for the switch lights up.

OFF Switch

This switch (1) is used to stop the fan and air conditioner.

- When OFF switch (1) is pressed, the set temperature and air flow display on display monitor (7) and the lamps above auto switch (5) and air conditioner switch (8) go out, and operation stops.



9JH02411

Fan Switch

This switch (2) is used to adjust the air flow.

The air flow can be adjusted to six levels.

- Press the ^ switch to increase the air flow; press the v switch to reduce the air flow.
- During auto operation, the air flow is automatically adjusted.

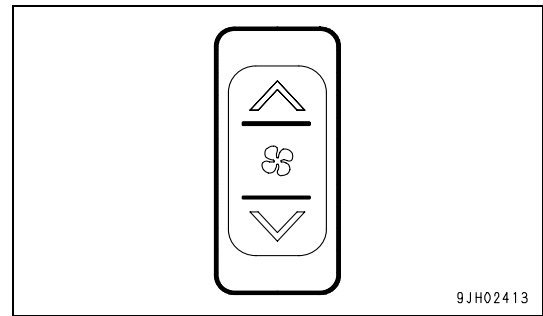

<Monitor display and air flow>

Liquid crystal display	Air flow
	Air flow "low"
	Air flow "medium 1"
	Air flow "medium 2"
	Air flow "medium 3"
	Air flow "medium 4"
	Air flow "high"

Temperature Control Switch

This switch (3) is used to control the temperature inside the cab. The temperature can be set between 18 °C (64.4 °F) and 32 °C (89.6 °F).

- Press the ^ switch to raise the set temperature; press the v switch to lower the set temperature.
- The temperature is generally set at 25 °C (77 °F).
- The temperature can be set in stages of 0.5 °C (0.9 °F).

<Monitor display and the function>

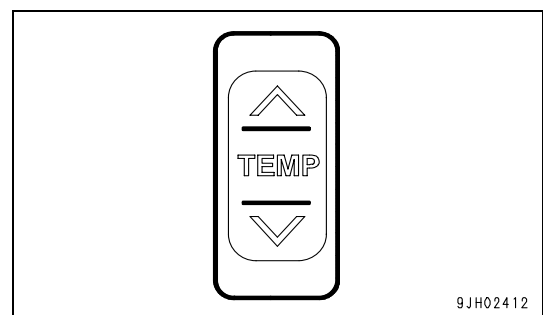

Monitor display [°C (°F)]	Set temperature
18.0 (64.4)	Max. cooling
18.5 to 31.5 (65.3 to 88.7)	Adjusts temperature inside cab to set temperature
32.0 (89.6)	Max. heating

REMARK

If the mode is set to auto mode and the temperature setting is set to 18.0 °C (64.4 °F) and 32.0 °C (89.6 °F), the air flow from the fan is always set to HIGH and does not change even when the set temperature is reached.

Vent Selector Switch

This switch (4) is used to select the vents.

- When switch (4) is pressed, the display on monitor display (7) switches and air blows out from the vents displayed.
- During automatic operation, the vents are automatically selected.

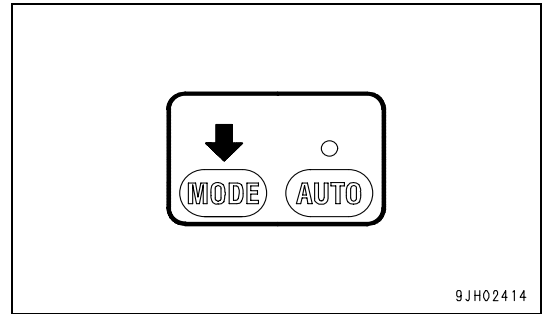

- (A): Rear vents (4 places)
- (B): Face vent (1 place)
- (C): Foot vent (1 place)
- (D1): Front window vent (1 place)
- (D2): Front window vent (1 place)

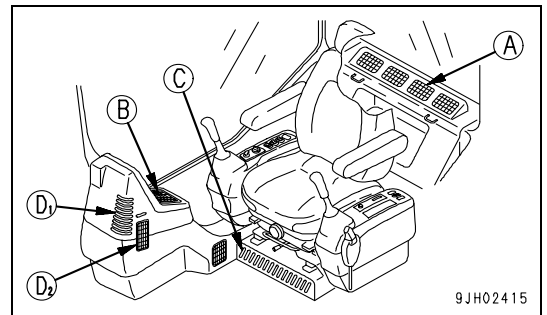

- Front window vent (D2) can be opened or closed by hand.

Liquid crystal display	Vent mode	Vent				Remarks
		(A)	(B)	(C)	(D)	
	Front and rear vents (including defroster vent)	○	○		(○)	—
	Front, rear, and foot vents (including defroster vent)	○	○	○	(○)	—
	Foot vent			○		—
	Front, foot vents (including defroster vent)		○	○	(○)	Cannot be selected for automatic operation
	Front vents (including defroster vent)		○		(○)	Cannot be selected for automatic operation

Note 1: Air blows out from vents marked ○

Note 2: The defroster vents can be opened or closed manually with the vent lever.

Auto Switch

With this switch (5), the air flow, vents, and air source (RECIRC/FRESH) are automatically selected according to the set temperature.

- When auto switch (5) is pressed, the lamp at the top of the auto switch lights up.
- Normally, press this switch, then use temperature control switch (3) to set the temperature, and run the air conditioner under automatic control.
- When the control is switched from automatic operation to manual operation, it is possible to operate the switch to change the air flow, vents, and air source (RECIRC/FRESH). When the manual control is used, the lamp at the top of the auto switch goes out.

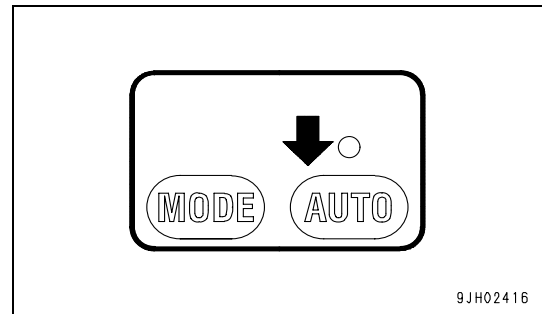

9JH02416

RECIRC	The outside air is shut off and only the air inside the cab is circulated. Use this position to carry out rapid cooling of the cab or when the outside air is dirty.
FRESH	Outside air is taken into the cab. Use this position to take in fresh air or when carrying out demisting.

REMARK

If the mode is set to auto mode and the temperature setting is set to 18.0 °C (64.4 °F) and 32.0 °C (89.6 °F), the air flow from the fan is always set to HIGH, but this does not indicate any abnormality.

FRESH/RECIRC Selector Switch

This switch (6) is used to switch the air source between recirculation of the air inside the cab and intake of air from the outside.

- When switch (6) is pressed, the lamp at the top of the selector switch lights up to show that air is being blown out.
- During automatic operation, the selection of inside air (RECIRC) and outside air (FRESH) is carried out automatically.

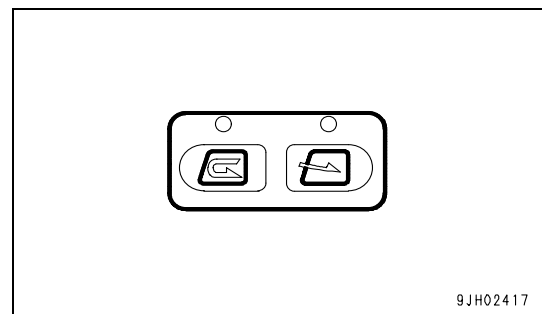

9JH02417

REMARK

Even when the switch is turned OFF, the lamp on top of FRESH/RECIRC selector switch (6) does not go out, but this does not indicate any abnormality.

RECIRC	The outside air is shut off and only the air inside the cab is circulated. Use this position to carry out rapid cooling of the cab or when the outside air is dirty.
FRESH	Outside air is taken into the cab. Use this position to take in fresh air or when carrying out demisting.

Display Monitor

This display monitor displays the status of temperature setting (a), air flow (b), and vents (c).

- When OFF switch (1) is pressed, the display of temperature setting (a) and air flow (b) goes out, and operation stops.

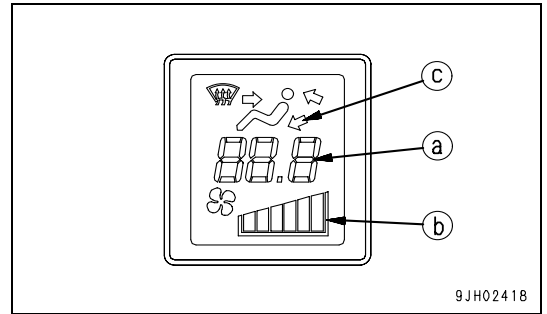

Air Conditioner Switch

This switch (8) is used to turn the air conditioner (cooling, dehumidifying, heating) ON or OFF.

- When the fan is acutated (the display monitor shows (b)) and air conditioner switch (8) is pressed, the air conditioner is switched ON, the lamp at the top of the air conditioner switch lights up, and the air conditioner starts. When it is pressed again to the OFF position, the lamp at the top of the air conditioner switch goes out.
- The air conditioner cannot be operated while the fan is stopped.

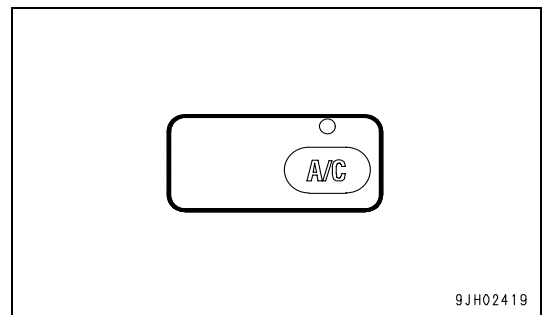

Defroster Selector Lever

This lever (9) is used in cold or rainy weather to remove the mist that forms on the front glass.

- (A) Selector lever forward: To defroster (open)
- (B) Selector lever back: Closed

The defroster can be used when the vent selector switch is set to face or face and foot.

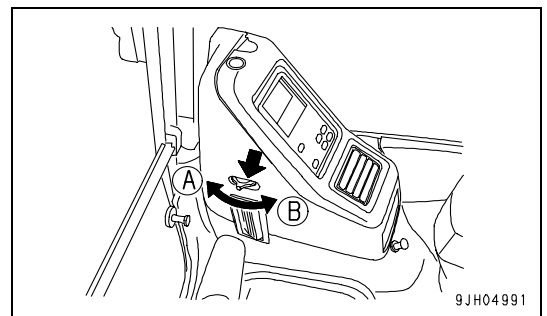

Method Of Operation

The air conditioner can be operated automatically or manually. Select the method of operation as desired.

Automatic Operation

1. Turn auto switch (5) ON.
 - The lamp at the top of switch (5) lights up.
 - The set temperature (a) and air flow (b) are displayed on the monitor.

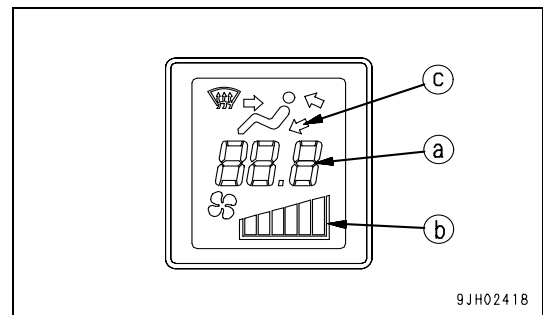
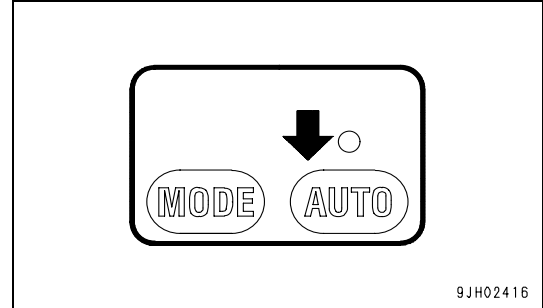

2. Use temperature set switch (3) to set to the desired temperature. The air flow, combination of vents, and selection of fresh or recirculated air is automatically selected according to the set temperature, and the air conditioner is operated automatically to provide the set temperature.

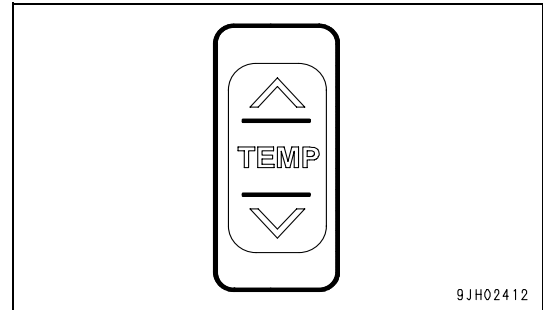

REMARK

When vent display monitor (c) displays (d) or (e), and the engine water temperature is low, the air flow is automatically limited to prevent cold air from blowing out.

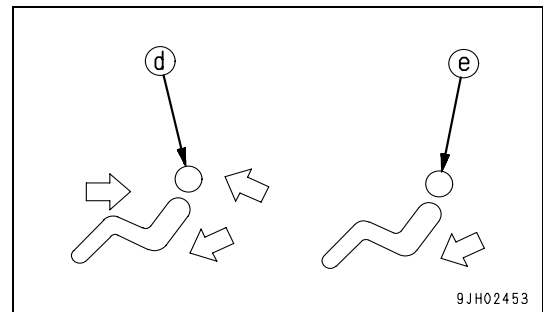

Stopping Automatic Operation

Press OFF switch (1). The displays for temperature setting (a) and air flow (b) on the display monitor, and the lamps above auto switch (5) and air conditioner switch (8) go out, and the operation stops.

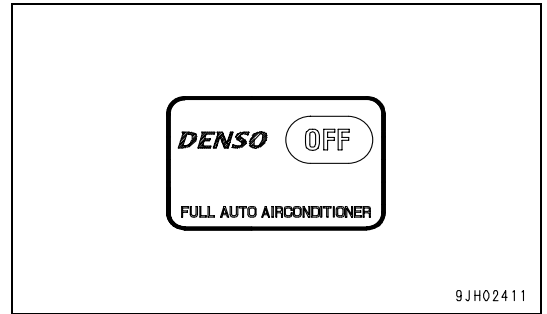

Manual Operation

1. Press fan switch (2) and adjust the air flow. When doing this, check that temperature setting (a) and air flow (b) are displayed on the display monitor.

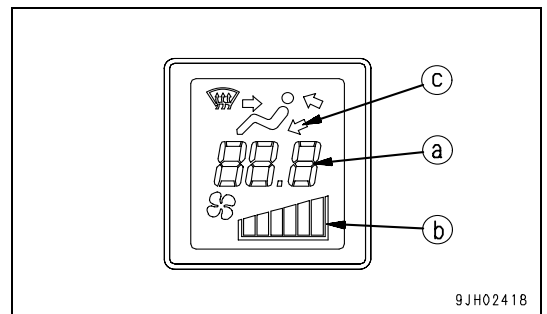
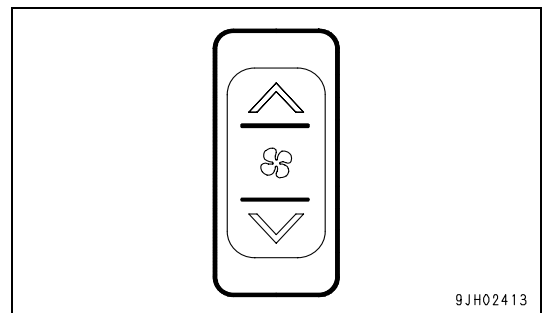

2. Turn air conditioner switch (8) ON. Check that the lamp at the top of the air conditioner switch lights up.

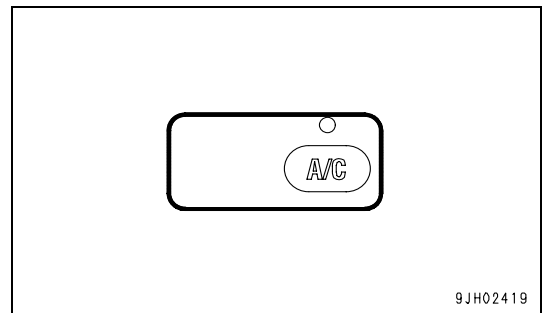

3. Press the temperature setting switch and adjust the temperature inside the cab.

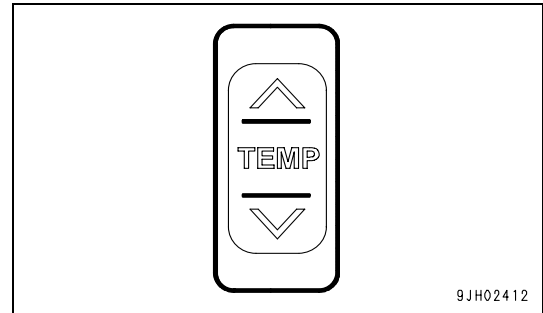

4. Press vent selector switch (4) and select the desired vents.
When this is done, the display for vent (c) of the display monitor changes according to the selection.

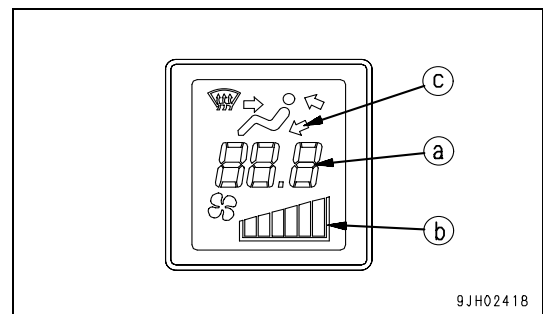
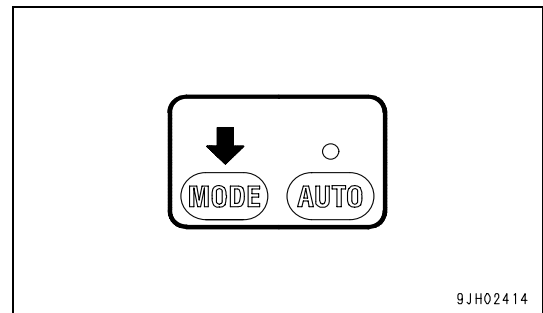

5. Press RECIRC/FRESH selector switch (6) and select recirculation of the air inside the cab (RECIRC) or intake of fresh air from outside (FRESH).

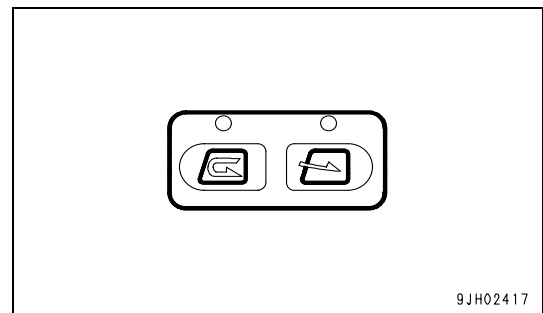

Stopping Manual Operation

Press OFF switch (1). The displays for temperature setting (a) and air flow (b) on the display monitor, and the lamps above auto switch (5) and air conditioner switch (8) go out, and the operation stops.

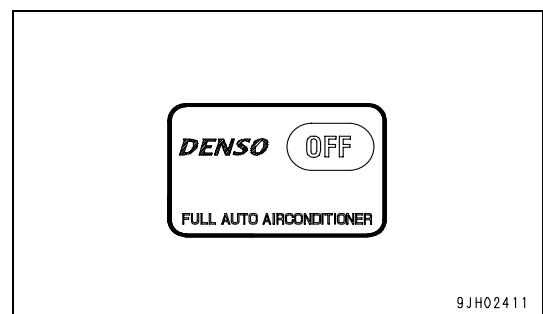

Operation with cold air to face and warm air to feet

To operate with cold air blowing to the face and warm air blowing to the feet, set as follows.

1. Press fan switch (2) and adjust the air flow. When doing this, check that temperature setting (a) and air flow (b) are displayed on the display monitor.

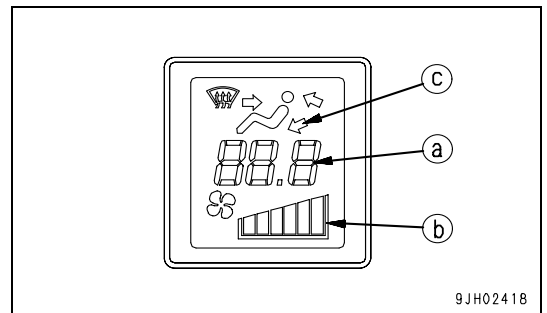
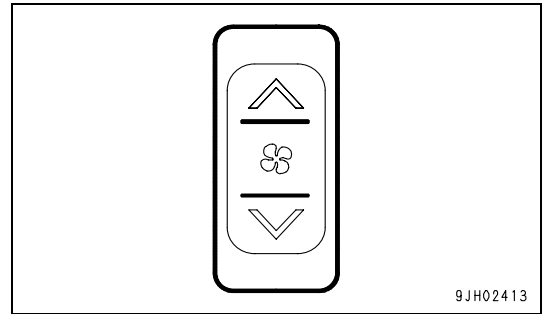

2. Press vent selector switch (4) and set the vent display on the display monitor to the display shown in the diagram on the right.

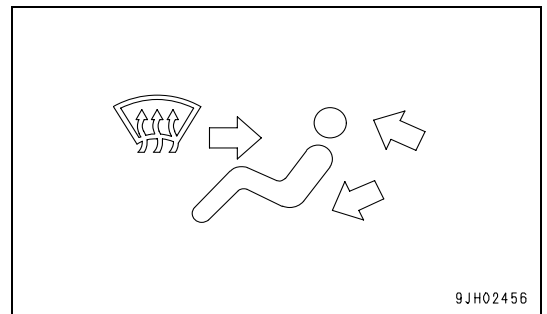

3. Turn air conditioner switch (8) ON. Check that the lamp at the top of the air conditioner switch lights up.

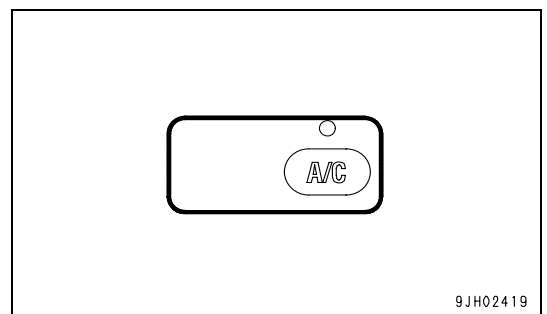

4. Adjust fan switch (2), temperature setting switch (3) and FRESH/RECIRC selector switch (6) to the desired positions.

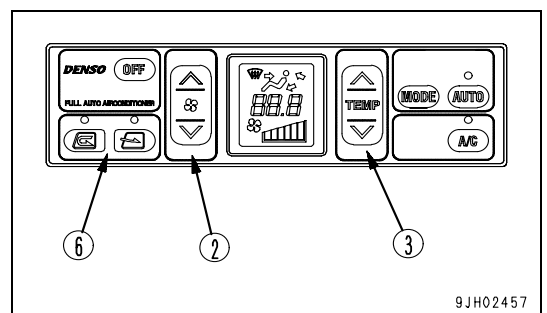

Defroster Operation

1. Press fan switch (2) and adjust the air flow. When doing this, check that temperature setting (a) and air flow (b) are displayed on the display monitor.

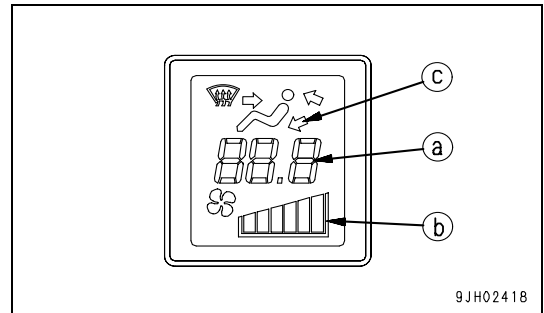
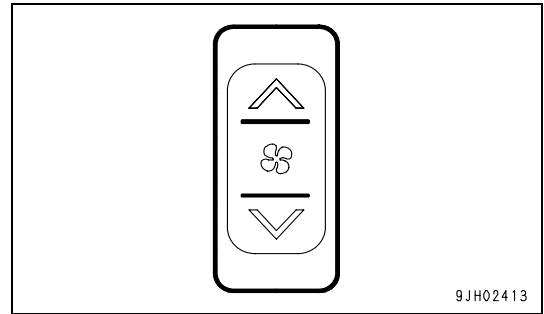

2. Press vent selector switch (4) and set the vent display on the display monitor to the display shown in (f) or (g) in the diagram on the right.

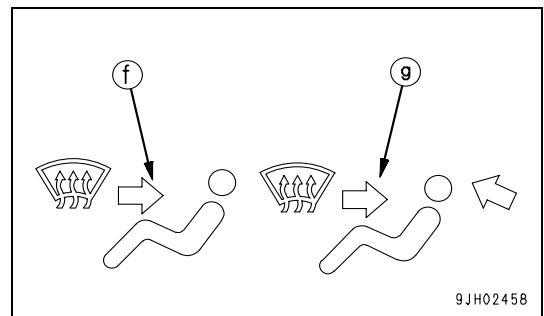
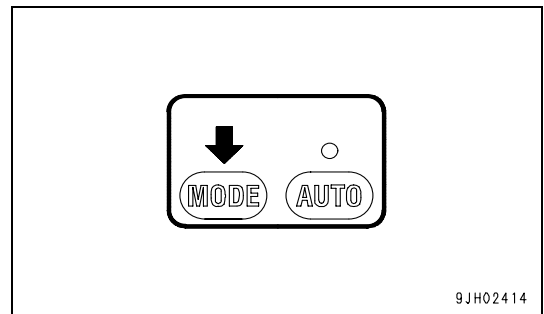

3. Press FRESH/RECIRC selector switch (6) and set it to take in fresh air.

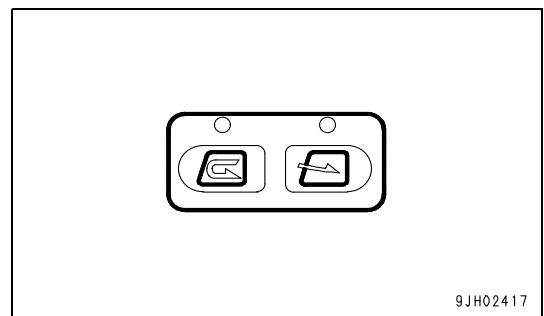

- Press temperature setting switch (3) and set the set temperature display on the display monitor to the maximum heating temperature of 32.0.

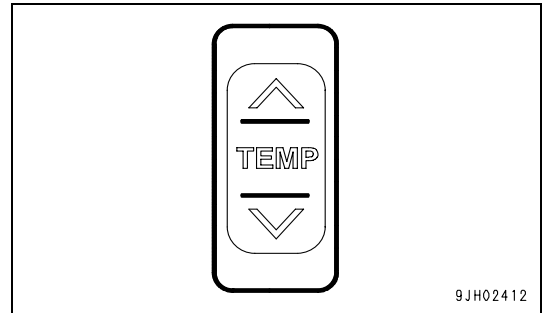

- Adjust vents (A), (B), and (D2) so that the air blows onto the window glass.

(Vents (C) and (D1) are fixed and cannot be adjusted.)

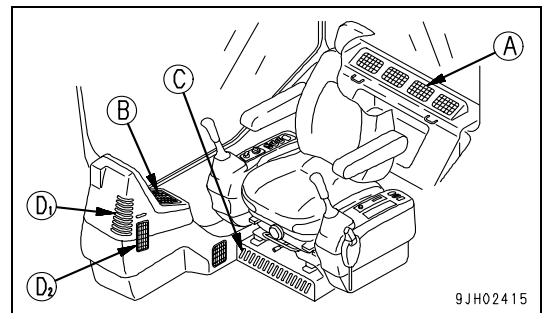

When operating in the rainy season or when it is desired to remove the mist from the window glass or to dehumidify the air, turn air conditioner switch (8) ON.

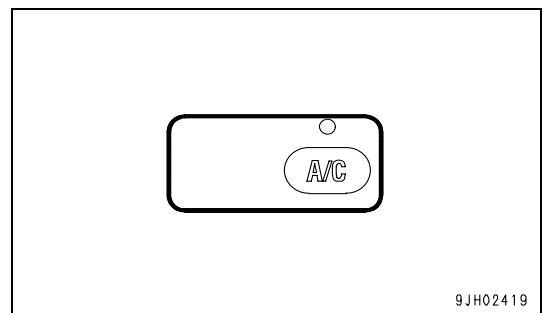

Use Air Conditioner With Care

NOTICE

- When running the air conditioner, always start with the engine running at low speed. Never start the air conditioner when the engine is running at high speed. It will cause failure of the air conditioner.
- If water gets into the control panel or sunlight sensor, it may lead to unexpected failure, so be careful not to let water get on these parts. In addition, never bring any flame near these parts.
- For the auto function of the air conditioner to work properly, always keep the sunlight sensor clean and do not leave anything around the sunlight sensor that may interfere with its sensor function.

Ventilation

- If you smoke when the cooler is on, the smoke may start to hurt your eyes, so turn the lever to FRESH to remove the smoke while continuing the cooling.
- When running the air conditioner for a long time, turn the lever to the FRESH position once an hour to carry out ventilation and cooling.

Temperature Control

- When the cooler is on, set the temperature so that it feels slightly cool when entering the cab (5 - 6 °C lower than the outside temperature). This temperature difference is considered to be the most suitable for your health, so always be careful to adjust the temperature properly.

Inspection and maintenance of air conditioner equipped machine

When carrying out an inspection and maintenance of a machine equipped with air conditioner, see "MAINTENANCE SCHEDULE CHART (4-16)" and follow the instruction on the table.

Other Functions

Self-diagnostic Function

It is possible to carry out troubleshooting of the various sensors and equipment used on the air conditioner.

1. Press OFF switch (1). The temperature setting and air flow display on the liquid crystal display portion go out and operation stops.
2. If the "∨" and "∧" parts of temperature setting switch (3) are kept pressed at the same time for at least 3 seconds, the troubleshooting mode is displayed on the liquid crystal display portion.

<Monitor display and failure mode>

Display	Failure mode
E--	No failure
E11	Disconnection in recirculated air sensor
E12	Short circuit in recirculated air sensor
E13	Disconnection in fresh air sensor
E14	Short circuit in fresh air sensor
E15	Disconnection in water temperature sensor
E16	Short circuit in water temperature sensor
E18	Short circuit in sunlight sensor
E21	Disconnection in vent sensor
E22	Short circuit in vent sensor
E43	Abnormality in vent damper
E44	Abnormality in air mix damper
E45	Abnormality in FRESH/RECIRC air damper
E51	Abnormality in refrigerant pressure

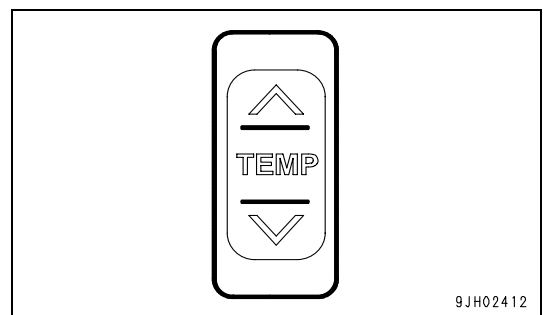

- When more than one failure is detected, press the "∨" or "∧" portion of temperature setting switch (3) to display the failures in turn.
- After completing the troubleshooting, press OFF switch (1) again to return to the normal display.

If any abnormality is detected by the self-diagnostic function, ask your Komatsu distributor to carry out inspection and repair.

Function To Switch Set Temperature Display Between Fahrenheit And Celsius

It is possible to switch the set temperature display between °F and °C.

If the "v" and "^" portions of temperature setting switch (3) are pressed at the same time for more than 5 seconds while the fan is running, the temperature display will switch between °F and °C.

(Note that the unit is not displayed.)

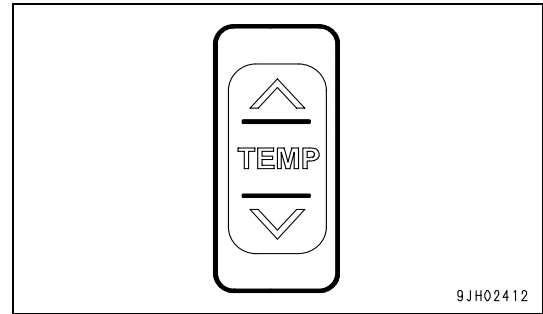

	Liquid crystal display range
°C	18.0 to 32.0
°F	64.4 to 89.6

RADIO

Control Panel

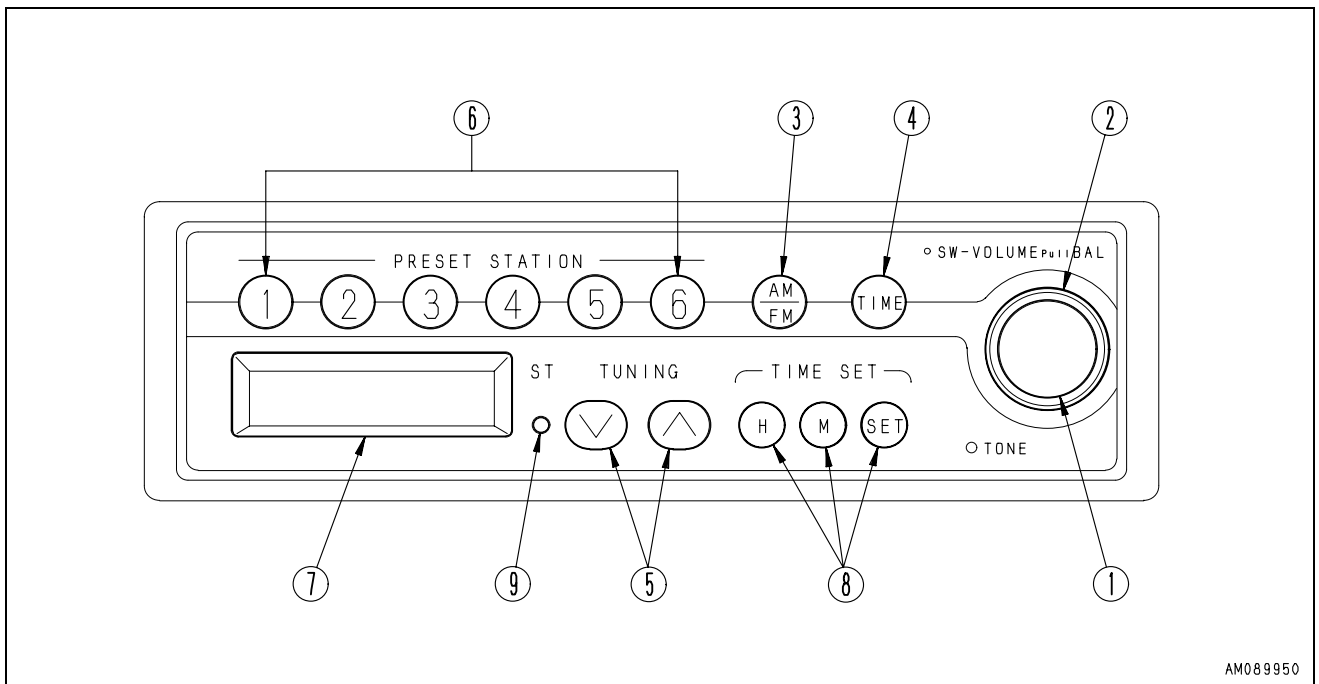

AM089950

- | | |
|---|---|
| (1) Power switch, Volume control knob, Balance control knob | (5) Tuning button, manual tuning |
| (2) Tone control knob | (6) Preset station buttons (1, 2, 3, 4, 5, 6) |
| (3) FM/AM selection button | (7) Display |
| (4) Display selection button | (8) Time reset button |
| | (9) Stereo indicator |

Power Switch/Volume Control (SW-VOLUME) and Balance (Pull BAL) Knob

When this knob (1) is pressed, the power for the radio is turned on and the display shows the frequency. If the knob is pressed again, the power is switched off.

Turn the knob to the right to increase the volume; turn the knob to the left to reduce the volume. Pull the knob out to the lock position and turn it to adjust the balance between the left and right speakers.

Turn it to the right to increase the sound from the right speaker; turn it to the left to increase the sound from the left speaker.

After adjusting the left and right balance, push the knob lightly to return it to its original position.

(If the knob is left pulled out, the volume cannot be adjusted.)

Tone Control Knob (TONE)

If this knob (2) is turned to the right from the center position, the high tone is emphasized; if it is turned to the left, the high tone is reduced.

FM/AM Selection Button (AM/FM)

Press this button(3) and select the desired band.

Each time the button is pressed, it switches AM → FM → AM ...

Display Selection Button (TIME)

This equipment gives priority to the frequency display. If the button (4) is pressed when the frequency is displayed, display will give the present time for 5 seconds. After 5 seconds pass, the display will automatically return to the frequency display. If any button other than TIME SET (H, M, SET) is pressed within the 5 seconds, the display will return to the frequency display.

Tuning Button (TUNING) Manual Tuning (MANUAL)

Press this button (5) to change the frequency.

Each time the UP button (∧) is pressed, the frequency will go up (FM: 0.1 MHz; AM: 9 kHz)

Each time the DOWN button (∨) is pressed, the frequency will go down (FM: 0.1 MHz; AM: 9 kHz)

Preset Station Buttons (1, 2, 3, 4, 5, 6)

If this button (6) is preset to the desired station, the station can be selected at a touch.

For details of the methods of presetting, see "Controls Of Radio (3-62)".

Display

This display (7) shows the reception band, frequency, preset No., and time.

Time Reset Button

This button(8) is used to correct the time.

H: Hour

M: Minute

SET: Sets to start of hour (00 minutes)

Stereo Indicator (ST)

This indicator (9) lights up when a stereo broadcast is received from the FM station.

Controls Of Radio

Preset Station Buttons

1. Press power switch (1) and display the frequency on display (7).
2. Turn the tuning button(5) (manual, auto) to adjust to the desired frequency.
3. Select a preset button to use for recording the frequency setting, and keep that button pressed for at least 1.5 seconds. The sound will disappear, but when the setting is recorded, the sound will appear and the preset number will appear on display (7) to show that the station has been preset.

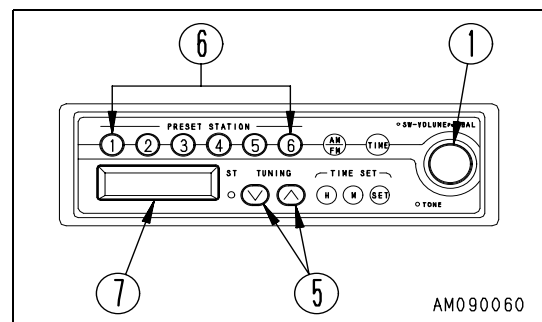

AM090060

After completion of presetting, press preset button (6), and release it within approx. 1.5 seconds. The setting will change to the frequency of the broadcasting station recorded for that button. One AM station and one FM station can be recorded for each preset button.

Manual Tuning

Press tuning button (5) and set to the desired frequency.

Each time the button is pressed, the frequency will move up or down in steps of 9 kHz (AM) or 0.1 MHz (FM).

- ∨ button: Move to a higher frequency station
- ∧ button: Move to a lower frequency station

- If the frequency reaches the top or bottom limit, it will automatically change as follows: top limit → bottom limit, or bottom limit → top limit

Automatic Tuning

Keep tuning button (5) pressed for at least 0.5 seconds. When a broadcasting station is picked up, it will automatically stop. To search for the next station, press tuning button (5) again for at least 0.5 seconds.

- ∨ button: Move to a higher frequency station
- ∧ button: Move to a lower frequency station

- If tuning button (5) is pressed during auto tuning, the auto tuning will be canceled and the frequency at the point where it is canceled will be picked up.

Setting Correct Time

1. Press display selector button (4) to display the time.
After 5 seconds, the display will return to the frequency display and the time cannot be corrected. If this happens, press display selector button (4) again.
2. Press time adjustment button (8) and adjust the hour and minute.
H button: Adjusts hour (advances one hour each time it is pressed)
M button: Adjusts minute (advances one minute each time it is pressed)
If the H or M button are kept pressed, the time will advance continuously until the button is released.
SET button: Sets to start of hour (when it is pressed, the minute returns to 00)
If the minute display is between 0 and 05, and the SET button is pressed, the minute reading will return to 00. If it is pressed when the minute display is between 55 and 59, the minute display will return to 00 and the hour will advance by 1. If the minute display is between 06 to 54, can not adjust.

Example

- 10:05 → 10:00
- 10:59 → 11:00
- 10:26 → 10:26

Press the H, M, and SET buttons to set to the correct time.

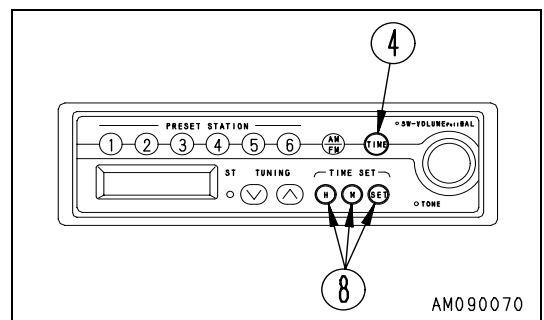

Antenna

NOTICE

Before transporting the machine or putting it inside a building, stow the antenna at position (A) to prevent any interference.

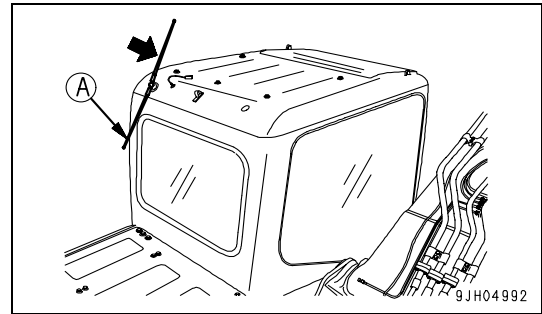

Use Radio With Care

- To ensure safety, always keep the sound to a level where it is possible to hear outside sounds during operation.
- If water gets into the speaker case or radio, it may lead to an unexpected failure, so be careful not to get water on the equipment.
- Do not wipe the scales or buttons with benzene, thinner, or any other solvent. Wipe with a soft dry cloth. Use a cloth soaked in alcohol if the equipment is extremely dirty.
- When the battery is replaced, the settings for the preset buttons are all cleared, so set again.

AUXILIARY ELECTRIC POWER

24V power source

NOTICE

Do not use this as the power source for 12V equipment.

Pull out the connector plug for taking out electric power from the rear side of the panel.

Maximum usable electric power is 85 W (24 V x 3.5 A).

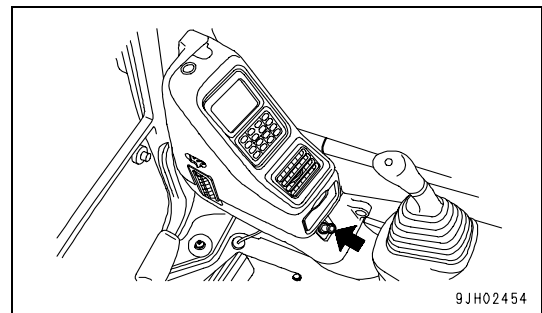

12V power source

(If equipped)

This power source can be used up to a capacity of 60W (12V x 5A).

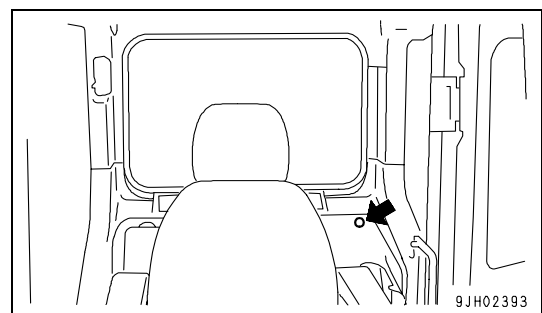

FUSE

NOTICE

Before replacing a fuse, be sure to turn off the starting switch.

The fuses protect the electrical equipment and wiring from burning out.

If the fuse becomes corroded, or white powder can be seen, or the fuse is loose in the fuse holder, replace the fuse.

Replace the fuse with another of the same capacity.

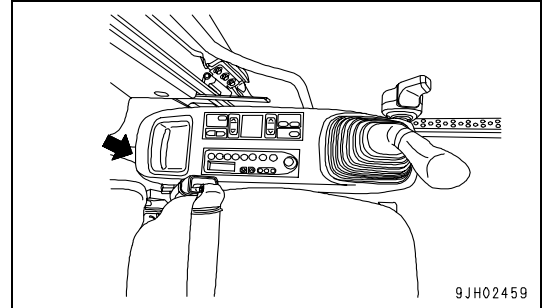

9JH02459

Fuse Capacities and Circuit Names

No.	Fuse	Circuit name
(1)	10A	Prolix circuit
(2)	10A	Solenoid valve
(3)	10A	PPC oil pressure lock solenoid
(4)	20A	Window washer, cigarette lighter
(5)	10A	Horn, flashlight (if equipped)
(6)	10A	Spare fuse
(7)	10A	Revolving warning lamp (if equipped)
(8)	10A	Spare fuse
(9)	10A	Radio, Left knob switch
(10)	20A	Monitors, buzzer
(11)	25A	Air conditioner unit
(12)	20A	Spare fuse
(13)	20A	Spare fuse
(14)	10A	OPT power supply (1)
(15)	10A	OPT power supply (2), 12V power supply (if equipped)
(16)	10A	Radio backup
(17)	10A	Network path (constant power source)
(18)	10A	Engine compartment lamp (if equipped)
(19)	10A	Room lamp
(20)	10A	Step light (if equipped)

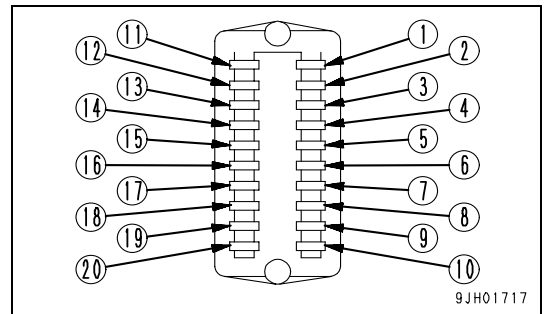

9JH01717

CIRCUIT BREAKER

NOTICE

When resetting the circuit breaker, always turn the starting switch OFF first.

- If the starting switch does not work even when the starting switch is turned on, open the circuit breaker box inside the grease pump box at the front right of the machine and carry out inspection.
- If an excess current is generated, the circuit breaker cuts off the electric circuit to protect the electrical components and wiring from damage. To return the circuit electric circuit to normal after it has been cut off, push in the reset button.

If the electric circuit is working normally, the reset button remains pushed in. If it comes out again immediately after it is pushed in, it is necessary to check the electric circuit.

REMARK

The circuit breaker is a circuit protection device installed to circuits where large current flows. It protects the electrical components and wiring from damage caused by an abnormal current in the same way as a normal fuse. After repairing and restoring the location of the abnormality, there is no need to replace the breaker. It can be used again.

If the starting motor does not work even when the starting switch is turned to the ON position, breaker (6) has probably cut off the circuit, so check and restore circuit breaker (6).

If the electrical equipment does not work even when the fuse is replaced, breaker (1) or (9) has probably cut off the circuit, so check and restore circuit breaker (1) or (9).

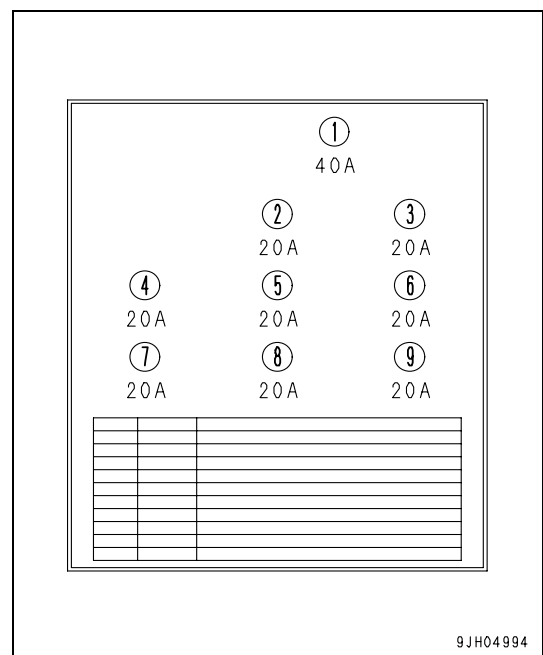
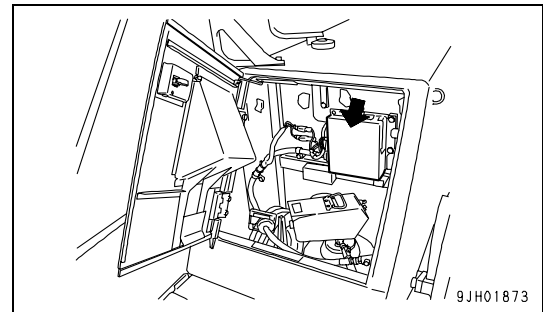

No.	Fuse capacity	Name of Circuit
(1)	40A	Fuse 1 to 15
(2)	20A	Work equipment headlamp, right side headlamp
(3)	20A	Power supply grease pump
(4)	20A	Pump controller
(5)	20A	Cab upper headlamp
(6)	20A	Starting switch, engine controller (control)
(7)	20A	Engine controller (power supply)
(8)	20A	Monitor, buzzer
(9)	20A	Fuse 16 to 20

CONTROLLERS

NOTICE

- Be careful not to get water, mud, or juice on the controller. This will cause failure.
- If any abnormality occurs in the controller, do not disassemble it yourself. Contact your Komatsu distributor for repairs.

Controller installed.

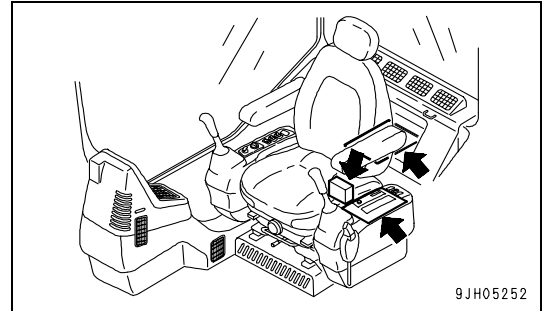

TOOL BOX

(Cloth bag)

This is inside the toolbox at the rear of the cab.

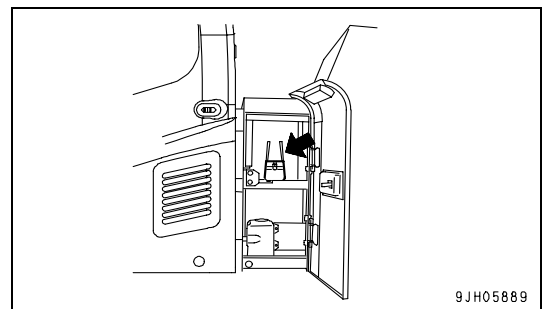

GREASE PUMP

This is stored inside the grease pump box on the right side of the chassis.

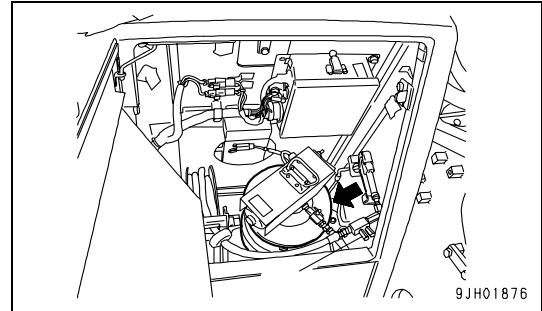

Method of Use

1. When power switch (1) is turned on, pump (3) is actuated and grease is sent under pressure to grease gun (2).
2. Grease is discharged when lever for grease gun (2) is pulled.

It is possible to check the greasing condition by looking at pressure gauges (4) and (5).

- (4): green (low pressure)
- (5): red (high pressure)

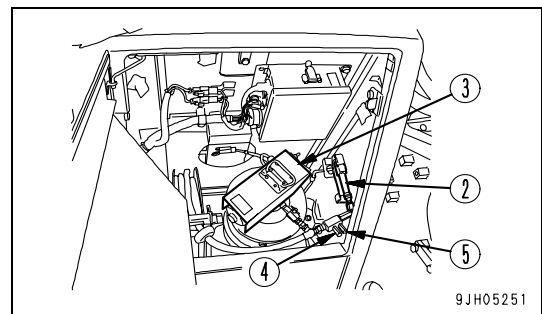
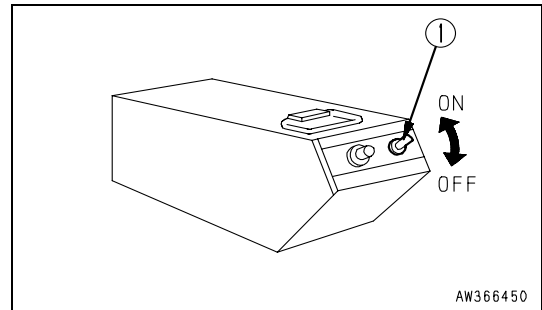

Greasing condition	Pressure gauge	
	Green color (low pressure)	Red color (high pressure)
When grease gun is empty		
Greasing in progress		
When tip is clogged		

3. When the lever of grease gun (2) is released, the supply of grease stops.
4. After using, turn power switch (1) OFF.

Precautions when Using

NOTICE

When not using the grease pump, always turn off power switch (1) to prevent pressure from building up inside grease gun (2).

- Set so that the nipple and the nozzle at the tip of the grease gun are perpendicular.

- When removing the nozzle at the tip of the grease gun from the nipple, carefully angle the tip of the nozzle slightly and remove it.

- When there is only a small amount of grease left in the grease can, the pump will not pump out grease, so move the grease to the center or fill the can with new grease.

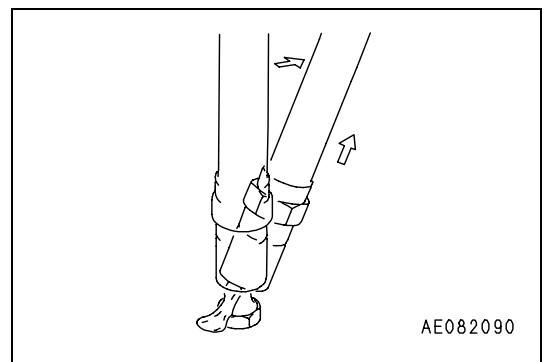
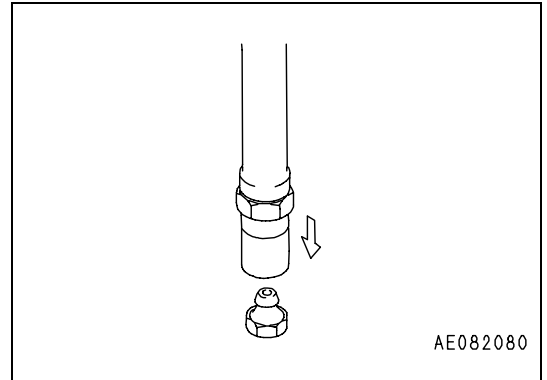

Supplying Grease

1. Remove 3 wing bolts (2) from grease can (1), then remove cover (3) from the pump.
2. Remove follow plate (4) inside the grease can.

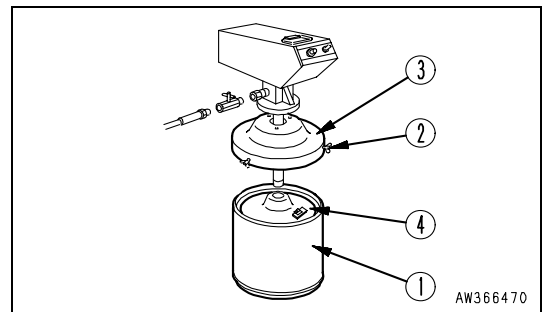

3. Fill grease can (1) with new grease, then set follow plate (4) on top of the grease.
 - Fill the hollow in the center of the follow plate with grease before setting the following plate on top of the grease.
4. Insert the pump into the packing at the center of follow plate (4), set cover (3) on grease can (1), then tighten 3 wing bolts (2) uniformly to hold in position.

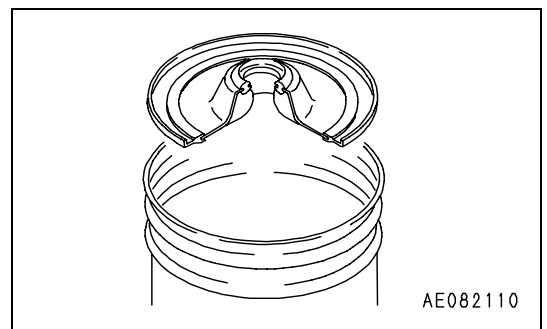

- The pump will operate for a short time and then stop, but the first grease includes air inside the pump, so it is cloudy white and not suitable for use.

5. Loosen check valve (5), and pump out all the grease which has air in it from hole (6) at the bottom of check valve (5).
6. After bleeding the air, close check valve (5) securely.

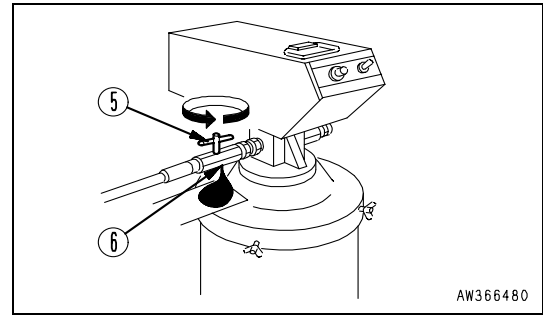

7. After bleeding the air inside the pump, pull the lever of the grease gun to completely discharge the grease mixed with air inside the hose and grease gun.
 - When filling with grease, be extremely careful not to let sand or dirt stick to the follow plate or pump suction portion.
 - If there is ample grease, but the pump does not pump out any grease, the follow plate may not be correctly set in position, so set it in position again correctly.
 - The standard grease can contains 16 liters (4.23 US gal). If an 18 liters (4.76 US gal) can is used, there will be more grease left.

REMARK

Always keep spare grease in the grease can storage box at the rear of the cab.

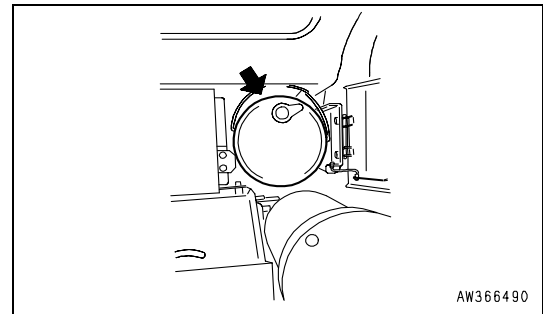

ACCUMULATOR

WARNING

The accumulator is charged with high-pressure nitrogen gas, so mistaken operation may cause an explosion which will lead to serious injury or damage. When handling the accumulator, always do as follows. The pressure in the control circuit cannot be completely removed. When removing the hydraulic equipment, do not stand in the direction that the oil spurts out when carrying out the operation.

Loosen the bolts slowly.

Do not disassemble the accumulator.

Do not bring it near flame or dispose of it in fire.

Do not make holes in it or weld it.

Do not hit it, roll it, or subject it to any impact.

When disposing of the accumulator, the gas must be released. Please contact your Komatsu distributor to have this work carried out.

This machine is equipped with an accumulator in the control circuit. The accumulator is a device to store oil pressure for the control circuit, and when it is installed, the control circuit can be actuated for a short time even after the engine is stopped. Due to this device, the work equipment lowers under its own weight, if the control lever is moved in the lowering direction.

The accumulator is installed to the position shown in the diagram on the right.

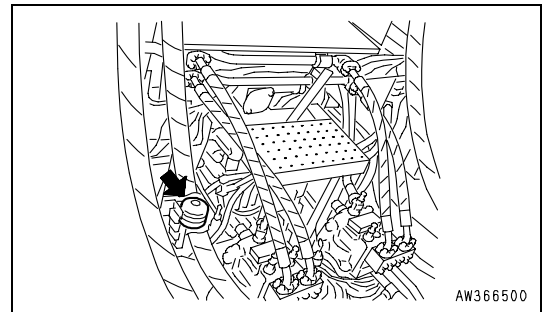

Releasing Hydraulic Pressure With Accumulator

1. Place the work equipment on the ground. Close the crusher attachment jaws, etc.
2. Stop the engine.
3. Turn the key in starting switch to the ON position.

4. Set lock lever (1) to FREE position (F), then operate the work equipment control levers and the attachment control pedal (if equipped) fully to the front, rear, left, and right to release the pressure in the control circuit.
5. Start the engine again, stop the engine after 2 - 3 seconds, then carry out the operation in Step 3.
6. Continue the operation in Step 4 until the hissing noise of pressure oil can no longer be heard. (Approx. 2 - 3 times)
7. Set lock lever (1) to the LOCK position (L), and lock the work equipment levers and attachment control pedal. Note that the pressure cannot be completely released, so if the accumulator in the control circuit is removed, loosen the screws slowly, and do not stand in the direction where the oil spurts out.
8. Turn the key in starting switch to the OFF position.

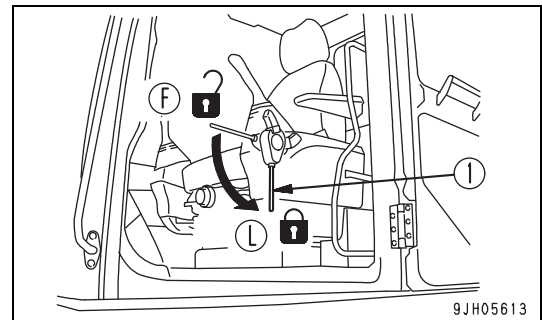
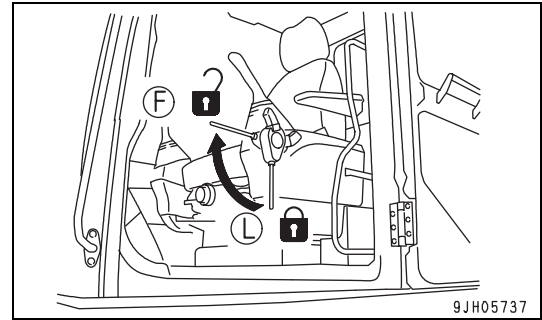

MACHINE OPERATIONS AND CONTROLS

BEFORE STARTING ENGINE

Walk-Around Checks

Before starting the engine, look around the machine and under the machine to check for loose nuts or bolts, or leakage of oil, fuel, or coolant, and check the condition of the work equipment and hydraulic system. Check also for loose wiring, play, and accumulation of dust at places which reach high temperatures.



WARNING

Remove any flammable materials from around the battery or engine muffler, turbocharger, or other high temperature engine parts. Leakage of fuel or oil will cause the machine to catch fire. Check carefully, and be sure to repair any abnormalities, or please contact your Komatsu distributor.

Carry out the following inspections and cleaning every day before starting the engine for the day's work.

1. Check for damage, wear, play in work equipment, cylinders, linkage, hoses
Check that there are no cracks, excessive wear, or play in the work equipment, cylinders, linkage, or hose. If any abnormality is found, repair it.
2. Remove the dirt from around the engine, battery, and radiator.
Check that there is no dirt accumulated around the engine or radiator. Check also that there is no flammable material (dry leaves, twigs, etc.) around the battery, engine muffler, turbocharger, or other high temperature parts of the engine. If any dirt or flammable materials are found, remove them.
3. Check for leakage of water or oil around engine
Check that there is no leakage of oil from the engine or leakage of water from the cooling system. If any abnormality is found, repair it.
4. Check for oil leakage from hydraulic equipment, hydraulic tank, hoses, joints
Check that there is no oil leakage. If any abnormality is found, repair the place where the oil is leaking.
5. Check for oil leakage from around engine, fuel tank, hoses, around fuel cooler
Check that there is no fuel leakage. If any abnormality is found, repair the place where the fuel is leaking.
6. Check the undercarriage (track, sprocket, idler, guard) for damage, wear, loose bolts, or leakage of oil from rollers.
If any abnormality is found, repair it.
7. Check for abnormality in handrails, steps, loose bolts.
If any abnormality is found, repair it. Tighten any loose bolts.

8. Check for abnormality in gauges, monitor.
Check that there is no abnormality in the gauges and monitor in the operator's cab. If any abnormality is found, replace the parts. Clean off any dirt on the surface.

9. Clean, check rear view mirror
Check that there is no damage to the rear view mirror. If it is damaged, replace it with a new mirror. Clean the surface of the mirror and adjust the angle so that the area at the rear can be seen from the operator's seat.

10. Seat belt and mounting clamps
Check that there is no abnormality in the seat belt or mounting clamps. If there is any damage, replace with new parts.

11. Check bucket with hook (if equipped) for damage.
Check that there is no damage to the hook, guide, or hook mount. If any abnormality is found, please contact your Komatsu distributor for repair.

Checks Before Starting

Always check the items in this section before starting the engine each day.

Check Coolant Level, Add Water

WARNING

- Do not open the radiator cap unless necessary. When checking the coolant, always wait for the engine to cool down and check the sub tank.
- Immediately after the engine is stopped, the coolant is at a high temperature and the radiator is under high internal pressure. If the cap is removed to check the coolant level in this condition, there is a hazard of burns. Wait for the temperature to go down, then turn the cap slowly to release the pressure before removing it.

1. Open the cover of the engine hood, check that the coolant is between the FULL and LOW lines on sub tank (1). Add water through the water filler of sub tank (1) to the FULL line if the level is low.
2. After adding coolant, tighten the cap securely.
3. If sub tank (1) is empty, check for water leakage, then check the water level in the radiator. If the water level is low, add water to the radiator, then add water to sub tank (1).

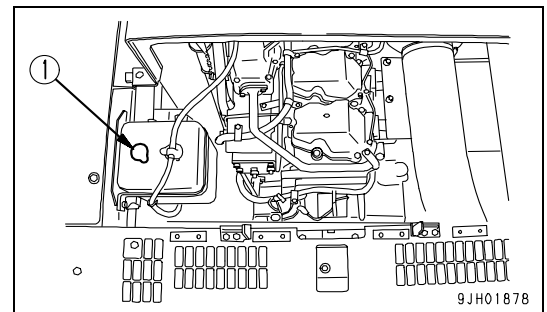

REMARK

Normally, when adding water to the radiator, open the engine hood, slowly loosen cap (2) of the radiator, and check that the pressure has been released. After checking, push in the cap, turn it to loosen it, then remove it.

After adding water, install cap (2) of the radiator.

For the procedure in cold weather, see "COLD WEATHER OPERATION (3-134)".

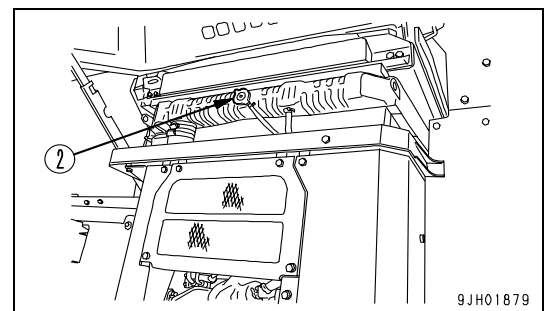
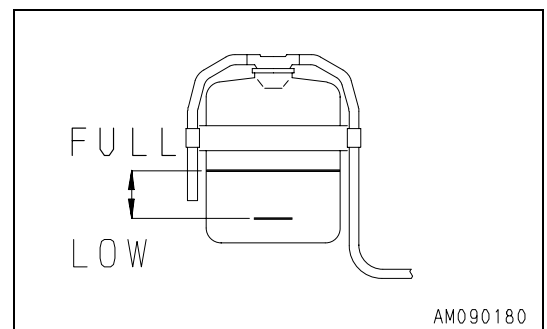

Check Oil Level In Engine Oil Pan, Add Oil**⚠ WARNING**

The parts and oil are at high temperature immediately after the engine is stopped, and may cause serious burns. Wait for the temperature to go down before starting the operation.

1. Open the front cover in the center of the engine hood.
2. Remove dipstick (G), and wipe the oil off with a cloth.
3. Insert dipstick (G) fully in the oil filler pipe, then take it out again.
4. The oil level should be between the H and L marks on dipstick (G).
If the oil level is below the L mark, add engine oil through oil filler (F).
5. If the oil is above the H mark, drain the excessive engine oil from drain plug (P) at the bottom of the engine oil pan, then check the oil level again.
6. If the oil level is correct, tighten the oil filler cap securely and close the engine hood.

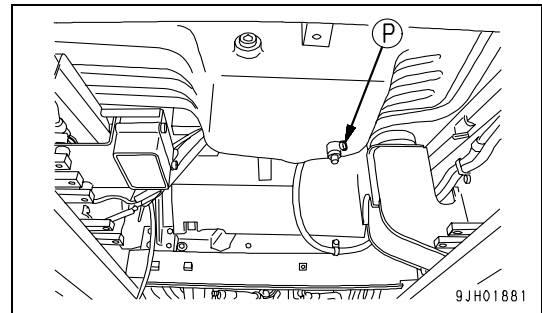
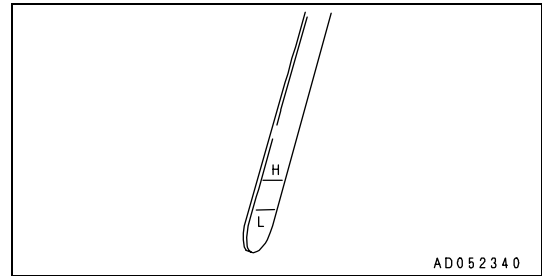
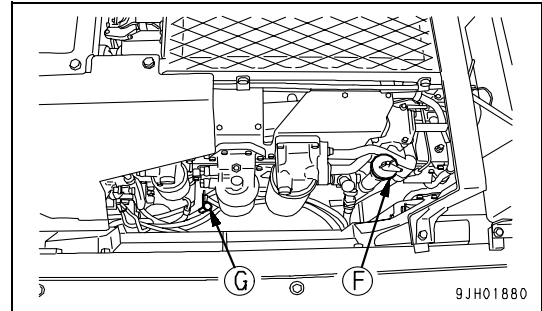
**REMARK**

When checking the oil level after the engine has been operated, wait for at least 15 minutes after stopping the engine before checking.

If the machine is at an angle, make it horizontal before checking.

Check Fuel Level, Add Fuel

WARNING

When adding fuel, never let the fuel overflow. This may cause a fire. If any fuel is spilled, wipe it up completely. Never bring flames near fuel because it is highly flammable and dangerous.

1. Open fuel filler cap (F) of the fuel tank.
2. When fuel filler cap (F) is opened, float gauge (G) moves up in accordance with the amount of fuel. Check if the fuel tank is full. When checking, use float gauge (G) and also check visually.
3. If the fuel tank is not full, supply fuel through the fuel filler until float gauge (G) rises to the maximum position.
Fuel tank capacity: 880 liters (232.50 US gal)
Position of tip of float gauge (G) when fuel tank is full: Approx. 50 mm (2 in) from top surface of fuel tank
4. After adding fuel, push float gauge (G) straight down with fuel filler cap (F). Be careful not to get float gauge (G) caught in the tab of fuel filler cap (F), and tighten fuel filler cap (F) securely.

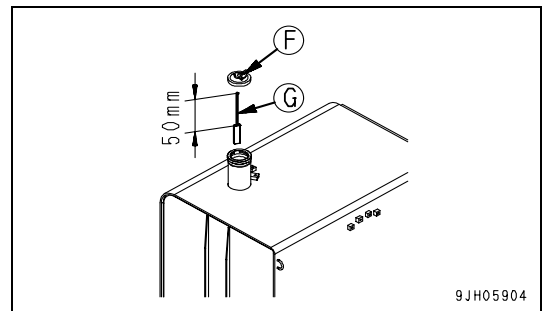
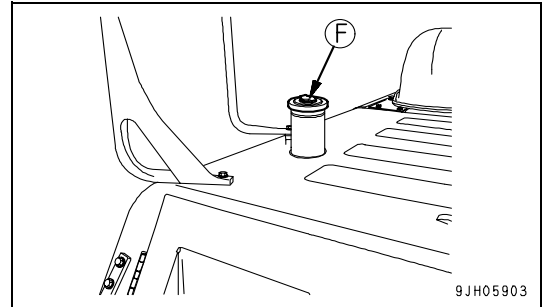

REMARK

If breather hole (1) in the cap becomes clogged, the pressure inside the tank will go down and the fuel may not flow, therefore clean the breather hole from time to time.

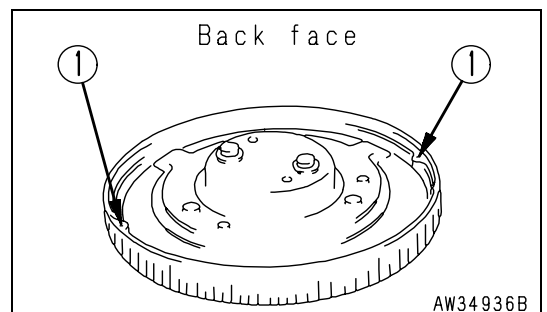

Drain Water And Sediment From Fuel Tank

1. Set the container to catch the fuel under drain port (1) on the front of the fuel tank on the right side of the machine.
2. Open drain valve (2) and drain the sediment and water accumulated at the bottom together with the fuel.
3. When clean fuel comes out, close drain valve (2).

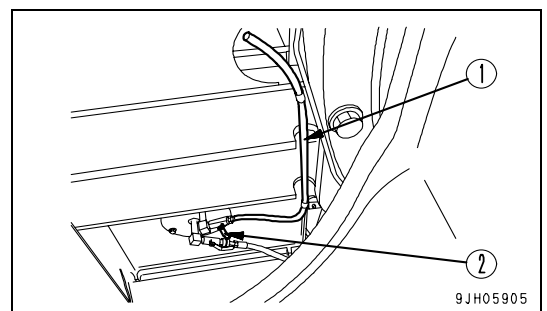

Check Oil Level In Hydraulic Tank, Add Oil

⚠ WARNING

When removing the oil filler cap, oil may spurt out, so turn the cap slowly to release the internal pressure before removing the cap.

1. If the work equipment is not in the condition shown in the diagram on the right, start the engine, run the engine at low speed, retract the arm and bucket cylinders, then lower the boom, set the bucket teeth in contact with the ground, and stop the engine.
2. Within 15 seconds after stopping the engine, turn the starting switch to the ON position, and operate the control levers (work equipment, travel) fully in each direction to release the internal pressure.

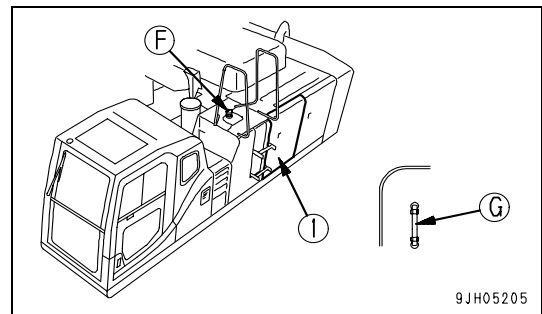
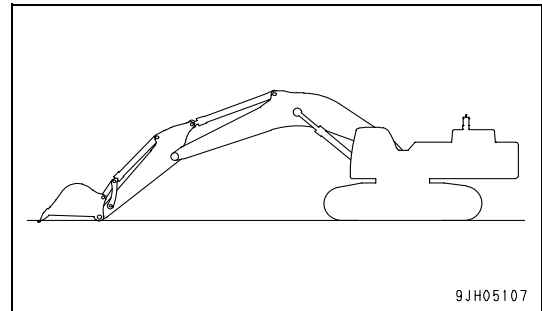

3. Open cover (1) on the left side of the machine and check sight gauge (G). The oil level should be between the H and L marks.

NOTICE

Do not add oil if the level is above the H line. This will damage the hydraulic equipment and cause the oil to spurt out.

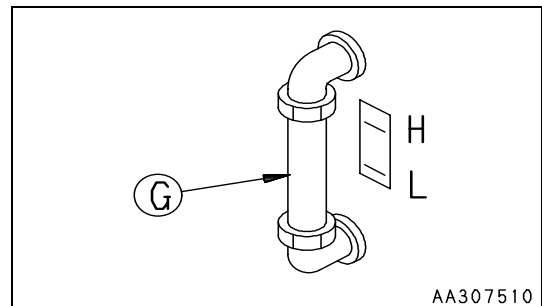

⚠ WARNING

If the oil is above the H level, stop the engine, wait for the hydraulic oil to cool down, then drain the excessive oil from drain plug (P1). When draining the oil, loosen bottom drain plug (P1), then loosen side drain plug (P2) and drain the oil. After draining the oil, tighten drain plugs (P1) and (P2).

(A): Rear

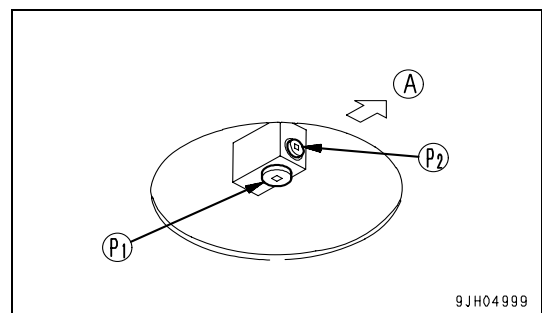

4. If the level is below the L mark, add oil through oil filler (F) at the top of the hydraulic tank.

REMARK

The oil level will vary depending upon the oil temperature. Accordingly, use the following as a guide:

Before operation: around L level

(Oil temperature 10 to 30 °C (50 to 86 °F))

Normal operation: around H level

(Oil temperature 50 to 80 °C (122 to 176 °F))

Check Oil Level In Swing Machinery Case, Add Oil

WARNING

The parts and oil are at high temperature immediately after the engine is stopped, and may cause serious burns. Wait for the temperature to go down before starting the operation.

1. Remove dipstick (G) and wipe the oil from the dipstick with a cloth.
2. Insert dipstick (G) fully in the guide.

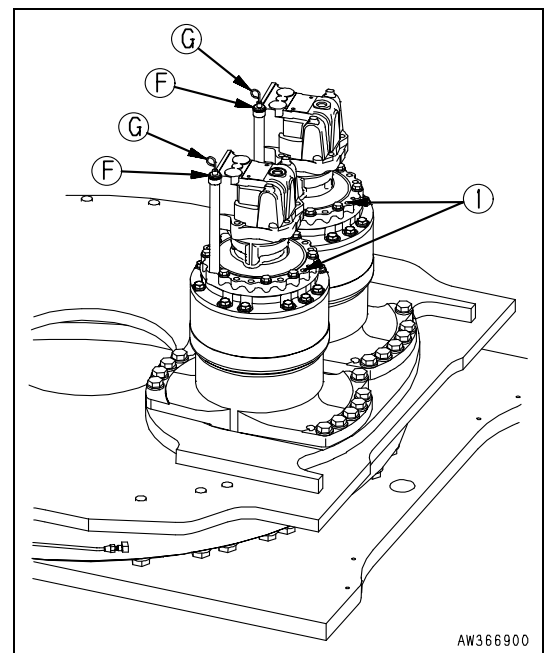

3. When dipstick (G) is pulled out, if the oil level is between the H and L marks of the gauge, oil level is proper.
4. If the oil does not reach the L mark on dipstick (G), add engine oil through dipstick insertion hole (F).

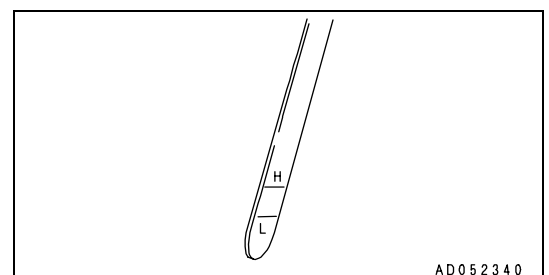

5. If the oil level exceeds the H mark on the dipstick, loosen drain valve (P) to drain the excess oil.
6. After checking oil level or adding oil, insert dipstick (G) into the hole.

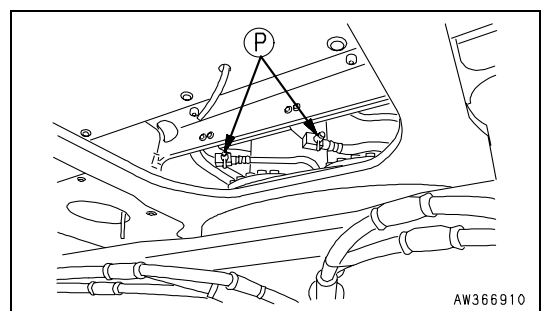

Check Oil Level In P.T.O Case, Add Oil

⚠ WARNING

The parts and oil are at high temperature immediately after the engine is stopped, and may cause serious burns. Wait for the temperature to go down before starting the operation.

NOTICE

Park the machine on flat ground and stop the engine. After waiting for more than 30 minutes after stopping the engine, check the oil level.

1. Open the left side cover and use dipstick (1) to check the oil level.

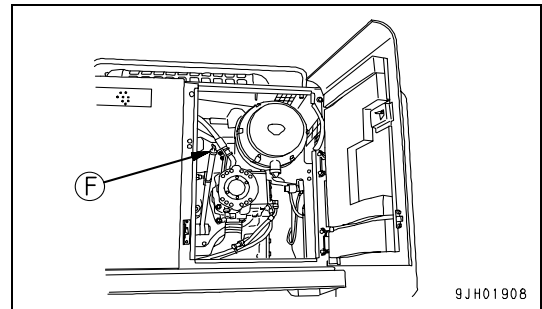

2. The oil level should be between the L and H marks. If necessary, add engine oil at the dipstick guide hole.

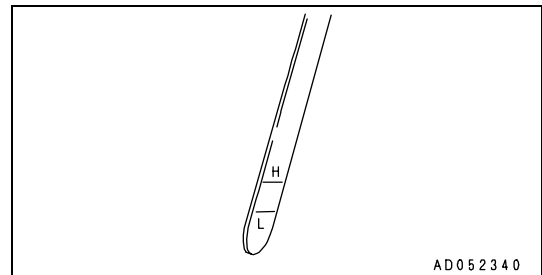

Check Air Cleaner For clogging

1. Confirm that the air cleaner clogging monitor does not flash.
2. If it flashes, immediately clean or replace the element. For details of method of cleaning the element, see "CHECK, CLEAN AND REPLACE AIR CLEANER ELEMENT (4-20)".

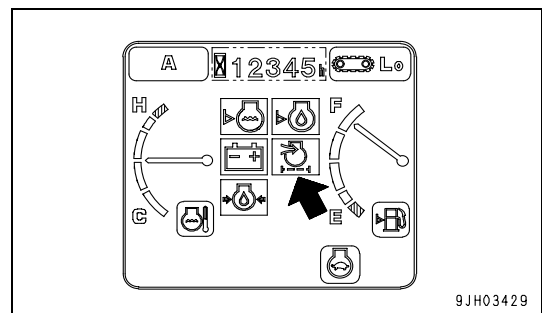

Check working Lamp switch

Turn the lamp switch to the ON position and check that the working lamp light up.

If the lamps do not light up, there is probably a broken bulb or disconnection in the wiring, so contact your Komatsu distributor for repairs.

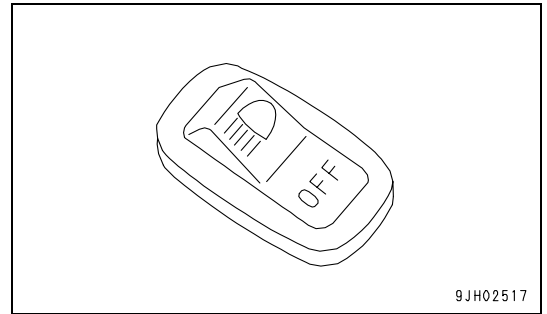

9JH02517

Check electrical wiring**CAUTION**

If fuses are frequently blown or if there are traces of short-circuiting on the electrical wiring, promptly ask your Komatsu distributor to locate the cause and make the repair.

Keep the top surface of the battery clean and check the breather hole in the battery cap. If it is clogged with dirt or dust, wash the battery cap to clear the breather hole.

Check that there is no damage to the fuse, that a fuse of the specified capacity is being used, that there are no signs of any disconnection, breakage, or short circuit in the electric wiring, check for any loose terminals, and tighten any loose terminals that are found.

Be particularly careful to check the wiring for the battery, starting motor, and alternator. In addition, if any flammable material is accumulated around the battery, remove it. For repairs or investigation of the cause, please contact your Komatsu distributor.

Check Function Of Horn

1. Turn the starting switch to the ON position.
2. Confirm that the horn sounds immediately when the horn button is pressed. If the horn does not sound, please contact your Komatsu distributor for repair.

Adjustment

Seat Adjustment

WARNING

When adjusting the position of the operator's seat, always set lock lever (1) to LOCK position (L) to prevent any accidental contact to the control levers.

- Always adjust the operator's seat before starting each operation or when the operators change shift.
- Adjust the seat so that the control levers and switches can be operated freely and easily with the operator's back against the backrest.

(A) Fore-and-aft adjustment

Pull lever (1) up, set the seat to the desired position, then release the lever.

Fore-and-aft adjustment: 160 mm (6.3 in) (16 stages)

(B) Adjusting reclining

NOTICE

The seat can be reclined to a large angle when the seat is pushed fully forward, but the reclining angle is reduced when the seat is moved back, so when moving the seat to the rear, return the seat back to its original position.

Pull up lever (2) and set the seat back to a position which is comfortable for operation, then release the lever.

Sit with your back against the seat back when adjusting. If your back is not touching the seat back, the seat back may suddenly move forward.

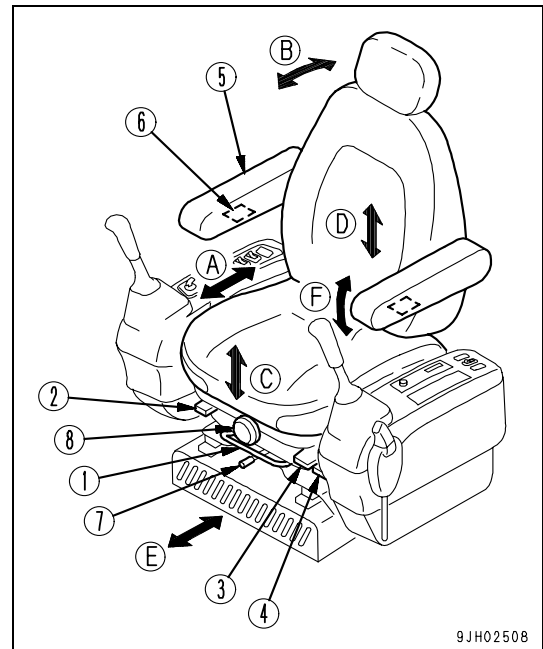

9JH02508

(C) Adjusting seat tilt

● Forward tilt

Push lever (3) up to adjust the angle of the front of the seat. (4 stages)

- To raise the angle at the front of the seat, keep the lever pushed up and apply your weight to the rear of the seat.
- To lower the angle at the front of the seat, keep the lever pushed up and apply your weight to the front of the seat.

● Rear tilt

Pull lever (4) up to adjust the angle of the rear of the seat. (4 stages)

- To raise the angle at the rear of the seat, keep the lever (3) pulled up and stand up slightly to remove your weight from the seat.
- To lower the angle at the rear of the seat, keep the lever (3) pulled up and apply your weight to the

Amount of tilt: Up 13°, down 13°

● Adjusting seat height

It is possible to move the seat up or down by combining adjustments forward tilt and rear tilt.

After setting the forward tilt or rear tilt to the desired height, operate the opposite part to set the seat horizontal then secure in position.

Height adjustment: 60 mm (2.4 in)

(D) Adjusting armrest angle

Armrest (5) can be made to spring up by hand approx. 90°.

In addition, by turning the bottom (6) of the armrest by hand it is possible to make fine vertical adjustments of the armrest angle.

Armrest adjustment angle: 25°.

REMARK

If the seatback is pushed forward without armrest (5) being raised, the armrest will automatically rise.

If the cable at the rear of the armrest (5) is tense (the seatback is pushed forward), armrest (5) cannot be adjusted even when the dial (6) is turned. When adjusting the angle of armrest (5), set the seatback to a position where it is easy to carry out operations, then adjust the angle.

(E) Overall fore-and-aft adjustment of seat

Move lever (7) to right, set to the desired position, then release the lever. In this case, the operator's seat, left and right control levers, and safety lock lever all slide together.

Fore-and-aft adjustment: 180 mm (7.1 in) (9 stages)

(F) Adjusting suspension

Turn knob (8) to the right to make the suspension harder, or to the left to make the suspension softer. Adjust the reading of the dial to match the operator's weight and select the optimum suspension.

REMARK

To obtain the optimum adjustment, turn the knob (8) so that the indicator of the weight display (kg) in the transparent portion of knob (8) is the same as the operator's weight.

Rearview Mirrors

⚠ WARNING

Adjust the position of the mirror to match the operator's physique and preference. When adjusting, set it to match the physique of the present operator or any other operator who will mount the machine so that the operators will be able to enter the cab or climb on or off the machine safely.

Loosen screw (1), screw (2), and bolt (3) installing the mirror, then adjust the position to give the best view from the operator's seat.

- Adjust the mirror mount so that it is possible to see any person (or object of height 1 m (3 ft 3 in) and diameter 30 cm (11.8 in)) at the rear left and right of the machine.
- Install the mirror to the mounting position and dimensions shown. The values given below are reference values for the range of view.

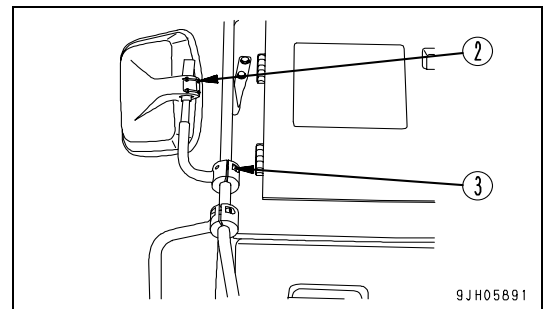
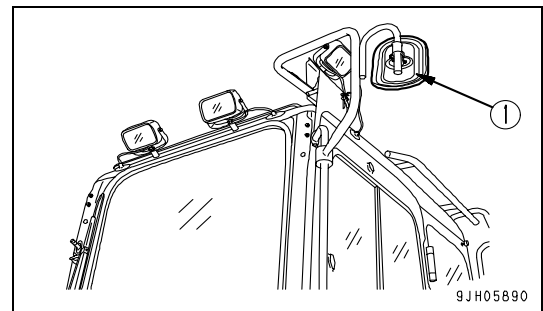

- Mounting position X : 430 mm (16.9 in)
- Range of view Y (right side) : 3500mm (11 ft 6 in)
- Range of view Z (left side) : 2700 mm (8 ft 10 in)

- Mirror A: must be able to see hatched area (A)
- Mirror B: must be able to see hatched area (B)

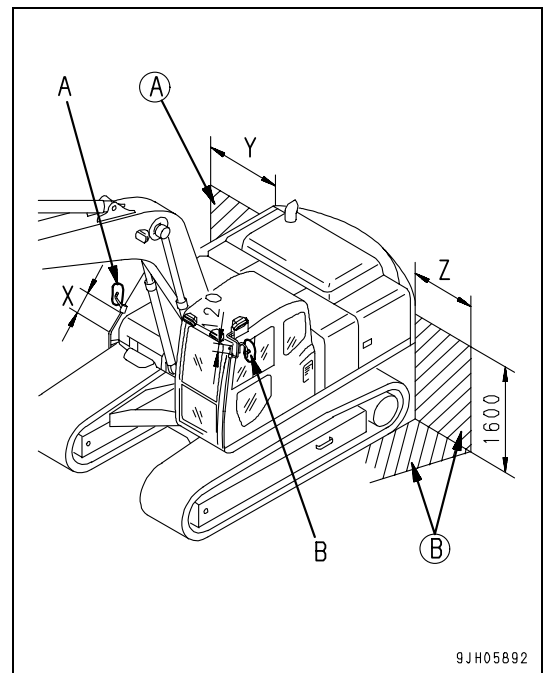

Seat Belt

WARNING

- Before fitting the seat belt, check that there is no abnormality in the belt mount bracket or mounting belt. If it is worn or damaged, replace the seat belt.
- Even if no abnormality can be seen in the belt, replace the seat belt every 3 years. The date of manufacture of the belt is shown on the back of the belt.
- Always wear the seat belt during operations.
- Fit the seat belt so that it is not twisted.

Fastening and Removing

This seat belt is retractable, so it is not necessary to adjust the length.

Fastening seat belt

Hold grip (2) and pull the belt out from retraction device (1), check that the belt is not twisted, then insert tongue (3) into buckle (4) securely.

When doing this, pull the belt lightly to check that it is properly locked.

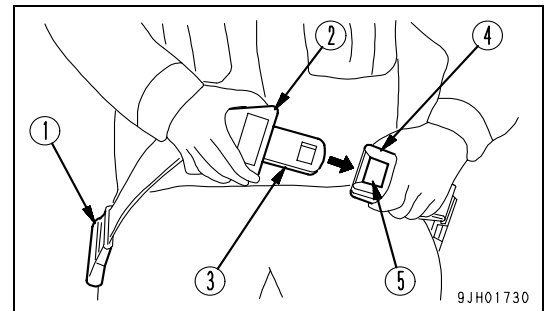

Removing belt

Press button (5) in buckle (4), and remove tongue (3) from buckle (4).

The belt is automatically retracted, so hold grip (2) and return the belt slowly to retraction device (1).

Operations Before Starting Engine

⚠ WARNING
 When starting the engine, check that lock lever (1) is securely at the LOCK position (L).
 If the control levers are not locked and they are touched by accident when starting the engine, the work equipment may move unexpectedly, and this may lead to a serious accident.

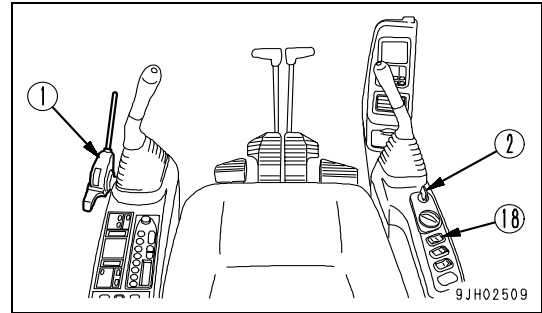

1. Check that lock lever (1) is at the LOCK position (L).
2. Check the position of each levers.
Set the control lever to the neutral position.

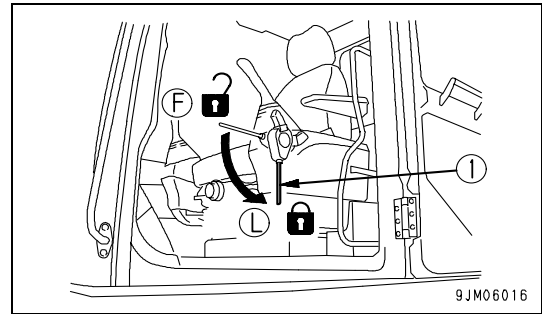

3. Insert the key in starting switch (2), turn the key to the ON position (B), then carry out the following checks.

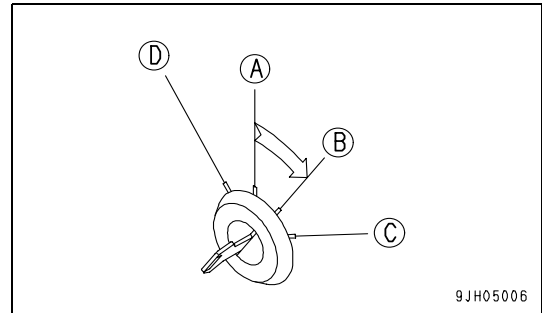

- If a password has been set, the input display screen is shown on the monitor screen.
After inputting the password, press input confirmation switch (3).

REMARK

For details of the method of setting, changing, or canceling the password, see "PROCEDURE FOR SETTING, CHANGING, CHANCELING PASSWORD".

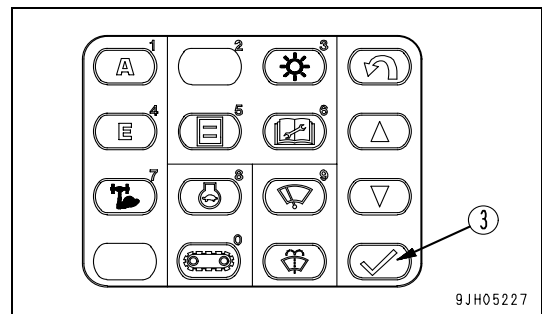
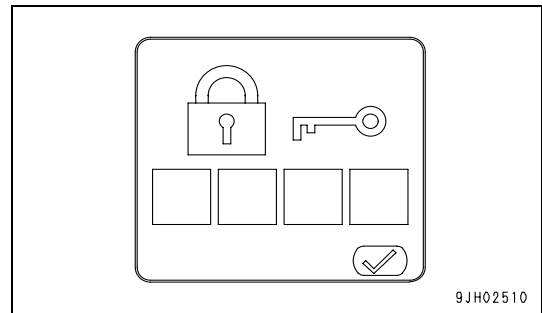

4. The buzzer sounds for approx. 1 second, and the following monitors and meters light up for approx. 3 seconds.

- Radiator water level monitor (4)
- Engine oil level monitor (5)
- Charge monitor (6)
- Fuel level monitor (7)
- Engine water temperature monitor (8)
- Engine oil pressure monitor (9)
- Engine water temperature gauge (10)
- Fuel gauge (11)
- Air cleaner clogging monitor (12)

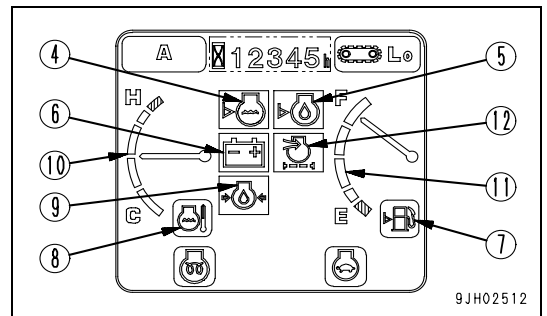

If the monitors do not light up or the buzzer does not sound, there is probably a failure in the monitor, so contact your Komatsu distributor for repairs.

5. After approx. 3 seconds, the screen switches to the working mode/travel speed display monitor. Then it switches to the normal screen.

- Fuel level monitor (7)
- Engine water temperature monitor (8)
- Engine water temperature gauge (10)
- Fuel gauge (11)
- Hydraulic oil temperature gauge (13)
- Hydraulic oil temperature monitor (14)

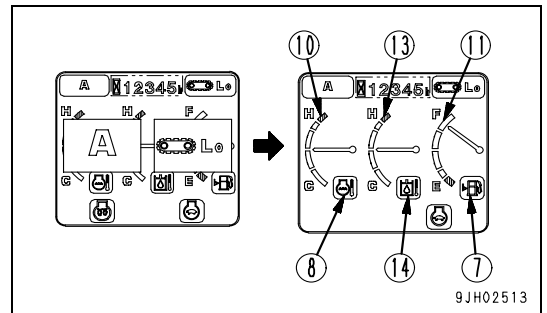

6. If the hydraulic oil temperature gauge goes out and caution lamp (15) stays lighted up red, carry out inspection immediately for the item which is lighted up red.

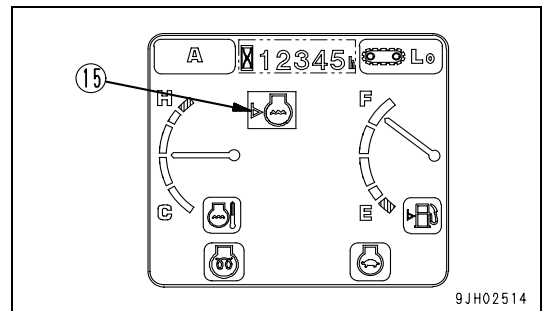

- 7. If there are any items where the maintenance time has passed, maintenance interval monitor (16) lights up for 30 seconds. Press maintenance switch (17), check the item, then carry out maintenance immediately.

For details of the method of checking the maintenance interval, see "Maintenance Switch (3-22)" in the Explanation of components.

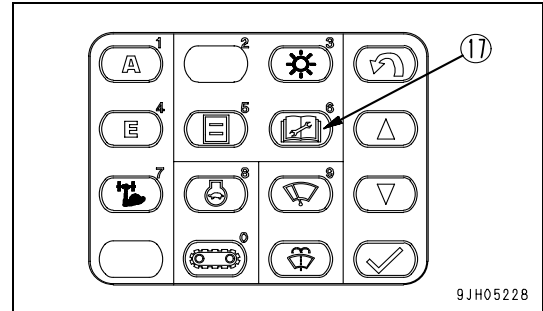
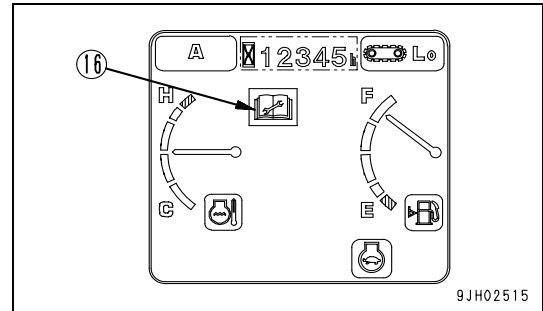

- 8. Press lamp switch (18) and check that the front lamp lights up.

If it does not light up, there is probably a blown bulb or disconnection, so contact your Komatsu distributor for repairs.

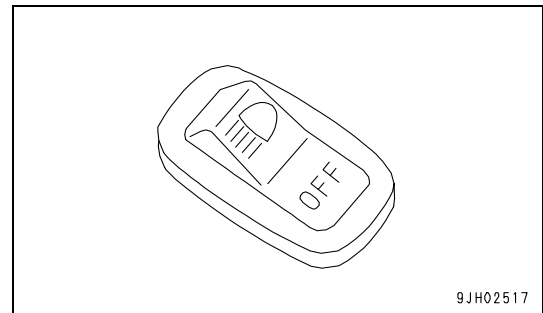

STARTING ENGINE

Normal Starting

WARNING

- Start the engine only after sitting down in the operator's seat.
- Do not attempt to start the engine by short-circuiting the engine starting circuit. Such an act may cause serious bodily injury or fire.
- Check that there are no persons or obstacles in the surrounding area, then sound the horn and start the engine.
- Exhaust gas is toxic. When starting the engine in confined spaces, be particularly careful to ensure good ventilation.

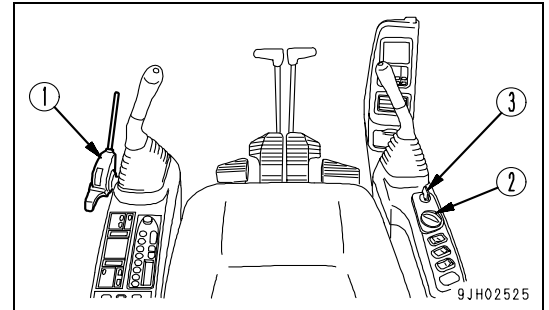

NOTICE

- Before starting the engine, check that the fuel control dial is at the low idling (MIN) position. If the fuel control dial is at the FULL position, the engine will accelerate suddenly and cause damage to the engine parts.
- Do not crank the starting motor continuously for more than 20 seconds. If the engine does not start, wait for at least 2 minutes before trying again.

REMARK

If the engine is stopped when it is not fully warmed up and it is started again a few minutes later, there may be a delay in the engine rotation during cranking. This is caused by fuel gas remaining inside the cylinder; it does not indicate any abnormality. In addition, even if this phenomenon occurs, there is no problem with the reliability or durability of the engine or other parts.

1. Check lock lever (1) is at the LOCK position (L). If the lock lever is in the FREE position (F), the engine does not start.

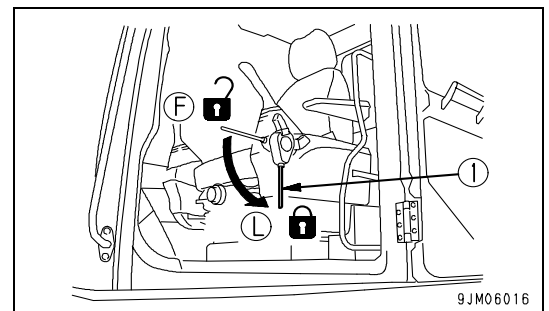

- 2. Set fuel control dial (2) at the low idling (MIN) position.
If it is at the high idling (MAX) position, always change it to the low idling (MIN) position.

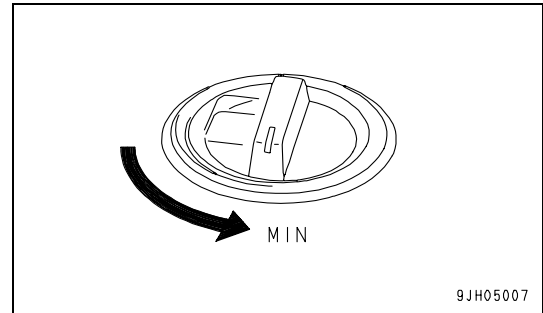

- 3. Turn the key in starting switch (3) to the START position (C).
The engine will start.

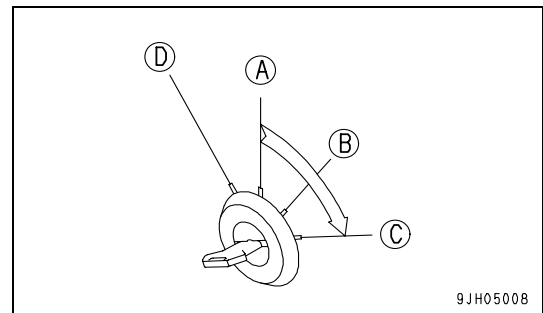

- 4. After the engine starts, release the key in starting switch (3).
The key will automatically return to the ON position (B).

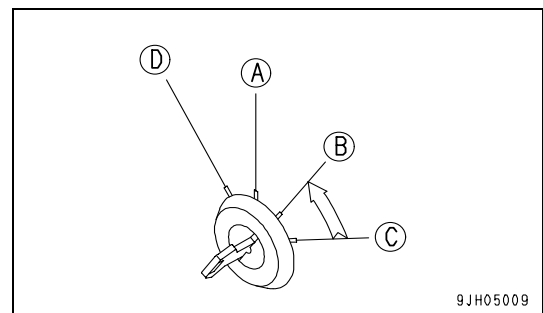

- 5. Even after the engine is started, do not touch the work equipment control levers and the travel pedals, while the engine hydraulic pressure monitor lamp is still lighted.

NOTICE

If the engine oil pressure monitor does not go out even after 4 to 5 seconds have passed, stop the engine immediately. Check the oil level, check for leakage of oil, and take the necessary action.

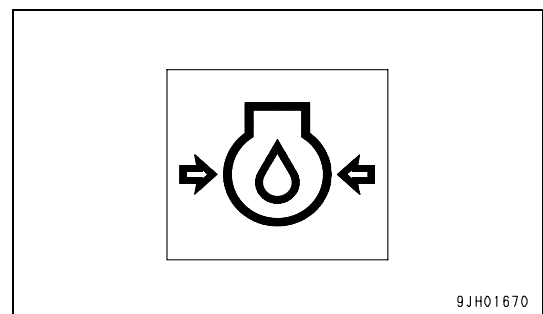

Starting Engine In Cold Weather

⚠ WARNING

- Start the engine only after sitting down in the operator's seat.
- Do not attempt to start the engine by short-circuiting the engine starting circuit. Such an act may cause a serious bodily injury or fire.
- Check that there are no persons or obstacles in the surrounding area, then sound the horn and start the engine.
- Never use starting aid fluids as they may cause explosions.
- Exhaust gas is toxic. When starting the engine in confined spaces, be particularly careful to ensure good ventilation.

NOTICE

- Before starting the engine, check that fuel control dial (2) is at the low idling (MIN) position. If the fuel control dial is at the FULL position, the engine will accelerate suddenly and cause damage to the engine parts, so set it to an intermediate or low speed position.
- Do not keep the starting motor rotating continuously for more than 20 seconds. If the engine fails to start, wait for about 2 minutes and repeat from Step 2.

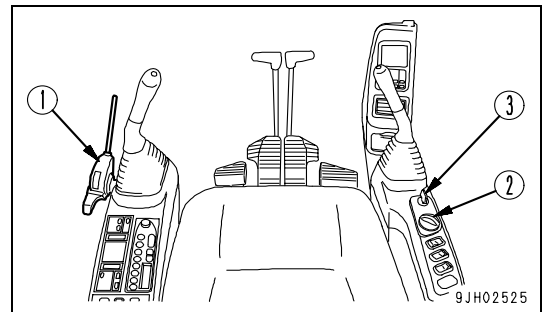

When starting in low temperatures, do as follows.

1. Check lock lever (1) is at the LOCK position (L). If the lock lever is in the FREE position (F), the engine does not start.

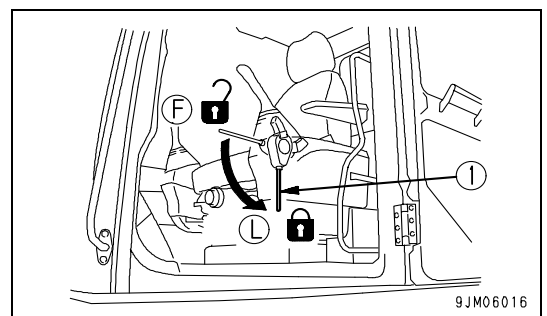

2. Set fuel control dial (2) at a low idling (MIN) position. Do not set fuel control dial (2) at the high idling (MAX) position.

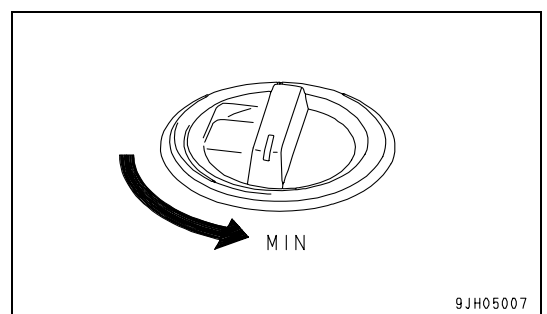

3. Hold the key in starting switch (3) at the HEAT position (D), and check that preheating monitor (4) lights up. After about 30 seconds, preheating monitor lamp (4) will flash to indicate that preheating is finished.

REMARK

The monitors and gauges will light up also when the key is turned to the HEAT position, but this is not an abnormality. If the temperature is low, the monitor screen may become dark or it may take time for the display to appear, but this is not an abnormality.

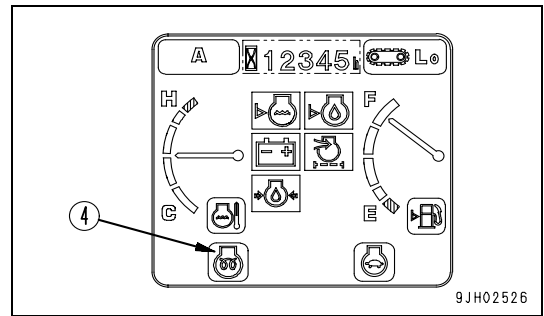
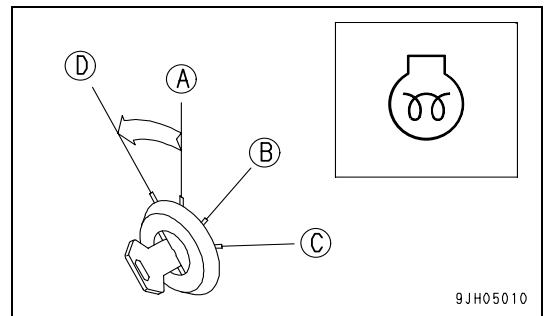

4. When preheating monitor (4) flashes, turn the key in starting switch (3) to the START position (C) to start the engine.

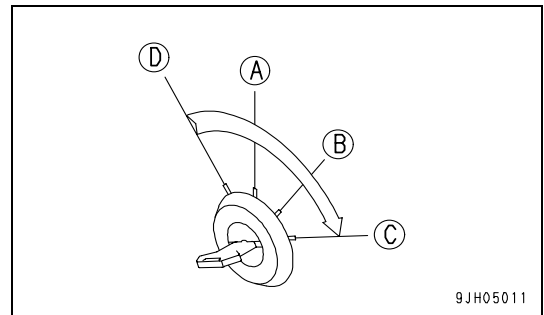

5. After the engine starts, release the key in starting switch (3). The key will automatically return to the ON position (B).

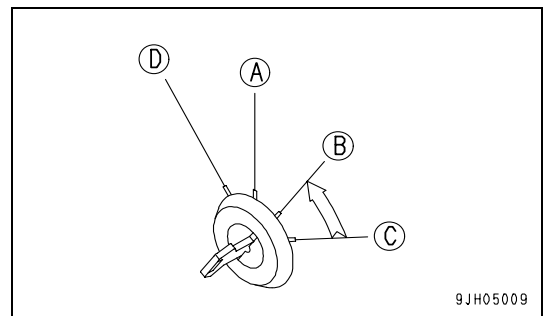

6. After starting the engine, do not touch the work equipment control lever or travel pedal while the engine oil pressure monitor lamp is lighted up.

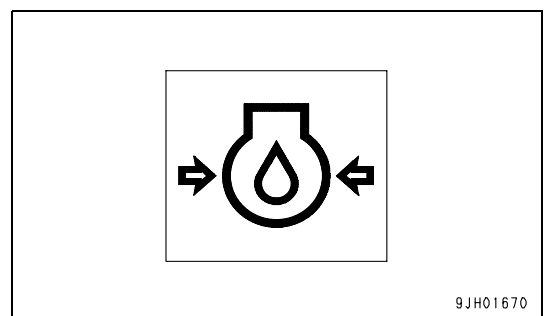

REMARK

The actuation time for the turbo protect function and the relationship with the engine coolant temperature are as shown below.

If the fuel control dial is operated within the time shown below, the engine speed will not change.

Cooling water temperature	Turbo protect time (sec.)
Above 10 °C (50 °F)	0
10 to -10 °C (50 to 14 °F)	Change 0 to 5
below -10 °C (14 °F)	5

- In cold weather, the turbo protect function is actuated, so the engine speed is maintained below 1000 rpm for several seconds. After that, the automatic warming-up function raises the engine speed to 1200 rpm.

AFTER STARTING ENGINE

WARNING

- If there has been any Emergency stop, abnormal actuation or trouble, turn the starting switch key to the OFF position.
- If the work equipment is operated without warming the machine up sufficiently, the response of the work equipment to the movement of the control lever will be slow, and the work equipment may not move as the operator desires, so always carry out the warming-up operation. Particularly in cold areas, be sure to carry out the warming-up operation fully.

Warming-Up Operation

NOTICE

- When the hydraulic oil is at a low temperature, do not carry out operations or move the levers suddenly. Always carry out the warming-up operation. This will help to extend the machine life. Do not suddenly accelerate the engine before the warming-up operation is completed.
- Do not run the engine at low idling or high idling continuously for more than 20 minutes. This will cause leakage of oil from the turbocharger oil supply piping. If it is necessary to run the engine at idling, apply a load from time to time or run the engine at a mid-range speed.

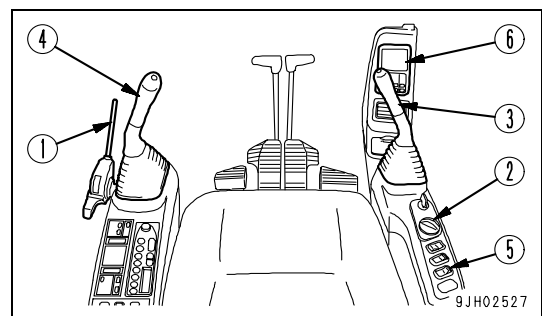

REMARK

If the hydraulic oil temperature is low, the hydraulic oil temperature monitor display will be white.

After starting the engine, do not immediately start operations. First, carry out the following operations and checks.

1. Turn fuel control dial (2) to center position (A) between the low idling (MIN) and high idling (MAX) positions and run the engine at a mid-range speed under no load until the engine water temperature monitor gives a green display.

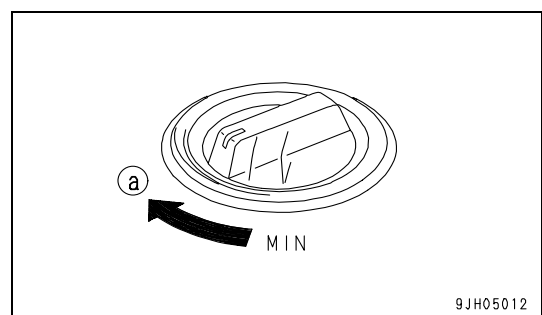

2. Set lock lever (1) to the FREE position (F) and raise the bucket from the ground.

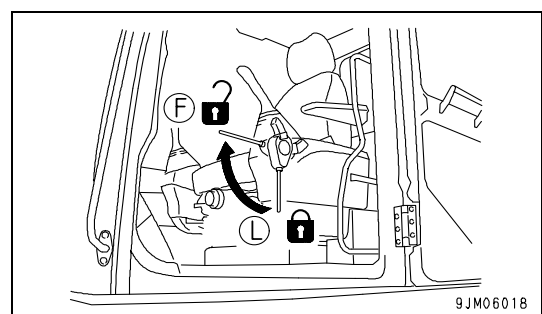

3. Operate bucket control lever (3) and arm control lever (4) slowly to move the bucket cylinder and arm cylinder to the end of the stroke.
4. Operate the bucket for 30 seconds and the arm for 30 seconds in turn fully for 5 minutes.
 - (A): Arm is pushed out
 - (B): Arm is pulled in
 - (C): Bucket is pushed out
 - (D): Bucket is pulled in

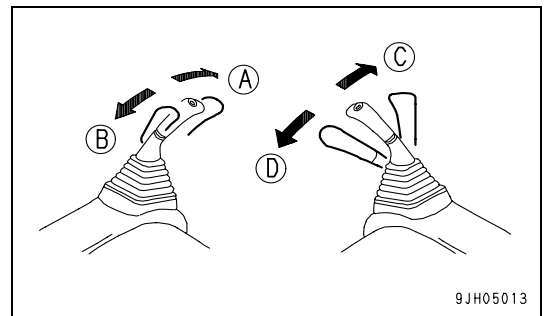

NOTICE

When the work equipment is retracted, take care that it does not interfere with the machine body or ground.

5. If the swing lock switch (6) is set to the ON (actuated) position and swing control lever (5) is operated at full stroke, oil temperature rise can be increased earlier.
 - (E): Left swing
 - (F): Right swing

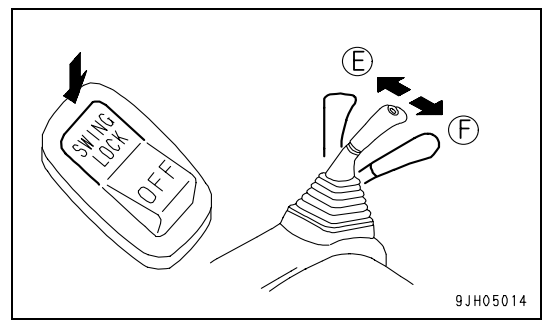

6. After carrying out the warming-up operation, check that all the gauges on machine monitor (6) and the caution lamps are in the following conditions.

- Radiator water level monitor (7): OFF
- Engine oil level monitor (8): OFF
- Charge monitor (9): OFF
- Fuel level monitor (10): Green display
- Engine water temperature monitor (11): Green display
- Engine oil pressure monitor (12): OFF
- Engine water temperature gauge (13): Indicator in black range
- Fuel gauge (14): Indicator in black range
- Preheating monitor (15): OFF
- Air cleaner clogging monitor (16): OFF
- Hydraulic oil temperature gauge (17): Indicator in black range
- Hydraulic oil temperature monitor (18): Green display

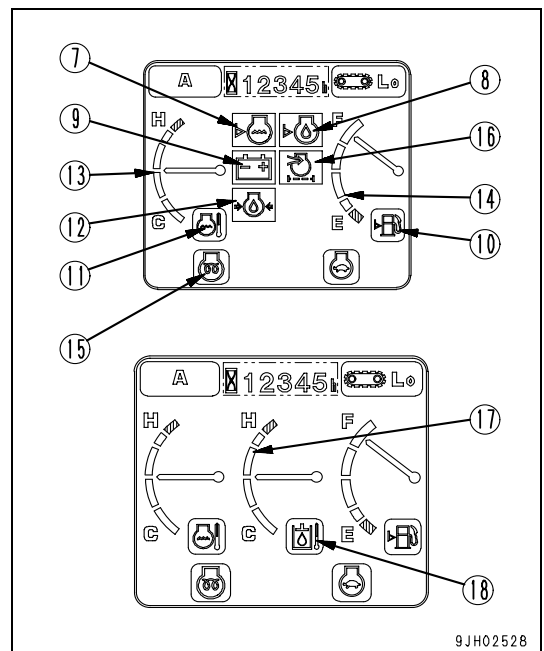

7. Check that there is no abnormal exhaust gas color, noise or vibration. If any abnormality is found, contact your Komatsu distributor.

8. If air cleaner clogging monitor (16) is lighted up, clean or replace the element immediately.

For details of the method of cleaning the element, see "CHECK, CLEAN AND REPLACE AIR CLEANER ELEMENT (4-20)".

9. Use working mode switch (19) on machine monitor (6) to select the working mode to be used.

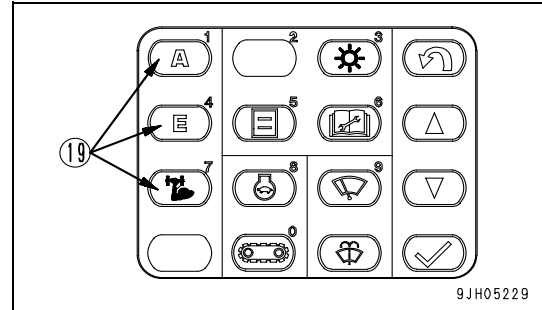

Working mode monitor display

10. A mode

For heavy-load operations

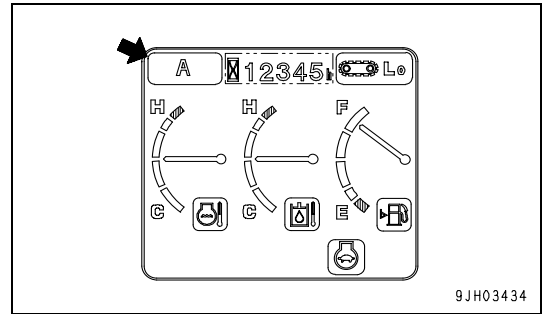

9JH03434

11. E mode

For operations with emphasis on fuel economy

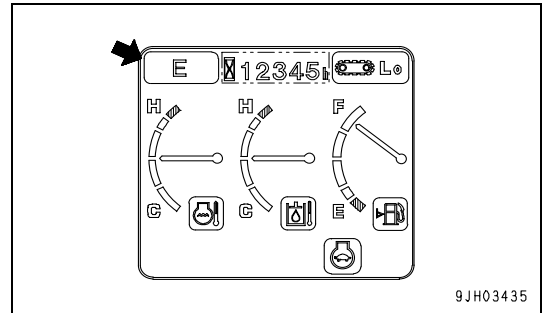

9JH03435

12. Heavy-duty lift

Boom lifting power increased when raising boom independently

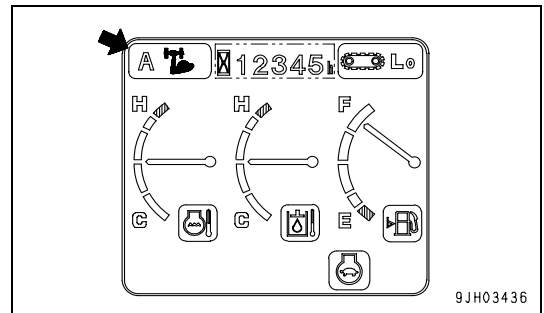

9JH03436

In Cold Weather Areas

(AUTOMATIC WARMING-UP OPERATION)

When starting the engine in cold areas, carry out the automatic warming-up operation after starting the engine. When the engine is started, if the engine water temperature is low (below 30 °C), the warming-up operation is carried out automatically.

The automatic warming-up operation is canceled if the engine water temperature reaches the specified temperature (30 °C) or if the warming-up operation is continued for 10 minutes. If the engine water temperature or hydraulic oil temperature are low after the automatic warming-up operation, warm the engine up further as follows.

NOTICE

- Do not suddenly accelerate the engine before the warming-up operation is completed.
Do not run the engine at low idling or high idling continuously for more than 20 minutes. This will cause leakage of oil from the turbocharger oil supply piping. If it is necessary to run the engine at idling, apply a load from time to time or run the engine at a mid-range speed.
- Never carry out operations or operate the levers suddenly when the hydraulic oil is still at low temperature. Always continue the warming-up operation until the work equipment monitor display is green. This will extend the service life of the machine.

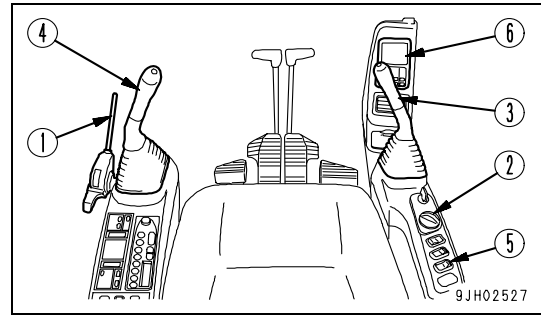

REMARK

If the hydraulic oil temperature is low, the hydraulic oil temperature monitor display will be white.

1. Turn the fuel control dial (2) to the medium speed position (a).

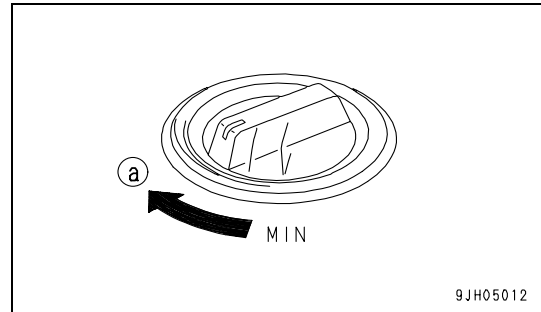

2. Set lock lever (1) to the FREE position (F) and raise the bucket from the ground.

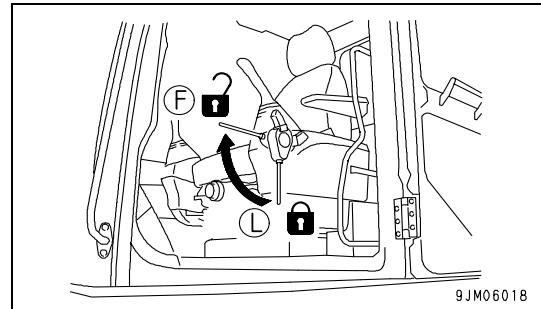

3. Operate bucket control lever (3) and arm control lever (4) slowly to move the bucket cylinder and arm cylinder to the end of the stroke.
4. Operate the bucket for 30 seconds and the arm for 30 seconds in turn fully for 5 minutes.
 - (A): Arm is pushed out
 - (B): Arm is pulled in
 - (C): Bucket is pushed out
 - (D): Bucket is pulled in

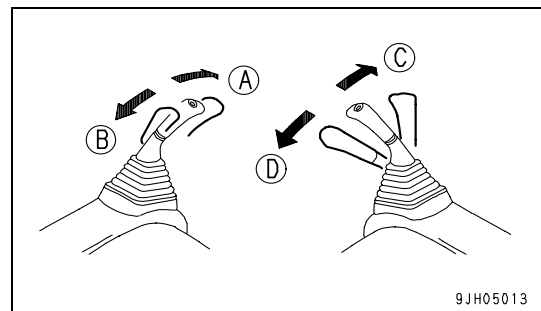

NOTICE

When the work equipment is retracted, take care that it does not interfere with the machine body or ground.

5. After carrying out the warming-up operation, check that each gauge and monitor lamp is in the following condition.

- Radiator water level monitor (7): OFF
- Engine oil level monitor (8): OFF
- Charge monitor (9): OFF
- Fuel level monitor (10): Green display
- Engine water temperature monitor (11): Green display
- Engine oil pressure monitor (12): OFF
- Engine water temperature gauge (13): Indicator in black range
- Fuel gauge (14): Indicator in black range
- Preheating monitor (15): OFF
- Air cleaner clogging monitor (16): OFF
- Hydraulic oil temperature gauge (17): Indicator in black range
- Hydraulic oil temperature monitor (18): Green display

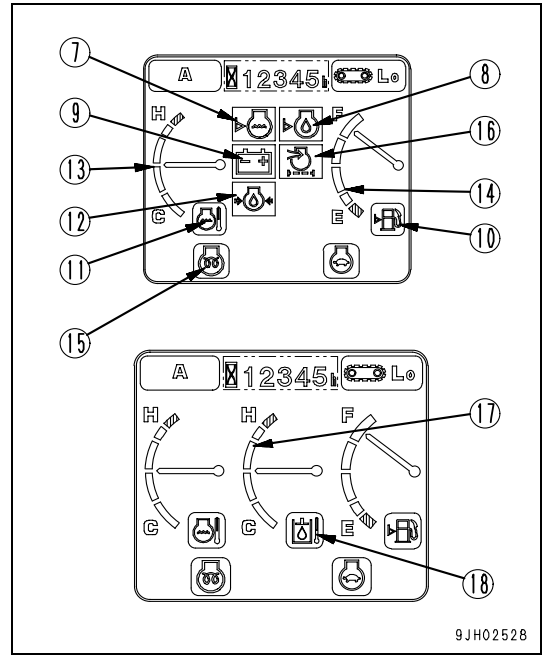

6. Check that there is no abnormal exhaust gas color, noise or vibration. If any abnormality is found, contact your Komatsu distributor.

7. If air cleaner clogging monitor (16) is lighted up, clean or replace the element immediately.

For details of the method of cleaning the element, see "CHECK, CLEAN AND REPLACE AIR CLEANER ELEMENT (4-20)".

8. Turn fuel control dial (2) to the full speed (MAX) position and carry out the operation is Step 4 for 3 - 5 minutes.

9. Repeat the following operation 3 - 5 times and operate slowly.
- | | |
|-----------------------|-------------------|
| Boom operation | RAISE ↔ LOWER |
| Arm operation | IN ↔ OUT |
| Bucket operation | CURL ↔ DUMP |
| Swing operation | LEFT ↔ RIGHT |
| Travel (Lo) operation | FORWARD ↔ REVERSE |

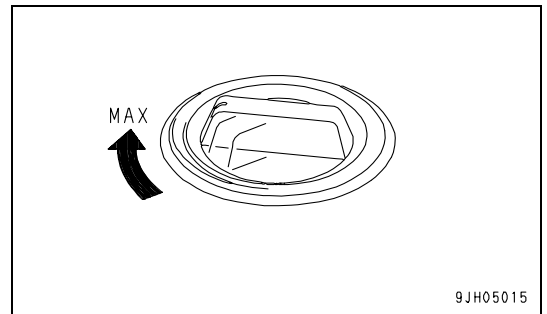

REMARK

If the above operation is not carried out, then may be a delay in response when starting or stopping the actuation of the travel, swing, or work equipment.

10. Use working mode switch (19) on machine monitor (6) to select the working mode to be used.

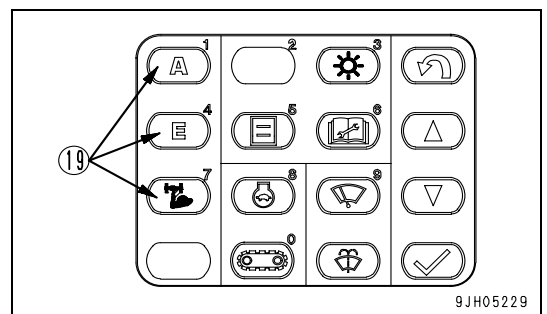

Working mode monitor display

11. A mode

For heavy-load operations

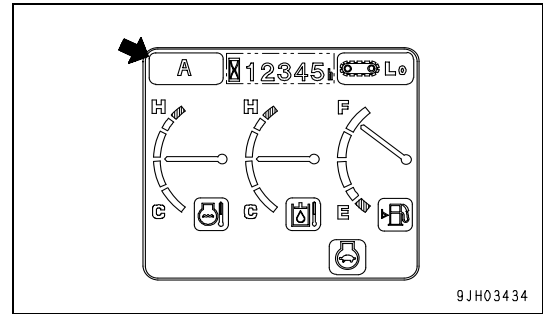

12. E mode

For operations with emphasis on fuel economy

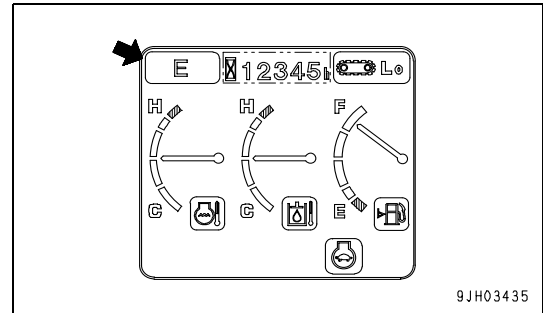

13. Heavy-duty lift

Boom lifting power increased when raising boom independently

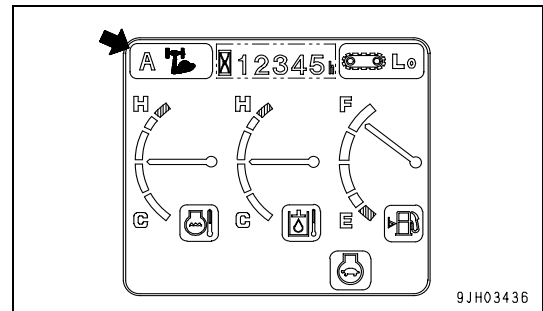

NOTICE

Canceling automatic warming-up operation

If it becomes necessary in an emergency to cancel the automatic warming-up operation or to lower the engine speed to low idling, do as follows.

- 14. Turn fuel control dial (2) to the full speed (MAX) position and hold it for 3 seconds.

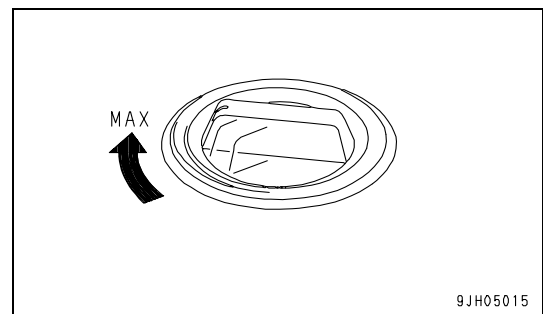

- When fuel control dial (2) is returned to the low idling (MIN) position, the engine speed will drop.

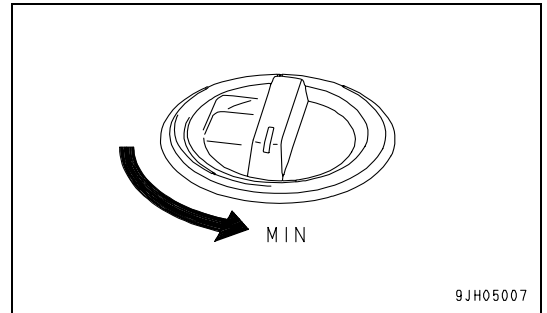

STOPPING THE ENGINE

NOTICE

If the engine is stopped abruptly, service life of component parts of the engine may be considerably reduced. Hence do not stop the engine abruptly except in an emergency. If the engine has overheated, do not try to stop it abruptly. Run it at low idling to allow it to cool down gradually, and then stop it.

- Run the engine at low idling for about 5 minutes to cool down gradually.
- Turn the key in starting switch (1) to the OFF position (A) and stop the engine.
- Remove the key from starting switch (1).

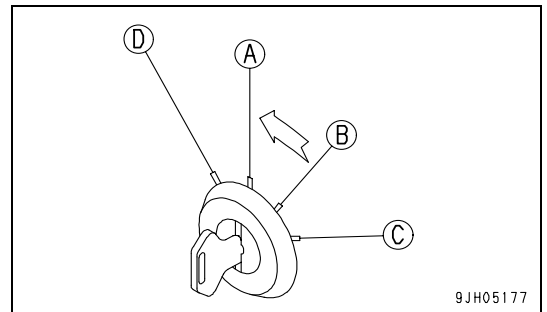
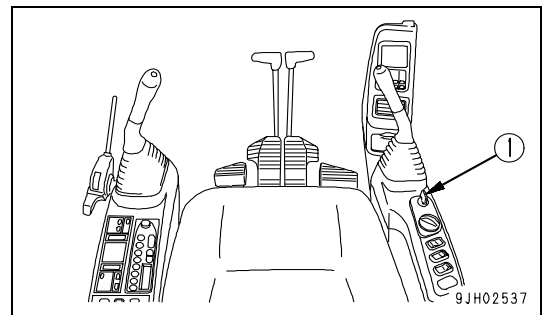

MACHINE OPERATION

Preparations For Moving The Machine

⚠ WARNING

- Before operating the steering levers, check the direction of the track frame.
If the sprocket is at the front, the operation of the travel levers is reversed.
- When moving off, check that the area around the machine is safe, and sound the horn before moving.
- Do not allow anyone in the area around the machine.
- Remove all obstacles from the travel path of the machine.
- The rear of the machine is a blind spot, so be particularly careful when travel in reverse.
- If the lever is moved inside the deceleration range, engine speed will rise suddenly. Operate the levers carefully.
- Before starting the machine off, check that the alarm sounds normally.

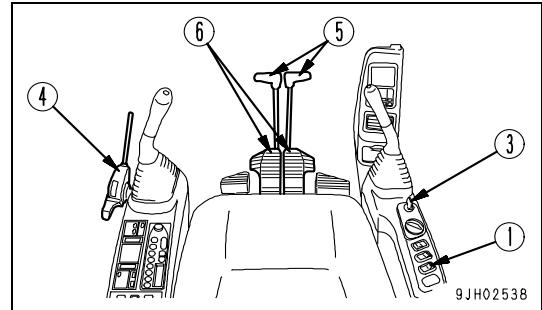

1. Set swing lock switch (1) to the ON (actuated) position and confirm that swing lock monitor lamp (2) lights up.

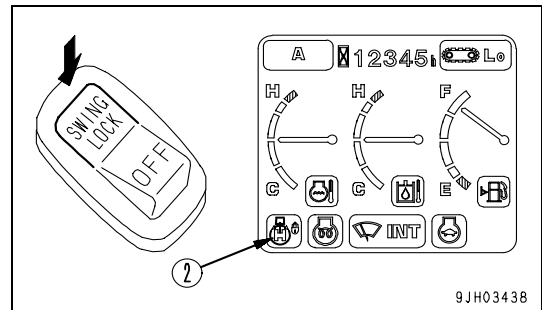

2. Turn fuel control dial (3) towards the full speed position to increase the engine speed.

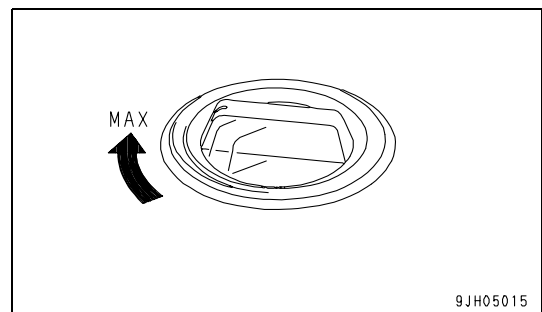

Moving Machine Forward

1. Set lock lever (4) in the FREE position (F), fold the work equipment, and raise it 40 to 50 cm (16 to 20 in) from the ground.

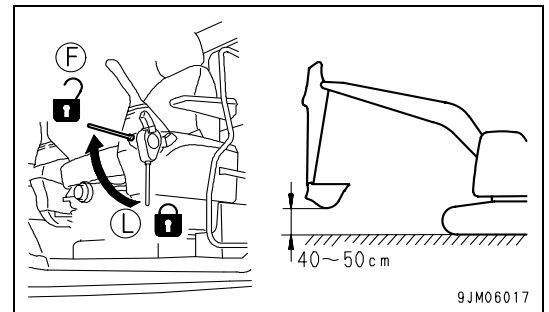

2. Operate right and left travel levers (5) or right and left travel pedals (6) as follows.

- When the sprocket (A) is at the rear of the machine

Push levers (5) forward slowly or depress the front part of pedals (6) slowly to move the machine off.

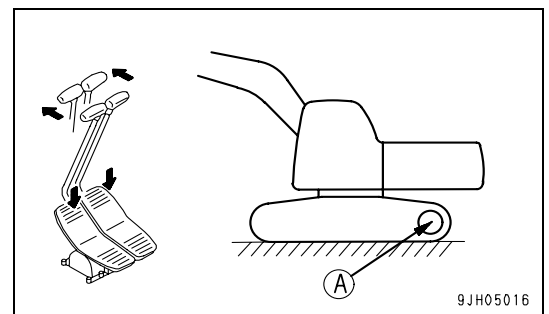

- When the sprocket (A) is at the front of the machine

Pull levers (5) backward slowly or depress the rear part of pedals (6) slowly to move the machine off.

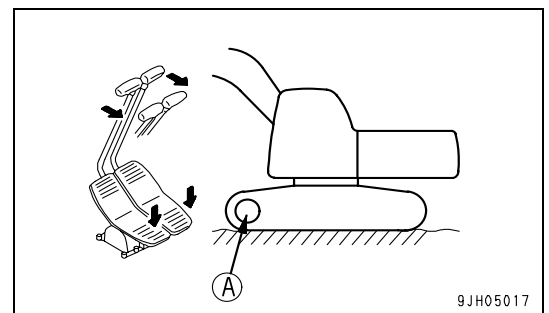

3. Check that the alarm sounds properly. If the alarm does not sound, please contact your Komatsu distributor for repair.

REMARK

In cold temperatures, if the machine travel speed is not normal, carry out the warming-up operation thoroughly. In addition, if the undercarriage is clogged with mud and the machine travel speed is not normal, remove the soil and mud from the undercarriage.

Moving Machine Backward

1. Set lock lever (4) in the FREE position (F), fold the work equipment, and raise it 40 to 50 cm (16 to 20 in) from the ground.

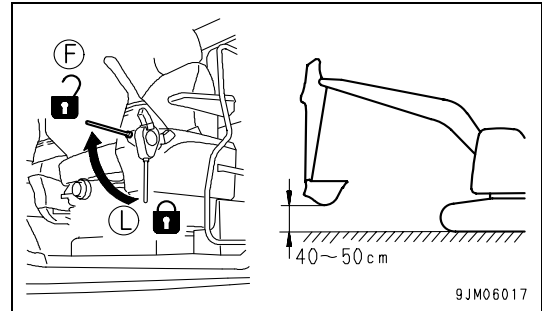

2. Operate right and left travel levers (5) or right and left travel pedals (6) as follows.

- When the sprocket (A) is at the rear of the machine

Pull levers (5) backward slowly or depress the rear part of pedals (6) to move the machine off.

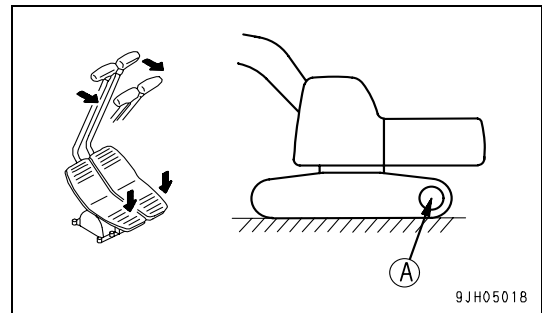

- When the sprocket (A) is at the front of the machine

Push levers (5) forward slowly or depress the front part of pedals (6) to move the machine off.

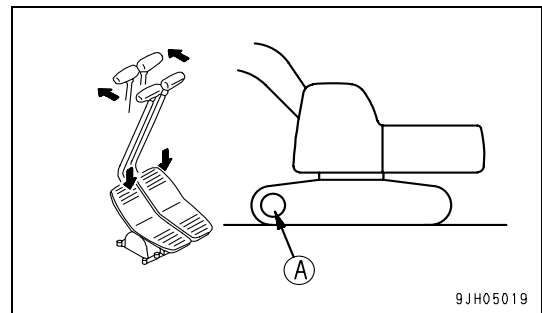

3. Check that the alarm sounds properly. If the alarm does not sound, please contact your Komatsu distributor for repair.

Stopping Machine

Avoid stopping suddenly. Give yourself ample room and return the lever slowly when stopping.

1. Put the left and right travel levers (1) in the neutral position, then stop the machine.

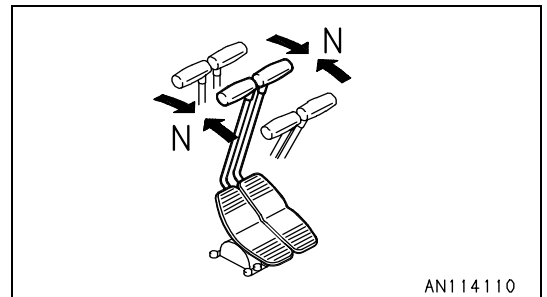
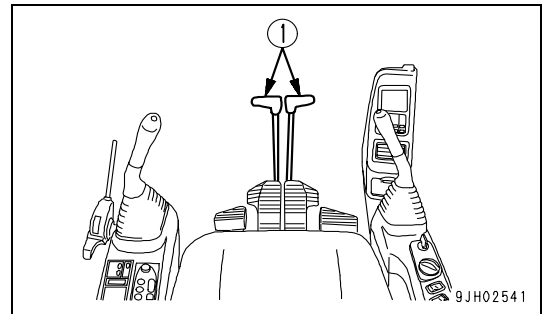

STEERING THE MACHINE

Steering

⚠ WARNING

Before operating the travel control levers, check the direction of the track frame (i.e. position of the sprocket) first. If the sprocket is at the front, the machine moves in the reverse direction to the operation of the travel lever.

Use the travel levers to change direction.

Avoid sudden changes of direction as far as possible. In particular, when carrying out counter-rotation (spin turn), stop the machine first before turning.

Operate two travel levers (1) as follows.

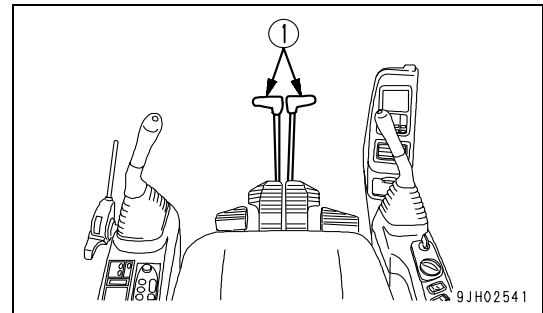

Steering the Machine when Stopped

When turning to the left:

Push the right travel lever forward to turn to the left when traveling forward; and pull it back to turn left when traveling in reverse.

- (A): Forward left turn
- (B): Reverse left turn

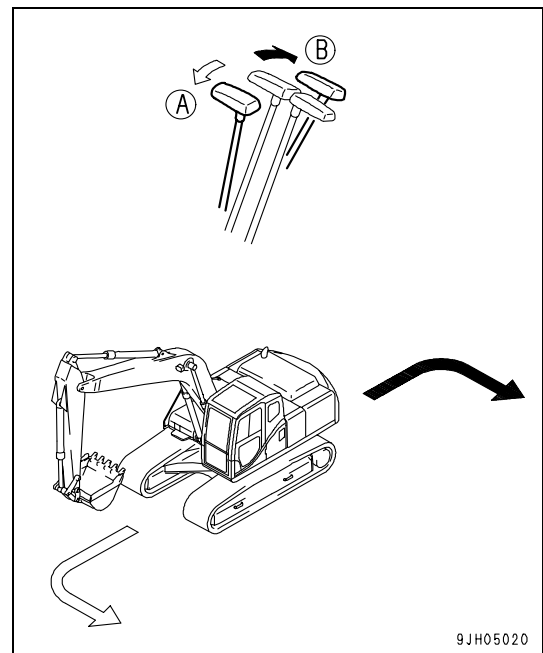

REMARK

When turning to the right, operate the left travel lever in the same way.

Changing Direction of the Machine

When turning to the left:

If the left travel lever is returned to the neutral position, the machine will turn to the left.

- (A): Forward left turn
- (B): Reverse left turn

REMARK

When turning to the right, operate the right travel lever in the same way.

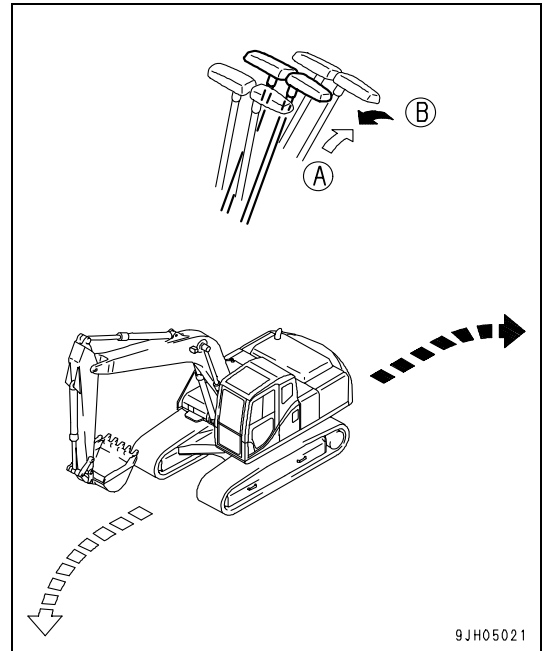

Counter-rotation Turn (Spin Turn)

When using counter-rotation (spin turn) to turn left, pull the left travel lever back and push the right travel lever forward.

REMARK

When using counter-rotation to turn right, pull the right travel lever back and push the left travel lever forward.

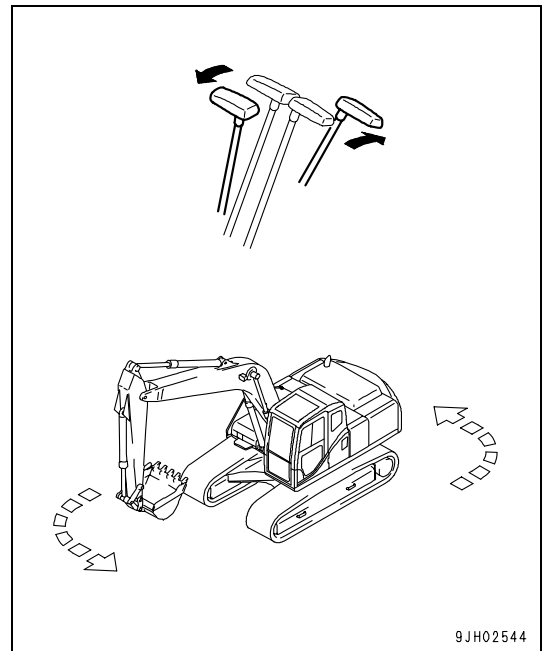

SWINGING

⚠ WARNING
 The tail of the machine extends outside the tracks. Before operating the swing, check that the area around the machine is safe.

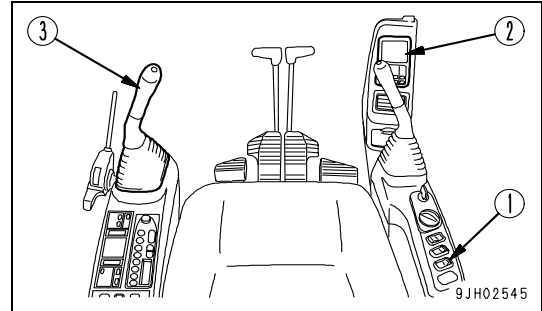

1. Before starting the swing operation, turn swing lock switch (1) OFF and check that swing lock monitor (2) has gone out.

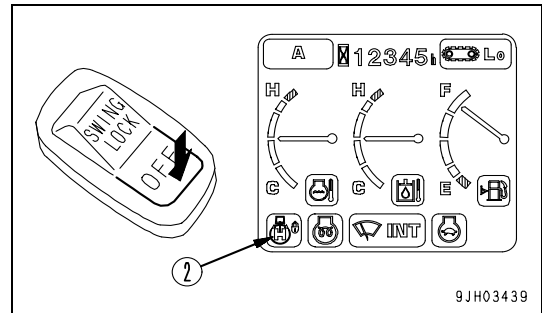

2. Operate left work equipment control lever (3) to swing the upper structure.

- (A): Left swing
- (B): Right swing

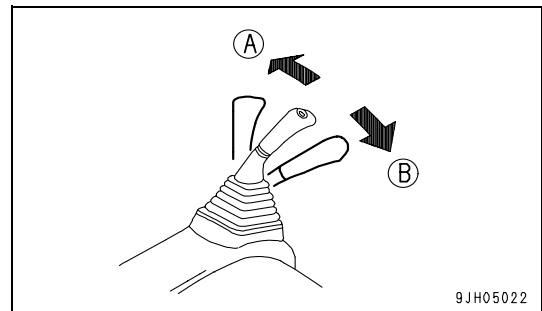

3. When not using the swing, turn swing lock switch (1) ON. Check that swing lock monitor (2) lights up.

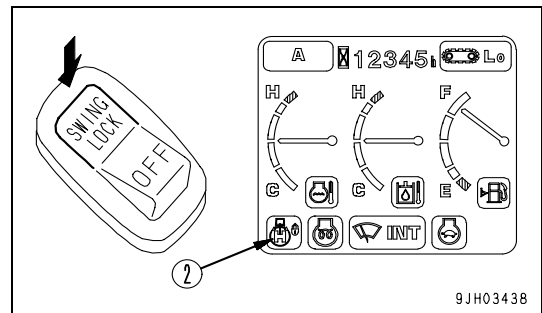

WORK EQUIPMENT CONTROLS AND OPERATIONS

WARNING

If the lever is operated when the engine speed has been lowered by the auto-deceleration function, the engine speed will suddenly rise, so operate the levers carefully.

The work equipment is operated by the left and right work equipment control levers. The left work equipment control lever operates the arm and swing, and the right work equipment control lever operates the boom and bucket.

The movements of the lever and work equipment are as shown in the diagrams on the right. When the levers are released, they automatically return to the neutral position and the work equipment is held in place.

- If the work equipment control levers are returned to the neutral position when the machine is stopped, even if the fuel control dial is set to FULL, the auto-deceleration mechanism will act to reduce the engine speed to a mid-range speed.

REMARK

With this machine, an accumulator is installed in the operating circuit, so if less than 15 seconds has passed since the engine was stopped, when the starting switch is turned to the ON position even when the engine is stopped, it is possible to operate the levers to lower the work equipment to the ground.

In addition, this operation can also be used to release the remaining pressure in the hydraulic cylinder circuit or to lower the boom after the machine has been loaded onto a trailer.

Arm operation

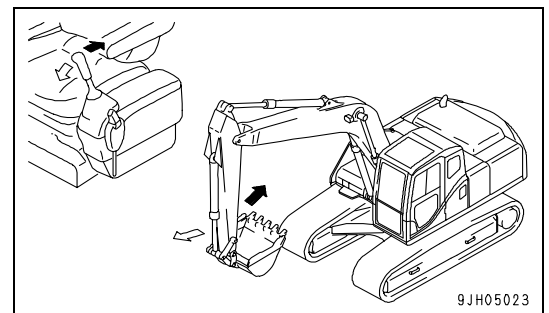

Swing operation

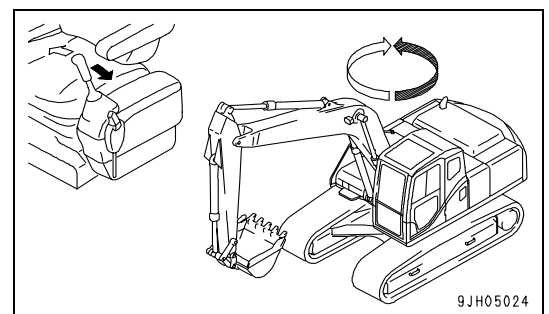

Boom operation

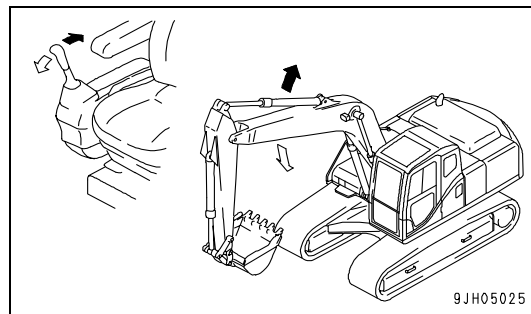

Bucket operation

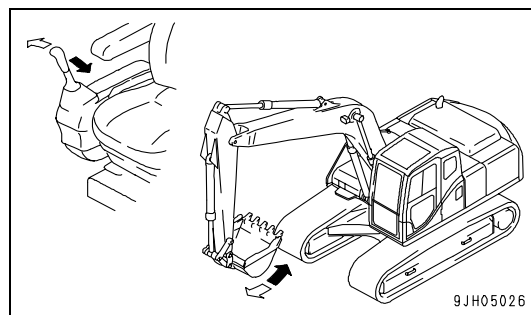

WORKING MODE

Working Mode

The mode selector switch can be used to switch the mode to match the operating conditions and purpose, thereby enabling work to be carried out efficiently.

Make effective use of each mode as follows.

When the starting switch is turned ON, the working mode is set to A mode (digging).

Use the working mode switch to set the mode to the most efficient mode to match the type of work.

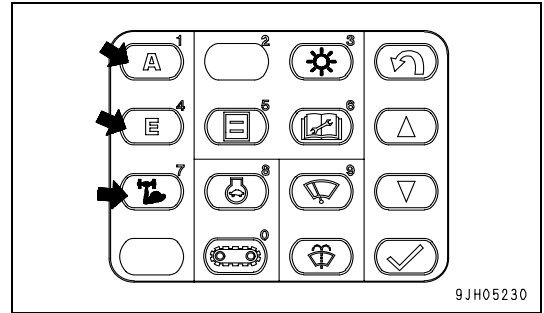

Working mode	Applicable operation
A mode	Normal digging, loading operations (operations with emphasis on productivity)
E mode	Normal digging, loading operations (operations with emphasis on fuel economy)
Heavy-duty lift mode	Normal digging, loading operations (boom lifting power increased when raising boom independently)

PROHIBITED OPERATIONS

WARNING

- If it is necessary to operate the work equipment control lever when the machine is traveling, stop the machine, then operate the control lever.
- If any lever is operated when the auto-deceleration is being actuated, the engine speed will suddenly increase, so be careful when operating.

Operations Using Swing Force

Do not use the swing force to compact soil or break objects. This is not only dangerous, but will also markedly reduce the life of the machine.

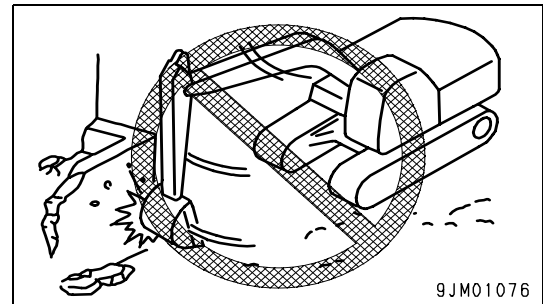

Operations Using Travel Force

Do not dig the bucket into the ground and use the travel force to carry out excavation. This will damage the machine or work equipment.

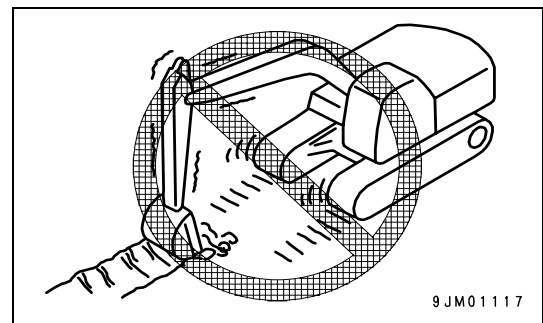

Prohibition of Operations Using Hydraulic Cylinders to Stroke Ends

If the work equipment is used with the cylinder rod operated to its stroke end, and given impact by some external force, the hydraulic cylinders will be damaged, causing personal injury. Avoid operations with the hydraulic cylinder fully retracted or fully extended.

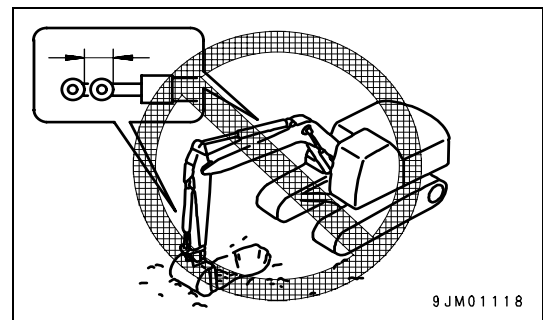

Operations Using Bucket Dropping Force

Do not use the dropping force of the machine for digging, or use the dropping force of the bucket as a pickaxe, breaker, or pile driver. This will markedly reduce the life of the machine.

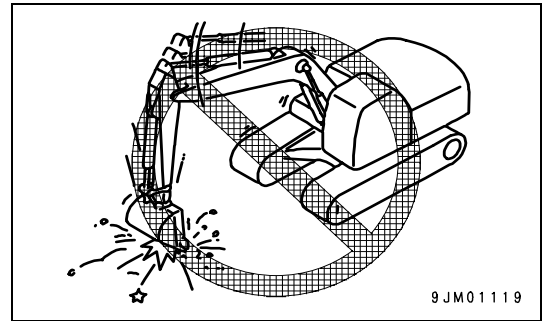

Operations Using Machine Dropping Force

Do not use the dropping force of the machine for digging.

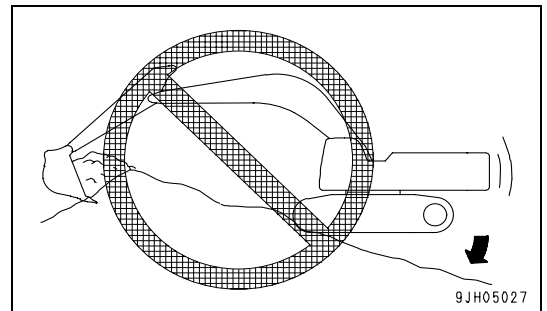
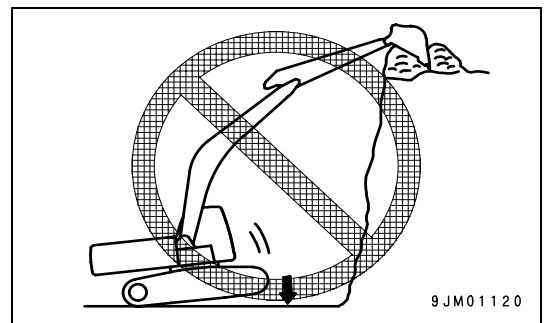

Digging Hard Rocky Ground

Do not attempt to directly excavate hard rocky ground with the work equipment. It is better to excavate it after breaking up by some other means. This will not only save the machine from damage but make for better economy.

Sudden Lever Shifting High Speed Travel

- (1) Never carry out sudden lever shifting as this may cause sudden starting.
- (2) Avoid sudden lever shifting from forward (A) to reverse (B) (or from reverse (B) to forward (A)).
- (3) Avoid sudden lever shifting change such as sudden stopping from near top speed (lever release operation).

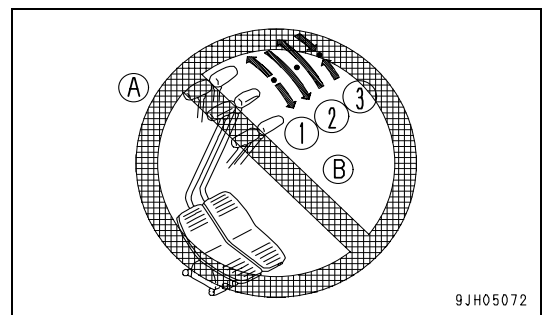

GENERAL OPERATION INFORMATION

Traveling

Traveling over boulders, tree stumps, or other obstacles will cause a big shock to the chassis (and in particular to the tracks), and this will cause damage to the machine. For this reason, always remove any obstacles or travel around them, or take other steps to avoid traveling over such obstacles as far as possible.

If there is no way to avoid traveling over an obstacle, reduce the travel speed, keep the work equipment close to the ground, and try to travel so that the center of the track passes over the obstacle.

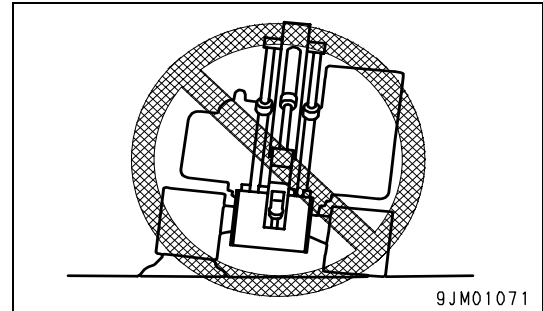

High Speed Travel

On uneven roadbeds such as rock beds or uneven roads with large locks, travel at Lo speed. When traveling at high speed, set the idler in the forward direction.

- To switch the travel speed, press travel speed selector switch (1). The travel speed is displayed as Lo, Mi, or Hi on the monitor display.

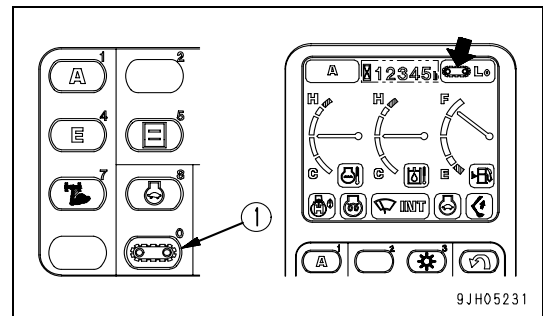

Precautions when carrying out operations continually with the work equipment in the same posture

Precautions when carrying out operations continually with the work equipment in the same posture.

When operations are carried out continuously with the cylinder operated slightly, operate the cylinder occasionally by a large amount to ensure greasing of the work equipment pins. This will prevent loss of grease at the pins.

Permissible Water Depth**NOTICE**

When driving the machine out of water, if the angle of the machine exceeds 15°C, the rear of the upper structure will go under water, and water will be thrown up by the radiator fan. This may cause the fan to break.

Be extremely careful when driving the machine out of water.

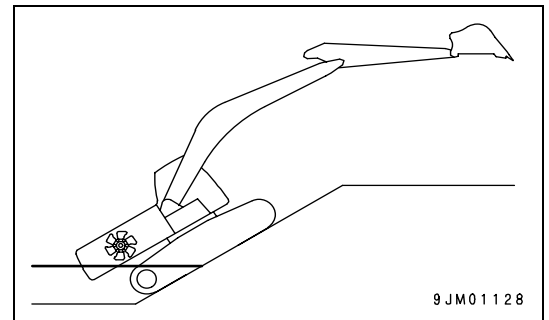

Do not drive the machine in water deeper than of the center of carrier roller (1).

Supply grease to the parts which have been under water for a long time until the used grease is projected out of the bearings (around the bucket pin, in particular).

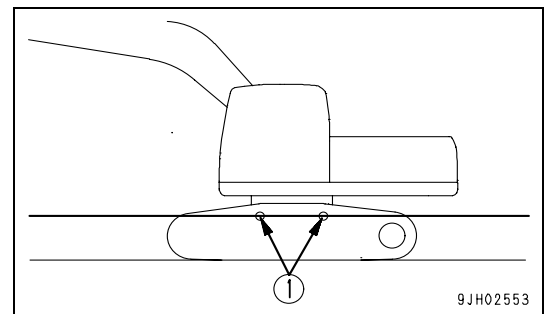

TRAVELING ON SLOPES

WARNING

- Turning or operating the work equipment when working on slopes may cause the machine to lose its balance and turn over, so avoid such operations. It is particularly dangerous to swing downhill when the bucket is loaded. If such operations have to be carried out, pile soil to make a platform (A) on the slope so that the machine can be kept horizontal when operating.
- Do not travel up or down steep slopes. There is danger that the machine may turn over.
- When traveling, raise the bucket approx. 40 to 50cm (15.8 to 19.7 in) from the ground. Do not travel downhill in reverse.
- Never turn on slopes or travel across slopes. Always go down to a flat place to perform these operations. It may be longer, but it will ensure safety.
- Always operate or travel in such a way that it is possible to stop safely at any time if the machine slips or becomes unstable.
- When traveling uphill, if the shoes slip or it is impossible to travel uphill using only the force of the tracks, do not use the pulling force of the arm to help the machine travel uphill. There is danger that the machine may turn over.

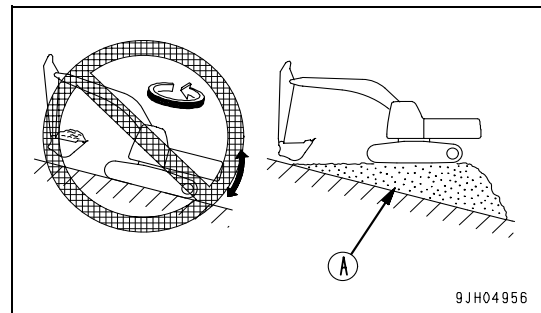
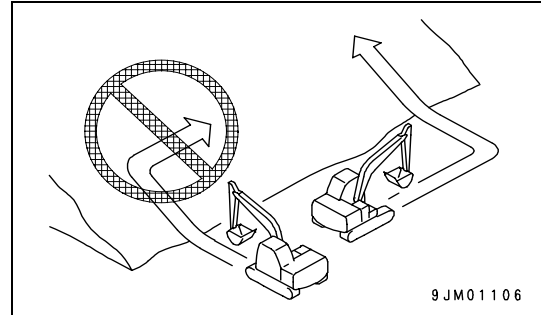

1. When traveling down steep hills, use the travel lever and fuel control lever to keep the travel speed low.

When traveling down slopes of more than 15°, set the work equipment in the posture shown in the figure on the right, and lower the engine speed.

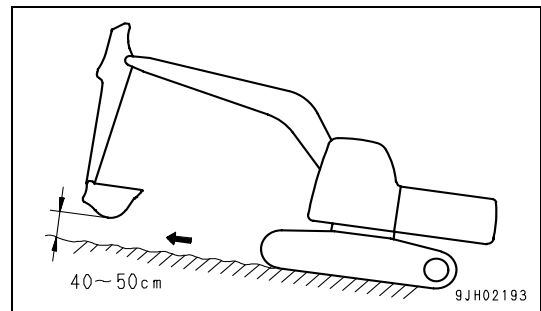

2. When traveling up a steep hill of more than 15°, set the work equipment to the posture shown in the diagram on the right.

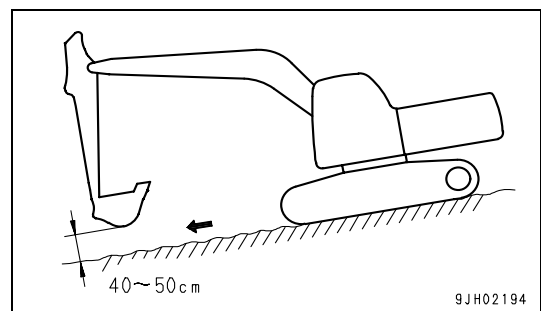

- When traveling up a steep slope, extend the work equipment to the front to improve the balance, keep the work equipment approximately 40 to 50cm (15.8 to 19.7 in) above the ground, and travel at low speed.

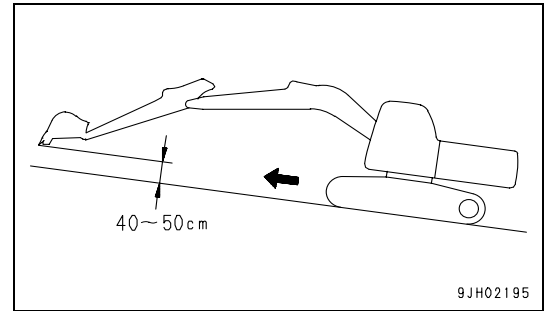

Traveling Downhill

Put the travel lever in the neutral position. This will cause the brake to be automatically applied.

Engine Stopped on Slope

If the engine stops when traveling uphill, move the travel levers to the neutral position, lower the bucket to the ground, stop the machine, then start the engine again.

Cab Doors on Slope

WARNING

Do not open or close the door when the machine is on a slope. The operating effort may suddenly change. Always keep the door locked in position when it is open and when it is closed.

- If the engine stops when the machine is on a slope, never use the left work equipment control lever to carry out swing operations. The upper structure will swing under its own weight.

ESCAPE FROM MUD

When operating, be careful not to get stuck in mud. If the machine gets stuck in mud, do as follows to get the machine out.

- If machine push-up switch (1) is turned ON, the pushing force of the boom is increased and it becomes easier to escape.

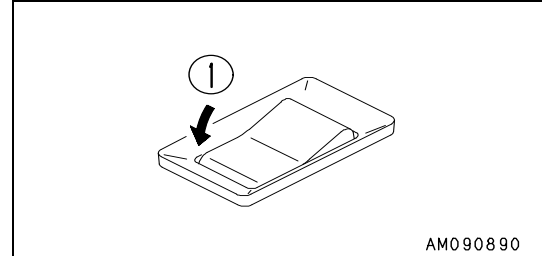

Stuck One Side Of Track

NOTICE

When using the boom or arm to raise the machine, always have the bottom of the bucket in contact with the ground. The angle between the boom and arm should be 90° to 110° . The same applies when using the bucket installed in the reverse direction.

When only one side is affixed in mud, use the bucket to raise the track, then lay boards or logs and drive the machine out.

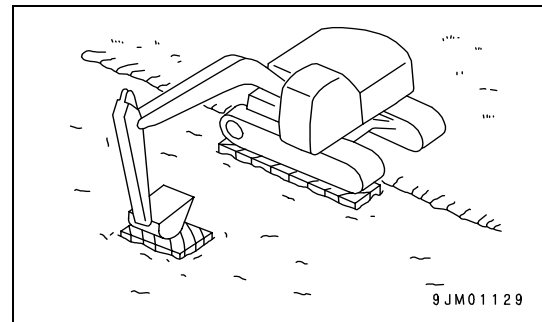

Stuck Both Sides Of Tracks

When the tracks on both sides are stuck in mud and they slip, making it impossible for the machine to move, lay boards or logs as explained above, and dig the bucket into the ground in front. Then pull in the arm as in normal digging operations and put the travel levers in the FORWARD position to pull the machine out.

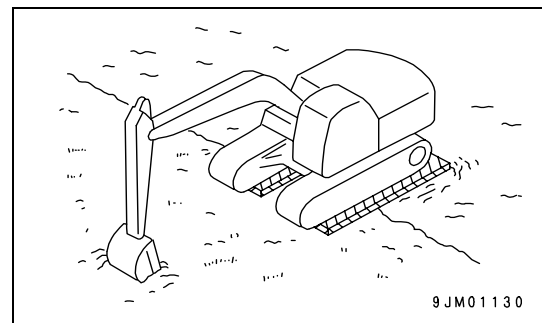

RECOMMENDED APPLICATIONS

In addition to the following, it is possible to further increase the range of applications by using various attachments.

Backhoe Work

A backhoe is suitable for excavating areas that are lower than the machine.

When the condition of the machine is as shown in the diagram on the right (angle between [bucket cylinder and link] and [arm cylinder and arm] is 90°), the maximum excavation force is obtained from the pushing force of each cylinder.

When excavating, use this angle effectively to optimize your working efficiency.

The range for excavating with the arm is from a 45° angle away from the machine to a 30° angle towards the machine.

There may be some differences depending on the excavation depth, but try to stay within the above range rather than operating the cylinder to the end of its stroke.

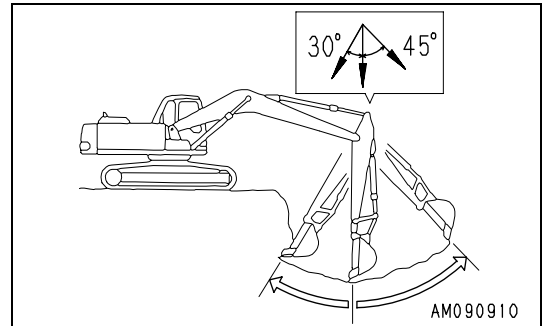
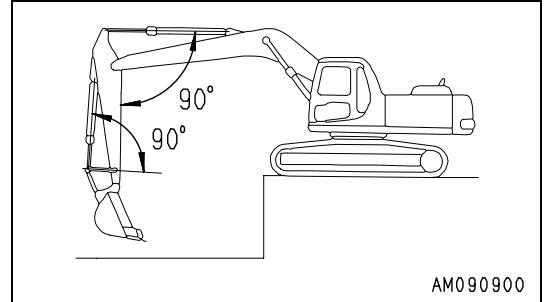

Ditching Work

Ditching work can be performed efficiently by attaching a bucket which matches the digging operation and then setting the tracks parallel to the line of the ditch to be excavated.

To excavate a wide ditch, first dig both sides and then finally remove the center portion.

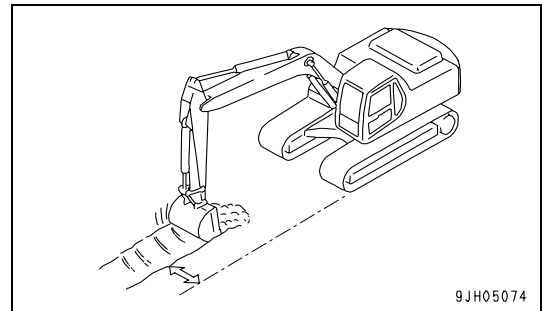

Loading Work

In places where the swing angle is small, work efficiency can be enhanced by locating the dump truck in a place easily visible to the operator.

Loading is easier and capacity greater if you begin from the front of the dump truck body than if loading is done from the side.

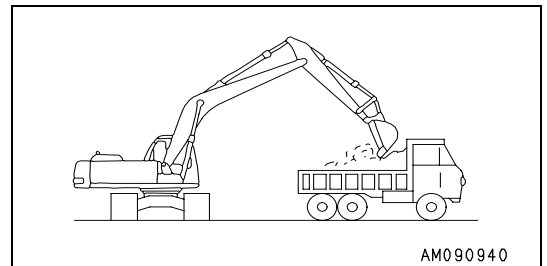

BUCKET REPLACEMENT

WARNING

- When pins are knocked in with a hammer, pieces of metal may fly and cause serious injury. When carrying out this operation, always wear goggles, hard hat, gloves, and other protective equipment.
- When the bucket is removed, place it in a stable condition.
- If pins are hit with a strong force, there is a hazard that the pin may fly out and injure people in the surrounding area. Make sure that there is no one in the surrounding area before starting the operation.
- When removing the pins, do not stand behind the bucket. In addition, be extremely careful not to put your foot under the bucket while standing at the side for the work.
- When removing or inserting pins, be extremely careful not to get your fingers caught.
- Never insert your fingers into the pin holes when aligning the holes.

Stop the machine on a firm and flat surface and do the work. When performing joint work, appoint a conductor and follow that person's instructions and signals.

Replacement

1. Place the bucket in contact with a flat surface.

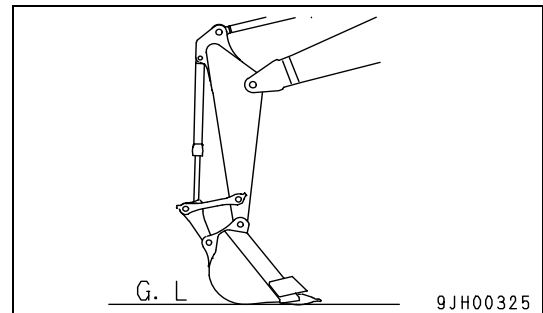

NOTICE

When removing the bucket, set the bucket cylinder (3) facing down as shown in the diagram in the right to prevent the front link (5) from jumping up under the weight of the bucket cylinder (3).

REMARK

When removing the pins, place the bucket so that it is in light contact with the ground. If the bucket is lowered strongly to the ground, the resistance will be increased and it will be difficult to remove the pins.

2. Remove the stopper bolts and nuts, then remove pins (A) and (B), and remove the bucket.

NOTICE

After removing the pins, make sure that mud or sand does not get on them. Dust seals are fitted at both ends of the bushings, so be careful not to damage them.

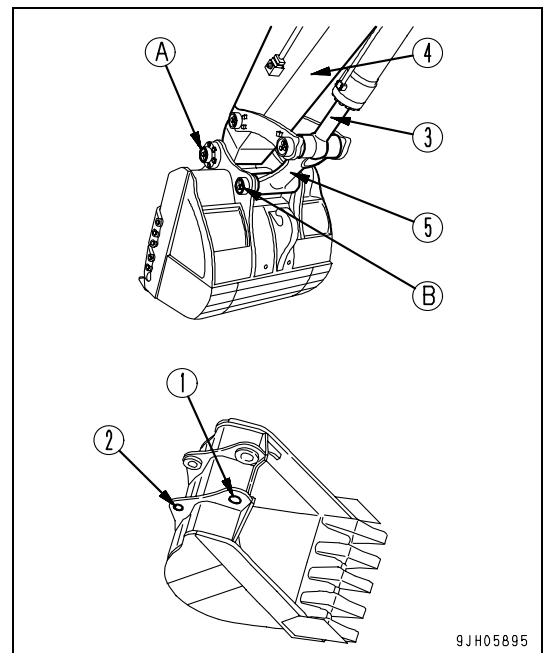

- Align the arm with holes (1) of the replacement bucket and the link with holes (2), then insert grease-coated pins (A) and (B) into hole (1) and hole (2) respectively.

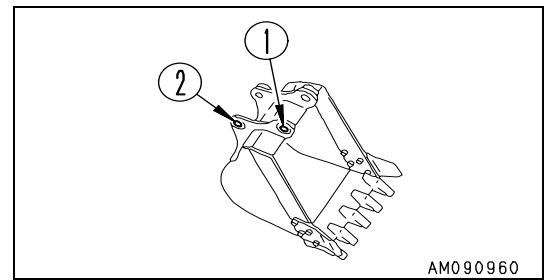
**REMARK**

Carry out installation in the reverse order to removal.

When installing the bucket (6), it is easy to damage the O-ring (7), so fit the O-ring (7) to the arm (4) in the position shown in the diagram on the right. After inserting the pin, fit the O-ring correctly in the groove.

Install the stopper bolts and nuts for each pin, then grease the pin. Lubricate with grease thoroughly until the grease comes out from the end face.

When replacing the bucket, replace the dust seal if it has been damaged. If a damaged seal is used without being replaced, sand and dirt may enter the pin portion and cause abnormal wear of the pin.

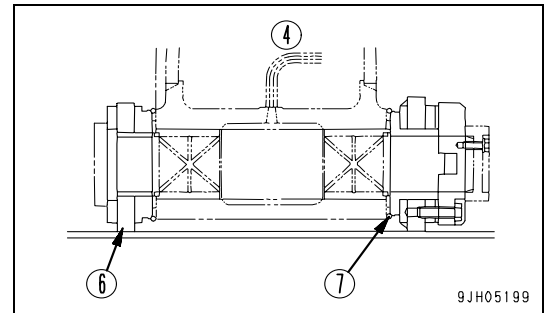

PARKING MACHINE

WARNING

- Avoid stopping suddenly. Give yourself ample room when stopping.
- When stopping the machine, select flat hard ground and avoid dangerous places. If it is unavoidably necessary to park the machine on a slope, insert blocks underneath the track shoes. As an additional safety measure, thrust the bucket into the ground.
- If the control lever is touched by accident, the work equipment or the machine may move suddenly, and this may lead to a serious accident. Before leaving the operator's compartment, always set the lock lever securely to LOCK position (L).

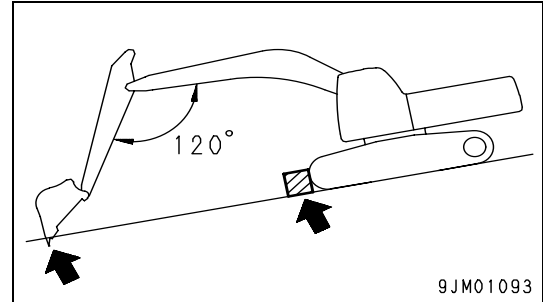

1. Put left and right travel levers (1) in the neutral position.
The machine stops.

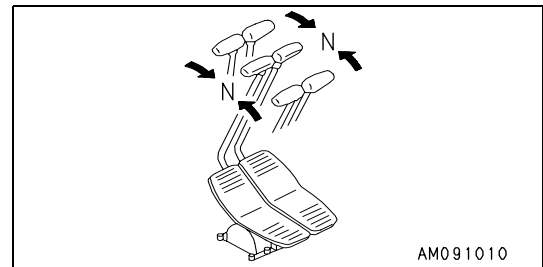
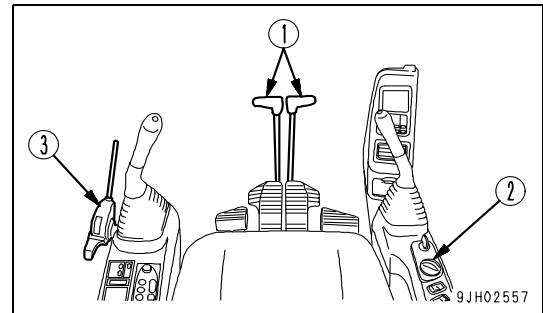

2. Turn fuel control dial (2) to lower the engine speed to low idling.

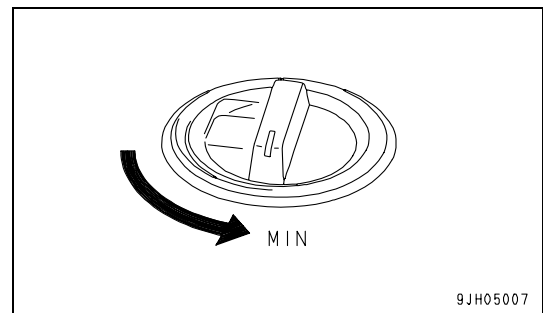

- Lower the bucket horizontally until the bottom touches the ground.

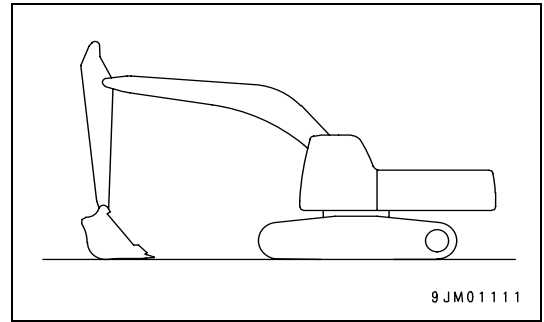

- Set lock lever (3) in the LOCK position (L).

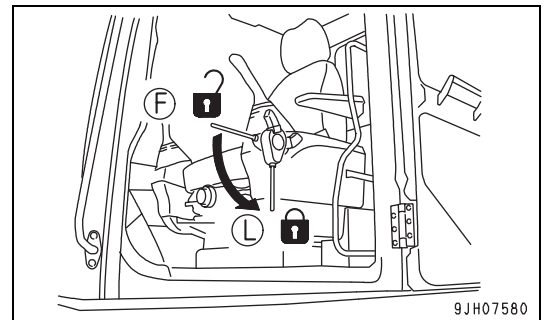

CHECK AFTER SHUT OFF ENGINE

Check the engine water temperature, engine oil pressure, and fuel level on the machine monitor.

REMARK

After stopping the engine, if the starting switch is turned within approx. 10 seconds to the ON or START position to start the engine again, the monitor display is not reset, and the screen before the starting switch was turned OFF is displayed.

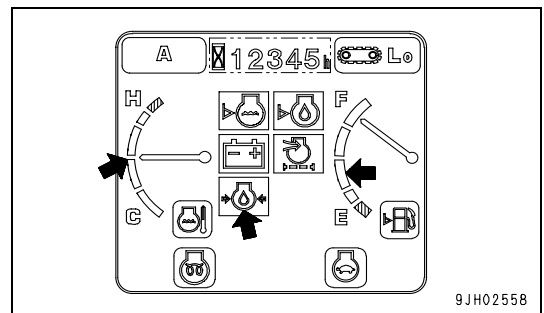

LOCKING

Always lock the following places.

- (1) Door of operator's cab
Always remember to close the window.
- (2) Fuel tank filler port
- (3) Engine hood
- (4) Battery box cover
- (5) Left side door of the machine (2 places)
- (6) Tool box side door
- (7) Hydraulic tank filler port
- (8) Spare pail cover

REMARK

Use the starting switch key to open and close all these places.

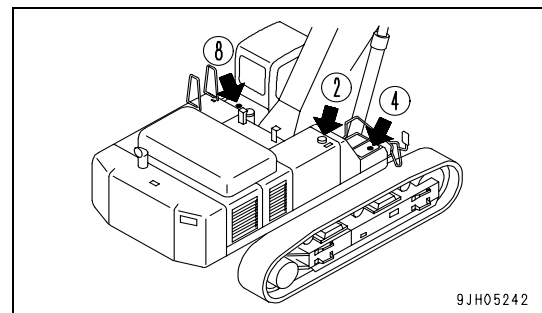
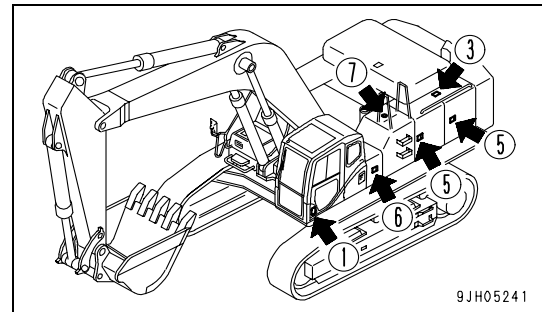

TRANSPORTATION

When transporting the machine, observe all related laws and regulations, and be careful to assure safety.

PRECAUTIONS FOR TRANSPORTATION



WARNING

**This machine must be divided into several units for transportation.
When transporting the machine, please consult your Komatsu distributor.**

LIFTING MACHINE



WARNING

- Never carry out the lifting operation with any person on the machine.
- Always make sure that the wire rope used for lifting the machine is of ample strength for the weight of the machine.
- Never try to lift the machine in any posture other than the posture given in the procedure below. There is danger that the machine may lose its balance.
- When lifting the machine, pay careful attention to the center of gravity to maintain the balance.

When lifting the machine, carry out the operation on flat ground as follows.

1. When lifting the machine, choose level ground and do as follows.
Pass the wire ropes between the 1st and 2nd track rollers from the front of the machine and the 1st and 2nd track rollers from the rear.
However, if the machine is equipped with a track roller guard, pass the wire ropes under the track.
2. Set the lifting angle of the wire rope to 30° to 40°, then lift the machine slowly.
3. After the machine comes off the ground, stop the lifting operation and wait for the machine to stabilize, then lift the machine slowly.
 - The lifting load is 35 tons.

SHIPPING MACHINE INFORMATION

WARNING

- When loading the machine, choose firm level ground. Keep well away from the road shoulder.
- Run the engine at low speed and operate slowly.

After placing the machine on the specified position of the trailer, secure it according to the following procedure.

1. Set all the control levers securely at LOCK position (L) with lock lever (1).

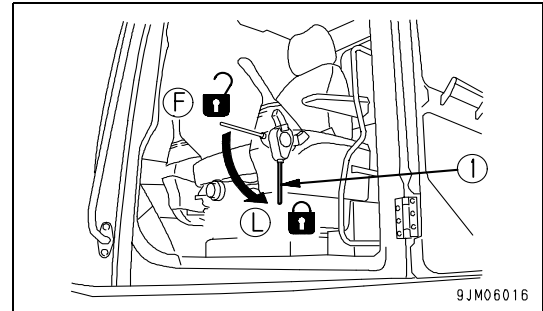

2. When transporting the machine, place wooden blocks under the front and rear track shoes to prevent the machine from moving. Also, hold it down with chains or wire rope of a suitable strength. Be particularly careful to ensure that the machine does not slip sideways.

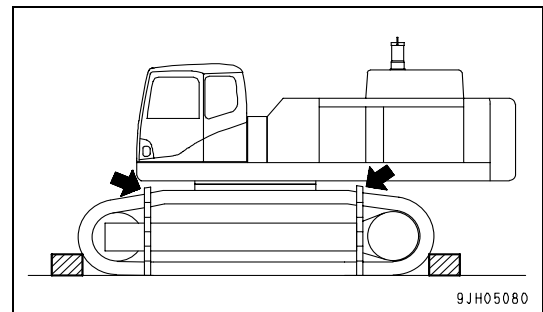

TRANSPORTATION POSTURE

This machine can be divided into three units or four units for transportation. When transporting the machine please contact your Komatsu distributor.

Three units for transportation

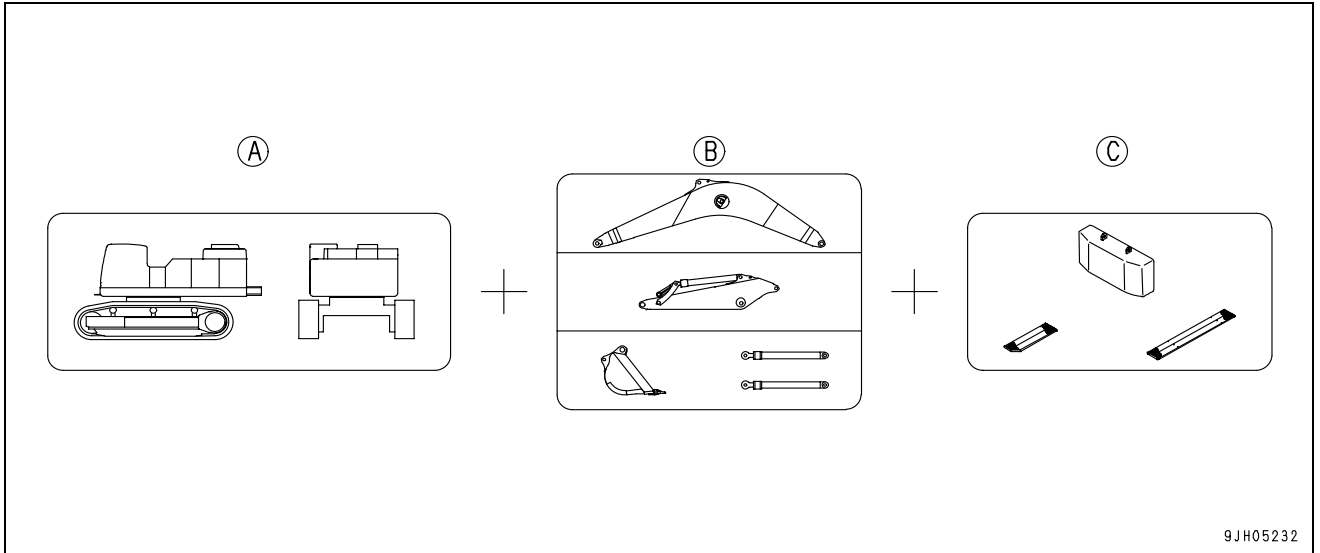

- (A) Upper structure + Undercarriage
- (B) Work equipment
- (C) Other

Four units for transportation

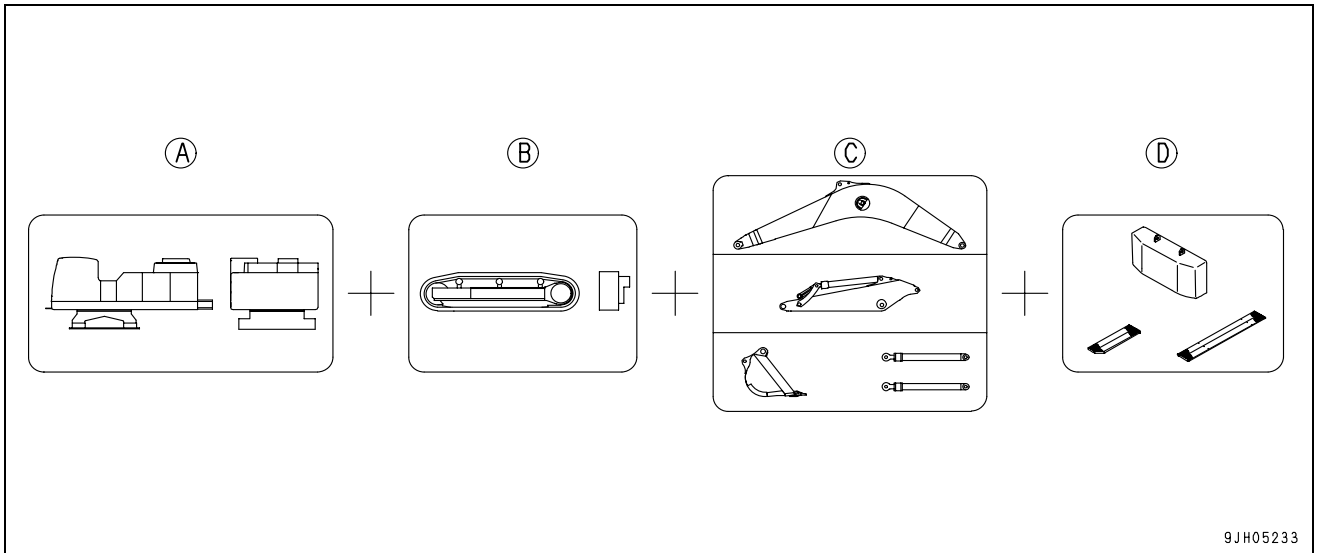

- (A) Upper structure
- (B) Undercarriage
- (C) Work equipment
- (D) Others

Posture for each unit

Upper Structure + Undercarriage

Unit		PC600-7	PC600LC-7
Overall width	mm (ft in)	3,195 (10' 6")	3,195 (10' 6")
A	mm (ft in)	3,330 (10' 11")	3,330 (10' 11")
B	mm (ft in)	6,170 (20' 3")	6,340 (20' 10")
Weight	kg (lb)	33,200 (73,206)	34,200 (75,411)

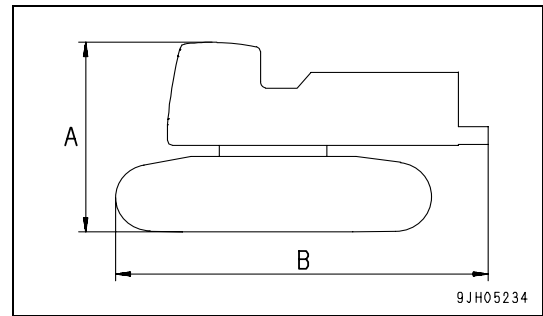

Upper Structure

Secure the upper structure to the platform with a chain and block.

Unit		PC600-7, PC600LC-7
Overall width	mm (ft in)	3,195 (10' 6")
A	mm (ft in)	2,500 (8' 2")
B	mm (ft in)	4,970 (16' 4")
Weight	kg (lb)	16,800 (37,044)

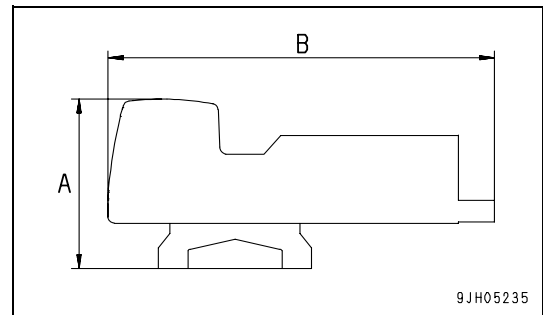

Undercarriage

If there is a warning tag hanging on the work equipment control lever, do not start the engine.

Unit		PC600-7	PC600LC-7
Quantity		2	2
A	mm (ft in)	1,260 (4' 2")	1,260 (4' 2")
B	mm (ft in)	5,340 (17' 6")	5,690 (18' 8")
C	mm (ft in)	875 (2' 10")	875 (2' 10")
Weight	kg [lb]	16,400 (8,200 x 2) [36,162 (18,081 x 2)]	17,400 (8,700 x 2) [38,367 (19,184 x 2)]

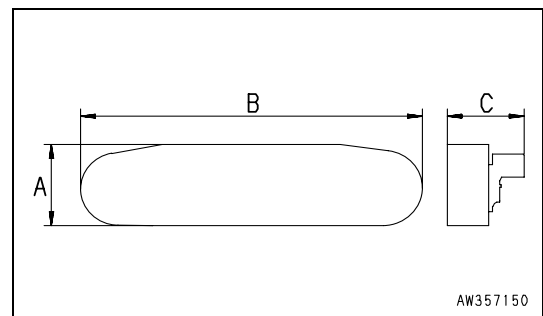

Work Equipment

- Boom

Unit		PC600-7, PC600LC-7
A	mm (ft in)	7,920 (25' 12")
B	mm (ft in)	2,040 (6' 8")
Overall width	mm (ft in)	1,190 (3' 11")
Weight	kg (lb)	4,820 (10,628)

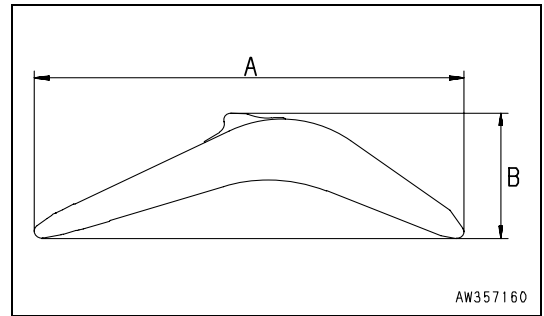

- Arm

Unit		PC600-7, PC600LC-7
A	mm (ft in)	4,870 (15' 12")
B	mm (ft in)	1,270 (4' 2")
Overall width	mm (ft in)	480 (1' 7")
Weight	kg (lb)	3,240 (7,144)

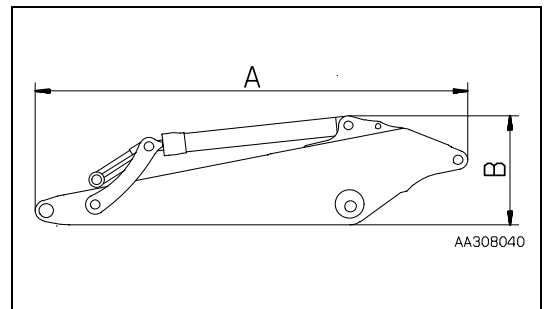

- Bucket (with side cutter, shroud)

Unit		PC600-7, PC600LC-7
A	mm (ft in)	2,040 (6' 8")
B	mm (ft in)	1,870 (6' 2")
Overall width	mm (ft in)	1,790 (5' 10")
Weight	kg (lb)	2,510 (5,535)

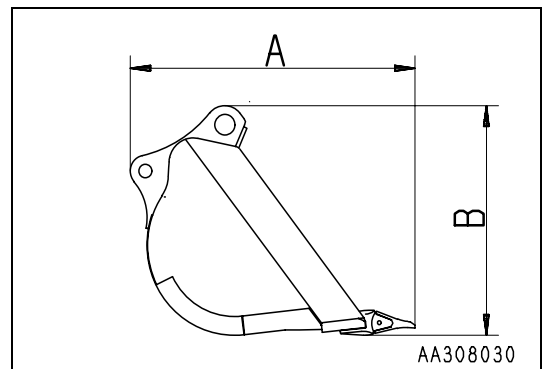

- Boom cylinder (same for all models)

Unit		PC600-7, PC600LC-7
Quantity		2
A	mm (ft in)	2,672 (8' 9")
Weight	kg (lb)	1,040 (520 x 2) [2,293 (1147 x 2)]

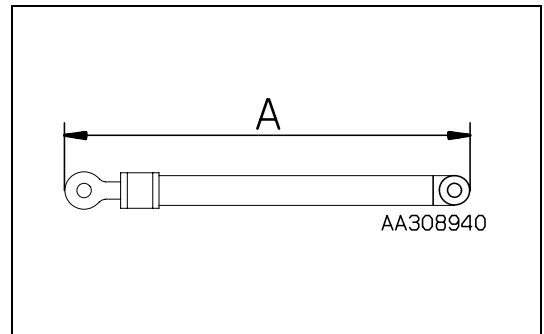

● Arm cylinder

Unit		PC600-7, PC600LC-7
A	mm (ft in)	3,108 (10' 2")
Weight	kg (lb)	770 (1,698)

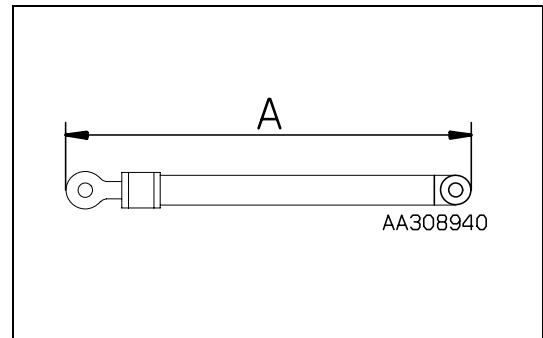

Others

● Counterweight

Unit		PC600-7, PC600LC-7
A	mm (ft in)	1,320 (4' 4")
B	mm (ft in)	3,195 (10' 6")
C	mm (ft in)	680 (2' 3")
Weight	kg (lb)	10,750 (23,704)

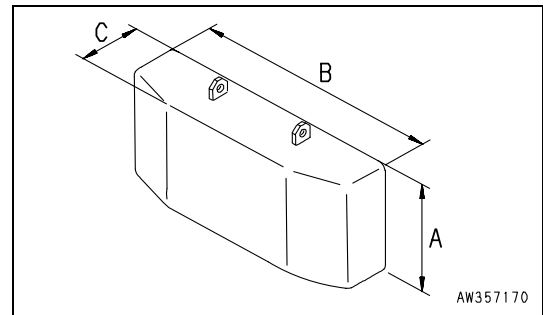

● Head guard (option)

Unit		PC600-7, PC600LC-7
A	mm (ft in)	1,816 (5' 11")
B	mm (ft in)	215 (8.5")
C	mm (ft in)	980 (3' 3")
Weight	kg (lb)	55 (121)

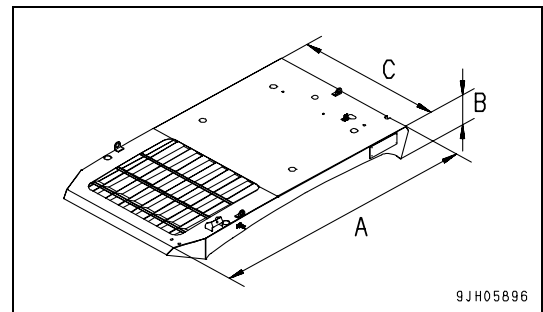

● Catwalk (1) (same for all models)

Unit		PC600-7, PC600LC-7
A	mm (ft in)	500 (1' 8")
B	mm (ft in)	1,910 (6' 3")
Weight	kg (lb)	32 (71)

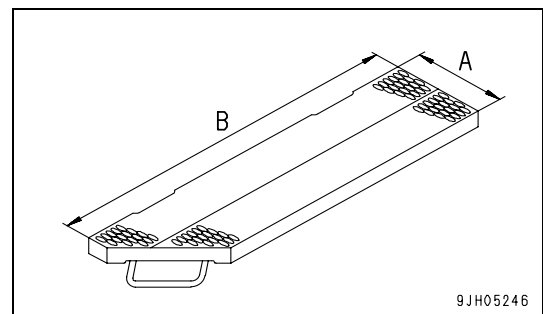

- Catwalk (2) (same for all models)

Unit		PC600-7, PC600LC-7
A	mm (ft in)	2,310 (7' 7")
B	mm (ft in)	500 (1' 8")
Weight	kg (lb)	37 (82)

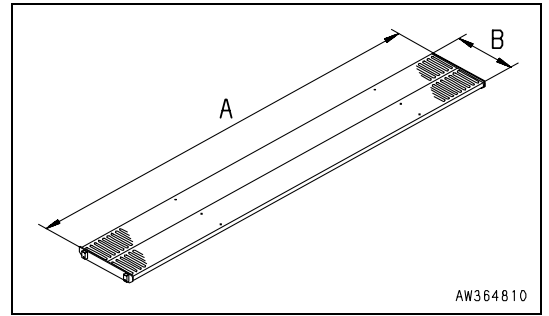

AW364810

PROCEDURE FOR INCREASING OR REDUCING TRACK FRAME GAUGE

WARNING

Never use the machine for operations with the track frame retracted.

Reducing Track Gauge

1. Remove center frame mounting bolts (1). (one side, front + rear: 16 bolts)

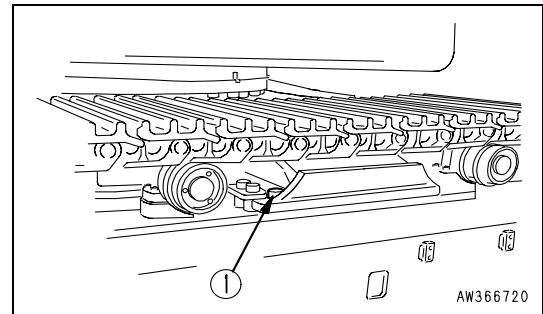

2. Swing the upper structure so that it is at 90° on the side of track frame (A) to be retracted, then use the work equipment to jack up the track frame.
3. Set blocks (B) (20 to 30 cm (8 to 12 in) wooden blocks) towards the outside of track frame (A), then use the boom cylinder to lower the machine slowly. The track frame (A) will slide and stop when it contacts the stopper.

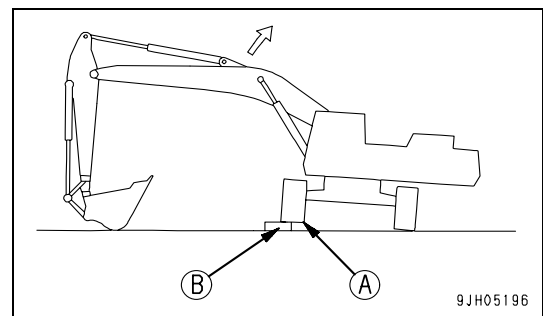

4. Lower the machine carefully and install bolts (2). (one side, front + rear: 8 bolts out of bolts (1))
5. Tightening torque: 1960 - 2450 N·m
(200 - 250 kgf·m, 1450 - 1810 lbft)
6. Follow the same procedure to retract the track frame on the other side.

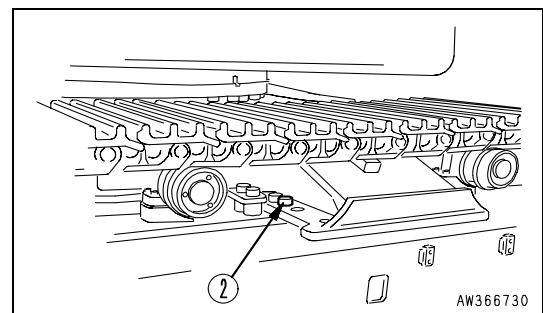

Increasing Track Gauge

1. Remove center frame mounting bolts (2) (one side, front + rear: 8 bolts) from the front and rear of the track frame on the side to be extended.

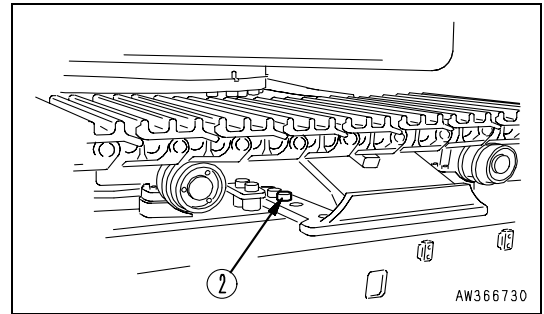

2. Swing the upper structure so that it is at 90° on the opposite side to track frame (A) to be extended.

REMARK

Height H of the track frame being raised should be less than 50 mm (2 in). Take care not to raise the track frame so much that the stopper bolt is distorted.

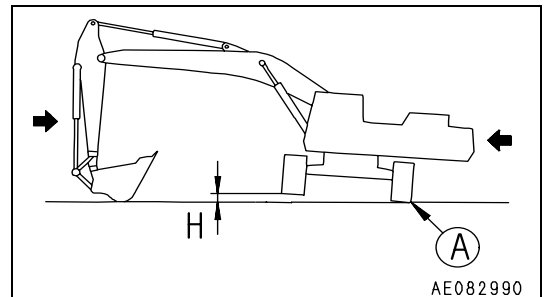

3. Using the arm, pull the machine to the front.
The track frame will slide.
4. Extend the track frame until it comes into contact with the stopper, then lower the machine slowly to the ground. Install bolts (1) (one side, front + rear: 16 bolts) and tighten to specified torque.
5. Tightening torque: 1960 - 2450 N·m
(200 - 250 kgf·m, 1450 - 1810 lbft)
6. Follow the same procedure to retract the track frame on the other side.
 - Stop the machine on firm level ground when extending or retracting the track frame gauge width.
 - Never operate the cylinders suddenly when extending or retracting the track frame gauge width. It is dangerous if they are operated suddenly.

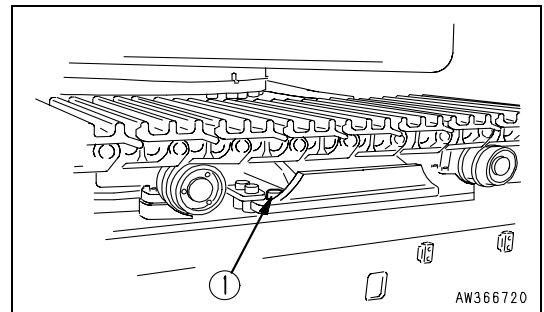

COLD WEATHER OPERATION

COLD WEATHER OPERATION INFORMATION

If the temperature becomes low, it becomes difficult to start the engine, and the coolant may freeze, so do as follows.

Fuel And Lubricants

Change to fuel and oil with low viscosity for all components. For details of the specified viscosity, see "LUBRICANTS, FUEL AND COOLANT SPECIFICATIONS (4-9)".

Coolant

WARNING

- Antifreeze is toxic. Be careful not to get it into your eyes or on your skin. If it should get into your eyes or on your skin, wash it off with large amount of fresh water and see a doctor at once.
- When changing the coolant or when handling coolant containing antifreeze that has been drained when repairing the radiator, please contact your Komatsu distributor. Antifreeze is toxic, so do not let it flow into drainage ditches or spray it on to the ground surface.
- Antifreeze is flammable, so do not bring any flame close. Do not smoke when handling antifreeze.

NOTICE

- Never use methanol, ethanol, or propanol-based antifreeze.
- Never use any water-leakage prevention agent or any antifreeze containing such an agent.
- Do not mix different types of antifreeze.

For details of the antifreeze mixture when changing the coolant, see "CLEAN INSIDE OF COOLING SYSTEM (4-25)".

Use a Permanent Antifreeze (ethylene glycol mixed with corrosion inhibitor, antifoam agent, etc.) meeting the standard requirements as shown below. With permanent antifreeze, no change of coolant is required for a year. If it is doubtful that an available antifreeze meets the standard requirements, ask the supplier of that antifreeze for information.

Standard requirements for permanent antifreeze

- SAE J1034
- FEDERAL STANDARD O-A-548D

REMARK

In areas where permanent antifreeze is not available, it is possible to use antifreeze whose main component is ethylene glycol and does not contain any corrosion inhibitor. (Such antifreeze can be used for the winter season only.) However, in such a case, the cooling water must be changed twice a year (spring and fall), so use permanent antifreeze when possible.

Battery

 **WARNING**

- The battery generates flammable gas, so do not bring fire or sparks near the battery.
- Battery electrolyte is dangerous. If it gets in your eyes or on your skin, wash it off with a large amount of water and consult a doctor.
- Battery electrolyte dissolves paint. If it gets on to the bodywork, wash it off immediately with water.
- If the battery electrolyte is frozen, do not charge the battery or start the engine with a different power source. There is danger that the battery may explode.
- Battery electrolyte is toxic, so do not let it flow into drainage ditches or spray it on to the ground surface.

When the ambient temperature drops, the capacity of the battery will also drop. If the battery charge ratio is low, the battery electrolyte may freeze. Maintain the battery charge as close as possible to 100%, and insulate it against cold temperature so that the machine can be started easily the next morning.

REMARK

Measure the specific gravity and calculate the rate of charge from the following conversion table.

Temperature (°C) \ Charging Rate(%)	20	0	-10	-20
100	1.28	1.29	1.30	1.31
90	1.26	1.27	1.28	1.29
80	1.24	1.25	1.26	1.27
75	1.23	1.24	1.25	1.26

- As the battery capacity drops markedly in low temperatures, cover the battery or remove it from the machine, keep it in a warm place, and install it again the next morning.
- If the electrolyte level is low, add distilled water in the morning before beginning work. Do not add the water after the day's work so as to prevent fluid in the battery from freezing in the night.

AFTER DAILY WORK COMPLETION

WARNING

Performing idle-running of the tracks is dangerous, so stay well away from the tracks.

To prevent mud, water, or the undercarriage from freezing and making it impossible for the machine to move on the following morning, always observe the following precautions.

- Remove any mud or water from the machine. In particular, remove any drops of water on the surface of the hydraulic cylinder rod. These drops of water may get inside the seal together with mud and damage the seal.
 - Park the machine on hard, dry ground.
If this is impossible, park the machine on wooden boards.
The boards help protect the tracks from being frozen in soil and the machine can start next morning.
 - Open the drain valve and drain any water collected in the fuel system to prevent it from freezing.
 - Fill the fuel tank to the full in order to prevent moisture from forming dew in the tank room, as the ambient temperature goes down.
 - After operation in water or mud, remove water from undercarriage as described below to extend undercarriage service life.
1. Swing 90° with engine at low idling and bring the work equipment to the side of the track.
 2. Jack up the machine until the track is raised slightly from the ground. Rotate the track under no load. Repeat this procedure on both the left and right sides.

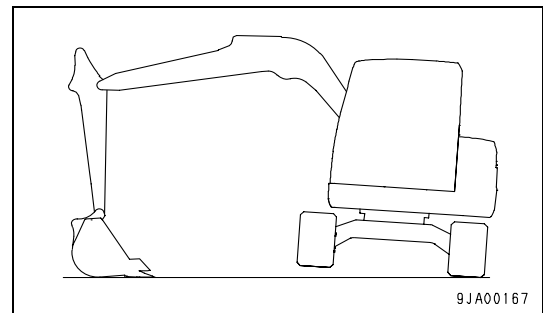

AFTER COLD WEATHER SEASON

When season changes and the weather becomes warmer, do as follows.

- Replace the fuel and oil for all parts with oil of the viscosity specified.
For details, see "LUBRICANTS, FUEL AND COOLANT SPECIFICATIONS (4-9)".
- If for any reason permanent antifreeze cannot be used, and an ethyl glycol base antifreeze (winter, one season type) is used instead, or if no antifreeze is used, drain the cooling system completely, then clean out the inside of the cooling system thoroughly, and fill with fresh soft water.

LONG TERM STORAGE

BEFORE STORAGE

NOTICE

When storing the machine, set the machine in the posture shown in the diagram on the right to protect the cylinder rod. (To prevent rusting of the cylinder rod)

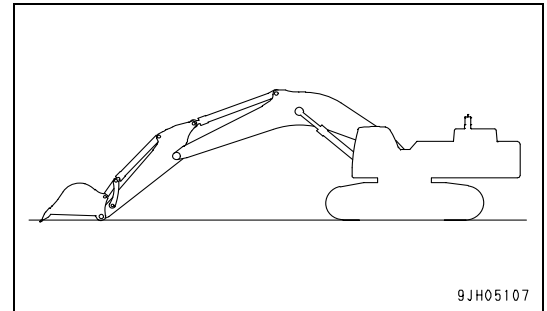

When putting the machine in storage for a long time, do as follows.

- Clean and wash all parts, then store the machine indoors. If the machine has to be stored outdoors, select level ground and cover the machine with a sheet.
- Completely fill the fuel tank, lubricate and change the oil before storage.
- Apply a thin coat of grease to the metal surface of the hydraulic piston rods.
- Disconnect the negative terminals of the battery and cover it, or remove it from the machine and store it separately.
- Lock each control lever and pedal with the lock lever.
- Set the stop valve to the "lock" position on machines ready for attachments. Install the blind plugs to the elbows.
- Set the selector valve to the "When not use" position on machines ready for attachments.

DURING STORAGE

WARNING

If it is unavoidably necessary to carry out the rust-preventive operation while the machine is indoors, open the doors and windows to improve ventilation and prevent gas poisoning.

- During storage, always operate the machine once a month so that a new film of oil will be coated over movable parts and component surfaces. At the same time, also charge the battery.
- For machines equipped with an air conditioner, run the air conditioner.
- When operating the work equipment, wipe off all the grease from the hydraulic cylinder rod.
- Rotate the tracks.

AFTER STORAGE

NOTICE

If the machine is to be used when the monthly rust prevention operation has not been carried out, please contact your Komatsu distributor.

When using the machine after long-term storage, do as follows before using it.

- Wipe off the grease from the hydraulic cylinder rods.
- Add oil and grease to all places.
- When a machine is stored for a long period, moisture in the air will get into the oil. Check the oil before and after starting the engine. If there is water in the oil, change the oil.

STARTING MACHINE AFTER LONG-TERM STORAGE

When starting the engine after the machine has been in storage for a long time, carry out the automatic warming-up operation.

If the engine is started according to the starting procedure for cold weather, the warming-up operation is carried out automatically.

(For details, see Section "Starting Engine In Cold Weather (3-91)" and Section "In Cold Weather Areas (3-97)")

TROUBLES AND ACTIONS

RUNNING OUT OF FUEL

WARNING

When air bleed plug (2) at the top of the fuel filter head or supply pump air breather (4) are removed, the system is still under pressure, so fuel may spurt out. Loosen these parts slowly before opening them.

When starting after running out of fuel, fill the filter cartridge with fuel and bleed the air from the fuel system before starting.

Procedure for Bleeding Air

1. Remove the fuel filter cartridge, fill the filter case with fuel, then install again.

NOTICE

- The common rail fuel injection system used on this machine consists of more precise parts than the conventional injection pump and nozzle, so problems may be caused by dust or dirt getting in. When carrying out inspection or maintenance of the fuel system, pay more attention than normal to the entry of dirt. If dirt is stuck to any part, use fuel to wash it off completely.
- If no clean fuel is available, bleed the air with priming pump (3) without removing the fuel cartridge.

NOTICE

- When adding fuel, do not remove cap (4). Always add fuel from the 8 small holes (A) on the dirty side.
- After adding fuel, remove cap (4) and install the fuel filter.
- Always fill with clean fuel. Be careful not to let any dirt or dust get into the fuel. In particular, center portion (B) is the clean side, so do not remove cap (4) when adding fuel. Be careful not to let dirt or dust get into center portion (B) on the clean side.

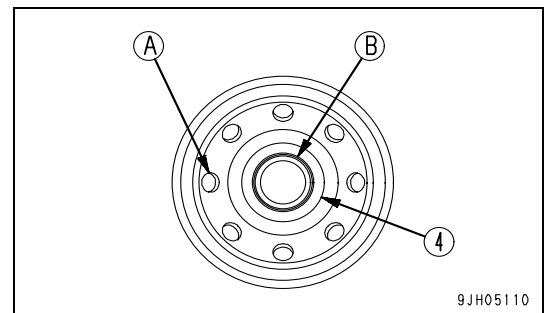

2. Loosen air bleed plug (2) at the top of the fuel filter head and open fuel supply valve (1) at the bottom of the fuel tank.
3. Loosen the knob of priming pump (3), pump the knob, and check that fuel comes out from air bleed plug (2).

After checking, tighten the plug.

Tightening torque: 7.8 to 9.8 N·m
(0.8 to 1 kgf·m, 5.8 to 7.2 lbft)

4. Open air breather (4) at the side of the supply pump, and pump priming pump (3) approx. 90 - 100 times.

With this operation, fuel will start to overflow from air breather (4). When no more bubbles come out with the fuel, tighten air breather (4).

Tightening torque: 4.9 to 6.9 N·m
(0.5 to 0.7 kgf·m, 3.6 to 5.1 lbft)

5. Pump the knob again several tens of times until it becomes stiff, then push in the knob of priming pump (3) and tighten it.
6. If the air is not bled properly, return to Step 3 and bleed the air again.
7. For normal starting operations, turn the key in the starting switch to the START position to start the engine.

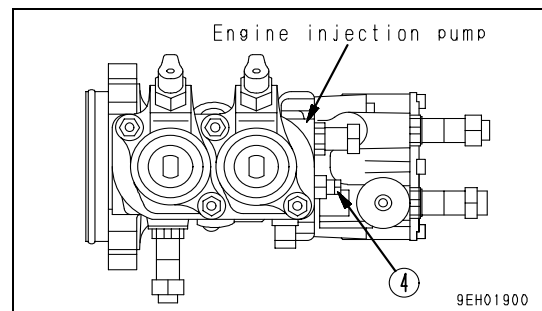
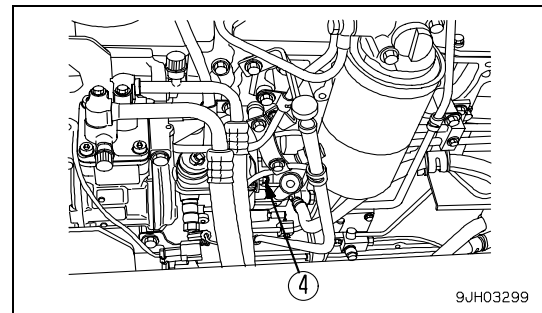
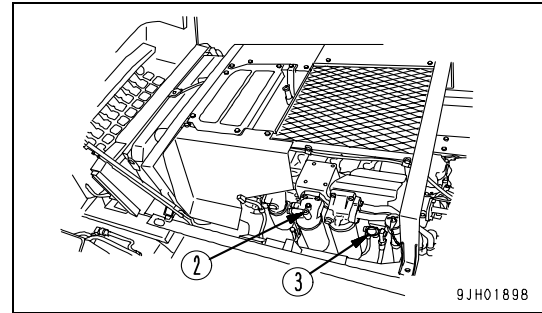
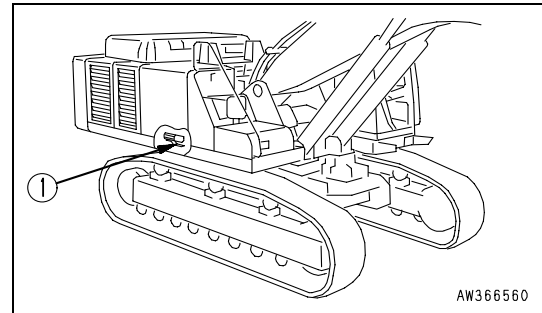

PHENOMENA THAT ARE NOT FAILURES

Note that the following phenomena are not failures:

- When the arm control lever is operated to the IN position and the work equipment is lowered under no load from a high position, the arm speed will drop momentarily when the arm is more or less at the vertical position.

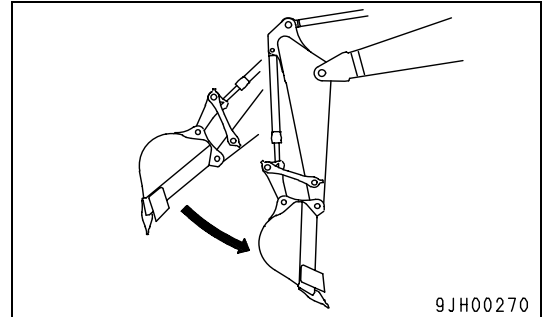

- When the bucket control lever is operated to the CURL position and the work equipment is lowered under no load from a high position, the bucket speed will drop momentarily when the bucket teeth are more or less at the horizontal position.

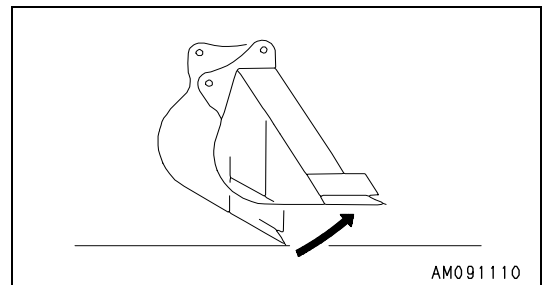

- When starting or stopping the swing, noise will be emitted from the brake valve.
- When going down a steep slope at low speed, a noise will be emitted from the travel motor.

TOWING THE MACHINE

WARNING

- When towing the machine, use a wire rope that has ample strength for the weight of the machine that is being towed.
- Do not apply a sudden load to the wire rope.

If the machine sinks in mud and cannot get out under its own power, or if the drawbar pull of the excavator is being used to tow a heavy object, use a wire rope as shown in the diagram on the right.

Place pieces of wood between wire ropes and body to prevent damage to ropes and body.

At this time, never use the hole for light-weight towing.

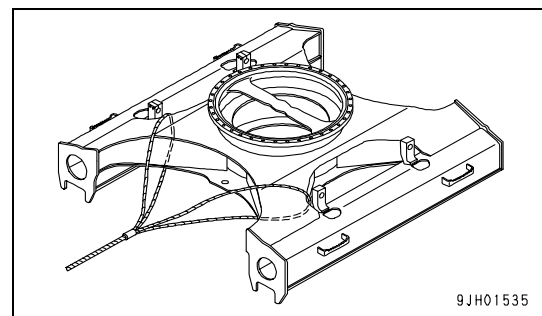
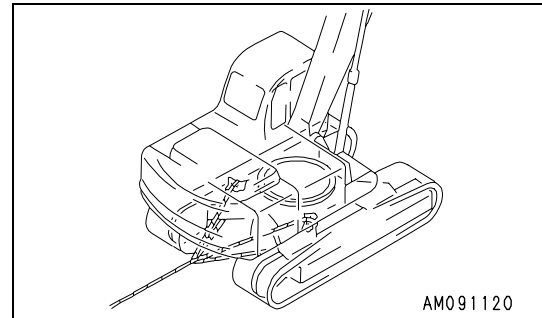

SEVERE JOB CONDITION

- When carrying out digging operations in water, if the work equipment mounting pin goes into the water, carry out greasing every time the operation is carried out.
- For heavy-duty operations and deep digging, carry out greasing of the work equipment mounting pins every time before operation.

After greasing, operate the boom, arm and bucket several times, then grease again.

DISCHARGED BATTERY

WARNING

- It is dangerous to charge a battery when mounted on a machine. Make sure that it is dismantled before charging.
- When checking or handling the battery, stop the engine and turn the starting switch key to the OFF position.
- The battery generates hydrogen gas, so there is a hazard of explosion. Do not bring lighted cigarettes near the battery, or do anything that will cause sparks.
- Battery electrolyte is dilute sulphuric acid, and it will attack your clothes and skin. If it gets on your clothes or on your skin, immediately wash it off with a large amount of water. If it gets in your eyes, wash it out with fresh water and consult a doctor.
- When handling batteries, always wear protective goggles and rubber gloves.
- When removing the battery, first disconnect the cable from the ground (normally the negative (-) terminal). When installing, install the positive (+) terminal first. If a tool touches the positive terminal and the chassis, there is danger that it will cause a spark, so be extremely careful.
- If the terminals are loose, there is danger that the defective contact may generate sparks that will cause an explosion. Terminals should be connected firmly.
- When removing or installing the terminals, check which is the positive (+) terminal and which is the negative (-) terminal.
- Patina on the terminals may cause self-discharge. Use sandpaper or wire brush to polish patina developed terminals, and connect cables after coating it with thin grease.

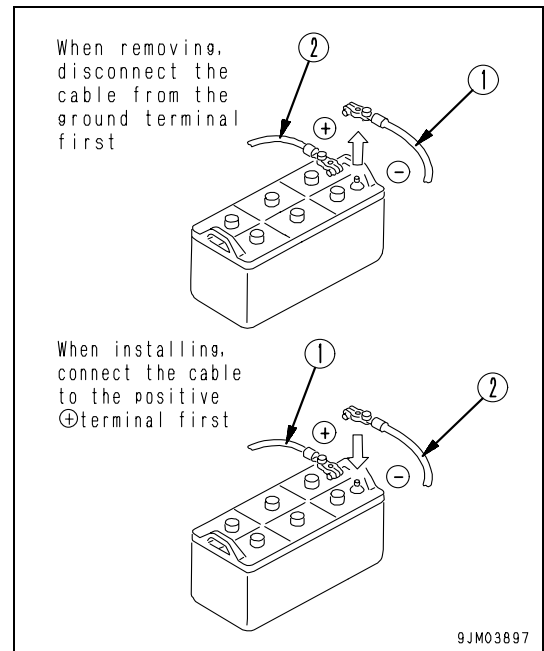

Battery Removal And Installation

- Before removing the battery, remove the ground cable (normally connected to the negative (-) terminal). If any tool touches between the positive terminal and the chassis, there is a hazard of sparks being generated.
- When installing the battery, connect the ground cable last.
- When replacing the battery, fix the battery securely in position with the battery mounting clamp. Tightening torque of mounting bolt: 9.8 to 19.6 N·m (1.0 to 2.0 kgf·m, 7.2 to 14.5 lbf)

Battery Charges

When charging the battery, if the battery is not handled correctly, there is a hazard that the battery may explode. Always follow the instructions of "DISCHARGED BATTERY (3-143)" and the instruction manual accompanying the charger, and do as follows.

- Set the voltage of the charger to match the voltage of the battery to be charged. If the voltage is not selected correctly, the charger may overheat and cause an explosion.
- Connect the positive (+) charger clip of the charger to the positive (+) terminal of the battery, then connect the negative (-) charger clip of the charger to the negative (-) terminal of the battery. Be sure to fix the clips securely.
- Set the charging current to 1/10 of the value of the rated battery capacity; when carrying out rapid charging, set it to less than the rated battery capacity.

If the charger current is too high, the electrolyte will leak or dry up, and this may cause the battery to catch fire and explode.

- If the battery electrolyte is frozen, do not charge the battery or start the engine with a different power source. There is a hazard that this will ignite the battery electrolyte and cause the battery to explode.
- Do not use or charge the battery if the battery electrolyte level is below the LOWER LEVEL line. This may cause an explosion. Always check the battery electrolyte level periodically and add distilled water to bring the electrolyte level to the UPPER LEVEL line.



Starting Engine With Booster Cables

When starting the engine with a booster cable, do as follows:

Connecting and Disconnecting Booster Cables

WARNING

- When connecting the cables, never contact the positive (+) and negative (-) terminals.
- When starting the engine with a booster cable, always wear safety glasses.
- Be careful not to let the normal machine and problem machine contact each other. This prevents sparks from generating near the battery which could ignite the hydrogen gas given off by the battery. If hydrogen gas explodes, it could cause serious injury.
- Be careful not to make a mistake when connecting a booster cable. In the last connection (to the upper structure frame), a spark will be caused, so connect the cable to a spot as far away from the battery as possible. (Avoid the work equipment, however, because it is not a good conductor)
- When removing the booster cable, exercise good care so that the booster cable clips may not contact each other, or they contact the chassis.

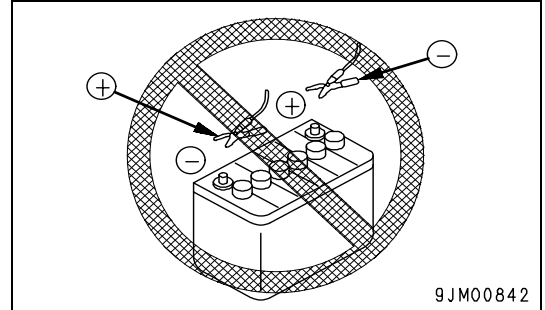

NOTICE

- The size of the booster cable and clip should be suitable for the battery size.
- The battery of the normal machine must be the same capacity as that of the engine to be started.
- Check the cables and clips for damage or corrosion.
- Make sure that the cables and clips are firmly connected.
- Check that the lock levers of both machines are in the LOCK position.
- Check that each lever is in the NEUTRAL position.

Booster Cable Connection

Keep the starting switch of the normal machine and problem machine at the OFF position.

Connect the booster cable as follows, in the order of the numbers marked in the diagram.

1. Connect one clip of booster cable (A) to the positive (+) terminal of the problem machine.
2. Connect the other clip of booster cable (A) to the positive (+) terminal of the normal machine.
3. Connect one clip of booster cable (B) to the negative (-) terminal of the normal machine.
4. Connect the other clip of booster cable (B) to the revolving frame of the problem machine.

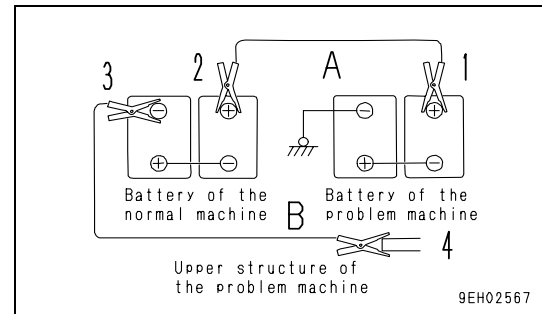

Starting the Engine

⚠ WARNING

Always check that the lock lever is set to the LOCK position, regardless of whether the machine is working normally or has failed. Check also that all the control levers are at the HOLD or neutral position.

1. Make sure the clips are firmly connected to the battery terminals.
2. Start the engine of the normal machine and keep it to run at high idling speed.
3. Turn the starting switch of the problem machine to the START position and start the engine.
If the engine doesn't start at first, try again after 2 minutes or so.

Booster Cable Disconnection

After the engine has started, disconnect the booster cables in the reverse of the order in which they were connected.

1. Remove one clip of booster cable (B) from the revolving frame of the problem machine.
2. Remove the other clip of booster cable (B) from the negative (-) terminal of the normal machine.
3. Remove one clip of booster cable (A) from the positive (+) terminal of the normal machine.
4. Remove the other clip of booster cable (A) from the positive (+) terminal of the problem machine.

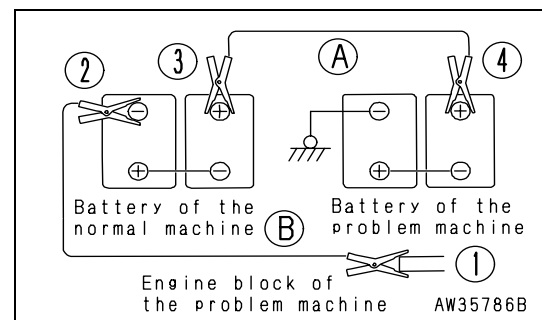

OTHER TROUBLE

Electrical System

- (): Always contact your Komatsu distributor when dealing with these items.
- In cases of abnormalities or causes which are not listed below, please contact your Komatsu distributor for repairs.

Problem	Main causes	Remedy
Lamp does not glow brightly even when the engine runs at high speed	•Defective wiring	(•Check, repair loose terminals, disconnections)
Lamp flickers while engine is running	•Defective adjustment of V belt tension	•Check, adjust V belt tension For details, see EVERY 250 HOURS SERVICE
Charge level monitor does not go out even when engine is running	•Defective alternator •Defective wiring	(•Replace) (•Check, repair)
Abnormal noise is generated from alternator	•Defective alternator	(•Replace)
Starting motor does not turn when starting switch is turned to ON	•Defective wiring •Defective starting motor •Insufficient battery charge •Defective safety relay •Defective engine controller	(•Check, repair) (•Replace) •Charge (•Replace) (•Replace)
Pinion of starting motor keeps going in and out	•Insufficient battery charge •Defective safety relay (direct starting motor)	•Charge (•Replace)
Starting motor turns engine sluggishly	•Insufficient battery charge •Defective starting motor	•Charge (•Replace)
Starting motor disengages before engine starts	•Defective wiring •Insufficient battery charge	(•Check, repair) (•Replace)
Pre-heating monitor does not light	•Defective wiring •Defective heater relay •Defective monitor	(•Check, repair) (•Replace) (•Replace)
Oil pressure monitor does not light up when engine is stopped (starting switch at ON position)	•Defective monitor •Defective sensor •Defective wiring	(•Replace) (•Replace) (•Check, repair)
Charge level monitor does not light up when engine is stopped (starting switch at ON position)	•Defective monitor •Defective wiring	(•Replace) (•Check, repair)

Chassis

- (): Always contact your Komatsu distributor when dealing with these items.
- In cases of abnormalities or causes which are not listed below, please contact your Komatsu distributor for repairs.

Problem	Main causes	Remedy
Speed of travel, swing, boom, arm, bucket is slow	•Lack of hydraulic oil	•Add oil to specified level, see CHECK BEFORE STARTING
Pump generates abnormal noise	•Clogged element in hydraulic tank strainer •Loose suction hose	•Clean, see EVERY 2000 HOURS SERVICE •Retighten
Excessive rise in hydraulic oil temperature	•Loose fan belt •Dirty oil cooler •Lack of hydraulic oil	•Check fan belt tension, see EVERY 500 HOURS SERVICE •Clean, see EVERY 500 HOURS SERVICE •Add oil to specified level, see CHECK BEFORE STARTING
Track comes off	•Track too loose	•Adjust track tension, see WHEN REQUIRED
Abnormal wear of sprocket		
Bucket rises slowly, does not rise	•Lack of hydraulic oil	•Add oil to specified level, see CHECK BEFORE STARTING
Does not swing	•Swing lock switch still applied	•Turn swing lock switch OFF

Engine

- (): Always contact your Komatsu distributor when dealing with these items.
- In cases of abnormalities or causes which are not listed below, please contact your Komatsu distributor for repairs.

Problem	Main causes	Remedy
Engine oil pressure monitor lights up	<ul style="list-style-type: none"> •Engine oil pan oil level is low (sucking in air) •Clogged oil filter cartridge •Defective tightening of oil pipe joint, oil leakage from damaged part •Disconnection, broken wiring to sensor 	<ul style="list-style-type: none"> •Add oil to specified level, see CHECK BEFORE STARTING •Replace cartridge, see EVERY 500 HOURS SERVICE (•Check, repair) (•Repair, connect wiring)
Steam is emitted from top part of radiator (pressure valve)	<ul style="list-style-type: none"> •Cooling water level low, water •Loosen fan belt 	<ul style="list-style-type: none"> •Add cooling water, repair, see leakage CHECK BEFORE STARTING •Check fan belt tension, see EVERY 500 HOURS SERVICE •Change cooling water, clean inside of cooling system, see WHEN REQUIRED
Radiator water level monitor lights up	<ul style="list-style-type: none"> •Dirt or scale accumulated in cooling system •Clogged radiator fin or damaged fin 	<ul style="list-style-type: none"> •Clean or repair, see EVERY 500 HOURS SERVICE
Engine water temperature gauge is in red range	<ul style="list-style-type: none"> •Defective engine water temperature gauge •Defective thermostat 	<ul style="list-style-type: none"> (•Replace engine water temperature gauge) (•Replace thermostat)
Engine water temperature monitor lights up	<ul style="list-style-type: none"> •Defective thermostat seal •Loose radiator filler cap (high altitude operation) •Disconnection, broken wiring to sensor 	<ul style="list-style-type: none"> (•Replace thermostat seal) •Tighten cap or replace packing (•Repair, connect wiring)
Engine water temperature gauge display stays at lowest level and does not rise	<ul style="list-style-type: none"> •Defective water temperature gauge monitor •Defective thermostat •In cold weather, cold wind is blowing strongly against engine 	<ul style="list-style-type: none"> (•Replace water temperature gauge monitor) •Replace thermostat (•Install radiator curtain)
Engine does not start even when starting motor is turned	<ul style="list-style-type: none"> •Lack of fuel •Air in fuel system •No fuel in fuel filter •Starting motor cranks engine too slowly •Starting motor does not turn •Defective valve clearance (defective compression) 	<ul style="list-style-type: none"> •Add fuel, see CHECK BEFORE STARTING (•Repair place where air is sucked in) •Fill filter with fuel. See EVERY 500 HOURS SERVICE. •See ELECTRICAL SYSTEM •See ELECTRICAL SYSTEM (•Adjust valve clearance)
Fuel stops from time to time	<ul style="list-style-type: none"> •Clogged Fuel tank cap 	<ul style="list-style-type: none"> (•Clean or replace fuel tank cap)

Problem	Main causes	Remedy
Excessive oil consumption	<ul style="list-style-type: none"> •Oil leakage •Excessive oil in oil pan 	<ul style="list-style-type: none"> (•Check, repair) •Add oil to specified level. See CHECK BEFORE STARTING.
Exhaust gas is white or blue	<ul style="list-style-type: none"> •Worn piston, ring, cylinder liner •Improper fuel •Defective turbocharger 	<ul style="list-style-type: none"> (•Replace) •Replace with specified fuel (•Check, replace)
Exhaust gas is black	<ul style="list-style-type: none"> •Clogged air cleaner element •Worn piston, ring, cylinder liner •Defective compression •Defective turbocharger •Defective exhaust brake •Defective injector 	<ul style="list-style-type: none"> •Clean or replace. See WHEN REQUIRED. (•Check, repair) •See adjustment of clearance above (•Check, replace) (•Check, replace, repair) (•Check, adjust, repair)
Engine hunts	<ul style="list-style-type: none"> •Air entering suction side of fuel line 	
There is knocking (combustion or mechanical)	<ul style="list-style-type: none"> •Poor quality fuel being used •Overheating 	
Error code is displayed on monitor	Please contact your Komatsu distributor	
Alarm buzzer sounds		
Engine suddenly loses power (entered delayed mode)		

Electronic Control System

If an error code is displayed on the machine monitor display, follow the self-diagnostic remedy table below.

Machine Monitoring System

Monitor display	Failure mode	Remedy
E02	TVC valve system error	When emergency pump drive switch is up, normal operations become normal, but carry out inspection immediately. (*)
E03	Swing brake system error	Turn the swing holding brake release switch is up to release the brake. When applying the swing brake, operate it manually with the swing lock switch. Depending on the cause of the problem, it may not be possible to release it. In any case, have it inspected immediately. (*)
E10	Abnormality in electronic governor system (engine stopped)	Carry out inspection immediately.
E11 E14	Abnormality in electronic governor system (abnormality in engine protection output) Abnormality in throttle (abnormality in fuel control dial)	It is possible to carry out normal working operations, but have inspection carried out immediately. Move machine to a safe posture, and carry out inspection immediately.
E15	Abnormality in electronic governor system	It is possible to carry out normal driving operations, but have inspection carried out immediately.
E0E	Abnormality in network	<ul style="list-style-type: none"> •If the engine can be operated, set the machine to a safe posture, then have inspection carried out immediately. •If the engine is operated and stalls, turn the emergency pump drive switch is up set the machine to a safe posture, then have inspection carried out immediately. •Even if the engine is stopped, have inspection carried out immediately.
CALL	Operation cannot be continued	Move machine to a safe posture, and carry out inspection immediately.
If no error code is displayed but work equipment or swing cannot be operated		Carry out inspection immediately.

(*)For details of handling the emergency pump drive switch and swing holding brake cancel switch, see "SWITCHES (3-27)".

Point Of Contact To Telephone When Error Occurs

If an error screen is displayed on the monitor, the screen changes as follows each time input confirmation switch (1) is pressed.
Error screen → screen A → screen B → screen C → error screen
Check the point of contact telephone number on screen B.

REMARK

If the point of contact telephone number has not been registered, screen B is not displayed.
If it is necessary to register the point of contact telephone number, ask your Komatsu distributor to register it.

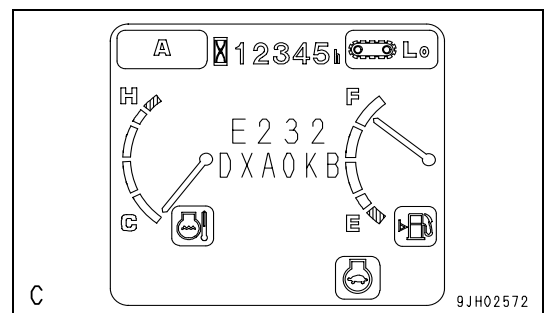
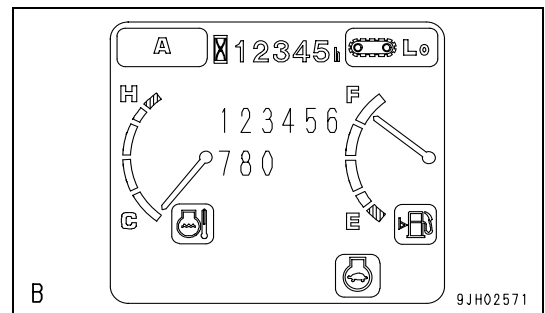
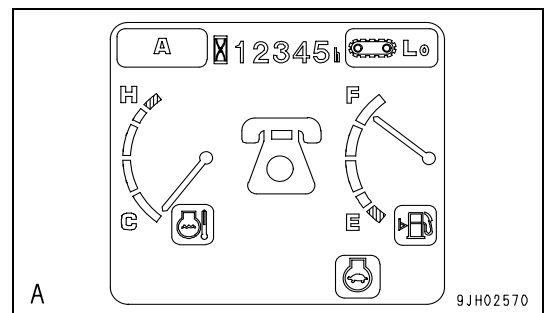
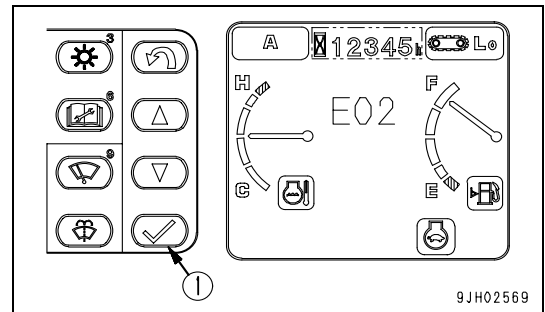

MAINTENANCE

WARNING

Please read and make sure that you understand the SAFETY section before reading this section.

MAINTENANCE INFORMATION

Do not carry out any inspection and maintenance operation that is not found in this manual.

Service Meter Reading

Check the service meter reading every day to see if the time has come for any necessary maintenance to be carried out.

Komatsu Genuine Replacement Parts

Use Komatsu genuine parts specified in the Parts Book as replacement parts.

Komatsu Genuine Lubricants

Use Komatsu genuine oils and grease. Choose oils and grease with proper viscosities specified for ambient temperature.

Windshield Washer Fluid

Use automobile window washer fluid, and be careful not to let any dirt get into it.

Fresh and Clean Lubricants

Use clean oil and grease. Also, keep the containers of the oil and grease clean. Keep foreign materials away from oil and grease.

Check Drained Oil and Used Filter

When replacing the filter after changing the oil, check the drained oil and old filter. If large amounts of metal particles or dirt are found, be sure to report to the person in charge and take the necessary action. When replacing the engine oil filter, fill the new filter with fresh, clean specified oil before installing.

Fuel Strainer

If your machine is equipped with a fuel strainer, do not remove it while fueling.

Welding Instructions

- Turn off the engine starting switch.
- Do not apply more than 200V continuously.
- Connect grounding cable within 1m (3.3 ft) from the area to be welded. If grounding cable is connected near instruments, connectors, etc., the instruments may malfunction.
- If a seal or bearing happen to come between the welding part and grounding point, change the grounding point to avoid such parts.
- Do not use the area around the work equipment pins or the hydraulic cylinders as the grounding point.

Do Not Drop Things Inside Machine

- When opening inspection windows or the oil filler port of the tank to carry out inspection, be careful not to drop nuts, bolts, or tools inside the machine.
If such things are dropped inside the machine, it will cause damage and malfunction of the machine, and will lead to failure. If you drop anything inside the machine, always remove it immediately.
- Do not put unnecessary things in your pockets. Carry only things which are necessary for inspection.

Dusty Jobsite

When working at dusty worksites, do as follows:

- Inspect the air cleaner clogging monitor frequently to see if the air cleaner is clogged.
- Clean the radiator core frequently to avoid clogging.
- Clean and replace the fuel filter frequently.
- Clean electrical components, especially the starting motor and alternator, to avoid accumulation of dust.
- When inspecting or changing the oil, move the machine to a place that is free of dust to prevent dirt from getting into the oil.

Avoid Mixing Lubricants

If a different type of oil has to be added, drain the old oil and replace all the oil with the new type of oil. Never mix different kinds of oil.

Locking the Inspection Covers

Lock inspection cover in position securely with the lock bar. If inspection or maintenance is carried out with the inspection cover not locked in position, there is a hazard that it may be suddenly blown shut by the wind and cause injury to the worker.

Hydraulic System - Air Bleeding

When hydraulic equipment has been repaired or replaced, or the hydraulic piping has been removed and installed again, the air must be bled from the circuit. For details, see "BLEEDING AIR FROM HYDRAULIC SYSTEM (4-37)".

Hydraulic Hose Installation

- When removing parts at locations where there are O-rings or gasket seals, clean the mounting surface, and replace with new parts.

When doing this, be careful not to forget to assemble the O-rings and gaskets.

- When installing the hoses, do not twist them or bend them into loops with a small radius.

This will cause damage to the hose and markedly reduce its service life.

Checks After Inspection and Maintenance Works

If you forget carrying out the checks after inspection and maintenance, unexpected problems may occur, and this may lead to serious injury or property damage. Always do as follows.

- Checks after operation (with engine stopped)
 - Have any inspection and maintenance points been forgotten?
 - Have all inspection and maintenance items been carried out correctly?
 - Have any tools or parts been dropped inside the machine? It is particularly dangerous if parts are dropped inside the machine and get caught in the lever linkage mechanism.
 - Is there any leakage of water or oil? Have all the bolts been tightened?
- Checks when operating engine
 - For details of the checks when operating the engine, see "TWO WORKERS FOR MAINTENANCE WHEN ENGINE IS RUNNING (2-36)" and pay careful attention to safety.
 - Are the inspection and maintenance items working properly?
 - Is there any leakage of fuel or oil when the engine speed is raised?

LUBRICANTS, COOLANT AND FILTERS

HANDLING OIL, FUEL, COOLANT, AND PERFORMING OIL CLINIC

Oil

- Oil is used in the engine and work equipment under extremely severe conditions (high temperature, high pressure), and deteriorates with use.
Always use oil that matches the grade and temperature for use given in the Operation and Maintenance Manual.

Even if the oil is not dirty, always change the oil after the specified interval.
- Oil corresponds to blood in the human body, so always be careful when handling it to prevent any impurities (water, metal particles, dirt, etc.) from getting in.
The majority of problems with machines are caused by the entry of such impurities.
Take particular care not to let any impurities get in when storing or adding oil.
- Never mix oils of different grades or brands.
- Always add the specified amount of oil.
Having too much oil or too little oil are both causes of problems.
- If the oil in the work equipment is not clear, there is probably water or air getting into the circuit. In such cases, please contact your Komatsu distributor.
- When changing the oil, always replace the related filters. In particular, when replacing the engine oil filter, fill the new filter with fresh, clean specified oil before installing.
- We recommend you have an analysis made of the oil periodically to check the condition of the machine. For those who wish to use this service, please contact your Komatsu distributor.

Fuel

- The fuel pump is a precision instrument, and if fuel containing water or dirt is used, it cannot work properly.
- Be extremely careful not to let impurities get in when storing or adding fuel.
- Always use the fuel specified in the Operation and Maintenance Manual.
Fuel may congeal depending on the temperature when it is used (particularly in low temperature below -15 °C (5 °F)). It is necessary to use the fuel that is suitable for the temperature.
- To prevent the moisture in the air from condensing and forming water inside the fuel tank, always fill the fuel tank after completing the day's work.
- Before starting the engine, or when 10 minutes have passed after adding fuel, drain the sediment and water from the fuel tank.
- If the engine runs out of fuel, or if the filters have been replaced, it is necessary to bleed the air from the circuit.

Cooling System Coolant

- River water contains large amount of calcium and other impurities, so if it is used, scale will stick to the engine and radiator, and this will cause defective heat exchange and overheating.
Do not use water that is not suitable for drinking.
- When using antifreeze, always observe the precautions given in the Operation and Maintenance Manual.
- Komatsu machines are supplied with Komatsu original anti-freeze in the coolant when the machine is shipped. This anti-freeze is effective in preventing corrosion of the cooling system. The anti-freeze can be used continuously for two years or 4000 hours. Therefore, it can be used as it is even in hot areas.
- Antifreeze is flammable, so be extremely careful not to expose it to flame or fire.
- The proportion of anti-freeze to water differs according to the ambient temperature. For details of the mixing proportions, see "CLEAN INSIDE OF COOLING SYSTEM (4-25)".
- If the engine overheats, wait for the engine to cool before adding coolant.
- If the coolant level is low, it will cause overheating and will also cause problems with corrosion from the air in the coolant.

Grease

- Grease is used to prevent twisting and noise at the joints.
- This construction equipment is used under heavy-duty conditions. Always use the recommended grease and follow the change intervals and recommended ambient temperatures given in this Operation and Maintenance Manual.
- The nipples not included in the MAINTENANCE section are nipples used when overhauling, so they do not need grease.
If any part becomes stiff or generates noise after being used for a long time, grease it.
- Always wipe off all of the old grease that is pushed out when greasing.
Be particularly careful to wipe off the old grease in places where sand or dirt sticking in the grease would cause wear of the rotating parts.

Carrying out KOWA (Komatsu Oil Wear Analysis)

KOWA is a maintenance service that makes it possible to prevent machine failures and downtime. With KOWA, the oil is periodically sampled and analyzed. This enables early detection of wear of the machine drive parts and other abnormalities.

Periodic use of KOWA makes the following possible:

- It enables abnormalities to be detected early, leading to reduction of repair costs and machine downtime.
- It enables repair schedules to be planned, leading to improved machine availability.

KOWA analysis items

- Analysis of metal wear particles
This uses an ICP (Inductively Coupled Plasma) analyzer to measure the density of metal wear particles in the oil.

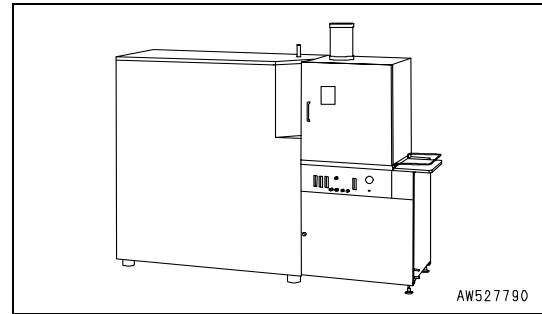

- Measurement of particle quantity
This uses a PQI (Particle Quantifier Index) measurer to measure the quantity of large iron particles in the oil.

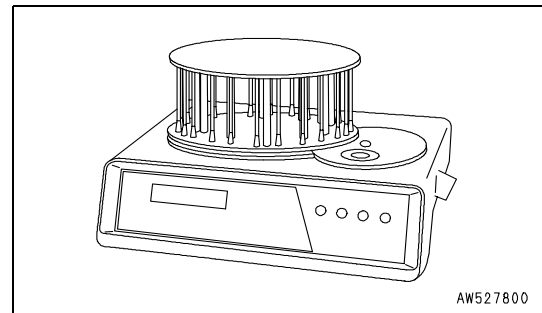

- Others
Measurements are made of items such as the ratio of water or fuel in the oil, and the dynamic viscosity.

Oil sampling

- Sampling interval
250 hours: Engine
500 hours: Other components
- Precautions when sampling
 - Make sure that the oil is well mixed before sampling.
 - Carry out sampling regularly at fixed intervals.
 - Do not carry out sampling on rainy or windy days when water or dust can get into the oil.

For further details of KOWA, please contact your Komatsu distributor.

Oil And Fuel Storage

- Keep indoors to prevent any water, dirt, or other impurities from getting in.
- When keeping drum cans for a long period, put the drum on its side so that the filler port of the drum can is at the side to prevent moisture from being sucked in.
If drum cans have to be stored outside, cover them with a waterproof sheet or take other measures to protect them.
- To prevent any change in quality during long-term storage, be sure to use in the order of first in - first out (use the oldest oil or fuel first).

Filters

- Filters are extremely important safety parts. They prevent impurities in the fuel and air circuits from entering important equipment and causing problems.
Replace all filters periodically. For details, see the Operation and Maintenance Manual.
However, when working in severe conditions, replace the filters at shorter intervals according to the oil and fuel (sulfur content) being used.
- Never try to clean the filters (cartridge type) and use them again. Always replace with new filters.
- When replacing oil filters, check if any metal particles are affixed to the old filter. If any metal particles are found, please contact your Komatsu distributor.
- When replacing the engine oil filter, fill the new filter with fresh, clean specified oil before installing.
- Do not open packs of spare filters until just before they are to be used.
- Always use Komatsu genuine filters.

ELECTRIC SYSTEM MAINTENANCE

- It is extremely dangerous if the electrical equipment becomes wet or the covering of the wiring is damaged. This will cause an electrical short circuit and may lead to malfunction of the machine. Do not wash the inside of the operator's compartment with water. When washing the machine or when washing the floor inside the operator's compartment, be careful not to let water get into the electrical components.
- Service relating to the electric system is checking fan belt tension, checking damage or wear in the fan belt and checking battery fluid level.
- Never install any electric components other than those specified by Komatsu.
- External electro-magnetic interference may cause malfunction of the control system controller, so before installing a radio receiver or other wireless equipment, please contact your Komatsu distributor.
- When working at the seashore, carefully clean the electric system to prevent corrosion.
- When installing any other electrical equipment, connect it to an independent power source connector. The cables to supply power to the optional equipment must never be connected to the fuse, starting switch, or battery relay.

WEAR PARTS

Replace wear parts such as the filter element or air cleaner element at the time of periodic maintenance or before they reach the wear limit. The wear parts should be replaced correctly in order to ensure more economic use of the machine. When replacing parts, always use Komatsu genuine parts.

As a result of our continuous efforts to improve product quality, the part number may change, so inform your Komatsu distributor of the machine serial number and check the latest part number when ordering parts.

WEAR PARTS LIST

The parts in parentheses are to be replaced at the same time.

Item	Part No.	Part Name	Q'ty	Change interval
Engine oil filter	600-211-1340	Cartridge	1	Every 500 hours
Fuel filter	600-319-3310	Cartridge	1	Every 500 hours
Additional fuel filter (If equipped)	600-319-3440	Element	1	Every 500 hours
	(600-311-3230)	(seal)	(1)	
	(600-311-3220)*1	(cup)	(1)	
Hydraulic oil filter	209-60-77530 (07000-05180)	Element (O-ring)	1 (1)	Every 1,000 hours
Hydraulic tank breather	20Y-60-21470	Element	1	Every 500 hours
Corrosion resistor	600-411-1151	Cartridge	1	Every 1,000 hours
Air cleaner	600-185-6100	Element assembly	1	-
	600-185-6110 (600-184-1671)	Outer element assembly (O-ring)	1 (1)	
Line filter	07063-21200	Element	2	-
	(07000-13038)	(O-ring)	(2)	
	(07000-12055)	(O-ring)	(2)	
	(07002-11023)	(O-ring)	(4)	
Pilot strainer	704-28-00751 (07002-13334)	Strainer (O-ring)	1 (1)	-
Additional filter for breaker (if equipped)	21M-970-1380	Element	1	-
	(07000-12011)	(O-ring)	(1)	
	(07000-12175)	(O-ring)	(1)	
Bucket	209-70-54210 (209-70-54240)	Horizontal pin type Tooth (Pin)	5 (5)	-
	209-70-14181	Side cutter (left)	1	
	209-70-14191	Side cutter (right)	1	
	(209-70-14210)	(Bolt)	(12)	
	(21T-32-11320)	(Nut)	(12)	
	(01643-33080)	(Washer)	(12)	

*1: This part is reusable. When there is any breakage, replace it all together.

LUBRICANTS, FUEL AND COOLANT SPECIFICATIONS

RESERVOIR	KIND OF FLUID	AMBIENT TEMPERATURE									
		-22 -30	-4 -20	14 -10	32 0	50 10	68 20	86 30	104 40	122°F 50°C	
Engine oil pan						SAE 30					
			SAE 10W								
		SAE 10W-30									
		SAE 15W-40									
P.T.O case	Engine oil					SAE 30					
Swing machinery case		SAE 10W									
Final drive case		SAE 30									
Hydraulic system		SAE 10W									
	SAE 10W-30										
	SAE 15W-40										
Fuel tank	Diesel fuel (*2)	ASTM D975 No.2									
		*1									
Grease fitting	Grease	NLGI No.2									
Cooling system	Water	Add antifreeze									

*1 :ASTM D975 No.1

*2 : Use only diesel fuel.

NOTICE

Use only diesel fuel.

The engine mounted on this machine employs electronic control and a high-pressure fuel injection device to obtain good fuel consumption and good exhaust gas characteristics. For this reason, it requires high precision for the parts and good lubrication.

If kerosene or other fuel with low lubricating ability is used, there will be a big drop in durability.

		Engine Oil pan	P.T.O case	Swing machinery case (Each of right and left)	Final drive case (Each of right and left)	Hydraulic oil system	Fuel tank	Cooling system
Specified oil amount	Liter	42	6	13	10.5	520	880	56
	US gal	11.10	1.59	3.43	2.77	137.38	232.50	14.80
Refill oil amount	Liter	37	6	13	10	360	-	-
	US gal	9.78	1.59	3.43	2.64	95.11	-	-

REMARK

When fuel sulfur content is less than 0.5%, change oil in the oil pan according to the periodic maintenance hours described in this manual.

Change oil according to the following table if fuel sulfur content is above 0.5%.

When starting the engine with an atmospheric temperature of lower than 0 °C (32 °F), be sure to use engine oil of SAE10W, SAE10W-30 and SAE15W-40, even though the atmospheric temperature goes up to 10 °C (50 °F) more or less during the day.

Use API classification CD as engine oil and if API classification CC, reduce the engine oil change interval to half.

There is no problem if single grade oil is mixed with multigrade oil (SAE10W-30, 15W-40), but be sure to add single grade oil that matches the temperature range in the table.

We recommend Komatsu genuine oil which has been specifically formulated and approved for use in engine and hydraulic work equipment applications.

Specified capacity: Total amount of oil including oil for components and oil in piping.

Refill capacity: Amount of oil needed to refill system during normal inspection and maintenance.

ASTM: American Society of Testing and Material

SAE: Society of Automotive Engineers

API: American Petroleum Institute

Fuel sulfur content	Charge interval of oil in engine oil pan
0.5 to 1.0%	1/2 of regular interval
Above 1.0%	1/4 of regular interval

No.	Supplier	Engine Oil [CD or CE] SAE10W, 30, 40 10W30, 15W40 (The 15W40 oil marked * is CE.)	Gear Oil [GL-4 or GL-5] SAE80, 90, 140	Grease [Lithium-Base] NLGI No.2	Anti-freeze Coolant [Ethylene Glycol Base] Permanent Type
1	KOMATSU	EO10-CD EO30-CD EO10-30CD EO15-40CD	GO90 GO140	G2-LI G2-LI-S	AF-ACL AF-PTL AF-PT(Winter, one season type)
2	AGIP	Diesel sigma S super dieselmulti- grade *Sigma turbo	Rotra MP	GR MU/EP	-
3	AMOCO	*Amoco 300	Multi-purpose gear oil	PYKON premium grease	-
4	ARCO	*Arcofleet S3 plus	Arco HD gear oil	Litholine HEP 2 Arco EP moly D	-
5	BP	Vanellus C3	Gear oil EP Hypogear EP	Energrease LS-EP2	Antifreeze
6	CALTEX	*RPM delo 400 RPM delo 450	Universal thuban Universal thuban EP	Marfak all purpose 2 Ultra-duty grease 2	AF engine coolant
7	CASTROL	*Turbomax *RX super CRD	EP EPX Hypoy Hypoy B Hypoy C	MS3 Spheerol EPL2	Anti-freeze
8	CHEVRON	*Delo 400	Universal gear	Ultra-duty grease 2	-
9	CONOCO	*Fleet motor oil	Universal gear lubricant	Super-sta grease	-
10	ELF	Multiperformance 3C Performance 3C	-	Tranself EP Tranself EP type 2	Glacelf
11	EXXON (ESSO)	Essolube D3 *Essolube XD-3 *Essolube XD-3 Extra *Esso heavy duty Exxon heavy duty	Gear oil GP Gear oil GX	Beacon EP2	All season coolant
12	GULF	Super duty motor oil *Super duty plus	Multi-purpose gear lubricant	Gulfcrown EP2 Gulfcrown EP special	Antifreeze and coolant
13	MOBIL	Delvac 1300 *Delvac super 10W-30, 15W-40	Mobilube GX Mobilube HD	Mobilux EP2 Mobilgease 77 Mobilgrease special	-

No.	Supplier	Engine Oil [CD or CE] SAE10W, 30, 40 10W30, 15W40 (The 15W40 oil marked * is CE.)	Gear Oil [GL-4 or GL-5] SAE80, 90, 140	Grease [Lithium-Base] NLGI No.2	Anti-freeze Coolant [Ethylene Glycol Base] Permanent Type
14	PENNZOIL	*Superme duty fleet motor oil	Multi-purpose 4092 Multi-purpose 4140	Multi-purpose white grease 705 707L White-bearing grease	Anti-freeze and summer coolant
15	PETRO- FINE	FINA kappa TD	FINA potonic N FINA potonic NE	FINA marson EPL2	FINA tamidor
16	SHELL	Rimura X	Spirax EP Spirax heavy duty	Albania EP grease	-
17	SUN	-	Sunoco GL5 gear oil	Sunoco ultra prestige 2EP Sun prestige 742	Sunoco antifreeze and summer cool- ant
18	TEXACO	*Ursa super plus Ursa premium	Multigear	Multifak EP2 Starplex 2	Coda 2055 startex antifreeze coolant
19	TOTAL	Rubia S *Rubia X	Total EP Total Transmission TM	Multis EP2	Antigal/antifreeze
20	UNION	*Guardol	MP gear lube LS	Unoba EP	-
21	VEEDOL	*Turbostar *Diesel star MDC	Multigear Multigear B Multigear C	-	Antifreeze

TIGHTENING TORQUE SPECIFICATIONS

TIGHTENING TORQUE LIST

⚠ CAUTION

If nuts, bolts, or other parts are not tightened to the specified torque, it will cause looseness or damage to the tightened parts, and this will cause failure of the machine or problems with operation. Always pay careful attention when tightening parts.

Unless otherwise specified, tighten the metric nuts and bolts to the torque shown in the table below.

If it is necessary to replace any nut or bolt, always use a Komatsu genuine part of the same size as the part that was replaced.

Thread diameter of bolt (a)(mm)	Width across flats (b)(mm)	Tightning torque [N·m (kgf·m)]	
		Target value	Permissible range
6	10	13.2 (1.35)	11.8 - 14.7 (1.2 - 1.5)
8	13	31 (3.2)	27 - 34 (2.8 - 3.5)
10	17	66 (6.7)	59 - 74 (6.0 - 7.5)
12	19	113 (11.5)	98 - 123 (10.0 - 12.5)
14	22	177 (18.0)	157 - 196 (16.0 - 20.0)
16	24	279 (28.5)	245 - 309 (25.0 - 31.5)
18	27	382 (39.0)	343 - 425 (35.0 - 43.5)
20	30	549 (56.0)	490 - 608 (50.0 - 62.0)
22	32	745 (76.0)	662 - 829 (67.5 - 84.5)
24	36	927 (94.5)	824 - 1030 (84.0 - 105.0)
27	41	1320 (135.0)	1180 - 1470 (120.0 - 150.0)
30	46	1720 (175.0)	1520 - 1910 (155.0 - 195.0)
33	50	2210 (225.0)	1960 - 2450 (200.0 - 250.0)
36	55	2750 (280.0)	2450 - 3040 (250.0 - 310.0)
39	60	3280 (335.0)	2890 - 3630 (295.0 - 370.0)
42	65	3830 (390.0)	3430 - 4220 (350.0 - 430.0)

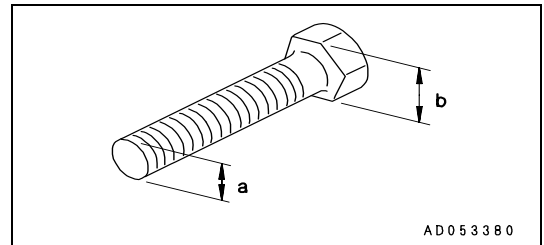

Apply the following table for Hydraulic Hose.

Nominal - No. of threads (a)	Width across flat a(mm)	Tightening torque					
		Target valve			Permissible range		
		N·m	kgf·m	lbft	N·m	kgf·m	lbft
9/16 - 18UNF	19	44	4.5	32.5	35 - 63	3.5 - 6.5	25.3 - 47.0
11/16 - 16UN	22	74	7.5	54.2	54 - 93	5.5 - 9.5	39.8 - 68.7
13/16 - 16UN	27	103	10.5	75.9	84 - 132	8.5 - 13.5	61.5 - 97.6
1-14UNS	32	157	16.0	115.7	128 - 186	13.0 - 19.0	94.0 - 137.4
13/16 - 12UN	36	216	22.0	159.1	177 - 245	18.0 - 25.0	130.2 - 180.8
* 1 - 7/16 - 12UN - 2B	41	215	22.0	159.1	176 - 234	18.0 - 24.0	130.2 - 180.8

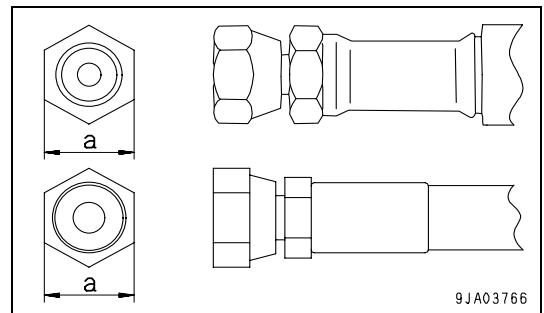

The torques marked * indicate the hightening torques for the hoses at the top of the swivel joint.

SAFETY CRITICAL PARTS

For using the machine safely for an extended period of time, you are requested to periodically replace the safety - critical and fire prevention- related parts listed in the table of important parts on the following page.

Material quality of these parts can change as time passes and they are likely to wear out or deteriorate. However, it is difficult to determine the extent of wear or deterioration at the time of periodic maintenance. Hence, it is required to replace them with new ones regardless of their condition after a certain period of usage. This is important to ensure that these parts maintain their full performance at all times.

Furthermore, should anything abnormal be found on any of these parts, replace it with a new one even if the periodic replacement time for the part has not yet arrived.

If any of the hose clamps show deterioration like deformation or cracking, replace the clamps at the same time as the hoses.

Also carry out the following checks with hydraulic hoses which need not be replaced periodically. Tighten a loosened clamp or replace a defective hose, as required.

When replacing the hoses, always replace the O-rings, gaskets, and other such parts at the same time.

Ask your Komatsu distributor to replace the critical parts.

SAFETY CRITICAL PARTS LIST

No.	Periodical exchange parts	Q'ty	Change interval
1	Fuel hose (fuel tank to strainer)	1	Every 2 years or 4,000 hours, whichever come first
2	Fuel hose (strainer to priming pump)	1	
3	Fuel hose (priming pump to supply pump)	1	
4	Fuel return hose (injection pump to fuel cooler)	1	
5	Fuel return hose (fuel cooler to fuel tank)	1	
6	Fuel spill hose (engine to fuel tank)	1	
7	Fuel drain hose	1	
8	Heater hose (heater to engine)	2	
9	Fuel hose (strainer to water separator)	1	Every 2 years or 4,000hours, whichever come first Option (Water separator equipped machines)
10	Fuel hose (water separator to priming pump)	1	
11	Water separatoris case, O-ring, plug	1	
12	Front pump outlet hose	2	Every 2 years or 4,000 hours, whichever come first
13	Rear pump outlet hose	2	
14	Pump branch hose	2	
15	In-line filter to valve hose	2	
16	Swing hose	4	
17	Suction hose	4	
18	Boom cylinder line hose (B/H)	4	
19	Arm cylinder line hose (B/H)	6	
20	Bucket cylinder line hose (B/H)	4	
21	Boom cylinder line hose (L/S)	4	
22	Arm cylinder line hose (L/S)	2	
23	Bucket cylinder line hose (L/S)	6	
24	Bottom dump cylinder line hose (L/S)	10	
25	Injector assembly	1 set	
26	High-pressure piping clamp	15	Every 8,000 hours
27	Fuel spray prevention cap	16	
28	Seat belt	1	Every 3 years

MAINTENANCE SCHEDULE

If the machine is equipped with a hydraulic breaker, the maintenance schedule for some parts will be different. For details, see "MAINTENANCE INTERVAL FOR HYDRAULIC BREAKER (4-18)" to confirm the correct maintenance schedule when carrying out maintenance.

MAINTENANCE SCHEDULE CHART

INITIAL 100 HOURS MAINTENANCE (ONLY AFTER THE FIRST 100 HOURS)

CLEAN STRAINER OF P.T.O LUBRICATING OIL FILTER 4-59

INITIAL 500 HOURS MAINTENANCE (ONLY AFTER THE FIRST 500 HOURS)

CHANGE OIL IN SWING MACHINERY CASE 4-63
 CHANGE OIL IN P.T.O CASE 4-64
 CHANGE OIL IN FINAL DRIVE CASE 4-69

WHEN REQUIRED

CHECK, CLEAN AND REPLACE AIR CREANER ELEMENT 4-20
 CLEAN INSIDE OF COOLING SYSTEM 4-25
 CHECK AND TIGHTEN TRACK SHOE BOLTS 4-27
 CHECK AND ADJUST TRACK TENSION 4-28
 CHECK ELECTRICAL INTAKE AIR HEATER 4-29
 REPLACE BUCKET TEETH (HORIZONTAL PIN TYPE) 4-30
 ADJUST BUCKET CLEARANCE 4-31
 REPLACE OF FAN BELT AND ADJUSTMENT OF AUTO TENSIONER 4-32
 CHECK WINDOW WASHER FLUID LEVEL, ADD FLUID 4-32
 CHECK AND ADJUST AIR CONDITIONER 4-33
 CLEAN LINE FILTER, REMOVE DIRT 4-34
 REPLACE BREAKER CIRCUIT ADDITIONAL OIL FILTER ELEMENT 4-35
 CLEAN PILOT LINE FILTER, REMOVE DIRT 4-36
 BLEEDING AIR FROM HYDRAULIC SYSTEM 4-37
 METHOD FOR RELEASING INTERNAL PRESSURE IN HYDRAULIC CIRCUIT 4-40
 CHECK NITROGEN GAS CHARGE PRESSURE IN ACCUMULATOR (control circuit) 4-41

CHECKS BEFORE STARTING

EVERY 10 HOURS MAINTENANCE

LUBRICATING 4-43

EVERY 100 HOURS MAINTENANCE

LUBRICATING SWING CIRCLE 4-46

EVERY 250 HOURS MAINTENANCE

CHECK OIL LEVEL IN FINAL DRIVE CASE, ADD OIL 4-47
 CHECK LEVEL OF BATTERY ELECTROLYTE 4-48
 CHECK, CLEAN FUEL TANK STRAINER 4-50
 CHECK AND TIGHTEN TRACK FRAME AND AXLE CONNECTING BOLTS 4-50
 CHECK ALTERNATOR DRIVE BELT TENSION, ADJUST 4-51
 CHECK AIR CONDITIONER COMPRESSOR BELT TENSION, ADJUST (ONLY FOR MACHINES
 EQUIPPED WITH AIR CONDITIONER) 4-52

EVERY 500 HOURS MAINTENANCE

REPLACE FUEL FILTER CARTRIDGE..... 4-53
 CHECK SWING PINION GREASE LEVEL, ADD GREASE 4-55
 CLEAN, CHECK RADIATOR FIN, OIL COOLER FIN, FUEL COOLER FIN, CONDENSER FIN
 (machines equipped with air conditioner)..... 4-56
 CLEAN FRESH/RECIRC AIR FILTERS OF AIR CONDITIONER (ONLY FOR MACHINES EQUIPPED
 WITH AIR CONDITIONER)..... 4-57
 REPLACE BREATHER ELEMENT IN HYDRAULIC TANK..... 4-58
 CLEAN STRAINER OF P.T.O LUBRICATING OIL FILTER 4-59
 CHECK FAN BELT 4-59
 CHANGE OIL IN ENGINE OIL PAN, REPLACE ENGINE OIL FILTER CARTRIDGE 4-60

EVERY 1000 HOURS MAINTENANCE

REPLACE HYDRAULIC OIL FILTER ELEMENT 4-62
 CHANGE OIL IN SWING MACHINERY CASE 4-63
 CHANGE OIL IN P.T.O CASE 4-64
 CHECK ALL TIGHTENING PARTS OF TURBOCHARGER 4-64
 CHECK PLAY TURBOCHARGER ROTOR..... 4-64
 REPLACE CORROSION RESISTOR CARTRIDGE..... 4-65
 GREASE FAN PULLEY AND TENSION PULLEY 4-65
 CHECK WELDED STRUCTURE 4-66
 CHECK NITROGEN GAS CHARGE PRESSURE IN ACCUMULATOR (for breaker)..... 4-68

EVERY 2000 HOURS MAINTENANCE

CHANGE OIL IN FINAL DRIVE CASE 4-69
 CLEAN HYDRAULIC TANK STRAINER..... 4-70
 CLEAN ENGINE BREATHER..... 4-71
 CLEAN, CHECK TURBOCHARGER 4-71
 CHECK ALTERNATOR, STARTING MOTOR..... 4-71
 CHECK ENGINE VALVE CLEARANCE, ADJUST 4-71
 CHECK INJECTOR..... 4-71

EVERY 4000 HOURS MAINTENANCE

CHECK WATER PUMP 4-72
 CHECK VIBRATION DAMPER..... 4-72
 CHECK FAN PULLEY AND TENSION PULLEY 4-72
 REPLACE INJECTOR ASSEMBLY 4-72
 CHECK FOR LOOSENESS OF HIGH-PRESSURE CLAMP, HARDENING OF RUBBER..... 4-73
 CHECK FOR MISSING FUEL SPRAY PREVENTION CAP, HARDENING OF RUBBER 4-74

EVERY 5000 HOURS MAINTENANCE

CHANGE OIL IN HYDRAULIC TANK 4-75

EVERY 8000 HOURS MAINTENANCE

REPLACE HIGH-PRESSURE PIPING CLAMP 4-77
 REPLACE FUEL SPRAY PREVENTION CAP 4-77

MAINTENANCE INTERVAL FOR HYDRAULIC BREAKER

For machine equipped with a hydraulic breaker, the hydraulic oil deteriorates faster than for normal bucket digging operations, so set the maintenance intervals as follows.

REPLACE HYDRAULIC OIL FILTER ELEMENT

- On new machines, replace the element after the first 100 to 150 hours, then carry out further replacement of the element according to the table on the right.

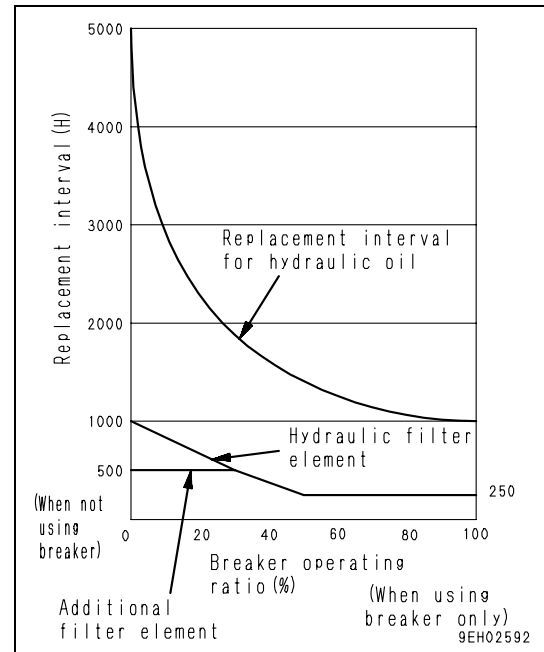

CHANGE OIL IN HYDRAULIC TANK

- Change the oil according to the table on the right.

REPLACE ADDITIONAL FILTER ELEMENT FOR BREAKER

- Use a guideline of 250 hours for use of the breaker (operating ratio for the breaker: 50 % or more), and replace the element according to the table on the right.

MAINTENANCE PROCEDURE

INITIAL 100 HOURS MAINTENANCE (ONLY AFTER THE FIRST 100 HOURS)

Carry out the following maintenance only after the first 100 hours.

- Clean strainer of P.T.O lubricating oil filter

For details of the method of maintaining, see EVERY 500 HOURS MAINTENANCE.

INITIAL 500 HOURS MAINTENANCE (ONLY AFTER THE FIRST 500 HOURS)

Carry out the following maintenance only after the first 500 hours.

- Change oil in swing machinery case
- Change oil in P.T.O case
- Change oil in final drive case

Special tools are needed for the inspection and maintenance, so please contact your Komatsu distributor to have this work carried out.

For details of the method of replacing or maintaining, see EVERY 1000 HOURS and EVERY 2000 HOURS SERVICE.

WHEN REQUIRED

CHECK, CLEAN AND REPLACE AIR CLEANER ELEMENT

WARNING

- When using compressed air, there is danger of dirt flying and causing personal injury. Always wear protective glasses, dust mask, or other protective equipment.
- When removing the outer element from the air cleaner body, it is dangerous to pull it out by force. When working at high places or where the foothold is poor, be careful not to fall because of the reaction when pulling out the outer element.

Checking

If air cleaner clogging monitor(1) of the monitor panel flashes, clean the air cleaner element.

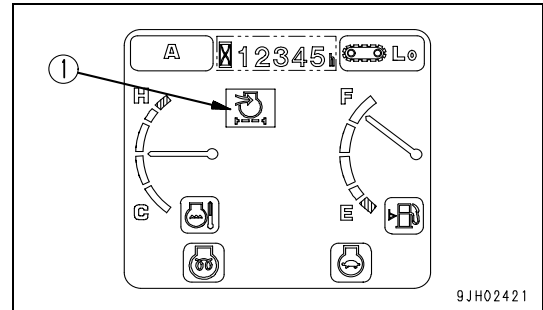

Replacing

- Replacing element, O-ring
If one year has passed since installing the element or if air cleaner clogging monitor (1) on the monitor panel flashes immediately after the element is cleaned, replace the outer element, inner element, and O-ring.
- Replacing evacuator valve
Replace it if it is damaged or the rubber is markedly deformed.

NOTICE

Do not clean the air cleaner element until the air cleaner clogging monitor on the monitor panel flashes. If the element is cleaned frequently before the clogging monitor flashes, the air cleaner will not be able to display its performance fully, and the cleaning efficiency will also go down.

In addition, during the cleaning operation, more dirt stuck to the element will fall inside the inner element.

Cleaning or replacing outer element

1. Open the engine hood at the front side of the machine, remove 6 hooks (2), then remove cover (3).

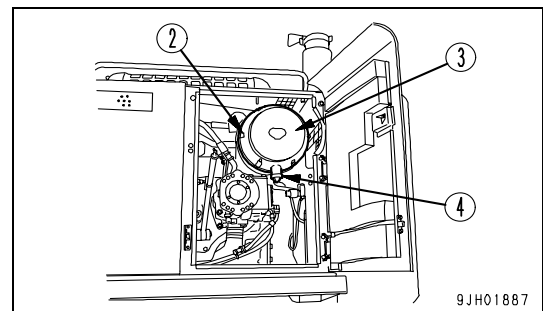

NOTICE

Before and after cleaning the element, do not leave or keep it in direct sunlight.

2. Hold the outer element (6), rock it lightly up and down and to the left and right, and rotate the element to the left and right to pull it out.

NOTICE

- **Never remove the inner element (5). It will allow dirt to enter and cause failure of the engine.**
- **Do not use a screwdriver or other tool.**

3. After removing the outer element (6), cover the air connector inside the air cleaner body with a clean cloth or tape to prevent dirt or dust from entering.

4. Wipe off or brush off the dirt stuck to cover (3) and the inside of the air cleaner body (7).

5. Remove any dirt or dust that is accumulated to evacuator valve (4) installed to cover (3).

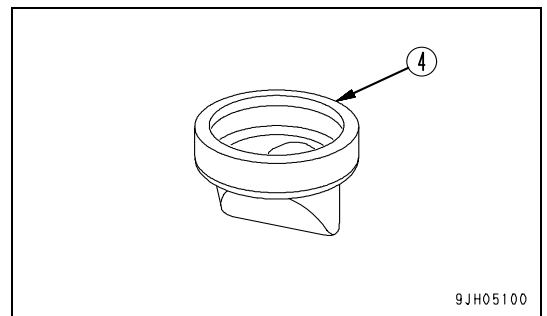
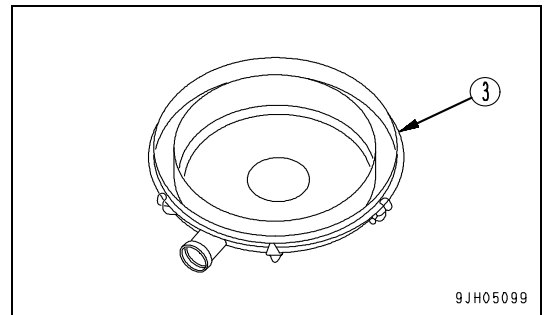
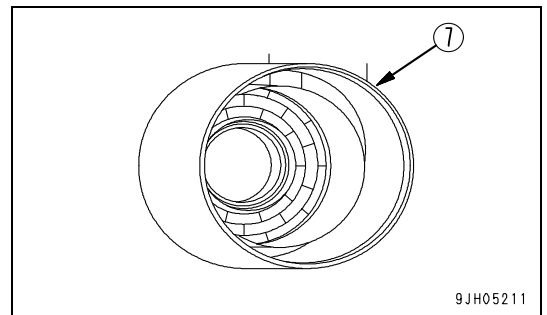
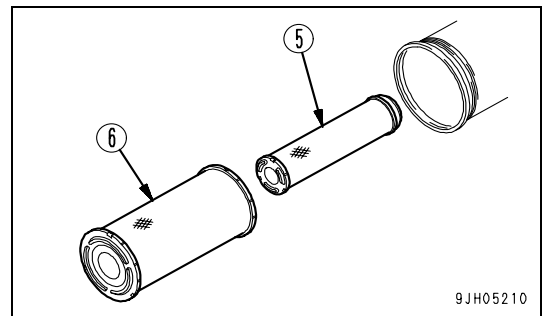

6. Direct dry compressed air (less than 0.69MPa (7kgf/cm², 99.4PSI)) to the outer element (4) from inside along its folds, then direct it from outside along its folds and again from inside.
7. Remove one seal from the element whenever the element has been cleaned.
8. Replace the outer element which has been cleaned 6 times repeatedly or used throughout a year. Replace the inner element at the same time.
9. Replace both inner and outer elements when the monitor (1) flashed soon after installing the cleaned outer element even though it has not been cleaned 6 times.
10. Check that there is no play in the inner element. If any play is found, push it in properly.
11. Remove the cloth or tape cover installed in Step 3.
12. If small holes or thinner parts are found on the element when it is checked by shining a light through it after cleaning, replace the element.

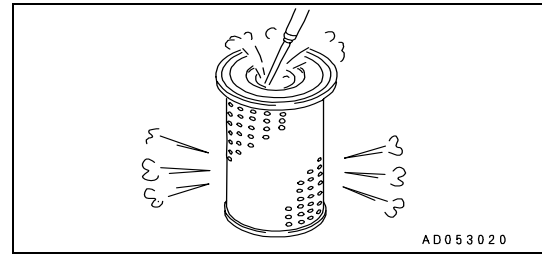

NOTICE

When cleaning the element, do not hit or beat it against anything.
Do not use an element whose folds or gasket or seal are damaged.

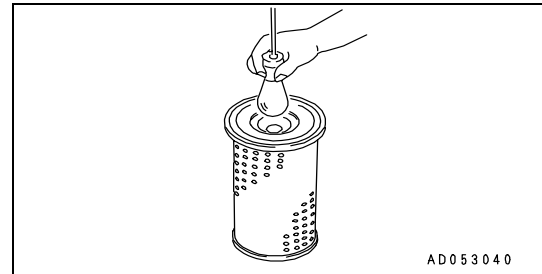

13. When replacing the element, push the indicator button at the bottom of the air cleaner to reset it.

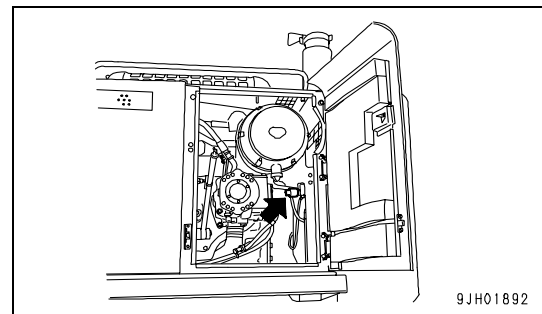

Install Air Cleaner Element

NOTICE

- Do not use any damaged gasket or seal or element with damaged pleats.
- Cleaning the element or O-ring after one year has passed and using them again will cause problems. Always replace them with new parts.
- The seal portion on imitation parts lacks precision, and allows the entry of dust, which leads to damage of the engine. Do not use such imitation parts.
- Do not run the engine with the inner element removed. It will cause damage to the engine.

1. Check that there is no dirt or oil stuck to the seal portion of the new element or cleaned element. Wipe off any dirt or oil.
2. When the outer element has been removed, check that the inner element has not come out of position and is not at an angle. If it is at an angle, insert your hand and push it in straight.
3. Push the outer element in straight with your hand when installing it to the air cleaner body. If the element is held and rocked lightly up and down and to the left and right while pushing it in, the element can be inserted easily.

NOTICE

When inserting the element, if the rubber at the tip is swollen or the outer element is not pushed in straight, and cover (3) is assembled by force to hook (2), there is danger that the hook and air cleaner body may be damaged, so be careful when assembling.

4. Install cover (3) as follows.
5. Align cover (3) with the element.
6. Hook the tip of hook (2) to the protruding part of the air cleaner body and lock it in position.
7. When locking hooks (2) in position, apply the hooks in turn on opposite sides (top, bottom, left, right) in the same way as when tightening bolts.
8. Always install cover (3) so that the evacuator (5) is facing the ground (A).
9. When cover (3) is installed, check that the clearance between the air cleaner body and cover (3) is not too large. If it is too large, install again.

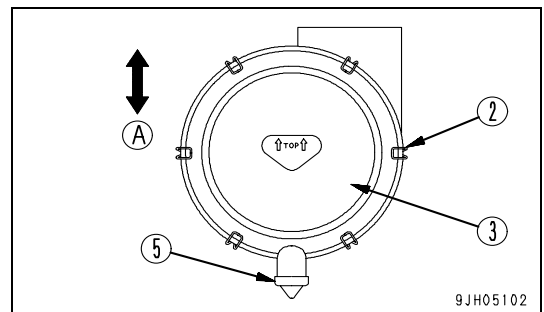
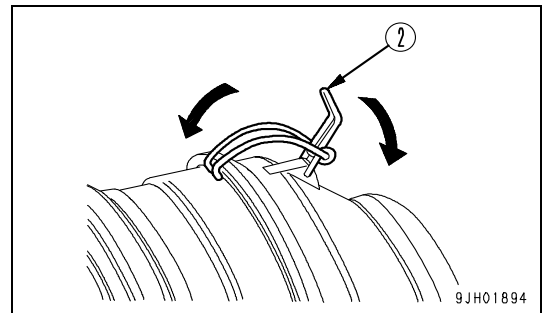

Replacing inner element

1. First remove the outer element, and then remove the inner element.
2. Cover the air connector side (outlet side) with a clean cloth or tape.
3. Clean the air cleaner body interior, then remove the cover from the air intake port in Step 2.
4. Install the new inner element to the body, then tighten the nut.

Do not clean the inner element and use it again.

NOTICE

The inner element must not be used again even after its cleaning. When replacing the outer element, replace the outer element at the same time.

5. Set the outer element in position, then lock cover (3) with hooks (2).

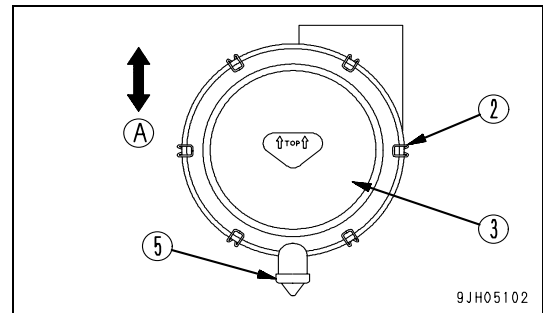
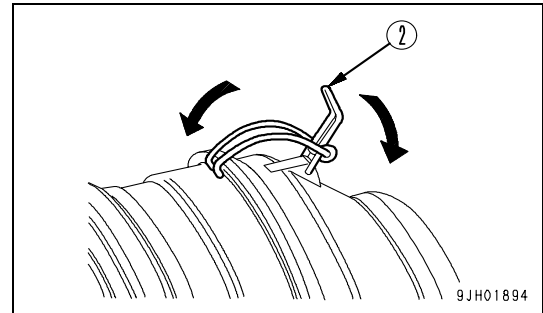

6. After replacing the element, press reset button (4) of the dust indicator to return the yellow display to its original position.

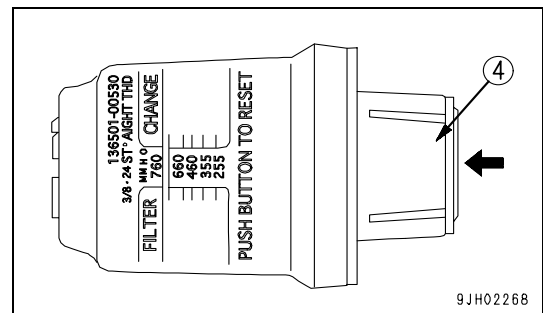

CLEAN INSIDE OF COOLING SYSTEM

⚠ WARNING

- Immediately after the engine is stopped, the coolant is at a high temperature and the radiator is under high internal pressure. If the cap is removed to drain the coolant in this condition, there is a hazard of burns. Wait for the temperature to go down, then turn the cap slowly to release the pressure before removing it.
- Cleaning is carried out with the engine running. When standing up or leaving the operator's seat, set the lock lever to LOCK position (L).
- For details of starting the engine, see "BEFORE STARTING ENGINE (3-73)" and "STARTING ENGINE (3-89)" in the OPERATION section.
- There is danger of touching the fan if the undercover is left removed. Never enter behind the machine when the engine is running.

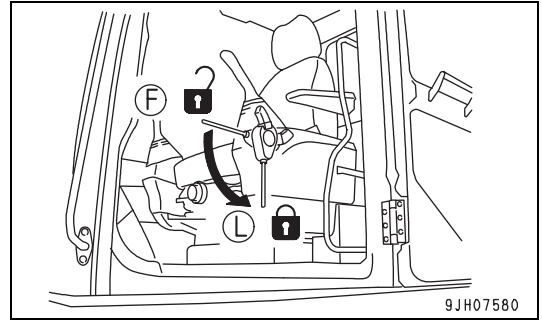

Clean the inside of the cooling system, change the coolant and replace the corrosion resistor according to the table below.

Kind of coolant	Cleaning inside of cooling system and changing coolant	Replacing corrosion resistor
Permanent type antifreeze (All season type)	Every year (autumn) or every 2000 hours, whichever comes first	Every 1000 hours and when cleaning the inside of the cooling system and when changing coolant
Non permanent type antifreeze containing ethylene glycol (winter, one season type)	Every 6 months (spring, autume) (Drain antifreeze in spring, add antifreeze in autumn)	
When no using antifreeze	Every 6 months or every 1000 hours, whichever come first	

Stop the machine on level ground when cleaning or changing the coolant.

Use a permanent type of antifreeze.

If, for some reason, it is impossible to use permanent type antifreeze, use an antifreeze containing ethylene glycol. The ratio of antifreeze to water depends on the ambient temperature, but to obtain the corrosion resistance effect, a minimum ratio of 30% by volume is necessary.

When deciding the ratio of antifreeze to water, check the lowest temperature in the past, and decide from the mixing rate table given below.

It is actually better to estimate a temperature about 10 °C (18 °F) lower when deciding the mixing rate.

Mixing rate of water and antifreeze

Min. atmospheric temperature	°C	-10	-15	-20	-25	-30	-35	-40
	°F	14	5	-4	-13	-22	-31	-40
Amount of antifreeze	liter	16.8	20.2	23.0	25.8	28.0	30.2	32.5
	US gal	4.44	5.34	6.08	6.82	7.40	7.98	8.59
Amount of water	liter	39.2	35.8	33.0	30.2	28.0	25.8	23.5
	US gal	10.36	9.46	8.72	7.98	7.40	6.82	6.21
Volume ratio (%)		30	36	41	46	50	54	58

⚠ WARNING

**Antifreeze is flammable, so keep it away from flame.
Antifreeze is toxic. When removing the drain plug, be careful not to get water containing antifreeze on you. If it gets in your eyes, flush your eyes with large amount of fresh water and see a doctor at once.**

Use city water for the cooling water.

If river water, well water or other such water supply must be used, contact your Komatsu distributor.

We recommend use of an antifreeze density gauge to control the mixing proportions.

- Prepare a container to catch drained coolant:
Min 56 liters (14.8 US gal) capacity.
- 1. Stop the engine, then turn valve (1) of corrosion resistor (2) to the CLOSE stopper position.
- 2. Turn cap (3) of the radiator water filler slowly.
- 3. Remove undercovers (4) and (6), then set a container to catch the coolant under engine coolant drain valve (7) at the bottom of the muffler and coolant drain valve (5) at the bottom of the radiator.
- 4. Open drain valves (5) and (7) and drain the water.
- 5. After draining the antifreeze solution, close drain valves (5) and (7), then fill with clean water. After the radiator is filled with water, start and run the engine at low idling speed. After the water temperature rises above 90 °C (194 °F), run the engine for about 10 minutes.
- 6. Stop the engine and open drain valves (5) and (7) to drain the water.
- 7. After draining the water, clean the radiator with detergent.
When carrying out the flushing operation, follow the instructions given with the flushing agent.
- 8. Close drain valves (5) and (7).
- 9. Replace the corrosion resistor, and turn valve (1) to the OPEN stopper position.
- 10. Install undercovers (4) and (6).
- 11. Fill with antifreeze and tap water until the water overflows from the water filler. Determine the proportions of antifreeze and water in accordance with the water and antifreeze mixture table.

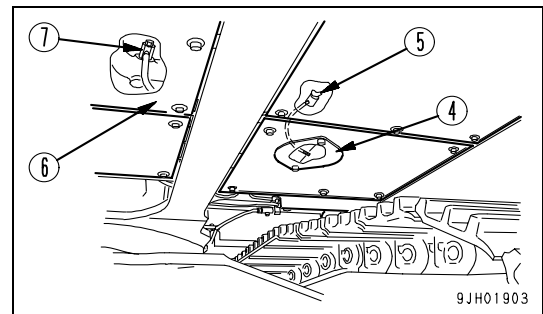
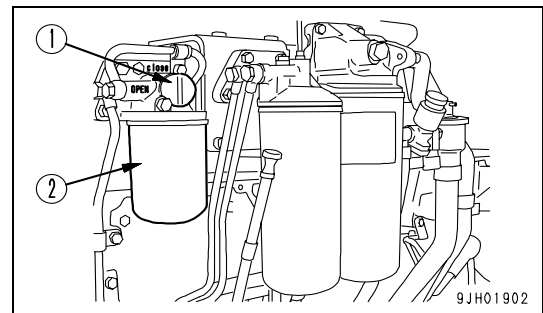
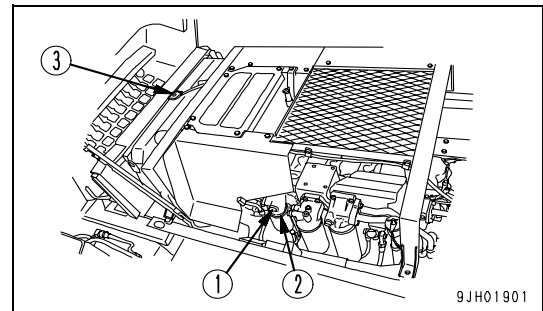

CHECK AND TIGHTEN TRACK SHOE BOLTS

If the machine is used with track shoe bolts (1) loose, they will break, so tighten any loose bolts immediately

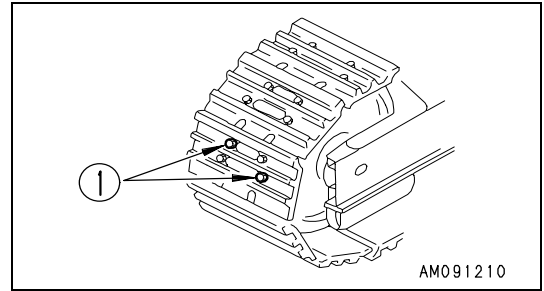

Tightening

1. First, tighten to a tightening torque of $784 \pm 78 \text{ N}\cdot\text{m}$ ($80 \pm 8 \text{ kgf}\cdot\text{m}$, $578.6 \pm 57.9 \text{ lbft}$), then check that the nut and shoe are in tight contact with the link mating surface.
2. After checking, further tighten to the tightening torque of $120^\circ \pm 10^\circ$.

Order for tightening

Tighten the bolts in the order shown in the diagram on the right. After tightening, check that the nut and shoe are in close contact with the link mating surface.

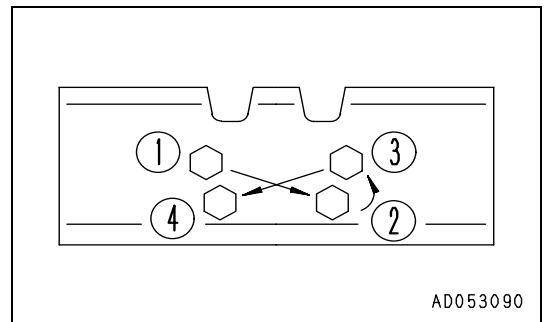

CHECK AND ADJUST TRACK TENSION

⚠ WARNING

For details of starting the engine and operating the work equipment, see "BEFORE STARTING ENGINE (3-73)", "STARTING ENGINE (3-89)", "AFTER STARTING ENGINE (3-94)", and "WORK EQUIPMENT CONTROLS AND OPERATIONS (3-109)" in the OPERATION section.

The wear of the pins and bushings on the undercarriage will vary with the working conditions and type of soil, so inspect the track tension frequently in order to maintain the standard tension. Stop the machine on firm, horizontal ground when carrying out the inspection and maintenance.

Checking

1. Run the engine at low idling, then move the machine forward for a distance equal to the track length on ground and stop the machine slowly.
2. Place wooden bar (3) on top of the track from No. 2 roller (1) to No. 3 roller (2).
3. Measure the maximum deflection between the bottom surface of the wooden bar and the top surface of the track shoe. Deflection "a" should be 10 to 30 mm (0.8 to 1.2 in).

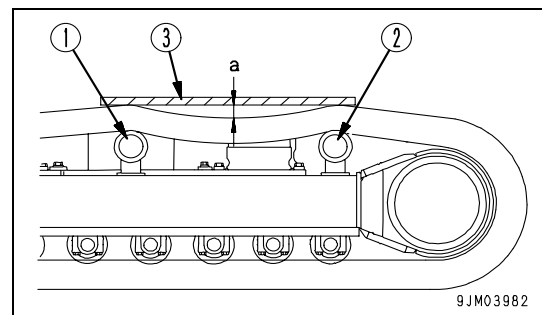

Adjustment

⚠ WARNING

Grease inside the adjusting mechanism is under high pressure. Grease coming from plug (1) under pressure can penetrate the body, causing injury or death. For this reason, do not loosen plug (1) more than one turn.

Do not loosen any part other than plug (1). Furthermore, do not bring your face in front of the plug (1). If the track tension is not relieved by this procedure, please contact your Komatsu distributor for repairs.

Increasing Track Tension

Prepare a grease gun.

1. Pump in grease through valve (1) using a grease gun.
2. To check that the tension is correct, move the machine slowly forward and in reverse.
3. Check the track tension again, and if the tension is not correct, adjust it again.

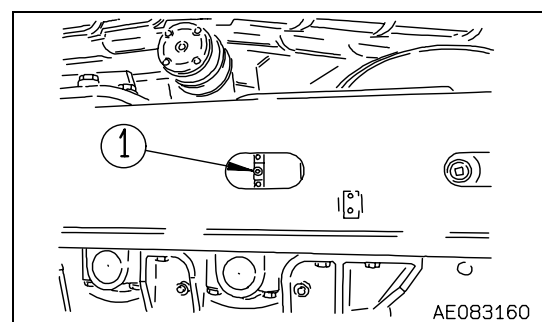

- Continue to pump in grease until (S) becomes 48 mm (1.9 in). If the tension is still loose, the pin and bushing are excessively worn, so they must be either turned or replaced. Please contact your Komatsu distributor.

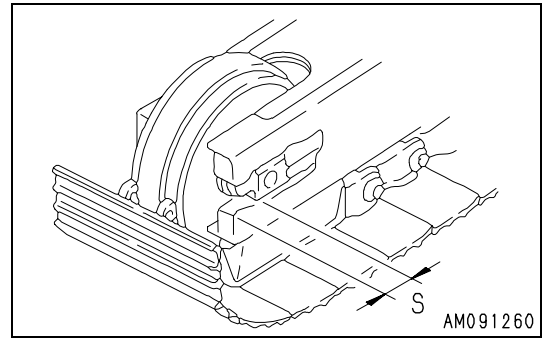

Loosening Track Tension

⚠ WARNING

It is extremely dangerous to release the grease by any method except the procedure given below. If the track tension is not relieved by this procedure, please contact your Komatsu distributor for repairs.

- Loosen plug (1) gradually to release the grease.
- Turn plug (1) a maximum of one turn.
- If the grease does not come out smoothly, move the machine forwards and backwards a short distance.
- Tighten plug (1).
- To check that the tension is correct, move the machine slowly forward.
- Check the track tension again, and if the tension is not correct, adjust it again.

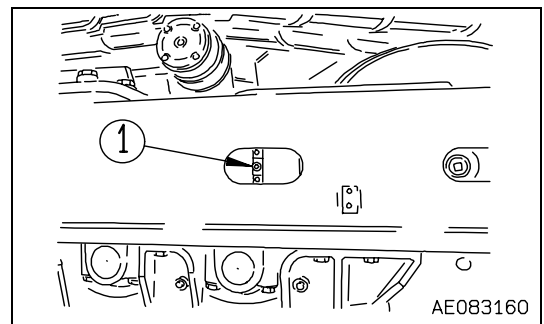

CHECK ELECTRICAL INTAKE AIR HEATER

Before the start of the cold season (once a year), contact your Komatsu distributor to have the electrical intake air heater repaired or checked for dirt or disconnections.

Remove the electrical intake air heater from the engine intake manifold, and check it for possible disconnections and dirt.

When inspecting and replacing the electrical intake air heater, replace the gasket with new one.

REPLACE BUCKET TEETH (HORIZONTAL PIN TYPE)

Replace the teeth before the wear reaches the adapter.

WARNING

- It is dangerous if the work equipment is mistakenly moved when replacing the teeth. Set the work equipment in a stable condition, stop the engine, then set the lock lever securely to the LOCK position (L).
- If the locking pin is knocked out with force, there is danger that the pin may fly out. Check that there is no one near the machine.
- Broken pieces may fly during the replacement operation, so always wear safety glasses, gloves, or other protective equipment.

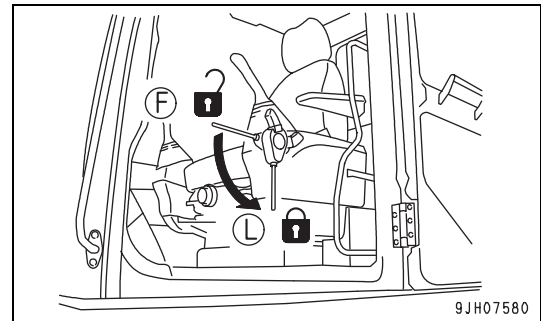

1. Set a block (3) under the bottom face of the bucket so that pin (1) can be removed. Turn the starting switch to the ON position within 15 seconds after stopping the engine, operate the control levers fully, check that the work equipment is stable, then set the safety lock lever to the LOCK position (L).

Set so that the bottom face of the bucket is horizontal.

2. Place a bar on the head of pin (1), hit the bar with a hammer to knock out the pin, then remove tooth (2).

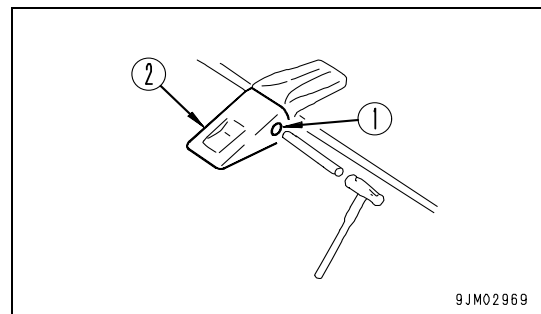

REMARK

If it cannot be removed by this method, for safety reasons, always contact your Komatsu distributor to have the replacement carried out.

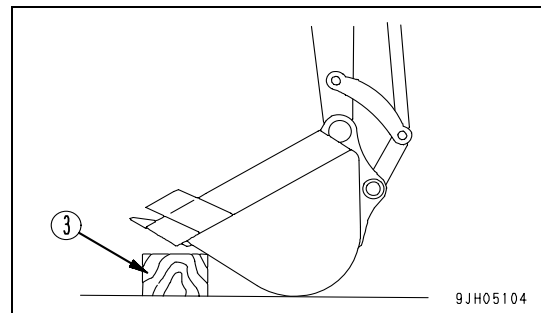

3. Clean the mounting face. Fit a new tooth (2) in the adapter, push in pin (1) partially by hand, then lock it with a hammer to install the tooth to the bucket.

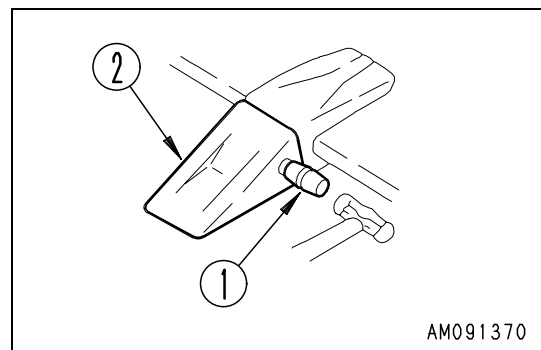

ADJUST BUCKET CLEARANCE

⚠ WARNING
 It is dangerous if the work equipment is mistakenly moved when adjusting the bucket clearance.
 Set the work equipment in a stable condition, stop the engine, then set the lock lever securely to the LOCK position (L).

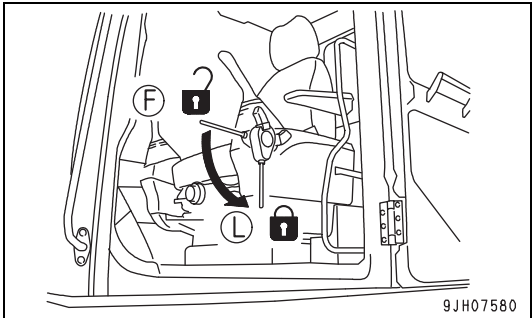

If there is excessive free play on the coupling section of the bucket and arm, adjust the bucket clearance in the following manner.

1. Set the work equipment to the position shown in the diagram on the right, then stop the engine and set lock lever (1) to the LOCK position (L).
2. Loosen 3 bolts (2), 6 bolts (3), plate (1) and plate (5).
3. Take out shims (4) equivalent in size to free play (a).
 Thickness of shim (4) is 0.5 mm or 1.0 mm (0.02 or 0.04 in).
 When free play (a) is less than a thickness of shim, do not compress the shims by tightening bolt (2).
4. Tighten 3 bolts (2) and 6 bolts (3).

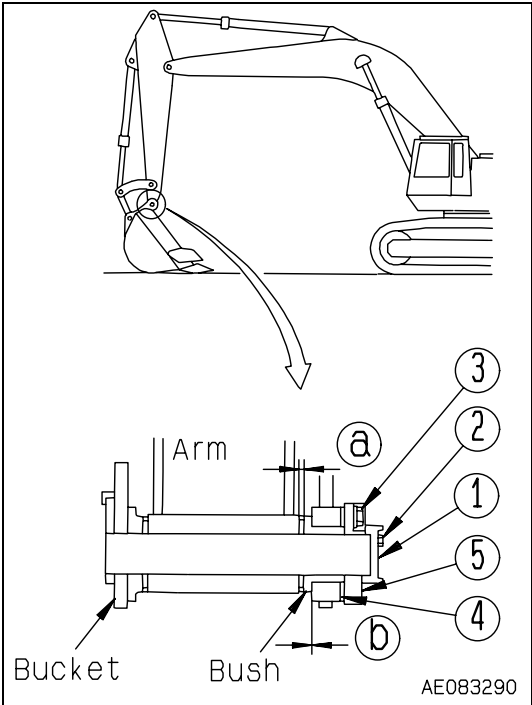

With this adjustment, clearance (b) becomes larger, but play (a) is removed.

REPLACE OF FAN BELT AND ADJUSTMENT OF AUTO TENSIONER

An auto-tensioner is installed, so there is no need to adjust until the belt is replaced.

CHECK WINDOW WASHER FLUID LEVEL, ADD FLUID

If there is air in the window washer fluid, check the level of the fluid in window washer tank (1), and if it is low, add automobile window washer fluid.

When adding fluid, be careful not to let any dust get in.

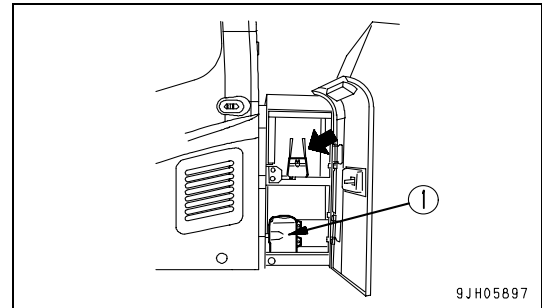

Mixture ratio of pure washer fluid and water

The proportion differs according to the ambient temperature, so dilute the washer fluid with water to the following proportions before adding.

Operation area and season	Mixture ratio	Freezing temperature
Normal	Pure washer fluid 1/3: water 2/3	- 10 °C (14 °F)
Winter in cold region	Pure washer fluid 1/2: water 1/2	- 20 °C (- 4 °F)
Winter in extremely cold region	Pure washer fluid	- 30 °C (- 22 °F)

There are two types depending on the freezing temperature:

-10 °C (14 °F) (general use) and -30 °C (-22 °F) (cold area use), so select according to the area and season.

CHECK AND ADJUST AIR CONDITIONER

(Only for machines equipped with air conditioner)

Check level of refrigerant (gas)

⚠ WARNING

If the refrigerant used in the cooler gets into your eyes or on your hands, it may cause loss of sight or frostbite. Do not touch the refrigerant. Never loosen any part of the refrigerant circuit. Do not bring any flame close to any point where the refrigerant gas is leaking.

If the level of the refrigerant (gas) is low, the cooling effect will be reduced. Run the engine at high idling, and check the flow of the refrigerant gas (freon 134a) in the refrigerant circuit through the sight glass (2) (inspection window) of the receiver (1) when the cooler is running at high speed.

(A) No bubbles in refrigerant flow: Suitable

(B) Some bubbles in flow (bubbles pass continuously):

Lack of refrigerant

(C) Colorless, transparent: No refrigerant

REMARK

When there are bubbles, the refrigerant gas level is low, so contact your refrigerant dealer to have refrigerant added. If the air conditioner is run with the refrigerant gas level low, it will cause damage to the compressor.

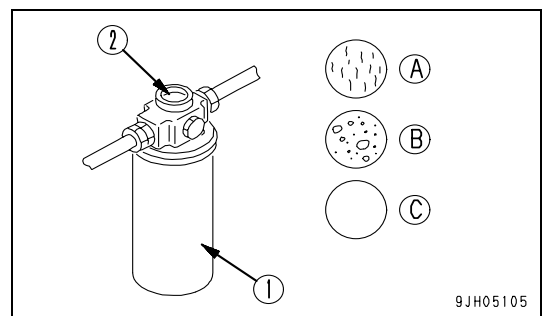
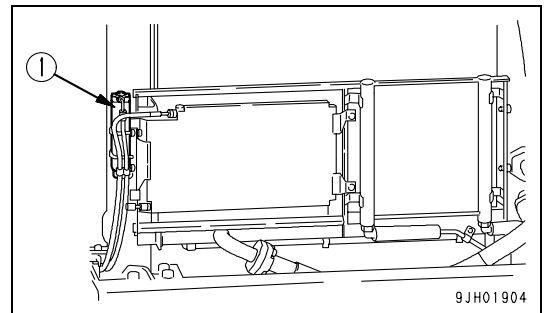

Inspection During Off Season

Even during the off-season, operate the air conditioner for 3 - 5 minutes once a month to maintain the oil film at all parts of the compressor.

Inspection and Maintenance Items

Check, maintenance items	Content of check, maintenance	Guideline for maintenance interval
Refrigerant (gas)	Charge amount	Twice a year (spring, autumn)
Condenser	Clogged fins	Every 500 hours
Compressor	Operating condition	Every 4000 hours
V-belt	Damage, tension	Every 250 hours
Blower motor, fan	Operating condition (does it make abnormal noise?)	When required
Control mechanism	Operating condition (does it function normally?)	When required
Piping mounts	Mounting condition, looseness at tightening or connecting portions, leakage of gas, damage	When required

CLEAN LINE FILTER, REMOVE DIRT

If there is any abnormality in the pump or other hydraulic equipment, remove the dirt from inside the line filter as follows.

Before removing the line filter, release the pressure inside the hydraulic circuit. For details, see "METHOD FOR RELEASING INTERNAL PRESSURE IN HYDRAULIC CIRCUIT (4-40)".

1. Remove 4 bolts (1), then remove flange (2).
2. After removing 4 bolts (3), temporarily screw 2 of them into cover (4).
3. Remove cover (4) and wash filter (5). When washing the filter, remove plug (6) and clean out all the dirt stuck to the side face of the case.
4. After washing filter (5), install it again. When installing the filter, cover, and flange again, replace backup ring (7) and O-rings (8), (9), and (10) with new parts.
After assembling the filter again, bleed the air. For details, see "BLEEDING AIR FROM HYDRAULIC SYSTEM (4-37)".

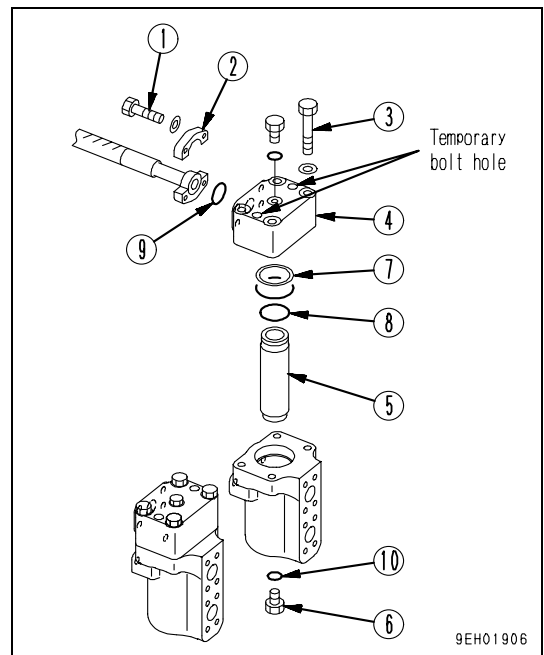
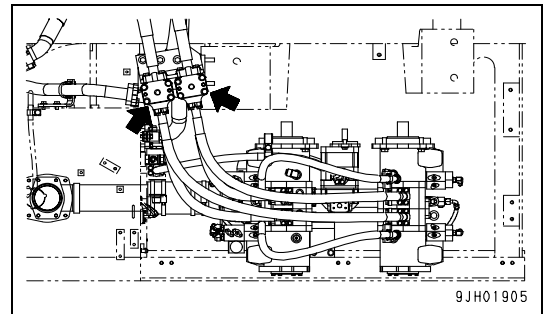

REPLACE BREAKER CIRCUIT ADDITIONAL OIL FILTER ELEMENT

(If equipped)

! WARNING
The parts and oil are at high temperature immediately after the engine is stopped, and may cause serious burns. Wait for the temperature to go down before starting the operation.

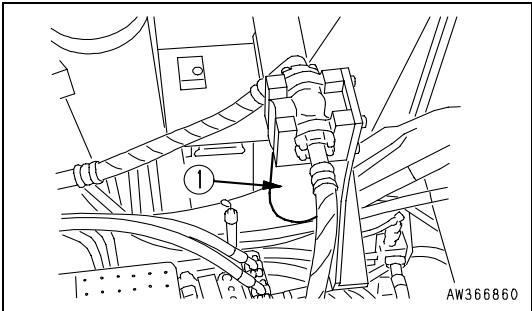

- Prepare a container to catch the oil.
1. Place a container under the filter element to catch the oil.
 2. Turn filter case (1) to the left to remove it, then take out element (2).
 3. Remove plug (3) from filter case (1).
 4. Clean the removed parts, then install new element (2) and O-ring (4).
 5. When installing, bring the case into contact with the filter holder, then tighten a further 1/2 turns.

NOTICE
For details of the replacement interval for the element, "MAINTENANCE INTERVAL FOR HYDRAULIC BREAKER (4-18)".

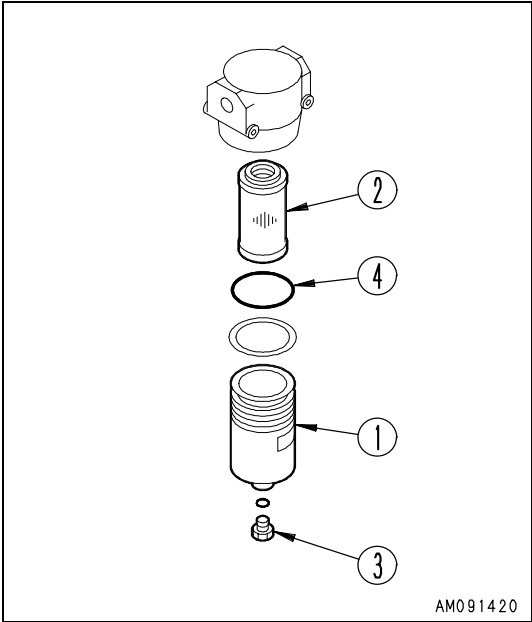

CLEAN PILOT LINE FILTER, REMOVE DIRT

Prepare a container to catch drained fuel.

1. Place a container under the pilot line filter to catch the oil.
2. Remove plug (1).
3. Remove strainer (2) and wash it.
4. Replace O-ring (3) with new one.
5. Install the washed strainer (2).
 Tightening torque for a strainer
 8.83 to 9.81 N·m (0.9 to 1.0 kgf·m, 6.5 to 7.2 lbft)
 Fix two positions of the cylinder.
6. Install the O-ring (3) and the plug (1).
 Tightening torque for a plug
 108.0 to 147.0 N·m (11 to 15 kgf·m, 79.6 to 108.5 lbft)

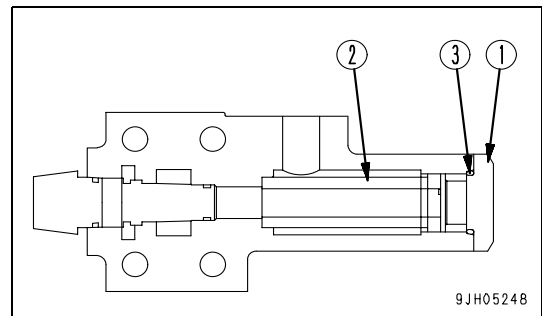
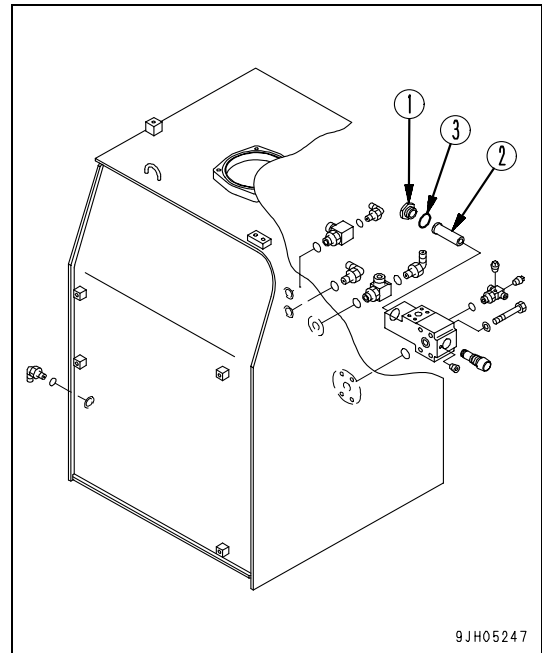

BLEEDING AIR FROM HYDRAULIC SYSTEM

For details, see "STARTING ENGINE (3-89)". If it is necessary to refer to the items for starting the engine, moving the machine off, steering, or stopping, see the OPERATION section.

⚠ WARNING

When starting the engine to bleed the air, follow the procedure given in "In Cold Weather Areas (3-97)".

NOTICE

- **Bleed the air as follows.**
 1. **Pump (work equipment, swing)**
 2. **Work equipment circuit**
- **Run the engine at less than 1000 rpm, and operate the cylinders slowly.**
- **Do not suddenly stop and cause the cylinder pressure to rise or operate to the end of the stroke.**
- **When operating the cylinder for the first stroke (extending and retracting), operate particularly slowly.**
- **When operating the cylinder for the first stroke, there is a large amount of air inside the circuit, so the work equipment will not move for at least 10 seconds. Be careful not to operate the lever to the end of the stroke.**
- **Use clean oil of NAS7 class or above when filling the pump. Be sure to use a clean oil can.**

Carry out Steps 1 - 3 below to bleed the air. If necessary, carry out Steps 4 - 6 in addition.

1. Bleeding air from pump
2. Loosen air bleed plug (1) and check that oil oozes out from the air bleeder (3).
3. If oil (4) does not ooze out, remove the pump case drain hose and elbow, then fill the inside of the pump case with hydraulic oil through drain port (2).
4. If the mouthpiece is lower than the surface of the oil in the hydraulic tank, oil will flow out from the drain hole when it is removed, so secure the mouthpiece of the hose at a position higher than the level of the oil in the hydraulic tank.
5. After completing the air bleed operation, tighten air bleed plug (1) and install the drain hose.

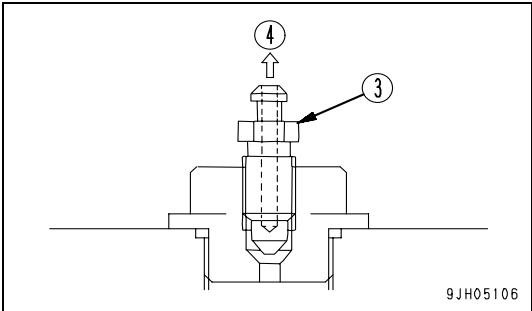
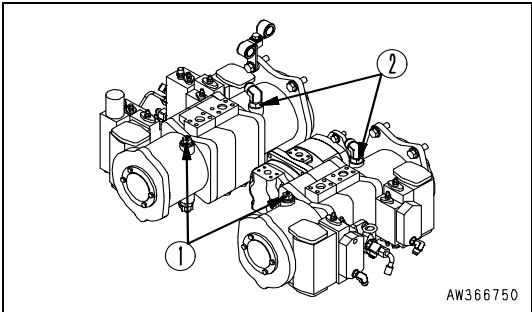

NOTICE

If the drain hose is installed first, oil will spurt out from plug (1) hole. If the pump is operated without filling the pump case with hydraulic oil, abnormal heat will be generated and this may cause premature damage to the pump.

6. Starting engine

Start the engine. For details, see "STARTING ENGINE (3-89)" and "In Cold Weather Areas (3-97)". After starting the engine, run it for 10 minutes at low idling, then go on to the next operation.

7. Bleeding air from cylinders
8. Run the engine at low idling, and extend and retract each cylinder 4 to 5 times, taking care so that a cylinder may not be brought up to its stroke end. (Stop the cylinder approx. 100 mm (3.9 in) short of its stroke end)
9. Next, operate each cylinder 3 to 4 times to the end of its stroke.
10. Finally, operate each cylinder 4 to 5 times to the end of its stroke to completely remove the air.

NOTICE

If the engine is run at high speed immediately after startup or a cylinder is pushed up to its stroke end, air taken inside the cylinder may cause damage to the piston packing.

11. Bleeding air from swing motor (bleed the air only when the oil inside the swing motor case has been drained)
 - When oil has been drained from inside swing motor case
12. Run the engine at low idling, loosen drain hose (1), and check that oil oozes out from drain hose (1).

NOTICE

When doing this, do not operate the swing.

13. If the oil does not ooze out, stop the engine, remove drain hose (1), then fill the motor case with hydraulic oil.
14. After completion of bleeding air, install drain hose (1).
15. Run the engine at low idling, and slowly swing the upper structure at least 2 times uniformly to the left and right.

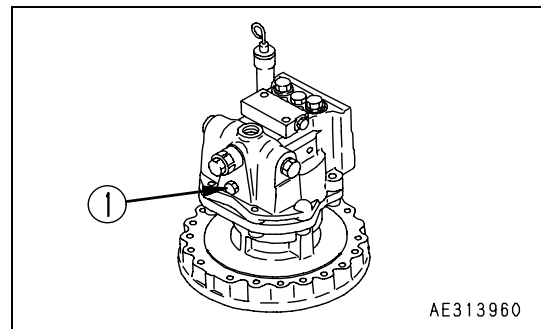

NOTICE

- **If the air is not bled from the swing motor, the motor bearings may be damaged.**
- **When replacing the travel motor safety valve, please contact your Komatsu distributor to have it replaced and to have the air bled.**

16. Bleeding air from attachment (when installed)

If an attachment has been installed, run the engine at low idling and operate the attachment pedal repeatedly (approx. 10 times) until the air has been bled from the attachment and circuit.

NOTICE

- **If the method of bleeding the air from the attachment itself is specified by the manufacturer, bleed the air according to the specified procedure.**
- **After completing the air bleeding operation, stop the engine, and leave the machine for 5 minutes before starting operations. This will remove the air bubbles in the oil inside the hydraulic cylinders.**
- **Check that there is no leakage of oil and wipe off any oil that has been spilled.**

17. Bleeding air from travel motor circuit

If the piping has been removed from the travel motor circuit, bleed the air after reassembling. To bleed the air, run the engine at low idling and do as follows.

- 18. Start the engine and run at low idling.
- 19. Remove travel motor cover (1), then loosen air bleed plug (2) one turn.

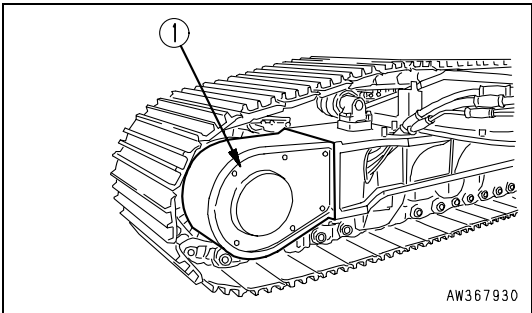

AW367930

NOTICE

Do not loosen plug (2) more than one turn.

- 20. Carry out fine operation of the travel lever and set to FORWARD and REVERSE 4 - 5 times.
- 21. When no more cloudy white oil comes out from air bleed plug (2), tighten air bleed plug (2).
- 22. Install the travel motor cover.
- 23. Operation
- 24. After completing the air bleed operation, stop the engine and wait for at least 5 minutes before starting operations. This will allow the bubbles in the oil inside the tank to escape.
- 25. Check that there is no leakage of oil, and wipe up any oil that has been spilled.

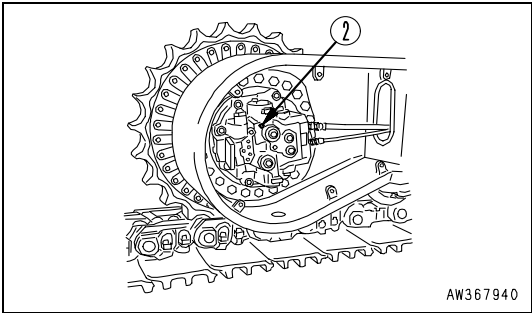

AW367940

METHOD FOR RELEASING INTERNAL PRESSURE IN HYDRAULIC CIRCUIT

RELEASING PRESSURE FROM WORK EQUIPMENT CIRCUIT, SWING CIRCUIT, TRAVEL CIRCUIT

⚠ WARNING

- The hydraulic system is always under internal pressure, so when inspecting or replacing the piping or hoses, always release the pressure in the circuit before starting. If the pressure is not released, high pressure oil may spurt out and cause serious personal injury.
- The parts and oil are at high temperature after the engine is stopped, and may cause serious burns. Wait for the temperature to go down before starting the operation.
- When the oil filler cap is removed, oil may spurt out, so turn the cap slowly to release the pressure before removing the cap.

1. Stop the machine on firm horizontal ground, lower the work equipment to the ground as shown in the diagram on the right, then stop the engine.
 - Set the lock lever at the FREE position (F).
2. Operate each work equipment control lever to the full stroke within 5 - 6 seconds after stopping the engine.
 - Leave the starting switch at the ON position.
3. Remove the cap of the hydraulic tank.
4. Start the engine, run for approx. 10 seconds, then stop the engine again.
 - Do not run the engine at more than 1000 rpm.
 - Set the work equipment control levers to the HOLD position.
5. Operate each work equipment control lever to the full stroke within 5 - 6 seconds after stopping the engine.
 - Repeat Steps 4 - 5 three times.

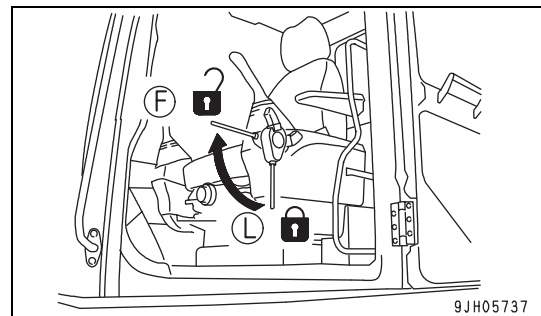
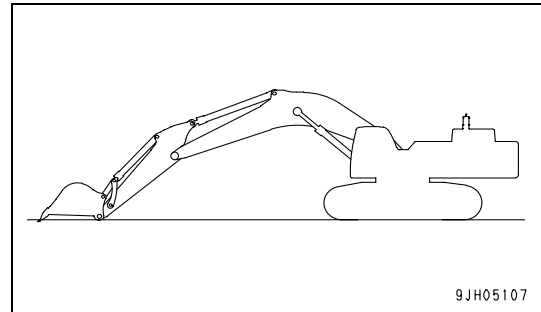

RELEASING PRESSURE IN ACCUMULATOR CIRCUIT

After stopping the engine, set the lock lever to the FREE position (F), then operate each work equipment control lever 3 - 4 times to the end of the stroke. After 1 minute, the internal pressure will be relieved.

- Do not loosen any piping until at least 1 minute has passed after relieving the internal pressure.

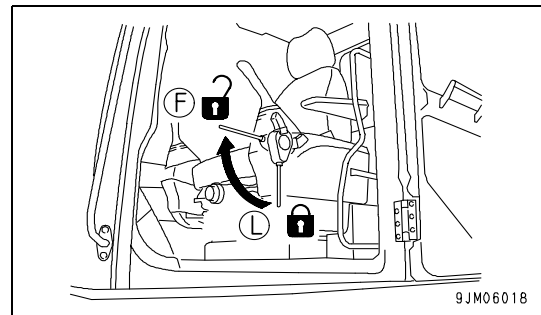

CHECK NITROGEN GAS CHARGE PRESSURE IN ACCUMULATOR (control circuit)**NOTICE**

If the nitrogen gas charge pressure in the accumulator is low and operations are continued, it will become impossible to release the remaining pressure inside the hydraulic circuit in a failure occurs on the machine.

Check the nitrogen gas charge pressure as follows.

1. Set the work equipment to maximum reach as shown in the diagram on the right.

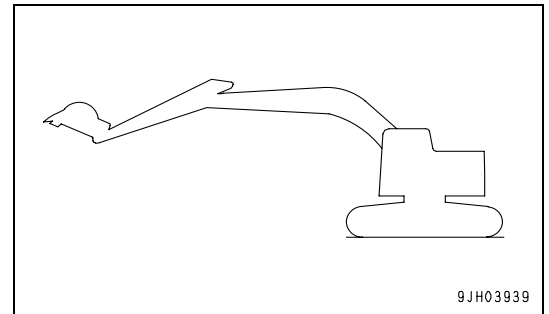

2. Stop the engine and carry out the LOWER operation for the boom.
3. Check that the tip of the bucket drops at least 1m.

If the tip of the bucket drops less than 1m, the charge pressure inside the accumulator is low, so please contact your Komatsu distributor.

CHECK BEFORE STARTING

For details of the following items, see "Checks Before Starting (3-75)" in the OPERATION section.

- Check coolant level, add water
- Check oil level in engine oil pan, add oil
- Check fuel level, add fuel
- Drain water and sediment from fuel tank
- Check oil level in hydraulic tank, add oil
- Check oil level in swing machinery case, add oil
- Check oil level in P.T.O case, add oil
- Check air cleaner for clogging
- Check working lamp switch
- Check electric wirings
- Check function of horn

EVERY 10 HOURS MAINTENANCE

LUBRICATING

1. Set to the greasing posture below, lower the work equipment to the ground, then stop the engine.
2. Using a grease pump, pump in grease through the grease fittings shown by arrows.
3. After greasing, wipe off any old grease that was pushed out.

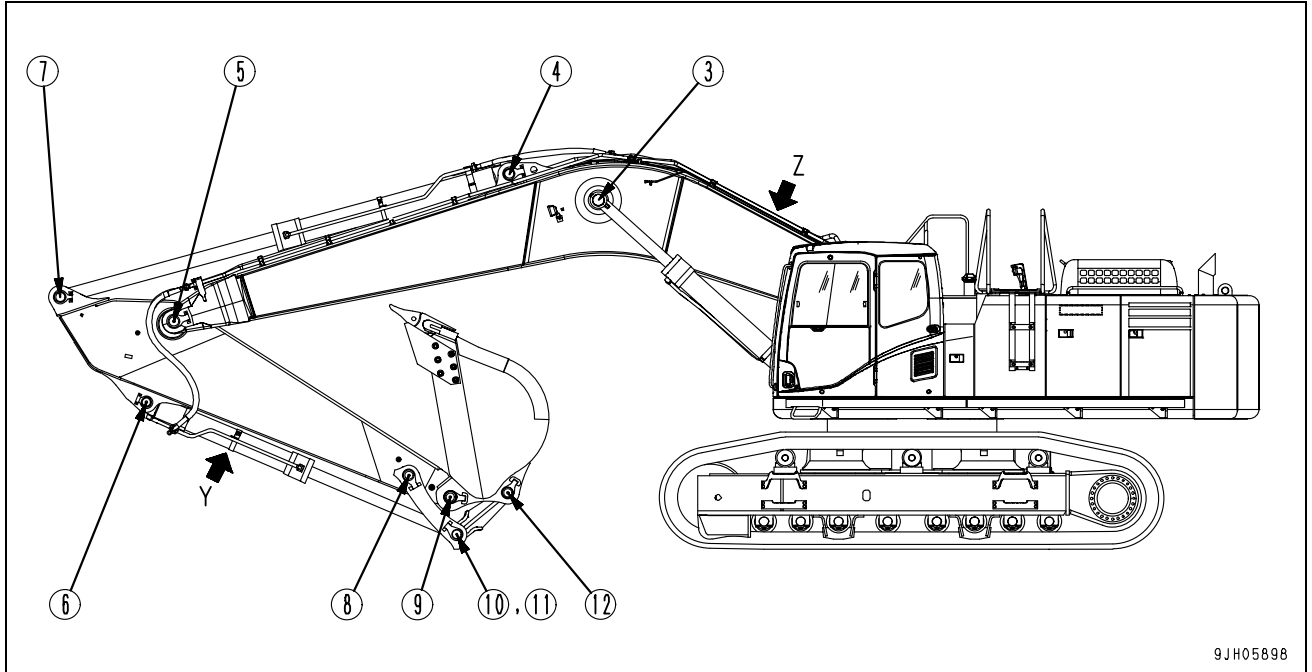

(1) Boom cylinder foot pin (2 places)

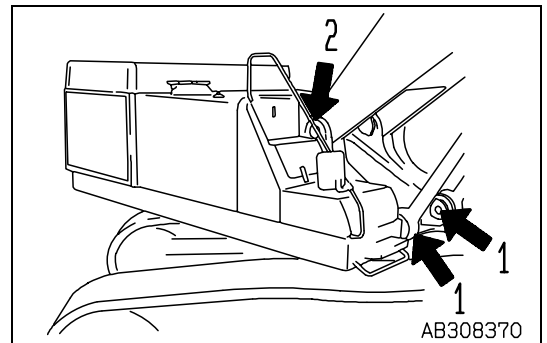

- (2) Boom foot pin (2 places)
- (3) Boom cylinder rod end pin (2 places)
- (4) Arm cylinder foot pin (1 place)

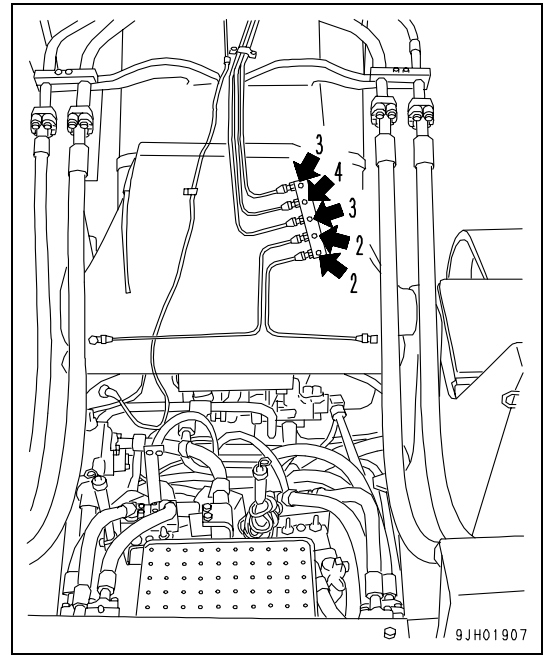

- (5) Boom-Arm coupling pin (1 place)
- (6) Bucket cylinder foot pin (1 place)
- (7) Arm cylinder rod pin (1 place)

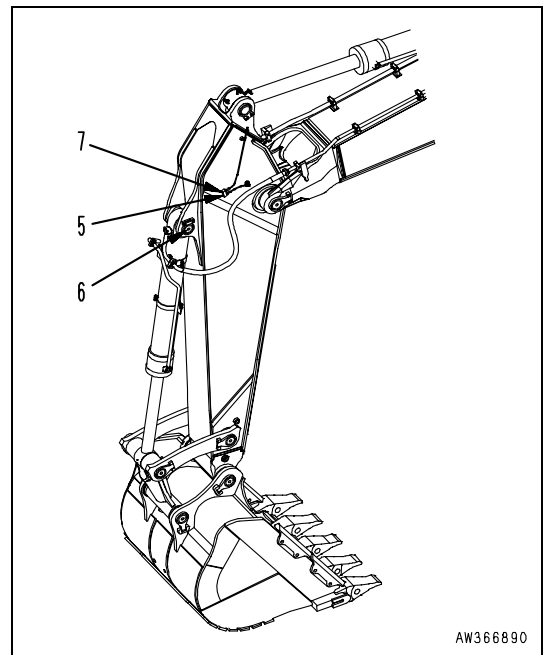

- (8) Arm-Link coupling pin (1 place)
- (9) Arm-Bucket coupling pin (1 place)

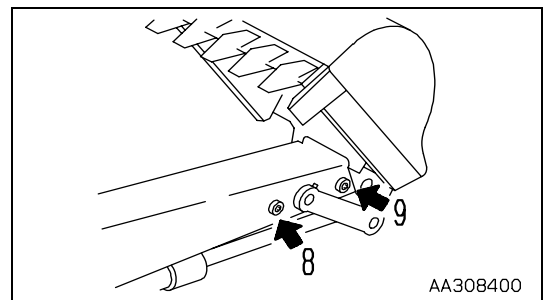

- (10) Link coupling pin (2 places)
- (11) Bucket cylinder rod pin (1 place)
- (12) Bucket-Link coupling pin (1 place)

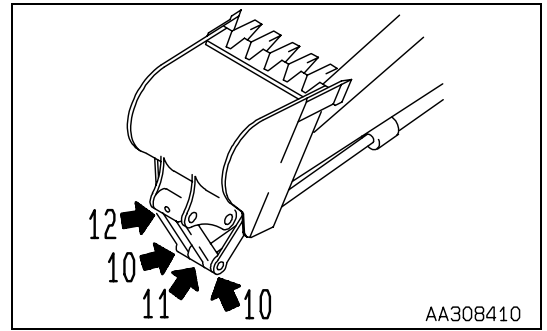

EVERY 100 HOURS MAINTENANCE

Maintenance for every 10 hours service should be carried out at the same time.

LUBRICATING SWING CIRCLE

(4 points)

1. Lower the work equipment to the ground.
2. Using a grease pump, pump in grease through the grease fittings shown by arrows.
3. After greasing, wipe off any old grease that was pushed out.

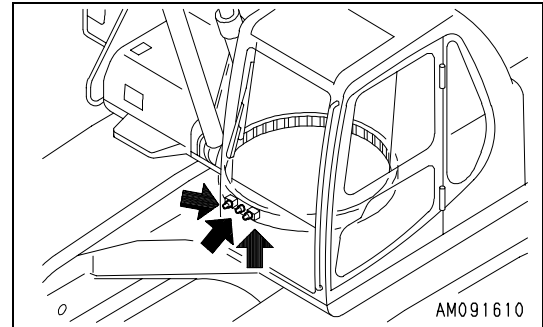

EVERY 250 HOURS MAINTENANCE

Maintenance for every 10 hours service should be carried out at the same time.

CHECK OIL LEVEL IN FINAL DRIVE CASE, ADD OIL

⚠ WARNING

- The parts and oil are at high temperature immediately after the engine is stopped, and may cause serious burns. Wait for the temperature to go down before starting the operation.
- If there is still pressure remaining inside the case, the oil or plug may fly out. Loosen the plug slowly to release the pressure.

- Prepare a handle.
1. Set the TOP mark at the top, with the UP mark and plug (P) perpendicular to the ground surface.
 2. Using a handle, remove plug (F) and check that the oil level is within a range of 10 mm (0.4 in) below the bottom edge of the plug hole.
 3. If the oil level is low, check again. Install plug (F), operate the travel lever, travel in FORWARD or REVERSE, and rotate the sprocket one turn. Carry out the inspection for Procedure 2 again.
 4. If the oil level is low, add engine oil through plug hole (F) until the oil overflows from plug hole (F).
 5. After checking, install plug (F).

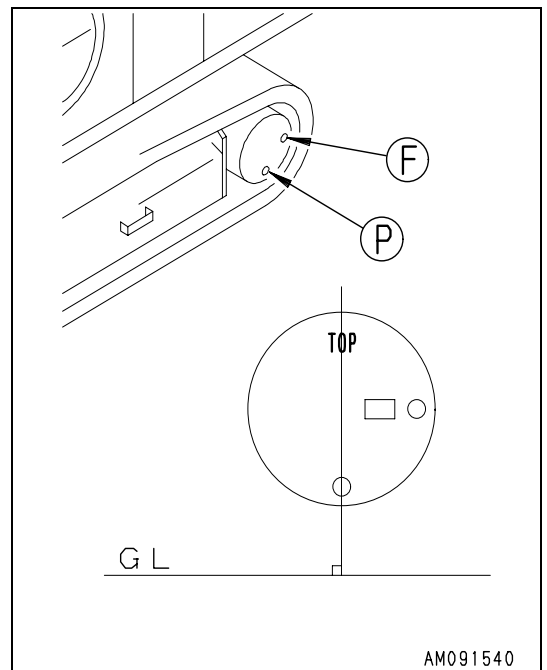

CHECK LEVEL OF BATTERY ELECTROLYTE

Carry out this check before operating the machine.

⚠ WARNING

- Do not use the battery if the battery electrolyte level is below the LOWER LEVEL line. This will accelerate deterioration of the inside of the battery and reduce the service life of the battery. In addition, it may also cause an explosion.
- The battery generates flammable gas and there is danger of explosion, so do not bring fire or sparks near the battery.
- Battery electrolyte is dangerous. If it gets in your eyes or on your skin, wash it off with a large amount of water and consult a doctor.
- When adding distilled water to the battery, do not allow the battery electrolyte to go above the UPPER LEVEL line. If the electrolyte level is too high, it may leak and cause damage to the paint surface or corrode other parts.

NOTICE

When adding distilled water in cold weather, add it before starting operations in the morning to prevent the electrolyte from freezing.

Inspect the battery electrolyte level at least once a month and follow the basic safety procedures given below.

Open cover (1) at the rear left side of the machine. The batteries are installed at (A) part.

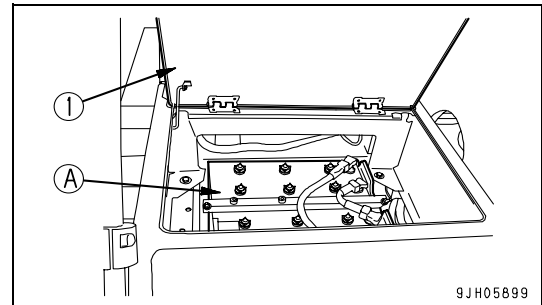

When checking electrolyte level from side of battery

If it is possible to check the electrolyte level from the side of the battery, check as follows.

1. Use a wet cloth to clean the area around the electrolyte level lines and check that the electrolyte level is between the UPPER LEVEL (U.L.) and LOWER LEVEL (L.L.) lines.

If the battery is wiped with a dry cloth, static electricity may cause a fire or explosion.

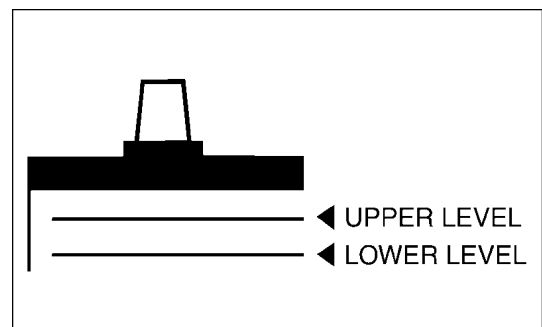

2. If the electrolyte level is below the midway point between the U.L. and L.L. lines, remove cap (1) and add distilled water to the U.L. line.
3. After adding distilled water, tighten cap (1) securely.

REMARK

If distilled water is added to above the U.L. line, use a syringe to lower the level to the U.L. line. Neutralize the removed fluid with baking soda (sodium bicarbonate), then flush it away with a large amount of water or consult your Komatsu distributor or battery maker.

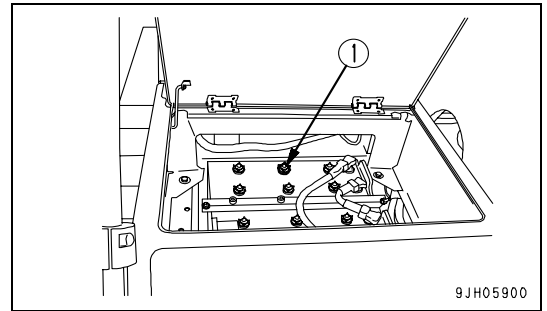

When it is impossible to check electrolyte level from side of battery

If it is impossible to check the electrolyte level from the side of the battery, or there is no display of the UPPER LEVEL line on the side of the battery, check as follows.

1. Remove cap (1) at the top of the battery, look through the water filler port, and check the electrolyte surface. If the electrolyte does not reach the sleeve, add distilled water so that the level reaches the bottom of the sleeve (UPPER LEVEL line) without fail.

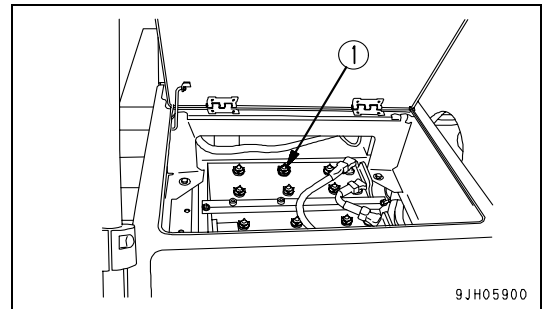

Use the diagram below for reference, and check if the electrolyte reaches the bottom of the sleeve.

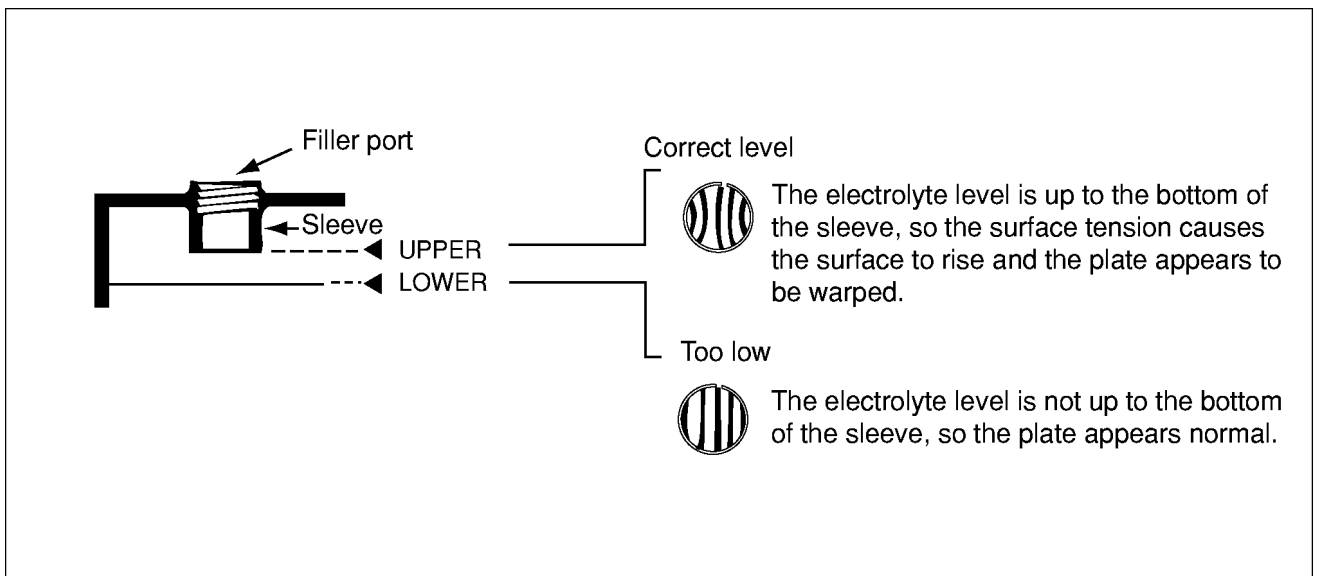

2. After adding distilled water, tighten cap (1) securely.

REMARK

If distilled water is added to above the bottom of the sleeve, use a syringe to lower the level to the bottom of the sleeve. Neutralize the removed fluid with baking soda (sodium bicarbonate), then flush it away with a large amount of water or consult your Komatsu distributor or battery maker.

When it is possible to use indicator to check electrolyte level

If it is possible to use an indicator to check the electrolyte level, follow the instructions given.

CHECK, CLEAN FUEL TANK STRAINER

Tighten the valve of the fuel tank, remove cap (1) of the strainer case under the oil pan, then take out the strainer and wash the strainer and strainer case.

After doing this, replace the strainer O-ring.

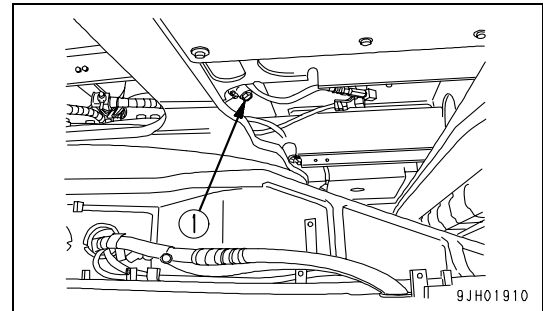

CHECK AND TIGHTEN TRACK FRAME AND AXLE CONNECTING BOLTS

Bolts (1) connecting the track frame and axle will break if they remain loose, so loose bolts must always be retightened.

- Tightening torque: 1960 to 2450 N·m
(200 to 250 kgf·m, 1446.6 to 1808.3 lbf·ft)

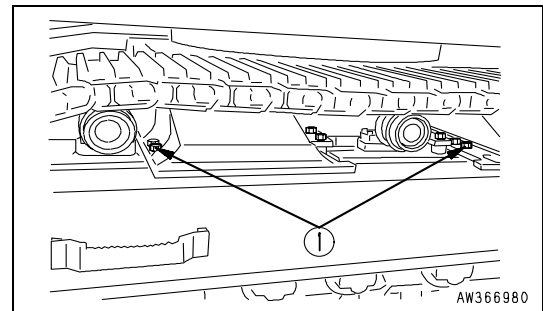

CHECK ALTERNATOR DRIVE BELT TENSION, ADJUST

Checking

If you push the belt at the center between the alternator (1) and the drive pulley (2) with your thumb

[approximately 98.1N (10 kgf)] and you get deflection of (A), it is normal.

(A): 13 to 16 mm (0.51 to 0.63 in)

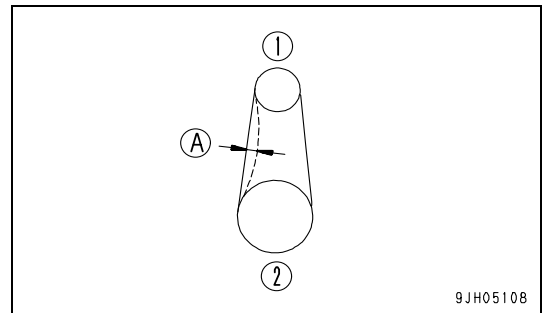

Adjustment

1. Loosen bolts and nuts (3) - (8) in number order, and move the alternator.

- Adjust the belt tension with nut (9) as follows:
TIGHTEN to INCREASE tension
LOOSEN to DECREASE tension

2. After adjusting the belt, tighten the bolts and nuts (3) to (8) in the order of (8) to (3) (the opposite order from loosening). Finally, tighten nut (9).

- Check each pulley for damage, wear of the V-groove, and wear of the V-belt. Check in particular that the V-belt does not contact the bottom of the V-groove.
- If the V-belt is elongated and there is no more allowance for adjustment, or if the belt is cracked or cut, replace the belt.
- When the V-belt has been replaced, adjust again after running for 1 hour.

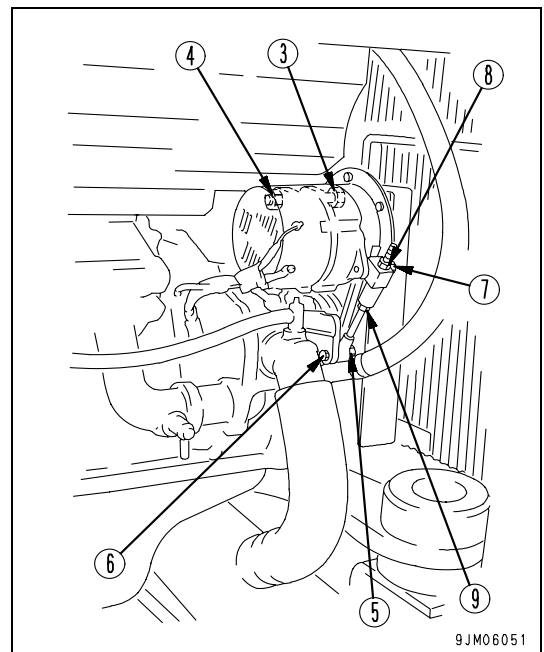

CHECK AIR CONDITIONER COMPRESSOR BELT TENSION, ADJUST

Checking

1. Remove 4 bolts (2), then remove cover (1).
2. The standard deflection for the drive belt is of (A) when pressed with a thumb [at approx.98.1 N (approximately 10 kgf)] at a point midway between the drive pulley (3) and the air conditioner compressor pulley (4).

(A): 10 mm (0.4 in)

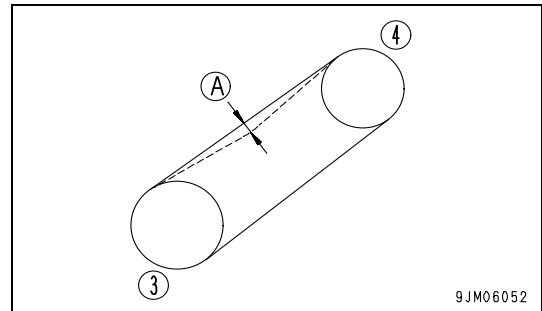
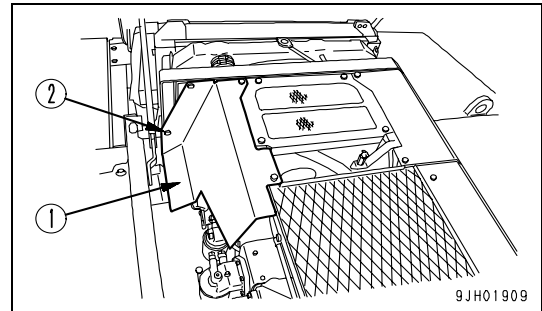

Adjustment

1. Loosen the bolts and nuts in the order (5) to (9), and move compressor.
 - Adjust the belt tension with nut (9) as follows:
TIGHTEN to INCREASE tension
LOOSEN to DECREASE tension
2. After adjusting the belt, tighten the bolts and nuts (5) to (8) in the order of (8) to (5) (the opposite order from loosening). Finally, tighten nut (9).
 - Check each pulley for damage, wear of the V-groove, and wear of the V-belt. Check in particular that the V-belt does not contact the bottom of the V-groove.
 - If the V-belt is elongated and there is no more allowance for adjustment, or if the belt is cracked or cut, replace the belt.
 - When the V-belt has been replaced, adjust again after running for 1 hour.
3. Install cover (1).

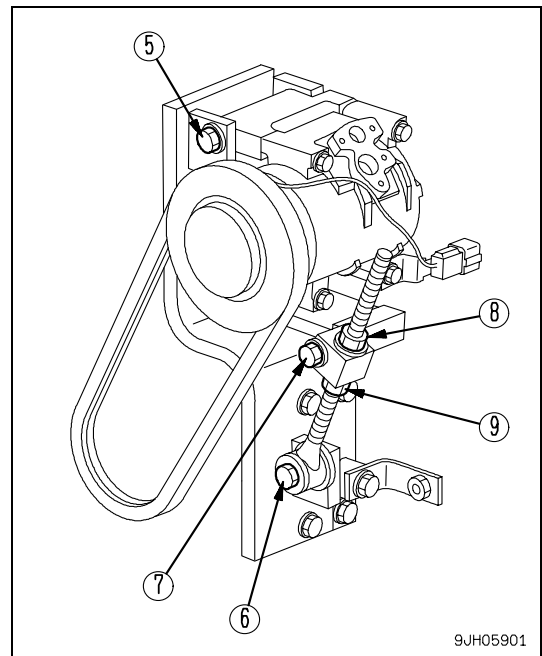

EVERY 500 HOURS MAINTENANCE

Maintenance for every 10, 100 and 250 hours service should be carried out at the same time.

REPLACE FUEL FILTER CARTRIDGE

WARNING

- After the engine has been operated, all parts are at high temperature, so do not replace the filter immediately. Wait for all parts to cool down before starting the operation.
- High pressure is generated inside the engine fuel piping system when the engine is running. When replacing the filter, wait for at least 30 seconds after stopping the engine to let the internal pressure go down before replacing the filter.
- Do not bring any fire or flame close.

NOTICE

- Genuine Komatsu fuel filter cartridges use a special filter that has highly efficient filtering ability. When replacing the filter cartridge, always use a genuine Komatsu part.
- The common rail fuel injection system used on this machine consists of more precise parts than the conventional injection pump and nozzle. If any part other than a genuine Komatsu filter cartridge is used, dust or dirt may get in and cause problems with the injection system. Always avoid using substitute parts.
- When carrying out inspection or maintenance of the fuel system, pay more attention than normal to the entry of dirt. If dirt is stuck to any part, use fuel to wash it off completely.

- Container to catch the oil
- Filter wrench

1. Set the container to catch the fuel under the filter cartridge.
2. Using a filter wrench, turn filter cartridge (1) counterclockwise to remove it.
3. Clean the filter holder, fill the new filter cartridge with clean fuel, coat the packing surface thinly with engine oil, then install to the filter holder.

NOTICE

- When adding fuel, do not remove cap (4). Always add fuel from the 8 small holes (A) on the dirty side.
- After adding fuel, remove cap (4) and install the fuel filter.
- Always fill with clean fuel. Be careful not to let any dirt or dust get into the fuel. In particular, center portion (B) is the clean side, so do not remove cap (4) when adding fuel. Be careful not to let dirt or dust get into center portion (B) on the clean side.

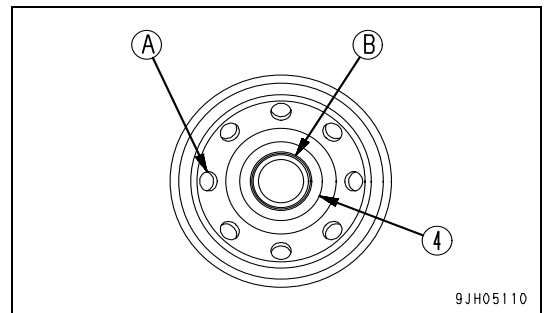
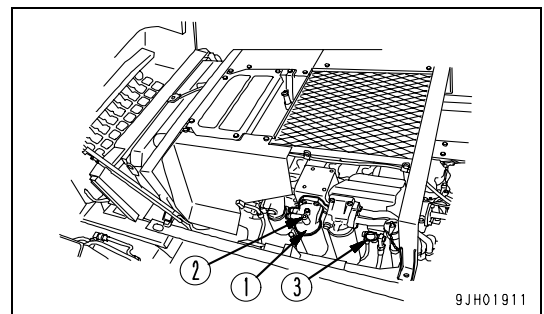

4. When installing, tighten until the packing surface contacts the seal surface of the filter holder, then tighten it up 1/2 to 3/4 of a turn.

If the filter cartridge is tightened too far, the packing will be damaged and this will lead to leakage of fuel. If the filter cartridge is too loose, fuel will also leak from the packing, so always tighten to the correct amount.

- When tightening with a filter wrench, be extremely careful not to dent or damage the filter.

5. After completion of the replacement of fuel filter cartridge (1), bleed the air.

Bleed the air as follows.

6. Add fuel to the fuel tank until full (to FULL mark on the fuel gauge).
7. After replacing filter cartridge (1), loosen air bleed plug (2).
8. Loosen the knob of priming pump (3), move it up and down, and continue until no more bubbles come out with the fuel.
9. Tighten air bleed plug (2), push in the knob of priming pump (3), then tighten it.

Use a genuine Komatsu part for the fuel filter cartridge. After replacing the filter cartridge, run the engine, and check for any leakage of oil from the filter seal surface.

Do not run the starting motor continuously for more than 20 seconds. This will put excessive load on the wiring harnesses and starting motor.

CHECK SWING PINION GREASE LEVEL, ADD GREASE

- Prepare a scale.
- 1. Remove bolts (1) (2 bolts) on the top of the revolving frame and remove cover (2).

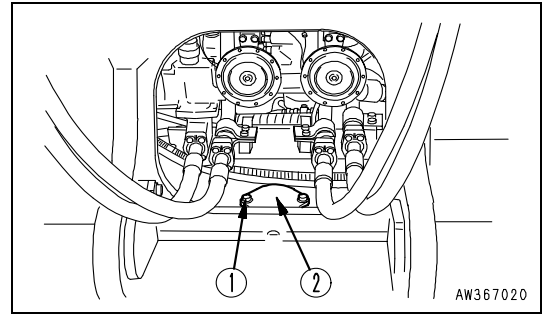

- 2. Insert a scale into the grease and check that the depth of the grease is approx. 60 mm (2.4 in). Add grease if necessary.

Insert the scale (A) in the position shown in the diagram on the right when measuring.

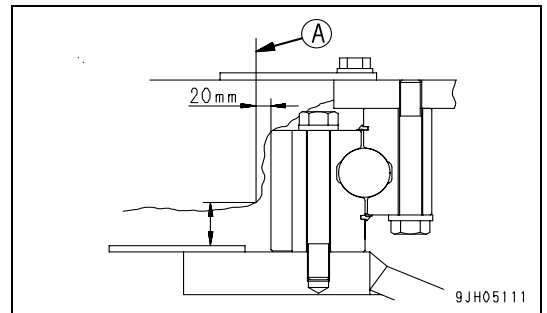

If the grease is particularly milky due to ingress of water, etc., then remove bolts (3) and cover (4) from the bottom of the track frame and remove the grease. Replace all of the grease with new grease.

The total amount of grease is 31 liters (28 kg) [8.2 US gal (61.7 lb)].

- 3. Install cover (2) with bolts (1).

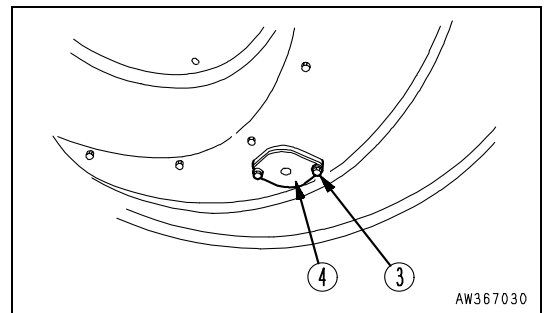

CLEAN, CHECK RADIATOR FIN, OIL COOLER FIN, FUEL COOLER FIN, CONDENSER FIN (machines equipped with air conditioner)

⚠ WARNING

If compressed air, high-pressure water, or steam hit your body directly, or they cause dirt or dust to be blown up, there is a hazard of serious injury. Always use safety glasses, dust mask, or other protective equipment.

NOTICE

When using compressed air, use from a distance to prevent damage to the fins. In particular, with the fuel cooler and aftercooler, blow with compressed air at an angle of 45° with the nozzle at a distance of at least 300 mm (11.8 in). Never blow the compressed air at right angles to the core. If the fins are damaged, it may cause water leakage or overheating. On dusty jobsites, check the fins daily, regardless of the maintenance interval.

1. Open the engine hood and rear duct (1) on the right side of the machine.
2. Direct compressed air to radiator fins (9), oil cooler fins (8) and condenser fins (4) to blow off the clogged dirt, twigs and leaves. At the same time, clean the net in front of the oil cooler. Clean the condenser fins (A) on machines equipped with air conditioner. Steam or water may be used instead of compressed air.
3. Check the rubber hose. Replace with a new one if the hose is found to have cracks or to be hardened by ageing. Also, check hose clamps for looseness.

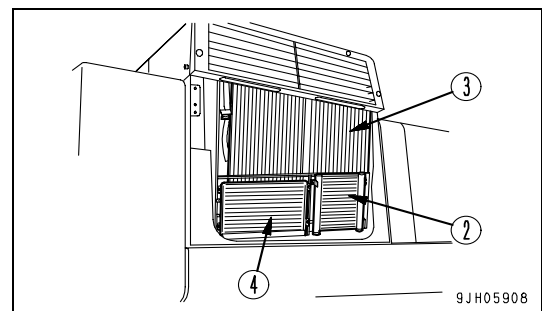
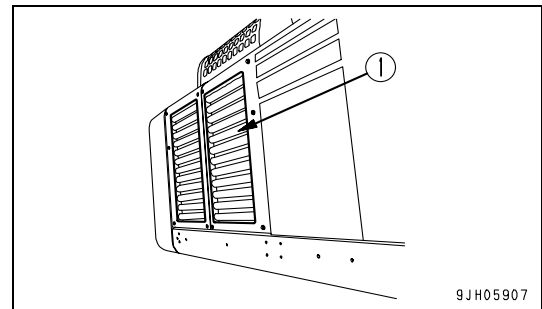

CLEAN FRESH/RECIRC AIR FILTERS OF AIR CONDITIONER (ONLY FOR MACHINES EQUIPPED WITH AIR CONDITIONER)

⚠ WARNING

If compressed air is used, there is danger that dirt may fly and cause personal injury. Always wear safety glasses, dust mask, and other protective equipment.

NOTICE

As a guideline, the filters should be cleaned every 500 hours, but on dusty jobsites, clean the filters more frequently.

REMARK

If the filter becomes clogged, the air flow will be reduced, and there will be an abnormal noise from the air conditioner unit.

CLEAN INTERNAL AIR FILTER

1. Remove wing bolts (1) from the inspection window at the bottom rear left on the inside of the operator's cab, then take out the recirculated air filter.
2. Clean the filter with compressed air. If there is oil on the filter, or if the filter is extremely dirty, wash it in a neutral agent. After rinsing it in water, dry it thoroughly before using it again. If the clogging of the filter cannot be removed by blowing with air or washing in water, replace the filter with a new part.

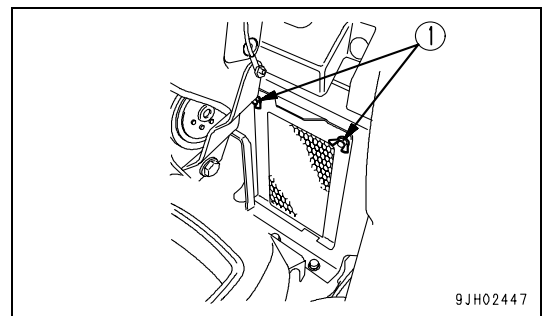

CLEAN EXTERNAL AIR FILTER

1. Pull up the lock release lever under the door release lever (1) to release the lock.

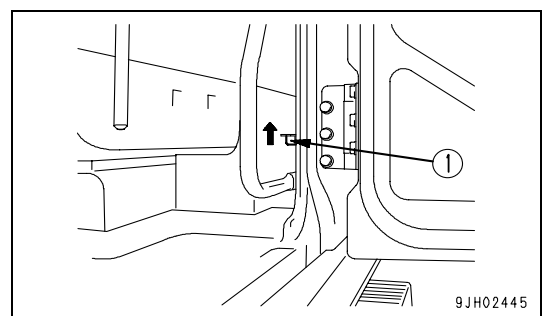

2. Open cover (2) at the bottom left of the operator's cab by hand, pull out filter case (3) from the inside, then remove the filter.

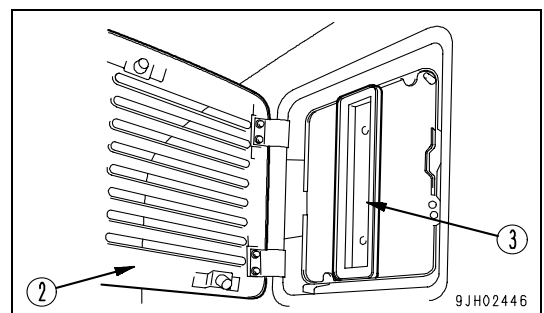

3. Clean the filter with compressed air. If there is oil on the filter, or if the filter is extremely dirty, wash it in a neutral agent. After rinsing it in water, dry it thoroughly before using it again.
If the clogging of the filter cannot be removed by blowing with air or washing in water, replace the filter with a new part.
4. After cleaning, insert the filter in filter case (3) again, open the cover at the bottom left of the operator's cab by hand, return the filter case to its original position, then close the cover. When doing this, check that the lock is applied.

REPLACE BREATHER ELEMENT IN HYDRAULIC TANK

⚠ WARNING

- The parts and oil are at high temperature after the engine is stopped, and may cause burns. Wait for the temperature to go down before starting the work.
- When removing the oil filler cap, turn it slowly to release the internal pressure, then remove it.

1. Remove the cap of oil filler (F) at the top of the hydraulic tank.

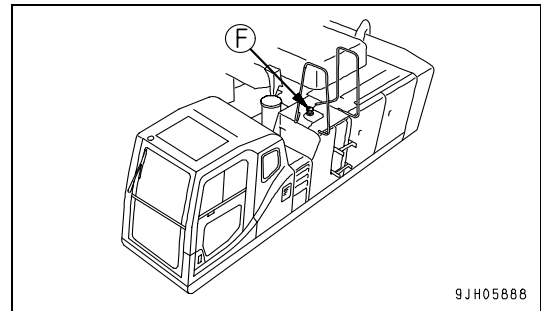

2. Replace element (1) inside the cap.

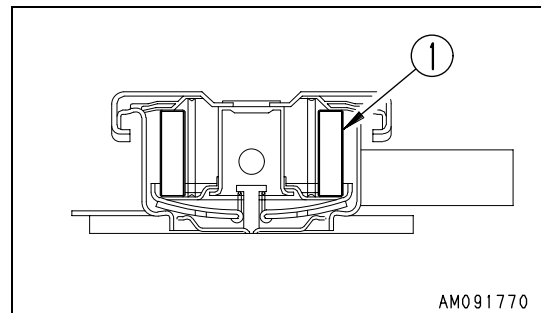

CLEAN STRAINER OF P.T.O LUBRICATING OIL FILTER

⚠ WARNING

- The parts and oil are at high temperature after the engine is stopped, and may cause serious burns. Wait for the temperature to go down before cleaning the engine breather.
- When using compressed air, there is a hazard that dirt may be blown up and cause serious injury. Always use safety glasses, dust mask, or other protective equipment.

1. Remove filter case (1).
2. Take out the strainer, remove any dirt stuck to the strainer, then wash it in flushing oil. If the strainer or O-ring are damaged, replace with a new part.
3. Install the strainer and filter case (1).

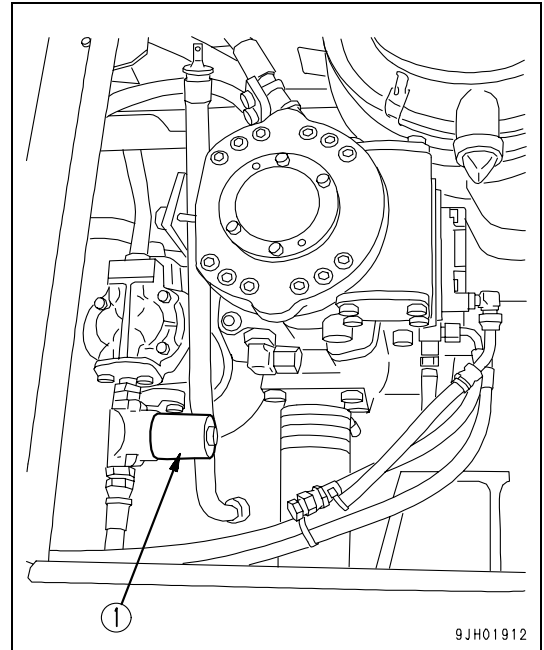

CHECK FAN BELT

Check the V-belt and when the following conditions exist, replace the V-belt:

- When the V-belt makes contact with the bottom of the groove in each pulley.
- When the V-belt is worn, and its surface is lower than the outer diameter of the pulley.
- When cracking and peeling of the V-belt occurs.

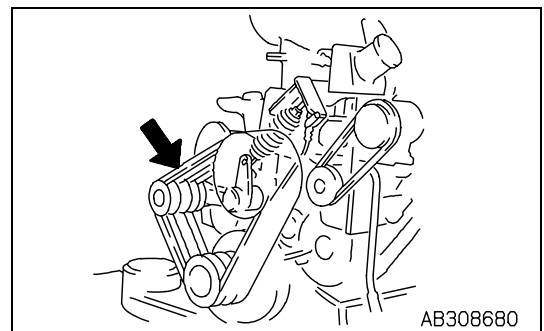

A device is installed to maintain the tension constant regardless of any elongation of the V-belt, so there is no need to carry out adjustment until the V-belt is replaced.

CHANGE OIL IN ENGINE OIL PAN, REPLACE ENGINE OIL FILTER CARTRIDGE

⚠ WARNING

The parts and oil are at high temperature immediately after the engine is stopped, and may cause serious burns. Wait for the temperature to go down before starting the operation.

- Oil pan refill capacity: 40 liters (10.6 US gal)
- Filter wrench

1. Remove cover (1) at the bottom of the engine, then set a container immediately under drain valve (2) to catch the drained oil.

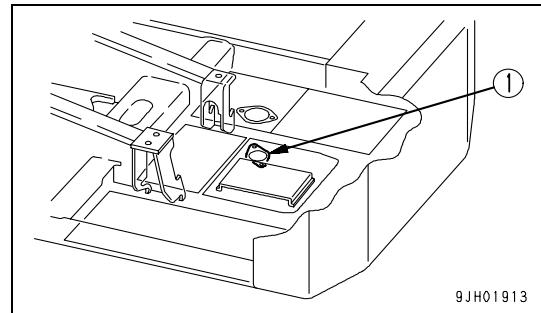

2. Be careful not to get oil on yourself. Move lever (3) of the drain valve down slowly to drain the oil, and after draining the oil, raise the lever to close it.

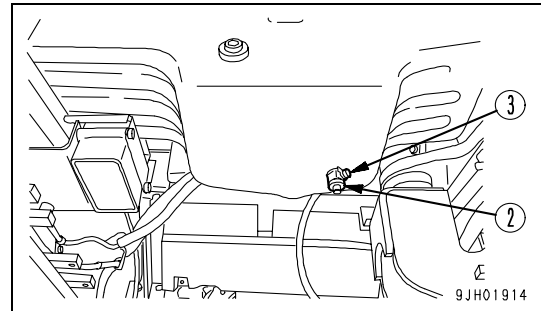

3. Open the cover of the engine hood, use a filter wrench from the top of the engine, turn filter cartridge (3) to the left, and remove it.

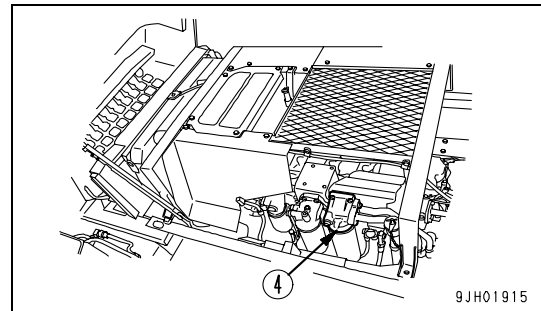

4. Clean the filter holder, fill the new filter cartridge with clean engine oil, coat the thread and packing surface of the new filter cartridge with clean engine oil (or coat it thinly with grease), then install it to the filter holder.

REMARK

Check that there is no old packing affixed to the filter holder. If there is any old packing affixed to the filter, it will cause leakage of oil.

5. When installing, bring the packing surface into contact with the seal surface of the filter holder, then tighten a further 3/4 - 1 turn.
 - When using a filter wrench for tightening, be extremely careful not to damage the filter or cause dents.
6. After replacing the filter cartridge, add engine oil through oil filler port (F) so that the oil level is between the H and L marks on dipstick (G).
7. Run the engine for a short time at low idling, then stop the engine. Check that the oil level gauge is between the H and L marks. For details, see "Check Oil Level In Engine Oil Pan, Add Oil (3-76)".

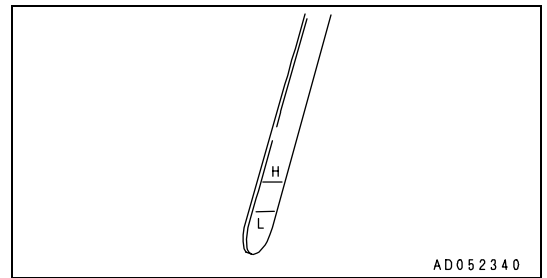
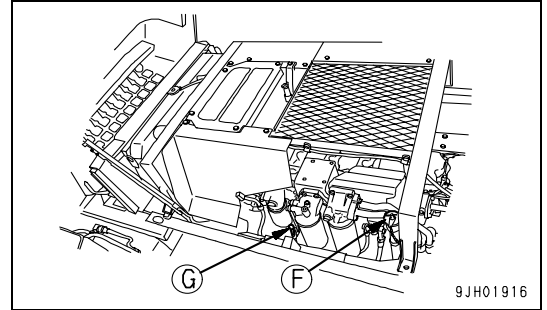

EVERY 1000 HOURS MAINTENANCE

Maintenance for every 10, 100, 250 and 500 hours service should be carried out at the same time.

REPLACE HYDRAULIC OIL FILTER ELEMENT

WARNING

- The parts and oil are at high temperature after the engine is stopped, and may cause burns. Wait for the temperature to go down before starting the work.
- When removing the oil filler cap, turn it slowly to release the internal pressure, then remove it.

1. Set the work equipment on the hard and flat ground in the maintenance posture as shown in the figure, then lower it to the ground and stop the engine.

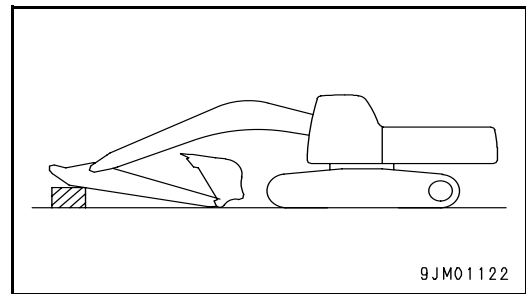

2. Remove the cap from oil filler (F) on top of the hydraulic tank, and release the internal pressure.

3. Loosen 4 bolts, then remove cover (1).

When doing this, the cover may fly out under the force of spring (2), so hold the cover down when removing the bolts.

4. After removing spring (2), valve (3) and strainer (5), take out element (4).

- If there are metal particles or foreign material inside strainer (5), please contact your Komatsu distributor.

5. Clean the removed parts in diesel oil.

6. Install the new element in the place where old element (4) was installed.

7. Set valve (3), strainer (5) and spring (2) on top of the element.

8. Set cover (1) in position, push it down by hand, and install the cover with the mousing bolts.

9. Install the cap of oil filler port (F).

10. To bleed the air, start the engine according to "STARTING ENGINE (3-89)" and run the engine at low idling for 10 minutes.

11. Stop the engine.

REMARK

Operate the machine after halting for more than 5 minutes to eliminate bubbles in the oil inside the tank.

12. Check for oil leakage and wipe off any spilled oil.

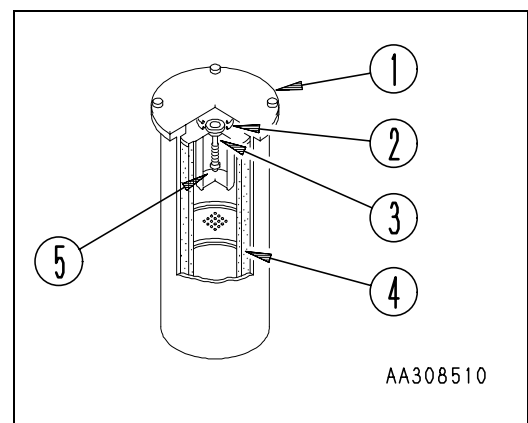
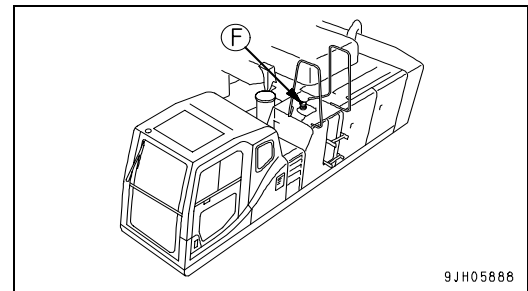

CHANGE OIL IN SWING MACHINERY CASE

⚠ WARNING

The parts and oil are at high temperature immediately after the engine is stopped, and may cause serious burns. Wait for the temperature to go down before starting the operation.

- Refill capacity: Each 13 liters (3.4 US gal)
1. Set a container under drain hose under the machine body to catch the oil.
 2. Loosen drain valve (P) under the machine body, drain the oil, then tighten the drain plug again.
 3. Remove dipstick (G) and air bleeding plug (1), then add the specified amount of engine oil through filler port (F) of the dipstick guide.
 4. After adding oil, install air bleed plug (1).
 5. Wipe off the oil on the dipstick with a cloth.
 6. Insert dipstick (G) fully in the oil filler pipe, then take it out again.
 7. The oil level should be between H and L marks on the dipstick (G). If the oil does not reach the L mark, add engine oil through oil filler port (F).
 8. If the oil is above the H mark, drain the excess engine oil from drain valve (P), and check the oil level again.
 9. Immediately after changing the oil, oil level is variable.
So operate for one hour, then check the oil level again.

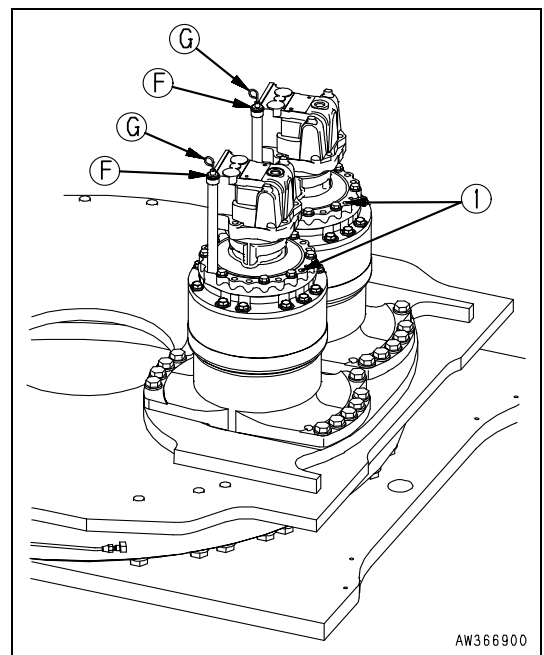
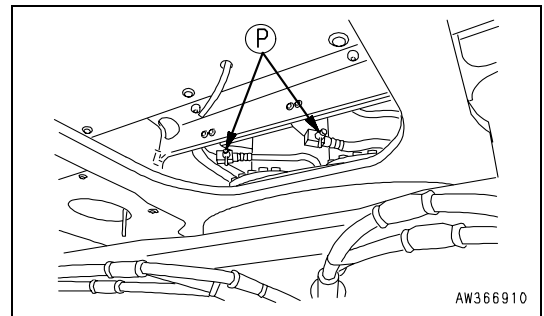

CHANGE OIL IN P.T.O CASE**⚠ WARNING**

The parts and oil are at high temperature immediately after the engine is stopped, and may cause serious burns. Wait for the temperature to go down before starting the operation.

NOTICE

Park the machine on flat ground and stop the engine. After waiting for more than 30 minutes after stopping the engine, check the oil level.

- Refill capacity: 6 liters (1.6 US gal)
1. Loosen drain plug (1) at the bottom of the PTO case, drain the oil, then tighten the plug again.
 2. Refill the specified quantity of engine oil through oil filler (F).

NOTICE

If excess oil is supplied, drain it to the specified amount to avoid overheating.

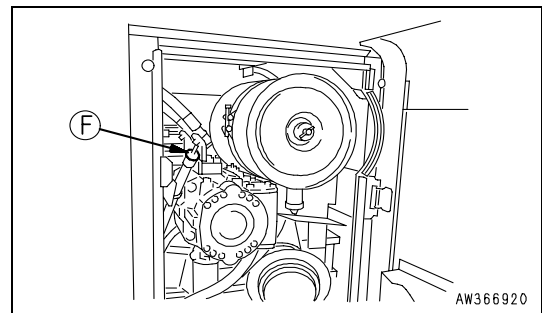
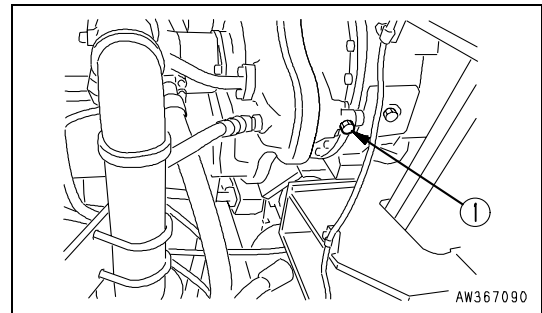
**CHECK ALL TIGHTENING PARTS OF TURBOCHARGER**

Please contact your Komatsu distributor to have the tightening portions of the turbocharger checked.

CHECK PLAY TURBOCHARGER ROTOR

Please contact your Komatsu distributor to have the rotor play checked.

REPLACE CORROSION RESISTOR CARTRIDGE

⚠ WARNING

The oil is at high temperature after the engine has been operated, so never replace the cartridge immediately after finishing operations.
 Wait for the oil to cool down before replacing cartridge.

- Container to catch coolant
 - Filter wrench
1. Turn valve (1) of corrosion resistor (2) to the CLOSE stopper position.
 2. Set a container under the cartridge to catch the coolant.
 3. Using a filter wrench, turn cartridge (2) to the left to remove it.
 4. Clean the filter holder, coat the seal surface of the new cartridge thinly with engine oil, then install the cartridge.
 - Always use a genuine Komatsu part for the cartridge.

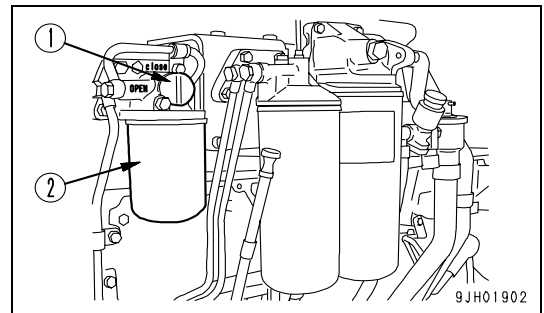

5. When installing the cartridge, bring the packing surface into contact with the seal surface of the filter holder, then tighten a further 2/3 times.
 If the filter cartridge is tightened too far, the gasket will be damaged and water will leak. If it is too loose, water will leak from the gap in the gasket, so always keep to the proper tightening angle.
6. Turn valve (1) of corrosion resistor (2) to the OPEN stopper position.
7. After replacing the cartridge, run the engine, and check for any leakage of water from the filter seal surface. If any water leakage is found, check the tightening of the filter cartridge.

GREASE FAN PULLEY AND TENSION PULLEY

Using a grease pump, apply grease through grease fittings (1) and (2).

- Grease fan pulley
 Apply grease through grease fitting (1) until grease comes out from the relief valve at the side of grease fitting (1).
- Grease tension pulley
 Apply grease through grease fitting (2) until grease comes out from the relief valve at the tip of the shaft at the side of grease fitting (2).

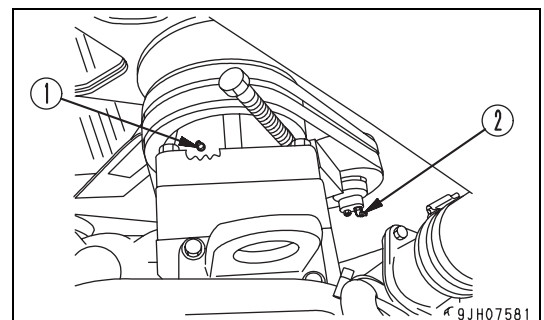

CHECK WELDED STRUCTURE

(Color check)

Cracks in welded structures can be seen easily with a color check. Check the revolving frame, center frame, boom, and arm every 1000 hours.

In particular, carry out a color check on the important check points (marked with a circle).

The procedure for the color check is as follows.

1. Prepare the materials needed for the color check. (Detergent, penetrating agent, developing solution)
2. Spray with detergent and wash to remove all the dirt and oil from the place to be checked.
3. After washing, dry the area, then spray with penetrating agent and leave for 5 - 20 minutes.
4. Spray with detergent, then clean the surface with a cloth.
5. Clean the surface again, then spray with developing solution.
6. Leave for 15 - 20 minutes, then check visually for cracks.
If there are any cracks, color can be seen.
7. If there are any cracks, carry out the repair procedure to repair.

(A): Important check points

(F): Front

● Revolving frame

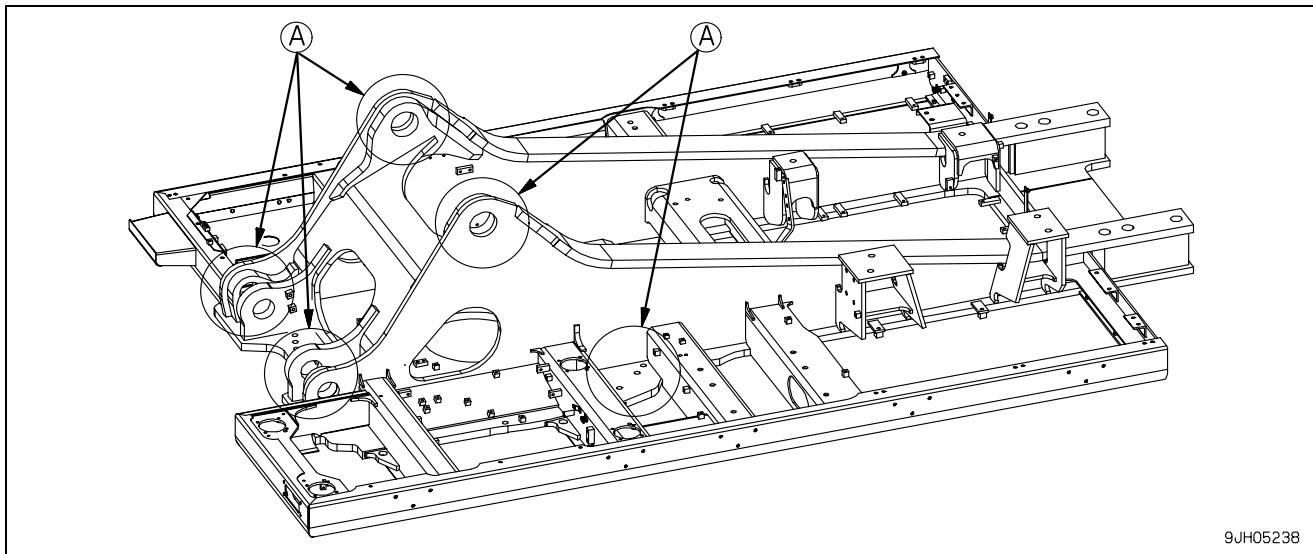

● Center frame

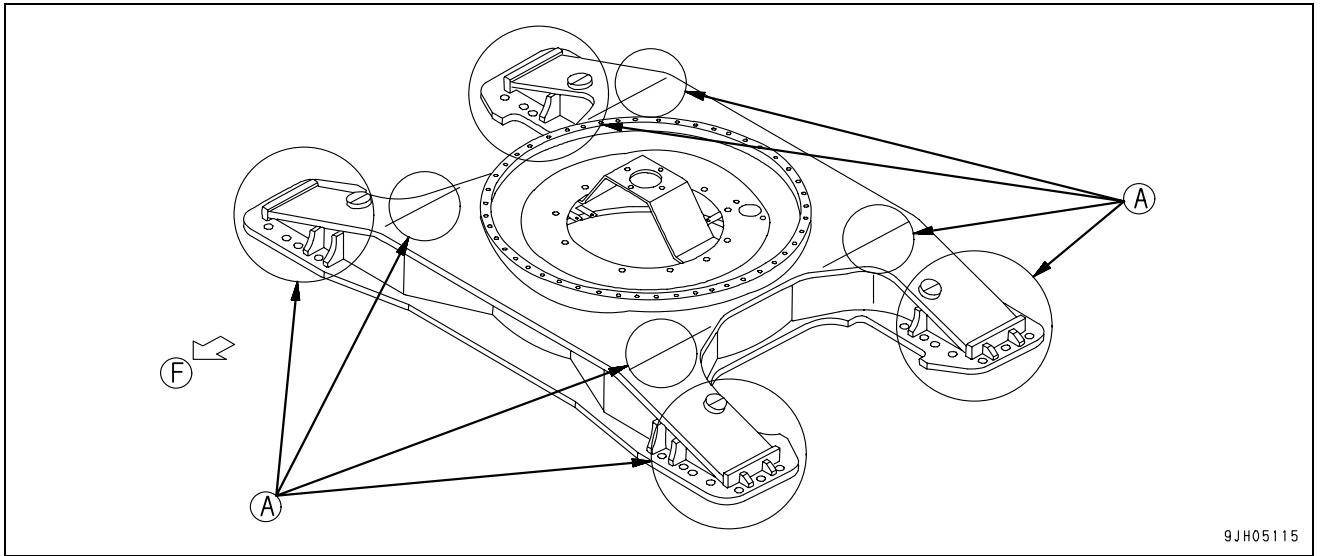

(A): Important check points

● Boom

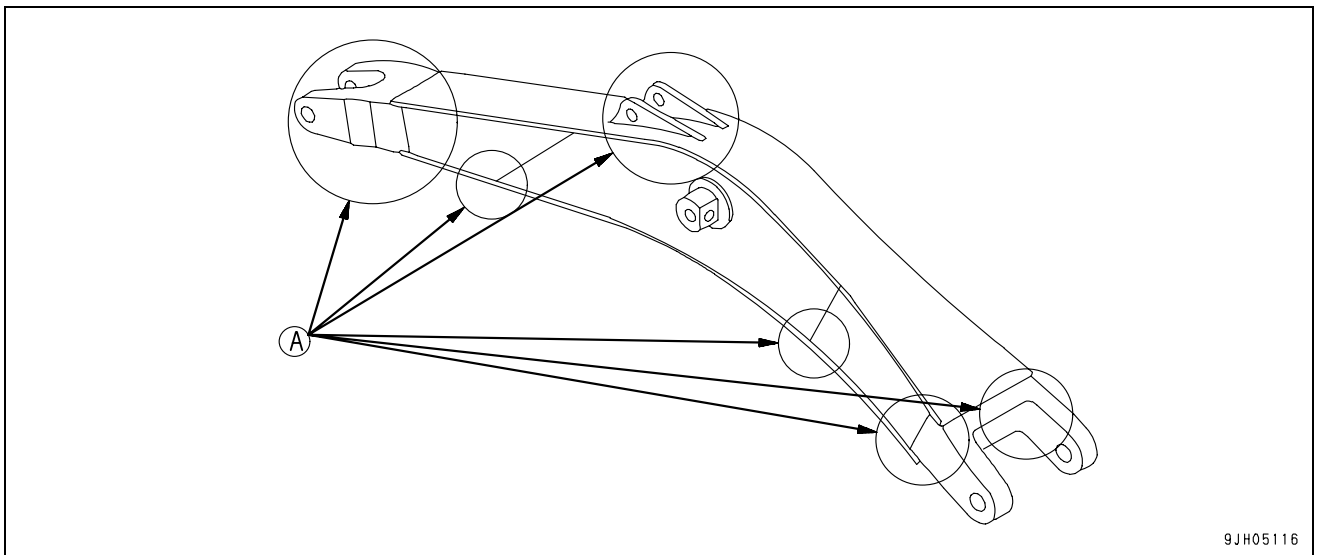

- Arm

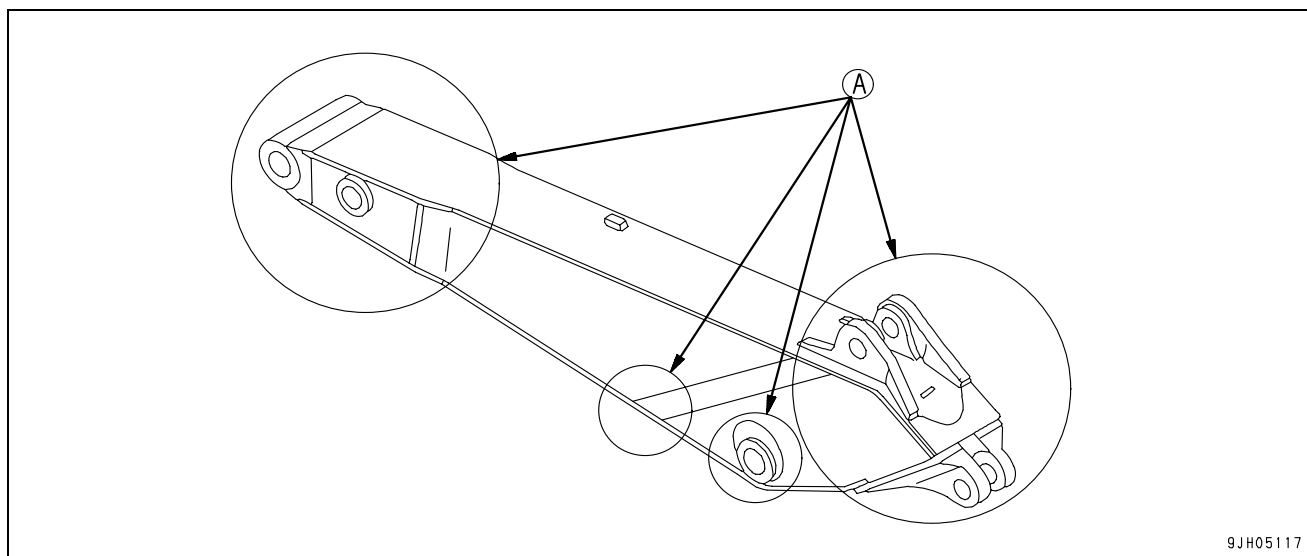

CHECK NITROGEN GAS CHARGE PRESSURE IN ACCUMULATOR (for breaker)

(If equipped)

A special tool is needed for inspecting and charging with nitrogen gas.

Please ask your Komatsu distributor.

EVERY 2000 HOURS MAINTENANCE

Maintenance for every 10, 100, 250, 500 and 1000 hours service should be carried out at the same time.

CHANGE OIL IN FINAL DRIVE CASE

⚠ WARNING

- The parts and oil are at high temperature immediately after the engine is stopped, and may cause serious burns. Wait for the temperature to go down before starting the operation.
- If there is still pressure remaining inside the case, the oil or plug may fly out. Loosen the plug slowly to release the pressure.

- Refill capacity: each 10 liters (2.6 US gal)
 - Prepare a handle.
1. Set the TOP mark at the top, with the TOP mark and plug (P) perpendicular to the ground surface.
 2. Remove plugs (P) and (F) with the handle and drain the oil.

REMARK

Check the O-rings in the plugs for damage. If necessary, replace with new ones.

3. Tighten plug (P).
4. Add engine oil through the hole of plug (F).
5. When the oil overflows from the hole of plug (F), install plug (F). Tighten plugs (P) and (F).

Tightening torque of plugs (P) and (F) :
 $68.6 \pm 9.8 \text{ N}\cdot\text{m}$ ($7 \pm 1 \text{ kgf}\cdot\text{m}$, $50 \pm 7 \text{ lbft}$)

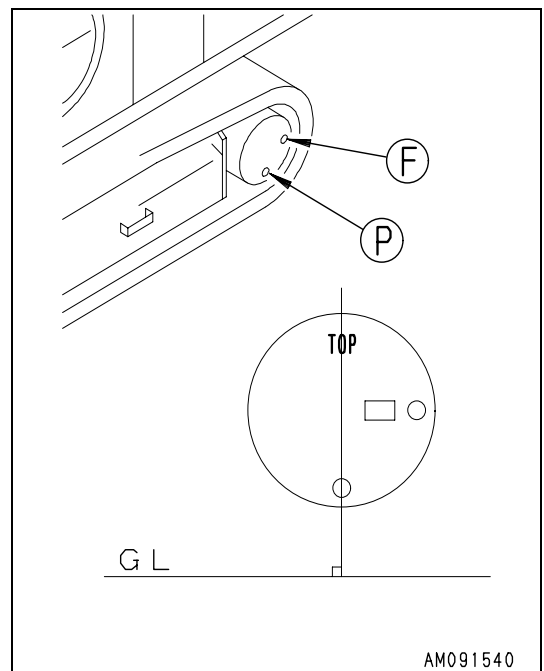

AM091540

CLEAN HYDRAULIC TANK STRAINER

⚠ WARNING

- After the engine is stopped, the parts and oil are at high temperature, so there is danger of burns. Wait for the temperature to go down before starting the operation.
- When the cap of the oil filler port is removed, oil may spurt out, so turn it slowly to release the internal pressure, then remove it carefully.
- When removing cover (1), the cover may fly off under the force of spring (2), so loosen the 4 bolts slowly.

1. Remove the cap from oil filler (F) on top of the hydraulic tank.
2. Remove cover (1) and lift up the top of rod (3) from above to take out spring (2) and strainer (4).
3. Remove any dirt stuck to strainer (4), then wash it in clean diesel oil or flushing oil. If strainer (4) is damaged, replace it with a new part.
4. When installing, check that the O-ring at the bottom of strainer (4) is not out of place or twisted, then coat the surface of the O-ring with grease, insert it on to tank protrusion (5), and install.
5. Install cover (1) with bolts.

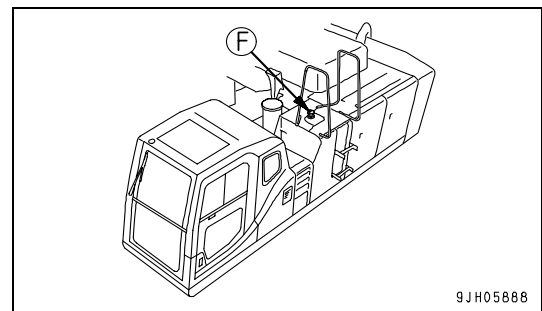

9JH05888

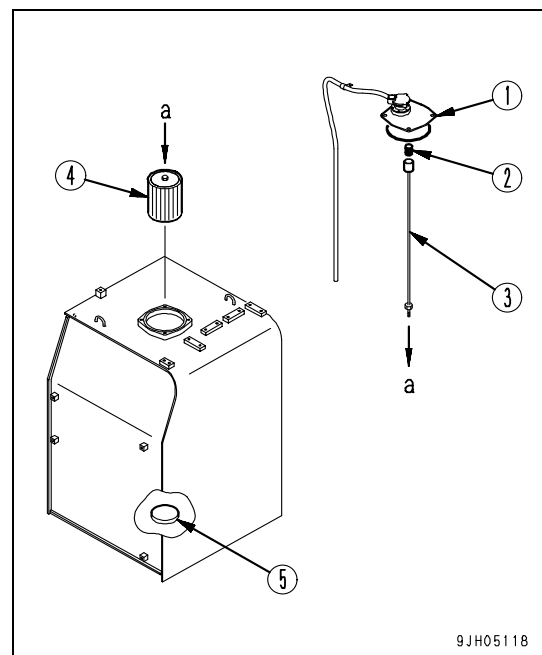

9JH05118

CLEAN ENGINE BREATHER

WARNING

- The parts and oil are at high temperature after the engine is stopped, and may cause serious burns. Wait for the temperature to go down before cleaning the engine breather.
- When using compressed air, there is a hazard that dirt may be blown up and cause serious injury. Always use safety glasses, dust mask, or other protective equipment.

1. Wipe away dust around the breather.
2. Remove breather (1).
3. Rinse the whole breather in diesel oil or flushing oil. Dry with compressed air, then install it.
4. Replace O-ring with new one. Coat a new O-ring with engine oil, set it, then install breather (1).

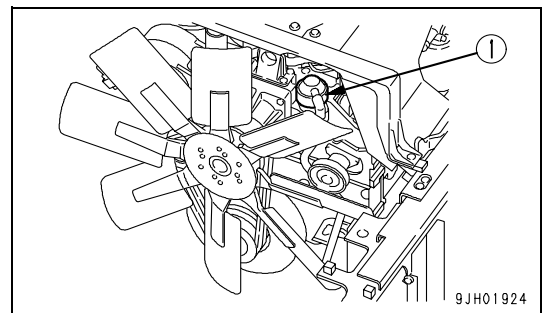

CLEAN, CHECK TURBOCHARGER

Contact your Komatsu distributor for cleaning and inspection.

CHECK ALTERNATOR, STARTING MOTOR

The brushes may be worn, or the bearing may have run out of grease, so contact your Komatsu distributor for inspection or repair.

When the engine is frequently started, ask for inspection every 1000 hours or every 6 months, whichever comes sooner.

CHECK ENGINE VALVE CLEARANCE, ADJUST

As special tool is required for removing and adjusting the parts, you shall request Komatsu distributor for service.

CHECK INJECTOR

Check the color of the exhaust gas visually. If there is any abnormality in the exhaust gas color, contact your Komatsu distributor for inspection.

For details, see "TROUBLES AND ACTIONS (3-139)" "Exhaust color is black".

EVERY 4000 HOURS MAINTENANCE

Maintenance for every 10, 100, 250, 500, 1000 and 2000 hours service should be carried out at the same time.

CHECK WATER PUMP

Check if there is oil leakage, water leakage, or clogging of the drain hole. If any abnormality is found, contact your Komatsu distributor for disassembly and repair or replacement.

CHECK VIBRATION DAMPER

There may be leakage from the damper, dents, or face runout, so please contact your Komatsu distributor for replacement.

CHECK FAN PULLEY AND TENSION PULLEY

Inspect the pulley for play and grease leakage.

If any fault is detected, ask Komatsu distributor to disassemble and repair or replace.

REPLACE INJECTOR ASSEMBLY

Please contact your Komatsu distributor to have the injector assembly replaced.

CHECK FOR LOOSENESS OF HIGH-PRESSURE CLAMP, HARDENING OF RUBBER

Check that there is no looseness in the high-pressure clamp mounting bolts (1) - (15) in the drawing on the next page. Check visually and feel with your finger to check that the rubber has not hardened. If there is any problem, the problem part must be replaced. In such a case, please contact your Komatsu distributor.

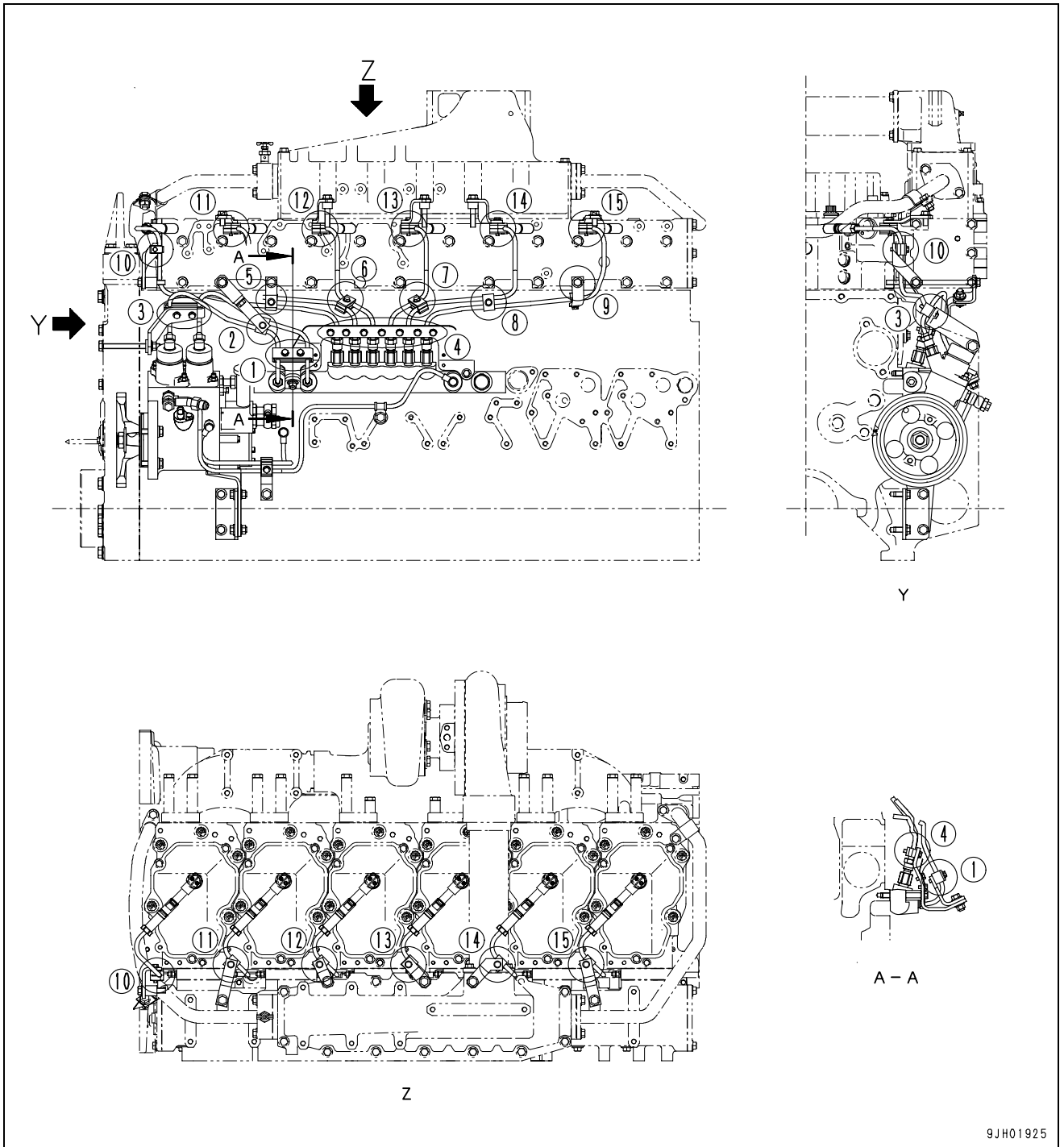

9JH01925

NOTICE

If the engine continues to be used when there are loose bolts, hardened rubber, or missing parts, there is danger of damage or breakage occurring due to vibration and wear at the connections of high-pressure piping. Always check that the proper high-pressure piping clamps are correctly installed.

CHECK FOR MISSING FUEL SPRAY PREVENTION CAP, HARDENING OF RUBBER

Fuel spray prevention caps (1) - (16) and fuel spray prevention cover (17) are protective parts installed to prevent fire caused by fuel leaking and spraying out on to high temperature parts of the engine. Check visually that there are no missing caps or loose bolts, and feel with your finger to check that the rubber has not hardened. If there is any problem, the problem part must be replaced. In such a case, please contact your Komatsu distributor.

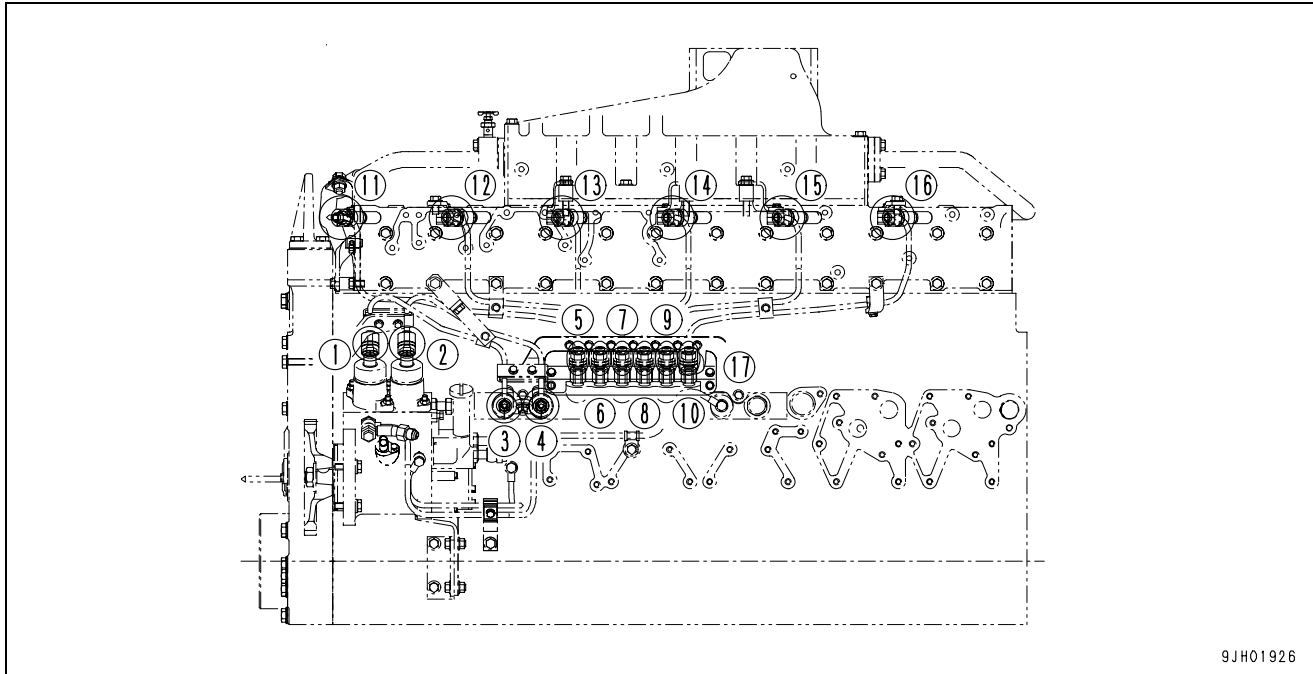

9JH01926

EVERY 5000 HOURS MAINTENANCE

Maintenance for every 10, 100, 250, 500, 1000 and 2000 hours service should be carried out at the same time.

CHANGE OIL IN HYDRAULIC TANK

WARNING

- The parts and oil are at high temperature after the engine is stopped, and may cause burns. Wait for the temperature to go down before starting the work.
- When removing the oil filler cap, turn it slowly to release the internal pressure, then remove it.

- Refill capacity: 360 liters (95.1 US gal)
 - Prepare a handle for socket wrench set
1. Swing the upper structure so that the drain plug under the hydraulic tank will be between both tracks.
 2. Retract the arm and bucket cylinders, then lower the boom and put the teeth in contact with the ground.
 3. Set the safety lock lever to the LOCK position and stop the engine.

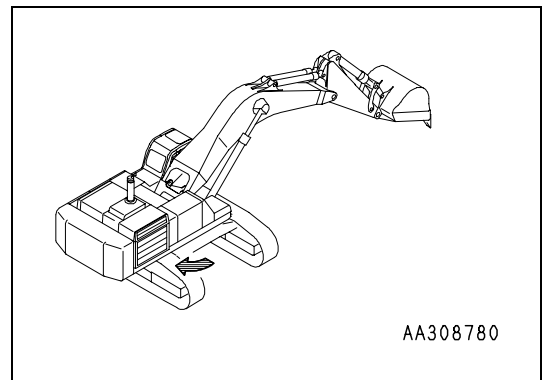

4. Remove the cap of oil filler (F) at the top of the hydraulic tank.

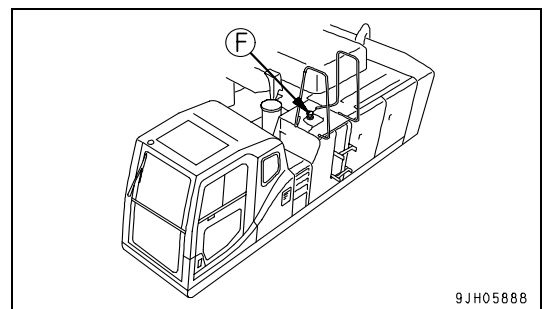

5. Set the container to catch the oil under the drain plug at the bottom of the chassis. Remove drain plug (P1), then loosen plug (P2) and drain the oil. After draining the oil, tighten drain plugs (P1) and (P2).

Tightening torque: $68.6 \pm 9.8 \text{ N}\cdot\text{m}$ ($7 \pm 1 \text{ kgf}\cdot\text{m}$, $50 \pm 7 \text{ lbft}$)

(A): Rear

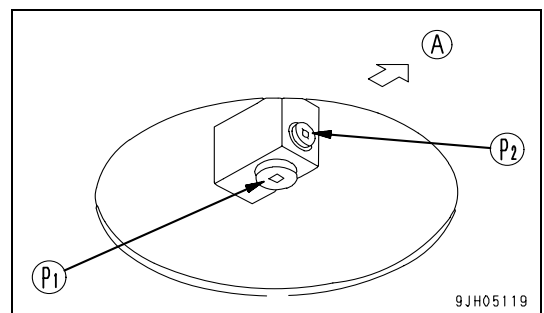

6. Remove the 10 mounting bolts of cover (2), take off the cover, then remove drain plug (3) at the bottom of the pump suction tube.
7. After draining the oil, tighten drain plug (3) and install cover (2).
When loosening drain plug (P2) be careful not to get oil on yourself.

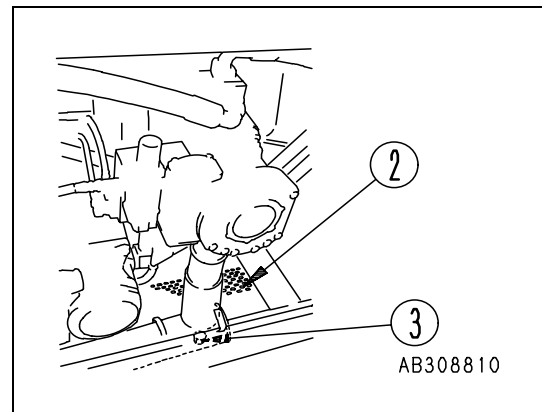

8. Tighten the bolts to install cover (2).
9. Add the specified amount of new and clean engine oil (for hydraulic system) through oil filler port (F). Check that the oil level is between H and L on the sight gauge.
10. Bleed the air from the circuit after cleaning or replacing the filter element or strainer, or after changing the oil.

EVERY 8000 HOURS MAINTENANCE

Maintenance for every 10, 100, 250, 500, 1000, 2000 and 4000 hours service should be carried out at the same time.

REPLACE HIGH-PRESSURE PIPING CLAMP

Please contact your Komatsu distributor to have the engine high-pressure clamp replaced.

REPLACE FUEL SPRAY PREVENTION CAP

Please contact your Komatsu distributor to have the fuel spray prevention cap replaced.

SPECIFICATIONS

SPECIFICATIONS

PC600-7 GALEO
 PC600LC-7 GALEO

Item	Unit	PC600-7	PC600LC-7
Operating weight (including one person)	kg (lb)	56,600 (124,803)	57,600 (127,008)
Bucket capacity	m ³ (cu.yd)	2.7 (3.5)	2.7 (3.5)
Name of engine	-	KOMATSU SA6D140E deisel engine	
Rated horsepower of engine	kW (HP)/rpm	287 (385)/1,800	287 (385)/1,800
A Overall length	mm (ft in)	12,810 (42' 0")	12,810 (42' 0")
B Overall height	mm (ft in)	4,300 (14' 1")	4,300 (14' 1")
C Overall width	mm (ft in)	3,900 (12' 10")	3,900 (12' 10")
D Track shoe width	mm (ft in)	600 (1' 12")	600 (1' 12")
E Height of cab	mm (ft in)	3,290 (10' 10")	3,290 (10' 10")
F Radius of upper structure	mm (ft in)	3,675 (12' 1")	3,675 (12' 1")
G Overall length of track	mm (ft in)	5,340 (17' 6")	5,690 (18' 8")
H Tumbler center distance	mm (ft in)	4,250 (13' 11")	4,600 (15' 1")
Min. ground clearance	mm (ft in)	780 (2' 7")	780 (2' 7")
Traveling speed (low/high)	km/h (MPH)	3.0/4.9 (1.9/3.0)	3.0/4.9 (1.9/3.0)
Swing speed	rpm	8.3	8.3

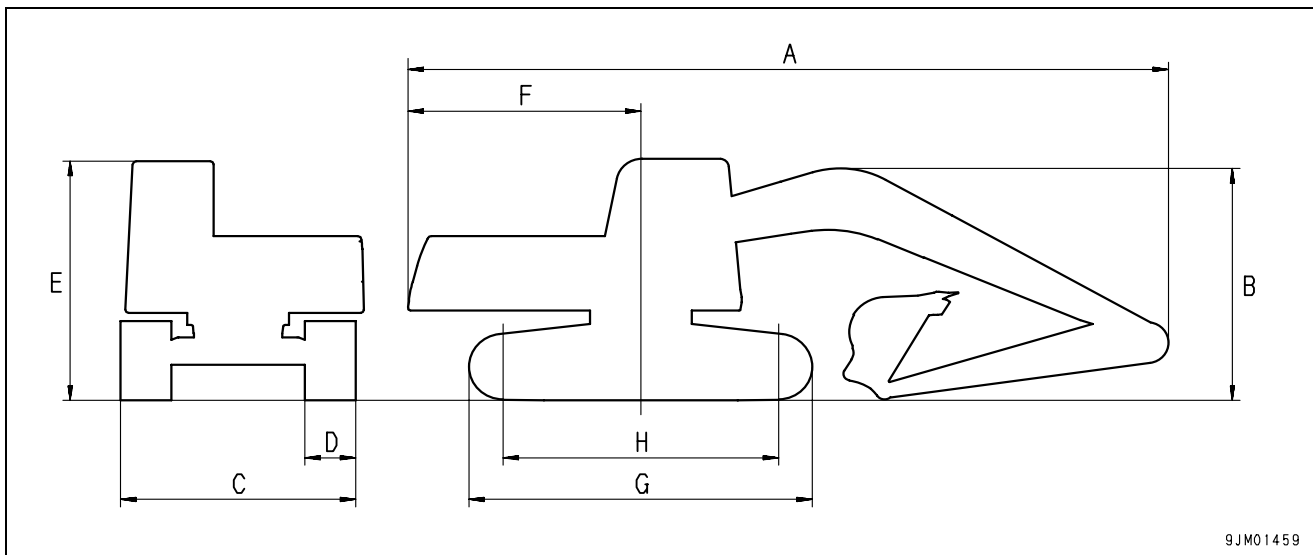

PC600-7 GALEO
 PC600LC-7 GALEO

	Working ranges	Unit	PC600-7	PC600LC-7
A	Max. digging reach	mm (ft in)	13,020 (42' 9")	13,020 (42' 9")
B	Max. digging depth	mm (ft in)	8,490 (27' 10")	8,490 (27' 10")
C	Max. digging height	mm (ft in)	11,880 (38' 12")	11,880 (38' 12")
D	Maximum vertical wall digging depth	mm (ft in)	7,510 (24' 8")	7,510 (24' 8")
E	Max. dumping height	mm (ft in)	7,960 (26' 1")	7,960 (26' 1")
F	Max. digging reached at ground level	mm (ft in)	12,800 (41' 12")	12,800 (41' 12")

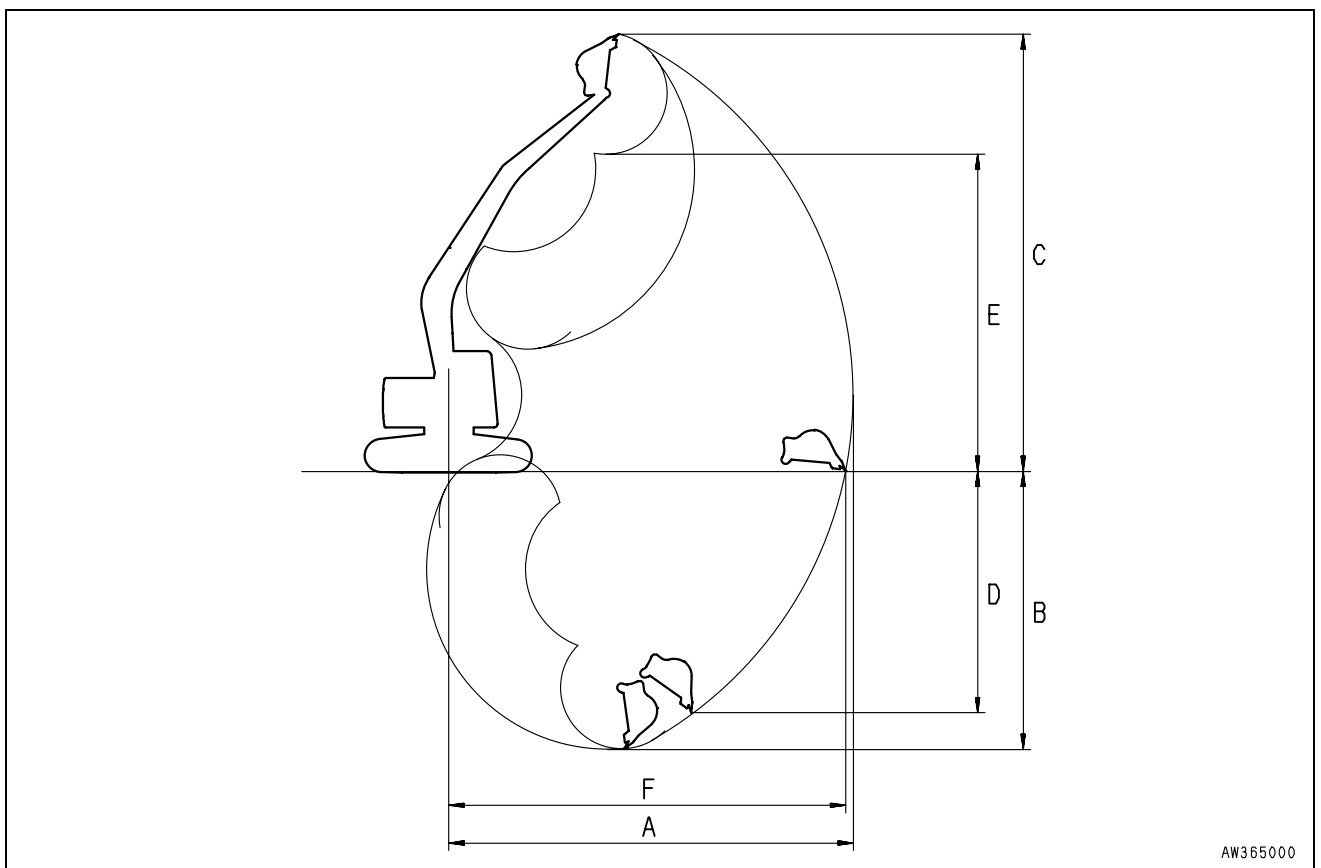

ATTACHMENTS AND OPTIONS

 **WARNING**

Please read and make sure that you understand the SAFETY section before reading this section.

GENERAL PRECAUTIONS FOR SAFETY

When installing attachments or options to the machine, it is necessary to pay attention to safety. Please obey the following precautions strictly when selecting, installing, or using attachments or options.

PRECAUTIONS WHEN SELECTING

- Please consult your Komatsu distributor before installing attachments or options to the machine. Depending on the type of attachment or option, it may be necessary to install a front guard, overhead guard, or other safety structure to the machine. There may also be problems of the attachment or option hitting the operator's cab.
- Install only attachments or options authorized by Komatsu. Komatsu cannot accept any responsibility for any accident, damage, or failure caused by the use of attachments or options not authorized by Komatsu.

READ THE INSTRUCTION MANUAL THOROUGHLY

- Before installing or using any attachment or option, make sure that you thoroughly read and understand the instruction manuals for the machine and the attachment or option.
- If you lose the instruction manual or it is damaged, always obtain a new copy from the attachment manufacturer or your Komatsu distributor.

PRECAUTIONS WHEN REMOVING OR INSTALLING

When removing or installing the attachment or option, obey the following precautions, and take care to ensure safety during the operation.

- Carry out the removal and installation operation on a flat, firm ground surface.
- When the operation is carried out by two or more workers, choose the leader and follow his instructions.
- Use a crane when handling heavy objects (more than 25 kg (55 lb)). (The crane must be operated by a qualified operator.)
- Never go under a load raised by the crane.
- Do not carry out operations with the load kept raised by the crane. Always use a stand to prevent the load from falling.
- When removing a heavy part, consider the balance after it is removed. To prevent the machine from tipping over, set a support in position if necessary before removing the part.
- Before installing or after removing the attachment or option, set it in a stable condition to prevent it from falling over.
- For details of the removal or installation operation, please consult your Komatsu distributor.

PRECAUTIONS WHEN USING

When long or heavy work equipment is installed, remember the following precautions. Before starting operations, move the machine to a safe place and carry out a test operation to make sure that you fully understand the movement, center of gravity, and working range of the machine.

- Do not swing the work equipment if the machine is at an angle. If the work equipment is swung with the machine at an angle, there is danger that the machine will tip over.
- Always maintain a safe distance from obstacles in the surrounding area when operating. If long work equipment is installed, the working range becomes larger.
- If heavy work equipment is installed, pay careful attention to the following precautions.
 - The swing overrun (the distance the work equipment moves before completely stopping after the swing brake is applied) will be greater. There is danger of hitting objects if the swing overrun is miscalculated, so allow extra space to the swing position when swinging.
 - The hydraulic drift of the work equipment (the amount of the work equipment moves down under its own weight when it is stopped in a raised position) also becomes greater. Do not stop the work equipment in a raised position; always lower it to the ground.
 - Do not swing, lower, or stop the work equipment suddenly. There is danger that the machine may tip over.
 - Do not suddenly extend or retract the boom cylinder. The shock may cause the machine to tip over.

ATTACHMENT GUIDE

WARNING

- Please read the instruction manual for the attachment and the sections of this manual related to attachments and options.
- When installing any attachment or option, there may be problems with safety, so please contact your Komatsu distributor before installing.
- Installing attachments or options without consulting your Komatsu distributor may not only cause problems with safety, but may also have an adverse effect on the operation of the machine and the life of the equipment.
- Any injuries, accidents, or damage resulting from the use of unauthorized attachments or options will not be the responsibility of Komatsu.

COMBINATIONS OF WORK EQUIPMENT

WARNING

Depending on the type or combination of work equipment, there is danger that the work equipment may hit the cab or machine body.

When using unfamiliar work equipment for the first time, check before starting if there is any danger of interference, and operate with caution.

Select the combination of boom, arm, and bucket from the combinations shown in the table below.

Bucket name	Capacity m ³ (cu.yd)	Bucket width mm (ft in)		Standard boom 7.6 m (24' 11")			SE boom 6.6 m (21' 8")
		Side cutter (Excluding side shroud)	Side cutter (Including side shroud)	Standard arm 3.5 m (11' 6")	semi-long Arm 4.3 m (14' 1")	Long arm 5.2 m (17' 1")	SE arm 2.9 m (9' 6")
Narrow	2.0 (2.6)	1,250 (4' 1")	1,430 (4' 8")	●	●	●	×
Narrow	2.3 (3.0)	1,400 (4' 7")	1,580 (5' 2")	●	○	×	×
Standard	2.7 (3.5)	1,600 (5' 3")	1,780 (5' 10")	● (Standard)	×	×	×
Stone crushing (strengthened)	2.8 (3.7)	1,870 (6' 2")	1,870 (6' 2")	×	×	×	×
Stone crushing (large size)	3.1 (4.1)	2,000 (6' 7")	2,000 (6' 7")	×	×	×	×
Wide (SE)	3.5 (4.6)	2,120 (6' 11")	2,120 (6' 11")	×	×	×	● (Standard)

●: for standard operations

○: Possible to use only light work

×: Impossible to use

Working Range Diagram

	Working ranges	Unit	PC600-7 Standard arm 3.5 m (11' 6")	PC600-7 semi-long arm 4.3 m (14' 1")	PC600-7 Long arm 5.2 m (17' 1")	PC600-7 SE arm 2.9 m (9' 6")
A	Max. digging reach	mm (ft in)	13,020 (42' 9")	13,740 (45' 1")	14,630 (47' 12")	11,550 (37' 11")
B	Max. digging depth	mm (ft in)	8,490 (27' 10")	9,275 (30' 5")	10,255 (33' 8")	7,060 (23' 2")
C	Max. digging height	mm (ft in)	11,880 (38' 12")	12,180 (39' 12")	12,560 (41' 2")	11,140 (36' 7")
D	Maximum vertical wall digging depth	mm (ft in)	7,510 (24' 8")	8,375 (27' 6")	9,275 (30' 5")	5,630 (18' 6")
E	Max. dumping height	mm (ft in)	7,960 (26' 1")	8,245 (27' 1")	8,600 (28' 3")	7,210 (23' 8")
F	Max. digging reached at ground level	mm (ft in)	12,800 (41' 12")	13,555 (44' 6")	14,435 (47' 4")	11,330 (37' 2")

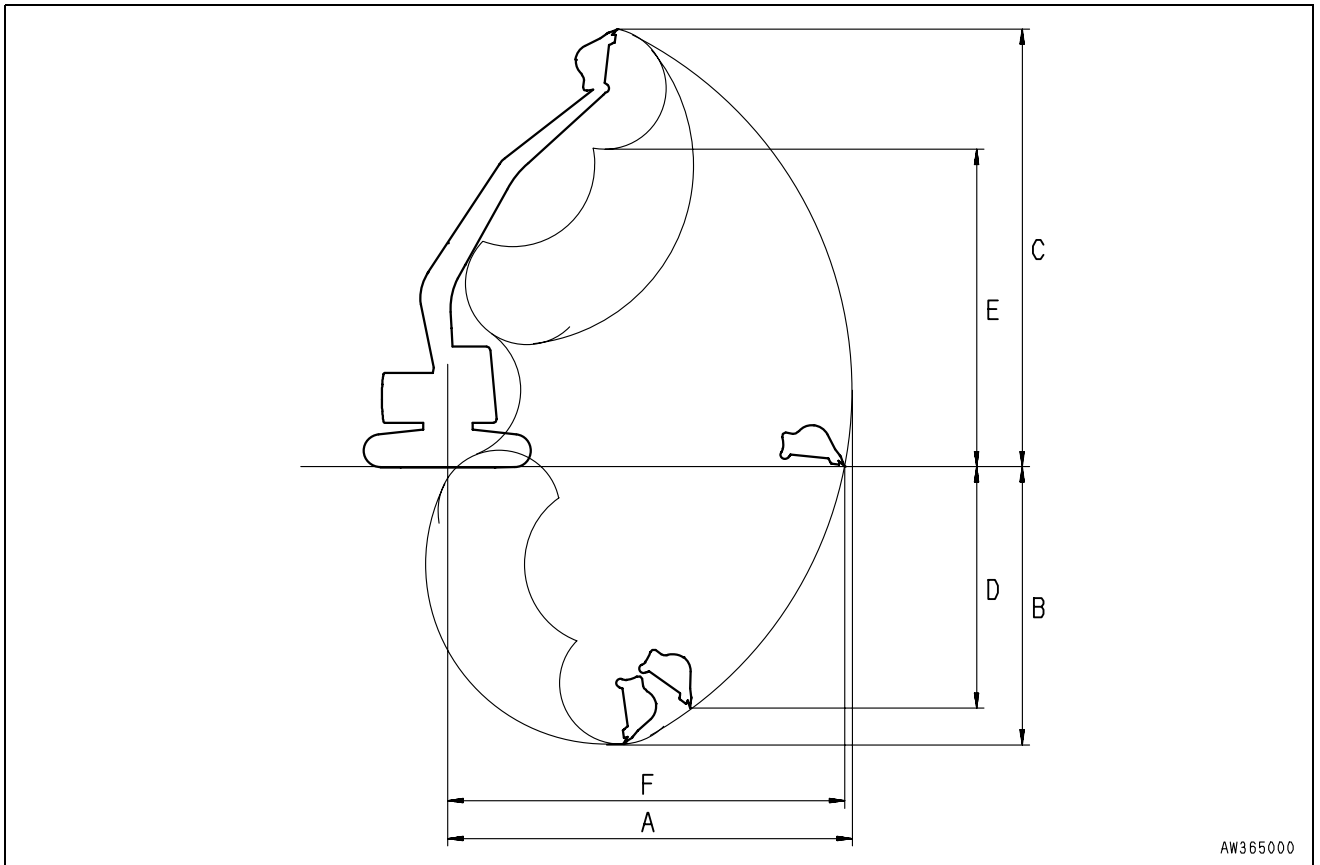

TRACK SHOES SELECTION

Select the most suitable track shoe to match the operating conditions.

Selection

Check the category from the uses in the table below, then select the shoes from the table below that.

- Category of use B is the wide shoe, so there are limits on the use. Check the precautions for use, examine the conditions of use thoroughly, and use the optimum shoes for the situation.
- When selecting the shoe width, choose the narrowest shoes possible to bring the machine within the range where there is no problem regarding the machine flotation and ground contact pressure. If wider shoes than necessary are used, the load on the track shoe will increase, so this may cause problems such as bending of the shoe, cracking of the link, damage of the pin, and looseness of the shoe bolts.

Category	Use	Precautions when using
A	Rocky ground, riverbeds, normal soil	<ul style="list-style-type: none"> • On rough ground with large obstacles such as boulders or fallen trees, travel at low speed.
B	Normal soil, soft ground	<ul style="list-style-type: none"> • These shoes cannot be used on rough ground where there are large obstacles such as boulders or fallen trees. • Travel at Hi or Mi speed only on flat ground, and if it is impossible to avoid going over obstacles, shift down and travel at half speed in Lo.

	PC600-7	PC600LC-7
	Specifications	
	Classification	
Standard	600 mm (1' 12") triple	A
Option	700 mm (2' 4") triple	-
	750 mm (2' 6") triple	B

Index

<A>

Accumulator	3-71
Air Conditioner Controls	3-47
Ashtray	3-46
Attachment Guide	6-4
Combinations of Work Equipment	6-4
Track Shoes Selection.....	6-6
Auxiliary Electric Power.....	3-64

Breaking-In The New Machine.....	1-8
Bucket Replacement.....	3-120

<C>

Cap With Lock.....	3-44
Circuit Breaker	3-66
Cold Weather Operation	3-134
After Cold Weather Season.....	3-136
After Daily Work Completion	3-136
Cold Weather Operation Information.....	3-134
Control Levers And Pedals	3-34
Controllers.....	3-67
Controls And Gauges.....	3-3

<D>

Detailed Controls And Gauges.....	3-5
Direction Of Machine.....	1-7
Door Lock.....	3-43

<E>

Electric System Maintenance	4-7
Emergency Exit From Operator's Cab	3-43
Engine After Starting	3-94
Engine Before Starting.....	3-73
Engine Serial No. Plate And Its Location	1-9
Engine, Check After Shut Off	3-123
Engine, Starting.....	3-89
Engine, Stopping The.....	3-101
Escape From Mud.....	3-118

<F>

Forward	1-2
Fuse	3-65

<G>

General Operation Information	3-114
General Precautions For Safety	6-2
Precautions When Removing Or Installing	6-2
Precautions When Selecting	6-2
Precautions When Using.....	6-3
Read The Instruction Manual Thoroughly	6-2
Grease Pump.....	3-68

<H>

Handling Oil, Fuel, Coolant, And Performing Oil Clinic	4-4
Hot and cool box.....	3-45

<I>

Introduction	1-7
--------------------	-----

<L>

Locking	3-124
Long term storage.....	3-137
After Storage	3-138
Before Storage	3-137
During Storage	3-137
Starting machine after long-term storage.....	3-138
Lubricants, Coolant And Filters.....	4-4
Lubricants, Fuel And Coolant Specifications	4-9

<M>

Machine Operation	3-102
Machine Operations And Controls.....	3-73
Machine View Illustrations	3-2
Machine, Steering The.....	3-106
Magazine Box	3-45
Maintenance Information	4-2
Maintenance Procedure.....	4-19
Check before starting	4-42
Every 10 hours	4-43
Every 100 hours	4-46
Every 250 hours	4-47
Every 500 hours	4-53
Every 1000 hours	4-62
Every 2000 hours	4-69
Every 4000 hours	4-72
Every 5000 hours	4-75
Every 8000 hours	4-77
Initial 100 Hours	4-19
Initial 500 Hours	4-19
When required.....	4-20
Maintenance Schedule	4-16
Maintenance Interval For Hydraulic Breaker...	4-18
Maintenance Schedule Chart.....	4-16
Monitoring System.....	3-5

<O>

Overall Machine View 3-2

<P>

Parking Machine 3-122
 Product Identification Number (Pin)/
 machine Serial No. Plate 1-9
 Product Information 1-9
 Prohibited Operations 3-112

<R>

Radio 3-61
 Recommended Applications 3-119

<S>

Safety Critical Parts 4-14
 Safety Critical Parts List 4-15
 Safety Information 1-5,2-2,2-12
 Safety Labels 2-4
 Location Of Safety Labels 2-5
 Safety Labels 2-6
 Safety Machine Operation 2-21
 Battery 2-31
 Lifting Objects With Bucket 2-34
 Operation 2-23
 Starting Engine 2-21
 Towing 2-33
 Transportation 2-30
 Safety Maintenance Information 2-35
 Service Meter Location 1-10
 Specifications 5-2
 Sun Roof 3-37
 Swinging 3-108
 Switches 3-27

<T>

Tightening Torque Specifications 4-13
 Tightening Torque List 4-13
 Tool Box 3-67
 Transportation 3-125
 Lifting Machine 3-125
 Precautions for Transportation 3-125
 Procedure for Increasing or
 Reducing Track Frame Gauge 3-132
 Shipping Machine Information 3-126
 Transportation Posture 3-127
 Traveling On Slopes 3-116
 Troubles And Actions 3-139
 Battery, Discharged 3-143
 Other Trouble 3-147
 Phenomena that are not failures 3-141
 Running Out Of Fuel 3-139
 Severe Job Condition 3-142
 Towing The Machine 3-142

<W>

Wear Parts 4-8
 Wear Parts List 4-8
 Windshield 3-38
 Work Equipment Controls And Operations 3-109
 Working Mode 3-111

<Y>

Your Machine Serial Numbers And Distributor 1-10

