

Operation & Maintenance Manual

BULLDOZER

GALEO

D275AX-5

SERIAL NUMBERS 20164 and up

NOTICE

Komatsu has Operation & Maintenance Manuals written in some other languages. If a foreign language manual is necessary, contact your local distributor for availability.

WARNING

Unsafe use of this machine may cause serious injury or Death. Operators and maintenance personnel must read this manual before operating or maintaining this machine. This manual should be kept near the machine for reference and periodically reviewed by all personnel who will come into contact with it.

KOMATSU

FOREWORD

CALIFORNIA

Proposition 65 Warning

Diesel engine exhaust and some of its constituents are known to the State of California to cause cancer, birth defects, and other reproductive harm.

CALIFORNIA

Proposition 65 Warning

Battery posts, terminals and related accessories contain lead and lead compounds, chemicals known to the State of California to cause cancer and birth defects or other reproductive harm.

Wash hands after handling.

FOREWORD

This manual provides rules and guidelines which will help you use this machine safely and effectively. The precautions in this manual must be followed at all times when performing operation and maintenance. Most accidents are caused by the failure to follow fundamental safety rules for the operation and maintenance of machines. Accidents can be prevented by knowing beforehand conditions that may cause a hazard when performing operation and maintenance.



WARNING

Before beginning operation or maintenance, operators and maintenance personnel must always observe the following points.

- Read this manual thoroughly and understand its contents fully.
- Read the safety messages and safety labels given in this manual carefully so that they should be understood fully.

Keep this manual at the storage location for the Operation and Maintenance Manual given below so that all personnel involved in working on the machine can consult it periodically.

In case this manual should be lost or damaged, immediately contact Komatsu or your Komatsu distributor to obtain a new copy.

When you sell the machine, make sure that this manual should be provided to the new owner together with the machine.

In this manual, measurements are expressed in international standard units (SI). For the reference purpose, weight units used in the past are also displayed in ().

Location to keep operation & maintenance manual
In door pocket inside of cab door

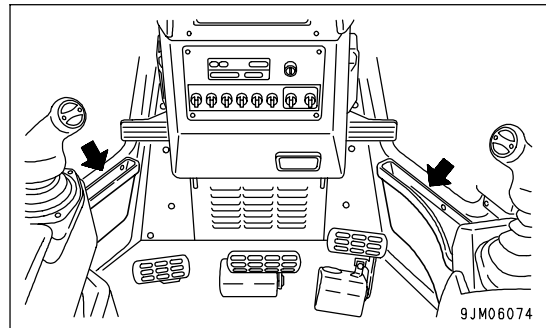

EMISSION CONTROL WARRANTY**EMISSION CONTROL WARRANTY STATEMENT (APPLIES TO CANADA ONLY)****1. Products Warranted**

Komatsu America International Company, Komatsu Mining Systems Inc. and Komatsu Utility Corporation (collectively "Komatsu") produce and/or market products under brand names of Komatsu, Dresser, Dressta, Haulpak and Galion. This emissions warranty applies to new engines bearing the Komatsu name installed in these products and used in Canada in machines designed for industrial off-highway use. This warranty applies only to these engines produced on or after January 1, 2000. This warranty will be administered by Komatsu distribution in Canada.

2. Coverage

Komatsu warrants to the ultimate purchaser and each subsequent purchaser that the engine is designed, built and equipped so as to conform, at the time of sale by Komatsu, with all U.S. Federal emission regulations applicable at the time of manufacture and that it is free from defects in workmanship or material which would cause it not to meet these regulations within five years or 3,000 hours of operation, whichever occurs first, as measured from the date of delivery of the engine to the ultimate purchaser.

3. Limitations

Failures, other than those resulting from defects in materials or workmanship, are not covered by this warranty. Komatsu is not responsible for failures or damage resulting from what Komatsu determines to be abuse or neglect, including, but not limited to: operation without adequate coolant or lubricants; over fueling; over speeding; lack of maintenance of lubricating, cooling or intake systems; improper storage, starting, warm-up, run-in or shutdown practices; unauthorized modifications of the engine. Komatsu is also not responsible for failures caused by incorrect fuel or by water, dirt or other contaminants in the fuel. Komatsu is not responsible for non-engine repairs, "downtime" expense, related damage, fines, all business costs or other losses resulting from a warrantable failure.

KOMATSU IS NOT RESPONSIBLE FOR INCIDENTAL OR CONSEQUENTIAL DAMAGES.

This warranty, together with the express commercial warranties, are the sole warranties of Komatsu. **THERE ARE NO OTHER WARRANTIES, EXPRESS OR IMPLIED, OR OF MERCHANTABILITY OR FITNESS FOR A PARTICULAR PURPOSE.**

GARANTIE SUR LE CONTRÔLE DES ÉMISSIONS**ÉNONCÉ DE GARANTIE SUR LE CONTRÔLE DES ÉMISSIONS (APPLICABLE AU CANADA SEULEMENT):****1. Produits garantis:**

Komatsu America International Company, Komatsu Mining Systems Inc. et Komatsu Utility Corporation (collectivement Komatsu) produisent et/ou font la mise en marché de produits portant les noms de marque Komatsu, Dresser, Dressta, Haulpak et Galion. Cette garantie sur les émissions s'applique à tous les nouveaux moteurs portant le nom Komatsu, installés dans ces produits et utilisés au Canada dans des machines conçues pour utilisation industrielle non-roulière. Cette garantie s'applique seulement sur les moteurs produits à partir du 1er Janvier 2000. Cette garantie sera administrée par la distribution de Komatsu au Canada.

2. Couverture:

Komatsu garantit à l'acheteur ultime et chaque acheteur subséquent que le moteur est conçu, construit et équipé en toute conformité, au moment de la vente par Komatsu, avec toutes les Réglementations fédérales américaines sur les émissions applicables au moment de la fabrication et qu'il est exempt de défauts de construction ou de matériaux qui auraient pour effet de contrevenir à ces réglementations en dedans de 5 ans ou 3000 heures d'opération, mesuré à partir de la date de livraison du moteur au client ultime.

3. Limitations:

Les bris, autres que ceux résultant de défauts de matériaux ou de construction, ne sont pas couverts par cette Garantie. Komatsu n'est pas responsable pour bris ou dommages résultant de ce que Komatsu détermine comme étant de l'abus ou négligence, incluant mais ne se limitant pas à: l'opération sans lubrifiants ou agent refroidissants adéquats; la suralimentation d'essence; la survitesse; le manque d'entretien des systèmes de lubrification, de refroidissement ou d'entrée; de pratiques non-propices d'entreposage, de mise en marche, de réchauffement, de conditionnement ou d'arrêt; les modifications non-autorisées du moteur. De plus, Komatsu n'est pas responsable de bris causés par de l'essence inadéquate ou de l'eau, des saletés ou autres contaminants dans l'essence. Komatsu n'est pas responsable des réparations non-relées au moteur, des dépenses encourues suite aux temps d'arrêts, des dommages relatifs, amendes, et de tout autre coût d'affaires ou autres pertes résultant d'un bris couvert par la garantie.

KOMATSU N'EST PAS RESPONSABLE DES INCIDENTS OU DOMMAGES CONSÉQUENTS.

Cette garantie, ainsi que les garanties expresses commerciales, sont les seules garanties de Komatsu. **IL N'Y A AUCUNE AUTRE GARANTIE, EXPRESSE OU SOUS-ENTENDUE, MARCHANDABLE OU PROPICE A UNE UTILISATION PARTICULIÈRE.**

INFORMATION IMPORTANTE SUR LE MOTEUR
CE MOTEUR EST CONFORME AUX NORMES AMÉRICAINES DE L'EPA (ANNÉE DU MODÈLE) ET DE LA CALIFORNIE POUR LES MOTEURS LARGES NON-ROUTIERS À IGNITION PAR COMPRESSION. CE MOTEUR EST CERTIFIÉ POUR OPÉRER À ESSENCE DIESEL.

AVERTISSEMENT
DES BLESSURES PEUVENT RÉSULTER ET LA GARANTIE S'ANNULER SI LES RPM DU TAUX D'ESSENCE OU L'ALTITUDE EXCÈDENT LES VALEURS MAXIMALES PUBLIÉES POUR CE MODÈLE ET SON APPLICATION.

IMPORTANT ENGINE INFORMATION
THIS ENGINE CONFORMS TO YYYY MODEL YEAR U.S. EPA REGULATION AND THE CALIFORNIA REGULATIONS LARGE NON ROAD COMPRESSION IGNITION ENGINES. THIS ENGINE IS CERTIFIED TO OPERATE ON DIESEL FUEL.

WARNING
INJURY MAY RESULT AND WARRANTY IS VOIDED IF FUEL RATE RPM OR ALTITUDES EXCEED PUBLISHED MAXIMUM VALUES FOR THIS MODEL AND APPLICATION.

ENGINE MODEL	SERIAL NO.	DISPLACEMENT	LITERS
ENGINE FAMILY			
EXHAUST EMISSION CONTROL SYSTEM		FIRING ORDER	1 - 5 - 3 - 6 - 2 - 4
ADV. LOAD OUTPUT	Kw (HP)	RPM	
VALVE LASH COLD (mm)	IN. EX.	FUEL RATE AT ADV.	mm ³ /STROKE
IDLE SPEED	RPM	FAMILY EMISSION LIMIT	
INITIAL INJECTION TIMING	DEG. BTDC	DATE OF MANUFACTURE	
KOMATSU LTD. MADE IN JAPAN			

MODÈLE DU MOTEUR

FAMILLE DU MOTEUR

SYSTÈME DE CONTRÔLE DES ÉMISSIONS D'ÉCHAPPEMENT

CHARGE DE SORTIE ADV.

PORTÉE DE VALVE À FROID (mm)

VITESSE STATIQUE

RÉGLAGE DE L'ALLUMAGE - INJECTION INITIALE

DEG. BTDC

NO. SÉRIE

DÉPLACEMENT

LITRES

SÉQUENCE DE MISE À FEU

mm³/BAITTEMENT

TAUX D'ESSENCE À ADV.

LIMITE D'ÉMISSION DE LA FAMILLE

DATE DE FABRICATION

KOMATSU LTD. FABRIQUÉ AU JAPON

ENGINE DATAPLATE - ENGLISH / FRENCH



SAFETY INFORMATION

To enable you to use this machine safely, safety precautions and labels are given in this manual and affixed to the machine to give explanations of situations involving potential hazards and of the methods of avoiding such situations.

Signal words

The following signal words are used to inform you that there is a potential hazardous situation that may lead to personal injury or damage.

In this manual and on machine labels, the following signal words are used to express the potential level of hazard.

- | | |
|--|---|
|  DANGER | Indicates an imminently hazardous situation which, if not avoided, will result in death or serious injury. |
|  WARNING | Indicates a potentially hazardous situation which, if not avoided, could result in death or serious injury. |
|  CAUTION | Indicates a potentially hazardous situation which, if not avoided, may result in minor or moderate injury. This word is used also to alert against unsafe practices that may cause property damage. |

Example of safety message using signal word

 WARNING
When standing up from the operator's seat, always place the lock lever in the LOCK position. If you accidentally touch the control levers when they are not locked, this may cause a serious injury or death.

Other signal words

In addition to the above, the following signal words are used to indicate precautions that should be followed to protect the machine or to give information that is useful to know.

NOTICE This word is used for precautions that must be taken to avoid actions which could shorten the life of the machine.

REMARKS This word is used for information that is useful to know.

- Safety labels

Safety labels are affixed to the machine to inform the operator or maintenance worker on the spot when carrying out operation or maintenance of the machine that may involve hazard.

This machine uses "Safety labels using words" and "Safety labels using pictograms" to indicate safety procedures.

Example of safety label using words

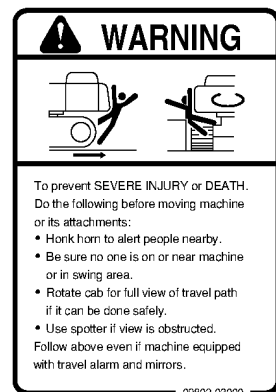

Part No

Safety labels using pictogram

Safety pictograms use a picture to express a level of hazardous condition equivalent to the signal word. These safety pictograms use pictures in order to let the operator or maintenance worker understand the level and type of hazardous condition at all times. Safety pictograms show the type of hazardous condition at the top or left side, and the method of avoiding the hazardous condition at the bottom or right side. In addition, the type of hazardous condition is displayed inside a triangle and the method of avoiding the hazardous condition is shown inside a circle.



Part No

Komatsu cannot predict every circumstance that might involve a potential hazard in operation and maintenance. Therefore, the safety messages in this manual and on the machine may not include all possible safety precautions. If any procedures or actions not specifically recommended or allowed in this manual are used, it is your responsibility to take the necessary steps to ensure safety.

In no event should you engage in prohibited uses or actions described in this manual.

The explanations, values, and illustrations in this manual were prepared based on the latest information available at that time. Continuing improvements in the design of this machine can lead to changes in detail which may not be reflected in this manual. Consult Komatsu or your Komatsu distributor for the latest available information of your machine or for questions regarding information in this manual.

The numbers in circles in the illustrations correspond to the numbers in () in the text. (For example: ① → (1))

INTRODUCTION

This Komatsu machine is designed to be used mainly for the following work:

- Dozing
- Cutting into hard or frozen ground or ditching
- Felling trees, removing stumps
- Pushing
- Ripping

For further details, see "WORK POSSIBLE USING BULLDOZER (PAGE 3-117)" and "RIPPER OPERATION (PAGE 3-124)".

FRONT/REAR, LEFT/RIGHT DIRECTIONS OF MACHINE

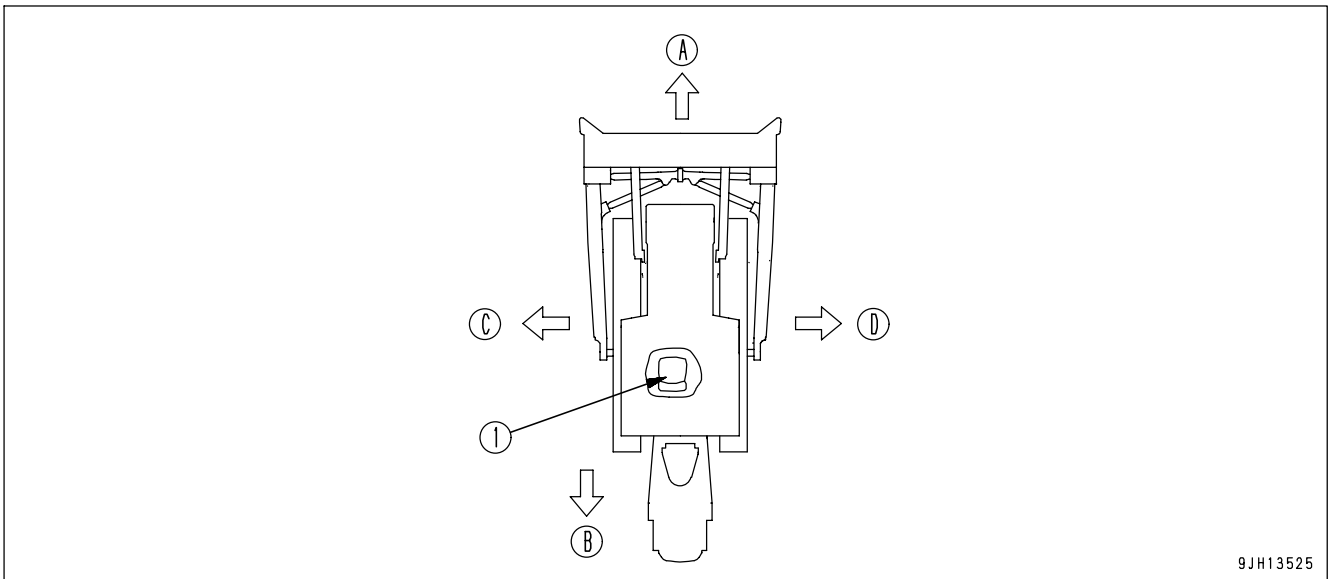

(1) Operator's seat

(A) Front

(B) Rear

(C) Left

(D) Right

In this manual, the terms front, rear, left, and right refer to the travel direction as seen from the operator's seat when the operator's seat is facing the front.

NECESSARY INFORMATION

When requesting service or ordering replacement parts, please inform your Komatsu distributor of the following items.

MACHINE SERIAL NO. PLATE AND POSITION

Under the front of the console box on the right side of the operator's seat.

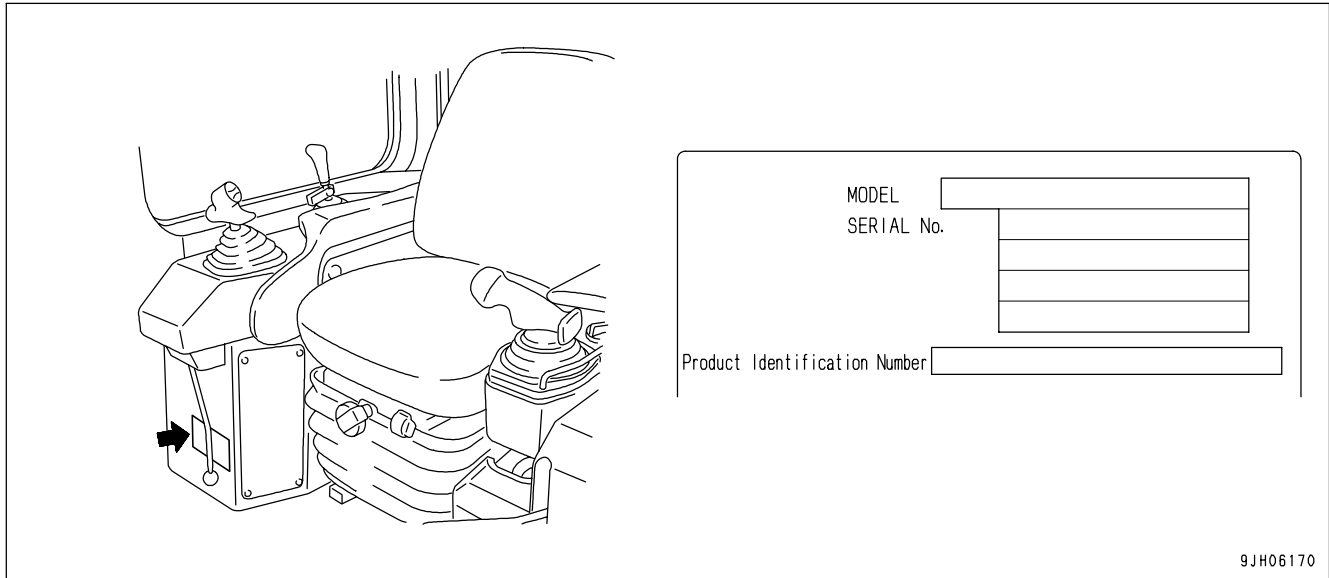

ENGINE SERIAL NO. PLATE AND POSITION

This is at the rear of the exhaust manifold cover on the left side of the engine as seen from the fan.
 (The EMISSION CONTROL INFORMATION LABEL is on the mounting bracket between the water separator and the engine oil filter.)

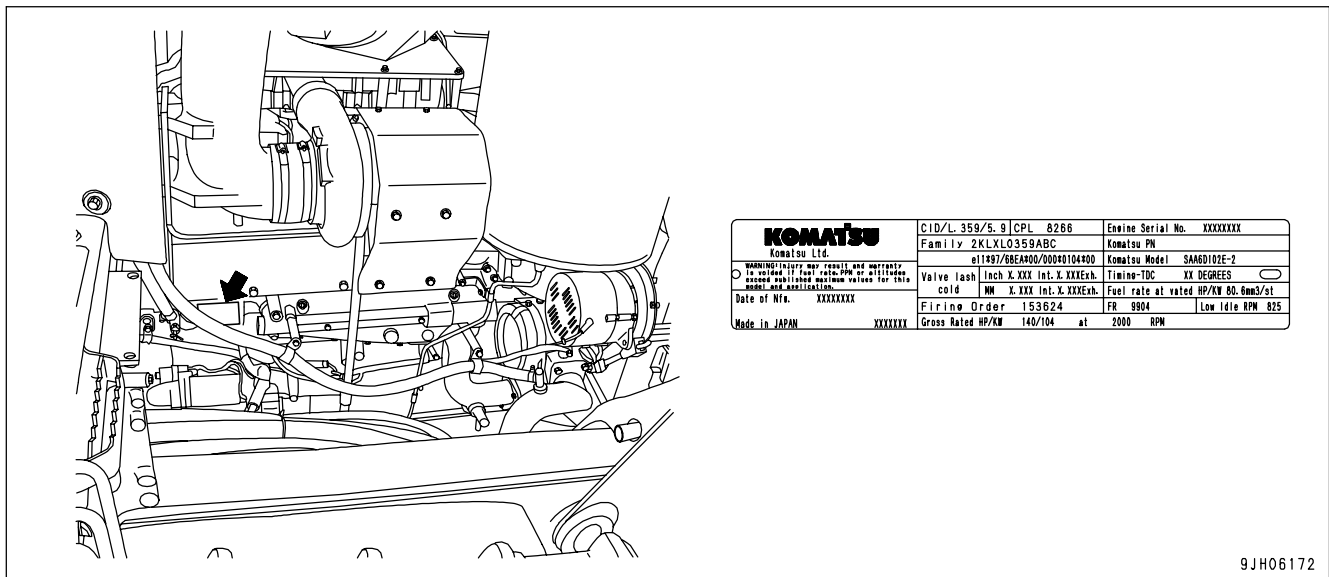

EPA: Environmental Protection Agency, U.S.A.

BLADE SERIAL NO. PLATE POSITION

This is located on the upper right of blade back surface.

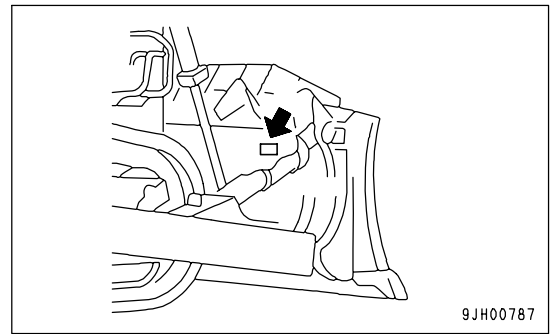

RIPPER SERIAL NO. PLATE POSITION

This is located on the left side surface of ripper beam.

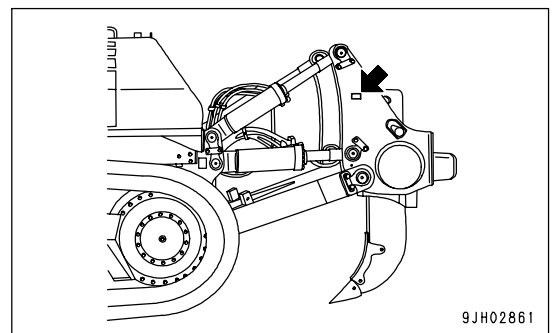

POSITION OF SERVICE METER

On top of the machine monitor

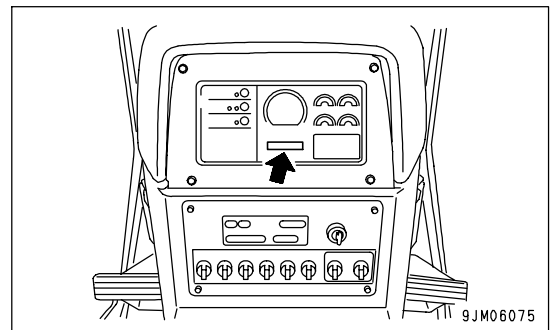

TABLE TO ENTER SERIAL NO. AND DISTRIBUTOR

Machine serial No.	
Engine serial No.	
Distributor name	
Address	-----

Service Personnel	
Phone/Fax	

CONTENTS

FOREWORD	1- 1
FOREWORD	1- 2
SAFETY INFORMATION	1- 5
INTRODUCTION	1- 7
FRONT/REAR, LEFT/RIGHT DIRECTIONS OF MACHINE	1- 7
NECESSARY INFORMATION	1- 8
MACHINE SERIAL NO. PLATE AND POSITION	1- 8
ENGINE SERIAL NO. PLATE AND POSITION	1- 8
BLADE SERIAL NO. PLATE POSITION	1- 9
RIPPER SERIAL NO. PLATE POSITION	1- 9
POSITION OF SERVICE METER	1- 9
TABLE TO ENTER SERIAL NO. AND DISTRIBUTOR	1- 10
SAFETY	2- 1
SAFETY	2- 2
SAFETY LABELS	2- 4
POSITIONS OF SAFETY PICTOGRAMS	2- 4
SAFETY LABELS	2- 5
GENERAL PRECAUTIONS	2- 9
PRECAUTIONS FOR OPERATION	2- 18
BEFORE STARTING ENGINE	2- 18
OPERATION	2- 20
TRANSPORTATION	2- 24
BATTERY	2- 25
TOWING	2- 27
PRECAUTIONS FOR MAINTENANCE	2- 28
OPERATION	3- 1
GENERAL VIEW	3- 2
GENERAL VIEW OF MACHINE	3- 2
GENERAL VIEW OF CONTROLS AND GAUGES	3- 3
EXPLANATION OF COMPONENTS	3- 5
FRONT PANEL	3- 5
SWITCHES	3- 36
CONTROL LEVERS, PEDALS	3- 40
DUST INDICATOR	3- 49
POWER SOURCE	3- 49
FUSE BOX	3- 50
FUSIBLE LINK	3- 53
DOOR OPEN LOCK	3- 53
SASH GLASS INTERMEDIATE LOCK	3- 54
DOOR POCKET	3- 54
ASHTRAY	3- 54
TOOL BOX	3- 55
CAR STEREO, HANDLING	3- 56
AIR CONDITIONER, HANDLING	3- 64
ACCUMULATOR, HANDLING	3- 70
OPERATION	3- 71
CHECK BEFORE STARTING ENGINE, ADJUST	3- 71
STARTING ENGINE	3- 92
OPERATIONS AND CHECKS AFTER STARTING ENGINE	3- 97

STOPPING ENGINE	3-100
CHECK AFTER STOPPING ENGINE	3-100
MOVING MACHINE	3-101
STOPPING MACHINE	3-103
SHIFTING GEAR	3-104
SHIFTING BETWEEN FORWARD AND REVERSE	3-107
STEERING MACHINE	3-109
PRECAUTIONS FOR OPERATION	3-112
PARKING MACHINE	3-114
CHECK AFTER FINISHING WORK	3-116
LOCKING	3-116
WORK POSSIBLE USING BULLDOZER	3-117
EFFECTIVE USE OF MODE SELECTION SYSTEM	3-119
RIPPER OPERATION	3-124
OPERATING METHOD FOR RIPPING OPERATIONS	3-127
ADJUSTING POSTURE OF WORK EQUIPMENT	3-132
TIPS FOR LONGER UNDERCARRIAGE LIFE	3-135
TRANSPORTATION	3-137
TRANSPORTATION PROCEDURE	3-137
LOADING, UNLOADING WORK	3-137
PRECAUTIONS FOR LOADING	3-138
METHOD OF LIFTING MACHINE	3-138
PRECAUTIONS FOR TRANSPORTATION	3-139
TRAVELING ON ROADS	3-139
REMOVAL OF CAB	3-140
INSTALLATION OF CAB	3-140
COLD WEATHER OPERATION	3-141
PRECAUTIONS FOR LOW TEMPERATURE	3-141
AFTER COMPLETION OF WORK	3-142
AFTER COLD WEATHER	3-142
LONG-TERM STORAGE	3-143
BEFORE STORAGE	3-143
DURING STORAGE	3-143
AFTER STORAGE	3-143
STARTING MACHINE AFTER LONG-TERM STORAGE	3-143
TROUBLESHOOTING	3-144
AFTER RUNNING OUT OF FUEL	3-144
METHOD OF TOWING MACHINE	3-145
IF BATTERY IS DISCHARGED	3-146
OTHER TROUBLE	3-149
WHEN MODE SELECTION SYSTEM FLASHES	3-154
MAINTENANCE	4- 1
GUIDES TO MAINTENANCE	4- 2
OUTLINES OF SERVICE	4- 5
HANDLING OIL, FUEL, COOLANT, AND PERFORMING OIL CLINIC	4- 5
OUTLINE OF ELECTRIC SYSTEM	4- 8
WEAR PARTS	4- 9
WEAR PARTS LIST	4- 9
RECOMMENDED FUEL, COOLANT, AND LUBRICANT	4- 10
USE OF FUEL, COOLANT AND LUBRICANTS ACCORDING TO AMBIENT TEMPERATURE	4- 11

RECOMMENDED BRANDS, RECOMMENDED QUALITY FOR PRODUCTS OTHER THAN KOMATSU GENUINE OIL -----	4- 12
STANDARD TIGHTENING TORQUES FOR BOLTS AND NUTS -----	4- 13
TORQUE LIST -----	4- 13
PERIODIC REPLACEMENT OF SAFETY CRITICAL PARTS -----	4- 14
SAFETY CRITICAL PARTS -----	4- 15
MAINTENANCE SCHEDULE CHART -----	4- 16
MAINTENANCE SCHEDULE CHART -----	4- 16
SERVICE PROCEDURE -----	4- 19
INITIAL 250 HOURS SERVICE (ONLY AFTER THE FIRST 250 HOURS) WHEN REQUIRED -----	4- 19
CHECK BEFORE STARTING -----	4- 20
EVERY 250 HOURS SERVICE -----	4- 46
EVERY 500 HOURS SERVICE -----	4- 47
EVERY 1000 HOURS SERVICE -----	4- 55
EVERY 2000 HOURS SERVICE -----	4- 62
EVERY 4000 HOURS SERVICE -----	4- 69
EVERY 8000 HOURS SERVICE -----	4- 76
SPECIFICATIONS -----	4- 80
SPECIFICATIONS -----	5- 1
SPECIFICATIONS -----	5- 2
ATTACHMENTS, OPTIONS -----	6- 1
GENERAL PRECAUTIONS -----	6- 2
PRECAUTIONS RELATED TO SAFETY -----	6- 2
SELECTION OF TRACK SHOE -----	6- 3
SELECTION OF TRACK SHOES -----	6- 3
PROCEDURE FOR SELECTING RIPPER POINT -----	6- 4
PROCEDURE FOR SELECTING RIPPER POINT -----	6- 4
CAP WITH LOCK, HANDLING -----	6- 5
METHOD OF OPENING AND CLOSING CAP WITH LOCK -----	6- 5
EFFECTIVE METHOD OF OPERATION FOR DUAL TILT DOZER -----	6- 6
BLADE CONDITION -----	6- 6
DOZING WORK -----	6- 8
LEVELING (SPREADING) OPERATION -----	6- 11
DITCHING OPERATION -----	6- 11
BOULDER RAISING OPERATION -----	6- 11
SIDE-CUTTING OPERATIONS -----	6- 12
HORIZONTAL DOZING OPERATIONS FROM SIDE SLOPE (ROUGH GROUND) -----	6- 12
SHOE SLIP CONTROL -----	6- 13
MODE SELECTION SWITCH PANEL (SHOE SLIP CONTROL) -----	6- 13
EFFECTIVE USE OF MODE SELECTION SYSTEM -----	6- 14
IF MODE SELECTION SYSTEM FLASHES -----	6- 21
HANDLING MACHINES EQUIPPED WITH KOMTRAX -----	6- 22
BASIC PRECAUTIONS -----	6- 22
INDEX -----	7- 1

SAFETY

WARNING

Please read and make sure that you fully understand the precautions described in this manual and the safety labels on the machine. When operating or servicing the machine, always follow these precautions strictly.

SAFETY

Safety Labels	2- 4
Positions of Safety Pictograms	2- 4
Safety Labels	2- 5
 General Precautions	 2- 9
Safety Rules	2- 9
If Abnormalities are Found	2- 9
Clothing and Personal Protective Items	2- 9
Fire Extinguisher and First Aid Kit	2- 9
Safety Features	2- 9
Keep Machine Clean	2- 10
Inside Operator's Compartment	2- 10
Precautions when Working in High Places	2- 11
Always Apply Lock when Leaving Operator's Seat	2- 10
Handrails and Steps	2- 11
Mounting and Dismounting	2- 11
No People on Attachments	2- 11
Crushing or Cutting Prevention	2- 12
Prevention of Burns	2- 12
Fire Prevention	2- 13
Action if Fire Occurs	2- 14
Window Washer Liquid	2- 14
Precautions when using ROPS	2- 14
Precautions for Attachments	2- 14
Cab Window Glasses	2- 14
Unauthorized Modification	2- 14
Safety at Worksite	2- 15
Working on Loose Ground	2- 15
Do not Go Close to High-Voltage Cables	2- 16
Ensure Good Visibility	2- 16
Ventilation for Enclosed Areas	2- 17
Checking Signalman's Signals and Signs	2- 17
Be Careful About Asbestos Dust	2- 17

Precautions for Operation	2- 18
Before Starting Engine	2- 18
Checks Before Starting Engine	2- 18
Precautions when Starting	2- 19
Precautions in Cold Areas	2- 19
Operation	2- 20
Checks Before Operation	2- 20
Precautions for Moving Machine Forward or in Reverse	2- 20
Precautions when Traveling	2- 21
Traveling on Slopes	2- 22
Prohibited Operations	2- 22
Using Brakes	2- 22
Operate Carefully on Snow	2- 22
Parking Machine	2- 23
Transportation	2- 24
Shipping	2- 24
Battery	2- 25
Battery Hazard Prevention	2- 25
Starting with Booster Cable	2- 26
Towing	2- 27
When Towing	2- 27
Precautions for Maintenance	2- 28
Warning Tag	2- 28
Keep Work Place Clean and Tidy	2- 28
Appoint Leader when Working with Others	2- 28
Stop Engine Before Carrying Out Inspection and Maintenance	2- 29
Two Workers for Maintenance when Engine is Running	2- 30
Proper Tools	2- 30
Handling Accumulator	2- 31
Personnel	2- 31
Attachments	2- 31
Work Under the Machine	2- 31
Noise	2- 32
Precautions when Using Hammer	2- 32
Repair Welding	2- 32
Removing Battery Terminal	2- 32
Precautions when Using High-Pressure Grease to Adjust Track Tension	2- 32
Do not Disassemble Recoil Spring	2- 33
Precaution with High-Pressure Oil	2- 33
Precaution for High Fuel Pressure	2- 33
Handling High-Pressure Hoses	2- 33
Precaution for High Voltage	2- 34
Waste Material	2- 34
Maintenance for Air Conditioner	2- 34
Compressed Air	2- 34
Periodic Replacement of Safety Critical Parts	2- 34

SAFETY LABELS

The following warning signs and safety labels are used on this machine.

- Be sure that you fully understand the correct position and content of labels.
- To ensure that the content of labels can be read properly, be sure that they are in the correct place and always keep them clean. When cleaning them, do not use organic solvents or gasoline. These may cause the labels to peel off.
- There are also other labels in addition to the warning signs and safety labels. Handle those labels in the same way.
- If the labels are damaged, lost, or cannot be read properly, replace them with new ones. For details of the part numbers for the labels, see this manual or the actual label, and place an order with Komatsu distributor.

POSITIONS OF SAFETY PICTOGRAMS

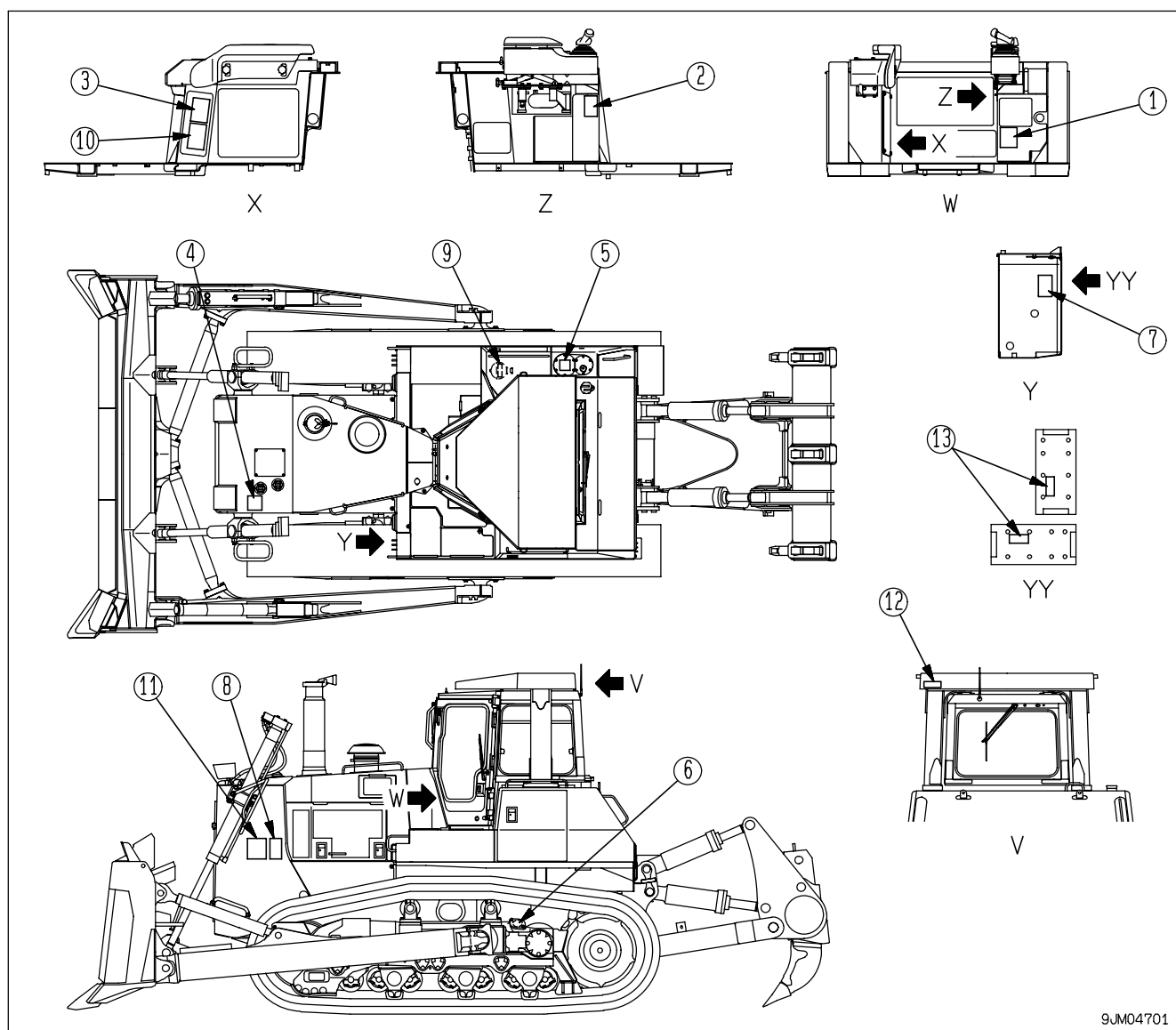

SAFETY LABELS

- (1) Caution before operating or maintaining machine
(09651-03001)



- (2) Caution before moving in reverse (09802-13000)

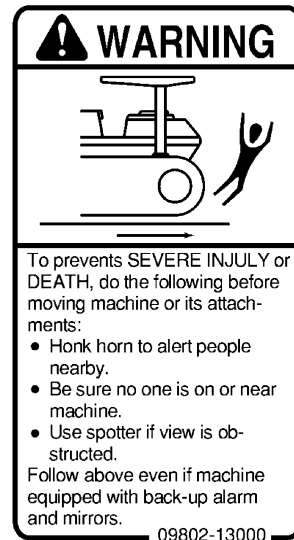

- (3) Caution for leaving operator's seat (09654-33001)

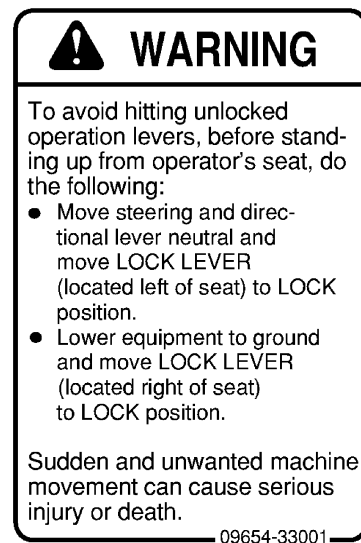

(4) Caution for high-temperature coolant (09668-03001)



(5) Caution for high-temperature hydraulic oil (09653-03001)



(6) Caution for check and adjust track tension (195-98-22931)



(7) Caution for handling electric wires (09808-03000)

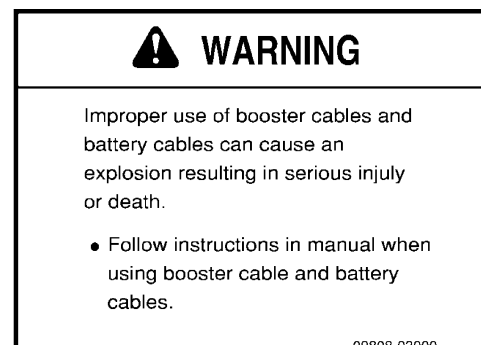

(8) Caution for engine running (09667-03001)



(9) Caution for handling accumulator (09659-53000)



(10) Caution for use of seat belt (195-98-12940)

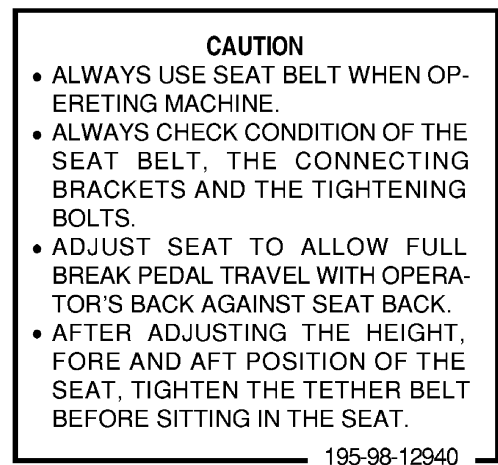

(11) Caution for approach when machine moving (09812-03000)



(12) Warning for ROPS (09620-30201)

ROLL-OVER PROTECTIVE STRUCTURE (ROPS) CERTIFICATION
 THIS KOMATSU ROPS, MODEL & TYPE No. [] SERIAL No. [] WHEN
 INSTALLED IN ACCORDANCE WITH THE MANUFACTURER'S INSTALLATION IN-
 STRUCTIONS ON A [] FOR MAXIMUM PRIME MOVER
KOMATSU MASS NOT GREATER THAN [] (LBS/Kg). IS CERTIFIED TO
 COMPLY WITH THE FOLLOWING REQUIREMENTS: a) ISO 3471 (ROPS) & ISO
 3449 (FOPS) b) SAE J [] & SAE J []

• Altering ROPS may weaken it. Consult Komatsu Distributor before altering.
 • ROPS may provide less protection if it has been structurally damaged or involved in roll-over.
 • Always wear seat belt when moving.

⚠ WARNING

Komatsu Ltd. Japan 2-3-6 Akasaka, Minato-ku, Tokyo, Japan 09620-30201

(13) Warning for battery (09664-30082)

⚠ WARNING

EXPLOSIVE GASES
 Cigarettes, flames or sparks could cause battery to explode. Always shield eyes and face from battery. DO not charge or use booster cables or adjust post connections without proper instruction and training.
 KEEP VENT CAPS TIGHT AND LEVEL

POISON causes severe burns
 Contains sulfuric acid. Avoid contact with skin, eyes or clothing. In event of accident flush with water and call a physician immediately.
 KEEP OUT OF REACH OF CHILDREN

09664-30082

GENERAL PRECAUTIONS

SAFETY RULES

- Only trained and authorized personnel can operate and maintain the machine.
- Follow all safety rules, precautions and instructions in this manual when operating or performing maintenance on the machine.
- If you are not feeling well, or if you are under the influence of alcohol or medication, your ability to safely operate or repair your machine may be severely impaired, putting yourself and everyone else on your job site in danger.
- When working with another operator or with the person on the worksite traffic duty, discuss the content of the operation beforehand and use the determined signals when carrying out the operation.

IF ABNORMALITIES ARE FOUND

If you find any problems in the machine during operation or maintenance (noise, vibration, smell, incorrect gauges, smoke, oil leakage, etc., or any abnormal display on the warning devices or monitor), report to the person in charge and have the necessary action taken. Do not operate the machine until the problem has been corrected.

CLOTHING AND PERSONAL PROTECTIVE ITEMS

- Do not wear loose clothing and accessories. There is a hazard that they may catch on control levers or other protruding parts.
- If you have long hair and it hangs out from your hard hat, there is a hazard that it may get caught up in the machine, so tie your hair up and be careful not to let it get caught.
- Always wear a hard hat and safety shoes. If the nature of the work requires it, wear safety glasses, mask, gloves, ear plugs, and safety belt when operating or maintaining the machine.
- Check that all protective equipment functions properly before using it.

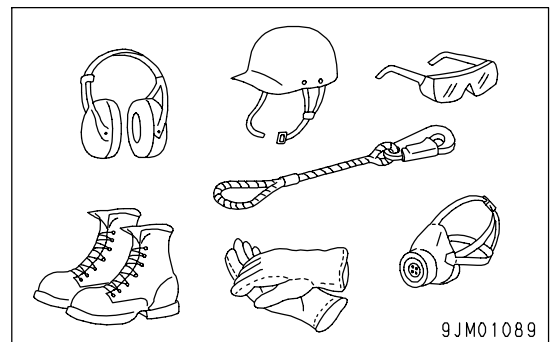

FIRE EXTINGUISHER AND FIRST AID KIT

Always follow the precautions below to prepare for action if any injury or fire should occur.

- Be sure that fire extinguishers have been provided and read the labels to ensure that you know how to use them in emergencies.
- Carry out periodic inspection and maintenance to ensure that the fire extinguisher can always be used.
- Provide a first aid kit in the storage point. Carry out periodic checks and add to the contents if necessary.

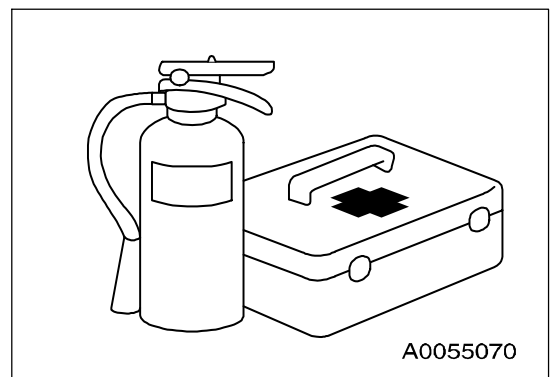

SAFETY FEATURES

- Be sure that all guards, covers and mirrors are in their proper position. Have guards and covers repaired immediately if they are damaged.
- Understand the method of use of safety features and use them properly.
- Never remove any safety features. Always keep them in good operating condition.

KEEP MACHINE CLEAN

- If water gets into the electrical system, there is a hazard that it will cause malfunctions or misoperation. Do not use water or steam to wash the electrical system (sensors, connectors).
- If inspection and maintenance is carried out when the machine is still dirty with mud or oil, there is a hazard that you will slip and fall, or that dirt or mud will get into your eyes. Always keep the machine clean.

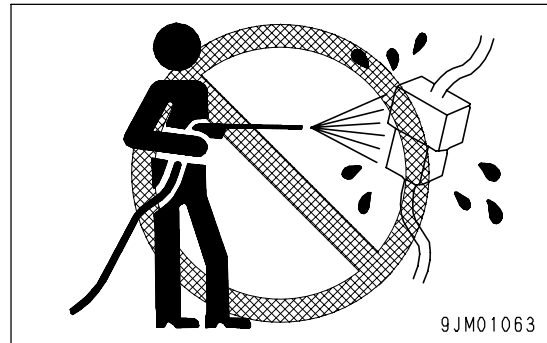

INSIDE OPERATOR'S COMPARTMENT

- When entering the operator's compartment, always remove all mud and oil from the soles of your shoes. If you operate the pedal with mud or oil affixed to your shoes, your foot may slip and this may cause a serious accident.
- Do not leave parts or tools lying around the operator's compartment.
- Do not stick suction pads to the window glass. Suction pads act as a lens and may cause fire.
- Do not use cellular telephones inside the operator's compartment when driving or operating the machine.
- Never bring any dangerous objects such as flammable or explosive items into the operator's compartment.

ALWAYS APPLY LOCK WHEN LEAVING OPERATOR'S SEAT

- Before standing up from the operator's seat, lower the work equipment completely to the ground, set work equipment lock lever and parking brake lever securely to the LOCK position (L), then stop the engine. If you accidentally touch the levers when they are not locked, there is a hazard that the machine may suddenly move and cause serious injury or property damage.

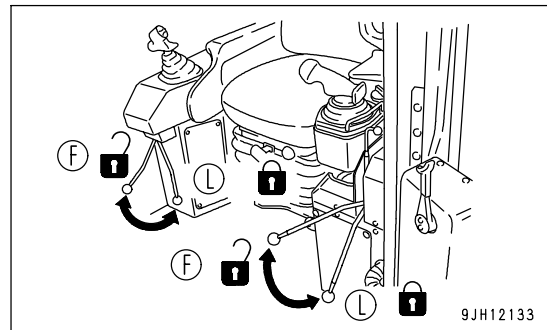

- When leaving the machine, always lower the work equipment completely to the ground, set work equipment lock lever and parking brake lever securely to the LOCK position, then stop the engine. Use the key to lock all the equipment. Always remove the key, take it with you, and keep it in the specified place.

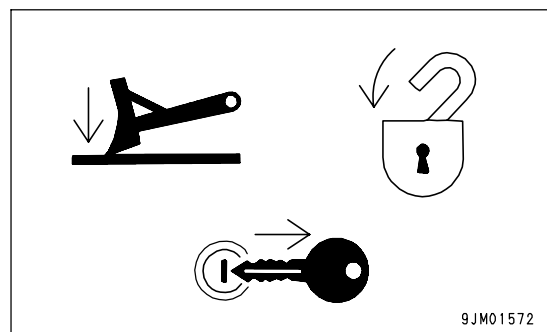

HANDRAILS AND STEPS

To prevent personal injury caused by slipping or falling off the machine, always do as follows.

- Use the parts marked by arrow A in the diagrams when getting on or off the machine.
Never use the parts marked by arrow B when getting on or off the machine. Use them only when moving along the top of the track or when checking or carrying out maintenance inside the side cover, or when filling the tank with oil.
- Never jump on or off the machine. In particular, never get on or off a moving machine. This may cause serious injury.

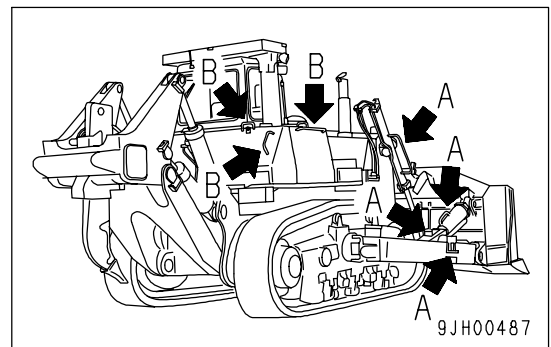
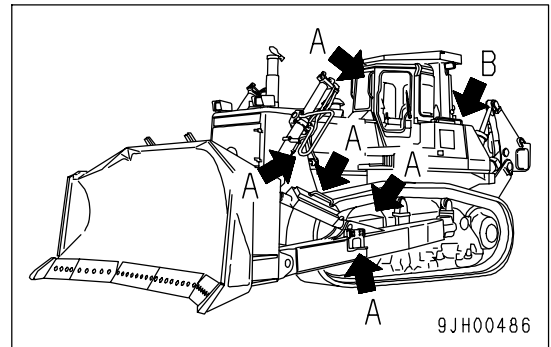

- To ensure safety, always face the machine and maintain three-point contact (both feet and one hand, or both hands and one foot) with the handrails and steps (including the track shoe) to ensure that you support yourself.
- Do not grip the control levers, or work equipment lock lever when getting on or off the machine.
- Never climb on the engine hood or covers where there are no non-slip pads.
- Before getting on or off the machine, check the handrails and steps (including the track shoe). If there is any oil, grease, or mud on the handrails or steps (including the track shoe), wipe it off immediately. Always keep these parts clean. Repair any damage and tighten any loose bolts.
- Do not get on or off the machine while holding tools in your hand.

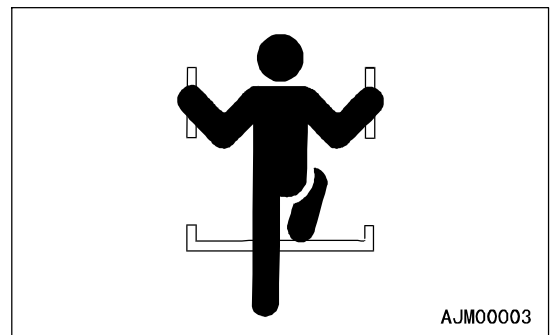

PRECAUTIONS WHEN WORKING IN HIGH PLACES

When working at high places, use a step ladder or other stand to ensure that the work can be carried out safely.

MOUNTING AND DISMOUNTING

- Never jump on or off the machine. Never get on or off a moving machine.
- If the machine starts to move when there is no operator on the machine, do not jump on to the machine and try to stop it.

NO PEOPLE ON ATTACHMENTS

Never let anyone ride on the work equipment, or other attachments. There is a hazard of falling and suffering serious injury.

CRUSHING OR CUTTING PREVENTION

The clearance around the work equipment will change according to the movement of the link. If you get caught, this may lead to serious personal injury. Do not allow anyone to approach any rotating or telescoping part.

PREVENTION OF BURNS**Hot coolant**

- To prevent burns from hot water or steam spurting out when checking or draining the coolant, wait for the water to cool to a temperature where it is possible to touch the radiator cap by hand before starting the operation. Even when the coolant has cooled down, loosen the cap slowly to relieve the pressure inside the radiator before removing the cap.

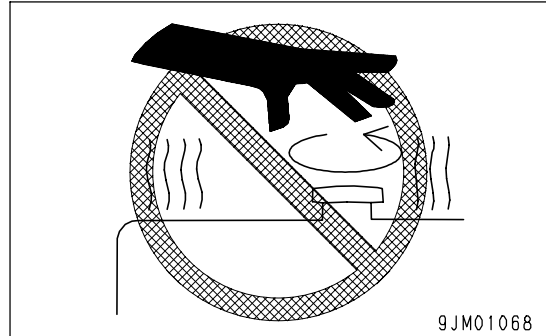
**Hot oil**

- To prevent burns from hot oil spurting out when checking or draining the oil, wait for the oil to cool to a temperature where it is possible to touch the cap or plug by hand before starting the operation. Even when the oil has cooled down, loosen the cap or plug slowly to relieve the internal pressure before removing the cap or plug.

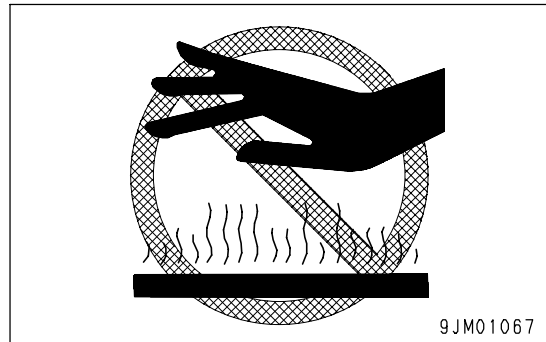

FIRE PREVENTION

- **Fire caused by fuel or oil**

Fuel, oil, antifreeze, and window washer liquid are particularly flammable and can be hazardous. To prevent fire, always observe the following:

- Do not smoke or use any flame near fuel or oil.
- Stop the engine before refueling.
- Do not leave the machine while adding fuel or oil.
- Tighten all fuel and oil caps securely.
- Do not spill fuel on overheated surfaces or on parts of the electrical system.
- Use well-ventilated areas for adding or storing oil and fuel.
- Keep oil and fuel in the determined place and do not allow unauthorized persons to enter.
- After adding fuel or oil, wipe up any spilled fuel or oil.
- When carrying out grinding or welding work on the chassis, move any flammable materials to a safe place before starting.
- When washing parts with oil, use a non-flammable oil. Diesel oil and gasoline may catch fire, so do not use them.
- Put greasy rags and other flammable materials into a safe container to maintain safety at the work place.
- Do not weld or use a cutting torch to cut any pipes or tubes that contain flammable liquids.



- **Fire caused by accumulation of flammable material.**

Remove any dry leaves, chips, pieces of paper, dust, or any other flammable materials accumulated or affixed around the engine, exhaust manifold, muffler, or battery, or inside the undercovers.

- **Fire coming from electric wiring**

Short circuits in the electrical system can cause fire.

- Always keep electric wiring connections clean and securely tightened.
- Check the wiring every day for looseness or damage. Tighten any loose connectors or wiring clamps. Repair or replace any damaged wiring.

- **Fire coming from hydraulic line**

Check that all the hose and tube clamps, guards, and cushions are securely fixed in position.

If they are loose, they may vibrate during operation and rub against other parts. This may lead to damage to the hoses, and cause high-pressure oil to spurt out, leading to fire damage or serious injury.

- **Explosion caused by lighting equipment**

- When checking fuel, oil, battery electrolyte, window washer fluid, or coolant, always use lighting with anti-explosion specifications. If such lighting equipment is not used, there is danger of explosion that may cause serious injury.
- When taking the electrical power for the lighting from the machine itself, follow the instructions in this manual.

ACTION IF FIRE OCCURS

If a fire occurs, escape from the machine as follows.

- Turn the start switch OFF to stop the engine.
- Use the handrails and steps to get off the machine.

WINDOW WASHER LIQUID

Use an ethyl alcohol base washer liquid.

Methyl alcohol base washer liquid may irritate your eyes, so do not use it.

PRECAUTIONS WHEN USING ROPS (Roll Over Protective Structure)

Install ROPS when working in places where there is danger of falling rocks, such as in mines and quarries, or in places where there is danger of rolling over.

- If ROPS is installed, do not remove it when operating the machine.
- ROPS is installed to protect the operator when machine rolls over. When machine rolls over, ROPS supports its weight and absorbs its impact energy.
- If ROPS is modified, its strength may lower. When modifying it, consult your Komatsu distributor.
- If ROPS is deformed by falling objects or by rolling over, its strength lowers and its design functions cannot be maintained. In this case, be sure to ask your Komatsu distributor about repair method.

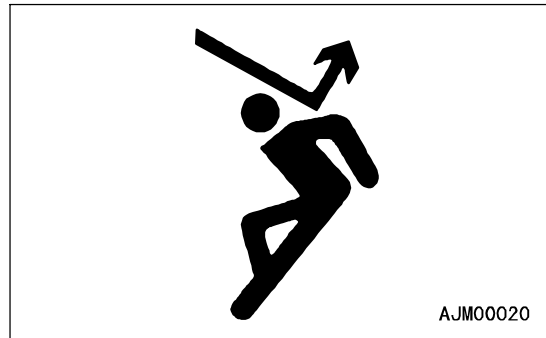

Even when the ROPS is installed, if you do not fasten your seat belt securely, it cannot protect you properly. Always fasten your seat belt when operating the machine.

PRECAUTIONS FOR ATTACHMENTS

- When installing optional parts or attachments, there may be problems with safety or legal restrictions. Therefore contact your Komatsu distributor for advice.
- Any injuries, accidents, product failures or other property damages resulting from the use of unauthorized attachments or parts will not be the responsibility of Komatsu.
- When installing and using optional attachments, read the instruction manual for the attachment, and the general information related to attachments in this manual.

CAB WINDOW GLASSES

If the cab glass on the work equipment side is broken, there is a hazard that the work equipment may contact the operator's body directly. Stop operation immediately and replace the glass.

UNAUTHORIZED MODIFICATION

Any modification made without authorization from Komatsu can create hazards. Before making a modification, consult your Komatsu distributor.

- Komatsu will not be responsible for any injuries, accidents, product failures or other property damages resulting from modifications made without authorization from Komatsu.

SAFETY AT WORKSITE

Before starting operations, thoroughly check the area for any unusual conditions that could be dangerous.

- When carrying out operations near combustible materials such as thatched roofs, dry leaves or dry grass, there is a hazard of fire, so be careful when operating.
- Check the terrain and condition of the ground at the worksite, and determine the safest method of operation. Do not operate where there is a hazard of landslides or falling rocks.
- If water lines, gas lines, or high-voltage electrical lines may be buried under the worksite, contact each utility and identify their locations. Be careful not to sever or damage any of these lines.
- Take necessary measures to prevent any unauthorized person from entering the operating area.
- In particular, if you need to operate on a road, protect pedestrian and cars by designating a person for worksite traffic duty or by installing fences around the worksite.
- When traveling or operating in shallow water or on soft ground, check the shape and condition of the bedrock, and the depth and speed of flow of the water before starting operations.

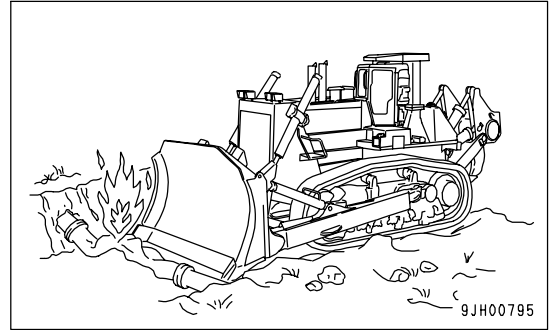
**WORKING ON LOOSE GROUND**

- Avoid traveling or operating your machine too close to the edge of cliffs, overhangs, and deep ditches. The ground may be weak in such areas. If the ground should collapse under the weight or vibration of the machine, there is a hazard that the machine may fall or tip over. Remember that the soil after heavy rain or blasting or after earthquakes is weak in these areas.
- When working on embankments or near excavated ditches, there is a hazard that the weight and vibration of the machine will cause the soil to collapse. Before starting operations, take steps to ensure that the ground is safe and to prevent the machine from rolling over or falling.

DO NOT GO CLOSE TO HIGH-VOLTAGE CABLES

Do not travel or operate the machine near electric cables. There is a hazard of electric shock, which may cause serious personal injury or death. On jobsites where the machine may go close to electric cables, always do as follows.

- Before starting work near electric cables, inform the local power company of the work to be performed, and ask them to take the necessary action.

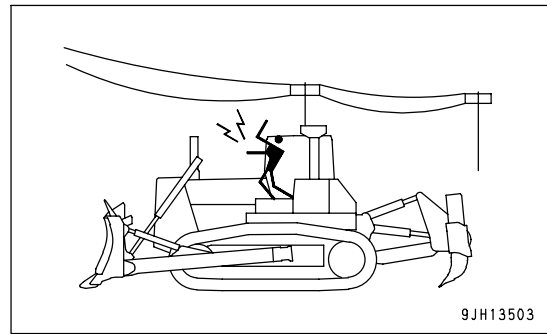

- Even going close to high-voltage cables can cause electric shock, which may cause serious burns or even death. Always maintain a safe distance (see the table on the right) between the machine and the electric cable. Check with the local power company about safe operating procedure before starting operations.
 - To prepare for any possible emergencies, wear rubber shoes and gloves. Lay a rubber sheet on top of the seat, and be careful not to touch the chassis with any exposed part of your body.
 - Use a signalman to give warning if the machine approaches too close to the electric cables.
 - When carrying out operations near high voltage cables, do not let anyone near the machine.
 - If the machine should come too close or touch the electric cable, to prevent electric shock, the operator should not leave the operator's compartment until it has been confirmed that the electricity has been shut off.
- Also, do not let anyone near the machine.

Voltage of Cables	Safety Distance
100 V - 200 V	Over 2 m (7 ft)
6,600 V	Over 2 m (7 ft)
22,000 V	Over 3 m (10 ft)
66,000 V	Over 4 m (14 ft)
154,000 V	Over 5 m (17 ft)
187,000 V	Over 6 m (20 ft)
275,000 V	Over 7 m (23 ft)
500,000 V	Over 11 m (36 ft)

ENSURE GOOD VISIBILITY

- Check for any persons or obstacles in the area around the machine and check the conditions of the jobsite to ensure that operations and travel can be carried out safely. Always do as follows.
 - Position a signalman if there are areas at the rear of the machine where the visibility is not good.
 - When working in dark places, turn on the working lamp and front lamps installed to the machine, and set up additional lighting in the work area if necessary.
 - Stop operations if the visibility is poor, such as in mist, snow, rain, or dust.

VENTILATION FOR ENCLOSED AREAS

Exhaust fumes from the engine can kill.

- If it is necessary to start the engine within an enclosed area, or when handling fuel, flushing oil, or paint, open the doors and windows to ensure that adequate ventilation is provided to prevent gas poisoning.

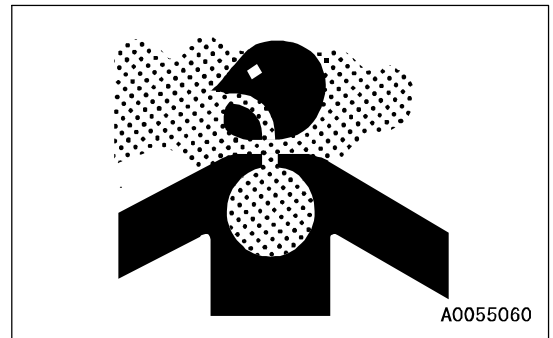
**CHECKING SIGNALMAN'S SIGNALS AND SIGNS**

- Set up signs to inform of road shoulders and soft ground. If the visibility is not good, position a signalman if necessary. Operators should pay careful attention to the signs and follow the instructions from the signalman.
- Only one signalman should give signals.
- Make sure that all workers understand the meaning of all signals and signs before starting work.

BE CAREFUL ABOUT ASBESTOS DUST

Asbestos dust in the air can cause lung cancer if it is inhaled. There is danger of inhaling asbestos when working on jobsites handling demolition work or work handling industrial waste. Always observe the following.

- Spray water to keep down the dust when cleaning. Do not use compressed air for cleaning.
- If there is danger that there may be asbestos dust in the air, always operate the machine from an upwind position. All workers should use an approved respirator.
- Do not allow other persons to approach during the operation.
- Always observe the rules and regulations for the work site and environmental standards.

This machine does not use asbestos, but there is a danger that imitation parts may contain asbestos, so always use genuine Komatsu parts.

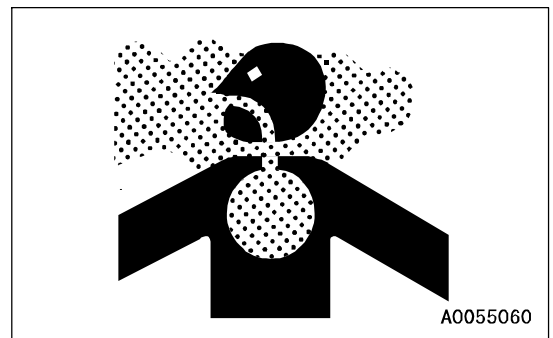

PRECAUTIONS FOR OPERATION

BEFORE STARTING ENGINE

If there is a warning tag hanging from the work equipment control lever, do not start the engine or touch the levers.

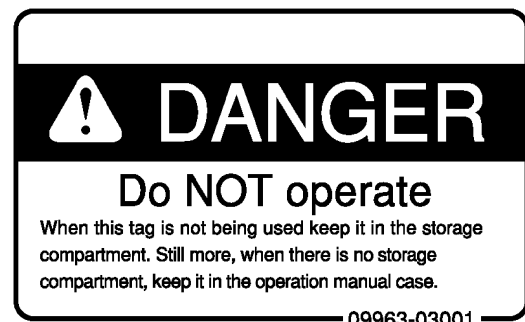
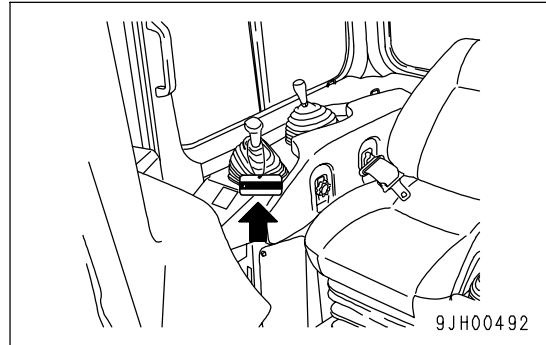

CHECKS BEFORE STARTING ENGINE

Carry out the following checks before starting the engine at the beginning of the day's work.

- Completely remove all flammable materials accumulated around the engine and battery, and remove any dirt from the windows, mirrors, handrails and steps.
- Remove all dirt from the surface of the lens of the front lamps and working lamps, and check that they light up correctly.
- Check the coolant level, fuel level, and oil level in engine oil pan, check for clogging of the air cleaner, and check for damage to the electric wiring.
- Adjust the operator's seat to a position where it is easy to carry out operations, and check that there is no damage or wear to the seat belt or mounting clamps.
- Check the operation of the instruments and gauges, check the angle of the mirror, and check that the control levers are all at the Neutral position.
- When starting the engine, check that the parking lever and work equipment lock lever are at the LOCK position.
- Adjust the mirrors so that you can get a good rear-view from the operator's seat.
For the details of adjustment, see "ADJUST MIRROR (PAGE 3-87)".
- Check that there are no persons or obstacles above, below, or in the area around the machine.

PRECAUTIONS WHEN STARTING

- When starting the engine, sound the horn as a warning.
- Start and operate the machine only while seated.
- Do not allow anyone apart from the operator to ride on the machine.
- Do not short circuit the starting motor circuit to start the engine. Short circuit can cause fire.

PRECAUTIONS IN COLD AREAS

- Carry out the warming-up operation thoroughly. If the machine is not thoroughly warmed up before the control levers are operated, the reaction of the machine will be slow, and this may lead to unexpected accidents.
- If the battery electrolyte is frozen, do not charge the battery or start the engine with a different power source. There is a hazard that this will ignite the battery and cause the battery to explode.
Before charging or starting the engine with a different power source, melt the battery electrolyte and check that there is no leakage of electrolyte before starting.

OPERATION

CHECKS BEFORE OPERATION

When carrying out the checks, move the machine to a wide area where there are no obstructions, and operate slowly. Do not allow anyone near the machine.

- Always fasten your seat belt.
- Check the operation of travel, steering and brake systems, and work equipment control system.
- Check for any problem in the sound of the machine, vibration, heat, smell, or gauges; check also that there is no leakage of oil or fuel.
- If any problem is found, carry out repairs immediately.

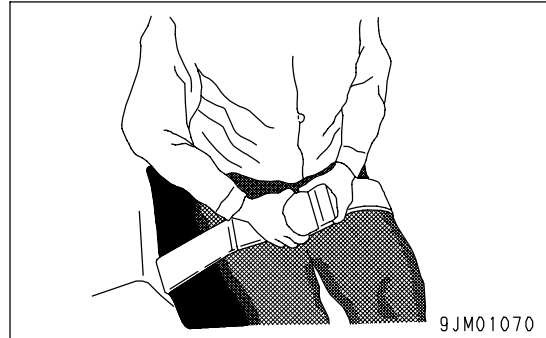

9JM01070

PRECAUTIONS FOR MOVING MACHINE FORWARD OR IN REVERSE

- Before travelling, check again that there is no one in the surrounding area, and that there are no obstacles.
- Before travelling, sound the horn to warn people in the area.
- Always operate the machine only when seated.
- Do not allow anyone apart from the operator to ride on the machine.
- Check that the backup alarm (alarm buzzer when machine travels in reverse) works properly.
- Always lock the door and windows of the operator's compartment in position (open or closed).

On jobsites where there is a hazard of flying objects or of objects entering the operator's compartment, check that the door and windows are securely closed.

- If there is an area to the rear of the machine where the visibility is obstructed, use a flagman. Be extremely careful not to hit anything and drive the machine slowly.

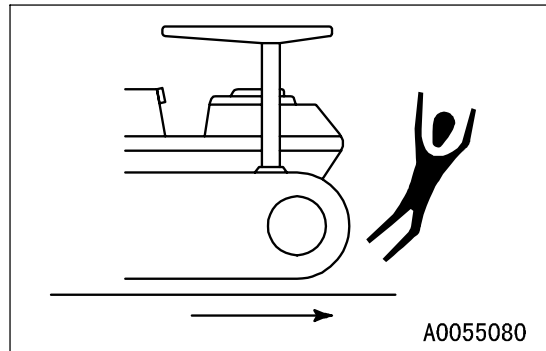

A0055080

Always be sure to carry out the above precautions even when the machine is equipped with mirrors.

PRECAUTIONS WHEN TRAVELING

- Never turn the starting switch to the OFF position when traveling. It is dangerous if the engine stops when the machine is traveling. When the engine is off, it is impossible to operate the steering. Apply the brakes and stop the machine immediately, if the engine stops.
- When traveling on flat ground, keep the work equipment 40 to 50 cm (16 to 20 in) high above the ground.
- When traveling on rough ground, travel at low speed and do not operate the steering suddenly. There is danger that the machine may turn over. The work equipment may hit the ground surface and cause the machine to lose its balance, or may damage the machine or structures in the area.

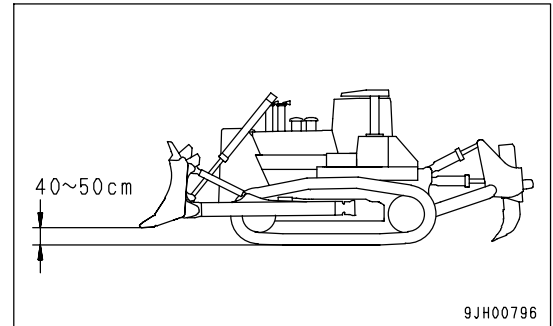

- Avoid traveling over obstacles when possible. If the machine has to travel over an obstacle, keep the work equipment close to the ground and travel at low speed. Never travel over obstacles which make the machine tilt strongly to one side.
- When traveling or carrying out operations, always keep a safe distance from people, structures, or other machines to avoid coming into contact with them.
- When passing over bridges or structures, check first that the structure is strong enough to support the weight of the machine. When traveling on public roads, check first with the relevant authorities and follow their instructions.
- When operating in tunnels, under bridges, under electric wires, or other places where the height is limited, operate slowly and be extremely careful not to let the machine body or work equipment hit anything.
- Do not approach the edge of a cliff carelessly. When dropping soil over a cliff for banking or reclamation, leave soil of one scoop at the edge of the cliff and push it with the next scoop.
- When the machine passes over the top of a hill or when a load is dumped over a cliff, the load is suddenly reduced, and there is danger that the travel speed rises suddenly. To prevent this, lower the travel speed.
- If the machine moves with only either side of the blade loaded, its tail may swing. Take care.

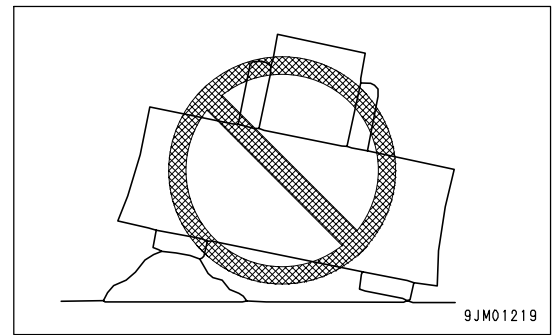

TRAVELING ON SLOPES

To prevent the machine from tipping over or slipping to the side, always do as follows.

- When traveling on slopes, keep the blade approximately 20 to 30 cm (8 to 12 in) above the ground. In case of emergency, quickly lower the blade to the ground to help the machine to stop. Apply the brake and use the engine as a brake, if necessary.
- Always travel straight up or down a slope. Traveling at an angle or across the slope is extremely dangerous.
- Do not turn on slopes or travel across slopes. Always go down to a flat place to change the position of the machine, then travel on to the slope again.
- Travel on grass, fallen leaves, or wet steel plates with low speed. Even with slight slopes there is a hazard that the machine may slip.
- When driving down a slope, never shift gear or place the transmission in neutral. The engine brake cannot be used and this creates a dangerous condition. Always travel downhill in the same speed range as when traveling uphill.
- When turning on a downhill ground, lower the travel speed.

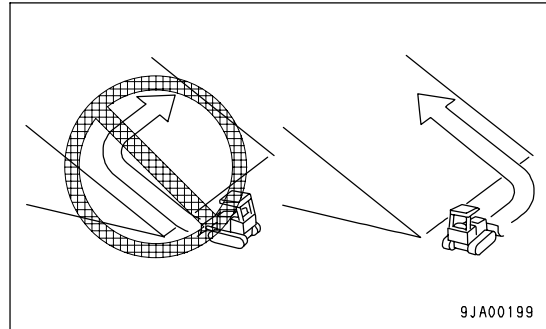

PROHIBITED OPERATIONS

- To make it easier to escape if there is any problem, set the tracks at right angles to the road shoulder or cliff with the sprocket at the rear when carrying out operations.
- When operating the machine, take care that it will not exceed its performance values such as stability, maximum using load, etc. to prevent rolling of the machine caused by an overload and disasters caused by breakage of the work equipment.

USING BRAKES

- When the machine is traveling, do not rest your foot on the brake pedal. If you travel with your foot resting on the pedal, the brake will always be applied, and this will cause the brakes to overheat and fail.
- Do not depress the brake pedal repeatedly if not necessary. If this is neglected, the brake will be overheated and will not work when required.
- When traveling downhill, use the braking force of the engine.

OPERATE CAREFULLY ON SNOW

- Snow-covered or frozen surfaces are slippery, so be extremely careful when traveling or operating the machine, and do not operate the levers suddenly. Even a slight slope may cause the machine to slip, so be particularly careful when working on slopes.
- With frozen ground surfaces, the ground becomes soft when the temperature rises, and this may cause the machine to tip over or make it impossible for the machine to escape.
- If the machine enters deep snow, there is a hazard that it may tip over or become buried in the snow. Be careful not to leave the road shoulder or to get trapped in a snow drift.
- When clearing snow, the road shoulder and objects placed beside the road are buried in the snow and cannot be seen. There is a hazard of the machine tipping over or hitting covered objects, so always carry out operations carefully.
- When traveling on snow-covered slopes, never apply the brakes suddenly. Reduce the speed and use the engine as a brake while applying the foot brake intermittently (depress the brake intermittently several times). If necessary, lower the blade to the ground to stop the machine.

PARKING MACHINE

- Park the machine on level ground where there is no danger of falling rocks or landslides, or of flooding if the land is low, and lower the work equipment to the ground.
- If it is necessary to park the machine on a slope, set the blocks (1) under the tracks to prevent the machine from moving, then dig the Point (2) of work equipment into the ground.
- After stopping the engine, operate the right work equipment control lever several times to the RAISE and LOWER positions to release the remaining pressure in the hydraulic circuit.

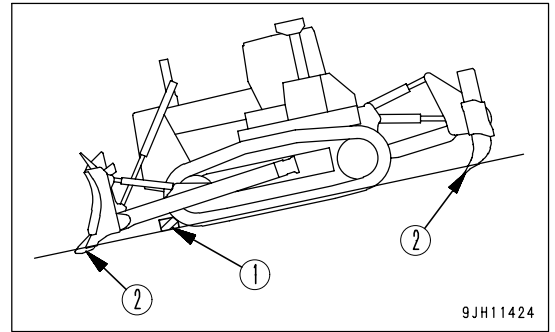

- When leaving the machine, set the work equipment lock lever and parking brake lever to the LOCK position (L), stop the engine, and use the key to lock all the equipment. Always remove the key and take it with you.

Work equipment posture: See "PARKING MACHINE (PAGE 3-114)".

Locks: See "LOCKING (PAGE 3-116)".

- Always close the door of the operator's compartment.

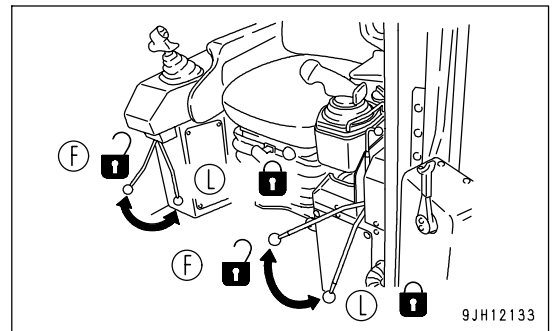

TRANSPORTATION

The machine can be divided into parts for transportation, so when transporting the machine, please contact your Komatsu distributor to have the work carried out.

SHIPPING

When shipping the machine on a trailer, do as follows.

- The weight, transportation height, and overall length of the machine differ according to the work equipment, so be sure to confirm the dimensions.
- When passing over bridges or structures on private land, check first that the structure is strong enough to support the weight of the machine. When traveling on public roads, check first with the relevant authorities and follow their instructions.
- For details of the shipping procedure, see "TRANSPORTATION (PAGE 3-137)" in the OPERATION section.

BATTERY

BATTERY HAZARD PREVENTION

Battery electrolyte contains sulphuric acid, and batteries generate flammable hydrogen gas, which may explode. Mistaken handling can lead to serious injury or fire. For this reason, always observe the following precautions.

- When the battery electrolyte is below LOWER LEVEL, don't either use or charge the battery. Otherwise, that may cause explosion. Always carry out periodic checks of the battery electrolyte, and add distilled water up to UPPER LEVEL.

For the method of checking the battery electrolyte, see "CHECK LEVEL OF BATTERY ELECTROLYTE (PAGE 4-50)".

- When working with batteries, always wear safety glasses and rubber gloves.
- Never smoke or use any flame near the battery.

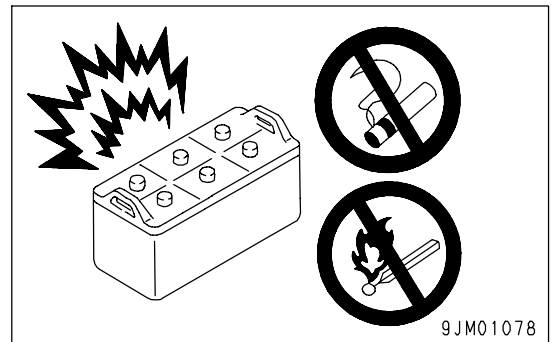

- If you spill acid on your clothes or skin, immediately flush the area with large amount of water.
- If acid gets into your eyes, flush them immediately with large amount of water and seek medical attention.

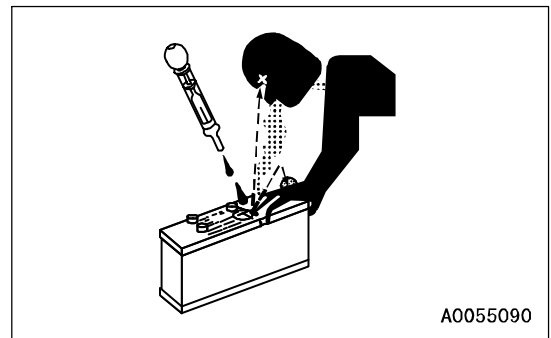

- Before working with batteries, turn the starting switch to the OFF position.

As there is a hazard that sparks will be generated, always do as follows.

- Do not let tools or other metal objects make any contact between the battery terminals. Do not leave tools or other metal objects lying around near the battery.
- Always disconnect the negative (-) terminal (ground side) first when removing the battery; when installing the battery, connect the positive (+) terminal first, and connect the ground last. Tighten the battery terminals securely.
- Tighten the battery terminals securely.
- Flammable hydrogen gas is generated when the battery is charged, so remove the battery from the chassis, take it to a well-ventilated place, and remove the battery caps before charging it.
- Tighten the battery caps securely.
- Install the battery securely to the determined place.

STARTING WITH BOOSTER CABLE

If any mistake is made in the method of connecting the booster cables, it may cause the battery to explode, so always do as follows.

- When starting with a booster cable, carry out the starting operation with two workers (one worker sitting in the operator’s seat and the other working with the battery).
- When starting from another machine, do not allow the two machines to touch.
- When connecting the booster cables, turn the starting switch OFF position for both the normal machine and problem machine. There is a hazard that the machine will move when the power is connected.
- Be sure to connect the positive (+) cable first when installing the booster cables. Disconnect the negative (-) cable (ground side) first when removing them.
- When removing the booster cables, be careful not to let the booster cable clips touch each other or to let the clips touch the machine.
- Always wear safety glasses and rubber gloves when starting the engine with booster cables.
- When connecting a normal machine to a problem machine with booster cables, always use a normal machine with the same battery voltage as the problem machine.
- For the procedure of starting the engine with booster cables, see "STARTING ENGINE WITH BOOSTER CABLE (PAGE 3-146)".

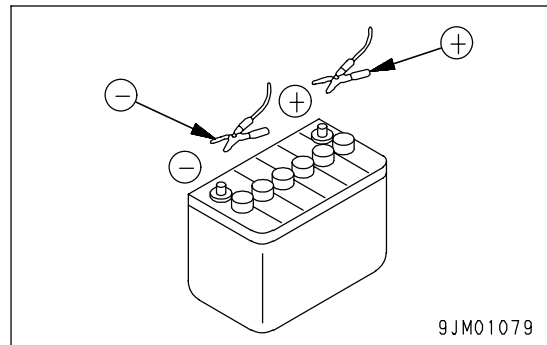
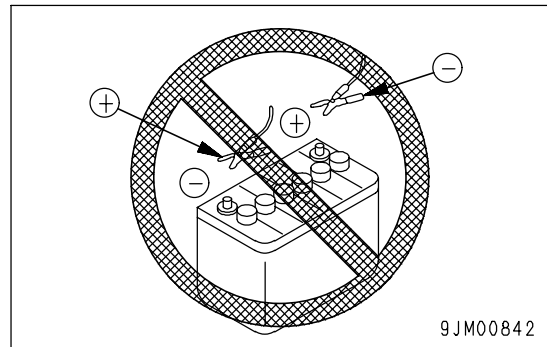

TOWING

WHEN TOWING

Injury or death could result if a disabled machine is towed incorrectly. Always observe the following rules.

- Never use a towing method different from the one described in this manual.

For the method of towing, see "METHOD OF TOWING MACHINE (PAGE 3-145)".

- When handling a wire rope, always wear leather gloves.
- When working with others to prepare for towing, signals should be agreed upon beforehand.
- If your machine is towed by another machine, stop the engine and release the brake. Please contact your Komatsu distributor to have the brake released.
- If this machine cannot travel under its own power, release the brakes, then tow the machine with another machine. Please contact your Komatsu distributor to have the brakes released.
- Towing on slopes is dangerous. When doing so, choose a gentle slope. If no gentle slope is available, make such a slope by earth-removal work.
- When connecting up a towing machine, do not let anyone enter the area between the towing machine and the equipment being towed.
- Do not straddle the towing cable or wire rope.
- When your machine is towed by another machine, ALWAYS use a wire rope with a sufficient towing capacity.
- Set the towing machine and the towing connection of the equipment being towed in a straight line when connecting it.
- Take up the slack in the wire rope and tow the machine.
- When lifting the machine up, use the towing hook.
- If the machine is stuck in sandy soil, dig out the soil around the towing hook, then use the towing hook to pull the machine out. Permissible load for towing hook: 37,500 kg (367,750 N).
- Do not use a broken (A), kinked (B) or frayed (C) wire rope.

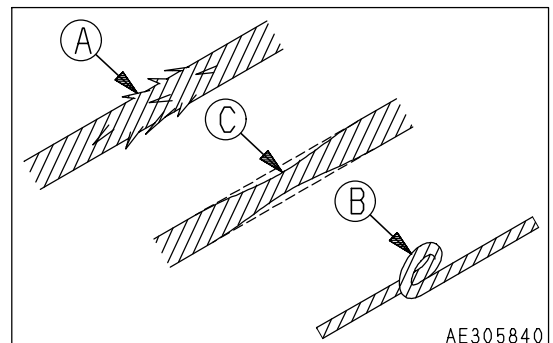
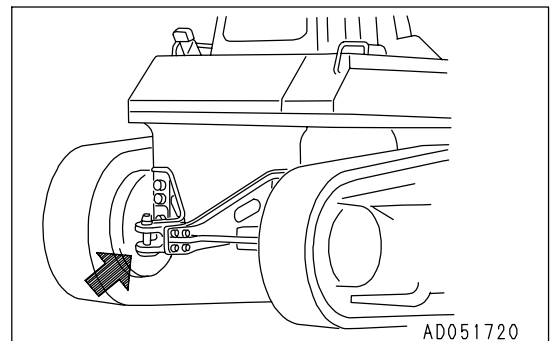
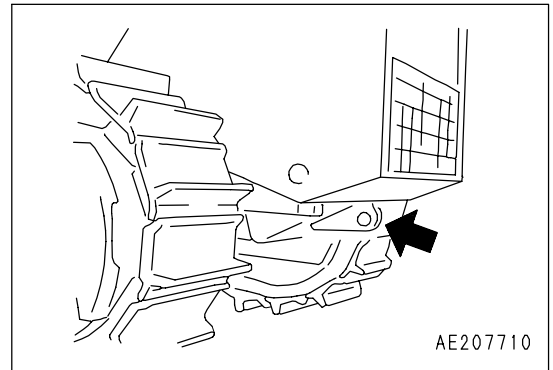

PRECAUTIONS FOR MAINTENANCE

WARNING TAG

- Always attach the "DO NOT OPERATE" warning tag to the work equipment control lever in the operator's cab to alert others that you are performing service or maintenance on the machine. Attach additional warning tags around the machine if necessary. Warning tag Part No. 09963-03001
Keep the tag in the operation manual pocket.
- If others start the engine, or touch or operate the work equipment control lever while you are performing service or maintenance, you could suffer serious injury or property damage.

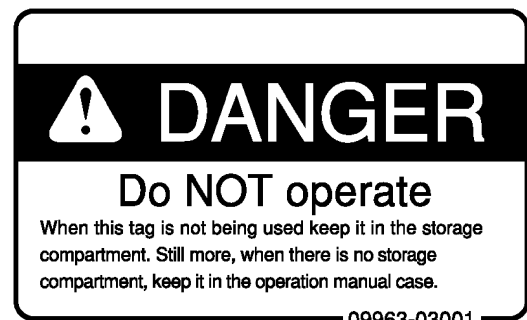
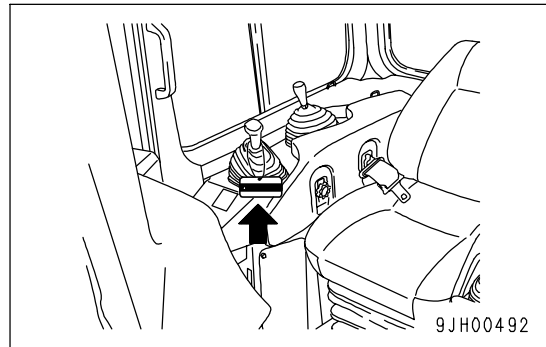

KEEP WORK PLACE CLEAN AND TIDY

- Do not leave hammers or other tools lying around in the work place. Wipe up all grease, oil, or other substances that will cause you to slip. Always keep the work place clean and tidy to enable you to carry out operations safely. If the work place is not kept clean and tidy, there is the danger that you will trip, slip, or fall over and injure yourself.

APPOINT LEADER WHEN WORKING WITH OTHERS

- When repairing the machine or when removing and installing the work equipment, appoint a leader and follow his instructions during the operation.

STOP ENGINE BEFORE CARRYING OUT INSPECTION AND MAINTENANCE

- Stop the machine on firm, level ground.
- Select a place where there is no hazard of landslides, falling rocks, or flooding.
- Lower the work equipment completely to the ground and stop the engine.

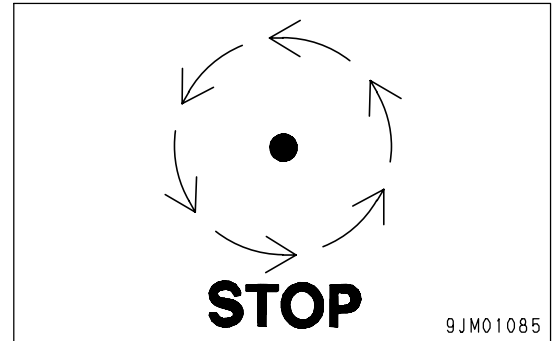

- After stopping the engine, operate the work equipment control lever to the RAISE and LOWER positions 2 or 3 times to release the pressure remaining in the hydraulic circuit, then set the work equipment lock lever and Parking brake lever to LOCK position (L).

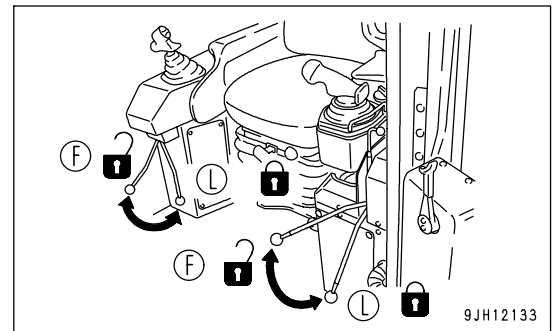

- Check that the battery relay is off and main power is not conducted. (Wait for approx. one minute after turning off the engine starting switch key and press the horn switch. If the horn does not sound, it is not activated.)
- Put blocks (1) under the track to prevent the machine from moving.

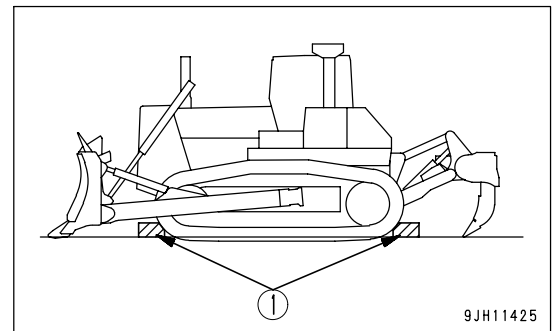

TWO WORKERS FOR MAINTENANCE WHEN ENGINE IS RUNNING

To prevent personal injury, do not carry out maintenance with the engine running. If maintenance must be carried out with the engine running, carry out the operation with at least two workers and do as follows.

- One worker must always sit in the operator’s seat and be ready to stop the engine at any time. All workers must maintain contact with the other workers.
- Place the parking brake lever and work equipment lock lever at the LOCK position (L) to prevent the work equipment from moving.
- Do not touch any control levers. If any control lever must be operated, give a signal to the other workers to warn them to move to a safe place.

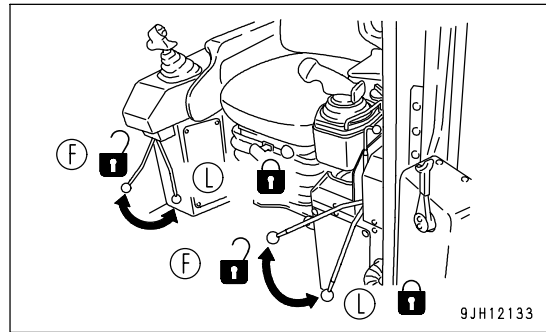

- When carrying out operations near the fan, fan belt, or other rotating parts, there is a hazard of being caught in the parts, so be careful not to come close.
- Never drop or insert tools or other objects into the fan or fan belt. Parts may break or be sent flying.

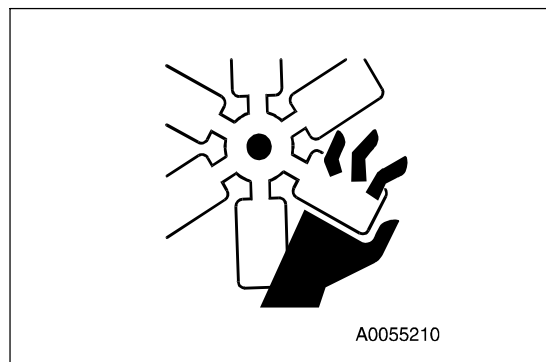

PROPER TOOLS

Use only tools suited to the task and be sure to use the tools correctly. Using damaged, low quality, faulty, makeshift tools or improper use of the tools could cause serious personal injury.

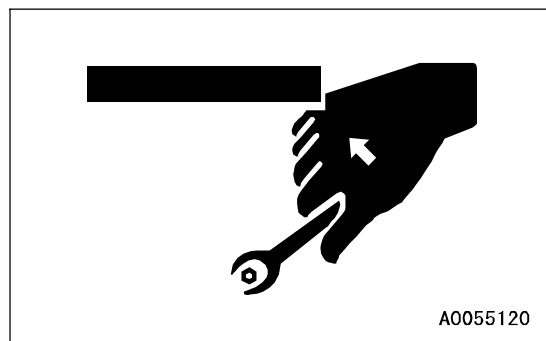

HANDLING ACCUMULATOR

- On machines equipped with an accumulator, for a short time after the engine is stopped, if the blade control lever is moved to the LOWER position, the work equipment will move down under its own weight.

After stopping the engine, always place the work equipment lock lever and parking lever in the LOCK position.

- When releasing the pressure inside the work equipment circuit on machines equipped with an accumulator, follow the procedure given in the following section.

Method of releasing pressure : See "ACCUMULATOR, HANDLING (PAGE 3-70)".

The accumulator is charged with high-pressure nitrogen gas. When handling the accumulator, careless procedure may cause an explosion which could lead to serious injury or property damage. For this reason, always observe the following precautions.

- Do not disassemble the accumulator.
- Do not bring it near flame or dispose of it in fire.
- Do not make holes in it, weld it, or use a cutting torch.
- Do not hit or roll the accumulator, or subject it to any impact.
- When disposing of the accumulator, the gas must be released.

Please contact your Komatsu distributor to have this work performed.



PERSONNEL

Do not allow any unauthorized personnel into the area when servicing the machine. If necessary, employ a guard.

ATTACHMENTS

- Appoint a leader before starting removal or installation operations for attachments.
- Place attachments that have been removed from the machine in a stable condition so that they do not fall. And take steps to prevent unauthorized persons from entering the storage area.



WORK UNDER THE MACHINE

- If it is necessary to go under the work equipment or the machine to carry out service and maintenance, support the work equipment and machine securely with blocks and stands strong enough to support the weight of the work equipment and machine.
- It is extremely dangerous to work under the machine if the track shoes are lifted off the ground and the machine is supported only with the work equipment. If any of the control levers is touched by accident, or there is damage occurring to the hydraulic piping, the work equipment or the machine will suddenly drop. This is extremely dangerous. Never work under the work equipment or the machine.

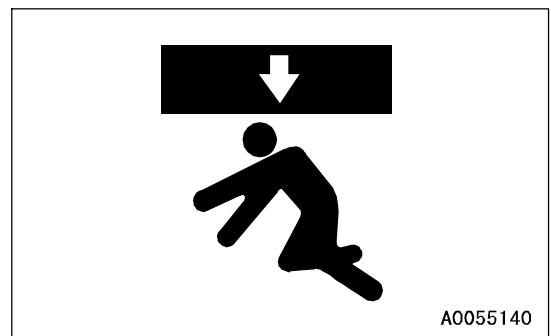

NOISE

When carrying out maintenance of the engine and you are exposed to noise for long periods of time, wear ear covers or ear plugs while working.

If the noise from the machine is too loud, it may cause temporary or permanent hearing problems.

PRECAUTIONS WHEN USING HAMMER

When using a hammer, pins may fly out or metal particles may be scattered. This may lead to serious injury. Always do as follows.

- If hard metal parts such as pins, bucket teeth, cutting edges, or bearings are hit with a hammer, there is a hazard that pieces might be scattered and cause serious personal injury. Always wear safety glasses and gloves.
- When hitting pins or bucket teeth, there is a hazard that broken pieces might be sent flying and injure people in the surrounding area. Always check that there is no one in the surrounding area.

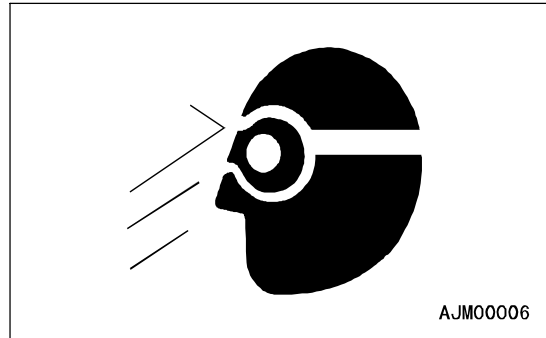

- There is a hazard that the pin hit with strong force may fly out and injure people in the surrounding area.

REPAIR WELDING

Welding operations must always be carried out by a qualified welder and in a place equipped with proper equipment. There is a hazard of gas, fire, or electrocution when carrying out welding, so never allow any unqualified personnel to carry out welding.

REMOVING BATTERY TERMINAL

When repairing the electrical system or when carrying out electrical welding, remove the negative (-) terminal of the battery to prevent the flow of current.

PRECAUTIONS WHEN USING HIGH-PRESSURE GREASE TO ADJUST TRACK TENSION

- Grease is pumped into the track tension adjustment system under high pressure. If the specified procedure for maintenance is not followed when making adjustment, grease drain valve (1) may fly out and cause serious injury or damage.
- When loosening grease drain valve (1) to loosen track tension, never loosen it more than one turn. In doing so, loosen the valve slowly.
- Never put your face, hands, feet, or any other part of your body directly in front of grease drain valve (1).

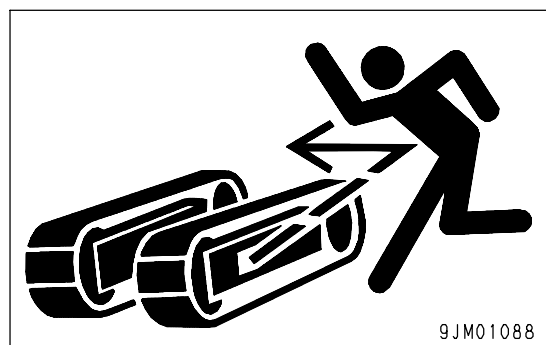
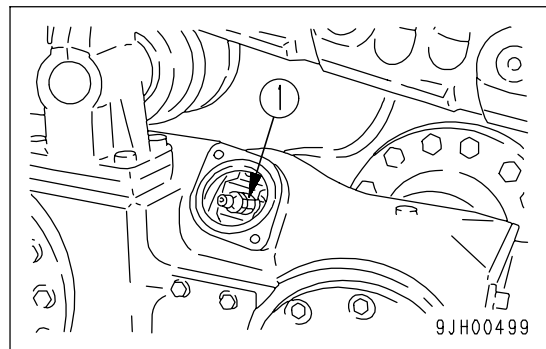

DO NOT DISASSEMBLE RECOIL SPRING

Never attempt to disassemble the recoils spring assembly. It contains a spring under high pressure which serves as a shock absorber for the idler. If it is disassembled by mistake, the spring will fly out and cause serious injury. When it becomes necessary to disassemble it, ask your Komatsu distributor to do the work.

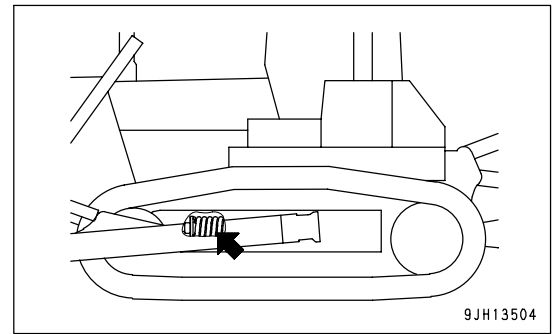
**PRECAUTION WITH HIGH-PRESSURE OIL**

The hydraulic system is always under internal pressure. When inspecting or replacing piping or hoses, always check that the pressure in the hydraulic circuit has been released. If the circuit is still under pressure, it will lead to serious personal injury, so always do as follows.

- Do not carry out inspection or replacement work when the hydraulic system is under pressure.
- If there is any leakage from the piping or hoses, the surrounding area will be wet, so check for cracks in the piping and hoses and for swelling in the hoses.

When carry out inspection, wear safety glasses and leather gloves.

- There is a hazard that high-pressure oil leaking from small holes may penetrate your skin or cause blindness if it contacts your eyes directly. If you are hit by a jet of high-pressure oil and suffer injury to your skin or eyes, wash the place with clean water, and consult a doctor immediately for medical attention.

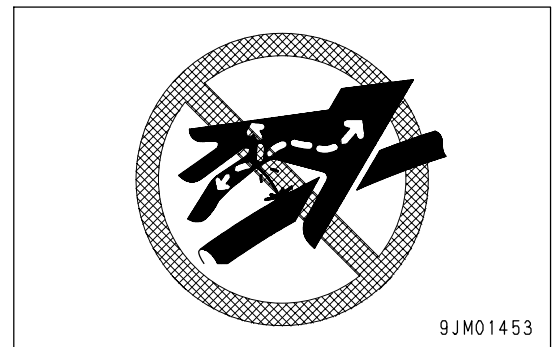
**PRECAUTION FOR HIGH FUEL PRESSURE**

When the engine is running, high-pressure is generated in the engine fuel piping. When carrying out inspection or maintenance of the fuel piping system, stop the engine and wait for at least 30 seconds to allow the internal pressure to go down before starting the operation.

HANDLING HIGH-PRESSURE HOSES

- If oil or fuel leaks from high-pressure hoses, it may cause fire or defective operation, which may lead to serious injury. If any loose bolts are found, stop work and tighten to the specified torque. If any damaged hoses are found, stop operations immediately and contact your Komatsu distributor.

Replace the hose if any of the following problems are found.

- Damaged or leaking hydraulic fitting.
- Frayed or cut covering or exposed reinforcement wire layer.
- Covering swollen in places.
- Twisted or crushed movable portion.
- Foreign material embedded in covering.

PRECAUTION FOR HIGH VOLTAGE

- When the engine is running and immediately after it is stopped, high voltage is generated inside the engine controller and the engine injector, and there is danger of electrocution. Never touch the inside of the controller or the engine injector portion.

If it is necessary to touch the inside of the controller or the engine injector portion, please contact your Komatsu distributor.

WASTE MATERIAL

To prevent pollution, pay careful attention to the method of disposing of waste materials.

- Always put oil drained from your machine in containers. Never drain oil directly onto the ground or dump into the sewage system, rivers, the sea, or lakes.
- Obey appropriate laws and regulations when disposing of harmful objects such as oil, fuel, coolant, solvent, filters, and batteries.

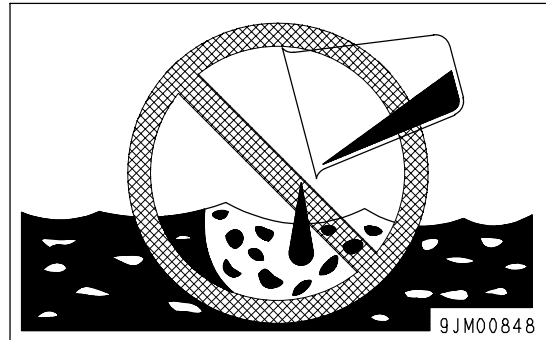
**MAINTENANCE FOR AIR CONDITIONER**

If air conditioner refrigerant gets into your eyes, it may cause blindness; if it touches your skin, it may cause frostbite. Never touch refrigerant.

COMPRESSED AIR

- When carrying out cleaning with compressed air, there is a hazard of serious injury caused by flying particles.
- When using compressed air to clean elements or the radiator, always wear safety glasses, dust mask, gloves, and other protective equipment.

PERIODIC REPLACEMENT OF SAFETY CRITICAL PARTS

- For using the machine safely for an extended period of time, replace safety-critical parts like hoses and seat belts periodically.

Replacement of safety-critical parts: See "PERIODIC REPLACEMENT OF SAFETY CRITICAL PARTS (PAGE 4-14)".

- The material of these components naturally changes over time, and repeated use causes deterioration, wear, and fatigue. As a result, there is a hazard that these components may fail and cause serious injury or death. It is difficult to judge the remaining life of these components from external inspection or the feeling when operating, so always replace them at the specified interval.
- Replace or repair safety-critical parts if any defect is found, even when they have not reached the specified replacement time.

OPERATION

WARNING

Please read and make sure that you understand the SAFETY section before reading this section.

GENERAL VIEW

GENERAL VIEW OF MACHINE

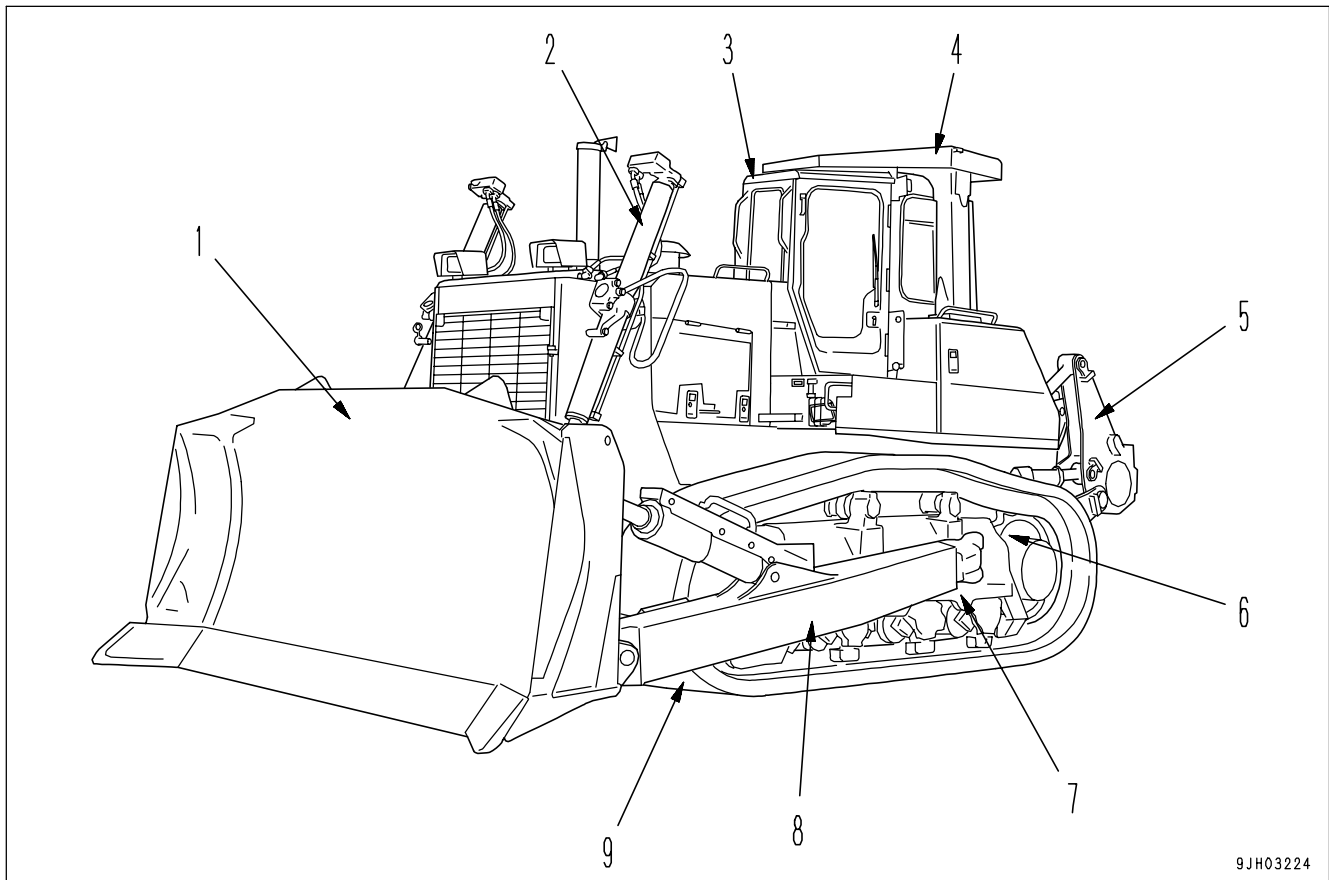

- (1) Blade
- (2) Blade lift cylinder
- (3) Cab
- (4) ROPS
- (5) Ripper

- (6) Sprocket
- (7) Track frame
- (8) Frame
- (9) Track shoe

GENERAL VIEW OF CONTROLS AND GAUGES

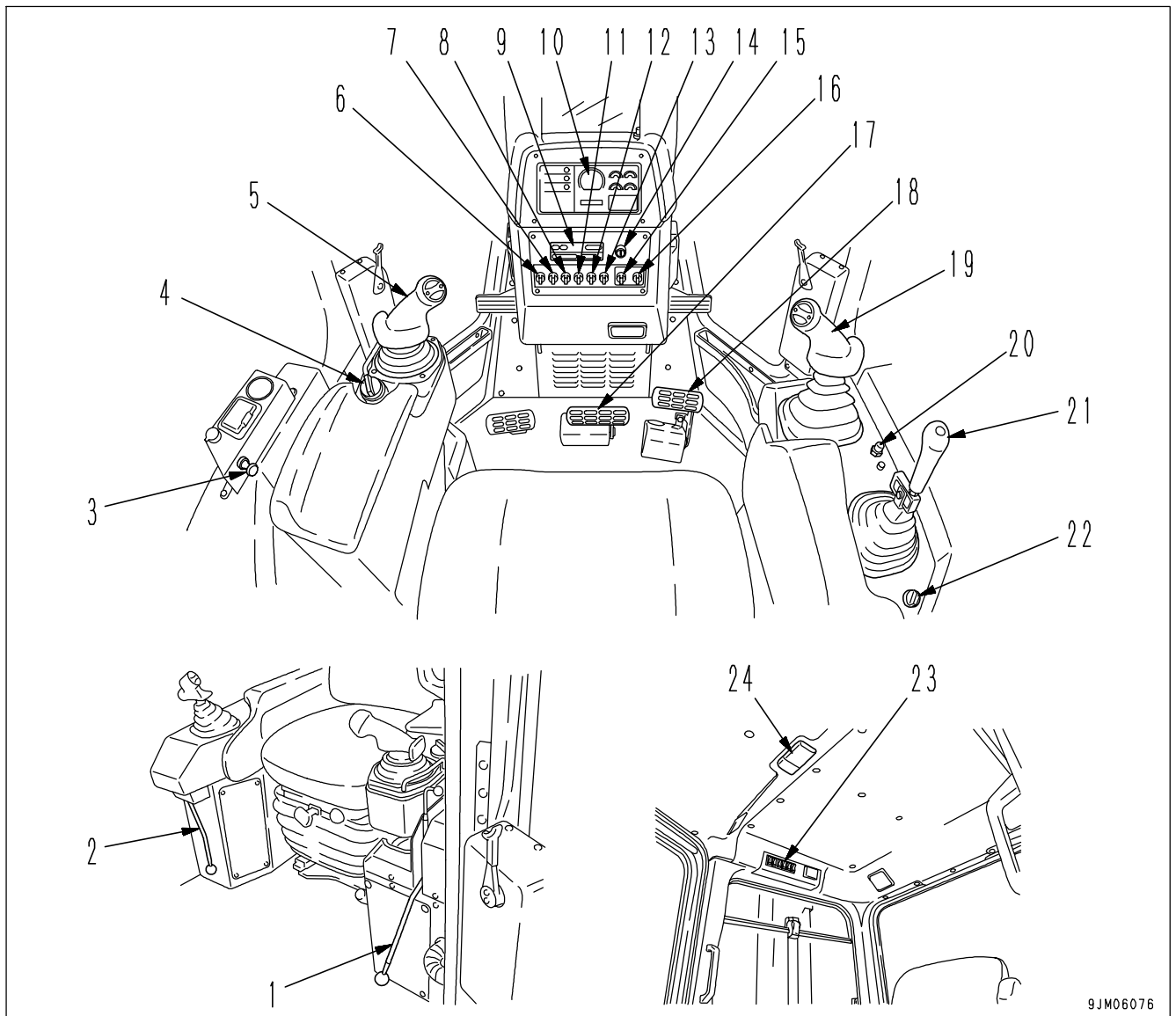

9JM06076

- | | |
|---|--|
| (1) Parking lever | (13) Pivot turn switch |
| (2) Work equipment lock lever | (14) Starting switch |
| (3) Cigarette lighter | (15) Information switch |
| (4) Fuel control dial | (16) Buzzer cancel switch |
| (5) Joystick (Steering, directional and gear shift lever) | (17) Brake pedal |
| (6) Additional heater switch (if equipped) | (18) Deceleration pedal |
| (7) Front lamp, working lamp switch | (19) Blade control lever |
| (8) Rear lamp switch | (20) Horn switch |
| (9) Air conditioner panel or heater panel | (21) Ripper control lever |
| (10) Display panel A
(Speed range display, Engine speed) | (22) Pin puller control switch (if equipped) |
| (11) Auto shift down switch | (23) Wiper switch |
| (12) Fan rotation selector switch | (24) Room lamp switch |

FRONT PANEL

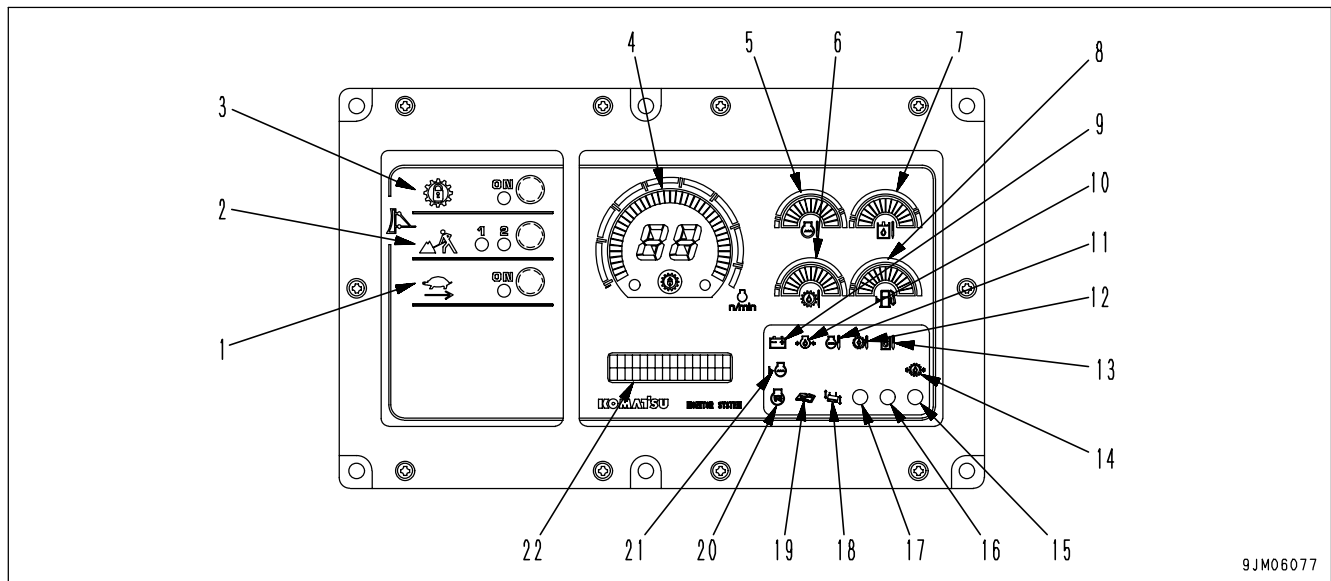

9JM06077

- | | |
|---|---|
| (1) Reverse slow mode selector switch | (12) Power train oil temperature caution lamp |
| (2) Economy mode switch | (13) Hydraulic oil temperature caution lamp |
| (3) Lock up mode switch | (14) HSS charge pressure caution lamp |
| (4) Display panel A (Speed range, Engine speed) | (15) Fan operation confirmation lamp |
| (5) Engine coolant temperature gauge | (16) Filter/oil change interval lamp |
| (6) Power train oil temperature gauge | (17) Warning lamp |
| (7) Hydraulic oil temperature gauge | (18) Dual/single tilt selector display lamp |
| (8) Fuel level gauge | (19) Maintenance caution lamp |
| (9) Charge level caution lamp | (20) Engine pre-heating pilot lamp |
| (10) Engine oil pressure caution lamp | (21) Radiator coolant level caution lamp |
| (11) Engine coolant temperature caution lamp | (22) Display panel B (Multi-information) |

EXPLANATION OF COMPONENTS

The following is an explanation of devices needed for operating the machine.

To perform suitable operations correctly and safely, it is important to completely understand methods of operating the equipment, and the meanings of the displays.

FRONT PANEL

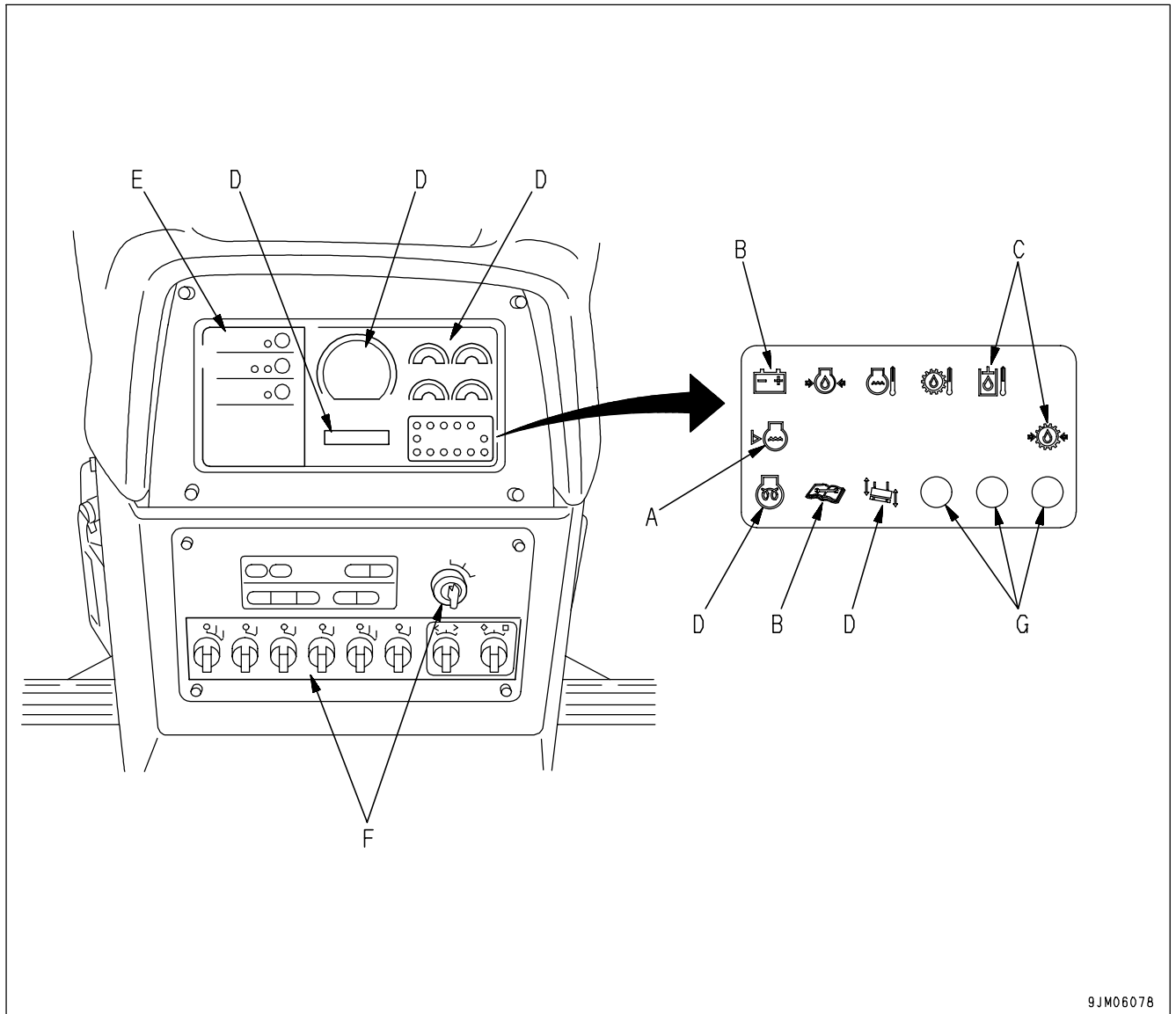

9JM06078

- | | |
|-----------------------------|---------------------------------|
| (A) Check monitor group | (E) Mode selection switch group |
| (B) Caution monitor group | (F) Switches |
| (C) Emergency caution items | (G) Lamps |
| (D) Meter group | |

A: Check monitor group (for details, see "CHECK MONITOR GROUP (PAGE 3-7)")

Before the engine is started, the basic items among the check before starting items that must be checked are displayed.

If there is any abnormality, the caution lamp for the location of the abnormality flashes.

NOTICE

When carrying out checks before starting, do not simply rely on the monitor. Always refer to the periodic maintenance items or "OPERATION (PAGE 3-71)" to carry out the checks.

B: Caution monitor group (See "CAUTION MONITOR GROUP (PAGE 3-9)")



If the caution lamp for any of these items flashes, check and repair the appropriate item as soon as possible.

These are items which need to be observed when the engine is running. If any problem occurs, the item needing immediate repair is displayed. If there is any problem, the problem location on the caution lamp will flash.

C: Emergency caution items (for details, see "EMERGENCY CAUTION ITEMS (PAGE 3-11)")



If the caution lamp for any of these items flashes, stop the engine immediately or run it at low idling, and take the following action.

This displays the abnormal items that action must be taken on immediately the engine is running.

If there is any abnormality, the monitor showing the location of the abnormality will flash and the alarm buzzer will sound.

D: Meter display portion (see METER GROUP (PAGE 3-14))

This consists of the preheating pilot lamp, power train oil temperature gauge, engine water temperature gauge, hydraulic oil temperature gauge, fuel gauge, dual/single selector display lamp, torque converter lock-up display lamp, display panel A (speed range display, engine speed) and display panel B (multi-information).

E: Mode selection switch group (see "MODE SELECTION SWITCH GROUP (PAGE 3-19)")

This consists of the lock-up mode switch, economy mode selector switch, shoe slip control switch, rockbed selection mode selector switch, and slow reverse mode selector switch.

F Switches (for details, see "SWITCHES (PAGE 3-21)")

These consist of the starting switch, buzzer cancel switch, head lamp, working lamp switch, rear lamp switch, auto shift down switch, pivot turn switch, information switch, Fan rotation selector switch, additional heater switch (if equipped).

G Lamps (for details, see "FUSE CAPACITY AND NAME OF CIRCUIT (PAGE 3-52)")

These consist of the warning lamp, filter, oil change interval lamp, Fan operation confirmation lamp.

CHECK MONITOR GROUP

NOTICE

- When performing the check before starting, do not rely only on these monitors. Always refer to "OPERATION (PAGE 3-71)" to perform these checks.
- Park the machine on level ground and then check the monitor lamps.
- Confirm that monitor lamps light up about 2 seconds after the starting switch is turned to the ON position. If any monitor lamp does not light, contact your Komatsu distributor to inspect and repair.

REMARK

- When the starting switch is turned to the ON position, before starting the engine, the caution lamps flash for 2 seconds, the warning lamps light up for 2 seconds, and the alarm buzzer sounds for 2 seconds.
- The caution lamps cannot be checked for any malfunction until at least 5 seconds after the engine has been stopped.

This displays the basic items among the check before starting items that must be checked before starting the engine. If there is any abnormality, the caution lamp for that location will flash.

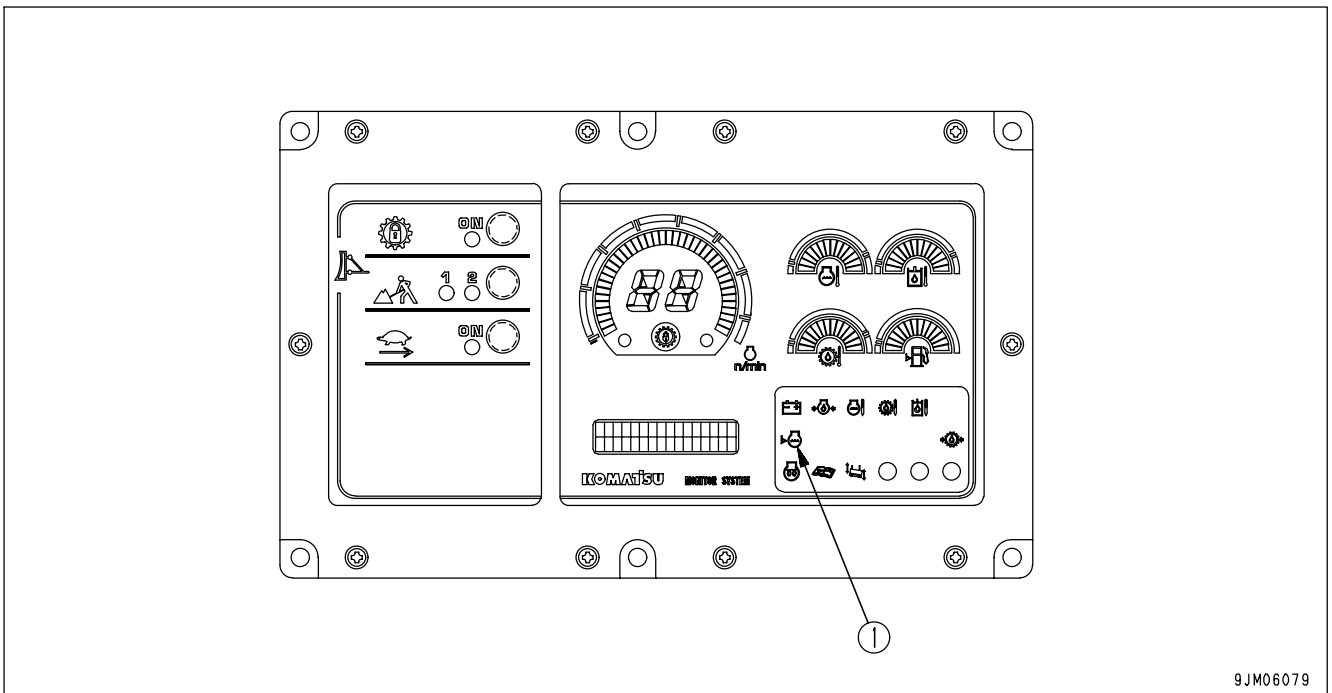

- (1) Radiator coolant level caution lamp

RADIATOR COOLANT LEVEL CAUTION LAMP

Lamp (1) warns the operator that the coolant level in the main and sub radiators has gone down.

If the lamp flashes, check the coolant level in the main and sub radiators, and add coolant.

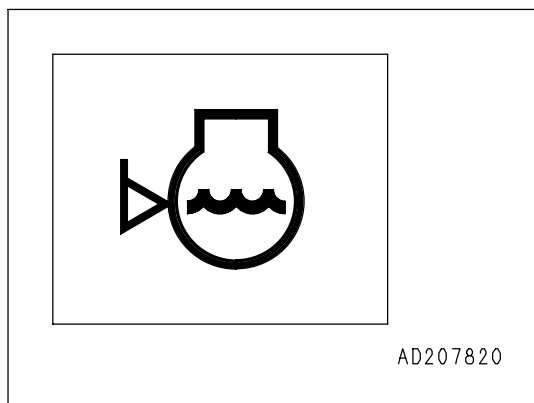

CAUTION MONITOR GROUP



If these caution lamps flash, check and repair the appropriate location as soon as possible.

NOTICE

- Park the machine on level ground and check the monitor lamps.
- Confirm that monitor lamps light up about 2 seconds after the starting switch is turned to the ON position. If any monitor lamp does not light, contact your Komatsu distributor to inspect and repair.

These are items which need to be observed when the engine is running. If any problem occurs, the item needing immediate repair is displayed. If there is any problem, the problem location on the caution lamp will flash.

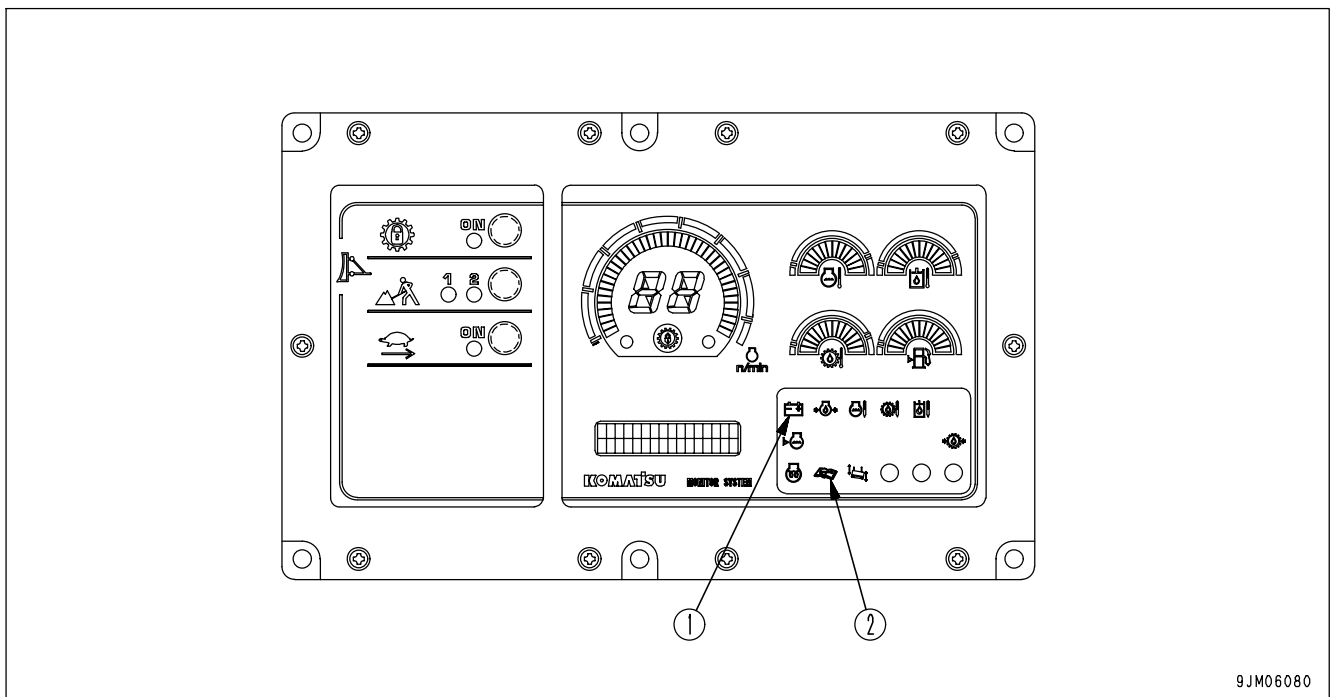

(1) Charge level caution lamp

(2) Maintenance caution lamp

CHARGE LEVEL CAUTION LAMP

Lamp (1) indicates an abnormality in the charging system while the engine is running.

If the monitor lamp flashes, check the V-belt tension. If any abnormality is found, see "OTHER TROUBLE (PAGE 3-149)".

REMARK

This monitor lamp lights when the starting switch is turned to ON immediately after the engine is started or immediately before the engine is stopped. It does not indicate a problem.

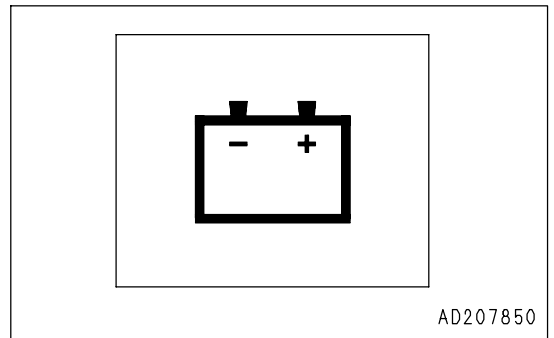

MAINTENANCE CAUTION LAMP

Monitor (2) flashes when the filter or oil change interval has been reached. DISPLAY PANEL B (Multi-information) (PAGE 3-18) to the maintenance mode and check or replace the applicable filter or oil.

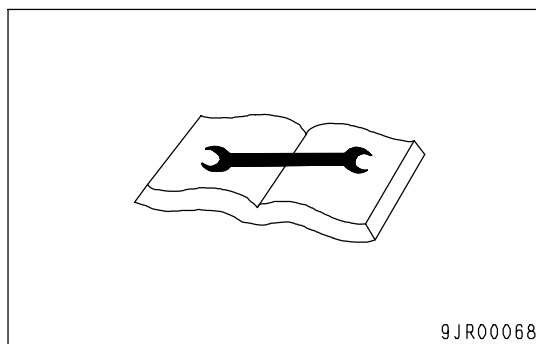

EMERGENCY CAUTION ITEMS

**CAUTION**

If the caution lamp for any of these items flashes, stop the engine immediately or run it at low idling, and take the following action.

NOTICE

- Park the machine on level ground and check the monitor lamps.
- Confirm that these caution lamps light for about 3 seconds after the starting switch is turned to ON. If any monitor lamp does not light, have your Komatsu distributor inspect and repair it.

These items need to be observed while the engine is running. If any abnormality occurs, items that need to be repaired immediately are displayed.

If there is any abnormality, alarm buzzer sounds intermittently and the abnormal location on the caution lamp will flash.

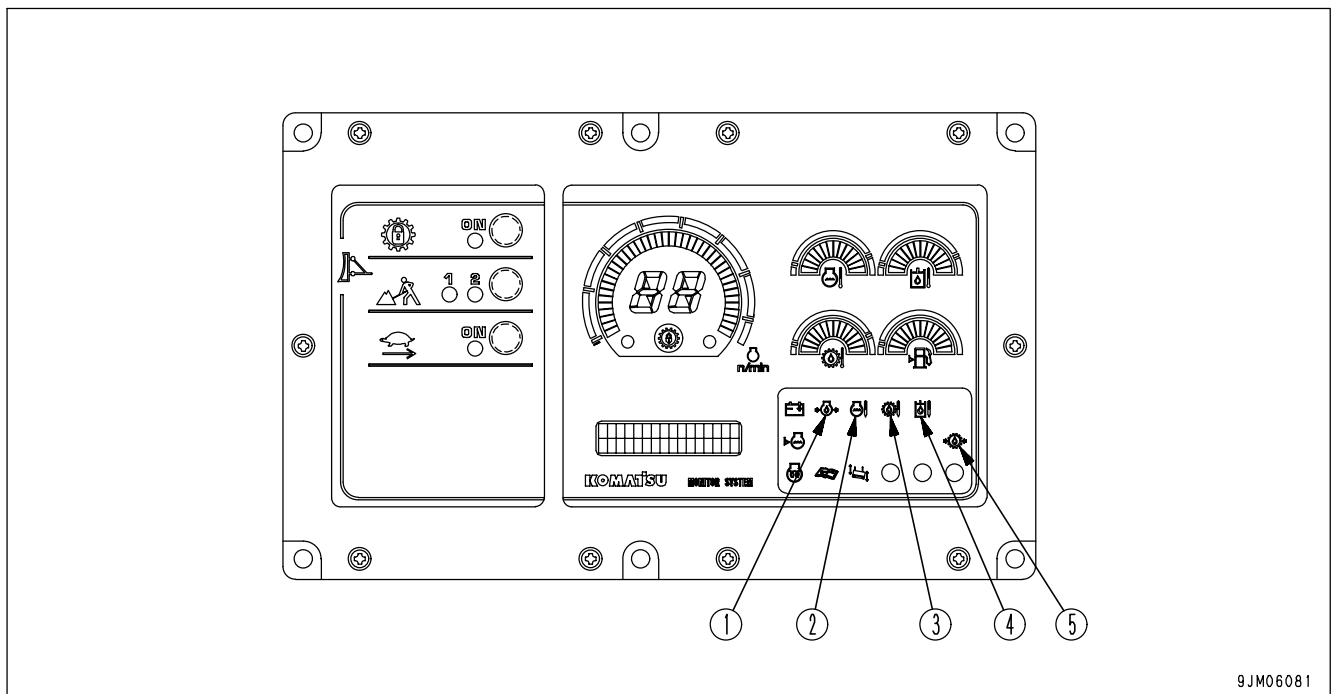

9JM06081

- | | |
|--|--|
| (1) Engine oil pressure caution lamp | (4) Hydraulic oil temperature caution lamp |
| (2) Engine coolant temperature caution lamp | (5) HSS charge pressure caution lamp |
| (3) Power train oil temperature caution lamp | |

ENGINE OIL PRESSURE CAUTION LAMP

This lamp (1) indicates low engine oil pressure.

If the monitor lamp flashes, stop the engine and check it immediately.

REMARK

The alarm buzzer sounds, when the starting switch is turned to ON immediately after the engine oil has been changed. It does not indicate a problem.

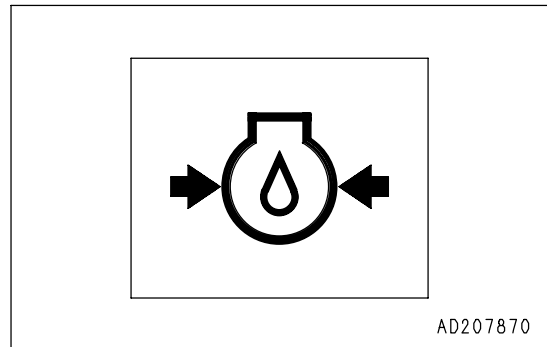
**ENGINE COOLANT TEMPERATURE CAUTION LAMP**

This lamp (2) indicates a rise in the coolant temperature.

When the monitor lamp flashes, run the engine at low idle speed until green range of the engine coolant temperature gauge lights.

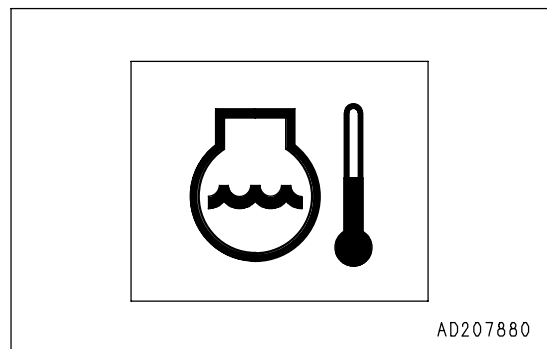
**POWER TRAIN OIL TEMPERATURE CAUTION LAMP**

Lamp (3) warns operator that the torque converter outlet port oil temperature has risen.

If it flashes, run the engine at low idling until the power train oil temperature gauge goes down to the green range.

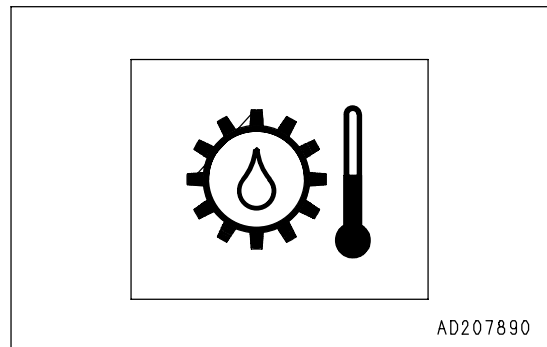
**HYDRAULIC OIL TEMPERATURE CAUTION LAMP**

Lamp (4) indicates a rise in the hydraulic oil temperature.

When the monitor lamp flashes, stop the machine and run the engine at the low idling speed until oil temperature falls.

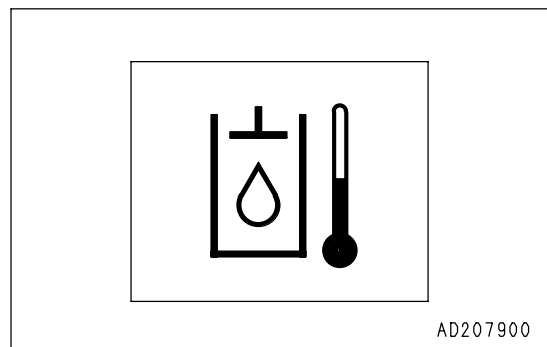

HSS CHARGE PRESSURE CAUTION LAMP

This monitor (5) warns the operator that the HSS charge pressure has dropped. If it flashes, stop the engine and carry out inspection.

REMARK

The buzzer may also sound, but this is not an abnormality.

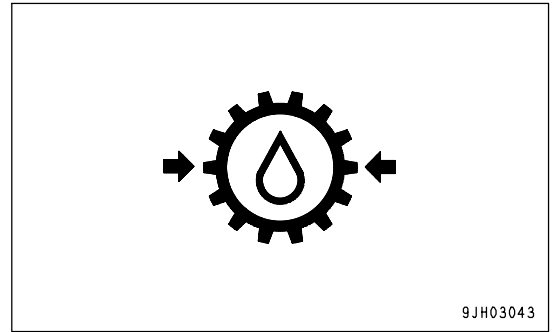

METER GROUP

NOTICE

While the engine is at rest, turn the starting switch to the ON position to see if the engine coolant temperature gauge, power train oil temperature gauge, fuel level gauge, and monitor lamps all light up.

If they do not, have your Komatsu distributor inspect and repair it.

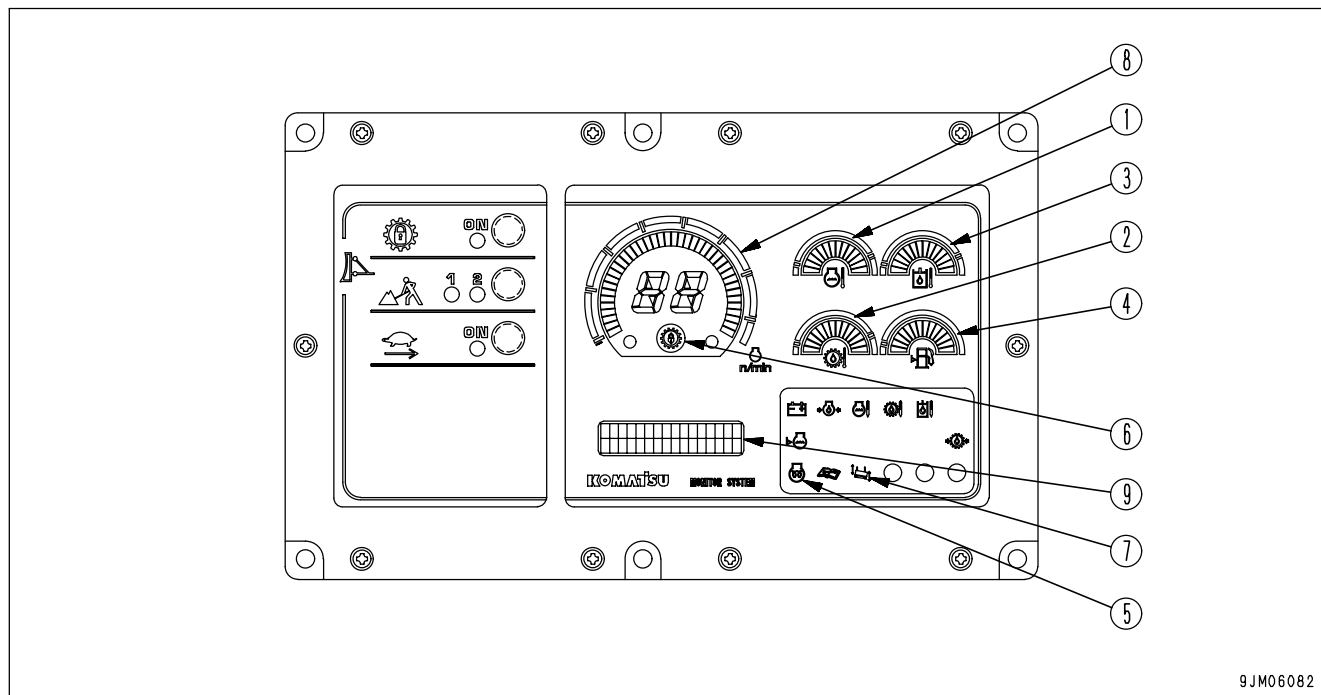

9JM06082

- | | |
|---|---|
| (1) Engine coolant temperature gauge | (7) Dual/single tilt selector display lamp
(Dual tilt dozer specification) |
| (2) Power train oil temperature gauge | (8) Display panel A
(Speed range display, Engine speed) |
| (3) Hydraulic oil temperature gauge | (9) Display panel B (Multi-information) |
| (4) Fuel level gauge | |
| (5) Engine pre-heating pilot lamp | |
| (6) Torque converter lock up pilot lamp | |

ENGINE COOLANT TEMPERATURE GAUGE

Gauge (1) indicates temperature of the engine coolant.

If the temperature is normal during operation, green range (B) will light.

If red range (C) lights during operation, move the fuel control dial to lower engine speed to approx. 3/4 of the full speed, and run until the coolant temperature enters green range (B).

During operation, if red range (C) lights, engine coolant temperature monitor flashes and the alarm buzzer sounds, stop the machine and run at low idle until coolant temperature enters green range (B).

(A): White range

(B): Green range

(C): Red range

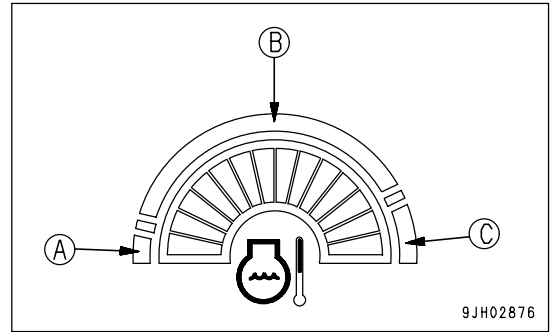
**NOTICE**

If the coolant temperature gauge often enters red range (C), check the radiator for clogging.

POWER TRAIN OIL TEMPERATURE GAUGE

Gauge (2) indicates the torque converter outlet oil temperature.

If the temperature is normal during operation, green range (B) will light.

If red range (C) lights up during operation, move the fuel control dial to lower engine speed to approx. 3/4 of the full speed, reduce the load and run until the oil temperature enters green range (B).

If red range (C) lights up, the power train oil temperature caution lamp flashes and the alarm buzzer sounds during operations, stop the machine, and run the engine at low idling until the oil temperature goes down to green range (B).

(A): White range

(B): Green range

(C): Red range

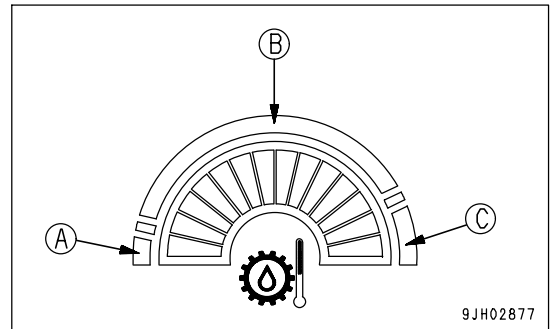
**NOTICE**

If the power train oil temperature gauge often enters red range (C), shift down one speed range to reduce the load on the power train when operating.

HYDRAULIC OIL TEMPERATURE GAUGE

Gauge (3) indicates the hydraulic oil temperature.

If the temperature is normal during operation, green range (B) will light.

If red range (C) lights up during operation, move the fuel control dial to lower engine speed to approx. 3/4 of the full speed, reduce the load and run until the oil temperature enters green range (B).

- (A): White range
- (B): Green range
- (C): Red range

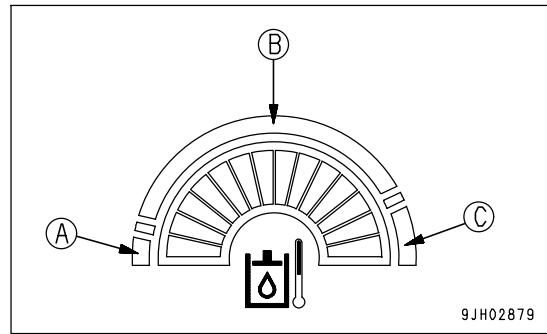
**FUEL LEVEL GAUGE**

Gauge (4) fuel level in the fuel tank.

During normal operation, the green range (B) should be lit.

If red range (A) lights up during operation, add fuel immediately. If this is not done, the engine speed will become irregular or an error display will be shown on the monitor.

- (A): Red range
- (B): Green range

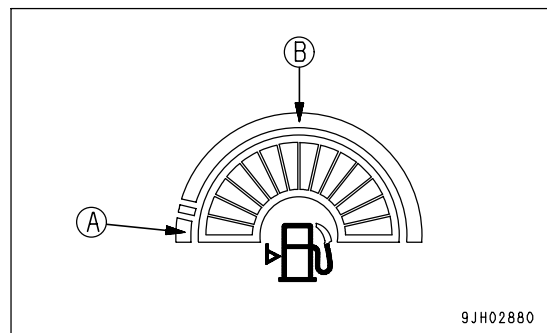
**REMARK**

- The display is not proportional to the amount of fuel remaining.
- If only the red range (A) lights up, there is less than 90 liters (23.78 US gal) of fuel remaining.

ENGINE PRE-HEATING PILOT LAMP

Lamp (5) indicates that engine is being pre-heated by the electrical heater during cold weather.

The engine controller detects the coolant temperature and automatically actuates pre-heating in low temperatures when starting the engine.

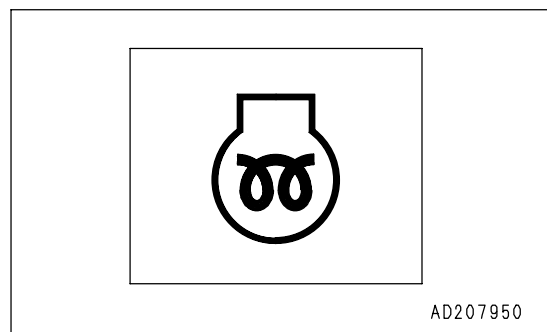

TORQUE CONVERTER LOCK UP PILOT LAMP

Lamp (6) lights up when the torque converter has been automatically locked up (when transmission is set to direct drive) after lock up switch for the monitor lamp has been turned ON. The lamp goes out when torque converter drive is being used.

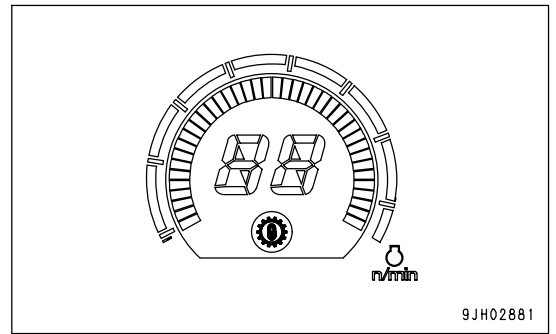

DUAL/SINGLE TILT SELECTOR DISPLAY LAMP

(Dual tilt dozer specification)

Lamp (7) lights green when the dual/single selector switch on the work equipment control lever is set to DUAL.

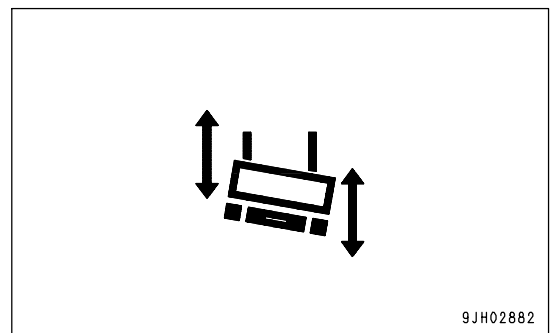

DISPLAY PANEL A (speed range display, engine speed)

Meter (8) displays transmission speed range (B) being used on the machine and engine speed.

- When the transmission is in 1st FORWARD, the display shows F1, and when it is in 1st REVERSE, the display shows R1.
- The peripheral bar graph (A) indicates the engine speed. When the red range (C) lights up during running, shift the gear to a lower speed to run the engine at a speed within the green range.

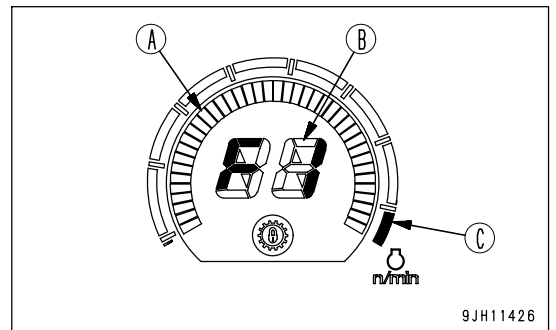

DISPLAY PANEL B (Multi-information)

This monitor (9) displays information related to the condition of the machine on the top and bottom lines of the display portion. The content of the display can be switched by operating the service mode selector switch.

(1) Operating mode (normal operation screen)

Use this mode when operating the machine.

REMARK

When starting switch is turned from the OFF position to the ON position, the multi-information is set to the operating mode.

The shift mode selected by operation of the "GEARSHIFTING USING SHIFT MODE SELECTION (PAGE 3-105)" through the shift mode selection is displayed on the left side of the monitor.

The total operating hours of the machine is displayed at the bottom right of the monitor. (Use the service meter function display to set the interval for periodic maintenance.)

When the engine is running, the service meter advances, even if the machine is not moving.

When the engine is running, the hourglass mark pilot display at the side of the meter lights up to show that the meter is advancing.

The meter advances by 1 for every hour of operation, regardless of the engine speed.

If there is a failure in the machine, the failure code is also displayed on the top line. If a failure code is displayed, carry out the remedy given in "OTHER TROUBLE (PAGE 3-149)".

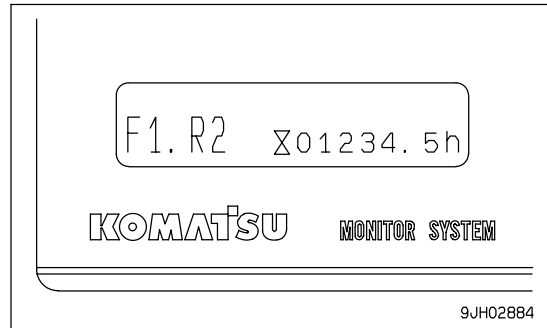

(2) Maintenance mode

The maintenance mode is displayed by continuing to turn the buzzer cancel switch in the ◇ direction for 2.5 seconds.

For details, see "METHOD OF USING DISPLAY PANEL B (Multi-information) (PAGE 3-27)".

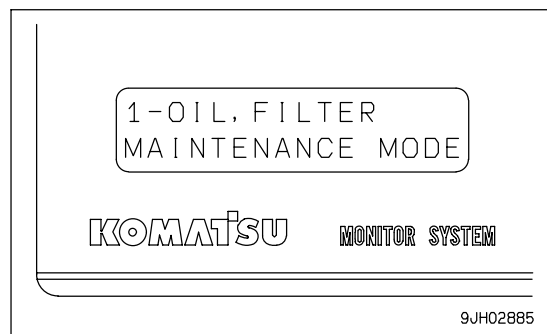

MODE SELECTION SWITCH GROUP

- Press each mode switch to turn it ON or OFF and to select the mode.
- For details of setting the mode to use, see "EFFECTIVE USE OF MODE SELECTION SYSTEM (PAGE 3-119)".
- It is impossible to use any combination of the lock up mode and any other mode.
- The economy mode and reverse slow mode can be used independently or in combination.

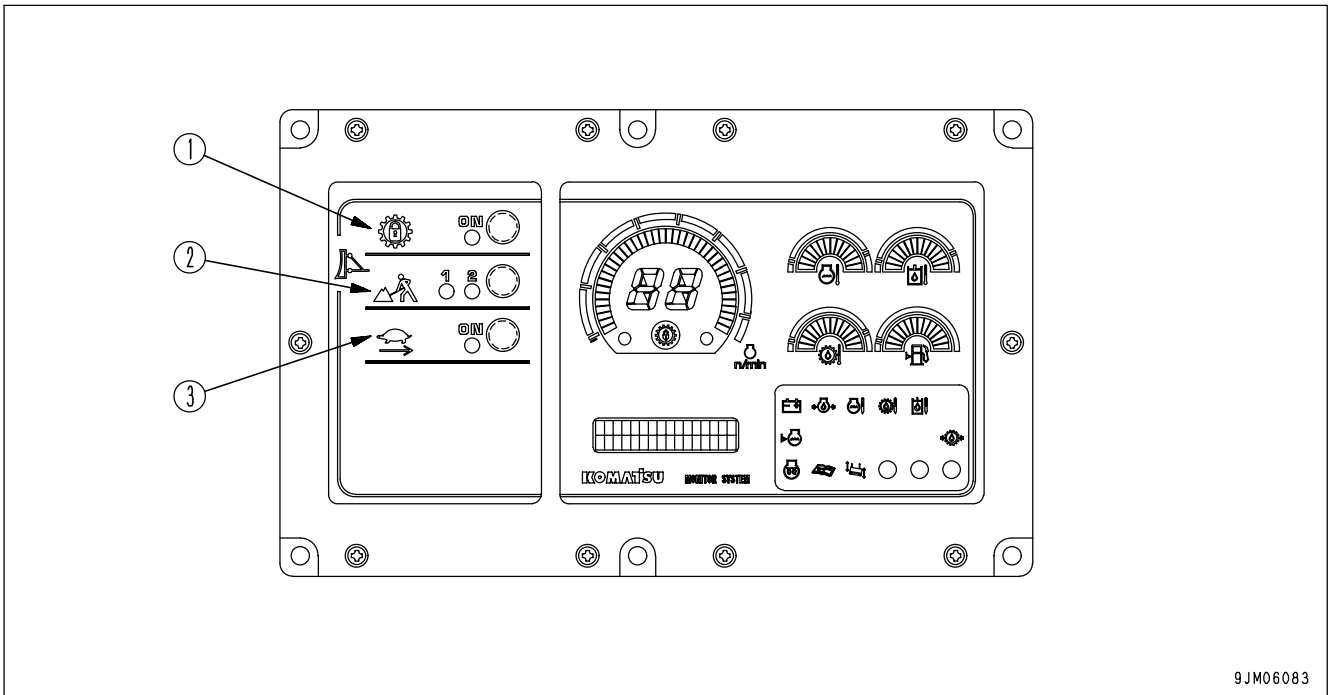

9JM06083

- (1) Lock up mode switch
- (2) Economy mode switch
- (3) Reverse slow mode selector switch

Selecting mode to match the type of work and quality of rock and soil makes to perform operations effectively.

Dozing		Ripping
Lock up mode	Economy mode	Reverse slow mode
○	×	×
×	○	○

○: Possible to use ×: Compound use not possible

LOCK UP MODE SWITCH

Switch (1) is used when more power is needed rather than high production (such as when dozing loose soil).

The drive is switched between torque converter drive and direct drive according to the load. When it is ON, the lamp lights up.

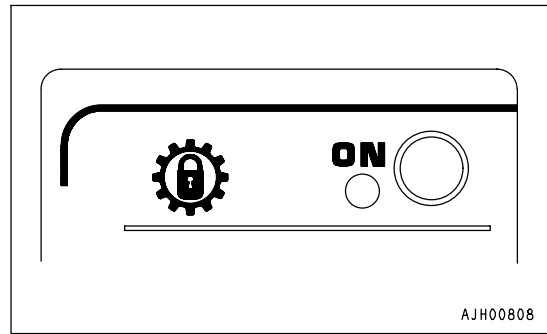
**ECONOMY MODE SWITCH**

Switch (2) is used for hauling work after ripping or for dozing blasted rock.

When the system is OFF, if the switch is pressed once, mode [1] lights up, and if it is pressed again, mode [2] lights up.

Select the mode according to the type of rock.

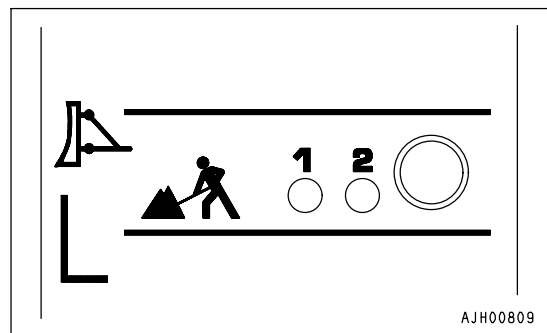
**REVERSE SLOW MODE SELECTOR SWITCH**

Switch (3) is used to make small reductions in the travel speed when traveling in R1, R2, or R3.

When it is turned ON, the lamp lights up.

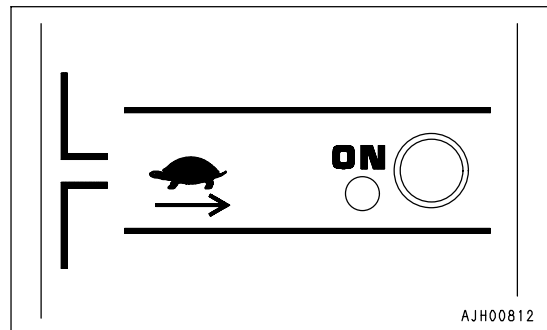

SWITCHES

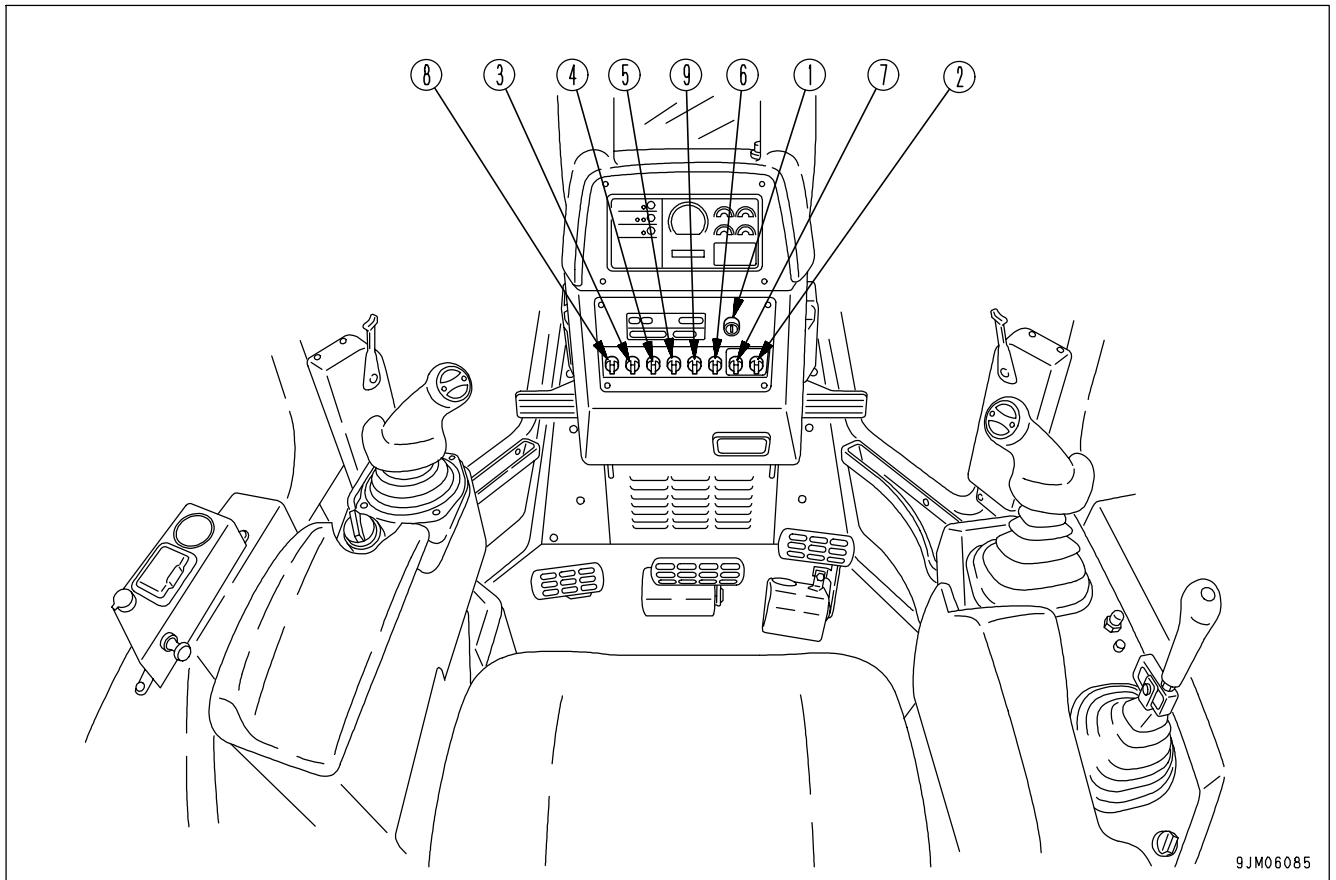

9JM06085

- | | |
|-------------------------------------|--|
| (1) Starting switch | (6) Pivot turn switch |
| (2) Buzzer cancel switch | (7) Information switch |
| (3) Front lamp/ working lamp switch | (8) Additional heater switch (if equipped) |
| (4) Rear lamp switch | (9) Fan rotation selector switch |
| (5) Auto shift down switch | |

STARTING SWITCH

This switch (1) is used to start or stop the engine.

(A): OFF position

At this position, the starting switch key can be inserted and removed. When the switch is turned to this position, all the electric circuits are turned off and the engine stops.

(B): ON position

In this position, electric current flows in the charging and lamp circuits.

Keep the starting switch key at the ON position while the engine is running.

(C): START position

This is the position to start the engine. Hold the key at this position while cranking the engine. Release the key immediately after the engine has been started. The key will return to ON position (B) when released.

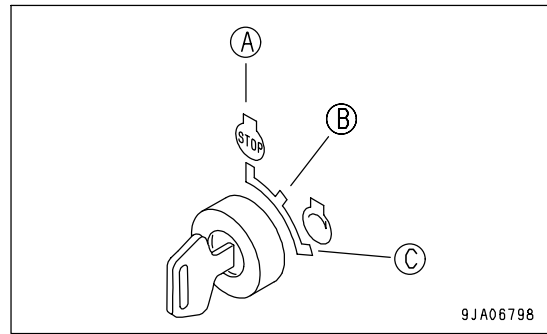
**BUZZER CANCEL SWITCH**

When switch (2) is operated to the left or right, the alarm buzzer stops.

When the information monitor is in the maintenance mode, switch (2) can be operated to move the cursor left or right.

(a) position: Cancel

(c) position: Select

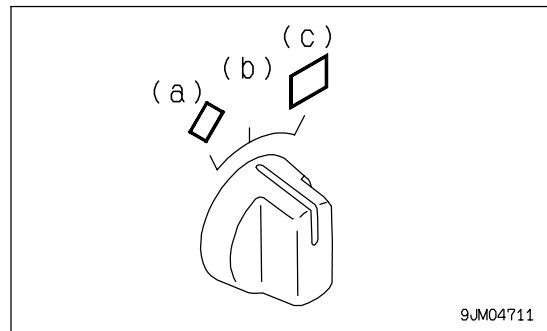
**FRONT LAMP/WORKING LAMP SWITCH**

Switch (3) lights up when the front lamp, left and right working lamps located on the front fender, and panel lamp light up.

(a) OFF position: Goes out

(b) ON position: Lights up

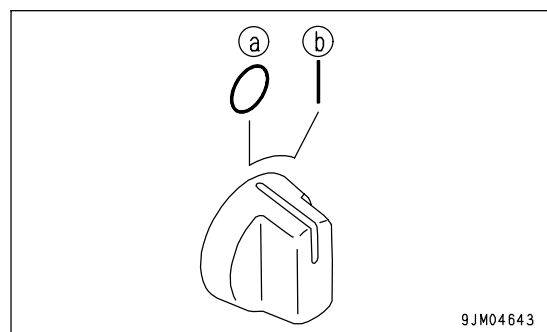

REAR LAMP SWITCH

Switch (4) lights up the rear lamp.

- (a) OFF position: goes off
- (b) ON position: lights up

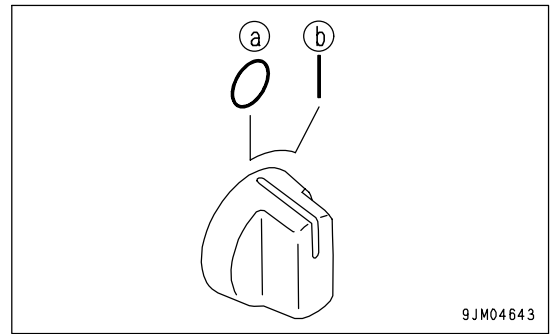

9JM04643

AUTO SHIFT DOWN SWITCH

When this switch (5) is operated to the right, if the travel speed drops because of the load conditions when traveling, the transmission automatically shifts to low speed.

- (a) OFF position: Automatic operation canceled
- (b) ON position: Automatically shifts down to low speed

For details, see "AUTO SHIFT DOWN OPERATION (PAGE 3-106)".

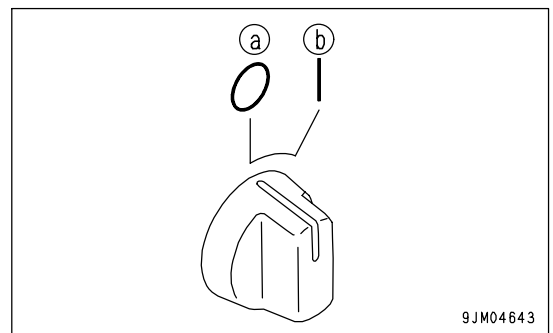

9JM04643

PIVOT TURN SWITCH

This switch (6) makes it possible to carry out pivot turns.

- OFF (a) position: Pivot turns cannot be carried out
- ON (b) position: Pivot turns can be carried out

For details, see "MAKING SHARP TURNS TO LEFT WHILE TRAVELING FORWARD (PAGE 3-110)".

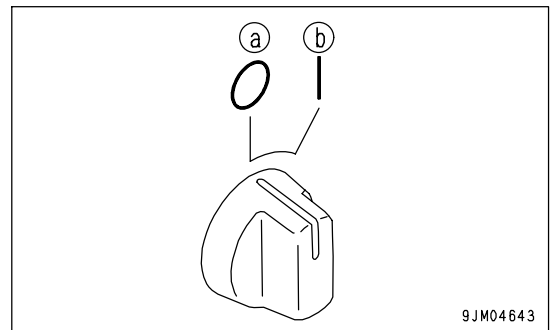

9JM04643

INFORMATION SWITCH

This switch (7) is used to carry out the switching of the information monitor display mode and the switching of the cursor with the maintenance mode.

- (a) position: Cursor moves to left
- (c) position: Cursor moves to right

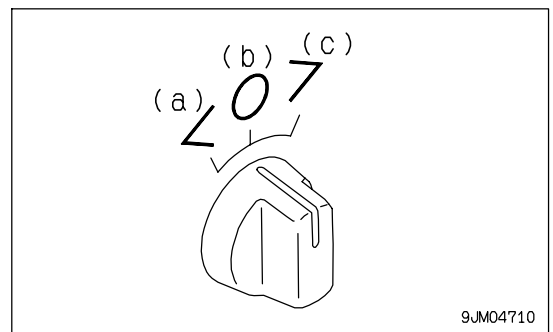

9JM04710

ADDITIONAL HEATER SWITCH

(If equipped)

This switch (8) is used to actuate the hot water heater.

- (a) position: Hot water heater OFF
- (b) position: Hot water heater Lo (ON)
- (c) position: Hot water heater Hi (ON)

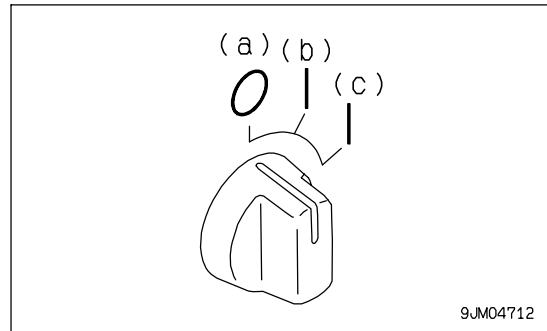
**FAN ROTATION SELECTOR SWITCH**

Use this switch (9) to switch the fan to reverse or cleaning mode.

- Position (a): normal mode
- Position (b): reverse mode
- Position (c): cleaning mode

Use the reverse mode to maintain the temperature in cold areas.

Use the cleaning mode to remove dirt when cleaning the radiator.

In the cleaning mode, the fan always rotates at 100% speed.

Always stop the engine before operating the fan selector switch.

If the fan selector switch is operated when the engine is running, the fan operation confirmation lamp will flash to indicate that it is impossible to operate the switch.

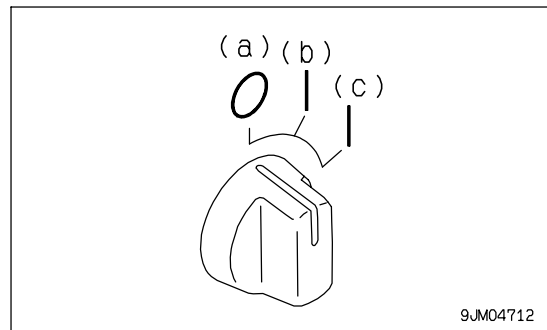

LAMPS

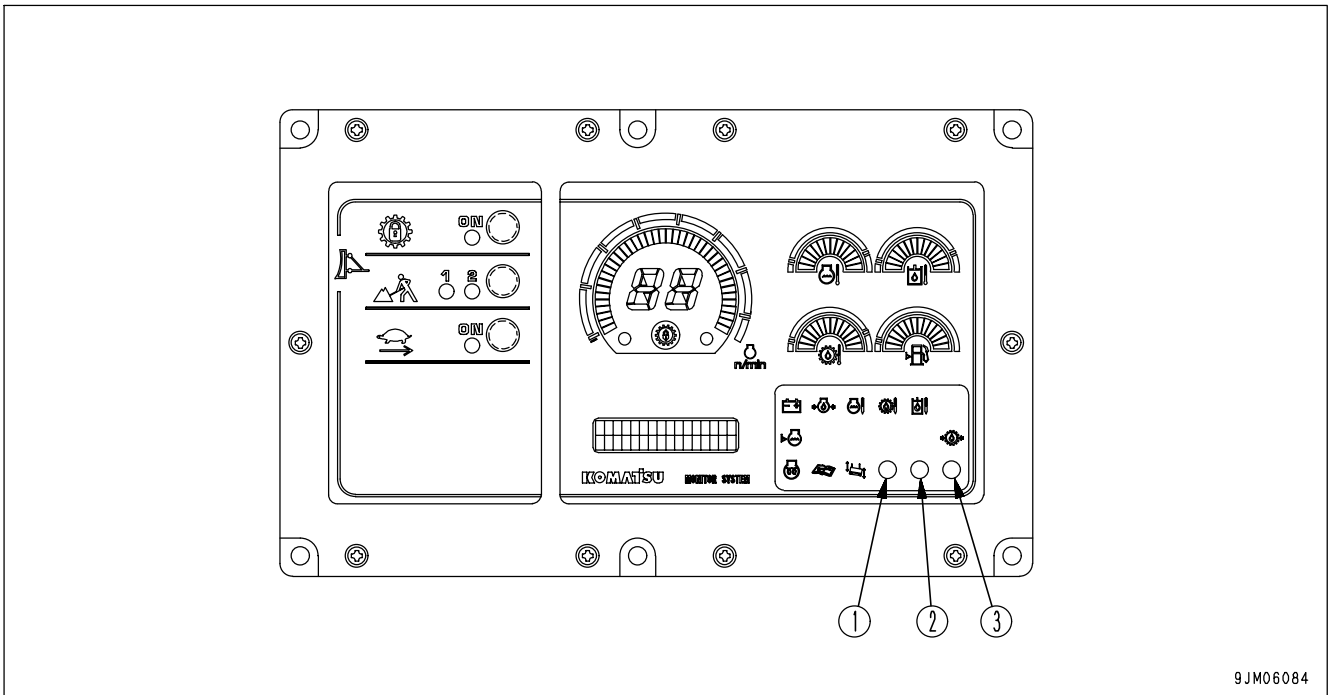

(1) Warning lamp

(2) Filter/oil change interval lamp

(3) Fan operation confirmation lamp

WARNING LAMP

NOTICE

If alarm buzzer sounds, stop work immediately and perform inspection and maintenance of the appropriate point.

When the caution lamp for the CAUTION (B) and CAUTION (C) groups on the machine monitor system flashes, and an abnormality has occurred in the electronic control system, lamp (1) also flashes at the same time.

If the lamp flashes, check the monitor panel to locate the abnormality.

When the monitor inside the CAUTION (C) group flashes, the alarm buzzer also sounds continuously.

See "FRONT PANEL (PAGE 3-5)".

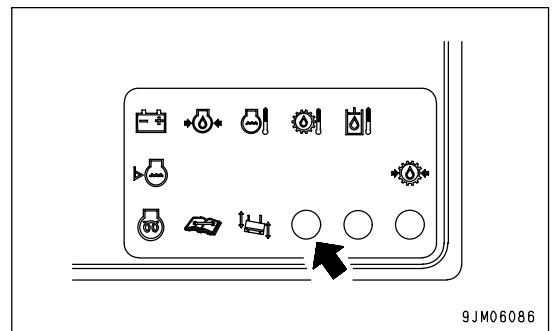

9JM06086

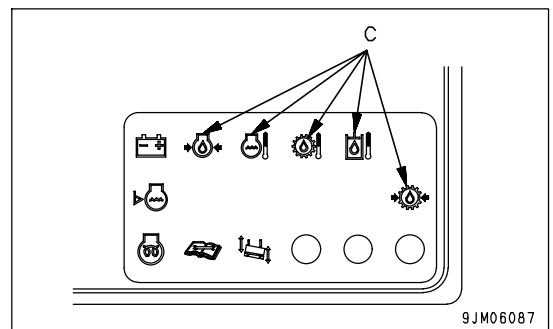

9JM06087

FILTER/OIL CHANGE INTERVAL LAMP

This lamp (2) lights up when it comes near the time for replacing the filter or oil.

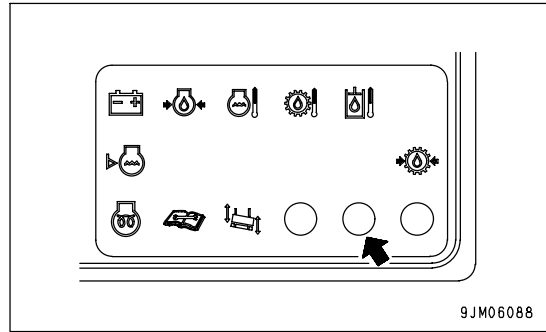

FAN OPERATION CONFIRMATION LAMP

If the fan rotation selector switch is operated when the engine is running, this lamp (3) flashes to warn the operator that the fan operation cannot be switched.

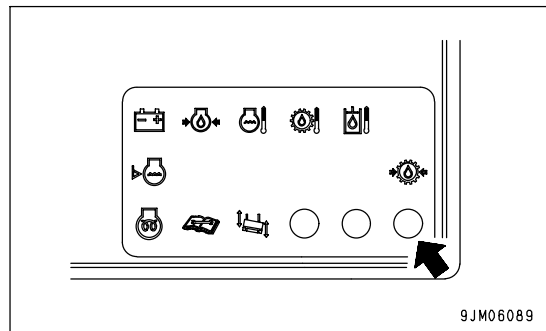

METHOD OF USING DISPLAY PANEL B (Multi-information)

EXPLANATION OF MODES AND CONTROLS

- Display panel B (1) has the function of displaying the following four types of mode. (The diagram on the right shows the normal screen before the mode display.)

Maintenance mode

This displays the time for replacing the filters or oil.

PM clinic auxiliary mode

This displays the engine speed and the oil pressure in the hydraulic circuits.

Fault display mode

This displays the fault code related to the electronic control.

Adjustment mode

This adjusts the brightness and contrast of the display.

- There are variations (sub-items) in the four types of mode. For an explanation of the variations, see the following items.

METHOD OF USING MAINTENANCE MODE (PAGE 3-29)

METHOD OF USING PM CLINIC AUXILIARY MODE (PAGE 3-31)

METHOD OF USING FAULT CODE DISPLAY MODE (PAGE 3-32)

METHOD OF USING USER ADJUST MODE (PAGE 3-33)

- Each mode is operated by using information switch (2) and buzzer cancel switch (3) on the dashboard in front of the operator's seat.

After operating the switch, release the switch, and the switch will return automatically to the center position as shown in the diagram on the right.

The functions of each position of the switches are as follows.

<: Moves mode to left

>: Moves mode to right

◇: Selects mode

□: Cancels mode

- The four types of mode can be selected in a cycle by operating information switch (2) to > and < to give the following sequence: Maintenance mode ←→ PM clinic auxiliary mode ←→ Fault code display mode ←→ Adjustment mode ←→ Maintenance mode.
- From the normal mode before giving the mode display, if buzzer cancel switch (3) is operated to ◇ and held for 2.5 seconds, the maintenance mode is displayed. After that, if information switch (2) is operated to >, the mode changes to the PM clinic auxiliary mode. If information switch (2) is operated to <, the mode changes to the user adjust mode.
- When any mode is being displayed, if the buzzer cancel switch is operated to □, the screen returns the normal screen shown before the mode display.

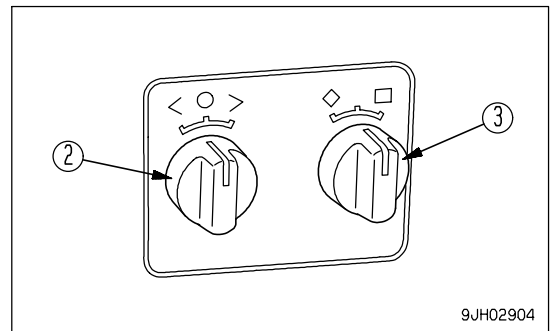
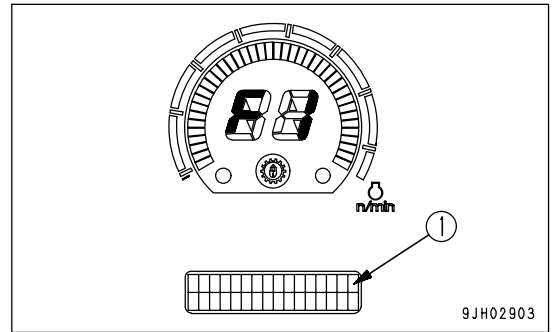

METHOD OF SELECTING MODES

1. When moving from the normal operation display to a user mode, the maintenance mode is displayed. Use the controls to change the mode as follows.

- > position: Go to PM clinic auxiliary mode
- < position: Go to user adjust mode
- position: Go to normal operation screen
- ◇ position: Go to maintenance mode selection screen.

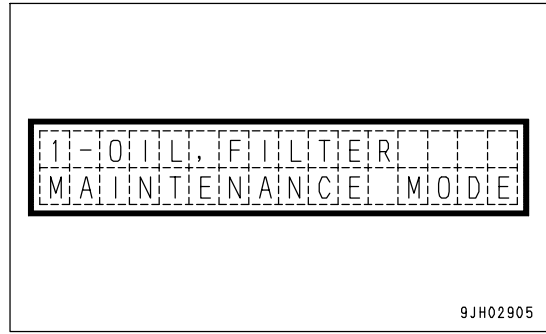

2. The diagram on the right shows the screen display for the PM clinic auxiliary mode. Use the controls to change the mode as follows.

- > position: Go to fault code display mode
- < position: Go to maintenance mode
- position: Go to normal operation screen
- ◇ position: Go to PM clinic auxiliary mode selection item screen

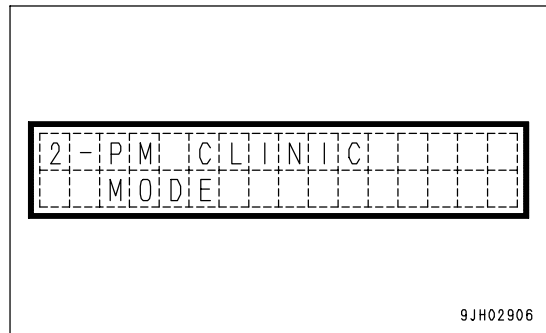

3. The diagram on the right shows the screen display for the fault code display mode. Use the controls to change the mode as follows.

- > position: Go to adjustment mode
- < position: Go to PM clinic auxiliary mode
- position: Go to normal operation screen
- ◇ position: Go to fault code selection item screen

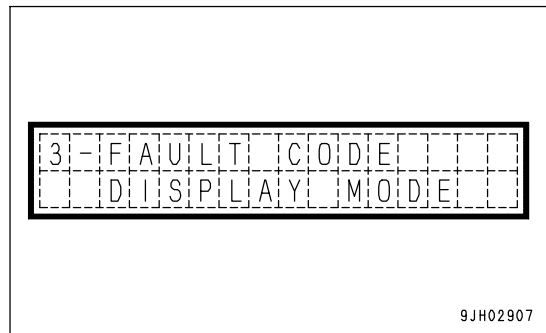

4. The diagram on the right shows the screen display for the user adjust mode. Use the controls to change the mode as follows.

- > position: Go to maintenance mode
- < position: Go to fault code display mode
- position: Go to normal operation screen
- ◇ position: Go to user adjust mode selection item screen

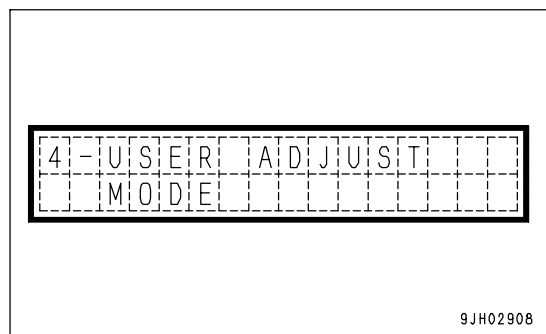

METHOD OF USING MAINTENANCE MODE

NOTICE

This function is only a guideline. If dirty oil or filters are found during daily maintenance, replace them immediately. If the controllers or monitor panel are replaced, the timer for this function will not work properly. Contact your Komatsu distributor for replacement.

The maintenance mode shows the replacement interval for the oil filters and oil on the monitor.

The content of the display is as follows.

- (1) The item is displayed.
- (2) The time remaining until replacement is displayed.
- (3) The number of times that replacement has been made until now is displayed.

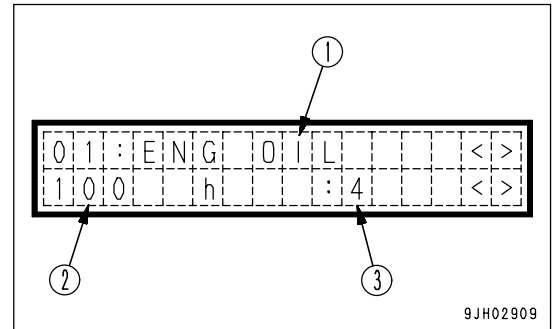

The display items can be displayed in order by operating the information switch to the left or right (<, >).

	Display	Item	Time to 1st replacement	Time to 2nd and following replacements
1.	ENG.OIL	Engine oil	500h	500h
2.	ENG.FLT	Engine oil filter	500h	500h
3.	BYPS.FLT	Bypass filter	0h	0h
4.	FUEL.FLT	Fuel filter	250h	500h
5.	CORR.FLT	Corrosion resistor	1000h	1000h
6.	P/L.OIL	Power train oil	250h	1000h
7.	P/L.FLT	Power train oil filter	250h	500h
8.	HYD.OIL	Hydraulic oil	250h	2000h
9.	HYD.FLT	Hydraulic filter	250h	2000h
10.	CHG.FLT	HSS charge filter	1000h	1000h
11.	DAMP.OIL	Damper oil	2000h	2000h
12.	F/D.OIL	Final drive oil	250h	2000h

When the oil or filter has been replaced, select the applicable item, then operate the buzzer cancel switch to \diamond .

The screen will ask if you want to display the replacement history. Operate the information switch to select YES, then operate the buzzer cancel switch to \diamond . The replacement account will increase by 1, the replacement interval will be reset, and the oil, filter change interval lamp will go out.

When this is done, if the maintenance caution lamp does not go out, there is another item close to the replacement time, so check the situation.

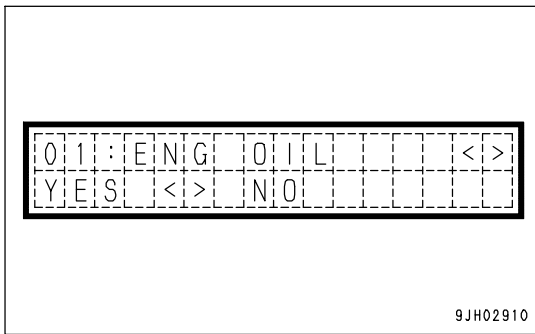

REMARK

To return to the function selection mode, operate the buzzer cancel switch to \square .

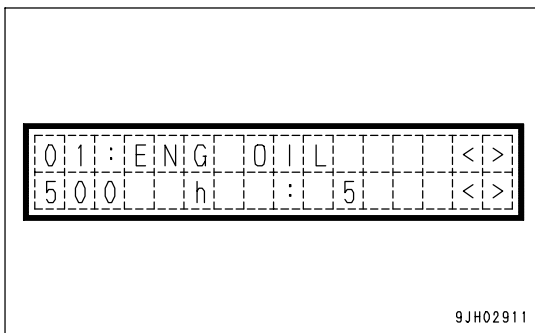

METHOD OF USING PM CLINIC AUXILIARY MODE

 **CAUTION**

When moving the work equipment or setting the transmission to the travel position for carrying out measurements, check carefully that the situation is safe.

The PM clinic auxiliary mode displays the engine speed, hydraulic oil pressure, and other items on display panel B. Display panel B displays the item on the top line (1), and the measured value on the bottom line (2).

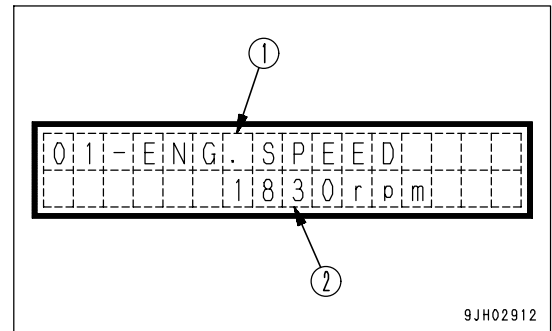

The display items consist of the six items in the table below.

The items can be selected by operating the information switch (<, >).

Display	Item	Measured value
01-ENG.SPEED	Engine speed	Speed (rpm)
02-BOOST PRSSURE	Boost pressure	Pressure (kPa)
03-HYD.PUMP PRES	Hydraulic oil pressure	Pressure (MPa)
04-BATTERY VOLT	Battery voltage	Voltage (mV)
05-HSS PUMP-A	HSS A circuit pressure	Pressure (MPa)
06-HSS PUMP-B	HSS B circuit pressure	Pressure (MPa)

REMARK

- Items such as the engine speed fluctuate and are difficult to see during the measurement. In such cases, operate the buzzer cancel switch to \diamond . This makes it possible to hold the display of the value.
- To cancel this mode, operate the buzzer cancel switch again to \diamond .
- To return to the function selection mode, operate the buzzer cancel switch to \square .

METHOD OF USING FAULT CODE DISPLAY MODE

NOTICE

The fault items observed by this function are connected with the electronic control, so even if a fault code is not displayed, there is probably some problem with the machine. If the operator feels any problem with the machine, the machine should be stopped immediately and checked.

When any disconnection or short circuit in any sensor is detected, the location and fault code are displayed by a 6-digit code on display panel B. When contacting your Komatsu distributor, inform your distributor of the code at the same time.

If the failure observation function has not determined the condition of the machine, the display is as shown in the diagram on the right.

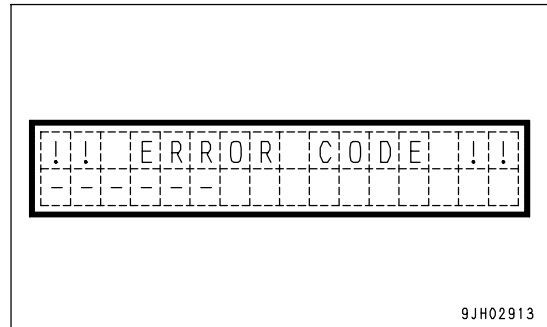

With this function, existing failures can be displayed up to a maximum of 20 items.

If multiple failures are occurring, the display automatically changes every 2 seconds, so check the code.

The display is shown repeatedly.

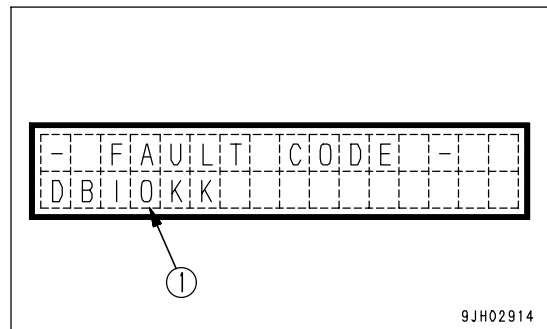

REMARK

To return to the function selection mode, operate the buzzer cancel switch to .

METHOD OF USING USER ADJUST MODE

With the user adjust mode, the brightness of the panel screen backlighting and the contrast of the liquid crystal panel can be changed, or the cooling fan can be set to maximum speed to clean the radiator when it is clogged.

These are displayed on display panel B.

1. Adjusting backlighting of liquid crystal display

The diagram on the right is the mode for adjusting the brightness of the backlighting of the liquid crystal panel. On this screen, operate the buzzer cancel switch to ◇ to switch to the screen to adjust the brightness.

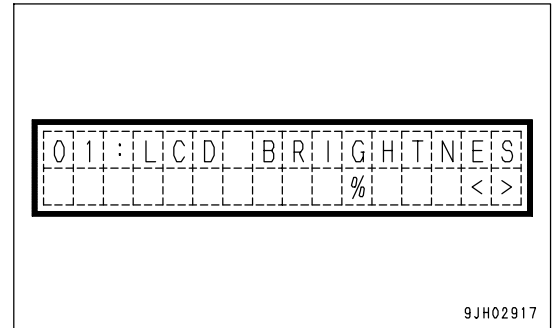

The brightness can be adjusted by operating the information switch.

The higher the number, the brighter the screen becomes; the lower the number, the darker the screen becomes.

> position: Number increases

< position: Number decreases

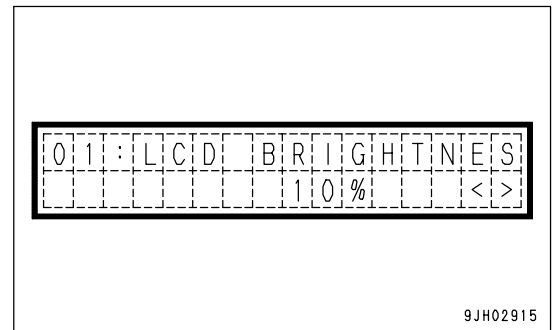

When the buzzer cancel switch is operated to ◇, the brightness of the liquid crystal display backlighting is set.

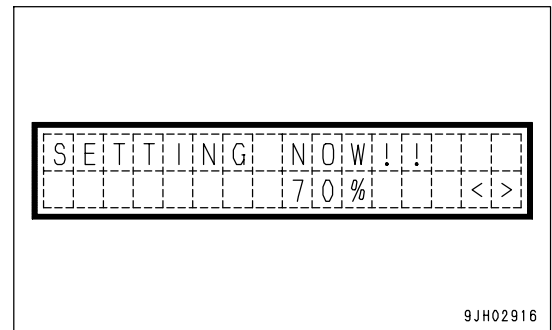

2. Adjusting backlighting of message display

The diagram on the right is the mode for adjusting the brightness of the backlighting of the message display. On the screen, operate the buzzer cancel switch to ◇ to switch to the screen for adjusting the brightness.

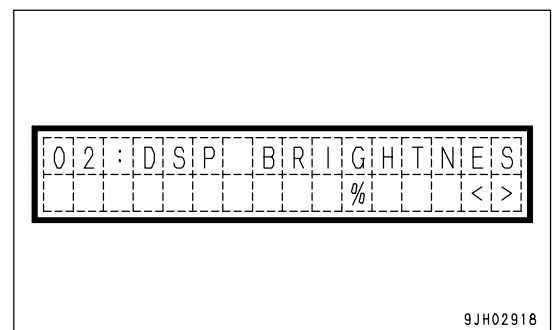

The brightness can be adjusted by operating the information switch.

The higher the number, the brighter the screen becomes; the lower the number, the darker the screen becomes.

- > position: Number increases
- < position: Number decreases

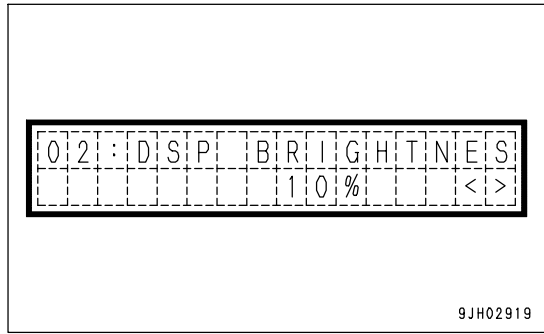

When the buzzer cancel switch is operated to ◇, the brightness of the message display backlighting is set.

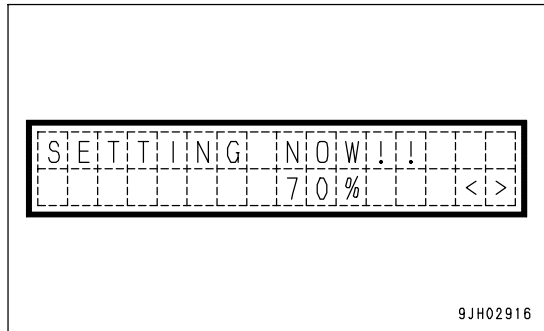

- Adjusting contrast of liquid crystal message display
The diagram on the right is the mode for adjusting the contrast of the liquid crystal message display.
On this screen, operate the buzzer cancel switch to ◇ to switch to the screen to adjust the contrast.

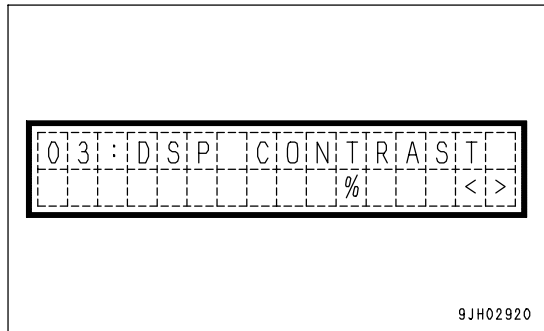

The contrast can be adjusted by operating the information switch.
The higher the number, the darker the screen becomes; the lower the number, the lighter the screen becomes.

- > position: Number increases
- < position: Number decreases

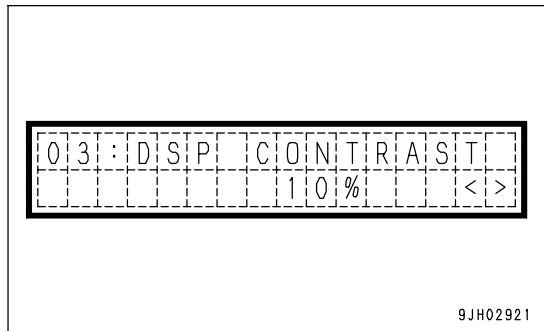

When the buzzer cancel switch is operated to ◇, the contrast of the liquid crystal display is set.

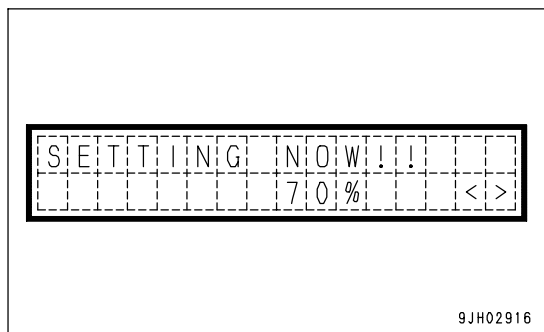

4. Mode to rotate cooling fan at maximum speed

The diagram on the right is the mode for rotating the cooling fan at maximum speed. On this screen, operate the buzzer cancel switch to \diamond to rotate the cooling fan at the maximum speed.

Note that this mode is effective only when the display in the diagram on the right is being given. After leaving this mode, the screen returns to the normal mode.

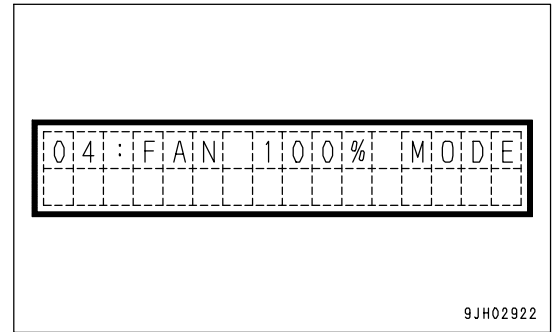

REMARK

- To return to the function selection mode, operate the buzzer cancel switch to \square .
- The brightness of the backlighting of the monitor panel differs according to whether the front lamp is lit or not. Entering this mode when the front lamps are lit makes it possible to adjust the brightness when the front lamps are lit. In the same way, entering this mode when the front lamps are not lit makes it possible to adjust the brightness when the front lamps are not lit.

SWITCHES

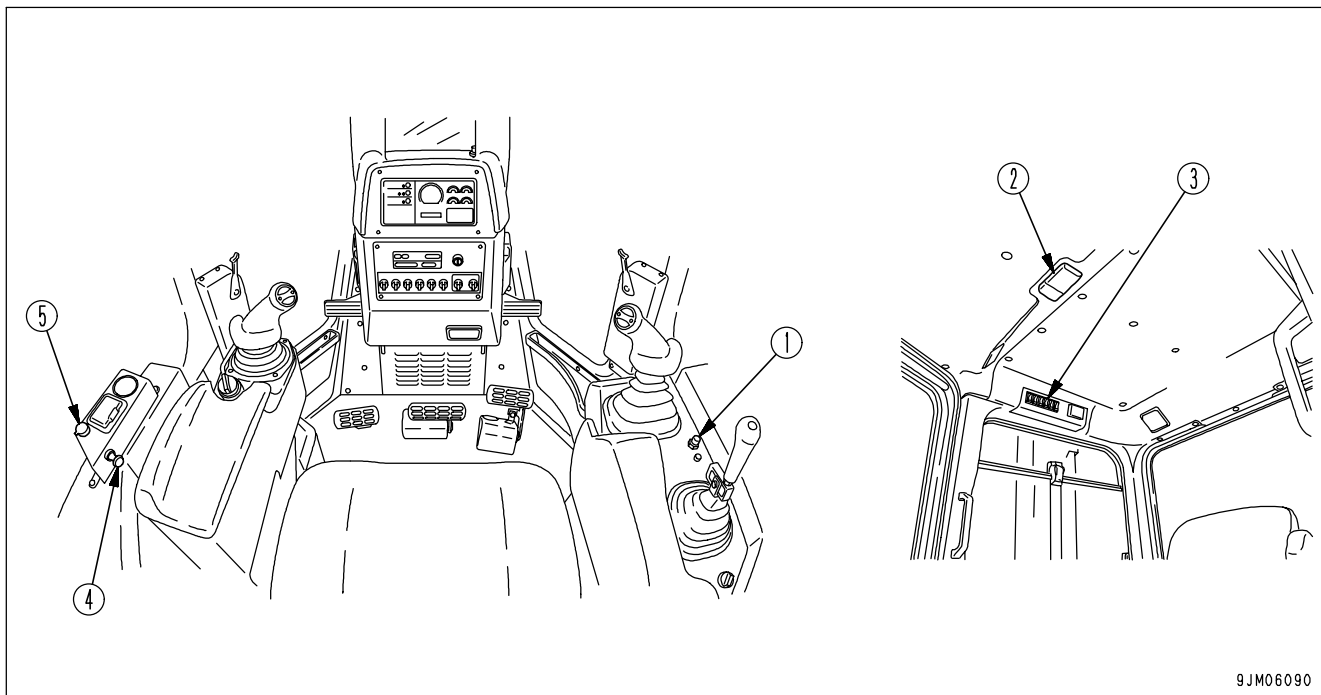

9JM06090

- (1) Horn switch
- (2) Room lamp switch
- (3) Wiper switch
- (4) Cigarette lighter
- (5) Accessory socket

HORN SWITCH

The horn sounds when button (1) at rear of the blade control lever on the right side of operator's seat is pressed.

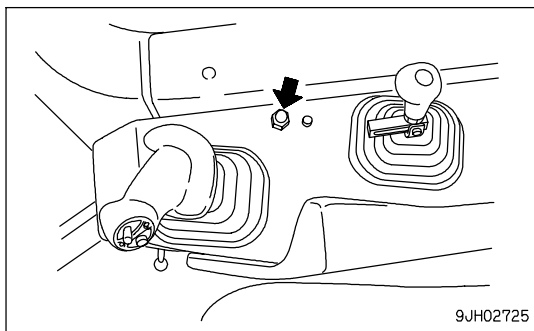

9JH02725

ROOM LAMP SWITCH

Switch (2) lights the room lamp.

ON position: Lamp lights up

OFF position: Lamp is out

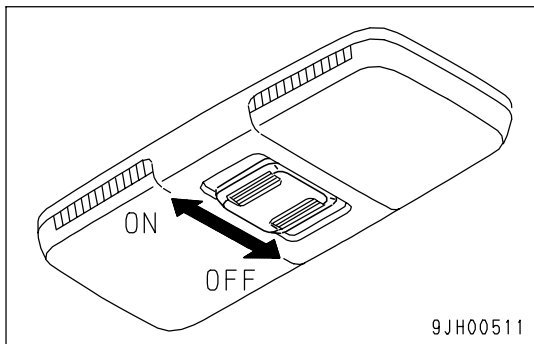

9JH00511

WIPER SWITCH

Switch (3) activates the wipers.

The wiper switches are as follows:

- (A) Rear window
- (B) Right door
- (C) Left door
- (D) Front window

This is also used as the window washer switch.

The switch is operated as follows.

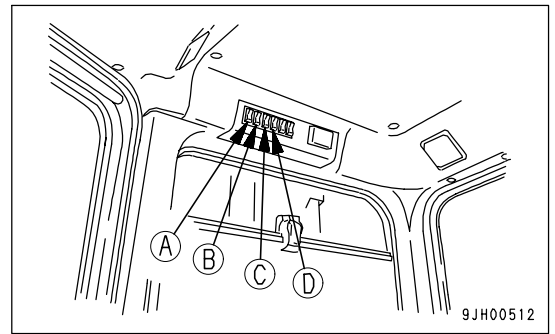

- Window washer only
Keep the switch pressed to the OFF position to spray out water.

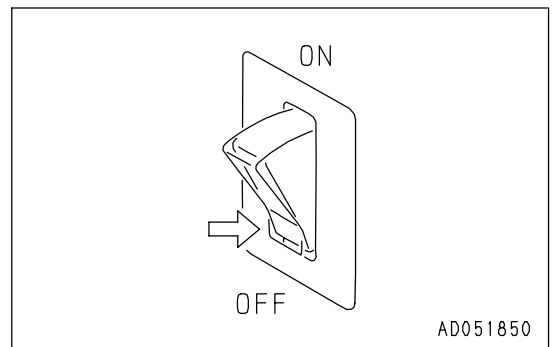

- Wiper only
If this is switched on, the wiper will start.

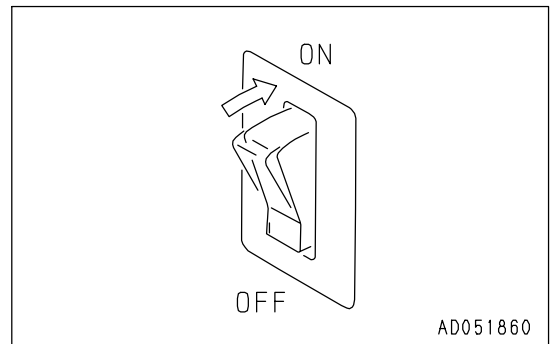

- Wiper and window washer
If this is kept pressed to the ON position while the wiper is working, water will be sprayed out.

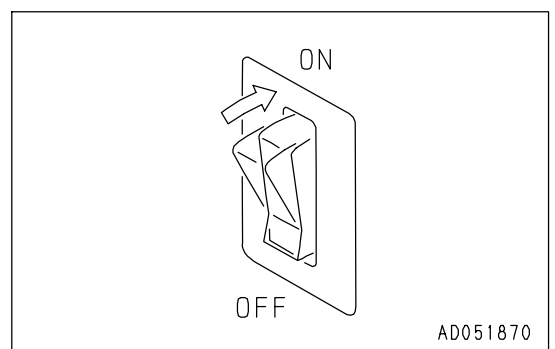

REMARK

When installing the cab, check the colors of the washer tank and window washer hoses, and be sure to connect correctly.

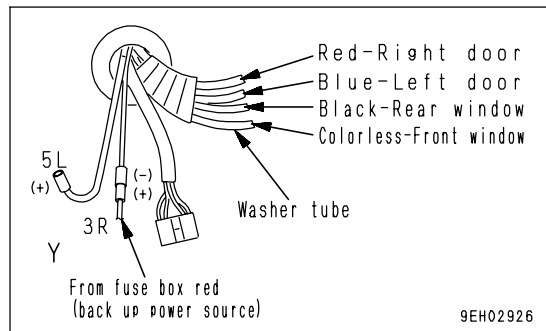
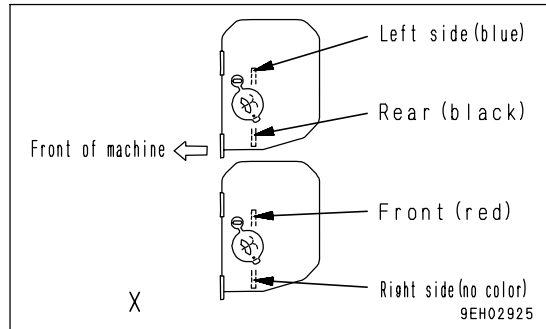
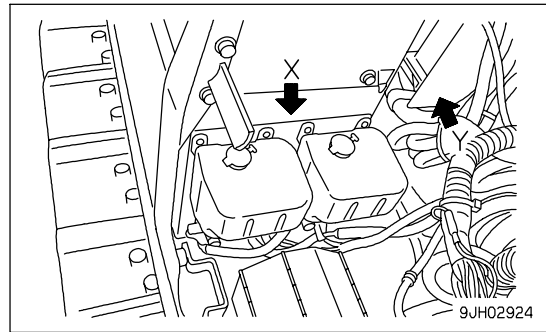

CIGARETTE LIGHTER

This lighter (4) is used to light cigarettes.

When the cigarette lighter is pushed in, it will return to its original position after a few seconds, so take it out to light your cigarette.

If the cigarette lighter is removed, the socket can be used as a power source.

NOTICE

This cigarette lighter is 24V. Do not use it as the power supply for 12V equipment. This will cause failure of the equipment.

The capacity of the cigarette lighter is 120W (24V x 5A).

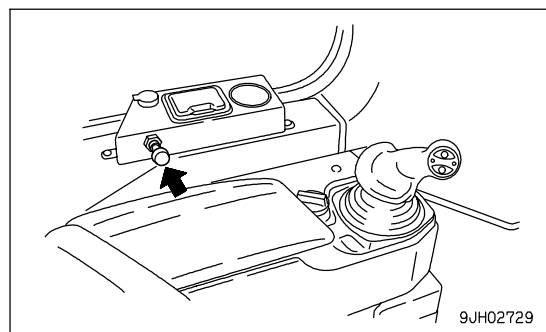

ACCESSORY SOCKET

Socket (5) is used as the power source for a wireless device or other 12V equipment.

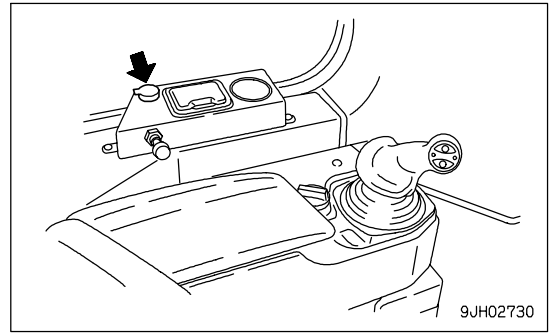

CONTROL LEVERS, PEDALS

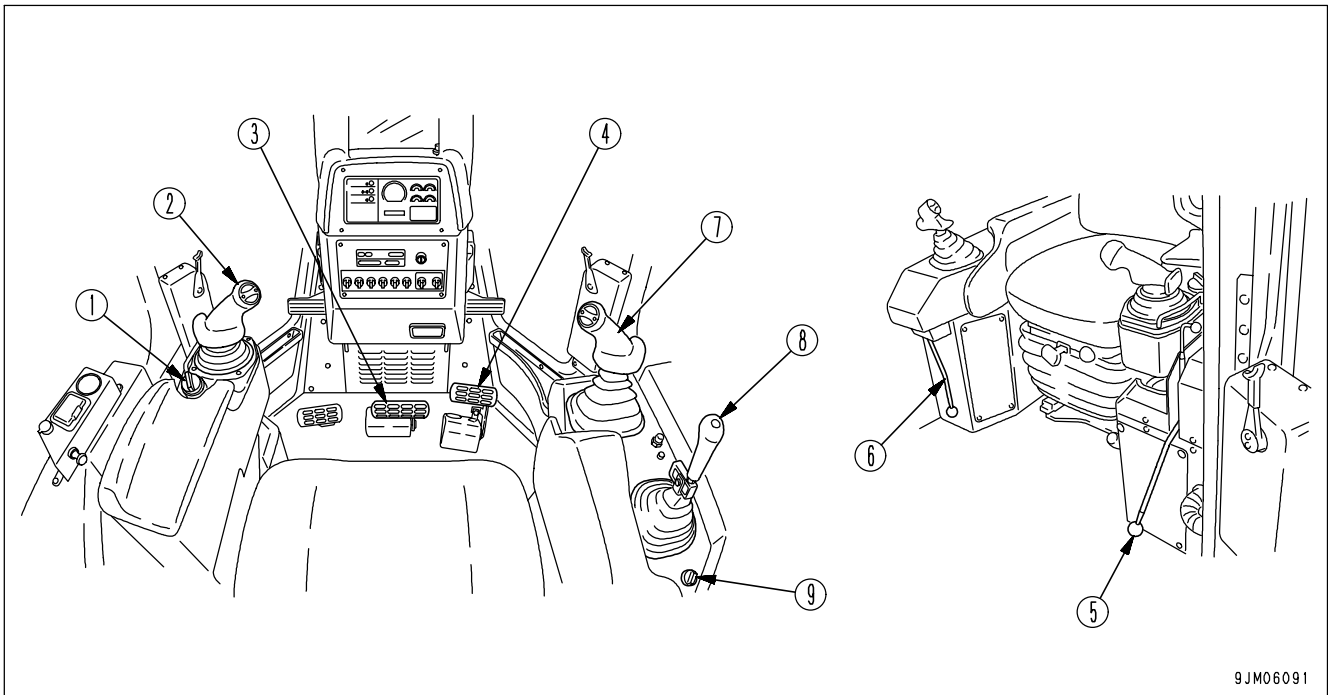

9JM06091

- (1) Fuel control dial
- (2) Joystick (steering, directional and gear shift lever)
- (3) Brake pedal
- (4) Decelerator pedal
- (5) Parking brake lever
- (6) Work equipment lock lever
- (7) Blade control lever
- (8) Ripper control lever
- (9) Pin puller control switch (for giant ripper)

FUEL CONTROL DIAL

Dial (1) is used to control the engine speed and output.

- (a) Low idling position: Turn fully to the left
- (b) High idling position: Turn fully to the right

REMARK

To stop the engine, turn the starting switch to the OFF position.

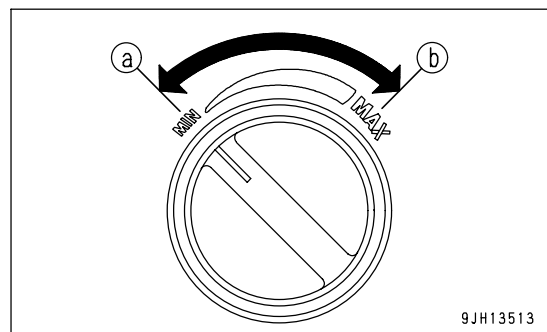

9JH13513

JOYSTICK (STEERING, DIRECTIONAL AND GEAR SHIFT LEVER)

(PCCS lever)

This lever (2) is used to switch between forward and reverse, to steer the machine, or carry out counterrotation turns.

REMARK

PCCS: Palm command control system

- **Forward-reverse shifting**

Position (a): FORWARD

Position (b): REVERSE

Position N: Neutral

Move to the front to drive forward; move to the rear to drive in reverse.

- **Steering**

Position (L): Left turn

Position (R): Right turn

With the lever moved to the front or rear, operate the lever partially to the left or right to turn the machine. The machine will turn gradually in the same direction as the lever is operated.

If the lever is moved fully to the left or right, the machine will turn in a small radius.

REMARK

- If the lever is released when steering the machine, the lever will return to the (a) position or the (b) position and the machine will be returned to straight movement.

- **Gear shifting**

When the steering, directional, and gearshift lever is at the FORWARD or REVERSE position and switch (c) or switch (d) is pushed, the transmission speed will change.

UP switch (c): Each time the switch is pressed, the transmission will shift up one speed.

DOWN switch (d): Each time the switch is pressed, the transmission will shift down one speed.

For details of the maximum speed in each speed range, see "SPECIFICATIONS (PAGE 5-2)".

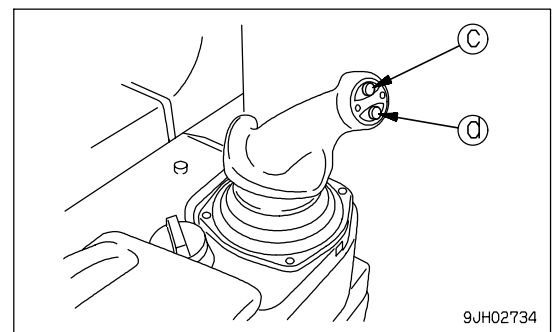
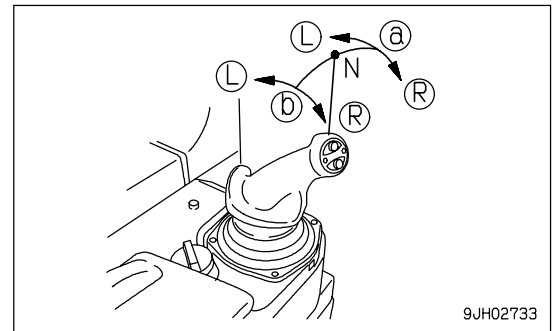
**REMARK**

- When the transmission is shifted, the speed range being used is displayed on the display panel on the monitor panel.

Example:

Neutral: N is displayed on the display panel.

FORWARD 2nd: F2 is displayed on the display panel.

REVERSE 3rd: R3 is displayed on the display panel.

When the parking lever is locked, P is displayed.

- For details of the gearshift operation using the shift mode, see "SHIFTING GEAR (PAGE 3-104)". Shift mode selection means the operation to set the selected speed range beforehand in the N position.

• Operating counter-rotation turn

! WARNING

When operating the counter-rotation turn, if the load on the left and right is not balanced, the machine may make a pivot turn, so check the ground conditions and be careful not to hit any obstacles when carrying out the operation.

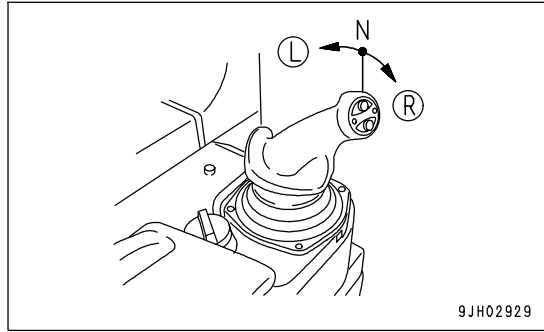

9JH02929

With the lever in the N position, move the lever partially in the direction of turn. The left and right tracks will rotate in opposite directions, and the machine will make a slow counter-rotation turn. If the lever is moved further, the speed of the counter-rotation turn will increase.

(R): Right counter-rotation turn

(L): Left counter-rotation turn

BRAKE PEDAL

! WARNING

Do not place your foot on this pedal unnecessarily.

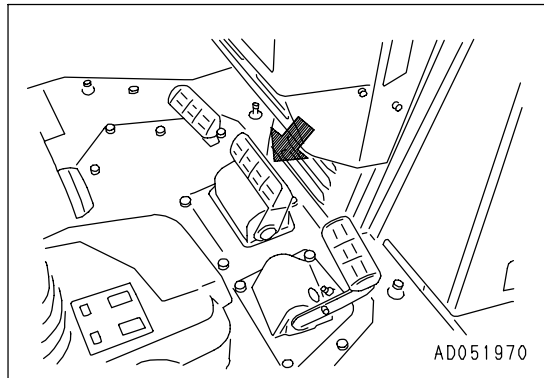

AD051970

Depress the pedal (3) to apply the right and left brakes.

DECELERATOR PEDAL

! WARNING

- Do not rest your foot on the pedal if you are not using it.
- When passing over the top of a slope or when dumping soil from a cliff, the load on the machine will suddenly be reduced and the travel speed will increase. This situation is dangerous, so use the decelerator pedal to reduce the travel speed of the machine

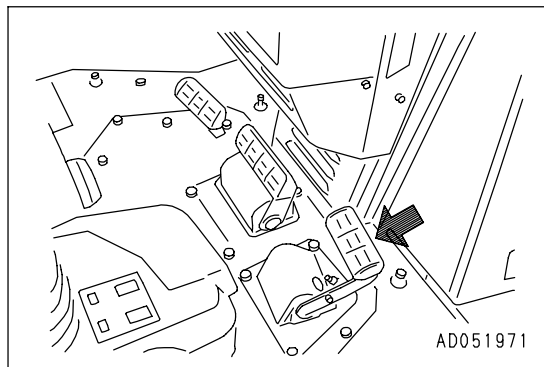

AD051971

Pedal (4) is used when reducing engine speed or stopping the machine.

When switching between forward and reverse, or when stopping the machine, use this pedal to reduce speed.

REMARK

When operating the decelerator pedal, there may be a particular noise, but there is no problem with quality or durability.

PARKING BRAKE LEVER

**WARNING**

When the machine is parked, always set the parking brake lever to the LOCK position (L).

This lever (5) is used to apply the parking brake.

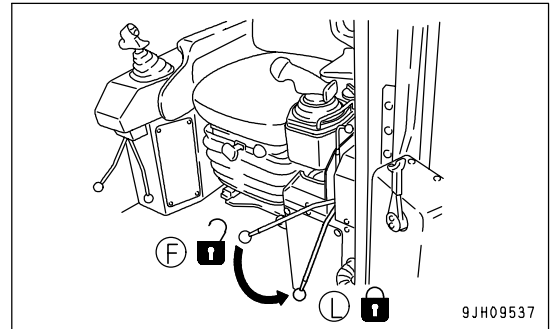
**REMARK**

- Before moving the parking brake lever to the LOCK position (L), return the steering, directional, and gearshift lever to the N position.
- When starting the engine, if the parking brake lever is not in the LOCK position (L), the limit switch is actuated and it is impossible to start the engine.

WORK EQUIPMENT LOCK LEVER

**WARNING**

- When standing up from the operator's seat, always move the work equipment lock lever securely to the LOCK position. If the blade control and ripper control levers are not locked and are touched by accident, it may lead to serious injury or damage.
- If the work equipment lock lever is not completely in the LOCK position (L), the lock may not be applied. Check that it is in the position shown in the diagram.
- When parking the machine or when performing maintenance, always lower the blade or ripper to the ground, then set the work equipment lock lever to the LOCK position (L).

Lever (6) is a device to lock the blade control and ripper control levers.

When it is set to the LOCK position (L), the TILT, RAISE, LOWER, and FLOAT operations are locked.

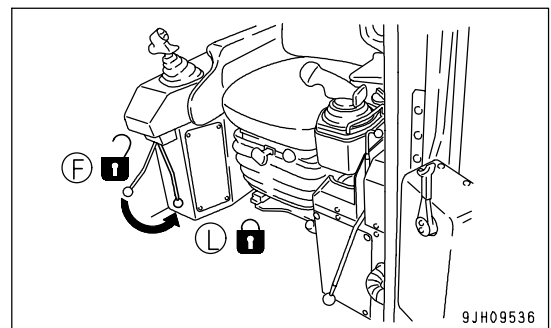
**REMARK**

When starting the engine, to ensure safety, always set the work equipment lock lever to the LOCK position (L).

BLADE CONTROL LEVER

Lever (7) is used to operate the blade.

SINGLE TILTDOZER

Lever (7) is used to raise or tilt the blade.

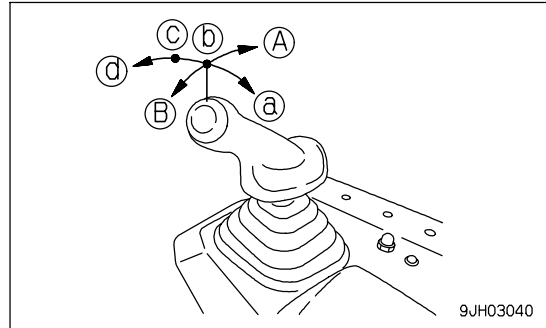

- Lifting control
- (a) RAISE
- (b) HOLD: Blade is stopped and held in this position.
- (c) LOWER
- (d) FLOAT: Blade will move freely according to external force.

REMARK

When released from FLOAT position, this lever (7) will not return to HOLD position, so it must be returned to HOLD by hand.

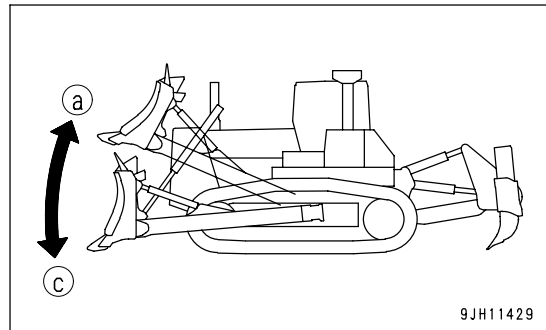

- Tilting control
- (A) RIGHT TILT
- (B) LEFT TILT

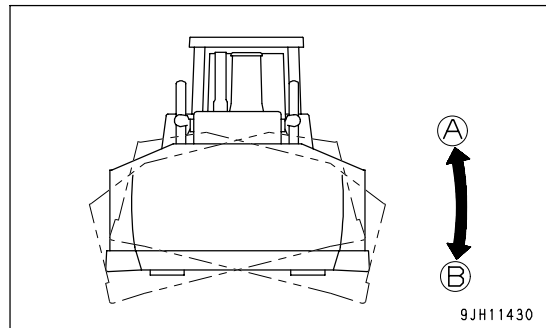

DUAL TILTDOZER

This lever is used to carry out the blade lift, tilt, and pitch operations.

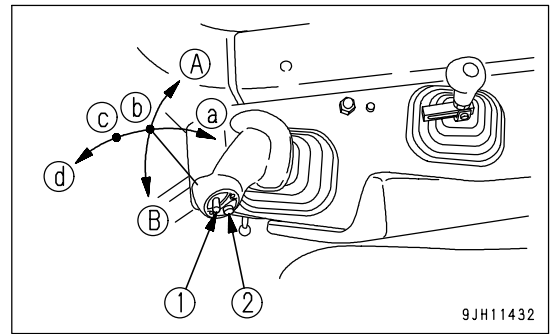

(1) Tilt switch
(2) Pitch button

- Lifting control
- (a) RAISE
- (b) HOLD: Blade is stopped and held in this position.
- (c) LOWER
- (d) FLOAT: Blade will move freely according to external force.

REMARK

When released from FLOAT position, this lever (7) will not return to HOLD position, so it must be returned to HOLD by hand.

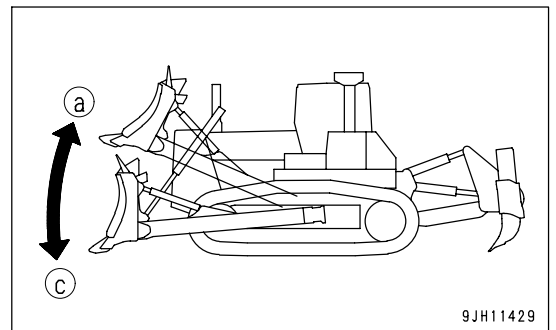

- Dual tilt operation
- Operate the tilt switch (1) to the (D) position.

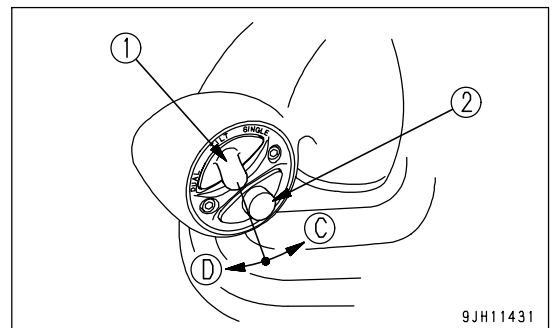

- (A) RIGHT TILT
- (B) LEFT TILT

REMARK

- With the dual tilt operation, a larger amount of tilt can be obtained than with the single tilt operation.
- With the dual tilt operation, the blade can be operated to RAISE, HOLD, or LOWER.

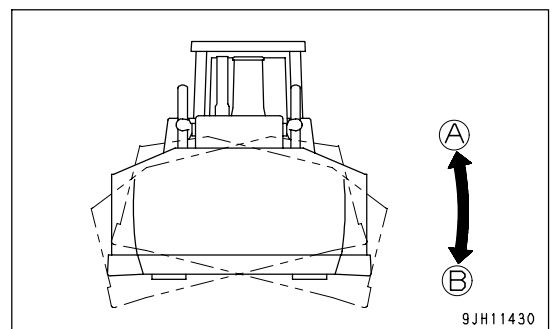

- Single tilt operation

Operate the tilt switch (1) to the (C) position.

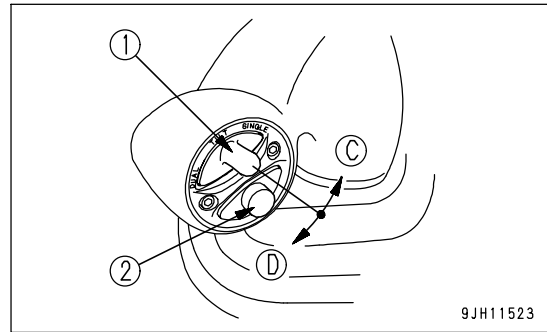

- (A) RIGHT TILT
- (B) LEFT TILT

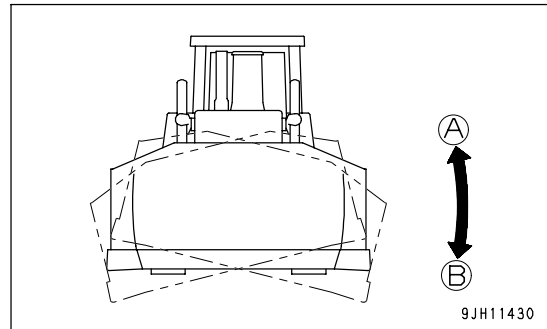

- Pitch control

Rear pitch (3)(cutting angle reduced)

Carry out operation (B) with the pitch button (2) pressed.

Forward pitch (4)(cutting angle increased)

Carry out operation (A) with the pitch button (2) pressed.

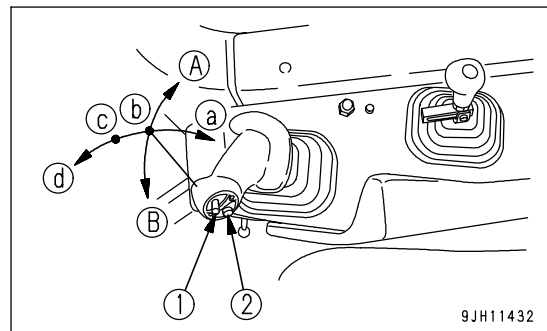

REMARK

- With the pitch operation, the blade can be operated to any of RAISE, HOLD, or LOWER.
- For details of the effective use of the dual tilt dozer, see "EFFECTIVE METHOD OF OPERATION FOR DUAL TILT DOZER (PAGE 6-6)".
- To operate the pitch, keep the pitch button pressed and operate the blade control lever to the left or right to start the operation.
- The pitch is the priority circuit, so if the pitch button is pressed during single tilt operation, the pitch will be actuated.

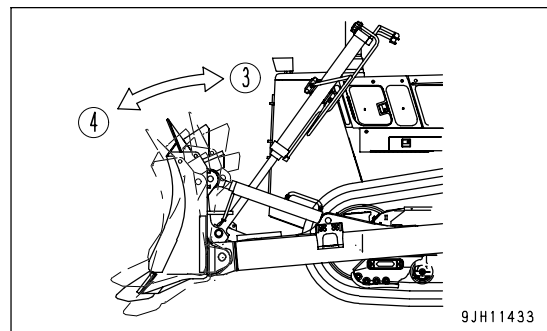

RIPPER CONTROL LEVER

(For variable ripper)

Lever (8) is used to operate the ripper.

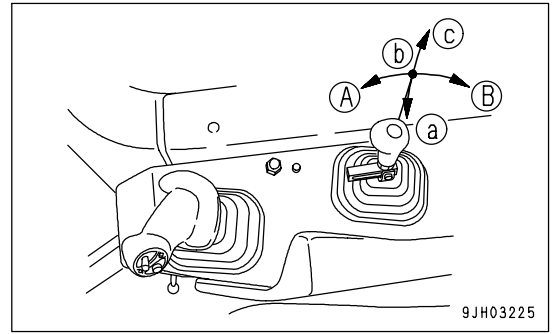

- Lifting control
- (a) RAISE
- (b) HOLD: Ripper is stopped and held in the same position.
- (c) LOWER

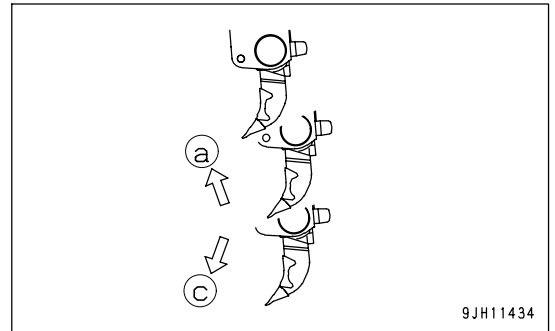

- Tilting control
- (A) Digging angle reduced: Cutting angle (α) becomes smaller.
- (B) Digging angle increased: Cutting angle (α) becomes larger.

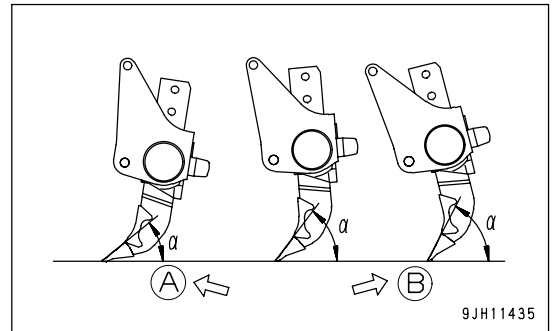

ADJUSTING FRONT-REAR POSITION OF RIPPER CONTROL LEVER

(Range of adjustment: ± 40 mm (1.6 in))

Lever (8) position can be adjusted to best suit the operator's physique. Follow the steps below for the adjustment.

- Adjustment within range of 40 mm (1.6 in) from neutral to rear

1. Loosen lock nut (1) with a wrench.
2. Set lever (2) to the optimum position.
3. Tighten lock bolt (1) with the wrench to hold lever (2) in position.

- Adjustment within range of 40 mm (1.6 in) from neutral to front

1. Remove lock bolt (1) with a wrench.
2. Remove lever (2) and reverse it 180°
3. Install lever (2) to lever (5), then set it to the optimum position.
4. Tighten lock bolt (1) with the wrench to hold lever (2) in position.
5. Loosen nut (3).
6. Reverse knob 180°.
7. Tighten nut (3).

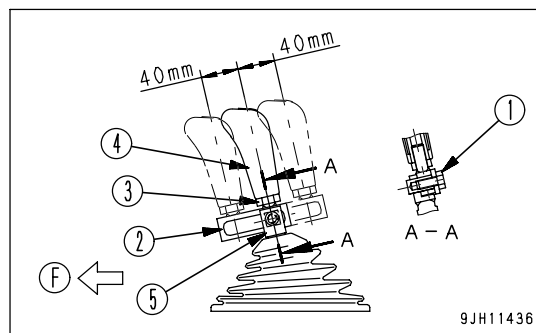

(F)Front of the machine

PIN PULLER CONTROL SWITCH (IF EQUIPPED)

Switch (9) is used to operate the pin puller.

- (a) PULL OUT: Pin is pulled out.
 (b) PUSH IN: Pin is pushed in.

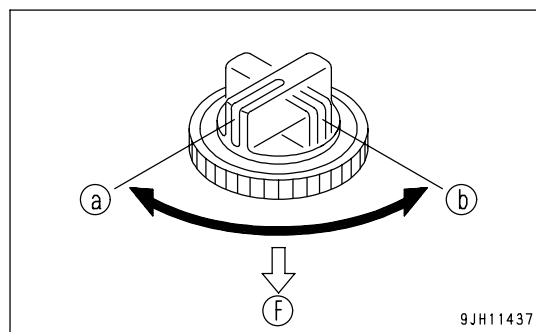

(F)Front of the machine

DUST INDICATOR

This is on the air cleaner bracket inside the engine room.

This device indicates that the air cleaner element is clogged.

For details on how to clean the element, see "CHECK, CLEAN AND REPLACE AIR CLEANER ELEMENT (PAGE 4-24)".

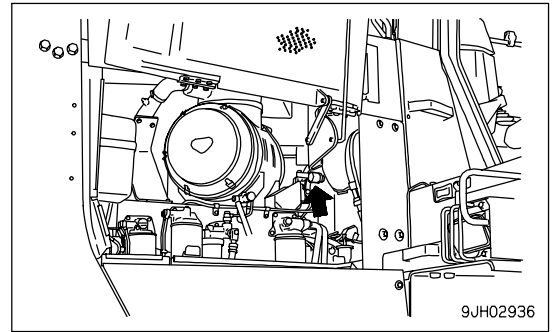

POWER SOURCE

The cigarette lighter socket (1) can be used as a power source for 24V equipment and the accessory socket (2) can be used for 12V equipment.

NOTICE

The cigarette lighter is 24V. Do not use it as the power source for 12V equipment.

The capacity of the cigarette lighter is 120W (24V x 5A).

The capacity of the accessory socket is 60W (12V x 5A).

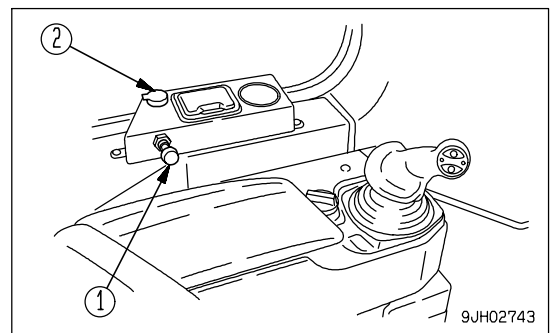

FUSE BOX

NOTICE

Before replacing a fuse, be sure to turn starting switch to the OFF position.

Fuses protect the electrical equipment and wiring from burning out.

If a fuse becomes corroded, or white powder can be seen, or a fuse is loose in the holder, replace the fuse.

Replace a fuse with another of the same capacity.

- Chassis

Open the fuse inspection cover at the bottom front left of the operator's compartment. Fuse box I is installed inside.

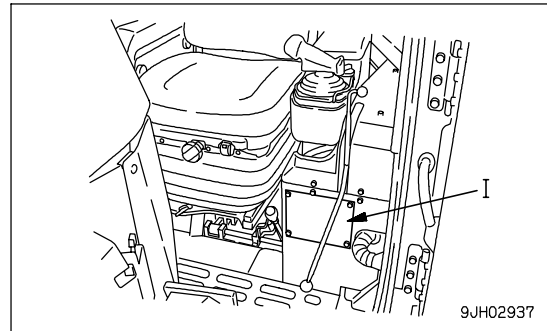

- (1) Fuse box fs1
- (2) Fuse box fs2
- (3) Fuse box fs4
- (4) Circuit breaker

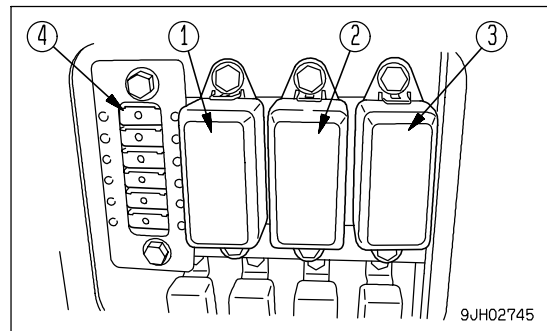

- Cab (machines equipped with cab)

Fuse box II is installed at the bottom of the overhead panel.

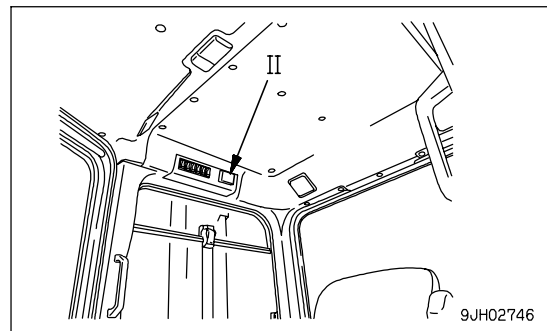

CIRCUIT BREAKER

- If the starting switch does not work, open the circuit breaker box and check.
- If excessive current flows through the circuit breaker, it cuts off the electric circuit to prevent damage to the electrical components and wiring.
- To restore the electric circuit after it has been cut off, push in reset button (1). (This springs out when the circuit is cut off.)
If the electric circuit is normal, reset button (1) will stay pushed in. If it comes out immediately when it is pushed in, the electric circuit must be checked.

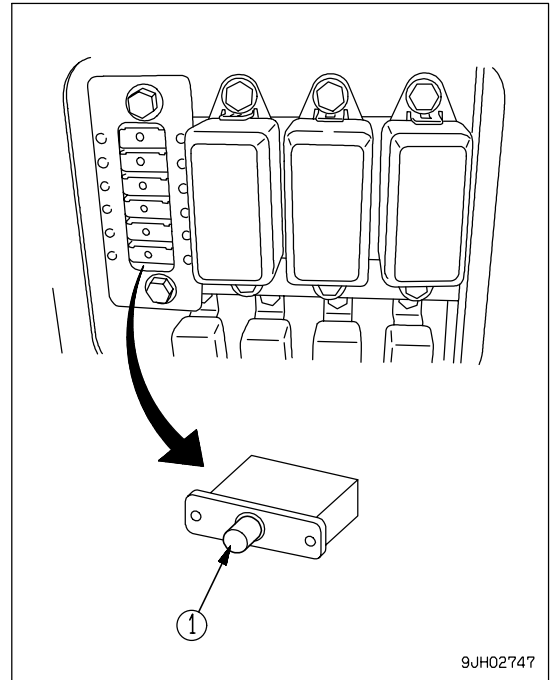

9JH02747

No.	Capacity	Circuit
(1)	20A	Steering controller
(2)	20A	Monitor panel
(3)	20A	Transmission controller
(4)	20A	Air con main power
(5)	20A	Head lamp
(6)	20A	Starter switch

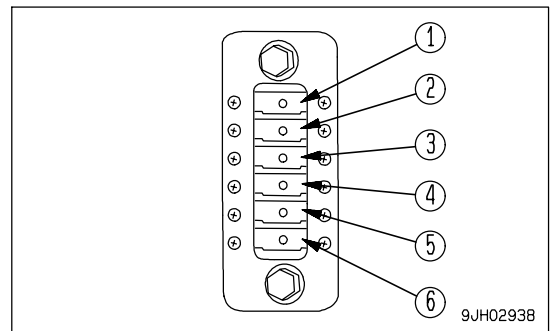

9JH02938

REMARK

The circuit breaker is a device installed in electric circuits where a large current flows. It is installed to protect the electric circuit. It protects the electric components and wiring from damage caused by an abnormal current in the same way as a normal fuse. After repairing and restoring the location of the abnormality, there is no need to replace the breaker. It can be used again.

FUSE CAPACITY AND NAME OF CIRCUIT

FUSE BOX I

(1) Fuse box fs1

No.	Fuse capacity	Circuit
1	20A	-
2	20A	CAB continuous power
3	10A	-
4	10A	-
5	20A	VHMS continuous power

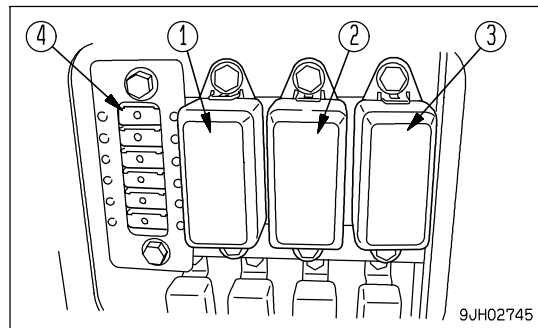

(2) Fuse box fs2

No.	Fuse capacity	Circuit
1	20A	Auxiliary power 1
2	20A	Fuel pump power
3	20A	Add heater power
4	20A	Work lamp
5	20A	Rear lamp

(3) Fuse box fs4

No.	Fuse capacity	Circuit
1	20A	Back up alarm
2	20A	Auxiliary power 2
3	20A	VHMS controller
4	20A	Ribbon heater, Horn
5	20A	Auxiliary acc signal

FUSE BOX II

NO.	Fuse capacity	Circuit
(1)	10A	Radio memory
(2)	20A	Radio, lamp, cigarette lighter
(3)	10A	Rear wiper
(4)	10A	Right door wiper
(5)	10A	Front wiper
(6)	10A	Left door wiper

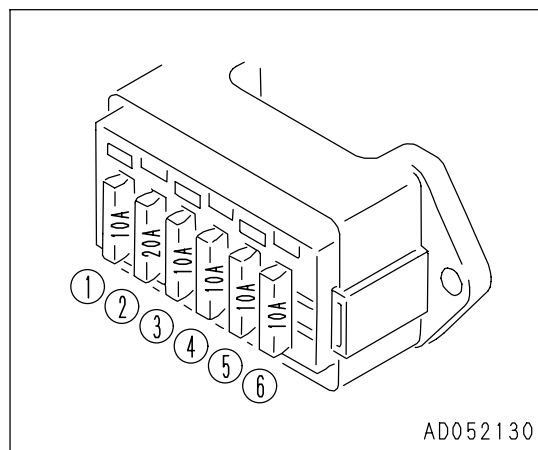

FUSIBLE LINK

If the starting motor does not work even when the starting switch is turned to the ON position, there may be a disconnection in fusible links (2) and (3) on top of the wiring, so remove the cover (1) at the side of the battery box cover on the left side of the machine and check or replace.

Capacity of (2): 32 A

Capacity of (3): 96 A

REMARK

A fusible link refers to the large-sized fuse wiring installed in the high current flow portion of the circuit to protect electrical components and wiring from burning, in the same way as an ordinary fuse.

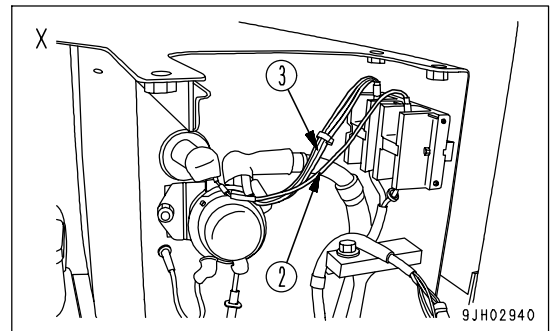
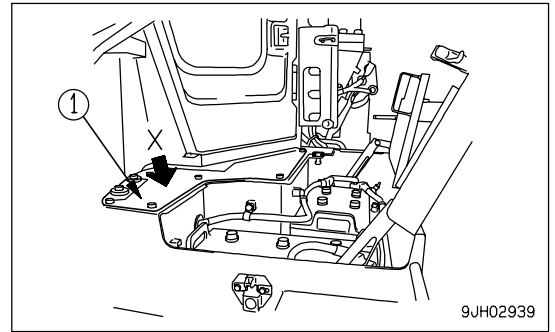

DOOR OPEN LOCK

NOTICE

- When keeping the door open, fix it securely to the catch.
- Always close the door when traveling or carrying out operations. Leaving the door open will cause the door to break.
- Keep the door locked open securely. The door may swing closed because of the vibration.

Use this when your want to keep the door held open.

1. Push the door against door catch (1). The door will be held by the door catch.

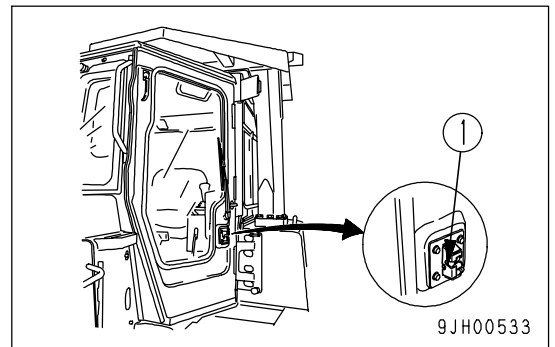

2. To release the door, move lever (2) inside the cab forward. This will release the catch.

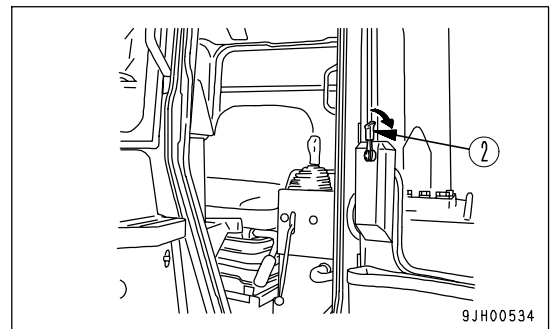

SASH GLASS INTERMEDIATE LOCK

When working with the cab sash glass open, use this lock to prevent the glass from chattering.

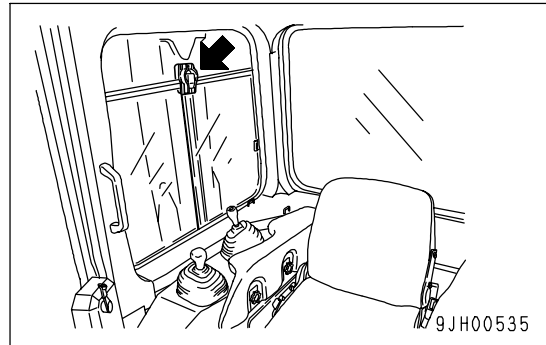

- When the lever is in the FREE position (F), the glass can be opened or closed.
- When the lever is moved (up or down) to the LOCK position (L), the glass is fixed in position.
- If the glass is not held securely, set the lever in the FREE position (F) and rotate clockwise (1) to strengthen the holding power.
- To reduce the holding power, turn counterclockwise (2).

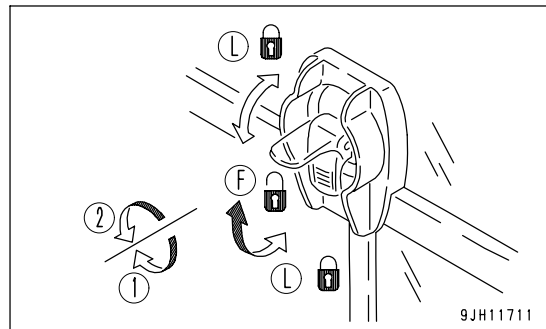

NOTICE

Always close the window when traveling or carrying out operations. Leaving the window open will cause the window to break.

DOOR POCKET

This is inside the left and right doors. Use them for storing things. Do not put heavy tools or other heavy objects in them.

If the pocket is dirty, loosen four bolts (1), then remove the pocket and rinse it.

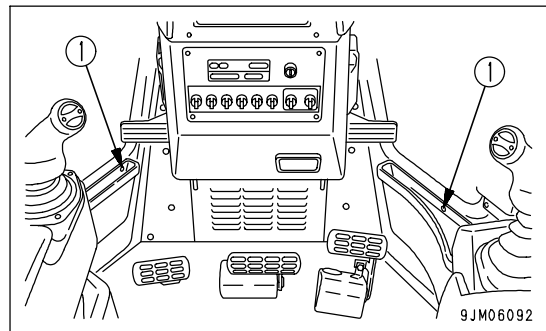

ASHTRAY

This is on the left side of the operator's seat.

Always make sure that you extinguish the cigarette before closing the lid.

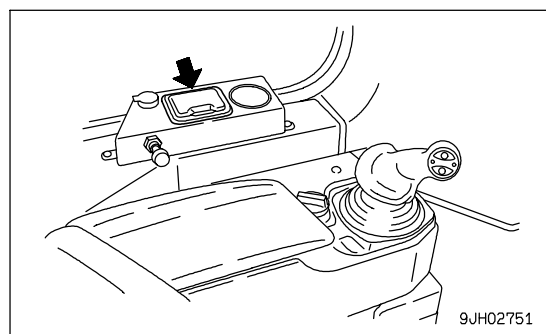

TOOL BOX

This is inside the front of the right fender.
It is used for storing tools.

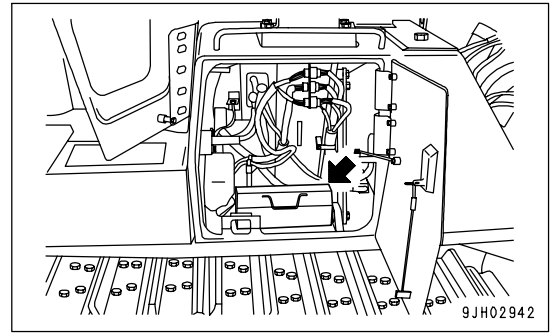

CAR STEREO, HANDLING

EXPLANATION OF COMPONENTS

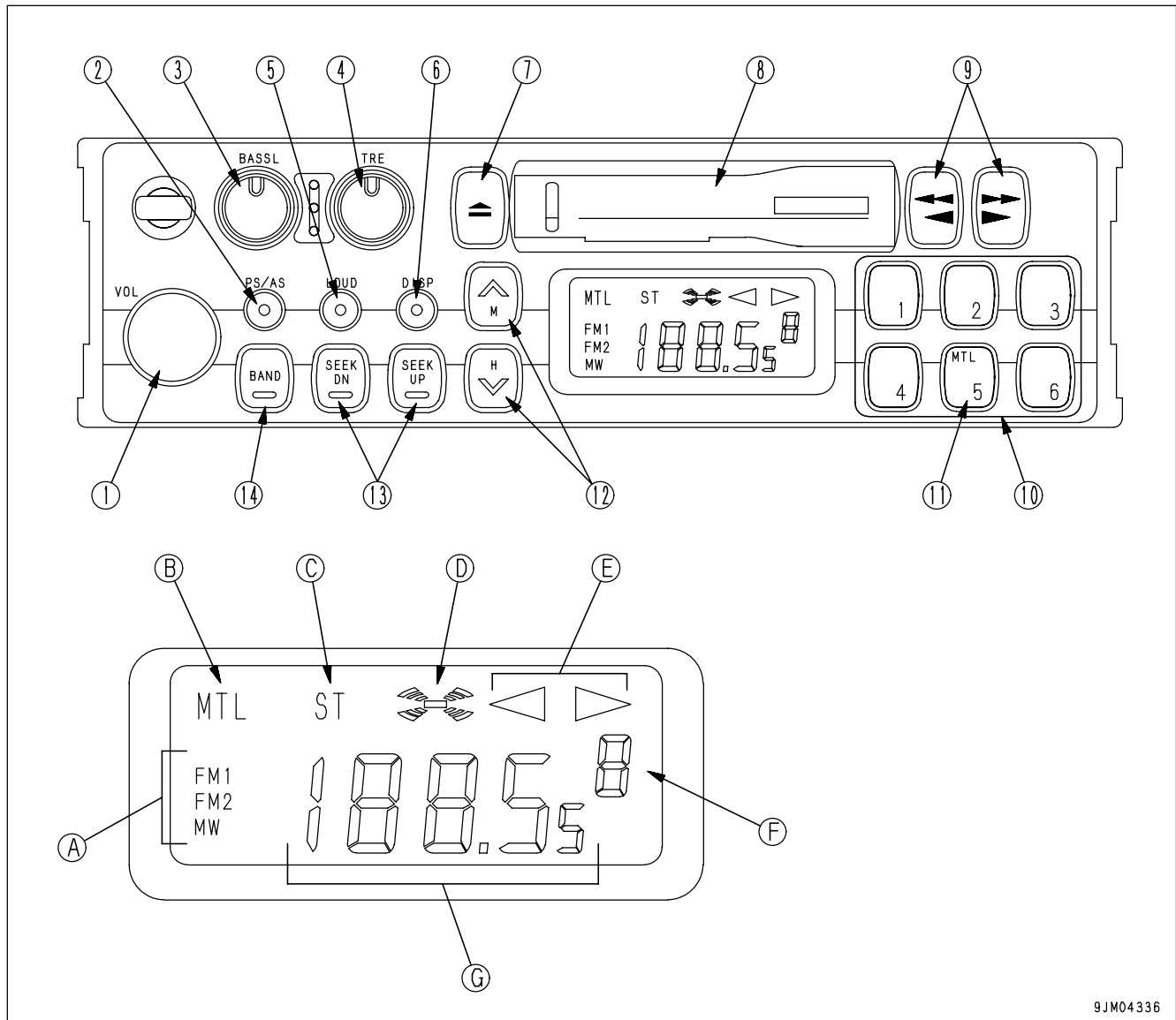

9JM04336

- (1) Power switch/volume
- (2) Auto-store/preset scan button
- (3) Bass control knob
- (4) Treble control knob
- (5) Loudness button
- (6) Time/radio display selector button
- (7) Tape eject button
- (8) Cassette door
- (9) Fast forward, rewind buttons
- (10) Preset buttons
- (11) Metal tape button
- (12) Manual tuning buttons
- (13) Seek tuning buttons
- (14) Band selector button
- (A) Band display
- (B) Metal tape display
- (C) FM stereo reception display
- (D) Loudness display
- (E) Tape direction display
- (F) Preset channel display
- (G) Time/frequency display

POWER SWITCH/VOLUME

Turn this knob (1) to the right until it clicks to turn the power on.
Turn it further to increase the volume.

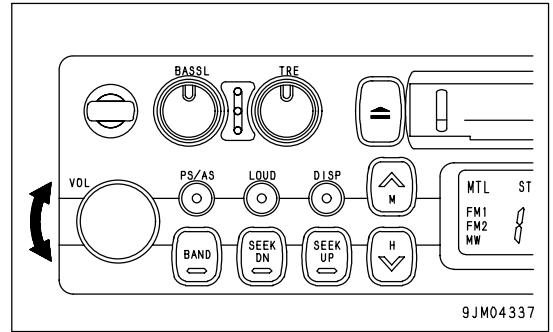

AUTO-STORE/PRESET SCAN BUTTON

Use this button (2) to actuate the preset scan and auto-store functions.

- Auto-store
Each time this button is pressed for more than 2 seconds while in radio reception, this auto-store function automatically starts to search for the desired station within a receivable band, and memorize the frequency in the preset memory. During this scanning process, the frequency shown in the right side of display continues to change. This indicates that each frequency is memorized in the auto-store.

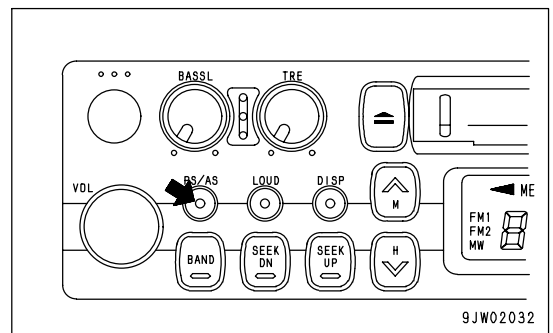

REMARK

The auto-store function cannot be used when the channel display is flashing.

When the display is flashing, the preset scan function is being used.

- Preset scan
If this button is pressed for less than 0.5 second while in radio reception, programs from the six preset stations in the same band will be broadcast one after another for 5 seconds each, starting from No. 1 through No. 6 stations consecutively.
When the desired station is found, press the button again. This stops the preset scan tuning process and switches to ordinary broadcasting. The same process will be repeated continuously until the button is pressed again.

BASS CONTROL KNOB

Turn this button (3) to the left to reduce the low tones; turn it to the right to emphasize the low tones.

- Direction (a): Low tone reduced
- Direction (b): Low tone emphasized

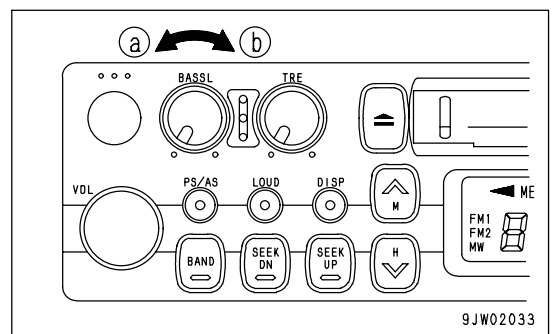

TREBLE CONTROL KNOB

Turn this button (4) to the left to reduce the low tones; turn it to the right to emphasize the high tones.

Direction (a): High tone reduced

Direction (b): High tone emphasized

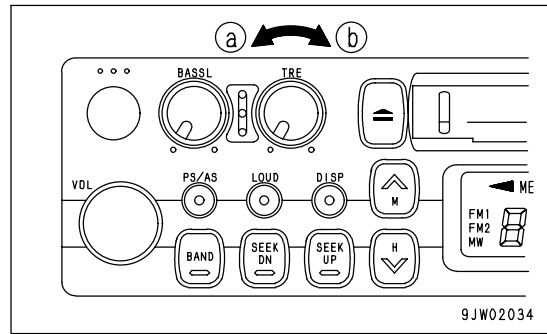

LOUDNESS BUTTON

This button (5) is used when playing at low volume. It makes it possible to hear more easily by emphasizing the low tone when the low tones are weak.

Push button: Actuated (ON)

Push button again: Canceled (OFF)

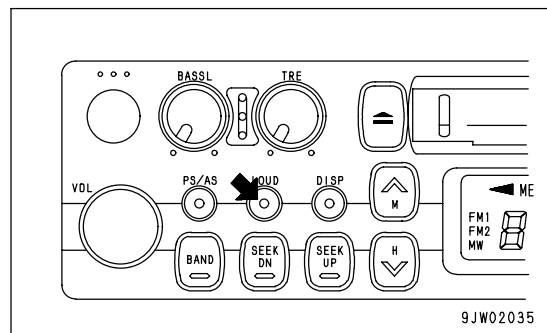

TIME/RADIO DISPLAY SELECTOR BUTTON

This button (6) is used to switch between the "Radio/tape display" and the "Time display".

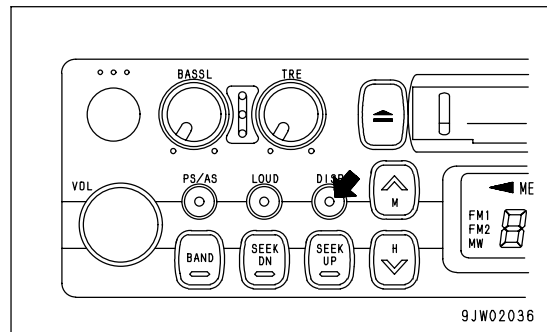

• Correcting the time

Press the button to set the time display.

(A) Correcting hour:

Keep the DISP button pressed and press the bottom (H) of the TUNING button to correct the hour.

(B) Correcting minute:

Keep the DISP button pressed and press the top (M) of the TUNING button to correct the minute.

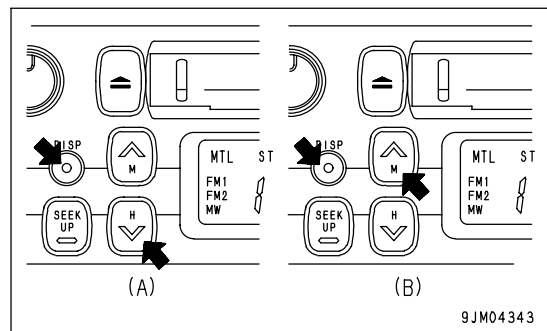

TAPE EJECT BUTTON

This button (7) is used to stop the tape and to eject the cassette. When this button is pressed, the tape is ejected and the radio plays.

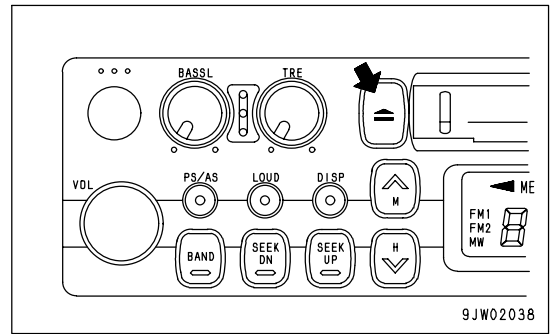

CASSETTE DOOR

Set the cassette with the exposed portion of the tape on the right side and insert it through the cassette door (8).

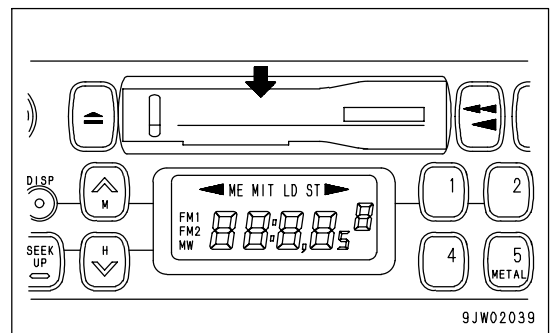

FAST FORWARD, REWIND BUTTONS

These buttons (9) are used to fast-forward or rewind the tape.

- Fast-forward/rewind

If you press the button pointing in the same direction as the lighted arrow indicating the direction of play, the tape will be fast-forwarded; if you press the button pointing in the opposite direction, the tape will rewind.

To stop the tape, lightly press the button that is not locked. The fast-forward or rewind operation will be canceled.

If the fast-forward and rewind buttons are pressed at the same time, the tape will change sides.

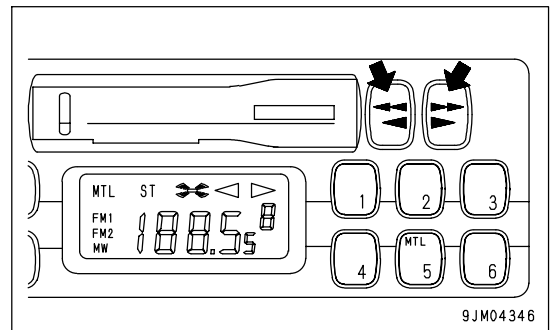

PRESET BUTTONS

These buttons (10) are used to call up the broadcast station frequencies preset in memory for each of buttons No. 1 to No. 6. It is possible to preset 18 stations (FM: 12; AM: 6) with these buttons.

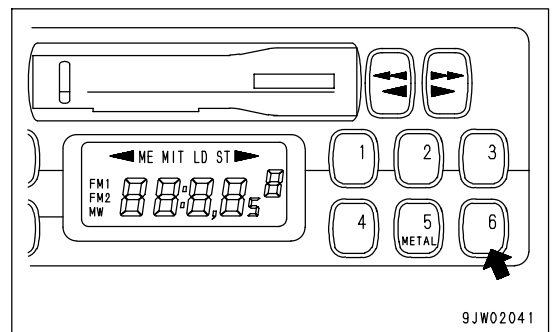

METAL TAPE BUTTON

(used also for preset button No. 5)

This button (11) is used when playing a metal or chrome tape. This button is also used for preset button No. 5. When it is pressed, "MTL" appears on the display.

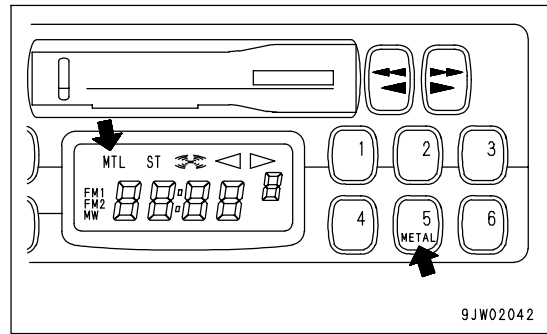

MANUAL TUNING BUTTONS

These buttons (12) are used for manual tuning.

When "TUN ^" button is pressed, the frequency goes up; when "TUN v" button is pressed, the frequency goes down. If the button is pressed down and held, the frequency will change continuously.

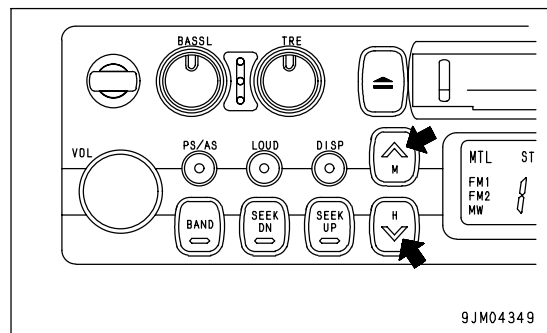

SEEK TUNING BUTTONS

These buttons (13) are used to seek tuning.

When the "SEEK UP" button is pressed, the search automatically goes up; when the "SEEK DN" button is pressed, the search automatically goes down.

When the next station that can be received is found, it automatically stops.

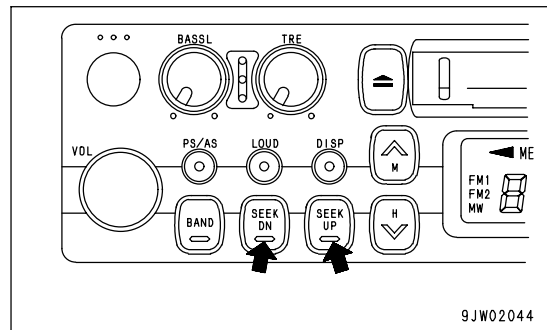

BAND SELECTOR BUTTON

When this button (14) is pressed, the band is switched between FM1, FM2, and MW (AM). The band is shown on the display.

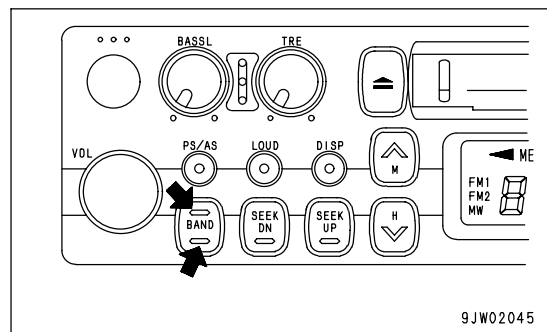

METHOD OF OPERATION

METHOD OF SETTING PRESET BUTTONS

It is possible to preset 6 MW (AM) stations and 12 FM stations (FM1: 6 stations, FM2: 6 stations).

REMARK

If you are playing the cassette, press the tape eject button to stop the tape.

METHOD OF AUTO PRESET

1. Use band selector button (1) to select MW (AM), FM1 or FM2.
2. Press auto-store/preset scan button (2) for less than 0.5 second.
3. The preset scan tuning function automatically searches for the desired station within the same band and can memorize as many as 6 stations in the preset memory.

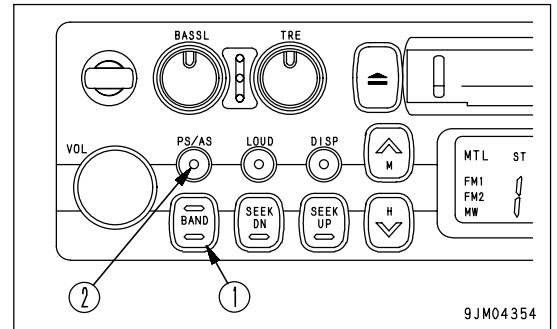

METHOD OF MANUAL PRESET

1. Use band selector button (1) to select MW (AM), FM1 or FM2.
2. Press manual tuning buttons (2) or seek tuning buttons (3).
3. Press preset button (4) of the number to be preset for 2 seconds while the frequency display is being shown on the display. (The preset channel and frequency are displayed and the presetting is completed).
4. Repeat the steps explained in Item 2 and 3 above to preset other stations to the subsequent numbers.
5. If you want to preset a station in the other bands, follow the steps explained in Item 1 through 4 above.

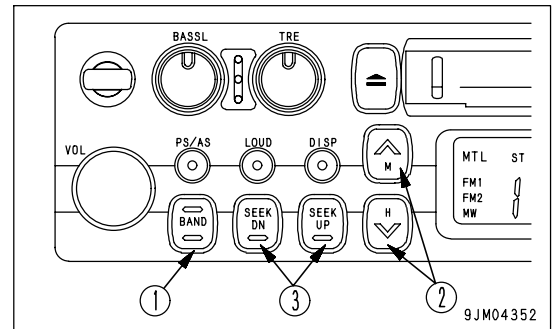

REMARK

- Also, use Steps 2 and 3 when changing the setting of a preset switch to another station.
- When the power is disconnected, such as when the battery is replaced, all the settings are deleted, so preset the stations again.

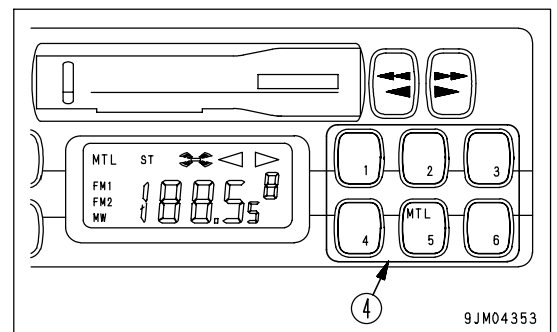

LISTENING TO RADIO

1. Turn the starting switch ON, then turn power switch (1) ON.
2. Use band selector button (2) to select MW (AM), FM1 or FM2.
3. Select the station with the preset buttons (3).

REMARK

In case you do not promptly remember the number assigned to a certain preset station, press auto-store/preset scan button (4) for less than 0.5 second. The preset 6 stations will broadcast one after another for 5 seconds each. When the desired station broadcasts, press the button again and scan tuning stops.

4. If you want to tune in to a station that is not preset, use either seek tuning button (5) or manual tuning button (6).
5. Adjust the volume, balance, and tone as desired.
6. When turning the radio OFF, turn power switch (1) to the left until it clicks.

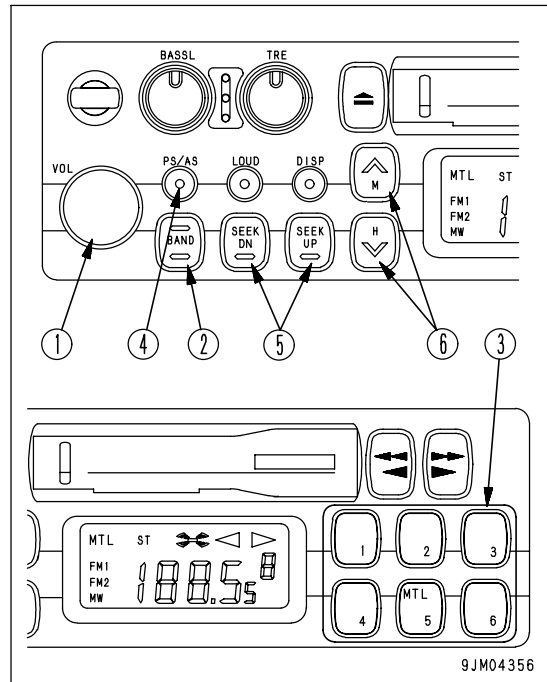

REMARK

- To switch to the radio when listening to a cassette, press the cassette eject button to stop the tape.
- If you insert a cassette when listening to the radio, the tape will start to play.

LISTENING TO CASSETTE TAPE

1. Turn the starting switch ON, then turn power switch (1) ON.
2. Set the cassette with the exposed portion of the tape on the right side and push it past the cassette door. The tape will automatically start playing.

If the arrow indicating the direction of play is pointing to the right, the top side is being played; if the arrow is pointing to the left, the bottom side is being played.

When the tape reaches the end, it is automatically reversed and the other side starts to play.

3. When finished with the tape, press the cassette eject button to eject the tape and automatically switch to the radio.

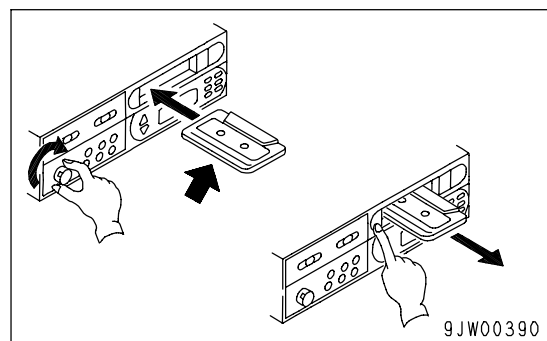
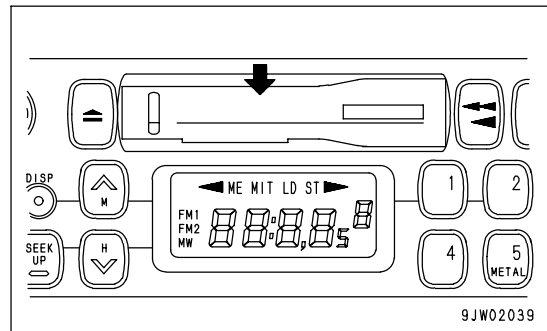

REVERSING TAPE

When listening to the tape, press both FAST FORWARD, REWIND buttons (A) and (B) at the same time lightly.

When this is done, the tape direction display will be reversed.

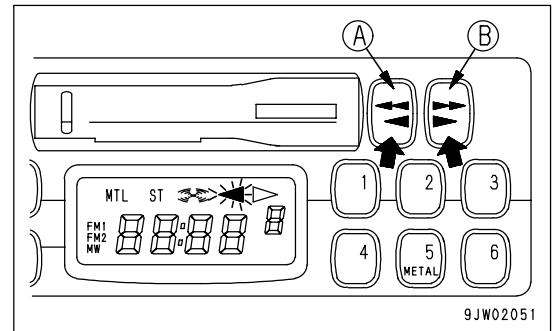
**PRECAUTION WHEN USING****WARNING**

- If a voltage greater than the specified voltage is input, it may cause fire, electrocution, or other failure. Never input any voltage other than the specified voltage.
- Places inside the radio are under high voltage. Do not remove the cover.
- Do not carry out any modifications. This may cause fire, electrocution, or other failure.
- If the sound cannot be heard, nothing is displayed, or any other problem occurs, turn off the power switch and ask your Komatsu distributor to make repairs without delay.

- Stow the antenna when traveling in places with low overhead clearance.
- To ensure safety during operations, keep the volume at a level where it is possible to hear other machines.
- If water gets inside the speaker case or radio (auto tuning), it may cause a serious problem, take care not to let water get in these items.
- Do not wipe the scales or buttons with solvent such as benzene or thinner. Wipe with a dry soft cloth. If the dirt cannot be removed easily, soak the cloth with alcohol.

NOTICE**Handling cassette tape**

- Clean the tape head approx. once a month with a commercially available head cleaning tape.
- Do not leave the tape any place where it is exposed to direct sunlight, any place that is excessively dusty, or any place where there is a magnetic field.
- Do not use 120-minute tapes. The tape is thin and it easily gets caught up inside the machine.
- If the tape is slack, it easily gets caught up inside the machine. Use a pencil to wind in the tape to remove any slack.
- Do not use any cassette tape if the label has started to come off. It may cause defective rotation, or it may be impossible to get the tape out of the machine.

AIR CONDITIONER, HANDLING

GENERAL LOCATIONS OF CONTROL PANEL

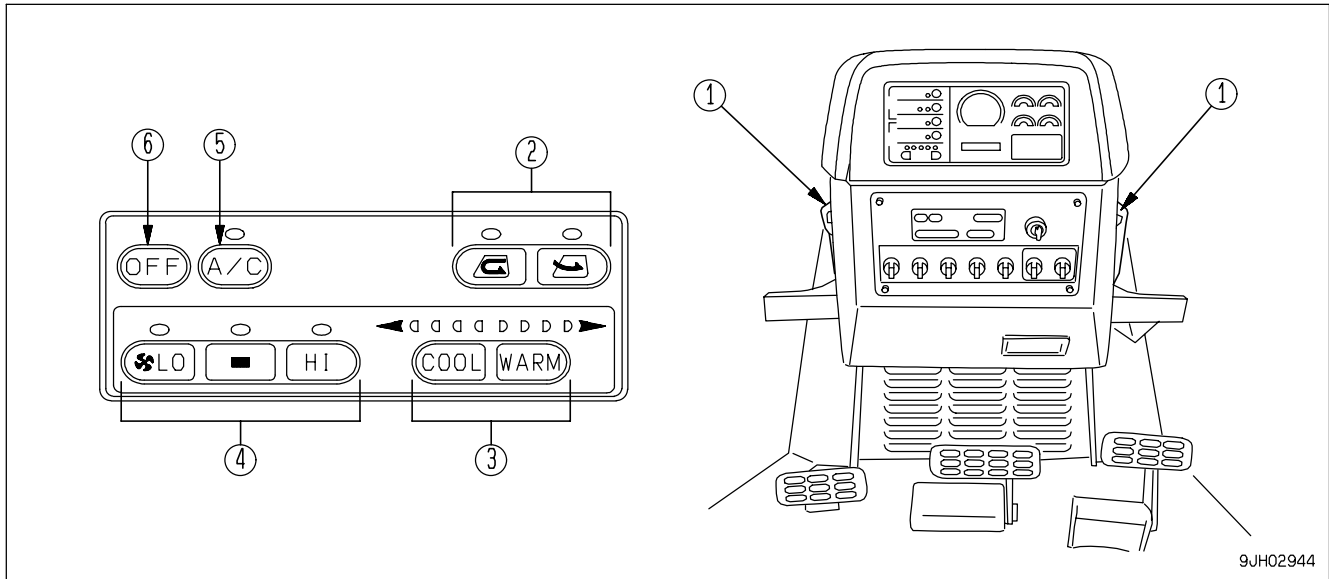

- (1) Vent selector lever
- (2) FRESH/RECIRC selector switch
- (3) Temperature control switch
- (4) Air flow selector switch
- (5) Air conditioner switch
- (6) OFF switch

VENT SELECTOR SWITCH (sending air to upper half of cab)

If lever (1) is pulled to position (b), the air from the air conditioner is all directed to the upper half of the cab.

This can be used when sending a cool breeze during hot weather.

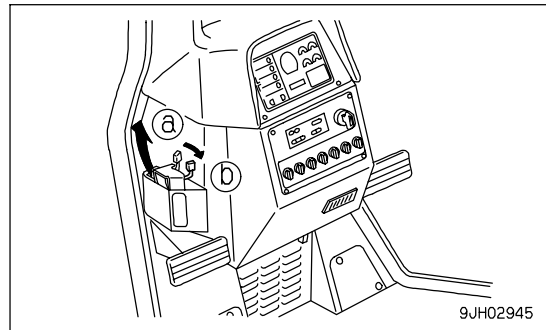

VENT SELECTOR SWITCH (sending air to feet)

If lever (1) is pushed to position (a), the air from the air conditioner is all directed to the feet.

This can be used to send warm air to the feet during cold weather.

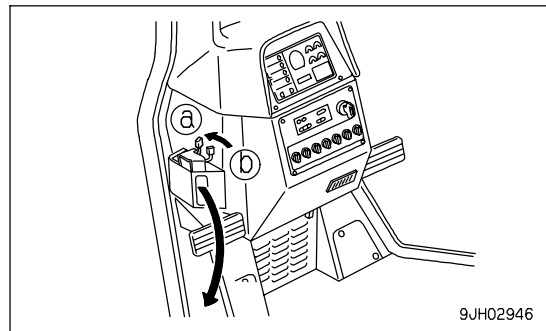

FRESH/RECIRC SELECTOR SWITCH (RECIRCULATE)

When switch (2) is pressed, the air inside the cab is recirculated and no fresh air is taken in from outside. This position is used when heating or cooling the cab quickly or when the outside air is dirty.

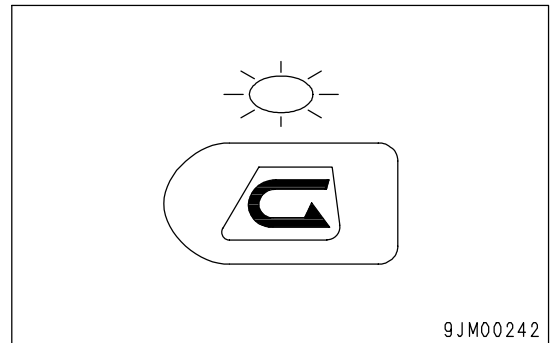

FRESH/RECIRC SELECTOR SWITCH (FRESH)

When switch (2) is pressed, fresh air is taken into the cab during heating or cooling.

This position is used to bring in clean fresh air into the cab or to remove the mist from the cab windows.

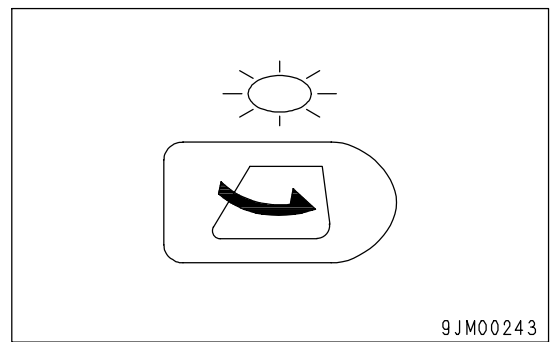

TEMPERATURE INDICATOR

The further the indicator is in the blue range (B), the lower the temperature is; the further the indicator is in the red range (R), the higher the temperature is.

The indicator range is divided into 7 levels, but within each range the temperature changes sleeplessly.

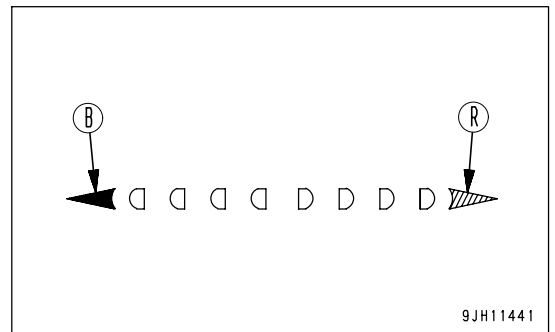

TEMPERATURE CONTROL SWITCH (COOL)

Use switch (3) to reduce the temperature.

Press this switch to reduce the temperature of the air sent from the air conditioner.

The lower the temperature becomes, the further the indicator moves into the blue range.

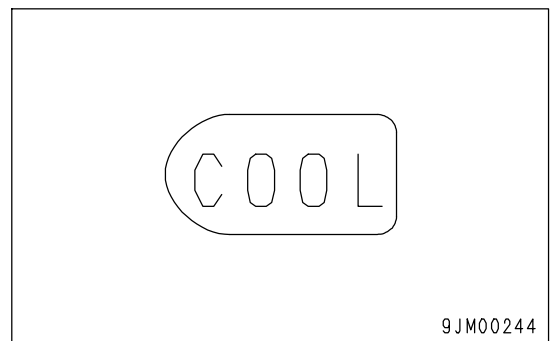

TEMPERATURE CONTROL SWITCH (WARM)

Use switch (3) to increase the temperature.

Press this switch to increase the temperature of the air sent from the air conditioner.

The higher the temperature becomes, the further the indicator moves into the red range.

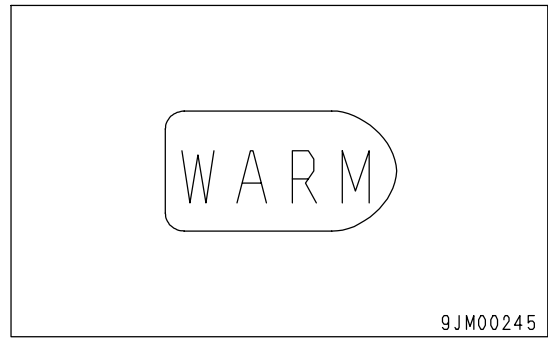
**AIR FLOW SELECTOR SWITCH (LO)**

Switch (4) is used to set the flow of air from the air conditioner to LOW.

When this switch is pressed, the air flow is set to the minimum amount of the three available levels.

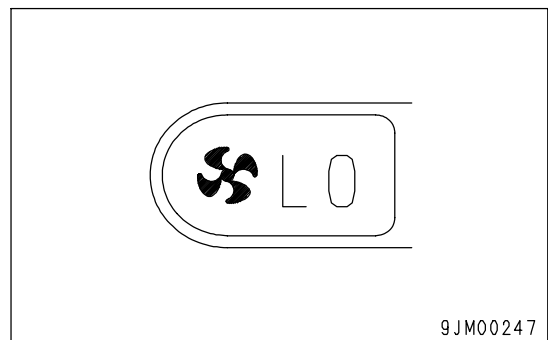
**AIR FLOW SELECTOR SWITCH (MID)**

Switch (4) is used to set the flow of air from the air conditioner to MID. When this switch is pressed, the air flow is set to the medium amount of the three available levels.

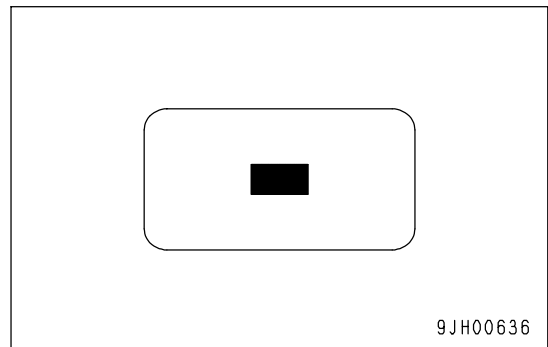
**AIR FLOW SELECTOR SWITCH (HI)**

Switch (4) is used to set the flow of air from the air conditioner to HI.

When this switch is pressed, the air flow is set to the maximum amount of the three available levels.

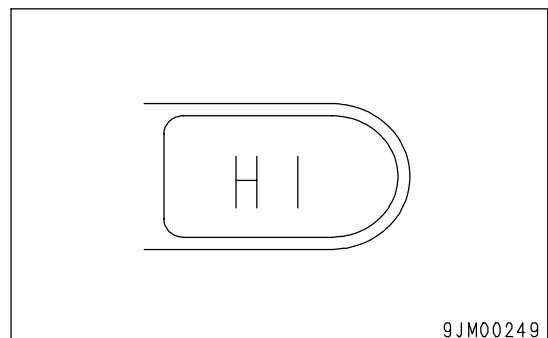

AIR CONDITIONER SWITCH

This switch (5) is used to switch the air conditioner ON/OFF.

REMARK

For machines equipped with a heater only, switch (5) is not available. (Option)

OFF SWITCH

Switch (6) is used to stop operation of the fan.

REMARK

When fresh air is taken into the cab, air pressure in the cab increases, which prevents the dust from entering. When neither heating nor cooling is needed, bring in clean fresh air, with your preferred air flow, to prevent dust from entering the cab.

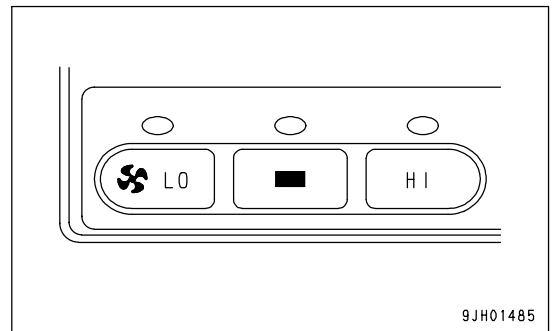
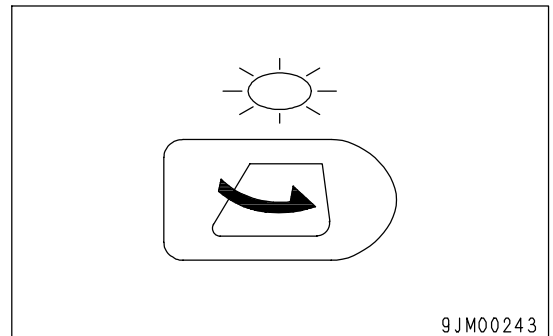

PRECAUTIONS WHEN USING AIR CONDITIONER

WHEN CARRYING OUT COOLING, VENTILATE THE CAB FROM TIME TO TIME

- If you smoke when using the air conditioner, your eyes may start to itch or burn, therefore ventilate the cab every so often to remove the smoke.
- When the air conditioner is used for long periods, carry out ventilation once every hour.

BE CAREFUL NOT TO COOL TOO MUCH

- For reasons of health, it is recommended that the cab should feel pleasantly cool when you enter it from the outside (5 to 6°C (9.0 to 10.8°F) lower than the outside temperature). Pay attention to the temperature when carrying out cooling.

SET SO THAT COLD AIR DOES NOT DIRECTLY BLOW ONTO THE GLASS SURFACE

- If the vents (left and right) in the middle of the dashboard are turned so that cold air plays directly on the cab door glass, moisture may condense on the outside of the cab door glass and reduce the visibility. (This occurs particularly in high temperatures.)

If this happens, turn the vent fully to the rear and raise the air conditioner temperature setting slightly.

CHECKS DURING OFF-SEASON

Even during the off-season, run the compressor at low speed for several minutes once a week to prevent the loss of the oil film on the lubricated parts of the compressor. (Run the engine at low speed and set the temperature control lever to the central position.)

REMARK

When the ambient temperature is low, if the compressor is suddenly run at high speed, it may cause failure of the compressor. Note that the system is set so that the compressor will not run when the cooler switch is turned on, if the ambient temperature is less than 2 to 6.5°C (35.6 to 43.7°F).

PROCEDURE FOR REPLACING RECEIVER

Replace the receiver once every 2 years.

After replacing the receiver, add compressor oil. Turn the receiver at an angle and measure the oil remaining inside the receiver, then add the same amount of oil (Denso Oil 6) to fill the receiver.

REMARK

- The replacement interval may become shorter depending on the conditions during use.
- If the receiver is used when the moisture absorption limit of the desiccant has been exceeded, the refrigerant circuit may become blocked and cause the compressor to break down.

PRECAUTIONS WHEN REPLACING RECEIVER

- If the receiver is left for more than 15 minutes with the blind cover removed, the moisture in the air will be absorbed, and this will reduce the life of the desiccant. If you remove the blind cover, connect the piping quickly, evacuate the system and fill with refrigerant.
- When removing the refrigerant from the refrigerant circuit, release it gradually from the low pressure side to prevent oil from flowing out.

CHECK COMPRESSOR BELT TENSION AND REFRIGERANT (GAS) LEVEL

If the compressor belt is loose, or the refrigerant level is low, cooling is not carried out efficiently.

For details, see "WHEN REQUIRED (PAGE 4-20)".

CLEANING AIR FILTER

If the air filter for the FRESH or RECIRC air intake becomes clogged, the cooling or heating capacity will drop.

To prevent this, clean the air filter with compressed air once a week.

For details of the cleaning method, see "WHEN REQUIRED (PAGE 4-20)".

ACCUMULATOR, HANDLING



WARNING

On machines equipped with an accumulator, for a short time after the engine is stopped, if the work equipment control lever is moved to the LOWER position, the work equipment will move down under its own weight.

After stopping the engine, always place the work equipment lock lever and parking lever in the LOCK position.

The accumulator is charged with high-pressure nitrogen gas, so improper operation may cause an explosion which will lead to serious injury or damage. When handling the accumulator, always do as follows:

- Pressure in the control circuit cannot be completely removed. When removing the hydraulic equipment, do not stand in the direction that oil spurts out when performing the operation.
- Loosen the bolts slowly.
- Do not disassemble the accumulator.
- Do not bring it near flame or dispose of it in fire.
- Do not make holes in it or weld it.
- Do not hit it, roll it, or subject it to any impact.
- When disposing of the accumulator, the gas must be released. Contact your Komatsu distributor for proper disposal.

The accumulator is a device to store the pressure in the control circuit, and when it is installed, the control circuit can be operated for a short time even after the engine is stopped.

Therefore, if the control lever is moved in the direction to lower the work equipment, it is possible for the work equipment to move under its own weight.

The accumulator is installed in the position shown in the diagram on the right.

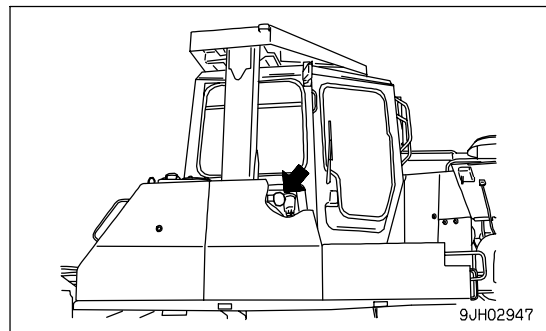

METHOD OF RELEASING PRESSURE IN OPERATING CIRCUIT ON MACHINE EQUIPPED WITH ACCUMULATOR

1. Lower the work equipment and stop the engine.
2. After stopping the engine, operate control lever full strokes to the front, rear, left, and right to release pressure inside the work equipment circuit.

However, the pressure cannot be completely released, so if accumulator in the work equipment circuit is removed, loosen the screws slowly, and never stand in the direction oil spurts out.

OPERATION

CHECK BEFORE STARTING ENGINE, ADJUST

WALK-AROUND CHECK

Before starting the engine, walk around the machine and look at the underside of chassis for anything unusual like loose bolts and nuts, leakage of fuel, oil and coolant. Also check the condition of the work equipment and the hydraulic system.

Also check for loose wiring, play, and collection of dust at places that reach high temperature.



WARNING

- Leakage of oil or fuel, or accumulation of flammable material around high temperature parts, such as the engine muffler or turbocharger, may cause fire.
Check carefully, and if any abnormality is found, repair it or contact your Komatsu distributor.
- Do not get on or off the machine from the rear. Using this position is dangerous because it is easy to slip and you cannot be seen from the operator's compartment. Always use the handrail and step at the side when getting on or off the machine.

If the machine is at an angle, make it level before checking.

Before starting the engine, look around the machine and under the machine to check for loose nut or bolts, or leakage of oil, fuel, or coolant, and check the condition of the work equipment and hydraulic system. Check also for loose wiring, play, and collection of dust at places which reach high temperatures.

Always carry out the items in this section before starting the engine each day.

1. Check for damage, wear, play in work equipment, cylinders, linkage, hoses
Check for cracks, excessive wear, play in work equipment, cylinders, linkage, and hoses. If any abnormality is found, repair it.
2. Remove dirt and debris from around the engine, battery, and radiator
Check for dirt accumulated around the engine or radiator. Also check for flammable material (dry leaves, twigs, grass, etc.) accumulated around the battery, engine muffler, turbocharger, or other high temperature engine parts. If any dirt or flammable materials are found, remove them.
3. Check for coolant and oil leakage around the engine
Check for oil leakage from the engine and coolant leaks from the cooling system. If any abnormality is found, repair it.
4. Check for leakage of oil from power train case, final drive case, hydraulic tank, hose, joints
Check that there is no oil leakage. If any abnormality is found, repair the place where the oil is leaking.
Check for leakage of oil from the undercover. Check the ground for traces of oil leakage.
5. Check the undercarriage (track, sprocket, idler, guard) for damage, wear, loose bolts, or leakage of oil from rollers
If any damage, wear, or oil leakage is found, repair the problem and tighten the bolts.
6. Check for damage to handrail and loose bolts
Repair any damage and tighten any loose bolts.

7. Check for damage to gauges, lamps on the instrument panel, and loose bolts

Check for damage to the panel, gauges, and lamps. Replace any damaged parts. Clean off any dirt on the surface.

8. Check for damage to seat belt and mounting clamps

Check that there is no abnormality in the seat belt or mounting clamps. If there is any damage, replace with new parts.

CHECK BEFORE STARTING

Always check the items in this section before starting the engine each day.

CHECK MACHINE MONITOR

1. Turn starting switch (1) to the ON position (B).
2. Check that the monitor and gauges light for 3 seconds, and the alarm buzzer sounds for 1 seconds.

REMARK

If the lamps do not light up, there may be a failure or disconnection in the monitor, please contact your Komatsu distributor.

NOTICE

Do not simply use the monitor to carry out the check before starting. Always carry out the check before starting according to the procedure on the following pages.

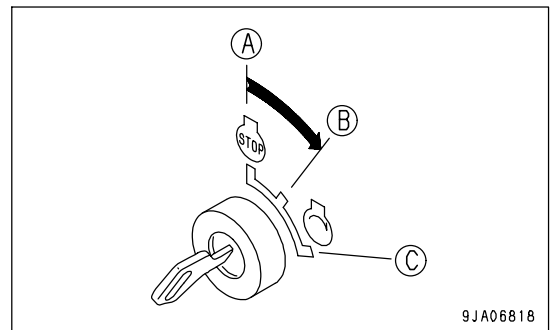
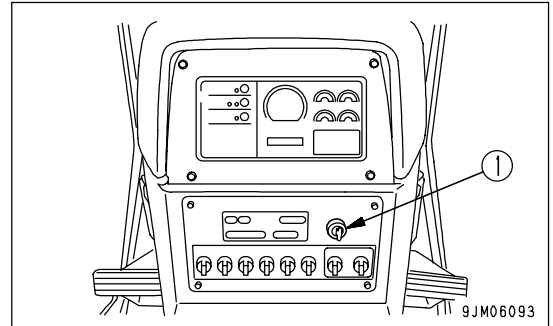

CHECK COOLANT LEVEL, ADD COOLANT

 **WARNING**

- Normally, do not open the radiator cap. When checking the coolant level, check the sub-tank when the engine is cold.
- Do not remove the cap when the radiator coolant is hot. Boiling coolant may spurt out. After the coolant temperature goes down, turn the cap slowly to release the pressure, then remove it.

1. Open the engine side cover on the left side of the chassis, and check that the coolant is between the FULL and LOW marks on sub-tank (1). If the coolant level is low, add coolant to the FULL level through the coolant filler port in sub-tank (1).

REMARK

The coolant may overflow from the sub-tank drain hose. This is no problem. It occurs because too much coolant has been added.

2. After adding coolant, tighten the cap securely.

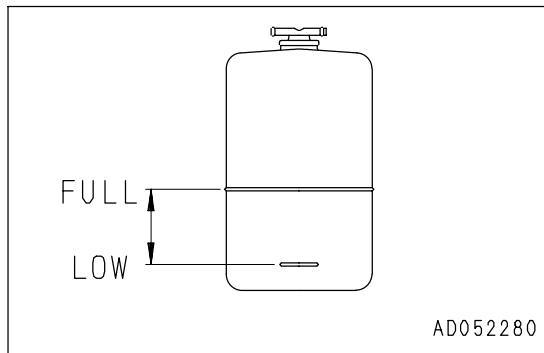
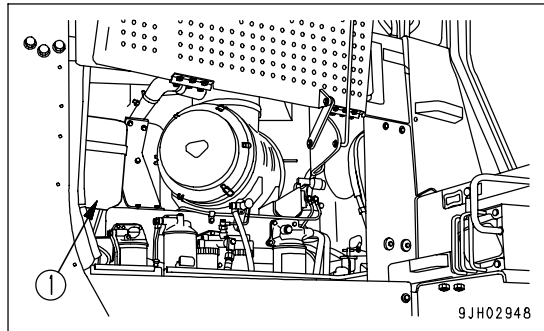

3. If the sub tank is empty, first check for leakage of water, then remove main radiator cap (2) and sub radiator cap (3), and check that the coolant water is above the bottom surface of the strainer as shown in the diagram on the right. Add water if the level is low.

4. After adding coolant, close the engine side cover.

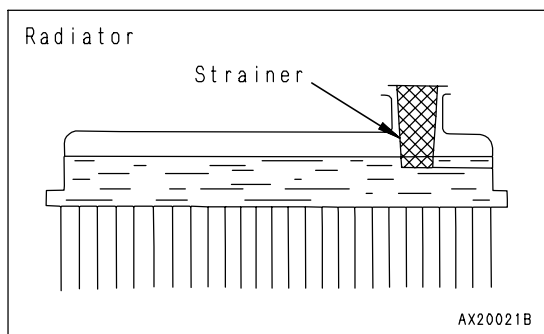
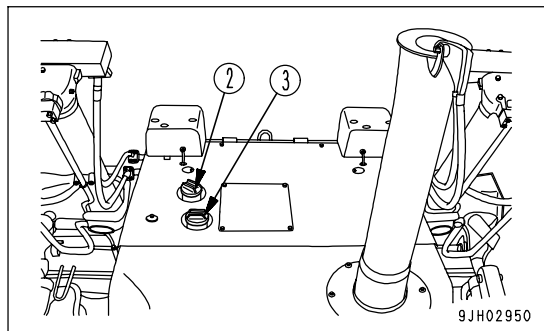

CHECK FUEL LEVEL, ADD FUEL

**WARNING**

When adding fuel, never let the fuel overflow. This may cause a fire. If the fuel is spilt, wipe it off completely.

1. Turn the starting switch to the ON position and check the fuel level with fuel gauge (G) on the monitor panel.
After checking, turn the switch back to the OFF position.

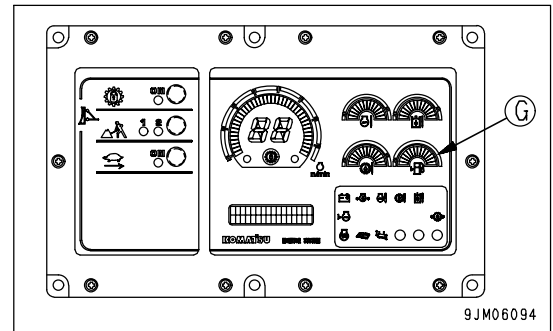

2. After completing work, fill the fuel tank through fuel filler port (F).
Check the fuel level with the fuel gauge at the fuel filler port.
3. After adding fuel, tighten the cap securely.
Fuel capacity: 840 liters (221.93 US gal)

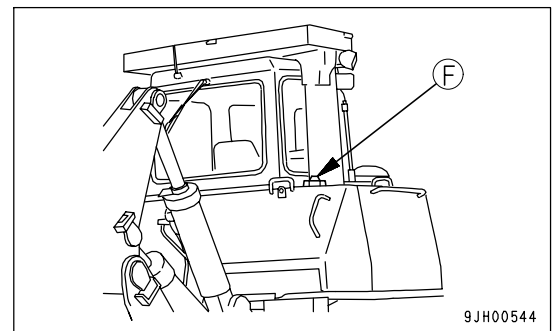
**REMARK**

- When dozing on a grade, make sure there is plenty of fuel in the tank so that the engine fuel line does not become aerated.
- If breather hole (1) on the cap is clogged, the pressure in the tank will drop and fuel will not flow.
Clean the hole from time to time.

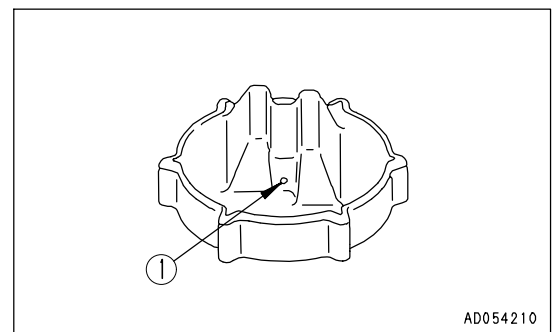

CHECK WATER SEPARATOR, DRAIN WATER AND SEDIMENT

(Machines equipped with additional fuel filter cartridge)

1. Open the side cover on the left side of the machine.
The water separator forms one unit with the additional fuel filter and is installed at the bottom.
2. It is possible to judge the water level and amount of sediment by looking through transparent cap (2). If there is any water or sediment collected at the bottom, set a container to catch the drain water under drain hose (3).
3. Loosen plug (1) and drain the water.
4. When fuel comes out from drain hose (3), tighten plug (1) immediately.
Tightening torque: 0.2 to 0.45 Nm (0.02 to 0.046 kgm, 0.1 to 0.3 lbft)

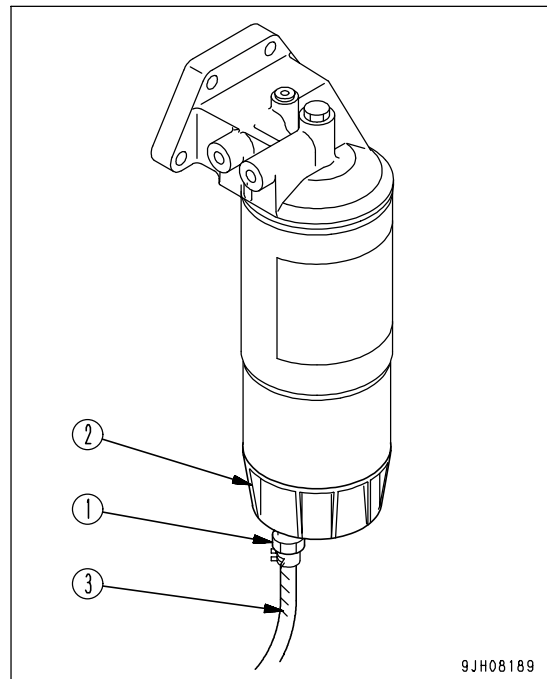

9JH08189

CHECK OIL LEVEL IN ENGINE OIL PAN, ADD OIL

**WARNING**

Parts and oil are at high temperature immediately after the engine is stopped and may cause serious burns. Wait for the oil temperature to go down before performing this operation.

1. Open the engine side cover on the left side of the chassis.
2. Remove dipstick (G), and wipe the oil off with a cloth.
3. Fully insert dipstick (G) into filler pipe (F), then remove it.

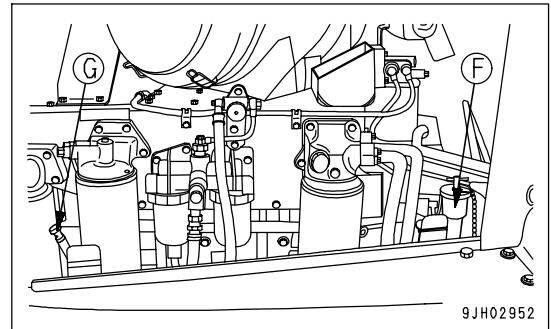

4. The oil level should be between the H and L marks on the ENGINE STOPPED side of dipstick (G).
If the oil level is below the L mark, add oil through oil filler (F).

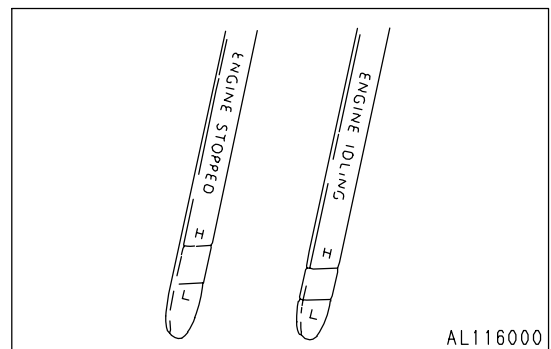

5. If the oil is above the H mark, remove drain plug (1), loosen drain valve (2) to drain the excess oil, then check the oil level again.
6. If the oil level is correct, tighten the oil filler cap securely and close the engine side cover.

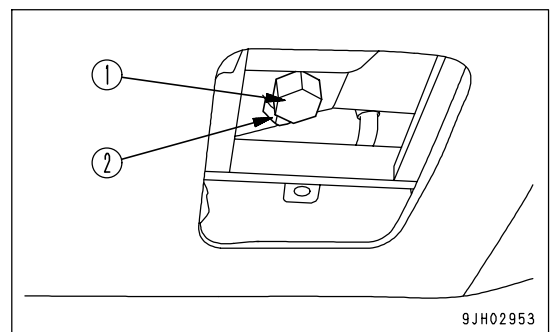
**REMARK**

- When checking the oil level after the engine has been operated, wait for at least 15 minutes after stopping the engine before checking.
- If the machine is at an angle make it horizontal before checking.
- When adding oil, remove the dipstick from the holder to release the air inside the crankcase.
- The dipstick is marked with the levels for "ENGINE STOPPED" on one side and "ENGINE IDLING" on the other side.

It is also possible to check the oil level with the engine idling, but be sure to remember the following points.

- Check oil when the engine coolant temperature gauge is within the green range.
- Read the dipstick on its reverse side marked with "ENGINE IDLING".

CHECK OIL LEVEL IN POWER TRAIN CASE, ADD OIL

1. Remove dipstick (G), and wipe the oil off with a cloth.
2. Fully insert dipstick (G) into filler pipe (F), then remove it.
3. Check that the oil level is between the H and L marks on dipstick (G).

If the oil level is below the L mark, add oil through oil filler (F). The dipstick has two sides for checking the oil level: COLD STOP for use when the engine is stopped and the oil temperature is low; and HOT IDLE for use when the engine is idling and the oil temperature is high.

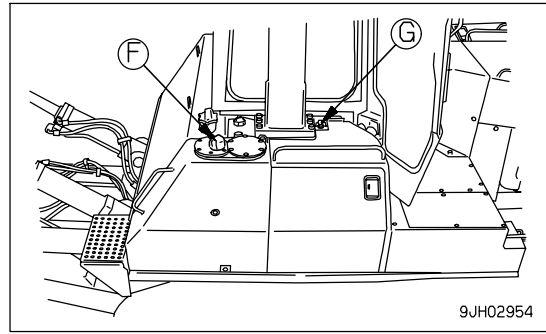

REMARK

When checking the oil level with the engine stopped before starting operations, check the oil level with the side marked COLD STOP. It is also possible to check the oil level even after starting operations when the power train oil temperature is high, but in this case, run the engine at idling and use the side marked HOT IDLE.

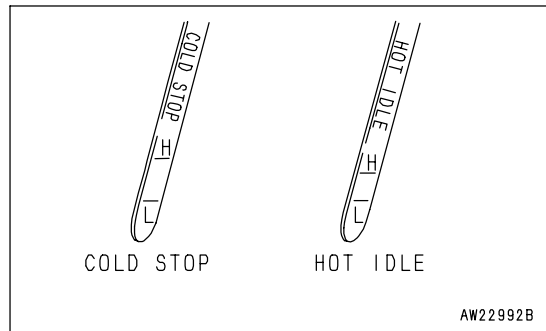

4. If the oil is above the H line, remove drain cover (1) at the left side at the bottom surface of the power train case, pull out drain hose (2) from the take-out port, loosen drain plug (3), drain the excess oil, then check the oil level again.
5. If the oil level is correct, tighten the oil filter cap securely.

REMARK

When inspecting, if the machine is at an angle, move it to a level place to carry out the check.

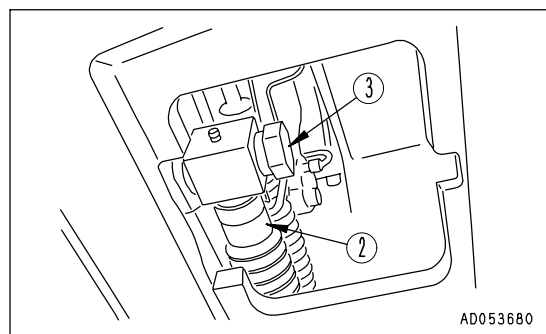
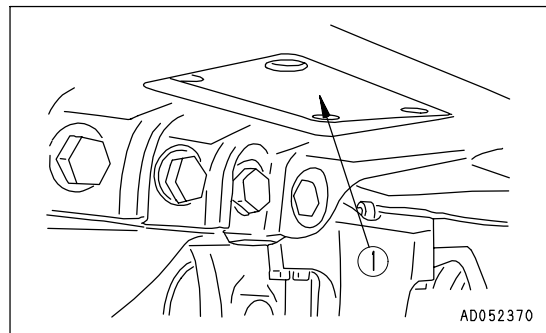

CHECK BRAKE PEDAL TRAVEL

Drive the machine, depress the brake pedal, and check that the machine stops.

CHECK DUST INDICATOR

1. Check for the yellow piston overlapping the red zone on the dust indicator (1).
2. If the yellow piston is overlapping the red zone, clean or replace the element immediately.

For details of the method of cleaning the element, see "CHECK, CLEAN AND REPLACE AIR CLEANER ELEMENT (PAGE 4-24)".

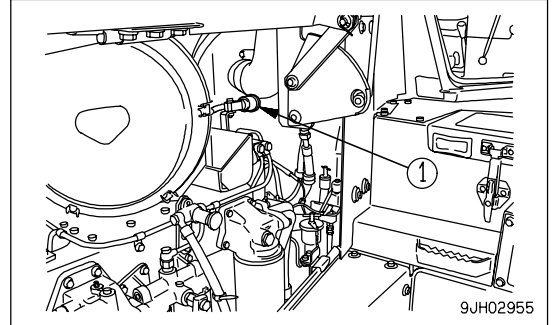

3. After checking, cleaning, and replacing, press the knob of dust indicator (1) to return the yellow piston to its original position.
 - In environments where the rubber deteriorates quickly or the surface becomes damaged (in direct sunlight, dusty areas, etc.), replace before it becomes dirty and it becomes difficult to judge the condition.

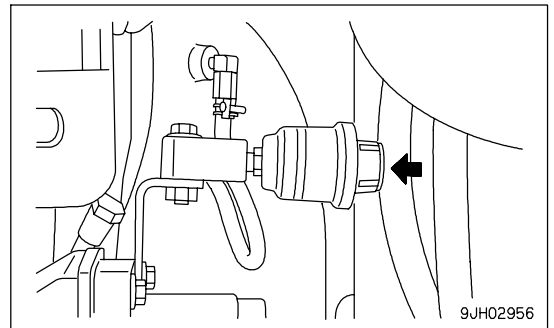

CHECK OIL LEVEL IN HYDRAULIC TANK, ADD OIL

! WARNING

- When removing the oil filler cap, oil may spurt out, so stop the engine and wait for the oil temperature to go down, then turn the cap slowly to release the internal pressure before removing the cap.
- If oil has been added to above the H mark, stop the engine and wait for the hydraulic oil to cool down. Then remove drain plug (P), loosen drain valve (1), and drain the excess oil.

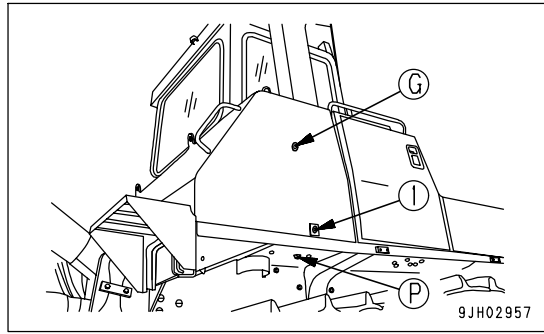

1. Lower blade to the ground and stop the engine. Wait for 5 minutes before checking oil level. Oil level should be between the H and L in sight gauge (G).

NOTICE

If the oil level is above the H line, do not add oil. Doing so may lead to damage to the oil pressure circuit and spouting out of oil.

2. If the level is below the L mark, add oil through oil filler (F).

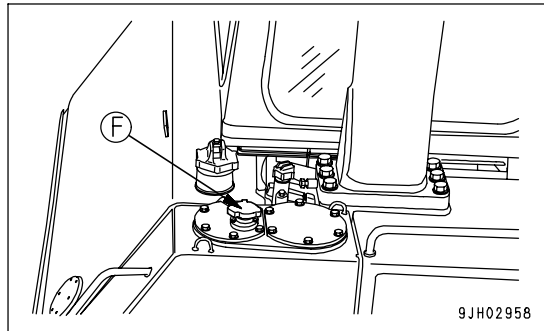

REMARK

When inspecting, if the machine is at an angle, move it to a level place to carry out the check.

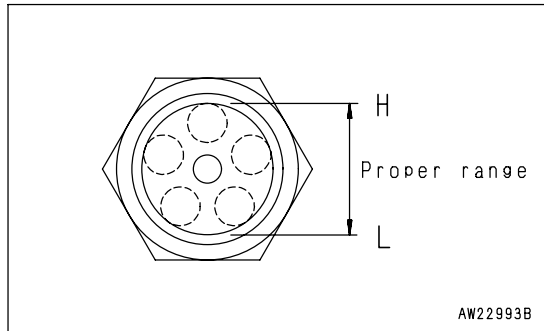

CHECK ELECTRIC WIRING

! WARNING

- If fuses are frequently blown or if there is a short circuit in the electrical wiring, locate the cause and repair or contact your Komatsu distributor.
- Accumulation of flammable material (dead leaves, twigs, grass, etc.) around the battery may cause fire, so always check and remove such material.
- Keep the top surface of the battery clean and check the breather hole in the battery cap. If it is clogged with dirt or dust, wash the battery cap to clear the breather hole.

Check for damage and wrong capacity of the fuse and any sign of disconnection or short circuit in the electric wiring. Check also for loose terminals and tighten any loose parts.

Check the wiring of the "battery", "starting motor" and "alternator" carefully in particular.

Always check if there is any accumulation of flammable material around the battery, and remove such flammable material.

Please contact your Komatsu distributor for investigation and correction of the cause.

CHECK THAT LAMPS LIGHT UP

1. Turn starting switch (1) to the ON position (B).

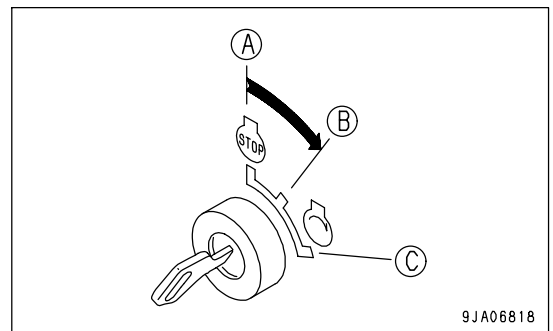

2. Turn the front lamp and working lamp switch to the ON (b) position, make sure the lamps light up.

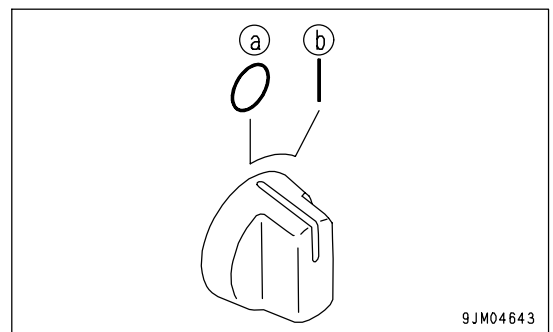

3. Turn the rear lamp switch to the ON (b) position, make sure the lamps on the left and right fenders light.
If the lamps do not light, check for a broken bulb or disconnected wire, contact your Komatsu distributor for repairs.

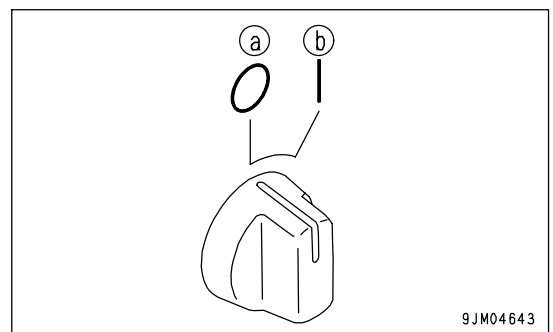

CHECK HORN SOUND

1. Turn starting switch (1) to the ON position (B).

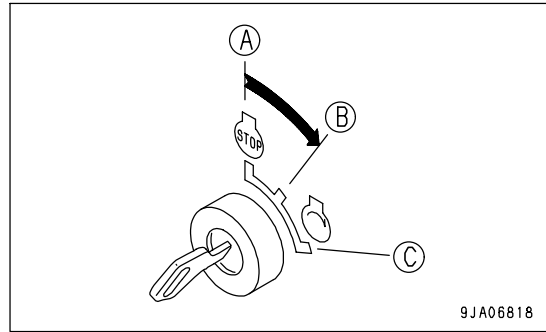

2. Push the horn switch and check that the horn sounds.

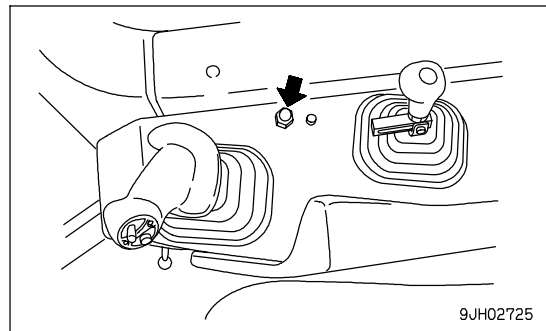

CHECK BACKUP ALARM SOUND

1. Turn starting switch to the ON position (B).

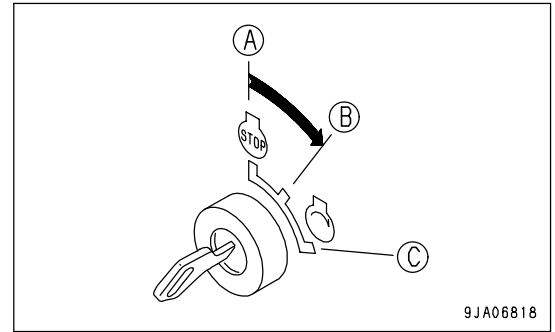

2. Set parking brake lever to the FREE position (F).

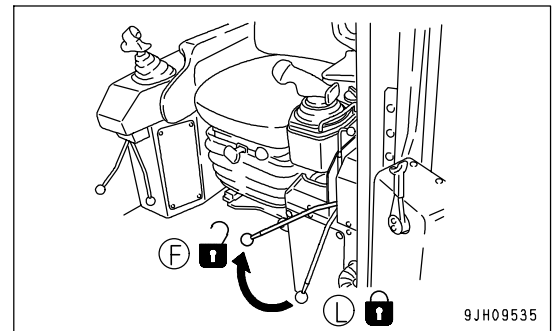

3. While depressing the brake pedal, set joystick to the REVERSE position. The buzzer must sound immediately. Buzzer will continue to sound until the joystick is moved to NEUTRAL or FORWARD position.
4. As soon as it is confirmed that the buzzer is working properly, set the joystick to the NEUTRAL position, put the parking brake lever to the LOCK position, and then release the brake pedal.

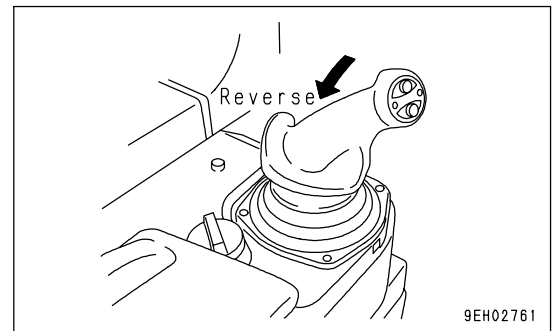

ADJUSTMENT

ADJUSTING OPERATOR'S SEAT

WARNING

- Adjust the seat position at the beginning of each shift or when operators change.
- Adjust seat so the brake pedal can be completely depressed with the operator's back against the backrest.

(A) Fore-and-aft adjustment

Pull lever (1), set the seat to a position where it is easy to operate, then release the lever.

Fore-aft adjustment: 200 mm (7.9 in) (10 stages)

(B) Weight and height adjustment of seat

- Turn knob (2) under the seat so that weight adjustment indicator (3) displays the green range. The height can be adjusted by turning the knob (2) while the green range is displayed.
- Turn the knob clockwise to raise the seat and turn the knob counterclockwise to lower the seat.

Height adjustment range: stepless, 75 mm (3 in)

Weight adjustment range: 50 to 130 kg (110 to 237 lb)

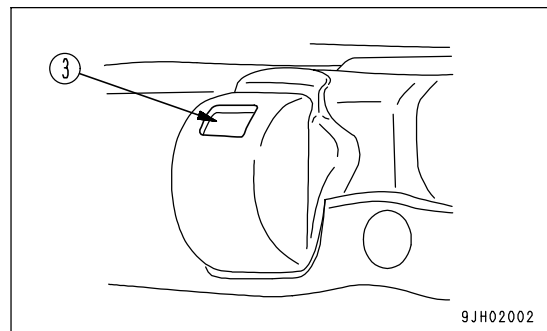
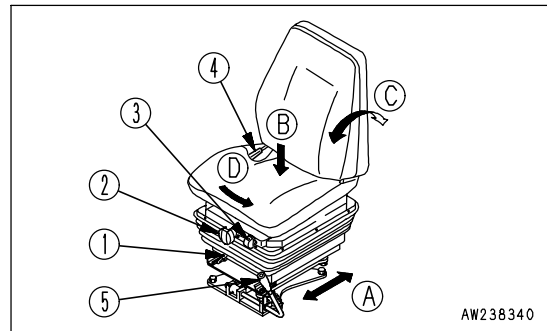

(C) Adjust reclining angle

REMARK

When the seat is pushed forward, the available reclining angle becomes greater; when the seat is pushed back, the available reclining angle becomes smaller. When moving the backrest, return the backrest to its original position before moving the seat.

Pull up lever (4), set the seatback to a position where it is easy to operate, then release the lever.

(D) Adjusting direction of seat

Pull lever (5) up to FREE position (F) to release the lock. It is then possible to change the direction of the seat to a position facing 15° to the right.

After changing the direction of the seat, return the lever securely to LOCK position (L).

- Change the direction of the seat to the right for the ease of operation of the ripper.

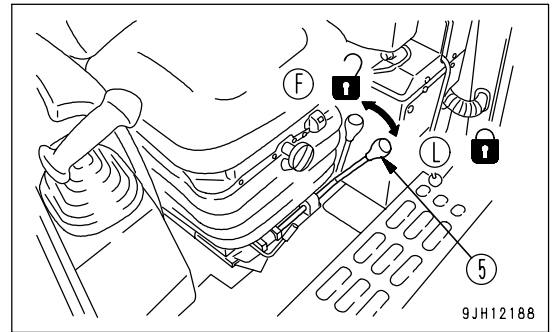
**REMARK**

If the direction of the seat is changed, the steering, directional, and gearshift lever is also interconnected and changes direction.

USING SEAT BELT

Always install a seat belt on machines equipped with ROPS.

**WARNING**

- Before fastening the seat belt, inspect the securing brackets and belt for abnormal conditions. Replace any worn or damaged seat belt or the securing brackets.
- Even no problem can be seen with the belt, always replace the seatbelt once every three years. The date of manufacture is given on the rear side of the belt.
- Adjust and fasten the seat belt before operating the machine.
- Always use the seat belt when operating the machine.
- Fit the seat belt across your lap without twisting.

FASTEN THE BELT AND REMOVE IT

1. Sit on the seat, depress the brake pedal fully, and adjust the seat so that your back is pressed against the backrest.
2. After adjusting the seat position, adjust tether belt (1). Tense the tether belt and install it when there is no one sitting on the seat.
3. Sit on the seat and hold tongue (4) connected to wind-in mechanism (2) and pull out the belt slowly so that the belt will cover your abdomen sufficiently.
4. Insert tongue (4) in buckle (3) until it clicks. The belt is pulled back into wind-in mechanism (2) until it is fitted to your abdomen. The belt is locked under this condition and cannot be extended anymore. Fit the belt to your abdomen without twisting it.

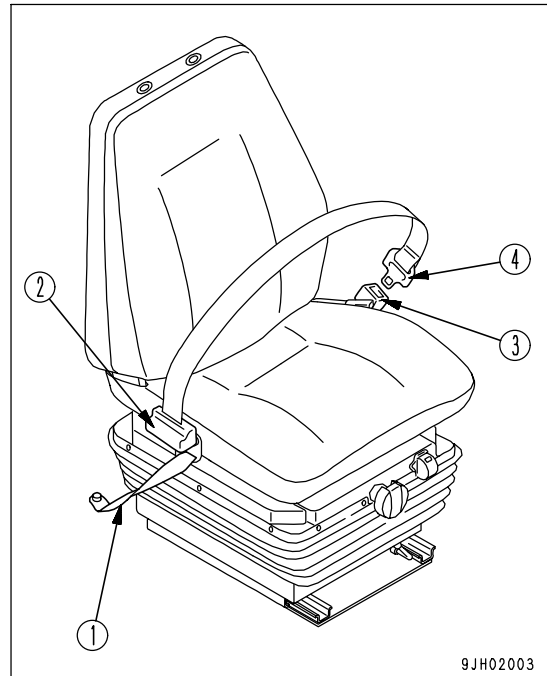

9JH02003

REMARK

If the belt is locked before the tongue is inserted in the buckle, let it return to the wind-in mechanism, then repeat the above procedure from the start.

5. Pull the belt to check that it is securely locked in position.
6. When removing the belt, press the red button on buckle (3).

The belt will automatically retract.

Check that the bolts of the clamp securing the belt to the chassis are not loose. Tighten them if they are loose.

Tightening torque: 24.5 ± 4.9 Nm (2.5 ± 0.5 kgm, 18.1 ± 3.6 lbft)

If the seat belt is scratched or frayed, if any fittings are broken or deformed from long service, replace the seat belt immediately.

ADJUST MIRROR

Loosen nut (1) of the mirror and adjust the mirror to a position where it gives the best view from the operator's seat.

In particular, be sure to adjust the mirror so that people at the rear left or right of the machine can be seen clearly.

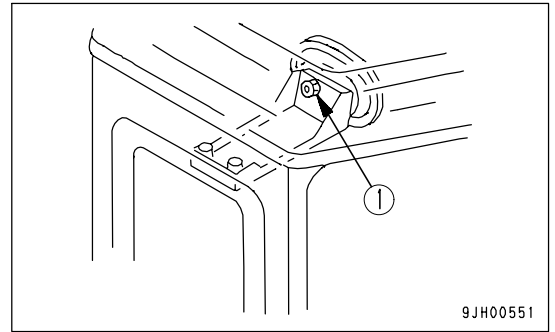

ADJUST JOYSTICK (PCCS LEVER)

! WARNING

After moving case (2) in order to adjust the position of the steering, directional, and gearshift lever, secure lock lever (1) into the notched hole, making sure it is in the LOCK position. If it is not completely locked, the steering, directional, and gearshift lever may unexpectedly move and cause damage, serious injury, or death.

The steering, directional, and speed lever (wrist control type single lever: joystick) can be adjusted by 100 mm (3.9 in) in 5 stages to the front or rear. Adjust to the most suitable position to match the adjustment of the operator's seat.

1. Pull up lock lever (1) to the FREE position (F) at the rear of case (2) on left side of the operator's compartment.
2. With lock lever (1) pulled up, use your other hand to grip the front of case (2), then move it forward with your left and right hands. The joystick moves with case (2).

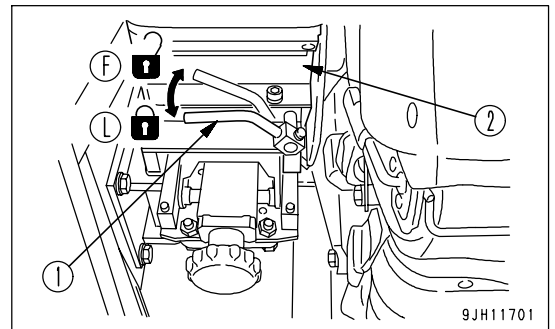

3. Move case (2) to the desired position until a click is heard. Then pull up lock lever (1) and release it. Lock lever (1) automatically returns to the LOCK position.
 - (a) Front
 - (b) Rear

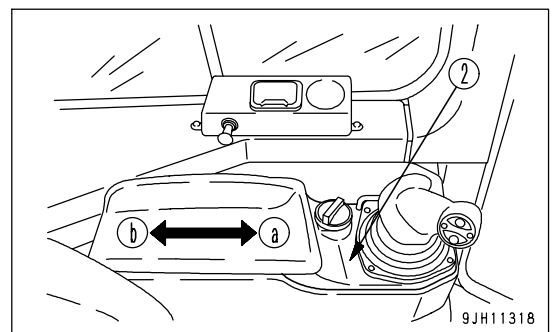

REMARK

PCCS: Palm command control system

ADJUST ARMREST

The height of the armrest on the left and right sides of the operator's seat can be adjusted to 3 positions. After adjusting the operator's seat, adjust the armrest to a suitable height.

ADJUST ARMREST (RIGHT)

Armrest (1) on the right side of the operator's cab part can be adjusted up 30 mm (1.2 in) or down 30 mm (1.2 in) based on the standard height (center) in three stages.

1. Loosen knob (2) (2 places).

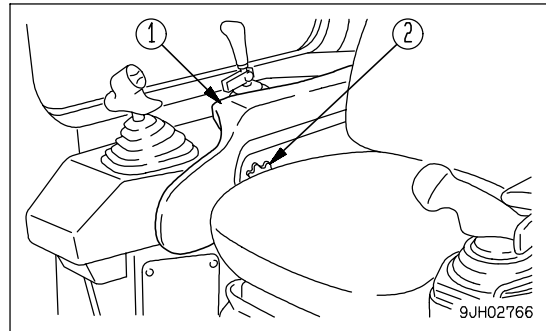

2. Move the armrest on the operator's seat to the front, then align the position of the 3 holes {high (H), middle (M), low (L)}.
3. Tighten knob (2) securely.

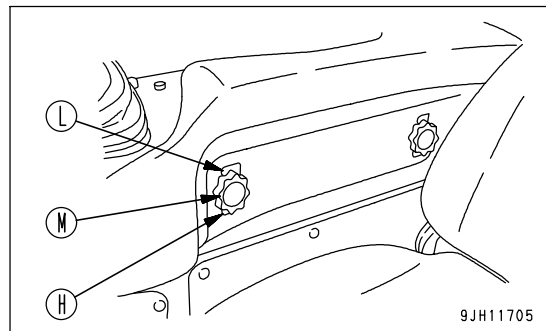

ADJUST ARMREST (LEFT)

The armrest on the left side of the operator's compartment can be adjusted to 2 heights.

1. When adjusting height of both armrest and case

It is possible to effortlessly adjust the standard height up 50 mm (2 in) or down 50 mm (2 in).

The steering, directional, and gearshift lever moves as a unit.

Turn up/down left adjustment knob (1) to adjust the height.

Turn the knob to adjust as follows.

Turn **CLOCKWISE** to move **UP**

Turn **COUNTERCLOCKWISE** to move **DOWN**

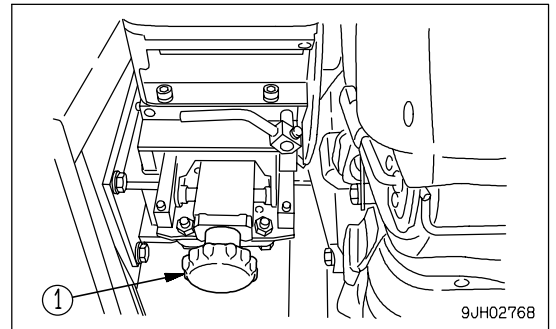
**2. When adjusting height of armrest only**

It is possible to effortlessly adjust up to 36 mm (1.4 in) upward from the armrest and case contact surface.

The steering, directional, and gearshift lever does not move.

Open the armrest, and turn knob (2) counterclockwise to adjust the height.

Only the armrest will move up. After adjusting it to the desired height, close the armrest.

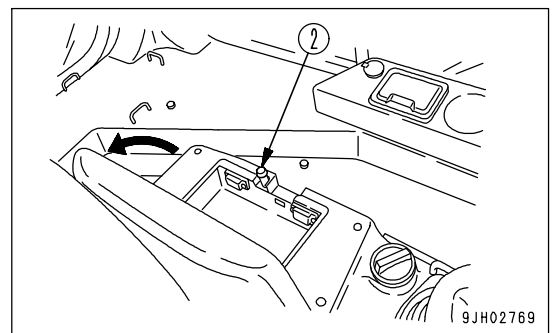

OPERATIONS AND CHECKS BEFORE STARTING ENGINE

! WARNING

- When starting the engine, check and make sure the work equipment lock lever (4) and parking brake lever (1) are secured in the LOCK position.
If the control levers are not locked and they are touched by accident when starting the engine, the work equipment may move unexpectedly, and this may lead to a serious injury or death.
- When standing up from the operator's seat, always set the work equipment lock lever (4) and parking brake lever (1) to the LOCK position, regardless of whether the engine is running or stopped.

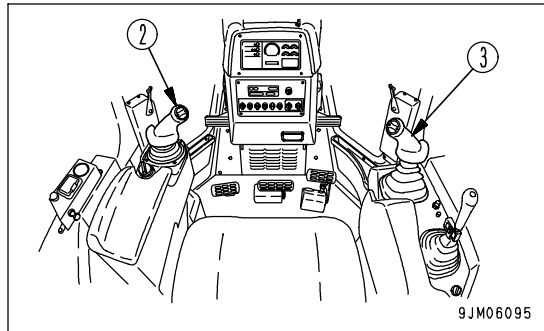
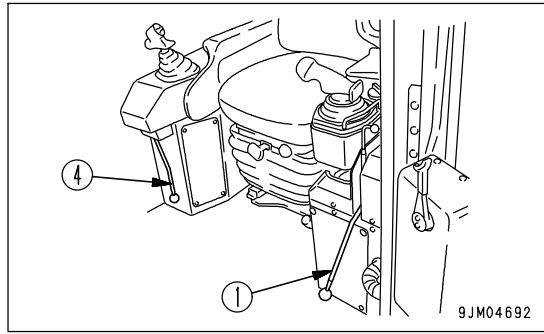

1. Check that parking brake lever (1) is locked.
If this lever is not in the LOCK position (L), the engine will not start.

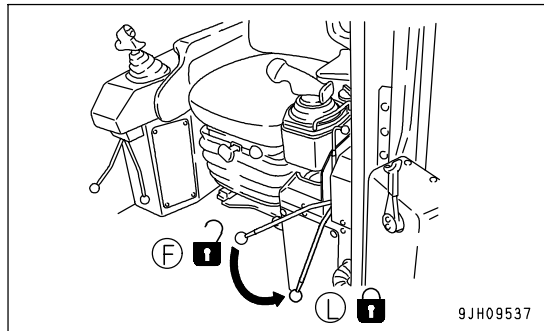

2. Check that joystick (2) is in the N (neutral) position.

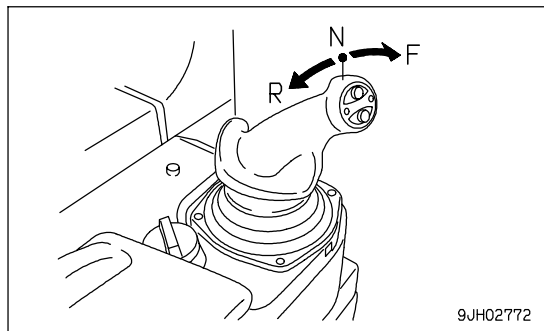

REMARK

The engine cannot be started if joystick (steering, directional, and gearshift lever) (2) is not in the N position. If joystick (steering, directional, and gearshift lever) (2) is in F or R, the letter P on display panel A will flash.

3. Check that the blade is lowered to the ground and that blade control lever (3) is in the HOLD position. If it is in the FLOAT position, the engine will not start.

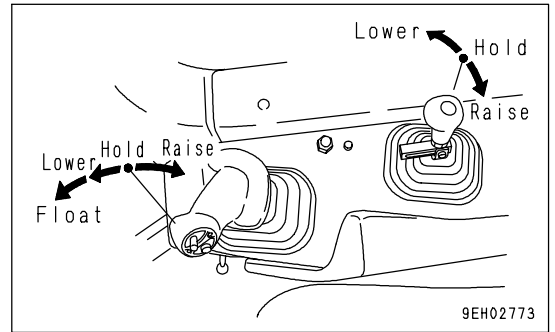

4. Check that the ripper is lowered to the ground.
5. Check that the work equipment lock lever (4) is LOCK position (L).

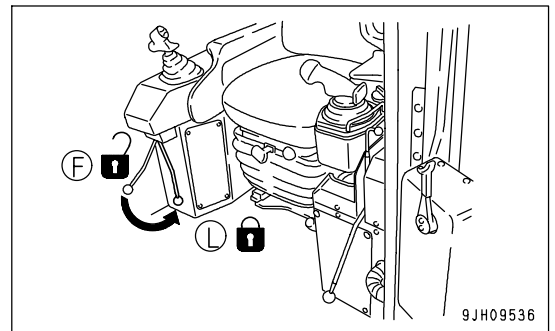

STARTING ENGINE

NORMAL STARTING

WARNING

- Check that there are no persons or obstacles in the surrounding area, then sound the horn and start the engine.
- Never use starting aid fluids as they may cause explosions.
- Exhaust gas is toxic. When starting the engine in confined spaces, be particularly careful to ensure good ventilation.

NOTICE

- Do not crank the starting motor continuously for more than 20 seconds. If the engine does not start, wait for at least 2 minutes, then repeat the procedure from Step 2.
- Before starting the engine, check that the fuel control dial is in the low idling (MIN) position.
- On this machine, to protect the turbocharger, a turbo protect function is provided. In cold weather, even if fuel control dial (1) is moved immediately after starting the engine, the engine speed may not change for several seconds.
- If the fuel control dial is in the FULL position, the engine will accelerate suddenly and cause damage to the engine parts, so set it to an intermediate or low speed position.

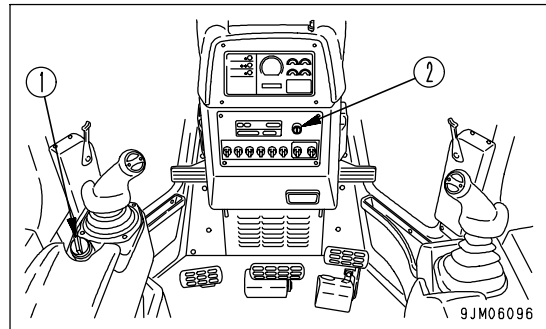

1. Turn fuel control dial (1) from the low idle (MIN) position to a slightly higher speed.

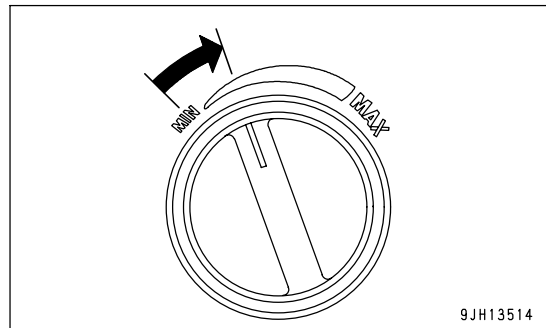

2. Insert the key into starting switch (2) and turn the key to the START position (C). The engine will start.

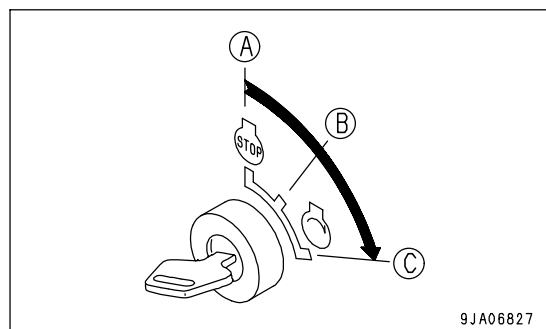

- 3. When the engine starts, release the key in starting switch (2).
The key will return automatically to the ON position (B).

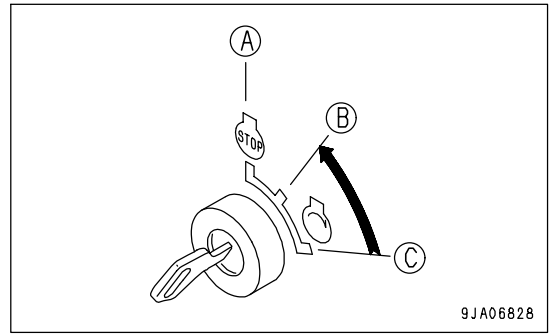

STARTING IN COLD WEATHER

WARNING

- Check that there are no persons or obstacles in the surrounding area, then sound the horn and start the engine.
- Never use starting aid fluids as they may cause explosions.

NOTICE

Do not keep the starting motor rotating continuously for more than 20 seconds.

If the engine fails to start, repeat steps 3 and 4 after waiting for about 2 minutes.

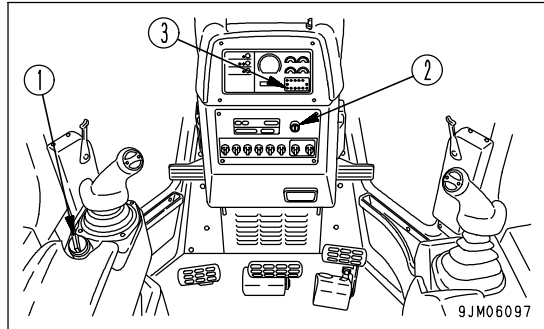

1. Turn fuel control dial (1) to the center position between MIN and MAX position.

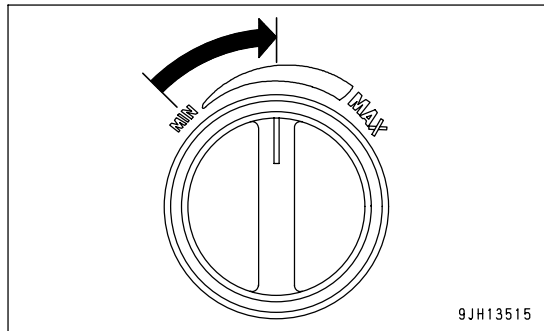

2. Insert the key into starting switch (2) and turn the key to the ON position (B).

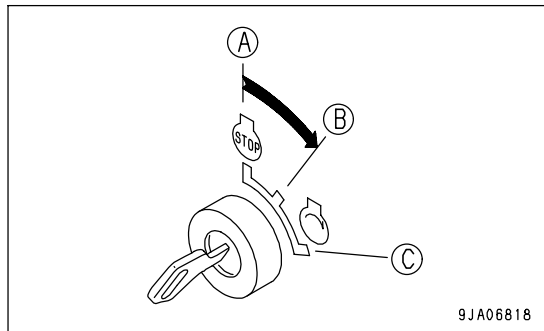

3. Check that preheating pilot lamp (3) on the monitor panel is lighted up.

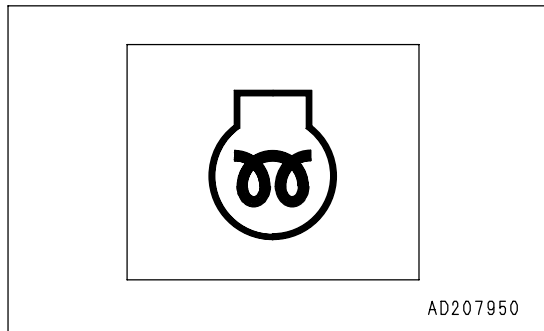

4. Keep in this condition until preheating pilot lamp (3) goes out.

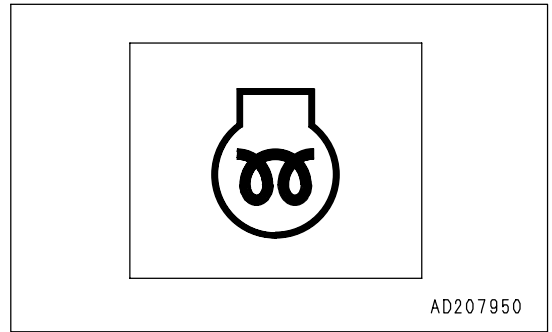

5. When preheating pilot lamp (3) goes off, turn the key of ignition switch (2) to the START position (C) to crank the engine.
The time that preheating pilot lamp (3) stays on changes according to the ambient temperature as shown in the table below.

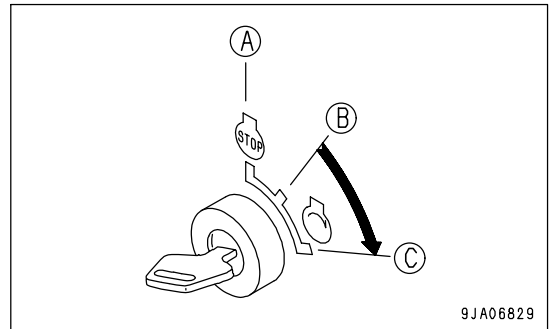

Ambient temperature	Pre-heat time
-5°C to -10°C (23°F to 14°F)	20 to 27 seconds
-10°C to -20°C (14°F to -4°F)	27 to 40 seconds
-20°C to -30°C (-4°F to -22°F)	40 seconds

6. When the engine starts, release the key in starting switch (2).
The key will return automatically to the ON position (B).

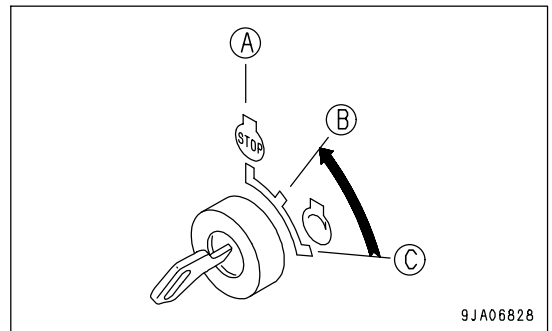

REMARK

Immediately after starting the engine, run at idle. While running the engine, release the decelerator pedal and do not operate the work equipment.

Guideline for idle time

- Cold weather: At least 15 seconds
- 1st start after changing engine oil or engine oil filter: 20 seconds

7. When the engine rotation stabilizes, return to the low idle (MIN) position of fuel control dial (1) and then carry out the warming-up operation.

REMARK

- Regardless of the ambient temperature, if the key in starting switch (2) is turned from OFF position to left, preheating pilot lamp (3) will light up and preheating will start. (Preheating continues while the starting switch is held at the left.)

For the details of the preheating time, see the table in Step 5.

- While preheating is being carried out, the preheating pilot lamp (3) lights up to show that preheating is being carried out. After it lights up for 36 seconds, it flashes for 16 seconds and goes out. When it goes out, complete the preheating immediately.
- If the engine does not start with the above operation, wait for about 2 minutes, and repeat steps from Step 3. And 4.
- The relationship between the actuation time of the turbo protect function and the engine cooling water temperature is as follows.

Even if the fuel control dial is operated within the time given below, the engine speed will not change.

REMARK

- The actuation time for the turbo protect function and the relationship with the engine coolant temperature are as shown below.

If the fuel control dial is operated within the time shown below, the engine speed will not change.

Coolant temperature	Turbo protect time (sec.)
Above 10°C (50°F)	0
10 to -10°C (50 to 14°F)	Change 0 to 5
below -10°C (14°F)	5

- In cold weather, the turbo protect function is actuated, so the engine speed is kept at 1000 rpm or below for several seconds. After that, it becomes the speed set by the position of the fuel control dial.

OPERATIONS AND CHECKS AFTER STARTING ENGINE



WARNING

- If there has been any Emergency stop, abnormal actuation or trouble, turn the starting switch key to the OFF position.
 - If the work equipment is operated without sufficiently warming the machine up, response of the work equipment to movement of the control lever will be slow, and the work equipment may not respond as the operator desires, so always perform the warming-up operation. Particularly in cold areas, be sure the warming-up operation is completed.
-

BREAKING IN THE MACHINE



CAUTION

Your Komatsu machine has been thoroughly adjusted and tested before shipment. However, operating the machine under severe conditions at the beginning can adversely affect the performance and shorten the machine life.

Be sure to break-in the machine for the initial 100 hours (as indicated by the service meter).

During break-in operations, follow the precautions described in this manual.

- Run the engine at idle for 15 seconds after starting it. During this time, do not operate the control levers or fuel control dial.
- Idle the engine for 5 minutes after starting it up.
- Avoid operation with heavy loads or at high speeds.
- Immediately after starting the engine, avoid sudden starts, sudden acceleration, unnecessary sudden stops, and sudden changes in direction.

WARMING UP OPERATIONS

NOTICE

- Do not perform operations or suddenly operate the levers when the hydraulic oil is at a low temperature. Always perform the warming-up operation until the hydraulic oil temperature monitor displays the green range. This will help extend the machine life.
Do not suddenly accelerate the engine before the machine reaches full operating temperature.
- Do not run the engine at low or high idle for more than 20 minutes. This will cause oil leaks from the turbocharger oil supply piping.
If it is necessary to run the engine at idling, apply a load from time to time or run the engine at a mid-range speed.
- If engine oil pressure caution lamp (3) flashes or the buzzer sounds intermittently, stop the engine and check for the cause.

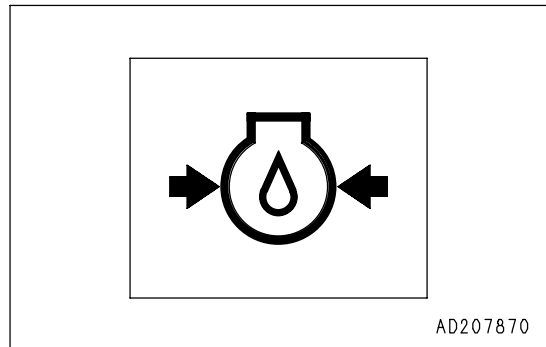
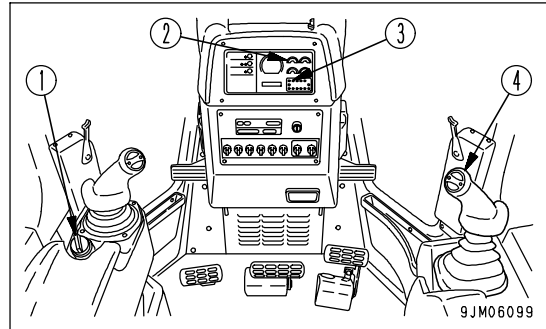

1. Turn fuel control dial (1) to the center position between LOW IDLE (MIN) and HIGH IDLE (MAX) and run the engine at medium speed for about 5 minutes with no load.

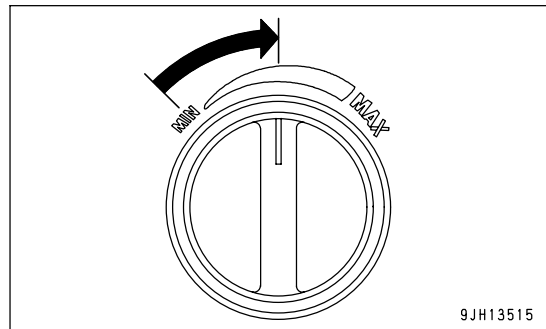

2. After warm-up is completed, check gauges and caution lamps for proper operation. If any problem is found, repair it. Continue to run the engine under a light load until engine coolant temperature gauge indicator (2) is within the green range (B).
(A): White range
(B): Green range
(C): Red range

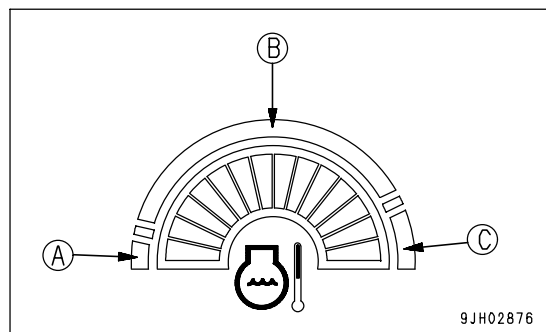

3. Check for abnormal exhaust gas color, noise, or vibration. If any problem is found, contact your Komatsu distributor.

IN COLD AREAS

1. Turn fuel control dial (1) to the center position between LOW IDLE (MIN) and HIGH IDLE (MAX) and run the engine at medium speed for about 10 minutes with no load.

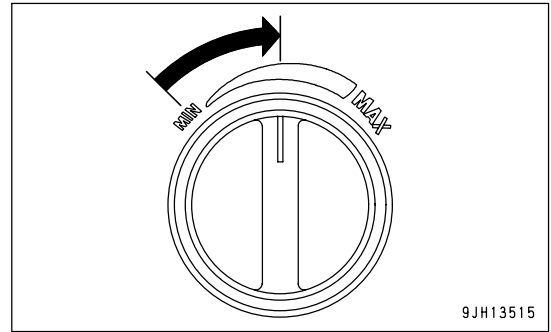

2. Operate blade control lever (4) to the RAISE position, then keep the blade raised to the maximum height and continue to relieve the circuit for 10 minutes.
3. Finally, operate blade control lever (4) and ripper control lever to operate the blade and ripper cylinders several times. If the oil temperature in the work equipment is not properly raised, there will be a time lag in the response of the work equipment and steering.

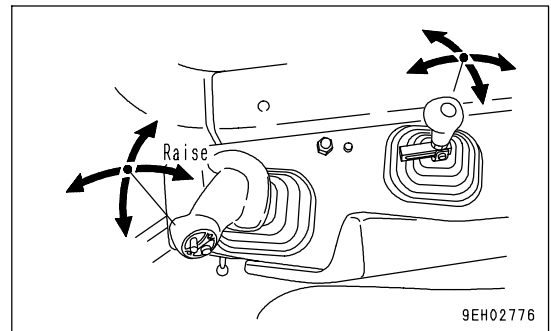

4. After warm-up is completed, check gauges and caution lamps for proper operation. If any problem is found, repair it. Continue to run the engine under a light load until engine coolant temperature gauge indicator (2) is within the green range (B).
 - (A): White range
 - (B): Green range
 - (C): Red range

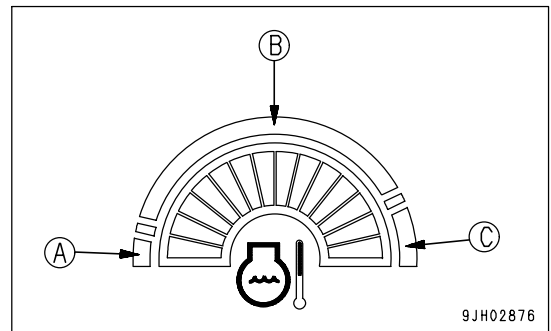
**REMARK**

If the power train oil temperature is not raised sufficiently, it will take longer to accelerate to the maximum speed.

5. Check for abnormal exhaust gas color, noise, or vibration. If any problem is found, contact your Komatsu distributor.

STOPPING ENGINE

NOTICE

If the engine is stopped without allowing it to cool down, there is danger that the service life of various parts of the engine will be reduced. Except in emergencies, never stop the engine suddenly.

If the engine overheats, do not stop it suddenly. Run it at low speed to allow it to cool down gradually, then stop it.

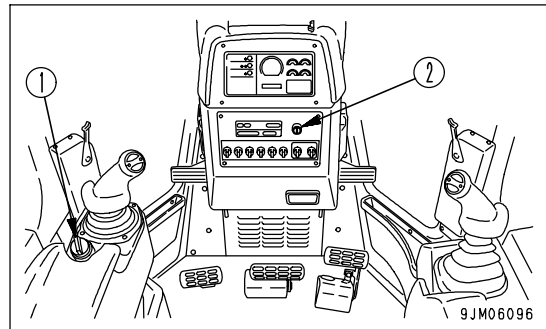

1. Turn fuel control dial (1) in the low idling (MIN) positions and run the engine at low idling speed for 5 minutes to allow the engine to gradually cool down.

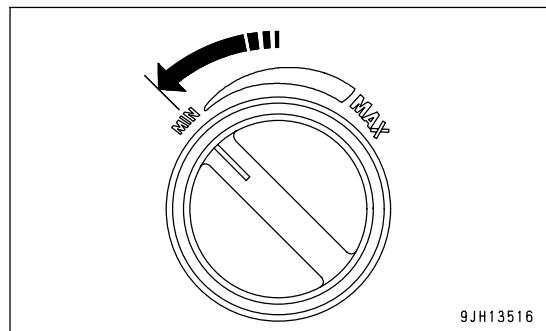

2. Turn the key in ignition switch (2) to the OFF position (A).
The engine will stop
3. Remove the key from starting switch (2).

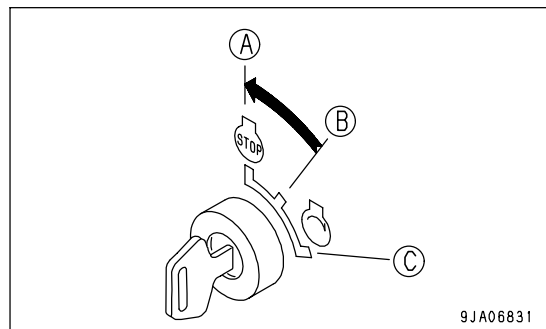

CHECK AFTER STOPPING ENGINE

1. Walk around the machine and check the work equipment, machine exterior, and undercarriage, also check for any leakage of oil or coolant. If any problems are found, repair them.
2. Fill the fuel tank.
3. Check the engine compartment for paper and debris. Clean out any paper and debris to avoid a fire hazard.
4. Remove any mud affixed to the undercarriage.

MOVING MACHINE

WARNING

- Before moving the machine, check that the area around the machine is safe, and always sound the horn before moving.
Do not allow anyone to enter the area around the machine.
The rear of the machine is a blind spot, so be extremely careful when traveling in reverse.
- When moving the machine down a slope, always keep brake pedal (8) depressed, even after releasing parking brake lever (1).
- When moving the machine up a steep slope, turn fuel control dial (5) to high idling (MAX) position and run the engine at full speed, and keep brake pedal (8) and decelerator pedal (6) depressed. Then operate steering, directional, and gearshift lever (4) from the N (neutral) position to the direction of travel and slowly release brake pedal (8). When the travel speed rises, slowly release decelerator pedal (6).

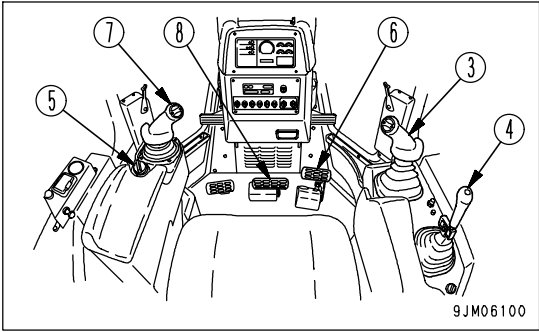
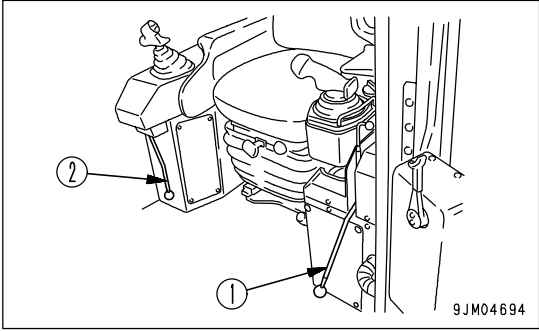

1. Operate parking brake lever (1) to the FREE (F) position.

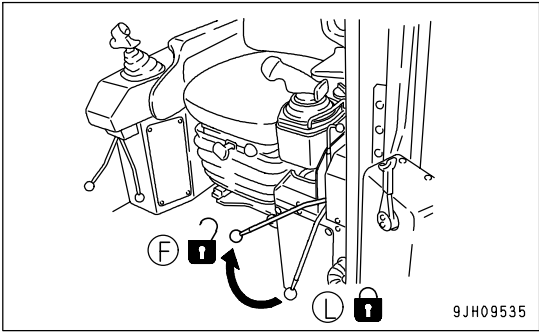

2. Operate work equipment lock lever (2) to the FREE (F) position.

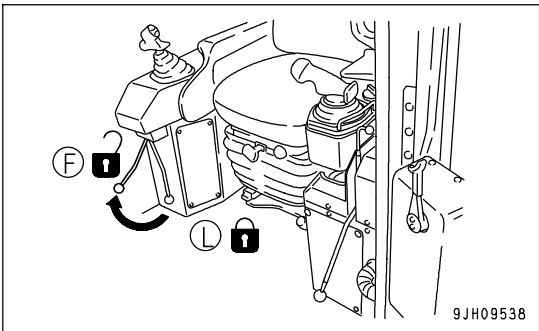

- Operate blade control lever (3) and ripper control lever (4) to the RAISE (a) position so that the blade will rise above the ground by 40 cm to 50 cm (15.8 in to 19.7 in) and the ripper will rise to the upper limit.

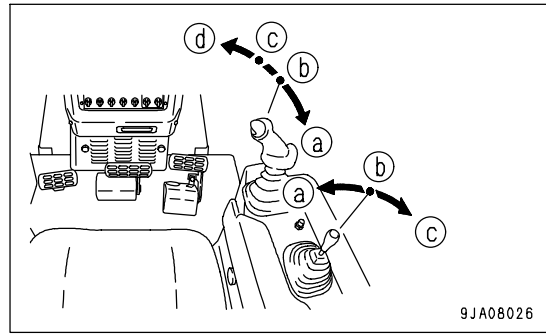

- Turn fuel control dial (5) to the full speed (MAX) position, and fully depress decelerator pedal (6).

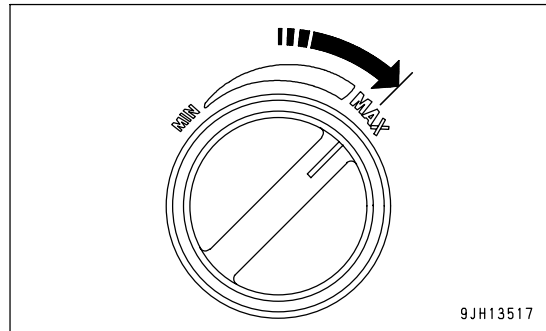

- Move joystick to the F (FORWARD) or R (REVERSE) position, gradually release decelerator pedal (6) and allow the machine to move.

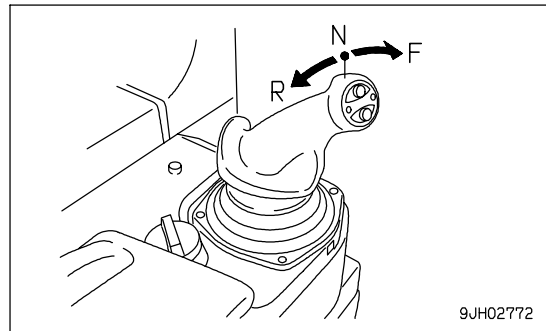

STOPPING MACHINE

! WARNING

- Avoid stopping suddenly. Give yourself ample room when stopping.
- When stopping the machine, select flat hard ground and avoid dangerous places. If it is unavoidably necessary to park the machine on a slope, place the parking brake lever (1) in the LOCK position and insert blocks underneath the track shoes. As an additional safety measure, thrust the blade into the ground.
- If the work equipment control lever is touched by accident, the work equipment may suddenly move, and may cause damage, serious injury, or death. Before leaving the operator's seat, always secure work equipment lock lever (2) in the LOCK position.

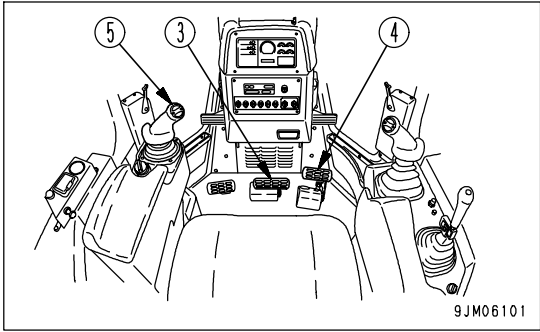
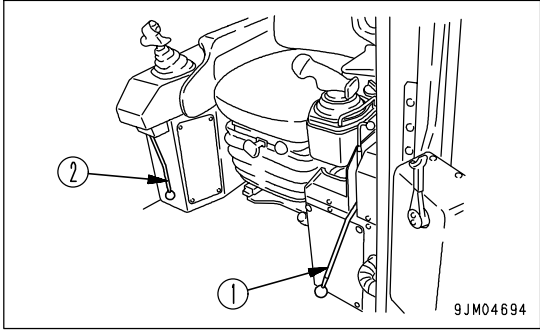

1. Depress brake pedal (3) to apply the brake.

NOTICE

If the brake is depressed when the engine speed or travel speed is high, the brake disc may make a slipping sound. Normally, depress decelerator pedal (4) to reduce the engine speed and travel speed before depressing the brake.

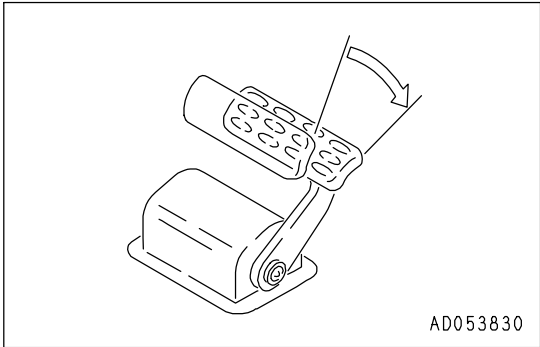

2. Set joystick (5) in the neutral position.

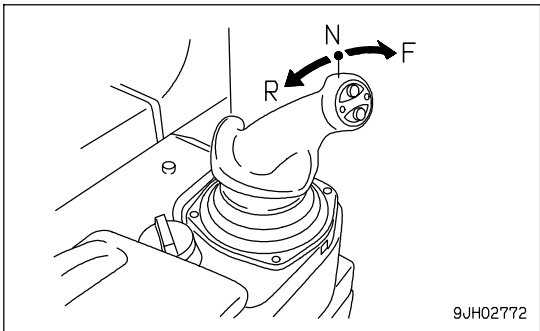

SHIFTING GEAR

The machine does not have to be stopped to shift gears.

- 1. Move steering, forward-reverse, gear shift lever (1) to the desired gear position to shift gears.

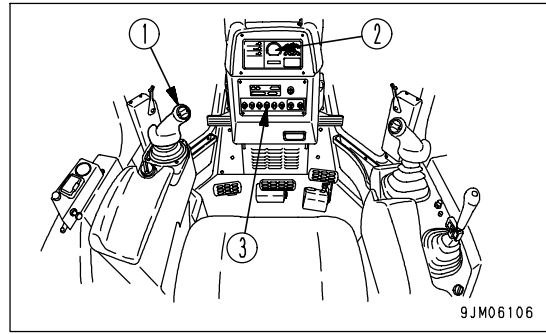

GEAR SHIFTING

- When the joystick is at the FORWARD or REVERSE position and switch (a) or switch (b) is pushed, the transmission speed will change.
 UP switch (a): Each time the switch is pressed, the transmission will shift up one speed.
 DOWN switch (b): Each time the switch is pressed, the transmission will shift down one speed.

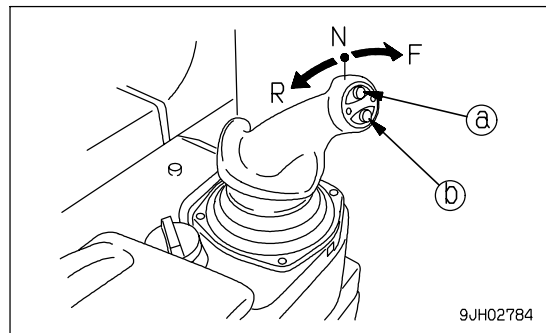

- When the lever is moved to the forward (to set to FORWARD) from the N position, the transmission shifts to F1. If the UP switch is pressed once when the transmission is in F1, the transmission shifts to F2. If the UP switch is pressed once when the transmission is in F2, the transmission shifts to F3. If the DOWN switch is pressed once when the transmission is in F3, the transmission shifts to F2. If the DOWN switch is pressed once when the transmission is in F2, the transmission shifts to F1.
- When the lever is moved to the rear (to set to REVERSE) from the N position, the transmission shifts to R1. If the UP switch is pressed once when the transmission is in R1, the transmission shifts to R2. If the UP switch is pressed once when the transmission is in R2, the transmission shifts to R3. If the DOWN switch is pressed once when the transmission is in R3, the transmission shifts to R2. If the DOWN switch is pressed once when the transmission is in R2, the transmission shifts to R1,

For details of the maximum speed in each speed range, see "SPECIFICATIONS (PAGE 5-2)".

REMARK

The speed range in use is displayed on the panel display according to the gearshift operation.

For example:

- Neutral: N is displayed on the display panel A (2)
- FORWARD 2nd: F2 is displayed on the display panel A (2)
- REVERSE 3rd: R3 is displayed on the display panel A (2)
- When the parking brake lever is locked, P is displayed.

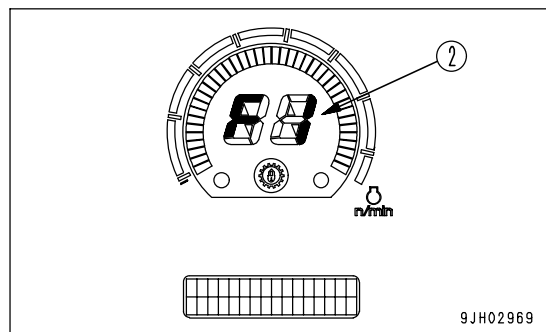

GEARSHIFTING USING SHIFT MODE SELECTION

- Shift mode selection means that the selected speed range is displayed in the N position before starting.
- When the joystick is in the N position, if UP switch (a) or DOWN switch (b) is pressed, the shift mode selection can be carried out.

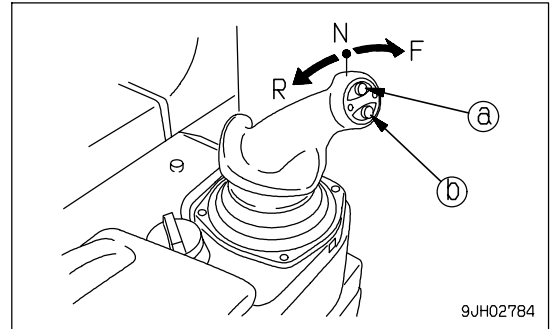

- The selected shift mode is displayed on display panel B (multi-information) of the monitor panel.
 - In [F1 - R1] shift mode (initial setting is completed) Lamps (c) and (d) are OFF.
 - In [F1 - R2] shift mode (initial setting is completed) Lamp (c) is ON and lamp (d) is OFF.
 - In [F2 - R2] shift mode (initial setting is completed) Lamp (d) is ON and lamp (c) is OFF.

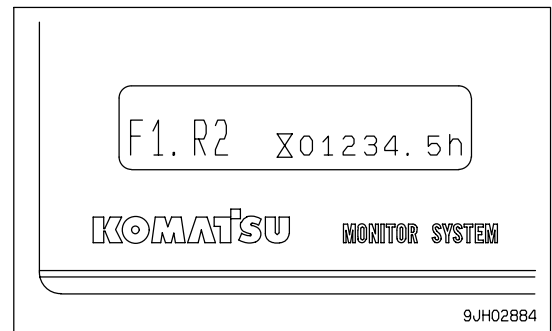

- Shift operation when [F1-R2] shift mode is set
When the joystick is at the N position and the UP switch is pressed once, the transmission is set to the [F1-R2] mode and lamp (c) lights up. Following this, if the joystick is operated forward (to set to FORWARD), the speed range is set to F1. If the lever is operated to the rear (to set to REVERSE), the speed range is automatically switched R1 → R2.
- Shift operation when [F2-R2] shift mode is set
When the joystick is at the N position and the UP switch is pressed twice, the transmission is set to the [F2-R2] mode and lamp (d) lights up. Following this, if the joystick is operated forward (to set to FORWARD), the speed range is set to F1 → F2. If the lever is operated to the rear (to set to REVERSE), the speed range is automatically switched R1 → R2.

REMARK

Even when the transmission is set to [F1-R1] mode, [F1-R2] mode, or [F2-R2] mode, if the UP switch or DOWN switch is operated, this will be given priority and manual operation can be carried out.

For example:

After the [F1-R2] mode has been set, if the joystick is operated forward (to set to FORWARD), the speed range is set to F1. However, if the lever is kept operated forward and UP switch (a) is pressed once, the speed range will shift to F2; if the UP switch is pressed twice, the speed range will shift to F3. When the transmission is in F3 and DOWN switch (b) is pressed once, the speed range will shift to F2; if the DOWN switch is pressed twice, the speed range will shift to F1.

On the other hand, if the joystick is operated to the rear (to set to REVERSE), the speed range is automatically switched R1 → R2. However, if the lever is kept operated to the rear and UP switch (a) is pressed once, the speed range will shift to R3; if the DOWN switch (b) is pressed once, the speed range will shift to R1.

However, the setting stays in the [F1-R2] mode. If the steering, directional, and gearshift lever is returned to N and then operated forward (to set to FORWARD), the speed range is set to F1; if the lever is operated to the rear (to set to REVERSE), the speed range is automatically switched R1 → R2.

REMARK

The default setting is [F1-R1].

After the starting switch is turned OFF, the shift mode returns to the default setting [F1-R1].

AUTO SHIFT DOWN OPERATION

If the travel speed drops due to the load conditions when traveling, the transmission is automatically shifted to a lower speed range. This is actuated by turning auto shift down switch (3) on the instrument panel at the front of the operator's compartment to the ON (b) position.

OFF position (a): Automatically canceled

ON position (b): Automatically shifted down to lower speed range

The transmission is automatically shifted down F2→ F1, F3 → F2, R2 → R1, R3 → R2.

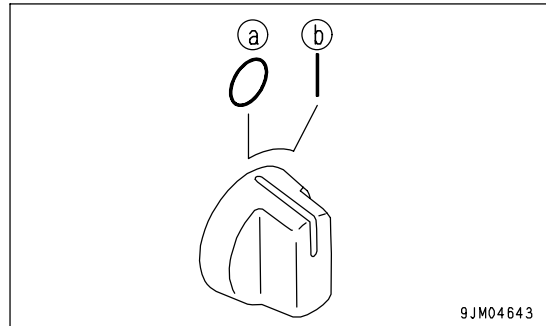

9JM04643

REMARK

- For safety reasons, during auto shift down, the transmission is prevented from shifting up.

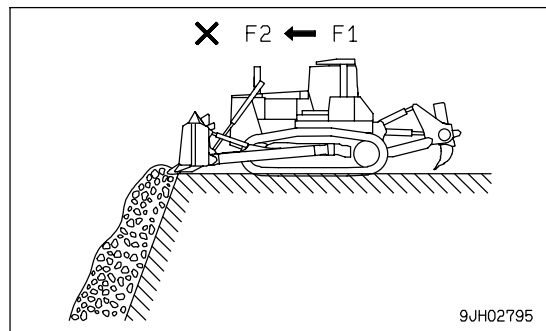

9JH02795

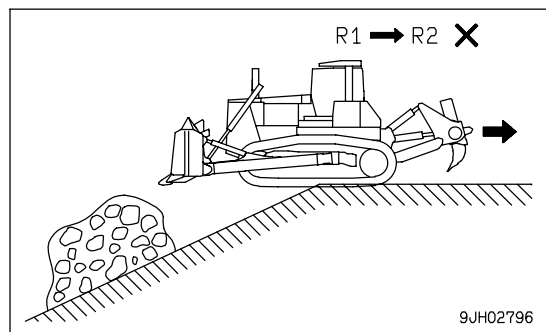

9JH02796

- If it is desired to shift up, use manual control and press the UP button on the steering, directional, and gearshift lever.

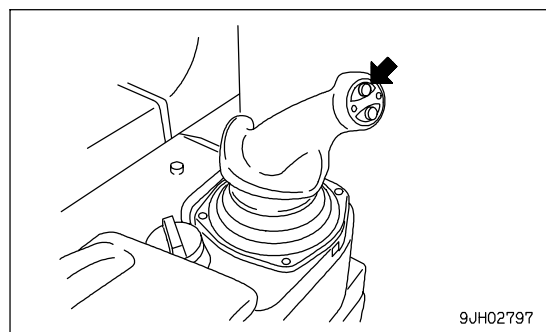

9JH02797

SHIFTING BETWEEN FORWARD AND REVERSE

! WARNING

When switching between FORWARD and REVERSE, first check that the direction of travel is safe.

! CAUTION

There is no need to stop the machine even when switching between FORWARD and REVERSE.

To increase safety, operator comfort, and the life of the transmission, leave the engine running at full speed, and always depress the decelerator pedal to lower the engine speed.

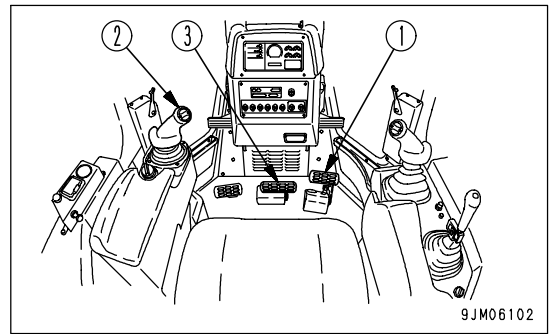

9JM06102

1. Depress decelerator pedal (1) to reduce the engine speed.

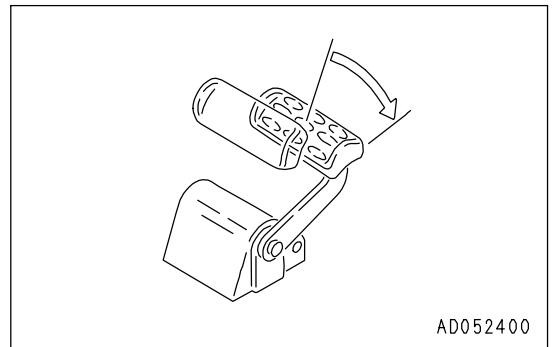

AD052400

2. Move joystick (2) to the neutral position, reduce the speed, then depress brake pedal (3) and stop the machine.

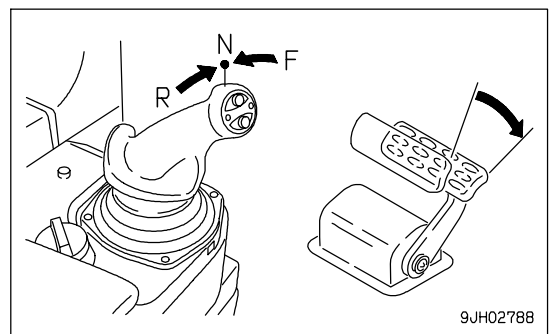

9JH02788

3. After depressing decelerator pedal (1), move steering, forward-reverse, gear shift lever (2) to the desired position.

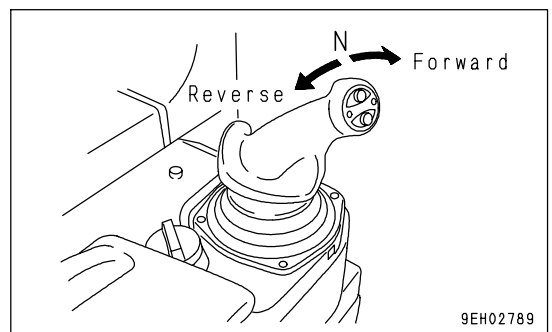

9EH02789

4. Release decelerator pedal (1) and raise the engine speed.

REMARK

When the joystick is placed in REVERSE, the backup alarm will sound.

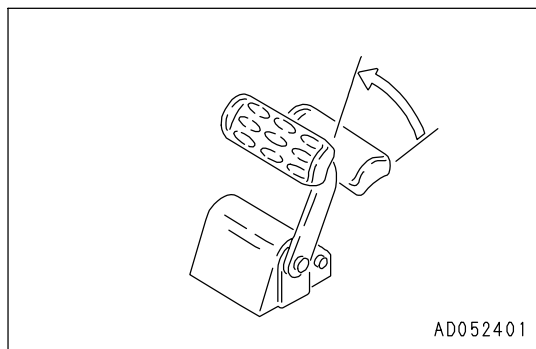

STEERING MACHINE



WARNING

- Avoid as much as possible turning the machine on a slope.
The machine will tend to slip sideways. Particular care should be taken on soft or clay soil.
- Never make a pivot turn at high speed.

NORMAL TURNING

To turn the machine while traveling, incline steering, forward-reverse, gear shift lever (1) in the direction of the turn.

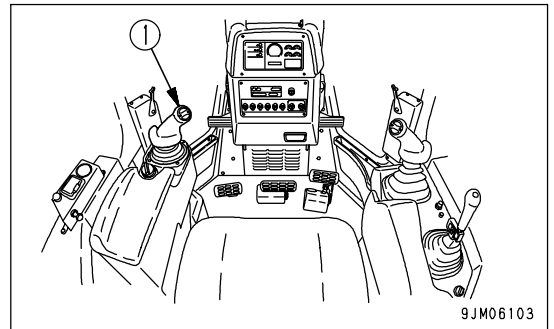

TURNING GRADUALLY TO LEFT WHILE TRAVELING FORWARD

If the joystick is pushed forward and moved partially to the left (L), the steering clutch is disengaged and the machine turns gradually to the left.

When turning gradually to the right, push the joystick forward, and move it partially to the right.
Do the same when traveling in reverse.

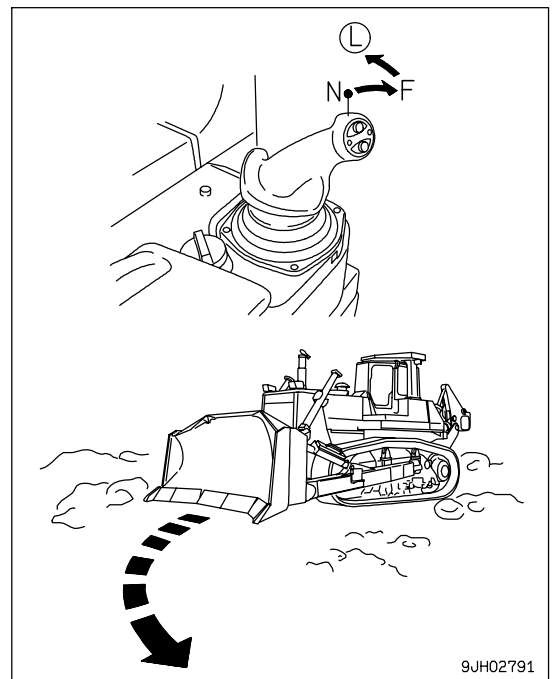

MAKING SHARP TURNS TO LEFT WHILE TRAVELING FORWARD

When the pivot turn mode switch is turned ON, pivot turns can be carried out in F1, R1, F2, or R2.

If the joystick is pushed forward and moved fully to the left (L), the steering clutch is disengaged, the brake is applied, and the machine turns sharply to the left.

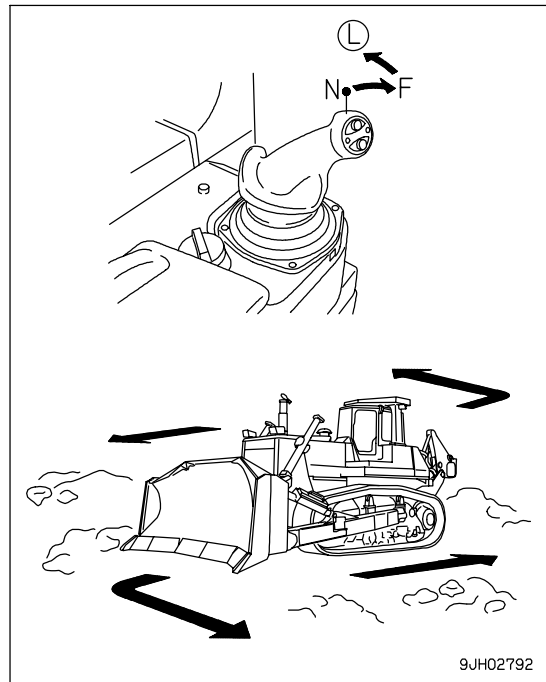

9JH02792

COUNTERROTATION TURNS TO LEFT WHEN TRAVELING FORWARD

NOTICE

When carrying out a counterrotation turn, if the load is not equal on the left and right sides, the machine may carry out a pivot turn, so check the ground conditions and be careful not to hit any obstacles.

With steering, forward-reverse, gear shift lever (1) in the N position, operate the lever partially to the left (L). The left and right tracks will rotate in opposite directions, and the machine will make a slow counterrotation turn. If the lever is moved further, the speed of the counterrotation turn will increase.

REMARK

When making a right counterrotation turn, move the steering, forward-reverse, gear shift lever (1) to the right (R) in the same way.

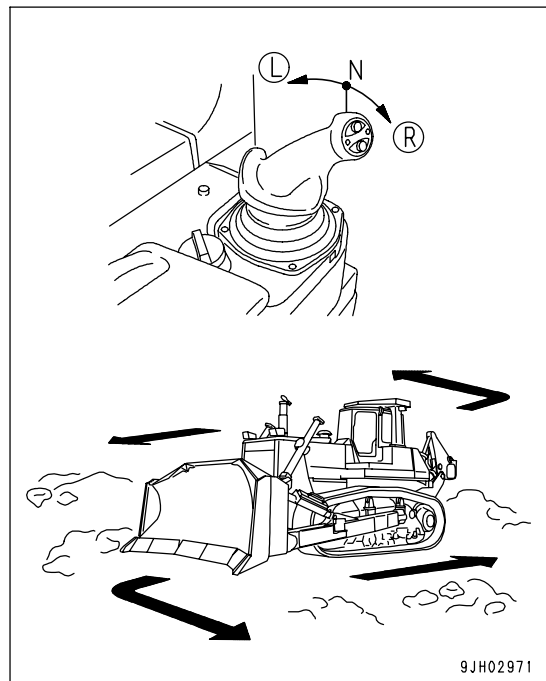

9JH02971

TURNING WHILE DESCENDING A SLOPE

With machines that can carry out counter rotation turns, on steep downhill slopes where the machine may travel under its own weight, or on downhill slopes where it is being pushed by a towed machine, the machine will not steer in the opposite direction, so do as follows.

REMARK

Cross steering means the phenomenon that the machine turns in the opposite direction to the actual steering direction.

TURNING GRADUALLY TO LEFT WHILE TRAVELING FORWARD

If the joystick (1) is pushed forward and moved partially to the left (L), the machine turns gradually to the left.

REMARK

When making gradual turns to the right, push the joystick (1) forward, and move it partially to the right. Do the same when traveling in reverse.

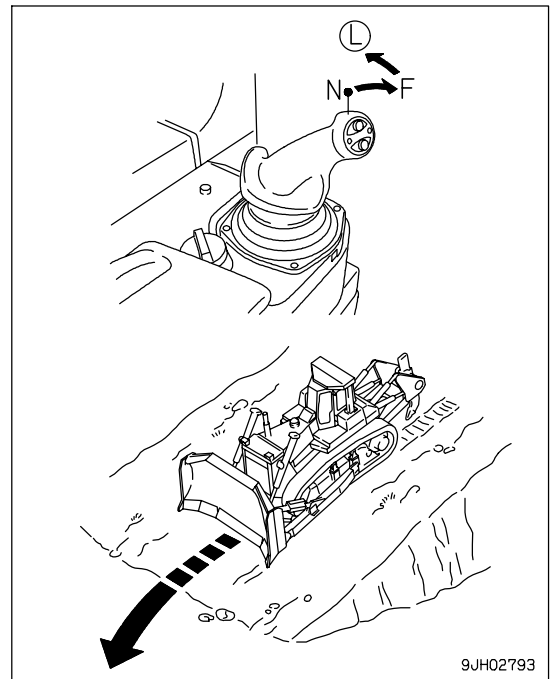

PRECAUTIONS FOR OPERATION

PAY ATTENTION TO GAUGES

If the red range of the power train oil temperature gauge lights up during operation, reduce the load and wait for the temperature to go down.

PERMISSIBLE WATER DEPTH

When operating in water, always keep top surface of the track frame above the surface of the water.

Also, be careful that the engine cooling fan will not come in contact with water. The fan can be damaged.

(A): Permissible water depth line

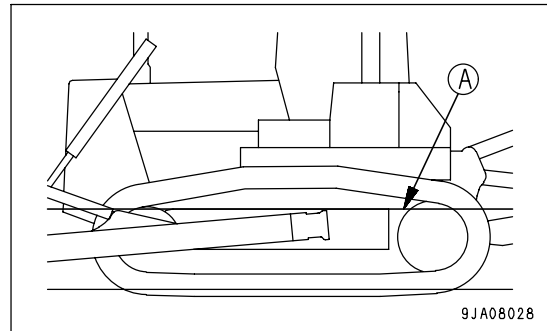

PRECAUTIONS WHEN TRAVELING FOR A LONG TIME

Avoid operating the machine at high speed for a long time, otherwise the temperature of hydraulic oil sharply rises, and that can cause oil leakage from the track rollers or final drive and lower durability.

If there is no way to avoid operating the machine at high speed for a long time, stop the machine every one hour for 30 minutes and let the track rollers and final drive cool off before starting up the machine again.

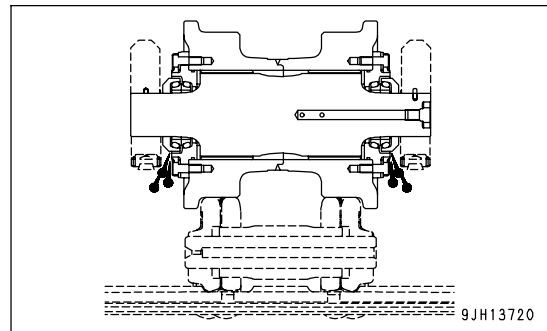

PRECAUTIONS WHEN TRAVELING UP OR DOWN HILLS

METHOD OF USING DECELERATOR PEDAL

When stepping on the decelerator pedal while going uphill, climbing ability will be reduced and the machine will stop. Furthermore, the engine may stall.

USE ENGINE AS BRAKE

When going downhill, move steering, forward-reverse, gear shift lever into low speed to run engine at slow speed and travel down slope using the engine as a brake.

Do not move the steering, forward-reverse, gear shift lever to the NEUTRAL position.

When traveling down hills of more than 15°, shift down to 1st speed (R1 or F1).

BRAKING WHEN TRAVELING DOWNHILL

While descending a slope using the engine as a brake, also apply the brakes.

Failure to brake may result in overrunning, causing engine trouble.

PRECAUTIONS ON SLOPE

BE CAREFUL OF FUEL LEVEL

If the fuel level in the fuel tank becomes low when working on slopes, the engine may suck in air because of the angle of the machine or the swaying of the machine. This makes the engine stop, so be careful not to let the fuel level in the fuel tank become too low.

BE CAREFUL OF OIL LEVEL

When operating machine on sloped areas of more than 20°, fill all appropriate components with oil to H level.

PRECAUTIONS WHEN ENGINE STOPS ON SLOPE

If the engine stops while working or traveling on a hill, immediately depress the brake pedal to bring the machine to a complete stop.

METHOD OF USING BRAKES

The following actions cause premature damage to the brakes, so avoid such operations.

- Using emergency brake at full speed
- Using brake with engine running at full speed in first gear (F1, R1) (Machine stall condition)

REMARK

Always depress the decelerator pedal to lower the engine speed before actuating the brakes.

PROHIBITED TO KEEP THE DOOR OPEN DURING OPERATIONS

Always keep the door closed when traveling or carrying out operations.

If the door is open, there is danger of damage from obstacles or strong vibration.

IT IS PROHIBITED TO MODIFY THE CAB GLASS IN ANY WAY THAT WILL OBSTRUCT THE VIEW

- For safety reasons, do not install anything on the cab glass that will obstruct the view.
- Always keep the glass clean to ensure safety during operations.

PRECAUTIONS FOR BLIND SPOTS CAUSED BY CAB STAY AND ROPS STAY



WARNING

The cab stay and ROPS stay cause blind spots.

When operating, always be sure to check carefully that there is no obstacle or worker in the surrounding area.

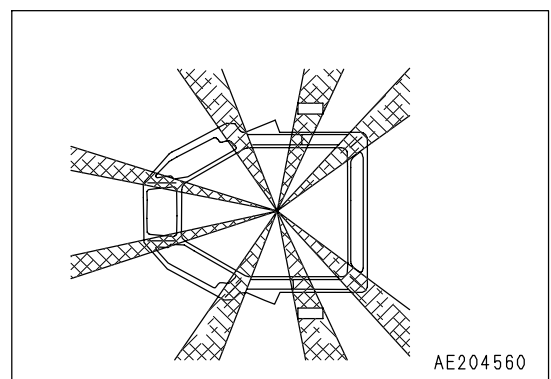

PARKING MACHINE

WARNING

- Avoid stopping suddenly. Give yourself ample room when stopping.
- When stopping the machine, select flat hard ground and avoid dangerous places. If it is unavoidably necessary to park the machine on a slope, place the parking brake lever (4) in the LOCK position and insert blocks underneath the track shoes. As an additional safety measure, thrust the blade into the ground.
- If the work equipment control lever is touched by accident, the work equipment may suddenly move, and may cause damage, serious injury, or death. Before leaving the operator's seat, always secure work equipment lock lever (7) in the LOCK position.

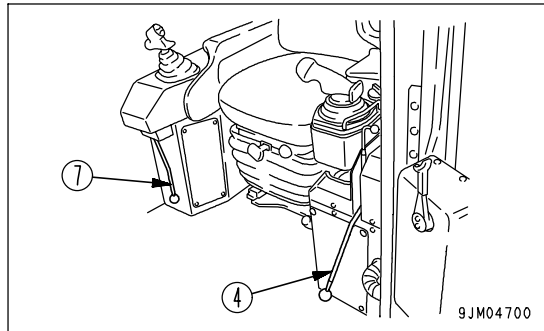
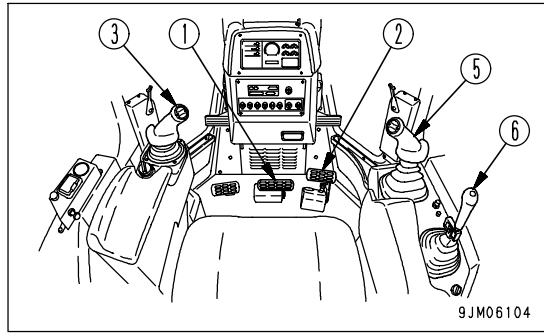

1. Depress brake pedal (1) to stop the machine.

NOTICE

If the brake pedal is depressed when the engine speed or machine travel speed is high, the brake disc may produce a slipping sound. When depressing the brake pedal, usually depress decelerator pedal (2) to reduce the engine speed and machine travel speed.

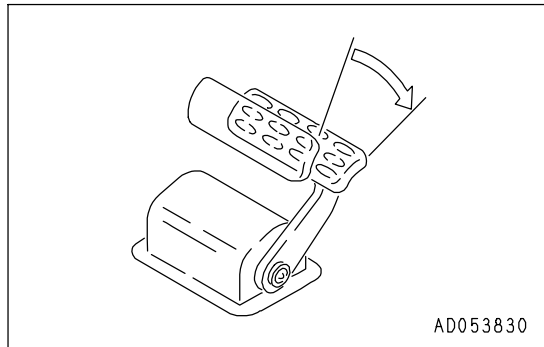

2. Place joystick (3) at the neutral position and set the speed range to 1st.

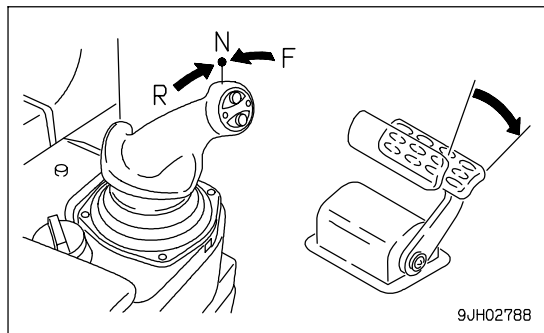

3. Operate parking brake lever (4) to the LOCK (L) position.

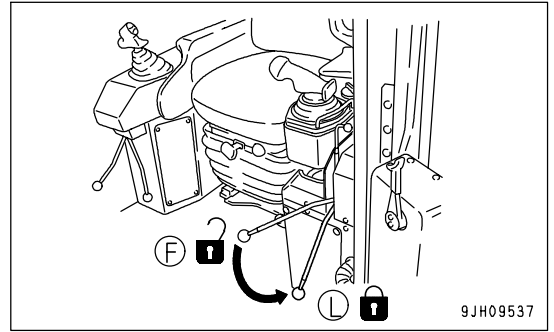

- 4. Operate blade control lever (5) and ripper control lever (6) to the LOWER (c) position to lower the blade and ripper to the ground.
- 5. Operate blade control lever (5) and ripper control lever (6) to the HOLD (b) position.

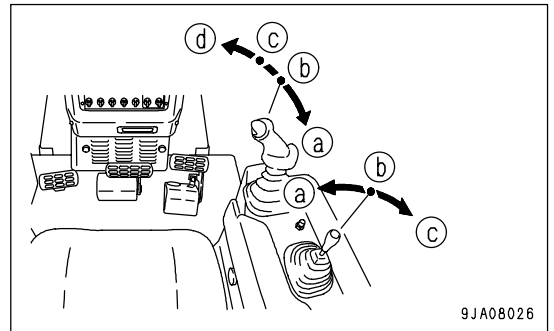

6. Set work equipment lock lever (7) to the LOCK position (L).

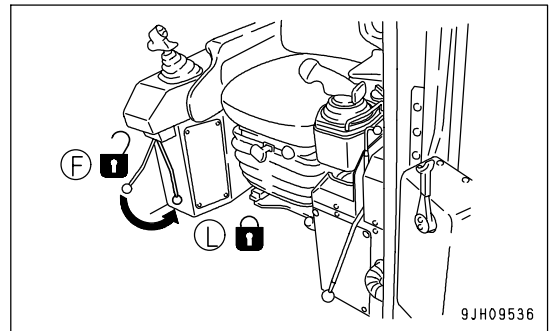

CHECK AFTER FINISHING WORK

Use the meters and caution lamps to check the engine coolant temperature, engine oil pressure, fuel, and power train oil temperature.

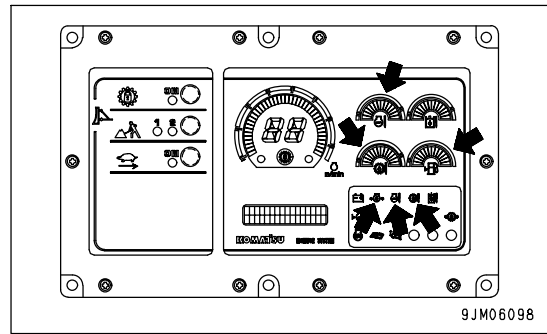

LOCKING

To prevent vandalism, there are locks in the following places. Places that can be locked with the starting switch key.

- Right and left engine side cover (1)
(left side: 2 places, right side: 2 places)
- Electrical component bow inspection cover (left)(2)
- Cab door opener (3)
- Lock-type caps (4) (if equipped)
 - Radiator cap
 - Fuel tank cap
 - Hydraulic tank cap
 - Power train oil filler pipe cap
- Battery inspection cover(5), (6)
- Tool box inspection cover (2)

Commercially available locks can be fitted to the following places.

- Battery inspection cover(5), (6)
- Tool box inspection cover (2)

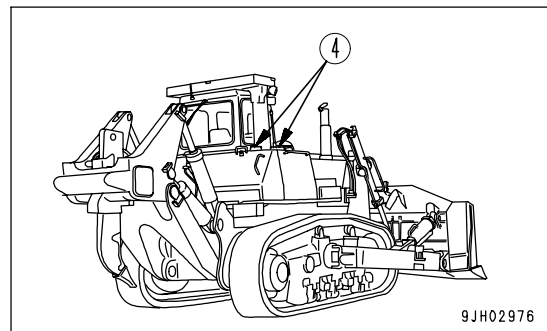
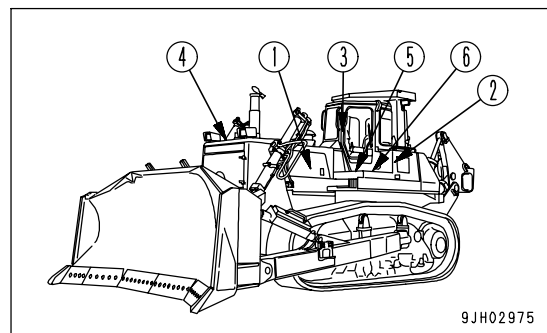

WORK POSSIBLE USING BULLDOZER

In addition to the following, it is possible to further increase the range of applications by using various attachments.

DOZING

A bulldozer digs and transports dirt in a forward direction. Slope excavation can always be most effectively carried out by proceeding from the top downward.

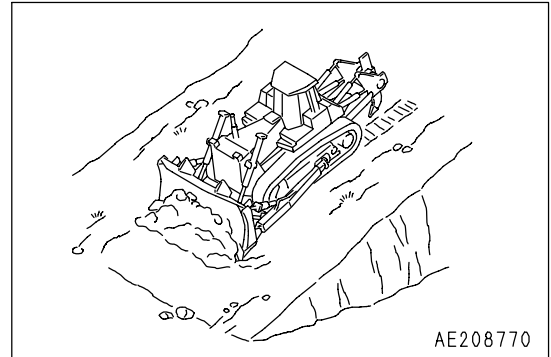

CUTTING INTO HARD OR FROZEN GROUND OR DITCHING

For digging and ditch excavation of hard or frozen ground tilt the blade. Even hard ground can be dug effectively by a tilted or angled blade.

If the ground is harder, use a ripper attachment for better efficiency.

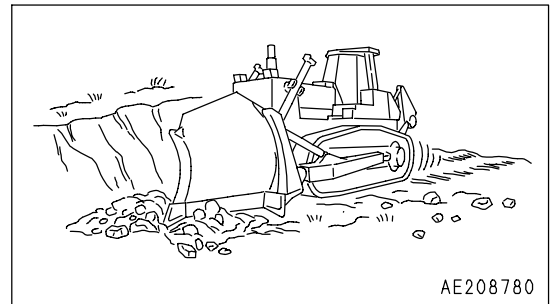

FELLING TREES, REMOVING STUMPS

NOTICE

Do not up root trees or stumps or fell trees by angling or tilting the blade.

For trees with a diameter of 10 to 30 cm (3.9 to 11.8 in), raise the blade high and push 2 or 3 times to fell the tree.

Next, travel in reverse, and dig the corner of the blade into the ground to cut and dig up the roots.

When doing this, never hit the tree at high speed or apply shock to fell the tree.

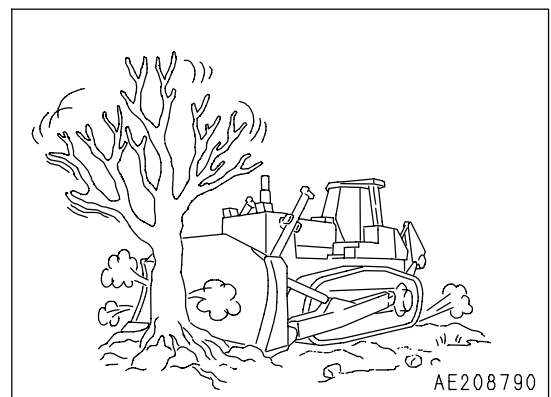

PUSHER OPERATIONS

- When carrying out pusher operations, always install a pusher plate.
- When approaching the other machine, depress the decelerator pedal to reduce the engine speed and approach slowly. After coming into contact, raise the travel speed slowly and push with full power.
- If the pivot turns switch is kept at the ON position, it is possible to carry out pivot turns, and this improves the ease of pusher operation.

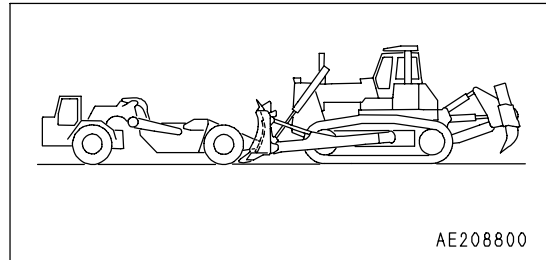

SMOOTHING

NOTICE

Avoid smoothing on rocky or stony ground. It can damage the blade.

When finishing the ground surface to a smooth finish after digging or filling operations, keep a full load of soil in the blade and operate the blade up or down in small movements while traveling forward. When leveling windrows or ruts left by the tracks, set the blade to the FLOAT position, travel at low speed in reverse and drag the blade over the ground surface.

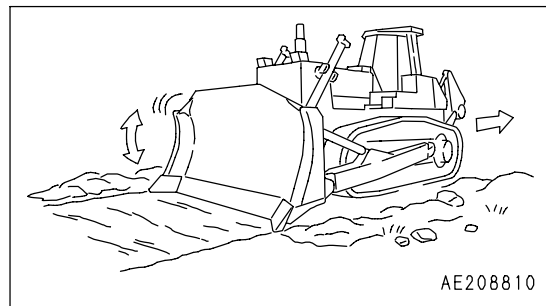

EFFECTIVE USE OF MODE SELECTION SYSTEM

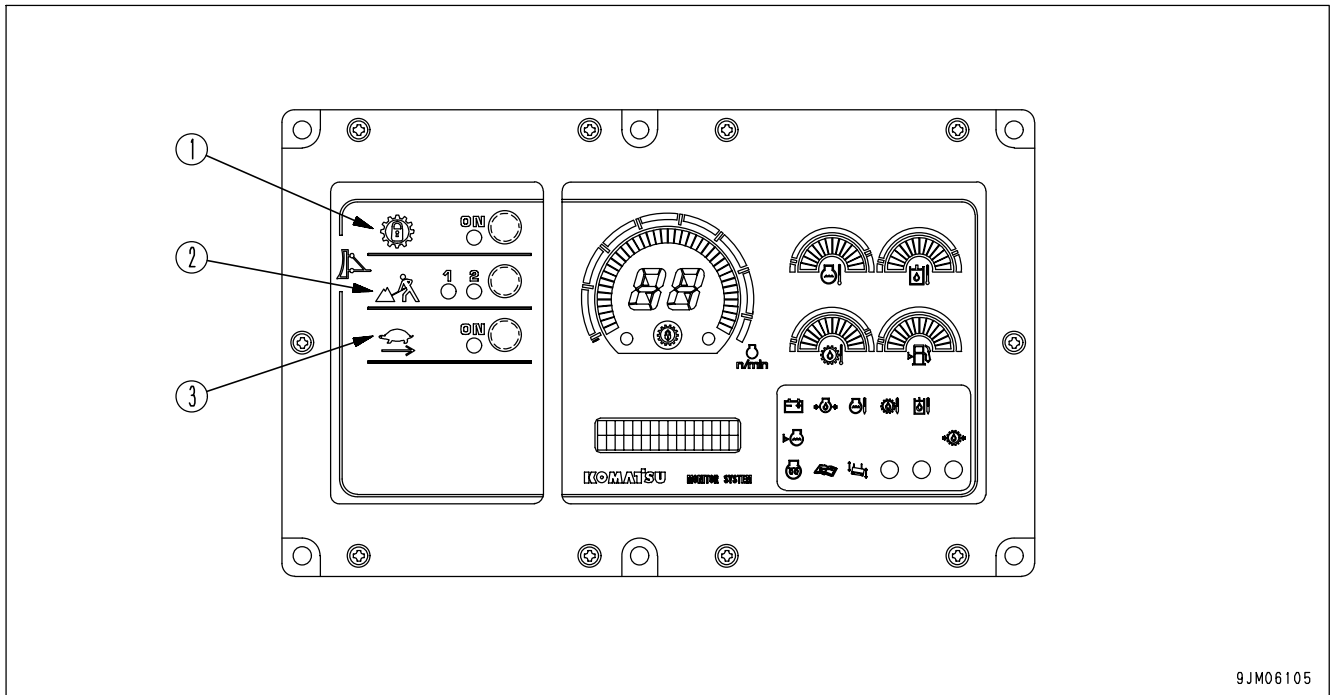

9JM06105

- (1) Lock up mode switch
- (2) Economy mode selector switch
- (3) Reverse slow mode selector switch

Selecting mode to match the type of work and quality of rock and soil makes to perform operations effectively. For the machine that is solely used for crushed rocks, it can be done that when the ignition switch is turned ON, all mode switches are turned ON. Contact your Komatsu distributor for such modification of the switches. When all the mode selection switches are off, the selection is suitable for conventional digging and dozing of bedrock. The condition when all the mode selection switches are off is called the standard mode. It is impossible to use any combination of the lock-up mode and any other mode. The economy mode, reverse slow mode, and shoe slip control mode can be used independently or in combination.

Dozing		Ripping
Lock up mode	Economy mode	Reverse slow mode
○	×	×
×	○	○

○: Possible to use ×: Compound use not possible

SELECTION OF MODE

DOZING OPERATIONS

LOCK UP MODE

By using the lock up mode, the travel speed increases, the operating efficiency is improved, and the fuel consumption is also reduced.

- Speed ranges that can be used: All speed ranges
- Applicable operations: Dozing loose material (suitable for long-distance hauling operations)

When the lock up mode is turned ON, direct drive or torque converter drive are automatically selected according to the load.

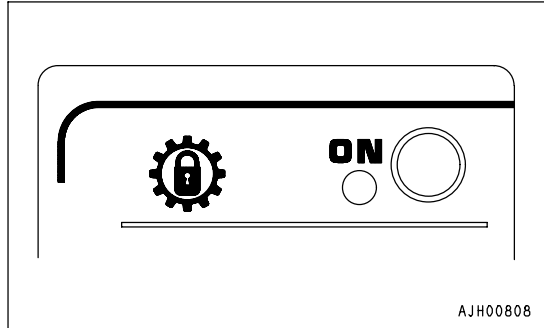

(Example)

- Slot dozing operations

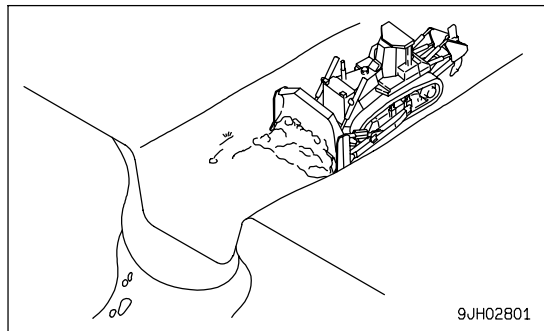

- Hillside dozing operations

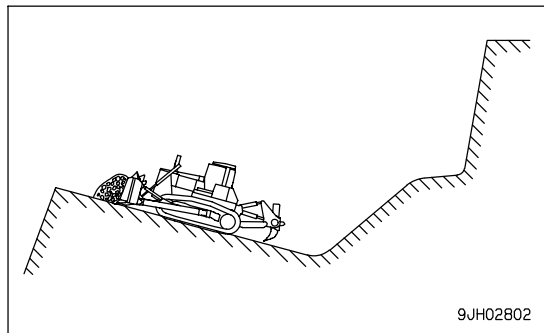

REMARK

- If dozing operations power carried out on a slope of an angle of more than 15°, the lock up may easily be canceled, so operations are easier to carry out in the standard mode.
- For normal ripping operations, if the lock up mode is used, the lock up will repeatedly switch between ON and OFF, so use the standard mode.
- Even with ripping operations, if the ground is extremely soft, the lock up mode can be used.

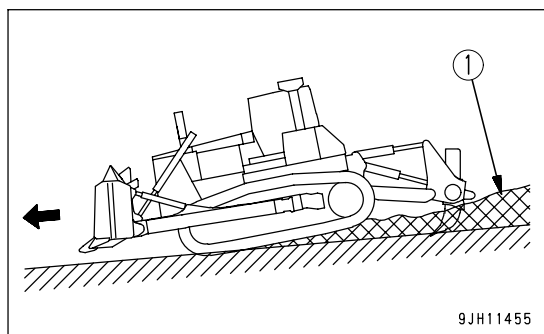

(1)Quality of earth and sand

ECONOMY MODE

Using the economy mode makes it possible to reduce wasteful shoe slippage and to reduce the fuel consumption.

- Speed ranges that can be used: F1
- Applicable operations: Hauling after ripping, dozing blasted rock, smoothing.

When the economy mode is turned ON, it is automatically set to [1]. Carry out dozing operations in this condition, then set to [2] and carry out operations. From this test, select the matching that gives power and low shoe slip ratio (frequency of deceleration operation).

Mode [1] is set to approx. 90% of full power and mode [2] is set to approx 70%.

(Example)

- Fine leveling operations

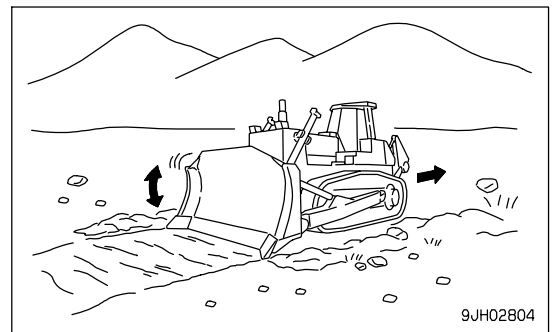
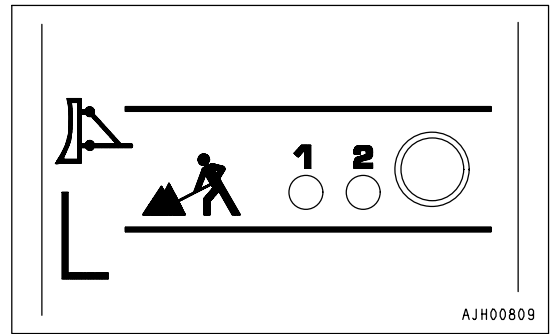

- Ripping and dozing operations

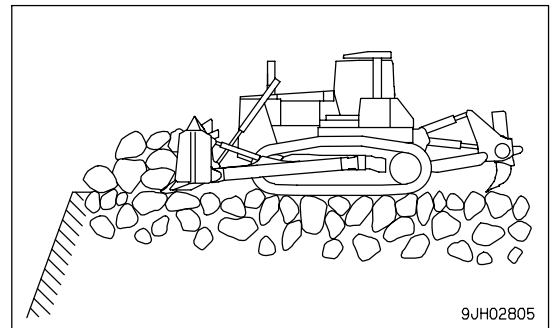

REVERSE SLOW MODE

This reduces the travel speed when traveling in reverse, reduces the frequency of operating the decelerator pedal, and improves the riding comfort for the operator.

- Speed ranges that can be used: R1, 2, 3
- Applicable operations: Travelling on bedrock

Use this mode to reduce the travel speed when traveling in R1, R2, or R3.

When the reverse slow mode is ON, the travel speed is set to approx. 80% of the full travel speed.

Use this mode to reduce the travel speed when traveling in reverse after ripping and dozing bedrock or when traveling in reverse after dozing on steep slopes. The travel speed differs in each mode according to whether it is used in combination with the economy mode.

When traveling on bedrock, if it is felt that the travel speed when traveling in reverse is too high, turn the reverse slow mode ON.

This will reduce the travel speed when traveling in reverse.

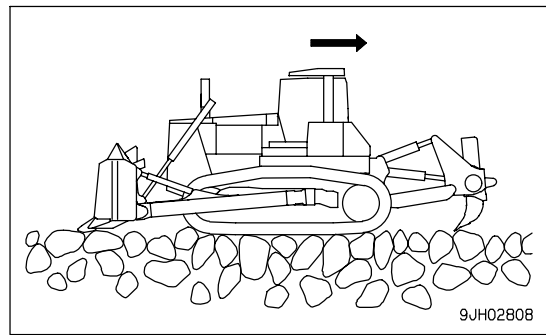
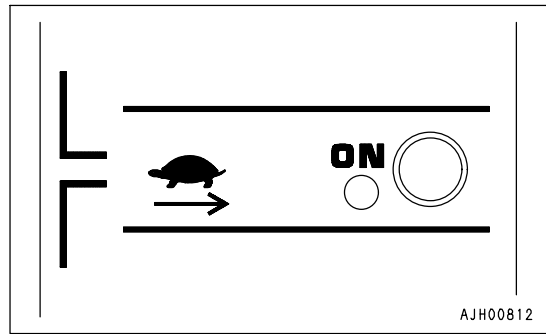

When traveling down slopes, if it is felt that the travel speed when traveling in reverse is too high, turn the reverse slow mode ON.

This will reduce the travel speed when traveling in reverse.

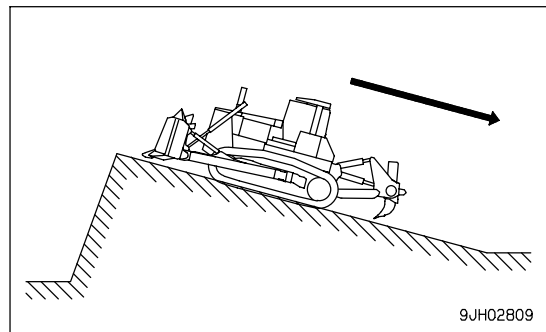

PROCEDURE FOR SELECTING MODE ACCORDING TO NATURE OR NEEDS TO WORK

Use the table below to select the mode that matches the nature or needs of the operation.

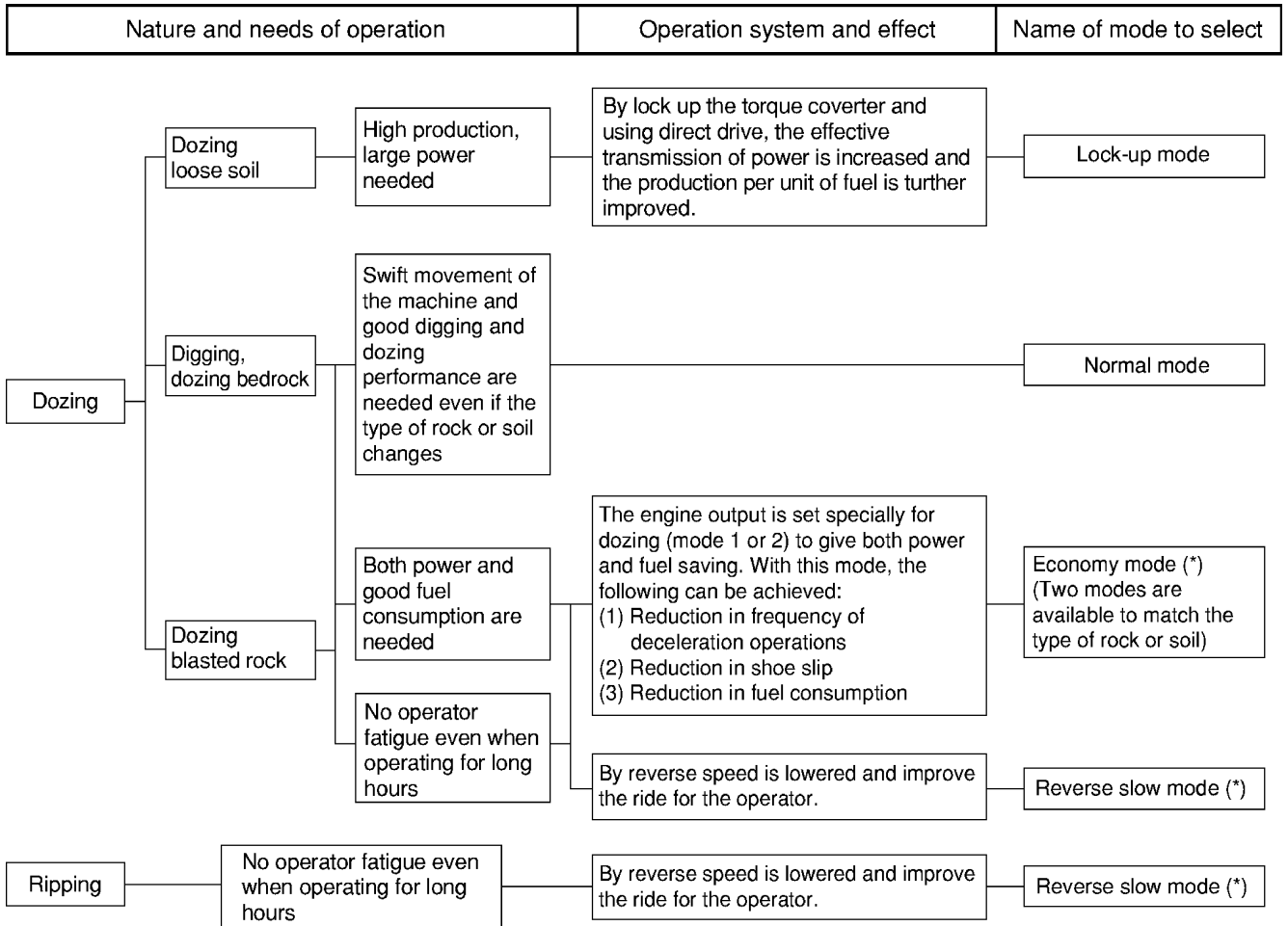

(*): The dozing economy mode and reverse slow mode can all be selected independently or in combination. In addition, it is possible to select and correct as needed, so it is possible to achieve precise matching for various types of operation.

RIPPER OPERATION

EFFECTIVE METHOD OF USE

- The optimum digging angle for the shank is when the shank is perpendicular to the ground (ripping angle: 45° to 50°).
- In comparatively soft rock (seismic velocity: 1500 m/s or below), it is also possible to carry out ripping with the shank tilted to the rear.
- On comparatively hard rock, if ripping is carried out with the shank tilted to the rear, there will be excessive wear of the point of tip (1), and the self-sharpening ability will be lost.
- During ripping operations, if the shoes slip because of boulders or resistance from the bedrock, use the tilt cylinder. When picking up a stone, advance the machine at a fixed gear speed (F1 or F2).

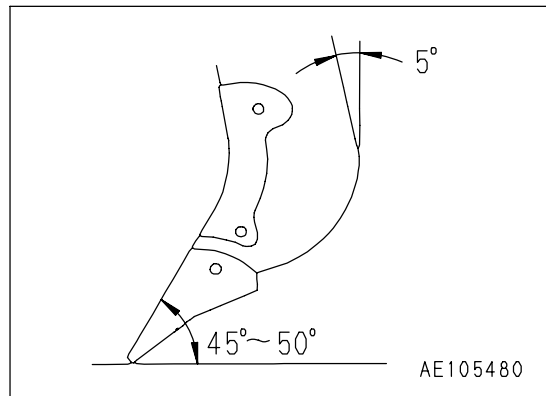

REMARK

- When raising boulders or digging up rockbed, do not put the transmission in neutral. If the transmission is in neutral, the reaction of the tilt cylinder will push the machine back. Always operate the machine with the transmission in FORWARD.
- Choosing a suitable ripper point to match the type of rock is one of the most important elements in using the ripper effectively. Ripper points are available for different types of rock, so select the most suitable ripper point from the list. For details, see "PROCEDURE FOR SELECTING RIPPER POINT (PAGE 6-4)".

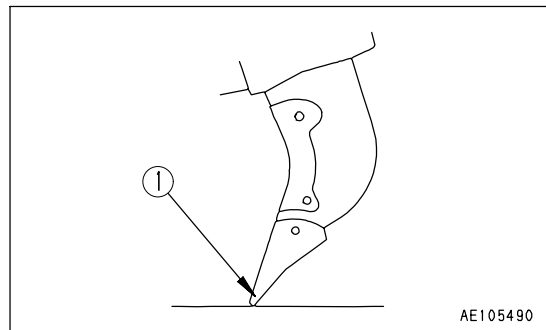

DIGGING UP BOULDERS OR ROCKBED

During ripper operations, if stubborn boulders or rockbed cause the travel speed to become slower, operate the tilt cylinder to dig up the boulder/rockbed.

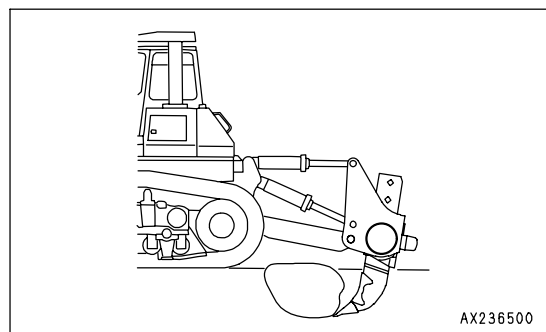

OPERATING ON SLOPES

When using the variable ripper, adjust the length of the tilt cylinder to select dimension L.

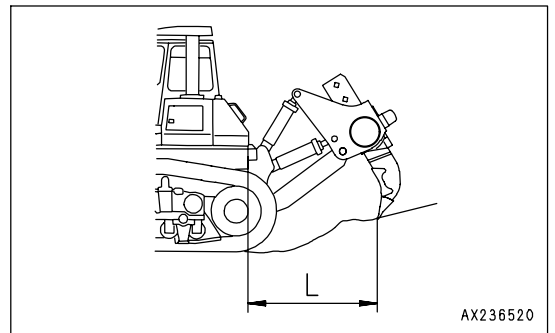
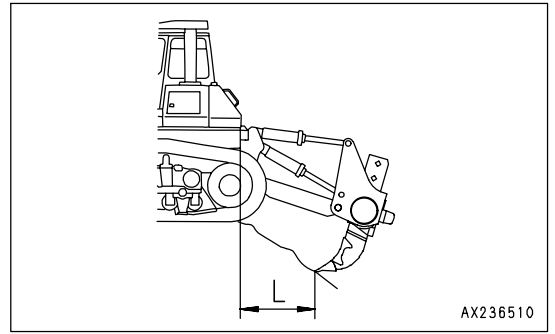

METHOD OF OPERATING PIN PULLER

- 1. Stop the machine in a safe place and lower the shank to the ground.
- 2. Operate the pin puller controller switch to the "PULL OUT" position (1) and remove the mounting pin.

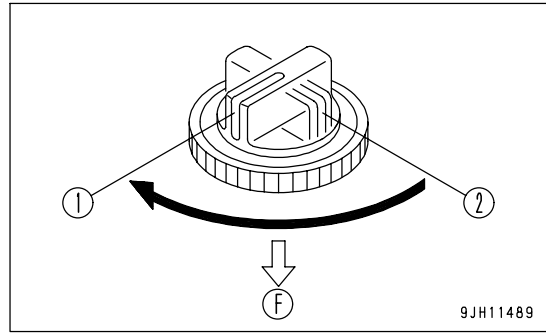

(F)Front of the machine

- 3. Move the ripper up or down to set to the desired shank position.

REMARK

Align mark of ripper (A) with top surface of holder (B).

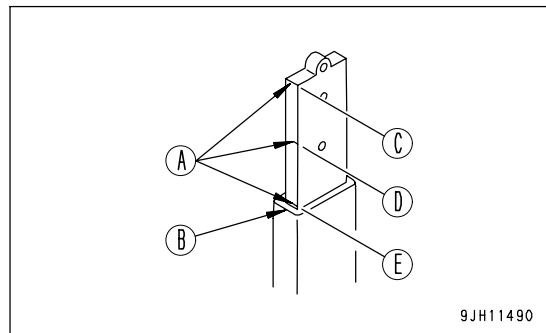

- (C)Depth Max.
- (D)Depth intermediate
- (E)Depth min.

- 4. Operate the pin puller control switch to insert the mounting pin. If the pin does not match the position of the hole in the shank, set the pin puller control switch to the "PUSH IN" position (2) and slowly move the ripper up or down.

REMARK

When raising the pin position to increase the digging depth, use a long protector to prevent wear of the shank.

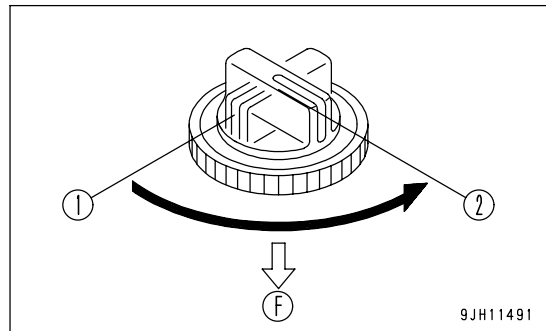

(F)Front of the machine

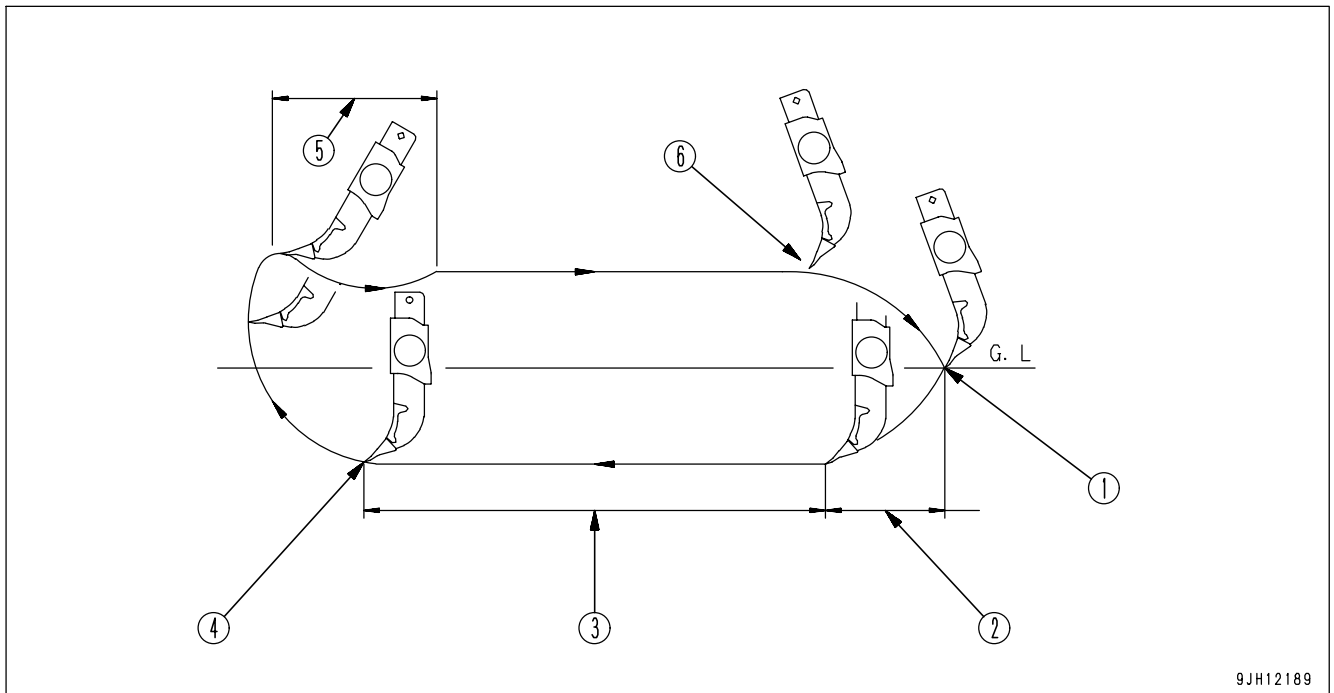
OPERATING METHOD FOR RIPPING OPERATIONS**BASIC OPERATING METHOD**

- (1) Point in contact with ground
- (2) Insert point to specified depth
- (3) Ripping
- (4) Start raising ripper
- (5) Shank tilted back
- (6) Start lowering ripper

TRACK OF RIPPER SHANK

Carry out the ripping operation as follows, passing through the points shown in the diagram above.

- (1) Tilt the ripper back, lower the ripper point to the ground that the place to begin ripping, and raise the rear of the machine.
- (2) To press the decelerator pedal and lower the engine speed, set the speed range to F1, and tilt the ripper to insert the point to the specified depth.
- (3) When the ripper point reaches the specified depth, raise the engine speed to full speed and travel forward. Tilt the shank and carry out ripping. If the circuit is relieved even when the shank is tilted, change the shank mounting hole to the hole below and reduce the ripping depth.
- (4) After completing the ripping, travel forward, raise the shank from the bed rock, then travel in reverse.
- (5) While traveling in reverse, tilt the ripper back, and when the starting point for the ripping is reached, lower the ripper.

REMARK

- If the ripper is applied with the rear of the machine raised from the ground, the drawbar pull will be low, so the ripping efficiency will be reduced.
- If the ripping depth is kept constant, there will be no unevenness, and this will increase the efficiency of the dozing operation.

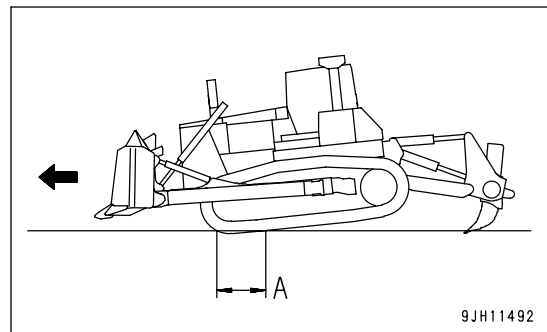

(A)Length of track on ground

RIPPING BY CLIFFS

- When carrying out ripping at the edge of a cliff, tilt the ripper back (B) to make depth (L) longer.

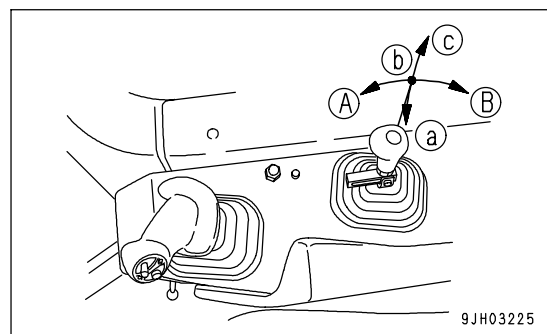

- Depress the decelerator pedal, drive slowly forward, and when the ripper point contacts the cliff, tilt the ripper in (A).

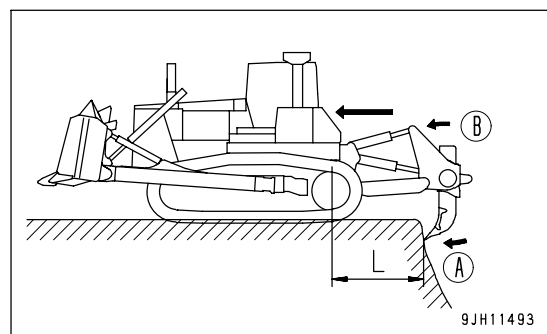

RIPPING BY SLOPE FACES

(Giant ripper)

- When carrying out ripping work at the edge of slope faces, make the ripper tilt back (B) angle small, and if there is an area where the slope face (1) has not been ripped, apply the ripper diagonally.

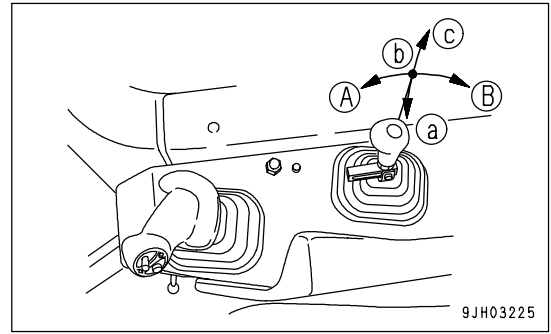

REMARK

In the case of the multi-shank ripper, carry out ripping at right angles to the slope face.

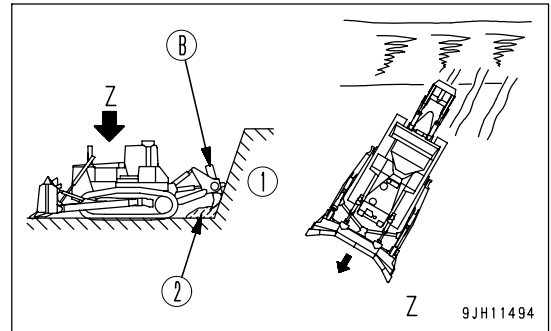

- (B)Tilt back (MAX)
- (1)Slope face
- (2)Ripping base

Cross ripping

- On jobsites with hard bedrock, for rocks and boulders which are impossible to break or dig up with one ripping pass, carry out the second ripping pass at right angles to the first ripping direction.
- At the edge of cliffs, where it is impossible to apply the ripper in a cross direction, make the space between the shanks smaller and carry out ripping.

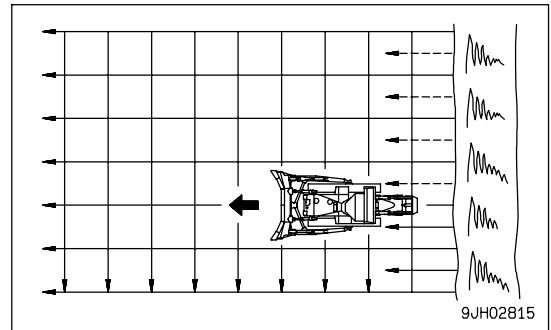

- During the ripping operation, if there is any hard bedrock, carry out ripping in the opposite direction to the direction where the ripper was applied. If it is still impossible to break up the rock, break up the area around the bedrock a little at the time.
- When carrying out concentrated ripping of hard bedrock, the work efficiency is high if the ripper is applied to the whole of the digging face.

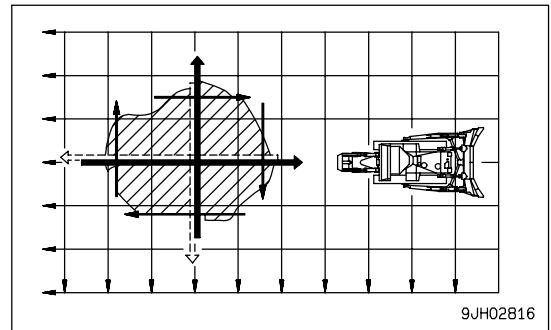

DIGGING UP BOULDERS

During the ripping operation, if boulders are found which are difficult to break and shoe slippage occurs, dig up the boulder as follows.

1. Depress the decelerator pedal and lower the engine speed to a point where there is no shoe slippage.

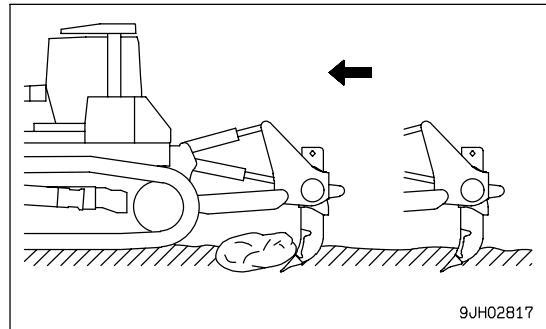

2. Operate the ripper lever to the TILT position and carry out ripping and digging.

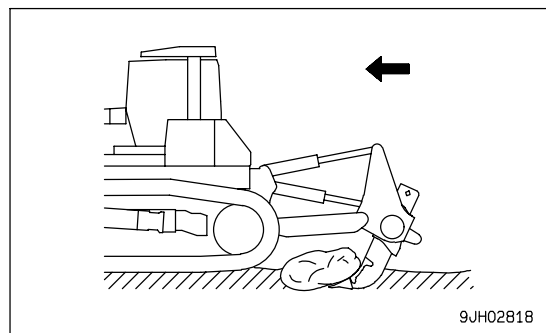

3. If there are boulders which are impossible to break or dig up with the tilt operation, move forward slightly and tilt the shank back, then operate the tilt again and dig up the boulder.

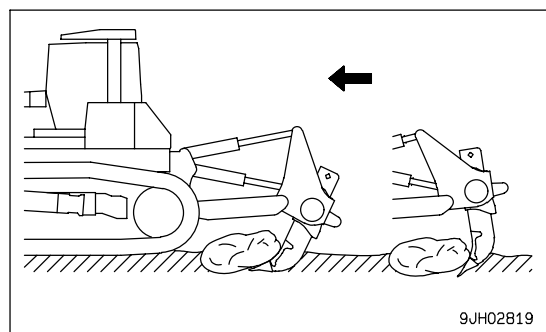

4. Even when the operation in Step 3 is repeated, if it is impossible to break or dig up the boulder, drive back about 10 cm, raise the shank, avoid the rock or boulder that cannot be ripped, then drive forward and start ripping again.

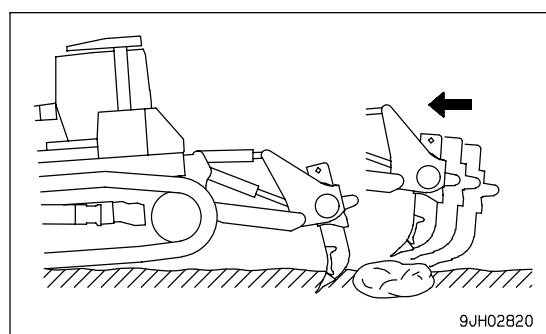

PRECAUTIONS WHEN RIPPING

- For the digging angle when ripping, set so that the top of the shank is perpendicular, then lower the ripper.
- Do not carry out ripping for long periods with the shank tilted back. The tip of the point will wear to a round shape.

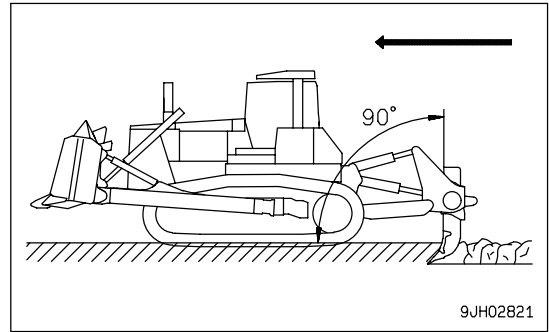

- Do not change the direction of travel during the ripping operation. This will cause breakage of the shank. When changing the direction of travel, remove the shanks from the ground before turning.

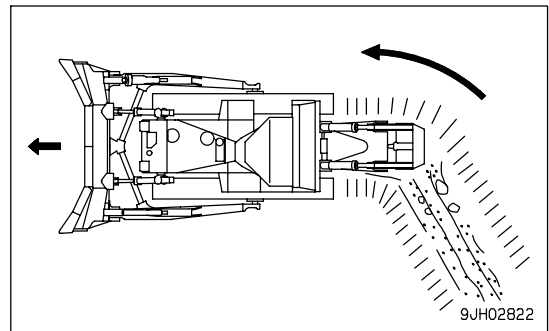

- Never drive in reverse when the ripper point is inserted in the bedrock. The pin installing the point (1) will break and the point will fall off. Stop the machine, tilt back (B) slightly, then raise the ripper slowly.

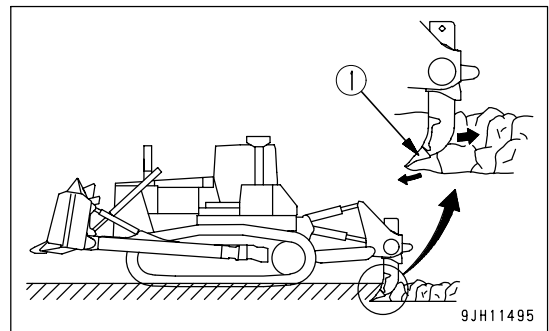

- After ripping, if the broken rock is comparatively large, avoid traveling over the ripping path (2) when traveling in reverse. When traveling in reverse (3), check the rear carefully to avoid heating any large rocks. As far as possible, choose level ground to travel over.

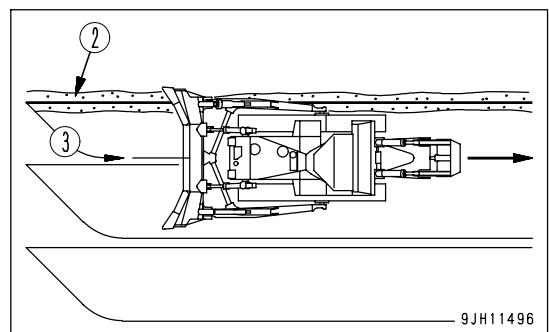

ADJUSTING POSTURE OF WORK EQUIPMENT



WARNING

When adjusting, it is dangerous if the work equipment is moved by mistake. Set the work equipment in a safe condition, then stop the engine and lock the work equipment securely with the work equipment lock lever.

BLADE ADJUSTMENT

TILTING THE TILTDOZER

NOTICE

The maximum tilt is 1000 mm (39.4 in).

Adjust the tilt so that it does not exceed the limit of 1000 mm (39.4 in).

If the maximum tilt is exceeded, excessive force will be brought to bear on all parts, and this will damage the machine.

According to the operation of the blade control lever, the following tilt amount can be obtained:

Right side: 570 mm (22.5 in) or more

Left side: 570 mm (22.5 in) or more

If more tilt is required, do as follows.

Use bar handle (2) installed to the left brace to turn brace (1) and change the length (ℓ) of the brace. This makes it possible to obtain a maximum tilt of 1000 mm (39.4 in).

- Standard distance (ℓ) between joints is 1460 mm (57.5 in)

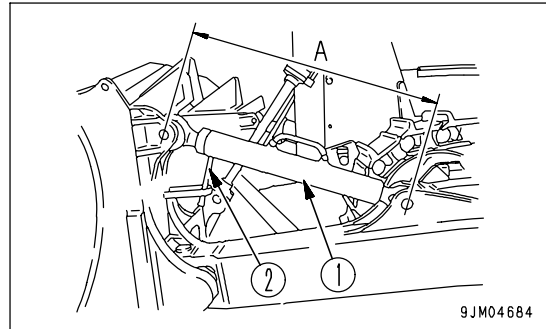

ADJUSTING SHIM IN BLADE CYLINDER CAP

Set the standard shim adjustment in the blade cylinder cap to 4 mm (0.16 in).

Remove shims to balance the wear of the cap and the ball at the end of the piston rod.

The proper clearance to be maintained with the shims is 0.2 to 0.5 mm (0.008 to 0.02 in).

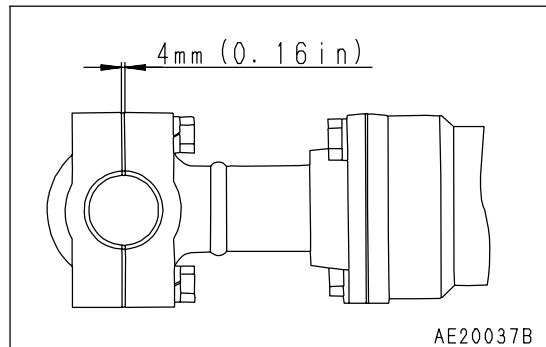

ADJUSTING BRACE

**WARNING**

If maintenance is carried out with the engine running, always have one worker sitting in the operator's seat while another worker carries out the maintenance. Both workers must mutually confirm the safety during the operation.

Adjustment can be carried out more easily if the engine is started, the inching operation used to carry out tilting to the left and right, and the blade shaken up and down while turning the brace handle (1).

- When extending the brace

It is easy to carry out the adjustment if the blade is set on top of a block and the brace handle is turned.

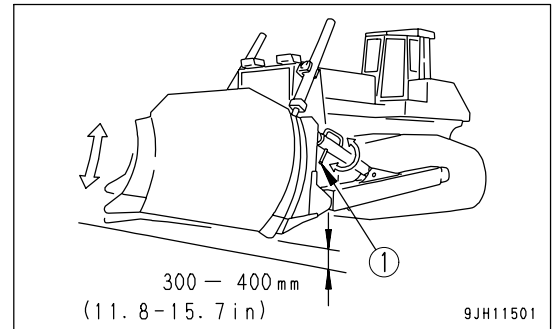
**REMARK**

When operated in this way, the blade is tilted, so the handle gradually becomes heavier. When this happens, return the blade from the tilt position to the horizontal position and turn the handle again according to the procedure given above.

SHIM ADJUSTMENT

Adjust the thickness of shim so that the ball joint play (4 places) in the axial direction (shown by the arrow) does not exceed 1 mm (0.04 in).

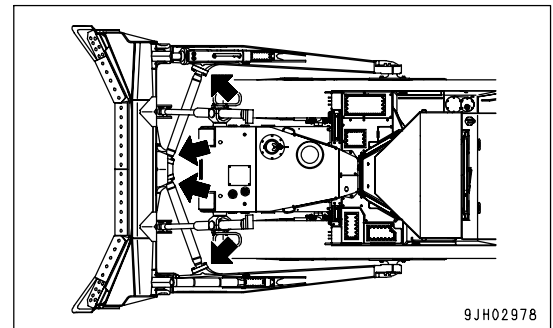

1. Remove shim (1) and tighten bolts (2) to eliminate the ball joint play.
2. Measure clearance "A" and remove bolts (2).
3. Install shim (1) having its thickness of "A" mm to "A + 1" mm ("A" in. to "A + 0.04" in) in place with bolts 2.
4. Confirm that ball joint can move smoothly after tightening bolts.

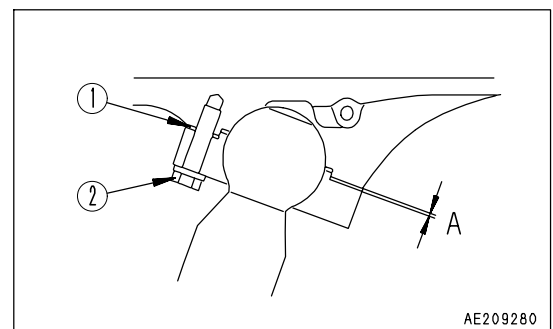

ADJUSTING RIPPER

ADJUSTING DIGGING DEPTH

There are mounting holes in the shank to choose to match the ripping depth. Normally, use the bottom hole, but if particularly deep ripping is needed, use the top hole.

- When a giant ripper is installed, use the pin puller.

For details, see "METHOD OF OPERATING PIN PULLER (PAGE 3-126)".

(Machines equipped with multi-shank ripper)

1. Place a pointed object on the tip of pin (1), then hit with a hammer to remove from the opposite side.
2. Remove pin (2) and change the position of the shank hole.
3. Insert pin (1) partially by hand then knock it in with a hammer.
 - The pin is made of one piece, so insert it partially by hand then knock it in with a hammer.

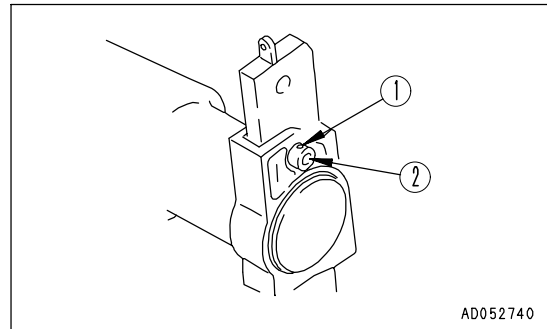

REPLACING POINT AND PROTECTOR

To protect the shank, if the protector and point installed to the tip are worn, replace them.

Place a pin remover on the pin marked by the arrow, then hit with a hammer to remove from the opposite side.

REMARK

The pin is a unitized type, so insert the pin partially by hand, then knock it in fully with a hammer.

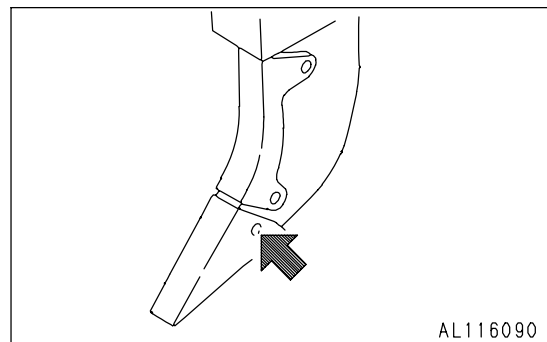

TIPS FOR LONGER UNDERCARRIAGE LIFE

Undercarriage life greatly varies depending on operation method, inspection and maintenance. For most efficient operation, keep the following point in mind.

OPERATION METHOD

- Select the track shoe that best suits the type of soil to be encountered in service.
Consult your Komatsu distributor when selecting track shoes.
- Do not allow shoe slippage to occur during operation. If slippage occurs, reduce load to the blade until slipping stops.
- Avoid sudden starts, acceleration or stops, unnecessary high speeds and sharp turns.
- Always operate machine in a straight line whenever possible. When making turns, be careful not to allow the machine to stay to one side, so operation in both turning directions can be done properly. Make turns with the largest possible radius.
- Prior to operation, clear boulders and obstacles to prevent machine from riding over them while operating.
- On a slope, operate the machine parallel to the inclination of the slope. Do not operate across the slope. Also when stopping the machine on a slope, the machine should face the top of the slope.
- When ground inclines to the left or right during digging operations, do not continue to dig with the incline. Move the machine back to level ground and start to dig again.
- Do not force the machine to carry out work that exceeds its working capability. Such work includes cases where the idler or sprocket come off the ground when the machine meets obstacles that resist the power of the machine during dozing or ripping operations.

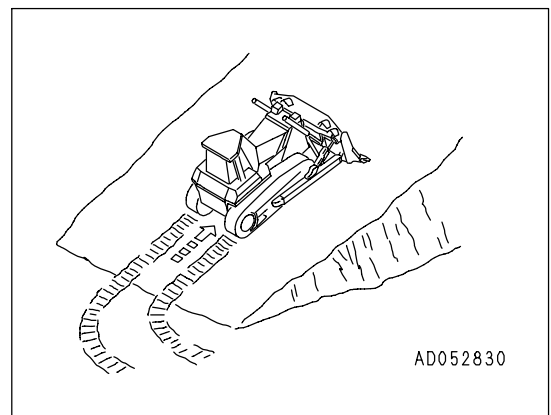

INSPECTION AND ADJUSTING

- Properly adjust track tension.
Tension should be measured at clearance (A) shown in the diagram - usually 20 to 30 mm (0.8 to 1.2 in) at this point. For rocky terrain, tighten tracks slightly. In clay or sandy areas, slightly loosen them. (For inspection and adjustment procedures, refer to "CHECK AND ADJUST TRACK TENSION (PAGE 4-29)").
- Check idler rollers for oil leakage as well as for loose bolts and nuts. If any trouble is detected, repair immediately.
- Check the clearance between the idler guide plate (1) and the track frame. If clearance (B) increases, idler may develop side motion and tracks may come off. (For inspection and adjustment procedures, refer to "ADJUST IDLER CLEARANCE (PAGE 4-33)").

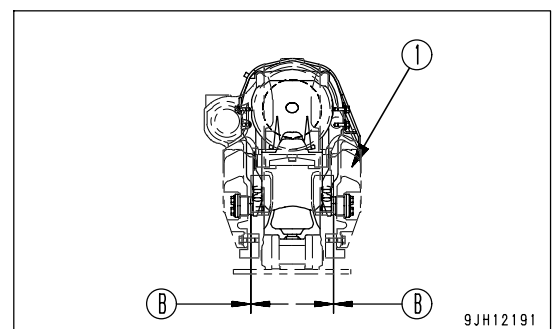
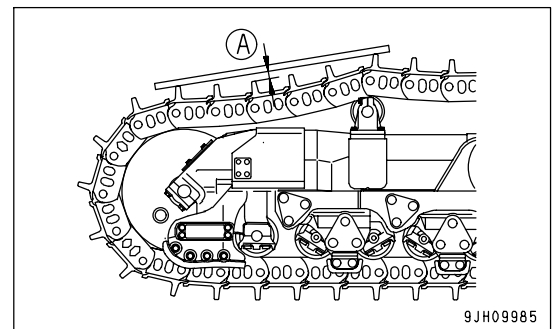

INSPECTION AND REPAIR

Frequent inspection and prompt repair will reduce repair costs.

The following items for inspection will serve as a guide to maintenance service of each undercarriage part. Perform periodical inspection and contact the Komatsu distributor in your area when machine has approached repairable limits and reversing limits.

MEASURING HEIGHT OF GROUSER

- After taking up slack in track shoes, measure height at center of shoe as shown below.

Standard height (h): 88 mm (3.5 in)

Repair limits: 30 mm (1.2 in)

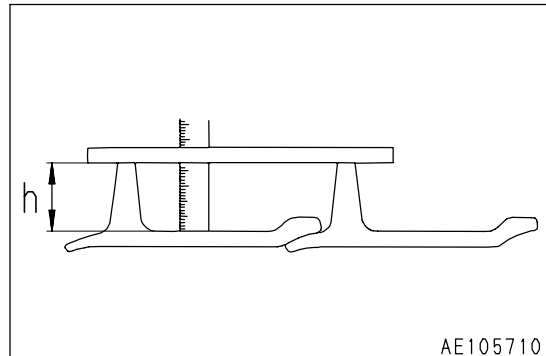

MEASURING OUTSIDE DIAMETER OF TRACK ROLLER

1. Measure height (size C) of link tread as shown.
2. Stop machine at position where link tread, whose size C has been measured completely, contacts roller tread. Then measure size B.
3. Calculate outside diameter of tread (size A)
 $A = (B - C) \times 2$
 Standard size (A): 255 mm (10.0 in)
 Repair limits: 185 mm (7.3 in) (Single roller)
 195 mm (7.7 in) (Double roller)

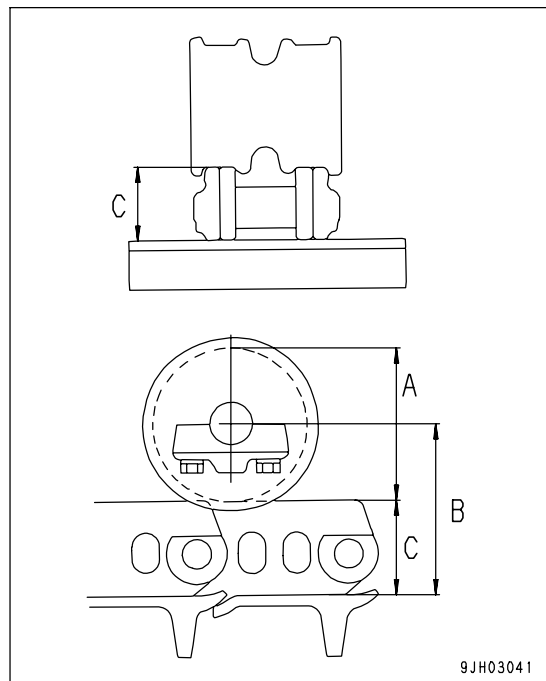

TRANSPORTATION

When transporting the machine, observe all related laws and regulations, and be careful to assure safety.

TRANSPORTATION PROCEDURE

When transporting the machine, choose the optimum transportation method in reference to the weight and dimensions shown in "SPECIFICATIONS (PAGE 5-2)". Note that machine specifications (weight and dimensions) vary depending on the kind of track shoes and work equipment.

A trailer should be used for transporting the machine.

LOADING, UNLOADING WORK



WARNING

- Make sure the ramp has sufficient width, length and thickness to enable the machine to be safely loaded and unloaded. If the ramp sags appreciably, reinforce it with blocks, etc.
- When loading and unloading the machine, park the trailer on a flat firm roadbed. Keep a fairly long distance between the road shoulder and the machine.
- Remove the mud from the undercarriage to prevent the machine from slipping to the side on slopes. Be sure the ramp surface is clean and free of grease, oil, ice and loose materials.
- Never change the direction of travel when on the ramps. If it is necessary to change direction, drive off the ramps and correct the direction, then drive on to the ramps again.

When loading or unloading, always use ramps or a platform and carry out the operations as follows.

LOADING

1. Load and unload on firm level ground only.
Maintain a safe distance from the edge of a road.
2. Apply the trailer brakes securely, then put blocks (1) under the tires to prevent the trailer from moving.
 - Set left and right ramps (2) parallel to each other and equally spaced to the left and right of center (3) of the trailer. Make angle of installation (4) a maximum of 15°. If the ramps bend a large amount under the weight of the machine, put blocks under the ramps to prevent them from bending.
3. Set parking brake lever to the FREE position (F).
4. Set the transmission in the 1st gear and run the engine at low idle.
5. Set the travel direction toward the ramps and drive slowly.
6. The center of gravity of the machine shifts suddenly at the border between the ramps and trailer, and the machine is unbalanced and becomes dangerous. Accordingly, pass the border slowly.
7. Stop the machine at the specified position on the trailer.

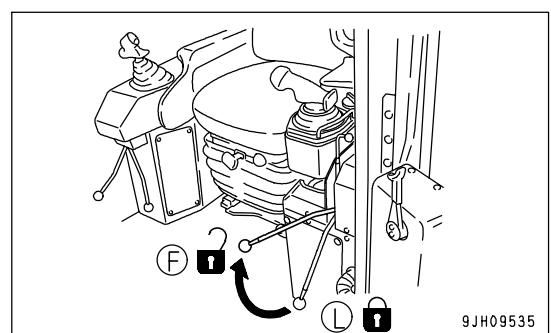
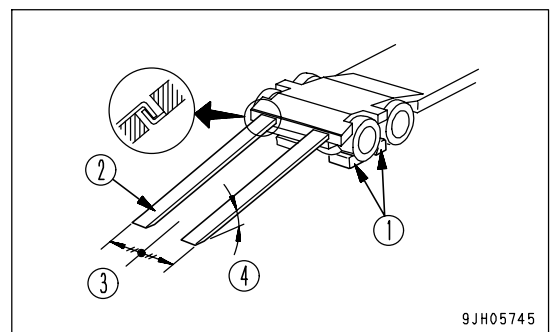

PRECAUTIONS FOR LOADING

After placing the machine on the specified position of the trailer, secure it according to the following procedure.

1. Lower the work equipment slowly.
 2. Secure control levers with the work equipment lock lever.
 3. Set the parking brake lever to the LOCK position.
 4. Turn the starting switch to the OFF position stopping the engine, then remove the key.
 5. Lock the cab door, left and right engine side covers, and the battery inspection cover.
 6. Place blocks under both ends of the tracks to prevent the machine from moving during transportation, and secure the machine with chains or wire rope of suitable strength.
- Be particularly careful to secure the machine in position so it does not slip to the side.

METHOD OF LIFTING MACHINE



WARNING

- Never perform lifting operations with any person on the machine.
- Always make sure that the wire rope (cable) used for lifting the machine is of ample strength for the weight of the machine.
- Never try to lift the machine in any posture other than the posture given in the procedure below.
There is danger that the machine may lose its balance.
- When lifting the machine, pay careful attention to the center of gravity to maintain the balance.

When lifting the machine, perform the operation on flat ground as follows:

1. Stop the engine and be sure to set the parking brake lever to the LOCK position.
2. Set the lifting position for the machine as shown in the diagram on the right.

NOTICE

This method of lifting applies to the standard specification machine.

The method of lifting differs according to the attachments and options installed.

For details of the procedure for machines that are not the standard specification, please consult your Komatsu distributor.

For weight, see "SPECIFICATIONS (PAGE 5-2)".

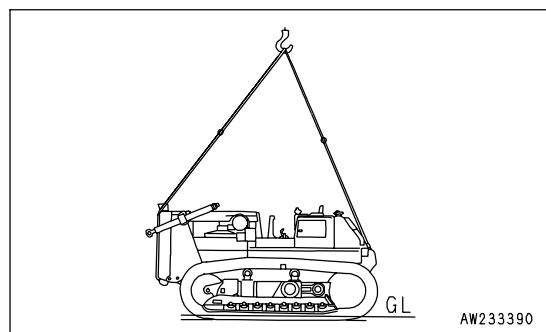
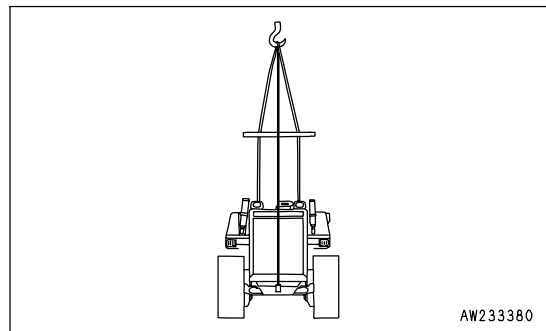

PRECAUTIONS FOR TRANSPORTATION



WARNING

Determine the route for transporting the machine by taking into account the width, height and weight of the machine.

Obey all state and local laws governing the weight, width and length of a load. Observe all regulations governing wide loads.

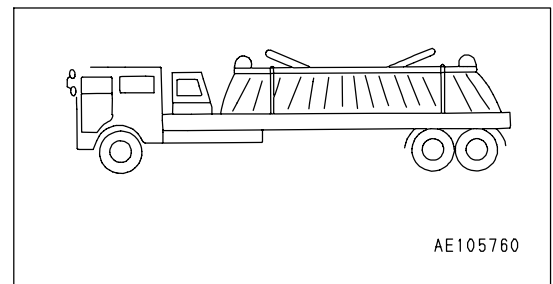
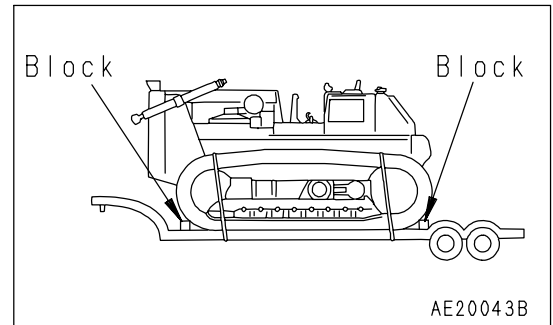

TRAVELING ON ROADS

- When traveling on paved roads, use flat shoes to protect their surface.
Even when travelling a short distance, always place boards to protect the road surface.

REMARK

Note that the asphalt road becomes soft in summer.

REMOVAL OF CAB

(Machine equipped with cab) (If equipped)

If it is necessary to remove the cab for transportation, disconnect the washer hoses, cab wiring, and washer motor wiring before removing the cab.

1. Pull the grommet portion in towards the cab from the hole in the machine cover, then remove.
2. Disconnect 4 washer hoses and the wiring (single wires x 2, 4-pin plug x 1) from the socket.
 - After removing, cover the washer hoses with a vinyl bag to prevent any dirt or dust from entering.
 - Before removing the cab, measure the clearance between the cab and each lever (joystick and blade control lever, etc.). Note the measurements to use as a standard when installing the cab again.

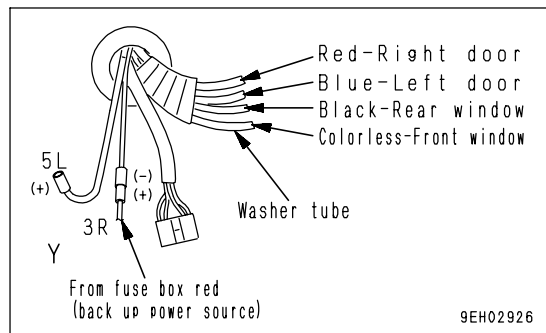
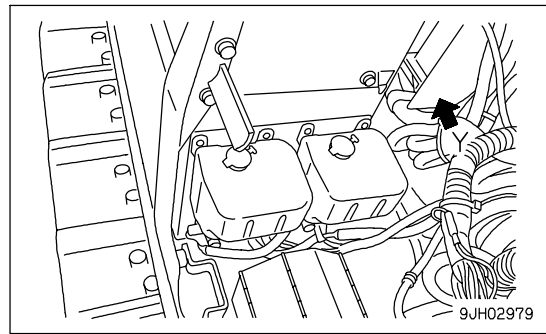

INSTALLATION OF CAB

(Machine equipped with cab) (If equipped)

Install the cab parts in the opposite order to removal.

Connect all parts that were disconnected.

1. Lower the cab slowly on top of the floor frame.
2. Align the cab with the floor frame, then install bolts and washers in holes (A) - (U).
Do not screw the bolts in fully. Screw them in 3 or 4 turns.
3. Tighten the bolts in holes (N) - (U) fully.
Tighten in the order (N), (U), (Q), (R), (O), (T), (P), (S).
4. Tighten the bolts, (A) to (M), completely.

If there are any unclear points about removing or installing the cab, please contact your Komatsu distributor.

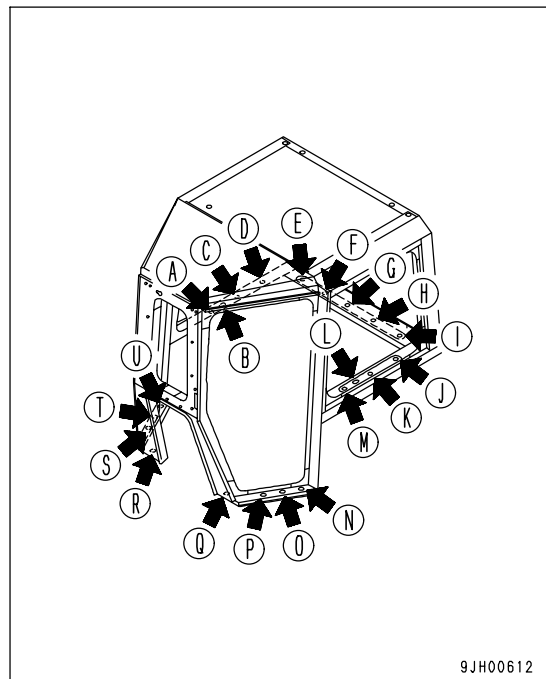

COLD WEATHER OPERATION

PRECAUTIONS FOR LOW TEMPERATURE

If the temperature becomes low, it becomes difficult to start the engine, and the coolant may freeze, so do as follows.

FUEL AND LUBRICANTS

Change to oil with low viscosity for all components. For details of the specified viscosity, see "RECOMMENDED FUEL, COOLANT, AND LUBRICANT (PAGE 4-10)".

COOLANT



WARNING

- Antifreeze is toxic. Be careful not to get it into your eyes or on your skin. If it should get into your eyes or on your skin, wash it off with large amounts of fresh water and see a doctor at once.
- When changing the coolant or when handling coolant containing antifreeze that has been drained when repairing the radiator, please contact your Komatsu distributor or request a specialist company to carry out the operation. Antifreeze is toxic. Do not let it flow into drainage ditches or spray it onto the ground surface.
- Antifreeze is flammable. Do not bring any flame close. Do not smoke when handling antifreeze.

NOTICE

- Use Komatsu Supercoolant wherever available, or use permanent type antifreeze coolant.
- Never use methanol, ethanol, or propanol-based antifreeze.
- Do not use any water leakage prevention agent, either alone, or in combination with antifreeze.
- Do not mix one brand of antifreeze with a different brand.

For details of the antifreeze mixture when changing the coolant, see "CLEAN INSIDE OF COOLING SYSTEM (PAGE 4-20)".

BATTERY

 **WARNING**

- The battery generates flammable gas. Do not bring fire or sparks near the battery.
- Battery electrolyte is dangerous. If it gets in your eyes or on your skin, wash it off with a large amount of water and consult a doctor.
- Battery electrolyte dissolves paint. If it gets on the bodywork, wash it off immediately with water.
- If the battery electrolyte is frozen, do not charge the battery or start the engine with a different power source. There is danger that the battery may explode.
- Battery electrolyte is toxic. Do not let it flow into drainage ditches or spray it on to the ground surface.

When the ambient temperature drops, the capacity of the battery will also drop. If the battery charge ratio is low, the battery electrolyte may freeze. Maintain the battery charge as close as possible to 100%. Insulate it against cold temperature to ensure the machine can be started easily the next morning.

REMARK

Measure the specific gravity and calculate the charging rate from the following conversion table.

Charging Rate (%)	Electrolyte Temperature	20°C (68°F)	0°C (32°F)	-10°C (14°F)	-20°C (-4°F)
	100		1.28	1.29	1.30
90		1.26	1.27	1.28	1.29
80		1.24	1.25	1.26	1.27
75		1.23	1.24	1.25	1.26

- As the battery capacity drastically drops in low temperatures, cover or remove the battery from the machine, store the battery in a warm place, and install it again the next morning.
- If the electrolyte level is low, add distilled water in the morning before beginning work. Do not add water after the day's work to prevent diluted electrolyte in the battery from freezing during the night.

AFTER COMPLETION OF WORK

To prevent mud, water, or the undercarriage from freezing and making it impossible for the machine to move on the following morning, observe the following precautions.

- Remove all the mud and water from the machine body. In particular, wipe the hydraulic cylinder rods clean to prevent damage to the seal caused by mud, dirt, or drops of water on the rod from getting inside the seal.
- Park the machine on hard, dry ground.
If this is impossible, park the machine on boards.
The boards prevent the tracks from freezing to the ground, and allow the machine to be moved the next morning.
- Open the drain valve and drain any water collected in the fuel system to prevent it from freezing.
- Fill the fuel tank to capacity. This minimizes moisture condensation in the tank when the temperature drops.

AFTER COLD WEATHER

When the season changes and the weather becomes warmer, do as follows.

- Replace the fuel and oil for all parts with oil of the viscosity specified.
For details, see "RECOMMENDED FUEL, COOLANT, AND LUBRICANT (PAGE 4-10)".
- When it is unnecessary to use the automatic starting aid (APS) (When the ambient temperature is above 15°C (59°F)), Always keep the fuel valve closed.

LONG-TERM STORAGE

BEFORE STORAGE

When keeping in long-term storage (more than one month), store as follows.

- Clean and wash all parts, then store the machine indoors. If the machine has to be stored outdoors, select level ground and cover the machine with a sheet.
- Completely fill the fuel tank. This prevents moisture from collecting.
- Lubricate and change the oil before storage.
- Apply a thin coat of grease to metal surface of the hydraulic piston rods and the idler adjusting rods.
- Disconnect the negative terminals of the battery and cover it or remove it from the machine and store it separately.
- Place all control levers in the neutral position, set the work equipment lock lever and parking brake lever in the LOCK position, and set the fuel control dial to the low idling position.
- To prevent corrosion, be sure to fill the cooling system with Supercoolant (AF-NAC) or permanent type antifreeze (density between 30% and 68%).

DURING STORAGE



WARNING

If it is necessary to perform the rust-prevention operation while the machine is indoors, open the doors and windows to improve ventilation and prevent gas poisoning.

- During storage, operate and move the machine for a short distance once a month so that a new film of oil will coat moving parts. At the same time, also charge the battery.
- Before operating the work equipment, wipe the grease off the hydraulic piston rod.
- For machines equipped with an air conditioner, run the air conditioner.

AFTER STORAGE

NOTICE

If the machine has been stored without carrying out the monthly rust-prevention operation, consult your Komatsu distributor before using it.

When using the machine after long-term storage, do as follows before using it.

- Wipe off the grease from the hydraulic cylinder rods.
- Add oil and grease at all lubrication points.
- When the machine is stored for a long period, moisture in the air will mix with the oil. Check the oil before and after starting the engine. If there is water in the oil, change all the oil.

STARTING MACHINE AFTER LONG-TERM STORAGE

When starting the engine after the machine has been in storage for a long period, carry out the warming-up operation thoroughly. For details, see the procedure in "WARMING UP OPERATIONS (PAGE 3-98)".

TROUBLESHOOTING

AFTER RUNNING OUT OF FUEL

When starting the engine again after running out of fuel, fill with fuel, then bleed the air from the fuel system before starting the engine.

Always watch the fuel level and be careful not to run out of fuel.

If the engine has stopped because of lack of fuel, it is necessary to use the priming pump to bleed the air completely from the fuel circuit.

PROCEDURE FOR BLEEDING AIR



CAUTION

- This engine consists of higher precision parts than on the conventional fuel injection pump and nozzle, so if dirt gets in, it will cause problems. If there is any dirt stuck to the fuel line, use fuel to wash it off completely.
- Be careful when opening the air bleed plug at the fuel filter head and the air bleeder of the supply pump. The system is still under pressure and fuel may spurt out.

1. Loosen air bleed plug (A), (B) at the fuel filter head (1).
2. Loosen the knob of priming pump (2), then pump the knob until no more bubbles come out of air bleed plug (A).
3. Wrap sealing tape around air bleed plug (A) before tightening it.
Tightening torque: 2.0 to 3.9 Nm (0.2 to 0.4 kgm , 1.4 to 2.9 lbft)

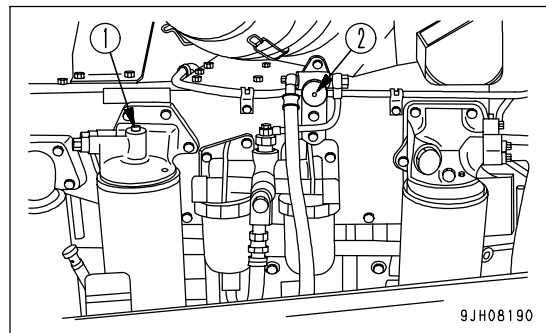

4. Operate the priming pump again and check that no more bubbles come out with the fuel from air bleed plug (B).
5. Tighten air bleed plug (B).
Tightening torque: 4.9 to 6.9 Nm (0.5 to 0.7 kgm , 3.6 to 5.1 lbft)

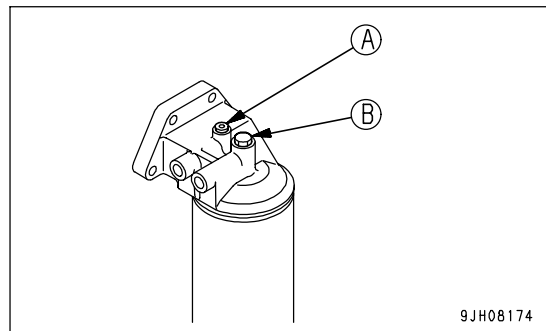

6. Loosen air bleeder (3) of the supply pump.
7. Pump priming pump (2) approx. 90 - 100 times until no more bubbles come out with the fuel from air bleeder (3), then tighten air bleeder (3).
Tightening torque: 4.9 to 6.9 Nm (0.5 to 0.7 kgm , 3.6 to 5.1 lbft)

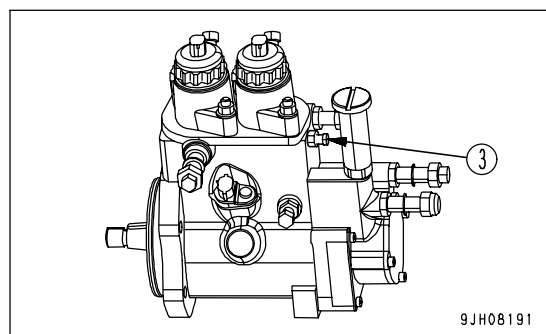

8. Continue pumping (approx. 50 times) until the priming pump (2) becomes stiff and the overflow valve release sound becomes continuous.

9. Push in the knob of priming pump (2) and tighten it.
10. Turn the key in the starting switch to the START position and start the engine.
When doing this, do not crank the starting motor continuously for more than 20 seconds. If the engine does not start, wait for at least 2 minutes, then try again. Perform this operation a maximum of 4 times.
11. If the engine does not start, repeat the operation from Step 1.

METHOD OF TOWING MACHINE

WARNING

- Be sure to use a wire rope sufficiently strong for the towing weight.
- When using the towing hook, be sure to use a shackle.
- Set the wire rope level and align it with the track frame.
- Tow the machine slowly.

If the machine sinks in mud and cannot get out under its own power, or if being used to tow a heavy object, fit the wire to the towing hook as shown in the diagram on the right, or in the case of machines with a drawbar, fit the wire to the drawbar pin when towing.

NOTICE

Permissible load for towing hook: 367,750 N (37,500 kg)

Always carry out towing operations within the specified range for the permissible load.

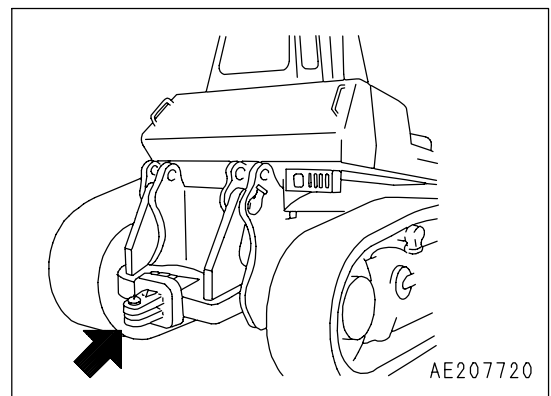
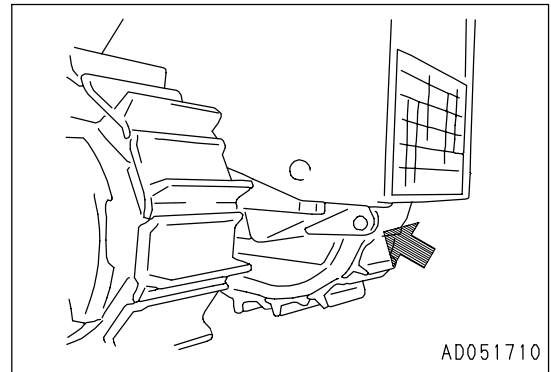

IF BATTERY IS DISCHARGED



WARNING

- It is dangerous to charge a battery when mounted on a machine. Make sure that it is dismantled before charging.
- When checking or handling the battery, stop the engine and turn the starting switch key to the OFF position.
- The battery generates hydrogen gas, so there is a hazard of explosion. Do not bring lighted cigarettes near the battery, or do anything that will cause sparks.
- Battery electrolyte is dilute sulfuric acid, and it will attack your clothes and skin. If it gets on your clothes or on your skin, immediately wash it off with a large amount of water. If it gets in your eyes, wash it out with fresh water and consult a doctor.
- When handling batteries, always wear safety glasses and rubber gloves.
- When removing the battery, first disconnect the cable from the ground (normally the negative (-) terminal). When installing, install the positive (+) terminal first.
If a tool touches the positive terminal and the chassis, there is danger that it will cause a spark, so be extremely careful.
- If the terminals are loose, there is danger that the defective contact may generate sparks that will cause an explosion.
- When removing or installing the terminals, check which is the positive (+) terminal and which is the negative (-) terminal.

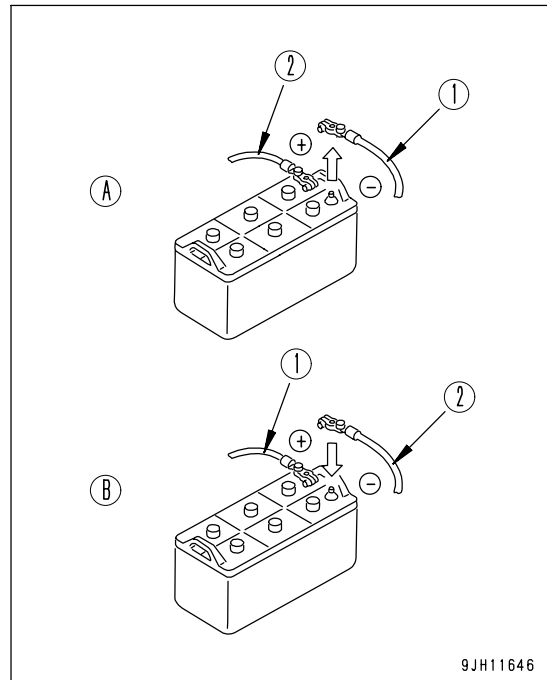

(A) When removing, disconnect the cable from the ground terminal first.

(B) When installing, connect the cable to the positive (+) terminal first.

STARTING ENGINE WITH BOOSTER CABLE

When starting the engine with a booster cable, do as follows.

REMOVAL, INSTALLATION OF BATTERY CABLE

1. Open battery cover (1), (2).
2. Before removing the battery, remove the ground cable (normally connected to the negative (-) terminal). If any tool touches between the positive terminal and the chassis, there is danger of sparks being generated. Loosen the nut of the terminal and remove the wires from the battery.
3. When installing the battery, connect the ground cable last.
Insert the hole of the terminal on the battery and tighten the nut.
Tightening torque: 9.8 to 19.6 Nm (1 to 2 kgm, 7.2 to 14.5 lbft)
4. Close battery cover (1).

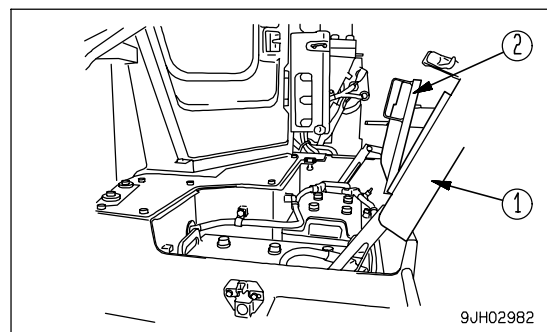

PRECAUTIONS WHEN CONNECTING AND DISCONNECTING BOOSTER CABLE

WARNING

- When connecting the cables, never contact the positive (+) and negative (-) terminals.
- When starting the engine with a booster cable, wear safety glasses and rubber gloves.
- Be careful not to let the normal machine and problem machine contact each other. This prevents sparks from generating near the battery which could ignite the hydrogen gas given off by the battery.
- Make sure that there is no mistake in the booster cable connections. The final connection is to the engine block of the problem machine, but sparks will be generated when this is done, so connect to a place as far as possible from the battery.
- When disconnecting the booster cable, take care not to bring the clips in contact with each other or with the machine body.

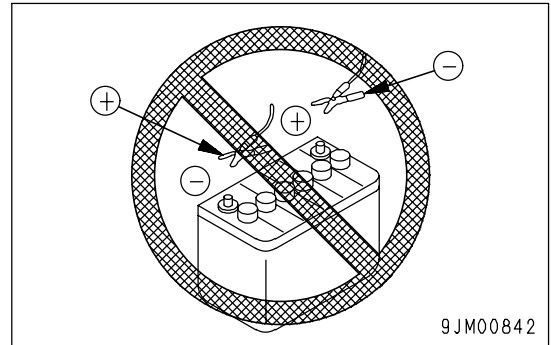

NOTICE

- The size of the booster cable and clip should be suitable for the battery size.
- The battery of the normal machine must be the same capacity as that of the engine to be started.
- Check the cables and clips for damage or corrosion.
- Make sure that the cables and clips are firmly connected.
- Check that the work equipment lock levers and parking brake levers of both machines are in the LOCK position.
- Check that each lever is in the NEUTRAL position.

CONNECTING THE BOOSTER CABLES

Keep the starting switch of the normal machine and problem machine in the OFF position. Connect the booster cable as follows, in the order of the numbers marked in the diagram.

1. Connect the clip of booster cable (A) to the positive (+) terminal of battery (C) on the problem machine.
2. Connect the clip at the other end of booster cable (A) to the positive (+) terminal of battery (D) on the normal machine.
3. Connect the clip of booster cable (B) to the negative (-) terminal of battery (D) on the normal machine.
4. Connect the clip at the other end of booster cable (B) to engine block (E) on the problem machine.

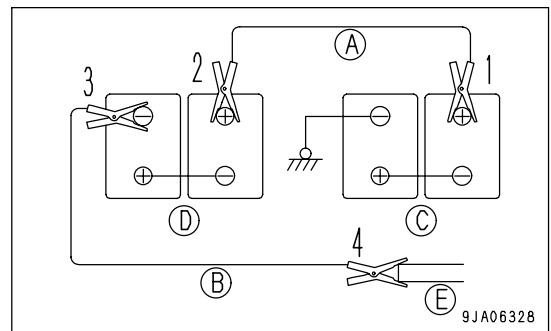

STARTING THE ENGINE

1. Make sure the clips are firmly connected to the battery terminals.
2. Start the engine of the booster machine and keep it running at high idling speed.
3. Turn the starting switch of problem machine to the START position, and start the engine. If the engine doesn't start at first, try it again after 2 minutes.

DISCONNECTING THE BOOSTER CABLES

After the engine has started, disconnect the booster cables in the reverse of the order in which they were connected.

1. Remove the clip of booster cable (B) from engine block (E) on the problem machine.
2. Remove the clip of booster cable (B) from the negative (-) terminal of battery (D) on the normal machine.
3. Remove the clip of booster cable (A) from the positive (+) terminal of battery (D) on the normal machine.
4. Remove the clip of booster cable (A) from the positive (+) terminal of battery (C) on the problem machine.

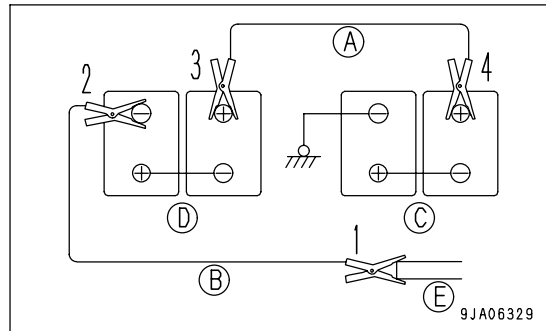

OTHER TROUBLE

ELECTRICAL SYSTEM

- (): Always contact your Komatsu distributor when dealing with these items.
- In cases of problems or causes which are not listed below, contact your Komatsu distributor for repairs.

Problem	Main cause	Remedy
Lamp does not glow brightly even when the engine runs at high speed	• Defective wiring	(• Check, repair loose terminals, disconnections Check fuses and diodes in fuse box)
Lamp flickers while engine is running	• Defective adjustment of fan belt tension	• Adjust fan belt tension For details, see EVERY 250 HOURS SERVICE
Charge lamp does not go out even when engine is running	• Defective alternator • Defective wiring	(• Replace) (• Check, repair Check fuse, diode in fuse box)
Abnormal noise is generated from alternator	• Defective alternator	(• Replace)
Starting motor does not crank when starting switch is turned ON	• Defective wiring • Insufficient battery charge	(• Check, repair) • Charge
Pinion of starting motor keeps going in and out	• Insufficient battery charge	• Charge
Starting motor turns engine sluggishly	• Insufficient battery charge • Defective starting motor	• Charge (• Replace)
Starting motor disengages before engine starts	• Defective wiring • Insufficient battery charge	(• Check, repair) • Charge
Engine pre-heating monitor lamp does not light up (When the temperature of the engine coolant exceed 20°C (68°F), this condition is normal)	• Defective wiring • Defective timer • Defective monitor • Disconnection in glow plug	(• Check, repair) (• Replace) (• Replace) (• Replace)
Air conditioner operation is defective	• Blown fuse • Insufficient battery charge • Defective air conditioner switch • Defective blower switch • Defective compressor	(• Check, repair) • Charge (• Replace air conditioner switch) (• Replace blower switch) (• Replace)
Blade does not pitch when pitch operation is carried out (dual tilt specification machine only)	• Defective wiring • Defective switch • Defective solenoid valve	(• Check, repair) (• Replace) (• Replace)

MONITOR PANEL

When an error code appears on the display panel B (multi-information), take appropriate remedies based upon the table below.

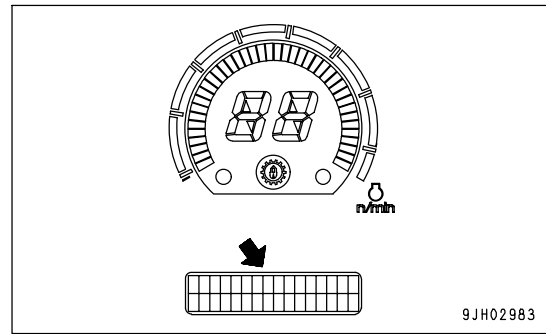

Abnormality code	Abnormality	Method of displaying abnormality	Remedy
E01	<ul style="list-style-type: none"> • Lock up torque converter does not come ON • Dual tilt does not work 	Abnormality code and service hour are displayed in turn on service meter portion	The automatic functions stop and some functions stop, but it is still possible to carry out operations. Please contact your Komatsu distributor immediately for repairs.
E02	<ul style="list-style-type: none"> • Tilt limit does not work • Does not shift up or shift down • Pitch does not work 	Abnormality code and service hour are displayed in turn on service meter portion, caution lamp flashes, buzzer sounds	If user stops engine and then starts again, operations are possible without limit functions. However, user must be careful. Please contact your Komatsu distributor immediately for repairs.
E03+CALL	<ul style="list-style-type: none"> • Number of speed ranges that can be used is limited • Engine does not run at full speed • Excessive shock when shifting gear • Turning ability becomes poor • Excessive braking shock • Abnormal engine coolant temperature sensor 	Abnormality code and service hour are displayed in turn on service meter portion, caution lamp flashes, buzzer sounds	Move machine to a safe place, then contact your Komatsu distributor immediately for repairs.
E04+CALL	<ul style="list-style-type: none"> • Engine control impossible • Travel impossible • Machine does not stop 	Abnormality code and service hour are displayed in turn on service meter portion, caution lamp flashes, buzzer sounds	Stop machine, then contact your Komatsu distributor immediately for repairs.

CHASSIS

- (): Always contact your Komatsu distributor when dealing with these items.
- In cases of problems or causes which are not listed below, contact your Komatsu distributor for repairs.

Problem	Main causes	Remedy
Oil pressure in torque converter fails to rise	<ul style="list-style-type: none"> • Improper tightening of oil pipe, pipe joint, air leaking in or oil leaking out because of damage • Wear, scuffing of gear pump • Insufficient oil in power train case • Clogged oil filter element strainer in power train case 	<ul style="list-style-type: none"> • Check, repair (• Check, replace) • Add oil to the specified level. For details, see CHECK BEFORE STARTING • Clean. For details, see EVERY 500 HOURS SERVICE
Torque converter is overheats	<ul style="list-style-type: none"> • Clogged radiator • Engine water temperature is high • Clogged oil cooler • Oil pressure too low • Lack of flow of lubricant caused by wear of power train gear pump 	<ul style="list-style-type: none"> • Clean radiator core • See Engine related parts (• Clean or replace) • Go to "Oil pressure in torque converter fails to rise" (• Replace gear pump)
Torque converter oil temperature gauge does not work	<ul style="list-style-type: none"> • Defective oil temperature gauge • Defective contact in wiring connection 	<ul style="list-style-type: none"> (• Replace oil temperature gauge) (• Check, repair)
Lacks drawbar pull (machine does not pick up speed)	<ul style="list-style-type: none"> • Lack of engine horsepower • Oil pressure in torque converter is too low 	<ul style="list-style-type: none"> • See Engine related parts • Go to "Oil pressure in torque converter fails to rise"
Machine will not move off when joystick is placed at FORWARD	<ul style="list-style-type: none"> • Insufficient oil in power train case • Transmission oil pressure does not rise • Defective lever wiring • Parking lever is at LOCK position 	<ul style="list-style-type: none"> • Add oil to the specified level. For details, see CHECK BEFORE • Go to oil pressure in torque converter fails to rise (• Check, repair) • Set to FREE position
Does not steer even when steering is operated	<ul style="list-style-type: none"> • Brake is not applied on side which is pulled • Parking lever is at LOCK position • Defective lever wiring • Abnormality HSS pump • Abnormality HSS motor 	<ul style="list-style-type: none"> (• Adjust linkage and check brake pressure) • Set to FREE position (• Check, repair) (• Check, replace) (• Check, replace)
Machine doesn't stop when brake pedal are depressed	<ul style="list-style-type: none"> • Defective brake adjustment 	<ul style="list-style-type: none"> (• Adjust linkage) (• Check brake pressure)
Track comes off	<ul style="list-style-type: none"> • Track is too loose 	<ul style="list-style-type: none"> • Adjust track tension. For details, see WHEN REQUIRED.
Sprocket develops abnormal wear	<ul style="list-style-type: none"> • Track is too loose or too tight 	<ul style="list-style-type: none"> • Adjust track tension. For details, see WHEN REQUIRED.
Machine does not travel in straight line	<ul style="list-style-type: none"> • Defective adjustment of HSS controller • Abnormality HSS pump 	<ul style="list-style-type: none"> (• Adjust) (• Replace)

Problem	Main causes	Remedy
Blade rises too slowly or does not rise at all (or blade tilts too slowly)	<ul style="list-style-type: none"> • Lack of hydraulic oil • Defective solenoid valve • Defective hydraulic switch • Work equipment lock lever is at LOCK position 	<ul style="list-style-type: none"> • Add oil to specified level. For details, see EVERY 250 HOURS SERVICE • Replace • Replace • Set to FREE position
Ripper moves too slowly, does not move	<ul style="list-style-type: none"> • Lack of hydraulic oil position • Defective hydraulic oil pressure switch • Defective solenoid valve • Work equipment lock lever is at LOCK position 	<ul style="list-style-type: none"> • Add oil to specified level. For details, see EVERY 250 HOURS SERVICE • Replace • Replace • Set to FREE position
Insufficient force of ripper	<ul style="list-style-type: none"> • Leakage from piping 	(• Tighten)

ENGINE

- (): Always contact your Komatsu distributor when dealing with these items.
- In cases of problems or causes which are not listed below, contact your Komatsu distributor for repairs.

Problem	Main causes	Remedy
Engine oil pressure monitor flashes when engine speed is raised after completion of warm-up	<ul style="list-style-type: none"> • Engine oil pan oil level is low (sucking in air) • Clogged oil filter cartridge • Defective tightening of oil pipe joint, oil leakage from damaged part • Defective monitor panel 	<ul style="list-style-type: none"> • Add oil to specified level, see CHECK BEFORE STARTING • Replace cartridge, see EVERY 500 HOURS SERVICE (• Check, repair) (• Replace)
Steam is emitted from top part of radiator (pressure valve)	<ul style="list-style-type: none"> • Coolant level low, water leakage • Dirt or scale accumulated in cooling system • Clogged radiator fins or damaged fins 	<ul style="list-style-type: none"> • Add coolant, repair, see CHECK BEFORE STARTING • Change coolant, clean inside of cooling system, see WHEN REQUIRED • Clean or repair, see WHEN REQUIRED
Engine water temperature monitor remains alight altitude operation)	<ul style="list-style-type: none"> • Defective thermostat • Loose radiator filler cap (high altitude operation) • Defective monitor panel 	<ul style="list-style-type: none"> (• Replace thermostat) • Tighten cap or replace packing (• Replace)
Engine does not start when starting motor is turned	<ul style="list-style-type: none"> • Lack of fuel • Air in fuel system • No fuel in fuel filter • Starting motor cranks engine sluggishly • Defective valve compression 	<ul style="list-style-type: none"> • Add fuel, see CHECK BEFORE STARTING • Repair place where air is sucked in (• Replace pump or nozzle) • See ELECTRICAL SYSTEM (• Adjust valve clearance)
Exhaust gas is white or blue	<ul style="list-style-type: none"> • Too much oil in oil pan • Improper fuel 	<ul style="list-style-type: none"> • Add oil to specified level, see CHECK BEFORE STARTING • Change to specified fuel
Exhaust gas occasionally turns black	<ul style="list-style-type: none"> • Clogged air cleaner element • Defective nozzle • Defective compression • Defective turbocharger 	<ul style="list-style-type: none"> • Clean or replace, see WHEN REQUIRED (• Replace nozzle) (• Adjust valve clearance) (• Clean or replace, turbocharger)
Combustion noise occasionally makes breathing sound	<ul style="list-style-type: none"> • Defective nozzle • Lack of fuel (in Air) 	<ul style="list-style-type: none"> (• Replace nozzle) • Add fuel
Abnormal noise generated (combustion or mechanical)	<ul style="list-style-type: none"> • Low grade fuel being used • Overheating • Damage inside muffler • Excessive valve clearance 	<ul style="list-style-type: none"> • Change to specified fuel • See item "Indicator of water temperature gauge is in red range on right side of gauge". (• Replace muffler) (• Adjust valve clearance)
Monitor displays error code	Please contact your Komatsu distributor	
Alarm buzzer sounds		
Engine horsepower lowered suddenly (Engine is running in duration mode)		

WHEN MODE SELECTION SYSTEM FLASHES

If the caution lamp flashes, or it becomes impossible to control the engine speed with the fuel control dial or decelerator pedal, stop operation immediately, check the monitor panel display, then contact your Komatsu distributor for repairs.

In addition to the above problems, if any of the problems in the table below occur, there is probably an abnormality in the work equipment lever switch, transmission speed range sensor, or other part, so please contact your Komatsu distributor for repairs.

Mode	Operation	Abnormality
Economy	Dozing	<ul style="list-style-type: none"> • Engine speed varies, difficult to carry out operation • No sense of control, engine stays at full or partial
Slow reverse	Reverse	<ul style="list-style-type: none"> • Ripper RAISE speed is slow • Slow reverse speed is slow
Lock-up	All operations	<ul style="list-style-type: none"> • Lock-up does not work • Gearshifting shock becomes excessive
-	Traveling under own power	<ul style="list-style-type: none"> • Engine speed becomes partial when traveling under own power

MAINTENANCE

WARNING

Please read and make sure that you understand the SAFETY section before reading this section.

GUIDES TO MAINTENANCE

Do not perform any inspection and maintenance operation that is not found in this manual.
Stop the machine on flat hard ground when performing inspections and maintenance.

CHECK SERVICE METER:

Check the service meter reading every day to see if the time has come for any necessary maintenance to be performed.

KOMATSU GENUINE REPLACEMENT PARTS:

Use Komatsu genuine parts specified in the Parts Book as replacement parts.

KOMATSU GENUINE OILS:

For lubrication of the machine, use the Komatsu genuine lubricants. Moreover use oil of the specified viscosity according to the ambient temperature.

ALWAYS USE CLEAN WASHER FLUID:

Use automobile window washer fluid, and be careful not to let any dirt get into it.

CLEAN OIL AND GREASE:

Use clean oil and grease. Also, keep the containers of the oil and grease clean. Keep foreign materials away from oil and grease.

CHECK FOREIGN MATERIAL IN DRAINED OIL:

After oil is changed or filters are replaced, check the old oil and filters for metal particles and foreign materials. If large quantity of metal particles or foreign materials are found, always report to the person in charge, and carry out suitable action.

FUEL STRAINER:

If your machine is equipped with a fuel strainer, do not remove it while fueling.

WELDING INSTRUCTIONS:

- Turn off the engine starting switch.
- Do not apply more than 200 V continuously.
- Connect grounding cable within 1 m (3.3 ft) of the area to be welded. If grounding cable is connected near instruments, connectors, etc., the instruments may malfunction.
- If a seal or bearing happens to come between the part being welded and grounding point, change the grounding point to avoid such parts.
- Do not use the area around the work equipment pins or the hydraulic cylinders as the grounding point.

OBJECTS IN YOUR POCKETS:

- When opening inspection windows or the oil filler port of the tank to carry out inspection, be careful not to drop nuts, bolts, or tools inside the machine.
If such things are dropped inside the machine, it may cause damage and/or malfunction of the machine, and will lead to failure. If you drop anything inside the machine, always remove it immediately.
- Do not put unnecessary things in your pockets. Carry only things which are necessary for inspection.

DUSTY WORKSITES:

When working at dusty worksites, do as follows:

- Inspect the air cleaner clogging monitor frequently to see if the air cleaner is clogged.
Clean the air cleaner element at a shorter interval than specified.
- Clean the radiator core frequently to avoid clogging.
- Clean and replace the fuel filter frequently.
- Clean electrical components, especially the starting motor and alternator, to avoid accumulation of dust.
- When inspecting or changing the oil, move the machine to a place that is free of dust to prevent dirt from getting into the oil.

AVOID MIXING OILS:

If a different brand or grade of oil has to be added, drain the old oil and replace all the oil with the new brand or grade of oil. Never mix different brand or grade of oil.

LOCKING INSPECTION COVERS:

Lock inspection cover securely into position with the lock bar. If inspection or maintenance is performed with inspection cover not locked in position, there is a danger that it may be suddenly blow shut by the wind and cause injury to the worker.

BLEEDING AIR:

When hydraulic equipment has been repaired or replaced, or the hydraulic piping has been removed and installed again, the air must be bled from the circuit. For details, see "BLEEDING AIR IN HYDRAULIC SYSTEM (PAGE 4-44)".

PRECAUTIONS WHEN INSTALLING HYDRAULIC HOSES:

- When removing parts at locations where there are O-rings or gasket seals, clean the mounting surface, and replace with new parts.
When doing this, be careful not to forget to assemble the O-rings and gaskets.
- When installing the hoses, do not twist them or bend them sharply. If they are installed so, their service life will be shortened extremely and they may be damaged.

CHECKS AFTER INSPECTION AND MAINTENANCE:

If you forget to perform the checks after inspection and maintenance, unexpected problems may occur, and this may lead to serious injury or property damage. Always do the following:

- Checks after operation (with engine stopped)
 - Have any inspection and maintenance points been forgotten?
 - Have all inspection and maintenance items been performed correctly?
 - Have any tools or parts been dropped inside the machine? It is particularly dangerous if parts are dropped inside the machine and get caught in the lever linkage mechanism.
 - Are there any leakage of coolant or oil? Have all nuts and bolts been tightened?
- Checks when operating engine
 - For details of the checks when operating the engine, see "PROPER TOOLS (PAGE 2-30)" and pay careful attention to safety.
 - Are the inspection and maintenance items working properly?
 - Is there any leakage of fuel or oil when the engine speed is raised?

PRECAUTIONS WHEN OPENING AND CLOSING ENGINE SIDE COVER:

- When standing on track to open the engine side cover, adopt a standing position, hold the side cover with both thumbs, and open it slowly with your other fingers.
- When the side cover is open, do not open or close the cab. Before opening or closing the cab, always close the engine side cover first.

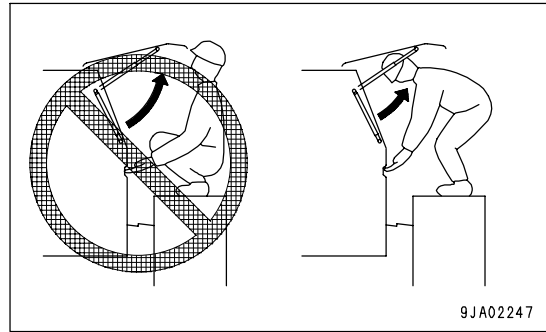

OUTLINES OF SERVICE

- Always use Komatsu genuine parts for replacement parts, grease or oil.
- When changing the oil or adding oil, do not mix different types of oil. When changing the type of oil, drain all the old oil and fill completely with the new oil. Always replace the filter at the same time. (There is no problem if the small amount of oil remaining in the piping mixes with the new oil.)
- Unless otherwise specified, when the machine is shipped from the factory, it is filled with the oil and coolant listed in the table below.

Item	Type
Engine oil pan	Engine oil EO15W40DH (Komatsu genuine parts)
Power train case Final drive case Damper case	Power train oil TO30 (Komatsu genuine parts)
Hydraulic system	Power train oil TO10 (Komatsu genuine parts)
Radiator	Supercoolant AF-NAC (Density: 30% or above) (Komatsu genuine parts)

HANDLING OIL, FUEL, COOLANT, AND PERFORMING OIL CLINIC

OIL

- Oil is used in the engine and hydraulic equipment under extremely severe conditions (high temperature, high pressure), and deteriorates with use.
Always use oil that matches the grade and maximum and minimum ambient temperatures recommended in the Operation and Maintenance Manual. Even if the oil is not dirty, always change the oil at the specified interval.
- Oil corresponds to blood in the human body, always be careful when handling it to prevent any impurities (water, metal particles, dirt, etc.) from getting in.
The majority of problems with the machine are caused by the entry of such impurities.
Take particular care not to let any impurities get in when storing or adding oil.
- Never mix oils of different grades or brands.
- Always add the specified amount of oil.
Having too much oil or too little oil are both causes of problems.
- If the oil in the work equipment is not clear, there is probably water or air getting into the circuit. In such cases, please contact your Komatsu distributor.
- When changing the oil, always replace the related filters at the same time.
- We recommend you have an analysis made of the oil periodically to check the condition of the machine. For those who wish to use this service, please contact your Komatsu distributor.
- When using commercially available oil, it may be necessary to reduce the oil change interval.
We recommend that you use the Komatsu oil clinic to carry out a detailed checks of the characteristics of the oil.

FUEL

- To prevent the moisture in the air from condensing and forming water inside the fuel tank, always fill the fuel tank after completing the day's work.
- The fuel pump is a precision instrument, and if fuel containing water or dirt is used, it cannot work properly.
- Be extremely careful not to let impurities get in when storing or adding fuel.
- Always use the fuel specified in the Operation and Maintenance Manual.
Fuel may congeal depending on the temperature when it is used (particularly in low temperatures below -15°C (5°F)), so it is necessary to use the fuel that is suitable for the temperature.
- Before starting the engine, or when 10 minutes have passed after adding fuel, drain the sediment and water from the fuel tank.
- If the engine runs out of fuel, or if the filters have been replaced, it is necessary to bleed the air from the circuit.
- If there is any foreign material in the fuel tank, wash the tank and fuel system.

COOLANT AND WATER FOR DILUTION

- The coolant has the important function of preventing corrosion as well as preventing freezing. Even in the areas where freezing is not an issue, the use of antifreeze coolant is essential. Komatsu machines are supplied with Komatsu Supercoolant (AF-NAC). Komatsu Supercoolant (AF-NAC) has excellent anticorrosion, antifreeze and cooling properties and can be used continuously for 2 years or 4000 hours. Komatsu Supercoolant (AF-NAC) is strongly recommended wherever available.
- When diluting the antifreeze coolant, use distilled water or tap water (soft water). Natural water, such as a river water or well water (hard water), contains large amounts of minerals (calcium, magnesium, etc.), and this makes it easier for scale to form inside the engine or radiator. Once scale is deposited inside the engine or radiator, it is extremely difficult to remove. It also causes overheating due to poor heat exchange, so when you dilute the coolant, we recommend that you use water with an overall hardness of less than 100 PPM.
- When using antifreeze, always observe the precautions given in the Operation and Maintenance Manual.
- Antifreeze coolant is flammable, so be sure to keep it away from flame.
- The ratio of Supercoolant (AF-NAC) to water differs according to the ambient temperature. For details of the ratio when mixing, see "CLEAN INSIDE OF COOLING SYSTEM (PAGE 4-20)". Supercoolant (AF-NAC) may be supplied already mixed. In such cases, never dilute with water.
- If the engine overheats, wait for the engine to cool before adding coolant.
- If the coolant level is low, it will cause overheating, and will also cause problems with corrosion due to air entering the coolant.

GREASE

- Grease is used to prevent seizure and noises at the joints.
- This construction equipment is used under heavy-duty conditions. Always use the recommended grease and follow the change intervals and recommended ambient temperatures given in this Operation and Maintenance Manual.
- The nipples not included in the MAINTENANCE section are nipples used when overhauling, so they do not need grease. If any part becomes stiff or generates noise after being used for a long time, grease it.
- Always wipe off all of the old grease that is pushed out when greasing. Be particularly careful to wipe off the old grease in places where sand or dirt sticking in the grease would cause wear of the rotating parts.

CARRYING OUT KOWA (Komatsu Oil Wear Analysis)

KOWA is a maintenance service that makes it possible to prevent machine failures and downtime. With KOWA, the oil is periodically sampled and analyzed. This enables early detection of wear of the machine drive parts and other problems.

We strongly recommend you to use this service. The oil analysis is carried out at actual cost, so the cost is low, and the results of the analysis are reported together with recommendations which will reduce repair costs and machine downtime.

KOWA ANALYSIS ITEMS

- Measurement of density of metal wear particles
This uses an ICP (Inductively Coupled Plasma) analyzer to measure the density of iron, copper, and other metal wear particles in the oil.

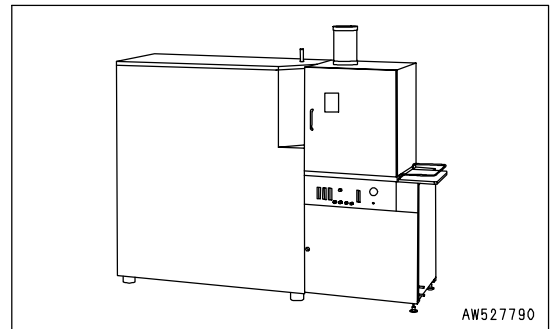

- Measurement of particle quantity
This uses a PQI (Particle Quantifier Index) measurer to measure the quantity of iron particles of 5 μ m or more, enabling early detection of failures.

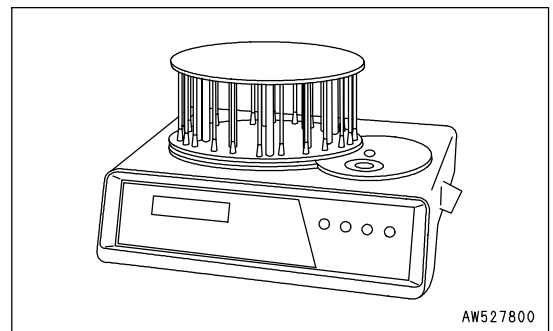

OIL SAMPLING

- Sampling interval
250 hours: Engine
500 hours: Other components
- Precautions when sampling
 - Make sure that the oil is well mixed before sampling.
 - Perform sampling at regular fixed intervals.
 - Do not perform sampling on rainy or windy days when water or dust can get into the oil.

For further details of KOWA, please contact your Komatsu distributor.

STORING OIL AND FUEL

- Keep indoors to prevent any water, dirt, or other impurities from getting in.
- When keeping drum cans for a long period, put the drum on its side so that the filler port of the drums is at the side to prevent moisture from being sucked in.
If drums have to be stored outside, cover them with a waterproof sheet or take other measures to protect them.
- To prevent any change in quality during long-term storage, be sure to use in the order of first in - first out (use the oldest oil or fuel first).

FILTERS

- Filters are extremely important safety parts. They prevent impurities in the fuel and air circuits from entering important equipment and causing problems.
Replace all filters periodically. For details, see the Operation and Maintenance Manual.
However, when working in severe conditions, replace the filters at shorter intervals according to the oil and fuel (sulfur content) being used.
- Never try to clean the filters (cartridge type) and use them again. Always replace with new filters.
- When replacing oil filters, check if any metal particles are attached to the old filter. If any metal particles are found, contact your Komatsu distributor.
- Do not open packs of spare filters until just before they are to be used.
- Always use Komatsu genuine filters.

OUTLINE OF ELECTRIC SYSTEM

- It is extremely dangerous if the electrical equipment becomes wet or the covering of the wiring is damaged. This will cause an electrical short circuit and may lead to malfunction of the machine. Do not wash the inside of the operator's cab with water. When washing the machine, be careful not to let water get into the electrical components.
- Service relating to the electric system is checking fan belt tension, checking damage or wear to the fan belt and checking battery fluid level.
- Never install any electric components other than those specified by Komatsu.
- External electro-magnetic interference may cause malfunction of the control system controller, before installing a radio receiver or other wireless equipment, contact your Komatsu distributor.
- Be careful to keep the electric system free of water when washing the machine or when it rains.
- When working at the seashore, carefully clean the electric system to prevent corrosion.
- When installing electrical equipment, connect it to the special power source connector.
Do not connect the optional power source to the fuse, starting switch, or battery relay.

WEAR PARTS

Replace wear parts such as the filter element or cutting edge at the time of periodic maintenance or before they reach the wear limit. The wear parts should be replaced correctly in order to ensure more economic use of the machine. When replacing parts, always use Komatsu genuine parts.

As a result of our continuous efforts to improve product quality, the part number may change, so inform your Komatsu distributor of the machine serial number and check for the latest part number when ordering parts.

WEAR PARTS LIST

The parts in parentheses are to be replaced at the same time.

Item	Part No.	Part Name	Weight	Q'ty	Replacement frequency
Engine oil filter	600-211-1340	Cartridge	-	1	Every 500 hours service
Power train oil filter	07063-01100 (07000-02130)	Element (O-ring)	-	1 (1)	Every 500 hours service
Steering lubrication oil filter	07063-01100 (07000-02130)	Element (O-ring)	-	1 (1)	Every 500 hours service
Fuel filter	600-319-3520	Cartridge	-	1	Every 500 hours service (Without additional fuel filter) Every 1000 hours service (With additional fuel filter)
Additional fuel filter	600-319-3440	Cartridge	-	1	Every 500 hours service
Hydraulic tank breather	20Y-60-21470	Element	-	1	Every 500 hours service
Main corrosion resistor	600-411-1171	Cartridge	-	1	Every 1000 hours service
Sub corrosion resistor	600-411-1511	Cartridge	-	1	Every 1000 hours service
Charge filter	07063-51054 (07000-02110)	Element (O-ring)	-	1 (1)	Every 1000 hours service
Hydraulic oil filter	207-60-71181 (07000-05195)	Element (O-ring)	-	1 (2)	Every 2000 hours service
Air cleaner	600-185-6100	Element Ass'y	-	2	-
	600-185-6110	Outer element	-	2	-
Blade	195-71-11654	Cutting edge	-	1	-
	17M-71-21550	Cutting edge	-	2	
	(195-71-52280)	(Bolt)	-	(21)	
	(01643-22460)	(Washer)	-	(21)	
	(17M-71-21530)	(Nut)	-	(21)	
	17M-71-21930	End bit (left)	-	1	
	17M-71-21940	End bit (right)	-	1	
	(195-71-52280)	(Bolt)	-	(14)	
(01643-22460)	(Washer)	-	(14)		
(17M-71-21530)	(Nut)	-	(14)		
Ripper (variable multi ripper)	17M-78-21330	Protector	-	3	-
	195-78-21331	Point	-	3	
	(09244-02508)	(Pin)	-	(9)	
Ripper (variable giant ripper)	17M-78-21330	Protector	-	1	-
	195-78-21331	Point	-	1	
	(09244-02508)	(Pin)	-	(3)	

NOTICE

When handling parts that weigh more than 25 kg (55 lb), remember that they are heavy objects, and take the necessary care.

RECOMMENDED FUEL, COOLANT, AND LUBRICANT

- Komatsu genuine oils are adjusted to maintain the reliability and durability of Komatsu construction equipment and components.

In order to keep your machine in the best conditioner for long periods of time, it is essential to follow the instructions in this Operation and Maintenance Manual.

- Failure to follow these recommendations may result in shortened life or excess wear of the engine, power train, cooling system, and/or other components.
- Commercially available lubricant additives may be good for the machine, but they may also cause harm. Komatsu does not recommend any commercially available lubricant additive.
- Use the oil recommended according to the ambient temperature in the chart below.
- Specified capacity means the total amount of oil including the oil in the tank and the piping. Refill capacity means the amount of oil needed to refill the system during inspection and maintenance.
- When starting the engine in temperatures below 0°C (32°F), be sure to use the recommended multi-grade oil, even if the ambient temperature may become higher during the course of the day.
- If the machine is operated at a temperature below -20°C (-4°F), a separate device is needed, so consult your Komatsu distributor.
- When the fuel sulfur content is less than 0.5%, change the engine oil according to the period inspection table given in this Operation and Maintenance Manual.

If the fuel sulfur content is more than 0.5%, change the oil according to the following table.

Fuel sulfur content	Engine oil change interval
0.5 to 1.0%	1/2 of regular interval
Above 1.0%	1/4 of regular interval

USE OF FUEL, COOLANT AND LUBRICANTS ACCORDING TO AMBIENT TEMPERATURE

Reservoir	Fluid Type	Ambient Temperature, degrees Celsius									Recommended Komatsu Fluids
		-22 -30	-4 -20	14 -10	32 0	50 10	68 20	86 30	104 40	122 °F 50°C	
Engine oil pan	Engine oil	SAE0W30EOS and HTHS 3.5min. (Note.1)									Komatsu EOS0W30
		SAE5W40EOS and HTHS 3.5min. (Note.1)									Komatsu EOS5W40
		SAE10W30									Komatsu EO10W30DH API CH-4 API CI-4
		SAE15W40									Komatsu EO15W40DH API CH-4 API CI-4
		SAE30DH									Komatsu EO30DH
Power train oil pan (incl. Transmission, torque converter and bevel gear case)	Power train oil (Note.2)	TO10									TO10
		TO30									TO30
Final drive case (each) Damper case	Power train oil	TO30									TO30
Hydraulic system	Power train oil	TO10									TO10
	Hydraulic oil	HO46-HM									HO46-HM
	Engine oil	SAE10W30DH									Komatsu EO10W30DH
		SAE15W40DH									Komatsu EO15W40DH
Grease fitting	Hyper grease (Note.3)	G2-T, G2-TE									G2-T, G2-TE
	Lithium EP grease	G2-LI									G2-LI
Cooling system	Supercoolant AF-NAC	AF-NAC (Note.4)									AF-NAC
Fuel tank	Diesel fuel	No.2-D									ASTM No.2-D
		No.1-D									ASTM No.1-D

- SAE: Society of Automotive Engineers
- ASTM: American Society of Testing and Material
- API: American Petroleum Institute

		Engine oil pan	Power train oil pan (incl. transmission, torque converter and bevel gear casses)	Damper case	Final drive case (each)	Hydraulic system	Fuel tank	Cooling system	
								Main circuit	Sub circuit
Specified amount	liter	55	150	1.5	40	270	840	110	20
	US gal	14.53	39.63	0.40	10.57	71.33	221.93	29.06	5.28
Refill capacity	liter	50	90	1.5	40	130	-	-	-
	US gal	13.21	23.78	0.40	10.57	34.35	-	-	-

NOTICE

Use only diesel fuel.

The engine mounted on this machine employs electronic control and a high-pressure fuel injection device to obtain good fuel consumption and good exhaust gas characteristics. For this reason, it requires high precision for the parts and good lubrication. If kerosene or other fuel with low lubricating ability is used, there will be a big drop in durability.

Note 1: SAE0W30EOS and SAE5W40EOS must be fully synthetic and HTHS (High-Temperature High-Shear Viscosity 150°C) must be equal to or higher than 3.5 cP. Komatsu EOS0W30 and EOS5W40 are the most suitable oils. If these oils are not available, follow the instruction "RECOMMENDED BRANDS, RECOMMENDED QUALITY FOR PRODUCTS OTHER THAN KOMATSU GENUINE OIL (PAGE 4-12)" at the end of this chapter.

Note 2: Powertrain oil has different properties from engine oil. Be sure to use the recommended oils.

Note 3: Hyper grease (G2-T, G2-TE) has a high performance.

When it is necessary to improve the lubricating ability of the grease in order to prevent squeaking of pins and bushings, the use of G2-T or G2-TE is recommended.

Note 4: Supercoolant (AF-NAC)

1) Coolant has the important function of anticorrosion as well as antifreeze.

Even in the areas where freezing is not an issue, the use of antifreeze coolant is essential.

Komatsu machines are supplied with Komatsu Supercoolant (AF-NAC). Komatsu Supercoolant (AF-NAC) has excellent anticorrosion, antifreeze and cooling properties and can be used continuously for 2 years or 4000 hours. Komatsu Supercoolant (AF-NAC) is strongly recommended wherever available.

2) For details of the ratio when diluting super coolant with water, see "CLEAN INSIDE OF COOLING SYSTEM (PAGE 4-20)".

When the machine is shipped from the factory, it may be filled with coolant containing 30% or more Supercoolant (AF-NAC). In this case, no adjustment is needed for temperatures down to -10°C (14°F). (never dilute with water)

3) To maintain the anticorrosion properties of Supercoolant (AF-NAC), always keep the density of Supercoolant between 30% and 68%.

RECOMMENDED BRANDS, RECOMMENDED QUALITY FOR PRODUCTS OTHER THAN KOMATSU GENUINE OIL

When using commercially available oils other than Komatsu genuine oil, consult your Komatsu distributor.

STANDARD TIGHTENING TORQUES FOR BOLTS AND NUTS

TORQUE LIST



If nuts, bolts, or other parts are not tightened to the specified torque, it will cause looseness or damage to the tightened parts, and this will cause failure of the machine or problems with operation.

Always pay careful attention when tightening parts.

Unless otherwise specified, tighten the metric nuts and bolts to the torque shown in the table below. If it is necessary to replace any nut or bolt, always use a Komatsu genuine part of the same size as the part that was replaced.

Thread diameter of bolt (a)(mm)	Width across flats (b)(mm)	Tightening torque					
		Target value			Service limit		
		Nm	kgm	lbft	Nm	kgm	lbft
6	10	13.2	1.35	9.8	11.8-14.7	1.2-1.5	8.7-10.8
8	13	31	3.2	23.1	27-34	2.8-3.5	20.3-25.3
10	17	66	6.7	48.5	59-74	6.0-7.5	43.4-54.2
12	19	113	11.5	83.2	98-123	10.0-12.5	72.3-90.4
14	22	172	17.5	126.6	153-190	15.5-19.5	112.1-141
16	24	260	26.5	191.7	235-285	23.5-29.5	170.0-213.4
18	27	360	37	267.6	320-400	33.0-41.0	238.7-296.6
20	30	510	52.3	378.3	455-565	46.5-58.0	336.3-419.5
22	32	688	70.3	508.5	610-765	62.5-78.0	452.1-564.2
24	36	883	90	651	785-980	80.0-100.0	578.6-723.3
27	41	1295	132.5	958.4	1150-1440	118.0-147.0	853.5-1063.3
30	46	1720	175.0	1265.8	1520-1910	155.0-195.0	1121.1-1410.4
33	50	2210	225.0	1627.4	1960-2450	200.0-250.0	1446.6-1808.3
36	55	2750	280.0	2025.2	2450-3040	250.0-310.0	1808.3-2242.2
39	60	3280	335.0	2423.1	2890-3630	295.0-370.0	2133.7-2676.2

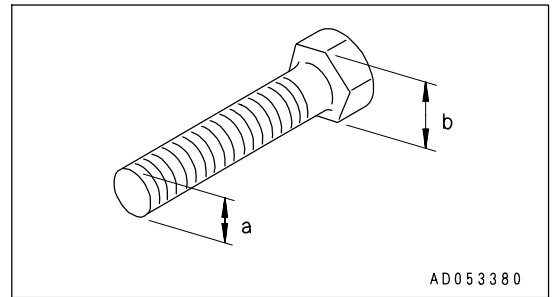

Apply the following table for Hydraulic Hose.

Nominal- No. of threads (a)	Width across flats (b) mm	Tightening torque					
		Target valve			Permissible range		
		Nm	kgm	lbft	Nm	kgm	lbft
9/16 -18UNF	19	44	4.5	32.5	34 - 54	3.5 - 5.5	25.3 - 39.8
11/16 -16UN	22	74	7.5	54.2	54 - 93	5.5 - 9.5	39.8 - 68.7
13/16 -16UN	27	103	10.5	75.9	84 - 132	8.5 - 13.5	61.5 - 97.6
1 -14UNS	32	157	16.0	115.7	128 - 186	13.0 - 19.0	94.0 - 137.4
1 3/16 -12UN	36	216	22.0	159.1	177 - 245	18.0 - 25.0	130.2 - 180.8

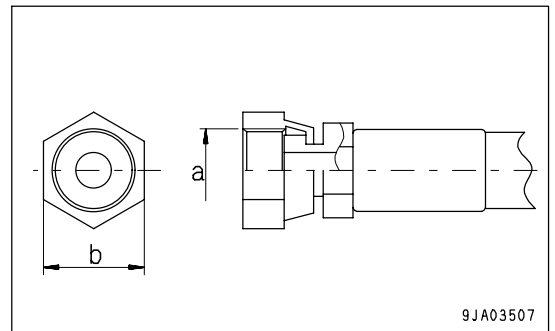

PERIODIC REPLACEMENT OF SAFETY CRITICAL PARTS

For using the machine safely for an extended period of time, you are required to periodically replace the safety (critical and fire prevention) related parts listed in the table of important parts on the following page.

Material quality of these parts can change as time passes and they are likely to wear out or deteriorate. However, it is difficult to determine the extent of wear or deterioration at the time of periodic maintenance. Hence, it is required to replace them with new ones regardless of their condition after a certain period of usage. This is important to ensure that these parts maintain their full performance at all times.

Furthermore, should anything abnormal be found on any of these parts, replace it with a new one even if the periodic replacement time for the part has not yet arrived.

If any of the hose clamps show deterioration like deformation or cracking, replace the clamps at the same time as the hoses.

Also perform the following checks with hydraulic hoses which need to be replaced periodically. Tighten all loose clamps and replace defective hoses, as required.

When replacing hoses, always replace O-rings, gaskets, and other such parts at the same time.

Have your Komatsu distributor replace the critical parts.

SAFETY CRITICAL PARTS

No.	Safety critical parts for periodic replacement	Q'ty	Replacement interval
1	Fuel hose (nozzle - fuel return hose)	1	Every 2 years or 4000 hours, whichever comes sooner
2	Fuel hose (scavenging pump - fuel return hose)	1	
3	Fuel hose (fuel tank - fuel strainer)	1	
4	Fuel hose (fuel strainer - scavenging pump)	1	
5	Fuel hose (hand priming pump - supply pump)	1	
6	Hose (torque converter oil cooler - power train assembly)	2	
7	Hose (power train pump - transmission filter / steering filter)	2	
8	Hose (transmission filter - power train assembly)	1	
9	Hose (steering filter - power train assembly)	1	
10	Inspection hose assembly for power train pressure	1	
11	Hose (HSS charge pump - HSS charge filter)	1	
12	Hose (HSS charge filter - HSS pump)	1	
13	Hose (HSS charge filter - HSS motor)	1	
14	Hose (HSS pump - central drain block)	1	
15	Hose (HSS pump - central drain block)	1	
16	Hose (central drain block - hydraulic tank)	2	
17	Hose (HSS pump - HSS motor)	2	
18	Hose (self-reducing pressure valve - HSS pump)	1	
19	Hose (HSS pump - pivot turn valve)	1	
20	Hose (pivot turn valve - HSS motor)	1	
21	Hose (pivot turn valve - drain relay block)	1	
22	Hose (HSS motor - oil cooler bypass valve)	1	
23	Hose (oil cooler bypass valve - hydraulic oil cooler)	2	
24	Hose (fan pump - relay tube)	1	
25	Hose (relay tube - fan motor)	2	
26	Hose (fan motor - hydraulic tank)	4	
27	Hose (self-reducing pressure valve - PPC lock valve)	2	
28	Hose (PPC lock valve - blade PPC lock valve)	1	
29	Hose (PPC lock valve - ripper PPC valve)	1	
30	Hose (blade PPC valve - main control valve)	4	
31	Hose (ripper PPC valve - main control valve)	4	
32	Hose (blade PPC valve - hydraulic tank)	1	
33	Hose (ripper PPC valve - hydraulic tank)	1	
34	Hose (hydraulic pump - main control valve)	3	
35	Hose (main control valve - ripper relay block)	4	
36	Hose (main control valve - hydraulic tank)	1	Every 2 years or 4000 hours, whichever comes sooner
37	Hose (ripper relay block - ripper cylinder)	8	
38	Hose (main control valve - blade tilt relay tube)	4	
39	Hose (main control valve - blade relay tube)	2	
40	Hose (blade relay tube - blade divider block)	2	
41	Hose (radiator guard top - lift cylinder)	2	
42	Injector assembly	1S	
43	Seat belt	1	Every 3 years
44	High-pressure tube clamp	1S	Every 8000 hours
45	Fuel spray prevention cap	1S	

MAINTENANCE SCHEDULE CHART

MAINTENANCE SCHEDULE CHART

INITIAL 250 HOURS SERVICE (ONLY AFTER THE FIRST 250 HOURS)

CHANGE OIL IN ENGINE OIL PAN, REPLACE ENGINE OIL FILTER CARTRIDGE AND BYPASS FILTER CARTRIDGE -----	4- 55
REPLACE POWER TRAIN OIL FILTER ELEMENT, STEERING LUBRICATING OIL FILTER ELEMENT -----	4- 58
CHANGE OIL IN POWER TRAIN CASE, WASH STRAINERS (POWER TRAIN PUMP STRAINER, SCAVENGING PUMP STRAINER) -----	4- 64
REPLACE CHARGE FILTER ELEMENT -----	4- 68
CHANGE OIL IN HYDRAULIC TANK, REPLACE HYDRAULIC OIL FILTER ELEMENT, CLEAN HYDRAULIC TANK STRAINER -----	4- 69
CHANGE OIL IN FINAL DRIVE CASE -----	4- 71

WHEN REQUIRED

CLEAN INSIDE OF COOLING SYSTEM -----	4- 20
CHECK, CLEAN AND REPLACE AIR CLEANER ELEMENT -----	4- 24
CHECK TRACK TENSION -----	4- 29
CHECK AND TIGHTEN TRACK SHOE BOLTS -----	4- 32
ADJUST IDLER CLEARANCE -----	4- 33
REVERSE AND REPLACE THE END BITS AND CUTTING EDGES -----	4- 34
CLEAN, CHECK RADIATOR FINS -----	4- 36
CLEAN FUEL TANK STRAINER -----	4- 36
DRAIN WATER AND SEDIMENT IN FUEL TANK -----	4- 37
CLEAN STEERING CLUTCH CASE BREATHER -----	4- 37
REPLACE AIR CONDITIONER BELT -----	4- 37
CLEAN, CHECK HYDRAULIC COOLER FINS -----	4- 37
CHECK UNDERCARRIAGE OIL -----	4- 38
CLEAN AIR CONDITIONER AIR FILTER (FRESH/RECIRC FILTER) -----	4- 39
CHECK, ADJUST AIR CONDITIONER -----	4- 40
LUBRICATE DOOR HINGE -----	4- 41
CHECK DOOR LATCH -----	4- 41
CHECK DOOR LOCK STRIKER -----	4- 41
REPLACE DOOR DAMPER -----	4- 42
CHECK WINDOW WASHER FLUID LEVEL, ADD FLUID -----	4- 42
REPLACE WIPER BLADE -----	4- 43
BLEED AIR FROM HEAD END OF RIGHT PITCH CYLINDER -----	4- 44
BLEEDING AIR IN HYDRAULIC SYSTEM -----	4- 44
CHECK ELECTRICAL INTAKE AIR HEATER -----	4- 45
LUBRICATING -----	4- 45

CHECK BEFORE STARTING

EVERY 250 HOURS SERVICE

LUBRICATING ----- 4- 47

CHECK ALTERNATOR DRIVE BELT TENSION, ADJUST ----- 4- 49

CHECK LEVEL OF BATTERY ELECTROLYTE ----- 4- 50

CHECK BRAKE PERFORMANCE ----- 4- 53

CHECK OIL LEVEL IN DAMPER CASE, ADD OIL ----- 4- 54

EVERY 500 HOURS SERVICE

CHANGE OIL IN ENGINE OIL PAN, REPLACE ENGINE OIL FILTER CARTRIDGE AND BYPASS
FILTER CARTRIDGE ----- 4- 55

REPLACE FUEL FILTER CARTRIDGE (MACHINES EQUIPPED WITHOUT ADDITIONAL FUEL
FILTER CARTRIDGE) ----- 4- 56

REPLACE POWER TRAIN OIL FILTER ELEMENT, STEERING LUBRICATING OIL FILTER
ELEMENT ----- 4- 58

CHECK OIL LEVEL IN FINAL DRIVE CASE, ADD OIL ----- 4- 59

REPLACE HYDRAULIC TANK BREATHER ELEMENT ----- 4- 59

REPLACE ADDITIONAL FUEL FILTER CARTRIDGE (IF EQUIPPED WITH MACHINES) ----- 4- 60

EVERY 1000 HOURS SERVICE

REPLACE FUEL FILTER CARTRIDGE (MACHINES EQUIPPED WITH ADDITIONAL FUEL FILTER
CARTRIDGE) ----- 4- 62

CHANGE OIL IN POWER TRAIN CASE, WASH STRAINERS (POWER TRAIN PUMP STRAINER,
SCAVENGING PUMP STRAINER) ----- 4- 64

CHECK, CLEAN FUEL STRAINER ----- 4- 66

CHECK FOR LOOSE ROPS MOUNT BOLTS ----- 4- 66

REPLACE MAIN CORROSION RESISTOR CARTRIDGE AND SUB CORROSION RESISTOR
CARTRIDGE ----- 4- 67

CHECK TIGHTENING PARTS OF TURBOCHARGER ----- 4- 67

REPLACE CHARGE FILTER ELEMENT ----- 4- 68

EVERY 2000 HOURS SERVICE

CHANGE OIL IN HYDRAULIC TANK, REPLACE HYDRAULIC OIL FILTER ELEMENT, CLEAN
HYDRAULIC TANK STRAINER ----- 4- 69

CHANGE OIL IN FINAL DRIVE CASE ----- 4- 71

CHANGE OIL IN DAMPER CASE, CLEAN DAMPER BREATHER ----- 4- 72

CHECK PIVOT BEARING OIL LEVEL, ADD OIL ----- 4- 73

CHECK OIL LEVEL IN RECOIL SPRING, ASSIST CYLINDER CASE, ADD OIL ----- 4- 74

CLEAN ENGINE BREATHER ELEMENT ----- 4- 74

CHECK ALTERNATOR, STARTING MOTOR ----- 4- 74

CHECK INJECTOR ----- 4- 75

EVERY 4000 HOURS SERVICE

CHECK WATER PUMP -----	4- 76
CHECK VIBRATION DAMPER -----	4- 76
CLEAN, CHECK TURBOCHARGER -----	4- 76
CHECK PLAY OF TURBOCHARGER ROTOR -----	4- 76
CHECK ENGINE VALVE CLEARANCE, ADJUST -----	4- 76
CHECKING FOR LOOSENESS OF HIGH-PRESSURE CLAMP, HARDENING OF RUBBER -----	4- 77
CHECKING FOR MISSING FUEL SPRAY PREVENTION CAP, HARDENING OF RUBBER -----	4- 78
REPLACE INJECTOR ASSEMBLY -----	4- 78
CHECK MAIN FRAME, WORK EQUIPMENT (BLADE, RIPPER) -----	4- 79

EVERY 8000 HOURS SERVICE

REPLACE HIGH-PRESSURE PIPING CLAMP -----	4- 80
REPLACE FUEL SPRAY PREVENTION CAP -----	4- 80

SERVICE PROCEDURE

INITIAL 250 HOURS SERVICE (ONLY AFTER THE FIRST 250 HOURS)

Perform the following maintenance only after the first 250 hours.

- Change oil in engine oil pan, replace engine oil filter cartridge
- Replace power train oil filter element, steering lubricating oil filter element
- Change oil in power train case, wash strainers (power train pump strainer, scavenging pump strainer)
- Replace charge filter element
- Change oil in hydraulic tank, replace hydraulic oil filter element, clean hydraulic tank strainer
- Change oil in final drive case

For details of the method of replacing or maintaining, see the section on EVERY 500 HOURS, 1000 HOURS and 2000 HOURS SERVICE.

WHEN REQUIRED

CLEAN INSIDE OF COOLING SYSTEM



WARNING

- Immediately after the engine is stopped, the coolant is at a high temperature and the radiator is under high internal pressure. If the cap is removed to drain the coolant in this condition, there is a hazard of burns. Wait for the temperature to go down, then turn the cap slowly to release the pressure before removing it.
- Cleaning is carried out with the engine running. When standing up or leaving the operator's seat, set the work equipment lock lever and the parking lever to the LOCK position.
- For details of starting the engine, see "CHECK BEFORE STARTING ENGINE, ADJUST (PAGE 3-71)" and "STARTING ENGINE (PAGE 3-92)" in the OPERATION section.
- Never enter front the machine when the engine is running.
There is danger of touching the fan.

Stop the machine on level ground when cleaning or changing the coolant.

Clean the inside of the cooling system, change the coolant and replace the corrosion resistor according to the table below.

Antifreeze coolant	Interval for cleaning inside of cooling system and changing antifreeze coolant	Replacing corrosion resistor
Komatsu supercoolant (AF-NAC)	Every two years or every 4000 hours whichever comes first	unnecessary(*1)
Permanent type antifreeze (All-season type, *2)	Every year (autumn) or every 2000 hours whichever comes first	Every 1000 hours and when cleaning the inside of the cooling system and when changing coolant

*1: When using Komatsu Supercoolant (AF-NAC), there is no need to use a corrosion resistor.

When no corrosion resistor is used, use the special cover (600-411-9000). Please consult your Komatsu distributor about the method of installing.

When using corrosion resistor, use Komatsu genuine corrosion resistor. If you use another corrosion resistor, it may cause serious problems such as corrosion of the engine and parts of the cooling system that use light metals such as aluminum.

*2: Permanent type antifreeze shall meet the requirements of ASTM D3306-03.

The coolant has the important function of preventing corrosion as well as preventing freezing.

Even in the areas where freezing is not an issue, the use of antifreeze coolant is essential.

Komatsu machines are supplied with Komatsu Supercoolant (AF-NAC). Komatsu Supercoolant (AF-NAC) has excellent anticorrosion, antifreeze and cooling properties and can be used continuously for 2 years or 4000 hours. Komatsu Supercoolant (AF-NAC) is strongly recommended wherever available.

To maintain the anticorrosion properties of Supercoolant (AF-NAC), always keep the density of Supercoolant between 30% and 68%.

When deciding the ratio of antifreeze to water, check the lowest temperature in the past, and decide from the mixing table given below.

It is actually better to estimate and temperature about 10°C (18°F) lower when deciding the mixing ratio.

The mixing ratio depends on the ambient temperature, but it should always be a minimum of 30% by volume (antifreeze/total amount of coolant x 100).

The freezing temperature of undiluted antifreeze is -15°C (5°F). Do not store undiluted antifreeze at a temperature of below -15°C (5°F).

Mixing rate of water and antifreeze

Min.atmospheric temperature	°C	Above -10	-15	-20	-25	-30
	°F	Above 14	5	-4	-13	-22
Amount of antifreeze	Liters	39.0	46.7	53.2	59.7	65.0
	US gal	10.30	12.34	14.06	15.77	17.17
Amount of water	Liters	91.0	83.3.1	76.8	70.3	65.0
	US gal	24.04	22.01	20.29	18.57	17.17
Volume ratio (%)	%	30	36	41	46	50

! WARNING

Antifreeze coolant is flammable, so keep it away from flame.
 Antifreeze coolant is toxic. When removing the drain plug, be careful not to get water containing antifreeze coolant on you. If it gets in your eyes, flush your eyes with large amount of fresh water and see a doctor at once.

Use antifreeze and appropriate water for diluting. (for details, see "COOLANT AND WATER FOR DILUTION (PAGE 4-6)")

We recommend use of an antifreeze density gauge to control the mixing proportions.
 Prepare a container whose capacity is larger than the specified coolant volume to catch drained coolant.
 Prepare a hose to supply antifreeze coolant and water.

1. Stop the engine, wait for the coolant to cool completely, then turn valve (3) of main corrosion resistor (1) and sub corrosion resistor (2) to the Close stopper position.

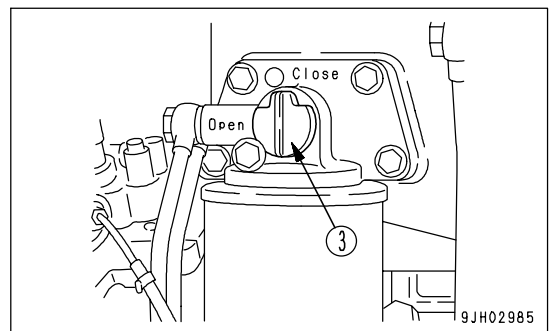
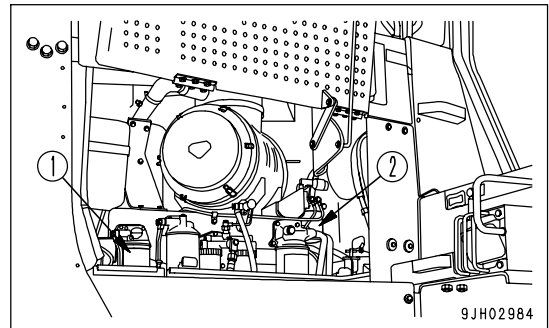

2. Turn main radiator cap (4) and sub radiator cap (5) slowly, and remove.

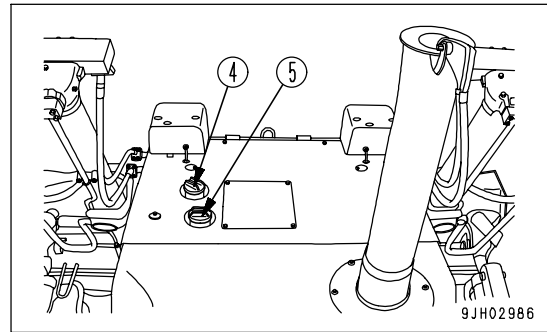

3. Prepare a container to catch the coolant, pull out hose (6) of the main radiator at the bottom front right of the machine, then open drain valve (7) and drain the water.

The sub radiator is at the bottom front left of the machine. Pull out drain hose (8) in the same way, then open drain valve (9) and drain the water.

4. Open the drain valve (11) in the water pump piping on the right side of the engine, and drain the coolant.

5. After draining the antifreeze solution, close drain valve (7), (9) and (11), then fill with clean water. After the radiator is filled with water, start and run the engine at low idling speed. After the water temperature rises above 90°C (194°F), run the engine for about 10 minutes.

6. Stop the engine, open drain valve (7), (9) and (11), and drain the water.

7. After draining the water, clean the cooling system with cleaning agent.

For the cleaning method, see the instructions for the cleaning agent.

8. Close drain valve (7), (9) and (11).

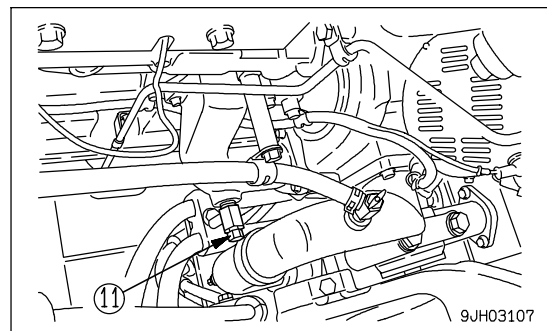
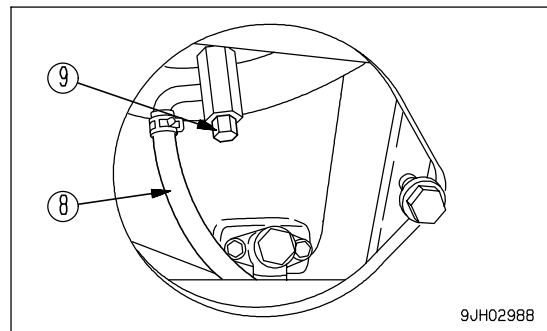
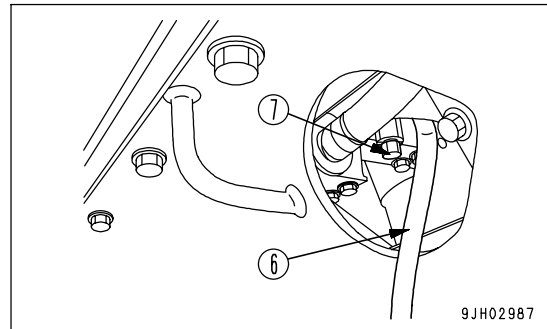

9. Replace the corrosion resistor, then open each valve (3).

For details of the procedure for replacing the corrosion resistor, see "REPLACE MAIN CORROSION RESISTOR CARTRIDGE AND SUB CORROSION RESISTOR CARTRIDGE (PAGE 4-67)".

10. Add coolant mixed with antifreeze until it overflows from the water filler.

Decide the proportions of antifreeze and water according to the table for the mixing rate of water and antifreeze.

11. To bleed the air from the cooling system, run the engine at low idle for 5 minutes, and for a further 5 minutes at high idle. (When doing this, leave the radiator cap off.)

12. Drain the coolant from sub-tank (10), clean the inside of the sub-tank, then add water until the coolant level is between the FULL and LOW marks.
13. Stop the engine, wait for approx. 3 minutes, then add coolant until the coolant level is near the coolant filler port, and tighten the cap. Check the coolant level and add coolant if necessary.

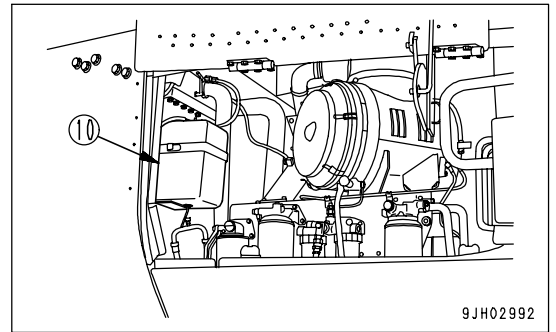

CHECK, CLEAN AND REPLACE AIR CLEANER ELEMENT**WARNING**

- Always wear protective glasses, dust mask, or other protective equipment.
- When removing the air cleaner element from the air cleaner body, it is dangerous to pull it out by force.
When working at high places or where the foothold is poor, be careful not to fall because of the reaction when pulling out the outer element.

CHECKING

If the internal yellow piston overlaps the red zone on the outside diameter of dust indicator (1), clean the air cleaner element. After cleaning, press the reset button to reset the piston.

NOTICE

Always wait for the yellow piston in the dust indicator to overlap the red zone on the outside before cleaning the element.

If the element is cleaned frequently before the yellow piston in the dust indicator overlaps the red zone on the outside, the air cleaner will be unable to display its normal performance and the cleaning effect will become poor.

In addition, the frequency of dust stuck to the element falling inside the inner element during the cleaning operation will increase.

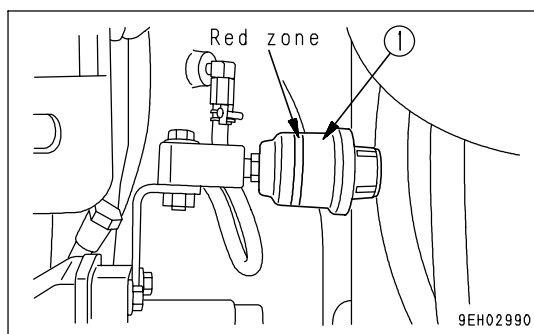

CLEANING OUTER ELEMENT

NOTICE

Before and after cleaning the element, do not leave or keep it in direct sunlight.

1. Remove 6 holders (2), then remove cover (3) and take out outer element (4).

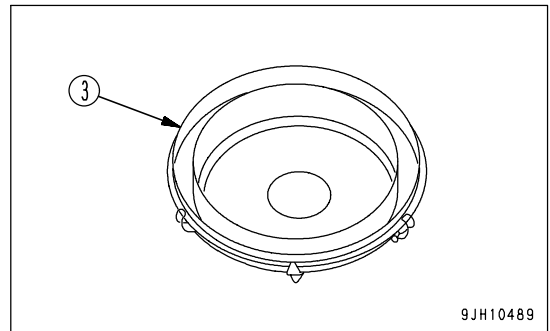
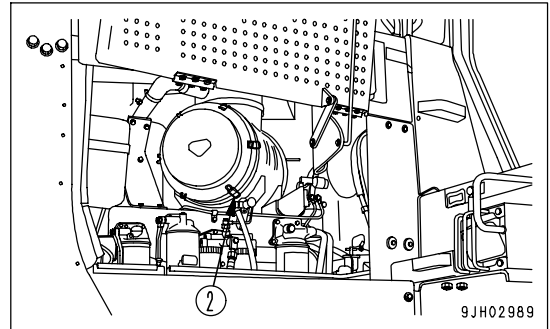

NOTICE

- Never remove the inner element (5). It will allow dirt to enter and cause failure of the engine.
- Do not use a screwdriver or other tool.

2. Hold the outer element (4), move it carefully up and down and to the left and right, and rotate the element to the left and right while pulling it out.
3. After removing the outer element, cover the air connector inside the air cleaner body with a clean cloth or tape to prevent dirt or dust from entering.

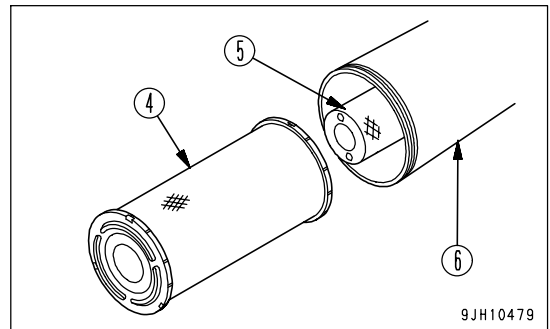

4. Use a brush or cloth to remove all the dirt stuck to cover (3) and the inside of air cleaner body (6).
5. Direct dry compressed air (Max. 0.69 MPa (7 kg/cm², 99.4 PSI)) from the inside of the outer element along its folds. Then direct the compressed air from the outside along the folds, and again from the inside.
 - 1) Check that the inner element is not loose. If it is loose, insert it securely.
 - 2) If the yellow piston overlaps the red zone (A) on the outer diameter immediately after the outer element is cleaned, replace both the inner and outer elements.

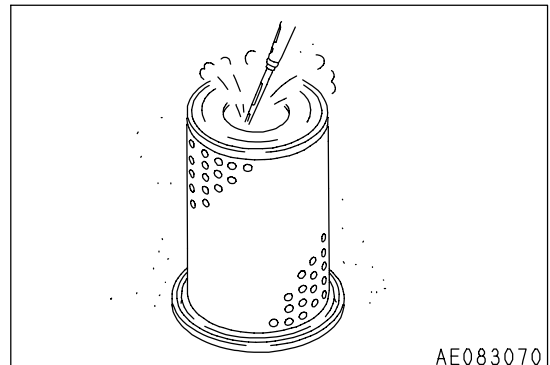

NOTICE

If small holes or thinner parts are found on the element when it is checked with an electric bulb after cleaning and drying, replace the element.

When cleaning the element, do not hit it or beat it against something.

Do not use an element whose folds or gasket or seal are damaged.

6. If small holes or thinner parts are found on the element when it is checked with an electric bulb after cleaning and drying, replace the element.

NOTICE

- The inner element must not be cleaned and used again. When replacing the outer element, replace the inner element at the same time.
- If the inner element is not installed properly and the outer element and cover are installed, there is danger that the outer element will be damaged.
- The seal portion on imitation parts lacks precision, and allows the entry of dust, which leads to damage of the engine. Do not use such imitation parts.

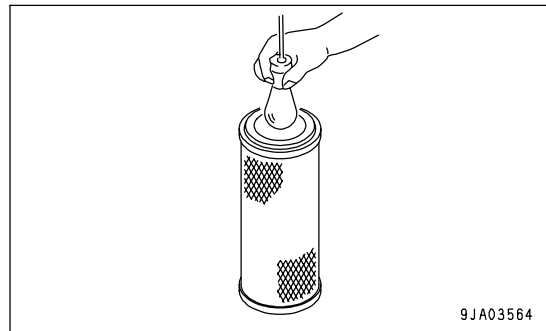

7. Remove the cloth or tape cover installed in Step 3.
8. Check that there is no dirt or oil stuck to the seal portion of the new element or cleaned element. Wipe off any dirt or oil.
9. Push the outer element in straight with your hand when installing it to the air cleaner body. If the outer element is held and rocked lightly up and down and to the left and right while pushing it in, the outer element can be inserted easily.

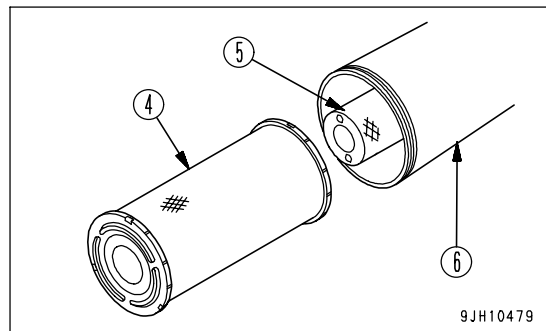

NOTICE

When inserting the element, if the rubber at the tip is swollen or the outer element is not pushed in straight, and cover (3) is assembled by force to hook (2), there is danger that the hook and air cleaner body may be damaged, so be careful when assembling.

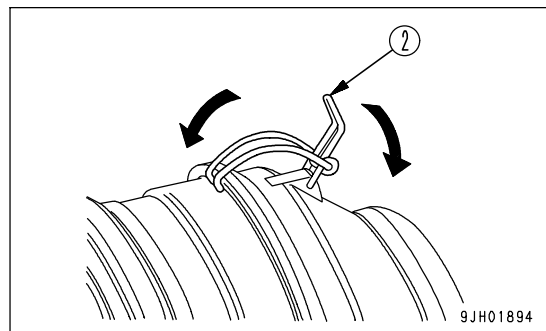

10. Install cover (3) as follows.
 - 1) Align cover (3) with the element.
 - 2) Hook the tip of hook (2) to the protruding part of the air cleaner body and lock it in position.
 - 3) When locking hooks (2) in position, apply the hooks in turn on opposite sides (top, bottom, left, right) in the same way as when tightening bolts.
 - 4) When cover (3) is installed, check that the clearance between the air cleaner body and cover (3) is not too large. If it is too large, install again.

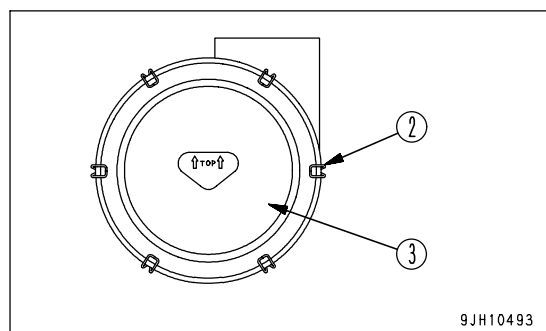

REPLACING ELEMENT

1. Open the left engine side cover.
2. Remove 6 holders (2), then remove cover(3).

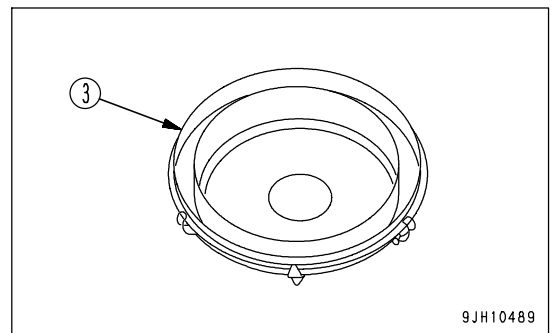
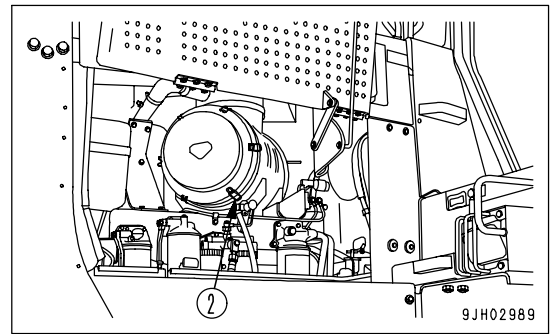

3. Hold the outer element (4), move it carefully up and down and to the left and right, and rotate the element to the left and right while pulling it out.
4. Use a brush or cloth to remove all the dirt stuck to cover (3) and the inside of air cleaner body (6).

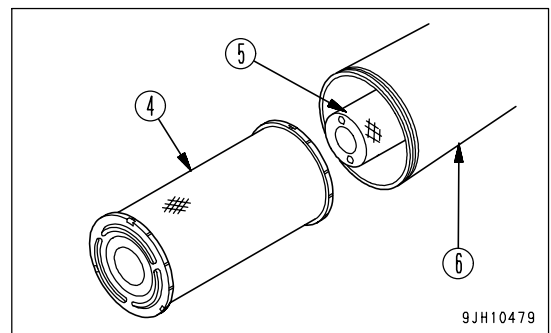

NOTICE

- The inner element must not be cleaned and used again. When replacing the outer element, replace the inner element at the same time.
- If the inner element is not installed properly and the outer element and cover are installed, there is danger that the outer element will be damaged.
- The seal portion on imitation parts lacks precision, and allows the entry of dust, which leads to damage of the engine. Do not use such imitation parts.

5. Remove inner element (5), then quickly install the new inner element.
Push the inner element in properly and check that it is fitted securely.
6. Push new outer element (4) straight into the air cleaner body with your hand.
If you hold the element and move it carefully up and down and to the left and right, it is easier to insert the element.
7. Replace O-ring (7) for cover (3) with new one.

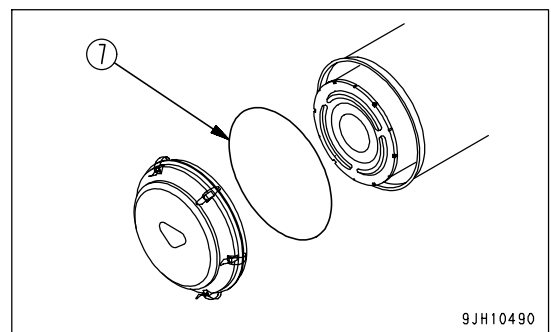

NOTICE

When inserting the element, if the rubber at the tip is swollen or the outer element is not pushed in straight, and cover (3) is assembled by force to hook (2), there is danger that the hook and air cleaner body may be damaged, so be careful when assembling.

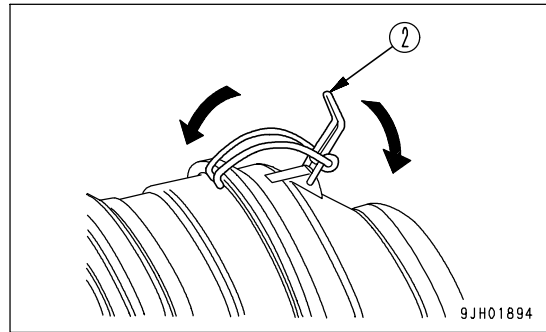

8. Install cover (3) as follows.

- 1) Align cover (3) with the element.
- 2) Hook the tip of hook (2) to the protruding part of the air cleaner body and lock it in position.
- 3) When locking hooks (2) in position, apply the hooks in turn on opposite sides (top, bottom, left, right) in the same way as when tightening bolts.
- 4) When cover (3) is installed, check that the clearance between the air cleaner body and cover (3) is not too large. If it is too large, install again.

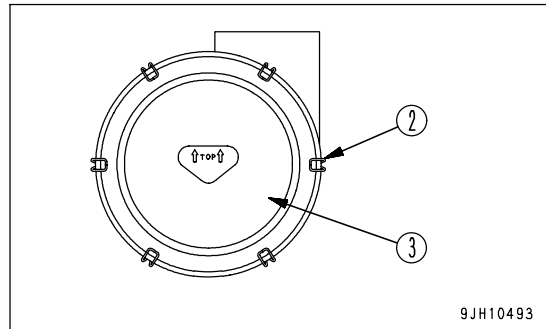

9. After replacing the element, press the dust indicator button to reset it.

The yellow piston will return to its original position.

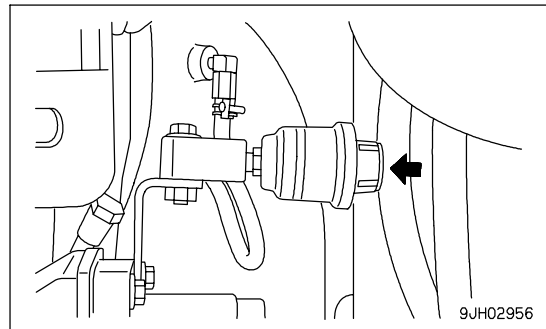

CHECK AND ADJUST TRACK TENSION

The wear of pins and bushings on the undercarriage will vary with the working conditions and types of soil. It is thus necessary to continually inspect the track tension so as to maintain the standard tension.

Carry out the check and adjustment under the same conditions as when operating (on jobsites where the track becomes clogged with mud, measure with the track clogged with mud).

INSPECTION

Stop the machine on level ground (stop with the transmission in FORWARD without applying the brake). Then place a straight bar on the track shoes between the carrier roller and the idler as shown in the figure, and measure the clearance between the bar and the grouser at the midpoint. If the clearance (A) is 20 to 30 mm (0.79 to 1.18 in), the tension is standard.

If the track tension is not at the standard value, adjust it in the following manner.

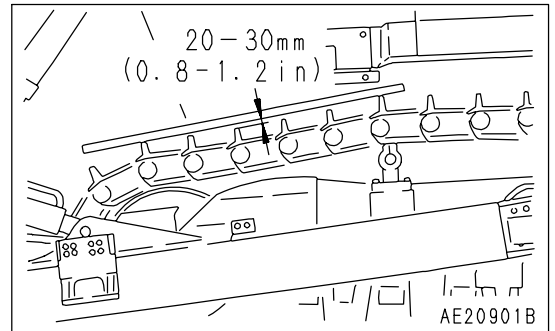

ADJUSTMENT

WARNING

Grease inside the adjusting mechanism is under high pressure. Grease coming from plug (4) under pressure can penetrate the body causing injury or death. For this reason, do not loosen plug (4) more than one turn. Do not loosen any part other than plug (4). Furthermore, do not bring your face in front of the grease fitting. If track tension is not relieved by this procedure, contact your Komatsu distributor for repairs.

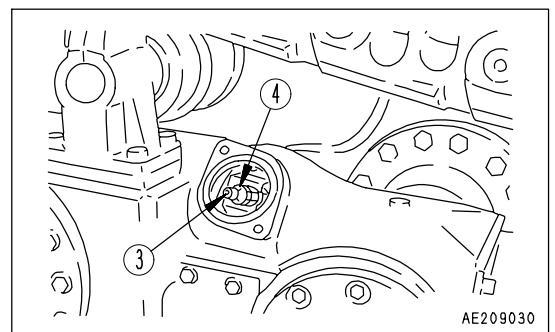
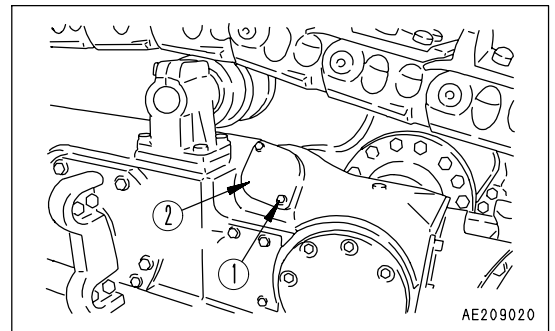

WHEN INCREASING TENSION

1. First remove the bolt (1) and then remove the cover (2).

NOTICE

- When removing cover (2), be careful not to let any dirt get inside.
- There is a safety label stuck to the back of cover (2). Be careful not to damage the safety label.

2. Pump in grease through the grease fitting (3) with a grease pump.
3. To check that the correct tension has been achieved, move the machine backwards and forwards.
4. Check the track tension again, and if the tension is not correct, adjust it again.
5. Continue to pump in grease until S becomes 475 mm (18.7 in).

If the tension is still loose, the pin and bushing are excessively worn, so they must be either turned or replaced. Please contact your Komatsu distributor.

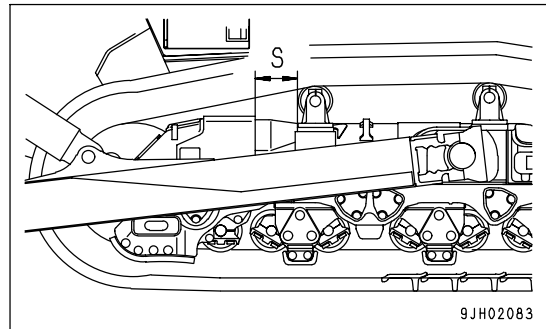

WHEN LOOSENING TENSION

 **WARNING**

It is extremely dangerous to release the grease by any method except the procedure given below.
If track tension is not relieved by this procedure, contact your Komatsu distributor for repairs.

1. Remove both bolts (1), then remove cover (2).

NOTICE

- When removing cover (2), be careful not to let any dirt get inside.
- There is a safety label stuck to the back of cover (2). Be careful not to damage the safety label.

2. Loosen plug (4) gradually to release the grease.
3. Turn plug (4) a maximum of one turn.
4. If the grease does not come out smoothly, move the machine backwards and forwards a short distance.
5. Tighten plug (4).
6. To check that the correct tension has been achieved, move the machine backwards and forwards.
7. Check the track tension again, and if the tension is not correct, adjust it again.

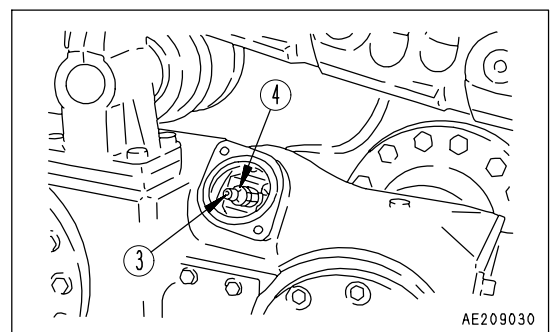
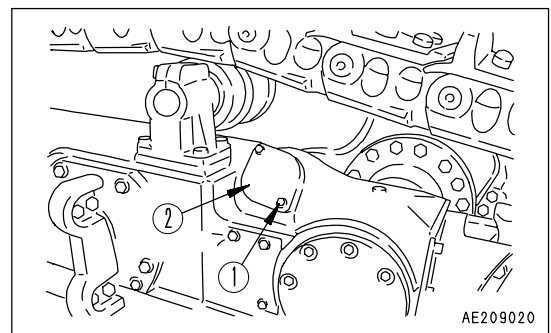

WHEN REMOVING TRACK

 **WARNING**

Depending on the situation, the operation to remove the track may be extremely dangerous.
Before removing the track, if the procedure "WHEN LOOSENING TENSION (PAGE 4-31)" does not loosen the track tension, contact your Komatsu distributor for repairs.

CHECK AND TIGHTEN TRACK SHOE BOLTS

If the machine is used with track shoe bolts being loose, they will break, so tighten any loose bolts immediately.

METHOD OF TIGHTENING SHOE BOLT

1. First tighten to a tightening torque of 490 ± 49 Nm (50 ± 5 kgm, 361.7 ± 36.2 lbft) then check that the nut and shoe are in close contact with the link contact surface.
2. After checking, tighten a further $180^\circ \pm 10^\circ$.

METHOD OF TIGHTENING MASTER LINK CONNECTING BOLT

1. First tighten to a tightening torque of 490 ± 49 Nm (50 ± 5 kgm, 361.7 ± 36.2 lbft) then check that the link contact surfaces are in close contact.
2. After checking, tighten a further $180^\circ \pm 10^\circ$.

ORDER FOR TIGHTENING

Tighten the bolts in the order shown in the diagram on the right.

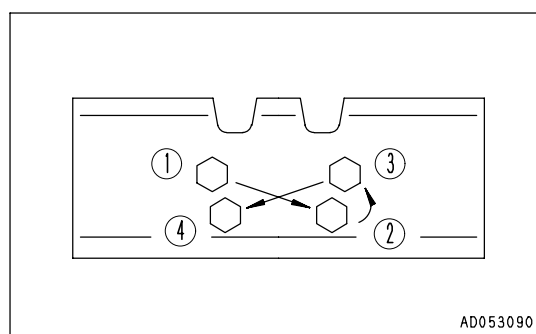

ADJUST IDLER CLEARANCE

The idler moves forward and backward under external pressure when this happens, side guide (1) and guide plate (2) become worn.

As they become worn, there is side play in the idler, or the idler turns at an angle, causing the track to come off or resulting in uneven wear, so adjust as follows.

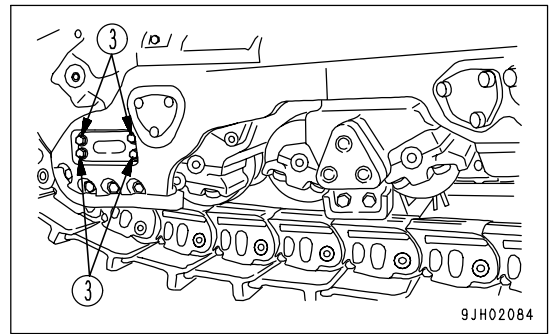

ADJUSTMENT

1. Drive the machine for 8 to 12 m (24.4 to 36.6 ft) on flat ground, then measure clearance A (4 places: left, right, inside outside) between the track frame and side guide (1).
2. If clearance A is more than 3 mm (0.1 in), remove bolt (3), then take out shim (4), and adjust to that the clearance on one side is less than 0.5 mm (0.02 in).

REMARK

There are two types of shim (thickness: 0.5 mm (0.02 in) and 1.0 mm (0.04 in)).

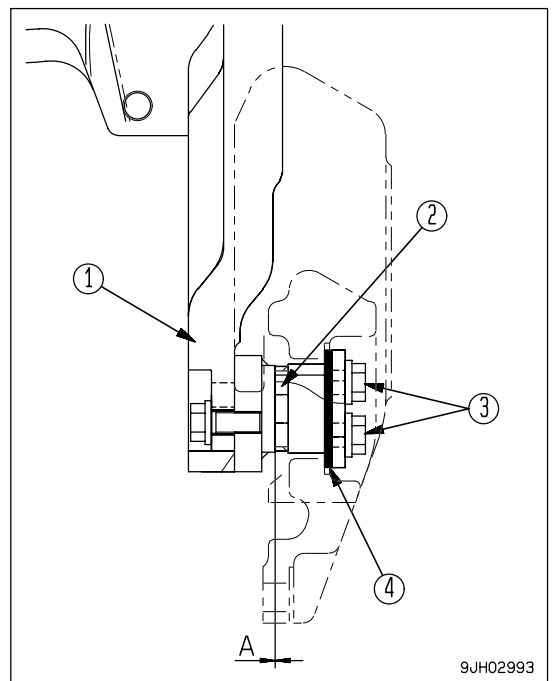

REVERSE AND REPLACE THE END BITS AND CUTTING EDGES



WARNING

It is dangerous if the work equipment moves by mistake when the cutting edges and end bits are being reversed or replaced. Set the work equipment in a stable condition, then stop the engine and lock the blade control lever securely with the work equipment lock lever.

Reverse or replace the end bits and cutting edges before it is worn out to the blade end.

- 1. Raise the blade to a proper height, position a block under the frame to prevent the blade from falling.
- 2. Operate the work equipment lock lever to the LOCK position.

If the cutting edge and the end bit on both sides are worn out, replace with new one.

If the mounting surface is worn, correct it before turning or replacing the end bits.

- 3. Loosen nut (1) and remove bolt (2). Then remove the cutting edge and the end bit and clean the mounting surface.

- 4. Reverse or replace the cutting edge and the end bit when worn out.

If bolt (1) and nut (2) are damaged, replace them with new ones at the same time.

- 5. Install the edge to the blade, then tighten partially. Drop the blade three to five times on to the ground or rock to remove any play in bolt (2), then tighten it to the correct tightening torque. When installing end bit (3), put top surface (4) of the end bit in close contact with stopper (5), then tighten with the bolts.

Tightening torque: 1499 ± 157 Nm (153 ± 16 kgm , 1106.6 ± 115.7 lbft)

- 6. After several hours of running, retourque the nuts.

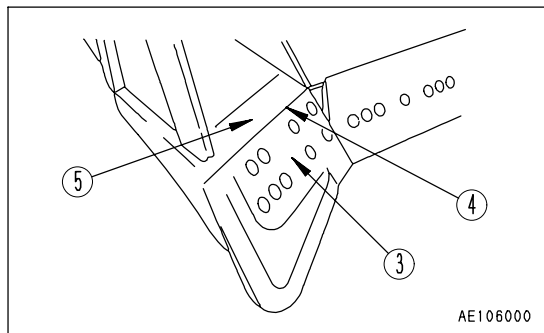
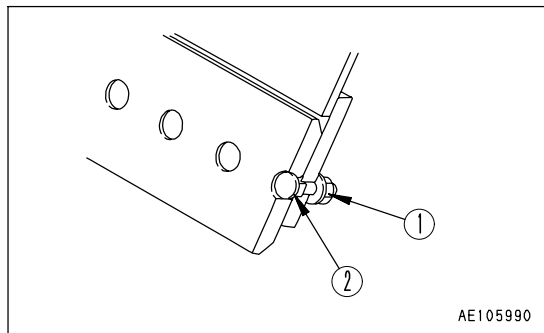

REMARK

The tightening operation is easier if the power wrench that has been supplied is used.

When the nut is rusted and is removed by gas cutting, cut on both side (6) of the nut as shown in the diagram.

Be careful not to damage seat surface (7).

If it is damaged, repair it. Be careful not to get spatter on the mounting surface.

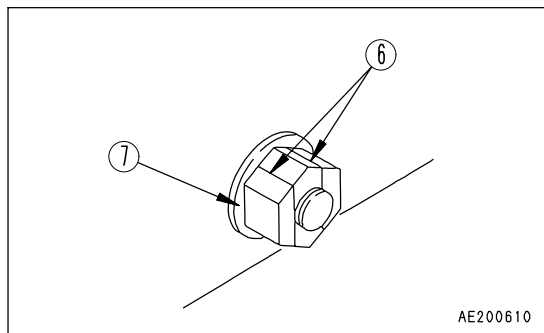

METHOD OF USING POWER WRENCH

The power wrench set is equipped with a special socket.

This socket is designed to grip the nuts and prevent the wrench set from pulling out. This means that tightening can be performed by one worker.

This socket has a double construction, and is designed so that the outside can rotate 30°

It is used as follows.

- (1) Cutting edges or end bit
- (2) Ratchet handle or torque wrench
- (3) Rotating socket
- (4) Reaction arm

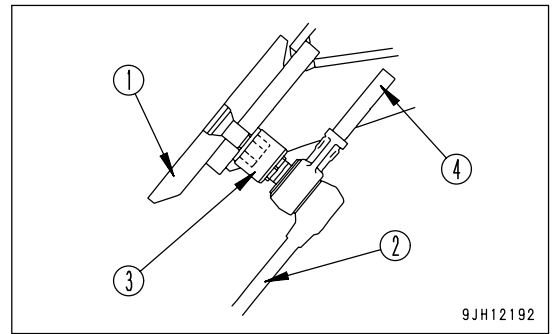

- 1. Align the hexagons of the inside socket (6) and outside socket (5), then insert the nut that is to be tightened or loosened.

- 2. After inserting the nut, turn the outside socket (5) 30° clockwise (7).

When this is done, the outside socket will catch the notch in the nut seat surface, and the wrench will not come off.

- 3. Put the reaction arm (4) in contact with the blade rib, and tighten or loosen.

- 4. Turn the outside socket (5) counterclockwise, and remove the wrench.

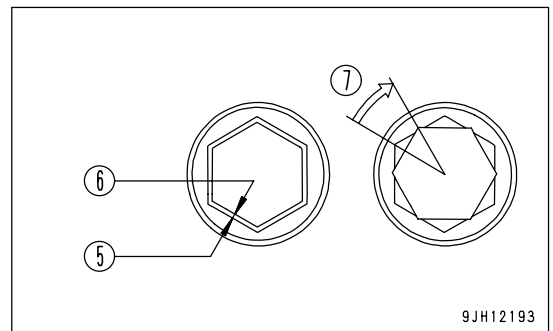

CLEAN AND CHECK RADIATOR FINS



WARNING

For the cleaning and check, stop the engine without fail and confirm that the fan is not rotating, and carry out the work.

If the radiator fins are clogged or dirty, clean and inspect them.

1. Remove four bolts (1) at corners of grill (2), then open the grill.

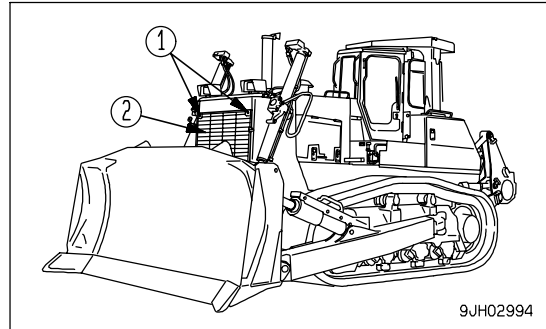

9JH02994

2. Clean the radiator fins clogged with mud, dust and leaves with compressed air. Steam or water may be used instead of compressed air.

REMARK

Check the hydraulic cooler hoses. If any hose is cracked or hardened by age, replace with a new hose. Also check and tighten all loose hose clamps.

When cleaning the radiator fins, reverse the rotation of the fan and change the direction of the air flow. Set the Fan rotation selector switch to the CLN position (C) and start the engine.

The fan rotates at 100% speed in reverse and cleans the fins.

The Fan rotation selector switch cannot be operated when the engine is running.

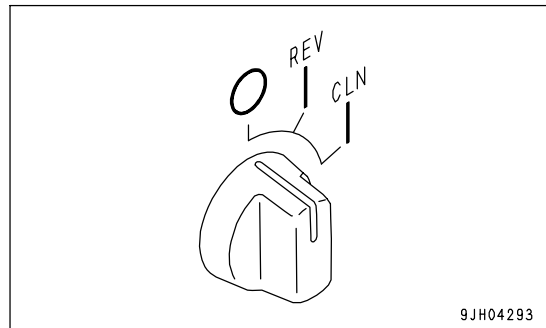

9JH04293

REMARK

If dirt is caught in the radiator fins, blow with compressed air to clean.

CLEAN FUEL TANK STRAINER

Clean the strainer if there is any dirt collected in it.

Remove the filler cap (1) of the fuel tank and take out strainer.

If the strainer is dirty, clean it with diesel fuel.

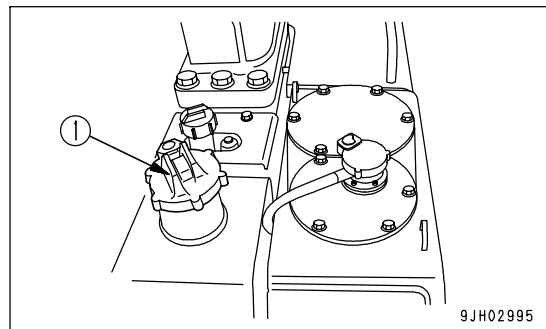

9JH02995

DRAIN WATER AND SEDIMENT IN FUEL TANK

Carry out this procedure after the machine has been at rest for a long time and after a long spell of rainy days.

Loosen valve (1) at the bottom of the fuel tank, and drain the water and sediment collected at the bottom of the tank together with the fuel.

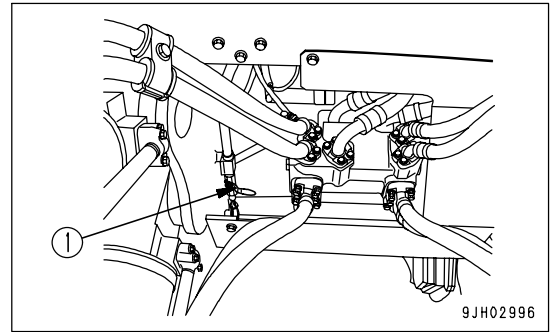

CLEAN STEERING CLUTCH CASE BREATHER

1. Open the rear cover.
2. Remove bolts (1), then remove cover (2).
3. Remove breather (3) on the side of the hydraulic tank, remove any dirt stuck to the breather, then wash with clean diesel oil or flushing oil.

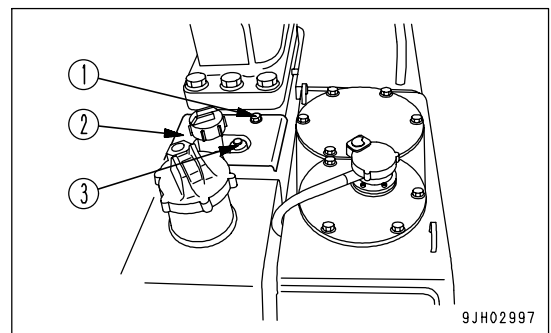

REPLACE AIR CONDITIONER BELT

1. Loosen 4 bolts (1) and jack bolt (2), then move compressor (3) to the side.
2. Replace the V-belt.
 - When adjusting the V-belt, do not push the compressor directly with the bar. Use jack bolt (2).
3. Tighten jack bolt (2) and bolts (1), and apply tension to the V-belt. The standard deflection for the belt is approx. 10 mm (0.4 in) when pressed with a finger force of approx. 58.8N (6 kg) at a point midway between the air conditioner compressor pulley and fan pulley.

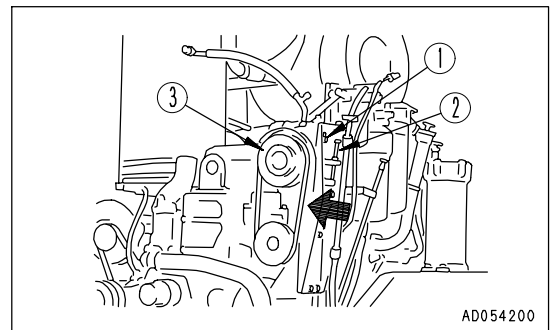

CLEAN AND CHECK HYDRAULIC COOLER FINS

If the hydraulic cooler fins are clogged or there is dirt caught in the fins, clean and check the fins.

1. Open the inspection cover on the right.
2. Use compressed air to remove the mud, dirt, and leaves clogging the hydraulic cooler fins. Steam or water may be used instead of compressed air.

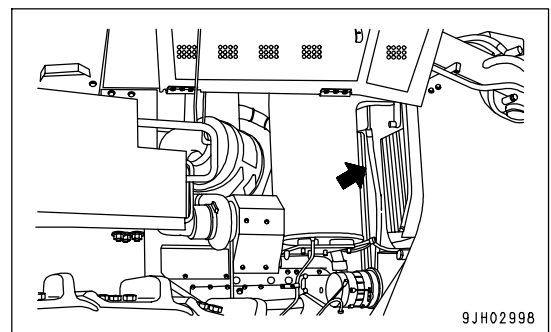

REMARK

Check the hydraulic cooler hoses. If any hose is cracked or hardened by age, replace with a new hose. Also check and tighten all loose hose clamps.

CHECK UNDERCARRIAGE OIL

Stop the machine on level ground, and check for any reduction in the oil at the idler (portion P), track roller (portion Q), and carrier roller (portion R).

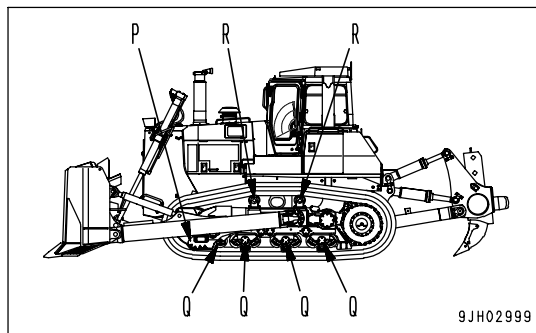

1. Loosen seal bolt (1) slowly and check if oil oozes out from the thread. If oil oozes out, the oil level has not gone down, so tighten the bolt.
2. If no oil comes out even when seal bolt is removed, the oil level is low. Contact your Komatsu distributor for repairs.

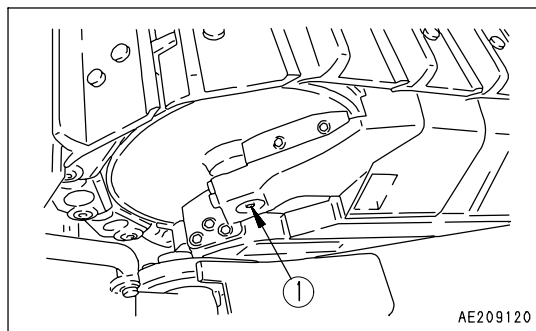

REMARK

Bogie shaft seal bolt (1) is located on both the inside and outside.

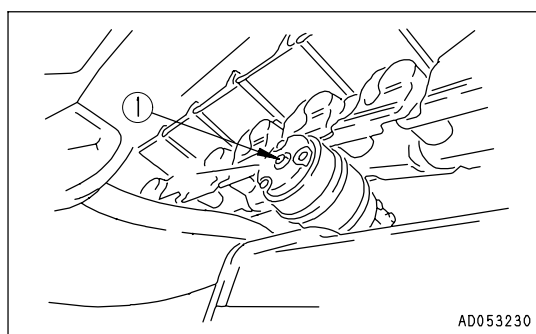
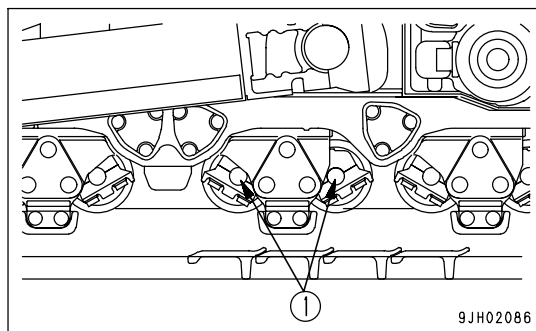

CLEAN AIR CONDITIONER AIR FILTER (FRESH/RECIRC FILTER)

Clean the air conditioner air filter if it becomes clogged or if there is dirt or oil stuck to it.

1. Open inspection cover (1) on the top of the left engine cover, then remove fresh air filters (2).
2. Open inspection cover (3) under the front panel and pull up recirculation air filter (4) to remove it.
3. Clean filters (2) and (4) with compressed air. If there is oil stuck to the filter, or it is extremely dirty, wash it in a neutral agent. After washing it, dry it completely before installing it again.

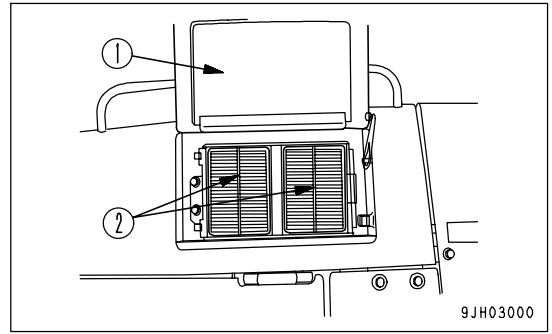

REMARK

If the filters cannot be cleaned with air or in water, replace them with new ones.

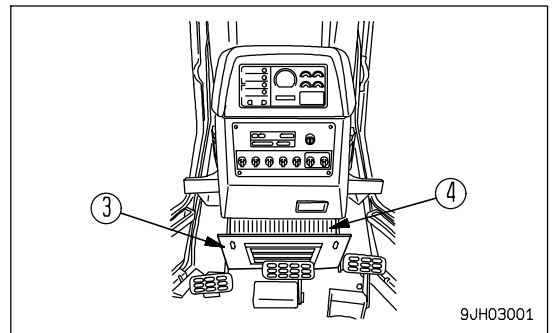

CHECK AND ADJUST AIR CONDITIONER

CHECK TENSION OF COMPRESSOR BELT

If the belt is loose, it will slip and will not be able to carry out cooling properly.

Check the belt tension from time to time. The deflection should be 10 mm (0.4 in) when pressed at a point midway between the drive pulley (1) and compressor pulley (2) with a finger force of approx. 58.8 N (6 kg).

When the V-belt is new, it will stretch at first, so always adjust it after 2 or 3 days.

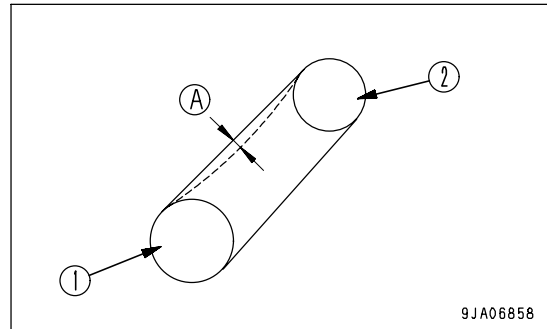

9JA06858

CHECK LEVEL OF REFRIGERANT(GAS)

! WARNING

- When handling refrigerant gas, always follow local laws and regulations.
- The refrigerant used in the cooler is colorless and odorless and does not harm the atmosphere, but if the liquid gets into your eyes or on your hands, it may cause loss of sight or frostbite, so never loosen any part of the refrigerant circuit.

If the level of the refrigerant (gas) is low, the cooling effect will be reduced. Run the engine at high idle, and check the flow of the refrigerant gas (R134a) in the refrigerant circuit through the sight glass (2) (inspection window) of the receiver (1) when the cooler is running at high speed.

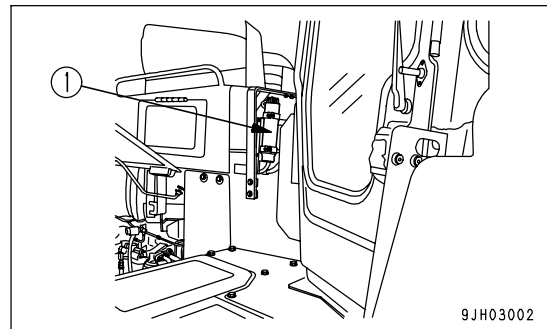

9JH03002

- (A) Correct: No bubbles are included in the flow
- (B) Low: Bubbles are included in the flow (bubbles pass continuously)
- (C) None: Colorless, transparent

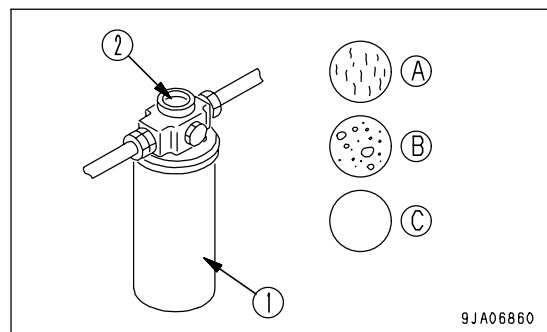

9JA06860

REMARK

- When there are bubbles, the refrigerant gas level is low, so contact your refrigerant dealer to have refrigerant added. If the air conditioner is run with the refrigerant gas level low, it will cause damage to the compressor.
- New Freon R134a is used as the refrigerant.

LUBRICATE DOOR HINGE

If the door makes a squeaking noise when it is opened or closed, spray lubricant in through the split in the hinge bushing. If the bushing is worn, replace the hinge.

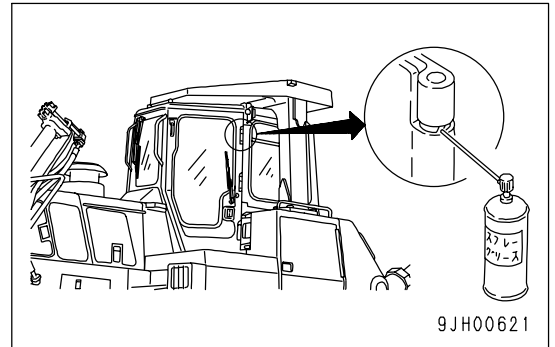

CHECK DOOR LATCH

WARNING
It is quite dangerous if the machine suddenly starts to move during the inspection work. Stop the engine and operate the parking brake lever to the LOCK (L) position without fail.

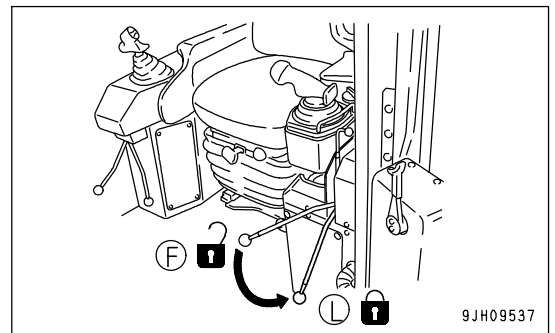

Check
Hold the door open-locked, and check that there is still grease inside the latch. If the amount of grease is low or there is no more grease, coat the inside of the latch with grease from portion (1).

REMARK
If there is no more grease inside the latch, the movement will become poor because of dust inside the latch, and the handle may be stiff when opening the door.

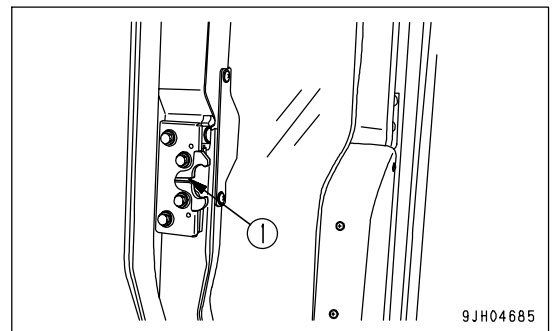

CHECK DOOR LOCK STRIKER

If wear (A) of the door of lock striker exceeds 0.5 mm (0.02 in), replace the striker. If it is used as it is, the play will increase and this may result in breakage of the hinge or door lock.

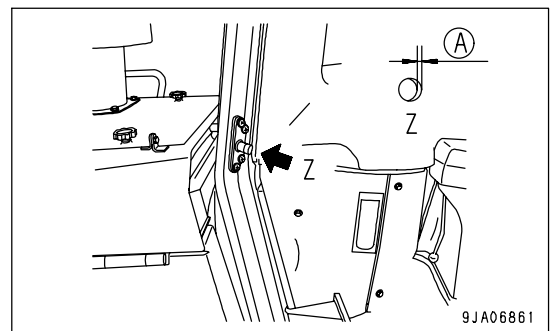

REPLACE DOOR DAMPER

If depth (A) of the groove of door damper rubber (1) is less than 2 mm (0.08 in), replace the damper.

There are 4 dampers: 1 each at the top and bottom on the left and right doors.

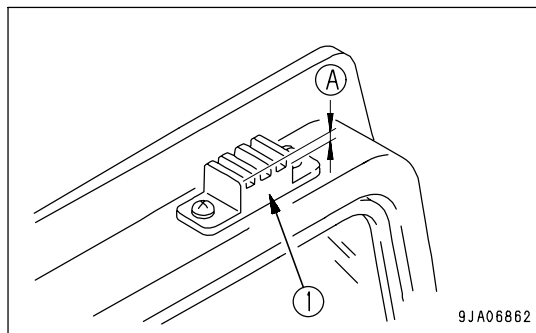
**CHECK WINDOW WASHER FLUID LEVEL, ADD FLUID**

If there is air in the window washer fluid, check the level and add fluid.

Open the battery cover, check the level of the fluid in window washer tank (1), and if it is low, add automobile window washer fluid.

When adding fluid, be careful not to let any dust get in.

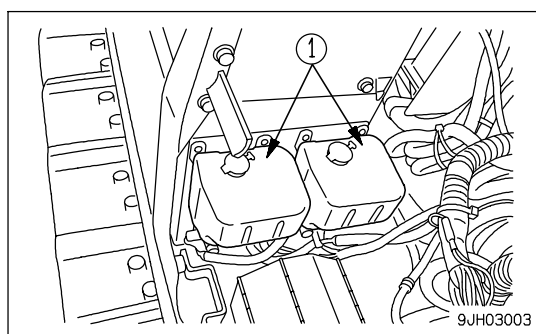

REPLACE WIPER BLADE

If the blade is damaged, it will not wipe the window clean, so replace the blade.

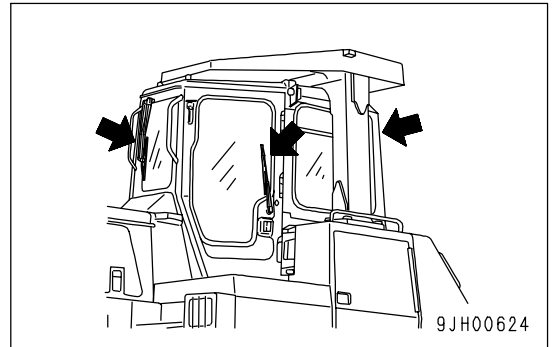

REPLACEMENT

FRONT, REAR WIPER

1. Remove screw (1), then remove the blade.
2. Install a new blade, then tighten screw (1) securely.

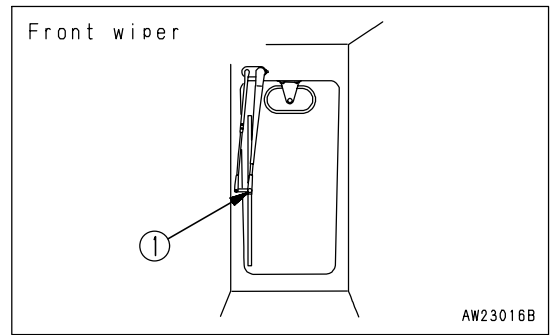

REAR WIPER

1. Remove E-ring (1).
The blade can then be removed.
2. Install a new blade, then install securely with E-ring (1).

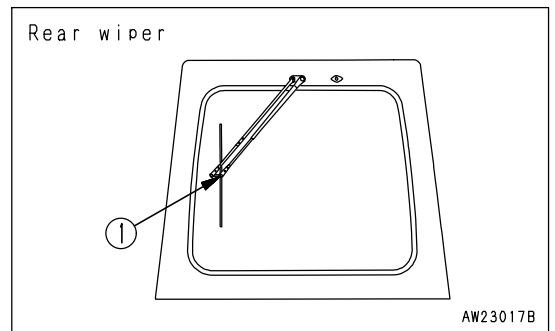

DOOR WIPER

1. It is hooked at portion (A), so move the blade in the direction of the arrow to remove it.
2. Install the new blade and hook it securely.

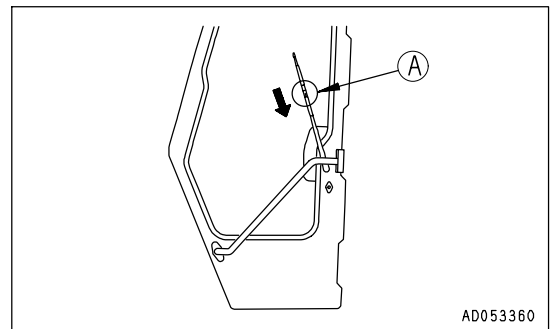

BLEED AIR FROM HEAD END OF RIGHT PITCH CYLINDER

(DUAL TILT DOZER ONLY)

Bleed the air if the work equipment has been removed or repaired.

1. Raise the blade and run the engine at low idling.
2. Operate the left and right tilt 5 to 10 times to bleed the air from the tilt circuit.
3. Operate the forward and rear pitch 5 to 10 times to bleed the air from the bottom end of the right cylinder.
4. Set the left and right cylinders at the neutral position, then carry out the following operations 5 - 10 times to bleed the air from the head end of the right pitch cylinder.
(1) Forward pitch → (2) Left tilt → (3) Right tilt → (4) Rear pitch

BLEEDING AIR IN HYDRAULIC SYSTEM

See "OPERATIONS AND CHECKS AFTER STARTING ENGINE (PAGE 3-97)".

Since the engine must be started and the blade must be operated, see OPERATION.

NOTICE

If the engine is run at high speed immediately after startup or a cylinder is pushed up to its stroke end, air taken inside the cylinder may cause damage to the piston packing.

1. Bleeding air from cylinders
 - 1) Run the engine at low idle, and extend and retract each cylinder 4 to 5 times, taking care that a cylinder is not moved to the end of its stroke. (Stop the cylinder approx. 100 mm (3.9 in) short of its stroke end)
 - 2) Next, operate each cylinder 3 to 4 times to the end of its stroke.
 - 3) Finally, operate each cylinder 4 to 5 times to the end of its stroke to completely remove the air.

CHECK ELECTRICAL INTAKE AIR HEATER

Check before the cold season starts (once a year).

Remove the electric heater from the engine intake manifold and check for wire disconnections and dirt clinging to it.

When checking and installing the electric heater, replace its gasket with a new one.

LUBRICATING

1. Lower the work equipment to the ground, then stop the engine.
2. Using a grease pump, pump in grease through the grease fittings shown by arrows.
3. After greasing, wipe off any old grease that was pushed out.

Fuel control (1 place)

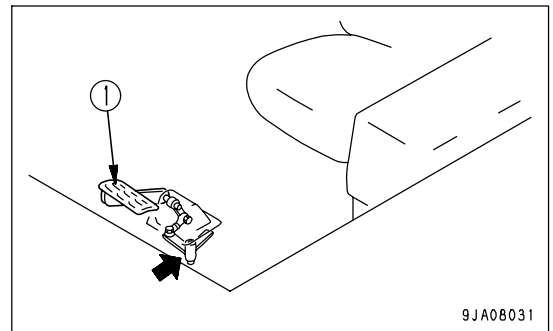

(1)Decelerator pedal

Steering, directional, gearshift lever rotating link (4 places)

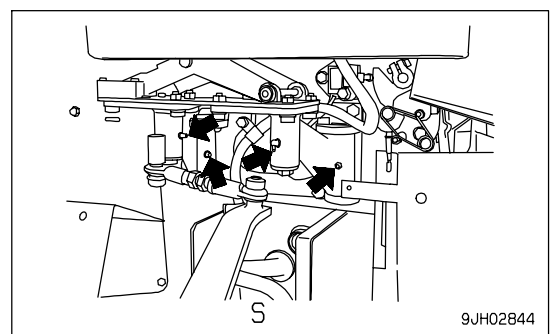
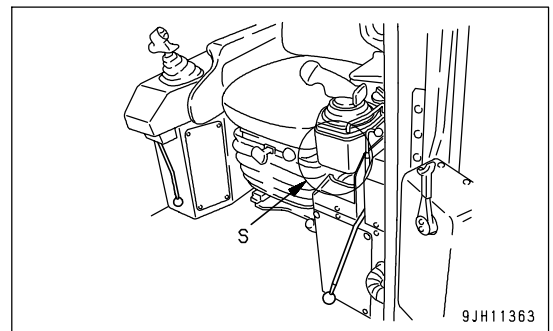

CHECK BEFORE STARTING

For details of the following items, see "CHECK BEFORE STARTING (PAGE 3-73)".

- Checking with machine monitor
- Check coolant level, add coolant
- Check fuel level, add fuel
- Check water separator, drain water and sediment
- Check oil level in engine oil pan, add oil
- Check oil level in power train case, add oil
- Check brake pedal travel
- Check dust indicator
- Check oil level in hydraulic tank, add oil
- Check electric wiring
- Check that lamps light up
- Check horn sound
- Check backup alarm sound
- Check seat belt for wear or damage
- Adjust mirror
- Adjust joystick
- Adjust armrest

EVERY 250 HOURS SERVICE

LUBRICATING

1. Lower the work equipment to the ground, then stop the engine.
2. Using a grease pump, pump in grease through the grease fittings shown by arrows.
3. After greasing, wipe off any old grease that was pushed out.

(1) Blade lift cylinder support yoke (4 places)

REMARK

These are at the front and rear of the left and right cylinders.

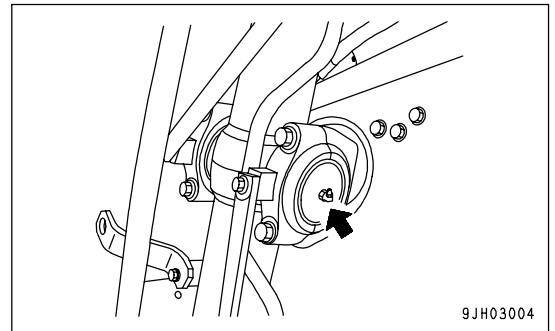

(2) Blade lift cylinder support shaft (2 places)

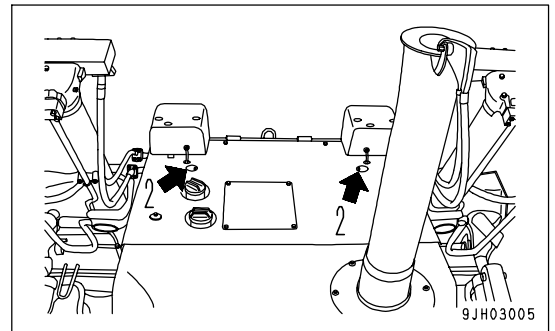

(3) Blade arm ball joint (4 places)

(4) Brace screw (2 places)

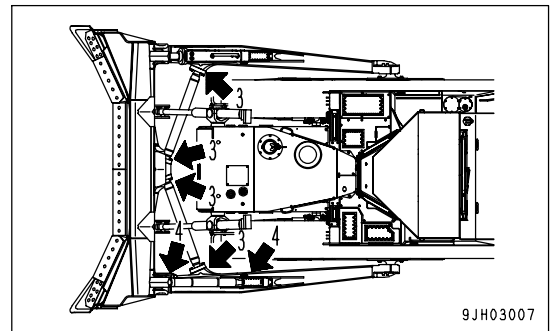

(5) Ripper tilt cylinder bottom pin (2 places)

(6) Ripper lift cylinder bottom pin (2 places)

(7) Ripper tilt cylinder rod end pin (2 places)

(8) Ripper lift cylinder rod end pin (2 places)

(9) Ripper arm pin (front) (2 places)

(10) Ripper arm pin (rear) (2 places)

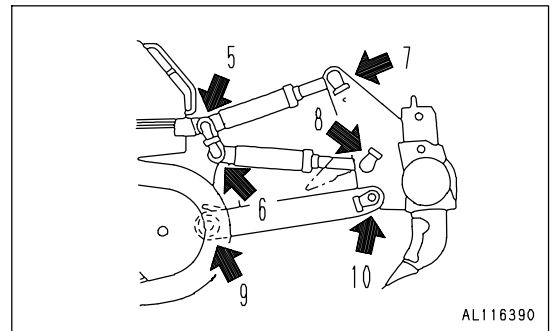

The illustration on the right shows Giant Ripper (if equipped).

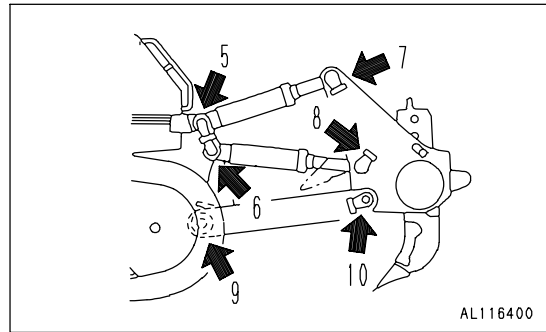

(11) Equalizer bar side shaft (2 places)

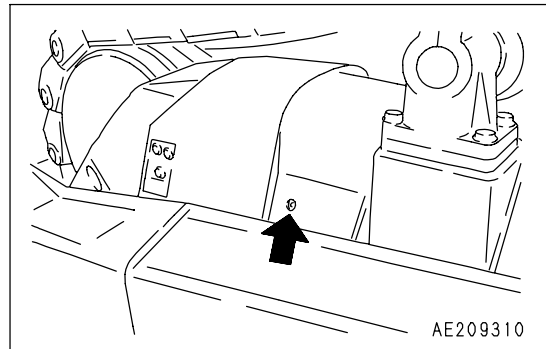

(12) Suspension (Equalizer bar center shaft) (1 place)

- 1) Carry out greasing of the suspension (equalizer bar center shaft) through the grease fittings marked by arrows.
- 2) Pump the greasing lever up and down 3 to 5 times.

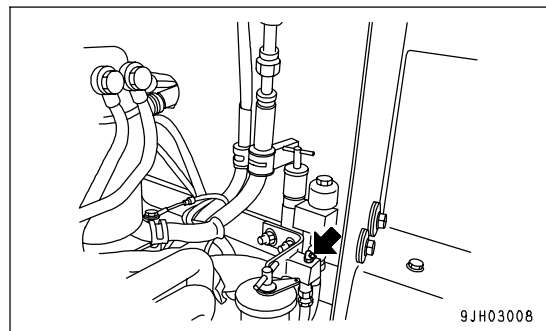

CHECK ALTERNATOR DRIVE BELT TENSION, ADJUST

CHECKING

Depress a belt at a mid point between drive pulley (1) and alternator pulley (2) with a thumb to apply 98 N (10 kg) - pressure, and when deflection amount (A) remains between 13 mm and 16 mm (0.51 in and 0.63 in), the deflection is within the standard value.

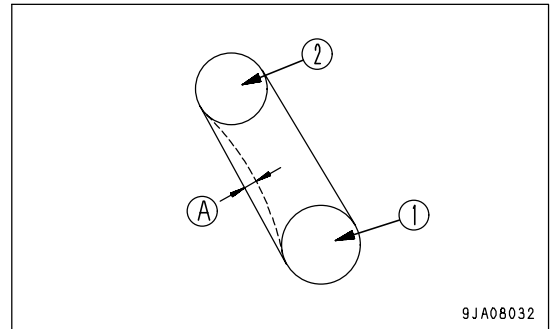

ADJUSTING

1. Remove cover mounting bolts (6) (2 places), and remove the cover.
2. Loosen bolts and nuts (1), (2), and (5), then turn nut (4) and adjust the belt tension.
3. After adjusting, tighten bolts and nuts (1), (2), and (5), to secure alternator (3) in position.
4. Reinstall the cover removed in step 1. Confirm that no part of the cover touches any moving part of the alternator.

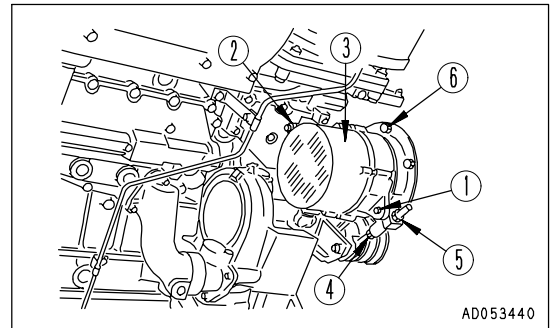

REMARK

- Check each pulley for breakage and wear of the V-groove. In particular, check that the V-belt does not touch the bottom of the V-groove.
- If any abnormality is found, ask your Komatsu distributor for replacement of the pulley.
- If the V-belt is so lengthened that it cannot be adjusted any more or if it has any cuts or cracks, replace it.
- When adjusting the V-belt, do not press the alternator directly with a bar, but put a wood piece, etc. in-between them.
- If the V-belt has been replaced with a new part, there will be initial elongation, so inspect and adjust it again after one-hour of operation.

CHECK LEVEL OF BATTERY ELECTROLYTE

Carry out this procedure before operating the machine.

**WARNING**

- Do not use the battery if the battery electrolyte level is below the LOWER LEVEL line. This will accelerate deterioration of the inside of the battery and reduce the service life of the battery. In addition, it may cause an explosion.
- The battery generates flammable gas and there is danger of explosion, do not bring fire or sparks near the battery.
- Battery electrolyte is dangerous. If it gets in your eyes or on your skin, wash it off with a large amount of water and consult a doctor.
- When adding distilled water to the battery, do not allow the battery electrolyte to go above the UPPER LEVEL line. If the electrolyte level is too high, it may leak and cause damage to the paint surface or corrode other parts.

NOTICE

If there is a fear that the battery water may freeze after refilling with purified water (e.g. commercially available replenishment water for a battery), do the replenishment before the day's work on the next day.

Inspect the battery electrolyte level at least once a month and follow the basic safety procedures given below.

Open cover (1), (2) at the rear left side of the machine. The batteries are installed at (A) part.

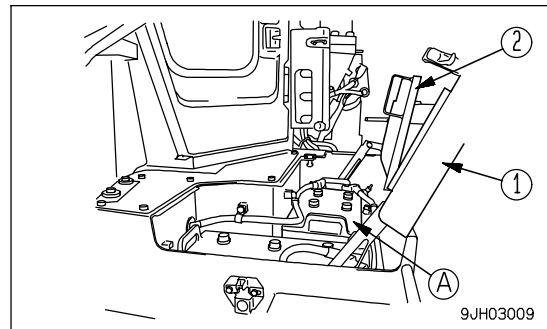

WHEN CHECKING ELECTROLYTE LEVEL FROM SIDE OF BATTERY

If it is possible to check the electrolyte level from the side of the battery, check as follows.

1. Use a wet cloth to clean the area around the electrolyte level lines and check that the electrolyte level is between the UPPER LEVEL (U.L.) and LOWER LEVEL (L.L.) lines.
If the battery is wiped with a dry cloth, static electricity may cause a fire or explosion.

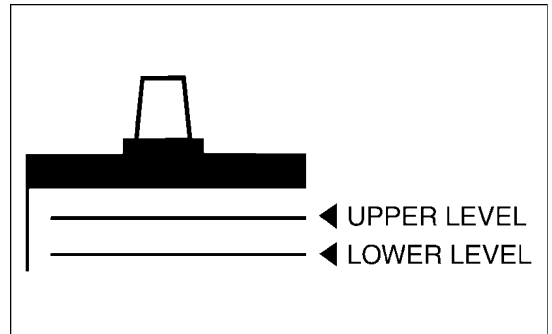

2. If the electrolyte level is below the midway point between the U.L and L.L lines, remove cap (3) and add distilled water to the U.L line.
3. After adding distilled water, tighten cap (3) securely.

REMARK

If distilled water is added to above the U.L. line, use a syringe to lower the level to the U.L. line. Neutralize the removed fluid with baking soda (sodium bicarbonate), then flush it away with a large amount of water or consult your Komatsu distributor or battery maker.

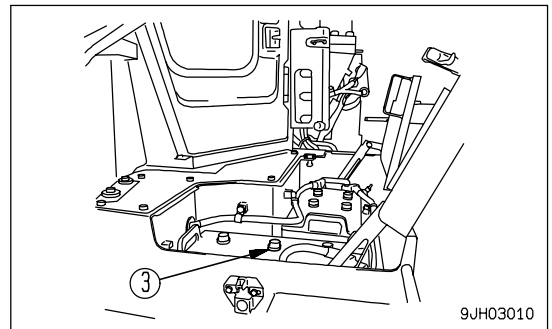

WHEN IT IS IMPOSSIBLE TO CHECK ELECTROLYTE LEVEL FROM SIDE OF BATTERY

If it is impossible to check the electrolyte level from the side of the battery, or there is no display of the UPPER LEVEL line on the side of the battery, check as follows.

1. Remove cap (3) at the top of the battery, look through the water filler port (4), and check the electrolyte surface. If the electrolyte does not reach the sleeve (5), add distilled water so that the level reaches the bottom of the sleeve (UPPER LEVEL line) without fail.
 - (A) Suitable level: Electrolyte level is up to bottom of sleeve, so surface tension causes electrolyte surface to bulge and poles appear bent.
 - (B) Low: Electrolyte level is not up to bottom of sleeve, so poles appear straight and not bent.
2. After adding distilled water, tighten cap (3) securely.

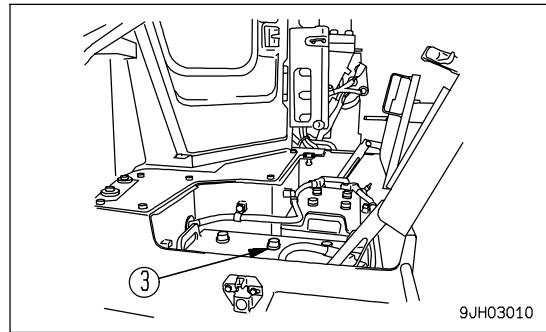

REMARK

If water is added to above the bottom tip of the sleeve, use a pipette to remove electrolyte. Neutralize the removed electrolyte with sodium bicarbonate, then flush it away with a large amount of water. If necessary, contact your Komatsu distributor or your battery maker.

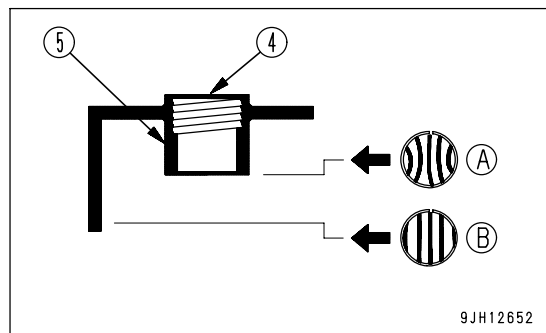

WHEN IT IS POSSIBLE TO USE INDICATOR TO CHECK ELECTROLYTE LEVEL

If it is possible to use an indicator to check the electrolyte level, follow the instructions given.

CHECK BRAKE PERFORMANCE



WARNING

If the machine moves during the following operation, please contact your Komatsu distributor for repairs immediately.

NOTICE

Do not place the joystick in the 1st speed position.
 Otherwise, it will cause damage to the machine.

Before starting the engine, check that the area around the machine is safe, then do as follows:

1. Start the engine.
2. After completing the warm-up operation, set fuel control dial (3) to the SLOW position.
3. Set work equipment lock lever (1) to the FREE position then operate blade control lever (6) and ripper control lever (7) to raise the blade and ripper.
 Leave the work equipment lock lever (1) in the FREE position.
4. Set parking lever (2) to the FREE position.
5. Depress brake pedal (5), set joystick (4) in FORWARD, then press the shift up button to enter 2nd speed.
6. Operate fuel control dial (3) and gradually raise the engine speed to full throttle. (Keep the brake pedal depressed.)
7. Check that the machine does not move. This indicates that brake performance is normal.

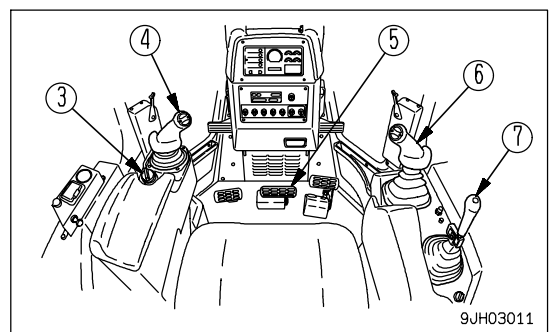
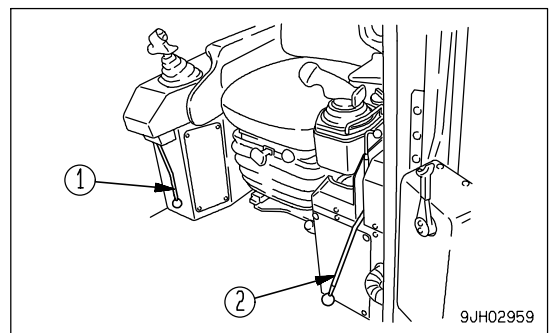

CHECK OIL LEVEL IN DAMPER CASE, ADD OIL

1. Open the engine side cover on the left side of the chassis.
2. Remove dipstick (G) and wipe the oil off with a cloth.
3. Fully insert dipstick (G) into filler pipe (F), then remove it.
4. The oil should be between the H and L marks on dipstick (G).
If the oil is below the L mark, add oil through the dipstick insertion port.

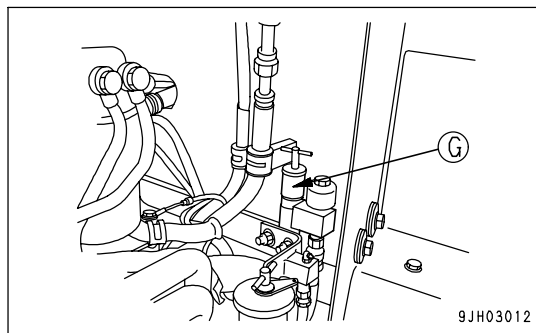

5. If the oil is above the H mark, open inspection cover (2) in the center of the bottom face of the power train case, drain the excess oil from engine damper drain plug (P) (this can be seen towards the front of the machine from the inspection window), then check the oil level again.

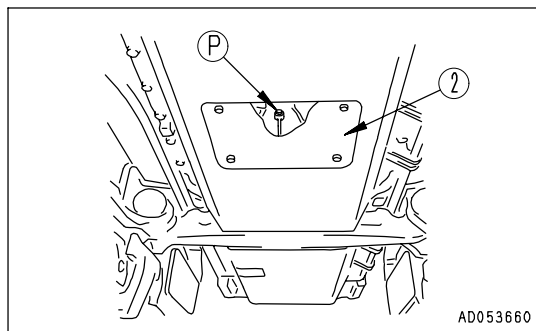
**REMARK**

- Check the oil level while the engine is stopped.
- If the machine is inclined, set it in a level position before checking the oil level.

EVERY 500 HOURS SERVICE

Maintenance for every 250 hours should be performed at the same time.

CHANGE OIL IN ENGINE OIL PAN, REPLACE ENGINE OIL FILTER CARTRIDGE

(including engine by-pass filter cartridge)



WARNING

The oil is at high temperature after the engine has been operated, so never change the oil immediately after finishing operations. Wait for the oil to cool down before changing it.

- Refill capacity: 50 liters (13.21 US gal)
- Prepare a socket wrench and filter wrench.

1. Remove the covers at the bottom left at the front of the machine and on the side face, and put a container directly underneath to catch the drained oil.

2. Remove drain plug (1) and loosen drain valve (2) slowly to avoid getting oil on yourself, and drain the oil.

Take care not to loosen drain valve (2) so much that the stopper pin in the valve is distorted.

Tightening torque for drain plug (1) : 68.6 ± 9.81 Nm (7 ± 1 kgm, 50.6 ± 7.2 lbft)

Tightening torque for drain valve (2): 63.7 ± 14.7 Nm (6.5 ± 1.5 kgm, 47.0 ± 10.8 lbft)

3. Check the drained oil, if there is excessive metal particles or foreign material, contact your Komatsu distributor.

4. Tighten drain valve (2), then tighten plug (1).

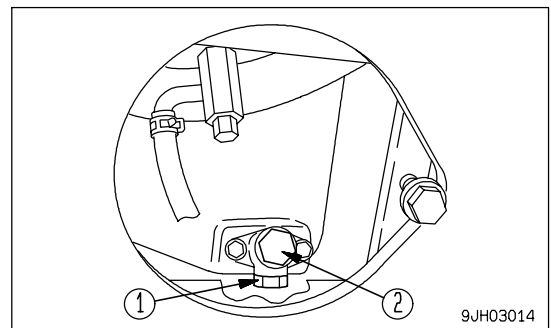
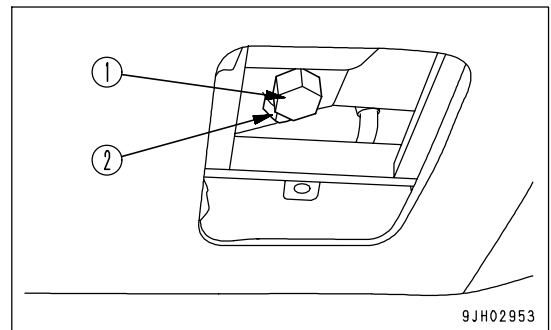

5. Using the filter wrench, turn engine oil filter cartridge (3) to the left and remove it.

6. Clean the filter holder, fill the new filter cartridge with engine oil, coat the packing surface and thread with engine oil (or coat it thinly with grease), then install the filter cartridge.

7. When installing the filter cartridge, bring the packing surface into contact with the filter holder, then tighten a further 3/4 to 1 turn.

8. After replacing the filter cartridge, add engine oil through oil filler port (F) until the oil level is between the H and L marks on the dipstick.

9. Run the engine at idling for a short time, then stop the engine, and check that the oil level is between the H and L marks on the dipstick. For details, see "CHECK OIL LEVEL IN ENGINE OIL PAN, ADD OIL (PAGE 3-77)".

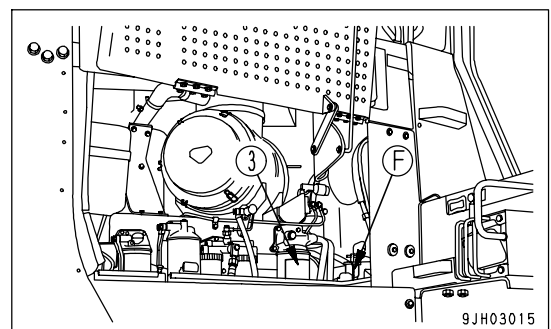

REPLACE FUEL FILTER CARTRIDGE (MACHINES EQUIPPED WITHOUT ADDITIONAL FUEL FILTER CARTRIDGE)

WARNING

- After the engine has been operated, all parts are at high temperature, so do not replace the filter immediately. Wait for all parts to cool down before starting the operation.
- High pressure is generated inside the engine fuel piping system when the engine is running. When replacing the filter, wait for at least 30 seconds after stopping the engine to let the internal pressure go down before replacing the filter.
- Do not bring any fire or flame close.
- Be careful when opening the air bleed plug in the fuel filter head. It is still under pressure, so fuel may spurt out.

NOTICE

- Genuine Komatsu fuel filter cartridges use a special filter that has highly efficient filtering ability. When replacing the filter cartridge, always use a genuine Komatsu part.
- The common rail fuel injection system used on this machine consists of more precise parts than the conventional injection pump and nozzle. If any part other than a genuine Komatsu filter cartridge is used, dust or dirt may get in and cause problems with the injection system. Always avoid using substitute parts.
- When carrying out inspection or maintenance of the fuel system, pay more attention than normal to the entry of dirt. If dirt is stuck to any part, use fuel to wash it off completely.

- Container to catch the oil
- Prepare a filter wrench

1. Set the container under the filter cartridge to catch the drained oil.
2. Close valve (1) of fuel strainer part.
3. Remove the drain plug at the bottom of the filter to drain fuel. After draining fuel, tighten the drain plug.

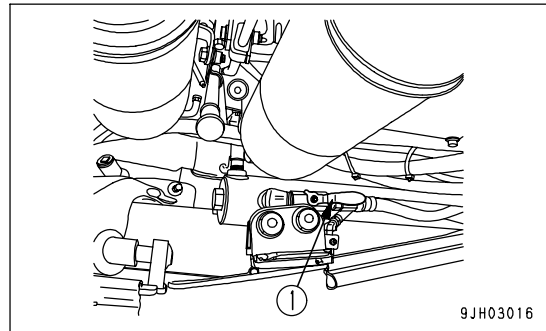

4. Using a filter wrench, turn filter cartridge (2) counterclockwise to remove it.

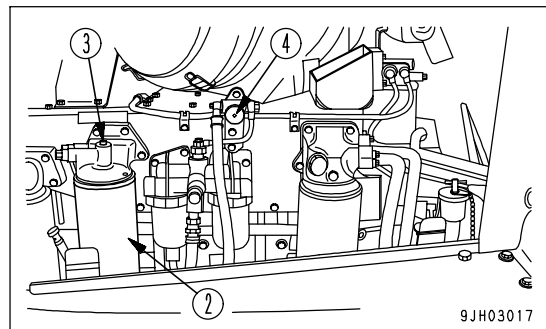

NOTICE

- Do not fill the fuel filter cartridge with fuel.
- Remove cap (B) and install the fuel filter.

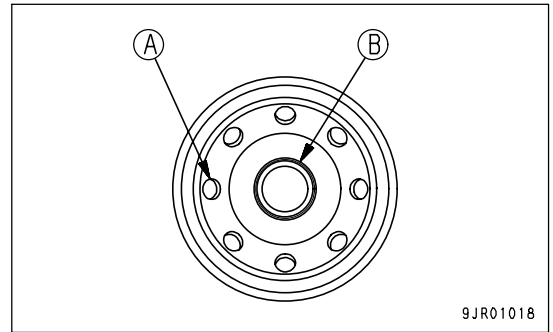

5. Clean the filter holder, coat the packing surface of the new filter cartridge thinly with oil, then install the filter cartridge to the filter holder.
6. When installing, tighten until the packing surface contacts the seal surface of the filter holder, then tighten it 3/4 of a turn. If the filter cartridge is tightened too far, the packing will be damaged and this will lead to leakage of fuel. If the filter cartridge is too loose, fuel will also leak from the packing, so always tighten the correct amount.
7. Open valve (1) of fuel strainer and loosen air bleeding plug (3).
8. Loosen the knob of priming pump (4), move it up and down, and continue until no more bubbles come out with the fuel from air bleed plug (3).
9. Tighten air bleed plug (3), push in the knob of priming pump (4), then tighten it.
10. After replacing the filter cartridge, start the engine and check for leakage from the filter seal surface.

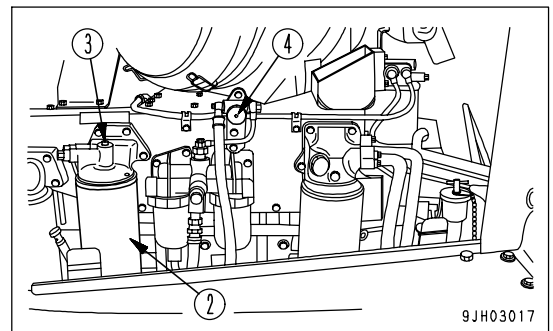
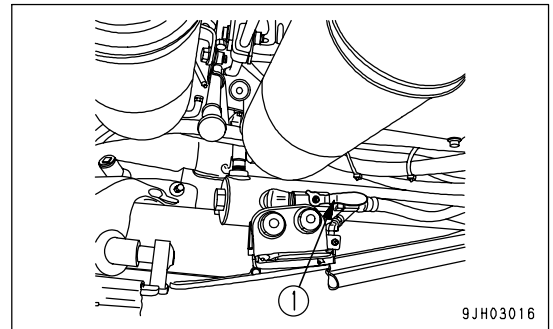

REMARK

When only the filter cartridge is replaced, it is sufficient that air bleeding is carried out for the filter head alone. But when the fuel piping is removed, air bleeding should also be carried out for the injection pump air-bleeding valve.

REPLACE POWER TRAIN OIL FILTER ELEMENT, STEERING LUBRICATING OIL FILTER ELEMENT

 **WARNING**

Before opening the filter cases, depress the brake pedal several times to release the pressure, then lock the brake pedal. If there is still pressure inside the filter, the oil may spurt out.

1. Remove the floor cover on right side fender.

- (1) Power train filter
- (2) Steering lubricating filter

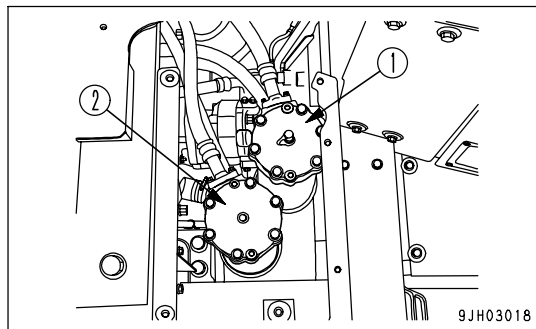

2. Remove bolts (3), pull up cover (4), then take out element (5).

3. Clean inside of the case and the removed parts, then install a new element.

Replace the O-ring with a new one.

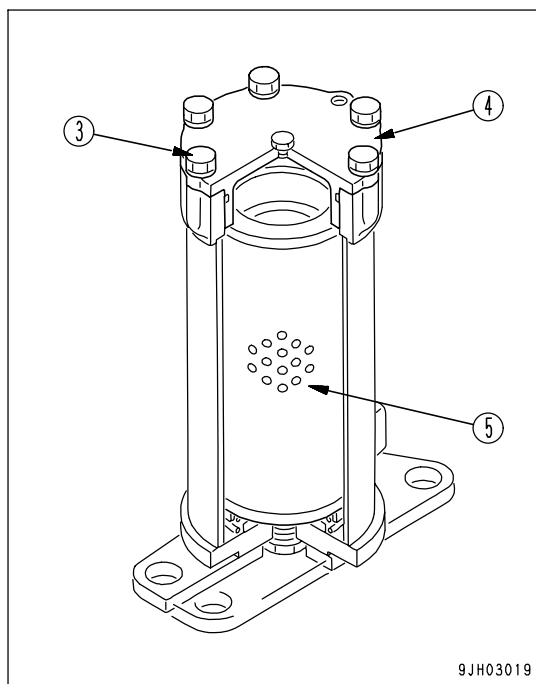

CHECK OIL LEVEL IN FINAL DRIVE CASE, ADD OIL

 **WARNING**

There is danger that oil may spurt out under internal pressure, so stand to the side, and gradually turn the plug to release internal pressure before removing the plug.

1. Place the machine on a horizontal place.
2. Remove oil level plug (G) and check whether the final drive case is filled with oil to lower edge of the plug hole.

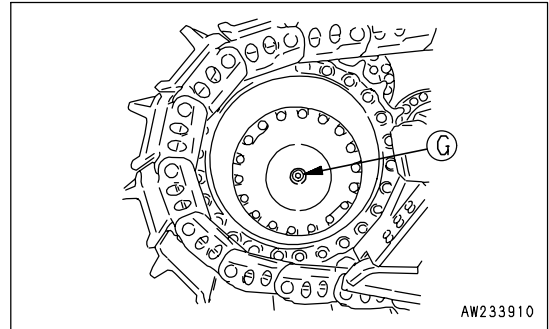

3. If the oil level is still too low, add oil through oil filter plug hole (F) until the oil overflows.
- Before removing oil plug (F), remove all the mud and dirt from around oil filler plug (F). Be careful not to let any dirt or sand get in when adding oil.

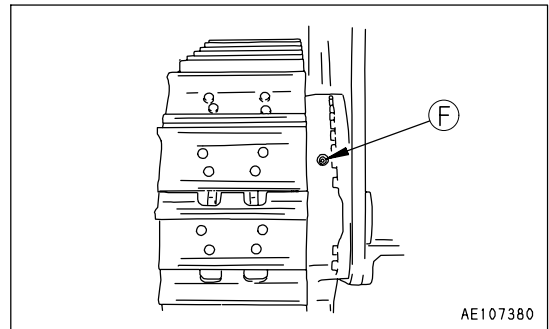

REPLACE HYDRAULIC TANK BREATHER ELEMENT

 **WARNING**

Replace the element when the oil is cold.
When removing breather cap (1), turn it slowly to release the internal pressure before removing it.

1. Remove breather cap (1) on the top of the hydraulic tank.
2. Replace element (2) inside the cap.

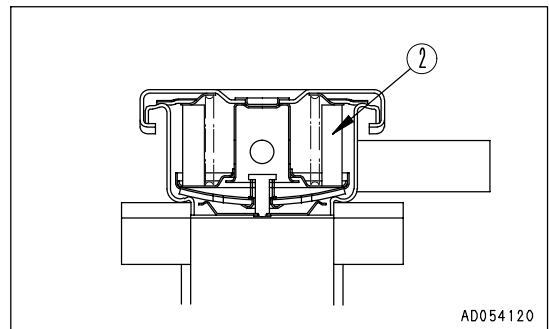
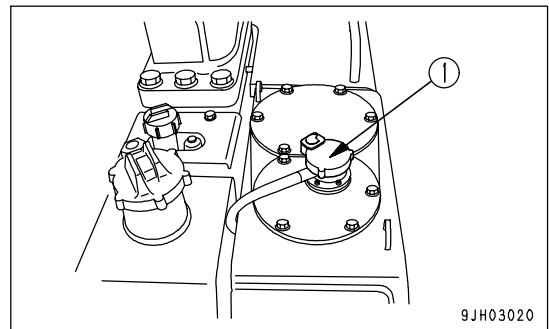

REPLACE ADDITIONAL FUEL FILTER CARTRIDGE (IF EQUIPPED WITH MACHINES)

**WARNING**

- After the engine has been operated, all parts are at high temperature, so do not replace the filter immediately. Wait for all parts to cool down before starting the operation.
- High pressure is generated inside the engine fuel piping system when the engine is running. When replacing the filter, wait for at least 30 seconds after stopping the engine to let the internal pressure go down before replacing the filter.
- Do not bring any fire or flame close.
- Be careful when opening the air bleed plug in the fuel filter head. It is still under pressure, so fuel may spurt out.

NOTICE

- Genuine Komatsu fuel filter cartridges use a special filter that has highly efficient filtering ability. When replacing the filter cartridge, always use a genuine Komatsu part.
- The common rail fuel injection system used on this machine consists of more precise parts than the conventional injection pump and nozzle. If any part other than a genuine Komatsu filter cartridge is used, dust or dirt may get in and cause problems with the injection system. Always avoid using substitute parts.
- When carrying out inspection or maintenance of the fuel system, pay more attention than normal to the entry of dirt. If dirt is stuck to any part, use fuel to wash it off completely.

- Container to catch the oil
- Prepare a filter wrench

1. Close the fuel valve.
2. Set the container to catch the fuel under the additional fuel filter cartridge.
3. Using a filter wrench, turn filter cartridge counterclockwise to remove it.
4. After removing the filter, remove transparent bowl (1) and inspect it. If there is any damage, replace it with a new part.
5. Clean transparent bowl (1) and remove seal (2). Coat new seal (2) with clean fuel or oil, then install it.
6. Install transparent bowl (1) to new filter cartridge (3).
Tightening torque: 10 Nm (1 kgm , 7.2 lbft)
7. Check that drain plug (4) at the bottom of the transparent bowl is tightened securely.
Tightening torque: 0.2 to 0.45 Nm (0.02 to 0.046 kgm , 0.1 to 0.3 lbft)

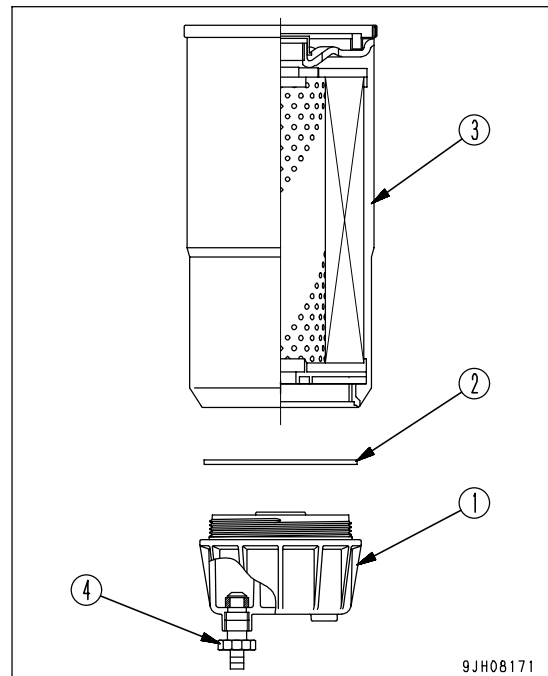

9JH08171

8. Clean the filter holder, fill the new filter cartridge with clean fuel, coat the packing surface thinly with oil, then install to the filter holder.

NOTICE

- When adding fuel, do not remove cap (B). Always add fuel from the 8 small holes (A) on the dirty side.
- After adding fuel, remove cap (B) and install the fuel filter.
- Always fill with clean fuel. Be careful not to let any dirt or dust get into the fuel. In particular, center portion is the clean side, so do not remove cap (B) when adding fuel. Be careful not to let dirt or dust get into center portion on the clean side.

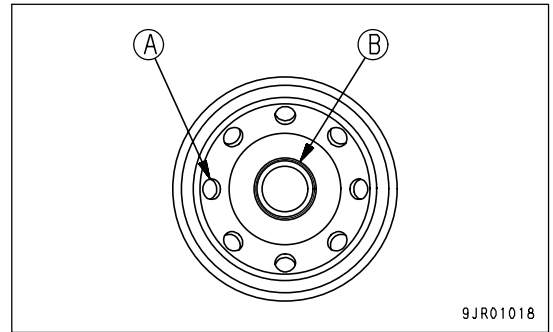

9. When installing, tighten until the packing surface contacts the seal surface of the filter holder, then tighten it 3/4 of a turn.
 If the filter cartridge is tightened too far, the packing will be damaged and this will lead to leakage of fuel. If the filter cartridge is too loose, fuel will also leak from the packing, so always tighten the correct amount.
 - When tightening with a filter wrench, be extremely careful not to dent or damage the filter.
10. When carrying out standard replacement of the fuel filter cartridge (every 1000 hours), replace the cartridge and bleed the air. For details, see "REPLACE FUEL FILTER CARTRIDGE (MACHINES EQUIPPED WITH ADDITIONAL FUEL FILTER CARTRIDGE) (PAGE 4-62)".
11. Open the fuel valve, start the engine, check that there is no leakage of fuel from the filter seal surface or water separator mounting surface, then run for approx. 10 minutes at low idling.

EVERY 1000 HOURS SERVICE

Maintenance for every 250 and 500 hours service should be carried out at the same time.

REPLACE FUEL FILTER CARTRIDGE (MACHINES EQUIPPED WITH ADDITIONAL FUEL FILTER CARTRIDGE)**WARNING**

- After the engine has been operated, all parts are at high temperature, so do not replace the filter immediately. Wait for all parts to cool down before starting the operation.
- High pressure is generated inside the engine fuel piping system when the engine is running. When replacing the filter, wait for at least 30 seconds after stopping the engine to let the internal pressure go down before replacing the filter.
- Do not bring any fire or flame close.
- Be careful when opening the air bleed plug in the fuel filter head. It is still under pressure, so fuel may spurt out.

NOTICE

- Genuine Komatsu fuel filter cartridges use a special filter that has highly efficient filtering ability. When replacing the filter cartridge, always use a genuine Komatsu part.
- The common rail fuel injection system used on this machine consists of more precise parts than the conventional injection pump and nozzle. If any part other than a genuine Komatsu filter cartridge is used, dust or dirt may get in and cause problems with the injection system. Always avoid using substitute parts.
- When carrying out inspection or maintenance of the fuel system, pay more attention than normal to the entry of dirt. If dirt is stuck to any part, use fuel to wash it off completely.

- Container to catch the oil
- Prepare a filter wrench

1. Set the container under the filter cartridge to catch the drained oil.
2. Close valve (1) of fuel strainer part.
3. Remove the drain plug at the bottom of the filter to drain fuel.
After draining fuel, tighten the drain plug.

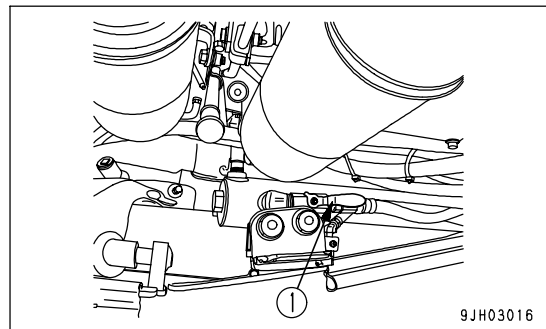

4. Using a filter wrench, turn filter cartridge (2) counterclockwise to remove it.

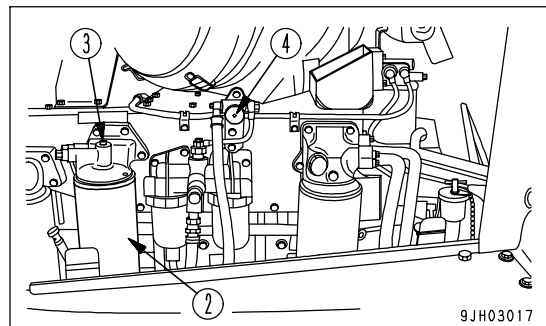

NOTICE

- Do not fill the fuel filter cartridge with fuel.
- Remove cap (B) and install the fuel filter.

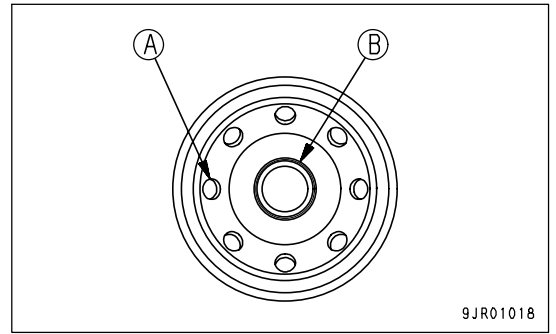

5. Clean the filter holder, coat the packing surface of the new filter cartridge thinly with oil, then install the filter cartridge to the filter holder.
6. When installing, tighten until the packing surface contacts the seal surface of the filter holder, then tighten it 3/4 of a turn. If the filter cartridge is tightened too far, the packing will be damaged and this will lead to leakage of fuel. If the filter cartridge is too loose, fuel will also leak from the packing, so always tighten the correct amount.
7. Open valve (1) of fuel strainer and loosen air bleeding plug (3).
8. Loosen the knob of priming pump (4), move it up and down, and continue until no more bubbles come out with the fuel from air bleed plug (3).
9. Tighten air bleed plug (3), push in the knob of priming pump (4), then tighten it.
10. After replacing the filter cartridge, start the engine and check for leakage from the filter seal surface.

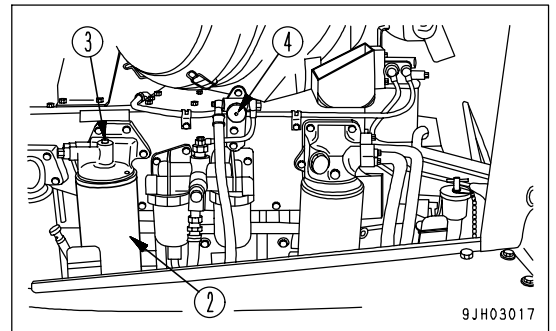
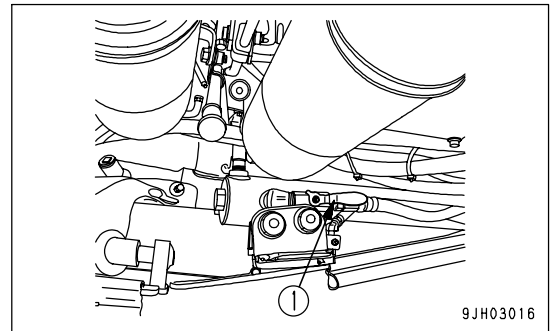

REMARK

When only the filter cartridge is replaced, it is sufficient that air bleeding is carried out for the filter head alone. But when the fuel piping is removed, air bleeding should also be carried out for the injection pump air-bleeding valve.

CHANGE OIL IN POWER TRAIN CASE, WASH STRAINERS (POWER TRAIN PUMP STRAINER, SCAVENGING PUMP STRAINER) **WARNING**

- The oil is at high temperature immediately after operations, so wait for the temperature to go down before starting the operation.
 - The undercover is heavy. Do not go directly under the cover when opening or closing it. When removing bolts (5), carry out the operation at the rear of the point immediately under the cover so that it is possible to escape at any time.
- Prepare the following.

- Refill capacity: 90 liters (23.78 US gal)

1. Remove drain cover (1) at the bottom left of the power train case, pull out drain hose (2) from the pick-up port, then loosen drain plug (P1) and drain the oil.
After draining the oil, tighten drain plug (P1).
Do not remove drain plug (P1).

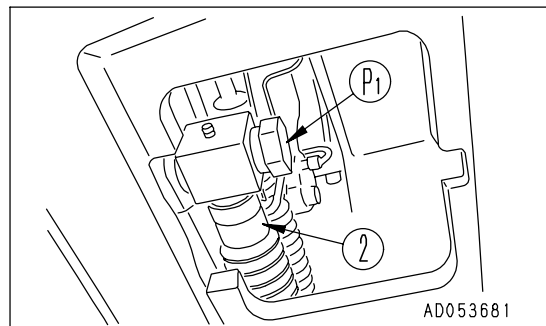
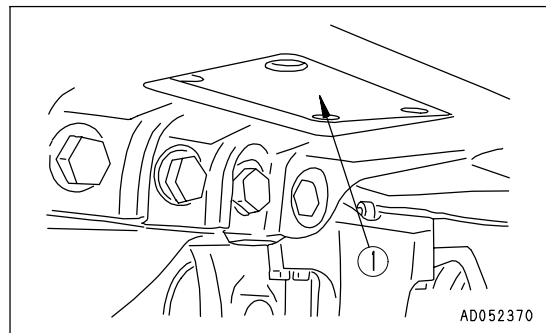

2. Remove inspection cover (3) in the undercover at the bottom rear of the machine as follows.

- 1) Remove 2 bolts (4) at the front (front of machine).
- 2) Hold cover (3) in position and gradually remove 2 bolts (5) at the rear (rear of machine). (Rain water may flow out when doing this.)
- 3) Lower cover (3) gradually to open it. (The front of the cover is attached by a hinge.)
If you look up, you can see the strainer at portion (P).

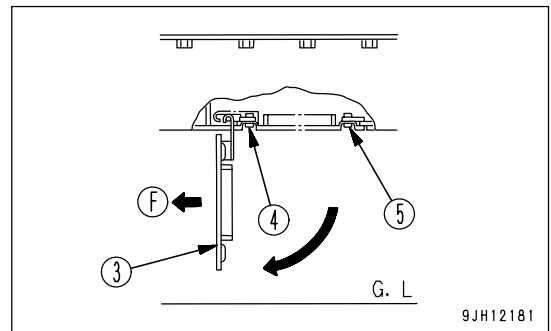
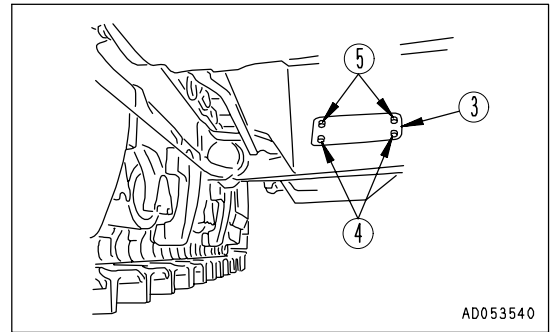

(F)Front of the machine

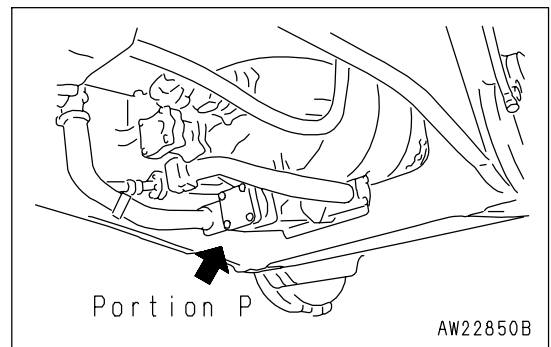

3. Remove drain plug (P2) in the strainer cover, and drain the oil (approx. 4 liters (1.06 US gal)) collected inside the piping.

4. Loosen mounting bolt (6) of the power train strainer, then remove cover (7).
5. Remove spring (8), then remove strainer (9).
6. Remove any dirt stuck to strainer (9), then wash it in clean diesel oil or flushing oil. Wash the removed parts and the inside of the case at the same time.
7. Loosen mounting bolt (10) of the scavenging pump strainer, then remove cover (11).
8. Remove strainer (12).
9. Remove any dirt stuck to strainer (12), then wash it in clean diesel oil or flushing oil. Wash the removed parts and the inside of the case at the same time.
10. Install the strainers in their original position.
11. Replace the power train filter element.

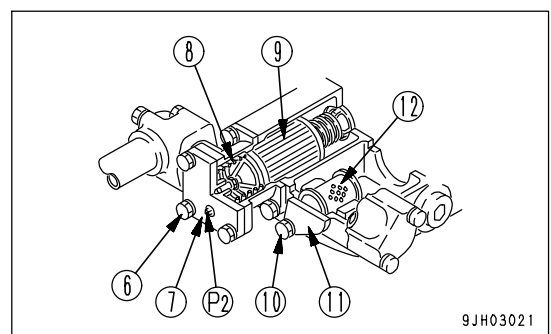

For details, see "REPLACE POWER TRAIN OIL FILTER ELEMENT, STEERING LUBRICATING OIL FILTER ELEMENT (PAGE 4-58)".

12. Refill the specified quantity of oil through oil filler (F).
13. After adding the oil, check that the oil is at the specified level.
For details, see "CHECK OIL LEVEL IN POWER TRAIN CASE, ADD OIL (PAGE 3-78)".
If the spring or strainer are damaged, replace them with new parts.

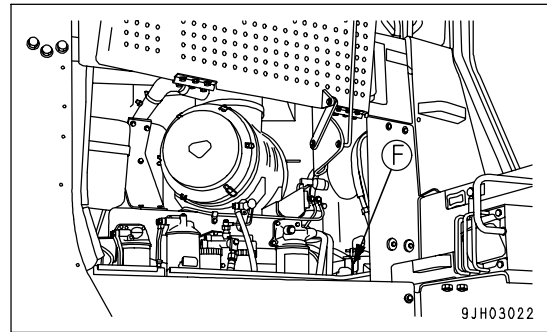

CHECK, CLEAN FUEL STRAINER

1. Tighten valve (1).
2. Remove cap (2), and wash the strainer and strainer case.
The strainer forms one unit with the cap.
3. After checking and cleaning, set the strainer in the case, then tighten cap (2).
4. After installing, open valve (1).

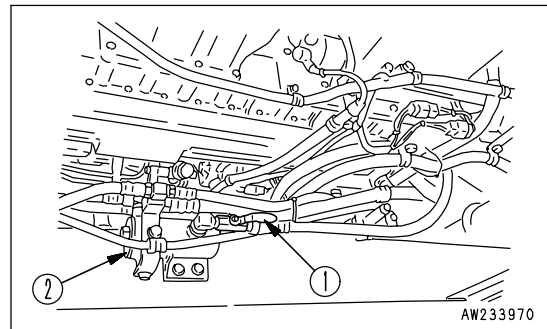

CHECK FOR LOOSE ROPS MOUNT BOLTS

Check for loose and damaged bolts. If any loose bolt is found, tighten to a torque of 1180 to 1470 Nm (120 to 150 kgm, 868 to 1,085 lbft).

If any damaged bolt is found, replace the bolt with a genuine Komatsu bolt.

REPLACE MAIN CORROSION RESISTOR CARTRIDGE AND SUB CORROSION RESISTOR CARTRIDGE

! WARNING

If the engine has been operated, all parts will be at a high temperature, so never try to replace the cartridge immediately after stopping the engine.

Always wait for the engine and other parts to cool down.

- Container to catch drained coolant
- Prepare a filter wrench for fuel filter element.

1. Turn valve (3) of main corrosion resistor (1) and sub corrosion resistor (2) to the Close stopper position.
2. Set a container to catch the coolant under the cartridge.
3. Using a filter wrench, turn cartridge (4) to the left to remove it.
4. Clean the filter holder, coat the packing surface and thread of the new cartridge with oil, then install it to the filter holder.
5. When installing, tighten until the packing surface contacts the seal surface of the filter holder, then tighten it up 2/3 of a turn. If the filter cartridge is tightened too far, the packing will be damaged and this will lead to leakage of coolant. If the filter cartridge is too loose, coolant will also leak from the packing, so always tighten to the correct amount.
6. Turn valve (3) of cartridge to the OPEN stopper position.
7. After replacing the cartridge, start the engine and check for any coolant leakage from the filter seal surface. If there is any leakage, check if the cartridge is tightened properly.

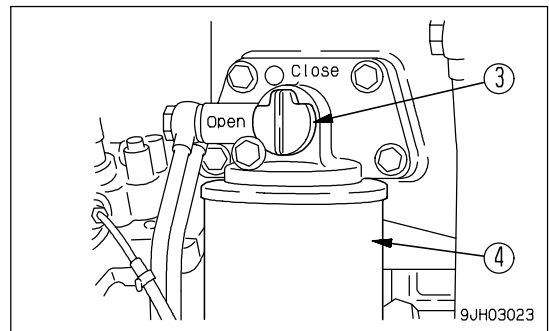
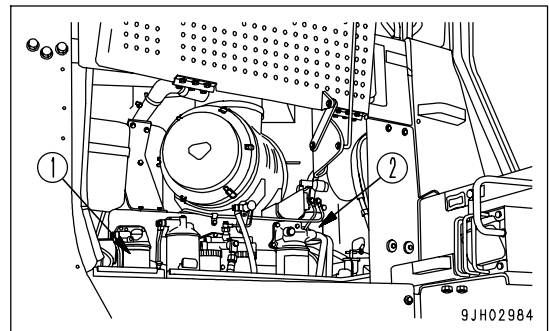

CHECK TIGHTENING PARTS OF TURBOCHARGER

Contact your Komatsu distributor to have the tightening portions checked.

REPLACE CHARGE FILTER ELEMENT

1. Remove inspection cover (1).

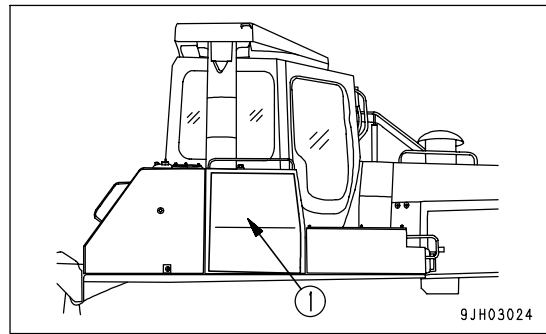

2. Loosen mounting bolt (2) and remove filter cover (3).

3. Remove drain plug (P) (which can be seen from under the fender) and drain the oil.

4. Remove spring (4), then take out element (5) .

5. Clean the removed parts and the inside of filter case (6), then install a new element.

Use a genuine Komatsu element.

6. Install inspection cover (3) with bolt (2).

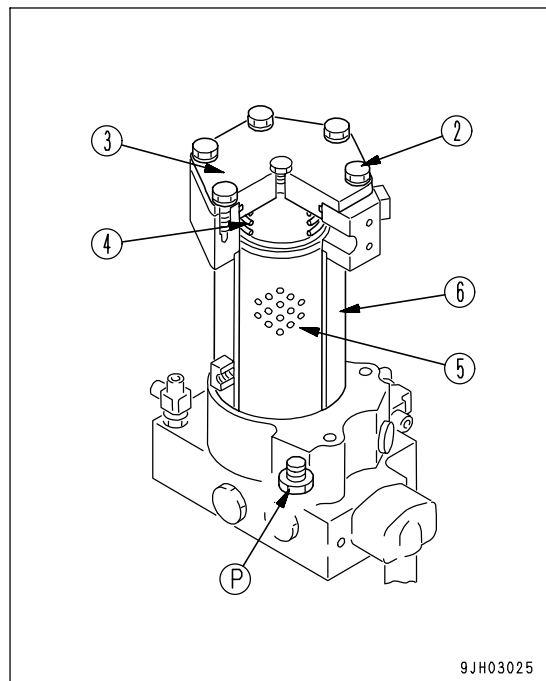

EVERY 2000 HOURS SERVICE

Maintenance for every 250, 500 and 1000 hours service should be carried out at the same time.

CHANGE OIL IN HYDRAULIC TANK, REPLACE HYDRAULIC OIL FILTER ELEMENT, CLEAN HYDRAULIC TANK STRAINER

WARNING

- The oil is at high temperature immediately after the machine has been operated. Wait for the oil to cool down before changing the oil.
- When removing the oil filler cap (F), turn it slowly to release the internal pressure, then remove it carefully.

• Refill capacity: 130 liters (34.35 US gal)

1. Lower the blade and ripper on the ground securely, stop the engine and slowly turn the cap of oil filler (F) to release the internal pressure. Then, remove the cap.

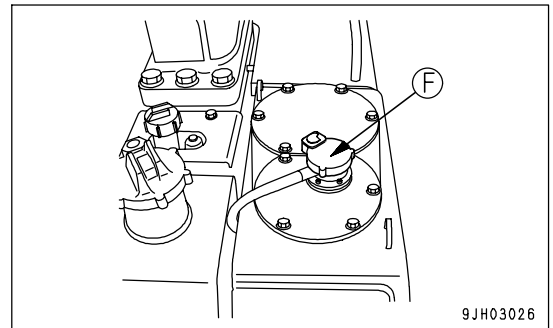

2. Remove drain plug (1) at the bottom of the tank and loosen drain valve (2). After draining the oil, tighten drain plug (1) and drain valve (2). When loosening drain valve (1), be careful not to get oil on yourself.

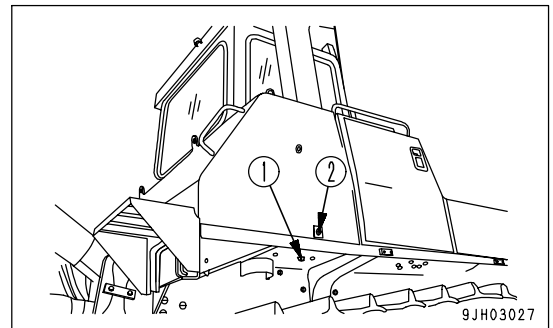

3. Remove bolts (3), then remove cover (4) and take out the element.
4. Clean the inside of case and removed parts and install a new element.

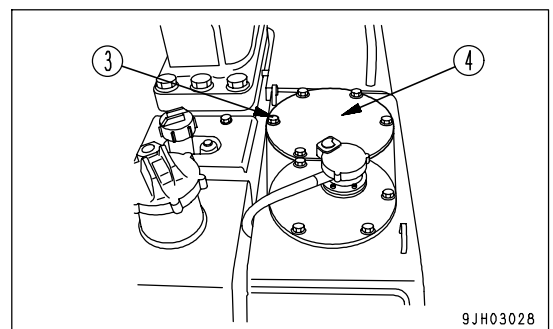

5. Remove bolts (5), then remove cover (6) and take out the strainer.
6. Wash the strainer in clean diesel oil or flushing oil.
7. Install the strainer to its original position.
8. Add oil through oil filler port (F) to the specified level.
9. After adding oil, check that the oil is at the specified level. For details, see "CHECK OIL LEVEL IN HYDRAULIC TANK, ADD OIL (PAGE 3-80)".

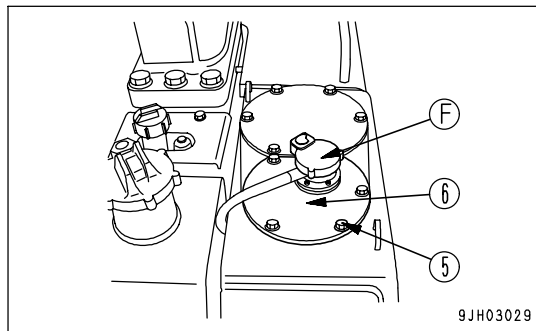

CHANGE OIL IN FINAL DRIVE CASE

! WARNING

- The oil is at high temperature immediately after the machine has been operated. Wait for the oil to cool down before starting the operation.
- There is danger that oil spouts out due to the internal pressure. When removing the plug, work from the side, turn the plug slowly to release the internal pressure, and remove it carefully.

- Refill capacity: 40 liters (10.57 US gal)

1. Remove oil filler plug (F), then remove drain plug (1) and level plug (G), and drain the oil.
Remove all the mud and dirt from around oil filler plug (F) before removing it. Be careful not to let any dirt or sand get in when adding oil.
2. After draining the oil, tighten the drain plug (1).
3. Remove level plug (G), refill oil from oil filler plug hole (F) until the oil overflows the level plug hole.
After refilling, tighten the plugs.

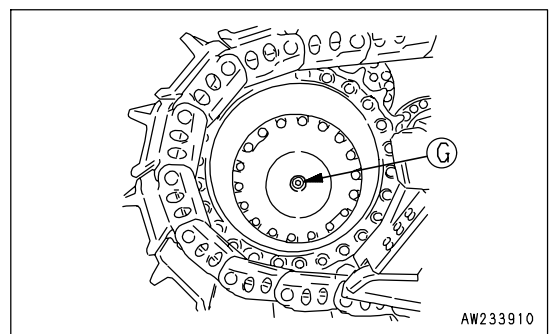
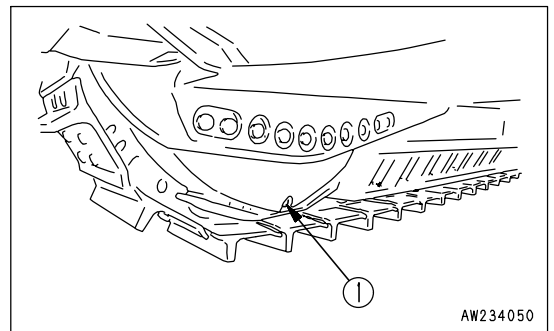
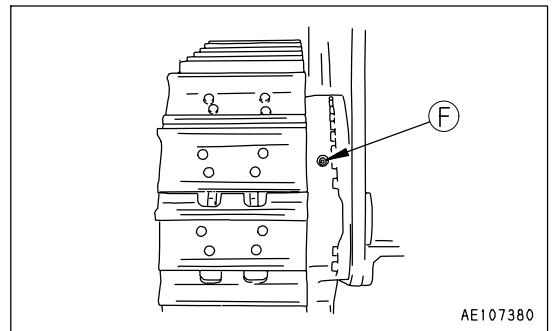

CHANGE OIL IN DAMPER CASE, CLEAN DAMPER BREATHER

! WARNING

- The oil is at high temperature immediately after the machine has been operated. Wait for the oil to cool down before carrying out maintenance.
- The undercover is heavy. Do not go directly under the cover when opening or closing it. When removing bolts (4), carry out the operation at the rear of the point immediately under the cover so that it is possible to escape at any time.

- Refill capacity: 1.5 liters (0.40 US gal)

1. Open the engine side cover on the left of the machine; you can see dipstick (G).

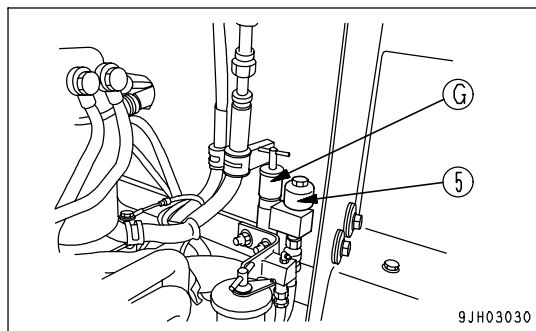

2. Remove the undercover (2) at the bottom rear of the chassis as follows.

1) Remove 2 bolts (3) toward the front of the chassis.

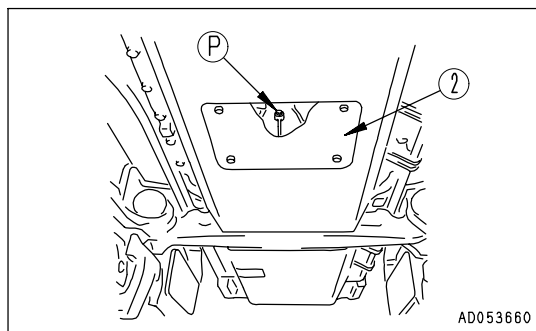

2) Hold cover (2) and gradually remove 2 bolts (4) at the rear of the chassis. (Be careful when doing this. Rain water may run out.)

3) Lower cover (2) slowly and open it. Drain plug (P) can be seen at the top.

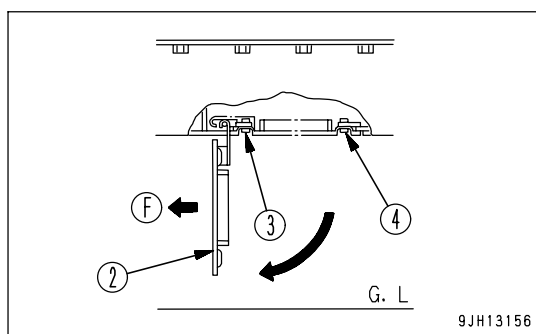

(F)Front of the machine

3. Remove dipstick (G), then remove drain plug (P) and drain the oil.
After draining the oil,tighten drain plug (P).
4. Add oil through the holder of dipstick (G). After adding the oil, insert dipstick (G).
5. Remove any dirt or dust stuck to breather (5), then wash with clean diesel oil or flushing oil. If it cannot be cleaned completely, replace with a new part.
6. Install undercover (2), then close engine side cover (1) on the left side of the machine.

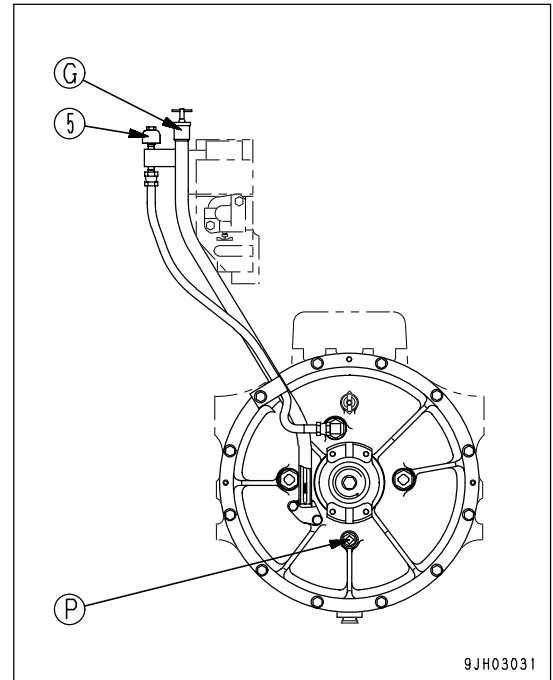

CHECK PIVOT BEARING OIL LEVEL, ADD OIL

1. Remove plug (1).
When removing plug (1), be careful not to let dirt or dust get it.

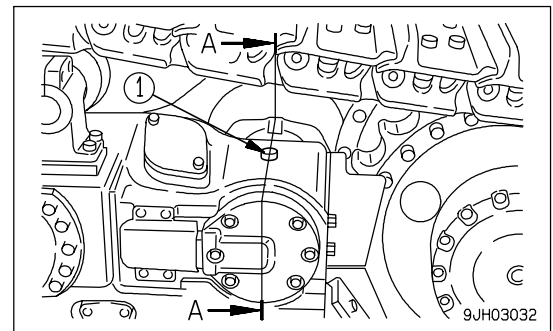

2. Check that the oil is at the level shown in the diagram. If the oil level is low, add engine oil through the hole of plug (1). Use class CD SAE 30 oil regardless of the ambient temperature.
(B): 25mm (1inch)

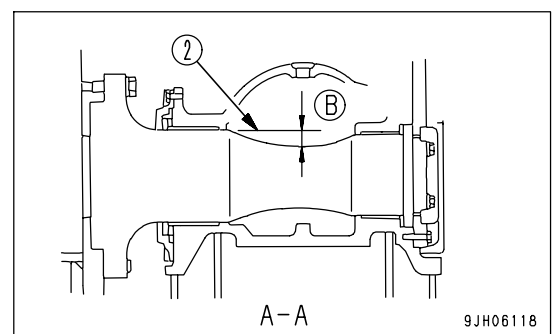

CHECK OIL LEVEL IN RECOIL SPRING, ASSIST CYLINDER CASE, ADD OIL

1. Remove bolts (1), then remove cover (2).

When removing the cover, be careful not to let dirt or sand get in.

2. Loosen the plug and confirm that the internal pressure is released.

Insert a scale and check that the oil level is 90 to 110 mm (3.6 to 4.4 in) from the bottom edge of the inspection port.

If the oil is insufficient, add oil.

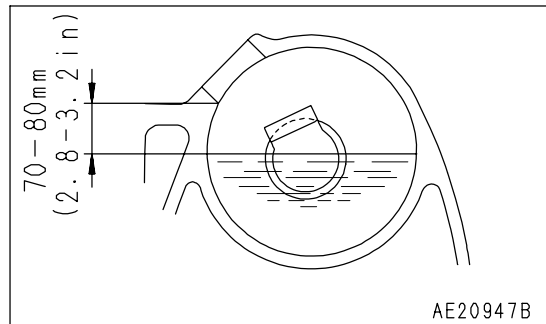
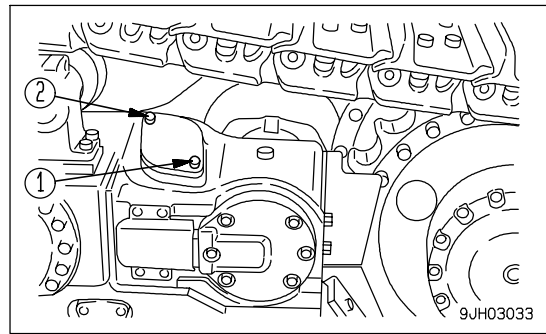

CLEAN ENGINE BREATHER ELEMENT

1. Loosen clamp (1), then remove the hose.
2. Remove bolt (2), then remove breather (3).
3. Rinse the whole breather in diesel oil or flushing oil. Dry with compressed air, then install it.
4. Check the breather hose, and if any deteriorated oil is stuck to the inside, replace the hose with a new hose.

REMARK

The engine breather element is at the front end on top of the engine (behind the radiator).

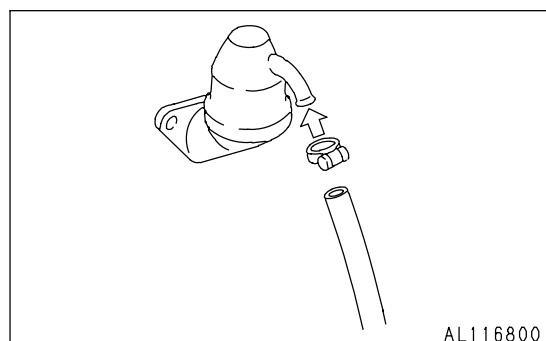
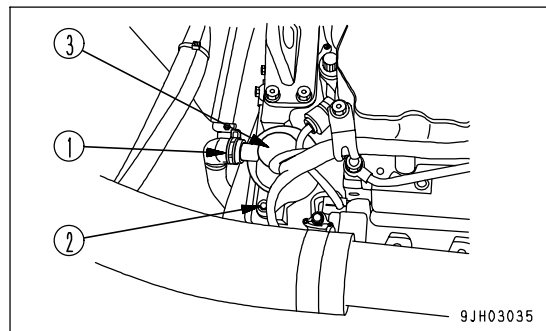

CHECK ALTERNATOR, STARTING MOTOR

The brushes may be worn or the bearing may have run out of grease, contact your Komatsu distributor for inspection and repairs.

If the engine is started frequently, have this inspection carried out every 1000 hours.

CHECK INJECTOR

Check the color of the exhaust gas visually. If there is any abnormality in the exhaust gas color, contact your Komatsu distributor for inspection.

For details, see "TROUBLESHOOTING (PAGE 3-144)" "Exhaust color is black".

EVERY 4000 HOURS SERVICE

Maintenance for every 250, 500, 1000 and 2000 hours service should be carried out at the same time.

CHECK WATER PUMP

Check for oil and coolant leakage, or clogging of the drain hole. If any abnormality is found, contact your Komatsu distributor for disassembly, repair, or replacement.

CHECK VIBRATION DAMPER

Check decrease of damper fluid, dent or out-of-flat. If there is any abnormality, contact Komatsu distributor for repair.

CLEAN, CHECK TURBOCHARGER

Contact your Komatsu distributor for cleaning or inspection.

CHECK PLAY OF TURBOCHARGER ROTOR

Contact your Komatsu distributor to have the rotor play checked.

CHECK ENGINE VALVE CLEARANCE, ADJUST

Special tools are needed for inspection and maintenance, so contact your Komatsu distributor.

CHECKING FOR LOOSENESS OF HIGH-PRESSURE CLAMP, HARDENING OF RUBBER

Check for any looseness in the high-pressure clamp mounting bolts (1) to (15) in the drawing in the illustrations below. Check visually and feel with your finger to check that the rubber has not hardened. If there is any problem, the problem part must be replaced. Contact your Komatsu distributor for part replacement.

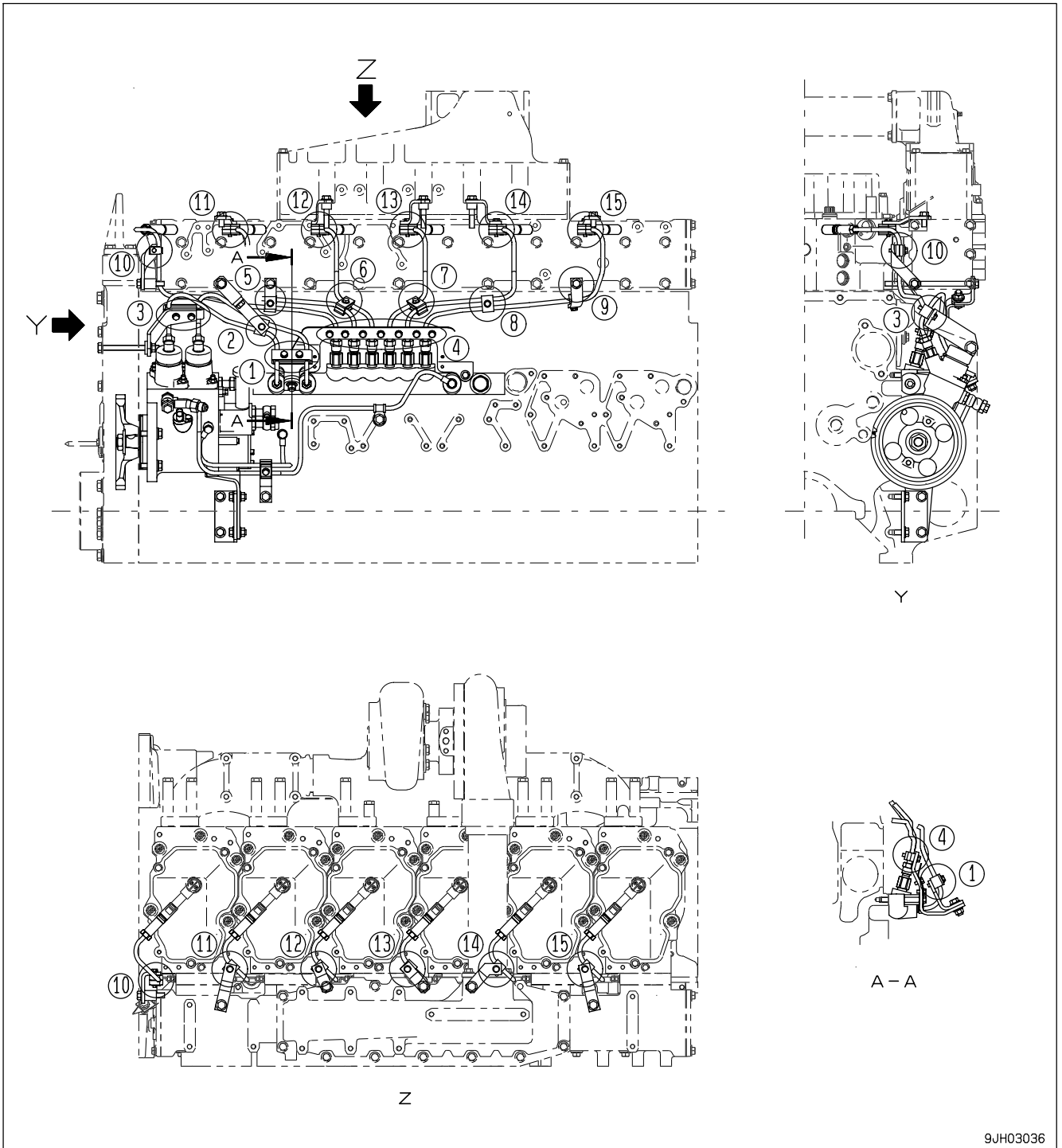

9JH03036

NOTICE

If the engine continues to be used when there are loose bolts, hardened rubber, or missing parts, there is danger of damage or breakage occurring due to vibration and wear at the connections of high-pressure piping. Always check that the proper high-pressure piping clamps are correctly installed.

CHECKING FOR MISSING FUEL SPRAY PREVENTION CAP, HARDENING OF RUBBER

Fuel spray prevention caps (1) - (16) and fuel spray prevention cover (17) are protective parts installed to prevent fire caused by fuel leaking and spraying out on to high temperature parts of the engine. Check visually that there are no missing caps or loose bolts, and feel with your finger to check that the rubber has not hardened. If there is any problem, the problem part must be replaced. Contact your Komatsu distributor for part replacement.

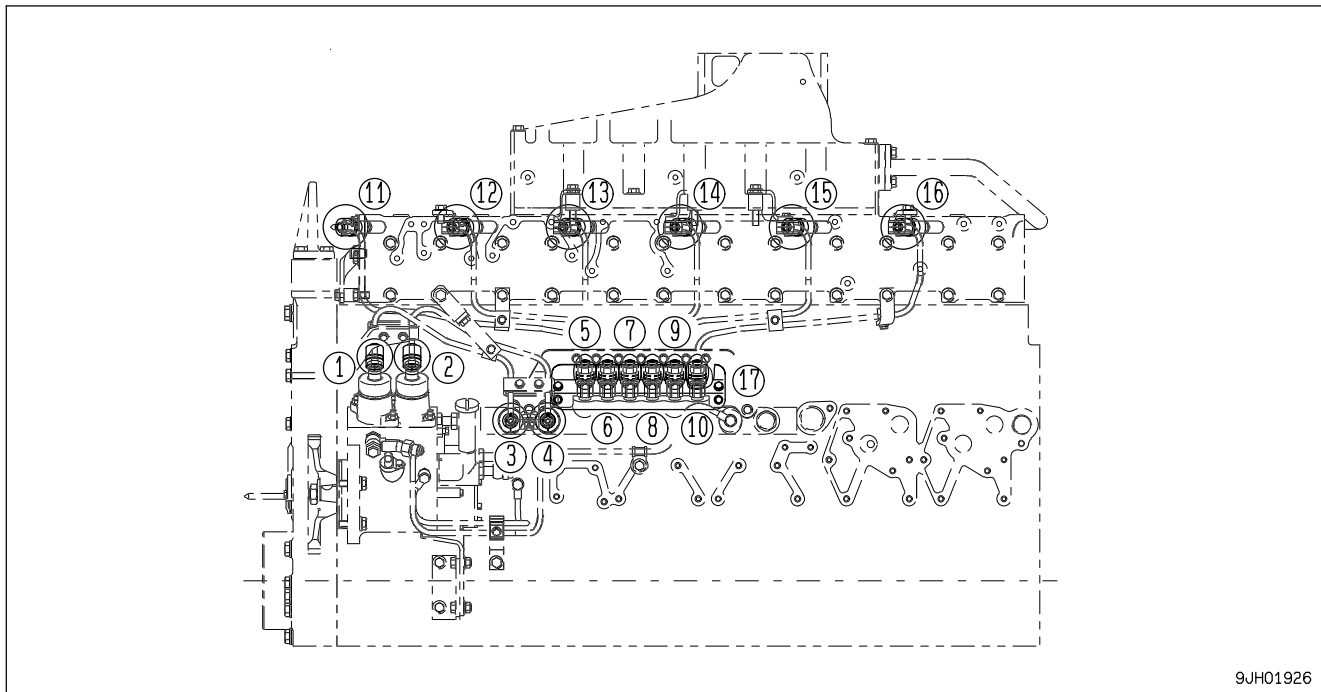

9JH01926

REPLACE INJECTOR ASSEMBLY

Please contact your Komatsu distributor to have the injector assembly replaced.

CHECK MAIN FRAME, WORK EQUIPMENT (BLADE, RIPPER)

Check after the first 4000 hours, and every 1000 hours after that.

- Preparation

Wipe off all the mud that is stuck around portions (A) - (L) of the work equipment and frame to make it easier to carry out the check.

- Visual check

Carefully check the base material of the steel casting and welding at portions (A) - (L), and check that there is no damage.

If any cracks or other damage is found, repair them.

Contact your Komatsu distributor for details of the repair procedure.

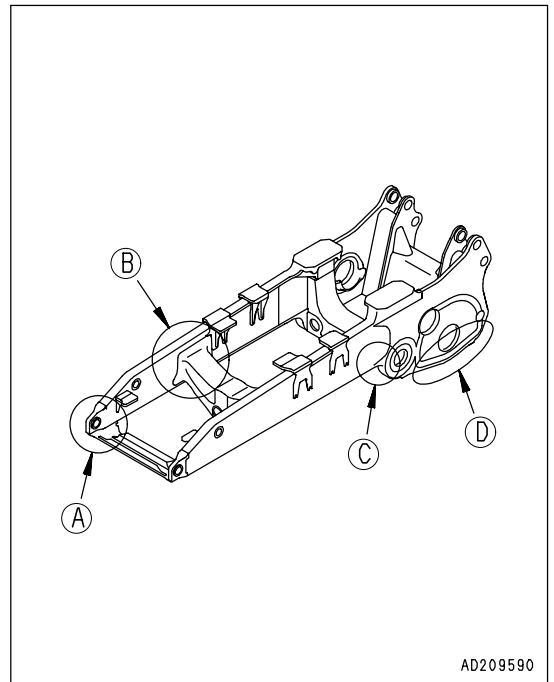

AD209590

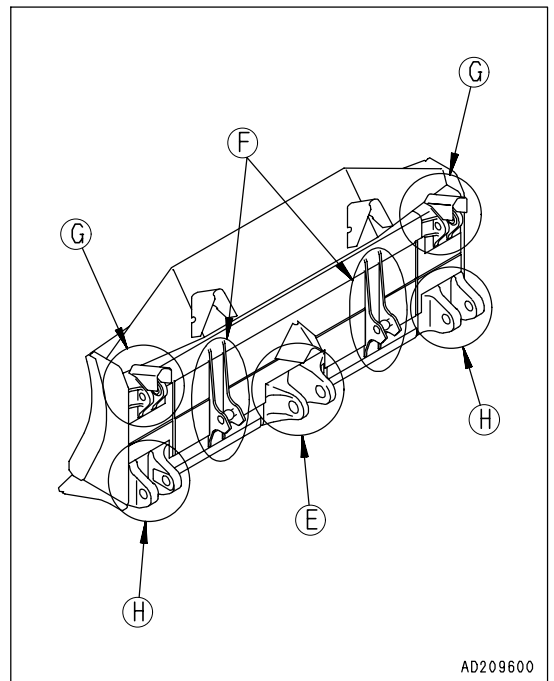

AD209600

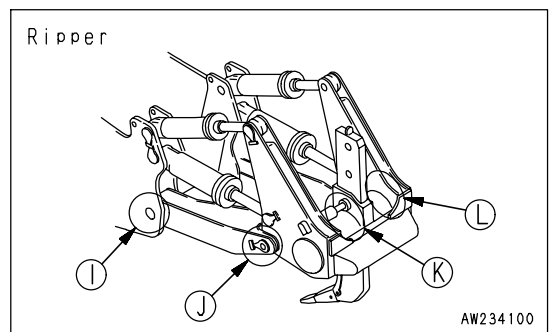

AW234100

EVERY 8000 HOURS SERVICE

Maintenance for every 10, 100, 250, 500, 1000, 2000, and 4000 hours of service should be performed at the same time.

REPLACE HIGH-PRESSURE PIPING CLAMPS

Contact your Komatsu distributor to have the engine high-pressure clamps replaced.

REPLACE FUEL SPLAY PREVENTION CAPS

Contact your Komatsu distributor to have the fuel spray prevention cap replaced.

SPECIFICATIONS

SPECIFICATIONS

	Item	Unit	D275AX-5	
			Semi-U tilt dozer	U tilt dozer
	Operating weight (without operator)	kg (lb)	57,650 (127,118) *1	58,600 (129,213) *2
	Blade unit weight (including cylinder)	kg (lb)	6,750 (14,884)	7,676 (16,926)
	Ripper unit weight	kg (lb)	4,462 (9,839) (Multi-shank ripper)	3,600 (7,938) (Giant ripper)
	Name of engine	-	KOMATSU SDA6D140E diesel engine	
	Engine horsepower	KW (HP)/rpm	306 (410)/2,000	
A	Overall length	mm (ft in)	8,905 (29' 3")	9,595 (31' 6")
B	Overall height	mm (ft in)	3,985 (13' 1")	
C	Overall width	mm (ft in)	4,300 (14' 1")	
	Travel speed (1st/2nd/3rd)	Forward	3.8/6.7/11.2 (2.4/4.2/7.0)	
		Reverse	4.9/8.7/14.9 (3.0/5.4/9.3)	

*1: Semi-U tilt dozer, multi-shank ripper, ROPS cab, air conditioner

*2: U tilt dozer, Giant ripper, ROPS cab, air conditioner

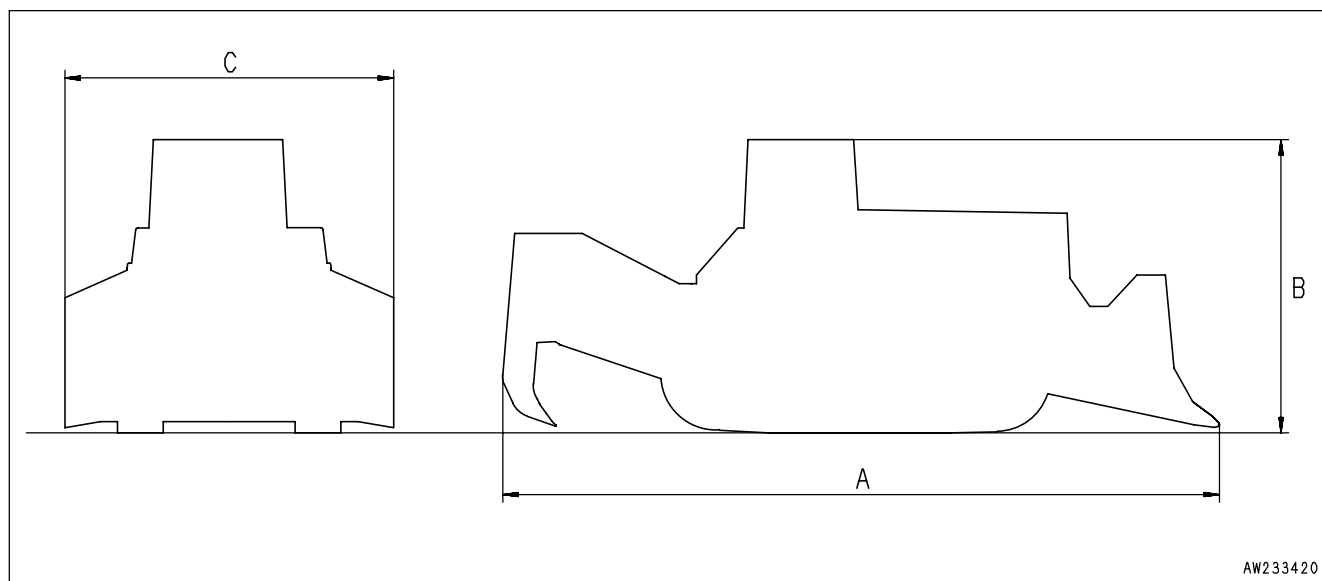

AW233420

ATTACHMENTS, OPTIONS

 **WARNING**

Please read and make sure that you understand the SAFETY section before reading this section.

GENERAL PRECAUTIONS

PRECAUTIONS RELATED TO SAFETY

If attachments or options other than those authorized by Komatsu are installed, this will not only affect the life of the machine, but will also cause problems with safety.

When installing attachments not listed in this Operation and Maintenance Manual, contact your Komatsu distributor first.

If you do not contact Komatsu, we cannot accept any responsibility for any accidents or failures.



WARNING

General precautions

- Read the instruction manual for the attachment carefully, and do not use the machine before you understand the operation method completely.

If you lose the instruction manual, be sure to order another copy from your Komatsu distributor.

- To prevent serious personal injury caused by misoperation, place your foot on the pedal only when operating the pedal.

Precautions for removal and installation

When removing or installing an attachment, observe the following items and work safely.

- Select a firm, level surface when installing or removing an attachment.
- When working in cooperation with one or more other workers, decide signs and observe them when carrying out the operation.
- When carrying a heavy part (25 kg (55 lb) or more), use a crane.
- When removing a heavy part, always place a support in position before removing it.

When lifting a load with a crane, be particularly careful of the center of gravity.

- It is dangerous to carry out operations when the load has been raised by a crane. Always lower the load onto a stand and check that it is safe.
- When leaving an attachment removed or installing it, place it in a stable position to prevent it from falling over.
- Never go under a load raised by a crane.

Always stand in a place which is safe even if the load should fall.

NOTICE

Qualifications are required to operate a crane. Never allow the crane to be operated by an unqualified person.

For details of removal and installation operations, contact your Komatsu distributor.

SELECTION OF TRACK SHOE

SELECTION OF TRACK SHOES

Select suitable track shoes to match the operating conditions.

METHOD OF SELECTING SHOES

If a wider shoe than necessary is used, the load on the track will increase, and this will cause the shoes to bend, links to crack, pins to break, shoe bolts to come loose, and various other problems.

Category	Use	Precautions when using	Track shoe width
A	Bedrock, normal soil	This shoe can be used for a wide range of work from crushed rock to general civil engineering work such as reclamation of residential land. There is no particular limit to its use.	610 mm (24 in)
B	Normal soil	Use this shoe for general soil, such as where the main work is scraper work and pusher work, reclaiming land for golf courses, or stripping the overburden for coal mines. This shoe cannot be used on bedrock. On jobsites where there are rocks in the soil, be careful to avoid letting the machine mount the rocks.	610 mm (24 in)
C	Soft soil	Use this shoe on soft ground where the shoe in category B sinks into the ground. Do not use this shoe on jobsites where there are rocks in the soil.	710 mm (28 in)/ 760 mm (29.9 in)

PROCEDURE FOR SELECTING RIPPER POINT

PROCEDURE FOR SELECTING RIPPER POINT

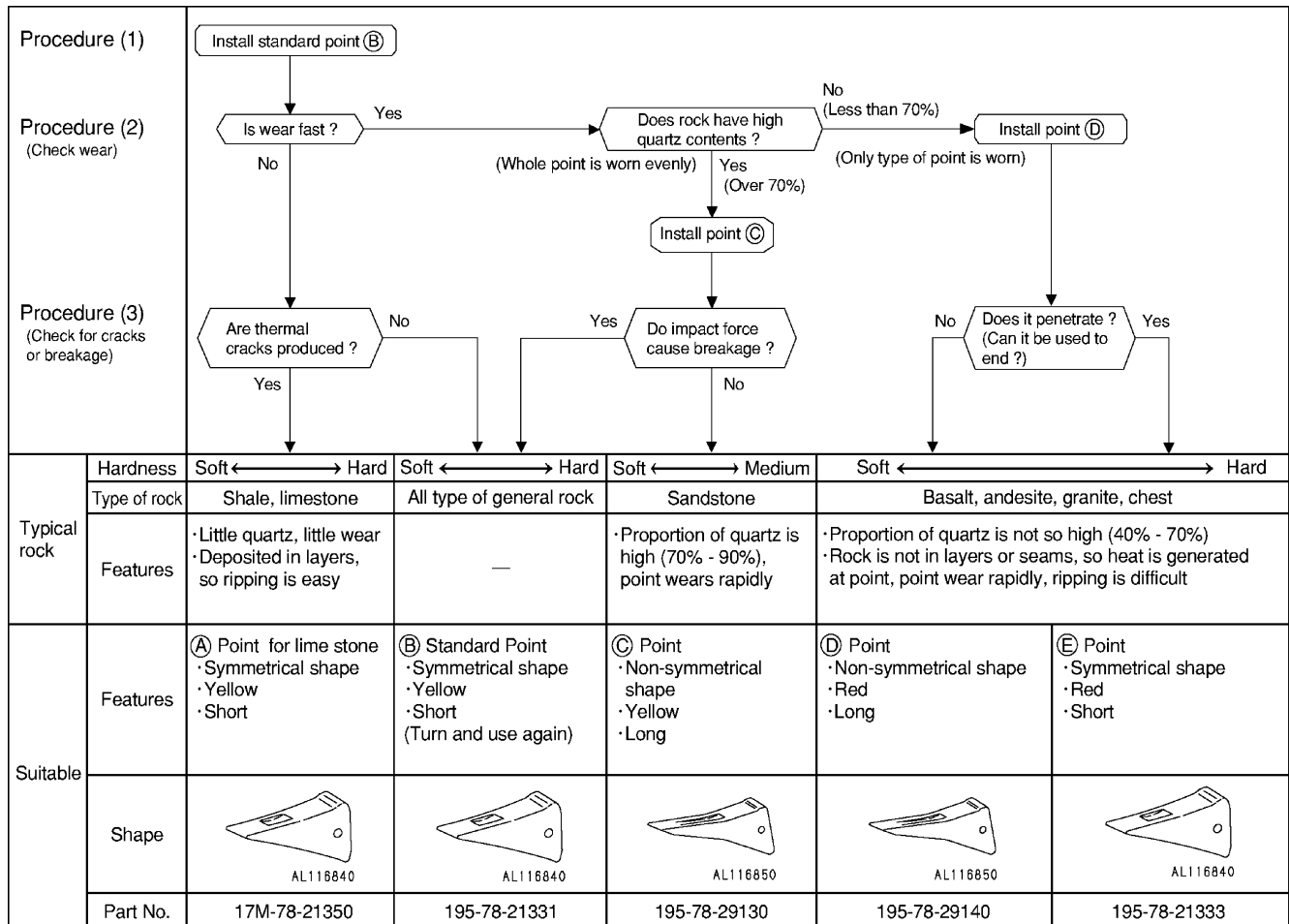

REMARK

- A symmetrical ripper point is suited to a terrain of hard rocks because it recovers penetrability by turning the point after the penetrability drops due to its worn tip.
- Ripper points usually lose their hardness when they undergo intense heat generated by a contact with rocks during the use. In this respect, red ripper points are suited to a terrain of hard rocks where those others are likely to slip during the use, because red ones are made of materials whose hardness less lowers under intense heat, compared with yellow ripper points.
- Where an amount of wear on a ripper point is limited, a heat- originated (thermal) crack on the point surface is not readily removed, and the point itself can break with the crack as a starting point. For this reason, ripper points for limestone are suited to a jobsite where they are comparatively free of wear.

CAP WITH LOCK, HANDLING

METHOD OF OPENING AND CLOSING CAP WITH LOCK

Lock-type caps are available for the radiator water filler, fuel tank filler cap, power train case oil filler cap, hydraulic tank oil filler cap, and hydraulic tank breather cap. The method of opening or closing the cap is as follows:

TO OPEN THE CAP

1. Insert the key. Make sure that you have inserted the key fully (1) before turning it. If the key is turned when only partially inserted, it may break.

(L) : Lock position

(F) : Open position

(A) : working angle of key 180°

(B) : 45°

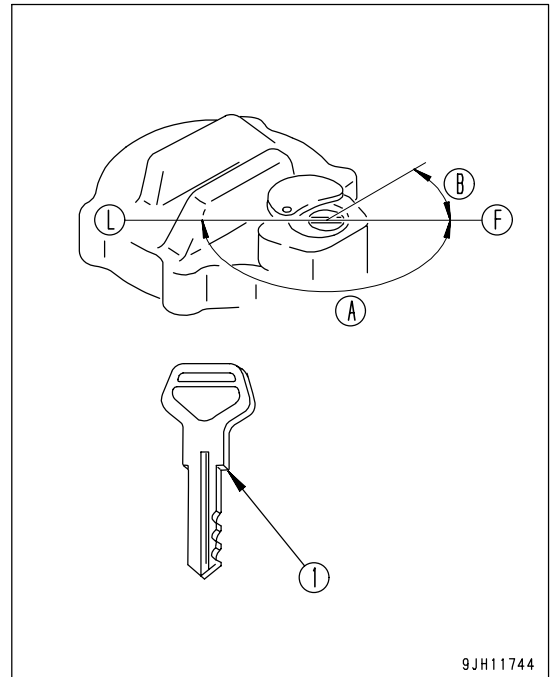

2. Turn the key counterclockwise to align the match mark (2) on the cap with the rotor groove, then turn the cap slowly. When a click is heard, the lock is released, enabling the cap to be opened.

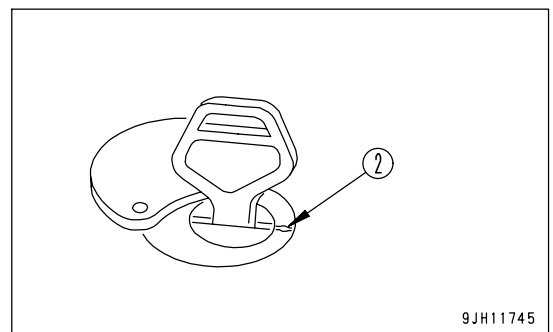

TO LOCK THE CAP

1. Turn the cap into place.
2. Turn the key clockwise and take the key out.

EFFECTIVE METHOD OF OPERATION FOR DUAL TILT DOZER

BLADE CONDITION

SINGLE TILT

Operate single/dual tilt selector switch to the SINGLE position, then operate the tilt.

Applicable operation

- Normal operations

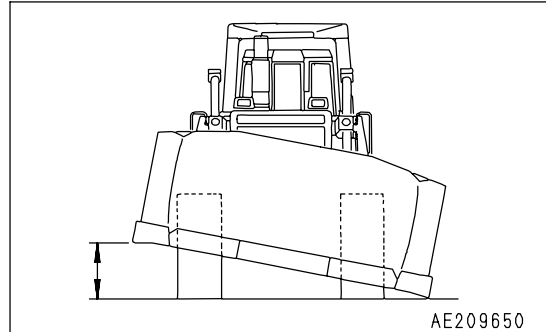

DUAL TILT

Operate single/dual tilt selector switch to the DUAL position, then operate the tilt.

Applicable operation

- Side cutting operations (high places)
- Horizontal dozing operations from side slope (rough ground)
- Ditching work

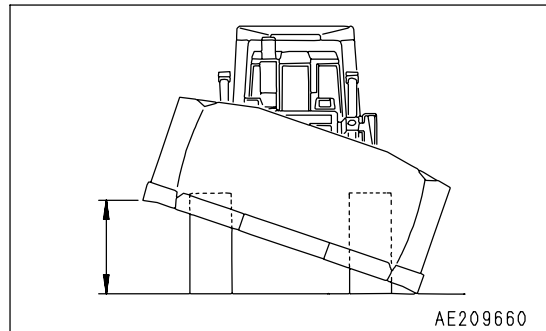

R PITCH (PITCH BACK)

Keep the pitch button pushed in and operate the left tilt.

Applicable operation

- Hauling
- Dozing soft soil (filling)
- Leveling operations (spreading)

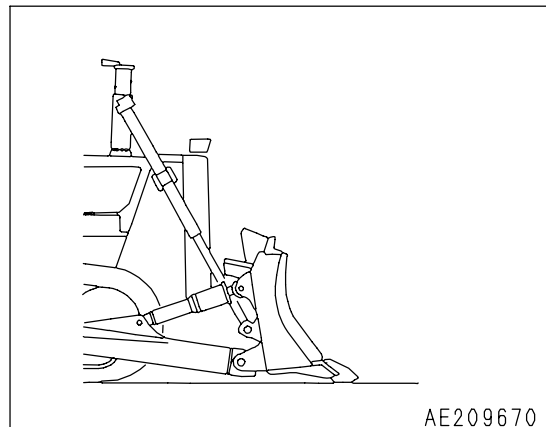

S PITCH (STANDARD)

Normal operations

Applicable operation

- Normal operations

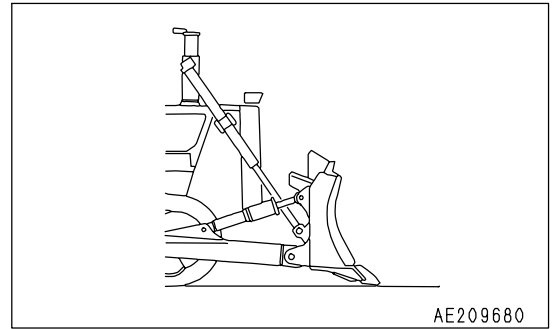

F PITCH (PITCH DUMP)

Keep the pitch button pushed in and operate the right tilt.

Applicable operation

- Digging natural ground and bed-rock (digging hard soil)
- Pushing soil over cliffs
- Pushing-up soil
(Reduces spillage of soil over the top surface of the blade, and reduces amount of soil carried back)

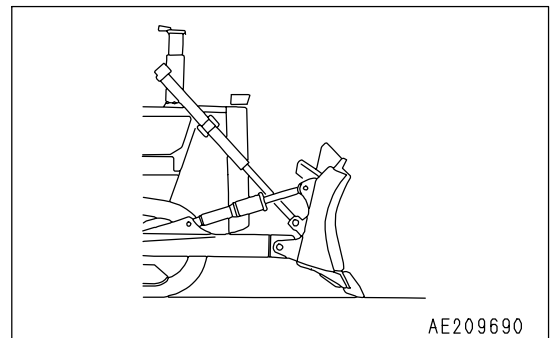

DOZING WORK

DOZING ON LEVEL GROUND, OR DOWNHILL

NATURAL GROUND, BEDROCK

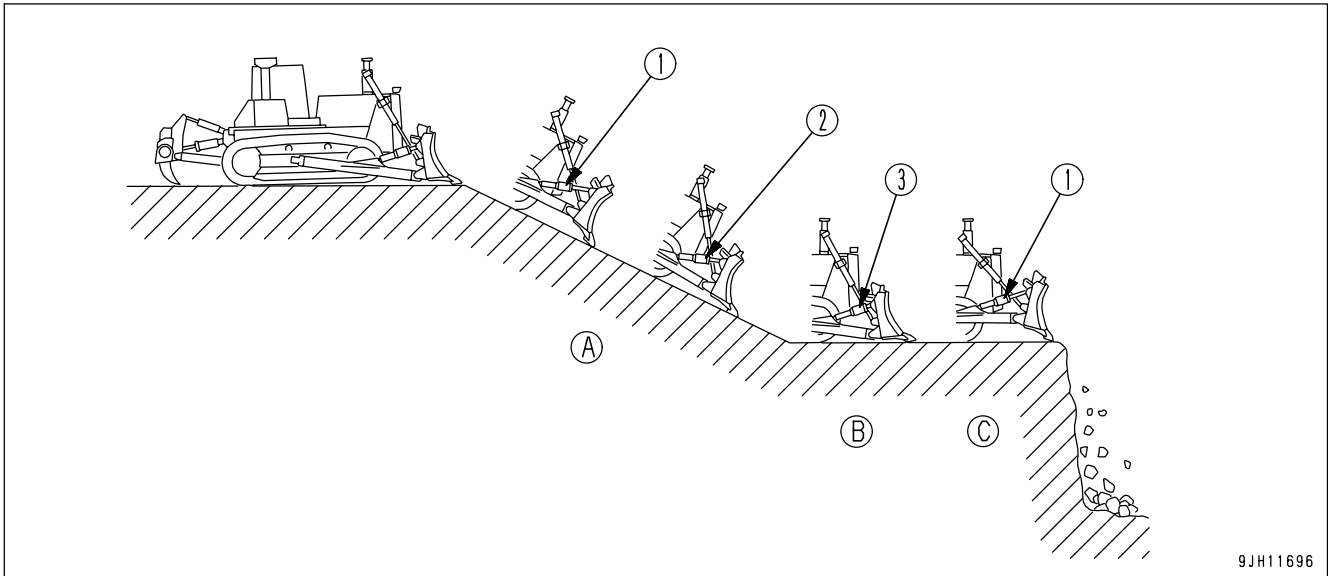

WARNING

If you feel that the situation is dangerous when dumping the soil, for safety reasons, use two movements to push the soil over the edge.

1. Dig with the FORWARD PITCH (1), and when the load on the blade is approx 80%, return to STRAIGHT PITCH (2) and continue digging (A).
2. Set to REAR PITCH (3) which gives a larger load, and haul the soil (B).
Adjust the cutting angle to the most effective angle for rolling the soil.
3. Use FORWARD PITCH (1) to dump the soil (C).

FILLING, SOFT SOIL

Carry out digging in R pitch or S pitch, and haul in R pitch.

REMARK

If the digging is carried out in R pitch, there is no sudden digging into the soil, and the operation can be carried out smoothly.

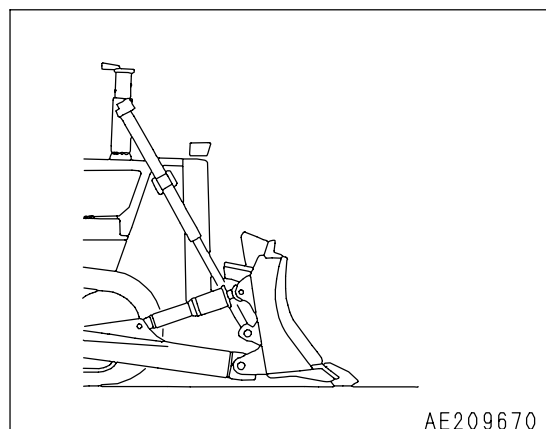

HARD SOIL (HARD CLAY, SHALE, ETC.)

If digging is carried out in F pitch, and the chassis is raised and the blade is tilted, the end bit will dig in better.

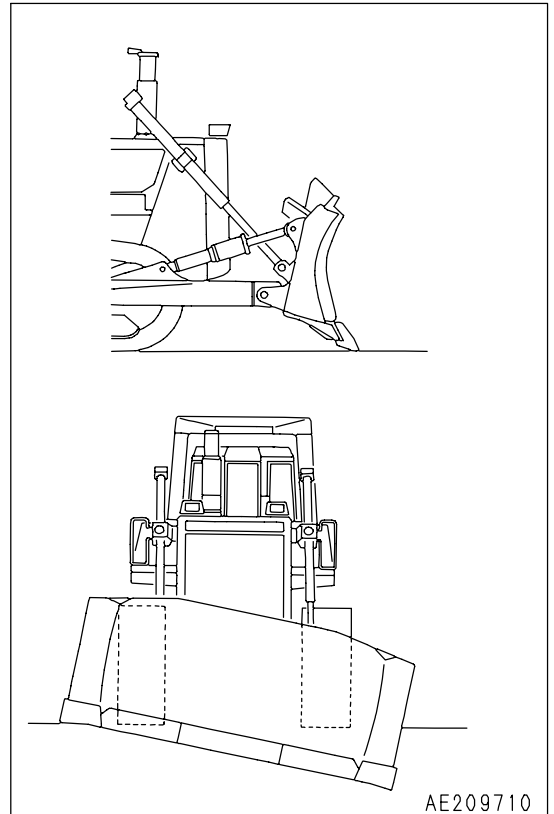

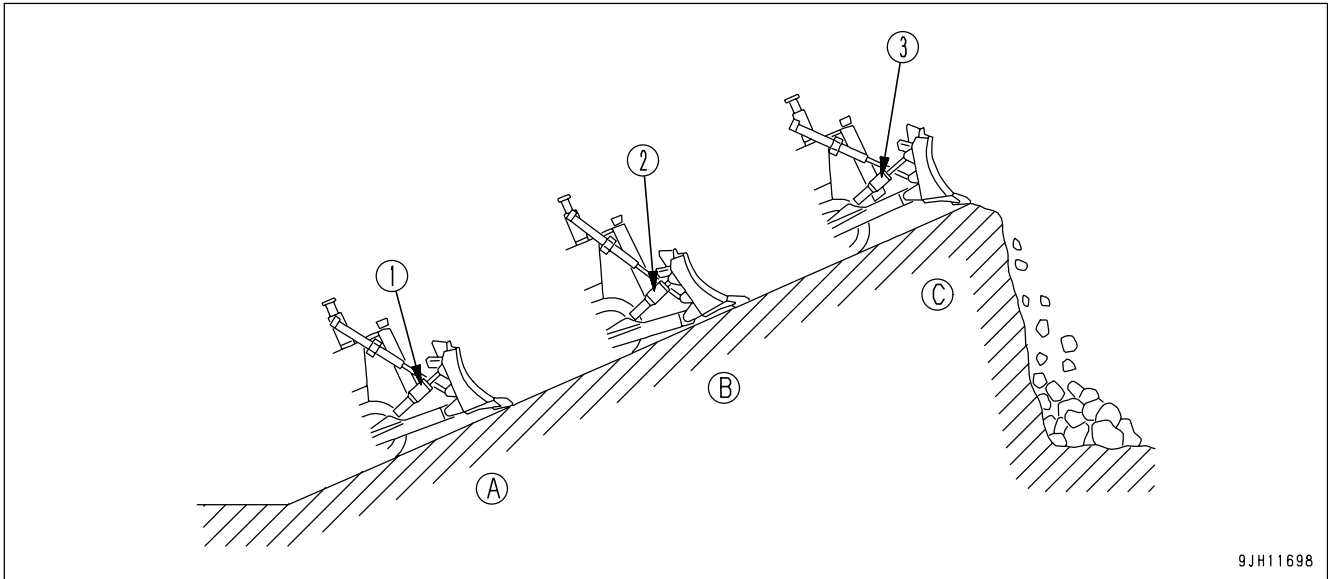
PUSHING-UP SOIL

9JH11698

1. Dig (A) with STRAIGHT PITCH (1).
When digging gradually (A), use REAR PITCH (2).
If the ground is hard, use FORWARD PITCH (3).
2. Haul (B) with REAR PITCH (2).
If there is any spillage of soil over the top of the blade, change to STRAIGHT PITCH (1).
3. Dump the soil (C) with FORWARD PITCH (3).
This dumps the soil more effectively, and less soil is carried back.

LEVELING (SPREADING) OPERATION

Carry out this operation with R itch.

When carry out this operation with R pitch, the end bit does not dig in, and the ground can be leveled (or the soil can be spread smoothly.)

REMARK

If the tilt cylinder is moved completely to the end of its stroke, the tilt operation cannot be carried out on one side, so move the cylinder back slightly from the end of its stroke to the S pitch position.

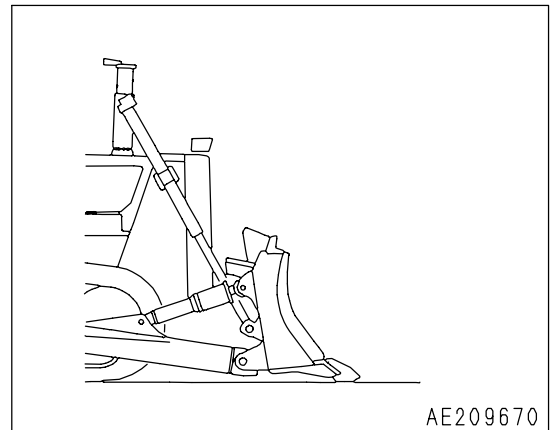

AE209670

DITCHING OPERATION

If the dual tilt is used, the digging width becomes smaller and a deeper ditch can be dug.

If R pitch is used, the digging can be carried out gradually, and this reduces the unevenness.

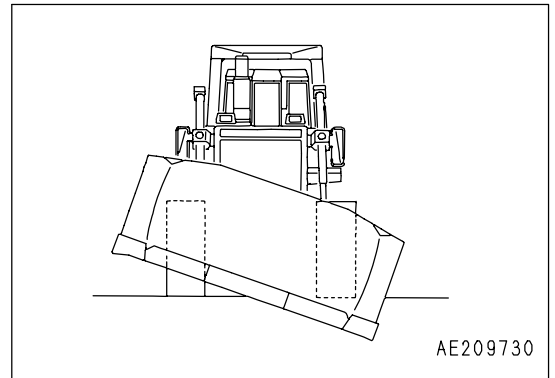

AE209730

BOULDER RAISING OPERATION

Because the dual tilt greatly increases the amount of tilt, the blade can dig in deep and hook under the boulder. In addition, the operating stroke is large, so operations to raise boulders can be carried out effectively.

(D): Dual tilt

(S): Single tilt

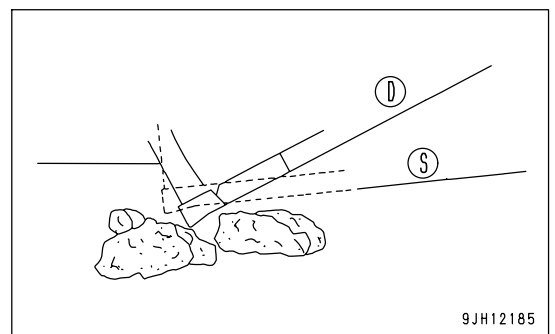

9JH12185

SIDE-CUTTING OPERATIONS

Carry out this operation in R pitch, and set the end face of the end bit in contact with the rock face to carry out cutting.

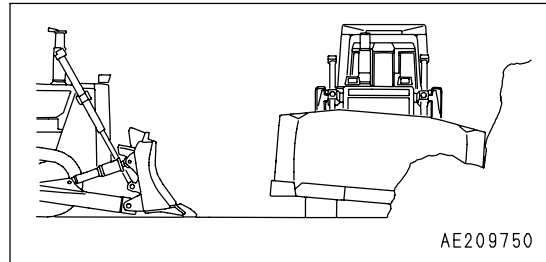

REMARK

With the dual tilt it is possible to increase the amount of tilt and to carry out side-cutting operations on higher walls.

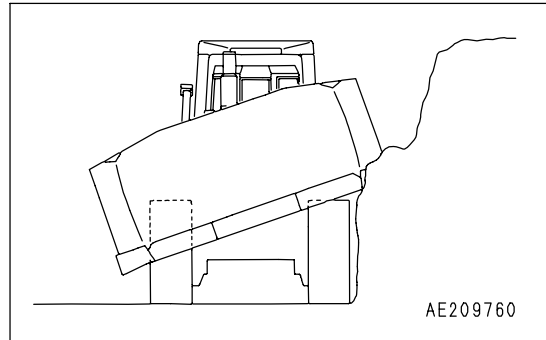

HORIZONTAL DOZING OPERATIONS FROM SIDE SLOPE (ROUGH GROUND)

The dual tilt can give a larger amount of tilt, so when dozing from a side slope, this is effective because the chassis becomes horizontal after a short digging distance.

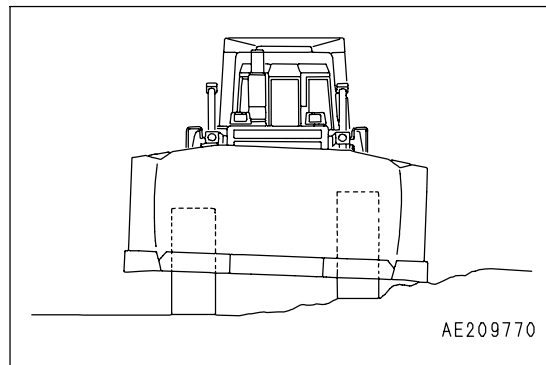

SHOE SLIP CONTROL

MODE SELECTION SWITCH PANEL (SHOE SLIP CONTROL)

- Press each mode switch to turn it ON or OFF and to select the mode.
- For details of setting the mode to use, see "EFFECTIVE USE OF MODE SELECTION SYSTEM (PAGE 3-119)".
- The economy mode, reverse slow mode, and shoe slip control mode can be used independently or in combination.

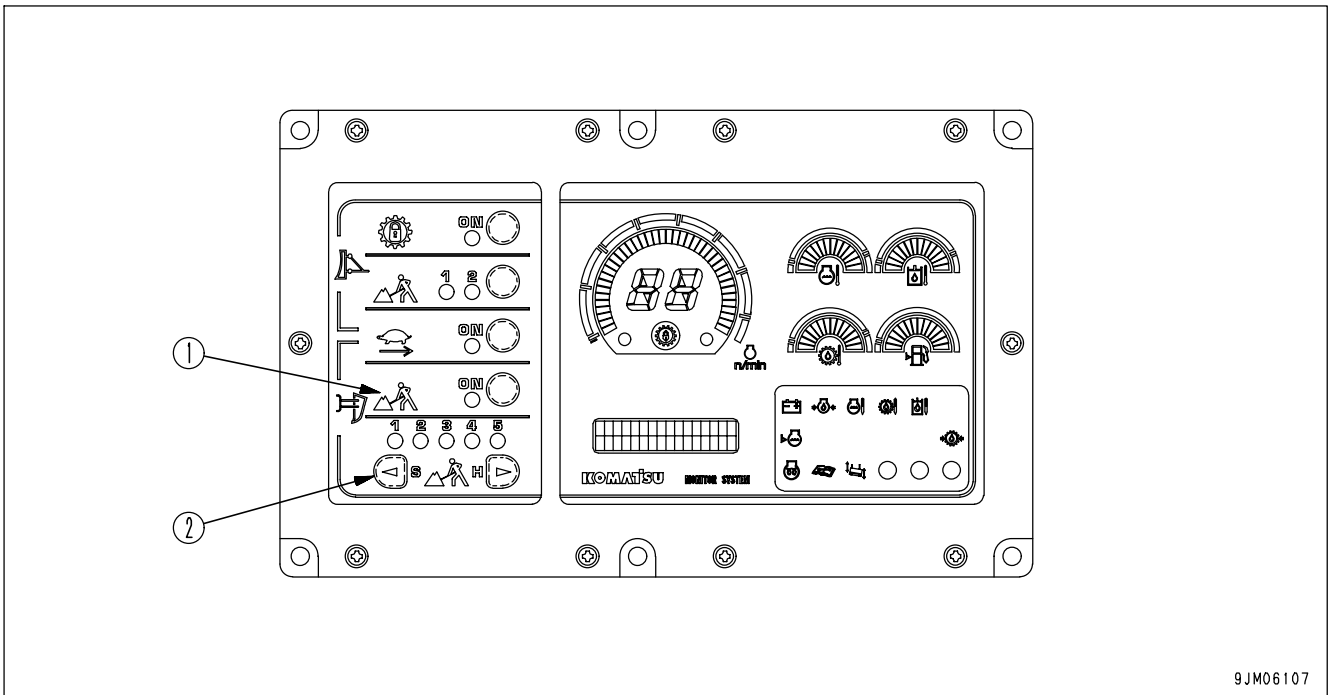

9JM06107

(1) Shoe slip control switch

(2) Rock selection mode selector switch

SHOE SLIP CONTROL SWITCH

This switch (1) is used for ripping operations. When it is switched ON, the lamp lights up.

NOTICE

If the shoe slip control is switched ON, the rock selection mode is automatically set to [3], so switch the rock selection mode to match the type of rock.

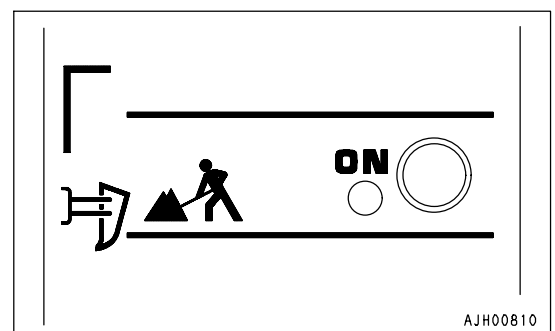

AJH00810

ROCK SELECTION MODE SELECTOR SWITCH

Using this switch (2) during ripping operations, turn the shoe slip control ON and select mode [1] - [5] according to the shoe slip ratio.

The lamp for the selected mode lights up.

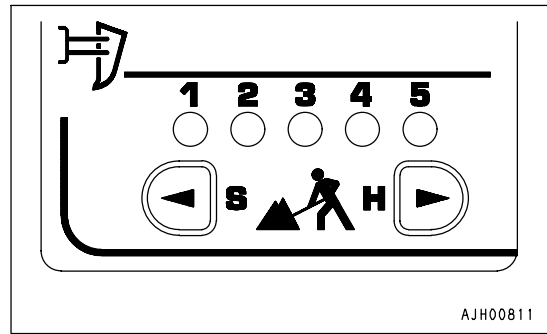

EFFECTIVE USE OF MODE SELECTION SYSTEM

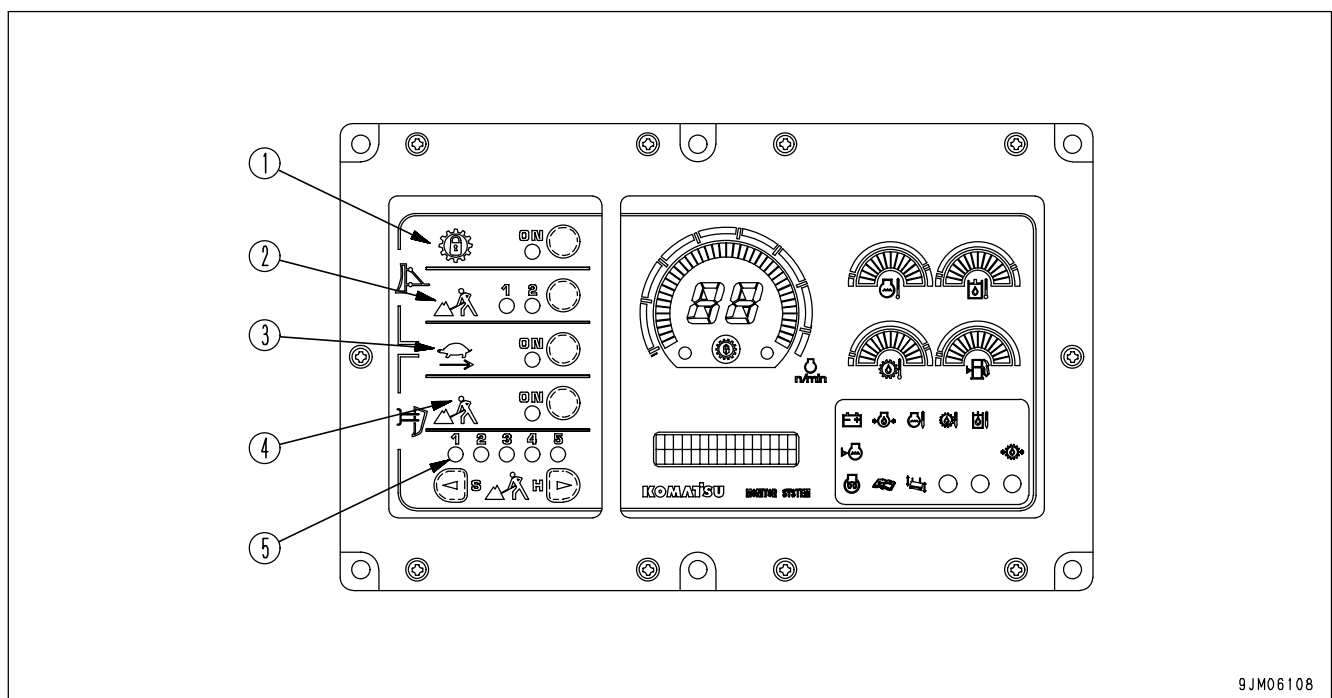

- (1) Lock up mode switch
- (2) Economy mode selector switch
- (3) Reverse slow mode selector switch
- (4) Shoe slip control switch
- (5) Rock selection mode selector switch

Selecting mode to match the type of work and quality of rock and soil makes to perform operations effectively. The condition when all the mode selection switches are off is called the standard mode. It is impossible to use any combination of the lock-up mode and any other mode. The economy mode, reverse slow mode, and shoe slip control mode can be used independently or in combination.

Dozing		Ripping	
Lock up mode	Economy mode	Reverse slow mode	Shoe slip control
○	×	×	×
×	○	○	○

○: Possible to use ×: Compound use not possible

SELECTION OF MODE

DOZING OPERATIONS

LOCK UP MODE

By using the lock up mode, the travel speed increases, the operating efficiency is improved, and the fuel consumption is also reduced.

- Speed ranges that can be used: All speed ranges
- Applicable operations: Dozing loose material (suitable for long-distance hauling operations)

When the lock up mode is turned ON, direct drive or torque converter drive are automatically selected according to the load.

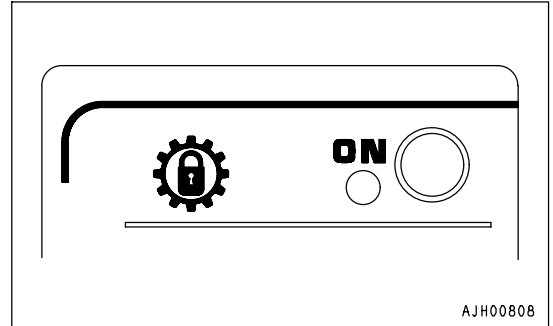

(Example)

- Slot dozing operations

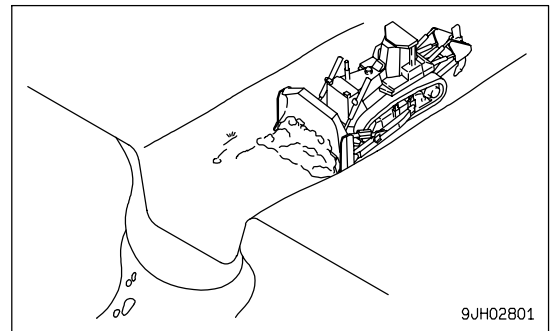

- Hillside dozing operations

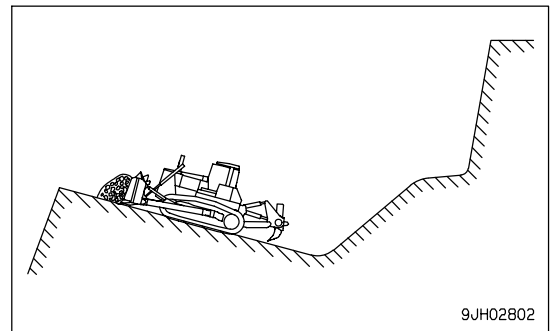

REMARK

- If dozing operations are carried out on a slope of more than 15 °, the lock-up tends to be canceled, so operations are easier to carry out in the standard mode.
- For normal ripping operations, if the lock-up mode is used, the lock-up will switch repeatedly between ON and OFF, so use the standard mode or shoe slip control mode.
- Even with ripping operations, if the ground is extremely soft, the lock-up mode can be used.

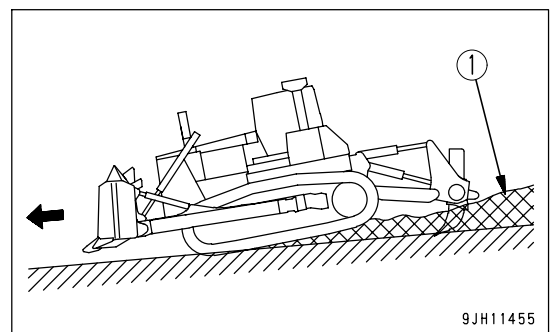

(1)Quality of earth and sand

ECONOMY MODE

Using the economy mode makes it possible to reduce wasteful shoe slippage and to reduce the fuel consumption.

- Speed ranges that can be used: F1
- Applicable operations: Hauling after ripping, dozing blasted rock, smoothing.

When the economy mode is turned ON, it is automatically set to [1]. Carry out dozing operations in this condition, then set to [2] and carry out operations. From this test, select the matching that gives power and low shoe slip ratio (frequency of deceleration operation).

Mode [1] is set to approx. 90% of full power and mode [2] is set to approx 70%.

(Example)

- Fine leveling operations

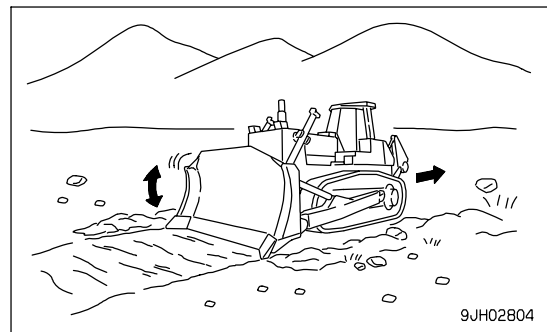
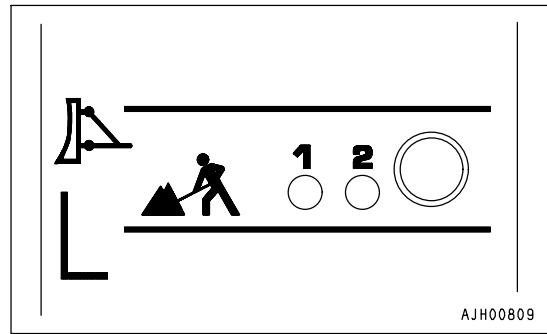

- Ripping and dozing operations

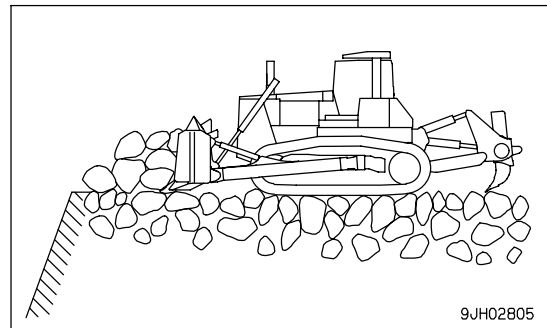
**REMARK**

- If the shoe slip control switch is turned ON and the ripper is lowered during dozing operations in the standard mode, the system will enter the shoe slip control mode. If this happens, return to the N position, set the speed range to F1, and this will return to the standard mode.
- If the economy mode and shoe slip control switches are turned ON and the ripper is lowered during dozing operations in the economy mode, the system will enter the shoe slip control mode. If this happens, return to the N position, set the speed range to F1, and this will return to the standard mode.

RIPPING OPERATIONS

SHOE SLIP CONTROL

This makes it possible to reduce the frequency of operation of the decelerator pedal by the operator, and contributes to reduction in operator fatigue. It also prevents wasteful shoe slippage, improves the service life of the undercarriage, and reduces fuel consumption.

- Speed ranges that can be used: F1
- Applicable operations: Ripping

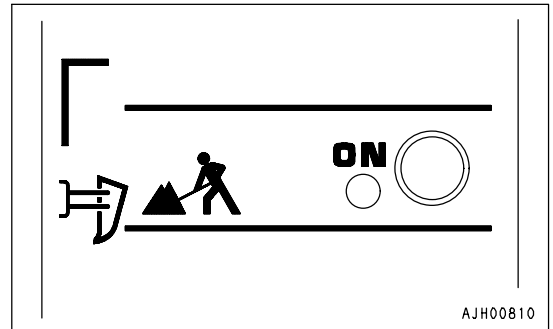

In normal ripping operations, the operator uses the decelerator pedal to control the engine speed while carrying out ripping. If the shoe slip control is turned ON, the shoe slip control system aids the operator in carrying out this control.

When the shoe slip control switch is turned ON, the rock selection mode is automatically set to [3].

Carry out operations in this condition, and if the shoe slip ratio is too high, press a switch in the hard direction to set the mode to [4] or [5].

If the shoe slip ratio is low and there seems to be lack of power, press the switch in the soft direction to set the mode to [2] or [1].

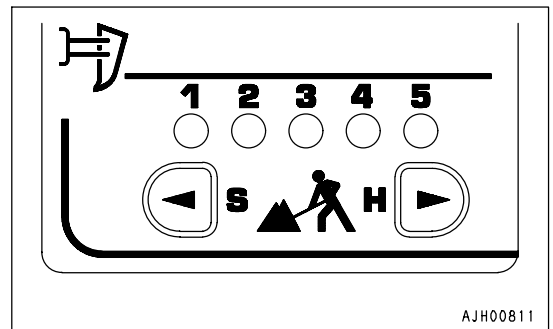

REMARK

- After the joystick is set to F1, the shoe slip control starts when the ripper lever is operated to LOWER (c) or TILT. Even when the operation alternates between dozing and ripping, there is no need to turn the switch ON or OFF.
- With this system, if shoe slippage occurs during ripping operations, the engine speed is lowered to prevent wasteful shoe slippage.
If shoe slippage occurs during ripping operations and the engine speed goes down, if the ripper lever is operated to TILT IN (A) or RAISE (a), the engine speed will rise (output is increased) to make it easier to carry out breaking operations.
- When carrying out ripping operations on hard rock, if the rear of the machine comes off the ground and there is sudden shoe slippage, it is possible to reduce the shoe slippage by operating the ripper to LOWER (c) and reducing the engine speed.

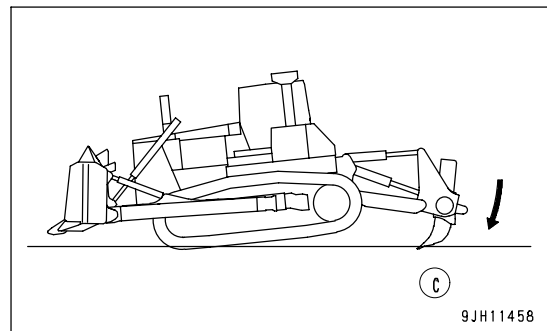
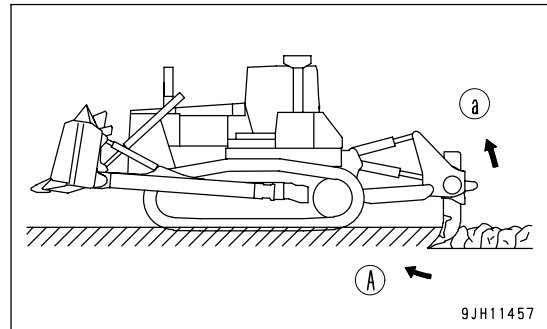
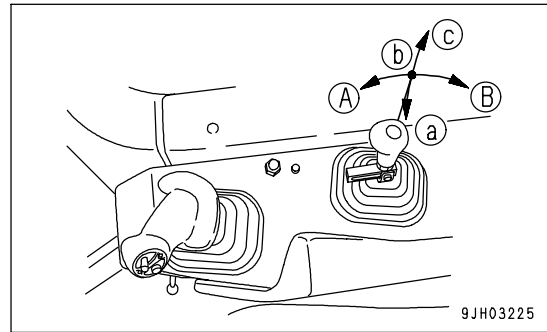

REVERSE SLOW MODE

This reduces the travel speed when traveling in reverse, reduces the frequency of operating the decelerator pedal, and improves the riding comfort for the operator.

- Speed ranges that can be used: R1, 2, 3

(If this mode is only necessary when traveling in R2 or R3, it is possible to change the setting of the service mode. To do this, please contact your Komatsu distributor.)

- Applicable operations: Traveling on bedrock, traveling down steep hills

Use this mode to reduce the travel speed when traveling in R1, R2, or R3.

When the reverse slow mode is ON, the travel speed is set to approx. 80% of the full travel speed.

Use this mode to reduce the travel speed when traveling in reverse after ripping and dozing bedrock or when traveling in reverse after dozing on steep slopes. The travel speed differs in each mode according to whether it is used in combination with the economy mode or with shoe slip control.

When using shoe slip control, the travel speed for bedrock setting modes [1] - [5] is set at approx. 70 - 90% of the full travel speed.

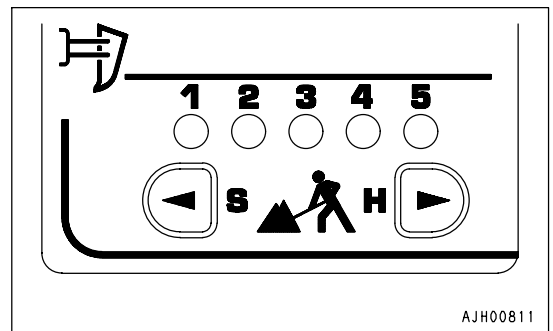
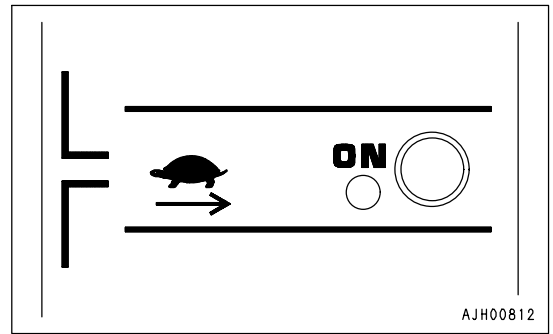

When traveling on bedrock, if it is felt that the travel speed when traveling in reverse is too high, turn the reverse slow mode ON. This will reduce the travel speed when traveling in reverse.

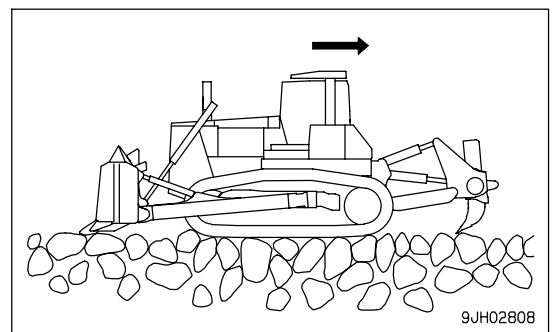

When traveling down slopes, if it is felt that the travel speed when traveling in reverse is too high, turn the reverse slow mode ON. This will reduce the travel speed when traveling in reverse.

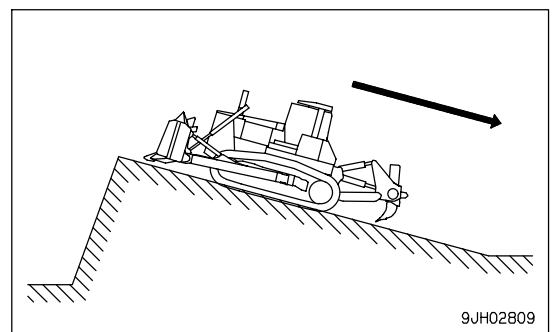

PROCEDURE FOR SELECTING MODE ACCORDING TO NATURE OR NEEDS TO WORK

Use the table below to select the mode that matches the nature or needs of the operation.

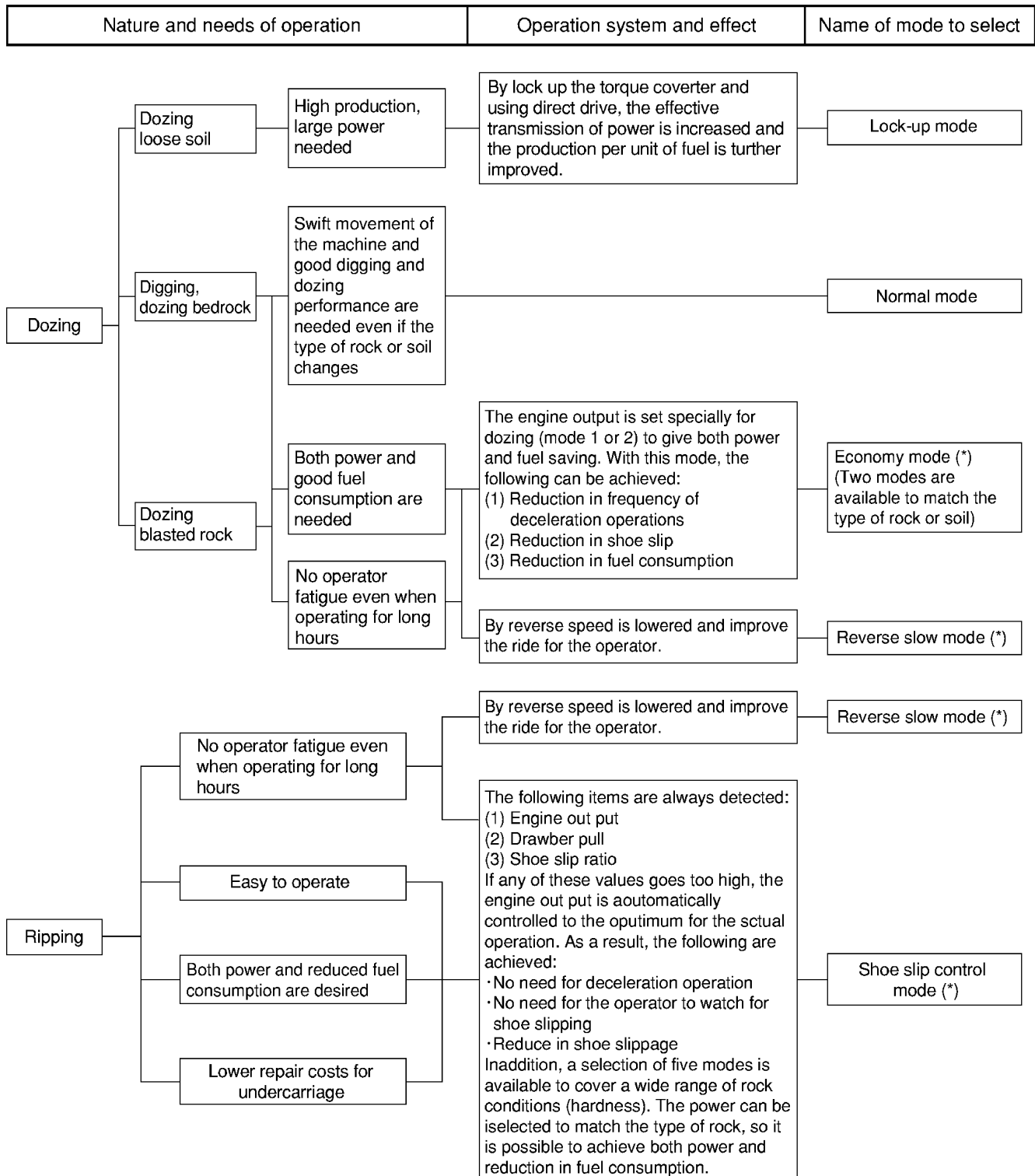

(*): The dozing economy mode, reverse slow mode, and ripping shoe slip control mode can all be selected independently or in combination. In addition, it is possible to select and correct as needed, so it is possible to achieve precise matching for various types of operation.

IF MODE SELECTION SYSTEM FLASHES

If the caution lamp flashes, or it becomes impossible to control the engine speed with the fuel control dial or decelerator pedal, stop operation immediately, check the monitor panel display, then contact your Komatsu distributor for repairs.

In addition to the above problems, if any of the problems in the table below occur, there is probably an abnormality in the work equipment lever switch, transmission speed range sensor, or other part, so please contact your Komatsu distributor for repairs.

Mode	Operation	Abnormality
Shoe slip control	Ripping	<ul style="list-style-type: none"> • When shoe slip occurs, it is impossible to throttle power • Even when there is shoe slippage, it is impossible to control • After slippage stops, it takes a long time for power to recover • It becomes difficult to break rock by operating lever to TILT or RAISE • Travel speed increases when shank is inserted • Travel speed is slow and drawbar pull is lacking • No sense of control, engine stays at full or partial • Chassis flies when starting ripping

HANDLING MACHINES EQUIPPED WITH KOMTRAX

- KOMTRAX is a machine management system that uses wireless communications.
- A contract with your Komatsu distributor is necessary before the KOMTRAX system can be used. Any customers desiring to use the KOMTRAX system should consult their Komatsu distributor.
- The KOMTRAX equipment is a wireless device using radio waves, so it is necessary to obtain authorization and conform to the laws of the country or territory where the machine equipped with KOMTRAX is being used. Always contact your Komatsu distributor before selling or exporting any machine equipped with KOMTRAX.
- When selling or exporting the machine or at other times when your Komatsu distributor considers it necessary, it may be necessary for your Komatsu distributor to remove the KOMTRAX equipment or to carry out action to stop communications.
- If you do not obey the above precautions, neither Komatsu nor your Komatsu distributor can take any responsibility for any problem that is caused or for any loss that results.

BASIC PRECAUTIONS



WARNING

- Never disassemble, repair, modify, or move the communications terminal, antenna, or cables. This may cause failure or fire on the KOMTRAX equipment or the machine itself. (Your Komatsu distributor will carry out removal and installation of KOMTRAX.)
- Do not allow cables or cords to become caught; do not damage or pull cables or cords by force. Short circuits or disconnected wires may cause failure or fire on the KOMTRAX equipment or the machine itself.
- For anyone wearing a pacemaker, make sure that the communications antenna is at least 22 cm (8.7 in) from the pacemaker. The radio waves may have an adverse effect on the operation of the pacemaker.

NOTICE

- Even when the key in the starting switch of the KOMTRAX system is at the OFF position, a small amount of electric power is consumed. When putting the machine into long-term storage, take the action given in "LONG-TERM STORAGE (PAGE 3-143)".
- Please contact your Komatsu distributor before installing a top guard or other attachment that covers the cab roof.
- Be careful not to get water on the communications terminal or wiring.

REMARK

- The KOMTRAX system uses wireless communications, so it cannot be used inside tunnels, underground, inside buildings, or in mountain areas where radio waves cannot be received. Even when the machine is outside, it cannot be used in areas where the radio signal is weak or in areas outside the wireless communication service area.
- There is absolutely no need to inspect or operate the KOMTRAX communications terminal, but if any abnormality is found, please consult your Komatsu distributor.

INDEX

<A>		ENGINE SERIAL NO. PLATE AND	
ACCUMULATOR, HANDLING -----	3- 70	POSITION -----	1- 8
ADJUSTING POSTURE OF WORK		EXPLANATION OF COMPONENTS -----	3- 5
EQUIPMENT -----	3-132	<F>	
AIR CONDITIONER, HANDLING -----	3- 64	FOREWORD -----	1- 2
ASHTRAY -----	3- 54	FRONT PANEL -----	3- 5
		FRONT/REAR, LEFT/RIGHT	
BLADE SERIAL NO. PLATE POSITION ----	1- 9	DIRECTIONS OF MACHINE -----	1- 7
<C>		FUSE BOX -----	3- 50
CAP WITH LOCK, HANDLING -----	6- 5	FUSIBLE LINK -----	3- 53
METHOD OF OPENING AND		<G>	
CLOSING CAP WITH LOCK -----	6- 5	GENERAL PRECAUTIONS -----	2- 9
CAR STEREO, HANDLING -----	3- 56	GENERAL PRECAUTIONS -----	6- 2
CHECK AFTER FINISHING WORK -----	3-116	PRECAUTIONS RELATED TO	
CHECK AFTER STOPPING ENGINE -----	3-100	SAFETY -----	6- 2
CHECK BEFORE STARTING ENGINE,		GENERAL VIEW -----	3- 2
ADJUST -----	3- 71	GENERAL VIEW OF CONTROLS AND	
COLD WEATHER OPERATION -----	3-141	GAUGES -----	3- 3
AFTER COLD WEATHER -----	3-142	GENERAL VIEW OF MACHINE -----	3- 2
AFTER COMPLETION OF WORK -----	3-142	GUIDES TO MAINTENANCE -----	4- 2
PRECAUTIONS FOR LOW		<H>	
TEMPERATURE -----	3-141	HANDLING MACHINES EQUIPPED	
CONTROL LEVERS, PEDALS -----	3- 40	WITH KOMTRAX -----	6- 22
<D>		BASIC PRECAUTIONS -----	6- 22
DOOR OPEN LOCK -----	3- 53	HANDLING OIL, FUEL, COOLANT, AND	
DOOR POCKET -----	3- 54	PERFORMING OIL CLINIC -----	4- 5
DUST INDICATOR -----	3- 49	<I>	
<E>		INSTALLATION OF CAB -----	3-140
EFFECTIVE METHOD OF OPERATION		INTRODUCTION -----	1- 7
FOR DUAL TILT DOZER -----	6- 6	<L>	
BLADE CONDITION -----	6- 6	LOADING, UNLOADING WORK -----	3-137
BOULDER RAISING OPERATION -----	6- 11	LOCKING -----	3-116
DITCHING OPERATION -----	6- 11	LONG-TERM STORAGE -----	3-143
DOZING WORK -----	6- 8	AFTER STORAGE -----	3-143
HORIZONTAL DOZING		BEFORE STORAGE -----	3-143
OPERATIONS FROM SIDE SLOPE		DURING STORAGE -----	3-143
(ROUGH GROUND) -----	6- 12	STARTING MACHINE AFTER	
LEVELING (SPREADING)		LONG-TERM STORAGE -----	3-143
OPERATION -----	6- 11	<M>	
SIDE-CUTTING OPERATIONS -----	6- 12	MACHINE SERIAL NO. PLATE AND	
EFFECTIVE USE OF MODE		POSITION -----	1- 8
SELECTION SYSTEM -----	3-119		

MAINTENANCE SCHEDULE CHART -----	4- 16	SAFETY CRITICAL PARTS -----	4- 15
METHOD OF LIFTING MACHINE -----	3-138	SAFETY INFORMATION -----	1- 5
MOVING MACHINE -----	3-101	SAFETY LABELS -----	2- 4
<N>		POSITIONS OF SAFETY	
NECESSARY INFORMATION -----	1- 8	PICTOGRAMS -----	2- 4
<O>		SAFETY LABELS -----	2- 5
OPERATING METHOD FOR RIPPING		SASH GLASS INTERMEDIATE LOCK -----	3- 54
OPERATIONS -----	3-127	SELECTION OF TRACK SHOE -----	6- 3
OPERATION -----	3- 71	SELECTION OF TRACK SHOES -----	6- 3
OPERATIONS AND CHECKS AFTER		SERVICE PROCEDURE -----	4- 19
STARTING ENGINE -----	3- 97	CHECK BEFORE STARTING -----	4- 46
OUTLINE OF ELECTRIC SYSTEM -----	4- 8	EVERY 1000 HOURS SERVICE -----	4- 62
OUTLINES OF SERVICE -----	4- 5	EVERY 2000 HOURS SERVICE -----	4- 69
<P>		EVERY 250 HOURS SERVICE -----	4- 47
PARKING MACHINE -----	3-114	EVERY 4000 HOURS SERVICE -----	4- 76
PERIODIC REPLACEMENT OF SAFETY		EVERY 500 HOURS SERVICE -----	4- 55
CRITICAL PARTS -----	4- 14	EVERY 8000 HOURS SERVICE -----	4- 80
POSITION OF SERVICE METER -----	1- 9	INITIAL 250 HOURS SERVICE (ONLY	
POWER SOURCE -----	3- 49	AFTER THE FIRST 250 HOURS) -----	4- 19
PRECAUTIONS FOR LOADING -----	3-138	WHEN REQUIRED -----	4- 20
PRECAUTIONS FOR MAINTENANCE -----	2- 28	SHIFTING BETWEEN FORWARD AND	
PRECAUTIONS FOR OPERATION -----	2- 18	REVERSE -----	3-107
BATTERY -----	2- 25	SHIFTING GEAR -----	3-104
BEFORE STARTING ENGINE -----	2- 18	SHOE SLIP CONTROL -----	6- 13
OPERATION -----	2- 20	EFFECTIVE USE OF MODE	
TOWING -----	2- 27	SELECTION SYSTEM -----	6- 14
TRANSPORTATION -----	2- 24	IF MODE SELECTION SYSTEM	
PRECAUTIONS FOR OPERATION -----	3-112	FLASHES -----	6- 21
PRECAUTIONS FOR		MODE SELECTION SWITCH PANEL	
TRANSPORTATION -----	3-139	(SHOE SLIP CONTROL) -----	6- 13
PROCEDURE FOR SELECTING		SPECIFICATIONS -----	5- 2
RIPPER POINT -----	6- 4	STANDARD TIGHTENING TORQUES	
PROCEDURE FOR SELECTING		FOR BOLTS AND NUTS -----	4- 13
RIPPER POINT -----	6- 4	STARTING ENGINE -----	3- 92
<R>		STEERING MACHINE -----	3-109
RECOMMENDED FUEL, COOLANT,		STOPPING ENGINE -----	3-100
AND LUBRICANT -----	4- 10	STOPPING MACHINE -----	3-103
USE OF FUEL, COOLANT		SWITCHES -----	3- 36
AND LUBRICANTS ACCORDING TO		<T>	
AMBIENT TEMPERATURE -----	4- 11	TABLE TO ENTER SERIAL NO. AND	
REMOVAL OF CAB -----	3-140	DISTRIBUTOR -----	1- 10
RIPPER OPERATION -----	3-124	TIPS FOR LONGER UNDERCARRIAGE	
RIPPER SERIAL NO. PLATE POSITION ---	1- 9	LIFE -----	3-135
<S>		TOOL BOX -----	3- 55
SAFETY -----	2- 2	TORQUE LIST -----	4- 13
		TRANSPORTATION -----	3-137
		TRANSPORTATION PROCEDURE -----	3-137
		TRAVELING ON ROADS -----	3-139
		TROUBLESHOOTING -----	3-144

INDEX

AFTER RUNNING OUT OF FUEL -----	3-144
IF BATTERY IS DISCHARGED -----	3-146
METHOD OF TOWING MACHINE -----	3-145
OTHER TROUBLE -----	3-149
WHEN MODE SELECTION SYSTEM FLASHES -----	3-154
<W>	
WEAR PARTS -----	4- 9
WEAR PARTS LIST -----	4- 9
WORK POSSIBLE USING BULLDOZER ---	3-117

D275AX-5 GALEO BULLDOZER

Form No. TEN00035-02

© 2007 KOMATSU
All Right Reserved
Printed in Japan 11-07
