

# Gen 5 DD Platform Operators Manual



13400 Outer Drive, West, Detroit, Michigan 48239-4001  
Telephone: 313-592-5000  
[www.demanddetroit.com](http://www.demanddetroit.com)

**Specifications are subject to change without notice. Detroit Diesel Corporation is registered to ISO 9001:2001.**

**Copyright © Detroit Diesel Corporation. All rights reserved. Detroit Diesel Corporation is a Daimler company.**

**Printed in U.S.A.**

# Table of Contents

<b>California Proposition 65 Warning and Engine Idle Notice</b> .....	4
<b>Forward</b> .....	5
Introduction.....	5
Non-Genuine and Rebuilt Component Quality Alert.....	5
Personnel Requirements.....	5
Engine Conversions and Modifications.....	6
<b>To the Operator</b> .....	7
To The Operator.....	7
Warranty.....	7
Trademark Information.....	7
<b>Caution Summary</b> .....	9
Caution Summary.....	9
<b>Engine Components</b> .....	17
Engine Components.....	17
DD13 Engine Components.....	17
DD15 Engine Components.....	18
Engine Model and Serial Number Designation.....	19
<b>Engine Operation</b> .....	22
Engine Operation.....	22
First Time Engine Operation.....	22
Engine Start and Routine Operation.....	25
Shifting a Manual Transmission.....	30
Vehicle Emergency Operation.....	31
<b>Detroit Diesel Electronic Controls System</b> .....	33
Detroit Diesel Electronic Controls System.....	33
Detroit Diesel Electronic Control System Operation.....	33
Detroit Diesel Electronic Control System Features.....	38
<b>Engine Systems</b> .....	41
Engine Systems.....	41
Aftertreatment System.....	41
Air System.....	44
Cooling System.....	44
Electrical System.....	45
Engine Brake System.....	45
Exhaust System and Exhaust Gas Recirculation System.....	45
Fuel System.....	46
Lubrication System.....	46
<b>Instrument Panel Indicators</b> .....	48
Instrument Panel Indicators.....	48
<b>Preventive Maintenance Intervals</b> .....	49
Preventive Maintenance Intervals.....	49
Scheduled Maintenance Intervals.....	49
Preventive Maintenance Tables.....	52

<b>Routine Preventive Maintenance</b> .....	59
Routine Preventive Maintenance.....	59
Inspection of the Aftertreatment System.....	59
Inspection of the Air Compressor.....	60
Inspection of the Air Intake System.....	60
Inspection of the Turbocharger and Charge Air Cooler.....	60
Inspection of the Batteries.....	61
Inspection of the Belts.....	62
Inspection of the Cooling System.....	64
Inspection of the Exhaust System.....	65
Inspection of the Fuel System.....	65
Inspection of Hoses and Fittings for Leaks.....	66
Inspection of the Lubricating System.....	67
<b>How to Procedures</b> .....	69
How To Procedures.....	69
How to Perform a Parked Regeneration.....	69
How to Select Diesel Exhaust Fluid.....	71
How to Check the Coolant Level.....	71
How to Select Coolants.....	72
How to Select Fuel.....	75
How to Drain the Fuel Coalescer.....	76
How to Restart an Engine Out of Fuel.....	77
How to Check the Lubricating Oil Level.....	79
How to Select Lubricating Oil.....	80
How to Clean an Engine.....	81
How to Operate the Cruise Control and Fast Idle.....	82
How to Operate the Engine Brakes.....	83
<b>Customer Assistance</b> .....	88
Availability of Detroit™ Service Outlets.....	88

# California Proposition 65 Warning and Engine Idle Notice

 **WARNING:** Breathing diesel engine exhaust exposes you to chemicals known to the State of California to cause cancer and birth defects or other reproductive harm.

- Always start and operate the engine in a well-ventilated area.
- If in an enclosed area, vent the exhaust to the outside.
- Do not modify or tamper with the exhaust system.
- Do not idle the engine except as necessary.

For more information go to [www.P65warnings.ca.gov/diesel](http://www.P65warnings.ca.gov/diesel).

d990086  
38351

# Forward

## Introduction

This manual is intended to be used by the operator of Detroit™ Gen 5 Heavy Duty engines. The manual covers basic information on engine components, engine operation, Detroit Diesel Electronic Controls (DDEC®) system, engine systems, aftertreatment system, instrument panel indicators, preventative maintenance, how to procedures, and customer assistance.

## Non-Genuine and Rebuilt Component Quality Alert

Electronic engine controls have been instrumental in aiding engine manufacturers meet federal emission requirements and the ever-increasing performance demands of the customer.

Maintenance procedures must be followed in order to continue satisfactory performance and durability and to ensure coverage of the engine under the manufacturer's warranty. Many of these maintenance procedures also ensure that the engine continues to comply with applicable emissions standards. Proper maintenance procedures, using specific components engineered to comply with emissions regulations, may be performed by an authorized Detroit™ service outlet, an independent outlet, or the operator or owner. The owner is responsible for determining the suitability of components to maintain emissions compliance during the engine's useful emission life.

Detroit™ cautions that the indiscriminate rebuilding of precision components, without the benefit of specifications, specialized equipment, and knowledge of the electronic operating system, will jeopardize performance or lead to more serious problems, and can take the engine outside of emission standards compliance.

There are several other components in an engine, including but not limited to the turbocharger, fuel injectors, camshaft s, pistons, diesel exhaust fluid pump, which are specifically designed and manufactured to exacting standards for emissions compliance. It is important that these components, if replaced, modified or substituted, can be verified thus ensuring that the engine remains in compliance with emissions standards. The use of inadequately engineered, manufactured or tested components in the repair or rebuild of the engine may be in violation of federal regulations.

Furthermore, modern engines exhibit operating parameters which require the use of proper fluids, such as fuel, coolant and lubricating oil, to maintain long engine life. The use of fluids that do not meet Detroit™ specifications may result in premature wear or engine failure.

## **Personnel Requirements**

Work on the engine should be carried out only by skilled technicians who have been instructed in the specific skills necessary for the type of work being performed.

## **Engine Conversions and Modifications**

The function and safety of the engine could be affected if unauthorized modifications are made to it. Detroit™ will not accept responsibility for any resulting damage.

Tampering with the fuel injection system and engine electronics could also affect engine power output or exhaust emission levels. Compliance with the manufacturer's settings and with statutory environmental protection regulations cannot then be guaranteed.

# To the Operator

## To The Operator

This manual contains instructions on the safe operation and preventive maintenance of Detroit™ Gen 5 Heavy Duty engines. Maintenance instructions cover routine engine services in enough detail to permit self-servicing, if desired. Keep this manual at all times. It contains important operating, maintenance, and safety instructions.

The operator should become familiar with the contents of this manual before operating the engine or carrying out maintenance procedures.

Power-driven equipment is only as safe as the person operating the controls. The operator is urged to keep fingers and clothing away from the revolving belts, drive shafts, pulleys, and other moving parts of the engine.

Throughout this manual **CAUTIONS** and **WARNINGS** regarding personal safety and **NOTES** regarding engine performance or service life will appear. To avoid personal injury and ensure long engine service life, always follow these instructions.

Whenever possible, it will benefit to rely on an authorized Detroit™ service outlet for any service needs from maintenance to major parts replacement. Authorized service outlets worldwide stock factory-original parts.

The information and specifications in this publication are based on the information in effect at the time of approval for printing. Contact an authorized Detroit™ service outlet for information on the latest revision. The right is reserved to make changes at any time without obligation.

Detroit™ engines are built in accordance with sound technological principles and based on state-of-the-art technology. Despite this, the engine may constitute a risk of damage to property or injury to persons if it is not used for its intended purpose.

The engine should not be modified or converted in an incorrect manner, nor should the safety instructions included in this manual be disregarded.

## Warranty

The applicable engine warranty information is contained in the booklet "Warranty Information for Detroit™ Engines," available from authorized Detroit™ service outlets.

## Trademark Information

DDC<sup>®</sup>, Detroit<sup>™</sup>, DDEC<sup>®</sup>, Optimized Idle<sup>®</sup>, DiagnosticLink<sup>®</sup>, BlueTec<sup>®</sup>, POWER Trac<sup>®</sup>, POWER COOL<sup>®</sup>, and POWER COOL PLUS<sup>®</sup> are registered trademarks of Detroit Diesel Corporation<sup>®</sup>. All other trademarks used are the property of their respective owners.



# Caution Summary

## Caution Summary

The following cautions must be observed by the operator of the vehicle or equipment in which this engine is installed and/or by those performing basic engine preventive maintenance. Failure to read and heed these cautions and exercise reasonable care for personal safety and the safety of others when operating the vehicle/equipment or performing basic engine preventive maintenance may result in personal injury and engine and/or vehicle/equipment damage.

### Engine Operation

Observe the following cautions when operating the engine.



#### **WARNING: PERSONAL INJURY**

To avoid injury from loss of vehicle/vessel control, the operator of a DDEC equipped engine must not use or read any diagnostic tool while the vehicle/vessel is moving.



#### **WARNING: HOT EXHAUST**

During parked regeneration the exhaust gases will be extremely HOT and could cause a fire if directed at combustible materials. The vehicle must be parked outside.



#### **CAUTION: LOSS OF VEHICLE CONTROL**

To avoid injury from the loss of vehicle control, do not use cruise control under these conditions:

- When it is not possible to keep the vehicle at a constant speed (on winding roads, in heavy traffic, in traffic that varies in speed, etc.).
- On slippery roads (wet pavement, ice- or snow-covered roads, loose gravel, etc.).



**WARNING: PERSONAL INJURY**

Diesel engine exhaust and some of its constituents are known to the State of California to cause cancer, birth defects, and other reproductive harm.

- Always start and operate an engine in a well ventilated area.
- If operating an engine in an enclosed area, vent the exhaust to the outside.
- Do not modify or tamper with the exhaust system or emission control system.



**WARNING: PERSONAL INJURY**

To avoid injury from engine shutdown in an unsafe situation, ensure the operator knows how to override the stop engine condition on a DDEC-equipped unit.



**CAUTION: LOSS OF VEHICLE CONTROL**

To avoid injury from loss of vehicle control, do not activate the Engine Brake system under the following conditions:

- On wet or slippery pavement, unless the vehicle is equipped with ABS (anti-lock braking system) and you have had prior experience driving under these conditions.
- When driving without a trailer (bobtailing) or pulling an empty trailer.
- If the tractor drive wheels begin to lock or there is fishtail motion after the Engine Brake is activated, deactivate the brake system immediately if this occurs.



**WARNING: BODILY INJURY**

To avoid injury from an explosion, do not use ether or starting fluid on engines equipped with a manifold (grid) heater.

**Preventive Maintenance**

Observe the following cautions when performing preventive maintenance.



**WARNING: PERSONAL INJURY**

To avoid injury when working near or on an operating engine, remove loose items of clothing and jewelry. Tie back or contain long hair that could be caught in any moving part causing injury.

**WARNING: PERSONAL INJURY**

To avoid injury when working on or near an operating engine, wear protective clothing, eye protection, and hearing protection.

**WARNING: HOT OIL**

To avoid injury from hot oil, do not operate the engine with the rocker cover(s) removed.

**WARNING: FIRE**

To avoid injury from fire, contain and eliminate leaks of flammable fluids as they occur. Failure to eliminate leaks could result in fire.

**CAUTION: USED ENGINE OIL**

To avoid injury to skin from contact with the contaminants in used engine oil, wear protective gloves and apron.

**WARNING: PERSONAL INJURY**

To avoid injury when using caustic cleaning agents, follow the chemical manufacturers usage, disposal, and safety instructions.

**WARNING: PERSONAL INJURY**

To avoid injury from hot surfaces, wear protective gloves, or allow engine to cool before removing any component.

**WARNING: PERSONAL INJURY**

To avoid injury, use care when working around moving belts and rotating parts on the engine.

**WARNING: FIRE**

To avoid injury from combustion of heated lubricating-oil vapors, stop the engine immediately if an oil leak is detected.



**WARNING: PERSONAL INJURY**

To avoid injury from contact with rotating parts when an engine is operating with the air inlet piping removed, install an air inlet screen shield over the turbocharger air inlet. The shield prevents contact with rotating parts.



**WARNING: HOT COOLANT**

To avoid scalding from the expulsion of hot coolant, never remove the cooling system pressure cap while the engine is at operating temperature. Wear adequate protective clothing (face shield, rubber gloves, apron, and boots). Remove the cap slowly to relieve pressure.



**WARNING: FIRE**

To avoid injury from fire, do not smoke or allow open flames when working on an operating engine.



**WARNING: FIRE**

To avoid injury from fire from a buildup of volatile vapors, keep the engine area well ventilated during operation.



**WARNING: PERSONAL INJURY**

To avoid injury from rotating belts and fans, do not remove and discard safety guards.



**WARNING: PERSONAL INJURY**

To avoid injury from slipping and falling, immediately clean up any spilled liquids.

## Compressed Air

Observe the following cautions when using compressed air.



**WARNING: EYE INJURY**

To avoid injury from flying debris when using compressed air, wear adequate eye protection (face shield or safety goggles) and do not exceed 276 kPa (40 psi) air pressure.

## Cooling System

Observe the following cautions when servicing the cooling system.



### **WARNING: HOT COOLANT**

To avoid scalding from the expulsion of hot coolant, never remove the cooling system pressure cap while the engine is at operating temperature. Wear adequate protective clothing (face shield, rubber gloves, apron, and boots). Remove the cap slowly to relieve pressure.



### **WARNING: PERSONAL INJURY**

To avoid injury from slipping and falling, immediately clean up any spilled liquids.

## Electrical System

Observe the following cautions when jump starting an engine, charging a battery, or working with the vehicle/application electrical system.



### **WARNING: ELECTRICAL SHOCK**

To avoid injury from electrical shock, do not touch battery terminals, alternator terminals, or wiring cables while the engine is operating.



### **WARNING: Battery Explosion and Acid Burn**

To avoid injury from battery explosion or contact with battery acid, work in a well ventilated area, wear protective clothing, and avoid sparks or flames near the battery. If you come in contact with battery acid:

- Flush your skin with water.
- Apply baking soda or lime to help neutralize the acid.
- Flush your eyes with water.
- Get medical attention immediately.



### **WARNING: PERSONAL INJURY**

To avoid injury from accidental engine startup while servicing the engine, disconnect/disable the starting system.

## Air Intake System

Observe the following cautions when working on the air intake system.



**WARNING: PERSONAL INJURY**

To avoid injury from hot surfaces, wear protective gloves, or allow engine to cool before removing any component.



**WARNING: PERSONAL INJURY**

To avoid injury from contact with rotating parts when an engine is operating with the air inlet piping removed, install an air inlet screen shield over the turbocharger air inlet. The shield prevents contact with rotating parts.

### Lubricating Oil and Filters

Observe the following cautions when replacing the engine lubricating oil and filter.



**WARNING: PERSONAL INJURY**

To avoid injury from slipping and falling, immediately clean up any spilled liquids.



**WARNING: FIRE**

To avoid injury from combustion of heated lubricating-oil vapors, stop the engine immediately if an oil leak is detected.



**WARNING: FIRE**

To avoid injury from fire, do not smoke or allow open flames when working on an operating engine.



**WARNING: FIRE**

To avoid injury from fire from a buildup of volatile vapors, keep the engine area well ventilated during operation.

### Fuel System

Observe the following cautions when fueling the vehicle or working with the fuel system.



**WARNING: FIRE**

To avoid injury from fire, keep all potential ignition sources away from diesel fuel, including open flames, sparks, and electrical resistance heating elements. Do not smoke when refueling.

**WARNING: PERSONAL INJURY**

To prevent the escape of high pressure fuel that can penetrate skin, ensure the engine has been shut down for a minimum of 10 minutes before servicing any component within the high pressure circuit. Residual high fuel pressure may be present within the circuit.

**WARNING: FIRE**

To avoid increased risk of a fuel fire, do not mix gasoline and diesel fuel.

**WARNING: FIRE**

To avoid injury from fire caused by heated diesel-fuel vapors:

- Keep those people who are not directly involved in servicing away from the engine.
- Stop the engine immediately if a fuel leak is detected.
- Do not smoke or allow open flames when working on an operating engine.
- Wear adequate protective clothing (face shield, insulated gloves and apron, etc.).
- To prevent a buildup of potentially volatile vapors, keep the engine area well ventilated during operation.

**Aftertreatment System**

Observe the following cautions when servicing the Aftertreatment System (ATS). Be advised that these two labels are attached to the Aftertreatment Device (ATD).



47158



47157



# Engine Components

## Engine Components

The following sections will be covered in this chapter:

- DD13 Engine Components
- DD15 Engine Components
- Engine Model and Serial Number

## DD13 Engine Components

Detroit™ Gen 5 Heavy Duty DD13 major engine components are shown below:

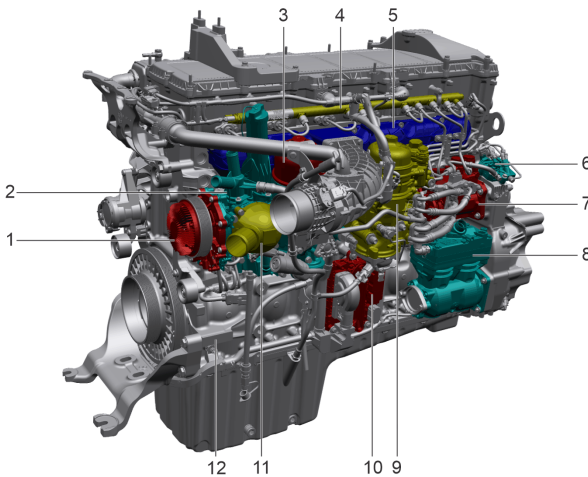

d010442

- |                                 |                                   |
|---------------------------------|-----------------------------------|
| 1. Water Pump                   | 7. High Pressure Fuel Pump        |
| 2. Oil Coolant Module           | 8. Air Compressor                 |
| 3. Oil Filter                   | 9. Fuel Filter Module             |
| 4. High Pressure Fuel Rail      | 10. Motor Control Module (MCM)    |
| 5. Air Intake Manifold          | 11. Coolant Thermostat            |
| 6. Hydrocarbon Fuel Doser Block | 12. Engine Serial Number Location |

**Figure 1. DD13 Left Side View**

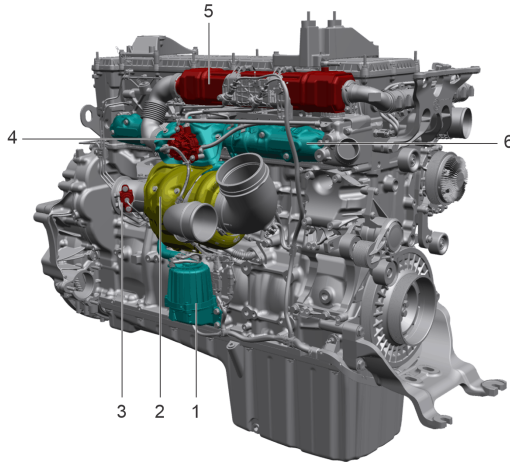

d010443

- 1. Crankcase Breather
- 2. Turbocharger
- 3. Fuel Doser Injector Valve
- 4. Exhaust Gas Recirculation (EGR) Valve Actuator
- 5. EGR Cooler
- 6. Exhaust Manifold

**Figure 2. DD13 Right Side View**

## DD15 Engine Components

Detroit™ Gen 5 Heavy Duty DD15 major engine components are shown below:

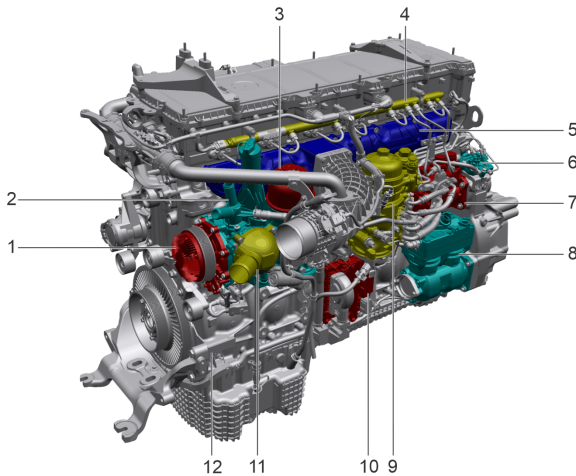

d010444

- |                                 |                                   |
|---------------------------------|-----------------------------------|
| 1. Water Pump                   | 7. High Pressure Fuel Pump        |
| 2. Oil Coolant Module           | 8. Air Compressor                 |
| 3. Oil Filter                   | 9. Fuel Filter Module             |
| 4. High Pressure Fuel Rail      | 10. Motor Control Module (MCM)    |
| 5. Air Intake Manifold          | 11. Coolant Thermostat            |
| 6. Hydrocarbon Fuel Doser Block | 12. Engine Serial Number Location |

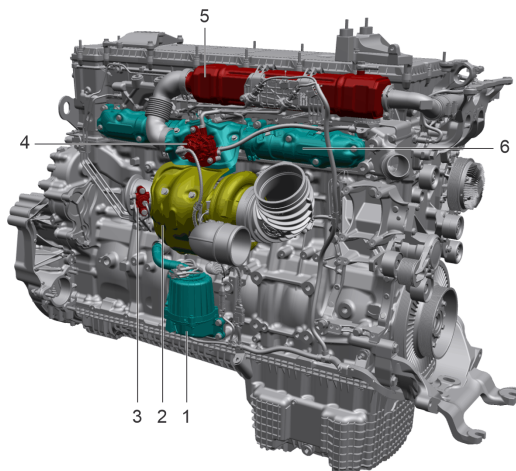
**Figure 3. DD15 Left Side View**

d010445

- |                              |   |
|------------------------------|---|
| 1. Crankcase Breather        | 4. Exhaust Gas Recirculation (EGR) Valve Actuator |
| 2. Turbocharger              | 5. EGR Cooler                                     |
| 3. Fuel Doser Injector Valve | 6. Exhaust Manifold                               |

**Figure 4. DD15 Right Side View**

## Engine Model and Serial Number Designation

The section covers engine model number, serial number and the locations of this information on the engine.

### Engine Model and Serial Number

The fourteen-digit engine model and manufacturing serial number is etched on a pad located on the left front of the engine cylinder block, above the date and time of manufacture. Using 472912S0608850 as an example:

- 472 = engine type (DD15)
- 912 = model
- S = assembly plant (Detroit™)
- 0608850 = serial number

### Engine Model Breakdown

**Table 1.**

HEAVY DUTY MODEL BREAKDOWN		
DESCRIPTION	ENGINE MODEL	DISPLACE-MENT
DD15	472912	14.8 L (DD15)
DD13	471952	12.8 L (DD13)

**Motor Control Module and Engine Serial Number**

The Motor Control Module (MCM) part number and Engine Serial Number (ESN) are located on the MCM label (see graphic below).

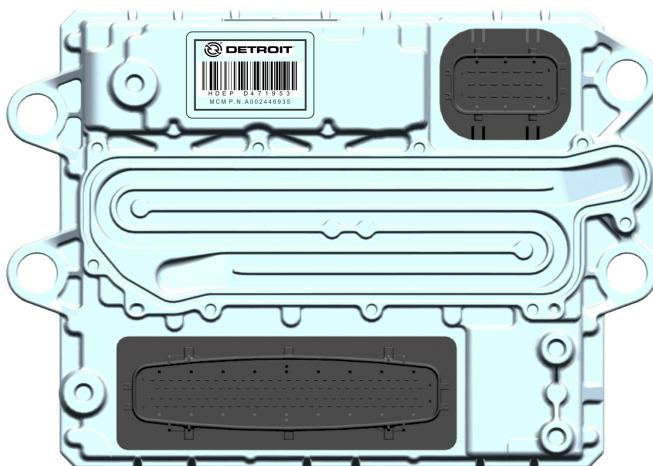

d000071

**Figure 5. Motor Control Module Label**

**Engine Certification Label**

An engine certification label is attached to the engine rocker cover. This label certifies the engine conforms to federal and state emissions regulations for its application. It gives the operating conditions under which certification was made (see graphic below).

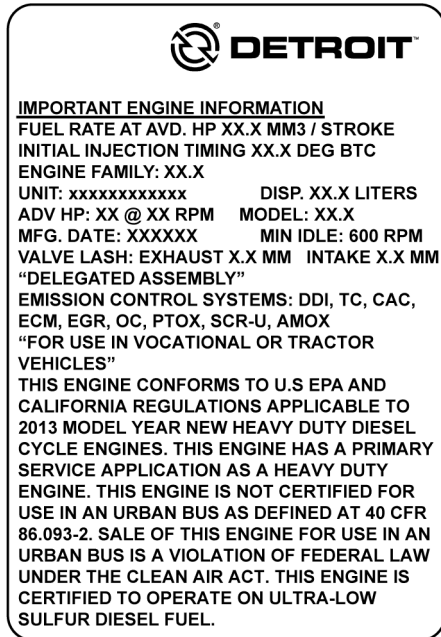

d990003d

**Figure 6. Motor Control Module Label**

# Engine Operation

## Engine Operation

This chapter will discuss how to properly operate a Detroit™ Gen 5 Heavy Duty engine. This chapter is broken down into sections that discuss various conditions of engine operation.

The following sections will be covered in this chapter:

- First Time Engine Operation
  - Engine First Start Preparations
  - Starting the Engine for the First Time
- Engine Start and Routine Operation
  - Starting the Engine
  - Idling the Engine
  - Running the Engine
  - Shutting Down the Engine
  - Cold Weather Operation
  - Monitoring the Engine Operation
- Shifting a Manual Transmission
- Vehicle Emergency Operation
  - Emergency Running Mode
  - Emergency Jump Starting
  - Stop Engine Override Option

## First Time Engine Operation

### Engine First Time Start Preparations

When preparing to start a new or newly overhauled engine, perform all of the operations listed below. Failure to follow these instructions may result in serious engine damage. This procedure includes the use of special tools to prime the fuel system. Authorized Detroit™ service outlets are properly equipped for this type of service. Never use the starting motor and fuel pump to prime the fuel system. Prolonged use of the starting motor and fuel pump to prime the fuel system can result in damage to the starter, fuel pump, and injectors.

Be sure to be familiar with all of the instruments, gauges and controls which are needed to operate the engine.

Note the location and function of the following:

- Oil pressure gauge
- Low oil pressure indicator
- Coolant temperature gauge

- High coolant temperature indicator
- Water-in-Fuel warning indicator
- Air restriction indicator

Watch for any signs of engine problems when starting or driving. If the engine overheats, uses excessive fuel or lubricating oil, vibrates, misfires, makes unusual noises or shows an unusual loss of power, turn the engine off as soon as possible and contact an authorized Detroit™ service outlet for further instructions. Engine damage may be avoided by a quick response to early indications of problems.

## After an Extended Storage

An engine in storage for an extended period of time (over winter, for example) may accumulate water in the oil pan through normal condensation of moisture (always present in the air) on the cold, internal surfaces of the engine.

Lubricating oil diluted by water cannot provide adequate bearing protection at engine startup leading to serious engine damage. For this reason, Detroit™ recommends replacing the engine lubricating oil and filter after extended storage.

## Checking the Cooling System

Check the cooling system as follows:

1. Make sure all draincocks in the cooling system are installed and are closed tightly.
2. Fill the coolant overflow surge tank with approved coolant; Refer to section "How to Select Coolants" until the coolant level stays between the low and full coolant marks on the tank. Do not overfill the coolant as overfilling will cause the surge tank to push coolant out.
3. Entrapped air must be purged after filling the cooling system. To do this, warm up the engine with the pressure cap removed. With the transmission in neutral, increase engine speed to 1000 rpm and add coolant to the surge tank as needed.
4. Check to make sure the front of the radiator and charge air cooler are unblocked and free of debris.

## Lubrication System Checks

The lubricating oil film on the rotating parts and bearings of a new or newly overhauled engine, or one which has been in storage for six months or more, may be insufficient when the engine is started for the first time.

To ensure an immediate flow of oil to all bearing surfaces at initial engine startup, prepare the engine as follows:

1. Charge the engine lubrication system with lubricating oil using a commercially-available pressure pre-lubricator. Fill the engine to the proper level with the recommended viscosity and grade of engine oil, Refer to section "Synthetic Oils and Additives".
2. After pre-lubricating, check the lubricating oil level, Refer to section "How to Check the Lubricating Oil Level". If necessary, top off by filling engine oil no more than 5.0 L (5.2 qt) at a time. Do not overfill as overfilling the oil pan can cause engine damage.

## Fuel System Checks

Make sure the fuel shutoff valve (if used) is open. If the shutoff valve is even partially closed, it may cause erratic engine operation due to an inadequate supply of fuel to the fuel pump. Fill the tanks with the recommended fuel. Keeping tanks full reduces water condensation and helps keep fuel cool, which is important to engine performance. Full tanks also reduce the chance for microbe (black slime) growth. For fuel recommendations, Refer to section "How to Select Fuel".

Do not use external starting aids. If an external starting aid is used, such as a starting fluid, the heat generated by the external fuel source will cause the injector tips to be damaged when the fuel cools them. The internal injector components can be scored from running without lubrication.

If air has entered the fuel system, the fuel system must be primed to ensure prompt starting and even running. Priming the fuel system includes the use of special tools. Authorized Detroit™ service outlets are properly equipped for this type of service. Never use the starting motor and fuel pump to prime the fuel system. Prolonged use of the starting motor and fuel pump to prime the fuel system can result in damage to the starter, fuel pump, and injectors. Priming of the fuel system is required if the fuel system has been opened.

Drain off any water that has accumulated in the coalescer. Water in fuel can seriously affect engine performance and may cause engine damage, Refer to section "How to Drain the Fuel Coalescer".

## Adding Fuel

To ensure maximum engine performance, always use Detroit™ approved fuels, Refer to section "How to Select Fuel". Higher sulfur levels will damage the engine Aftertreatment System (ATS).

When adding fuel, pay attention to the following:

1. Add winter or summer grade fuel according to the season of the year.
2. Work in the cleanest conditions possible.
3. Prevent water from entering the fuel tank.

## Checking Other Engine and ATS Related Parts

Check the engine compartment as follows:



1. Make sure the transmission is filled to the proper level with the fluid recommended by the transmission manufacturer. Do not overfill.
2. The Diesel Exhaust Fluid (DEF) must be checked and filled regularly with DEF meeting Detroit™ quality specification, Refer to section "Diesel Exhaust Fluid Availability".
3. Make sure cable connections to the storage batteries are clean and tight.
4. Check batteries, Refer to section "Inspection of the Batteries".

## Starting the Engine for the First Time

To start the engine, the transmission should be in neutral and the ignition key turned to the ON position.

At the start of every ignition cycle, the instrument panel indicator lights will come on. This is the result of the electronic engine control system, called Detroit Diesel Electronic Control® (DDEC®), diagnosing the system to ensure everything is functional, including the cluster for the warning indicators. If no faults are detected, all indicators will go out in approximately five seconds.

The warning indicators must go out before starting the engine. If the warning indicators stay on, or do not come on momentarily after turning on the ignition, contact an authorized Detroit™ service outlet. Operating the engine under these circumstances may result in engine damage.

## Engine Start and Routine Operation

### Starting the Engine

Check as follows:

Before starting the engine, carefully read all operating instructions in this manual and do all the recommended pre-trip inspections and daily maintenance. Check the coolant level, Refer to section "Inspection of the Cooling System". Check the lubricating oil level, Refer to section "How to Check the Lubricating Oil Level". Check fuel levels, and drain contaminants from the fuel coalescer, Refer to section "How to Drain the Fuel Coalescer".

1. Place the transmission in neutral, and set the parking brake.
2. Turn on the ignition (key ON, engine OFF).
3. Wait for the engine warning indicators on the instrument panel to go out.



**WARNING: PERSONAL INJURY**

Diesel engine exhaust and some of its constituents are known to the State of California to cause cancer, birth defects, and other reproductive harm.

- Always start and operate an engine in a well ventilated area.
- If operating an engine in an enclosed area, vent the exhaust to the outside.
- Do not modify or tamper with the exhaust system or emission control system.



**WARNING: PERSONAL INJURY**

To avoid injury before starting and running the engine, ensure the vehicle is parked on a level surface, parking brake is set, and the wheels are blocked.



**WARNING: ENGINE EXHAUST**

To avoid injury from inhaling engine exhaust, always operate the engine in a well-ventilated area. Engine exhaust is toxic.

4. Rotate the ignition to start the engine. To prevent serious starter motor damage, release the ignition switch immediately after the engine has started.
5. If the engine does not start after 20 seconds, stop. Try again after waiting for 60 seconds.
6. Monitor the oil pressure gauge immediately after starting the engine. Refer to section "Checking the Oil Pressure"
7. Do not place the engine under full load until it reaches operating temperature.
8. Check the engine for leaks. If any leaks are found, shut down the engine immediately and have the leaks repaired by an authorized Detroit™ service outlet.
  - Check all hoses, hose clamps, and pipe unions on the engine for tightness.
  - Check the oil feed and return lines at the turbocharger for leaks.
  - Check for coolant, fuel, or lubricating oil leaks.
9. Shut down the engine.
10. Check the lubricating oil level, Refer to section "How to Check the Lubricating Oil Level".
11. Inspect the cooling system, Refer to section "Inspection of the Cooling System".

## Idling the Engine

The common belief that idling a diesel engine causes no engine damage is wrong. Idling produces sulfuric acid, which is absorbed by the lubricating oil and eats into bearings, rings, valve stems and engine surfaces. During long engine idling periods, the engine coolant temperature may fall below the normal operating range. The incomplete combustion of fuel in a cold engine will cause crankcase oil dilution, formation of lacquer or gummy deposits on the valves, pistons, and rings, and rapid accumulation of sludge in the engine. If the operator must idle the engine for cab heat or cooling, the high idle function of the cruise control switches should be used. For more information on high idle using the cruise control switches, Refer to section "Detroit Diesel Electronic Control System Features". An idle speed of 900 rpm should be enough to provide cab heat in above 0°C (32°F) temperatures. Never allow the engine to idle for more than 30 minutes. When prolonged idling is necessary, maintain an engine speed of 900 rpm.

## Running the Engine

While the engine is operating, monitor the battery charge indicator and the oil pressure. Unnecessary idling should be avoided whenever possible.

## Checking the Oil Pressure

Monitor the oil pressure as follows:

1. Observe the oil pressure gauge immediately after starting the engine. An oil pressure gauge that registers 50 psi (3.4 bar) is a good indicator that all moving parts are getting lubrication. The engine oil pressure operating ranges for Detroit™ Gen 5 Heavy Duty engines are listed in the table below.
2. If low oil pressure is indicated contact an authorized Detroit™ service outlet for further instructions.

**Table 2.**

Oil Pressure Operating Ranges	
50 psi (3.4 bar)	Normal Oil Pressure
25 psi (1.7 bar)	Low Oil Pressure
0 psi (0 bar)	Very Low Oil Pressure

## Warming up the Engine

Run the engine at part throttle for about five minutes to allow it to warm up before applying a load.

## Checking the Transmission

While the engine is idling, check the automatic transmission (if equipped) for proper oil level and add oil as required. For additional information on checking the transmission, Refer to the Original Equipment Manufacturer (OEM) literature and the Transmission Fluid Service brochure DDC-SVC-BRO-0118.

## Checking the Turbocharger

Check the turbocharger as follows:

1. Make a visual inspection of the turbocharger for oil leaks, exhaust leaks, excessive noise, or vibration.
2. If a leak, unusual noise, or vibration is noted, stop the engine immediately. Do not restart the engine until the cause of the concern has been investigated and corrected. Authorized Detroit™ service outlets are properly equipped for this type of service.

## Monitoring the Engine Speed

During operation of the vehicle, the operator should limit the engine speed to 1900 rpm or less. No extra engine power is achieved at engine speeds above 1900 rpm. Shifting gears without pressing the clutch, or using the engine brakes to reduce engine speed, may result in serious powertrain damage due to higher engine speeds. Never exceed 2000 rpm; higher engine speeds may result in extensive engine damage.

**NOTICE:** Any engine overspeed (engine speed exceeds 2500 rpm) while the vehicle is moving (vehicle speed over 0 MPH) is considered to be an operator-induced engine overspeed. Any mechanical engine failure within 2000 miles (3218 km) of an operator-induced engine overspeed event will not be eligible for warranty coverage.

## Shutting Down the Engine

Immediately shutting down the engine should be avoided. Shutting the engine off immediately retains more cylinder block heat than if the engine runs at idle for five minutes. If any of the following conditions occur, shut down the engine immediately:

- The oil pressure swings back and forth or falls sharply.
- Engine power and rpm fall, even though the accelerator pedal remains steady.
- The exhaust pipe gives off heavy smoke.
- The coolant and/or oil temperature climb abnormally.
- Abnormal sounds suddenly occur in the engine or turbocharger.

Contact an authorized Detroit™ service outlet if any of the above conditions is present.

Stop an engine under normal operating conditions as follows:

1. Reduce engine speed to idle and place the transmission in neutral.
2. Allow the engine to run between idle and 1000 rpm with no load for five minutes. This allows the engine to cool and permits the turbocharger to slow down. After five minutes, shut down the engine.

## Cold Weather Operation

Special precautions must be taken to protect the engine during cold weather. To avoid engine damage, do not use any type of aerosol spray, e.g., ether, starting fluid or brake cleaner to aid in starting the engine.

## Winter Fronts

Winter fronts on Detroit™ Gen 5 Heavy Duty engines are seldom necessary due to the modern design of the engine cooling system. The coolant thermostat is mounted on the inlet side of the cooling system and regulates coolant flow from the radiator into the engine. The thermostat regulates coolant flow to control the temperature of the coolant within the coolant circuit. The following benefits are a result from regulating the coolant at the inlet temperature side of the engine:

- Reduced thermal cycling of the engine
- Operating temperature is reached faster
- Improved vehicle heating because of better temperature regulation

The use of a winter front should be avoided as this has been shown to cause false fault codes and performance issues with the engine and aftertreatment system.

Winter fronts can result in the following:

- Excessive fan run time due to higher Charge Air Cooler (CAC) outlet temperatures resulting from low air flow through the CAC.
- Increased fuel consumption.
- Failure of the DEF system heaters to turn on when needed due to incorrect temperature calculations. This results in fault codes, poor performance of the aftertreatment system, and power reduction.
- Failure of critical emission equipment that will result in vehicle speed inducement to a maximum of 5 mph.

There are two specific situations where a winter front may be temporarily needed:

- To improve cab heating while idling under extreme cold ambient temperature.
- When the ambient temperature remains below  $-30^{\circ}\text{C}$  ( $-22^{\circ}\text{F}$ ) and the engine is unable to maintain running coolant temperature of  $80^{\circ}\text{C}$  ( $175^{\circ}\text{F}$ ) during normal over-the-road operation

If either of the above situations is encountered, a winter front may be temporarily used. A minimum of 25% of the grille must be open in sectioned stripes that run perpendicular to the charge air cooler tube flow direction. This assures even cooling across each tube and reduces header-to-tube stress and possible failure.

## **Monitoring the Engine Operation**

While the engine is operating, monitor the instrument panel indicators, battery charge indicator and the oil pressure. Unnecessary idling should be avoided whenever possible. When prolonged idling is necessary, maintain an engine speed of 900 rpm.

## **Monitoring the Oil Pressure**

When the engine has reached its normal operating temperature, the engine oil pressure must not drop below the normal operating range.

If oil pressure drops below the normal operating range or if an oil pressure warning indicator becomes active, stop the engine and determine the cause. It may be necessary to take the vehicle to an authorized Detroit™ service outlet.

## **Monitoring the Instrument Panel**

During engine operation, monitor the instrument panel and instrument panel indicators for any warnings or messages concerning the vehicle's operating status. The instrument panel will display engine speed, vehicle speed, as well as alert the driver of various temperatures, pressures and other vehicle conditions. For more information, Refer to section "Instrument Panel Indicators". If the instrument panel indicates a malfunction, the operator is responsible to take action to avoid equipment damage.

## **Monitoring the Battery Charging System**

The battery charge indicator must turn off once the engine starts. If the indicator comes on while the engine is running, do the following:

1. Shut down the engine.
2. Have the charging system and batteries tested. Authorized Detroit™ service outlets are properly equipped for these types of service

## **Shifting a Manual Transmission**

### **Shifting a Manual Transmission**

Depending on the transmission model, the gear split may vary from 400 to 500 rpm. The electronic governor provides almost no overrun capability and if the transmission is downshifted too early, a temporary loss of pulling power will be experienced until the engine speed falls below rated speed.

In general, when using a 7- or 9-speed transmission, the operator should always downshift between 1150 and 1250 rpm for the DD13 and between 1000 and 1100 rpm for the DD15. This is true even on steep grades with heavy loads. When using an 18-, 15-, or 13-speed transmission, the operator will need to downshift at an rpm that allows "less than rated" rpm before throttle application in the next gear down. The operator may want to limit engine speed to 1900 rpm in all gears as fuel economy is not as efficient above 1800 rpm.

## Vehicle Emergency Operation

### Emergency Running Mode

Detroit™ Gen 5 Heavy Duty engines are equipped with Detroit Diesel Electronic Control® (DDEC®) which monitors and controls the Detroit™ powertrain functions and operation. As soon as an engine fault is detected, it is evaluated and one of the following measures is initiated.

- DDEC® will turn on an instrument panel indicator when certain predetermined conditions are present.
- If the fault is serious enough to impair normal operation, DDEC® switches over to a limp mode. The limp speed is dependent on engine control parameters and could be as low as 1000 rpm. This allows the operator to safely move the vehicle to a service location or a safe stopping area.

To prevent possible serious equipment damage, have any faults corrected immediately by an authorized Detroit™ service outlet.

### Emergency Jump Starting

The engine's electronic system operates on 12 volts DC. If a Detroit™ Gen 5 Heavy Duty engine requires emergency jump starting, do not exceed 16 volts DC as this may damage the MCM and or other electrical equipment.

Before attempting to jump start the engine, the jumper cables must be connected using the sequence of first, positive-to-positive, and then last, negative-to-chassis or suitable ground. Reversing battery polarity may damage the electrical equipment. Failure to connect jumper cables in the proper sequence can result in alternator and/or equipment damage.

### Stop Engine Override Option

The engine shutdown feature is designed to prevent engine damage from occurring; extending the engine run time during an engine shutdown could cause engine damage. The Stop Engine Override feature allows the operator to override the automatic stop engine sequence. Only use the Stop Engine Override during emergency situations where moving the vehicle to a safe location is critical. The

override should not be used for extended periods of time. For more information on Stop Engine Override, Refer to section "Detroit Diesel Electronic Control System Operation".



# Detroit Diesel Electronic Controls System

## Detroit Diesel Electronic Controls System

All Detroit™ Gen 5 Heavy Duty engines are equipped with an electronic control system called Detroit Diesel Electronic Control® (DDEC®). The DDEC ® system monitors the functions that regulates the Detroit™ powertrain.

The following sections will be covered in this chapter:

- Detroit Diesel Electronic Control System Operation
  - Common Powertrain Controller
  - Motor Control Module
  - Aftertreatment Control Module
  - Transmission Control Module
  - Check Engine Indicator
  - Stop Engine Indicator
  - Stop Engine Override
  - Engine Power Reduction
- Detroit Diesel Electronic Control System Features
  - Cruise Control
  - Data Recording
  - DDEC ® Protection System
  - Engine Brake
  - Idle Shutdown Timer

## Detroit Diesel Electronic Control System Operation

### Detroit Diesel Electronic Control System Operation

Detroit™ Gen 5 Heavy Duty engines are equipped with Detroit Diesel Electronic Control® (DDEC®) software. This software assures optimal engine performance. The installation of software upgrades may cause minor changes in features and engine performance.

During normal operation the DDEC ® system requires 12 volts to operate. However, in the event of a power supply malfunction, the system will continue to operate at reduced voltage. When this occurs, the Check Engine Indicator will be activated. The engine will only operate at reduced rpm until the battery voltage reaches a point where DDEC ® will no longer function and the engine shuts down.

The engine and powertrain operation is monitored and controlled via a series of sensors, electronic valves, solenoids and switches. The system has three to four control modules; four if equipped with a Detroit Transmission:

- Common Powertrain Controller (CPC)
- Motor Control Module (MCM)

- Aftertreatment Control Module (ACM)
- Transmission Control Module (TCM)

The four control modules are connected by a proprietary datalink through which all necessary data and information can be exchanged.

## Common Powertrain Controller

The CPC is typically located in the cab, behind the dash (see graphic below).

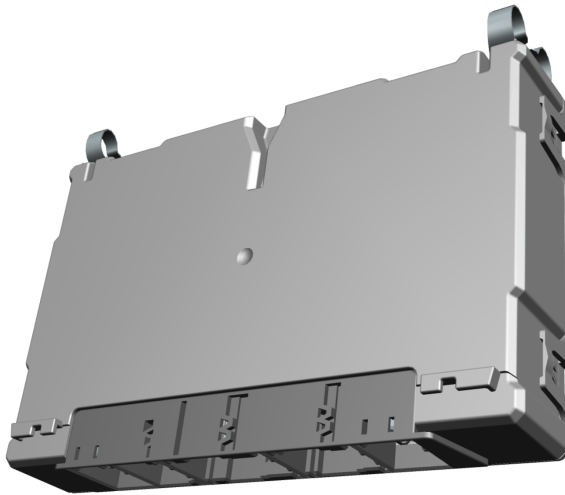

d500375

### Figure 7. Common Powertrain Controller

The CPC communicates with other control units installed on the vehicle including the MCM, the ACM and the TCM (if equipped) over the data link. Data for specific applications is stored in the CPC. These include idle speed, maximum running speed, and speed limitation. From this data, instructions are calculated for controlling the vehicle and transmitted to the CPC via the proprietary datalink.

## Motor Control Module

The MCM is located on the left-hand side of the engine (see graphic below).

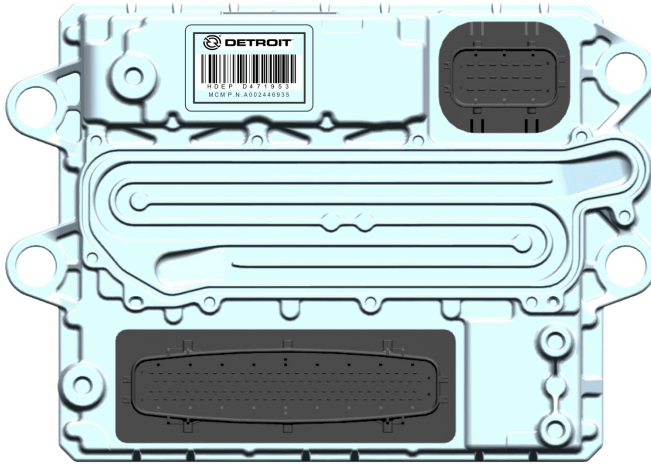

d000071

### Figure 8. Motor Control Module

The MCM processes the data received from the CPC, for example the position of the accelerator pedal, engine brake, etc. The data is evaluated together with the data from the sensors on the engine, such as coolant and fuel temperature, and oil pressure. The data is then compared to the characteristic maps or lines stored in the MCM. From this data, quantity and timing of injection can be calculated.

### Aftertreatment Control Module

The ACM is located on the back side of the Aftertreatment System (ATS) (see graphic below).

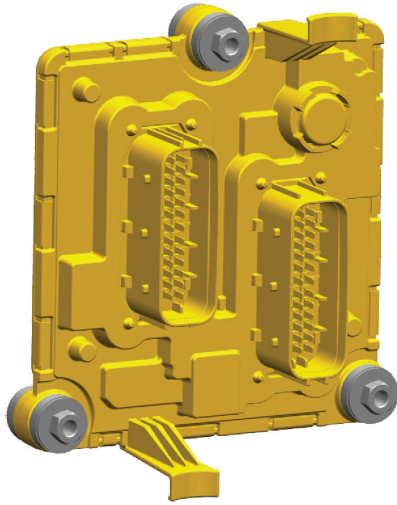

d141015

### **Figure 9. Aftertreatment Control Module**

The ACM controls the aftertreatment functions. When a malfunction or other problem is detected, the system selects an appropriate response to deliver to the operator. The ACM uses the inputs from the sensors to control the ATS. The data is compared to the characteristic maps stored in the ACM.

### **Transmission Control Module**

Vehicles equipped with a Detroit Transmission will also be equipped with a TCM. The TCM will be mounted on the left side of the transmission (see graphic below).



d500374

### Figure 10. Transmission Control Module

The TCM includes control logic to provide overall Transmission management. The TCM monitors various speed, load, and clutch inputs in conjunction with the CPC, which drive the outputs that are required to shift the Transmission.

## Check Engine Indicator

Should the Check Engine Indicator come on for any reason, the vehicle can still be operated and the driver can proceed to the required destination. This condition should be reported to an authorized Detroit™ service outlet .

Depending on the fault, DDEC® can give a warning only, ramp down engine power or initiate a shut down. Ramp down will reduce engine power to a predetermined value, but will not shut down the engine. With the shutdown option, the engine will begin a stepped power down sequence until it shuts down completely.

## Stop Engine Indicator

When the Stop Engine Indicator comes on, the system has detected a major malfunction that requires immediate attention. It is the operator's responsibility to shut down the engine to avoid serious damage.

The conditions that will cause the Stop Engine Indicator to come on are:

- High coolant temperature
- Low coolant level
- High oil temperature
- Low oil pressure
- Auxiliary shutdown

Whenever the Check Engine or Stop Engine Indicator comes on, the DDEC<sup>®</sup> system will identify the fault and store this information in its memory. If the malfunction is intermittent, the warning indicator will come on and go off as the system senses the changing engine condition.

## **Stop Engine Override**

The engine shutdown feature is designed to prevent engine damage from occurring and extending the engine run time during an engine shutdown can cause engine damage. The Stop Engine Override feature allows the operator to override the automatic stop engine sequence. Only use the Stop Engine Override during emergency situations where moving the vehicle to a safe location is critical. It should not be used for extended periods of time. DDEC<sup>®</sup>, will record the number of times the override is activated after an engine fault occurs.

A Stop Engine Override is used to override the engine shutdown sequence. This override resets the 60 second (30 second for oil pressure) shutdown timer, restoring power to the level when the Stop Engine Indicator was illuminated. The Stop Engine Override switch must be recycled after five seconds to obtain a subsequent override. Continuously activating the Stop Engine Override will not prevent the engine shutdown sequence.

It takes 30 seconds from the time the automatic shutdown sequence begins until engine shutdown. Therefore, the operator must select the override just prior to engine shutdown and continue to do so until the vehicle can be brought to a stop in a safe location. Once the vehicle is in a safe location do not continue to run the engine. The operator has the responsibility to take action to avoid equipment damage.

## **Engine Power Reduction and Shutdown**

During engine power reduction an engine power ramp down will reduce engine power to a predetermined value, but will not shut down the engine. With the shutdown option, the engine will begin a stepped power down sequence until it shuts down completely.

The engine should not be restarted after it has been shut down by the engine protection system, unless the problem has been located and corrected. It is the operator's responsibility to shut down the engine to avoid serious damage.

## **Detroit Diesel Electronic Control System Features**

### **Detroit Diesel Electronic Control System Features**

The electronic control system called Detroit Diesel Electronic Control<sup>®</sup> (DDEC<sup>®</sup>) offers a variety of features and options designed to alert the operator of any engine, aftertreatment, and transmission (if equipped with DT12) malfunctions. Options

can range from warning panel indicators to automatic reduction in engine power followed by automatic engine shutdown. The DDEC<sup>®</sup> system activates an instrument panel indicator to provide a visual warning of a system malfunction or operating status. The DDEC<sup>®</sup> system has the ability to perform diagnostics for self-checks and continuous monitoring of system components.

## Cruise Control

For added driver convenience and comfort, DDEC<sup>®</sup> features a cruise control option. It can be operated in any gear above 1100 rpm or road speed faster than 32 kph (20 mph), up to the rated engine speed. It can also be programmed to hold the road speed at or below the maximum vehicle speed. For information on operating the cruise control, Refer to section "How to Operate the Cruise Control and Fast Idle".

## Data Recording

The DDEC<sup>®</sup> has the ability to extract detailed data on vehicle use and performance using DDEC<sup>®</sup> Reports software. This detailed data (or DDEC<sup>®</sup> Data) is stored in the CPC and contains information on performance such as fuel economy, idle time, and time in top gear. Critical incidents such as detailed diagnostic data records and hard braking events are also stored. DDEC<sup>®</sup> Data can be downloaded using DDEC<sup>®</sup> Reports software to produce reports.

## DDEC<sup>®</sup> Protection System

The DDEC<sup>®</sup> protection system monitors all sensors, electronic components, and recognizes system malfunctions. If a critical fault is detected, a warning indicator will illuminate. The malfunction codes are logged into the control unit's memory.

This system has a stepped-power shutdown sequence and an immediate speed reduction without shutdown feature, either of which can be triggered by a major engine malfunction, such as low oil pressure, high coolant temperature, or low coolant level. Engines equipped with the power down/shutdown option have a Stop Engine Override to allow engine operation for a short period of time. Extending the engine run time during an engine shutdown can cause equipment damage.

## Engine Brake

The engine brake is enabled by a cab mounted ON/OFF control with an intensity selection to select (HI/MED/LO) braking power. For more information on engine brakes Refer to section "Engine Brake System". For information on how to operate the engine brakes, Refer to section "How to Operate the Engine Brakes".

## **Idle Shutdown Timer**

This feature is an optional, predetermined timed idle shutdown system. Its purpose is to conserve fuel by eliminating excessive idling and allowing a turbocharger cool-down period. The idle shutdown timer activates when the transmission is in neutral with the vehicle parking brakes set and the engine is at idle or in fast-idle mode.

## **California Engine Idle Limiting**

For California (50-state) EPA certification engines that idle above 900 rpm, the California Engine Idle Limiting feature is enabled. The engine will generally shut down after five minutes of continuous idling when the transmission is in neutral or park and the parking brake is set or after 15 minutes when the transmission is in neutral or park and the parking brake is not set. The automatic shutdown feature that is applied above 900 rpm is required for all California certified engines with the exception of engines used in specific vehicle types which the state of California has determined to be exempt from the idle shutdown requirement.

Non-California (49-state) EPA certification engines have the automatic shutdown feature enabled.

In California and Opt-in states, extended idling above 900 rpm is not allowed unless the engine is performing a parked DPF regeneration or engaged in PTO operations such as pumping, hydraulics, etc.



# Engine Systems

## Engine Systems

The following sections will be covered in this chapter:

- Aftertreatment System
  - Diesel Exhaust Fluid Information
- Air System
- Cooling System
- Electrical System
- Engine Brake System
- Exhaust System and Exhaust Gas Recirculation (EGR) System
- Fuel System
- Lubrication System
  - Engine Oil Capacities

## Aftertreatment System

### Aftertreatment Systems

Detroit™ Gen 5 Heavy Duty engines are equipped with the second generation of the Global Aftertreatment System (GATS 2.0). The function of the Aftertreatment System (ATS) is to reduce emission levels in the engine exhaust. Mounted onto the ATS are eight sensors, a Diesel Exhaust Fluid (DEF) doser, and an Aftertreatment Control Module (ACM). The sensors monitor various temperatures, pressures and levels within the ATS. The DEF doser measures DEF pressure and injects DEF into the ATS when needed. The ACM controls the functions and analyzes the data of the ATS electronic components by means of the ATS wiring harness. For information on performing a parked DPF regeneration, Refer to section "How to Perform a Parked Regeneration".

Proper maintenance of the ATS is essential to ensure the engine continues to comply with applicable emissions standards. For a listing of required service intervals Refer to section "Preventive Maintenance Tables".

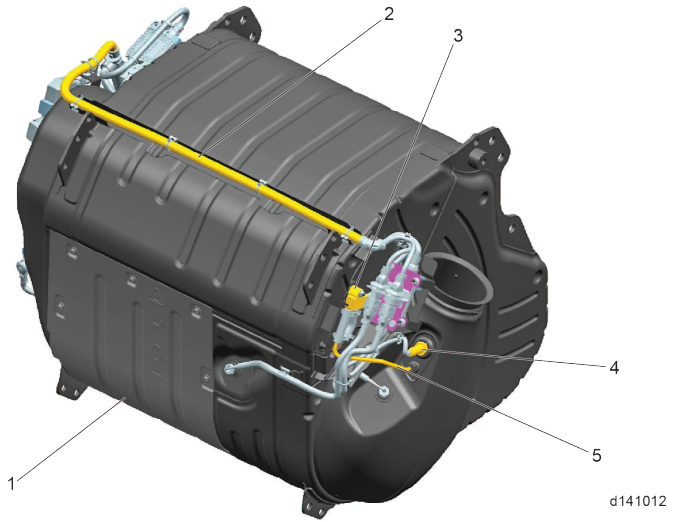

- 1. Service Cover
- 2. ATS Wiring Harness
- 3. ATS Delta Pressure Sensor
- 4. Inlet NOx Sensor
- 5. ATS Delta Pressure Tube

**Figure 11. ATS Top View**

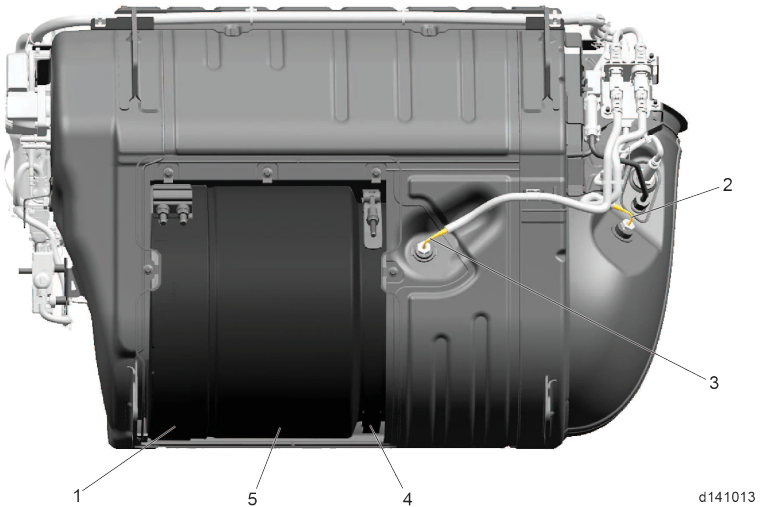

- 1. DPF Outboard Clamp
- 2. DOC Inlet Temperature Sensor
- 3. DOC Outlet Temperature Sensor
- 4. DPF Inboard Clamp
- 5. DPF

**Figure 12. ATS Side View**

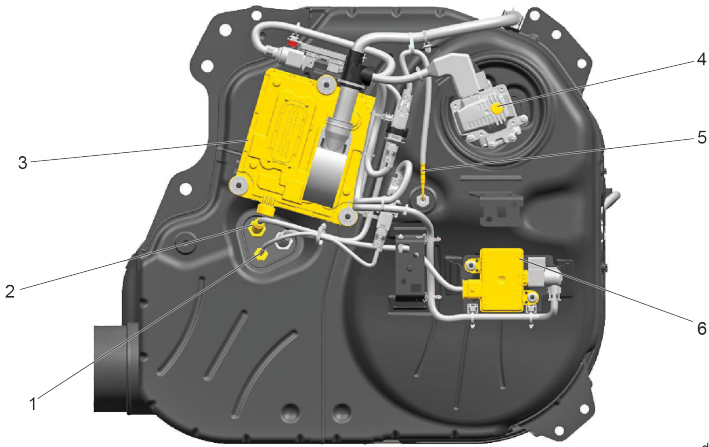

d141014a

- |                                     |                                     |
|-------------------------------------|-------------------------------------|
| 1. 1. SCR Outlet Temperature Sensor | 4. 4. DEF Dosing Unit               |
| 2. 2. Outlet NOx Sensor             | 5. 5. DPF Outlet Temperature Sensor |
| 3. 3. ACM                           | 6. 6. Soot Sensor ECU               |

**Figure 13. ATS Rear View**

### Service Record

It is mandatory that proper service records are maintained of the DPF servicing and cleaning. This record is an agent to warranty considerations. The record must include information such as:

- Date of cleaning or replacement
- Vehicle mileage at the time of cleaning or replacement
- DPF part number and serial number(s)

### Diesel Exhaust Fluid Information

#### Diesel Exhaust Fluid Information

The ATS requires DEF to maintain exhaust emissions at levels compliant with emissions standards. The following sections provide information regarding DEF anti-tampering features and DEF tanks. For additional information on DEF availability, specifications, handling and storage Refer to section "Diesel Exhaust Fluid Availability".

## Diesel Exhaust Fluid System Anti-Tampering Feature

Detroit Diesel Electronic Controls (DDEC<sup>®</sup>) monitors for faults in DEF system components and monitors the DEF supply pressure. If DDEC<sup>®</sup> detects that components critical to the ATS or DEF supply system are disconnected (which could indicate tampering), or if the diagnostics detect abnormal system pressures indicative of DEF supply blockage, the warning indicator will illuminate and DDEC<sup>®</sup> will initiate time and mileage counters. If the sensors detect that the ATS has been tampered with, the malfunction indicator illuminates to warn the driver, and the engine performance is limited, with a 90 km/h (55 mph) speed limit. If the system fault is not corrected, the stop engine indicator illuminates and an 8 km/h (5 mph) speed limit will be applied. Similar warnings and penalties will result when insufficient DEF quantity is present.

## Diesel Exhaust Fluid Tank

The DEF tank holds the DEF supply. The filler neck has a smaller diameter 19 mm (0.75 in.) than the filler neck of the diesel fuel tank and is fitted with a magnetic insert so that diesel fuel cannot be mistakenly added to the DEF tank. If diesel fuel is added to the DEF tank or DEF is added to the diesel fuel tank, immediately contact an authorized Detroit<sup>™</sup> service outlet for further instructions.

## Air System

### Air System

On Detroit<sup>™</sup> Gen 5 Heavy Duty engines, outside air enters the engine through the air filter and is drawn into the turbocharger where it is compressed. The compressed air is then forced through the charge air cooler (heat exchanger) where it is cooled. Next, cooled air flows to the intake manifold and into the cylinders, where the air mixes with atomized fuel from the fuel injectors.

For optimum engine protection from dust and other airborne contaminants, service the dry-type air cleaners when the maximum allowable air restriction has been reached. The air cleaner restriction indicator (filter minder) should be inspected per the maintenance intervals, Refer to section "Preventive Maintenance Tables", or more often if the engine is operated under severe dusty conditions. Replace the air filter if the filter minder has reached maximum allowable restriction. Do not allow the air inlet restriction to exceed maximum allowable restriction. Always use air filters that meet Detroit<sup>™</sup> specifications. The use of air filters that do not meet Detroit<sup>™</sup> specifications may result in premature wear or equipment failure.

## Cooling System

## Cooling System

A radiator/thermo-modulated fan cooling system is used on Detroit™ Gen 5 Heavy Duty engines. This system uses a water pump to circulate coolant within the engine. The thermostat controls the flow of coolant. The thermostat is mounted on the inlet side of the cooling system and regulates coolant flow from the radiator into the engine. The thermostat regulates coolant flow to control the temperature of the coolant within the coolant circuit. The following benefits are a result from regulating the coolant at the inlet temperature side of the engine:

- Reduced thermal cycling of the engine
- Operating temperature is reached faster
- Improved vehicle heating because of better temperature regulation

Always use coolants that meet Detroit™ specifications . Failure to maintain the cooling system at required concentrations or using coolants that do not meet Detroit™ specifications will result in premature wear or engine failure . For a listing of required cooling system service intervals, Refer to section "Preventive Maintenance Tables". The "How to Procedures" section of this manual contains additional information on "How to Select Coolants".

## Electrical System

### Electrical System

The electrical system used in Detroit™ Gen 5 Heavy Duty engines consists of a starting motor, starting switch, battery-charging alternator, storage batteries, and necessary wiring. For information on the Detroit Diesel Electronic Control (DDEC®) system Refer to section "Detroit Diesel Electronic Controls System".

## Engine Brake System

### Engine Brake System

The Detroit™ Gen 5 Heavy Duty engine may be equipped with an engine brake. Before operating the vehicle, the operator must become familiar with the engine brake system to obtain optimum benefit from it. The engine brake control systems may vary slightly, depending on the engine brake configuration and cab options design. However, basic operator controls are similar for all models. The Detroit Diesel Electronic Control® (DDEC®) system may activate or deactivate the engine brakes based on a number of monitored engine parameters. For information on engine brakes operation, Refer to section "How to Operate the Engine Brakes".

## **Exhaust System and Exhaust Gas Recirculation System**

### **Exhaust System and Exhaust Gas Recirculation System**

The Detroit™ Gen 5 Heavy Duty engine exhaust can be divided into two major systems, the exhaust system and the Exhaust Gas Recirculation (EGR) system. The exhaust system consists of a turbocharger, heat shields, an exhaust manifold, and its associated parts. Hot exhaust gas from the exhaust manifold is used to drive the turbocharger. For a listing of required exhaust system service intervals, Refer to section "Preventive Maintenance Tables".

The EGR system consists of an EGR valve and actuator, EGR hot pipe, EGR venturi, EGR cooler, and its associated parts. The purpose of the EGR System is to reduce engine exhaust gas emissions in accordance with EPA regulations.

The EGR actuator opens and closes the EGR valve to allow hot exhaust gas to enter the EGR cooler. The EGR system dramatically reduces cuts NOx formation by routing a measured amount of cooled exhaust gases into the cylinders to lower combustion temperatures. Lower temperatures result in lower NOx levels.

## **Fuel System**

### **Fuel System**

The Detroit™ Gen 5 Heavy Duty fuel system is an Amplified Common Rail System (ACRS). The fuel system consists of fuel injectors, high pressure fuel rail, low and high pressure fuel pumps, fuel filter module, prefilter, final filter, low pressure fuel sensor, supply fuel temperature sensor, fuel rail pressure sensor, water in fuel sensor, and the necessary connecting fuel lines.

Detroit™ Gen 5 Heavy Duty engines are designed to operate on Ultra-Low Sulfur Diesel (ULSD) fuel. Always use ULSD fuel and fuel filters that meet Detroit™ specifications. The use of fuels and/or fuel filters that do not meet Detroit™ specifications may result in premature wear or engine failure, Refer to section "How to Select Fuel".

Proper maintenance of the fuel system is essential to ensure the engine continues to comply with applicable emissions standards. For a listing of required service intervals, Refer to section "Preventive Maintenance Tables".

## **Lubrication System**

## Lubrication System

The lubrication system of a Detroit™ Gen 5 Heavy Duty engine consists of an oil coolant module, oil filter, oil cooler, oil pan, oil pump, oil suction manifold, oil pressure regulator valve, oil thermostat, and oil pressure sensor. Clean, pressurized oil is fed to all components via passages in the engine block and cylinder head.

Always use lubricating oils and oil filters that meet Detroit™ specifications. The use of lubricating oils and/or oil filters that do not meet Detroit™ specifications may result in premature wear or engine failure. Consult with an authorized Detroit™ service outlet to obtain the proper engine oil filter. For additional information on selecting lubricating oil, Refer to section "Synthetic Oils and Additives". For a listing of required lubrication system service intervals, Refer to section "Preventive Maintenance Tables".

## Engine Oil Capacities

Fill the engine to the proper level with the recommended viscosity and grade of engine oil. For instructions on checking the lubricating oil level, Refer to section "How to Check the Lubricating Oil Level". The engine oil capacities for the Detroit™ Gen 5 Heavy Duty engine are listed in the table below. Contact a Detroit™ service outlet if more specific information is needed.

**Table 3.**

<b>Engine Oil Capacities</b>	
Service Fill (Oil and Filter Change)	43.0 L (45.0 qt)
Oil Pan Capacity, High Limit	40.0 L (42.0 qt)
Oil Pan Capacity, Low Limit	35.0 L (37.0 qt)

## Instrument Panel Indicators

### Instrument Panel Indicators

The instrument panel indicators provide messages and warnings in regards to the vehicle's operating status. The color of the indicators correspond to the level of importance:

- Red (warning)
- Amber (caution)
- Green (active status)
- Grey (passive status)
- White (informational)
- Blue (active status)

If the vehicle is equipped with the Maintenance System and it is enabled, the Maintenance System will alert the operator, via the instrument panel, when maintenance is due for any of the components monitored by the system. The Maintenance System adjusts the maintenance intervals by monitoring vehicle parameters over the life of the vehicle. After performing a maintenance interval reset, the maintenance system will collect data for the next fifty hours before the next interval prediction is calculated. Consult the vehicle's Driver/Maintenance manual for details about the Maintenance System and which components it monitors.

A detailed description of each of the instrument panel indicators can be found in the vehicle's driver manual. If the instrument panel indicates a malfunction, the operator has the responsibility to take action to avoid equipment damage.



# Preventive Maintenance Intervals

## Preventive Maintenance Intervals

The preventive maintenance intervals should be followed as closely as possible to obtain long life and optimum performance from the engine. Following the preventative maintenance tables will be the least costly way of obtaining safe and reliable vehicle operation, Refer to section "Preventive Maintenance Tables".

The following sections will be covered in this chapter:

- Scheduled Maintenance Intervals
  - Aftertreatment System
  - Air Compressor
  - Air System
  - Belt Drive
  - Cooling System
  - Exhaust and Exhaust Gas Recirculation System
  - Engine Steam Clean
  - Fuel Filters
  - Lubricating Oil and Filter
  - Valve Lash Checking and Adjustment
  - Vibration Damper
- Preventative Maintenance Tables

## Scheduled Maintenance Intervals

### Scheduled Maintenance Intervals

Before placing a new vehicle in service, determine the correct maintenance schedule application for the intended use of the vehicle. Complete each maintenance operation at the required interval. Vehicles equipped with the optional maintenance system will alert the operator when routine maintenance intervals are due. The maintenance system may adjust the maintenance intervals by monitoring vehicle parameters over the life of the vehicle. The intervals are based on a collaboration of field and fleet data. For a more accurate analysis of when maintenance items should be serviced, Refer to section "Preventive Maintenance Tables". Each maintenance table shows which maintenance operation must be performed at the recommended interval (in miles, kilometers, and hours).

## **Aftertreatment System (ATS)**

A Check Engine Indicator or mileage/time intervals indicate when ash cleaning is required. Use DETROIT Diesel Corporation's authorized DPF cleaning procedure. Failure to follow this procedure could result in engine and/or aftertreatment damage, causing degraded vehicle performance including excess fuel consumption and decreased engine life.

Once the DPF has reached maximum ash volume, the recommended service for the DPF is to remove the DPF and replace with a Reliabilt® clean DPF. Using alternate cleaning methods, instead of replacing the DPF at the required interval, may result in the cleaned DPF failing to reach the next ash clean interval. The aftertreatment may experience damage to the DOC, DPF or SCR assemblies as a result of alternate cleaning methods. Cleaning accumulated ash from the DPF is a necessary part of vehicle maintenance.

The DEF filter is considered a maintenance item and will require periodic maintenance. The aftertreatment system should be serviced per estimated maintenance intervals, Refer to section "Preventive Maintenance Tables".

## **Air Compressor**

The air compressor incorporates three of the major systems of a diesel engine (air, lubrication, and coolant). Proper inspection of the air compressor includes inspecting for air, oil, and coolant leaks. A failed air compressor can create inadequate internal sealing resulting in excessive crankcase pressure, or allowing an engine to ingest oil. The air compressor should be inspected per the maintenance intervals, Refer to section "Preventive Maintenance Tables".

## **Air System**

The air cleaner restriction indicator (filter minder) should be inspected per the maintenance intervals, Refer to section "Preventive Maintenance Tables", or more often if the engine is operated under severe dusty conditions. Replace the air filter if the filter minder has reached maximum allowable restriction. Do not allow the air inlet restriction to exceed maximum allowable restriction.

A clogged air cleaner element will cause excessive air intake restriction and reduced air supply to the engine resulting in increased fuel consumption, inefficient engine operation, aftertreatment failure, and reduced engine life. High intake restriction will also cause oil pullover from the turbocharger into the charge air system.

The air system should also be periodically inspected for leaks. Leaks in the air system can cause dirt ingestion into the engine, performance problems, or aftertreatment failure.

## **Belt Drive**

Detroit™ Gen 5 Heavy Duty engines utilize a specially designed belt material which is exclusive to the Original Equipment Manufacturer (OEM). Replacement with an aftermarket part may lead to shortened maintenance intervals and excessive noise. Consult with an authorized Detroit™ service outlet to obtain proper engine belts.

Drive belts wear differently based on environmental conditions and vehicle duty cycle. If the vehicle is operated in extremely hot or cold climates, or is exposed to significant dust/debris/road salt, the lifetime of the belts may be significantly reduced. The belts should be replaced per the maintenance intervals, Refer to section "Preventive Maintenance Tables".

## **Cooling System**

Proper maintenance of the cooling system is vital to its performance and longevity. The cooling system deals with cavitation, temperature and pressure swings, and continuous threats to the additive package.

Failure to maintain the cooling system at required concentrations or using coolants that do not meet Detroit™ specifications will result in severe damage to the engine cooling system and related components. The cooling system should be maintained per the maintenance intervals, Refer to section "Preventive Maintenance Tables".

## **Exhaust System and Exhaust Gas Recirculation (EGR) System**

The exhaust manifold and other exhaust system connections should be inspected for leaks. The EGR system should be inspected for leaks periodically. Sealing of the exhaust and EGR system is critical. Have worn or damaged parts repaired or replaced. The exhaust and EGR systems should be inspected per the maintenance intervals, Refer to section "Preventive Maintenance Tables".

## **Engine Steam Clean**

Steam cleaning of the engine is required as part of the preventative maintenance. The engine should be steam cleaned every 100,000 km (60,000 mi) or 2,000 hours, whichever comes first.

## **Fuel Filters**

The prefilter is housed within the fuel filter module. The prefilter element filters out large particles and is fastened onto the prefilter cap. The final filter is housed within the fuel filter module. The final filter has the task of separating out the water contained in the fuel and also filtering out small particles. The final filter is fastened onto the final filter cap. Fuel filters should be replaced per the maintenance intervals, Refer to section "Preventive Maintenance Tables".

Incorporated into the fuel filter module is a coalescer. The coalescer removes water and/or sediment. Water in fuel can seriously affect engine performance and may cause engine damage. A water-in-fuel (WIF) dash indicator will warn the driver when trapped water needs to be drained. For instruction on how to drain the fuel coalescer, Refer to section "How to Drain the Fuel Coalescer".

## **Lubricating Oil and Filter**

Detroit™ Gen 5 Heavy Duty engines are equipped with a single cartridge-style oil filter that is part of the oil coolant module. Incorporated into the module is a drain back port which allows residual oil to be returned to the oil pan when the filter is removed. This design, including the cartridge-style element, allows for a more environmentally safe oil change. The lubricating oil and filter should be replaced per the maintenance intervals, Refer to section "Preventive Maintenance Tables".

## **Valve Lash Checking and Adjustment**

Valve lash adjustments should be performed by an authorized Detroit™ service outlet. Proper valve lash clearance allows the engine to produce the best possible performance with the lowest emissions. Valve lash checking and adjustment should be serviced per the maintenance intervals, Refer to section "Preventive Maintenance Tables".

## **Vibration Damper**

The vibration damper should be inspected periodically and replaced if dented or leaking. Heat from normal engine operation may, over a period of time, cause the fluid within the damper to break down and lose its dampening properties. For this reason, the vibration damper must be replaced at time of a major engine overhaul, regardless of apparent condition.

## **Preventive Maintenance Tables**

### **Preventive Maintenance Tables**

Service interval definitions using 93K222(CK-4) and 93K223(FA-4) oil with ULSD fuel:

### **Efficient Long Haul**

Efficient Long Haul (over-the-road transport) service applies to vehicles that annually travel more than 96,000 km (60,000 mi) and average greater than 7 miles per gallon with minimal city stop-and-go operation and minimum idle.

## Long Haul

Long Haul (over-the-road transport) service applies to vehicles that annually travel more than 96,000 km (60,000 mi) and average between 6.0 and 6.9 miles per gallon with minimal city stop-and-go operation.

## Short Haul

Short Haul service applies to vehicles that annually travel 48,000 to 96,000 km (30,000 to 60,000 mi) and average between 5.1 and 5.9 miles per gallon.

## Severe Service

Severe service applies to vehicles that annually travel up to 48,000 km (30,000 mi) or average less than 5 miles per gallon or that operate under severe conditions. Severe service also applies to RV applications. Only one of these conditions needs to be met to categorize an application as severe service.

**Table 4.**

<b>DD13: Maintenance Intervals</b>				
Using DFS 93K222(CK-4) or 93K223(FA-4) Approved Oils with ULSD Fuel				
<b>Component</b>	<b>Efficient Long Haul (7.0 or better MPG)***</b>	<b>Long Haul (6.0-6.9 MPG)***</b>	<b>Short Haul (5.1-5.9 MPG)***</b>	<b>Severe (Up to 5.0 MPG)***</b>
Lubricating Oil §	Replace every 105,000 km (65,000 mi)	Replace every 89,000 km (55,000 mi)	Replace every 64,000 km (40,000 mi) or 1000 hours †	Replace every 56,000 km (35,000 mi) or 750 hrs †
Oil Filter §	Replace at Every Oil Change			
Engine Fuel Filter*	Replace at Every Oil Change			
Engine Fuel Filter * w/ Frame-Mounted Filter	Replace every 161,000 km (100,000 mi)	Replace every 161,000 km (100,000 mi)	Replace every 128,000 km (80,000 mi) or 1000 hours †	Replace every 113,000 km (70,000 mi) or 750 hrs †
Frame Mounted Fuel Filters ‡	Replace at Every Oil Change			
Valve Lash Adjustment	Adjust every 800,000 km (500,000 mi)			Adjust every 322,000 km (200,000 mi)

<b>DD13: Maintenance Intervals</b>				
Coolant - Standard Life	Maintain at every oil change or 1 yr † Replace every 482,000 km (300,000 mi)	Maintain at every oil change or 1 yr † Replace every 482,000 km (300,000 mi)	Maintain at every oil change or 1 yr † Replace every 482,000 km (300,000 mi)	Maintain at every oil change or 6 months † Replace every 482,000 km (300,000 mi)
Coolant - Extended Life	Maintain every 210,000 km (130,000 mi) or 1 yr † Replace every 965,000 km (600,000 mi)	Maintain every 178,000 km (110,000 mi) or 1 yr † Replace every 965,000 km (600,000 mi)	Maintain every 128,000 km (80,000 mi) 1 yr † Replace every 965,000 km (600,000 mi)	Maintain every 112,000 km (70,000 mi) or 1 yr † Replace every 965,000 km (600,000 mi)
Belts <sup>1</sup>	Inspect at oil change** Replace every 240,000 km (150,000 mi)	Inspect at oil change** Replace every 240,000 km (150,000 mi)	Inspect at oil change** Replace every 165,000 km (105,000 mi) 2,690 hrs †	Inspect at oil change** Replace every 165,000 km (105,000 mi) 2,690 hrs †
Air Intake System	Inspect at oil change	Inspect at oil change	Inspect at oil change	Inspect at oil change
Air Cleaner	Inspect at oil change	Inspect at oil change	Inspect at oil change	Inspect at oil change
Exhaust System	Inspect at oil change	Inspect at oil change	Inspect at oil change	Inspect at oil change
Air Compressor <sup>2</sup>	Inspect at oil change	Inspect at oil change	Inspect at oil change	Inspect at oil change

<b>DD13: Maintenance Intervals</b>				
Aftertreatment System	Inspect external hardware and connections every 6 months or at oil change intervals. †			
Diesel Particulate Filter	A Check Engine Indicator or mileage/time intervals indicate when ash cleaning is required. Use DETROIT Diesel Corporation's authorized DPF cleaning procedure. Failure to follow this procedure could result in engine and/or aftertreatment damage, causing degraded vehicle performance including excess fuel consumption and decreased engine life. Estimated intervals shown are below.			
	Greater than 1,030,000 km (640,000 mi) or 14,000 hrs	886,000 to 1,030,000 km (550,000 to 640,000 mi) or 12,000 to 14,000 hrs	734,000 to 886,000 km (455,000 (550,000 mi) or 10,000 to 12,000 hrs	Less than 886,000 km (455,000 mi) or 10,000 hrs
DEF Pump Filter	Replace filter every 800,000 km (500,000 mi) or 3 yrs.†			
<p>- 1 Vehicles used a majority of time on rough, dirty, rocky roads should have their belts replaced sooner than recommended. Debris can get caught in the belt system and wear out belts sooner than vehicles used on paved highway roads.</p> <p>- 2 Bendix air compressors have a recommended service interval of the unloader valve at a specified mileage interval. For more information on Bendix air compressor maintenance visit <a href="http://www.Bendix.com">www.Bendix.com</a>, call 1-800-AIR-BRAKE, or email <a href="mailto:info@Bendix.com">info@Bendix.com</a></p> <p>- †Whichever comes first. Note: Reaching the Davco change line supersedes these intervals.</p> <p>- *Engine fuel filters should be changed at recommended service intervals, or when the "Fuel Filter Service Indicator" activates on the dashboard. For maximum life of fuel system components, it is not recommended to exceed 100k mi on engine fuel filters under any condition.</p> <p>-** Check per section "Inspection of the Belts".</p> <p>- ***Fuel Economy represents overall fuel economy (including idle time)</p> <p>- ‡Currently, only Detroit™ Fuel Filter/Water Separator &amp; Davco 385/482/485/487 are the only frame-mounted filtration systems compatible for Detroit™ Engines.</p> <p>- §Maintenance System can be enabled for this component.</p> <p>Refer to "Routine Preventive Maintenance" and "How To Procedures" for a description of all items.</p>				

**Table 5.**

<b>DD15: Maintenance Intervals</b>				
Using DFS 93K222(CK-4) or 93K223(FA-4) Approved Oils with ULSD Fuel				
<b>Component</b>	<b>Efficient Long Haul (7.0 or better MPG)***</b>	<b>Long Haul (6.0-6.9 MPG)***</b>	<b>Short Haul (5.1-5.9 MPG)***</b>	<b>Severe (Up to 5.0 MPG)***</b>
Lubricating Oil §	Replace every 121,000 km (75,000 mi)	Replace every 97,000 km (60,000 mi)	Replace every 72,000 km (45,000 mi) or 1000 hrs †	Replace every 56,000 km (35,000 mi) or 750 hrs †
Oil Filter §	Replace at Every Oil Change			
Engine Fuel Filter*	Replace at Every Oil Change			
Engine Fuel Filter * w/ Frame-Mounted Filter	Replace every 161,000 km (100,000 mi)	Replace every 161,000 km (100,000 mi)	Replace every 144,000 km (90,000 mi) or 1000 hrs †	Replace every 113,000 km (70,000 mi) or 750 hrs †
Frame Mounted Fuel Filters ‡	Replace at Every Oil Change			
Valve Lash Adjustment	Adjust every 800,000 km (500,000 mi)			Adjust every 322,000 km (200,000 mi)
Coolant - Standard Life	Maintain at every oil change or 1 yr † Replace every 482,000 km (300,000 mi)	Maintain at every oil change or 1 yr † Replace every 482,000 km (300,000 mi)	Maintain at every oil change or 1 yr † Replace every 482,000 km (300,000 mi)	Maintain at every oil change or 6 months † Replace every 482,000 km (300,000 mi)
Coolant - Extended Life	Maintain at every <b>other</b> oil change or 1 yr † Replace every 965,000 km (600,000 mi)	Maintain at every <b>other</b> oil change or 1 yr † Replace every 965,000 km (600,000 mi)	Maintain at every <b>other</b> oil change or 1 yr † Replace every 965,000 km (600,000 mi)	Maintain at every <b>other</b> oil change or 1 yr † Replace every 965,000 km (600,000 mi)



<b>DD15: Maintenance Intervals</b>				
Belts <sup>1</sup>	Inspect at oil change** Replace every 322,000 km (200,000 mi)	Inspect at oil change** Replace every 322,000 km (200,000 mi)	Inspect at oil change** Replace every 161,000 km (100,000 mi) 2,600 hrs †	Inspect at oil change** Replace every 161,000 km (100,000 mi) 2,600 hrs †
Air Intake System	Inspect at oil change	Inspect at oil change	Inspect at oil change	Inspect at oil change
Air Cleaner	Inspect at oil change	Inspect at oil change	Inspect at oil change	Inspect at oil change
Exhaust System	Inspect at oil change	Inspect at oil change	Inspect at oil change	Inspect at oil change
Air Compressor <sup>2</sup>	Inspect at oil change	Inspect at oil change	Inspect at oil change	Inspect at oil change

<b>DD15: Maintenance Intervals</b>				
Aftertreatment System	Inspect external hardware and connections every 6 months or at oil change intervals. †			
Diesel Particulate Filter	A Check Engine Indicator or mileage/time intervals indicate when ash cleaning is required. Use DETROIT Diesel Corporation's authorized DPF cleaning procedure. Failure to follow this procedure could result in engine and/or aftertreatment damage, causing degraded vehicle performance including excess fuel consumption and decreased engine life. Estimated intervals shown are below.			
	Greater than 1,030,000 km (640,000 mi) or 14,000 hrs	886,000 to 1,030,000 km (550,000 to 640,000 mi) or 12,000 to 14,000 hrs	734,000 to 886,000 km (455,000 (550,000 mi) or 10,000 to 12,000 hrs	Less than 886,000 km (455,000 mi) or 10,000 hrs
DEF Pump Filter	Replace filter every 800,000 km (500,000 mi) or 3 yrs.†			
<p>- 1 Vehicles used a majority of time on rough, dirty, rocky roads should have their belts replaced sooner than recommended. Debris can get caught in the belt system and wear out belts sooner than vehicles used on paved highway roads.</p> <p>- 2 Bendix air compressors have a recommended service interval of the unloader valve at a specified mileage interval. For more information on Bendix air compressor maintenance visit <a href="http://www.Bendix.com">www.Bendix.com</a> , call 1-800-AIR-BRAKE, or email <a href="mailto:info@Bendix.com">info@Bendix.com</a></p> <p>- †Whichever comes first. Note: Reaching the Davco change line supersedes these intervals.</p> <p>- *Engine fuel filters should be changed at recommended service intervals, or when the "Fuel Filter Service Indicator" activates on the dashboard. For maximum life of fuel system components, it is not recommended to exceed 100k mi on engine fuel filters under any condition.</p> <p>-** Check per section "Inspection of the Belts".</p> <p>- ***Fuel Economy represents overall fuel economy (including idle time)</p> <p>- ‡Currently, only Detroit™ Fuel Filter/Water Separator &amp; Davco 385/482/485/487 are the only frame-mounted filtration systems compatible for Detroit™ Engines.</p> <p>- §Maintenance System can be enabled for this component.</p> <p>Refer to "Routine Preventive Maintenance" and "How To Procedures" for a description of all items.</p>				

# Routine Preventive Maintenance

## Routine Preventive Maintenance

This chapter describes some of the maintenance items listed in the maintenance interval tables. The daily instructions apply to routine or daily starting of the engine. For basic engine maintenance procedures which can be performed by the operator, Refer to section "How To Procedures".

The following sections will be covered in this chapter:

- Inspection of the Aftertreatment System
- Inspection of the Air Compressor
- Inspection of the Air Intake System
- Inspection of the Turbocharger and Charge Air Cooler
- Inspection of the Batteries
- Inspection of the Belts
- Inspection of the Cooling System
  - Checking for Coolant Leaks
  - Checking the Coolant Level
- Inspection of the Exhaust System
- Inspection of the Fuel and Fuel Tank
- Inspection of Hoses and Fittings for Leaks
- Inspection of the Lubricating Oil Filter
- Checking the Lubricating Oil Level
- Checking the Lubricating System for Leaks

## Inspection of the Aftertreatment System

### Inspection of the Aftertreatment System

Inspect the Aftertreatment System (ATS) as recommended using the appropriate engine duty cycle, Refer to section "Preventive Maintenance Tables".

Inspect the aftertreatment system as follows:

1. Check the aftertreatment and exhaust pipes for damage or restrictions.
2. Inspect the aftertreatment inlet and outlet pipes for leaks.
3. Inspect the aftertreatment for signs of fluid leaks.

**NOTE:** If any of the above conditions exist it may be necessary to take the vehicle to an authorized Detroit™ service outlet.

## Diesel Exhaust Fluid Filter Replacement

The Diesel Exhaust Fluid (DEF) pump is a chassis-mounted filter, which filters out debris from the DEF. If the DEF is contaminated, contact an authorized Detroit™ service outlet for further instructions. Replacing the DEF filter requires the use of special diagnostic tools to prime the DEF system. Authorized Detroit™ service outlets are properly equipped for this type of service.

## Inspection of the Air Compressor

### Inspection of the Air Compressor

The air compressor incorporates three of the major systems of a diesel engine (air, lubrication, and cooling). Inspect the air compressor, as part of the air system, following the recommendations in the maintenance tables using the appropriate engine duty cycle, Refer to section "Preventive Maintenance Tables".

Inspect the air compressor as follows:

1. Inspect the air compressor for air, oil, and coolant leaks.
2. Inspect the lines and connection points for leaks or damage.

**NOTE:** If any of the above conditions exist it may be necessary to take the vehicle to an authorized Detroit™ service outlet.

## Inspection of the Air Intake System

### Inspection of the Air Intake System

Inspect the air intake system as part of the air system following recommendations in the maintenance tables using the appropriate engine duty cycle, Refer to section "Preventive Maintenance Tables".

Inspect the air intake system as follows:

1. Inspect all the connections in the air system to make sure they are tight and leak-free.
2. Check all hoses and ducting for punctures, deterioration, or other damage.

**NOTE:** If any of the above conditions exist it may be necessary to take the vehicle to an authorized Detroit™ service outlet.

## Inspection of the Turbocharger and Charge Air Cooler

## Inspection of the Turbocharger and Charge Air Cooler

The turbocharger and charge air cooler should be inspected periodically.

Inspect the turbocharger and charge air cooler as follows:

**NOTE:** If any of the following conditions exist, it may be necessary to take the vehicle to an authorized Detroit™ service outlet.

1. Inspect the turbocharger mounting, intake and exhaust ducting, and connections for leaks daily.
2. Check the turbocharger lubricating oil inlet and outlet lines for leaks or restrictions to oil flow.
3. Inspect for torn air inlet piping or boots and loose or damaged clamps.



### **WARNING: PERSONAL INJURY**

To avoid injury from hot surfaces, wear protective gloves, or allow engine to cool before removing any component.

4. Check the turbocharger for unusual noise or vibration and if excessive, stop the engine and cease operation until the cause is determined.
5. Check the charge air cooler, duct work, and flexible connections for leaks.
6. Periodically inspect the charge air cooler for buildup of dirt, mud, etc. and wash off using a mild soap solution.

## Inspection of the Batteries

### Inspection of the Batteries

Batteries should be inspected periodically. A good practice is to include the battery inspection as part of the pre-start inspection.

Inspect the batteries as follows:

1. Inspect the overall condition of the batteries. Check for cracks in the battery cases.
2. Inspect the cables, clamps and hold-down brackets regularly. If necessary, clean and reapply a light coating of petroleum jelly. Damaged or corroded parts should be replaced.
3. Check battery connections for corrosion and tightness. If necessary, remove connections, wire brush any corrosion from terminals and cable ends and reapply a light coating of petroleum jelly.

**NOTE:** If any of the above conditions exist it may be necessary to take the vehicle to an authorized Detroit™ service outlet.

4. If the engine is to be out of service for more than 30 days, remove the batteries and store in a cool, dry place. Keep batteries fully charged. Have any batteries that fail to hold a charge replaced.

## Inspection of the Belts

### Inspection of the Belts





Detroit™ Gen 5 Heavy Duty engines utilize a specially designed belt material which is exclusive to the Original Equipment Manufacturer (OEM). Replacement with an aftermarket part may lead to shortened maintenance intervals and excessive noise. Consult with an authorized Detroit™ service outlet to obtain proper engine belts.

Belts will track slightly forward on the non-grooved pulleys when the engine is running. Once the engine is turned off, the belt will re-center itself. Do not use any type of cleaning solvent on the rubber parts of the tensioner or on belts. Detroit does not approve the use of belt dressing or other like products as this may result in premature belt wear. The belts should be replaced as recommended in the maintenance tables using the appropriate engine duty cycle, Refer to section "Preventive Maintenance Tables".



Inspect as follows:

1. Check the maintenance records to be sure the belts are not overdue for a maintenance interval, Refer to section "Preventive Maintenance Tables". Have the belts replaced if necessary.
2. Inspect the belt contact surfaces for chips, flaking, cracks, and discoloration using the guidelines listed below. If any damage is noted, have both belts replaced.

**Table 6.**

<b>Poly-V-Belt Inspection Concerns</b>	
<b>ABRASION</b>	<b>CHUNK-OUT</b>
 <p>d130019</p>	 <p>d130020</p>
<b>IMPROPER INSTALL</b>	<b>CRACKING</b>
 <p>d130021</p>	 <p>d130022</p>

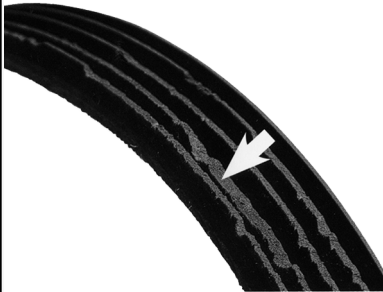
**Table 7.**

<b>Poly-V-Belt Inspection Concerns</b>	
PILLING	UNEVEN RIB WEAR
 <p style="text-align: right; margin-right: 50px;">d130023</p>	 <p style="text-align: right; margin-right: 50px;">d130024</p>
MISALIGNMENT	GRAVEL PENETRATION
 <p style="text-align: right; margin-right: 50px;">d130025</p>	 <p style="text-align: right; margin-right: 50px;">d130026</p>

3. In the area where the belt contacts the pulleys there will be a polished shine on the pulley created by the belt contact. If misalignment is occurring, the belt may be riding off-centered on the pulley. In these scenarios, it may be necessary to take the vehicle to an authorized Detroit™ service outlet.

## Inspection of the Cooling System



## Inspection of the Cooling System

A coolant system properly maintained and protected with supplemental coolant inhibitors can be operated up to the intervals listed in this manual using the appropriate engine duty cycle, Refer to section "Preventive Maintenance Tables". At these intervals the coolant must be drained and disposed of in an environmentally responsible manner according to state and/or federal recommendations. Authorized Detroit™ service outlets are properly equipped for this type of service.

Inspect the cooling system as follows:

### Checking for Coolant Leaks

Perform daily visual checks for cooling system leaks. Look for an accumulation of coolant when the engine is running and when it is stopped. Check all cooling system pipes and hoses for damage and leaks and ensure they are positioned to avoid chafing, and are securely fastened. Coolant leaks may be more apparent on an engine when it is cold. If coolant leaks exist, it may be necessary to take the vehicle to an authorized Detroit™ service outlet.

### Checking the Coolant Level

The coolant level should be inspected daily as part of the pre-start inspection, Refer to section "Checking the Coolant Level (Cold Check)". If necessary, fill the cooling system with approved coolant, Refer to section "How to Select Coolants".

### Testing the Coolant

Refer to the Coolant Requirements For Engine Cooling Systems brochure (DDC-SVC-BRO-0002) for the latest information on coolants and coolant testing.

## Inspection of the Exhaust System

### Inspection of the Exhaust System

Inspect the exhaust system as recommended in the maintenance tables using the appropriate engine duty cycle, Refer to section "Preventive Maintenance Tables".

Inspect the exhaust system as follows:

1. Check the exhaust manifold and other connections for leaks tightness.
2. Inspect the exhaust pipes for damage or restrictions.

**NOTE:** If any of the above conditions exist, it may be necessary to take the vehicle to an authorized Detroit™ service outlet.

## Inspection of the Fuel System

## Inspection of the Fuel System

The fuel system should be inspected periodically. A good practice is to include the fuel system inspection as part of the pre-start inspection.

Inspect the fuel and fuel tanks as follows:

1. Inspect all engine-mounted lines and connections for leaks.
2. Visually inspect the fuel tank suction and return lines. Check for an accumulation of fuel under the tank.

**NOTE:** If any of the above conditions exist, it may be necessary to take the vehicle to an authorized Detroit™ service outlet.

**NOTICE:** Keep the fuel tank filled to reduce condensation. Before adding fuel, Refer to section "How to Select Fuel". Condensation formed in a partially filled tank promotes the growth of microorganisms that can clog fuel filters and restrict fuel flow.

3. The water/sediment at the bottom of the fuel tank should be serviced as recommended in the maintenance tables using the appropriate engine duty cycle, Refer to section "Preventive Maintenance Tables".
4. The fuel tank mounts should be inspected as recommended in the for the appropriate engine duty cycle, Refer to section "Preventive Maintenance Tables".

## Fuel Filter Replacement

All engine mounted fuel filters should be changed at the same time. If the fuel is contaminated contact an authorized Detroit™ service outlet for further instructions. After replacing the fuel filters, the fuel system will require priming. Priming the fuel system includes the use of special tools. Authorized Detroit™ service outlets are properly equipped for this type of service. Never use the starting motor and fuel pump to prime the fuel system. Prolonged use of the starting motor and fuel pump to prime the fuel system can result in damage to the starter, fuel pump, and injectors.

## Inspection of Hoses and Fittings for Leaks

### Inspection of Hoses and Fittings for Leaks

All hoses, lines and connection points should be inspected periodically. A good practice is to include the hoses, lines and connection point inspection as part of the pre-start inspection. Leaks are not only detrimental to mechanical operation, but they can also result in added expense caused by the need to replenish lost fluids.

Inspect hoses and fittings for leaks as follows:

**NOTE:** If any of the below conditions exist, it may be necessary to take the vehicle to an authorized Detroit™ service outlet.

1. Make a visual check for leaks at all engine-mounted lines and connections.
2. Inspect all hoses for leaks, and check all fittings, clamps and ties carefully. Look for cover damage and/or indications of twisted, worn, crimped, brittle, cracked or leaking hoses and lines. Hoses with their outer cover worn through or with damaged metal reinforcements should be considered unfit for further use and replaced.
3. Make sure hoses are not resting on or touching shafts, couplings, or heated surfaces including exhaust manifolds, sharp edges, or other obvious hazardous areas.
4. Since all machinery vibrates and moves to a certain extent, clamps and ties can fatigue with age. To ensure continued proper support, inspect fasteners frequently and tighten or have them replaced as necessary.
5. Take immediate corrective action for any loose or cracked fittings or ruptured or worn through hoses.

## Inspection of the Lubricating System

### Inspection of the Lubrication System

Detroit™ Gen 5 Heavy Duty engines are equipped with a single cartridge-style oil filter that is part of the oil coolant module. Incorporated into the module is a drain back port, which allows residual oil to be returned to the oil pan when the filter is removed. This design, including the cartridge-style element, allows for a more environmentally safe oil change. The lubricating oil and filter should be replaced as recommended in the maintenance tables using the appropriate engine duty cycle, Refer to section "Preventive Maintenance Tables".

### Checking the Lubricating Oil Level

The lubricating oil level should be inspected daily as part of the pre-start inspection, Refer to section "How to Check the Lubricating Oil Level". If necessary, fill the engine to the proper level with the recommended viscosity and grade of engine oil Refer to section "Synthetic Oils and Additives".

### Checking the Lubricating System for Leaks

Check as follows:

1. Inspect all lubricating oil lines for wear and/or chafing.
2. Check for oil leaks after starting the engine.

**NOTE:** If any of the above conditions exist it may be necessary to take the vehicle to an authorized Detroit™ service outlet.

## **Lubricating Oil and Oil Filter Replacement**

The oil filter is an integral part of the lubrication system. Proper filter selection and maintenance are important to satisfactory engine performance and service life. Authorized Detroit™ service outlets are properly equipped for this type of service. Oil filter replacement should be used to maintain a clean system, but is not sufficient to clean a contaminated system. If the oil is contaminated by fuel or coolant, contact an authorized Detroit™ service outlet for further instructions.

# How to Procedures

## How To Procedures

The following sections will be covered in this chapter:

- How to Perform a Parked Regeneration
- How to Select Diesel Exhaust Fluid
  - Diesel Exhaust Fluid Availability
  - Diesel Exhaust Fluid Specifications
  - Diesel Exhaust Fluid Handling and Storage
- How to Check the Coolant Level
  - Checking the Coolant Level (Cold Check)
  - Checking the Coolant Level (Hot Check)
- How to Select Coolants
  - Extended Life Coolants
  - Standard Life Coolants
  - Detroit™ Genuine Coolant Engine Products
  - Water Requirements
  - Recycle Coolants
  - Coolants Not Permitted
  - Non-Formulated Additives Not Permitted.
- How to Select Fuel
  - Quality
  - Contaminated Fuel
  - Fuel Additives
  - Biodiesel Fuels
- How to Drain the Fuel Coalescer
- How to Restart an Engine Out of Fuel
- How to Check the Lubricating Oil Level
- How to Select Lubricating Oil
  - Synthetic Oils
  - Supplemental Additives
- How to Clean an Engine
- How to Operate the Cruise Control and Fast Idle
  - How to Operate the Cruise Control
  - How to Operate Fast Idle Using Cruise Control
- How to Operate the Engine Brakes
  - Engine Brake Activation Conditions
  - Engine Brake Operation

## How to Perform a Parked Regeneration

## How to Perform a Parked Regeneration

The parked regeneration process will take approximately 50 to 60 minutes, depending on the amount of soot accumulated in the Diesel Particulate Filter (DPF). Under factory default settings, the regeneration request selection is disabled when the DPF regeneration indicator is not illuminated (active). During a parked regeneration, the operator must stay with the vehicle throughout the regenerating process.

A parked regeneration will STOP and the engine will return to low idle if any of the following happens:

- The key is turned to the OFF position.
- The vehicle is put into gear.
- The clutch is cycled.
- The parking brake is released.

When the parked regeneration request is accepted, the engine speed will increase to 1250 rpm. Engine speed may fluctuate to 1100 rpm during the regeneration depending on ambient temperature conditions. The regeneration is complete when the engine returns to low idle.

Perform a Parked Regeneration as follows:



### WARNING: PERSONAL INJURY

Diesel engine exhaust and some of its constituents are known to the State of California to cause cancer, birth defects, and other reproductive harm.

- Always start and operate an engine in a well ventilated area.
- If operating an engine in an enclosed area, vent the exhaust to the outside.
- Do not modify or tamper with the exhaust system or emission control system.



### WARNING: PERSONAL INJURY

To avoid injury before starting and running the engine, ensure the vehicle is parked on a level surface, parking brake is set, and the wheels are blocked.



### WARNING: ENGINE EXHAUST

To avoid injury from inhaling engine exhaust, always operate the engine in a well-ventilated area. Engine exhaust is toxic.

1. Keep engine at idle (cannot be in Fast Idle or PTO Mode). Put transmission in neutral.
2. Set park brake.

- Using the in-cab controls, activate the high idle regeneration mode.

## How to Select Diesel Exhaust Fluid

### Diesel Exhaust Fluid Availability

Diesel Exhaust Fluid (DEF) is available in various container sizes at authorized Detroit™ service outlets, truck stops and many truck service outlets. DEF is available in container sizes as small as 2.5 gallons for convenient, in-vehicle storage in case of emergency use.

### Diesel Exhaust Fluid Specifications

DEF is a simple, non-toxic and inexpensive pre-mixed fluid composed of 2/3 pure water and 1/3 automotive grade urea. DEF is manufactured to strict quality standards to ensure proper emissions control. The American Petroleum Institute has developed a quality certification program to ensure the quality of DEF available at service outlets. Only DEF that meets DIN70700 or ISO 22241-1 specifications should be used.

### Diesel Exhaust Fluid Handling and Storage

When stored at temperatures between -12°C and 32°C (10°F and 90° F), DEF has a maximum shelf life of 12 months. For best shelf life, it is recommended that DEF containers be stored in a controlled environment.

## How to Check the Coolant Level

### Checking the Coolant Level (Cold Check)

Check coolant level as follows:

- Ensure that all coolant plugs in the bottom of the radiator and on the radiator outlet pipe are secure and tight.
- Check the coolant level. The cooling system is correctly filled when the coolant is between the full and low marks on the surge tank.
- If necessary, fill the surge tank with approved coolant, Refer to section "How to Select Coolants". Do not overfill the cooling system as overfilling will cause the surge tank to push coolant out of the overflow.

### Checking the Coolant Level (Hot Check)

Check the coolant levels as follows:

1. Allow the engine to run for approximately five minutes at a moderate speed.
2. After the coolant temperature reaches 50°C (122°F), recheck the coolant level in the surge tank. The cooling system is correctly filled when the coolant is between the full and low marks on the surge tank.
3. Stop the engine and allow it to cool down. If necessary, fill the surge tank with approved coolant, Refer to section "How to Select Coolants". Do not overfill the cooling system as overfilling will cause the surge tank to push coolant out of the overflow.

## How to Select Coolants

### How to Select Coolants

Refer to the Coolant Requirements for Engine Cooling Systems (DDC-SVC-BRO-0002) manual for the most up-to-date coolant information.

Coolants used in Detroit™ engines must meet DFS 93K217 Specification with the following basic requirements:

- Provide an adequate heat transfer medium.
- Protect against cavitation damage.
- Provide a corrosion/erosion-resistant environment.
- Prevent formation of scale or sludge deposits.
- Be compatible with cooling system hose and seal materials.
- Provide adequate freeze protection.

The concentration of Extended Life Coolant (ELC) corrosion inhibitors will gradually deplete, at a much slower rate than Standard Life Coolant (SLC) corrosion inhibitors, during normal engine operation. Corrosion inhibitor limits are established by the coolant manufacturer. Therefore Detroit™ recommends following the manufacturer's recommendations as to minimum and maximum limits.

### Extended Life Coolants

Extended Life Coolants (ELC) contain Organic Acid Technology (OAT), which provides corrosion protection and inhibit liner cavitation. These coolants require less maintenance over the useful life of the engine.

ELC antifreeze coolants are commercially available from Detroit™ service outlets and other manufacturers as either concentrated or pre-mixed formulations. Concentrated coolants should be mixed at 50% (50% coolant/50% water). All ELCs used must also meet DFS 93K217 specification. Detroit™ requires that these types of coolants be free of nitrite and phosphate. Detroit™ has found that ELC's containing nitrite may lead to a breakdown of the coolant and subsequent damage to the cooling system.



ELC types of coolants should not be mixed with Standard Life Coolants. If an ELC coolant and SLC coolant are mixed, the long-life advantages of the ELC coolant will be lost. In this event, the coolant should be re-inhibited with OAT inhibitors and confirmed by analysis or else it must be maintained as an SLC coolant.

## Standard Life Coolants

Standard Life Coolants (SLC) contains inhibitor salts, including nitrites, to prevent liner cavitation. These coolants require interval testing to maintain inhibitor concentration.

SLC antifreeze coolants are commercially available from Detroit™ service outlets and other manufacturers as either concentrated or as pre-mixed coolant.

Concentrated coolants should be mixed at 50% (50% coolant/50% water). All fully formulated coolants used must also meet DFS 93K217 specification.

## Water Requirements

Distilled or de-ionized water is preferred as it is absent the adverse effects caused by tap water minerals. High levels of dissolved chlorides, sulfates, magnesium, and calcium found in some tap water causes scale deposits, sludge deposits and/or corrosion. These deposits have been shown to cause component failures and poor heat transfer, resulting in overheating. If tap water is used, the mineral content in the water must be below the maximum concentration listed in the table below.

**Table 8.**

Maximum Mineral Concentration in Water		
Minerals	Maximum Concentration	
	Parts per Million	Grains per Gallon
Chlorides	40	2.5
Sulfates	100	5.8
Total Dissolved Solids	340	20
Magnesium + Calcium Content	170	10

## Recycled Coolants

Antifreeze coolants made with ethylene or propylene glycol, recycled by reverse osmosis, distillation, and ion exchange and properly re-inhibited to meet ASTM D6471 or D6472 requirements have been demonstrated to provide service equivalent to non-recycled coolants. Recycled coolants of these types are preferred. However, suppliers of these recycled glycols must provide evidence the product is free of the contaminants listed below:

- Acetates

- Acetone
- Ammonia
- Boron
- Ethanol
- Formates
- Glycolates
- Ketones
- Nitrate
- Nitrite
- Phenols
- Phosphorus
- Silicon
- Toluene

Other recycled coolants, especially coolants recycled through filtration processes, are not recommended.

### **Coolants Not Permitted**

The following coolants are not to be used in Detroit™ Gen 5 Heavy Duty engines :

- Automotive/Passenger car-type coolants must not be used because they offer no liner pitting protection. Also, these types of coolants generally contain high levels of phosphates and silicates.
- Methyl alcohol-based coolant must not be used because of its effects on the nonmetallic components of the cooling system and its low boiling point.
- Methoxy propanol-based coolant must not be used because it is not compatible with fluorocarbon elastomer seals found in the cooling system.
- Glycol-based coolants formulated for Heating/Ventilation/Air Conditioning (HVAC) must not be used. These coolants generally contain high levels of phosphates, which will form deposits on hot internal engine surfaces, reduce heat transfer, and cause water pump seal leaks.
- Waterless-type coolants must not be used.
- Nitrite Organic Acid Technology (NOAT) must not be used because engine components can become more vulnerable to failure.

### **Non-Formulated Additives Not Permitted**

The following additives should not be used in Detroit™ Gen 5 Heavy Duty engines :

- Soluble Oils: Soluble oil additives are not approved. A small amount of oil adversely affects heat transfer. For example, a 1.25% concentration of soluble oil increases the fire deck temperature 6%. A 2.5% concentration increases the fire deck temperature 15%. The use of soluble oil additives may result in engine overheating and/or failure.

- **Chromates:** Chromate additives are not approved. Chromate additives can form chromium hydroxide, commonly called "green slime." This, in turn, can result in engine damage due to poor heat transfer. Cooling systems operated with a chromate-inhibited coolant must be chemically cleaned with specially formulate cleaning agents available through authorized Detroit™ service outlets. Only use Detroit™ approved cleaning agents.
- **Phosphate Inhibitors:** Phosphate has tendency to form deposits on surfaces transferring high heat which ultimately affect cooling capabilities. Phosphate deposits on water pump seals will result in coolant leakage across seal faces.

## How to Select Fuel

### How to Select Fuel

Refer to the Lubricating, Oil, Fuel & Filters (DDC-SVC-BRO-0001) manual for the most up-to-date fuel selection information.

All DD Platform engines are designed to operate on Ultra-Low Sulfur Diesel (ULSD) fuel. For optimal fuel system performance, Detroit Diesel recommends Top Tier Diesel (see figure below).

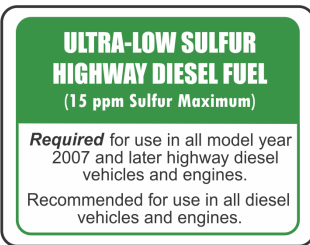

d990371

## Quality

Use only Ultra-Low Sulfur Diesel (ULSD) fuel (15 PPM sulfur content maximum), based on ASTM Standard D 2622 test procedure. Using fuel other than ULSD will damage the fuel and aftertreatment systems.

Fuel quality is an important factor in obtaining satisfactory engine performance, long engine life, and acceptable exhaust emission levels. In general, fuels meeting the properties of ASTM Standard D 975 (grades 1-D and 2-D) have provided satisfactory performance.

The fuels used must be clean, completely distilled, stable, and non-corrosive.

## **Contaminated Fuel**

Do not use fuel that has been contaminated. Generally, fuel contamination occurs as the result of improper fuel handling. The most common types of contamination are water, dirt, and microbial growth (black slime). The formation of varnishes and gums resulting from poor stability or extended storage, or stale fuel, also affects fuel quality. The best treatment for contamination is prevention; maintain a clean storage system and choose a reputable fuel supplier.

## **Fuel Additives**

The regular use of aftermarket fuel additives is not required or recommended due to potential engine and aftertreatment damage. These additives increase operating costs without providing benefit. The use of supplemental fuel additives does not necessarily void the engine warranty. However, warranty and repair expenses which are determined, by Detroit™ or its representative, to have resulted from a fuel additive will not be covered by Detroit™ warranty.

## **Biodiesel Fuels**

Detroit™ supports biodiesel as a renewable fuel. Biodiesel fuels are mono alkali esters of long chain fatty acids commonly referred to as Fatty Acid Methyl Esters (FAME) and are derived from renewable resources through a chemical process called transesterification. Detroit™ approves the use of biodiesel fuel blends up to 5%.

## **How to Drain the Fuel Coalescer**

### **How to Drain the Fuel Coalescer**

Incorporated into the fuel filter module is a coalescer. The coalescer removes water and/or sediment and is located in the lower portion of the fuel filter module (see graphic below). Water in fuel can seriously affect engine performance and may cause engine damage. A water-in-fuel (WIF) dash indicator will warn the driver when trapped water needs to be drained.

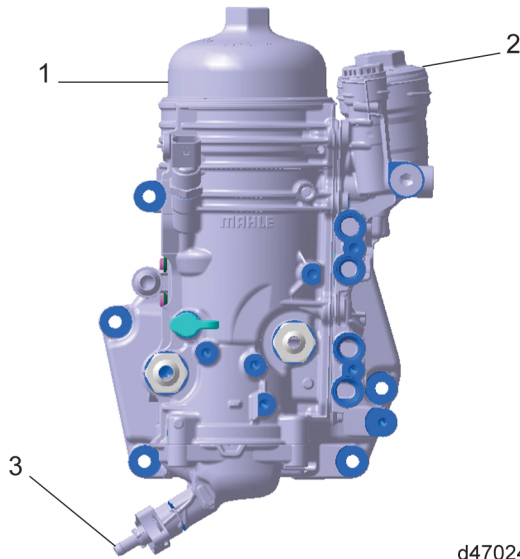

- |                          |                      |
|--------------------------|----------------------|
| 1. Final Fuel Filter Cap | 3. Water Drain Valve |
| 2. Pre Filter Cap        |                      |

#### Figure 14. Fuel Filter Module

1. Place a catch pan under the fuel coalescer to collect any water/fuel or sediment drained from the fuel coalescer.
2. Open the water drain valve (3) located under the fuel filter module (see above graphic). Collect and dispose of water/fuel or sediment drained from the fuel coalescer in an environmentally responsible manner, according to state and/or federal recommendations.
3. Allow the water/fuel or sediment to drain.
4. Close the water drain valve (3) (see above graphic). Do not over-tighten the water drain valve. Failure to properly tighten the water drain valve may cause damage to the water drain valve and housing.
5. Prime the fuel system with the built-in hand primer (about 50 strokes). The hand primer should not be used to prime any other type of fuel system service, as it will not provide sufficient priming, which may cause damage to the high pressure fuel pump.

## How to Restart an Engine Out of Fuel

## How to Restart an Engine Out of Fuel

Restarting an engine that has run out of fuel includes the use of special tools to prime the fuel system. Authorized Detroit™ service outlets are properly equipped for this type of service. Never use the starting motor and fuel pump to prime the fuel system. Prolonged use of the starting motor and fuel pump to prime the fuel system can result in damage to the starter, fuel pump, and injectors.

Use the following procedure to prime the fuel system:

1. Fill the fuel tank with the recommended grade of fuel; Refer to section "How to Select Fuel". If only partial filling is possible, add a minimum of 10% of the total tank volume of fuel to the tank. If a vehicle is on uneven ground, more fuel may be required.
2. Prime the fuel system by connecting one of the following approved external priming pumps to the priming port on the fuel filter module:
  - DAVCO Shop Pro FXP 95
  - ESOC® 250EXL
  - ESOC® 250E
  - ESOC® 455

**Table 9.**

**In an emergency situation the engine-mounted hand primer can be used to prime the fuel system by operating the engine-mounted hand primer for three minutes or 250 strokes.**

3. Turn ON the ignition (key ON, engine OFF).
4. Wait for the engine system indicators on the instrument panel to go out.



### **WARNING: PERSONAL INJURY**

Diesel engine exhaust and some of its constituents are known to the State of California to cause cancer, birth defects, and other reproductive harm.

- Always start and operate an engine in a well ventilated area.
- If operating an engine in an enclosed area, vent the exhaust to the outside.
- Do not modify or tamper with the exhaust system or emission control system.



### **WARNING: PERSONAL INJURY**

To avoid injury before starting and running the engine, ensure the vehicle is parked on a level surface, parking brake is set, and the wheels are blocked.



### **WARNING: ENGINE EXHAUST**

To avoid injury from inhaling engine exhaust, always operate the engine in a well-ventilated area. Engine exhaust is toxic.

5. Crank the engine for 20 seconds.
6. If the engine does not start, allow for a 60-second cool down and repeat previous steps two through five. The starting cycle can be repeated up to three times. If engine still fails to start, contact an authorized Detroit™ service outlet.
7. Once the engine has started, monitor the oil pressure gauge or warning indicator. Refer to section "Checking the Oil Pressure".
8. Check for leaks. If necessary, have leaks repaired.
9. Allow the engine to reach operating temperature of 60°C (140°F).
10. Increase engine speed to 1800 rpm for three minutes.
11. Return the engine to idle and allow to idle (600 rpm) for approximately one minute, then shut down the engine.
12. Check for leaks. If necessary, have leaks repaired.

## **How to Check the Lubricating Oil Level**

### **How to Check the Lubricating Oil Level**

Check the oil level daily with the engine stopped and on a level surface. If the engine has just been stopped and is warm, wait approximately 20 minutes to allow the oil to drain back into the oil pan before checking.

If the engine operating temperature is below 60° C (140° F), the engine must be on a level surface and then shut down for 60 minutes for an accurate oil level reading. Otherwise, the engine must be brought up to an operating temperature of 60° C (140° F), parked on a level surface and then shut down for approximately 20 minutes for an accurate oil level reading.

1. Remove the oil dipstick from the guide tube. Use a clean rag to wipe off the end of the oil dipstick.
2. Wait 15 seconds to allow any crankcase pressure to dissipate through the guide tube and let the oil level settle in the oil pan.
3. Reinstall the oil dipstick and make sure it is fully inserted into the guide tube. Remove the oil dipstick again and read the oil level. Figure below shows the maximum oil level (1) and minimum oil level (2). If the oil reading is in the crosshatch area or between the bends of the dipstick, then the oil is at the proper level for engine operation.

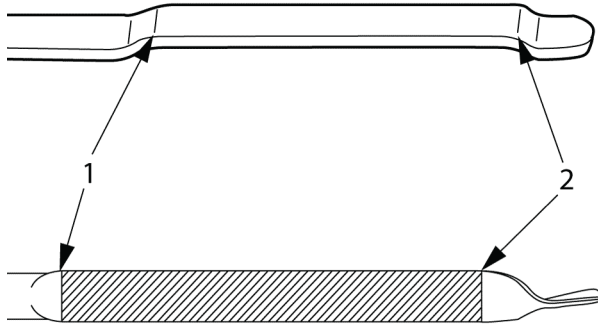

42141

4. If necessary, top off the engine oil by filling no more than 5.0 L (5.2 qt) at a time. Use only Detroit™ approved oil, Refer to section "Synthetic Oils and Additives". Do not overfill as overfilling the oil pan can cause engine damage.

## How to Select Lubricating Oil

### How to Select Lubricating Oil

Refer to DDC-SVC-BRO-0001 for more information.

**Detroit Fluids Specification (DFS) DFS 93K223 (API FA-4) or DFS 93K222 (API CK-4) oils are recommended for use in the engine.**



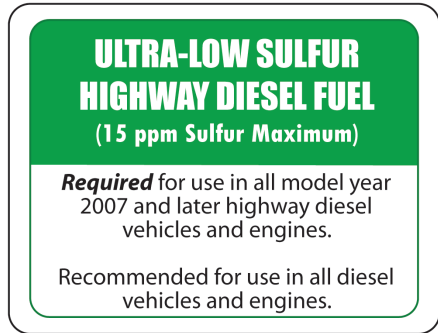
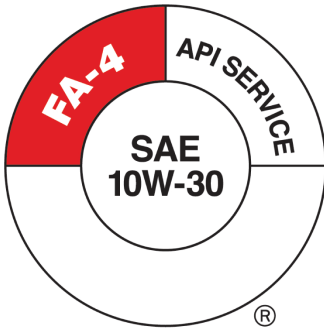

d470246c

For optimal fuel economy, use DFS 93K223 approved API FA-4 engine oil.

## Synthetic Oils and Additives

### Synthetic Oils

Synthetic oils may be used in Detroit™ Gen 5 Heavy Duty engines provided they are approved by DFS. The use of synthetic oils does not necessarily ensure the extension of the recommended oil drain intervals beyond the limits.

### Supplemental Additives

Lubricants meeting the Detroit™ specifications outlined in this publication already contain a balanced additive treatment. Supplemental additives are generally not necessary and can even be harmful. These additives may be marketed as either oil treatments or engine treatments, and are discouraged from use in Detroit™ Gen 5 Heavy Duty engines. Repair expenses which result in component malfunctions, or damage attributed to the use of oil additives, are not covered by Detroit™ warranty.

## How to Clean an Engine

### How to Clean an Engine

Observance of all environmental protection regulations is required.

Information on suitable cleaning and protective products is available from any authorized Detroit™ service outlet.

Use the following minimum working distance between the high-pressure nozzle and the surface being cleaned:

- Approximately 700 mm (28 in.) for circular pattern jets
- Approximately 300 mm (12 in.) for 25-degree flat jets and dirt cutters

Do not use compressed air or pressurized water to clean or dry the engine if any part of the engine is disassembled.

Power clean the engine as follows:

1. Allow engine to cool down to room temperature before spraying the engine.
2. Thoroughly clean the entire engine using a steam cleaner or high pressure washer with mild soap and warm water. To prevent damage to engine components, keep the water moving at all times while cleaning. Never direct water onto electrical components, plug connectors, seals or flexible hoses.



**WARNING: EYE INJURY**

To avoid injury from flying debris when using compressed air, wear adequate eye protection (face shield or safety goggles) and do not exceed 276 kPa (40 psi) air pressure.

3. Once the engine is clean, blow the electrical connectors dry with compressed air to remove most of the standing water.
4. Allow the engine to dry completely before making any kind of repair.
5. Ensure that there is no standing water in any electrical connectors.

## How to Operate the Cruise Control and Fast Idle

### How to Operate the Cruise Control and Fast Idle

The cruise control should not be used when it is not possible to keep the vehicle at constant speed due to:

- Winding roads
- Heavy traffic
- Slippery pavement
- Descending grades calling for engine brake assistance

### How to Operate the Cruise Control

Engine speed and power are varied under cruise control to maintain the set vehicle speed. Cruise control may also be programmed to permit fast idle using the cruise control switches

Set the cruise control as follows:

1. The vehicle must be above Min Cruise Set Speed and below Max Cruise Set Speed.
2. If the Cruise Enable Switch is left in the ON position at key OFF, the switch must be cycled OFF before cruise control activation can take place.
3. DDEC<sup>®</sup> will look for a one-time activation of the clutch (if equipped) and service brake before allowing cruise control to be enabled.
4. Turn the Cruise Enable ON.
5. Use SET/CST once the desired road speed has been achieved to lock in the road speed.
6. The cruise control indicator will come on.
7. Use RSM/ACC to increase road speed by 1.6 kph (1.0 mph).
8. Use SET/CST to reduce road speed.
9. The service brake will disable the cruise control.
10. RSM/ACC will restore the previously set cruise speed, if the cruise control was disabled.
  - Cruise Control will maintain the set speed under normal road and load conditions. It cannot limit vehicle speeds on downgrades if available engine braking effort is exceeded, nor can it maintain speed on upgrades if power requirements exceed engine power capability.
  - When using cruise control after downshifting on a hill to pull the hill, hitting the RSM/ACC Switch will keep the truck accelerating in the lower gears up to the rated engine speed.
  - Cruise Control will disengage below 1000 rpm or 32 kph (20 mph). When using cruise control, if wanting to pull the engine below 1000 rpm, the accelerator pedal would have to be held to the floor to keep the engine pulling at wide-open throttle. The engine will pull down to about 1050 rpm.

## How to Operate Fast Idle Using Cruise Control

Set the fast idle as follows:

1. The vehicle must be at base idle, transmission in neutral, and parking brake set.
2. Turn the Cruise Enable ON to activate the fast idle. If the Cruise Enable Switch is left in the ON position at key OFF, the switch must be cycled OFF then ON.
3. The engine rpm should set to a pre-defined speed.
4. Use RSM/ACC to increase engine rpm.
5. Use SET/CST to decrease engine rpm.
6. Turning the Cruise Enable OFF, will disable the fast idle.

## How to Operate the Engine Brakes

### How to Operate the Engine Brakes

The engine brake controls allow the driver to turn the engine brakes on and off and select a Low, Medium, or High level of braking. There is very little audible difference when the engine brakes are activated in either the medium or the high position.

- The "Low" setting activates braking on three cylinders, yielding about one-third engine braking horsepower.
- The "Medium" setting activates all six cylinders, supplying about two thirds engine braking horsepower.
- The "High" setting activates all six cylinders along with varied EGR control, supplying full engine brake horsepower.

### Engine Brake Activation Conditions

The engine braking system only permits fully automatic operation when the following conditions are met:

- Engine brake is activated on.
- An engine brake level (Low/Med/High) is selected.
- Vehicle meets the programmed minimum speed.
- The clutch pedal is depressed.
- The accelerator pedal is at zero percent activation.

The Detroit Diesel Electronic Control® (DDEC®) system will deactivate the engine brake system when the engine speed falls below a preset rpm or when the vehicle slows down to a preset speed. This prevents stalling the engine. The engine brakes can also be used with vehicle cruise control turned ON. Some systems may be programmed to activate themselves only when the brake pedal is pressed.

During normal vehicle operation the engine brakes may go into a self-activation mode to assist in maintaining proper temperatures during an active DPF regeneration, this mode is called Thermo Coast. While the vehicle is operating in Thermo Coast the operator may notice that the engine brakes are active even though the engine brake selection is off.

### Anti-Lock Braking Systems (ABS)

The ABS has the ability to turn the engine brake OFF if a wheel-slip condition is detected. The engine brake will automatically turn itself ON once the wheel slip is no longer detected.

### Clutch Pedal and Throttle Position Controls

Engine brakes have two additional controls, one activated by the position of the clutch pedal and the other activated by the position of the throttle. These controls permit fully automatic operation of the engine braking system.

## Engine Brake and Cruise Control

Engines with cruise control and engine brake function enabled can operate the engine brake automatically while in cruise control. If the Cruise Control/Engine Brake function is turned ON in the DDEC® system programming, the engine brake will come on low when the set road speed increases above cruise set speed. If vehicle speed continues to increase, the DDEC® system will increase the engine brake's braking power progressively. When the vehicle returns to the set cruise speed the engine brake will turn off.

## Engine Brake Operation

Always allow the engine to reach full normal operating temperature before activating the engine brake system to ensure positive engine brake engagement. The engine brake system depends on a full-pressure flow of warm engine lubricating oil for proper lubrication of moving parts and optimum performance.

The minimum operating speed for the engine brake is 900 rpm. A Check Engine Indicator will be illuminated when the predetermined high engine speed is exceeded.

Under normal driving conditions the engine brake system can be left in the ON position. However, this should change if roads become wet or slippery.

After being activated, the engine brake system is automatically activated each time the accelerator pedal is depressed. The engine brake automatically deactivates itself when the clutch pedal is pressed while shifting gears. Shifting gears without pressing the clutch or using the engine brakes to reduce engine RPM may result in serious powertrain damage due to higher engine speeds. Never exceed 2000 rpm as these higher engine speeds may result in extensive engine damage.

## Operating on Flat, Dry Pavement

Operate the engine brakes when driving on flat, dry pavement as follows:

1. If driving on flat, dry, open stretches with a light load and greater slowing power is not required, the engine brake should be placed in the LOW position.
2. If the service brakes are still needed, the engine brake should be moved to a higher position until the need to use the service brakes to slow the vehicle down is no longer present.
3. If carrying a heavier load and road traction is good, the engine brake should be moved to the HIGH position.
4. Check the engine brake often for proper position since road conditions can change quickly. Steps should never be skipped when operating the engine brakes. Always go from OFF to LOW, and then to a higher position.

## Operating Down a Long, Steep Grade

Extra caution should be taken when operating a vehicle down a long steep grade. Failure to keep the vehicle within safe control speed limits while descending a grade may result in vehicle or property damage or both.

During operation of the vehicle, the operator should limit the engine speed to 1900 rpm or less. No extra engine power is achieved at engine speeds above 1900 rpm. Shifting gears without pressing the clutch, or using the engine brakes to reduce engine speed, may result in serious powertrain damage due to higher engine speeds. Never exceed 2000 rpm as higher engine speeds may result in extensive engine damage.

Any engine overspeed (engine speed exceeds 2500 rpm) while the vehicle is moving (vehicle speed over 0 MPH) is considered to be an operator-induced engine overspeed. Any mechanical engine failure within 3218 km (2000 mi) of an operator-induced engine overspeed event will not be eligible for Detroit warranty coverage.

Operate the engine brakes when descending a long, steep grade as follows:

1. Before beginning the descent, determine if the brake system is operating properly by briefly depressing the accelerator pedal. The operator should be able to feel the system activate.
2. Ensure the engine brake is in the appropriate power position (LOW/MED/HIGH).



### CAUTION: BRAKE FADE

To avoid injury, do not over apply the vehicle service brakes when descending a long, steep grade. Excessive use of the vehicle brakes will cause them to heat up, reducing their stopping ability. This condition, referred to as “brake fade”, may result in loss of braking, which could lead to personal injury or vehicle/property damage or both.

3. Do not exceed the safe control speed of the vehicle. Example: An operator could descend a 6% grade, under control only at 16 kph (10 mph) without an engine brake, but at 40 kph (25 mph) with an engine brake. Do not descend that same hill at 80 kph (50 mph) and still expect to remain under control. Operators should get to know how much slowing power the engine brakes can provide. Operators should get to know the engine brake system before climbing hills and should not exceed a safe control speed.



### WARNING: PERSONAL INJURY

Failure to keep the vehicle within safe control speed limits while descending a grade may result in loss of vehicle control, which could cause personal injury.

4. Check the engine brake status often for proper position (LOW/MED/HIGH) since road conditions can change quickly. Never skip a step when operating the engine brake system. Always go from OFF to LOW and then to a higher position.

## Operating on Wet Slippery Pavement

Experience with the engine brake system on dry pavement is recommended before attempting to use it on wet or slippery roads.

Operate the engine brake system on wet or slippery pavement as follows:

1. On wet or slippery pavement, start with the status in the OFF position and use the gear that would normally be used under these conditions.



### CAUTION: LOSS OF VEHICLE CONTROL

To avoid injury from loss of vehicle control, do not activate the Engine Brake system under the following conditions:

- On wet or slippery pavement, unless the vehicle is equipped with ABS (anti-lock braking system) and you have had prior experience driving under these conditions.
- When driving without a trailer (bobtailing) or pulling an empty trailer.
- If the tractor drive wheels begin to lock or there is fishtail motion after the Engine Brake is activated, deactivate the brake system immediately if this occurs.

**NOTE:** On single trailers or combinations, a light air application of the trailer brakes may be desirable to help keep the trailer stretched out. Follow the manufacturer's recommended operating procedure when using the trailer brakes.

2. If the vehicle is maintaining traction, turn ON the engine brakes to the LOW position. If the drive wheels are maintaining traction and greater slowing power is desired, move the braking position to the next highest position.
3. If the vehicle drive wheels begin to lock or there is a fishtail motion, turn the engine brake system OFF immediately and do not activate it until road conditions improve.
4. Check the engine brake status often for proper position (LOW/MED/HIGH) since road conditions can change quickly. Never skip a step when operating the engine brake system. Always go from OFF to LOW and then to a higher position.

## Customer Assistance

### Availability of Detroit™ Service Outlets

Detroit™ products have a complete network of Detroit™ service outlets worldwide that are prepared to meet the customer's parts and service needs:

- Service by trained personnel
- Sales team to help determine specific power requirements
- In many areas, emergency service 24 hours a day
- Complete parts support
- Product information and literature

Detroit™ recognizes that despite the best intentions of everyone concerned, misunderstandings may occur. Normally, any situation that arises in connection with the sale, operation or service of a Detroit™ product will be handled by the authorized Detroit™ service outlet. The service locator at [www.demanddetroit.com](http://www.demanddetroit.com) can be used for help in finding an authorized Detroit™ service outlet.