

Operation & Maintenance Manual

BULLDOZER

D65EX -15E0

D65PX -15E0

D65WX -15E0

SERIAL NUMBERS D65EX- 69001
 D65PX- 69001 and up
 D65WX-69001

ecot3

⚠ WARNING

Unsafe use of this machine may cause serious injury or death. Operators and maintenance personnel must read this manual before operating or maintaining this machine. This manual should be kept near the machine for reference and periodically reviewed by all personnel who will come into contact with it.

NOTICE

Komatsu has Operation & Maintenance Manuals written in some other languages. If a foreign language manual is necessary, contact your local distributor for availability.

KOMATSU

FOREWORD

CALIFORNIA

Proposition 65 Warning

Diesel engine exhaust and some of its constituents are known to the State of California to cause cancer, birth defects, and other reproductive harm.

CALIFORNIA

Proposition 65 Warning

Battery posts, terminals and related accessories contain lead and lead compounds, chemicals known to the State of California to cause cancer and birth defects or other reproductive harm.

Wash hands after handling.

BEFORE READING THIS MANUAL

This manual gives details of the operation and methods of inspection and maintenance for this machine that must be obeyed in order to use the machine safely. Most accidents are caused by the failure to follow fundamental safety rules for the operation and maintenance of machines.

Read, understand and follow all precautions and warnings in this manual and on the machine before performing operation and maintenance. Failure to do so may result in serious injury or death.

Komatsu cannot predict every circumstance that might involve a potential hazard when the machine is used. Therefore, the safety messages in this manual and on the machine may not include all possible safety precautions. If you carry out any operation, inspection, or maintenance under conditions that are not described in this manual, understand that it is your responsibility to take the necessary precautions to ensure safety. In no event should you or others engage in the prohibited uses or actions described in this manual. Improper operation and maintenance of the machine can be hazardous and could result in serious injury or death.

If you sell the machine, be sure to give this manual to the new owner together with the machine.

Always keep this Operation and Maintenance Manual in the location shown on the right so that all relevant personnel can read it at any time.

Operation and Maintenance Manual Storing Place

For a machine with a cab, a pocket is provided on the inside of both right and left doors.

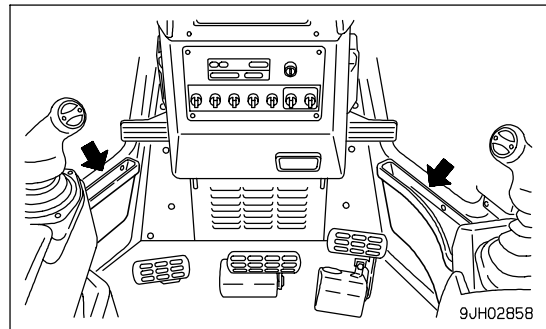

For a machine with a ROPS canopy, a pocket is provided at the end of the floor.

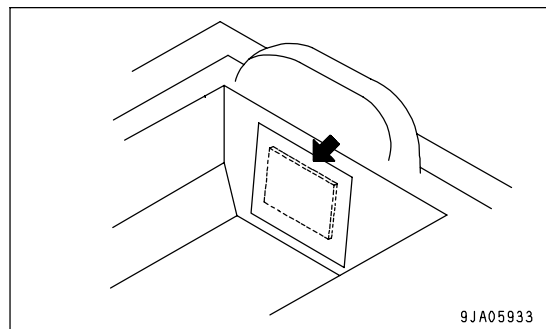

If this manual is lost or damaged, contact your distributor immediately to arrange for its replacement. For details regarding the machine serial No. you will need to provide your Komatsu distributor, see "TABLE TO ENTER SERIAL NO. AND DISTRIBUTOR (PAGE 1-11)".

This manual uses the international units (SI) for units of measurement. For reference, units that have been used in the past are given in ().

The explanations, values, and illustrations in this manual have been prepared based on the latest information available as of the date of its publication. Continuing improvements in the design of this machine may lead to additional changes that are not reflected in this manual. Consult Komatsu or your Komatsu distributor for the latest available information concerning your machine or with questions regarding information contained in this manual.

- The numbers in circles in the illustrations correspond to the numbers in () in the text.

(For example: ① → (1))

Komatsu delivers machines that comply with all applicable regulations and standards of the country to which it has been shipped. If this machine has been purchased in another country, it may lack certain safety devices and specifications that are necessary for use in your country. If there is any question about whether your product complies with the applicable standards and regulations of your country, consult Komatsu or your Komatsu distributor before operating the machine.

EMISSION CONTROL WARRANTY

EMISSION CONTROL WARRANTY STATEMENT (APPLIES TO CANADA ONLY)

1. Products Warranted

Komatsu America International Company, Komatsu Mining Systems Inc. and Komatsu Utility Corporation (collectively "Komatsu") produce and/or market products under brand names of Komatsu, Dresser, Dressta, Haulpak and Galion. This emissions warranty applies to new engines bearing the Komatsu name installed in these products and used in Canada in machines designed for industrial off-highway use. This warranty applies only to these engines produced on or after January 1, 2000. This warranty will be administered by Komatsu distribution in Canada.

2. Coverage

Komatsu warrants to the ultimate purchaser and each subsequent purchaser that the engine is designed, built and equipped so as to conform, at the time of sale by Komatsu, with all U.S. Federal emission regulations applicable at the time of manufacture and that it is free from defects in workmanship or material which would cause it not to meet these regulations within five years or 3,000 hours of operation, whichever occurs first, as measured from the date of delivery of the engine to the ultimate purchaser.

3. Limitations

Failures, other than those resulting from defects in materials or workmanship, are not covered by this warranty. Komatsu is not responsible for failures or damage resulting from what Komatsu determines to be abuse or neglect, including, but not limited to: operation without adequate coolant or lubricants; over fueling; over speeding; lack of maintenance of lubricating, cooling or intake systems; improper storage, starting, warm-up, run-in or shutdown practices; unauthorized modifications of the engine. Komatsu is also not responsible for failures caused by incorrect fuel or by water, dirt or other contaminants in the fuel. Komatsu is not responsible for non-engine repairs, "downtime" expense, related damage, fines, all business costs or other losses resulting from a warrantable failure.

KOMATSU IS NOT RESPONSIBLE FOR INCIDENTAL OR CONSEQUENTIAL DAMAGES.

This warranty, together with the express commercial warranties, are the sole warranties of Komatsu. **THERE ARE NO OTHER WARRANTIES, EXPRESS OR IMPLIED, OR OF MERCHANTABILITY OR FITNESS FOR A PARTICULAR PURPOSE.**

GARANTIE SUR LE CONTRÔLE DES ÉMISSIONS

ÉNONCÉ DE GARANTIE SUR LE CONTRÔLE DES ÉMISSIONS (APPLICABLE AU CANADA SEULEMENT):

1. Produits garantis:

Komatsu America International Company, Komatsu Mining Systems Inc. et Komatsu Utility Corporation (collectivement Komatsu) produisent et/ou font la mise en marché de produits portant les noms de marque Komatsu, Dresser, Dressta, Haulpak et Galion. Cette garantie sur les émissions s'applique à tous les nouveaux moteurs portant le nom Komatsu, installés dans ces produits et utilisés au Canada dans des machines conçues pour utilisation industrielle non-routière. Cette garantie s'applique seulement sur les moteurs produits à partir du 1er Janvier 2000. Cette garantie sera administrée par la distribution de Komatsu au Canada.

2. Couverture:

Komatsu garantit à l'acheteur ultime et chaque acheteur subséquent que le moteur est conçu, construit et équipé en toute conformité, au moment de la vente par Komatsu, avec toutes les Réglementations fédérales américaines sur les émissions applicables au moment de la fabrication et qu'il est exempt de défauts de construction ou de matériaux qui auraient pour effet de contrevenir à ces réglementations en dedans de 5 ans ou 3000 heures d'opération, mesuré à partir de la date de livraison du moteur au client ultime.

3. Limitations:

Les bris, autres que ceux résultant de défauts de matériaux ou de construction, ne sont pas couverts par cette Garantie. Komatsu n'est pas responsable pour bris ou dommages résultant de ce que Komatsu détermine comme étant de l'abus ou négligence, incluant mais ne se limitant pas à: l'opération sans lubrifiants ou agent refroidissants adéquats; la suralimentation d'essence; la survitesse; le manque d'entretien des systèmes de lubrification, de refroidissement ou d'entrée; de pratiques non-propices d'entreposage, de mise en marche, de réchauffement, de conditionnement ou d'arrêt; les modifications non-autorisées du moteur. De plus, Komatsu n'est pas responsable de bris causés par de l'essence inadéquate ou de l'eau, des saletés ou autres contaminants dans l'essence. Komatsu n'est pas responsable des réparations non-relées au moteur, des dépenses encourues suite aux temps d'arrêts, des dommages relatifs, amendes, et de tout autre coût d'affaires ou autres pertes résultant d'un bris couvert par la garantie.

KOMATSU N'EST PAS RESPONSABLE DES INCIDENTS OU DOMMAGES CONSÉQUENTS.

Cette garantie, ainsi que les garanties expresses commerciales, sont les seules garanties de Komatsu. **IL N'Y A AUCUNE AUTRE GARANTIE, EXPRESSE OU SOUS-ENTENDUE, MARCHANDABLE OU PROPICE A UNE UTILISATION PARTICULIÈRE.**

NOTE IMPORTANTE CONCERNANT LE MOTEUR
 Ce moteur est conforme aux normes XXX US EPA et California Tier 3 relatives aux moteurs à compression destinés aux engins ne devant pas circuler sur route. Ce moteur fonctionne à partir de gazole. **AVERTISSEMENT:** Des blessures peuvent résulter de l'usage de ce modèle dans des conditions d'alimentation, de régime et d'altitude excédant celles publiées par le constructeur; dans ces cas, la garantie peut aussi ne plus jouer.

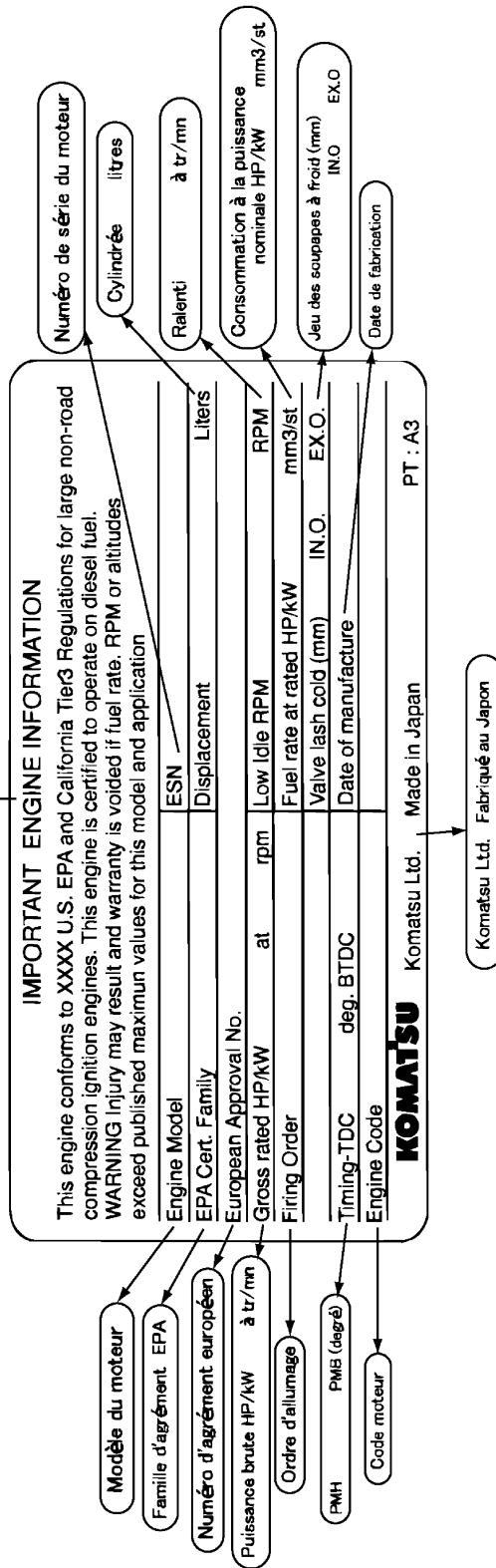



ENGINE DATEPLATE - ENGLISH / FRENCH

IMPORTANT SAFETY INFORMATION

To enable you to use the machine safely, and to prevent injury to operators, service personnel or bystanders, the precautions and warnings included in this manual and the safety signs attached to the machine must always be followed.

To identify important safety messages in the manual and on the machine labels, the following signal words are used.

The "Safety Alert Symbol" identifies important safety messages on machines, in manuals, and elsewhere. When you see this symbol, be alert to the risk of personal injury or death. Follow the instructions in the safety message.

- | | |
|--|--|
|  DANGER | This signal word indicates an imminently hazardous situation which, if not avoided, will result in death or serious injury. |
|  WARNING | This signal word indicates a potentially hazardous situation which, if not avoided, could result in death or serious injury. |
|  CAUTION | This signal word indicates a potentially hazardous situation exists which, if not avoided, may result in minor or moderate injury. |

The following signal words are used to alert you to information that must be followed to avoid damage to the machine.

NOTICE	This precaution is given where the machine may be damaged or the service life reduced if the precaution is not followed.
---------------	--

REMARKS	This word is used for information that is useful to know.
----------------	---

INTENDED USE

USE OF MACHINE

This Komatsu machine is designed to be used mainly for the following work:

- Dozing
- Smoothing
- Cutting into hard or frozen ground or ditching
- Felling trees, removing stumps

See the section "WORK POSSIBLE USING BULLDOZER (PAGE 3-108)" for further details.

GENERAL VIEW AND DIRECTIONS OF MACHINE

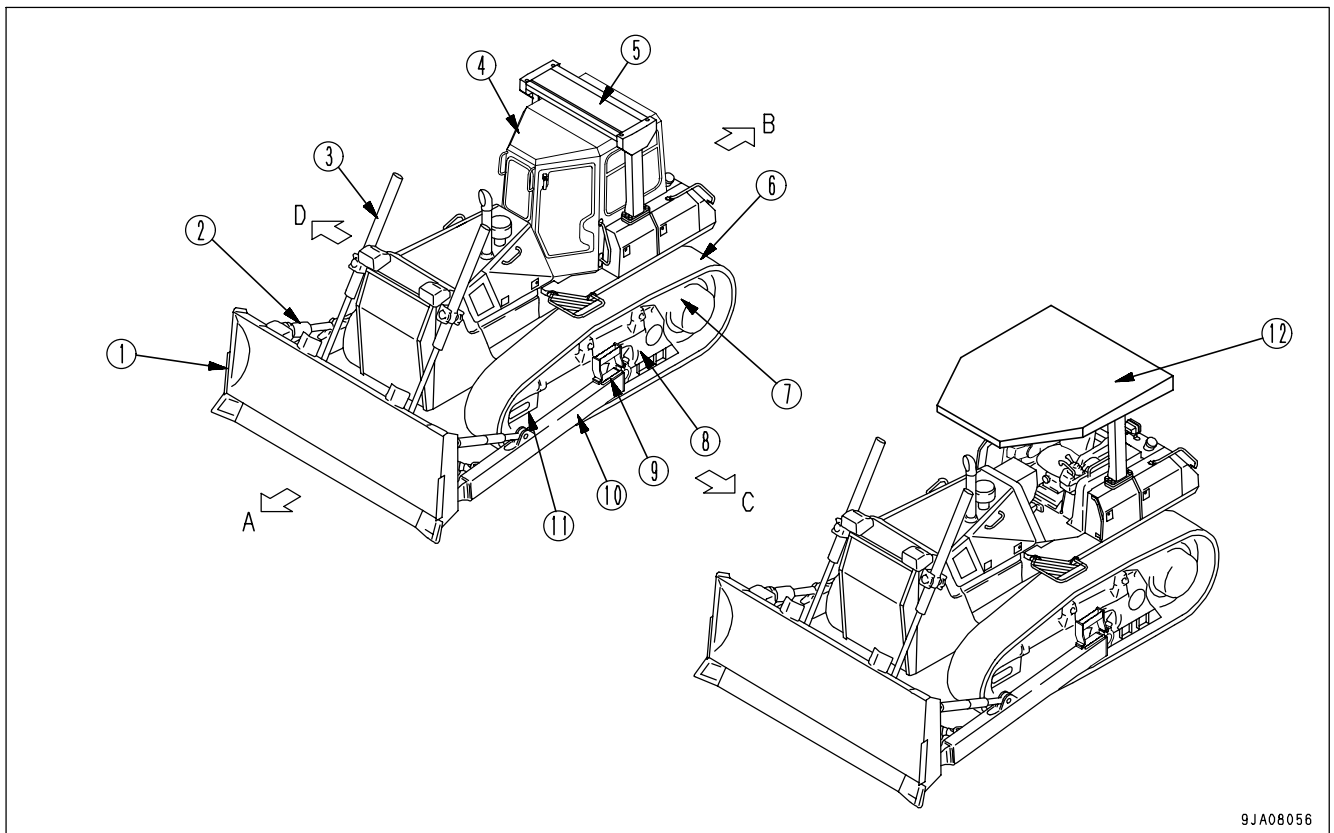

In this manual, the directions of the machine (front, rear, left, right) are determined according to the view from the operator's seat in the direction of travel (front) of the machine.

- | | |
|-------------------|------------------|
| (1) Blade | (7) Sprocket |
| (2) Tilt cylinder | (8) Track frame |
| (3) Lift cylinder | (9) Step |
| (4) Cab | (10) Frame |
| (5) ROPS guard | (11) Idler |
| (6) Track shoe | (12) ROPS canopy |
| (A) Front | (C) Left |
| (B) Rear | (D) Right |

VISIBILITY FROM OPERATOR'S SEAT

The visibility standards (ISO 5006) for this machine require a view shown in the diagram below.

PROXIMITY VISIBILITY

The figure bellows shows a front visibility from the machine at a spot 1.0 m away from the side and 1.5 m above the ground. Shaded area (A) in the figure shows an area whose view is blocked by part of the machine. Operate the machine, fully aware that the machine has a portion that an operator cannot see.

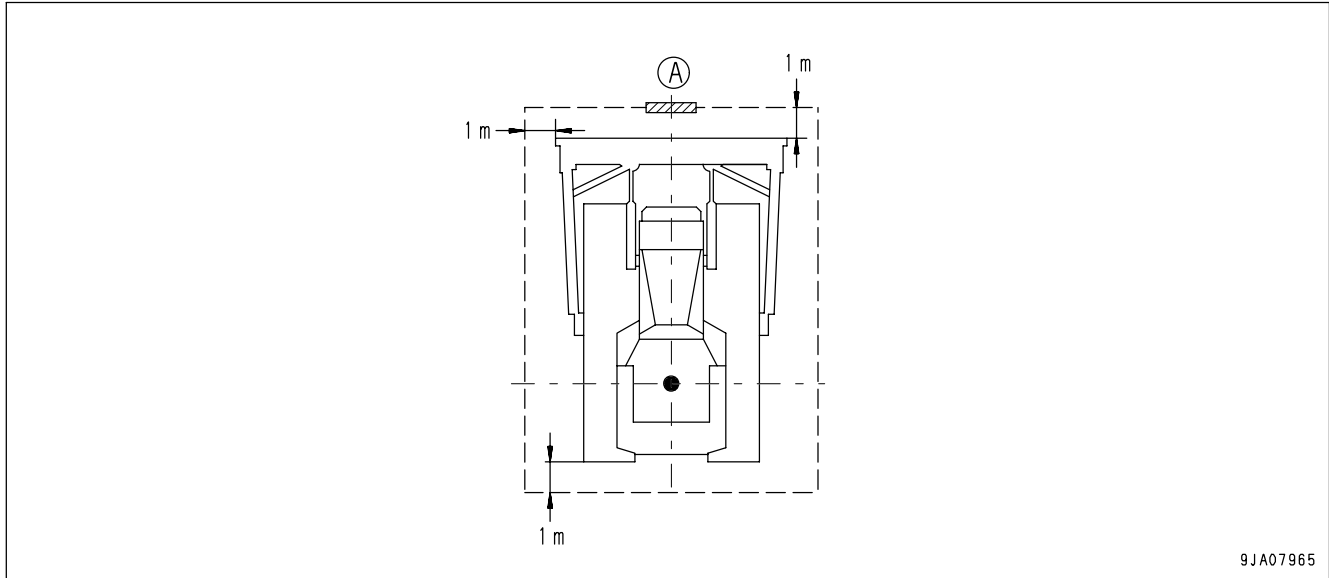

12M CIRCUMFERENCE VISIBILITY

The figure below shows a visibility from the machine within a circle of 12 m in radius. Shaded area (B) in the figure shows an area whose view is blocked by part of the machine. Operate the machine, fully aware that the machine has a portion that an operator cannot see.

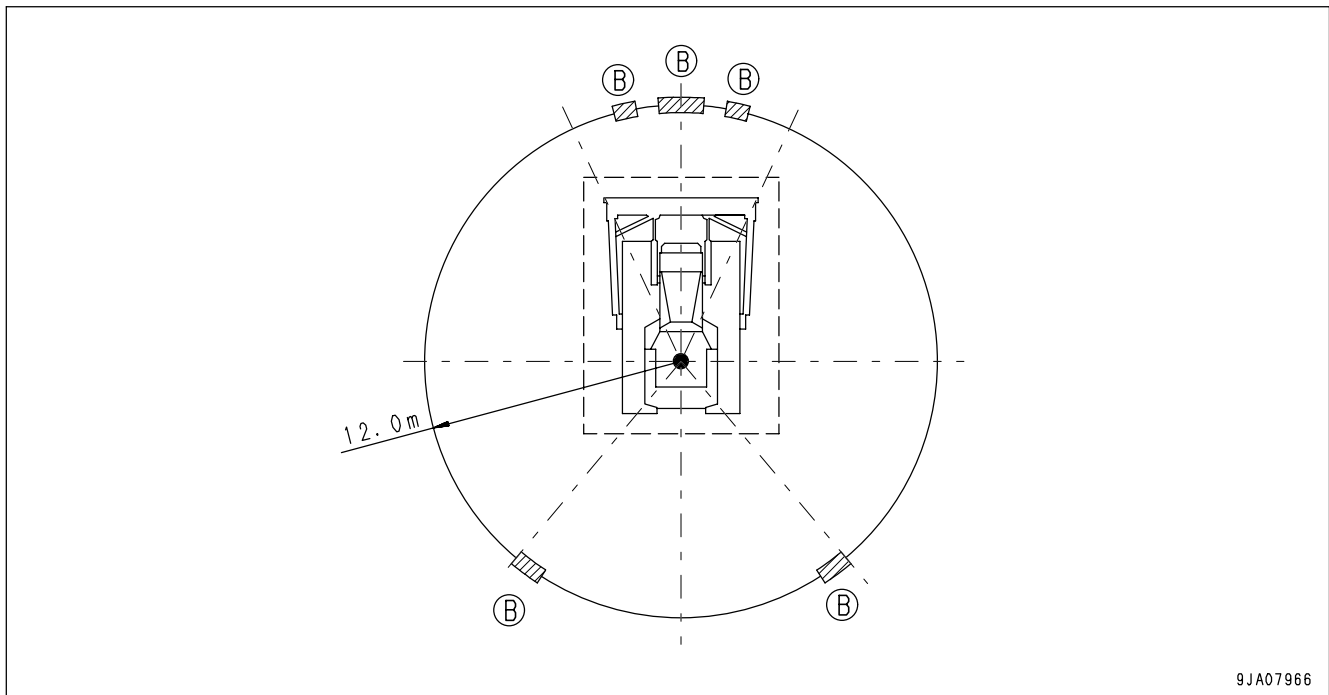

LOCATION OF PLATES, TABLE TO ENTER SERIAL NO. AND DISTRIBUTOR

When ordering replacement parts, please inform your Komatsu distributor of the following.

PRODUCT IDENTIFICATION NUMBER (PIN)/MACHINE SERIAL NO. PLATE

This is at the front bottom right of the operator's seat.
The design of the nameplate differs according to the territory.

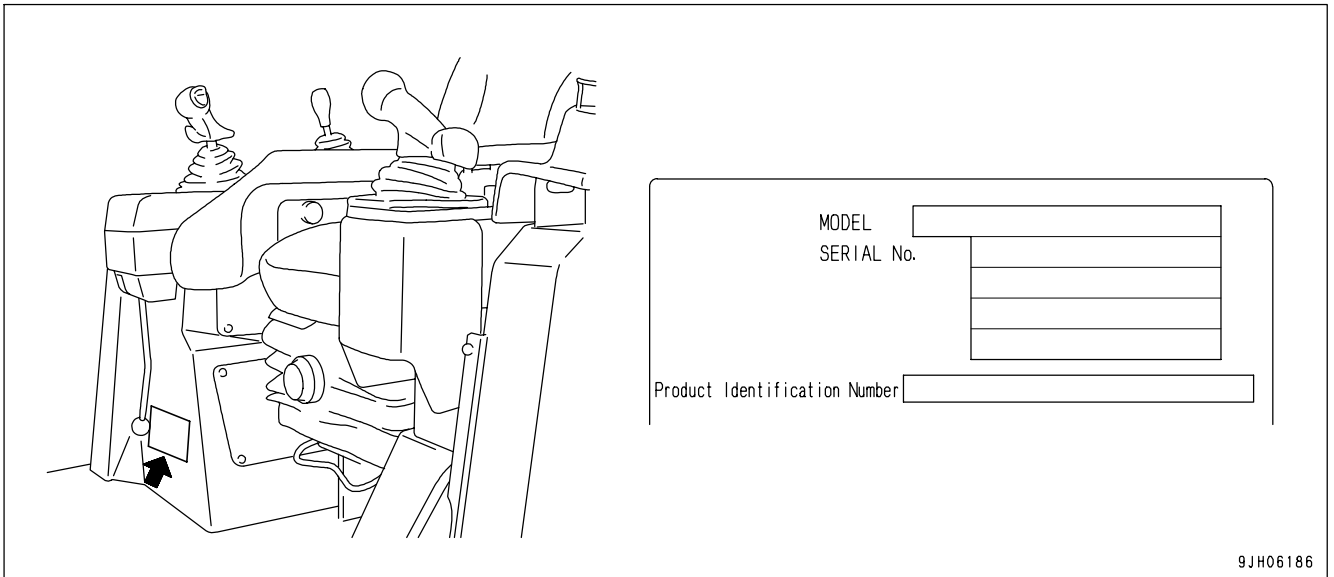

ENGINE SERIAL NO. PLATE POSITION

The engine serial No. plate is located on the side of the engine front cover on the left side of the machine.

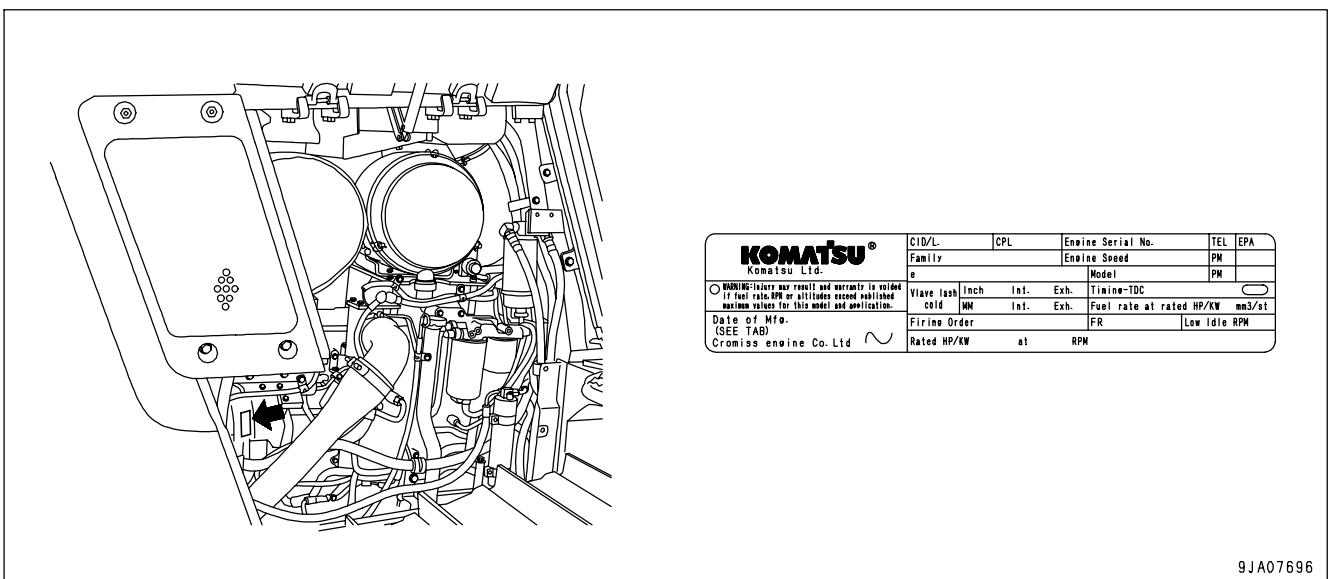

ADDITIONAL EPA NAMEPLATE

The additional EPA nameplate is located on top of the engine head cover on the left side of the machine.

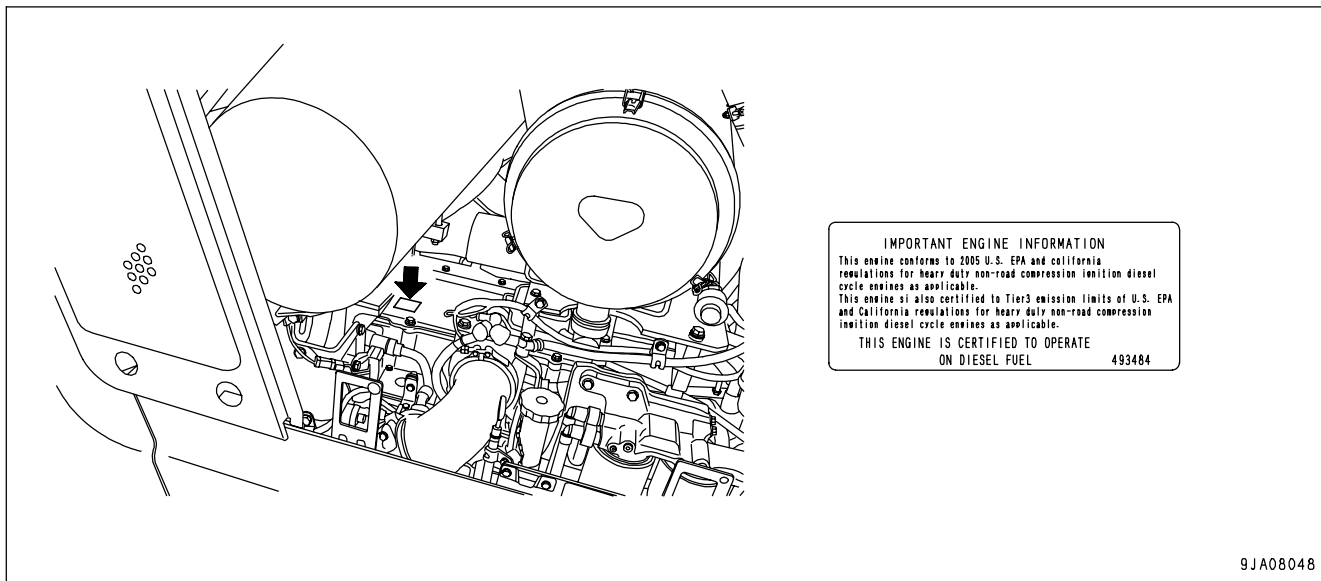

EPA: Environmental Protection Agency, U.S.A.

SERVICE METER POSITION

The service meter is provided at the lower part of the monitor panel.

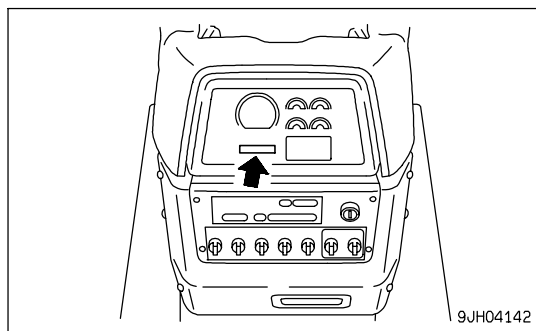

TABLE TO ENTER SERIAL NO. AND DISTRIBUTOR

Machine serial No.	
Engine serial No.	
Product identification number (PIN)	
Distributor name	
Address	
Service Personnel	
Phone/Fax	

CONTENTS

FOREWORD	1- 1
BEFORE READING THIS MANUAL	1- 2
IMPORTANT SAFETY INFORMATION	1- 6
INTENDED USE	1- 7
USE OF MACHINE	1- 7
GENERAL VIEW AND DIRECTIONS OF MACHINE	1- 7
VISIBILITY FROM OPERATOR'S SEAT	1- 8
LOCATION OF PLATES, TABLE TO ENTER SERIAL NO. AND DISTRIBUTOR	1- 9
PRODUCT IDENTIFICATION NUMBER (PIN)/MACHINE SERIAL NO. PLATE	1- 9
ENGINE SERIAL NO. PLATE POSITION	1- 9
ADDITIONAL EPA NAMEPLATE	1- 10
SERVICE METER POSITION	1- 10
TABLE TO ENTER SERIAL NO. AND DISTRIBUTOR	1- 11
SAFETY	2- 1
SAFETY	2- 2
SAFETY LABELS	2- 5
POSITIONS OF SAFETY PICTOGRAMS	2- 5
SAFETY LABELS	2- 6
GENERAL PRECAUTIONS COMMON TO OPERATION AND MAINTENANCE	2- 10
PRECAUTIONS BEFORE STARTING OPERATION	2- 10
PREPARATIONS FOR SAFE OPERATION	2- 10
FIRE PREVENTION	2- 12
PRECAUTIONS WHEN GETTING ON OR OFF MACHINE	2- 13
DO NOT GET CAUGHT IN WORK EQUIPMENT	2- 14
PRECAUTIONS RELATED TO PROTECTIVE STRUCTURES	2- 15
UNAUTHORIZED MODIFICATION	2- 15
PRECAUTIONS RELATED TO ATTACHMENTS AND OPTIONS	2- 15
PRECAUTIONS WHEN RUNNING ENGINE INSIDE BUILDING	2- 15
PRECAUTIONS FOR OPERATION	2- 16
PRECAUTIONS FOR JOBSITE	2- 16
STARTING ENGINE	2- 19
OPERATION	2- 21
TRANSPORTATION	2- 25
TOWING	2- 26
PRECAUTIONS FOR MAINTENANCE	2- 27
PRECAUTIONS BEFORE STARTING INSPECTION AND MAINTENANCE	2- 27
PRECAUTIONS FOR INSPECTION AND MAINTENANCE	2- 31
OPERATION	3- 1
GENERAL VIEW	3- 2
GENERAL VIEW OF MACHINE	3- 2
GENERAL VIEW OF CONTROLS AND GAUGES	3- 3
EXPLANATION OF COMPONENTS	3- 6
FRONT PANEL	3- 6
SWITCHES	3- 33
CONTROL LEVERS AND PEDALS	3- 37
CIRCUIT BREAKER	3- 46
FUSE	3- 47
FUSIBLE LINK	3- 48
ELECTRIC POWER TAKE-OUT ADAPTER	3- 49

CAP WITH LOCK -----	3- 50
DOOR - OPEN LOCK -----	3- 52
SASH GLASS INTERMEDIATE LOCK -----	3- 52
DOOR POCKET -----	3- 53
OPENING AND CLOSING ENGINE SIDE COVER -----	3- 53
ASHTRAY -----	3- 54
CUP HOLDER -----	3- 54
TOOL BOX -----	3- 54
SHOVEL HOLDER -----	3- 55
CAR STEREO, HANDLING -----	3- 56
AIR CONDITIONER, HANDLING -----	3- 64
OPERATION -----	3- 70
CHECK BEFORE STARTING ENGINE, ADJUST -----	3- 70
STARTING ENGINE -----	3- 87
OPERATIONS AND CHECKS AFTER STARTING ENGINE -----	3- 92
STOPPING ENGINE -----	3- 95
MACHINE OPERATION -----	3- 96
SHIFTING GEARS -----	3- 99
SHIFTING BETWEEN FORWARD AND REVERSE -----	3-102
STEERING MACHINE -----	3-104
PRECAUTIONS FOR OPERATION -----	3-106
WORK POSSIBLE USING BULLDOZER -----	3-108
ADJUSTING POSTURE OF WORK EQUIPMENT -----	3-110
PARKING MACHINE -----	3-114
CHECK AFTER FINISHING WORK -----	3-115
LOCKING -----	3-116
TIPS FOR LONGER UNDERCARRIAGE LIFE -----	3-117
TRANSPORTATION -----	3-120
TRANSPORTATION MEANS -----	3-120
REMOVING CAB -----	3-120
PRECAUTIONS WHEN REMOVING WORK EQUIPMENT -----	3-121
PRECAUTIONS WHEN REMOVING ROPS -----	3-121
LOADING, UNLOADING WORK -----	3-122
LIFTING MACHINE -----	3-125
TRAVELING ON ROADS -----	3-127
COLD WEATHER OPERATION -----	3-128
PRECAUTIONS FOR LOW TEMPERATURE -----	3-128
AFTER COMPLETION OF WORK -----	3-129
AFTER COLD WEATHER -----	3-129
LONG-TERM STORAGE -----	3-130
BEFORE STORAGE -----	3-130
DURING STORAGE -----	3-130
AFTER STORAGE -----	3-130
TROUBLESHOOTING -----	3-131
AFTER RUNNING OUT OF FUEL -----	3-131
METHOD OF TOWING MACHINE -----	3-132
IF BATTERY IS DISCHARGED -----	3-133
OTHER TROUBLE -----	3-137
MAINTENANCE -----	4- 1
GUIDE TO MAINTENANCE -----	4- 2

OUTLINE OF SERVICE	4- 5
HANDLING OIL, FUEL, COOLANT, AND PERFORMING OIL CLINIC	4- 5
RELATING TO ELECTRIC SYSTEM	4- 8
HANDLING HYDRAULIC SYSTEM	4- 9
WEAR PARTS LIST	4- 10
WEAR PARTS LIST	4- 10
RECOMMENDED FUEL, COOLANT, AND LUBRICANT	4- 12
USE OF FUEL, COOLANT AND LUBRICANTS ACCORDING TO AMBIENT TEMPERATURE	4- 13
RECOMMENDED BRANDS, RECOMMENDED QUALITY FOR PRODUCTS OTHER THAN KOMATSU GENUINE OIL	4- 14
STANDARD TIGHTENING TORQUES FOR BOLTS AND NUTS	4- 15
TORQUE LIST	4- 15
PERIODIC REPLACEMENT OF SAFETY CRITICAL PARTS	4- 16
SAFETY CRITICAL PARTS	4- 16
MAINTENANCE SCHEDULE CHART	4- 18
MAINTENANCE SCHEDULE CHART	4- 18
SERVICE PROCEDURE	4- 20
WHEN REQUIRED	4- 20
CHECK BEFORE STARTING	4- 42
EVERY 50 HOURS SERVICE	4- 43
EVERY 250 HOURS SERVICE	4- 44
EVERY 500 HOURS SERVICE	4- 53
EVERY 1000 HOURS SERVICE	4- 59
EVERY 2000 HOURS SERVICE	4- 68
EVERY 4000 HOURS SERVICE	4- 74
EVERY 8000 HOURS SERVICE	4- 77
SPECIFICATIONS	5- 1
SPECIFICATIONS	5- 2
ATTACHMENTS, OPTIONS	6- 1
GENERAL PRECAUTIONS	6- 2
PRECAUTIONS RELATED TO SAFETY	6- 2
SELECTION OF TRACK SHOE	6- 3
METHOD OF SELECTING SHOES	6- 3
HANDLING HYDRAULIC RIPPER	6- 4
GENERAL VIEW	6- 4
EXPLANATION OF COMPONENTS	6- 5
OPERATION	6- 6
TROUBLESHOOTING	6- 8
MAINTENANCE	6- 9
SPECIFICATIONS	6- 9
HANDLING TRIMMING DOZER	6- 10
GENERAL VIEW	6- 10
EXPLANATION OF COMPONENTS	6- 11
OPERATION	6- 13
MAINTENANCE	6- 16
SPECIFICATIONS	6- 20
AIR SUSPENSION SEAT	6- 21
DELUXE SEAT	6- 23
HEADREST	6- 25
EQUIPPING FIRE EXTINGUISHER AND FIRST-AID KIT	6- 26

HANDLING MACHINES EQUIPPED WITH KOMTRAX -----	6- 27
BASIC PRECAUTIONS -----	6- 27
INDEX -----	7- 1

SAFETY

WARNING

Please read and make sure that you fully understand the precautions described in this manual and the safety labels on the machine. When operating or servicing the machine, always follow these precautions strictly.

SAFETY

SAFETY LABELS	2- 5
POSITIONS OF SAFETY PICTOGRAMS	2- 5
SAFETY LABELS	2- 6
GENERAL PRECAUTIONS COMMON TO OPERATION AND MAINTENANCE	2- 10
PRECAUTIONS BEFORE STARTING OPERATION	2- 10
ENSURING SAFE OPERATION	2- 10
UNDERSTANDING THE MACHINE	2- 10
PREPARATIONS FOR SAFE OPERATION	2- 10
PRECAUTIONS REGARDING SAFETY-RELATED EQUIPMENT	2- 10
INSPECTING MACHINE	2- 10
WEAR WELL-FITTING CLOTHES AND PROTECTIVE EQUIPMENT	2- 10
KEEP MACHINE CLEAN	2- 11
PRECAUTIONS INSIDE OPERATOR'S COMPARTMENT	2- 11
PROVIDE FIRE EXTINGUISHER AND FIRST AID KIT	2- 11
IF ANY PROBLEM IS FOUND	2- 11
FIRE PREVENTION	2- 12
ACTION IF FIRE OCCURS	2- 12
PRECAUTIONS TO PREVENT FIRE	2- 12
PRECAUTIONS WHEN GETTING ON OR OFF MACHINE	2- 13
USE HANDRAILS AND STEPS WHEN GETTING ON OR OFF MACHINE	2- 13
NO JUMPING ON OR OFF MACHINE	2- 13
NO PEOPLE ON ATTACHMENTS	2- 14
PRECAUTIONS WHEN STANDING UP FROM OPERATOR'S SEAT	2- 14
PRECAUTIONS WHEN LEAVING MACHINE	2- 14
EMERGENCY EXIT FROM OPERATOR'S CAB	2- 14
DO NOT GET CAUGHT IN WORK EQUIPMENT	2- 14
PRECAUTIONS RELATED TO PROTECTIVE STRUCTURES	2- 15
UNAUTHORIZED MODIFICATION	2- 15
PRECAUTIONS RELATED TO ATTACHMENTS AND OPTIONS	2- 15
PRECAUTIONS WHEN RUNNING ENGINE INSIDE BUILDING	2- 15

PRECAUTIONS FOR OPERATION	2- 16
PRECAUTIONS FOR JOBSITE	2- 16
INVESTIGATE AND CONFIRM JOBSITE CONDITIONS	2- 16
WORKING ON LOOSE GROUND	2- 16
DO NOT GO CLOSE TO HIGH-VOLTAGE CABLES	2- 17
ENSURE GOOD VISIBILITY	2- 17
CHECKING SIGNS AND SIGNALMAN'S SIGNALS	2- 17
BEWARE OF ASBESTOS DUST	2- 18
STARTING ENGINE	2- 19
USE WARNING TAGS	2- 19
CHECKS BEFORE STARTING ENGINE	2- 19
PRECAUTIONS WHEN STARTING	2- 20
PRECAUTIONS IN COLD AREAS	2- 20
STARTING WITH BOOSTER CABLES	2- 20
OPERATION	2- 21
CHECKS BEFORE OPERATION	2- 21
PRECAUTIONS WHEN TRAVELING IN FORWARD OR REVERSE	2- 21
PRECAUTIONS WHEN TRAVELING	2- 22
TRAVELING ON SLOPES	2- 23
PRECAUTIONS WHEN OPERATING	2- 23
METHOD OF USING BRAKES	2- 23
TRAVELING ON SNOW-COVERED OR FROZEN SURFACES	2- 18
PARKING MACHINE	2- 24
TRANSPORTATION	2- 25
LOADING AND UNLOADING	2- 25
TOWING	2- 26
PRECAUTIONS WHEN TOWING	2- 26

PRECAUTIONS FOR MAINTENANCE	2- 27
PRECAUTIONS BEFORE STARTING INSPECTION AND MAINTENANCE	2- 27
DISPLAY WARNING TAG DURING INSPECTION AND MAINTENANCE	2- 27
KEEP WORKPLACE CLEAN AND TIDY	2- 27
SELECT SUITABLE PLACE FOR INSPECTION AND MAINTENANCE	2- 27
ONLY AUTHORIZED PERSONNEL	2- 27
APPOINT LEADER WHEN WORKING WITH OTHERS	2- 27
STOP ENGINE BEFORE CARRYING OUT INSPECTION AND MAINTENANCE	2- 28
TWO WORKERS FOR MAINTENANCE WHEN ENGINE IS RUNNING	2- 29
INSTALLING, REMOVING, OR STORING ATTACHMENTS	2- 29
PRECAUTIONS WHEN WORKING AT HIGH PLACES	2- 29
PRECAUTIONS WHEN WORKING UNDER MACHINE OR WORK EQUIPMENT	2- 30
PROPER TOOLS	2- 30
PRECAUTIONS FOR INSPECTION AND MAINTENANCE	2- 31
PRECAUTIONS WHEN WELDING	2- 31
HANDLING BATTERY	2- 31
PRECAUTIONS WHEN USING HAMMER	2- 32
PRECAUTIONS WITH HIGH-TEMPERATURE COOLANT	2- 32
PRECAUTIONS WITH HIGH-TEMPERATURE OIL	2- 32
PRECAUTIONS WITH HIGH-PRESSURE OIL	2- 33
PRECAUTIONS WITH HIGH-PRESSURE FUEL	2- 33
HANDLING HIGH-PRESSURE HOSES AND PIPING	2- 33
NOISE	2- 33
PRECAUTIONS WITH HIGH-PRESSURE GREASE WHEN ADJUSTING TRACK TENSION	2- 34
DO NOT DISASSEMBLE RECOIL SPRING	2- 34
HANDLING ACCUMULATOR AND GAS SPRING	2- 34
PRECAUTIONS WITH COMPRESSED AIR	2- 35
MAINTENANCE OF AIR CONDITIONER	2- 35
DISPOSING OF WASTE MATERIALS	2- 35
METHOD OF SELECTING WINDOW WASHER FLUID	2- 35
PERIODIC REPLACEMENT OF SAFETY CRITICAL PARTS	2- 35

SAFETY LABELS

The following safety labels are used on this machine.

- Make sure that you fully understand the location and content of each safety label, together with the means of avoiding the danger shown.
- To ensure that the contents of safety labels can be read properly, be sure that they are in the correct place and always keep them clean. When cleaning the labels, do not use organic solvents or gasoline. They may cause the labels to peel off.
- If the labels are damaged, lost, or cannot be read properly, contact your Komatsu distributor immediately regarding their replacement. For details concerning the part numbers for the labels, see this manual or the actual label.
- There are also other labels on the machine in addition to the safety labels. Handle those labels in the same way.

POSITIONS OF SAFETY PICTOGRAMS

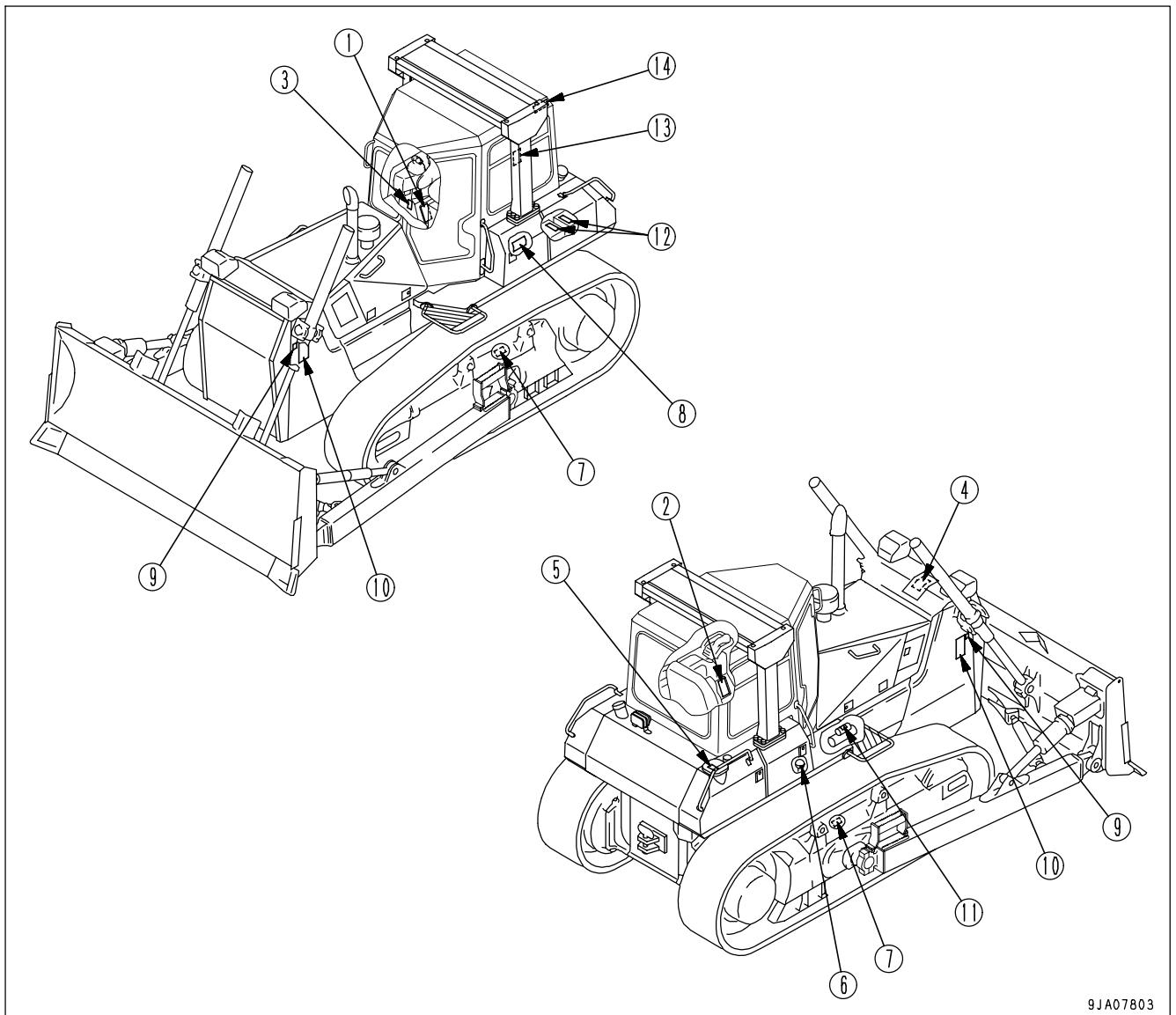

9JA07803

SAFETY LABELS

- (1) Caution before operating or maintaining machine
(09651-03001)

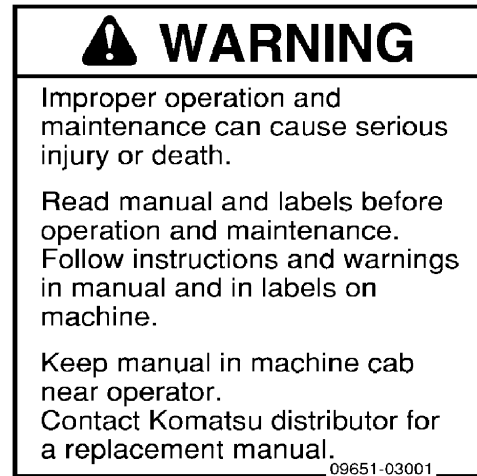

- (2) Caution before moving in reverse (09802-13000)

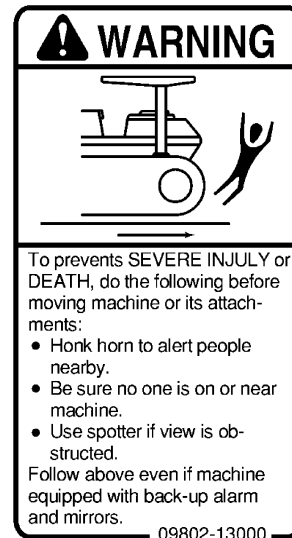

- (3) Caution for leaving operator's seat (09654-33001)

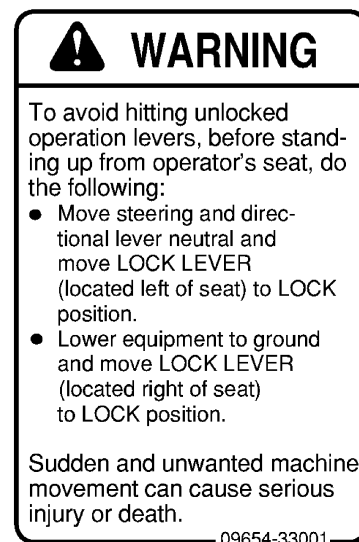

(4) Caution for high-temperature coolant (09668-03001)



(5) Caution for high-temperature oil (09653-03001)



(6) Caution for accumulator (09659-53000)



(7) Caution for adjusting track tension (09657-03003)
 The safety label is attached to the back side of the cover of the track adjustment window.



(8) Caution for battery cable (09808-03000)

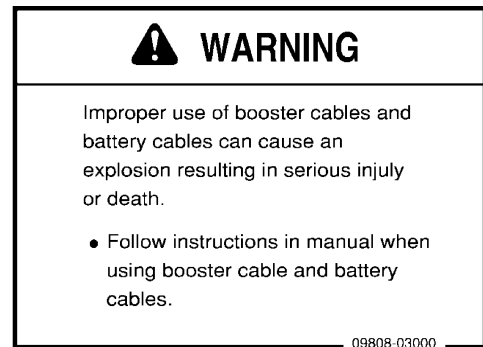

(9) Caution for engine running (09667-03001)



(10) Caution for approach when machine moving (09812-13000)



(11) Jump start prohibited (09842-A0481)



Start the engine only after sitting down in the operator's seat.

Do not attempt to start the engine by short-circuiting the engine starting circuit. Such an act may cause a serious bodily injury or fire.

(12) Precautions when handling battery

<p>⚠ DANGER/POISON EXPLOSIVE GASES cigarettes, flames or sparks could cause battery to explode. Always shield eyes and face from battery. Do not charge or use booster cables or adjust post connections without order instruction and training. KEEP VENT CAPS TIGHT AND LEVEL POISON causes severe burns contains sulfuric acid in event of accident flush with water and call a physician immediately KEEP OUT OF REACH OF CHILDREN</p>
--

(This plate is stick on the machine by the battery maker.)

(13) Caution for ROPS (09620-B2000)

KOMATSU		ROPS CERTIFICATION	
<small>This protective structure complies with the standard provided that it is properly equipped on the machine which mass is less than the specified maximum mass.</small>			
<small>ROPS : ISO 5471:1994, SAE J1040 MAY94</small>		<small>FOPS : ISO 3449:1992</small>	
<small>MODEL</small>		<small>MACHINE MODEL</small>	
<small>SERIAL No.</small>		<small>MAX. MASS</small>	
<small>kg (lb)</small>			
⚠ WARNING	<ul style="list-style-type: none"> • If some modification is applied to the ROPS, it might not enough strength and might not be complied with the standard. Consult Komatsu Distributor before altering. • ROPS may provide less protection if it has been structurally damaged or involved roll-over. Consult Komatsu Distributor in that case. • Always wear seat belt when moving. 		
<small>Komatsu Ltd.</small>		<small>2-3-6 Akasaka, Minato-ku, Tokyo, Japan</small>	<small>09620-B2000</small>

(14) Caution for FOPS (09620-C2000)

KOMATSU		FOPS CERTIFICATION	
<small>This protective structure was provided to comply with the following standard.</small>			
<small>FOPS : ISO 3449:1992</small>			
<small>MODEL</small>		<small>MACHINE MODEL</small>	
<small>SERIAL No.</small>		<small>MAX. MASS</small>	
<small>kg (lb)</small>			
⚠ WARNING	<ul style="list-style-type: none"> • If some modification is applied to the FOPS, it might not enough strength and might not be complied with the standard. Consult Komatsu Distributor before altering. • FOPS may provide less protection if it has been structurally damaged or involved roll-over. Consult Komatsu Distributor in that case. 		
<small>Komatsu Ltd.</small>		<small>2-3-6 Akasaka, Minato-ku, Tokyo, Japan</small>	<small>09620-C2000</small>

GENERAL PRECAUTIONS COMMON TO OPERATION AND MAINTENANCE

Mistakes in operation, inspection, or maintenance may result in serious personal injury or death. Before carrying out operation, inspection, or maintenance, always read this manual and the safety labels on the machine carefully and obey the warnings.

PRECAUTIONS BEFORE STARTING OPERATION

ENSURING SAFE OPERATION

- Only trained and authorized personnel can operate and maintain the machine.
- Follow all safety, precautions, and instructions in this manual when operating or performing inspection or maintenance on the machine.
- If you are not feeling well, or if you are under the influence of alcohol or medication, your ability to safely operate or repair your machine may be severely impaired, putting yourself and everyone else on your job site in danger.
- When working with another operator or with the person on the worksite traffic duty, discuss the content of the operation beforehand and use the determined signals when carrying out the operation.

UNDERSTANDING THE MACHINE

Before operating the machine, read this manual thoroughly. If there are any places in this manual that you do not understand, ask the person in charge of safety to give an explanation.

PREPARATIONS FOR SAFE OPERATION

PRECAUTIONS REGARDING SAFETY-RELATED EQUIPMENT

- Be sure that all guards, covers and mirrors are in their proper position. Have guards and covers repaired immediately if they are damaged.
- Understand the method of use of safety features and use them properly.
- Never remove any safety features. Always keep them in good operating condition.

INSPECTING MACHINE

Check the machine before starting operations. If any abnormality is found, do not operate the machine until repairs of the problem location have been completed.

WEAR WELL-FITTING CLOTHES AND PROTECTIVE EQUIPMENT

- Do not wear loose clothes or any accessories. If these catch on the control levers or protruding parts, there is danger that it may cause the machine to move unexpectedly.
- Always wear a hard hat and safety shoes. If the nature of the work requires it, wear safety glasses, mask, gloves, ear plugs, and safety belt when operating or maintaining the machine.
- If you have long hair and it hangs out from your hard hat, there is a hazard that it may get caught up in the machine, so tie your hair up and be careful not to let it get caught.
- Check that all protective equipment functions properly before using it.

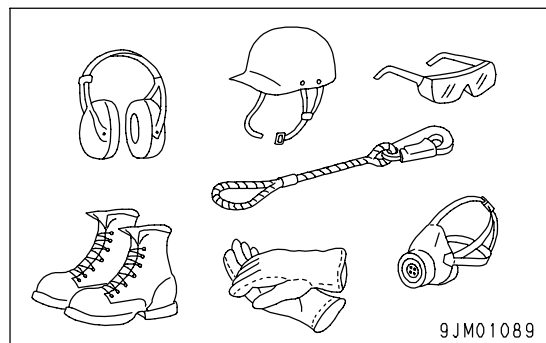

KEEP MACHINE CLEAN

- If you get on or off the machine or carry out inspection and maintenance when the machine is dirty with mud or oil, there is a hazard that you will slip and fall. Wipe off any mud or oil from the machine. Always keep the machine clean.
- If water gets into the electrical system, there is a hazard that it will cause malfunctions or misoperation. If there is any misoperation, there is danger that the machine may move unexpectedly and cause serious personal injury or death. When washing the machine with water or steam, do not allow the water or steam to come into direct contact with electrical components.

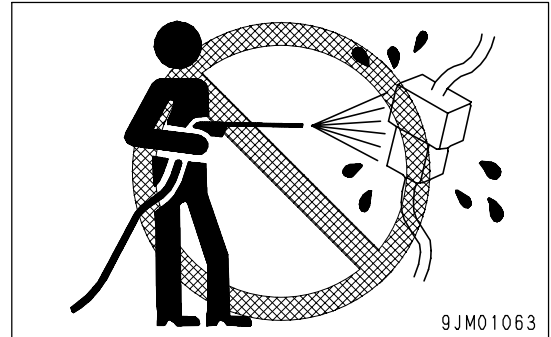
**PRECAUTIONS INSIDE OPERATOR'S COMPARTMENT**

- When entering the operator's compartment, always remove all mud and oil from the soles of your shoes. If you operate the pedal with mud or oil affixed to your shoes, your foot may slip and this may cause a serious accident.
- Do not leave tools or a machine parts lying around inside the operator's compartment. If tools or parts get into the control devices, it may obstruct operation and cause the machine to move unexpectedly, resulting in serious personal injury or death.
- Do not stick suction pads to the window glass. Suction pads act as a lens and may cause fire.
- Do not use a cell phone when driving or operating the machine. This may lead to mistakes in operation, which could cause serious personal injury or death.
- Never bring any dangerous objects such as flammable or explosive items into the operator's compartment.

PROVIDE FIRE EXTINGUISHER AND FIRST AID KIT

Always follow the precautions below to prepare for action if any injury or fire should occur.

- Be sure that fire extinguishers have been provided and read the labels to ensure that you know how to use them in emergencies.
- Carry out periodic inspection and maintenance to ensure that the fire extinguisher can always be used.
- Provide a first aid kit in the storage point. Carry out periodic checks and add to the contents if necessary.

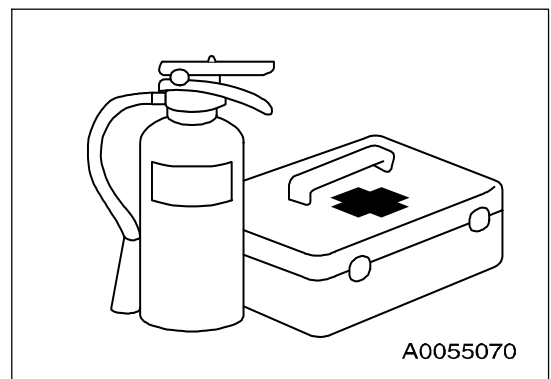
**IF ANY PROBLEM IS FOUND**

If you find any problems in the machine during operation or maintenance (noise, vibration, smell, incorrect gauges, smoke, oil leakage, etc., or any abnormal display on the warning devices or monitor), report to the person in charge and have the necessary action taken. Do not operate the machine until the problem has been corrected.

FIRE PREVENTION

ACTION IF FIRE OCCURS

- Turn the start switch OFF to stop the engine.
- Use the handrails and steps to get off the machine.
- Do not jump off the machine. There is the danger of falling and suffering serious injury.

PRECAUTIONS TO PREVENT FIRE

• Fire caused by fuel, oil, antifreeze, or window washer fluid

Do not bring any flame or fire close to flammable substances such as fuel, oil, antifreeze, or window washer fluid. There is danger that they may catch fire. To prevent fire, always observe the following:

- Do not smoke or use any flame near fuel or other flammable substances.
- Stop the engine before adding fuel.
- Do not leave the machine when adding fuel or oil.
- Tighten all fuel and oil caps securely.
- Be careful not to spill fuel on overheated surfaces or on parts of the electrical system.
- After adding fuel or oil, wipe up any spilled fuel or oil.
- Put greasy rags and other flammable materials into a safe container to maintain safety at the workplace.
- When washing parts with oil, use a non-flammable oil. Do not use diesel oil or gasoline. There is danger that they may catch fire.
- Do not weld or use a cutting torch to cut any pipes or tubes that contain flammable liquids.
- Determine well-ventilated areas for storing oil and fuel. Keep the oil and fuel in the determined place and do not allow unauthorized persons to enter.
- When carrying out grinding or welding work on the machine, move any flammable materials to a safe place before starting.

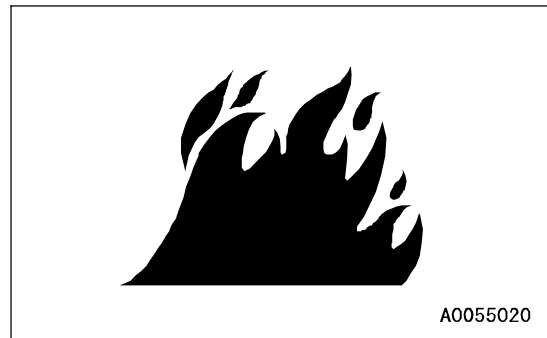

• Fire caused by accumulation of flammable material.

Remove any dry leaves, chips, pieces of paper, coal dust, or any other flammable materials accumulated or affixed around the engine, exhaust manifold, muffler, or battery, or inside the undercovers.

• Fire coming from electric wiring

Short circuits in the electrical system can cause fire. To prevent fire, always observe the following.

- Keep all electric wiring connections clean and securely tightened.
- Check the wiring every day for looseness or damage. Tighten any loose connectors or wiring clamps. Repair or replace any damaged wiring.

• Fire coming from piping

Check that all the hose and tube clamps, guards, and cushions are securely fixed in position.

If they are loose, they may vibrate during operation and rub against other parts. There is danger that this may lead to damage to the hoses and cause high-pressure oil to spurt out, leading to fire, serious personal injury or death.

- **Explosion caused by lighting equipment**
 - When checking fuel, oil, battery electrolyte, or coolant, always use lighting with anti-explosion specifications.
 - When taking the electrical power for the lighting from the machine itself, follow the instructions in this manual.

PRECAUTIONS WHEN GETTING ON OR OFF MACHINE

USE HANDRAILS AND STEPS WHEN GETTING ON OR OFF MACHINE

To prevent personal injury caused by slipping or falling off the machine, always do as follows.

- Use the handrails and steps marked by arrows in the diagram on the right when getting on or off the machine.

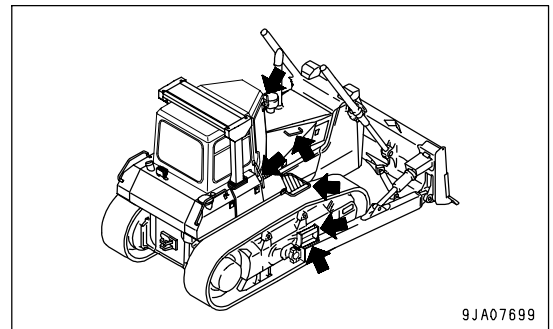
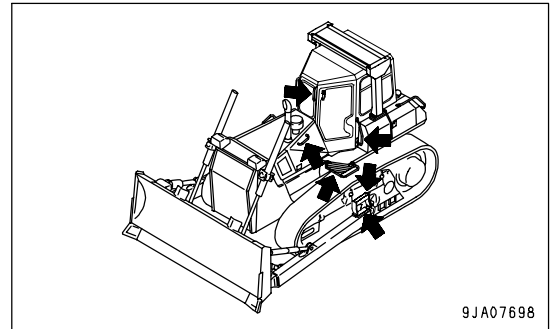

- Always face the machine and maintain at least three-point contact (both feet and one hand, or both hands and one foot) with the handrail and steps to ensure that you support yourself.

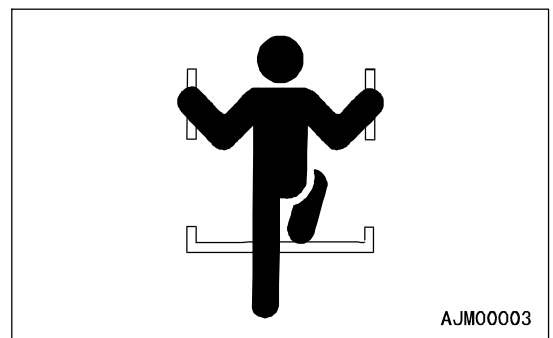

- Before getting on or off the machine, check the handrails and steps, and if there is any oil, grease, or mud on them, wipe it off immediately. In addition, repair any damage and tighten any loose bolts.
- Do not grip the control levers and work equipment lock lever when getting on or off the machine.
- Never climb on the engine hood or covers where there are no non-slip pads.
- Do not get on or off the machine while holding tools in your hand.

NO JUMPING ON OR OFF MACHINE

- Never jump on or off the machine. Never get on or off a moving machine.
- If the machine starts to move when there is no operator on the machine, do not jump on to the machine and try to stop it.

NO PEOPLE ON ATTACHMENTS

Never let anyone ride on the work equipment or other attachments. There is a hazard of falling and suffering serious personal injury or death.

PRECAUTIONS WHEN STANDING UP FROM OPERATOR'S SEAT

When standing up from the operator's seat to adjust the operator's seat, always lower the work equipment completely to the ground, set work equipment lock lever (1) and parking brake lever (2) to the LOCK position (L), and stop the engine.

If the control lever is touched by accident, there is danger that the machine may suddenly move and cause serious personal injury.

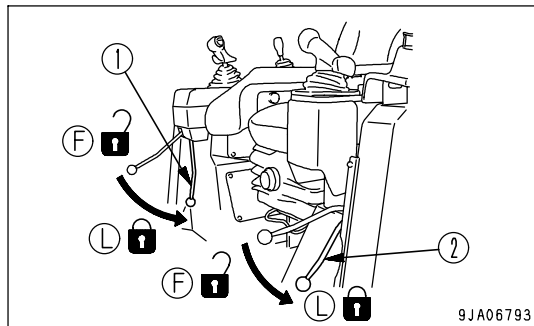
**PRECAUTIONS WHEN LEAVING MACHINE**

If the proper procedures are not taken when parking the machine, the machine may suddenly move off by itself, and this may lead to serious personal injury or death. Always do the following.

- When leaving the machine, always lower the work equipment completely to the ground, set work equipment lock lever (1) and parking brake lever (2) to the LOCK position (L), and stop the engine.

Always lock all parts, take the key with you and leave it in the specified place.

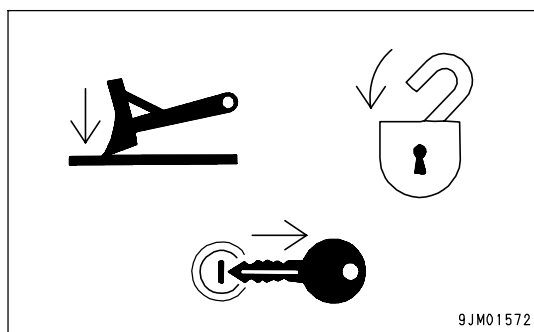
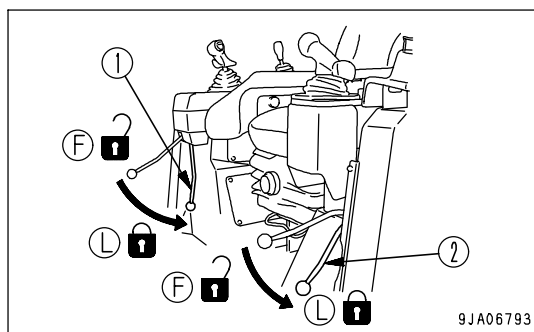
**EMERGENCY EXIT FROM OPERATOR'S CAB**

Machines equipped with a cab have doors on the left and right sides. If the door on the one side does not open, escape from the door on the other side.

DO NOT GET CAUGHT IN WORK EQUIPMENT

The clearance in the area around the work equipment changes according to the movement of the link. If you get caught, you may suffer serious personal injury or death. Do not allow anyone to come close to any rotating or extending/retracting portion.

PRECAUTIONS RELATED TO PROTECTIVE STRUCTURES

The operator's compartment is equipped with a structure (ROPS, FOPS) to protect the operator by absorbing the impact energy. If the machine weight (mass) exceeds the certified value (shown on the ROLL-OVER PROTECTIVE STRUCTURE (ROPS) CERTIFICATION plate), ROPS will not be able to fulfill its function. Do not increase machine weight beyond the certified value by modifying the machine or by installing attachments to the machine. Also, if the function of the protective equipment is impeded, the protective equipment will not be able to protect the operator, and the operator may suffer injury or death. Always observe the following.

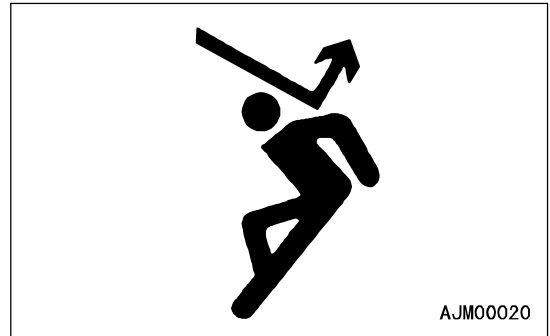

- If the machine is equipped with a protective structure, do not remove the protective structure and carry out operations without it.
- If the protective structure is welded, or holes are drilled in it, or it is modified in any other way, its strength may drop. Consult your Komatsu distributor before carrying out any modifications.
- If the protective structure is damaged or deformed by falling objects or by rolling over, its strength will be reduced and it will not be able to fulfill its function properly. In such cases, always contact your Komatsu distributor for advice on the method of repair.
- Even if the protective structure is installed, always fasten your seat belt properly when operating the machine. If you do not fasten your seatbelt properly, it cannot display its effect.

UNAUTHORIZED MODIFICATION

- Komatsu will not be responsible for any injuries, accidents, product failures or other property damages resulting from modifications made without authorization from Komatsu.
- Any modification made without authorization from Komatsu can create hazards. Before making a modification, consult your Komatsu distributor.

PRECAUTIONS RELATED TO ATTACHMENTS AND OPTIONS

- Any injuries, accidents, product failures or other property damages resulting from the use of unauthorized attachments or parts will not be the responsibility of Komatsu.
- When installing optional parts or attachments, there may be problems with safety or legal restrictions. Therefore contact your Komatsu distributor for advice.
- When installing and using optional attachments, read the instruction manual for the attachment, and the general information related to attachments in this manual.

PRECAUTIONS WHEN RUNNING ENGINE INSIDE BUILDING

The engine exhaust gas contains substances that may damage your health or even cause death. Start or operate the engine in a place where there is good ventilation. If the engine or machine must be operated inside a building or under ground, where the ventilation is poor, take steps to ensure that the engine exhaust gas is removed and that ample fresh air is brought in.

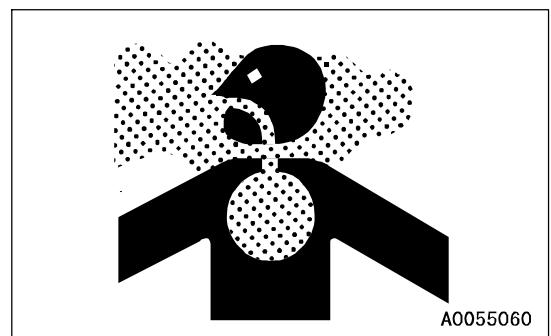

PRECAUTIONS FOR OPERATION

PRECAUTIONS FOR JOBSITE

INVESTIGATE AND CONFIRM JOBSITE CONDITIONS

On the jobsite, there are various hidden dangers that may lead to personal injury or death. Before starting operations, always check the following to confirm that there is no danger on the jobsite.

- When carrying out operations near combustible materials such as thatched roofs, dry leaves or dry grass, there is a hazard of fire, so be careful when operating.
- Check the terrain and condition of the ground at the worksite, and determine the safest method of operation. Do not operate where there is a hazard of landslides or falling rocks.
- If water lines, gas lines, or high-voltage electrical lines may be buried under the worksite, contact each utility and identify their locations. Be careful not to sever or damage any of these lines.
- Take necessary measures to prevent any unauthorized person from entering the operating area.
- In particular, if you need to operate on a road, protect pedestrian and cars by designating a person for worksite traffic duty or by installing fences around the worksite.
- When traveling or operating in water or on soft ground, check the water depth, speed of the current, bedrock, and shape of the ground beforehand and avoid any place that will obstruct travel.

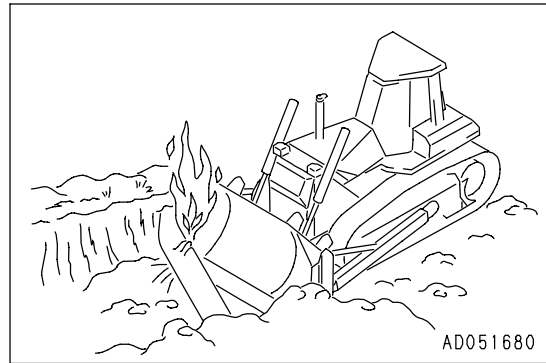

WORKING ON LOOSE GROUND

- Avoid traveling or operating your machine too close to the edge of cliffs, overhangs, and deep ditches. The ground may be weak in such areas. If the ground should collapse under the weight or vibration of the machine, there is a hazard that the machine may fall or tip over. Remember that the soil after heavy rain or blasting or after earthquakes is weak in these areas.
- When working on embankments or near excavated ditches, there is a hazard that the weight and vibration of the machine will cause the soil to collapse. Before starting operations, take steps to ensure that the ground is safe and to prevent the machine from rolling over or falling.

DO NOT GO CLOSE TO HIGH-VOLTAGE CABLES

Do not travel or operate the machine near electric cables. There is a hazard of electric shock, which may cause serious personal injury or death. On jobsites where the machine may go close to electric cables, always do as follows.

- Before starting work near electric cables, inform the local power company of the work to be performed, and ask them to take the necessary action.
- Even going close to high-voltage cables can cause electric shock, which may cause serious burns or even death. Always maintain a safe distance (see the table on the right) between the machine and the electric cable. Check with the local power company about safe operating procedure before starting operations.
- To prepare for any possible emergencies, wear rubber shoes and gloves. Lay a rubber sheet on top of the seat, and be careful not to touch the chassis with any exposed part of your body.
- Use a signalman to give warning if the machine approaches too close to the electric cables.
- When carrying out operations near high voltage cables, do not let anyone near the machine.
- If the machine should come too close or touch the electric cable, to prevent electric shock, the operator should not leave the operator’s compartment until it has been confirmed that the electricity has been shut off.
Also, do not let anyone near the machine.

Voltage of Cables	Safety Distance
100V - 200V	Over 2 m (7 ft)
6,600V	Over 2 m (7 ft)
22,000V	Over 3 m (10 ft)
66,000V	Over 4 m (14 ft)
154,000V	Over 5 m (17 ft)
187,000V	Over 6 m (20 ft)
275,000V	Over 7 m (23 ft)
500,000V	Over 11 m (36 ft)

ENSURE GOOD VISIBILITY

This machine is equipped with mirrors to ensure good visibility, but even then there are places that cannot be seen from the operator’s seat, so be careful when operating.

When traveling or carrying out operations in places with poor visibility, it is impossible to check for obstacles in the area around the machine and to check the condition of the jobsite. This leads to danger of serious personal injury or death. When traveling or carrying out operations in places with poor visibility, always observe the following.

- Position a signalman if there are areas where the visibility is not good.
- Only one signalman should give signals.
- When working in dark places, turn on the working lamp and front lamps installed to the machine, and set up additional lighting in the work area if necessary.
- Stop operations if the visibility is poor, such as in mist, snow, rain, or dust.
- When checking the mirrors installed to the machine, remove all dirt and adjust the angle of the mirror to ensure good visibility.

CHECKING SIGNS AND SIGNALMAN'S SIGNALS

- Set up signs to inform of road shoulders and soft ground. If the visibility is not good, position a signalman if necessary. Operators should pay careful attention to the signs and follow the instructions from the signalman.
- Only one signalman should give signals.
- Make sure that all workers understand the meaning of all signals and signs before starting work.

BEWARE OF ASBESTOS DUST

Asbestos dust in the air can cause lung cancer if it is inhaled. There is danger of inhaling asbestos when working on jobsites handling demolition work or work handling industrial waste. Always observe the following.

- Spray water to keep down the dust.
- Do not use compressed air.
- If there is danger that there may be asbestos dust in the air, always operate the machine from an upwind position, and make sure that all workers operate on the upwind side.
- All workers should use anti-dust masks.
- Do not allow other persons to approach during the operation.
- Always observe the rules and regulations for the work site and environmental standards.

This machine does not use asbestos, but there is a danger that imitation parts may contain asbestos, so always use genuine Komatsu parts.

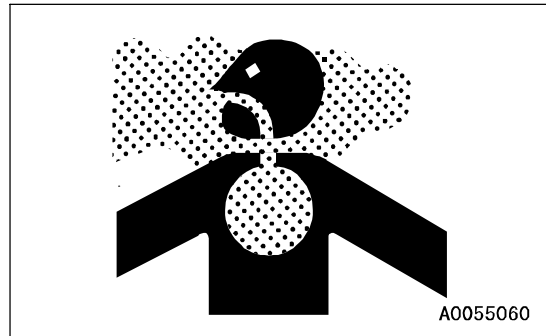

STARTING ENGINE

USE WARNING TAGS

If there is any "DANGER! Do NOT operate!" warning tag displayed, it means that someone is carrying out inspection and maintenance of the machine. If the warning sign is ignored and the machine is operated, there is danger that the person carrying out inspection or maintenance may be caught in the rotating parts or moving parts and suffer serious personal injury or death. Do not start the engine or touch the levers.

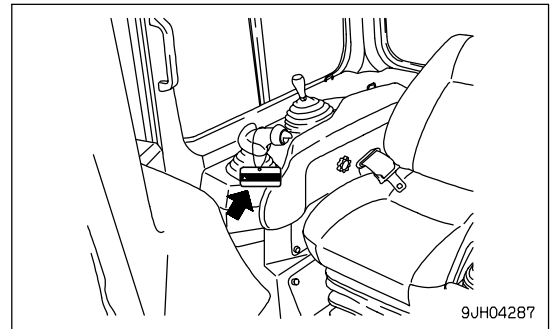

CHECKS BEFORE STARTING ENGINE

Carry out the following checks before starting the engine at the beginning of the day's work to ensure that there is no problem with the operation of the machine. If this inspection is not carried out properly problems may occur with the operation of the machine, and there is danger that this may lead to serious personal injury or death.

- Remove all dirt from the surface of the window glass to ensure a good view.
 - Be sure to carry out "WALK-AROUND CHECK (PAGE 3-70)".
 - Remove all dirt from the surface of the lens of the front lamps and working lamps, and check that they light up correctly.
 - Check the coolant level, fuel level, and oil level in engine oil pan, check for clogging of the air cleaner, and check for damage to the electric wiring.
 - Check that there is no mud or dust accumulated around the movable parts of any pedals, and check that the pedals work properly.
 - Adjust the operator's seat to a position where it is easy to carry out operations, and check that there is no damage or wear to the seat belt or mounting clamps.
 - Check that the gauges work properly, check the angle of the mirror, and check that the control levers are all at the Neutral position.
 - Before starting the engine, check that work equipment lock lever (1) and parking brake lever (2) are in LOCK position (L).
 - Adjust the mirror so that the rear of the machine can be seen easily from the operator's seat.
- For details of the adjustment procedure, see "ADJUST MIRROR (PAGE 3-83)".
- Check that there are no persons or obstacles above, below, or in the area around the machine.

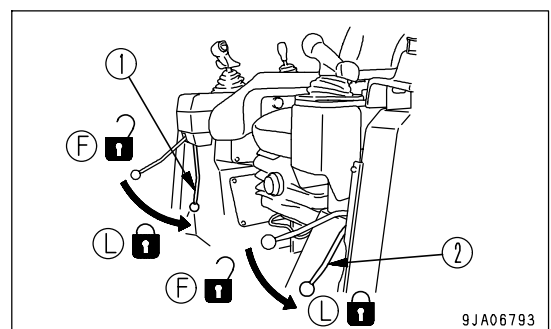

PRECAUTIONS WHEN STARTING

- Start and operate the machine only while seated.
- When starting the engine, sound the horn as a warning.
- Do not allow anyone apart from the operator to ride on the machine.
- Do not attempt to start the engine by short-circuiting the engine starting circuit. This may cause fire, serious personal injury or death.

PRECAUTIONS IN COLD AREAS

- Carry out the warming-up operation thoroughly. If the machine is not thoroughly warmed up before the control levers are operated, the reaction of the machine will be slow, and this may lead to unexpected accidents.
- If the battery electrolyte is frozen, do not charge the battery or start the engine with a different power source. There is a hazard that this will ignite the battery and cause the battery to explode. Before charging or starting the engine with a different power source, melt the battery electrolyte and check that there is no leakage of electrolyte before starting.

STARTING WITH BOOSTER CABLES

If any mistake is made in the method of connecting the booster cables, it may cause the battery to explode, so always do as follows.

- Always wear safety goggles and rubber gloves when starting the engine with booster cable.
- When connecting a normal machine to a problem machine with booster cables, always use a normal machine with the same battery voltage as the problem machine.
- When starting with a booster cable, carry out the starting operation with two workers (one worker sitting in the operator’s seat and the other working with the battery).
- When starting from another machine, do not allow the two machines to touch.
- When connecting the booster cables, turn the starting switch to the OFF position for both the normal machine and problem machine. There is a hazard that the machine will move when the power is connected.
- Be sure to connect the positive (+) cable first when installing the booster cables. Disconnect the negative (-) cable (ground side) first when removing them.
- When removing the booster cables, be careful not to let the booster cable clips touch each other or to let the clips touch the machine.
- For details of the starting procedure when using booster cables, see "STARTING ENGINE WITH BOOSTER CABLE (PAGE 3-135)" in the OPERATION section.

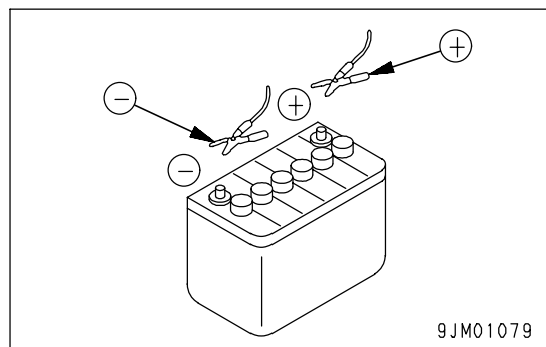
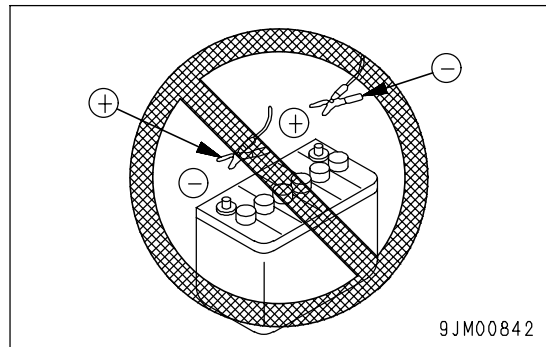

OPERATION

CHECKS BEFORE OPERATION

If the checks before starting are not carried out properly, the machine will be unable to display its full performance, and there is also danger that it may lead to serious personal injury or death.

When carrying out the checks, move the machine to a wide area where there are no obstructions, and pay careful attention to the surrounding area. Do not allow anyone near the machine.

- Always wear the seatbelt. There is danger that you may be thrown out of the operator's seat and suffer serious injury when the brakes are applied suddenly.
- Check the operation of travel, steering and brake systems, and work equipment control system.
- Check for any problem in the sound of the machine, vibration, heat, smell, or gauges; check also that there is no leakage of oil or fuel.
- If any problem is found, carry out repairs immediately.

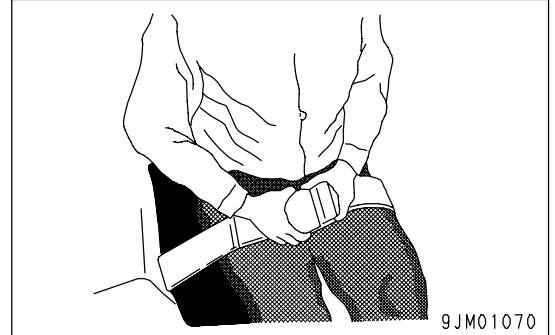

PRECAUTIONS WHEN TRAVELING IN FORWARD OR REVERSE

- Lock the cab door and windows securely, both when they are open and when they are closed.
- Do not allow anyone apart from the operator to ride on the machine.
- If there are any persons in the area around the machine, there is danger that they may be hit or caught by the machine, and this may lead to serious personal injury or death. Always observe the following before traveling.
 - Always operate the machine only when seated.
 - Before moving off, check again that there is no person or obstruction in the surrounding area.
 - Before moving, sound the horn to warn people in the surrounding area.
 - Check that the backup alarm (alarm buzzer when machine travels in reverse) works properly.
 - If there is an area to the rear of the machine which cannot be seen, position a signalman.

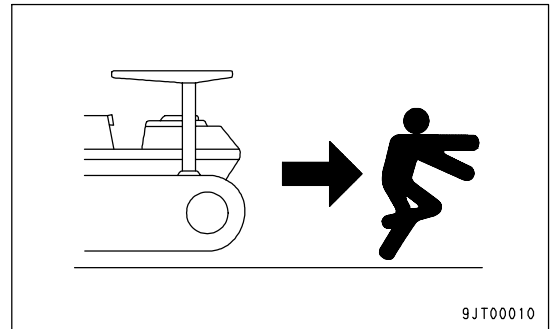

Always be sure to carry out the above precautions even when the machine is equipped with mirrors.

PRECAUTIONS WHEN TRAVELING

- Never turn the starting switch key to the OFF position when the machine is traveling. If the engine stops when the machine is traveling, it may become impossible to operate the steering, and this may cause serious personal injury or death. If the engine stops, depress the brake pedal immediately to stop the machine.
- When traveling or carrying out operations, always keep a safe distance from people, structures, or other machines to avoid coming into contact with them.
- When traveling the machine on a flat land, hold the work equipment at height (A) of 40 cm to 50 cm (16 in to 20 in) above the ground. If that height is not maintained between the work equipment and the ground, the work equipment may get stuck in the ground and tip over.

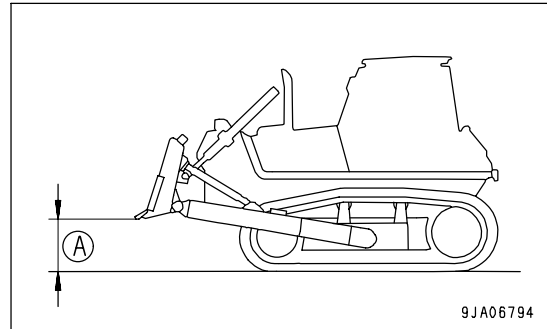

- Avoid traveling over obstacles when possible. If the machine has to travel over an obstacle, keep the work equipment close to the ground and travel at low speed. There is more danger of the machine tipping over to the left or right than tipping over to the front or rear, so do not travel over obstacles which make the machine tilt strongly to the left or right sides.
- When traveling on rough ground, travel at low speed and do not operate the steering suddenly. There is danger that the machine may turn over. The work equipment may hit the ground surface and cause the machine to lose its balance, or may damage the machine or structures in the area.
- When using the machine, to prevent personal injury caused by damage to the work equipment or by the machine overturning due to overloading, do not exceed the permitted performance of the machine or the maximum permitted load for the structure of the machine.
- When passing over bridges or structures, check first that the structure is strong enough to support the weight of the machine.
- When operating in tunnels, under bridges, under electric wires, or other places where the height is limited, operate slowly and be extremely careful not to let the machine body or work equipment hit anything.

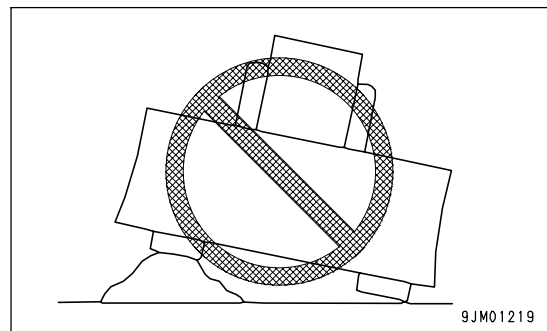

TRAVELING ON SLOPES

To prevent the machine from tipping over or slipping to the side, always do as follows.

- Keep the work equipment approx. 20 to 30 cm (8 to 12 in) above the ground. In case of emergency, lower the work equipment to the ground immediately to help stop the machine.
- Always travel straight up or down a slope. Traveling at an angle or across the slope is extremely dangerous.
- Do not turn on slopes or travel across slopes. Always go down to a flat place to change the position of the machine, then travel on to the slope again.
- Travel on grass, fallen leaves, or wet steel plates with low speed. Even with slight slopes there is a hazard that the machine may slip.
- When traveling downhill, never shift gear or place the transmission at neutral. It is dangerous not to use the braking force of the engine. Always place the transmission in a low gear before starting to travel downhill.
- Depress the brake or use the braking effect of the engine as necessary.

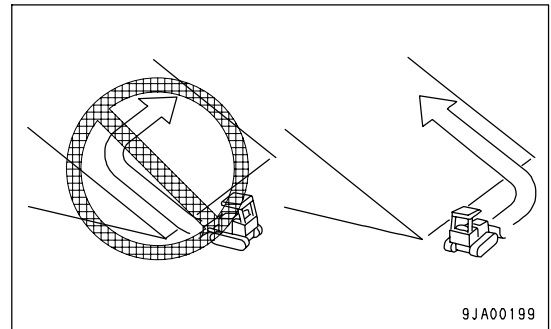

9JA00199

PRECAUTIONS WHEN OPERATING

- When using the machine, to prevent personal injury caused by damage to the work equipment or by the machine overturning due to overloading, do not exceed the permitted performance of the machine or the maximum permitted load for the structure of the machine.
- Be careful not to approach too close to the edge of cliffs. When making embankments or landfills, or when dropping soil over a cliff, dump one pile, then use the next pile of soil to push the first pile.
- The load suddenly becomes lighter when the soil is pushed over a cliff or when the machine reaches the top of a slope. When this happens, there is danger that the travel speed will suddenly increase, so be sure to reduce the speed.
- If the machine moves with only either side of the blade loaded, its tail may swing. Take care.

METHOD OF USING BRAKES

- When the machine is traveling, do not rest your foot on the brake pedal. If you travel with your foot resting on the pedal, the brake will always be applied, and this will cause the brakes to overheat and fail.
- Do not depress the brake pedal repeatedly if not necessary.
- When traveling downhill, use the braking force of the engine.

TRAVELING ON SNOW-COVERED OR FROZEN SURFACES

- Snow-covered or frozen surfaces are slippery, so be extremely careful when traveling or operating the machine, and do not operate the levers suddenly. Even a slight slope may cause the machine to slip, so be particularly careful when working on slopes.
- With frozen ground surfaces, the ground becomes soft when the temperature rises, and this may cause the machine to tip over or make it impossible for the machine to escape.
- If the machine enters deep snow, there is a hazard that it may tip over or become buried in the snow. Be careful not to leave the road shoulder or to get trapped in a snow drift.
- When clearing snow, the road shoulder and objects placed beside the road are buried in the snow and cannot be seen. There is a hazard of the machine tipping over or hitting covered objects, so always carry out operations carefully.
- When traveling on snow-covered slopes, never apply the foot brake suddenly. Reduce the speed and use the engine as a brake while applying the foot brake intermittently (depress the brake intermittently several times). If necessary, lower the work equipment to the ground to stop the machine.

PARKING MACHINE

- Park the machine on firm, level ground.
- Select a place where there is no hazard of landslides, falling rocks, or flooding.
- Lower the work equipment completely to the ground.
- When leaving the machine, set work equipment lock lever (1) to the LOCK position and parking brake lever (2) to the LOCK position (L), and stop the engine.
- Always close the operator's cab door, and use the key to lock all the equipment in order to prevent any unauthorized person from moving the machine. Always remove the key, take it with you, and leave it in the specified place.

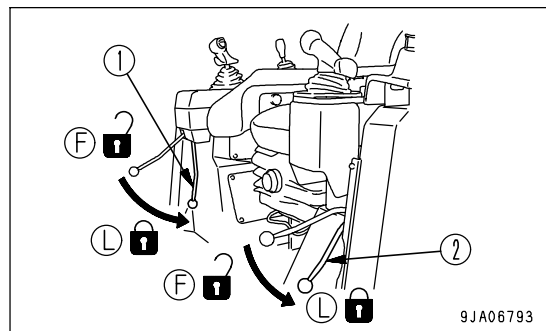

- If it is necessary to park the machine on a slope, always do as follows.
 - Set the work equipment on the downhill side and dig it into the ground.
 - In addition, put blocks under the tracks to prevent the machine from moving.

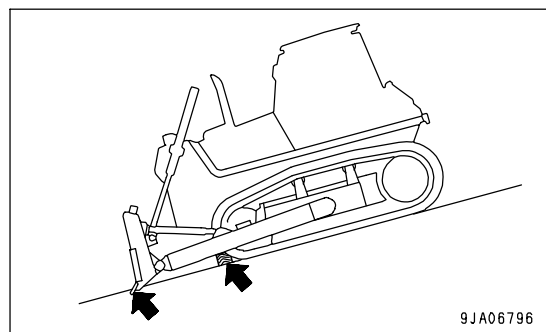

TRANSPORTATION

When the machine is transported on a trailer, there is danger of serious personal injury or death during transportation. Always do as follows.

- Always check the machine dimensions carefully. Depending on the work equipment installed, the machine weight, transportation height, and overall length may differ.
- Check beforehand that all bridges and other structures on the transportation route are strong enough to withstand the combined weight of the transporter and the machine being transported.
- The machine can be divided into parts for transportation, so when transporting the machine, please contact your Komatsu distributor to have the work carried out.

LOADING AND UNLOADING

When loading or unloading the machine, mistaken operation may bring the hazard of the machine tipping over or falling, so particular care is necessary. Always do as follows.

- Perform loading and unloading on firm, level ground only. Maintain a safe distance from the edge of the road or cliff.
 - Always use ramps of adequate strength. Be sure that the ramps are wide, long, and thick enough to provide a safe loading slope. Take suitable steps to prevent the ramps from moving out of position or coming off.
 - Be sure the ramp surface is clean and free of grease, oil, ice and loose materials. Remove dirt from machine-tracks. On a rainy day, in particular, be extremely careful since the ramp surface is slippery.
 - Run the engine at low idling and drive the machine slowly at low speed.
 - When on the ramps, do not operate any lever except for the travel lever.
 - Never correct your steering on the ramps. If necessary, drive off the ramps, correct the direction, then enter the ramps again.
 - The center of gravity of the machine will change suddenly at the joint between the ramps and the track or trailer, and there is danger of the machine losing its balance. Travel slowly over this point.
 - When loading or unloading to an embankment or platform, make sure that it has suitable width, strength, and grade.
 - For machines equipped with a cab, always lock the door after boarding the machine. If this is not done, the door may suddenly open during transportation.
- Refer to "TRANSPORTATION (PAGE 3-120)".

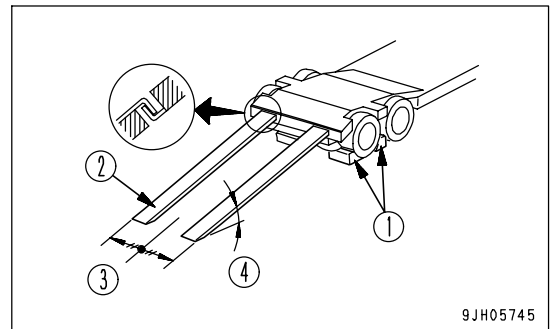

- (1) Blocks
- (2) Ramp
- (3) Centerline of trailer
- (4) Angle of ramps: Max. 15°

TOWING

PRECAUTIONS WHEN TOWING

Always use the correct towing equipment and towing method. Any mistake in the selection of the wire rope or towing bar or in the method of towing a disabled machine may lead to serious personal injury or death.

For details of the procedure for towing, see the "METHOD OF TOWING MACHINE (PAGE 3-132)"

- Always confirm that the wire rope or drawbar used for towing has ample strength for the weight of the machine being towed.
- Never use a wire rope which has cut strands (A), reduced diameter (B), or kinks (C). There is danger that the rope may break during the towing operation.
- Always wear leather gloves when handling wire rope.
- Never tow a machine on a slope.
- During the towing operation, never stand between the towing machine and the machine being towed.

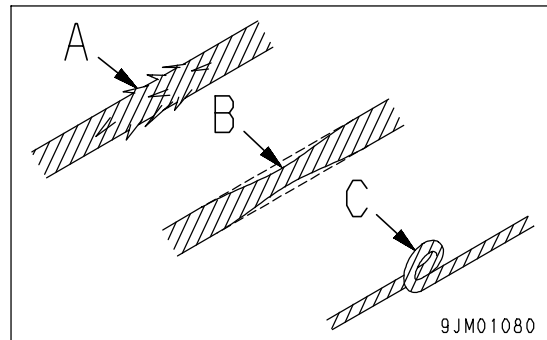

PRECAUTIONS FOR MAINTENANCE

PRECAUTIONS BEFORE STARTING INSPECTION AND MAINTENANCE

DISPLAY WARNING TAG DURING INSPECTION AND MAINTENANCE

Always display the "DANGER! Do NOT operate" warning tag during the inspection and maintenance. If there is any "DANGER! Do NOT operate!" warning tag displayed, it means that someone is carrying out inspection and maintenance of the machine. If the warning sign is ignored and the machine is operated, there is danger that the person carrying out inspection or maintenance may be caught in the rotating parts or moving parts and suffer serious personal injury or death. Do not start the engine or touch the levers.

- If necessary, put up signs around the machine also.
Warning tag part number: 09963-03001
When not using this warning tag, keep it in the toolbox.
If there is no toolbox, keep it in the pocket for the Operation and Maintenance Manual

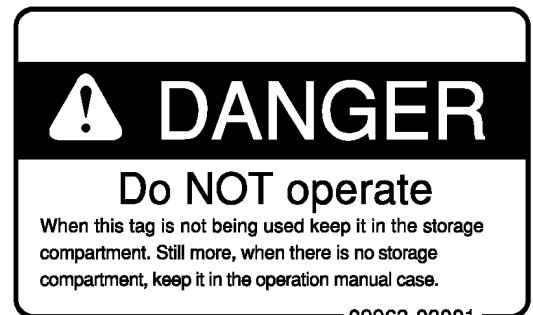
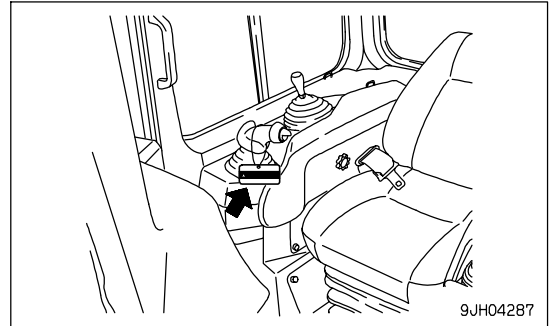

KEEP WORKPLACE CLEAN AND TIDY

Do not leave hammers or other tools lying around in the work place. Wipe up all grease, oil, or other substances that will cause you to slip. Always keep the work place clean and tidy to enable you to carry out operations safely. If the work place is not kept clean and tidy, there is the danger that you will trip, slip, or fall over and injure yourself.

SELECT SUITABLE PLACE FOR INSPECTION AND MAINTENANCE

- Stop the machine on firm, level ground.
- Select a place where there is no hazard of landslides, falling rocks, or flooding.

ONLY AUTHORIZED PERSONNEL

Do not allow any unauthorized personnel into the area when servicing the machine. If necessary, employ a guard.

APPOINT LEADER WHEN WORKING WITH OTHERS

When repairing the machine or when removing and installing the work equipment, appoint a leader and follow his instructions during the operation.

STOP ENGINE BEFORE CARRYING OUT INSPECTION AND MAINTENANCE

- Lower the work equipment completely to the ground and stop the engine before performing any inspection and maintenance.

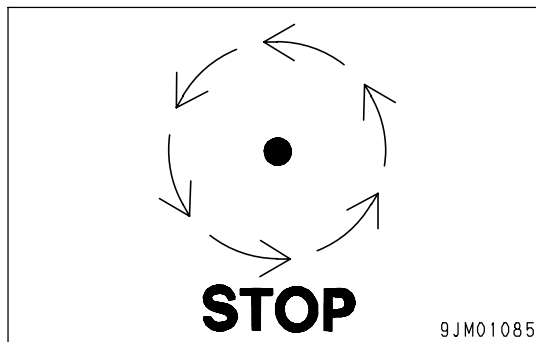

- Turn the starting switch to the ON position, operate the work equipment control lever to the RAISE and LOWER position 2 or 3 times repeatedly to release the remaining pressure in the hydraulic circuit, then set parking brake lever (1) and work equipment lock lever (2) to the LOCK position (L).

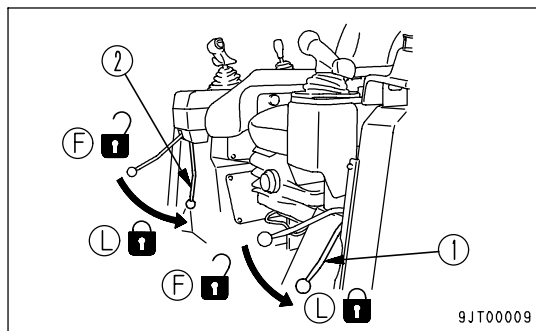

- Put blocks under the track to prevent the machine from moving.

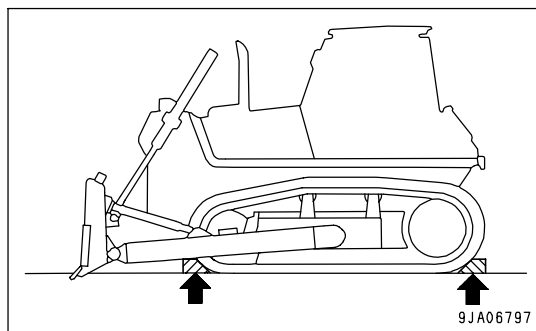

TWO WORKERS FOR MAINTENANCE WHEN ENGINE IS RUNNING

To prevent personal injury, do not carry out maintenance with the engine running. If maintenance must be carried out with the engine running, carry out the operation with at least two workers and do as follows.

- One worker must always sit in the operator's seat and be ready to stop the engine at any time. All workers must maintain contact with the other workers.
- When carrying out operations near the fan, fan belt, or other rotating parts, there is a hazard of being caught in the parts, so be careful not to come close.
- Never drop or insert tools or other objects into the fan, fan belt, or other rotating parts. There is danger that they may contact the rotating parts and break or be sent flying.

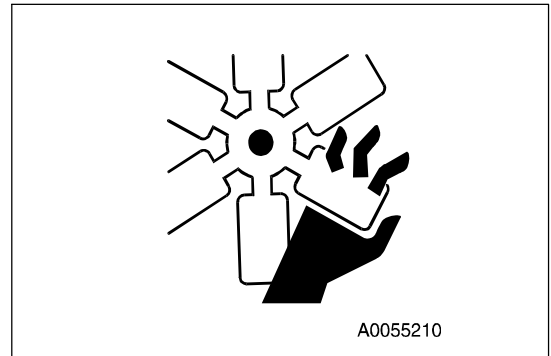

- Set work equipment lock lever (1) and parking brake lever (2) to the LOCK position (L) to prevent the work equipment from moving.
- Do not touch any control levers. If any control lever must be operated, give a signal to the other workers to warn them to move to a safe place.

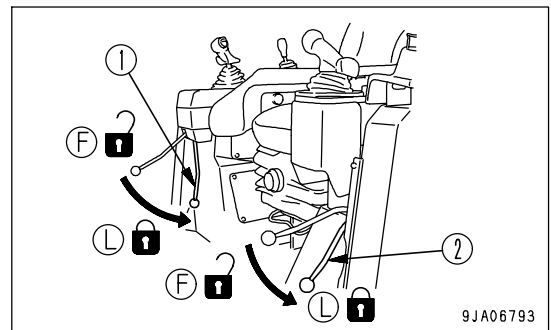
**INSTALLING, REMOVING, OR STORING ATTACHMENTS**

- Appoint a leader before starting removal or installation operations for attachments.
- Place attachments that have been removed from the machine in a stable condition so that they do not fall. And take steps to prevent unauthorized persons from entering the storage area.

**PRECAUTIONS WHEN WORKING AT HIGH PLACES**

When working at high places, use a step ladder or other stand to ensure that the work can be carried out safely.

PRECAUTIONS WHEN WORKING UNDER MACHINE OR WORK EQUIPMENT

- Make sure the hoists or jacks you use are in good repair and strong enough to handle the weight of the component. Never use jacks at places where the machine is damaged, bent, or twisted. Never use frayed, twisted or pinched wire rope. Never use bent or distorted hooks.
- It is extremely dangerous to work under the machine if the track shoes are lifted off the ground and the machine is supported only with the work equipment. If any of the control levers is touched by accident, or there is damage occurring to the hydraulic piping, the work equipment or the machine will suddenly drop. This is extremely dangerous. Never work under the work equipment or the machine.
- If it is necessary to raise the work equipment or the machine and then go under it to carry out inspection or maintenance, support the work equipment and machine securely with blocks and stands strong enough to support the weight of the work equipment and machine.
If the work equipment and machine are not supported, there is a hazard that they may come down and that this may lead to serious personal injury or death.
- Never use concrete blocks for supports. They can collapse under even light loads.

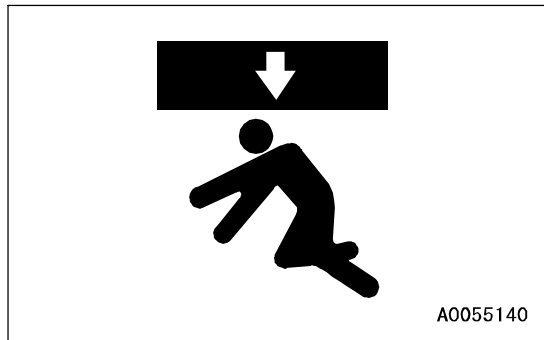

PROPER TOOLS

Use only tools suited to the task and be sure to use the tools correctly. Using damaged, deformed, or low quality tools, or making improper use of the tools may cause serious personal injury.

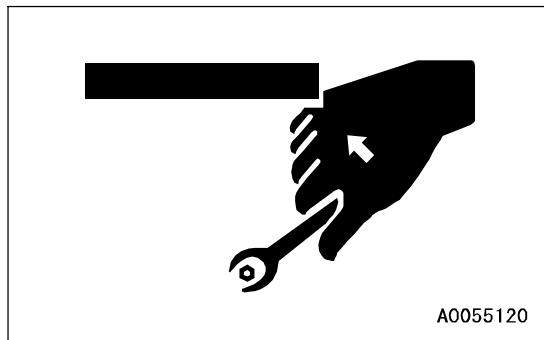

PRECAUTIONS FOR INSPECTION AND MAINTENANCE

PRECAUTIONS WHEN WELDING

Welding operations must always be carried out by a qualified welder and in a place equipped with proper equipment. There is a hazard of gas, fire, or electrocution when carrying out welding, so never allow any unqualified personnel to carry out welding.

HANDLING BATTERY

Before inspecting or handling the battery, turn the key in the starting switch to the OFF position.

- **Danger of battery exploding**

When the battery is being charged, flammable hydrogen gas is generated and may explode. In addition, the battery electrolyte includes dilute sulphuric acid. Any mistake in handling may cause serious personal injury, explosion, or fire, so always observe the following.

- Do not use or charge the battery if the battery electrolyte is below the LOWER LEVEL mark. This will cause explosion. Always carry out periodic inspection of the battery electrolyte level, and add distilled water (or commercially available battery filler solution) to the UPPER LEVEL mark.
- Do not smoke or bring any flame close to the battery.
- Hydrogen gas is generated when the battery is being charged, so remove the battery from the machine, take it to a well-ventilated place, remove the battery caps, then carry out the charging.
- After charging, tighten the battery caps securely.

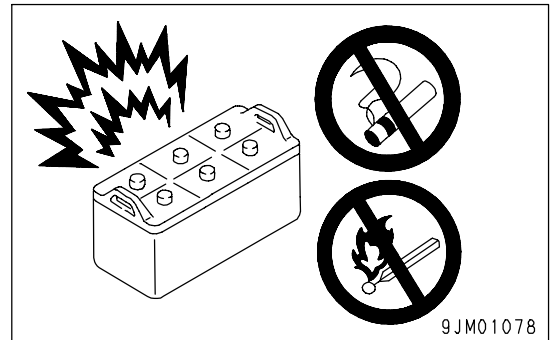

- **Danger from dilute sulphuric acid**

When the battery is being charged, flammable hydrogen gas is generated and may explode. In addition, the battery electrolyte includes dilute sulphuric acid. Any mistake in handling may cause serious personal injury, explosion, or fire, so always observe the following.

- When handling the battery, always wear protective goggles and rubber gloves.
- If battery electrolyte gets into your eyes, immediately wash your eyes with large amounts of fresh water. After that, get medical attention immediately.
- If battery electrolyte gets on your clothes or skin, wash it off immediately with large amounts of water.

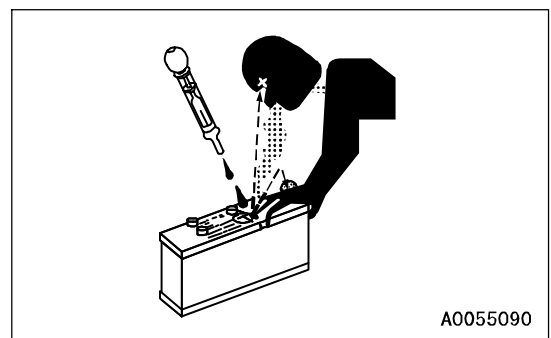

- **Removing battery cables**

Before repairing the electrical system or carrying out electric welding, turn the starting switch OFF. Wait for approx. 1 minute, then remove the negative (-) battery cable to stop the flow of electricity.

• Danger of sparks

There is hazard that sparks will be generated, so always observe the following.

- Do not let tools or other metal objects make any contact between the battery cables. Do not leave tools lying around near the battery.
- When removing the battery cables, remove the ground cable (negative (-) cable) first. When installing, connect the positive (+) cable first, then connect the ground. Tighten the battery cable terminals securely.
- Secure the battery firmly in the specified position.

PRECAUTIONS WHEN USING HAMMER

When using a hammer, pins may fly out or metal particles may be scattered. This may lead to serious personal injury or death. Always do as follows.

- When hitting pins or bucket teeth, there is a hazard that broken pieces might be sent flying and injure people in the surrounding area. Always check that there is no one in the surrounding area.
- If hard metal parts such as pins, bucket teeth, cutting edges, or bearings are hit with a hammer, there is a hazard that pieces might be scattered and cause serious personal injury or death. Always wear safety glasses and gloves.
- If the pin is hit with strong force, there is a hazard that it may fly out and injure people in the surrounding area. Do not allow anyone to enter the surrounding area.

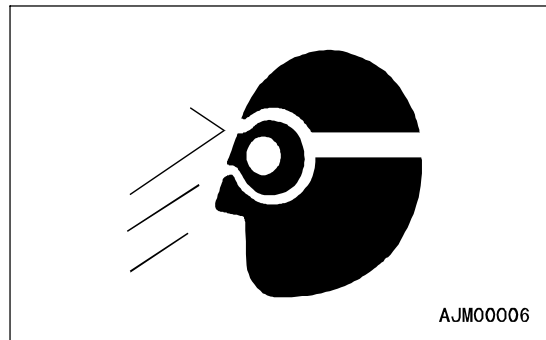

PRECAUTIONS WITH HIGH-TEMPERATURE COOLANT

To prevent burns from boiling water or steam spurting out when checking or draining the coolant, wait for the coolant to cool down to a temperature where the radiator cap can be touched by hand. Then loosen the cap slowly to release the pressure inside the radiator, and remove the cap.

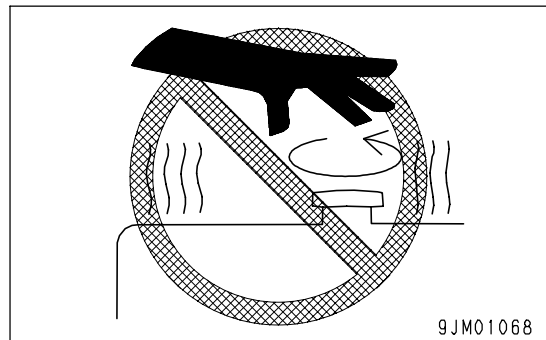

PRECAUTIONS WITH HIGH-TEMPERATURE OIL

To prevent burns from hot oil spurting out or from touching high-temperature parts when checking or draining the oil, wait for the oil to cool down to a temperature where the cap or plug can be touched by hand. Then loosen the cap or plug slowly to release the internal pressure and remove the cap or plug.

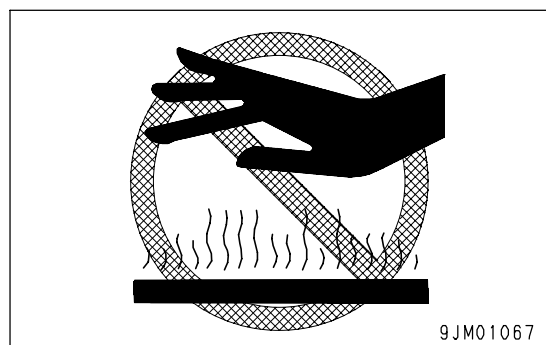

PRECAUTIONS WITH HIGH-PRESSURE OIL

The hydraulic system is always under internal pressure. In addition, the fuel piping is also under internal pressure when the engine is running and immediately after the engine is stopped. When carrying out inspection or replacement of the piping or hoses, check that the internal pressure in the circuit has been released. If this is not done, it may lead to serious personal injury or death. Always do as follows.

- Do not carry out inspection or replacement operations when the system is still under pressure.
For details of the procedure for releasing the pressure, see "PROCEDURE FOR BLEEDING AIR IN HYDRAULIC SYSTEM (PAGE 4-41)".
- If there is any leakage from the piping or hoses, the surrounding area will be wet, so check for cracks in the piping and hoses and for swelling in the hoses.

When carry out inspection, wear safety glasses and leather gloves.

- There is a hazard that high-pressure oil leaking from small holes may penetrate your skin or cause loss of sight if it contacts your skin or eyes directly. If you are hit by a jet of high-pressure oil and suffer injury to your skin or eyes, wash the place with clean water, and consult a doctor immediately for medical attention.

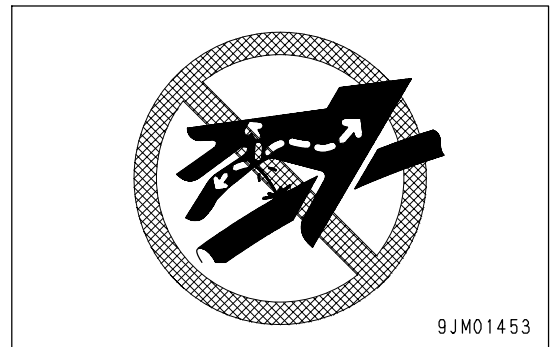
**PRECAUTIONS WITH HIGH-PRESSURE FUEL**

When the engine is running, high-pressure is generated in the engine fuel piping. When carrying out inspection or maintenance of the fuel piping system, stop the engine and wait for at least 30 seconds to allow the internal pressure to go down before starting the operation.

HANDLING HIGH-PRESSURE HOSES AND PIPING

- If oil or fuel leaks from high-pressure hoses or piping, it may cause fire or misoperation, and lead to serious personal injury, or death. If the hose or piping mounts are loose or oil or fuel is found to be leaking from the mount, stop operations and tighten to the specified torque.

If any damaged or deformed hoses or piping are found, please consult your Komatsu distributor.

Replace the hose if any of the following problems are found.

- Damaged hose or deformed hydraulic fitting.
- Frayed or cut covering or exposed reinforcement wire layer.
- Covering swollen in places.
- Twisted or crushed movable portion.
- Foreign material embedded in covering.

NOISE

When carrying out maintenance of the engine and you are exposed to noise for long periods of time, wear ear covers or ear plugs while working.

If the noise from the machine is too loud, it may cause temporary or permanent hearing problems.

PRECAUTIONS WITH HIGH-PRESSURE GREASE WHEN ADJUSTING TRACK TENSION

- Grease is pumped into the track tension adjustment system under high pressure.
If the specified procedure for maintenance is not followed when making adjustment, grease drain plug (1) may fly out and cause serious injury or property damage.
- When loosening grease drain plug (1) to loosen the track tension, never loosen it more than one turn. Loosen the grease drain plug slowly.
- Never put your face, hands, feet, or any other part of your body close to grease drain plug (1).

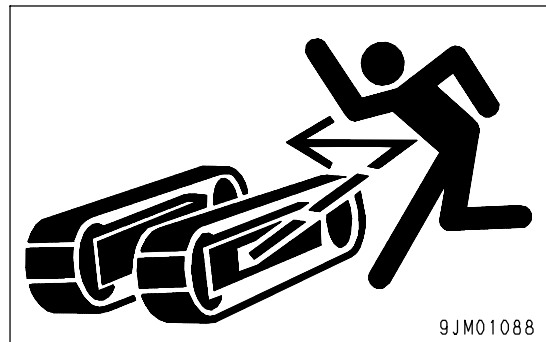
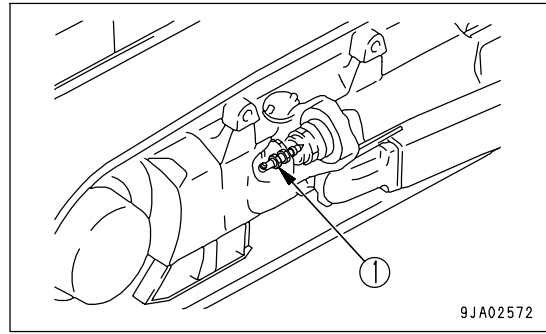

DO NOT DISASSEMBLE RECOIL SPRING

Never disassemble the recoil spring assembly. The recoil spring assembly has a powerful spring that acts to reduce the impact on the idler. If it is disassembled by mistake, the spring may shoot out and cause serious personal injury or death.

It is necessary to disassemble the recoil spring assembly, always ask your Komatsu distributor to carry out the operation.

HANDLING ACCUMULATOR AND GAS SPRING

This machine is equipped with an accumulator. Even after the engine stops, if the work equipment control lever is operated soon after stop of the engine in the direction to lower the work equipment, the work equipment goes down under its own weight.

After stopping the engine, set the parking brake lever and the work equipment lock lever to the LOCK position. The accumulator and gas spring are charged with high-pressure nitrogen gas. If the accumulator is handled mistakenly, it may cause an explosion that could lead to serious personal injury or death. For this reason, always observe the following precautions.

- Do not disassemble the accumulator.
- Do not bring it near flame or dispose of it in fire.
- Do not make holes in it, weld it, or use a cutting torch.
- Do not hit or roll the accumulator, or subject it to any impact.
- When disposing of the accumulator, the gas must be released. Please contact your Komatsu distributor to have this work performed.



PRECAUTIONS WITH COMPRESSED AIR

- When carrying out cleaning with compressed air, there is a hazard of serious personal injury caused by flying dust or particles.
- When using compressed air to clean the filter element or radiator, wear safety glasses, anti-dust mask, gloves, and other protective equipment.

MAINTENANCE OF AIR CONDITIONER

- If air conditioner refrigerant gets into your eyes, it may cause loss of sight; if it contacts your skin, it may cause frostbite. Never loosen any parts of the cooling circuit.

DISPOSING OF WASTE MATERIALS

To prevent pollution, pay careful attention to the method of disposing of waste materials.

- Always put oil drained from your machine in containers. Never drain oil directly onto the ground or dump into the sewage system, rivers, the sea, or lakes.
- Obey appropriate laws and regulations when disposing of harmful objects such as oil, fuel, coolant, solvent, filters, and batteries.

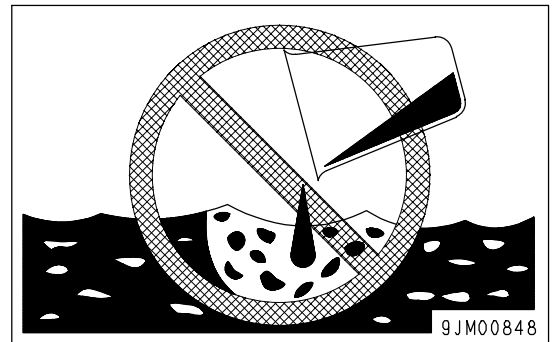
**METHOD OF SELECTING WINDOW WASHER FLUID**

Use an ethyl alcohol base washer liquid.

Methyl alcohol base washer liquid may irritate your eyes, so do not use it.

PERIODIC REPLACEMENT OF SAFETY CRITICAL PARTS

- To enable this machine to be used safely for a long period, always carry out periodic replacement of safety critical parts that have a particularly close relation to safety, such as hoses and the seatbelt.
For details of the replacement of safety critical parts, see "PERIODIC REPLACEMENT OF SAFETY CRITICAL PARTS (PAGE 4-16)".
- The material of these components naturally changes over time, and repeated use causes deterioration, wear, and fatigue. As a result, there is a hazard that these components may fail and cause serious personal injury or death. It is difficult to judge the remaining life of these components from external inspection or the feeling when operating, so always replace them at the specified interval.
- Replace or repair safety-critical parts if any defect is found, even when they have not reached the specified replacement time.

OPERATION

WARNING

Please read and make sure that you understand the SAFETY section before reading this section.

GENERAL VIEW

GENERAL VIEW OF MACHINE

Machine equipped with ROPS cab

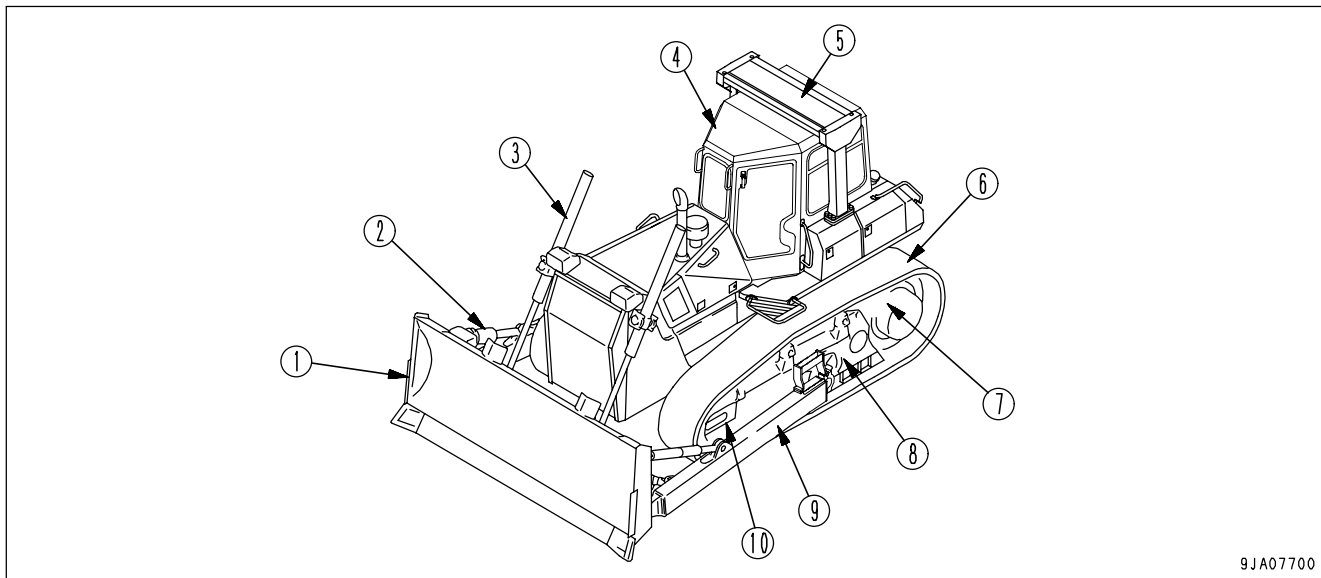

Machine equipped with ROPS canopy

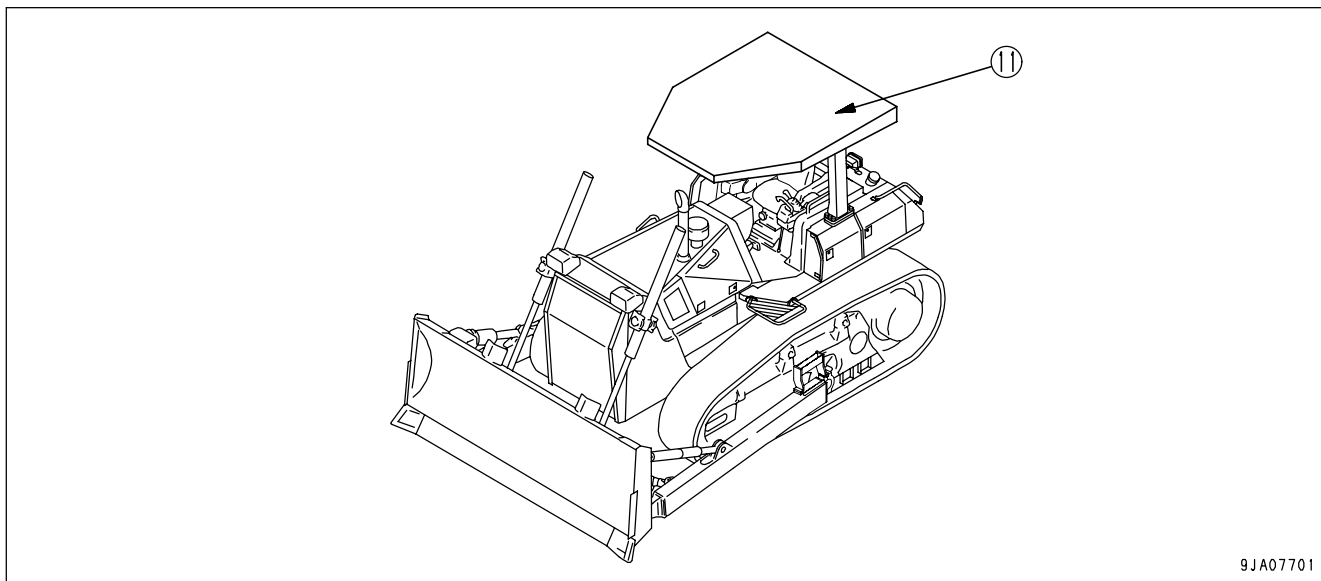

- (1) Blade
- (2) Tilt cylinder
- (3) Lift cylinder
- (4) Cab
- (5) ROPS guard
- (6) Track shoe

- (7) Sprocket
- (8) Track frame
- (9) Frame
- (10) Idler
- (11) ROPS canopy

GENERAL VIEW OF CONTROLS AND GAUGES

Machine equipped with cab

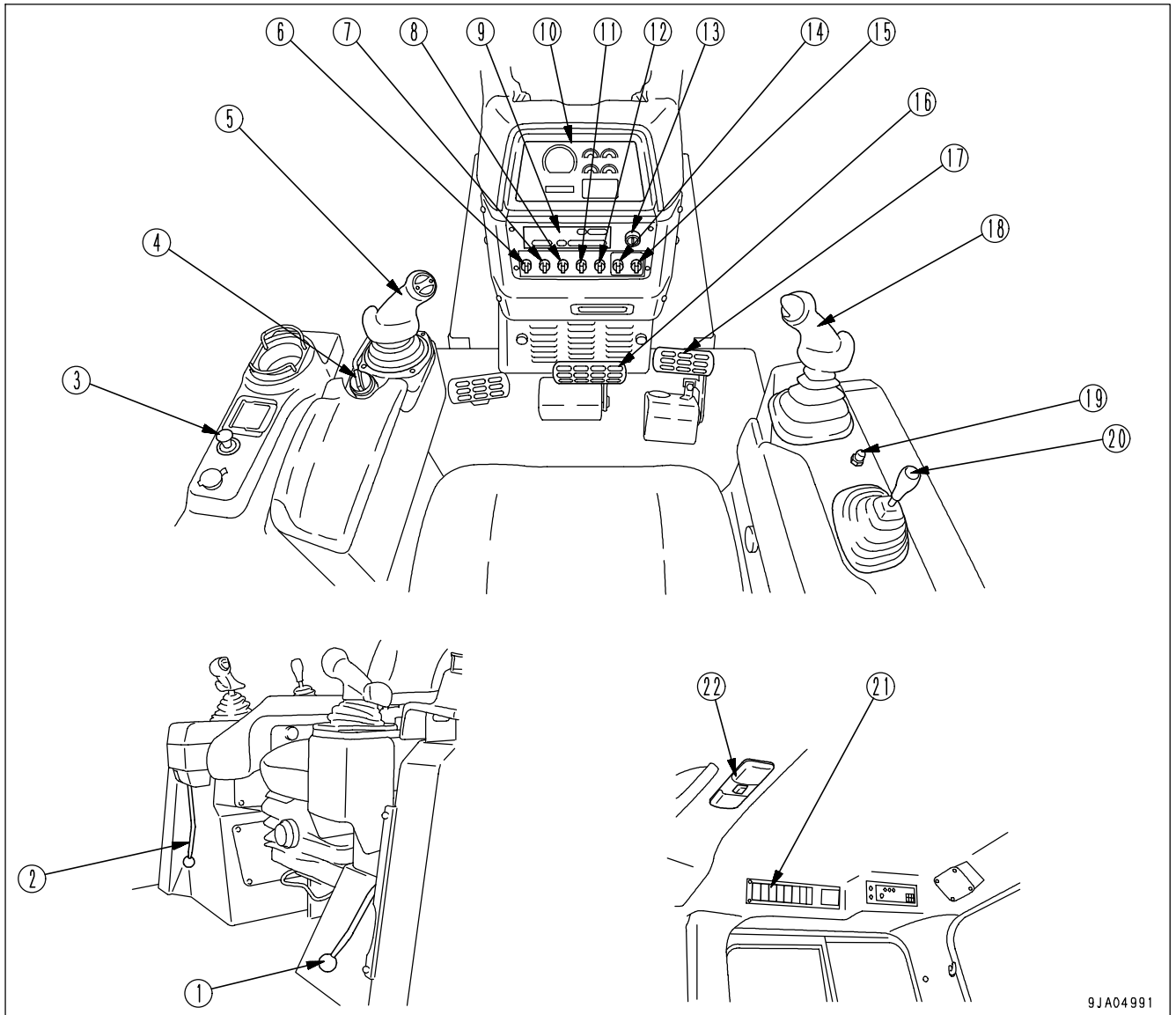

- (1) Parking brake lever
- (2) Work equipment lock lever
- (3) Cigarette lighter
- (4) Fuel control dial
- (5) Steering, forward-reverse, gear shift lever
- (6) Auto shift down switch
- (7) Preset mode switch
- (8) Head lamp switch
- (9) Air conditioner panel or heater panel
- (10) Monitor panel
- (11) Rear lamp switch

- (12) Fan rotation selector switch
- (13) Starting switch
- (14) Information switch
- (15) Buzzer cancel switch
- (16) Brake pedal
- (17) Decelerator pedal
- (18) Blade control lever
- (19) Horn switch
- (20) Ripper control lever (if equipped)
- (21) Wiper switch
- (22) Room lamp switch

9JA04991

Machine equipped with ROPS canopy

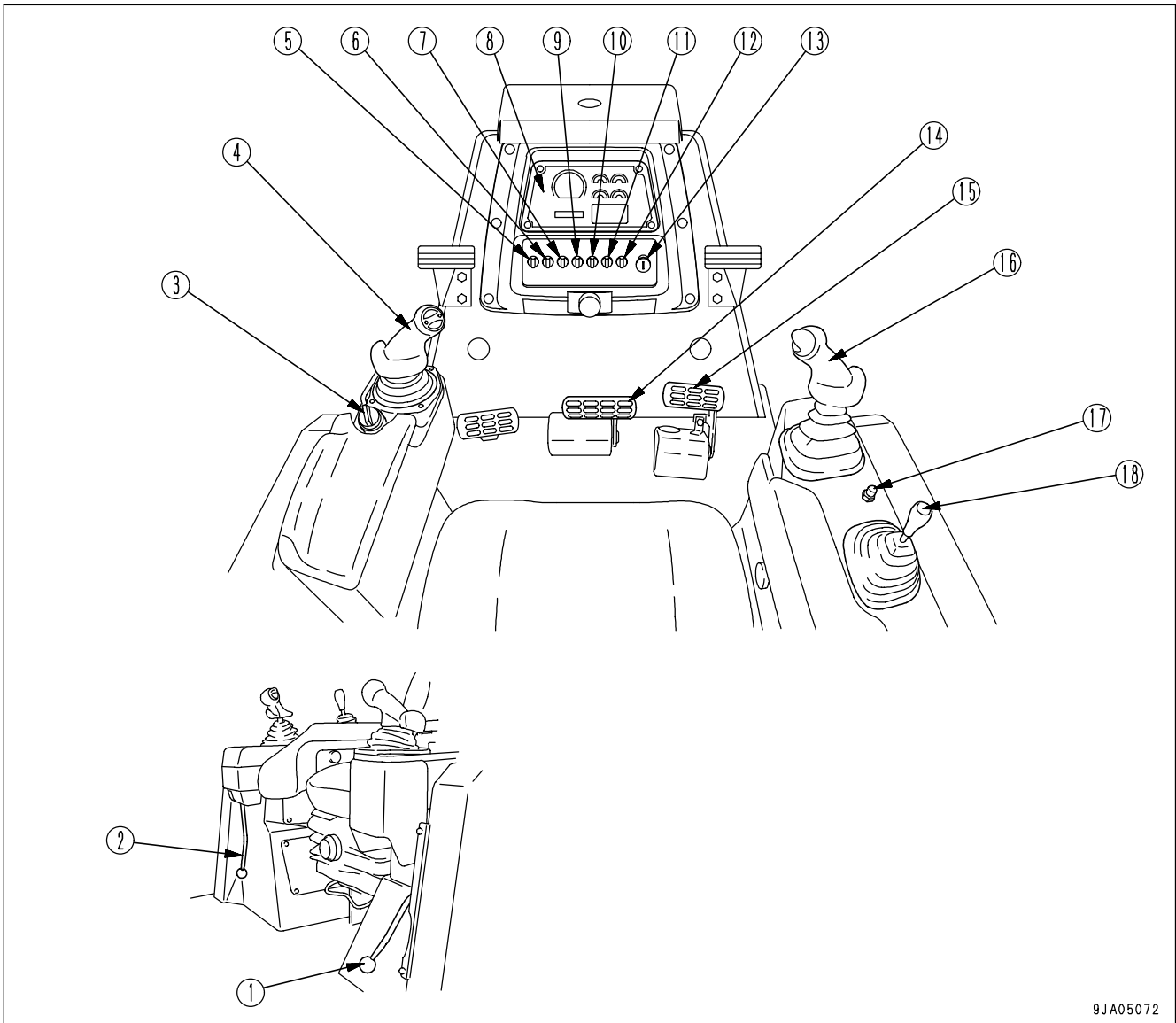

9JA05072

- | | |
|---|---|
| (1) Parking brake lever | (10) Fan rotation selector switch |
| (2) Work equipment lock lever | (11) Information switch |
| (3) Fuel control dial | (12) Buzzer cancel switch |
| (4) Steering, forward-reverse, gear shift lever | (13) Starting switch |
| (5) Auto shift down switch | (14) Brake pedal |
| (6) Preset mode switch | (15) Decelerator pedal |
| (7) Head lamp switch | (16) Blade control lever |
| (8) Monitor panel | (17) Horn switch |
| (9) Rear lamp switch | (18) Ripper control lever (if equipped) |

MONITOR PANEL

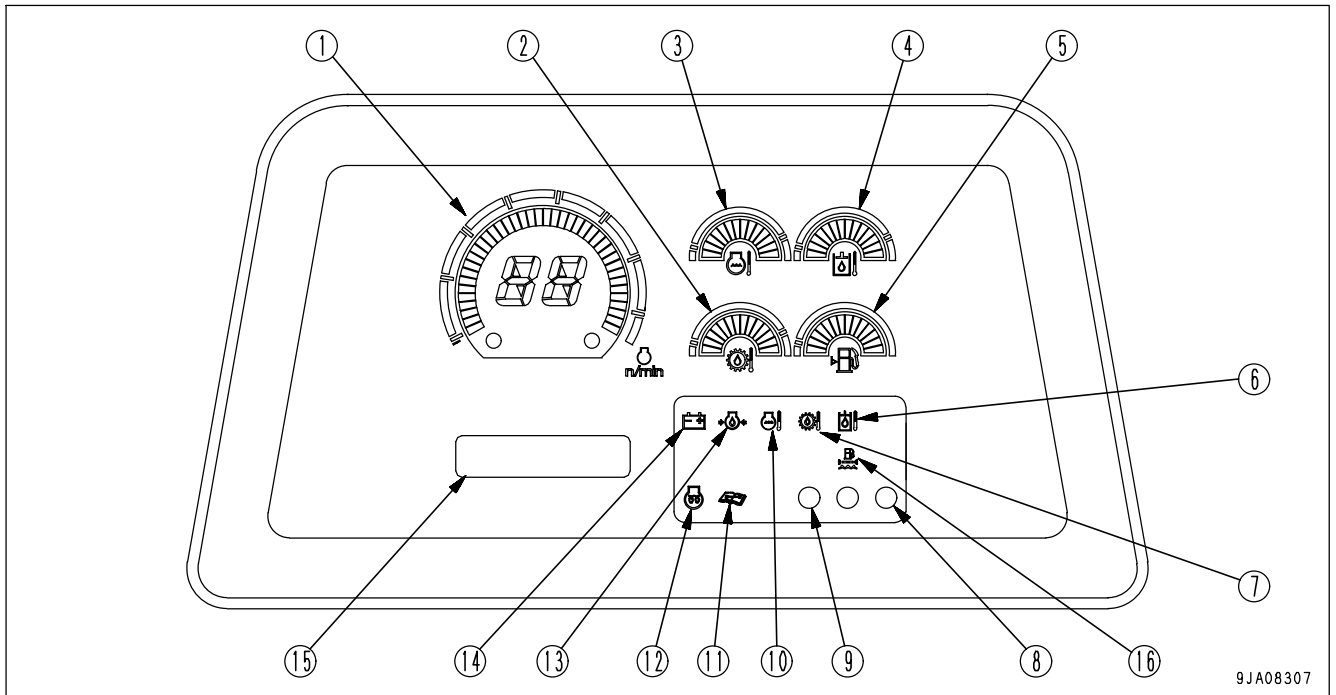

- | | |
|---|--|
| (1) Display panel A (Speed range, Engine speed) | (9) Warning lamp |
| (2) Power train oil temperature gauge | (10) Engine coolant temperature caution lamp |
| (3) Engine coolant temperature gauge | (11) Maintenance caution lamp |
| (4) Hydraulic oil temperature gauge | (12) Engine pre-heating pilot lamp |
| (5) Fuel level gauge | (13) Engine oil pressure caution lamp |
| (6) Hydraulic oil temperature caution lamp | (14) Battery charge circuit caution lamp |
| (7) Power train oil temperature caution lamp | (15) Display panel B (Multi-information) |
| (8) Fan operation confirmation lamp | (16) Water separator caution lamp |

EXPLANATION OF COMPONENTS

The following is an explanation of devices needed for operating the machine.

To perform suitable operations correctly and safely, it is important to completely understand methods of operating the equipment, and the meanings of the displays.

FRONT PANEL

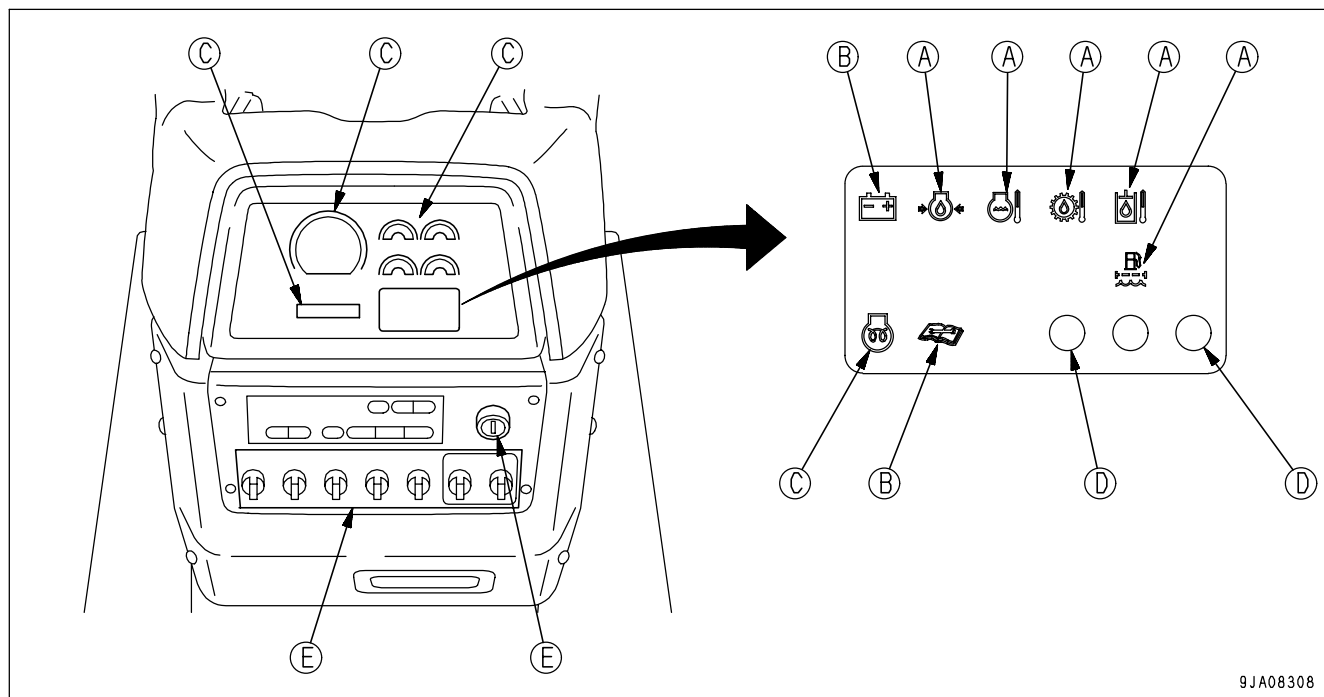

9JA08308

- A: Emergency caution items
- B: Caution items
- C: Meter group

- D: Lamp
- E: Switch

CHECK MONITOR SYSTEM

MONITOR SYSTEM

NOTICE

- Stop the machine on level ground and carry out the monitor check.
- Stop the engine, then turn the starting switch to the ON position and check that the lamps light up for approx. 2 seconds. If they do not light up, please ask your Komatsu distributor to carry out inspection.
- The monitor check cannot be carried out until at least 5 seconds has passed after the engine was stopped.

When carrying out the checks before starting, use the monitor system check.

1. Turn the starting switch to the ON position.
2. Check that the monitor liquid-crystal display and the lamps all light up for 2 seconds, that the alarm buzzer sounds for 2 seconds, and that "KOMATSU SYSTEM CHECK" is displayed for 3 seconds on display panel B (multi-information) (1).
3. • After 2 seconds, the current status of the machine is displayed on liquid-crystal display (2).
 - After 2 seconds, the lamp portion (3) goes out.
 - After 3 seconds, the operating mode is displayed on display panel B (multi-information) (1).

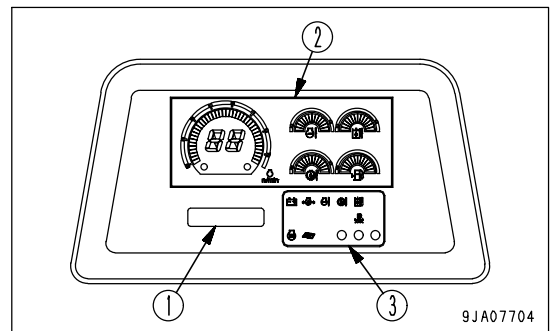

REMARK

The following cases do not indicate any problem.

- If the preheating heater is actuated in cold weather, HEAT lamp (4) does not go out until the preheating is completed.
- When the replacement time for oil and filters is reached, maintenance caution lamp (5) lights up or flashes for 30 seconds and the action code is displayed on display panel B (multi-information) (1).

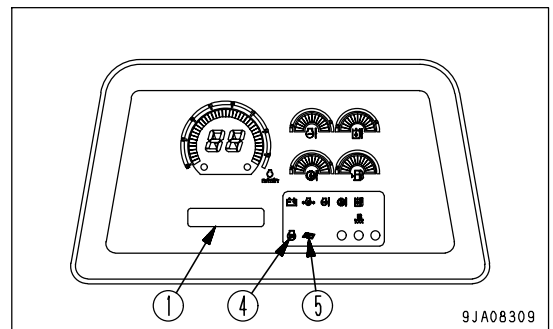

EMERGENCY CAUTION ITEMS

CAUTION

If any of the caution lamps begins to flash, stop the engine or reduce the engine speed to low idle immediately and check the trouble spot for necessary actions.

These items must be monitored when the engine is running. If there is any problem, the caution lamp for the location of the problem and warning lamp (A) flash, and the alarm buzzer sounds intermittently. Take the necessary action immediately.

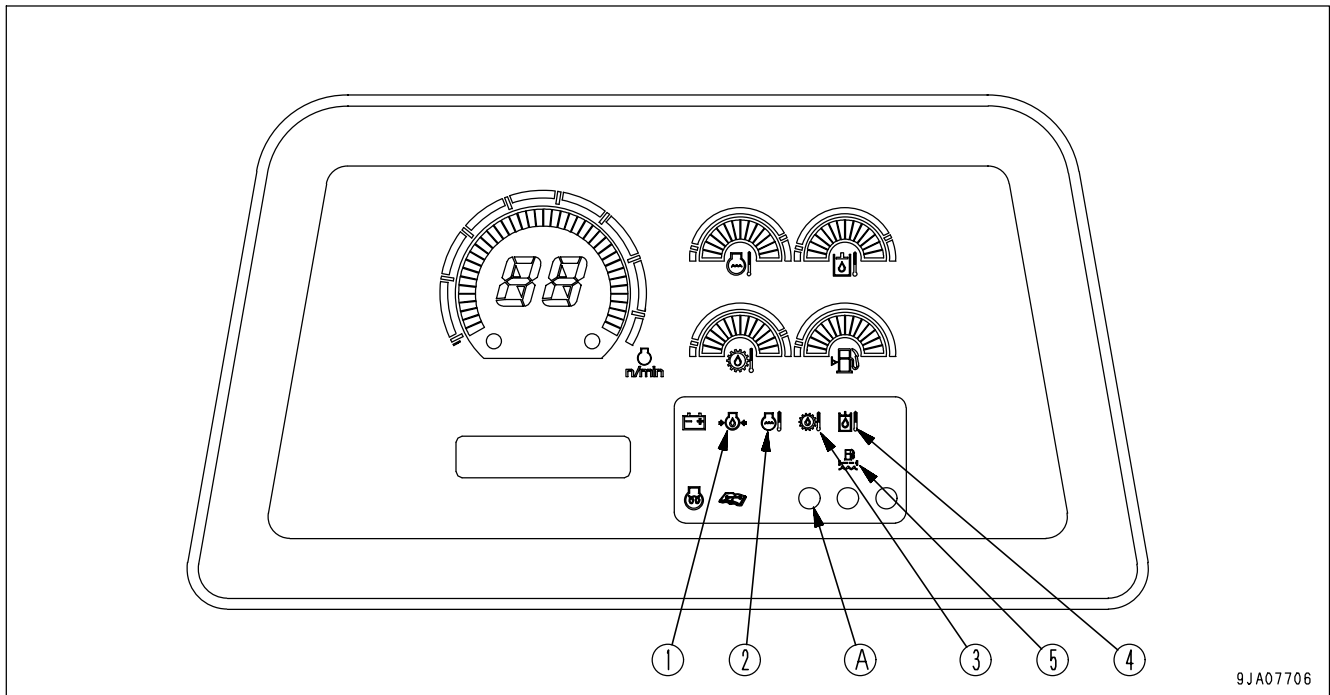

9JA07706

- (1) Engine oil pressure caution lamp
- (2) Engine coolant temperature caution lamp
- (3) Power train oil temperature caution lamp
- (4) Hydraulic oil temperature caution lamp
- (5) Water separator caution lamp

ENGINE OIL PRESSURE CAUTION LAMP

This lamp (1) indicates low engine oil pressure. If the monitor lamp flashes, stop the engine and check it immediately.

REMARK

The alarm buzzer sounds, when the starting switch is turned to ON immediately after the engine oil has been changed. It does not indicate a problem.

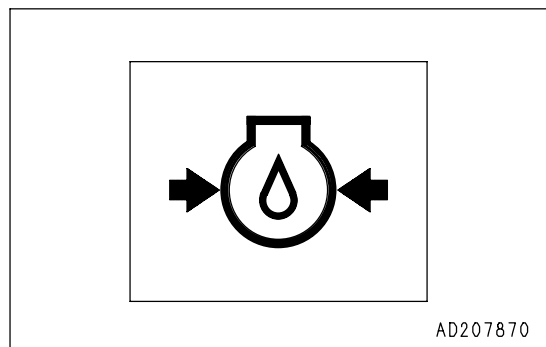

AD207870

ENGINE COOLANT TEMPERATURE CAUTION LAMP

This lamp (2) indicates a rise in the coolant temperature.

When the monitor lamp flashes, run the engine at low idle speed until green range of the engine coolant temperature gauge lights.

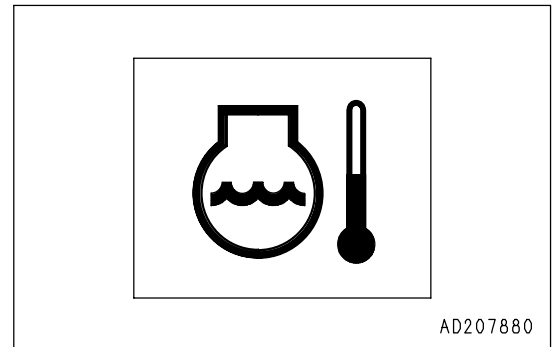
**POWER TRAIN OIL TEMPERATURE CAUTION LAMP**

Lamp (3) warns operator that the torque converter outlet port oil temperature has risen.

If it flashes, run the engine at low idling until the power train oil temperature gauge goes down to the green range.

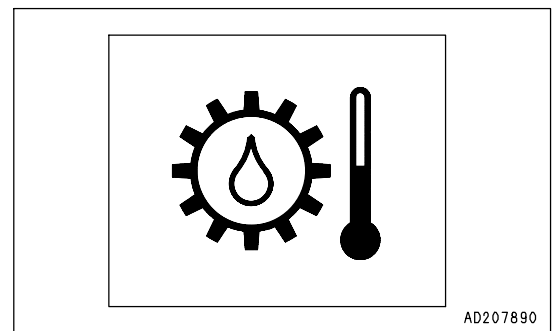
**HYDRAULIC OIL TEMPERATURE CAUTION LAMP**

Lamp (4) indicates a rise in the hydraulic oil temperature.

When the monitor lamp flashes, stop the machine and run the engine at the low idling speed until oil temperature falls.

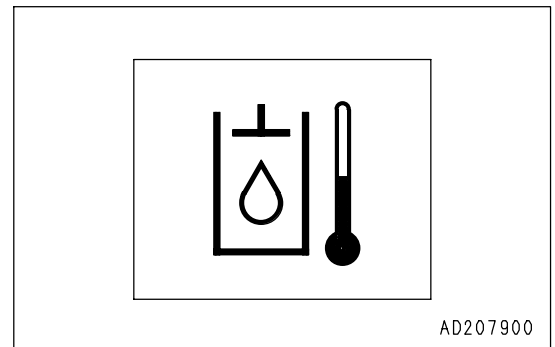
**WATER SEPARATOR CAUTION LAMP**

This lamp (5) warns of a rise in the water level in the water separator. When it lights up, drain water from the water separator. The water separator is located is in one piece with the fuel pre-filter and located in the lower part.

For draining water from the water separator, see "CHECK, DRAIN WATER SEPARATOR (PAGE 3-74)".

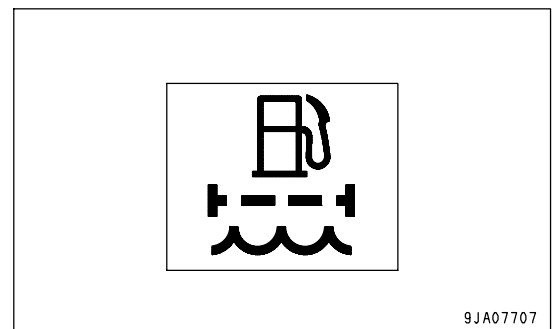

CAUTION ITEMS

 **CAUTION**

If these caution lamps flash, check and repair the appropriate location as soon as possible.

These are items which need to be observed when the engine is running. If any problem occurs, the item needing immediate repair is displayed. If there is any problem, the problem location on the caution lamp will flash.

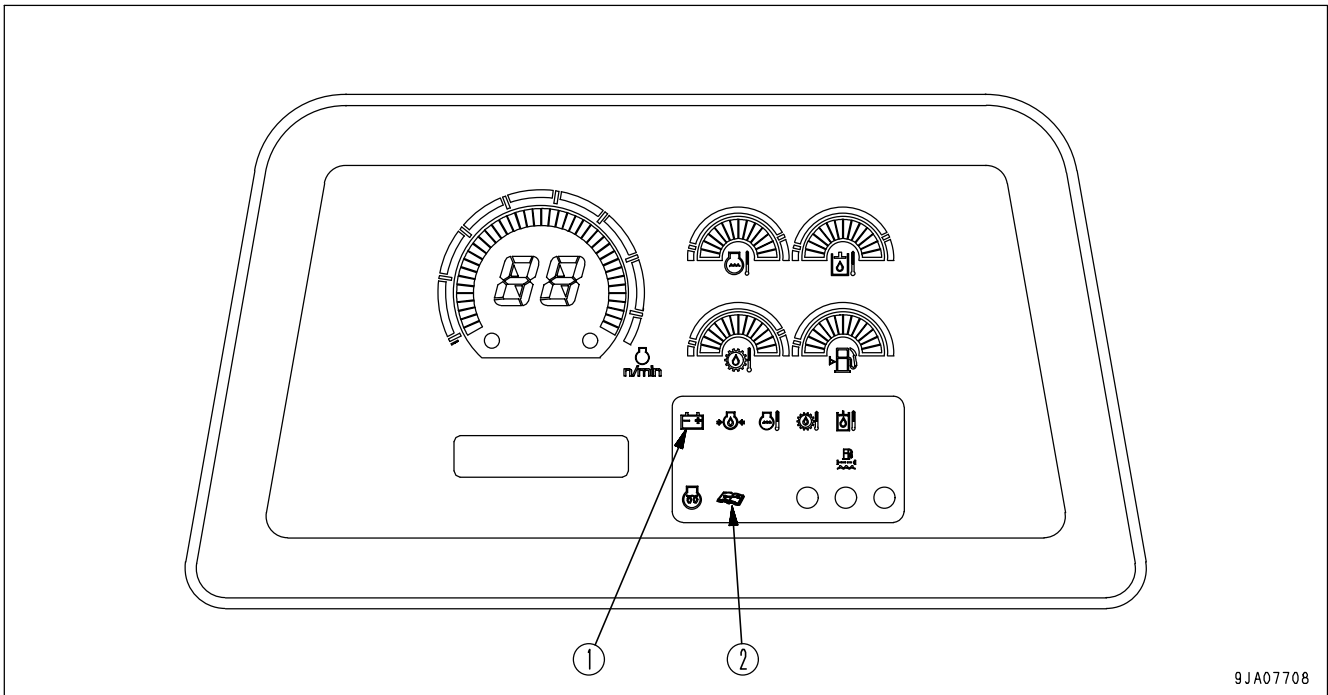

9JA07708

(1) Battery charge circuit caution lamp

(2) Maintenance caution lamp

BATTERY CHARGE CIRCUIT CAUTION LAMP

This lamp (1) indicates a problem in the charging system while the engine is running.

If the monitor lamp flashes, check the V-belt tension. If any problem is found, see "OTHER TROUBLE (PAGE 3-137)".

REMARK

This lamp may light up momentarily when the engine is started or when the engine is stopped. It does not indicate a problem.

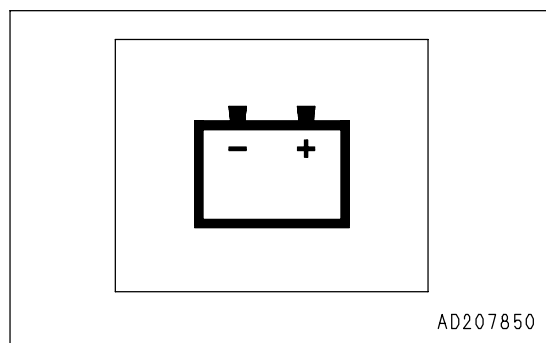

AD207850

MAINTENANCE CAUTION LAMP

This lamp (2) lights up for approx. 30 seconds after the starting switch is turned to the ON position if the filter or oil replacement interval has been reached.

After replacing the indicated filter or oil displayed on display panel B (multi-information), reset the interval. For details, see "METHOD OF USING OIL AND FILTER MAINTENANCE MODE (PAGE 3-26)".

The lamp goes out.

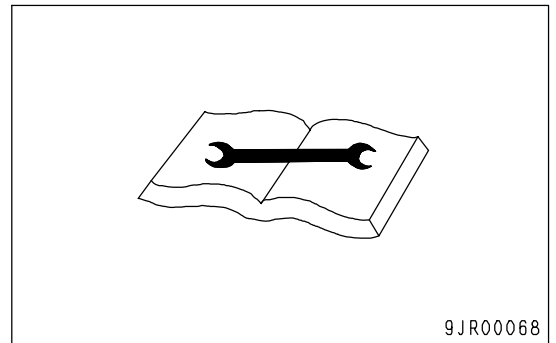

METER GROUP

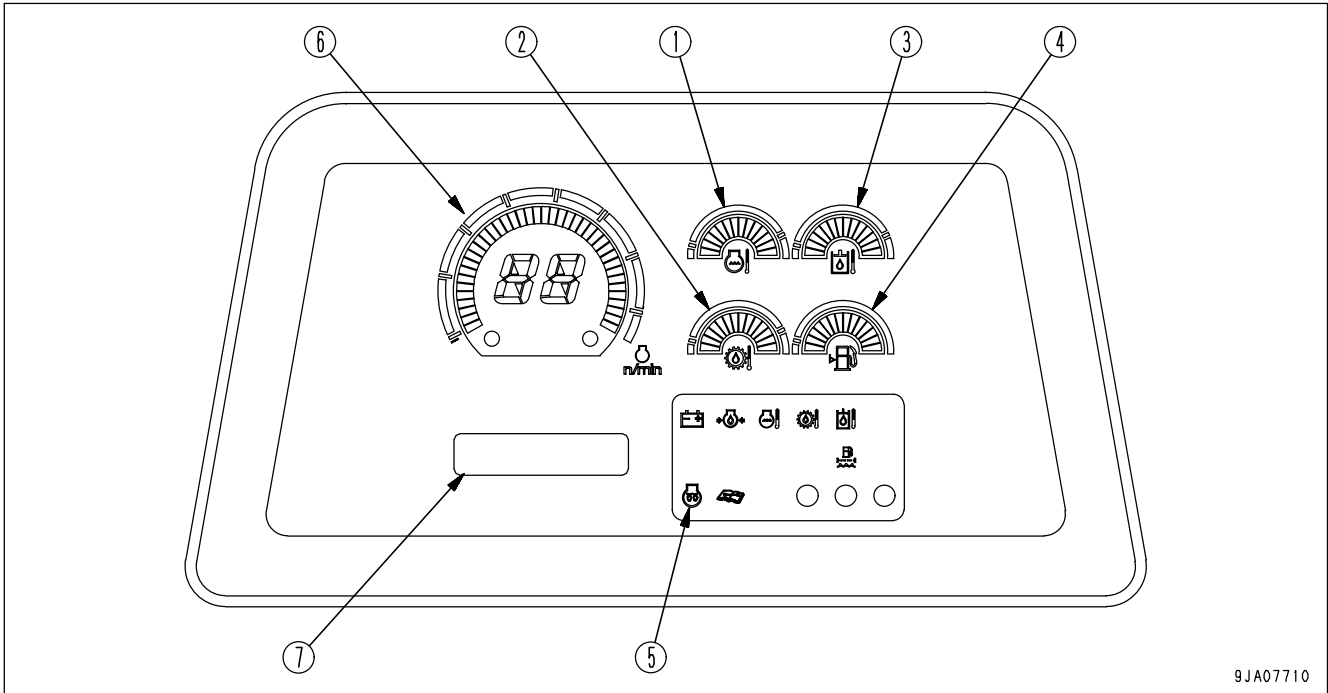

9JA07710

- (1) Engine coolant temperature gauge
- (2) Power train oil temperature gauge
- (3) Hydraulic oil temperature gauge
- (4) Fuel level gauge
- (5) Engine pre-heating pilot lamp
- (6) Display panel A
(Speed range display, Engine speed)
- (7) Display panel B (multi-information)

ENGINE COOLANT TEMPERATURE GAUGE

NOTICE

If the coolant temperature gauge often enters red range (C), check the radiator for clogging.

Gauge (1) indicates temperature of the engine coolant.
 If the temperature is normal during operation, green range (B) will light.
 If red range (C) lights during operation, move the fuel control dial to lower engine speed to approx. 3/4 of the full speed, and run until the coolant temperature enters green range (B).
 If red range (C) lights up during operation, and the engine coolant temperature caution lamp flashes and the alarm buzzer sounds, stop the machine, run the engine at low idle, and wait for the coolant temperature to return to green range (B).

- (A): White range
- (B): Green range
- (C): Red range

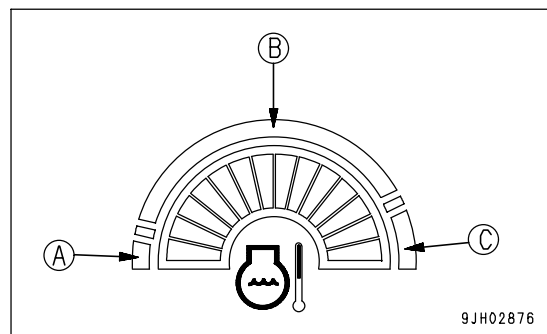

9JH02876

POWER TRAIN OIL TEMPERATURE GAUGE

NOTICE

If the power train oil temperature gauge often enters red range (C), shift down one speed range to reduce the load on the power train when operating.

Gauge (2) indicates the torque converter outlet oil temperature. If the temperature is normal during operation, green range (B) will light.

If red range (C) lights up during operation, move the fuel control dial to lower engine speed to approx. 3/4 of the full speed, reduce the load and run until the oil temperature enters green range (B).

If red range (C) lights up during operation, and the power train oil temperature caution lamp flashes and the alarm buzzer sounds, stop the machine, run the engine at low idle, and wait for the oil temperature to go down to green range (B).

(A): White range

(B): Green range

(C): Red range

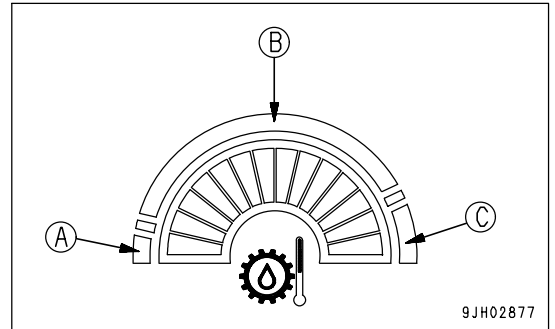

HYDRAULIC OIL TEMPERATURE GAUGE

Gauge (3) indicates the hydraulic oil temperature.

If the temperature is normal during operation, green range (B) will light.

If red range (C) lights up during operation, move the fuel control dial to lower engine speed to approx. 3/4 of the full speed, reduce the load and run until the oil temperature enters green range (B).

(A): White range

(B): Green range

(C): Red range

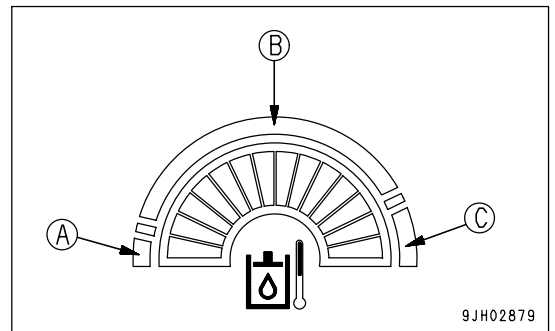

FUEL LEVEL GAUGE

Gauge (4) fuel level in the fuel tank.

During normal operation, the green range (B) should be lit.

If red range (A) lights up during operation, add fuel immediately. If this is not done, the engine speed will become irregular or an error display will be shown on the monitor.

(A): Red range

(B): Green range

REMARK

- The display is not proportional to the amount of fuel remaining.
- If only the red range (A) lights up, there is less than 60 liters (15.85 US gal) of fuel remaining.

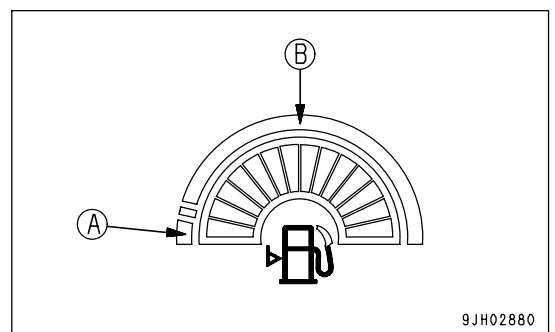

ENGINE PRE-HEATING PILOT LAMP

This lamp (5) indicates that the engine is being preheated with an electric heater in cold weather.

When the engine starting switch is turned to the ON position, the engine controller detects the engine coolant temperature and automatically starts to preheat the engine at low temperature.

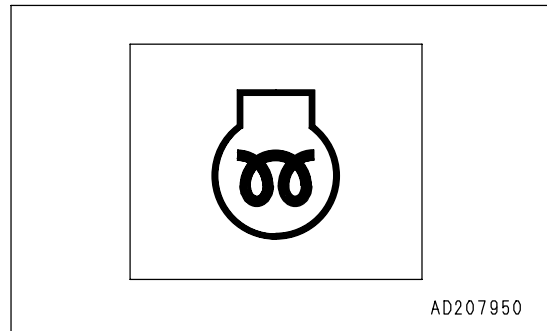
**DISPLAY PANEL A (speed range display, engine speed)**

Meter (6) displays the transmission speed range being used on the machine and engine speed.

- The travel direction (A) and speed range (B) are displayed in the center of the speed range display.

(A) F: FORWARD

R: REVERSE

N: Neutral

P: Parking brake lever at LOCK position

(B) 1: 1st

2: 2nd

3: 3rd

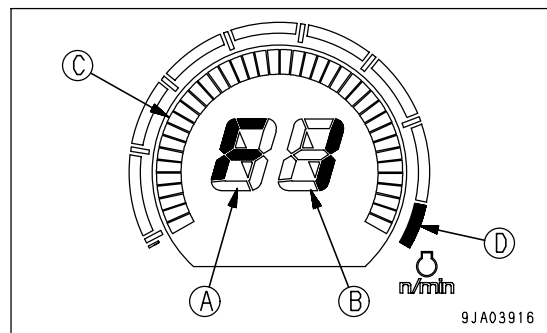

Example: F1 is displayed for FORWARD 1st

- Bar graph (C) around the outside of the display shows the engine speed. If the bar graph reaches red range (D) during operation, take action to reduce the engine speed. Always keep the bar graph in the green range.

DISPLAY PANEL B (multi-information)

The top and bottom lines in display panel B (multi-information) display information related to the condition of the machine.

The content of the display is divided into "OPERATING MODE" and "MAINTENANCE MODE". Use the buzzer cancel switch to switch between the operating mode and maintenance mode.

For details of switching the mode, see "BUZZER CANCEL SWITCH (PAGE 3-23)".

OPERATING MODE (default screen)

Use this mode when operating the machine.

REMARK

When the starting switch is turned from the OFF position to the ON position, display panel B (multi-information) always displays the operating mode.

The following information is displayed by the operating mode.

Top line (A): Action code

If any problem occurs on the machine, an action code is displayed. If an action code appears, take the applicable action. For details, see "OTHER TROUBLE (PAGE 3-137).

This displays various types of filter or oil replacement intervals have been reached.

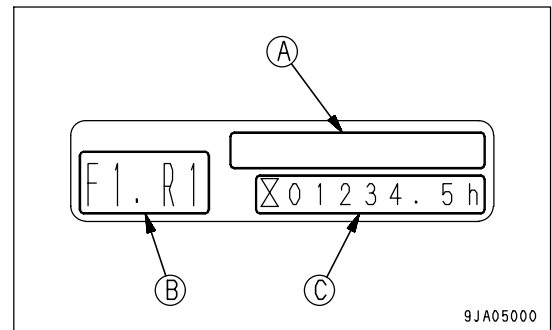

Bottom line, left (B): Preset mode

When the preset mode switch is ON, the selected preset mode is displayed.

For details of selecting the preset mode, see "GEARSHIFTING OPERATION USING PRESET MODE FUNCTION (PAGE 3-100)".

Bottom line, right (C): Service meter or engine speed

Use the information switch to switch the display between the service meter and engine speed. For details of switching the display, see "INFORMATION SWITCH (PAGE 3-23)".

Service meter

This displays the total number of hours that the machine has been operated. Use the display to determine the intervals for periodic maintenance.

While the engine is running, the service meter advances, even if the machine is not being operated.

While the engine is running, the hourglass mark at the side of the meter flashes to show that the meter is advancing.

The meter advances 0.1h for every 6 minutes that the engine is running, regardless of the engine speed.

Maintenance mode

This displays various types of information related to maintenance of the machine.

For details, see "METHOD OF USING MAINTENANCE MODE (PAGE 3-24)".

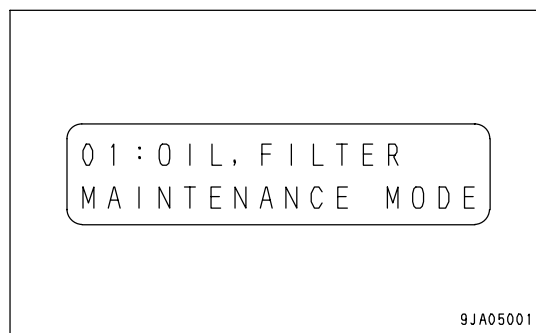

LAMPS

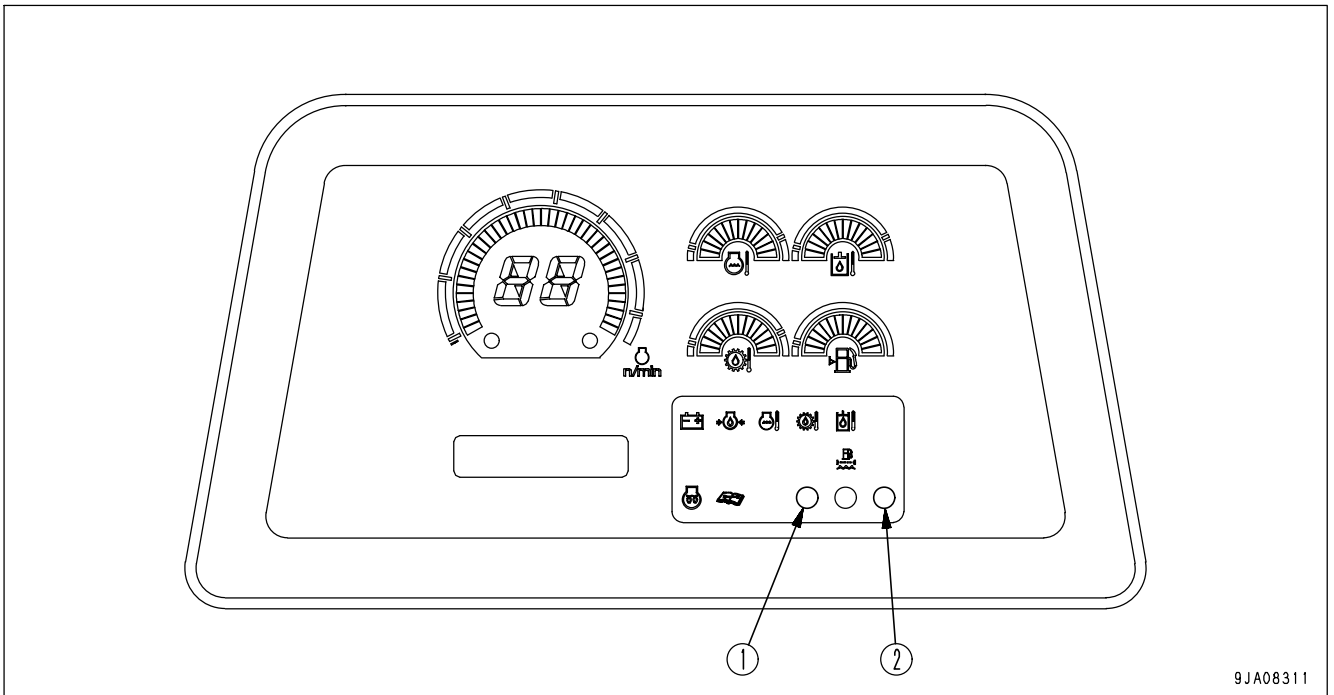

9JA08311

(1) Warning lamp

(2) Fan operation confirmation lamp

WARNING LAMP

(Red)

NOTICE

If alarm buzzer sounds, stop work immediately and perform inspection and maintenance of the appropriate point.

This lamp (1) flashes when the caution lamp flashes and when an action code is displayed on display panel B (multi-information).

When the caution lamp (A) of an emergency warning item flashes, or when the part of an action code is displayed, the alarm buzzer sounds continuously at the same time.

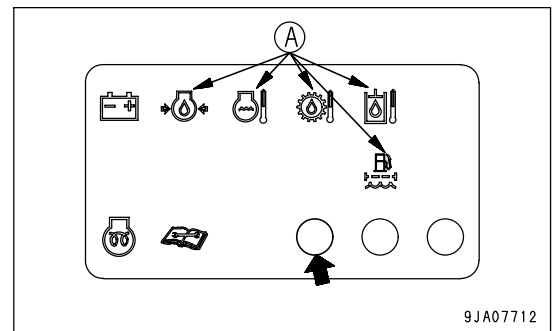

9JA07712

FAN OPERATION CONFIRMATION LAMP

(Orange)

This lamp (2) lights up or flashes in the following operation, and the fan begins to turn.

- When the engine starting switch is turned to the ON position, and the engine is started up with this lamp (2) off, the fan turns in the normal direction.
- After the engine starting switch is turned to the ON position, and the fan rotation selector switch is turned to the CLN position, this lamp (2) lights up. If the engine is started up with lamp (2) on, the fan turns in the reverse direction.
- When the fan rotation selector switch is turned to the CLN position, while the engine is running, this lamp (2) flashes for three seconds, indicating that the fan rotation direction cannot be changed.

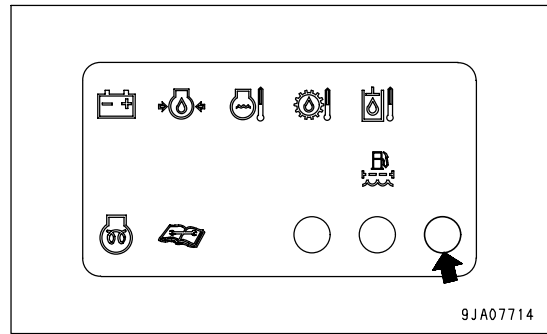

SWITCHES

Machine equipped with cab

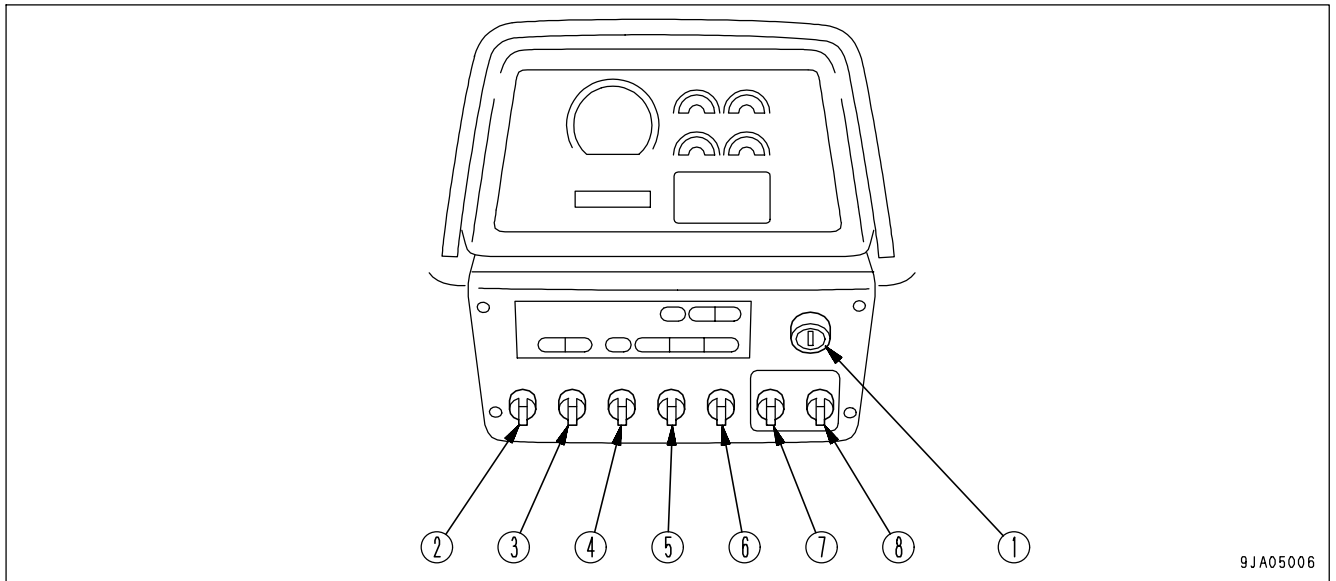

9JA05006

Machine equipped with ROPS canopy

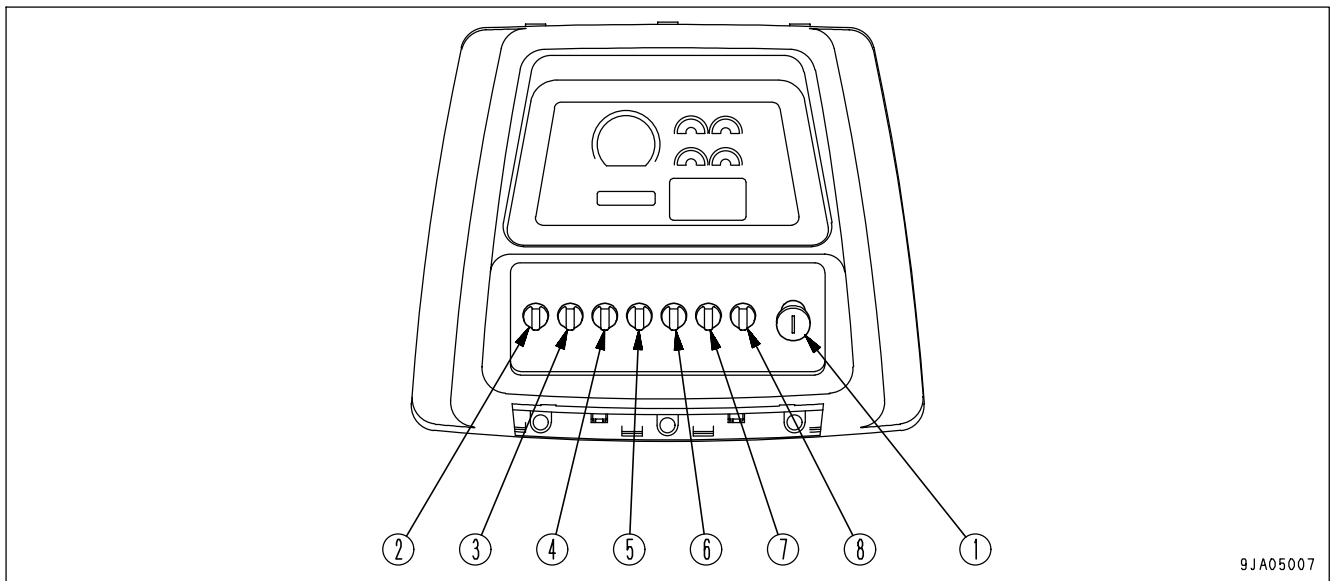

9JA05007

- | | |
|----------------------------|----------------------------------|
| (1) Starting switch | (5) Rear lamp switch |
| (2) Auto shift down switch | (6) Fan rotation selector switch |
| (3) Preset mode switch | (7) Information switch |
| (4) Head lamp switch | (8) Buzzer cancel switch |

STARTING SWITCH

This switch (1) is used to start or stop the engine.

(A): OFF position

At this position, the starting switch key can be inserted and removed. When the switch is turned to this position, all the electric circuits are turned off and the engine stops.

(B): ON position

In this position, electric current flows in the charging and lamp circuits.

Keep the starting switch key at the ON position while the engine is running.

(C): START position

This is the position to start the engine. Hold the key at this position while cranking the engine. Release the key immediately after the engine has been started. The key will return to ON position (B) when released

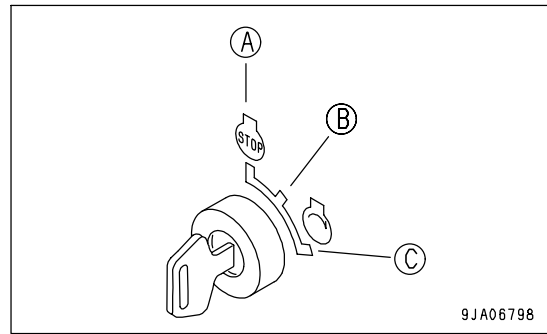
**AUTO SHIFT DOWN SWITCH**

This switch (2) is used to actuate the auto shift down function and shift the transmission automatically to a low speed range.

○ (OFF) position: Stopped

┆ (ON) position: Actuated

For details, see "AUTO DOWN SHIFT OPERATION (PAGE 3-101)".

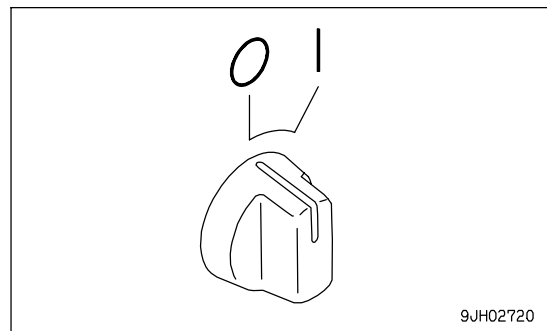
**PRESET MODE SWITCH**

This switch (3) is used to actuate the preset mode function.

○ (OFF) position: Stopped

┆ (ON) position: Actuated

For details, see "GEARSHIFTING OPERATION USING PRESET MODE FUNCTION (PAGE 3-100)".

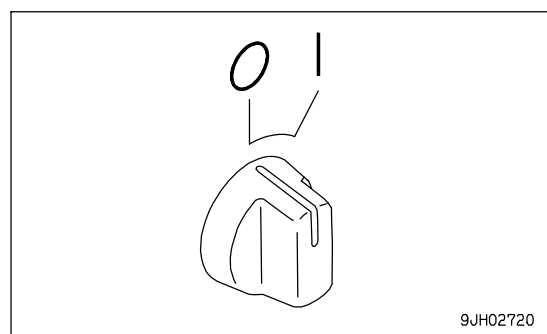

HEAD LAMP SWITCH

This switch (4) lights up when the front lamp, and panel lamp light up.

- (OFF) position: Lights out
- ┆ (ON) position: Lights on

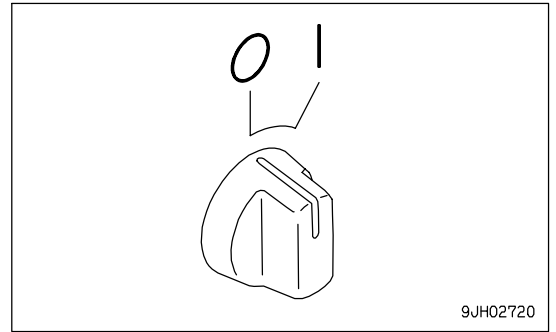
**REAR LAMP SWITCH**

This switch (5) lights up the rear lamps.

- (OFF) position: Lights out
- ┆ (ON) position: Lights on

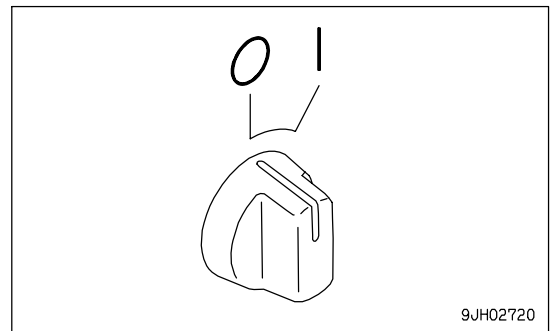

FAN ROTATION SELECTOR SWITCH

This switch (6) is used to switch the direction of rotation of the cooling fan.

When it is released from the CLN position, it will automatically return to the ○ position.

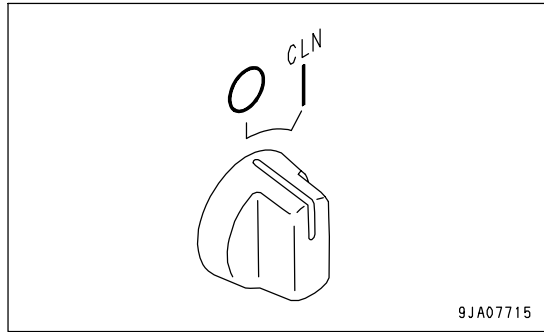

9JA07715

○ position : Normal rotation

Use this switch normally with the fan operation confirmation lamp in the OFF condition.

Cooling air is blown out to the front from the radiator mask.

The fan turns in RPM commensurate with the cooling water temperature, thus assuring effective cooling of the engine.

CLN position: Cleaning

Use this switch with the fan operation confirmation lamp in the ON condition.

The fan turns in the reverse direction and at a high speed without any relation to the cooling water temperature.

Use this mode to clean the radiator fins.

For the "ON" or "OFF" condition of the fan operation confirmation lamp, see "FAN OPERATION CONFIRMATION LAMP (PAGE 3-18)".

REMARK

- The fan rotation direction cannot be changed, even if it is tried when the engine is running.
The fan operation confirmation lamp begins to flash to tell you that the fan rotation direction cannot be changed.
- When the fan operation check lamp lights up and the fan is turning in the reverse direction, the machine does not start even if the steering - forward / reverse shifting- gearshift lever is operated to the FORWARD or REVERSE position. This is to protect the radiator. To start the machine, turn the engine starting switch key to the OFF position once and then turn to the ON position once again, after making sure that the fan operation check lamp has gone off.
- When the fan is turning to clean the radiator fins, and the engine starting switch is turned to the OFF position, power is not switched off immediately in order to protect the hydraulic circuit.

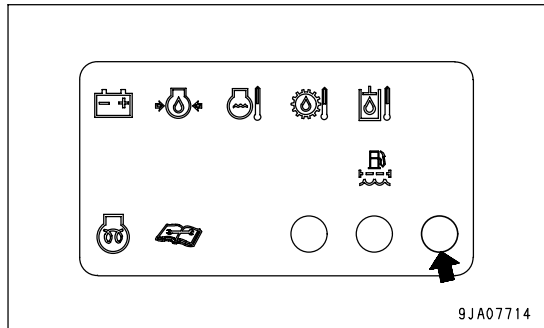

9JA07714

INFORMATION SWITCH

This switch (7) is used to operate display panel B (multi-information).

When the switch is released, it returns automatically to the center position.

- **When display panel B (multi-information) is in the operation mode**

turn the switch to < or > to switch the display to service meter or engine speed.

- **When display panel B (multi-information) is in the maintenance mode**

It is used to move between sub modes, between items, to move the cursor, or to change values.

For details, see "METHOD OF USING MAINTENANCE MODE (PAGE 3-24)".

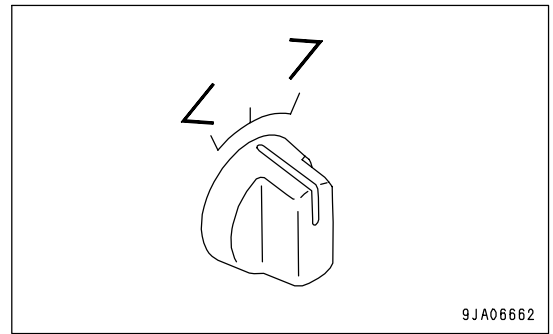
**BUZZER CANCEL SWITCH**

This switch (8) is used to operate control panel B (multi-information) or to stop the alarm buzzer.

When the switch is released, it returns automatically to the center position.

- **When display panel B (multi-information) is in operation mode**

- When the alarm buzzer is sounding, turn this switch to the left or right to stop the buzzer.
- If the switch is held at the ◊ position for at least 2.5 seconds, the display switches to the maintenance mode.

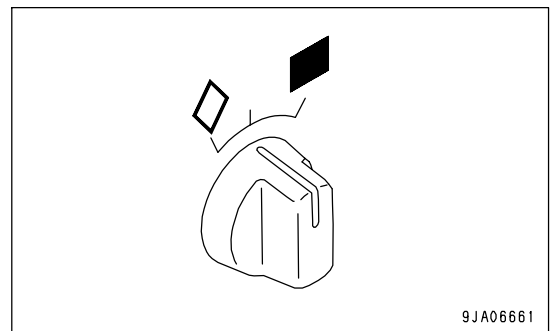

- **When display panel B (multi-information) is in the maintenance mode**

■ position: Cancel or reset to operation mode

◊ position: Confirms selection or selected item

For details, see "METHOD OF USING MAINTENANCE MODE (PAGE 3-24)".

METHOD OF USING MAINTENANCE MODE

To switch from the operation mode to the maintenance mode, turn the buzzer cancel switch to the ◊ position and hold it there for at least 2.5 seconds. The screen will switch to the maintenance mode.

On the first screen, the oil and filter maintenance mode is displayed.

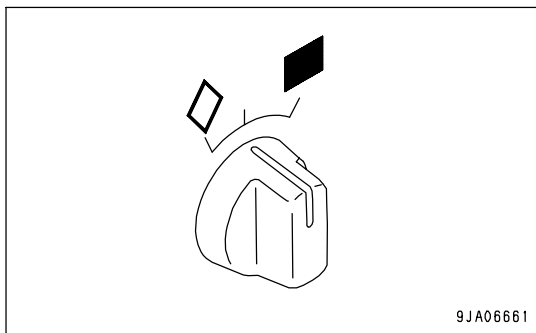

EXPLANATION OF MODES AND OPERATION

The maintenance mode has the following 4 sub modes.

Sub mode	Function	Reference items
Oil/filter maintenance mode	Oil or filter replacement time is displayed	METHOD OF USING OIL AND FILTER MAINTENANCE MODE(3-26 PAGE)
PM clinic auxiliary mode	The engine RPM and battery voltage are shown.	METHOD OF USING PM CLINIC AUXILIARY MODE(3-28 PAGE)
Fault code display mode	Fault codes for electronic control related parts are displayed	METHOD OF USING FAULT CODE DISPLAY MODE(3-29 PAGE)
Adjustment mode	Adjusts monitor brightness, etc.	METHOD OF USING USER ADJUST MODE(3-30 PAGE)

Use information switch (1) and buzzer cancel switch (2) to operate each mode.

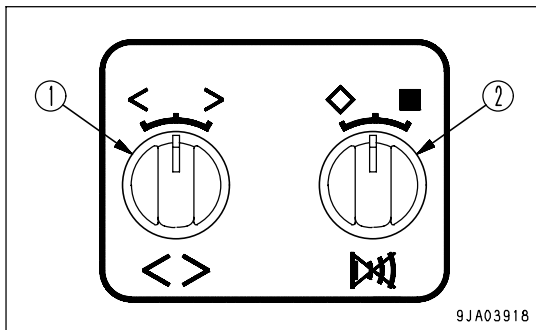

METHOD OF SELECTING EACH MODE

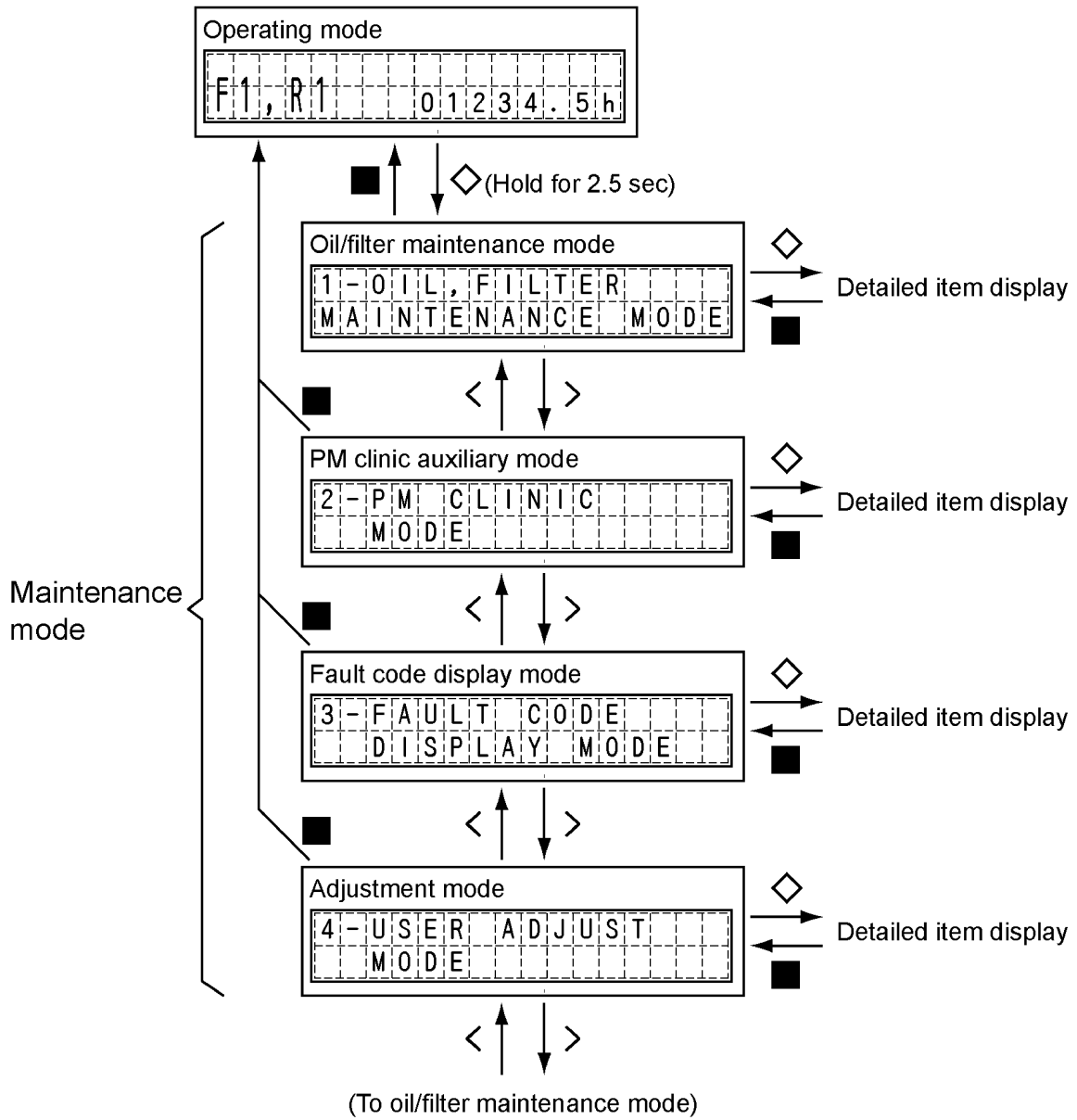

METHOD OF USING OIL AND FILTER MAINTENANCE MODE

NOTICE

This function is only a guideline. If dirty oil or filters are found during daily maintenance, replace them immediately. If the controllers or monitor panel are replaced, the timer for this function will not work properly. Contact your Komatsu distributor for replacement.

In the oil and filter maintenance mode, the replacement intervals for oil and filters are displayed on display panel B (multi-information).

- (1) The item is displayed.
- (2) The time remaining until replacement is displayed.
- (3) The quantity of replacements until now is displayed.

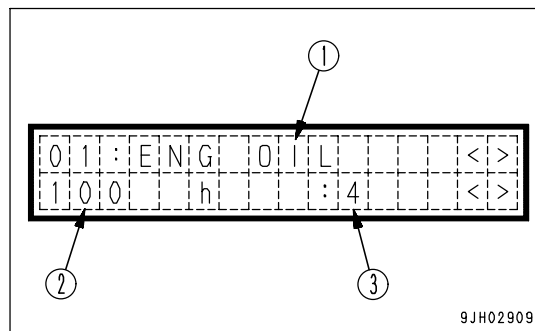

The display items can be displayed in order by operating the information switch to the left or right (<, >).

Code	Display	Maintenance Work Item	Replacement Interval (h)	
			1st Replacement (may not be changed)	2nd Replacement and thereafter (may be changed)
01	ENG OIL	Engine oil	500h	500h
02	ENG FILT	Engine oil filter	500h	500h
03	FUEL FILT	Fuel main filter	1000h	1000h
04	HYD FILT	Hydraulic oil filter	2000h	2000h
06	CORR RES	Corrosion resistor	1000h	1000h
07	DAMP OIL	Damper oil	2000h	2000h
08	FNL OIL	Final drive oil	1000h	1000h
10	HYD OIL	Hydraulic oil	2000h	2000h
12	HSS FILT	HSS charge filter (*)	-	-
19	POWL OIL	Power train oil	1000h	1000h
20	POWL FILT	Power train oil filter	500h	500h
41	F. PRE-FLT	Fuel pre-filter	500h	500h

- The 1st replacement interval may not be changed. If it needs to be changed for some particular reason, treat the 1st maintenance work as has been finished in the maintenance mode, and change the 2nd or subsequent replacement interval.
- The item with an asterisk (*) in the table is shown on the display but not in use in this machine.

When the oil or filter has been replaced, select the applicable item, then operate the buzzer cancel switch to \diamond .

A question asking if the replacement history is to be updated is displayed.

Use the information switches (<, >) to select YES, then turn the buzzer cancel switch to \diamond . The number of times of replacement increases by 1 and the replacement time is also reset.

When this is done, if the maintenance caution lamp does not go out, there is another item close to the replacement time, so check that item.

REMARK

To return to the maintenance mode, operate the buzzer cancel switch to \blacksquare .

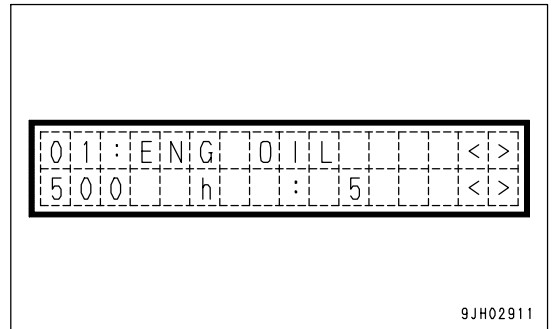
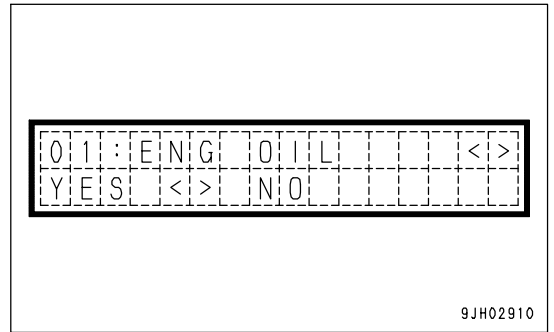

METHOD OF USING PM CLINIC AUXILIARY MODE

CAUTION

When moving the work equipment or setting the transmission to the travel position for carrying out measurements, check carefully that the situation is safe.

In the PM Clinic auxiliary mode, the engine RPM and battery voltage are shown in display B (multi-information). Display panel B (Multi-information) displays the item on the top line (1) and the measured value on the bottom line (2).

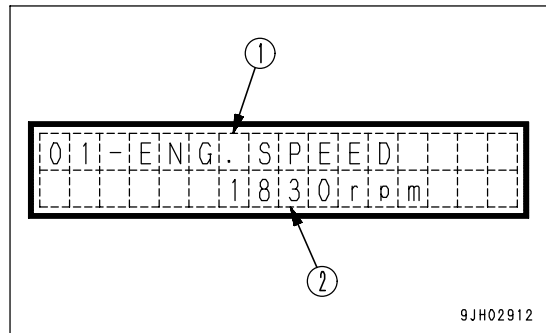

The display items consist of the seven items in the table below. The items can be selected by operating the information switch (<, >).

Display	Item	Measured value
01-ENG SPEED	Engine rotation speed	Rotation (rpm)
02-COOLANT TEMP.	Engine cooling water temperature	Temperature (°C)
05-BOOST PRESS.	Boost pressure	Pressure (kPa)
06-BOOST TEMP.	Boost temperature	Temperature (°C)
07-T/C TEMP.	Power train oil temperature	Temperature (°C)
08-HYD TEMP.	Work equipment oil temperature	Temperature (°C)
13-BATTERY VOLT.	Battery voltage	Voltage (mV)

REMARK

- Items such as the engine speed fluctuate and are difficult to see during the measurement. In such cases, operate the buzzer cancel switch to ◊. This makes it possible to hold the display of the value.
- To cancel this mode, operate the buzzer cancel switch again to ◊.
- To return to the maintenance mode, operate the buzzer cancel switch to ■.

METHOD OF USING FAULT CODE DISPLAY MODE

NOTICE

The fault items observed by this function are connected with the electronic control, so even if a fault code is not displayed, there is probably some problem with the machine. If the operator feels any problem with the machine, the machine should be stopped immediately and checked.

When any disconnection or short circuit in any sensor is detected, the location and fault code are displayed by a 6-digit code on display panel B (multi-information). When contacting your Komatsu distributor, inform your distributor of the code at the same time.

If the failure observation function has not determined the condition of the machine, the display is as shown in the diagram on the right.

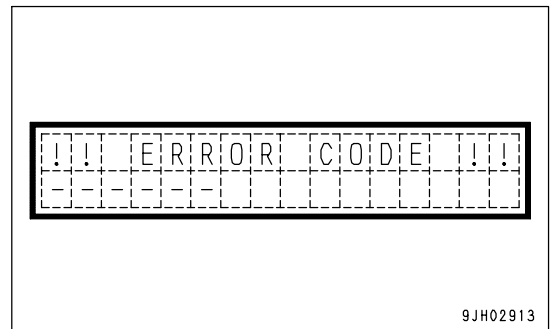

With this function, existing failures can be displayed up to a maximum of 20 items.

If multiple failures are occurring, the display automatically changes every 2 seconds, so check the code (1).

The display is shown repeatedly.

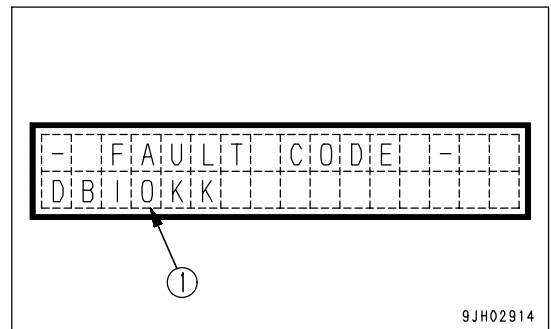

REMARK

To return to the maintenance mode, operate the buzzer cancel switch to ■.

METHOD OF USING USER ADJUST MODE

The adjust mode has functions of changing the intensity of the panel backlight and the contrast of LCD panel. They are shown in display B.

1. Adjusting backlighting of liquid crystal display

- 1) The diagram on the right is the mode for adjusting the brightness of the backlighting of the liquid crystal panel. This display will be switched to the screen brightness adjustment display, if the alarm buzzer cancellation switch is turned to the \diamond position.

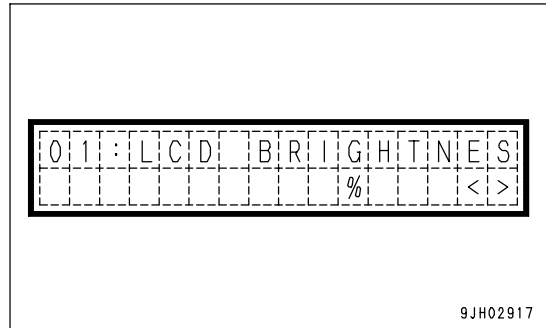

- 2) The brightness can be adjusted by operating the information switch. The higher the number, the brighter the screen becomes; the lower the number, the darker the screen becomes.
 > position: Number increases
 < position: Number decreases

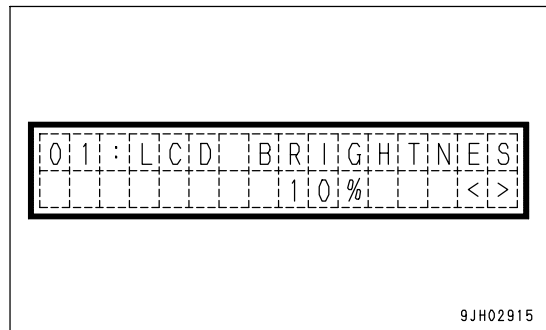

- 3) The brightness of the backlight for the LCD gauges may be held constant by turning the alarm buzzer cancellation switch to the \diamond position.

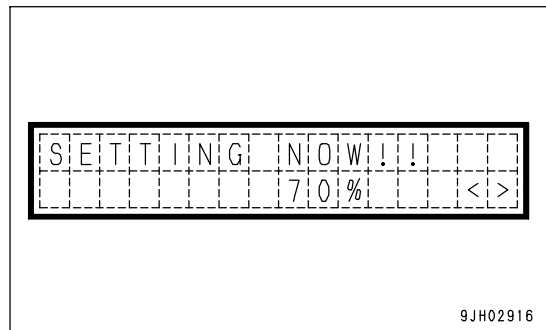

REMARK

- To return to the maintenance mode, operate the buzzer cancel switch to \blacksquare .
- The brightness of the backlighting of the monitor panel differs according to whether the front lamp is lit or not. Entering this mode when the front lamps are lit makes it possible to adjust the brightness when the front lamps are lit. In the same way, entering this mode when the front lamps are not lit makes it possible to adjust the brightness when the front lamps are not lit.

2. Adjusting backlighting of display panel B (multi-information)

1) The diagram on the right is the mode for adjusting the brightness of the backlighting of the display panel B (multi-information).

On the screen, operate the buzzer cancel switch to \diamond to switch to the screen for adjusting the brightness.

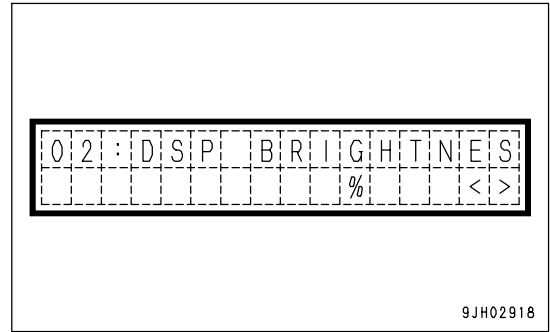

2) The brightness can be adjusted by operating the information switch.

The higher the number, the brighter the screen becomes; the lower the number, the darker the screen becomes.

> position: Number increases

< position: Number decreases

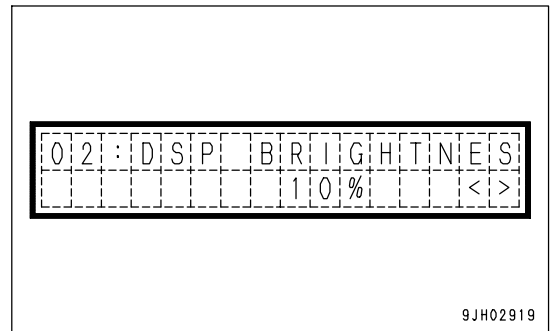

3) When the buzzer cancel switch is operated to \diamond , the brightness of the display panel B (multi-information) backlighting is set.

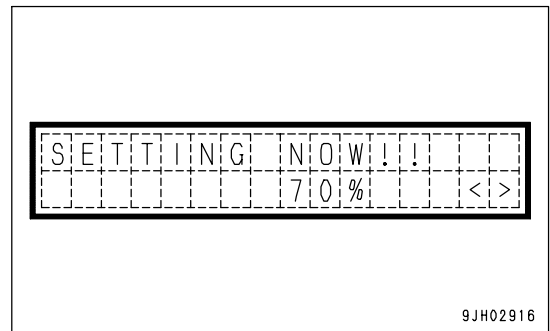

REMARK

- To return to the maintenance mode, operate the buzzer cancel switch to \blacksquare .
- The brightness of the backlighting of the monitor panel differs according to whether the front lamp is lit or not. Entering this mode when the front lamps are lit makes it possible to adjust the brightness when the front lamps are lit. In the same way, entering this mode when the front lamps are not lit makes it possible to adjust the brightness when the front lamps are not lit.

3. Adjusting contrast of liquid crystal display panel B (multi-information)

1) The diagram on the right is the mode for adjusting the contrast of the liquid crystal display panel B (multi-information).

On this screen, operate the buzzer cancel switch to \diamond to switch to the screen to adjust the contrast.

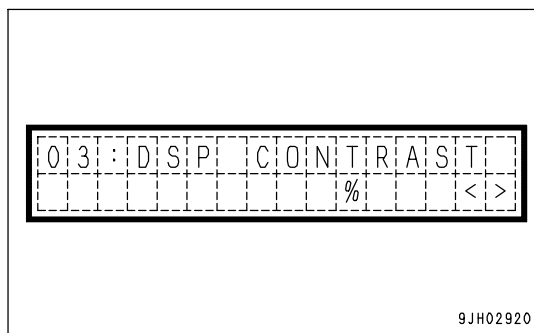

2) The contrast can be adjusted by operating the information switch.

The higher the number, the deeper the screen becomes; the lower the number, the lighter the screen becomes.

- > position: Number increases
- < position: Number decreases

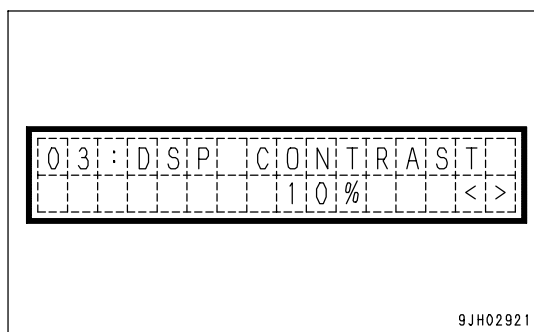

3) When the buzzer cancel switch is operated to \diamond , the contrast of the liquid crystal display panel B (multi-information) is set.

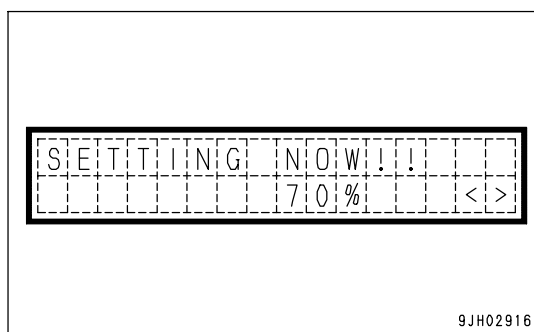

REMARK

To return to the maintenance mode, operate the buzzer cancel switch to \blacksquare .

SWITCHES

Machine equipped with cab

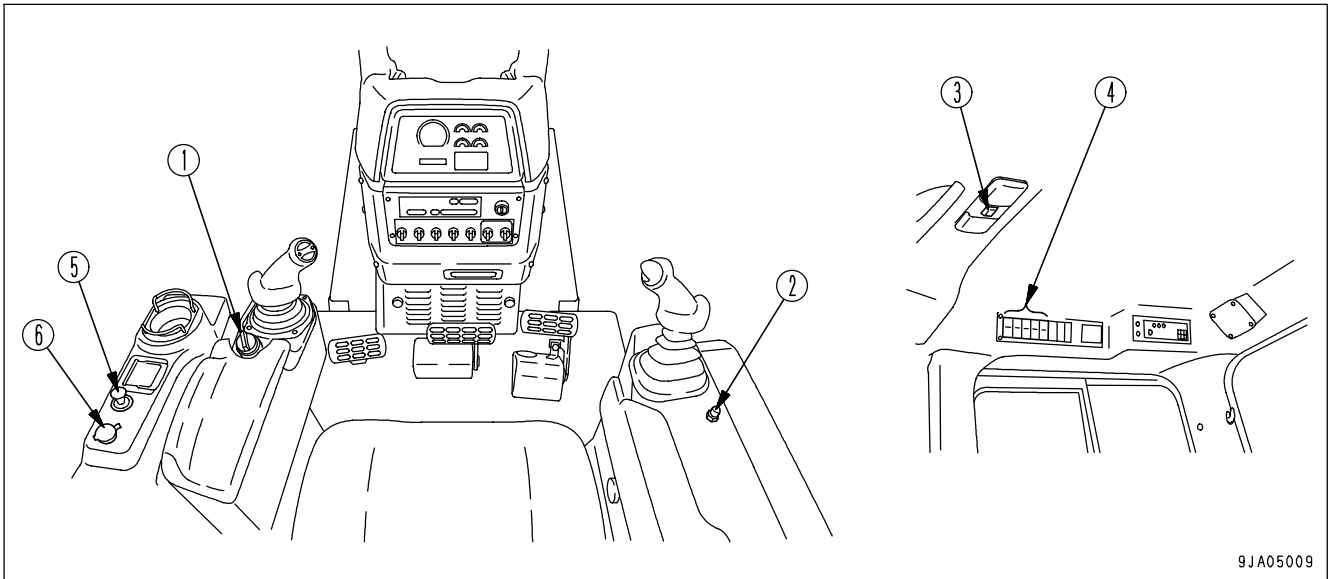

9JA05009

Machine equipped with ROPS canopy

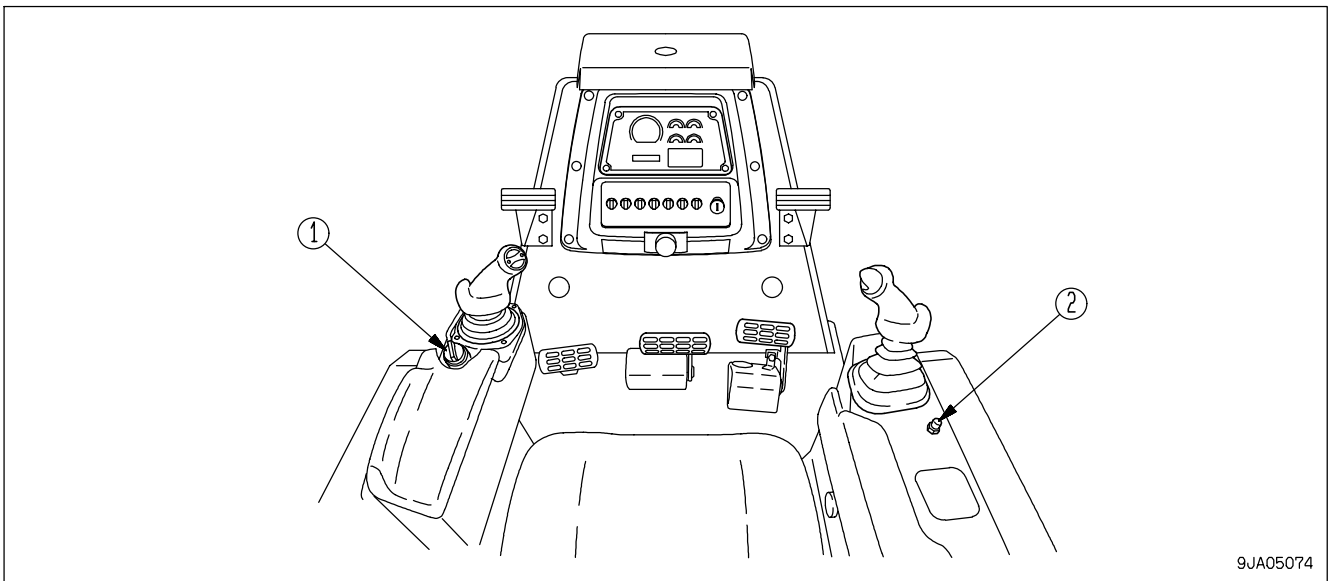

9JA05074

- (1) Fuel control dial
- (2) Horn switch
- (3) Room lamp switch

- (4) Wiper switch
- (5) Cigarette lighter
- (6) Accessory socket

FUEL CONTROL DIAL

Dial (1) is used to control the engine speed and output.

(a) Low idling position: Turn fully to the left

(b) High idling position: Turn fully to the right

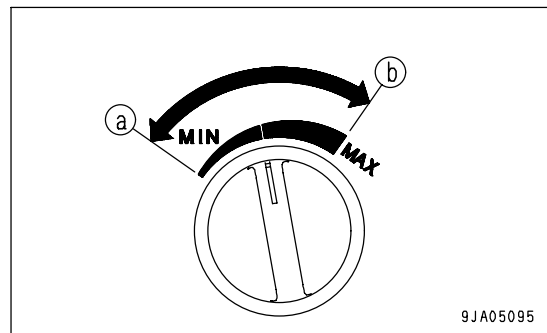
**HORN SWITCH**

The horn sounds when the button (2) at the rear of the blade control lever at the right side of the operator's seat is pressed.

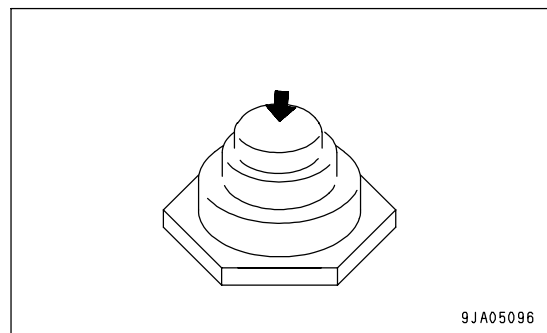
**ROOM LAMP SWITCH**

This (3) illuminates the room lamp.

(A) ON position: Lamps light up

(B) OFF position: Lamps are out

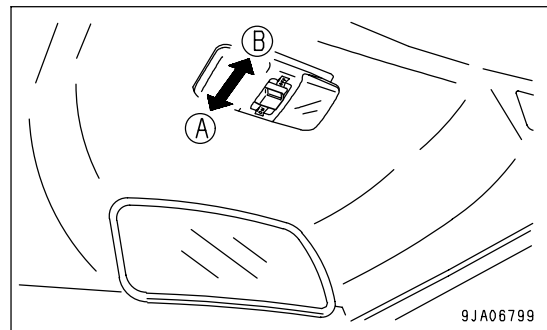

WIPER SWITCH

This (4) activates the wipers.

The wiper switches are as follows:

- (A): Left door (LH)
- (B): Front window (FF)
- (C): Right door (RH)
- (D): Rear window (RR)
- (E): Wiper intermittent operation switch (INT)

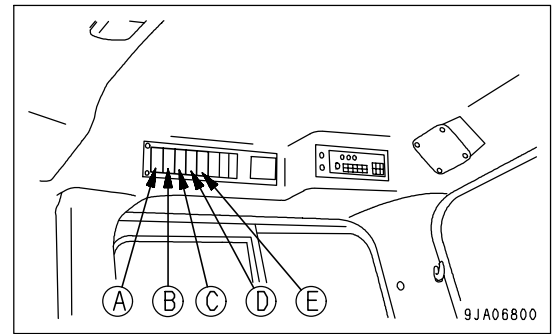

This is also used as the window washer switch.

The switch is operated as follows.

- Wiper only
 - (J) ON position: Wiper is operated
 - (K) OFF position: Wiper stops

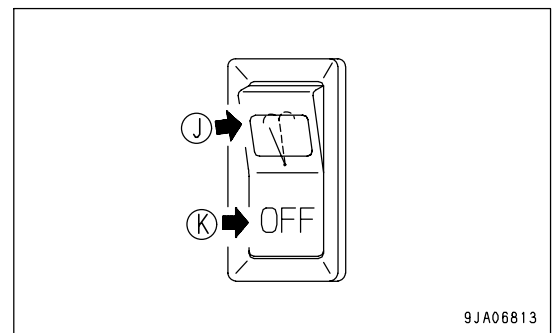

- Wiper and window washer
 - If this is kept pressed to the ON position (J) while the wiper is working, water will be sprayed out.

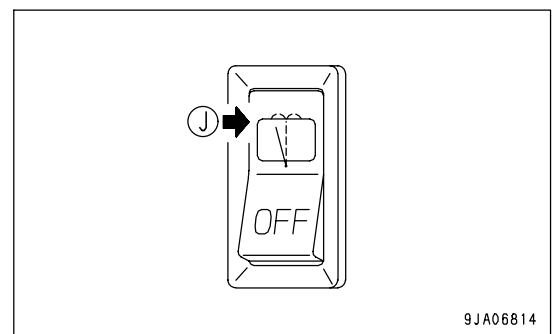

- Only wind washer
 - If this is kept to the OFF position (K), water will be sprayed out.

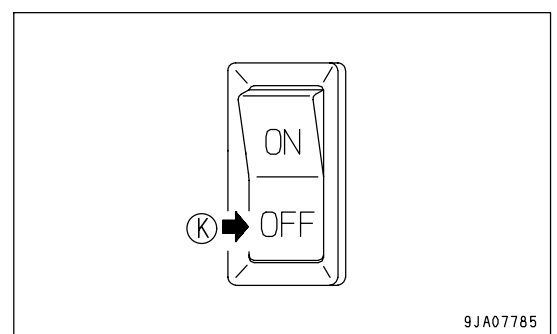

- Wiper intermittent operation switch

When this switch is turned to the ON position (J) to start the wiper moving, the wiper works once in every four seconds.

REMARK

When the wiper intermittent operation switch is ON position (J), if the wiper switch for each window is turned ON position (J), the wiper will move intermittently.

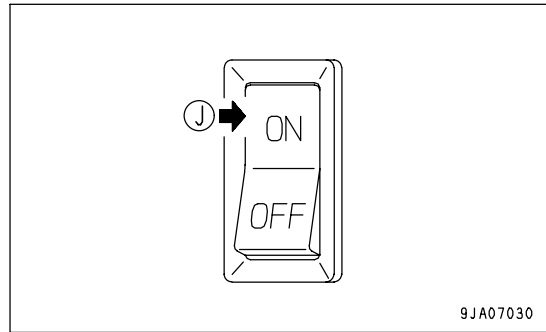
**CIGARETTE LIGHTER**

This (5) is used to light cigarettes.

When the cigarette lighter is pushed in, it will return to its original position after a few seconds, so take it out to light your cigarette.

If the cigarette lighter is removed, the socket can be used as a power source.

NOTICE

This cigarette lighter is 24V. Do not use it as the power supply for 12V equipment. This will cause failure of the equipment.

The capacity of the cigarette lighter is 120W (24V x 5A).

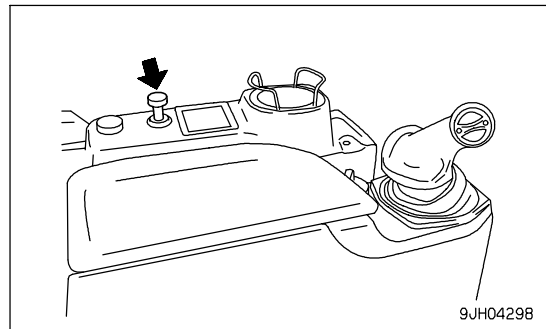
**ACCESSORY SOCKET**

This (6) is used as the power source for a wireless or other 12V equipment.

Accessory socket capacity: 60W (12V x 5A)

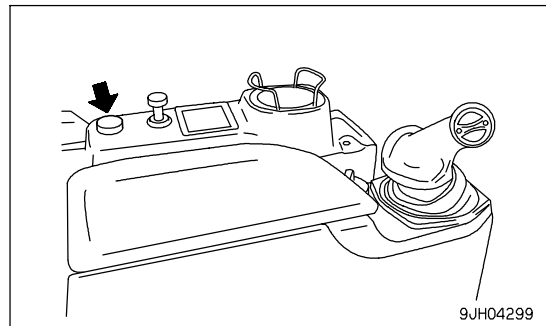

CONTROL LEVERS AND PEDALS

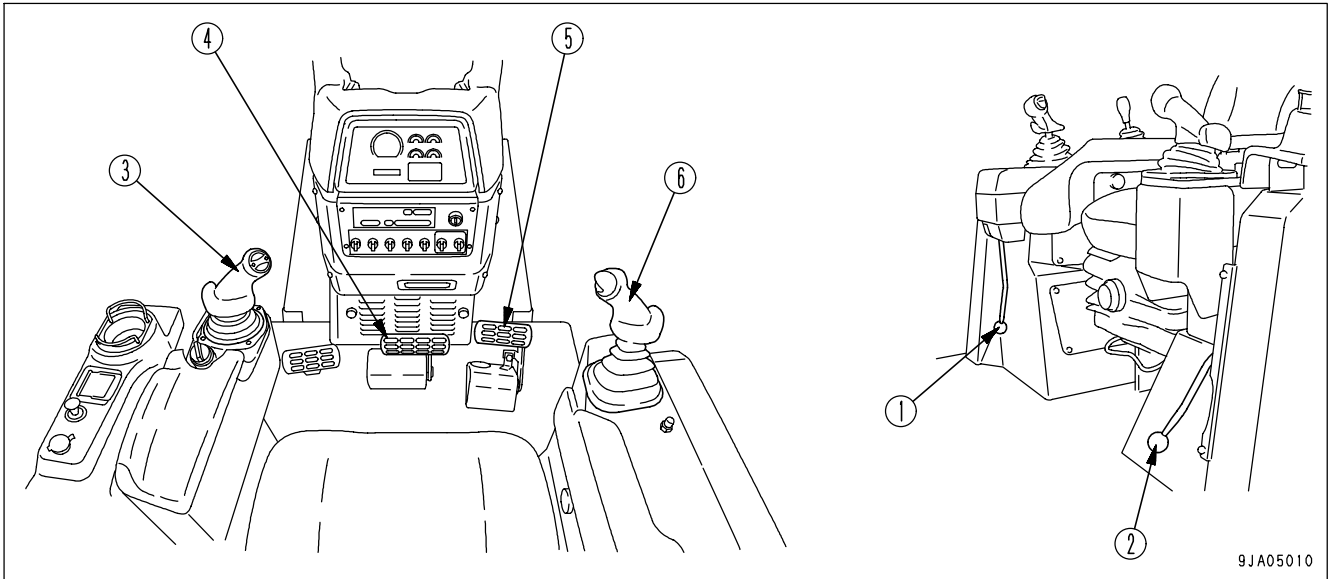

- | | |
|---|-------------------------|
| (1) Work equipment lock lever | (4) Brake pedal |
| (2) Parking brake lever | (5) Decelerator pedal |
| (3) Steering, forward-reverse, gear shift lever | (6) Blade control lever |

WORK EQUIPMENT LOCK LEVER



- When leaving the operator's compartment, set the work equipment lock lever securely to the LOCK position. If the work equipment lock lever is not at the LOCK position and the control levers are touched by mistake, it may lead to serious personal injury.
- If the work equipment lock lever is not set securely to the LOCK position, the work equipment may move and cause serious injury. Check that it is in the position shown in the diagram.
- When parking the machine or when carrying out maintenance, always lower the work equipment to the ground, then set the work equipment lock lever to the LOCK position.

This lever (1) is a lock device for the work equipment control lever.

(L) LOCK position: Work equipment does not move even when work equipment control lever is operated

(F) FREE position: Work equipment moves according to operation of work equipment control lever

REMARK

When starting the engine, to ensure safety, always set the work equipment lock lever to the LOCK position.

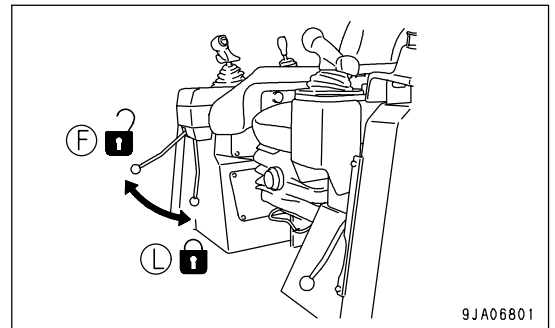

PARKING BRAKE LEVER

**WARNING**

- When parking the machine, always set the parking brake lever in the LOCK position.
- If the parking brake lever is operated, the brake is applied, even when the machine is traveling.
The machine will suddenly stop, so this is dangerous. For this reason, do not operate the parking brake lever when the machine is moving, except in emergencies.

This lever (2) is the control lever for the parking brake.

(L) LOCK position: Parking brake is applied

(F) FREE position: Parking brake is released

REMARK

- Before moving the parking brake lever to the LOCK position, return the steering, forward-reverse, gear shift lever to the NEUTRAL position.
- When starting the engine, if the parking brake lever is not in the LOCK position, the limit switch is actuated and it is impossible to start the engine.

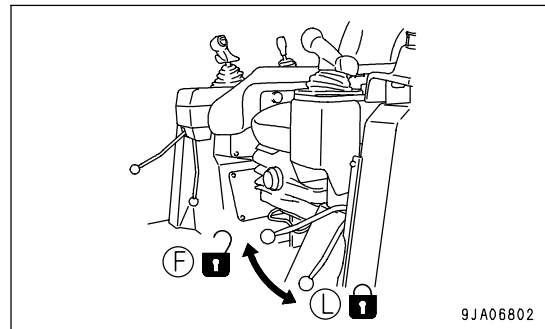
**STEERING, FORWARD-REVERSE, GEAR SHIFT LEVER**

This control lever (3) serves to change forward or reverse direction of machine travel, steer the machine to the right or left, change the traveling speed and make a counter-rotation.

- **Forward-reverse shifting**

Position (A): FORWARD

Position (B): REVERSE

Position (N): NEUTRAL

Operate the lever to the front to travel FORWARD.

Operate the lever to the rear to travel in REVERSE.

- **Steering**

Position (L): Left turn

Position (R): Right turn

If the lever is set in the forward or reverse travel position and moved to the left or right, the machine will turn in the direction that the lever is moved. The turning radius changes according to the amount that the lever is moved. If the lever is moved fully to the left or right, the turning radius will become smaller.

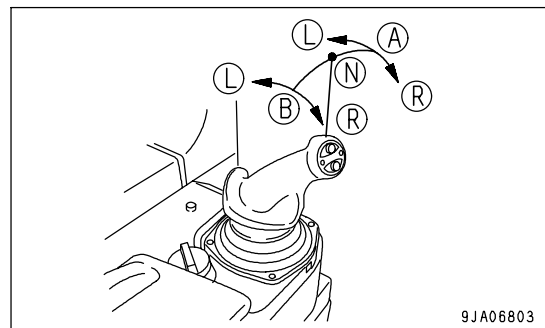
**REMARK**

When moving the joystick lever, and the lever is released, it will return to (A) or (B) and the machine will travel in a straight line.

• **Gear shifting**

When UP switch (U) or DOWN switch (D) is pushed, the transmission speed will change.

UP switch (U): Each time the switch is pressed, the transmission will up shift one speed.

DOWN switch (D): Each time the switch is pressed, the transmission will down shift one speed.

There are 3 forward and 3 reverse speed ranges.

For details of the maximum speed in each speed range, see "SPECIFICATIONS (PAGE 5-2)".

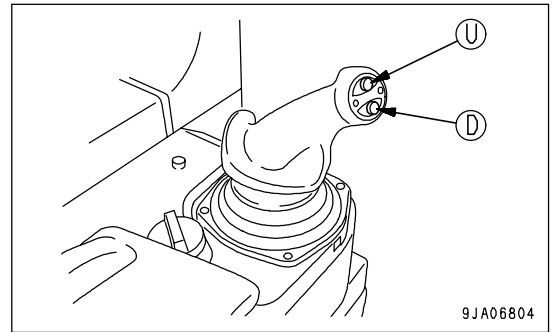

REMARK

The speed range being used is displayed on panel A on the monitor panel according to the gearshift operation.

<Example>

Neutral: N is displayed on the display panel.

FORWARD 2nd: F2 is displayed on the display panel.

REVERSE 3rd: R3 is displayed on the display panel.

When the parking brake lever is locked, P is displayed.

- For details of the method of shifting gears according to the shift mode, see the "SHIFTING GEARS (PAGE 3-99)". Shift mode selection means that the selected speed range is displayed at the NEUTRAL position (N) before starting.

• **Operating counter-rotation turn**

 **WARNING**

When operating the counter-rotation turn, if the load on the left and right is not balanced, the machine may make a pivot turn, so check the ground conditions and be careful not to hit any obstacles when carrying out the operation.

With the lever at the NEUTRAL position (N), move the lever partially in the direction of turn. The left and right tracks will rotate in opposite directions, and the machine will make a slow counterrotation turn. If the lever is operated further, the speed of the counterrotation turn will increase.

(R): Right counterrotation turn

(L): Left counterrotation turn

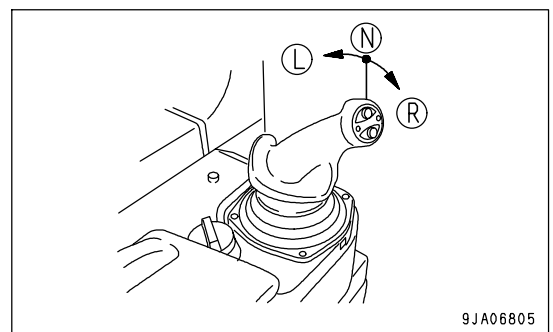

BRAKE PEDAL**WARNING**

Do not place your foot on this pedal unnecessarily.

Depress the pedal (4) to apply the right and left brakes.

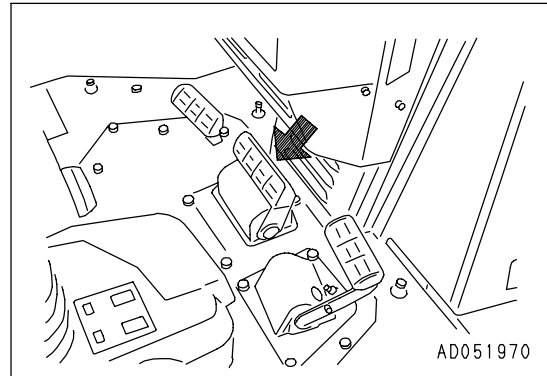
**DECELERATOR PEDAL****WARNING**

- Do not place your foot on this pedal unnecessarily.
- When passing over the top of a hill or when a load is dumped over a cliff, the load is suddenly reduced, so there is danger that the travel speed will also increase suddenly. To prevent this, depress the decelerator pedal to reduce the travel speed.

This pedal (5) is used when reducing the engine speed or stopping the machine.

When switching between forward and reverse, or when stopping the machine, use this pedal to reduce speed.

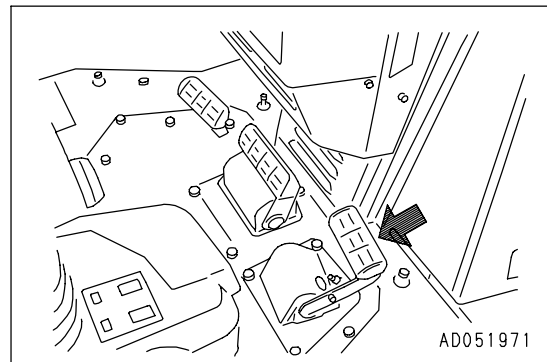

BLADE CONTROL LEVER

POWER TILTDOZER

This lever (6) is used to lift or tilt the blade.

- Lifting control
- (A) RAISE: Blade goes up
- (B) HOLD: Blade is stopped and held in this position.
- (C) LOWER: Blade goes down
- (D) FLOAT: Blade will move freely according to external force.

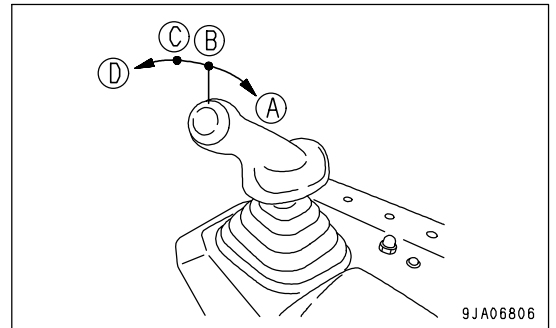

REMARK

- If the lever is in the FLOAT position, even when it is released, it does not return to the HOLD position, so return it by hand.
- If the engine is stopped when the control lever is in the FLOAT position, the lever is returned automatically to the HOLD position.
- In low temperatures, it may take a short time for the blade control lever to be held in the FLOAT position, so hold the lever in position for at least 1 second.

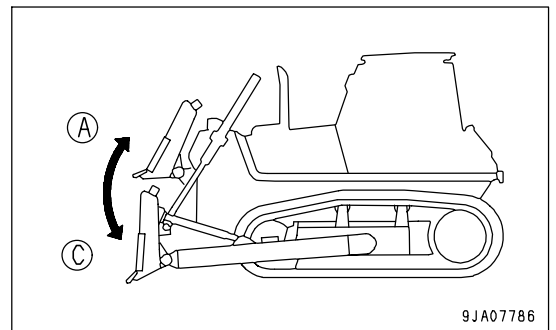

- Tilting control
- (B) HOLD: Blade is stopped and held in this position.
- (E) LEFT TILT
- (F) RIGHT TILT

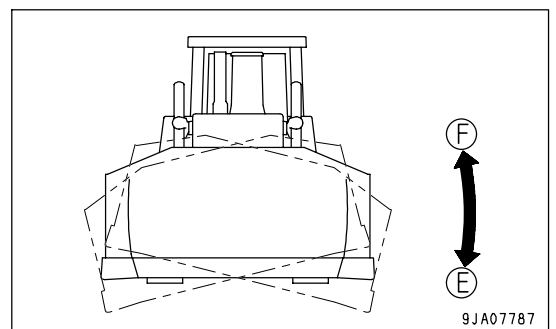
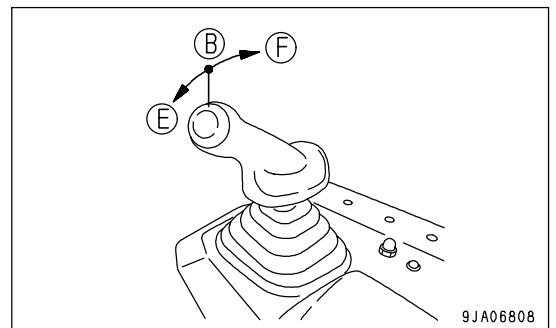

POWERTILT POWER PITCHDOZER

This lever (6) is used to lift or tilt and pitch the blade.

- Lifting control

- (A) RAISE: Blade goes up
- (B) HOLD: Blade is stopped and held in this position.
- (C) LOWER: Blade goes down
- (D) FLOAT: Blade will move freely according to external force.

REMARK

- If the lever is in the FLOAT position, even when it is released, it does not return to the HOLD position, so return it by hand.
- If the engine is stopped when the control lever is in the FLOAT position, the lever is returned automatically to the HOLD position.
- In low temperatures, it may take a short time for the blade control lever to be held in the FLOAT position, so hold the lever in position for at least 1 second.

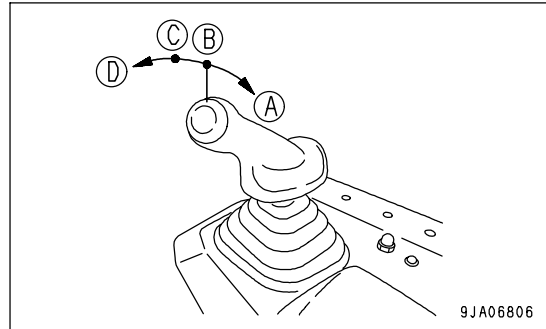

9JA06806

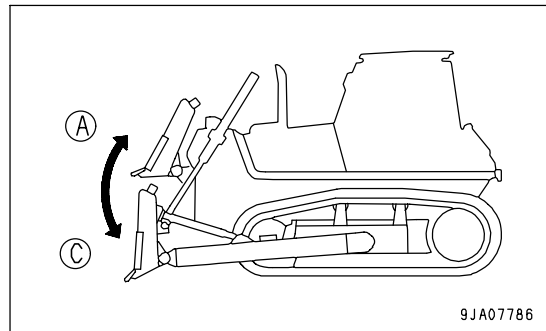

9JA07786

- Tilting control

- (B) HOLD: Blade is stopped and held in this position.
- (E) LEFT TILT
- (F) RIGHT TILT

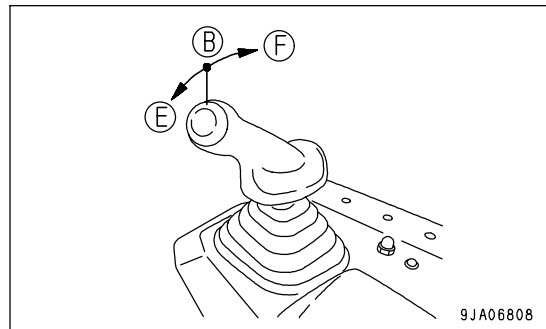

9JA06808

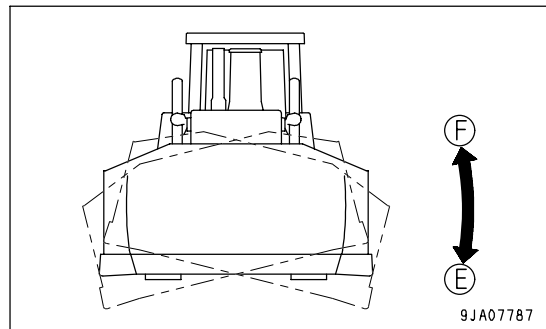

9JA07787

- Pitch control

After moving the lever to the neutral position without fail, tilt the blade while pressing any of the switches (M) in the center of the knob. Then the angle of the blade edge changes.

(B) Hold: The blade stops and holds a stationary posture.

(G) Rear pitch: Blade edge angle small

(H) Front pitch: Blade edge angle large

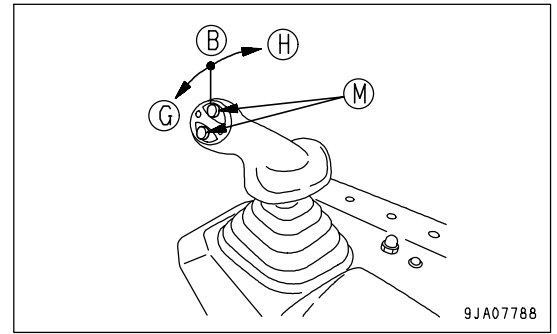

9JA07788

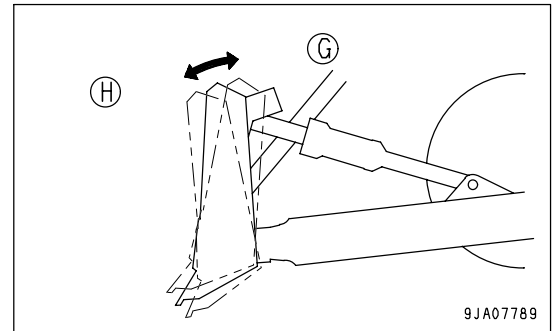

9JA07789

• Precautions when using pitch control

When using the pitch operation, the tilt operation changes as follows.

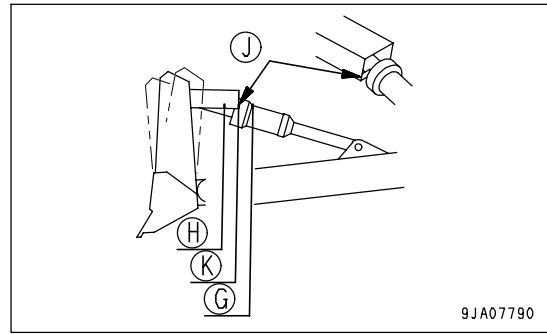

- (G) Rear pitch
- (H) Front pitch
- (J) Pitch gauge
- (K) Standard pitch

Pitch condition	Tilt operation	D65EX	D65PX	D65WX
		Amount of tilt		
Max. forward pitch	Only left tilt operation is possible	Max. 870 mm (34.3 in)	Max. 890 mm (35.1 in)	Max. 820 mm (32.3 in)
Forward pitch (H)		Compared with standard: LEFT tilt is LARGER RIGHT tilt is SMALLER		
Standard pitch (K)	Both left and right tilt operations are possible	460 mm (18.1 in) (both left and right)	450 mm (17.7 in) (both left and right)	410 mm (16.2 in) (both left and right)
Rear pitch (G)		Compared with standard: LEFT tilt is SMALLER RIGHT tilt is LARGER		
Max. rear pitch	Only right tilt operation is possible	Max. 870 mm (34.3 in)	Max. 890 mm (35.1 in)	Max. 820 mm (32.3 in)

ANGLE DOZER

This lever (6) is used to lift or tilt the blade.

- Lifting control
- (A) RAISE: Blade goes up
(B) HOLD: Blade is stopped and held in this position.
(C) LOWER: Blade goes down
(D) FLOAT: Blade will move freely according to external force.

REMARK

- If the lever is in the FLOAT position, even when it is released, it does not return to the HOLD position, so return it by hand.
- If the engine is stopped when the control lever is in the FLOAT position, the lever is returned automatically to the HOLD position.
- In low temperatures, it may take a short time for the blade control lever to be held in the FLOAT position, so hold the lever in position for at least 1 second.

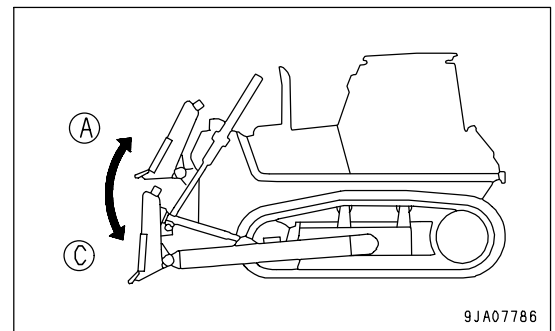
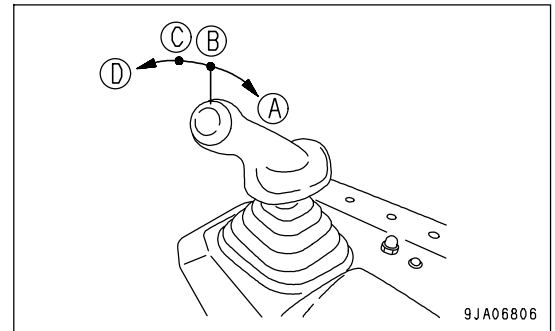

CIRCUIT BREAKER

NOTICE

- When resetting the circuit breaker, always turn off the power first (turn the starting switch OFF).
- If the reset button for the circuit breaker comes out immediately when it is pushed in, it is necessary to carry out an inspection of the electrical circuit.

If the starting switch does not work when it is turned to the ON position, the circuit has probably been cut off by the circuit breaker.

Inspect the circuit breaker.

REMARK

The circuit breaker is a device installed in electric circuits where a large current flows. It is installed to protect the electric circuit. It protects the electric components and wiring from damage caused by an abnormal current in the same way as a normal fuse. After repairing and restoring the location of the abnormality, there is no need to replace the breaker. It can be used again.

1. Open the cover at the bottom of the front panel. Circuit breakers (1) and (2) can be seen.
(Circuit breaker (2) is installed only on machines equipped with an air conditioner.)
2. When the circuit breaker has cut off the circuit, reset button (3) springs out.
Push reset button (3) in.

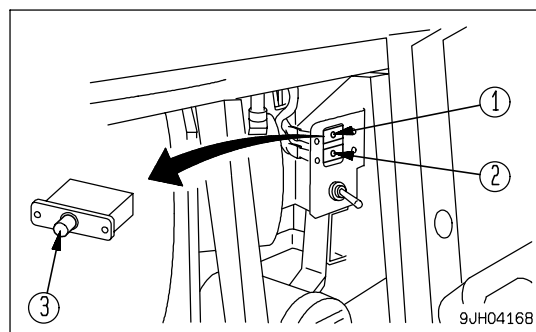

No	Fuse capacity	Circuit
(1)	20A	Starting switch
(2)	20A	Air conditioner

FUSE

NOTICE

Before replacing a fuse, be sure to turn starting switch to the OFF position.

The fuses protect the electrical equipment and wiring from burning out.

If the fuse becomes corroded, or white powder can be seen, or the fuse is loose in the fuse holder, replace the fuse.

Replace the fuse with another of the same capacity.

- Chassis

Fuse boxes (A) and (B) are installed under the battery cover.

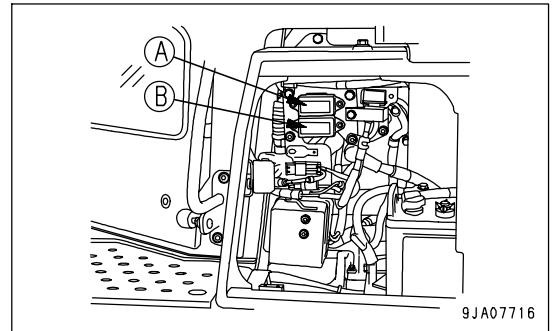

- Cab (machines equipped with cab)

Fuse box (C) is installed in the overhead panel.

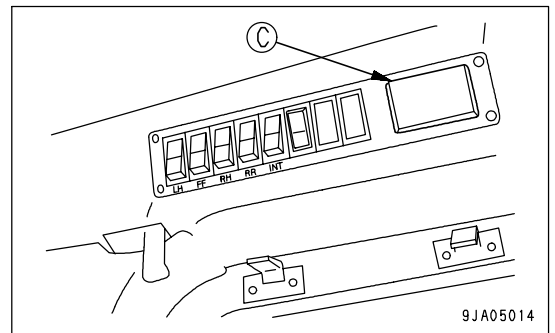

FUSE CAPACITY AND CIRCUIT NAME

Fuse box (A)

NO.	Fuse capacity	Circuit
(1)	20A	Spare power source
(2)	20A	Horn, Ribbon heater, Air suspension seat
(3)	20A	Front lamp, Rear lamp
(4)	20A	Transmission, Steering controller
(5)	5A	Engine controller

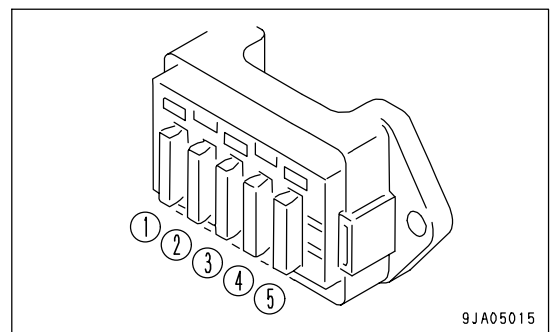

Fuse box (B)

NO.	Fuse capacity	Circuit
(1)	5A	Backup alarm
(2)	15A	Continuous power source
(3)	30A	Truck power source
(4)	30A	Engine power source
(5)	30A	Air conditioner

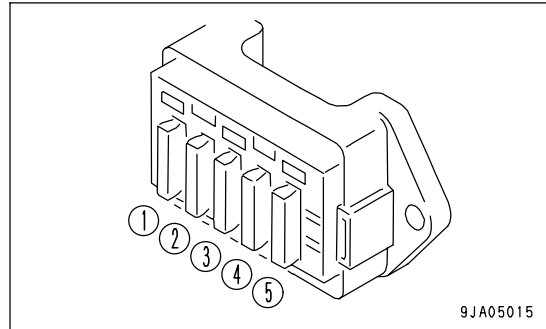

Fuse box (C)

NO.	Fuse capacity	Circuit
(1)	10A	Radio memory
(2)	20A	Radio, lamp, cigarette lighter
(3)	20A	Heated glass (if equipped)
(4)	10A	Rear wiper
(5)	10A	Front wiper
(6)	10A	Left and right door wiper

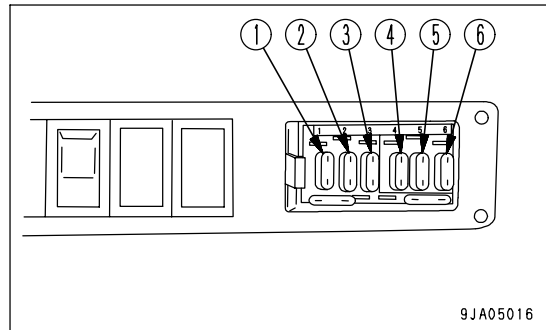

FUSIBLE LINK

If any of the electrical equipment in the operator’s cab does not work, a fusible link built in the wiring harness is suspected of disconnection. In that case, check the link and replace it with a new one, if necessary.

REMARK

A fusible link refers to the large-sized fuse wiring installed in the high current flow portion of the circuit to protect electrical components and wiring from burning, in the same way as an ordinary fuse.

When opening the battery cover on the left side of the truck, you can see fusible link (1) and (2).

Capacity of fusible link (1): 65A

Capacity of fusible link (2): 120A

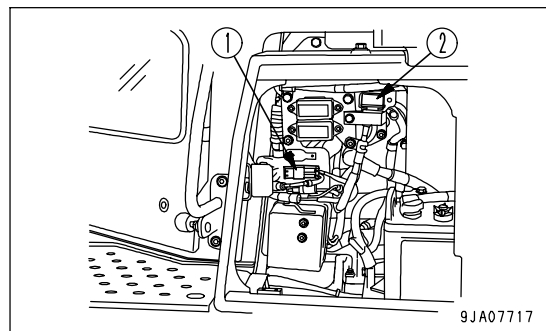

ELECTRIC POWER TAKE-OUT ADAPTER

MACHINE EQUIPPED WITH CAB

NOTICE

The power for the cigarette lighter is 24V. Do not use it as the power source for 12V equipment.

The cigarette lighter socket (1) can be used as a power source for 24V equipment and the accessory socket (2) can be used for 12V equipment.

Capacity of cigarette lighter : 120W (24V x 5A)

Capacity of accessory socket : 60W (12V x 5A)

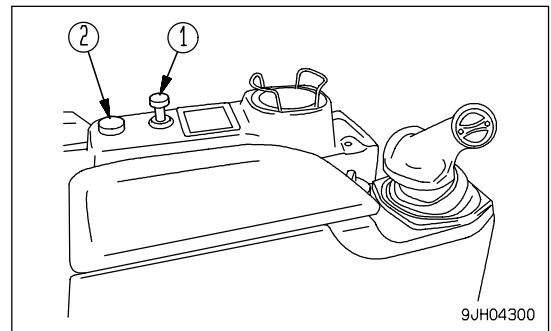

MACHINE EQUIPPED WITH ROPS CANOPY

NOTICE

- Do not use as a power supply for 12V equipment.
This will cause failure of the equipment.
- When using as a power supply pickup, do not install equipment which exceeds 120W (24V x 5A).

1. Open the battery cover on the left side of the machine body.
2. There is the connector for the spare power take-off.
(Connector CN800 (3) can be used.)

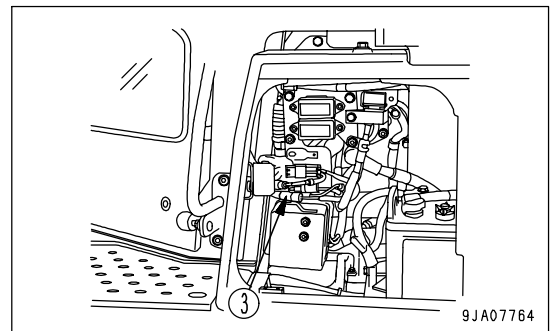

CAP WITH LOCK

Lock-type caps are available for the hydraulic tank oil filler cap and fuel tank filler cap.
For details of the locations of the caps with locks, see "LOCKING (PAGE 3-116)".

Use the starting switch key to open and close the locks on the caps.

METHOD OF OPENING HYDRAULIC CAP

OPENING THE CAP

1. Insert the key. Make sure that you have inserted the key fully (1) before turning it. If the key is turned when only partially inserted, it may break.

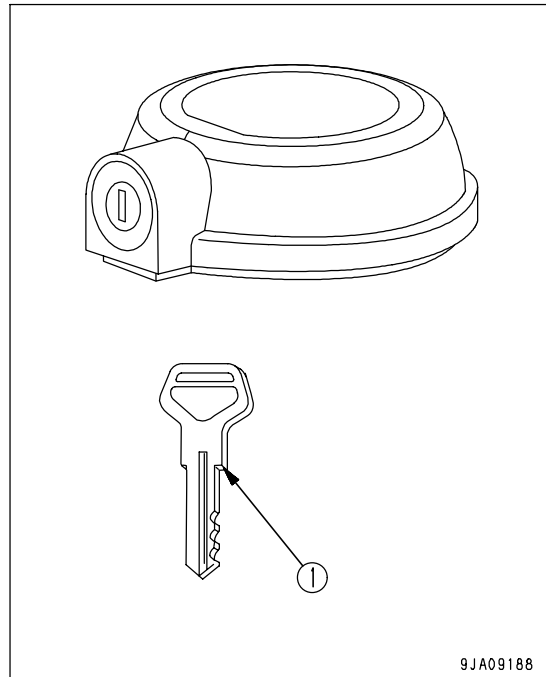

2. Turn the key counterclockwise 180° in direction (A). The cap can then be opened.
(A): Open
(B): Lock

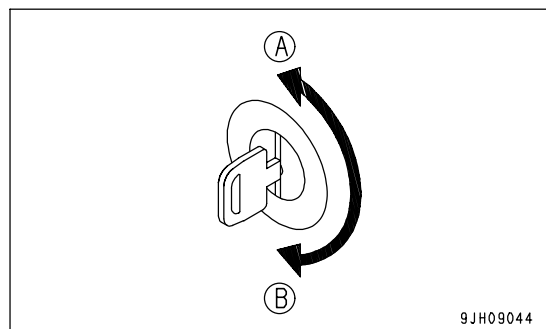

LOCKING THE CAP

1. Insert the key.
2. Turn the key clockwise in direction (B), then remove the key.

METHOD OF OPENING FUEL CAP

OPENING THE CAP

1. Insert the key. Make sure that you have inserted the key fully (1) before turning it. If the key is turned when only partially inserted, it may break.

(L) : Lock position

(F) : Open position

(A) : working angle of key 180°

(B) : 45°

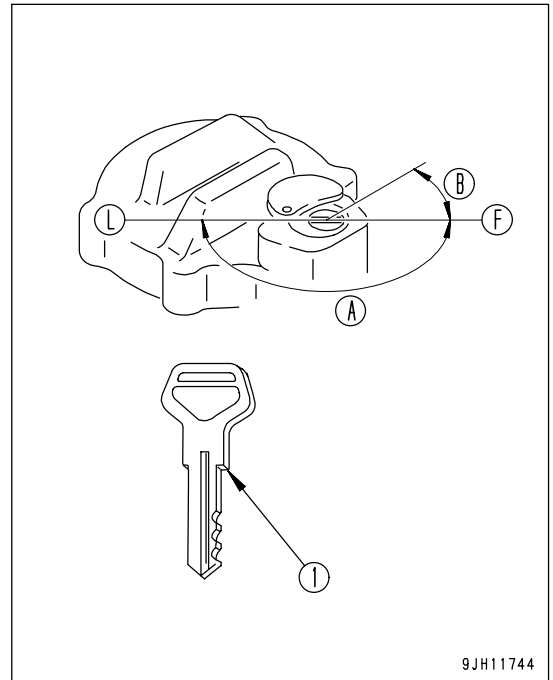

2. Turn the key counterclockwise to align the match mark (2) on the cap with the rotor groove, then turn the cap slowly. When a click is heard, the lock is released, enabling the cap to be opened.

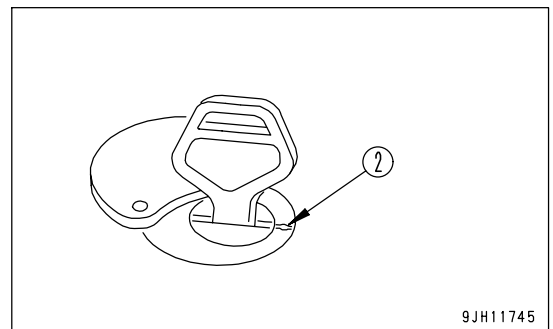

LOCKING THE CAP

1. Turn the cap into place.
2. Turn the key clockwise and take the key out.

DOOR - OPEN LOCK

(Machine equipped with cab)

Use this when you want to keep the door held open.

1. Push the door against the door catch (1). The door will be held by the door catch.

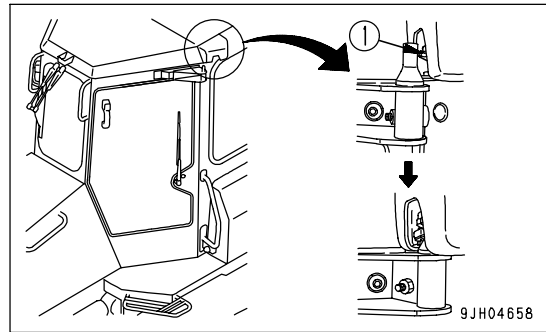

2. To release the door, move lever (2) inside the cab to the front of the cab. This will release the catch.

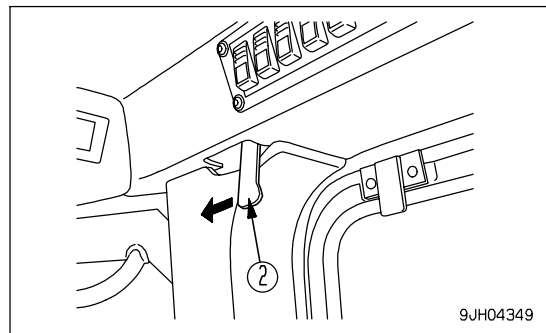

NOTICE

- When keeping the door open, fix it securely to the catch.
- Always close the door when traveling or carrying out operations. Leaving the door open will cause the door to break.
- Keep the door locked open securely. The door may swing closed because of the vibration.

SASH GLASS INTERMEDIATE LOCK

(Machine equipped with cab)

When working with the cab sash glass open, use this lock to prevent the glass from chattering.

- When the lever is in the FREE position (F), the glass can be opened or closed.
- When the lever is in the LOCK position (L), the glass is held in position.

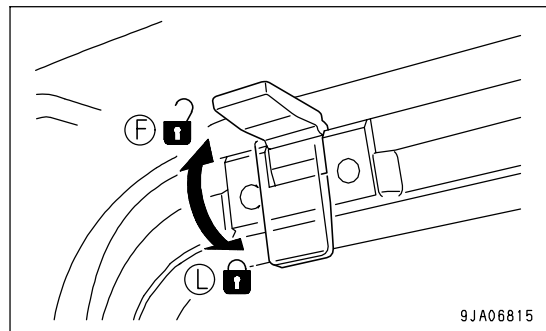
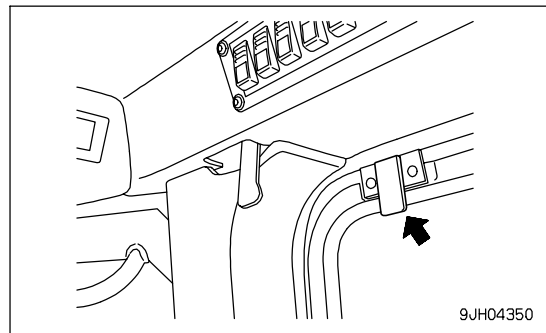

DOOR POCKET

(Machine equipped with cab)

This is inside the left and right doors. Use it for storing the Operation and Maintenance Manual or other things.

Do not put heavy tools or other heavy objects in it.

If the pocket is dirty, turn 4 clips (1), then remove the pocket and rinse it.

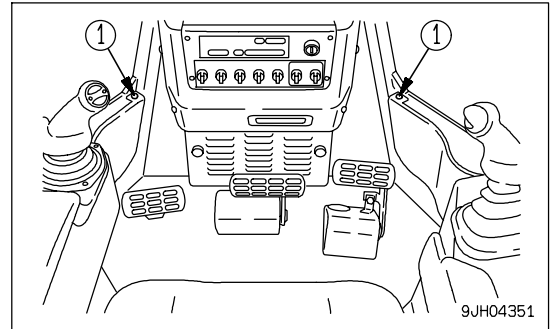

OPENING AND CLOSING ENGINE SIDE COVER

When opening

Pull door release lever (1) to release the lock, then pull the cover up.

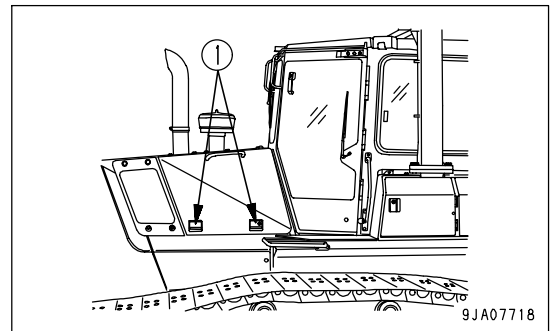

When closing

NOTICE

When closing the cover, always release the gas damper lock first.

If the gas damper lock is not released and any attempt is made to close the cover, the gas damper may break.

Push the orange button in the center of the gas damper (1) to release the lock, then push the cover down.

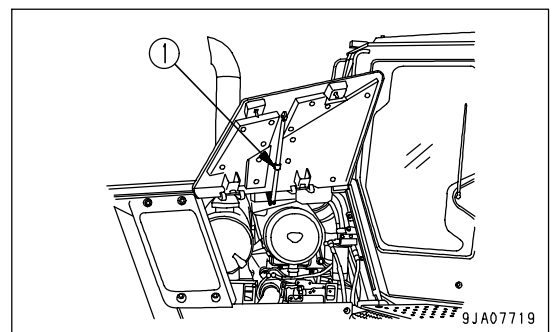

ASHTRAY

This is on the left side of the operator's seat.

Always make sure that you extinguish the cigarette before closing the lid.

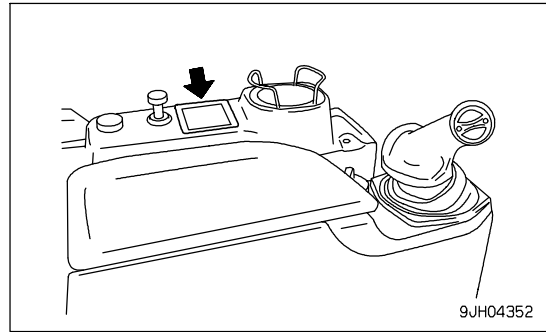

CUP HOLDER

(If equipped)

This is the place to put cans or cups.

If drinks are put in places other than the cup holder, the can or cup will fall over and make the surrounding area or equipment dirty.

Please make full use of the cup holder.

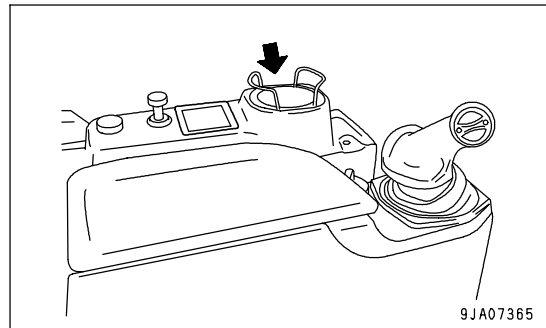

TOOL BOX

The tool box is inside the battery check cover at the rear left.

Keep the tools in this box.

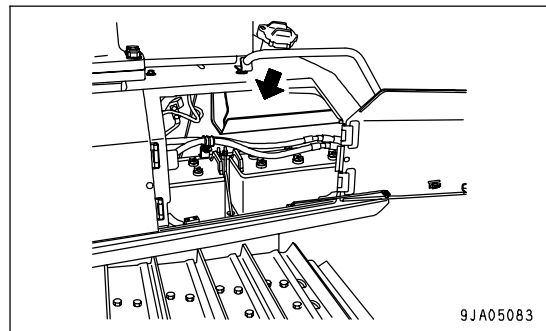

SHOVEL HOLDER

(If equipped)

This can be used for storing a shovel with a rounded blade.

- Method of installing

1. Position the shovel with stopper(1) and holder(2).
2. Tighten the adjustment nut (3) so the shovel does not move.

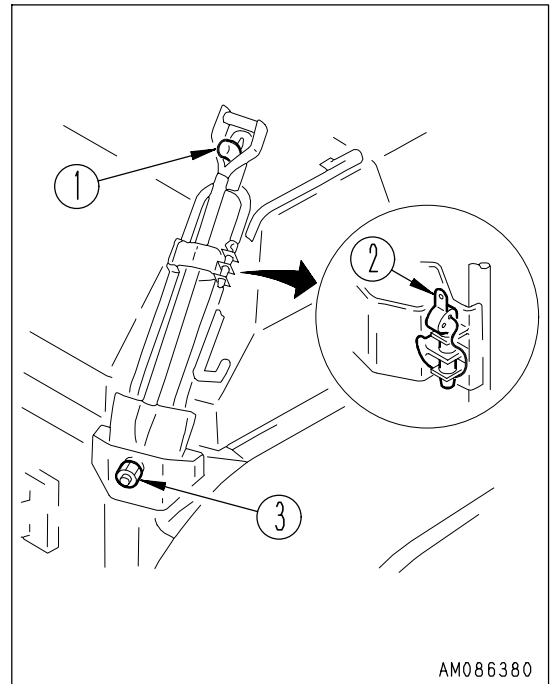

CAR STEREO, HANDLING

(Machine equipped with cab) (If equipped)

EXPLANATION OF COMPONENTS

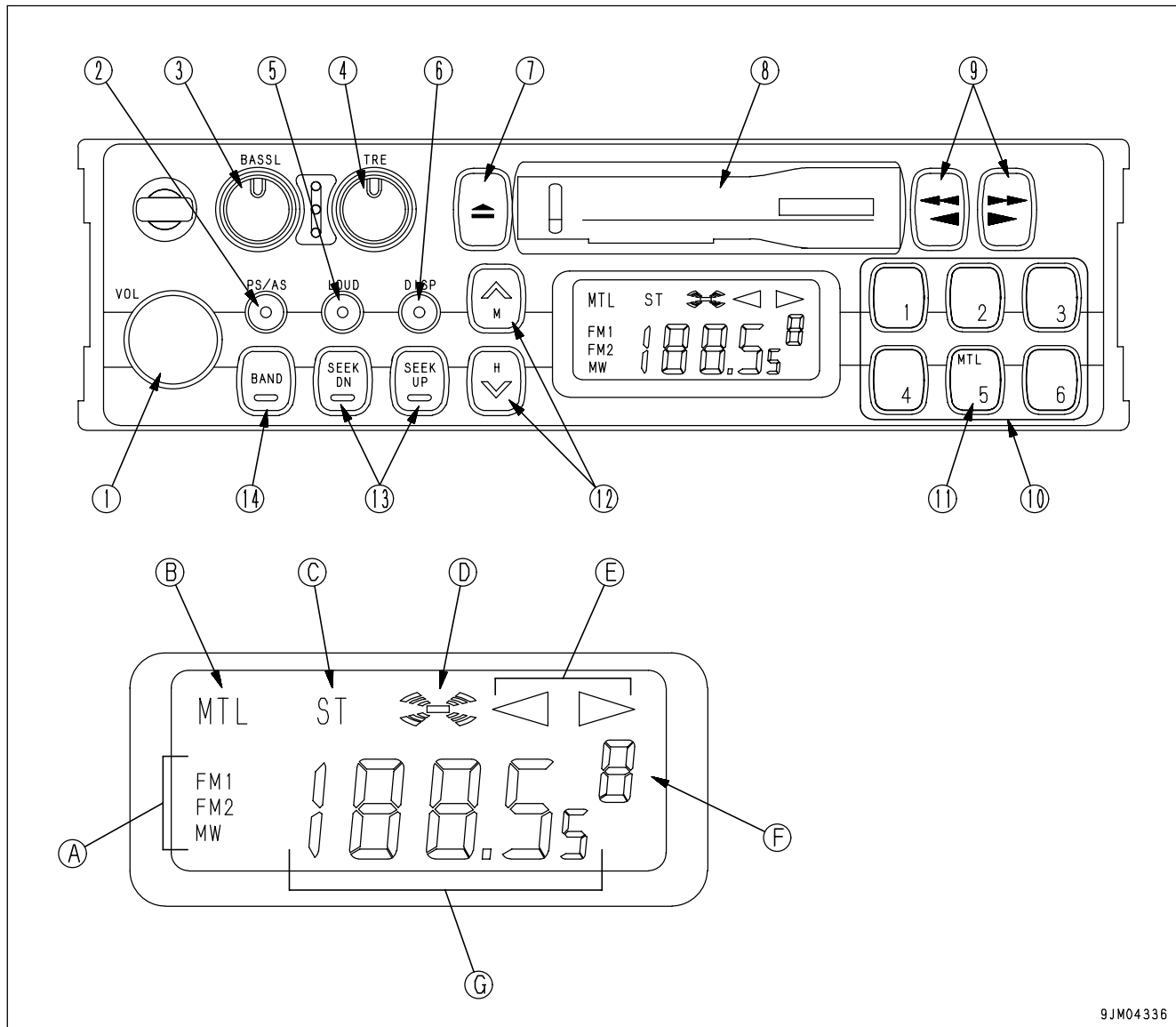

9JM04336

- | | |
|--|----------------------------------|
| (1) Power switch/volume | (8) Cassette door |
| (2) Auto-store/preset scan button | (9) Fast forward, rewind buttons |
| (3) Bass control knob | (10) Preset buttons |
| (4) Treble control knob | (11) Metal tape button |
| (5) Loudness button | (12) Manual tuning buttons |
| (6) Time/radio display selector button | (13) Seek tuning buttons |
| (7) Tape eject button | (14) Band selector button |
| (A) Band display | (E) Tape direction display |
| (B) Metal tape display | (F) Preset channel display |
| (C) FM stereo reception display | (G) Time/frequency display |
| (D) Loudness display | |

POWER SWITCH/VOLUME

Turn this knob (1) to the right until it clicks to turn the power on.
Turn it further to increase the volume.

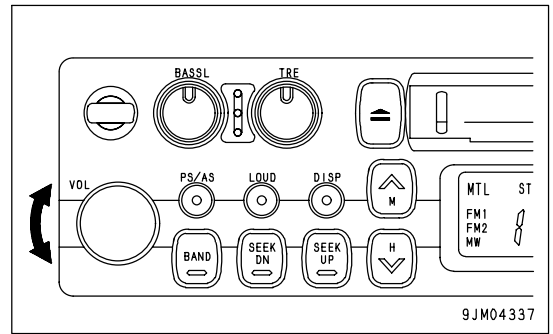

AUTO-STORE/PRESET SCAN BUTTON

Use this button (2) to actuate the preset scan and auto-store functions.

- Auto-store
Each time this button is pressed for more than 2 seconds while in radio reception, this auto-store function automatically starts to search for the desired station within a receivable band, and memorize the frequency in the preset memory. During this scanning process, the frequency shown in the right side of display continues to change. This indicates that each frequency is memorized in the auto-store.

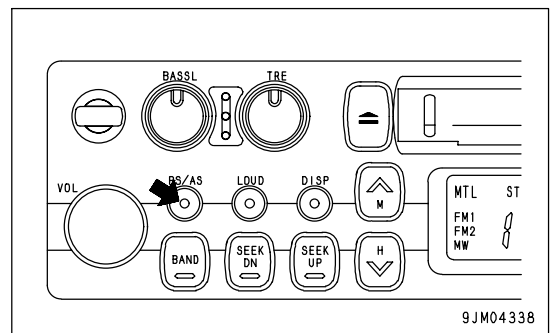

REMARK

The auto-store function cannot be used when the channel display is flashing.

When the display is flashing, the preset scan function is being used.

- Preset scan
If this button is pressed for less than 0.5 second while in radio reception, programs from the six preset stations in the same band will be broadcast one after another for 5 seconds each, starting from No. 1 through No. 6 stations consecutively.
When the desired station is found, press the button again. This stops the preset scan tuning process and switches to ordinary broadcasting. The same process will be repeated continuously until the button is pressed again.

BASS CONTROL KNOB

Turn this button (3) to the left to reduce the low tones; turn it to the right to emphasize the low tones.

- Direction (a): Low tone reduced
- Direction (b): Low tone emphasized

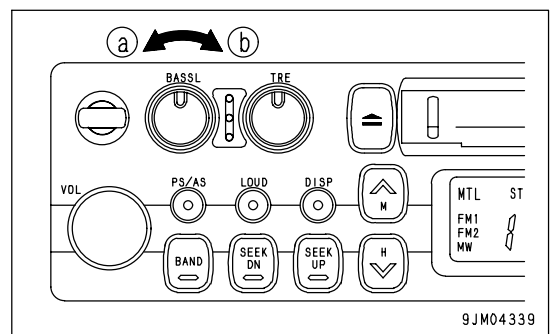

TREBLE CONTROL KNOB

Turn this button (4) to the left to reduce the low tones; turn it to the right to emphasize the high tones.

Direction (a): High tone reduced

Direction (b): High tone emphasized

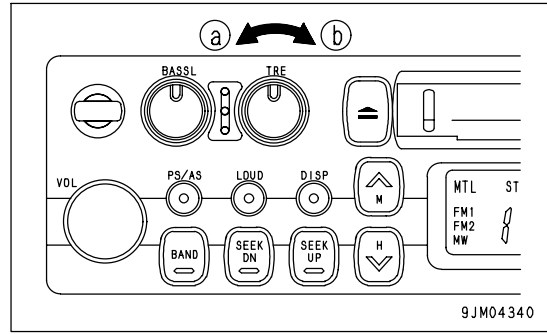

LOUDNESS BUTTON

This button (5) is used when playing at low volume. It makes it possible to hear more easily by emphasizing the low tone when the low tones are weak.

Push button: Actuated (ON)

Push button again: Canceled (OFF)

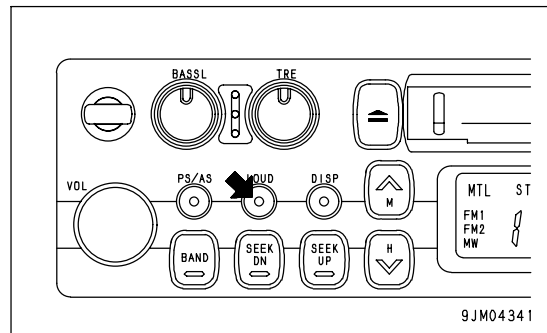

TIME/RADIO DISPLAY SELECTOR BUTTON

This button (6) is used to switch between the "Radio/tape display" and the "Time display".

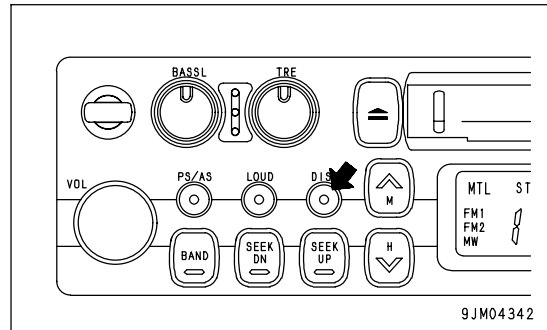

• Correcting the time

Press the button to set the time display.

(A) Correcting hour:

Keep the DISP button pressed and press the bottom (H) of the TUNING button to correct the hour.

(B) Correcting minute:

Keep the DISP button pressed and press the top (M) of the TUNING button to correct the minute.

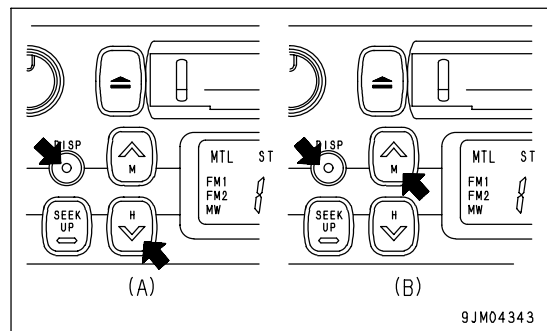

TAPE EJECT BUTTON

This button (7) is used to stop the tape and to eject the cassette. When this button is pressed, the tape is ejected and the radio plays.

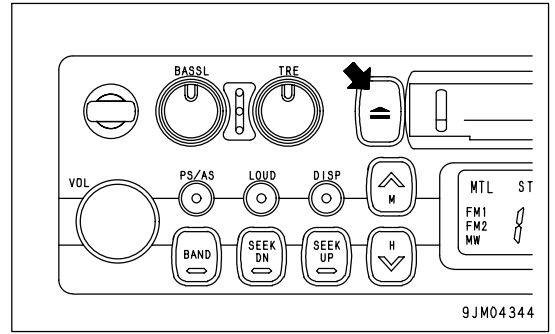

CASSETTE DOOR

Set the cassette with the exposed portion of the tape on the right side and insert it through the cassette door (8).

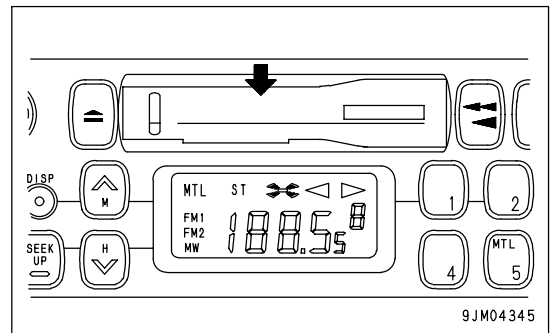

FAST FORWARD, REWIND BUTTONS

These buttons (9) are used to fast-forward or rewind the tape.

- Fast-forward/rewind

If you press the button pointing in the same direction as the lighted arrow indicating the direction of play, the tape will be fast-forwarded; if you press the button pointing in the opposite direction, the tape will rewind.

To stop the tape, lightly press the button that is not locked. The fast-forward or rewind operation will be canceled.

If the fast-forward and rewind buttons are pressed at the same time, the tape will change sides.

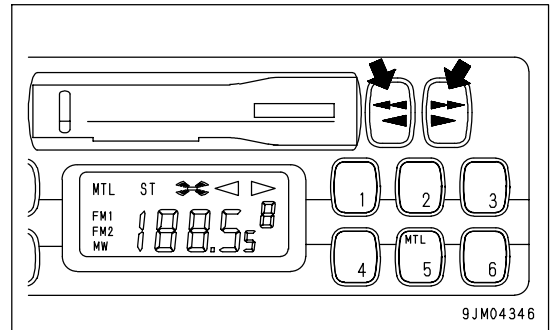

PRESET BUTTONS

These buttons (10) are used to call up the broadcast station frequencies preset in memory for each of buttons No. 1 to No. 6. It is possible to preset 18 stations (FM: 12; AM: 6) with these buttons.

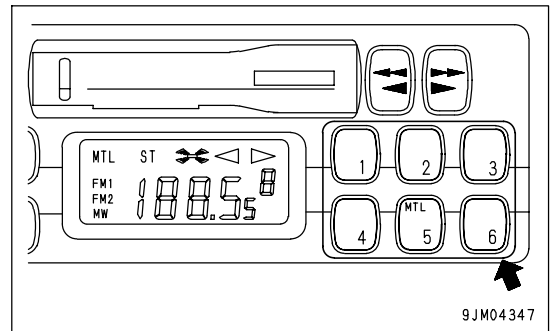

METAL TAPE BUTTON

(used also for preset button No. 5)

This button (11) is used when playing a metal or chrome tape. This button is also used for preset button No. 5. When it is pressed, "MTL" appears on the display.

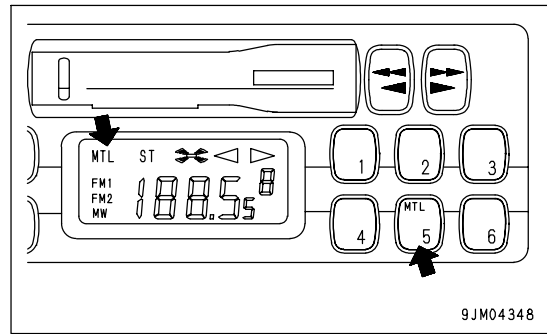

MANUAL TUNING BUTTONS

These buttons (12) are used for manual tuning.

When "TUN ^" button is pressed, the frequency goes up; when "TUN v" button is pressed, the frequency goes down. If the button is pressed down and held, the frequency will change continuously.

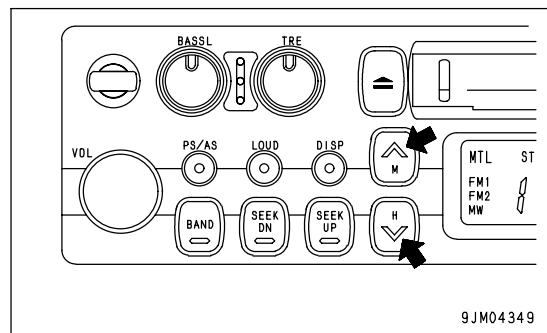

SEEK TUNING BUTTONS

These buttons (13) are used to seek tuning.

When the "SEEK UP" button is pressed, the search automatically goes up; when the "SEEK DN" button is pressed, the search automatically goes down.

When the next station that can be received is found, it automatically stops.

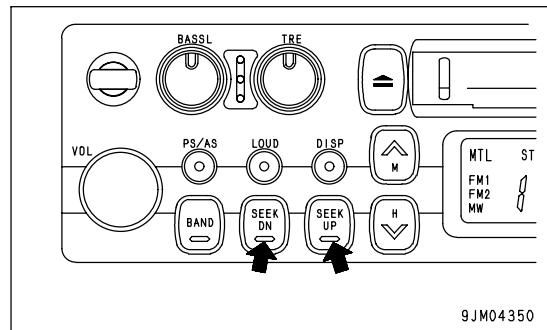

BAND SELECTOR BUTTON

When this button (14) is pressed, the band is switched between FM1, FM2, and MW (AM). The band is shown on the display.

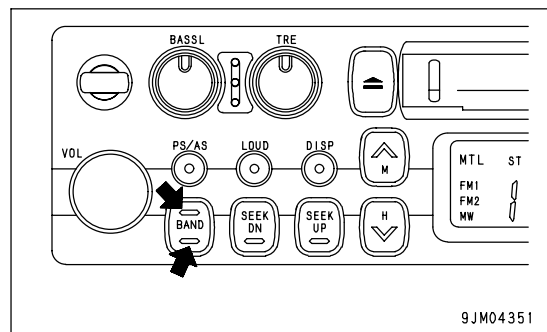

METHOD OF OPERATION

METHOD OF SETTING PRESET BUTTONS

It is possible to preset 6 MW (AM) stations and 12 FM stations (FM1: 6 stations, FM2: 6 stations).

REMARK

If you are playing the cassette, press the tape eject button to stop the tape.

METHOD OF AUTO PRESET

1. Use band selector button (1) to select MW (AM), FM1 or FM2.
2. Press auto-store/preset scan button (2) for less than 0.5 second.
3. The preset scan tuning function automatically searches for the desired station within the same band and can memorize as many as 6 stations in the preset memory.

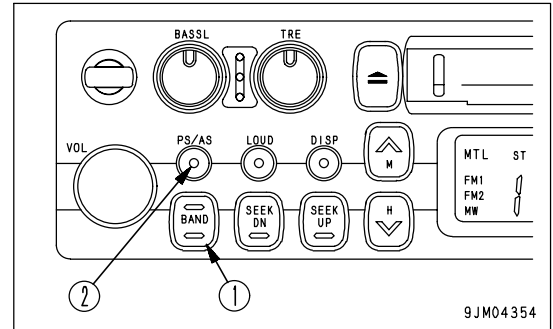

METHOD OF MANUAL PRESET

1. Use band selector button (1) to select MW (AM), FM1 or FM2.
2. Press manual tuning buttons (2) or seek tuning buttons (3).
3. Press preset button (4) of the number to be preset for 2 seconds while the frequency display is being shown on the display. (The preset channel and frequency are displayed and the presetting is completed).
4. Repeat the steps explained in Item 2 and 3 above to preset other stations to the subsequent numbers.
5. If you want to preset a station in the other bands, follow the steps explained in Item 1 through 4 above.

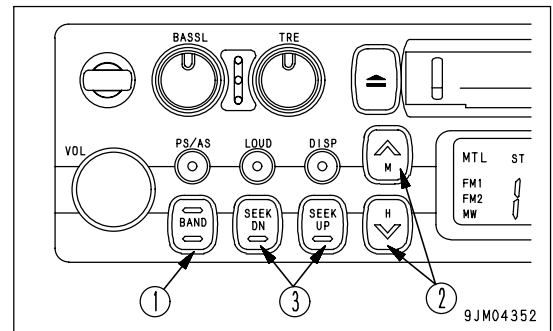

REMARK

- Also, use Steps 2 and 3 when changing the setting of a preset switch to another station.
- When the power is disconnected, such as when the battery is replaced, all the settings are deleted, so preset the stations again.

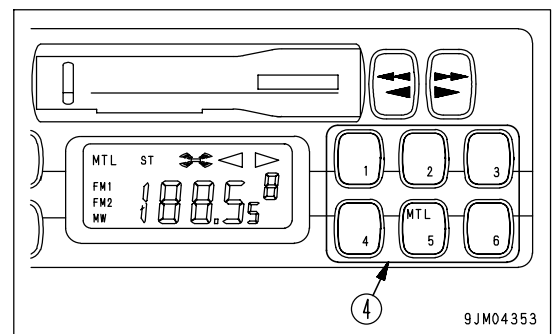

LISTENING TO RADIO

1. Turn the starting switch ON, then turn power switch (1) ON.
2. Use band selector button (2) to select MW (AM), FM1 or FM2.
3. Select the station with the preset buttons (3).

REMARK

In case you do not promptly remember the number assigned to a certain preset station, press auto-store/preset scan button (4) for less than 0.5 second. The preset 6 stations will broadcast one after another for 5 seconds each. When the desired station broadcasts, press the button again and scan tuning stops.

4. If you want to tune in to a station that is not preset, use either seek tuning button (5) or manual tuning button (6).
5. Adjust the volume, balance, and tone as desired.
6. When turning the radio OFF, turn power switch (1) to the left until it clicks.

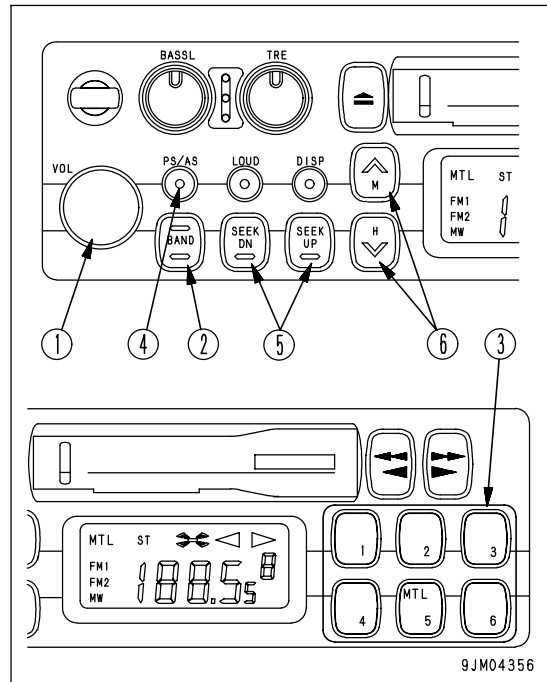

REMARK

- To switch to the radio when listening to a cassette, press the cassette eject button to stop the tape.
- If you insert a cassette when listening to the radio, the tape will start to play.

LISTENING TO A CASSETTE TAPE

1. Turn the starting switch ON, then turn power switch (1) ON.
2. Set the cassette with the exposed portion of the tape on the right side and push it past the cassette door. The tape will automatically start playing.

If the arrow indicating the direction of play is pointing to the right, the top side is being played; if the arrow is pointing to the left, the bottom side is being played.

When the tape reaches the end, it is automatically reversed and the other side starts to play.

3. When finished with the tape, press the cassette eject button to eject the tape and automatically switch to the radio.

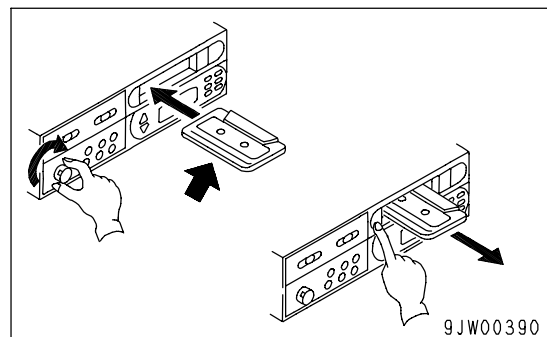
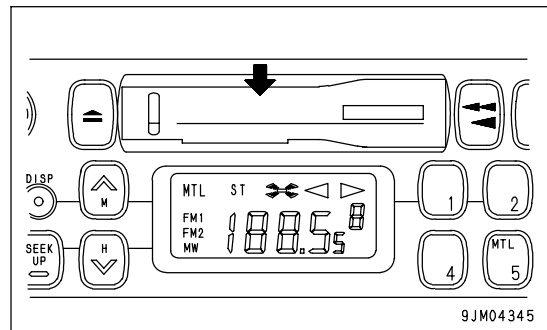

REVERSING TAPE

When listening to the tape, press both FAST FORWARD, REWIND buttons (A) and (B) at the same time lightly.

When this is done, the tape direction display will be reversed.

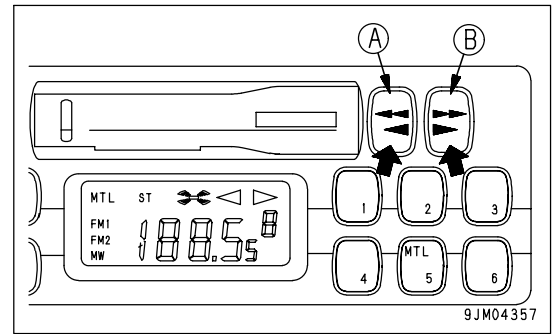
**PRECAUTION WHEN USING****WARNING**

- If a voltage greater than the specified voltage is input, it may cause fire, electrocution, or other failure. Never input any voltage other than the specified voltage.
- Places inside the radio are under high voltage. Do not remove the cover.
- Do not carry out any modifications. This may cause fire, electrocution, or other failure.
- If the sound cannot be heard, nothing is displayed, or any other problem occurs, turn off the power switch and ask your Komatsu distributor to make repairs without delay.

- Stow the antenna when traveling in places with low overhead clearance.
- To ensure safety during operations, keep the volume at a level where it is possible to hear other machines.
- If water gets inside the speaker case or radio (auto tuning), it may cause a serious problem, take care not to let water get in these items.
- Do not wipe the scales or buttons with solvent such as benzene or thinner. Wipe with a dry soft cloth. If the dirt cannot be removed easily, soak the cloth with alcohol.

NOTICE**Handling cassette tape**

- Clean the tape head approx. once a month with a commercially available head cleaning tape.
- Do not leave the tape any place where it is exposed to direct sunlight, any place that is excessively dusty, or any place where there is a magnetic field.
- Do not use 120-minute tapes. The tape is thin and it easily gets caught up inside the machine.
- If the tape is slack, it easily gets caught up inside the machine. Use a pencil to wind in the tape to remove any slack.
- Do not use any cassette tape if the label has started to come off. It may cause defective rotation, or it may be impossible to get the tape out of the machine.

AIR CONDITIONER, HANDLING

(Machine equipped with cab) (If equipped)

By taking fresh air into the cab through a filter, it is possible to raise the pressure inside the cab. This makes it possible to provide a pleasant working environment even on dusty jobsites.

GENERAL LOCATIONS AND FUNCTION OF CONTROL PANEL

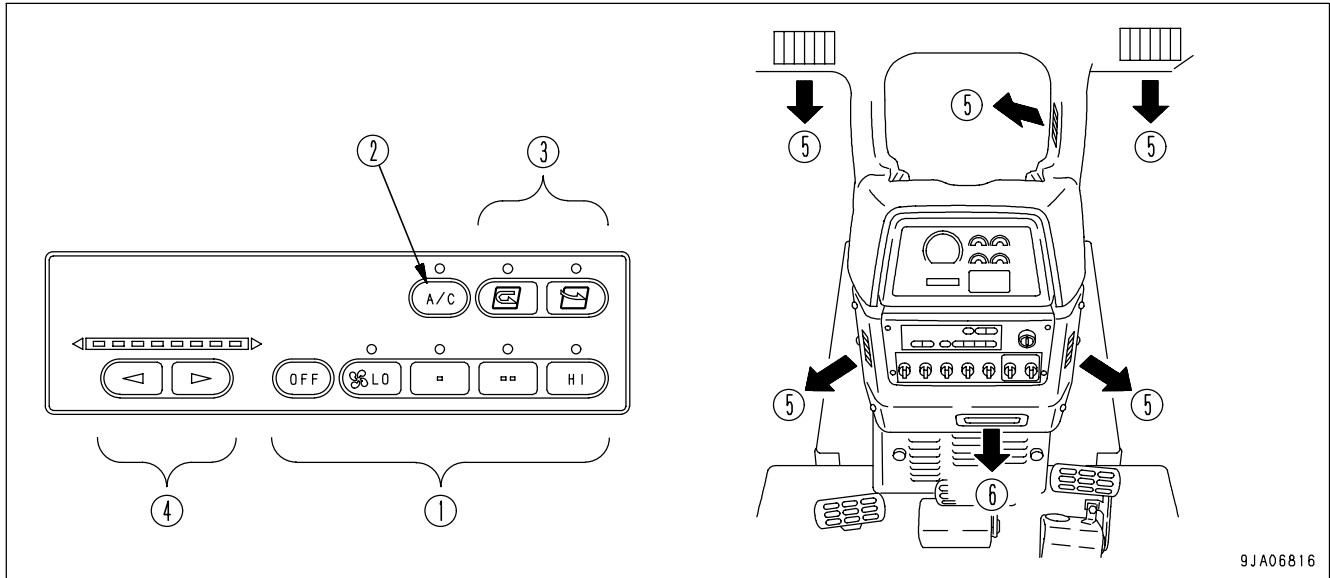

- (1) Fan switch
- (2) Air conditioner switch
- (3) Fresh/recirc selector switch
- (4) Temperature control switch
- (5) Defroster
- (6) Air flow to foot

FAN SWITCH

This switch (1) can be used to adjust the airflow in four stages. It also acts as the main switch for the air conditioner. When the OFF switch is pressed, the fan stops. When the switch is pressed, the indicator lamp above the switch lights up to display the airflow.

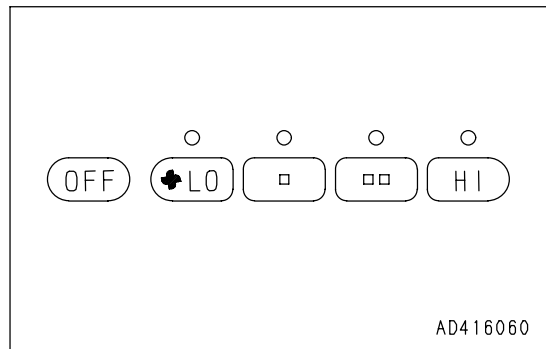

AIR CONDITIONER SWITCH

This switch (2) is used to start or stop the cooling or dehumidifying function.

When the fan switch is turned ON and the air conditioner switch is pressed, the indicator lamp above the switch lights up. When the switch is pressed again, the switch is turned OFF and the indicator lamp goes out.

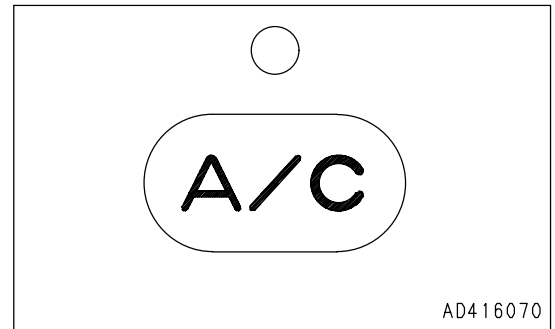
**FRESH/RECIRC SELECTOR SWITCH**

This switch (3) is used to select between recirculation of the air inside the cab or intake of fresh air from outside.

When the switch is pressed, indicator lamp (A) at the top of the switch lights up.

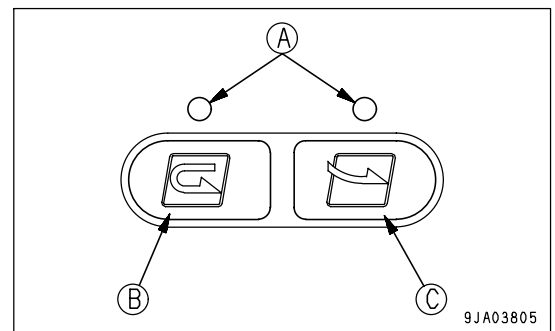
**Recirculation of air inside cab**

Press this switch (B) to use only the air inside the cab. Use this position to carry out rapid heating or cooling of the cab or when the outside air is dirty.

Intake of fresh air from outside

Press this switch (C) to carry out heating or cooling with fresh air taken in from the outside. Use this position when fresh air is taken in from outside the cab, or when removing the mist from the cab windows.

REMARK

When fresh air is taken into the cab, air pressure in the cab increases, which prevents the dust from entering. When neither heating nor cooling is needed, bring in clean fresh air, with your preferred air flow, to prevent dust from entering the cab.

TEMPERATURE CONTROL SWITCH

This switch (4) can be used to adjust the temperature steplessly between low temperature and high temperature.

The temperature level indicator lamps (A) light up to display the temperature of the air coming from the vents.

The more blue lamps on, the lower the temperature is.

The color of the indicator lamp (A) changes while the switch is being pressed.

When the temperature reaches the desired level, release the switch to set the temperature.

The settings for each mode are retained in memory even when the starting switch is turned OFF.

However, in the following cases, the settings must be reset.

- When the machine has been out of use for more than 7 days
- When the battery voltage is extremely low
- When there has been abnormal interference from outside
- When the fan switch is turned OFF (the setting is not kept in memory with only the air conditioner switch)

If the air conditioner is used in the FRESH position, the inside of the cab will be pressurized and this will prevent the entry of dust.

The higher the position of the fan switch, the more effective the pressurizing becomes.

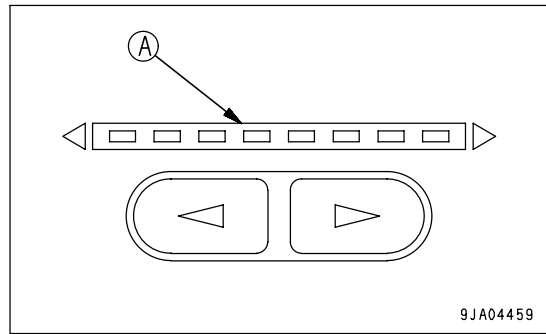

METHOD OF OPERATION

Switch		Fan switch	Air conditioner switch	Temperature control switch	FRESH/RECIRC selector switch
		Condition of use			
Cooling	Rapid	HI	ON	All blue	RECIRC
	Normal	HI - LO	ON	More than half are blue	FRESH
Dehumidifying, heating		HI - LO	ON	More than half are red	FRESH
Heating	Rapid	HI	OFF	All red	RECIRC
	Normal	HI - LO	OFF	More than half are red	FRESH
Defroster		HI	ON	More than half are red	FRESH
Ventilation or pressurizing		HI - LO	OFF	All blue	FRESH

When defrosting, set the temperature control switch so that all lamps are red. This will improve defrosting and demisting.

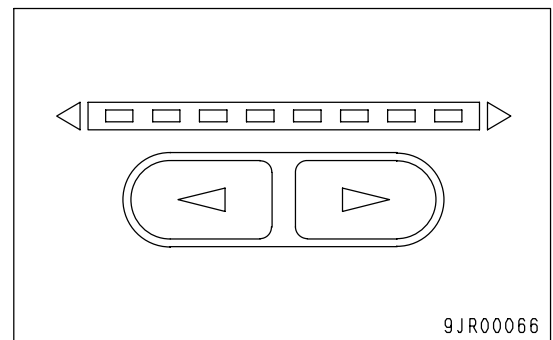

WHEN NOT USING THE AIR CONDITIONER REGULARLY

Run the air conditioner in cooling or dehumidification + heating mode for several minutes from time to time to prevent the loss of the oil film in various parts of the compressor.

REMARK

If the temperature inside the cab is low, the air conditioner may not work. In such cases, use the recirculated air to warm up the inside of the cab, then turn the air conditioner switch on. The air conditioner will be run.

COOL BOX

When the cooling is being used, this can be used for keeping drinks and other things cool.

When the heating is being used, it can be used to keep things warm.

Do not use the cool box for things which smell or leak water or break easily.

Do not use it as a holder for tools or other small objects.

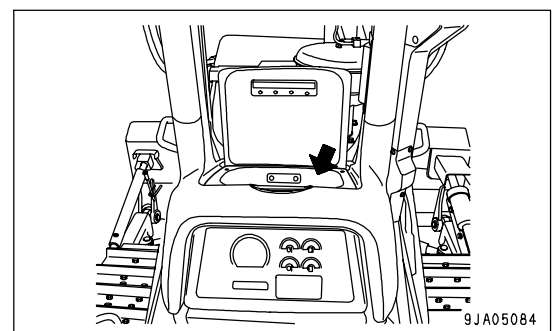

PRECAUTIONS WHEN USING

PRECAUTIONS WHEN USING THE COOLING

- If you smoke when using the air conditioner in the RECIRC mode, your eyes may start to itch or burn. Ventilate the cab ever so often to remove the smoke.
- When using the air conditioner for a long period of time, carry out ventilation process at least once every hour.

When using the air conditioner, it is recommended for health reasons, that it should only feel slightly cooler (5 or 6 °C (9 or 10.8°F) lower than the outside temperature) when you enter the cab.

Therefore, adjust the temperature to a suitable level.

SET SO THAT COLD AIR DOES NOT DIRECTLY BLOW ONTO THE GLASS SURFACE

- If the vents (left and right) in the middle of the dashboard are turned so that cold air blows directly on the cab door glass, moisture may condense on the outside of the cab door glass and reduce the visibility. (This occurs particularly in high temperatures.)

If this happens, close the louvers of the vent and change the direction to prevent the cold air from blowing directly on the surface of the glass.

INSPECTION DURING OFF-SEASON

Even during the off-season, run the compressor at low speed for several minutes once a week to prevent the loss of the oil film on the lubricated parts of the compressor.

(Run the engine at low speed and set to a mid-range temperature when carrying out this operation.)

REMARK

When the ambient temperature is low, if the compressor is suddenly run at high speed, it may cause failure of the compressor. Note that the system is set so that the compressor will not run when the cooler switch is turned on, if the ambient temperature is less than 2 to 6.5°C (35.6 to 43.7°F).

PROCEDURE FOR REPLACING RECEIVER

Replace the receiver once every 2 years.

After replacing the receiver, add compressor oil. Turn the receiver at an angle and measure the oil remaining inside the receiver, then add the same amount of oil (Denso Oil 6) to fill the receiver.

REMARK

- The replacement interval may become shorter depending on the conditions during use.
- If the receiver is used when the moisture absorption limit of the desiccant has been exceeded, the refrigerant circuit may become blocked and cause the compressor to break down.

PRECAUTIONS WHEN REPLACING RECEIVER

- If the receiver is left for more than 15 minutes with the blind cover removed, the moisture in the air will be absorbed, and this will reduce the life of the desiccant. If you remove the blind cover, connect the piping quickly, evacuate the system and fill with refrigerant.
- When removing the refrigerant from the refrigerant circuit, release it gradually from the low pressure side to prevent oil from flowing out.

CHECK COMPRESSOR BELT TENSION AND REFRIGERANT (GAS) LEVEL

If the compressor belt is loose, or the refrigerant level is low, cooling is not carried out efficiently.

For details, see "WHEN REQUIRED (PAGE 4-20)".

CLEANING AIR FILTER

If the air filter for the FRESH or RECIRC air intake becomes clogged, the cooling or heating capacity will drop.

To prevent this, clean the air filter with compressed air once a week.

For details of the cleaning method, see "WHEN REQUIRED (PAGE 4-20)".

OPERATION

CHECK BEFORE STARTING ENGINE, ADJUST

WALK-AROUND CHECK

Before starting the engine, walk around the machine and look at the underside of chassis for anything unusual like loose bolts and nuts, leakage of fuel, oil and coolant. Also check the condition of the work equipment and the hydraulic system.

Also check for loose wiring, play, and collection of dust at places that reach high temperature.



WARNING

- Leakage of oil or fuel, or accumulation of flammable material around high temperature parts, such as the engine muffler or turbocharger, may cause fire.
Check carefully, and if any abnormality is found, repair it or contact your Komatsu distributor.
- Do not get on or off the machine from the rear. Using this position is dangerous because it is easy to slip and you cannot be seen from the operator's compartment. Always use the handrail and step at the side when getting on or off the machine.

If the machine is at an angle, reposition it level before checking.

Perform the following inspections and cleaning every day before starting engine for the day's work.

1. Check for damage, wear, play in work equipment, cylinders, linkage, and hoses.
Check that there are no cracks, excessive wear, or play in the work equipment, cylinders, linkage, or hoses. If any problem is found, repair it.
2. Remove dirt and debris from around the engine, battery, and radiator.
Check for dirt accumulated around the engine and radiator. Also check for flammable material (dry leaves, twigs, etc.) around the battery, engine muffler, turbocharger, or other high temperature engine parts. If any dirt or flammable materials are found, remove them.
3. Checking engine for leak of water, oil and air
Check the engine for leak of engine oil, leak of water from the cooling system and leak of air from the suction system. If any leak is found, repair it.
4. Check for oil leakage of oil from power train case, final drive case, hydraulic tank, hoses, and joints
Check that there is no oil leakage. If any problem is found, repair the place where the oil is leaking.
Check for leakage of oil from the undercover. Check the ground for traces of oil leakage.
5. Check the undercarriage (track, sprocket, idler, guard) for damage, wear, loose bolts, or leakage of oil from rollers.
If any problem is found, repair it.
6. Check for problems in handrails, steps, loose bolts.
If any problem is found, repair it. Tighten any loose bolts.
7. Check for problems in gauges and monitor
Check that there is no problem in the gauges and monitor in the operator's cab. If any problem is found, replace the parts. Clean off any dirt on the surface.

8. Check for damage to seat belt and mounting clamps (if equipped)

Check that there is no abnormality in the seat belt or mounting clamps. If there is any damage, replace with new parts.

CHECK BEFORE STARTING

Always check the items in this section before starting the engine each day.

CHECK OIL LEVEL IN ENGINE OIL PAN, ADD OIL**WARNING**

Parts and oil are at high temperature immediately after the engine is stopped and may cause serious burns. Wait for the oil temperature to go down before performing this operation.

1. Open the engine side cover on the left side of the chassis.
2. Remove dipstick (G) and wipe the oil off with a cloth.
3. Fully insert dipstick (G) into filler pipe (F), then remove it.

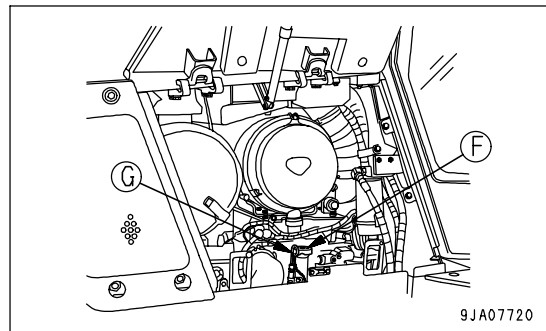

4. The oil level should be between the H and L marks on dipstick (G).
If the oil level is below the L mark, add oil through oil filler port(F).

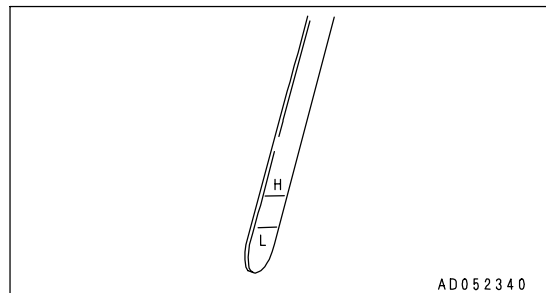

5. When the oil level is higher than H, remove cover (1) in the underpart of the truck.

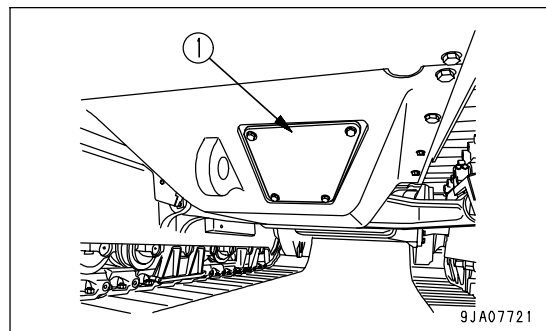

6. Take the end of hose (2) out of the inspection window.
7. Loosen drain plug (P), drain excess oil and check the oil level again.

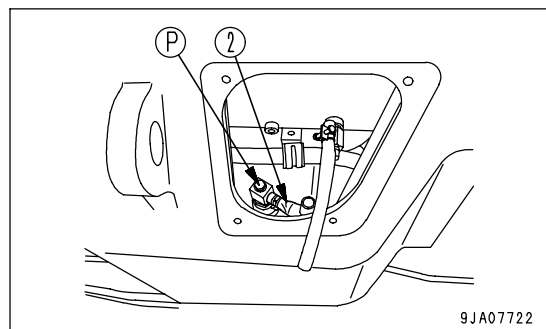

8. If the oil level is correct, tighten the oil filler cap securely and close the engine side cover.

REMARK

- If the machine is at an angle, reposition it to level before checking.
- When checking the oil level after the engine has been operated, allow the engine to cool for 15 minutes before checking.

CHECK DUST INDICATOR

1. Open engine side cover on the left side of machine.
2. Check if a yellow piston in the display of dust indicator (1) has moved into the red area (7.5 kPa).
3. If the yellow piston has already moved into the red area (7.5 kPa), either clean the filter element or replace it with new one immediately.

For cleaning the filter element, refer to the section, "CHECK, CLEAN AND REPLACE AIR CLEANER ELEMENT (PAGE 4-20)", in this manual.

4. After checking, cleaning, and replacing, press the knob of dust indicator (1) to return the yellow piston to its original position.

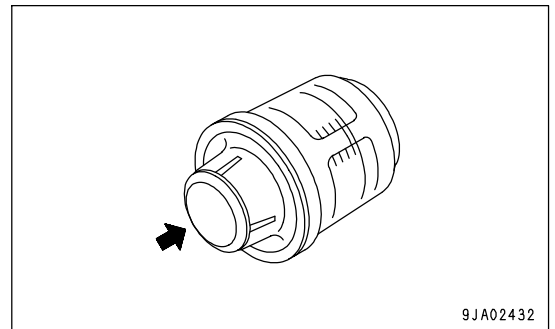
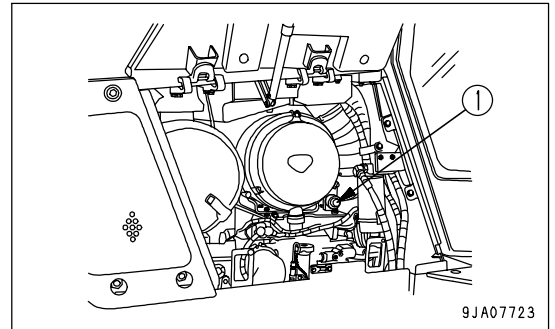

CHECK, DRAIN WATER SEPARATOR

The water separator serves to separate moisture mixed in the fuel.

1. Open up the engine side cover on the left side of the machine.
The water separator is in one piece with fuel pre-filter (1) and located in the lower part.
2. Through transparent cap (2), a water level and sediments, if any, can be seen. When water and sediments have accumulated, put a container beneath drain hose (3).
3. Loosen plug (4) to drain water and sediments.
4. When draining is finished, be sure to screw in plug (4).
Specified tightening torque: 0.2 to 0.45 Nm (0.02 to 0.046 kgm, 0.1 to 0.3 lbft)

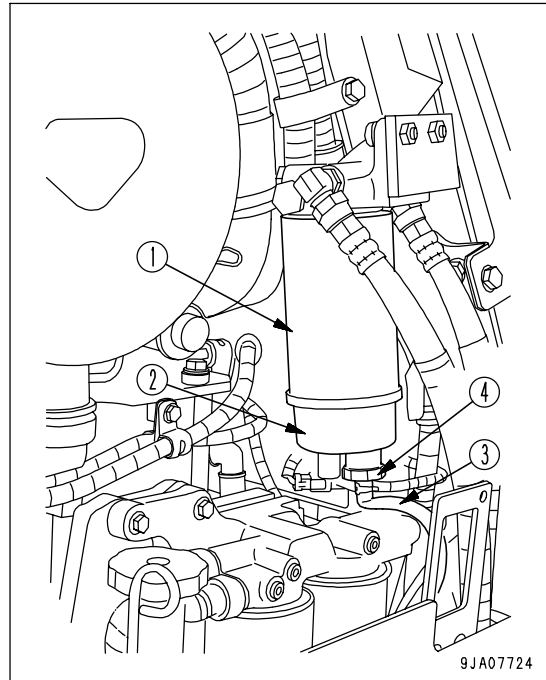

CHECK COOLANT LEVEL, ADD COOLANT

**WARNING**

- Do not open the radiator cap unless necessary. When checking the coolant, always wait for the engine to cool down and check the sub tank.
- Immediately after the engine is stopped, the coolant is at a high temperature and the radiator is under high internal pressure. If the cap is removed to check the coolant level in this condition, there is a hazard of burns. Wait for the temperature to go down, then turn the cap slowly to release the pressure and remove it carefully.

1. Open up inspection cover (1) on the right side of the truck to check if a cooling water level in sub-tank (2) remains within the FULL - LOW range. If not, refill the tank with clean water up to the FULL level through the filler port in sub-tank (2).

REMARK

In summer, the coolant may overflow from the sub-tank drain hose. This is no problem. It occurs because too much coolant has been added.

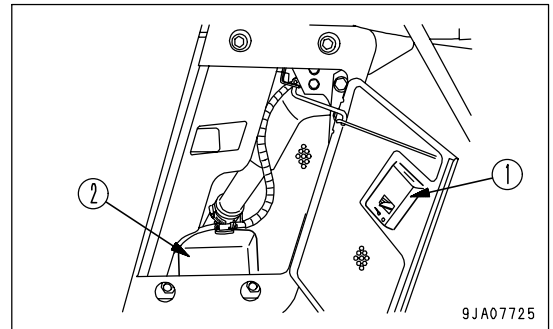

2. After adding coolant, tighten the cap securely.
3. If the sub-tank is empty, check for leakage of coolant, then add it to the radiator and sub-tank.
4. After adding coolant, close the engine side cover.

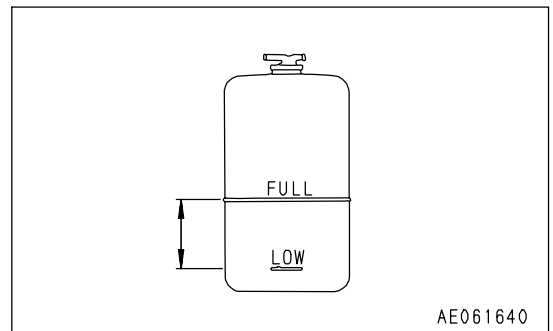

CHECK OIL LEVEL IN POWER TRAIN CASE, ADD OIL**! WARNING**

The parts and oil are at high temperature after the engine is stopped, and may cause serious burns. Wait for the temperature to go down before starting the operation.

1. Open cover on the right side of the machine.
2. Remove dipstick (G), and wipe the oil off with a cloth.
3. Fully insert dipstick (G) into filler pipe (F), then remove it.
4. The oil level should be between the (H) and (L) marks on dipstick (G).
If the oil level is below the (L) mark, add oil through oil filler (F).

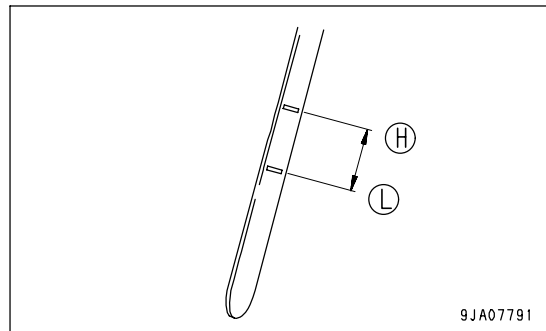
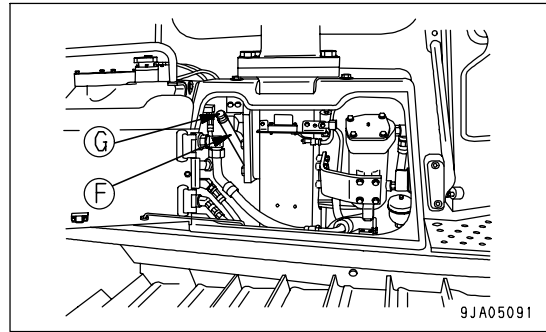

5. If the oil level is above the H mark, remove cover (1) on the bottom of the machine.
Loosen drain plug (P), drain the excess oil, then check the oil level again.
6. If the oil level is correct, insert dipstick (G) fully into the dipstick guide again.

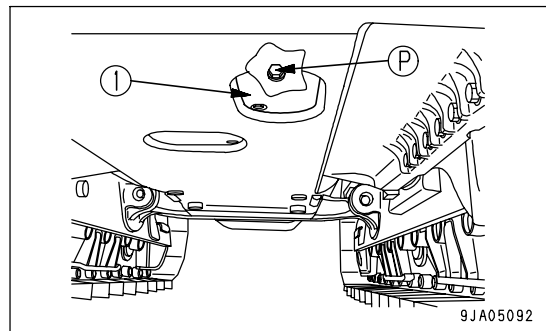
**REMARK**

- If the machine is at an angle, reposition it to level before checking.
- When checking the oil level after the engine has been operated, allow the engine to cool for 15 minutes before checking.

CHECK ELECTRIC WIRING**! CAUTION**

- If the circuit breakers are activated and the fuses are blown frequently or there is a trace of short-circuiting in the wirings, check the cause immediately and either correct it by yourself or call your Komatsu distributor for the repair.
- Keep the top surface of the battery clean and check the breather hole in the battery cap. If it is clogged with dirt or dust, wash the battery cap to clear the breather hole.

Check that the circuit breakers are in normal condition (with the red button pushed in), that the fuses have no damage and fuses of the specified capacity are in use and that there is no trace of disconnection or short-circuiting in the wirings and no damage in the covers. Moreover check the terminals for loosening and retighten loosened one, if any.

Be particularly careful to check the wiring for the battery, starting motor, and alternator.

In addition, if any flammable material is accumulated around the battery, remove it.

For repairs or investigation of the cause, please contact your Komatsu distributor.

CHECK BRAKE PEDAL TRAVEL

**WARNING**

If the brake pedal stroke is not 70 to 90 mm (2.8 to 3.5 in) (below 70 mm or over 90 mm), the brake and steering force is too strong or insufficient. If the stroke is 91 mm (3.6 in) or longer, adjust it.

1. Depress the brake pedal all the way until it stops.
2. Check that the distance of travel (A) at the center of the pedal is 70 to 90 mm (2.8 to 3.5 in).
3. When this value exceeds 91 mm (3.6 in), or the brake fails to work, please contact your Komatsu distributor for adjustment.

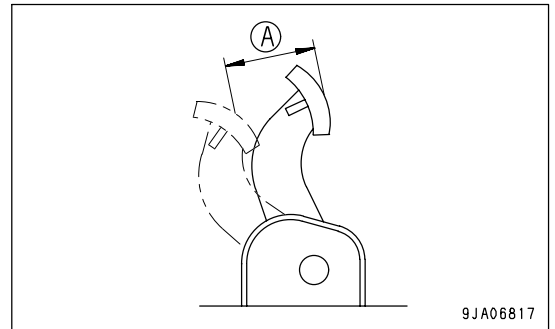

CHECKING WITH MACHINE MONITOR

1. Turn starting switch (1) to the ON position (B).
2. Check that all the monitors and gauges light up for approx. 2 seconds and the alarm buzzer sounds for approx. 2 seconds.

REMARK

If the lamps do not light up, there may be a failure or disconnection in the monitor, please contact your Komatsu distributor.

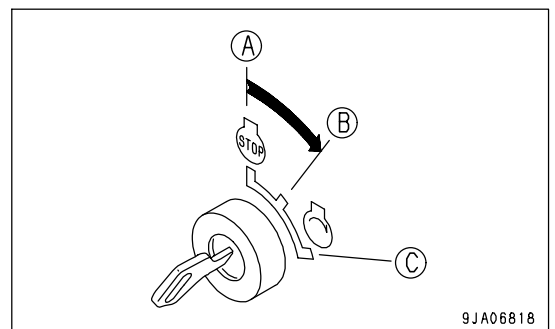
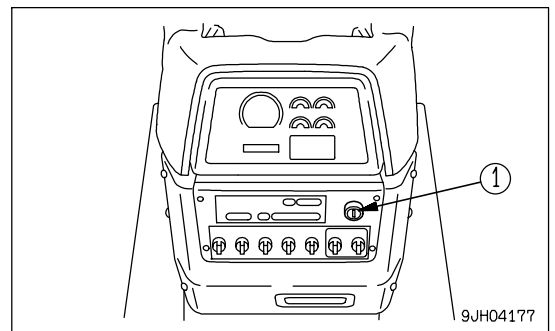

CHECK FUEL LEVEL, ADD FUEL

**WARNING**

When adding fuel, never spill the fuel or let it overflow. It will cause fire.

If any fuel has spilled, wipe it up completely. If fuel has spilled over soil or sand, remove that soil or sand.

Fuel is highly flammable and dangerous. Never bring flames near fuel.

1. Turn the engine starting switch to the ON position and check the fuel level gauge (G) on the monitor panel for fuel level. After checking, turn the switch back to the OFF position.

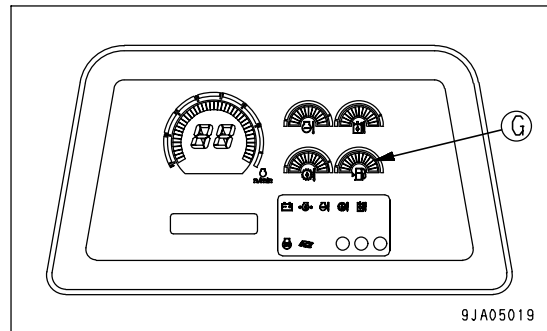

2. After completing work, fill the fuel tank through fuel filler port (F).
Fuel capacity: 415 liters (109.64 US gal)

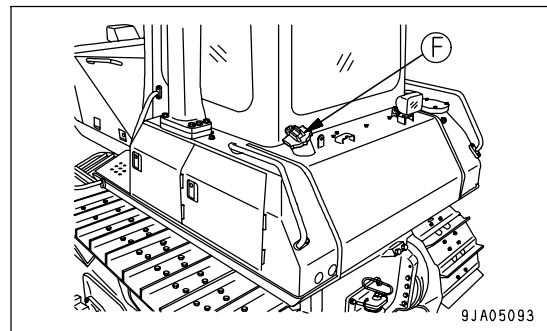

3. After adding fuel, tighten the cap securely.

REMARK

- When dozing on a grade, make sure there is plenty of fuel in the tank so that the engine fuel line does not become aerated.
- If breather hole (1) on the cap is clogged, the pressure in the tank will drop and fuel will not flow.

Clean the hole from time to time.

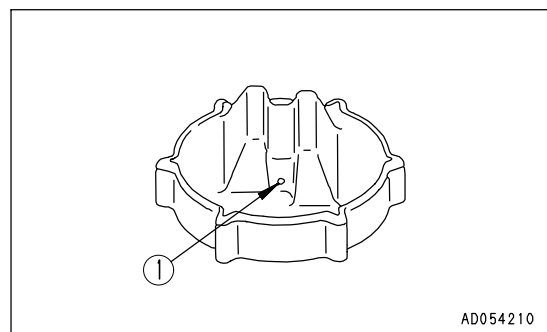

CHECK HORN SOUND

Check that the horn sounds. If it does not sound at all or the sound is extremely feeble, a defect or broken wire is suspected, ask your Komatsu distributor for possible repairs.

1. Turn starting switch to the ON position (B).

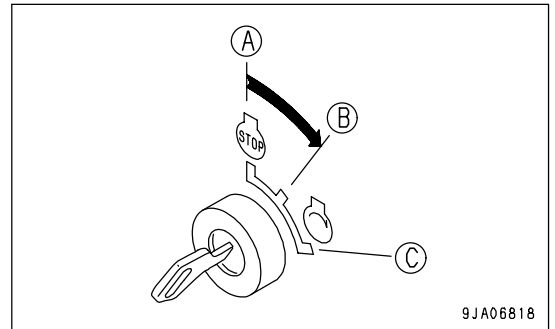

2. Push the horn switch and check that the horn sounds.

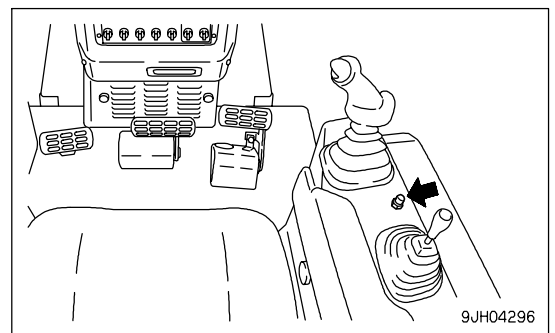

CHECK THAT LAMPS LIGHT UP

Check that the head lamp, rear lamp, additional working lamp (if equipped), and instrument lamp light up normally and they are free from stain and damage.

If the lamps do not light, check for a broken bulb or disconnected wire, contact your Komatsu distributor for repairs.

1. Turn starting switch to the ON position (B).

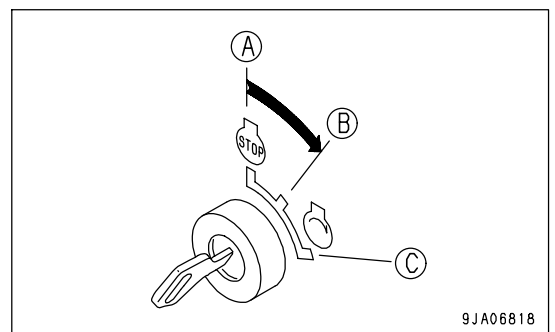

2. Turn the Head lamp and Rear lamp switches to the I position (ON), and check that all the lamps light up.

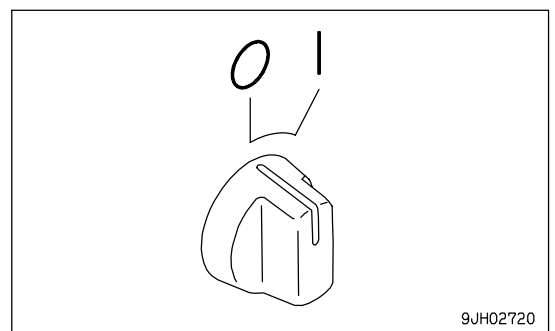

CHECK OF OPERATION OF BACKUP ALARM

Check that the backup alarm sounds normally. If it does not, a defect or broken wire is suspected, ask your Komatsu distributor for possible repairs.

1. Turn starting switch to the ON position (B).

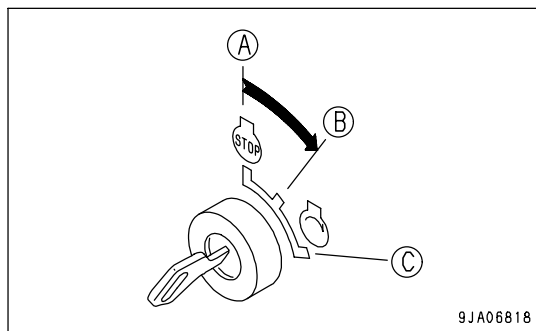

2. Set the steering, forward-reverse, gear shift lever in the REVERSE position (R).

The alarm must sound immediately at this time. The alarm keeps sounding until the steering, forward-reverse, gear shift lever is set to the NEUTRAL position (N) or FORWARD position (F).

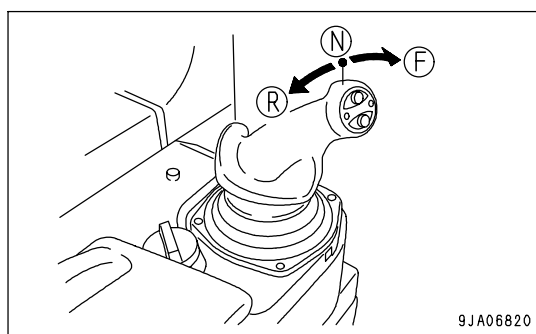

ADJUSTMENT

ADJUST OPERATOR'S SEAT



WARNING

When adjusting the position of the operator's seat, always set the work equipment lock lever to the LOCK position to prevent any accidental contact with the control levers.

- Always adjust the operator's seat before starting each operation or when the operators change shift.
- When adjusting the seat, put your back against the backrest and adjust to a position where the brake pedal can be fully depressed.

(A) Fore-and-aft adjustment

Pull lever (1), set the seat to a position where it is easy to operate, then release the lever.

Fore-aft adjustment: 160 mm (6.3 in) (8 stages)

(B) Weight adjustment of seat

Turn knob (2) under the seat to match the weight adjustment scale with your own weight.

The weight can be adjusted to 50 to 120 kg (110 to 265 lb).

REMARK

To make the seat softer, adjust the weight to make it lighter; to make the seat harder, adjust the weight to make it heavier.

When traveling on rough road surfaces, make the seat harder before starting operations.

(C) Adjust reclining angle

Pull up lever (3) and set the seat back to a position which is comfortable for operation, then release the lever.

Sit with your back against the seat back when adjusting. If your back is not touching the seat back, the seat back may suddenly move forward.

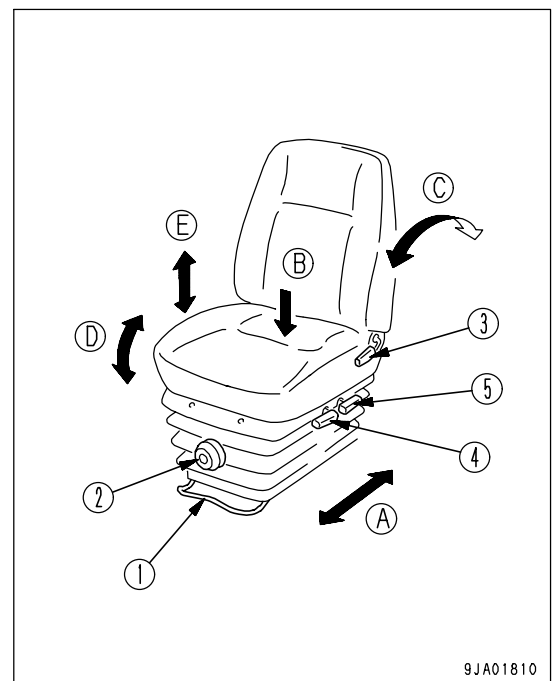

REMARK

The seat can be reclined more when the seat is pushed to the front. The amount of reclining decreases as the seat is pushed back, so when moving the seat back, return the seatback to the upright position.

(D) Seat angle adjustment

- Front angle adjustment of seat (5 stages)

To raise the front of the seat, apply your weight to the seatback, while pulling up lever (4).

To lower the front of the seat, apply your weight to the front of the seat, while pulling up lever (4).

- Rear angle adjustment of seat (5 stages)

To raise the rear of the seat, stand up on your feet a little, while pulling up lever (5).

To lower the rear of the seat, apply your weight to the rear of the seat, while pulling up lever (5).

(E) Seat height adjustment

Pull up levers (4) and (5) alternately to adjust the angle of the seat.

Then, release the levers to lock the seat.

(Height adjustment distance: 5 stages, 60 mm (2.4 in))

FASTENING AND REMOVING SEAT BELT

(If equipped)

**WARNING**

- Before fastening the seat belt, check that there is no problem in the securing brackets or belt. If there is any wear or damage, replace.
- Even if there appears to be no problem in the seat belt, replace the seat belt once every 3 years. The date of manufacture is woven on the reverse side of the belt.
- Adjust and fasten the seat belt before operating the machine.
- Always use the seat belt when operating the machine.
- Do not use the seat belt with either half of the belt twisted.

Check that the bolts of the clamp securing the belt to the chassis are not loose. Tighten them if they are loose.

The tightening torque for the mounting bolt is 24.5 ± 4.9 Nm (2.5 ± 0.5 kgm, 18.1 ± 3.6 lbft).

If the belt surface is scratched or frayed or if the fittings are broken or deformed, replace the seat belt unit.

FASTENING AND REMOVING SEAT BELT

1. After adjusting the seat position, adjust tether belt (1). Tense the tether belt and install it when there is no one sitting on the seat.
2. Sit on the seat and hold tongue (4) connected to wind-in mechanism (2) and pull out the belt slowly so that the belt will cover your abdomen sufficiently.
3. Insert tongue (4) in buckle (3) until it clicks. The belt is pulled back into wind-in mechanism (2) until it is fitted to your abdomen. The belt is locked under this condition and cannot be extended anymore. Fit the belt to your abdomen without twisting it.

REMARK

If the belt is locked before the tongue is inserted in the buckle, let it return to the wind-in mechanism, then repeat the above procedure from the start.

4. Pull the belt to check that it is securely locked in position.
5. When removing the belt, press the red button on buckle (3). The belt will automatically retract.

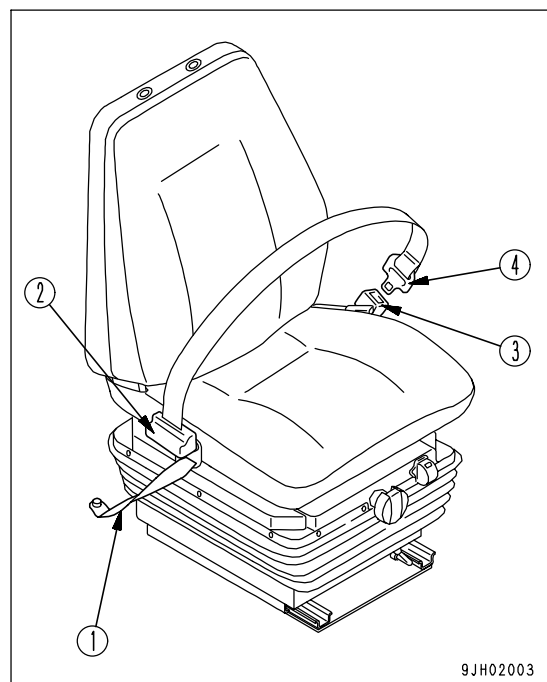

9JH02003

ADJUST MIRROR

(If equipped)

Loosen nut (1) of the mirror and adjust the mirror to a position where it gives the best view from the operator's seat.

In particular, be sure to adjust the mirror so that people at the rear left or right of the machine can be seen clearly.

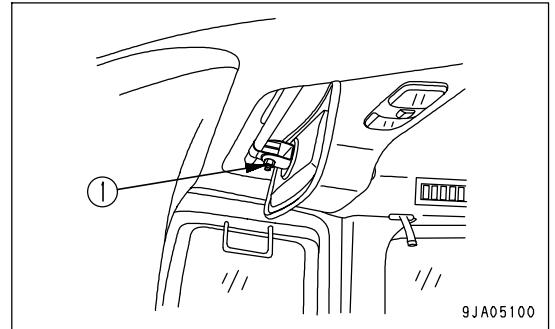
**ADJUST LEFT CONSOLE BOX**

WARNING

- Before adjusting the position of the left console box, always set the parking brake lever to the LOCK position.
- After adjusting the position of the left console box, push and pull the console box to the front and rear to check that it is locked and cannot move. If it is not locked properly, the console box may suddenly move during operations, causing misoperation of the steering, forward-reverse, gear shift lever, and resulting in failure.

The left console box can be adjusted by 90 mm (3.5 in) in 9 stages to the front or rear. Adjust it to the most suitable position to match the adjustment of the operator's seat.

1. Pull up lock lever (2) at the rear of console box (1) at the left side of the operator's seat, and set the lock lever to the FREE position.

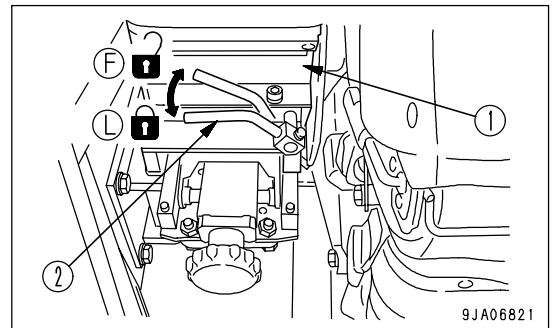
**NOTICE**

Do not grip the steering, forward-reverse, gear shift lever when removing console box (1). There is danger that the lever may break.

2. With the lock lever (2) pulled up, use your other hand to grip the front of console box (1), then move it to the front or rear with your left and right hands.
3. Move console box (1) to the desired position until a click is heard. Then pull up lock lever (2) and release it. Lock lever (2) automatically returns to LOCK position (L).

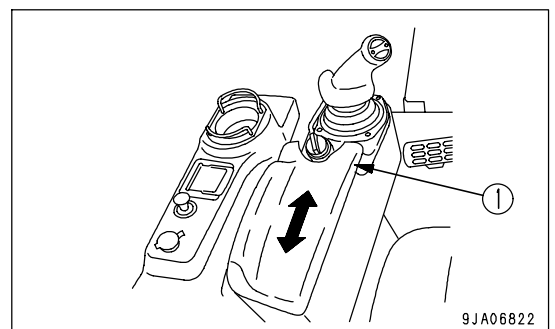

ADJUST ARMREST

The height of the armrest on the left and right sides of the operator's seat can be adjusted to 3 positions. After adjusting the operator's seat, adjust the armrest to a suitable height.

ADJUST ARMREST (RIGHT)

Arm rest (1) can be adjusted in three stages; 30 mm (1.2 in) upward and 25 mm (1.0 in) downward from standard height (B).

- 1. Loosen knob (2) (2 places).

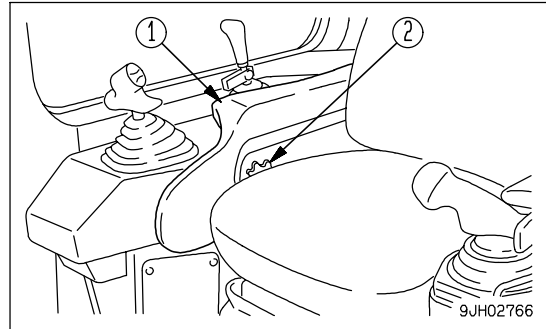

- 2. Move the armrest on the operator's seat to the front, then align the position of the 3 holes ((A), (B),(C)).
- 3. Return the armrest to the rear.
- 4. Tighten knob (2) securely.

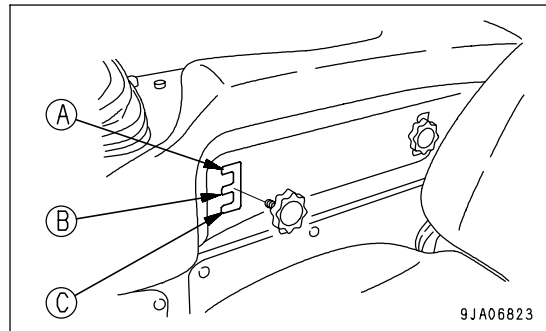

ADJUST ARMREST (LEFT)

The height of the armrest on the left side of the operator's seat can be adjusted steplessly up and down 60 mm (2.4 in) together with the console box.

Turn up/down left adjustment knob (1) to adjust the height. Turn the knob to adjust as follows.

Turn CLOCKWISE to move DOWN

Turn COUNTERCLOCKWISE to move UP

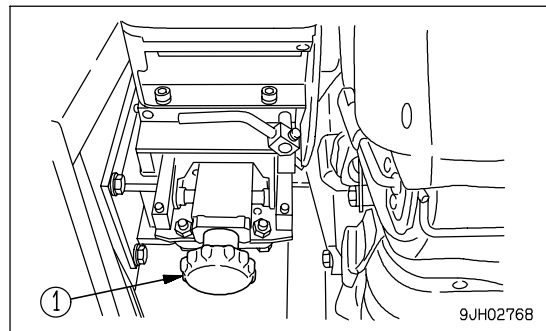

OPERATION AND CHECK BEFORE STARTING ENGINE

! WARNING

When starting the engine, check that the parking brake lever and work equipment lock lever are placed securely at the LOCK position.

If the work equipment control lever is touched by accident when the engine is started, the work equipment may move unexpectedly and cause serious injury or damage.

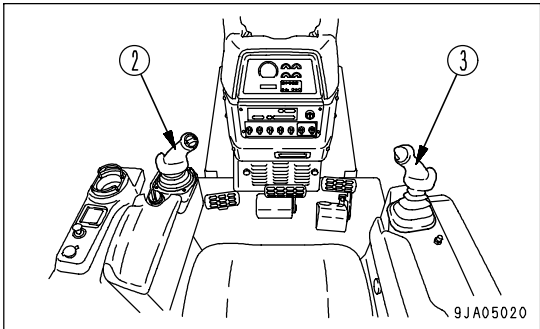
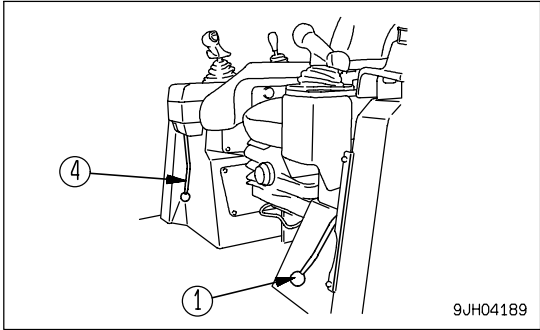

1. Check that parking brake lever (1) is in the LOCK position (L).

REMARK

If this parking brake lever is not in the LOCK position, the engine will not start.

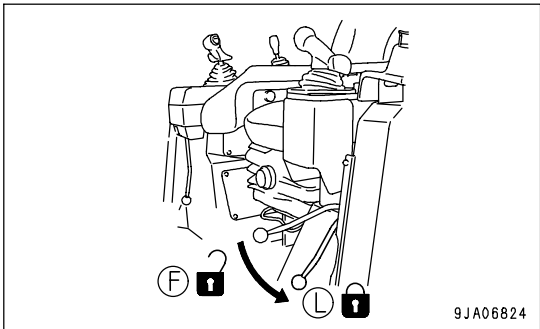

2. Check that steering, forward-reverse, gear shift lever (2) is in the NEUTRAL position (N).

REMARK

- The engine cannot be started if steering, forward-reverse, gear shift lever (2) is not in the NEUTRAL position.
- If steering, forward-reverse, gear shift lever (2) is in FORWARD or REVERSE, the letter P on display panel A will flash.

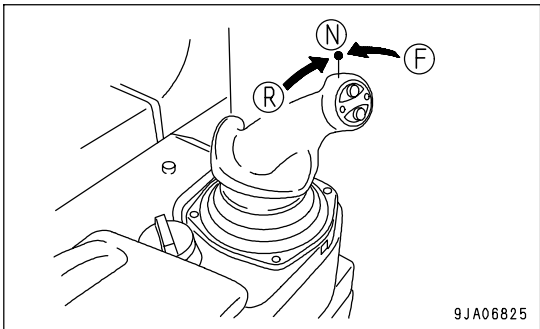

3. Check that the blade is lowered to the ground and that blade control lever (3) is in the HOLD position (B).

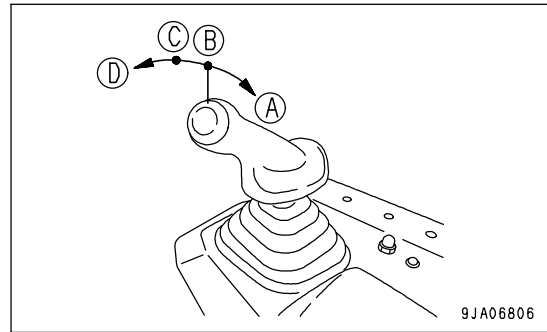

4. Check that the work equipment lock lever (4) is LOCK position (L).

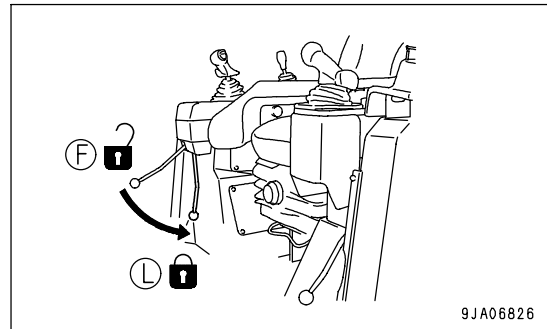

STARTING ENGINE

NORMAL STARTING



WARNING

- Sit down in the operator's seat before starting the engine.
- Do not attempt to start the engine by short-circuiting the engine starting circuit. Such an act may cause serious bodily injury or fire.
- Check that there are no persons or obstacles in the surrounding area, then sound the horn and start the engine.
- Exhaust gas is toxic. When starting the engine in confined spaces, be particularly careful to ensure good ventilation.

NOTICE

- Do not continue to crank the starting motor continuously for more than 60 seconds under any circumstances. If the engine does not start, wait for at least 2 minutes, then repeat the procedure from Step 2.
- Before starting the engine, check that the fuel control dial is at the low idle (MIN) position.
- The machine is equipped with a function to automatically warm up engine cooling water temperature more quickly and another function to protect the turbocharger. In a cold weather startup, the engine revolution may not change for several seconds immediately after the startup even if fuel control dial (1) is operated.
- If the fuel control dial is in the FULL position, the engine will accelerate suddenly and cause damage to the engine parts, so set it to an intermediate or low speed position.

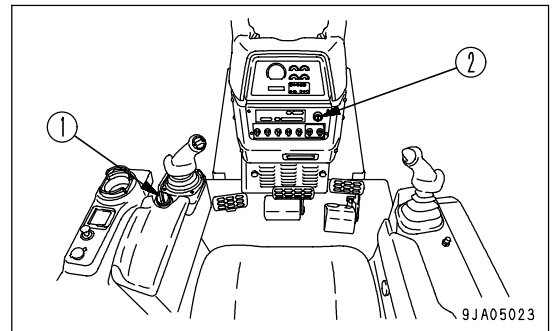

1. Turn fuel control dial (1) from the low idle (MIN) position to a slightly higher speed.

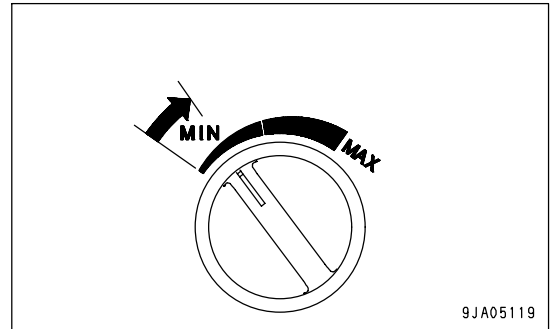

2. Insert the key into starting switch (2) and turn the key to the START position (C). The engine will start.

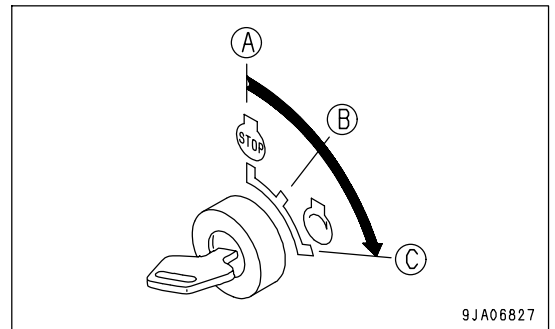

3. When the engine starts, release the key in starting switch (2).
The key will return automatically to the ON position (B).

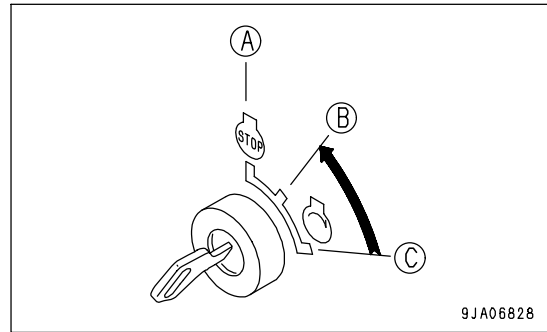

STARTING IN COLD WEATHER

**WARNING**

- Start the engine only after sitting down in the operator's seat.
- Do not attempt to start the engine by short-circuiting the engine starting circuit. Such an act may cause a serious bodily injury or fire.
- Check that there are no persons or obstacles in the surrounding area, then sound the horn and start the engine.
- Never use starting aid fluids as they may cause explosions.
- Exhaust gas is toxic. When starting the engine in confined spaces, be particularly careful to ensure good ventilation.

NOTICE

- Do not continue to crank the starting motor continuously for more than 60 seconds under any circumstances. If the engine does not start, wait for at least 2 minutes, then repeat the procedure from Step 2.
- Before starting the engine, check that the fuel control dial is at the low idle (MIN) position.
- The machine is equipped with a function to automatically warm up engine cooling water temperature more quickly and another function to protect the turbocharger. In a cold weather startup, the engine revolution may not change for several seconds immediately after the startup even if fuel control dial (1) is operated.
- If the fuel control dial is in the FULL position, the engine will accelerate suddenly and cause damage to the engine parts, so set it to an intermediate or low speed position.

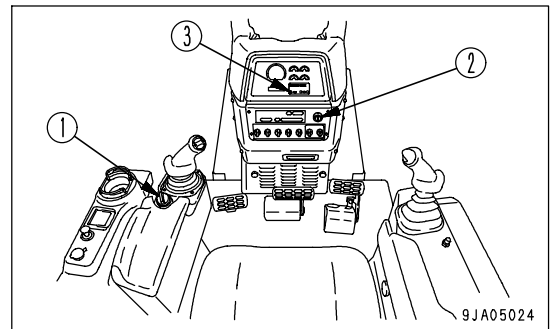

1. Turn fuel control dial (1) to the center position between MIN and MAX position.

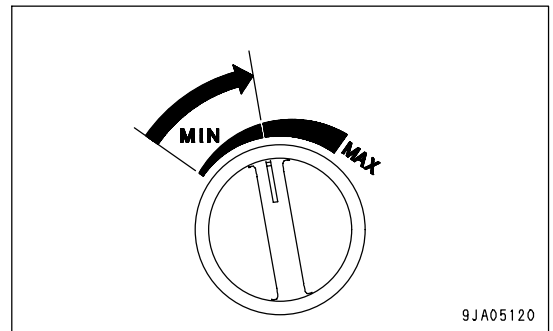

2. Insert the key into starting switch (2) and turn the key to the ON position (B).

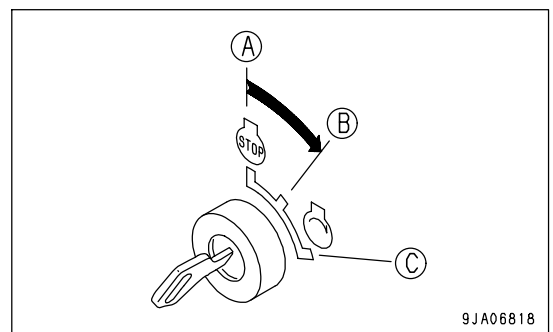

3. Check that engine pre-heating pilot lamp (3) on the monitor panel lights up.
4. Maintain the key in the on position until the pre-heating pilot lamp (3) goes off.

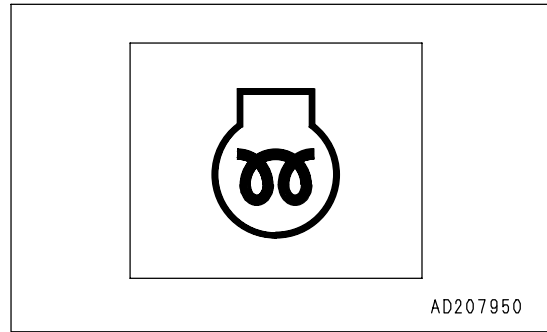

5. When preheating pilot lamp (3) goes off, turn the key of ignition switch (2) to the START position (C) to crank the engine.
The time that preheating pilot lamp (3) stays on changes according to the ambient temperature as shown in the table below.

Ambient temperature	Pre-heat time
-3°C to -10°C (27°F to 14°F)	5 to 15 seconds
-10°C to -20°C (14°F to -4°F)	15 to 32 seconds
-20°C to -30°C (-4°F to -22°F)	32 to 45 seconds

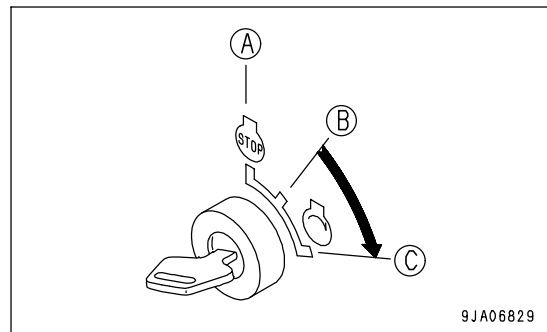

6. When the engine starts, release the key in starting switch (2).
The key will return automatically to the ON position (B).

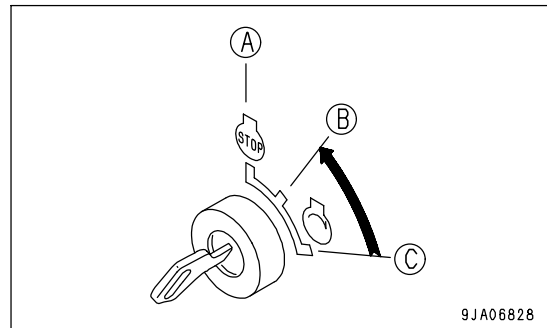

REMARK

Immediately after an engine startup, keep the engine idling, and while the engine is idling, keep the foot off the deceleration pedal and do not operate the work equipment.

- When the engine rotation stabilizes, return to the low idle (MIN) position of fuel control dial (1) and then carry out the warming-up operation.

REMARK

- Regardless of the ambient temperature, if the key in starting switch (2) is turned from OFF position to left, preheating pilot lamp (3) will light up and preheating will start. (Preheating continues while the starting switch is held at the left.)
For the details of the preheating time, see the table in Step 5.
- While preheating is being carried out, the preheating pilot lamp (3) lights up to show that preheating is being carried out.
- If the engine does not start with the above operation, wait for about 2 minutes, and repeat steps 3. And 4.
- The relationship between the actuation time of the turbo protect function and the engine coolant temperature is as follows.
Even if the fuel control dial is operated within the time given below, the engine speed will not change.

Turbo protect function

The turbo protect function is a function to protect the turbocharger by keeping the engine speed at less than 1000 rpm immediately after the engine is started.

When the turbocharger protection function and engine cooling water auto warming-up function are activated at the same time, the former takes priority over the latter.

- While the turbocharger protection function is in operation, the engine revolution is held at 1000 rpm even if the fuel control dial is set at above 1000 rpm.
- While the turbocharger protection function is in operation, the engine revolution is held at 1000 rpm even if the fuel control dial is operated.
- When the turbo protect function is canceled, the engine speed is set to the speed for the position of the fuel control dial.
- The relationship between the length of time of actuating the turbo protect function and the temperature of the engine coolant is as shown in the table.

Coolant temperature	Turbo protect time (sec.)
Above 10°C (50°F)	0
10 to -30°C (50 to -22°F)	Change 0 to 20

Engine Cooling Water Auto Warming-up Function

This is a function to automatically warm up engine cooling water more quickly by raising an engine idling speed.

When the turbocharger protection function and engine cooling water auto warming-up function are activated at the same time, the former takes priority over the latter.

- While the turbocharger protection function is in operation, the engine revolution is held at 1200 rpm even if the fuel control dial is set at any rpm. However, if the fuel control dial is held at the engine full speed (MAX) for more than three seconds, the engine will gradually pick up the speed up to the full idling.
- This function continues to work for a maximum of 10 minutes, or until the engine cooling water temperature reaches 30°C (86°F).
- If the deceleration pedal is depressed while this function is in operation, the engine rpm goes down below 1200 rpm.

OPERATIONS AND CHECKS AFTER STARTING ENGINE

WARNING

- If there has been any abnormal actuation or trouble, turn the starting switch key to the OFF position.
- If the work equipment is operated without warming the machine up sufficiently, the response of the work equipment to the movement of the control lever will be slow and the work equipment may not respond as the operator desires, so always carry out the warming-up operation. Particularly in cold areas, be sure to carry out the warm-up operation completely.

BREAKING IN THE NEW MACHINE

NOTICE

Your Komatsu machine has been thoroughly adjusted and tested before shipment from the factory. However, operating the machine under full load before breaking the machine in can adversely affect the performance and shorten the machine life.

Be sure to break in the machine for the initial 100 hours (as indicated on the service meter).

Make sure that you fully understand the content of this manual, and pay careful attention to the following points when breaking in the machine.

- Run the engine at idle for 15 seconds after starting it. During this time, do not operate the control levers or fuel control dial.
- Idle the engine for 5 minutes after starting it up.
- Avoid operation with heavy loads or at high speeds.
- Immediately after starting the engine, avoid sudden starts, sudden acceleration, unnecessary sudden stops, and sudden changes in direction.

WARMING UP OPERATIONS

NOTICE

Do not accelerate the engine suddenly until the warming-up operation has been completed.

Do not run the engine at low idle or high idle continuously for more than 20 minutes.

If it is necessary to continue to run the engine at idle, apply a load from time to time or run the engine at a mid-range speed.

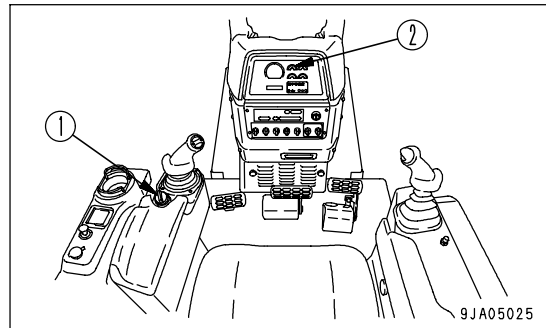

1. Turn fuel control dial (1) to the mid point between the low idling speed (MIN) and full speed (MAX) to start up the engine.

REMARK

The machine holds an engine revolution at 1200 rpm by means of its engine cooling water warming-up function until after the engine cooling water temperature reaches 30°C (86°F).

For more details on this function, see "STARTING IN COLD WEATHER (PAGE 3-89)".

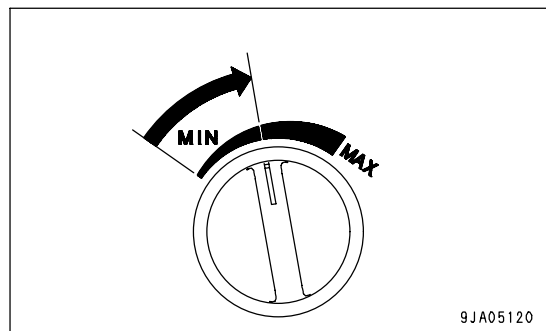

2. After warm-up is completed, check gauges and caution lamps for proper operation. If any problem is found, repair it. Continue to run the engine under a light load until engine coolant temperature gauge indicator (2) is within the green range (B).

- (A): White range
- (B): Green range
- (C): Red range

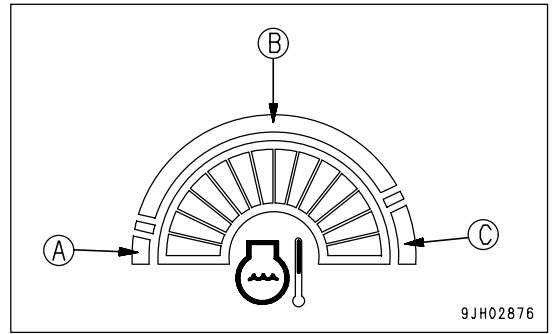

3. Check for abnormal exhaust gas color, noise, or vibration. If any problem is found, contact your Komatsu distributor.

STARTING IN COLD WEATHER

(Ambient temperature below 10°C (50°F))

NOTICE

- When the hydraulic oil is at a low temperature, do not carry out operations or move the levers suddenly. Always carry out the warm-up operation. This will help to extend the machine life. Do not suddenly accelerate the engine before the warm-up operation is completed.
- Do not run the engine at low idle or high idle continuously for more than 20 minutes. This will cause leakage of oil from the turbocharger oil supply piping. If it is necessary to run the engine at idle, apply a load from time to time or run the engine at a mid-range speed.

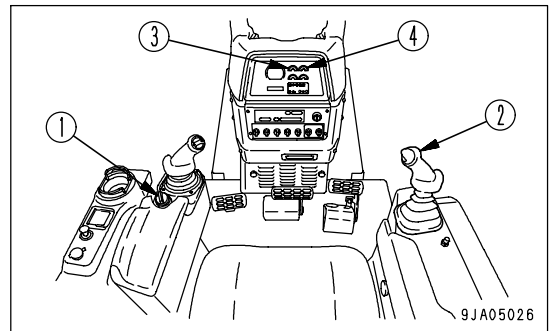

1. Turn fuel control dial (1) to the mid point between the low idling speed (MIN) and full speed (MAX) to start up the engine.

REMARK

The machine holds an engine revolution at 1200 rpm by means of its engine cooling water warming-up function until after the engine cooling water temperature reaches 30°C (86°F). For more details on this function, see "STARTING IN COLD WEATHER (PAGE 3-89)".

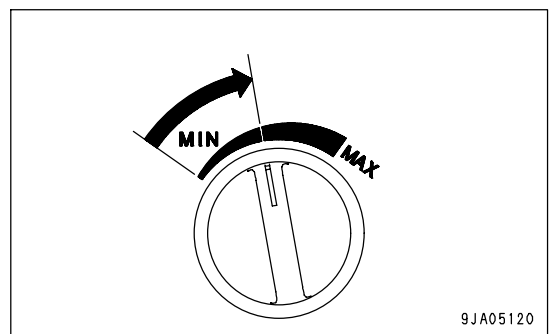

2. Blade control lever (2) to the full RAISE position, then hold the lever in position, and operate slowly to the left tilt relief and right tilt relief positions for 5 minutes.
3. Then operate blade control lever (2) to the full RAISE position (up to the lever stroke end) and hold it in that position; alternate the right and left TILT relief intermittently; lower the blade to the ground by operating the control lever to the LOWER position; operate the control lever to the FLOAT position (up to the lever stroke end); and alternate right and left TILT relief intermittently for five minutes.
4. Lower the blade to the ground, move the control lever fully to the FLOAT position (lever stroke end) and hold the lever in position for 1 minute. Next, release the lever and check that it stays in the FLOAT position. After waiting for 3 minutes, return the lever to the HOLD position.
5. After warm-up run is completed, check gauges and caution lamps for proper operation. If any abnormality is found, repair it.

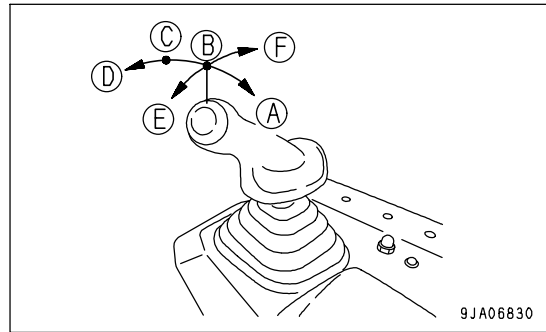

- | | |
|-----------|----------------|
| (A) RAISE | (D) FLOAT |
| (B) HOLD | (E) LEFT TILT |
| (C) LOWEW | (F) RIGHT TILT |

- Continue to run the engine at light load until engine coolant temperature gauge indicator (3) and Hydraulic oil temperature gauge (4) fall within the green range (B).

- (A): White range
- (B): Green range
- (C): Red range

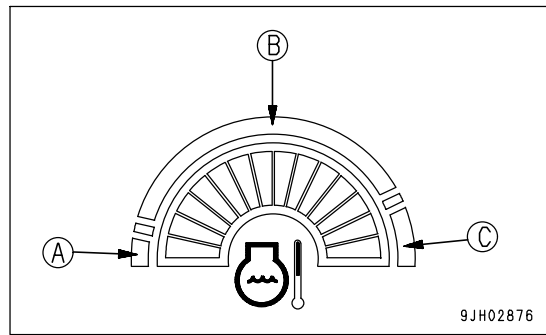

REMARK

If the power train oil temperature is not raised sufficiently, it will take longer to accelerate to the maximum speed.

6. Check for abnormal exhaust gas color, noise, or vibration. If any problem is found, contact your Komatsu distributor.

STOPPING ENGINE

NOTICE

If the engine is stopped without allowing it to cool down, there is danger that the service life of various parts of the engine will be reduced. Except in emergencies, never stop the engine suddenly.

If the engine overheats, do not stop it suddenly. Run it at low speed to allow it to cool down gradually, then stop it.

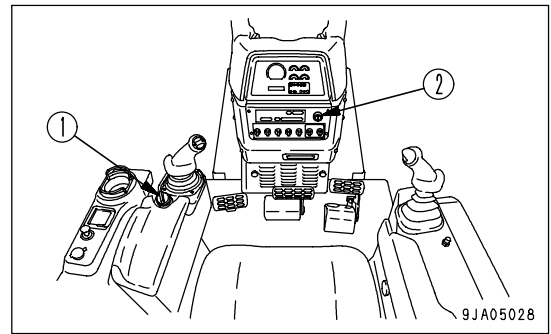

1. Lower the work equipment to the ground.
2. Place fuel control dial (1) in the low idle (MIN) position and run the engine at low idle speed for about 5 minutes to allow it to gradually cool down.

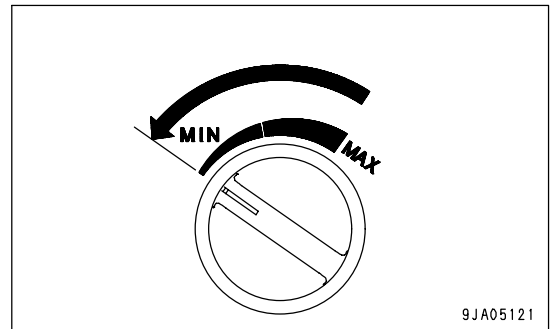

3. Turn the key in ignition switch (2) to the OFF position (A).
The engine will stop

REMARK

- When engine starting switch (2) key is turned to the OFF position, the engine stops, but the machine's main power source is not turned off immediately. This is a time lag provided for the controller to memorize the operation status and then terminate the system. While this process continues, the main power is maintained. The power holding time varies depending on the operation condition.
- Also when the cooling fan is used for a cleaning purpose, the machine's main power source is not turned off immediately, even if engine starting switch (2) key is turned to the OFF position. This time lag is provided to protect the hydraulic circuit, and in this case, the machine's main power is maintained for seven seconds.

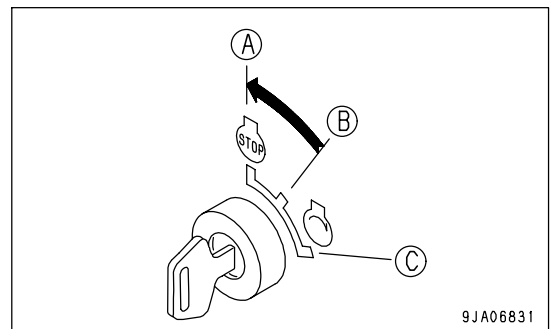

4. Remove the key from starting switch (2).

MACHINE OPERATION

MOVING MACHINE

WARNING

- When moving the machine, check that the area around the machine is safe, and sound the horn before moving.
Do not allow anyone to enter the area around the machine.
There is a blind spot at the rear of the machine, so be particularly careful when traveling in reverse.
- When moving the machine on a slope, always keep brake pedal (7) depressed even after releasing parking break lever (1).
- When moving the machine up a steep slope, turn fuel control dial (4) to the max. position, and keep brake pedal (7) and deceleration pedal (5) depressed. Then move joystick (steering, directional, and gearshift lever) (6) from the N position to the direction of travel and release brake pedal (7) slowly. When the travel speed rises, release deceleration pedal (5) slowly.

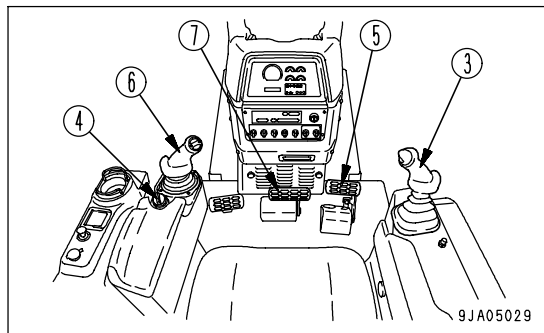
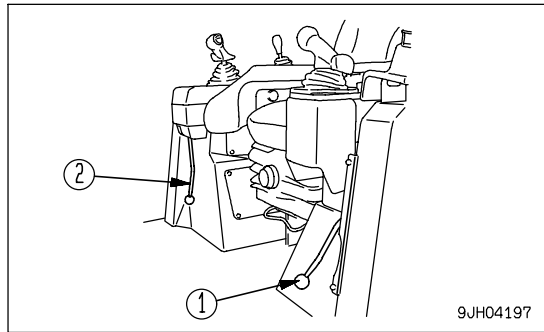

1. Operate parking brake lever (1) to the FREE (F) position.

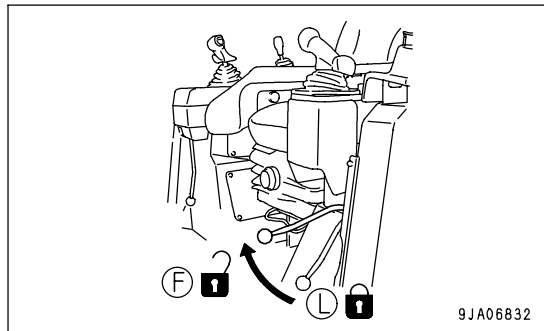

2. Operate work equipment lock lever (2) to the FREE (F) position.

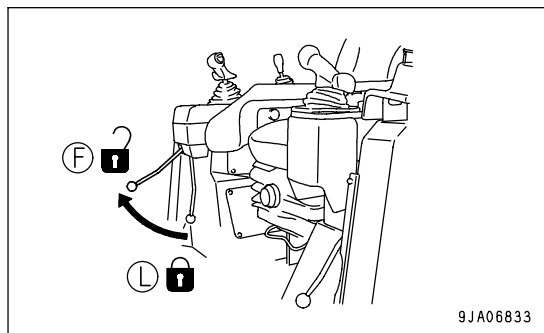

3. Put blade control lever (2) in the RAISE position (R) to raise the blade 40 to 50cm (15.8 to 19.7 in) off the ground.

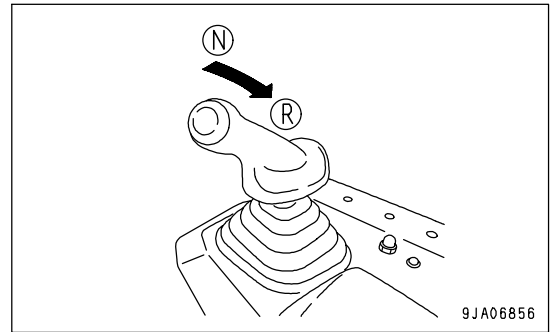

4. Turn fuel control dial (4) to the full speed (MAX) position, and fully depress decelerator pedal (5).

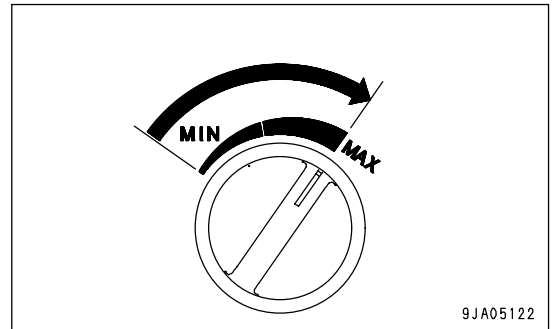

5. Operate steering - forward / reverse shifting - gearshift lever (6) to the FORWARD (F) position or REVERSE (R) position and gradually release deceleration pedal (5).

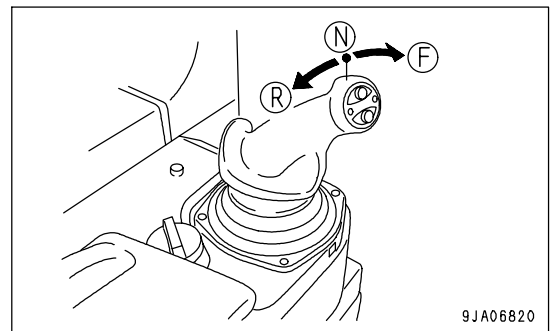
**REMARK**

Check that the backup alarm buzzer (rear side warning buzzer) properly sounds, when steering - forward / reverse shifting - gearshift lever (6) is operated to the REVERSE (R) position. If it does not, call on your Komatsu distributor for repairs.

STOPPING MACHINE

**WARNING**

Avoid stopping suddenly. Give yourself ample room when stopping.

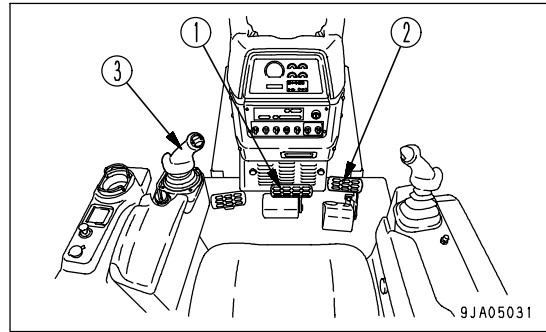

1. Depress brake pedal (1) to stop the machine.

NOTICE

If the brake pedal is depressed when the engine speed or machine travel speed is high, the brake disc may produce a slipping sound. When depressing the brake pedal, usually depress decelerator pedal (2) to reduce the engine speed and machine travel speed.

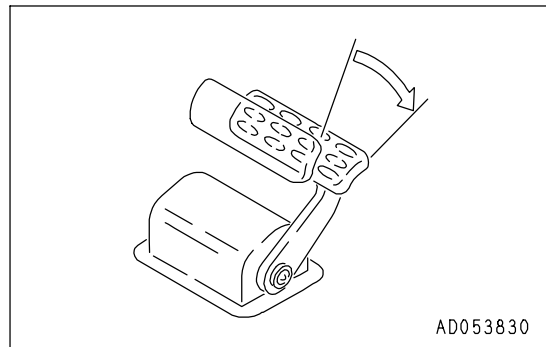

2. Move steering, forward-reverse, gear shift lever (3) to the NEUTRAL position (N), depress brake pedal (1) further, and stop the machine.

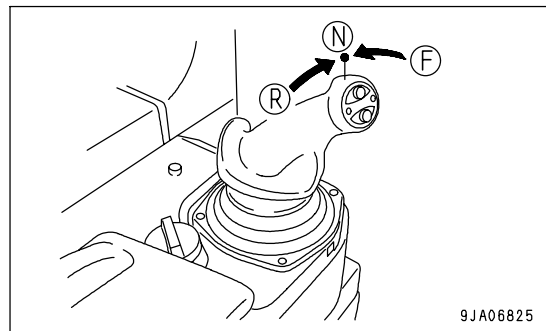

SHIFTING GEARS

The machine does not have to be stopped to shift gears.

1. Move steering, forward-reverse, gear shift lever (1) to the desired gear position to shift gears.

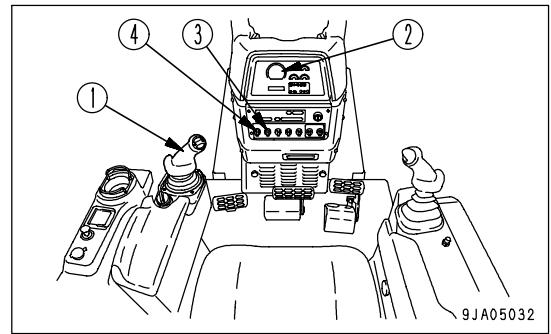

GEARSHIFTING OPERATION

When UP switch (U) or DOWN switch (D) is pushed, the transmission speed will change.

UP switch (U): Each time the switch is pressed, the transmission will up shift one speed.

DOWN switch (D): Each time the switch is pressed, the transmission will down shift one speed.

There are 3 forward and 3 reverse speed ranges.

For details of the maximum speed in each speed range, see "SPECIFICATIONS (PAGE 5-2)".

REMARK

- The present speed range is displayed in the center of display panel A (2).
 - 1st: 1 is displayed
 - 2nd: 2 is displayed
 - 3rd: 3 is displayed
- If the machine has failed, the speed range and speed range display may change automatically.

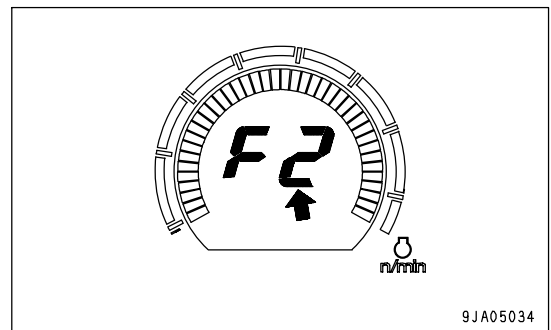
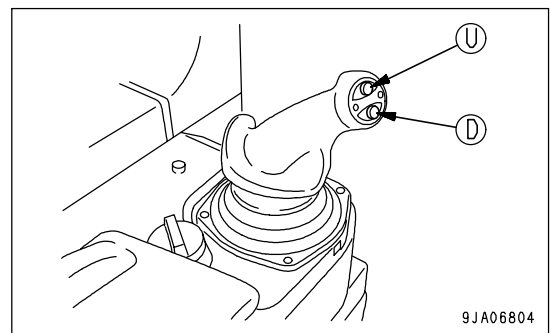

GEARSHIFTING OPERATION USING PRESET MODE FUNCTION

If the preset mode function is used, the speed ranges used when the machine travels in forward and reverse can be preset as desired.

1. Set steering, forward-reverse, gear shift lever (1) to the NEUTRAL position (N).

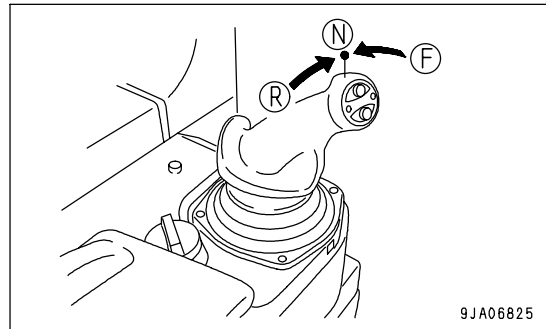

2. When preset mode switch (3) is set to the I position (ON), the function is actuated.

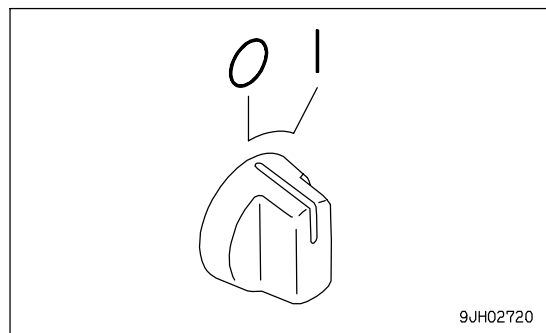

3. When the preset mode function is actuated, [F1-R1] is displayed at the left side of the bottom line of display panel B (multi-information) on the monitor panel, and the [F1-R1] mode is set.

REMARK

When preset mode switch (3) is set to the ON position (a), the default [F1-R1] mode is set.

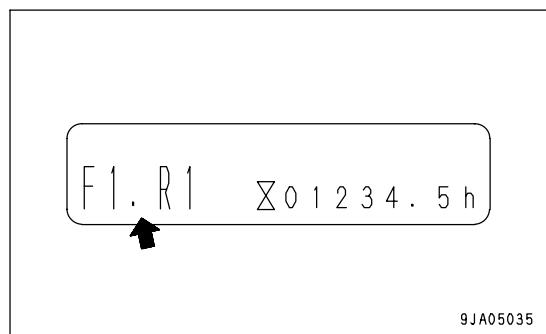

4. If it is desired to select another mode, press UP switch (U) or DOWN switch (D) on steering, forward-reverse, gear shift lever (1) and display the desired mode on control panel B (multi-information).
The types of mode and method of selection are as follows.

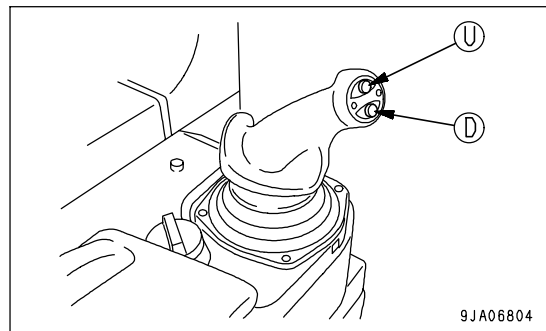
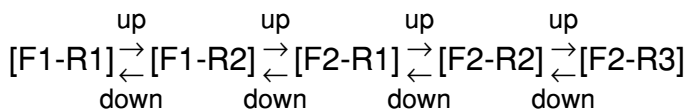

- Example of shift control when [F2-R2] mode is set.
When steering, forward-reverse, gear shift lever is set to F position, speed range F2 is automatically selected.
When steering, forward-reverse, gear shift lever is set to R position, speed range R2 is automatically selected.

REMARK

Even when the preset mode function is being actuated, it is possible to select the speed range by operating the UP switch or DOWN switch when the machine is traveling forward or in reverse.

However, the preset mode remains set as it is. If the steering, forward-reverse, gear shift lever is returned to the NEUTRAL position and then operated again to the FORWARD or REVERSE position, the set speed range is selected.

A particular advantage is that when the auto shift down function described below is being actuated, it is possible to save the trouble of shifting up when traveling in reverse after the transmission has shifted down during digging.

AUTO DOWN SHIFT OPERATION

If the travel speed drops because of the load conditions when traveling, this function automatically down shifts to a lower speed range.

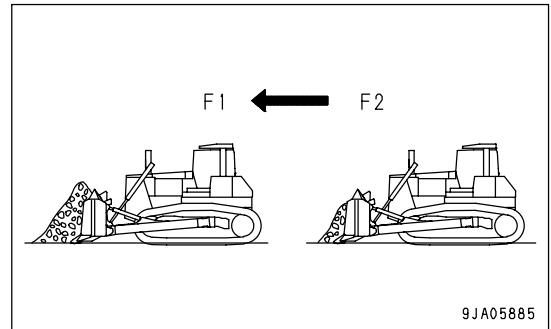

1. The function is actuated when auto shift down switch (4) on the front panel is set to I position (ON).

- (OFF) position: Canceled
- I (ON) position: Actuated

The transmission is automatically shifted down F2→ F1, F3 → F2, R2 → R1, R3 → R2.

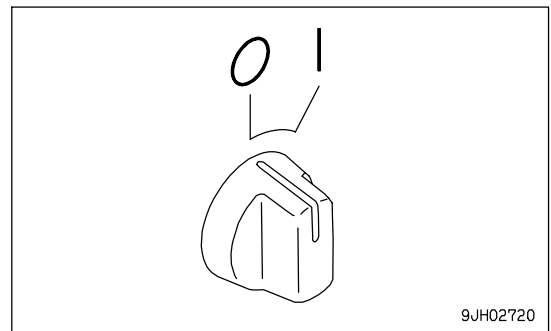

REMARK

While the preset mode is in operation, it is designed the way the machine does not automatically shift up for a safety reason, even after it automatically shifts down.

To shift up, press UP (U) button manually.

However, the preset mode setting remains the same. The machine returns to the set travel speed when the steering - forward/ reverse shifting - gearshift lever is once operated to the neutral position and then either to the FORWARD or to the REVERSE position again.

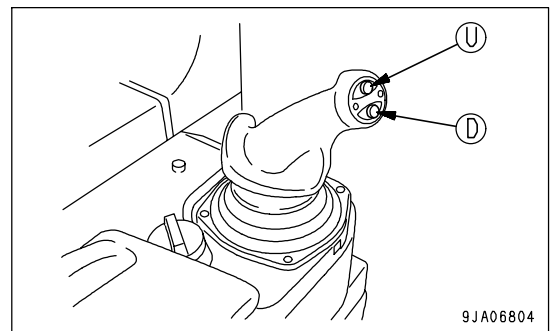

SHIFTING BETWEEN FORWARD AND REVERSE

WARNING

When switching between FORWARD and REVERSE, first check that the direction of travel is safe.

CAUTION

The travel direction can be changed without stopping the machine. Do not change it while the engine is running at the full speed, however, but depress the decelerator pedal to lower the engine speed before changing the travel direction for safety, comfort, and longer life of the power train.

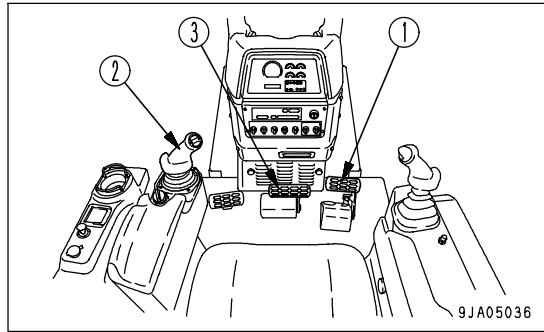

1. Depress decelerator pedal (1) to reduce the engine speed.

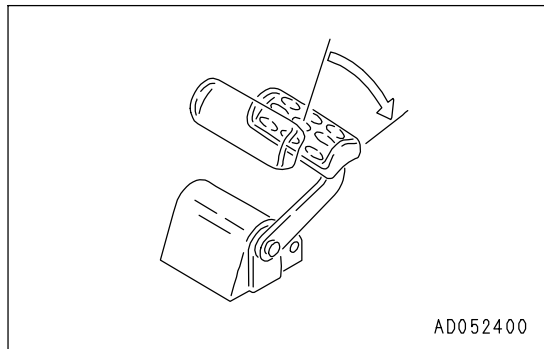

2. Move steering, forward-reverse, gear shift lever (2) to the NEUTRAL position (N), reduce the speed, then depress brake pedal (3) and stop the machine.

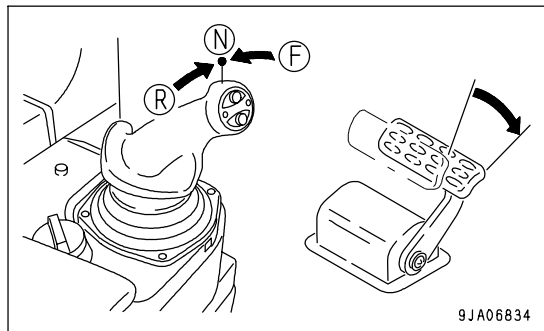

3. After depressing decelerator pedal (1), move steering, forward-reverse, gear shift lever (2) to the desired position.

- Position (F): Forward
- Position (N): Neutral
- Position (R): Reverse

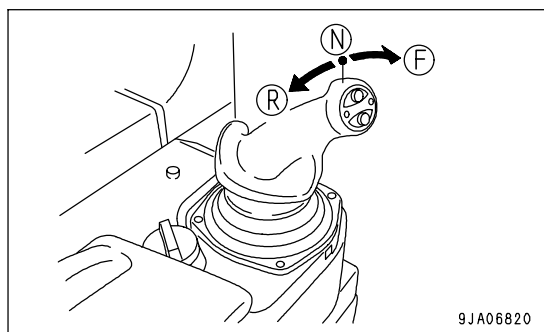

REMARK

Check that the backup alarm buzzer (rear side warning buzzer) properly sounds, when the steering - forward / reverse shifting - gearshift lever is operated to the REVERSE (R) position. If it does not, call on your Komatsu distributor for repairs.

4. Release decelerator pedal (1) and raise the engine speed.

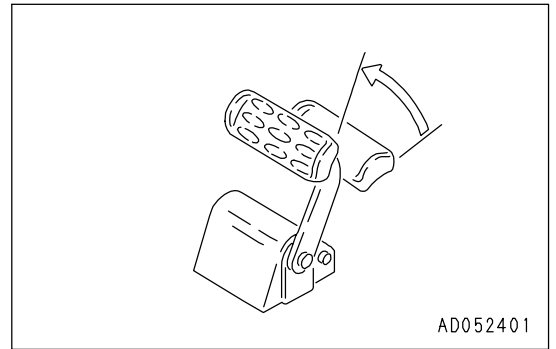

AD052401

REMARK

If the forward- reverse control lever is shifted when the machine is traveling downhill, a directional change may automatically take place via 1st gear for safety. For example, when the forward- reverse control lever is shifted from F2 to R2, the directional change may take place in the sequence of F2 to R1 to R2.

STEERING MACHINE

WARNING

- Avoid as much as possible turning the machine on a slope.
The machine will tend to slip sideways. Particular care should be taken on soft or clay soil.
- Never make a pivot turn at high speed.

NORMAL TURNING

WARNING

When performing a counterrotation turn, the feeling of operation when your head is facing the rear is different from the feeling if you are facing the front. Never carry out a counterrotation turn while facing the rear.

To turn the machine while traveling, incline steering, forward-reverse, gear shift lever (1) in the direction of the turn.

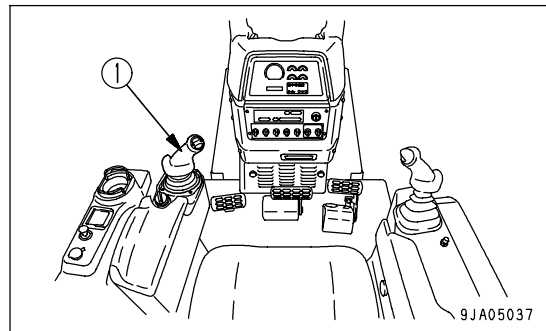

TURNING LEFT WHILE TRAVELING FORWARD

NOTICE

If the lever is moved partially to the forward or reverse position and then is moved in the direction of turn, the machine may carry out a counterrotation turn, so operate the lever fully to the forward or reverse position.

If steering, forward-reverse, gear shift lever (1) is moved to the FORWARD position (F) and moved partially to the left (L), the machine will start to turn gradually. After that, the lever can be moved further towards the end of its travel to set the desired turning radius.

REMARK

To turn gradually to the right while traveling forward, if the steering, forward-reverse, gear shift lever (1) is operated to the FORWARD position (F) and moved slowly to the right, the machine will start to turn gradually. After that, the lever can be moved further towards the end of its travel to set the desired turning radius.

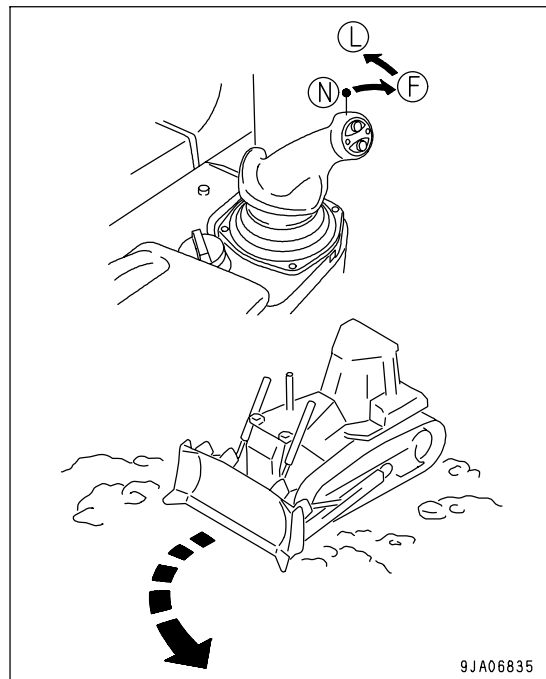

WHEN MAKING PIVOT TURN TO LEFT WHILE TRAVELING**NOTICE**

When carrying out a counterrotation turn, if the load is not equal on the left and right sides, the machine may carry out a pivot turn, so check the ground conditions and be careful not to hit any obstacles.

With steering, forward-reverse, gear shift lever (1) in the NEUTRAL position (N), operate the lever partially to the left (L). The left and right tracks will rotate in opposite directions, and the machine will make a slow counterrotation turn. If the lever is moved further, the speed of the counterrotation turn will increase.

REMARK

When making a right counterrotation turn, move the steering, forward-reverse, gear shift lever (1) to the right (R) in the same way.

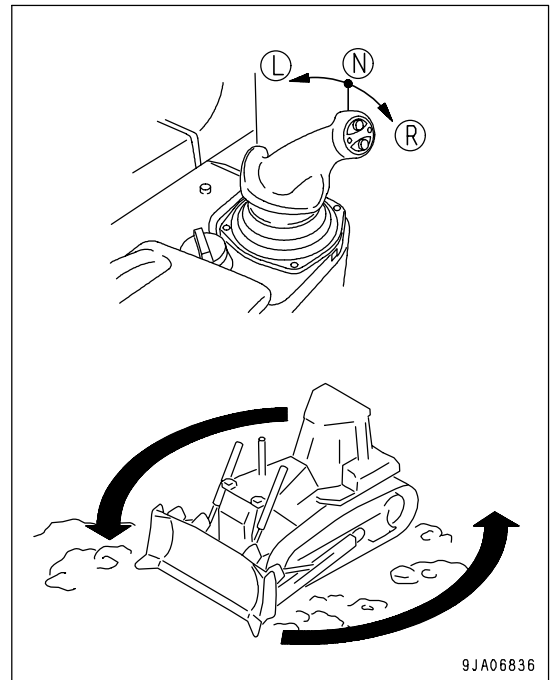

9JA06836

PRECAUTIONS FOR OPERATION

PAY ATTENTION TO GAUGES

When the red range lights on the power train oil temperature gauge while operating, reduce the load and wait for the temperature to decrease.

PERMISSIBLE WATER DEPTH

When operating in water, always keep the bottom of carrier rollers (1) above the surface of the water. Also, be careful that the engine cooling fan will not come in contact with water. The fan can be damaged.

After using the machine in the water for a long time, grease the work equipment and equalizer bar through each grease fitting. For more details on the lubrication method, see "LUBRICATING (PAGE 4-44), GREASE EQUALIZER BAR SIDE PIN (PAGE 4-46) and GREASE EQUALIZER BAR CENTER PIN (PAGE 4-46)".

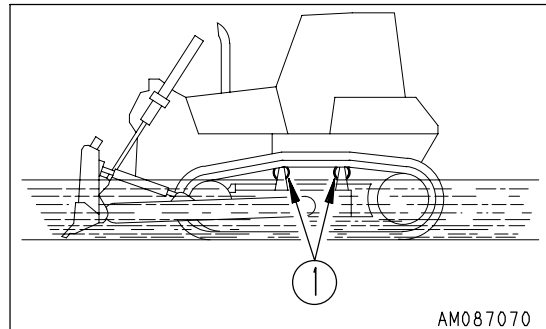

PRECAUTIONS WHEN TRAVELING UP OR DOWN HILLS

METHOD OF USING DECELERATOR PEDAL

When stepping on the decelerator pedal while going uphill, climbing ability will be reduced and the machine will stop. Furthermore, the engine may stall.

USE ENGINE AS BRAKE

When going downhill, move steering, forward-reverse, gear shift lever into low speed to run engine at slow speed and travel down slope using the engine as a brake.

Do not move the steering, forward-reverse, gear shift lever to the NEUTRAL position.

When traveling down hills of more than 15°, shift down to 1st speed (R1 or F1).

BRAKING WHEN TRAVELING DOWNHILL

While descending a slope using the engine as a brake, also apply the brakes.

Failure to brake may result in overrunning, causing engine trouble.

PRECAUTIONS ON SLOPES

BE CAREFUL OF FUEL LEVEL

If the fuel level in the fuel tank becomes low when working on slopes, the engine may suck in air because of the angle of the machine or the swaying of the machine. This makes the engine stop, so be careful not to let the fuel level in the fuel tank become too low.

BE CAREFUL OF OIL LEVEL

When operating machine on sloped areas of more than 20°, fill all appropriate components with oil to H level.

PRECAUTIONS WHEN ENGINE STOPS ON SLOPES

If the engine stops while working or traveling on a hill, immediately depress the brake pedal to bring the machine to a complete stop.

METHOD OF USING BRAKES

The following actions cause premature damage to the brakes, so avoid such operations.

- Using emergency brake at full speed
- Using brake with engine running at full speed in first gear (F1, R1) (Machine stall condition)

REMARK

Always depress the decelerator pedal to lower the engine speed before actuating the brakes.

IT IS PROHIBITED TO KEEP THE DOOR OPEN DURING OPERATIONS

(Machine equipped with cab)

Always keep the door closed when traveling or carrying out operations.

If the door is open, there is danger of damage from obstacles or strong vibration.

IT IS PROHIBITED TO MODIFY THE CAB GLASS IN ANY WAY THAT WILL OBSTRUCT THE VIEW

(Machine equipped with cab)

- For safety reasons, do not install anything on the cab glass that will obstruct the view.
- Always keep the glass clean to ensure safety during operations.

PRECAUTIONS FOR BLIND SPOTS CAUSED BY CAB AND ROPS STRUCTURES

(Machine equipped with cab)



WARNING

The cab structure may cause blind spots.

When operating, always be sure to check carefully that there is no obstacle or worker in the surrounding area.

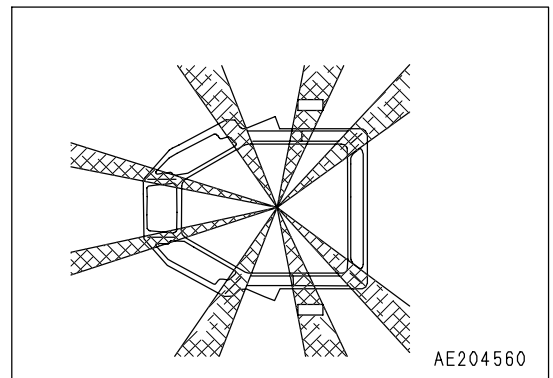

WORK POSSIBLE USING BULLDOZER

In addition to the following, it is possible to further increase the range of applications by using various attachments.

DOZING

A bulldozer digs and transports dirt in a forward direction. Slope excavation can always be most effectively carried out by proceeding from the top downward.

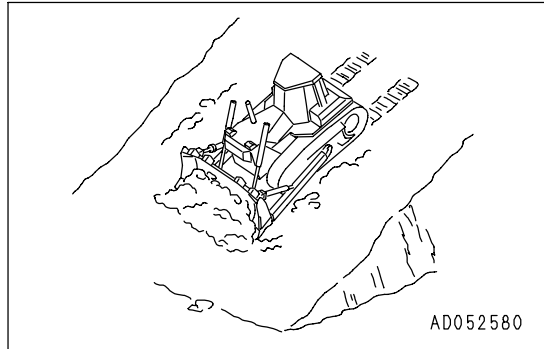

When dozing toward one side only, operate with angled blade (angledozer only).

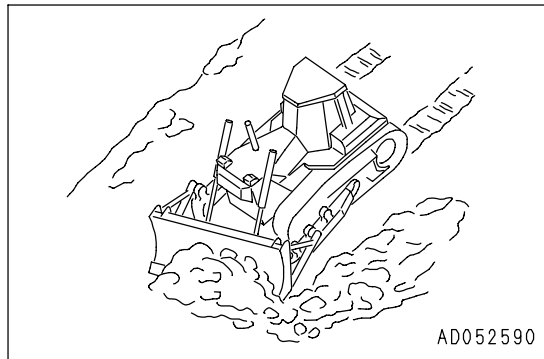

SMOOTHING

NOTICE

Avoid smoothing on rocky or stony ground. It can damage the blade.

To finish the ground to a flat surface after digging or leveling, put a full load of soil in front of the blade and operate the blade up and down in small movements while traveling forward. Finally, place the blade at FLOAT and travel at low speed in reverse while pulling the blade over the ground surface. Before doing this, hold the lever by hand at the FLOAT position for at least 1 second to make sure that it stays in position. To prevent damage to the blade, be careful not to travel over any stones or rocks.

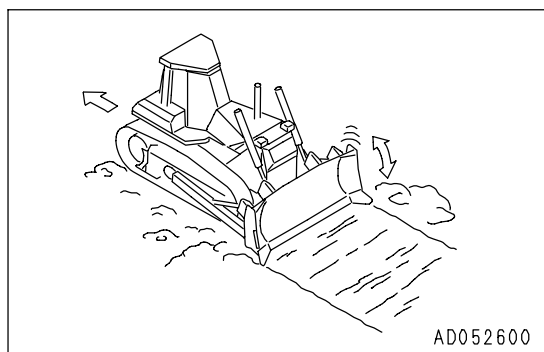

CUTTING INTO HARD OR FROZEN GROUND OR DITCHING

For digging and ditch excavation of hard or frozen ground, tilt the blade. Even hard ground can be dug effectively by a tilted or angled blade.

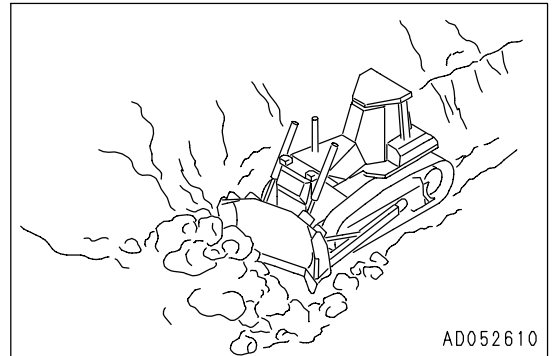

FELLING TREES, REMOVING STUMPS

NOTICE

Do not uproot trees or stumps or fell trees by angling or tilting the blade.

For trees with a diameter of 10 to 30 cm (3.9 to 11.8 in), raise the blade high and push 2 or 3 times to fell the tree.

Next, travel in reverse, and dig the corner of the blade into the ground to cut and dig up the roots.

When doing this, never hit the tree at high speed or apply shock to fell the tree.

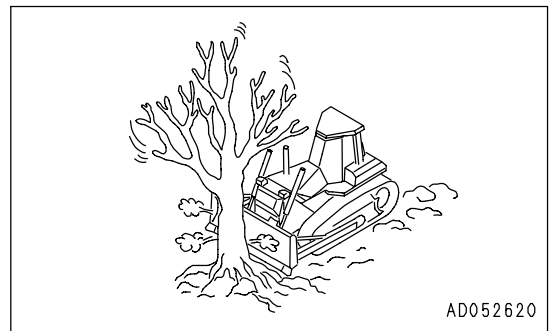

ADJUSTING POSTURE OF WORK EQUIPMENT

ADJUST ANGLE OF BLADE EDGE



WARNING

It is dangerous if the work equipment moves by mistake when adjusting angle of the blade edge. Set the work equipment in a stable condition, then stop the engine and lock the work equipment securely with the work equipment lock lever.

Blade cutting edge angle (A) can be adjusted to meet soil conditions.

POWER TILTDOZER

Power tiltdozer with screw-adjustable tilt brace.

Turn the brace with bar handle (1) to extend a distance between the joints (B), and then blade cutting edge angle (A) increases. To decrease the angle, shorten the distance.

Standard blade cutting edge angle (A) is 55°.

Standard distance between the joints (B) is as shown below.

D65EX: 1150 mm (45.31 in)

D65PX: 1146 mm (45.15 in)

D65WX: 1150 mm (45.31 in)

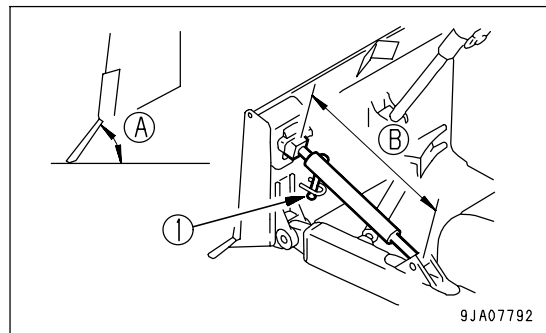

9JA07792

REMARK

When the machine is installed with a fixed type tilt brace, a blade cutting edge angle cannot be adjusted.

Standard blade cutting edge angle (A) is 55°.

When the blade cutting edge is held at the standard angle, the tilt amount is as shown below.

D65EX: 460 mm (18.1 in)

D65PX: 450 mm (17.7 in)

D65WX: 410 mm (16.2 in)

ANGLEDZOZER

The angle of the blade edge of the angleddozer cannot be adjusted.

Standard blade cutting edge angle (A) is 55°.

Standard distance between the joints (B) is as shown in the table below.

Model	Standard	Use Range
D65EX	1127mm (44.4in)	1117-1137mm (44.0-44.8in)
D65PX	1096mm (43.2in)	1086-1106mm (42.8-43.6in)

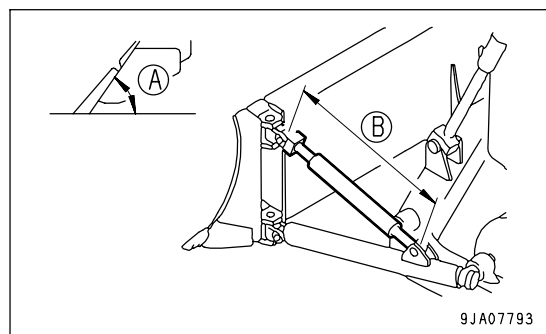

9JA07793

ADJUSTING SHIMS IN ASSEMBLING WORK EQUIPMENT

1. When assembling the work equipment, adjust an amount of play at each part (C) to the right values shown in the following table.

Shim adjusting position		(1) Tilt	(2) Lift	(3) Center	(4) Trunnion
Item					
Optimum value	mm (in)	0.2 - 0.5 (0.008 - 0.020)	0.2 - 0.5 (0.008 - 0.020)	0.2 - 0.5 (0.008 - 0.020)	0.2 - 1.0 (0.008 - 0.039)
Thickness of standard shims	mm (in)	5 (0.197)	4 (0.158)	5 (0.197)	10 (0.4)

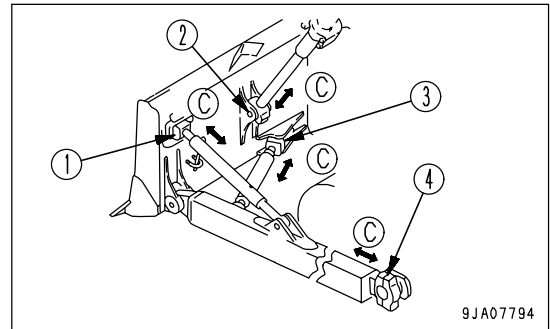

2. After the assembly, grease shim adjusting positions (1) to (3) and check that each part turns smoothly.

ADJUSTING TENSION OF CENTER BRACE

(Power tilt dozer only)

(Powertilt, Power pitch dozer only)

In case the work equipment assembly is disassembled for transportation and reassembled at a worksite, tension of the center brace has to be adjusted anew. Otherwise the bushing at the connecting part of blade and straight frame will likely slip off, allowing sand and dirt to enter the bushing, which eventually leads to premature wear or damage of the bushing. Make this adjustment as follows:

! WARNING

Except when operating the blade in Step 4, always lock the blade control lever securely with the work equipment lock lever.

1. Adjust with shim (2) so that the play of ball joint (1) is 0.2 to 0.5 mm (0.008 to 0.020 in).
2. Loosen bolt (3).
3. Install the blade assembly.
4. Operate the blade control lever to float the blade.
5. Insert bar (4) in the center brace hole and turn the bar to the protruding side. At that time, adjust clearance between the track shoe and frame (D) so that it is equal on the right and left sides.

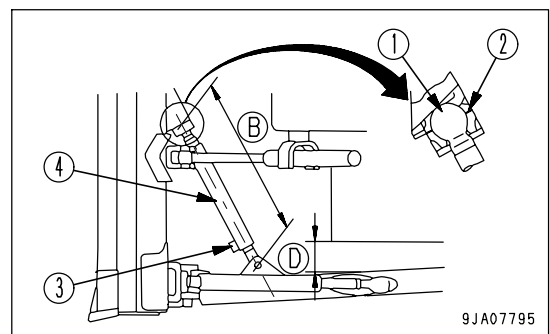

Rotating torque: 24.5 to 49 Nm (2.5 to 5 kgm, 18.1 to 36.2 lbft)
(Blade at FLOAT)

Standard distance between the joints (B) is as shown below.

D65EX: 995mm (39.2 in)

D65PX: 992mm (39.1 in)

D65WX: 995mm (39.2 in)

6. Tighten bolt (3).

Tightening torque: 490.3 to 608 Nm (50 to 62 kgm, 361.7 to 448.4 lbft)

ADJUST AMOUNT OF TILT

ANGLEDZER



WARNING

When adjusting the amount of tilt, it is dangerous if the work equipment is moved by mistake. Set the work equipment in a safe condition, then stop the engine and lock the work equipment securely with the work equipment lock lever.

NOTICE

An amount of tilt (A) can be increased to a maximum of 400 mm (15.8 in).
Adjust an amount of tilt (A) within 400 mm (15.8 in).

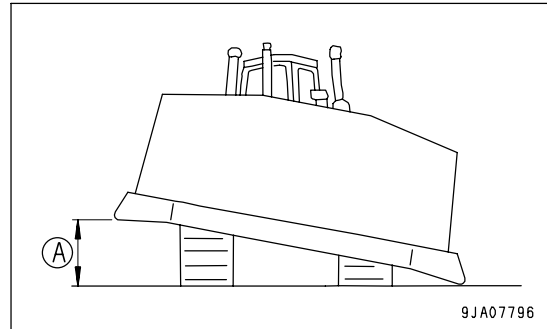

1. Raise the blade up to the height of 400 mm to 500 mm (15.8 in to 19.7 in) above the ground, and put block (B) beneath the blade edge.

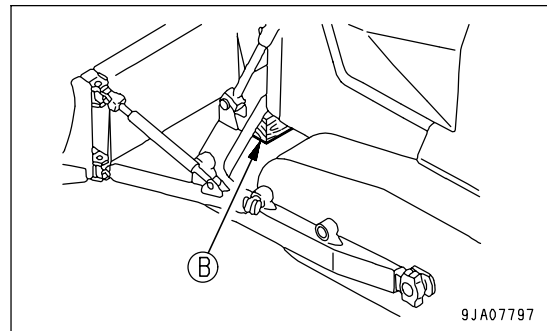

2. Loosen the bolt (1) of the brace, insert a suitable bar into hole (2) of the brace, and turn it.

REMARK

When turning the brace with bar, keep the blade above the ground.

Right tilt: Make right side shorter, left side longer

Left tilt: Make left side shorter, right side longer

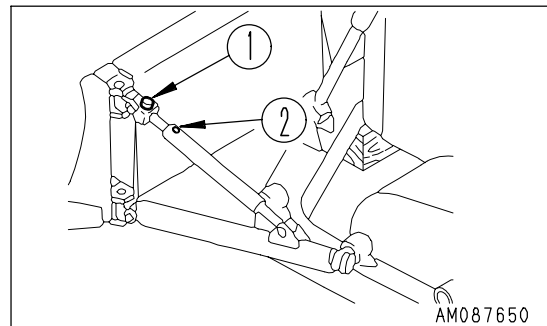

3. Tighten set bolt (1).

METHOD OF ANGLING BLADE

Angledozer only

When dozing toward one side only, operate with angled blade.

⚠ WARNING

- When adjusting the amount of angling, it is dangerous if the work equipment is moved by mistake. Set the work equipment in a safe condition, then stop the engine and lock the work equipment securely with the work equipment lock lever.
- Be careful when removing arm (2). After arm (2) is removed, the blade can move freely.

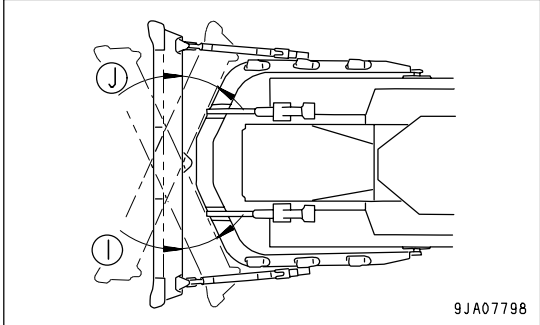

(I) Left angle : 25°
 (J) Right angle: 25°

1. Raise the blade up to the height of 400 mm to 500 mm (15.8 in to 19.7 in) above the ground, and put block (B) beneath the blade edge.

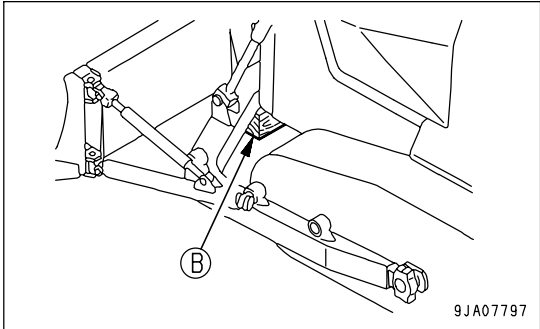

2. Remove pins (1) on the left and right sides, then remove arm (2) from the frame.
 3. Insert arm (2) into any desired bracket (C) on the frame (three brackets provided on one side) and fasten it with pin (1) so that it does not slip off.

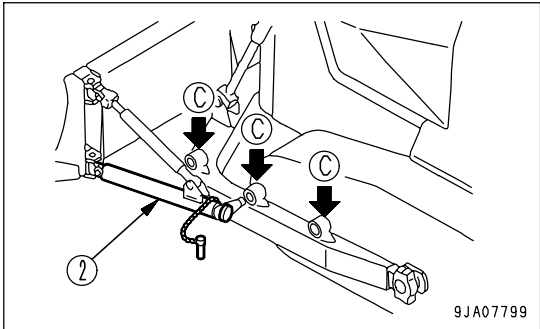
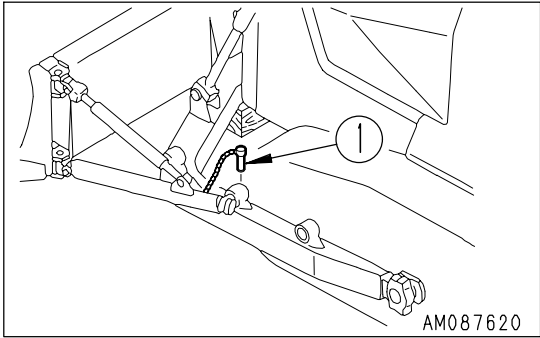

PARKING MACHINE

WARNING

- When stopping the machine, select flat hard ground and avoid dangerous places.
If it is unavoidably necessary to park the machine on a slope, place the parking brake lever in the LOCK position and insert blocks underneath the track shoes. As an additional safety measure, thrust the blade into the ground.
- If the work equipment control lever is touched by accident, the work equipment may move suddenly, and this may lead to a serious accident. Before leaving the operator's seat, always operate the work equipment lock lever and parking brake lever to place it securely at the LOCK position.

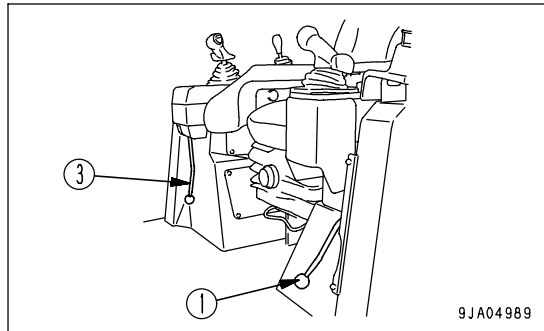
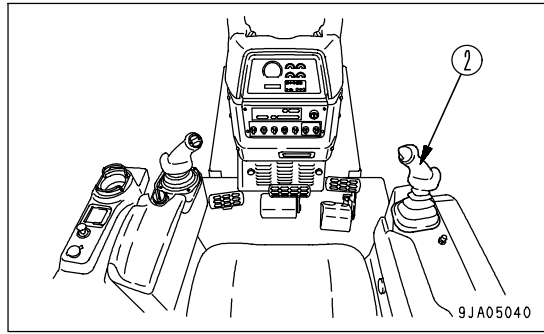

1. Stop the machine. For details, see "STOPPING MACHINE (PAGE 3-98)".
2. Set parking brake lever (1) to the LOCK position (L) and apply the parking brake.

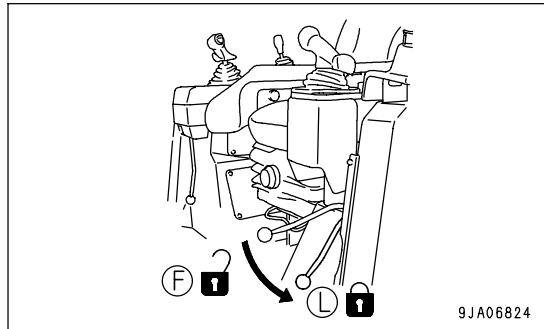

3. Push blade control lever (2) down to position (C) to lower the blade on the ground.

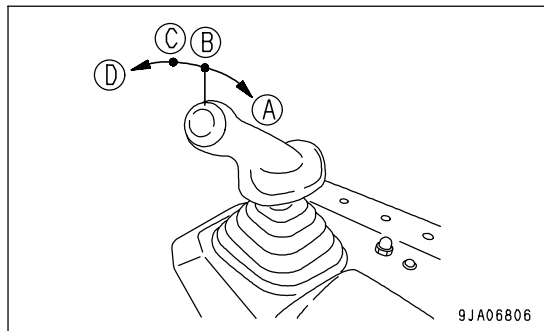

4. Set work equipment lock lever (3) in the LOCK position (L).

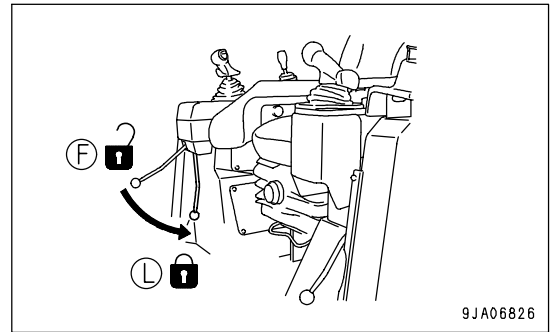

CHECK AFTER FINISHING WORK

BEFORE STOPPING ENGINE

Use the meters and caution lamps to check the engine coolant temperature, engine oil pressure, fuel, and power train oil temperature.

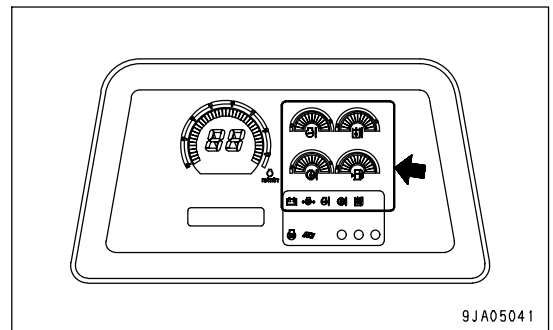

AFTER STOPPING ENGINE

1. Walk around the machine and check the work equipment, machine exterior, and undercarriage, also check for any leakage of oil or coolant. If any problems are found, repair them.
2. Fill the fuel tank.
3. Check the engine compartment for paper and debris. Clean out any paper and debris to avoid a fire hazard.
4. Remove any mud affixed to the undercarriage.

LOCKING

To prevent vandalism, there are locks in the following places.
Places that can be locked with the starting switch key.

- Top cover at front of chassis (1)
- Right and left engine side covers (2)
- Battery inspection cover (3)
- Inspection cover for fuel tank drain valve(4)
- Cab door opener (5) (Machine equipped with cab)
- Fuel tank filler cap (6)
- Hydraulic tank filler cap (7)
- Power train filter inspection cover (8)
- Engine cooling water sub-tank inspection cover (9)

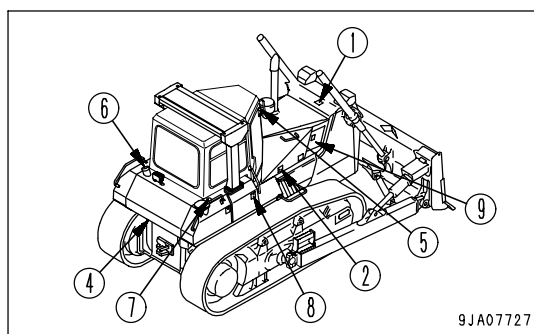
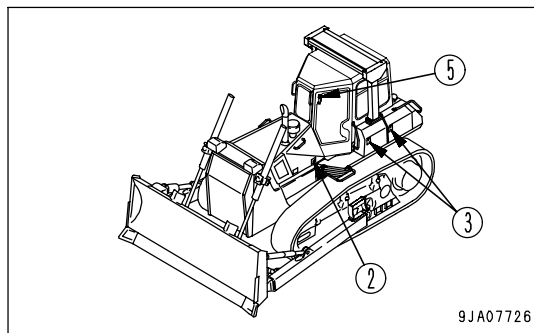

TIPS FOR LONGER UNDERCARRIAGE LIFE

Undercarriage life greatly varies depending on operation method, inspection and maintenance. For most efficient operation, keep the following points in mind.

OPERATION METHOD

- Select the track shoe that best suits the type of soil to be encountered in service.
Please consult your Komatsu distributor when selecting track shoes.
- Do not allow shoe slipping to occur during operation.
If shoe slipping occurs, reduce load on the blade until slipping stops.
- Avoid sudden starts, acceleration or stops, unnecessary high speeds and sharp turns.
- Always operate machine in a straight line whenever possible. When making turns, be careful not to allow the machine to stay to one side, so operation in both turning directions can be done properly. Make turns with the largest possible radius.
- Prior to operation, clear boulders and obstacles to prevent machine from riding over them while operating.
- On a slope, operate the machine parallel to the inclination of the slope. Do not operate across the slope. Also when stopping the machine on a slope, the machine should face the top of the slope.
- When ground inclines to the left or right during digging operations, do not continue to dig with the incline. Move the machine back to level ground and start to dig again.
- Do not force the machine to carry out work that exceeds its working capability. Such work includes cases where the idler or sprocket come off the ground when the machine meets obstacles that resist the power of the machine during dozing or ripping operations.

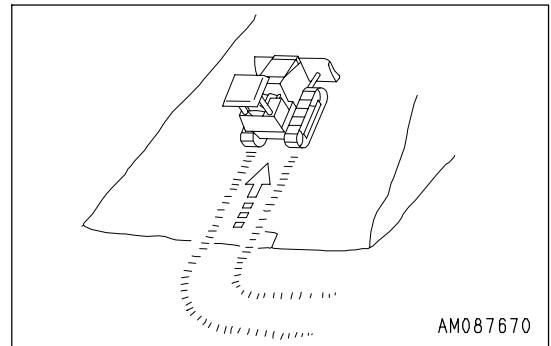

INSPECTION AND ADJUSTMENT

- Adjust the track shoe tension to an adequate level.
The track shoe tension can be measured in terms of clearance "a" between the front idler and carrier rollers as shown in the figure at right. While this clearance is normally 20 mm to 30 mm (0.8 to 1.2 in), increase the tension slightly on a rocky terrain and decrease on the clayish ground.
An excessively loose track shoe can create an abnormal vibration to the machine during the work or cause the sprocket teeth to wear prematurely.
(For an inspection and maintenance method, see "CHECK TRACK SHOE TENSION, ADJUST (PAGE 4-26)". Referring to that section, carry out an inspection and adjustment of track shoe tension.)
- Check idler rollers for oil leakage as well as for loose bolts and nuts. If any trouble is detected, repair immediately.

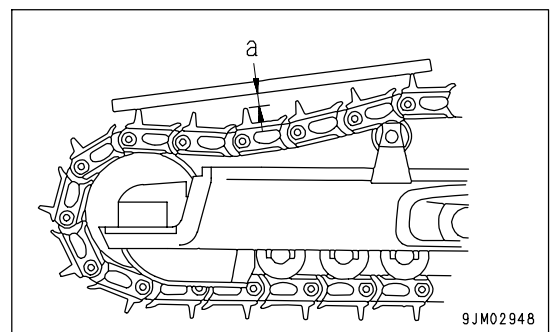

- Check a clearance (B) between front idler guide plate (1) and track frame (2). As clearance (B) becomes larger, it can cause the front idler to sway sideways and cause the track shoe to jump off rollers. (For an inspection and maintenance method, see "ADJUST IDLER CLEARANCE (PAGE 4-39)".

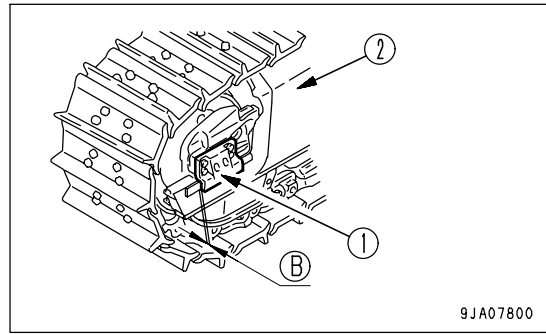

INSPECTION AND REPAIR

Frequent inspection and prompt repair will reduce repair costs.

The following items for inspection will serve as a guide to maintenance service of each undercarriage part. Perform periodical inspection and contact the Komatsu distributor in your area when machine has approached repairable limits and reversing limits.

MEASURING LINK PITCH

1. Insert a wooden block between track shoe and sprocket to take up the slack in track shoes.

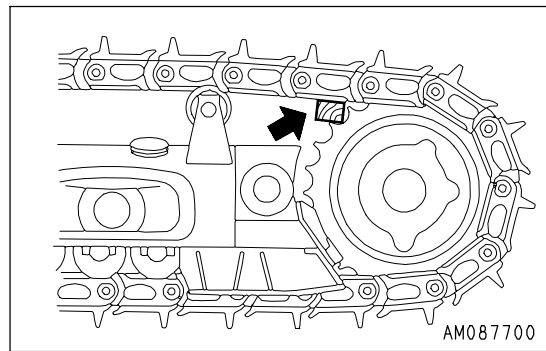

2. Measure the pitch length (L) of 4 links at a straight portion at least 2 links from master pin (A). Divide this measurement by four to obtain the link pitch.

- Basic link pitch (P): 203 mm (8.0 in)
- Link pitch limit for turning: 206 mm (8.1 in)

There is no link window on the master link.

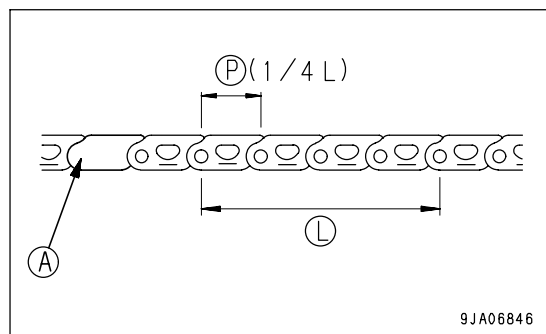

REMARK

The measured value under decimal of link pitch is different from the basic value depending upon the precision of measure or the tolerance of product even if it isn't worn out.

Don't judge it's worn out too soon, do it with the trend of measured value after that.

MEASURING HEIGHT OF GROUSER

(D65EX,D65WX)

After taking up slack in track shoes, measure height at center of shoe as shown below.

- Standard height (h): 65 mm (2.6 in)
- Repair limits: 25 mm (1.0 in)

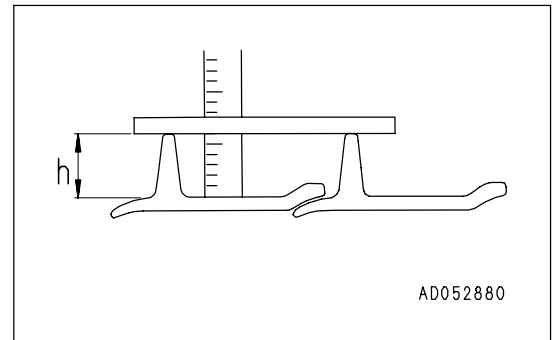
**MEASURING OUTSIDE DIAMETER OF TRACK ROLLER**

1. Measure the height (dimension C) of the link tread as shown in the diagram.
2. Stop machine at position where link tread, whose size C has been measured completely, contacts roller tread. Then measure size B.
3. Calculate outside diameter of tread (size A):

$$A = (B - C) \times 2$$

- Standard size (A): 210 mm (8.3 in)
- Repair limits: 172 mm (6.8 in)

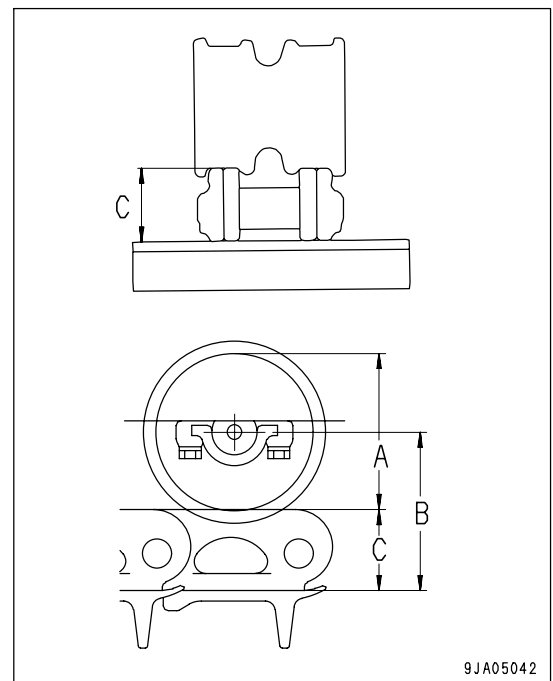

TRANSPORTATION

When transporting the machine, observe all related laws and regulations, and be careful to assure safety.

TRANSPORTATION MEANS

When transporting the machine, choose the transportation method in reference to the weight and dimensions shown in "SPECIFICATIONS (PAGE 5-2)".

Note that the machine specifications (weight and dimensions) vary depending on the kind of track shoes, blade, or other equipment.

REMOVING CAB

If it is necessary to remove the cab for transportation, there is danger that the seal may be damaged when removing or installing the cab, so please contact your Komatsu distributor.

When installing the cab, please contact your Komatsu distributor, too.

PRECAUTIONS WHEN REMOVING WORK EQUIPMENT

If there is any pressure remaining in the tilt piping after the work equipment has been removed, it may be difficult to remove the quick coupler of the tilt hose, so remove the work equipment as follows.

1. Lower the blade to the ground and set it horizontal to the ground surface.

REMARK

If the blade is tilted, the tilt piping will be under internal pressure, so set the blade horizontal to the ground.

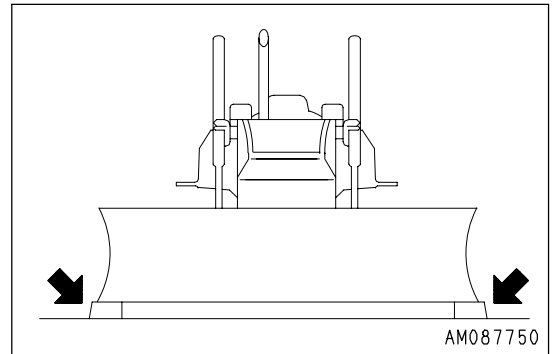

2. Remove the quick coupler (1), then remove the work equipment assembly.

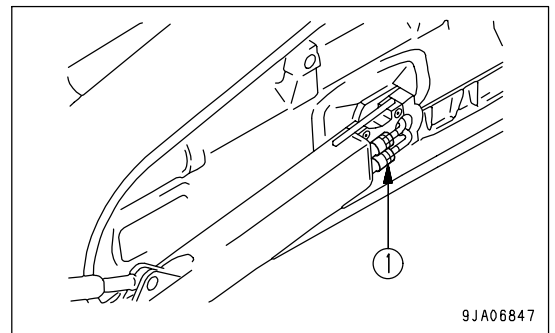

3. Remove right and left trunnions (2).
(D65PX,D65WX)

REMARK

- If the machine model is D65PX and D65WX, remove right and left trunnions (2).
- If the machine model is D65EX, it is not necessary to remove right and left trunnions (2), because the width including them (A) is less than 3.0 m.
- If the machine model is D65EX with a 3-m long semi U blade, it is not necessary to remove the work equipment, because the blade width is less than 3.0 m.

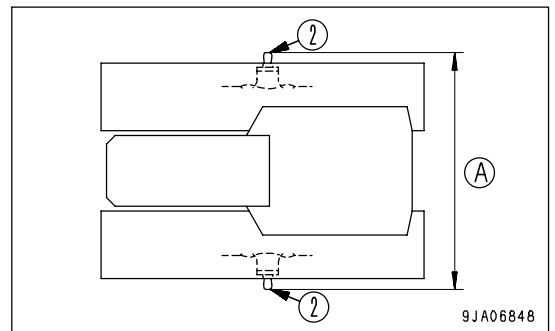

4. Tie the tilt hose with a band to prevent it from being damaged.

PRECAUTIONS WHEN REMOVING ROPS

When removing ROPS for transporting the machine, do as follows:

NOTICE

ROPS is an important safety component. Be sure to tighten mounting bolts (1) securely to the specified torque when installing.

Tightening torque: 785 to 980 Nm (80 to 100 kgm, 578.6 to 723.3 lbft)

1. Loosen bolts (1) and remove ROPS.

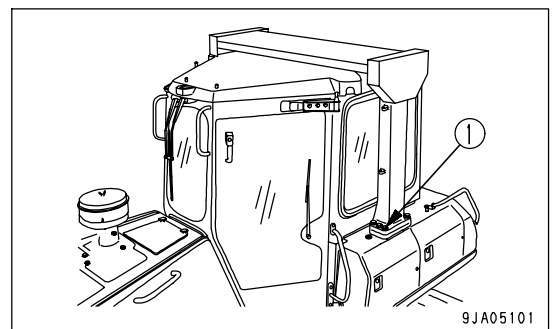

LOADING, UNLOADING WORK



WARNING

- Since loading and unloading of the machine is dangerous, be extremely careful.
- When loading or unloading the machine, operate it slowly with the engine speed low and the transmission in the 1st gear.
- Use ramps having sufficient width, length, thickness, and strength. Install them securely and set their angle to 15° or less. If the ramps are deflected appreciably, reinforce them with blocks.
- Perform the loading work of the machine on firm, level ground. Secure sufficient distance between the shoulder of the road and the trailer.
- Remove mud from the undercarriage of the machine so that the machine will not slip sideways on the ramps. In addition, remove water, snow, ice, grease, oil, etc. from the ramps.
- Never steer the machine on the ramps, since steering on the ramps can cause the machine to tip over. If it is necessary to change the travel direction, return to the ground or to the bed of the trailer, then change the travel direction.
- The center of gravity of the machine shifts suddenly at the border between the ramps and trailer, and the machine is unbalanced and becomes dangerous. Accordingly, pass the border slowly.

When loading or unloading, always use ramps or a platform. Proceed as follows.

LOADING WORK

1. Load and unload on firm level ground only.

Maintain a safe distance from the edge of a road.

2. Apply the trailer brakes securely and put blocks (1) under the tires to hold the trailer in position. Set gap (3) between ramps (2) to match the distance between the left and right tracks, and keep angle (4) to a maximum of 15°.

If ramps (2) bend appreciably under the weight of the machine, put wooden block (5) under the ramps to support them.

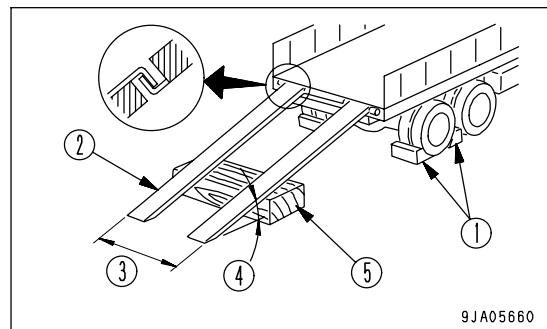

3. Start the engine.

In a cold weather, carry out an engine warming-up run, referring to the section, "STARTING IN COLD WEATHER (PAGE 3-93)", in this manual.

4. Set parking brake lever to the FREE position (F).
5. Set the transmission in the 1st gear and run the engine at low idle.
6. Set the travel direction toward the ramps and drive slowly.
7. The center of gravity of the machine shifts suddenly at the border between the ramps and trailer, and the machine is unbalanced and becomes dangerous. Accordingly, pass the border slowly.
8. Stop the machine at the specified position on the trailer.

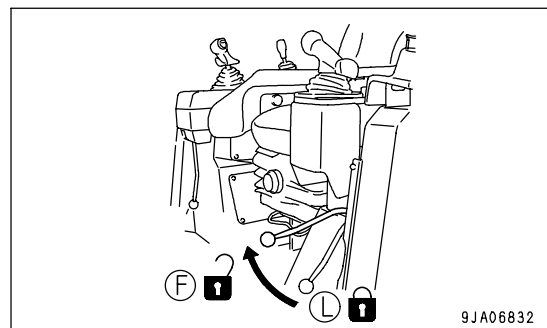

SECURING MACHINE

NOTICE

Be sure to lower the car radio antenna to the stow position (if the machine is equipped with a cab).

Load the machine onto a trailer as follows:

1. Lower the work equipment slowly.
(When transporting with work equipment installed)
2. Set the work equipment lock lever to the LOCK position (L) securely.
(When transporting with work equipment installed)

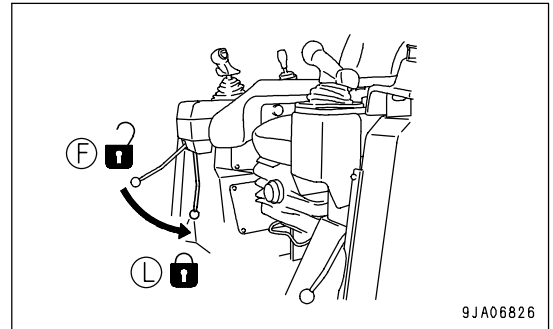

3. Set the parking brake lever to the LOCK position (L) securely.
4. Stop the engine, then remove the key from the starting switch.

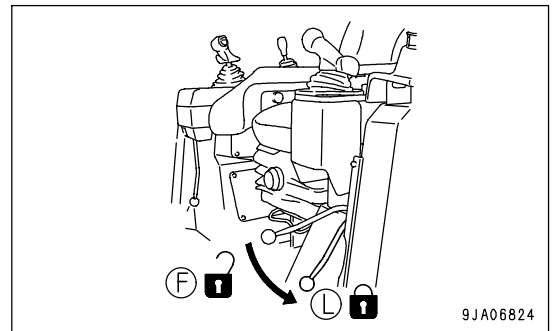

5. Fix the machine as explained below so that it will not move during transportation.

In particular, fix the machine securely to prevent it from slipping sideways.

- 1) Put blocks (1) in front and behind the track shoes of both sides.
- 2) Set up chain or wire, following (A) or (B).
 - A: Secure chain or wire around the track shoes.
 - B: Secure chain or wire through the holes of track links.
- 3) Protect the wire from contacting directly with angular parts of the machine, by inserting pads.

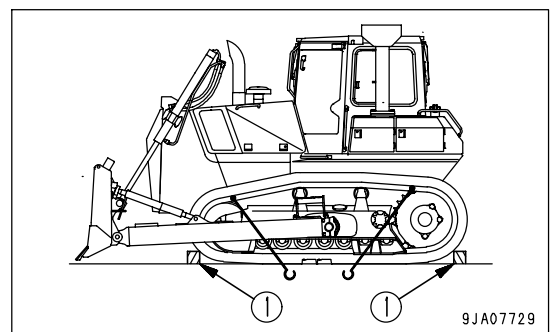
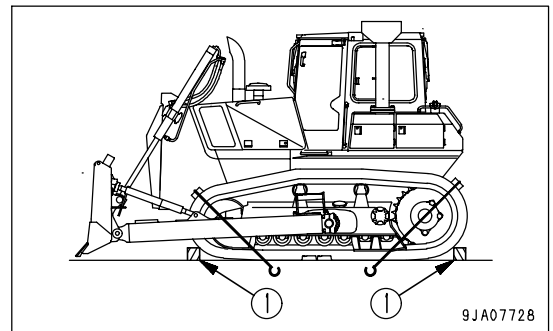

UNLOADING WORK

1. Load and unload on firm level ground only. Maintain a safe distance from the edge of a road.

2. Apply the trailer brakes securely and put blocks (1) under the tires to hold the trailer in position. Set gap (3) between ramps (2) to match the distance between the left and right tracks, and keep angle (4) to a maximum of 15°.

If ramps (2) bend appreciably under the weight of the machine, put wooden block (5) under the ramps to support them.

3. Remove the chains and wire ropes fastening the machine.

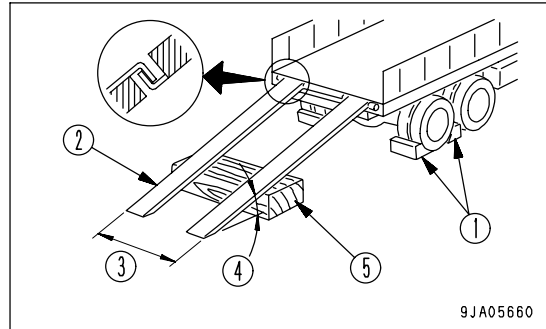

4. Start the engine.

In a cold weather, carry out an engine warming-up run, referring to the section, "STARTING IN COLD WEATHER (PAGE 3-93)", in this manual.

5. Set main work equipment lock lever to FREE position (F), and raise the work equipment.

(When transporting with work equipment installed)

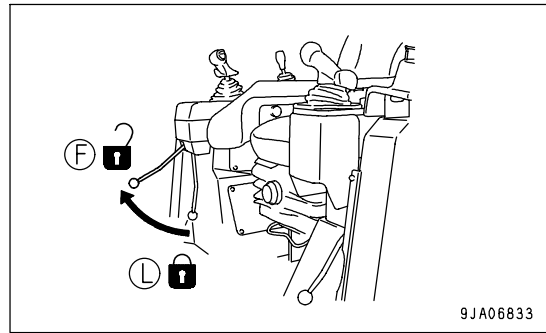

6. Set parking brake lever to the FREE position (F).

7. Set the transmission in the 1st gear and run the engine at low idle.

8. Set the travel direction toward the ramps and drive slowly.

9. The center of gravity of the machine shifts suddenly at the border between the ramps and trailer, and the machine is unbalanced and becomes dangerous. Accordingly, pass the border slowly.

10. Drive down the ramps slowly and carefully until the machine leaves the ramps perfectly.

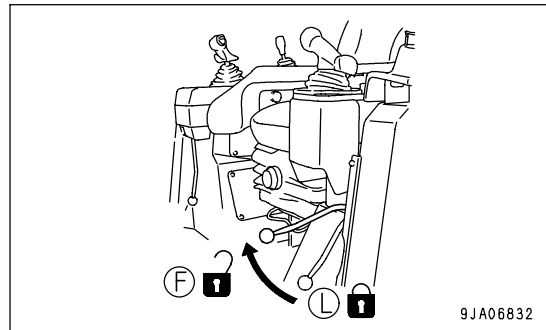

LIFTING MACHINE



WARNING

- The person using the crane to carry out lifting operations must be a qualified crane operator.
- Never carry out lifting operations if any person is on the machine being lifted.
- Always use a wire rope that has ample strength for the weight of the machine being lifted.
- Keep the machine horizontal when lifting it.
- When carrying out lifting operations, set the work equipment lock lever and parking brake lever to the LOCK position to prevent the machine or work equipment from moving unexpectedly.
- Never enter the area under or around a raised machine.
- There is danger of the machine losing its balance.

Use the procedure below to set the machine in the proper posture and use the lifting equipment when lifting the machine.

NOTICE

This method of lifting applies to the standard specification machine.

The method of lifting differs according to the attachments and options installed.

For details of the procedure for machines that are not the standard specification, please consult your Komatsu distributor.

For weight, see "SPECIFICATIONS (PAGE 5-2)".

PROCEDURE FOR LIFTING OPERATIONS

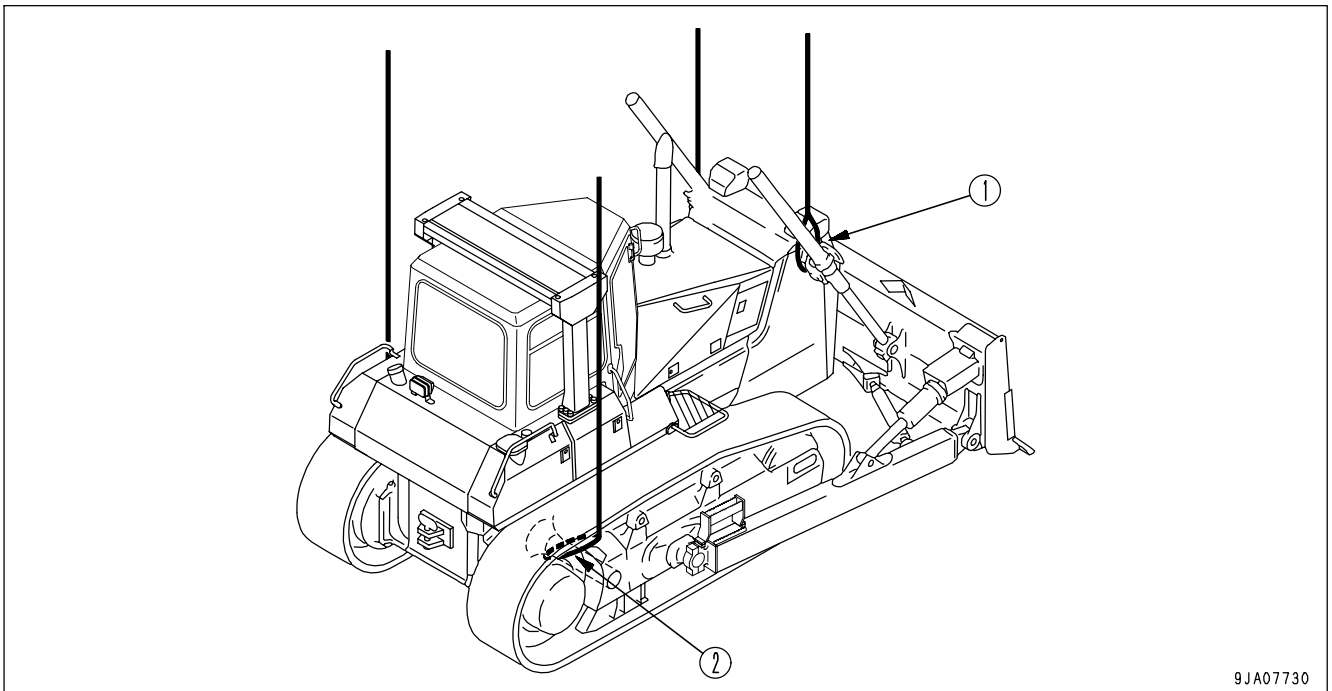

- Hang the front wire ropes to each cylinder support (1) on the right and left sides.
- Fit the wire ropes at the rear to both left and the right pivot shafts (2).

For machine equipped with ripper

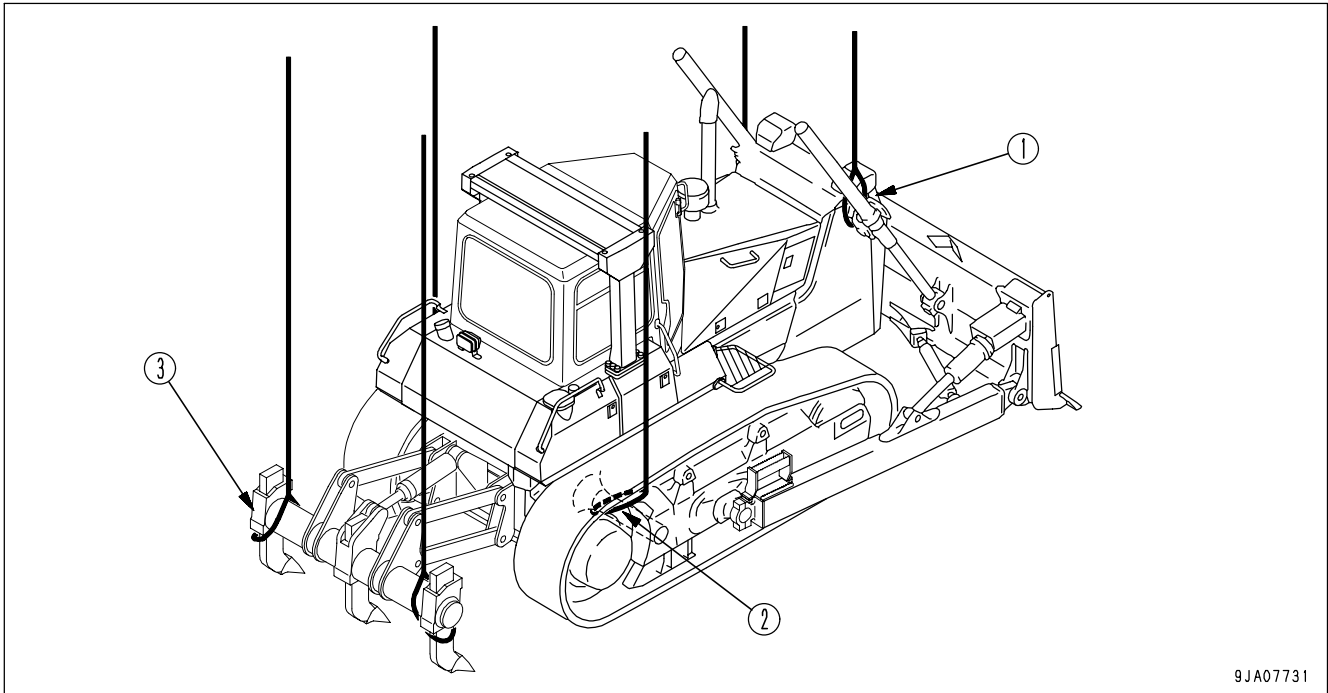

- Fit the wire ropes at the center to both left and the right pivot shafts (2).
- Hang the rear wire rope to ripper beam (3).

When lifting the machine, stop it on a level place, then observe the following procedure.

1. Stop the engine and set the parking brake lever to the LOCK position (L) securely.

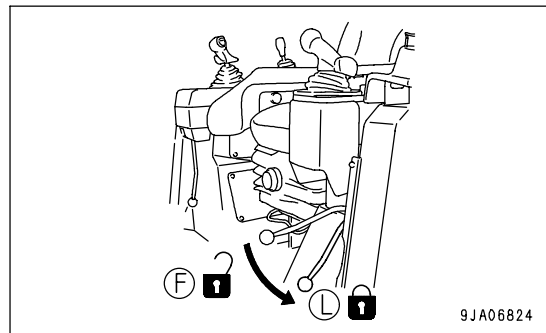

2. Set the work equipment lock lever to the LOCK position (L) securely.
3. Install wire ropes, slings, etc. matched to the weight of the machine to the lifting points as shown in the above figure.

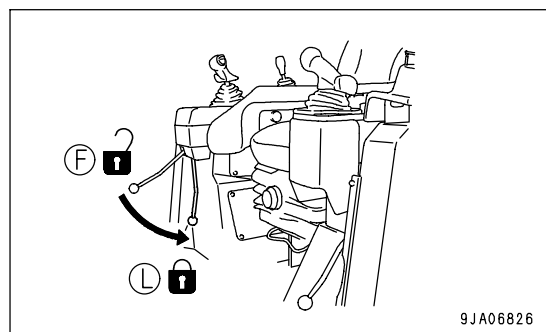

NOTICE

- Use protectors to prevent the wire rope from being cut on sharp corners and to prevent the wire rope from cutting into the machine bodywork.
- When using a spreader bar, select an ample width to prevent contact with the machine.

4. After setting the wire ropes, lift up the machine and stop at 100 to 200 mm (3.9 to 7.9 in) above the ground, and check that the wire ropes are not slack and the machine is level, then lift up slowly.

TRAVELING ON ROADS

- When traveling on paved roads, use flat shoes to protect their surface.
Even when travelling a short distance, always place boards to protect the road surface.

REMARK

Note that the asphalt road becomes soft in summer.

COLD WEATHER OPERATION

PRECAUTIONS FOR LOW TEMPERATURE

If the temperature becomes low, it becomes difficult to start the engine, and the coolant may freeze, so do as follows.

FUEL AND LUBRICANTS

Change to oil with low viscosity for all components. For details of the specified viscosity, see "RECOMMENDED FUEL, COOLANT, AND LUBRICANT (PAGE 4-12)".

COOLANT



WARNING

- Antifreeze is toxic. Be careful not to get it into your eyes or on your skin. If it should get into your eyes or on your skin, wash it off with large amounts of fresh water and see a doctor at once.
- When changing the coolant or when handling coolant containing antifreeze that has been drained when repairing the radiator, please contact your Komatsu distributor or request a specialist company to carry out the operation. Antifreeze is toxic. Do not let it flow into drainage ditches or spray it onto the ground surface.
- Antifreeze is flammable. Do not bring any flame close. Do not smoke when handling antifreeze.

NOTICE

Please use Komatsu genuine supercoolant (AF-NAC) for the coolant. As a basic rule, we do not recommend the use of any coolant other than Komatsu genuine supercoolant.

For details on the amount of antifreeze mixture and on when to change the coolant, see "CLEAN INSIDE OF COOLING SYSTEM (PAGE 4-23)".

BATTERY

 **WARNING**

- The battery generates flammable gas. Do not bring fire or sparks near the battery.
- Battery electrolyte is dangerous. If it gets in your eyes or on your skin, wash it off with a large amount of water and consult a doctor.
- Battery electrolyte dissolves paint. If it gets on the bodywork, wash it off immediately with water.
- If the battery electrolyte is frozen, do not charge the battery or start the engine with a different power source. There is danger that the battery may explode.
- Battery electrolyte is toxic. Do not let it flow into drainage ditches or spray it on to the ground surface.

When the ambient temperature drops, the capacity of the battery will also drop. If the battery charge ratio is low, the battery electrolyte may freeze. Maintain the battery charge as close as possible to 100%. Insulate it against cold temperature to ensure the machine can be started easily the next morning.

REMARK

Measure the specific gravity and calculate the charging rate from the following conversion table.

Electrolyte Temperature	20°C (68°F)	0°C (32°F)	-10°C (14°F)	-20°C (-4°F)
Charging Rate (%)				
100	1.28	1.29	1.30	1.31
90	1.26	1.27	1.28	1.29
80	1.24	1.25	1.26	1.27
75	1.23	1.24	1.25	1.26

- As the battery capacity drastically drops in low temperatures, cover or remove the battery from the machine, store the battery in a warm place, and install it again the next morning.
- If the electrolyte level is low, add distilled water in the morning before beginning work. Do not add water after the day's work to prevent diluted electrolyte in the battery from freezing during the night.

AFTER COMPLETION OF WORK

To prevent mud, water, or the undercarriage from freezing and making it impossible for the machine to move on the following morning, observe the following precautions.

- Remove all the mud and water from the machine body. In particular, wipe the hydraulic cylinder rods clean to prevent damage to the seal caused by mud, dirt, or drops of water on the rod from getting inside the seal.
- Park the machine on hard, dry ground.
If this is impossible, park the machine on boards.
The boards prevent the tracks from freezing to the ground, and allow the machine to be moved the next morning.
- Open the drain valve and drain any water collected in the fuel system to prevent it from freezing.
- Fill the fuel tank to capacity. This minimizes moisture condensation in the tank when the temperature drops.

AFTER COLD WEATHER

When the season changes and the weather becomes warmer, do as follows.

- Replace the fuel and oil for all parts with oil of the viscosity specified.
For details, see "RECOMMENDED FUEL, COOLANT, AND LUBRICANT (PAGE 4-12)".

LONG-TERM STORAGE

BEFORE STORAGE

When keeping in long-term storage (more than one month), store as follows.

- Clean and wash all parts, then store the machine indoors. If the machine has to be stored outdoors, select level ground and cover the machine with a sheet.
- Completely fill the fuel tank. This prevents moisture from collecting.
- Lubricate and change the oil before storage.
- Apply a thin coat of grease to metal surface of the hydraulic piston rods and the idler adjusting rods.
- Disconnect the negative terminals of the battery and cover it or remove it from the machine and store it separately.
- Place all control levers in the neutral position, set the work equipment lock lever and parking brake lever in the LOCK position, and set the fuel control dial to the low idling position.
- To prevent rust, fill with Komatsu genuine supercoolant (AF-NAC) to give a density of at least 30% for the engine coolant.

DURING STORAGE



WARNING

If it is necessary to perform the rust-prevention operation while the machine is indoors, open the doors and windows to improve ventilation and prevent gas poisoning.

- During storage, operate and move the machine for a short distance once a month so that a new film of oil will coat moving parts. At the same time, also charge the battery.
- When operating the work equipment, wipe off all the grease from the hydraulic cylinder rods.
- If the machine is equipped with an air conditioner, operate the air conditioner for 3 to 5 minutes once a month to lubricate all parts of the air conditioner compressor. Always run the engine at low idle when doing this. In addition, check the refrigerant level twice a year.

AFTER STORAGE

NOTICE

If the machine has been stored without carrying out the monthly rust-prevention operation, consult your Komatsu distributor before using it.

When using the machine after long-term storage, do as follows before using it.

- Wipe off the grease from the hydraulic cylinder rods.
- Add oil and grease at all lubrication points.
- When the machine is stored for a long period, moisture in the air will mix with the oil. Check the oil before and after starting the engine. If there is water in the oil, change all the oil.

TROUBLESHOOTING

AFTER RUNNING OUT OF FUEL

When starting the engine again after running out of fuel, fill with fuel, then bleed the air from the fuel system before starting the engine.

PROCEDURE FOR BLEEDING AIR

1. Insert the key into the engine starting switch and turn the key to ON position (B). Then the electric priming pump begins to work.

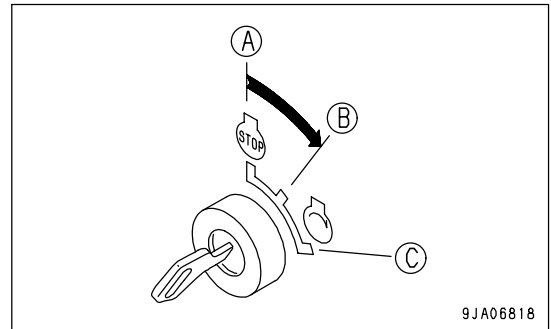

2. After holding the key in ON position (B) for 30 seconds, turn it back to OFF position (A) and hold it there for 10 seconds.

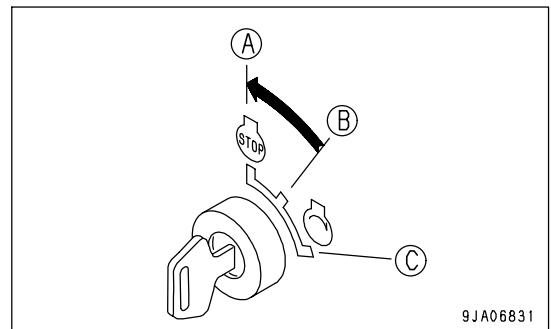

3. Repeat Steps 1 and 2 four times.
4. Turn the engine starting switch key to START position (C) to start up the engine.

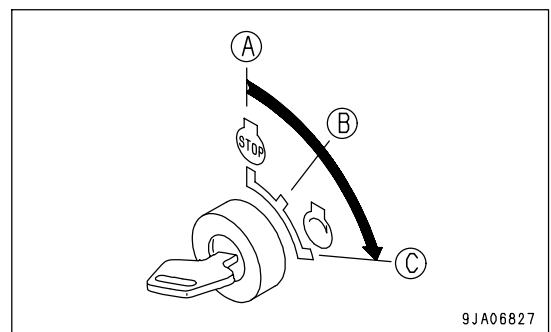

5. If the engine does not start up even after the engine starting motor is kept running for 20 seconds, repeat the procedures of Step 1 through Step 4.

METHOD OF TOWING MACHINE



WARNING

Serious injury or death could result if a disabled machine is towed incorrectly or if there is a mistake in the selection or inspection of the wire rope.

- If the engine does not start, put blocks under the track to prevent the machine from moving, then release the brake. If blocks are not use, there is danger that the machine may move suddenly.
- Always check that the wire rope used for towing has ample strength for the weight of the machine being towed.
- Never use a wire rope which has cut strands (A), reduced diameter (B), or kinks (C). There is danger that the rope may break during the towing operation.
- Always wear leather gloves when handling wire rope.
- Never tow a machine on a slope.
- During the towing operation, never stand between the towing machine and the machine being towed.
- Operate the machine slowly and be careful not to apply any sudden load to the wire rope.

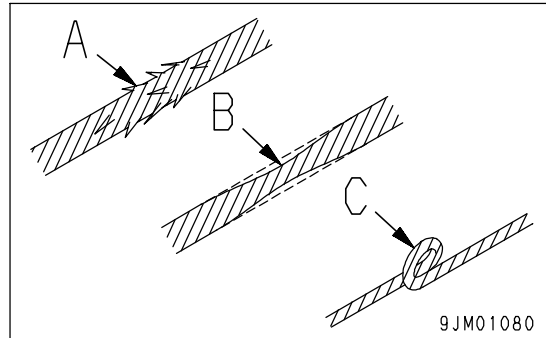

NOTICE

The maximum towing capacity for this machine is 140,000 N (14,275 kg).

Always carry out towing operations within the maximum towing capacity.

For details of the method of towing, please contact your Komatsu distributor.

- If the engine stops or the oil pressure in the brake circuit lowers because of a trouble in the hydraulic system, the brake works and the machine cannot move. To move the machine in this case, the oil pressure in the brake circuit must be heightened to the specified level with a special device. Ask your Komatsu distributor.
- Moving a machine by towing is only used to move it to a place where it is possible to carry out inspection and maintenance. It is not intended for moving the machine long distances. Do not use this method for towing the machine for long distances.
- If it is impossible to operate the steering and brakes of the machine being towed, do not let anyone ride on the machine.
- Keep the angle of the towing line to the minimum. Operate the machine so that the angle does not become greater than 30° from the straight line.

If the machine gets stuck in the mud or a heavy thing needs to be towed, install a towing wire rope to the draw bar pin.

- Connect a wire rope to the part indicated with the arrow in the diagram at right.

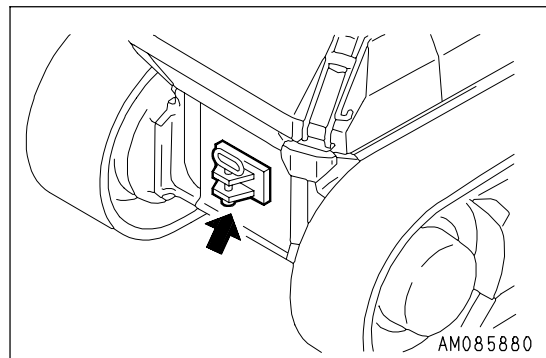

IF BATTERY IS DISCHARGED

WARNING

- It is dangerous to charge a battery when mounted on a machine. Make sure that it is dismantled before charging.
 - When checking or handling the battery, stop the engine and turn the starting switch key to the OFF position.
 - The battery generates hydrogen gas, so there is a hazard of explosion. Do not bring lighted cigarettes near the battery, or do anything that will cause sparks.
 - Battery electrolyte is dilute sulfuric acid, and it will attack your clothes and skin. If it gets on your clothes or on your skin, immediately wash it off with a large amount of water. If it gets in your eyes, wash it out with fresh water and consult a doctor.
 - When handling batteries, always wear safety glasses and rubber gloves.
 - When removing the battery, first disconnect the cable from the ground (normally the negative (-) terminal). When installing, install the positive (+) terminal first.
- If a tool touches the positive terminal and the chassis, there is danger that it will cause a spark, so be extremely careful.
- If the terminals are loose, there is danger that the defective contact may generate sparks that will cause an explosion.
 - When removing or installing the terminals, check which is the positive (+) terminal and which is the negative (-) terminal.

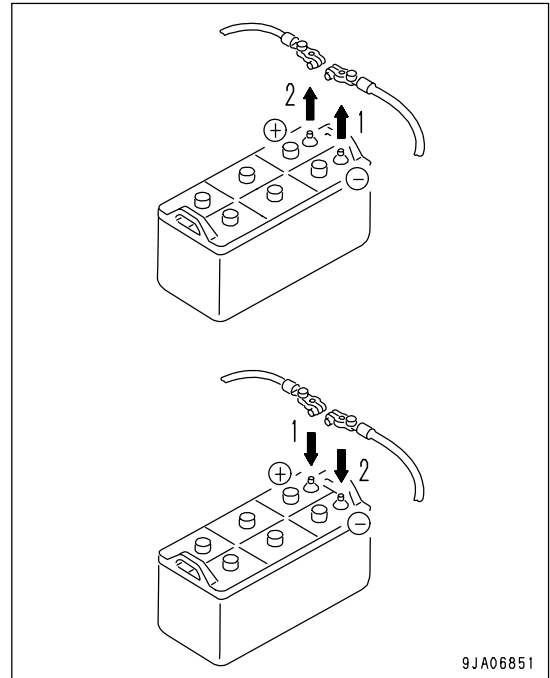

9JA06851

REMOVE AND INSTALL BATTERY

1. Open the battery cover.
2. Before removing battery, remove the ground cable (normally connected to the negative (-) terminal). If any tool touches between the positive terminal and the chassis, there is danger of sparks being generated. Loosen the nuts of the terminal and remove the wires from the battery.
3. After installing the battery, fix it with the battery hold down.
Tightening torque: 1.47 to 1.96 Nm (0.15 to 0.2 kgm, 1.1 to 1.4 lbft)
4. When installing the battery, connect the ground cable last.
Insert the hole of the terminal on the battery and tighten the nut.
Tightening torque: 5.9 to 9.8 Nm
(0.6 to 1.0 kgm, 4.3 to 7.2 lbft)

PRECAUTIONS FOR BATTERY CHARGING

If the battery is charged improperly, it may explode. Accordingly, charge it according to "IF BATTERY IS DISCHARGED (PAGE 3-133)" and the instruction manual attached to the charger, and observe the following items.

- Set the voltage of the charger to match the voltage of the battery to be charged. If the correct voltage is not selected, the charger may overheat and cause an explosion.
- Connect the positive (+) charger clip of the charger to the positive (+) terminal of the battery, then connect the negative (-) charger clip of the charger to the negative (-) terminal of the battery. Be sure to attach the clips securely.
- Set the charging current to 1/10 of the value of the rated battery capacity; when carrying out rapid charging, set it to less than the rated battery capacity.
If the charger current is too high, the electrolyte will leak or dry up, and this may cause the battery to catch fire and explode.
- If the battery electrolyte is frozen, do not charge the battery or start the engine with a different power source. There is a danger that this will ignite the battery electrolyte and cause the battery to explode.
- Do not use or charge the battery if the battery electrolyte level is below the LOWER LEVEL line. This may cause an explosion. Check the battery electrolyte level periodically and add distilled water to bring the electrolyte level to the UPPER LEVEL line.

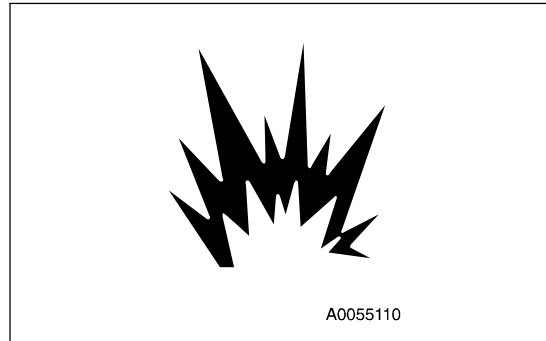

STARTING ENGINE WITH BOOSTER CABLE

When starting the engine with a booster cable, do as follows.

PRECAUTIONS WHEN CONNECTING AND DISCONNECTING BOOSTER CABLE

WARNING

- When connecting the cables, never contact the positive (+) and negative (-) terminals.
- When starting the engine with a booster cable, wear safety glasses and rubber gloves.
- Be careful not to let the normal machine and problem machine contact each other. This prevents sparks from generating near the battery which could ignite the hydrogen gas given off by the battery.
- Make sure that there is no mistake in the booster cable connections. The final connection is to the engine block of the problem machine, but sparks will be generated when this is done, so connect to a place as far as possible from the battery.
- When disconnecting the booster cable, take care not to bring the clips in contact with each other or with the machine body.

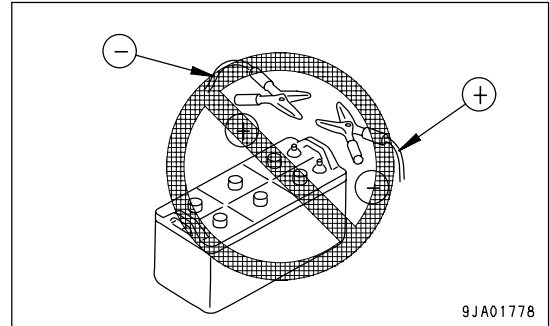

NOTICE

- The starting system for this machine uses 24V. For the normal machine, also use a 24V battery.
- The size of the booster cable and clip should be suitable for the battery size.
- The battery of the normal machine must be the same capacity as that of the engine to be started.
- Check the cables and clips for damage or corrosion.
- Make sure that the cables and clips are firmly connected.
- Check that the work equipment lock levers and parking brake levers of both machine are in the LOCK position.
- Check that each lever is in the NEUTRAL position.

CONNECTING THE BOOSTER CABLE

Keep the starting switch of the normal machine and problem machine in the OFF position.

Connect the booster cable as follows, in the order of the numbers marked in the diagram.

1. Connect the clip of booster cable (A) to the positive (+) terminal of battery (C) on the problem machine.
2. Connect the clip at the other end of booster cable (A) to the positive (+) terminal of battery (D) on the normal machine.
3. Connect the clip of booster cable (B) to the negative (-) terminal of battery (D) on the normal machine.
4. Connect the clip at the other end of booster cable (B) to engine block (E) on the problem machine.

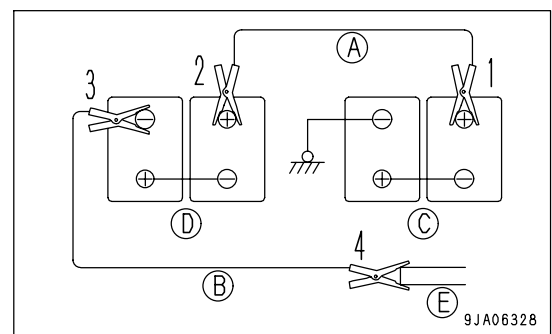

STARTING ENGINE

**WARNING**

Always check that the work equipment lock lever is set to the LOCK position, regardless of whether the machine is working normally or has failed. Check also that all the control levers are in the HOLD or NEUTRAL position.

1. Make sure the clips are firmly connected to the battery terminals.
 2. Start engine of the normal machine and run it at high idle speed.
 3. Turn the starting switch of the problem machine to the START position and start the engine.
- If the engine doesn't start at first, try again after 2 minutes or so.

DISCONNECTING THE BOOSTER CABLE

After the engine has started, disconnect the booster cables in the reverse of the order in which they were connected.

1. Remove the clip of booster cable (B) from engine block (E) on the problem machine.
2. Remove the clip of booster cable (B) from the negative (-) terminal of battery (D) on the normal machine.
3. Remove the clip of booster cable (A) from the positive (+) terminal of battery (D) on the normal machine.
4. Remove the clip of booster cable (A) from the positive (+) terminal of battery (C) on the problem machine.

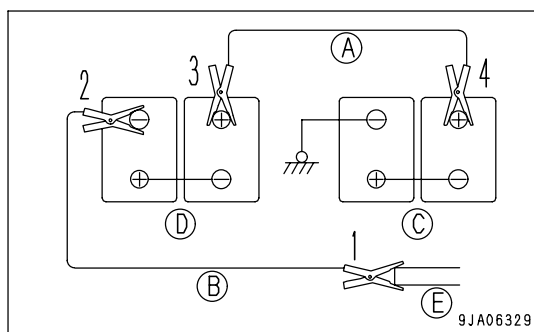

OTHER TROUBLE

ELECTRICAL SYSTEM

- (): Always contact your Komatsu distributor when dealing with these items.
- In cases of problems or causes which are not listed below, contact your Komatsu distributor for repairs.

Problem	Main cause	Remedy
<ul style="list-style-type: none"> • Lamp does not glow brightly even when the engine runs at high speed • Lamp flickers while engine is running 	<ul style="list-style-type: none"> • Defective wiring 	<ul style="list-style-type: none"> (• Check, repair loose terminals, disconnections • Check fuses and diodes in fuse box)
Battery charge circuit caution lamp does not go out even when engine is running	<ul style="list-style-type: none"> • Defective belt • Defective alternator • Defective wiring 	<ul style="list-style-type: none"> • Replace (• Replace) (• Check, repair Check fuse, diode in fuse box)
Abnormal noise is generated from alternator	<ul style="list-style-type: none"> • Defective alternator 	(• Replace)
Starting motor does not turn when starting switch is turned to ON	<ul style="list-style-type: none"> • Defective wiring • Insufficient battery charge 	<ul style="list-style-type: none"> (• Check, repair) • Charge
Pinion of starting motor keeps going in and out	<ul style="list-style-type: none"> • Insufficient battery charge 	• Charge
Starting motor turns engine sluggishly	<ul style="list-style-type: none"> • Insufficient battery charge • Defective starting motor 	<ul style="list-style-type: none"> • Charge (• Replace)
Starting motor disengages before engine starts	<ul style="list-style-type: none"> • Defective wiring • Insufficient battery charge 	<ul style="list-style-type: none"> (• Check, repair) • Charge
Engine preheating pilot lamp does not light up (When the temperature of the engine coolant exceed 20°C (68°F), this condition is normal)	<ul style="list-style-type: none"> • Defective wiring • Defective monitor • Disconnection in glow plug 	<ul style="list-style-type: none"> (• Check, repair) (• Replace) (• Replace)
Air conditioner operation is defective	<ul style="list-style-type: none"> • Blown fuse • Insufficient battery charge • Defective air conditioner switch • Defective blower switch • Defective compressor 	<ul style="list-style-type: none"> (• Check, repair) • Charge (• Replace air conditioner switch) (• Replace blower switch) (• Replace)

MONITOR PANEL

When an error code appears on the display panel B (multi-information), take appropriate remedies based upon the table below.

- (1): Display panel B
(2): Warning lamp (red)

REMARK

If different kinds of failures occur at the same time, their failure codes are arranged in the order of seriousness in the display.

The order of seriousness in this case is E04, E03, E02 and E01, starting from the most serious one.

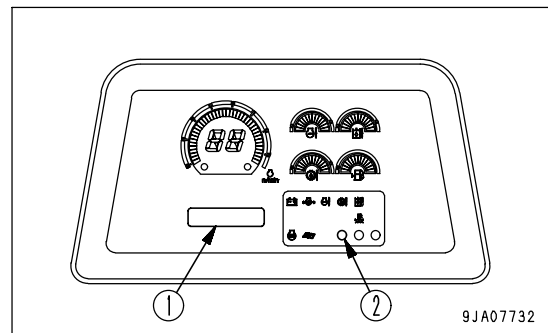

Action code	Display panel B	Warning lamp	Alarm buzzer	Remedy
E01	Top line: Displays E01 Bottom line: Displays service meter	-	-	Failure in part of function, stops. When continuing operations, be extremely careful of location of failure. After completing operations, contact Komatsu distributor for repairs
E02	Top line: Displays E02 Bottom line: Displays service meter	Flashes	Sounds	Serious failure in part of function, stops. When continuing operations, be extremely careful of location of failure. After completing operations, contact Komatsu distributor for repairs
E03	Top line: Displays E03 Bottom line: Displays telephone number (If no telephone number is set, displays 0)	Flashes	Sounds	After moving to safe place, stop machine immediately. Contact Komatsu distributor for repairs
E04	Top line: Displays E04 Bottom line: Displays telephone number (If no telephone number is set, displays 0)	Flashes	Sounds	Stop machine immediately. Contact Komatsu distributor for repairs

Note: If a problem display appears on display panel B, check the fault code. For details, see "METHOD OF USING FAULT CODE DISPLAY MODE (PAGE 3-29)".

When contacting your Komatsu distributor, please give the fault code also.

CHASSIS

- (): Always contact your Komatsu distributor when dealing with these items.
- In cases of problems or causes which are not listed below, contact your Komatsu distributor for repairs.

Problem	Main causes	Remedy
Oil pressure in torque converter fails to rise	<ul style="list-style-type: none"> • Improper tightening of oil pipe, pipe joint, air leaking in or oil leaking out because of damage • Wear, scuffing of gear pump • Insufficient oil in power train case • Clogged oil filter element strainer in power train case 	<ul style="list-style-type: none"> • Check, repair (• Check, replace) • Add oil to the specified level. For details, see CHECK BEFORE STARTING • Clean. For details, see EVERY 500 HOURS SERVICE
Torque converter is overheats	<ul style="list-style-type: none"> • Clogged radiator • Engine coolant temperature is high • Clogged oil cooler • Oil pressure too low • Lack of flow of lubricant caused by wear of power train gear pump 	<ul style="list-style-type: none"> • Clean radiator core • See ENGINE related parts (• Clean or replace) • Go to "Oil pressure in torque converter fails to rise" (• Replace gear pump)
Torque converter oil temperature gauge does not work	<ul style="list-style-type: none"> • Defective oil temperature gauge • Defective contact in wiring connection 	<ul style="list-style-type: none"> (• Replace oil temperature gauge) (• Check, repair)
Lacks drawbar pull (machine does not pick up speed)	<ul style="list-style-type: none"> • Lack of engine horsepower • Oil pressure in torque converter is too low 	<ul style="list-style-type: none"> • See ENGINE related parts • Go to " Oil pressure in torque converter fails to rise"
Machine will not move when joystick is placed in FORWARD	<ul style="list-style-type: none"> • Insufficient oil in power train case • Transmission oil pressure does not rise • Defective Brake • Defective lever wiring • Parking brake lever is in LOCK position 	<ul style="list-style-type: none"> • Add oil to specified level. For details, see CHECK BEFORE STARTING • Go to oil pressure in torque converter fails to rise (• Adjust linkage) (• Check, repair) • Set to FREE position
Does not steer even when steering is operated	<ul style="list-style-type: none"> • Defective lever wiring • Abnormal HSS pump • Abnormal HSS motor 	<ul style="list-style-type: none"> (• Check, repair) (• Check, replace) (• Check, replace)
Machine doesn't stop when brake pedal are depressed	<ul style="list-style-type: none"> • Defective brake adjustment 	<ul style="list-style-type: none"> (• Adjust linkage) (• Check brake pressure)

Problem	Main causes	Remedy
Track comes off	<ul style="list-style-type: none"> • Track is too loose 	<ul style="list-style-type: none"> • Adjust track tension. For details, see WHEN REQUIRED
Sprocket develops abnormal wear	<ul style="list-style-type: none"> • Track is too loose or too tight 	<ul style="list-style-type: none"> • Adjust track tension. For details, see WHEN REQUIRED
Machine does not travel in straight line	<ul style="list-style-type: none"> • Initial improper adjustment of HSS controller • Defective HSS pump 	<ul style="list-style-type: none"> (• Adjust) (• Replace)
Blade rises too slowly or does not rise at all (or blade tilts too slowly)	<ul style="list-style-type: none"> • Lack of hydraulic oil • Defective hydraulic pump • Work equipment lock lever is in LOCK position 	<ul style="list-style-type: none"> • Add oil to specified level. For details, see EVERY 250 HOURS SERVICE • Check • Set to FREE position

ENGINE

- (): Always contact your Komatsu distributor when dealing with these items.
- In cases of problems or causes which are not listed below, contact your Komatsu distributor for repairs.

Problem	Main causes	Remedy
Engine oil pressure monitor flashes when engine speed is raised after completion of warm-up	<ul style="list-style-type: none"> • Engine oil pan oil level is low (sucking in air) • Clogged oil filter cartridge • Defective tightening of oil pipe joint, oil leakage from damaged part • Defective monitor panel 	<ul style="list-style-type: none"> • Add oil to specified level, see CHECK BEFORE STARTING • Replace cartridge, see EVERY 500 HOURS SERVICE (• Check, repair) (• Replace)
Steam is emitted from top part of radiator (pressure valve)	<ul style="list-style-type: none"> • Coolant level low, water leakage • Dirt or scale accumulated in cooling system • Clogged radiator fins or damaged fins • Defective thermostat • Loose radiator filler cap (high altitude operation) • Defective monitor panel 	<ul style="list-style-type: none"> • Add coolant, repair, see CHECK BEFORE STARTING • Change coolant, clean inside of cooling system, see WHEN REQUIRED • Clean or repair, see WHEN REQUIRED (• Replace thermostat) • Tighten cap or replace packing (• Replace)
Engine water temperature monitor remains alight altitude operation)		
Engine does not start when starting motor is turned	<ul style="list-style-type: none"> • Lack of fuel • Air in fuel system • No fuel in fuel filter • Starting motor cranks engine sluggishly • Defective electric priming pump • Defective valve compression 	<ul style="list-style-type: none"> • Add fuel, see CHECK BEFORE STARTING • Repair place where air is sucked in (• Replace pump or nozzle) • See ELECTRICAL SYSTEM • See ELECTRICAL SYSTEM (• Adjust valve clearance)
Exhaust gas is white or blue	<ul style="list-style-type: none"> • Too much oil in oil pan • Defective cooling water temperature sensor • Improper fuel 	<ul style="list-style-type: none"> • Refill with engine oil up to the specified level, referring to CHECK BEFORE STARTING. • Replace the sensor or repair the wiring harness. • Change to specified fuel
Exhaust gas occasionally turns black	<ul style="list-style-type: none"> • Clogged air cleaner element • Defective nozzle • Defective compression • Defective turbocharger 	<ul style="list-style-type: none"> • Clean or replace, see WHEN REQUIRED (• Replace nozzle) (• Adjust valve clearance) (• Clean or replace, turbocharger)

Problem	Main causes	Remedy
Combustion noise occasionally makes breathing sound	<ul style="list-style-type: none"> • Defective nozzle • Lack of fuel (in Air) 	(<ul style="list-style-type: none"> • Replace nozzle • Add fuel)
Abnormal noise generated (combustion or mechanical)	<ul style="list-style-type: none"> • Low grade fuel being used • Overheating • Damage inside muffler • Excessive valve clearance 	<ul style="list-style-type: none"> • Change to specified fuel • See item "Indicator of water temperature gauge is in red range on right side of gauge". (<ul style="list-style-type: none"> • Replace muffler • Adjust valve clearance)
Monitor displays error code	Please contact your Komatsu distributor	
Alarm buzzer sounds		
Engine horsepower lowered suddenly (Engine is running in duration mode)		

MAINTENANCE

WARNING

Please read and make sure that you understand the SAFETY section before reading this section.

GUIDE TO MAINTENANCE

Do not perform any inspection and maintenance operation that is not found in this manual.

CHECK SERVICE METER:

Check the service meter reading every day to see if the time has come for any necessary maintenance to be performed.

KOMATSU GENUINE REPLACEMENT PARTS:

Use Komatsu genuine parts specified in the Parts Book as replacement parts.

KOMATSU GENUINE OILS:

For lubrication of the machine, use the Komatsu genuine lubricants. Moreover use oil of the specified viscosity according to the ambient temperature.

ALWAYS USE CLEAN WASHER FLUID:

Use automobile window washer fluid, and be careful not to let any dirt get into it.

CLEAN OIL AND GREASE:

Use clean oil and grease. Also, keep the containers of the oil and grease clean. Keep foreign materials away from oil and grease.

CHECKING FOREIGN MATERIALS IN DRAINED OIL:

After oil is changed or filters are replaced, check the old oil and filters for metal particles and foreign materials. If large quantity of metal particles or foreign materials are found, always report to the person in charge, and carry out suitable action.

FUEL STRAINER:

If your machine is equipped with a fuel strainer, do not remove it while fueling.

WELDING INSTRUCTIONS:

- Cut off power. Wait for approx. one minute after turning off the engine starting switch key, and then disconnect the negative (-) terminal of the battery.
- Do not apply more than 200 V continuously.
- Connect grounding cable within 1 m (3.3 ft) of the area to be welded. If grounding cable is connected near instruments, connectors, etc., the instruments may malfunction.
- If a seal or bearing happens to come between the part being welded and grounding point, change the grounding point to avoid such parts.
- Do not use the area around the work equipment pins or the hydraulic cylinders as the grounding point.

DO NOT DROP THINGS INSIDE MACHINE:

- When opening inspection windows or the oil filler port of the tank to carry out inspection, be careful not to drop nuts, bolts, or tools inside the machine.
If such things are dropped inside the machine, it may cause damage and/or malfunction of the machine, and will lead to failure. If you drop anything inside the machine, always remove it immediately.
- Do not put unnecessary things in your pockets. Carry only things which are necessary for inspection.

DUSTY WORKSITES:

When working at dusty worksites, do as follows:

- Inspect the dust indicator frequently to see if the air cleaner is dirty or clogged.
- Clean the radiator core frequently to avoid clogging.

- Clean and replace the fuel filter frequently.
- Clean electrical components, especially the starting motor and alternator, to avoid accumulation of dust.
- When inspecting or changing the oil, move the machine to a place that is free of dust to prevent dirt from getting into the oil.

AVOID MIXING OILS:

If a different brand or grade of oil has to be added, drain the old oil and replace all the oil with the new brand or grade of oil. Never mix different brand or grade of oil.

PRECAUTIONS FOR OPENING AND CLOSING ENGINE SIDE COVER:

- Open the engine side cover all the way and ensure that it is locked open before letting go.
- When standing on the track to open the engine side cover, bend at the knees and open the cover in a standing position to avoid back strain.

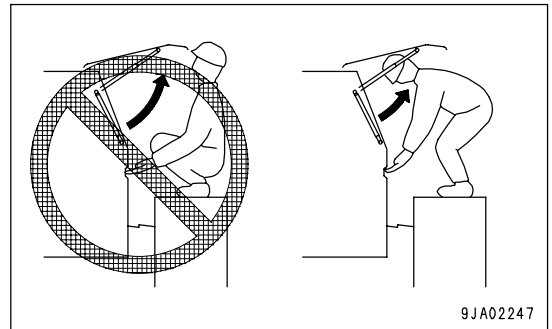

9JA02247

- Before opening the cab door, always close the engine side cover.

If the lock for the engine side cover is not released, it will not close. If any attempt is made to close it without releasing the lock, the gas damper may break.

When closing the cover, push the orange button in the center of the gas damper (1) to release the lock, then close the cover.

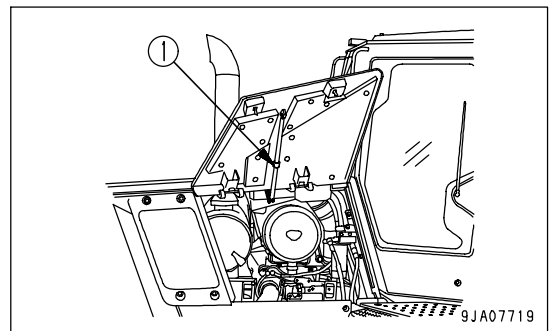

9JA07719

LOCKING THE INSPECTION COVER:

Lock inspection cover securely into position with the lock bar. If inspection or maintenance is performed with inspection cover not locked in position, there is a danger that it may be suddenly blow shut by the wind and cause injury to the worker.

HYDRAULIC SYSTEM-AIR BLEEDING:

After repairing or replacing hydraulic equipment or after removing the hydraulic piping, it is necessary to bleed the air from the circuit. For details, see "PROCEDURE FOR BLEEDING AIR IN HYDRAULIC SYSTEM (PAGE 4-41)".

PRECAUTIONS WHEN INSTALLING HYDRAULIC HOSES:

- When removing parts at locations where there are O-rings or gasket seals, clean the mounting surface, and replace with new parts.
When doing this, be careful not to forget to assemble the O-rings and gaskets.
- When installing the hoses, do not twist them or bend them sharply. If they are installed so, their service life will be shortened extremely and they may be damaged.

CHECKS AFTER INSPECTION AND MAINTENANCE WORK:

If you forget to perform the checks after inspection and maintenance, unexpected problems may occur, and this may lead to serious injury or property damage. Always do the following:

- Checks after operation (with engine stopped)
 - Have any inspection and maintenance points been forgotten?
 - Have all inspection and maintenance items been performed correctly?
 - Have any tools or parts been dropped inside the machine? It is particularly dangerous if parts are dropped inside the machine and get caught in the lever linkage mechanism.
 - Are there any leakage of coolant or oil? Have all nuts and bolts been tightened?
- Checks when engine is running
 - For the checks when the engine is running, see "TWO WORKERS FOR MAINTENANCE WHEN ENGINE IS RUNNING (PAGE 2-29)" in the SAFETY section, and take care of safety sufficiently.
 - Check that the inspected and maintained parts work normally.
 - Raise the engine speed and check for fuel leakage and oil leakage.

FUEL AND LUBRICANTS TO MATCH THE AMBIENT TEMPERATURE:

Select the fuel and lubricants to match the ambient temperature.

For details, see "RECOMMENDED FUEL, COOLANT, AND LUBRICANT (PAGE 4-12)".

OUTLINE OF SERVICE

- Always use Komatsu genuine parts for replacement parts, grease or oil.
- When changing the oil or adding oil, do not mix different types of oil. When changing the type of oil, drain all the old oil and fill completely with the new oil. Always replace the filter at the same time. (There is no problem if the small amount of oil remaining in the piping mixes with the new oil.)
- Unless otherwise specified, when the machine is shipped from the factory, it is filled with the oil and coolant listed in the table below.

Item	Type
Engine oil pan	Engine oil EO15W40DH (Komatsu genuine parts)
Power train case Final drive case Damper case Idler (each)	Power train oil TO30 (Komatsu genuine parts)
Hydraulic system	Power train oil TO10 (Komatsu genuine parts)
Radiator	Supercoolant AF-NAC (Density: 30% or above) (Komatsu genuine parts)

HANDLING OIL, FUEL, COOLANT, AND PERFORMING OIL CLINIC

OIL

- Oil is used in the engine and hydraulic equipment under extremely severe conditions (high temperature, high pressure), and deteriorates with use.
Always use oil that matches the grade and maximum and minimum ambient temperatures recommended in the Operation and Maintenance Manual. Even if the oil is not dirty, always change the oil at the specified interval.
- Oil corresponds to blood in the human body, always be careful when handling it to prevent any impurities (water, metal particles, dirt, etc.) from getting in.
The majority of problems with the machine are caused by the entry of such impurities.
Take particular care not to let any impurities get in when storing or adding oil.
- Never mix oils of different grades or brands.
- Always add the specified amount of oil.
Having too much oil or too little oil are both causes of problems.
- If the oil in the work equipment is not clear, there is probably water or air getting into the circuit. In such cases, please contact your Komatsu distributor.
- When changing the oil, always replace the related filters at the same time.
- We recommend you have an analysis made of the oil periodically to check the condition of the machine. For those who wish to use this service, please contact your Komatsu distributor.
- When using commercially available oil, it may be necessary to reduce the oil change interval.
We recommend that you use the Komatsu oil clinic to carry out a detailed checks of the characteristics of the oil.

FUEL

- To prevent the moisture in the air from condensing and forming water inside the fuel tank, always fill the fuel tank after completing the day's work.
- The fuel pump is a precision instrument, and if fuel containing water or dirt is used, it cannot work properly.
- Be extremely careful not to let impurities get in when storing or adding fuel.
- Always use the fuel specified for the temperature in the Operation and Maintenance Manual.
 - If the fuel is used at temperatures lower than the specified temperature (particularly at temperatures below -15 °C (5°F), the fuel will solidify.
 - If the fuel is used at temperatures higher than the specified temperature, the viscosity will drop, and this may result in problems such as a drop in output.
- Before starting the engine, or when 10 minutes have passed after adding fuel, drain the sediment and water from the fuel tank.
- If the engine runs out of fuel, or if the filters have been replaced, it is necessary to bleed the air from the circuit.
- If there is any foreign material in the fuel tank, wash the tank and fuel system.

NOTICE

Always use diesel oil for the fuel.

To ensure good fuel consumption characteristics and exhaust gas characteristics, the engine mounted on this machine uses an electronically controlled high-pressure fuel injection device. This device requires high precision parts and lubrication, so if low viscosity fuel with low lubricating ability is used, the durability may drop markedly.

COOLANT AND WATER FOR DILUTION

- The coolant has the important function of preventing corrosion as well as preventing freezing. Even in the areas where freezing is not an issue, the use of antifreeze coolant is essential. Komatsu machines are supplied with Komatsu Supercoolant (AF-NAC). Komatsu Supercoolant (AF-NAC) has excellent anticorrosion, antifreeze and cooling properties and can be used continuously for 2 years or 4000 hours. As a basic rule, we do not recommend the use of any coolant other than Komatsu genuine supercoolant (AF-NAC). If you use another coolant, it may cause serious problems such as corrosion of the engine and parts of the cooling system that use light metals such as aluminum.
- When using Komatsu Supercoolant (AF-NAC), there is no need to use a corrosion resistor. For details, see "CLEAN INSIDE OF COOLING SYSTEM (PAGE 4-23)".
- When diluting the antifreeze coolant, use distilled water or tap water (soft water). Natural water, such as a river water or well water (hard water), contains large amounts of minerals (calcium, magnesium, etc.), and this makes it easier for scale to form inside the engine or radiator. Once scale is deposited inside the engine or radiator, it is extremely difficult to remove. It also causes overheating due to poor heat exchange, so when you dilute the coolant, we recommend that you use water with an overall hardness of less than 100 PPM.
- When using antifreeze, always observe the precautions given in the Operation and Maintenance Manual.
- Antifreeze coolant is flammable, so be sure to keep it away from flame.
- The ratio of Supercoolant (AF-NAC) to water differs according to the ambient temperature. For details of the ratio when mixing, see "CLEAN INSIDE OF COOLING SYSTEM (PAGE 4-23)". Even in areas where it is not necessary to prevent freezing, use Supercoolant (AF-NAC) at a mixing ratio of at least 30% to prevent corrosion of the cooling system. Supercoolant (AF-NAC) may be supplied in premix. In this case, never add diluting water.
- If the engine overheats, wait for the engine to cool before adding coolant.
- If the coolant level is low, it will cause overheating, and will also cause problems with corrosion due to air entering the coolant.

GREASE

- Grease is used to prevent seizure and noises at the joints.
- This construction equipment is used under heavy-duty conditions. Always use the recommended grease and follow the change intervals and recommended ambient temperatures given in this Operation and Maintenance Manual.
- The nipples not included in the MAINTENANCE section are nipples used when overhauling, so they do not need grease.
If any part becomes stiff or generates noise after being used for a long time, grease it.
- Always wipe off all of the old grease that is pushed out when greasing.
Be particularly careful to wipe off the old grease in places where sand or dirt sticking in the grease would cause wear of the rotating parts.

CARRYING OUT KOWA (Komatsu Oil Wear Analysis)

KOWA is a maintenance service that makes it possible to prevent machine failures and downtime. With KOWA, the oil is periodically sampled and analyzed. This enables early detection of wear of the machine drive parts and other problems.

We strongly recommend you to use this service. The oil analysis is carried out at actual cost, so the cost is low, and the results of the analysis are reported together with recommendations which will reduce repair costs and machine downtime.

KOWA ANALYSIS ITEMS

- Measurement of density of metal wear particles
This uses an ICP (Inductively Coupled Plasma) analyzer to measure the density of iron, copper, and other metal wear particles in the oil.

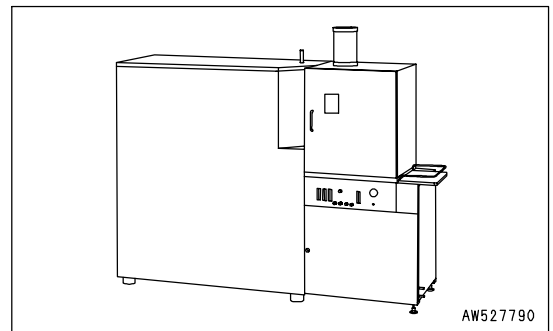

- Measurement of quantity of particles
This uses a PQI (Particle Quantifier Index) measurer to measure the quantity of iron particles of 5µm or more, enabling early detection of failures.

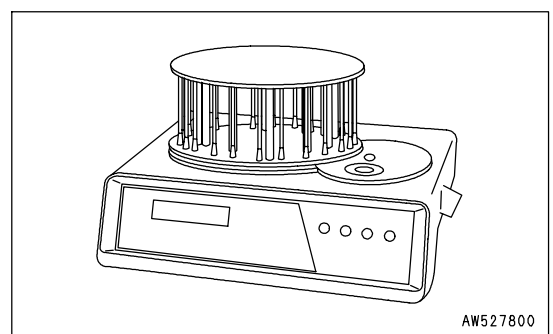

- Others
Measurements are made of items such as the ratio of water in the oil, density of the antifreeze coolant, ratio of fuel in the oil, and dynamic viscosity, enabling a highly precise diagnosis of the machine's health.

OIL SAMPLING

- Sampling interval
 - 250 hours: Engine
 - 500 hours: Other components
- Precautions when sampling
 - Make sure that the oil is well mixed before sampling.
 - Perform sampling at regular fixed intervals.
 - Do not perform sampling on rainy or windy days when water or dust can get into the oil.

For further details of KOWA, please contact your Komatsu distributor.

STORING OIL AND FUEL

- Keep indoors to prevent any water, dirt, or other impurities from getting in.
- When keeping drum cans for a long period, put the drum on its side so that the filler port of the drums is at the side to prevent moisture from being sucked in.
If drums have to be stored outside, cover them with a waterproof sheet or take other measures to protect them.
- To prevent any change in quality during long-term storage, be sure to use in the order of first in - first out (use the oldest oil or fuel first).

FILTERS

- Filters are extremely important safety parts. They prevent impurities in the fuel and air circuits from entering important equipment and causing problems.
Replace all filters periodically. For details, see the Operation and Maintenance Manual.
However, when working in severe conditions, replace the filters at shorter intervals according to the oil and fuel (sulfur content) being used.
- Never try to clean the filters (cartridge type) and use them again. Always replace with new filters.
- When replacing oil filters, check if any metal particles are attached to the old filter. If any metal particles are found, contact your Komatsu distributor.
- Do not open packs of spare filters until just before they are to be used.
- Always use Komatsu genuine filters.

RELATING TO ELECTRIC SYSTEM

- It is extremely dangerous if the electrical equipment becomes wet or the covering of the wiring is damaged. This will cause an electrical short circuit and may lead to malfunction of the machine. Do not wash the inside of the operator's cab with water. When washing the machine, be careful not to let water get into the electrical components.
- Service relating to the electric system is checking fan belt tension, checking damage or wear to the fan belt and checking battery fluid level.
- Never install any electric components other than those specified by Komatsu.
- External electro-magnetic interference may cause malfunction of the control system controller, before installing a radio receiver or other wireless equipment, contact your Komatsu distributor.
- Be careful to keep the electric system free of water when washing the machine or when it rains.
- When working at the seashore, carefully clean the electric system to prevent corrosion.
- When installing electrical equipment, connect it to the special power source connector.
Do not connect the optional power source to the fuse, starting switch, or battery relay.

HANDLING HYDRAULIC SYSTEM

- During operations and after completion of operations, the hydraulic equipment is at a high temperature. During operations, it is also under high pressure, so when carrying out inspection and maintenance of hydraulic related equipment, be careful of the following points.
 - Stop the machine on flat ground, lower the work equipment completely to the ground, and carry out the operation so that there is no pressure on the cylinder circuits.
 - Always stop the engine.
 - Immediately after stopping operations, the hydraulic oil and lubricating oil is at high temperature and high pressure, so wait for the oil temperature to go down before starting maintenance.
Even after the temperature has gone down, some parts may still be under internal pressure, so when loosening plugs, bolts, or hose connections, do not stand directly in front of the parts, and loosen slowly to release the internal pressure before removing.
 - When carrying out inspection and maintenance of the hydraulic circuit, always release the air in the hydraulic tank to remove the internal pressure.
- Inspection and maintenance include checking the hydraulic system for oil level, replacement of filter elements and replacement of hydraulic oil.
- If high-pressure hoses have been removed, check that there is no damage to the O-rings. If any damage is found, replace the O-ring.
- It is necessary to bleed the air from the circuits when the hydraulic filter element or strainer have been replaced or washed, or when hydraulic equipment has been repaired or replaced, or when the hydraulic piping has been removed.
- The accumulator is charged with high-pressure nitrogen gas, and it is extremely dangerous if it is handled incorrectly. For details of the method of handling, see "CHECKING CHARGE PRESSURE OF NITROGEN GAS IN ACCUMULATOR (FOR CONTROL CIRCUIT) (PAGE 4-69)".

WEAR PARTS LIST

Replace wear parts such as the filter element or air cleaner element at the time of periodic maintenance or before they reach the wear limit. The wear parts should be replaced correctly in order to ensure more economic use of the machine. When replacing parts, always use Komatsu genuine parts.

As a result of our continuous efforts to improve product quality, the part number may change, so inform your Komatsu distributor of the machine serial number and check for the latest part number when ordering parts.

WEAR PARTS LIST

The parts in parentheses are to be replaced at the same time.

Item		Part No.	Part Name	Weight (kg(lb))	Q'ty	Replacement frequency
Engine oil filter		6742-01-4540	Cartridge	–	1	Every 500 hours service
Power train filter		14X-49-32750 (07000-72110)	Element (O-ring)	–	1 (1)	
Fuel pre-filter		600-319-3610	Cartridge (with O-ring for clear ball)	–	1	
Fuel main filter		6754-71-6130	Cartridge (with cap)	–	1	Every 1000 hours service
Corrosion resistor		600-411-1191	Cartridge	–	1	
Hydraulic tank breather element		20Y-60-21410	Element	–	1	
Hydraulic oil filter		14X-60-31150 (07000-15195)	Element (O-ring)	–	1 (1)	Every 2000 hours service
Air cleaner		600-185-5100	Element Ass'y	–	1	–
Air conditioner	Fresh filter	14X-911-7750	Filter	–	2	–
	Recirc filter	20Y-979-6261	Filter	–	2	–
Blade	D65EX Tiltdozer	14X-71-11310	Cutting edge	38.4	2	–
		14X-71-11330	End bit (left)	14.2	1	
		14X-71-11340	End bit (right)	14.2	1	
		(02090-11270)	(Bolt)	–	(28)	
		(02290-11219)	(Nut)	–	(28)	
	D65PX Tilt dozer Tilt pitch dozer	14Y-71-11210	Cutting edge	45.5	2	–
		14Y-71-11330	End bit (left)	13.6	1	
		14Y-71-11340	End bit (right)	13.6	1	
		(02090-11270)	(Bolt)	–	(32)	
		(02290-11219)	(Nut)	–	(32)	
	D65EX Angle dozer	144-70-11131	Cutting edge	45.5	2	–
		14X-71-11330	End bit (left)	14.2	1	
		14X-71-11340	End bit (right)	14.2	1	
		(02090-11270)	(Bolt)	–	(32)	
		(02290-11219)	(Nut)	–	(32)	
	D65PX Angle dozer	130-70-51130	Cutting edge (center)	39.0	1	–
130-920-2180		Cutting edge (side)	34.0	2		
13F-Z27-1581		End bit (left)	10.8	1		
13F-Z27-1571		End bit (right)	10.8	1		
(02090-11270)		(Bolt)	–	(31)		
(02091-11210)		(Bolt)	–	(4)		
(02290-11219)		(Nut)	–	(35)		

Item	Part No.	Part Name	Weight (kg(lb))	Q'ty	Replacement frequency	
Blade	D65EX Semi-U blade (tilt dozer)	130-70-41130	Cutting edge (right)	37.5	1	-
		130-920-2180	Cutting edge (left)	34.0	1	
		(02090-11270)	(Bolt)	-	(17)	
		(02290-11219)	(Nut)	-	(17)	
		175-71-22272	End bit (left)	39.0	1	
		175-71-22282	End bit (right)	39.0	1	
		(02090-11495)	(Bolt)	-	(14)	
	(02290-11422)	(Nut)	-	(14)		
	D65EX Semi-U blade (3m) (tilt dozer)	14X-952-1270	Cutting edge	29.8	2	-
		(02090-11270)	(Bolt)	-	(14)	
		(02290-11219)	(Nut)	-	(14)	
		150-70-21356	End bit (left)	26.2	1	
		150-70-21346	End bit (right)	26.2	1	
		(02090-11280)	(Bolt)	-	(12)	
	(02290-11219)	(Nut)	-	(12)		
	D65WX Semi-U blade (tilt dozer)	14X-952-1450	Cutting edge	32.0	2	-
		(02090-11270)	(Bolt)	-	(18)	
		(02290-11219)	(Nut)	-	(18)	
		175-71-22272	End bit (left)	39.0	1	
		175-71-22282	End bit (right)	39.0	1	
		(02090-11495)	(Bolt)	-	(14)	
(02290-11422)		(Nut)	-	(14)		
(01643-22245)	(Washer)	-	(14)			

NOTICE

When handling parts that weigh more than 25 kg (55 lb), remember that they are heavy objects, and take the necessary care.

RECOMMENDED FUEL, COOLANT, AND LUBRICANT

- Komatsu genuine oils are adjusted to maintain the reliability and durability of Komatsu construction equipment and components.

In order to keep your machine in the best conditioner for long periods of time, it is essential to follow the instructions in this Operation and Maintenance Manual.

- Failure to follow these recommendations may result in shortened life or excess wear of the engine, power train, cooling system, and/or other components.
- Commercially available lubricant additives may be good for the machine, but they may also cause harm. Komatsu does not recommend any commercially available lubricant additive.
- Use the oil recommended according to the ambient temperature in the chart below.
- Specified capacity means the total amount of oil including the oil in the tank and the piping. Refill capacity means the amount of oil needed to refill the system during inspection and maintenance.
- When starting the engine in temperatures below 0°C (32°F), be sure to use the recommended multi-grade oil, even if the ambient temperature may become higher during the course of the day.
- If the machine is operated at a temperature below -20°C (-4°F), a separate device is needed, so consult your Komatsu distributor.
- When the fuel sulfur content is less than 0.5%, change the engine oil according to the period inspection table given in this Operation and Maintenance Manual.

If the fuel sulfur content is more than 0.5%, change the oil according to the following table.

Sulfur content (%)	Oil change interval
Less than 0.5	500 hours
0.5 - 1.0	250 hours
1.0 and up	Not recommendable (*)

* If these fuels are used, there is danger that serious trouble may occur because of early deterioration of the engine oil or early wear of the internal parts of the engine. If the local situation makes it necessary to use these fuels, always remember the following.

- 1) Be sure to check Total Basic Number (TBN) of oil frequently by TBN handy checker etc., and change oil based on the result.
- 2) Always be aware that oil change interval is extremely shorter than standard.
- 3) Be sure to carry out periodic engine inspection by distributor's expert since change interval of periodic replacement parts and overhaul interval are also shorter.

USE OF FUEL, COOLANT AND LUBRICANTS ACCORDING TO AMBIENT TEMPERATURE

Reservoir	Fluid Type	Ambient Temperature, degrees Celsius										Recommended Komatsu Fluids
		-22 -30	-4 -20	14 -10	32 0	50 10	68 20	86 30	104 40	122 °F 50°C		
Engine oil pan	Engine oil	(Note.1)										Komatsu EOS0W30
		(Note.1)										Komatsu EOS5W40
		(Note.1)										Komatsu EO10W30DH
		(Note.1)										Komatsu EO15W40DH
		(Note.1)										Komatsu EO30DH
Damper case Idler (each)	Power train oil (Note.2)	(Note.1)										TO30
Power train case	Power train oil	(Note.1)										TO10
		(Note.1)										TO30
Final drive case (each)	Power train oil	(Note.1)										TO30
Hydraulic system	Power train oil	(Note.1)										TO10
	Hydraulic oil	(Note.1)										HO46-HM
	Engine oil	(Note.1)										Komatsu EO10W30DH
(Note.1)										Komatsu EO15W40DH		
Grease fitting	Hyper grease (Note.3)	(Note.1)										G2-T, G2-TE
	Lithium EP grease	(Note.1)										G2-LI
Cooling system	Supercoolant AF-NAC (Note.4)	(Note.1)										AF-NAC
Fuel tank	Diesel fuel	(Note.1)										ASTM Grade No.1-D S15 ASTM Grade No.1-D S500
		(Note.1)										ASTM Grade No.2-D S15 ASTM Grade No.2-D S500

• ASTM: American Society of Testing and Material

		Engine oil pan	Damper case	Idler (each)	Hydraulic system	Power train case	Final drive case (each)		Fuel tank	Cooling system (including sub-tank)
							EX	PX,WX		
Specified capacity	Liters	33	1.3	0.15	95	68	24	27	415	37
	US gal	8.72	0.34	0.04	25.10	17.97	6.34	7.13	109.64	9.78
Refill capacity	Liters	28	1.3	0.15	55	48	24	27	–	–
	US gal	7.40	0.34	0.04	14.53	12.68	6.34	7.13	–	–

NOTICE

Always use diesel oil for the fuel.

To ensure good fuel consumption characteristics and exhaust gas characteristics, the engine mounted on this machine uses an electronically controlled high-pressure fuel injection device. This device requires high precision parts and lubrication, so if low viscosity fuel with low lubricating ability is used, the durability may drop markedly.

Note 1: HTHS (High-Temperature High-Shear Viscosity 150°C), specified by ASTM D4741 must be equal to or higher than 3.5 mPa-S. Komatsu EOS0W30 and EOS5W40 are the most suitable oils.

Note 2: Powertrain oil has different properties from engine oil. Be sure to use the recommended oils.

Note 3: Hyper grease (G2-T, G2-TE) has a high performance.

When it is necessary to improve the lubricating ability of the grease in order to prevent squeaking of pins and bushings, the use of G2-T or G2-TE is recommended.

Note 4: Supercoolant (AF-NAC)

1) Coolant has the important function of anticorrosion as well as antifreeze.

Even in the areas where freezing is not an issue, the use of antifreeze coolant is essential.

Komatsu machines are supplied with Komatsu Supercoolant (AF-NAC). Komatsu Supercoolant (AF-NAC) has excellent anticorrosion, antifreeze and cooling properties and can be used continuously for 2 years or 4000 hours. Komatsu Supercoolant (AF-NAC) is strongly recommended wherever available.

2) For details of the ratio when diluting super coolant with water, see "CLEAN INSIDE OF COOLING SYSTEM (PAGE 4-23)".

When the machine is shipped from the factory, it may be filled with coolant containing 30% or more Supercoolant (AF-NAC). In this case, no adjustment is needed for temperatures down to -10°C (14°F). (never dilute with water)

3) To maintain the anticorrosion properties of Supercoolant (AF-NAC), always keep the density of Supercoolant between 30% and 68%.

RECOMMENDED BRANDS, RECOMMENDED QUALITY FOR PRODUCTS OTHER THAN KOMATSU GENUINE OIL

When using commercially available oils other than Komatsu genuine oil, consult your Komatsu distributor.

STANDARD TIGHTENING TORQUES FOR BOLTS AND NUTS

TORQUE LIST



If nuts, bolts, or other parts are not tightened to the specified torque, it will cause looseness or damage to the tightened parts, and this will cause failure of the machine or problems with operation.

Always pay careful attention when tightening parts.

Unless otherwise specified, tighten the metric nuts and bolts to the torque shown in the table below. If it is necessary to replace any nut or bolt, always use a Komatsu genuine part of the same size as the part that was replaced.

Thread diameter of bolt (a)(mm)	Width across flats (b)(mm)	Tightening torque					
		Target value			Service limit		
		Nm	kgm	lbft	Nm	kgm	lbft
6	10	13.2	1.35	9.8	11.8-14.7	1.2-1.5	8.7-10.8
8	13	31	3.2	23.1	27-34	2.8-3.5	20.3-25.3
10	17	66	6.7	48.5	59-74	6.0-7.5	43.4-54.2
12	19	113	11.5	83.2	98-123	10.0-12.5	72.3-90.4
14	22	172	17.5	126.6	153-190	15.5-19.5	112.1-141
16	24	260	26.5	191.7	235-285	23.5-29.5	170.0-213.4
18	27	360	37	267.6	320-400	33.0-41.0	238.7-296.6
20	30	510	52.3	378.3	455-565	46.5-58.0	336.3-419.5
22	32	688	70.3	508.5	610-765	62.5-78.0	452.1-564.2
24	36	883	90	651	785-980	80.0-100.0	578.6-723.3
27	41	1295	132.5	958.4	1150-1440	118.0-147.0	853.5-1063.3
30	46	1720	175.0	1265.8	1520-1910	155.0-195.0	1121.1-1410.4
33	50	2210	225.0	1627.4	1960-2450	200.0-250.0	1446.6-1808.3
36	55	2750	280.0	2025.2	2450-3040	250.0-310.0	1808.3-2242.2
39	60	3280	335.0	2423.1	2890-3630	295.0-370.0	2133.7-2676.2

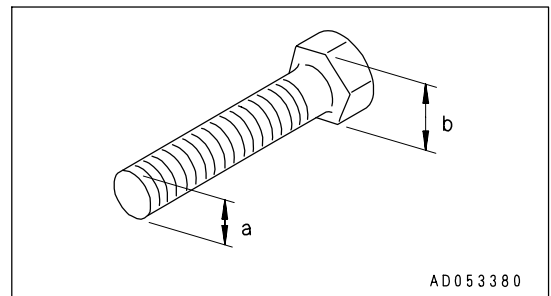

Apply the following table for Hydraulic Hose.

Nominal- No. of threads (a)	Width across flats (b) mm	Tightening torque					
		Target valve			Permissible range		
		Nm	kgm	lbft	Nm	kgm	lbft
9/16 -18UNF	19	44	4.5	32.5	34 - 54	3.5 - 5.5	25.3 - 39.8
11/16 -16UN	22	74	7.5	54.2	54 - 93	5.5 - 9.5	39.8 - 68.7
13/16 -16UN	27	103	10.5	75.9	84 - 132	8.5 - 13.5	61.5 - 97.6
1 -14UNS	32	157	16.0	115.7	128 - 186	13.0 - 19.0	94.0 - 137.4
1 3/16 -12UN	36	216	22.0	159.1	177 - 245	18.0 - 25.0	130.2 - 180.8

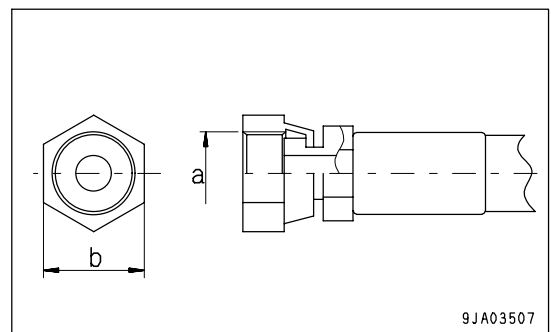

PERIODIC REPLACEMENT OF SAFETY CRITICAL PARTS

To ensure safety at all times when operating or driving the machine, the user of the machine must always carry out periodic maintenance. In addition, to further improve safety, the parts in the safety-critical parts list on the next page must also be replaced at the specified interval. These parts are particularly closely connected to safety and fire prevention, so please contact your Komatsu distributor to have them replaced.

Material quality of these parts can change as time passes and they are likely to wear out or deteriorate. However, it is difficult to determine the extent of wear or deterioration at the time of periodic maintenance. Hence, it is required to replace them with new ones regardless of their condition after a certain period of usage. This is important to ensure that these parts maintain their full performance at all times.

Furthermore, should anything abnormal be found on any of these parts, replace it with a new one even if the periodic replacement time for the part has not yet arrived.

If any of the hose clamps show deterioration like deformation or cracking, replace the clamps at the same time as the hoses.

Also perform the following checks with hydraulic hoses which need to be replaced periodically. Tighten all loose clamps and replace defective hoses, as required.

When replacing hoses, always replace O-rings, gaskets, and other such parts at the same time.

Have your Komatsu distributor replace the critical parts.

SAFETY CRITICAL PARTS

NO.	Safety critical parts for periodic replacement	Q'ty	Replacement interval
1	Fuel hose (fuel tank - fuel strainer)	1	Every 2 years or 4000 hours, whichever comes sooner
2	Fuel hose (fuel strainer to fuel pre-filter)	1	
3	Fuel hose (fuel pre-filter to engine inlet)	1	
4	Fuel return hose (engine outlet to fuel tank)	1	
5	Hose (power train strainer - power train pump)	1	
6	Hose (power train pump - power train filter)	1	
7	Hose (power train filter - transmission case)	1	
8	Hose (transmission case - steering case)	1	
9	Hose (power train lubrication pump - steering case)	1	
10	Hose (Scavenging pump - Steering case)	1	
11	Hose (torque converter case - mission oil cooler)	1	
12	Hose (mission oil cooler - transmission case)	1	
13	Brake pressure detection hose	1	
14	Torque converter inlet post pressure detection hose	1	
15	Torque converter outlet post pressure detection hose	1	
16	Main relief valve pressure detection hose	1	
17	Hose (HSS pump - main control valve)	2	
18	Hose (HSS pump - central drain block)	1	
19	Hose (self-reducing pressure valve - hydraulic tank)	1	
20	Hose (main valve - HSS motor)	2	
21	Hose (main valve - hydraulic tank)	1	

NO.	Safety critical parts for periodic replacement	Q'ty	Replacement interval
22	Hose (main valve - central drain block)	1	Every 2 years or 4000 hours, whichever comes sooner
23	Hose (main control valve - blade tilt relay block)	2	
24	Hose (blade tilt relay block - Tilt cylinder)	8	
25	Hose (main valve - blade tilt relay tube)	2	
26	Hose (Radiator guard upper part - Lift cylinder)	4	
27	Hose (self-reducing pressure valve - fan pump)	1	
28	Hose (hydraulic tank - fan pump)	1	
29	Hose (self-reducing pressure valve - fan motor)	1	
30	Hose (fan motor - hydraulic oil cooler)	1	
31	Hose (hydraulic tank - fan motor)	1	
32	Hose (hydraulic oil cooler - hydraulic tank)	1	
33	Hose (central drain block - HSS motor)	1	
34	Hose (PPC valve - main valve)	4	
35	Hose (central PPC block - main valve)	2	
36	Hose (fan pump - central PPC block)	1	
37	Hose (PPC lock valve - central PPC block)	1	
38	Hose (self-reducing pressure valve - central PPC block)	1	
39	Hose (PPC valve - PPC lock valve)	1	
40	Hose (PPC valve - central drain block)	1	
41	Hose (central drain block - hydraulic tank)	1	
42	Hose (HSS delivery hose - pressure detection block)	1	
43	Hose (HSS pump - pressure detection block)	1	
44	Accumulator (for operating circuit)	1	
45	High-pressure tube clamp	1S	Every 8000 hours
46	Fuel spray prevention cap	1S	
47	Seat belt (If equipped)	1	Every 3 years

MAINTENANCE SCHEDULE CHART

MAINTENANCE SCHEDULE CHART

WHEN REQUIRED

CHECK, CLEAN AND REPLACE AIR CLEANER ELEMENT	4- 20
CLEAN INSIDE OF COOLING SYSTEM	4- 23
CHECK TRACK SHOE TENSION, ADJUST	4- 26
CHECK AND TIGHTEN TRACK SHOE BOLTS	4- 28
REVERSE AND REPLACE END BITS AND CUTTING EDGES	4- 29
CLEANING AND INSPECTION OF FINS OF RADIATOR, OIL COOLER, CONDENSER AND AFTER-COOLER	4- 31
CHECK, ADJUST AIR CONDITIONER	4- 35
GREASE DOOR HINGE	4- 36
CHECK DOOR LOCK STRIKER	4- 36
REPLACE DOOR DAMPER	4- 36
CHECK DOOR LATCH	4- 37
CHECK WINDOW WASHER FLUID LEVEL, ADD FLUID	4- 37
REPLACE WIPER BLADE	4- 38
CHECK IDLER OIL LEVEL	4- 39
ADJUST IDLER CLEARANCE	4- 39
LUBRICATING UNIVERSAL JOINT	4- 40
PROCEDURE FOR BLEEDING AIR IN HYDRAULIC SYSTEM	4- 41

CHECK BEFORE STARTING

EVERY 50 HOURS SERVICE

Drain water, sediment from fuel tank	4- 43
--	-------

EVERY 250 HOURS SERVICE

LUBRICATING	4- 44
GREASE EQUALIZER BAR SIDE PIN	4- 46
GREASE EQUALIZER BAR CENTER PIN	4- 46
CHECK OIL LEVEL IN FINAL DRIVE CASE, ADD OIL	4- 46
CHECK OIL LEVEL IN HYDRAULIC TANK, ADD OIL	4- 47
CHECK LEVEL OF BATTERY ELECTROLYTE	4- 48
CHECK, CLEAN ADDITIONAL FUEL STRAINER	4- 50
CHECK BRAKE PERFORMANCE	4- 51
CLEAN AIR CONDITIONER AIR FILTER (FRESH/RECIRC FILTER)	4- 52

EVERY 500 HOURS SERVICE

CHANGE OIL IN ENGINE OIL PAN, REPLACE ENGINE OIL FILTER CARTRIDGE	4- 53
REPLACE POWER TRAIN OIL FILTER ELEMENT	4- 55
REPLACE FUEL PRE-FILTER CARTRIDGE	4- 56

EVERY 1000 HOURS SERVICE

REPLACE FUEL MAIN FILTER CARTRIDGE ----- 4- 59

CHANGE OIL IN POWER TRAIN CASE, CLEAN STRAINERS (POWER TRAIN STRAINER,
SCAVENGING PUMP STRAINER) ----- 4- 62

REPLACE HYDRAULIC TANK BREATHER ELEMENT ----- 4- 64

CHECK OIL LEVEL IN DAMPER CASE, ADD OIL ----- 4- 65

CHANGE OIL IN FINAL DRIVE CASE ----- 4- 66

CLEAN BREATHER ----- 4- 66

REPLACE CORROSION RESISTOR CARTRIDGE ----- 4- 67

CHECK ALL TIGHTENING POINTS OF ENGINE EXHAUST PIPE CLAMPS ----- 4- 67

CHECK FOR LOOSE ROPS MOUNT BOLTS ----- 4- 67

INSPECTION OF AFTER-COOLER CIRCUIT FOR LOOSENED BOLTS AND NUTS ----- 4- 67

EVERY 2000 HOURS SERVICE

CHANGE OIL IN HYDRAULIC TANK, REPLACE OIL FILTER ELEMENT ----- 4- 68

CHECKING CHARGE PRESSURE OF NITROGEN GAS IN ACCUMULATOR (FOR CONTROL
CIRCUIT) ----- 4- 69

CHANGE OIL IN DAMPER CASE ----- 4- 72

CHECK VIBRATION DAMPER ----- 4- 73

CHECK ALTERNATOR ----- 4- 73

CHECK ENGINE VALVE CLEARANCE, ADJUST ----- 4- 73

EVERY 4000 HOURS SERVICE

REPLACE ACCUMULATOR (FOR CONTROL CIRCUIT) ----- 4- 74

CHECK WATER PUMP ----- 4- 74

CHECK STARTING MOTOR ----- 4- 74

CHECKING FOR LOOSENESS OF HIGH-PRESSURE CLAMP, HARDENING OF RUBBER ----- 4- 75

CHECKING FOR MISSING FUEL SPRAY PREVENTION CAP, HARDENING OF RUBBER ----- 4- 76

EVERY 8000 HOURS SERVICE

Replace high-pressure piping clamp ----- 4- 77

Replace fuel spray prevention cap ----- 4- 77

SERVICE PROCEDURE

WHEN REQUIRED

CHECK, CLEAN AND REPLACE AIR CLEANER ELEMENT



WARNING

- If inspection, cleaning, or maintenance is carried out with the engine running, dirt will get into the engine and damage it. Always stop the engine before carrying out these operations.
- When using compressed air, there is danger that dirt may be blown around and cause serious injury. Always use protective glasses, dust mask, and other protective equipment.

CHECKING

If the yellow piston at the display portion of dust indicator (1) becomes red (7.5 kPa), clean the outer element.

NOTICE

Do not clean the filter element until after a yellow piston in the dust indicator display has come in the red area (7.5 kPa).

If the filter element is cleaned frequently before the yellow piston in the dust indicator display comes in the red area (7.5 kPa), the air cleaner cannot exert its inherent cleaning capability, reducing its cleaning effect. In addition, dust sticking to the element falls into the inner element each time the element is cleaned.

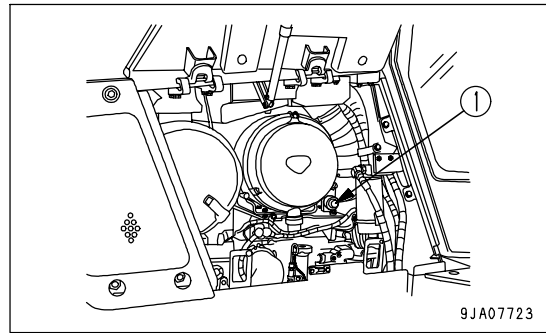

CLEANING OR REPLACING OUTER ELEMENT

1. Open the left engine side cover.
2. Remove three clips (2), then remove cover (3).

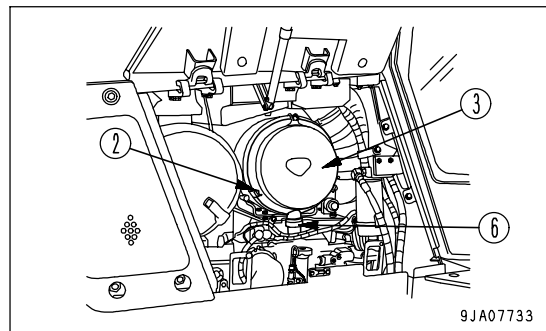

NOTICE

Never remove inner element (5). If it is removed, dust will enter and cause engine trouble.

3. Remove outer element (4).

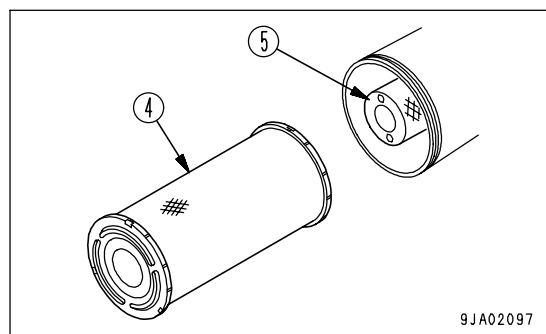

4. Clean the interior of the air cleaner body, cover (3) and evacuator valve (6).

NOTICE

The inner element must not be used again even after cleaning. When replacing the outer element, replace the inner element at the same time.

5. Direct dry compressed air (Max. 0.69 MPa (7 kg/cm², 99.4 PSI)) from the inside of the outer element along its folds. Then direct the compressed air from the outside along the folds, and again from the inside.

- 1) Replace any outer element which has been cleaned 6 times or used for 1 year. Replace the inner element at the same time.
- 2) Even if the outer element has not been cleaned 6 times, if the yellow piston in the dust indicator goes to the 5 kPa position immediately after cleaning (when the engine is running at high idling, replace both the inner and the outer element.

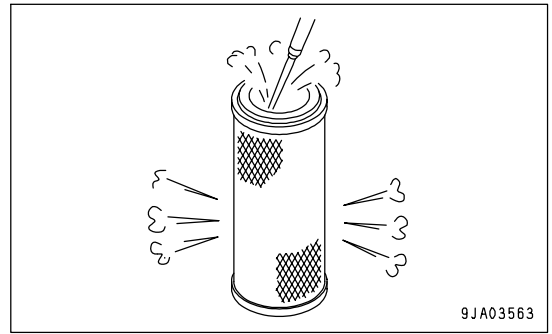

6. If small holes or thinner parts are found on the element when it is checked by shining a light through it after cleaning, replace the element.

NOTICE

When cleaning the element, do not hit or beat it against anything. Do not use an element whose folds, gasket or seal are damaged.

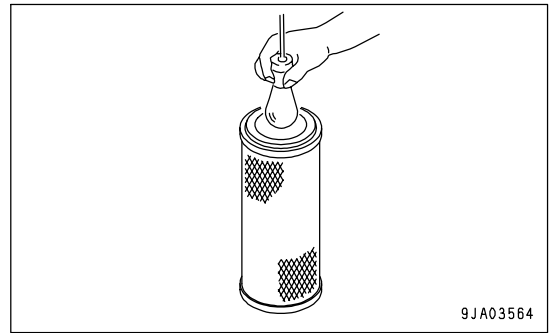

7. Before installing the outer element, check that the inner element is fitted securely. If the inner element is not fitted securely, push it in properly.

CAUTION
When installing the cover (3), check O-ring (7) and replace it if there are any scratches or damage.

8. Set the cleaned outer element in position, then secure cover (3) with mounting clips (2).

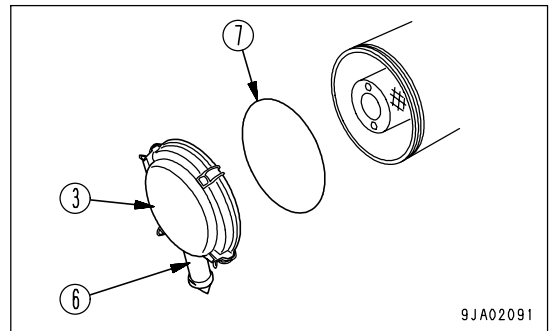

9. Push the button of dust indicator (1) and return the yellow piston to its original position.

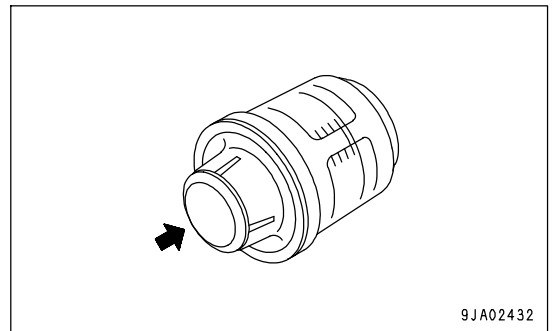

10. Close the left engine side cover.

REPLACING ELEMENT

1. Open the left engine side cover.
2. Remove three clips (2), then remove cover (3).

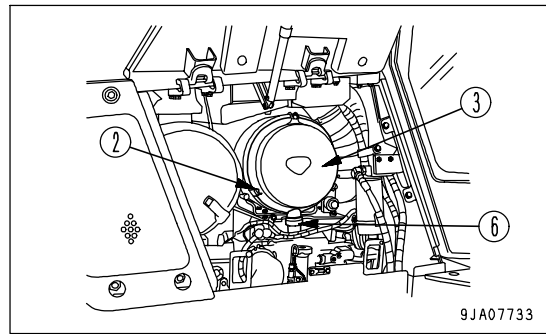

3. Remove outer element (4).
Do not remove inner element (5) at this time, however.
4. Clean the interior of the air cleaner body, cover (3) and evacuator valve (6).

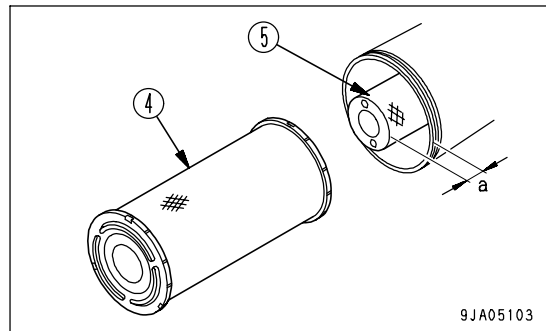

NOTICE

If the outer element and cover are installed when the inner element is not installed properly, the outer element may break.

When installation is correct, protrusion "a" of the inner element from the air cleaner body is 35 mm.

5. Remove inner element (5), then quickly install the new inner element.
Push the inner element in properly and check that it is fitted securely.
6. Set the new outer element (4) in position.
7. Replace O-ring (7) for cover (3) with new one.
8. Set the arrow mark on cover (3) at the top, install to the air cleaner body, then secure with clip (2).

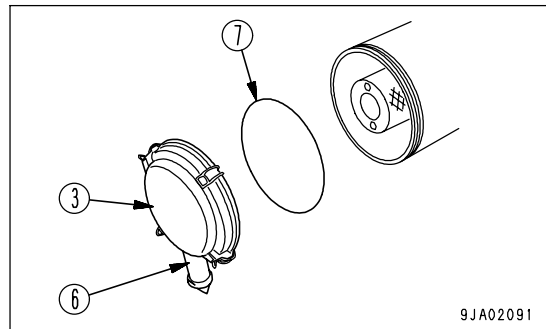

9. Push the button of dust indicator (1) and return the yellow piston to its original position.

REMARK

Immediately after a new element has been installed, the yellow piston of the dust indicator may go to the 2nd position, but this does not indicate any abnormality.

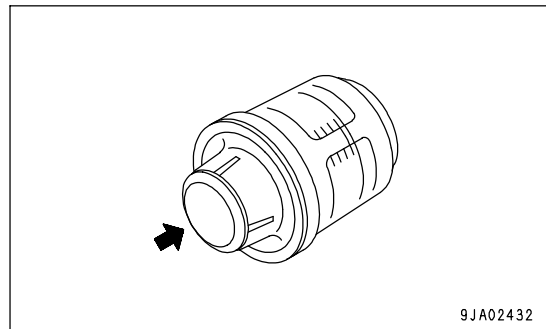

10. Close the left engine side cover.

CLEAN INSIDE OF COOLING SYSTEM

 **WARNING**

- Immediately after the engine is stopped, the cooling water is at high temperature and the radiator is under high internal pressure. If the radiator cap is removed in this condition and the water is drained, it may cause burns. To prevent this, wait for the temperature to go down, then turn the cap slowly to release the internal pressure.
- Start the engine and clean the inside of the cooling system.. When standing up or leaving the operator's seat, set the work equipment lock lever and parking brake lever to the LOCK position.
- For details when starting the engine, see "CHECK BEFORE STARTING ENGINE, ADJUST (PAGE 3-70)" and "STARTING ENGINE (PAGE 3-87)".
- If the undercover is removed, there is danger of touching the fan.
Never enter the area at the rear of the machine when the engine is running.

Stop the machine on level ground when cleaning or changing the coolant.

Clean the inside of the cooling system, change the coolant according to the table below.

Antifreeze coolant	Interval for cleaning inside of cooling system and changing antifreeze coolant	Precautions for use
Komatsu supercoolant (AF-NAC)	Every two years or every 4000 hours whichever comes first	1*

*1: When using Komatsu Supercoolant (AF-NAC), there is no need to use a corrosion resistor. When no corrosion resistor is used, use the special cover (600-411-9000). Please consult your Komatsu distributor about the method of installing.
When using corrosion resistor, use Komatsu genuine corrosion resistor. If you use another corrosion resistor, it may cause serious problems such as corrosion of the engine and parts of the cooling system that use light metals such as aluminum.

The coolant has the important function of preventing corrosion as well as preventing freezing. Even in the areas where freezing is not an issue, the use of antifreeze coolant is essential. Komatsu machines are supplied with Komatsu Supercoolant (AF-NAC). Komatsu Supercoolant (AF-NAC) has excellent anticorrosion, antifreeze and cooling properties and can be used continuously for 2 years or 4000 hours. As a basic rule, we do not recommend the use of any coolant other than Komatsu genuine supercoolant (AF-NAC). If you use another coolant, it may cause serious problems such as corrosion of the engine and parts of the cooling system that use light metals such as aluminum.

To maintain the anticorrosion properties of Supercoolant (AF-NAC), always keep the density of Supercoolant between 30% and 68%.

When deciding the ratio of antifreeze to water, check the lowest temperature in the past, and decide from the mixing table given below.

It is actually better to estimate and temperature about 10°C (18°F) lower when deciding the mixing ratio.

The mixing ratio depends on the ambient temperature, but it should always be a minimum of 30% by volume (antifreeze/total amount of coolant x 100).

Even in areas where it is not necessary to prevent freezing, use Supercoolant (AF-NAC) at a mixing ratio of at least 30% to prevent corrosion of the cooling system.

The freezing temperature of undiluted antifreeze is -15°C (5°F). Do not store undiluted antifreeze at a temperature of below -15°C (5°F).

Mixing rate of water and antifreeze

Min. atmospheric temperature	°C	-10	-15	-20	-25	-30
	°F	14	5	-4	-13	-22
Amount of antifreeze	liter	11.1	13.3	15.2	17.0	18.5
	US gal	2.93	3.51	4.02	4.49	4.89
Amount of water	liter	25.9	23.7	21.8	20.0	18.5
	US gal	6.84	6.26	5.76	5.28	4.89
Volume ratio (%)		30	36	41	46	50



WARNING

- Antifreeze is flammable, so keep it away from flame.
Antifreeze is toxic. When open the drain valve, be careful not to get water containing antifreeze on you. If it gets in your eyes, flush your eyes with large amount of fresh water and see a doctor at once.
- When changing the coolant or draining the coolant from the radiator before carrying out repairs, ask a specialist company to handle any coolant containing antifreeze, or contact your Komatsu distributor. Antifreeze is toxic, so never pour it into drainage water ditches or drain it onto the ground surface.

Use antifreeze and appropriate water for diluting (for details, see "COOLANT AND WATER FOR DILUTION (PAGE 4-6)")

We recommend use of an antifreeze density gauge to control the mixing proportions.

Prepare a container whose capacity is larger than the specified coolant volume to catch drained coolant.

Prepare a hose to supply antifreeze coolant and water.

1. Stop the engine and tighten 2 valves of the corrosion resistor.

2. Turn radiator cap (1) slowly until it hits the stopper and by so doing, relieving the internal pressure.
3. Turn radiator cap (1) until it hits the next stopper, while depressing it. Keep turning the radiator cap (1) until it hits the last stopper.
4. Put containers to catch the coolant under drain valve (2) at the bottom of the radiator and under drain valve (3) at the side of the cylinder block.
Open drain valve (2) and drain valve (3), and drain the water.
5. After draining the antifreeze solution, close drain valve (2), (3), then fill with clean water. After the radiator is filled with water, start and run the engine at low idling speed. After the water temperature rises above 90°C (194°F), run the engine for about 10 minutes.

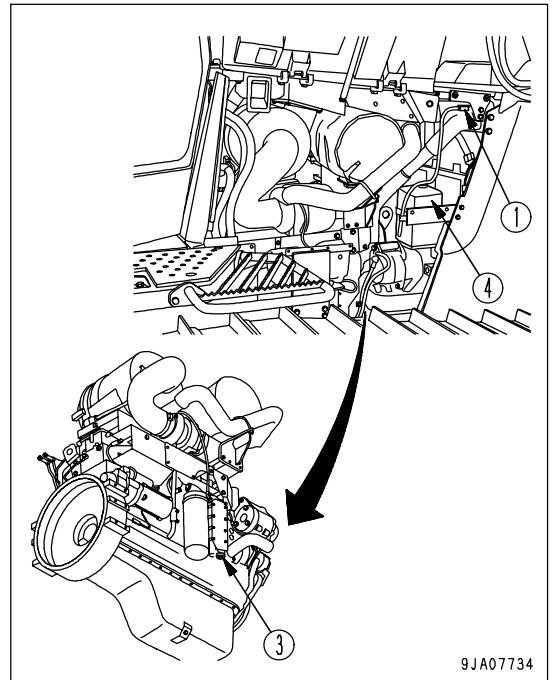

9JA07734

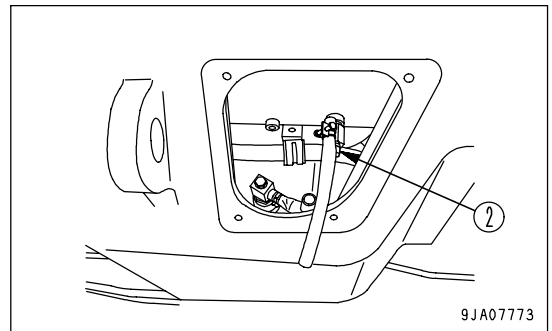

9JA07773

6. Stop the engine and open drain valve (2), (3) to drain the water.
7. After draining the water, clean the cooling system with cleaning agent.
For the cleaning method, see the instructions for the cleaning agent.
8. Replace the corrosion resistor, then open 2 valves.
For details of the procedure for replacing the corrosion resistor, see "REPLACE CORROSION RESISTOR CARTRIDGE (PAGE 4-67)".
9. Close drain valve (2), (3).
10. Add coolant mixed with antifreeze until it overflows from the water filler.
Decide the proportions of antifreeze and water according to the table for the mixing rate of water and antifreeze.
11. To remove air in the cooling system, run the engine for 5 minutes at low idle, then for 5 minutes at high idle.
(While doing this, leave the radiator cap removed.)
12. Drain the coolant from sub-tank (4), clean the inside of the sub-tank, then add water until the coolant level is between the FULL and LOW marks.
13. Stop the engine, wait for approx. 3 minutes, then add coolant until the coolant level is near the coolant filler port, and tighten the cap. Check the coolant level and add coolant if necessary.

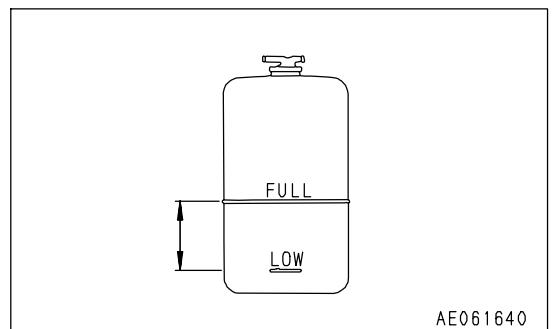

AE061640

CHECK TRACK SHOE TENSION, ADJUST

The wear of pins and bushings on the undercarriage will vary with the working conditions and types of soil. It is thus necessary to continually inspect the track tension so as to maintain the standard tension.

Carry out the check and adjustment under the same conditions as when operating (on jobsites where the track becomes clogged with mud, measure with the track clogged with mud).

INSPECTION

Stop the machine on level ground (stop with the transmission in FORWARD without applying the brake). Then place a straight bar on the track shoes between the carrier roller and the idler as shown in the figure, and measure the clearance between the bar and the grouser at the midpoint. If the clearance (a) is 20 to 30 mm (0.79 to 1.18 in), the tension is standard.

If the track tension is not at the standard value, adjust it in the following manner.

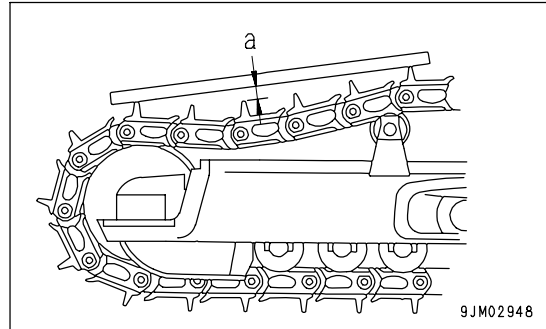

ADJUSTMENT



WARNING

There is danger of plug (1) flying out under the high internal pressure of the grease. Never loosen plug (1) more than 1 turn.

Never loosen any part other than plug (1). Never put your face in the mounting direction of plug (1).

If the track tension cannot be loosened with the procedure given here, please contact your Komatsu distributor.

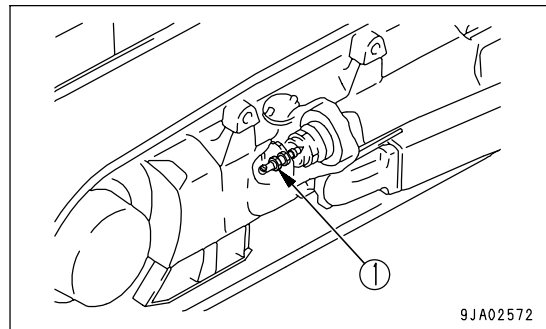

WHEN INCREASING TENSION

Prepare a grease pump.

1. Pump in grease through grease fitting (2) with a grease pump.
2. To check that the correct tension has been achieved, move the machine backwards and forwards.
3. Check the track tension again, and if the tension is not correct, adjust it again.

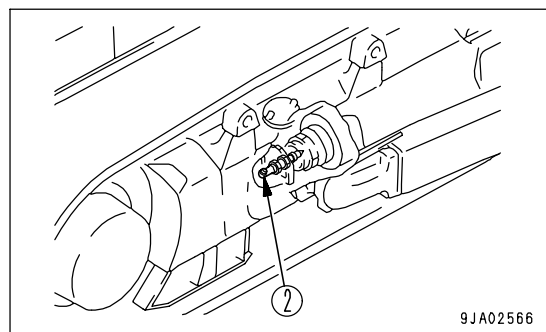

- Continue to pump in grease until S becomes 0 mm. If the tension is still loose, the pins and bushings are excessively worn, so they must be either turned or replaced. Please contact your Komatsu distributor.

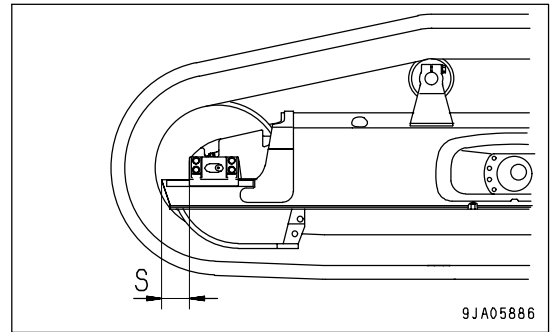

9JA05886

WHEN LOOSENING TENSION



WARNING

It is extremely dangerous to release the grease by any method except the procedure given below. If the track tension is not relieved by this procedure, please contact your Komatsu distributor.

- Loosen plug (1) gradually to release the grease.
- When loosening plug (1), turn it a maximum of one turn.
- If the grease does not come out smoothly, move the machine forwards and backwards a short distance.
- Tighten plug (1).
- To check that the correct tension has been achieved, move the machine backwards and forwards.
- Check the track tension again, and if the tension is not correct, adjust it again.

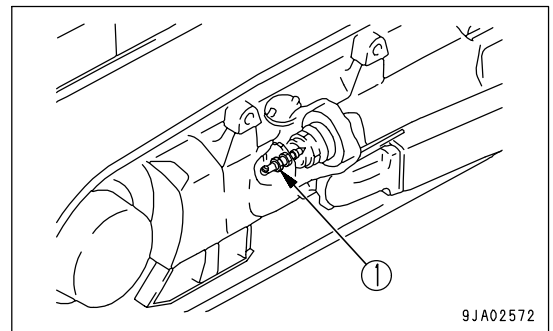

9JA02572

CHECK AND TIGHTEN TRACK SHOE BOLTS

Track shoes may be broken, if they are used with loosened shoe bolts (1). Hence whenever a loosened bolt is found, be sure to retighten it.

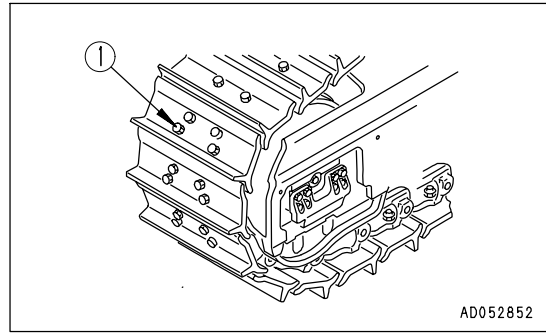

AD052852

METHOD OF TIGHTENING (TRACK SHOE BOLTS)

1. Torque the track shoe bolts to 539 ± 49 Nm (55 ± 5 kgm, 398 ± 36.2 lb ft). Then ensure the nut and shoes are in close contact with the link contact surface.
2. After checking, tighten a further. $120^\circ \pm 10^\circ$.

METHOD OF TIGHTENING (MASTER CONNECTING BOLT)

1. First tighten to a tightening torque of 343 ± 39 Nm (35 ± 4 kgm, 253 ± 29 lbft) then check that the link contact surfaces are in close contact.
2. After checking the link contact surfaces, tighten the bolt by 180° (Allowable range: $0^\circ - 20^\circ$).

ORDER FOR TIGHTENING

Tighten the bolts in the order shown in the diagram on the right.

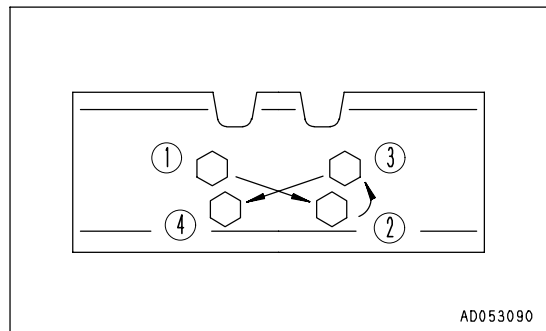

AD053090

REVERSE AND REPLACE END BITS AND CUTTING EDGES



It is dangerous if the work equipment moves during the turning or replacement operation.
 Set the work equipment in a stable condition, set the work equipment lock lever to the LOCK position, then stop the engine.

Reverse or replace the end bits and cutting edges before it is worn out to the blade end.

1. Raise the blade to a proper height, position a block under the frame to prevent the blade from falling.
2. Set the work equipment lock lever to the LOCK position and stop the engine.
3. Measure the wear of the end bit and cutting edge in accordance with the wear standards given below.

Wear standards

Item			Judgement criteria (mm)	
No.	Dimension to be measured	Work equipment	Basic dimension	Allowable max. value
1	Height of end bit (outside)	A,G	242	187
		B,C	204	187
		D	292	237
		E,F	315	237
		H	222	204
2	Width of end bit	A,B,C	325	300
		D	435	410
		E,F	540	515
		G,H	325	310
3	Height of end bit (inside)	A,B,C,G	204	187
		D,E,F	254	237
		H	222	204
4	Height of cutting edge (Center of bolt mounting hole to edge)	A to H	102	85

The symbols in the work equipment column have the following meaning.

- A: Powertilt dozer (D65EX)
- B: Powertilt dozer (D65PX)
- C: Powertilt, Power pitch dozer (D65PX)
- D: Semi-U blade (3m)(D65EX)
- E: Semi-U blade (D65EX)
- F: Semi-U blade (D65WX)
- G: Angledozer (D65EX)
- H: Angledozer (D65PX)

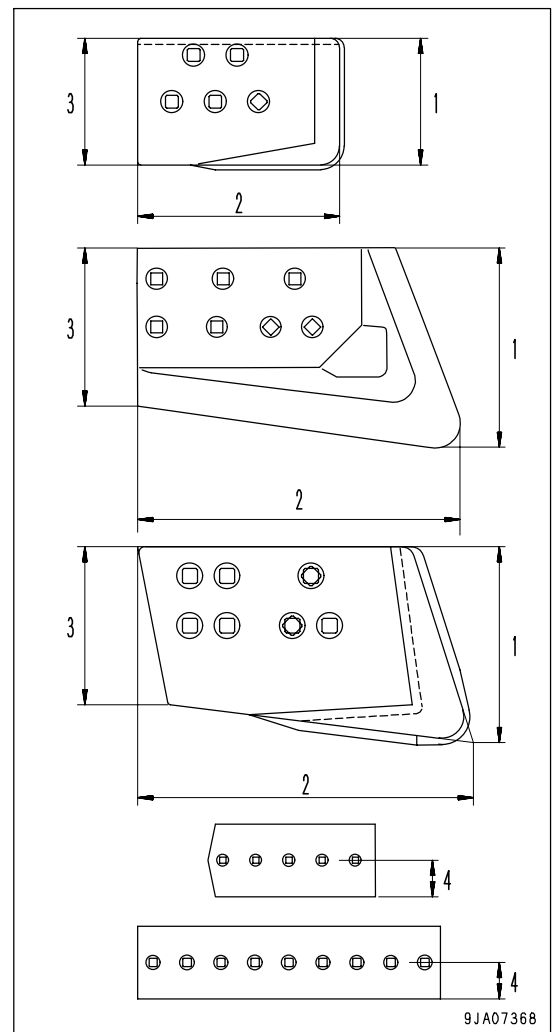

REMARK

- If the cutting edge and the end bit on both sides are worn out, replace with new ones.
- If it has been worn out up to the fitting surface, repair the fitting surface and then reverse or replace.

4. Remove the cutting edge and the end bit and clean the mounting surface.

5. Reverse or replace the cutting edge and the end bit when worn out.

1) Remove nut (1) and bolt (2), then replace or reverse the cutting edge and the end bit.

2) Install the cutting edge on the blade and tighten the bolt temporarily. Press the blade against the ground to eliminate the play of bolt (2), then tighten the bolt to the specified torque.

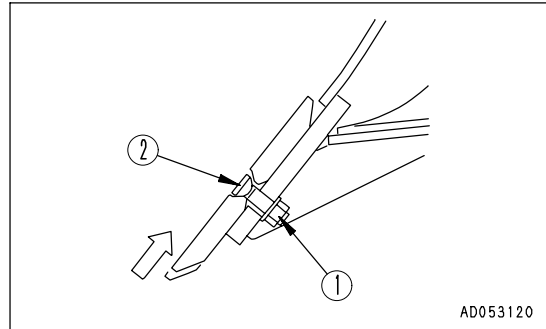

Nut tightening torque:

Powerlift dozer : 461 ± 69 Nm (47 ± 7 kgm , 340 ± 51 lbft.)

Powerlift, Power pitch dozer : 461 ± 69 Nm (47 ± 7 kgm , 340 ± 51 lbft.)

Angledozer : 441 ± 49 Nm (45 ± 5 kgm , 325.5 ± 36.2 lbft.)

Semi-U dozer :

Cutting edge : 461 ± 69 Nm (47 ± 7 kgm , 340 ± 51 lbft.)

End bit : 745 ± 108 Nm (76 ± 11 kgm , 550 ± 80 lbft.)

If bolt (2) and nut (1) are damaged, replace them with new ones at the same time.

6. After several hours of running, retorque the nuts.

CLEANING AND INSPECTION OF FINS OF RADIATOR, OIL COOLER, CONDENSER AND AFTER-COOLER

If the radiator fins are clogged or dirty, clean and inspect them.

CLEANING BY COOLING FAN REVERSE TURN

NOTICE

When working on jobsites where the fins often become clogged, always do as follows after completing operations.

When rotating the cooling fan in the reverse direction, be extremely careful of flying dust.

Open the engine side cover on the left side of the machine and be careful not to let dust accumulate inside the engine room.

When rotating the fan in reverse, do not open the engine side cover on the right side of the machine.

When stopping the engine when the cooling fan is rotating in the reverse direction, first run the engine at low idling, then stop it.

After running the fan in the reverse direction, check that there are no dry leaves, dust, or other flammable materials on the engine. In particular, be careful to check that there are no dry leaves, dust, or other flammable materials around places that become hot during operations, such as the exhaust manifold, turbocharger, and top of the exhaust pipe. If any flammable materials are found, remove them.

The dust and dirt stuck to the radiator and cooler can be blown out by rotating the cooling fan in the reverse direction.

1. Turn starting switch (1) to the "OFF" position and stop the engine.
2. Turn starting switch (1) to the "ON" position.
3. Set fan rotation selector switch (2) to the cleaning position (CLN).

Cooling fan operation checking lamp (3) lights up.

REMARK

Even if it is attempted to reverse a rotation direction of the cooling fan while the engine is running, the rotation direction cannot be changed.

In that case, cooling fan operation checking lamp (3) flashes and warns that the fan rotation cannot be reversed.

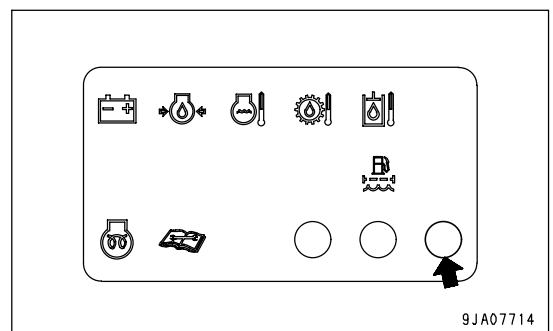
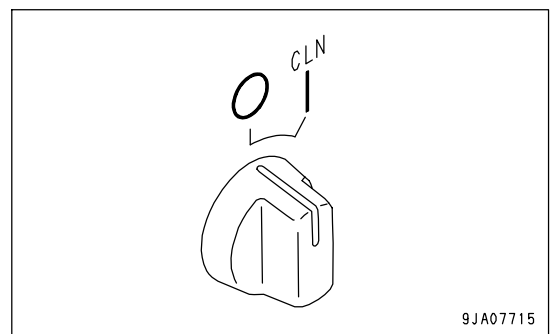
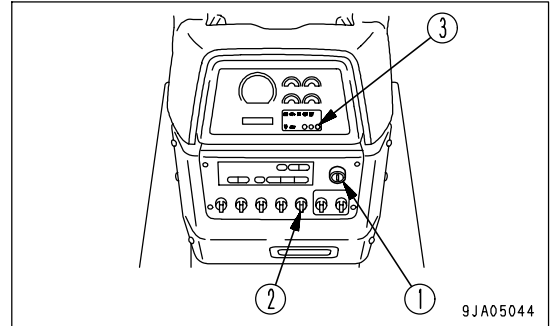

4. Turn engine starting switch key (1) to the ON position to start up the engine. Then the cooling fan begins to rotate in the reverse direction.
5. Run the engine at high idle.
Select the time for running the engine at high idle as follows according to the condition of clogging.
Normal clogging: 1 to 2 minutes
Excessive clogging: 2 to 3 minutes
6. After completing the cleaning, run the engine at low idle for approx. 10 seconds.
7. Turn starting switch (1) to the "OFF" position and stop the engine.
8. Turn starting switch (1) to the "ON" position.
9. Check first that cooling fan operation checking lamp (3) is unlighted and then start up the engine. The cooling fan begins to turn in the normal direction.

CLEANING WITH COMPRESSED AIR



WARNING

- Directing compressed air, pressurized water, or steam directly at your body, or using these and causing dust to fly may cause personal injury. Always wear protective glasses, anti-dust mask, and other protective equipment.
- When carrying out cleaning, always stop the engine and check that the fan is not rotating. If you touch the fan when it is rotating, it will cause serious personal injury.

CLEANING OF RADIATOR FINS AND AFTER-COOLER FINS

When the radiator fins and after-cooler fins are clogged or lots of dust is accumulated, clean them with compressed air.

1. Remove bolts (1) (4 bolts).
2. Open the A side (hinge side) of the radiator mask. It opens approx. 10 mm (0.4 in).
3. Open the B side of the radiator mask.
4. Blow off dirt, dust and dry leaf shreds clogging the radiator fins and after-cooler fins with compressed air. Steam and water may also be used for cleaning instead of compressed air.

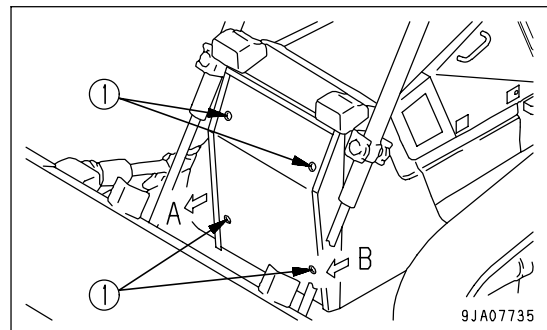

REMARK

Check the hydraulic cooler hoses. If any hose is cracked or hardened by age, replace with a new hose. Also check and tighten all loose hose clamps.

5. When closing the radiator mask, always push in the A side first, then push in the B side, align the bolt holes, and tighten bolts (1).

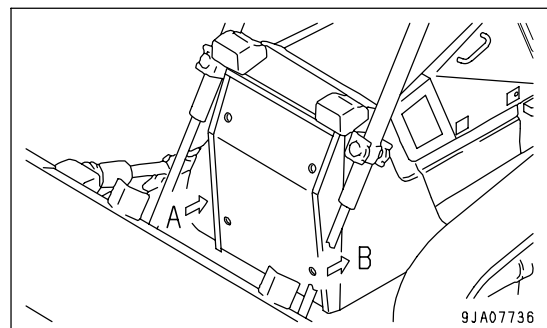

CLEANING OF OIL COOLER FINS AND CONDENSER FINS

When the oil cooler fins and condenser fins are clogged or lots of dust is accumulated, clean them with compressed air.

1. Open up right and left side covers (1).

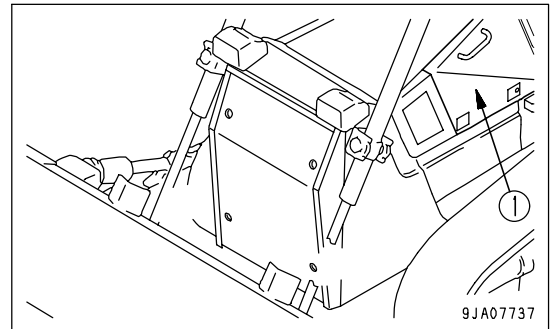

2. Remove right and left bolts (3) - 4 bolts in total - to remove right and left lower side covers (5).
3. Remove right and left bolts (4) - 8 bolts in total - to remove right and left small side covers (6).

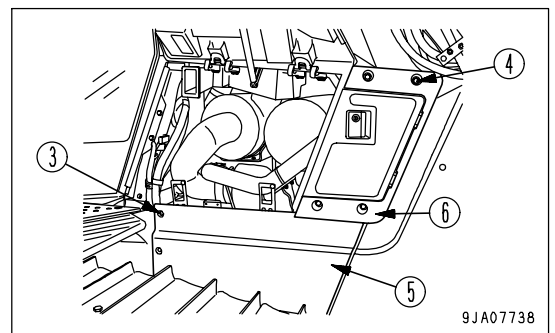

4. Remove bolts (2) - 2 bolts in total - to remove sub-tank assembly together with stay (7).

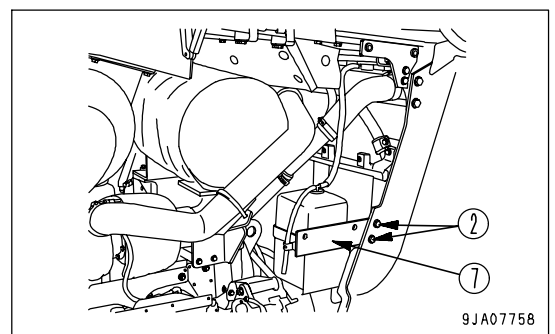

5. Put the removed sub-tank assembly on radiator guard seat (8) and temporarily fasten it to radiator guard seat (9) with removed bolt (2) - 1 bolt only.

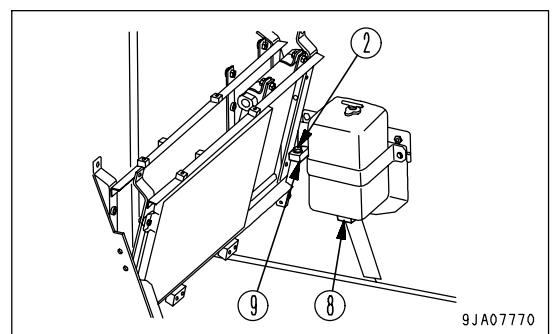

6. Remove right and left bolts (11) - 2 bolts in total, and loosen bolts (12) - 2 bolts in total - to swing back oil cooler (9) and air conditioner condenser (10).
7. Blow off dirt, dust and dry leaf shreds clogging the oil cooler fins and air conditioner condenser fins with compressed air. Steam and water may also be used for cleaning instead of compressed air.
8. Put oil cooler (9) and air conditioner condenser (10) back to the original position by swinging them forth, tighten bolts (12) and install bolts (11).
9. Reassemble the temporarily fastened sub-tank assembly in the original position.
10. Install right and left lower side covers (5) and small side covers (6) and close the engine side covers.

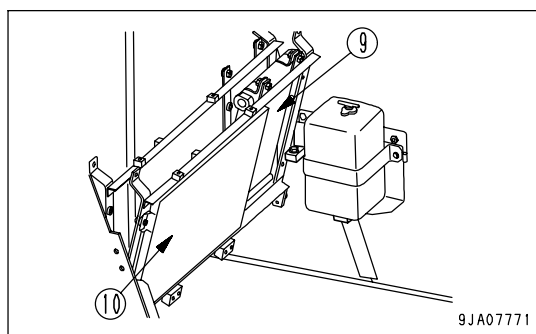
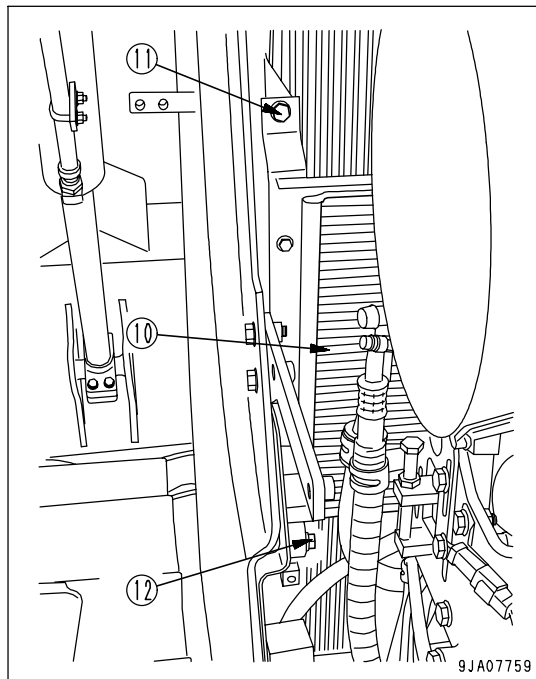

CHECK, ADJUST AIR CONDITIONER

(Machine equipped with cab)

CHECKING TENSION OF COMPRESSOR BELT

If the driving belt slackens, it is likely to slip, lowering the cooling efficiency. Depress the mid point between drive pulley (1) and compressor pulley (2) with a thumb (approx. 98 N (10 kg)) every now and then to make sure that deflection amount (A) is approx. 15 mm to 18 mm (0.59 to 0.71 in).

When it is a new belt, elongation is expected in the initial period of use, so be sure to make an adjustment in a few days after the replacement.

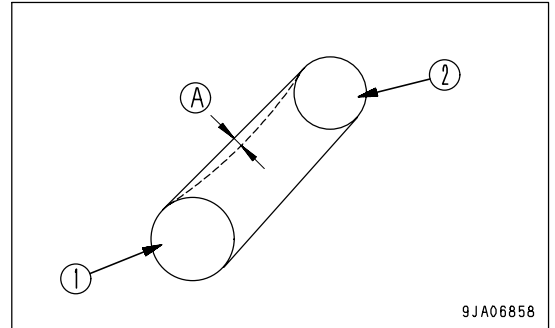

CHECK LEVEL OF REFRIGERANT

! WARNING

If the refrigerant used in the air conditioner gets into your eyes or on your hands, it may cause loss of sight or frostbite. Do not touch the refrigerant. Never loosen any part of the refrigerant circuit. Do not bring any flame close to any point where the refrigerant gas is leaking.

If the level of the refrigerant (gas) is low, the cooling effect will be reduced. Run the engine at high idle, and check the flow of the refrigerant gas (R134a) in the refrigerant circuit through the sight glass (2) (inspection window) of the receiver (1) when the cooler is running at high speed.

- (A) Correct: No bubbles are included in the flow
- (B) Low: Bubbles are included in the flow (bubbles pass continuously)
- (C) None: Colorless, transparent

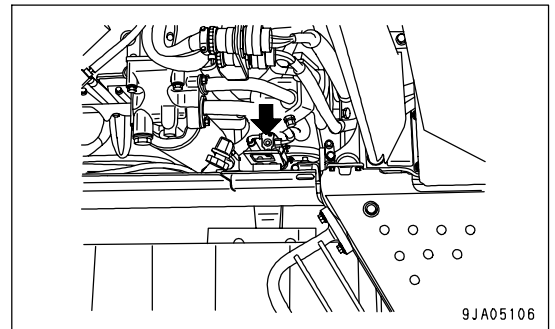

REMARK

- When there are bubbles, the refrigerant gas level is low, so contact your refrigerant dealer to have refrigerant added. If the air conditioner is run with the refrigerant gas level low, it will cause damage to the compressor.
- New Freon R134a is used as the refrigerant.

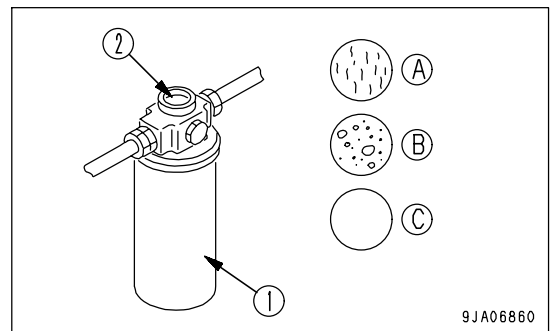

OPERATING AIR CONDITIONER OFF-SEASON

Even during the off-season, operate the air conditioner for 3 to 5 minutes once a month to maintain the oil film at all parts of the compressor.

GREASE DOOR HINGE

(Machine equipped with cab)

If the door makes a squeaking noise when it is opened or closed, spray lubricant in through the split in the hinge bushing. If the bushing is worn, replace the hinge.

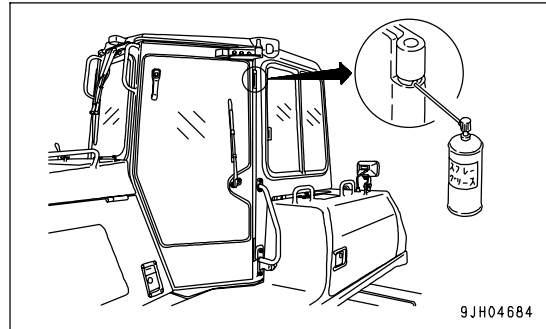

CHECK DOOR LOCK STRIKER

(Machine equipped with cab)

If wear (A) of the door of lock striker exceeds 0.5 mm (0.02 in), replace the striker. If it is used as it is, the play will increase and this may result in breakage of the hinge or door lock.

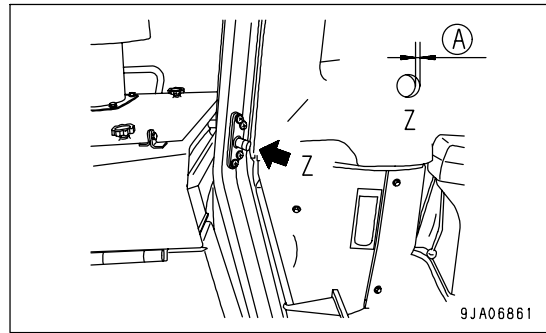

REPLACE DOOR DAMPER

(Machine equipped with cab)

If depth (A) of the groove of door damper rubber (1) is less than 2 mm (0.08 in), replace the damper.

There are 4 dampers: 1 each at the top and bottom on the left and right doors.

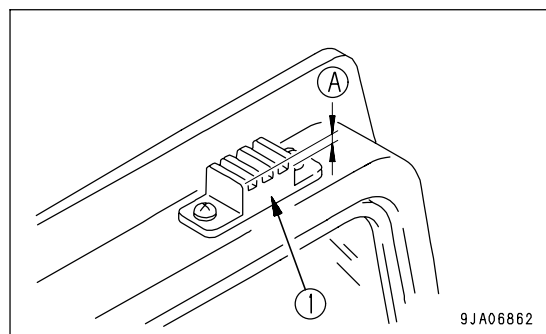

CHECK DOOR LATCH

(Machine equipped with cab)

Hold the door open and check that there is still grease inside the latch. If the amount of grease is low or there is no more grease, coat the inside of the latch with grease from portion (1).

REMARK

If there is no more grease inside the latch, the movement will become poor because of dust inside the latch, and the handle may be stiff when opening the door.

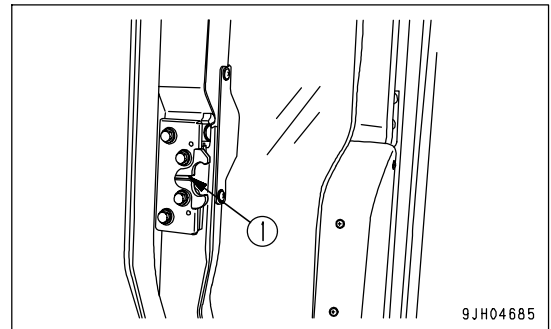

CHECK WINDOW WASHER FLUID LEVEL, ADD FLUID

(Machine equipped with cab)

If there is air in the window washer fluid, check the level and add fluid.

Open the engine side cover on the right side, check the level of the fluid in window washer tank(1), and if it is low, add automobile window washer fluid.

When adding fluid, be careful not to let any dust get in.

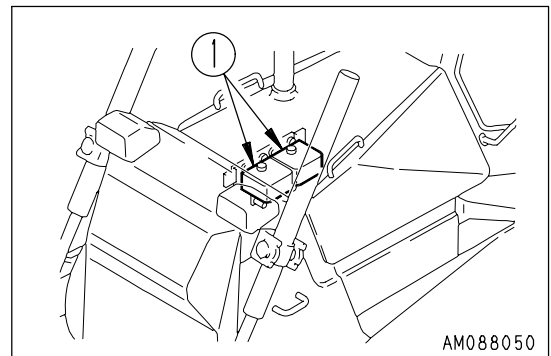

PROPORTION FOR MIXING FLUID WITH WATER

The proportion differs according to the ambient temperature, so dilute the washer fluid with water to the following proportions before adding.

Area, season	Proportions	Freezing temperature
Normal	Washer fluid 1/3: water 2/3	-10°C (14°F)
Winter in cold area	Washer fluid 1/2 : water 1/2	-20°C (-4°F)
Winter in extremely cold area	Pure washer fluid	-30°C (-22°F)

There are two types depending on the freezing temperature:

-10°C (14°F) (general use) and -30°C (-22°F) (cold area use), select according to the area and season.

REPLACE WIPER BLADE

(Machine equipped with cab)

If the blade is damaged, it will not wipe the window clean, so replace the blade.

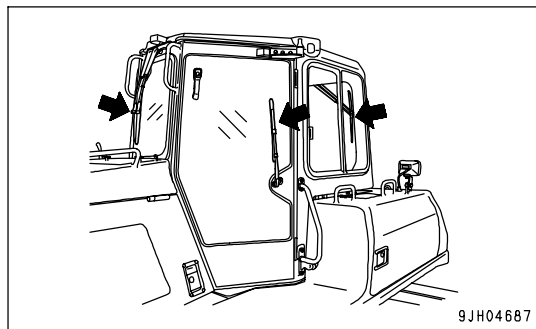

REPLACEMENT

FRONT, DOOR WIPER

1. It is hooked at portion (A), so move the blade in the direction of the arrow to remove it.
2. Install the new blade and hook it securely.

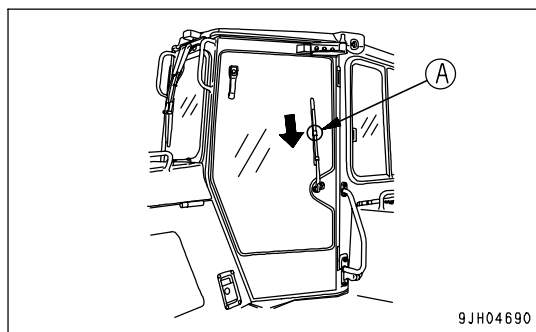
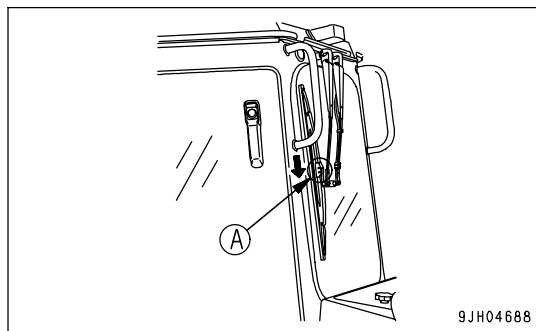

REAR WIPER

1. Remove E-ring (1).
The blade can then be removed.
2. Install a new blade, then install securely with E-ring (1).

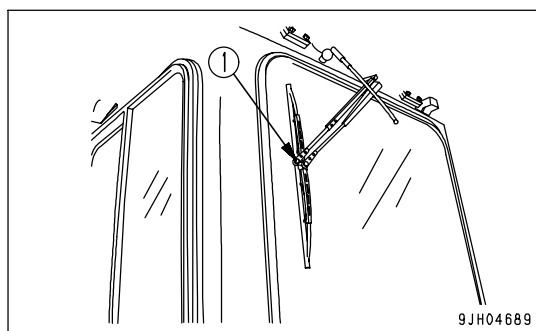

CHECK IDLER OIL LEVEL



WARNING

If the oil level in the idler is low, new oil must be added, and the machine body must be inclined in this case. Since this work is dangerous, ask your Komatsu distributor.

If the oil level in the idler is low, noise will be generated and there will be seizure, so check the oil level and add oil as follows.

INSPECTION

1. Remove bolt (1), then remove guide plate (2) and shim (3).

REMARK

When removing shim (3) keep it in a safe place and be careful not to lose it.

2. Loosen plug (4) slowly. If oil oozes through the threads at this time, the quantity of oil is sufficient. Tighten plug (4).
3. If any oil does not flow out when plug (4) is removed, the quantity of oil is insufficient. In this case, ask your Komatsu distributor for repair.
4. Install guide plate (2) and shim (3) with bolt (1).

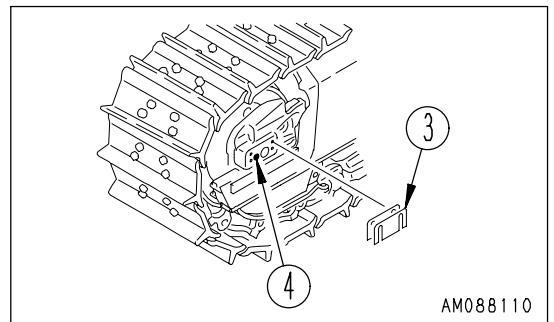
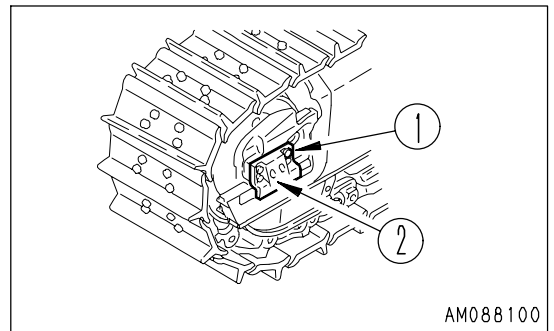

REMARK

When installing guide plate (2), install the same number and thickness of shim (3) as removed in Step 1. The optimum clearance may be obtained, if the adjustment is made at the same time. For details of adjusting the shim thickness, see "ADJUST IDLER CLEARANCE (PAGE 4-39)".

ADJUST IDLER CLEARANCE

Since the idlers are forced to move forward and backward by an external force guide plates will be worn out. Wear of these plates will cause the vibration of idlers from side to side or inclination of the idlers, and running off of track links from the idlers or unevenly worn idler and links may result. Therefore, adjust the idlers according to the following procedure.

ADJUSTMENT

1. Travel for 1 or 2 meters on flat ground, then measure clearance (A) between track frame (1) and guide plate (2) (4 places: left, right, inside, outside).
2. If the clearance (A) exceeds 4.0 mm (0.16 in), loosen bolt (3), and pull out the shim to adjust the clearance at one end to 0.5 to 1.0 mm (0.02 to 0.04 in).
Thickness of one shim is 1.0 mm (0.04 in).

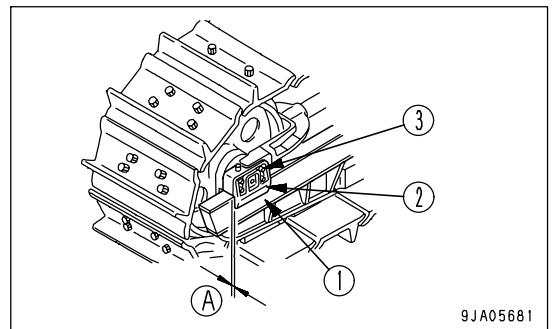

LUBRICATING UNIVERSAL JOINT

**WARNING**

The undercover is heavy. Never try to open or close the cover when directly beneath it. When removing bolts(2), carry out the work from the rear of the cover so that you can easily get out of the way.

1. Remove the undercover from the rear bottom of the machine body as follows.

- 1) Remove two bolts (1) from the front side of the machine body.
- 2) Holding the cover, remove two bolts (2) from the rear side of the machine body.

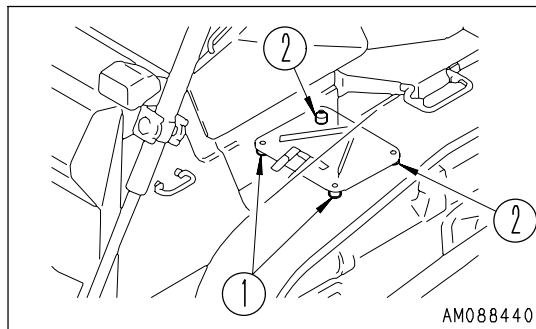

3) Lower and open the cover gradually.

- (A) Front of machine
- (B) Dangerous place

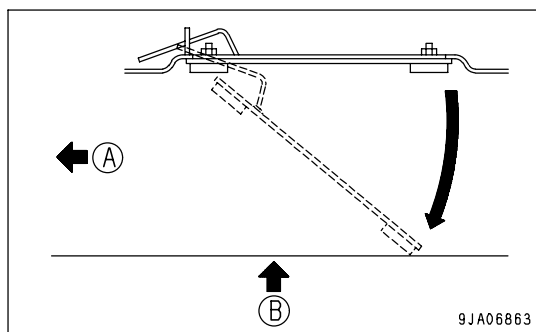

2. Apply grease to the grease fittings (2 places) shown by arrows.

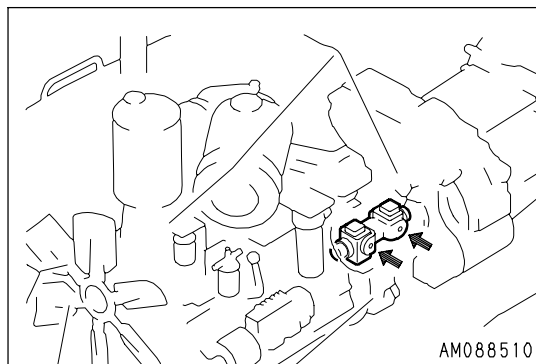

PROCEDURE FOR BLEEDING AIR IN HYDRAULIC SYSTEM

See "STARTING ENGINE (PAGE 3-87)".

Since the engine must be started and the blade must be operated, see OPERATION.

NOTICE

If the engine is run at high speed immediately after startup or a cylinder is pushed up to its stroke end, air taken inside the cylinder may cause damage to the piston packing.

1. Bleed air from left pitch cylinder
(Powertilt, Power pitch dozer only)

Bleeding air from the hydraulic system is required when removing and installing the work equipment or when making the repairs.

- 1) Start the engine and run it at low idle for at about 5 minutes.
- 2) Raise the blade.
- 3) Bleeding air in the tilt hydraulic circuit by repeating left and right tilt operation five to ten times.
- 4) Bleeding air from the bottom of left cylinder by operating the blade to pitch forward and backward 5 to 10 times repeatedly.
- 5) Set the left and right cylinders at the neutral position, then carry out the following operations 5 to 10 times to bleed the air from the head end of the left pitch cylinder.

(1) Forward pitch → (2) Left tilt → (3) Right tilt → (4) Backward pitch

2. Bleeding air from cylinders

- 1) Run the engine at low idle, and extend and retract each cylinder 4 to 5 times, taking care that a cylinder is not moved to the end of its stroke. (Stop the cylinder approx. 100 mm (3.9 in) short of its stroke end)
- 2) Next, operate each cylinder 3 to 4 times to the end of its stroke.
- 3) Finally, operate each cylinder 4 to 5 times to the end of its stroke to completely remove the air.

CHECK BEFORE STARTING

For details of the following items, see "CHECK BEFORE STARTING (PAGE 3-72)" in the OPERATION section.

- Check oil level in engine oil pan, add oil
- Check dust indicator
- Check, drain water separator
- Check coolant level, add coolant
- Check oil level in power train case, add oil
- Check electric wiring
- Check brake pedal travel
- Checking with machine monitor
- Check fuel level, add fuel
- Check horn sound
- Check that lamps light up
- Check backup alarm sound

EVERY 50 HOURS SERVICE**DRAIN WATER, SEDIMENT FROM FUEL TANK**

Carry out this procedure before operating the machine.

- Prepare a container to catch the fuel that is drained.

1. Open cover (1).
2. Open valve (2) at the bottom of the tank and drain the sediment and water that has accumulated at the tank bottom together with fuel.

When doing this, be careful not to get fuel on yourself.

3. When clean fuel comes out, close drain valve (2).

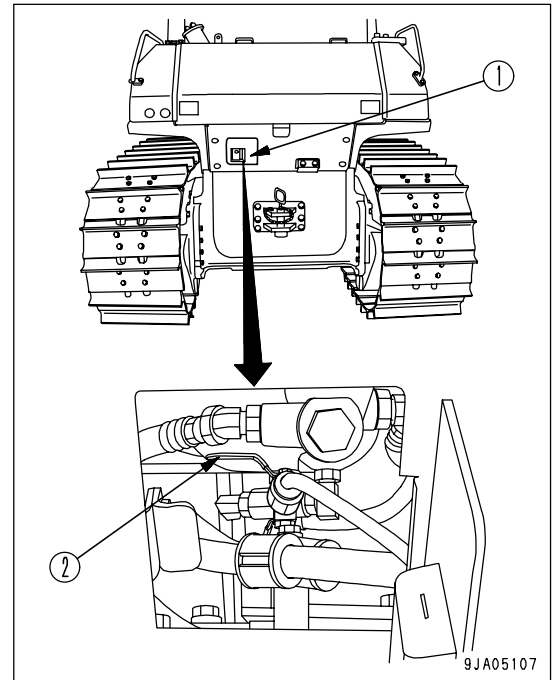

EVERY 250 HOURS SERVICE

Maintenance for every 50 hours service should be carried out at the same time.

LUBRICATING

1. Lower the blade to the ground, then stop the engine.
2. Using a grease pump, pump in grease through the grease fittings shown by arrows.
3. After greasing, wipe off any old grease that was pushed out.

POWER TILTDOZER

- (1) Lift cylinder support yoke (4 places)
- (2) Lift cylinder support shaft (2 places)

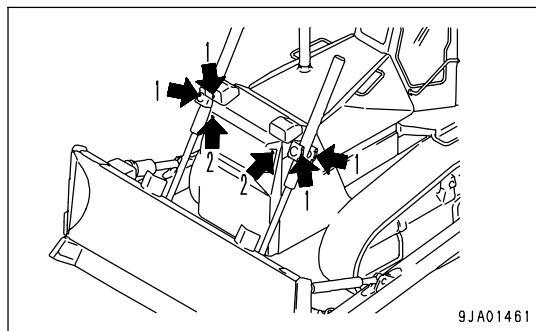

- (3) Lift cylinder ball joint (2 places)
- (4) Tilt cylinder ball joint (1 place)
- (5) Tilt brace ball joint (1 place)
- (6) Brace ball joint (2 places)
- (7) Tilt brace thread (1 place) (screw-adjustable)

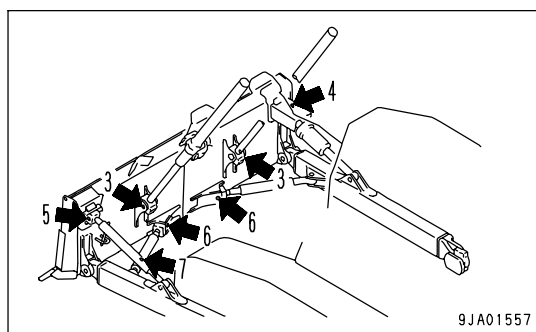

POWER TILT-POWER PITCH DOZER

- (1) Lift cylinder support yoke (4 places)
- (2) Lift cylinder support shaft (2 places)

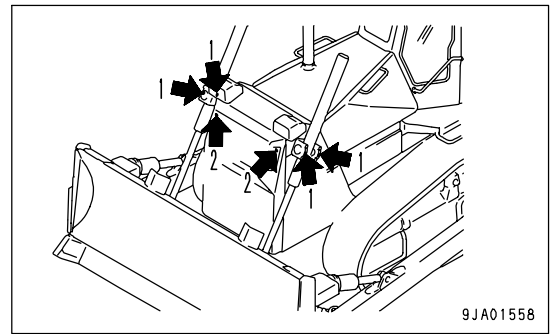

- (3) Lift cylinder ball joint (2 places)
- (4) Tilt cylinder ball joint (1 place)
- (5) Pitch cylinder ball joint (1 place)
- (6) Brace ball joint (2 places)

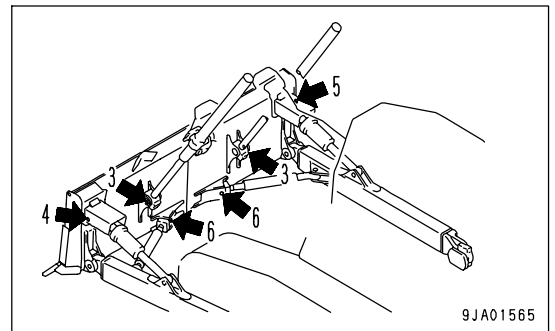

ANGLED OZER

- (1) Lift cylinder support yoke (4 places)
- (2) Lift cylinder support shaft (2 places)

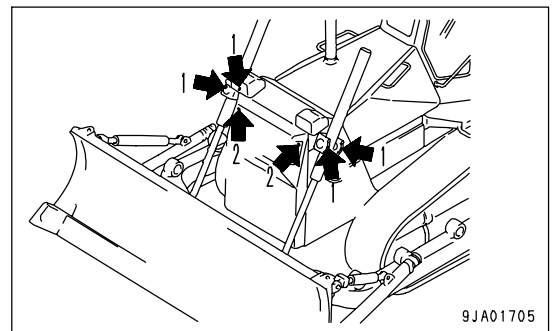

- (3) Lift cylinder ball joint (2 places)
- (4) Tilt brace ball joint (2 places)
- (5) Tilt brace thread (2 places)

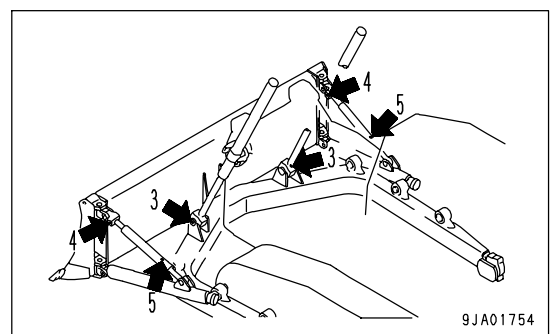

GREASE EQUALIZER BAR SIDE PIN

Left and right, 1 places each

1. Remove all dirt from the top of the track frame and cover.
2. Clean the grease fitting indicated with the arrow, then supply grease to that fitting with a grease pump.

REMARK

- Supply 3 shots of grease (Operate the grease pump lever 3 times) to each grease fitting, and check that grease is newly discharged through the seal lip.
- If grease is not newly discharged through the lip, continue supplying grease until it is discharged.

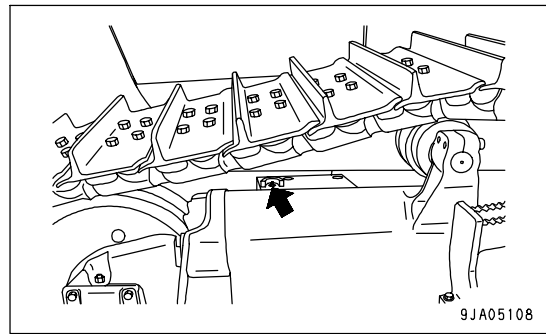
**GREASE EQUALIZER BAR CENTER PIN**

(1 place)

1. Open the engine side cover on the left side of the chassis.
2. Clean the grease fitting indicated with the arrow, then supply grease to that fitting with a grease pump.

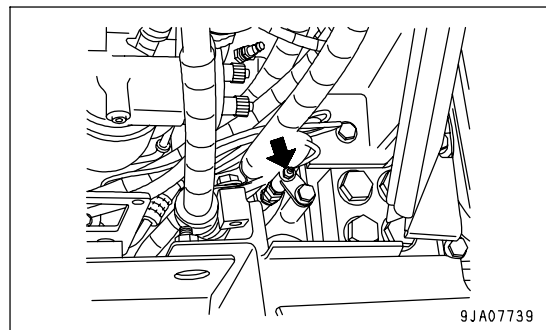
**CHECK OIL LEVEL IN FINAL DRIVE CASE, ADD OIL****WARNING**

- The oil is at high temperature immediately after the machine has been operated. Wait for the oil to cool down before starting the operation.
- If there is still pressure remaining inside the case, the oil or plug may fly out.
Loosen the plug slowly to release the pressure.

1. Stop the machine so that drain plug (3) is directly at the bottom.
2. Remove oil level plug (2) and check whether the final drive case is filled with oil to lower edge of the plug hole.
3. If the oil level is too low, add oil through the oil filler plug hole(1).
4. When oil starts to overflow from oil level plug (2), stop filling and install oil level plug (2) and oil filler plug (1).

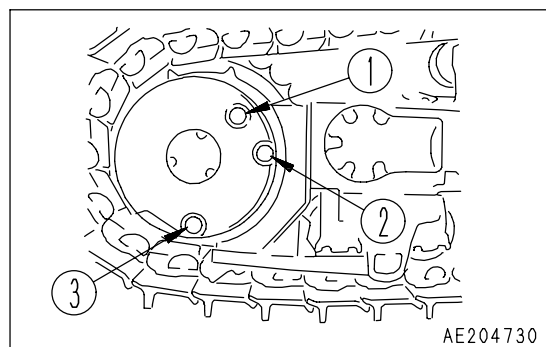

CHECK OIL LEVEL IN HYDRAULIC TANK, ADD OIL

**WARNING**

- The parts and oil are at high temperature immediately after the engine is stopped, and may cause burns. Wait for the temperature to go down before starting the work.
- When removing the oil filler cap, oil may spurt out, so push the cap down to release the internal pressure, then remove the cap carefully.

NOTICE

- Do not add oil if the level is above the H line. This will damage the hydraulic equipment and cause the oil to spurt out.
 - Always lock the cap with the key.
1. Lower blade to the ground and stop the engine. Wait for 5 minutes before checking oil level. Oil level should be between the H and L in sight gauge (G).

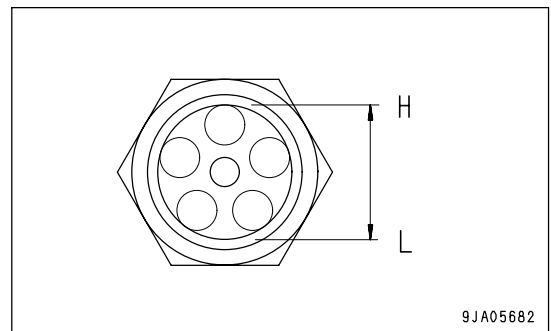
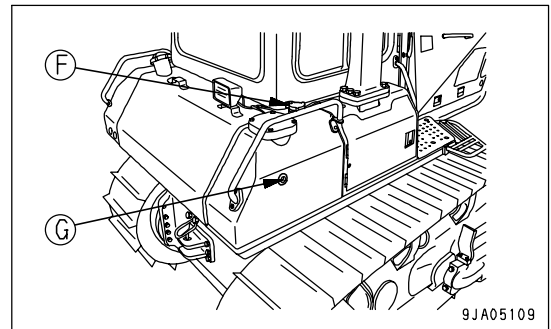

2. If the level is below the L mark, add oil through oil filler (F) as follows.

- 1) Push down cap of oil filler (F) to release the air and remove the internal pressure.
- 2) Keep cap pushed down, turn it slowly counterclockwise, then remove cap.
- 3) Refill the specified quantity of oil through oil filler (F).
- 4) Install cap.

When installing cap to the tank, push it down, then turn it clockwise.

REMARK

If the cap is not installed correctly, it will cause leakage of oil.

When installing the cap, press the cap down, and turn it until it is securely in contact with the stopper.

The cap is the lock addition type.

About handling method of cap with the lock, see "CAP WITH LOCK (PAGE 3-50)".

CHECK LEVEL OF BATTERY ELECTROLYTE

Carry out this procedure before operating the machine.



WARNING

- Do not use the battery if the battery electrolyte level is below the LOWER LEVEL line. This will accelerate deterioration of the inside of the battery and reduce the service life of the battery. In addition, it may cause an explosion.
- The battery generates flammable gas and there is danger of explosion, do not bring fire or sparks near the battery.
- Battery electrolyte is dangerous. If it gets in your eyes or on your skin, wash it off with a large amount of water and consult a doctor.
- When adding distilled water to the battery, do not allow the battery electrolyte to go above the UPPER LEVEL line. If the electrolyte level is too high, it may leak and cause damage to the paint surface or corrode other parts.

NOTICE

If there is a fear that the battery water may freeze after refilling with purified water (e.g. commercially available replenishment water for a battery), do the replenishment before the day's work on the next day.

Inspect the battery electrolyte level at least once a month and follow the basic safety procedures given below.

WHEN CHECKING ELECTROLYTE LEVEL FROM SIDE OF BATTERY

If it is possible to check the electrolyte level from the side of the battery, check as follows.

1. Open the battery cover on the left side of the machine body.
2. Use a wet cloth to clean the area around the electrolyte level lines and check that the electrolyte level is between the UPPER LEVEL (U.L.) and LOWER LEVEL (L.L.) lines.
If the battery is wiped with a dry cloth, static electricity may cause a fire or explosion.

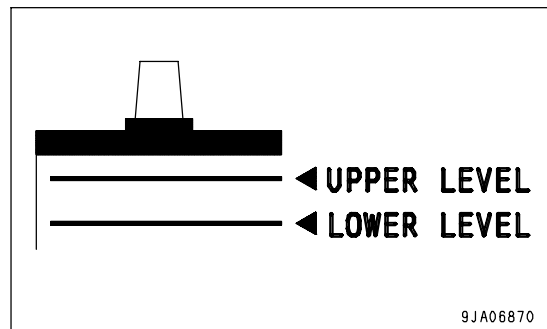

3. If the electrolyte level is below the midway point between the U.L and L.L lines, remove cap (1) and add distilled water to the U.L line.
4. After adding distilled water, tighten cap (1) securely.

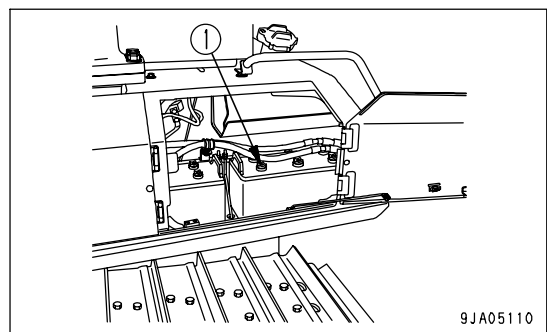

REMARK

If distilled water is added to above the U.L. line, use a syringe to lower the level to the U.L. line. Neutralize the removed fluid with baking soda (sodium bicarbonate), then flush it away with a large amount of water or consult your Komatsu distributor or battery maker.

WHEN IT IS IMPOSSIBLE TO CHECK ELECTROLYTE LEVEL FROM SIDE OF BATTERY

If it is impossible to check the electrolyte level from the side of the battery, or there is no display of the UPPER LEVEL line on the side of the battery, check as follows.

1. Open the battery cover on the left side of the machine body.
2. Remove cap (1) at the top of the battery, look through the water filler port (2), and check the electrolyte surface. If the electrolyte does not reach the sleeve (3), add distilled water so that the level reaches the bottom of the sleeve (UPPER LEVEL line) without fail.
 - (A) Suitable level: Electrolyte level is up to bottom of sleeve, so surface tension causes electrolyte surface to bulge and poles appear bent.
 - (B) Low: Electrolyte level is not up to bottom of sleeve, so poles appear straight and not bent.
3. After adding distilled water, tighten cap (1) securely.

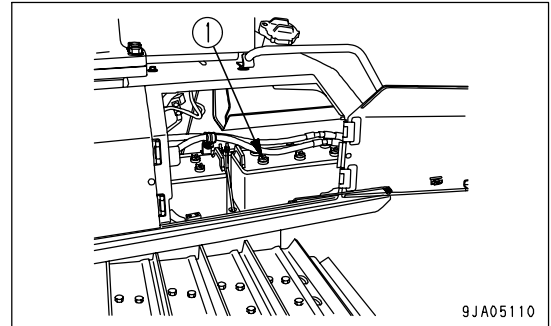

REMARK

If water is added to above the bottom tip of the sleeve, use a pipette to remove electrolyte. Neutralize the removed electrolyte with sodium bicarbonate, then flush it away with a large amount of water. If necessary, contact your Komatsu distributor or your battery maker.

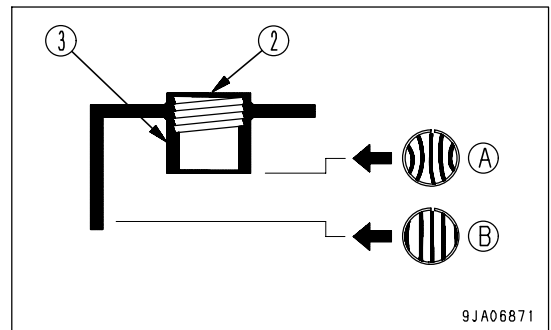

WHEN IT IS POSSIBLE TO USE INDICATOR TO CHECK ELECTROLYTE LEVEL

If it is possible to use an indicator to check the electrolyte level, follow the instructions given.

CHECK, CLEAN ADDITIONAL FUEL STRAINER

(If equipped)

1. Open cover (1).
2. Close fuel supply valve (2), then remove strainer cap (3).
The strainer forms one unit with the strainer cap.
3. Remove any dirt stuck to the strainer, then wash in clean diesel fuel or flushing oil. If the strainer is damaged, replace it.
4. After checking and cleaning, install the strainer, then tighten cap (3).
5. After installing, open fuel supply valve (2).

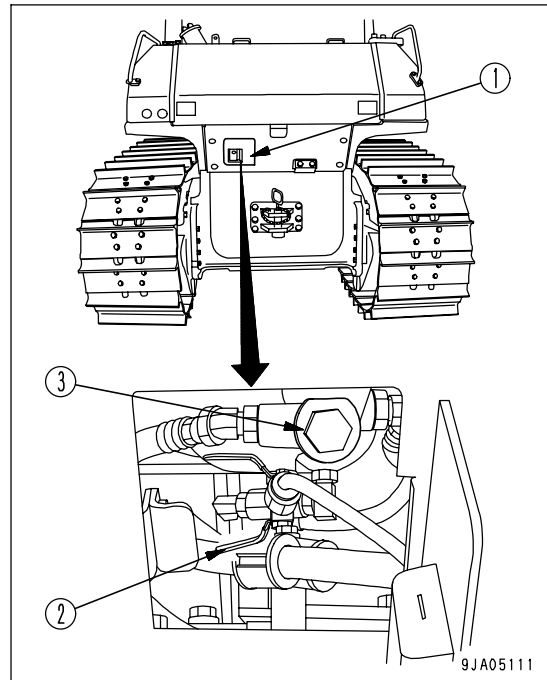

9JA05111

CHECK BRAKE PERFORMANCE



WARNING

If the machine moves during the following operation, please contact your Komatsu distributor for repairs immediately.

NOTICE

Do not place the gear shift lever in 1st under any circumstances. The machine will be damaged.

Before starting the engine, check that the area around the machine is safe, then do as follows:

1. Start the engine.
2. Set work equipment lock lever (1) to the FREE position (F) then operate blade control lever (2) to raise the blade.
Leave the work equipment lock lever(1) to the FREE position (F).
3. Set parking brake lever (3) to the FREE position (F).

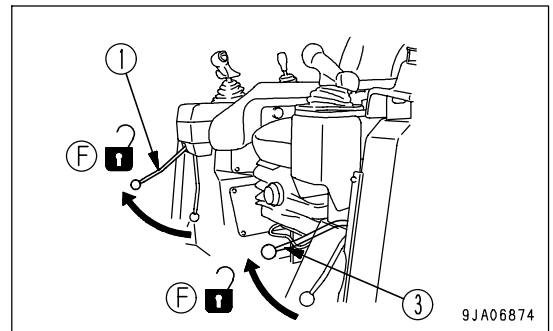

4. Depress brake pedal (4), set steering, forward-reverse, gear shift lever (5) in FORWARD, then press the shift up button to enter 2nd speed.
5. Operate fuel control dial (6) and gradually raise the engine speed to full throttle. (Keep the brake pedal depressed.)
6. Check that the machine does not move. This indicates that brake performance is normal.

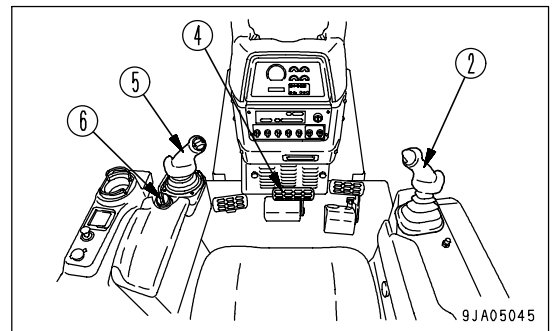

CLEAN AIR CONDITIONER AIR FILTER (FRESH/RECIRC FILTER)

(Machine equipped with cab)

Clean the air conditioner air filter if it becomes clogged or if there is dirt or oil stuck to it.

In places where there is a lot of dust, clean the air filter once a week. In addition, clean the air conditioner air filter at the same time, when cleaning the engine air cleaner.

1. Loosen mounting bolts (1), pull up inspection cover (2) to the rear, and remove it.
2. Remove inside cover (3), then remove FRESH filter (4).

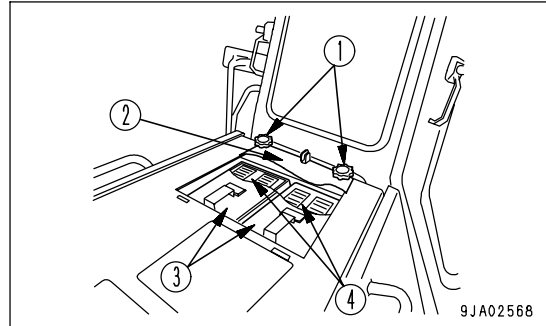

3. Remove the filter box, then brush out the dirt accumulated inside the box through the cleaning hole (5) in the hood. When doing this, be careful not to let any dirt or dust get into the fresh air intake port (6) leading to the cab.

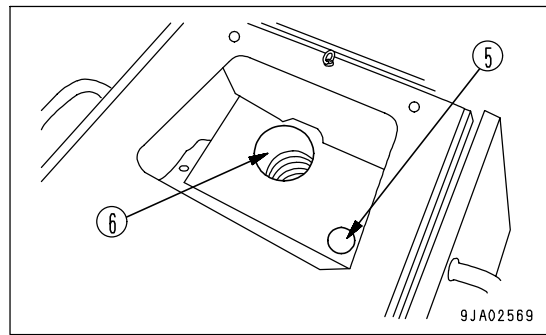

4. Open inspection cover (7) under the front panel, then pull up RECIRC filter (8) and remove it.
5. Clean filters (4) and (8) with compressed air. If the filters are stained with oil or extremely dirty, wash them in neutral detergent. After washing the filters, dry them up, then install them.

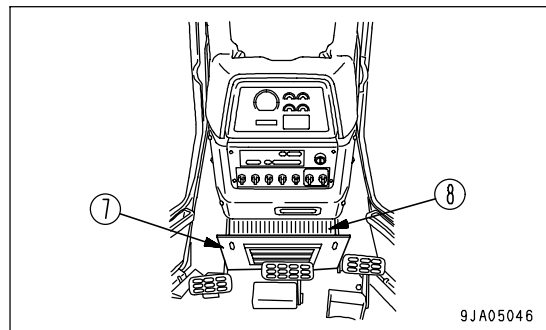

REMARK

If the filters cannot be cleaned with air or in water, replace them with new ones.

EVERY 500 HOURS SERVICE

Maintenance for every 50 and 250 hours service should be carried out at the same time.

CHANGE OIL IN ENGINE OIL PAN, REPLACE ENGINE OIL FILTER CARTRIDGE

! WARNING

Parts and oil are at high temperature immediately after the engine is stopped and may cause serious burns. Wait for the oil temperature to go down before performing this operation.

- Refill capacity: 28 liters (7.40 US gal)
- Prepare a socket wrench and filter wrench.

1. Remove the cover (1) on the bottom of the machine and set a container to catch the drained oil directly under the drain plug.

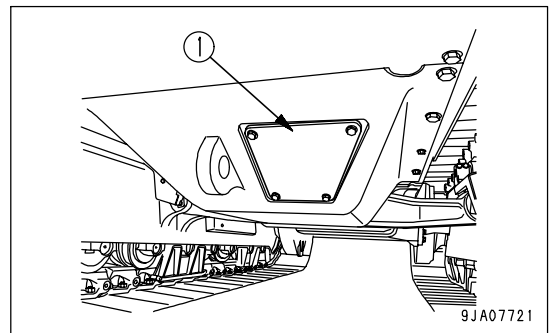

2. Take the end of hose (2) out of the inspection window.
3. Loosen drain plug (P) to drain oil. Do it slowly so that you do not get splashed with drained oil.
4. Check the drained oil, and if there are excessive metal particles or foreign material, please contact your Komatsu distributor.
5. Install drain plug (P).

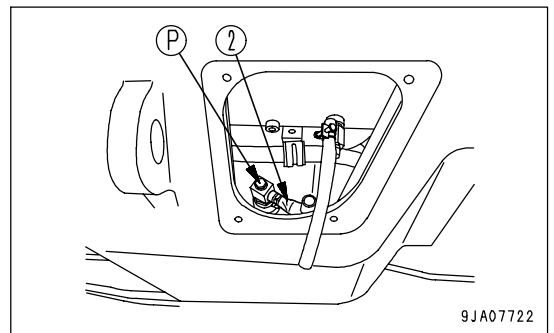

6. Open the engine side cover on the right side of the machine.
7. Remove bolts (3) - 2 bolts in total - to remove lower side cover (4).

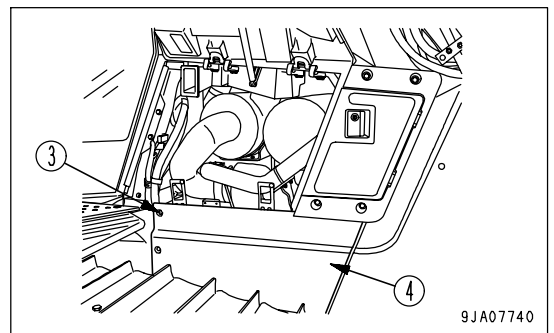

8. Remove bolts (5) - 4 bolts in total - to remove washer tank assembly (6).
9. Turn engine oil filter cartridge (7) to the left with a filter wrench.
10. Clean the filter holder, fill the new filter cartridge with clean oil, coat the thread and packing portion of the new filter cartridge with oil (or coat thinly with grease), then install.
11. When installing the filter cartridge, bring the packing surface into contact with the filter holder, then tighten a further 3/4 to 1 turn.

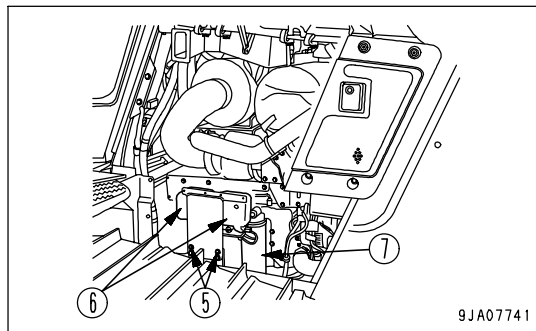

12. After replacing the filter cartridge, add oil through oil filler (F) until the oil level is between the H and L marks on the dipstick (G).
13. Run the engine at idle for a short time, then stop the engine, and check that the oil level is between the H and L marks on the dipstick. For details, see "CHECK OIL LEVEL IN ENGINE OIL PAN, ADD OIL (PAGE 3-72)".

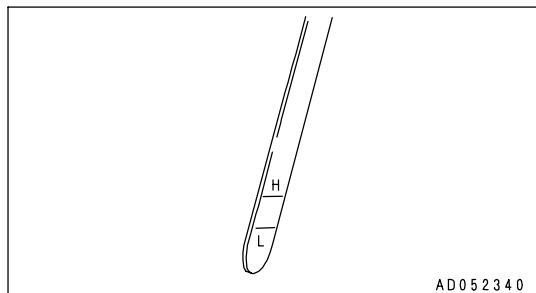
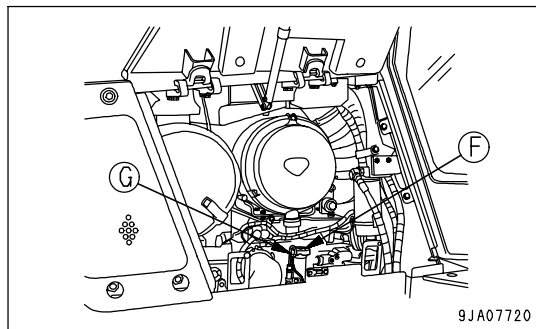

REPLACE POWER TRAIN OIL FILTER ELEMENT

! WARNING

The parts and oil are at high temperature after the engine is stopped, and may cause serious burns. Wait for the temperature to go down before starting the operation.

1. Open cover on the right side of the machine.
2. Remove bolts (1) (4 bolts), then remove cover (2).
3. Remove the grommet under the fender, loosen drain plug (P), and drain the oil from inside the filter case.
4. Take out plate (3), element (4), valve (5), and spring (6).
5. Clean the inside of the case, then wash plate (3), valve (5), and spring (6).
6. Install spring (6), valve (5), new element (4), and plate (3).
7. Replace O-ring (8) with a new part, then install cover (2) with bolt (1).
8. Install drain plug (P).
9. Loosen air vent plug (7) and start engine. Tighten the plug when oil comes out.

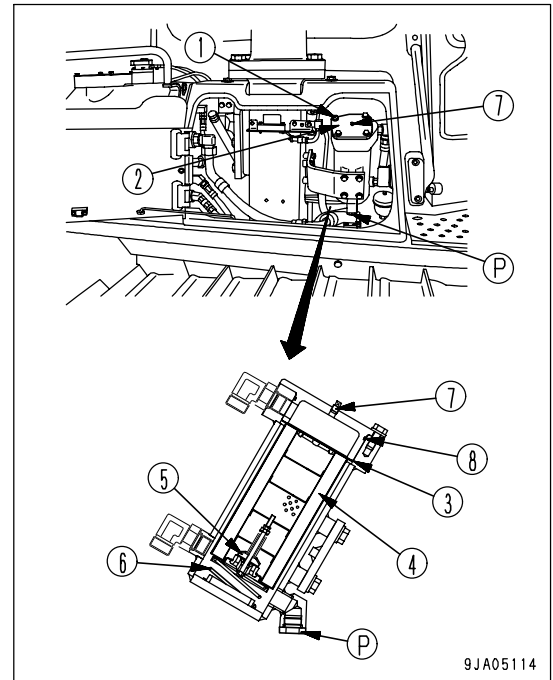

9JA05114

REPLACE FUEL PRE-FILTER CARTRIDGE



WARNING

- After the engine has been operated, all parts are at high temperature, so do not replace the filter immediately. Wait for all parts to cool down before starting the operation.
- High pressure is generated inside the engine fuel piping system when the engine is running. When replacing the filter, wait for at least 30 seconds after stopping the engine to let the internal pressure go down before replacing the filter.
- Do not bring any fire or flame close.

NOTICE

- Genuine Komatsu fuel filter cartridges use a special filter that has highly efficient filtering ability. When replacing the filter cartridge, always use a genuine Komatsu part.
- The common rail fuel injection system used on this machine consists of more precise parts than the conventional injection pump and nozzle. If any part other than a genuine Komatsu filter cartridge is used, dust or dirt may get in and cause problems with the injection system. Always avoid using substitute parts.
- When carrying out inspection or maintenance of the fuel system, pay more attention than normal to the entry of dirt. If dirt is stuck to any part, use fuel to wash it off completely.

Prepare a filter wrench and a container to catch the fuel.

1. Open the inspection cover at the bottom of the fuel tank.
2. Close fuel tank valve (1).

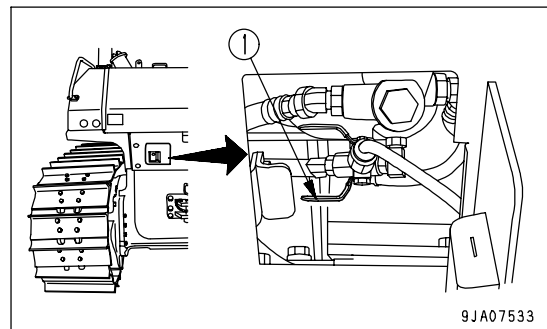

3. Open up the engine side cover on the left side of the machine.
4. Put a container under filter cartridge (4) to receive drained oil.
5. Remove connector (2) of the water separator caution lamp.
After removing the connector, cover it with a vinyl bag to prevent water from getting on it.
6. Turn transparent cap (3) to the left with a filter wrench. (This cap is to be used again, so replace it with a new one if there is any damage on it.)
7. Using a filter wrench, turn cartridge (4) to the left to remove it.
8. Fix earlier removed cap (3) to the base of a new filter cartridge.
At that time, be sure to replace the O-ring (6) with a new one.
 - Specified tightening torque of transparent cap: 11 Nm (1.0 kgm)

When the O-ring has been replaced, coat the surface with clean fuel before installing it.

9. When installing, bring the packing surface into contact with the seal surface of filter cartridge (4), then tighten it a further 1/4 -1/2 turns.

If the transparent cap is tightened too much, the O-ring may be damaged, and this will cause leakage of fuel. If it is not tightened enough, fuel will leak through the gap at the O-ring. Always be sure to tighten to the specified angle.

10. Clean the filter holder, fill the new filter cartridge with clean fuel, coat the packing surface thinly with oil, then install to the filter holder.

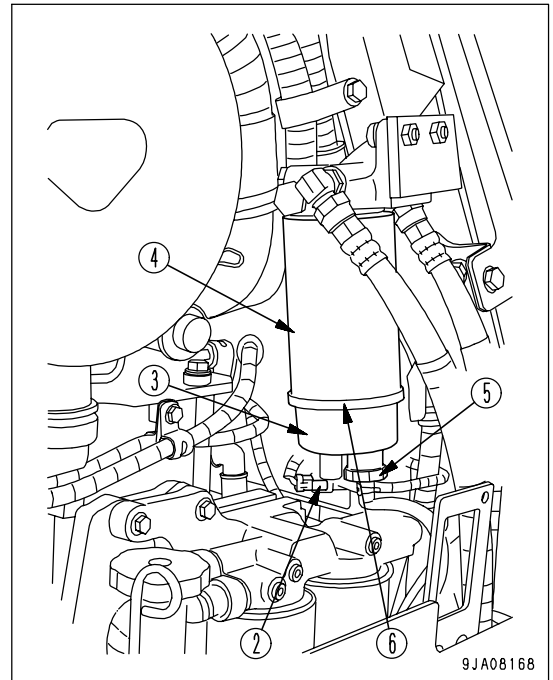

NOTICE

- When adding fuel, do not remove cap (B). Always add fuel from the 8 small holes (A) on the dirty side.
- After adding fuel, remove cap (B) and install the fuel filter.
- Always fill with clean fuel. Be careful not to let any dirt or dust get into the fuel. In particular, center portion is the clean side, so do not remove cap (B) when adding fuel. Be careful not to let dirt or dust get into center portion on the clean side.

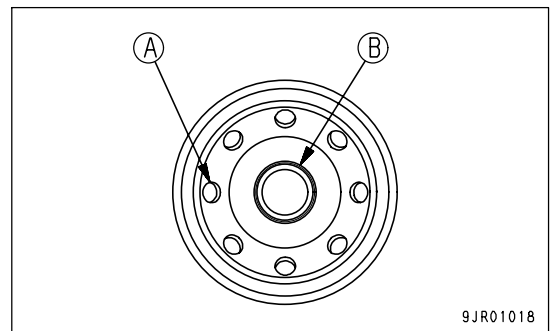

11. When installing, tighten until the packing surface contacts the seal surface of the filter holder, then tighten it 3/4 of a turn.
If the filter cartridge is tightened too far, the packing will be damaged and this will lead to leakage of fuel. If the filter cartridge is too loose, fuel will also leak from the packing, so always tighten the correct amount.
 - When tightening with a filter wrench, be extremely careful not to dent or damage the filter.
12. Make sure that drain plug, which is provided in the lower part of transparent plug (3), is firmly tightened.
Specified tightening torque of drain plug: 0.2 to 0.45 Nm (0.02 to 0.046 kgm , 0.1 to 0.3 lbf)
13. Remove the vinyl bag covering connector (2), then connect connector (2).

REMARK

- If water gets on the connector (2), the sensor may malfunction and the water separator monitor may light up.
When removing connector (2), be extremely careful not to let water get on the connector.
- If water gets on connector (2), dry it completely before connecting it.

14. Turn valve (1) at the bottom of the fuel tank to the left to open it.
15. After completing the replacement of filter cartridge (4), bleed the air.

Bleed the air as follows:

16. Add fuel to the fuel tank until full (to FULL mark on the fuel gauge).
17. Insert the key in the starting switch and turn the key to the ON position (B).
The electric priming pump is actuated.

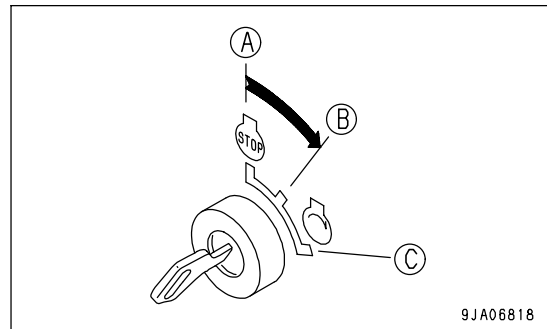

18. Hold the key at the ON position (B) for 30 seconds, then return it to OFF position (A) and wait for 10 seconds.
19. Repeat Steps 17 and 18 four times.

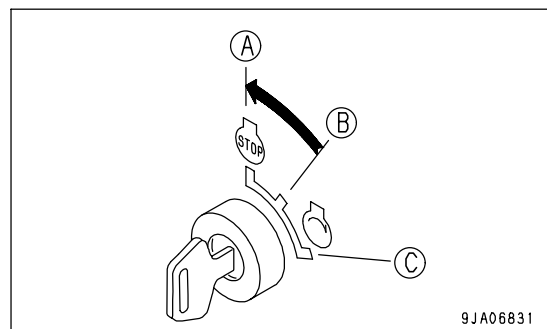

20. Start the engine, check that there is no leakage of fuel from the filter seal surface or water separator mounting surface, then run for approx. 10 minutes at low idling.

EVERY 1000 HOURS SERVICE

Maintenance for every 50, 250 and 500 hours should be carried out at the same time.

REPLACE FUEL MAIN FILTER CARTRIDGE

Carry out this operation after carrying out the maintenance in the "REPLACE FUEL PRE-FILTER CARTRIDGE (PAGE 4-56)" for every 500 hours.

WARNING

- After the engine has been operated, all parts are at high temperature, so do not replace the filter immediately. Wait for all parts to cool down before starting the operation.
- High pressure is generated inside the engine fuel piping system when the engine is running. When replacing the filter, wait for at least 30 seconds after stopping the engine to let the internal pressure go down before replacing the filter.
- Do not bring any fire or flame close.

NOTICE

- Genuine Komatsu fuel filter cartridges use a special filter that has highly efficient filtering ability. When replacing the filter cartridge, always use a genuine Komatsu part.
- The common rail fuel injection system used on this machine consists of more precise parts than the conventional injection pump and nozzle. If any part other than a genuine Komatsu filter cartridge is used, dust or dirt may get in and cause problems with the injection system. Always avoid using substitute parts.
- When carrying out inspection or maintenance of the fuel system, pay more attention than normal to the entry of dirt. If dirt is stuck to any part, use fuel to wash it off completely.

Prepare a filter wrench and a container to catch the fuel.

1. Open the inspection cover at the bottom of the fuel tank.
2. Close fuel tank valve (1).

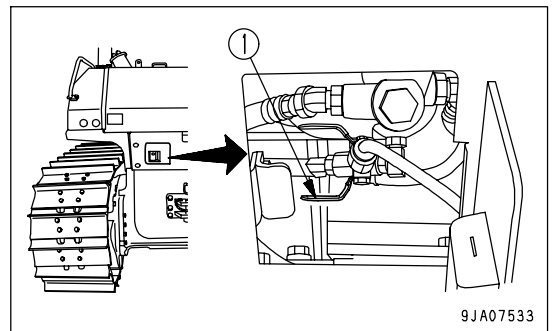

3. Open up the engine side cover on the left side of the machine.
4. Remove bolts (2) - 2 bolts in total- to remove lower side cover (3).

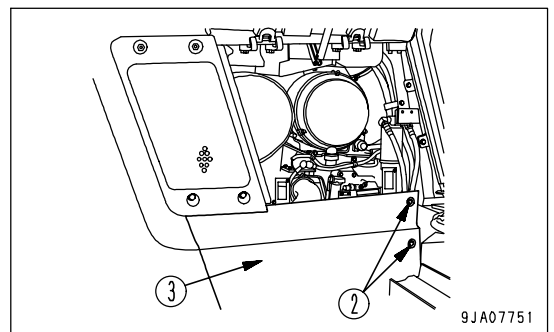

5. Put a container under filter cartridge (4) to receive drained oil.
6. Using a filter wrench, turn cartridge (4) to the left to remove it.

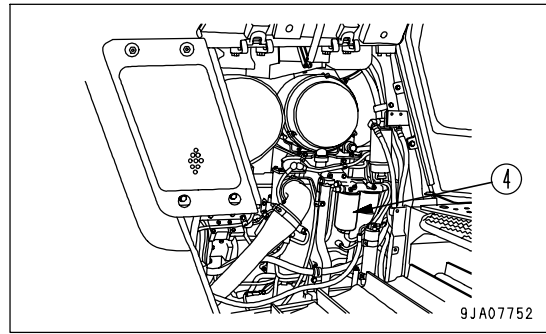

NOTICE

- Do not fill the new filter cartridge with fuel.
- Remove cap (B) and install the filter cartridge.

7. Clean the filter holder, coat the packing surface of the new filter cartridge thinly with oil, then install the filter cartridge to the filter holder.

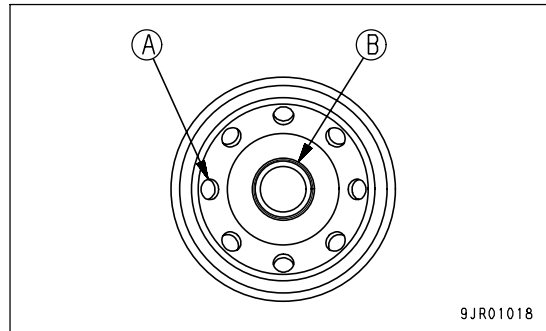

8. When installing, tighten until the packing surface contacts the seal surface of the filter holder, then tighten it 3/4 of a turn.

If the filter cartridge is tightened too far, the packing will be damaged and this will lead to leakage of fuel. If the filter cartridge is too loose, fuel will also leak from the packing, so always tighten the correct amount.

9. Open fuel tank valve (1).

10. Bleed air from fuel filter cartridge (4) after the replacement.

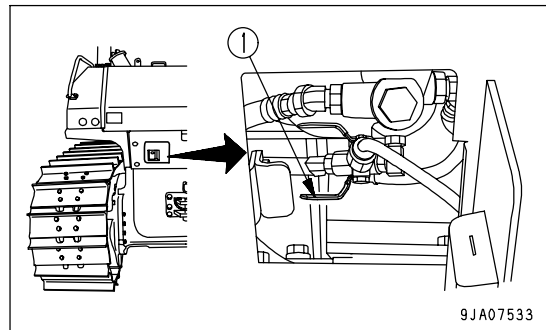

Bleed the air as follows:

11. Add fuel to the fuel tank until full (to FULL mark on the fuel gauge).
12. Insert the key into the engine starting switch and turn the key to ON position (B). Then the electric priming pump begins to work.

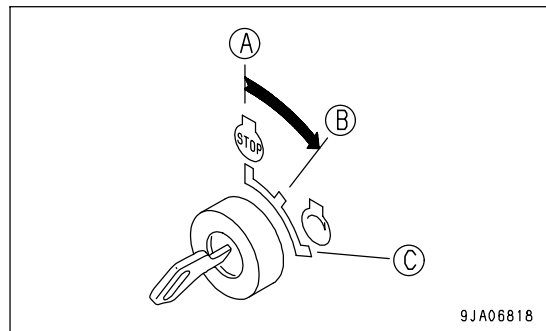

13. After holding the key in ON position (B) for 30 seconds, turn it back to OFF position (A) and hold it there for 10 seconds.

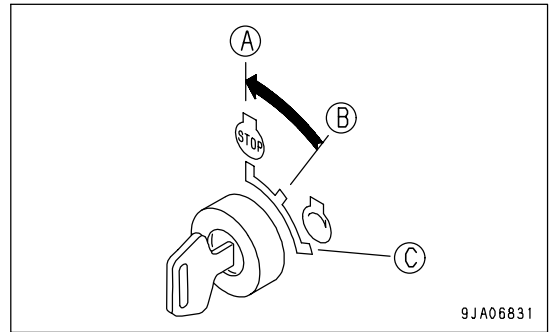

14. Repeat the operation in Step 12 and 13 four times.
15. Turn the engine starting switch key to START position (C) to start up the engine and check the filter sealing face for fuel leak. If leak is noticed, check the filter cartridge for its tightening condition. If it is correctly tightened and fuel still leaks, remove the filter cartridge once and check the contact face with the packing for damage or any caught- in foreign material. If any, replace it with a new one.

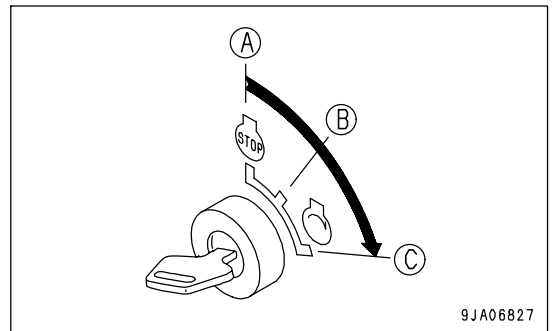

CHANGE OIL IN POWER TRAIN CASE, CLEAN STRAINERS (POWER TRAIN PUMP STRAINER, SCAVENGING PUMP STRAINER)

! WARNING

- The oil is at high temperature immediately after the machine has been operated. Wait for the oil to cool down before starting the operation.
- The undercover is heavy. Never try to open or close the cover when directly beneath it. When removing bolts(3), carry out the work from the rear of the cover so that you can easily get out of the way.

- Refill capacity: 48 liters (12.68 US gal)
- 1. Remove cover (1) at the bottom rear of the machine.
- 2. Loosen drain plug (P) (with slit) and drain the oil.
After draining the oil, tighten drain plug (P).

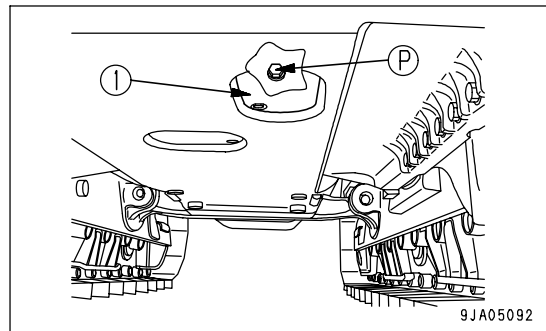

- 3. Remove the undercover from the rear bottom of the machine body as follows.

- 1) Remove two bolts (2) from the front side of the machine body.
- 2) Holding the cover, remove two bolts (3) from the rear side of the machine body.

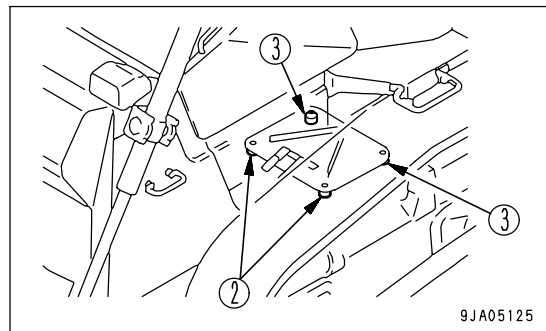

- 3) Lower and open the cover gradually.
- (A) Front of machine
- (B) Dangerous place

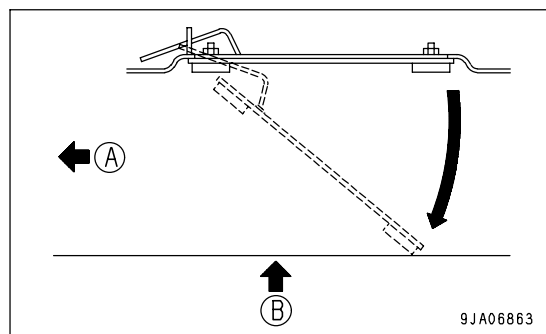

4. Loosen mounting bolt (4) of the power train strainer, then remove cover (5).
5. Take out spring (6), then take out strainer (7).
6. Remove all dirt from strainer (7), then wash in clean diesel oil or flushing oil. Clean the case interior and the removed parts.

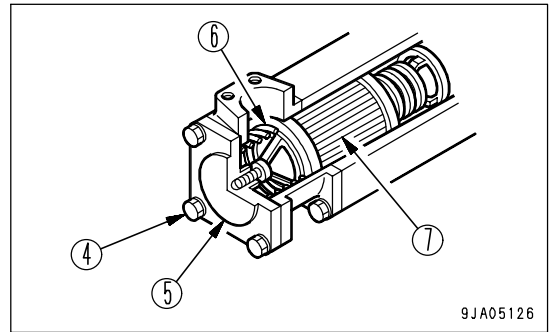

7. Loosen mounting bolt (8) of the scavenging pump strainer, then remove cover (9).
8. Take out spring (10), then take out strainer (11).
9. Remove all dirt from strainer (11), then wash in clean diesel oil or flushing oil. Clean the case interior and the removed parts.

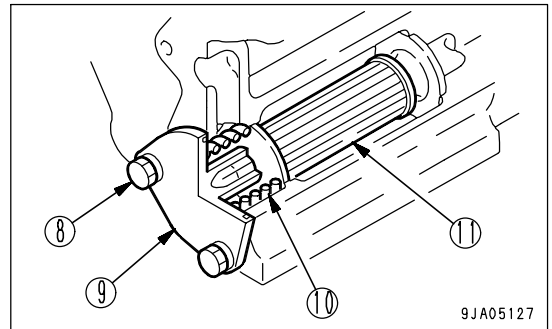

If the spring or strainer are damaged, replace them.

10. Install the strainers in their original position.
11. After installing, replace the element in the power train oil filter. For details, see "REPLACE POWER TRAIN OIL FILTER ELEMENT (PAGE 4-55)".
12. Open cover on the right side of the machine.
13. Refill the specified quantity of oil through oil filler (F).
14. Check that the oil is at the specified level. For details, see "CHECK OIL LEVEL IN POWER TRAIN CASE, ADD OIL (PAGE 3-76)".
15. Close the cover at right side of machine.

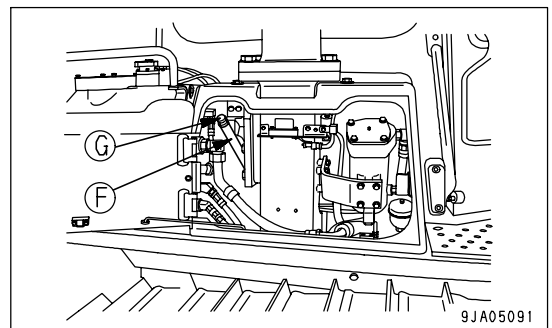

REPLACE HYDRAULIC TANK BREATHER ELEMENT

**WARNING**

- The parts and oil are at high temperature immediately after the engine is stopped, and may cause burns. Wait for the temperature to go down before starting the work.
- When removing the oil filler cap, oil may spurt out, so push the cap down to release the internal pressure, then remove the cap carefully.

1. Push down cap (1) of oil filler (F) to release the air and remove the internal pressure.
2. Keep cap (1) pushed down, turn it slowly counterclockwise, then remove cap (1).

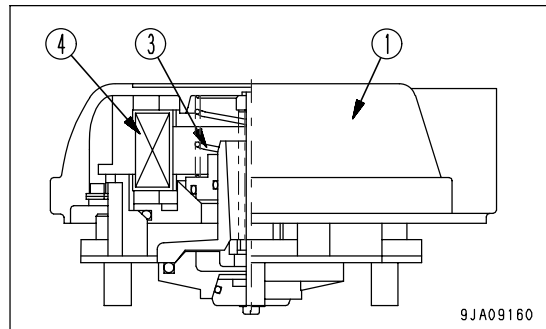
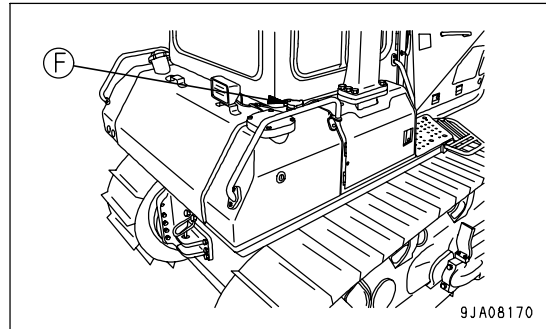

3. Remove ring (2) from inside the lip of cap (1).
4. Remove valve (3).
5. Replace filter element (4).

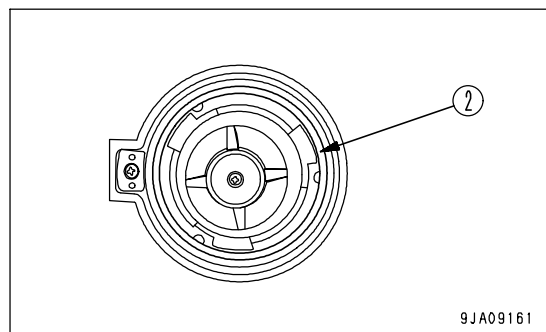

6. Install valve (3) and ring (2) in their original positions.
7. Install cap (1).
When installing cap (1) to the tank, push it down, then turn it clockwise.

REMARK

If the cap is not installed correctly, it will cause leakage of oil.

When installing the cap, press the cap down, and turn it until it is securely in contact with the stopper.

The cap is the lock addition type.

About handling method of cap with the lock, see "CAP WITH LOCK (PAGE 3-50)".

CHECK OIL LEVEL IN DAMPER CASE, ADD OIL

⚠ WARNING

- The oil is at high temperature immediately after the machine has been operated. Wait for the oil to cool down before starting the operation.
- The undercover is heavy. Never try to open or close the cover when directly beneath it. When removing bolts(2), carry out the work from the rear of the cover so that you can easily get out of the way.

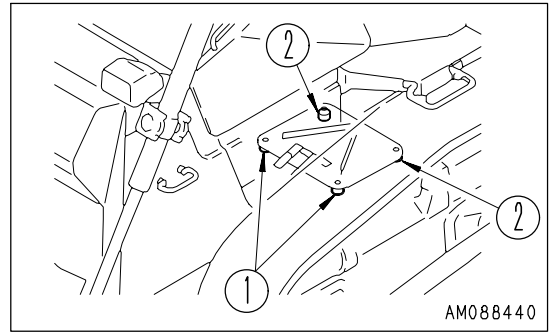

If the quantity of the oil in the damper is insufficient, the damper may be seized. Accordingly, check, and add or replace the oil according to the following procedure.

1. Remove the undercover from the rear bottom of the machine body as follows.
 - 1) Remove two bolts (1) from the front side of the machine body.
 - 2) Holding the cover, remove two bolts (2) from the rear side of the machine body.
 - 3) Lower and open the cover gradually.
 - (A) Front of machine
 - (B) Dangerous place

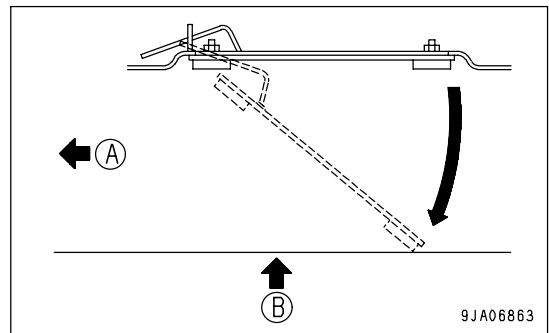

2. Remove oil level plug (3) and check the oil level. The proper oil level is the bottom edge of the plug hole. Tighten plug (3).

REMARK

- Check the oil level while the engine is stopped.
- If the machine is inclined, set it in a level position before checking the oil level.

3. If the oil level is below the bottom edge of the plug hole, remove oil filler plug (4) and add new oil. Add new oil until the oil level reaches the bottom edge of oil level plug (3).
4. After adding the oil, tighten plugs (3) and (4).

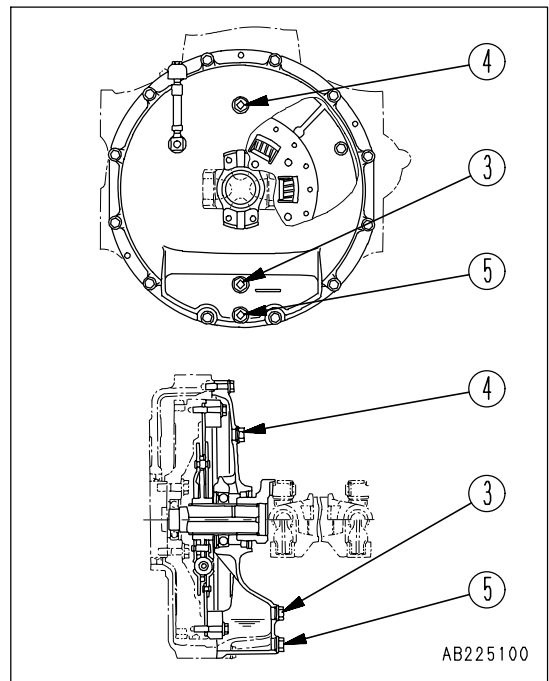

CHANGE OIL IN FINAL DRIVE CASE

**WARNING**

- The oil is at high temperature immediately after the machine has been operated. Wait for the oil to cool down before starting the operation.
- If there is still pressure remaining inside the case, the oil or plug may fly out. Loosen the plug slowly to release the pressure.

• Refill capacity:

D65EX : (each) 24 liters (6.34US gal)

D65PX,WX: (each) 27 liters (7.13US gal)

1. Stop the machine so that drain plug (3) is directly at the bottom.
2. Remove oil level plug (2) and oil filler plug (1), then remove drain plugs (3) and (4), and drain the oil.
3. After draining the oil, install drain plugs (3) and (4).
4. Add oil to the specified level through the hole in oil filler plug (1).
5. Check that the oil is at the specified level. For details, see "CHECK OIL LEVEL IN FINAL DRIVE CASE, ADD OIL (PAGE 4-46)".

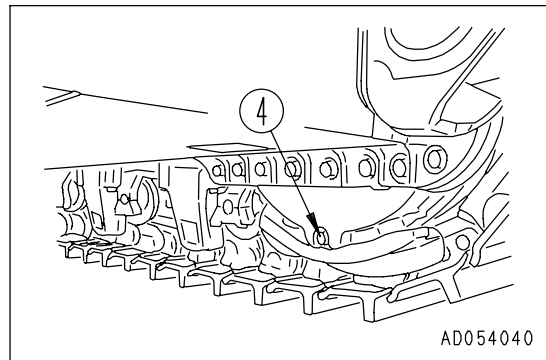
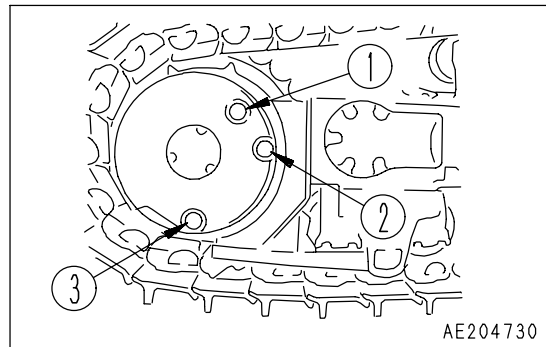
**CLEAN BREATHER**

1. Open cover on the right side of the machine.
2. Remove breather (1), then use clean diesel fuel or flushing fluid to rinse the dirt out from the inside.

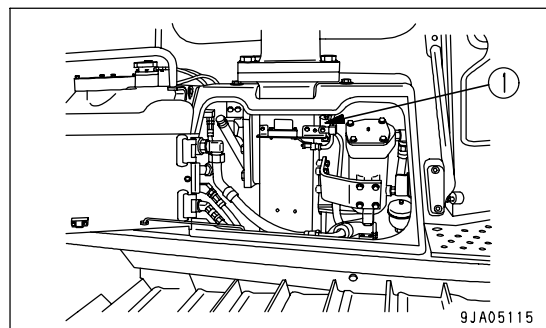

REPLACE CORROSION RESISTOR CARTRIDGE

Use Komatsu genuine cartridge.

1. Screw in 2 valves (1) at the top of the corrosion resistor.
2. Using a filter wrench, turn cartridge (2) to the left to remove it.
3. Apply engine oil to the sealing surface of a new cartridge, then install it to the filter holder.
4. When installing, screw in cartridge until seal comes in contact with sealing surface, then tighten approx. 2/3 turn.
5. Open valves (1) (2 places).

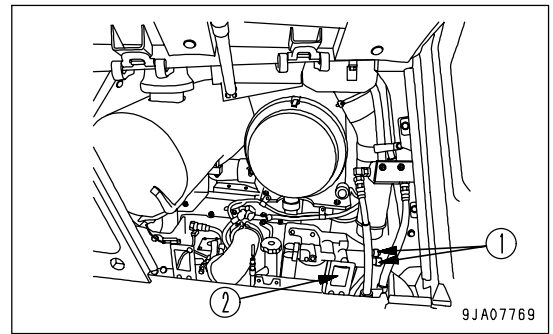

CHECK ALL TIGHTENING POINTS OF ENGINE EXHAUST PIPE CLAMPS

Please ask your Komatsu distributor to check the tightening of the clamps between the air cleaner - turbocharger - aftercooler - engine.

CHECK FOR LOOSE ROPS MOUNT BOLTS

Check that the bolts are not loose and that there is no damage.

If any bolt is loose, tighten it to the following torque.

If there is any damage, replace the bolt with a genuine Komatsu part.

Tightening torque: 785 to 980 Nm (80 to 100 kgm, 578.6 to 723.3 lbft)

INSPECTION OF AFTER-COOLER CIRCUIT FOR LOOSENED BOLTS AND NUTS

Check each clamp for loosening. If any clamp is found loosened, tighten it further.

EVERY 2000 HOURS SERVICE

Maintenance for every 50, 250, 500 and 1000 hours service should be carried out at the same time.

CHANGE OIL IN HYDRAULIC TANK, REPLACE OIL FILTER ELEMENT**WARNING**

- The parts and oil are at high temperature immediately after the engine is stopped, and may cause burns. Wait for the temperature to go down before starting the work.
- When removing the oil filler cap, oil may spurt out, so push the cap down to release the internal pressure, then remove the cap carefully.

- Refill capacity: 55 liters (14.53 US gal)

1. Lower the work equipment to the ground, then stop the engine.
2. Push down cap of oil filler (F) to release the air and remove the internal pressure.
3. Keep cap pushed down, turn it slowly counterclockwise, then remove cap.
4. Remove the cover (1) at the bottom of the hydraulic tank.
5. Loosen drain valve (2), drain the oil, tighten drain valve (2) again, then install cover (1). When loosening drain valve (2), be careful not to get oil on yourself.
6. Remove bolt (3), then remove cover (4).
7. Take out spring (5), valve (6), and element (7).
8. Clean the inside of the case, then wash spring (5) and valve (6).
9. Install new element (7), valve (6), and spring (5).
10. Install cover (4) with bolt (3).

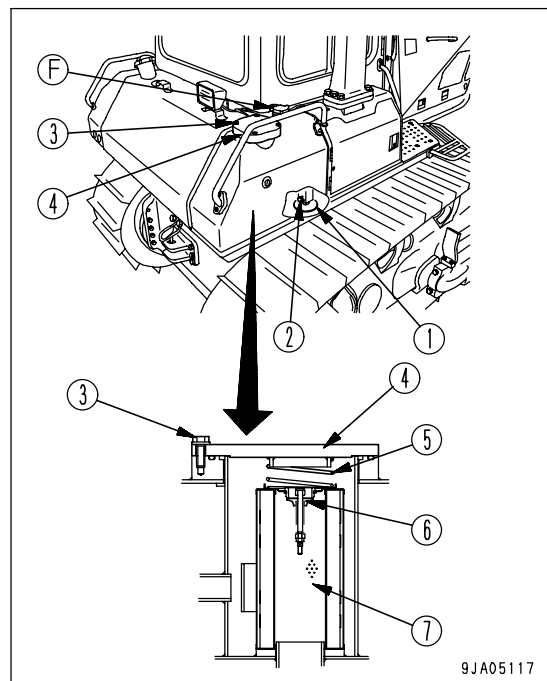

11. Add the refill amount of engine oil through oil filler port (F), then install the cap.
When installing cap to the tank, push it down, then turn it clockwise.

REMARK

If the cap is not installed correctly, it will cause leakage of oil.

When installing the cap, press the cap down, and turn it until it is securely in contact with the stopper.

12. Check that the oil is at the specified level. For details, see "CHECK OIL LEVEL IN HYDRAULIC TANK, ADD OIL (PAGE 4-47)".

CHECKING CHARGE PRESSURE OF NITROGEN GAS IN ACCUMULATOR (FOR CONTROL CIRCUIT)

WARNING

The accumulator is charged with high-pressure nitrogen gas, so mistaken operation may cause an explosion, which will lead to serious injury or damage. When handling the accumulator, always do as follows.

- The pressure in the hydraulic circuit cannot be completely removed. When removing the hydraulic equipment, do not stand in the direction that the oil spurts out when carrying out the operation. In addition, loosen the bolts slowly when carrying out the operation.
- Do not disassemble the accumulator.
- Do not bring it near flame or dispose of it in fire.
- Do not make holes in it or weld it.
- Do not hit it, roll it, or subject it to any impact.
- When disposing of the accumulator, the gas must be released. Please contact your Komatsu distributor to have this work carried out.

FUNCTION OF ACCUMULATOR

The accumulator stores the pressure in the control circuit. Even after the engine is stopped, the control circuit can be operated, so the following actions are possible.

- If the control lever is operated in the direction to lower the work equipment, it is possible for the work equipment to go down under its own weight.
- The pressure in the hydraulic circuit can be released.

The accumulator is installed to the position shown in the diagram on the right.

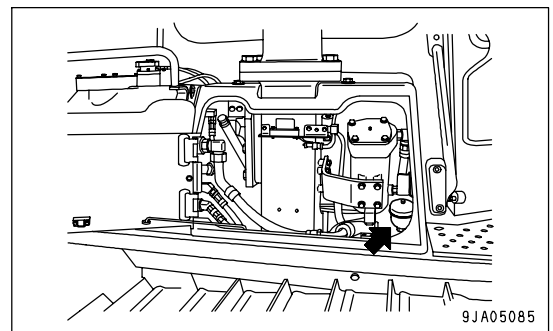

CHECKING FUNCTION OF ACCUMULATOR

Replace the accumulator every 2 years or every 4000 hours, whichever comes sooner.

Check the nitrogen gas charge pressure as follows.

1. Stop the machine on firm, level ground.
2. Operate the parking brake lever to LOCK position (L).

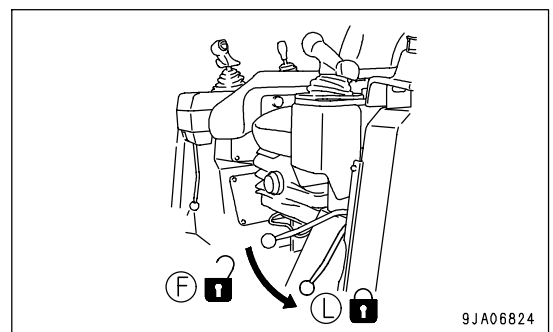

3. Raise the work equipment (blade) to the maximum height.

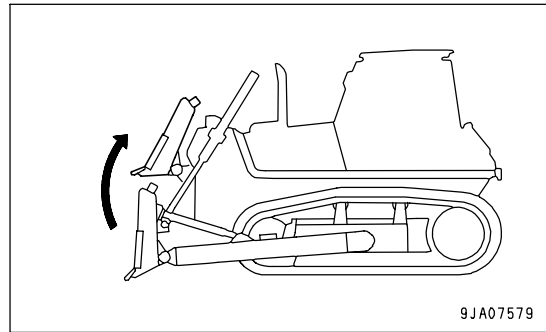

NOTICE

Carry out the following procedure for lowering the blade to the ground within 15 seconds after stopping the engine. When the engine is stopped, the pressure inside the accumulator gradually goes down, so this inspection can be carried out only immediately after the engine is stopped.

- 4. While holding the work equipment at the highest position, turn the engine starting switch key to OFF position (A).
- 5. Turn the engine starting switch key to ON position (B).

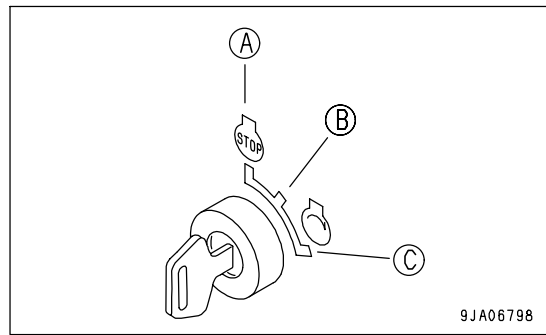

- 6. Turn the work equipment lock lever to FREE position (F).
- 7. Operate the blade control lever fully in the direction to lower the blade.

REMARK

Check that the area around the machine is safe, then operate the blade control lever to the LOWER position.

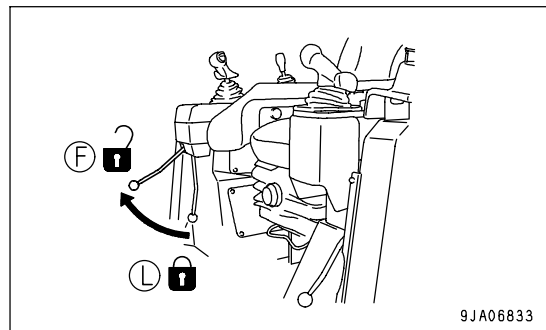

- 8. Check that the work equipment goes down to the ground under its own weight.
- 9. This completes the inspection.

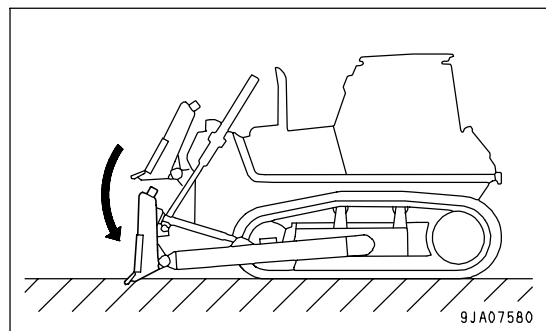

NOTICE

If the nitrogen gas charge pressure in the accumulator is low and operations are continued, it will become impossible to release the remaining pressure inside the hydraulic circuit if a failure occurs on the machine.

In the following cases, the charge pressure of the accumulator has gone down. Please contact your Komatsu distributor.

- Work equipment does not go down
- Stops while going down

METHOD OF RELEASING PRESSURE IN HYDRAULIC CIRCUIT

NOTICE

Finish the steps of operating the blade control lever to the front and back, and to the right and left, to each stroke end within 15 seconds after the engine has stopped. After the engine stops, pressure inside the accumulator begins to gradually go down, so the pressure cannot be released except right after the engine stops.

1. Lower the work equipment and stop the engine.
2. Turn the starting switch to the ON position.
3. Set the work equipment lock lever to the FREE position.
4. Operate the blade control lever fully to the front, rear, left, and right to release the pressure from the hydraulic circuit.

In order to release pressure from the ripper hydraulic circuit, operate the ripper control lever to the right and left to each stroke end.

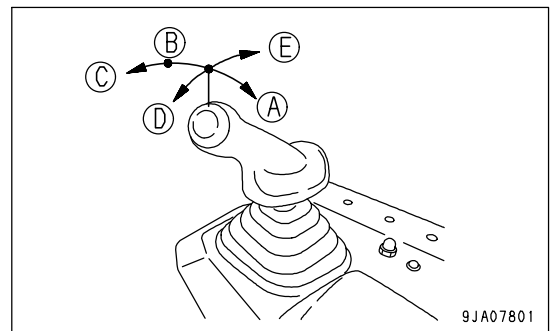

- (A) RAISE
- (B) LOWER
- (C) FLOAT
- (D) LEFT TILT
- (E) RIGHT TILT

5. Set the work equipment lock lever to the LOCK position.

CHANGE OIL IN DAMPER CASE

! WARNING

- The parts and oil is very hot just after the operation. Wait until the oil temperature drops, then start the work.
- The undercover is heavy (28 kg (62 lb)). Never try to open or close the cover when directly beneath it. When removing bolts (2), carry out the work from the rear of the cover so that you can easily get out of the way.
- When removing drain plug (5) of the damper case, take care not to get oil over yourself.

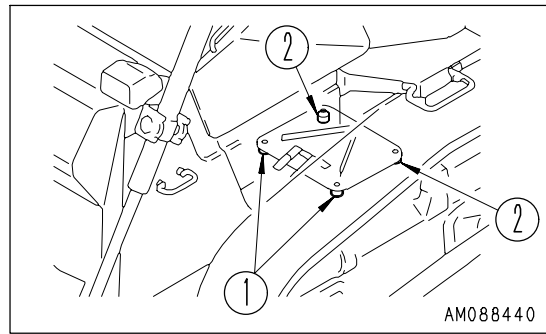

- Quantity of replacement oil: 1.3 liters (0.34 US gal)
1. Remove the undercover from the rear bottom of the machine body as follows.
 - 1) Remove two bolts (1) from the front side of the machine body.
 - 2) Holding the cover, remove two bolts (2) from the rear side of the machine body.
 - 3) Lower and open the cover gradually.
 - (A) Front of machine
 - (B) Dangerous place

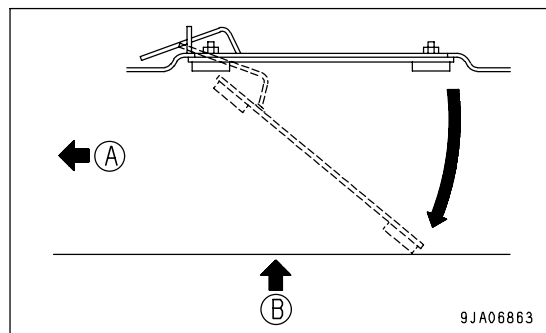

2. Remove oil level plug (3) and oil filler plug (4), then remove drain plug (5) to drain the oil. After the all oil is drained, tighten plug (5).
3. Add oil through the hole of oil filler plug (4) until the oil level reaches the bottom edge of the hole of oil level plug (3).
4. After refilling the oil, tighten plugs (3) and (4).

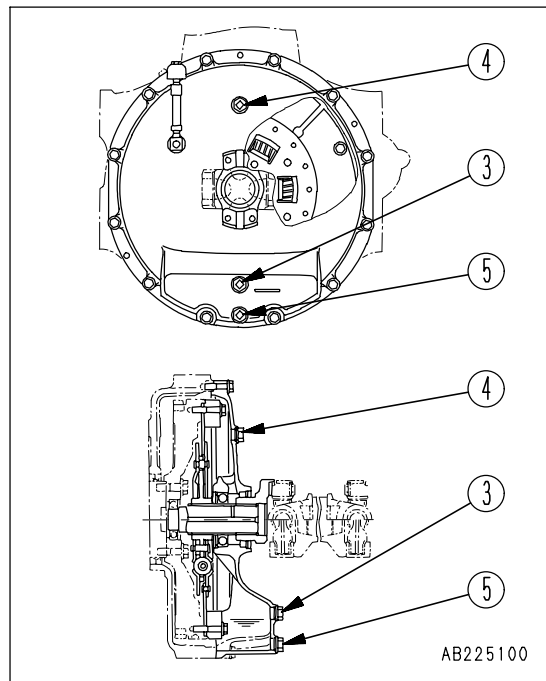

CHECK VIBRATION DAMPER

For the check and replacement of the vibration damper, special tools are required. Contact Komatsu Ltd. or its distributor in the territory for the replacement. It has to be replaced with a new one in the following cases.

Mating mark (1) is notched both on the damper hub and on the inertia member of the vibration damper to show any misalignment between the two.

If this misalignment exceeds 1.6 mm (0.063 in), or if there is any dent found on the damper metal surface deeper than 3.2 mm (0.1 in), then (2) the vibration damper must be replaced.

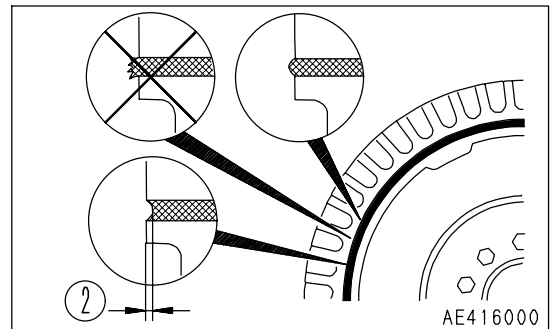
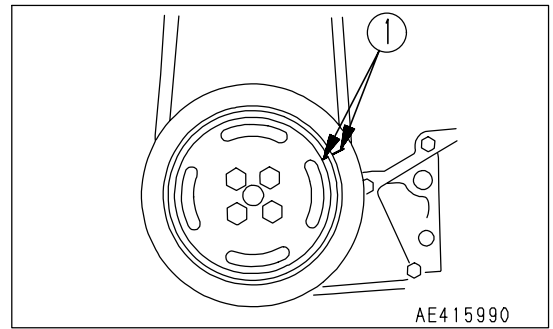

CHECK ALTERNATOR

Contact your Komatsu distributor to have the alternator checked.

If the engine is started frequently, have this inspection carried out every 1000 hours.

CHECK ENGINE VALVE CLEARANCE, ADJUST

Special tools are needed for inspection and maintenance, please contact your Komatsu distributor.

EVERY 4000 HOURS SERVICE

Maintenance for every 50, 250, 500, 1000 and 2000 hours service should be carried out at the same time.

REPLACE ACCUMULATOR (FOR CONTROL CIRCUIT)

Replace the accumulator every 2 years or every 4000 hours, whichever comes sooner.



WARNING

The accumulator is charged with high-pressure nitrogen gas, so mistaken operation may cause an explosion, which will lead to serious injury or damage. When handling the accumulator, always do as follows.

- The pressure in the hydraulic circuit cannot be completely removed. When removing the hydraulic equipment, do not stand in the direction that the oil spurts out when carrying out the operation. In addition, loosen the bolts slowly when carrying out the operation.
- Do not disassemble the accumulator.
- Do not bring it near flame or dispose of it in fire.
- Do not make holes in it or weld it.
- Do not hit it, roll it, or subject it to any impact.
- When disposing of the accumulator, the gas must be released. Please contact your Komatsu distributor to have this work carried out.

If operations are continued after the performance of the accumulator has dropped, it will be impossible to release the remaining pressure in the hydraulic circuit if there should be a failure on the machine. Please ask your Komatsu distributor to replace the accumulator.

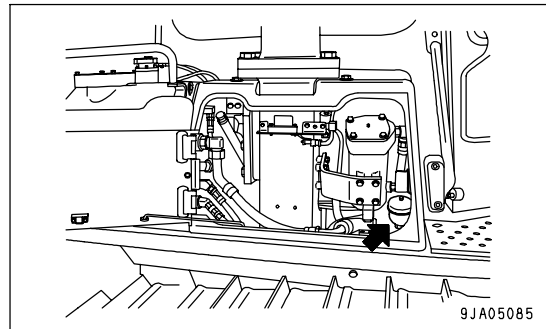

CHECK WATER PUMP

Check the water pump and its relative parts for water leak, and if anything abnormal is found, call on your Komatsu distributor for repairs or replacement.

CHECK STARTING MOTOR

Contact your Komatsu distributor to have the starting motor checked.

If the engine is started frequently, have this inspection carried out every 1000 hours.

CHECKING FOR LOOSENESS OF HIGH-PRESSURE CLAMP, HARDENING OF RUBBER

Check clamp (1) visually and touch by hand to check that there are no loose bolts or hardening of the rubber. If there are any loose bolts or hardened rubber, please contact your Komatsu distributor for replacement.

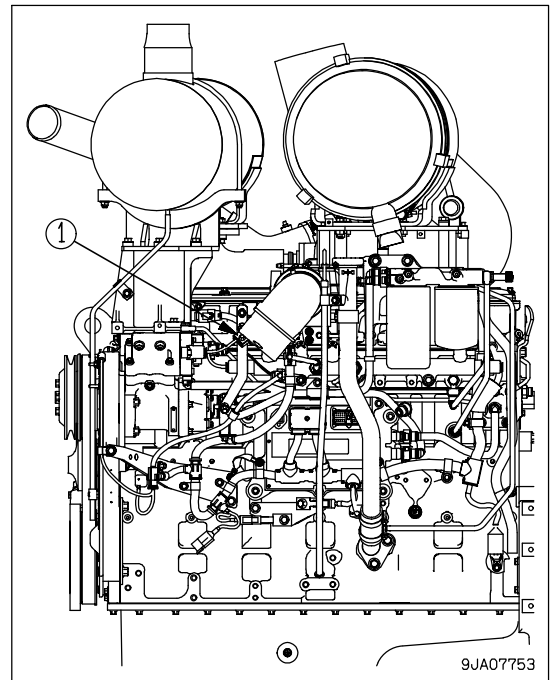
**NOTICE**

If the engine continues to be used when there are loose bolts, hardened rubber, or missing parts, there is danger of damage or breakage occurring due to vibration and wear at the connections of high-pressure piping. Always check that the proper high-pressure piping clamps are correctly installed.

CHECKING FOR MISSING FUEL SPRAY PREVENTION CAP, HARDENING OF RUBBER

Check fuel spray prevention caps (1) through (14) visually or with a finger to see if any of them has slipped off, or the rubber portion is hardened. If any such abnormality is found, call on your Komatsu distributor for repairs or replacement. Fuel spray prevention caps (1) through (14) are a protective part that serves to prevent leaked fuel from splashing over highly heated portions of the engine, causing fire as a result.

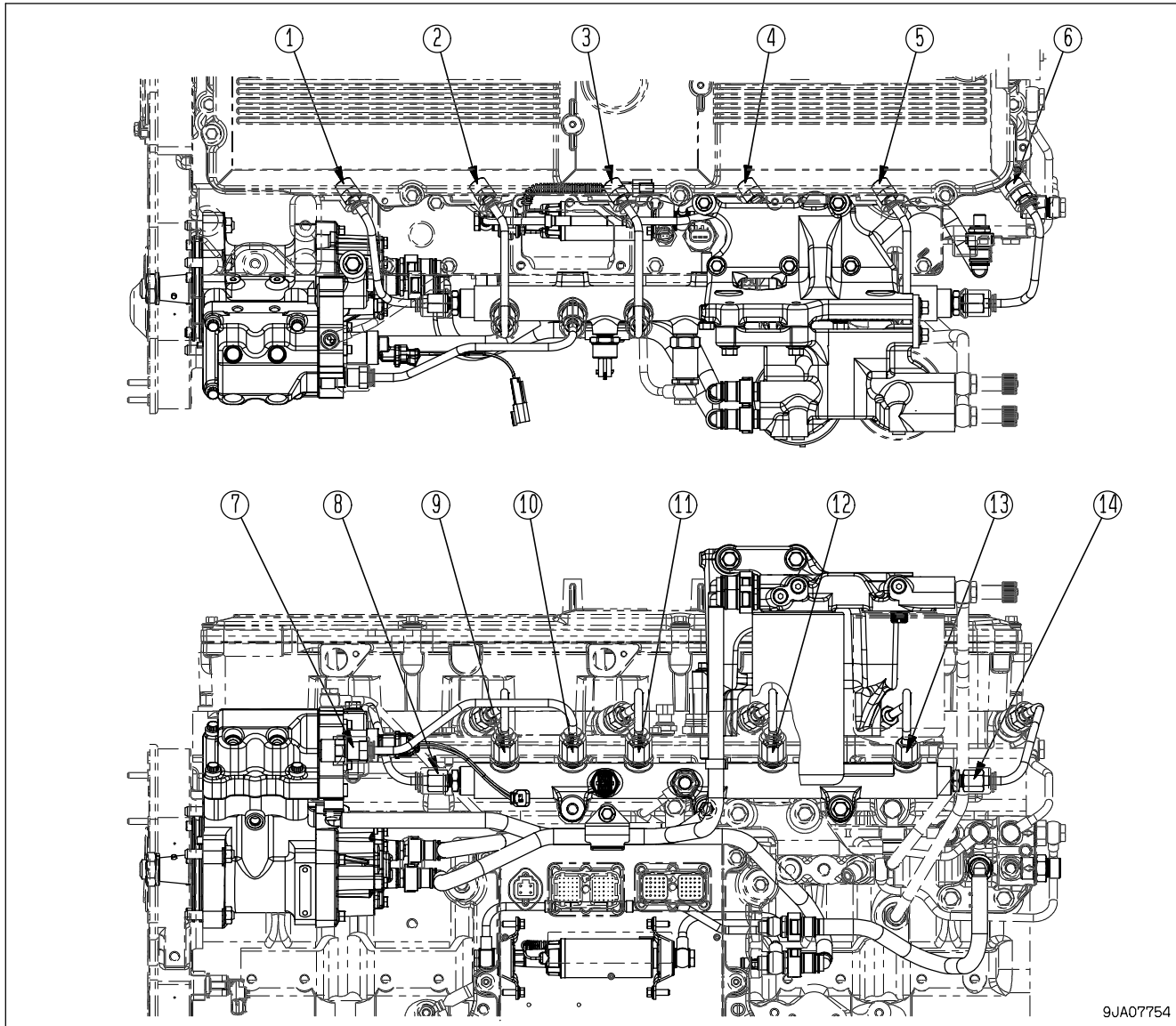

9JA07754

EVERY 8000 HOURS SERVICE

Maintenance for every 50, 250, 500, 1000, 2000 and 4000 hours service should be carried out at the same time.

REPLACE HIGH-PRESSURE PIPING CLAMP

Contact your Komatsu distributor to have the engine high-pressure clamps replaced.

REPLACE FUEL SPLAY PREVENTION CAPS

Contact your Komatsu distributor to have the fuel spray prevention cap replaced.

SPECIFICATIONS

SPECIFICATIONS

D65EX and D65WX: Semi-U dozer with ROPS guard, cab and air conditioner

D65PX: Power tilt-dozer with ROPS guard, cab and air conditioner

Item		Unit	D65EX-15E0	D65PX-15E0	D65WX-15E0
Machine weight		kg (lb)	20,280 (44,710)	21,000 (46,300)	21,140 (46,610)
Name of engine		-	Komatsu SAA6D114E-3 diesel engine		
Engine horsepower		kW{HP}/rpm	153{205}/1,950		
A	Overall length	mm (ft in)	5,440 (17'10")	5,520 (18'1")	5,440(17'10")
B	Overall height	mm (ft in)	3,220 (10'7")	3,220 (10'7")	3,220 (10'7")
C	Overall width	mm (ft in)	3,460 (11'4")	3,970 (13'0")	3,640 (11'11")
Travel speed (1st/2nd/3rd)		Forward	km/h (MPH)		
		Reverse	km/h (MPH)		
			3.3/6.3/10.1 (2.1/3.9/6.3)		
			4.4/8.2/12.9 (2.8/5.1/8.1)		

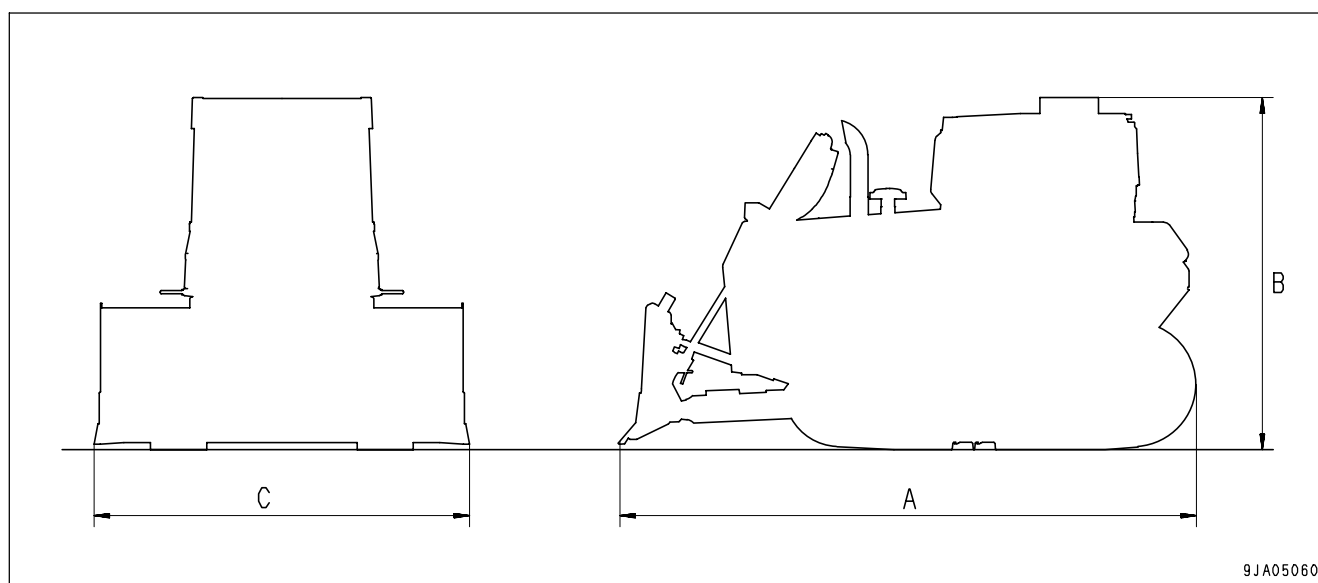

9JA05060

ATTACHMENTS, OPTIONS

 **WARNING**

Please read and make sure that you understand the SAFETY section before reading this section.

GENERAL PRECAUTIONS

PRECAUTIONS RELATED TO SAFETY

If attachments or options other than those authorized by Komatsu are installed, this will not only affect the life of the machine, but will also cause problems with safety.

When installing attachments not listed in this Operation and Maintenance Manual, contact your Komatsu distributor first.

If you do not contact Komatsu, we cannot accept any responsibility for any accidents or failures.



WARNING

General precautions

- Read the instruction manual for the attachment carefully, and do not use the machine before you understand the operation method completely.

If you lose the instruction manual, be sure to order another copy from your Komatsu distributor.

- To prevent serious personal injury caused by misoperation, place your foot on the pedal only when operating the pedal.

Precautions for removal and installation

When removing or installing an attachment, observe the following items and work safely.

- Select a firm, level surface when installing or removing an attachment.
- When working in cooperation with one or more other workers, decide signs and observe them when carrying out the operation.
- When carrying a heavy part (25 kg (55 lb) or more), use a crane.
- When removing a heavy part, always place a support in position before removing it.

When lifting a load with a crane, be particularly careful of the center of gravity.

- It is dangerous to carry out operations when the load has been raised by a crane. Always lower the load onto a stand and check that it is safe.
- When leaving an attachment removed or installing it, place it in a stable position to prevent it from falling over.
- Never go under a load raised by a crane.

Always stand in a place which is safe even if the load should fall.

NOTICE

Qualifications are required to operate a crane. Never allow the crane to be operated by an unqualified person.

For details of removal and installation operations, contact your Komatsu distributor.

SELECTION OF TRACK SHOE

Select suitable track shoes to match the operating conditions.

METHOD OF SELECTING SHOES

If a wider shoe than necessary is used, the load on the track will increase, and this will cause the shoes to bend, links to crack, pins to break, shoe bolts to come loose, and various other problems.

Category	Use	Precautions when using
A	Bedrock, normal soil	This shoe can be used for a wide range of work from crushed rock to general civil engineering work such as reclamation of residential land. There is no particular limit to its use.
B	Normal soil	Use this shoe for general soil, such as where the main work is scraper work and pusher work, reclaiming land for golf courses, or stripping the overburden for coal mines. This shoe cannot be used on bedrock. On jobsites where there are rocks in the soil, be careful to avoid letting the machine mount the rocks.
C	Soft soil	Use this shoe on soft ground where the shoe in category B sinks into the ground. Do not use this shoe on jobsites where there are rocks in the soil.
D	Extremely soft ground (swamp)	<ul style="list-style-type: none"> • With A, B, or C, use these shoes only in places where the machine sinks. • These shoes cannot be used on rough ground where there are large obstacles such as boulders or fallen trees. • Travel at Hi or Mi speed only on flat ground, and if it is impossible to avoid going over obstacles, shift down and travel at half speed in Lo.

REMARK

- Use heavy single shoes for machines operating in category A (rocky ground).
- Using heavy single shoes in categories B or C will help to improve the wear life.

	D65EX		D65PX		D65WX	
	Specifications	Category	Specifications	Category	Specifications	Category
Standard	510mm Single	A	950mm Swamp	D	810mm Single	C
Option	560mm Single	B	915mm Single	D	660mm Single	C
Option	610mm Single	C	---	---	---	---
Option	660mm Single	C	---	---	---	---
Option	810mm Single	C	---	---	---	---
Option	510mm Heavy single	A	---	---	---	---
Option	560mm Heavy single	B	---	---	---	---
Option	610mm Heavy single	C	---	---	---	---
Option	510mm Triple	B	---	---	---	---

HANDLING HYDRAULIC RIPPER

- This hydraulic ripper is for D65EX and D65WX dozers.

GENERAL VIEW

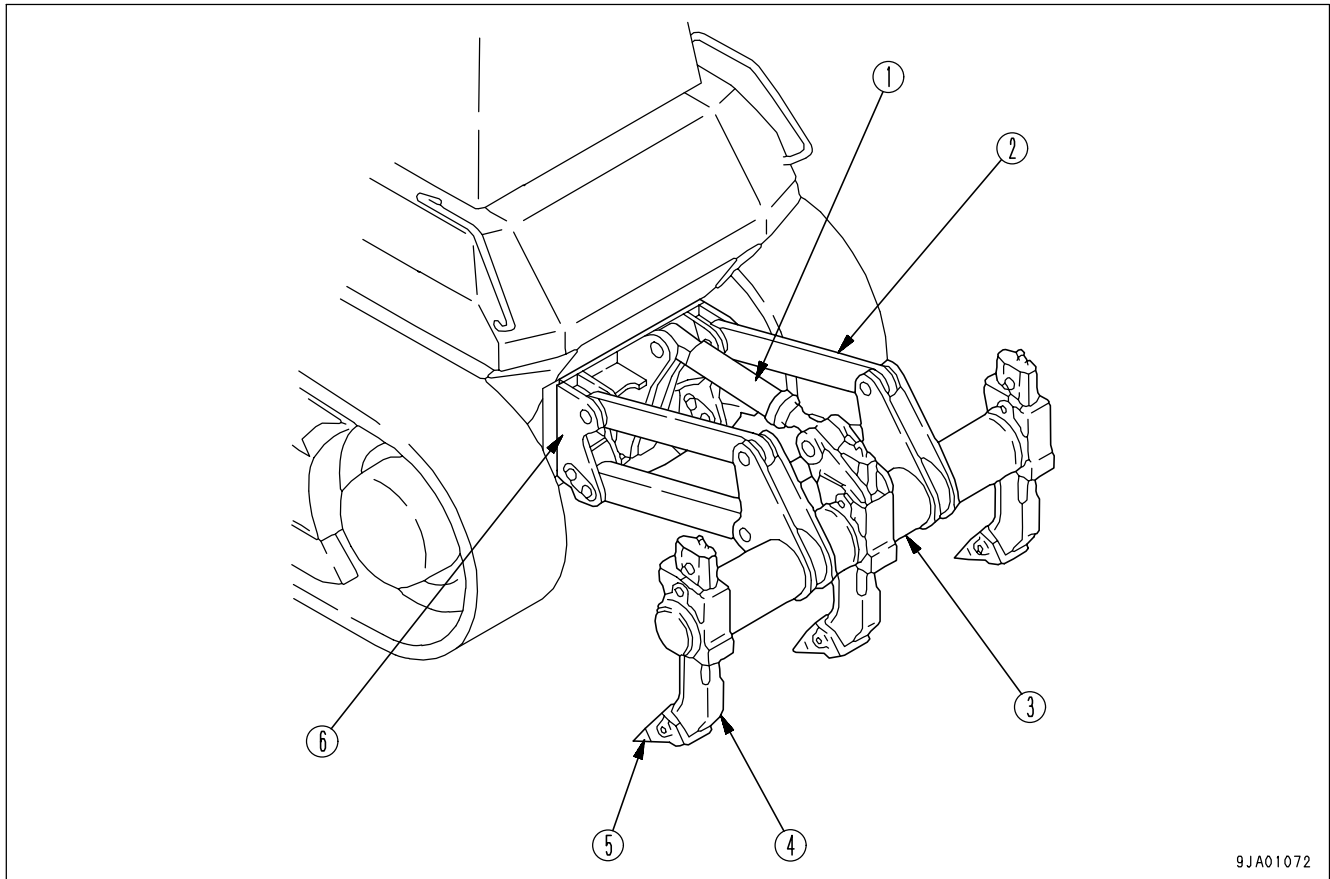

9JA01072

- | | |
|------------------------|-------------|
| (1) Hydraulic cylinder | (4) Shank |
| (2) Link | (5) Point |
| (3) Beam | (6) Support |

EXPLANATION OF COMPONENTS

RIPPER CONTROL LEVER

**WARNING**

When carrying out inspection or maintenance of the machine, or when parking the machine, lower the ripper to the ground and set the work equipment lock lever to the LOCK position.

This lever is used to operate the ripper.

- (A) RAISE: Ripper goes up
- (B) HOLD: Ripper is stopped and held in the same position.
- (C) LOWER: Ripper goes down

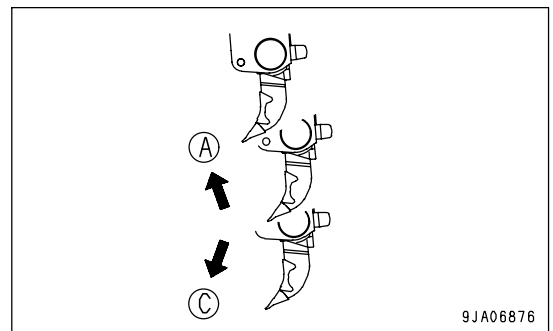
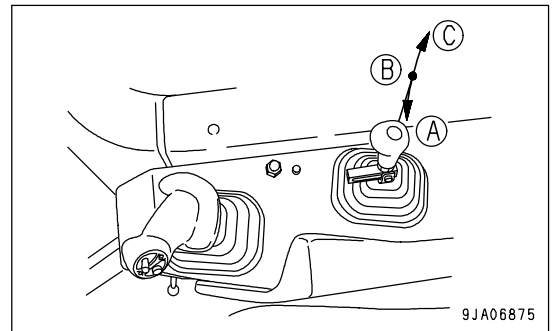
**REMARK**

If the work equipment lock lever is set to LOCK position (L), the operation of the ripper is locked.

For details of the operation of the work equipment lock lever, see "WORK EQUIPMENT LOCK LEVER (PAGE 3-37)".

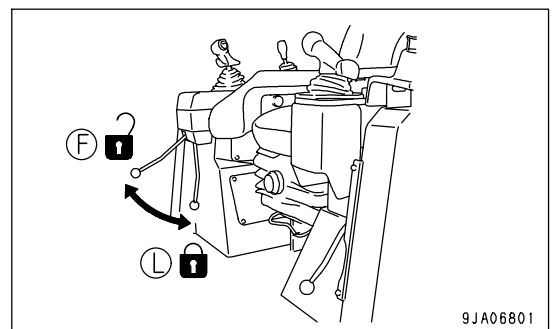

OPERATION

CHECK BEFORE STARTING ENGINE, ADJUST

WALK-AROUND CHECK

1. Check for wear of the point at the tip of the shank, check the mounting condition, and check for damage to the rivets. If any problem is found, replace or repair.

PRECAUTIONS WHEN OPERATING

- Travel in low speed and lower the ripper gradually when starting to move the machine off. When the optimum digging depth is reached, move the control lever to the HOLD position. Do not dig the shank in deep when starting digging operations.
- During ripping operations, never turn the machine suddenly or travel in reverse. When turning the machine suddenly or traveling in reverse, raise the shank from the ground surface.
- When carrying out digging operations with only one shank, always use the center shank. Remove both side shanks.
- When starting to travel up a steep slope or when reaching the bottom of the slope, the point may touch the ground. On hard ground, there is danger of the point breaking if it touches the ground, so raise the shank to the maximum height.

ADJUSTING POSTURE OF WORK EQUIPMENT

ADJUSTMENT OF DIGGING DEPTH

There are mounting holes for the pin in the shank. Select the mounting hole to match the digging depth.

Pin hole position	Use	Max. digging depth
(A)	When there is special need to dig deeply	595mm (23.4 in)
(B)	Normal	485mm (21.9 in)
(C)	When not using ripper	-

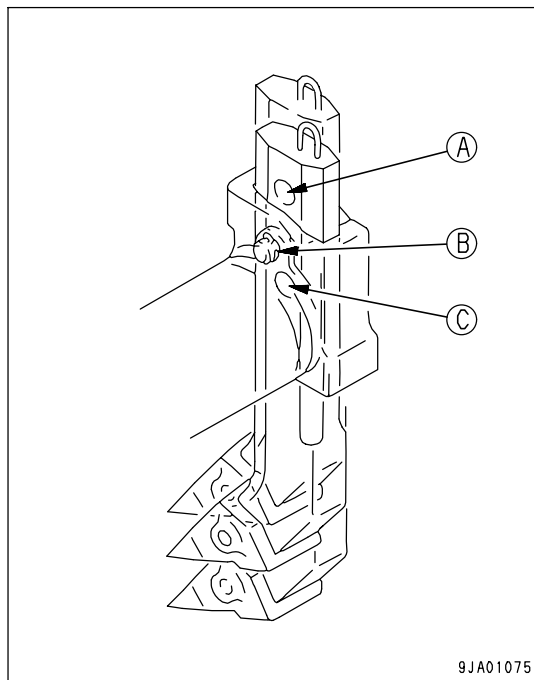

9JA01075

When changing the digging depth, do as follows.

1. Remove cotter pin (1).
2. Remove pin (2), change the position of the shank hole, then insert pin (2).
3. Insert cotter pin (1).

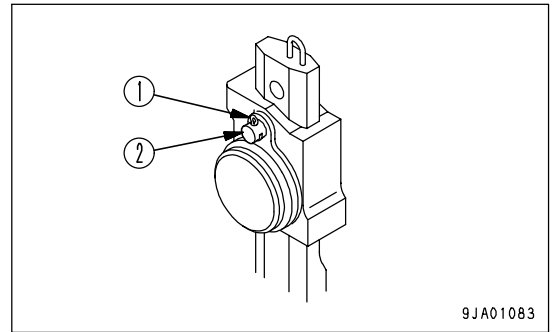

ADJUSTING DIGGING ANGLE

Adjust the position of the mounting pin hole in the beam and upper link.

- Digging angle
 - Position (1): 45°
 - Position (2): 55°

The pin is locked with lock plate (3).

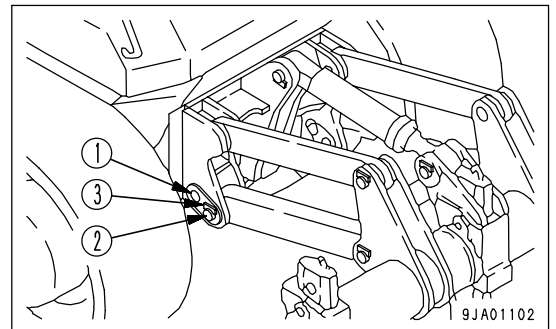

REPLACEMENT OF POINT

A point is installed to protect the shank. If the point is worn, replace it as follows.

1. Put a pin remover in contact with the pin marked by the arrow and tap with a hammer to remove.
2. Replace the point.
3. Insert the pin half way, then knock it in fully with a hammer.

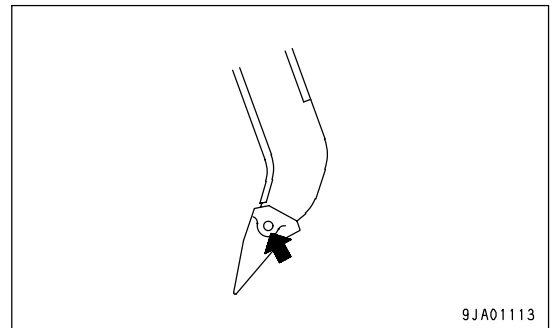

TROUBLESHOOTING

OTHER TROUBLE

- (): Always contact your Komatsu distributor when dealing with these items.
- In cases of problems or causes which are not listed below, contact your Komatsu distributor for repairs.

Problem	Main causes	Remedy
Slow ripper raising and function, lack of ripping force	<ul style="list-style-type: none"> • Improper hydraulic oil • Defective pump • Defective adjustment of relief valve • Defective control valve, safety valve • Defective valve spool • Defective piston ring, packing, valve • Clogging inside piping 	<ul style="list-style-type: none"> • Add oil to specified level, see EVERY 250 HOURS SERVICE (• Check, repair) (• Check, repair) (• Check, repair) (• Check, repair) (• Check, repair)
Cylinder lacks holding power	<ul style="list-style-type: none"> • Leakage of oil from piping, hose • Defective piston ring, packing • Defective piston valve • Defective valve spool • Defective safety valve, suction valve 	<ul style="list-style-type: none"> • Tighten (• Replace) (• Check, repair) (• Check, repair) (• Check, repair)
Oil pressure does not rise	<ul style="list-style-type: none"> • Clogging inside piping • Defective adjustment of relief valve 	<ul style="list-style-type: none"> (• Repair) (• Check, adjust)

MAINTENANCE

EVERY 250 HOURS SERVICE

LUBRICATING

1. Lower the ripper to the ground and stop the engine.
2. Using a grease pump, pump in grease through the grease fittings shown by arrows.
3. After greasing, wipe off any old grease that was pushed out.

- (1) Ripper cylinder foot pin (1 place)
- (2) Ripper cylinder rod end pin (1 place)
- (3) Link pin (8 places)

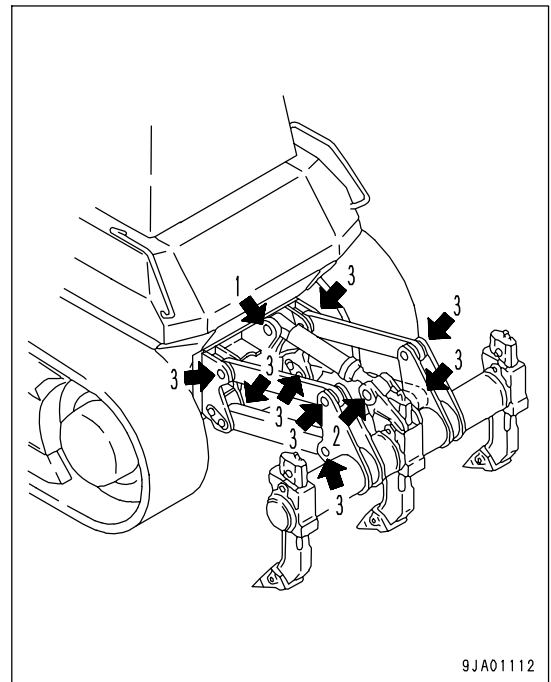

CHECK OIL LEVEL IN HYDRAULIC TANK, ADD OIL

1. Stop the machine on level ground.
Set the blade perpendicular and lower it to the ground, lower the ripper to the ground, then stop the engine.
2. For details of checking the oil level in the hydraulic tank, see "CHECK OIL LEVEL IN HYDRAULIC TANK, ADD OIL (PAGE 4-47)".

SPECIFICATIONS

D65EX: Power tilt-dozer with ROPS guard, cab and air conditioner

D65WX: Semi-U dozer with ROPS guard, cab and air conditioner

	Item	Unit	D65EX-15E0	D65WX-15E0
	Operating weight (not including operator)	kg (lb)	21,400 (47,187)	22,820 (50,318)
	Weight of ripper as individual part	kg (lb)	1,610 (3,550)	1,610 (3,550)
A	Overall length	mm (ft in)	6,480 (21'3")	6,665 (21'10")
	No. of shanks		3	3

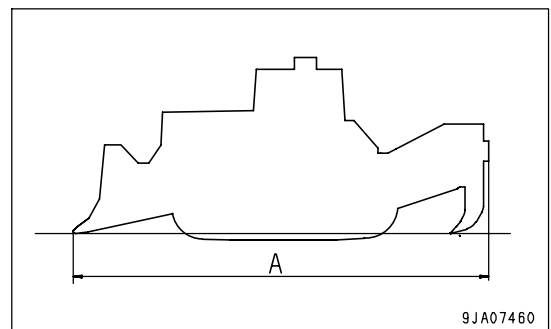

HANDLING TRIMMING DOZER

This trimming dozer is applicable for the D65EX.

GENERAL VIEW

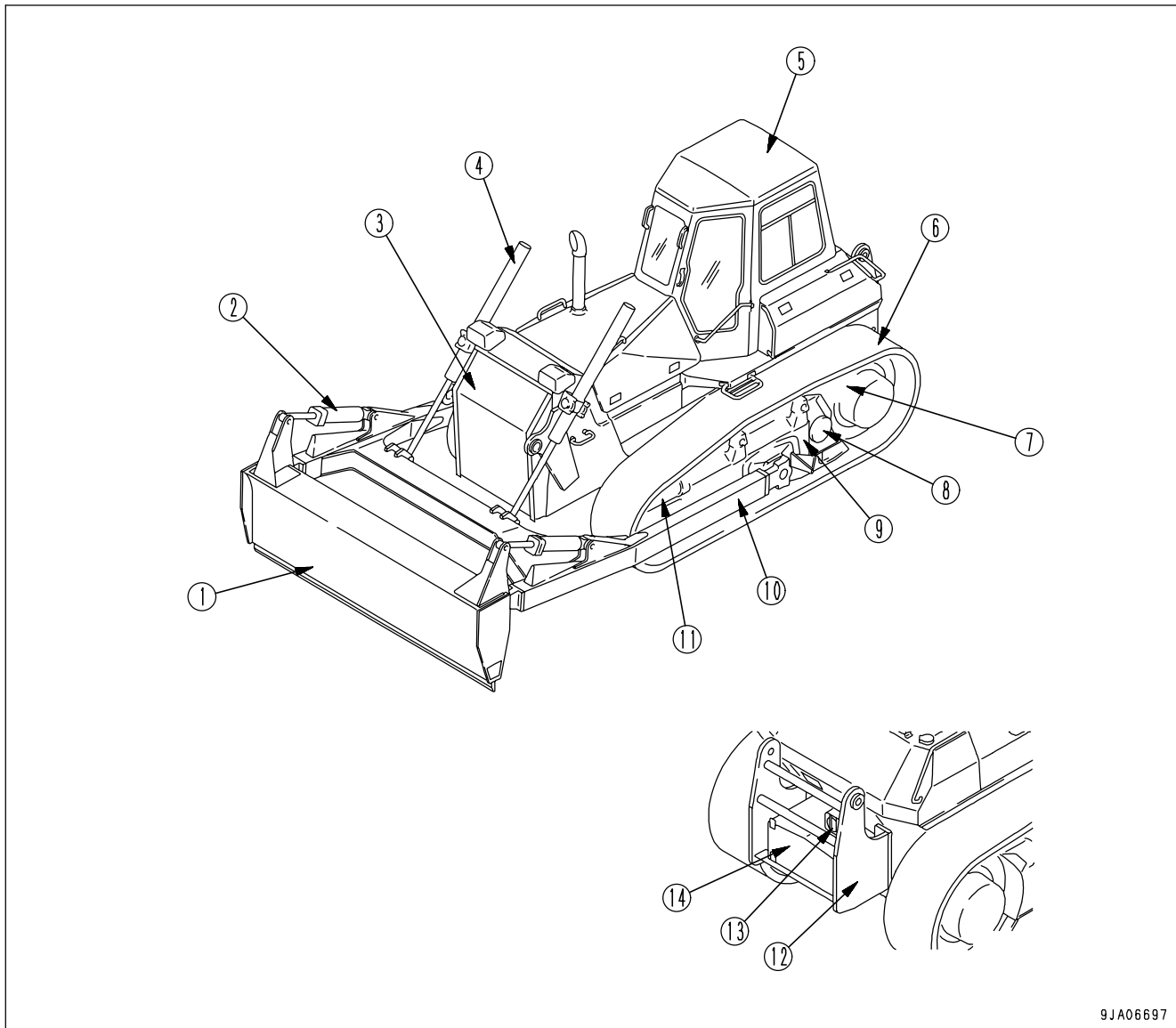

9JA06697

- | | |
|-----------------------|------------------------------------|
| (1) Blade | (8) Pivot shaft |
| (2) Trimming cylinder | (9) Track frame |
| (3) Radiator mask | (10) Frame |
| (4) Lift cylinder | (11) Idler |
| (5) Cab | (12) Rear guard |
| (6) Track shoe | (13) Red back-up lamp |
| (7) Sprocket | (14) Extra fuel tank (if equipped) |

EXPLANATION OF COMPONENTS

BLADE CONTROL LEVER

This lever is used to raise or trim the blade.

- Lifting control
- (a) RAISE:
- (b) HOLD: Blade is stopped and held in this position.
- (c) LOWER:
- (d) FLOAT: Blade will move freely according to external force.

REMARK

- When released from FLOAT position, this lever will not return to HOLD position, so it must be moved back by hand.
- Before starting the engine, check that the blade control lever is at the HOLD position.
- The blade operation is locked by the work equipment lock lever. For details of the operation of the work equipment lock lever, see "WORK EQUIPMENT LOCK LEVER (PAGE 3-37)".

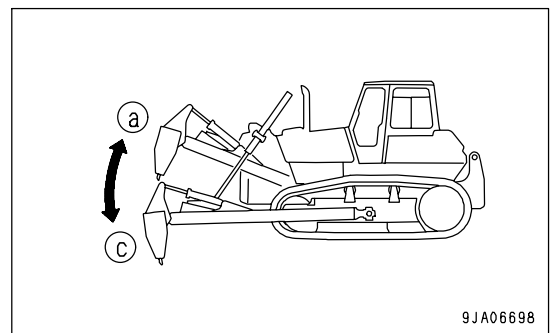
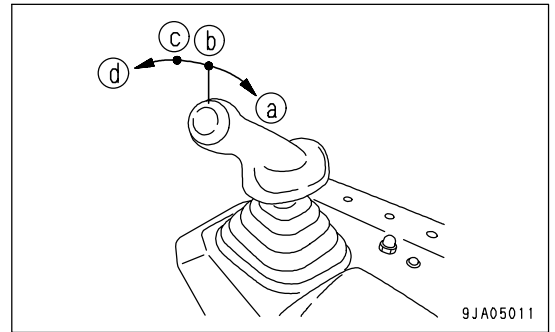

- Trimming control
- (b) HOLD : Blade is stopped and held in this position.
- (e) REAR : Blade inclines to rear direction.
- (f) FRONT: Blade inclines to front direction.

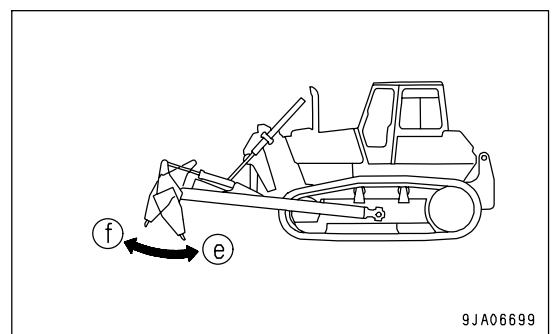
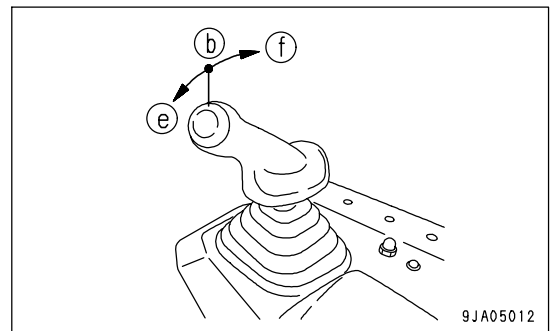

RED BACKUP LAMP

When the steering - forward / reverse shifting - gearshift lever is operated to REVERSE position (R), the alarm buzzer begins to intermittently sound on the spot and red backup lamp (1) lights up, warning people around of reverse travel.

REMARK

The alarm buzzer keeps sounding and the red backup lamp remains lighted until after the steering - forward / reverse shifting - gearshift lever is shifted to neutral position (N) or FORWARD position (F).

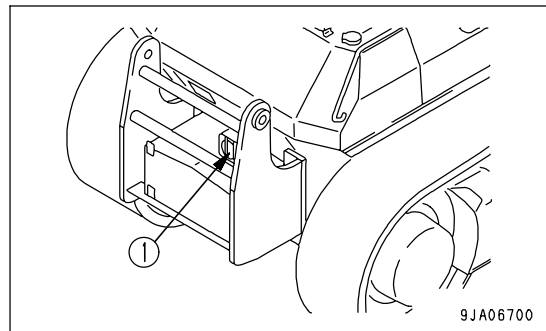
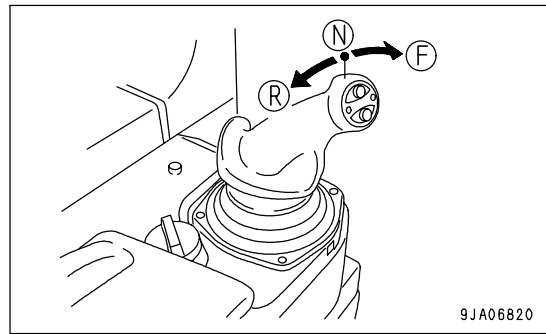

OPERATION

WORK POSSIBLE USING TRIMMING DOZER

TRIMMING

By tilting the blade to the front or rear, it is possible to smoothly push or scoop up a variety of loose materials inside the ship's hold, ranging from heavy materials such as iron ore to comparatively light materials such as coal, salt, sugar, and grain.

REMARK

It is possible to operate easily using the steering, forward-reverse, gear shift lever together with the brake pedal.

This is a power-turn machine, so it can carry out pivot turns and counterrotation turns smoothly to enable it to operate right into the corners of confined ship's holds.

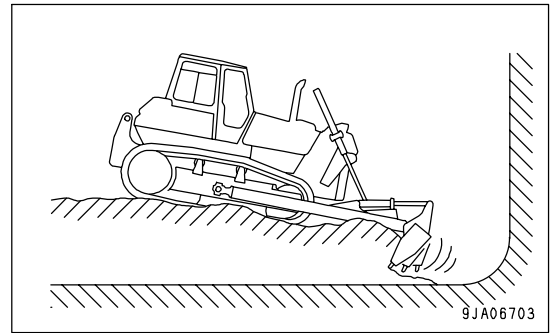
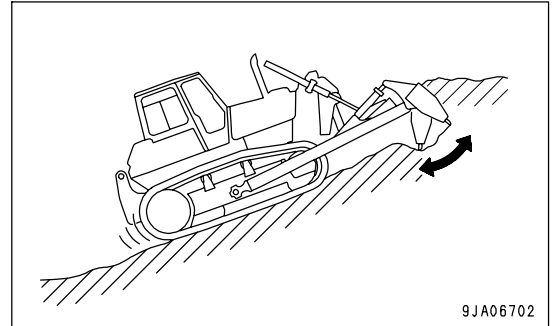

PRECAUTIONS WHEN OPERATING

1. This machine must not be used for earth moving or digging operations.
2. Never move the machine to the front and rear when the machine is jacked up by the blade.

LIFTING MACHINE

**WARNING**

- The person using the crane to carry out lifting operations must be a qualified crane operator.
- Never carry out lifting operations if any person is on the machine being lifted.
- Always use a wire rope that has ample strength for the weight of the machine being lifted.
- Keep the machine horizontal when lifting it.
- When carrying out lifting operations, set the work equipment lock lever and parking brake lever to the LOCK position to prevent the machine or work equipment from moving unexpectedly.
- Never enter the area under or around a raised machine.
- There is danger of the machine losing its balance.

Use the procedure below to set the machine in the proper posture and use the lifting equipment when lifting the machine.

NOTICE

Use protectors, etc. so that the wire ropes will not be broken at sharp edges or narrow places.

For details of the weight, see "SPECIFICATIONS (PAGE 6-20)".

PROCEDURE FOR LIFTING OPERATIONS

When lifting the machine, stop it on a level place, then observe the following procedure.

1. Stop the engine and set the parking brake lever to the LOCK position (L) securely.
2. Close the cab door, window and side cover securely.

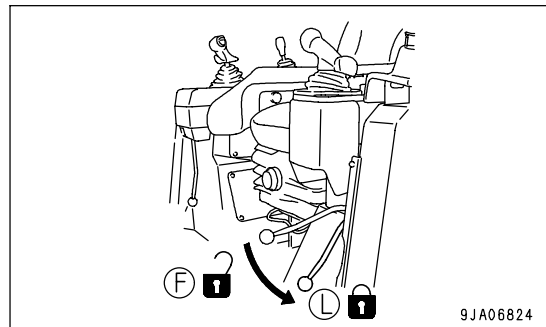

3. Set the work equipment lock lever to the LOCK position (L) securely.

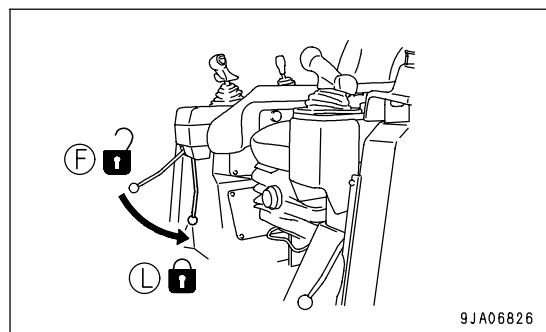

4. Use a wire rope and sling that matches the weight of the machine.
5. Install shackles to the lifting holes at the top of the rear guard and the front of the radiator guard then fit the wire.
6. When applying tension to the wire with a crane, fit wooden blocks at the points where the wire touches the chassis.

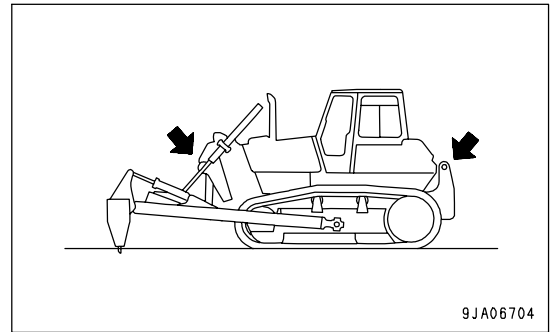

7. Lift the machine slowly, keeping slinging angle (A) at 30° to 40°.

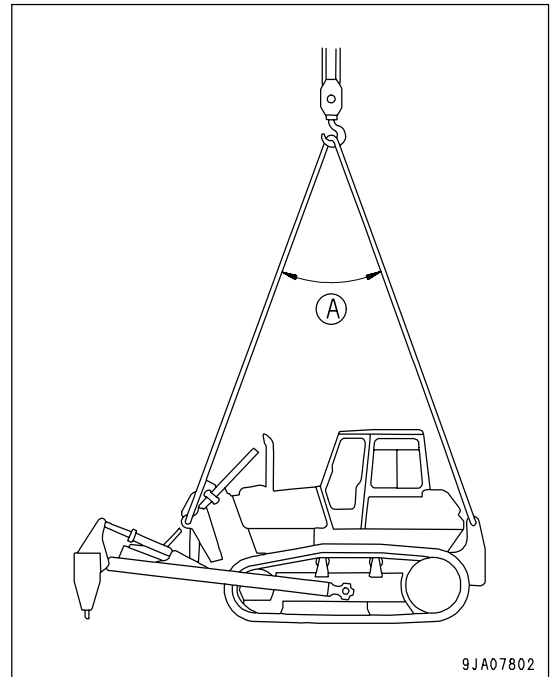

8. After setting the wire ropes, lift up the machine and stop at 100 to 200 mm (3.9 to 7.9 in) above the ground, and check that the wire ropes are not slack and the machine is level, then lift up slowly.

MAINTENANCE



CAUTION

- When opening the engine side cover to carry out inspection and maintenance of machines equipped with a trimming dozer, grip the lift cylinder hose by hand and move it to the outside, then open the cover until it is locked.
- The cover is also held by a gas damper, but there are cases where the gas damper may not be able to hold it in cold weather, so always open the cover until it is locked.

CHECK BEFORE STARTING

CHECK FUEL LEVEL (MACHINE EQUIPPED WITH EXTRA FUEL TANK)



WARNING

When adding fuel, never spill the fuel or let it overflow. It will cause fire.

If any fuel has spilled, wipe it up completely. If fuel has spilled over soil or sand, remove that soil or sand.

Fuel is highly flammable and dangerous. Never bring flames near fuel.

1. Turn the engine starting switch to the ON position and check the fuel level gauge (G) on the monitor panel for fuel level. After checking, turn the switch back to the OFF position.

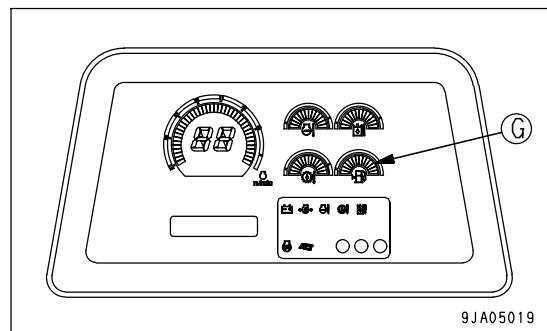

2. Remove the cap of the top tank, the use dipstick (G) to check the level of the fuel in the top tank.
3. After completing work, fill the fuel tank through fuel filler port (F).

Fuel capacity: Upper tank : 415 liters (109.64 US gal)

Extra tank : 110 liters (29.06 US gal)

Total : 525 liters (138.70 US gal)

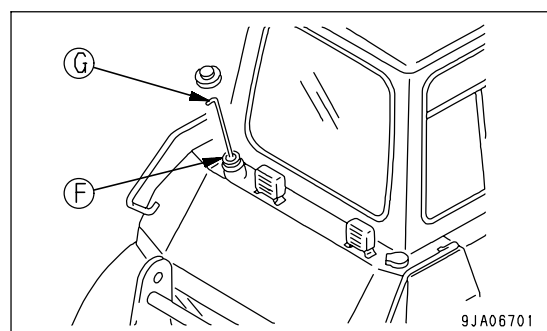

REMARK

After completion of operations, add fuel through fuel filler port (F) to fill the tank.

4. After adding fuel, tighten the cap securely.

REMARK

- The top tank and extra tank are connected, so if fuel is added through fuel filler port (F) of the top tank, it is supplied first to the extra tank. When the extra tank is full, the fuel is supplied to the top tank.
- The fuel gauge on the monitor panel shows the condition of the extra tank, regardless of the amount of fuel in the top tank. Use dipstick (G) to check the amount of fuel in the top tank.

CHECK OF OPERATION OF BACKUP ALARM AND RED BACKUP LAMP

Check that the backup alarm works properly and that the red backup lamp lights up.

If the backup alarm does not work or the lamp does not light up, there is probably a failure or disconnection in the wiring, so please ask your Komatsu distributor to carry out repairs.

1. Turn starting switch to the ON position (B).

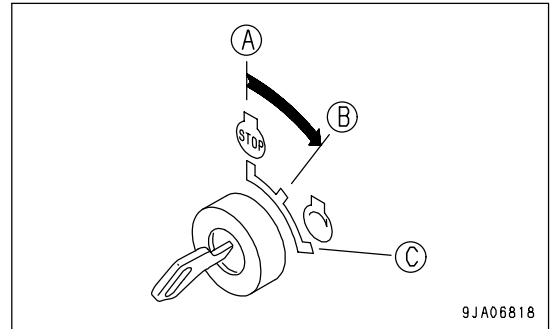

2. Set parking brake lever to the FREE position (F).

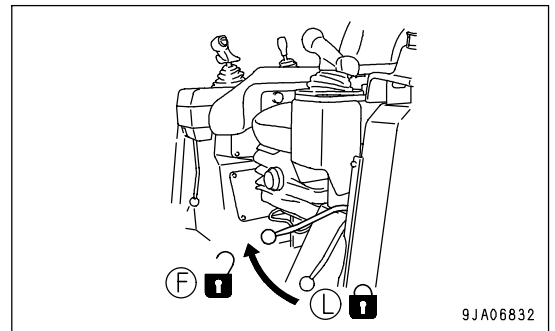

3. Operate the steering - forward / reverse shifting - gearshift lever to REVERSE position (R).

The alarm buzzer should begin to intermittently sound on the spot and likewise red backup lamp (1) must lights up immediately.

The alarm buzzer keeps sounding and the red backup lamp remains lighted until after the steering - forward / reverse shifting - gearshift lever is shifted to neutral position (N) or FORWARD position (F).

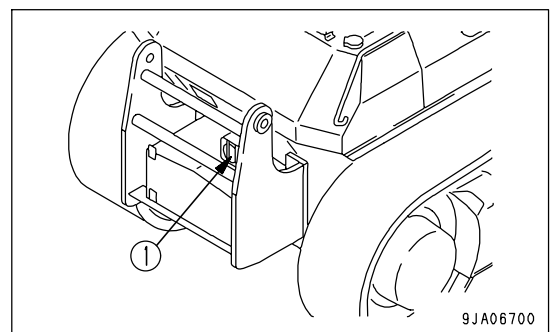
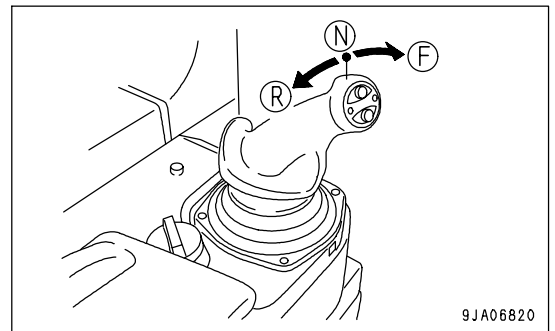

WHEN REQUIRED

REPLACE CUTTING EDGE

Replace the cutting edge before it wears to the end face of the blade.

The cutting edge is welded to the blade.

When replacing the cutting edge, please ask your Komatsu distributor to carry out the replacement operation.

Cutting edges part no.: 144-978-1120 (1 piece; weld)

Weight: 100 kg (221 lb)/piece

EVERY 50 HOURS SERVICE

DRAIN WATER, SEDIMENT FROM FUEL TANK (MACHINE EQUIPPED WITH EXTRA FUEL TANK)

Carry out this procedure before operating the machine.

- Prepare a container to catch the fuel that is drained.

1. Open the inspection cover at bottom of upper fuel tank and loosen valve (1), and drain sediment accumulated on the bottom together with mixed water and fuel.

When doing this, be careful not to get fuel on yourself.

2. When clear fuel comes out, close drain valve (1).

3. Loosen valve (2) at the bottom of the extra tank and drain sediment accumulated on the bottom together with mixed water and fuel.

When doing this, be careful not to get fuel on yourself.

4. When clean fuel comes out, close drain valve (2).

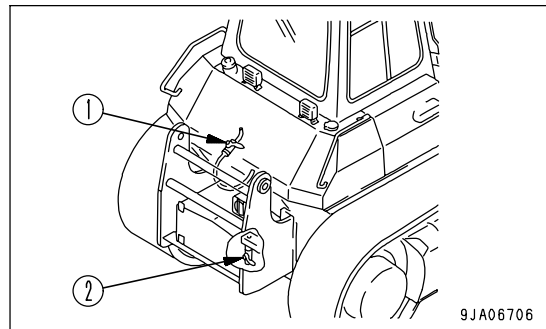

EVERY 250 HOURS SERVICE**LUBRICATING**

1. Lower the blade to the ground, then stop the engine.
2. Using a grease pump, pump in grease through the grease fittings shown by arrows.
3. After greasing, wipe off any old grease that was pushed out.

- (1) Lift cylinder support yoke (4 places)
- (2) Lift cylinder support shaft (2 places)

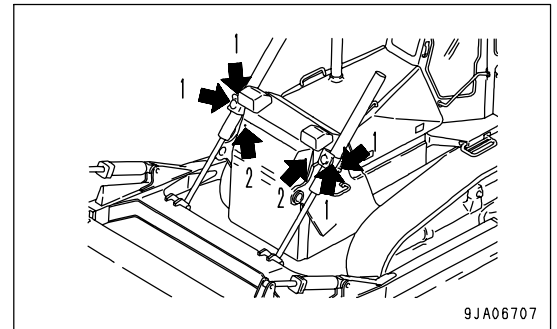

- (3) Lift cylinder ball joint (2 places)
- (4) Frame shaft (2 places)
- (5) Trimming cylinder bottom shaft (2 places)
- (6) Trimming cylinder piston rod (2 places)

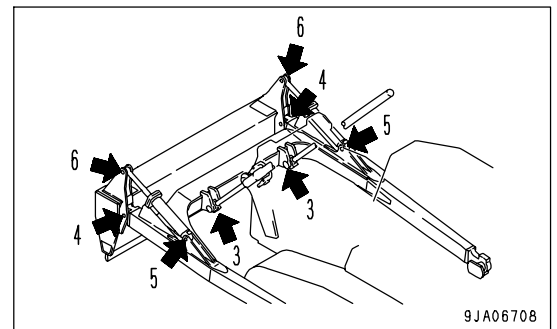

SPECIFICATIONS

With trimming dozer and ROPS cab

	Item	Unit	D65EX-15E0	
	Machine weight	kg (lb)	20,900 (46,085)	
A	Overall length (Incl. rear guard)	mm (ft in)	6,475 (21'3")	
B	Overall height	mm (ft in)	3,220 (10'7")	
C	Overall width	mm (ft in)	3,210 (10'6")	
	Blade	Maximum lift above ground	mm (ft in)	1,610 (5'3")
		Maximum drop below ground	mm (ft in)	685 (2'3")
		Tilting angle, forward	Degrees	29
		Tilting angle, rearward	Degrees	22

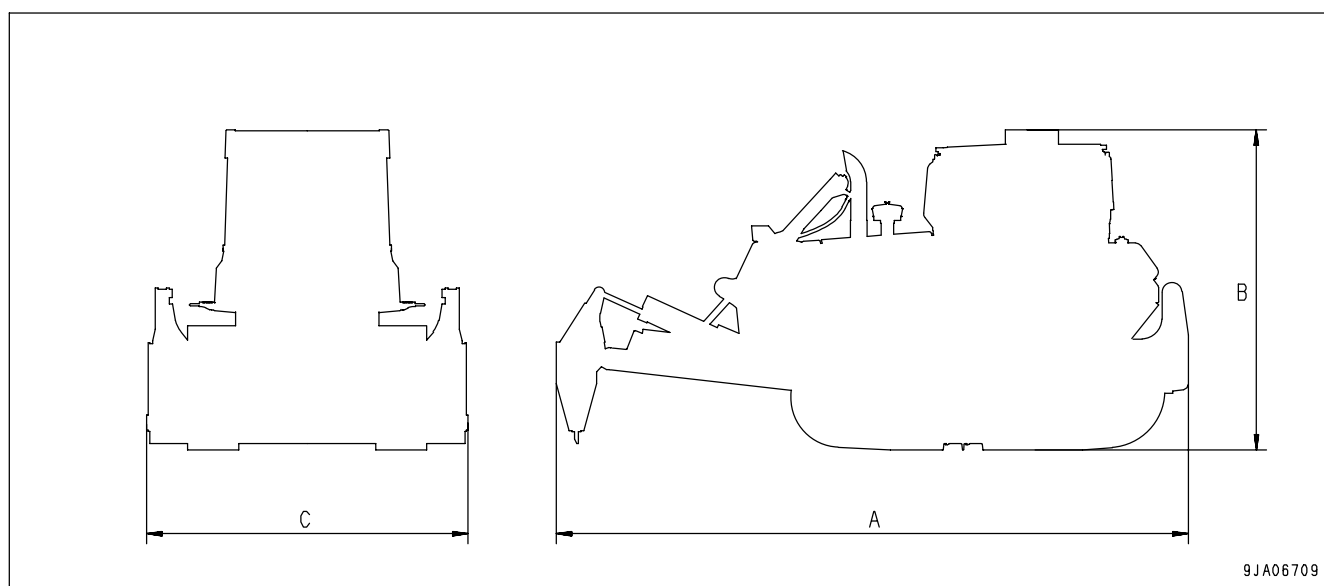

9JA06709

AIR SUSPENSION SEAT

ADJUSTMENT



WARNING

When adjusting the position of the operator's seat, always set the work equipment lock lever to the LOCK position to prevent any accidental contact with the control levers.

- Always adjust the operator's seat before starting each operation or when the operators change shift.
- When adjusting the seat, put your back against the backrest and adjust to a position where the brake pedal can be fully depressed.

NOTICE

There is danger of damage to the air compressor, so do not keep lever (3) operated continuously for more than 1 minute.

Adjustments (C), (D), and (I) use the air compressor built into the seat, so turn the engine starting switch to the ON position when carrying out the adjustment.

(A) Fore-and-aft adjustment

Pull lever (1), set the seat to a position where it is easy to operate, then release the lever.

Fore-aft adjustment: 170 mm (6.7 in) (17 stages)

(B) Adjusting seat angle

Move lever (2) up, move the seat cushion at the front up or down to set to the desired position, then release the lever.

Amount of adjustment

Forward tilt: 3 degrees

Rear tilt: 11 degrees

(C) Setting seat for operator's weight

To protect the operator, it is necessary to adjust the suspension to match the weight of the operator.

Pull lever (3) up fully (pull it until a click can be felt). When the lever is released, the weight adjustment is carried out automatically. To ensure that the weight adjustment is carried out correctly, the operator should sit in the normal operating position when operating the lever. If the operator raises his body from the seat or changes the amount of weight applied to the seat during adjustment, the air in the suspension may be discharged.

If lever (3) is pulled lightly, the weight adjustment starts, but always pull the lever up fully (pull it until a click is felt) before releasing it.

When operators change shifts, first release the air, then carry out the above operation.

If the operator raises his body from the seat or changes the amount of weight applied to the seat during adjustment, the air in the suspension may be discharged.

Amount of adjustment: 80 mm (3.2 in)

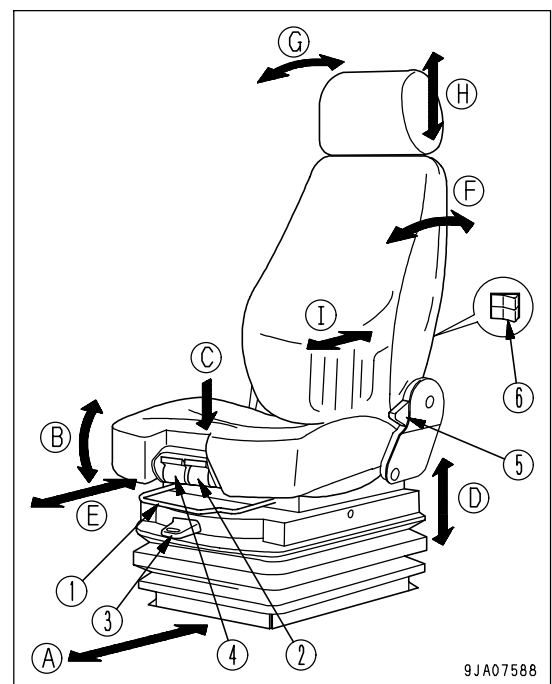

9JA07588

After the automatic weight adjustment is carried out, the seat height is at the lowest point in the adjustment range. Adjust the seat to the appropriate height.

(D) Seat height adjustment

The seat height adjustment uses an air system, and it can be adjusted steplessly.

When adjusting the height, pull lever (3) up fully or push it down fully (when pulling it up, pull it until a click is felt).

When the seat is set at the desired height, release the lever. If the lever is kept pulled up, the position where the seat does not rise any further is the maximum height. When the seat reaches the maximum height, the suspension automatically goes down slightly to secure the amount of movement of the lever.

To prevent the suspension from reaching the bottom, do not set to the seat height below the adjustment range.

(E) Fore-and-aft adjustment of seat cushion

Operate lever (4) up, set the seat cushion to the desired position, then release the lever.

Fore-and-aft adjustment: 60 mm (2.4 in)

(F) Adjusting reclining angle

Move lever (5) up and move the backrest to the front or rear.

Push your back against the backrest when carrying out this adjustment. If your back is not pressing against the backrest, the backrest may suddenly spring forward.

Amount of adjustment

Forward tilt: 20 degrees (over 20 degrees is free)

Rear tilt: 60 degrees

REMARK

The seat can be reclined more when the seat is pushed to the front. The amount of reclining decreases as the seat is pushed back, so when moving the seat back, return the seatback to the upright position.

NOTICE

If the seat back is reclined too far, the seat back may hit the rear glass, so use it in a position where it does not contact the glass.

(G) Adjusting headrest angle

Rotate the backrest to the front or rear and set to the desired angle.

Amount of adjustment: 38 degrees

(H) Adjusting headrest height

Move the headrest up or down and set to the desired height.

Amount of adjustment: 100 mm (3.9 in)

(I) Lumbar support

Operate switch (6) to give a suitable tension to the lumbar region.

When + is pressed: Tension becomes stronger

When - is pressed: Tension becomes weaker

Adjust the backrest to the desired curve.

DELUXE SEAT

(Rotating seat)

ADJUSTMENT



WARNING

When adjusting the position of the operator's seat, always set the work equipment lock lever to the LOCK position to prevent any accidental contact with the control levers.

- Always adjust the operator's seat before starting each operation or when the operators change shift.
- When adjusting the seat, put your back against the backrest and adjust to a position where the brake pedal can be fully depressed.

(A) Fore-and-aft adjustment

Pull lever (1), set the seat to a position where it is easy to operate, then release the lever.

Fore-aft adjustment: 200 mm (7.9 in) (10 stages)

(B) Weight and height adjustment of seat

- Turn knob (2) under the seat so that weight adjustment indicator (3) displays the green range. The height can be adjusted by turning the knob (2) while the green range is displayed.
- Turn the knob clockwise to raise the seat and turn the knob counterclockwise to lower the seat.

Height adjustment range: stepless, 75 mm (3 in)

Weight adjustment range: 50 to 130 kg (110 to 237 lb)

(C) Adjust reclining angle

REMARK

When the seat is pushed forward, the available reclining angle becomes greater; when the seat is pushed back, the available reclining angle becomes smaller. When moving the backrest, return the backrest to its original position before moving the seat.

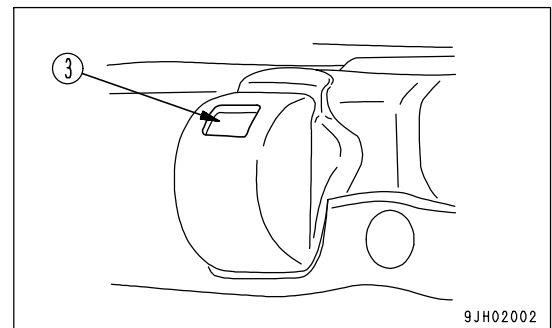
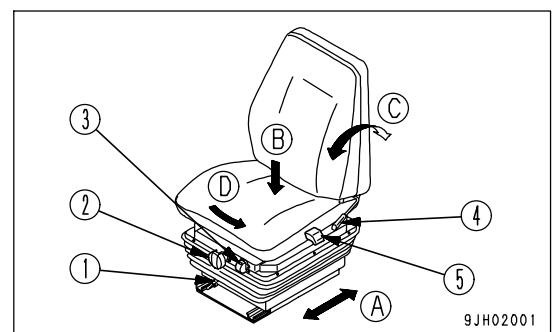

Pull up lever (4), set the seatback to a position where it is easy to operate, then release the lever.

(D) Adjusting direction of seat

NOTICE

Depending on the position of the seat, when changing the direction of the seat, it may contact the console or other parts.

Be extremely careful.

Pull up lever (5) to unlock the seat. The seat can then be turned 15° to the right.

After changing the direction of the seat, return the lever securely to lock the seat.

- Change the direction of the seat to the right for the ease of operation of the ripper.

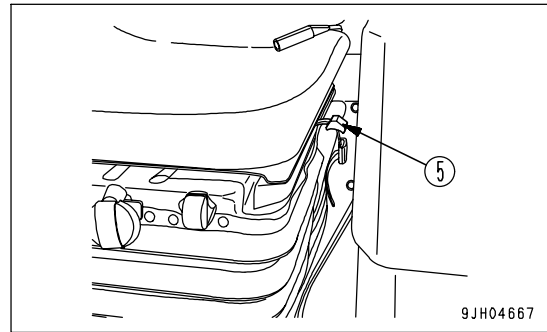

HEADREST

Removal of headrest

Pull up the headrest.

REMARK

The headrest cannot be fixed to halfway.

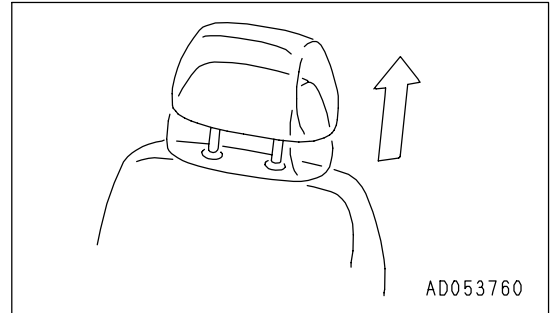

EQUIPPING FIRE EXTINGUISHER AND FIRST-AID KIT

Equipping the fire extinguisher and the first-aid kit at the illustrated position needs brackets (if equipped).

The fire extinguisher and the first-aid kit can be installed to the positions shown in the following illustration.

(1) First Aid Kit

(2) Fire Extinguisher

For information on parts which are required to install these items on the machine, call your Komatsu distributor.

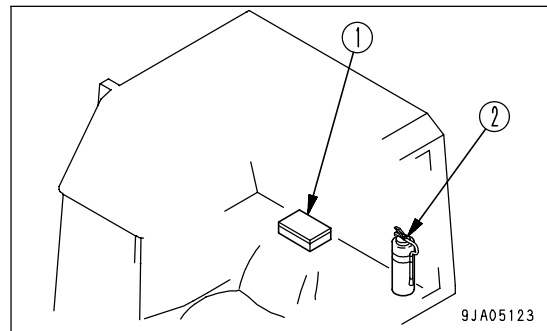

HANDLING MACHINES EQUIPPED WITH KOMTRAX

- KOMTRAX is a machine management system that uses wireless communications.
- A contract with your Komatsu distributor is necessary before the KOMTRAX system can be used. Any customers desiring to use the KOMTRAX system should consult their Komatsu distributor.
- The KOMTRAX equipment is a wireless device using radio waves, so it is necessary to obtain authorization and conform to the laws of the country or territory where the machine equipped with KOMTRAX is being used. Always contact your Komatsu distributor before selling or exporting any machine equipped with KOMTRAX.
- When selling or exporting the machine or at other times when your Komatsu distributor considers it necessary, it may be necessary for your Komatsu distributor to remove the KOMTRAX equipment or to carry out action to stop communications.
- If you do not obey the above precautions, neither Komatsu nor your Komatsu distributor can take any responsibility for any problem that is caused or for any loss that results.

BASIC PRECAUTIONS



WARNING

- Never disassemble, repair, modify, or move the communications terminal, antenna, or cables. This may cause failure or fire on the KOMTRAX equipment or the machine itself. (Your Komatsu distributor will carry out removal and installation of KOMTRAX.)
- Do not allow cables or cords to become caught; do not damage or pull cables or cords by force. Short circuits or disconnected wires may cause failure or fire on the KOMTRAX equipment or the machine itself.
- For anyone wearing a pacemaker, make sure that the communications antenna is at least 22 cm (8.7 in) from the pacemaker. The radio waves may have an adverse effect on the operation of the pacemaker.

NOTICE

- Even when the key in the starting switch of the KOMTRAX system is at the OFF position, a small amount of electric power is consumed. When putting the machine into long-term storage, take the action given in "LONG-TERM STORAGE (PAGE 3-130)".
- Please contact your Komatsu distributor before installing a top guard or other attachment that covers the cab roof.
- Be careful not to get water on the communications terminal or wiring.

REMARK

- The KOMTRAX system uses wireless communications, so it cannot be used inside tunnels, underground, inside buildings, or in mountain areas where radio waves cannot be received. Even when the machine is outside, it cannot be used in areas where the radio signal is weak or in areas outside the wireless communication service area.
- There is absolutely no need to inspect or operate the KOMTRAX communications terminal, but if any abnormality is found, please consult your Komatsu distributor.

INDEX

<A>		FIRE PREVENTION -----	2- 12
ADJUSTING POSTURE OF WORK		PRECAUTIONS BEFORE STARTING	
EQUIPMENT -----	3-110	OPERATION -----	2- 10
AIR CONDITIONER, HANDLING -----	3- 64	PRECAUTIONS RELATED TO	
AIR SUSPENSION SEAT -----	6- 21	ATTACHMENTS AND OPTIONS -----	2- 15
ASHTRAY -----	3- 54	PRECAUTIONS RELATED TO	
		PROTECTIVE STRUCTURES -----	2- 15
BEFORE READING THIS MANUAL -----	1- 2	PRECAUTIONS WHEN GETTING ON	
<C>		OR OFF MACHINE -----	2- 13
CAP WITH LOCK -----	3- 50	PRECAUTIONS WHEN RUNNING	
CAR STEREO, HANDLING -----	3- 56	ENGINE INSIDE BUILDING -----	2- 15
CHECK BEFORE STARTING ENGINE,		PREPARATIONS FOR SAFE	
ADJUST -----	3- 70	OPERATION -----	2- 10
CIRCUIT BREAKER -----	3- 46	UNAUTHORIZED MODIFICATION -----	2- 15
COLD WEATHER OPERATION -----	3-128	GENERAL VIEW -----	3- 2
AFTER COLD WEATHER -----	3-129	GENERAL VIEW OF CONTROLS AND	
AFTER COMPLETION OF WORK -----	3-129	GAUGES -----	3- 3
PRECAUTIONS FOR LOW		GENERAL VIEW OF MACHINE -----	3- 2
TEMPERATURE -----	3-128	GUIDE TO MAINTENANCE -----	4- 2
CONTROL LEVERS AND PEDALS -----	3- 37	<H>	
CUP HOLDER -----	3- 54	HANDLING HYDRAULIC RIPPER -----	6- 4
<D>		EXPLANATION OF COMPONENTS -----	6- 5
DELUXE SEAT -----	6- 23	GENERAL VIEW -----	6- 4
DOOR - OPEN LOCK -----	3- 52	MAINTENANCE -----	6- 9
DOOR POCKET -----	3- 53	OPERATION -----	6- 6
<E>		SPECIFICATIONS -----	6- 9
EQUIPPING FIRE EXTINGUISHER AND		TROUBLESHOOTING -----	6- 8
FIRST-AID KIT -----	6- 26	HANDLING MACHINES EQUIPPED	
EXPLANATION OF COMPONENTS -----	3- 6	WITH KOMTRAX -----	6- 27
<F>		HANDLING TRIMMING DOZER -----	6- 10
FRONT PANEL -----	3- 6	EXPLANATION OF COMPONENTS -----	6- 11
FUSE -----	3- 47	GENERAL VIEW -----	6- 10
FUSIBLE LINK -----	3- 48	MAINTENANCE -----	6- 16
<G>		OPERATION -----	6- 13
GENERAL PRECAUTIONS -----	6- 2	SPECIFICATIONS -----	6- 20
PRECAUTIONS RELATED TO		HEADREST -----	6- 25
SAFETY -----	6- 2	<I>	
GENERAL PRECAUTIONS COMMON		IMPORTANT SAFETY INFORMATION -----	1- 6
TO OPERATION AND MAINTENANCE -----	2- 10	INTENDED USE -----	1- 7
DO NOT GET CAUGHT IN WORK		GENERAL VIEW AND DIRECTIONS	
EQUIPMENT -----	2- 14	OF MACHINE -----	1- 7
		USE OF MACHINE -----	1- 7
		VISIBILITY FROM OPERATOR'S	
		SEAT -----	1- 8

<L>		SAFETY CRITICAL PARTS -----	4- 16
LOCATION OF PLATES, TABLE TO		PRECAUTIONS FOR MAINTENANCE -----	2- 27
ENTER SERIAL NO. AND		PRECAUTIONS BEFORE STARTING	
DISTRIBUTOR -----	1- 9	INSPECTION AND MAINTENANCE -----	2- 27
ADDITIONAL EPA NAMEPLATE -----	1- 10	PRECAUTIONS FOR INSPECTION	
ENGINE SERIAL NO. PLATE		AND MAINTENANCE -----	2- 31
POSITION -----	1- 9	PRECAUTIONS FOR OPERATION -----	2- 16
PRODUCT IDENTIFICATION		OPERATION -----	2- 21
NUMBER (PIN)/MACHINE		PRECAUTIONS FOR JOBSITE -----	2- 16
SERIAL NO. PLATE -----	1- 9	STARTING ENGINE -----	2- 19
SERVICE METER POSITION -----	1- 10	TOWING -----	2- 26
TABLE TO ENTER SERIAL NO. AND		TRANSPORTATION -----	2- 25
DISTRIBUTOR -----	1- 11		
LONG-TERM STORAGE -----	3-130	<R>	
AFTER STORAGE -----	3-130	RECOMMENDED FUEL, COOLANT,	
BEFORE STORAGE -----	3-130	AND LUBRICANT -----	4- 12
DURING STORAGE -----	3-130	RECOMMENDED BRANDS,	
		RECOMMENDED QUALITY FOR	
<M>		PRODUCTS OTHER THAN	
MAINTENANCE SCHEDULE CHART -----	4- 18	KOMATSU GENUINE OIL -----	4- 14
MAINTENANCE SCHEDULE CHART -----	4- 18	USE OF FUEL, COOLANT AND	
		LUBRICANTS ACCORDING TO	
<O>		AMBIENT TEMPERATURE -----	4- 13
OPENING AND CLOSING ENGINE			
SIDE COVER -----	3- 53	<S>	
OPERATION -----	3- 70	SAFETY -----	2- 2
CHECK AFTER FINISHING WORK -----	3-115	SAFETY LABELS -----	2- 5
LOCKING -----	3-116	POSITIONS OF SAFETY	
MACHINE OPERATION -----	3- 96	PICTOGRAMS -----	2- 5
OPERATIONS AND CHECKS AFTER		SAFETY LABELS -----	2- 6
STARTING ENGINE -----	3- 92	SASH GLASS INTERMEDIATE LOCK -----	3- 52
PARKING MACHINE -----	3-114	SELECTION OF TRACK SHOE -----	6- 3
PRECAUTIONS FOR OPERATION -----	3-106	METHOD OF SELECTING SHOES -----	6- 3
SHIFTING BETWEEN FORWARD		SERVICE PROCEDURE -----	4- 20
AND REVERSE -----	3-102	CHECK BEFORE STARTING -----	4- 42
SHIFTING GEARS -----	3- 99	EVERY 1000 HOURS SERVICE -----	4- 59
STARTING ENGINE -----	3- 87	EVERY 2000 HOURS SERVICE -----	4- 68
STEERING MACHINE -----	3-104	EVERY 250 HOURS SERVICE -----	4- 44
STOPPING ENGINE -----	3- 95	EVERY 4000 HOURS SERVICE -----	4- 74
WORK POSSIBLE USING		EVERY 50 HOURS SERVICE -----	4- 43
BULLDOZER -----	3-108	EVERY 500 HOURS SERVICE -----	4- 53
OUTLINE OF SERVICE -----	4- 5	EVERY 8000 HOURS SERVICE -----	4- 77
HANDLING HYDRAULIC SYSTEM -----	4- 9	WHEN REQUIRED -----	4- 20
HANDLING OIL, FUEL, COOLANT,		SHOVEL HOLDER -----	3- 55
AND PERFORMING OIL CLINIC -----	4- 5	SPECIFICATIONS -----	5- 2
RELATING TO ELECTRIC SYSTEM -----	4- 8	STANDARD TIGHTENING TORQUES	
		FOR BOLTS AND NUTS -----	4- 15
<P>		TORQUE LIST -----	4- 15
PERIODIC REPLACEMENT OF SAFETY		SWITCHES -----	3- 33
CRITICAL PARTS -----	4- 16		

INDEX

<T>

TIPS FOR LONGER UNDERCARRIAGE

LIFE	3-117
TOOL BOX	3- 54
TRANSPORTATION	3-120
LIFTING MACHINE	3-125
LOADING, UNLOADING WORK	3-122
PRECAUTIONS WHEN REMOVING ROPS	3-121
PRECAUTIONS WHEN REMOVING WORK EQUIPMENT	3-121
REMOVING CAB	3-120
TRANSPORTATION MEANS	3-120
TRAVELING ON ROADS	3-127
TROUBLESHOOTING	3-131
AFTER RUNNING OUT OF FUEL	3-131
IF BATTERY IS DISCHARGED	3-133
METHOD OF TOWING MACHINE	3-132
OTHER TROUBLE	3-137

<W>

WEAR PARTS LIST	4- 10
WEAR PARTS LIST	4- 10

D65EX-15E0, D65PX-15E0, D65WX-15E0 BULLDOZER

Form No. TEN00103-06

©2008 KOMATSU
All Rights Reserved
Printed in Japan 02-08
