

# Operation & Maintenance Manual

DUMP TRUCK

**HD325-7**  
**HD405-7**

SERIAL NUMBERS

HD325-7001-7025  
HD325-7101 and up  
HD405-3001-3035  
HD405-7101 and up

**ecot3**

**⚠ WARNING**

Unsafe use of this machine may cause serious injury or death. Operators and maintenance personnel must read this manual before operating or maintaining this machine. This manual should be kept near the machine for reference and periodically reviewed by all personnel who will come into contact with it.

**NOTICE**

Komatsu has Operation & Maintenance Manuals written in some other languages. If a foreign language manual is necessary, contact your local distributor for availability.

**KOMATSU**

# FOREWORD

## **CALIFORNIA**

### **Proposition 65 Warning**

Diesel engine exhaust and some of its constituents are known to the State of California to cause cancer, birth defects, and other reproductive harm.

## **CALIFORNIA**

### **Proposition 65 Warning**

Battery posts, terminals and related accessories contain lead and lead compounds, chemicals known to the State of California to cause cancer and birth defects or other reproductive harm.

**Wash hands after handling.**

## BEFORE READING THIS MANUAL

This manual gives details of the operation and methods of inspection and maintenance for this machine that must be obeyed in order to use the machine safely. Most accidents are caused by the failure to follow fundamental safety rules for the operation and maintenance of machines.

Read, understand and follow all precautions and warnings in this manual and on the machine before performing operation and maintenance. Failure to do so may result in serious injury or death.

Komatsu cannot predict every circumstance that might involve a potential hazard when the machine is used. Therefore, the safety messages in this manual and on the machine may not include all possible safety precautions. If you carry out any operation, inspection, or maintenance under conditions that are not described in this manual, understand that it is your responsibility to take the necessary precautions to ensure safety. In no event should you or others engage in the prohibited uses or actions described in this manual. Improper operation and maintenance of the machine can be hazardous and could result in serious injury or death.

If you sell the machine, be sure to give this manual to the new owner together with the machine.

Always keep this Operation and Maintenance Manual in the location shown on the right so that all relevant personnel can read it at any time.

Storage location for the Operation and Maintenance Manual:

On inside of left door

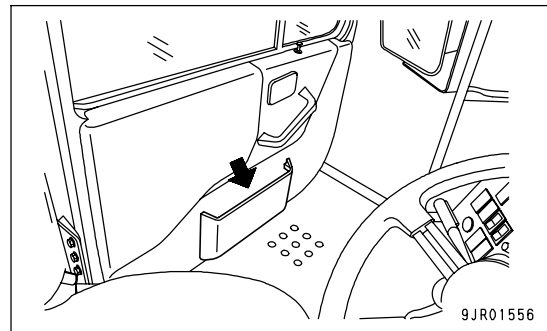

If this manual is lost or damaged, contact your distributor immediately to arrange for its replacement. For details regarding the machine serial No. you will need to provide your Komatsu distributor, see "TABLE TO ENTER SERIAL NO. AND DISTRIBUTOR (PAGE 1-8)".

This manual uses the international units (SI) for units of measurement. For reference, units that have been used in the past are given in ( ).

The explanations, values, and illustrations in this manual have been prepared based on the latest information available as of the date of its publication. Continuing improvements in the design of this machine may lead to additional changes that are not reflected in this manual. Consult Komatsu or your Komatsu distributor for the latest available information concerning your machine or with questions regarding information contained in this manual.

- The numbers in circles in the illustrations correspond to the numbers in ( ) in the text.

(For example: ① → (1))

Komatsu delivers machines that comply with all applicable regulations and standards of the country to which it has been shipped. If this machine has been purchased in another country, it may lack certain safety devices and specifications that are necessary for use in your country. If there is any question about whether your product complies with the applicable standards and regulations of your country, consult Komatsu or your Komatsu distributor before operating the machine.

**EMISSION CONTROL WARRANTY****EMISSION CONTROL WARRANTY STATEMENT (APPLIES TO CANADA ONLY)****1. Products Warranted**

Komatsu America International Company, Komatsu Mining Systems Inc. and Komatsu Utility Corporation (collectively "Komatsu") produce and/or market products under brand names of Komatsu, Dresser, Dressta, Haulpak and Galion. This emissions warranty applies to new engines bearing the Komatsu name installed in these products and used in Canada in machines designed for industrial off-highway use. This warranty applies only to these engines produced on or after January 1, 2000. This warranty will be administered by Komatsu distribution in Canada.

**2. Coverage**

Komatsu warrants to the ultimate purchaser and each subsequent purchaser that the engine is designed, built and equipped so as to conform, at the time of sale by Komatsu, with all U.S. Federal emission regulations applicable at the time of manufacture and that it is free from defects in workmanship or material which would cause it not to meet these regulations within five years or 3,000 hours of operation, whichever occurs first, as measured from the date of delivery of the engine to the ultimate purchaser.

**3. Limitations**

Failures, other than those resulting from defects in materials or workmanship, are not covered by this warranty. Komatsu is not responsible for failures or damage resulting from what Komatsu determines to be abuse or neglect, including, but not limited to: operation without adequate coolant or lubricants; over fueling; over speeding; lack of maintenance of lubricating, cooling or intake systems; improper storage, starting, warm-up, run-in or shutdown practices; unauthorized modifications of the engine. Komatsu is also not responsible for failures caused by incorrect fuel or by water, dirt or other contaminants in the fuel. Komatsu is not responsible for non-engine repairs, "downtime" expense, related damage, fines, all business costs or other losses resulting from a warrantable failure.

**KOMATSU IS NOT RESPONSIBLE FOR INCIDENTAL OR CONSEQUENTIAL DAMAGES.**

This warranty, together with the express commercial warranties, are the sole warranties of Komatsu. **THERE ARE NO OTHER WARRANTIES, EXPRESS OR IMPLIED, OR OF MERCHANTABILITY OR FITNESS FOR A PARTICULAR PURPOSE.**

**GARANTIE SUR LE CONTRÔLE DES ÉMISSIONS****ÉNONCÉ DE GARANTIE SUR LE CONTRÔLE DES ÉMISSIONS (APPLICABLE AU CANADA SEULEMENT):****1. Produits garantis:**

Komatsu America International Company, Komatsu Mining Systems Inc. et Komatsu Utility Corporation (collectivement Komatsu) produisent et/ou font la mise en marché de produits portant les noms de marque Komatsu, Dresser, Dressta, Haulpak et Galion. Cette garantie sur les émissions s'applique à tous les nouveaux moteurs portant le nom Komatsu, installés dans ces produits et utilisés au Canada dans des machines conçues pour utilisation industrielle non-roulière. Cette garantie s'applique seulement sur les moteurs produits à partir du 1er Janvier 2000. Cette garantie sera administrée par la distribution de Komatsu au Canada.

**2. Couverture:**

Komatsu garantit à l'acheteur ultime et chaque acheteur subséquent que le moteur est conçu, construit et équipé en toute conformité, au moment de la vente par Komatsu, avec toutes les Réglementations fédérales américaines sur les émissions applicables au moment de la fabrication et qu'il est exempt de défauts de construction ou de matériaux qui auraient pour effet de contrevenir à ces réglementations en dedans de 5 ans ou 3000 heures d'opération, mesuré à partir de la date de livraison du moteur au client ultime.

**3. Limitations:**

Les bris, autres que ceux résultant de défauts de matériaux ou de construction, ne sont pas couverts par cette Garantie. Komatsu n'est pas responsable pour bris ou dommages résultant de ce que Komatsu détermine comme étant de l'abus ou négligence, incluant mais ne se limitant pas à: l'opération sans lubrifiants ou agent refroidissants adéquats; la suralimentation d'essence; la survitesse; le manque d'entretien des systèmes de lubrification, de refroidissement ou d'entrée; de pratiques non-propices d'entreposage, de mise en marche, de réchauffement, de conditionnement ou d'arrêt; les modifications non-autorisées du moteur. De plus, Komatsu n'est pas responsable de bris causés par de l'essence inadéquate ou de l'eau, des saletés ou autres contaminants dans l'essence. Komatsu n'est pas responsable des réparations non-relées au moteur, des dépenses encourues suite aux temps d'arrêts, des dommages relatifs, amendes, et de tout autre coût d'affaires ou autres pertes résultant d'un bris couvert par la garantie.

**KOMATSU N'EST PAS RESPONSABLE DES INCIDENTS OU DOMMAGES CONSÉQUENTS.**

Cette garantie, ainsi que les garanties expresses commerciales, sont les seules garanties de Komatsu. **IL N'Y A AUCUNE AUTRE GARANTIE, EXPRESSE OU SOUS-ENTENDUE, MARCHANDABLE OU PROPICE A UNE UTILISATION PARTICULIÈRE.**

**NOTE IMPORTANTE CONCERNANT LE MOTEUR**  
 Ce moteur est conforme au normes XXX US EPA et California Tier 3 relatives aux moteurs à compression destinés aux engins ne devant pas circuler sur route. Ce moteur fonctionne à partir de gazole. **AVERTISSEMENT:** Des blessures peuvent résulter de l'usage de ce modèle dans des conditions d'alimentation, de régime et d'altitude excédant celles publiées par le constructeur; dans ces cas, la garantie peut aussi ne plus jouer.

**IMPORTANT ENGINE INFORMATION**

This engine conforms to XXXX U.S. EPA and California Tier3 Regulations for large non-road compression ignition engines. This engine is certified to operate on diesel fuel.  
**WARNING** Injury may result and warranty is voided if fuel rate, RPM or altitudes exceed published maximum values for this model and application

Engine Model	ESN	Displacement	Liters
EPA Cert. Family			
European Approval No.			
Gross rated HP/kW	at rpm	Low Idle RPM	RPM
Firing Order		Fuel rate at rated HP/kW	mm3/st
Timing-TDC	deg. BTDC	Valve lash cold (mm)	IN.O. EX.O.
Engine Code		Date of manufacture	

**KOMATSU** Komatsu Ltd. Made in Japan PT : A3

Komatsu Ltd. Fabriqué au Japon

The diagram includes the following callouts:

- Modèle du moteur** (Engine Model)
- Famille d'agrément EPA** (EPA Cert. Family)
- Numéro d'agrément européen** (European Approval No.)
- Puissance brute HP/kW à tr/mn** (Gross rated HP/kW at rpm)
- Ordre d'allumage** (Firing Order)
- PMH (degré)** (Timing-TDC deg. BTDC)
- Code moteur** (Engine Code)
- Numéro de série du moteur** (ESN)
- Cylindrée litres** (Displacement Liters)
- Ralenti à tr/mn** (Low Idle RPM)
- Consommation à la puissance nominale HP/kW mm3/st** (Fuel rate at rated HP/kW)
- Jeu des soupapes à froid (mm) IN.O. EX.O.** (Valve lash cold (mm) IN.O. EX.O.)
- Date de fabrication** (Date of manufacture)



**ENGINE DATEPLATE - ENGLISH / FRENCH**

## SAFETY INFORMATION

To enable you to use the machine safely, and to prevent injury to operators, service personnel or bystanders, the precautions and warnings included in this manual and the safety signs attached to the machine must always be followed.

To identify important safety messages in the manual and on the machine labels, the following signal words are used.

The "Safety Alert Symbol" identifies important safety messages on machines, in manuals, and elsewhere. When you see this symbol, be alert to the risk of personal injury or death. Follow the instructions in the safety message.

- |  |  |
|--|--|
|  <b>DANGER</b>  | This signal word indicates an imminently hazardous situation which, if not avoided, will result in death or serious injury.        |
|  <b>WARNING</b> | This signal word indicates a potentially hazardous situation which, if not avoided, could result in death or serious injury.       |
|  <b>CAUTION</b> | This signal word indicates a potentially hazardous situation exists which, if not avoided, may result in minor or moderate injury. |

The following signal words are used to alert you to information that must be followed to avoid damage to the machine.

- |                |  |
|----------------|--|
| <b>NOTICE</b>  | This precaution is given where the machine may be damaged or the service life reduced if the precaution is not followed. |
| <b>REMARKS</b> | This word is used for information that is useful to know.  |

## INTENDED USE

### USE OF MACHINE

This Komatsu machine is designed to be used mainly for the following work:

- Traveling with a load

### DIRECTIONS OF MACHINE

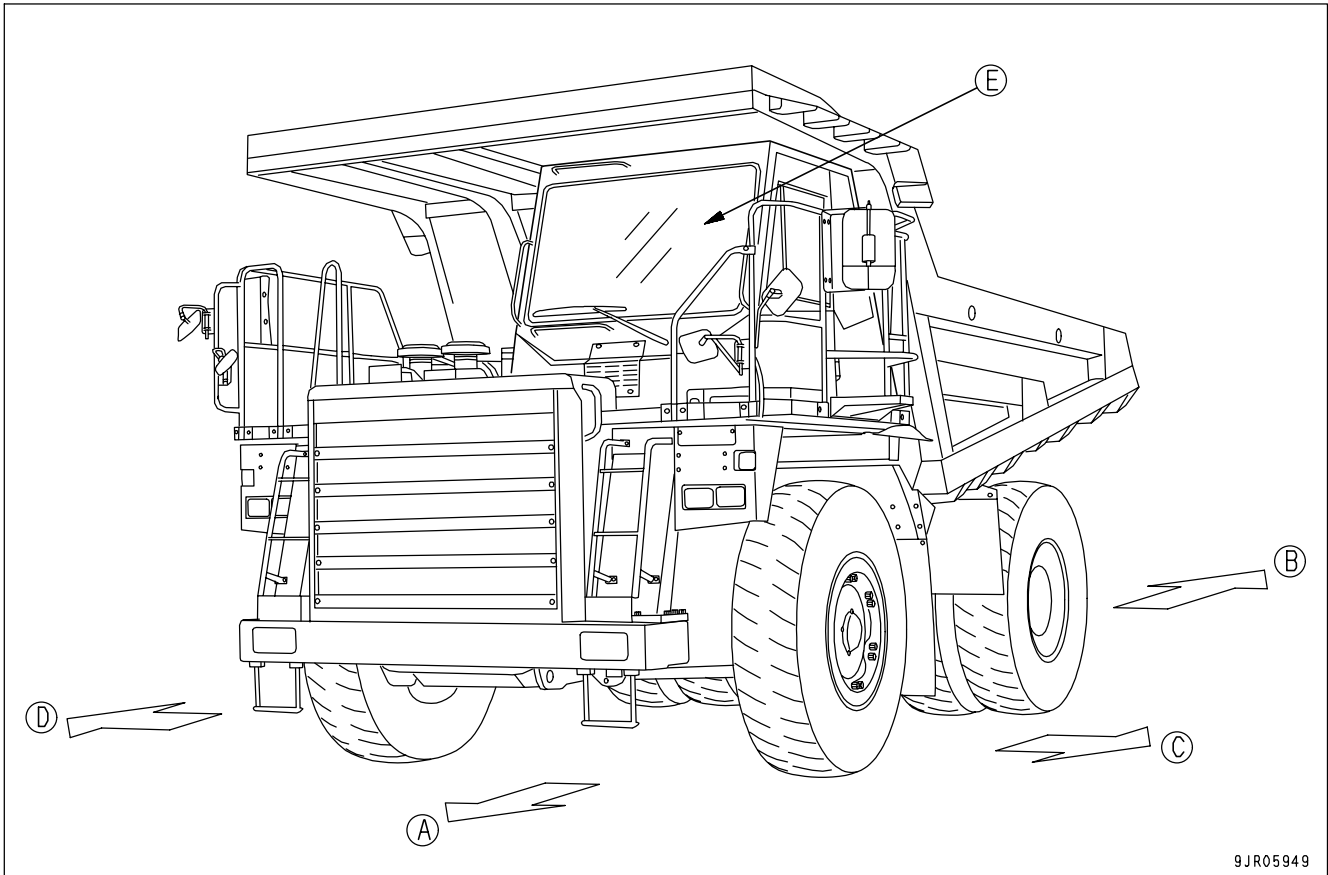

9JR05949

In this manual, the directions of the machine (front, rear, left, right) are determined according to the view from the operator's seat in the direction of travel (front) of the machine.

- (A) FRONT
- (B) REAR
- (C) LEFT

- (D) RIGHT
- (E) OPERATOR'S SEAT

### VISIBILITY FROM OPERATOR'S SEAT

This machine complies with the visibility standard (ISO 5006).

This machine maintains a close visibility of a height of 1.5 m at a point 1 m away from the outside surface of the machine, and a visibility for a circumference of 12 m.

# LOCATION OF PLATES, TABLE TO ENTER SERIAL NO. AND DISTRIBUTOR

When requesting service or ordering replacement parts, please inform your Komatsu distributor of the following items.

## PRODUCT IDENTIFICATION NUMBER (PIN)/MACHINE SERIAL NO. PLATE

It is located on the left front end of the frame.

The design of the nameplate differs according to the territory.

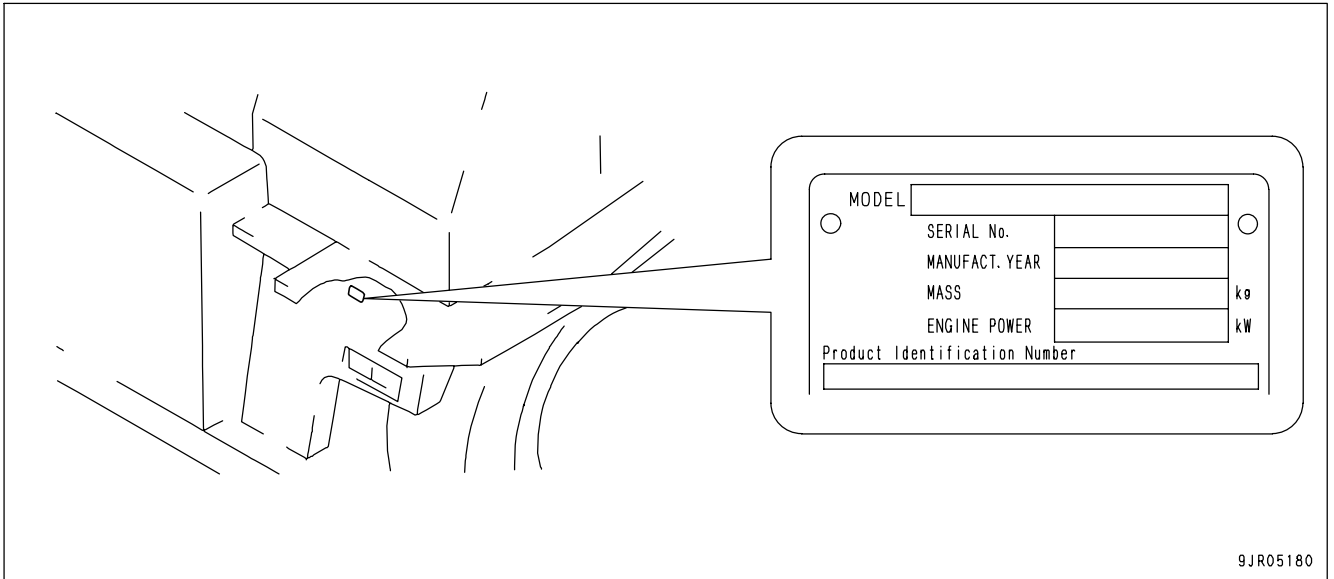

## EPA REGULATIONS, ENGINE NUMBER PLATE

On the top of the engine cylinder head cover.

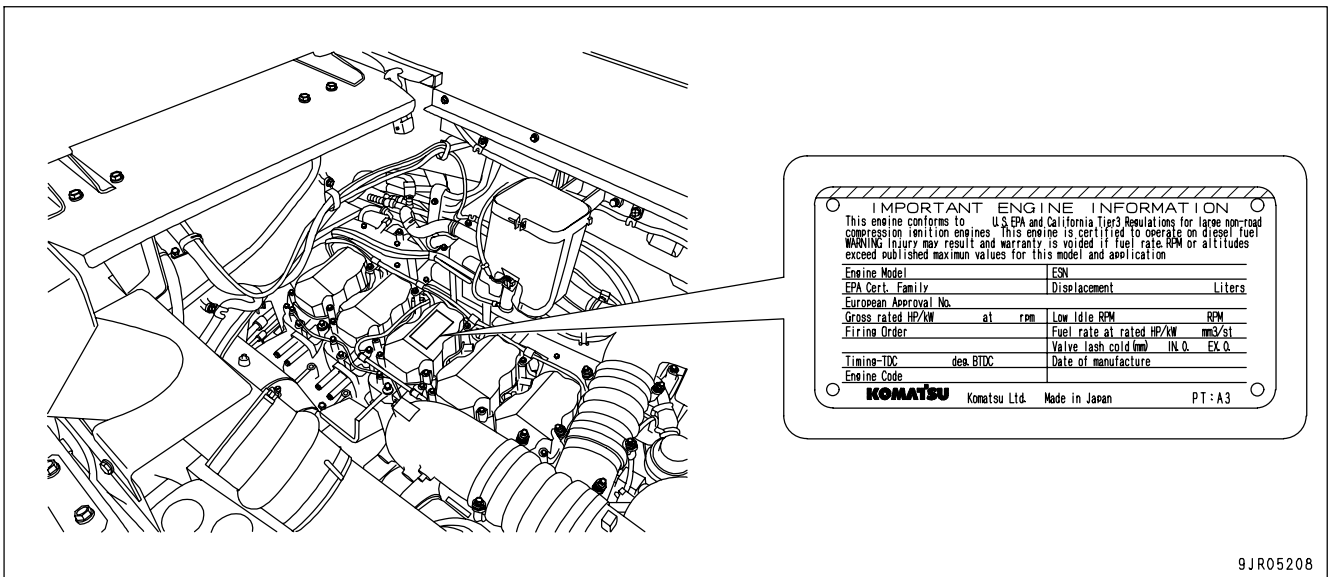

EPA: Environmental Protection Agency, U.S.A.



**SERVICE METER POSITION**

It is at the center bottom of the machine monitor.

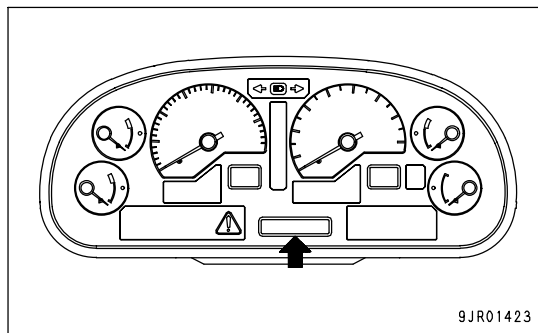

**TABLE TO ENTER SERIAL NO. AND DISTRIBUTOR**

Machine serial No.	
Engine serial No.	
Product identification number (PIN)	
Distributor name	
Address	-----
	-----
	-----
Service Personnel	-----
Phone/Fax	-----

**CONTENTS**

FOREWORD ----- 1- 1

    BEFORE READING THIS MANUAL ----- 1- 2

    SAFETY INFORMATION ----- 1- 5

    INTENDED USE ----- 1- 6

        USE OF MACHINE ----- 1- 6

        DIRECTIONS OF MACHINE ----- 1- 6

        VISIBILITY FROM OPERATOR'S SEAT ----- 1- 6

    LOCATION OF PLATES, TABLE TO ENTER SERIAL NO. AND DISTRIBUTOR ----- 1- 7

        PRODUCT IDENTIFICATION NUMBER (PIN)/MACHINE SERIAL NO. PLATE ----- 1- 7

        EPA REGULATIONS, ENGINE NUMBER PLATE ----- 1- 7

        SERVICE METER POSITION ----- 1- 8

        TABLE TO ENTER SERIAL NO. AND DISTRIBUTOR ----- 1- 8

SAFETY ----- 2- 1

    SAFETY ----- 2- 2

    SAFETY LABELS ----- 2- 5

        POSITION FOR ATTACHING SAFETY LABELS ----- 2- 6

        SAFETY LABELS ----- 2- 7

    GENERAL PRECAUTIONS COMMON TO OPERATION AND MAINTENANCE ----- 2- 12

        PRECAUTIONS BEFORE STARTING OPERATION ----- 2- 12

        PREPARATIONS FOR SAFE OPERATION ----- 2- 12

        FIRE PREVENTION ----- 2- 14

        PRECAUTIONS WHEN GETTING ON OR OFF MACHINE ----- 2- 15

        DO NOT GET CAUGHT IN DUMP BODY ----- 2- 17

        PRECAUTIONS RELATED TO PROTECTIVE STRUCTURES ----- 2- 17

        UNAUTHORIZED MODIFICATION ----- 2- 17

        PRECAUTIONS RELATED TO ATTACHMENTS AND OPTIONS ----- 2- 18

        PRECAUTIONS WHEN RUNNING ENGINE INSIDE BUILDING ----- 2- 18

    PRECAUTIONS FOR OPERATION ----- 2- 19

        PRECAUTIONS FOR JOBSITE ----- 2- 19

        STARTING ENGINE ----- 2- 21

        OPERATION ----- 2- 23

        TRANSPORTATION ----- 2- 27

        TOWING ----- 2- 28

    PRECAUTIONS FOR MAINTENANCE ----- 2- 29

        PRECAUTIONS BEFORE STARTING INSPECTION AND MAINTENANCE ----- 2- 29

        PRECAUTIONS FOR INSPECTION AND MAINTENANCE ----- 2- 33

        TIRES ----- 2- 38

OPERATION ----- 3- 1

    GENERAL VIEW ----- 3- 2

        GENERAL VIEW OF MACHINE ----- 3- 2

        GENERAL VIEW OF CONTROLS AND GAUGES ----- 3- 3

    EXPLANATION OF COMPONENTS ----- 3- 5

        MACHINE MONITOR ----- 3- 5

        OTHER FUNCTIONS OF MACHINE MONITOR ----- 3- 26

        SWITCHES ----- 3- 30

        CONTROL LEVERS AND PEDALS ----- 3- 39

        BODY PIVOT PIN ----- 3- 44

        LOCATION OF FIRE EXTINGUISHER ----- 3- 44

        DUST INDICATOR ----- 3- 45

FUSES .....	3- 46
CAR RADIO .....	3- 49
CAR STEREO .....	3- 55
AIR CONDITIONER .....	3- 64
OPERATION .....	3- 69
CHECK BEFORE STARTING ENGINE .....	3- 69
STARTING ENGINE .....	3- 88
OPERATIONS, CHECKS AFTER STARTING ENGINE .....	3- 90
STOPPING ENGINE .....	3- 91
CHECKS AFTER STOPPING ENGINE .....	3- 91
MOVING MACHINE OFF (FORWARD, REVERSE), STOPPING .....	3- 92
SHIFTING GEAR .....	3- 97
TRAVELING DOWNHILL .....	3- 99
STEERING THE MACHINE .....	3-108
LOADING OPERATIONS .....	3-108
DUMP OPERATIONS .....	3-109
PRECAUTIONS FOR OPERATION .....	3-110
PARKING MACHINE .....	3-111
CHECKS AFTER COMPLETION OF WORK .....	3-112
LOCKING .....	3-112
HANDLING TIRES .....	3-113
DETERMINING AND MAINTAINING TRAVEL ROAD .....	3-116
DETERMINING TRAVEL ROAD .....	3-116
MAINTAINING TRAVEL ROAD .....	3-116
TRANSPORTATION .....	3-117
PRECAUTIONS WHEN TRANSPORTING .....	3-117
STEPS FOR TRANSPORTATION .....	3-117
METHOD OF SECURING MACHINE .....	3-117
METHOD OF LIFTING MACHINE .....	3-118
COLD WEATHER OPERATION .....	3-121
PRECAUTIONS FOR LOW TEMPERATURE .....	3-121
PRECAUTIONS AFTER COMPLETION OF WORK .....	3-122
AFTER COLD WEATHER .....	3-123
LONG-TERM STORAGE .....	3-124
BEFORE STORAGE .....	3-124
DURING STORAGE .....	3-124
AFTER STORAGE .....	3-124
PRECAUTIONS BEFORE TRAVELING AFTER LONG-TERM STORAGE .....	3-124
TROUBLESHOOTING .....	3-125
AFTER RUNNING OUT OF FUEL .....	3-125
IF TRANSMISSION HAS TROUBLE .....	3-126
METHOD OF LOWERING DUMP BODY IN EMERGENCY .....	3-127
METHOD OF TOWING MACHINE .....	3-129
IF BATTERY IS DISCHARGED .....	3-133
OTHER TROUBLE .....	3-136
MAINTENANCE .....	4- 1
GUIDES TO MAINTENANCE .....	4- 2
OUTLINE OF SERVICE .....	4- 5
HANDLING OIL, FUEL, COOLANT, AND PERFORMING OIL CLINIC .....	4- 5
OUTLINE OF ELECTRIC SYSTEM .....	4- 9

WEAR PARTS .....	4- 10
WEAR PARTS LIST .....	4- 10
RECOMMENDED FUEL, COOLANT, AND LUBRICANT .....	4- 11
USE OF FUEL, COOLANT AND LUBRICANTS ACCORDING TO AMBIENT TEMPERATURE .....	4- 12
RECOMMENDED BRANDS, RECOMMENDED QUALITY FOR PRODUCTS OTHER THAN KOMATSU GENUINE OIL .....	4- 13
STANDARD TIGHTENING TORQUES FOR BOLTS AND NUTS .....	4- 14
TORQUE LIST .....	4- 14
PERIODIC REPLACEMENT OF SAFETY CRITICAL PARTS .....	4- 15
SAFETY CRITICAL PARTS .....	4- 16
MAINTENANCE SCHEDULE CHART .....	4- 17
MAINTENANCE SCHEDULE CHART .....	4- 17
SERVICE PROCEDURE .....	4- 20
INITIAL 250 HOURS SERVICE (ONLY AFTER THE FIRST 250 HOURS) .....	4- 20
WHEN REQUIRED .....	4- 21
CHECK BEFORE STARTING .....	4- 42
EVERY 250 HOURS SERVICE .....	4- 43
EVERY 500 HOURS SERVICE .....	4- 55
EVERY 1000 HOURS SERVICE .....	4- 61
EVERY 2000 HOURS SERVICE .....	4- 73
EVERY 4000 HOURS SERVICE .....	4- 77
EVERY 8000 HOURS SERVICE .....	4- 80
EVERY 15000 HOURS SERVICE .....	4- 81
SPECIFICATIONS .....	5- 1
SPECIFICATIONS .....	5- 2
ATTACHMENTS, OPTIONS .....	6- 1
SELECTING DUMP BODY .....	6- 2
HANDLING AIR SUSPENSION SEAT .....	6- 3
SEAT ADJUSTMENT .....	6- 3
REMOVAL AND INSTALLATION OF HEADREST .....	6- 5
HANDLING AUTOMATIC SPIN REGULATOR (ASR) .....	6- 6
EXPLANATION OF COMPONENTS .....	6- 6
ACTUATION OF ASR SYSTEM .....	6- 7
PRECAUTIONS WHEN USING .....	6- 7
BLEEDING AIR FROM ASR CIRCUIT .....	6- 8
HANDLING ABS .....	6- 9
EXPLANATION OF COMPONENTS .....	6- 9
ABS SYSTEM CHECK AFTER STARTING ENGINE .....	6- 11
OPERATION OF ABS .....	6- 11
PRECAUTIONS WHEN USING .....	6- 12
HANDLING PAYLOAD METER II (CARD TYPE) .....	6- 13
METHOD OF USING ACCURATELY .....	6- 14
GENERAL LOCATIONS .....	6- 15
CONTENT OF DISPLAY (CONTROLLER, EXTERNAL DISPLAY LAMPS) .....	6- 20
EXTERNAL DISPLAY LAMPS .....	6- 24
DETAILS OF DATA STORED IN MEMORY OF PAYLOAD METER .....	6- 26
OPERATION OF SWITCHES .....	6- 31
PROBLEM AND WARNING DISPLAY (ERROR CODE) .....	6- 53
WHEN ERROR CODE F-09 IS DISPLAYED (PROCEDURE FOR REPLACING BATTERY) .....	6- 60

---

OPERATION WHEN ERROR CODE F.CAL IS DISPLAYED OR CONTROLLER HAS BEEN REPLACED .....	6- 63
ARSC (AUTOMATIC RETARDER SPEED CONTROL) .....	6- 66
EXPLANATION OF COMPONENTS .....	6- 67
METHOD OF OPERATION .....	6- 70
USE OF REAR VIEW MONITOR .....	6- 73
NAME AND FUNCTION OF EACH PART OF REAR VIEW MONITOR .....	6- 73
SETTING OF REAR VIEW MONITOR .....	6- 76
CAUTIONS WHEN USING REAR VIEW MONITOR .....	6- 76
HANDLING DUMPING COUNTER .....	6- 77
HANDLING MACHINES EQUIPPED WITH KOMTRAX .....	6- 78
BASIC PRECAUTIONS .....	6- 78
INDEX .....	7- 1

# SAFETY

## **WARNING**

Please read and make sure that you fully understand the precautions described in this manual and the safety labels on the machine. When operating or servicing the machine, always follow these precautions strictly.

---

## SAFETY

SAFETY LABELS .....	2- 5
POSITION FOR ATTACHING SAFETY LABELS .....	2- 6
SAFETY LABELS .....	2- 7
GENERAL PRECAUTIONS COMMON TO OPERATION AND MAINTENANCE .....	2- 12
PRECAUTIONS BEFORE STARTING OPERATION .....	2- 12
ENSURING SAFE OPERATION .....	2- 12
UNDERSTANDING THE MACHINE .....	2- 12
PREPARATIONS FOR SAFE OPERATION .....	2- 12
PRECAUTIONS REGARDING SAFETY-RELATED EQUIPMENT .....	2- 12
INSPECTING MACHINE .....	2- 12
WEAR WELL-FITTING CLOTHES AND PROTECTIVE EQUIPMENT .....	2- 12
KEEP MACHINE CLEAN .....	2- 13
PRECAUTIONS INSIDE OPERATOR'S COMPARTMENT .....	2- 13
PROVIDE FIRE EXTINGUISHER AND FIRST AID KIT .....	2- 13
IF ANY PROBLEM IS FOUND .....	2- 13
FIRE PREVENTION .....	2- 14
ACTION IF FIRE OCCURS .....	2- 14
PRECAUTIONS TO PREVENT FIRE .....	2- 14
PRECAUTIONS WHEN GETTING ON OR OFF MACHINE .....	2- 15
USE HANDRAILS AND STEPS WHEN GETTING ON OR OFF MACHINE .....	2- 15
NO JUMPING ON OR OFF MACHINE .....	2- 15
NO PEOPLE ON DUMP BODY .....	2- 15
PRECAUTIONS WHEN STANDING UP FROM OPERATOR'S SEAT .....	2- 16
PRECAUTIONS WHEN LEAVING MACHINE .....	2- 16
EMERGENCY EXIT FROM OPERATOR'S CAB .....	2- 16
DO NOT GET CAUGHT IN DUMP BODY .....	2- 17
PRECAUTIONS RELATED TO PROTECTIVE STRUCTURES .....	2- 17
UNAUTHORIZED MODIFICATION .....	2- 17
PRECAUTIONS RELATED TO ATTACHMENTS AND OPTIONS .....	2- 18
PRECAUTIONS WHEN RUNNING ENGINE INSIDE BUILDING .....	2- 18

PRECAUTIONS FOR OPERATION .....	2- 19
PRECAUTIONS FOR JOBSITE .....	2- 19
INVESTIGATE AND CONFIRM JOBSITE CONDITIONS .....	2- 19
WORKING ON LOOSE GROUND .....	2- 19
DO NOT GO CLOSE TO HIGH-VOLTAGE CABLES .....	2- 19
ENSURE GOOD VISIBILITY .....	2- 20
CHECKING SIGNS AND SIGNALMAN'S SIGNALS .....	2- 20
BEWARE OF ASBESTOS DUST .....	2- 20
STARTING ENGINE .....	2- 21
USE WARNING TAGS .....	2- 21
CHECKS BEFORE STARTING ENGINE .....	2- 21
PRECAUTIONS WHEN STARTING ENGINE .....	2- 22
PRECAUTIONS IN COLD AREAS .....	2- 22
STARTING WITH BOOSTER CABLES .....	2- 22
OPERATION .....	2- 23
CHECKS BEFORE OPERATION .....	2- 23
PRECAUTIONS WHEN TRAVELING IN FORWARD OR REVERSE .....	2- 23
PRECAUTIONS WHEN TRAVELING .....	2- 24
TRAVELING ON SLOPES .....	2- 24
PRECAUTIONS WHEN OPERATING .....	2- 24
PRECAUTIONS WHEN LOADING DUMP BODY .....	2- 25
PRECAUTIONS WHEN OPERATING DUMP BODY .....	2- 25
TRAVELING ON SNOW-COVERED OR FROZEN SURFACES .....	2- 25
PARKING MACHINE .....	2- 26
TRANSPORTATION .....	2- 27
LOADING AND UNLOADING .....	2- 27
TOWING .....	2- 28
WHEN TOWING .....	2- 28



PRECAUTIONS FOR MAINTENANCE .....	2- 29
PRECAUTIONS BEFORE STARTING INSPECTION AND MAINTENANCE .....	2- 29
DISPLAY WARNING TAG DURING INSPECTION AND MAINTENANCE .....	2- 29
KEEP WORKPLACE CLEAN AND TIDY .....	2- 29
SELECT SUITABLE PLACE FOR INSPECTION AND MAINTENANCE .....	2- 29
ONLY AUTHORIZED PERSONNEL .....	2- 29
APPOINT LEADER WHEN WORKING WITH OTHERS .....	2- 29
STOP ENGINE BEFORE CARRYING OUT INSPECTION AND MAINTENANCE .....	2- 30
TWO WORKERS FOR MAINTENANCE WHEN ENGINE IS RUNNING .....	2- 31
INSTALLING, REMOVING, OR STORING ATTACHMENTS .....	2- 32
PRECAUTIONS WHEN WORKING AT HIGH PLACES .....	2- 32
PRECAUTIONS WHEN WORKING UNDER MACHINE .....	2- 32
PROPER TOOLS .....	2- 32
PRECAUTIONS FOR INSPECTION AND MAINTENANCE .....	2- 33
PRECAUTIONS WHEN WELDING .....	2- 33
HANDLING BATTERY .....	2- 33
PRECAUTIONS WHEN USING HAMMER .....	2- 34
PRECAUTIONS WITH HIGH-TEMPERATURE COOLANT .....	2- 34
PRECAUTIONS WITH HIGH-TEMPERATURE OIL .....	2- 34
PRECAUTIONS WITH HIGH-PRESSURE OIL .....	2- 35
PRECAUTIONS WITH HIGH-PRESSURE FUEL .....	2- 35
HANDLING HIGH-PRESSURE HOSES AND PIPING .....	2- 35
NOISE .....	2- 35
HANDLING SUSPENSION CYLINDER, ACCUMULATOR, GAS SPRING .....	2- 36
PRECAUTIONS WITH COMPRESSED AIR .....	2- 36
MAINTENANCE OF AIR CONDITIONER .....	2- 36
DISPOSING OF WASTE MATERIALS .....	2- 36
METHOD OF SELECTING WINDOW WASHER FLUID .....	2- 36
PERIODIC REPLACEMENT OF SAFETY CRITICAL PARTS .....	2- 37
TIRES .....	2- 38
HANDLING TIRES .....	2- 38
PRECAUTIONS WHEN STORING TIRES .....	2- 39

## SAFETY LABELS

The following warning signs and safety labels are used on this machine.

- Be sure that you fully understand the correct position and content of labels.
- To ensure that the content of labels can be read properly, be sure that they are in the correct place and always keep them clean. When cleaning them, do not use organic solvents or gasoline. These may cause the labels to peel off.
- There are also other labels in addition to the warning signs and safety labels. Handle those labels in the same way.
- If the labels are damaged, lost, or cannot be read properly, replace them with new ones. For details of the part numbers for the labels, see this manual or the actual label, and place an order with Komatsu distributor.

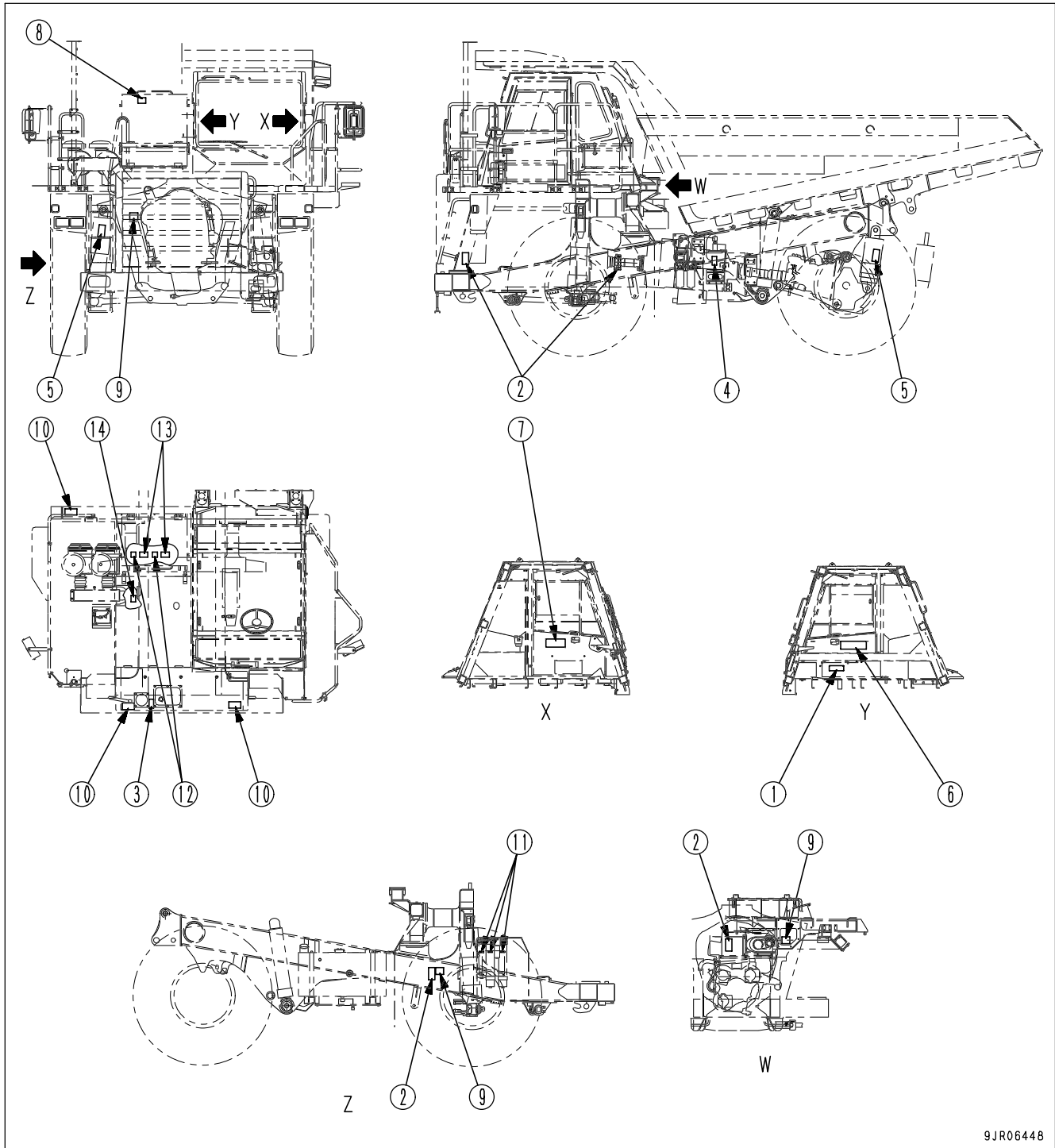

9JR06448

## SAFETY LABELS

## (1) Precaution about modifying ROPS (09620-B2000)

ROPS CERTIFICATION			
This protective structure complies with the standard provided that it is properly equipped on the machine which mass is less than the specified maximum mass.			
ROPS: ISO 5071-1994, SAE: J1043-1994		ROPS: ISO 3449-1997	
MODEL	_____	MACHINE MODEL	_____
SERIAL No.	_____	MAX. MASS	_____ kg (lb)
<b>WARNING</b>		<ul style="list-style-type: none"> <li>• If some modification is applied to the ROPS, it might not enough strength and might not be complied with the standard. Consult Komatsu Distributor before altering.</li> <li>• ROPS may provide less protection if it has been structurally damaged or involved roll-over. Consult Komatsu Distributor in that case.</li> <li>• Always wear seat belt when moving.</li> </ul>	
Komatsu Ltd. 2-3-6 Akasaka, Minato-ku, Tokyo, Japan 09620-50100			

## (2) Caution for rotation of engine fan, fan belt (09667-23001)

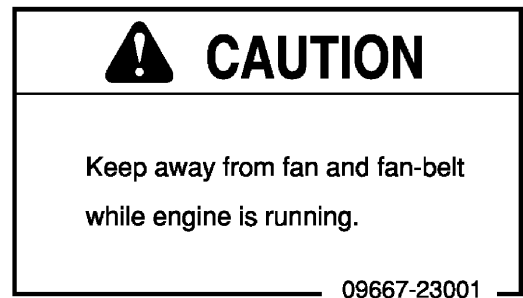

## (3) Caution for opening radiator cap (09668-03001)



## (4) Caution for opening hydraulic tank cap (09653-03001)



## (5) Warning for handling suspension (09659-33000)

**⚠ WARNING**

Explosion hazard.

Suspension cylinder is charged with high-pressure nitrogen gas.

To prevent SEVERE INJURY or DEATH, handle with care:



- Do not hit
- Keep away from flame
- Do not weld or drill cylinder
- Do not remove and disassemble

Filling and discharging of gas in this cylinder must only be done by trained Komatsu service personnel.

09659-33000

## (6) Warnings for electric wire

Warnings for crush hazard when inspection and maintenance  
(56B-93-12181)

<p style="text-align: center;"><b>⚠ DANGER</b></p>  <p><b>HAZARDOUS VOLTAGE HAZARD.</b> SERIOUS INJURY OR DEATH CAN OCCUR IF MACHINE OR ATTACHMENTS ARE NOT KEPT SAFE DISTANCE AWAY FROM ELECTRIC LINES.</p> <table border="1" style="width: 100%; border-collapse: collapse;"> <thead> <tr> <th>VOLTAGE</th> <th>SAFE DISTANCE</th> </tr> </thead> <tbody> <tr> <td>LOW VOLTAGE</td> <td></td> </tr> <tr> <td>100 V 200 V</td> <td>2 m</td> </tr> <tr> <td>6 600 V</td> <td>2 m</td> </tr> <tr> <td>22 000 V</td> <td>3 m</td> </tr> <tr> <td>66 000 V</td> <td>4 m</td> </tr> <tr> <td>SPECIAL HIGH VOLTAGE</td> <td></td> </tr> <tr> <td>187 000 V</td> <td>6 m</td> </tr> <tr> <td>226 000 V</td> <td>7 m</td> </tr> <tr> <td>500 000 V</td> <td>11 m</td> </tr> </tbody> </table>	VOLTAGE	SAFE DISTANCE	LOW VOLTAGE		100 V 200 V	2 m	6 600 V	2 m	22 000 V	3 m	66 000 V	4 m	SPECIAL HIGH VOLTAGE		187 000 V	6 m	226 000 V	7 m	500 000 V	11 m	<p style="text-align: center;"><b>⚠ DANGER</b></p> <p><b>CRUSH HAZARD</b> TO HOLD THE DUMP BODY IN A SAFE RAISED POSITION, ALWAYS DO THE FOLLOWING:</p> <ul style="list-style-type: none"> <li>• MOVE HOIST CONTROL LEVER TO "HOLD" AND SAFETY "LOCK" TO LOCK.</li> <li>• LOCK DUMP BODY WITH SAFETY PIN.</li> <li>• PLACE BLOCK BETWEEN FRAME AND BODY.</li> </ul> <p>SEE MANUAL FOR MORE COMPLETE INSTRUCTIONS. FAILURE TO FOLLOW THESE INSTRUCTIONS COULD RESULT IN SEVERE INJURY OR DEATH.</p> <div style="text-align: center;">  <p>SAFETY BLOCK      SAFETY PIN</p> </div>	<p style="text-align: center;"><b>NOTICE</b></p> <p><b>1 EMERGENCY STEERING SYSTEM (DAILY CHECK)</b> CHECK THE FUNCTION WITH THE ENGINE STOP ON FLAT GROUND.</p> <ol style="list-style-type: none"> <li>1. TURN THE STARTING SWITCH TO THE "ON" POSITION.</li> <li>2. APPLY THE EMERGENCY STEERING SWITCH TO THE "ON" POSITION AND CHECK THE STEERING WHEEL CAN BE OPERATED.</li> <li>3. TURN THE EMERGENCY STEERING SWITCH TO "OFF" POSITION.</li> <li>4. RELEASE THE PARKING BRAKE. THE SYSTEM WILL ACTIVATE WITHIN 1 SECOND.</li> <li>5. APPLY THE PARKING BRAKE.</li> </ol> <p><b>2 BRAKE SYSTEM (DAILY CHECK)</b> CHECK THE FUNCTION ON FLAT GROUND. REFER TO "OPERATION &amp; MAINTENANCE MANUAL" FOR PROPER DIRECTIONS.</p> <p>DO NOT USE RETARDER BRAKE FOR PARKING.</p>	<p style="text-align: center;"><b>NOTICE</b></p> <p>WHEN LEAVING OPERATOR SEAT</p> <ol style="list-style-type: none"> <li>1. LOWER DUMP BODY.</li> <li>2. PARK THE MACHINE ON LEVEL GROUND.</li> <li>3. STOP ENGINE AND APPLY PARKING BRAKE COMPLETELY.</li> </ol> <p>BLOCK WHEELS SECURELY BEFORE LEAVING MACHINE. IDLE ENGINE FOR 5 MINUTES BEFORE SHUTTING IT DOWN.</p> <hr/> <p style="text-align: center;"><b>⚠ WARNING</b></p> <p>IF THE RETARDER OIL TEMPERATURE CAUTION LAMP LIGHTS UP, STOP MACHINE IMMEDIATELY. OR THE BRAKES WILL FAIL. SET THE SHIFT LEVER TO THE "N" POSITION, RUN THE ENGINE UNDER NO LOAD AT A MID-RANGE SPEED, AND WAIT FOR THE LAMP TO GO OUT.</p> <p style="text-align: right; font-size: small;">56B-93-12181</p>
VOLTAGE	SAFE DISTANCE																						
LOW VOLTAGE																							
100 V 200 V	2 m																						
6 600 V	2 m																						
22 000 V	3 m																						
66 000 V	4 m																						
SPECIAL HIGH VOLTAGE																							
187 000 V	6 m																						
226 000 V	7 m																						
500 000 V	11 m																						

- If the machine comes too close to electric cables, there is danger of electrocution.  
Always keep a safe distance from electric cables.
- There is danger that the dump body may come down.  
Before carrying out inspection or maintenance with the dump body raised, always read the Operation and Maintenance Manual and take the correct action.

(7) Caution before starting  
 Caution when traveling in reverse  
 (569-93-81730)

<p><b>⚠ WARNING</b></p> <p>IMPROPER OPERATION AND MAINTENANCE CAN CAUSE SERIOUS INJURY OR DEATH.</p> <p>READ MANUAL AND LABELS BEFORE OPERATION AND MAINTENANCE.          FOLLOW INSTRUCTIONS AND WARNINGS IN MANUAL AND IN LABELS ON MACHINE.</p> <p>KEEP MANUAL IN MACHINE CAB NEAR OPERATOR.          CONTACT KOMATSU DISTRIBUTOR FOR A REPLACEMENT MANUAL.</p>	<p><b>⚠ WARNING</b></p>  <p>TO PREVENT SEVERE INJURY OR DEATH, DO THE FOLLOWING BEFORE MOVING MACHINE OR ITS DUMP BODY:</p> <ul style="list-style-type: none"> <li>• HONK HORN TO ALERT PEOPLE NEARBY.</li> <li>• BE SURE NO ONE IS ON OR NEAR MACHINE.</li> <li>• USE SPOTTER IF VIEW IS OBSTRUCTED.</li> </ul> <p>FOLLOW ABOVE EVEN IF MACHINE IS EQUIPPED WITH BACK-UP ALARM AND MIRRORS.</p>	<p><b>NOTICE</b></p> <p>BE SURE TO LOWER DUMP BODY AND KEEP HOIST CONTROL LEVER AT THE FLOAT POSITION DURING TRAVEL.</p>  <p>569-93-81730</p>
--	---	--

(8) Caution when handling battery cable (09808-03000)



**⚠ WARNING**

Improper use of booster cables and battery cables can cause an explosion resulting in serious injury or death.

- Follow instructions in manual when using booster cable and battery cables.

09808-03000

(9) Exhaust pipe is hot! (09817-A1103)

	
09817-A1103	

Sign indicates a burn hazard from touching heated parts, such as engine, motor, or muffler during or right after operation.

Never touch when hot.

(10) Caution for avoiding falling down (09805-13000)



(11) Precautions for handling accumulator (09659-53000)

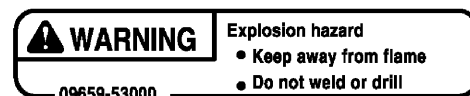

(12) Caution when handling battery (09664-30011)  
 (For North America only)

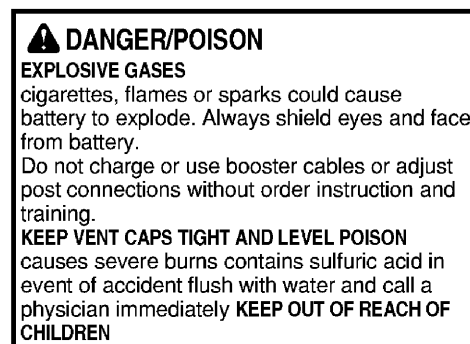

Distr. By  
 KOMATSU AMERICA CORP.  
 :Rolling Meadows IL60008, USA  
 KOMATSU LATIN AMERICA CORP.  
 :Miami, FL 33126, USA

(13) Caution when handling battery  
 This safety label is provided by the battery manufacturer.



(14) Jump start prohibited (09842-A0481)

This safety label is fixed to the engine starting motor.



Start the engine only after sitting down in the operator's seat.

Do not attempt to start the engine by short-circuiting the engine starting circuit. Such an act may cause a serious bodily injury or fire.



## GENERAL PRECAUTIONS COMMON TO OPERATION AND MAINTENANCE

Mistakes in operation, inspection, or maintenance may result in serious personal injury or death. Before carrying out operation, inspection, or maintenance, always read this manual and the safety labels on the machine carefully and obey the warnings.

### PRECAUTIONS BEFORE STARTING OPERATION

#### ENSURING SAFE OPERATION

- Only trained and authorized personnel can operate and maintain the machine.
- Follow all safety, precautions, and instructions in this manual when operating or performing inspection or maintenance on the machine.
- If you are not feeling well, or if you are under the influence of alcohol or medication, your ability to safely operate or repair your machine may be severely impaired, putting yourself and everyone else on your job site in danger.
- When working with another operator or with the person on the worksite traffic duty, discuss the content of the operation beforehand and use the determined signals when carrying out the operation.

#### UNDERSTANDING THE MACHINE

Before operating the machine, read this manual thoroughly. If there are any places in this manual that you do not understand, ask the person in charge of safety to give an explanation.

### PREPARATIONS FOR SAFE OPERATION

#### PRECAUTIONS REGARDING SAFETY-RELATED EQUIPMENT

- Be sure that all guards, covers and mirrors are in their proper position. Have guards and covers repaired immediately if they are damaged.
- Understand the method of use of safety features and use them properly.
- Never remove any safety features. Always keep them in good operating condition.

#### INSPECTING MACHINE

Check the machine before starting operations. If any abnormality is found, do not operate the machine until repairs of the problem location have been completed.

#### WEAR WELL-FITTING CLOTHES AND PROTECTIVE EQUIPMENT

- Do not wear loose clothes or any accessories. If these catch on the control levers or protruding parts, there is danger that it may cause the machine to move unexpectedly.
- Always wear a hard hat and safety shoes. If the nature of the work requires it, wear safety glasses, mask, gloves, ear plugs, and safety belt when operating or maintaining the machine.
- If you have long hair and it hangs out from your hard hat, there is a hazard that it may get caught up in the machine, so tie your hair up and be careful not to let it get caught.
- Check that all protective equipment functions properly before using it.

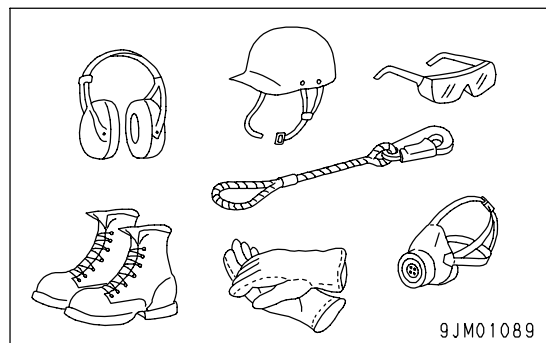

**KEEP MACHINE CLEAN**

- If you get on or off the machine or carry out inspection and maintenance when the machine is dirty with mud or oil, there is a hazard that you will slip and fall. Wipe off any mud or oil from the machine. Always keep the machine clean.
- If water gets into the electrical system, there is a hazard that it will cause malfunctions or misoperation. If there is any misoperation, there is danger that the machine may move unexpectedly and cause serious personal injury or death. When washing the machine with water or steam, do not allow the water or steam to come into direct contact with electrical components.

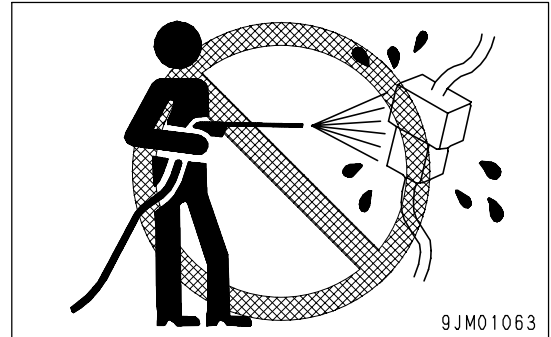
**PRECAUTIONS INSIDE OPERATOR'S COMPARTMENT**

- When entering the operator's compartment, always remove all mud and oil from the soles of your shoes. If you operate the pedal with mud or oil affixed to your shoes, your foot may slip and this may cause a serious accident.
- Do not leave tools or a machine parts lying around inside the operator's compartment. If tools or parts get into the control devices, it may obstruct operation and cause the machine to move unexpectedly, resulting in serious personal injury or death.
- Do not stick suction pads to the window glass. Suction pads act as a lens and may cause fire.
- Do not use a cell phone when driving or operating the machine. This may lead to mistakes in operation, which could cause serious personal injury or death.
- Never bring any dangerous objects such as flammable or explosive items into the operator's compartment.

**PROVIDE FIRE EXTINGUISHER AND FIRST AID KIT**

Always follow the precautions below to prepare for action if any injury or fire should occur.

- Be sure that fire extinguishers have been provided and read the labels to ensure that you know how to use them in emergencies.
- Carry out periodic inspection and maintenance to ensure that the fire extinguisher can always be used.
- Provide a first aid kit in the storage point. Carry out periodic checks and add to the contents if necessary.

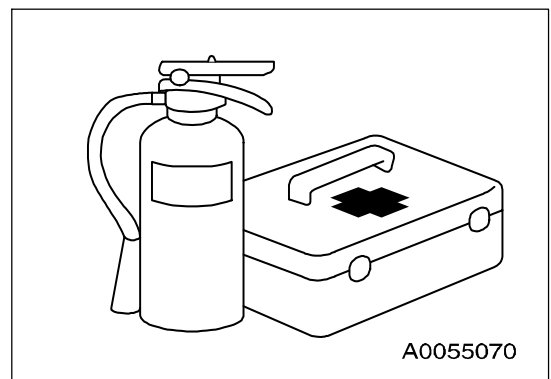
**IF ANY PROBLEM IS FOUND**

If you find any problems in the machine during operation or maintenance (noise, vibration, smell, incorrect gauges, smoke, oil leakage, etc., or any abnormal display on the warning devices or monitor), report to the person in charge and have the necessary action taken. Do not operate the machine until the problem has been corrected.

## FIRE PREVENTION

### ACTION IF FIRE OCCURS

- Turn the start switch OFF to stop the engine.
- Use the handrails and steps to get off the machine.
- Do not jump off the machine. There is the danger of falling and suffering serious injury.

### PRECAUTIONS TO PREVENT FIRE

#### • Fire caused by fuel, oil, antifreeze, or window washer fluid

Do not bring any flame or fire close to flammable substances such as fuel, oil, antifreeze, or window washer fluid. There is danger that they may catch fire. To prevent fire, always observe the following:

- Do not smoke or use any flame near fuel or other flammable substances.
- Stop the engine before adding fuel.
- Do not leave the machine when adding fuel or oil.
- Tighten all fuel and oil caps securely.
- Be careful not to spill fuel on overheated surfaces or on parts of the electrical system.
- After adding fuel or oil, wipe up any spilled fuel or oil.
- Put greasy rags and other flammable materials into a safe container to maintain safety at the workplace.
- When washing parts with oil, use a non-flammable oil. Do not use diesel oil or gasoline. There is danger that they may catch fire.
- Do not weld or use a cutting torch to cut any pipes or tubes that contain flammable liquids.
- Determine well-ventilated areas for storing oil and fuel. Keep the oil and fuel in the determined place and do not allow unauthorized persons to enter.
- When carrying out grinding or welding work on the machine, move any flammable materials to a safe place before starting.

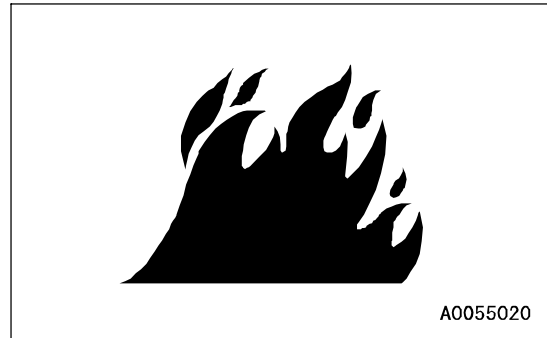

#### • Fire caused by accumulation of flammable material.

Remove any dry leaves, chips, pieces of paper, coal dust, or any other flammable materials accumulated or affixed around the engine, exhaust manifold, muffler, or battery, or inside the undercovers.

#### • Fire coming from electric wiring

Short circuits in the electrical system can cause fire. To prevent fire, always observe the following.

- Keep all electric wiring connections clean and securely tightened.
- Check the wiring every day for looseness or damage. Tighten any loose connectors or wiring clamps. Repair or replace any damaged wiring.

#### • Fire coming from piping

Check that all the hose and tube clamps, guards, and cushions are securely fixed in position.

If they are loose, they may vibrate during operation and rub against other parts. There is danger that this may lead to damage to the hoses and cause high-pressure oil to spurt out, leading to fire, serious personal injury or death.

- **Explosion caused by lighting equipment**
  - When checking fuel, oil, battery electrolyte, or coolant, always use lighting with anti-explosion specifications.

## PRECAUTIONS WHEN GETTING ON OR OFF MACHINE

### USE HANDRAILS AND STEPS WHEN GETTING ON OR OFF MACHINE

To prevent personal injury caused by slipping or falling off the machine, always do as follows.

- Use the handrails and steps marked by arrows in the diagram on the right when getting on or off the machine.

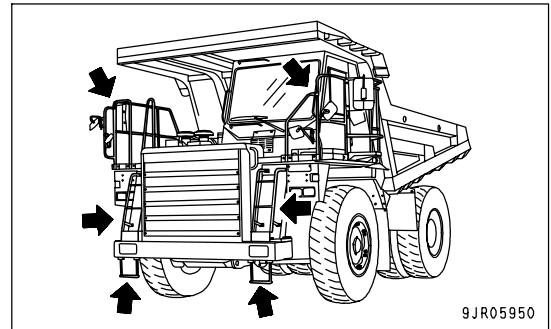

- Always face the machine and maintain at least three-point contact (both feet and one hand, or both hands and one foot) with the handrail and steps to ensure that you support yourself.

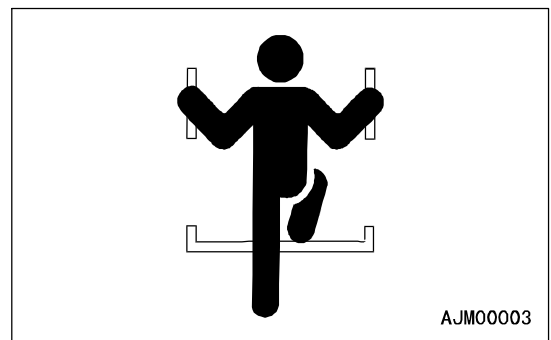

- Before getting on or off the machine, check the handrails and steps, and if there is any oil, grease, or mud on them, wipe it off immediately. In addition, repair any damage and tighten any loose bolts.
- Do not grip the control levers when getting on or off the machine.
- Never climb on the engine hood or covers where there are no non-slip pads.
- Do not get on or off the machine while holding tools in your hand.

### NO JUMPING ON OR OFF MACHINE

- Never jump on or off the machine. Never get on or off a moving machine.
- If the machine starts to move when there is no operator on the machine, do not jump on to the machine and try to stop it.

### NO PEOPLE ON DUMP BODY

Never let anyone ride in the dump body. There is danger of falling and suffering serious personal injury.

**PRECAUTIONS WHEN STANDING UP FROM OPERATOR'S SEAT**

Before standing up from the operator's seat to adjust the operator's seat, always lower the dump body completely, lock with dump lever lock knob (1), set gear shift lever (2) to the N position, set parking brake switch (3) to the PARKING position, then stop the engine.

If this is not done and the control levers are touched by mistake, there is danger that the machine may suddenly move and cause serious personal injury or death.

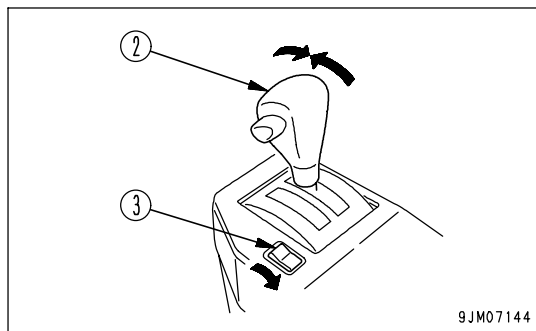
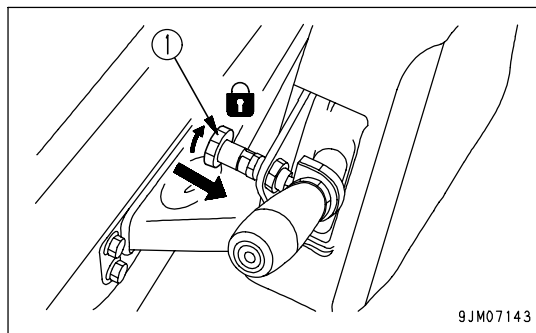

**PRECAUTIONS WHEN LEAVING MACHINE**

If the proper procedures are not taken when parking the machine, the machine may suddenly move off by itself, and this may lead to serious personal injury or death. Always do the following.

- When leaving the machine, always lower the dump body completely, lock with dump lever lock knob (1), set gear shift lever (2) to the N position, set parking brake switch (3) to the PARKING position, then stop the engine.

Lock all places and always take the key with you and leave it in the specified location.

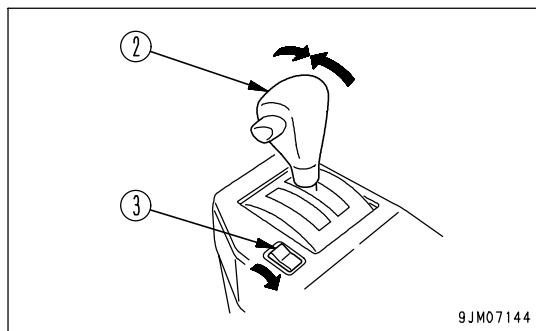
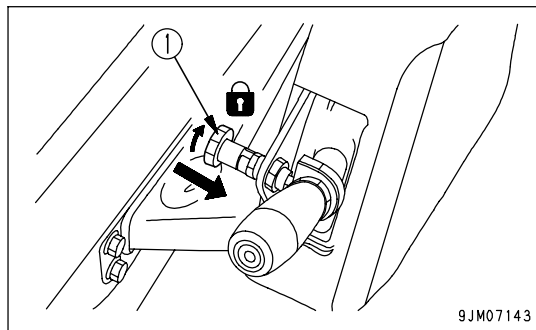

**EMERGENCY EXIT FROM OPERATOR'S CAB**

Machines equipped with a cab have doors on the left and right sides. If the door on the one side does not open, escape from the door on the other side.

## DO NOT GET CAUGHT IN DUMP BODY

The clearance in the area around the dump body changes according to the movement of the dump body. If you are caught, there is danger that you will suffer serious injury or death.

Do not allow anyone near any of the rotating or telescopic parts.

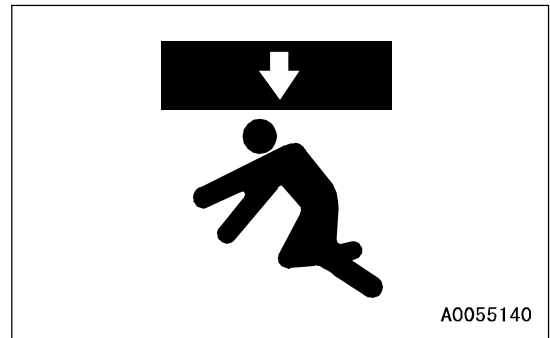

## PRECAUTIONS RELATED TO PROTECTIVE STRUCTURES

The operator's compartment is equipped with a structure (ROPS, FOPS) to protect the operator by absorbing the impact energy. If the machine weight (mass) exceeds the certified value (shown on the ROLL-OVER PROTECTIVE STRUCTURE (ROPS) CERTIFICATION plate), ROPS will not be able to fulfill its function. Do not increase machine weight beyond the certified value by modifying the machine or by installing attachments to the machine. Also, if the function of the protective equipment is impeded, the protective equipment will not be able to protect the operator, and the operator may suffer injury or death. Always observe the following.

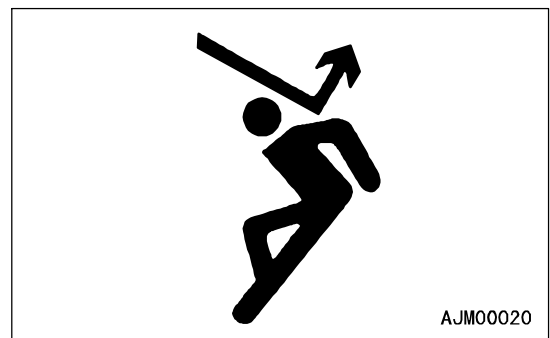

- If the machine is equipped with a protective structure, do not remove the protective structure and carry out operations without it.
- If the protective structure is welded, or holes are drilled in it, or it is modified in any other way, its strength may drop. Consult your Komatsu distributor before carrying out any modifications.
- If the protective structure is damaged or deformed by falling objects or by rolling over, its strength will be reduced and it will not be able to fulfill its function properly. In such cases, always contact your Komatsu distributor for advice on the method of repair.
- Even if the protective structure is installed, always fasten your seat belt properly when operating the machine. If you do not fasten your seatbelt properly, it cannot display its effect.

## UNAUTHORIZED MODIFICATION

- Komatsu will not be responsible for any injuries, accidents, product failures or other property damages resulting from modifications made without authorization from Komatsu.
- Any modification made without authorization from Komatsu can create hazards. Before making a modification, consult your Komatsu distributor.
- Do not try to increase the capacity of the dump body or make any other modifications. Such modifications will cause a drop in the braking efficiency, the balance of the machine will become poor, and this may lead to an unexpected accident.

## PRECAUTIONS RELATED TO ATTACHMENTS AND OPTIONS

- Any injuries, accidents, product failures or other property damages resulting from the use of unauthorized attachments or parts will not be the responsibility of Komatsu.
- When installing optional parts or attachments, there may be problems with safety or legal restrictions. Therefore contact your Komatsu distributor for advice.
- When installing and using optional attachments, read the instruction manual for the attachment, and the general information related to attachments in this manual.

## PRECAUTIONS WHEN RUNNING ENGINE INSIDE BUILDING

The engine exhaust gas contains substances that may damage your health or even cause death. Start or operate the engine in a place where there is good ventilation. If the engine or machine must be operated inside a building or under ground, where the ventilation is poor, take steps to ensure that the engine exhaust gas is removed and that ample fresh air is brought in.



# PRECAUTIONS FOR OPERATION

## PRECAUTIONS FOR JOBSITE

### INVESTIGATE AND CONFIRM JOBSITE CONDITIONS

On the jobsite, there are various hidden dangers that may lead to personal injury or death. Before starting operations, always check the following to confirm that there is no danger on the jobsite.

- Check the terrain and condition of the ground at the worksite, and determine the safest method of operation. Do not operate where there is a hazard of landslides or falling rocks.
- Take necessary measures to prevent any unauthorized person from entering the operating area.
- When traveling or operating in water or on soft ground, check the water depth, speed of the current, bedrock, and shape of the ground beforehand and avoid any place that will obstruct travel.
- Maintain the travel path on the jobsite so that there is no obstruction to travel operations.

### WORKING ON LOOSE GROUND

- Avoid traveling or operating your machine too close to the edge of cliffs, overhangs, and deep ditches. The ground may be weak in such areas. If the ground should collapse under the weight or vibration of the machine, there is a hazard that the machine may fall or tip over. Remember that the soil after heavy rain or blasting or after earthquakes is weak in these areas.
- When working on embankments or near excavated ditches, there is a hazard that the weight and vibration of the machine will cause the soil to collapse. Before starting operations, take steps to ensure that the ground is safe and to prevent the machine from rolling over or falling.

### DO NOT GO CLOSE TO HIGH-VOLTAGE CABLES

Do not travel or operate the machine near electric cables. There is a hazard of electric shock, which may cause serious personal injury or death. On jobsites where the machine may go close to electric cables, always do as follows.

- Before starting work near electric cables, inform the local power company of the work to be performed, and ask them to take the necessary action.

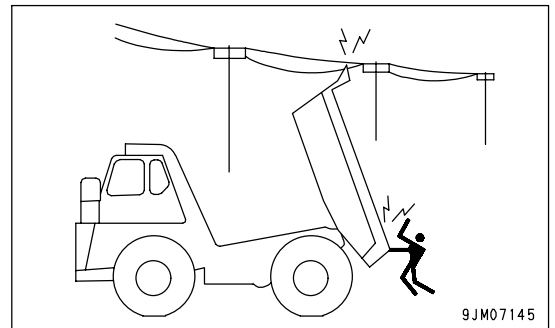

- Even going close to high-voltage cables can cause electric shock, which may cause serious burns or even death. Always maintain a safe distance (see the table on the right) between the machine and the electric cable. Check with the local power company about safe operating procedure before starting operations.
- To prepare for any possible emergencies, wear rubber shoes and gloves. Lay a rubber sheet on top of the seat, and be careful not to touch the chassis with any exposed part of your body.
- Use a signalman to give warning if the machine approaches too close to the electric cables.
- When carrying out operations near high voltage cables, do not let anyone near the machine.
- If the machine should come too close or touch the electric cable, to prevent electric shock, the operator should not leave the operator's compartment until it has been confirmed that the electricity has been shut off. Also, do not let anyone near the machine.

Voltage of Cables	Safety Distance
100V - 200V	Over 2 m (7 ft)
6,600V	Over 2 m (7 ft)
22,000V	Over 3 m (10 ft)
66,000V	Over 4 m (14 ft)
154,000V	Over 5 m (17 ft)
187,000V	Over 6 m (20 ft)
275,000V	Over 7 m (23 ft)
500,000V	Over 11 m (36 ft)



**ENSURE GOOD VISIBILITY**

This machine is equipped with mirrors to ensure good visibility, but even then there are places that cannot be seen from the operator's seat, so be careful when operating.

When traveling or carrying out operations in places with poor visibility, it is impossible to check for obstacles in the area around the machine and to check the condition of the jobsite. This leads to danger of serious personal injury or death. When traveling or carrying out operations in places with poor visibility, always observe the following.

- Position a signalman if there are areas where the visibility is not good.
- Only one signalman should give signals.
- When working in dark places, turn on the working lamp and front lamps installed to the machine, and set up additional lighting in the work area if necessary.
- Stop operations if the visibility is poor, such as in mist, snow, rain, or dust.
- When checking the mirrors installed to the machine, remove all dirt and adjust the angle of the mirror to ensure good visibility.
- If the machine is equipped with cameras, clean off any dirt from the lens and make sure that the camera gives a clear view.

**CHECKING SIGNS AND SIGNALMAN'S SIGNALS**

- Set up signs to inform of road shoulders and soft ground. If the visibility is not good, position a signalman if necessary. Operators should pay careful attention to the signs and follow the instructions from the signalman.
- Only one signalman should give signals.
- Make sure that all workers understand the meaning of all signals and signs before starting work.

**BEWARE OF ASBESTOS DUST**

Asbestos dust in the air can cause lung cancer if it is inhaled. There is danger of inhaling asbestos when working on jobsites handling demolition work or work handling industrial waste. Always observe the following.

- Spray water to keep down the dust.
- Do not use compressed air.
- If there is danger that there may be asbestos dust in the air, always operate the machine from an upwind position, and make sure that all workers operate on the upwind side.
- All workers should use anti-dust masks.
- Do not allow other persons to approach during the operation.
- Always observe the rules and regulations for the work site and environmental standards.

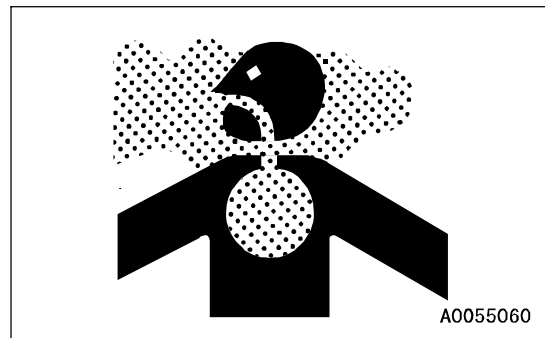

This machine does not use asbestos, but there is a danger that imitation parts may contain asbestos, so always use genuine Komatsu parts.

## STARTING ENGINE

### USE WARNING TAGS

If there is any "DANGER! Do NOT operate!" warning tag displayed, it means that someone is carrying out inspection and maintenance of the machine. If the warning sign is ignored and the machine is operated, there is danger that the person carrying out inspection or maintenance may be caught in the rotating parts or moving parts and suffer serious personal injury or death. Do not start the engine or touch the levers.

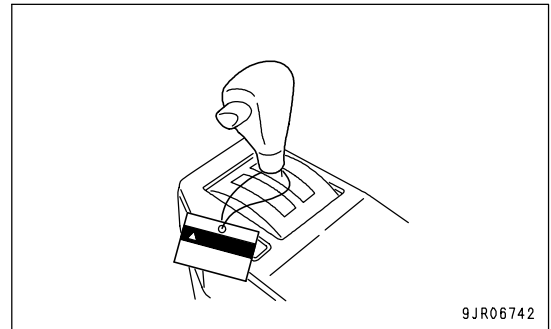

9JR06742

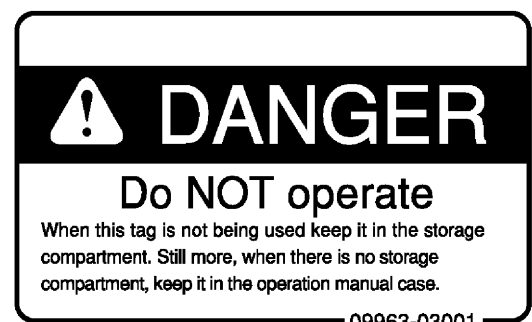

### CHECKS BEFORE STARTING ENGINE

Carry out the following checks before starting the engine at the beginning of the day's work to ensure that there is no problem with the operation of the machine. If this inspection is not carried out properly problems may occur with the operation of the machine, and there is danger that this may lead to serious personal injury or death.

- Remove all dirt from the surface of the window glass to ensure a good view.
- Carry out the "WALK-AROUND CHECK (PAGE 3-69)".
- Remove all dirt from the surface of the lens of the front lamps, working lamps, and rear combination lamp, and check that they light up correctly.
- Check the coolant level, fuel level, and oil level in engine oil pan, check for clogging of the air cleaner, and check for damage to the electric wiring.
- Check that there is no mud or dust accumulated around the movable parts of the accelerator pedal or brake pedal, and check that the pedals work properly.
- Adjust the operator's seat to a position where it is easy to carry out operations, and check that there is no damage or wear to the seat belt or mounting clamps.
- Check that the gauges work properly, check the angle of the mirrors, and check that the gear shift lever is at the N position and that the dump control lever is at the HOLD position.
- Before starting the engine, check that the lock knob of the dump control lever is at the LOCK position.
- Adjust the mirrors so that the rear of the machine can be seen easily from the operator's seat. For details of the method of adjusting, see "ADJUSTING MIRROR (PAGE 3-84)".
- Check that there are no persons or obstacles above, below, or in the area around the machine.
- Check that the parking brake switch is at the PARKING position.

**PRECAUTIONS WHEN STARTING ENGINE**

- Start and operate the machine only while seated.
- When starting the engine, sound the horn as a warning.
- If another person is allowed on the machine, that person may sit only in the assistant's seat.
- Do not attempt to start the engine by short-circuiting the engine starting circuit. This may cause fire, serious personal injury or death.
- Check that the backup alarm (alarm buzzer when machine travels in reverse) works properly.

**PRECAUTIONS IN COLD AREAS**

- Carry out the warming-up operation thoroughly. If the machine is not thoroughly warmed up before the control levers are operated, the reaction of the machine will be slow, and this may lead to unexpected accidents.
- If the battery electrolyte is frozen, do not charge the battery or start the engine with a different power source. There is a hazard that this will ignite the battery and cause the battery to explode. Before charging or starting the engine with a different power source, melt the battery electrolyte and check that there is no leakage of electrolyte before starting.

**STARTING WITH BOOSTER CABLES**

If any mistake is made in the method of connecting the booster cables, it may cause the battery to explode, so always do as follows.

- Always wear safety goggles and rubber gloves when starting the engine with booster cable.
- When connecting a normal machine to a problem machine with booster cables, always use a normal machine with the same battery voltage as the problem machine.
- When starting with a booster cable, carry out the starting operation with two workers (one worker sitting in the operator's seat and the other working with the battery).
- When starting from another machine, do not allow the two machines to touch.
- When connecting the booster cables, turn the starting switch to the OFF position for both the normal machine and problem machine. There is a hazard that the machine will move when the power is connected.
- Be sure to connect the positive (+) cable first when installing the booster cables. Disconnect the negative (-) cable (ground side) first when removing them.
- When removing the booster cables, be careful not to let the booster cable clips touch each other or to let the clips touch the machine.
- For details of the starting procedure when using booster cables, see "STARTING ENGINE WITH BOOSTER CABLE (PAGE 3-134)" in the OPERATION section.

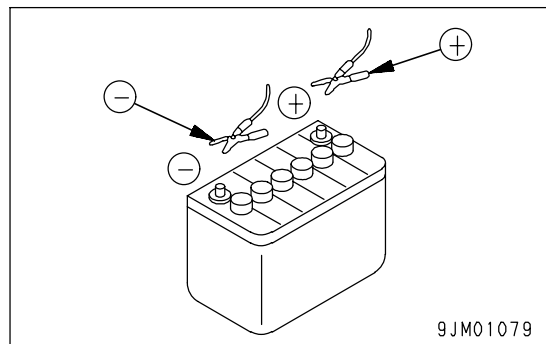
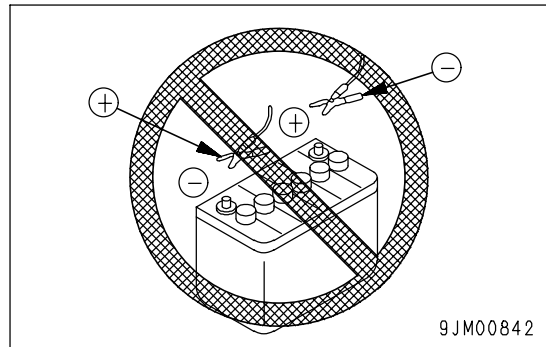

## OPERATION

### CHECKS BEFORE OPERATION

If the checks before starting are not carried out properly, the machine will be unable to display its full performance, and there is also danger that it may lead to serious personal injury or death.

When carrying out the checks, move the machine to a wide area where there are no obstructions, and pay careful attention to the surrounding area. Do not allow anyone near the machine.

- Always wear the seatbelt. There is danger that you may be thrown out of the operator's seat and suffer serious injury when the brakes are applied suddenly.
- Check the operation of travel, steering and brake systems, and dump body control system.
- Check for any problem in the sound of the machine, vibration, heat, smell, or gauges; check also that there is no leakage of oil or fuel.
- If any problem is found, carry out repairs immediately.

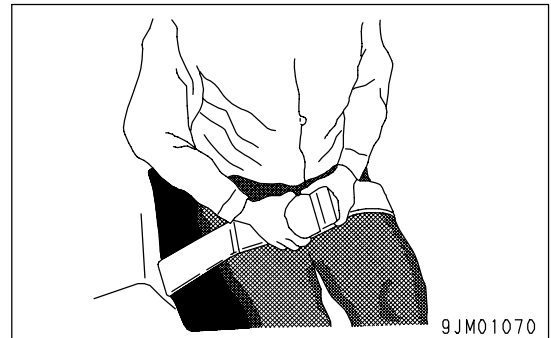

### PRECAUTIONS WHEN TRAVELING IN FORWARD OR REVERSE

- Lock the cab door and windows securely, both when they are open and when they are closed.
- If another person is allowed on the machine, that person may sit only in the assistant's seat.
- If there are any persons in the area around the machine, there is danger that they may be hit or caught by the machine, and this may lead to serious personal injury or death. Always observe the following before traveling.
  - Always operate the machine only when seated.
  - Before moving off, check again that there is no person or obstruction in the surrounding area.
  - Before moving, sound the horn to warn people in the surrounding area.
  - Check that the backup alarm (alarm buzzer when machine travels in reverse) works properly.
  - If there is an area to the rear of the machine which cannot be seen, position a signalman.

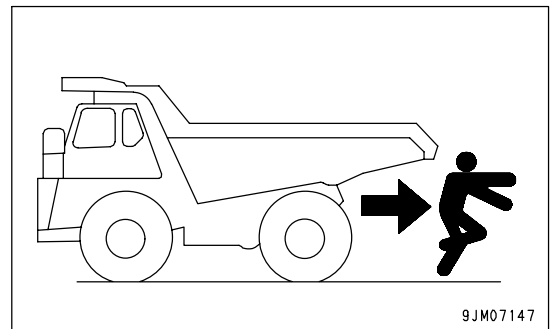

Always be sure to carry out the above precautions even when the machine is equipped with mirrors and cameras.

**PRECAUTIONS WHEN TRAVELING**

- Never turn the key in the starting switch to the OFF position. It is dangerous if the engine stops when the machine is traveling, because the steering becomes heavy. There is danger that this will cause misoperation of the steering wheel and may lead to serious personal injury or death. If the engine stops, depress the brake pedal immediately to stop the machine.
- When traveling or carrying out operations, always keep a safe distance from people, structures, or other machines to avoid coming into contact with them.
- Try to avoid having the machine climb over obstacles. If that is unavoidable, let the machine do that at a low speed. Nonetheless avoid a big obstacle that greatly tilts the machine to the right or left, because in such a case the machine can easily overturn sideways.
- When traveling on rough ground, travel at low speed and avoid sudden changes in direction to prevent the machine from turning over.
- Do not load the dump body above the maximum payload. The brakes will lose their effect.
- Lower the dump body, setting the dump lever at FLOAT position, then travel.
- When passing over bridges or structures, check first that the structure is strong enough to support the weight of the machine.
- When operating in tunnels, under bridges, under electric wires, or other places where the height is limited, operate slowly and be extremely careful not to let the machine body or work equipment hit anything.
- If you drive the machine at high speed continuously for a long time, the tires will overheat and the internal pressure will become abnormally high. This may cause the tires to burst. If a tire bursts, it produces a large destructive force, and this may cause serious injury or death.

If you are going to travel continuously, please consult your Komatsu distributor.

- When travelling, and particularly when travelling downhill, never set the gear shift lever to the Neutral position. Always keep it in a speed range when travelling.
  - If the gear shift lever is at Neutral, it will be impossible to use the braking force of the engine and the steering will become heavier. In addition, there will be insufficient cooling oil for the retarder, so there is danger that this will result in overheating, which will lead to defective operation of the brakes.
  - The transmission and other parts of the power train may be damaged, and there is danger that this will lead to serious injury or death.

**TRAVELING ON SLOPES**

To prevent the machine from tipping over or slipping to the side, always do as follows.

- When traveling downhill, use the retarder brake to reduce speed. Do not turn the steering wheel suddenly.
- Travel on grass, fallen leaves, or wet steel plates with low speed. Even with slight slopes there is a hazard that the machine may slip.
- If the engine should stop on a slope, apply the brakes fully and apply the parking brake also to stop the machine.
- Do not shift gear while traveling downhill or travel downhill with the transmission in neutral.  
It is dangerous if the engine has no braking effect. Always set the transmission to a lower gear before starting to travel downhill.

**PRECAUTIONS WHEN OPERATING**

- When using the machine, to prevent personal injury caused by damage to the work equipment or by the machine overturning due to overloading, do not exceed the permitted performance of the machine or the maximum permitted load for the structure of the machine.
- When operating in tunnels, or under bridges or electric wires, or in other places where the height is limited, operate slowly and be extremely careful not to let the dump body contact anything.
- To prevent accidents caused by hitting other objects, always operate the machine at a speed which is safe for operation, particular in confined spaces, indoors, and in places where there are other machines.

**PRECAUTIONS WHEN LOADING DUMP BODY**

- Do not load the dump body so that the load is on one side. Always carry out loading that the load is spread uniformly.
- Do not leave or return to the operator's seat while the dump body is being loaded.

**PRECAUTIONS WHEN OPERATING DUMP BODY**

- Before starting the dumping operation, check to be sure there is no person or object behind the machine.
- Stop the machine in the correct position, and check again that there is no person or object behind the machine. Give the determined signal, then slowly operate the dump body. If necessary, use blocks for the wheels or position a flagman.
- Not carry out dumping operations on slopes. The machine stability will become poor and there is danger that it may tip over.
- Do not travel with the body raised.
- Be careful when raising the dump body. When the dump body is raised, the center of gravity of the machine changes continuously. If the ground is soft, this will affect the stability of the machine.
- Take care particularly when dumping sticky material (wet clay, frozen material, etc.) on a soft ground. The stability of the machine is reduced and there is danger that it may tip over.

**TRAVELING ON SNOW-COVERED OR FROZEN SURFACES**

- Snow-covered or frozen surfaces are slippery, so be extremely careful when traveling or operating the machine, and do not operate the levers suddenly. Even a slight slope may cause the machine to slip, so be particularly careful when working on slopes.
- With frozen ground surfaces, the ground becomes soft when the temperature rises, and this may cause the machine to tip over or make it impossible for the machine to escape.
- When traveling on snow-covered roads, always fit tire chains.
- If the machine enters deep snow, there is a hazard that it may tip over or become buried in the snow. Be careful not to leave the road shoulder or to get trapped in a snow drift.
- Do not apply the brakes suddenly on snow-covered slopes. Reduce speed, use the braking force of the engine, and pump the brakes (depress the brake pedal several times) to stop the machine.
- Do not try to carry out dumping operations when the load inside the dump body is frozen. There is danger that this may cause the machine to tip over.

**PARKING MACHINE**

- Park the machine on firm, level ground.
- Select a place where there is no hazard of landslides, falling rocks, or flooding.
- When leaving the machine, always lower the dump body completely, lock with dump lever lock knob (1), set gear shift lever (2) to the N position, set parking brake switch (3) to the PARKING position, then stop the engine.
- Always close the operator's cab door, and use the key to lock all the equipment in order to prevent any unauthorized person from moving the machine. Always remove the key, take it with you, and leave it in the specified place.

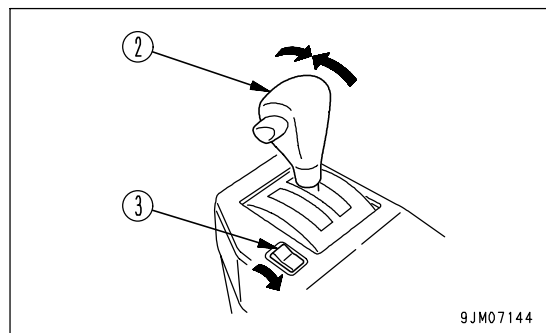
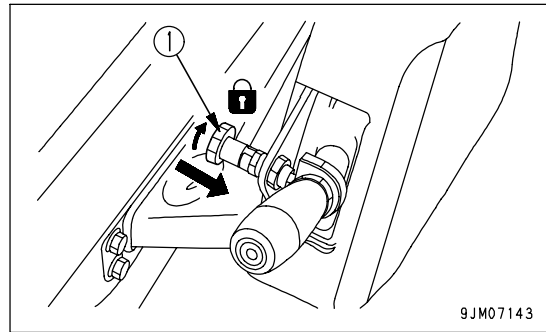

- If it is necessary to park the machine on a slope, set blocks under the wheels to prevent the machine from moving.

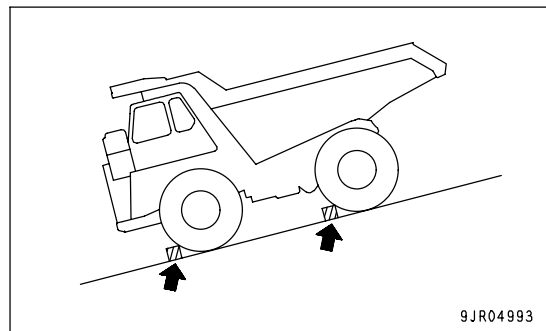

## TRANSPORTATION

When the machine is transported on a trailer, there is danger of serious personal injury or death during transportation. Always do as follows.

- Always check the machine dimensions carefully. Depending on the attachments installed, the machine weight, transportation height, and overall length may differ.
- Check beforehand that all bridges and other structures on the transportation route are strong enough to withstand the combined weight of the transporter and the machine being transported.
- The machine can be divided into parts for transportation, so when transporting the machine, please contact your Komatsu distributor to have the work carried out.
- For the procedure when transporting, see "TRANSPORTATION (PAGE 3-117)".

## LOADING AND UNLOADING

When loading or unloading the machine, mistaken operation may bring the hazard of the machine tipping over or falling, so particular care is necessary. Always do as follows.

- Perform loading and unloading on firm, level ground only. Maintain a safe distance from the edge of the road or cliff.
- Always use ramps of adequate strength. Be sure that the ramps are wide, long, and thick enough to provide a safe loading slope. Take suitable steps to prevent the ramps from moving out of position or coming off.
- Be sure the ramp surface is clean and free of grease, oil, ice and loose materials. Remove dirt from the tire of the machine. On a rainy day, in particular, be extremely careful since the ramp surface is slippery.
- Run the engine at low idling and drive the machine slowly at low speed.
- Never correct your steering on the ramps. If necessary, drive off the ramps, correct the direction, then enter the ramps again.
- When loading or unloading to an embankment or platform, make sure that it has suitable width, strength, and grade.
- For machines equipped with a cab, always lock the door after loading the machine. If this is not done, the door may open during transportation.

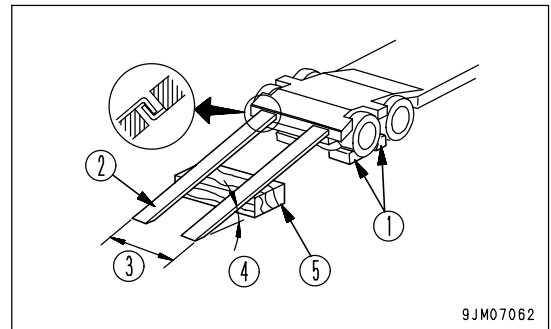

- (1) Blocks
- (2) Ramp
- (3) Width of ramps: Same width as tiers
- (4) Angle of ramps: Max. 15°
- (5) Block

For details, see "TRANSPORTATION (PAGE 3-117)".



## TOWING

### WHEN TOWING

Always use the correct towing equipment and towing method. Any mistake in the selection of the wire rope or towing bar or in the method of towing a disabled machine may lead to serious personal injury or death.

For details of the procedure for towing, see the "METHOD OF TOWING MACHINE (PAGE 3-129)"

- Always confirm that the wire rope or drawbar used for towing has ample strength for the weight of the machine being towed.
- Never use a wire rope which has cut strands (A), reduced diameter (B), or kinks (C). There is danger that the rope may break during the towing operation.
- Always wear leather gloves when handling wire rope.
- Never tow a machine on a slope.
- During the towing operation, never stand between the towing machine and the machine being towed.

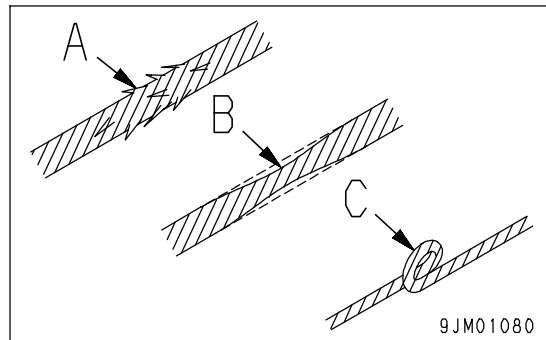

## PRECAUTIONS FOR MAINTENANCE

### PRECAUTIONS BEFORE STARTING INSPECTION AND MAINTENANCE

#### DISPLAY WARNING TAG DURING INSPECTION AND MAINTENANCE

If there is any "DANGER! Do NOT operate!" warning tag displayed, it means that someone is carrying out inspection and maintenance of the machine. If the warning sign is ignored and the machine is operated, there is danger that the person carrying out inspection or maintenance may be caught in the rotating parts or moving parts and suffer serious personal injury or death. Do not start the engine or touch the levers.

- If necessary, put up signs around the machine also.  
Warning tag part number: 09963-03001  
When not using this warning tag, keep it in the toolbox.  
If there is no toolbox, keep it in the pocket for the Operation and Maintenance Manual

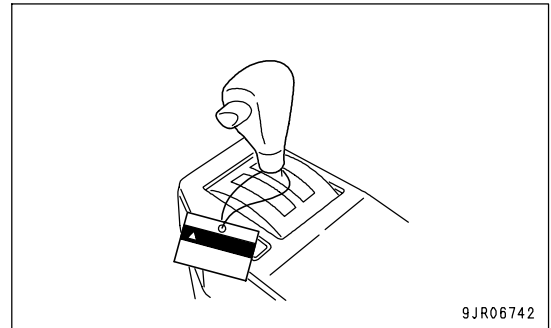

9JR06742

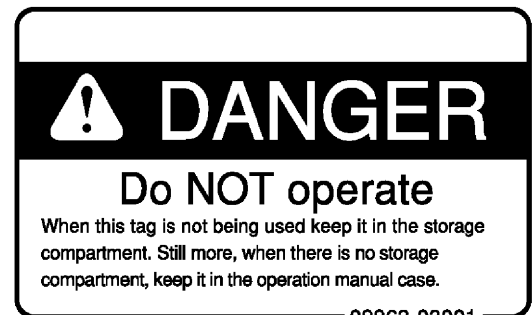

#### KEEP WORKPLACE CLEAN AND TIDY

Do not leave hammers or other tools lying around in the work place. Wipe up all grease, oil, or other substances that will cause you to slip. Always keep the work place clean and tidy to enable you to carry out operations safely. If the work place is not kept clean and tidy, there is the danger that you will trip, slip, or fall over and injure yourself.

#### SELECT SUITABLE PLACE FOR INSPECTION AND MAINTENANCE

- Stop the machine on firm, level ground.
- Select a place where there is no hazard of landslides, falling rocks, or flooding.

#### ONLY AUTHORIZED PERSONNEL

Do not allow any unauthorized personnel into the area when servicing the machine. If necessary, employ a guard.

#### APPOINT LEADER WHEN WORKING WITH OTHERS

When repairing the machine or when removing and installing the work equipment, appoint a leader and follow his instructions during the operation.

**STOP ENGINE BEFORE CARRYING OUT INSPECTION AND MAINTENANCE**

- Always stop the machine before performing any inspection and maintenance.

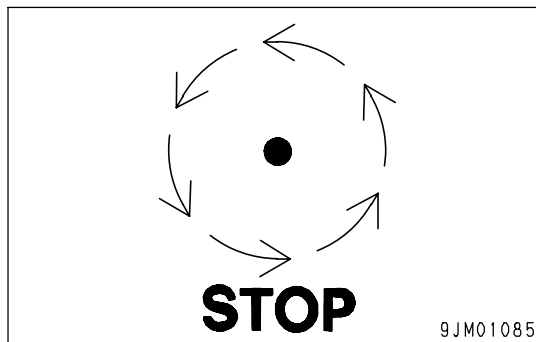

- Lower the dump body completely, set dump lever (1) to the HOLD position, lock with dump lever lock knob (2), then stop the engine.

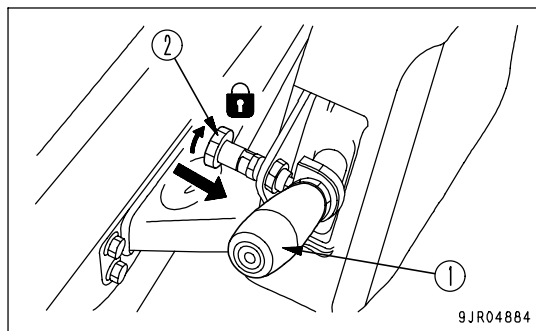

- Set parking brake switch (3) to the PARKING position to apply the parking brake, then put blocks in front of and behind the tires to prevent the machine from moving.

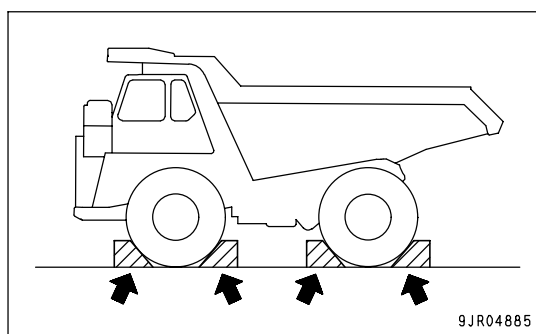
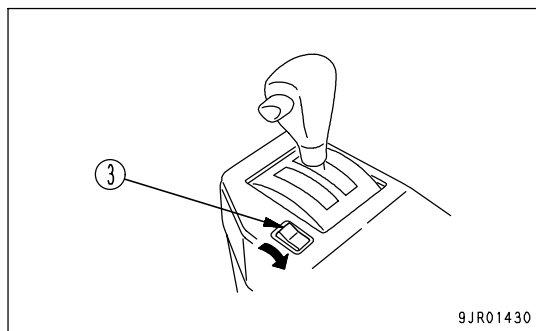

**TWO WORKERS FOR MAINTENANCE WHEN ENGINE IS RUNNING**

To prevent personal injury, do not carry out maintenance with the engine running. If maintenance must be carried out with the engine running, carry out the operation with at least two workers and do as follows.

- One worker must always sit in the operator's seat and be ready to stop the engine at any time. All workers must maintain contact with the other workers.
- When carrying out operations near the fan, fan belt, or other rotating parts, there is a hazard of being caught in the parts, so be careful not to come close.
- Never drop or insert tools or other objects into the fan, fan belt, or other rotating parts. There is danger that they may contact the rotating parts and break or be sent flying.

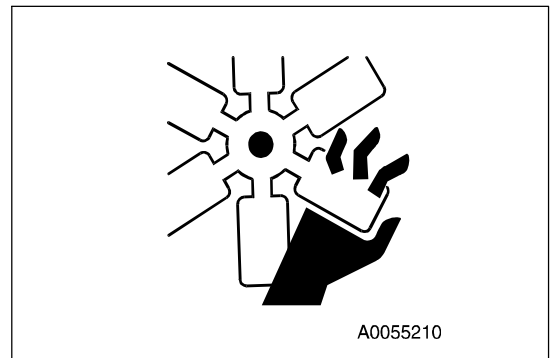

- Lower the dump body completely, set dump lever (1) to the HOLD position, lock with dump lever lock knob (2), and take steps to prevent the dump body from moving.

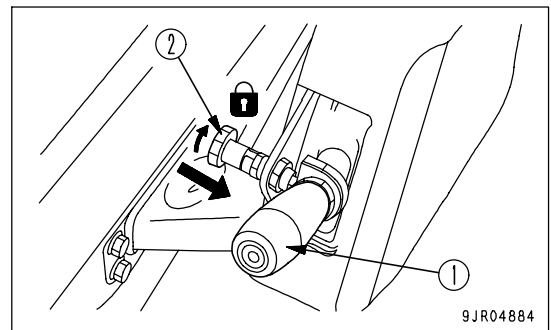

- Set parking brake switch (3) to the PARKING position to apply the parking brake, then put blocks in front of and behind the tires to prevent the machine from moving.
- Do not touch any control levers. If any control lever must be operated, give a signal to the other workers to warn them to move to a safe place.

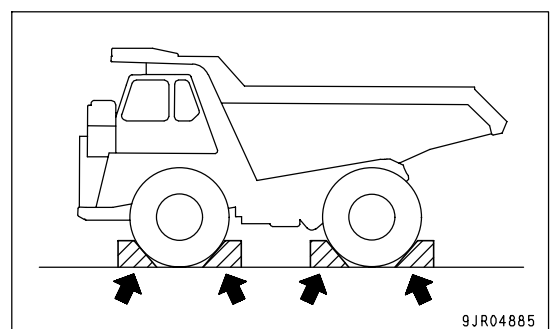
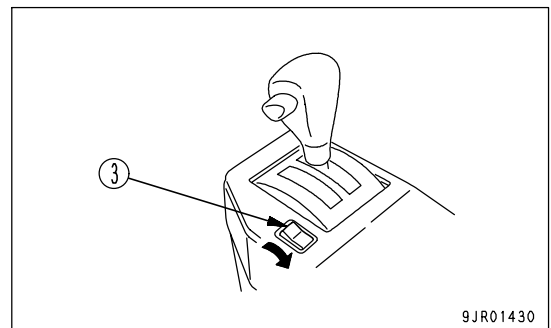

**INSTALLING, REMOVING, OR STORING ATTACHMENTS**

- Appoint a leader before starting removal or installation operations for attachments.
- Place attachments that have been removed from the machine in a stable condition so that they do not fall. And take steps to prevent unauthorized persons from entering the storage area.



**PRECAUTIONS WHEN WORKING AT HIGH PLACES**

When working at high places, use a step ladder or other stand to ensure that the work can be carried out safely.

**PRECAUTIONS WHEN WORKING UNDER MACHINE**

- When carrying out inspection with the dump body raised, always set the dump control lever to the HOLD position, set the lock knob to the LOCK position, then insert the body pivot pin. If the body pivot pin is not inserted, the dump body may go down when the dump control lever is operated, and catch or cause serious injury or even death to the person carrying out the inspection.
- Always carry out the operation to remove or insert the body pivot pin with at least two workers. This operation is carried out with the dump body raised, so if the dump body comes down during the operation, it may lead to serious injury or even death.

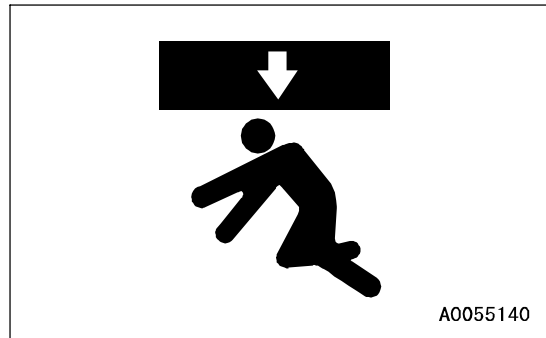

For details, see "BODY PIVOT PIN (PAGE 3-44)".

- Make sure the hoists or jacks you use are in good repair and strong enough to handle the weight of the component. Never use jacks at places where the machine is damaged, bent, or twisted. Never use frayed, twisted or pinched wire rope. Never use bent or distorted hooks.
- Never use concrete blocks for supports. They can collapse under even light loads.

**PROPER TOOLS**

Use only tools suited to the task and be sure to use the tools correctly. Using damaged, deformed, or low quality tools, or making improper use of the tools may cause serious personal injury.

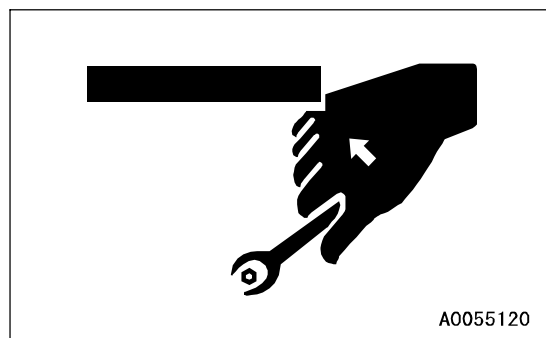

## PRECAUTIONS FOR INSPECTION AND MAINTENANCE

### PRECAUTIONS WHEN WELDING

Welding operations must always be carried out by a qualified welder and in a place equipped with proper equipment. There is a hazard of gas, fire, or electrocution when carrying out welding, so never allow any unqualified personnel to carry out welding.

### HANDLING BATTERY

Before inspecting or handling the battery, turn the key in the starting switch to the OFF position.

- **Danger of battery exploding**

When the battery is being charged, flammable hydrogen gas is generated and may explode. In addition, the battery electrolyte includes dilute sulphuric acid. Any mistake in handling may cause serious personal injury, explosion, or fire, so always observe the following.

- Do not use or charge the battery if the battery electrolyte is below the LOWER LEVEL mark. This will cause explosion. Always carry out periodic inspection of the battery electrolyte level, and add distilled water (or commercially available battery filler solution) to the UPPER LEVEL mark.
- Do not smoke or bring any flame close to the battery.
- Hydrogen gas is generated when the battery is being charged, so remove the battery from the machine, take it to a well-ventilated place, remove the battery caps, then carry out the charging.
- After charging, tighten the battery caps securely.

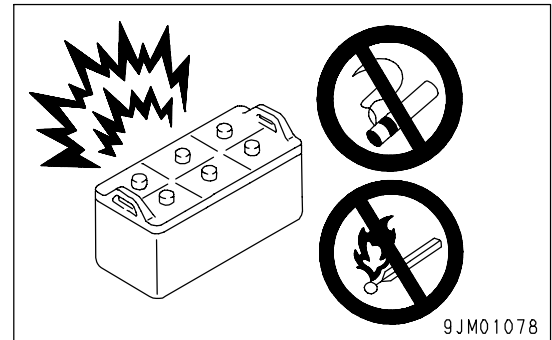

- **Danger from dilute sulphuric acid**

When the battery is being charged, flammable hydrogen gas is generated and may explode. In addition, the battery electrolyte includes dilute sulphuric acid. Any mistake in handling may cause serious personal injury, explosion, or fire, so always observe the following.

- When handling the battery, always wear protective goggles and rubber gloves.
- If battery electrolyte gets into your eyes, immediately wash your eyes with large amounts of fresh water. After that, get medical attention immediately.
- If battery electrolyte gets on your clothes or skin, wash it off immediately with large amounts of water.

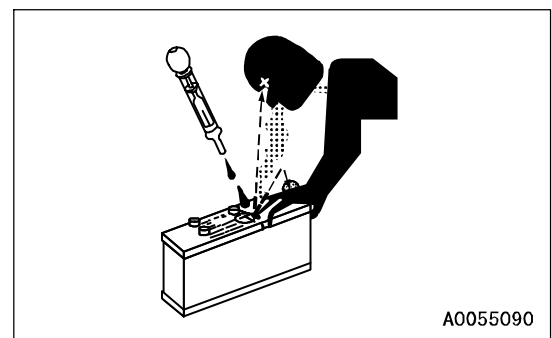

- **Removing battery cables**

Before repairing the electrical system or carrying out electric welding, turn the starting switch OFF. Wait for approx. 1 minute, then remove the negative (-) battery cable to stop the flow of electricity.

**• Danger of sparks**

There is hazard that sparks will be generated, so always observe the following.

- Do not let tools or other metal objects make any contact between the battery cables. Do not leave tools lying around near the battery.
- When removing the battery cables, remove the ground cable (negative (-) cable) first. When installing, connect the positive (+) cable first, then connect the ground. Tighten the battery cable terminals securely.
- Secure the battery firmly in the specified position.

**PRECAUTIONS WHEN USING HAMMER**

When using a hammer, pins may fly out or metal particles may be scattered. This may lead to serious personal injury or death. Always do as follows.

- If pins are hit with a hammer, there is a hazard that the metal particles may fly out and injure people in the surrounding area. Always make sure that no-one is in the surrounding area before using the hammer.
- If hard metal parts such as pins, or bearings are hit with a hammer, there is a hazard that pieces might be scattered and cause serious personal injury or death. Always wear safety glasses and gloves.
- If the pin is hit with strong force, there is a hazard that it may fly out and injure people in the surrounding area. Do not allow anyone to enter the surrounding area.

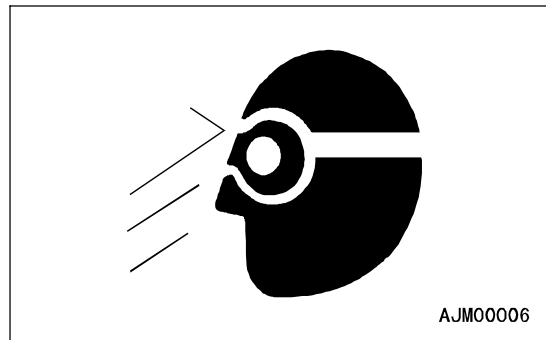

**PRECAUTIONS WITH HIGH-TEMPERATURE COOLANT**

To prevent burns from boiling water or steam spurting out when checking or draining the coolant, wait for the coolant to cool down to a temperature where the radiator cap can be touched by hand. Then loosen the cap slowly to release the pressure inside the radiator, and remove the cap.

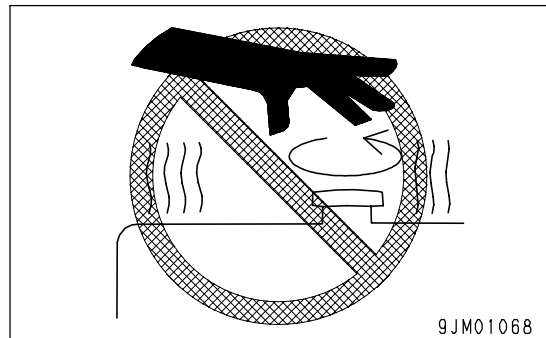

**PRECAUTIONS WITH HIGH-TEMPERATURE OIL**

To prevent burns from hot oil spurting out or from touching high-temperature parts when checking or draining the oil, wait for the oil to cool down to a temperature where the cap or plug can be touched by hand. Then loosen the cap or plug slowly to release the internal pressure and remove the cap or plug.

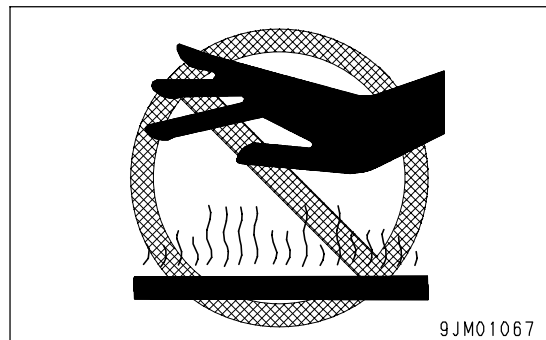

**PRECAUTIONS WITH HIGH-PRESSURE OIL**

The hydraulic system is always under internal pressure. In addition, the fuel piping is also under internal pressure when the engine is running and immediately after the engine is stopped. When carrying out inspection or replacement of the piping or hoses, check that the internal pressure in the circuit has been released. If this is not done, it may lead to serious personal injury or death. Always do as follows.

- Do not carry out inspection or replacement work with the circuit under pressure.
- If there is any leakage from the piping or hoses, the surrounding area will be wet, so check for cracks in the piping and hoses and for swelling in the hoses.

When carry out inspection, wear safety glasses and leather gloves.

- There is a hazard that high-pressure oil leaking from small holes may penetrate your skin or cause loss of sight if it contacts your skin or eyes directly. If you are hit by a jet of high-pressure oil and suffer injury to your skin or eyes, wash the place with clean water, and consult a doctor immediately for medical attention.

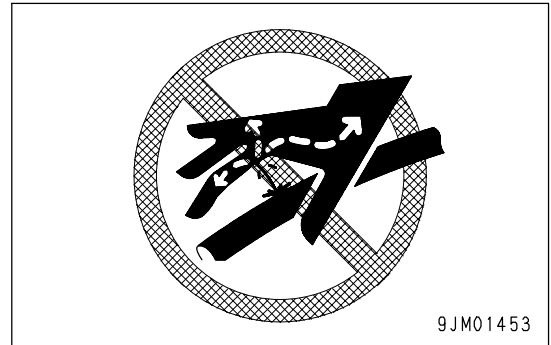
**PRECAUTIONS WITH HIGH-PRESSURE FUEL**

When the engine is running, high-pressure is generated in the engine fuel piping. When carrying out inspection or maintenance of the fuel piping system, stop the engine and wait for at least 30 seconds to allow the internal pressure to go down before starting the operation.

**HANDLING HIGH-PRESSURE HOSES AND PIPING**

- If oil or fuel leaks from high-pressure hoses or piping, it may cause fire or misoperation, and lead to serious personal injury, or death. If the hose or piping mounts are loose or oil or fuel is found to be leaking from the mount, stop operations and tighten to the specified torque.

If any damaged or deformed hoses or piping are found, please consult your Komatsu distributor.

Replace the hose if any of the following problems are found.

- Damaged hose or deformed hydraulic fitting.
- Frayed or cut covering or exposed reinforcement wire layer.
- Covering swollen in places.
- Twisted or crushed movable portion.
- Foreign material embedded in covering.

**NOISE**

When carrying out maintenance of the engine and you are exposed to noise for long periods of time, wear ear covers or ear plugs while working.

If the noise from the machine is too loud, it may cause temporary or permanent hearing problems.



**HANDLING SUSPENSION CYLINDER, ACCUMULATOR, GAS SPRING**

The suspension cylinders, accumulator, and gas springs are charged with high-pressure nitrogen gas. If any mistake is made in handling, there is danger that it may cause an explosion or serious personal injury. To prevent accidents, always do as follows.

- Do not remove or disassemble unless necessary.
- Do not bring it near flame or dispose of it in fire.
- Do not make holes in it, weld it, or use a cutting torch.
- Do not hit or roll the accumulator, or subject it to any impact.
- Ask your Komatsu distributor when sealing gas into the cylinder or replacing gas from it.
- When disposing of the accumulator, the gas must be released. Please contact your Komatsu distributor to have this work performed.



**PRECAUTIONS WITH COMPRESSED AIR**

- When carrying out cleaning with compressed air, there is a hazard of serious personal injury caused by flying dust or particles.
- When using compressed air to clean the filter element or radiator, wear safety glasses, anti-dust mask, gloves, and other protective equipment.

**MAINTENANCE OF AIR CONDITIONER**

If air conditioner refrigerant gets into your eyes, it may cause loss of sight; if it contacts your skin, it may cause frostbite. Never loosen any parts of the cooling circuit.

**DISPOSING OF WASTE MATERIALS**

To prevent pollution, pay careful attention to the method of disposing of waste materials.

- Always put oil drained from your machine in containers. Never drain oil directly onto the ground or dump into the sewage system, rivers, the sea, or lakes.
- Obey appropriate laws and regulations when disposing of harmful objects such as oil, fuel, coolant, solvent, filters, and batteries.

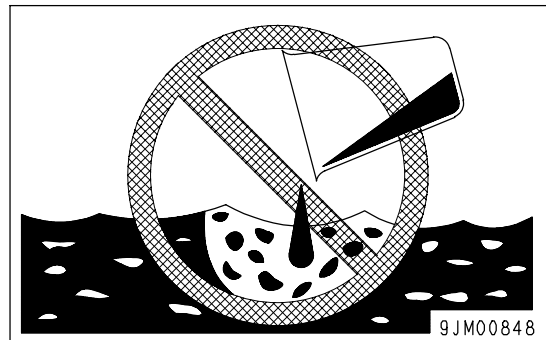

**METHOD OF SELECTING WINDOW WASHER FLUID**

Use an ethyl alcohol base washer liquid.

Methyl alcohol base washer liquid may irritate your eyes, so do not use it.

**PERIODIC REPLACEMENT OF SAFETY CRITICAL PARTS**

- For using the machine safely for an extended period of time, replace safety-critical parts like hoses and seat belts periodically.  
Replacement of safety-critical parts: See "PERIODIC REPLACEMENT OF SAFETY CRITICAL PARTS (PAGE 4-15)".
- The material of these components naturally changes over time, and repeated use causes deterioration, wear, and fatigue. As a result, there is a hazard that these components may fail and cause serious personal injury or death. It is difficult to judge the remaining life of these components from external inspection or the feeling when operating, so always replace them at the specified interval.
- Replace or repair safety-critical parts if any defect is found, even when they have not reached the specified replacement time.

## TIRES

### HANDLING TIRES

If tires or rims are handled mistakenly, there is danger that the tire may explode or be damaged, or that the rim may fly off and cause serious personal injury or death.

To maintain safety, always do as follows.

- Maintenance, disassembly, repair, and assembly of the tires and rims requires special equipment and special technology, so always ask your Komatsu distributor to carry out these operations.
- Use only specified tires and inflate them to the specified pressure.

Suitable inflation pressure : see HANDLING TIRES (PAGE 3-113).

- When pumping up the tires, check that no other person is standing near the tire, and install an air chuck with a clip that can be secured to the air valve.

To prevent the tire inflation pressure from becoming too high, measure the pressure from time to time with an air gauge while pumping up the tire.

- If the tire pressure goes down abnormally or the rim parts do not fit the tire, there is a problem with the tire or rim parts. Always contact your Komatsu distributor for repairs.
- If the rim parts are not fitted properly when the tire is being pumped up, there is danger that the rim parts may fly off, so set up a protective fence around the tire, and do not stand directly in front of the rim. Stand beside the tread when pumping up the tire.
- Do not adjust the tire inflation pressure immediately after traveling at high speed or carrying out operations under heavy load.
- Never carry out welding or light a fire near the tire.
- Always release all pressure from a single tire or from both tires of a dual assembly prior to removing any rim components.
- Before removing the tire from the machine for repairs, remove the valve partially to release the air from the tire, then remove the tire.

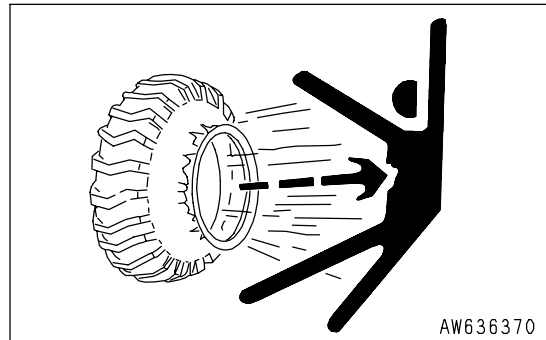

AW636370

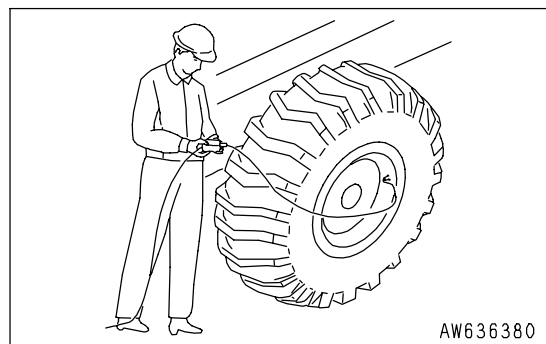

AW636380

**PRECAUTIONS WHEN STORING TIRES**

Tires for construction equipment are extremely heavy, it may lead to serious personal injury or death. To maintain safety, always do as follows.

- As a basic rule, store the tires in a warehouse which unauthorized persons cannot enter.  
If the tires must be stored outside, always erect a fence and put up "No Entry" signs.
- Stand the tire on level ground, and block it securely so that it cannot roll or fall over if any person should touch it.  
Do not lay the tire on its side. This will deform the tire and cause it to deteriorate.
- If the tire should fall over, do not attempt to stop it. Get out of the way quickly.

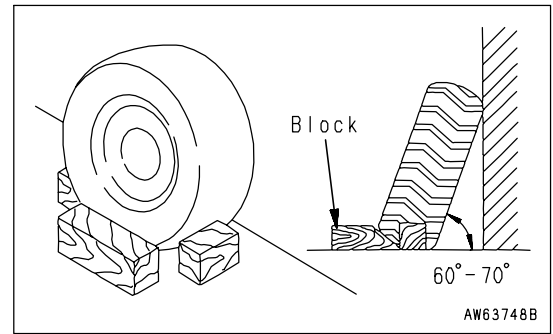



# OPERATION

## **WARNING**

Please read and make sure that you understand the SAFETY section before reading this section.

---

# GENERAL VIEW

## GENERAL VIEW OF MACHINE

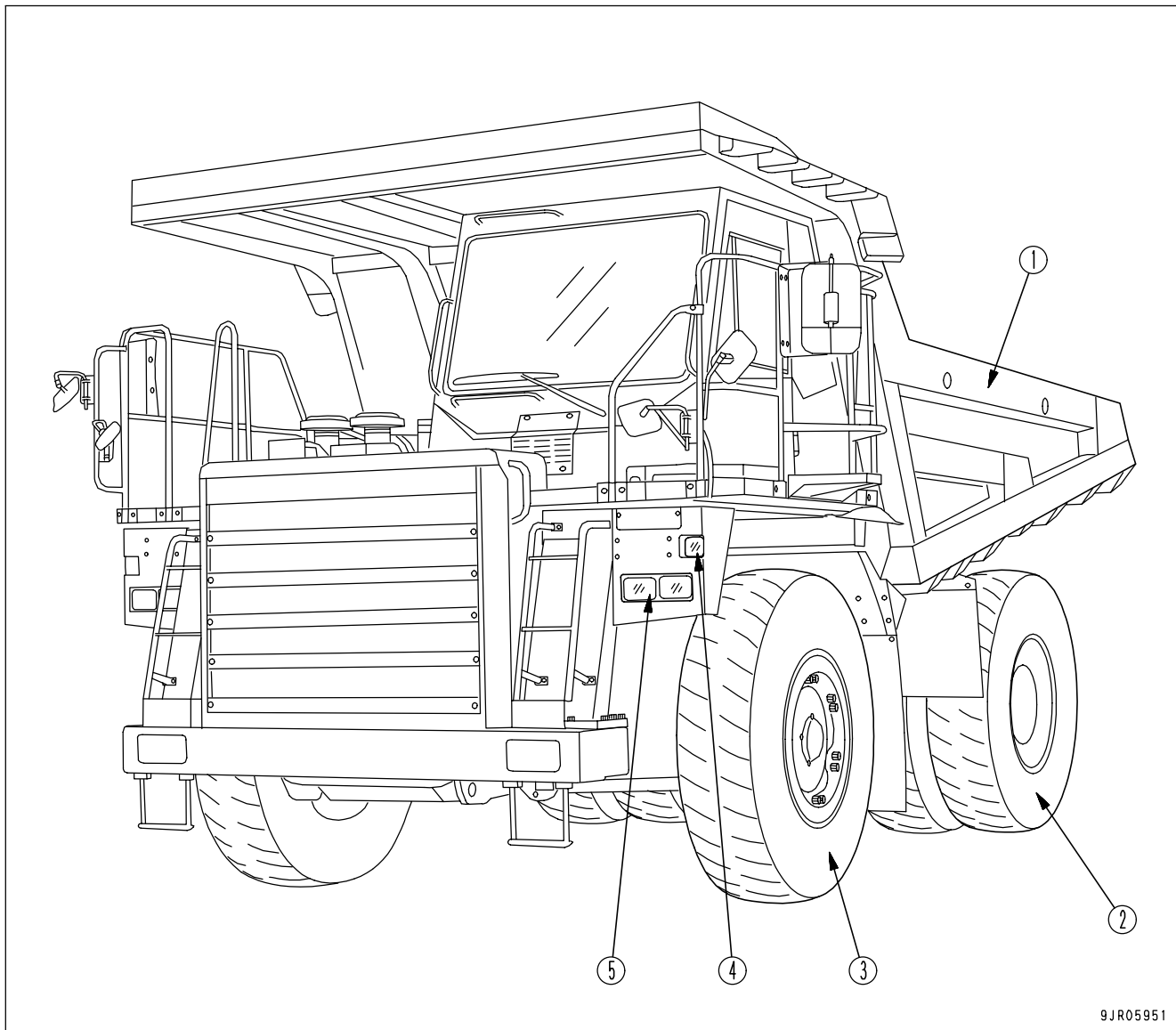

This illustration shows the HD325-7.

- |                 |                       |
|-----------------|-----------------------|
| (1) Dump body   | (4) Turn signal light |
| (2) Rear wheel  | (5) Head lamp         |
| (3) Front wheel |                       |

## GENERAL VIEW OF CONTROLS AND GAUGES

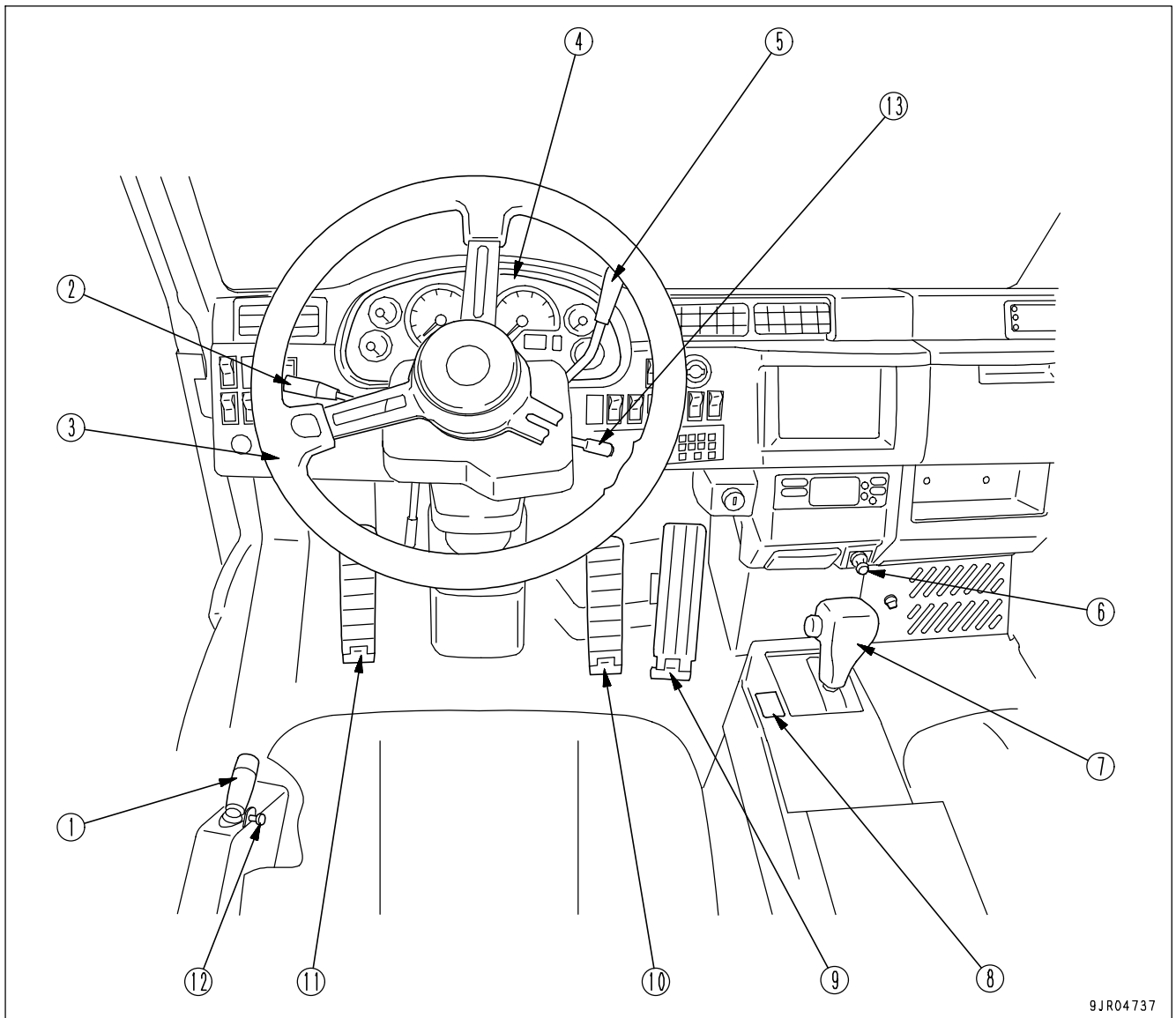

9JR04737

- |   |   |
|---|---|
| (1) Dump lever                                    | (8) Parking brake switch                          |
| (2) Lamp switch, Turn signal lever, Dimmer switch | (9) Accelerator pedal                             |
| (3) Steering wheel                                | (10) Brake pedal                                  |
| (4) Machine monitor                               | (11) Secondary brake pedal                        |
| (5) Retarder control lever                        | (12) Dump lever lock knob                         |
| (6) Cigarette lighter                             | (13) Auto retarder (ARSC) set lever (if equipped) |
| (7) Gear shift lever                              |   |



- Enlargement of machine monitor

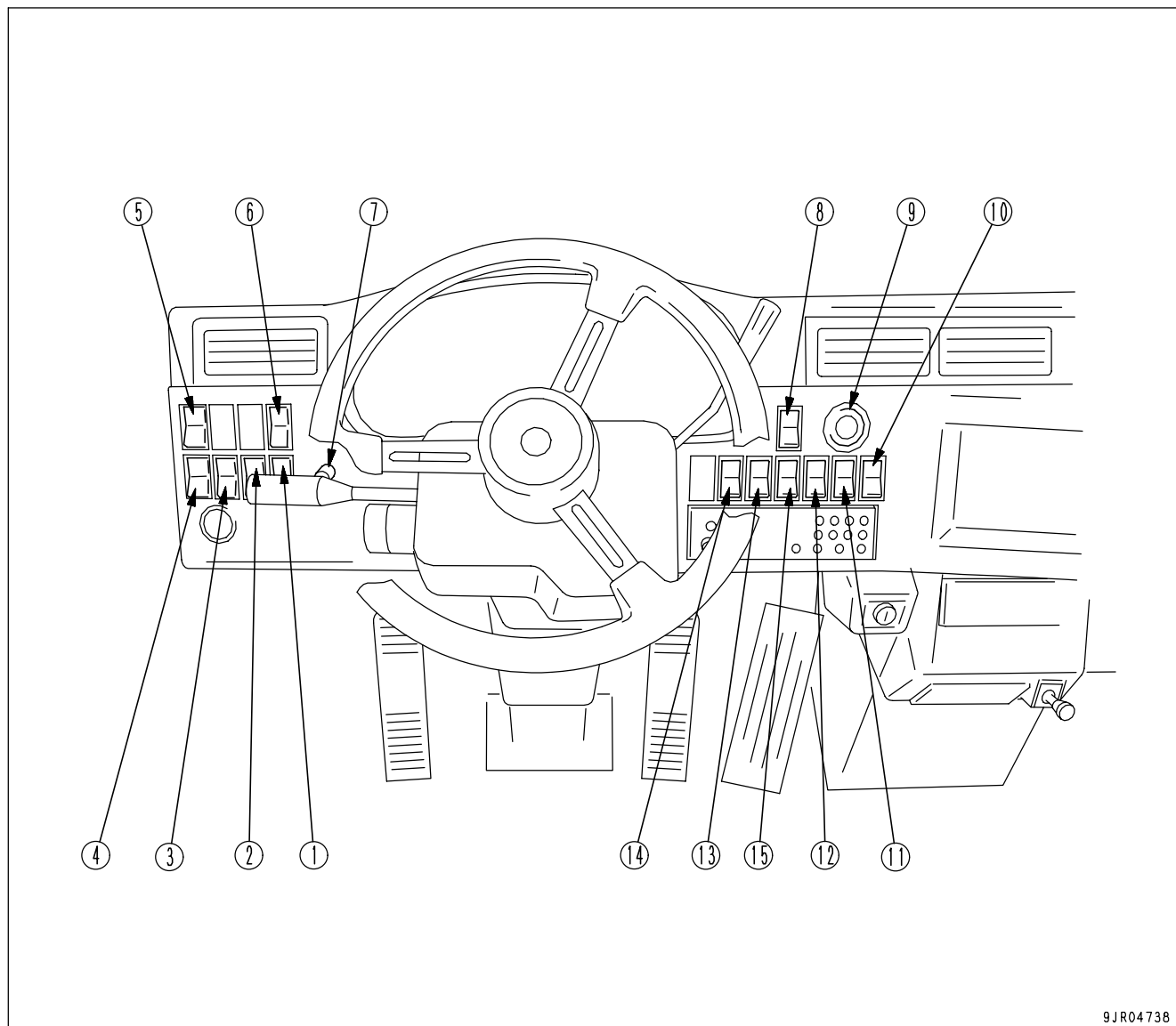

9JR04738

- |   |  |
|---|--|
| (1) Machine monitor mode selector switch 2    | (9) Emergency steering switch                  |
| (2) Machine monitor mode selector switch 1    | (10) Power mode selector switch                |
| (3) Fog lamp switch (if equipped)             | (11) AISS LOW switch                           |
| (4) Yellow rotating lamp switch (if equipped) | (12) Front brake cut-off switch                |
| (5) Side lamp switch (if equipped)            | (13) Auto retarder (ARSC) switch (if equipped) |
| (6) Machine monitor bulb check switch         | (14) ASR switch (if equipped)                  |
| (7) Night lighting dimmer switch              | (15) ABS switch (if equipped)                  |
| (8) Hazard lamp switch                        |  |

## EXPLANATION OF COMPONENTS

The following is an explanation of devices needed for operating the machine.

To perform suitable operations correctly and safely, it is important to completely understand methods of operating the equipment, and the meanings of the displays.

### MACHINE MONITOR

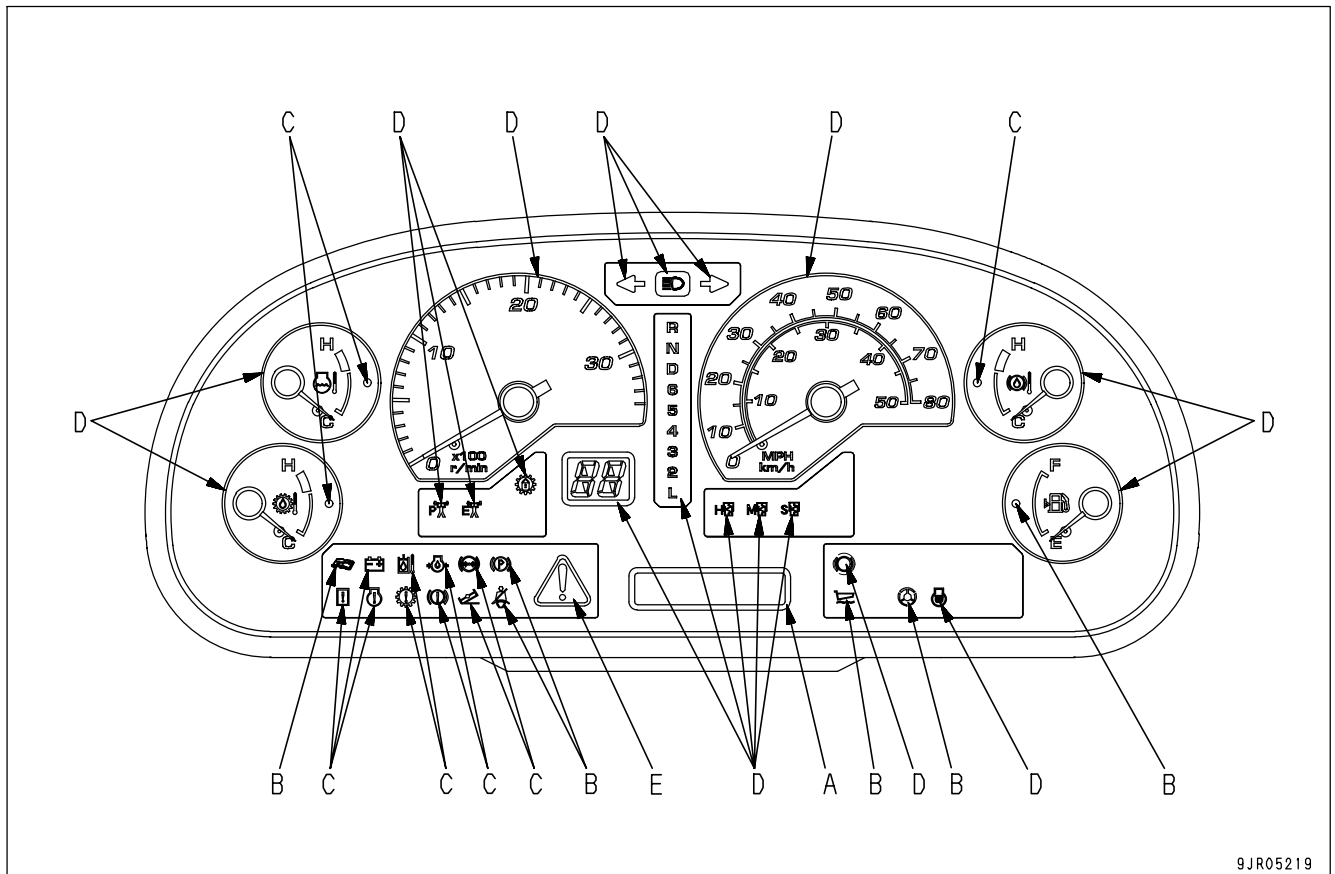

9JR05219

A: Character display

B: Caution items

C: Emergency stop items

D: Meter display portion

E: Central warning lamp

#### NOTICE

When the engine starting switch is turned to the ON position before starting the engine, a system check is carried out for 3 seconds.

- The central warning lamp lights up for 2 seconds, and then goes out.
- The alarm buzzer sounds for 2 seconds, and then stops.
- The monitor lamp lights up for 2 seconds and then goes out for 1 second.
- The shift indicator displays 88 for 2 seconds and then goes out for 1 second.
- After a 3-second system check, the meter starts to function.
- The character display shows "KOMATSU" for 3 seconds.
- If the lamps do not work, there is probably a failure or disconnection, so please contact your Komatsu distributor for inspection.
- When the starting switch is turned ON, if the shift lever is not at the neutral position, after completion of the system check, the shift lever position pilot lamp and the central warning lamp will light up, and the alarm buzzer will continue to sound intermittently. When this happens, if the shift lever is set at neutral, N is displayed, the central warning lamp goes out, and the buzzer stops.

**Check central warning lamp, alarm buzzer, monitor lamps, and meters.**

Before starting the engine, turn the starting switch to the ON position, press machine monitor check bulb switch (1), and check that there is no failure in the monitor lamps.

In addition to the gauges that function during the system check, the meter display portion is also actuated. When this happens, the character display shows the machine model and the software version of the machine monitor.

The gauges that do not function have probably failed, so please contact your Komatsu distributor for inspection.

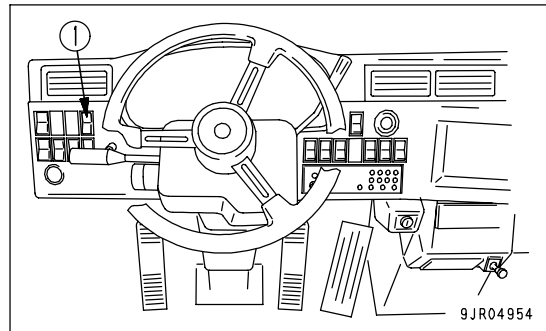

## CHARACTER DISPLAY

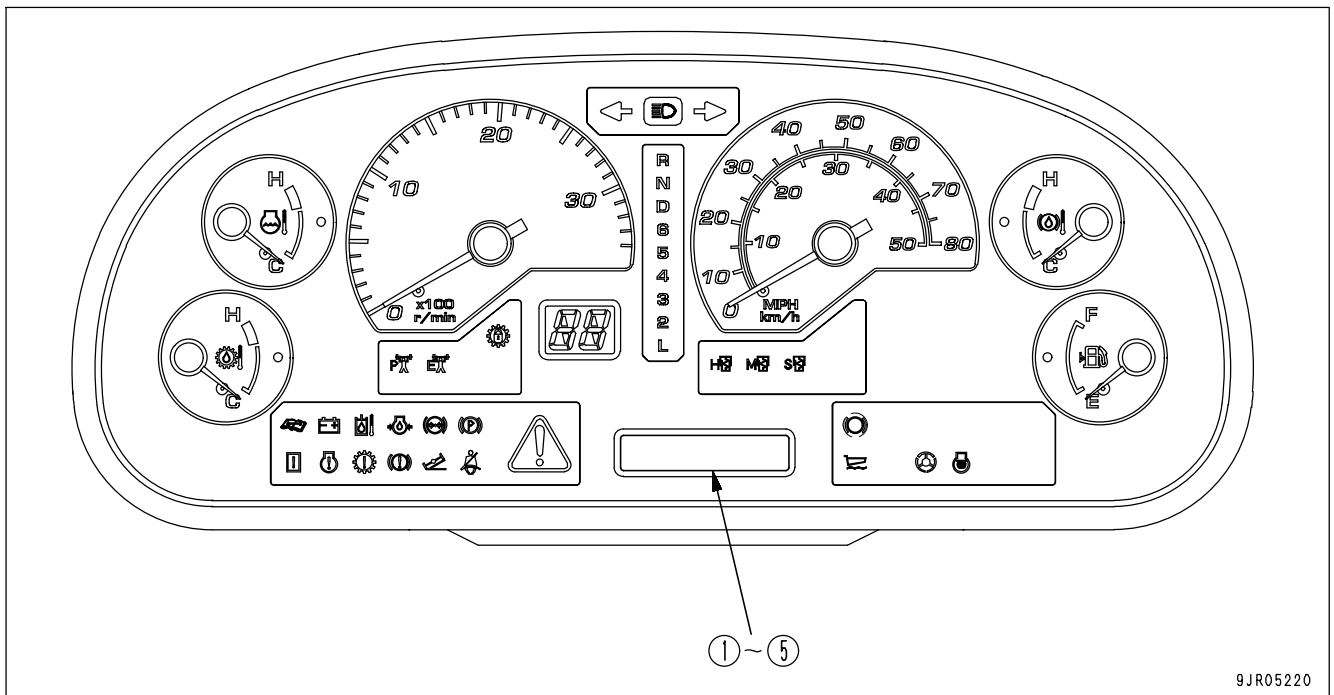

9JR05220

The character display can display the following items.

- |                             |  |
|-----------------------------|--|
| (1) Service meter           | (4) Action code display                  |
| (2) Odometer                | (5) Filter, oil replacement time display |
| (3) Reverse travel odometer |  |

Normally, the service meter/odometer is displayed on the character display.

If the machine has failed, or if there has been excessive load on the machine, or if it is necessary to carry out inspection and maintenance, an action code is displayed to recommend suitable action.

When the time for replacing the filter or changing the oil is reached, after completion of the system check with the starting switch at the ON position, the maintenance monitor caution lamps flash or light up, and at the same time, the filter or oil to be replaced is displayed.

## NOTICE

Information regarding the failure of the machine or maintenance is displayed on the character display when the starting switch is at the ON position, check the display to confirm that there is no problem before starting to travel.

**SERVICE METER**

This meter (1) shows the total time that the machine has been operating.

While the engine is running, the service meter advances even if the machine is not moving.

The meter advances by 1 for every hour of operation, regardless of the engine speed.

Even if the starting switch is at the OFF position, the service meter will display as long as the top part (◇) of machine monitor mode selector switch 1 is being pressed.

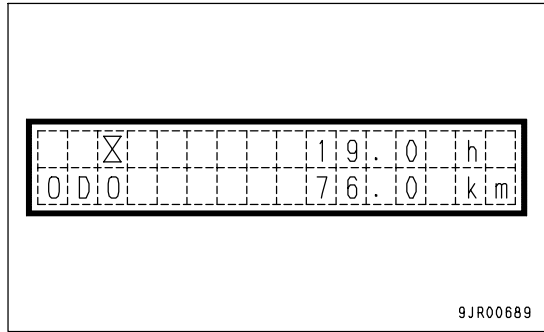

9JR00689

**NOTICE**

When the starting switch is at the OFF position, if the service meter is displayed even though the top (◇) of machine monitor mode selector switch 1 is not being pressed, there is probably a failure in the machine, so please contact your Komatsu distributor for inspection.

**ODOMETER**

This meter (2) indicates the total distance traveled in kilometers.

Even when the starting switch is at the OFF position, while the top (◇) of machine monitor mode selector switch 1 is being pressed, it indicates the total distance traveled.

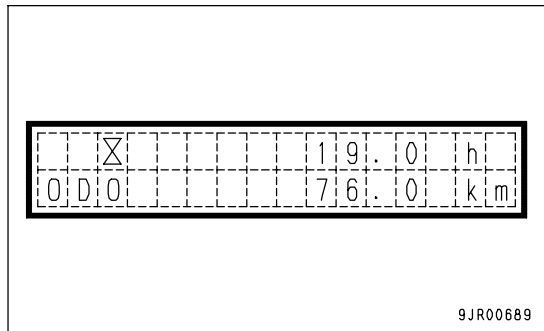

9JR00689

**NOTICE**

When the starting switch is at the OFF position, if the total distance is displayed even although the top (◇) of machine monitor mode selector switch 1 is not being pressed, there is probably a failure in the machine, so please contact your Komatsu distributor for inspection.

**REVERSE TRAVEL ODOMETER**

This meter (3) indicates the total distance traveled in reverse in kilometers.

For details of the method of displaying the total distance traveled in reverse, see "OTHER FUNCTIONS OF MACHINE MONITOR (PAGE 3-26)".

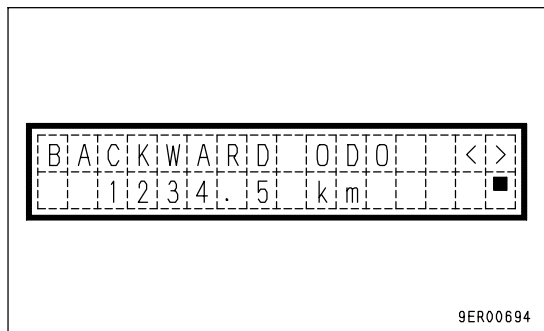

9ER00694

ACTION CODE DISPLAY



If action code E03 is displayed, stop the machine immediately. Then see "ACTION CODE (PAGE 3-141)" and contact your Komatsu distributor for repairs.

If the machine has failed, or if there has been excessive load on the machine, or if it is necessary to carry out inspection and maintenance, an action code is displayed on this panel (4) to recommend suitable action.

If more than one failure occurs at the same time, the most important action code is displayed. The order of importance, starting from the highest, is E03, E02, and E01. If failures of equal importance occur at the same time, the latest one is displayed.

When action codes E02 or E03 occur, the alarm buzzer sounds intermittently and the central warning lamp lights up.

E03: When this code is displayed, stop the machine immediately, check the failure code, and contact your Komatsu distributor for repairs.

REMARK

- The top line of the character display displays "E03" and the bottom line displays "CHECK RIGHT NOW" and "CALL" in turn for 3 seconds each.
- The telephone number is displayed on the right of the "CALL" display. If the telephone number has not been set, there is a blank. For details of the method of setting the telephone number, see "INPUT METHOD FOR TELEPHONE NUMBER (PAGE 3-29)".

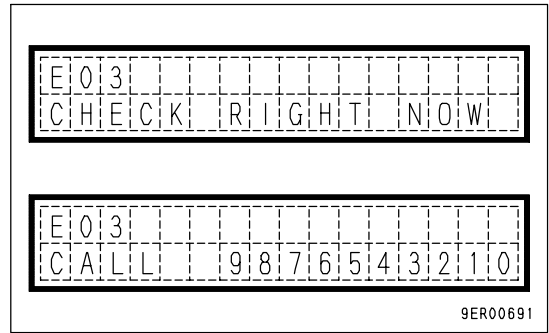

E02: If overrun related information is displayed, reduce the engine speed and the speed of the machine while continuing operations.

If the overheat related display is given, stop the machine and run the engine under no load at a mid-range speed.

If an action code is still displayed after doing this, check the failure code and contact your Komatsu distributor for repairs.

REMARK

The top line of the character display displays "E02" and the bottom line displays the condition of the machine related to overrun or overheat.

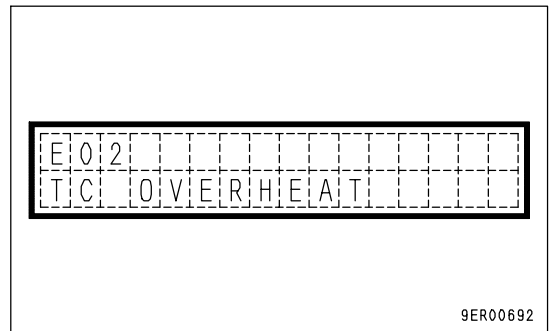

E01: If maintenance location is displayed and the maintenance caution lamp lights up, carry out inspection and maintenance of the displayed item after the completion of operations or when the shift changes.

If "MAINTENANCE" is displayed together with E01, check the failure code and contact your Komatsu distributor for repairs.

**REMARK**

"E01" is displayed on the top line of the character display and "MAINTENANCE" or the part of the machine requiring inspection, filling of fluid, or replacement is displayed on the bottom line.

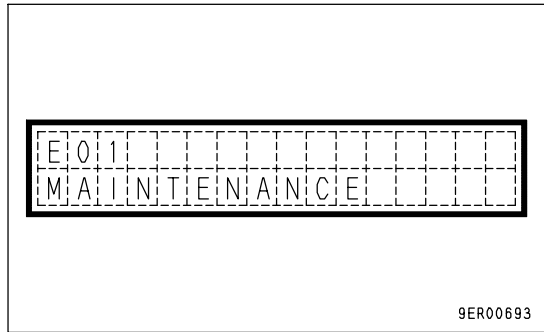

9ER00693

**FILTER, OIL REPLACEMENT TIME DISPLAY**

After completion of the system check, this display (5) shows for 30 seconds the filters and oil which are near the replacement interval. The maintenance caution lamp also flashes or lights up at the same time.

After replacing the filter or changing the oil, reset the replacement interval. For details, see "RESET METHOD FOR FILTER, OIL REPLACEMENT TIME (PAGE 3-27)".

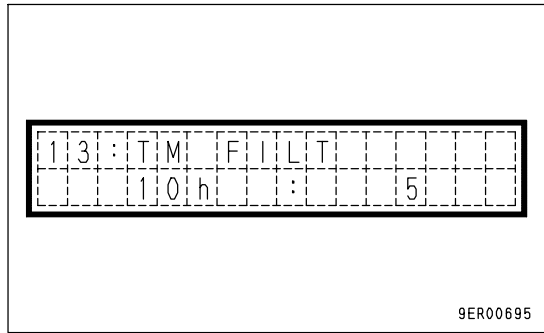

9ER00695

**REMARK**

- The top line of the character display shows the name and ID number of the item needing replacement. The line at the bottom shows the remaining time until replacement and the total number of times the item has been replaced.
- After giving the display for 30 seconds, the display does not appear again until the starting switch is turned again to the ON position.
- If the action code is being displayed, the message in the diagram above is not displayed on the character display.
- If there two or more items to be displayed, they are displayed every three seconds.
- If there are more than 10 items to be displayed, all the items are displayed once each.
- The display is given when the time reaches 30 hours before the filter and oil replacement interval.
- When the replacement interval approaches, the maintenance caution lamp flashes, and if the replacement interval has passed, the lamp lights up.

Items for display of filter, oil replacement time

Item	Replacement interval	Character display	ID number
Fuel prefilter	500	FUEL P FILT	41
Engine oil filter	500	ENG FILT	02
Engine oil	500	ENG OIL	01
Transmission oil filter (Pump outlet port)	500	TM FILT	13
Fuel main filter	1000	FUEL FILT	03
Corrosion resistor	1000	CORR RES	06
Torque converter, transmission and rear brake cooling oil	1000	TC/TM/BKOIL	24
Brake oil filter	1000	BK OIL FILT	14
Brake cooling oil filter	1000	BK C FILT	16
Steering, hoist oil filter	2000	HYD FILT	04
Differential case oil	2000	DIFF OIL	11
Final drive oil	2000	FNL OIL	08
Steering, hoist oil	4000	HYD OIL	10

#### REMARK

See the section below for details of procedure for replacing the filter and oil.

- Fuel prefilter  
"REPLACE FUEL PREFILTER CARTRIDGE (PAGE 4-56)"
- Engine oil filter  
"CHANGE OIL IN ENGINE OIL PAN, REPLACE ENGINE OIL FILTER CARTRIDGE (PAGE 4-55)"
- Engine oil  
"CHANGE OIL IN ENGINE OIL PAN, REPLACE ENGINE OIL FILTER CARTRIDGE (PAGE 4-55)"
- Transmission oil filter (Pump outlet port)  
"REPLACE TRANSMISSION OIL FILTER ELEMENT (PAGE 4-58)"
- Fuel main filter  
"REPLACE FUEL MAIN FILTER CARTRIDGE (PAGE 4-61)"
- Corrosion resistor  
"REPLACE CORROSION RESISTOR CARTRIDGE (PAGE 4-63)"
- Torque converter, transmission and rear brake cooling  
"CHANGE OIL IN TRANSMISSION CASE, BRAKE SUB TANK, WASH STRAINER (PAGE 4-64)"
- Brake oil filter  
"REPLACE BRAKE OIL FILTER ELEMENT (PAGE 4-68)"
- Brake cooling oil filter  
"REPLACE TRANSMISSION AND REAR BRAKE COOLING OIL FILTER ELEMENT (PAGE 4-67)"
- Steering, hoist oil filter  
"REPLACE STEERING, HOIST OIL TANK FILTER ELEMENT (PAGE 4-73)"
- Differential case oil  
"CHANGE OIL IN DIFFERENTIAL CASE (PAGE 4-75)"
- Final drive oil  
"CHANGE OIL IN FINAL DRIVE CASE (PAGE 4-74)"
- Steering, hoist oil  
"CHANGE OIL IN STEERING, HOIST OIL TANK (PAGE 4-77)"



CAUTION ITEMS

**!** CAUTION

If the monitor lights up during travel, inspect the location of the problem quickly and take the necessary action.

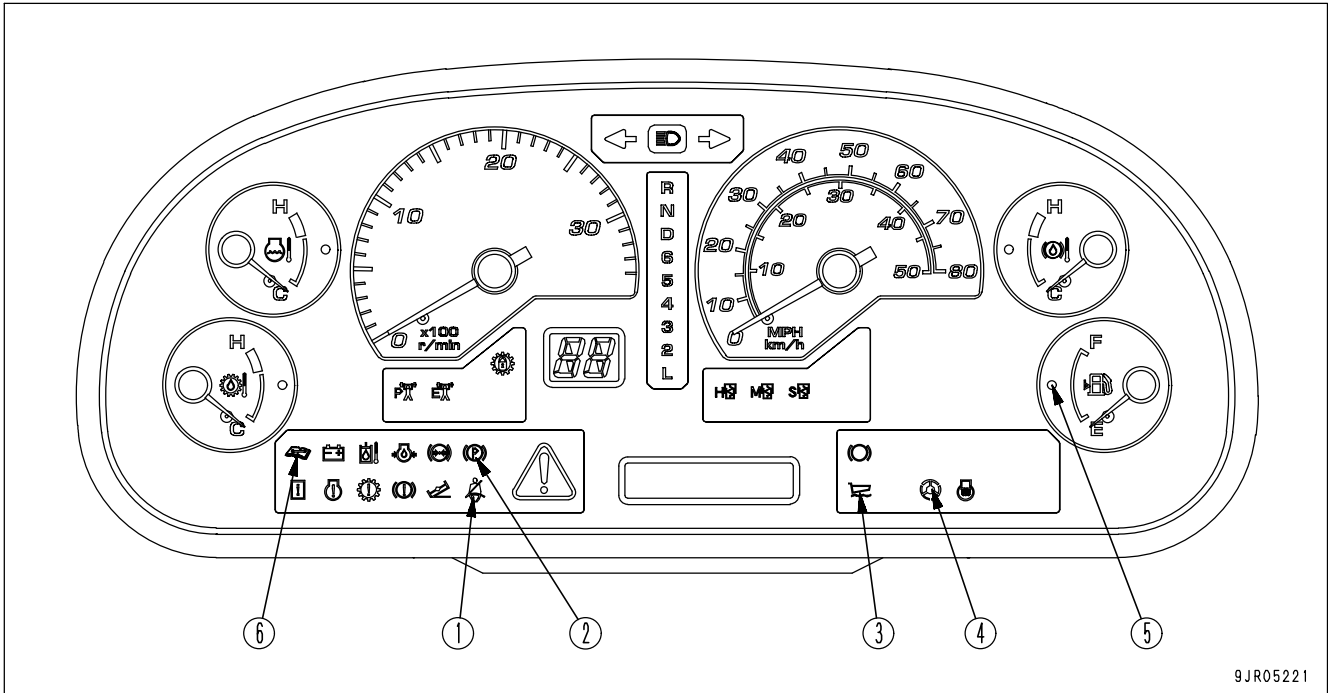

9JR05221

- (1) Seat belt caution lamp
- (2) Parking brake pilot lamp
- (3) Dump body pilot lamp
- (4) Emergency steering pilot lamp
- (5) Fuel level caution lamp
- (6) Maintenance caution lamp

**SEAT BELT CAUTION LAMP**

This monitor (1) lights up if the seat belt is not fastened. There is danger when traveling, so always fasten your seat belt.

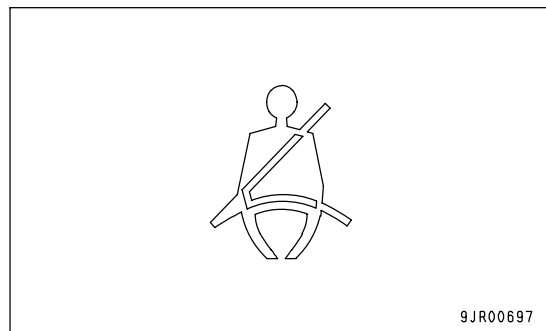

9JR00697

**PARKING BRAKE PILOT LAMP**

This monitor (2) lights up when the parking brake is applied.

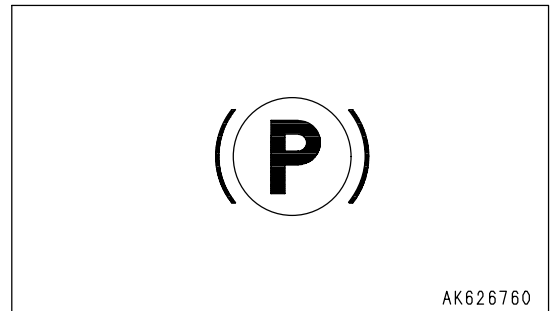

**DUMP BODY PILOT LAMP**

This monitor (3) lights up when the dump body is raised or the dump body lever is at any position other than "FLOAT".



**EMERGENCY STEERING PILOT LAMP**

This monitor (4) lights up when the emergency steering is actuated.

(Machines equipped with auto emergency steering)

If any problem should occur in the steering oil pressure circuit when the machine is traveling, the auto emergency steering is actuated and the related lamp lights up.

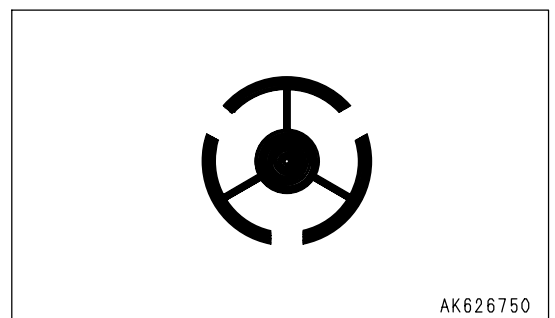

**FUEL LEVEL CAUTION LAMP**

This monitor (5) lights up when the level of the fuel remaining in the fuel tank goes below 60 liters (15.85 US gal).

If it lights up, check the fuel level and add fuel.

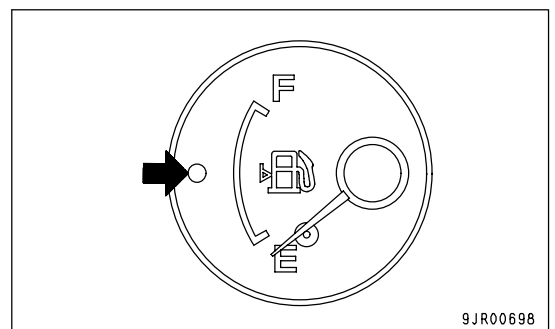

**MAINTENANCE CAUTION LAMP**

This monitor (6) lights up if any of the the following are applicable. When it lights up, action code "E01" and the location needing maintenance are displayed on the character display at the same time, so carry out inspection, filling, or replacement.

- Drop in engine oil level
- Clogged engine oil filter
- Clogged air cleaner
- Clogged transmission oil filter
- Drop in engine cooling water level

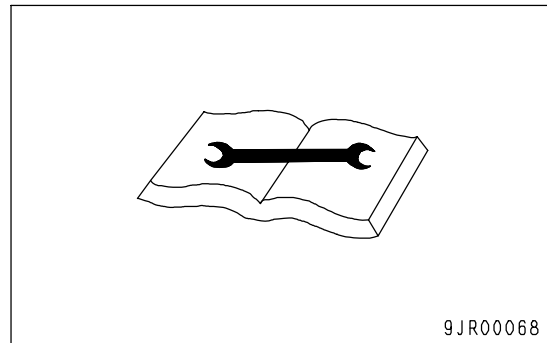
**REMARK**

In addition to the above, if the filter or oil replacement time is displayed on the character display, the lamp will flash or light up.

EMERGENCY STOP ITEM

**! CAUTION**

If the monitor lights up, stop operations immediately, then check the corresponding area and carry out the action.

If any problem is found in the emergency stop items, the alarm buzzer will sound intermittently, and the monitor for the location of the problem and the central warning lamp will light up.

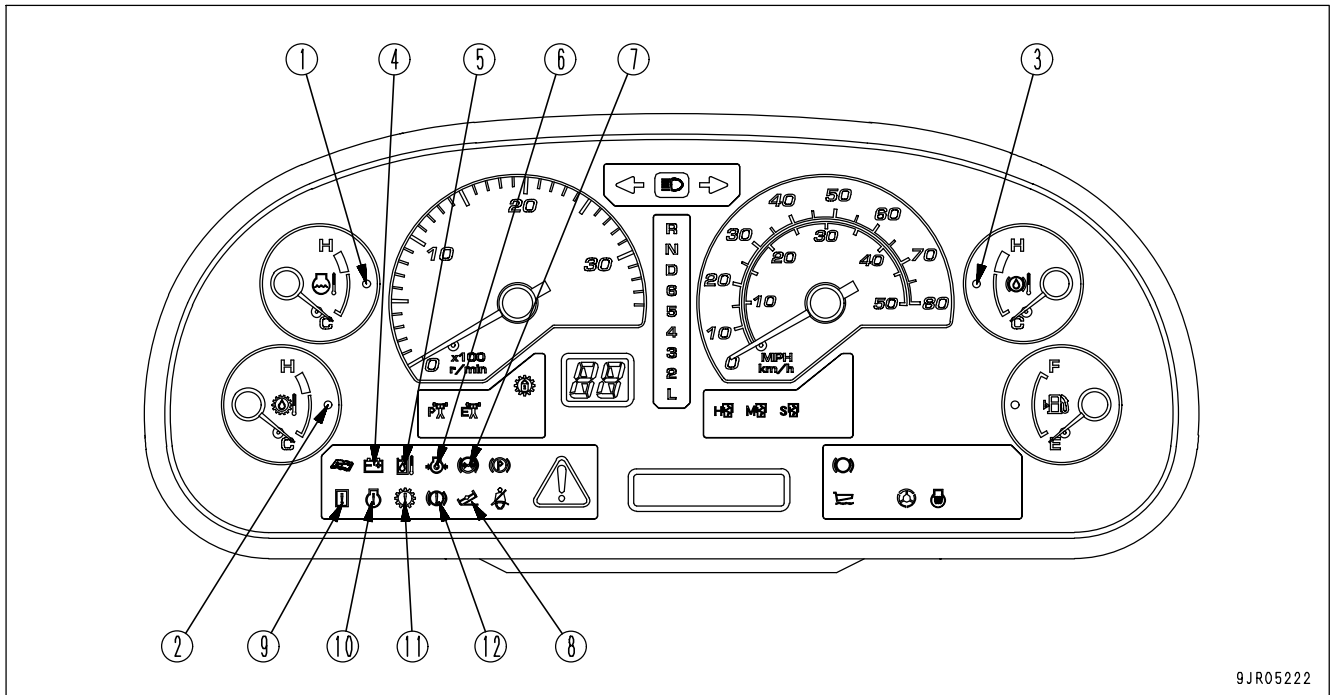

9JR05222

- |   |   |
|---|---|
| (1) Engine water temperature caution lamp                         | (8) Tilt caution lamp                           |
| (2) Torque converter oil temperature caution lamp                 | (9) Machine monitor, option system caution lamp |
| (3) Retarder oil temperature caution lamp                         | (10) Engine system caution lamp                 |
| (4) Battery charge circuit caution lamp                           | (11) Transmission system caution lamp           |
| (5) Steering oil temperature caution lamp                         | (12) Retarder system caution lamp               |
| (6) Engine oil pressure caution lamp                              |   |
| (7) Brake oil pressure caution lamp<br>(accumulator oil pressure) |   |

**ENGINE WATER TEMPERATURE CAUTION LAMP**

This monitor (1) warns the operator that the engine coolant temperature has risen.

When it lights up, "E02 ENGINE OVERHEAT" is displayed on the character display at the same time, and the engine output is automatically limited.

Run the engine under no load at a mid-range speed until the lamp goes out.

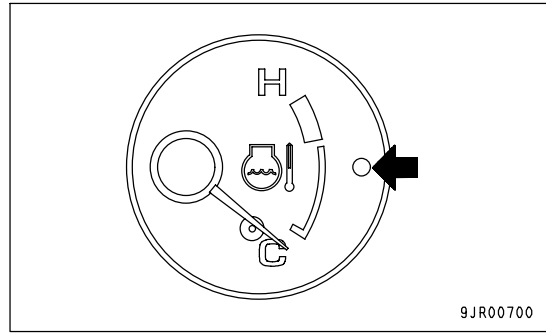

**TORQUE CONVERTER OIL TEMPERATURE CAUTION LAMP**

This monitor (2) warns the operator that the torque converter oil temperature has risen.

When it lights up, "E02 TC OVERHEAT" is displayed on the character display at the same time, so stop the machine in a safe place, set the gear shift lever to the N position, and run the engine under no load at a mid-range speed until the lamp goes out.

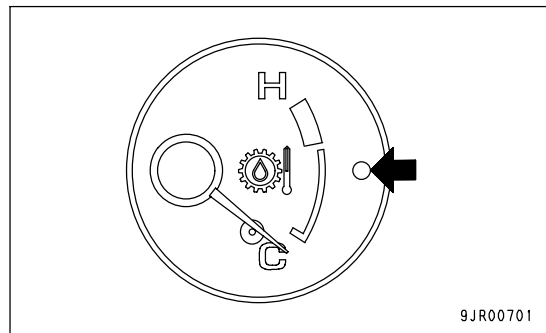

**RETARDER OIL TEMPERATURE CAUTION LAMP**

This monitor (3) warns the operator that the brake oil temperature has risen.

When it lights up, "E02 BRAKE OVERHEAT" is displayed on the character display at the same time, so stop the machine in a safe place, set the gear shift lever to the N position, and run the engine under no load at a mid-range speed until the lamp goes out.

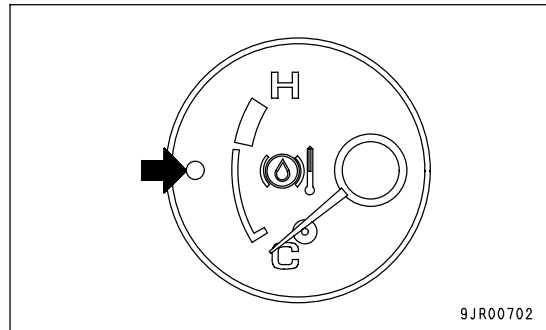

**BATTERY CHARGE CIRCUIT CAUTION LAMP**

This monitor (4) lights up when the engine is running to warn the operator of a problem in the charging system.

When it lights up, "E03 CHECK RIGHT NOW" is displayed on the character display at the same time, so stop the machine immediately at a safe place, then stop the engine and check the charging circuit.

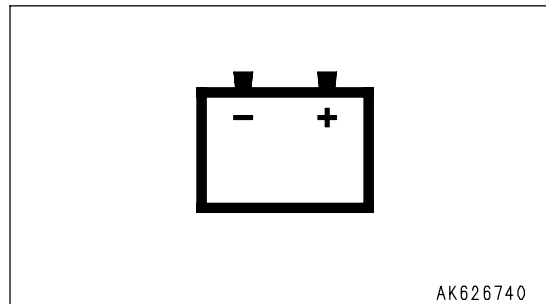

**STEERING OIL TEMPERATURE CAUTION LAMP**

This monitor (5) lights up to warn the operator that the steering oil temperature has risen.

When it lights up, "E02 STRG OVERHEAT" is displayed on the character display at the same time, so stop the machine in a safe place, set gear the shift lever to the N position, and run the engine under no load at a mid-range speed until the lamp goes out.

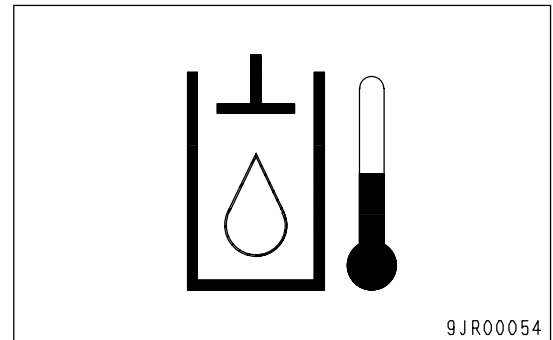
**ENGINE OIL PRESSURE CAUTION LAMP**

This monitor (6) lights up to warn the operator that the engine lubricating oil pressure has dropped.

When it lights up, "E03 CHECK RIGHT NOW" is displayed on the character display, and the engine output is automatically limited. Stop the machine immediately at a safe place, then stop the engine and carry out inspection.

The lamp lights up if the engine lubricating oil pressure goes below the specified value when the engine is running,  
If the engine is not running, the lamp does not light up.

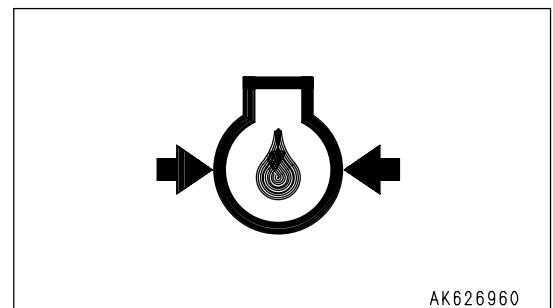
**BRAKE OIL PRESSURE CAUTION LAMP**

This monitor (7) lights up to warn the operator that the brake accumulator oil pressure has dropped below the specified value. The central warning lamp and alarm buzzer are not actuated when the engine is stopped.

If the accumulator oil pressure is still lower than the specified value 30 seconds after the engine has been started, "E03 CHECK RIGHT NOW" is displayed on the character display, so stop the machine immediately at a safe place, then stop the engine and carry out inspection.

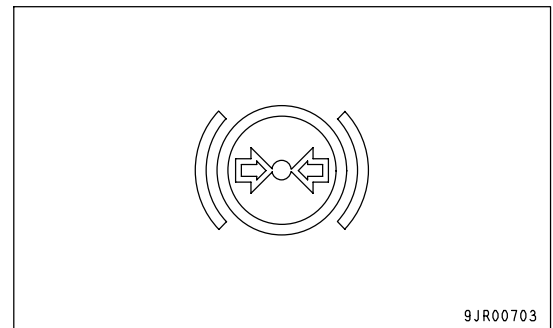
**TILT CAUTION LAMP**

This monitor (8) lights up if the dump body has left its seat when the rear frame of the machine has tilted beyond the safety range to the left or right.

Lower the dump body and move the machine to a safe place where the machine is stable.

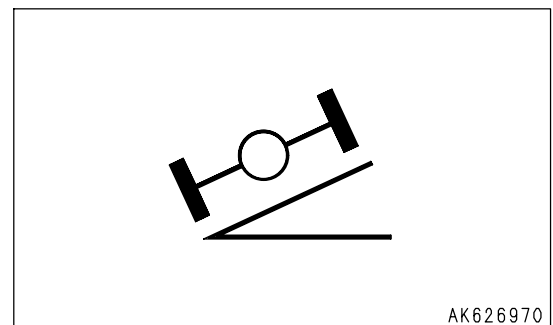

**MACHINE MONITOR, OPTION SYSTEM CAUTION LAMP**

This monitor (9) lights up when a problem has been detected in the machine monitor or in the system for an installed option.

When it lights up, "E03 CHECK RIGHT NOW" is displayed on the character display at the same time, so stop the machine immediately at a safe place, then stop the engine and carry out inspection.

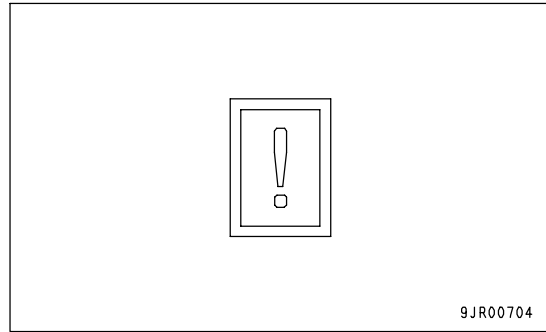

**ENGINE SYSTEM CAUTION LAMP**

This monitor (10) lights up when a problem has been detected in the system controlled by the engine controller.

When it lights up, "E03 CHECK RIGHT NOW" is displayed on the character display at the same time, so stop the machine immediately at a safe place, then stop the engine and carry out inspection.

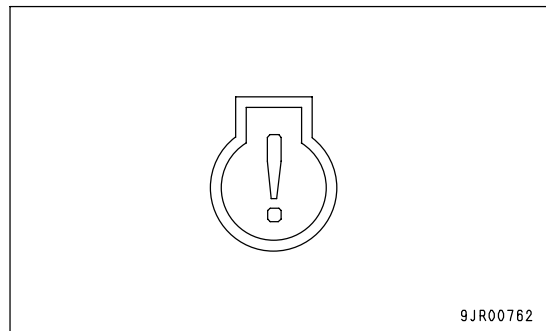

**TRANSMISSION SYSTEM CAUTION LAMP**

This monitor (11) lights up when a problem has been detected in the system controlled by the transmission controller.

When it lights up, "E03 CHECK RIGHT NOW" is displayed on the character display at the same time, so stop the machine immediately at a safe place, then stop the engine and carry out inspection.

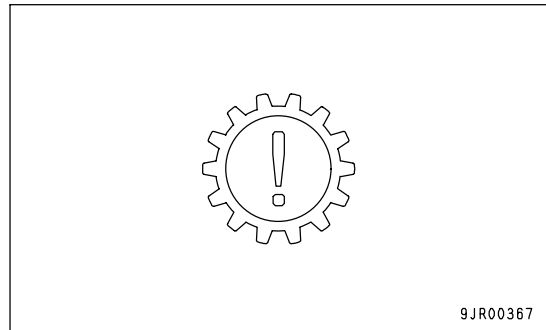

**RETARDER SYSTEM CAUTION LAMP**

This monitor (12) lights up when a problem has been detected in the system controlled by the retarder controller.

When it lights up, "E03 CHECK RIGHT NOW" is displayed on the character display at the same time, so stop the machine immediately at a safe place, then stop the engine and carry out inspection.

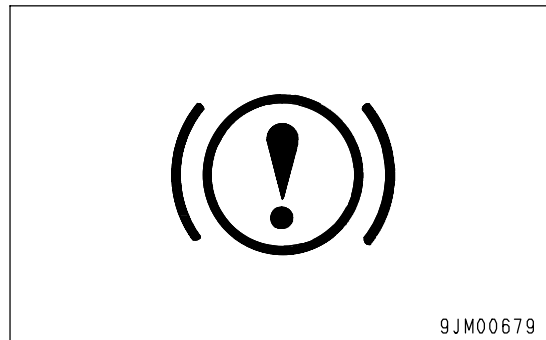

METER DISPLAY PORTION

PILOT DISPLAY PORTION

When the starting switch is ON, the pilot display lights up when the display items are functioning.

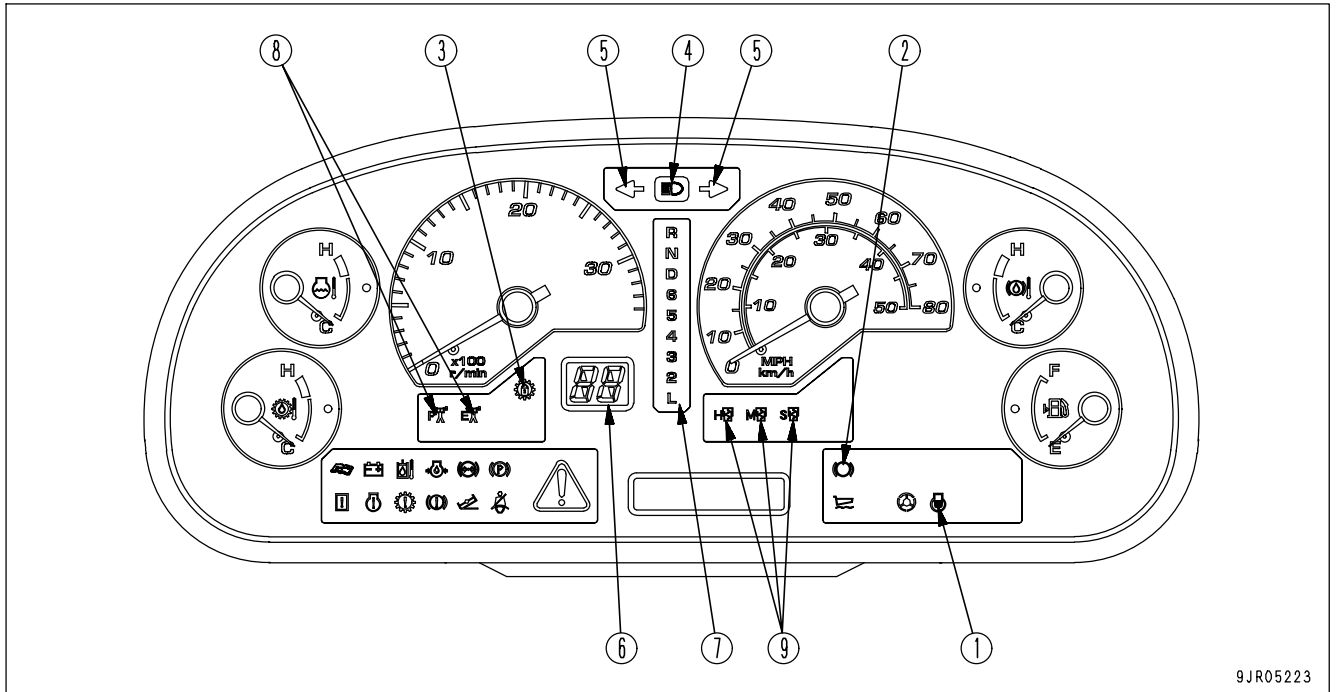

9JR05223

- (1) Preheating pilot lamp
- (2) Retarder pilot lamp
- (3) Lockup pilot lamp
- (4) Head lamp high beam pilot lamp
- (5) Turn signal pilot lamp
- (6) Shift indicator
- (7) Shift lever position pilot lamp
- (8) Power mode pilot lamp
- (9) Auto suspension mode pilot lamp (if equipped)

ENGINE PRE-HEATING PILOT LAMP

This monitor (1) lights up when the electrical heater for pre-heating the engine is being actuated. When the starting switch is turned to the ON position in cold weather, the monitor lights up. It goes out after 20 to 30 seconds to indicate that the pre-heating has been completed.

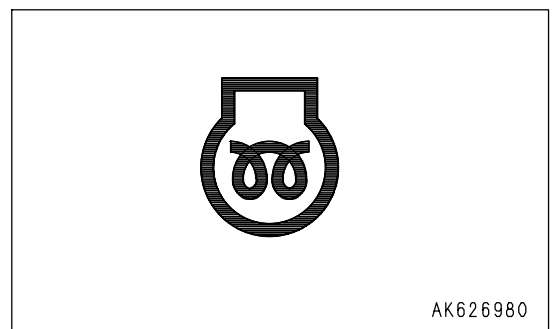

AK626980



**RETARDER PILOT LAMP**

This monitor (2) lights up when the retarder control lever is pulled and the retarder is actuated.

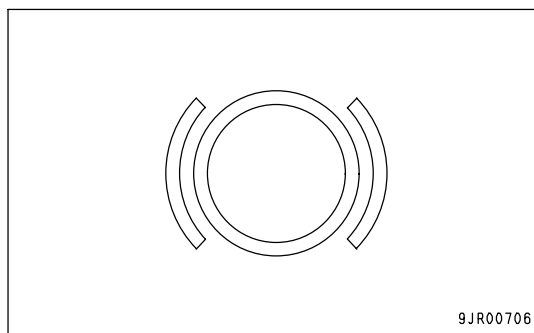
**LOCKUP PILOT LAMP**

This monitor (3) lights up when the torque converter lockup is engaged and the transmission is shifted to direct drive.

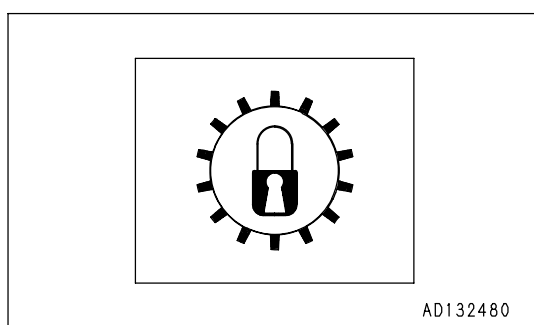
**HEAD LAMP HIGH BEAM PILOT LAMP**

This monitor (4) lights up when the head lamps are set to high beam.

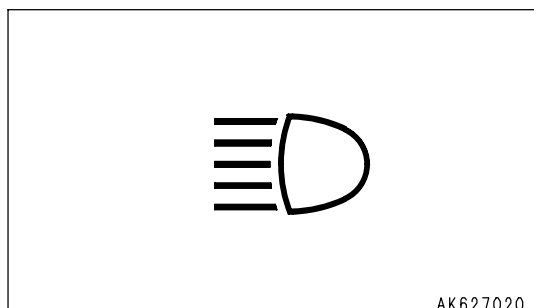
**TURN SIGNAL PILOT LAMP**

This monitor (5) flashes at the same time as the turn signal lamp flashes.

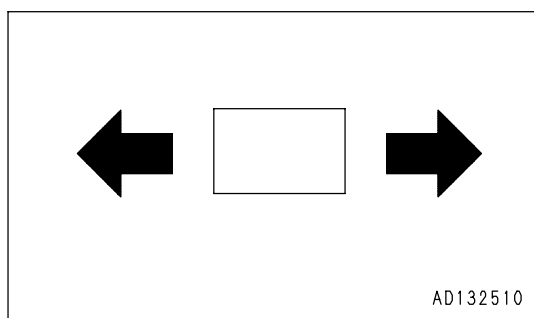

**SHIFT INDICATOR**

This monitor (6) shows the transmission shift range (speed range).

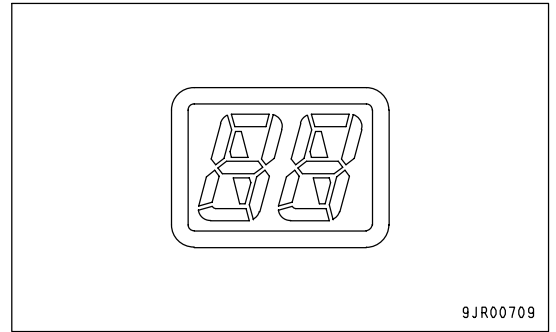

**SHIFT LEVER POSITION PILOT LAMP**

This monitor (7) displays the position of the shift lever.  
The letter or number for the speed range selected by the shift lever lights up.

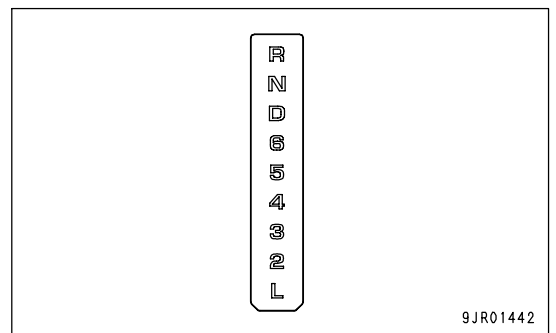

**POWER MODE PILOT LAMP**

This monitor (8) displays the power mode.  
When the mode is selected with the power mode selector switch, either High Power (P) or Economy (E) lights up.

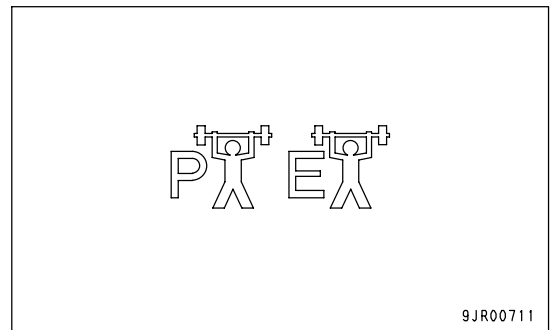

**AUTO SUSPENSION MODE PILOT LAMP**

(If equipped)

This monitor (9) displays the suspension mode, when the machine is equipped with the suspension controller.

On machines equipped with an automatic suspension system, the suspension system automatically switches the damping characteristics of the suspension according to the size of the load, use of the brake, operation of the steering, and operation of the dump control.

Normally it is set to the soft mode when the dump truck is traveling empty and to the medium mode when it is traveling loaded. When the foot brake is operated or the machine is suddenly turned, or the dump control is operated, the suspension mode is switched to insure the stability of the machine to the front and rear, and left and right.

H : Hard mode

M : Medium mode

S : Soft mode

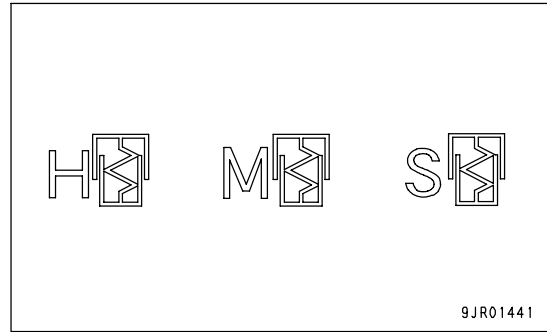

METERS

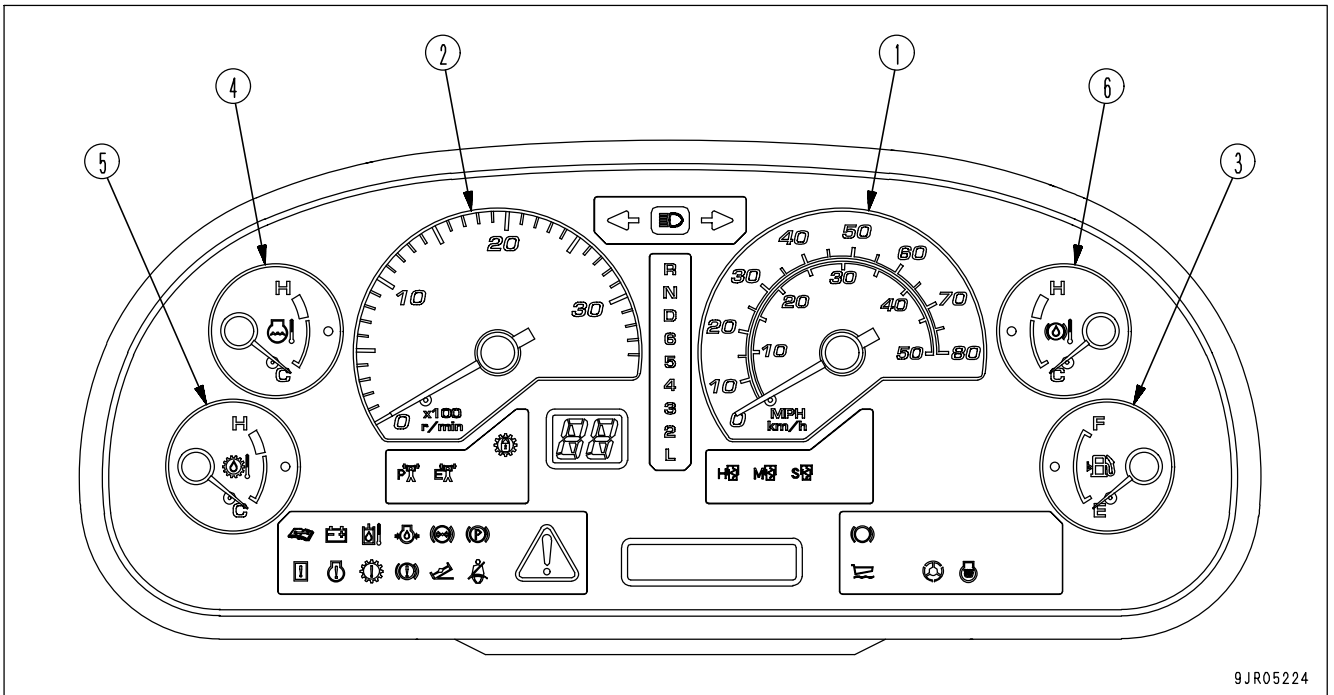

9JR05224

- (1) Speedometer
- (2) Engine tachometer
- (3) Fuel gauge
- (4) Engine water temperature gauge
- (5) Torque converter oil temperature gauge
- (6) Retarder oil temperature gauge

SPEEDOMETER

This meter (1) indicates the travel speed of the machine.

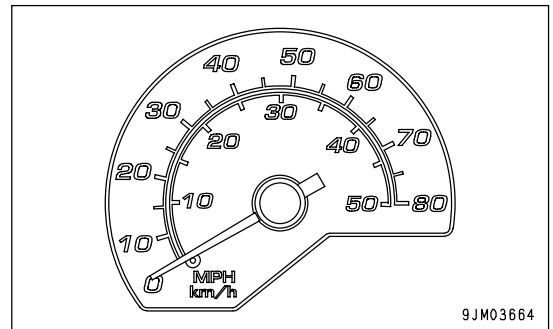

9JM03664

ENGINE TACHOMETER

This meter (2) shows the engine speed.

If the gauge indicates the red range during operations, the alarm buzzer will sound and the central warning lamp will light up at the same time, so reduce the engine speed and the machine travel speed.

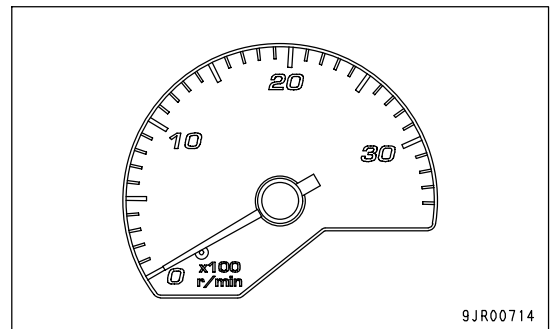

9JR00714

**FUEL GAUGE**

This meter (3) shows the amount of fuel remaining in the fuel tank. When the fuel level caution lamp lights up, it indicates that there is less than 60 liters (15.85 US gal) of fuel remaining in the tank, so check and add fuel.

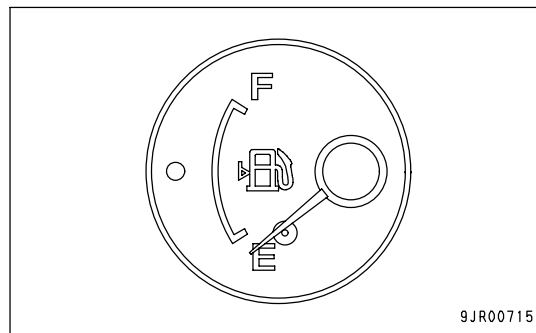

9JR00715

**ENGINE WATER TEMPERATURE GAUGE**

This meter (4) indicates the engine water temperature.

It should be in the white range during operation.

If it is in the red range during operation, the alarm buzzer will sound and the central warning lamp will light up at the same time. "E02 ENGINE OVERHEAT" is displayed on the character display, so run at the engine under no load at a mid-range speed and wait until the meter enters the white range.

If it is in the red range, the engine output is automatically limited.

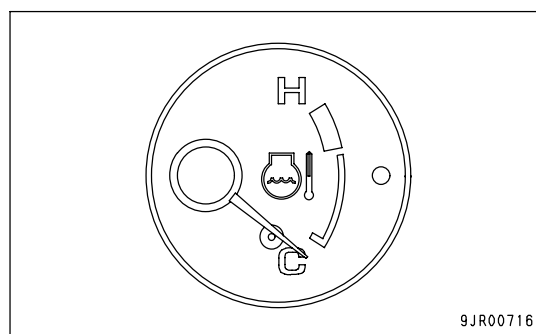

9JR00716

**TORQUE CONVERTER OIL TEMPERATURE GAUGE**

This meter (5) indicates the torque converter oil temperature.

It should be in the white range during operation.

If it is in the red range during operation, the alarm buzzer will sound and the central warning lamp will light up. "E02 TC OVERHEAT" is displayed on the character display, so run the engine under no load at a mid-range speed and wait until the meter enters the white range.

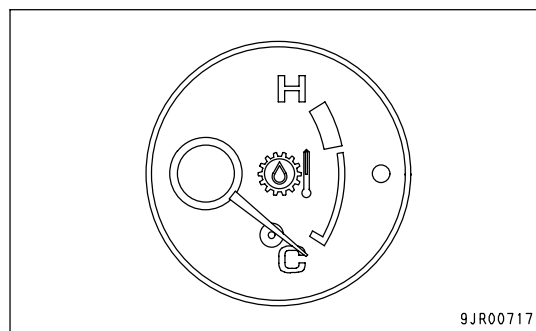

9JR00717

**RETARDER OIL TEMPERATURE GAUGE**

This meter (6) indicates the retarder oil temperature.

It should be in the white range during operation.

If it is in the red range during operation, the alarm buzzer will sound and the central warning lamp will light up at the same time. "E02 BRAKE OVERHEAT" is displayed on the character display, so stop the machine in a safe place, set the gear shift lever to the N position, run the engine under no load at a mid-range speed and wait until the lamp goes out.

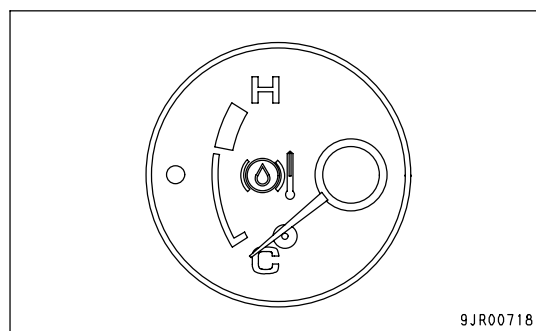

9JR00718

### CENTRAL WARNING LAMP

If the machine is in the following condition, this lamp will flash, and at the same time, the alarm buzzer will sound intermittently.

- When a problem has occurred in any of "EMERGENCY STOP ITEM (PAGE 3-15)".
- When action code "E02" or "E03" is displayed on the character display.
- If the parking brake is applied, but the gear shift lever is not at the N position.
- When the dump lever is not at the FLOAT position or the dump body is raised and the gear shift lever is not at the N position.
- When the engine tachometer indicates the red range.

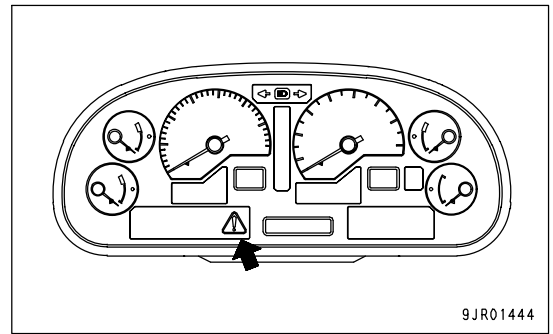

## OTHER FUNCTIONS OF MACHINE MONITOR

### DISPLAY METHOD FOR REVERSE TRAVEL ODOMETER

Use this when checking the total travel distance in reverse.

1. Check that the character display is showing the service meter/odometer, or the action code. If it is giving any other display, turn the starting switch OFF, then turn the starting switch to the ON position and wait for the above display to be given.
2. Press the (◇) of machine monitor mode selector switch 1. It displays the overall distance traveled in reverse.
3. When completing the operation, press (■) of machine monitor mode selector switch 1 or turn the starting switch OFF.

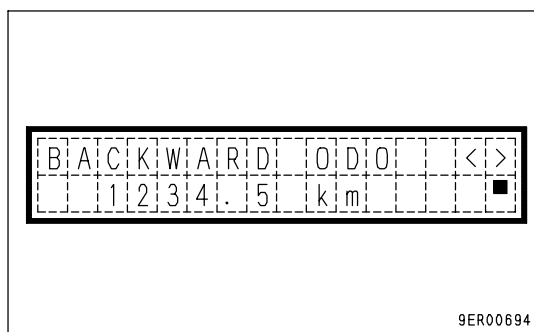

**RESET METHOD FOR FILTER, OIL REPLACEMENT TIME**

The filter and oil replacement time is displayed on the character display, so if the filter and oil have been replaced, reset the filter and oil change time.

1. Press the (◇) of machine monitor mode selector switch 1, and display the reverse travel in odometer.
2. Press (>) or (<) of machine monitor mode selector switch 2 and display "MAINTENANCE MONITOR".

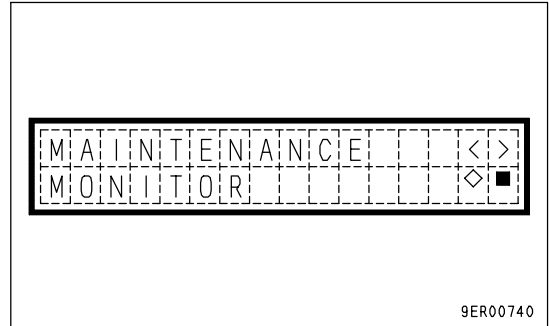

3. Press the (◇) of machine monitor mode selector switch 1. It will change to the display in the diagram on the right. The bottom line shows two items: the replacement time on the left and the total number of times the item has been replaced on the right.

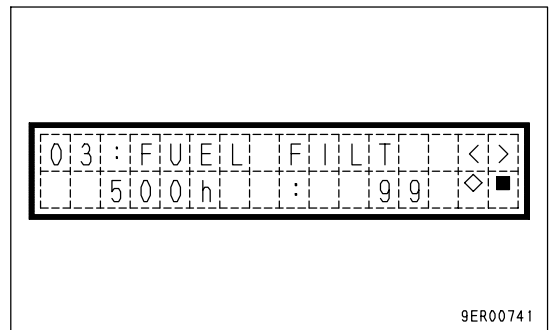

4. Press (>) or (<) of machine monitor mode selector switch 2 and display the item to be reset.

5. Press the (◇) of machine monitor mode selector switch 1. It will change to the display in the diagram on the right. The top line shows [Reset] and [Item to be reset] in turn.

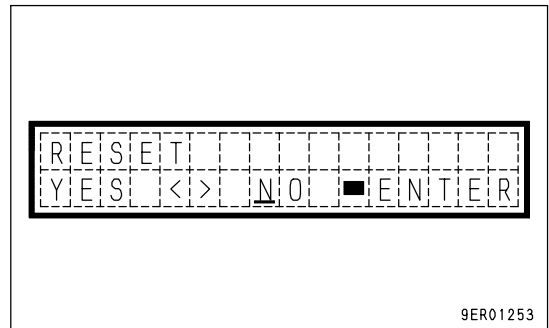

6. When resetting the replacement time, press (>) or (<) of machine monitor mode selector switch 2, align the cursor with "YES", then press (■) of machine monitor mode selector switch 1. It will reset and returned to the previous screen. To abandon, align the cursor with "NO", then press (■) of machine monitor mode selector switch 1.

7. When resetting the replacement time for another item, carry out the procedure from Step 4. After completing, press (■) of machine monitor mode selector switch 1 twice or turn the starting switch OFF.



**METHOD FOR SELECTING LANGUAGE**

Use this when switching the language displayed on the character display.

1. Press the (◇) of machine monitor mode selector switch 1 and display the reverse travel odometer.
2. Press (>) or (<) of machine monitor mode selector switch 2 and display "LANGUAGE".

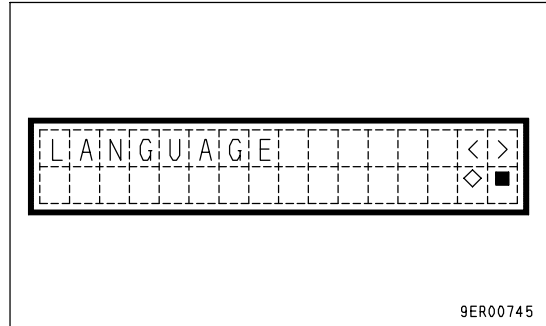

3. Press the (◇) of machine monitor mode selector switch 1. The presently selected language is displayed.
4. Press (>) or (<) of machine monitor mode selector switch 2 and select the language.

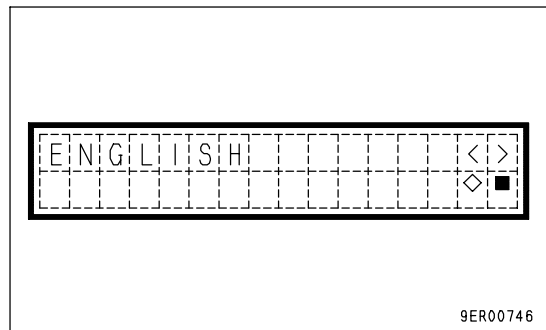

The available languages are English, Japanese, German, French, Italian, Spanish, and Swedish.

Language	Display
English	ENGLISH
Japanese	日本語
German	DEUTSCH
Franch	FRANCAIS
Italian	ITALIANO
Spanish	Español
Swedish	SVENSKA

5. When the (◇) of machine monitor mode selector switch 1 is pressed, the language is set and the screen returns to the previous screen.
6. When completing the operation, press (■) of machine monitor mode selector switch 1 twice or turn the starting switch OFF.

**INPUT METHOD FOR TELEPHONE NUMBER**

When an error for action code "E03" occurs, it is possible to display the telephone number.

1. Press the (◇) of machine monitor mode selector switch 1 and display the reverse travel odometer.
2. Press (>) or (<) of machine monitor mode selector switch 2 and display "TEL".

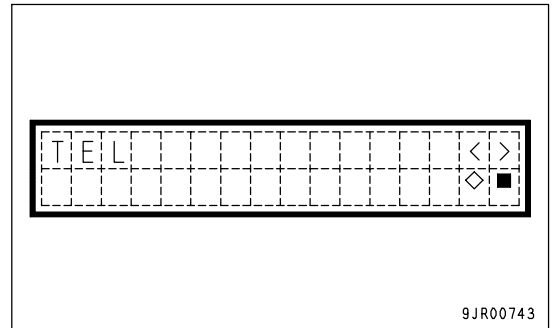

3. Press (◇) of machine monitor mode selector switch 1. It will change to the display in the diagram on the right.

Once the telephone number is input, the input number will be displayed next time.

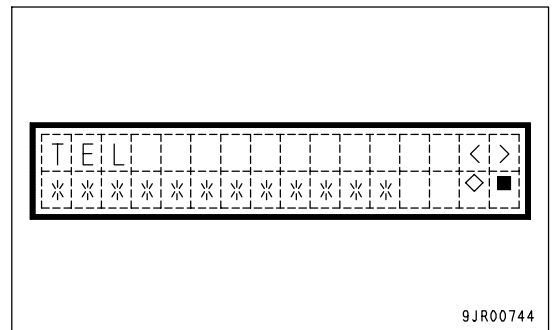

4. Up to 12 digits can be displayed for the telephone number. Input from the first digits.  
The cursor is displayed at the input position. Press (>) or (<) of machine monitor mode selector switch 2 and display "0 - 9". To leave a blank, select "\*\*".

When the input value is decided, press (◇) of machine monitor mode selector switch 1. The cursor will move to the next position.

5. Repeat the procedure in Step 4 until the last digit. At the last digit, press (◇) of machine monitor mode selector switch 1 to return to the previous screen.  
If there is a mistake in the input or the input is to be stopped, press (■) of machine monitor mode selector switch 1 to return to the previous screen.
6. When completing the operation, press (■) of machine monitor mode selector switch 1 twice or turn the starting switch OFF.

## SWITCHES

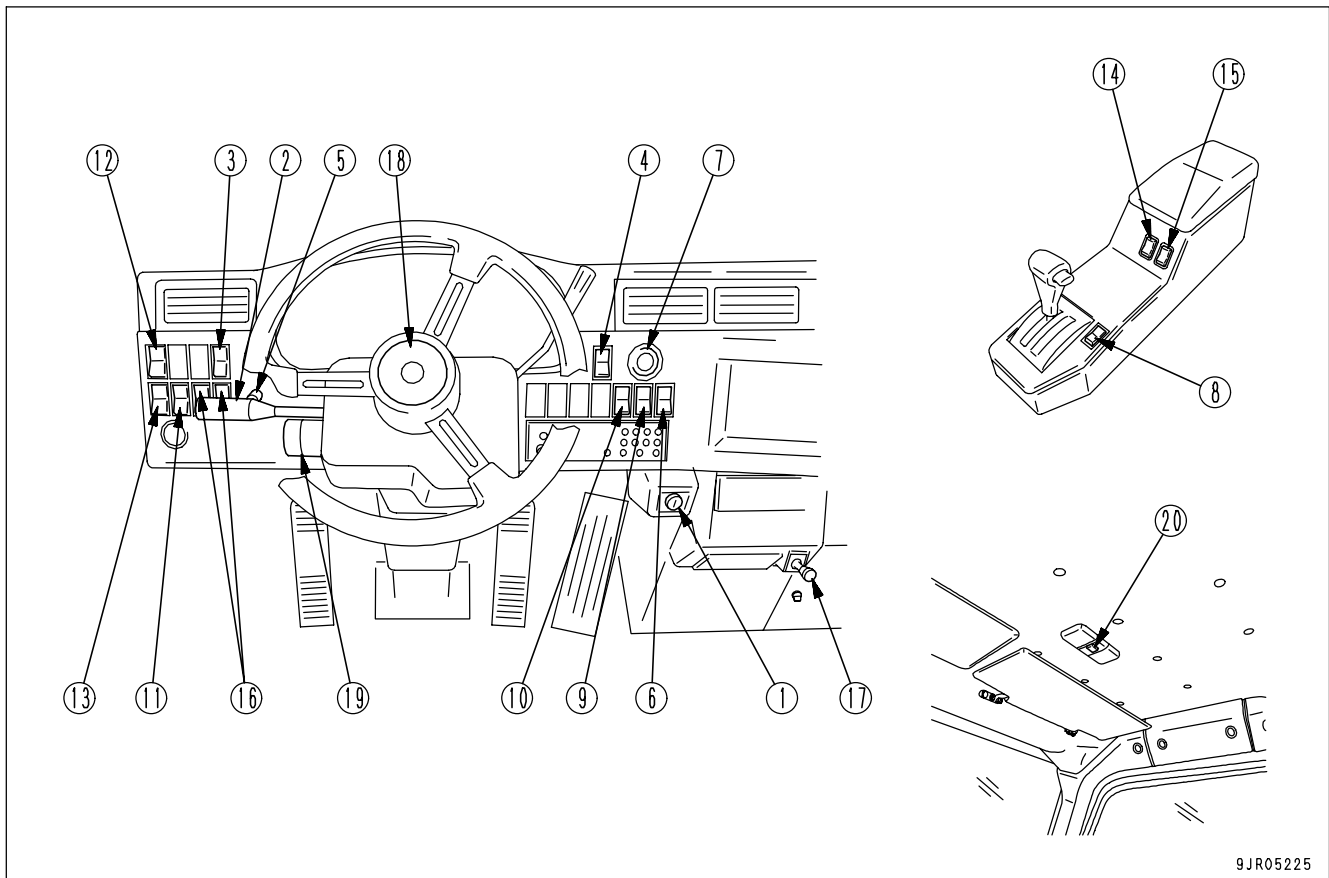

9JR05225

- |                                       |  |
|---------------------------------------|--|
| (1) Starting switch                   | (10) Front brake cut-off switch                |
| (2) Lamp switch                       | (11) Fog lamp switch (if equipped)             |
| Turn signal lever                     | (12) Side lamp switch (if equipped)            |
| Dimmer switch                         | (13) Yellow rotating lamp switch (if equipped) |
| (3) Machine monitor bulb check switch | (14) Power window switch (right) (if equipped) |
| (4) Hazard lamp switch                | (15) Power window switch (left)                |
| (5) Night lighting dimmer switch      | (16) Machine monitor mode selector switch 1, 2 |
| (6) Power mode selector switch        | (17) Cigarette lighter                         |
| (7) Emergency steering switch         | (18) Horn button                               |
| (8) Parking brake switch              | (19) Wiper, window washer switch               |
| (9) AISS LOW switch                   | (20) Room lamp switch                          |

**STARTING SWITCH**

This switch (1) is used to start or stop the engine.

**OFF position :**

At this position, the starting switch key can be inserted or removed. When the key is turned to this position, all the electric circuits are switched off and the engine stops.

**ON position :**

In this position, electric current flows in the charging and lamp circuits.

Keep the starting switch key at the ON position while the engine is running.

When turning the starting switch ON or OFF, if the starting switch is held at a position between ON and OFF, the controller may detect this as a problem. If this happens, return the starting switch to the OFF position, then operate it as usual to the ON position.

In cold weather, if the starting switch is turned to the ON position, pre-heating is automatically started and the engine pre-heating pilot lamp lights up. After the pre-heating is completed, the engine pre-heating pilot lamp goes out.

**START position :**

This is the position to start the engine. Hold the key at this position while cranking. Release the key immediately after the engine has been started. The key will return to the ON position when released.

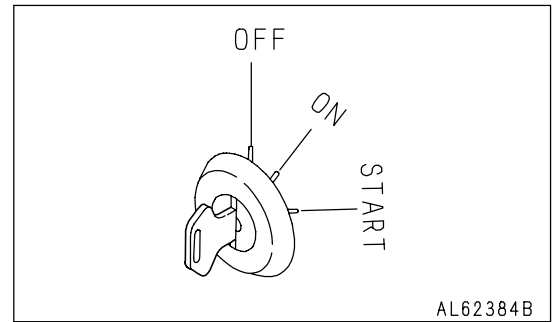

**LAMP SWITCH**

This switch (2) lights up the head lamps, side clearance lamps, tail lamps, machine monitor lighting, and rear lamps.

Position (a): OFF

Position (b): Side clearance lamps, tail lamps, rear lamps, and machine monitor lighting light up

Position (c): Front lamps light up in addition to lamps at position (b)

The lamp switch can be operated regardless of the position of the lever.

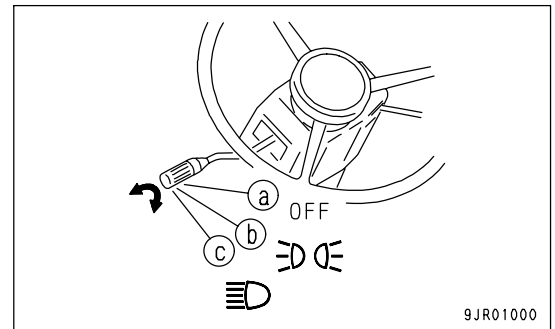

**TURN SIGNAL LEVER**

This lever (2) operates the turn signal lamp.

(a) Right turn: Push the lever forward

(b) Left turn: Push the lever back

When the lever is operated, the turn signal pilot lamp also flashes.

The lever is automatically returned when the steering wheel is turned back. If the lever does not return, move it by hand.

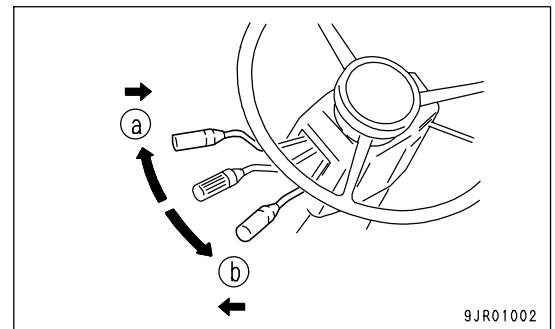

**DIMMER SWITCH**

This switch (2) is used to switch the head lamps between high beam and low beam.

Each time switch (2) is moved up in direction (a), the head lamps switch between high beam and low beam. When the switch is released, it automatically returns to its original position (b).

When the lamp switch is OFF, if the switch is operated in direction (a), the head lamps light up at the high beam position.

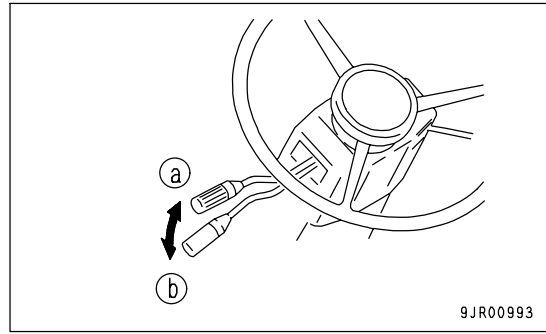

**MACHINE MONITOR BULB CHECK SWITCH**

Turn the starting switch ON, press this switch (3) and check for any blown bulbs.

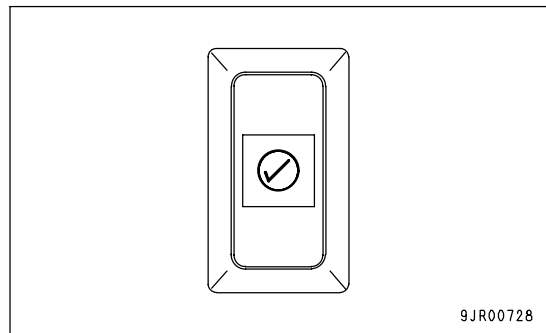

**HAZARD LAMP SWITCH**

This switch (4) is used to make the left and right turn signal indicators flash.

(a): OFF

(b): Turn signal lamp and turn signal pilot lamp flash

When working at night, the symbol inside the switch lights up regardless of the selected position of the switch.

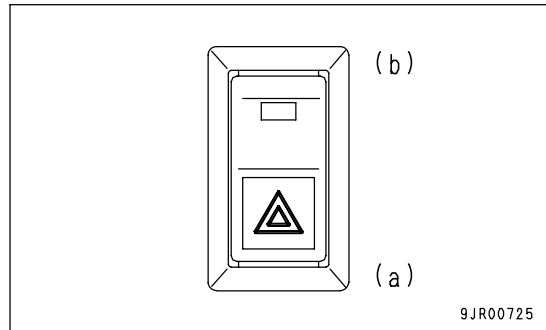

**NIGHT LIGHTING DIMMER SWITCH**

This switch (5) is used to adjust the brightness of the lighting inside the machine monitor and the pilot lamp display. Turn it to the right to make the display brighter; turn it to the left to make the display dimmer.

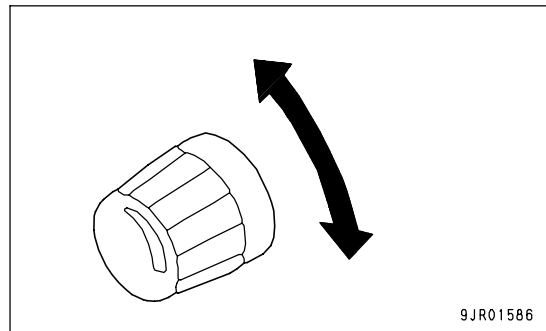

**POWER MODE SELECTOR SWITCH**

This switch (6) is used to switch the power mode. This makes it possible to travel economically in a way suited to the operating conditions.

If portion (a) of the switch is pressed, high-power mode pilot lamp (P) lights up and the system is switched to the high-power mode. If portion (b) of the switch is pressed, economy mode pilot lamp (E) lights up and the system is switched to the economy mode.

(a): High power mode (general operations)

Normal standard operating conditions

(b): Economy mode (operations on flat ground)

Work with emphasis on fuel consumption, such as work on flat ground where the maximum power is not needed

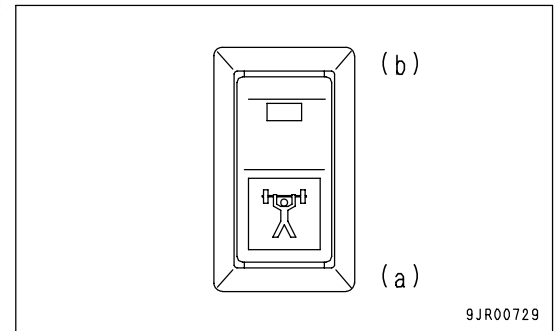

When working at night, the symbol inside the switch lights up regardless of the selected position of the switch.

**EMERGENCY STEERING SWITCH**

This switch (7) is used to actuate the emergency steering pump.

When the switch is pressed, the emergency pump is actuated to make it possible to operate the steering.

When the switch is ON, the pilot lamp (red) inside the switch and the pilot lamp on the machine monitor light up.

The emergency steering pump can be used for a maximum of 90 seconds.

When the emergency steering is being used, keep the travel speed to a maximum of 5 km/h (3.1 MPH).

On machines equipped with auto emergency steering, the auto emergency steering is actuated automatically in the following cases.

- When the steering hydraulic pump fails
- When the engine has stopped during operation

When the emergency steering is actuated, stop the machine promptly and perform inspection.

If the starting switch is at the ON position and the parking brake switch is at the TRAVEL position when the engine is stopped, the automatic emergency steering is actuated after 1 second, so set the parking brake switch to the PARKING position.

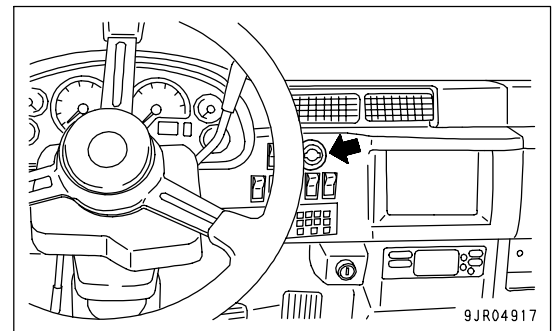

## PARKING BRAKE SWITCH

**WARNING**

When parking or leaving the machine, always apply the parking brake.

This switch (8) is used to actuate and release the parking brake valve.

(a): Parking

The parking brake is applied.

(b): Travel

The parking brake is released.

When the switch is set to the PARKING position, the parking brake pilot lamp lights up.

When the switch is set to the TRAVEL position, if the gear shift lever is at any position other than N, the central warning lamp will flash and the alarm buzzer will sound.

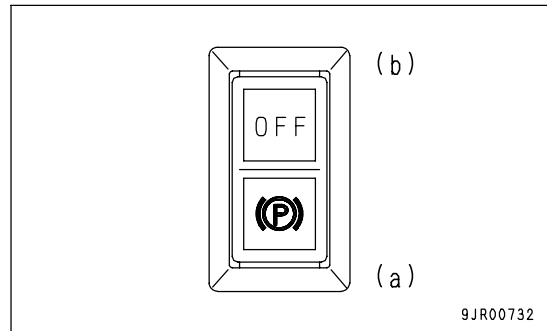

If any problem occurs in the brake circuit and the pressure in the accumulator goes down, the secondary brake is automatically applied.

For details of the method of releasing the secondary brake, see "WHEN PARKING BRAKE HAS BEEN ACTUATED IN EMERGENCY (PAGE 3-132)".

When working at night, the symbol inside the switch lights up regardless of the selected position of the switch.

**REMARK**

If the engine is stopped with the parking brake switch at TRAVEL or the parking brake is operated mistakenly to TRAVEL while the engine is stopped, when the engine is started again, the parking brake is applied even though the parking brake switch is at TRAVEL. In this case, after starting the engine, operate the parking brake switch to PARKING and then back to TRAVEL to cancel the parking brake.

**AISS LOW SWITCH**

Using this switch (9), it is possible to switch the AISS freely between AUTO and LOW. Use each position as follows.

(a): AUTO position

For normal operations

(b): LOW position

When fine control of the machine is needed, such as when putting it into a garage.

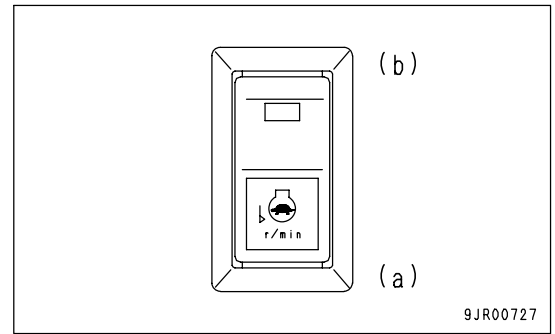

If the switch is at AUTO position:

- If the parking brake or retarder brake are operated, the idle is automatically adjusted to low speed. When the parking brake and retarder brake are released, the idle is automatically adjusted to high speed.
- The water temperature is detected, and when it is at low temperature, the idle is automatically adjusted to high speed to reduce the warming-up time.

When working at night, the symbol inside the switch lights up regardless of the selected position of the switch.

**FRONT BRAKE CUT-OFF SWITCH**



- When traveling on icy roads, on snow, or on other slippery road surfaces, set the front brake cut-off switch to the (b) position and travel slowly at a safe speed.
- If the front brake cut-off switch is set to the (a) position when traveling on icy road, on snow, or on other slippery road surfaces, there is danger that the steering will be impossible to control.

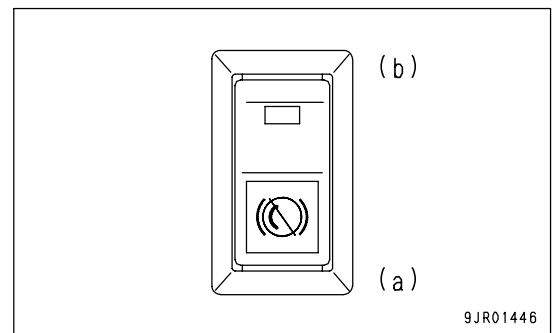

This switch (10) can be used to switch the braking method of according to the road surface conditions.

If the (b) portion of the switch is pressed, the front brake cut function is actuated, and the front wheel brakes are not applied.

(a): When the brake pedal is depressed, the brakes are applied to both the front and rear wheels.

(b): When the brake pedal is depressed, the front brakes are not applied. The brakes are applied only to the rear wheels.

**REMARK**

When the secondary brake is applied, the front and rear wheel brakes and the parking brakes are applied, regardless of the position of the front brake OFF switch.

When working at night, the symbol inside the switch lights up regardless of the selected position of the switch.



**FOG LAMP SWITCH**

(If equipped)

This switch (11) is used to switch on the fog lamp.

(a): Fog lamp goes out

(b): Fog lamp lights up

When working at night, the symbol inside the switch lights up regardless of the selected position of the switch.

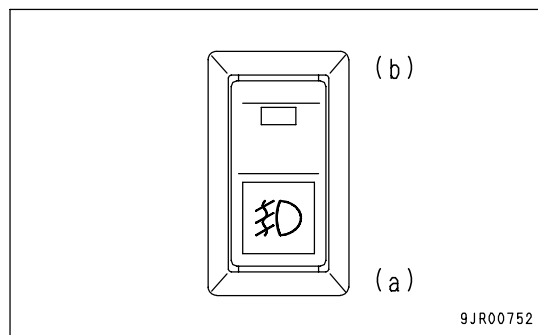

**SIDE LAMP SWITCH**

(If equipped)

This switch (12) is used to switch on the side lamp.

(a): Side lamp goes out

(b): Side lamp lights up

When working at night, the symbol inside the switch lights up regardless of the selected position of the switch.

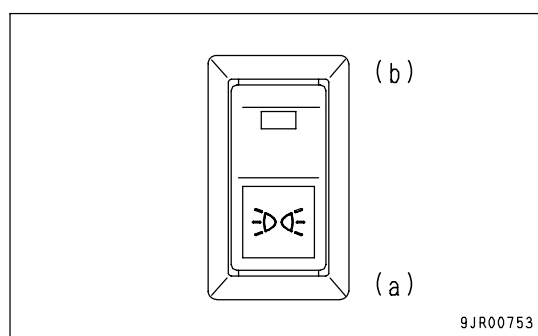

**YELLOW ROTATING LAMP SWITCH**

(If equipped)

This switch (13) is used to switch the yellow rotating lamp on and off. When the lamp is switched on, it lights up and rotates.

(a): Yellow rotating lamp goes out

(b): Yellow rotating lamp lights up

When working at night, the symbol inside the switch lights up regardless of the selected position of the switch.

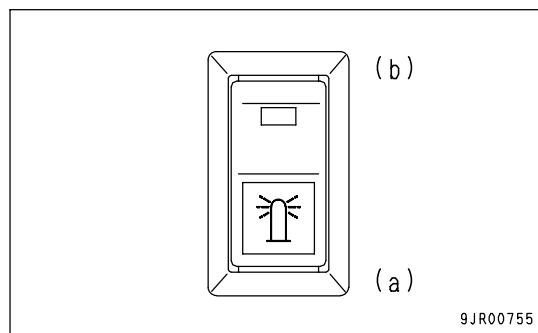

**POWER WINDOW SWITCH (RIGHT) (LEFT)**  
 (The right power window is optional.)

**! WARNING**

When closing the window glass, be careful not to get anyone's hands or head caught.  
 There is danger of serious injury if anyone is caught in the window glass.

**! CAUTION**

After fully opening or fully closing the window glass, do not keep the switch operated in the same direction.  
 This may cause failure of the power window.

Switches (14) and (15) are used to open and close the window glass. The switches can only be used when the starting switch is at the ON position.

- (a): Glass goes down
- (b): Glass goes up

When the glass reaches the top or bottom and stops, release the switch.

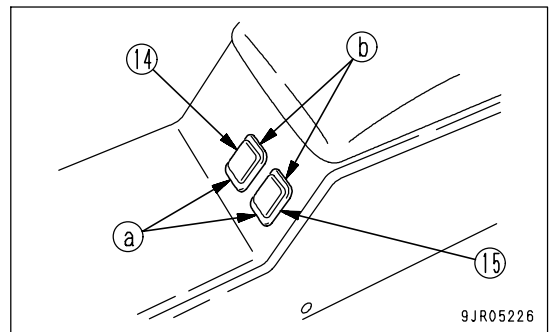

**MACHINE MONITOR MODE SELECTOR SWITCH 1, 2**

This switch (16) is used to operate the character display.

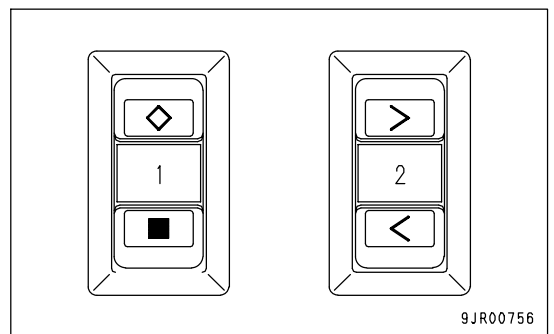

**CIGARETTE LIGHTER**

This switch (17) is used to light cigarettes.

When the cigarette lighter is pushed in, it will return to its original position after several seconds, then pull it out and use it to light your cigarette.

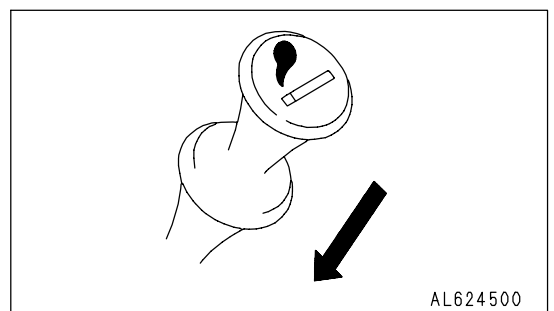

**HORN BUTTON**

When the horn button (18) in the center of the steering wheel is pressed, the horn will sound.

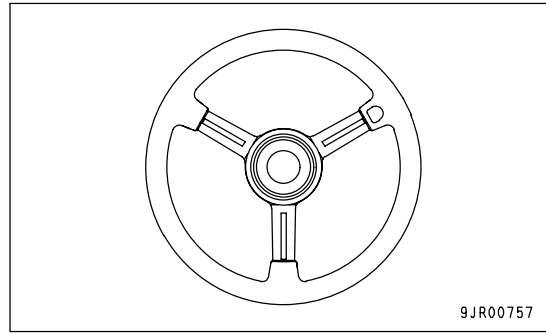

**WIPER, WINDOW WASHER SWITCH**

This switch (19) is used to operate the wiper for the front glass. Using the wiper when the glass is dry will scratch the glass. Spray with window washer fluid before actuating the wiper.

Front wiper

Position (a) (OFF): Stopped

Position (b) (INT): Wiper moves once every 4 - 7 seconds

Position (c) (LOW): Wiper moves at low speed

Position (d) (Hi): Wiper moves at high speed

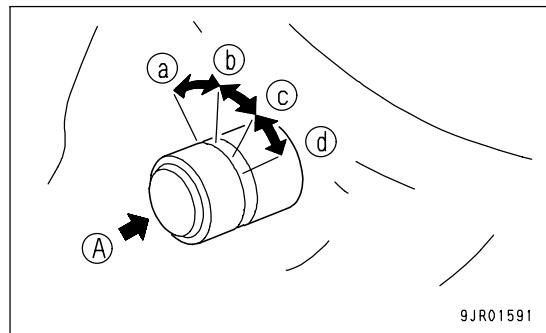

When the button (A) at the tip of the switch is pressed, washer fluid is sprayed out.

Do not keep the button pressed for more than 10 seconds.

**ROOM LAMP SWITCH**

The switch (20) is used to turn the room lamp ON and OFF.

Position (a): OFF

Position (b): Lights up when the door opens

Position (c): Lights up

**REMARK**

- The room lamp lights up even when the main switch is OFF, so when leaving the operator's seat, set the switch to position (a) or (b).
- When carrying out operations with the door fully opened, set the switch to position (a) (OFF).

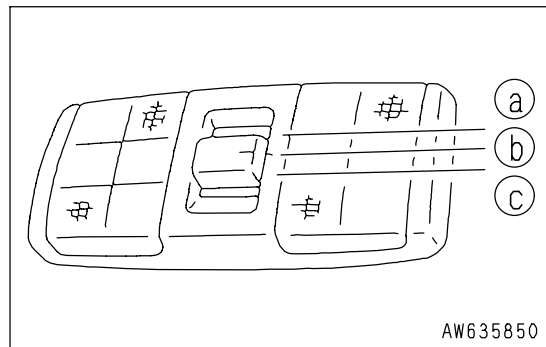

**CONTROL LEVERS AND PEDALS**

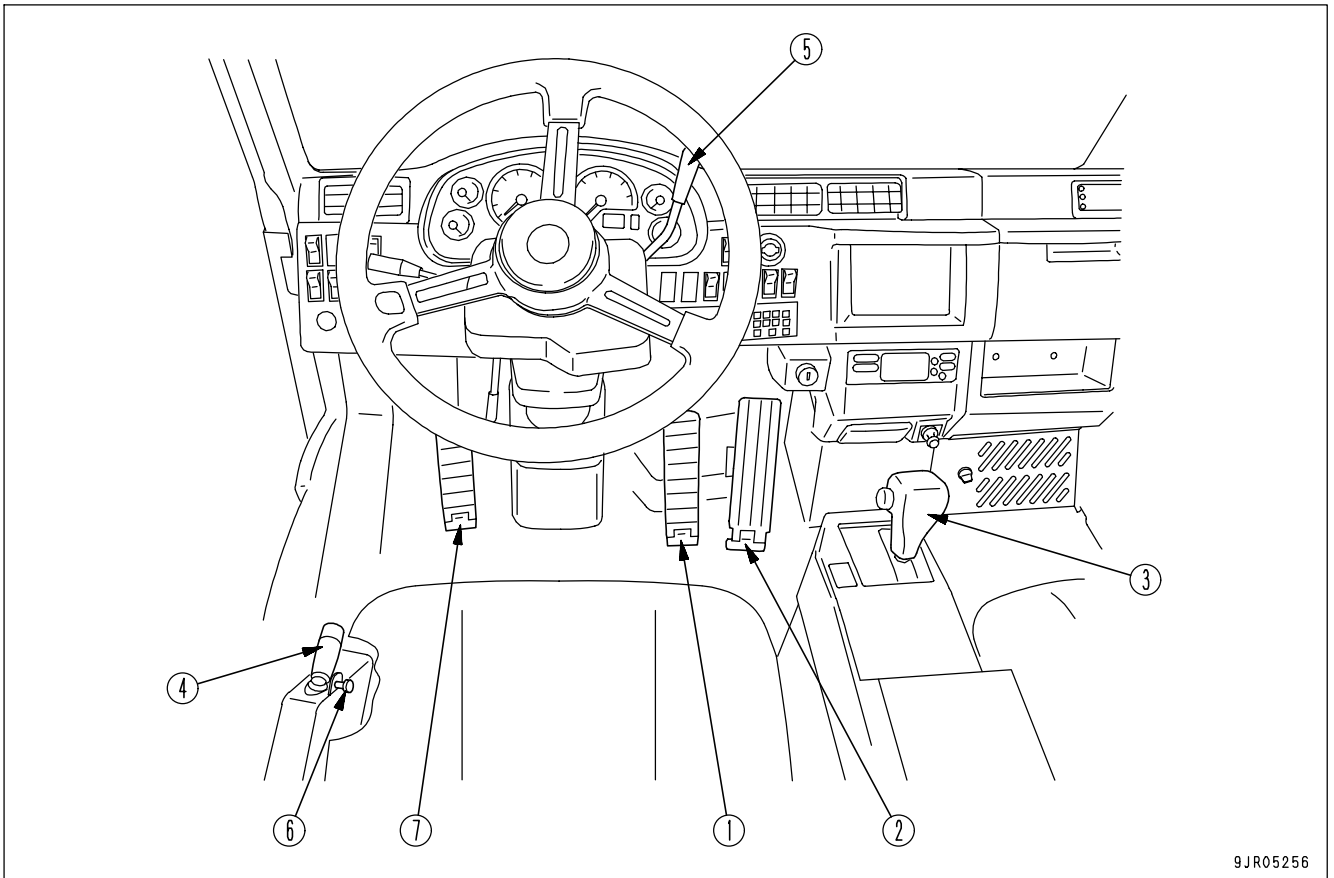

9JR05256

- |                       |                            |
|-----------------------|----------------------------|
| (1) Brake pedal       | (5) Retarder control lever |
| (2) Accelerator pedal | (6) Dump lever lock knob   |
| (3) Gear shift lever  | (7) Secondary brake pedal  |
| (4) Dump lever        |                            |

**BRAKE PEDAL**

This pedal (1) is used to apply the wheel brakes.

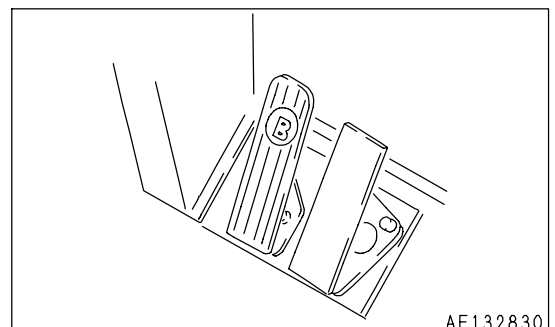

AE132830

**ACCELERATOR PEDAL**

This pedal (2) is used to adjust the engine speed.  
It can be operated freely between the engine low idle position and the full throttle position.

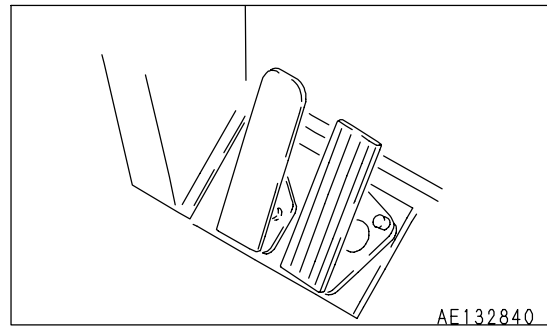
**GEAR SHIFT LEVER**

The gear range can be selected with this lever (3) to match the travel conditions.

D position:

This is used for normal travel.

If the lever is placed in this position, the transmission is shifted automatically from 2nd torque converter drive to 7th speed to match the travel speed of the machine.

If the dump body is raised, the shift lever is fixed at 1st. Always lower the dump body when traveling.

The maximum speed in this position is 70.0 km/h (43.5 MPH).

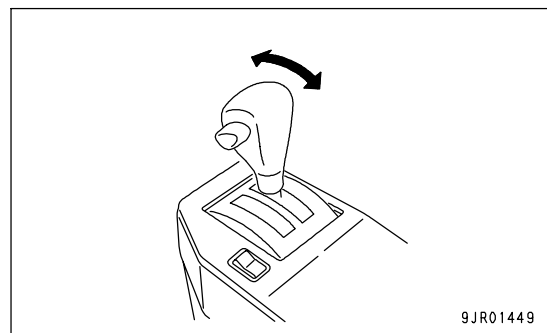
**REMARK**

To comply with the EU safety standards (EN 474-6 5.1.3), if the machine travels with the dump body not completely lowered, the transmission is fixed in 1st and the gear cannot be shifted.

R position:

This is used when traveling in reverse.

This position uses the torque converter drive. The maximum travel speed in this position is 10.6 km/h (6.6 MPH).

It is impossible to travel in reverse if the dump body is raised. Lower the dump body, set the dump lever to the "FLOAT" position, then set the gearshift lever to the "R" position.

6 - L position:

These positions are used in places where it is difficult to travel at high speed, or when traveling on soft ground, or when starting the machine off on a slope when it is loaded. They are also used when going downhill if it is needed to use the braking force of the engine.

While the dump body is raised, the transmission is fixed to the 1st gear and is not changed. Keep the dump body lowered during travel.

- The speed ranges for each position are as follows.

Position	Speed range	Max. speed [km/h (MPH)]
6	1st torque converter - 6th direct	52.4 (32.6)
5	1st torque converter - 5th direct	38.5 (23.9)
4	1st torque converter - 4th direct	28.7 (17.8)
3	1st torque converter - 3rd direct	21.3 (13.2)
2	1st torque converter - 2nd direct	15.8 (9.8)
L	1st torque converter - 1st direct	10.3 (6.4)

When operating the gear shift lever, set it securely to the desired position.

If it is not securely in position, the shift position display on the panel may go out and the transmission system caution lamp may light up.

Before shifting between forward and reverse, stop the machine completely and then run the engine at low idle.

When starting the engine, if the gear shift lever is not at the N (neutral) position, the engine will not start.

When the starting switch is at the ON position, if the gear shift lever is not at the N (neutral) position, the gear shift lever position pilot lamp will flash, the central warning lamp will light up, and the alarm buzzer will sound.

If the parking brake is applied or the gear shift lever is not at the N (neutral) position, the central warning lamp will light up and the alarm buzzer will sound.

If the gear shift lever is set to any position other than N (neutral) when the dump lever is at a position other than FLOAT or the body is still raised, the central warning lamp will light up and the alarm buzzer will sound.

The gear shift lever must not be returned to the N (neutral) position while traveling.

Before operating the gear shift lever from N to F or R, release the accelerator pedal to reduce the engine speed to low idling.

When moving the shift lever from the N (neutral) position to the R (reverse) position or from the D positions to position 6, press the lock button on the shift lever before moving it.

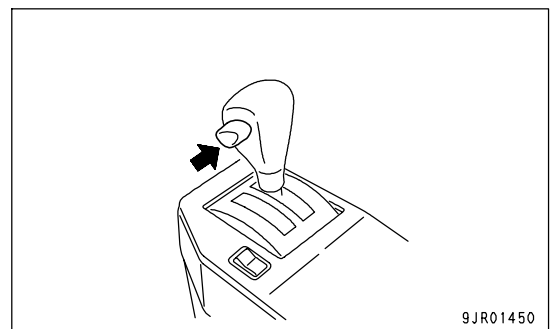

DUMP LEVER

**CAUTION**

To prevent damage to the dump body through vibration from the road surface, always lower the dump body before traveling.

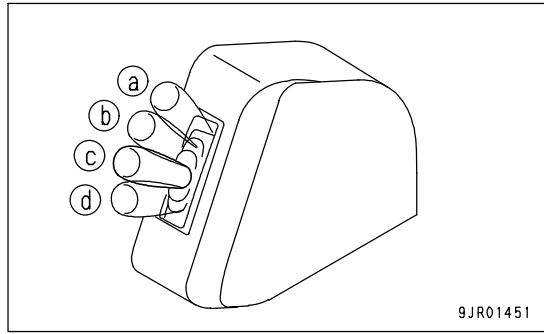

This lever (4) is used to operate the dump body.

- (a) RAISE
- (b) HOLD: The dump body stops and is held in position.
- (c) FLOAT: The dump body moves freely under external force.
- (d) LOWER

Always set to the FLOAT position when traveling.

RETARDER CONTROL LEVER

**CAUTION**

The retarder must not be used as a parking brake.

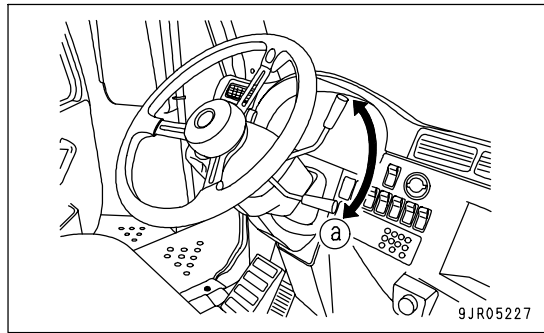

Use this lever (5) to operate the retarder when traveling downhill. The more the lever is pulled in direction (a), the greater the braking force becomes.

When the retarder is operated, the retarder pilot lamp lights up.

When leaving the operator's seat, always apply the parking brake.

DUMP LEVER LOCK KNOB

**WARNING**

When carrying out inspection of the machine with the dump body raised, always set the dump lever to the HOLD position, lock with the dump lever lock knob, then use the body pivot pin.

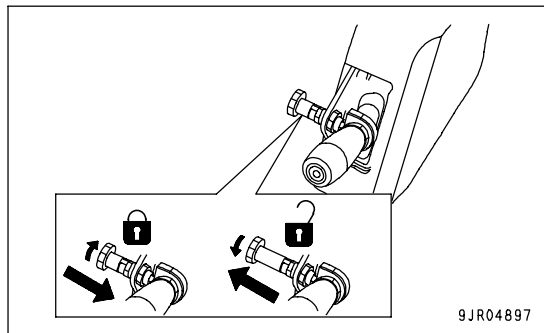

This device (6) is used to lock the dump lever.

To set to the FREE position, pull the lock knob up until it stops, then turn it to lock it in position.

To set to the LOCK position, pull the lock knob up, then turn it to release the lock. The knob will be pushed in by the force of the spring, and the lock will be applied. After doing this, check that the dump lever is locked.

**SECONDARY BRAKE PEDAL**

Use this pedal (7) to apply the front and rear wheel brakes and the parking brake.

Use this pedal if the service brakes cannot be applied properly for any reason, such as damage to the brake pedal.

**REMARK**

If the pressure in the accumulator goes down, the secondary brake is automatically applied. For details of the method of canceling the secondary brake, see "WHEN PARKING BRAKE HAS BEEN ACTUATED IN EMERGENCY (PAGE 3-132)".

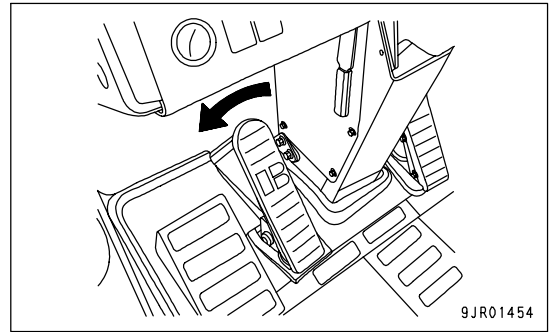



## BODY PIVOT PIN



### WARNING

When carrying out inspection of the machine with the dump body raised, always set the dump lever to the HOLD position, lock with the dump lever lock knob, then use the body pivot pin.

This is a safety device for the dump body, and is used when carrying out inspection or maintenance with the dump body raised. Raise the dump body fully, insert body pivot pins (1). Always insert the body pivot pins on both sides.

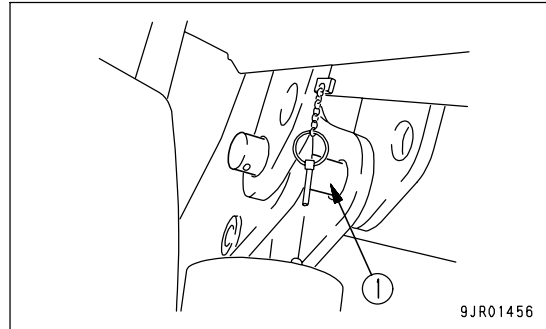

### STOWING BODY PIVOT PIN

Store the body pivot pin under the rear of the dump body. Insert body pivot pin (1), then insert lock pin (2) to stow the body pivot pin.

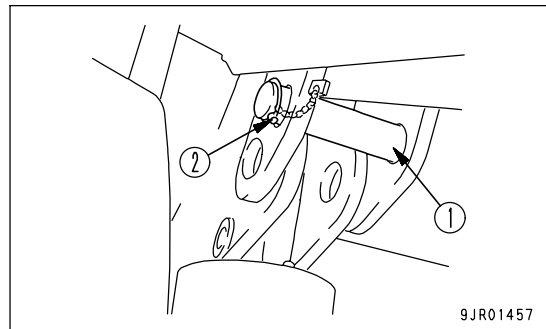

### LOCATION OF FIRE EXTINGUISHER

(If equipped)

Fire extinguisher (1) is installed to the left front of the machine.

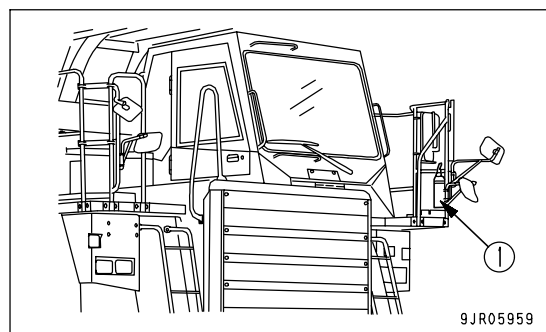

## DUST INDICATOR

This device indicates clogging of the air cleaner.

Depending on the degree of clogging of the element, red line (1) appears in the transparent portion. If red line (1) indicates 7.5 kPa (30 INCHES H<sub>2</sub>O) (0.076 kg/cm<sup>2</sup>, 1.1 PSI), clean the element immediately.

After cleaning, press top portion (2) of the indicator to return red line (1) to its original position.

The diagram shows a cylindrical dust indicator. It has a transparent section in the middle. A red line, labeled (1), is visible within this section. The top of the device has a small protrusion, labeled (2), which is used to press the indicator back to its original position. The diagram is enclosed in a rectangular box with the part number 9JR00621 in the bottom right corner.

3 - 45

### FUSES

The fuses protect the electrical equipment and wiring from burning out.

If the fuse becomes corroded, or white powder can be seen, or the fuse is loose in the fuse holder, replace the fuse.

#### NOTICE

- When replacing any fuse, always turn the power off (turn the starting switch to OFF).
- When replacing the fuse, always use a fuse of the same capacity and type.

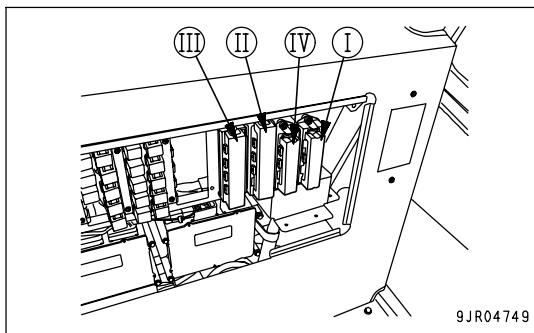

9JR04749

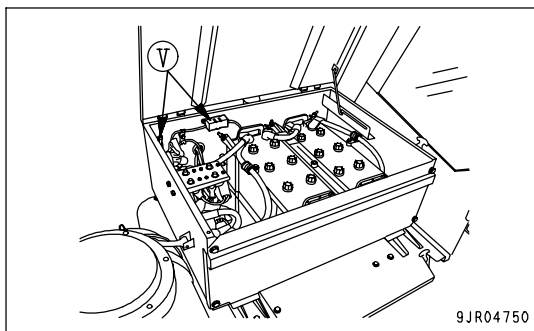

9JR04750

### FUSE CAPACITY AND CIRCUIT NAME

Fuse box I

No.	Capacity	Name of circuit
(1)	10A	Main lamp, Side lamp
(2)	10A	Turn signal lamp
(3)	20A	Head lamp (low beam)
(4)	20A	Head lamp (high beam)
(5)	20A	Head lamp (low beam)
(6)	20A	Head lamp (high beam)
(7)	10A	Brake lamp
(8)	20A	Backup lamp
(9)	10A	Clearance lamp
(10)	20A	-

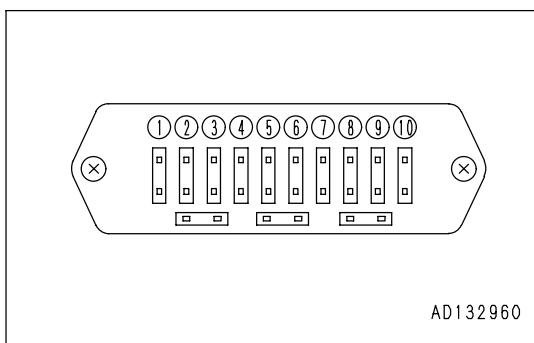

AD132960

Fuse box II

No.	Capacity	Name of circuit
(11)	10A	Machine monitor, Payload meter II (if equipped), Controller (if equipped)
(12)	10A	Rear view monitor (if equipped) Download ACC
(13)	10A	Parking brake circuit
(14)	20A	Power window (left)
(15)	20A	Power window (right)
(16)	10A	Payload meter II controller (if equipped)
(17)	10A	Horn
(18)	10A	Machine monitor
(19)	10A	Transmission controller
(20)	20A	B terminal
(21)	10A	Retarder controller ABS controller (if equipped)
(22)	20A	Hazard lamp
(23)	10A	Emergency steering
(24)	10A	Room lamp, Radio
(25)	10A	Machine monitor, KOMTRAX (if equipped)

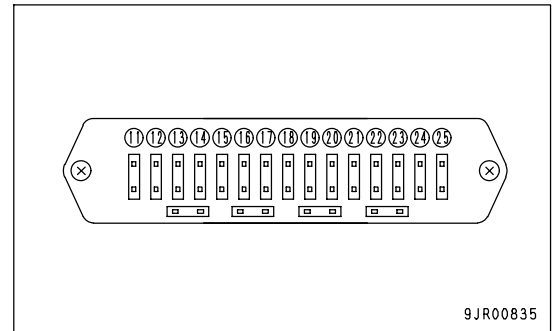

Fuse box III

No.	Capacity	Name of circuit
(26)	20A	Fog lamp (if equipped)
(27)	20A	Air conditioner controller (if equipped)
(28)	20A	Heater (if equipped)
(29)	20A	Heater (if equipped)
(30)	20A	ABS controller (if equipped)
(31)	20A	Retarder controller
(32)	10A	Transmission controller, Power source for gear shift lever
(33)	10A	Emergency steering, Parking brake relay
(34)	10A	Radio (if equipped)
(35)	10A	Engine controller
(36)	30A	Engine controller
(37)	-	-
(38)	-	-
(39)	10A	KOMTRAX (if equipped)
(40)	20A	Spare

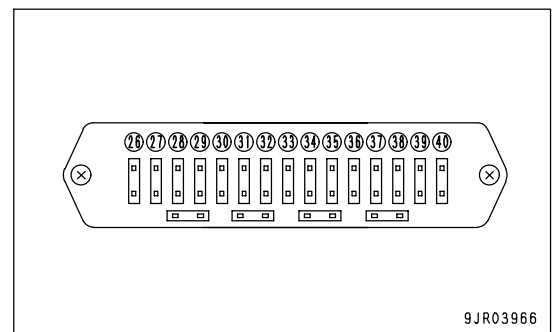

Fuse box IV

No.	Capacity	Name of circuit
(41)	10A	Room lamp
(42)	10A	Power source for engine preheat
(43)	20A	Yellow rotating lamp (if equipped), Step lamp (if equipped)
(44)	20A	Side lamp (if equipped)
(45)	20A	Air suspension seat (if equipped)
(46)	10A	Payload external display lamp (if equipped)
(47)	10A	Tachograph (if equipped), Cigarette lighter
(48)	20A	Air conditioner (if equipped)
(49)	20A	Spare
(50)	20A	Front wiper

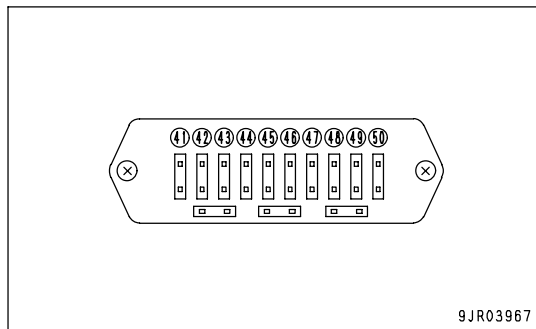

Fuse box V

No.	Capacity	Name of circuit
(51)	10A	Power source for emergency steering system
(52)	300A	Power source for engine heater

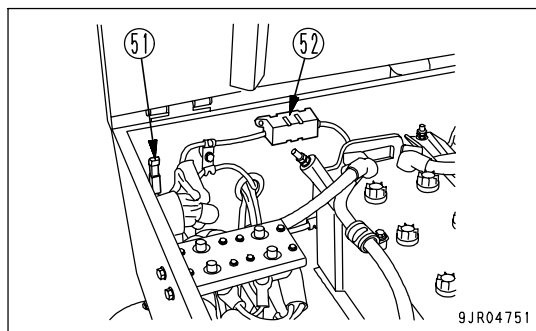

Precautions when adding electrical equipment

 **CAUTION**

If the electrical equipment system is changed, problems may occur in the machine control. Do not make any changes to the electrical system.

If you want to make any change to the electrical system, please contact your Komatsu distributor.

**CAR RADIO**

(If equipped)

**EXPLANATION OF COMPONENTS**

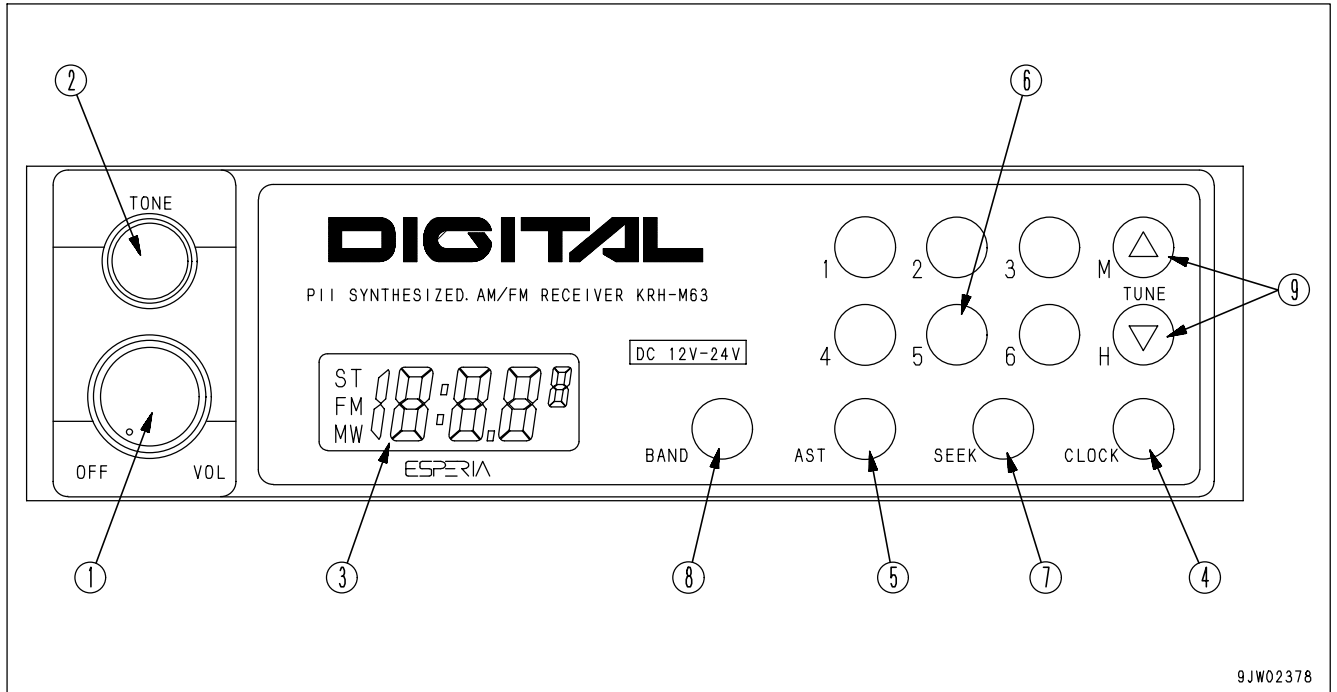

9JW02378

- |                                       |                          |
|---------------------------------------|--------------------------|
| (1) Power switch/Volume               | (6) Preset switch        |
| (2) Tone control knob                 | (7) Seek                 |
| (3) Display                           | (8) Band selector switch |
| (4) Clock button/Displaying frequency | (9) Tuning switch        |
| (5) AST                               |                          |

**POWER SWITCH/VOLUME**

When this switch (1) is turned to the right, it clicks and the power is turned on. If it is turned further, the speaker volume is adjusted.

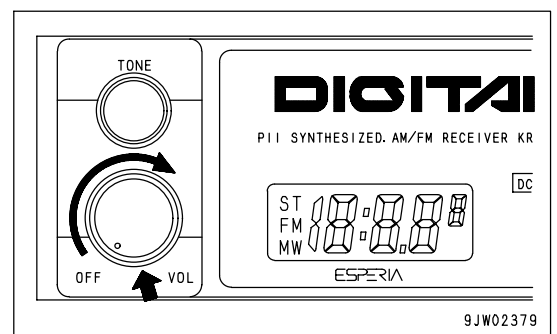

9JW02379

**TONE CONTROL KNOB**

If this knob (2) is turned to the right, the high tone is emphasized; if it is turned to the left, the high tone is reduced.

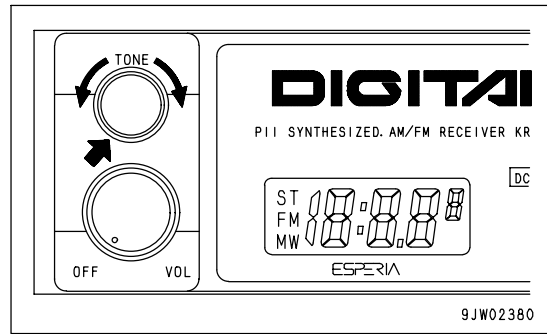

**DISPLAY**

This display (3) shows the radio reception frequency and the operating mode.

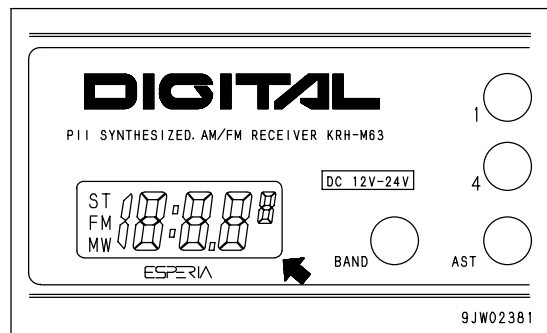

**CLOCK BUTTON/DISPLAYING FREQUENCY**

When this button (4) is pressed, the display changes to the time. If it is pressed again, it displays the frequency.

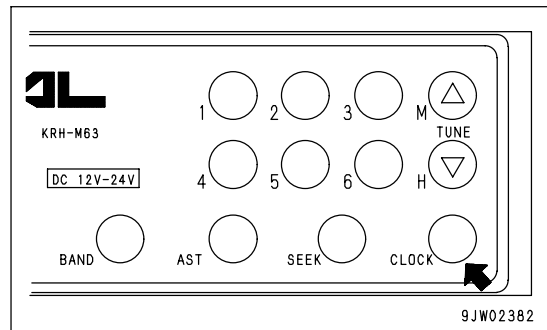

**AST**

When this button (5) is pressed, the preset stations are called up in turn.

When the desired broadcasting station is reached, press the button again to stop it.

If the button is kept pressed continuously for 2 seconds, it is set to auto memory.

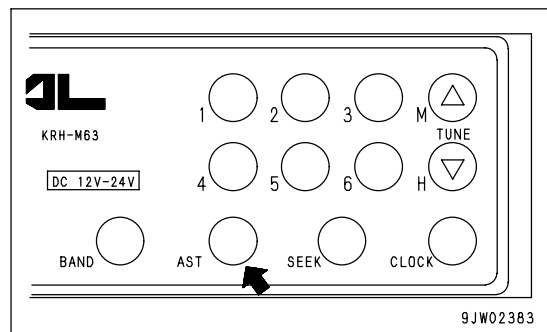

**PRESET SWITCH**

With this switch (6), each button can be set to one station each for FM and MW (AM). (For details of the method of resetting, see "METHOD OF PRESET (PAGE 3-53)".)

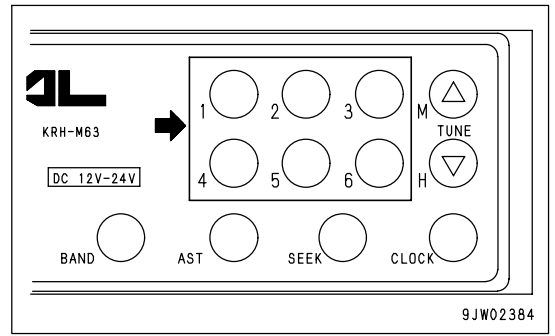

**SEEK**

When this switch (7) ("SEEK") is pressed, it automatically searches for stations that can be received, and when it receives a station, it stops.

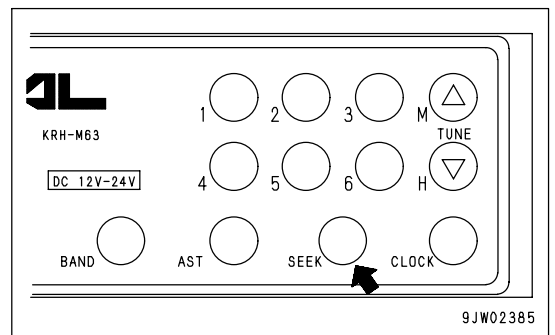

**BAND SELECTOR SWITCH**

When this switch (8) ("BAND") is pressed, the band is switched between FM and MW (AM).

The reception band and frequency are displayed on the display.

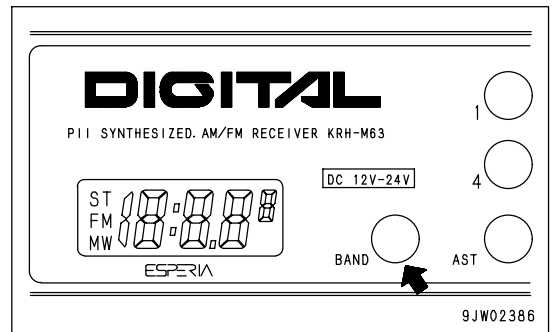

**TUNING SWITCH**

When the "TUNE" button  $\Delta$  of switch (9) is pressed, the frequency goes up; when the  $\nabla$  button is pressed, the frequency goes down. If it is kept pressed, the frequency changes continuously.

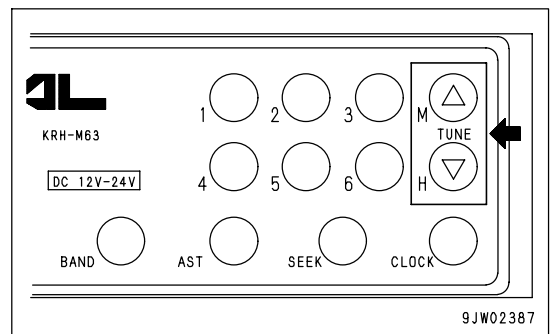



METHOD OF OPERATION

LISTENING TO RADIO

1. This switches on power (1) for the radio.
2. "BAND" switch (2) is used to select MW (AM) or FM.
3. Use the preset switch or tuning switch (3) to select the station.
4. Adjust the volume and tone as desired.
5. To turn the radio OFF, turn VOL knob (1) to the left until a click is heard.

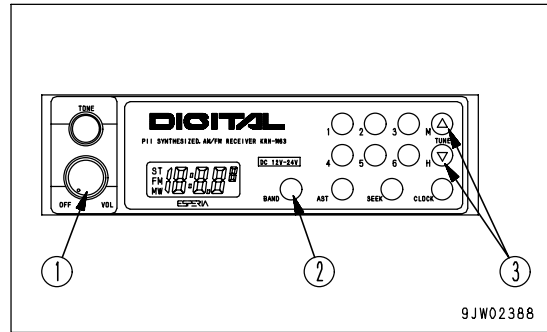

METHOD OF AUTOMATIC TUNING

When the "SEEK" switch is pressed, it moves up to higher frequencies and when it finds a station that can be received, it stops automatically.

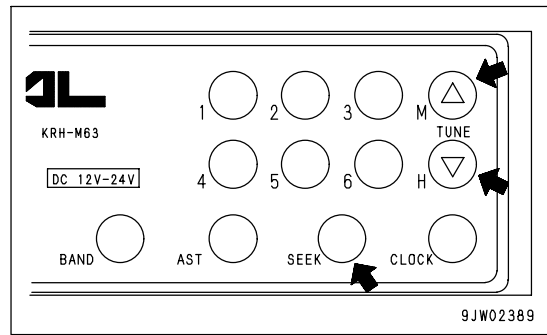

METHOD OF MANUAL TUNING

When the TUNE button Δ is pressed, the frequency goes up; when the ▽ button is pressed, the frequency goes down. If it is kept pressed, the frequency changes continuously.

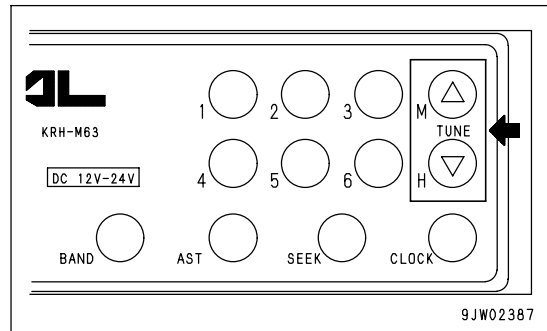

**METHOD OF PRESET**

1. Select the desired preset station.

Use the "BAND" button to select MW (AM) or FM, and use the "TUNE" button to select the frequency of the broadcasting station.

2. Decide the number of the button to be preset, and keep it pressed for 2 seconds. The number of the button will be displayed and the presetting is completed.

3. Repeat Steps 1 to 2 to preset other broadcasting stations.

- To change the setting of a preset switch to another station, repeat Steps 1 to 2.
- If the battery is replaced or the power is switched off, all the preset settings are deleted. Carry out the presetting operation again.
- It is possible to preset 6 AM (MW) stations and 6 FM stations.

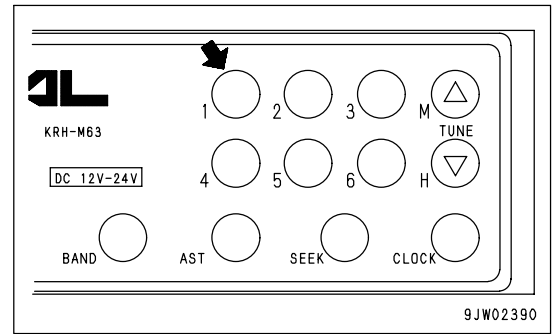

**METHOD OF AUTOMATIC MEMORY**

If the "AST" button is pressed for 2 seconds, the broadcasting stations that can be received in the area are called up in turn, and the broadcasting stations are automatically saved in the preset memory.

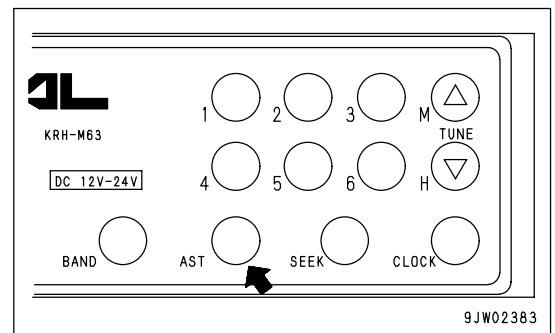

**AUTOMATIC SWITCHING RECEPTION OF MONAURAL/STEREO**

If the reception of the FM stereo broadcast being received is weak (when you are far from the broadcasting station or are surrounded by hills), the radio is automatically switched from stereo to monaural to reduce the interference. When the stereo broadcast becomes stronger, it automatically switches back to stereo broadcasting.

**ADJUSTING TIME**

1. Turn the radio power ON. If the display shows the frequency, set the CLOCK button to the time display.
2. To set the time, keep the CLOCK button pressed and
  - Press the  $\triangle$  button to change the minutes
  - Press the  $\nabla$  button to change the hours

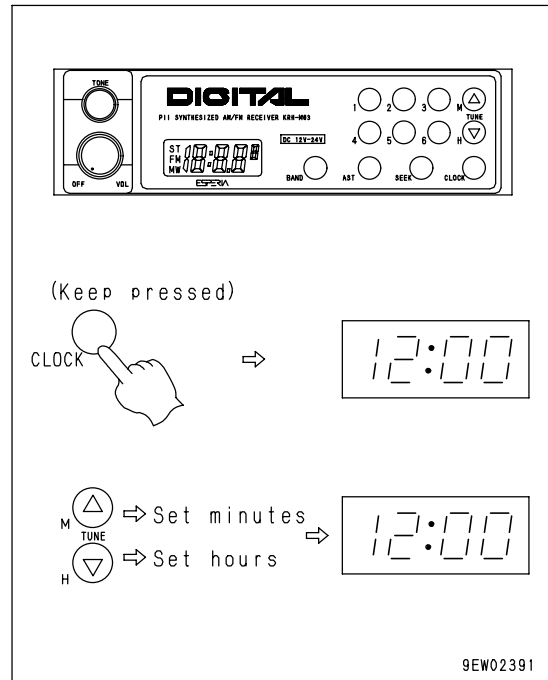
**PRECAUTIONS FOR USE**

- Stow the antenna when traveling in places with low overhead clearance.
- To ensure safety, always keep the sound to a level where it is possible to hear outside sounds during operation.
- If water gets into the speaker case or radio, it may lead to an unexpected failure, so be careful not to get water on the equipment.
- Do not wipe the scales or buttons with solvent such as benzene or thinner. Wipe with a dry soft cloth. If the dirt cannot be removed easily, soak the cloth with alcohol.

**CAR STEREO**

(If equipped)

**EXPLANATION OF COMPONENTS**

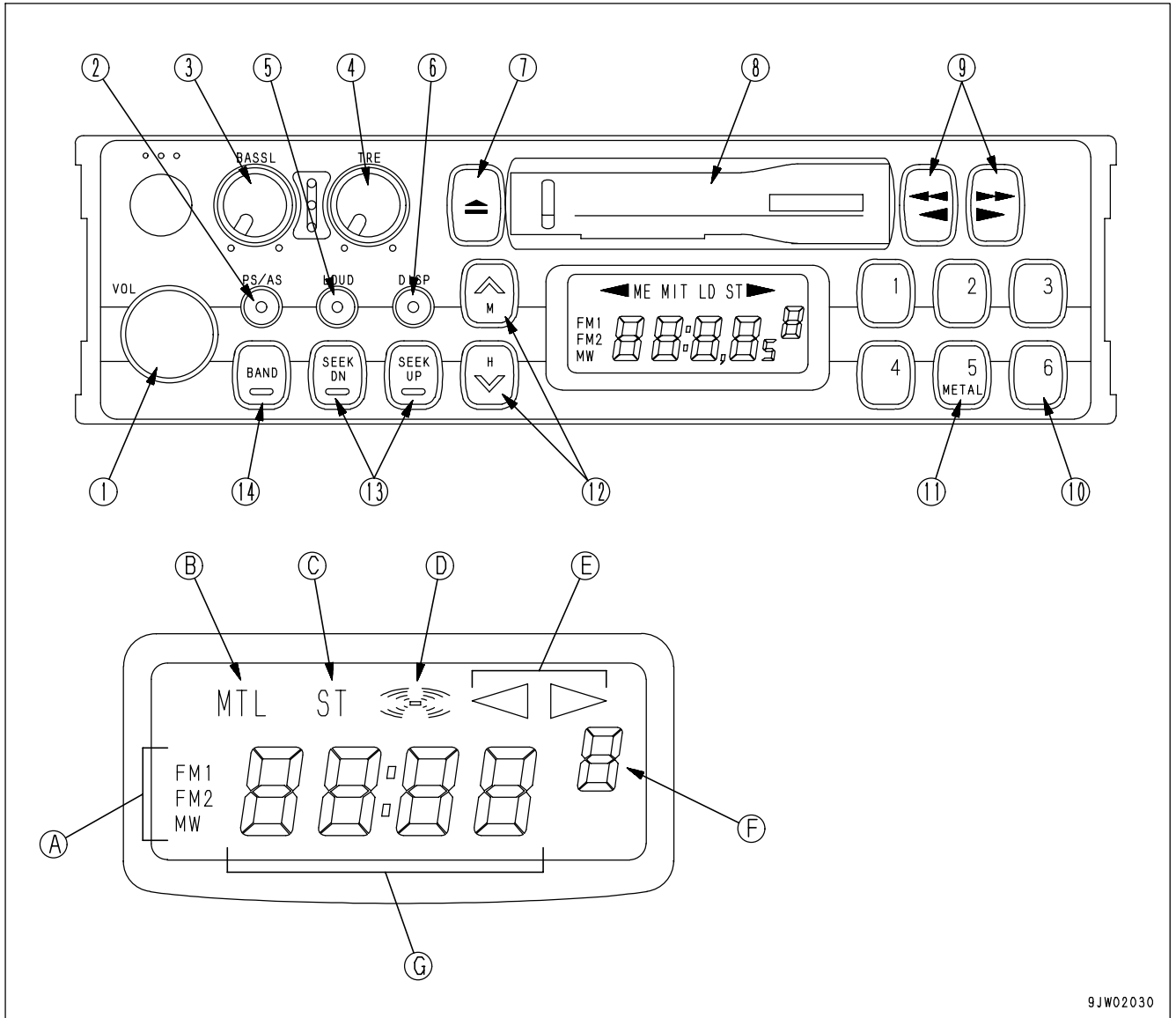

9JW02030

- (1) Power switch/volume
- (2) Auto-store/preset scan button
- (3) Bass control knob
- (4) Treble control knob
- (5) Loudness button
- (6) Time/radio display selector button
- (7) Tape eject button
- (8) Cassette door
- (9) Fast forward, rewind buttons
- (10) Preset buttons
- (11) Metal tape button
- (12) Manual tuning buttons
- (13) Seek tuning buttons
- (14) Band selector button
- (A) Band display
- (B) Metal tape display
- (C) FM stereo reception display
- (D) Loudness display
- (E) Tape direction display
- (F) Preset channel display
- (G) Time/frequency display

**POWER SWITCH/VOLUME**

Turn this knob (1) to the right until it clicks to turn the power on.  
Turn it further to increase the volume.

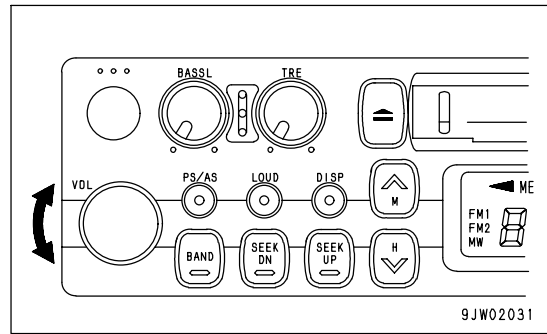

**AUTO-STORE/PRESET SCAN BUTTON**

Use this button (2) to actuate the preset scan and auto-store functions.

- Auto-store  
Each time this button is pressed for more than 2 seconds while in radio reception, this auto-store function automatically starts to search for the desired station within a receivable band, and memorize the frequency in the preset memory. During this scanning process, the frequency shown in the right side of display continues to change. This indicates that each frequency is memorized in the auto-store.

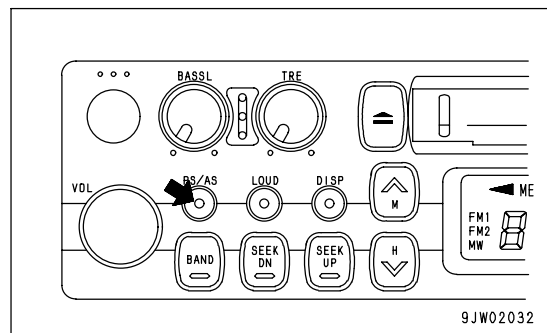

**REMARK**

The auto-store function cannot be used when the channel display is flashing.

When the display is flashing, the preset scan function is being used.

- Preset scan  
If this button is pressed for less than 0.5 second while in radio reception, programs from the six preset stations in the same band will be broadcast one after another for 5 seconds each, starting from No. 1 through No. 6 stations consecutively.  
When the desired station is found, press the button again. This stops the preset scan tuning process and switches to ordinary broadcasting. The same process will be repeated continuously until the button is pressed again.

**BASS CONTROL KNOB**

Turn this button (3) to the left to reduce the low tones; turn it to the right to emphasize the low tones.

- Direction (a): Low tone reduced
- Direction (b): Low tone emphasized

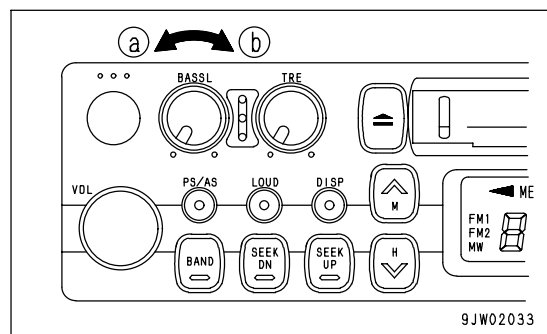

**TREBLE CONTROL KNOB**

Turn this button (4) to the left to reduce the low tones; turn it to the right to emphasize the high tones.

Direction (a): High tone reduced

Direction (b): High tone emphasized

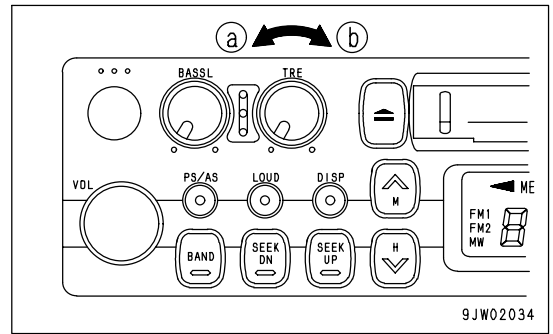

**LOUDNESS BUTTON**

This button (5) is used when playing at low volume. It makes it possible to hear more easily by emphasizing the low tone when the low tones are weak.

Push button: Actuated (ON)

Push button again: Canceled (OFF)

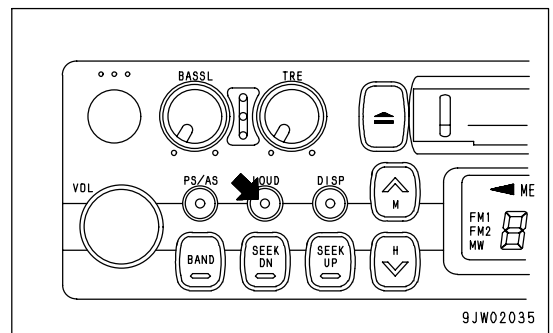

**TIME/RADIO DISPLAY SELECTOR BUTTON**

This button (6) is used to switch between the "Radio/tape display" and the "Time display".

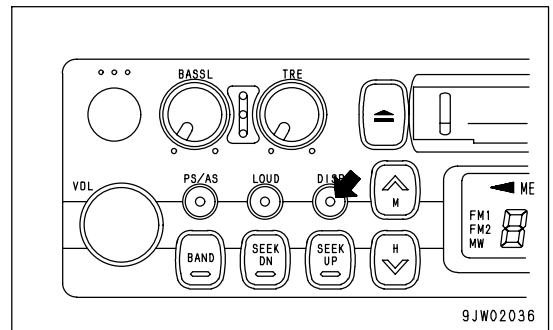

• Correcting the time

Press the button to set the time display.

(A) Correcting hour:

Keep the DISP button pressed and press the bottom (H) of the TUNING button to correct the hour.

(B) Correcting minute:

Keep the DISP button pressed and press the top (M) of the TUNING button to correct the minute.

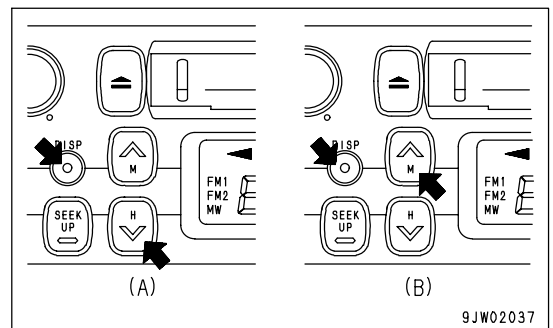

**TAPE EJECT BUTTON**

This button (7) is used to stop the tape and to eject the cassette. When this button is pressed, the tape is ejected and the radio plays.

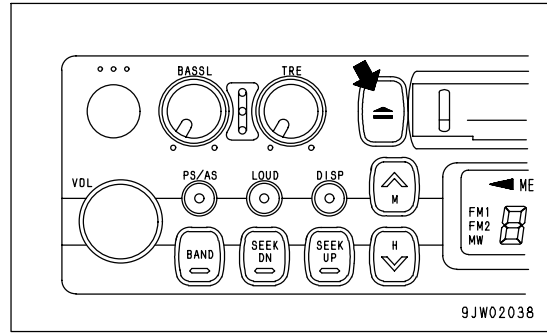

**CASSETTE DOOR**

Set the cassette with the exposed portion of the tape on the right side and insert it through the cassette door (8).

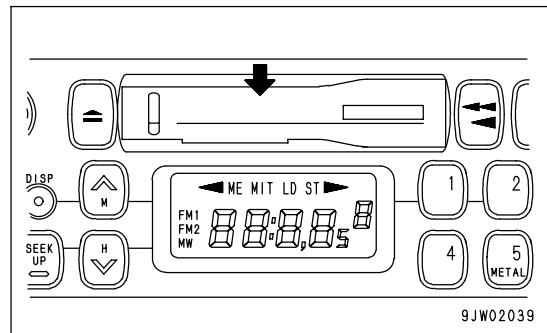

**FAST FORWARD, REWIND BUTTONS**

These buttons (9) are used to fast-forward or rewind the tape.

- Fast-forward/rewind

If you press the button pointing in the same direction as the lighted arrow indicating the direction of play, the tape will be fast-forwarded; if you press the button pointing in the opposite direction, the tape will rewind.

To stop the tape, lightly press the button that is not locked. The fast-forward or rewind operation will be canceled.

If the fast-forward and rewind buttons are pressed at the same time, the tape will change sides.

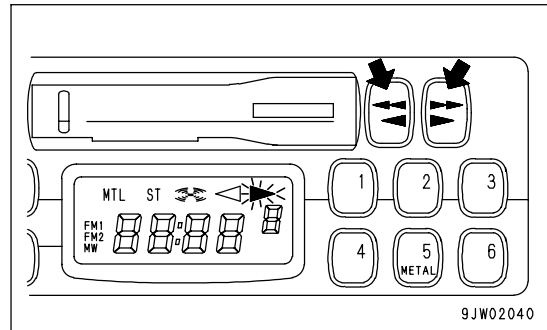

**PRESET BUTTONS**

These buttons (10) are used to call up the broadcast station frequencies preset in memory for each of buttons No. 1 to No. 6. It is possible to preset 18 stations (FM: 12; AM: 6) with these buttons.

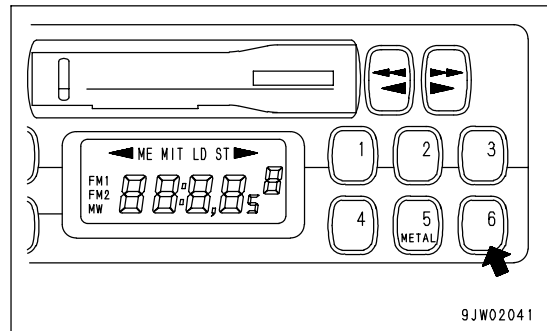

**METAL TAPE BUTTON**

(used also for preset button No. 5)

This button (11) is used when playing a metal or chrome tape. This button is also used for preset button No. 5. When it is pressed, "MTL" appears on the display.

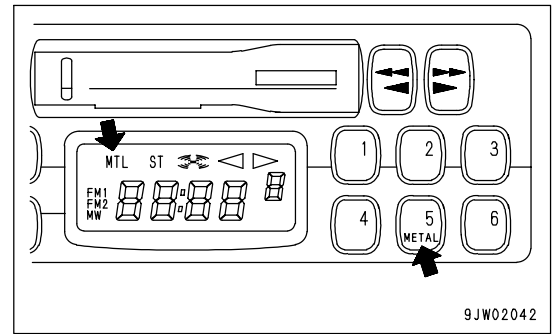

**MANUAL TUNING BUTTONS**

These buttons (12) are used for manual tuning.

When "TUN ^" button is pressed, the frequency goes up 9 kHz for AM or 0.1 MHz for FM; when "TUN v" button is pressed, the frequency goes down 9 kHz for AM or 0.1 MHz for FM.

If the button is pressed down and held, the frequency will change continuously.

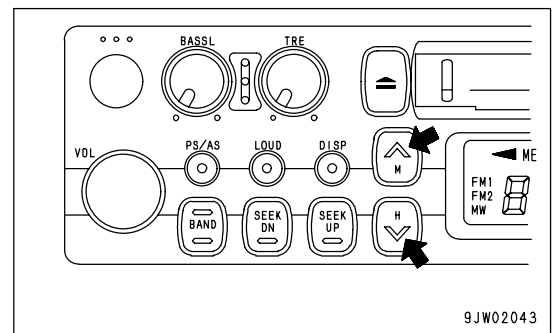

**SEEK TUNING BUTTONS**

These buttons (13) are used to seek tuning.

When the "SEEK UP" button is pressed, the search automatically goes up; when the "SEEK DN" button is pressed, the search automatically goes down.

When the next station that can be received is found, it automatically stops.

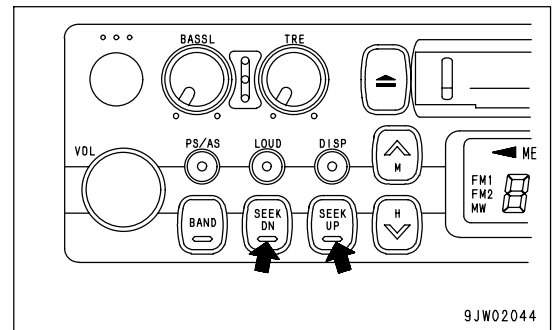

**BAND SELECTOR BUTTON**

When this button (14) is pressed, the band is switched between FM1, FM2, and MW (AM). The band is shown on the display.

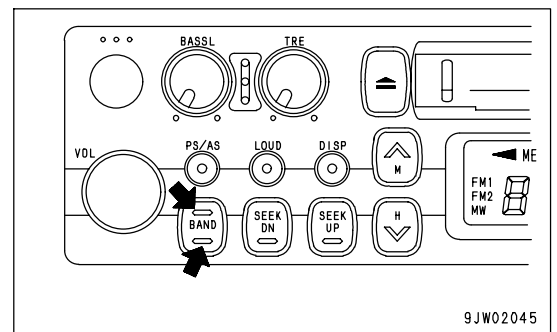



### METHOD OF OPERATION

#### METHOD OF SETTING PRESET BUTTONS

To listen to a preset station, use band selector button (1) to select AM, FM1, or FM2, then press the preset switch number to listen to the desired station.

It is possible to preset six AM stations and 12 FM stations (FM1: 6, FM2: 6).

1. If you are playing a cassette, press the tape eject button to stop the tape.
2. Select the station to be preset.  
Use band selector button (1) to select MW (AM), FM1, or FM2, then use the manual tuning button to select the frequency of the broadcasting station.
3. Press manual memory button (2) or seek tuning button (3).
4. Press preset button (4) of the number to be preset for 2 seconds while the frequency display is being shown on the display. (The preset channel and frequency are displayed and the presetting is completed).
5. Repeat Steps 2 to 4 to preset other stations.

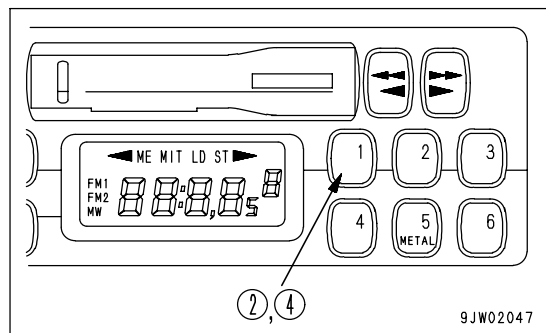
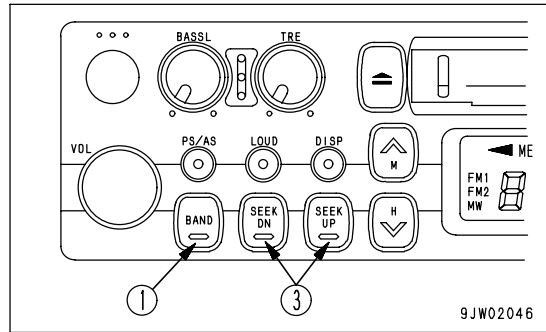

#### REMARK

- Use Steps 2 to 4 also when changing the setting of a preset switch to another station.
- When the power is disconnected, such as when the battery is replaced, all the settings are deleted, so preset the stations again.

**MANUAL MEMORY BUTTON**

Select the station to be preset with manual tuning button (1) or seek tuning button (2), then keep button No.1 to button No.6 of button (3) pressed for 2 seconds while the frequency is being displayed to preset the station.

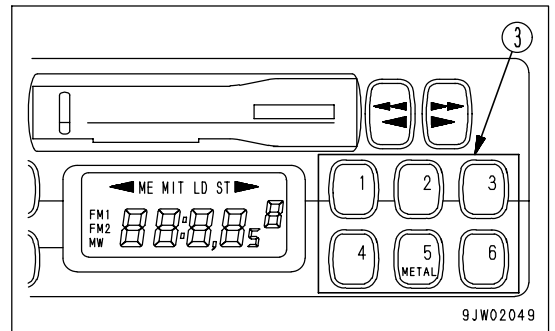
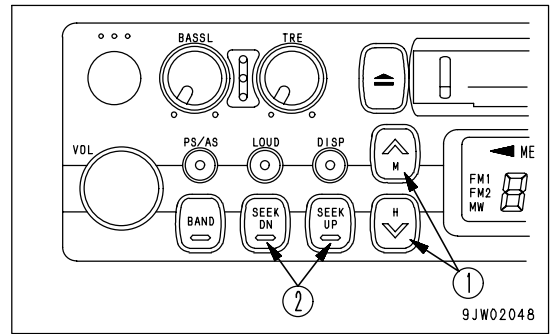

**LISTENING TO RADIO**

1. Turn the starting switch ON, then turn power switch (1) ON.
2. Set band selector button (2) to AM or FM.
3. Select the station with the preset buttons or manual tuning button (3).
4. Adjust the volume, balance, and tone as desired.
5. When turning the radio OFF, turn power switch (1) to the left until it clicks.

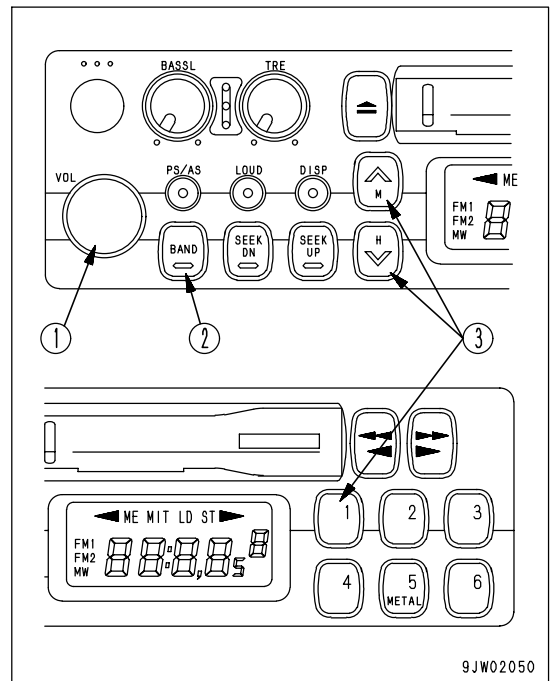

**REMARK**

- To switch to the radio when listening to a cassette, press the cassette eject button to stop the tape.
- If you insert a cassette when listening to the radio, the tape will start to play.

**LISTENING TO CASSETTE TAPE**

1. Turn the starting switch ON, then turn power switch (1) ON.
2. Set the cassette with the exposed portion of the tape on the right side and push it past the cassette door. The tape will automatically start playing.  
 If the arrow indicating the direction of play is pointing to the right, the top side is being played; if the arrow is pointing to the left, the bottom side is being played.  
 When the tape reaches the end, it is automatically reversed and the other side starts to play.
3. When finished with the tape, press the cassette eject button to eject the tape and automatically switch to the radio.

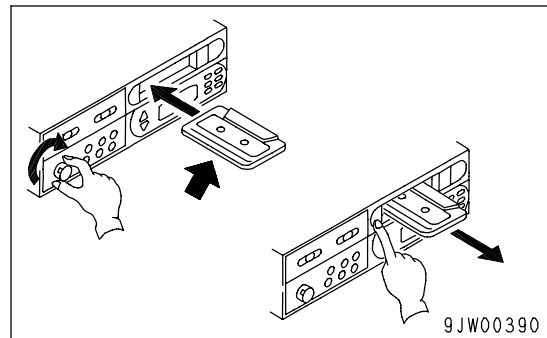
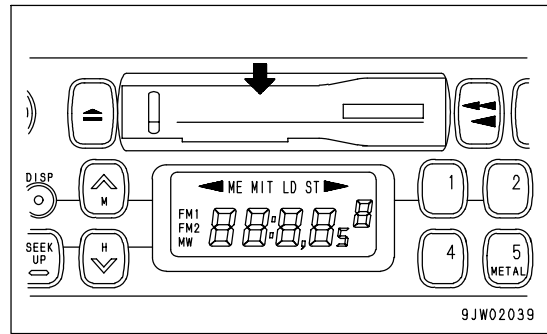

**REVERSING TAPE**

When listening to the tape, press both FAST FORWARD, REWIND buttons (A) and (B) at the same time lightly.  
 When this is done, the tape direction display will be reversed.

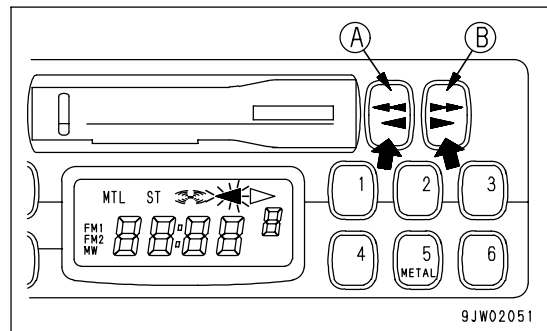

**PRECAUTIONS FOR USE**

- Stow the antenna when traveling in places with low overhead clearance.
- To ensure safety during operations, keep the volume at a level where it is possible to hear other machines.
- If water gets inside the speaker case or radio (auto tuning), it may cause a serious problem, take care not to let water get in these items.
- Do not wipe the scales or buttons with solvent such as benzene or thinner. Wipe with a dry soft cloth. If the dirt cannot be removed easily, soak the cloth with alcohol.

**NOTICE****Handling cassette tape**

- Clean the tape head approx. once a month with a commercially available head cleaning tape.
- Do not leave the tape any place where it is exposed to direct sunlight, any place that is excessively dusty, or any place where there is a magnetic field.
- Do not use 120-minute tapes. The tape is thin and it easily gets caught up inside the machine.
- If the tape is slack, it easily gets caught up inside the machine. Use a pencil to wind in the tape to remove any slack.
- Do not use any cassette tape if the label has started to come off. It may cause defective rotation, or it may be impossible to get the tape out of the machine.

### AIR CONDITIONER

(If equipped)

By taking fresh air into the cab through a filter, it is possible to raise the pressure inside the cab. This makes it possible to provide a pleasant working environment even on dusty jobsites.

### GENERAL LOCATIONS ON CONTROL PANEL

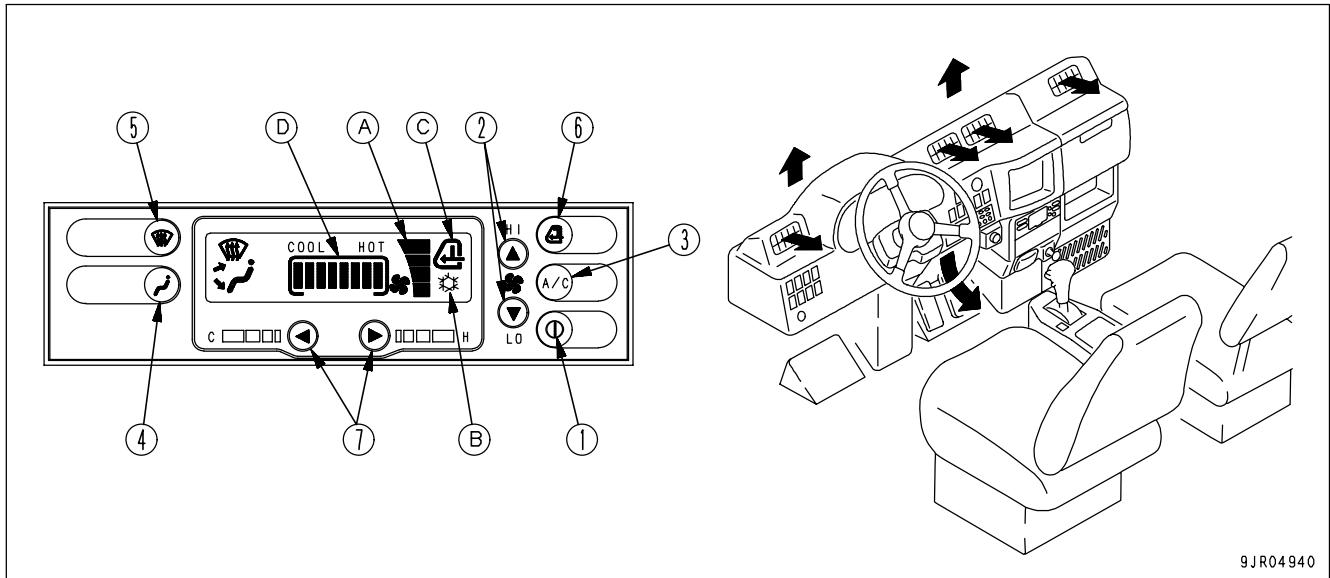

- (1) ON/OFF switch
- (2) Fan switch
- (3) Air conditioner switch
- (4) Mode selector switch
- (5) DEF switch
- (6) RECIRC/FRESH selector switch
- (7) Temperature control switch

Air conditioner monitor

- (A) Air flow bar
- (B) Air conditioner operation symbol
- (C) RECIRC/FRESH selector symbol
- (D) Temperature bar

### ON/OFF SWITCH

Use this switch (1) to turn the air conditioner ON/OFF.

When the switch is turned ON, the air conditioner monitor displays the setting being used when the switch was previously turned OFF.

### FAN SWITCH

With this switch (2) it is possible to adjust the air flow from the fan to 4 levels.

Press the ^ switch to increase the air flow; press the v switch to reduce the air flow.

The air flow is shown in air flow bar (A) on the air conditioner monitor.

### AIR CONDITIONER SWITCH

Use this switch (3) to actuate the cooling, heating, or dehumidifying functions, or to stop the air conditioner.

When the switch is pressed, air conditioner operation symbol (B) is displayed on the air conditioner monitor. When the switch is pressed again, the air conditioner is switched OFF and the operation symbol goes out.

**MODE SELECTOR SWITCH**



Use this switch (4) to select the vents.

There are three combinations of vents: FACE, FACE/FOOT, and FOOT.

Each time the switch is pressed, the vent display on the air conditioner monitor changes in the order FACE, FACE/FOOT, FOOT, FACE.

**REMARK**

Air also blows out from the defroster vent in FOOT mode.

Air conditioner monitor display	Condition of vents
	FACE
	FACE/FOOT
	FOOT

**DEF SWITCH**

Use this switch (5) to change the vents to the DEF mode.

When the switch is pressed, the vent display on the air conditioner monitor changes as shown in the diagram on the right.

When the DEF switch is pressed in any of the FACE, FACE/FOOT, or FOOT modes, the system changes to the DEF mode. In addition, when the DEF mode is being used, if the mode selector switch is pressed, it will return to the mode being used before switching to the DEF mode.

**REMARK**

Air also blows out from the foot vent in DEF mode.

Air conditioner monitor display	Condition of vents
	DEF



**RECIRC/FRESH SELECTOR SWITCH**

Use this switch (6) to switch between recirculation of the internal air (RECIRC) or intake of external air (FRESH). When the switch is pressed, the display of RECIRC/FRESH selector symbol (C) on the air conditioner monitor changes.

(It changes in the order RECIRC, FRESH, RECIRC.)

**RECIRC:** Only the air inside the cab is circulated. Use this position when it is needed to carry out quick heating or cooling of the cab, or when the outside air is dirty (smells or is dusty).

**FRESH:** Fresh air is taken in from the outside for normal heating or cooling of the cab. Use this position to make the air inside the cab fresh or to remove the mist from the cab windows. When the air conditioner takes in fresh air from the outside, the pressure inside the cab rises and this prevents the entry of dirt. The higher the position of the fan switch, the more efficient this becomes.

Air conditioner monitor display	Condition of vents
	RECIRC
	FRESH

**TEMPERATURE CONTROL SWITCH**

Use this switch (7) to adjust the temperature of the air blowing out from the vents. The adjustment can be made to 8 levels from low temperature to high temperature.

The temperature of the air blowing out from the vents is displayed on temperature bar (D) on the monitor. The lower the number of segments lighted up on the bar, the lower the temperature is.

Press the > switch to raise the temperature; press the < switch to lower the temperature.

Even when the starting switch is turned OFF, the settings of each mode are retained in memory. However, in the following cases, the settings must be made again.

- When there has been abnormal interference from outside

**METHOD OF OPERATION**

With the FACE vents, it is possible to adjust the direction of the air flow and to turn it on or off.

However, do not set to the FACE mode with the vents closed.

**COOLING**

1. Press ON/OFF switch (1) to turn on the air conditioner power.
2. Press fan switch (2) to set the air flow to the maximum.
3. Press temperature control switch (3) to lower the temperature.
4. Press air conditioner switch (4) to set to COOLING.
5. Press RECIRC/FRESH selector switch (5) to set to RECIRC.
6. Press mode selector switch (6) to set the vents to FACE.
7. When the temperature inside the cab goes down, set to the desired temperature and air flow.

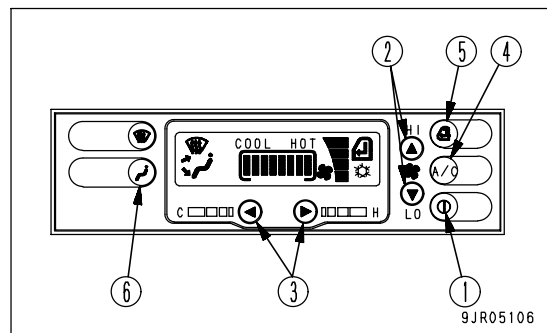

**NOTICE**

If operations are continued for a long time with the air conditioner set to the lowest temperature and minimum air flow, there is danger that the receiver drier may freeze.

If it freezes and no cold air comes out, stop using the cooling, and set to a higher temperature and the maximum air flow. Run for a short time under these conditions, then return to the cooling operation.

**HEATING**

1. Press ON/OFF switch (1) to turn on the air conditioner power.
2. Press fan switch (2) to set the air flow to the maximum.
3. Press temperature control switch (3) to raise the temperature.
4. Press RECIRC/FRESH selector switch (4) to set to FRESH.
5. Press mode selector switch (5) to set the vents to FOOT.
6. When the temperature inside the cab goes up, set to the desired temperature and air flow.

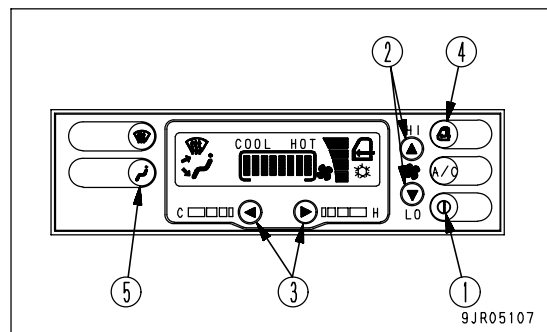

**REMARK**

The heating uses the heat from the engine cooling water, so it is effective only when the cooling water is hot.

**DEHUMIDIFYING, DEFROSTING**

1. Press ON/OFF switch (1) to turn on the air conditioner power.
2. Press fan switch (2) to set to the desired air flow.
3. Press temperature control switch (3) to set to the desired temperature.
4. Press RECIRC/FRESH selector switch (4) to set to FRESH.
5. Press mode selector switch (5) or DEF switch (6) to set the vents to the desired position.
6. Press air conditioner switch (7) to operate the cooling.

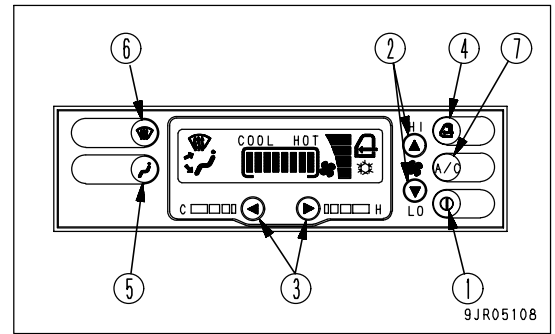
**REMARK**

- If the ambient temperature is below 0°C (32°F), the air conditioner cooling may not work. In this case, set to RECIRC and warm up the inside of the cab, then turn the air conditioner switch ON to operate the cooling.
- When defrosting, if the temperature control switch is pressed to set the temperature bar to the maximum (all 8 segments on the bar light up), this will improve the efficiency of removing the frost and preventing mist.



## PRECAUTIONS WHEN USING AIR CONDITIONER

To prevent putting any excessive load on the engine or compressor, turn the air conditioner ON only when the engine is running.

### Carry out ventilation from time to time when using the cooling.

- When turning the cooling on, if the temperature inside the cab is high, open the doors and windows to bring in fresh air before starting the air conditioner.
- If you smoke when using the cooling, your eyes may sting. If this happens, switch temporarily to cooling and ventilation to remove the smoke.
- When using the air conditioner for a long time, carry out ventilation and cooling once every hour.

### Be careful not to cool the cab too much.

For reasons of health, the optimum setting for cooling is considered to be when it feels slightly cool (5 or 6°C (9 or 10.8°F) lower than the ambient temperature) when you enter the cab. Do not make the temperature inside the cab too low or direct the air flow directly onto your skin.

Be extremely careful to select the appropriate temperature.

### When cooling is not being used (off-season)

To prevent leakage of the refrigerant from the air conditioner cooling circuit, operate the air conditioner for several minutes 2 or 3 times a month during the off-season. If the air conditioner is left for a long time when the refrigerant is leaking, it may cause internal rust.

## INSPECTION AND MAINTENANCE

Even when not using the air conditioner, run the compressor at low speed for several minutes once a week to prevent the loss of the oil film at various parts of the compressor. (Run the engine at low speed and set the temperature control lever to the central position.)

Clean the air filter and check the refrigerant. For details, see "CLEAN AIR CONDITIONER AIR FILTER (PAGE 4-30)" and "CHECK REFRIGERANT (GAS) LEVEL (PAGE 4-31)".

To enable the air conditioner to perform to the full and to maintain a pleasant working environment, always contact your Komatsu distributor to have the air conditioner refilled with refrigerant and to carry out other checks.

# OPERATION

## CHECK BEFORE STARTING ENGINE

### WALK-AROUND CHECK

Before starting the engine, look around the machine and under the machine to check for loose nuts or bolts, or leakage of oil, fuel, or coolant, and check the condition of the hydraulic system.

Check also for loose wiring, play, and accumulation of dust in places that get very hot and are exposed to extremely high temperatures.



### WARNING

- Always hang the warning tag from the gear shift lever.
- Leakage of oil or fuel, or accumulation of flammable material around the battery or high temperature parts of the engine, such as the engine muffler or turbocharger, may cause fire. Check carefully, and if any problem is found, repair it or contact your Komatsu distributor.

Perform the following inspections and cleaning every day before starting engine for the day's work.

1. Check the dump body, frame, tires, cylinders, linkage, and hoses for cracks or excessive wear or play.  
Check the dump body, frame, tires, cylinders, linkage, and hoses for cracks or excessive wear or play, and carry out repairs if any problem is found.
2. Remove dirt from around engine, battery, radiator, and aftercooler.  
Check that there is no dirt or dust accumulated around the engine, radiator or aftercooler. Check also that there is no flammable material (dry leaves, twigs, etc.) accumulated around the battery, or engine, muffler, turbocharger, or other high temperature parts of the engine. Remove any dirt or flammable materials that are found.
3. Check for leakage of water or oil around engine  
Check that there is no oil leakage from the engine or coolant leakage from the cooling system. If any problem is found, repair it.
4. Check for leakage from fuel line.  
Check that there is no leakage of fuel or damage to the hoses and tubes. If any problem is found, carry out repairs.
5. Check for oil leakage from transmission case, differential case, final drive case, steering/hoist oil tank, hoses, and joints  
Check that there is no oil leakage. If any problem is found, repair the place where the oil is leaking.  
Check for leakage of oil from the undercover. Check the ground for traces of oil leakage.
6. Check for damaged or worn tires, wheels, and wheel hub bolts and nuts, check for loose wheel hub bolts and nuts.  
Check for cracks or peeling of the tires and for cracks or wear to the wheels (side rim, rim base, lock ring). Tighten any loose wheel hub bolts or nuts. If any abnormality is found, repair or replace the part.  
If any valve caps are missing, install new caps.
7. Check for loose air cleaner mounting bolts.  
Check for the loose bolts. If loose, tighten them.

8. Check dump body mount rubber  
Check for any cracks, embedded foreign objects, or loose bolts.
9. Check for damage to handrail, loose bolts  
Repair any damage and tighten any loose bolts.
10. Check for damage to gauges, lamps on the instrument panel and loose bolts.  
Check for damage to the panel, gauges and lamps. If any problem is found, replace the parts. Clean off any dirt on the surface. Tighten any loose bolts.
11. Check rear view mirror, under view mirror  
Check that the mirrors are not damaged. Replace them if they are damaged. Clean the surface of the mirrors and adjust the angle so that the operator can see the area to the rear and under the machine from the operator's seat.
12. Check for damage to the seat belt and mounting clamps.  
Check for damage to seat belt and mounting clamps. If damages are found, replace with the new one.
  - Check for any loose bolts of the clamps mounting the equipment to the machine. Tighten any loose bolts.
  - When the belt has been used for a long time, if any external damage or fraying of the belt can be seen, or if the clamps are broken or deformed, replace the seat belt.
13. Inspect tires.



## WARNING

If worn or damaged tires are used, they may burst and cause serious injury or death.

To ensure safety, do not use the following tires.

### Wear:

- Tires with a tread grooves of less than 15% of that of a new tire
- Tires with extreme uneven wear or with stepped-type wear

### Damage:

- Tires with damage that has reached the cords, or with cracks in the rubber
- Tires with cut or pulled cords
- Tires with peeled (separated) surface
- Tires with damaged bead
- Leaking or improperly repaired tubeless tires
- Deteriorated, deformed or abnormally damaged tires, which do not seem usable

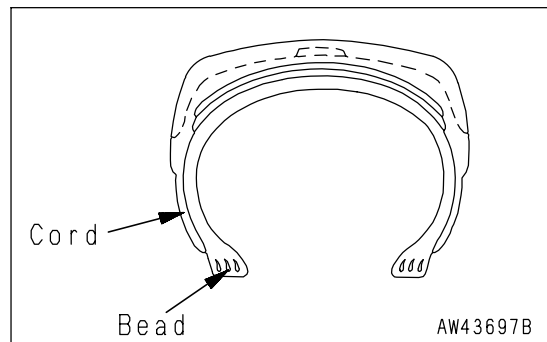

14. Inspect rims.



## WARNING

Check the rims (wheels) and rings for deformation, corrosion and cracks. In particular, check the side rings, lock rings and rim flanges thoroughly.

**CHECK BEFORE STARTING**

Always perform the procedures in this section before starting the engine each day.

**CHECK COOLANT LEVEL, ADD COOLANT****WARNING**

- Do not open the radiator cap unless necessary. When checking the coolant, always wait for the engine to cool down and check the sub tank.
- Immediately after the engine is stopped, the coolant is at a high temperature and the radiator is under high internal pressure. If the cap is removed to check the coolant level in this condition, there is a hazard of burns. Wait for the temperature to go down, then turn the cap slowly to release the pressure and remove it carefully.

1. Check that the cooling water in sub tank (1) is between the FULL and LOW marks.
2. If the level is LOW, remove cap (2) and add the engine coolant up to the FULL mark.

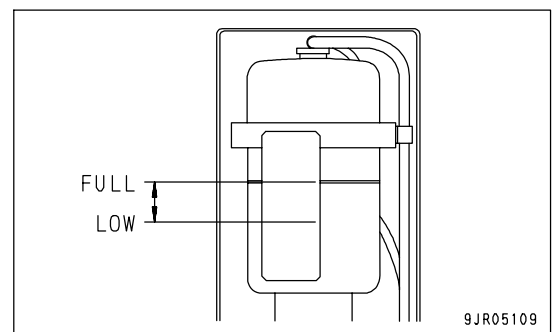
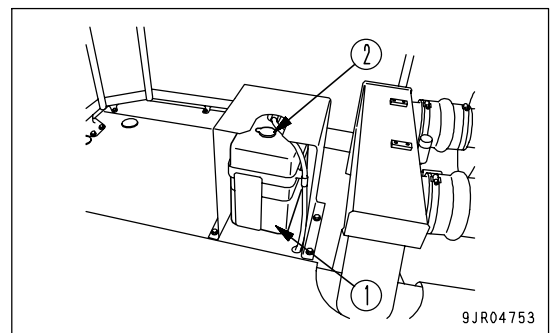

3. If there is no coolant in the sub tank, add water to the radiator through water filler (3) at the top of the radiator, then add water to the sub tank.
4. Check that there is no oil in the engine coolant or any other problem.
5. After adding coolant, tighten the cap securely.
6. If more coolant is added than normal, then check for water leakage.

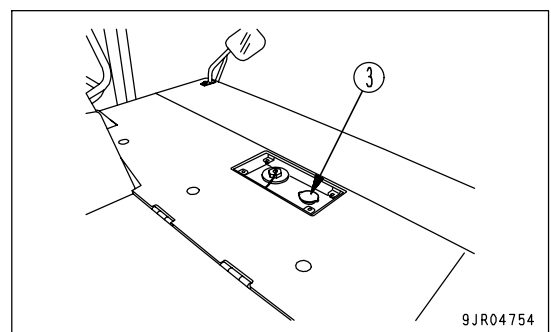

**CHECK DUST INDICATOR**

1. Check that the red line in the transparent portion of dust indicator (1) does not indicate 7.5 kPa (30 INCHES H<sub>2</sub>O) (0.076 kg/cm<sup>2</sup>, 1.1 PSI).
2. If the red line indicates 7.5 kPa (30 INCHES H<sub>2</sub>O) (0.076 kg/cm<sup>2</sup>, 1.1 PSI), clean or replace the air cleaner element immediately.  
For details of the method of cleaning the element, see "CHECK, CLEAN OR REPLACE AIR CLEANER (PAGE 4-21)".
3. After checking, cleaning, or replacing, press the top of dust indicator (1) to return the red line to its original position.

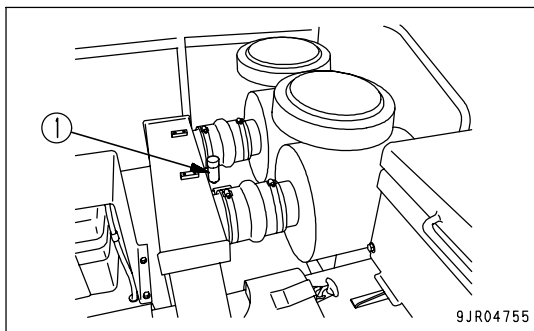

## CHECK OIL LEVEL IN ENGINE OIL PAN, ADD OIL

**WARNING**

Parts and oil are at high temperature immediately after the engine is stopped and may cause serious burns. Wait for the oil temperature to go down before performing this operation.

1. Check the oil level with dipstick (G).
2. Take out the dipstick (G) and wipe off the oil with cloth.
3. Fully insert dipstick (G) into filler pipe, then remove it.  
When inserting, insert so that the oil level gauge indicator is facing the engine.
4. The oil level should be between the H and L marks on the ENGINE STOPPED side of dipstick (G).  
If the oil is below the L mark, add oil through oil filler (F).

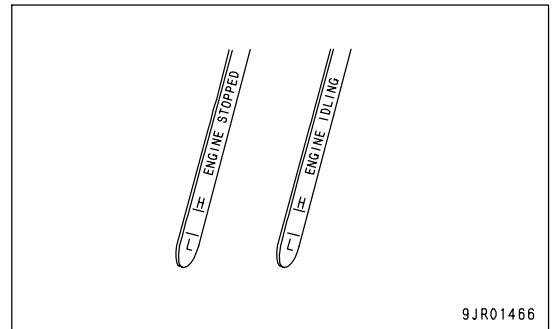
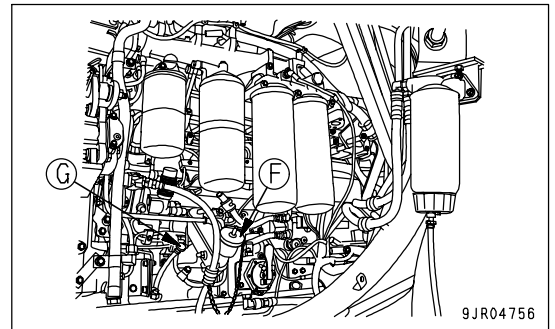

5. If the oil is above the H mark, remove drain plug (1), and loosen drain valve (2) to drain the excess engine oil, then check the engine oil level again.
6. If the oil level is correct, tighten the handle of the oil filler cap securely.

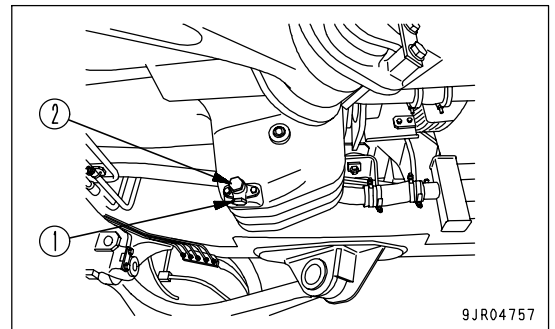
**REMARK**

- When checking the oil level after the engine has been operated, wait for at least 15 minutes after stopping the engine.
- If the machine is at an angle, make it horizontal before checking.
- The dipstick has the oil level marked on both sides: ENGINE STOPPED for measuring when the engine is stopped, and ENGINE IDLING for measuring when the engine is idle.
- When checking the oil level, stop the engine and check with the ENGINE STOPPED side of the dipstick. It is also possible to check when the engine is idle, but the following procedure must be used.
  - Check that the engine water temperature is in the white range.
  - Use the ENGINE IDLING side of the dipstick.
  - Remove the oil filler cap.

**CHECK OIL LEVEL IN TRANSMISSION CASE, ADD OIL**

1. After starting the engine, run the engine at low idle and check the oil level with sight gauge (G2).
2. If the oil level is low, add oil through oil filler (F).

**NOTICE**

- The oil level changes according to the oil temperature, so carry out the check after completing the warming-up operation.
- During operations, or when the engine is running at idle after operations, the oil level should be above (G2).
- When checking the oil level with the engine stopped, check with sight gauge (G1) as a guide line, and make the final check with (G2).
- When checking the oil level with the engine stopped, wait for 20 minutes after stopping the engine and check with sight gauge (G1).

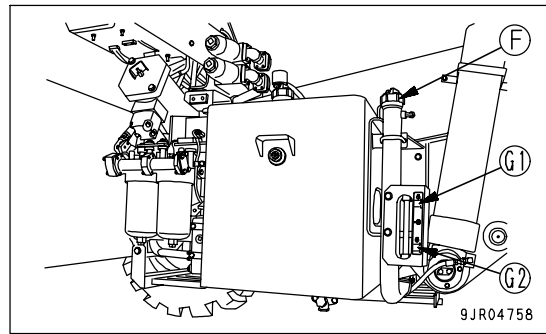
**CHECK OIL LEVEL IN STEERING AND HOIST OIL TANK, ADD OIL**

**WARNING**

If the oil filler cap is removed without releasing the internal pressure, oil will spurt out, so turn the oil filler cap slowly to release the internal pressure, then remove it carefully.

1. Check with sight gauge (G).
2. If the oil level is not up to the window of sight gauge (G), add oil through oil filler (F).

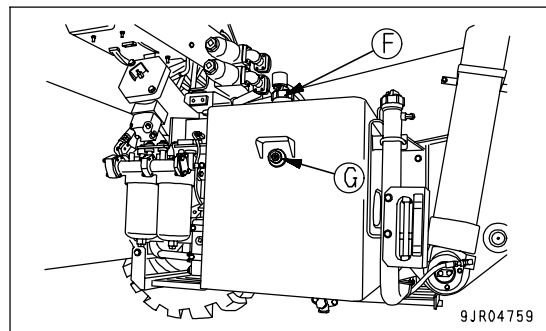

**CHECK OIL LEVEL IN BRAKE SUB-TANK, ADD OIL****WARNING**

Immediately after the machine is stopped, the pressure inside the tank is high, so if the cap is opened, hot oil will spurt out and may cause burns. Turn the cap slowly to release the pressure inside the tank before opening the oil filler cap.

1. Check with sight gauge (H). If the oil level is up to the window of sight gauge (H), it is suitable.

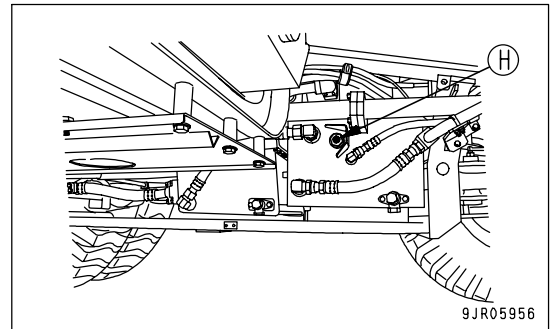

2. If the oil level is not up to the window of sight gauge (H), add oil through oil filler (F).

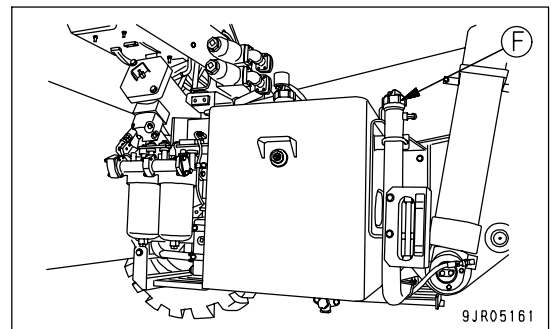
**CHECK FOR LEAKAGE OF OIL FROM REAR BRAKE OIL RECOVERY TANK BREATHER**

1. Check that no oil is leaking to the ground from the breather. Check also that no oil is leaking from overflow tube (1) of the rear brake oil recovery tank.
2. If any oil is leaking, recover the oil. For details, see "RECOVER OIL LEAKING FROM FLOATING SEAL (PAGE 4-71)".

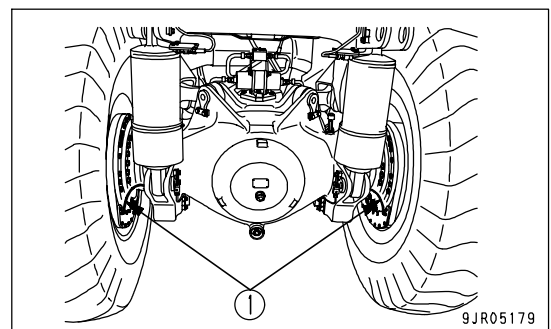



**DRAIN WATER, SEDIMENT FROM FUEL TANK**

Loosen valve (1) at the bottom of the fuel tank, and drain the water and sediment collected at the bottom of the tank together with the fuel.

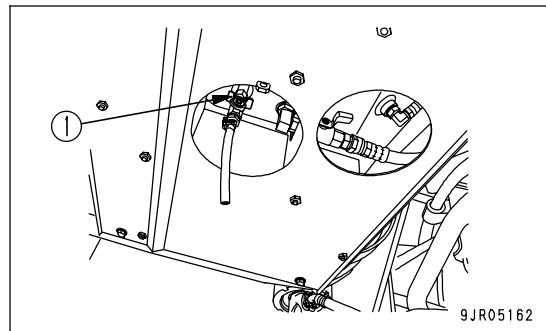
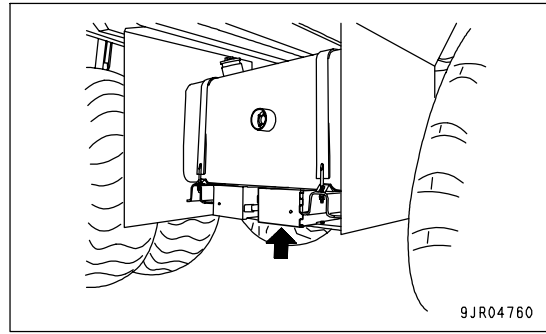

**CHECK FUEL LEVEL, ADD FUEL**

**! WARNING**

When adding fuel, never let the fuel overflow. This may cause a fire. If any fuel is spilled, wipe it up completely. Never bring flames near fuel because it is highly flammable and dangerous.

1. Check the fuel level with fuel gauge (G), which is installed in the side of the fuel tank.
2. After completing operations, add fuel through fuel filler (F) to fill the tank.  
Fuel capacity: 500 liters (132.1 US gal)
3. After adding fuel, tighten the cap securely.

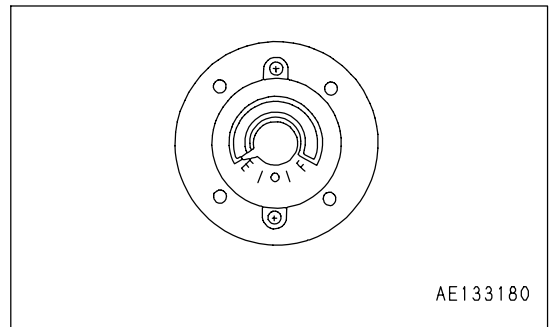
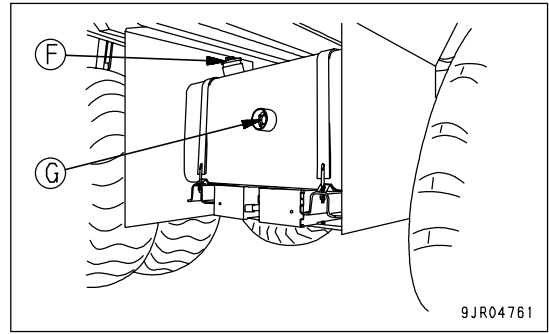

**REMARK**

- If the breather hole in the cap (1) becomes clogged, the pressure inside the tank will go down and the fuel may not flow, therefore clean the breather hole from time to time.
- To prevent air from being sucked into the engine, do not let the level in the fuel tank go down too low.

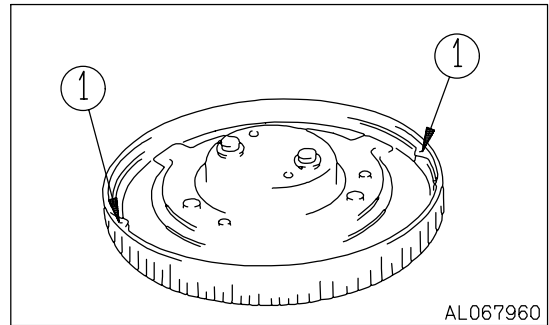

**CHECK WHEEL HUB NUTS, TIGHTEN**

Check for loose wheel hub nuts (1). If any are found, tighten them.  
Tightening torque: 1520 to 1850 Nm  
(155 to 189 kgm, 1121 to 1367 lbft)

Insert a socket wrench in a pipe, and apply a force of 1740 N (177 kg) at a point 1 m from the fulcrum to give a tightening torque of 1740 Nm (177 kgm, 1280 lbft).

When tightening the hub nuts after replacing the tires, travel for 5 to 6 km, then check the tightening torque to ensure that there are no loose bolts.

If any stud bolt used to install the rim is broken, replace all the stud bolts for that wheel.

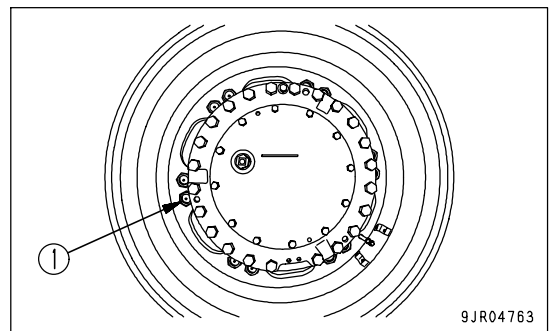

**CHECK CENTRAL WARNING LAMP, ALARM BUZZER, MONITOR LAMPS AND METERS**

Before starting the engine, turn the starting switch to the ON position, press machine monitor check switch (1), and check that there is no failure in any monitor lamp.

If any instrument does not work, there is probably a failure, so please contact your Komatsu distributor for inspection.

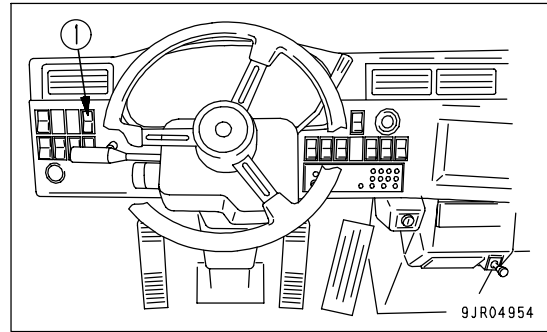
**CHECK BRAKING EFFECT**

Check if the braking capacity of the parking brake, foot brake, and retarder brake.

If any abnormality is found, ask Komatsu distributor to repair.

**CHECK BRAKING CAPACITY OF SECONDARY BRAKE**

**WARNING**

- If the machine moves, it will lead to serious injury. If machine begins to move during the inspection of braking capacity, lower the engine speed immediately, set shift lever at N position, and then set parking brake switch at PARKING position.
- If inspection is carried out when the body pilot lamp is lighted up and the shift indicator shows "F1", there is danger that the internal parts of the transmission may be damaged.

Before carrying out inspection, lower the dump body securely and check that the body pilot lamp has gone out, then place the gear shift lever at the "D" position and check that the shift indicator shows "F2".

Check the braking capacity of the secondary brake as follows.

1. Stop the machine on flat ground, raise the oil pressure to the maximum, set the parking brake to TRAVEL, then depress secondary brake pedal (1).
2. Set gear shift lever (2) to the D position, gradually raise the engine speed, and check that the machine does not move even when the engine reaches full speed. If the machine does not move, it is normal.
3. Lower the engine speed and set the shift lever to "N" position and set the parking brake switch to the "PARK" position.

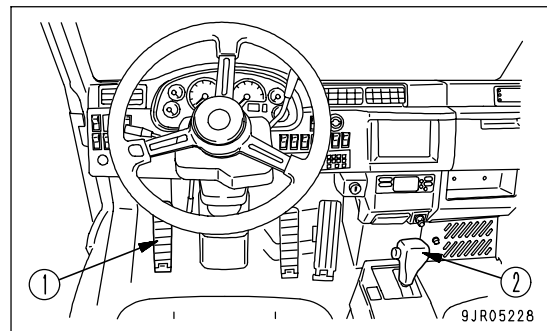

## CHECK EMERGENCY STEERING

### Check manual emergency steering

1. Turn starting switch key to the ON position.
2. Turn emergency steering switch (1) ON, and check that the steering wheel can be operated.

If the steering wheel cannot be operated, please contact your Komatsu distributor.

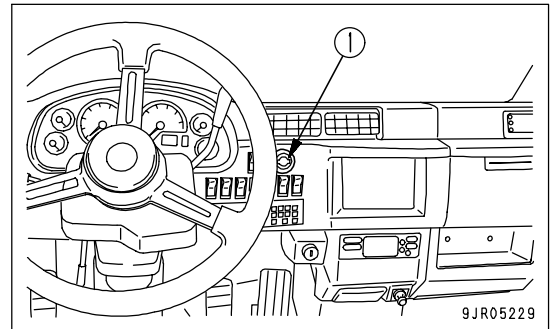

### Check auto-emergency steering

(Machines equipped with auto emergency steering)

1. Turn the starting switch key to the START position and start the engine.
2. Check that the brake oil pressure caution lamp is OFF, then pull retarder control lever (2) fully and stop the engine.
3. Turn starting switch key to the ON position.
4. Check that the emergency steering motor is actuated and the steering can be operated 1 sec. after parking brake switch (3) is set to the TRAVEL position.

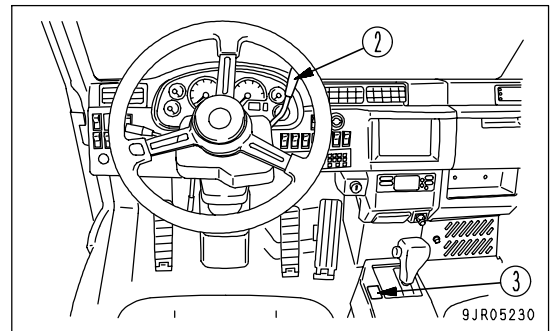

## CHECK BACKUP ALARM

1. Turn the engine starting switch to the ON position.
2. Place the gear shift lever in the R position and check that the backup alarm is working.

## CHECK ELECTRIC WIRING



### WARNING

- If the fuses frequently blow or if there are traces of short circuits in the electrical wiring, locate the cause and immediately perform repairs, or contact your Komatsu distributor for repairs.
- Keep the top surface of the battery clean and check the breather hole in the battery cap. If it is clogged with dirt or dust, wash the battery cap to clean the breather hole.

Check for damage and wrong capacity of the fuse and any sign of disconnection or short circuit in the electrical wiring. Check also for loose terminals and tighten any loose parts.

Check the wiring of the "battery", "starting motor" and "alternator" carefully, in particular.

Always check if there is any accumulation of flammable material around the battery, and remove such flammable material.

Please contact your Komatsu distributor for investigation and correction of any problems found.

**CHECK INFLATION PRESSURE OF TIRES**

Measure the inflation pressure with a tire pressure gauge, while the tires are cool, before starting work.

Check for damage or wear to the tires and the rims.

Check for loose wheel hub bolts.

The proper inflation pressure is shown below.

- HD325

Tire size	Inflation pressure
18.00-33-32PR (standard)	0.56MPa {5.75kg/cm <sup>2</sup> , 81.7 PSI}
18.00R33 ★ ★ (if equipped)	0.69MPa {7.00kg/cm <sup>2</sup> , 99.4 PSI}

- HD405

Tire size	Inflation pressure
18.00R33 ★ ★	0.69MPa {7.00kg/cm <sup>2</sup> , 99.4 PSI}

**NOTICE**

If the tires are used when the inflation pressure is less than the value given in the table above, the rim may be damaged.

Always keep the tire inflation pressure within +0 to +0.03 MPa {0.3 kg/cm<sup>2</sup>, 4.3 PSI} of the value in the table above.

**CHECK WATER SEPARATOR**

The water separator and fuel prefilter (1) are made one and composed of (2) to (4) in the lower section.

1. Water and sediment on the bottom can be checked through transparent cap (2). If there is water or sediment, prepare a container to receive it under drain hose (4).
2. Loosen drain valve (3) to drain the water.
3. If fuel starts flowing out through drain hose (4), close valve (3) immediately.

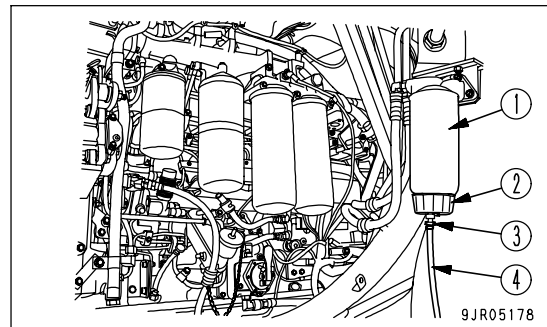
**DOES BODY POSITIONER OPERATE NORMALLY?**

1. Turn the starting switch key to the START position and start the engine.
2. Operate the dump control lever to the RAISE position, then release it.  
Check that the dump body stops before the end of the stroke.

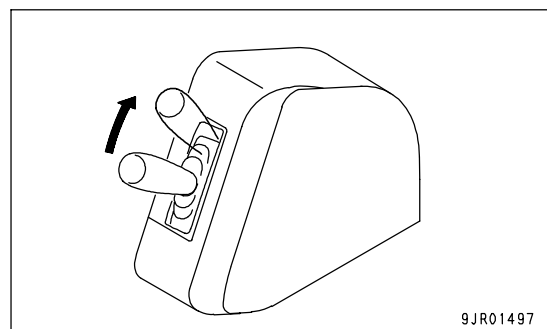
**REMARK**

If the dump body reaches the end of the stroke, the contact of the body will cause an impact. The body positioner is functioning, so the dump body stops without any impact.

## ADJUSTMENT BEFORE OPERATION

### ADJUSTING OPERATOR'S SEAT



## WARNING

- Park the machine in a safe place and stop the engine when carrying out adjustment of the operator's seat.
- Adjust the seat before starting operations or when changing operators.
- Adjust the position of the operator's seat so that you can depress the brake pedal fully with your back against the seat backrest.

#### (A) Fore-and-aft adjustment

Pull lever (1) up, set the seat to the desired position, then release the lever.

Amount of adjustment: 180 mm (7.1 in)  
(10 mm (0.4 in) x 18 stages)

#### (B) Adjusting seat angle

Move lever (2) up and push down on the rear of the seat to tilt it backward.

Move lever (2) down and push down on the front of the seat to tilt it forward.

Adjustment range: 13 degrees (Tilt forward/tilt back angle)

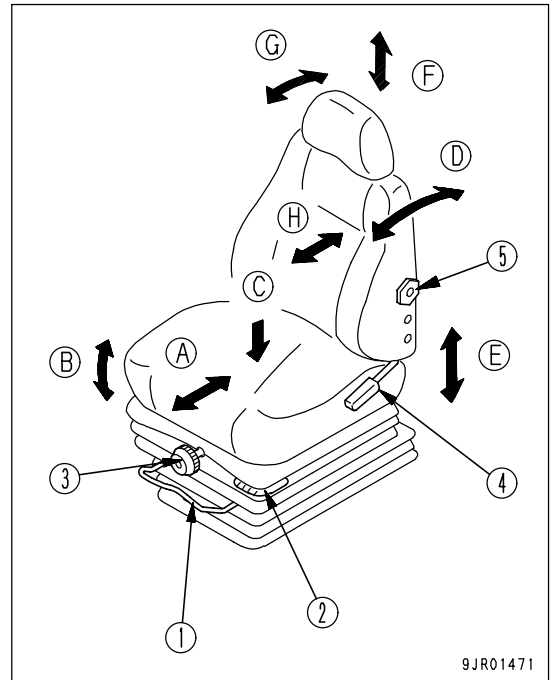

#### (C) Setting seat for operator's weight

Turn grip (3) to adjust the strength of the suspension.

Adjustment range: (Target) 50 to 120 kg (110 to 265 lb)

#### (D) Adjusting backrest angle

Move lever (4) up and move the backrest to the front or rear.

When doing this, keep your back pressed against the seat back.

If your back is not against the seat back, the seat back may spring back suddenly.

Adjustment range: 66° to the front (3° x 22 stages)

72° to rear (3° x 24 stages)

#### (E) Seat height adjustment

Move lever (2) up/down, then move the seat up or down as desired. Since lever (2) is also used for adjusting seat angle, set the seat to the desired height while adjusting the angle.

Adjustment range: 60 mm (2.4 in)

9JR01471

(F) Adjusting headrest height

Move the headrest up and down to the desired height.

Adjustment range: 50 mm (2.0 in)

(G) Adjusting headrest angle

Rotate the headrest to the front or rear.

(H) Lumbar support

Turn grip (5) to adjust the tension applied to the lower back.

## ADJUST SEAT BELT

**WARNING**

- Before fastening the seat belt, check that there is no problem in the securing brackets or belt. If there is any wear or damage, replace.
- Even if there appears to be no problem in the seat belt, replace the seat belt once every 3 years. The date of manufacture is woven on the reverse side of the belt.
- Adjust and fasten the seatbelt before starting to travel.
- Always use the seatbelt when traveling.
- Do not use the seat belt with either half of the belt twisted.

**Fastening and removing belt**

Fasten the belt so that it is tight without being too tight.

1. Sit on the seat, depress the brake pedal fully, and adjust the seat so that your back is pressed against the backrest.
2. Sit in the seat, pull the right side of the belt, then insert tongue (1) into buckle (2) until a click is heard.
3. When removing the belt, press the red button in buckle (2) to free the belt.

Fit the belt so that it follows your body and is not twisted.

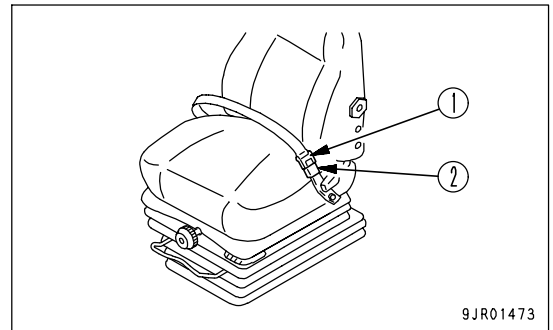

## ADJUST STEERING WHEEL TILT

**WARNING**

Always stop the machine before adjusting the tilt of the steering wheel.

The tilt of the steering wheel can be adjusted to the front and rear, and up and down. Pull lever up and set the steering wheel to the desired position, then push lever down to lock the steering wheel securely in position.

Amount of adjustment: Front/rear: 80 mm/80 mm (3.2 in/3.2 in)  
 (from center of steering wheel)  
 Up: 33 mm (1.3 in)  
 Down: 17 mm (0.7 in)

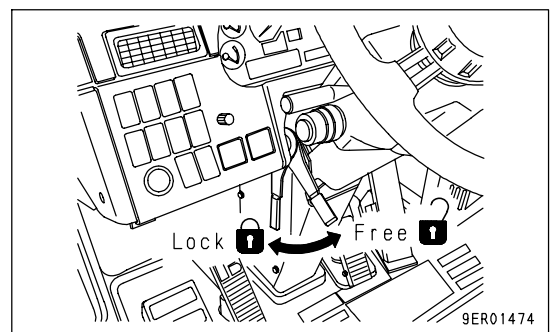



ADJUSTING MIRROR

**! WARNING**

Be sure to adjust the mirrors before starting work. If they are not adjusted properly, you cannot secure the visibility and may be injured or may injure someone seriously.

Loosen the bolt and nut installing the mirror, then adjust the mirror to a position which gives the best view from the operator's seat.

- Adjust the position and angle of each mirror so that it reflects a sight 200 mm above the ground and up to 1500 mm. In the adjustment, make sure that part of the dump truck's image also comes into view.

• View Range

Mirror A: Must be possible to see hatched portion (A) and part of the machine

Mirror B: Must be possible to see hatched portion (B) and part of the machine

Mirror C: Must be possible to see hatched portion (C) and part of the machine

Mirror D: Must be possible to see hatched portion (D) and part of the machine

Mirror E: Must be possible to see area to rear of hatched portion (E), area around ground contact of tires (E'), ground surface (E''), and top edge of body

Mirror F: Must be possible to see area to rear of hatched portion (F), area around ground contact of tires (F'), ground surface (F''), and top edge of body

Rear monitor (if equipped): Must be possible to see hatched portion (G)

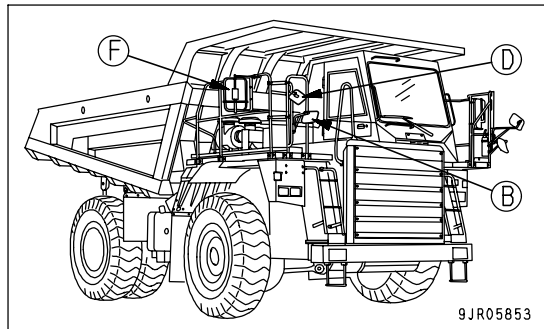
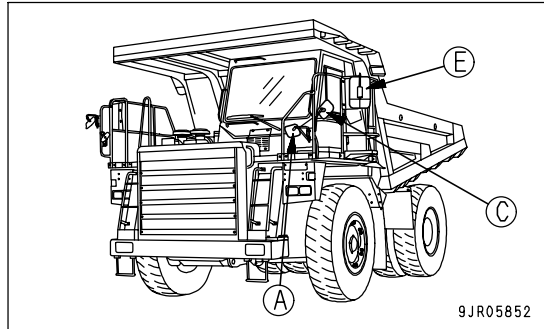

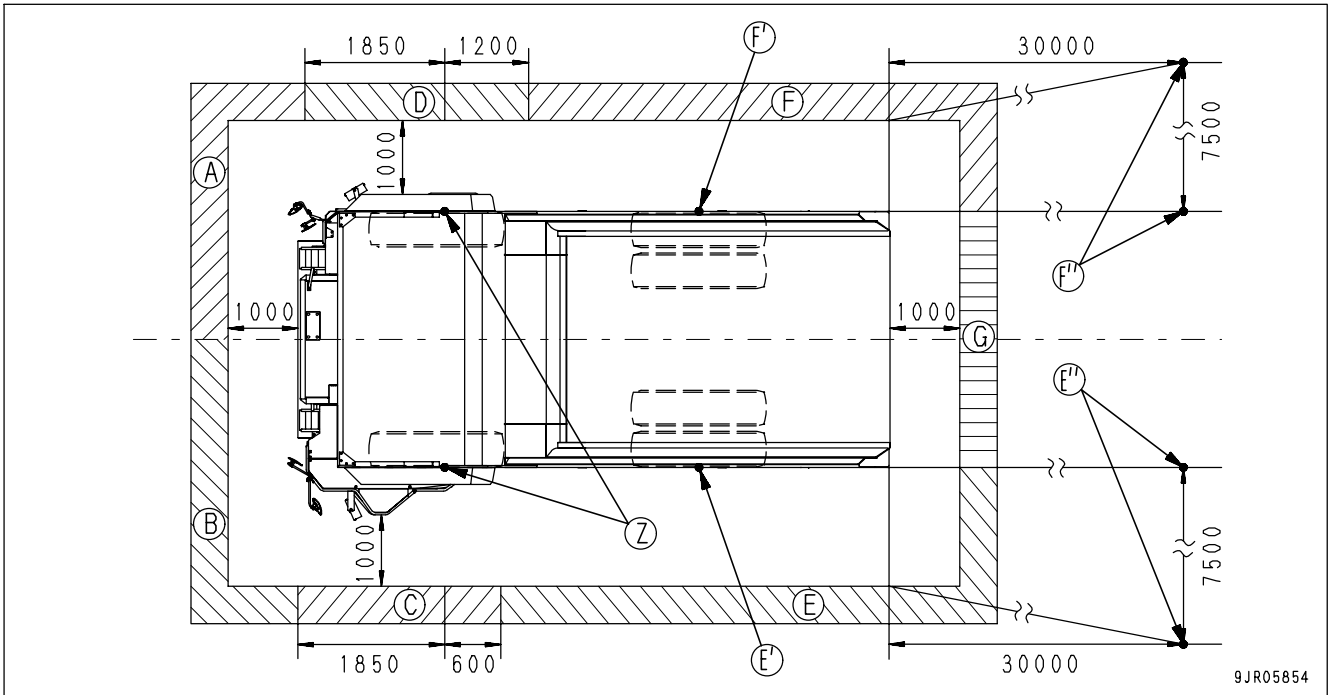

9JR05854

(Z): Ground contact point of tire used as base

**OPERATIONS, CHECKS BEFORE STARTING**

**! WARNING**

- When starting the engine, check that the gear shift lever is set in the N (neutral) position and that the parking brake switch is at PARKING position.
- Before standing up from the operator's seat, place the gear shift lever at N (neutral) position, and set the parking brake switch to the PARKING position.

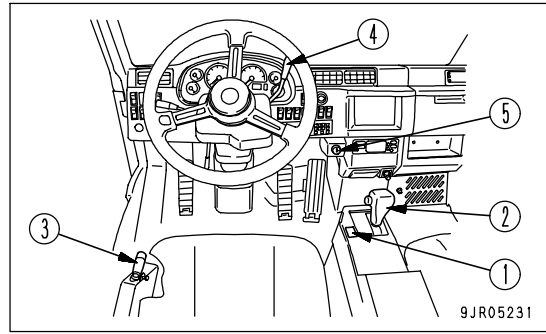

1. Check that parking brake switch (1) is in the PARKING position.

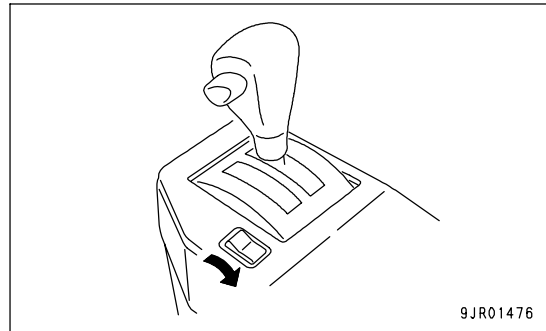

2. Check that gear shift lever (2) is at the N position.

**REMARK**

If the starting switch is turned to the ON position when the gear shift lever is not at the N position, the gear shift lever position pilot lamp and central warning lamp will flash, and the alarm buzzer will sound.

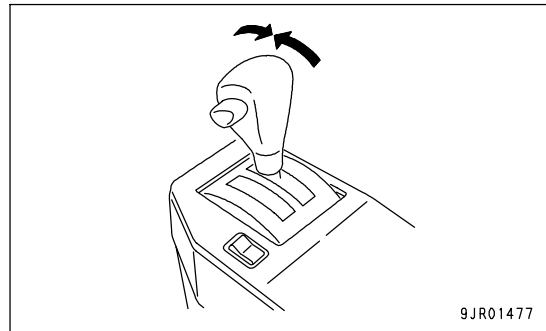

3. Check that dump lever (3) is at the HOLD position.

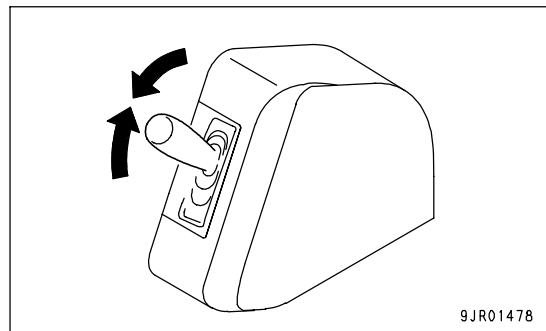

4. Check that retarder control lever (4) is at the RELEASED position.

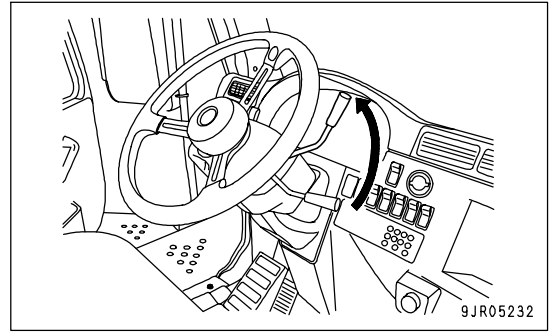

5. Check that there is no problem in the machine monitor when starting switch (5) is turned to the ON position.

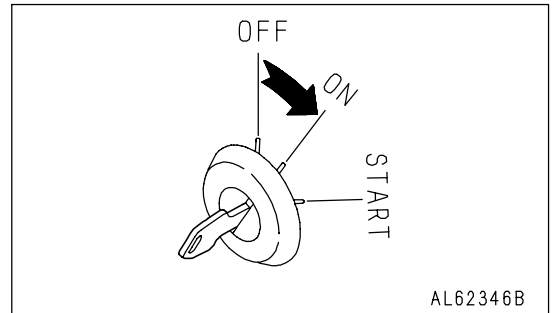

### STARTING ENGINE

#### WARNING

- Start the engine only after sitting down in the operator's seat.
- Do not attempt to start the engine by short-circuiting the engine starting circuit. Such an act may cause a serious bodily injury or fire.
- Check that there are no persons or obstacles in the surrounding area, then sound the horn and start the engine.
- Never use starting aid fluids as they may cause explosions.
- Exhaust gas is toxic. When starting the engine in confined spaces, be particularly careful to ensure good ventilation.

#### NOTICE

- Do not accelerate the engine sharply until it is warmed up.
- Do not operate the starting motor continuously for more than 20 seconds.
- If the engine fails to start, wait for 2 minutes or so, and then try to start again.
- When starting the engine, do not depress the accelerator pedal. Even if the accelerator pedal is depressed just after the engine is started, the engine speed is limited by the turbo protect function. After the turbo protect time, however, the engine speed rises sharply and the turbocharger may be damaged.

1. Turn the key of starting switch (1) to the ON position.  
 The preheater pilot lamp lights up, depending on the engine water temperature, and the engine is preheated. After the pre-heating time, the preheater pilot lamp goes off.

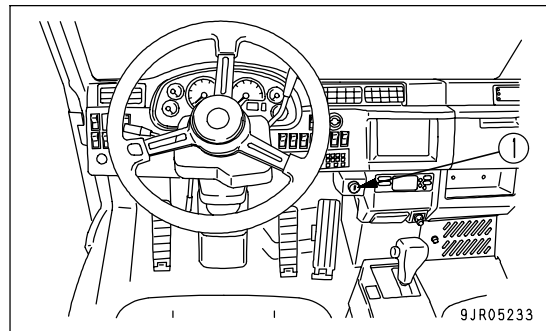

The pre-heating times are as shown below.

Engine water temperature	Preheating time
Above -5°C (23°F)	-
-5°C to -20°C (23°F to -4°F)	20 to 40 sec
Below -20°C (-4°F)	40 sec

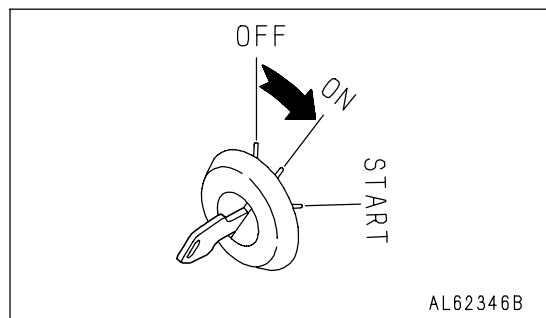

#### REMARK

When the key of the starting switch is turned to the ON position, if the engine water temperature is -5 °C or higher, the engine is not pre-heated. At this time, the engine can be started without pre-heating operation.

2. After the preheater pilot lamp goes off, turn the key of the starting switch to the START position, and the engine will start.

**REMARK**

When starting the engine, the monitor may flash while the starting motor is turning, but if the monitor lamp goes out after the engine is started, there is no problem.

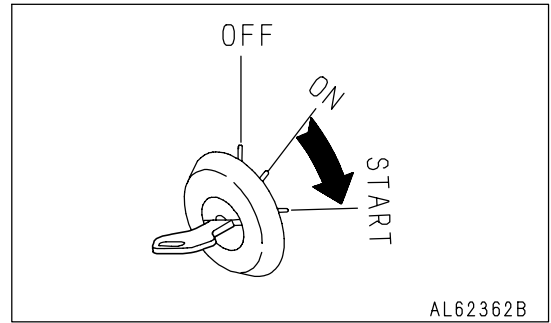

3. After the engine starts, release the key of the starting switch.

**REMARK**

If the engine fails to start, return the key of the starting switch to the OFF position, and then start the operation again from step 1. If the starting switch is not returned to the OFF position, the automatic preheater does not operate.

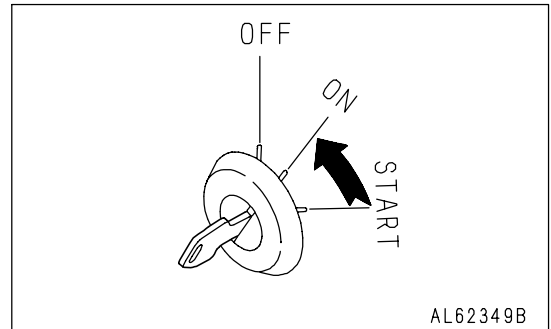

4. Just after the engine starts, do not depress the accelerator pedal but run the engine idle at low speed for at least 15 seconds.

When the engine is started for the first time after the engine oil or engine oil filter is replaced, continue the low idle run for at least 20 seconds to circulate the engine oil in the engine.

**REMARK**

- Since the turbocharger rotates at very high speed, it is seized if not lubricated well. To prevent this, the turbo protect mechanism works for a certain time just after the engine starts, depending on the engine water temperature.

Engine water temperature	Turbo protect time
Above 10°C (50°F)	0 sec
-10°C to 10°C (14°F to 50°F)	0 to 5 sec
Below -10°C (14°F)	5 sec

- Just after the engine starts, the injection characteristics are changed for a certain time to keep the low idle speed a little high, depending on the engine water temperature. The engine acceleration characteristics are also changed so that the engine will be accelerated moderately.

Engine water temperature	Injection characteristics change time
Above 20°C (68°F)	0 sec
0°C to 20°C (32°F to 68°F)	0 to 6 sec
-20°C to 0°C (-4°F to 32°F)	6 to 12 sec
-30°C to -20°C (-22°F to -4°F)	12 to 15 sec

## OPERATIONS, CHECKS AFTER STARTING ENGINE

### BREAKING-IN THE MACHINE



Your Komatsu machine has been thoroughly adjusted and tested before shipment. However, operating the machine under severe conditions at the beginning can adversely affect the performance and shorten the machine life.

Be sure to break-in the machine for the initial 100 hours (as indicated by the service meter).

During break-in operations, follow the precautions described in this manual.

- Idle the engine for 5 minutes after starting it up.
- Avoid operation with heavy loads or at high speeds.
- Immediately after starting the engine, avoid sudden starts, sudden acceleration, unnecessary sudden stops, and sudden changes in direction.

### WARMING-UP OPERATION

#### NOTICE

- Avoid accelerating the engine suddenly before the warming-up operation is completed.  
Do not run the engine for more than 20 minutes at low idling or high idling.  
If it is necessary to idle the engine, apply a load from time to time or run at a mid-range speed.
- On machines equipped with auto emergency steering, if the machine is not fully warmed up, the emergency steering may be actuated momentarily when the parking brake switch is set to TRAVEL or the dump control lever is operated.

After the engine starts, do not start operating the machine immediately. First, carry out the following operations and checks.

1. After starting the engine, run the engine at idle for 5 minutes for warming up operation.
2. After the warming-up operation, check that the machine monitor is normal.  
If there is any problem, carry out maintenance or repair.  
When the AISS LOW switch is at the AUTO position and the engine water temperature is still low, high idle revolution is automatically maintained.
3. Check if there is no problem in the steering operation, flashing of lights, sound of horn, exhaust gas color, noise, or vibration. If any problem is found, repair it.  
When the steering oil temperature is low, the steering will become slightly heavier, so avoid operating the steering when traveling at high speed.

## STOPPING ENGINE

### NOTICE

If the engine is suddenly stopped without allowing it to cool down, there is danger that the life of the engine parts will be shortened, so never stop the engine suddenly except in emergency.

Allow the engine to cool down gradually before stopping it.

1. Set the gear shift lever to the N position, then set the parking brake switch to the PARKING position.
2. Lower the dump body and set the dump lever to the HOLD position.
3. Run the engine at low idle for about 5 minutes to cool down gradually.
4. Turn the key of starting switch (1) to the OFF position to stop the engine.
5. Remove the key from starting switch (1).

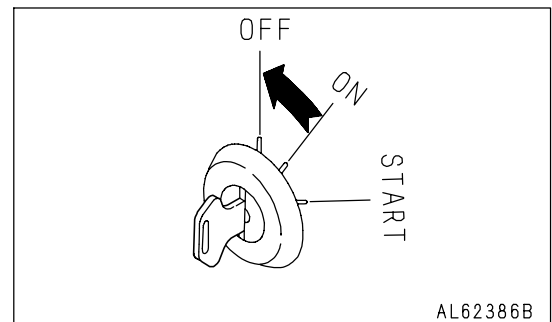
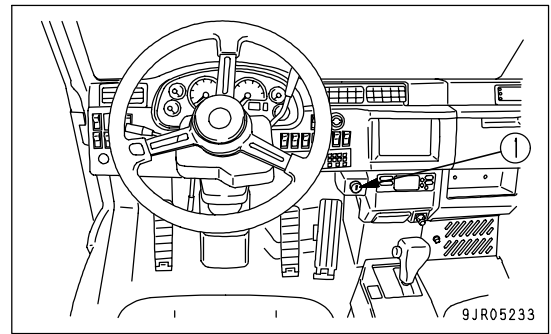

## CHECKS AFTER STOPPING ENGINE

1. Walk around the machine and check the dump body, body work, and undercarriage, and check also for leakage of oil and water.
2. Fill the fuel tank.
3. Check the engine compartment for paper and debris. Clean out any paper and debris to avoid a fire hazard.
4. Remove any mud affixed to the undercarriage.



### MOVING MACHINE OFF (FORWARD, REVERSE), STOPPING

#### MOVING MACHINE FORWARD

#### **WARNING**

- When moving the machine off, check that the area around the machine is safe, then sound the horn before starting.
- Do not allow people to get near the machine.
- Clear the machine's travel path of any obstacle.
- Pay a particular attention to the blind spot at the rear of the machine, when traveling the machine in reverse.

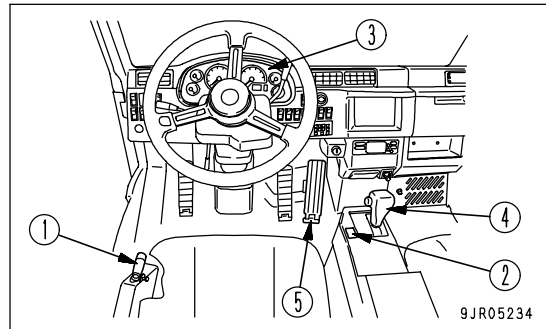

1. Check that there is no warning display on the machine monitor.
2. Fasten the seat belt.
3. Check that dump lever (1) is at the FLOAT position and that the dump body pilot lamp is out.  
If the dump body pilot lamp is lighted up, operate the dump lever to the HOLD position, then operate it to the FLOAT position to cancel the dump body HOLD condition.

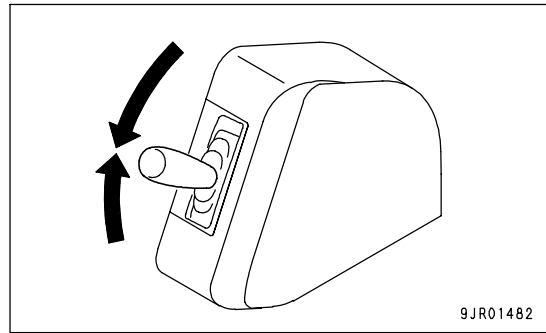

#### REMARK

When the engine is started, the dump lever is at the FLOAT position, but the dump body is at HOLD.

4. Depressed the brake pedal fully. Then set parking brake switch (2) to the TRAVEL position to release the parking brake.

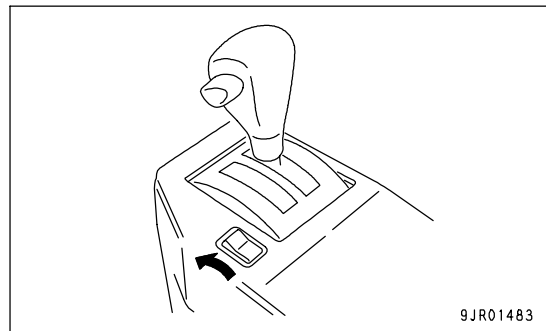

#### REMARK

If the engine is stopped with the parking brake switch at TRAVEL, the parking brake will be applied automatically even though the parking brake switch is at TRAVEL. When starting the engine again, operate the parking brake switch to PARKING, and then move it back to TRAVEL to cancel the parking brake.

5. Check that retarder pilot lamp (3) is not lighted up, then set gear shift lever (4) to the desired position.

**NOTICE**

- When operating the shift lever, be sure to set it in position securely. If the lever is not placed in position properly, the shift position display on the panel may go out and the Transmission system caution lamp may light up.
- Always release the accelerator pedal before shifting from N to R or F.

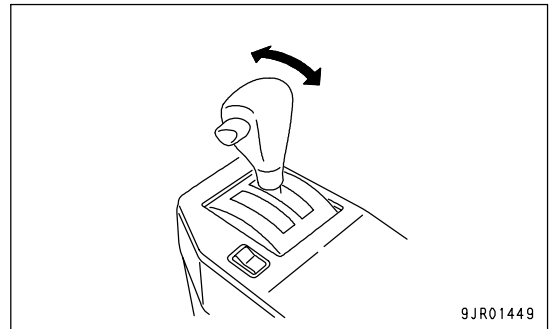
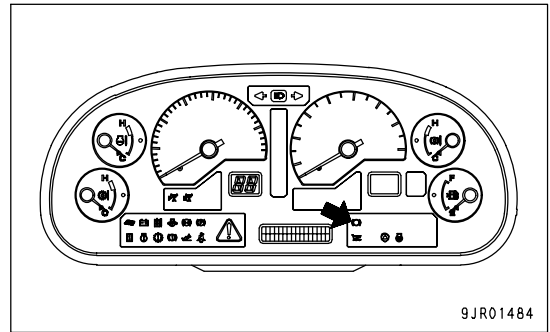

6. Depress accelerator pedal (5) to move the machine off.

**NOTICE**

- If the shift lever is shifted to a position other than N when the parking brake has not been released, the central warning lamp will flash and the alarm buzzer will sound.
- If the shift lever is shifted to a position other than N when the dump lever is at a position other than FLOAT or the body is raised, the central warning lamp will flash and the alarm buzzer will sound.
- Do not operate the shift lever with the accelerator pedal depressed. The throttle is automatically throttled, but a big shock is generated, and will also reduce the service life of the machine.

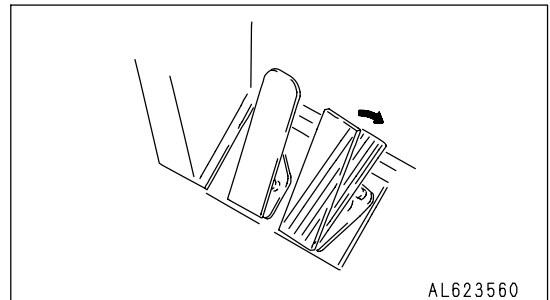

### MOVING MACHINE IN REVERSE

#### **WARNING**

- When switching between FORWARD and REVERSE, check that the new direction of travel is safe.  
There is a blind spot behind the machine, so use extreme caution when reversing the machine.
- Always stop the machine completely before shifting between FORWARD and REVERSE.

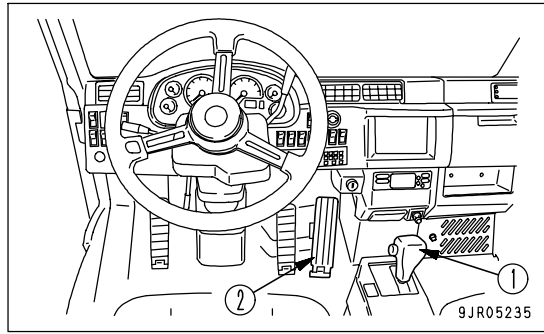

Place gear shift lever (1) in the R position, then gradually depress accelerator pedal (2) to move the machine off.

#### REMARK

- The machine cannot travel in reverse when the dump body is raised. Lower the dump body, set the dump lever to the FLOAT position, then set the gear shift lever to the R position.
- If the gear shift lever is set to the R position when the machine is traveling forward at a speed of 4 km/h (2.5MPH) or more, the transmission is placed in Neutral until the travel speed is reduced, the brake is automatically applied, and the engine is also throttled.

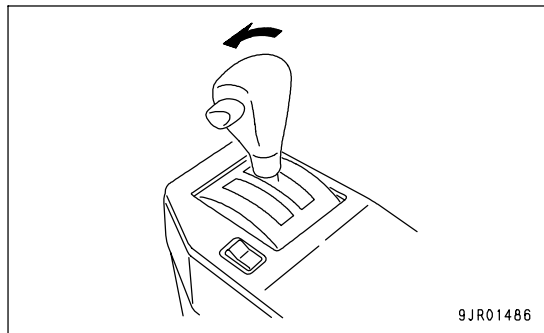

#### NOTICE

- When shifting between FORWARD and REVERSE, stop the machine completely, and run the engine at low idle when shifting the lever. After moving the gear shift lever, do not depress the accelerator until you detect that the transmission clutch has engaged.
- Do not operate the gear shift lever with the accelerator pedal depressed. This will cause a big shock, and will also reduce the service life of the machine.

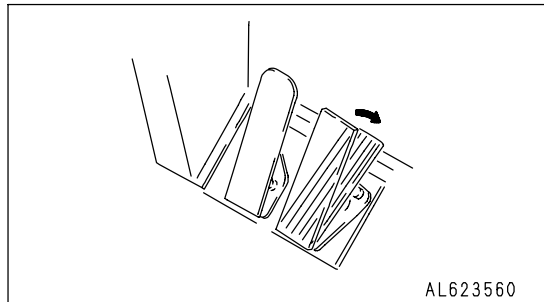

## STOPPING MACHINE

**WARNING**

- Avoid stopping suddenly. Give yourself ample room when stopping.
- If the foot brake is used repeatedly or is kept depressed for a long time, the brake may overheat and its life will be shortened.
- If the parking brake is used to stop the machine, the brake will be damaged. Do not use the parking brake except when stopping in emergencies or when parking the machine after stopping it.

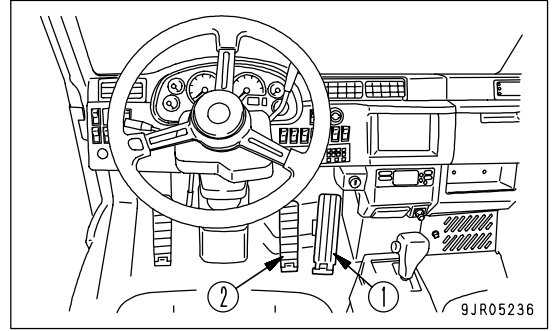
**NORMAL STOPPING**

Release accelerator pedal (1), and depress brake pedal (2) to stop the machine.

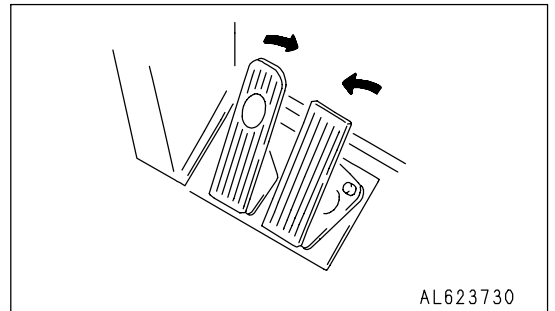

**STOPPING IN EMERGENCY**

If there should be a failure in the foot brake, stop the machine as follows.

**WARNING**

- When the machine stops, put blocks under the tires immediately.
- Immediately after making an emergency stop, the brake disc will be at high temperature, so wait for it to cool down before carrying out repair or adjustment. Ask your Komatsu distributor for repair and adjustment.

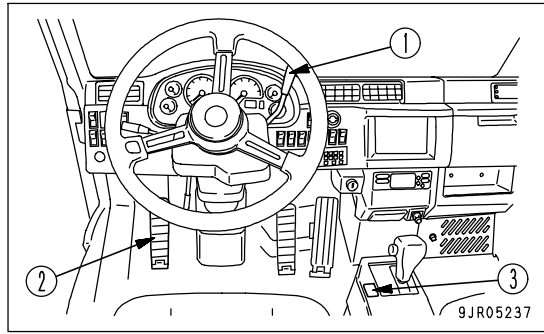

1. Pull retarder control lever (1) fully to apply the retarder.

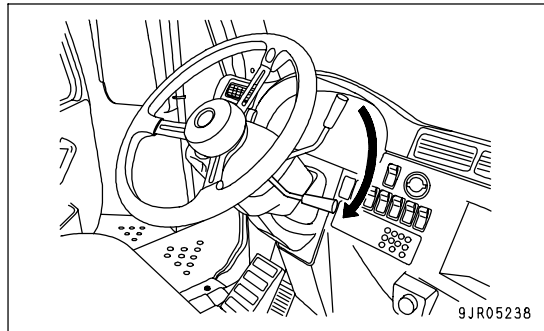

2. If sufficient braking force cannot be obtained simply by operating the retarder force, depress secondary brake pedal (2) to stop the machine.  
 The secondary brake applies the front and rear wheel brakes and the parking brake.

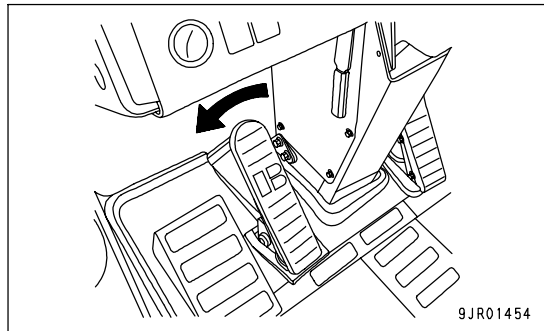

**REMARK**

If the machine is stopped with the secondary brake, the central warning lamp will flash and the alarm buzzer will sound. If this happens, return the gearshift lever to the N position to cancel the warning lamp and alarm buzzer.

3. When the machine stops, set parking brake switch (3) to the PARKING position.
4. If an emergency stop has been made, put blocks under the tires immediately, then try to find the cause, and repair it on site.

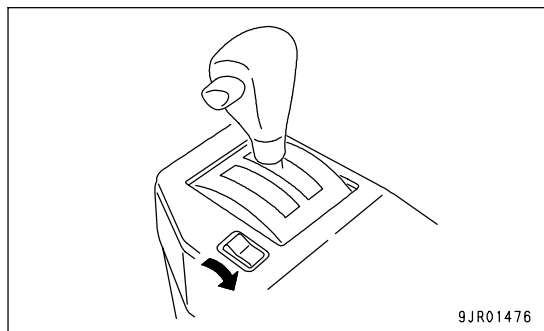

## SHIFTING GEAR



### WARNING

Do not move the gear shift lever to the N position when the machine is traveling or when it is traveling down a slope. Always place the transmission in gear before traveling.

- If the transmission is in Neutral, the engine cannot provide any braking effect and the steering wheel will become heavier. In addition, there will be lack of cooling oil for the retarder, so there is danger that it will overheat or that the actuation of the brake will be poor.
- There may also be damage to the transmission or other parts of the power train, and there is danger of unexpected accidents.

When shifting gear, do as follows.

This machine has an automatic transmission, so set gear shift lever (1) to the desired position, and the transmission will automatically shift to a position to match the travel speed.

Regardless of the position of the gear shift lever, if the dump body is raised, the speed range is set to 1st. Always lower the dump body when traveling.

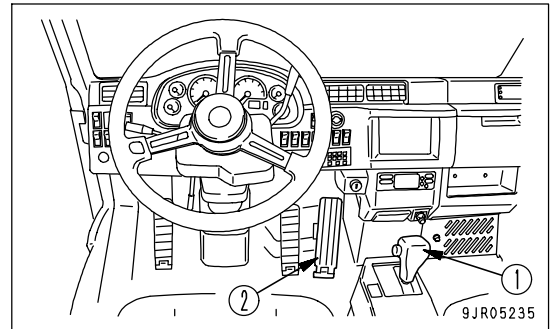

### NOTICE

- When shifting between FORWARD and REVERSE, stop the machine completely, and run the engine at low idle when shifting the lever. After moving the shift lever, do not depress the accelerator until you detect that the transmission clutch has engaged.
- Do not operate the shift lever with the accelerator pedal depressed. The throttle is automatically throttled, but a big shock is generated, and will also reduce the service life of the machine.

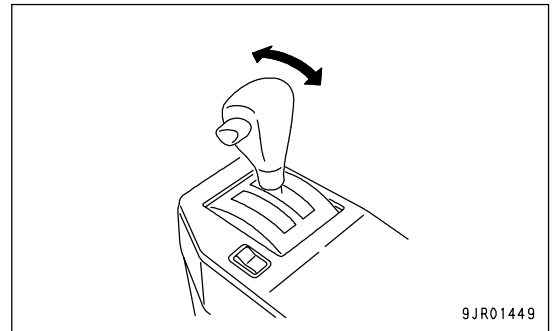

### SHIFTING UP

1. When accelerator pedal (2) is depressed to accelerate the machine, the lockup clutch is engaged to shift the transmission to direct drive.
2. If the machine is accelerated further, the transmission will automatically shift up.

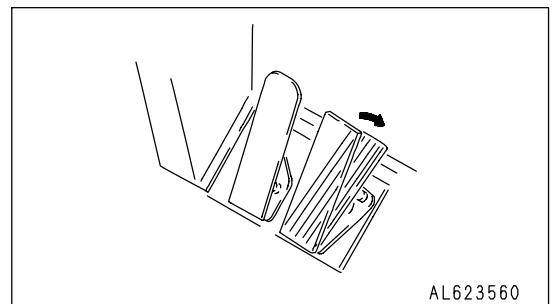

**SHIFTING DOWN**

If accelerator pedal (2) is released, the machine speed will be reduced, and the transmission will automatically shift down.

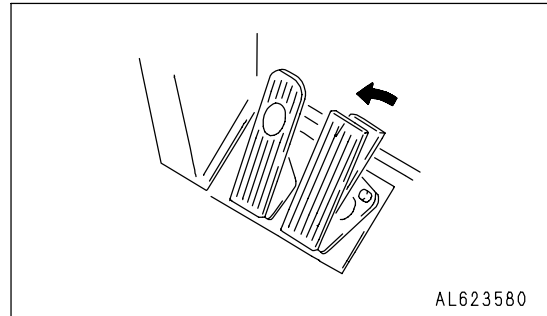
**DOWN SHIFT INHIBIT**

If the gear shift lever is operated when the machine is traveling, and the travel speed is faster than the maximum speed for each gear position, the transmission is not shifted immediately but is shifted down when the travel speed drops. This prevents overrunning of the engine.

**SHIFTING DOWN WHEN USING FOOTBRAKE**

When the foot brake is used to reduce the travel speed, if the machine is traveling with the transmission in the range from 2nd to 4th, the transmission will not shift down to a lower range until the travel speed goes down to the 2nd range or the brake is released. Maintaining the speed range reduces the speed when shifting, and this reduces the shock.

**SKIP SHIFT**

For normal gearshifting, the transmission shifts one gear range at a time.

When traveling uphill and the travel speed drops suddenly, the transmission jumps one gear range when shifting down to reduce the transmission shock.

**OVERRUN PREVENTION DEVICE**

If the engine tachometer enters the red range during operations, the alarm buzzer will sound and the central warning lamp will light up at the same time, so lower the engine speed and the travel speed. If the machine is accelerated to a speed higher than the maximum speed set for each range of the shift lever, the overrun prevention device is actuated to apply the retarder and reduce the travel speed.

## TRAVELING DOWNHILL

When traveling downhill, travel at a safe speed which matches the width of the road, the condition of the road surface, and other conditions of the jobsite.



### WARNING

- When the machine stops, put blocks under the tires immediately.
- For details of the maximum permitted speed when traveling downhill with the retarder operated, see the brake performance graph for the downhill distance and grade.  
It is dangerous if the machine travels downhill at a speed greater than the maximum permitted speed on the brake performance graph. This may damage the retarder brake.
- If the retarder oil temperature caution lamp on the machine monitor lights up when the retarder is being used to travel downhill, shift the transmission down.  
(When the caution lamp lights up, the central warning lamp also lights up and the alarm buzzer sounds.)  
If the caution lamp does not go out even when the transmission is shifted down, stop the machine, return the gear shift lever to the Neutral position, run the engine at 2000 rpm, and wait for the caution lamp to go out.
- If the retarder stops having any effect when the machine is traveling downhill with the retarder operated, do as follows.
  1. Release the retarder control lever fully, then operate the retarder control lever again.
  2. If the retarder still does not work even when the retarder control lever is operated again, release the retarder control lever fully. Then depress the brake pedal, stop the machine, and ask your Komatsu distributor to carry out repairs.
- Operate the retarder gradually. If it is operated suddenly, there is danger that the tires may slip.
- Do not move the gear shift lever to the N position when the machine is traveling or when it is traveling down a slope. Always place the transmission in gear before traveling.
  - o If the transmission is in Neutral, the engine cannot provide any braking effect and the steering wheel will become heavier. In addition, there will be lack of cooling oil for the retarder, so there is danger that it will overheat or that the actuation of the brake will be poor.
  - o There may also be damage to the transmission or other parts of the power train, and there is danger of unexpected accidents.

### NOTICE

- When traveling downhill, operate the retarder control lever. This makes it possible to shift down more quickly than for normal deceleration. In addition, it is also possible to travel without shifting up.
- When traveling downhill, do not use the foot brake except in emergencies. Using the foot brake will cause the front brake to overheat and will reduce the service life.
- Do not accelerate or shift up while operating the retarder.  
The engine speed will rise, and this may cause the alarm buzzer to sound and the central warning lamp to flash.



1. Before starting to travel downhill, release accelerator pedal (1) and operate retarder control lever (2) to slow the machine down.

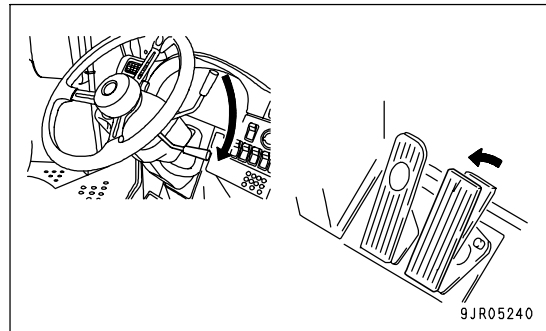
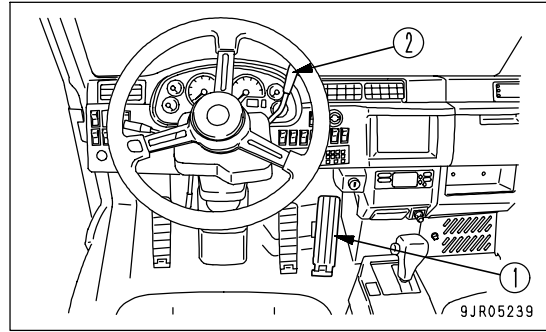

2. Leave the gear shift lever in position D. When the machine reduces speed, the transmission will automatically shift down to the appropriate gear range.

If the condition of the road makes it necessary to travel downhill in 1st, set the gear shift lever to any position except D (6, 5, 4, 3, 2, L).

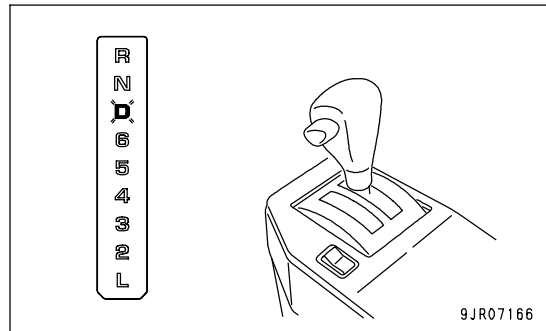

3. When traveling downhill, operate retarder control lever (2), run the engine at a speed of 1800 to 2200 rpm, and travel so that the retarder brake oil temperature gauge is in the white range.

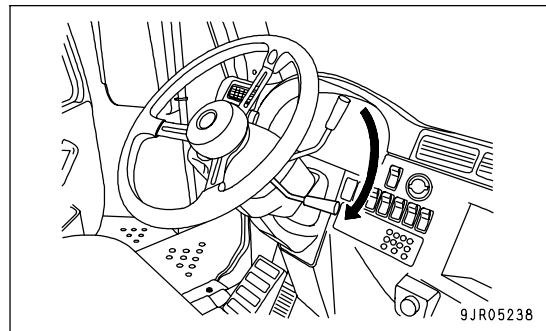

## BRAKE PERFORMANCE CURVE

- Method of using graph

Example: Downhill distance: 1500 m (4921 ft)

Travel resistance: -11% [grade resistance: -13%, rolling resistance: 2%]

Load HD325: 32 tons

HD405: 40 tons

Obtain the maximum permissible speed and the transmission speed range from the graph when traveling downhill under the above conditions.

1. Use the brake performance graph for the downhill distance of 1500 m (4921 ft).
2. Starting from point (A) which corresponds to the overall weight of the machine, draw a perpendicular line down.
3. Take the point where it crosses the line for travel resistance -11% as (B) and draw a horizontal line.
4. Take the point where it crosses the performance curve as (C), and draw a perpendicular line down. Take the point where this line crosses the travel speed scale as (D).
5. The following information can be obtained from this procedure.

From point (D): Maximum permissible speed = 28 km/h (17.4 MPH)

From point (C): Speed range = F4

This maximum permissible speed is one guideline determined from the retarder brake performance, so on an actual jobsite, determine a safe downhill travel speed (below the maximum permissible speed) to match the conditions of the jobsite so that the retarder brake oil temperature gauge is always in the green range.

HD325

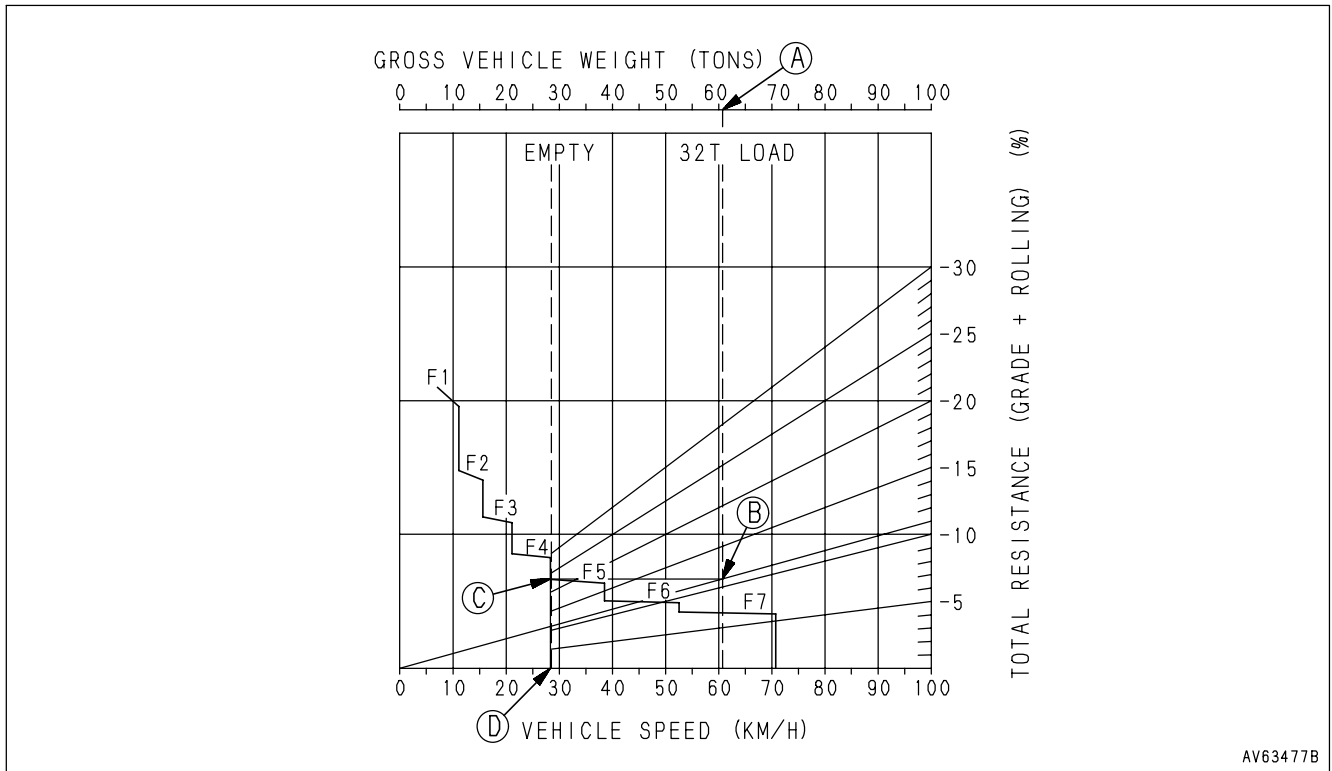

HD405

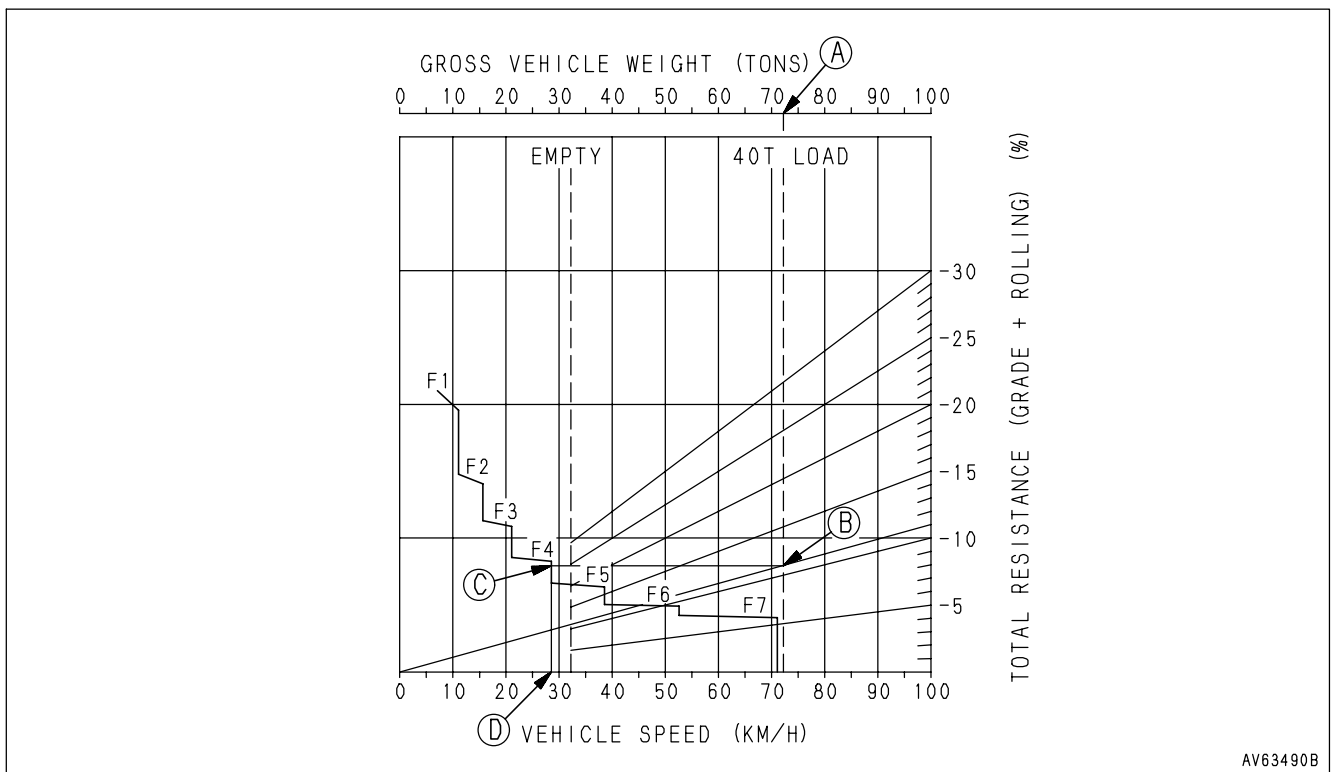

- Brake performance  
 [Downhill distance: 450 m (1476 ft)]

HD325

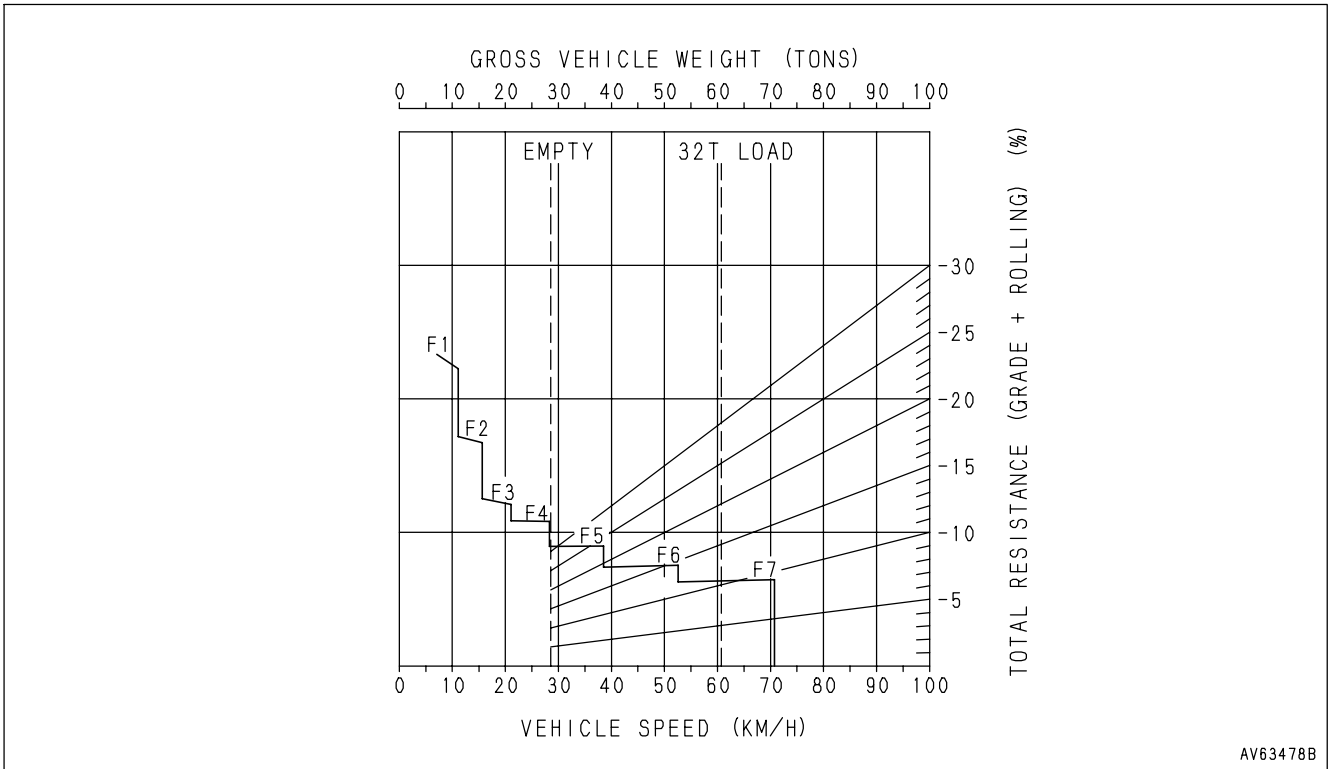

HD405

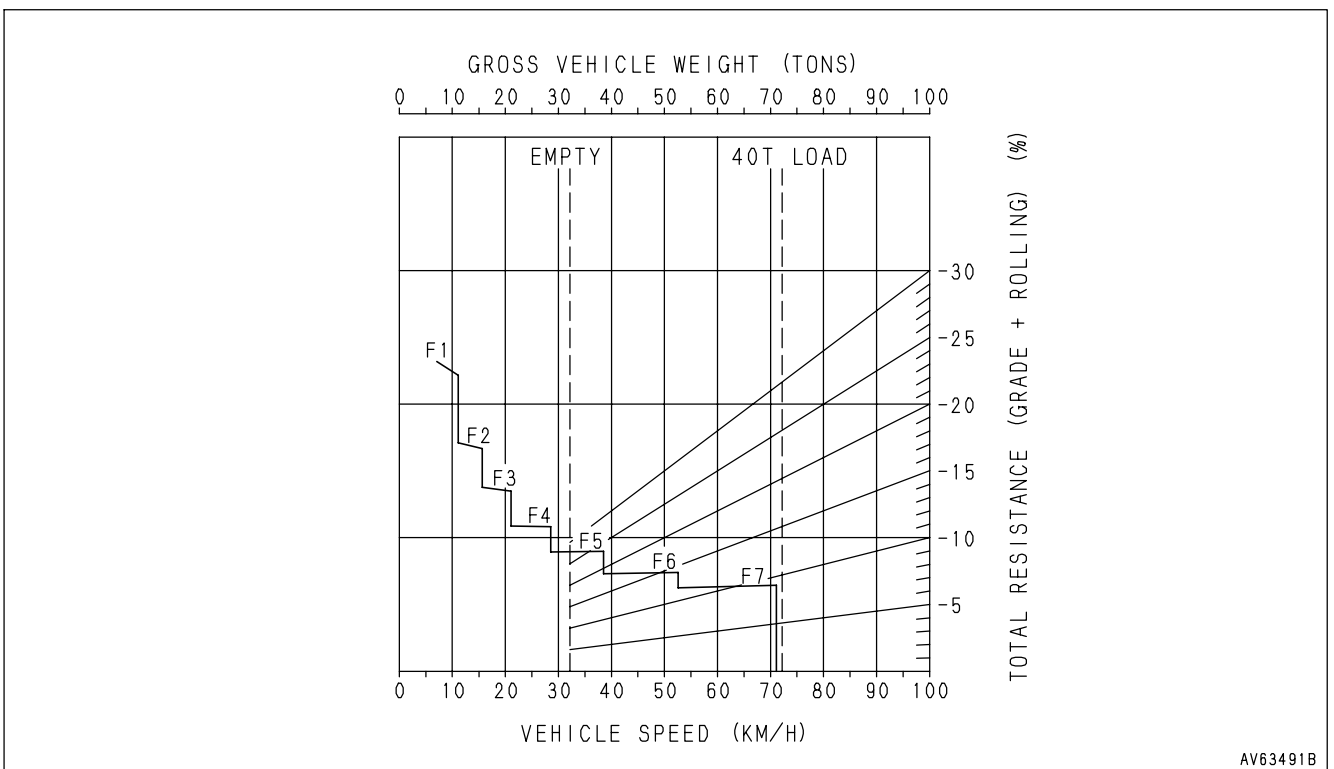

- Brake performance  
[Downhill distance: 600 m (1968 ft)]

HD325

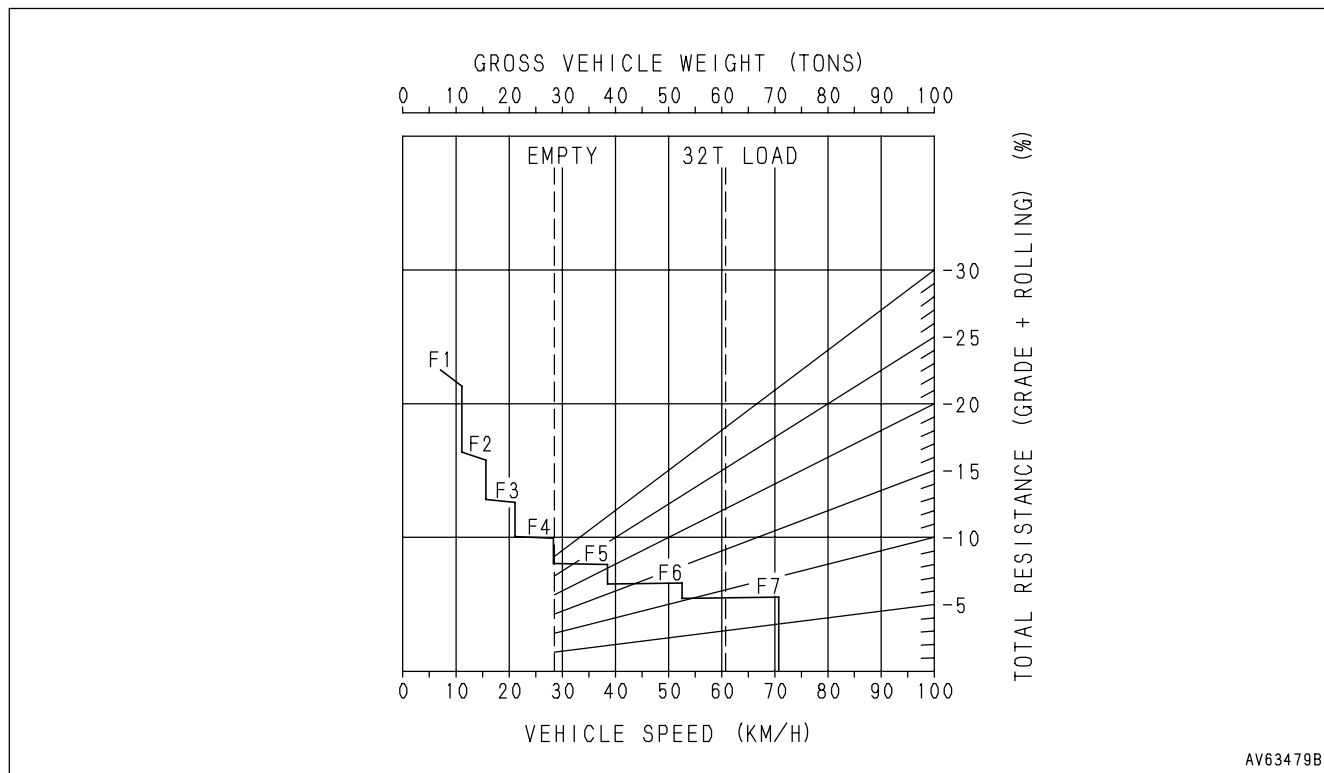

AV63479B

HD405

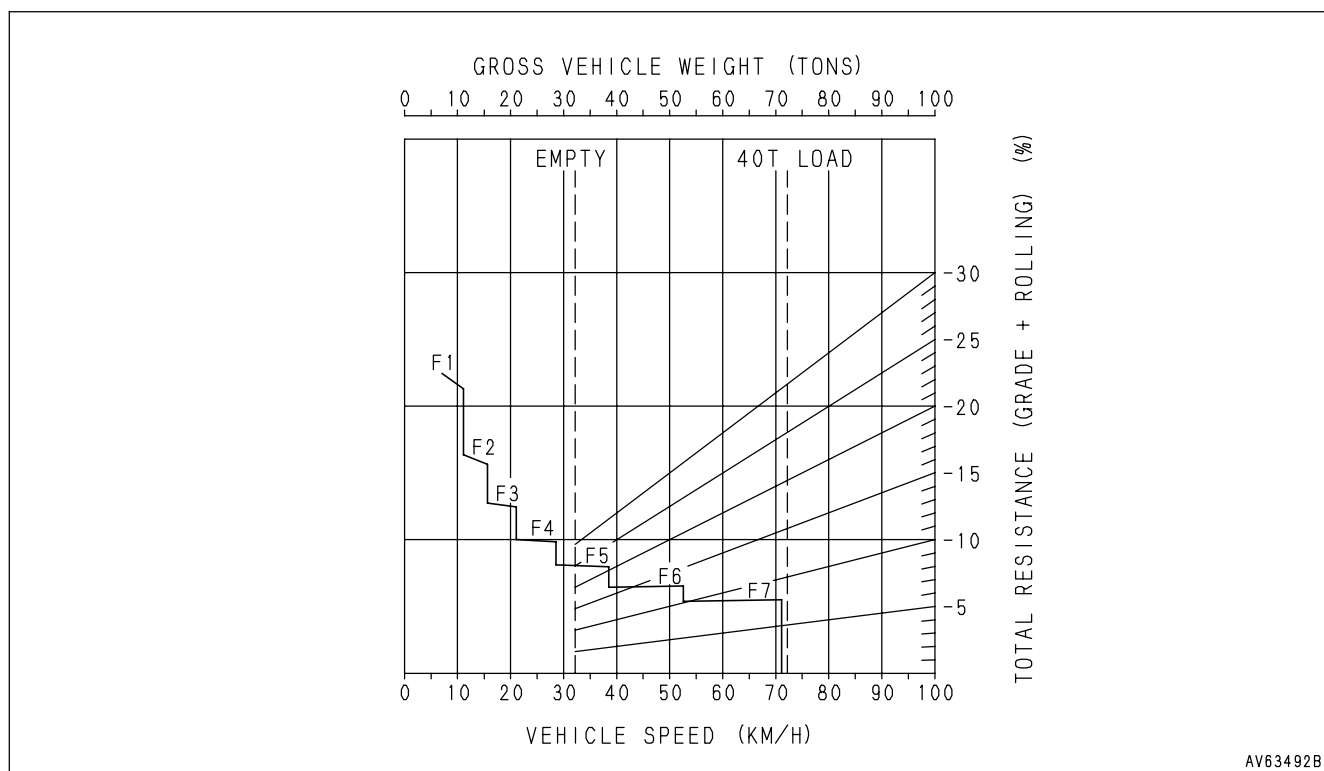

AV63492B

- Brake performance  
 [Downhill distance: 900 m (2952 ft)]

HD325

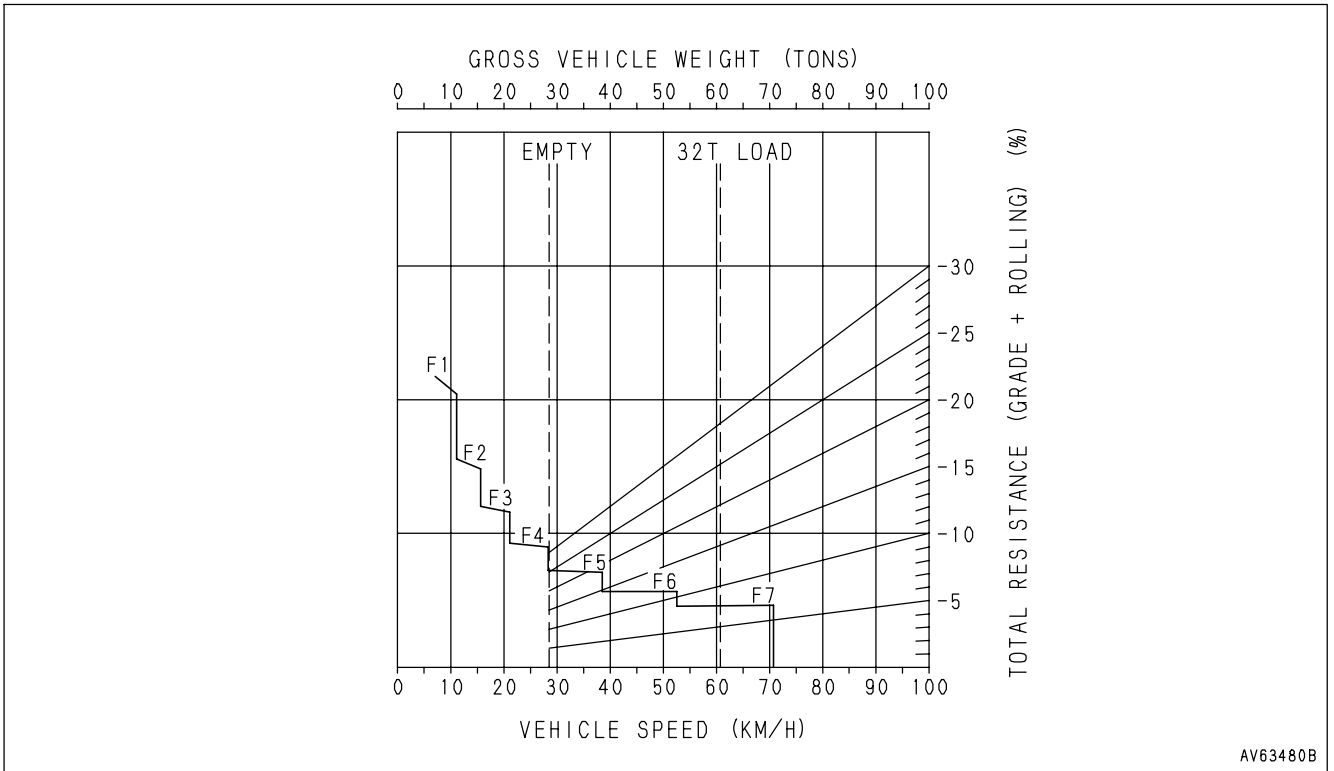

HD405

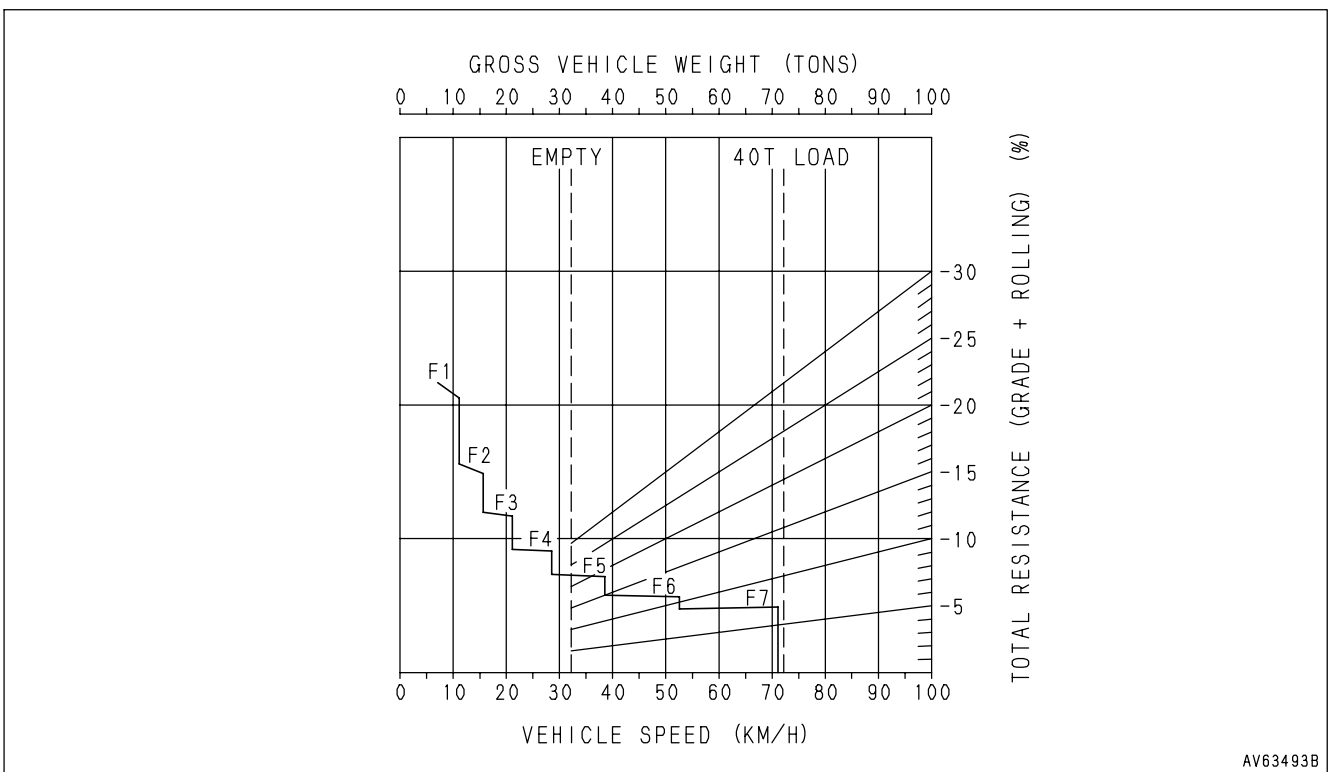

- Brake performance  
[Downhill distance: 1500 m (4921 ft)]

HD325

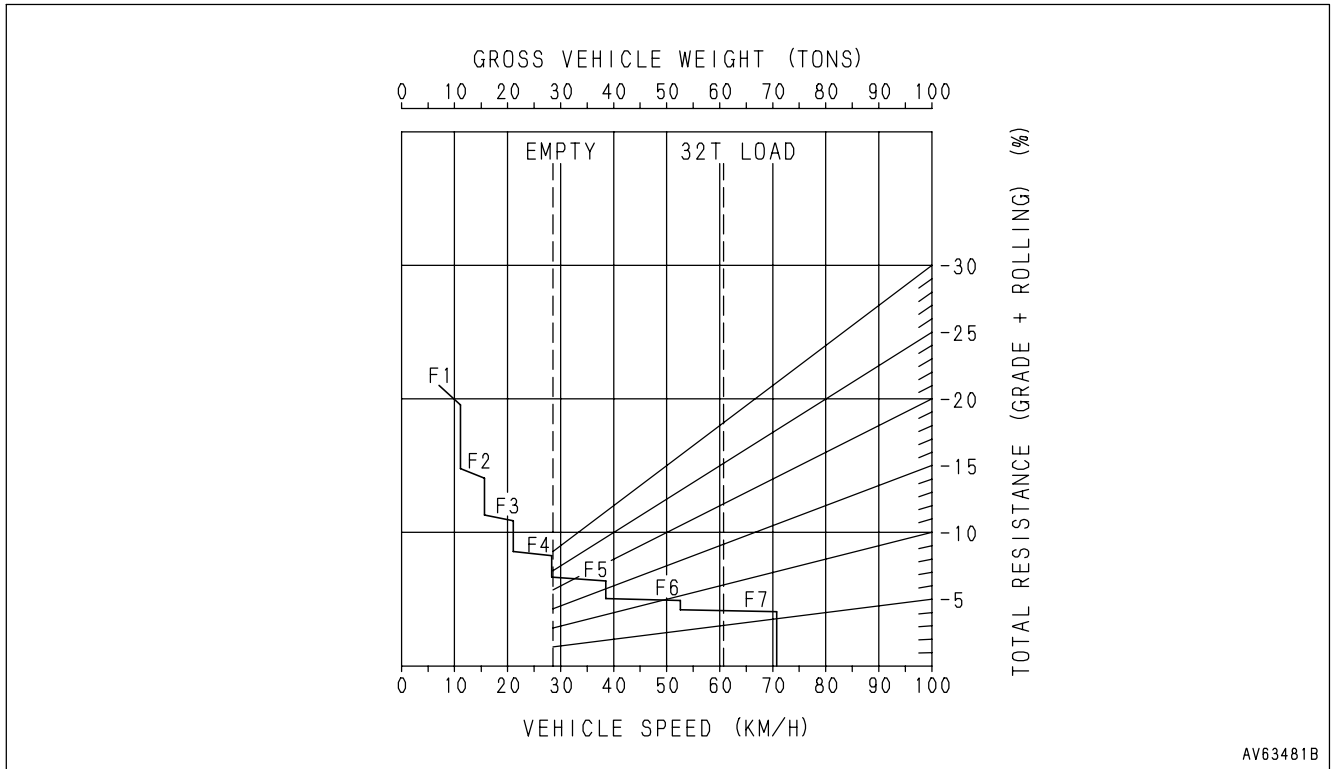

AV63481B

HD405

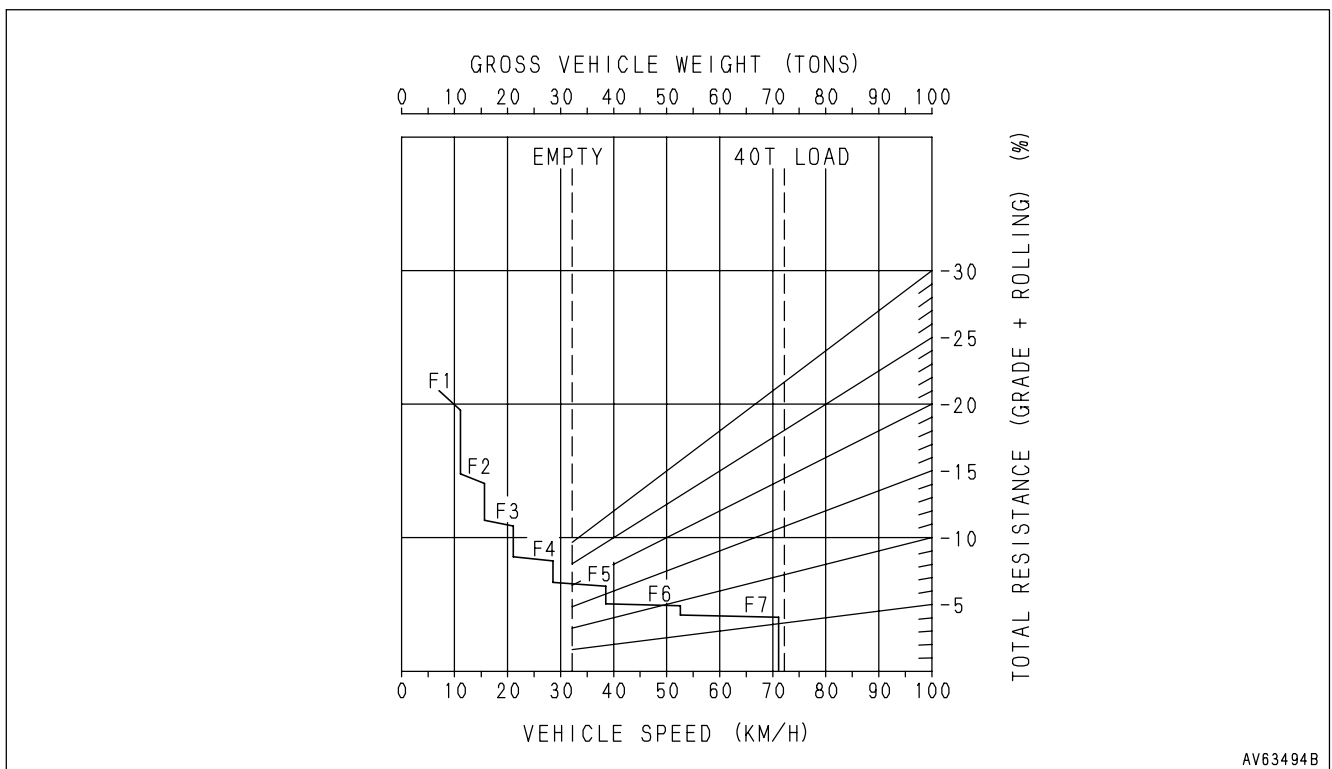

AV63494B

- Brake performance  
 [Downhill distance: Continuous]

HD325

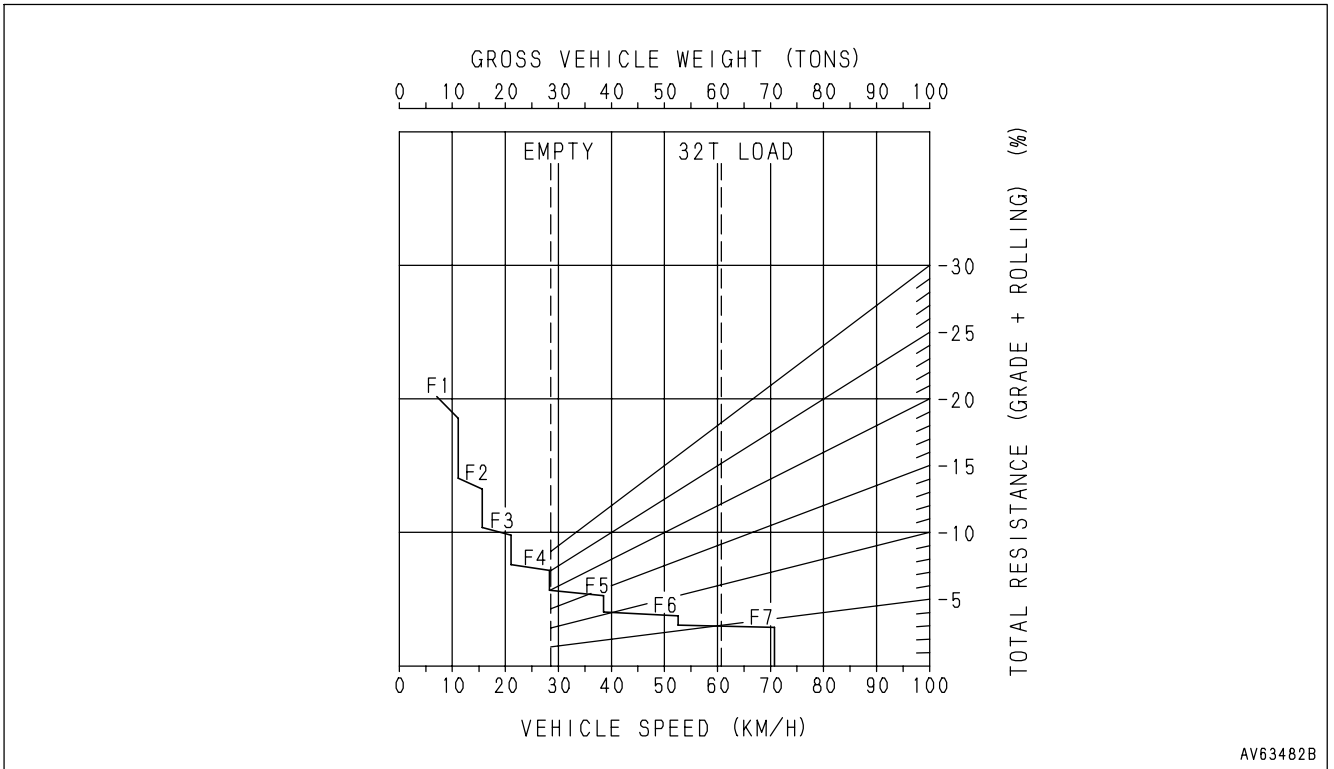

HD405

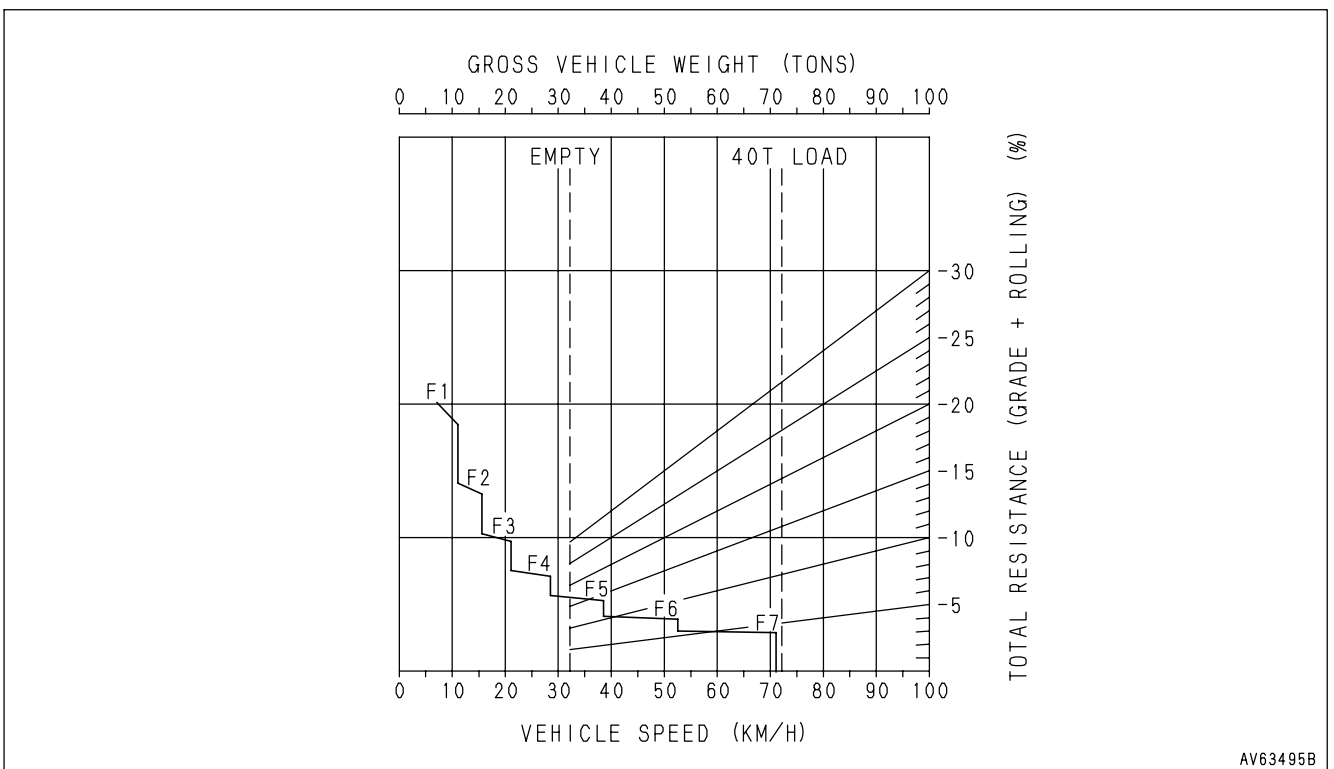



## STEERING THE MACHINE



### WARNING

If the machine is turned at high speed or on a steep slope, there is danger that it will turn over, so do not operate the steering in such conditions.



### CAUTION

Do not continue to apply force to the steering wheel when it has been turned fully to the left or right. This will make the oil temperature in the circuit rise and will cause overheating.

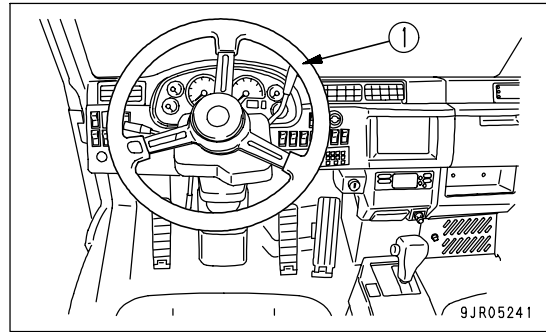

To turn the machine when traveling, turn steering wheel (1) in the direction of the turn.

When traveling around a curve, release the accelerator pedal before entering the curve, shift down to a lower speed range, then depress the accelerator pedal to travel around the curve. Never coast around the curves at high speed.

### REMARK

- The angle of the steering wheel may change (the position of the spoke may change slightly) when the machine is traveling, but this is not a failure.
- If force is applied to the steering wheel when the tires have been turned fully to the left or right, the steering wheel will turn a little at a time, but this is not a failure.

## LOADING OPERATIONS

When using a large wheel loader to load large rocks, if the rocks are loaded directly into the dump body parts of the dump body may be deformed. To prevent this, when loading large rocks, first load sand or soil to act as a cushion, then load the rocks on top of this to reduce the impact on the dump body.

In addition, when loading rocks that exceed the following conditions, install the optional dump body reinforcement plate.

- Rocks with one side over 0.5 m (1 ft 8 in)
- Rocks of hardness more than 4.5 (Mohs scale)
- Rocks with a weight of more than 300 kg (662 lb)
- When transporting steel ingots

### NOTICE

- When traveling, always set the dump lever to the FLOAT position regardless of whether the dump body is empty or loaded.
- If the dump lever is not at the FLOAT position and the gear shift lever is not at the N position, the central warning lamp will flash and the alarm buzzer will sound.

## DUMP OPERATIONS

**WARNING**

- When dumping a load, always carry out the dumping operation in accordance with the signals from the flagman.
- When dumping large rocks, operate the dump body slowly.
- Do not load the dump body while it is still raised.
- When carrying out inspection with the dump body raised, always use the body pivot pins, set the dump lever to the HOLD position and lock it securely. For details, see "BODY PIVOT PIN (PAGE 3-44)".

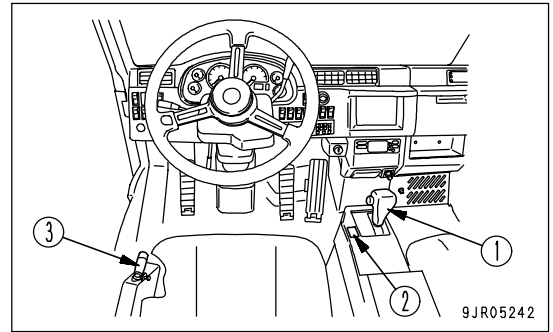

Operate the dump body as follows.

1. Place gear shift lever (1) at the N position, and set parking brake switch (2) to the PARKING position.

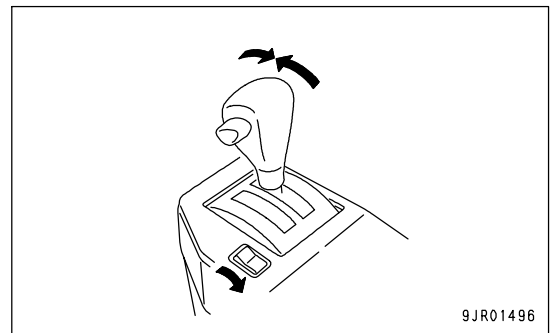

2. Move dump lever (3) to the RAISE position, then depress the accelerator pedal to raise the dump body.

If the dump lever is released when it is at the RAISE position, it is held at the RAISE position and the dump body will continue to rise.

The dumping speed increases in proportion to the engine speed.

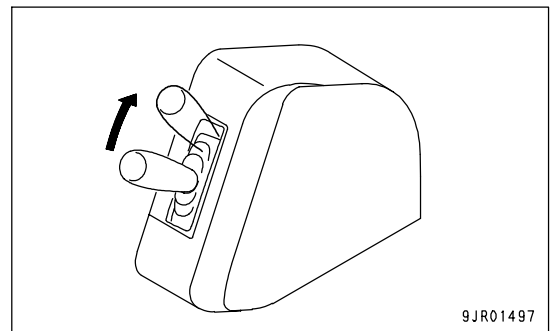

3. When the dump body rises to the previously set position, dump lever (3) returns to the HOLD position. The dump body is held at that position.

If it is necessary to raise the dump body further, operate dump lever (3) to the RAISE position and the dump body will rise. If dump lever (3) is released, dump lever (3) will return to the HOLD position and the dump body will stop at that position.

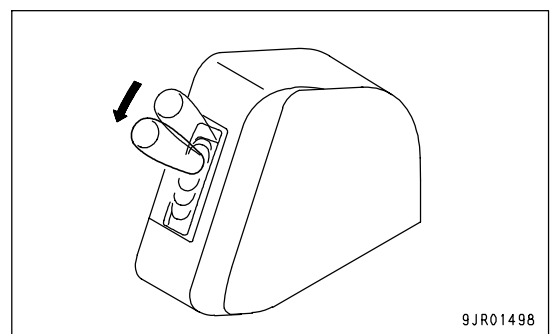

4. When dump lever (3) is moved to the LOWER position, the dump body will start to move down.

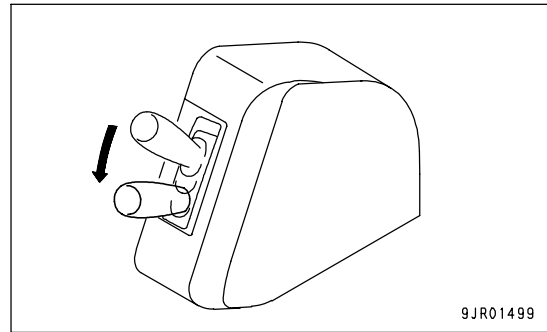

5. When the dump body has moved down a certain distance, move dump lever (3) to the FLOAT position. (When the lever is released, it will return to the FLOAT position.) The dump body will then move down under its own weight.

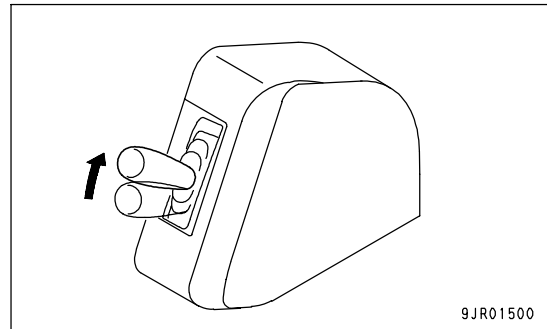

#### NOTICE

- If the dump control lever is not at the FLOAT sign position or the gear shift lever is not at the N position, the central warning lamp will light up and the alarm buzzer will sound.

On machines equipped with auto emergency steering, if the machine is not fully warmed up, the emergency steering may be actuated momentarily when the parking brake switch is set to TRAVEL or the dump control lever is operated.

- When raising the dump body, to prevent any impact load on the hydraulic circuit or hoist cylinder, let the accelerator pedal back when the dump body is near the maximum angle.
- Regardless of the position of the gear shift lever, if the parking brake switch is at the "TRAVEL" position and the dump body is raised, the speed range is fixed at 1st. Lower the dump body before traveling.

The dump control is carried out electrically. If there is any problem in the sensors or valves, a failure code is displayed and the dump body is held in position. If it is desired to move the dump body forcibly for inspection or repair, please ask your Komatsu distributor to carry out the operation.

## PRECAUTIONS FOR OPERATION

- When traveling on roads in rain or snow, or when traveling on muddy or soft ground, consider the loaded condition of the machine and be extremely careful not to let the tires slip or the machine spin and sink into the ground.
- If the engine should stop when the machine is traveling, stop the machine immediately, then move the gear shift lever to the N position, and start the engine again.
- If the central warning lamp and pilot lamp for any EMERGENCY item on the machine monitor should flash and the buzzer sounds during operation, stop the machine immediately and investigate the cause.  
For details, see "TROUBLESHOOTING (PAGE 3-125)".
- When loading, be careful to load the dump body uniformly, and be particularly careful to avoid loading too much at the front.
- On slippery road surfaces, apply the retarder control lever slowly and shift the transmission down to prevent the rear wheels from locking.
- When traveling through pools of water, water may get inside the front brakes and cause a big drop in the braking force, so drive carefully in such areas. If water should get into the brakes, apply the brakes several times while traveling to produce friction heat between the pad and disc to remove the water.

**PARKING MACHINE**

**! WARNING**

- Avoid stopping suddenly. Give yourself ample room when stopping.
- Park the machine on firm, horizontal ground.  
Do not park the machine on a slope.  
If it is unavoidably necessary to park the machine on a slope, put blocks under the tires to prevent the machine from moving.
- If the gear shift lever is touched by mistake, the machine may move suddenly, and this may lead to a serious injury or death. Before standing up from the operator's seat, always set the parking brake switch securely to the PARKING position.
- The retarder must not be used as a parking brake.
- Do not use the retarder for long-term parking, regardless of the engine speed.

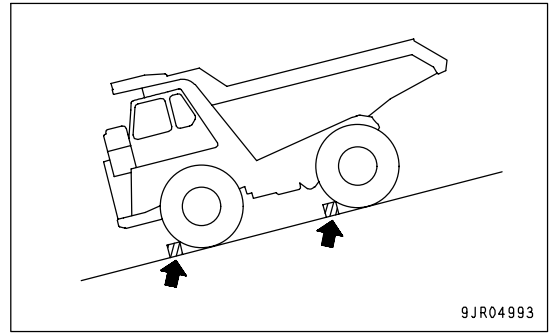

**! CAUTION**

To prevent damage to the parking brake, apply the parking brake only when parking the machine.

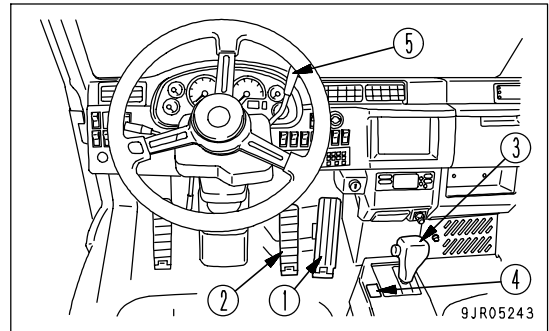

1. Release accelerator pedal (1), then depress brake pedal (2) to stop the machine.

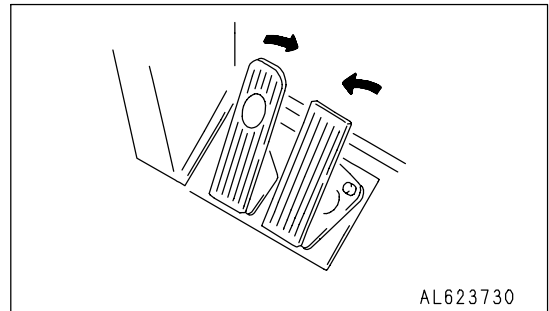

2. Move gear shift lever (3) to the N position, then set parking brake switch (4) to the PARKING position to apply the parking brake.

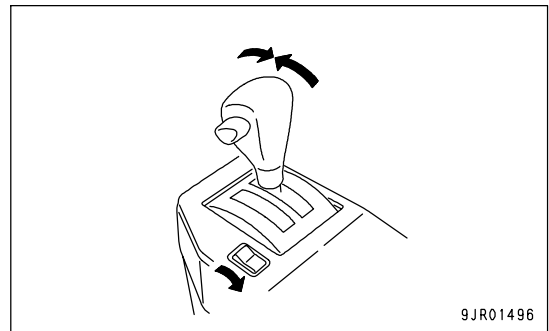

3. When in the operator's compartment, pull retarder control lever (5) fully to apply the retarder.

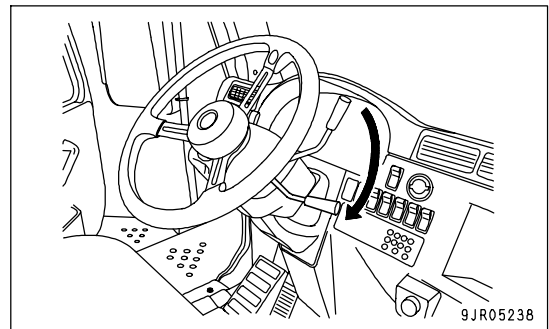

**NOTICE**

- The retarder must not be used as a parking brake.
- Do not use the retarder for long-term parking, regardless of the engine speed.

## CHECKS AFTER COMPLETION OF WORK

Use the machine monitor to check the engine water temperature, engine oil pressure, and fuel level. If the engine has overheated, do not stop the engine suddenly. Run it at a mid-range speed to cool it gradually before stopping.

## LOCKING

Always lock the following places.

- (1) Fuel filler cap of fuel tank
- (2) Cab door (left, right)

## REMARK

The starting switch key is used for locking places (1) and (2).

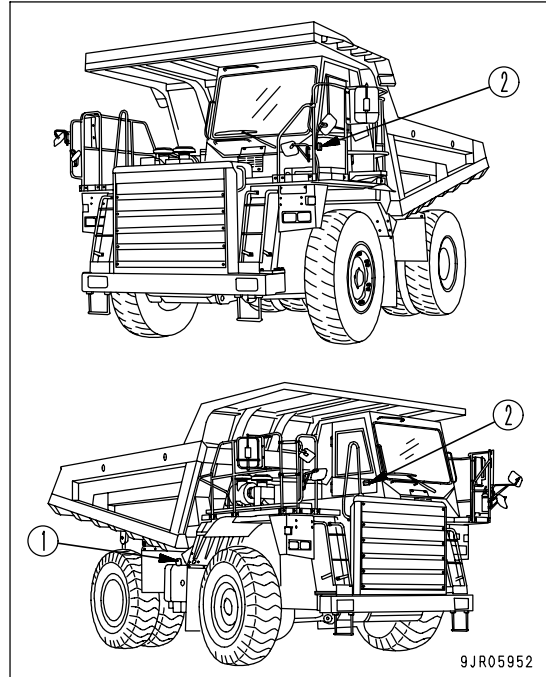

## HANDLING TIRES

### PRECAUTIONS WHEN HANDLING TIRES

#### WARNING

To ensure safety, the defective tires given below must be replaced with new tires.

- Tires where the bead wire has been cut, broken, or greatly deformed
- Excessively worn tires where more than 1/4 of the circumference of the carcass ply (excluding the breaker) is exposed
- Tires where damage to the carcass exceeds 1/3 of the tire width
- Tires where ply separation has occurred
- Tires where radial cracks extend to the carcass
- Tires where there is abnormal deterioration, deformation, and damage, and the tire cannot withstand use.

Please contact your Komatsu distributor when replacing the tires. It is dangerous to jack up the machine without taking due care.

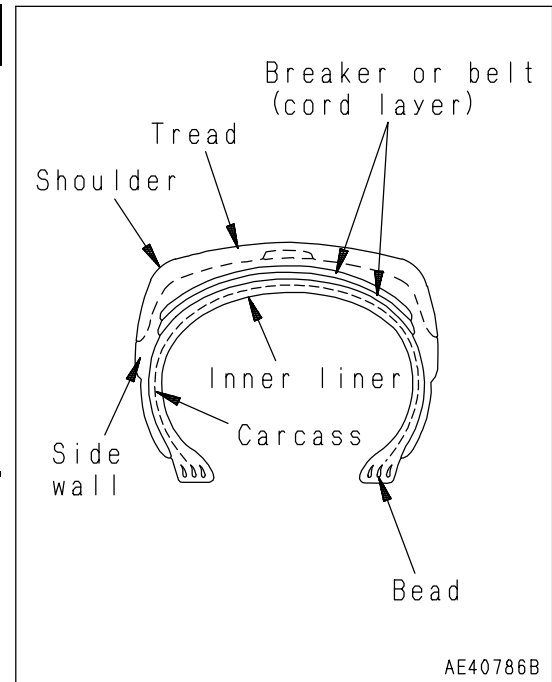

AE40786B

### T.Km.P.H (Ton-Km-Per-Hour Rating)

Tires for construction equipment are used under severe conditions that bear no comparison with the tires used on cars, buses, or ordinary trucks, so they are specially designed to withstand these conditions.

Compared with ordinary tires, far greater heat is produced in the rubber internal parts of off-road tires when the machine is traveling. If they are used continuously under conditions which exceed the permitted load and travel speed of the tire, the internal temperature will exceed the limit, and the rubber may become soft and heat separation occur.

To prevent such problems from occurring, the T.Km.P.H. is used as a standard to allow the machine to travel safely. If operations are carried out which exceed the T.Km.P.H. of the tire (when the T.Km.P.H. of the work exceeds the T.Km.P.H. of the tires), tire trouble will occur more frequently. In such cases, do as follows.

- Make the operating conditions easier so that the operation T.Km.P.H. of the work is lowered.
- Increase the size of the tires to a tire with a high T.Km.P.H.

**TIRE T.Km.P.H.AND MAXIMUM SPEED FOR CONTINUOUS TRAVEL (REFERENCE)**

- HD325

	Tire T.Km.P.H.for ambient temperature				Max.speed for continuous travel for ambient temperature (km/h)				
	16°C	27°C	38°C	49°C		16°C	27°C	38°C	49°C
Size 18.00-33-32PR (standard) structure CR(RL) Code No. E3 (TRA)	215	202	190	177	When empty (front wheel standard)	30	28	27	25
					When loaded (rear wheel standard)	20	19	18	17
Size 18.00-33-32PR (if equipped) structure CR(ELS2) Code No. E4 (TRA)	182	171	161	150	When empty (front wheel standard)	26	24	23	21
					When loaded (rear wheel standard)	17	16	15	14
Size 18.00R33 ★ ★ (if equipped) structure CR Code No. E4 (TRA)	214	192	170	158	When empty (front wheel standard)	27	24	21	20
					When loaded (rear wheel standard)	17	15	14	13

- HD405

	Tire T.Km.P.H.for ambient temperature				Max.speed for continuous travel for ambient temperature (km/h)				
	16°C	27°C	38°C	49°C		16°C	27°C	38°C	49°C
Size 18.00R33 ★ ★ (standard) structure CR Code No. E4 (TRA)	214	192	170	158	When empty (front wheel standard)	27	24	21	20
					When loaded (rear wheel standard)	17	15	14	13

**METHOD OF CALCULATING WORK T.Km.P.H.**

Work T.Km.P.H. = average load per tire x average travel speed for one day

Average travel speed = round trip distance x number of round trips per day/total operating hours per day

Average load = (load when empty + load when loaded) /2

The total operating hours per day includes the stopping time and rest periods.

\* The T.Km.P.H. in the table may differ slightly according to the tire maker, so concerning operations which require travel near the travel speed given in the table, consult your Komatsu distributor.

**PRECAUTIONS FOR LONG DISTANCE TRAVEL**

If the machine travels continuously at high speed for a long distance, there will be a marked increase in the generation of heat in the tire. This may cause premature damage to the tire, so be careful of the following points.

- Travel only when empty.
- Check the tire inflation pressure before starting for the day when the tires are cold, and adjust to the following inflation pressure.
- Do not reduce the tire inflation pressure when traveling.

- HD325

Tire size	Inflation pressure
18.00-33-32PR (standard)	0.56MPa {5.75kg/cm <sup>2</sup> , 81.7 PSI}
18.00R33 ★ ★ (if equipped)	0.69MPa {7.00kg/cm <sup>2</sup> , 99.4 PSI}

- HD405

Tire size	Inflation pressure
18.00R33 ★ ★	0.69MPa {7.00kg/cm <sup>2</sup> , 99.4 PSI}

**NOTICE**

If the tires are used when the inflation pressure is less than the value given in the table above, the rim may be damaged.

Always keep the tire inflation pressure within +0 to +0.03 MPa {0.3 kg/cm<sup>2</sup>, 4.3 PSI} of the value in the table above.

- The maximum travel speed must be kept to less than 40 km/h (24.9 MPH). Stop for at least one hour for every one hour of travel to allow the tires and other components to cool down.
- Never travel with water or dry ballast in the tires.



## DETERMINING AND MAINTAINING TRAVEL ROAD

Determining and traveling the road in the jobsite is an extremely important factor both for reasons of safety and for reducing the cycle time. To ensure safety in operations, do as follows.

### DETERMINING TRAVEL ROAD

- As far as possible, restrict the travel road to one-way travel.
- If it is impossible to keep to one-way traffic, make the road with ample width to enable trucks traveling in opposite directions to pass each other. If it is impossible to provide a sufficient road width, provide passing places at various points along the road.
- Always design the road so that the loaded truck passes on the side closest to the hill face.
- If there are curves with poor visibility along the road, set up mirrors.
- In places where the road shoulder is weak or likely to collapse, set up a sign at a point at least 1.5 m (4 ft 11 in) from the road shoulder to warn of the danger.
- It is important to set up lighting or reflectors to enable the road to be traveled at night.
- The grade of slope should be kept within 10% (approx. 6°) as far as possible, and emergency escape points should be set up on downhill slopes in case of any brake failure.
- Make the road as straight as possible, and particularly in intermediate areas with curves, where the machine is traveling at high speed, make the radius of the curve as large as possible.
- Small S curves are particularly dangerous, so avoid such curves. The radius of the curve must be a minimum of 12 to 15 m (39 ft 4 in to 49 ft 3 in).
- Make the radius of curves as large as possible.
- Make the road wider at curves than it is in straight areas.
- Make the outside of the curve slightly higher.
- Be particularly careful to strengthen the road shoulder on the outside of curves.
- As far as possible, design the road so that no other roads cross it. In particular, if roads cross at an angle on slopes, a stepped difference is formed in the road. This is extremely dangerous, as it causes the machine to roll when traveling at high speed.
- Cut the slope face to provide a special road for the trucks.

### MAINTAINING TRAVEL ROAD

Carry out the necessary action according to the conditions to insure that the road can always be traveled in safety.

- Remove any unevenness in the travel surface, sloping to the left or right, or drooping of the road shoulder. Make the road of ample strength and remove such obstacles as rocks and tree stumps.
- Maintain the road from time to time with a bulldozer or motor grader.
- Spray the road with water at suitable intervals to prevent dust from rising and reducing the visibility.

## TRANSPORTATION

### PRECAUTIONS WHEN TRANSPORTING

Always obey the traffic regulations when transporting the machine by road.



### WARNING

This machine must be disassembled for transportation. When transporting the machine, please consult your Komatsu distributor.

### STEPS FOR TRANSPORTATION

As a basic rule, always transport the machine on a trailer.

When selecting the trailer, see the weights and dimensions given in "SPECIFICATIONS (PAGE 5-2)".

Note that the specifications for the weights and dimensions for transportation differ according to the type of tires and type of dump body.

### METHOD OF SECURING MACHINE

After loading the machine in the specified position, secure it in place as follows.

1. Set the parking brake switch to the PARKING position to apply the parking brake.

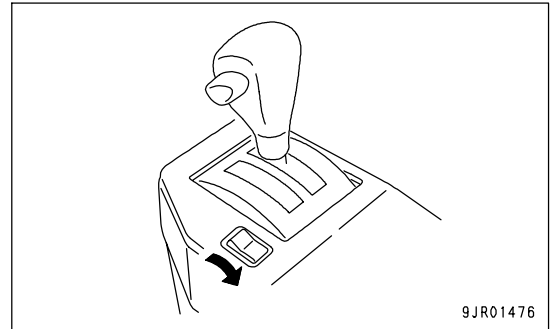

2. Turn the key in the starting switch to the OFF position to stop the engine.

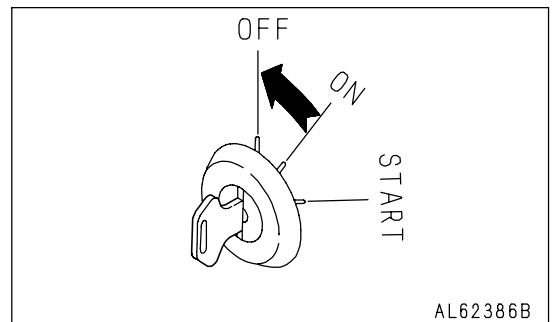

3. Remove the key from the starting switch.

4. To prevent the machine from moving during transportation, insert blocks under the front and rear of each tire and secure the machine firmly in position with chains or wire rope. Be particularly careful to secure the machine firmly so that it does not slide to the side.

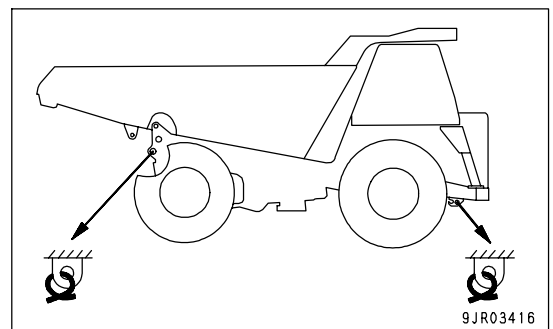

### NOTICE

Always retract the antenna and reassemble the mirrors so that they are within the width of the machine.

## METHOD OF LIFTING MACHINE

When lifting the machine at a port or any other place, always use the following procedure to lift it.



### WARNING

- The operator carrying out the lifting operation using a crane must be a properly qualified crane operator.
- Never raise the machine with any worker on it.
- Always make sure that the wire rope is of ample strength for the weight of this machine.
- When lifting, keep the machine horizontal.
- Always stop the engine and apply the brake before starting the lifting operation.
- Never enter the area around or under the machine when it is raised.

Never try to lift the machine in any posture other than the posture given in the procedure below or using lifting equipment other than in the procedure below.

There is a hazard that the machine may lose its balance.

### NOTICE

This method of lifting applies to the standard specification machine.

The method of lifting differs according to the attachments and options installed.

For details of the procedure for machines that are not the standard specification, please consult your Komatsu distributor.

For the weight of the standard specification machine, see "WEIGHT TABLE (PAGE 3-119)".

### NOTICE

- Use protectors to prevent the wire rope from being cut on sharp corners and to prevent the wire rope from cutting into the machine bodywork.
- When using a spreader bar, select an ample width to prevent contact with the machine.

Please consult your Komatsu distributor before carrying out lifting work.

**LOCATION OF LIFTING POSITION MARK**

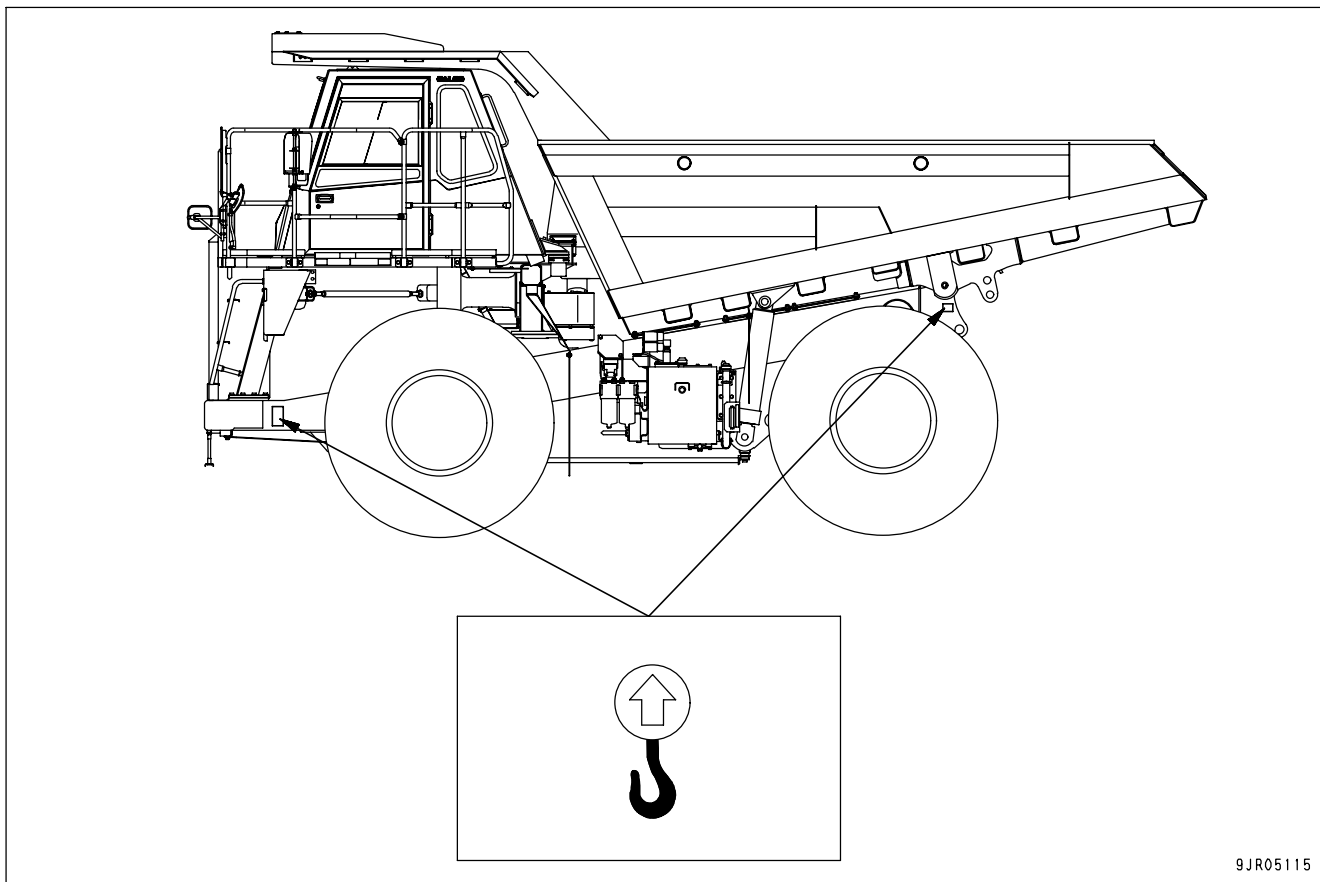

9JR05115

**WEIGHT TABLE**

	Machine weight	Front wheel load	Rear wheel load	Center of gravity (from front axle)
HD325-7	31600 kg (69678 lb)	16337 kg (36023 lb)	15263 kg (33655 lb)	1811 mm (5 ft 11 in)
HD405-7	34400 kg (75852 lb)	17440 kg (38455 lb)	16960 kg (37397 lb)	1849 mm (6 ft 1 in)

### LIFTING PROCEDURE

Lifting work can be carried out only with machines displaying a lifting mark.

When carrying out the lifting operation, stop the machine on firm level ground, and do as follows.

1. Start the engine, set the dump lever to the FLOAT position, and check that the body pilot lamp goes out.

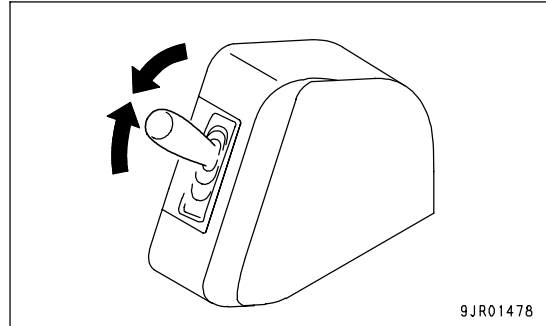

2. Stop the engine, apply the brake, and check that the area around the operator's compartment is safe.

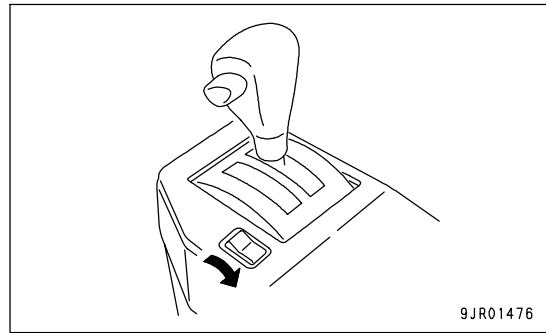

3. Select wire ropes, slings, spreader bars and other lifting equipment to match the weight of the machine, and fit the wire ropes to the lifting positions.

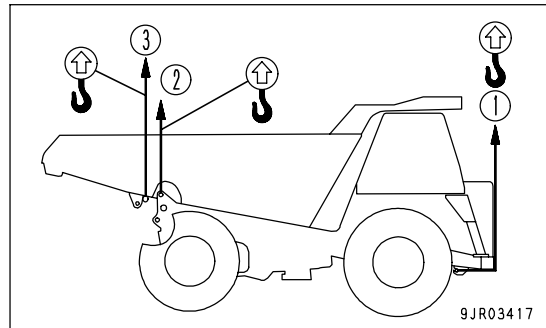

**REMARK**

The lifting positions for the machine differs according to the conditions.

Machine with body:Positions (1) and (3)

Total:4 places (2 at front, 2 at rear)

Machine without body:Positions (1) and (2)

Total:4 places (2 at front, 2 at rear)

4. Fit protector blocks at the contact points between the lifting equipment and the body to prevent damage to the King equipment.
5. When the machine comes off the ground (raised 10 to 20 cm(3.9 to 7.9 in)), stop the lifting operation, check carefully that the machine is balanced and that the wire ropes are not loose, then continue the lifting operation slowly.

## COLD WEATHER OPERATION

### PRECAUTIONS FOR LOW TEMPERATURE

If the temperature becomes low, it becomes difficult to start the engine, and the coolant may freeze, so do as follows.

### FUEL AND LUBRICANTS

Change to fuel and oil with low viscosity for all components. For details of the specified viscosity, see "RECOMMENDED FUEL, COOLANT, AND LUBRICANT (PAGE 4-11)".

### COOLANT



#### WARNING

- Antifreeze is toxic. Be careful not to get it into your eyes or on your skin. If it should get into your eyes or on your skin, wash it off with large amounts of fresh water and see a doctor at once.
- When changing the coolant or when handling coolant containing antifreeze that has been drained when repairing the radiator, please contact your Komatsu distributor or request a specialist company to carry out the operation. Antifreeze is toxic. Do not let it flow into drainage ditches or spray it onto the ground surface.
- Antifreeze is flammable. Do not bring any flame close. Do not smoke when handling antifreeze.

### NOTICE

Please use Komatsu genuine supercoolant (AF-NAC) for the coolant. As a basic rule, we do not recommend the use of any coolant other than Komatsu genuine supercoolant.

For details on the amount of antifreeze mixture and on when to change the coolant, see "CLEAN INSIDE OF COOLING SYSTEM (PAGE 4-27)".

**BATTERY**

 **WARNING**

- The battery generates flammable gas. Do not bring fire or sparks near the battery.
- Battery electrolyte is dangerous. If it gets in your eyes or on your skin, wash it off with a large amount of water and consult a doctor.
- Battery electrolyte dissolves paint. If it gets on the bodywork, wash it off immediately with water.
- If the battery electrolyte is frozen, do not charge the battery or start the engine with a different power source. There is danger that the battery may explode.
- Battery electrolyte is toxic. Do not let it flow into drainage ditches or spray it on to the ground surface.

When the ambient temperature drops, the capacity of the battery will also drop. If the battery charge ratio is low, the battery electrolyte may freeze. Maintain the battery charge as close as possible to 100%. Insulate it against cold temperature to ensure the machine can be started easily the next morning.

Measure the specific gravity and calculate the rate of charge from the following conversion table.

Charging Rate (%)	Electrolyte Temperature	20°C (68°F)	0°C (32°F)	-10°C (14°F)	-20°C (-4°F)
	100		1.28	1.29	1.30
90		1.26	1.27	1.28	1.29
80		1.24	1.25	1.26	1.27
75		1.23	1.24	1.25	1.26

When adding distilled water in cold weather, add it before starting operations in the morning to prevent the electrolyte from freezing.

**INSTALLATION OF RADIATOR CURTAIN**

(If equipped)

If the display for the engine water temperature gauge does not enter the white range, install a radiator curtain. It is possible to adjust the degree of opening of the radiator curtain (fully closed, one side open, and both sides open). Adjust to a suitable condition to match the ambient temperature so that the engine water temperature gauge display enters the white range.

**PRECAUTIONS AFTER COMPLETION OF WORK**

To prevent mud, water, or the undercarriage from freezing and making it impossible for the machine to move on the following morning, observe the following precautions.

- Mud and water on the machine body should be completely removed. This is to prevent damage to the seal caused by water in mud or dirt getting inside the seal and freezing.
- Park the machine on hard, dry ground.  
If this is impossible, park the machine on wooden boards.  
The boards help protect the tracks from being frozen in soil and the machine can start next morning.
- Open the drain valve and drain any water collected in the fuel system to prevent it from freezing.
- As the battery capacity drops markedly in low temperatures, cover the battery or remove it from the machine, keep it in a warm place, and install it again the next morning.
- If the electrolyte level is low, add distilled water in the morning before beginning work. Do not add water after the day's work to prevent diluted electrolyte in the battery from freezing during the night.

**AFTER COLD WEATHER**

When the season changes and the weather becomes warmer, do as follows.

- Replace the fuel and oil for all parts with oil of the viscosity specified.  
For details, see "RECOMMENDED FUEL, COOLANT, AND LUBRICANT (PAGE 4-11)".



## LONG-TERM STORAGE

### BEFORE STORAGE

When keeping in long-term storage (more than one month), store as follows.

- After every part is washed and dried, house the machine in a dry building. Never leave it outdoors.  
In case it is indispensable to leave it outdoors, park the machine on the flat ground and cover it with canvas etc.
- Completely fill the fuel tank. This prevents moisture from collecting.
- Lubricate and change the oil before storage.
- Coat the exposed portion of the hydraulic cylinder piston rod with grease.
- Disconnect the negative terminals of the battery and cover it or remove it from the machine and store it separately.
- Apply the parking brake.
- Set the tire inflation pressure for each tire to within the range of the specified inflation pressure for the type of tire.
- Push the retarder control lever forward to the OFF position.
- Place the gear shift lever at the N position and turn the starting switch OFF.
- To prevent rust, fill with Komatsu genuine supercoolant (AF-NAC) to give a density of at least 30% for the engine coolant.

### DURING STORAGE



#### WARNING

If it is necessary to perform the rust-prevention operation while the machine is indoors, open the doors and windows to improve ventilation and prevent gas poisoning.

During the storage period, operate the machine once a month to prevent loss of the oil film at the lubricated parts. At the same time, charge the battery.

Before operating the work equipment, wipe off all the grease from hydraulic piston rods.

### AFTER STORAGE

#### NOTICE

If the machine has been stored without carrying out the monthly rust-prevention operation, consult your Komatsu distributor before using it.

When using the machine after long-term storage, do as follows before using it.

- Wipe off the grease from the hydraulic cylinder rods.
- Add oil and grease at all lubrication points.
- When the machine is stored for a long period, moisture in the air will mix with the oil. Check the oil before and after starting the engine. If there is water in the oil, change all the oil.

### PRECAUTIONS BEFORE TRAVELING AFTER LONG-TERM STORAGE

1. Check all the oil and water levels before traveling.
2. When traveling after long-term storage, travel forward at a speed of 10 to 15 km/h (6.2 to 9.3 MPH) for 5 minutes or 1 km to run the machine in, then change to normal travel.

## TROUBLESHOOTING

### AFTER RUNNING OUT OF FUEL

If you have run out of fuel, add fuel to the fuel tank and bleed air from the fuel system and then start the engine.

#### PROCEDURE FOR BLEEDING AIR



### CAUTION

- The fuel injection pump and nozzle of this engine consist of more precise parts than the conventional ones. If foreign matter enters them, it can cause a trouble. Accordingly, if dust sticks to the fuel system, wash it off with clean fuel.
- When opening the air bleeding plug at the fuel filter head, take care. Fuel may spout because of residual pressure.

1. Fill the fuel tank with fuel.
2. Loosen air bleeding plug (1) at the fuel main filter head.  
Do not loosen the plug at the filter stand of the fuel prefilter. If it is loosened, air is not bled.
3. Loosen wing bolt (3) which is fixing lever (4) of priming pump (2). Move lever (4) up and down to let fuel flow out of air bleeding plug (1) until bubbles do not come out any more.
4. Tighten air bleeding plug (1) and then tighten wing bolt (3) of priming pump (2) securely to lock lever (4).
  - Tightening torque for air bleeding plug  
7.8 to 9.8Nm{0.8 to 1kgm}
  - Tightening torque for wing screw  
6.9 to 12.7Nm{0.7 to 1.3kgm}
5. Turn the key in the starting switch to the START position and start the engine.  
When doing this, do not crank the starting motor continuously for more than 20 seconds. If the engine does not start, wait for at least 2 minutes, then try again. Perform this operation a maximum of 4 times.
6. If the engine does not start, repeat the procedure from Step 2.

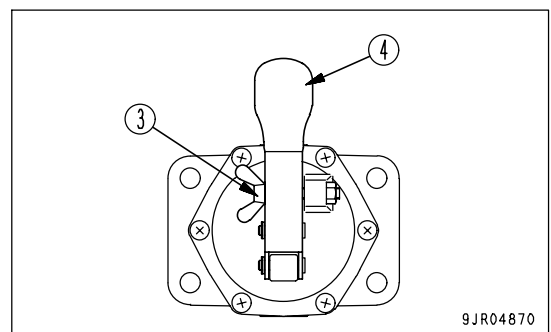
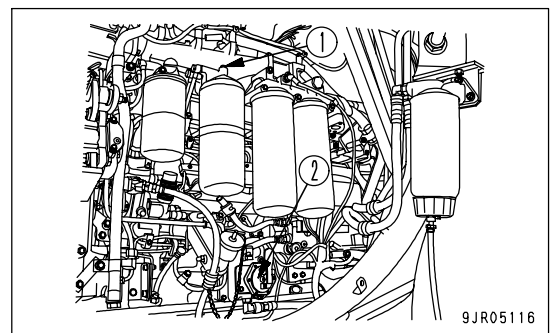

## IF TRANSMISSION HAS TROUBLE

If the transmission has any trouble, operate the machine according to the following procedure.

1. Decelerate the machine with the brake and stop it on a safe place.
2. Set the gear shift lever to the N position, then set the parking brake switch to the PARKING position.
3. In some trouble modes, the gear is not shifted even if the gear shift lever is operated.

In this case, perform the following procedure.

- 1) When the starting switch is at the ON position or the engine is started, disconnect (pull out) emergency connector (1) (No. A1 (female), A1 (male), white 1-pin connector), then connect (insert) again.
- 2) Set the parking brake switch to the TRAVEL position.
- 3) Operate the gear shift lever to move the machine to a safe place without depressing the accelerator pedal.

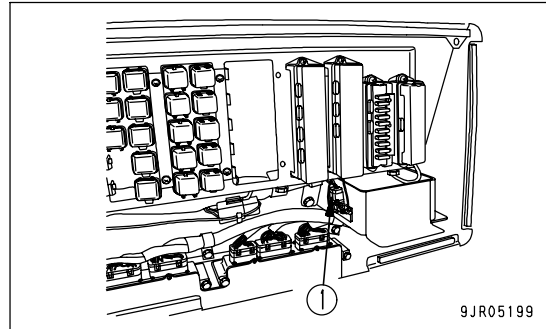

9JR05199

If the gear shift lever is operated with the accelerator pedal depressed, the emergency escape function will not work. In addition, the emergency escape function may not work for some failure codes.

While the emergency escape function is working, the shift indicator of the machine monitor displays "E" and the shift range (gear speed) of the transmission alternately.

**METHOD OF LOWERING DUMP BODY IN EMERGENCY**

**! WARNING**

There is danger of being trapped by the dump body, so when lowering the dump body in an emergency, always carry out the operation from the ground and do not go under the dump body.

When the dump body needs to be lowered to the seat while the engine cannot be started for some trouble, perform the following procedure.

The following tool is needed to lower the dump body.

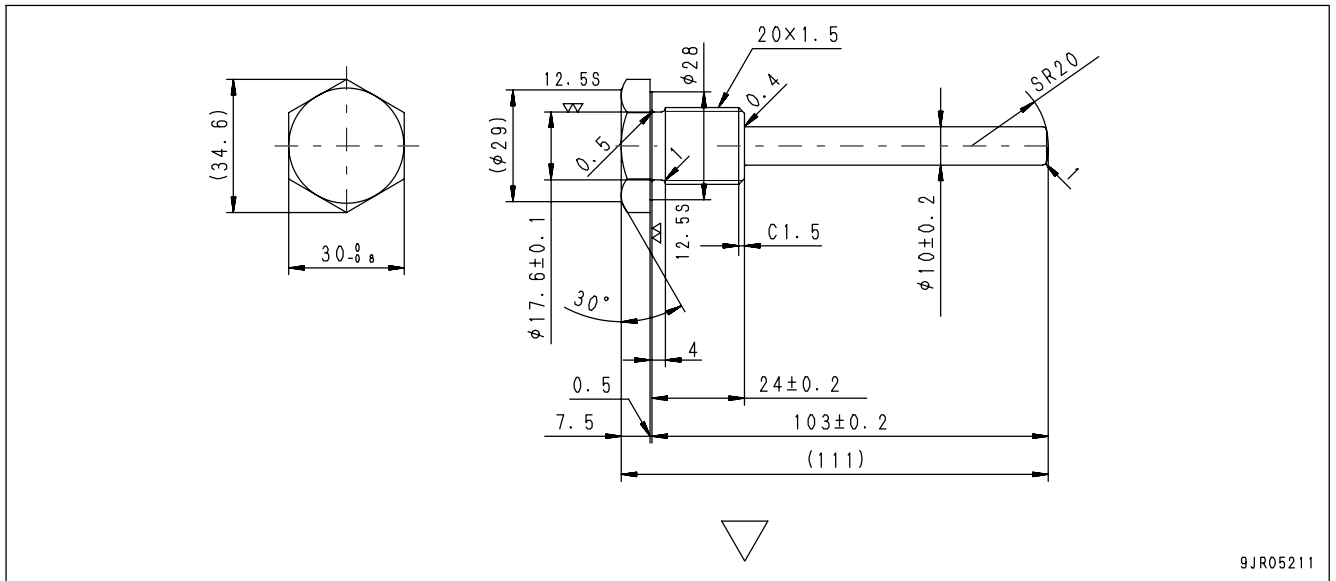

9JR05211

1. Remove hydraulic tank cap (F) and release the remaining pressure in the hoist circuit.

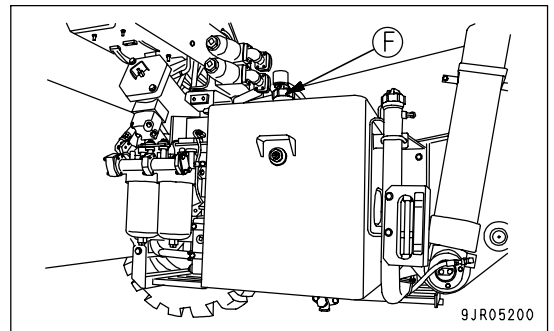

9JR05200

2. Remove hoist valve plug (1) at the rear of the hydraulic tank, then screw in the tool slowly.

The dump body will go down under its own weight, so adjust the amount that the tool is screwed in to let the dump body down slowly.

3. Remove the tool and install plug (1).

If the dump body does not go down even when the above method is used, please consult your Komatsu distributor.

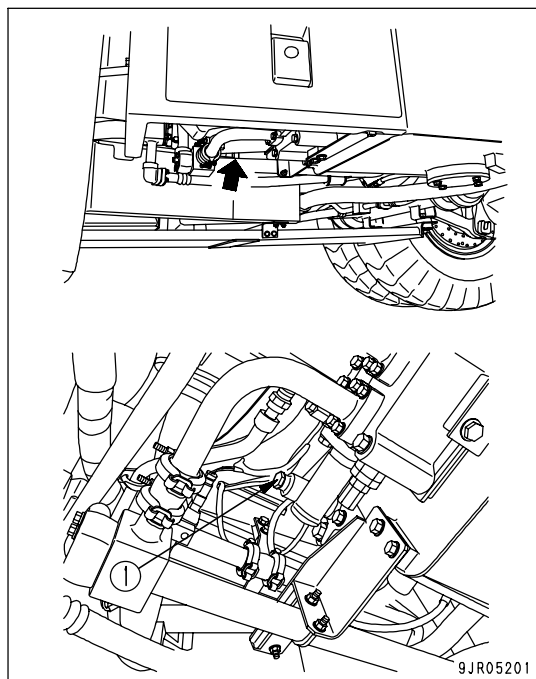

## METHOD OF TOWING MACHINE



### WARNING

Injury or death could result if a disabled machine is towed incorrectly or if there is a mistake in the selection of the wire rope or drawbar.

- Always confirm that the wire rope or drawbar used for towing has ample strength for the weight of the machine being towed.
- Never use a wire rope which has cut strands (A), reduced diameter (B), or kinks (C). There is danger that the rope may break during the towing operation.
- Always wear leather gloves when handling wire rope.
- Never tow a machine on a slope.
- Never go between the towing machine and the towed machine during the towing operation.
- If the machine moves suddenly, a load is applied suddenly to the towing wire or drawbar, and the towing wire or drawbar may break. Move the machine gradually to a constant speed.
- Be extremely careful if there is a failure in the engine or brake system: the brakes will not work.
- If the steering and the brakes on the disabled machine cannot be operated, do not let anyone ride on the disabled machine.

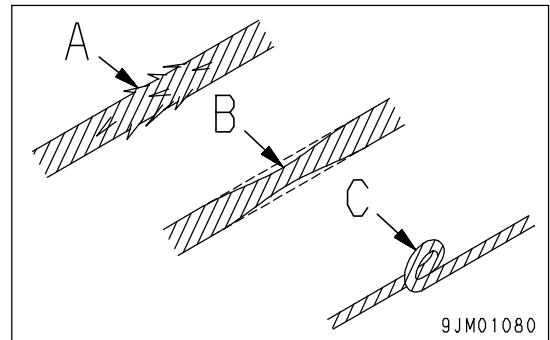

### NOTICE

- The permissible towing capacity for this machine is as shown below. Do not tow any load greater than this.  
 HD325: 232000 N (23700 kg)  
 HD405: 253000 N (25800 kg)
- Towing is only permitted in order to move a disabled machine to a place where it is possible to carry out inspection and maintenance. It must not be towed for long distances.
- Please consult your Komatsu distributor for information about towing a disabled machine.

This machine must not be towed except in emergencies. When towing the machine, take the following precautions.

- When towing a machine, tow it at a low speed of less than 2 km/h (1.2 MPH), and for a distance of a few meters to a place where repairs can be carried out. The machine should be towed only in emergencies. If the machine must be moved long distances, use a transporter.
- Use a towing machine of the same class as the machine being towed.  
Check that the towing machine has ample braking power, weight, and rimpull to allow it to control both machines on slopes or on the tow road.
- Use the specified hook for both the towing machine and the machine being towed.
- To protect the operator if the towing wire or towing bar breaks, install protective plates on both the towing machine and the machine being towed.
- There are towing hooks under the front frame (standard) and under the rear axle (if equipped). Do not use any other part as a towing hook.

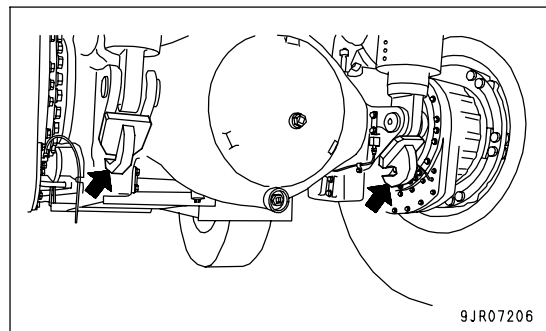
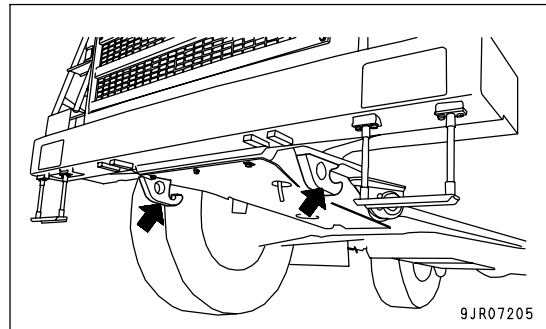

- When fitting the towing wire, check the condition of the hook to make sure that there is no problem.
- Keep the angle of the towing wire as small as possible.  
Keep the angle between the center lines of the two machines to within 30 degrees.
- Towing may be carried out under various differing conditions, so it is impossible to determine beforehand the requirements for towing.  
Towing on flat horizontal roads will require the minimum rimpull, while towing on slopes or on uneven road surfaces will require the maximum rimpull.
- If the pressure in a hydraulic circuit has dropped because of leakage of oil, the parking brake will be applied, so release the parking brake before towing.
- Before releasing the parking brake, always put blocks under all four wheels. If the wheels are not blocked, there is danger that the machine may move.  
Connect with the towing wire or drawbar, and remove the blocks from the wheels when the disabled machine is in a condition where it cannot run away.
- When carrying out the operation to release the parking brake, check that the surrounding area is safe.
- If the parking brake is released, the brakes will not work, so pay careful attention to safety.
- When towing down a slope, use two towing machines. One machine should be uphill from the disabled machine and should be connected with towing wire or a drawbar to pull the disabled machine back and keep it stable. The other machine should tow the disabled machine downhill.

## WHEN ENGINE RUNS

- If the transmission and steering wheel can be operated, and the engine is running, it is possible to tow the machine out of mud or to move it for a short distance to the edge of the road.
- Check the effect of the brakes, and if the brakes do not work properly, take the action given in "When engine does not run".
- Check if it is possible to steer the machine. If the machine cannot be steered, follow the procedure given in "WHEN ENGINE DOES NOT RUN".
- The operator should sit on the machine being towed and operate the steering in the direction that the machine is towed.
- Always run the engine to allow the steering and brakes to be used.

## WHEN ENGINE DOES NOT RUN

- The brakes will not work, so be extremely careful.
- Connect the towing machine securely to the towed machine. Use two towing machines of the same class or larger than the machine being towed: connect one machine each to the front and rear of the machine being towed.
- If it is necessary to change the direction of the machine being towed, it is possible to use the emergency steering, but it can be used for a maximum of only 90 seconds.
- If the emergency steering cannot be used, disconnect two hydraulic hoses each on the left and right from the steering cylinders, then carry out the towing operation. When removing the hoses, block the hoses with plugs and fit oil containers to the mouthpiece of the cylinder to prevent oil from draining to the ground.



## WHEN PARKING BRAKE HAS BEEN ACTUATED IN EMERGENCY

If the pressure in the hydraulic circuit goes down abnormally because of oil leakage or some other cause, the parking brake is automatically applied.

It is necessary to tow or move the machine, the parking brake must be released. Release the parking brake as follows.

## METHOD OF RELEASING PARKING BRAKE IN EMERGENCY

Please ask your Komatsu distributor to release the parking brake.



### WARNING

- If any abnormality occurs in the hydraulic circuit, there is danger that the wheel brakes may not be applied properly, so always travel at low speed when towing the machine.
- When carrying out the operation to release the parking brake, check that the surrounding area is safe, and always put blocks under all four wheels before starting the operation. If the wheels are not blocked, there is danger that the machine may suddenly move.
- Always stop the engine before starting the operation to release the parking brake.

1. Stop the engine.

2. Put blocks under the wheels.

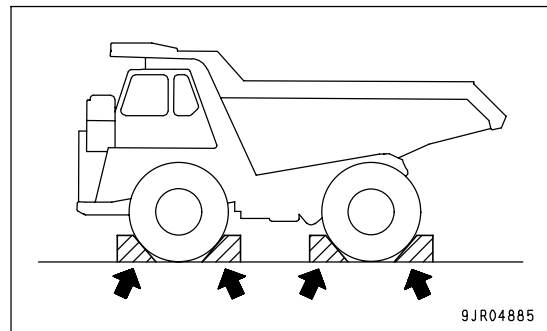

3. Turn parking brake adjustment screw (1) clockwise.

4. Check that there is a clearance between the parking brake pad and disc brake.

5. When the parking brake is released, tow the machine immediately to a safe position.

For details of the method of towing, see "METHOD OF TOWING MACHINE (PAGE 3-129)".

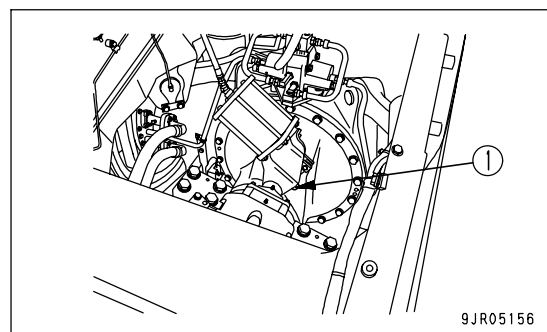

## IF BATTERY IS DISCHARGED

### WARNING

- It is dangerous to charge a battery when mounted on a machine. Make sure that it is dismantled before charging.
  - When checking or handling the battery, stop the engine and turn the starting switch key to the OFF position.
  - The battery generates hydrogen gas, so there is a hazard of explosion. Do not bring lighted cigarettes near the battery, or do anything that will cause sparks.
  - Battery electrolyte is dilute sulfuric acid, and it will attack your clothes and skin. If it gets on your clothes or on your skin, immediately wash it off with a large amount of water. If it gets in your eyes, wash it out with fresh water and consult a doctor.
  - When handling batteries, always wear safety glasses and rubber gloves.
  - When removing the battery, first disconnect the cable from the ground (normally the negative (-) terminal). When installing, install the positive (+) terminal first.
- If a tool touches the positive terminal and the chassis, there is danger that it will cause a spark, so be extremely careful.
- If the terminals are loose, there is danger that the defective contact may generate sparks that will cause an explosion.
  - When removing or installing the terminals, check which is the positive (+) terminal and which is the negative (-) terminal.

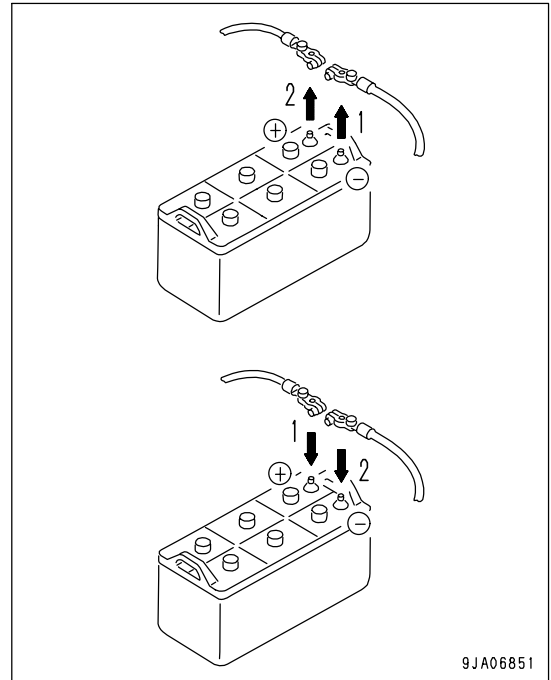

## REMOVAL AND INSTALLATION OF BATTERY

- Before removing the battery, remove the ground cable (normally connected to the negative (-) terminal). If any tool touches between the positive terminal and the chassis, there is a hazard of sparks being generated.
- When installing the battery, connect the ground cable last.
- When replacing the battery, hold the battery securely in position with the battery mounting clamps.

Tightening torque of mounting nut: 9.8 to 14 Nm  
(1 to 1.5 kgm, 7.2 to 10.8 lbf)

### NOTICE

After securing the battery, check that it does not move. If it moves, tighten it again securely.

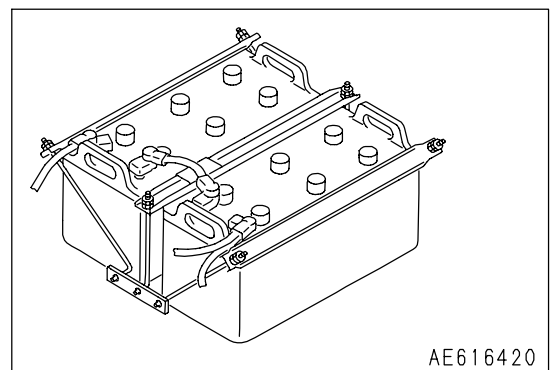

## PRECAUTIONS FOR CHARGING BATTERY

### CHARGING BATTERY WHEN MOUNTED ON MACHINE

When charging the battery, if the battery is mistakenly handled, there is danger of explosion. Follow the precautions in "IF BATTERY IS DISCHARGED (PAGE 3-133)" and the instructions given in the charger manual, and always do as follows.

- Set the voltage of the charger to match the voltage of the battery to be charged. If the correct voltage is not selected, the charger may overheat and cause an explosion.
- Connect the positive (+) charger clip of the charger to the positive (+) terminal of the battery, then connect the negative (-) charger clip of the charger to the negative (-) terminal of the battery. Be sure to attach the clips securely.
- Set the charging current to 1/10 of the value of the rated battery capacity; when carrying out rapid charging, set it to less than the rated battery capacity.  
If the charger current is too high, the electrolyte will leak or dry up, and this may cause the battery to catch fire and explode.
- If the battery electrolyte is frozen, do not charge the battery or start the engine with a different power source. There is a danger that this will ignite the battery electrolyte and cause the battery to explode.
- Do not use or charge the battery if the battery electrolyte level is below the LOWER LEVEL line. This may cause an explosion. Check the battery electrolyte level periodically and add distilled water to bring the electrolyte level to the UPPER LEVEL line.

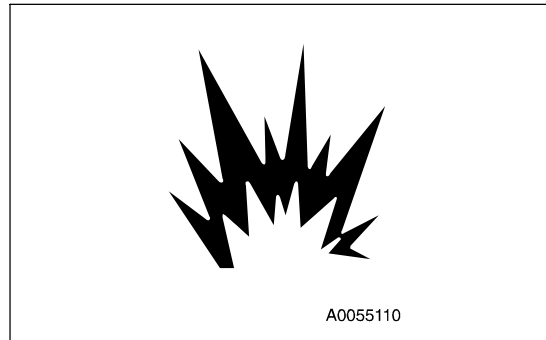

## STARTING ENGINE WITH BOOSTER CABLE

When starting the engine with a booster cable, do as follows.

### PRECAUTIONS WHEN CONNECTING AND DISCONNECTING BOOSTER CABLE

#### WARNING

- When connecting the cables, never contact the positive (+) and negative (-) terminals.
- When starting the engine with a booster cable, wear safety glasses and rubber gloves.
- Be careful not to let the normal machine and problem machine contact each other. This prevents sparks from generating near the battery which could ignite the hydrogen gas given off by the battery.
- Make sure that there is no mistake in the booster cable connections. The final connection is to the engine block of the problem machine, but sparks will be generated when this is done, so connect to a place as far as possible from the battery.
- When disconnecting the booster cable, take care not to bring the clips in contact with each other or with the machine body.

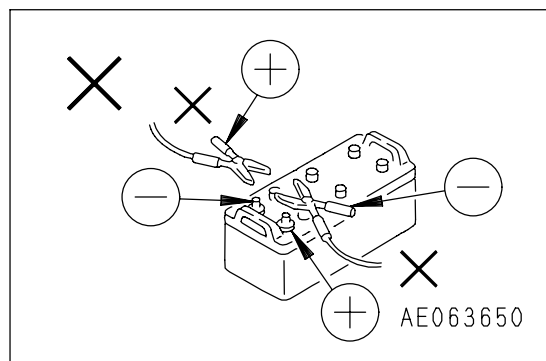

### NOTICE

- The size of the booster cable and clip should be suitable for the battery size.
- The battery of the normal machine must be the same capacity as that of the problem machine.
- Check the cables and clips for damage or corrosion.
- Make sure that the cables and clips are firmly connected.

### CONNECTING THE BOOSTER CABLES

Keep the starting switch of the normal machine and problem machine in the OFF position.

Connect the booster cable as follows, in the order of the numbers marked in the diagram.

1. Connect one clip of booster cable (A) to the positive (+) terminal of the problem machine.
2. Connect the other clip of booster cable (A) to the positive (+) terminal of the normal machine.
3. Connect one clip of booster cable (B) to the negative (-) terminal of the normal machine.
4. Connect the other clip of booster cable (B) to the engine block of the problem machine.

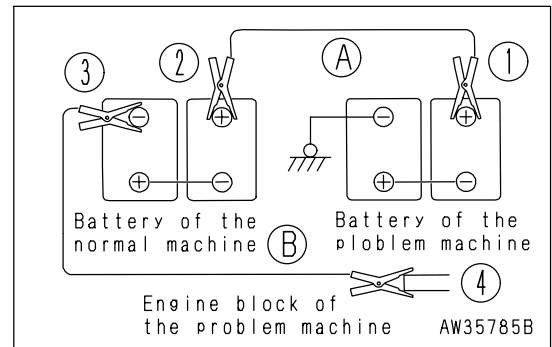

### STARTING THE ENGINE



## CAUTION

Make sure that the parking brake switch is at PARKING position and the gear shift lever is at N (neutral) position for both normal machine and the problem machine.

1. Make sure the clips are firmly connected to the battery terminals.
2. Start engine of the normal machine and run it at high idle speed.
3. Turn the starting switch of the problem machine to the START position and start the engine.  
If the engine doesn't start at first, try again after 2 minutes or so.

### DISCONNECTING THE BOOSTER CABLES

After the engine has started, disconnect the booster cables in the reverse of the order in which they were connected.

1. Remove one clip of booster cable (B) from the engine block of the problem machine.
2. Remove the other clip of booster cable (B) from the negative (-) terminal of the normal machine.
3. Remove one clip of booster cable (A) from the positive (+) terminal of the normal machine.
4. Remove the other clip of booster cable (A) from the positive (+) terminal of the problem machine.

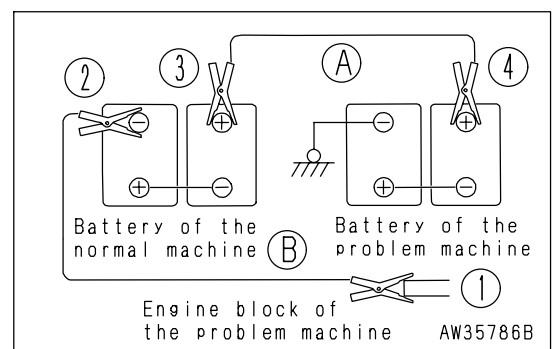

## OTHER TROUBLE

### ELECTRICAL SYSTEM

- ( ): Always contact your Komatsu distributor when dealing with these items.
- In cases of problems or causes which are not listed below, contact your Komatsu distributor for repairs.

Problem	Main causes	Remedy
Lamp does not glow brightly even when engine runs at high speed	<ul style="list-style-type: none"> <li>• Defective wiring</li> <li>• Insufficient battery charge</li> </ul>	<ul style="list-style-type: none"> <li>( • Check, repair loose terminals, disconnections)</li> <li>• Charge, Add distilled water</li> </ul>
Lamp flickers while engine is running	<ul style="list-style-type: none"> <li>• Defective adjustment of belt tension</li> </ul>	<ul style="list-style-type: none"> <li>• Adjust alternator belt tension. See EVERY 250 HOURS SERVICE.</li> </ul>
Battery charge system caution pilot lamp lights up while engine is running	<ul style="list-style-type: none"> <li>• Defective alternator</li> <li>• Defective wiring</li> </ul>	<ul style="list-style-type: none"> <li>( • Replace)</li> <li>( • Check, repair)</li> </ul>
Abnormal noise is generated from alternator	<ul style="list-style-type: none"> <li>• Defective alternator</li> </ul>	<ul style="list-style-type: none"> <li>( • Replace)</li> </ul>
Starting motor does not turn when starting switch is turned to ON	<ul style="list-style-type: none"> <li>• Defective wiring</li> <li>• Defective starting switch</li> <li>• Insufficient battery charge</li> <li>• Defective battery switch</li> <li>• Loose ground cable terminals between engine and chassis</li> </ul>	<ul style="list-style-type: none"> <li>( • Check, repair)</li> <li>( • Replace switch)</li> <li>• Charge</li> <li>( • Replace switch)</li> <li>( • Check, repair)</li> </ul>
Starting motor turns engine sluggishly	<ul style="list-style-type: none"> <li>• Defective wiring</li> <li>• Insufficient battery charge</li> </ul>	<ul style="list-style-type: none"> <li>( • Check, repair)</li> <li>• Charge</li> </ul>
Starting motor disengages before engine starts	<ul style="list-style-type: none"> <li>• Defective wiring</li> <li>• Insufficient battery charge</li> </ul>	<ul style="list-style-type: none"> <li>( • Check, repair)</li> <li>• Charge</li> </ul>

## CHASSIS

- ( ): Always contact your Komatsu distributor when dealing with these items.
- In cases of problems or causes which are not listed below, contact your Komatsu distributor for repairs.

Problem	Main causes	Remedy
Torque converter oil temperature caution lamp flashes	<ul style="list-style-type: none"> <li>• Leakage of oil or entry of air due to damage or defective tightening of oil pipe, pipe joint</li> <li>• Wear, scuffing of gear pump</li> <li>• Insufficient oil in transmission case</li> <li>• Loose fan belt</li> <li>• Clogged oil cooler</li> <li>• Long distance traveled in torque converter range</li> <li>• Disconnected, broken wiring to sensor</li> </ul>	<ul style="list-style-type: none"> <li>( • Check, repair)</li> <li>( • Check, repair)</li> <li>• Add oil to specified level. See CHECK BEFORE STARTING.</li> <li>• Replace belt. See EVERY 500 HOURS SERVICE.</li> <li>( • Clean or replace)</li> <li>• Drive in direct range</li> <li>( • Repair, connect wiring)</li> </ul>
Steering wheel is heavy	<ul style="list-style-type: none"> <li>• Lack of grease at link</li> <li>• Internal leakage inside steering cylinder</li> </ul>	<ul style="list-style-type: none"> <li>• Add grease</li> <li>( • Replace cylinder seal)</li> </ul>
Steering wheel pulls	<ul style="list-style-type: none"> <li>• Tire inflation pressure not uniform on left and right</li> <li>• Dragging, pulling of front brake</li> </ul>	<ul style="list-style-type: none"> <li>• Make tire inflation pressure uniform. See CHECK BEFORE STARTING.</li> <li>• Check wear of front brake pad. For details, see EVERY 500 HOURS SERVICE.</li> </ul>
Braking effect is poor when brake pedal is depressed	<ul style="list-style-type: none"> <li>• Pad has reached wear limit</li> <li>• Rear disc has reached wear limit</li> <li>• Insufficient oil pressure</li> <li>• Insufficient brake oil</li> </ul>	<ul style="list-style-type: none"> <li>( • Replace pad)</li> <li>( • Replace disc)</li> <li>• Charge to specified pressure</li> <li>• Add oil to the transmission case. See CHECK BEFORE STARTING.</li> <li>• Bleed air. See WHEN REQUIRED.</li> </ul>
Brake pulls to one side	<ul style="list-style-type: none"> <li>• Air in brake circuit</li> </ul>	<ul style="list-style-type: none"> <li>• Bleed air. See WHEN REQUIRED.</li> </ul>
Dump body speed is slow	<ul style="list-style-type: none"> <li>• Defective gear pump</li> <li>• Insufficient oil</li> </ul>	<ul style="list-style-type: none"> <li>( • Replace gear pump)</li> <li>• Add oil to specified level. See CHECK BEFORE STARTING.</li> </ul>
Suspension is hard	<ul style="list-style-type: none"> <li>• Entry of soil or sand due to breakage of dust seal, gas leakage due to breakage of U-packing</li> <li>• Gas leaking from valve core</li> </ul>	<ul style="list-style-type: none"> <li>( • Replace U-packing)</li> <li>( • Replace valve core)</li> </ul>
Wheel on one side tends to slip	<ul style="list-style-type: none"> <li>• Air in rear brake circuit (between slack adjuster and rear brake)</li> <li>• Excessive difference in wear between left and right tires</li> <li>• Excessive difference in division of load between left and right wheels (unbalanced load)</li> <li>• Excessive deformation of disc</li> </ul>	<ul style="list-style-type: none"> <li>• Bleed air from rear brakes (left, right). See WHEN REQUIRED.</li> <li>( • Replace tires)</li> <li>• Make load uniform</li> <li>( • Disassemble and adjust brake)</li> </ul>

**IF ACCELERATOR PEDAL HAS FAILED**

In addition to the potentiometer detecting the pedal depression depth, the switch (check switch) is installed on the accelerator pedal assembly in order to detect whether the accelerator pedal is depressed or not.

If the pedal depression depth is not detected correctly due to a failure of the accelerator pedal or incorrect electric wiring, the engine controller controls the engine speed responding to the signal from this check switch. The engine runs at 1500 rpm when the accelerator pedal is depressed, while the engine runs at low idle when the pedal is released. The engine speed varies depending on the load.

After using the accelerator pedal to move the machine to a safe place, check the service code and contact your Komatsu distributor.

There are two methods when operating the accelerator pedal: either release the pedal (check switch is OFF, low idle), or depress the pedal fully (1500 rpm).

If the accelerator pedal is held at an intermediate position, the system may not be able to judge if the accelerator pedal is being operated or not.

**REMARK**

If the engine controller cannot perform normal reception of the signal of the accelerator pedal depth, the central warning lamp flashes and simultaneously the alarm buzzer sounds and user code 02 appears.

## ENGINE

- ( ): Always contact your Komatsu distributor when dealing with these items.
- In cases of problems or causes which are not listed below, contact your Komatsu distributor for repairs.

Problem	Main causes	Remedy
Engine oil pressure caution lamp lights up	<ul style="list-style-type: none"> <li>• Insufficient oil in oil pan</li> <li>• Clogged oil filter cartridge</li> <li>• Oil leakage due to damage caused by defective tightening of oil pan, pipe joint</li> <li>• Disconnection, broken wiring to sensor</li> </ul>	<ul style="list-style-type: none"> <li>• Add oil to specified level. See CHECK BEFORE STARTING.</li> <li>• Replace cartridge, see EVERY 500 HOURS SERVICE.</li> <li>( • Check, repair)</li> <li>( • Repair, connect wiring)</li> </ul>
Steam spurts out from top of radiator (pressure valve)	<ul style="list-style-type: none"> <li>• Insufficient coolant, coolant leakage</li> <li>• Loose fan belt</li> </ul>	<ul style="list-style-type: none"> <li>• Check, add coolant. See CHECK BEFORE STARTING.</li> <li>• Replace belt. See EVERY 500 HOURS SERVICE.</li> </ul>
Drop in engine water level is displayed on the character display and the maintenance caution lamp lights up.	<ul style="list-style-type: none"> <li>• Dirt or scale accumulated in cooling system</li> <li>• Radiator fins clogged or damaged</li> </ul>	<ul style="list-style-type: none"> <li>• Change coolant, clean inside of cooling system. See WHEN REQUIRED.</li> <li>• Clean or repair. See WHEN REQUIRED.</li> </ul>
Coolant temperature gauge is in red range	<ul style="list-style-type: none"> <li>• Defective coolant temperature gauge</li> <li>• Defective thermostat</li> <li>• Defective thermostat seal</li> </ul>	<ul style="list-style-type: none"> <li>( • Replace coolant temperature gauge)</li> <li>( • Replace thermostat)</li> <li>( • Replace thermostat seal)</li> </ul>
Engine coolant temperature caution lamp flashes	<ul style="list-style-type: none"> <li>• Loose radiator filler cap</li> <li>• Disconnection, broken wiring to sensor</li> </ul>	<ul style="list-style-type: none"> <li>• Tighten or replace cap.</li> <li>( • Repair, connect wiring)</li> </ul>
Coolant temperature gauge display stays at lowest level and does not rise	<ul style="list-style-type: none"> <li>• Defective coolant temperature gauge</li> <li>• Defective thermostat</li> <li>• In cold weather, cold wind is blowing strongly against engine</li> </ul>	<ul style="list-style-type: none"> <li>( • Replace coolant temperature gauge)</li> <li>( • Replace thermostat)</li> <li>( • Install radiator curtain)</li> </ul>
Engine does not start even when starting motor is turned	<ul style="list-style-type: none"> <li>• Insufficient fuel</li> <li>• Air in fuel system</li> <li>• No fuel in fuel filter</li> <li>• Starting motor cranks engine too slowly</li> <li>• Starting motor does not turn</li> <li>• Defective valve clearance (defective compression)</li> </ul>	<ul style="list-style-type: none"> <li>• Add fuel. See CHECK BEFORE STARTING.</li> <li>( • Repair place where air is leaking in)</li> <li>• Fill filter with fuel. See EVERY 500 HOURS SERVICE.</li> <li>• See electrical components</li> <li>• See electrical components</li> <li>( • Adjust valve clearance)</li> </ul>
Fuel stops from time to time	<ul style="list-style-type: none"> <li>• Crushed fuel tank breather tube</li> </ul>	<ul style="list-style-type: none"> <li>( • Replace breather tube)</li> </ul>



Problem	Main causes	Remedy
Excessive oil consumption	<ul style="list-style-type: none"> <li>• Oil leakage</li> <li>• Excessive oil in oil pan</li> </ul>	<ul style="list-style-type: none"> <li>( • Check, repair)</li> <li>• Add oil to specified level. See CHECK BEFORE STARTING.</li> </ul>
Exhaust gas is white or bluish	<ul style="list-style-type: none"> <li>• Worn piston, ring, cylinder liner</li> <li>• Improper fuel</li> <li>• Defective turbocharger</li> </ul>	<ul style="list-style-type: none"> <li>( • Replace)</li> <li>• Replace with specified fuel</li> <li>( • Check, replace)</li> </ul>
Exhaust gas is black	<ul style="list-style-type: none"> <li>• Clogged air cleaner element</li> <li>• Worn piston, ring, cylinder liner</li> <li>• Defective compression</li> <li>• Defective turbocharger</li> <li>• Defective Injector</li> </ul>	<ul style="list-style-type: none"> <li>• Clean or replace. See WHEN REQUIRED.</li> <li>( • Check, repair)</li> <li>• See adjustment of valve clearance above</li> <li>( • Check, replace)</li> <li>( • Check, adjust, repair)</li> </ul>
Engine hunts	<ul style="list-style-type: none"> <li>• Air entering suction side of fuel line</li> </ul>	<ul style="list-style-type: none"> <li>( • Repair place where air is leaking in)</li> </ul>
Combustion noise occasionally makes breathing sound	<ul style="list-style-type: none"> <li>• Defective nozzle</li> </ul>	<ul style="list-style-type: none"> <li>( • Replace nozzle)</li> </ul>
There is knocking (combustion or mechanical)	<ul style="list-style-type: none"> <li>• Poor quality fuel being used</li> <li>• Overheating</li> </ul>	<ul style="list-style-type: none"> <li>• Replace with specified fuel</li> <li>• See "Water temperature gauge is in red range" above.</li> </ul>

**ACTION CODE**

If any problem occurs, stop the machine, apply the parking brake and check the service code, then contact your Komatsu distributor for repairs.

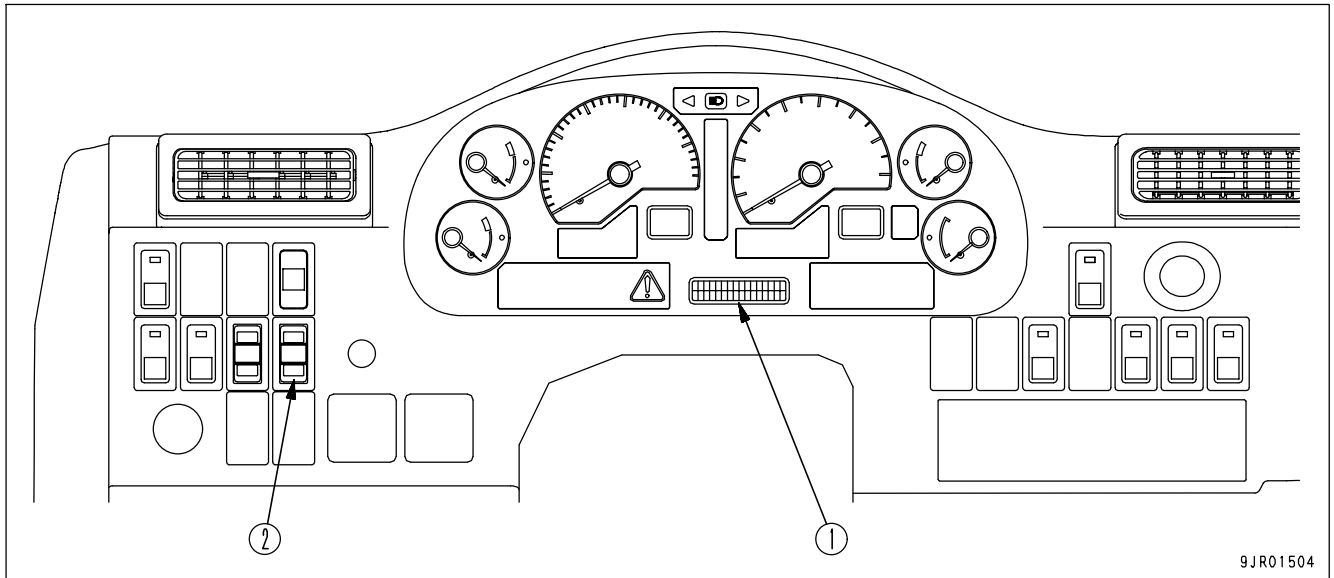

If action code "E03" is displayed on the character display (1), or if an action code is displayed after taking the remedy when action code "E02" was displayed, or if "MAINTENANCE" is displayed together with action code "E01", do as follows to check the failure code.

1. If an action code is displayed, pressed the top (>) portion of machine monitor mode selector switch (2) and check the failure code. The failure code is displayed on character display (1).
2. Press the top (>) portion of machine monitor mode selector switch (2) again. The service meter and odometer will be displayed for several seconds, and the screen will then return to the action code screen. If more than one failure has occurred, the next failure code is displayed.
3. Check the failure code, then contact your Komatsu distributor for repairs.

**REMARK**

- The 6-digit code displayed on the left of the line at the top of the character display is the failure code.
- The code displayed at the right side of the failure code shows the controller that detected the failure code.  
 MON: Machine monitor  
 TM: Transmission controller  
 ENG: Engine controller  
 BK: Retarder controller
- The line at the bottom of the character display shows the system where the failure was generated.



# MAINTENANCE

## **WARNING**

Please read and make sure that you understand the SAFETY section before reading this section.

---

## GUIDES TO MAINTENANCE

Do not perform any inspection and maintenance operation that is not found in this manual.

### CHECK SERVICE METER:

Check the service meter reading every day to see if the time has come for any necessary maintenance to be performed.

### KOMATSU GENUINE REPLACEMENT PARTS:

Use Komatsu genuine parts specified in the Parts Book as replacement parts.

### KOMATSU GENUINE OILS:

For lubrication of the machine, use the Komatsu genuine lubricants. Moreover use oil of the specified viscosity according to the ambient temperature.

### ALWAYS USE CLEAN WASHER FLUID:

Use automobile window washer fluid, and be careful not to let any dirt get into it.

### ALWAYS USE CLEAN OIL AND GREASE:

Use clean oil and grease. Also, keep the containers of the oil and grease clean. Keep foreign materials away from oil and grease.

### CHECKING FOREIGN MATERIALS IN DRAINED OIL AND ON FILTERS:

After oil is changed or filters are replaced, check the old oil and filters for metal particles and foreign materials. If large quantity of metal particles or foreign materials are found, always report to the person in charge, and carry out suitable action.

### OIL CHANGE:

If your machine is equipped with a fuel strainer, do not remove it while fueling.

### WELDING INSTRUCTIONS:

- Turn off the engine starting switch.
- Do not apply more than 200 V continuously.
- Connect grounding cable within 1 m (3.3 ft) of the area to be welded. If grounding cable is connected near instruments, connectors, etc., the instruments may malfunction.
- If a seal or bearing happens to come between the part being welded and grounding point, change the grounding point to avoid such parts.
- Do not use the area around the pins or the hydraulic cylinders as the grounding point.  
Sparks will cause damage to the plated portion.

### DO NOT DROP THINGS INSIDE MACHINE:

- When opening inspection windows or the oil filler port of the tank to carry out inspection, be careful not to drop nuts, bolts, or tools inside the machine.  
If such things are dropped inside the machine, it may cause damage and/or malfunction of the machine, and will lead to failure. If you drop anything inside the machine, always remove it immediately.
- Do not put unnecessary things in your pockets. Carry only things which are necessary for inspection.

**DUSTY WORKSITES:**

When working at dusty worksites, do as follows:

- Inspect the dust indicator frequently to see if the air cleaner is clogged.  
Clean the air cleaner element at a shorter interval than specified.
- Clean the radiator core frequently to avoid clogging.
- Clean and replace the fuel filter frequently.
- Clean electrical components, especially the starting motor and alternator, to avoid accumulation of dust.
- When inspecting or changing the oil, move the machine to a place that is free of dust to prevent dirt from getting into the oil.

**AVOID MIXING OILS:**

If a different brand or grade of oil has to be added, drain the old oil and replace all the oil with the new brand or grade of oil. Never mix different brand or grade of oil.

**LOCKING INSPECTION COVERS:**

Lock inspection cover securely into position with the lock bar. If inspection or maintenance is performed with inspection cover not locked in position, there is a danger that it may be suddenly blow shut by the wind and cause injury to the worker.

**PRECAUTION WHEN REMOVING HYDRAULIC HOSE:**

The hydraulic system is always under the internal pressure. When inspecting or replacing piping or hoses, always check that the pressure in the hydraulic circuit has been released. If inspection or maintenance is carried out while the circuit is still under pressure, it will lead to serious injury. For details of the method of releasing the pressure, see each inspection and maintenance item.

In particular, with the brake circuit, depress the brake pedal at least 20 times to reduce the accumulator pressure to 0 before the operation.

**BLEEDING AIR FROM HYDRAULIC CIRCUIT:**

If the hydraulic components have been repaired or replaced and if the hydraulic hoses, pipes, etc. have been disconnected, it is necessary to bleed air in the circuit. See "WHEN REQUIRED (PAGE 4-21)".

**PRECAUTIONS WHEN INSTALLING HYDRAULIC HOSES:**

- When removing parts at locations where there are O-rings or gasket seals, clean the mounting surface, and replace with new parts.  
When doing this, be careful not to forget to assemble the O-rings and gaskets.
- When installing the hoses, do not twist them or bend them sharply. If they are installed so, their service life will be shortened extremely and they may be damaged.

**CHECKS AFTER INSPECTION AND MAINTENANCE:**

If you forget to perform the checks after inspection and maintenance, unexpected problems may occur, and this may lead to serious injury or property damage. Always do the following:

- Checks after operation (with engine stopped)
  - Have any inspection and maintenance points been forgotten?
  - Have all inspection and maintenance items been performed correctly?
  - Have any tools or parts been dropped inside the machine? It is particularly dangerous if parts are dropped inside the machine and get caught in the lever linkage mechanism.
  - Are there any leakage of coolant or oil? Have all nuts and bolts been tightened?
- Check when the engine is running
  - See "TWO WORKERS FOR MAINTENANCE WHEN ENGINE IS RUNNING (PAGE 2-31)" in the section on safety for checking when the engine is running. Pay enough attention for safety.
  - Check if the inspected and serviced area is normally operated.
  - Increase the engine speed to check for the leak of fuel and oil.

## OUTLINE OF SERVICE

- Always use Komatsu genuine parts for replacement parts, grease or oil.
- When changing the oil or adding oil, do not mix different types of oil. When changing the type of oil, drain all the old oil and fill completely with the new oil. Always replace the filter at the same time. (There is no problem if the small amount of oil remaining in the piping mixes with the new oil.)
- Unless otherwise specified, when the machine is shipped from the factory, it is filled with the oil and coolant listed in the table below.

Item	Type
Engine oil pan	Engine oil EO15W40-DH (Komatsu genuine parts)
Transmission case	Power train oil TO30 (Komatsu genuine parts)
Steering hoist oil tank	Power train oil TO10 (Komatsu genuine parts)
Front suspension Rear suspension	Hydraulic oil HO-MVK (Komatsu genuine parts)
Differential case Final drive case	Power train oil TO30 (Komatsu genuine parts)
Radiator	Supercoolant AF-NAC (Density:30% or above) (Komatsu genuine parts)

## HANDLING OIL, FUEL, COOLANT, AND PERFORMING OIL CLINIC

### OIL

- Oil is used in the engine and hydraulic equipment under extremely severe conditions (high temperature, high pressure), and deteriorates with use.  
Always use oil that matches the grade and maximum and minimum ambient temperatures recommended in the Operation and Maintenance Manual. Even if the oil is not dirty, always change the oil at the specified interval.
- Oil corresponds to blood in the human body, always be careful when handling it to prevent any impurities (water, metal particles, dirt, etc.) from getting in.  
The majority of problems with the machine are caused by the entry of such impurities.  
Take particular care not to let any impurities get in when storing or adding oil.
- Never mix oils of different grades or brands.
- Always add the specified amount of oil.  
Having too much oil or too little oil are both causes of problems.
- If the oil in the work equipment is not clear, there is probably water or air getting into the circuit. In such cases, please contact your Komatsu distributor.
- When changing the oil, always replace the related filters at the same time.
- We recommend you have an analysis made of the oil periodically to check the condition of the machine. For those who wish to use this service, please contact your Komatsu distributor.
- When using commercially available oil, it may be necessary to reduce the oil change interval.  
We recommend that you use the Komatsu oil clinic to carry out a detailed checks of the characteristics of the oil.



## FUEL

- To prevent the moisture in the air from condensing and forming water inside the fuel tank, always fill the fuel tank after completing the day's work.
- The fuel pump is a precision instrument, and if fuel containing water or dirt is used, it cannot work properly.
- Be extremely careful not to let impurities get in when storing or adding fuel.
- Always use fuel that matches the temperatures given in the Operation and Maintenance Manual.
  - If the fuel is used in temperatures lower than the specified temperature for use (particularly at temperatures of lower than -15°C), the properties of the fuel will make it congeal.
  - If the fuel is used in temperatures higher than the specified temperature for use, the viscosity will go down, and this may result in a drop in output or other problems.
- Before starting the engine, or when 10 minutes have passed after adding fuel, drain the sediment and water from the fuel tank.
- If the engine runs out of fuel, or if the filters have been replaced, it is necessary to bleed the air from the circuit.
- If there is any foreign material in the fuel tank, wash the tank and fuel system.

## NOTICE

**Use only diesel fuel.**

**The engine mounted on this machine employs electronic control and a high-pressure fuel injection device to obtain good fuel consumption and good exhaust gas characteristics. For this reason, it requires high precision for the parts and good lubrication. If kerosene or other fuel with low lubricating ability is used, there will be a big drop in durability.**

## COOLANT AND WATER FOR DILUTION

- The coolant has the important function of preventing corrosion as well as preventing freezing. Even in the areas where freezing is not an issue, the use of antifreeze coolant is essential. Komatsu machines are supplied with Komatsu Supercoolant (AF-NAC). Komatsu Supercoolant (AF-NAC) has excellent anticorrosion, antifreeze and cooling properties and can be used continuously for 2 years or 4000 hours. As a basic rule, we do not recommend the use of any coolant other than Komatsu genuine supercoolant (AF-NAC). If you use another coolant, it may cause serious problems such as corrosion of the engine and parts of the cooling system that use light metals such as aluminum.
- When using Komatsu Supercoolant (AF-NAC), there is no need to use a corrosion resistor. For details, see "CLEAN INSIDE OF COOLING SYSTEM (PAGE 4-27)".
- When diluting the antifreeze coolant, use distilled water or tap water (soft water). Natural water, such as a river water or well water (hard water), contains large amounts of minerals (calcium, magnesium, etc.), and this makes it easier for scale to form inside the engine or radiator. Once scale is deposited inside the engine or radiator, it is extremely difficult to remove. It also causes overheating due to poor heat exchange, so when you dilute the coolant, we recommend that you use water with an overall hardness of less than 100 PPM.
- When using antifreeze, always observe the precautions given in the Operation and Maintenance Manual.
- Antifreeze coolant is flammable, so be sure to keep it away from flame.
- The ratio of Supercoolant (AF-NAC) to water differs according to the ambient temperature. For details of the ratio when mixing, see "CLEAN INSIDE OF COOLING SYSTEM (PAGE 4-27)". Even in areas where it is not necessary to prevent freezing, use Supercoolant (AF-NAC) at a mixing ratio of at least 30% to prevent corrosion of the cooling system. Supercoolant (AF-NAC) may be supplied in premix. In this case, never add diluting water.
- If the engine overheats, wait for the engine to cool before adding coolant.
- If the coolant level is low, it will cause overheating, and will also cause problems with corrosion due to air entering the coolant.

**GREASE**

- Grease is used to prevent seizure and noises at the joints.
- This construction equipment is used under heavy-duty conditions. Always use the recommended grease and follow the change intervals and recommended ambient temperatures given in this Operation and Maintenance Manual.
- Grease fittings not listed in the inspection and maintenance section are grease fittings that are used at the time of overhaul, so there is no need to grease these points.  
When using the machine after it has been in storage for a long time, carry out greasing if there is any stiffness or screeching.
- Always wipe off all of the old grease that is pushed out when greasing.  
Be particularly careful to wipe off the old grease in places where sand or dirt sticking in the grease would cause wear of the rotating parts.

**CARRYING OUT KOWA (Komatsu Oil Wear Analysis)**

KOWA is a maintenance service that makes it possible to prevent machine failures and downtime. With KOWA, the oil is periodically sampled and analyzed. This enables early detection of wear of the machine drive parts and other problems.

We strongly recommend you to use this service. The oil analysis is carried out at actual cost, so the cost is low, and the results of the analysis are reported together with recommendations which will reduce repair costs and machine downtime.

**KOWA ANALYSIS ITEMS**

- Measurement of density of metal wear particles  
This uses an ICP (Inductively Coupled Plasma) analyzer to measure the density of iron, copper, and other metal wear particles in the oil.

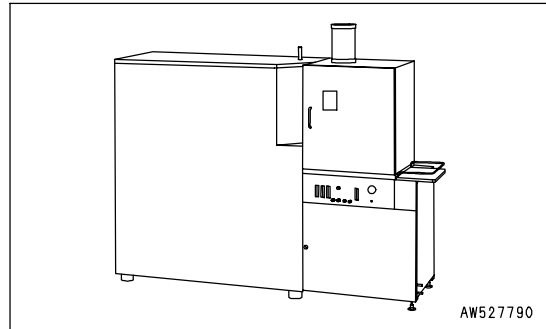

- Measurement of quantity of particles  
This uses a PQI (Particle Quantifier Index) measurer to measure the quantity of iron particles of 5µm or more, enabling early detection of failures.

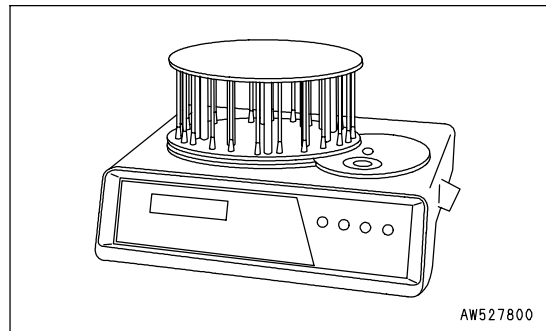

- Others  
Measurements are made of items such as the ratio of water in the oil, density of the antifreeze coolant, ratio of fuel in the oil, and dynamic viscosity, enabling a highly precise diagnosis of the machine's health.

**OIL SAMPLING**

- Sampling interval  
250 hours: Engine  
500 hours: Other components
- Precautions when sampling
  - Make sure that the oil is well mixed before sampling.
  - Perform sampling at regular fixed intervals.
  - Do not perform sampling on rainy or windy days when water or dust can get into the oil.

For further details of KOWA, please contact your Komatsu distributor.

## STORING OIL AND FUEL

- Keep indoors to prevent any water, dirt, or other impurities from getting in.
- When keeping drum cans for a long period, put the drum on its side so that the filler port of the drums is at the side to prevent moisture from being sucked in.  
If drums have to be stored outside, cover them with a waterproof sheet or take other measures to protect them.
- To prevent any change in quality during long-term storage, be sure to use in the order of first in - first out (use the oldest oil or fuel first).

## FILTERS

- Filters are extremely important safety parts. They prevent impurities in the fuel and air circuits from entering important equipment and causing problems.  
Replace all filters periodically. For details, see the Operation and Maintenance Manual.  
However, when working in severe conditions, replace the filters at shorter intervals according to the oil and fuel (sulfur content) being used.
- Never try to clean the filters (cartridge type) and use them again. Always replace with new filters.
- When replacing oil filters, check if any metal particles are attached to the old filter. If any metal particles are found, contact your Komatsu distributor.
- Do not open packs of spare filters until just before they are to be used.
- Always use Komatsu genuine filters.

## OUTLINE OF ELECTRIC SYSTEM

- It is extremely dangerous if the electrical equipment becomes wet or the covering of the wiring is damaged. This will cause an electrical short circuit and may lead to malfunction of the machine. Do not wash the inside of the operator's cab with water. When washing the machine, be careful not to let water get into the electrical components.
- Service relating to the electric system is checking fan belt tension, checking damage or wear to the fan belt and checking battery fluid level.
- Never install any electric components other than those specified by Komatsu.
- External electro-magnetic interference may cause malfunction of the control system controller, before installing a radio receiver or other wireless equipment, contact your Komatsu distributor.
- When working at the seashore, carefully clean the electric system to prevent corrosion.
- When installing an operator's cab cooler or any other electrical equipment, connect it to an independent power source connector. The cables to supply power to the optional equipment must never be connected to the fuse, starting switch, or battery relay.

## WEAR PARTS

Wear parts such as the filter element, air cleaner element, etc. are to be replaced at the time of periodic maintenance or before their abrasion limits.

The wear parts should be changed correctly in order to use the machine economically.

For part change, Komatsu genuine parts of excellent quality should be used.

When ordering parts, please check the part number in the parts book.

## WEAR PARTS LIST

The parts in parentheses are to be replaced at the same time.

Item	Part No.	Part Name	Q'ty	Replacement frequency
Engine oil filter	600-211-1340	Cartridge	2	EVERY 500 HOURS
Fuel pre-filter (*)	600-319-4540	Cartridge	1	
Transmission oil filter	569-16-81160 (07000-12125)	Element (O-ring)	2 (2)	
Fuel main filter (*)	600-319-3550	Cartridge	2	EVERY 1000 HOURS
Transmission, rear brake cooling oil filter	07063-51210 (07000-F5190)	Element (O-ring)	1 (1)	
Brake oil filter	569-43-83920 (07000-12065) (07001-02065)	Element (O-ring) (Back-up ring)	1 (1) (1)	
Corrosion resistor	600-411-1171	Cartridge	1	
Steering, hoist oil filter	07063-51142 (07000-F5185)	Element (O-ring)	1 (1)	EVERY 2000 HOURS
Water separator	600-311-9350	Case	2	-
	600-311-9360	O-ring	2	
	600-311-9370	Screen	2	
Air cleaner	600-185-5100	Element Ass'y	2	
	600-185-5110	Outer element	2	
Payload meter (if equipped) inner battery	581-86-55710	Battery	1	

\*: If the fuel filter gets clogged before its periodic replacement time is arrived at, replace both the fuel pre-filter and fuel main filter together.

## RECOMMENDED FUEL, COOLANT, AND LUBRICANT

- Komatsu genuine oils are adjusted to maintain the reliability and durability of Komatsu construction equipment and components.

In order to keep your machine in the best conditioner for long periods of time, it is essential to follow the instructions in this Operation and Maintenance Manual.

- Failure to follow these recommendations may result in shortened life or excess wear of the engine, power train, cooling system, and/or other components.
- Commercially available lubricant additives may be good for the machine, but they may also cause harm. Komatsu does not recommend any commercially available lubricant additive.
- Use the oil recommended according to the ambient temperature in the chart below.
- Specified capacity means the total amount of oil including the oil in the tank and the piping. Refill capacity means the amount of oil needed to refill the system during inspection and maintenance.
- When starting the engine in temperatures below 0°C (32°F), be sure to use the recommended multi-grade oil, even if the ambient temperature may become higher during the course of the day.
- If the machine is operated at a temperature below -20°C (-4°F), a separate device is needed, so consult your Komatsu distributor.
- When the fuel sulfur content is less than 0.2%, change the engine oil according to the period inspection table given in this Operation and Maintenance Manual.

If the fuel sulfur content is more than 0.2%, change the oil according to the following table.

Sulfur content (%)	Oil change interval
Less than 0.2%	500 hours
0.2 to 0.5%	250 hours
0.5% and up	Not recommendable (*)

\* If these fuels are used, there is danger that serious trouble may occur because of early deterioration of the engine oil or early wear of the internal parts of the engine. If the local situation makes it necessary to use these fuels, always remember the following.

- 1) Be sure to check Total Basic Number (TBN) of oil frequently by TBN handy checker etc., and change oil based on the result.
- 2) Always be aware that oil change interval is extremely shorter than standard.
- 3) Be sure to carry out periodic engine inspection by distributor's expert since change interval of periodic replacement parts and overhaul interval are also shorter.

USE OF FUEL, COOLANT AND LUBRICANTS ACCORDING TO AMBIENT TEMPERATURE

Reservoir	Fluid Type	Ambient Temperature, degrees Celsius										Recommended Komatsu Fluids					
		-22	-4	14	32	50	68	86	104	122 °F	-30		-20	-10	0	10	20
Engine oil pan	Engine oil	(Note.1)										Komatsu EOS0W30					
		(Note.1)										Komatsu EOS5W40					
		(Note.1)										Komatsu EO10W30DH					
		(Note.1)										Komatsu EO15W40DH					
		(Note.1)										Komatsu EO30DH					
Transmission Case (incl. brake oil tank)	Power train oil (Note.2)	(Note.1)										TO10					
		(Note.1)										TO30					
Hydraulic tank	Power train oil	(Note.1)										TO10					
Front suspension Rear suspension	Hydraulic oil	(Note.1)										HO-MVK					
Differential case Final drive case	Power train oil	(Note.1)										TO30					
		(Note.1)										TO50					
Grease fitting	Hyper grease (Note.3)	(Note.1)										G2-T, G2-TE					
	Lithium EP grease	(Note.1)										G2-LI					
Cooling system	Supercoolant AF-NAC (Note.4)	(Note.1)										AF-NAC					
Fuel tank	Diesel fuel	(Note.1)										ASTM Grade No.1-D S15 ASTM Grade No.1-D S500					
		(Note.1)										ASTM Grade No.2-D S15 ASTM Grade No.2-D S500					

• ASTM: American Society of Testing and Material

Capacity		Reservoir	Engine oil pan	Transmission case (Including brake sub tank)	Hydraulic tank	Front suspension (each)	Rear suspension (each)
		Specified	Liters	58	211	165	13.8
US gal	15.32		55.78	43.56	3.64	2.19	
Refill	Liters	50	90	129	-	-	
	US gal	13.21	23.78	34.06	-	-	

Capacity		Reservoir	Differential case	Final drive case (each)	Fuel tank	Cooling system
		Specified	Liters	50	15	500
US gal	13.2		3.96	132.1	36.46	
Refill	Liters	45	15	-	134	
	US gal	11.88	3.96	-	35.40	

**NOTICE**

Always use diesel oil for the fuel.

To ensure good fuel consumption characteristics and exhaust gas characteristics, the engine mounted on this machine uses an electronically controlled high-pressure fuel injection device. This device requires high precision parts and lubrication, so if low viscosity fuel with low lubricating ability is used, the durability may drop markedly.

Note 1: HTHS ( High-Temperature High-Shear Viscosity 150°C), specified by ASTM D4741 must be equal to or higher than 3.5 mPa-S. Komatsu EOS0W30 and EOS5W40 are the most suitable oils.

Note 2: Powertrain oil has different properties from engine oil. Be sure to use the recommended oils.

Note 3: Hyper grease (G2-T, G2-TE) has a high performance.

When it is necessary to improve the lubricating ability of the grease in order to prevent squeaking of pins and bushings, the use of G2-T or G2-TE is recommended.

Note 4: Supercoolant (AF-NAC)

1) Coolant has the important function of anticorrosion as well as antifreeze.

Even in the areas where freezing is not an issue, the use of antifreeze coolant is essential.

Komatsu machines are supplied with Komatsu Supercoolant AF-NAC. Komatsu Supercoolant AF-NAC has excellent anticorrosion, antifreeze and cooling properties and can be used continuously for 2 years or 4000 hours.

Komatsu Supercoolant AF-NAC is strongly recommended wherever available.

2) For details of the ratio when diluting super coolant with water, see "CLEAN INSIDE OF COOLING SYSTEM (PAGE 4-27)".

Supercoolant AF-NAC may be supplied in premix. In this case, always top off with premix solution. (never dilute with water)

3) To maintain the anticorrosion properties of Supercoolant AF-NAC, always keep the density of Supercoolant between 30% and 68%.

**RECOMMENDED BRANDS, RECOMMENDED QUALITY FOR PRODUCTS OTHER THAN KOMATSU GENUINE OIL**

When using commercially available oils other than Komatsu genuine oil, consult your Komatsu distributor.



# STANDARD TIGHTENING TORQUES FOR BOLTS AND NUTS

## TORQUE LIST

Unless otherwise specified, tighten the metric nuts and bolts to the torque shown in the table below.

The tightening torque is determined by the width across the flats (b) of the nut and bolt.

If it is necessary to replace any nut or bolt, always use a Komatsu genuine part of the same size as the part that was replaced.

Thread diameter of bolt (a)(mm)	Width across flats (b)(mm)	Tightening torque					
		Target value			Service limit		
		Nm	kgm	lbft	Nm	kgm	lbft
6	10	13.2	1.35	9.8	11.8-14.7	1.2-1.5	8.7-10.8
8	13	31	3.2	23.1	27-34	2.8-3.5	20.3-25.3
10	17	66	6.7	48.5	59-74	6.0-7.5	43.4-54.2
12	19	113	11.5	83.2	98-123	10.0-12.5	72.3-90.4
14	22	177	18	130.2	157-196	16.0-20.0	115.7-144.7
16	24	279	28.5	206.1	245-309	25.0-31.5	180.8-227.8
18	27	382	39	282.1	343-425	35.0-43.5	253.2-314.6
20	30	549	56	405.0	490-608	50.0-62.0	361.7-448.4
22	32	745	76	549.7	662-829	67.5-84.5	488.2-611.2
24	36	927	94.5	683.5	824-1030	84.0-105.0	607.6-759.5
27	41	1320	135.0	976.5	1180-1470	120.0-150.0	868.0-1085.0
30	46	1720	175.0	1265.8	1520-1910	155.0-195.0	1121.1-1410.4
33	50	2210	225.0	1627.4	1960-2450	200.0-250.0	1446.6-1808.3
36	55	2750	280.0	2025.2	2450-3040	250.0-310.0	1808.3-2242.2
39	60	3280	335.0	2423.1	2890-3630	295.0-370.0	2133.7-2676.2

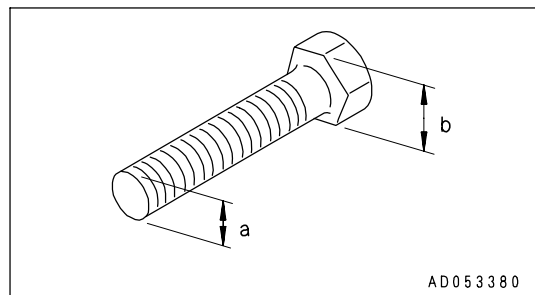

### NOTICE

When tightening panels or other parts having tightening fixtures made of plastic, be careful not to use excessive torque: doing so will damage the plastic parts. Pay enough attention when you tighten up.

Apply the following table for Hydraulic Hose.

- Face seal

Nominal - No. of threads (a)	Width across flats (b) (mm)	Tightening torque					
		Target value			Permissible range		
		Nm	kgm	lbft	Nm	kgm	lbft
9/16 -18UNF	19	44	4.5	32.5	35 - 63	3.5 - 6.5	25.3 - 47.0
11/16 -16UN	22	74	7.5	54.2	54 - 93	5.5 - 9.5	39.8 - 68.7
13/16 -16UN	27	103	10.5	75.9	84 - 132	8.5 - 13.5	61.5 - 97.6
1 -14UNS	32	157	16.0	115.7	128 - 186	13.0 - 19.0	94.0 - 137.4
13/16 -12UN	36	216	22.0	159.1	177 - 245	18.0 - 25.0	130.2 - 180.8

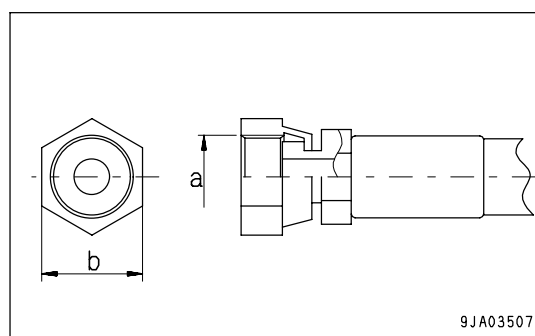

## PERIODIC REPLACEMENT OF SAFETY CRITICAL PARTS

To ensure safety at all times when operating or driving the machine, the user of the machine must always carry out periodic maintenance. In addition, to further improve safety, the parts in the safety-critical parts list on the next page must also be replaced at the specified interval. These parts are particularly closely connected to safety and fire prevention, so please contact your Komatsu distributor to have them replaced.

Material quality of these parts can change as time passes and they are likely to wear out or deteriorate. However, it is difficult to determine the extent of wear or deterioration at the time of periodic maintenance. Hence, it is required to replace them with new ones regardless of their condition after a certain period of usage. This is important to ensure that these parts maintain their full performance at all times.

Furthermore, should anything abnormal be found on any of these parts, replace it with a new one even if the periodic replacement time for the part has not yet arrived.

If any of the hose clamps show deterioration like deformation or cracking, replace the clamps at the same time as the hoses.

Also perform the checks with hydraulic hoses which need to be replaced periodically. Tighten all loose clamps and replace defective hoses, as required.

When replacing hoses, always replace O-rings, gaskets, and other such parts at the same time.

**SAFETY CRITICAL PARTS**

No.	Safety critical parts for periodic replacement	Replacement interval	Remarks
1	Fuel hose (Fuel tank - Fuel prefilter)	Every 4000 hours or 2 years, whichever comes sooner	
2	Fuel hose (Fuel prefilter - Feed pump)		
3	Fuel hose (Engine - Fuel tank)		
4	Spill hose (Engine output connector - Fuel tank)		
5	Water separator (Case, O-ring, plug)		
6	Rubber hose for brake piping		Replace as Ass'y
7	High-pressure hose in steering oil pressure circuit (pump ↔ demand valve ↔ steering valve ↔ steering cylinder)		
8	High-pressure hose in hoist circuit (pump ↔ demand valve ↔ hoist valve ↔ hoist cylinder)		
9	Hose at discharge side of retarder cooling pump		
10	Hose at discharge side of transmission pump		
11	Accumulator		Replace as Ass'y
12	Seat belt		

# MAINTENANCE SCHEDULE CHART

## MAINTENANCE SCHEDULE CHART

### INITIAL 250 HOURS SERVICE (ONLY AFTER THE FIRST 250 HOURS)

Change oil in engine oil pan, replace engine oil filter cartridge .....	4- 55
Replace fuel prefilter cartridge .....	4- 56
Replace transmission oil filter element (pump outlet port) .....	4- 58
Change oil in transmission case, brake sub tank .....	4- 64
Replace transmission and rear brake cooling oil filter element .....	4- 67
Replace brake oil filter element .....	4- 68
Replace steering, hoist oil tank filter element .....	4- 73
Clean hydraulic tank strainer .....	4- 74
Change oil in final drive case .....	4- 74
Change oil in differential case .....	4- 75
Change oil in steering, hoist oil tank .....	4- 77

### WHEN REQUIRED

Check, clean or replace air cleaner .....	4- 21
Clean inside of cooling system .....	4- 27
Check level of window washer fluid, add fluid .....	4- 29
Clean air conditioner air filter .....	4- 30
Check refrigerant (gas) level .....	4- 31
Check dump body .....	4- 31
Check length of suspension cylinder, check oil level .....	4- 32
Bleed air from rear brake .....	4- 34
Bleed air from front brake .....	4- 35
Adjust parking brake .....	4- 36
Clean, check radiator fins and after cooler fins .....	4- 37
Check play of output coupling of output shaft .....	4- 38
Selection and inspection of tires .....	4- 39

### CHECK BEFORE STARTING

**EVERY 250 HOURS SERVICE**

Check oil level in differential case, add oil -----	4- 43
Check oil level in final drive case, add oil -----	4- 43
Lubrication -----	4- 44
Lubrication drive shaft (*) -----	4- 45
Check drive shaft -----	4- 45
Check level of battery electrolyte -----	4- 46
Check alternator belt tension, adjust -----	4- 48
Check air conditioner compressor belt tension, adjust -----	4- 49
Clean breathers -----	4- 50
Check frame -----	4- 51
Check braking capacity of foot brake -----	4- 51
Check braking capacity of retarder brake -----	4- 52
Check braking capacity of parking brake -----	4- 52
Check, clean automatic suspension -----	4- 53
Check of accumulator gas pressure -----	4- 54

\*: For machines equipped with the standard drive shaft, carry out greasing every 250 hours.

For machines equipped with the extended greasing interval drive shaft, carry out greasing every 4000 hours.

**EVERY 500 HOURS SERVICE**

Change oil in engine oil pan, replace engine oil filter cartridge -----	4- 55
Replace fuel prefilter cartridge -----	4- 56
Replace transmission oil filter element (pump outlet port) -----	4- 58
Check wear of front disc brake pads -----	4- 59
Check fan belt tension, adjust -----	4- 60

**EVERY 1000 HOURS SERVICE**

Replace fuel main filter cartridge -----	4- 61
Replace corrosion resistor cartridge -----	4- 63
Change oil in transmission case, brake sub tank, wash strainer -----	4- 64
Replace transmission and rear brake cooling oil filter element -----	4- 67
Replace brake oil filter element -----	4- 68
Lubrication -----	4- 69
Check wear of rear brake disc -----	4- 70
Recover oil leaking from floating seal -----	4- 71
Check of engine air intake piping clamps for looseness -----	4- 72

**EVERY 2000 HOURS SERVICE**

Replace steering, hoist oil tank filter element -----	4- 73
Clean hydraulic tank strainer -----	4- 74
Change oil in final drive case -----	4- 74
Change oil in differential case -----	4- 75
Clean differential case breather -----	4- 75
Check alternator -----	4- 76
Check, adjust engine valve clearance -----	4- 76
Check vibration damper -----	4- 76
Check accumulator gas pressure -----	4- 76

**EVERY 4000 HOURS SERVICE**

Change oil in steering, hoist oil tank -----	4- 77
Grease extended greasing interval drive shaft (*) -----	4- 77
Check starting motor -----	4- 78
Check water pump -----	4- 78
Check fan pulley and tension pulley -----	4- 78
Check accumulator -----	4- 78
Checking for looseness of high-pressure clamp, hardening of rubber -----	4- 78
Checking for missing fuel spray prevention cap, hardening of rubber -----	4- 79

\*: For machines equipped with the extended greasing interval drive shaft, carry out greasing every 4000 hours.  
 For machines equipped with the standard drive shaft, carry out greasing every 250 hours.

**EVERY 8000 HOURS SERVICE**

Replace high-pressure piping clamp -----	4- 80
Replace fuel spray prevention cap -----	4- 80
Overhaul starting motor and alternator -----	4- 80

**EVERY 15000 HOURS SERVICE**

Check, replace steering A arm mounting bolt -----	4- 81
---	-------

## SERVICE PROCEDURE

### INITIAL 250 HOURS SERVICE (ONLY AFTER THE FIRST 250 HOURS)

Perform the following maintenance only after the first 250 hours.

- Change oil in engine oil pan, replace engine oil filter cartridge
- Replace fuel prefilter cartridge
- Replace transmission oil filter element
- Change oil in transmission case, brake sub tank
- Replace transmission and rear brake cooling oil filter element
- Replace brake oil filter element
- Replace steering, hoist oil tank filter element
- Clean hydraulic tank strainer
- Change oil in final drive case
- Change oil in differential case
- Change oil in steering, hoist oil tank

For details of the method of replacing or maintaining, see EVERY 500 HOURS, EVERY 1000 HOURS, EVERY 2000 HOURS SERVICE and EVERY 4000 HOURS SERVICE.

**WHEN REQUIRED**

**CHECK, CLEAN OR REPLACE AIR CLEANER**

After the outer element has been cleaned 6 times, or if the air cleaner element has been used for one year, replace the outer element, inner element, and O-ring. For details of the procedure for replacement, see "REPLACE ELEMENT (PAGE 4-25)".

If the maintenance caution lamp lights up and the character display displays action code "E01" and "AIR FILTER" during operation immediately after the outer element is cleaned, replace the element even if the outer element has not been cleaned 6 times or the air cleaner element has not been used more than 1 year.

**CHECKING**

**NOTICE**

**Do not replace the element before the dust indicator reaches 7.5 kPa. If it is cleaned frequently, the filtering effect of the air cleaner will drop, and this will reduce the service life of the engine.**

1. Check if the dust indicator (1) displays 7.5 kPa. If it is displaying 7.5 kPa, clean the outer element.

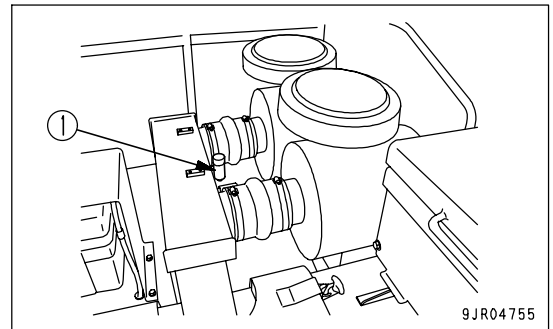

**REMARK**

There is maintenance caution lamp (2) on the machine monitor. If the maintenance caution lamp lights up and the character display (3) displays "E01" and "AIR FILTER" during operation, the air cleaner is clogged. Clean the air cleaner element in this case, too.

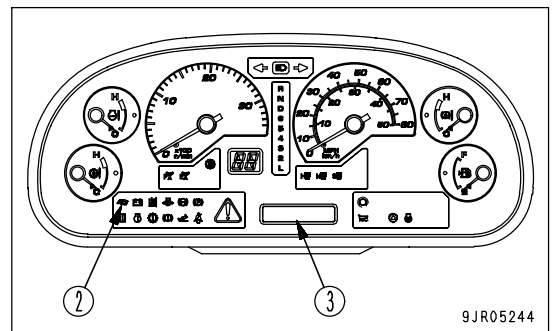



## CLEAN OUTER ELEMENT

**WARNING**

- Dirt will fly if compressed air is used for cleaning. If dirt gets into your eyes it may cause blindness, and if you breathe in the dust it may damage your lungs. To prevent these problems, always wear safety glasses, dust mask, and other protective equipment.
- When pulling out the air cleaner element, make sure that you are standing on a firm place. If your footing is not secure when you carry out the operation, there is danger of falling and suffering injury.

## NOTICE

When cleaning the element, clean only the outer element. Do not clean the inner element. There is danger that dirt and dust may get inside the engine when the outer element is being cleaned, and this will damage the engine.

1. Stop the engine.
2. Remove 3 hooks (5) of dust cup (4), then remove the dust cup.

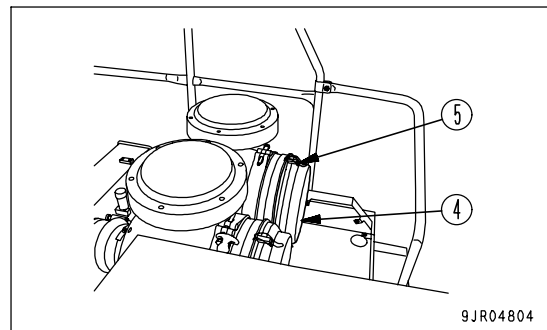

3. Hold outer element (6) with both hands, and move it up and down and to the left and right while pulling it out.
4. Hold inner element (7) so that it does not come out, and clean the inside of the air cleaner body with a dry cloth.
5. Use a dry cloth or compressed air to clean off the dirt stuck to dust cup (4) and vacuator valve (8).
6. Check that there are no cracks in the lip of the vacuator valve (8). If any cracks are found, replace with a new part.

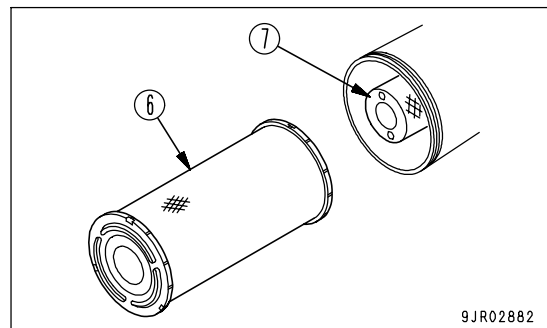

## NOTICE

- If a damaged element is used, dust will pass the air cleaner filter and be sucked into the engine. Do not use any cleaning method that will damage the element. If the element is damaged, replace it with a new element.
- Never tap or hit the element against any other object when cleaning it.
- Do not use an element with damaged folds or a damaged gasket or seal.

7. Blow dry compressed air (0.69 MPa {7 kg/cm<sup>2</sup>}) from the inside of outer element (6) along the folds. Next, blow along the folds from the outside, then blow again from the inside.

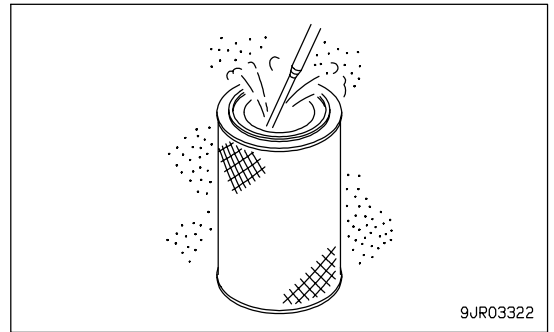

9JR03322

8. After cleaning, shine a light bulb from inside outer element (6) to check. If any holes or thin places are found, replace the outer element.

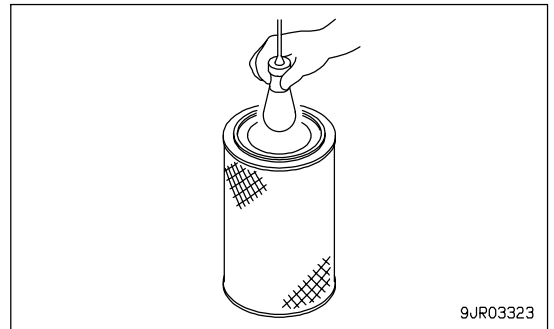

9JR03323

9. Install outer element (6) in the air cleaner body.

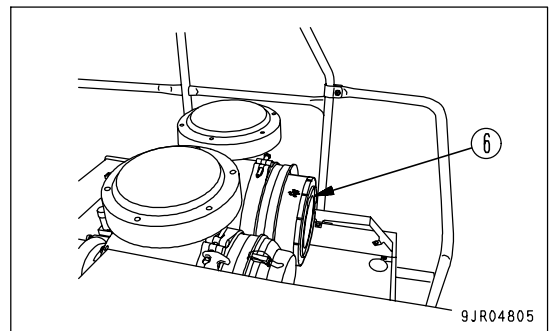

9JR04805

10. Check that O-ring (9) is fitted to dust cup (4). Next, set so that vacuator valve (8) of dust cup (4) is at the bottom, and insert it into the air cleaner body.

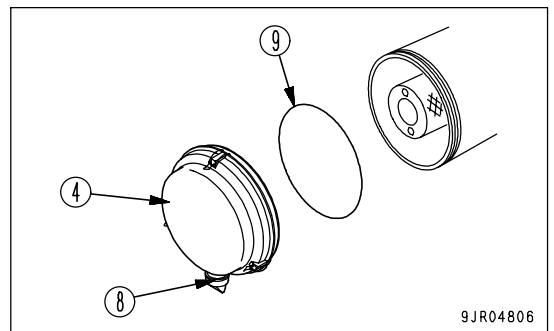

9JR04806

11. Clip hooks (5) of dust cup (4) to the protruding parts of the air cleaner body to lock in position.

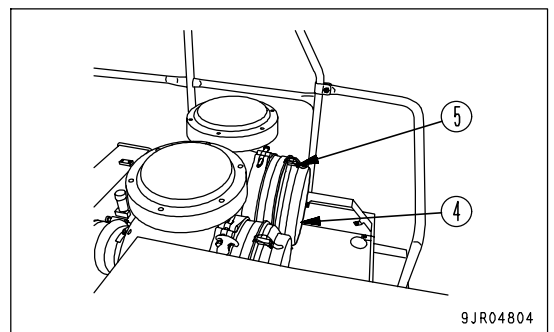

9JR04804

12. Push the head of dust indicator (1) to cancel the clogging display.

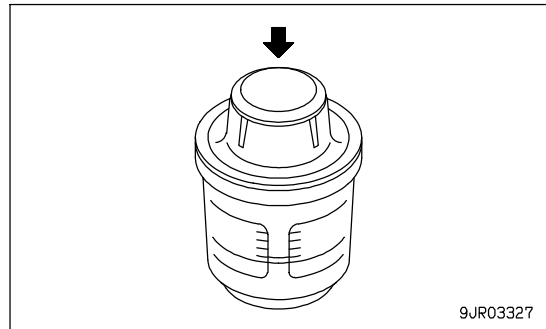
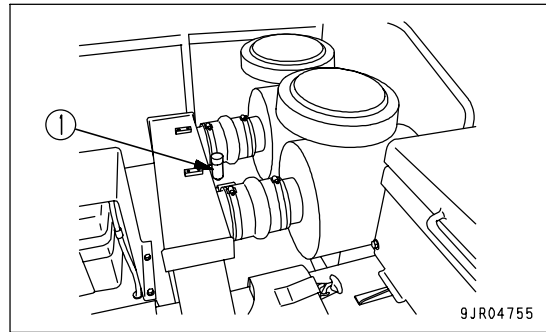

REPLACE ELEMENT

 **WARNING**

When pulling out the air cleaner element, make sure that you are standing on a firm place. If your footing is not secure when you carry out the operation, there is danger of falling and suffering injury.

1. Stop the engine.
2. Remove 3 hooks (5) of dust cup (4), then remove the dust cup.

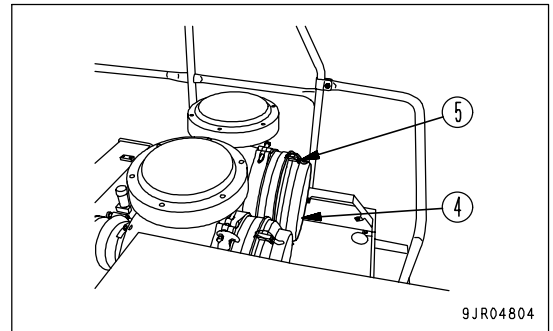

3. Hold outer element (6) with both hands, and move it up and down and to the left and right while pulling it out.
4. Hold inner element (7) so that it does not come out, and clean the inside of the air cleaner body with a dry cloth.
5. Use a dry cloth or compressed air to clean off the dirt stuck to dust cup (4) and vacuator valve (8).

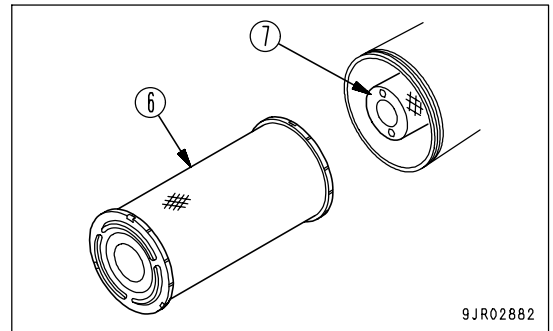

6. Check that there are no cracks in the lip of the vacuator valve (8). If any cracks are found, replace with a new part.
7. Pull out inner element (7) and install a new inner element.
8. Install outer element (6) in the air cleaner body.

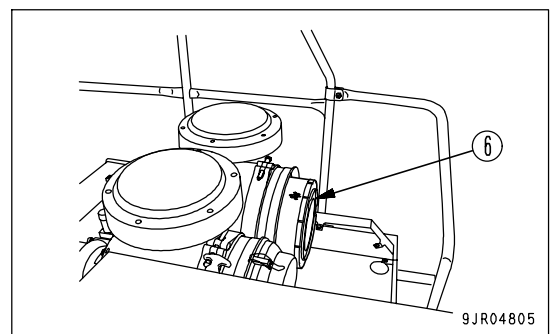

9. Replace O-ring (9) with a new part.

Next, set so that vacuator valve (8) of dust cup (4) is at the bottom, and insert it into the air cleaner body.

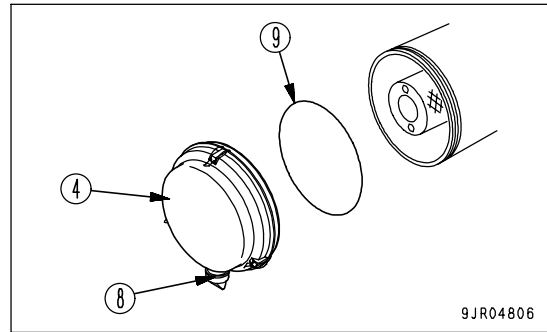

9JR04806

10. Clip hooks (5) of dust cup (4) to the protruding parts of the air cleaner body to lock in position.

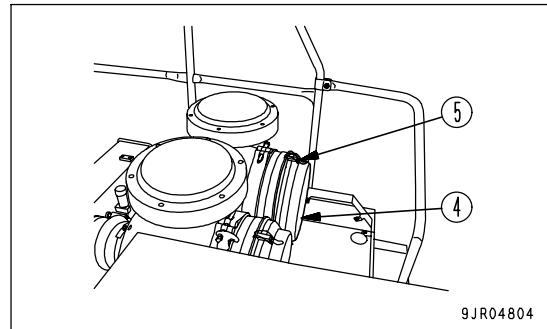

9JR04804

11. Push the head of dust indicator (1) to cancel the clogging display.

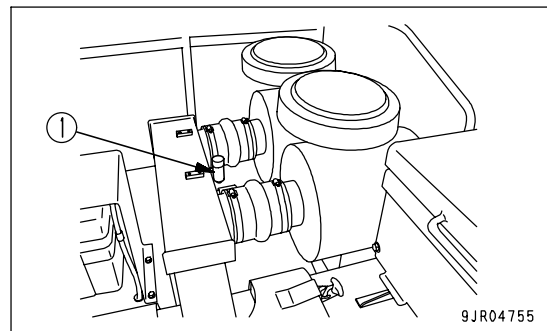

9JR04755

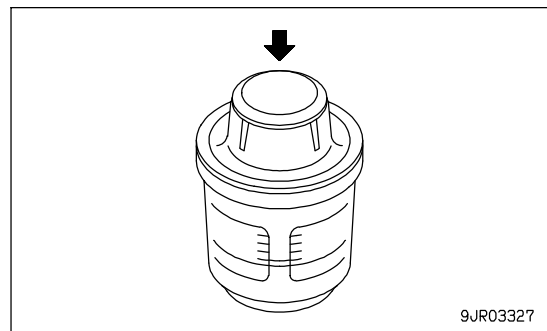

9JR03327

**CLEAN INSIDE OF COOLING SYSTEM**

 **WARNING**

- Immediately after the engine is stopped, the engine coolant is hot and the pressure inside the radiator is high. Removing the cap and draining the water under this condition could cause burns. Allow the engine to cool down, then turn the cap slowly to release the pressure.
- Start the engine and flush the system. When standing up or leaving the operator's seat, set the gear shift lever to the N position and set the parking brake switch to the PARKING position.
- For details of starting the engine, see "OPERATIONS, CHECKS BEFORE STARTING (PAGE 3-86)" and "STARTING ENGINE (PAGE 3-88)" in the OPERATION section of the Operation and Maintenance Manual.
- When the undercover is removed, there is danger of touching the fan.  
Never go to the front of the machine when the engine is running.

Stop the machine on level ground when cleaning or changing the coolant.

Clean the inside of the cooling system, change the coolant according to the table below.

Antifreeze coolant	Interval for cleaning inside of cooling system and changing antifreeze coolant	Precautions for use
Komatsu supercoolant (AF-NAC)	Every two years or every 4000 hours whichever comes first	1*

\*1: When using Komatsu Supercoolant (AF-NAC), there is no need to use a corrosion resistor. When no corrosion resistor is used, use the special cover (600-411-9000). Please consult your Komatsu distributor about the method of installing. When using corrosion resistor, use Komatsu genuine corrosion resistor. If you use another corrosion resistor, it may cause serious problems such as corrosion of the engine and parts of the cooling system that use light metals such as aluminum.

The coolant has the important function of preventing corrosion as well as preventing freezing. Even in the areas where freezing is not an issue, the use of antifreeze coolant is essential. Komatsu machines are supplied with Komatsu Supercoolant (AF-NAC). Komatsu Supercoolant (AF-NAC) has excellent anticorrosion, antifreeze and cooling properties and can be used continuously for 2 years or 4000 hours. As a basic rule, we do not recommend the use of any coolant other than Komatsu genuine supercoolant (AF-NAC). If you use another coolant, it may cause serious problems such as corrosion of the engine and parts of the cooling system that use light metals such as aluminum.

To maintain the anticorrosion properties of Supercoolant (AF-NAC), always keep the density of Supercoolant between 30% and 68%.

When deciding the ratio of antifreeze to water, check the lowest temperature in the past, and decide from the mixing table given below.

It is actually better to estimate and temperature about 10°C (18°F) lower when deciding the mixing ratio. The mixing ratio depends on the ambient temperature, but it should always be a minimum of 30% by volume (antifreeze/total amount of coolant x 100).

Even in areas where it is not necessary to prevent freezing, use Supercoolant (AF-NAC) at a mixing ratio of at least 30% to prevent corrosion of the cooling system.

The freezing temperature of undiluted antifreeze is -15°C (5°F). Do not store undiluted antifreeze at a temperature of below -15°C (5°F).

**Mixing rate of water and antifreeze**

Min. atmospheric temperature	°C	-10	-15	-20	-25	-30
	°F	14	5	-4	-13	-22
Amount of antifreeze	Liters	40.2	48.3	55.0	61.7	67.0
	US gal	10.62	12.76	14.53	16.30	17.70
Amount of water	Liters	93.8	85.7	79.0	72.3	67.0
	US gal	24.78	22.64	20.87	19.10	17.70
Volume ratio	%	30	36	41	46	50

**! WARNING**

Antifreeze coolant is flammable, so keep it away from flame.

Antifreeze coolant is toxic. When removing the drain plug, be careful not to get water containing antifreeze coolant on you. If it gets in your eyes, flush your eyes with large amount of fresh water and see a doctor at once.

Use antifreeze and appropriate water for diluting (for details, see "COOLANT AND WATER FOR DILUTION (PAGE 4-6)")

We recommend use of an antifreeze density gauge to control the mixing proportions.

Prepare a container whose capacity is larger than the specified coolant volume to catch drained coolant.

Prepare a hose to supply antifreeze coolant and water.

1. Stop the engine, then set corrosion resistor valve (1) to the CLOSE position.

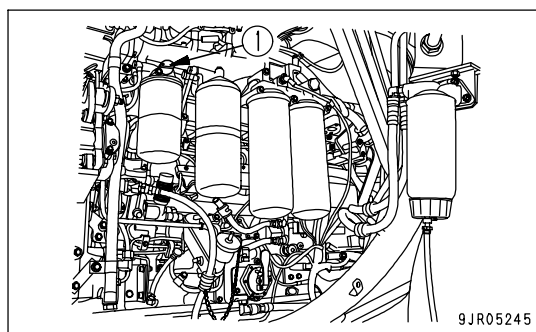

2. Loosen radiator cap (2) slightly to release the air, then remove the cap.

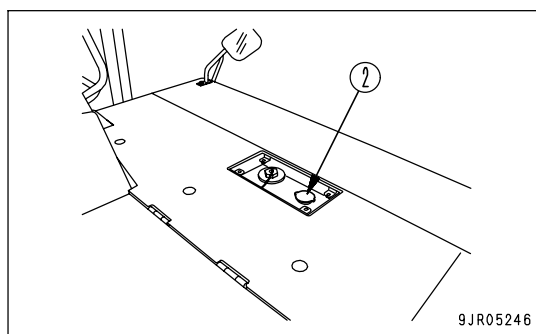

3. Place containers to catch the coolant under drain valve (3) at the bottom of the radiator and drain plug (4) at the side face of the cylinder block.  
Open drain valve (3) and drain plug (4), and drain the water.
4. After draining the water, close drain valve (3) and drain plug (4), and fill with tap water.
5. When the radiator is full, start the engine, and run it at low idle.  
Keep the engine running at low idle for 10 minutes until the water temperature reaches more than 90°C (194°F).
6. Stop the engine, open drain valves (3) and drain plug (4), and drain the water. After draining the water, close them.
7. Replace the corrosion resistor, then set valve (1) to the OPEN position to open it.  
For replacing corrosion resistor, see "REPLACE CORROSION RESISTOR CARTRIDGE (PAGE 4-63)".
8. Add coolant mixed with antifreeze until it overflows from the water filler.  
Decide the proportions of antifreeze and water according to the table for the mixing rate of water and antifreeze.
9. To remove the air contained in the coolant, run the engine at low idle for 5 minutes, then run for a another 5 minutes at high idle. (When doing this, leave the water filler cap OFF.)
10. Stop the engine. About 3 minutes later, supply city water up to the water filler, then close radiator cap.
11. Drain the cooling water from inside subtank (5), flush the inside of the subtank, then fill with water to a point between the FULL and LOW marks.

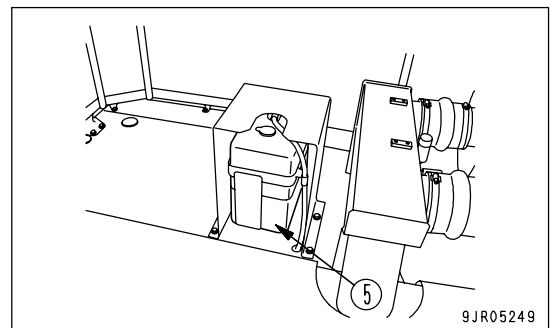
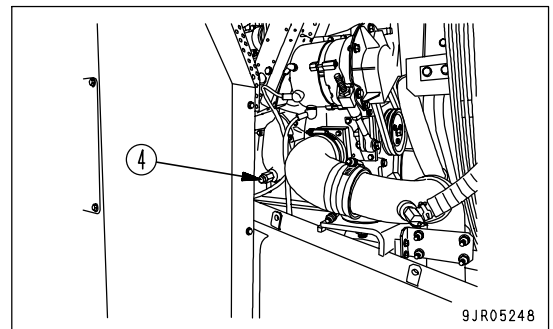
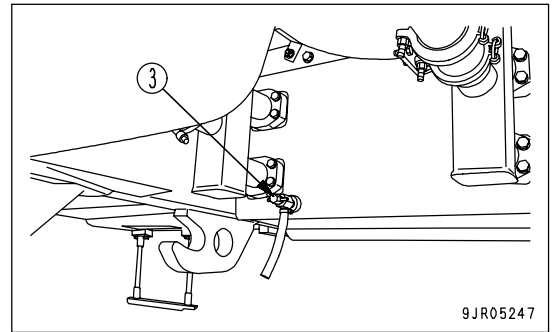

**CHECK LEVEL OF WINDOW WASHER FLUID, ADD FLUID**

Carry out this check if there is air in the window washer fluid.

Check the level of the fluid in window washer tank (1), and if it is low, fill with automobile window washer fluid.

Be careful not to let dirt or dust get in when adding fluid.

When operating at below freezing point, use fluid with antifreeze.

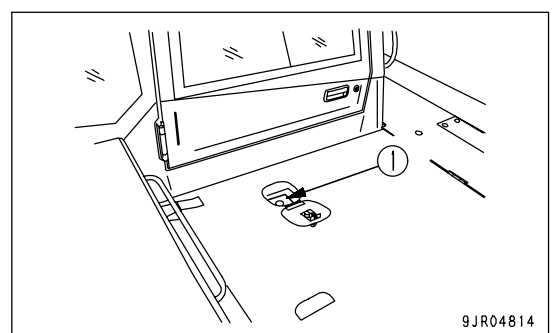



## CLEAN AIR CONDITIONER AIR FILTER

If the air filter at the suction port of the air conditioner unit or the air filter at the fresh air intake port become clogged, the cooling or heating capacity will drop, so clean the filters once a week.

1. Open cover (1) at the front face of the cab.
2. Pull out the air filter (FRESH filter) and clean it with compressed air.

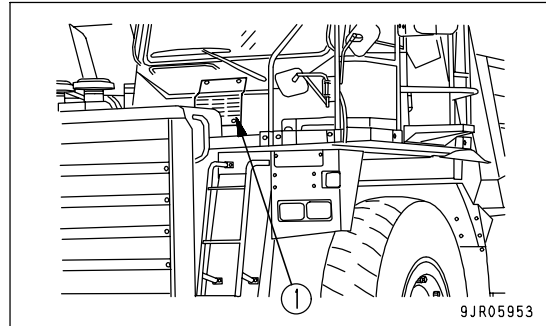

3. Open cover (2) at the front right of the operator's seat.
4. Pull out the air filter (RECIRC filter) at the air intake port of the air conditioner unit, then blow the dust off with a weak jet of compressed air or clean it off with a soft brush.

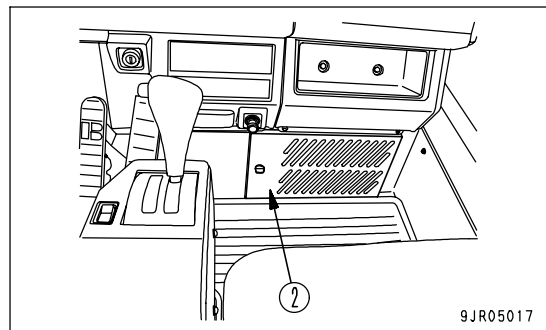

**CHECK REFRIGERANT (GAS) LEVEL**

 **WARNING**

If the refrigerant used in the air conditioner gets into your eyes or on your hands, it may cause loss of sight or frostbite. Do not touch the refrigerant. Never loosen any part of the refrigerant circuit.

Do not bring any flame close to any point where the refrigerant gas is leaking.

If the cooling effect is poor, there is possibly lack of refrigerant (gas).

In this case, check sight glass (2) of receiver drier (1) on the left side of the radiator.

Before carrying out inspection, set to the following conditions.

- Start the engine and run it at approx. 1,500 rpm.
- Turn the air conditioner ON/OFF switch to the ON position.
- Set the air flow to the maximum position.
- Set the temperature to the lowest position.
- Open the doors and windows fully.
- Turn the air conditioner switch ON.

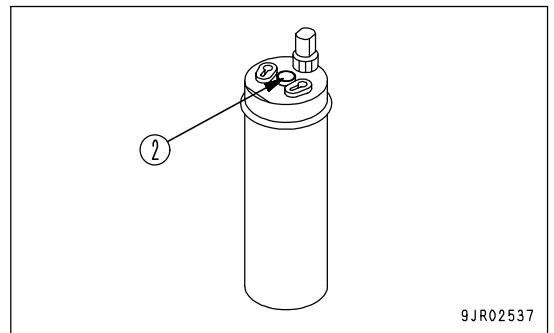
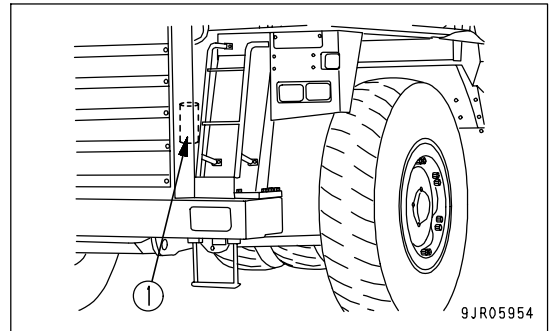

If the condition of sight glass (2) is "correct" as shown in the diagram on the right, the condition is normal. (After the air conditioner switch is turned ON, a small number of bubbles will be seen, but after that, the fluid becomes a transparent, milky white color.)

If the condition of sight glass (2) is "insufficient" as shown in the diagram on the right, there is lack of refrigerant, so ask your Komatsu distributor to charge with refrigerant. (After the air conditioner switch is turned ON, bubbles can be seen continuously.)

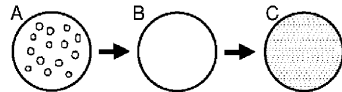
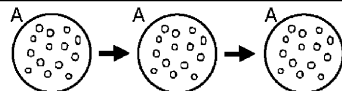
Refrigerant	Condition in sight glass
Correct	
Insufficient	

- A: Bubbles mixed with liquid refrigerant
- B: All refrigerant is clear liquid
- C: Oil and refrigerant are separated; liquid is thin milky white

**CHECK DUMP BODY**

Check that there are no cracks in the dump body.

1. Clean the dump body to make it easier to check.
2. Check all parts of the dump body for damage.

If any cracks or abnormal wear are found, carry out repairs.

Contact your Komatsu distributor for details of the repair procedure.

**CHECK LENGTH OF SUSPENSION CYLINDER, CHECK OIL LEVEL**

When traveling, if the unevenness of the road surface is transmitted directly to the chassis (the machine bounces or the cylinders retract and hit the stopper), carry out the following checks.

**CHECK LENGTH OF CYLINDER**

**Front**

Check that the bottom of the suspension cylinder cover is within range (A) shown by the arrow on the label when the machine is unloaded and on flat ground.

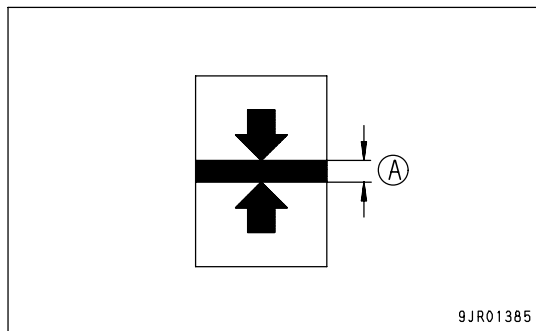

At the same time, when the machine is not loaded, remove cover (1), then measure dimension (B) from the shoulder of the rod head of the suspension cylinder to the top surface of the flange.

(B)	223 - 243 mm (8.8 - 9.6 in)
Reference (C)	441 - 461 mm (17.4 - 18.2 in)
Flange thickness (D)	50 mm (2.0 in)

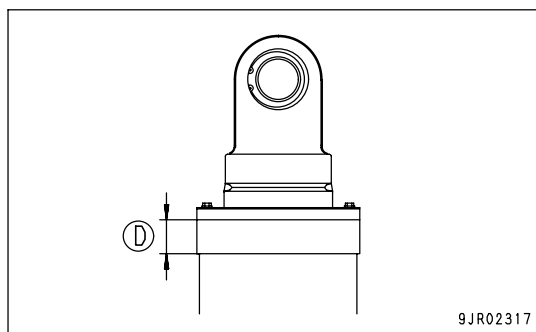
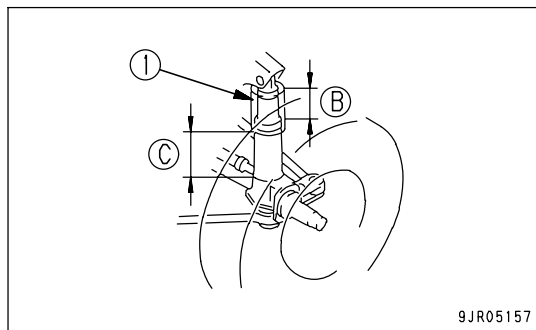

After checking, contact your Komatsu distributor for repairs if any problem is found.

Rear

Measure dimension (E) from the shoulder of the rod head of the suspension cylinder to the top surface of the flange.

(E)	166 - 186 mm (6.5 - 7.3 in)
Flange thickness (F)	65 mm (2.6 in)

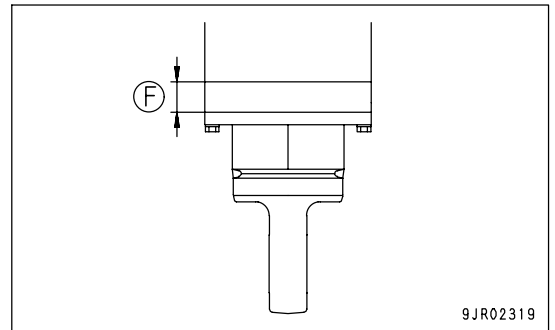
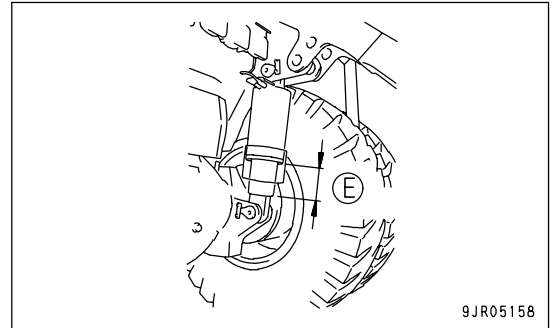

After checking, contact your Komatsu distributor for repairs if any problem is found.

**BLEED AIR FROM REAR BRAKE****WARNING**

Stop the machine on level ground and put blocks under the wheels before bleeding the air.

To make it easier to bleed the air, warm the oil up to a temperature of at least 40°C (104°F) before bleeding the air. Bleed the air from the rear brakes in the same way on both the left and right sides.

1. Start the engine, check that the oil in the transmission case is the specified level, and check if the brake oil pressure caution lamp is out.
2. Remove the cap installed to bleeder screw (1) in the block, then insert a vinyl hose.  
Prepare a container with oil in it and put the other end of the hose approx. 50 mm (2.0 in) into the oil.  
(Use a commercially available vinyl hose.)
3. Depress the brake pedal and loosen bleeder screw (1) approx. 3/4 turns. Keep the pedal depressed until no more bubbles come out from the vinyl hose.
4. Pull the retarder control lever and loosen bleeder screw (1) approx. 3/4 turns. Keep the retarder control lever depressed until no more bubbles come out from the vinyl hose.
5. After bleeding the air, tighten bleeder screw (1) securely and fit the cap.
6. Repeat the above procedure in Step 4 to bleed the air from bleeder screw (2) of the slack adjuster.
7. Repeat the above procedure in Step 4 to bleed the air from bleeder screw (3) of the rear brake.
8. Add oil. For details, see "CHECK OIL LEVEL IN TRANSMISSION CASE, ADD OIL (PAGE 3-74)".

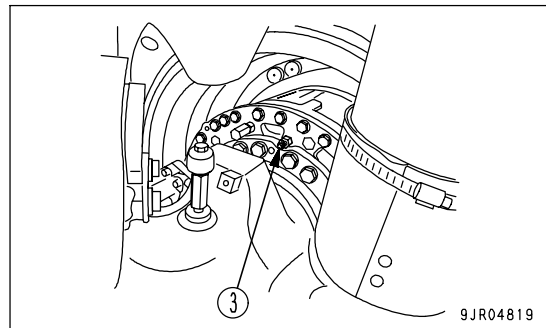
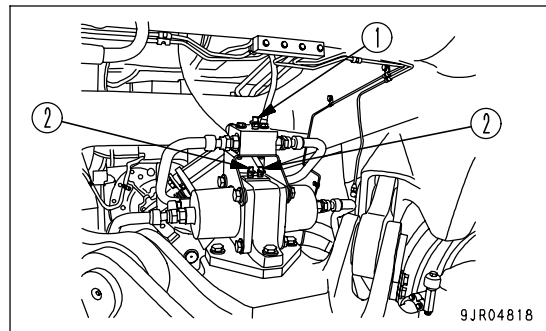

**BLEED AIR FROM FRONT BRAKE****WARNING**

Stop the machine on level ground and put blocks under the wheels before bleeding the air.

To make it easier to bleed the air, warm the oil up to a temperature of at least 40°C (104°F) before bleeding the air. Repeat the same procedure on the left and right sides.

When bleeding the air from the front brakes and rear brakes at the same time, bleed the air from the rear brakes first.

1. Start the engine, check that the oil in the transmission case is at the specified level, that the brake oil pressure caution lamp is out, and that the front brake cut-off switch is at the OFF position.
2. Remove the cap of bleeder screw (1), then insert a vinyl hose (inside diameter: 8 mm (0.315 in)). Prepare a container with oil in it and insert the other end of the hose approx. 50 mm (2.0 in) into the oil. (Use any commercially available vinyl hose.)
3. Depress the brake pedal and loosen bleeder screw (1) approx. 3/4 turns. Keep the pedal depressed until no more bubbles come out from the vinyl hose.
4. After bleeding the air, tighten bleeder screw (1) securely and fit the cap.

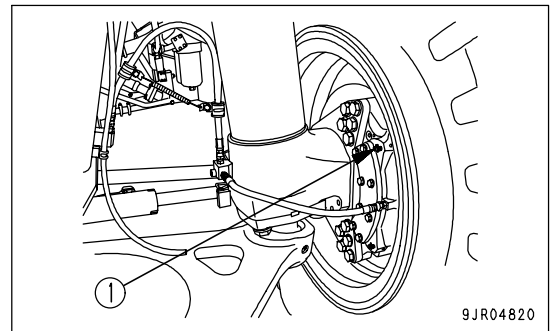

5. Add oil. For details, see "CHECK OIL LEVEL IN TRANSMISSION CASE, ADD OIL (PAGE 3-74)".

## ADJUST PARKING BRAKE

**WARNING**

- When carrying out the adjustment, raise the air pressure high enough to prevent the parking brake from being applied automatically, and hang a warning sign on the parking brake valve lever to prevent any other person from operating it.
- Never put any oil or grease on the surface of the pad or disc.

If the parking brake effect is poor, adjust as follows.

1. Check that the brake oil pressure caution lamp is turned OFF (the brake accumulator pressure is sufficiently high), and then release the parking brake.
2. Turn bolt (1) counterclockwise and bring in the pad into tight contact with the disc.
3. Turn bolt (1) back 2/3 turns in the clockwise direction.

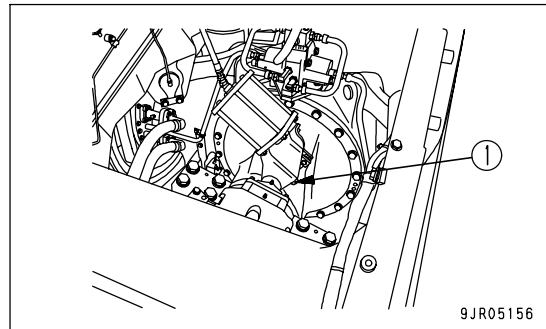

Measure the thickness of the pad, and if it is less than 1.5 mm (0.06 in), contact your Komatsu distributor to have it replaced.

When making the first adjustment after replacing the pad, turn bolt (1) turn in the clockwise direction.

After adjusting, check the braking capacity of the parking brake. See "CHECK BRAKING CAPACITY OF PARKING BRAKE (PAGE 4-52)". If the machine moves, contact your Komatsu distributor for inspection.

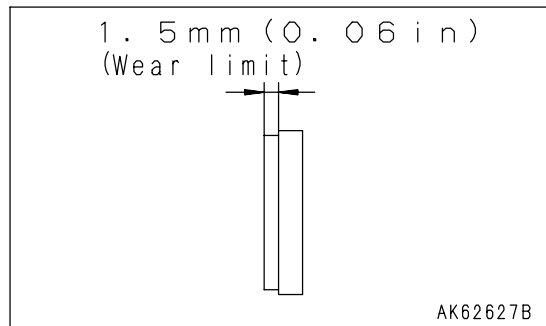

**CLEAN, CHECK RADIATOR FINS AND AFTER COOLER FINS**

**! WARNING**

If compressed air scattered around dust and debris, there is danger of injury. Always wear protective equipment such as protective glasses and mask.

If radiator fins (1) or aftercooler fins (2) become clogged or bent, it will cause overheating of the engine, so always clean or carry out inspection, and ask your Komatsu distributor to take the necessary action.

- Cleaning can be carried out by using jets of air, steam, or water, but be careful not to let the nozzle contact the fin.
- When using compressed air or steam, keep the nozzle at a right angle to the radiator and after cooler.
- Examine the rubber hose, and if any cracks or brittle places are found, replace the hose. In addition, check also for loose hose clamps.

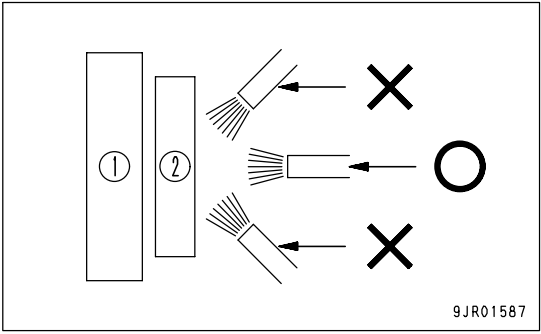

**NOTICE**

If steam jet nozzle (3) is brought too close to fins (4), the fins can be damaged, so keep a good distance in between when cleaning.

Use the following values as a benchmark.

- Jet pressure: Lower than 9.8 MPa (100 kg/cm<sup>2</sup>)
- Nozzle diameter: Less than 2 mm (0.08 in)
- Distance between nozzle and fin (A): More than 100 mm (4 in)

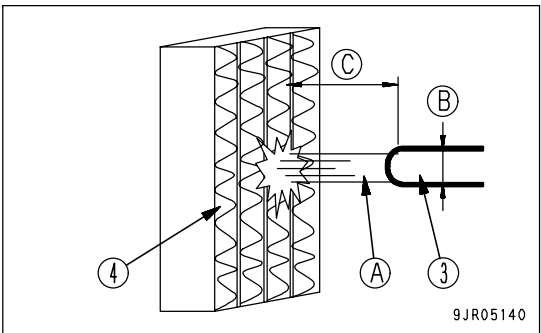



## CHECK PLAY OF OUTPUT COUPLING OF OUTPUT SHAFT

**WARNING**

To prevent the machine from moving, set the parking brake switch to PARKING, stop the engine, then put blocks under the wheels.

If any abnormal noise occurs around the output shaft (1) or front drive shaft (2), the rubber inside the output shaft may be deteriorated or damaged, so check the play of the coupling (3) as follows.

1. Set wire (4) as shown in the diagram.  
Using the tip of the wire as a benchmark, measure the amount of movement (L) of the coupling.
2. Using bar (5), rotate the coupling at a force of approx. 49 N {5 kg} in the direction around the circumference.  
When doing this, mark the position of the wire.
3. Check that the engine fan is not rotating.

**REMARK**

If excessive force is used in rotating the coupling, the engine rotates freely and it becomes impossible to judge accurately.

4. Rotate the coupling in the reverse direction from Step 2.  
When doing this, mark the position of the wire in the same way as in Step 2.

5. Measure the amount of movement (L) of the coupling using the marks made in Steps 2 and 4.

If amount of movement (L) is more than 15 mm (0.6 in), the rubber inside the output shaft may be deteriorated or damaged, so contact your Komatsu distributor and ask for disassembly and inspection of the internal parts of the output shaft.

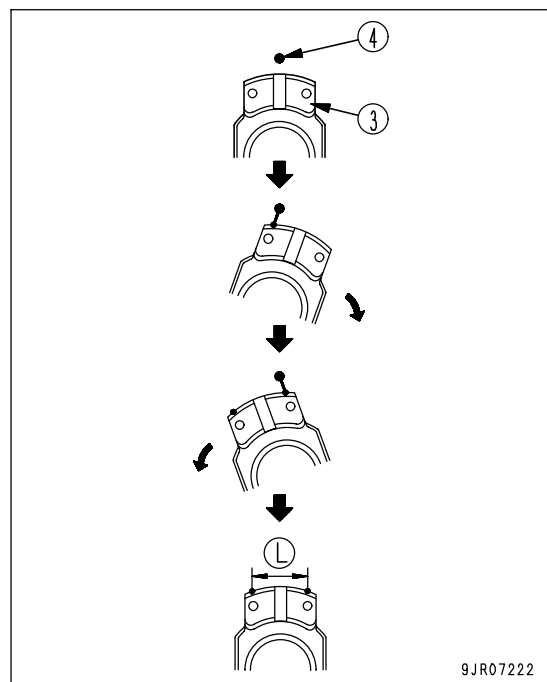
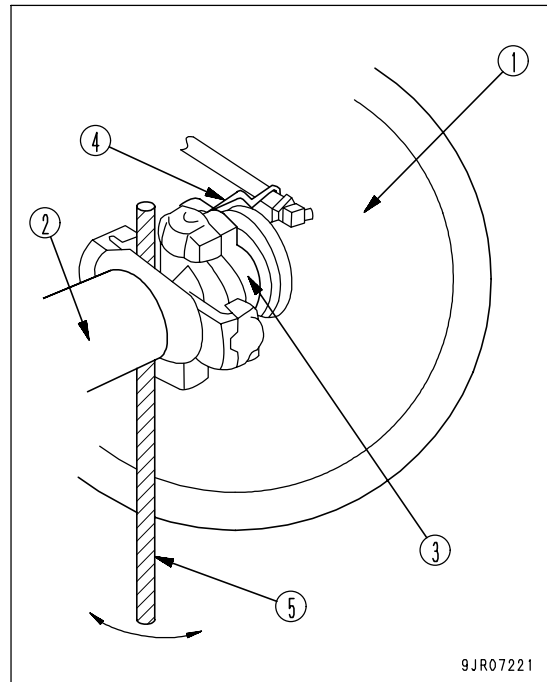

**SELECTION AND INSPECTION OF TIRES**

**! WARNING**

If a tire or a rim is handled improperly, the tire may burst or may be damaged and the rim may be broken and scattered, and that can cause serious injury or death.

- Since maintenance, disassembly, repair and assembly of the tires and rims require special equipment and skill, be sure to ask a tire repair shop to do the work.
- Do not heat or weld the rim to which the tire is installed. Do not make a fire near the tire.

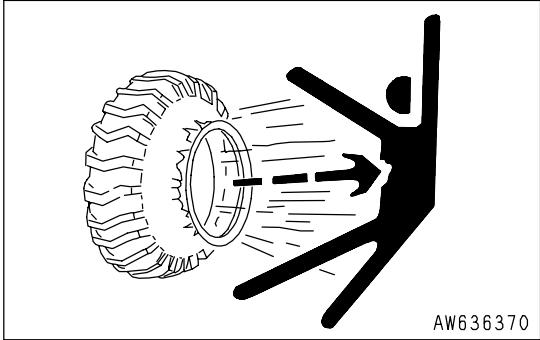

**SELECTION OF TIRES**

**! WARNING**

Select the tires according to the conditions of use and the weight of the attachments on the machine. Use only specified tires and inflate them to the specified pressure.

Select the tires according to the conditions of use and the weight of the attachments of the machine. Use the following table.

Since the travel speed indicated on the speedometer varies with the tire size, consult your Komatsu distributor when using optional tires.

	Max. load [kg (lb)]	Size	Operating model	Remarks
Front wheel	10900	18.00R33 ★ ★	HD325: if equipped HD405: standard	Type 1 for construction equipment
	10300	18.00-33-32PR	HD325: standard HD405: not equipped	
Rear wheel	10900	18.00R33 ★ ★	HD325: if equipped HD405: standard	
	10300	18.00-33-32PR	HD325: standard HD405: not equipped	

CHECK OF INFLATION PRESSURE OF TIRES AND INFLATION OF THEM

**! WARNING**

- When inflating a tire, check that any person will not enter the working area and use an air chuck which has a clip and which can be fixed to the air valve.
- While inflating the tire, check the inflation pressure occasionally so that it will not rise too high.
- If the rim is not fitted normally, it may be broken and scattered while the tire is inflated. Accordingly, place a guard around the tire and do not work in front of the rim but work on the tread side of the tire.
- Abnormal drop of inflation pressure and abnormal fitting of the rim indicate a trouble in the tire or rim. In this case, be sure to ask a tire repair shop for repair.
- Be sure to observe the specified inflation pressure.
- Do not adjust the inflation pressure of the tires just after high-speed travel or heavy-load work.

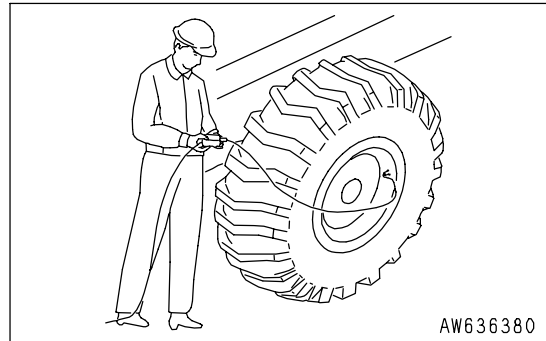

**Check**

Measure the inflation pressure with a tire pressure gauge, while the tires are cool, before starting work.

**Inflation of tires**

Adjust the inflation pressure properly.

When inflating a tire, use an air chuck which can be fixed to the air valve of the tire as shown in the figure. Do not work in front of the rim but work on the tread side of the tire.

The proper inflation pressure is shown below.

- HD325

Tire size	Inflation pressure
18.00-33-32PR (standard)	0.56MPa {5.75kg/cm <sup>2</sup> , 81.7 PSI}
18.00R33 ★ ★ (if equipped)	0.69MPa {7.00kg/cm <sup>2</sup> , 99.4 PSI}

- HD405

Tire size	Inflation pressure
18.00R33 ★ ★	0.69MPa {7.00kg/cm <sup>2</sup> , 99.4 PSI}

**NOTICE**

If the tires are used when the inflation pressure is less than the value given in the table above, the rim may be damaged. Always keep the tire inflation pressure within +0 to +0.03 MPa {0.3 kg/cm<sup>2</sup>, 4.3 PSI} of the value in the table above.

**PRECAUTIONS WHEN REPLACING TIRE**

If the hub nuts (1) have been tightened again after replacing the tire, travel for 5 to 6 km, then tighten again to settle all the contacting parts.

In particular, there are more contacting parts on the rear wheels than on the front wheels, so it will take time for the parts to settle. For this reason, repeat the tightening process for the first 50 hours after installation.

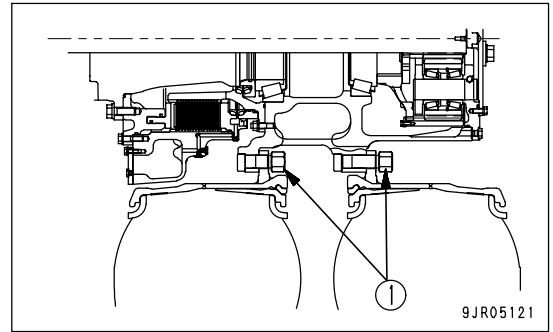

**CHECK BEFORE STARTING**

For details of the following items, see "CHECK BEFORE STARTING (PAGE 3-71)".

- Check coolant level, add coolant
- Check dust indicator
- Check oil level in engine oil pan, add oil
- Check oil level in transmission case, add oil
- Check oil level in steering and hoist oil tank, add oil
- Check oil level in brake sub-tank, add oil
- Check for leakage of oil from rear brake oil recovery tank breather
- Drain water, sediment from fuel tank
- Check fuel level, add fuel
- Check wheel hub nuts, tighten
- Check central warning lamp, alarm buzzer, monitor lamps and meters
- Check braking effect
- Check braking capacity of secondary brake
- Check manual emergency steering
- Check auto-emergency steering
- Check backup alarm
- Check electric wiring
- Check inflation pressure of tires
- Check water separator
- Does body positioner operate normally?

**EVERY 250 HOURS SERVICE**

**CHECK OIL LEVEL IN DIFFERENTIAL CASE, ADD OIL**

**! WARNING**

- The parts and oil are at high temperature after the engine is stopped, and may cause serious burns. Wait for the temperature to go down before starting the operation.
- If there is still pressure remaining inside the case, the oil or plug may fly out. Turn the plug slowly to release the pressure, then remove it carefully.

1. Remove plug (G) and check that the oil level is near the bottom of the plug hole.
2. If the oil level is too low, add oil through the plug hole until the oil overflows.

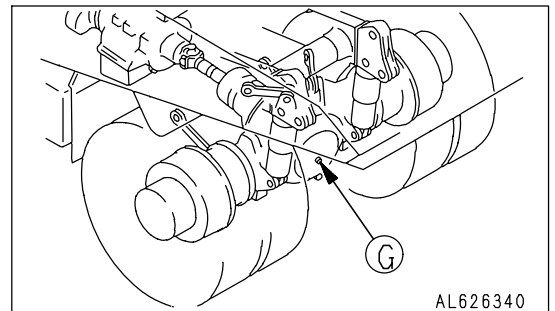

AL626340

**CHECK OIL LEVEL IN FINAL DRIVE CASE, ADD OIL**

**! WARNING**

- The parts and oil are at high temperature after the engine is stopped, and may cause serious burns. Wait for the temperature to go down before starting the operation.
- If there is still pressure remaining inside the case, the oil or plug may fly out. Turn the plug slowly to release the pressure, then remove it carefully.

1. Stop the machine so that casting line (1) is horizontal and drain plug (P) is immediately at the bottom.
2. Remove plug (G) and check that the oil level is near the bottom of the plug hole.
3. If the oil level is too low, add oil through the plug hole until the oil overflows.

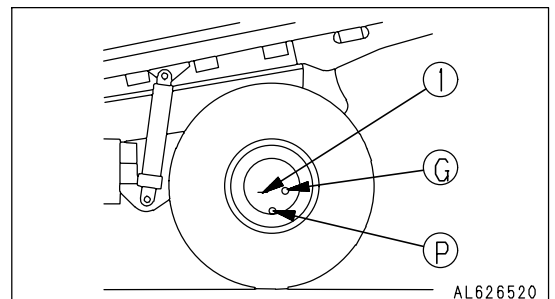

AL626520

**LUBRICATION**

1. Stop the engine.
2. Use the grease pump to pump in grease through the grease fitting marked by the arrow.
3. After greasing, wipe off old grease that was pushed out.

Carry out the greasing operation every day when operating in places where the grease flows out easily, such as when traveling through mud or water.

(1) Dump body hinge pin (left and right: 1 place each)

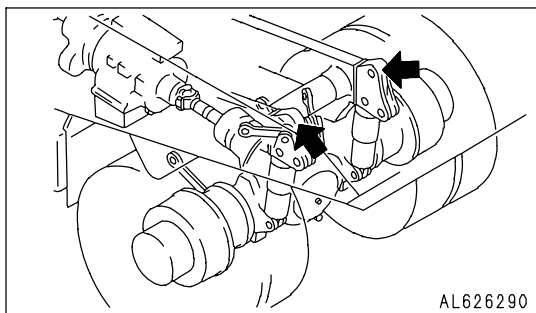

(2) Rear suspension (left and right: 2 places each)

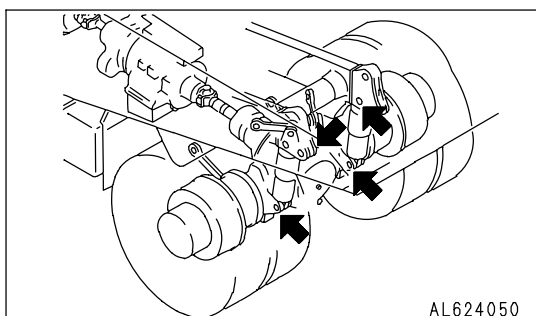

(3) Rear axle support (left and right: 4 places each)  
Portion a is for centralized greasing (4 places)

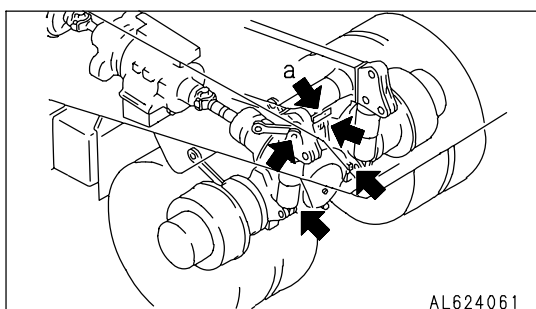

(4) Hoist cylinder pin (left and right: 2 places each)  
Lower the dump body before greasing.

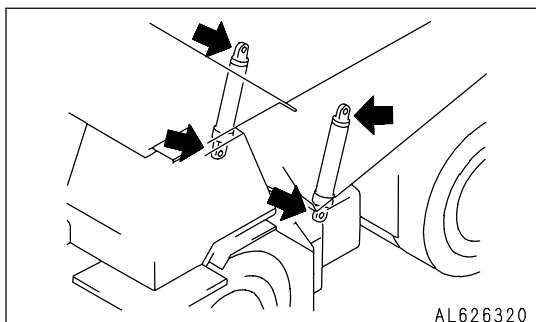

- (5) Front suspension (left and right: 2 places each)  
Set the steering facing directly to the front before greasing.

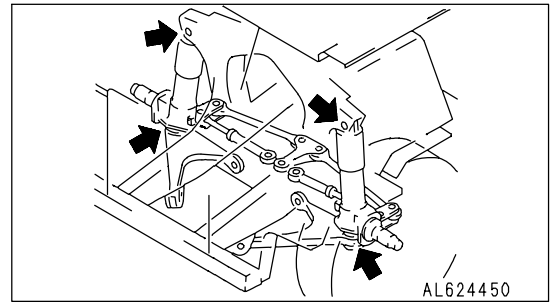

- (6) Steering linkage (13 places)  
Portion "b" is for centralized greasing (5 places)

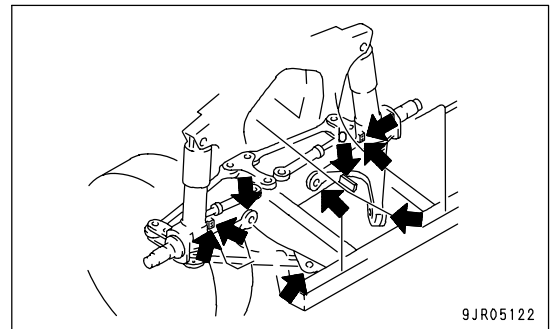

**LUBRICATE DRIVE SHAFT (5 PLACES)**

1. Using a grease pump, pump in grease through the grease fittings marked by the arrows.
2. Add grease to the spider portion until grease comes out from the cap seals (5 places).
3. For the spline portion, continue greasing until grease comes out from the vent.
4. After greasing, wipe off any old grease that was pushed out.

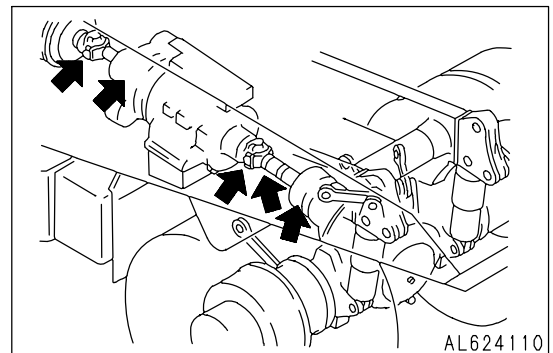

Carry out the greasing operation every day when operating in places where the grease flows out easily after traveling through mud or water.

**CHECK DRIVE SHAFT**

If there is any problem, such as looseness of the drive shaft connection, play in the spline or bearing portion, or runout of the shaft, please contact your Komatsu distributor for repair.

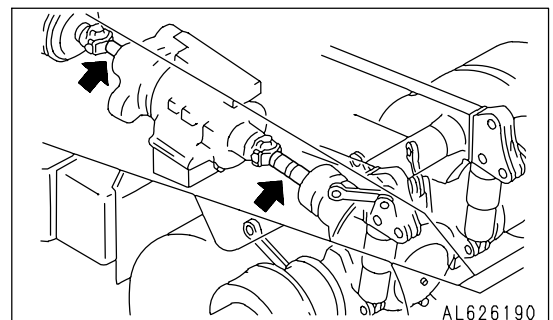



## CHECK LEVEL OF BATTERY ELECTROLYTE

Carry out this procedure before operating the machine.



### WARNING

- Do not use the battery if the battery electrolyte level is below the LOWER LEVEL line. This will accelerate deterioration of the inside of the battery and reduce the service life of the battery. In addition, it may cause an explosion.
- The battery generates flammable gas and there is danger of explosion, do not bring fire or sparks near the battery.
- Battery electrolyte is dangerous. If it gets in your eyes or on your skin, wash it off with a large amount of water and consult a doctor.
- When adding distilled water to the battery, do not allow the battery electrolyte to go above the UPPER LEVEL line. If the electrolyte level is too high, it may leak and cause damage to the paint surface or corrode other parts.

### NOTICE

If there is a fear that the battery water may freeze after refilling with purified water (e.g. commercially available replenishment water for a battery), do the replenishment before the day's work on the next day.

Inspect the battery electrolyte level at least once a month and follow the basic safety procedures given below.

### WHEN CHECKING ELECTROLYTE LEVEL FROM SIDE OF BATTERY

If it is possible to check the electrolyte level from the side of the battery, check as follows.

1. Use a wet cloth to clean the area around the electrolyte level lines and check that the electrolyte level is between the UPPER LEVEL (U.L.) and LOWER LEVEL (L.L.) lines.  
If the battery is wiped with a dry cloth, static electricity may cause a fire or explosion.

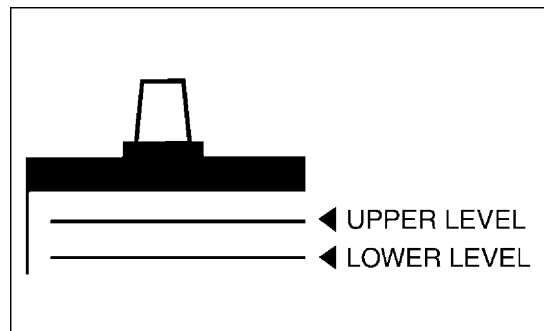

2. If the electrolyte level is below the midway point between the U.L and L.L lines, remove cap (1) and add distilled water to the U.L line.
3. After adding distilled water, tighten cap (1) securely.

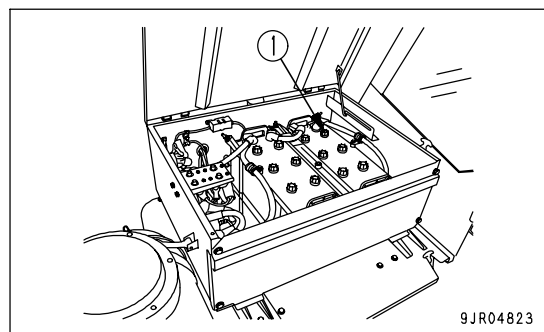

### REMARK

If distilled water is added to above the U.L. line, use a syringe to lower the level to the U.L. line. Neutralize the removed fluid with baking soda (sodium bicarbonate), then flush it away with a large amount of water or consult your Komatsu distributor or battery maker.

**WHEN IT IS IMPOSSIBLE TO CHECK ELECTROLYTE LEVEL FROM SIDE OF BATTERY**

If it is impossible to check the electrolyte level from the side of the battery, or there is no display of the UPPER LEVEL line on the side of the battery, check as follows.

1. Remove cap (1) at the top of the battery, look through the water filler port, and check the electrolyte surface. If the electrolyte does not reach the sleeve, add distilled water so that the level reaches the bottom of the sleeve (UPPER LEVEL line) without fail.

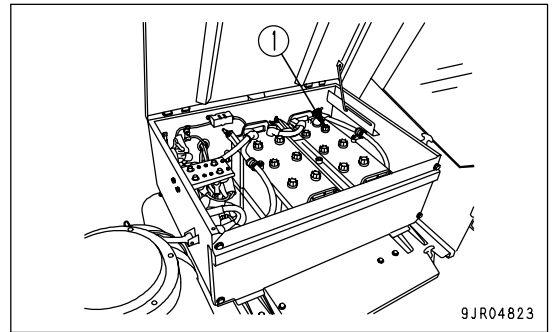

Use the diagram below for reference, and check if the electrolyte reaches the bottom of the sleeve.

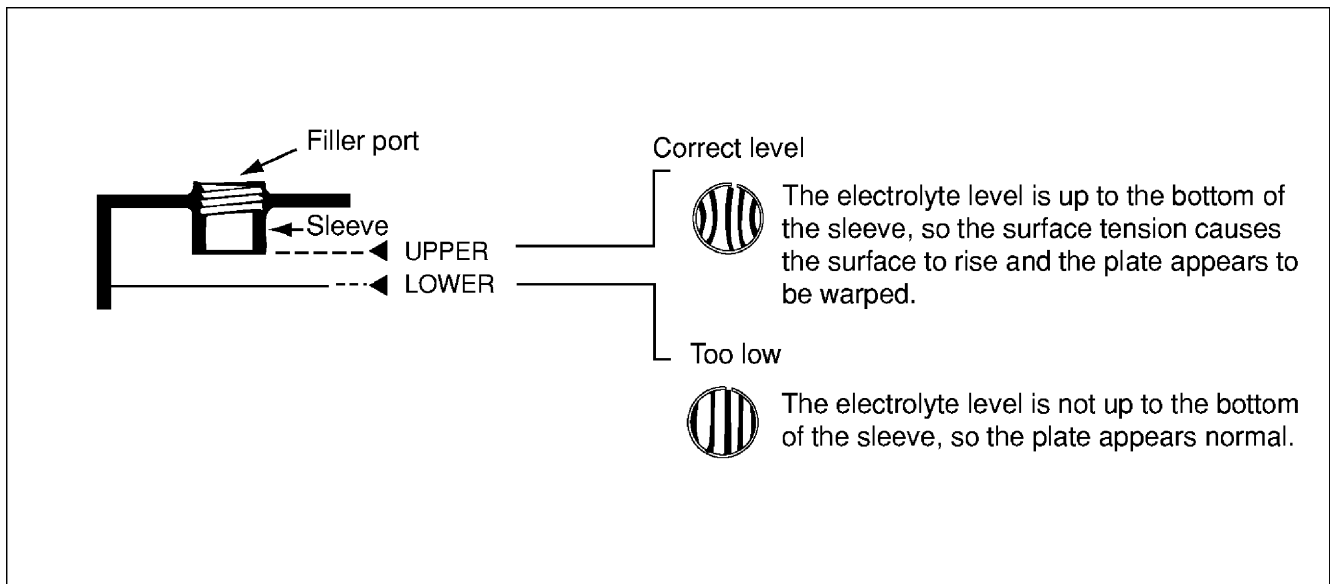

2. After adding distilled water, tighten cap (1) securely.

**REMARK**

If water is added to above the bottom tip of the sleeve, use a pipette to remove electrolyte. Neutralize the removed electrolyte with sodium bicarbonate, then flush it away with a large amount of water. If necessary, contact your Komatsu distributor or your battery maker.

**WHEN IT IS POSSIBLE TO USE INDICATOR TO CHECK ELECTROLYTE LEVEL**

(If equipped)

If it is possible to use an indicator to check the electrolyte level, follow the instructions given.

## CHECK ALTERNATOR BELT TENSION, ADJUST

### CHECKING

Press the belt with your thumb with a force of approx. 98 N {10 kg} at the midpoint between drive pulley (1) and alternator pulley (2).

Standard deflection (A): 13 -16 mm (0.5 - 0.6 in)

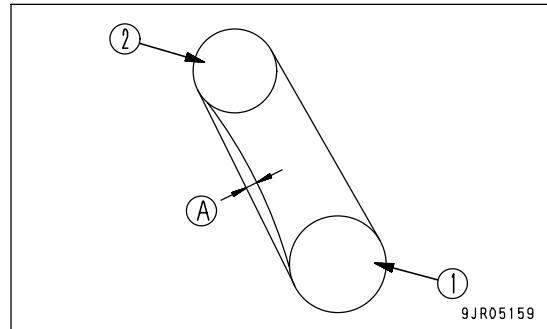

### ADJUSTING

1. Remove cover mounting bolts (6) (2 places), and remove the cover.
2. Loosen bolts and nuts (1), (2) and (5), then turn nut (4) to adjust the tension of the belt.
3. After adjusting, tighten bolts and nuts (1), (2) and (5) to secure alternator (3).
4. Reinstall the cover removed in step 1. Confirm that no part of the cover touches any moving part of the alternator.

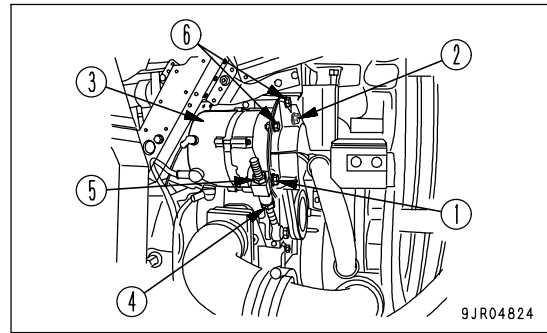

### REMARK

- Check each pulley for breakage and wear of the V-groove. In particular, check that the V-belt does not touch the bottom of the V-groove.
- If any abnormality is found, ask your Komatsu distributor for replacement of the pulley.
- If the V-belt is so lengthened that it cannot be adjusted any more or if it has any cuts or cracks, replace it.
- When adjusting the V-belt, do not press the alternator directly with a bar, but put a wood piece, etc. in-between them.
- If the V-belt has been replaced with a new part, there will be initial elongation, so inspect and adjust it again after one-hour of operation.

## CHECK AIR CONDITIONER COMPRESSOR BELT TENSION, ADJUST

### CHECKING

Press the middle of the belt between the air conditioner compressor pulley (1) and drive pulley (2) with the thumb (about 58.8 N {6 kg}).

If deflection (A) is 10 mm (0.4 in), the belt tension is normal.

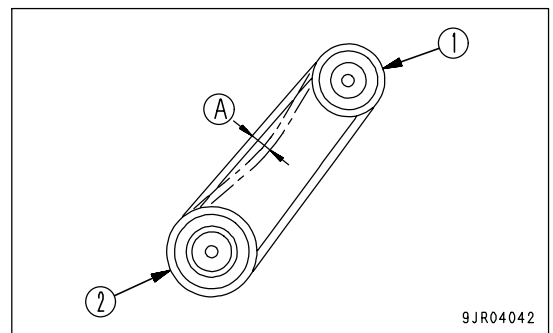
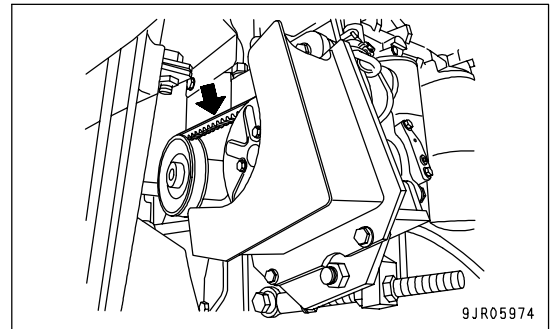

### ADJUSTING

1. Loosen bolt (1).

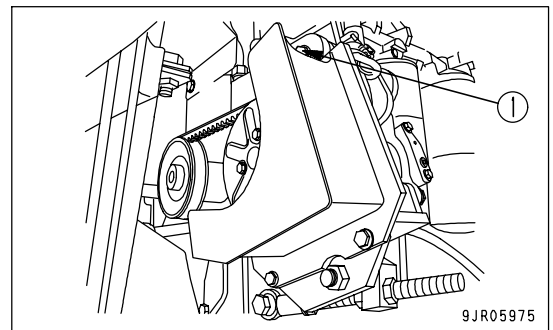

2. Turn nut (2) to adjust so that the belt deflects by approx. 10 mm (0.4 in) when pressed with a finger force of approx. 58.8 N (6 kg) at a point midway between the air conditioner compressor pulley and drive pulley.
3. Tighten bolt (1) and nut (2) to secure the compressor in position.
4. Check each pulley for damage, wear of the V-groove, and wear of the V-belt. In particular, be sure to check that the V-belt is not touching the bottom of the V-groove.

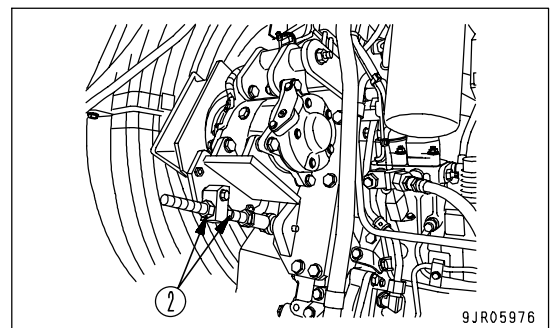

5. If the V-belt is so lengthened that it cannot be adjusted any more or if it has any cuts or cracks, replace it.
6. If the V-belt has been replaced with a new part, there will be initial elongation, so adjust the belt again after operating for 2 to 3 days.

**CLEAN BREATHERS**

Remove the mud and dirt from around the breather, then remove the breather and wash out the dirt from inside with clean diesel oil or flushing oil.

- Transmission, brake sub tank (2 places)

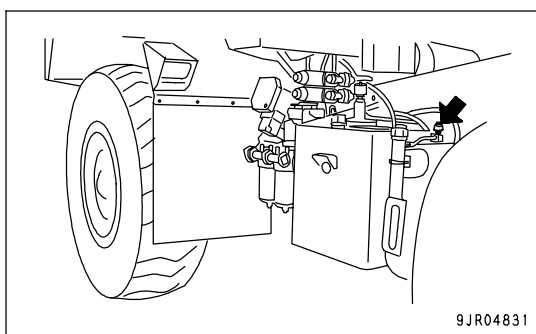
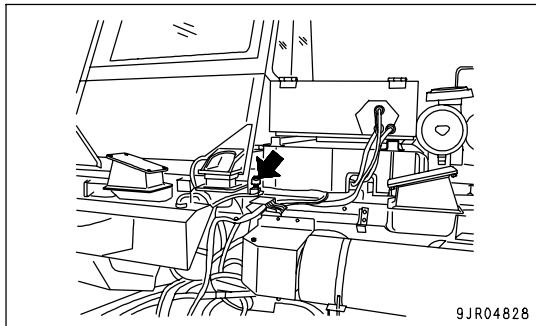

- Steering, hoist oil tank

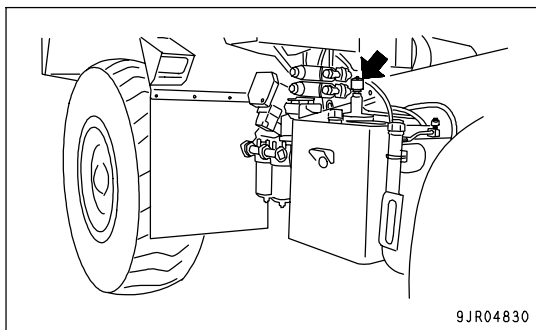

1. Remove nut (1), then remove cover (2) and wash element (3).
2. Install element (3), then install cover (2) and nut (1).

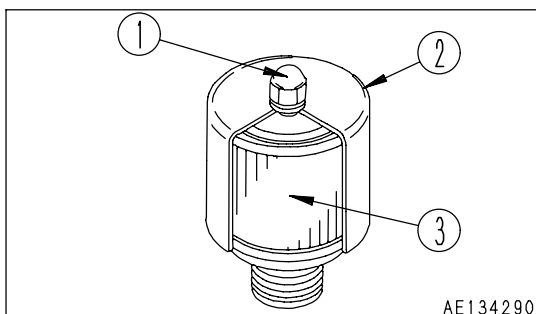

CHECK FRAME

 **WARNING**

When carrying out inspection of the machine with the dump body raised, always set the dump lever to the HOLD position, lock with the dump lever lock knob, then use the body pivot pin.

1. Wash the frame to make it easier to check.
2. Check all parts of the frame for damage.  
 In particular, check the colored portions in the diagram and if any cracks or damage are found, repair the damage. Please contact your Komatsu distributor for details of the repair procedure.

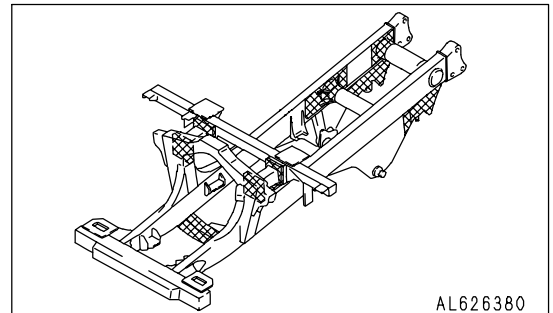

CHECK BRAKING CAPACITY OF FOOT BRAKE

 **WARNING**

- If the machine moves, it will lead to serious injury. If machine begins to move during the inspection of braking capacity, lower the engine speed immediately, set shift lever at N position, and then set parking brake switch at PARKING position.
  - If inspection is carried out when the body pilot lamp is lighted up and the shift indicator shows "F1", there is danger that the internal parts of the transmission may be damaged.
- Before carrying out inspection, lower the dump body securely and check that the body pilot lamp has gone out, then place the gear shift lever at the "D" position and check that the shift indicator shows "F2".

Check the braking capacity of the foot brake as follows.

1. Stop the machine on flat ground and depress service brake (1).
2. Set shift lever (2) to the D position, gradually raise the engine speed, and check that the machine does not move even when the engine speed reaches 1550 rpm.
3. Lower the engine speed, set shift lever at N position, and then set parking brake valve lever at PARKING position. If any abnormality is found, ask your Komatsu distributor for repair.

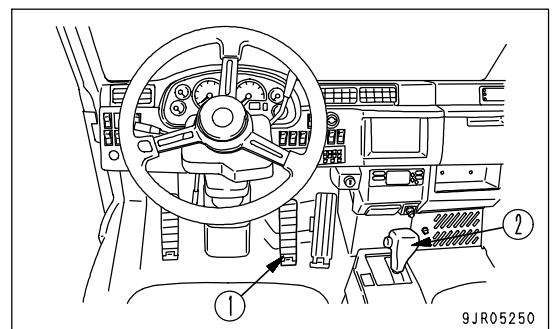

NOTICE

If the dump body is not seated and the parking brake is at "TRAVEL", the speed range is set to F1, even when the gear shift lever is at the "D" position.

## CHECK BRAKING CAPACITY OF RETARDER BRAKE

 **WARNING**

- If the machine moves, it will lead to serious injury or death. If machine begins to move during the inspection of braking capacity, lower the engine speed immediately, set gear shift lever at N position, and then depress the foot brake.
- If inspection is carried out when the body pilot lamp is lighted up and the shift indicator shows "F1", there is danger that the internal parts of the transmission may be damaged.

Before carrying out inspection, lower the dump body securely and check that the body pilot lamp has gone out, then place the gear shift lever at the "D" position and check that the shift indicator shows "F2".

Check the braking capacity of the retarder brake as follows.

1. Stop the machine on flat ground and pull retarder control lever (1) fully.
2. Set shift lever (2) to the D position, gradually raise the engine speed. If the machine does not move even when the engine speed reaches 1200 rpm, it is normal.
3. Lower the engine speed, set gear shift lever at N position. If any problem is found, ask your Komatsu distributor for repair.

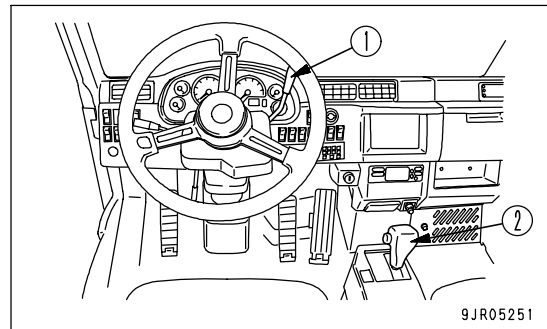
**NOTICE**

If the dump body is not seated and the parking brake is at "TRAVEL", the speed range is set to F1, even when the gear shift lever is at the "D" position.

## CHECK BRAKING CAPACITY OF PARKING BRAKE

 **WARNING**

- If the machine moves, it will lead to serious injury or death. If machine begins to move during the inspection of braking capacity, lower the engine speed immediately, set gear shift lever at N position, and then depress the foot brake.
- If inspection is carried out when the body pilot lamp is lighted up and the shift indicator shows "F1", there is danger that the internal parts of the transmission may be damaged.

Before carrying out inspection, lower the dump body securely and check that the body pilot lamp has gone out, then place the gear shift lever at the "D" position and check that the shift indicator shows "F2".

Check the braking capacity of the parking brake as follows.

1. Stop the machine on flat ground and set parking brake switch (1) to PARKING.
2. Set shift lever (2) to the D position, gradually raise the engine speed. If the machine does not move even when the engine speed reaches 1200 rpm, it is normal.
3. Lower the engine speed, set gear shift lever at N position. If any problem is found, ask your Komatsu distributor for repair.

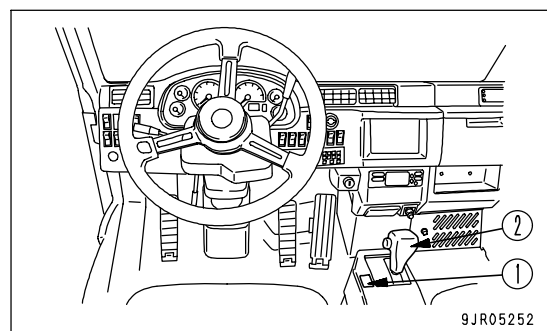

CHECK, CLEAN AUTOMATIC SUSPENSION

**! WARNING**

Follow the precautions below strictly.

- One should sit on the operator's seat, preparing to stop the engine at any moment, and contact with the other.
- Set the parking brake switch at PARKING position to prevent the machine from moving.
- When working near fan or belts, do not bring your body or any materials closer that can be dragged into.
- Do not touch the gearshift lever. When you operate the dump lever, always give a signal to your fellow workers to tell them to move to a safe area.
- If the materials or tools are dropped onto fan or belts, they fly away or cut. Never drop or insert materials or tools.

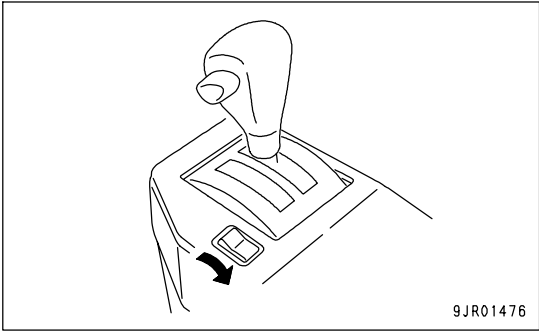
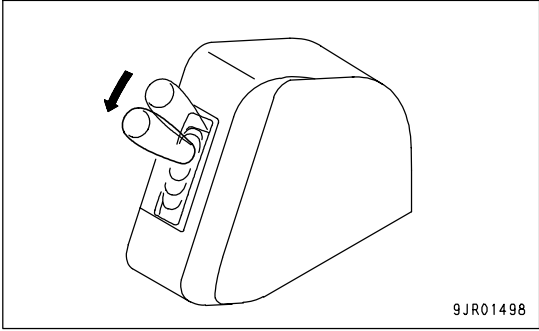

1. When bolts of inspection cover (1) are loosened and the cover is moved to the side, the inspection hole can be seen.

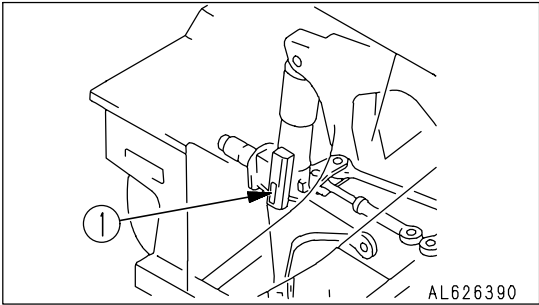

2. Check the positions of the link. Check that it moves to the following positions:
  - For normal travel when empty: soft (a)
  - When the brake is depressed: medium (b)
  - When the dump lever is at any position other than FLOAT: hard (c)

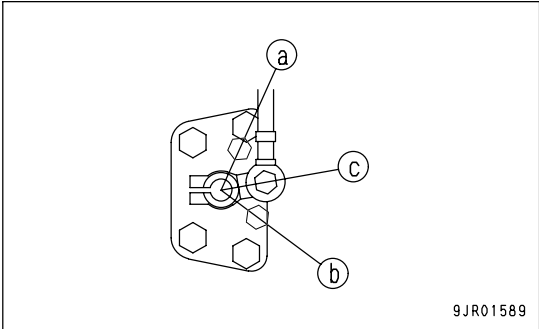

If any problem is found, please contact your Komatsu distributor for inspection and adjustment.

If operations are carried out on muddy or wet ground, mud will stick to the link, and the movement may become slow, so check and clean.



**CHECK OF ACCUMULATOR GAS PRESSURE**

For handling of the accumulator, see "HANDLING SUSPENSION CYLINDER, ACCUMULATOR, GAS SPRING (PAGE 2-36)".

**REMARK**

If the engine stops during travel, the brake can be operated with the oil pressure in the accumulator temporarily.

**CHECK OF FUNCTION**

1. Stop the machine on a flat place and set the parking brake switch to the PARKING position.
2. Start the engine and run it at medium speed for 1 minute, and then stop it.
3. Turn the starting switch to the ON position and depress the brake pedal several times. After the brake pedal is depressed some times, the brake oil pressure caution lamp lights up.
  - If the brake oil pressure caution lamp lights up when the brake pedal is depressed 4 times or less, the gas pressure in the accumulator may be low. Ask your Komatsu distributor for inspection.
  - If the brake oil pressure caution lamp does not light up when the brake pedal is depressed 5 times, the gas pressure in the accumulator is normal.

**REMARK**

Check the function within 5 minutes after stopping the engine. If the engine is kept stopped, the gas pressure in the accumulator lowers and cannot be checked.

### EVERY 500 HOURS SERVICE

Maintenance for every 250 hours service should be carried out at the same time.

### CHANGE OIL IN ENGINE OIL PAN, REPLACE ENGINE OIL FILTER CARTRIDGE



#### WARNING

- The parts and oil are at high temperature after the engine is stopped, and may cause burns. Wait for the temperature to go down before starting the work.

- Refill capacity: 38 liters (10.04 US gal)
- Prepare a filter wrench

1. Remove drain plug (1), then install the standard drain hose.
2. Set a container in position to catch the oil, then loosen drain the valve (2) slowly to avoid getting oil on yourself, and drain the oil. Be careful not to loosen drain valve (2) too much. This will deform the stopper pin inside the valve.
3. Check the drained oil, and if there are excessive metal particles or foreign material, please contact your Komatsu distributor.
4. Remove the drain hose, then tighten drain valve (2) and drain plug (1).

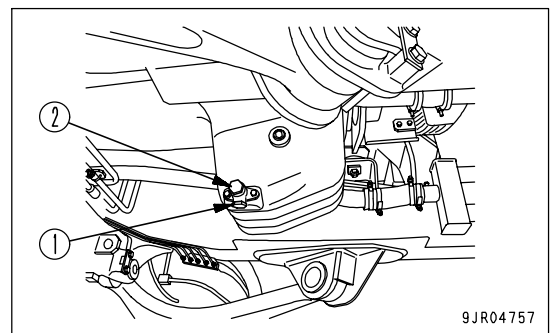

Tightening torque

Drain plug (1), drain valve (2):  $68.6 \pm 9.8\text{Nm}$   
 (7 ± 1 kgm, 50.6 ± 7.2 lbf)

5. Using the filter wrench, turn filter cartridge (3) to the left and remove it. When doing this, do not carry out the operation from immediately below and be careful not to get oil over yourself. In particular, immediately after the engine is stopped, a large amount of oil may come out, so wait for about 10 minutes before starting the operation.
6. Clean the filter holder, fill the new filter cartridge with oil, then coat the seal and thread of the filter cartridge with oil (or coat thinly with grease) and install.
7. When installing the filter cartridge, tighten until the packing face is in contact with the filter holder, then tighten a further 3/4 - 1 turn.
8. Pour in the specified amount of engine oil from oil filler (F).
9. Run the engine for a short time at idle, then check the oil if it is filled up to a specified level. For details, see "CHECK OIL LEVEL IN ENGINE OIL PAN, ADD OIL (PAGE 3-73)".

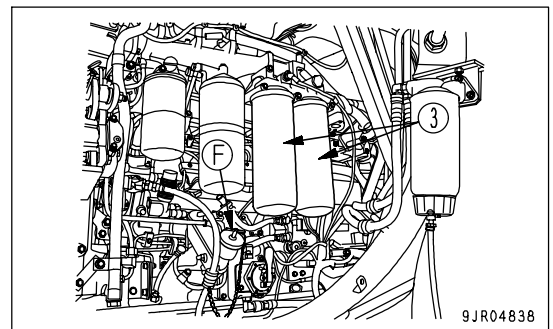

## REPLACE FUEL PREFILTER CARTRIDGE

**WARNING**

- After the engine has been operated, all parts are at high temperature, so do not replace the filter immediately. Wait for all parts to cool down before starting the operation.
- High pressure is generated inside the engine fuel piping system when the engine is running. When replacing the filter, wait for at least 30 seconds after stopping the engine to let the internal pressure go down before replacing the filter.
- Do not bring any fire or flame close.

## NOTICE

- Genuine Komatsu fuel filter cartridges use a special filter that has highly efficient filtering ability. When replacing the filter cartridge, always use a genuine Komatsu part.
  - The common rail fuel injection system used on this machine consists of more precise parts than the conventional injection pump and nozzle. If any part other than a genuine Komatsu filter cartridge is used, dust or dirt may get in and cause problems with the injection system. Always avoid using substitute parts.
  - When carrying out inspection or maintenance of the fuel system, pay more attention than normal to the entry of dirt. If dirt is stuck to any part, use fuel to wash it off completely.
- Container to catch the oil
  - Prepare a filter wrench

1. Close supply valve (1) of the fuel tank.
2. Set an oil receiving container under the fuel prefilter cartridge.

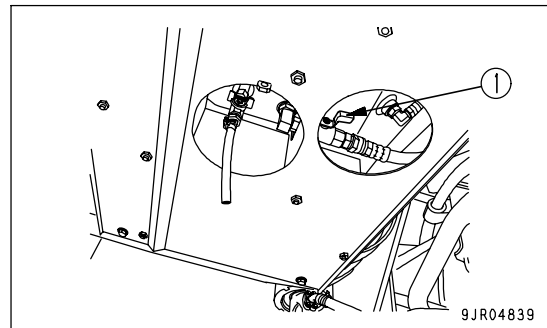

3. Turn cup (3) of water separator installed at the bottom of the filter cartridge (2) to the left and remove it. (This cup is used again.)
4. Using a filter wrench, turn filter cartridge (2) counterclockwise to remove it.
5. Install cup (3) to the bottom of the new fuel pre-filter cartridge. (When doing this, always replace the O-ring.)
  - Tightening torque of cup: 10 Nm {1.0 kgm, 7.2 lbft}
6. Clean the filter holder.

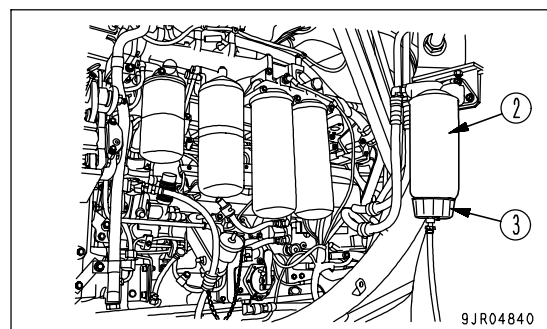

**NOTICE**

When filling the filter cartridge with fuel, carry out the filling operation with cap (A) fitted.

Cap (A) acts to prevent the entry of dirt or dust into the filter cartridge.

7. Fill the filter cartridge with clean fuel through the 8 small holes (B) in the new filter cartridge.
8. Coat the packing surface of the filter cartridge with oil.

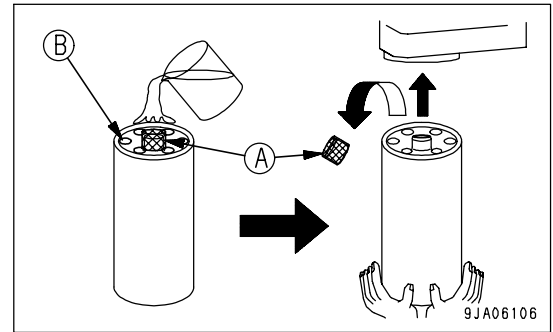

9. Remove filter cartridge cap (A) and install to the filter holder.
10. When installing, tighten until the packing surface contacts the seal surface of the filter holder, then tighten it 3/4 of a turn.  
If the filter cartridge is tightened too far, the packing will be damaged and this will lead to leakage of fuel. If the filter cartridge is too loose, fuel will also leak from the packing, so always tighten the correct amount.
  - When tightening with a filter wrench, be extremely careful not to dent or damage the filter.
11. Check that the drain plug at the bottom of the water separator cup is tightened securely.  
Tightening torque: 0.2 to 0.45 Nm (0.02 to 0.046 kgm, 0.1 to 0.3 lbft)
12. Open supply valve (1).
13. When replacing the fuel main filter cartridge (EVERY 1000 HOURS), replace the cartridge, then bleed the air.  
For details, see "REPLACE FUEL MAIN FILTER CARTRIDGE (PAGE 4-61)". Do not put any fuel in the fuel main filter cartridge.
14. Start the engine, check that there is no leakage of fuel from the filter seal surface or water separator mounting surface, then run for approx. 10 minutes at low idling.

## REPLACE TRANSMISSION OIL FILTER ELEMENT

### PUMP OUTLET PORT



## WARNING

- The parts and oil are at high temperature after the engine is stopped, and may cause burns. Wait for the temperature to go down before starting the work.
- When removing the oil filler cap, turn it slowly to release the internal pressure, then remove it.

1. Set the container to catch the oil under the filter case.
2. Remove drain plug (1) at the bottom of the filter case, drain the oil, then tighten the plug again.
3. Loosen hexagonal portion (3) of case (2), then remove case (2).
4. Remove the element and clean the inside of the case.
5. Replace the filter gasket and O-ring with new parts. Coat the gasket and O-ring thinly with clean engine oil before installing.
6. Assemble the new element, then set the case in position and install it.

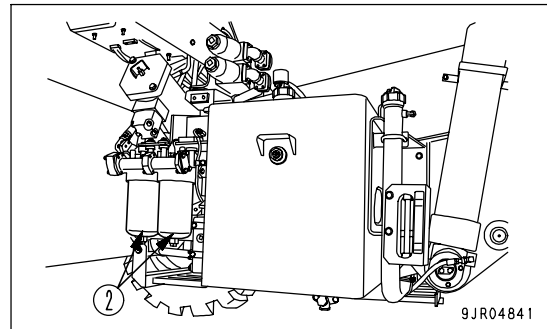

- Tightening torque for drain: 49 to 58.8 Nm  
(5 to 6 kgm, 36.2 to 43.4 lbft)
- Tightening torque for case: 58.8 to 78.5 Nm  
(6 to 8 kgm, 43.4 to 57.9 lbft)

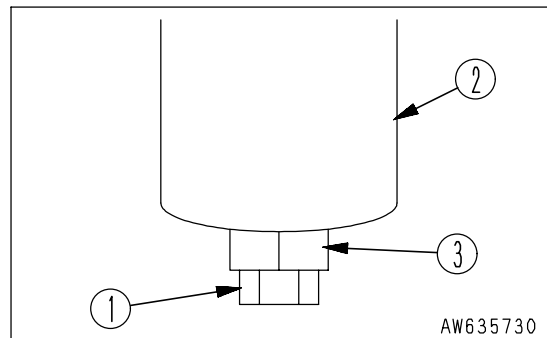

7. Run the engine for a short time at idle, then stop the engine, and check that the oil is up to the specified level. For details, see "CHECK OIL LEVEL IN TRANSMISSION CASE, ADD OIL (PAGE 3-74)".

Run the engine at high idle, and when the oil is warmed up, if the Maintenance caution lamp flashes, replace the element immediately.

CHECK WEAR OF FRONT DISC BRAKE PADS

**! WARNING**

- If the pad is continued to use after the period of wear limit, not only the disc will be damaged but also the brake will lose its effect, and it is dangerous. If the period of wear limit approaches, check frequently the condition to change the pad at proper time.
- Perform inspection every 250 hours if the work site is covered by lots of earth and sand and if it is at the location where the foot brake is frequently used.

1. Insert the inspection gauge into the wear inspection hole (1) and check.

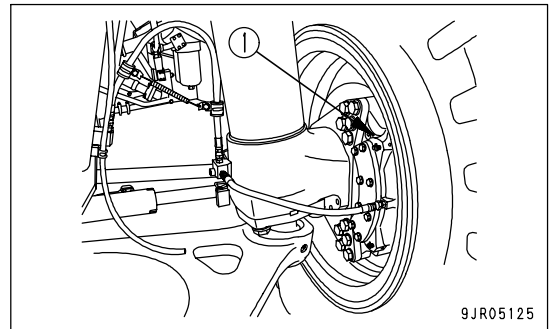

2. The wear limit where stepped portion (3) of gauge (2) contacts caliper (4) is 3 mm (0.1 in) (remaining thickness of pad), so replace pad (5).

- (A): Near wear limit
- (B): Wear limit reached, so replace pad

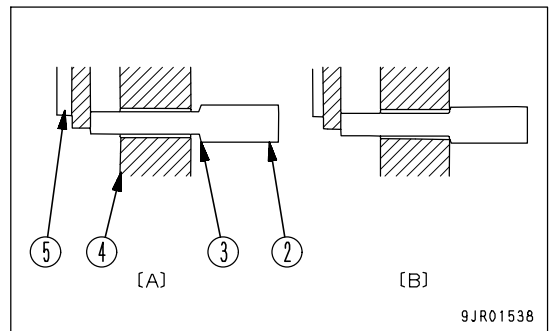

After the inspection, if it is necessary to change the pad, contact your Komatsu distributor.

The pad wear is not necessarily the same for the left and right wheels, so always check the pads on both the left and right. If any of the pads has reached the wear limit, always replace all 4 pads.

If the work is performed on the muddy and watery ground, the mud sticks to caliper or disc. Leaving the mud will increase the wear of pad, so wash out thoroughly with water.

## CHECK FAN BELT TENSION, ADJUST

### TESTING

Press the belt with your thumb with a force of approx. 98 N {10 kg} (for each belt) at the midpoint between fan pulley (1) and crankshaft pulley (2).

Standard deflection (A): 17 - 19 mm (0.67 - 0.74 in)

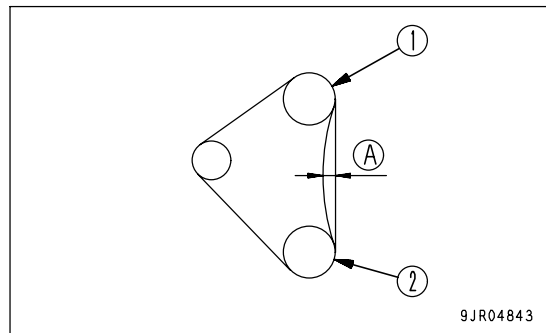
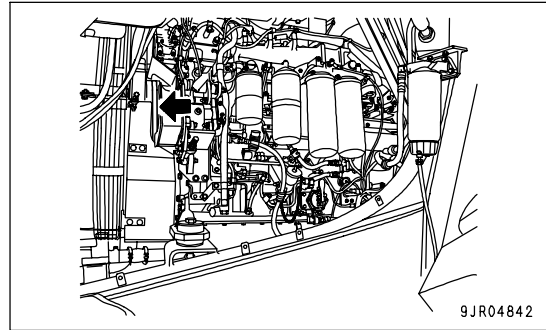

### ADJUSTING

1. Loosen nut (1).
2. Move pulley (3) with adjustment bolt (2) to adjust so that the deflection is approx. 17-19 mm (0.67 - 0.74) when the belt is pressed with your thumb with a force of approx. 98 N {10 kg} (for each belt) at the midpoint between the fan pulley and crankshaft pulley.

When replacing the belt, the standard deflection for the new belt is 13-15 mm (0.5 - 0.6 in).

3. Check for damage to the pulleys, and wear of the groove and belt. Be particularly careful to check that the belt is not in contact with the bottom of the groove.

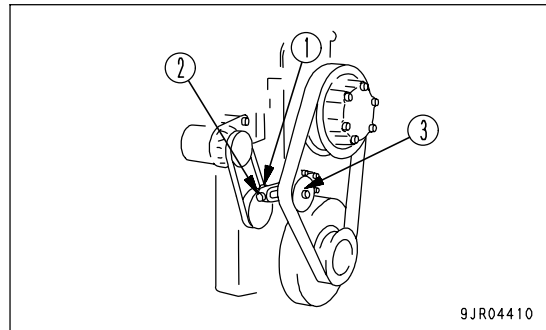

If the belt is stretched and there is no allowance for adjustment, or it is cut or cracked, replace it with a new belt.

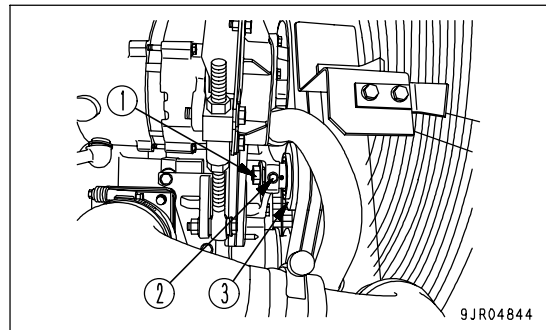

**EVERY 1000 HOURS SERVICE**

Carry out maintenance for EVERY 250 HOURS and EVERY 500 HOURS SERVICE at the same time.

**REPLACE FUEL MAIN FILTER CARTRIDGE**

**⚠ WARNING**

- After the engine has been operated, all parts are at high temperature, so do not replace the filter immediately. Wait for all parts to cool down before starting the operation.
- High pressure is generated inside the engine fuel piping system when the engine is running. When replacing the filter, wait for at least 30 seconds after stopping the engine to let the internal pressure go down before replacing the filter.
- Do not bring any fire or flame close.

**NOTICE**

- Genuine Komatsu fuel filter cartridges use a special filter that has highly efficient filtering ability. When replacing the filter cartridge, always use a genuine Komatsu part.
- The common rail fuel injection system used on this machine consists of more precise parts than the conventional injection pump and nozzle. If any part other than a genuine Komatsu filter cartridge is used, dust or dirt may get in and cause problems with the injection system. Always avoid using substitute parts.
- When carrying out inspection or maintenance of the fuel system, pay more attention than normal to the entry of dirt. If dirt is stuck to any part, use fuel to wash it off completely.

- Prepare a filter wrench

After replacing the fuel pre-filter cartridge, replace the fuel main filter cartridge.

1. Close supply valve (1) of the fuel tank.
2. Set the container to catch the fuel under the filter cartridge.

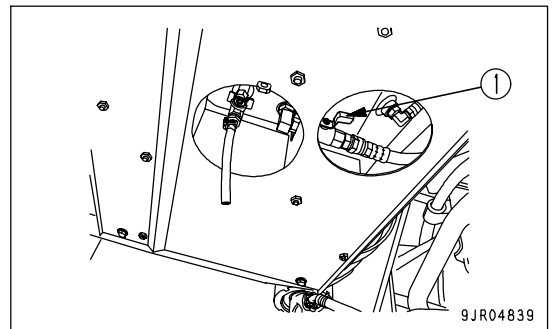

3. Using a filter wrench, turn filter cartridge (2) counterclockwise to remove it.
4. Clean the filter holder, coat the packing surface of the new filter cartridge thinly with oil, then install the filter cartridge to the filter holder.

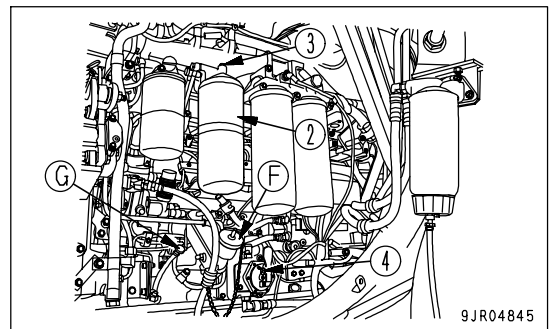

**NOTICE**

Do not add fuel to fuel main filter cartridge (2).



5. When installing, tighten until the packing surface contacts the seal surface of the filter holder, then tighten it 3/4 of a turn.

If the filter cartridge is tightened too far, the packing will be damaged and this will lead to leakage of fuel. If the filter cartridge is too loose, fuel will also leak from the packing, so always tighten the correct amount.

- When tightening with a filter wrench, be extremely careful not to dent or damage the filter.

6. After replacing filter cartridge (2), loosen air bleed plug (3), and open supply valve (1).

Do not loosen the plug at the filter stand of the fuel prefilter. If it is loosened, air is not bled.

7. Fill the fuel tank with fuel.

8. Loosen wing bolt (5) which is fixing lever (6) of priming pump (4). Move lever (6) up and down to let fuel flow out of air bleeding plug (3) until bubbles do not come out any more.

9. Tighten air bleeding plug (3) and then tighten wing bolt (5) of priming pump (4) securely to lock lever (6).

- Tightening torque for air bleeding plug  
7.8 to 9.8Nm{0.8 to 1kgm}
- Tightening torque for wing screw  
6.9 to 12.7Nm{0.7 to 1.3kgm}

10. After replacing the filter cartridge, start the engine, and check for any leakage of fuel from the filter seal surface. If there is any leakage of oil, check the tightening condition of the filter cartridge. If there is still leakage of oil, repeat Steps 1 - 3 to remove the filter cartridge. If there is any damage or foreign material embedded in the packing surface, replace the cartridge with a new part and repeat Steps 4 - 10 to install.

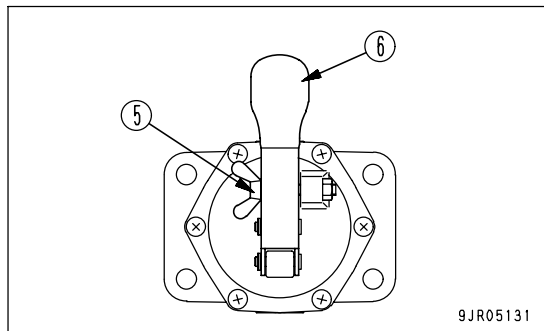
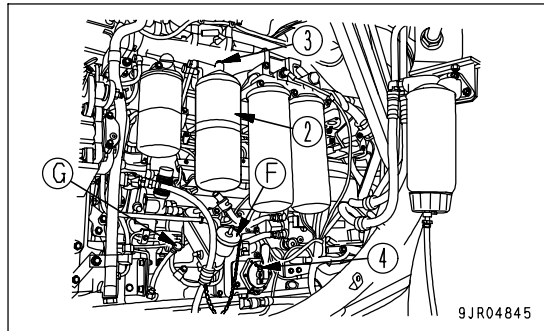

## REPLACE CORROSION RESISTOR CARTRIDGE



### WARNING

All the engine parts are at high temperature after the engine has been operated, so never replace the cartridge immediately after finishing operations.

Wait for the oil to cool down before replacing the cartridge.

- Prepare a filter wrench

1. Set valve (1) at the top of the corrosion resistor to the CLOSED position, to close it.
2. Set the container to catch the water under the cartridge.
3. Using a filter wrench, remove cartridge (2).
4. Clean the filter holder, coat the steel surface of the new filter cartridge with clean engine oil, then install it.
5. When installing, tighten until the gasket contacts the seal surface of the filter holder, then tighten a further 2/3 turns. If the filter cartridge is tightened too far, the gasket will be damaged and this will lead to leakage of water. If the filter is too loose, water will also leak from the gap at the gasket, so always tighten the correct amount.

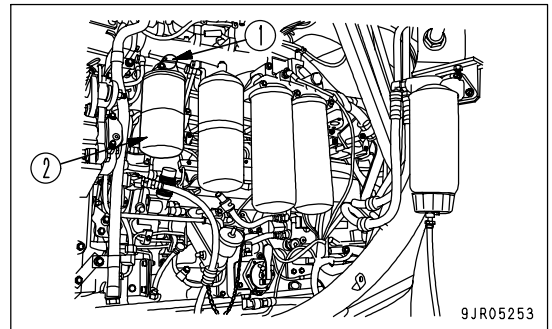

6. Set valve (1) to the OPEN position to open it.
7. After replacing the cartridge, start the engine and check that there is no leakage of water from the filter seal surface. If there is any leakage of water, check the tightening of the filter cartridge.

## CHANGE OIL IN TRANSMISSION CASE, BRAKE SUB TANK, WASH STRAINER

### WARNING

- The parts and oil are at high temperature immediately after the engine is stopped, and may cause burns. Wait for the temperature to go down before starting the work.
- When removing the oil filler cap, turn it slowly to release the internal pressure, then remove it.

- Refill capacity: 90 liters (23.78 US gal)

Change the oil every 1000 hours or every 10,000 km, whichever comes sooner.

Carry out the following items at the same time in order to drain oil completely.

- CHANGE OIL IN TRANSMISSION CASE, BRAKE SUB TANK, WASH STRAINER (PAGE 4-64)
- REPLACE TRANSMISSION AND REAR BRAKE COOLING OIL FILTER ELEMENT (PAGE 4-67)
- REPLACE BRAKE OIL FILTER ELEMENT (PAGE 4-68)

1. Stop the engine.
2. Set a container to catch the oil directly under the drain plug of the transmission case.
3. Remove drain plug (1).
4. Loosen drain valve (2) and drain the oil, then tighten the plug again.
5. Install drain plug (1).
6. Set a container to catch the oil directly under the drain plug of the brake sub tank.
7. Remove drain plug (3).
8. Loosen drain valve (4) and drain the oil. After draining the oil, tighten drain valve (4).
9. Install drain plug (3).
10. Remove bolts (5), then remove the cover and take out strainer (6).
11. Remove any dirt stuck to the strainer, then wash in clean diesel fuel or flushing oil. If the strainer is damaged, replace it.
12. Install strainer (6).
13. Install the cover with bolts (5).

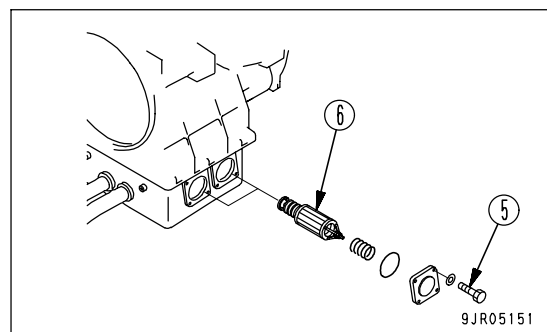
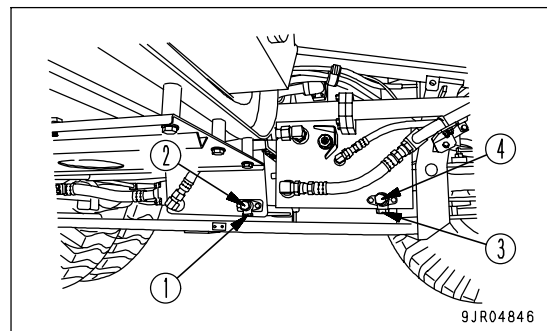

14. Remove plug (7). If this plug is removed, it is easier to drain the oil from the brake chamber.

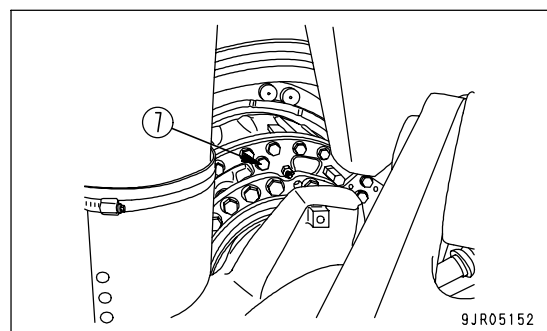

- Remove retarder drain plug (8) and drain the oil from the brake chamber.

**NOTICE**

Drain the oil from the brake chamber on both the left and right sides.

- After completely draining the oil from the brake chamber, install plug (7) and retarder drain plug (8).

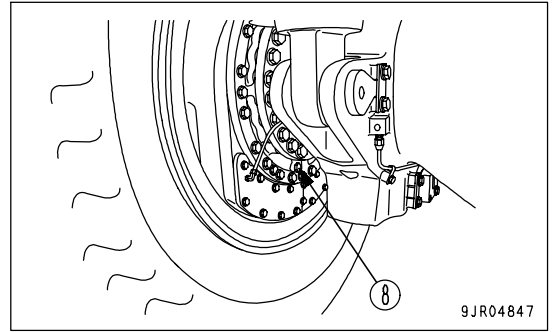

**NOTICE**

Do not start up the engine without the transmission being filled with oil. If the engine is started up while the transmission is empty or short of oil, the transmission hydraulic pump will suffer damage.

- Before starting the engine, add 80 liters (21.14 US gal) of oil through oil filler port (F).

When oil is added, the level will temporarily go above the oil level on sight gauge (G), but this does not indicate any abnormality.

- Start the engine and run at low idling.
- Add oil through oil filler port (F) until the oil level is between the H and L marks on sight gauge (G).

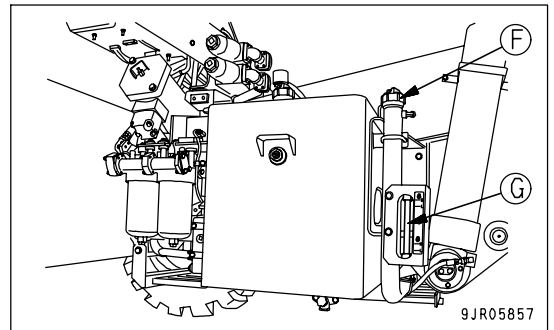

Make sure that the oil level in the brake oil tank does not go down below the mark in the sight gauge (H) while the engine is running at low idling. If the oil level goes down below (H) mark, stop the engine and raise the oil level in the brake oil tank.

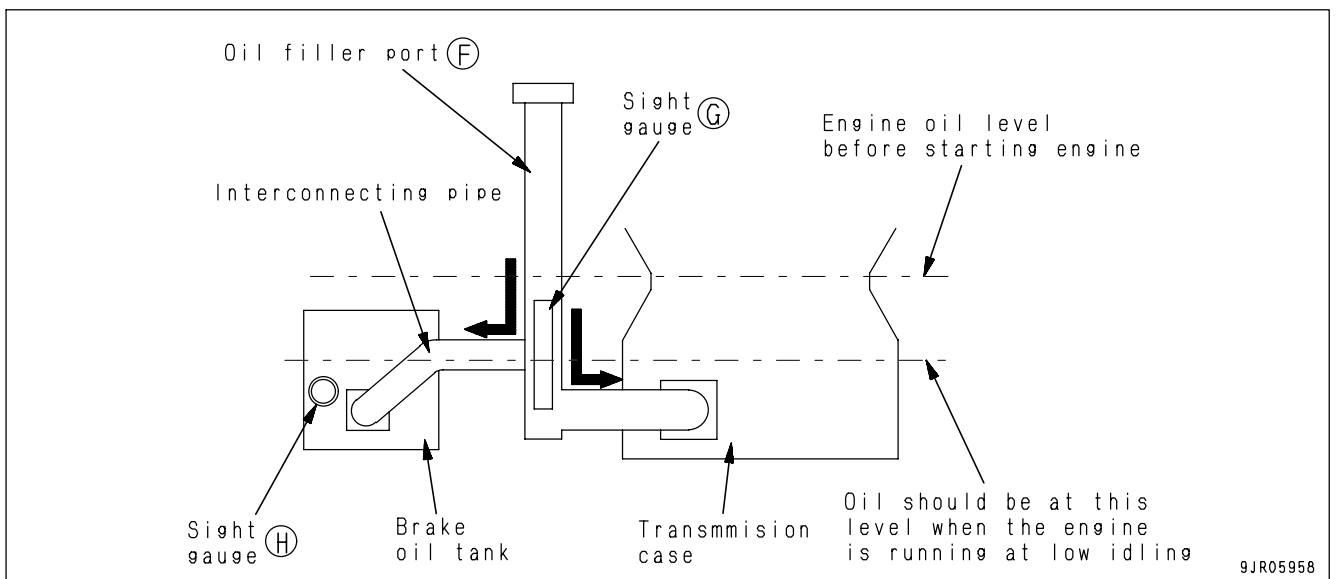
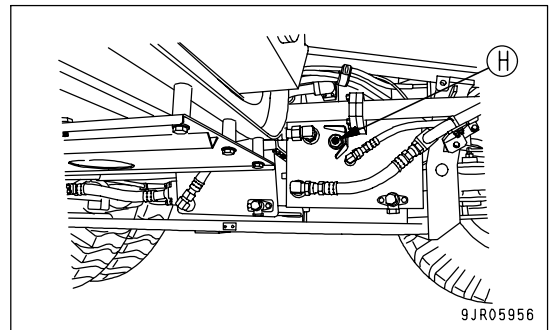

20. Remove the cap from bleeder screw (9) and insert a vinyl hose. (Use a commercially available vinyl hose.)
21. Put the other end of the vinyl hose approx. 50 mm into a container of oil.
22. Loosen bleeder screw (9) approx. 3/4 turns and run the engine at low idling until no more bubbles come out from the vinyl hose.
23. When no more bubbles come out, tighten bleeder screw (9) securely, remove the vinyl hose, then install the cap.

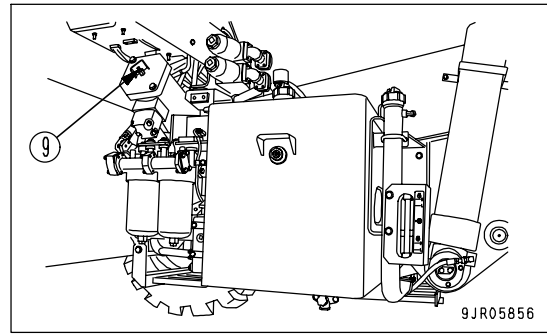

24. Carry out the warming-up operation of the engine until the torque converter oil temperature gauge goes above 40°.
25. When the torque converter oil temperature gauge rises to 40°, bleed the air from the brakes.  
Front brake: See "BLEED AIR FROM FRONT BRAKE (PAGE 4-35)".  
Rear brake: See "BLEED AIR FROM REAR BRAKE (PAGE 4-34)".

#### NOTICE

- Do not attempt to use the oil drained during air bleeding again. Such a practice can cause damage on the machine's tool and equipment.
  - Make sure that the oil level in the brake oil tank does not go down below (H) level in the sight gauge during air bleeding. If it does, the brake oil pump could be damaged.
26. After finishing air bleeding, stop the engine (for 2 to 3 minutes), and adjust the oil level so that it reaches the specified level. For details, see "CHECK OIL LEVEL IN TRANSMISSION CASE, ADD OIL (PAGE 3-74)".
  27. Check the oil level in the brake sub-tank and adjust the oil level so that it reaches the specified level. For details, see "CHECK OIL LEVEL IN BRAKE SUB-TANK, ADD OIL (PAGE 3-75)".

**REPLACE TRANSMISSION AND REAR BRAKE COOLING OIL FILTER ELEMENT****WARNING**

- The parts and oil are at high temperature immediately after the engine is stopped, and may cause burns. Wait for the temperature to go down before starting the work.
- When removing the oil filler cap, turn it slowly to release the internal pressure, then remove it.

1. Turn the cap of oil filler (F) slowly to release the internal pressure, then remove the cap.
2. Remove bolt (1), then remove cover (2).
3. Take out the element, then wash the inside of the case and the removed parts.
4. Install the new element, then install cover (2) with bolt (1).

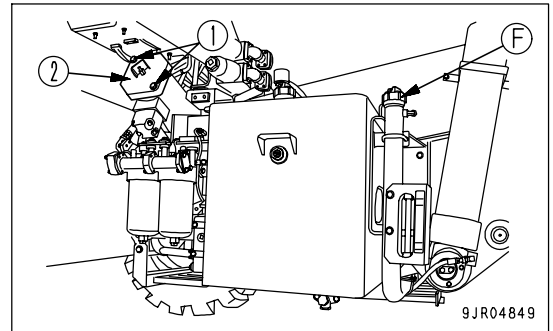

If the filter Maintenance caution lamp (if equipped) lights up when the engine water temperature gauge is in the white range and the engine is running at 1200 to 2100 rpm, replace the element immediately.

## REPLACE BRAKE OIL FILTER ELEMENT

**WARNING**

- The parts and oil are at high temperature immediately after the engine is stopped, and may cause burns. Wait for the temperature to go down before starting the work.
- When removing the oil filler cap, turn it slowly to release the internal pressure, then remove it.

- Prepare a filter wrench

1. Depress the brake pedal at least 20 times to reduce the pressure inside the brake control accumulator to 0.

**REMARK**

When the pressure in the accumulator is released, the operating effort of the brake pedal becomes lighter and the oil pressure noise disappears.

2. Remove the bolt, then remove accumulator cover (1), and put a container to catch the drain oil under the brake oil filter.

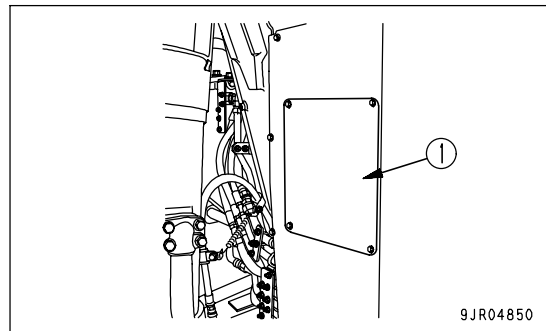

3. Remove filter case (2).

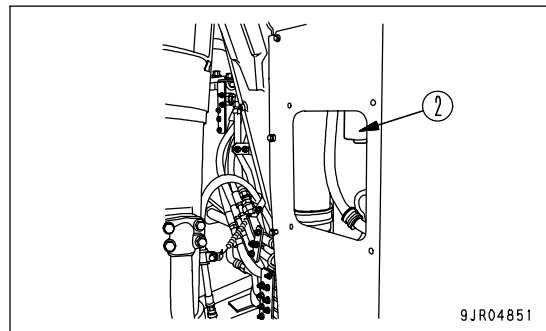

4. Take out the element and wash the inside of the filter case.  
Replace O-ring (3) and backup ring (4) on the filter case with new parts, coat thinly with clean oil, then install.
5. Assemble a new element in the filter case, coat the O-ring of the element thinly with clean oil, then install.  
Tightening torque: 78.4 to 98 Nm  
{8 to 10 kgm, 57.9 to 72.3 lbf}
6. Install accumulator cover (1).

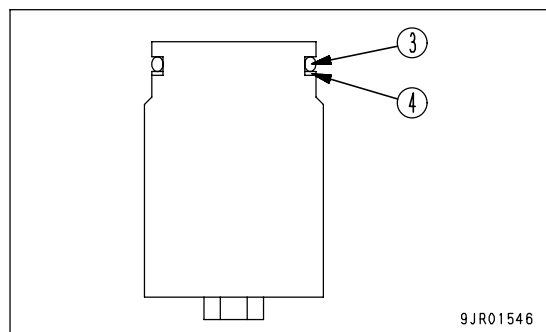

**LUBRICATION**

1. Using a grease pump, pump in grease through grease fittings marked by arrows.
2. After greasing, wipe off any old grease that was pushed out.

(1) Transmission mount (1 place)

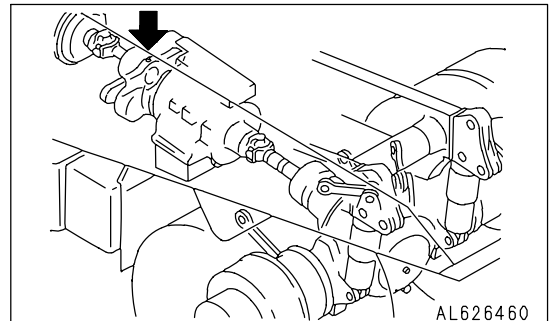

(2) Automatic suspension link (left and right: 1 place each)

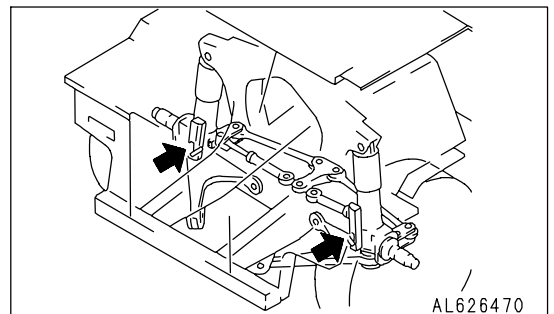

(3) Tension pulley and fan pulley (2 places)

Pump in grease through the grease fitting until grease oozes out from the seal.

**NOTICE**

Do not use air pressure or oil pressure to carry out high-pressure greasing.

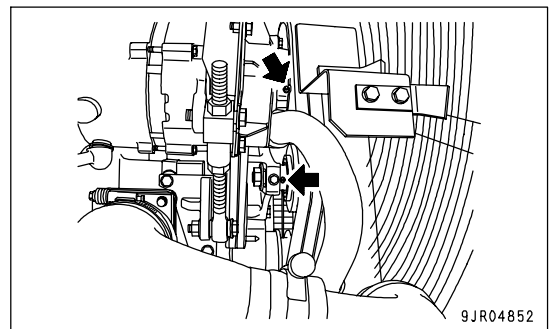

(4) Parking brake (3 places)

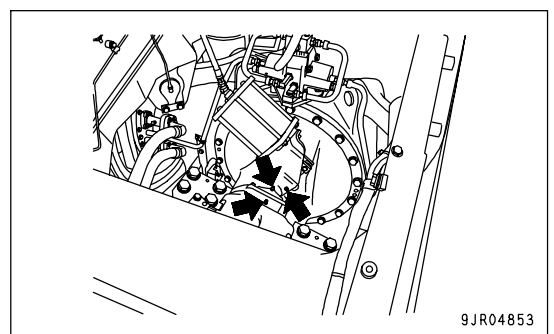



## CHECK WEAR OF REAR BRAKE DISC

**WARNING**

- Carry out this check when the brake oil temperature is below 60°C (140°F).
- If the disc wear approaches the wear limit, check the condition frequently, regardless of the maintenance interval. In addition, check the retarder capacity carefully.
- Always carry out this operation with the engine stopped.

1. Stop the machine on level ground, set the parking brake switch to the PARKING position, then check that the other brakes are not applied before starting inspection.
2. Remove cap nut (1).

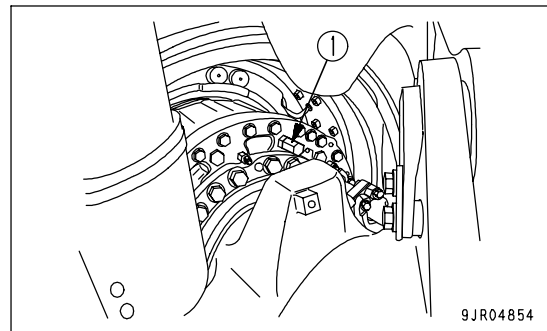

3. Push in until rod (2) of the gauge contacts the piston. Do not depress the brake pedal when doing this.
4. If slit (3) of rod (2) goes in beyond guide end face (4), it means that the disc has reached the wear limit. If this happens, please contact your Komatsu distributor for inspection and maintenance.
5. Install cap nut (1) removed in Step 2.

Tightening torque: 128 to 186 Nm  
(13 to 19 kgm, 94 to 137.4 lbft)

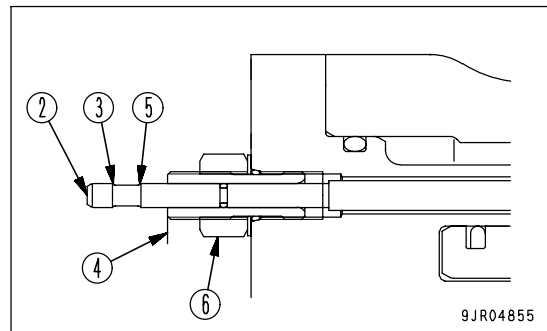
**REMARK**

- On a new machine, the position of the guide is adjusted so that slit (5) comes to guide end face (4), so do not loosen locknut (6) except when replacing the disc.
- When the engine is started and the rod is pushed in, the rod is pushed back by the brake cooling oil pressure, so carry out this operation with the engine stopped.

**RECOVER OIL LEAKING FROM FLOATING SEAL****WARNING**

- The parts and oil are at high temperature immediately after the engine is stopped, and may cause serious burns. Wait for the temperature to go down before starting the operation.
- If there is still pressure remaining inside the case, the oil or plug may fly out.  
Loosen the plug slowly to release the pressure.

Use the same procedure to recover the oil on the left and right sides.

1. Place a container to catch the oil under drain plug (P).
2. Remove drain plug (P), drain the oil, then tighten the plug again.

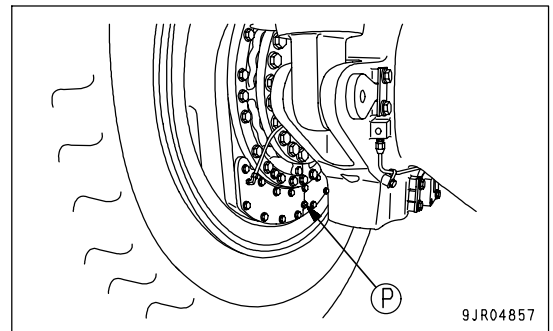

**CHECK OF ENGINE AIR INTAKE PIPING CLAMPS FOR LOOSENESS**

Check the clamps between the air cleaner, turbocharger, aftercooler, and engine for looseness. If any clamp is loosened, retighten it.

Tightening torque of clamp (1):  $8.8 \pm 0.5 \text{ Nm}$  { $0.9 \pm 0.05 \text{ kgm}$ ,  $6.5 \pm 0.4 \text{ lbft}$ }

Tightening torque of clamp (2):  $10.5 \pm 0.5 \text{ Nm}$  { $1.07 \pm 0.05 \text{ kgm}$ ,  $7.7 \pm 0.4 \text{ lbft}$ }

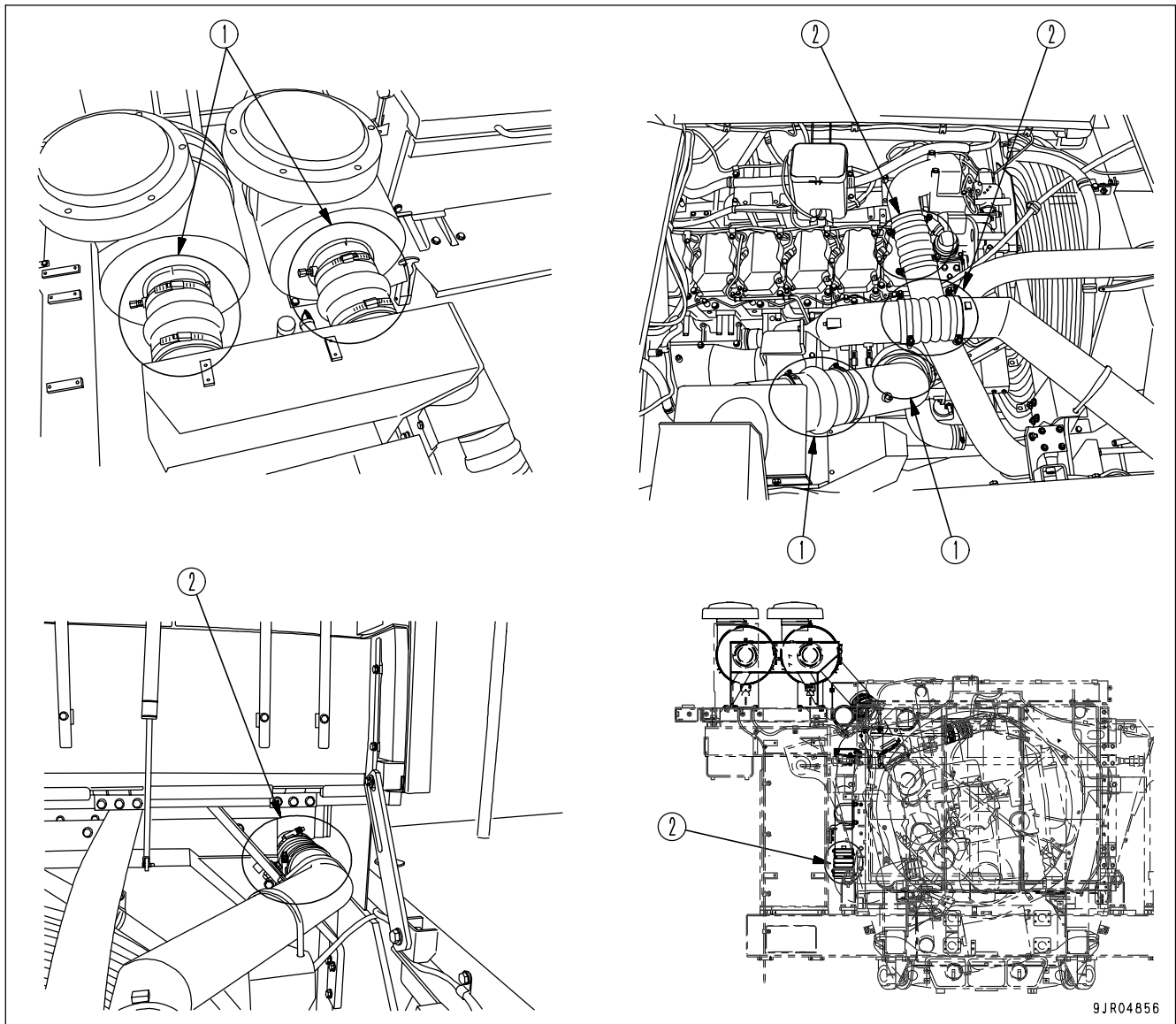

## EVERY 2000 HOURS SERVICE

Carry out maintenance for EVERY 250 HOURS, EVERY 500 HOURS and EVERY 1000 HOURS SERVICE at the same time.

### REPLACE STEERING, HOIST OIL TANK FILTER ELEMENT



#### WARNING

- The parts and oil are at high temperature immediately after the engine is stopped, and may cause burns. Wait for the temperature to go down before starting the work.
- When removing the oil filler cap, turn it slowly to release the internal pressure, then remove it.

1. Turn the cap of oil filler (F) slowly to release the internal pressure, then remove the cap.
2. Remove bolt (1), then remove cover (2).
3. Take out the element, then wash the inside of the case and the removed parts.
4. Install the new element, then install cover (2) with bolt (1).

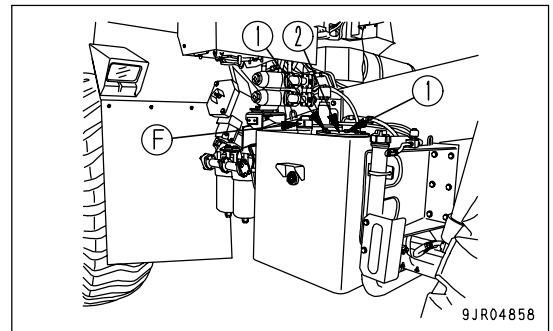

If the filter Maintenance caution lamp (if equipped) lights up when the engine water temperature gauge is in the white range and the engine is running at 1200 to 2100 rpm, replace the element immediately.

## CLEAN HYDRAULIC TANK STRAINER



### WARNING

- The parts and oil are at high temperature after the engine is stopped, and may cause serious burns. Wait for the temperature to go down before starting the operation.
- If there is still pressure remaining inside the case, the oil or plug may fly out. Turn the plug slowly to release the pressure, then remove it carefully.

1. Lower the dump body and stop the engine.
2. Turn the cap of oil filler (F) slowly to release the internal pressure.
3. Remove plugs (1) of the 2 strainers at the front of the hydraulic tank.
4. Take the strainer out from strainer case (2), then wash it in clean diesel fuel.
5. Install the strainer and plug (1) to strainer case (2).
6. Tighten the cap of oil filler (F).

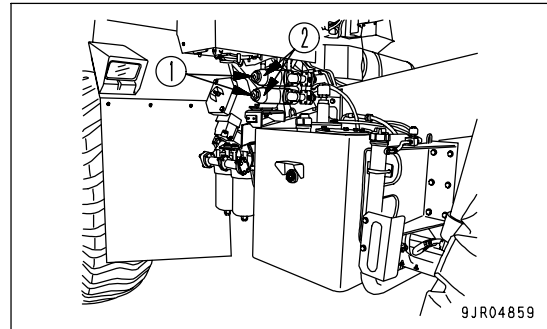

## CHANGE OIL IN FINAL DRIVE CASE



### WARNING

- The parts and oil are at high temperature after the engine is stopped, and may cause serious burns. Wait for the temperature to go down before starting the operation.
- If there is still pressure remaining inside the case, the oil or plug may fly out. Turn the plug slowly to release the pressure, then remove it carefully.

- Refill capacity: Left, right 13 liters (3.43 US gal)

1. Stop the machine so that casting line (1) is horizontal and drain plug (P) is at the bottom.
2. Remove drain plug (P), drain the oil, then tighten the plug again.
3. Add oil through the hole for plug (G) to the specified level.
4. After adding oil, check that the oil is at the specified level. See "CHECK OIL LEVEL IN FINAL DRIVE CASE, ADD OIL (PAGE 4-43)".

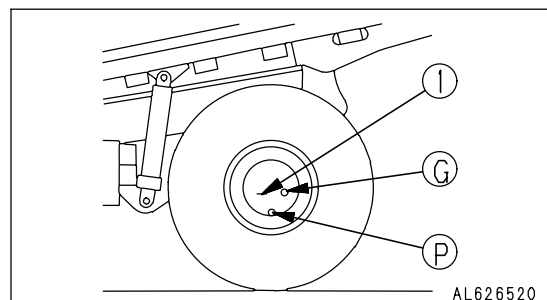

**CHANGE OIL IN DIFFERENTIAL CASE**

**! WARNING**

- The parts and oil are at high temperature after the engine is stopped, and may cause serious burns. Wait for the temperature to go down before starting the operation.
- If there is still pressure remaining inside the case, the oil or plug may fly out. Turn the plug slowly to release the pressure, then remove it carefully.

- Refill capacity: 45 liters (11.88 US gal)

1. Remove drain plug (P), drain the oil, then tighten the plug again.
2. Add oil through the hole for plug (G) to the specified level.
3. After adding oil, check that the oil is at the specified level. See "CHECK OIL LEVEL IN DIFFERENTIAL CASE, ADD OIL (PAGE 4-43)".

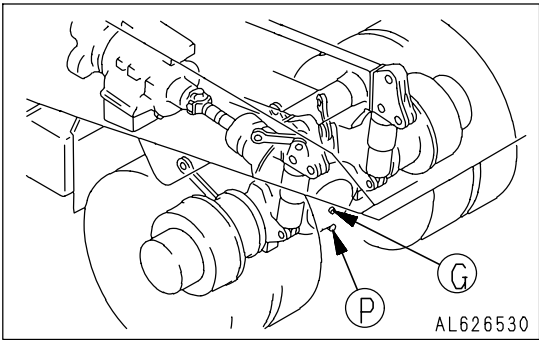

**CLEAN DIFFERENTIAL CASE BREATHER**

**! WARNING**

- The parts and oil are at high temperature after the engine is stopped, and may cause serious burns. Wait for the temperature to go down before cleaning the engine breather.
- When using compressed air, there is a hazard that dirt may be blown up and cause serious injury. Always use safety glasses, dust mask, or other protective equipment.

1. Remove all mud and dirt from around the breather before removing the breather. Use clean diesel fuel or flushing oil to rinse the dirt out from the inside.
2. After flushing, install the breather.

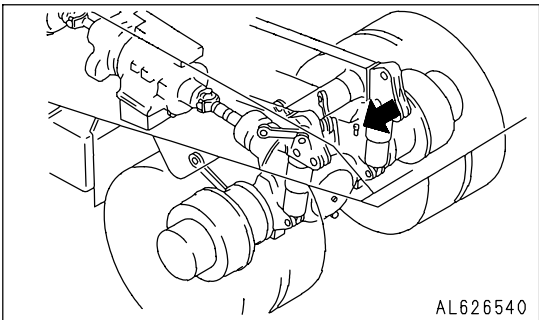

**CHECK ALTERNATOR**

When carrying out the EVERY 2000 HOURS SERVICE or EVERY YEAR SERVICE, remove the belt and check that the alternator rotates smoothly. If it does not rotate smoothly, please ask your Komatsu distributor to carry out inspection and repair.

**CHECK, ADJUST ENGINE VALVE CLEARANCE**

Special tools are needed for inspection and maintenance, so contact your Komatsu distributor.

**CHECK VIBRATION DAMPER**

Check that there are no cracks or peeling in the outside surface of the rubber.

If any cracks or peeling are found, contact your Komatsu distributor to have the parts replaced.

**CHECK ACCUMULATOR GAS PRESSURE**

Please contact your Komatsu distributor to have the gas pressure checked when making periodically replacement of safety parts or carrying out the legally required 2000 hour or every year service.

### EVERY 4000 HOURS SERVICE

Maintenance for every 250, 500, 1000 and 2000 hours service should be carried out at the same time.

### CHANGE OIL IN STEERING, HOIST OIL TANK

**! WARNING**

- The parts and oil are at high temperature immediately after the engine is stopped, and may cause burns. Wait for the temperature to go down before starting the work.
- When removing the oil filler cap, turn it slowly to release the internal pressure, then remove it.

- Refill capacity: 129 liters (34.08 US gal)

1. Lower the dump body and stop the engine.
2. Turn the cap of oil filler (F) to release the internal pressure before removing the cap.
3. Remove drain plug (1), then loosen drain plug (2) slowly to avoid getting oil on yourself, and drain the oil.
4. Pour in the specified amount of engine oil from oil filler (F).
5. After adding oil, check that the oil is at the specified level. See CHECK OIL LEVEL IN STEERING AND HOIST OIL TANK, ADD OIL (PAGE 3-74).

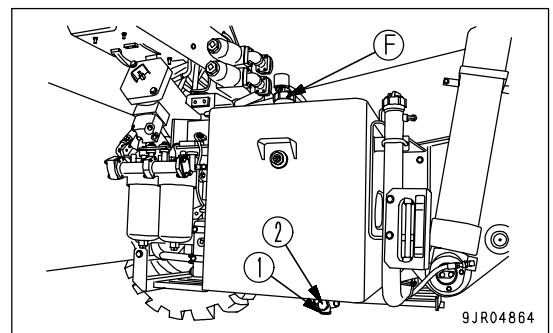

### GREASE EXTENDED GREASING INTERVAL DRIVE SHAFT (4 places)

(If equipped)

Carry out greasing every 4000 hours or every two years (whichever comes sooner).

1. Using a grease pump, pump in grease through the grease fittings marked by the arrows.
2. Apply grease to the spider portion until grease comes out from the seal of the cap.
3. After greasing, wipe off any old grease that was pushed out.

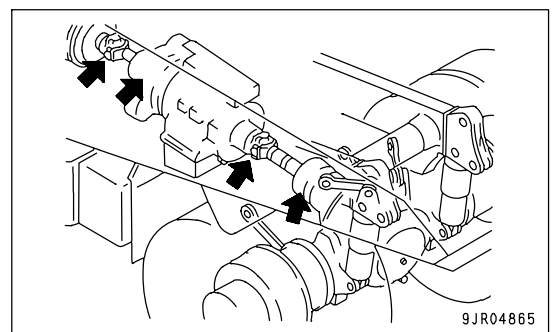



### CHECK STARTING MOTOR

The brush may be worn or have no grease on the bearing, so contact your Komatsu distributor for inspection or repair.

If the engine is started frequently, carry out inspection every 1000 hours.

### CHECK WATER PUMP

Check around the water pump for water leakage. If any part is leaking, ask your Komatsu distributor for inspection/repair.

### CHECK FAN PULLEY AND TENSION PULLEY

Check for play of the pulley and leakage of grease. If any problem is found, please contact your Komatsu distributor.

### CHECK ACCUMULATOR

At 4000 hours or 2 years, whichever comes sooner, ask your Komatsu distributor to replace the accumulator parts.

### CHECKING FOR LOOSENESS OF HIGH-PRESSURE CLAMP, HARDENING OF RUBBER

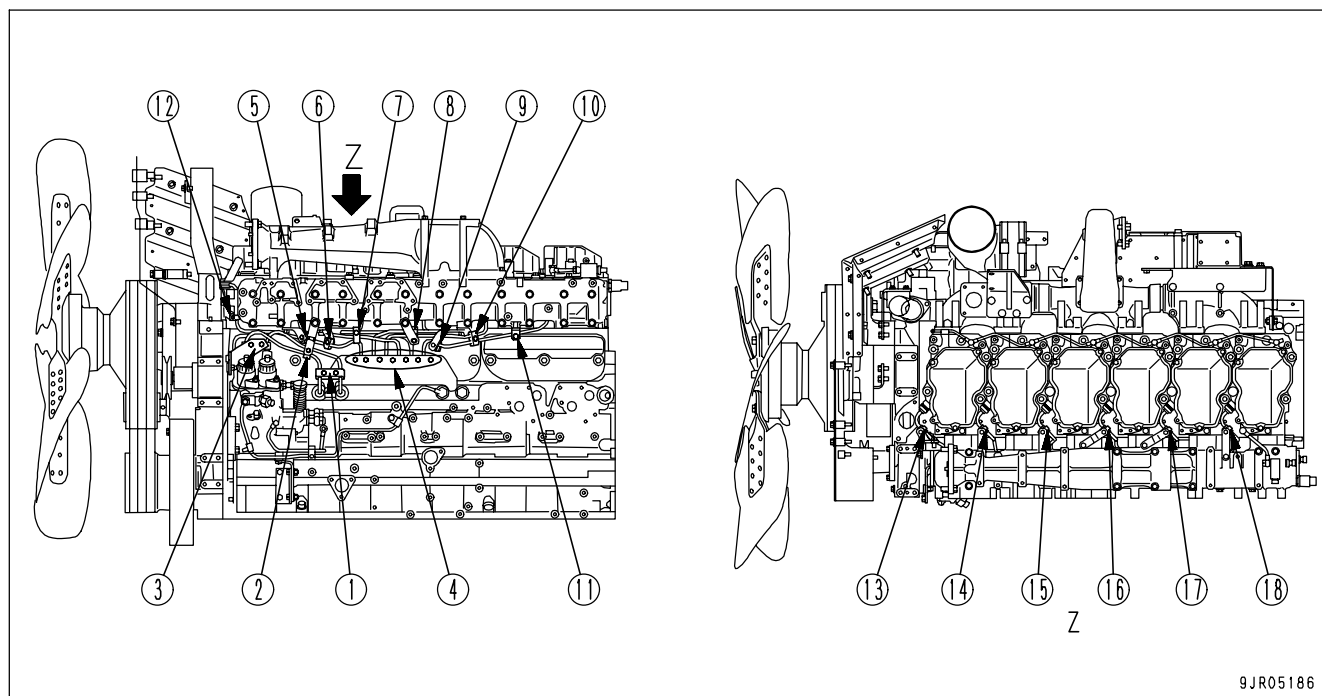

9JR05186

Check clamps (1) to (18) for loose bolts and hardening of the rubber parts. If there are any loose bolts or hardened rubber, please contact your Komatsu distributor for replacement.

**CHECKING FOR MISSING FUEL SPRAY PREVENTION CAP, HARDENING OF RUBBER**

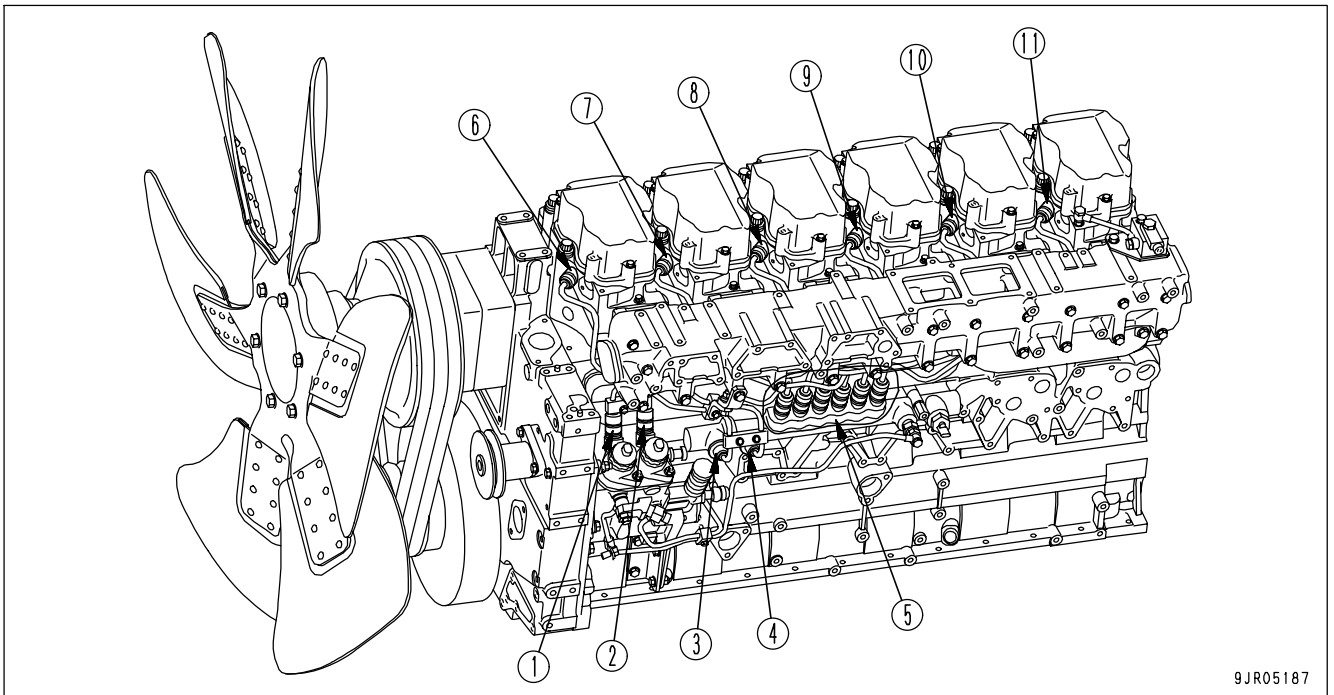

9JR05187

Check that no spray prevention caps (1) to (11) are missing and that there is no hardening of any rubber parts. If any missing caps or hardening of rubber are found, please ask your Komatsu distributor to install or replace.

**EVERY 8000 HOURS SERVICE**

Maintenance for every 250, 500, 1000, 2000, and 4000 hours service should be carried out at the same time.

**REPLACE HIGH-PRESSURE PIPING CLAMP**

Ask your Komatsu distributor to carry out this work.

**REPLACE FUEL SPRAY PREVENTION CAP**

Ask your Komatsu distributor to carry out this work.

**OVERHAUL STARTING MOTOR AND ALTERNATOR**

Ask your Komatsu distributor to carry out this work.

**EVERY 15000 HOURS SERVICE**

Maintenance for every 250, 500, 1000, 2000, 4000, 6000, 8000 and hours of service should be performed at the same time.

**CHECK, REPLACE STEERING A ARM MOUNTING BOLT**

Check and replace the A arm mounting bolts, lock plate, and holder.

Please consult your Komatsu distributor when checking and replacing.

- (1) A arm
- (2) Front suspension
- (3) Lock plate
- (4) Bolt
- (5) Holder

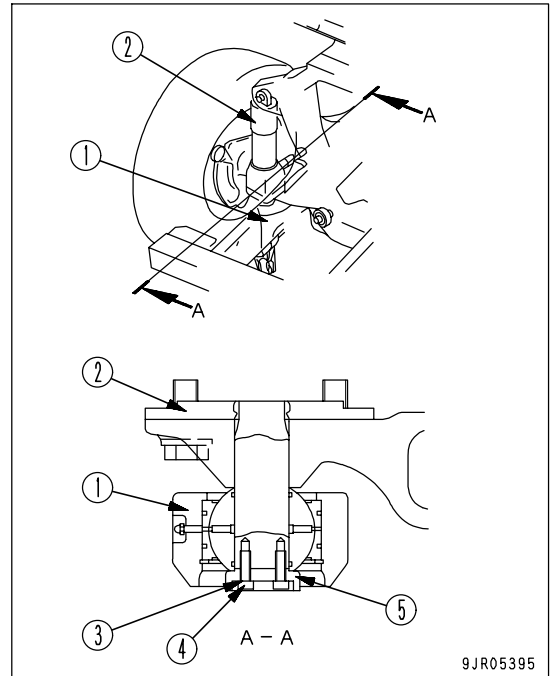



# **SPECIFICATIONS**

# SPECIFICATIONS

Item		Unit	HD325-7	HD405-7	
Overall weight (unladen weight + max. payload + 1 operator (75kg (165 lb)))		kg (lb)	63675 (140403)	74475 (164217)	
Unladen weight		kg (lb)	31600 (69678)	34400 (75852)	
Max. payload		kg (lb)	32000 (70560)	40000 (88200)	
Dump body capacity	Struck	m <sup>3</sup> (cu-yd)	18 (23.5)	20 (26.2)	
	Heaped (2 : 1)	m <sup>3</sup> (cu-yd)	24 (31.4)	27.3 (35.7)	
Dumping speed (at 2100 rpm) (raised)		sec	10		
Engine type		-	Komatsu SAA6D140E-5 diesel engine		
Flywheel horsepower of engine		kW(HP)/rpm	386 (518)/2,000		
Max. torque		Nm(kgm, lbft)/rpm	2,170 (221, 1598.5)/1,400		
A	Overall length	mm (ft in)	8,465 (27' 9")		
B	Overall height	mm (ft in)	4,000 (13' 1")		
C	Overall height at dumping	mm (ft in)	7,930 (26')		
D	Overall width	mm (ft in)	3,660 (12')		
E	Min. ground clearance (bottom of rear axle)	mm (ft in)	500 (1' 8")		
Min. turning radius		mm (ft in)	7,200 (23' 7")		
Travel speed	Forward	1st	km/h (MPH)	10.3 (6.4)	10.3 (6.4)
		2nd	km/h (MPH)	15.8 (9.8)	15.8 (9.8)
		3rd	km/h (MPH)	21.3 (13.2)	21.2 (13.2)
		4th	km/h (MPH)	28.7 (17.8)	28.7 (17.8)
		5th	km/h (MPH)	38.5 (23.9)	38.4 (23.9)
		6th	km/h (MPH)	52.4 (32.6)	51.2 (31.8)
		7th	km/h (MPH)	70.0 (43.5)	70.0 (43.5)
	Reverse	1st	km/h (MPH)	10.6 (6.6)	10.6 (6.6)
Temperature range when using		°C (°F)	-20 to 45°C (-4 to 113°F)		

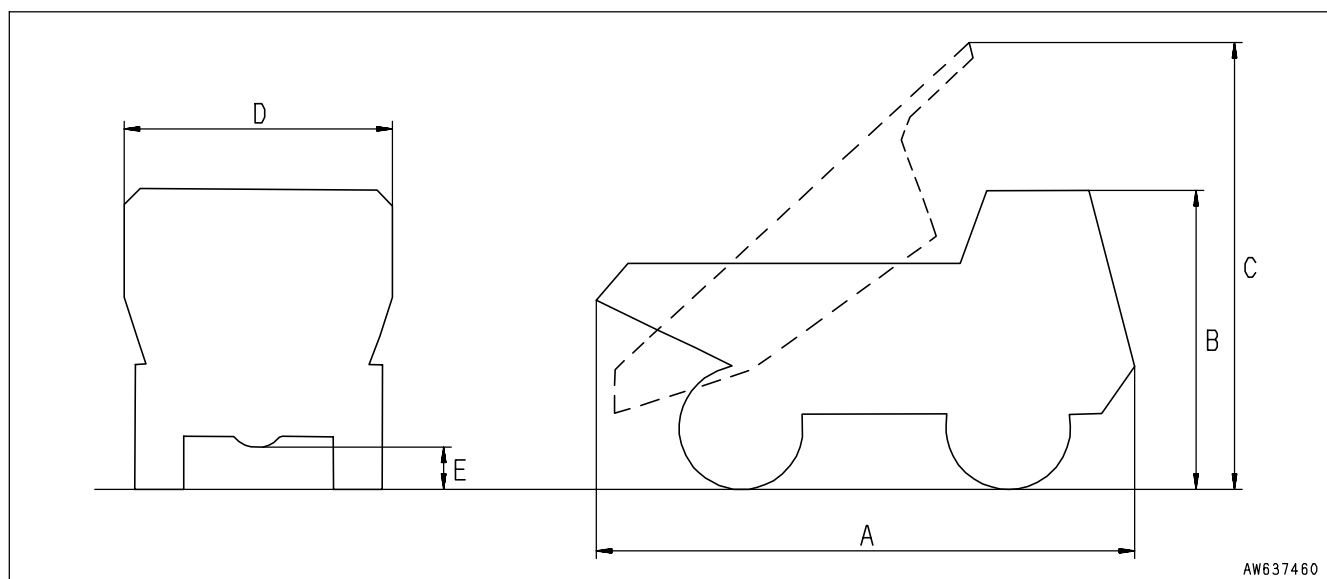

# ATTACHMENTS, OPTIONS

 **WARNING**

Please read and make sure that you understand the SAFETY section before reading this section.

---



## SELECTING DUMP BODY

(Set for HD325-7 only)

Select the dump body from the following table.

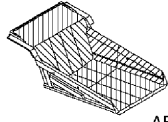
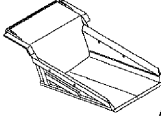
Purpose	Body type	Features	Body shape
Transporting rocks	Rock body	<ul style="list-style-type: none"> <li>A liner is installed to the whole inside surface of the dump body to allow the loading of crushed rock, coal, or timber. Example: Coal mine</li> </ul>	 <p>AE134880</p>
Transporting soil or sand	Linerless body	<ul style="list-style-type: none"> <li>This is suitable for jobsites where soil or sand is loaded. No liner is installed. Example: Loading loose soil for landfills</li> </ul>	 <p>AE134890</p>

# HANDLING AIR SUSPENSION SEAT

## SEAT ADJUSTMENT

### WARNING

- Park the machine in a safe place and stop the engine when carrying out adjustment of the operator's seat.
- Adjust the seat before starting operations or when changing operators.
- Adjust the position of the operator's seat so that you can depress the brake pedal fully with your back against the seat backrest.

Adjustments (E), (J), and (K) use the air compressor built into the seat, so turn the engine starting switch to the ON position when carrying out the adjustment.

#### (A) Fore-and-aft adjustment

Pull lever (1) up, set the seat to the desired position, then release the lever.

Amount of adjustment: 180 mm (7.1 in)  
(10 mm (0.4 in) x 18 stages)

#### (B) Adjusting seat angle

Move lever (2) up and apply your weight to the rear of the seat. The seat will tilt to the rear.

Move lever (3) up and apply your weight to the front of the seat. The seat will tilt to the front.

Amount of adjustment: 24 degrees (front and rear tilt: 3 stages each)

#### (C) Adjusting height of seat

Move levers (2) and (3) up and move the seat up or down to the desired position.

These levers are also used for adjusting the seat angle, so adjust the seat angle to set the seat to the desired height.

Amount of adjustment: 65 mm (2.6 in)

#### (D) Adjusting fore-and-aft position of seat cushion

Push in lever (4), set the seat cushion to the desired position, then release the lever.

Amount of adjustment: 60 mm (2.4 in)

#### (E) Setting seat for weight

Sit on the seat, raise your body slightly, then operate switch (5) to adjust the strength of the suspension.

Amount of adjustment: 50 - 130 kg (110 - 287 lb)(target)

When + is pressed: Suspension becomes stronger

When - is pressed: Suspension becomes weaker

#### (F) Adjusting reclining angle

Move lever (6) up and move the backrest to the front or rear.

Push your back against the backrest when carrying out this adjustment. If your back is not pressing against the backrest, the backrest may suddenly spring forward.

Amount of adjustment: Front tilt: Free

Rear tilt: 40 degrees (2 degrees x 20 stages)

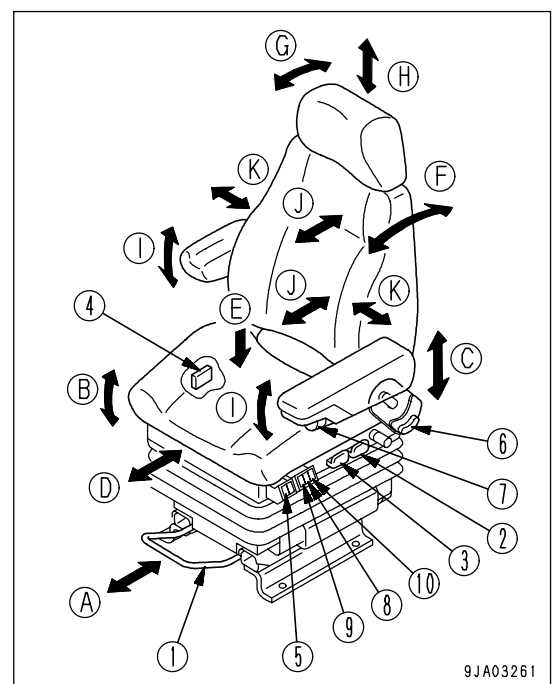

9JA03261

**(G) Adjusting headrest angle**

Rotate the headrest to the front or rear.

Amount of adjustment:

Front tilt: 13 degrees

Rear tilt: 13 degrees

**(H) Adjusting headrest height**

Move the headrest up or down.

Amount of adjustment: 80 mm (3.2 in)

**(I) Adjusting armrest angle**

Rotate the knob (7) and adjust the angle of the armrest. (Left side only)

Amount of adjustment: 73 degrees (front: 54 degrees; rear: 19 degrees)

If the arm rest is turned, it will spring up. (Both left and right sides)

**(J) Lumbar support**

Operate switch (8) to give a suitable tension to the lower lumbar region.

Operate switch (9) to give a suitable tension to the upper lumbar region.

When + is pressed: Tension becomes stronger

When - is pressed: Tension becomes weaker

**(K) Side support**

Operate switch (10) to give a suitable tension to the left and right lumbar region.

When + is pressed: Tension becomes stronger

When - is pressed: Tension becomes weaker

## REMOVAL AND INSTALLATION OF HEADREST

### REMOVAL

If the headrest is not needed, remove it as follows.

1. Pull up the headrest to the position where it stops.
2. From the top of the seat back, turn stopper (1) (under the material at the top of the seat) of the headrest bar on one side in the direction of the arrow, and pull up the headrest.  
When stopper (1) is turned, it will come out of groove (2).
3. Turn stopper (1) on the other side in the direction of the arrow, and pull up the headrest.  
When both stoppers (1) come out of groove (2), the headrest can be removed.

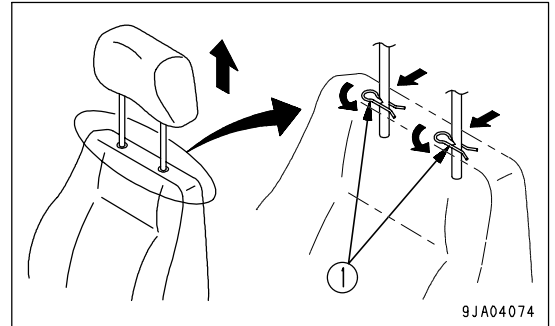

### INSTALLATION

1. Insert the bars into the holes in the top of the seat and push down.

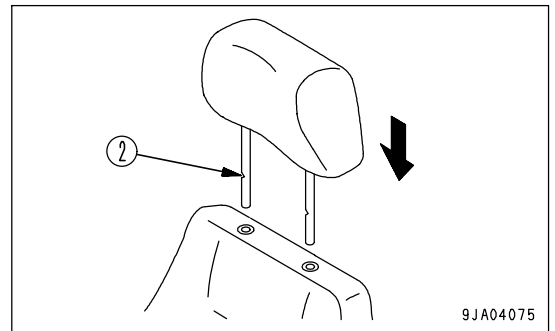

# HANDLING AUTOMATIC SPIN REGULATOR (ASR)

ASR is a function to prevent slipping of the drive wheels caused by excessive torque. Accordingly, the machine can start and travel normally even on a bad or frozen road surface.

## EXPLANATION OF COMPONENTS

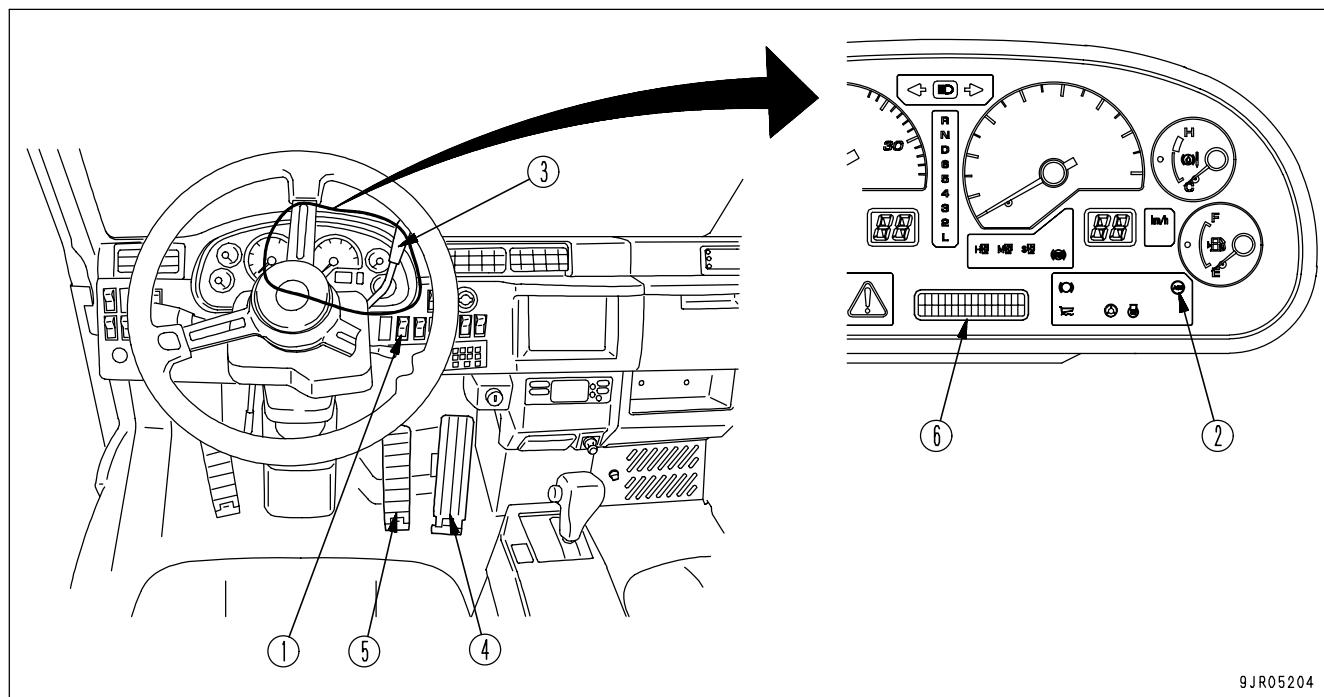

9JR05204

- (1) ASR switch
- (2) ASR actuation lamp
- (3) Retarder control lever

- (4) Accelerator pedal
- (5) Brake pedal
- (6) Character display

### ASR SWITCH

This switch (1) turn to the ASR system ON/OFF.

- (a): ASR system OFF
- (b): ASR system ON

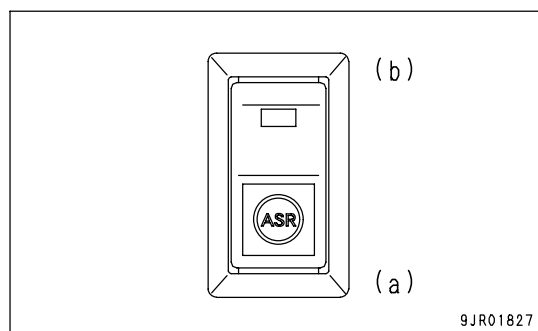

9JR01827

**ASR ACTUATION LAMP**

When the ASR switch is ON, this lamp (2) lights up if the system detects slipping from the rear wheels and actuates the ASR.

**RETARDER CONTROL LEVER**

When the ASR is actuated and this lever (3) is used to actuate the retarder, the actuation of the ASR system is canceled.

**ACCELERATOR PEDAL**

The ASR system is actuated only when this pedal (4) is being depressed and the travel speed is 0 to 30 km/h (0 to 18.6 MPH). If the pedal is released while the ASR is being actuated, the actuation of the ASR system is canceled.

**BRAKE PEDAL**

If this pedal (5) is depressed while the ASR is being actuated, the actuation of the ASR system is canceled.

**CHARACTER DISPLAY**

If any problem occurs in the ASR system, an action code is shown on this display (6).

**ACTUATION OF ASR SYSTEM**

The ASR system can be actuated when the ASR switch is ON.

When the system detects slipping of the rear wheels and the ASR is actuated, the ASR actuation lamp lights up.

**PRECAUTIONS WHEN USING****WARNING**

- The ASR system is actuated when the ASR switch is at the ON position.
- If any problem occurs in the system and it cannot carry out proper control, an action code is shown on the character display on the machine monitor, and the ASR system is canceled.  
Drive the machine immediately to a safe place, stop the machine, and turn the ASR switch OFF.
- On road surfaces with an extremely low wear coefficient (icy road surfaces, etc.) or on steep slopes, it may be impossible to drive safely even when the ASR is actuated.

- 
- On road surfaces where it is possible to carry out normal travel even when the ASR switch is turned OFF, if the road surface is slippery, be extremely careful not to let the machine slip to the side.
  - If both rear wheels slip at the same speed, the ASR will not function. In this case, adjust the engine output with the accelerator pedal.

## BLEEDING AIR FROM ASR CIRCUIT

If the piping or valves in the ASR circuit have been replaced, bleed the air from the ASR circuit as follows.

1. Start the engine, check that the oil in the transmission case is the specified level, and check if the brake oil pressure caution lamp is out.
2. Turn the ASR switch ON, remove the cover behind the operator's seat, and connect connector TEST (1). The valve opens and oil pressure is applied to the ASR circuit.
3. Bleed the air from the rear brakes. For details, see MAINTENANCE, "BLEED AIR FROM REAR BRAKE (PAGE 4-34)".
4. After completing the air-bleeding operation, remove connector TEST (1) and install the cover.

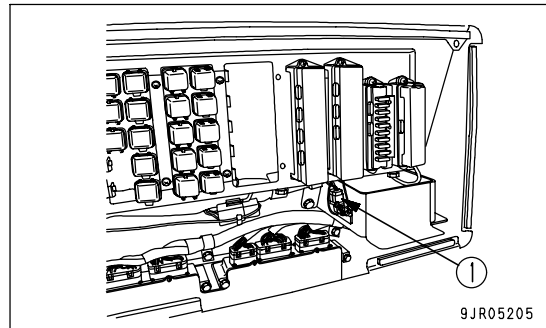

## HANDLING ABS

The ABS (anti-skid brake system) is a brake system that ensures the steering ability and stable machine posture. It works by automatically suppressing the skidding caused by the wheels locking when the brakes are applied suddenly or are applied on snow-covered roads or other slippery road surfaces.

### EXPLANATION OF COMPONENTS

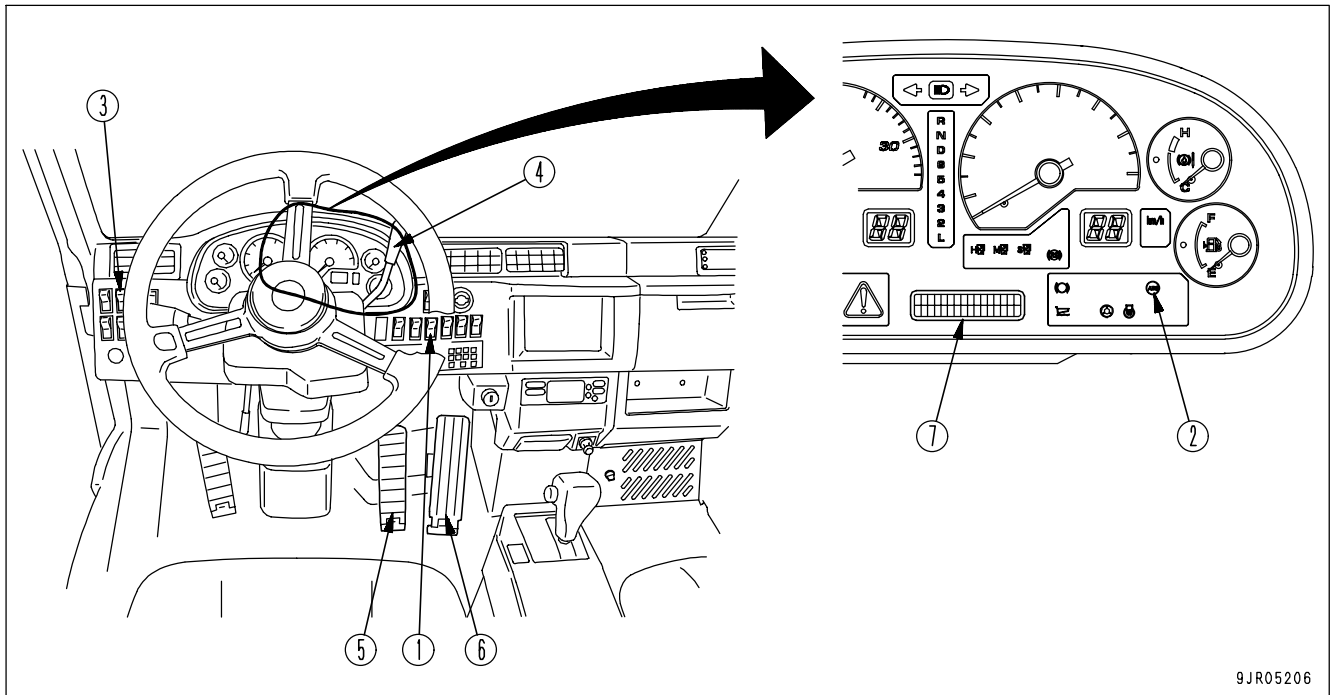

- |                             |                       |
|-----------------------------|-----------------------|
| (1) ABS main switch         | (5) Brake pedal       |
| (2) ABS operation lamp      | (6) Accelerator pedal |
| (3) ABS system check switch | (7) Character display |
| (4) Retarder control lever  |                       |

#### ABS MAIN SWITCH

The switch (1) is used to turn the ABS system ON/OFF.

- (a): ABS system OFF
- (b): ABS system ON

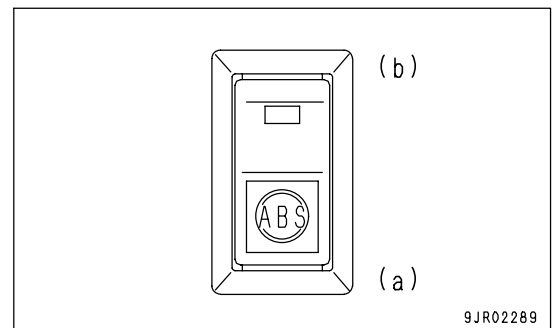

#### ABS OPERATION LAMP

When the ABS main switch is ON and a tendency for the tires to lock is detected, the ABS is actuated and lamp (2) lights up.



**ABS SYSTEM CHECK SWITCH**

This switch (3) is used to check the ABS system after the engine is started.

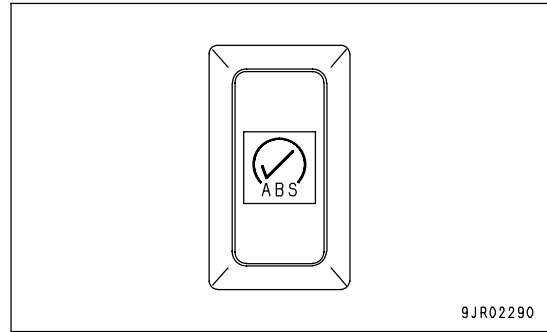
**RETARDER CONTROL LEVER**

When the retarder is being actuated with this lever (4), the ABS is actuated if there is a tendency for the tires to lock.

**BRAKE PEDAL**

When the wheel brakes are being applied with this pedal (5), the ABS is actuated if there is a tendency for the tires to lock.

**ACCELERATOR PEDAL**

If this pedal (6) is depressed when the ABS is being actuated, the ABS is canceled.

**CHARACTER DISPLAY**

If any problem occurs in the ABS system, the action code is displayed on this display (7).

## ABS SYSTEM CHECK AFTER STARTING ENGINE

After starting the engine, check the ABS system.

1. Set the machine in the following condition. If the machine is not in the following condition, the ABS system cannot be checked.
  - Parking brake applied
  - Brake oil pressure normal
  - ABS main switch ON
  - No problem in ABS system
2. Keep the brake pedal depressed until the ABS system check is completed.
3. Keep the ABS system check switch pressed for approx. 1 second.  
The ABS operation lamp flashes and the ABS check system starts.

### REMARK

The ABS system checks the ABS control valve, ABS cut valve, oil pressure switch, and oil pressure sensor. This check is completed in approx. 12 seconds.

4. When the flashing of the ABS operation lamp stops, the check is completed. Release the brake pedal.

## OPERATION OF ABS

The ABS can be actuated only when the ABS main switch is ON.

If the retarder control lever is operated or the brake pedal is depressed, the ABS is actuated.

If there is a tendency for the wheels to lock, the ABS system is actuated and the ABS operation lamp lights up.

## PRECAUTIONS WHEN USING



### WARNING

- When the ABS is actuated on a slippery road surface, the stopping distance will become slightly longer. In addition, when traveling at extremely low speed, the wheels may lock, so be very careful when driving.
  - When traveling on roads with an extremely low friction coefficient (icy roads, etc.) or when traveling up or down a steep hill, it may not be possible to ensure safe travel even with the ABS installed. In such cases, carry out maintenance on the road surface before traveling on it.
  - When the ARSC is being used, even if there is a tendency for the wheels to lock, the ABS is not actuated. The ABS is actuated when the retarder control lever or brake pedal are operated.
  - After turning the ABS main switch ON, it takes a short time for the preparation of the ABS operation, so the ABS is not actuated for 2 seconds. Turn the ABS main switch ON beforehand if it is to be actuated.
- 
- It is possible to carry out normal travel even when the ABS main switch is OFF. However, be extremely careful about the machine slipping to the side when traveling on slippery road surfaces.
  - Even if there is a failure in the ABS system, it is possible to carry out normal travel. However, be extremely careful about the machine slipping to the side when traveling on slippery road surfaces. If any problem occurs in the ABS system, the system is automatically turned OFF, so the condition becomes the same as for a machine which does not have the ABS installed.
  - Even when the ABS system is installed, the secondary brake function is maintained, but when the secondary brake is actuated, even if the wheels lock, the ABS is not actuated.
  - When equipping the machine with a wireless system, install it as far as possible from the system equipment and wiring. In addition, when equipping the machine with a wireless system, check carefully that the wireless and operating system do not break any laws regulating use of the airwaves.

## HANDLING PAYLOAD METER II (CARD TYPE)

- The payload meter inputs the signals from the pressure sensors, clinometer, body float detection, and neutral detection, and uses the built-in microcomputer to calculate the amount loaded. It then displays the calculated load on the panel display and also displays the load on the external display lamps.
- The payload meter always carries out self-diagnosis of the system, and if any problem or warning occurs, it displays the content.
- It is also possible to use the switches on the payload meter itself to display the aggregate payload or total number of cycles from a certain time, and to forcibly display problem and warning items that are now occurring, or have already occurred and been restored to normal.
- The payload meter automatically records dump truck operation data, such as the payload, time, distance, and travel speed for each cycle, together with the time and date of starting or stopping the engine, time and date of the occurrence and remedy for abnormalities or warnings, and the aggregate payload and total number of cycles from any given time.

These automatically saved data are retained even when the power is turned off, so it is possible to send (download) the data with the communications cable (ANSI/EIARS-232C) from the payload meter through the communications cable connection port inside the cab.

The downloaded data are saved in a CSV type text file, so it is possible to read them with Excel or any commercially available software and to use a PC to process the dump truck operating data.

Furthermore, if a memory card is inserted in the payload meter, these data can be written to the memory card and then read to a personal computer from the memory card, so the data can be processed in the same way as with cable communications using a personal computer.

### REMARK

When reading the data to a PC, it is necessary to use the PC software provided by Komatsu.

When using a card system, a memory card and memory card reader are needed.

- It is possible to set the machine ID, open ID, and travel speed limit for each payload meter (in other words, for each machine).

## METHOD OF USING ACCURATELY

### 1. Recorded payload data

When the dump lever is operated from FLOAT to any position other than the FLOAT, the payload is recorded. The reason for this is the following two points.

- To measure the payload that has actually been carried  
The payload can be measured more accurately by measuring the load that is actually dumped after subtracting the loss caused by spillage of the load during travel.
- The measurement is carried out based on the pressure of each suspension, and after the machine has traveled, the variation of the friction force at each place has been evened out, so it is possible to measure accurately.

When dumping the load, if the machine shakes and the payload display fluctuates, wait for the payload display to stabilize before dumping the load. (If the dump truck is stopped suddenly at the dumping point, it will take time for the payload display to stabilize.)

### 2. The payload display at the loading point (immediately after the loading) may be slightly less (1-5 tons) than the value displayed at the dumping point. This is caused by the differences in the friction force of the suspension, and it is impossible to remove this.

Even if the displayed value at the measurement location is slightly different, it is not caused by any failure in the payload meter.

GENERAL LOCATIONS

CONTROLLER SCREEN

**⚠ CAUTION**

When not inserting or removing memory card (9), always keep cover (10) closed.

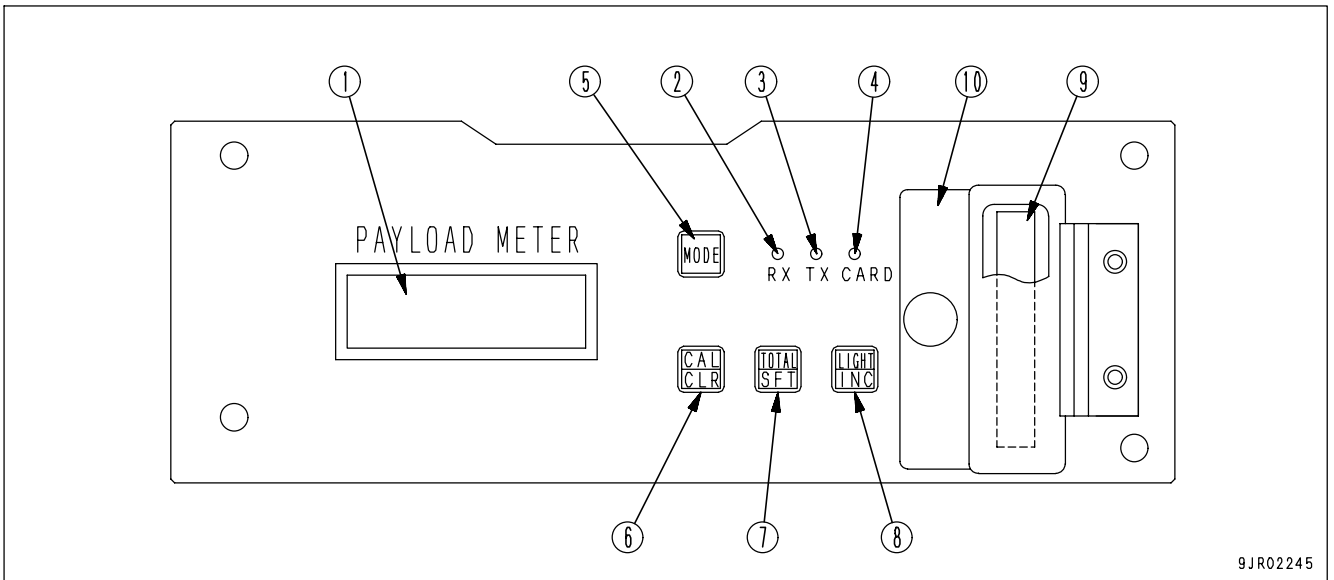

- |   |                              |
|---|------------------------------|
| (1) Display panel                       | (6) Calibration/clear switch |
| (2) Reception pilot lamp (Rx busy)      | (7) Total/shift switch       |
| (3) Transmission pilot lamp (Tx busy)   | (8) Light/increment switch   |
| (4) Memory card access lamp (CARD busy) | (9) Memory card              |
| (5) MODE switch                         | (10) Cover                   |

**REMARK**

Transmission pilot lamp (3) lights up when the communication cable is not connected to the personal computer or when it is not properly connected.

LEFT FACE OF CONTROLLER

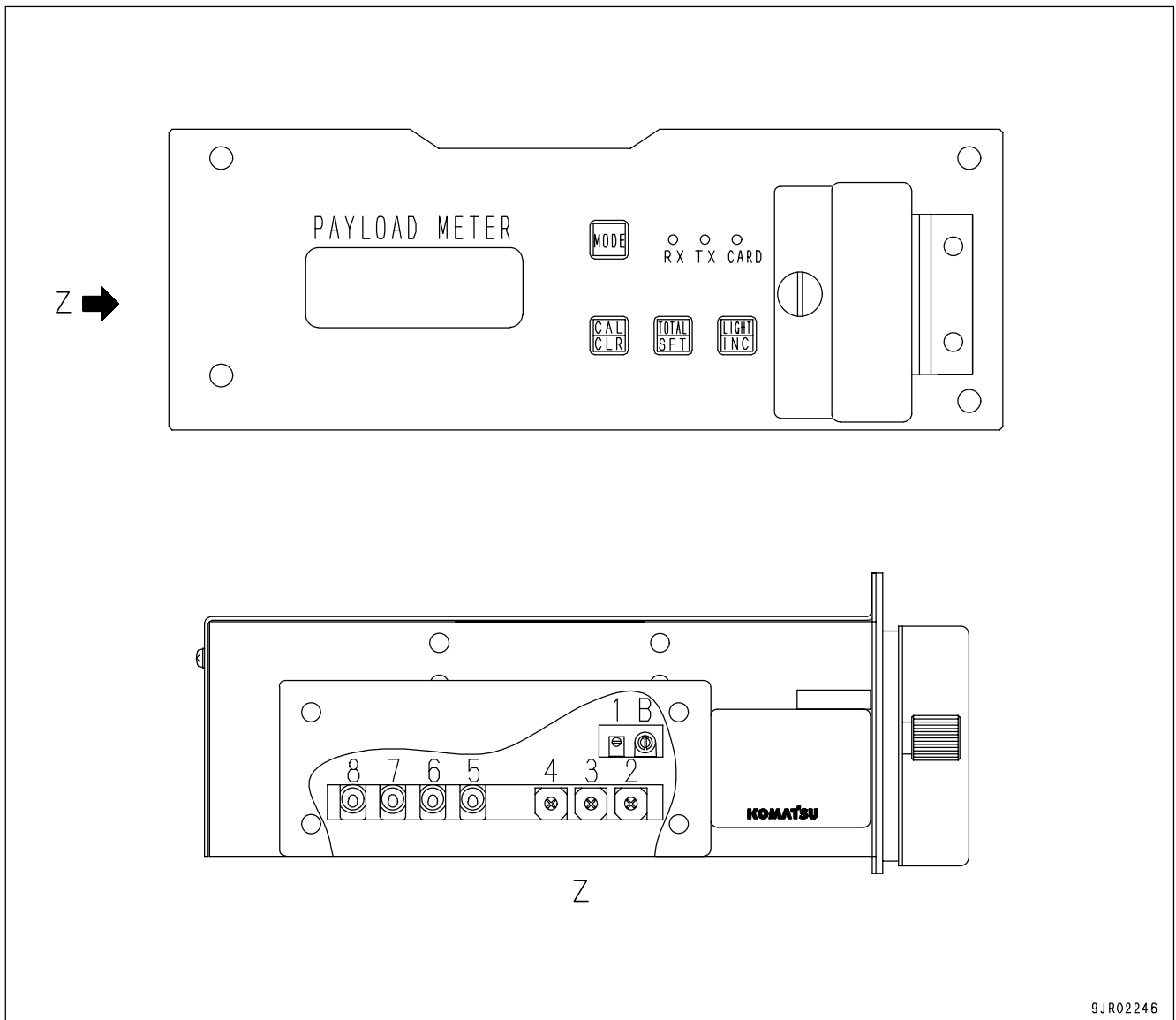

9JR02246

## DETAILS OF SWITCHES ON LEFT SIDE

No.	Name	Type	Remarks
1	Payload gain adjustment trimmer	Rotary volume	-20% to 20% (Turn to left) - (Turn to right)
2	Speed regulation switch	0 - F Rotary switch	0: 107 % to 7: 100 % to F: 92 %
3	Distant regulation switch	0 - F Rotary switch	0: 107 % to 7: 100 % to F: 92 %
4	Model selection switch	0 - F Rotary switch	Refer to model selection chart
5	Use of memory-card switch	2-Stage selector switch	Up: not used; Down: used
6	Use of clinometer switch	2-Stage selector switch	Up: not used; Down: used
7	Mass unit setting switch	2-Stage selector switch	Up: metric tons; Down: short tons
8	Forced prohibition setting for switches	2-Stage selector switch	Up: permitted Down: prohibited According to permitted/prohibited setting table for switches
B	Buzzer volume regulation	Rotary volume	For MIN volume, turn to RIGHT For MAX volume, turn to LEFT

**NOTICE**

The switches on the left side are set when the machine is shipped from the factory.

Do not touch any switch except No. 7 and No. B.

If you wish to adjust any switch except No. 7 and No. B to compensate the payload calculation value or speed or distance calculation value, please contact your Komatsu distributor.



## MODEL SELECTION CODE CHART

Model selection code display	Model		
0	HD1200-1 STD	Large-tire	Cummins engine
1	HD785-3 STD	Large-tire	Komatsu engine
2	HD465-5/-7 STD	Small-tire	Komatsu engine
3	HD325-6/-7 STD	Large-tire	Komatsu engine
4		-	
5		-	
6	HD785-3 STD	Small-tire	Komatsu engine
7	HD465-5/-7 STD	Large-tire	Komatsu engine
8	HD405-6/-7 Quarry	Large-tire	Komatsu engine
9	HD985-3/-5 STD	30.00-51	Komatsu engine
A	HD605-5/-7 Quarry	Large-tire	Komatsu engine
B	HD785-5 STD	Large-tire	Komatsu engine
C		-	
D		-	
E		-	
F		-	

## PERMITTED/PROHIBITED SETTING TABLE FOR SWITCHES

		Left side switch No. 8	
		Down (prohibited)	Up (permitted)
Left side switch No. 5	Up (memory card not used)	(1)	(2)
	Down (memory card used)	(3)	(4)

- (1) Left side switch No. 5 (up) and No. 8 (down)  
Only calibration operation, data all clear, time and date setting operation are permitted.
- (2) Left side switch No. 5 (up) and No. 8 (up)  
Operation of all switches is permitted.
- (3) Left side switch No. 5 (down) and No. 8 (down)  
Only calibration operation, data all clear, card dump, time and date setting operation are permitted.
- (4) Left side switch No. 5 (down) and No. 8 (up)  
Operation of all switches is permitted.

**EXTERNAL DISPLAY LAMPS**

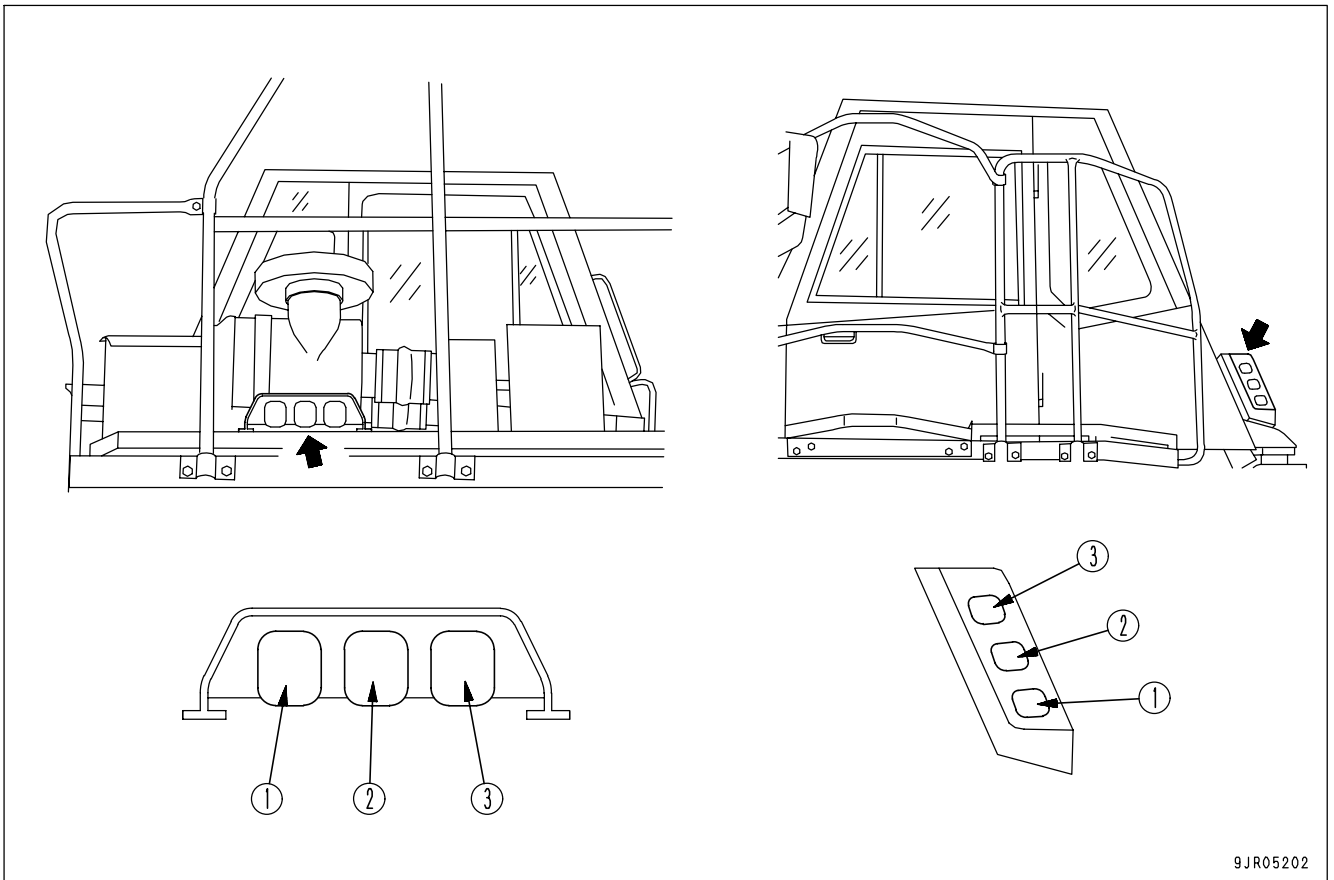

- (1) Green lamp
- (2) Yellow lamp
- (3) Red lamp

**COMMUNICATIONS CABLE CONNECTION PORT FOR PERSONAL COMPUTER**

- Download connector (rear of assistant's seat)

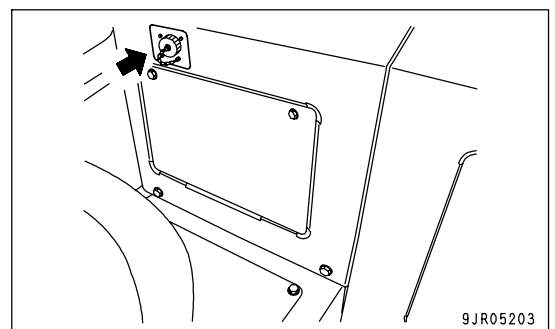

## CONTENT OF DISPLAY (CONTROLLER, EXTERNAL DISPLAY LAMPS)

### WHEN THE POWER IS ON

When the power is turned ON, the displays on the controller display and external display lamps are as follows.

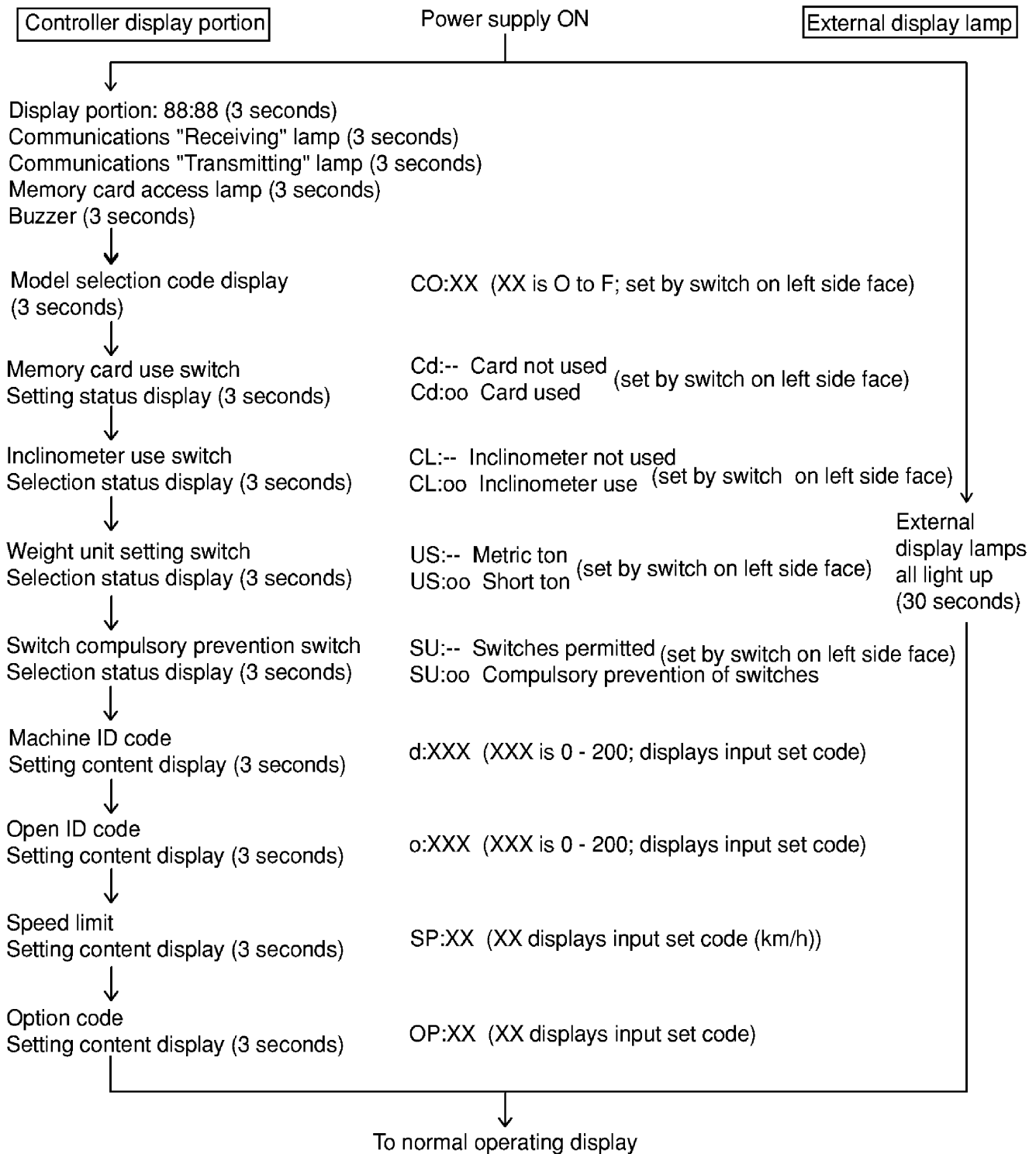

If the engine is started during this flow of displays, even if there are items remaining which should still be displayed, the display switches after several seconds to the display given during normal operations. The machine ID code, option ID code, speed limit, and option code, see "OPERATOR CHECK MODE (PAGE 6-35)".

**DISPLAY DURING NORMAL OPERATIONS**

Condition of machine		Gearshift lever position	Dump lever position (*1)	Display panel	External display lamps
When empty	Stopped	N	FLOAT	Payload display (*2)	Payload display
	Traveling	Except N	FLOAT	Time display	OFF
During loading, until 50% of standard payload is reached	Stopped (*3)	N	FLOAT	Payload display	Payload display and display of estimate
	Traveling	Except N	FLOAT	Payload display	OFF
During loading, after 50% of standard payload is reached	Stopped	N	FLOAT	Payload display	Payload display and display of estimate
	Traveling (*4)	Except N	FLOAT	Travel distance displayed in units of meter from 0 to 160 m (every 5 m) -> after completion, time display	OFF
When loaded	Traveling	Except N	FLOAT		OFF
	Stopped (*5)	N	FLOAT	Payload display	Payload display
When dumping (*6)		N	FLOAT-> RAISE-> LOWER-> FLOAT	Total payload display (*7) goes out	OFF
When problem or warning is generated		-	-	See "PROBLEM AND WARNING DISPLAY (ERROR CODE)(6-53 PAGE)".	See "PROBLEM AND WARNING DISPLAY (ERROR CODE)(6-53 PAGE)".

See the next page for details of Notes \*1 to \*7.

- \*1: Between the start of the loading operation and the start of the dumping operation, always keep the dump lever at the FLOAT position. If the dump lever is operated to any position other than FLOAT, the data will not be recorded when dumping, or the data will be recorded, but the data for time, distance, and speed will not be recorded accurately.  
With the display, [b-FL] may be displayed instead of the total payload when dumping, and after completion of loading, the time display may be given instead of the distance display when starting to travel.
- \*2: When the load is less than 5% of the standard payload, 0 t is displayed.
- \*3: If there is no new load within 5 minutes from the time of the previous load:  
Both the display panel and external display lamps will change to the display for "When empty, Stopped" in the table.
- \*4: If the machine is stopped again before traveling 160 m, both the display panel and external display lamps will return to the display for "During loading, Stopped" in the table.  
If the load is dumped before traveling 160 m, both the display panel and external display lamps will jump to the display for "When dumping" in the table.
- \*5: If loading is carried out again when this happens:  
Immediately after loading again, both the display panel and external display lamps will return to the display for "During loading, Stopped" in the table.
- \*6: If the load that is dumped is not more than 50% of the standard payload, the machine will not recognize that a load has been dumped. It will consider it only as a movement of the dump lever. (See \*1)
- \*7: The display for the total payload is given in units of 100 t (rounded to the nearest 100).  
For the method of clearing the total payload (resetting of the measurement to 0), see "FORCED DISPLAY OF TOTAL PAYLOAD AND OVERALL NUMBER OF CYCLES (PAGE 6-33)".  
When dumping, if the gearshift lever is at any position other than N, [b-FL] flashes. If the dump lever is at any position other than FLOAT from the beginning of the loading operation to the end of the dumping operation, the data will not be recorded accurately. (See \*1)

The payload meter retains the existing condition when it is empty, during loading, and when it is loaded, even if the power is turned OFF, so when the operator starts operation again, the system starts from the existing machine condition.

**NOTICE**

When stopping the machine empty, stopping it during loading, or stopping it when loaded, always set to the gearshift lever at the N position. (See "DISPLAY DURING NORMAL OPERATIONS (PAGE 6-21)".)

If this is not done, the time that the machine is stopped will not be calculated, and it will be included in the travel time when empty or the travel time when loaded. As a result, the average travel speed will appear to be lower and the data stored in the payload meter will not be accurate. In addition, the external display lamps will also stay OFF.

**NOTICE**

In the following cases (1) to (4), the condition of the dump truck as seen by the payload meter will be different from the actual condition of the dump truck.

- (1) When a new controller has been installed
- (2) When the controller has been replaced  
See "OPERATION WHEN ERROR CODE F.CAL IS DISPLAYED OR CONTROLLER HAS BEEN REPLACED (PAGE 6-63).
- (3) When the built-in battery has been replaced  
See "WHEN ERROR CODE F-09 IS DISPLAYED (PROCEDURE FOR REPLACING BATTERY) (PAGE 6-60).
- (4) In addition, if either of the following conditions should occur
  - The external display lamps give the estimate display although no loading is taking place.
  - The display gives the time display when loading even if more than 50% of the standard payload is loaded and the machine starts to travel. (The distance display is not given when traveling 0 to 160 m.)

In the case of (1) or (4), carry out calibration with the machine empty, then load it close to the rated payload and dump the load. The payload meter will recognize the empty (stopped) condition.

Note that the cycle data recorded when dumping may be partially inaccurate.

**NOTICE**

- After starting dumping (operating the dump lever from FLOAT to RAISE), do not turn the power OFF within 5 seconds after completing the dumping (operating the dump lever from LOWER to FLOAT).
- Also, with operations other than dumping, do not turn the power OFF within 5 seconds after operating the dump lever to FLOAT from any position other than FLOAT.
- If the starting switch has been left at the ON position (power ON) for a long period without starting the engine, first turn the starting switch to the OFF position, then start the engine.
- If the engine is started without turning the starting switch first to the OFF position, the time that the starting switch was at the ON position without starting the engine will also be calculated as part of the "Stopped, Empty" time or the "Stopped, Loaded" time.

## EXTERNAL DISPLAY LAMPS

### DISPLAY LEVEL FOR LAMPS



### WARNING

If the red lamp lights up, the machine is overloaded. Do not haul a load under this condition. To prevent overloading, we recommend loading only up to a range where the yellow lamp lights up.

- The external lamps display the payload as follows.

	Color of lamp	HD325-7	HD405-7
1	Green	16.0 tons and up	20.0 tons and up
2	Yellow	28.8 tons and up	36.0 tons and up
3	Red	33.6 tons and up	40.0 tons and up

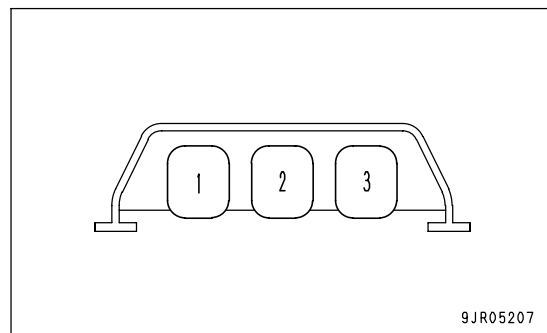

**ESTIMATE DISPLAY**

- When the load changes in steps for each bucket loaded, the system estimates the total payload if one more bucket is loaded, and flashes the appropriate lamp to prevent overloading.
- The predicted load display and actual payload display are shown at the same time.

[Example: Case of HD325, expected number of bucket loads: 4]

1st bucket 8 tons

2nd bucket 8 tons (total: 16 tons)

3rd bucket 8 tons (total: 24 tons)

4th bucket 8 tons (total: 32 tons)

When the machine is loaded in this way, the external display lamps light up as shown in the chart below.

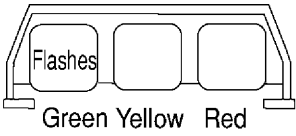
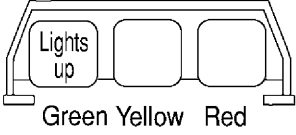
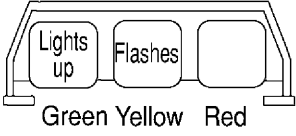
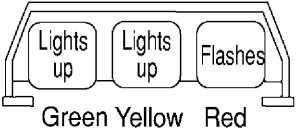
No. of loads	External display lamp	Remarks
1st bucket	 <p>Flashes Green Yellow Red</p>	<ul style="list-style-type: none"> <li>• The weight actually loaded is 8 tons, so no lamp lights up.</li> <li>• The predicted load is 16 tons, so the green lamp flashes.</li> </ul>
2nd bucket	 <p>Lights up Green Yellow Red</p>	<ul style="list-style-type: none"> <li>• The weight actually loaded is 16 tons, so the green lamp lights up.</li> <li>• The predicted load is 24 tons, so no lamp flashes.</li> </ul>
3rd bucket	 <p>Lights up Flashes Green Yellow Red</p>	<ul style="list-style-type: none"> <li>• The weight actually loaded is 24 tons, so the green lamp lights up.</li> <li>• The predicted load is 32 tons, so the yellow lamp flashes.</li> </ul>
4th bucket	 <p>Lights up Lights up Flashes Green Yellow Red</p>	<ul style="list-style-type: none"> <li>• The weight actually loaded is 32 tons, so the green and yellow lamps light up.</li> <li>• The predicted load is 40 tons, so the red lamp flashes.</li> </ul>



## DETAILS OF DATA STORED IN MEMORY OF PAYLOAD METER

The payload meter stores the data in this section in non-volatile RAM.

This data are retained even when the power is switched OFF, so they can be used later as follows.

- (1) Using the communications cable (RS-232C), it is possible to send (download) the data to a PC, and to save these data to a CSV type text file. It is possible to read the data with Excel or any commercially available software, and to process the data and make an accounts book.
- (2) The data in the non-volatile RAM can be downloaded to a memory card inserted in the payload meter, and the data can be read from this memory card to a personal computer. After reading it to the personal computer, it can be processed in the same way as in Item (1).

### REMARK

For details of the procedure for Items (1) and (2), please see the software manual provided with the personal computer.

**CYCLE DATA**

One cycle is taken as the time from the point where the load is dumped to the point where the next load is dumped, and the data between these two points are recorded.

The cycle data are sent to the RAM every time the load is dumped.

The maximum number of cycles that can be stored in memory is 2900 cycles.

Item	Unit	Range	
Engine operation No.	Integer	1 - 65535	These show value, set value when dumping
Month	Month	1 - 12	
Day	Day	1 - 31	
Time Hour	Hour	0 - 23	
Time Min	Minute	0 - 59	
Machine ID	Integer	0 - 200	
Open ID	Integer	0 - 200	
Payload	MT or ST	0 - 6553.5	
Travel time when empty	MIN	0 - 6553.5	
Travel distance when empty	km	0 - 25.5	
Max. travel speed when empty	km/h	0 - 99	
Average travel speed when empty	km/h	0 - 99	
Stopping time when empty	MIN	0 - 6553.5	
Stopping time during loading	MIN	0 - 6553.5	
Travel time when loaded	MIN	0 - 6553.5	
Travel distance when loaded	km	0 - 25.5	
Max. travel speed when loaded	km/h	0 - 99	
Average speed when loaded	km/h	0 - 99	
Stopping time when loaded	MIN	0 - 6553.5	
Dumping time	MIN	0 - 25.5	Shows set value when dumping
Speed limit	km/h	0 - 99	
Warning items for each cycle			See (*1)
-----			
Analog spare 1			See (*2)
Max. electric potential	V	0 - 4.0	
Min. electric potential	V	0 - 4.0	
Average electric potential	V	0 - 4.0	
Analog spare 2			
Max. electric potential	V	0 - 4.0	
Min. electric potential	V	0 - 4.0	
Average electric potential	V	0 - 4.0	
Digital spare 1			
Times for Lo	Times	0 - 255	
Digital spare 2			
Times for Lo	Times	0 - 255	

(MT: Metric Ton; ST: Short Ton)

\*1: Problems and warnings that occur during the cycle are displayed simply.

For details, see the output examples in the software manual.

\*2: The data processing on the personal computer (display, printing, saving, etc.) is independent from the other data in the cycle data, and is handled as spare signal input data.

**ENGINE ON/OFF DATA**

When the engine is started or stopped, these data are recorded in RAM.

The maximum limit for engine ON/OFF data is 115 sets of ON/OFF.

Item	Unit	Range	
Engine operation No.	Integer	1 - 65535	Consecutive numbers for engine operation (*1)
Year (last 2 digits)	Year	0 - 99	Shows when engine was switched ON
Month	Month	1 - 12	
Day	Day	1 - 31	
Time Hour	Hour	0 - 23	
Time Min	Minute	0 - 59	
Year (last 2 digits)	Year	0 - 99	Shows when engine was switched OFF
Month	Month	1 - 12	
Day	Day	1 - 31	
Time Hour	Hour	0 - 23	
Time Min	Minute	0 - 59	
Total payload	MT or ST	0 - 9999000	Total payload from time engine was switched ON to time engine was switched OFF
Overall number of cycles	Times	0 - 9999	

(MT: Metric Ton; ST: Short Ton)

\*1: Every time the engine is switched ON, the engine operation No. advances by one, and is recorded. The engine operation No. in the cycle data and the engine operation No. in the problem/warning data, which are recorded from the time the engine is switched ON to the time it is switched OFF, are all recorded as an equal value. As a result, when using a personal computer later to compile the data, it is possible to determine what time during the engine operation the cycle data or system problem refers to.

**PROBLEM, WARNING DATA**

When a problem or warning occurs or is restored in the payload meter system, these data are recorded in RAM. The maximum limit for problem/warning data is 230 sets of occur/restore.

Item	Unit	Range	
Error code	-		See section on "PROBLEM AND WARNING DISPLAY (ERROR CODE)(6-53 PAGE)".
Engine operation No. when occurred	Integer	0 - 65535	(*1)
Number of times of occurrence since engine was switched ON	Times	1 - 255	
Year (last 2 digits)	Year	0 - 99	] See section on problem/warning display (error code)
Month	Month	1 - 12	
Day	Day	1 - 31	
Time Hour	Hour	0 - 23	
Time Min	Minute	0 - 59	
Engine operation No. when restored	Integer	0 - 65535	
Year (last 2 digits)	Year	0 - 99	] Shows when problem restored
Month	Month	1 - 12	
Day	Day	1 - 31	
Time Hour	Hour	0 - 23	
Time Min	Minute	0 - 59	

\*1 \*2: Every time the engine is switched ON, the engine operation No. advances by one, and is recorded. The engine operation No. in the cycle data and the engine operation No. in the problem/warning data, which are recorded from the time the engine is switched ON to the time it is switched OFF, are all recorded as an equal value. As a result, when using our personal computer later to compile the data, it is possible to determine what time during the engine operation the cycle data or system problem refers to.

When the engine operation No. is 0, it shows that the problem occurred or was restored when only the power was ON (starting switch key turned to ON), and the engine was not started.

**TOTAL PAYLOAD, OVERALL NUMBER OF CYCLES DATA**

- The total payload and overall number of cycles from any desired time are calculated and are recorded with each act of dumping.
- The calculation of both values is started from the point where the ZERO CLEAR switch is pressed for the total payload and overall number of cycles.
- Both total values can be displayed on the monitor panel by the using the operation given in "FORCED DISPLAY OF TOTAL PAYLOAD AND OVERALL NUMBER OF CYCLES (PAGE 6-33)". (See the same section for details of the method for ZERO CLEAR.)  
The total payload is also displayed automatically when dumping.
- The maximum limit that can be recorded for the total payload and overall number of cycles is 999900.0 metric tons or short tons, and 9999 cycles.

Item	Unit	Range	
Total payload	MT or ST	0 - 999900.0	] This shows the total value from the zero clear point  Data and time shows time of zero clear operation
Overall number of cycles	Times	0 - 9999	
Year (last 2 digits)	Year	0 - 99	
Month	Month	1 - 12	
Day	Day	1 - 31	
Time Hour	Hour	0 - 23	
Time Min	Minute	0 - 59	

(MT: Metric Ton; ST: Short Ton)

**OTHER DATA**

Content	Item	Unit	Range	
Set data for operator check mode	Machine ID	Integer	0 - 200	] Set using switch input operation For details, see section on operator check mode
	Open ID	Integer	0 - 200	
	Speed limit	km/h	0 - 99	
	Option code	Integer	0 - 11	
Calibration data	Year (last 2 digits)	Year	0 - 99	] Data and time when calibration was carried out
	Month	Month	1 - 12	
	Day	Day	1 - 31	
	Time Hour	Hour	0 - 23	
	Time Min	Minute	0 - 59	
Data written by user	Data 1	-	20 characters	] Comments which can be written freely to the payload meter. However, they can only be input using the cable communications from the personal computer. (See the software manual.)
	Data 2	-	20 characters	
	Data 3	-	20 characters	
	Data 4	-	20 characters	

## OPERATION OF SWITCHES

By operating the switches on the payload meter, it is possible to force the following operations.

- "CARRYING OUT CALIBRATION (PAGE 6-32)"
- "FORCED DISPLAY OF TOTAL PAYLOAD AND OVERALL NUMBER OF CYCLES (PAGE 6-33)"  
"FORCED DISPLAY OF PROBLEMS, WARNINGS WHEN THEY HAVE OCCURRED (PAGE 6-33)"
- "OPERATOR CHECK MODE (PAGE 6-35)"
  - (a) Memory card dump operation
  - (b) Data all clear operation
  - (c) Display of existing problems/warnings/restore status, status of input signals
  - (d) Machine ID setting
  - (e) Open ID setting
  - (f) Speed limit setting
  - (g) Option code setting
  - (h) Adjusting time, date
- "DIMMING LIGHTS ON MONITOR DISPLAY (PAGE 6-50)"
- "ADJUSTING BUZZER SOUND LEVEL (PAGE 6-50)"
- "SETTING MASS UNIT (SELECTING METRIC TON OR SHORT TON) (PAGE 6-50)"
- "SETTING FORCED PROHIBITION FOR SWITCHES (PAGE 6-50)"
- "SERVICE CHECK MODE (PAGE 6-51)"

## CARRYING OUT CALIBRATION

### WHEN CARRYING OUT CALIBRATION

#### NOTICE

Carry out calibration in the following cases.

- When delivering the machine, and once a month after that.
- When the oil and gas pressure for the suspension cylinder has been adjusted. (When the suspension is adjusted.)
- When the chassis has been modified and the mass of the machine when empty has changed more than 100 kilograms.
- When the suspension pressure sensor has been replaced.
- When anything else has been done to suspension related parts.

When the condition of the machine as judged by the payload meter is different from the actual condition of the dump truck. (See the precautions for "DISPLAY DURING NORMAL OPERATIONS (PAGE 6-21)".)

### METHOD OF CARRYING OUT CALIBRATION (METHOD OF OPERATION)

1. Empty the dump body. When doing this, remove all the mud that is stuck to the dump body.
2. Move the gearshift lever to the N position and keep CAL/CLR switch (1) pressed for at least 2 seconds. (The letters CAL flash)
3. Drive the machine, and when the travel speed reaches 10 km/h (6.2 MPH), press CAL/CLR switch (1). In this condition, continue to drive the machine, and if the display changes to the time display after approx. 30 seconds, the procedure is completed.
4. Move the machine to a safe place and stop the engine.
5. Start the engine again.
6. Move the dump lever as follows: FLOAT -> RAISE -> LOWER -> FLOAT.

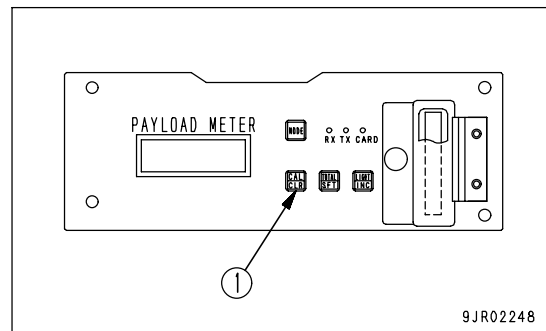

Steps 4 to 6 are additional items to perform when installing new parts, but carry out these steps also to ensure accuracy.

#### NOTICE

- Carry out this operation on flat, level ground.
- Travel in a straight line. (Distance: approx. 100 m (328 ft 1 in))
- When traveling, keep the travel speed to a range of 5 to 10 km/h (3.1 to 6.2 MPH).  
The calibration data is stored in the RAM, and is retained even if the power is switched OFF.
- If you want to stop calibration during the operation, when the letters CAL in Step 2 are flashing, press CAL/CLR switch (1) and the display will change from a flashing CAL to a flashing SCH. Press CAL/CLR switch (1) again and the display will return to the normal display.

During the normal operation display, calibration can be carried out when the dump lever is at the FLOAT position.

However, if any errors have occurred on the machine, for some of the errors, it may be impossible to carry out calibration. For details, see "PROBLEM AND WARNING DISPLAY (ERROR CODE) (PAGE 6-53)".

## FORCED DISPLAY OF TOTAL PAYLOAD AND OVERALL NUMBER OF CYCLES

### FORCED DISPLAY OF PROBLEMS, WARNINGS WHEN THEY HAVE OCCURRED

- The payload meter displays the total payload when the load is dumped, but it is also possible to use the following operation to display the total payload and overall number of cycles.
- For the total payload and overall number of cycles, each time the load is dumped, its weight is added. Furthermore, it is possible to clear this figure and return the total to 0 at any time. However, when this operation is carried out, if any problem or warning has occurred, the error code for that problem or warning is displayed in turn. (During normal operation, only the item with the highest priority is displayed.)

#### Method for forced display operation

The forced display of the total payload and overall number of cycles, clear, and forced display of the warning codes during occurrence can only be carried out if the dump lever is at the FLOAT position during the normal operation display.

If any new problem or warning should occur during the display, the system will return automatically to the display during normal operation when this happens.

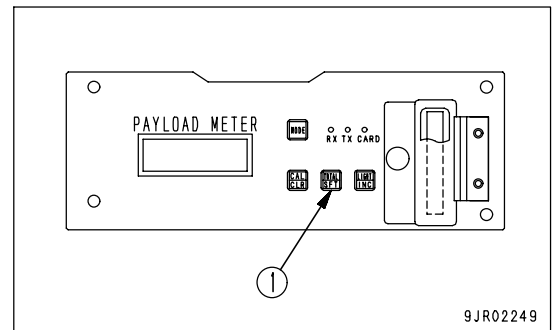

1. Press TOTAL/SFT switch (1).

2. If no problems or warnings are occurring at present

The total payload is displayed (100 t units, rounded to the nearest 100 t) (lights up).

1) Press TOTAL/SFT switch (1) again.

The overall number of cycles is displayed. (Unit: times) (lights up)

2) Press TOTAL/SFT switch (1) again.

":" is displayed (lights up) for 2 seconds, then the display returns to the display for normal operation.

3. If problems or warnings are occurring at present

The error code is displayed. (Flashes)

1) Press TOTAL/SFT switch (1) again.

If any other problem or warning is occurring at present, the next error code is displayed. (Flashes)

2) Press TOTAL/SFT switch (1) again.

If no other problem or warning is occurring at present, ":" is displayed (flashes) for 2 seconds, then the display returns to the normal operation display.

It is possible to clear all the data for total payload and overall number of cycles whenever desired.

After the values are cleared, the total payload and overall number of cycles are calculated again from 0.

#### REMARK

Before clearing the data, download the necessary data for the total payload and overall number of cycles to a personal computer or save the data to the memory card.



**Method of clearing total payload and overall number of cycles**

1. Press TOTAL/SFT switch (1) to display the total payload and overall number of cycles.
2. Keep CAL/CLR switch (2) pressed for at least 2 seconds.  
The total payload or overall number of cycles display will flash.
3. Keep CAL/CLR switch (2) pressed again for at least 2 seconds.  
After "0000" is displayed for 2 seconds, if the display returns to the normal operation display, the zero clear operation is completed.

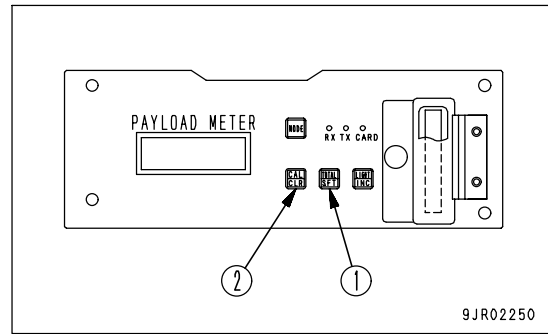
**REMARK**

- The zero clear operation for the total load and overall number of cycles is carried out at the same time. It is impossible to carry out the zero clear operation individually for only one of these items.
- The maximum limit for the total payload and overall number of cycles is as follows.  
Total payload: 999900.0 t  
Overall number of cycles: 9999 times
- If either the total payload or overall number of cycles goes above the set value, error code [H: FUL] is displayed.
- Carry out the zero clear operation for the total payload and overall number of cycles before error code [H:FUL] is displayed.
- If either the total payload or overall number of cycles exceeds the maximum limit, both values will be automatically cleared.
- Once error code [H:FUL] is displayed, it is impossible to forcibly clear the data or cancel the display until the value exceeds the limit and the data are automatically cleared.

## OPERATOR CHECK MODE

By using the operator check mode, it is possible to forcibly display, set, or correct the following.

(a) Memory card dump

The data stored in the payload meter is written en bloc to the memory card installed in the payload meter.

### REMARK

This function only works when switch "5" (memory card switch) on the left side face of the controller is set to "used."

(b) Data all clear

This forcibly erases all the cycle data, engine ON/OFF data, and problem and warning data.

The data for total payload and overall number of cycles are not cleared. For details, see "Method of clearing total payload and overall number of cycles (PAGE 6-34)".

### REMARK

Before clearing the data, download the necessary data to a personal computer or carry out (a) Memory card dump.

(c) Display of existing problems/warnings/restore status, status of input signals

This distinguishes between problems and warnings that are now occurring and problems and warnings that have occurred in the past and have been restored to normal, and automatically displays the error code.

It also partially displays the condition of the signals from the sensors that are input to the payload meter.

(d) Machine ID setting

This is used when inputting, correcting, or setting the dump truck ID.

Available range for setting: 0 - 200

### REMARK

There is no particular effect on the function of the payload meter if this is not set, but when using cable communications with the personal computer, communications cannot be carried out if the machine ID is not the same as the machine ID set in the personal computer.

(e) Open ID setting

This is used when inputting, correcting, or setting the desired ID.

Available range for setting: 0 - 200

There is no particular effect on the function of the payload meter if this is not set.

[Example of use of open ID]

Number to indicate location of work face

Operator ID number

(f) Speed limit setting

If there is a speed limit on the road that the dump truck uses, it is possible to display a warning on the payload meter if the dump truck exceeds that speed. This function is used when inputting, correcting, or setting the speed limit.

Available range for setting: 10 - 99 [km/h]

If the speed limit warning is not needed, set it to 99.

## (g) Option code setting

This is used when inputting, correcting, or setting the options to give the desired baud rate for the cable communications function (RS-232C), ON/OFF for the PMC and TALKS (if equipped), and ON/OFF for the automatic transmission function. The code can be set as shown in the table below.

Option code	Communications baud rate (bit/sec)	Automatic transmission function	Option setting		
			TALKS setting	PMC setting	Data transmission type when completing dumping (when PMC is set)
0	9600	NO	NO	NO	-
1	9600	YES	NO	NO	-
2	1200	NO	NO	NO	-
3	1200	YES	NO	NO	-
4	9600	NO	YES	NO	-
5	9600	YES	YES	NO	-
6	1200	NO	YES	NO	-
7	1200	YES	YES	NO	-
8	9600	NO	YES	YES	Z1
9	9600	NO	YES	YES	Z2
10	9600	NO	NO	YES	Z1
11	9600	NO	NO	YES	Z2

**NOTICE**

When sending (downloading) the data stored in the payload meter to the personal computer using a communications cable, always set the option code to 0 or 2 before starting. (When PMC or TALKS are installed, set the option code to a number between 4 and 11.)

We recommend that you normally set the option code to 0.

## (h) Adjusting time, date

Use this to set the time and date on the payload meter.

Of the functions in the operator check mode, the following can also be set from the personal computer using the personal computer download software supplied by Komatsu.

- Machine ID setting
- Open ID setting
- Speed limit setting
- Option code setting

Note that the option codes can only be changed from 0 to 2, from 4 to 6, or from 6 to 4.

- Adjusting time, date

For details, see the software manual.

**METHOD OF OPERATION**

The operator check mode is actuated when the dump lever is at the FLOAT position and the gearshift lever is at the N position during display for normal operations. However, it does not work during the period from the start of the loading operation to completion of the loading operation.

**NOTICE**

To operate the operator check mode, set the gearshift lever to the N position and the dump lever to the FLOAT position. If the levers are operated to any other position, the payload meter will return to the normal operation display, but the content set and input in the operator check mode may not be properly processed.

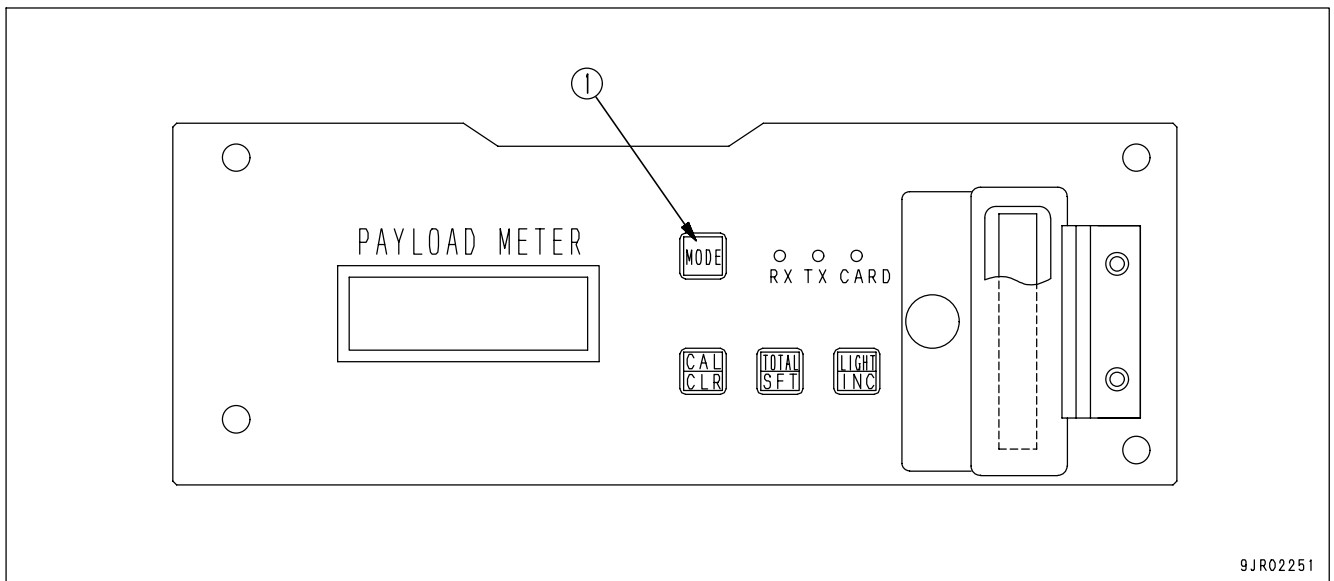

In the operator check mode, press MODE switch (1) to change the item. When the MODE switch (1) is pressed at the final item (time, date), it will return to the normal operation display.

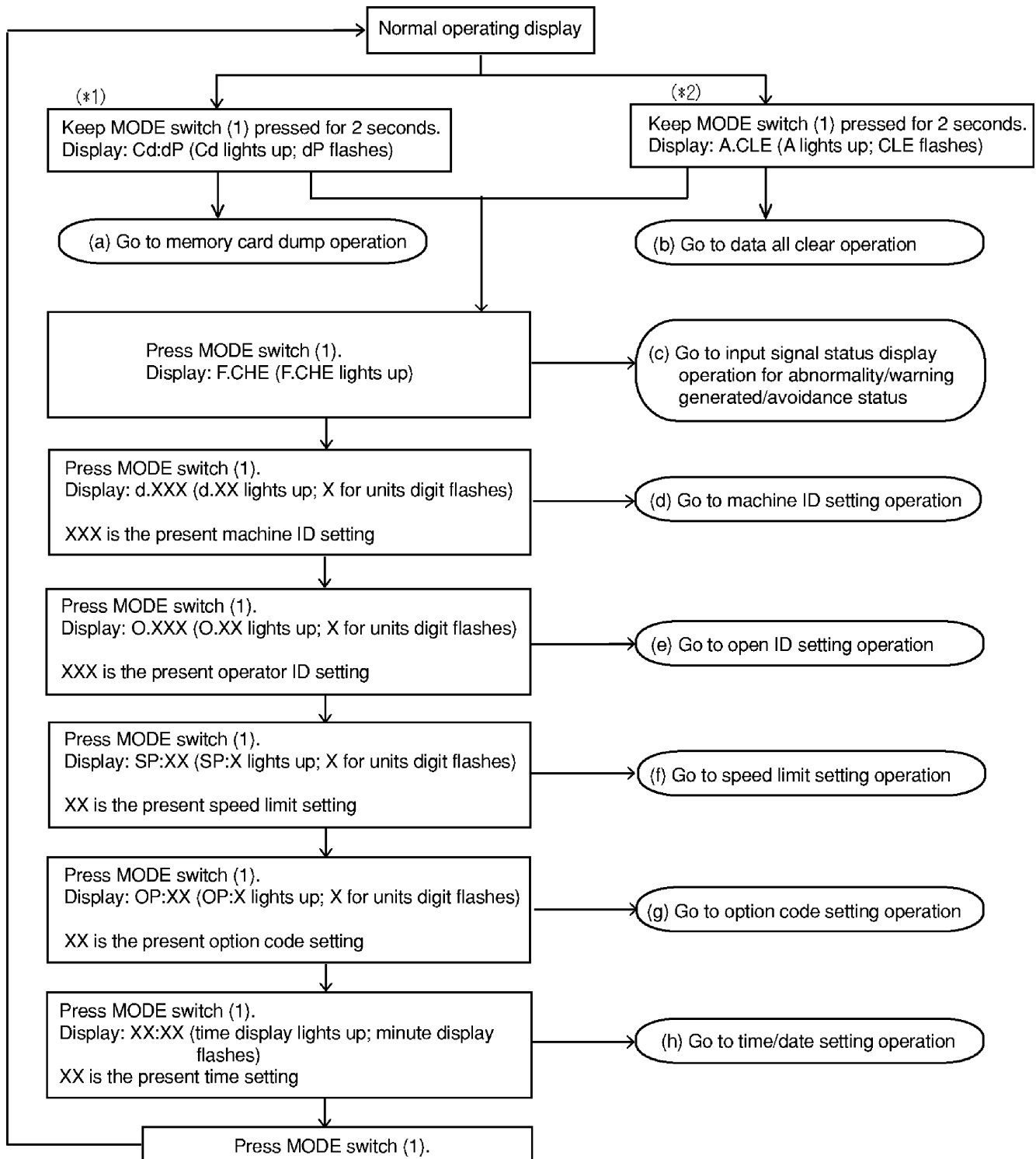

\*1: This is actuated only when switch No. 5 (memory card switch) on the left side face of the controller is set to "used".

\*2: This is actuated only when switch No. 5 (memory card switch) on the left side face of the controller is set to "not used".

(a) Memory card dump operation

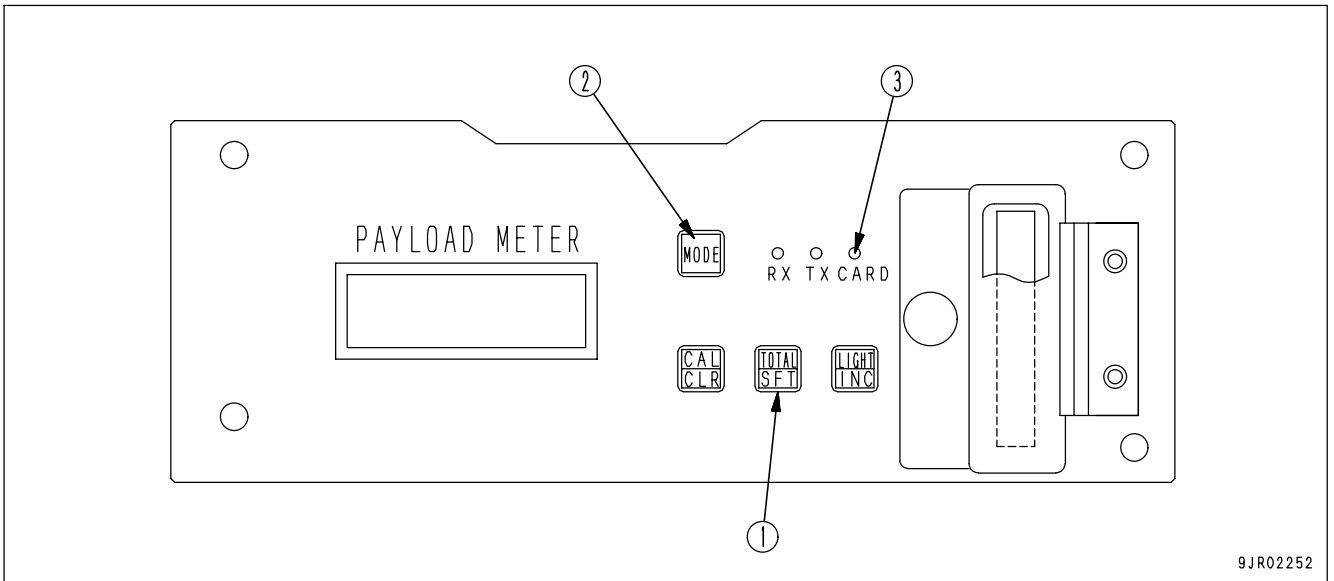

1. When the display is Cd:dP (Cd lights up, dP flashes), press TOTAL/SFT switch (1). The lighted up Cd display will change and start flashing.

**REMARK**

If you wish to stop the memory card dump operation when the display is Cd:dP (both Cd and dP are flashing), press MODE switch (2). The memory card dump operation is not carried out, and the display returns to the normal operation display.

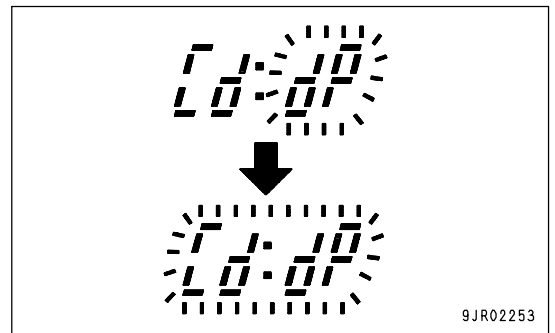

2. Press TOTAL/SFT switch (1) again.  
The panel display goes out and memory card access lamp (3) lights up.  
When the memory card dump operation is completed, it automatically returns to the normal operation display.

The memory card dump function works only when switch No. 5 (memory card switch) on the left side face of the controller is set to "used".

**(b) Data all clear operation**

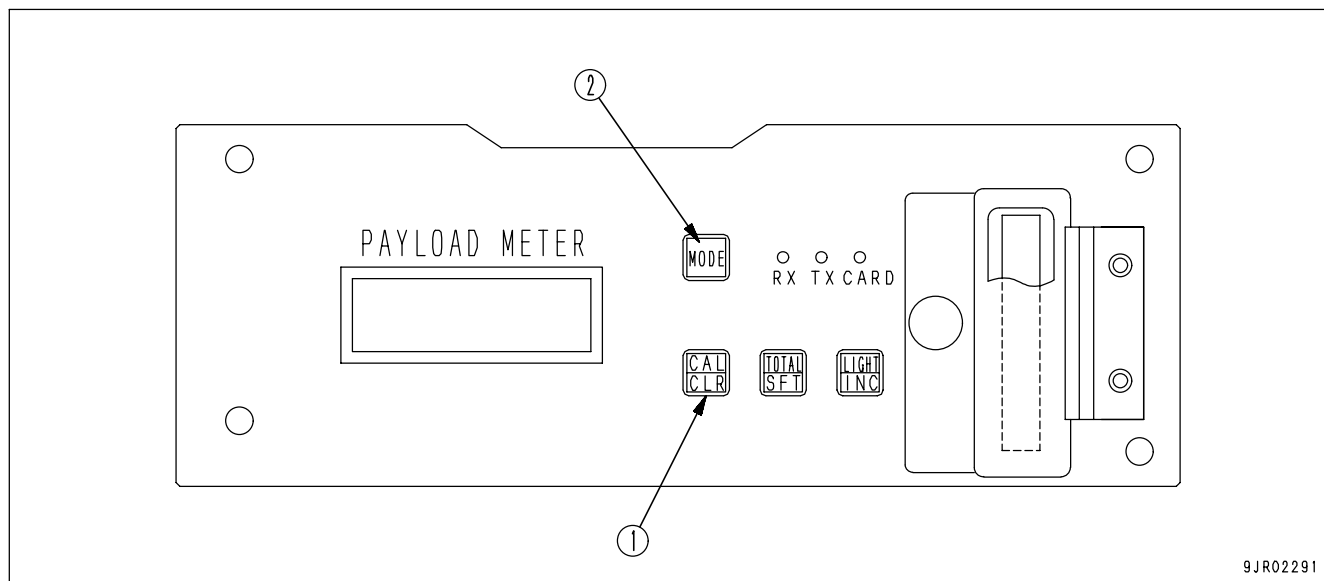

1. When the display is A.CLE (A lights up, CLE flashes), keep CAL/CLR switch (1) pressed for at least 2 seconds. The lighted up A display will change and start flashing.

**REMARK**

If you wish to stop the data all clear operation when the display is A.CLE (both A and CLE are flashing), press MODE switch (2). The data all clear operation is not carried out, and the display returns to the normal operation display.

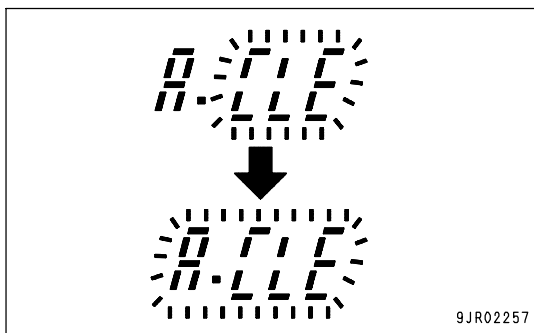

2. Keep CAL/CLR switch (1) pressed again for at least 2 seconds.  
A.CLE lights up, and when the data clear operation is completed, the display automatically returns to the normal operation display.

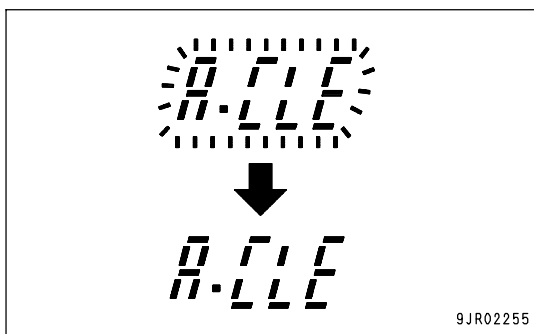

**REMARK**

Before clearing the data, download the necessary data to a personal computer or carry out (a) Memory card dump operation.

(c) Display of existing problems/warnings/restore status, status of input signals

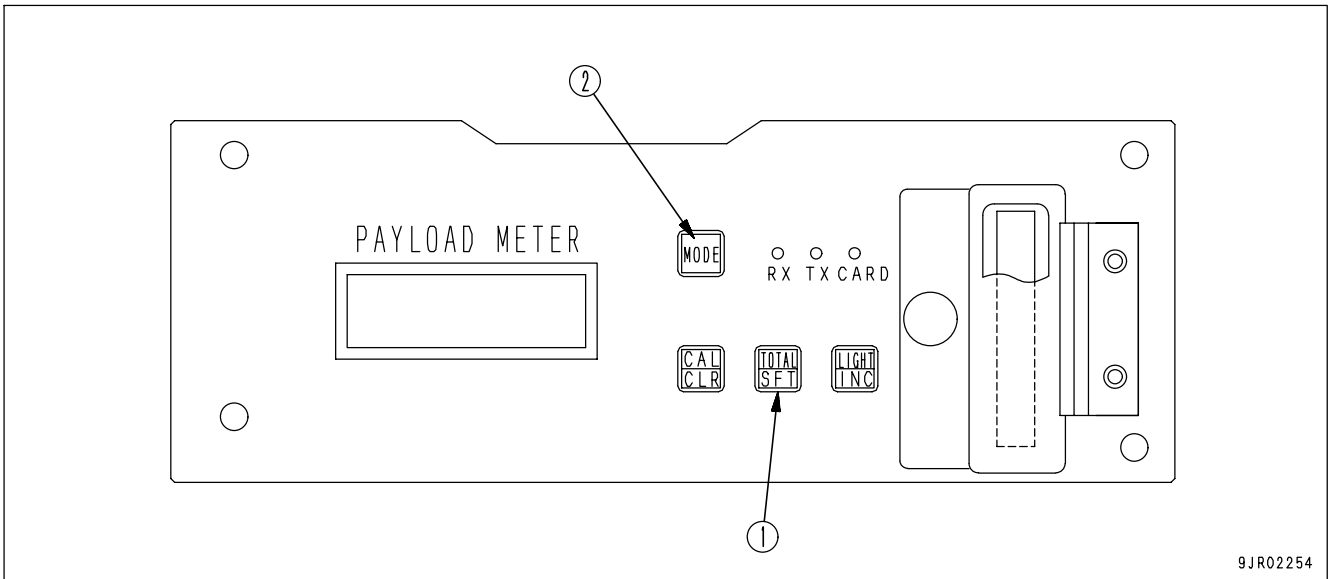

1. When the display is F.CHE (flashing), press TOTAL/SFT switch (1). The existing problems or warnings will be shown as follows.
  - 1) If there are no existing problems or warnings, F.--- (flashing for 6 sec.) is displayed.
  - 2) If there are any existing problems or warnings, The error codes are displayed in turn. (The error codes flash for 6 sec. each.)
  
2. The system will then automatically proceed to the following display for problems and warnings that have occurred in the past.
  - 1) If no problems or warnings have occurred in the past (there is no record of occurrence or restoration in the payload meter), F.--- (flashing for 3 sec.) is displayed.
  - 2) If any problems or warnings have occurred in the past, but the condition has now been restored, The error codes are displayed in turn. (The error codes flash for 3 sec. each.) After all the error codes for problems that occurred in the past have been displayed, F.--- (lights up for 3 sec.) is displayed.
  
3. The system will then automatically proceed to the following display for sensor signals input to the payload meter.
  - 1) Condition of signal for gearshift lever position  
 Display: C1:XX (lights up for 3 sec.)  
 "N": C1:oo  
 Other than "N" : C1:--
  - 2) Condition of signal for dump lever position  
 Display: C2:XX (lights up for 3 sec.)  
 FLOAT: C2:oo  
 Other than FLOAT: C2:--
  - 3) Condition of signal for engine oil pressure  
 Display: C3:XX (lights up for 3 sec.)  
 Engine running: C3:oo  
 Engine stopped: C3:--



- 4) Condition of signal for battery charge  
Display: C4:XX (lights up for 3 sec.)  
Engine running: C4:00  
Engine stopped: C4:--
  - 5) Condition of signal for analog spare input 1  
Display: C5:XX (lights up for 3 seconds)  
XX: Input signal (V)
  - 6) Condition of signal for analog spare input 2  
Display: C6:XX (lights up for 3 seconds)  
XX: Input signal (V)
  - 7) Condition of signal for digital spare input 1  
Display: C7:XX (lights up for 3 sec.)  
Hi: C7:00  
Lo: C7:--
  - 8) Condition of signal for digital spare input 2  
Display: C8:XX (lights up for 3 sec.)  
Hi: C8:00  
Lo: C8:--
4. With the display for Step 3.8), press TOTAL/SFT switch (1) and return again to Step 1.1) or Step 1.2).
5. If MODE switch (2) is pressed at any time from the display following Step 1.1) or Step 1.2) up to Step 3.8), the display will return to the normal operation display.

(d) Machine ID setting

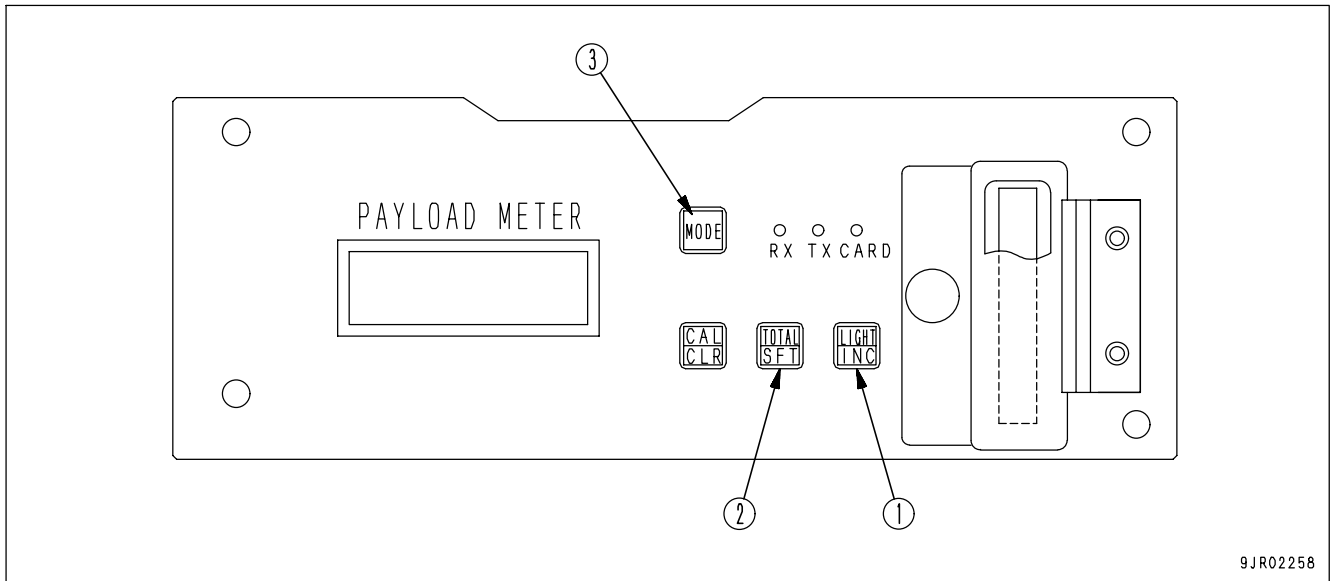

9JR02258

1. With the display at d.XXX (d.XX lights up, digit for units flashes), if it is necessary to correct the digit for the units, press LIGHT/INC switch (1) and correct the number.

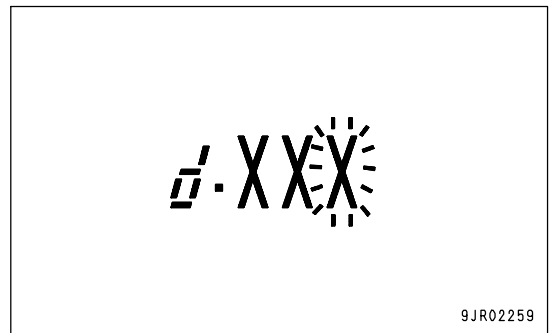

9JR02259

2. Press TOTAL/SFT switch (2).  
The flashing digit in d.XXX moves one place to the left and it is possible to correct the digit for the tens.  
If it is necessary to correct the digit for the tens, press LIGHT/INC switch (1) and correct the number.

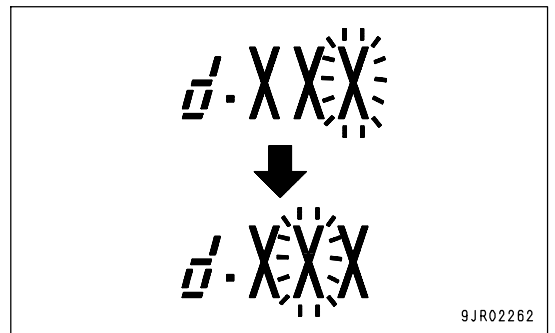

9JR02262

3. Press TOTAL/SFT switch (2).  
The flashing digit in d.XXX moves one place to the left and it is possible to correct the digit for the hundreds.  
If it is necessary to correct the digit for the hundreds, press LIGHT/INC switch (1) and correct the number.

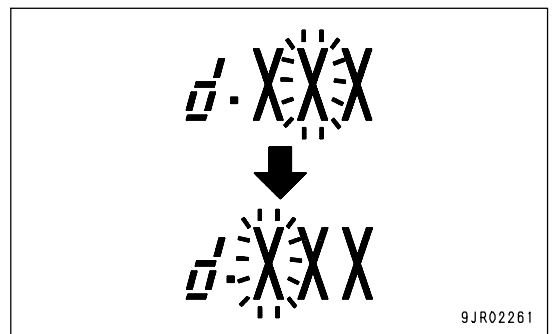

9JR02261

4. If TOTAL/SFT switch (2) is pressed again, the flashing digit will return to the digit for the units and it becomes possible to correct the units again.
5. After completing the correction of the Machine ID, press MODE switch (3). The display will return to the normal operation display.  
If the number that has been input is not permitted, when MODE switch (3) is pressed, the display will return to Step 1.

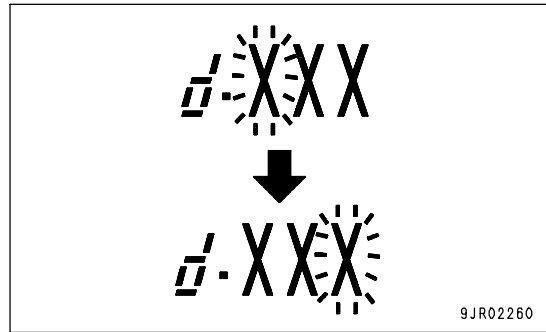

(e) Open ID setting

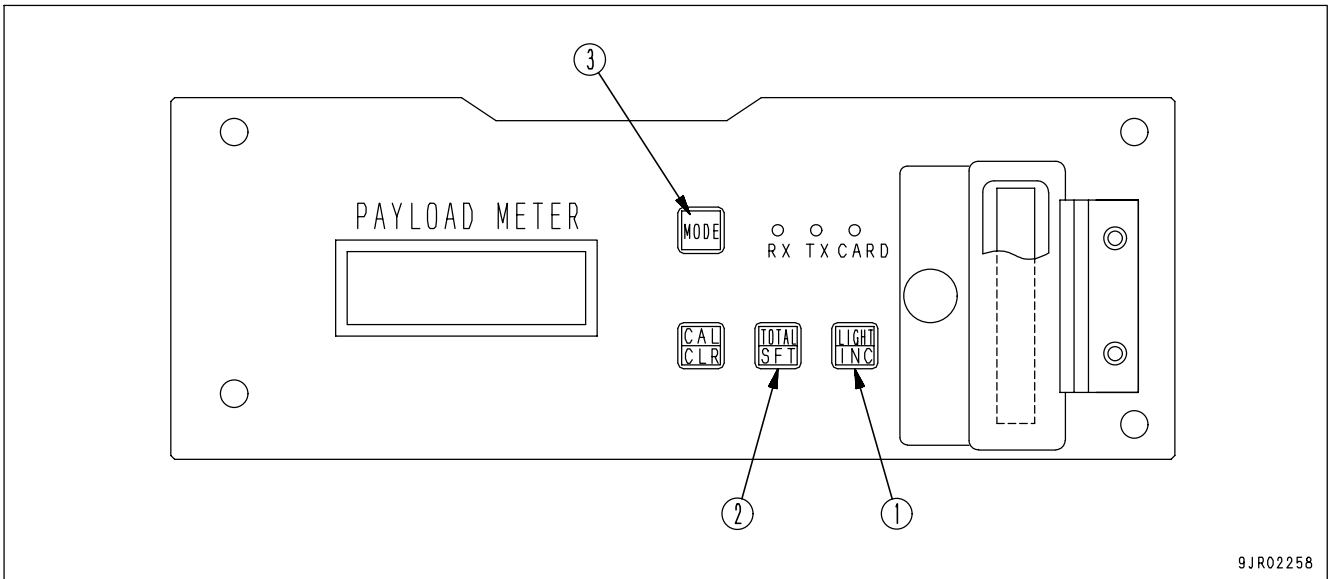

1. With the display at O.XXX (O.XX lights up, digit for units flashes), if it is necessary to correct the digit for the units, press LIGHT/INC switch (1) and correct the number.

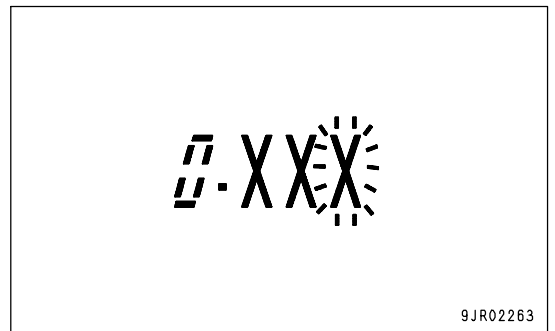

2. Press TOTAL/SFT switch (2).  
The flashing digit in O.XXX moves one place to the left and it is possible to correct the digit for the tens.  
If it is necessary to correct the digit for the tens, press LIGHT/INC switch (1) and correct the number.

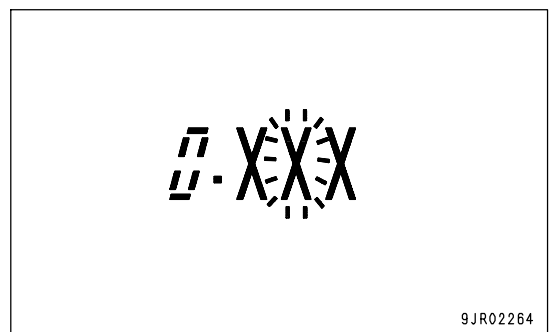

3. Press TOTAL/SFT switch (2).  
The flashing digit in O.XXX moves one place to the left and it is possible to correct the digit for the hundreds.  
If it is necessary to correct the digit for the hundreds, press LIGHT/INC switch (1) and correct the number.

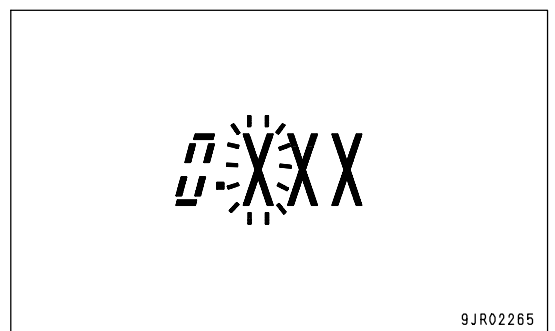

4. If TOTAL/SFT switch (2) is pressed again, the flashing digit will return to the digit for the units and it becomes possible to correct the units again.
5. After completing the correction of the Open ID, press MODE switch (3). The display will return to the normal operation display.  
If the number that has been input is not permitted, when MODE switch (3) is pressed, the display will return to Step 1.

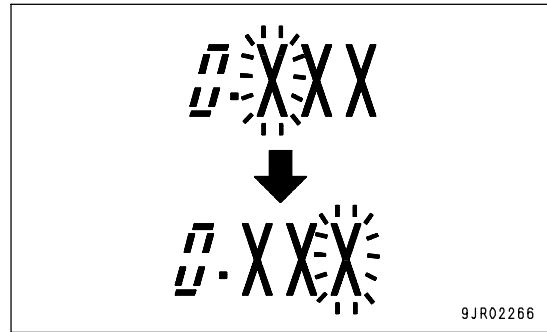

(f) Speed limit setting

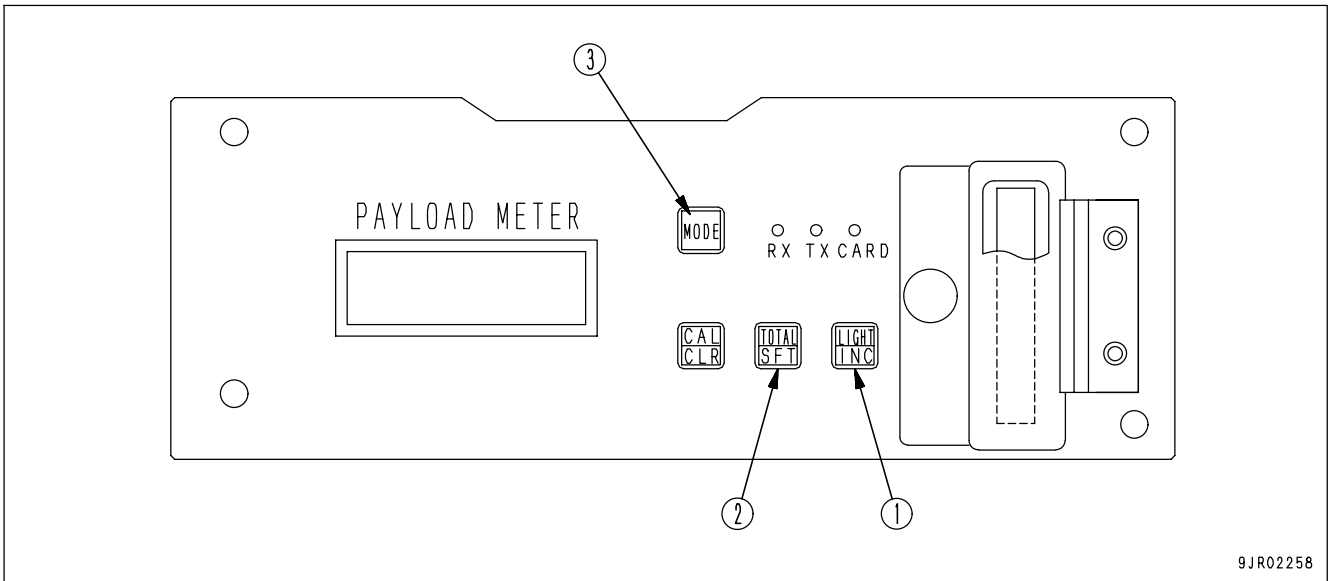

9JR02258

1. With the display at SP.XX (SP.X lights up, digit for units flashes), if it is necessary to correct the digit for the units, press LIGHT/INC switch (1) and correct the number.

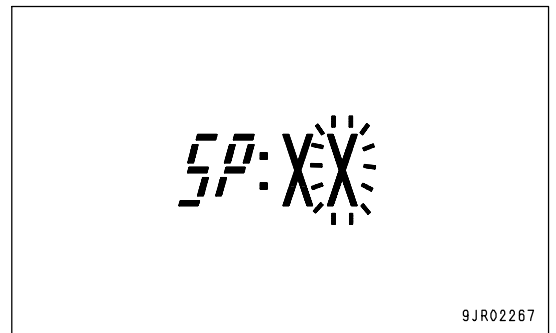

9JR02267

2. Press TOTAL/SFT switch (2).  
The flashing digit in SP.XX moves one place to the left and it is possible to correct the digit for the tens.  
If it is necessary to correct the digit for the tens, press LIGHT/INC switch (1) and correct the number.

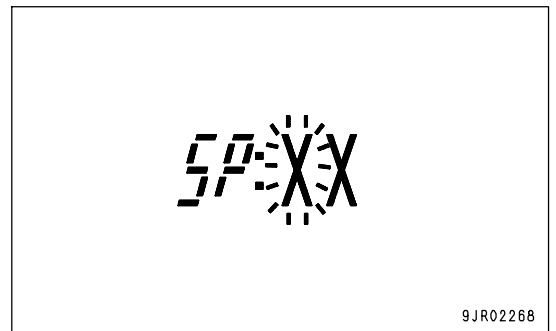

9JR02268

3. If TOTAL/SFT switch (2) is pressed again, the flashing digit will return to the digit for the units and it becomes possible to correct the units again.

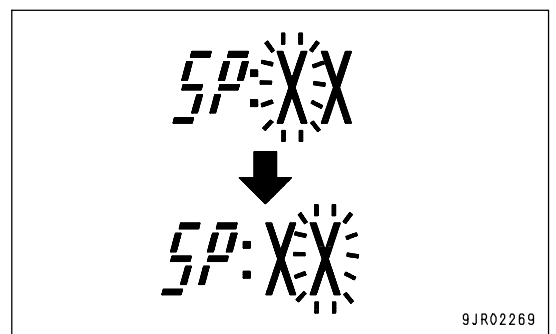

9JR02269

4. After completing the correction of the Speed Limit, press MODE switch (3). The display will return to the normal operation display.  
If the number that has been input is not permitted, when MODE switch (3) is pressed, the display will return to Step 1.

(g) Option code setting

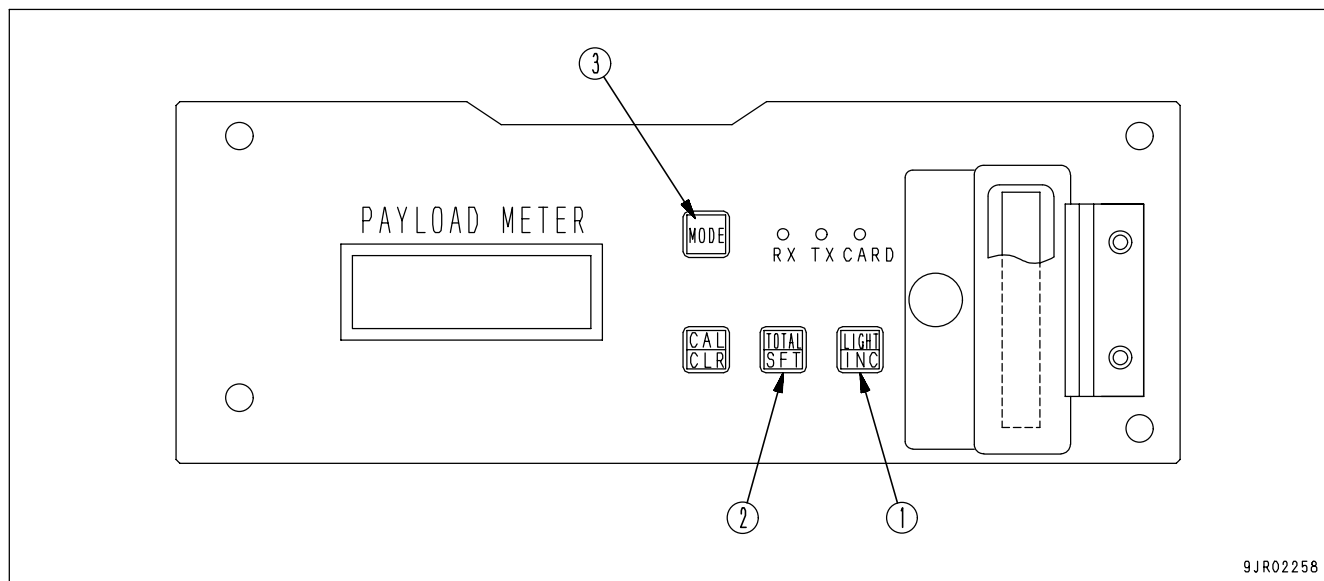

1. With the display at OP.XX (OP.X lights up, digit for units flashes), if it is necessary to correct the digit for the units, press LIGHT/INC switch (1) and correct the number.

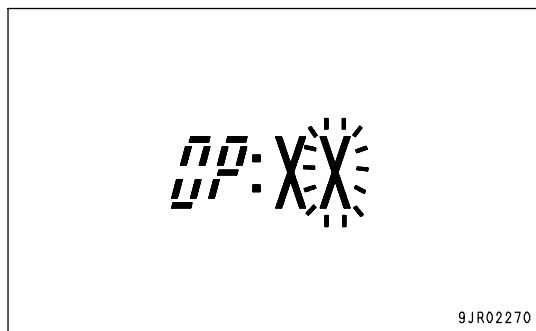

2. Press TOTAL/SFT switch (2).  
The flashing digit in OP.XX moves one place to the left and it is possible to correct the digit for the tens.  
If it is necessary to correct the digit for the tens, press LIGHT/INC switch (1) and correct the number.

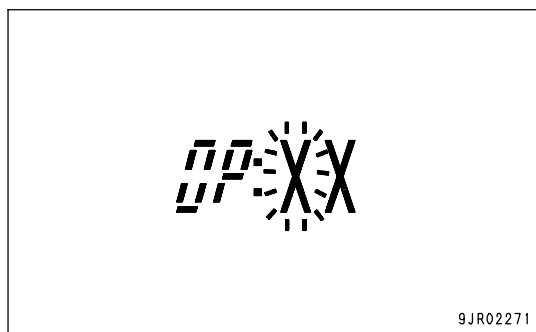

3. If TOTAL/SFT switch (2) is pressed again, the flashing digits will return to the digit for the units and it becomes possible to correct the units again.

4. After completing the correction of the Option Code, press MODE switch (3). The display will return to the normal operation display.  
If the number that has been input is not permitted, when MODE switch (3) is pressed, the display will return to Step 1.

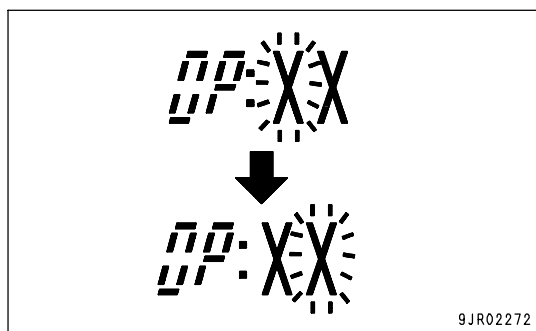

(h) Adjusting time, date

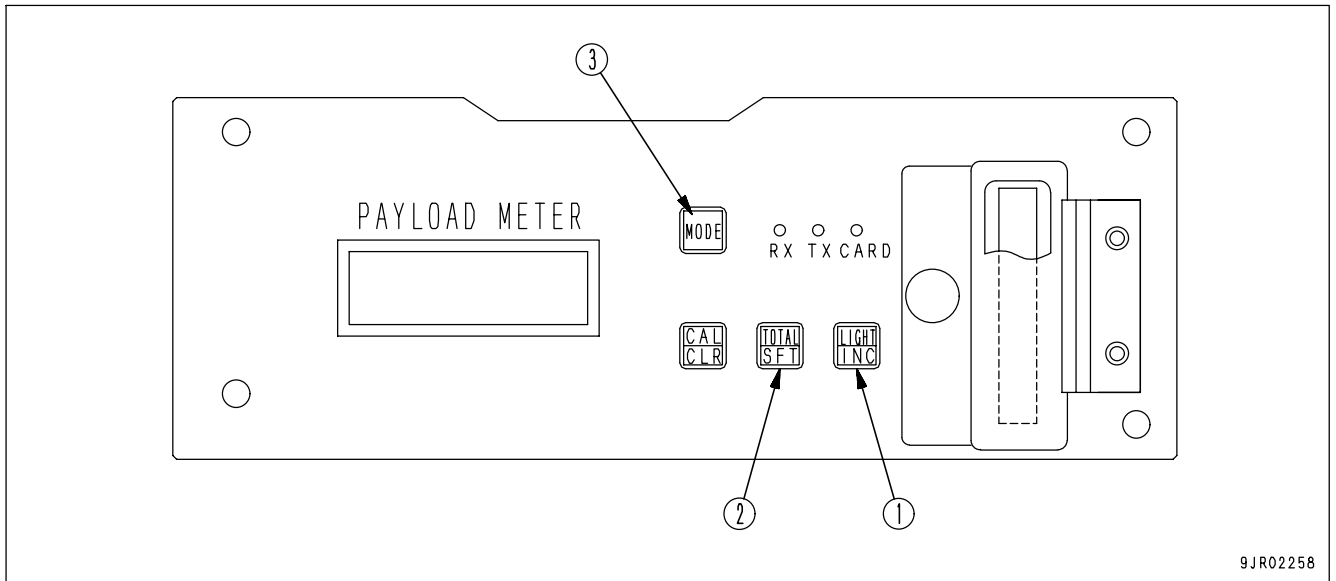

9JR02258

1. With the display at XX.XX (Time display lights up, Minute display flashes), if it is necessary to correct the minute display, press LIGHT/INC switch (1) and correct the number.

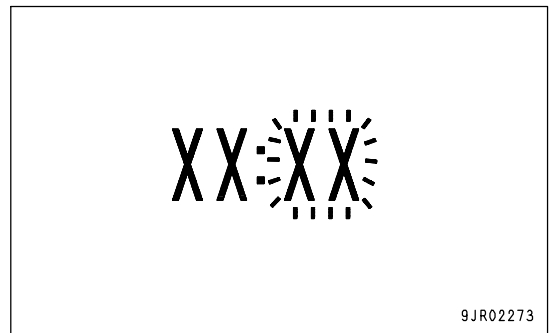

9JR02273

2. Press TOTAL/SFT switch (2).  
The flashing location moves from the minute display to the hour display and it is possible to correct the hour display.  
If it is necessary to correct the hour display, press LIGHT/INC switch (1) and correct the number.  
Display the time as a 24-hour clock.

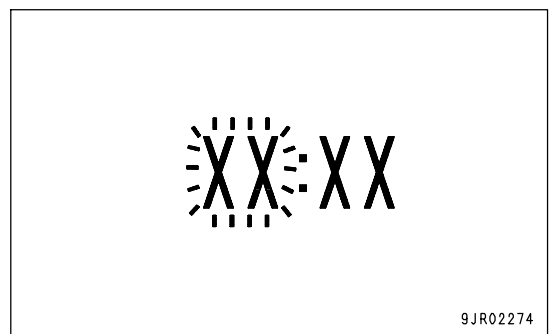

9JR02274

3. Each time TOTAL/SFT switch (2) is pressed, the flashing location will change Day, Month, Year. If it is necessary to correct, press LIGHT/INC switch (1) and correct the number.

4. When the year display is flashing, if TOTAL/SFT switch (2) is pressed again, the flashing location will return to the minute display and it becomes possible to correct the minute display again.

5. After completing the correction of the time and date, press MODE switch (3). The display will return to the normal operation display.



## DIMMING LIGHTS ON MONITOR DISPLAY

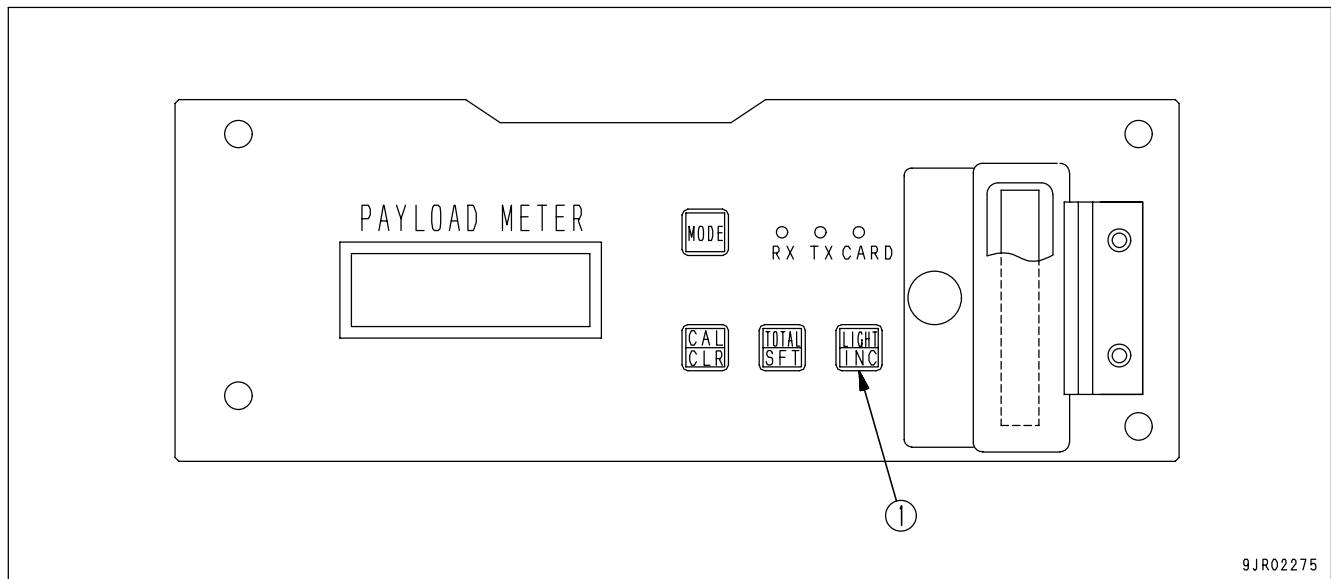

If you want to change the brightness of the monitor display, do as follows.

Press LIGHT/INC switch (1). Each time the switches pressed, the lighting will become one level darker; and if the switches pressed when that the lighting is darkest, it will return to the brightest level.

The brightness can be changed in ten stages.

If the switch is kept pressed, the brightness will change continuously.

## ADJUSTING BUZZER SOUND LEVEL

For details, see "LEFT FACE OF CONTROLLER (PAGE 6-16)".

### NOTICE

The switches on the left side are set when the machine is shipped from the factory.

Do not touch any switch except No. 7 and No. B.

If you wish to adjust any switch except No. 7 and No. B to compensate the payload calculation value or speed or distance calculation value, please contact your Komatsu distributor.

## SETTING MASS UNIT (SELECTING METRIC TON OR SHORT TON)

For details, see "LEFT FACE OF CONTROLLER (PAGE 6-16)".

The payload display unit changes from the point where the setting for the mass unit is changed.

The values stored in the payload meter memory will also have the unit changed for any data put into memory from the time the setting is changed.

Is not possible to convert units or data already stored in payload meter memory, so before switching the units, we recommend that you download all the data to the personal computer or carry out the memory card dump.

### NOTICE

The switches on the left side are set when the machine is shipped from the factory.

Do not touch any switch except No. 7 and No. B.

If you wish to adjust any switch except No. 7 and No. B to compensate the payload calculation value or speed or distance calculation value, please contact your Komatsu distributor.

## SETTING FORCED PROHIBITION FOR SWITCHES

For details, see "LEFT FACE OF CONTROLLER (PAGE 6-16)".

In addition, when setting forced prohibition for the switches, please ask your Komatsu distributor.

## SERVICE CHECK MODE

By operating the service check mode, it is possible to carry out display, setting, and correction forcibly of the following items.

If it is designed to correct the method of operation and setting, please ask your Komatsu distributor.

(a) Detailed display of calibration data

This display shows the data, suspension pressure, etc. for the latest calibration.

(b) Detailed display of payload calculation data (analog data)

The display shows the suspension pressure and machine angle when calculating the present payload.

(c) Memory card dump (service area)

This writes all the data displayed for (a) and (b) to the memory card installed in the body.

(d) Data all clear (service area)

This forcibly deletes (a) calibration data and (b) analog data, except for the latest calibration data.

(e) Input signal status display

This displays some of the signal status for the sensors input to the payload meter and the present recognition status display of the payload meter.

(f) Forced initialization

This forcibly deletes all the data in the payload meter.

(g) Extra payload setting when loading

The extra load for the payload can be forcibly input, corrected, or set when loading.

(h) Payload fixed display and cycle data recording, payload value setting

1. The payload fixed display

1) When TALKS is not set: Time that machine is stopped after traveling 160 m with at least 50% of set payload loaded until starting to dump

2) When TALKS is set: Time that machine is stopped from permission to move off until starting to dump

When displaying the payload in 1) or 2), it is possible to input, correct, or set the displayed payload and completion of loading (when traveling 160 m with at least 50% of the set payload loaded or when starting to dump), not the real-time payload.

2. Cycle data recording, switching payload value

If the payload fixed display in Item 1 above is applicable, this inputs, corrects, or sets the payload in the cycle data to the fixed display payload value.

(i) Setting loading completion recognition travel distance

This inputs, corrects, or sets the travel distance recognized as completion of loading by the payload meter.

(j) Setting loading start recognition payload

This inputs, corrects, or sets the payload recognized as the start of loading by the payload meter.

(k) Setting 0 ton display range

This inputs, corrects, or sets the range for the zero display on the payload display.

## (I) Setting external display lamp display range

This inputs, corrects, or sets the payload range for the lamps to light up when displaying the payload.

Of the functions in the service check mode, the following can also be set from the personal computer using the personal computer download software supplied by Komatsu.

- Calibration data
- Payload calculation data (analog data)

**PROBLEM AND WARNING DISPLAY (ERROR CODE)**

The payload meter always carries out self-diagnosis of the system, and if any problem or warning occurs, it is displayed by the monitor panel and the external display lamps.

For details of the detection items and displays, see the problem and warning item table.

**NOTICE**

- If any problem or warning occurs, if it is within the timing possible for display, it is displayed on the monitor panel and the buzzer sounds for 3 seconds.
- If a problem or warning is currently being displayed, and another problem which has low priority for display occurs, if the timing possible for display overlaps, the newly occurring problem will be displayed and the buzzer will sound for 3 seconds. Following this, the problems and warnings will be displayed according to the timing possible for display. If the timing possible for display overlaps, the problem with the higher display priority in the chart is displayed.

Priority of display	Content	Judgment standard	Content of error code display			Timing possible for display	Recording of problem and warning data (display code for personal computer software)	Remarks								
			Panel display	External display lamps	Display canceled											
1	Dump lever not at FLOAT (except when dumping)	-	b-FL lights up	All flash	When problem is removed	Gearshift lever at N	-	-								
			b-FL lights up	-	When problem is removed				Gearshift lever at position other than N	-						
2	Memory card removed	-	Cd flashes	-	When problem is removed	Removal detection only for card dump	-	Detected only when card dump operation is run								
3	Drop in backup battery voltage	Defective contact or voltage below 2.7V	F-09 flashes	-	When problem is removed	Except when loading	Record (000-009)	Rated voltage: 3.6V								
									4	Cycle data memory FULL	See (*1)	Except when loading	Record (000-011)	-		
															Engine ON/OFF data memory FULL	(000-012)
															Problem, warning data memory FULL	(000-013)
Total payload, overall number of cycles data memory FULL	(000-014)															
5	Disconnection at R terminal	Output with the engine running is less than 2V	F-18 flashes	All flash	When problem is removed	When engine is running	Record (000-018)	-								
6	Problem in sensor power source (18V)	Output below 1.5V and power source voltage over 20V	F-20 flashes	All flash	When problem is removed	When normal	Record (000-020)	Calibration cannot be carried out when problem has occurred								

Priority of display	Content	Judgment standard	Content of error code display			Timing possible for display	Recording of problem and warning data (display code for personal computer software)	Remarks
			Panel display	External display lamps	Display canceled			
7	Short circuit or disconnection in front left suspension sensor system	Suspension pressure sensor input signal 0 kg/cm <sup>2</sup> or below	F-21 flashes	All flash	When problem is removed	When normal	Record (000-021)	Calibration cannot be carried out when problem has occurred
			F-22 flashes					
			F-23 flashes					
			F-24 flashes					
8	Short circuit or disconnection in front right suspension sensor system	Suspension pressure sensor input signal 200 kg/cm <sup>2</sup> or above	F-25 flashes	All flash	When problem is removed	When normal	Record (000-025)	Calibration cannot be carried out when problem has occurred
			F-26 flashes					
			F-27 flashes					
			F-28 flashes					
9	Short circuit or disconnection in rear left suspension sensor system	Suspension pressure sensor input signal 0 kg/cm <sup>2</sup> or below	F-31 flashes	All flash	When problem is removed	When normal	Record (000-031)	Applicable only when clinometer switch is set to "used"
			F-32 flashes					
10	Short circuit or disconnection in rear right suspension sensor system	Suspension pressure sensor input signal 200 kg/cm <sup>2</sup> or above	F-31 flashes	All flash	When problem is removed	When normal	Record (000-032)	Calibration cannot be carried out when problem has occurred
			F-32 flashes					
11	Short circuit or disconnection in clinometer system	Clinometer input signal more than +100 EG or more	F-31 flashes	All flash	When problem is removed	When normal	Record (000-031)	Applicable only when clinometer switch is set to "used"
			F-32 flashes					
12	Short circuit or disconnection in clinometer system	Clinometer input signal more than -100 EG or more	F-31 flashes	All flash	When problem is removed	When normal	Record (000-032)	Calibration cannot be carried out when problem has occurred
			F-32 flashes					
13	Short circuit or disconnection in clinometer system	Recorded data for calibration corrupted	F-31 flashes	All flash	When problem is removed	When normal	Record (000-031)	Calculation of payload is stopped when problem has occurred
			F-32 flashes					
14	Short circuit or disconnection in clinometer system	Recorded data for calibration corrupted	F-31 flashes	All flash	When problem is removed	When normal	Record (000-031)	Calculation of payload is stopped when problem has occurred
			F-32 flashes					
15	Short circuit or disconnection in clinometer system	Recorded data for calibration corrupted	F-31 flashes	All flash	When problem is removed	When normal	Record (000-031)	Calculation of payload is stopped when problem has occurred
			F-32 flashes					
16	Short circuit or disconnection in clinometer system	Recorded data for calibration corrupted	F-31 flashes	All flash	When problem is removed	When normal	Record (000-031)	Calculation of payload is stopped when problem has occurred
			F-32 flashes					
17	Calibration not carried out or problem in RAM	Recorded data for calibration corrupted	F-31 flashes	All flash	When problem is removed	When normal	Record (000-031)	Calculation of payload is stopped when problem has occurred
			F-32 flashes					

Priority of display	Content	Judgment standard	Content of error code display			Timing possible for display	Recording of problem and warning data (display code for personal computer software)	Remarks
			Panel display	External display lamps	Display canceled			
18	Short circuit in No. 1 relay for external display lamps	When coil continuity is ON, relay coil is short circuited with power source	F-41 flashes	See Remarks column	When problem is removed	Except when loading (see Remarks column for details of external display lamps)	Record (000-041)	External lamps are actuated as follows  Applicable lamps Machine stopped: Always ON When traveling: OFF  Other lamps When loading: Standard actuation When not loading Machine stopped: Flash When traveling: OFF
19	Short circuit in No. 2 relay for external display lamps		F-42 flashes				(000-042)	
20	Short circuit in No. 3 relay for external display lamps		F-43 flashes				(000-043)	
21	Short circuit in No. 4 relay for external display lamps		F-44 flashes				(000-044)	
22	Short circuit in No. 5 relay for external display lamps		F-45 flashes				(000-045)	
23	Defective payload for cycle data (*2)		See (*2)	L.bad flashes	-		Empty machine starts to travel	
24	Exceeding speed limit	Travel speed exceeds set speed limit	SP: SP flashes	-	Set value -2 km/h	When problem has occurred	-	-
25	Defective communications or defective setting of option code		F-71 flashes F-73 flashes F-80 flashes F-81 flashes F-91 flashes F-92 flashes F-93 flashes F-94 flashes F-95 flashes F-96 flashes F-97 flashes F-98 flashes F-99 flashes	-	When problem is removed	-	Record (000-071) (000-073) (000-080) (000-081) (000-091) (000-092) (000-093) (000-094) (000-095) (000-096) (000-097) (000-098) (000-099)	-

**\*1: Warning display when memory is full**

## 1. Cycle data

- 1) If more than 2600 cycles are recorded (less than 300 cycles remaining):

L: FUL flashes 7 times

: flashes 1 time

This is repeated.

- 2) If more than 2900 cycles are recorded (0 cycles remaining):

L: FUL lights up (3 sec.)

: flashes 1 time

This is repeated.

- 3) If more cycles are recorded, cycles 2901 and 2902 are recorded, but each time, the oldest cycle data is deleted in turn to make space to record the new cycle.

(The display stays the same as in condition 2.)

## 2. Engine ON/OFF data

- 1) If more than 105 sets are recorded (less than 10 sets remaining):

E: FUL flashes 7 times

: flashes 1 time

This is repeated 2 times, then the display goes out.

- 2) If more than 115 sets are recorded (0 sets remaining):

E: FUL lights up (3 sec.)

: flashes 1 time

This is repeated 2 times, then the display goes out.

- 3) If more sets are recorded, sets 116 and 117 are recorded, but each time, the oldest ON/OFF data is deleted in turn to make space to record the new set.

## 3. Problem and warning data

- 1) If more than 220 sets are recorded (less than 10 sets remaining):

F: FUL flashes 7 times (3 sec.)

: flashes 1 time

This is repeated.

- 2) If more than 230 sets are recorded (0 sets remaining):

F: FUL lights up (3 sec.)

: flashes 1 time

This is repeated.

- 3) If more problems or warnings are generated, sets 231 and 232 are recorded, but each time, the oldest problem and warning data are deleted in turn to make space to record the new set.

(The display stays the same as in condition 2.)



4. Data for total payload, overall number of cycles

- 1) If the overall number of cycles goes above 9994 (less than 5 times remaining) or the difference between the total payload recorded in memory and 999900 tons (maximum limit) is less than 5 times the rated payload:

H: FUL flashes 7 times (3 sec.)

: flashes

This is repeated.

- 2) If the overall number of cycles goes above 9997 (less than 2 times remaining) or the difference between the total payload recorded in memory and 999900 tons (maximum limit) is less than 2 times the rated payload:

H: FUL lights up (3 sec.)

: flashes 1 time

This is repeated.

- 3) If the overall number of cycles reaches 9999 times or the total payload exceeds 999900 tons, both the total payload and the overall number of cycles are cleared automatically. The data for both values are then calculated again from 0.

(The display returns to the normal operation display.)

5. To cancel the data FULL for Items 1 to 3, see "OPERATOR CHECK MODE (PAGE 6-35)". If data FULL is displayed for Item 4, it cannot be canceled until it is automatically cleared. Before the data FULL display appears, use the forced ZERO CLEAR to clear the data.

For details of the method of operation, see "FORCED DISPLAY OF TOTAL PAYLOAD AND OVERALL NUMBER OF CYCLES (PAGE 6-33)".

6. There is no order of priority for displays 1 to 4.

If multiple data 4 occur at the same time, they are displayed in order except during loading.

**\*2: Defective cycle data payload**

The payload meter carries out the detection of the payload based on the signal from the suspension pressure sensor. It is always carrying out this detection, but the result is somewhat inaccurate because of the dynamic friction of the suspension during loading and immediately after loading. To make the recorded payload more accurate, the payload meter records the payload by detecting the payload immediately before dumping, where the dynamic friction of the suspension while the machine is being loaded is canceled by traveling with the machine loaded, and this is written to the memory. (It is recorded as one part of the cycle data.)

For this reason, if the dumping operation (operation of the dump lever) is carried out while the chassis is still pitching after the machine is stopped at the dumping point, the payload sent to the payload meter memory may not be accurate.

In addition, if the dump truck is stopped at the dumping point by braking suddenly, or if it mounts the blocks used to stop the wheels, or hits something and stops, the payload that is sent to the memory may not be accurate.

If the load is dumped while the machine is still pitching as in the conditions given above, the payload meter will display "Defective cycle data payload" in than the chart of Problem and Warning Items to warn the operator. In this case, the detected payload is also written to memory.

**NOTICE**

- When stopping the machine at the dumping point, avoid braking suddenly, mounting rocks or the blocks used to stop the wheels, or hitting things.
- When operating the dumped lever to dumped the load, stop the machine at the dumping point and wait for the pitching to stop before operating the lever.  
(As a guideline, wait for at least 3 sec after stopping the machine before operating the dumped lever.)
- Make the dumping point as horizontal as possible, and makes the unevenness of the travel path as small as possible.

## WHEN ERROR CODE F-09 IS DISPLAYED (PROCEDURE FOR REPLACING BATTERY)

The payload meter has an internal battery to prevent the recorded data from being deleted when the key in the starting switch is turned to the OFF position.

If the voltage of the battery drops, F-09 is displayed as an error message, so replace the battery as follows.

### REPLACING BATTERY



### CAUTION

When replacing the battery, unload the machine and move it to a safe place.

- Parts to prepare
  - Crosshead screwdriver
  - New battery (581-86-55710)

#### NOTICE

- Remove your gloves when carrying out the operation.
- Be careful not to let any dirt or metal particles get inside the controller.
- Be careful not to drop any nuts or washers inside the controller.

1. Turn the key in the starting switch to the ON position and download the data stored in the payload meter to a personal computer, or carry out the memory card dump operation.

#### NOTICE

When doing this, do not start the engine.

2. Return the starting switch to the OFF position.
3. Remove 4 screws (1) (M6) holding the payload meter, then pull the payload meter to the front.

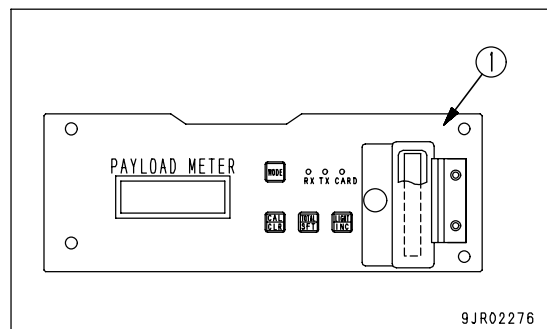

4. Remove the connector, remove screws (3) (top surface M3 x 9, left face M3 x 4) from top cover (2) of the payload meter, then remove left side cover (4).

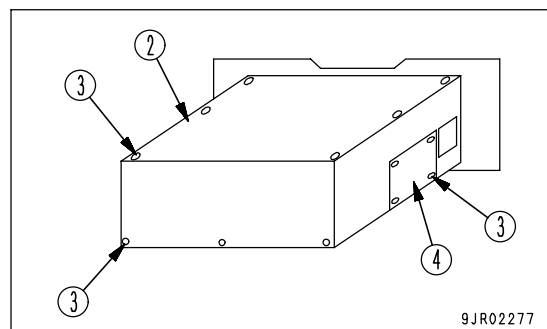

5. Remove the cover of the payload meter. As seen from the top, battery holder (5) is installed at position (B) in the diagram on the right stop using procedure (A) shown in the diagram, remove battery (7) from battery holder (5) without removing connector (6), then put it carefully on top of the motherboard.

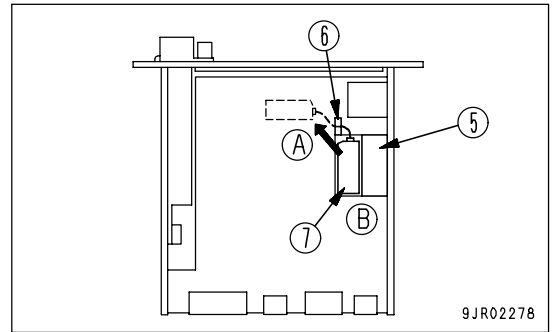
**NOTICE**

**Remove connector (6) after removing the battery from battery holder (5). If it is attempted to use force to remove connector (6) when the battery is still in battery holder (5), there is danger that connector (6) may be damaged.**

6. Pull battery connector (6) straight out from the motherboard connector, then remove the battery.
7. Insert the connector of the new battery straight into the connector of the motherboard.
8. Put the battery in the battery holder, and pass the wiring through the notch.  
When doing this, insert the wiring into the bottom of the holder and pass it in through the notch.

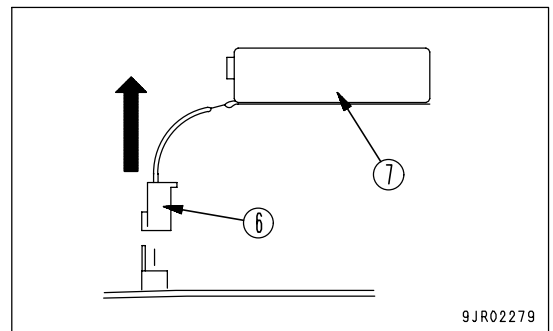

9. Install top cover (2).
10. Assemble the payload meter to its original position in the panel.

## PROCEDURE AFTER REPLACING BATTERY

When the battery is replaced, the backup power for the non-volatile memory inside the payload meter is momentarily cut, so mistaken data (garbage) may enter the memory and cause mistakes in the payload meter's recognition of the condition of the machine.

The following operation is necessary to remove this data.

1. Turn the starting switch to the ON position. (F.CAL may flash.)
2. Using the operator check mode, set the machine ID, open ID, speed limit, option code, date and time.
3. Without turning the starting switch to the OFF position, start the engine. (F.CAL may flash.)
4. Carry out calibration.
5. Load to near the rated payload, then dump the load.
6. Move the machine to a safe place, wait for at least 5 sec. after dumping the load in Step 5, then stop the engine.
7. Turn the starting switch to the ON position again.  
Do not start the engine when doing this.
8. Carry out the DATA ALL CLEAR in the operator check mode.
9. Forcibly clear the data for the total payload and overall number of cycles.  
With this operation, all the mistaken data inside the payload meter are cleared. Apart from the calibration data, all the data recorded in the Steps 1 to 6 (these data are all inaccurate data) are also deleted.  
If this operation is carried out in the wrong order, the cycle data (beginning only) will be defective.
10. After the above operation is completed, the payload meter will function normally.

## NOTICE

- Replace the battery within 48 hours.
- The service life of the battery is approx. 2 years.

## OPERATION WHEN ERROR CODE F.CAL IS DISPLAYED OR CONTROLLER HAS BEEN REPLACED

If F.CAL is displayed, mistaken data have probably been written to the memory inside the payload meter.

In addition, when the controller is replaced, old data may be recorded to the new controller, or the machine condition recognized by the controller may be different from the actual condition. To remove these data, carry out the following operation.

1. Turn the starting switch to the ON position.
2. Forcibly carry out initialization. For details, see "CARRYING OUT FORCED INITIALIZATION (PAGE 6-64)".
3. Turn the starting switch to the ON position. (F.CAL may flash.)
4. Using the operator check mode, set the machine ID, open ID, speed limit, option code, date and time.
5. Without turning the starting switch to the OFF position, start the engine. (F.CAL may flash.)
6. Carry out calibration.
7. Load to near the rated payload, then dump the load.
8. Move the machine to a safe place, wait for at least 5 sec. after dumping the load in Step 7, then stop the engine.
9. Turn the starting switch to the ON position again.  
Do not start the engine when doing this.
10. Carry out the DATA ALL CLEAR in the operator check mode.
11. Forcibly clear the data for the total payload and overall number of cycles.  
With this operation, all the mistaken data inside the payload meter are cleared. Apart from the calibration data, all the data recorded in the Steps 3 to 8 (these data are all inaccurate data) are also deleted.  
If this operation is carried out in the wrong order, the cycle data (beginning only) will be defective.
12. After the above operation is completed, the payload meter will function normally.

**CARRYING OUT FORCED INITIALIZATION**

**CAUTION**

When this function is performed, all of the data recorded in the payload meter are deleted. Do not carry out this operation unless necessary.

Check the date and time before starting, and always be sure that the machine is empty. This operation is possible only when the power is ON.

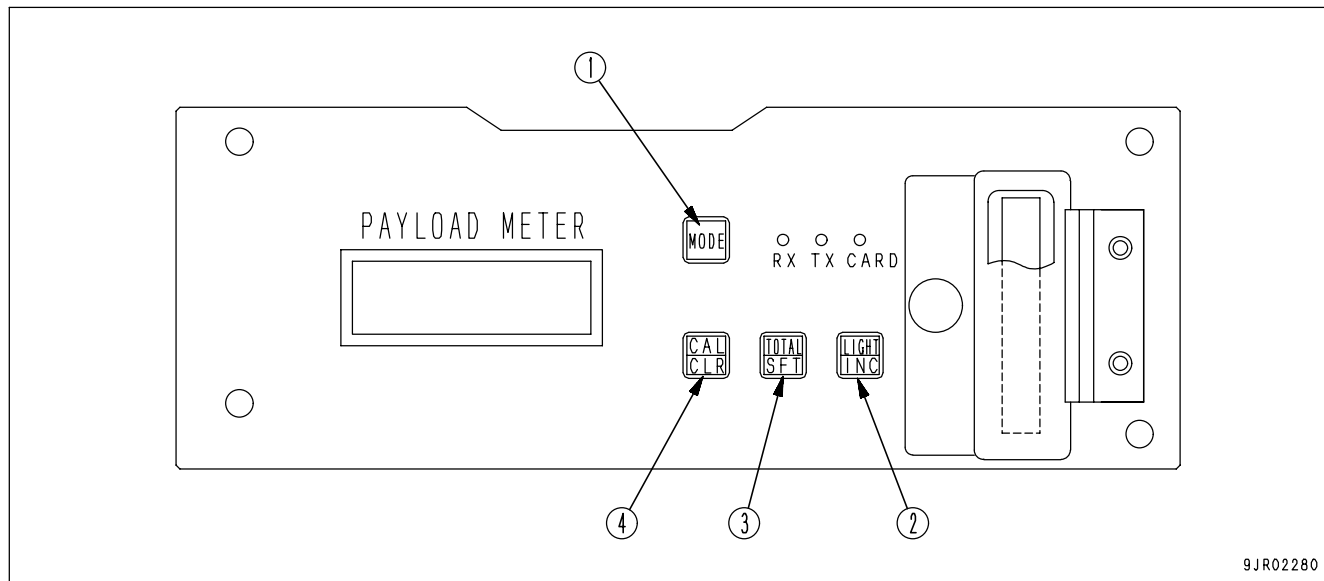

9JR02280

1. In the normal display condition, keep MODE switch (1) and LIGHT/INC switch (2) pressed at the same time for at least 2 seconds.  
CHEC will flash on the payload meter display.

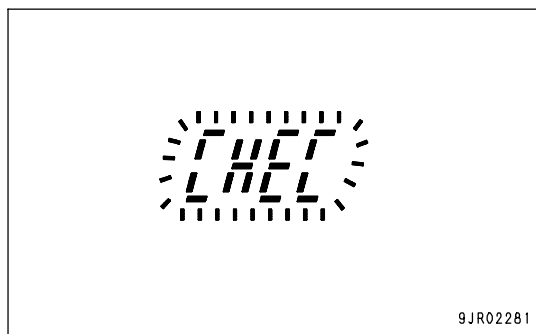

9JR02281

2. When CHEC is displayed, keep LIGHT/INC switch (2), TOTAL/SFT switch (3), and CAL/CLR switch (4) pressed at the same time for at least 2 seconds.  
00:00 will flash on the display.

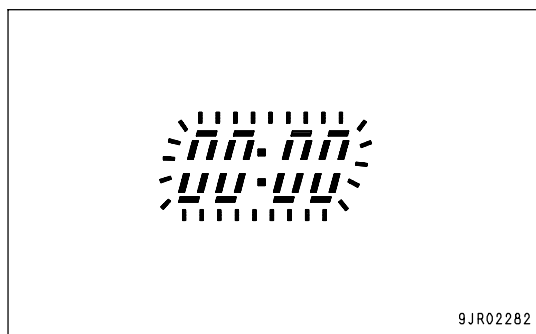

9JR02282

3. Keep CAL/CLR switch (4) pressed for at least 2 seconds. The 00:00 display will light up for 2 seconds, and when all the data is cleared, the display will automatically change to F.CAL.  
After this, carry out the procedure given in "OPERATION WHEN ERROR CODE F.CAL IS DISPLAYED OR CONTROLLER HAS BEEN REPLACED (PAGE 6-63)".

If it is desired to stop the forced initialization when 00:00 is flashing on the display, press MODE switch (1). The display will return to the flashing CHEC display without carrying out the forced initialization.



## ARSC (AUTOMATIC RETARDER SPEED CONTROL)

When traveling downhill, if the switch is pressed at the speed that is to be maintained, the retarder is automatically actuated to prevent the travel speed from exceeding the set speed, so this makes retarder operations easy.



### WARNING

- The ARSC system is actuated when the auto retarder (ARSC) switch is at the ON position. Before starting down the hill, check that a suitable set speed is displayed on the auto retarder set travel speed indicator and that the auto retarder READY pilot lamp is lighted up.
- If the speed is set to a speed that exceeds the maximum permissible speed obtained from the brake performance graph, there is danger that there will be overheating and that the retarder brake may be damaged. Always set the speed so that it does not exceed the maximum permissible speed.
- When the ARSC is actuated on slippery road surfaces, the wheels may lock. If this happens, make less use of the ARSC.
- If any abnormality occurs in the system and braking cannot be carried out properly, the alarm sounds and the system is turned OFF to cancel the ARSC. If necessary, control the machine with the retarder control lever and foot brake to stop the machine in a safe place, then turn the auto retarder (ARSC) switch OFF.

EXPLANATION OF COMPONENTS

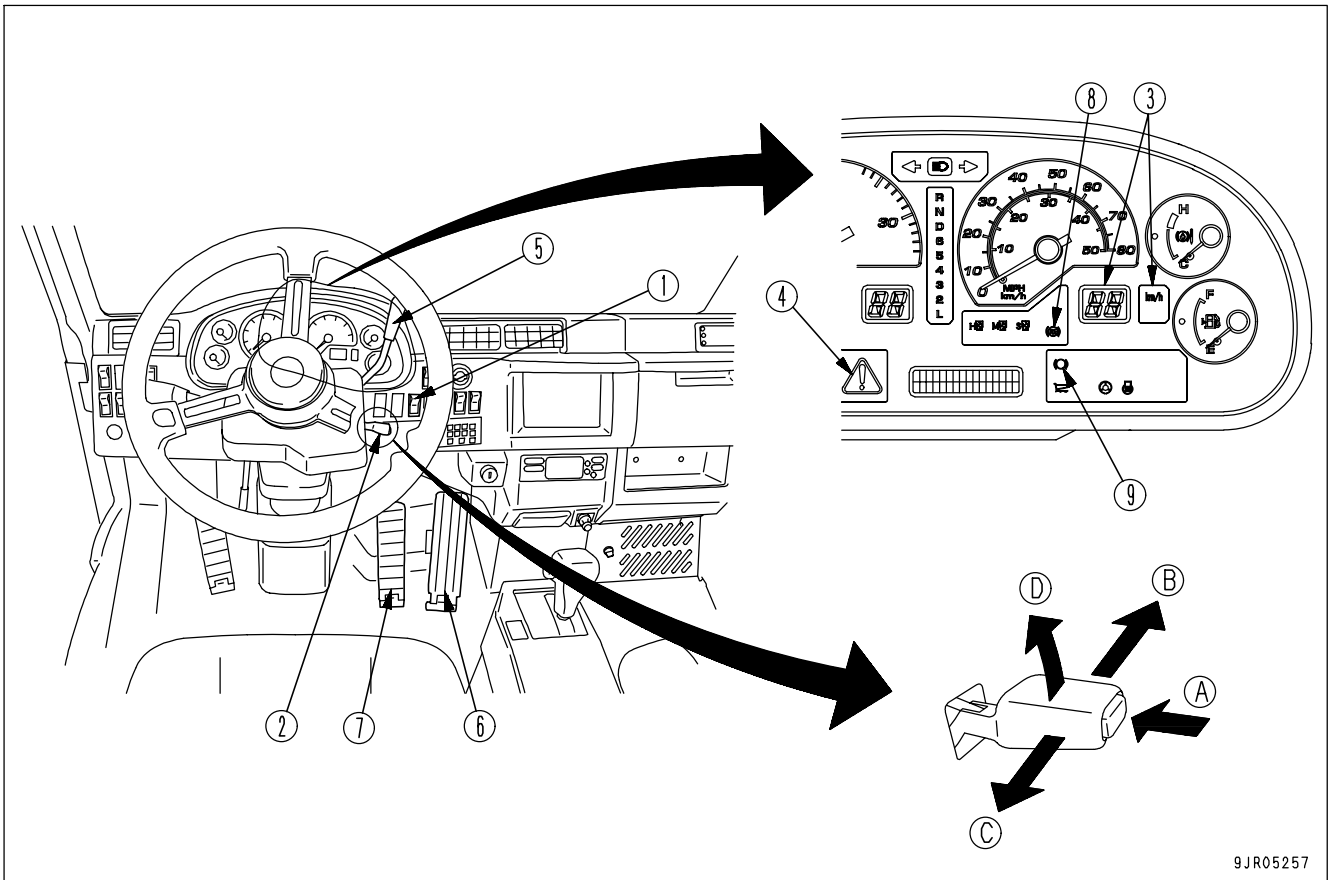

9JR05257

- (1) Auto retarder (ARSC) switch
- (2) Auto retarder (ARSC) set lever
- (3) Auto retarder set speed indicator
- (4) Central warning lamp
- (5) Retarder control lever
- (6) Accelerator pedal
- (7) Brake pedal
- (8) Auto retarder READY pilot lamp
- (9) Retarder pilot lamp

- (A) Set
- (B) Increase speed
- (C) Decrease speed
- (D) Cancel

**AUTO RETARDER (ARSC) SWITCH**

Use this switch (1) to switch the auto retarder (ARSC) system ON/OFF.

- (a): Auto retarder system OFF
- (b): Auto retarder system ON

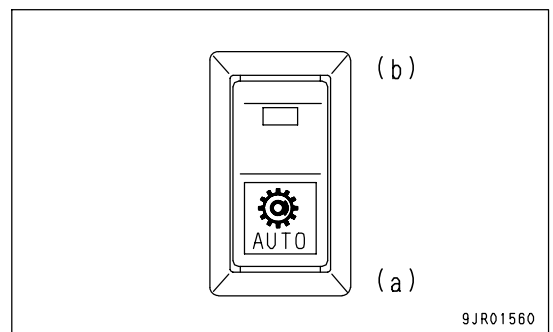

9JR01560

**AUTO RETARDER (ARSC) SET LEVER**

It is possible to use this lever (2) to set, cancel, or make fine adjustment of the ARSC set speed.

- (a) Set
- (b) Increase speed (tap up)
- (c) Decrease speed (tap down)
- (d) Cancel

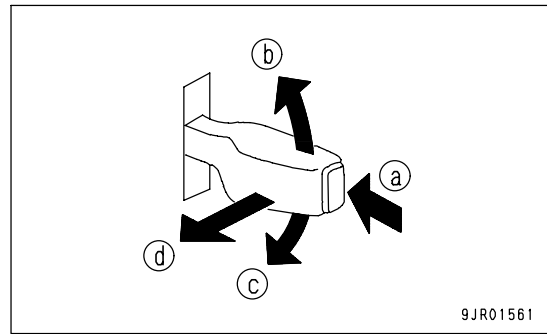
**AUTO RETARDER SET SPEED INDICATOR**

This display (3) shows the set travel speed (km/h or MPH).

When the auto retarder (ARSC) switch is OFF, the lamp goes out.

When the set travel speed has been cancelled, 0 is displayed.

When the machine starting switch is ON, or when the auto retarder (ARSC) switch is ON, the previously set travel speed is displayed.

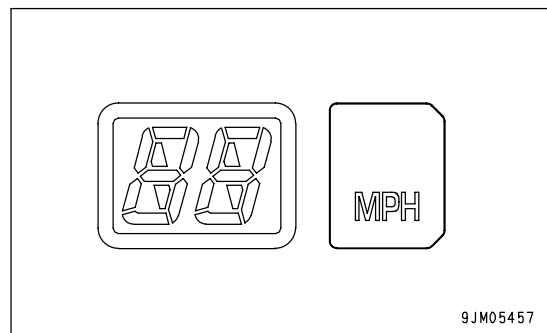
**CENTRAL WARNING LAMP**

This lamp (4) lights up if there is a serious problem in the ARSC system when the auto retarder (ARSC) switch is ON.

**RETARDER CONTROL LEVER**

Even when the ARSC is in operation, the retarder can be operated with this lever (5).

During operation of the ARSC, there is greater play when the lever starts to be pulled. If the retarder lever is operated suddenly (pulled too much), the brakes will be applied suddenly.

**ACCELERATOR PEDAL**

The ARSC is actuated only when the accelerator pedal (6) is not being pressed.

**BRAKE PEDAL**

This pedal (7) operates the wheel brake even when the ARSC is being operated.

**AUTO RETARDER READY PILOT LAMP**

When this lamp (8) is lighted up, it shows that operation of the ARSC is possible at the set travel speed. When it is out, the ARSC is not actuated.

It lights up for 3 seconds when the starting switch is turned ON to check the bulb.

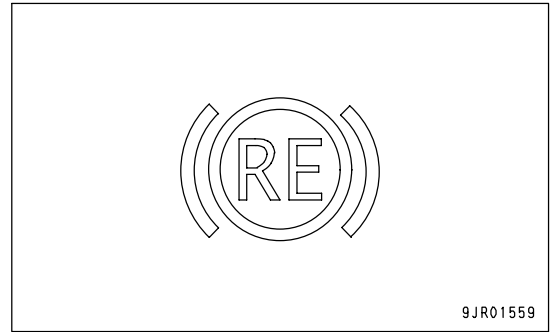
**RETARDER PILOT LAMP**

This lamp (9) lights up when the retarder is operated, even when the ARSC is being operated.

## METHOD OF OPERATION

### ACTUATION OF ARSC SYSTEM

The ARSC system is actuated when the auto retarder (ARSC) switch is ON.

When the set switch of the auto retarder (ARSC) set lever is pressed, the travel speed at that point is set as the downhill travel speed. When traveling downhill, if the machine attempts to exceed the set travel speed, the retarder is automatically actuated.

The set travel speed is displayed on the auto retarder set speed indicator and is saved in memory.

If the accelerator is depressed during operation of the ARSC, the ARSC is canceled and the speed increases.

If the brake pedal or retarder control lever are operated while the ARSC is being operated, it is possible to reduce the speed or stop the machine in the same way as during normal operation of the brakes.

If the set travel speed is near the gear shifting point or there is a change in the grade of the slope, the transmission may shift (shift up or shift down) even when the ARSC is being operated.

The time taken for the machine travel speed to match the set speed may differ according to the grade of the slope. There may also be a slight difference between the set travel speed and the speed displayed on the speedometer.

### METHOD OF SPEED SETTING



If the speed is set to a speed that exceeds the maximum permissible speed obtained from the brake performance graph, there is danger that there will be overheating and that the retarder brake may be damaged. Always set the speed so that it does not exceed the maximum permissible speed.

If the actual machine speed during the setting operation is less than 10 km/h (6.2 MPH), the speed is set to 10 km/h (6.2 MPH). If it is higher than 55 km/h (34.2 MPH), it is set to 55 km/h (34.2 MPH). In all other cases, it is set to the actual travel speed.

The travel speeds that can be set depend on the selection of the gearshift lever as follows.

When the gearshift lever is at the D, 6, 5, 4, 3, 2, or L positions, the range for the set speed is 10 to 55 km/h (6.2 to 34.2 MPH).

It is impossible to set the speed when the gearshift lever is at the N or R positions.

### METHOD OF CARRYING OUT FINE ADJUSTMENT OF SET TRAVEL SPEED

When it is desired to raise the set travel speed by 1 km/h (tap up), move the auto retarder (ARSC) set lever up once. When it is desired to lower the set travel speed by 1 km/h (tap down), move the auto retarder (ARSC) set lever down once.

### REMARK

Release the auto retarder (ARSC) set lever after changing the set travel speed.

If the set switch and cancel are operated at the same time, the cancel operation is given priority.

If the set switch and tap up are operated at the same time, the tap up operation is given priority.

If the set switch and tap down are operated at the same time, the tap down operation is given priority.

The tap up and tap down operations are used for making fine adjustment of the set travel speed.

It is possible to adjust the set travel speed up to  $\pm 5$  km/h (3.1 MPH) when traveling in ARSC (when the accelerator pedal is released). When the accelerator pedal is being depressed, the ARSC is canceled, so it is possible to operate freely in a range from 10 to 55 km/h (from 6.2 to 34.2 MPH).

**METHOD OF INCREASING SET TRAVEL SPEED**

If it is desired to increase the set speed, depress the accelerator pedal to increase speed, and when the desired set travel speed is reached, press the set switch on the auto retarder (ARSC) set lever. The set travel speed will be changed to the new speed.

**METHOD OF DECREASING SET TRAVEL SPEED**

If it is desired to decrease the set speed, operate the retarder control lever to reduce speed, and when the desired set travel speed is reached, press the set switch on the auto retarder (ARSC) set lever. The set travel speed will be changed to the new speed.

**REMARK**

After using the retarder control lever to reduce the speed, return it to its original position. If the lever is operated suddenly, the brakes will be applied suddenly.

**SAVING SET TRAVEL SPEED**

If the machine starting switch is turned OFF or the auto retarder (ARSC) switch is turned OFF, the set travel speed remains in the memory. When the starting switch is turned ON or the auto retarder (ARSC) switch is turned ON, the previous set speed is displayed again on the auto retarder set speed indicator.

**TRAVELING AGAIN AT SET TRAVEL SPEED**

If you travel repeatedly on the same slope, set the travel speed. It is then possible to use that set travel speed by actuating the ARSC without having to reset.

Before entering a downhill slope, if the travel speed has been adjusted to a speed lower than the set speed displayed on the auto retarder set speed indicator, the auto retarder READY pilot lamp lights and the ARSC is actuated when the accelerator pedal is released.

**REMARK**

When traveling at a speed greater than the set speed displayed on the auto retarder set speed indicator, the ARSC is not actuated even when the accelerator pedal is released. When this happens, the auto retarder READY pilot lamp also does not light up. Always adjust the travel speed to a speed lower than the set speed displayed on the auto retarder set speed indicator, and check that the auto retarder READY pilot lamp lights up.

Before starting down the hill, check that a suitable set speed is displayed on the auto retarder set travel speed indicator and that the auto retarder READY pilot lamp is lighted up.

**METHOD OF CANCELING SET TRAVEL SPEED**

Method 1: If the cancel operation is carried out for more than 1 second, the control is stopped. When this happens, the auto retarder set speed indicator shows 0.

Method 2: If the auto retarder (ARSC) switch is turned OFF, the control is canceled. When this happens, the auto retarder set speed indicator goes out.

**REMARK**

For Method 1, cancel operation must be continued for at least 1 second (different from other switches) to cancel the control. This is to prevent any problem of the control being canceled if the switch is touched by mistake.

**RECOMMENDED SET TRAVEL SPEED**

Set the travel speed so that the engine speed is at least 1800 rpm, and travel so that the retarder oil temperature gauge is in the white range.

If there is danger that the retarder oil temperature may overheat, the retarder oil temperature caution lamp lights up and the set travel speed is automatically reduced in 1 km/h (0.6 MPH) steps every 3 seconds. The minimum setting when automatically lowering the travel speed is 10 km/h (6.2 MPH).

# USE OF REAR VIEW MONITOR

## **WARNING**

- Never operate any of the switches while in running. If you do so, there is the fear that you may make an error in the truck operation, or neglect to watch the hauling road ahead for safety, and as a result cause a serious personal injury.
- The rear view monitor is an aid for checking obstacles in the rear. An image appearing on the monitor is limited. So when backing up the dump truck, be sure to make a visual check, not relying solely on the monitor.
- An image on the rear view monitor does not show an actual distance, so drive the dump truck slowly, when backing it up.

When the dump truck is backed up and the rear view monitor is set in operation, a monitor display enables the driver to check the rear for safety.

### NAME AND FUNCTION OF EACH PART OF REAR VIEW MONITOR

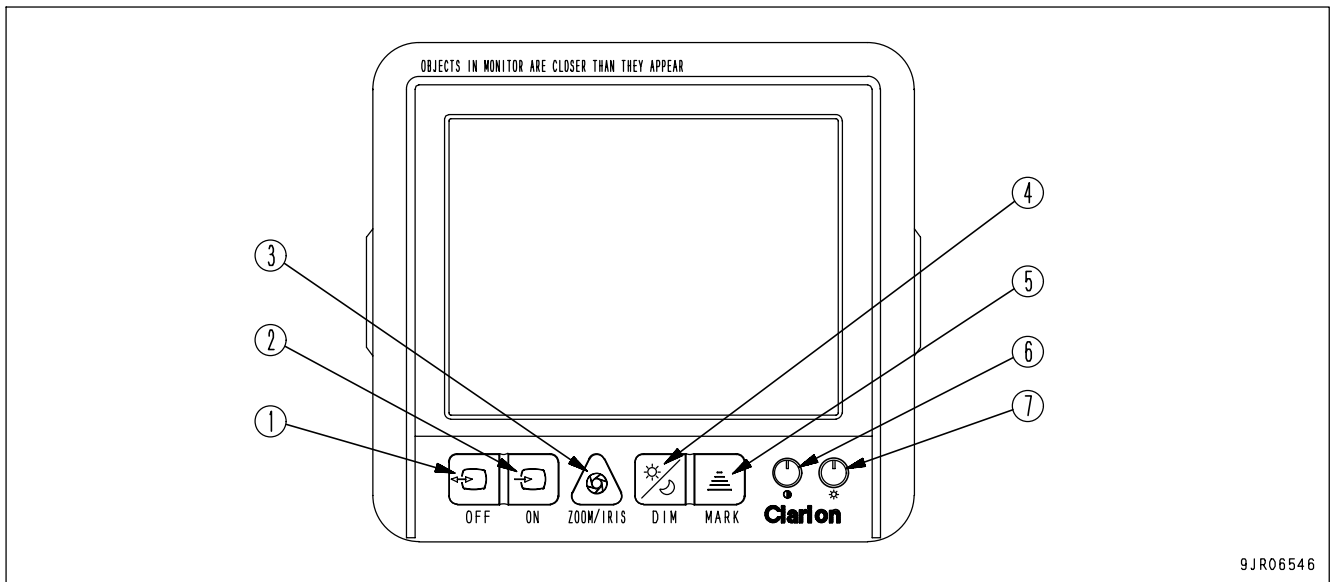

- |   |   |
|---|---|
| <p>(1) Auto Switch</p> <p>(2) Manual Switch</p> <p>(3) Zoom / Iris Switch (Reverse Light Compensation Switch)</p> | <p>(4) Bright / Dim Light Selector Switch</p> <p>(5) Mark Switch (not operable with this machine)</p> <p>(6) Contrast Adjustment Knob</p> <p>(7) Brightness Adjustment Knob</p> |
|---|---|

#### AUTO SWITCH

When an image of a camera is shown on the monitor display and this switch (1) is pressed, the camera image disappears and the display turns into a waiting condition.

When the gearshift lever is put into the "R" position while the display is in the waiting condition, an image of the rear view automatically appears.

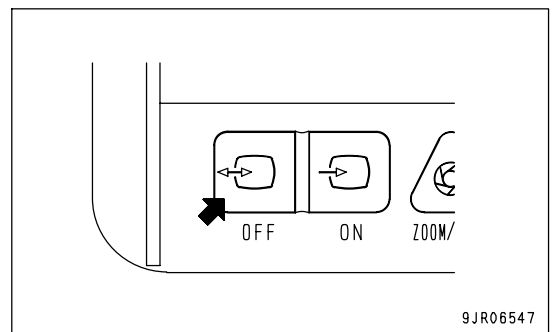



**MANUAL SWITCH**

When this switch (2) is pressed, an image of a camera appears on the monitor display.

At that time, a mark "CAM1" appears on the upper left side of the display and a figure "5" on the upper right side of the display.

**REMARK**

- When the manual switch is pressed to call an image and the operation is suspended thereafter, the image disappears in approx. 5 minutes, turning the display into a waiting condition. This is a function in case the operator forgets to switch off the display (timer function).
- The time until the monitor display is automatically switched off is shown on the upper right side of the display. It changes by minute and in the descending order as 5→4 →3 → 2 → 1. Moreover, when the remaining time comes down to just 10 seconds before the monitor display goes off, the last figure "1" on the upper right side begins to flash.
- When the manual switch is pressed to call an image and it is pressed again while the image is shown on the monitor display, it remains on the display for approx. 5 more minutes from the moment the switch is pressed.
- When the gearshift lever is in the "R" position, the timer function does not work.

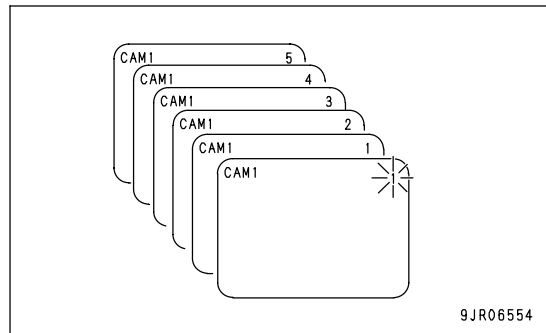
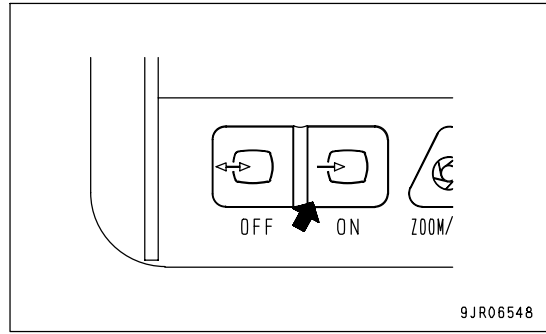

**ZOOM/IRIS SWITCH (REVERSE LIGHT COMPENSATION SWITCH)**

Zoom Function (press the switch)

By pressing this switch (3), an image on the monitor display can be enlarged by 1.4 times.

At that time, a mark of "ZOOM" is shown on the upper right side of the display.

When the switch is pressed again, "ZOOM" disappears and the display returns to the original image.

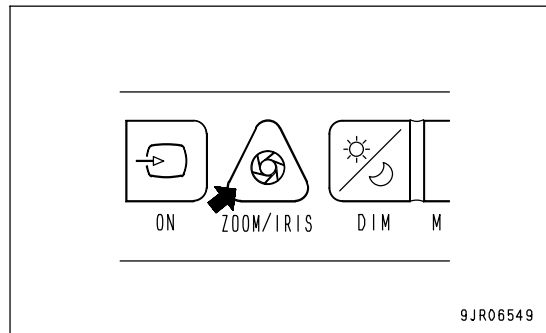

Iris Function (Reverse Light Compensation Function) (Keep the switch pressed for more than 1 second.)

**! WARNING**

When the iris function is activated (turned "ON"), the whole monitor display becomes brighter. As a result, some portion on the display becomes difficult to read or discern, while it is easy to do so with the iris function turned "OFF". Therefore do not use this function except when it is necessary to read or see a dim portion.

When it is difficult to see a monitor display due to a reverse light, keep this switch (3) for more than 1 second, and then the iris function (reverse light compensation function) is turned "ON", turning the display brighter and making it easier to see.

At that time, a mark of "IRIS" appears on the upper left side of the display.

If the switch is further kept pressed for more than 1 second, the iris function (reverse light compensation function) is turned "OFF" and "IRIS" mark goes off.

**BRIGHT/DIM LIGHT SELECTOR SWITCH**

When this switch is pressed, the brightness of the monitor display lowers.

A mark of "DIM" appears on the upper left side of the display then. When the switch is pressed again, the brightness returns to the original level, and "DIM" mark goes off.

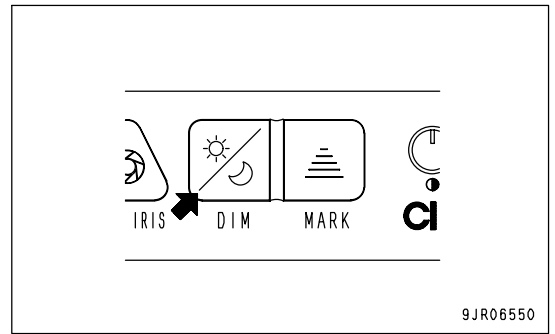

**MARK SWITCH**

The shown mark position does not correspond with the machine. Do not use this function.

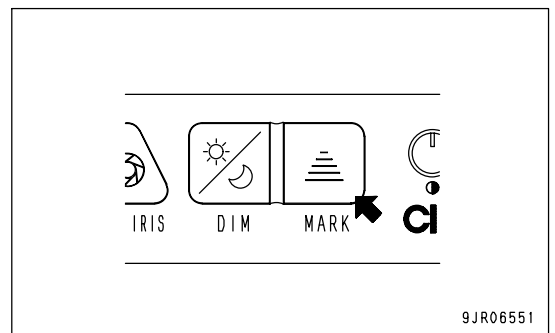

**CONTRAST ADJUSTMENT KNOB**

With this knob (6), contrast on the monitor display can be adjusted to be either stronger or weaker.

To side (A): Contrast becomes stronger.

To side (B): Contrast becomes weaker.

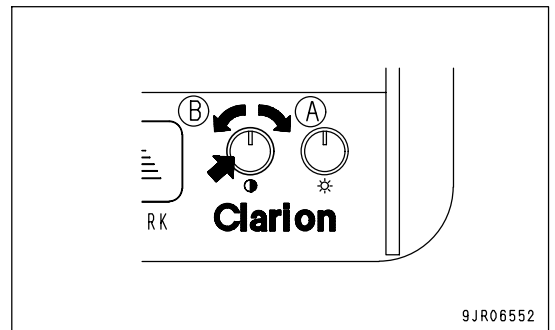

**BRIGHTNESS ADJUSTMENT KNOB**

With this knob (7), brightness (luminance) on the monitor display can be adjusted.

To side (A): Brightness increases.

To side (B): Brightness decreases.

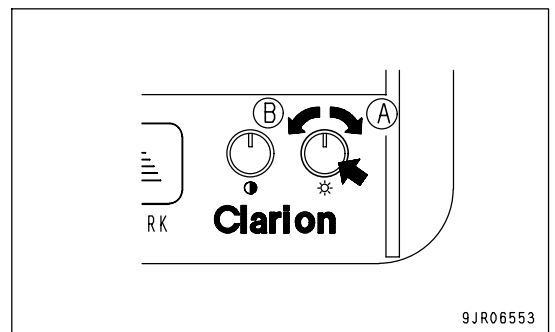

## SETTING OF REAR VIEW MONITOR

### HOW TO SET DISPLAY MODE

A mark of "CAM1", "DIM", "IRIS" and "ZOOM" appears on the upper left side of the monitor display, depending on the sort of ongoing operation.

Every mark is set to go off in approx. 2 seconds after it lights up (2- second display mode).

The display can be changed to a constantly lighted condition by the following method (continuous display mode).

1. Press mark switch (2) while pressing manual switch (1) at the same time.

A "Cam1" mark lights up on the upper left side of the monitor display, and the display mode changes to the continuous display mode.

2. When it is required to return to the 2- second display mode, press mark switch (2), while pressing manual switch (1) at the same time, the same way as in step 1 above.

After a "Cam1" mark remains lighted for approx. 2 seconds on the upper left side of the monitor display, only the mark disappears, and the display mode changes to the 2- second display mode.

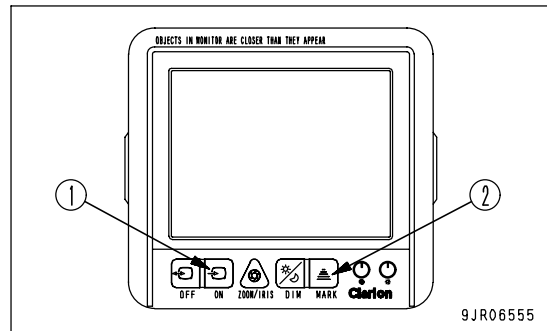

### REMARK

In either case of the 2- second display mode and continuous display mode, the display remains lighted all the time in the remaining time after the mark goes off and before the monitor display goes off, too.

## CAUTIONS WHEN USING REAR VIEW MONITOR

### WARNING

- Do not attempt to disassemble or modify the monitor. There is a danger of electric shock or fire.
- Do not attempt to open the monitor backside cover. There is a danger of electric shock, as high voltage power is conducted internally.
- Do not use the monitor if it is suspected of defect. There is a fear of electric shock or fire, should it be used in spite of a defect. In that case, ask your Komatsu distributor for repair or replacement.
- In case a foreign material has got into the monitor or it gets wet, or if a smoke comes out of the monitor or it gives a bad smell, stop the use immediately. It poses a big danger to use the monitor when any such abnormality exists. In that case, consult your Komatsu distributor.
- When replacing a fuse, be sure to use one with the specified capacity of 3A. Should a fuse with a higher- than- specified capacity be used, it can cause fire.

- As a general rule, this product should be replaced after a total usage time of approximately 3000 hours (or approximately 3 years), though this may differ according to usage conditions.
- When cleaning the monitor, use dry soft cloth or wet cloth after having well wrung the water out. If it is very dirty, use neutral detergent. Do not use thinner or alcohol.
- Sometimes an image on the monitor display is blurred due to the camera lens being smeared. In that case, clean the camera lens with dry soft cloth or wet cloth after having well wrung the water out.

## HANDLING DUMPING COUNTER

The dumping counter is an automatic counting function to count the number of loads that have been dumped.

The number of loads dumped is displayed on the character display.

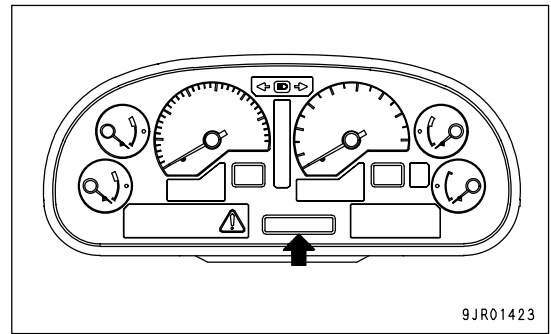

### METHOD OF DISPLAYING, RESETTING DUMPING COUNTER

1. Check that the character display is showing the service meter/odometer, or the action code. If it is giving any other display, turn the starting switch OFF, then turn the starting switch to the ON position and wait for the above display to be given.
2. Press (◇) of machine monitor mode selector switch 1. The character display shows the dumping counter.

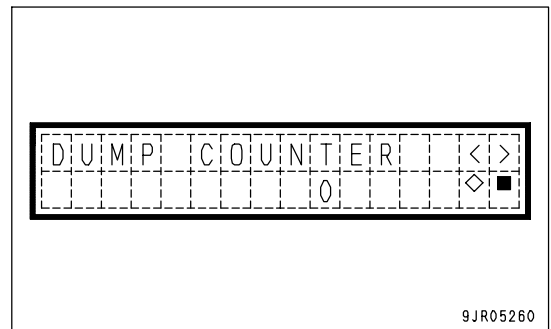

3. When resetting the number of loads dumped, press (◇) of machine monitor mode selector switch 1. The display shows the screen on the right.
4. Press (◇) of machine monitor mode selector switch 1. The number of loads dumped is reset and the display returns to the previous screen.

To abandon the resetting operation, press (■) of machine monitor mode selector switch 1 to return to the previous screen.

5. When completing the operation, press (■) of machine monitor mode selector switch 1 or turn the starting switch OFF.

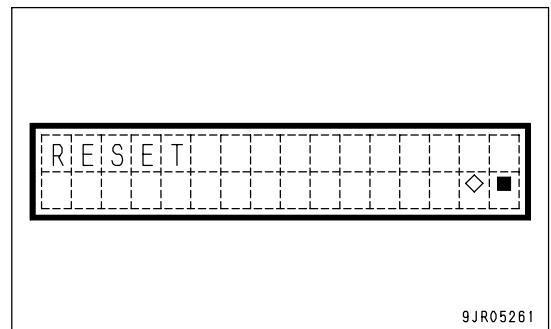

## HANDLING MACHINES EQUIPPED WITH KOMTRAX

- KOMTRAX is a machine management system that uses wireless communications.
- A contract with your Komatsu distributor is necessary before the KOMTRAX system can be used. Any customers desiring to use the KOMTRAX system should consult their Komatsu distributor.
- The KOMTRAX equipment is a wireless device using radio waves, so it is necessary to obtain authorization and conform to the laws of the country or territory where the machine equipped with KOMTRAX is being used. Always contact your Komatsu distributor before selling or exporting any machine equipped with KOMTRAX.
- When selling or exporting the machine or at other times when your Komatsu distributor considers it necessary, it may be necessary for your Komatsu distributor to remove the KOMTRAX equipment or to carry out action to stop communications.
- If you do not obey the above precautions, neither Komatsu nor your Komatsu distributor can take any responsibility for any problem that is caused or for any loss that results.

## BASIC PRECAUTIONS



### WARNING

- Never disassemble, repair, modify, or move the communications terminal, antenna, or cables. This may cause failure or fire on the KOMTRAX equipment or the machine itself. (Your Komatsu distributor will carry out removal and installation of KOMTRAX.)
- Do not allow cables or cords to become caught; do not damage or pull cables or cords by force. Short circuits or disconnected wires may cause failure or fire on the KOMTRAX equipment or the machine itself.
- For anyone wearing a pacemaker, make sure that the communications antenna is at least 22 cm (8.7 in) from the pacemaker. The radio waves may have an adverse effect on the operation of the pacemaker.

## NOTICE

- Even when the key in the starting switch of the KOMTRAX system is at the OFF position, a small amount of electric power is consumed. When putting the machine into long-term storage, take the action given in "LONG-TERM STORAGE (PAGE 3-124)".
- Please contact your Komatsu distributor before installing a top guard or other attachment that covers the cab roof.
- Be careful not to get water on the communications terminal or wiring.

## REMARK

- The KOMTRAX system uses wireless communications, so it cannot be used inside tunnels, underground, inside buildings, or in mountain areas where radio waves cannot be received. Even when the machine is outside, it cannot be used in areas where the radio signal is weak or in areas outside the wireless communication service area.
- There is absolutely no need to inspect or operate the KOMTRAX communications terminal, but if any abnormality is found, please consult your Komatsu distributor.

## INDEX

<A>		PRECAUTIONS BEFORE STARTING	
AIR CONDITIONER .....	3- 64	OPERATION .....	2- 12
ARSC (AUTOMATIC RETARDER		PRECAUTIONS RELATED TO	
SPEED CONTROL) .....	6- 66	ATTACHMENTS AND OPTIONS .....	2- 18
EXPLANATION OF COMPONENTS .....	6- 67	PRECAUTIONS RELATED TO	
METHOD OF OPERATION .....	6- 70	PROTECTIVE STRUCTURES .....	2- 17
<B>		PRECAUTIONS WHEN GETTING ON	
BEFORE READING THIS MANUAL .....	1- 2	OR OFF MACHINE .....	2- 15
BODY PIVOT PIN .....	3- 44	PRECAUTIONS WHEN RUNNING	
<C>		ENGINE INSIDE BUILDING .....	2- 18
CAR RADIO .....	3- 49	PREPARATIONS FOR SAFE	
CAR STEREO .....	3- 55	OPERATION .....	2- 12
CHECK BEFORE STARTING ENGINE .....	3- 69	UNAUTHORIZED MODIFICATION .....	2- 17
CHECKS AFTER COMPLETION OF		GENERAL VIEW .....	3- 2
WORK .....	3-112	GENERAL VIEW OF CONTROLS AND	
CHECKS AFTER STOPPING ENGINE .....	3- 91	GAUGES .....	3- 3
COLD WEATHER OPERATION .....	3-121	GENERAL VIEW OF MACHINE .....	3- 2
AFTER COLD WEATHER .....	3-123	GUIDES TO MAINTENANCE .....	4- 2
PRECAUTIONS AFTER		<H>	
COMPLETION OF WORK .....	3-122	HANDLING ABS .....	6- 9
PRECAUTIONS FOR LOW		ABS SYSTEM CHECK AFTER	
TEMPERATURE .....	3-121	STARTING ENGINE .....	6- 11
CONTROL LEVERS AND PEDALS .....	3- 39	EXPLANATION OF COMPONENTS .....	6- 9
<D>		OPERATION OF ABS .....	6- 11
DETERMINING AND MAINTAINING		PRECAUTIONS WHEN USING .....	6- 12
TRAVEL ROAD .....	3-116	HANDLING AIR SUSPENSION SEAT .....	6- 3
DETERMINING TRAVEL ROAD .....	3-116	REMOVAL AND INSTALLATION OF	
MAINTAINING TRAVEL ROAD .....	3-116	HEADREST .....	6- 5
DUMP OPERATIONS .....	3-109	SEAT ADJUSTMENT .....	6- 3
DUST INDICATOR .....	3- 45	HANDLING AUTOMATIC SPIN	
<E>		REGULATOR (ASR) .....	6- 6
EXPLANATION OF COMPONENTS .....	3- 5	ACTUATION OF ASR SYSTEM .....	6- 7
<F>		BLEEDING AIR FROM ASR CIRCUIT ...	6- 8
FUSES .....	3- 46	EXPLANATION OF COMPONENTS .....	6- 6
<G>		PRECAUTIONS WHEN USING .....	6- 7
GENERAL PRECAUTIONS COMMON		HANDLING DUMPING COUNTER .....	6- 77
TO OPERATION AND MAINTENANCE .....	2- 12	HANDLING MACHINES EQUIPPED	
DO NOT GET CAUGHT IN DUMP		WITH KOMTRAX .....	6- 78
BODY .....	2- 17	BASIC PRECAUTIONS .....	6- 78
FIRE PREVENTION .....	2- 14	HANDLING OIL, FUEL, COOLANT, AND	
		PERFORMING OIL CLINIC .....	4- 5
		HANDLING PAYLOAD METER II (CARD	
		TYPE) .....	6- 13
		CONTENT OF DISPLAY	
		(CONTROLLER, EXTERNAL	
		DISPLAY LAMPS) .....	6- 20

DETAILS OF DATA STORED IN MEMORY OF PAYLOAD METER -----	6- 26	METHOD OF LOWERING DUMP BODY IN EMERGENCY -----	3-127
EXTERNAL DISPLAY LAMPS -----	6- 24	METHOD OF SECURING MACHINE -----	3-117
GENERAL LOCATIONS -----	6- 15	MOVING MACHINE OFF (FORWARD, REVERSE), STOPPING -----	3- 92
METHOD OF USING ACCURATELY ----	6- 14	<O> OPERATION -----	3- 69
OPERATION OF SWITCHES -----	6- 31	OPERATIONS, CHECKS AFTER STARTING ENGINE -----	3- 90
OPERATION WHEN ERROR CODE F.CAL IS DISPLAYED OR CONTROLLER HAS BEEN REPLACED -----	6- 63	OTHER FUNCTIONS OF MACHINE MONITOR -----	3- 26
PROBLEM AND WARNING DISPLAY (ERROR CODE) -----	6- 53	OUTLINE OF ELECTRIC SYSTEM -----	4- 9
WHEN ERROR CODE F-09 IS DISPLAYED (PROCEDURE FOR REPLACING BATTERY) -----	6- 60	OUTLINE OF SERVICE -----	4- 5
HANDLING TIRES -----	3-113	<P> PARKING MACHINE -----	3-111
<I> IF TRANSMISSION HAS TROUBLE -----	3-126	PERIODIC REPLACEMENT OF SAFETY CRITICAL PARTS -----	4- 15
INTENDED USE -----	1- 6	PRECAUTIONS FOR MAINTENANCE ----	2- 29
DIRECTIONS OF MACHINE -----	1- 6	PRECAUTIONS BEFORE STARTING INSPECTION AND MAINTENANCE ----	2- 29
USE OF MACHINE -----	1- 6	PRECAUTIONS FOR INSPECTION AND MAINTENANCE -----	2- 33
VISIBILITY FROM OPERATOR'S SEAT -----	1- 6	TIRES -----	2- 38
<L> LOADING OPERATIONS -----	3-108	PRECAUTIONS FOR OPERATION -----	2- 19
LOCATION OF FIRE EXTINGUISHER ----	3- 44	OPERATION -----	2- 23
LOCATION OF PLATES, TABLE TO ENTER SERIAL NO. AND DISTRIBUTOR -----	1- 7	PRECAUTIONS FOR JOBSITE -----	2- 19
PRODUCT IDENTIFICATION NUMBER (PIN)/MACHINE SERIAL NO. PLATE -----	1- 7	STARTING ENGINE -----	2- 21
SERVICE METER POSITION -----	1- 8	TOWING -----	2- 28
TABLE TO ENTER SERIAL NO. AND DISTRIBUTOR -----	1- 8	TRANSPORTATION -----	2- 27
LOCKING -----	3-112	PRECAUTIONS FOR OPERATION -----	3-110
LONG-TERM STORAGE -----	3-124	PRECAUTIONS WHEN TRANSPORTING -----	3-117
AFTER STORAGE -----	3-124	<R> RECOMMENDED FUEL, COOLANT, AND LUBRICANT -----	4- 11
BEFORE STORAGE -----	3-124	RECOMMENDED BRANDS, RECOMMENDED QUALITY FOR PRODUCTS OTHER THAN KOMATSU GENUINE OIL -----	4- 13
DURING STORAGE -----	3-124	USE OF FUEL, COOLANT AND LUBRICANTS ACCORDING TO AMBIENT TEMPERATURE -----	4- 12
PRECAUTIONS BEFORE TRAVELING AFTER LONG-TERM STORAGE -----	3-124	<S> SAFETY -----	2- 2
<M> MACHINE MONITOR -----	3- 5	SAFETY CRITICAL PARTS -----	4- 16
MAINTENANCE SCHEDULE CHART -----	4- 17	SAFETY INFORMATION -----	1- 5
METHOD OF LIFTING MACHINE -----	3-118		

## INDEX

---

SAFETY LABELS -----	2- 5
POSITION FOR ATTACHING SAFETY LABELS -----	2- 6
SELECTING DUMP BODY -----	6- 2
SERVICE PROCEDURE -----	4- 20
CHECK BEFORE STARTING -----	4- 42
EVERY 1000 HOURS SERVICE -----	4- 61
EVERY 15000 HOURS SERVICE -----	4- 81
EVERY 2000 HOURS SERVICE -----	4- 73
EVERY 250 HOURS SERVICE -----	4- 43
EVERY 4000 HOURS SERVICE -----	4- 77
EVERY 500 HOURS SERVICE -----	4- 55
EVERY 8000 HOURS SERVICE -----	4- 80
INITIAL 250 HOURS SERVICE (ONLY AFTER THE FIRST 250 HOURS) -----	4- 20
WHEN REQUIRED -----	4- 21
SHIFTING GEAR -----	3- 97
SPECIFICATIONS -----	5- 2
STANDARD TIGHTENING TORQUES FOR BOLTS AND NUTS -----	4- 14
STARTING ENGINE -----	3- 88
STEERING THE MACHINE -----	3-108
STEPS FOR TRANSPORTATION -----	3-117
STOPPING ENGINE -----	3- 91
SWITCHES -----	3- 30
 <T>	
TORQUE LIST -----	4- 14
TRANSPORTATION -----	3-117
TRAVELING DOWNHILL -----	3- 99
TROUBLESHOOTING -----	3-125
AFTER RUNNING OUT OF FUEL -----	3-125
IF BATTERY IS DISCHARGED -----	3-133
METHOD OF TOWING MACHINE -----	3-129
OTHER TROUBLE -----	3-136
 <U>	
USE OF REAR VIEW MONITOR -----	6- 73
CAUTIONS WHEN USING REAR VIEW MONITOR -----	6- 76
NAME AND FUNCTION OF EACH PART OF REAR VIEW MONITOR -----	6- 73
SETTING OF REAR VIEW MONITOR -----	6- 76
 <W>	
WEAR PARTS -----	4- 10
WEAR PARTS LIST -----	4- 10



HD325-7, HD405-7 DUMP TRUCK

---

Form No. TEN00137-09

©2008 KOMATSU  
All Rights Reserved  
Printed in Japan 09-08

---