

# Operation & Maintenance Manual

HYDRAULIC  
EXCAVATOR

**PC1250 -7**  
**PC1250SP-7**  
**PC1250LC -7**

SERIAL NUMBERS 20001 and up

## WARNING

Unsafe use of this machine may cause serious injury or death. Operators and maintenance personnel must read this manual before operating or maintaining this machine. This manual should be kept near the machine for reference and periodically reviewed by all personnel who will come into contact with it.

## NOTICE

Komatsu has Operation & Maintenance Manuals written in some other languages. If a foreign language manual is necessary, contact your local distributor for availability.

**KOMATSU**

# FOREWORD

## **CALIFORNIA**

### **Proposition 65 Warning**

Diesel engine exhaust and some of its constituents are known to the State of California to cause cancer, birth defects, and other reproductive harm.

## **CALIFORNIA**

### **Proposition 65 Warning**

Battery posts, terminals and related accessories contain lead and lead compounds, chemicals known to the State of California to cause cancer and birth defects or other reproductive harm.

**Wash hands after handling.**

## FOREWORD

This manual provides rules and guidelines which will help you use this machine safely and effectively. The precautions in this manual must be followed at all times when performing operation and maintenance. Most accidents are caused by the failure to follow fundamental safety rules for the operation and maintenance of machines. Accidents can be prevented by knowing beforehand conditions that may cause a hazard when performing operation and maintenance.



### WARNING

Operators and maintenance personnel must always do as follows before beginning operation or maintenance.

- Always be sure to read and understand this manual thoroughly before performing operation and maintenance.
- Read the safety messages given in this manual and the safety labels affixed to the machine thoroughly and be sure that you understand them fully.

Keep this manual in the storage location for the operation and maintenance manual given below, and have all personnel read it periodically.

If this manual has been lost or has become dirty and cannot be read, request a replacement manual immediately from Komatsu or your Komatsu distributor.

If you sell the machine, be sure to give this manual to the new owners together with the machine.

Komatsu delivers machines that comply with all applicable regulations and standards of the country to which it has been shipped. If this machine has been purchased in another country or purchased from someone in another country, it may lack certain safety devices and specifications that are necessary for use in your country. If there is any question about whether your product complies with the applicable standards and regulations of your country, consult Komatsu or your Komatsu distributor before operating the machine.

Storage location for the Operation and Maintenance Manual:  
magazine box on the left side of the operator's seat.

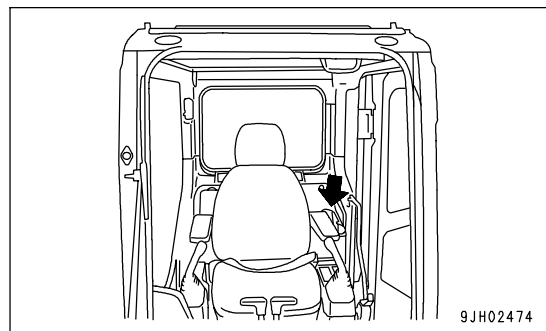

**EMISSION CONTROL WARRANTY****EMISSION CONTROL WARRANTY STATEMENT (APPLIES TO CANADA ONLY)****1. Products Warranted**

Komatsu America International Company, Komatsu Mining Systems Inc. and Komatsu Utility Corporation (collectively "Komatsu") produce and/or market products under brand names of Komatsu, Dresser, Dressta, Haulpak and Galion. This emissions warranty applies to new engines bearing the Komatsu name installed in these products and used in Canada in machines designed for industrial off-highway use. This warranty applies only to these engines produced on or after January 1, 2000. This warranty will be administered by Komatsu distribution in Canada.

**2. Coverage**

Komatsu warrants to the ultimate purchaser and each subsequent purchaser that the engine is designed, built and equipped so as to conform, at the time of sale by Komatsu, with all U.S. Federal emission regulations applicable at the time of manufacture and that it is free from defects in workmanship or material which would cause it not to meet these regulations within five years or 3,000 hours of operation, whichever occurs first, as measured from the date of delivery of the engine to the ultimate purchaser.

**3. Limitations**

Failures, other than those resulting from defects in materials or workmanship, are not covered by this warranty. Komatsu is not responsible for failures or damage resulting from what Komatsu determines to be abuse or neglect, including, but not limited to: operation without adequate coolant or lubricants; over fueling; over speeding; lack of maintenance of lubricating, cooling or intake systems; improper storage, starting, warm-up, run-in or shutdown practices; unauthorized modifications of the engine. Komatsu is also not responsible for failures caused by incorrect fuel or by water, dirt or other contaminants in the fuel. Komatsu is not responsible for non-engine repairs, "downtime" expense, related damage, fines, all business costs or other losses resulting from a warrantable failure.

**KOMATSU IS NOT RESPONSIBLE FOR INCIDENTAL OR CONSEQUENTIAL DAMAGES.**

This warranty, together with the express commercial warranties, are the sole warranties of Komatsu. **THERE ARE NO OTHER WARRANTIES, EXPRESS OR IMPLIED, OR OF MERCHANTABILITY OR FITNESS FOR A PARTICULAR PURPOSE.**

**GARANTIE SUR LE CONTRÔLE DES ÉMISSIONS****ÉNONCÉ DE GARANTIE SUR LE CONTRÔLE DES ÉMISSIONS (APPLICABLE AU CANADA SEULEMENT):****1. Produits garantis:**

Komatsu America International Company, Komatsu Mining Systems Inc. et Komatsu Utility Corporation (collectivement Komatsu) produisent et/ou font la mise en marché de produits portant les noms de marque Komatsu, Dresser, Dressta, Haulpak et Galion. Cette garantie sur les émissions s'applique à tous les nouveaux moteurs portant le nom Komatsu, installés dans ces produits et utilisés au Canada dans des machines conçues pour utilisation industrielle non-roulière. Cette garantie s'applique seulement sur les moteurs produits à partir du 1er Janvier 2000. Cette garantie sera administrée par la distribution de Komatsu au Canada.

**2. Couverture:**

Komatsu garantit à l'acheteur ultime et chaque acheteur subséquent que le moteur est conçu, construit et équipé en toute conformité, au moment de la vente par Komatsu, avec toutes les Réglementations fédérales américaines sur les émissions applicables au moment de la fabrication et qu'il est exempt de défauts de construction ou de matériaux qui auraient pour effet de contrevenir à ces réglementations en dedans de 5 ans ou 3000 heures d'opération, mesuré à partir de la date de livraison du moteur au client ultime.

**3. Limitations:**

Les bris, autres que ceux résultant de défauts de matériaux ou de construction, ne sont pas couverts par cette Garantie. Komatsu n'est pas responsable pour bris ou dommages résultant de ce que Komatsu détermine comme étant de l'abus ou négligence, incluant mais ne se limitant pas à: l'opération sans lubrifiants ou agent refroidissants adéquats; la suralimentation d'essence; la survitesse; le manque d'entretien des systèmes de lubrification, de refroidissement ou d'entrée; de pratiques non-propices d'entreposage, de mise en marche, de réchauffement, de conditionnement ou d'arrêt; les modifications non-autorisées du moteur. De plus, Komatsu n'est pas responsable de bris causés par de l'essence inadéquate ou de l'eau, des saletés ou autres contaminants dans l'essence. Komatsu n'est pas responsable des réparations non-relées au moteur, des dépenses encourues suite aux temps d'arrêts, des dommages relatifs, amendes, et de tout autre coût d'affaires ou autres pertes résultant d'un bris couvert par la garantie.

**KOMATSU N'EST PAS RESPONSABLE DES INCIDENTS OU DOMMAGES CONSÉQUENTS.**

Cette garantie, ainsi que les garanties expresses commerciales, sont les seules garanties de Komatsu. **IL N'Y A AUCUNE AUTRE GARANTIE, EXPRESSE OU SOUS-ENTENDUE, MARCHANDABLE OU PROPICE A UNE UTILISATION PARTICULIÈRE.**



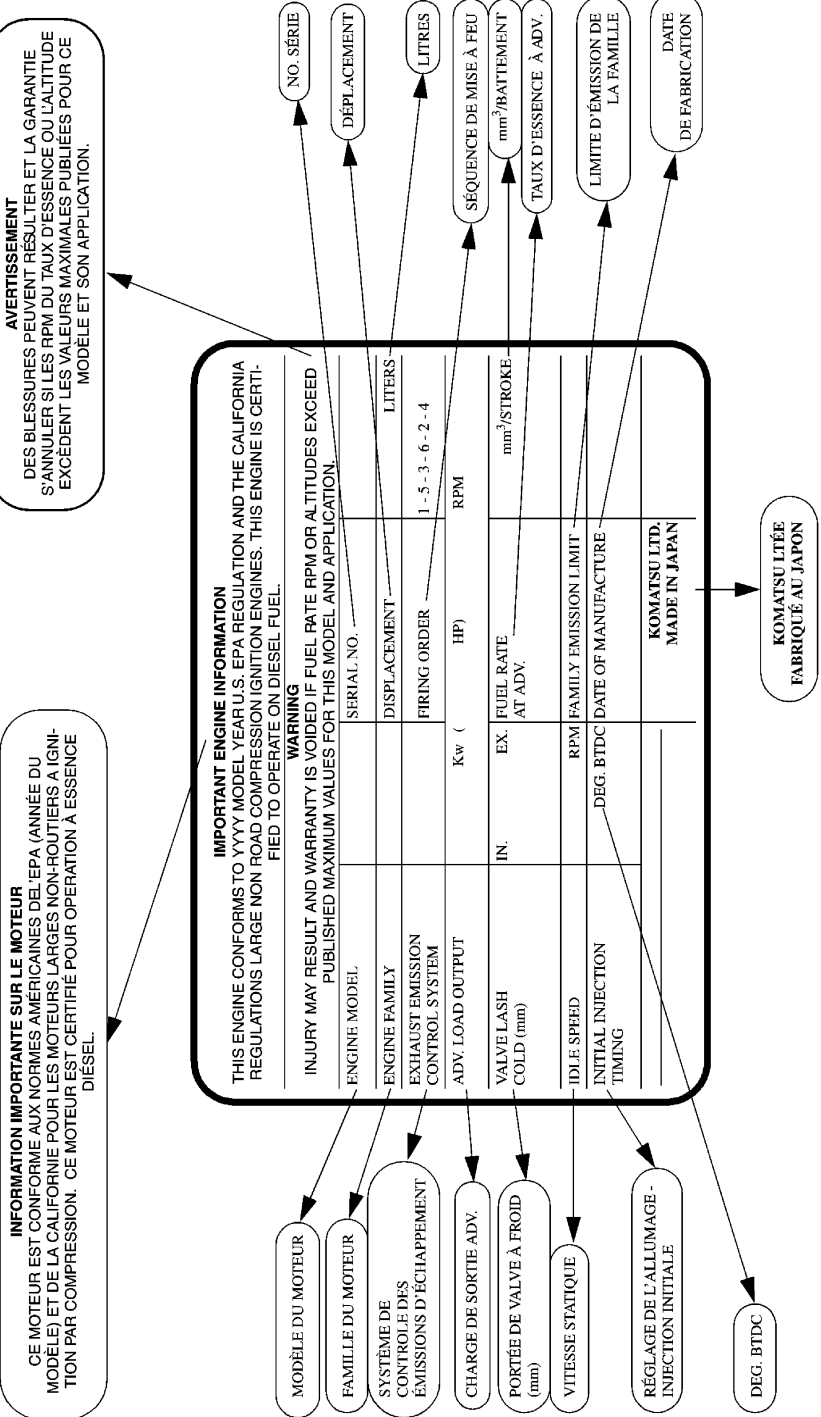

ENGINE DATAPLATE - ENGLISH / FRENCH



## SAFETY INFORMATION

To enable you to use this machine safely, safety precautions and labels are given in this manual and affixed to the machine to give explanations of situations involving potential hazards and of the methods of avoiding such situations.

### Signal words

The following signal words are used to inform you that there is a potential hazardous situation that may lead to personal injury or damage.

In this manual and on machine labels, the following signal words are used to express the potential level of hazard.

- |  |   |
|--|---|
|  <b>DANGER</b>  | Indicates an imminently hazardous situation which, if not avoided, will result in death or serious injury.  |
|  <b>WARNING</b> | Indicates a potentially hazardous situation which, if not avoided, could result in death or serious injury.   |
|  <b>CAUTION</b> | Indicates a potentially hazardous situation which, if not avoided, may result in minor or moderate injury. This word is used also to alert against unsafe practices that may cause property damage. |

### Example of safety message using signal word



When standing up from the operator's seat, always place the lock lever in the **LOCK** position.

If you accidentally touch the control levers when they are not locked, this may cause a serious injury or death.

---

### Other signal words

In addition to the above, the following signal words are used to indicate precautions that should be followed to protect the machine or to give information that is useful to know.

**NOTICE** This word is used for precautions that must be taken to avoid actions which could shorten the life of the machine.

**REMARKS** This word is used for information that is useful to know.

- Safety labels

Safety labels are affixed to the machine to inform the operator or maintenance worker on the spot when carrying out operation or maintenance of the machine that may involve hazard.

This machine uses "Safety labels using words" and "Safety labels using pictograms" to indicate safety procedures.

#### Example of safety label using words

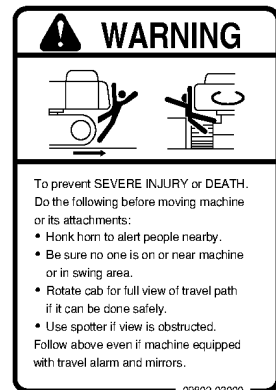

Part No

#### Safety labels using pictogram

Safety pictograms use a picture to express a level of hazardous condition equivalent to the signal word. These safety pictograms use pictures in order to let the operator or maintenance worker understand the level and type of hazardous condition at all times. Safety pictograms show the type of hazardous condition at the top or left side, and the method of avoiding the hazardous condition at the bottom or right side. In addition, the type of hazardous condition is displayed inside a triangle and the method of avoiding the hazardous condition is shown inside a circle.



Part No

Komatsu cannot predict every circumstance that might involve a potential hazard in operation and maintenance. Therefore, the safety messages in this manual and on the machine may not include all possible safety precautions. If any procedures or actions not specifically recommended or allowed in this manual are used, it is your responsibility to take the necessary steps to ensure safety.

In no event should you engage in prohibited uses or actions described in this manual.

The explanations, values, and illustrations in this manual were prepared based on the latest information available at that time. Continuing improvements in the design of this machine can lead to changes in detail which may not be reflected in this manual. Consult Komatsu or your Komatsu distributor for the latest available information of your machine or for questions regarding information in this manual.

The numbers in circles in the illustrations correspond to the numbers in ( ) in the text. (For example: ① → (1))

## INTRODUCTION

This Komatsu machine is designed to be used mainly for the following work:

- Digging work
- Leveling work
- Ditching work
- Loading work

See the section "RECOMMENDED APPLICATIONS (PAGE 3-116)" for further details.

## DIRECTIONS OF MACHINE

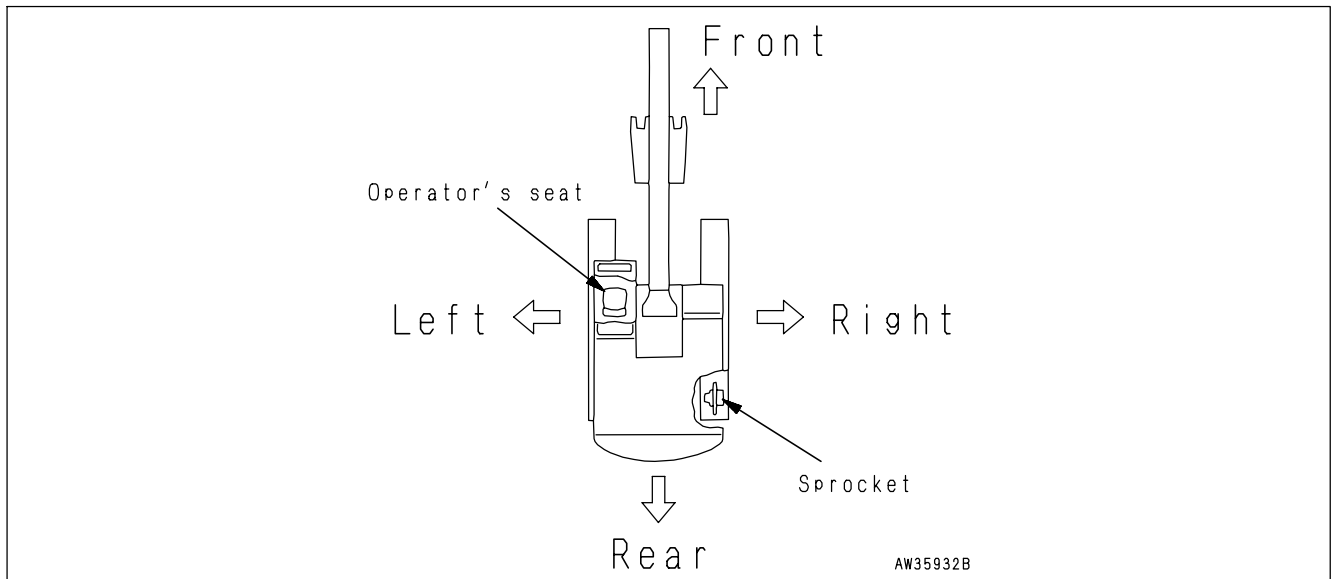

In this manual, the terms front, rear, left, and right refer to the travel direction as seen from the operator's seat when the operator's seat is facing the front and the sprocket is at the rear of the machine.

## BREAKING-IN THE NEW MACHINE

### NOTICE

Your Komatsu machine has been thoroughly adjusted and tested before shipment from the factory. However, operating the machine under full load before breaking the machine in can adversely affect the performance and shorten the machine life.

**Be sure to break in the machine for the initial 100 hours (as indicated on the service meter).**

Make sure that you fully understand the content of this manual, and pay careful attention to the following points when breaking in the machine.

- Run the engine at idle for 15 seconds after starting it. During this time, do not operate the control levers or fuel control dial.
- Idle the engine for 5 minutes after starting it up.
- Avoid operation with heavy loads or at high speeds.
- Immediately after starting the engine, avoid sudden starts, sudden acceleration, unnecessary sudden stops, and sudden changes in direction.

## PRODUCT INFORMATION

When requesting service or ordering replacement parts, please inform your Komatsu distributor of the following items.

### MACHINE SERIAL NUMBER PLATE AND ITS LOCATION

On the front bottom right of the operator's cab (side of upper frame)

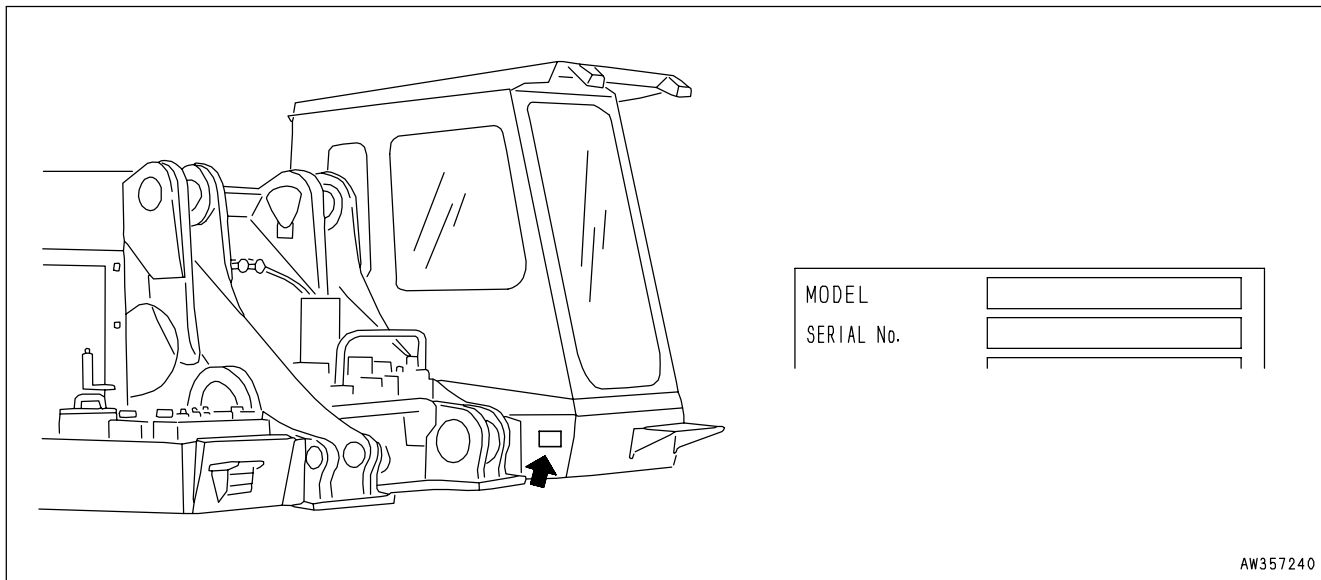

### ENGINE SERIAL NUMBER PLATE AND ITS LOCATION

- This is at the top of the starting motor on the right side face of the engine (rear of machine)

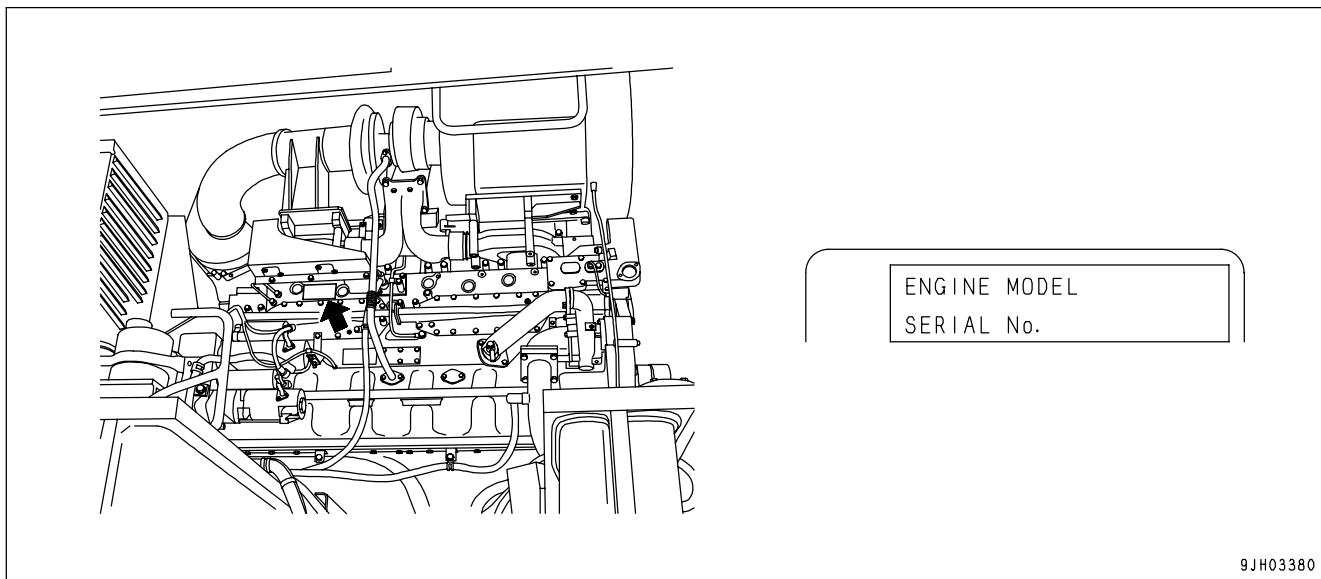

- This is the exhaust manifold on the left side face of the engine (front of machine).

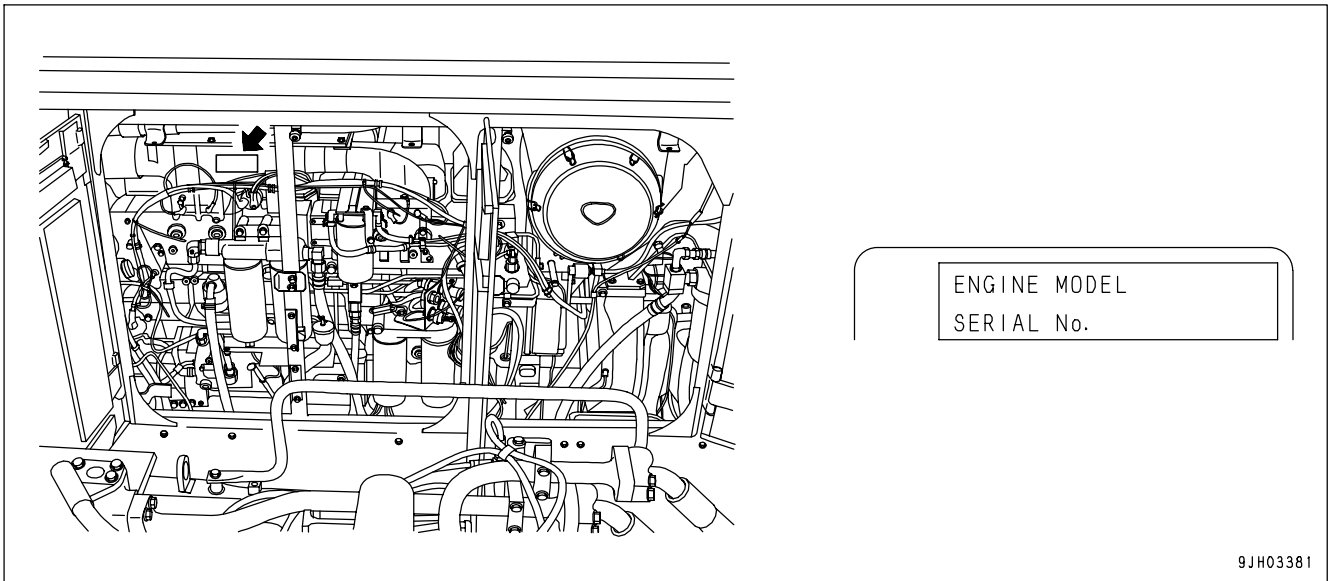

**SERVICE METER LOCATION**

On top of the machine monitor

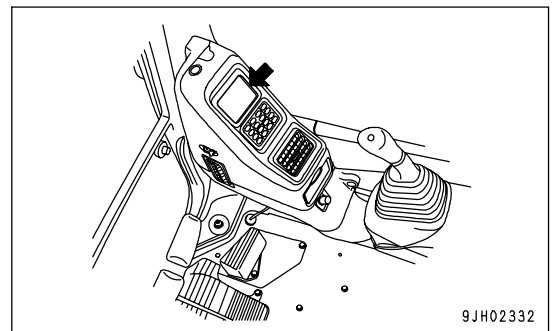

**YOUR MACHINE SERIAL NUMBERS AND DISTRIBUTOR**

|                    |       |
|--------------------|-------|
| Machine serial No. |       |
| Engine serial No.  |       |
| Distributor name   |       |
| Address            | ----- |
|                    | ----- |
|                    | ----- |
| Service Personnel  | ----- |
| Phone/Fax          | ----- |

# CONTENTS

|  |       |
|--|-------|
| FOREWORD .....                                     | 1- 1  |
| FOREWORD .....                                     | 1- 2  |
| SAFETY INFORMATION .....                           | 1- 5  |
| INTRODUCTION .....                                 | 1- 7  |
| DIRECTIONS OF MACHINE .....                        | 1- 7  |
| BREAKING-IN THE NEW MACHINE .....                  | 1- 7  |
| PRODUCT INFORMATION .....                          | 1- 8  |
| MACHINE SERIAL NUMBER PLATE AND ITS LOCATION ..... | 1- 8  |
| ENGINE SERIAL NUMBER PLATE AND ITS LOCATION .....  | 1- 8  |
| SERVICE METER LOCATION .....                       | 1- 9  |
| YOUR MACHINE SERIAL NUMBERS AND DISTRIBUTOR .....  | 1- 10 |
| CONTENTS .....                                     | 1- 11 |
| SAFETY .....                                       | 2- 1  |
| SAFETY .....                                       | 2- 2  |
| SAFETY LABELS .....                                | 2- 4  |
| LOCATION OF SAFETY LABELS .....                    | 2- 5  |
| SAFETY LABELS .....                                | 2- 6  |
| GENERAL PRECAUTIONS .....                          | 2- 12 |
| SAFETY MACHINE OPERATION .....                     | 2- 20 |
| STARTING ENGINE .....                              | 2- 20 |
| OPERATION .....                                    | 2- 22 |
| TRANSPORTATION .....                               | 2- 28 |
| BATTERY .....                                      | 2- 29 |
| TOWING .....                                       | 2- 31 |
| SAFETY MAINTENANCE INFORMATION .....               | 2- 32 |
| OPERATION .....                                    | 3- 1  |
| MACHINE VIEW ILLUSTRATIONS .....                   | 3- 2  |
| OVERALL MACHINE VIEW .....                         | 3- 2  |
| CONTROLS AND GAUGES .....                          | 3- 3  |
| DETAILED CONTROLS AND GAUGES .....                 | 3- 5  |
| MONITORING SYSTEM .....                            | 3- 5  |
| SWITCHES .....                                     | 3- 29 |
| CONTROL LEVERS AND PEDALS .....                    | 3- 35 |
| EMERGENCY EXIT FROM OPERATOR'S CAB .....           | 3- 37 |
| DOOR LOCK .....                                    | 3- 37 |
| CAP WITH LOCK .....                                | 3- 38 |
| HOT AND COOL BOX .....                             | 3- 40 |
| MAGAZINE BOX .....                                 | 3- 40 |
| ASHTRAY .....                                      | 3- 40 |
| AIR CONDITIONER CONTROLS .....                     | 3- 41 |
| RADIO .....  | 3- 56 |
| AUXILIARY ELECTRIC POWER .....                     | 3- 60 |
| FUSE .....   | 3- 61 |
| CIRCUIT BREAKER .....                              | 3- 62 |
| CONTROLLER .....                                   | 3- 64 |
| TOOL BOX .....                                     | 3- 64 |
| GREASE PUMP .....                                  | 3- 65 |
| ACCUMULATOR .....                                  | 3- 68 |



|  |       |
|--|-------|
| MACHINE OPERATIONS AND CONTROLS .....                        | 3- 69 |
| BEFORE STARTING ENGINE .....                                 | 3- 69 |
| STARTING ENGINE .....  | 3- 87 |
| AFTER STARTING ENGINE .....                                  | 3- 91 |
| STOPPING THE ENGINE .....                                    | 3- 99 |
| MACHINE OPERATION .....                                      | 3-100 |
| STEERING THE MACHINE .....                                   | 3-104 |
| SWINGING .....   | 3-106 |
| WORK EQUIPMENT CONTROLS AND OPERATIONS .....                 | 3-107 |
| WORKING MODE .....   | 3-108 |
| PROHIBITED OPERATIONS .....                                  | 3-109 |
| GENERAL OPERATION INFORMATION .....                          | 3-111 |
| TRAVELING ON SLOPES .....                                    | 3-113 |
| ESCAPE FROM MUD .....  | 3-115 |
| RECOMMENDED APPLICATIONS .....                               | 3-116 |
| BUCKET REPLACEMENT .....                                     | 3-117 |
| PARKING MACHINE .....  | 3-119 |
| CHECK AFTER SHUT OFF ENGINE .....                            | 3-121 |
| MACHINE INSPECTION AFTER DAILY WORK .....                    | 3-121 |
| LOCKING .....  | 3-121 |
| TRANSPORTATION .....   | 3-122 |
| PRECAUTIONS FOR TRANSPORTATION .....                         | 3-122 |
| LIFTING MACHINE .....  | 3-122 |
| SHIPPING MACHINE INFORMATION .....                           | 3-123 |
| TRANSPORTATION POSTURE .....                                 | 3-124 |
| COLD WEATHER OPERATION .....                                 | 3-131 |
| COLD WEATHER OPERATION INFORMATION .....                     | 3-131 |
| AFTER DAILY WORK COMPLETION .....                            | 3-133 |
| AFTER COLD WEATHER SEASON .....                              | 3-133 |
| LONG TERM STORAGE .....                                      | 3-134 |
| BEFORE STORAGE .....   | 3-134 |
| DURING STORAGE .....   | 3-134 |
| AFTER STORAGE .....  | 3-134 |
| STARTING MACHINE AFTER LONG-TERM STORAGE .....               | 3-135 |
| TROUBLES AND ACTIONS .....                                   | 3-136 |
| RUNNING OUT OF FUEL .....                                    | 3-136 |
| PHENOMENA THAT ARE NOT FAILURES .....                        | 3-136 |
| TOWING THE MACHINE .....                                     | 3-137 |
| SEVERE JOB CONDITION .....                                   | 3-137 |
| DISCHARGED BATTERY .....                                     | 3-138 |
| OTHER TROUBLE .....  | 3-142 |
| MAINTENANCE .....  | 4- 1  |
| MAINTENANCE INFORMATION .....                                | 4- 2  |
| OUTLINE OF SERVICE .....                                     | 4- 4  |
| HANDLING OIL, FUEL, COOLANT, AND PERFORMING OIL CLINIC ..... | 4- 4  |
| ELECTRIC SYSTEM MAINTENANCE .....                            | 4- 8  |
| WEAR PARTS .....   | 4- 9  |
| WEAR PARTS LIST .....  | 4- 9  |
| LUBRICANTS, FUEL AND COOLANT SPECIFICATIONS .....            | 4- 10 |

|  |       |
|--|-------|
| TIGHTENING TORQUE SPECIFICATIONS-----                                | 4- 14 |
| TIGHTENING TORQUE LIST -----   | 4- 14 |
| SAFETY CRITICAL PARTS -----  | 4- 15 |
| SAFETY CRITICAL PARTS LIST -----                                     | 4- 15 |
| MAINTENANCE SCHEDULE -----   | 4- 16 |
| MAINTENANCE SCHEDULE CHART -----                                     | 4- 16 |
| MAINTENANCE PROCEDURE -----  | 4- 18 |
| INITIAL 100 HOURS MAINTENANCE (ONLY AFTER THE FIRST 100 HOURS) ----- | 4- 18 |
| INITIAL 500 HOURS MAINTENANCE (ONLY AFTER THE FIRST 500 HOURS) ----- | 4- 18 |
| WHEN REQUIRED -----  | 4- 19 |
| CHECK BEFORE STARTING -----  | 4- 42 |
| EVERY 10 HOURS MAINTENANCE -----                                     | 4- 43 |
| EVERY 100 HOURS MAINTENANCE -----                                    | 4- 45 |
| EVERY 250 HOURS MAINTENANCE -----                                    | 4- 46 |
| EVERY 500 HOURS MAINTENANCE -----                                    | 4- 54 |
| EVERY 1000 HOURS MAINTENANCE -----                                   | 4- 69 |
| EVERY 2000 HOURS MAINTENANCE -----                                   | 4- 78 |
| EVERY 4000 HOURS MAINTENANCE -----                                   | 4- 80 |
| EVERY 5000 HOURS MAINTENANCE -----                                   | 4- 81 |
| SPECIFICATIONS -----   | 5- 1  |
| SPECIFICATIONS -----   | 5- 2  |
| ATTACHMENTS AND OPTIONS -----  | 6- 1  |
| GENERAL PRECAUTIONS FOR SAFETY -----                                 | 6- 2  |
| PRECAUTIONS WHEN SELECTING -----                                     | 6- 2  |
| READ THE INSTRUCTION MANUAL THOROUGHLY -----                         | 6- 2  |
| PRECAUTIONS WHEN REMOVING OR INSTALLING -----                        | 6- 2  |
| PRECAUTIONS WHEN USING -----   | 6- 2  |
| ATTACHMENT GUIDE -----   | 6- 3  |
| COMBINATIONS OF WORK EQUIPMENT -----                                 | 6- 3  |
| SELECTION OF TRACK SHOES -----                                       | 6- 7  |
| AUTO-GREASING SYSTEM -----   | 6- 8  |
| EXPLANATION OF COMPONENTS -----                                      | 6- 8  |
| OPERATION -----  | 6- 14 |
| TROUBLESHOOTING -----  | 6- 18 |
| MAINTENANCE -----  | 6- 19 |
| LOADING SHOVEL -----   | 7- 1  |
| EXPLANATION OF COMPONENTS -----                                      | 7- 2  |
| SWITCHES -----   | 7- 2  |
| FUUSE -----  | 7- 5  |
| OPERATIONS -----   | 7- 6  |
| OPERATION OF WORK EQUIPMENT -----                                    | 7- 6  |
| PRECAUTIONS DURING OPERATION -----                                   | 7- 8  |
| EXCAVATOR WORK -----   | 7- 12 |
| PRECAUTIONS WHEN DISASSEMBLING MACHINE -----                         | 7- 13 |
| RELEASING PRESSURE -----   | 7- 13 |
| TRANSPORTATION -----   | 7- 14 |
| MACHINE CONFIGURATION FOR TRANSPORT -----                            | 7- 14 |
| WEAR PARTS -----   | 7- 22 |
| WEAR PARTS LIST -----  | 7- 22 |

|                                     |       |
|-------------------------------------|-------|
| MAINTENANCE -----                   | 7- 23 |
| CHECK BEFORE STARTING -----         | 7- 23 |
| EVERY 10 HOURS MAINTENANCE -----    | 7- 25 |
| EVERY 5000 HOURS MAINTENANCE -----  | 7- 26 |
| SPECIFICATION -----                 | 7- 28 |
| COMBINATION OF WORK EQUIPMENT ----- | 7- 29 |
| COMBINATION OF WORK EQUIPMENT ----- | 7- 29 |
| INDEX -----                         | 8- 1  |

# SAFETY

## **WARNING**

Please read and make sure that you fully understand the precautions described in this manual and the safety labels on the machine. When operating or servicing the machine, always follow these precautions strictly.

---

## SAFETY

|  |       |
|--|-------|
| SAFETY LABELS .....  | 2- 4  |
| LOCATION OF SAFETY LABELS .....  | 2- 5  |
| SAFETY LABELS .....  | 2- 6  |
| <br>   |       |
| SAFETY INFORMATION .....   | 2- 12 |
| Safety Rules .....   | 2- 12 |
| If Problems are Found .....  | 2- 12 |
| Working Wear and Personal Protective Items .....                       | 2- 12 |
| Fire Extinguisher and First Aid Kit .....                              | 2- 12 |
| Safety Equipment .....   | 2- 12 |
| Keep Machine Clean .....   | 2- 13 |
| Keep Operator's Compartment Clean .....                                | 2- 13 |
| Leaving Operator's Seat with Lock .....                                | 2- 13 |
| Handrails and Steps .....  | 2- 14 |
| Mounting and Dismounting .....   | 2- 14 |
| No Persons on Attachments .....  | 2- 14 |
| Burn Prevention .....  | 2- 15 |
| Fire Prevention and Explosion Prevention .....                         | 2- 15 |
| Action if Fire Occurs .....  | 2- 16 |
| Windshield Washer Fluid .....  | 2- 16 |
| Falling Objects, Flying Objects and Intruding Objects Prevention ..... | 2- 16 |
| Attachment Installation .....  | 2- 17 |
| Attachment Combinations .....  | 2- 17 |
| Cab Window Glasses .....   | 2- 17 |
| Unauthorized Modifications .....                                       | 2- 17 |
| Safety at Jobsite .....  | 2- 17 |
| Working on Loose Ground .....  | 2- 18 |
| Distance to High Voltage Cables .....                                  | 2- 18 |
| Ensure Good Visibility .....   | 2- 18 |
| Ventilation for Enclosed Area .....                                    | 2- 19 |
| Signalman's Signal and Signs .....                                     | 2- 19 |
| Emergency Exit from Operator's Cab .....                               | 2- 19 |
| Asbestos Dust Hazard Prevention .....                                  | 2- 19 |

|  |           |
|--|-----------|
| SAFETY MACHINE OPERATION .....   | 2- 20     |
| Starting Engine .....  | 2- 20     |
| Checks Before Starting Engine .....  | 2- 20     |
| Safety Rules for Starting Engine .....                                     | 2- 20     |
| Starting Engine in Cold Weather .....                                      | 2- 21     |
| Operation .....  | 2- 22     |
| Checks Before Operation .....  | 2- 22     |
| Safety Rules for Changing Machine Directions .....                         | 2- 22     |
| Safety Rules for Traveling .....   | 2- 23     |
| Traveling on Slopes .....  | 2- 23     |
| Operations on Slopes .....   | 2- 24     |
| Prohibited Operations .....  | 2- 25     |
| Operations on Snow .....   | 2- 26     |
| Parking Machine .....  | 2- 27     |
| Transportation .....   | 2- 28     |
| Shipping the Machine .....   | 2- 28     |
| Battery .....  | 2- 29     |
| Battery Hazard Prevention .....  | 2- 29     |
| Starting Engine with Booster Cables .....                                  | 2- 30     |
| Towing .....   | 2- 31     |
| Safety Rules for Towing .....  | 2- 31     |
| <br>SAFETY MAINTENANCE INFORMATION .....                                   | <br>2- 32 |
| Warning tag .....  | 2- 32     |
| Keep work place clean and tidy .....                                       | 2- 32     |
| Appoint leader when working with others .....                              | 2- 32     |
| Stop engine before carrying out maintenance .....                          | 2- 33     |
| Two workers for maintenance when engine is running .....                   | 2- 34     |
| Proper tools .....   | 2- 34     |
| Accumulator .....  | 2- 34     |
| Personnel .....  | 2- 35     |
| Attachments .....  | 2- 35     |
| Work under the machine .....   | 2- 35     |
| Noise .....  | 2- 35     |
| When using hammer .....  | 2- 35     |
| Welding works .....  | 2- 36     |
| Removing battery terminals .....   | 2- 36     |
| Safety first when using high-pressure grease to adjust track tension ..... | 2- 36     |
| Do not disassemble recoil springs .....                                    | 2- 36     |
| Safety rules for high-pressure oil .....                                   | 2- 37     |
| Safety handling high-pressure hoses .....                                  | 2- 37     |
| Waste materials .....  | 2- 37     |
| Air conditioner maintenance .....  | 2- 38     |
| Compressed air .....   | 2- 38     |
| Periodic replacement of safety critical parts .....                        | 2- 38     |

## SAFETY LABELS

The following warning signs and safety labels are used on this machine.

- Be sure that you fully understand the correct position and content of labels.
- To ensure that the content of labels can be read properly, be sure that they are in the correct place and always keep them clean. When cleaning them, do not use organic solvents or gasoline. These may cause the labels to peel off.
- There are also other labels in addition to the warning signs and safety labels. Handle those labels in the same way.
- If the labels are damaged, lost, or cannot be read properly, replace them with new ones. For details of the part numbers for the labels, see this manual or the actual label, and place an order with Komatsu distributor.

### LOCATION OF SAFETY LABELS

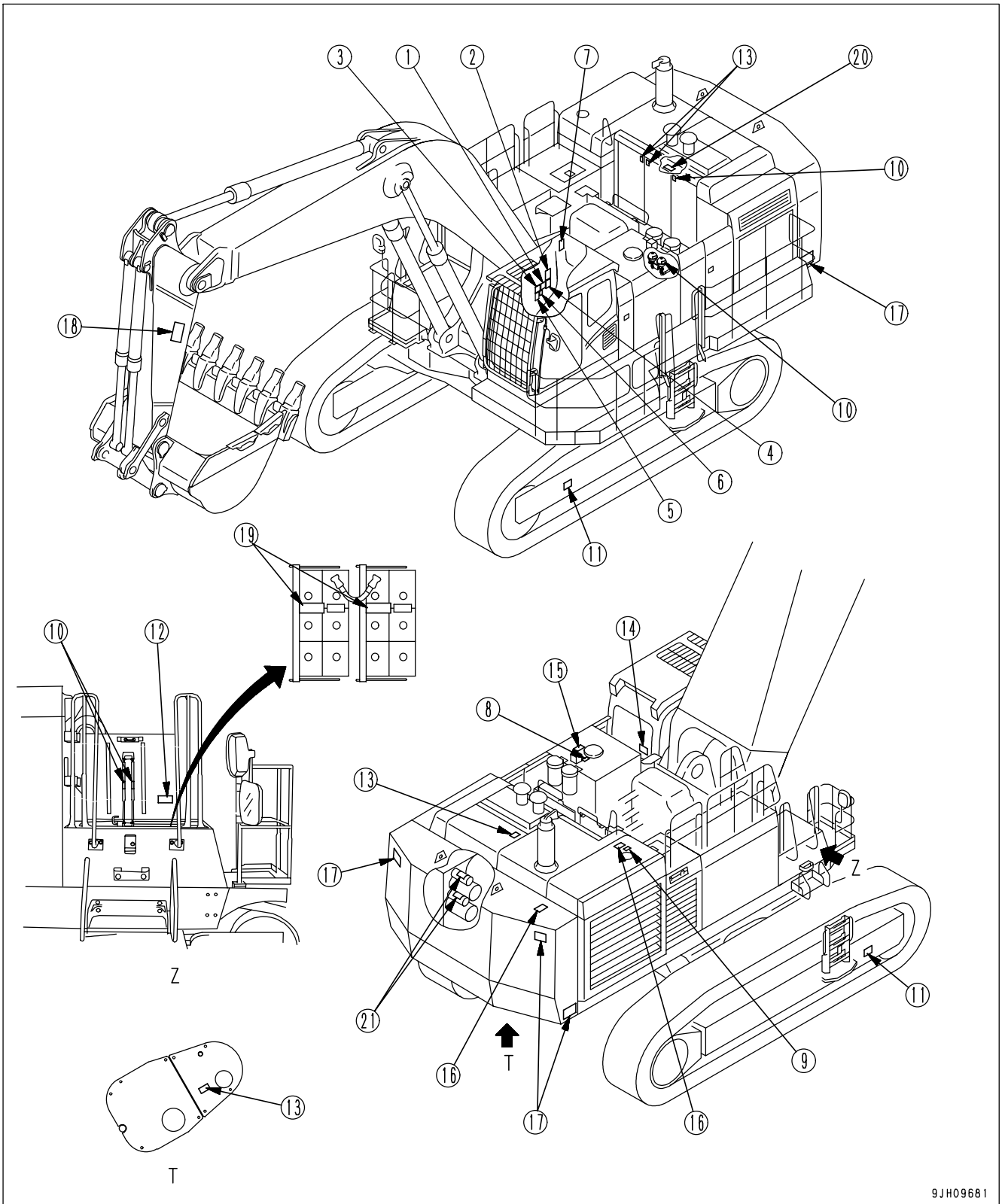

9JH09681



**SAFETY LABELS**

- (1) Caution before operating or maintaining machine  
(09651-03001)

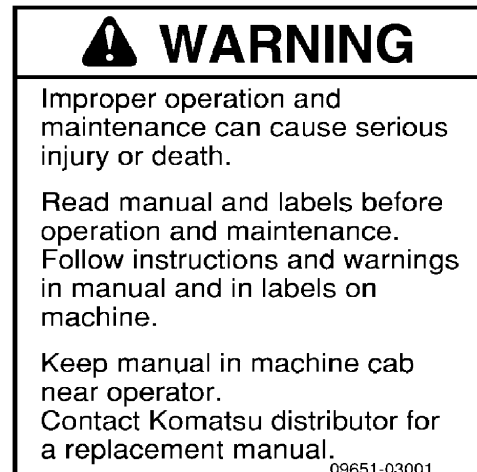

- (2) Caution before operating (09802-03000)

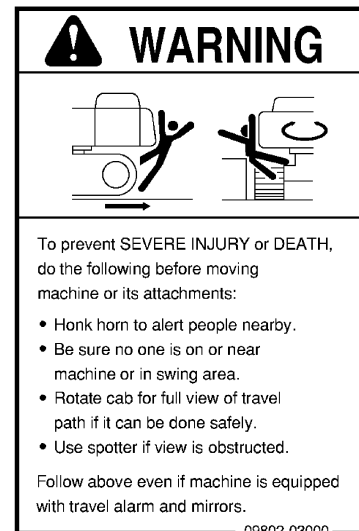

- (3) Caution for leaving operator's seat (09654-03001)



(4) Caution for going close to electric cables (09801-03001)

**⚠ DANGER**

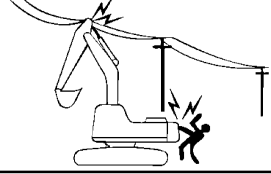

Hazardous voltage hazard.  
Serious injury or death can occur if machine or attachments are not kept safe distance away from electric lines.

| VOLTAGE              |           | SAFE DISTANCE |
|----------------------|-----------|---------------|
| LOW VOLTAGE          | 100V 200V | 2m            |
|                      | 6.600V    | 2m            |
|                      | 22.000V   | 3m            |
| SPECIAL HIGH VOLTAGE | 66.000V   | 4m            |
|                      | 154.000V  | 5m            |
|                      | 187.000V  | 6m            |
|                      | 275.000V  | 7m            |
|                      | 500.000V  | 11m           |

09801-03001

(5) Caution for operating pattern (09822-03000)

**⚠ WARNING**

**In order to prevent an accident resulting in injury or death caused by error-operation, confirm the machine motion and indicated operating pattern, when operating machines. Pay attention to the circumference and operate slowly when confirming the machine motion.**

**ISO pattern**

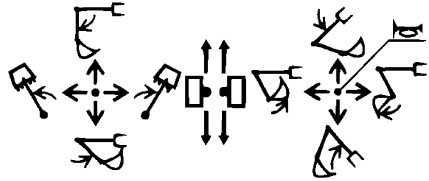

09822-03000

- (6) Caution when opening or closing front window  
(09839-03000)

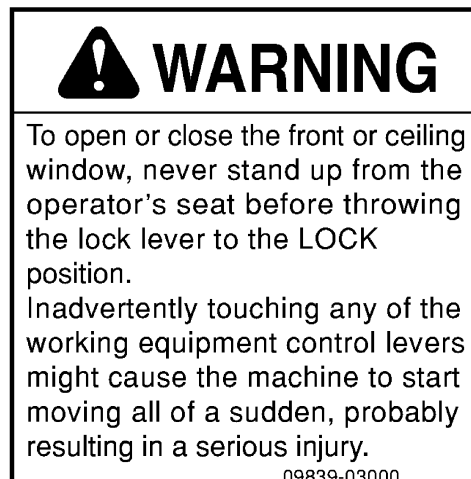

- (7) Caution when stowing front window (09803-03000)

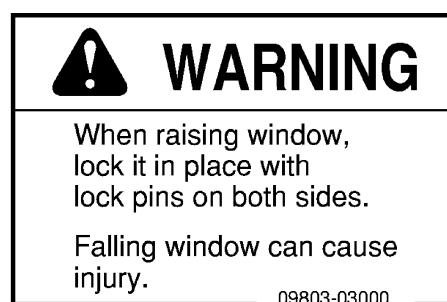

- (8) Caution for high-temperature hydraulic oil (09653-03001)



- (9) Caution with high-temperature coolant (09668-03001)



(10) Caution for handling accumulator and gas spring  
(09659-53000)



(11) Caution for adjusting track tension (09657-03003)



(12) Caution for handling cable (09808-03000)

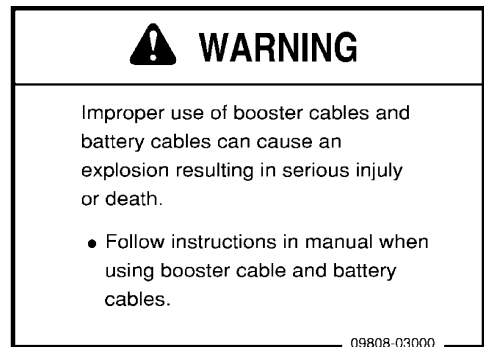

(13) Stopping rotation for inspection and maintenance  
(09667-03001)

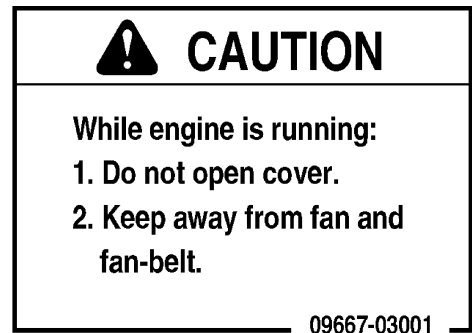

- (14) Explanation of methods for emergency escape  
(20Y-00-31170)

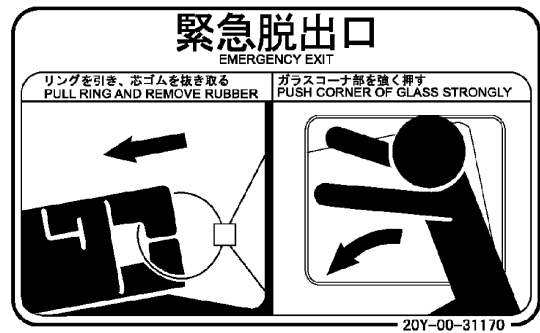

- (15) Caution against falling (09805-23000)



- (16) Caution against falling (09805-13000)



- (17) Prohibited to enter within swing range (09133-23000)



(18) Beware of work equipment (09134-A1681)



Sign indicates a hazard of being hit by the working device of the machine.

Keep away from machine during operation.

(19) Caution when handling battery (14X-98-11370)

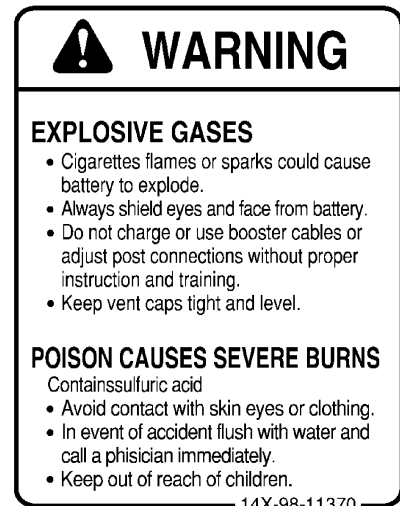

(20) Jump start prohibited (09842-A0481)



Start the engine only after sitting down in the operator's seat.

Do not attempt to start the engine by short-circuiting the engine starting circuit. Such an act may cause a serious bodily injury or fire.

## GENERAL PRECAUTIONS

### SAFETY RULES

- Only trained and authorized personnel can operate and maintain the machine.
- Follow all safety rules, precautions and instructions in this manual when operating or performing maintenance on the machine.
- If you are not feeling well, or if you are under the influence of alcohol or medication, your ability to safely operate or repair your machine may be severely impaired, putting yourself and everyone else on your job site in danger.
- When working with another operator or with the person on the worksite traffic duty, discuss the content of the operation beforehand and use the determined signals when carrying out the operation.

### IF PROBLEMS ARE FOUND

If you find any problems in the machine during operation or maintenance (noise, vibration, smell, incorrect gauges, smoke, oil leakage, etc., or any abnormal display on the warning devices or monitor), report to the person in charge and have the necessary action taken. Do not operate the machine until the problem has been corrected.

### WORKING WEAR AND PERSONAL PROTECTIVE ITEMS

- Do not wear loose clothing and accessories. There is a hazard that they may catch on control levers or other protruding parts.
- If you have long hair and it hangs out from your hard hat, there is a hazard that it may get caught up in the machine, so tie your hair up and be careful not to let it get caught.
- Always wear a hard hat and safety shoes. If the nature of the work requires it, wear safety glasses, mask, gloves, ear plugs, and safety belt when operating or maintaining the machine.
- Check that all protective equipment functions properly before using it.

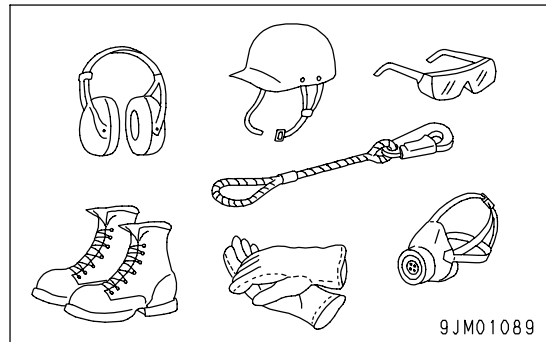

### FIRE EXTINGUISHER AND FIRST AID KIT

Always follow the precautions below to prepare for action if any injury or fire should occur.

- Be sure that fire extinguishers have been provided and read the labels to ensure that you know how to use them in emergencies.
- Carry out periodic inspection and maintenance to ensure that the fire extinguisher can always be used.
- Provide a first aid kit in the storage point. Carry out periodic checks and add to the contents if necessary.

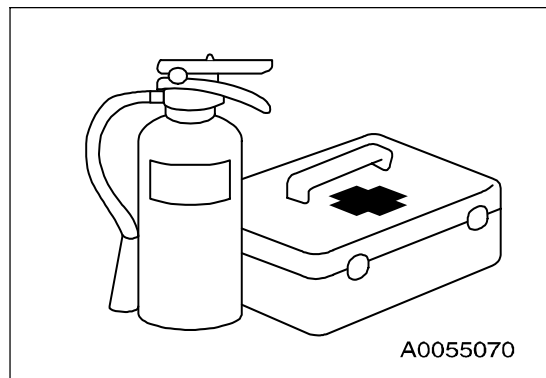

### SAFETY EQUIPMENT

- Be sure that all guards, covers and mirrors are in their proper position. Have guards and covers repaired immediately if they are damaged.
- Understand the method of use of safety features and use them properly.
- Never remove any safety features. Always keep them in good operating condition.

**KEEP MACHINE CLEAN**

- If water gets into the electrical system, there is a hazard that it will cause malfunctions or misoperation. Do not use water or steam to wash the electrical system (sensors, connectors).
- If inspection and maintenance is carried out when the machine is still dirty with mud or oil, there is a hazard that you will slip and fall, or that dirt or mud will get into your eyes. Always keep the machine clean.

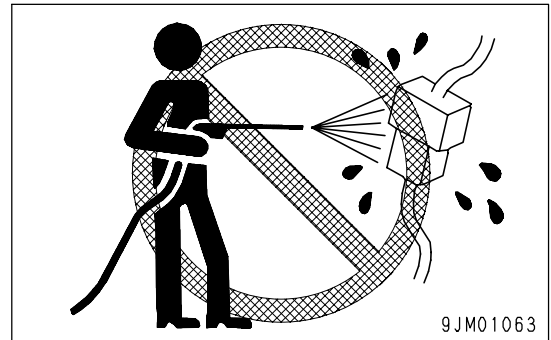
**KEEP OPERATOR'S COMPARTMENT CLEAN**

- When entering the operator's compartment, always remove all mud and oil from the soles of your shoes. If you operate the pedal with mud or oil affixed to your shoes, your foot may slip and this may cause a serious accident.
- Do not leave parts or tools lying around the operator's compartment.
- Do not stick suction pads to the window glass. Suction pads act as a lens and may cause fire.
- Do not use cellular telephones inside the operator's compartment when driving or operating the machine.
- Never bring any dangerous objects such as flammable or explosive items into the operator's compartment.

**LEAVING OPERATOR'S SEAT WITH LOCK**

- Before standing up from the operator's seat (such as when opening or closing the front window or roof window, or when removing or installing the bottom window, or when adjusting the operator's seat), lower the work equipment completely to the ground, set safety lock lever (1) securely to the LOCK position (L), then stop the engine. If you accidentally touch the levers when they are not locked, there is a hazard that the machine may suddenly move and cause serious injury or property damage.

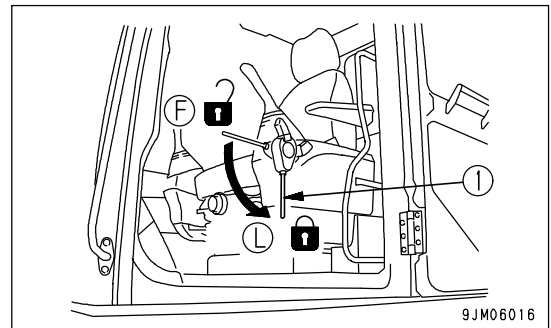

(F): Free

(L): Lock

- When leaving the machine, always lower the work equipment completely to the ground, set lock lever (1) securely to the LOCK position, then stop the engine. Use the key to lock all the equipment. Always remove the key, take it with you, and keep it in the specified place.

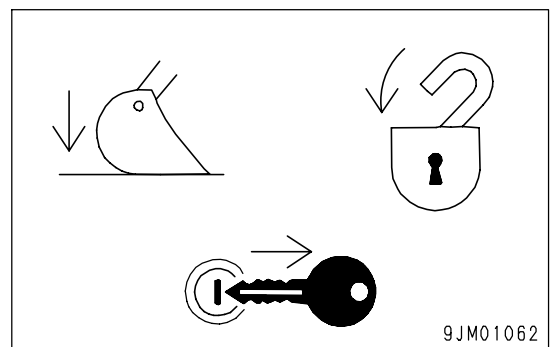



**HANDRAILS AND STEPS**

To prevent personal injury caused by slipping or falling off the machine, always do as follows.

- Use the handrails and steps marked by arrows in the diagram on the right when getting on or off the machine.

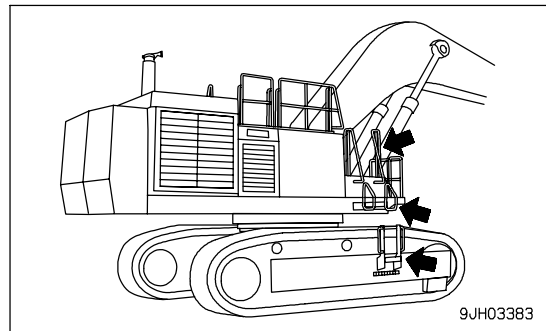
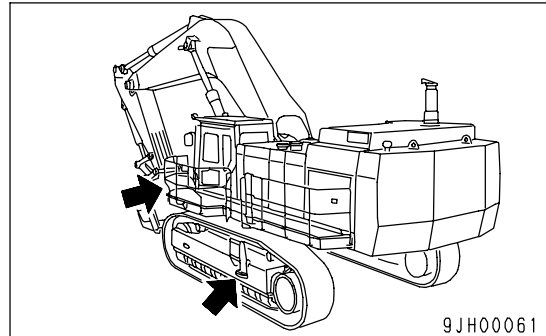

- To ensure safety, always face the machine and maintain three-point contact (both feet and one hand, or both hands and one foot) with the handrails and steps (including the track shoe) to ensure that you support yourself.
- Do not grip the control levers, or work equipment lock lever when getting on or off the machine.
- Never climb on the engine hood or covers where there are no non-slip pads.
- Before getting on or off the machine, check the handrails and steps (including the track shoe). If there is any oil, grease, or mud on the handrails or steps (including the track shoe), wipe it off immediately. Always keep these parts clean. Repair any damage and tighten any loose bolts.
- Do not get on or off the machine while holding tools in your hand.

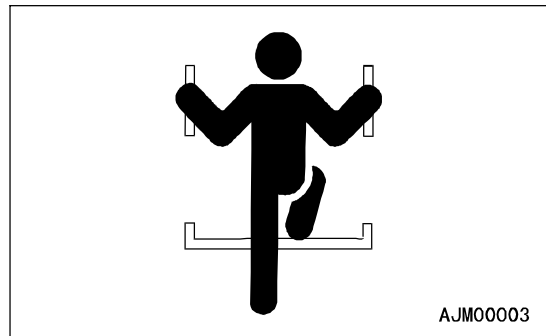
**MOUNTING AND DISMOUNTING**

- Never jump on or off the machine. Never get on or off a moving machine.
- If the machine starts to move when there is no operator on the machine, do not jump on to the machine and try to stop it.

**NO PERSONS ON ATTACHMENTS**

Never let anyone ride on the work equipment, or other attachments. There is a hazard of falling and suffering serious injury.

**BURN PREVENTION****Hot coolant**

- To prevent burns from hot water or steam spurting out when checking or draining the coolant, wait for the water to cool to a temperature where it is possible to touch the radiator cap by hand before starting the operation. Even when the coolant has cooled down, loosen the cap slowly to relieve the pressure inside the radiator before removing the cap.

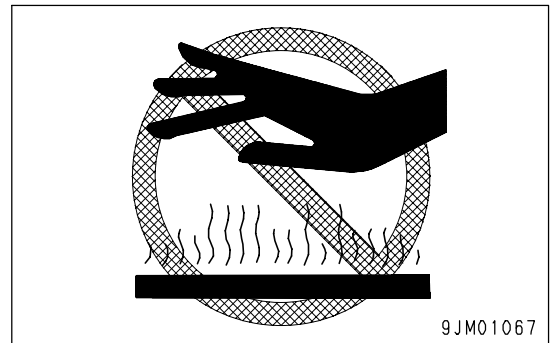
**Hot oil**

- To prevent burns from hot oil spurting out when checking or draining the oil, wait for the oil to cool to a temperature where it is possible to touch the cap or plug by hand before starting the operation. Even when the oil has cooled down, loosen the cap or plug slowly to relieve the internal pressure before removing the cap or plug.

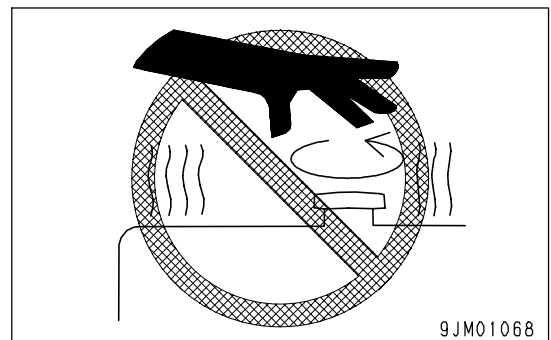
**FIRE PREVENTION AND EXPLOSION PREVENTION****• Fire caused by fuel or oil**

Fuel, oil, antifreeze, and window washer liquid are particularly flammable and can be hazardous. To prevent fire, always observe the following:

- Do not smoke or use any flame near fuel or oil.
- Stop the engine before refueling.
- Do not leave the machine while adding fuel or oil.
- Tighten all fuel and oil caps securely.
- Do not spill fuel on overheated surfaces or on parts of the electrical system.
- Use well-ventilated areas for adding or storing oil and fuel.
- Keep oil and fuel in the determined place and do not allow unauthorized persons to enter.
- After adding fuel or oil, wipe up any spilled fuel or oil.
- When carrying out grinding or welding work on the chassis, move any flammable materials to a safe place before starting.
- When washing parts with oil, use a non-flammable oil. Diesel oil and gasoline may catch fire, so do not use them.
- Put greasy rags and other flammable materials into a safe container to maintain safety at the work place.
- Do not weld or use a cutting torch to cut any pipes or tubes that contain flammable liquids.

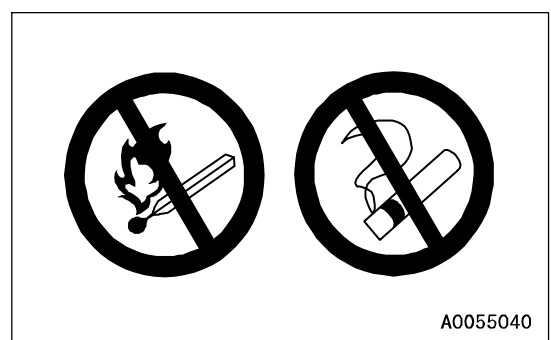
**• Fire caused by accumulation of flammable material.**

Remove any dry leaves, chips, pieces of paper, dust, or any other flammable materials accumulated or affixed around the engine, exhaust manifold, muffler, or battery, or inside the undercovers.

- **Fire coming from electric wiring**

Short circuits in the electrical system can cause fire.

- Always keep electric wiring connections clean and securely tightened.
- Check the wiring every day for looseness or damage. Tighten any loose connectors or wiring clamps. Repair or replace any damaged wiring.

- **Fire coming from hydraulic line**

Check that all the hose and tube clamps, guards, and cushions are securely fixed in position.

If they are loose, they may vibrate during operation and rub against other parts. This may lead to damage to the hoses, and cause high-pressure oil to spurt out, leading to fire damage or serious injury.

- **Explosion caused by lighting equipment**

- When checking fuel, oil, battery electrolyte, window washer fluid, or coolant, always use lighting with anti-explosion specifications. If such lighting equipment is not used, there is danger of explosion that may cause serious injury.
- When taking the electrical power for the lighting from the machine itself, follow the instructions in this manual.

### ACTION IF FIRE OCCURS

If a fire occurs, escape from the machine as follows.

- Turn the start switch OFF to stop the engine.
- Use the handrails and steps to get off the machine.

### WINDSHIELD WASHER FLUID

Use an ethyl alcohol base washer liquid.

Methyl alcohol base washer liquid may irritate your eyes, so do not use it.

### FALLING OBJECTS, FLYING OBJECTS AND INTRUDING OBJECTS PREVENTION

On jobsites where there is a hazard that falling objects, flying objects, or intruding objects may hit or enter the operator's cab, consider the operating conditions and install the necessary guards to protect the operator.

- When carrying out demolition or breaker operations, install a front guard and use a laminated coating sheet on the front glass.
- When working in mines or quarries where there is a hazard of falling rock, install FOPS (Falling Objects Protective Structure) and a front guard, and use a laminated coating sheet on the front glass.
- When carrying out the above operations, always close the front window. In addition, always ensure that bystanders are a safe distance away and are not in hazard from falling or flying objects.
- The above recommendations assume that the conditions are for standard operations, but it may be necessary to add additional guards according to the operating conditions on the jobsite. Always contact your Komatsu distributor for advice.

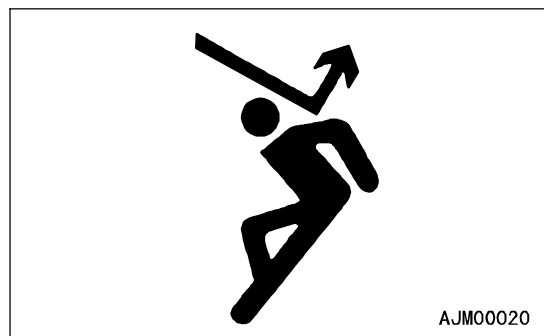
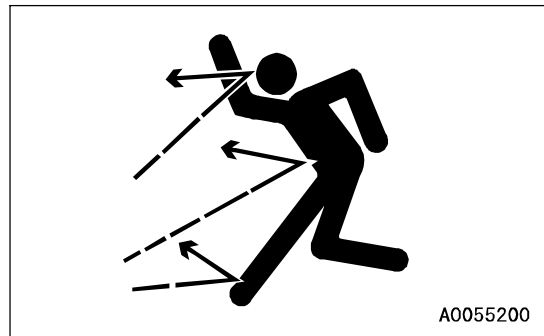

**ATTACHMENT INSTALLATION**

- When installing optional parts or attachments, there may be problems with safety or legal restrictions. Therefore contact your Komatsu distributor for advice.
- Any injuries, accidents, product failures or other property damages resulting from the use of unauthorized attachments or parts will not be the responsibility of Komatsu.
- When installing and using optional attachments, read the instruction manual for the attachment, and the general information related to attachments in this manual.

**ATTACHMENT COMBINATIONS**

Depending on the type or combination of work equipment, there is a hazard that the work equipment may hit the cab or other parts of the machine. Before using unfamiliar work equipment, check if there is any hazard of interference, and operate with caution.

**CAB WINDOW GLASSES**

- If a pane of the cab window on the work equipment side is broken, the work equipment may directly hit the operator. In that case, stop the machine immediately and replace the broken pane with new one.
- The ceiling window is made of organic glass (polycarbonate), and as such it is apt to break easily when receiving damage on the surface, thereby deteriorating its protective characteristic. If there is a crack or damage caused by a fallen rock, or when any sign of them is noticed, replace it with a new window.

**UNAUTHORIZED MODIFICATIONS**

Any modification made without authorization from Komatsu can create hazards. Before making a modification, consult your Komatsu distributor.

- Komatsu will not be responsible for any injuries, accidents, product failures or other property damages resulting from modifications made without authorization from Komatsu.

**SAFETY AT JOBSITE**

Before starting operations, thoroughly check the area for any unusual conditions that could be dangerous.

- When carrying out operations near combustible materials such as thatched roofs, dry leaves or dry grass, there is a hazard of fire, so be careful when operating.
- Check the terrain and condition of the ground at the worksite, and determine the safest method of operation. Do not operate where there is a hazard of landslides or falling rocks.
- If water lines, gas lines, or high-voltage electrical lines may be buried under the worksite, contact each utility and identify their locations. Be careful not to sever or damage any of these lines.
- Take necessary measures to prevent any unauthorized person from entering the operating area.

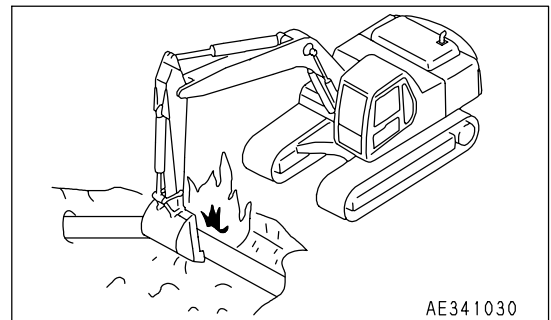

- When traveling or operating in shallow water or on soft ground, check the shape and condition of the bedrock, and the depth and speed of flow of the water before starting operations.

**WORKING ON LOOSE GROUND**

- Avoid traveling or operating your machine too close to the edge of cliffs, overhangs, and deep ditches. The ground may be weak in such areas. If the ground should collapse under the weight or vibration of the machine, there is a hazard that the machine may fall or tip over. Remember that the soil after heavy rain or blasting or after earthquakes is weak in these areas.
- When working on embankments or near excavated ditches, there is a hazard that the weight and vibration of the machine will cause the soil to collapse. Before starting operations, take steps to ensure that the ground is safe and to prevent the machine from rolling over or falling.

**DISTANCE TO HIGH VOLTAGE CABLES**

Do not travel or operate the machine near electric cables. There is a hazard of electric shock, which may cause serious personal injury or death. On jobsites where the machine may go close to electric cables, always do as follows.

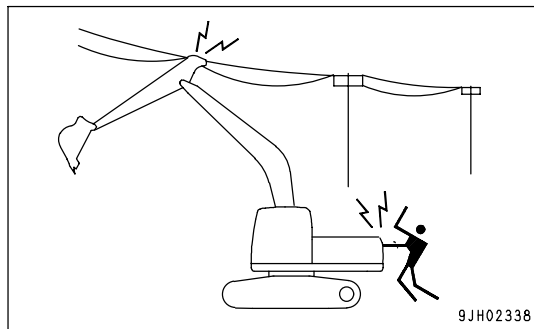

- Before starting work near electric cables, inform the local power company of the work to be performed, and ask them to take the necessary action.

- Even going close to high-voltage cables can cause electric shock, which may cause serious burns or even death. Always maintain a safe distance (see the table on the right) between the machine and the electric cable. Check with the local power company about safe operating procedure before starting operations.
- To prepare for any possible emergencies, wear rubber shoes and gloves. Lay a rubber sheet on top of the seat, and be careful not to touch the chassis with any exposed part of your body.
- Use a signalman to give warning if the machine approaches too close to the electric cables.
- When carrying out operations near high voltage cables, do not let anyone near the machine.
- If the machine should come too close or touch the electric cable, to prevent electric shock, the operator should not leave the operator’s compartment until it has been confirmed that the electricity has been shut off. Also, do not let anyone near the machine.

| Voltage of Cables | Safety Distance   |
|-------------------|-------------------|
| 100 V - 200 V     | Over 2 m (7 ft)   |
| 6,600 V           | Over 2 m (7 ft)   |
| 22,000 V          | Over 3 m (10 ft)  |
| 66,000 V          | Over 4 m (14 ft)  |
| 154,000 V         | Over 5 m (17 ft)  |
| 187,000 V         | Over 6 m (20 ft)  |
| 275,000 V         | Over 7 m (23 ft)  |
| 500,000 V         | Over 11 m (36 ft) |

**ENSURE GOOD VISIBILITY**

- Check for any persons or obstacles in the area around the machine and check the conditions of the jobsite to ensure that operations and travel can be carried out safely. Always do as follows.
  - When working in dark places, turn on the working lamp and front lamps installed to the machine, and set up additional lighting in the work area if necessary.
  - Stop operations if the visibility is poor, such as in mist, snow, rain, or dust.

**VENTILATION FOR ENCLOSED AREA**

Exhaust fumes from the engine can kill.

- If it is necessary to start the engine within an enclosed area, or when handling fuel, flushing oil, or paint, open the doors and windows to ensure that adequate ventilation is provided to prevent gas poisoning.

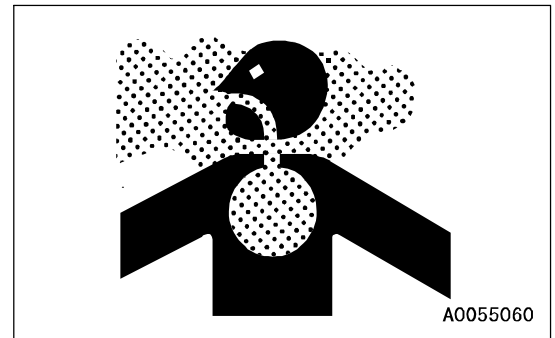
**SIGNALMAN'S SIGNAL AND SIGNS**

- Set up signs to inform of road shoulders and soft ground. If the visibility is not good, position a signalman if necessary. Operators should pay careful attention to the signs and follow the instructions from the signalman.
- Only one signalman should give signals.
- Make sure that all workers understand the meaning of all signals and signs before starting work.

**EMERGENCY EXIT FROM OPERATOR'S CAB**

If the cabin door does not open, open the rear window and use it as an emergency escape exit. For details, see "Emergency exit from operator's compartment" in this manual.

**ASBESTOS DUST HAZARD PREVENTION**

Asbestos dust in the air can cause lung cancer if it is inhaled. There is danger of inhaling asbestos when working on jobsites handling demolition work or work handling industrial waste. Always observe the following.

- Spray water to keep down the dust when cleaning. Do not use compressed air for cleaning.
- If there is danger that there may be asbestos dust in the air, always operate the machine from an upwind position. All workers should use an approved respirator.
- Do not allow other persons to approach during the operation.
- Always observe the rules and regulations for the work site and environmental standards.

This machine does not use asbestos, but there is a danger that imitation parts may contain asbestos, so always use genuine Komatsu parts.



## SAFETY MACHINE OPERATION

### STARTING ENGINE

If there is a warning tag hanging from the work equipment control lever, do not start the engine or touch the levers.

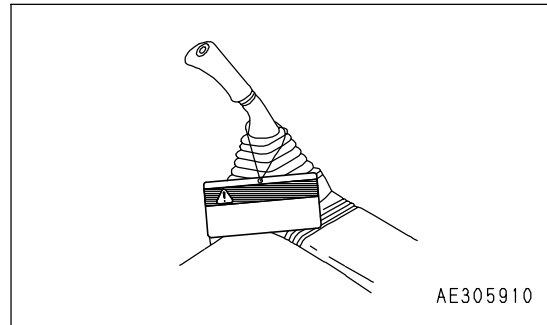

### CHECKS BEFORE STARTING ENGINE

Carry out the following checks before starting the engine at the beginning of the day's work.

- Remove all dirt from the surface of the window glass to ensure a good view.
- Remove all dirt from the lens surface of the front lamps and working lamp and check that they light up properly. When cleaning the working lamp (side face of boom), use equipment designed for working at high places.
- Check the coolant level, fuel level, and oil level in engine oil pan, check for clogging of the air cleaner, and check for damage to the electric wiring.
- Adjust the operator's seat to a position where it is easy to carry out operations, and check that there is no damage or wear to the seat belt or mounting clamps.
- Check the operation of the instruments and gauges, check the angle of the mirror, and check that the control levers are all at the Neutral position.
- Before starting the engine, make sure that the lock lever is in the LOCK position.
- Adjust the mirrors so that the rear of the machine can be seen clearly from the operator's seat. When adjusting, see "Rearview Mirrors (PAGE 3-83)".
- Check that there are no persons or obstacles above, below, or in the area around the machine.

### SAFETY RULES FOR STARTING ENGINE

- When starting the engine, sound the horn as a warning.
- Start and operate the machine only while seated.
- Do not allow anyone apart from the operator to ride on the machine.
- Do not short circuit the starting motor circuit to start the engine. Short circuit can cause fire.

**STARTING ENGINE IN COLD WEATHER**

- Carry out the warming-up operation thoroughly. If the machine is not thoroughly warmed up before the control levers are operated, the reaction of the machine will be slow, and this may lead to unexpected accidents.
- If the battery electrolyte is frozen, do not charge the battery or start the engine with a different power source. There is a hazard that this will ignite the battery.

Before charging or starting the engine with a different power source, melt the battery electrolyte and check for frost and leakage of battery electrolyte before starting.



## OPERATION

### CHECKS BEFORE OPERATION

When carrying out the checks, move the machine to a wide area where there are no obstructions, and operate slowly. Do not allow anyone near the machine.

- Always fasten your seat belt.
- Check that the movement of the machine matches the display on the control pattern card. If it does not match, replace it immediately with the correct control pattern card.
- Check the operation of the work equipment, travel system and swing system.
- Check for any problem in the sound of the machine, vibration, heat, smell, or gauges; check also that there is no leakage of oil or fuel.
- If any problem is found, carry out repairs immediately.

### SAFETY RULES FOR CHANGING MACHINE DIRECTIONS

- Before traveling, position the upper structure so that the sprocket is at the rear of the operator's cab. If the sprocket is at the front of the operator's cab, the machine makes a movement reverse to the control lever movement (for example, forward becomes reverse, and left becomes right). Be careful to avoid such a reverse movement of the machine.
  - Before travelling, check again that there is no one in the surrounding area, and that there are no obstacles.
  - Before travelling, sound the horn to warn people in the area.
  - Always operate the machine only when seated.
  - Do not allow anyone apart from the operator to ride on the machine.
  - Check that the travel alarm works properly.
  - Always lock the door and windows of the operator's compartment in position (open or closed).
- On jobsites where there is a hazard of flying objects or of objects entering the operator's compartment, check that the door and windows are securely closed.
- If there is an area to the rear of the machine which cannot be seen, position a signal person. Take special care not to hit other machines or people when turning or swinging the machine.

Always be sure to carry out the above precautions even when the machine is equipped with mirrors.

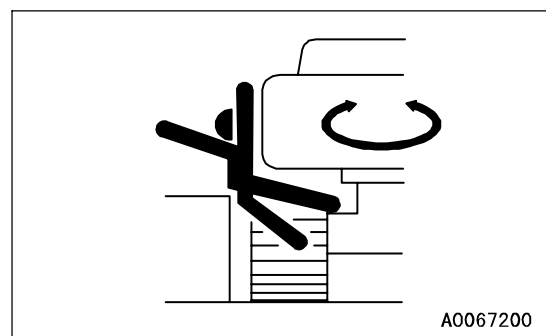
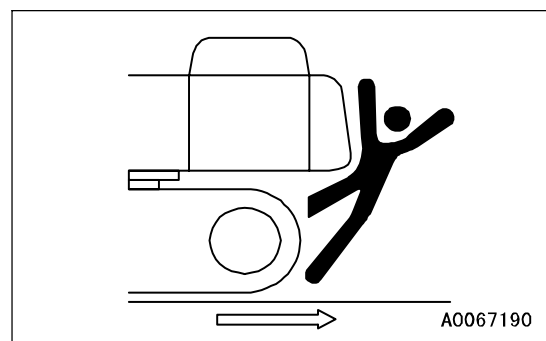
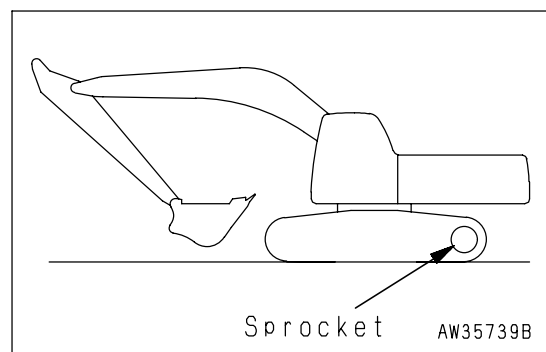

**SAFETY RULES FOR TRAVELING**

- When traveling on flat ground, keep the work equipment 40 to 50 cm (16 to 20 in) high above the ground.
- When traveling on rough ground, travel at low speed and do not operate the steering suddenly. There is danger that the machine may turn over. The work equipment may hit the ground surface and cause the machine to lose its balance, or may damage the machine or structures in the area.
- When traveling on rough ground or steep slopes, if the machine is equipped with auto-deceleration, always turn the auto-deceleration switch OFF (cancel).
- Avoid traveling over obstacles when possible. If the machine has to travel over an obstacle, keep the work equipment close to the ground and travel at low speed. Never travel over obstacles which make the machine tilt strongly to one side.
- When traveling or carrying out operations, always keep a safe distance from people, structures, or other machines to avoid coming into contact with them.
- When passing over bridges or structures, check first that the structure is strong enough to support the weight of the machine. When traveling on public roads, check first with the relevant authorities and follow their instructions.
- When operating in tunnels, under bridges, under electric wires, or other places where the height is limited, operate slowly and be extremely careful not to let the machine body or work equipment hit anything.

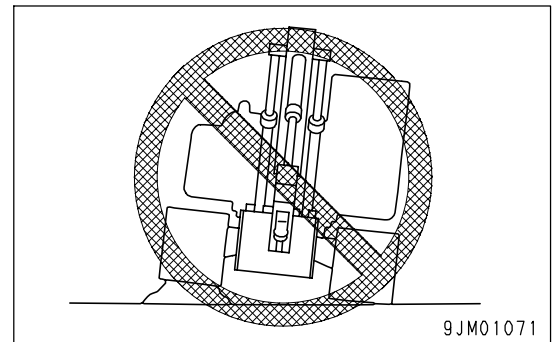
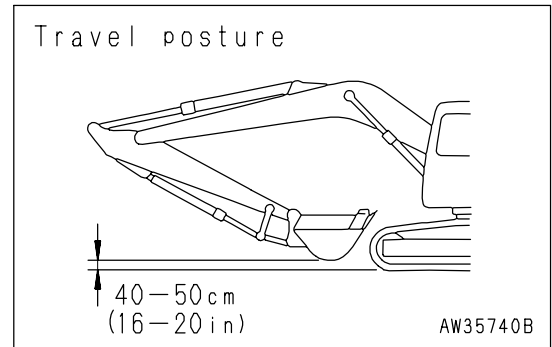
**TRAVELING ON SLOPES**

To prevent the machine from tipping over or slipping to the side, always do as follows.

- Keep the work equipment approx. 20 to 30 cm (8 to 12 in) above the ground. In case of emergency, lower the work equipment to the ground immediately to help stop the machine.
- When travel up slopes, set the operator's cab facing uphill, when travel down slopes, set the operator's cab facing downhill. Always check the firmness of the ground under the front of the machine when traveling.

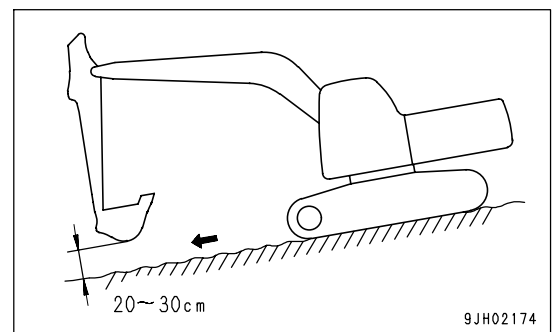
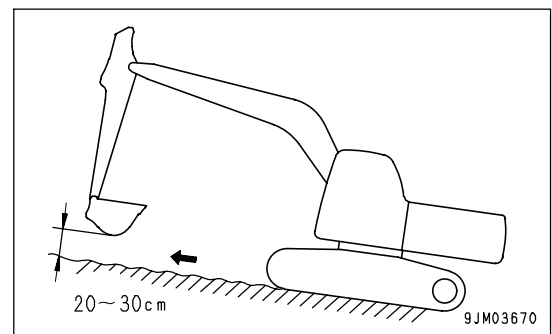

- When traveling up a steep slope, extend the work equipment to the front to improve the balance, keep the work equipment approximately 20 to 30 cm (8 to 12 in) above the ground, and travel at low speed.
- When traveling downhill, lower the engine speed, keep the travel lever close to the neutral position, and travel at low speed.

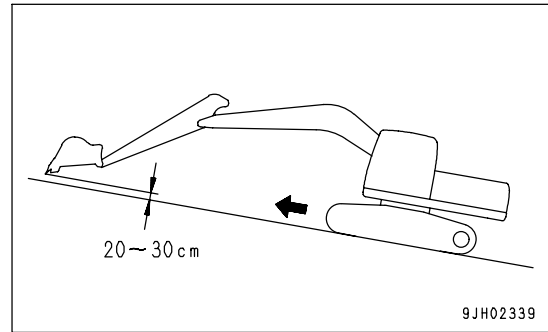

- Always travel straight up or down a slope. Traveling at an angle or across the slope is extremely dangerous.
- Do not turn on slopes or travel across slopes. Always go down to a flat place to change the position of the machine, then travel on to the slope again.
- Travel on grass, fallen leaves, or wet steel plates with low speed. Even with slight slopes there is a hazard that the machine may slip.
- If the engine stops when the machine is traveling on a slope, move the control levers immediately to the neutral position and start the engine again.

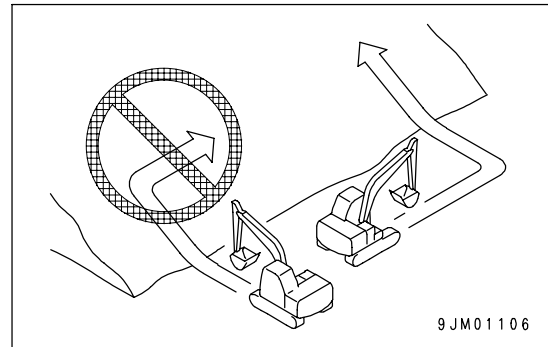

### OPERATIONS ON SLOPES

- When working on slopes, there is a hazard that the machine may lose its balance and turn over when the swing or work equipment are operated. This may lead to serious injury or property damage, so always provide a stable place when carrying out these operations, and operate carefully.
- Do not swing the work equipment from the uphill side to the downhill side when the bucket is loaded. This operation is dangerous, and may cause the machine to tip over.
- If the machine has to be used on a slope, pile the soil to make a platform that will keep the machine as horizontal as possible.

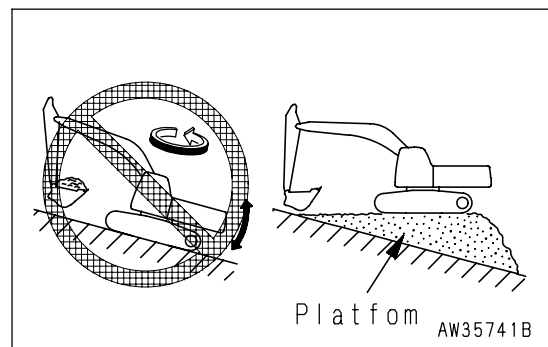

**PROHIBITED OPERATIONS**

- Never dig the work face under an overhang. There is a hazard that rocks may fall or that the overhang may collapse and fall on top of the machine.

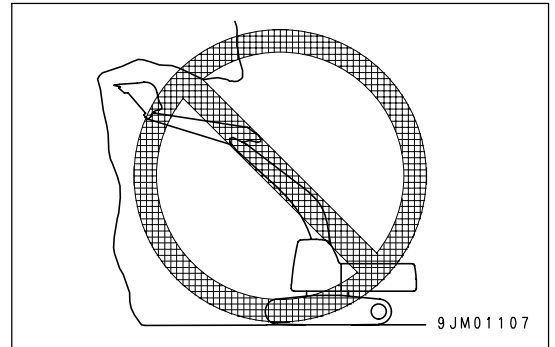

- Do not excavate too deeply under the front of the machine. The ground under the machine may collapse and cause the machine to fall.

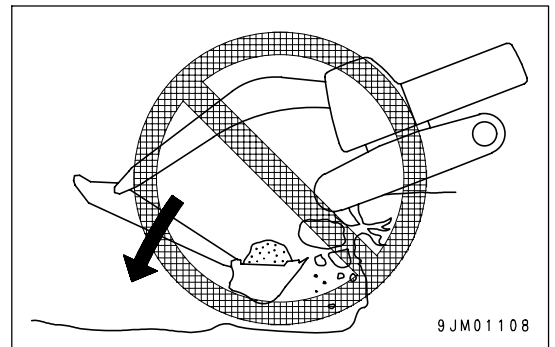

- To make it easier to escape if there is any problem, set the tracks at right angles to the road shoulder or cliff with the sprocket at the rear when carrying out operations.

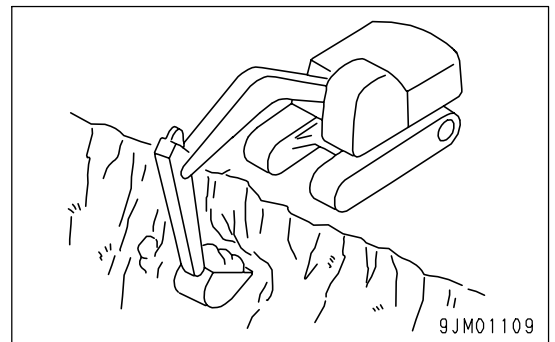

- Do not carry out demolition work under the machine. There is a hazard that the machine may become unstable and tip over.
- When working on or from the top of buildings or other structures, check the strength and the structure before starting operations. There is a hazard of the building collapsing and causing serious injury or damage.

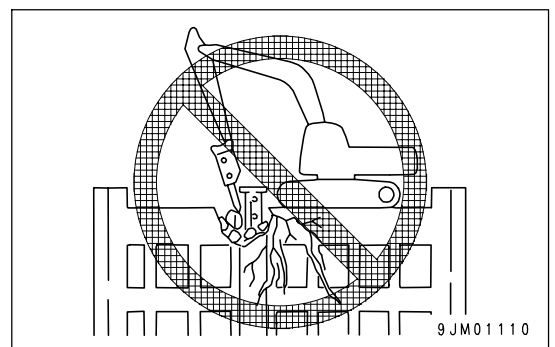

- When carrying out demolition work, do not carry out demolition above your head. There is a hazard of broken parts falling or of the building collapsing and causing serious injury or property damage.

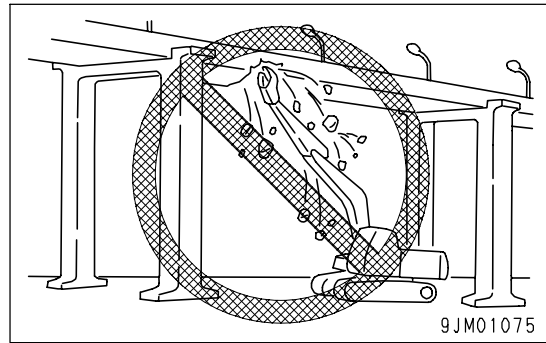

- Do not use the impact force of the work equipment for breaking work. There is a hazard of damage to the work equipment, or a hazard of serious personal injury being caused by flying pieces of broken materials, or of the machine tipping over due to reaction from the impact.
- Generally speaking, the machine is more liable to overturn when the work equipment is at the side than when it is at the front or rear.

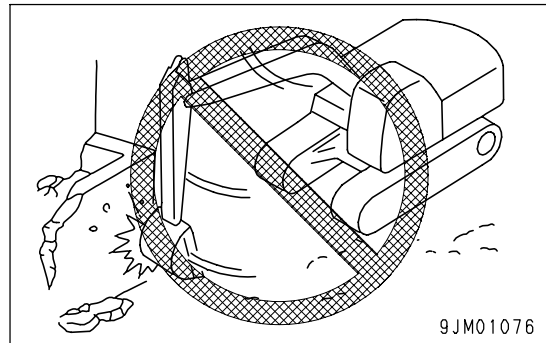

- When using a breaker or other heavy work equipment, there is a hazard of the machine losing its balance and tipping over. When operating on flat ground as well as on slopes.
  - Do not suddenly lower, swing, or stop the work equipment.
  - Do not suddenly extend or retract the boom cylinder. There is a hazard that impact will cause the machine to tip over.
- Do not pass the bucket over the head of other workers or over the operator's seat of dump trucks or other hauling equipment. The load may spill or the bucket may hit the dump truck and cause serious personal injury or death.

### OPERATIONS ON SNOW

- Snow-covered or frozen surfaces are slippery, so be extremely careful when traveling or operating the machine, and do not operate the levers suddenly. Even a slight slope may cause the machine to slip, so be particularly careful when working on slopes.
- With frozen ground surfaces, the ground becomes soft when the temperature rises, and this may cause the machine to tip over or make it impossible for the machine to escape.
- If the machine enters deep snow, there is a hazard that it may tip over or become buried in the snow. Be careful not to leave the road shoulder or to get trapped in a snow drift.
- When clearing snow, the road shoulder and objects placed beside the road are buried in the snow and cannot be seen. There is a hazard of the machine tipping over or hitting covered objects, so always carry out operations carefully.

**PARKING MACHINE**

- Park the machine on firm, level ground.
- Select a place where there is no hazard of landslides, falling rocks, or flooding.
- Lower the work equipment completely to the ground.

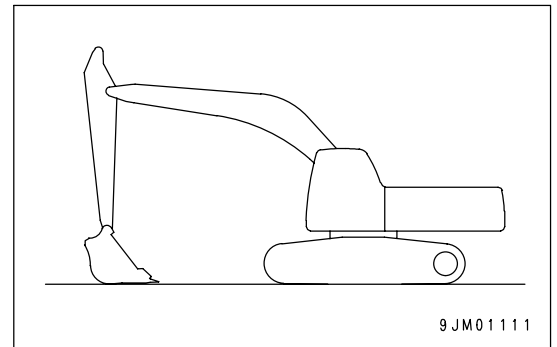

- When leaving the machine, set safety lock lever (1) to the LOCK position (L), then stop the engine.
- Always close the operator's cab door, and use the key to lock all the equipment in order to prevent any unauthorized person from moving the machine. Always remove the key, take it with you, and leave it in the specified place.
- When parking the machine on a public road, set up signs and fences to prevent interference with passing traffic and to enable the machine to be seen clearly even at night.
- If it is necessary to park the machine on a slope, always do as follows.

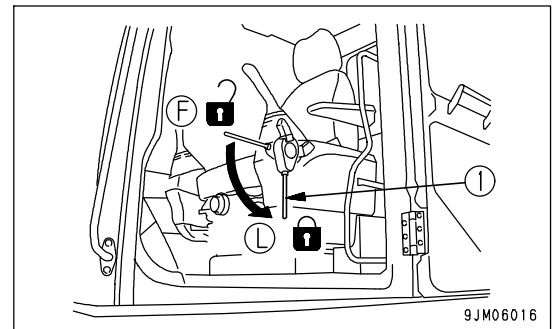

- Set the bucket on the downhill side, then dig it into the ground.
- Put blocks under the tracks to prevent the machine from moving.

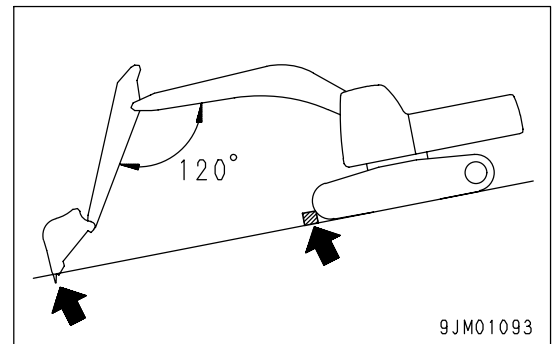

## TRANSPORTATION

The machine can be divided into parts for transportation, so when transporting the machine, please contact your Komatsu distributor to have the work carried out.

### LOADING AND UNLOADING

When loading or unloading the machine, mistaken operation may bring the hazard of the machine tipping over or falling, so particular care is necessary. Always do as follows.

- Perform loading and unloading on firm, level ground only. Maintain a safe distance from the edge of the road or cliff.
- Never use the work equipment to load or unload the machine. There is danger that the machine may fall or tip over.
- Always use ramps of adequate strength. Be sure that the ramps are wide, long, and thick enough to provide a safe loading slope. Take suitable steps to prevent the ramps from moving out of position or coming off.
- Be sure the ramp surface is clean and free of grease, oil, ice and loose materials. Remove dirt from machine-tracks. On a rainy day, in particular, be extremely careful since the ramp surface is slippery.
- Turn the auto-decelerator switch OFF (auto-deceleration function released).
- Run the engine at low speed and travel slowly.
- When on the ramps, do not operate any lever except for the travel lever.
- Never correct your steering on the ramps. If necessary, drive off the ramps, correct the direction, then enter the ramps again.
- The center of gravity of the machine will change suddenly at the joint between the ramps and the track or trailer, and there is danger of the machine losing its balance. Travel slowly over this point.
- When loading or unloading to an embankment or platform, make sure that it has suitable width, strength, and grade.
- When swinging the upper structure on the trailer, the trailer is unstable, so pull in the work equipment and swing slowly.
- For machines equipped with a cab, always lock the door after boarding the machine. If this is not done, the door may suddenly open during transportation. Refer to "TRANSPORTATION (PAGE 3-122)".

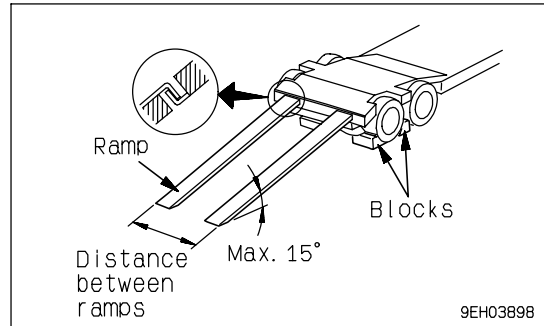

### SHIPPING THE MACHINE

When shipping the machine on a trailer, do as follows.

- The weight, transportation height, and overall length of the machine differ according to the work equipment, so be sure to confirm the dimensions.
- When passing over bridges or structures on private land, check first that the structure is strong enough to support the weight of the machine. When traveling on public roads, check first with the relevant authorities and follow their instructions.
- For details of the procedure when transporting the machine, see TRANSPORTATION (PAGE 3-122).

## BATTERY

### BATTERY HAZARD PREVENTION

Battery electrolyte contains sulphuric acid, and batteries generate flammable hydrogen gas, which may explode. Mistaken handling can lead to serious injury or fire. For this reason, always observe the following precautions.

- Do not use or charge the battery if the battery electrolyte level is below the LOWER LEVEL line. This may cause an explosion. Check the battery electrolyte level periodically and add distilled water to bring the electrolyte level to the UPPER LEVEL line.
- When working with batteries, always wear safety glasses and rubber gloves.
- Never smoke or use any flame near the battery.

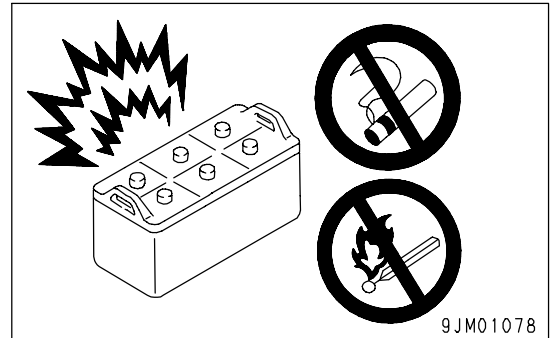

- If you spill acid on your clothes or skin, immediately flush the area with large amount of water.
- If acid gets into your eyes, flush them immediately with large amount of water and seek medical attention.

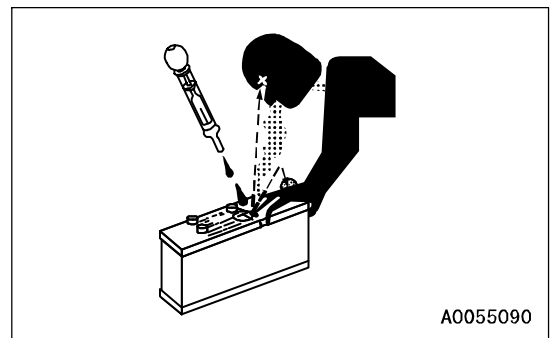

- Before working with batteries, turn the starting switch to the OFF position.

As there is a hazard that sparks will be generated, always do as follows.

- Do not let tools or other metal objects make any contact between the battery terminals. Do not leave tools or other metal objects lying around near the battery.
- Always disconnect the negative (-) terminal (ground side) first when removing the battery; when installing the battery, connect the positive (+) terminal first, and connect the ground last.
- Attach the battery terminal securely.
- Flammable hydrogen gas is generated when the battery is charged, so remove the battery from the chassis, take it to a well-ventilated place, and remove the battery caps before charging it.
- Tighten the battery caps securely.
- Install the battery securely to the determined place.



### STARTING ENGINE WITH BOOSTER CABLES

If any mistake is made in the method of connecting the booster cables, it may cause the battery to explode, so always do as follows.

- When starting with a booster cable, carry out the starting operation with two workers (one worker sitting in the operator's seat and the other working with the battery).
- When starting from another machine, do not allow the two machines to touch.
- When connecting the booster cables, turn the starting switch OFF position for both the normal machine and problem machine. There is a hazard that the machine will move when the power is connected.
- Be sure to connect the positive (+) cable first when installing the booster cables. Disconnect the negative (-) cable (ground side) first when removing them.
- When removing the booster cables, be careful not to let the booster cable clips touch each other or to let the clips touch the machine.
- Always wear safety glasses and rubber gloves when starting the engine with booster cables.
- When connecting a normal machine to a problem machine with booster cables, always use a normal machine with the same battery voltage as the problem machine.
- For details of the starting procedure when using booster cables, see "Starting Engine with Booster Cables (PAGE 3-140)" in the OPERATION section.

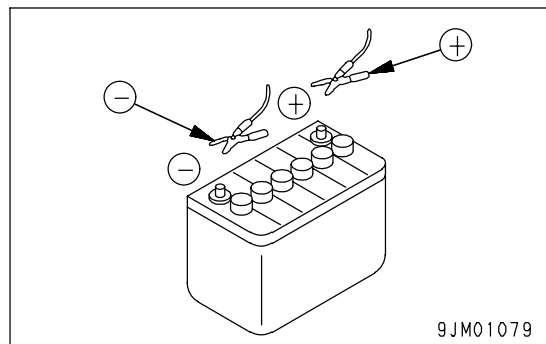
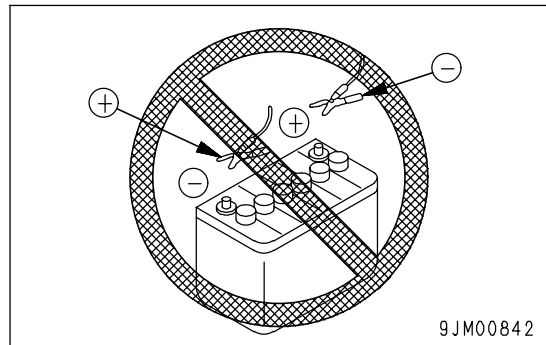

## TOWING

### SAFETY RULES FOR TOWING

Serious injury or death could result if a disabled machine is towed incorrectly or if there is a mistake in the selection or inspection of the wire rope.

For towing, see "TOWING THE MACHINE (PAGE 3-137)".

- Always wear leather gloves when handling wire rope.
- Fix the wire rope to the track frame.
- During the towing operation, never stand between the towing machine and the machine being towed.
- Never tow a machine on a slope.

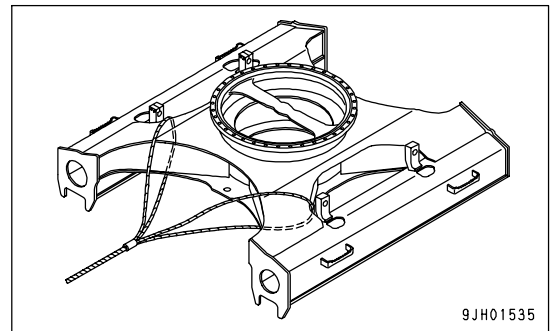
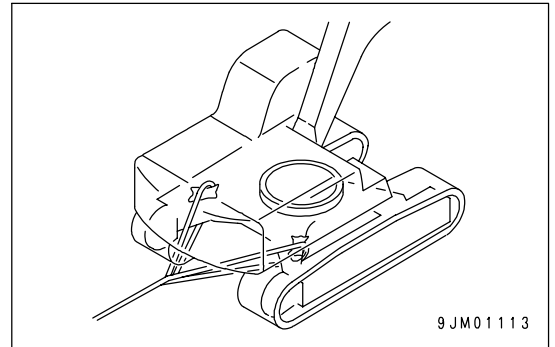

- Never use a wire rope which has cut strands (A), reduced diameter (B), or kinks (C). There is danger that the rope may break during the towing operation.

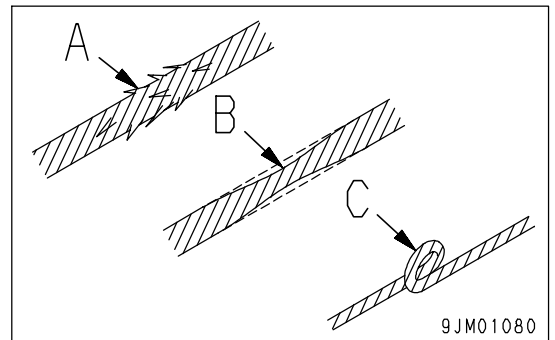

## SAFETY MAINTENANCE INFORMATION

### WARNING TAG

- Always attach the "DO NOT OPERATE" warning tag to the work equipment control lever in the operator's cab to alert others that you are performing service or maintenance on the machine. Attach additional warning tags around the machine if necessary. Warning tag Part No. 09963-03000

Keep this warning tag in the tool box while it is not used. If there is not the tool box, keep the tag in the operation manual pocket.

- If others start the engine, or touch or operate the work equipment control lever while you are performing service or maintenance, you could suffer serious injury or property damage.

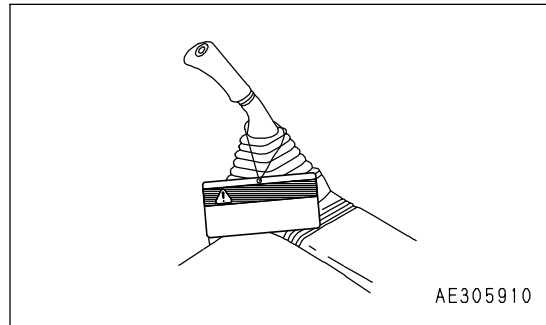

### KEEP WORK PLACE CLEAN AND TIDY

- Do not leave hammers or other tools lying around in the work place. Wipe up all grease, oil, or other substances that will cause you to slip. Always keep the work place clean and tidy to enable you to carry out operations safely. If the work place is not kept clean and tidy, there is the danger that you will trip, slip, or fall over and injure yourself.
- When cleaning the ceiling window which is made of organic glass (polycarbonate), use tap water and avoid use of organic solvents for cleaning. An organic solvent like benzene, toluene or methanol can invite a chemical reaction like dissolution and decomposition on the window glass, deteriorating polycarbonate in use.

### APPOINT LEADER WHEN WORKING WITH OTHERS

- When repairing the machine or when removing and installing the work equipment, appoint a leader and follow his instructions during the operation.

**STOP ENGINE BEFORE CARRYING OUT MAINTENANCE**

- Stop the machine on firm, level ground.
- Select a place where there is no hazard of landslides, falling rocks, or flooding.
- Lower the work equipment completely to the ground and stop the engine.
- Turn the starting switch to the ON position. Operate the work equipment control lever back and forth, left and right at the full stroke 2 to 3 times to eliminate the remaining internal pressure in the hydraulic circuit, and then push up safety lock lever (1) to the LOCK position (L).

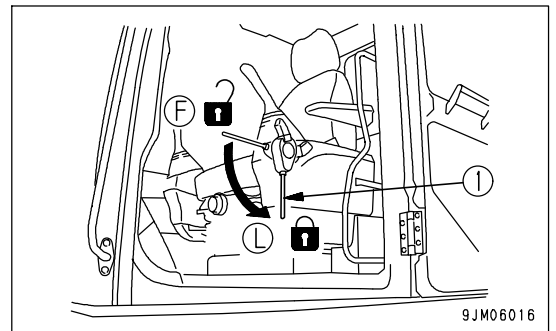
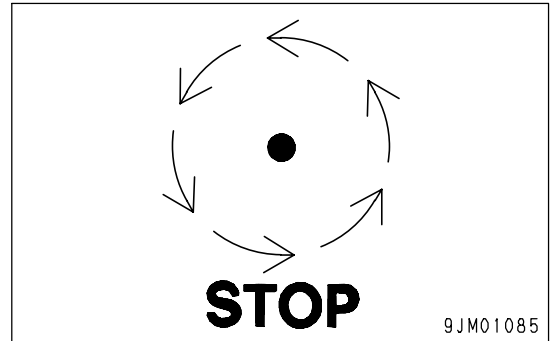

- Put blocks under the track to prevent the machine from moving.

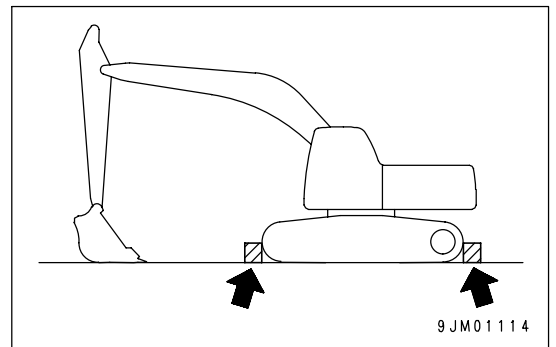

**TWO WORKERS FOR MAINTENANCE WHEN ENGINE IS RUNNING**

To prevent personal injury, do not carry out maintenance with the engine running. If maintenance must be carried out with the engine running, carry out the operation with at least two workers and do as follows.

- One worker must always sit in the operator's seat and be ready to stop the engine at any time. All workers must maintain contact with the other workers.

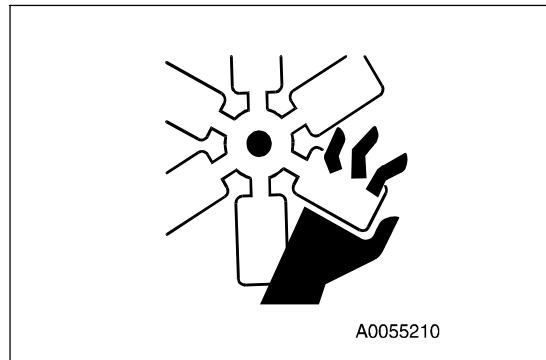

- Set safety lock lever (1) to the LOCK position (L) to prevent the work equipment from moving.
- When carrying out operations near the fan, fan belt, or other rotating parts, there is a hazard of being caught in the parts, so be careful not to come close.
- Do not touch any control levers. If any control lever must be operated, give a signal to the other workers to warn them to move to a safe place.

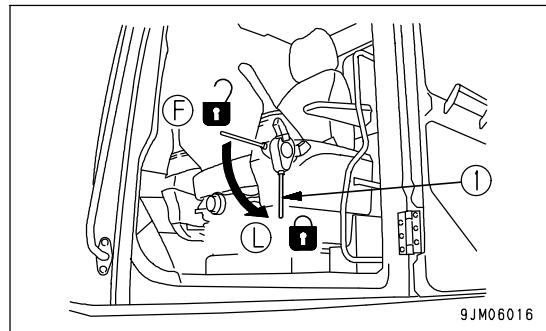

- Never drop or insert tools or other objects into the fan or fan belt. Parts may break or be sent flying.

**PROPER TOOLS**

Use only tools suited to the task and be sure to use the tools correctly. Using damaged, low quality, faulty, makeshift tools or improper use of the tools could cause serious personal injury.

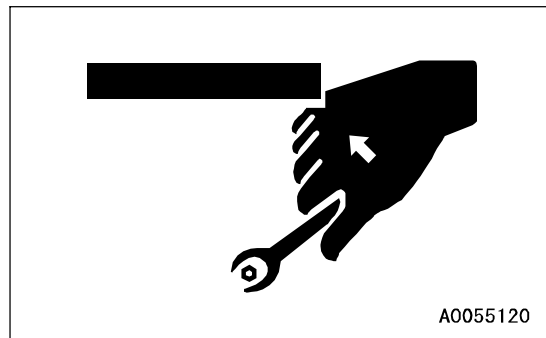
**ACCUMULATOR**

The accumulator is charged with high-pressure nitrogen gas. When handling the accumulator, careless procedure may cause an explosion which could lead to serious injury or property damage. For this reason, always observe the following precautions.

- Do not disassemble the accumulator.
- Do not bring it near flame or dispose of it in fire.
- Do not make holes in it, weld it, or use a cutting torch.
- Do not hit or roll the accumulator, or subject it to any impact.
- When disposing of the accumulator, the gas must be released. Please contact your Komatsu distributor to have this work performed.



**PERSONNEL**

Do not allow any unauthorized personnel into the area when servicing the machine. If necessary, employ a guard.

**ATTACHMENTS**

- Appoint a leader before starting removal or installation operations for attachments.
- Place attachments that have been removed from the machine in a stable condition so that they do not fall. And take steps to prevent unauthorized persons from entering the storage area.

**WORK UNDER THE MACHINE**

- If it is necessary to go under the work equipment or the machine to carry out service and maintenance, support the work equipment and machine securely with blocks and stands strong enough to support the weight of the work equipment and machine.
- It is extremely dangerous to work under the machine if the track shoes are lifted off the ground and the machine is supported only with the work equipment. If any of the control levers is touched by accident, or there is damage occurring to the hydraulic piping, the work equipment or the machine will suddenly drop. This is extremely dangerous. Never work under the work equipment or the machine.

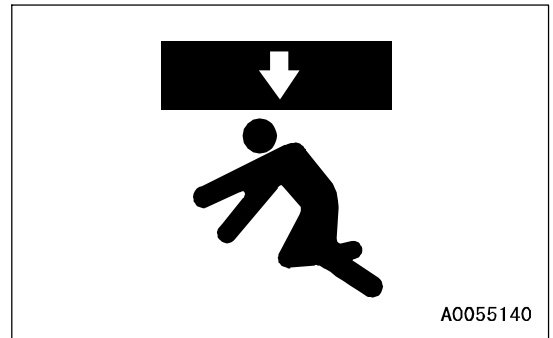
**NOISE**

When carrying out maintenance of the engine and you are exposed to noise for long periods of time, wear ear covers or ear plugs while working.

If the noise from the machine is too loud, it may cause temporary or permanent hearing problems.

**WHEN USING HAMMER**

When using a hammer, pins may fly out or metal particles may be scattered. This may lead to serious injury. Always do as follows.

- If hard metal parts such as pins, bucket teeth, cutting edges, or bearings are hit with a hammer, there is a hazard that pieces might be scattered and cause serious personal injury or death. Always wear safety glasses and gloves.
- When hitting pins or bucket teeth, there is a hazard that broken pieces might be sent flying and injure people in the surrounding area. Always check that there is no one in the surrounding area.

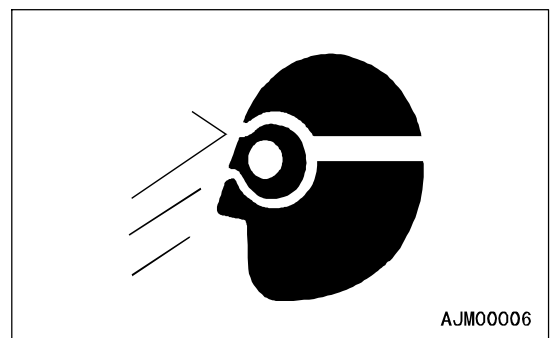

- There is a hazard that the pin hit with strong force may fly out and injure people in the surrounding area.

**WELDING WORKS**

Welding operations must always be carried out by a qualified welder and in a place equipped with proper equipment. There is a hazard of gas, fire, or electrocution when carrying out welding, so never allow any unqualified personnel to carry out welding.

**REMOVING BATTERY TERMINALS**

When repairing the electrical system or when carrying out electrical welding, remove the negative (-) terminal of the battery to prevent the flow of current.

**SAFETY FIRST WHEN USING HIGH-PRESSURE GREASE TO ADJUST TRACK TENSION**

- Grease is pumped into the track tension adjustment system under high pressure.  
If the specified procedure for maintenance is not followed when making adjustment, grease drain plug (1) may fly out and cause serious injury or property damage.
- When loosening grease drain plug (1) to loosen the track tension, never loosen it more than one turn. Loosen the grease drain plug slowly.
- Never put your face, hands, feet, or any other part of your body close to grease drain plug (1).

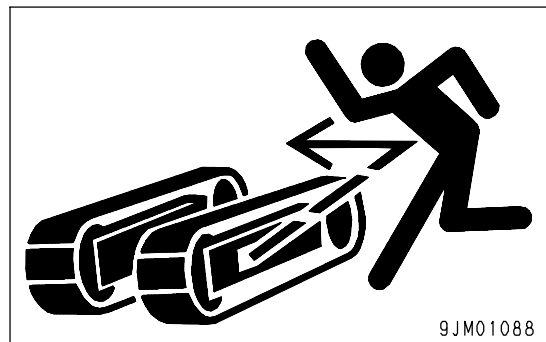
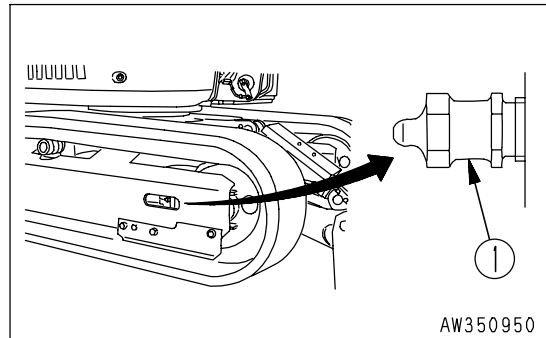
**DO NOT DISASSEMBLE RECOIL SPRINGS**

Never attempt to disassemble the recoils spring assembly. It contains a spring under high pressure which serves as a shock absorber for the idler. If it is disassembled by mistake, the spring will fly out and cause serious injury. When it becomes necessary to disassemble it, ask your Komatsu distributor to do the work.

### SAFETY RULES FOR HIGH-PRESSURE OIL

The hydraulic system is always under internal pressure. When inspecting or replacing piping or hoses, always check that the pressure in the hydraulic circuit has been released. If the circuit is still under pressure, it will lead to serious personal injury, so always do as follows.

- For details of the method of releasing the pressure, see "METHOD FOR RELEASING INTERNAL PRESSURE IN HYDRAULIC CIRCUIT (PAGE 4-40)". If the circuit is still under pressure, do not carry out any inspection or replacement operation.
- If there is any leakage from the piping or hoses, the surrounding area will be wet, so check for cracks in the piping and hoses and for swelling in the hoses.

When carry out inspection, wear safety glasses and leather gloves.

- There is a hazard that high-pressure oil leaking from small holes may penetrate your skin or cause blindness if it contacts your eyes directly. If you are hit by a jet of high-pressure oil and suffer injury to your skin or eyes, wash the place with clean water, and consult a doctor immediately for medical attention.

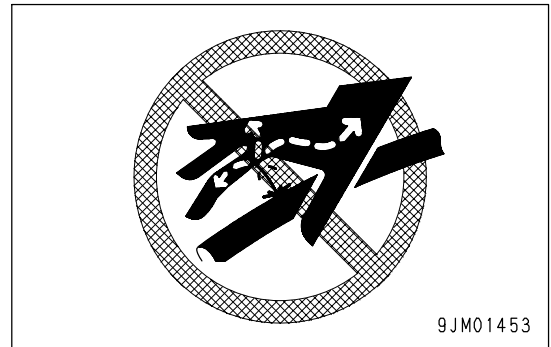

### SAFETY HANDLING HIGH-PRESSURE HOSES

- If oil or fuel leaks from high-pressure hoses, it may cause fire or defective operation, which may lead to serious injury. If any loose bolts are found, stop work and tighten to the specified torque. If any damaged hoses are found, stop operations immediately and contact your Komatsu distributor.

Replace the hose if any of the following problems are found.

- Damaged or leaking hydraulic fitting.
- Frayed or cut covering or exposed reinforcement wire layer.
- Covering swollen in places.
- Twisted or crushed movable portion.
- Foreign material embedded in covering.

### WASTE MATERIALS

To prevent pollution, pay careful attention to the method of disposing of waste materials.

- Always put oil drained from your machine in containers. Never drain oil directly onto the ground or dump into the sewage system, rivers, the sea, or lakes.
- Obey appropriate laws and regulations when disposing of harmful objects such as oil, fuel, coolant, solvent, filters, and batteries.

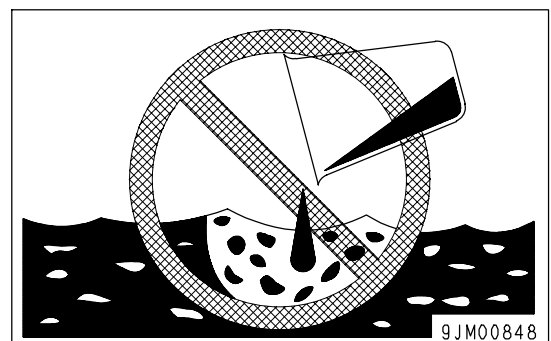



**AIR CONDITIONER MAINTENANCE**

If air conditioner refrigerant gets into your eyes, it may cause blindness; if it touches your skin, it may cause frostbite. Never touch refrigerant.

**COMPRESSED AIR**

- When carrying out cleaning with compressed air, there is a hazard of serious injury caused by flying particles.
- When using compressed air to clean elements or the radiator, always wear safety glasses, dust mask, gloves, and other protective equipment.

**PERIODIC REPLACEMENT OF SAFETY CRITICAL PARTS**

- In order for the machine to be operated safely for a long time, it is necessary to add oil and to carry out service and maintenance at periodic intervals. In order to further increase safety, components with a strong relationship to safety, such as hoses and seat belts, must be replaced at periodic intervals.  
Replacement of safety critical parts: See "SAFETY CRITICAL PARTS (PAGE 4-15)".
- The material of these components naturally changes over time, and repeated use causes deterioration, wear, and fatigue. As a result, there is a hazard that these components may fail and cause serious injury or death. It is difficult to judge the remaining life of these components from external inspection or the feeling when operating, so always replace them at the specified interval.
- Replace or repair safety-critical parts if any defect is found, even when they have not reached the specified replacement time.

# OPERATION

 **WARNING**

Please read and make sure that you understand the SAFETY section before reading this section.

---

# MACHINE VIEW ILLUSTRATIONS

## OVERALL MACHINE VIEW

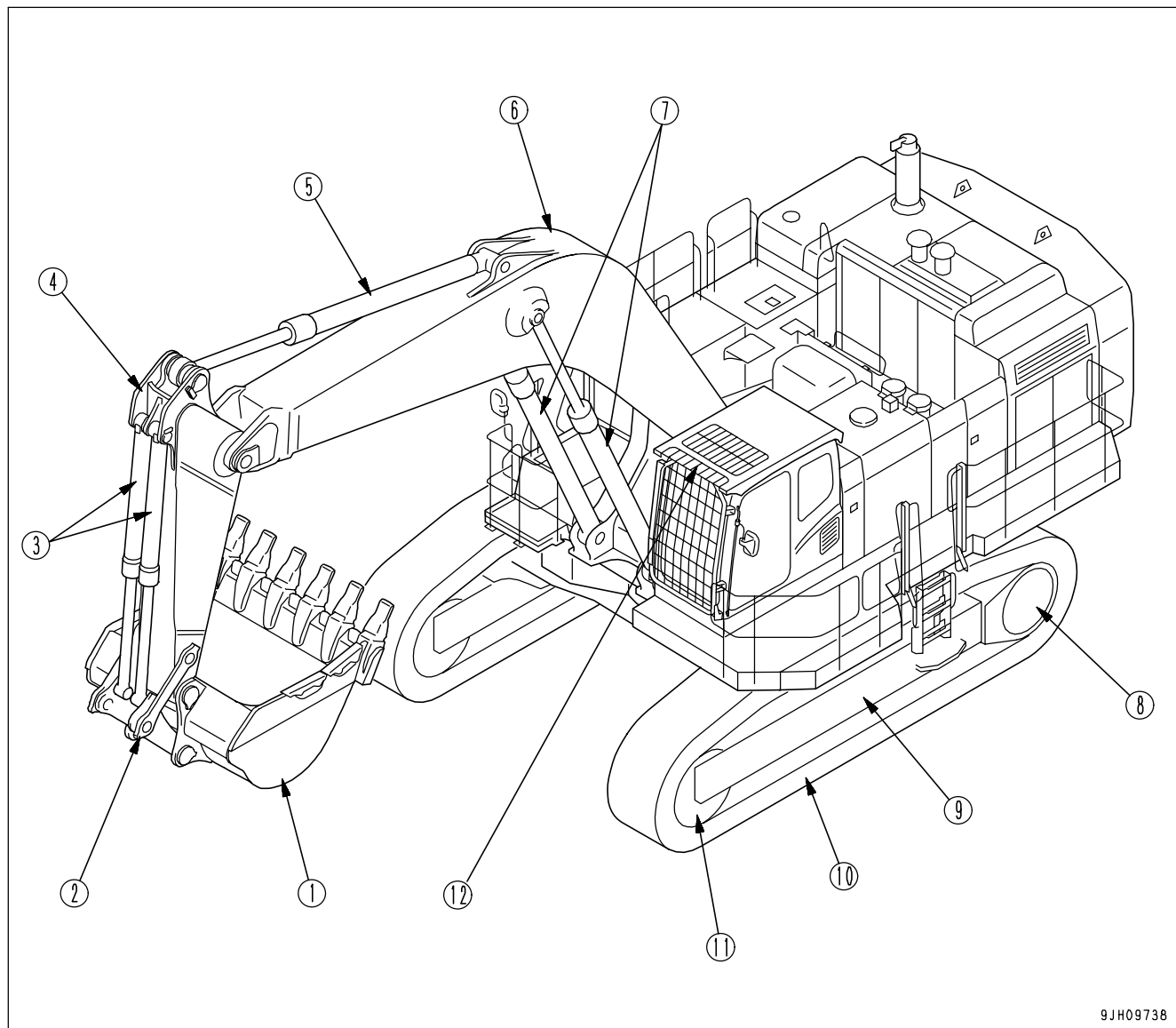

- |                     |                     |
|---------------------|---------------------|
| (1) Bucket          | (7) Boom cylinder   |
| (2) Bucket link     | (8) Sprocket        |
| (3) Bucket cylinder | (9) Track frame     |
| (4) Arm             | (10) Track shoe     |
| (5) Arm cylinder    | (11) Idler          |
| (6) Boom            | (12) Overhead guard |

## CONTROLS AND GAUGES

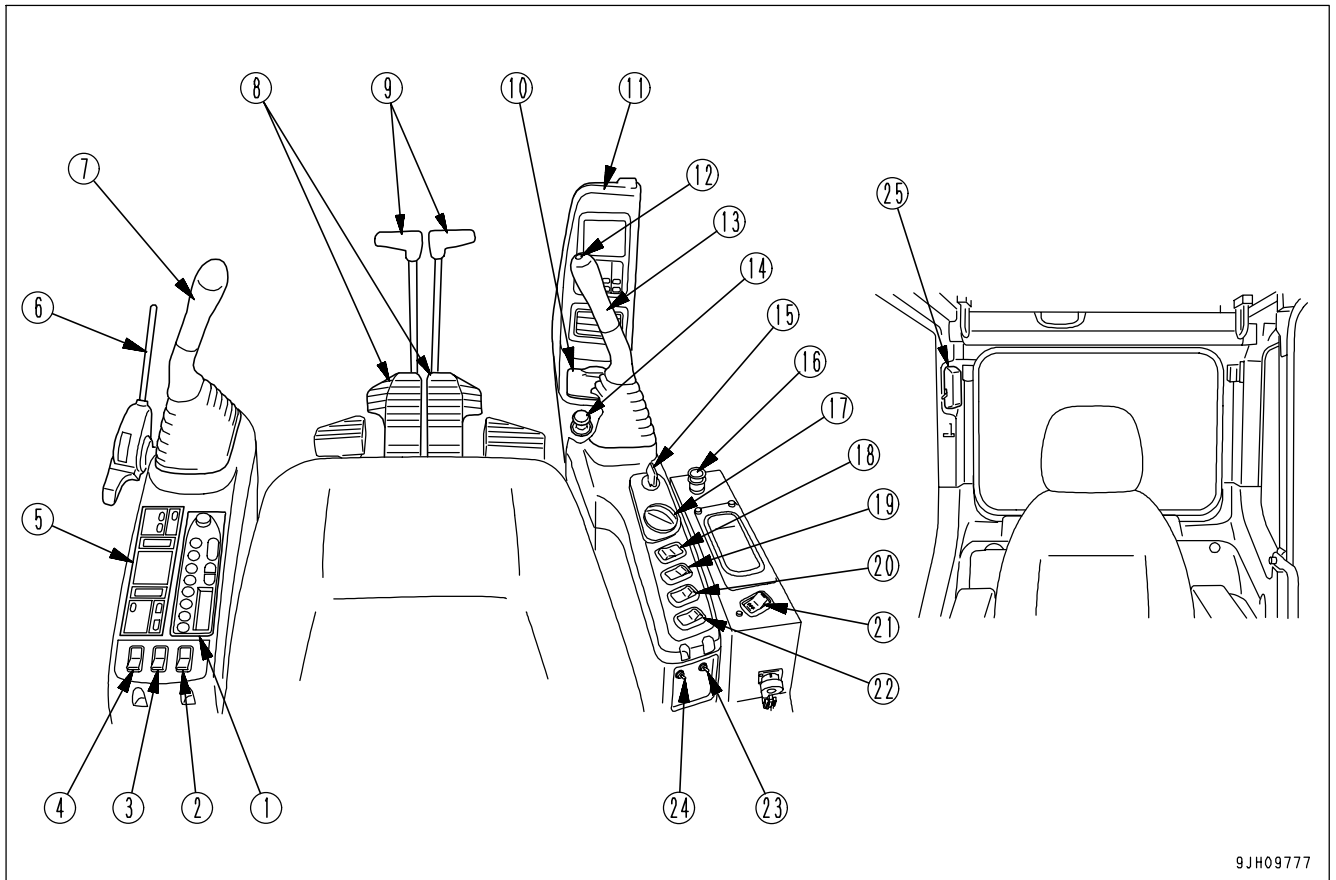

9JH09777

- |  |   |
|--|---|
| (1) Car radio  | (13) Right work equipment control lever |
| (2) Large capacity airflow air conditioner blower switch (if equipped) | (14) Cigarette lighter                  |
| (3) Rotating lamp switch (if equipped)                                 | (15) Starting switch                    |
| (4) Lower wiper switch (machines equipped with fixed front window cab) | (16) Step light switch                  |
| (5) Airconditioner control panel                                       | (17) Fuel control dial                  |
| (6) Safety lock lever  | (18) Lamp switch                        |
| (7) Left work equipment control lever                                  | (19) Alarm buzzer stop switch           |
| (8) Travel pedal   | (20) Swing lock switch                  |
| (9) Travel lever   | (21) Boom shockless control switch      |
| (10) Ashtray   | (22) Machine push-up switch             |
| (11) Machine monitor   | (23) Swing holding brake release switch |
| (12) Horn switch   | (24) Emergency pump drive switch        |
|  | (25) Room lamp switch                   |

Machine monitor

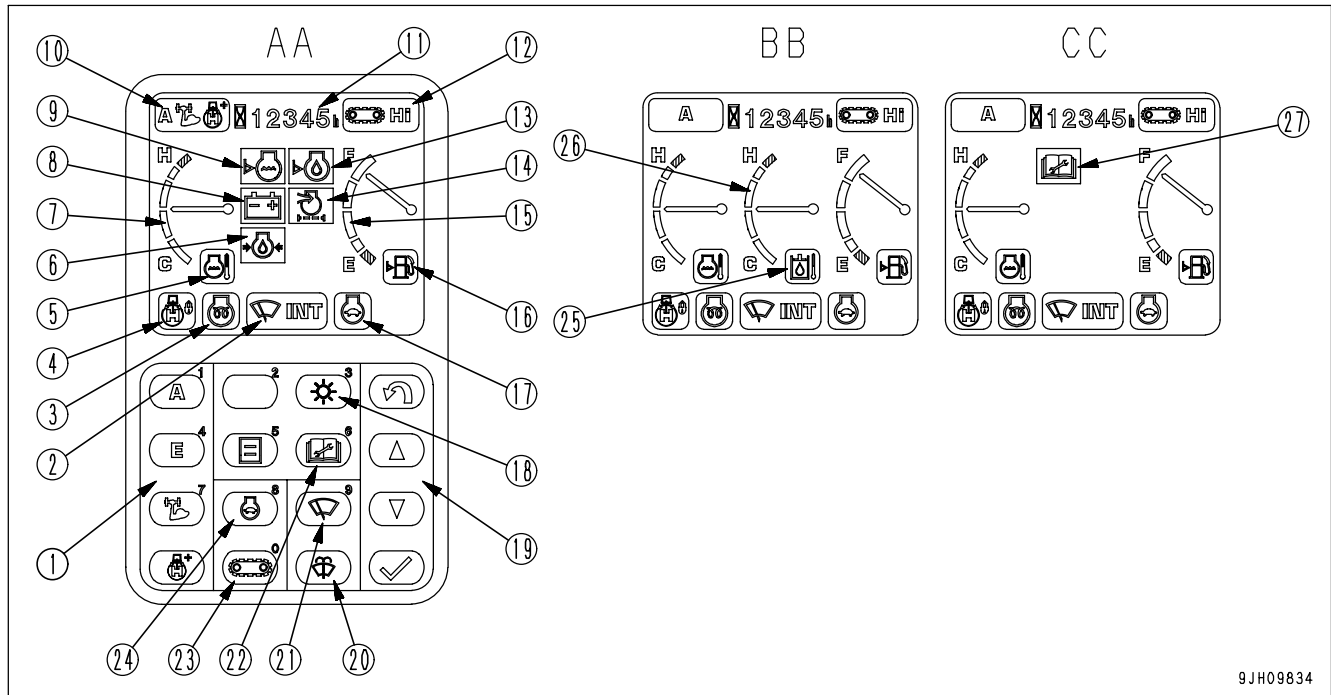

9JH09834

- AA: Screen with all lamps lighted up
- BB: Screen for standard
- CC: Maintenance time warning screen

- |  |  |
|--|--|
| <ul style="list-style-type: none"> <li>(1) Working mode selector switch</li> <li>(2) Wiper monitor</li> <li>(3) Engine pre-heating monitor</li> <li>(4) Swing lock monitor</li> <li>(5) Engine water temperature monitor</li> <li>(6) Engine oil pressure monitor</li> <li>(7) Engine water temperature gauge</li> <li>(8) Charge monitor</li> <li>(9) Radiator water level monitor</li> <li>(10) Working mode monitor</li> <li>(11) Service meter</li> <li>(12) Travel speed monitor</li> <li>(13) Engine oil level monitor</li> <li>(14) Air cleaner clogging monitor</li> </ul> | <ul style="list-style-type: none"> <li>(15) Fuel gauge</li> <li>(16) Fuel level monitor</li> <li>(17) Auto-deceleration monitor</li> <li>(18) Display control switch</li> <li>(19) Input control switch</li> <li>(20) Window washer switch</li> <li>(21) Wiper switch</li> <li>(22) Maintenance switch</li> <li>(23) Travel speed selector switch</li> <li>(24) Auto-deceleration switch</li> <li>(25) Hydraulic oil temperature monitor</li> <li>(26) Hydraulic oil temperature gauge</li> <li>(27) Maintenance interval monitor</li> </ul> |
|--|--|

# DETAILED CONTROLS AND GAUGES

The following is an explanation of devices needed for operating the machine.

To perform suitable operations correctly and safely, it is important to completely understand methods of operating the equipment, and the meanings of the displays.

## MONITORING SYSTEM

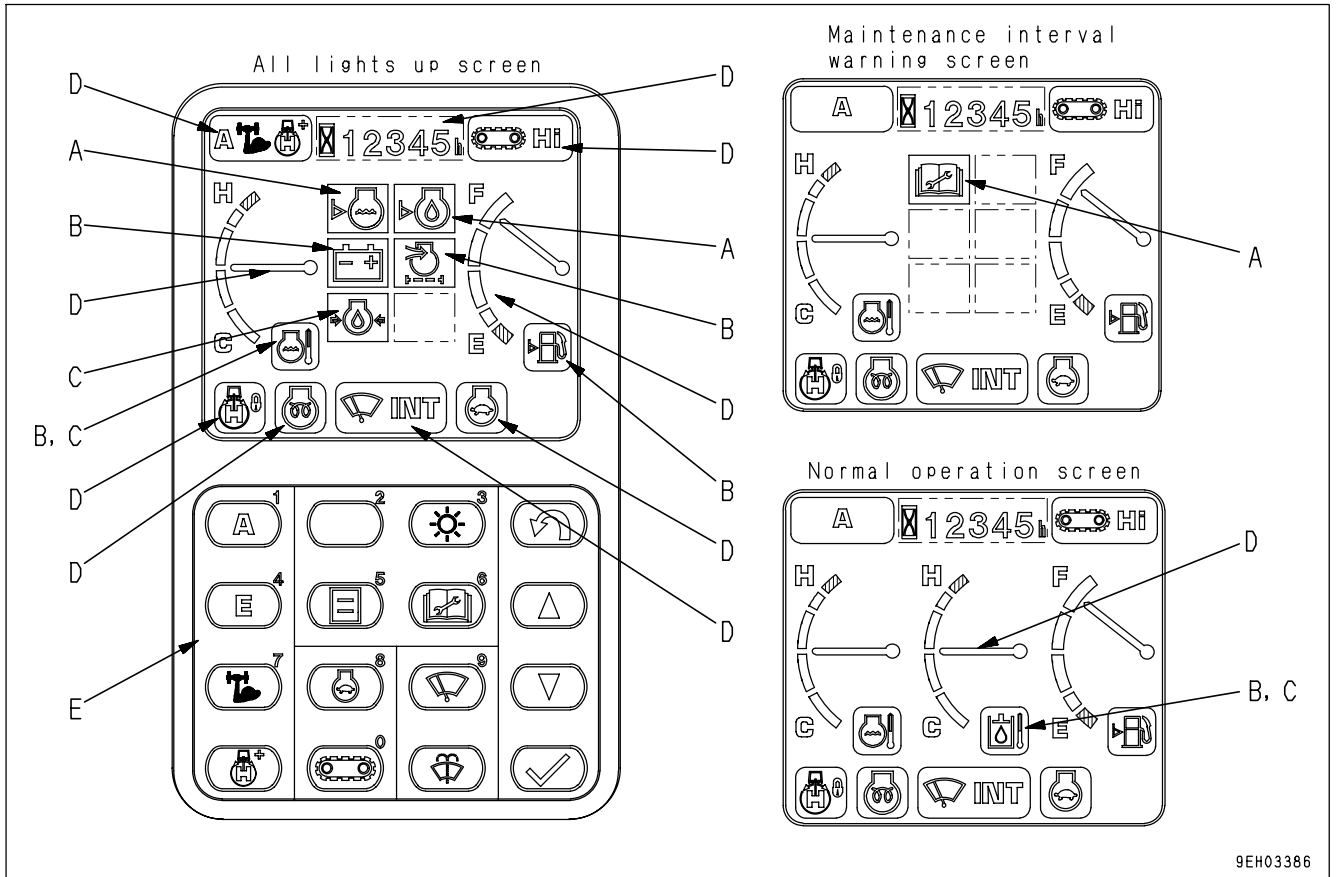

9EH03386

- A: Basic check Items
- B: Caution Items
- C: Emergency Stop Items

- D: Meter Display Portion
- E: Monitor Switches

### Basic Operation of Machine Monitor

#### If There Is Abnormality When Starting Engine

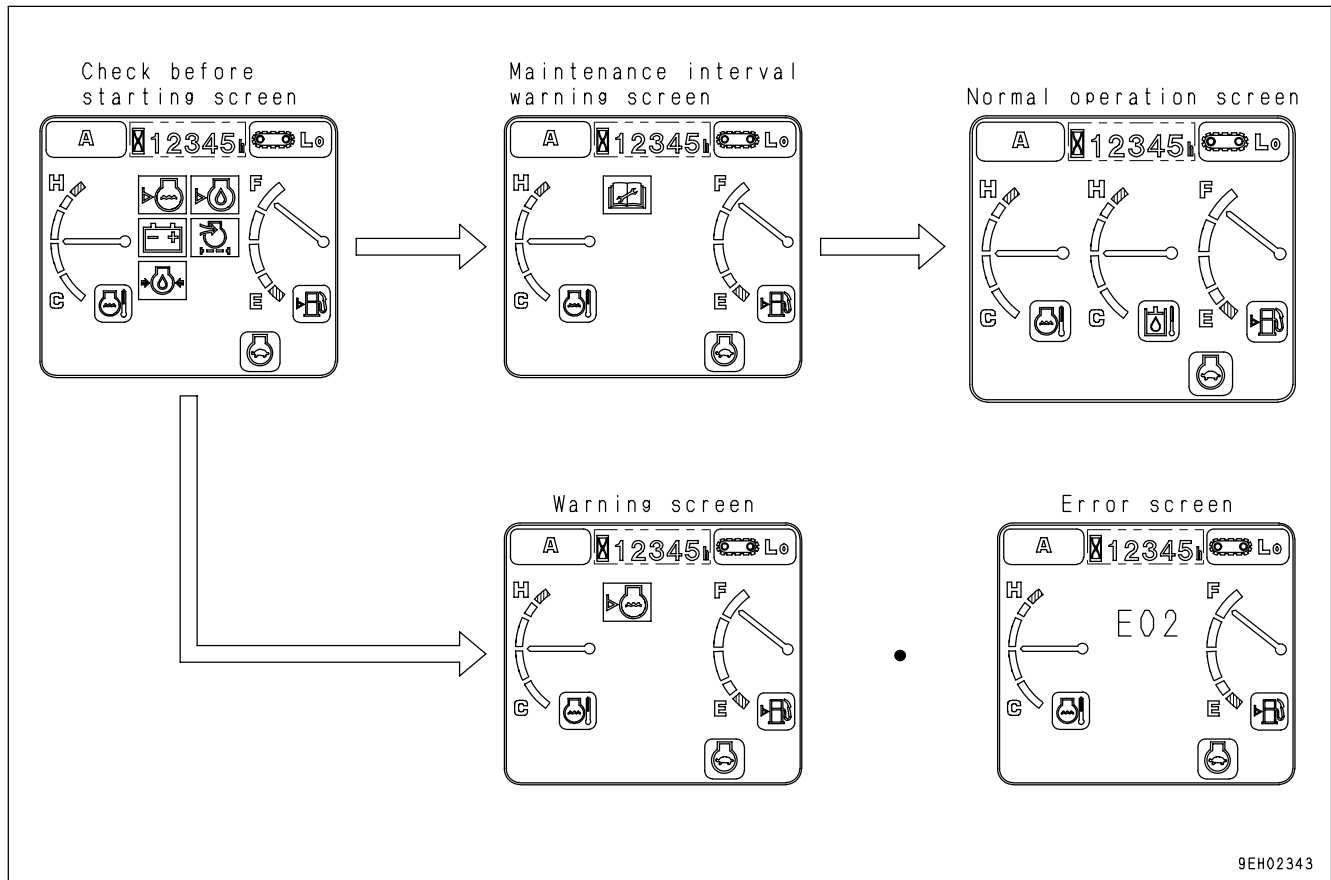

- If there is any abnormality when starting the engine, the check before starting screen changes to the maintenance warning screen, warning screen, or an error screen.
- After displaying the check before starting screen for 2 seconds, the screen changes to the maintenance warning screen.
- After displaying the maintenance warning screen for 30 seconds, the screen returns to the normal screen.
- After displaying the check before starting screen for 2 seconds, the screen changes to the warning screen or error screen.

If Any Abnormality Occurs During Operation

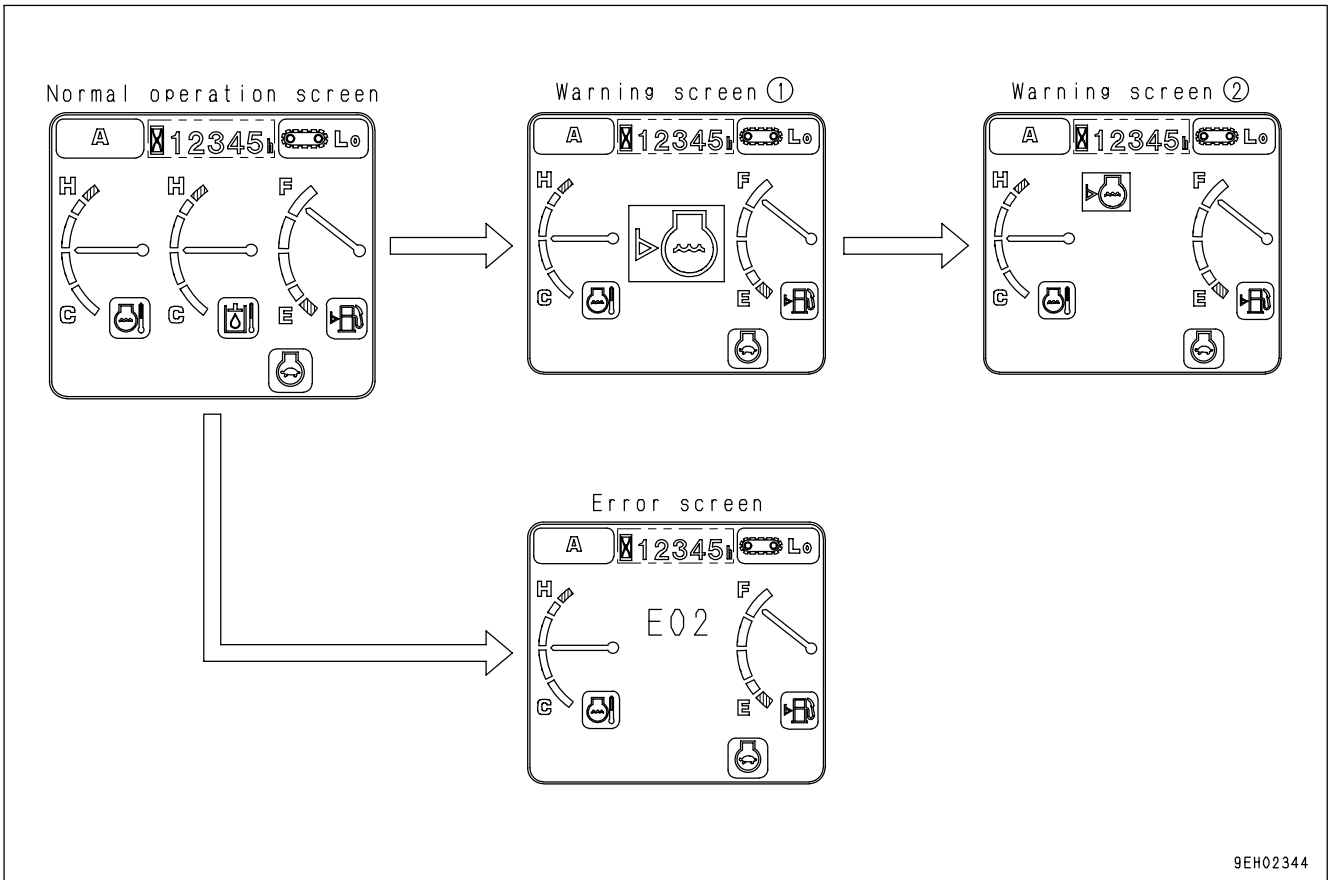

- If any abnormality occurs during operation, the normal operation screen changes to warning screen (1) or the error screen.
- After displaying warning screen (1) for 2 seconds, the screen automatically changes to warning screen (2).



**Basic Check Monitors**



These monitors do not guarantee the condition of the machine.

Do not simply rely on the monitor when carrying out checks before starting (daily inspection). Always get off the machine and check each item directly.

Displays basic items among the check before starting items that must be checked before starting the engine. If there is any abnormality, monitor for the location of abnormality will light up.

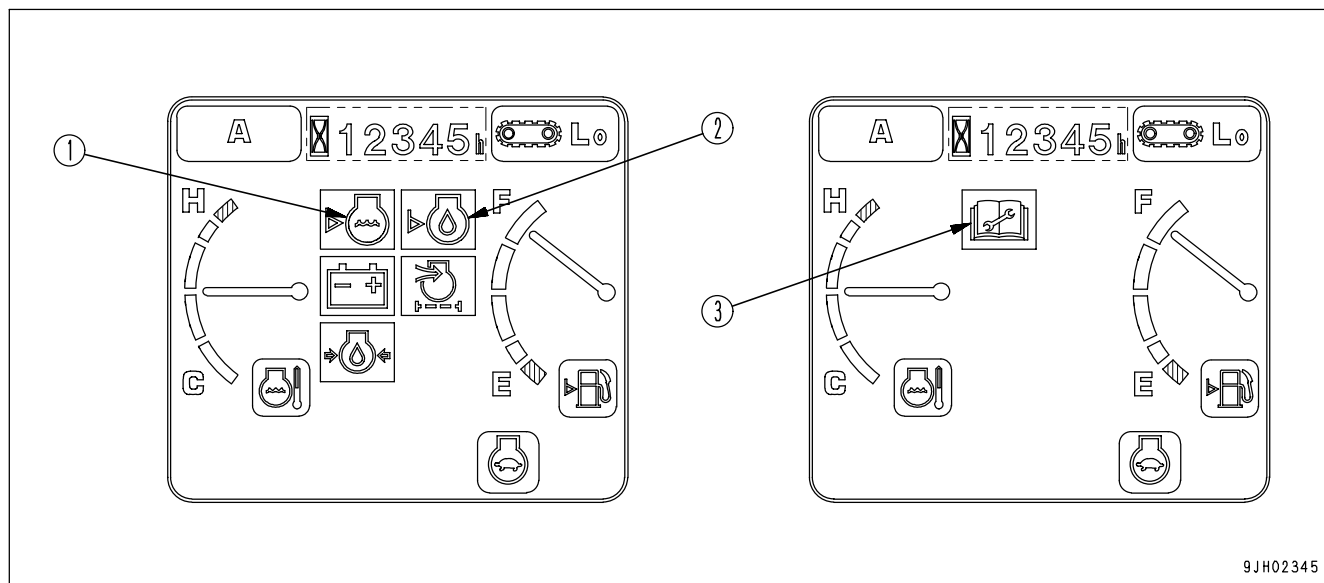

A(1) Radiator coolant level monitor  
A(2) Engine oil level monitor

A(3) Maintenance interval monitor

**Radiator Coolant Level Monitor**

Monitor (1) warns the operator that there has been a drop in the radiator coolant level.

If the radiator coolant is low, the lamp lights up red, so check coolant level in the radiator and subtank, and add coolant.

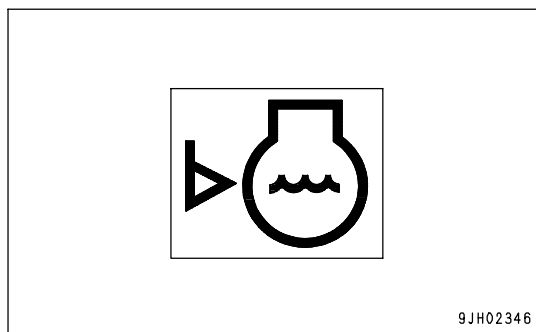

**Engine Oil Level Monitor**

Monitor (2) warns the operator that the oil level in the engine oil pan has dropped.

If oil level in the engine oil pan is low, the lamp lights up red, so check the oil level, and add oil.

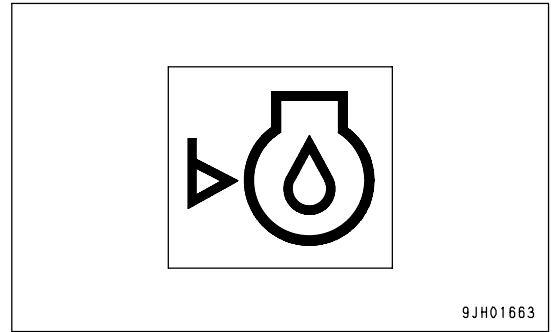
**Maintenance Interval Monitor**

This monitor (3) lights up red to warn the operator when the set time has passed from the time of the previous maintenance.

This monitor screen goes out after 30 seconds and switches to the normal screen.

- For details of the method of checking the maintenance interval, see "Maintenance Switch (PAGE 3-24)" in the Detailed controls and gauges.

If it is desired to change settings for the maintenance interval, have your Komatsu distributor change the settings.

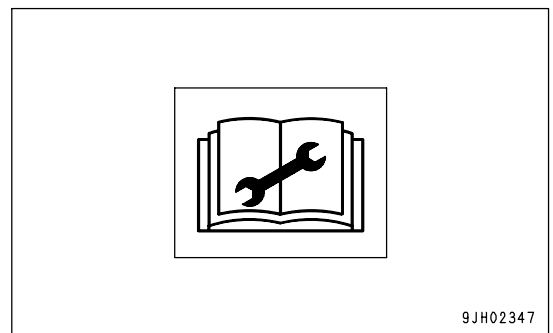

Caution Monitors



If the warning monitor lights up red, stop operations as soon as possible and perform inspection and maintenance of the applicable location. If the warning is ignored, it may lead to failure.

These are items that should be observed while the engine is running. If any abnormality occurs, the screen displays the item that needs immediate action.

If there is an abnormality, the monitor for the abnormal location lights up red.

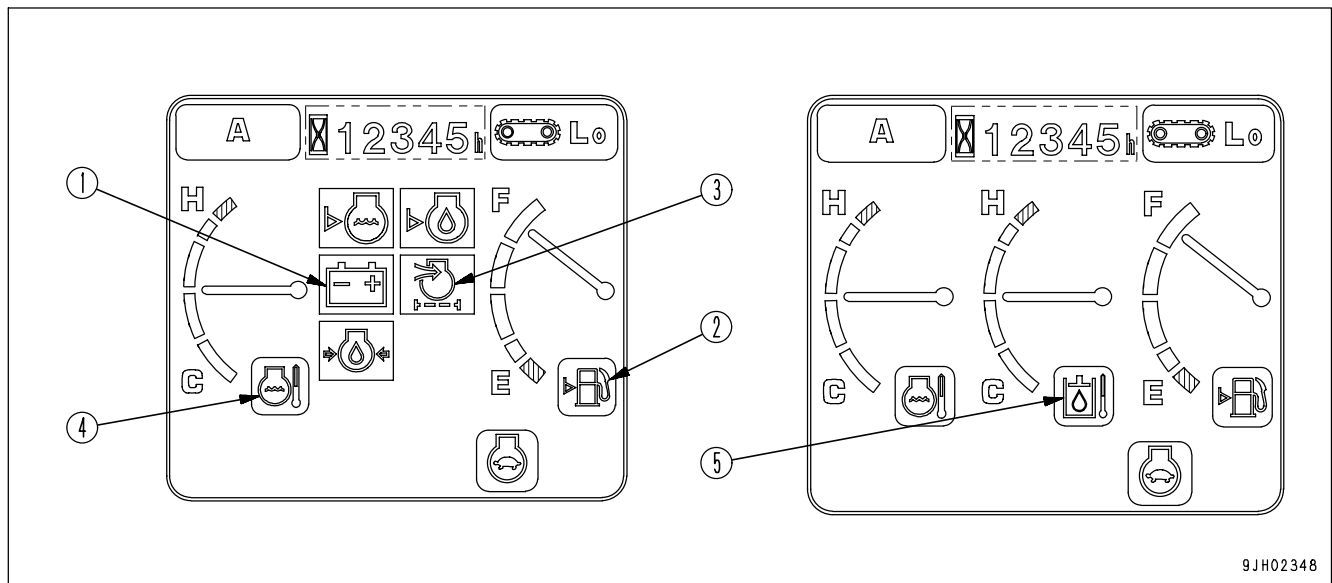

- B(1) Charge level monitor
- B(2) Fuel level monitor
- B(3) Air cleaner clogging monitor

- B(4) Engine coolant temperature monitor
- B(5) Hydraulic oil temperature monitor

Charge Level Monitor

Monitor (1) warns the operator of an abnormality in the charging system while the engine is running.

If the battery is not being charged properly while the engine is running, monitor (1) lights up red.

If monitor lights up red, check the V-belt for looseness. If any abnormality is found, perform the necessary actions. For details, see "OTHER TROUBLE (PAGE 3-142)".

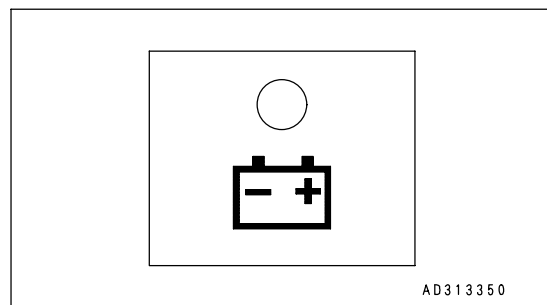

REMARK

- While the starting switch is ON, the lamp will remain lit and will go off when the engine is started.
- When the engine is started or stopped with the starting switch at the ON position, the lamp may light up and the buzzer and horn may sound momentarily, but this does not indicate any abnormality.

**Fuel Level Monitor**

Monitor (2) lights up to warn the operator the fuel level in the tank is low.

If the remaining amount of fuel goes down to 300 liters (79.26 US gal), the light changes from green to red, so add fuel as soon as possible.

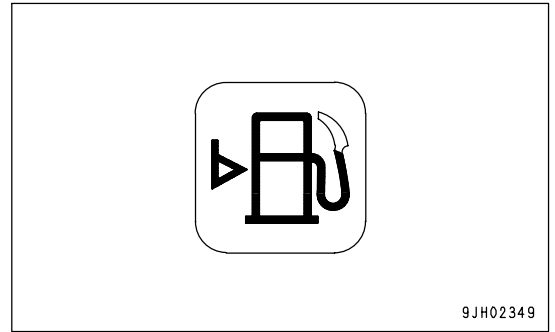
**Air Cleaner Clogging Monitor**

Monitor (3) warns the operator of a clogged air cleaner.

If the monitor lights up red, stop the engine, inspect and clean the air cleaner.

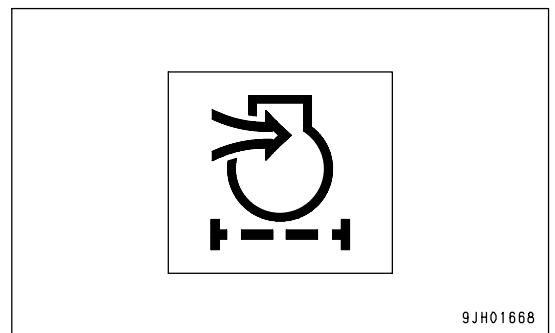
**Engine Coolant Temperature Monitor**

If monitor (4) lights up white in low temperatures, perform warming-up operation. For details, see "Warming-up Operation (PAGE 3-91)".

Continue warming-up operation until monitor (4) changes to green.

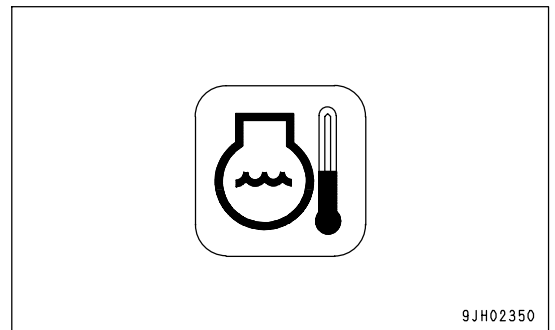
**Hydraulic Oil Temperature Monitor**

If monitor (5) lights up white in low temperatures, perform warming-up operation. For details, see "Warming-up Operation (PAGE 3-91)".

Continue warming-up operation until monitor (5) changes to green.

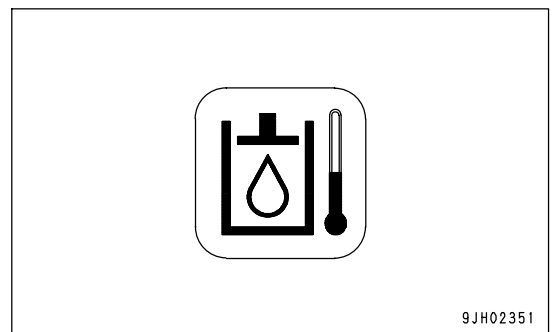

### Emergency Monitors



If the monitor lights up red, stop the engine immediately or run at low idle, check applicable location, then perform necessary actions.

These items should be observed while the engine is running. If there is a problem, the monitor for the abnormal location lights up red and buzzer sounds, perform action immediately.

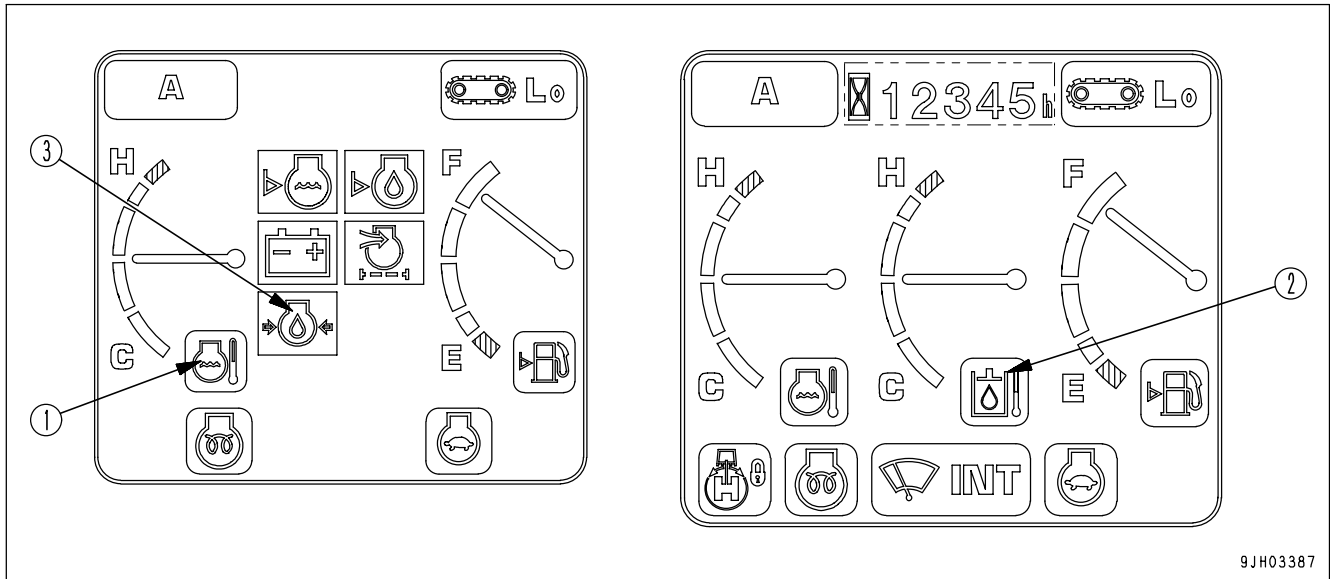

C(1) Engine coolant temperature monitor  
C(2) Hydraulic oil temperature monitor

C(3) Engine oil pressure monitor

#### Engine Coolant Temperature Monitor

Monitor (1) warns operator that the engine coolant temperature has risen.

If engine coolant temperature becomes abnormally high, monitor lights up red, overheat prevention system is automatically actuated, and the engine speed goes down.

Stop operations and run engine at low idle until monitor (1) changes to green.

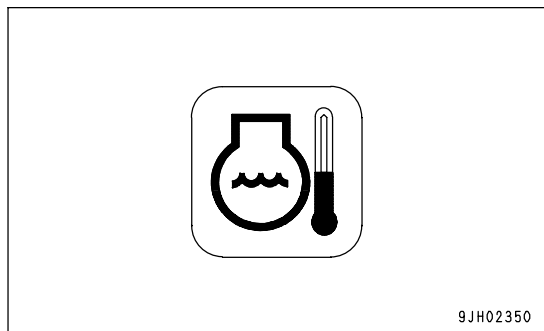

**Hydraulic Oil Temperature Monitor**

Monitor (2) warns operator that the hydraulic oil temperature has risen.

If monitor lights up red during operations, run engine at low idle or stop the engine and wait until the oil temperature goes down and monitor (2) changes to green.

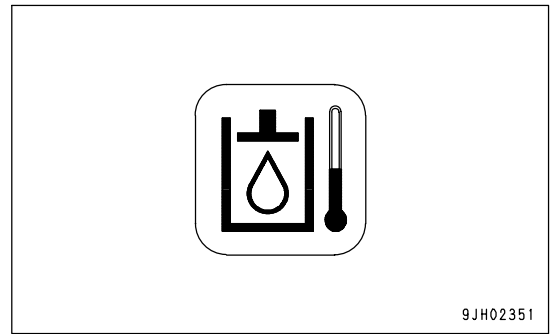

**Engine Oil Pressure Monitor**

Monitor (3) lights up red if the engine lubrication oil pressure goes below normal level. If monitor lights up red, stop the engine immediately, check the lubrication system and level of oil in the engine oil pan.

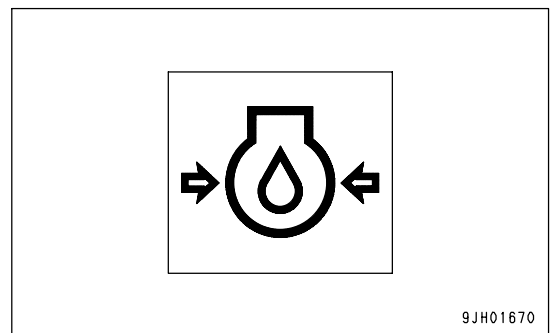

**REMARK**

Color when the monitor lights up for basic check items, caution items, and emergency stop items are as follows.

| Type of monitor                    | Color when monitor lights up |               |                    |
|------------------------------------|------------------------------|---------------|--------------------|
|                                    | When normal                  | When abnormal | At low temperature |
| Radiator coolant level monitor     | OFF                          | Red           | -                  |
| Engine oil level monitor           | OFF                          | Red           | -                  |
| Maintenance interval monitor       | OFF                          | Red           | -                  |
| Charge monitor                     | OFF                          | Red           | -                  |
| Fuel level monitor                 | Green                        | Red           | -                  |
| Air cleaner clogging monitor       | OFF                          | Red           | -                  |
| Engine coolant temperature monitor | Green                        | Red           | White              |
| Hydraulic oil temperature monitor  | Green                        | Red           | White              |
| Engine oil pressure monitor        | OFF                          | Red           | -                  |

**Meter Display Portion**

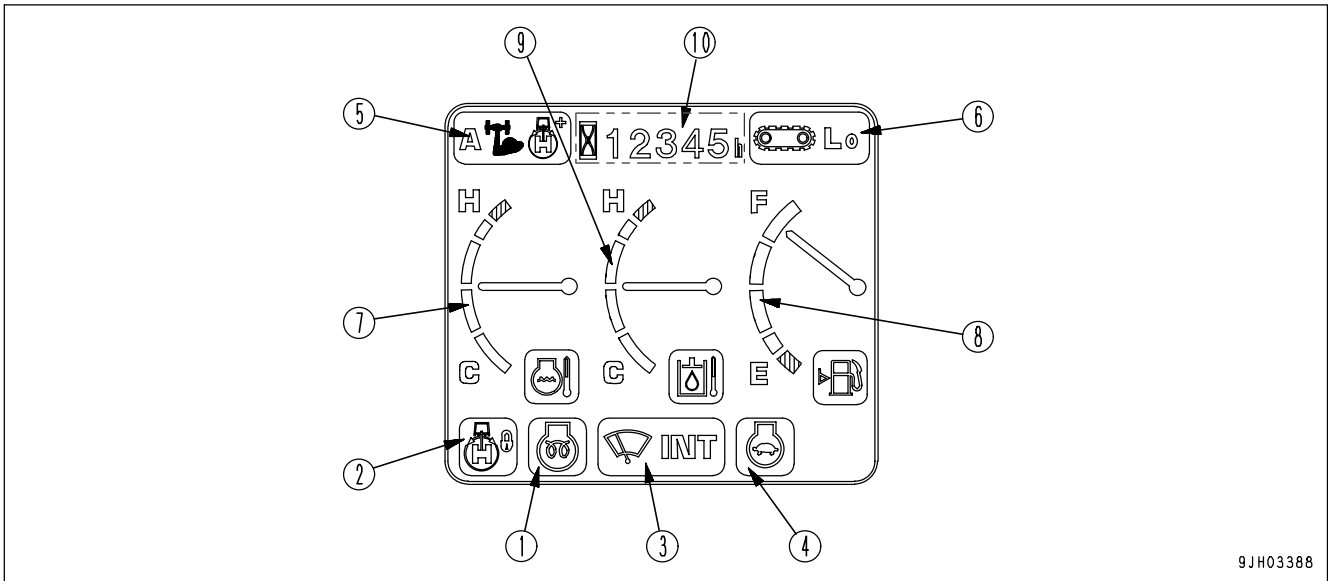

9JH03388

- D(1) Engine pre-heating monitor
- D(2) Swing lock monitor
- D(3) Wiper monitor
- D(4) Auto-deceleration monitor
- D(5) Working mode monitor
- D(6) Travel speed monitor
- D(7) Engine water temperature gauge
- D(8) Fuel gauge
- D(9) Hydraulic oil temperature gauge
- D(10) Service meter

**Pilot Display**

When the starting switch is ON, the pilot display lights up when the display items are functioning.

**Engine Pre-heating Monitor**

Monitor lamp (1) indicates pre-heating time required when starting the engine at an ambient temperature below 0°C (32°F).

The monitor lamp lights when the ignition switch is turned to the HEAT position and flashes after 30 seconds to show pre-heating is completed. (Monitor lamp will go off after 10 seconds.)

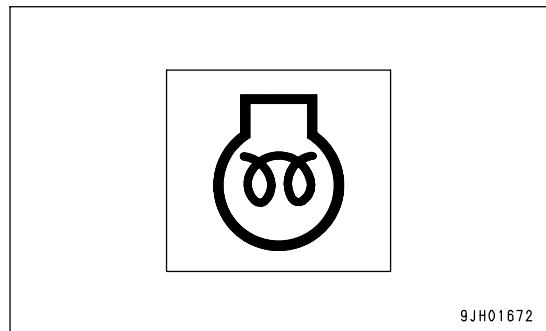

9JH01672

**Swing Lock Monitor**

This monitor (2) informs the operator that the swing lock has been actuated.

When actuated: Lights up

The monitor lights up when the swing lock switch is turned to the ON (LOCK) position.

The monitor flashes when the swing holding brake release switch is turned ON.

**REMARK**

The swing motor is equipped with a disc brake that mechanically stops the rotation. When the swing lock monitor is lighted up, the brake remains applied.

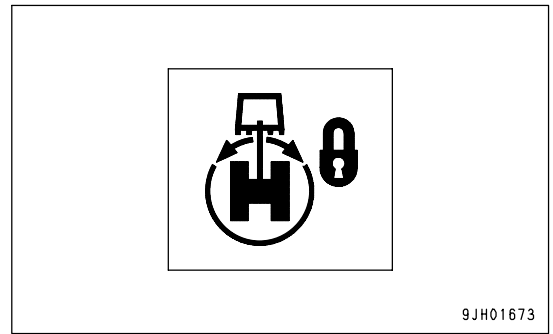

**Wiper Monitor**

Monitor (3) indicates operating status of the wiper.

The monitor display when wiper switch is operated, as follows.

When ON lights up: Wiper moves continuously

When INT lights up: Wiper moves intermittently

OFF: Wiper stops

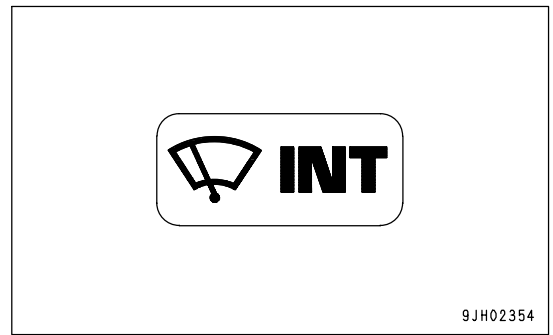

**Auto-deceleration Monitor**

Monitor (4) shows if the auto-deceleration is being actuated.

The monitor display when auto-deceleration switch is operated, as follows.

Auto-deceleration monitor ON: Auto-deceleration actuated

Auto-deceleration monitor OFF: Auto-deceleration canceled

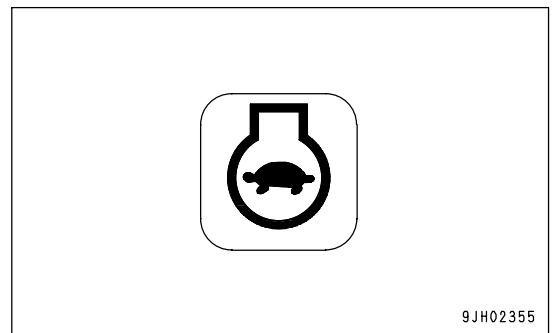

**Working Mode Monitor**

Monitor (5) displays the set working mode.

The monitor display when working mode switch is operated, as follows.

A : A mode (for heavy-load operations)

E : E mode (for operations with emphasis on fuel economy)

X: Heavy-duty lift (boom lifting power increased when raising boom independently)

Y: Swing priority mode (priority given to swing when operating boom and swing simultaneously)

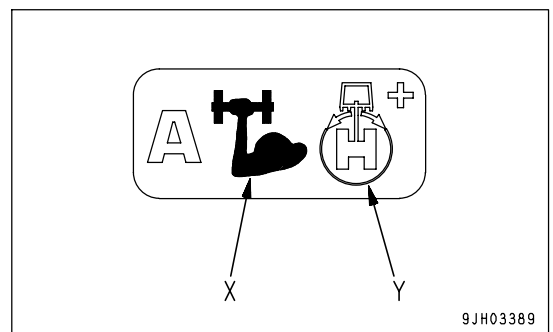



**Travel Speed Monitor**

Monitor (6) displays set mode for the travel speed.  
 The monitor display when the travel speed selector switch is operated, as follows.  
 Lo : Low speed  
 Hi : High speed

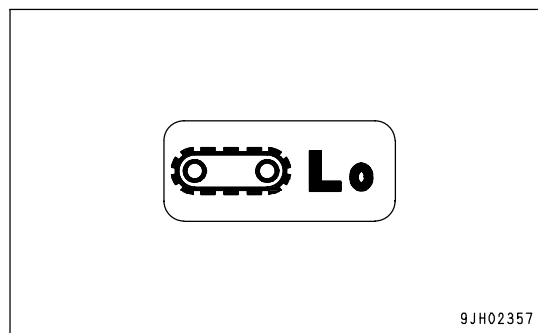

**Gauges and Meter**

**Engine Coolant Temperature Gauge**

This meter (7) indicates the engine cooling water temperature.  
 During normal operations, the indicator should be in the black range. If the indicator enters the red range during operations, the overheat prevention system is actuated.

The overheat prevention system acts as follows.  
 Red range position (A): Engine water temperature monitor (1) lights up red  
 Red range position (B): Engine speed is reduced to low idle, engine water temperature monitor (1) lights up red, and alarm buzzer sounds at same time.

The overheat prevention system remains actuated until the indicator returns to the black range.  
 When the engine is started, if the indicator is at position (C), engine coolant temperature monitor (1) lights up white.  
 In this case, carry out the warming-up operation. For details, see "Warming-up Operation (PAGE 3-91)".

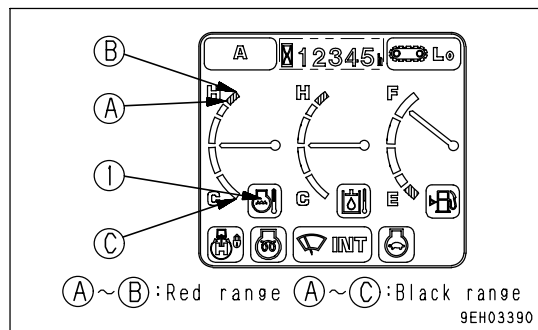

**Fuel Gauge**

This meter (8) displays the level of the fuel in the fuel tank.

During operations, the indicator should be in the black range.

If the indicator enters red range (A) during operations, there is less than 300 liters (79.26 US gal) of fuel remaining in the tank, so check and add fuel.

**REMARK**

If the indicator enters red range (B), there is less than 210 liters (55.48 US gal) of fuel remaining.

When the indicator is in the red range (A) to (B), fuel level monitor (1) lights up red.

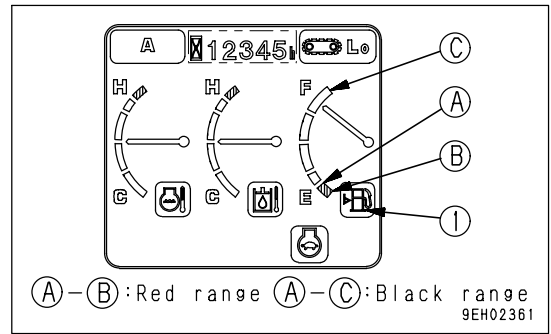

If the indicator enters the red range, do not carry out operations on steep slopes. There is danger that the engine will stall.

The correct fuel level may not be displayed for a short time when the starting switch is turned ON, but this is not an abnormality.

**Hydraulic Oil Temperature Gauge**

This meter (9) displays the hydraulic oil temperature.

During operations, the indicator should be in the black range.

If the indicator enters red range (A) during operations, the hydraulic oil temperature has gone above 102°C (215.6°F). Stop the engine or run it at low idling and wait for the hydraulic oil temperature to go down.

**REMARK**

When the indicator is in the red range (A), the hydraulic oil temperature is as follows.

Red range position (A): More than 102°C (215.6°F)

Red range position (B): More than 105°C (221°F)

When the indicator is in the red range (A) to (B), hydraulic oil temperature monitor (1) lights up red.

If the indicator is at position (C) when the engine is started, the hydraulic oil temperature is more than 25°C (77°F), and hydraulic oil temperature monitor (1) lights up white. In this case, carry out the warming-up operation. For details, see "Warming-up Operation (PAGE 3-91)".

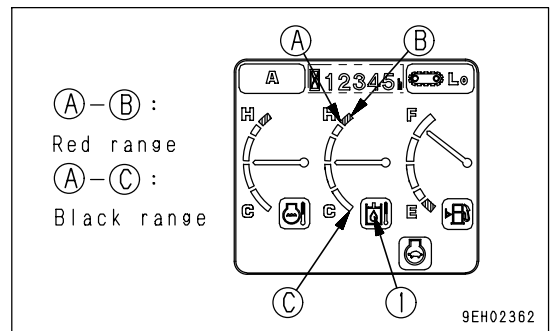

**Service Meter**

Monitor (10) displays the total time that the machine has been operated.

Use the time display to set the maintenance interval. When the starting switch is ON, the service meter advances even if the machine is not moving.

The service meter advances by 1 for every hour of operation, regardless of the engine speed.

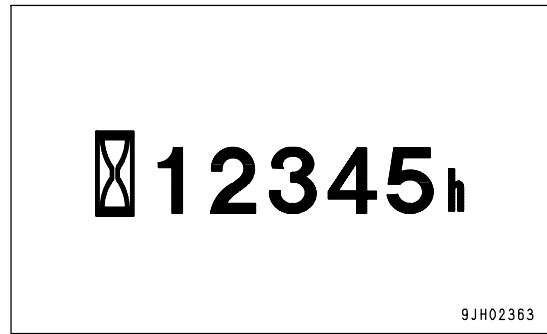

Monitor Switches Portion

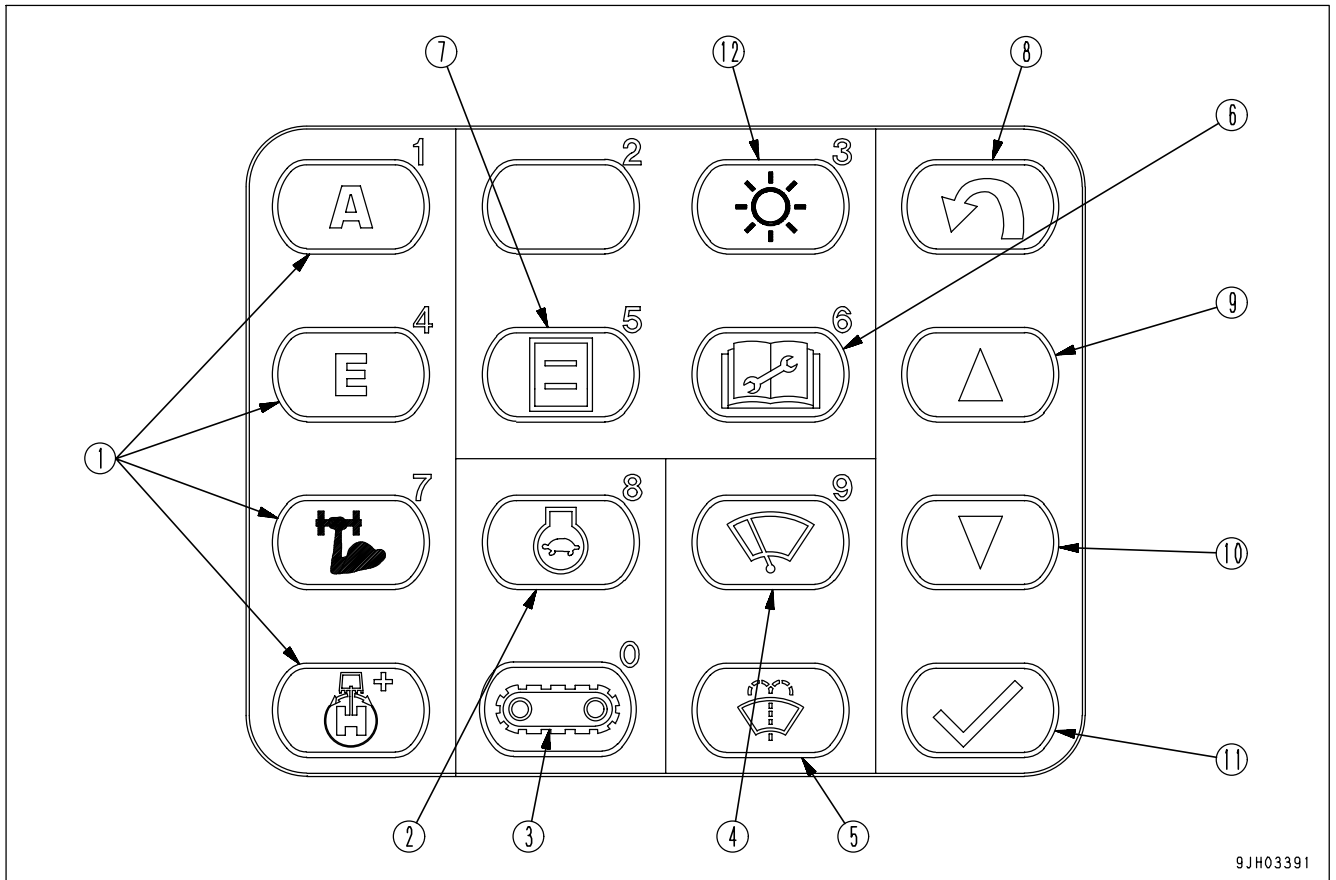

9JH03391

- E(1) Working mode selector switch (Basic mode)
- E(2) Auto-deceleration switch (Selection switch)
- E(3) Travel speed selector switch
- E(4) Wiper switch
- E(5) Window washer switch
- E(6) Maintenance switch

- E(7) Has no function
- E(8) Back switch
- E(9) Up switch
- E(10) Down switch
- E(11) Input confirmation switch
- E(12) Adjusting brightness and contrast

**Working Mode Selector Switch (Basic Switch)**

This switch (1) is used to set the power and movement of the work equipment.

Operations can be carried out more easily by selecting the mode to match the type of operation.

- A mode: For heavy-load operations
- E mode: For operations with emphasis on fuel economy

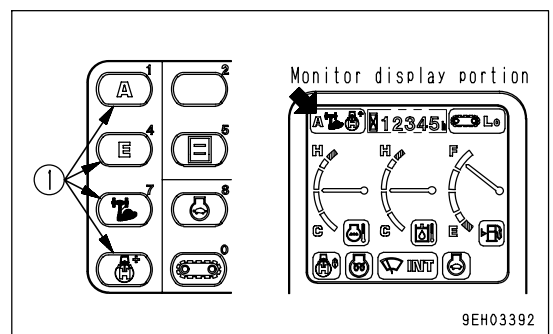

9EH03392

Heavy-duty lift mode: boom lifting power increased when raising boom independently

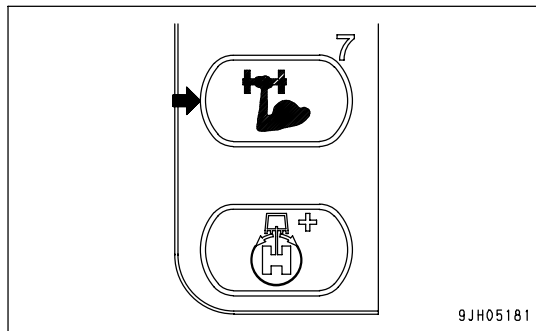

Swing priority mode: priority given to swing when operating boom and swing simultaneously

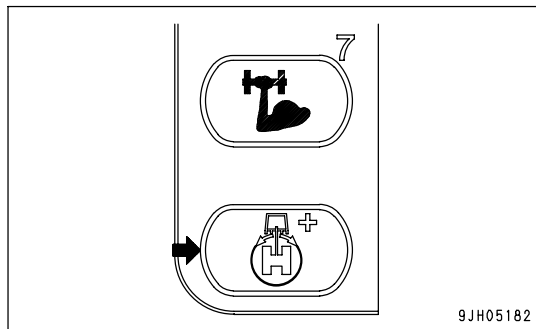

- When the engine is started, the working mode is set automatically to A mode. When the switch is pressed, it is possible to select the other modes. The monitor display on the monitor display portion changes for each mode.
- If it is desired to have the working mode set to start automatically in E, L, or B mode (default option setting), have your Komatsu distributor change the setting.

**REMARK**

When the mode selector switch is pressed, the mode is displayed in the center of the monitor display, and the screen returns to the normal screen after 2 seconds. (The diagram on the right is an example of the display for the E mode.)

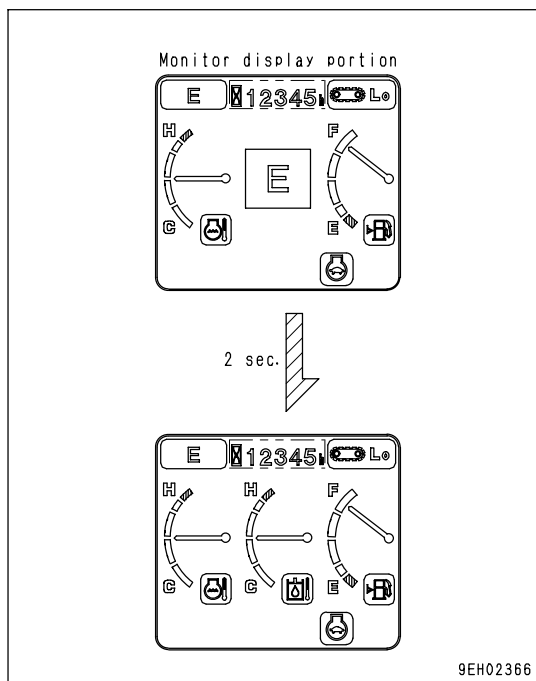

**Auto-deceleration Switch (Selection Switch)**

This switch (2) turns on the function to reduce fuel consumption and lowers the engine speed automatically when the work equipment control levers are at neutral.

Monitor display ON: Auto-deceleration actuated

Monitor display OFF: Auto-deceleration canceled

Each time that the switch is pressed, the auto-deceleration switches between actuated and canceled.

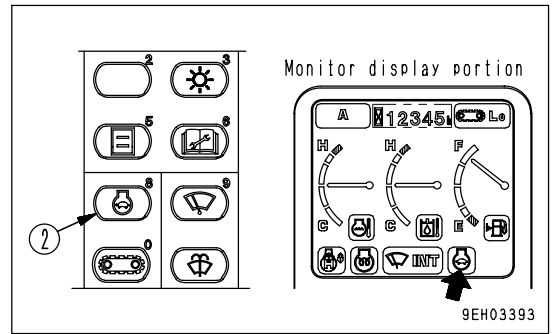

• Auto-deceleration function

When the auto-deceleration function is ON, if the work equipment and travel levers are returned to the N position, the engine speed will drop after 4 seconds from the operating speed to idling speed.

This makes it possible to reduce fuel consumption.

If any lever is operated when the machine is in this condition, engine speed will return to the previous operating speed to make it possible to perform operations.

**REMARK**

When the auto-deceleration switch is pressed and the auto-deceleration is actuated, the mode is displayed in the center of the monitor display, and the screen returns to the normal screen after 2 seconds.

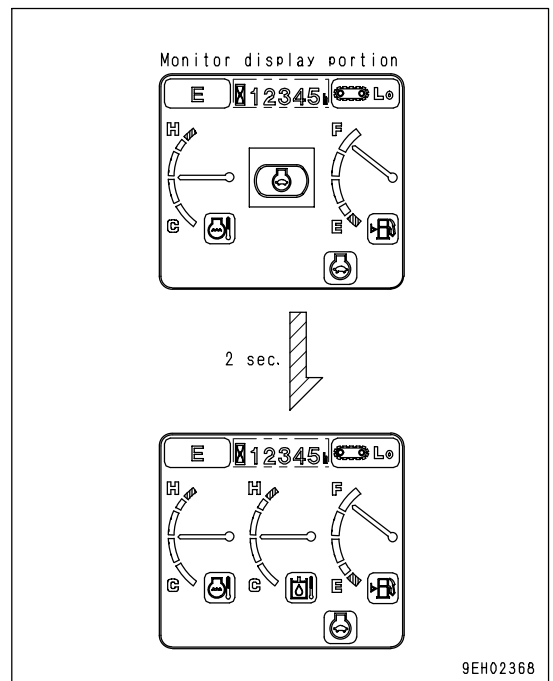

Travel Speed Selector Switch

**WARNING**

- When loading or unloading from a trailer, always travel at low speed (with travel speed selector switch (3) at the Lo position). Never operate travel speed selector switch (3) while loading or unloading.
- If the travel speed is switched between Hi and Lo when the machine is traveling, the machine may deviate to one side, even when traveling in a straight line.  
Stop the machine before switching the travel speed.

This switch (3) is used to set the travel speed to 2 stages.  
 Lo lights up : Low-speed travel  
 Hi lights up : Hi-speed travel  
 When the engine is started, the speed is automatically set to Lo.  
 Each time that the switch is pressed, the display changes Lo → Hi → Lo in turn.

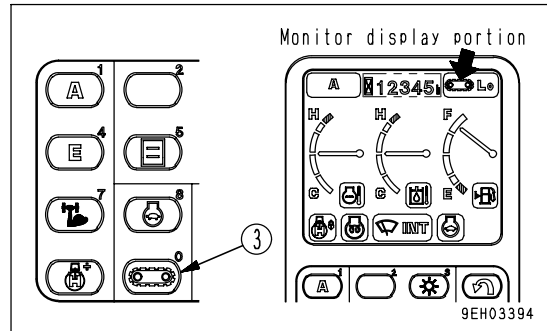

When traveling in high speed (Hi), if travel power is needed, such as when traveling on soft ground or on slopes, the speed automatically switches to low speed (Lo), so there is no need to operate the switch. The monitor display stays at Hi.

**REMARK**

Each time that the travel speed selector switch is operated, the mode is displayed in the center of the monitor display, and the screen returns to the normal screen after 2 seconds.

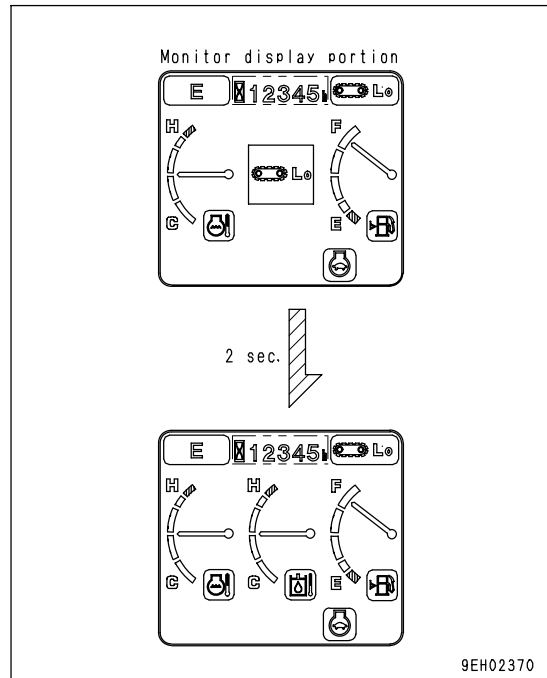

**Wiper Switch**

This switch (4) actuates the front window wiper.

Each time the switch is pressed, it changes ON → INT → stop (OFF).

Monitor display ON lighted up : Wiper moves continuously

Monitor display INT lighted up : Wiper moves intermittently

Monitor display OFF : Wiper stops

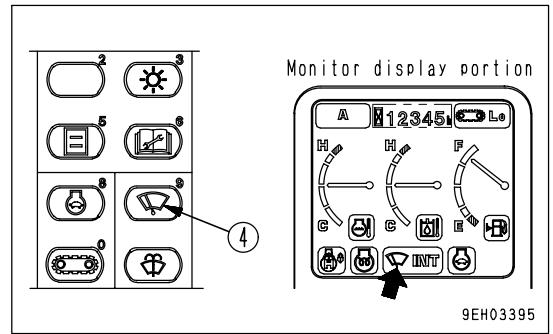

**REMARK**

Each time that the wiper switch is operated, the mode is displayed in the center of the monitor display. The screen returns to the normal screen after 2 seconds.

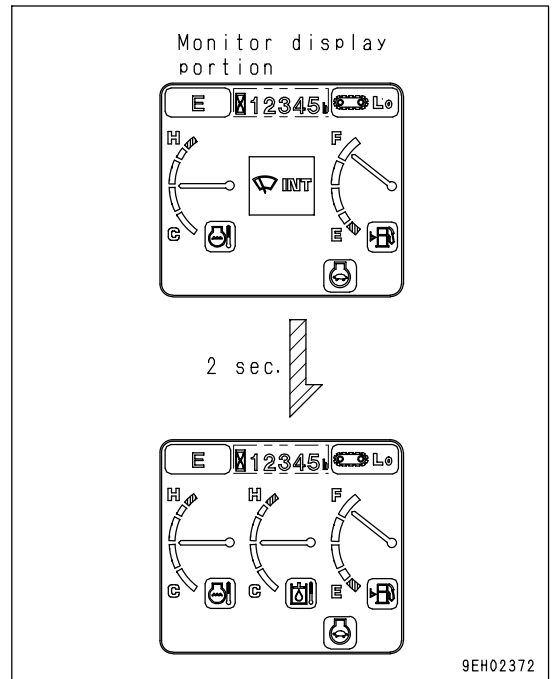

**Window Washer Switch**

This switch (5) is kept continuously pressed, window washer fluid is sprayed out on the front glass. When the switch is released, the spray stops.

- If switch (5) is kept pressed when the wiper is stopped, the window washer fluid will spray, and at the same time, the wiper will be actuated continuously. When switch (5) is released, the wiper will continue to operate for 2 cycles, then stop.
- If the wiper is moving intermittently and switch (5) is kept pressed continuously, window washer fluid will spray, and at the same time, the wiper will be actuated continuously. When switch (5) is released, the wiper will continue to operate for 2 cycles, then return to intermittent operation.

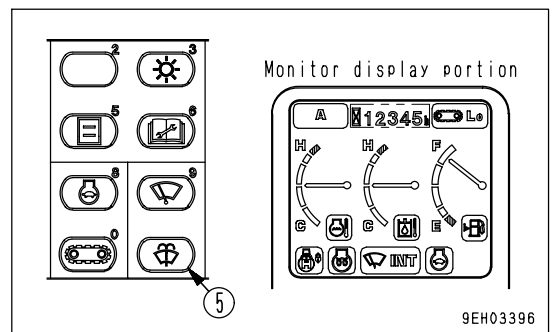



**Maintenance Switch**

- Switch (6) is used to check the time remaining until maintenance.

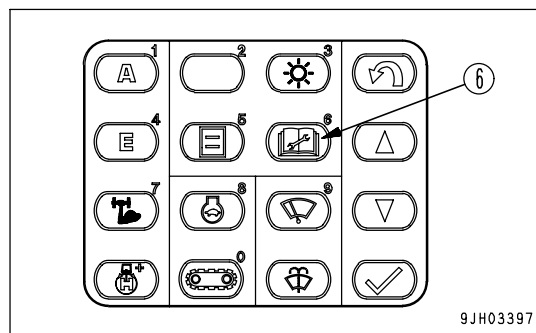

- When switch (6) is pressed, screen on the monitor display changes to the maintenance screen, as shown in diagram on the right.

The time remaining until maintenance is indicated by the color of each monitor display. After confirming the maintenance time, perform the maintenance.

White display: More than 30 hours remaining until maintenance

Yellow display: Less than 30 hours remaining until maintenance

Red display : Maintenance time has already passed

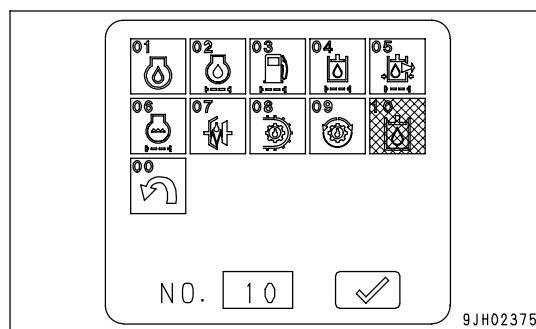

**NOTICE**

1. If the monitor display changes to the maintenance warning screen when the engine is started or when the machine is being operated, stop operations immediately. When this happens, the monitor corresponding to the maintenance warning screen will light up red.
2. Press switch (6) to display the maintenance screen and check that there is no abnormality in any other monitor.
3. If another monitor is lighted up red on the maintenance screen, carry out maintenance for that item also.

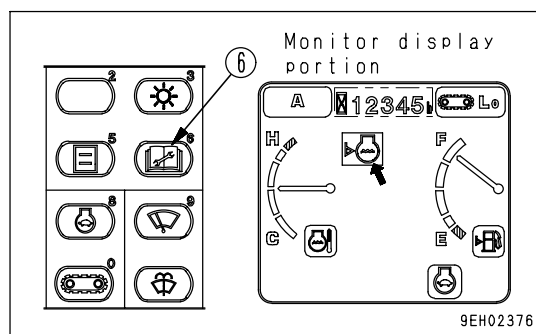

- Maintenance display items are as follows:

| Monitor No. | Maintenance item                | Default set screen (H) |
|-------------|---------------------------------|------------------------|
| 01          | Change engine oil               | 500                    |
| 02          | Replace engine oil filter       | 500                    |
| 03          | Replace fuel filter             | 500                    |
| 04          | Replace hydraulic oil filter    | 500                    |
| 05          | Replace hydraulic tank breather | 1000                   |
| 06          | Replace corrosion resistor      | 1000                   |
| 07          | Change PTC case oil             | 1000                   |
| 08          | Change final drive case oil     | 2000                   |
| 09          | Change swing machinery case oil | 1000                   |
| 10          | Change hydraulic oil            | 5000                   |

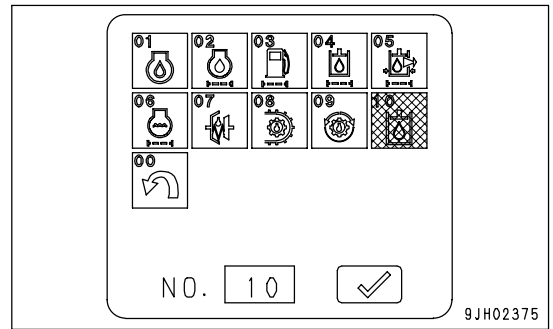

If it is desired to change settings for the maintenance interval, have your Komatsu distributor change the settings.

- The method of checking time remaining until maintenance is as follows:

1. Look at the maintenance screen, press up switch (9) or down switch (10) on the monitor switch portion, and select the item. (Color of the monitor for selected item is inverted to black.)

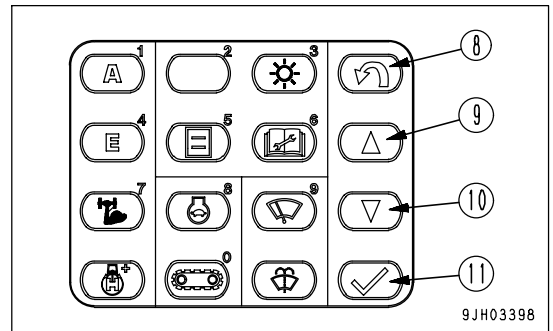

2. After selecting the monitor item, press input confirmation switch (11). Display screen will switch to the time remaining until maintenance. (Press back switch (8) to return to the previous screen.)

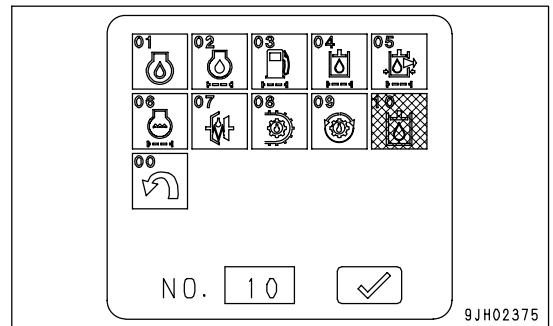

3. Check the time remaining until maintenance.
  - (a): Time remaining until maintenance
  - (b): Default setting for maintenance interval

When only checking the time remaining until maintenance, press back switch (8) twice.

The screen will return to the normal operation monitor screen. When canceling time remaining until maintenance and returning to the default time setting, press inout confirmation switch (11). The screen will switch to the default setting screen.

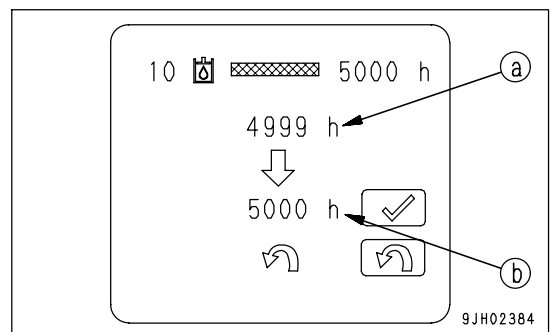

- 4. After checking the time on the default setting screen, press input confirmation switch (11).  
The screen will return to the maintenance screen.  
(Press back switch (8) to return to the previous screen.)

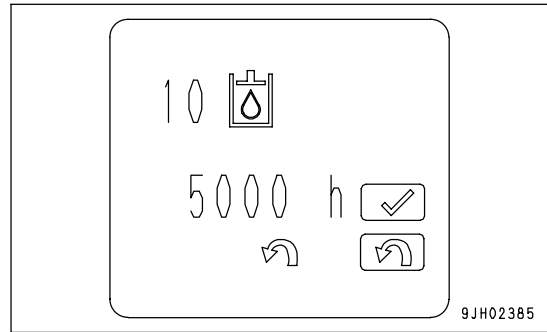

**Back Switch**

Press switch (8) when in the maintenance mode, brightness/contrast adjustment mode, or select mode. The screen will return to the previous screen on the monitor display.

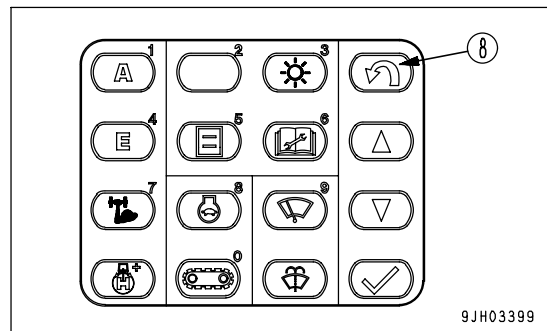

**Up Switch, Down Switch**

Press up switch (9) or down switch (10) when in the maintenance mode, brightness/contrast adjustment mode, or select mode to move the cursor on the monitor display (colors of selected monitor are inverted) up, down, left, or right.

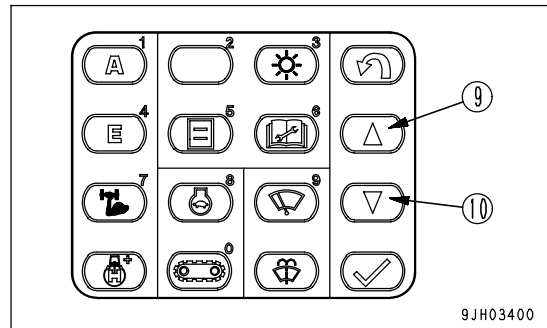

**Input Confirmation Switch**

Press switch (11) to confirm selected mode when in the maintenance mode, brightness/contrast adjustment mode, or select mode.

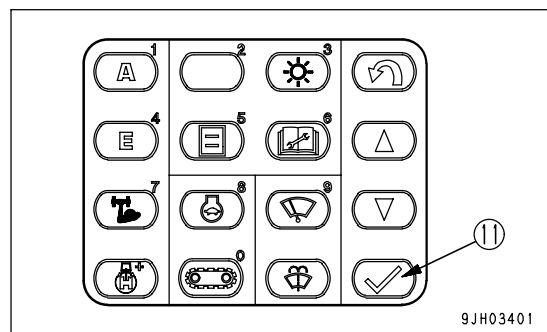

**Liquid Crystal Monitor Adjustment Switch**

Press switch (12) to adjust the brightness or contrast of the display monitor.

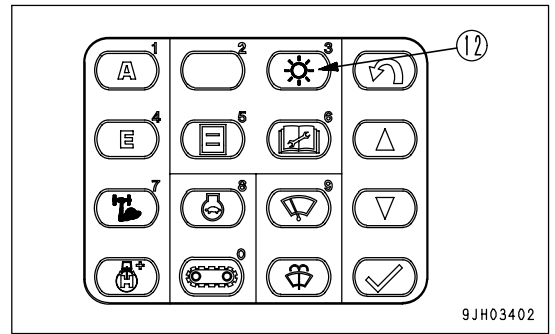

**Adjusting brightness and contrast**

1. When monitor adjustment switch (12) is pressed, the monitor display screen changes to the brightness/contrast screen shown in the diagram on the right.

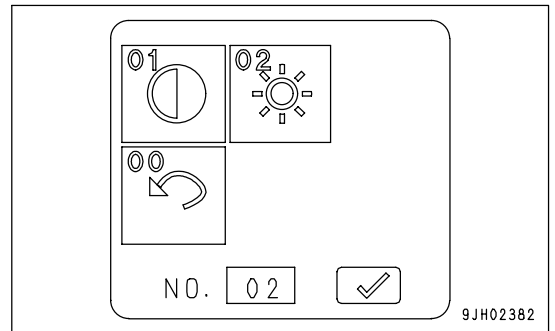

- Adjusting brightness
2. Use the brightness/contrast screen and press up switch (9) or down switch (10) to select brightness of the monitor. (The selected monitor is inverted to black.)

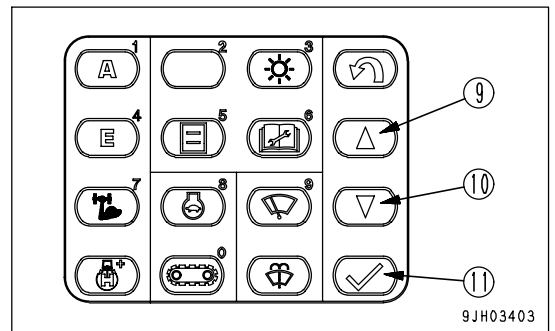

3. When the screen changes to the brightness adjustment screen, press up switch (9) or down switch (10) to adjust the brightness.
4. After completing adjustment of the brightness, press input confirmation switch (11).

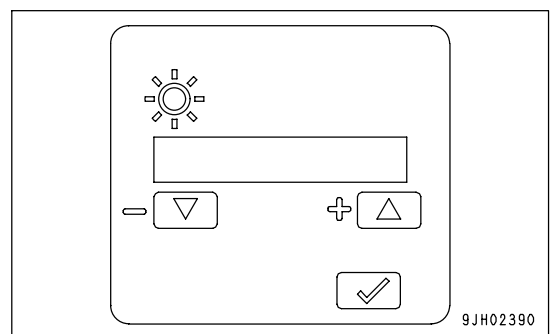

- Adjusting contrast

2. Use the brightness/contrast screen and press up switch (9) or down switch (10) to select the contrast monitor.

(The selected monitor is inverted to black.)

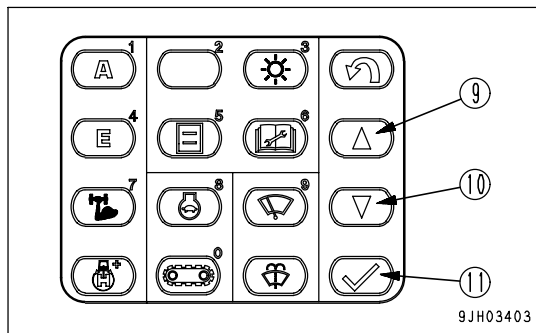

3. When the screen changes to the contrast adjustment screen, press up switch (9) or down switch (10) to adjust the contrast.

4. After completing adjustment of the contrast, press input confirmation switch (11).

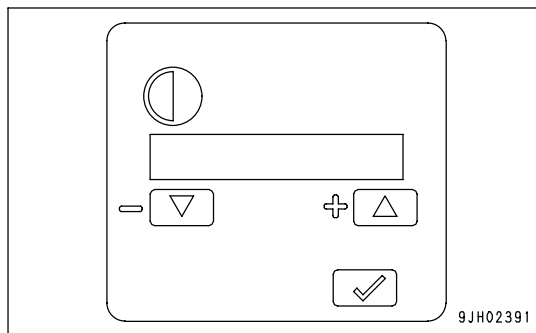

SWITCHES

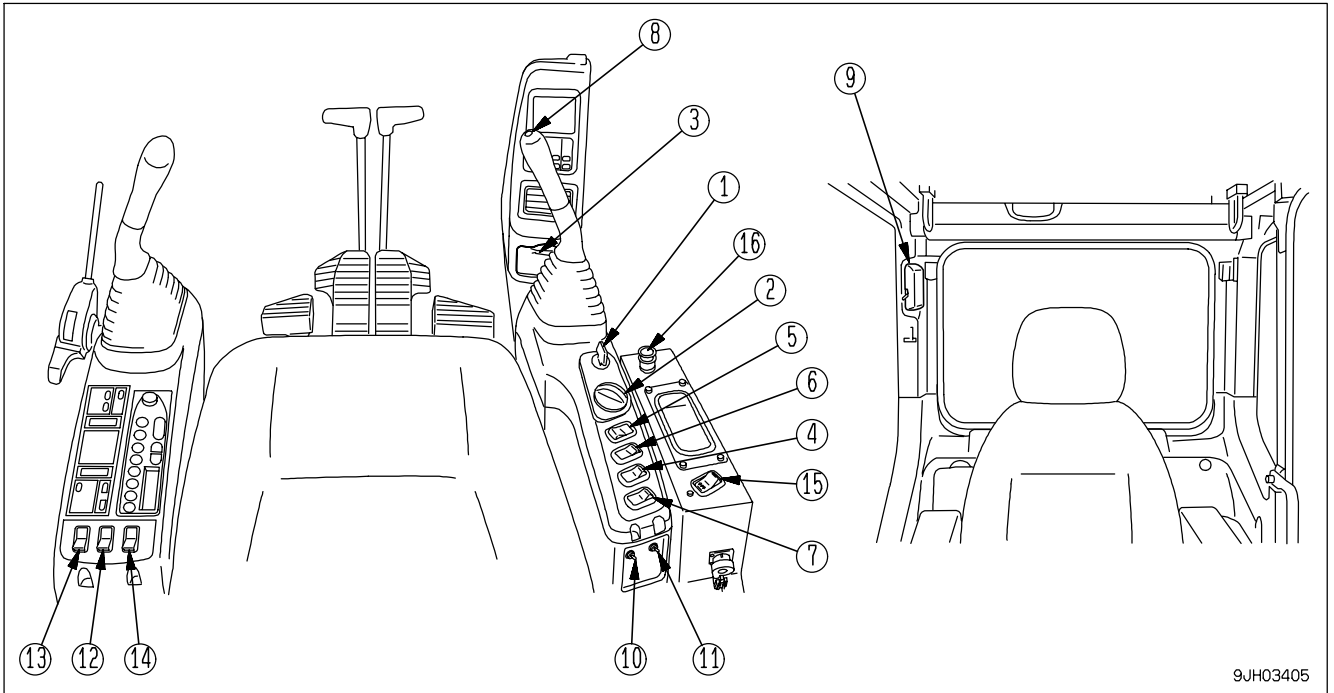

9JH03405

- (1) Starting switch
- (2) Fuel control dial
- (3) Cigarette lighter
- (4) Swing lock switch
- (5) Lamp switch
- (6) Alarm buzzer stop switch
- (7) Machine push-up switch
- (8) Horn switch
- (9) Room lamp switch
- (10) Pump drive emergency switch
- (11) Swing holding brake release switch
- (12) Rotating lamp switch (if equipped)
- (13) Lower wiper switch (machines equipped with fixed front window cab)
- (14) Large capacity airflow air conditioner blower switch (if equipped)
- (15) Boom shockless control switch
- (16) Step light switch

**Starting Switch**

Starting switch (1) is used to start or stop the engine.

**OFF position**

The key can be inserted or withdrawn. The switches for the electric system except the room lamp, are all turned off and the engine is stopped.

**ON position**

Electric current flows in the charging and lamp circuits. Keep the starting switch key at the ON position while the engine is running.

**START position**

This is the engine-start position. Keep the key at this position during cranking. Immediately after starting the engine, release the key. It will automatically return to the ON position.

**HEAT (preheat) position**

When starting the engine in winter, set the key to this position. When the key is set to the HEAT position, the pre-heating monitor lights up. Keep the key at this position until the monitor lamp flashes. Immediately after the pre-heating monitor flashes, release the key. The key automatically returns to the OFF position. Then, start the engine by turning the key to the START position.

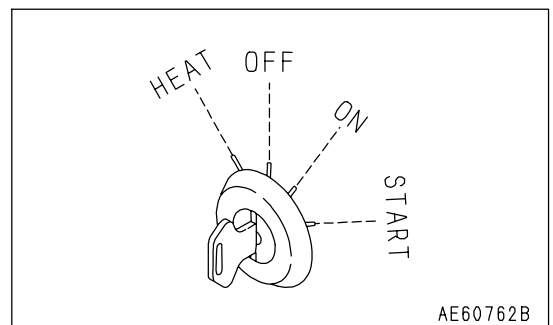

AE60762B

**Fuel Control Dial**

Dial (2) adjusts the engine speed and output.

- (a) Low idling (MIN): Turned fully to the left
- (b) Full speed (MAX): Turned fully to the right

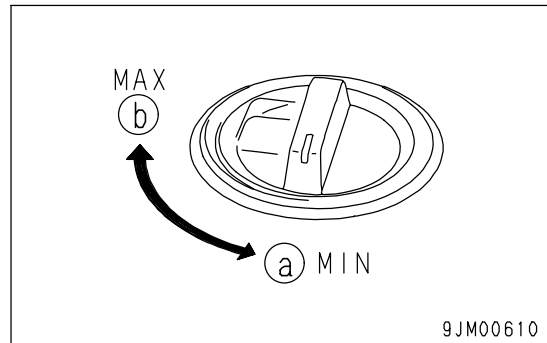

9JM00610

**Cigarette Lighter**

Lighter (3) is used to light cigarettes.

To use, push the lighter in. After a few seconds it will spring back.

Pull out the lighter and light your cigarette.

By removing the cigarette lighter, the socket is available as a power source for the yellow flashing lamp.

Max. current is 85 W (24V x 3.5 A).

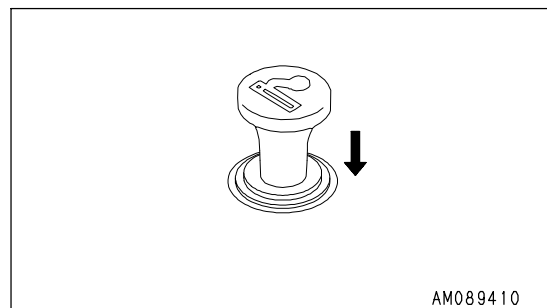

AM089410

**Swing Lock Switch**

**WARNING**

- When not using the swing operation, e.g. when traveling, put the swing lock switch to the OFF position.
- On slopes, even when the swing lock switch is at the ON position, the weight of the work equipment may cause the upper structure to swing if the swing control lever is operated in the downhill direction.

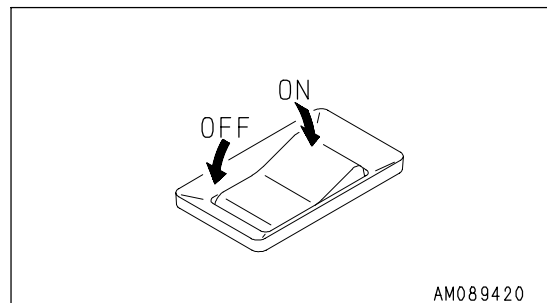

AM089420

This switch (4) is used to lock the upper structure so that it cannot swing.

ON position (actuated) : The swing lock is always applied, and the upper structure will not swing even if the swing is operated. In this condition, the swing lock lamp lights up.

OFF position (canceled) : The swing lock is applied only when all the control levers of the work equipment are at neutral; when any of the control levers is operated, it is cancelled.

The swing lock is actuated approx. 5 seconds after all the control levers are placed in the neutral position.

**Lamp Switch**

Switch (5) is used to turn on the front lamps, working lamps, additional lamps at top front of the cab, and monitor lighting.

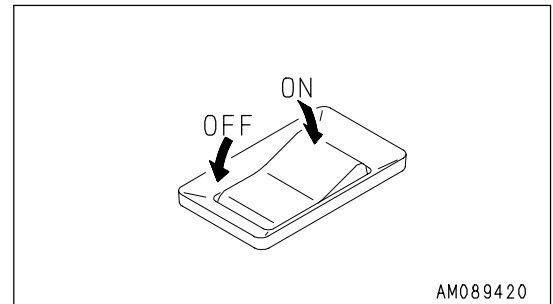
**Alarm Buzzer Stop Switch**

This switch (6) is used (when the engine is running) to stop the alarm buzzer when it has sounded to warn of a problem in a warning item.

**REMARK**

This switch is an automatic reset type. If the STOP position is pressed, the alarm buzzer stops and the switch automatically returns to its original position.

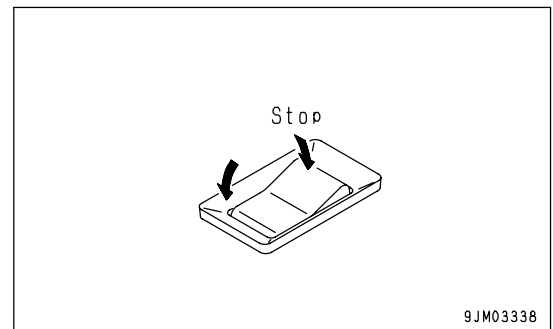
**Machine Push-up Switch****WARNING**

When using the boom thrust force to push up the chassis when moving down from a bench, there is danger that the machine may suddenly go down and turn over, so set to the high-pressure setting.

This switch (7) is used to switch the safety valve set pressure at the head end of the boom cylinder to two levels.

**(a) Low pressure setting:**

The boom thrust force is weak, so swaying of the chassis is small during digging operations, and digging can be performed smoothly.

This is used for general digging operations on normal ground, soft rock, or blasted rock.

**(b) High pressure setting:**

The boom thrust force becomes more powerful, so it is easy to twist and swing or escape from soft ground. It is effective in performing digging operations using the bucket and weight of the machine in confined areas.

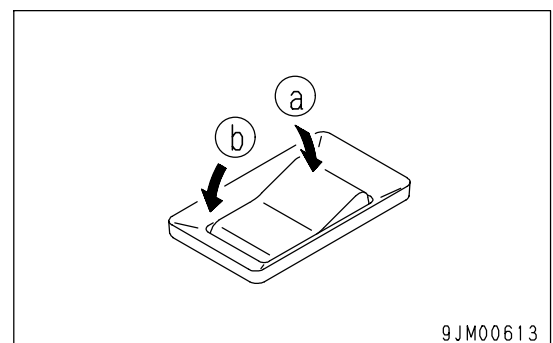



**Horn Switch**

When the switch (8) at the tip of the right work equipment control lever is pressed, the horn will sound.

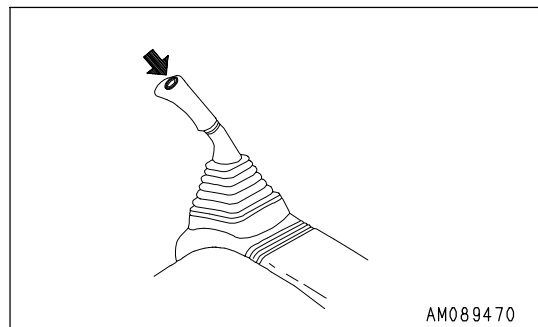

**Room Lamp Switch**

**NOTICE**

It is possible to turn on the interior cab room lamp even when starting switch is in the OFF position, do not forget to turn it off.

This switch (9) is used to light up the room lamp.

ON position: Lights up

OFF position: Goes out

It will also light up even when the engine is not running.

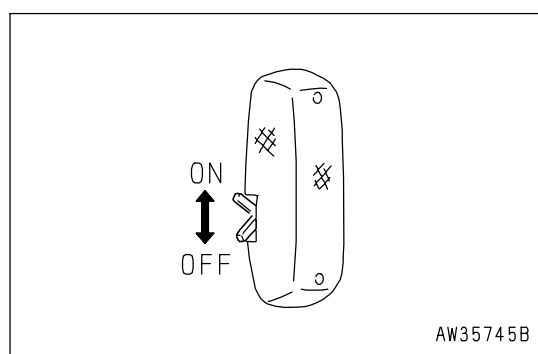

**Emergency Pump Drive Switch**

**NOTICE**

Emergency pump drive switch is provided to make it possible to perform work for a short time when there is a failure in the pump control system. It is necessary to repair the abnormal location as soon as possible.

Switch (10) makes it possible to temporarily perform operations should any abnormality occur in the pump control system (when monitor display shows E02).

(a) When abnormal : Move switch up

(b) When normal : Move switch down

If the display shows E02, move the switch up to make it possible to carry out work.

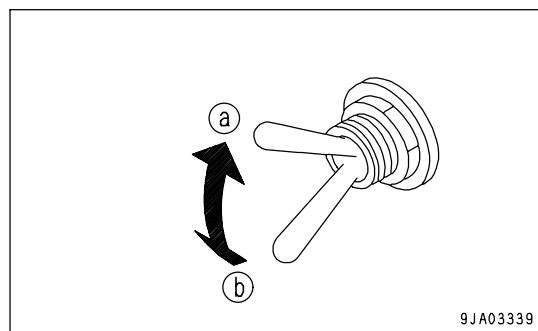

**Swing Parking Brake Release Switch**

**NOTICE**

This switch makes it possible to perform swing operations for a short even when there is a problem in the swing parking brake electric system. **DO NOT use this switch except in emergencies. Repair the problem as soon as possible.**

Switch (11) makes it possible to temporarily perform operations should any abnormality occur in the swing brake system (when monitor display shows E03).

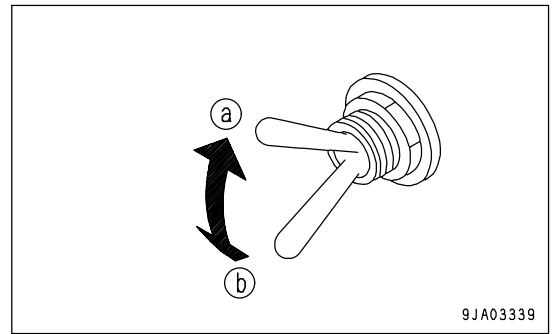

(a) Release: Position for abnormality (switch moved up)

(b) Normal: Normal position (switch moved down)

- When the monitor display is "E03", move this switch up to make it possible to perform operations.
- When this switch is set to release position (a), the swing lock monitor flashes.

**Rotating Lamp Switch (If Equipped)**

This switch (12) is used to light up the yellow rotating lamp on top of the cab.

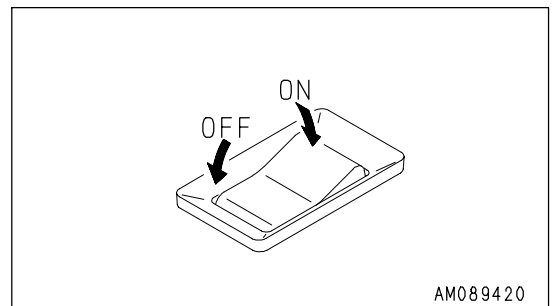

**Lower Wiper Switch**

This switch (13) operates the lower wiper (A).

ON position: Lower wiper is actuated

OFF position: Lower wiper stops

If this switch is turned to the ON position at the same time as the wiper switch, the wiper and lower wiper (A) will be actuated in turn.

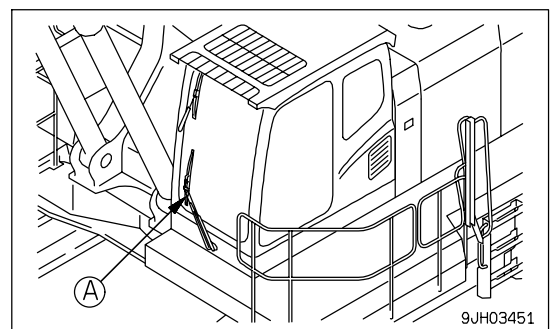
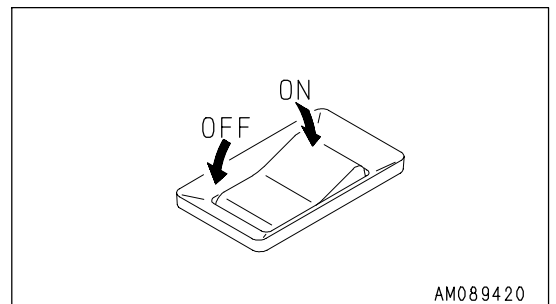

**Large Capacity Airflow Air Conditioner Blower Switch**

(if equipped)

Switch (14) operates the large capacity airflow air conditioner blower.

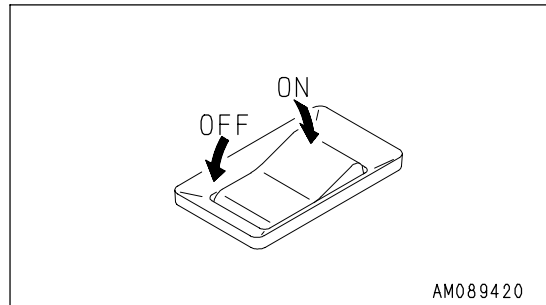

**Boom Shockless Control Switch**

This switch (13) controls the shaking of the work equipment when the boom is stopped.

Effect

- The shaking and spillage of load from the bucket is reduced.
- Operator fatigue is reduced when operating for long periods, so operations can be performed safely.

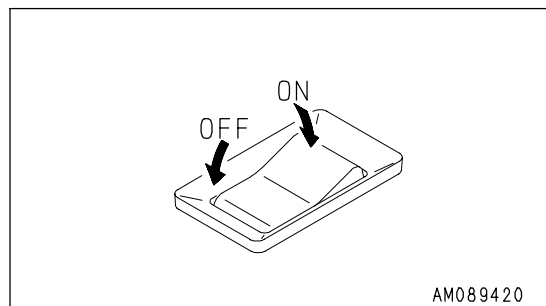

**REMARK**

- When the switch is at the ON position and the boom is stopped, the movement of the boom until it stops will increase slightly. Be careful when using this operation until you become accustomed to it.
- The boom drifts down and it is difficult to position it, so set this switch to the OFF position when carrying out operations with a raised load.

**Step Light Switch**

Use this switch (16) when getting off the machine at night.

- When the switch is pressed, the step light will light up for approx. 60 seconds.
- Even if the starting switch key is at the OFF position, the step light will light up for approx. 60 seconds when the switch is pressed.

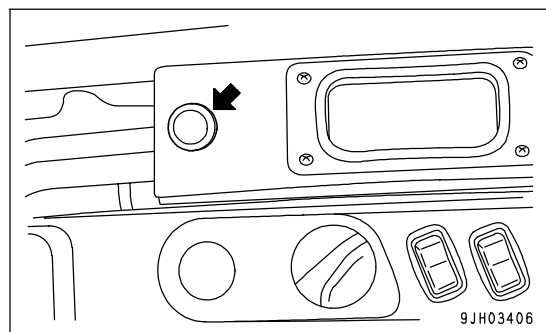

**CONTROL LEVERS AND PEDALS**

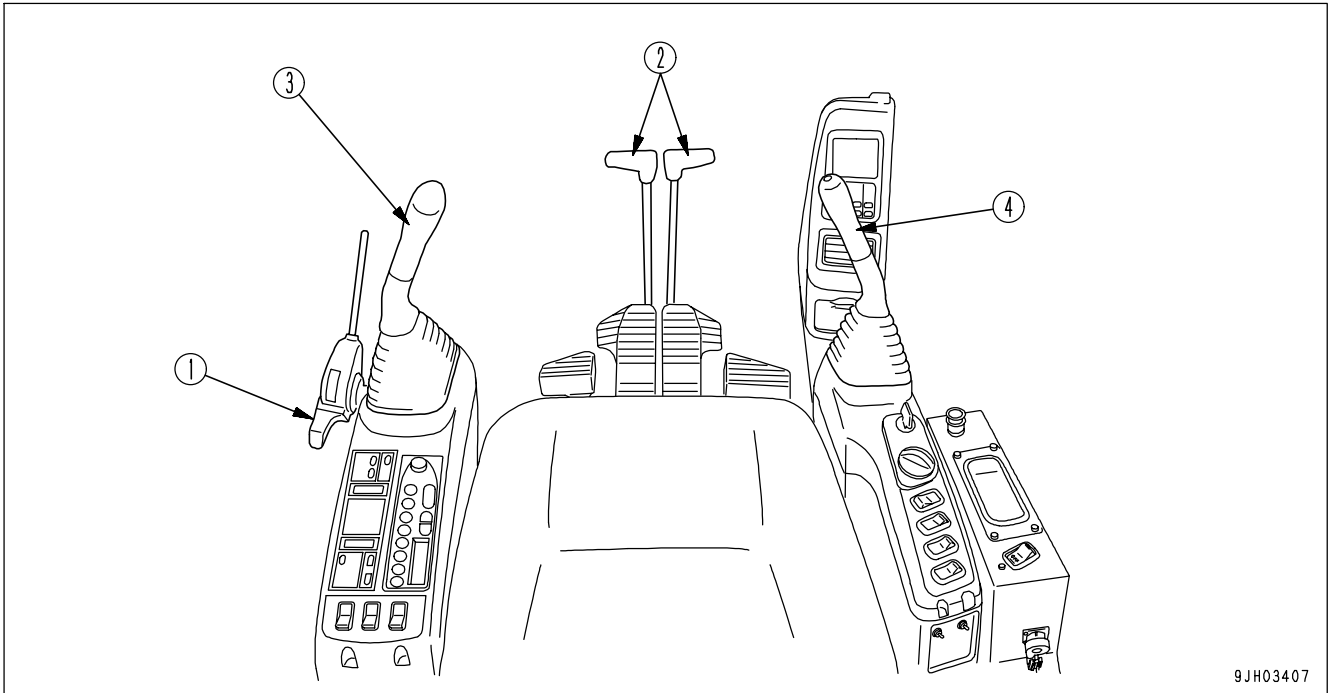

9JH03407

- (1) Safety lock lever
- (2) Travel levers (Machines with pedal and auto-deceleration device)
- (3) Left work equipment control lever (with auto-deceleration device)
- (4) Right work equipment control lever (with auto-deceleration device)

**Safety Lock Lever**



- When leaving the operator's compartment, set the safety lock lever securely to the LOCK position (L). If the safety lock lever is not at the LOCK position (L) and the control levers are touched by mistake, it may lead to serious personal injury.
- Check that the condition of the lever is as shown in the diagram.
- When pulling the safety lock lever up, be careful not to touch the work equipment control lever.  
When pushing the safety lock lever down, be careful not to touch the work equipment control lever.

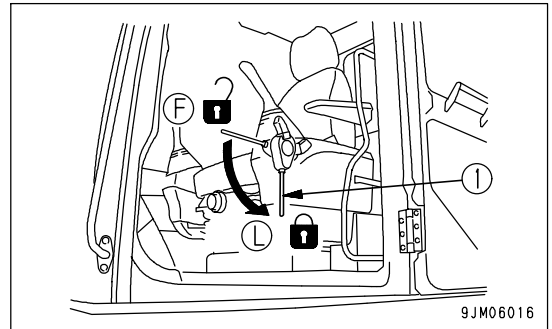

9JM06016

Lever (1) is a device to lock the work equipment, swing, travel, and attachment (if equipped) control levers. Push the lever down to apply the lock. This lock lever is a hydraulic lock, so even if it is in the lock position (L), the work equipment control lever and travel lever will move, but the work equipment, travel motor, and swing motor will not work.

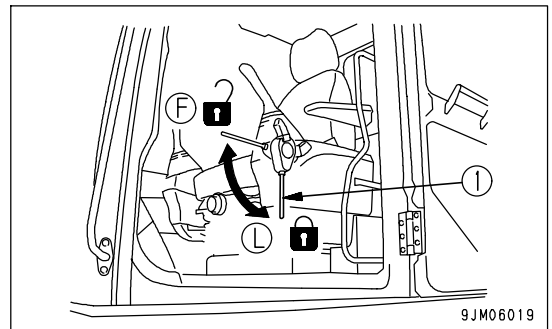

9JM06019

Travel Levers

**WARNING**

- Do not rest your foot on the pedal during operations. If the pedal is depressed by mistake, the machine may suddenly move and cause a serious accident. Be extremely careful when operating the pedal for travel or steering operations. When you are not using the pedal, do not rest your foot on it.
- If the track frame is facing the rear, the direction of travel operations will be reversed when the travel lever is operated. (The machine will travel forward when operated in reverse, and in reverse when operated forward; the left and right directions will also be reversed.)
- When operating the travel levers, check if the track frame is facing the front or the rear. (If the sprocket is at the rear, the track frame is facing the front.)

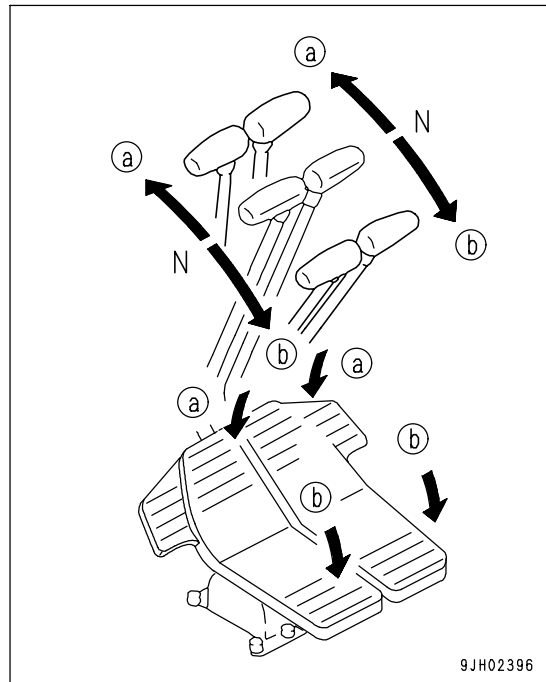

This lever (2) is used to change the direction of travel between forward and reverse. ( ) shows the pedal operation.

(a) FORWARD: The lever is pushed forward  
(The pedal is angled forward)

(b) REVERSE: The lever is pulled back  
(The pedal is angled back)

N (Neutral): The machine stops

**REMARK**

Machines equipped with travel alarm (If equipped)

If the lever is shifted to the forward or reverse position from the neutral position, the alarm sounds to warn that the machine is starting to move.

**Work Equipment Control Lever**

This left lever (3) is used to operate the arm and upper structure.

Arm operation

(A): Arm OUT

(B): Arm IN

Swing operation

(C): Swing to right

(D): Swing to left

N (Neutral): When the lever in this position, the upper structure and the arm will be retained in the position in which they stop.

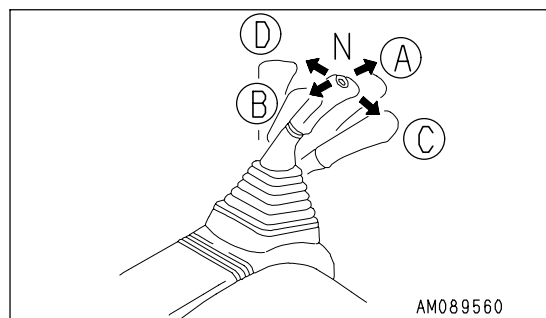

This right lever (4) is used to operate the boom and bucket.

Boom operation

(a): RAISE

(b): LOWER

Bucket operation

(c): DUMP

(d): CURL

N (Neutral): When the lever in this position, the boom and the bucket will be retained in the position in which they stop.

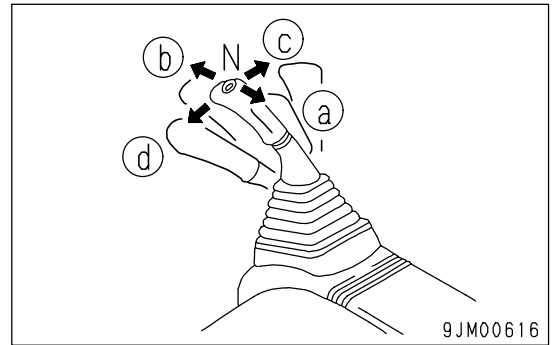

**EMERGENCY EXIT FROM OPERATOR'S CAB**

- If for some reason, the cab door does not open, remove the rear window and use it as an emergency escape.
- Remove the rear window as follows.
  1. Pull ring (1) and completely remove seal (2) from the rubber core.

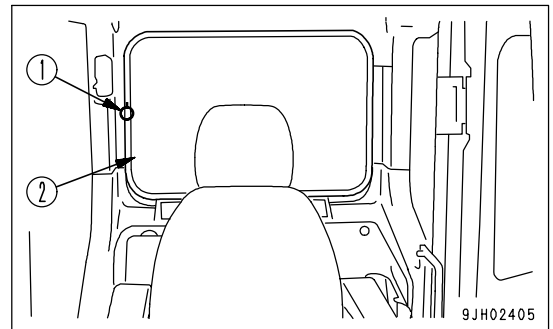

2. With pressure push on corner of the window, the glass will fall outside.

- Do not remove the rear window except when using it as an emergency exit.

**DOOR LOCK**

Use the door lock to fix the door in position after opening it.

1. Push the door against catch (1) to lock it in position.
2. When closing the door, push down the lever (2) on the left of the operator's seat to release the catch.
3. When attaching the door in position, lock it firmly to the catch.

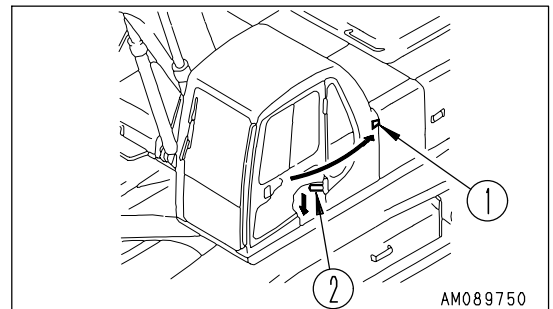

### CAP WITH LOCK

Use the starting switch key to open and close the locks on the caps and covers.

For details of the locations of the caps and covers with locks, see "LOCKING (PAGE 3-121)".

Insert the key as far as it will go to the shoulder. If the key is turned before it is inserted all the way, it may break.

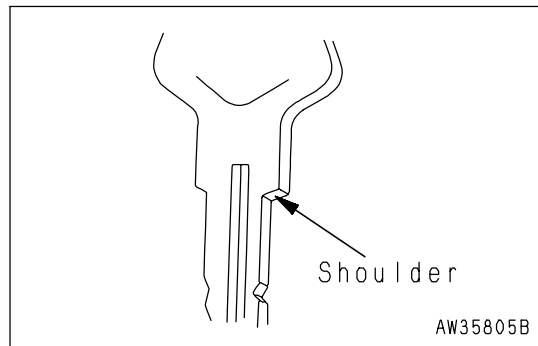

### Opening and Closing Caps with Lock

#### Opening the Cap

1. Insert the key into the key slot.
2. Turn the key clockwise (but, for the B type, turn counterclockwise), align the key slot with the match mark on the cap, then open the cap.

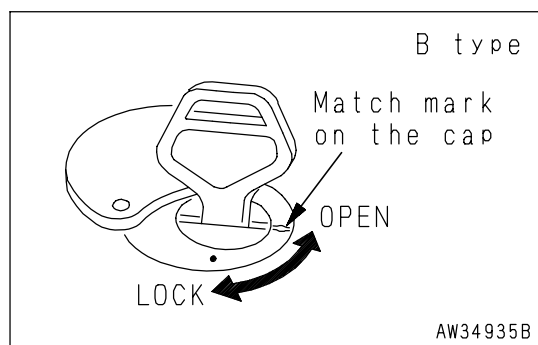
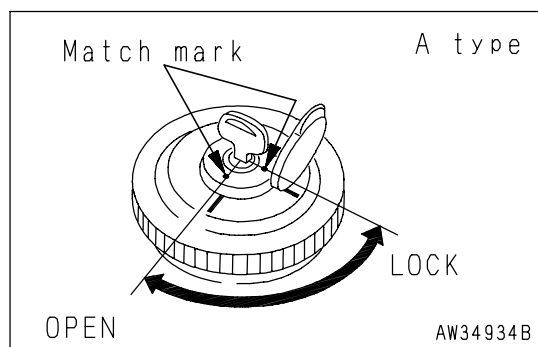

#### Locking the Cap

1. Turn the cap until tight, then insert the key into the key slot.
2. Turn the key counterclockwise (but, for the B type, turn clockwise) and take the key out.

### Opening and Closing Cover with Lock

#### Opening the Cover (Locked Cover)

1. Insert the key into the key slot.
2. Turn the key counterclockwise and open the cover by pulling the cover grip.

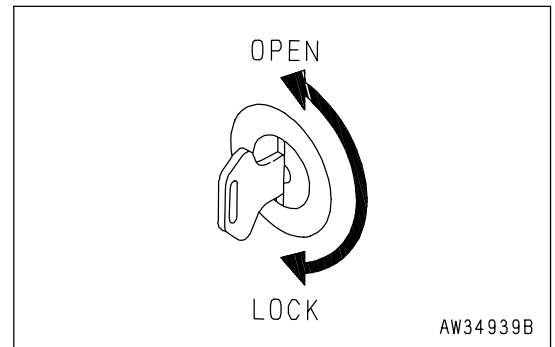

#### Locking the Cover

1. Close the cover and insert the key into the key slot.
2. Turn the key clockwise and take the key out.



**HOT AND COOL BOX**

Located on the right side at rear of the operator's seat. It is interconnected with the air conditioner. Box stays warm when the heater is used, and box stays cool when the air conditioning is used.

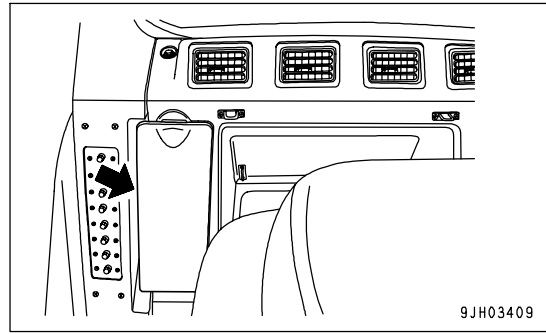

**MAGAZINE BOX**

(with cup holder)

Located on left side of the operator's seat. Keep the Operation and Maintenance Manual in this box so that it can be taken out and read whenever necessary.

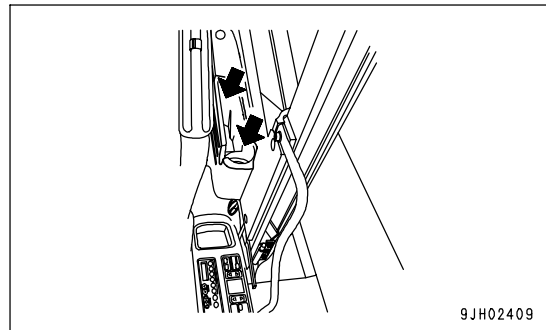

**ASHTRAY**

This is under the machine monitor at the front right of the operator's compartment.

Always make sure that you extinguish your cigarette, then put it in the ashtray and close the lid.

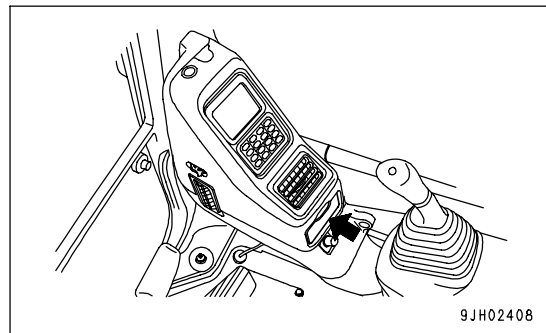

## AIR CONDITIONER CONTROLS

### Air Conditioner Control Panel

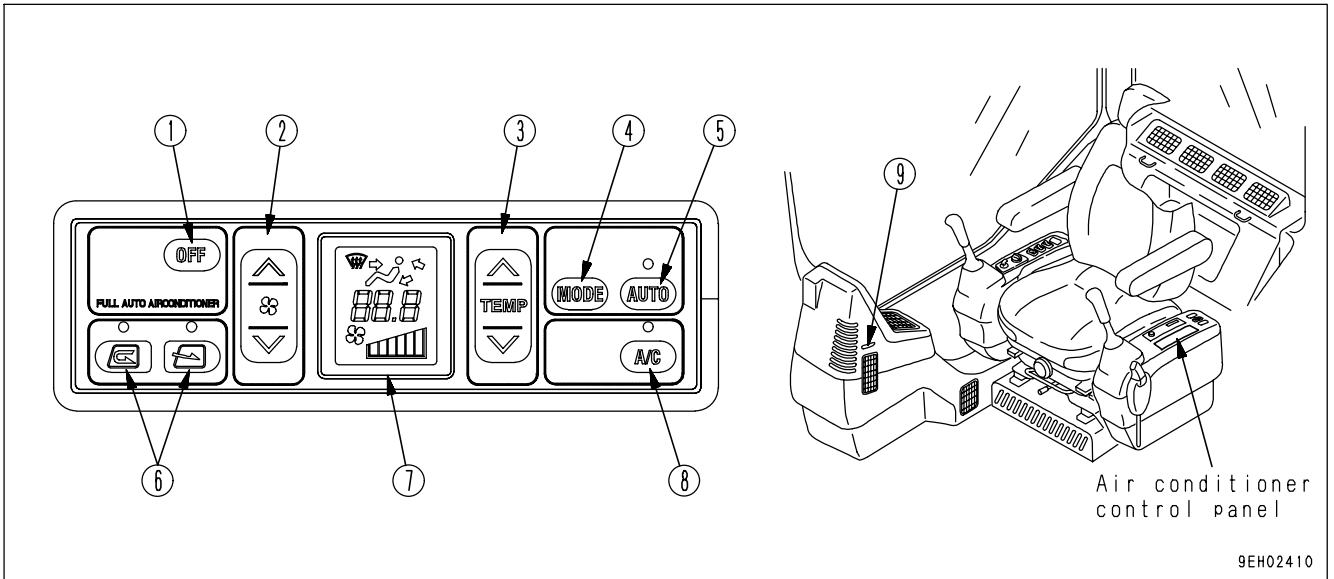

- |                                |                                  |
|--------------------------------|----------------------------------|
| (1) OFF switch                 | (6) FRESH/RECIRC selector switch |
| (2) Fan switch                 | (7) Display monitor              |
| (3) Temperature control switch | (8) Air conditioner switch       |
| (4) Vent selector switch       | (9) Defroster selector lever     |
| (5) Auto switch                |                                  |

#### OFF Switch

Switch (1) is used to stop the fan and air conditioner.

- When OFF switch (1) is pressed, the set temperature and air flow display on display monitor (7), the lamps above auto switch (5), and air conditioner (8) go out, and operation stops.



**Fan Switch**

Switch (2) is used to adjust the air flow.

The air flow can be adjusted to six levels.

- Press the ^ switch to increase the air flow; press the v switch to reduce the air flow.
- During auto operation, the air flow is automatically adjusted.

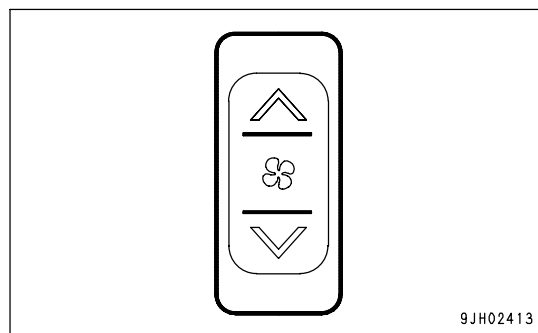

**<Monitor display and air flow>**

| Liquid crystal display | Air flow            |
|------------------------|---------------------|
|                        | Air flow "low"      |
|                        | Air flow "medium 1" |
|                        | Air flow "medium 2" |
|                        | Air flow "medium 3" |
|                        | Air flow "medium 4" |
|                        | Air flow "high"     |

**Temperature Control Switch**

Switch (3) is used to control temperature inside the cab. The temperature can be set between 18°C (64.4°F) and 32°C (89.6°F).

- Press the ^ switch to raise the set temperature; press the v switch to lower the set temperature.
- The temperature is generally set at 25°C (77°F).
- The temperature can be set in stages of 0.5°C (0.9°F).

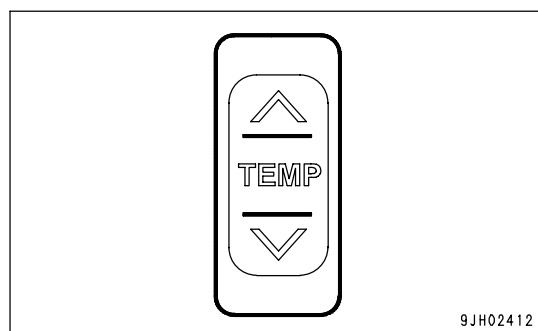

**<Monitor display and the function>**

| Monitor display °C | Set temperature                                   |
|--------------------|---|
| 18.0               | Max. cooling                                      |
| 18.5 to 31.5       | Adjusts temperature inside cab to set temperature |
| 32.0               | Max. heating                                      |

**Vent Selector Switch**

Switch (4) is used to select the vents.

- When switch (4) is pressed, the display on monitor display (7) switches and air blows out from the vents displayed.
- During automatic operation, the vents are automatically selected.

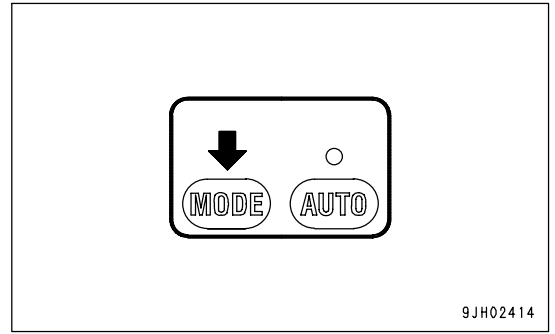

- (A): Rear vents (4 places)
- (B): Face vent (1 place)
- (C): Foot vent (1 place)
- (D1): Front window vent (1 place)
- (D2): Front window vent (1 place)

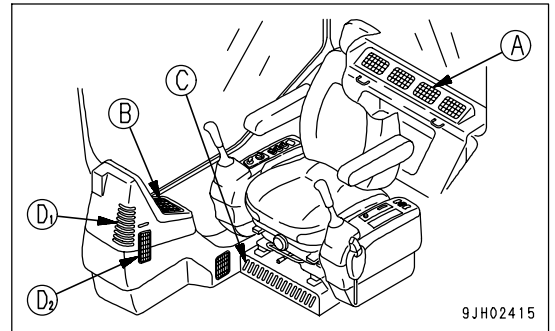

- Front window vent (D2) can be opened or closed by hand.

| Liquid crystal display | Vent mode  | Vent |     |     |     | Remarks                                    |
|------------------------|--|------|-----|-----|-----|--|
|                        |  | (A)  | (B) | (C) | (D) |  |
|                        | Front and rear vents (including defroster vent)        | ○    | ○   |     | (○) | —  |
|                        | Front, rear, and foot vents (including defroster vent) | ○    | ○   | ○   | (○) | —  |
|                        | Foot vent  |      |     | ○   |     | —  |
|                        | Front, foot vents (including defroster vent)           |      | ○   | ○   | (○) | Cannot be selected for automatic operation |
|                        | Front vents (including defroster vent)                 |      | ○   |     | (○) | Cannot be selected for automatic operation |

Note 1: Air blows out from vents marked ○

Note 2: The defroster vents can be opened or closed manually with the vent lever.

**Auto Switch**

With switch (5), the air flow, vents, and air source (RECIRC/FRESH) are automatically selected according to the set temperature.

- When auto switch (5) is pressed, the lamp above the auto switch lights up.
- Press switch (5), then use temperature control switch (3) to set the temperature, and run the air conditioner under automatic control.
- When the control is switched from automatic operation to manual operation, it is possible to operate the to change air flow, vents, and air source (RECIRC/FRESH). When manual control is used, lamp above the auto switch goes out.

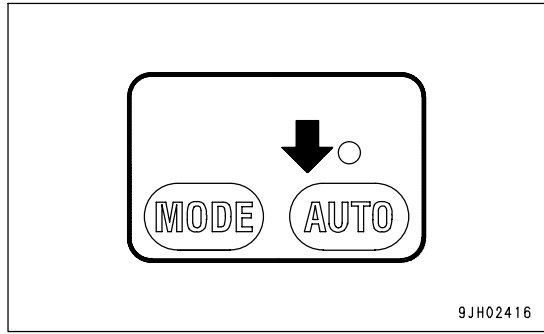

|        |  |
|--------|--|
| RECIRC | Outside air is shut off and only air inside the cab is circulated.<br>Use this setting to perform rapid cooling of the cab or when outside air is dirty. |
| FRESH  | Outside air is taken into the cab.<br>Use this setting to take in fresh air when performing demisting.   |

**FRESH/RECIRC Selector Switch**

Switch (6) is used to switch the air source between recirculation of the air inside the cab and intake of fresh air from the outside.

- When switch (6) is pressed, the lamp above the selector switch lights up to show that air is being blown out.
- During automatic operation, the selection of inside air (RECIRC) and outside air (FRESH) is performed automatically.

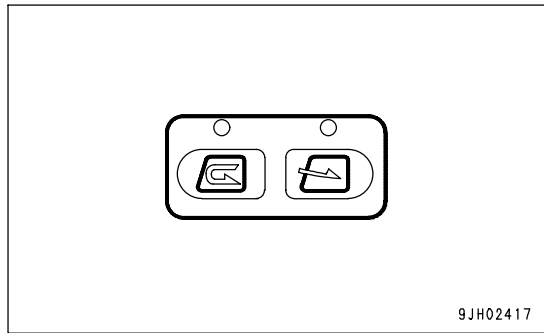

|        |  |
|--------|--|
| RECIRC | Outside air is shut off and only air inside the cab is circulated.<br>Use this setting to perform rapid cooling of the cab or when outside air is dirty. |
| FRESH  | Outside air is taken into the cab.<br>Use this setting to take in fresh air when performing demisting.   |

**Display Monitor**

Monitor (7) displays the status of temperature setting (a), air flow (b), and vents (c).

- When OFF switch (1) is pressed, the display of temperature setting (a) and air flow (b) goes out, and operation stops.

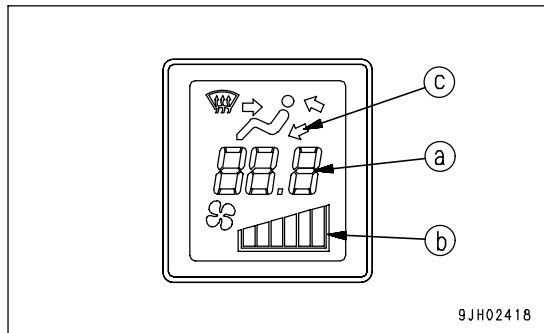

**Air Conditioner Switch**

Switch (8) is used to turn the air conditioner (cooling, dehumidifying, heating) ON or OFF.

- When the fan is actuated (display (b) is shown) and air conditioner switch (8) is pressed, the air conditioner is switched ON, lamp above the air conditioner switch lights up, and the air conditioner starts.

When switch (8) is pressed again, the air conditioner is switched OFF, lamp above the air conditioner switch goes out, and the air conditioner stops.

- Air conditioner cannot be operated while the fan is off.

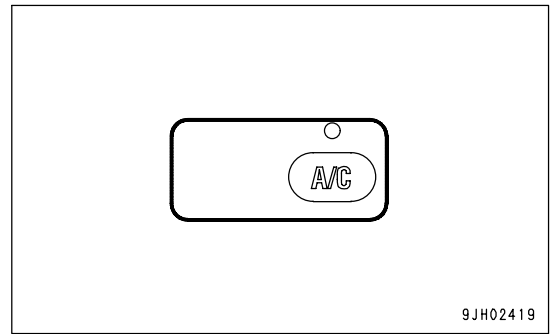

**Defroster Selector Lever**

This switch (9) is used in cold or rainy weather to remove the mist that forms on the front glass.

Selector lever forward: To defroster (open)

Selector lever back: Closed

The defroster can be used when the vent selector switch is set to face or face and foot.

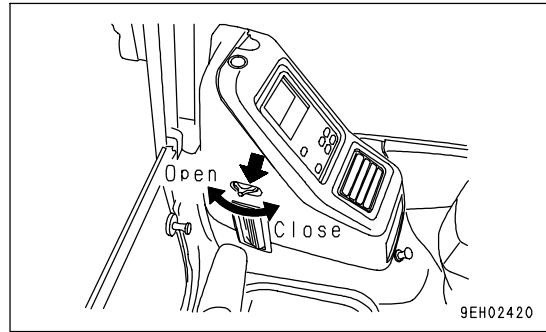

**Method of Operation**

The air conditioner can be operated automatically or manually. Select the method of operation as desired.

**Automatic Operation**

1. Turn auto switch (5) ON.
  - The lamp above switch (5) lights up.
  - The set temperature (a) and air flow (b) are displayed on the monitor.

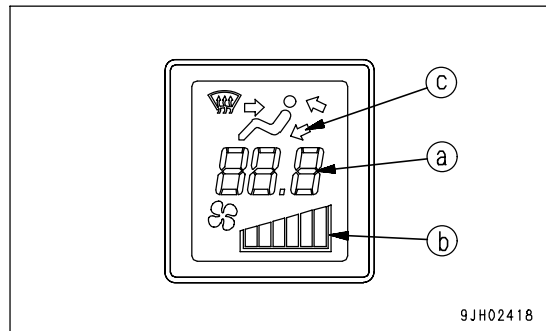
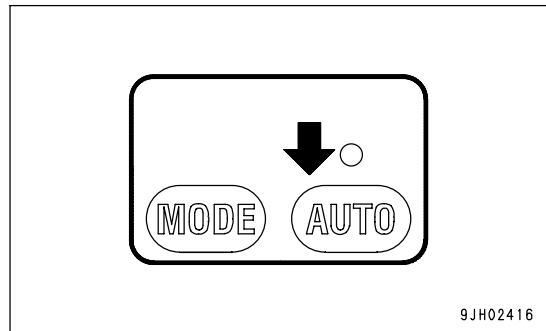

2. Use temperature set switch (3) to set to the desired temperature. The air flow, combination of vents, and selection of fresh or recirculated air is automatically selected according to the set temperature, and the air conditioner is operated automatically to provide the set temperature.

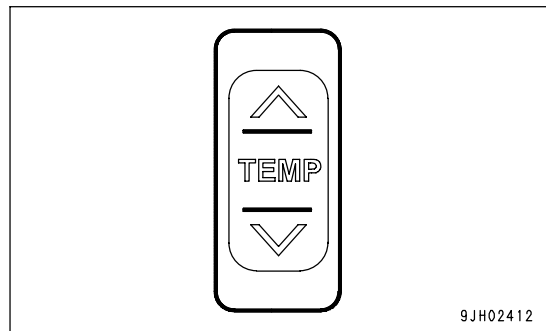

**REMARK**

When vent display monitor (c) displays (d) or (e), and engine coolant temperature is low, the air flow is automatically limited to prevent cold air from blowing out.

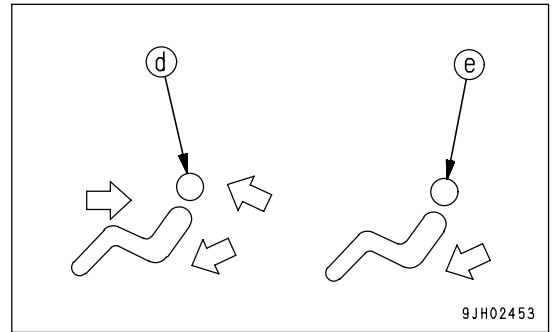

**Stopping Automatic Operation**

Press OFF switch (1). The displays for temperature setting (a) and air flow (b) on monitor (7), and lamps above auto switch (5) and air conditioner switch (8) go out, the operation stops.



**Manual Operation**

1. Press fan switch (2) and adjust the air flow. When doing this, check that temperature setting (a) and air flow (b) are displayed on monitor (7).

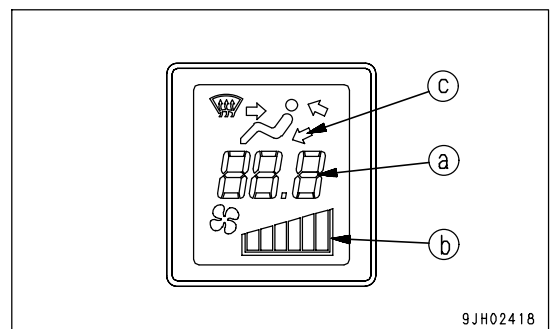
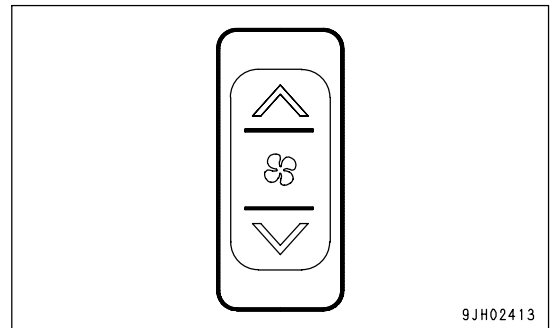



2. Turn air conditioner switch (8) ON. Check that the lamp above air conditioner switch lights up.

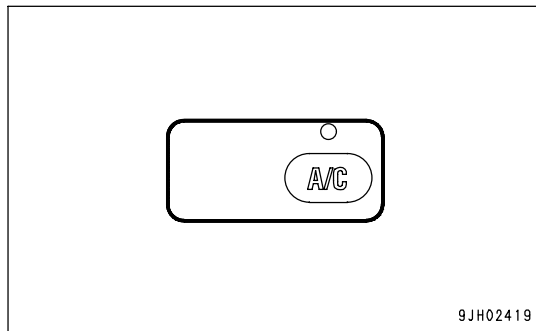

3. Press temperature setting switch (3) and adjust temperature inside the cab.

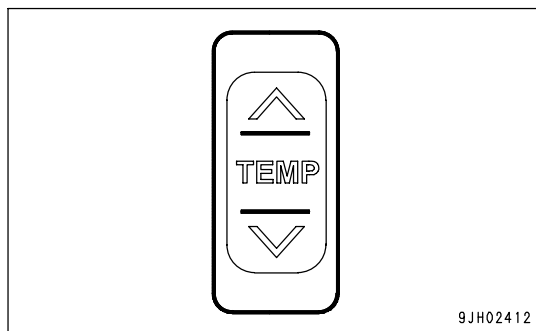

4. Press vent selector switch (4) and select the desired vents. When this is done, the display for vent (c) of the display monitor changes according to the selection.

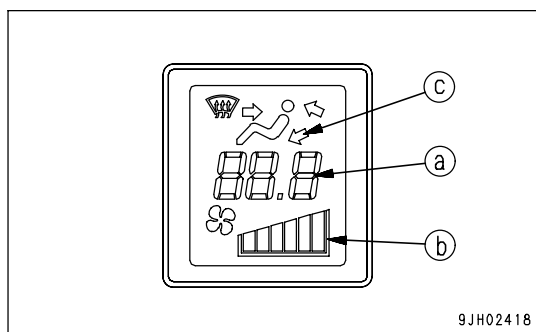
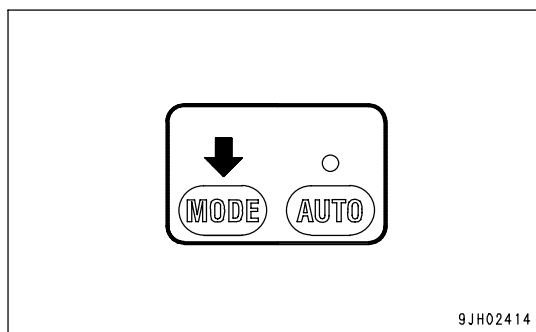

5. Press RECIRC/FRESH selector switch (6) and select recirculation of the air inside the cab (RECIRC) or intake of fresh air from outside (FRESH).

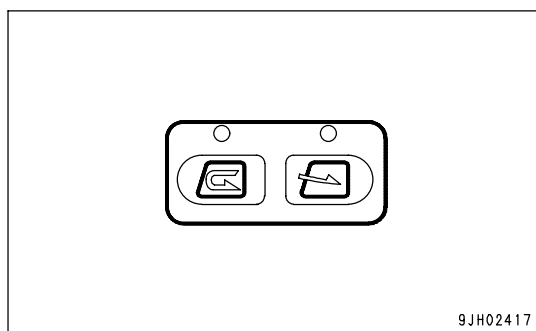

**Stopping Manual Operation**

Press OFF switch (1). The displays for temperature setting (a) and air flow (b) on monitor (7), and lamps above auto switch (5) and air conditioner switch (8) go out, the operation stops.



**Operation with Cold Air to Face and Warm Air to Feet**

To operate with cold air blowing to the face and warm air blowing to the feet, set as follows.

1. Press fan switch (2) and adjust the air flow. When doing this, check that temperature setting (a) and air flow (b) are displayed on monitor (7).

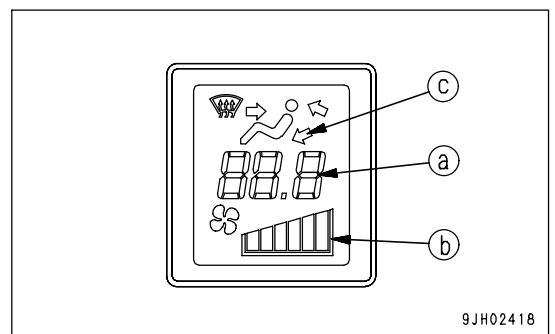
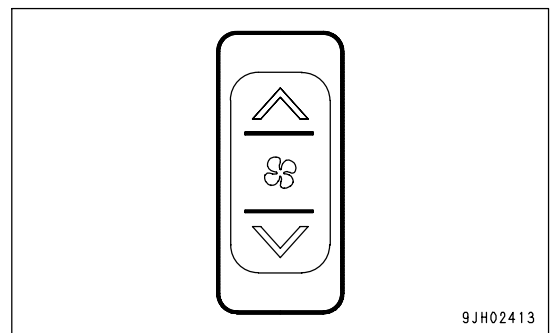

2. Press vent selector switch (4) and set the vent display on the display monitor to the display shown in the diagram on the right.

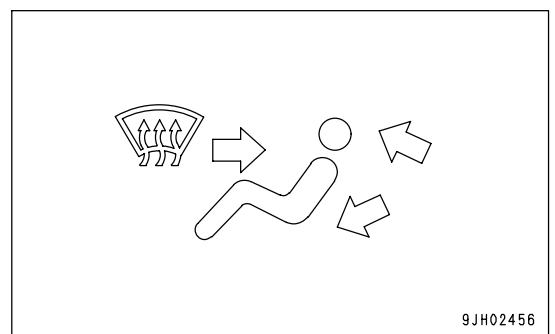

3. Turn air conditioner switch (8) ON. Check that the lamp above air conditioner switch lights up.

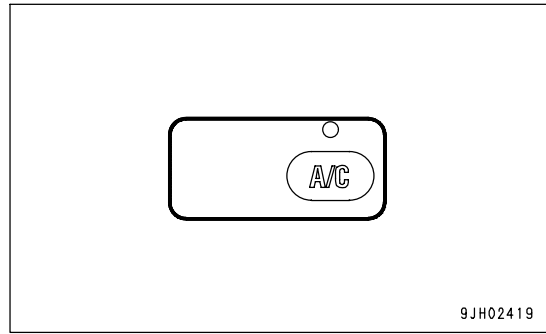

4. Adjust fan switch (2), temperature setting switch (3) and RECIRC/FRESH selector switch (6) to the desired positions.

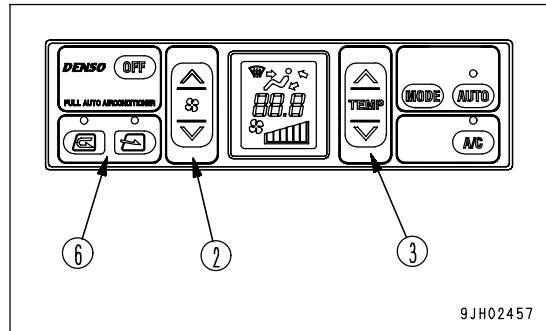

**Defroster Operation**

1. Press fan switch (2) and adjust the air flow. When doing this, check that temperature setting (a) and air flow (b) are displayed on monitor (7).

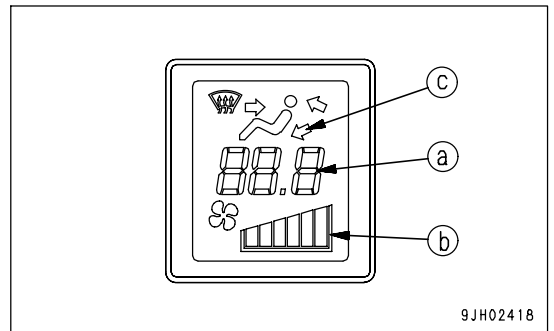
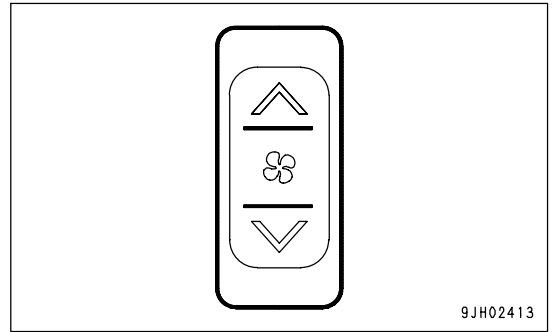

2. Press vent selector switch (4) and set vent display on the display monitor to (f) or (g) as shown in diagram on the right.

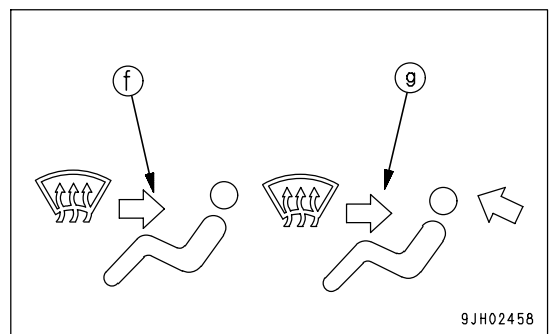
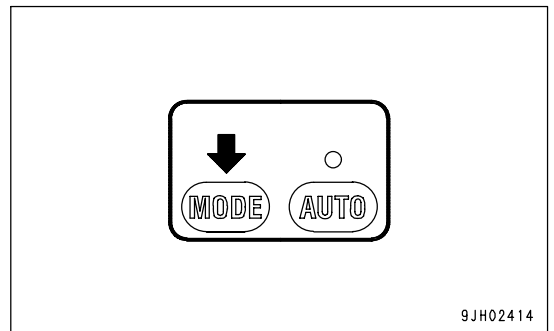

3. Press RECIRC/FRESH selector switch (6) and set it to take in fresh air.

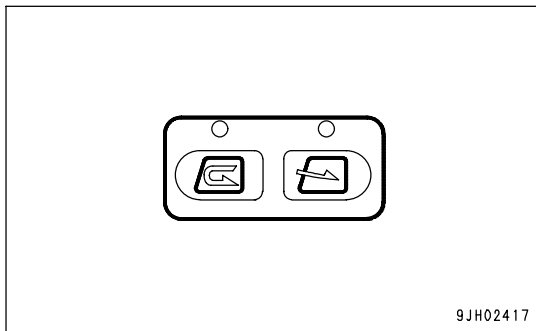

4. Press temperature setting switch (3) and set temperature on the display (7) monitor to maximum heating.

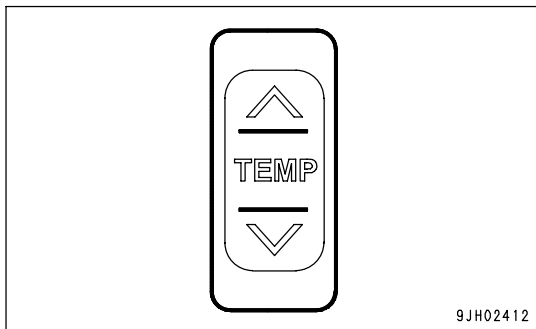

5. Adjust vents (A), (B), and (D2) so air blows onto the window glass.  
(Vents (C) and (D1) are fixed and cannot be adjusted.)

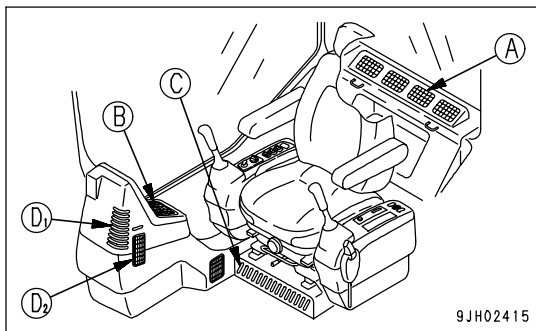

When operating in the rainy season or when it is desired to remove the mist from the window glass or to dehumidify the air, turn air conditioner switch (8) ON.

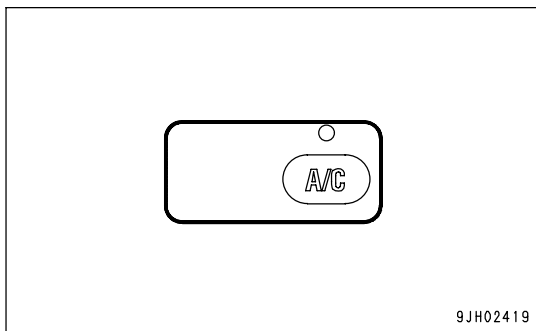

## Use Air Conditioner with Care

### NOTICE

- When running the air conditioner, always start with the engine running at low speed. Never start the air conditioner when the engine is running at high speed. It will cause failure of the air conditioner.
- If water gets into the control panel or sunlight sensor, it may lead to unexpected failure, be careful not to let water get on these parts. In addition, never bring any flame near these parts.
- For the auto function of the air conditioner to work properly, always keep the sunlight sensor clean and do not leave anything around the sunlight sensor that may interfere with its sensor function.

### Ventilation

- If you smoke when the air conditioner is on, the smoke may start to hurt your eyes, so open the window and turn the lever to FRESH for a while to remove the smoke while continuing the cooling.

When running the air conditioner for a long time, turn the lever to the FRESH position once an hour to carry out ventilation and cooling.

### Temperature Control

When the cooler is on, set the temperature so that it feels slightly cool when entering the cab (5 or 6 °C (9 or 10.8 °F) lower than the outside temperature). This temperature difference is considered to be the most suitable for your health, so always be careful to adjust the temperature properly.

### Other Functions

#### Self-diagnostic Function

It is possible to perform troubleshooting of various sensors and equipment used on the air conditioner.

1. Press OFF switch (1). The temperature setting and air flow display on the liquid crystal display portion go out and operation stops.
2. If the "v" and "^" parts of temperature setting switch (3) are kept pressed at the same time for at least 3 seconds, the troubleshooting mode is displayed on the liquid crystal display portion.

<Monitor display and failure mode>

| Display | Failure mode                                |
|---------|---|
| E--     | No failure                                  |
| E11     | Disconnection in recirculated air sensor    |
| E12     | Short circuit in recirculated air sensor    |
| E13     | Disconnection in fresh air sensor           |
| E14     | Short circuit in fresh air sensor           |
| E15     | Disconnection in coolant temperature sensor |
| E16     | Short circuit in coolant temperature sensor |
| E18     | Short circuit in sunlight sensor            |
| E21     | Disconnection in vent sensor                |
| E22     | Short circuit in vent sensor                |
| E43     | Problem in vent damper                      |
| E44     | Problem in air mix damper                   |
| E45     | Problem in RECIRC/FRESH air damper          |
| E51     | Problem in refrigerant pressure             |

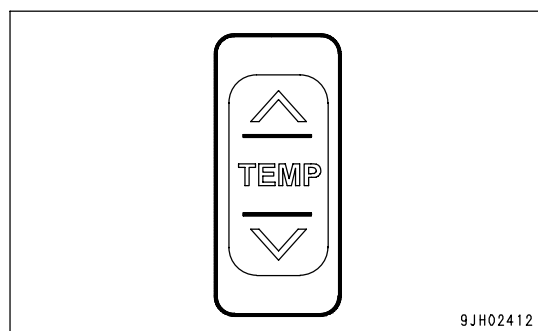
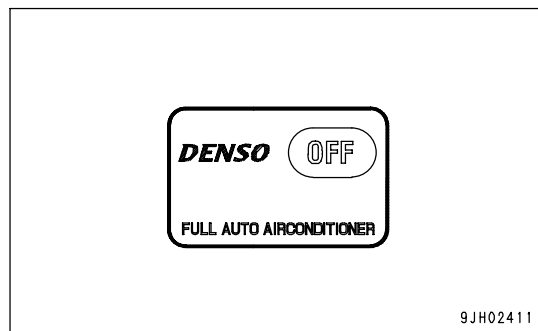

**Function to Switch Set Temperature Display Between Fahrenheit and Celsius**

It is possible to switch the set temperature display between °F and °C.

If the "∨" and "∧" portions of temperature setting switch (3) are pressed at the same time for more than 5 seconds while the fan is running, the temperature display will switch between °F and °C. (Note that the unit is not displayed.)

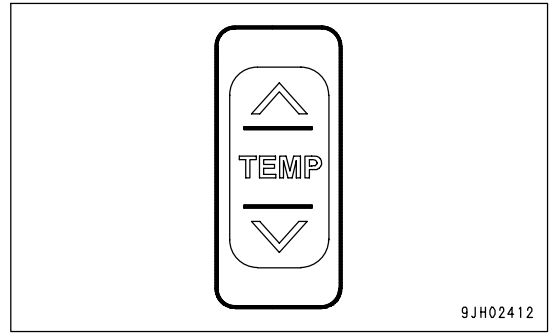

|    | Liquid crystal display range |
|----|------------------------------|
| °C | 18.0 to 32.0                 |
| °F | 63 to 91                     |



# RADIO

## Control Panel

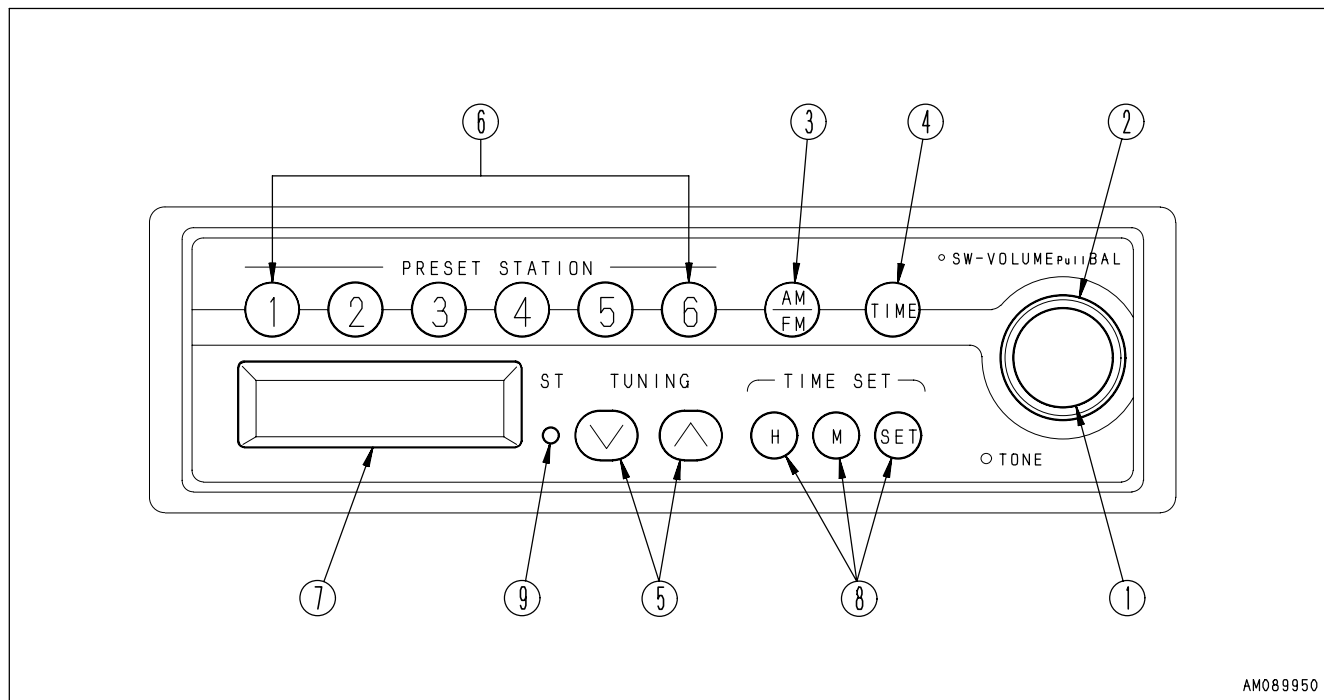

- |   |                            |
|---|----------------------------|
| (1) Power switch/Volume control knob/Balance knob | (6) Preset buttons         |
| (2) Tone control knob                             | (7) Display                |
| (3) FM/AM selector button                         | (8) Time connection button |
| (4) Display selector button                       | (9) Stereo indicator       |
| (5) Manual tuning                                 |                            |

### Power Switch/Volume Control (SW-VOLUME) and Balance (Pull BAL) Knob

Press this knob (1) to turn the power for the radio on. The frequency is displayed on display (7). Press again to turn the power off.

Turn the knob to adjust the volume as follows.

Turn CLOCKWISE to INCREASE volume

Turn COUNTERCLOCKWISE to REDUCE volume

If the knob is pulled until it locks, it can be turned to the left or right to adjust the balance of the left and right speakers.

Turn CLOCKWISE to increase volume from RIGHT speaker

Turn COUNTERCLOCKWISE to increase volume from LEFT speaker

After adjusting the left and right balance, press lightly to return the knob to its original position. (If it is left pulled out, the overall volume cannot be adjusted.)

### Tone Control Knob (TONE)

Turn the knob (2) to adjust the tone as follows.

Turn CLOCKWISE to emphasize the high sounds.

Turn COUNTERCLOCKWISE to suppress the high sounds.

### FM/AM Selection Button (AM/FM)

Press button (3) to select the desired band.

Each time the button is pressed, it switches AM -> FM -> AM ...

**Display Selection Button (TIME)**

The radio gives priority to the frequency display. If button (4) is pressed when the frequency is displayed, display will give the present time for 5 seconds. After 5 seconds pass, display will automatically return the frequency display. If any button other than TIME SET (H, M, SET) is pressed within the 5 seconds, display will return to the frequency display.

**Tuning Button (TUNING)**

Use this buttons (5) to change the frequency.

For further details, see "Method of Tuning (PAGE 3-58)"

**Preset Station Buttons (1, 2, 3, 4, 5, 6)**

If these buttons (6) are set to the frequency of the desired broadcasting station, the station can be selected at a touch.

For details of the method of presetting, see "Method of Setting with Preset Button (PAGE 3-58)".

**Display**

This display (7) shows the reception band, frequency, preset No., and time.

**Time Reset Button**

Button (8) is used to set the correct time.

H: Hour

M: Minute

SET: Sets to start of hour (00 minutes)

**Stereo Indicator (ST)**

This lamp (9) lights up when a stereo broadcast is picked up when receiving an FM broadcasting station.

## Controls of Radio

### Method of Setting with Preset Button

1. Press power switch (1) and display the frequency on display (7).
2. Turn the tuning button (5) (manual, auto) to adjust to the desired frequency.
3. Select a preset button to use for recording the frequency setting, and keep that button pressed for at least 1.5 seconds. The sound will disappear, but when the setting is recorded, the sound will appear and the preset number will appear on display (7) to show that the station has been preset.

After completion of presetting, press preset button (6), and release it within approx. 1.5 seconds. The setting will change to the frequency of the broadcasting station recorded for that button. One AM station and one FM station can be recorded for each preset button.

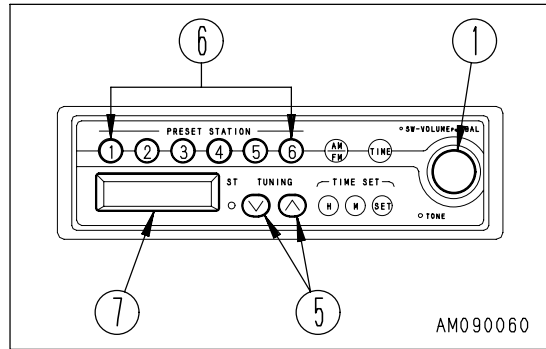

### Method of Tuning

1. Press power switch (1) and display the frequency on display (7).
2. Use tuning button (5) to set to the desired frequency. There are two methods for tuning: auto tuning and manual tuning.

- Manual tuning

Press tuning button (5) and set to the desired frequency.

Each time the button is pressed, the frequency will move up or down in steps of 9 kHz (AM) or 0.1 MHz (FM).

∨ button: Move to a lower frequency station

∧ button: Move to a higher frequency station

When the frequency reaches the top or bottom frequency, it automatically continues as follows: Top → Bottom, or Bottom → Top.

- Auto tuning

Keep tuning button (5) pressed for at least 0.5 seconds. When a broadcasting station is picked up, it will automatically stop. To search for the next station, press tuning button (5) again for at least 0.5 seconds.

∨ button: Move to a lower frequency station

∧ button: Move to a higher frequency station

If this button is pressed during auto tuning, the auto tuning will be cancelled and the setting will return to the frequency in use before the button was pressed.

### Setting Correct Time

1. Press display selector button (4) to display the time.

After 5 seconds, the display will return to the frequency display and the time cannot be corrected. If this happens, press display selector button (4) again.

2. Press time adjustment button (8) and adjust the hour and minute.

H button: Adjusts hour (advances one hour each time it is pressed)

M button: Adjusts minute (advances one minute each time it is pressed)

If the H or M button are kept pressed, the time will advance continuously until the button is released.

SET button: Every time SET button is depressed, hour and minute are reset in the following manner.

If the minute display is between 0 and 05, the minute reading will return to 00.

If the minute display is between 55 and 59, the minute display will return to 00 and the hour will advance by

If the minute display is between 06 and 54, no resetting can be made.

Example:

10:05 → 10:00

10:59 → 11:00

10:26 → 10:26

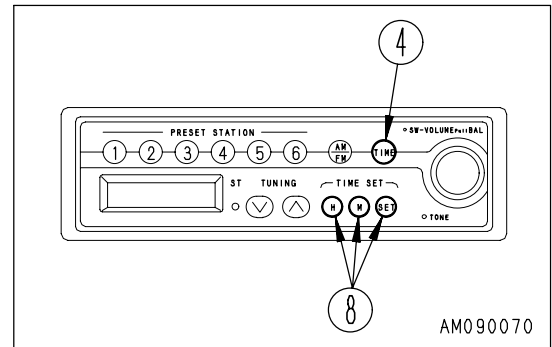

### Antenna

#### NOTICE

Before transporting the machine or putting it inside a building, stored the antenna to prevent any interference.

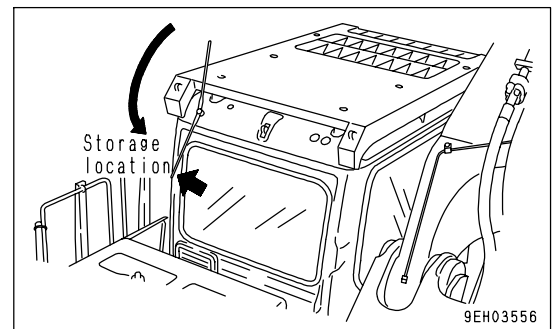

### Use Radio with Care

- To ensure safety, always keep the sound to a level where it is possible to hear outside sounds during operation.
- If water gets into the speaker case or radio, it may lead to an unexpected failure, so be careful not to get water on the equipment.
- Do not wipe the scales or buttons with solvent such as benzene or thinner. Wipe with a dry soft cloth. If the dirt cannot be removed easily, soak the cloth with alcohol.
- When the battery is replaced, the settings for the preset buttons are all cleared, so set them again.

## AUXILIARY ELECTRIC POWER

### 24V Power Source

#### NOTICE

Do not use this as the power supply for 12V equipment.  
It will cause failure of the equipment.

Pull out the connector plug for taking out electric power from the rear side of the panel.

Maximum usable electric power is 85 W (24 V x 3.5 A).

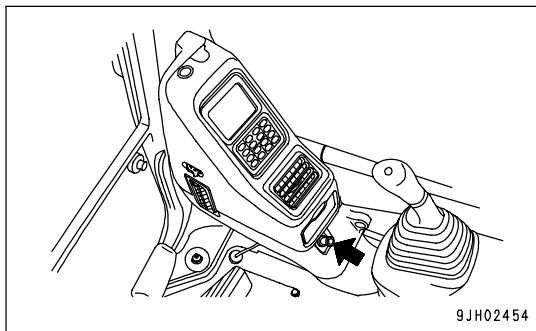

### 12V Power Source

(If equipped)

This power source can be used up to a capacity of 60W (12V x 5A).

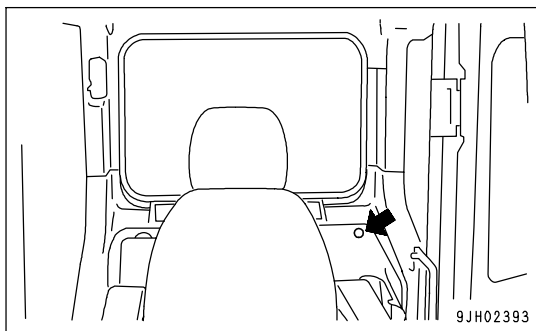

**FUSE**

**NOTICE**

Before replacing a fuse, be sure to turn off the starting switch.

The fuses protect the electrical equipment and wiring from burning out.

If the fuse becomes corroded, or white powder can be seen, or the fuse is loose in the fuse holder, replace the fuse.

Replace the fuse with another of the same capacity.

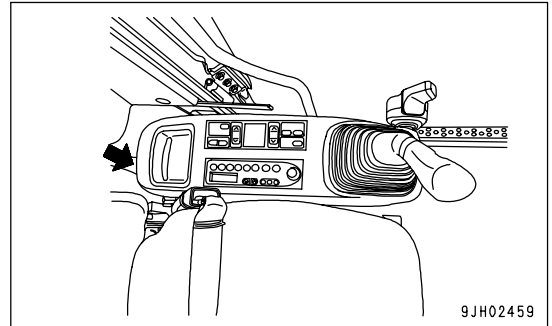

**Fuse Capacities and Circuit Names**

| No.  | Fuse capacity | Circuit                                   |
|------|---------------|---|
| (1)  | 10A           | Prolix circuit                            |
| (2)  | 10A           | Solenoid valve                            |
| (3)  | 10A           | PPC hydraulic lock solenoid               |
| (4)  | 20A           | Window washer, cigarette lighter          |
| (5)  | 10A           | Horn, flash lamp light (if equipped)      |
| (6)  | 10A           | Auto greasing system (if equipped)        |
| (7)  | 10A           | Rotating lamp (if equipped)               |
| (8)  | 10A           | Spare                                     |
| (9)  | 10A           | Radio                                     |
| (10) | 10A           | Spare                                     |
| (11) | 25A           | Air conditioner unit                      |
| (12) | 20A           | VHMS (if equipped)                        |
| (13) | 20A           | Spare                                     |
| (14) | 10A           | Optional power source (1)                 |
| (15) | 10A           | Optional power source (2), 12V power port |
| (16) | 10A           | Radio backup                              |
| (17) | 10A           | network pass (direct from battery)        |
| (18) | 20A           | VHMS (if equipped)(direct from battery)   |
| (19) | 10A           | Room lamp                                 |
| (20) | 10A           | Step light                                |

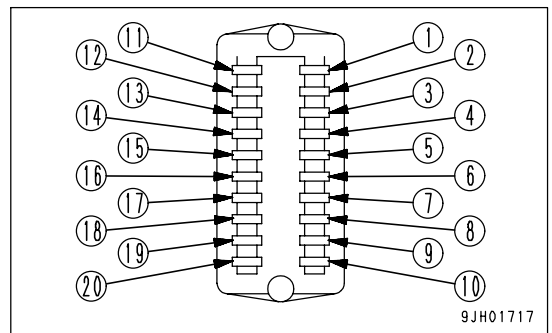

## CIRCUIT BREAKER

### NOTICE

When resetting the circuit breaker, always turn the starting switch OFF first.

- If the starting switch does not work even when the starting switch is turned ON, open the circuit breaker box inside the grease pump box at the front right of the machine and carry out inspection.
- If an excess current is generated, the circuit breaker cuts off electrical current to protect electrical components and wiring from damage. To return the circuit electrical current to normal after it has been cut off, push in the reset button.  
If the electric circuit is working normally, the reset button remains in. If the reset button pops out again immediately after it is pushed in, it is necessary to check the electric circuit.

### REMARK

- The circuit breaker is a circuit protection device installed to circuits where large current flows. It protects the electrical components and wiring from damage caused by an abnormal current in the same way as a normal fuse. After repairing and restoring the location of the abnormality, there is no need to replace the breaker. It can be used again.
- If the starting motor does not work even when the starting switch is turned to the ON position, breaker (8), (9) has probably cut off the circuit, so check and restore circuit breaker (8), (9).
- If the electrical equipment does not work even when the fuse is replaced, breaker (1) or (11) has probably cut off the circuit, so check and restore circuit breaker (1) or (11).

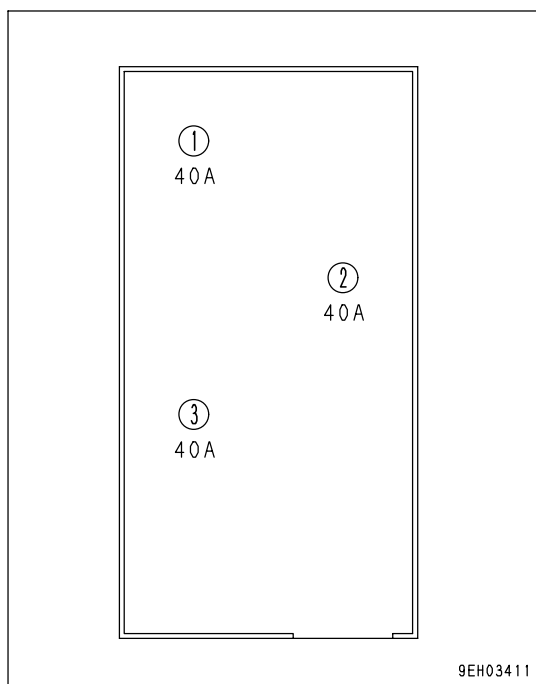
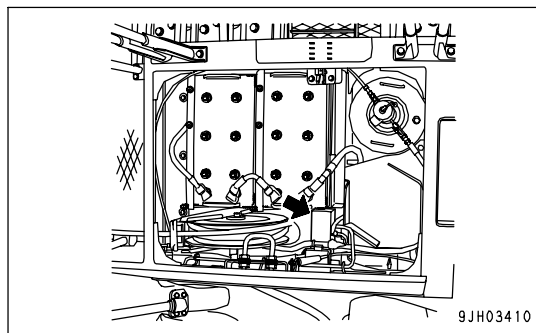

| No. | Fuse capacity | Circuit name               |
|-----|---------------|----------------------------|
| (1) | 40A           | Fuse box                   |
| (2) | 40A           | Circuit breaker No. 4 - 7  |
| (3) | 40A           | Circuit breaker No. 8 - 11 |

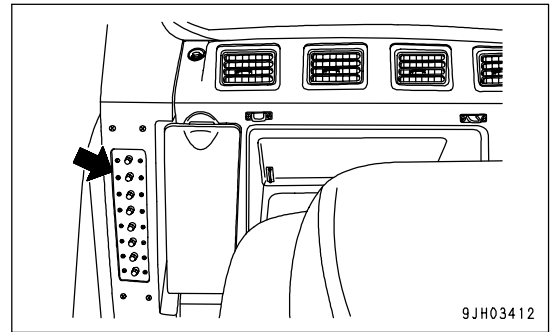

| No.  | Fuse capacity | Name of circuit                            |
|------|---------------|--|
| (4)  | 20A           | Monitor                                    |
| (5)  | 20A           | Working lamp, right front light of machine |
| (6)  | 20A           | Pump controller                            |
| (7)  | 20A           | Cab upper head lamp                        |
| (8)  | 20A           | Starting switch                            |
| (9)  | 20A           | Engine controller (direct from battery)    |
| (10) | 20A           | Monitor (direct from battery)              |
| (11) | 20A           | Fuse box (direct from battery)             |

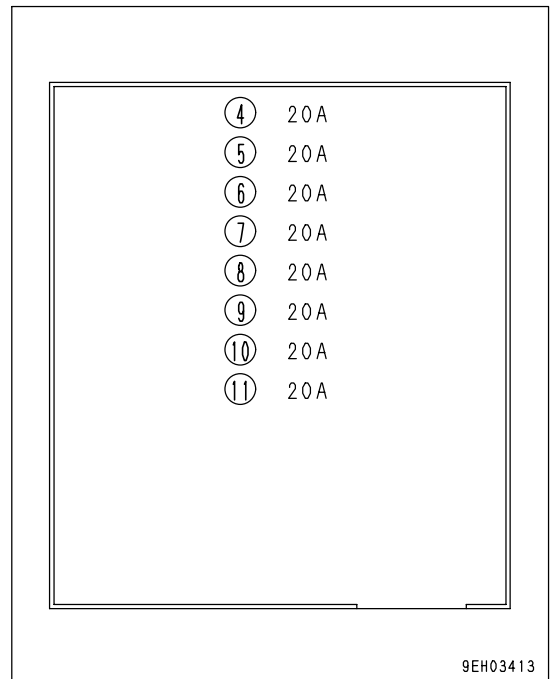



## CONTROLLER

Controller installed.

### NOTICE

- Do not let water, mud, or juice spill on the controller. This will cause failures.
- If any problem occurs in the controller, do not repair it by yourself. Please contact your Komatsu distributor for repairs.

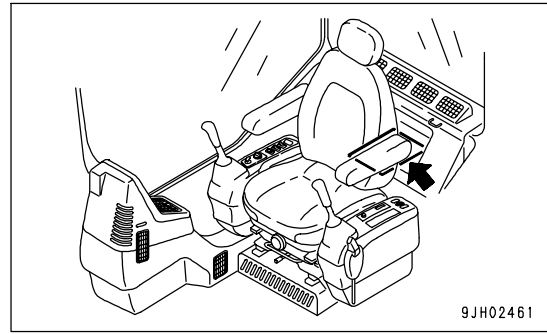

## TOOL BOX

(Cloth bag)

This is inside the storage box inside the cover (1) on the left side at the rear of the cab.

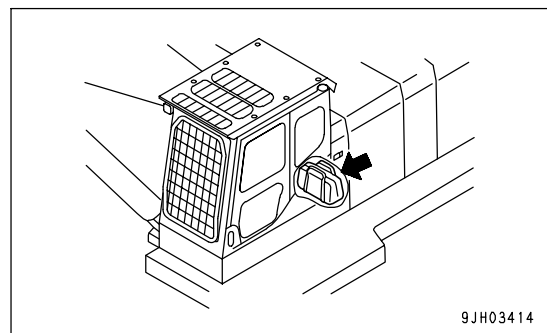

## GREASE PUMP

This is stored inside the grease pump box on the right side of the chassis.

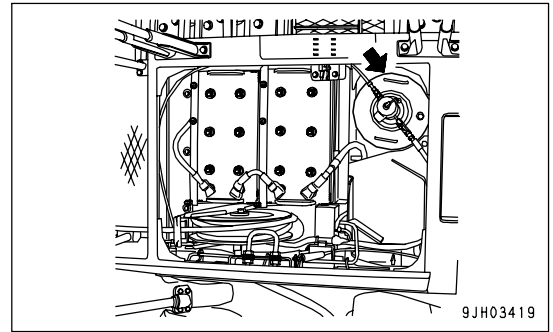

### Method of Use

1. Open cover (1).
2. Rotate the lever of valve (2) upward 90° to set it to the (A) position.
3. When the lever of grease gun (3) is pulled, grease is discharged and the pump also starts automatically.
4. When the lever of grease gun (3) is released, the supply of grease stops.
5. After using, rotate the lever of valve (2) downward 90° to set it to the (B) position.

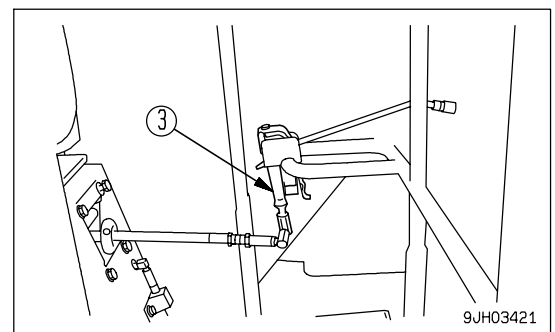
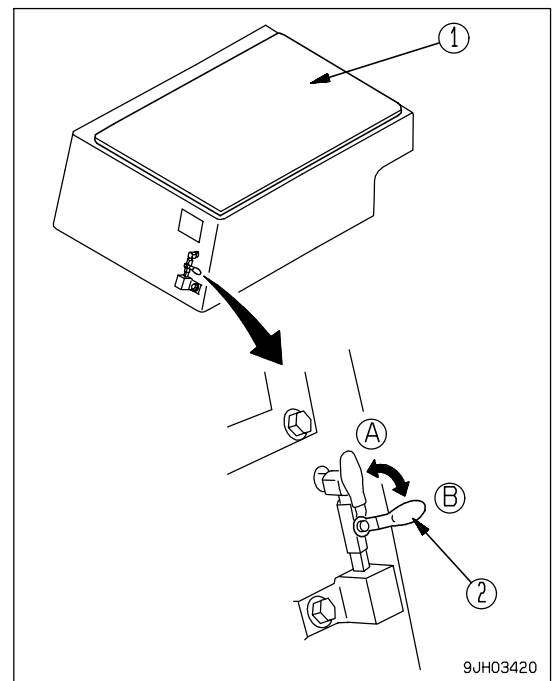

**Precautions when Using**

**NOTICE**

When not using the grease pump, always rotate the lever of valve (2) down 90° to set it to the (B) position to prevent internal pressure from forming inside grease gun (3).

- Set so that the grease fitting and the nozzle at the tip of the grease gun are perpendicular.

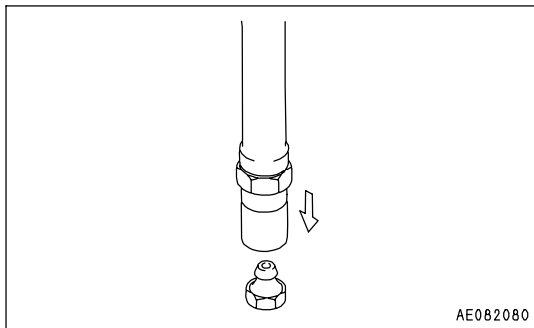

- When removing the nozzle at the tip of the grease gun from the nipple, carefully angle the tip of the nozzle slightly and remove it.
- When there is only a small amount of grease left in the grease can, the pump will not pump out grease, so move the grease to the center or fill the can with new grease.

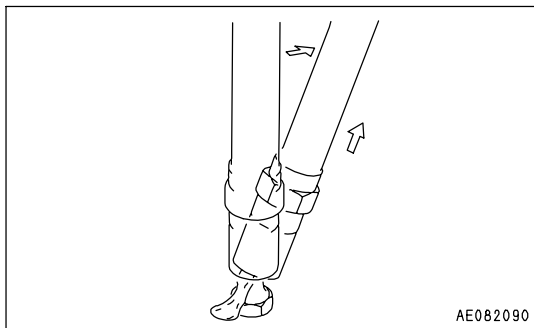

**Supplying Grease**

1. Remove 3 wing bolts (2) from grease can (1), then remove cover (3) from the pump.
2. Remove follow plate (4) inside the grease can.

**REMARK**

If the hollow in the center of the follow plate is not fully filled with grease, air will be sucked in and it may not be possible to use all the grease.

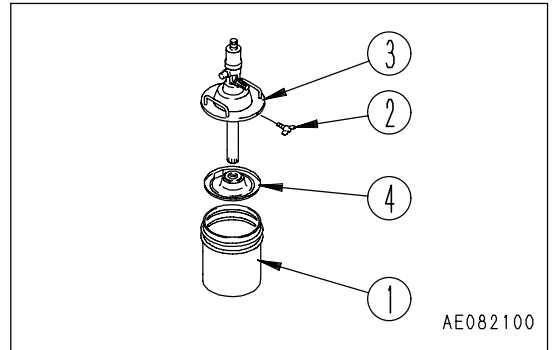

3. Fill grease can (1) with new grease, then set follow plate (4) on top of the grease.
  - Fill the hollow in the center of the follow plate with grease before setting the following plate on top of the grease.
4. Insert the pump into the packing at the center of follow plate (4), set cover (3) on grease can (1), then tighten 3 wing bolts (2) uniformly to hold in position.
  - The pump will operate for a short time and then stop, but the first grease includes air inside the pump, so it is cloudy white and not suitable for use.
5. Loosen check valve (5), and pump out all the grease which has air in it from hole (6) at the bottom of check valve (5).
6. After bleeding the air, close check valve (5) securely.

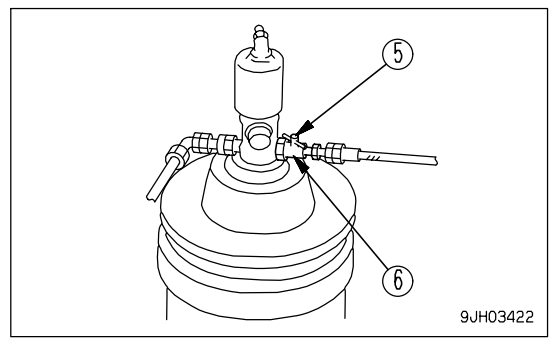
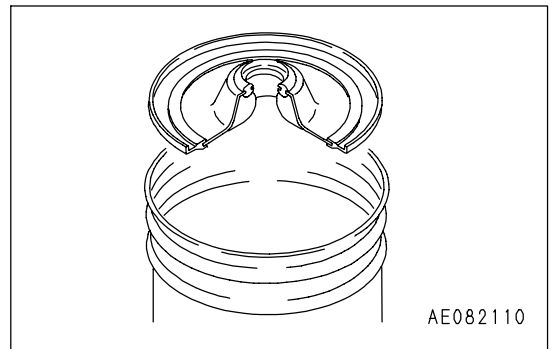

7. After bleeding the air inside the pump, pull the lever of the grease gun to completely discharge the grease mixed with air inside the hose and grease gun.
  - When filling with grease, be extremely careful not to let sand or dirt stick to the follow plate or pump suction portion.
  - If there is ample grease, but the pump does not pump out any grease, the follow plate may not be correctly set in position, so set it in position again correctly.
  - The standard grease can contains 16 liters (4.23 US gal). If an 18 liters (4.76 US gal) can is used, there will be more grease left.

**REMARK**

Put the spare grease can beside the grease pump in the grease pump box at the right side of the machine.

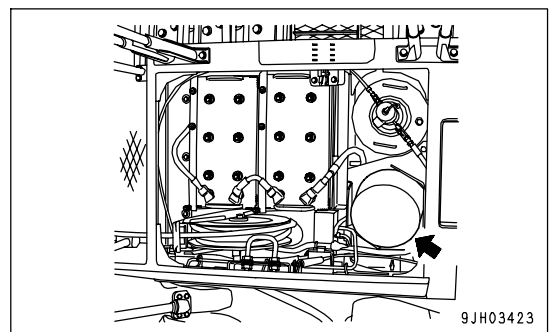

## ACCUMULATOR

### WARNING

The accumulator is charged with high-pressure nitrogen gas, improper operation may cause an explosion which could lead to serious injury or damage. When handling the accumulator, always do as follows:

- Pressure in the control circuit cannot be completely removed. When removing the hydraulic equipment, do not stand in the direction that oil spurts out when performing the operation.
- Loosen the bolts slowly.
- Do not disassemble the accumulator.
- Do not bring it near flame or dispose of it in fire.
- Do not make holes in it or weld it.
- Do not hit it, roll it, or subject it to any impact.
- When disposing of the accumulator, the gas must be released. Contact your Komatsu distributor for proper disposal.

This machine is equipped with an accumulator in the control circuit. The accumulator is a device to store oil pressure for the control circuit. Because an accumulator is installed, the control circuit can be actuated for a short time even after the engine is stopped. As a result, if the control lever is moved in the LOWER direction, the work equipment will go down under its own weight.

The accumulator is installed to the position shown in the diagram on the right.

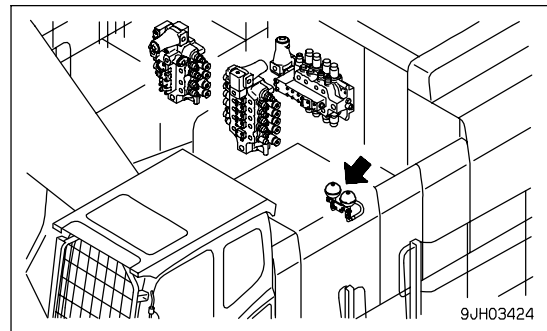

### Releasing Hydraulic Pressure with Accumulator

1. Place the work equipment on the ground. Close the crusher attachment jaws, etc.
2. Stop the engine.
3. Turn the key in starting switch to the ON position.
4. Move lock lever to the free position. Move the work equipment control lever and attachment control pedal to full strokes back and forth, right and left to release pressure in the control circuit.
5. Move the lock lever to the LOCK position. Lock the control lever and attachment control pedal.

# MACHINE OPERATIONS AND CONTROLS

## BEFORE STARTING ENGINE

### Walk-around Checks

Before starting the engine, walk around the machine and look at the underside of chassis for anything unusual like loose bolts and nuts, leakage of fuel, oil and coolant. Also check the condition of the work equipment and the hydraulic system.

Also check for loose wiring, play, and collection of dust at places that reach high temperature.



### WARNING

**Remove any flammable materials from around the battery, engine, muffler, turbocharger, or other high temperature engine parts. Leakage of fuel or oil will cause the machine to catch fire. Check carefully, be sure to repair any problem, or contact your Komatsu distributor.**

Perform the following inspections and cleaning every day before starting engine for the day's work.

1. Check for damage, wear, play in work equipment, cylinders, linkage, hoses  
Check for cracks, excessive wear, play in work equipment, cylinders, linkage, and hoses. If any problem is found, repair it.
2. Remove dirt and debris from around the engine, battery, and radiator.  
Check for dirt accumulated around the engine and radiator. Also check for flammable material (dry leaves, twigs, etc.) around the battery, engine muffler, turbocharger, or other high temperature engine parts. If any dirt or flammable materials are found, remove them.
3. Check for coolant and oil leakage around the engine  
Check for oil leakage from the engine and coolant leaks from the cooling system. If any problem is found, repair it.
4. Check for oil leakage from hydraulic equipment, hydraulic tank, hoses, and joints  
Check for oil leakage. If any problem is found, repair the area where oil is leaking.
5. Check the undercarriage (track, sprocket, idler, guard) for damage, wear, loose bolts, or leakage of oil from rollers.  
If any problem is found, repair it.
6. Check for problems in handrails, steps, loose bolts.  
If any problem is found, repair it. Tighten any loose bolts.
7. Check for problem in gauges, monitor.  
Check for problem in the gauges and monitor in the operator's cab. If any problem is found, replace the parts.  
Clean off any dirt from the surface.

8. Clean, check rear view mirror

Check for damage to the rear view mirror. If damaged, replace it with a new mirror. Clean surface of the mirror and adjust angle so area at the rear can be seen from the operator's seat.

9. Seat belt and mounting clamps

Check for damage or wear to the seat belt and mounting clamps. If there is any damage, replace with new parts.

10. Check stopper plate

Check that there is no abnormality in the stopper plate. If any abnormality is found, clean it or replace it with a new part.

## Checks Before Starting

Always check the items in this section before starting the engine each day.

### Check Coolant Level, Add Coolant



## WARNING

- Do not open the radiator cap unless necessary. When checking the coolant, always wait for the engine to cool down and check the sub tank.
- Immediately after the engine is stopped, the coolant is at a high temperature and the radiator is under high internal pressure. If the cap is removed to check the coolant level in this condition, there is a hazard of burns. Wait for the temperature to go down, then turn the cap slowly to release the pressure and remove it carefully.

1. Open cover (1) of the sub tank inspection window at the front of the radiator side (right side of machine) of the engine hood, and check that the coolant level is between the FULL and LOW lines on the two sub tanks (2). If the coolant level is low, add water through the water filler to sub tanks (2) to the FULL level.
2. After adding coolant, tighten the cap securely.
3. If the sub-tank is empty, check for water leakage, and check the water level in the radiator. If the cooling water is insufficient, supply water to the radiator and then to the sub-tank.

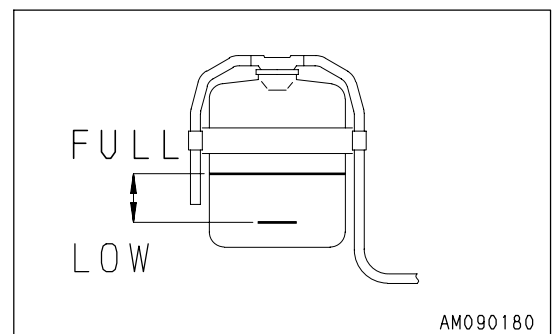
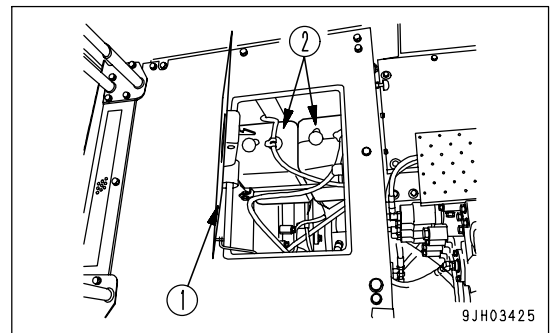



**REMARK**

- When adding water to the radiator, remove cover (3), then loosen radiator cap (4) slowly. After checking that the pressure has been released, push in the cap, keep it pushed in, then loosen it further and remove it.
- Check that the level of the coolant is above the hatched portion in the diagram on the right. If the water level is low, add water through the water filler port.
- After adding water, install radiator cap (4).  
When operating in cold areas, see "COLD WEATHER OPERATION (PAGE 3-131)"

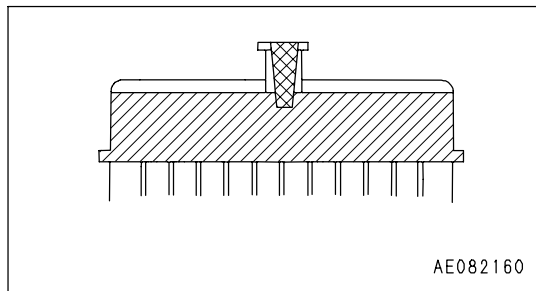
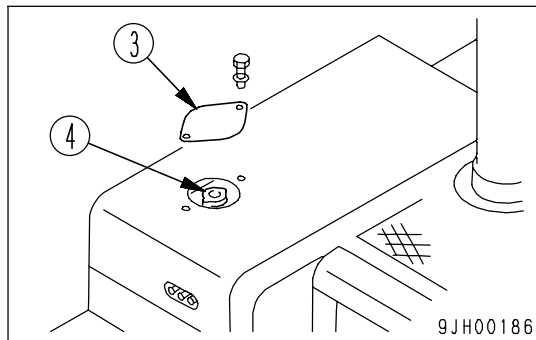

## Check Oil Level in Engine Oil Pan, Add Oil

**WARNING**

Parts and oil are at high temperature immediately after the engine is stopped and may cause serious burns. Wait for the oil temperature to go down before performing this operation.

1. Open the front cover in the center of the engine hood.
2. Remove dipstick (G), and wipe the oil off with a cloth.
3. Fully insert dipstick (G) into filler pipe (F), then remove it.

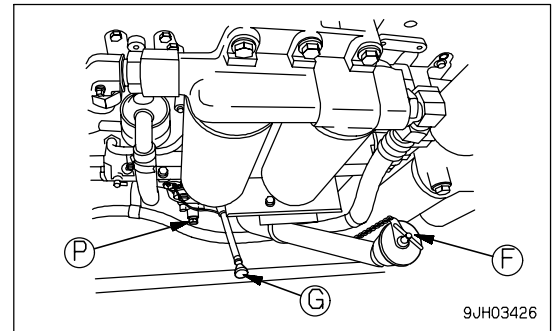

4. The oil level should be between the H and L marks on dipstick (G).  
If oil level is below the L mark, add engine oil through filler pipe (F).

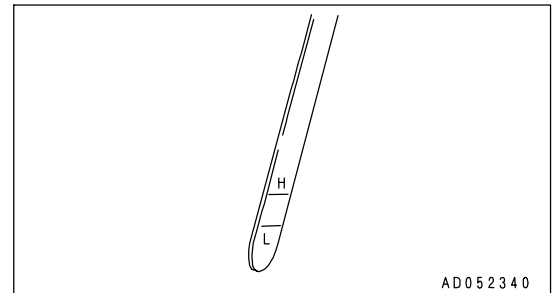

5. If the engine oil level is higher than the H mark, drain the excess through drain plug (P), and check the level again.
6. If oil level is correct, securely tighten the oil filler cap and close the engine hood.

**REMARK**

When checking the oil level after the engine has been operated, wait for at least 15 minutes after stopping the engine before checking.

If the machine is at an angle, make it horizontal before checking.

## Check Fuel Level, Add Fuel

**WARNING**

When adding fuel, never let the fuel overflow. This may cause a fire. If any fuel is spilled, wipe it up completely. Never bring flames near fuel because it is highly flammable and dangerous.

1. Use sight gauge (G) at the front face of the fuel tank to check that the tank is filled with fuel.
2. If the level is not within the sight gauge, watch sight gauge (G) from fuel filler port (F) while adding fuel.  
Fuel tank capacity: 1360 liters (359.31 US gal)
3. After adding fuel, tighten the cap securely.

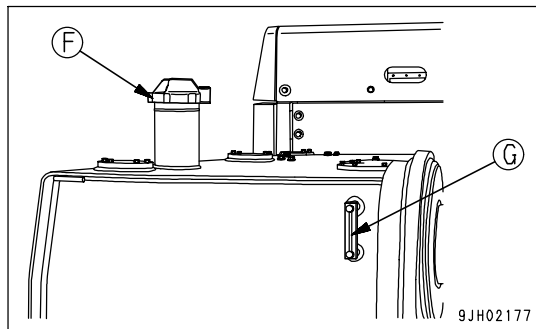
**REMARK**

If breather hole (1) in the cap is clogged, the pressure in the tank will drop and fuel will not flow. Clean the hole from time to time.

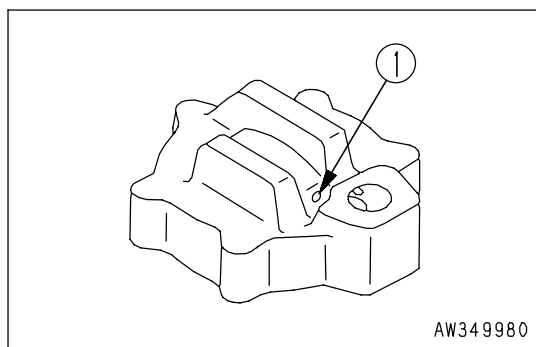

## Check Oil Level in Hydraulic Tank, Add Oil

**WARNING**

If the oil filler cap is removed without releasing the internal pressure, oil will spurt out, so turn the oil filler cap slowly to release the internal pressure, then remove it carefully.

1. If work equipment is not in the condition shown in diagram on the right, start engine, run at low idle, retract the arm and bucket cylinders, then lower the boom, set bucket teeth in contact with the ground, and stop the engine.
2. Within 15 seconds after stopping the engine, turn starting switch to the ON position, and operate the control levers (work equipment, travel) in each direction to release the internal pressure.

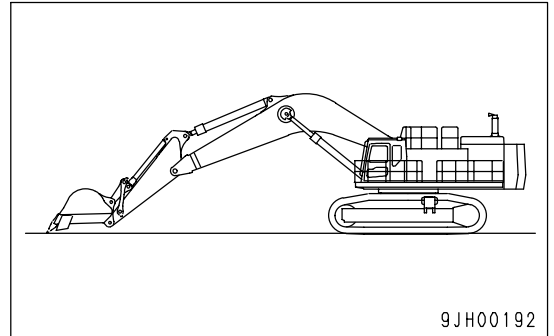

3. Check oil level gauge (G) at the rear of the hydraulic tank on the right side of the machine. The oil level should be within the specified range for that oil temperature. If the oil level is low, add oil.

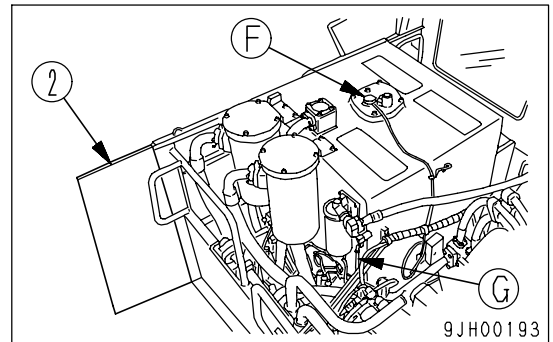

The proper way to check the hydraulic oil level is as follows.

- When the hydraulic oil is at normal temperature (15°C to 30°C), the oil level should be within the blue range of gauge label (a) in the diagram on the right.
- When the hydraulic oil is at high temperature (50°C to 80°C), the oil level should be within the red range of gauge label (b) in the diagram on the right.

4. If the level is below the correct line, add oil through filler port (F) at the top of the hydraulic tank.

**NOTICE**

Do not add oil above the correct level. This may damage the hydraulic circuit and cause the oil to spurt out.

5. If oil is added to above the correct line, and drain the excess oil as follows.

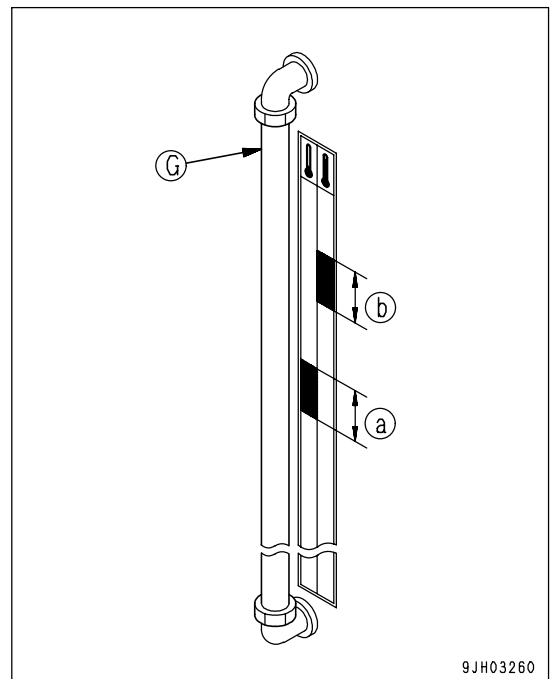

**WARNING**

If the oil is above the H level, stop the engine, wait for the hydraulic oil to cool down, then drain the excess oil from drain plug (P1). When draining the oil, loosen bottom drain plug (P1), then loosen the side drain plug (P2) and drain the oil. After draining the oil, tighten drain plugs (P1) and (P2).

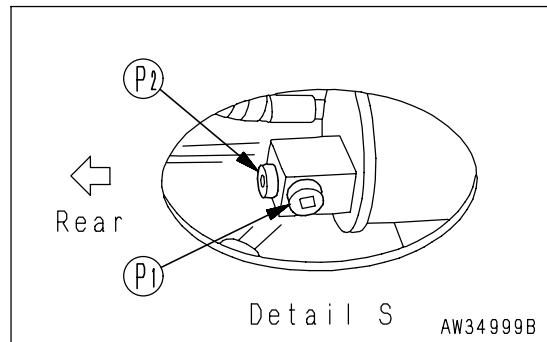
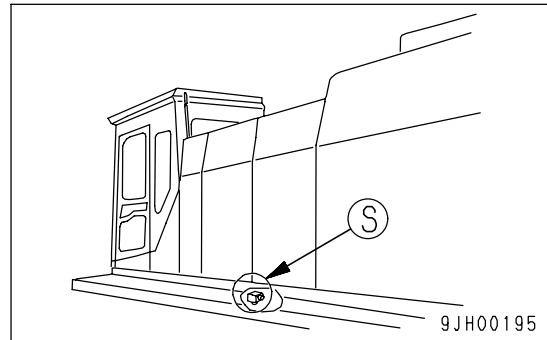

## Check Oil Level in Swing Machinery Case, Add Oil

**WARNING**

Parts and oil are at high temperature immediately after the engine is stopped and may cause serious burns. Wait for the oil temperature to go down before performing this operation.

1. Remove dipstick (G) of the front and rear machine, and wipe the oil off with a cloth.
2. Fully insert dipstick (G) into the filler pipe.

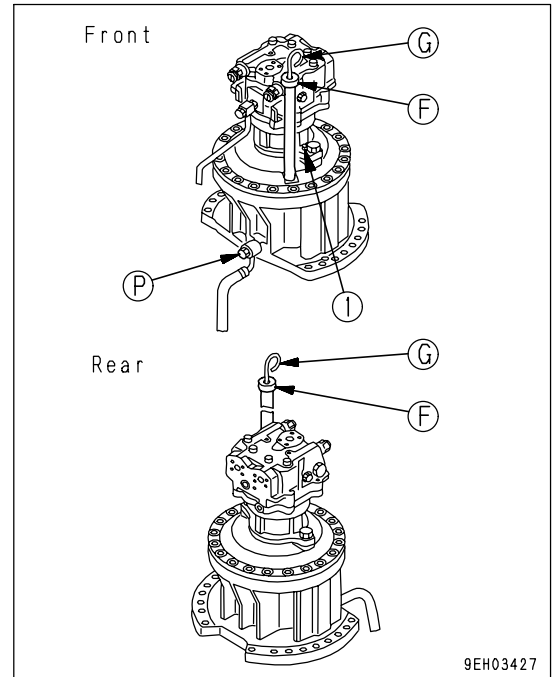

3. When dipstick (G) is pulled out, if oil level is between the H and L marks of the gauge, oil level is proper.
4. If the oil level is below the L mark on dipstick (G), add engine oil through dipstick guide (F) to the correct level. After adding oil, remove air bleed plug (1) (at the front of the machine only).
5. If the oil level exceeds the H mark on the dipstick, loosen drain valve (P) to drain the excess oil.
6. After checking the oil level and adding oil, insert dipstick (G) into the dipstick guide and install air bleed plug (1) (at the front of the machine only)

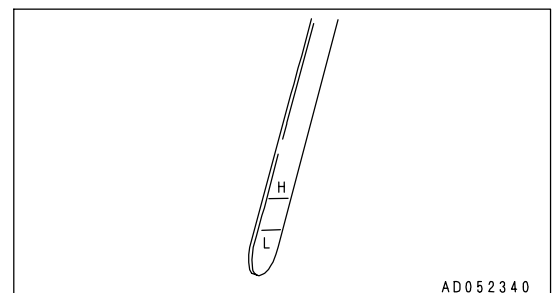

Check Oil Level in PTO Case, Add Oil



**WARNING**

Parts and oil are at high temperature immediately after the engine is stopped and may cause serious burns. Wait for the oil temperature to go down before performing this operation.

**NOTICE**

Park the machine on flat ground and stop the engine. After waiting for more than 30 minutes after stopping the engine, check the oil level.

1. Open the cover at the front of the engine room and check the level with dipstick (F).

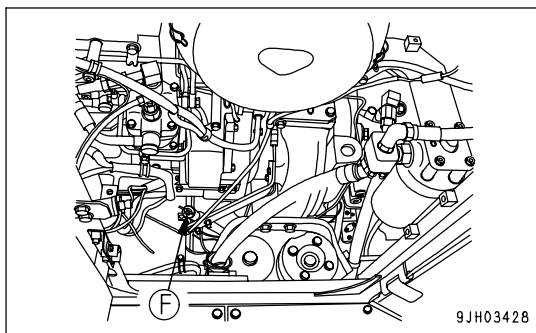

2. The oil level should be between the L and H marks. If necessary, add oil at the dipstick guide hole.

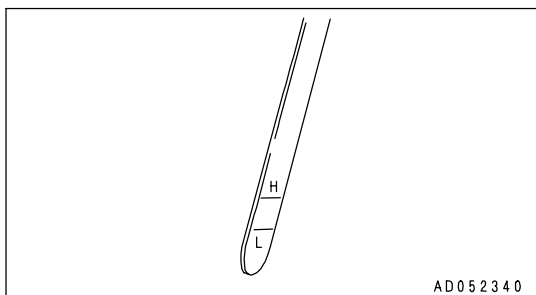

**Check Air Cleaner For Clogging**

1. Confirm that the air cleaner clogging monitor does not light up.
2. If it lights up, immediately clean or replace the element.

For details of method of cleaning the element, see "CHECK, CLEAN AND REPLACE AIR CLEANER ELEMENT (PAGE 4-19)".

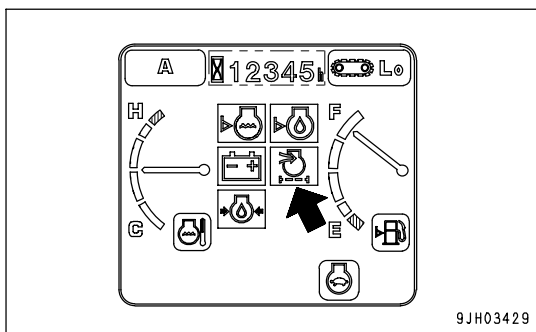

**Check Working Lamp Switch**

Turn the lamp switch to the ON position and check that the working lamp light up.

If the lamps do not light up, there is probably a broken bulb or disconnection in the wiring, contact your Komatsu distributor for repairs.

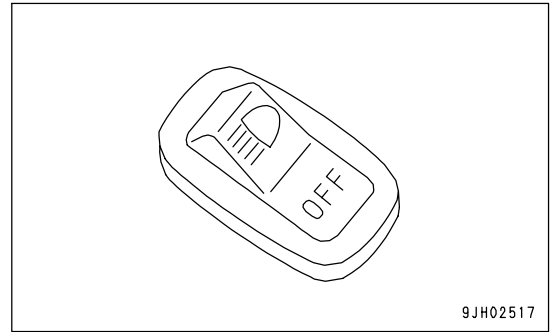



## Check Electric Wiring

### CAUTION

- If fuses are frequently blown or if there are traces of short-circuiting on the electrical wiring, promptly ask your Komatsu distributor to locate the cause and make the repair.
- Keep the top surface of the battery clean and check the breather hole in the battery cap. If it is clogged with dirt or dust, wash the battery cap to clear the breather hole.

Check that there is no damage to the fuses; that fuses of the specified capacity are used; that there is no disconnection or trace of short-circuiting in the electric wiring and no damage to the covering. Check also that there is no loosened terminals. If any, tighten them.

Moreover, pay particular attention to the electric wiring when checking the battery, engine starting motor and alternator.

Be sure to check that there is no inflammable material accumulated around the battery. If any is found, remove immediately.

## Check Function of Horn

1. Turn the starting switch to the ON position.
2. Press the horn switch and check that the horn sounds immediately.

Note that if the air tank is empty or the water drain valve in the air tank is at the OPEN position, the horn will not sound. Check that the water drain Valve is at the CLOSE position, start the engine and wait for 1 or 2 minutes, then press the horn switch again to check if it sounds.

If the horn still does not sound, please contact your Komatsu distributor for repairs.

## Drain Water And Sediment from Fuel Tank

### NOTICE

Never use trichlene for washing the inside of the tank.

Use diesel fuel only.

1. Prepare a container to catch the fuel that is drained.
2. Tank drain hose (2) out through the hole in cover (3) .
3. Open drain valve (1) at the bottom of the aftercooler and drain the water and sediment gathered at the bottom of the tank together with fuel. When doing this, be careful not to get fuel on yourself.
4. When only clean fuel comes out, close drain valve (1).

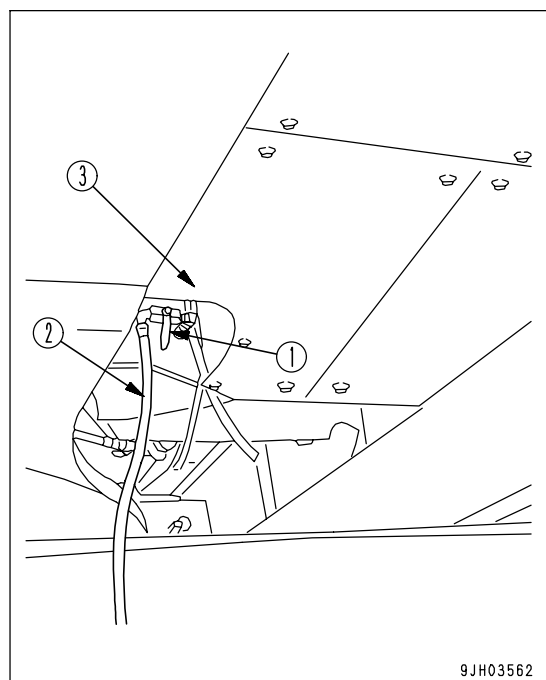

9JH03562

## Adjustment

### Seat Adjustment



## WARNING

When adjusting the position of the operator's seat, always set the lock lever to the LOCK position to prevent any accidental contact with the control levers.

- Always adjust the operator's seat before starting each operation or when the operators change shift.
- Adjust the operator's seat so control levers and switches can be operated freely and easily with the operator's back against the backrest.

#### (A) Fore-and-aft adjustment

Pull lever (1) up, set the seat to the desired position, then release the lever.

Fore-and-aft adjustment: 160 mm (6.3 in) (16 stages)

#### (B) Adjusting reclining

#### NOTICE

The operator's seat can be reclined to a large angle when the seat is completely pushed forward, but the reclining angle is reduced when the seat is moved backward. So return the seat to its upright position before moving the seat to the rear.

Pull up lever (2) and set the backrest to a position that is comfortable for operation, then release the lever.

Sit with your back against the seat backrest when adjusting. If your back is not against the backrest, the backrest may suddenly move forward.

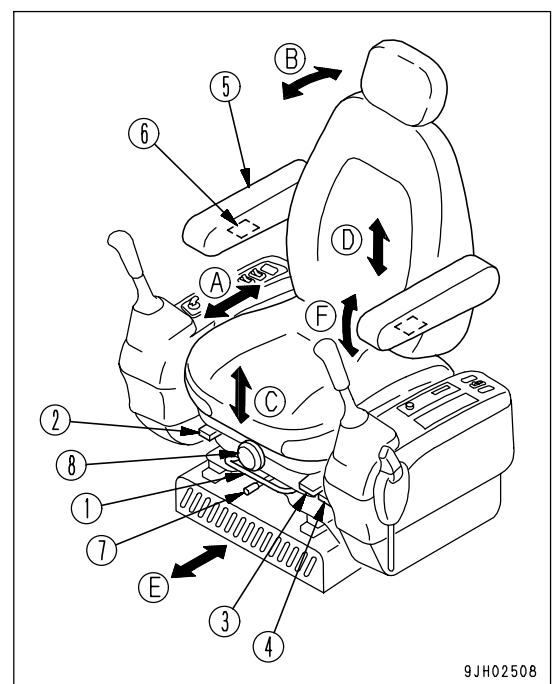

9JH02508

**(C) Adjusting seat tilt**

- Forward tilt

Push lever (3) down to adjust angle of the front of seat. (4 stages)

- To raise the angle at front of the seat, keep the lever pushed down and apply your weight to the rear of seat.
- To lower the angle at front of the seat, keep the lever pushed down and apply your weight to the front of seat.

- Rear tilt

Pull lever (4) up to adjust angle of the rear of seat. (4 stages)

- To raise the angle at rear of the seat, keep lever (3) pulled up, and stand up slightly to remove your weight from the seat.
- To lower the angle at rear of the seat, keep lever (3) pulled up, and apply your weight to the seat.

Amount of tilt: Up 13°, down 13°

- Adjusting seat height

It is possible to move the seat up or down by combining adjustments forward tilt and rear tilt.

After setting the forward tilt or rear tilt to the desired height, operate the opposite part to set the seat horizontal then secure in position.

Height adjustment: 60 mm (2.4 in)

**(D) Adjusting armrest angle**

Armrest (5) can be made to spring up by hand approx. 90°.

In addition, by turning the bottom (6) of the armrest by hand it is possible to make fine vertical adjustments of the armrest angle.

Armrest adjustment angle: 25°.

**REMARK**

If the seat back is tipped to the front without raising the armrest(5), armrest will rise automatically.

**(E) Overall fore-and-aft adjustment of seat**

Move lever (7) to right, set to the desired position, then release the lever. In this case, the operator's seat, left and right control levers, and lock lever all slide together.

Fore-and-aft adjustment: 180 mm (7.1 in) (9 stages)

**(F) Adjusting suspension**

Turn knob (8) to the right to make the suspension harder, or to the left to make the suspension softer. Adjust the reading of the dial to match the operator's weight and select the optimum suspension.

**REMARK**

To obtain the optimum adjustment, turn the knob (8) so that the indicator of the weight display (kg) in the transparent portion of knob (8) is the same as the operator's weight.

**Rearview Mirrors**

Loosen nut (1) and bolt (2) mounting the mirror, and adjust to the position which gives the best view from the operator's seat of the blind spot to the left and right sides at the rear of the machine.

- Adjust the mirror mount so that it is possible to see people (or objects with a height of 1 m (3.3 ft) or a diameter of 30 cm (12 in)) at the rear left and right of the machine
- Install the mirror to the dimensions listed in the table below. Recognition areas are also shown in the table for reference.

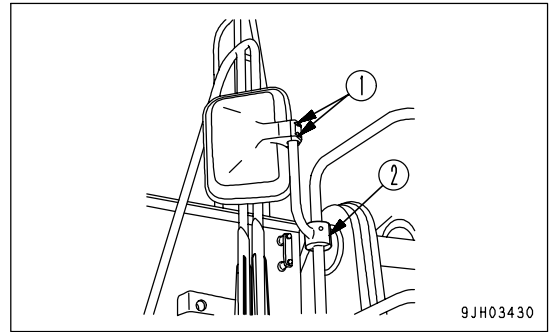

Mounting position X : 350 mm (13.8 in)

Range of view Y (right side) : 3500 mm (11 ft 6 in)

Range of view Z (left side) : 3500 mm (11 ft 6 in)

Mirror A : Must be able to see hatched area (A)

Mirror B : Must be able to see hatched area (B)

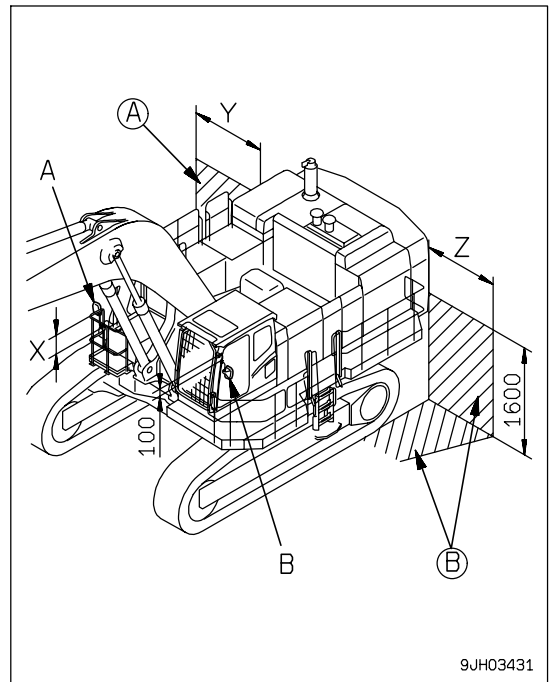

## Seat Belt



### WARNING

- Before fitting the seat belt, check that there is no problem in the belt mount bracket or mounting belt. If it is worn or damaged, replace the seat belt.
- Even if no problem can be seen in the belt, replace the seat belt every 3 years. The date of manufacture of the belt is shown on the back of the belt.
- Always wear the seat belt during operations.
- Fit the seat belt so that it is not twisted.

## Fastening and Removing

This seat belt has a wind-in device, so it is not necessary to adjust the length.

### Fastening Seat Belt

Hold grip (2) and pull the belt out from wind-in device (1), check that the belt is not twisted, then insert tongue (3) into buckle (4) securely.

When doing this, pull the belt lightly to check that it is properly locked.

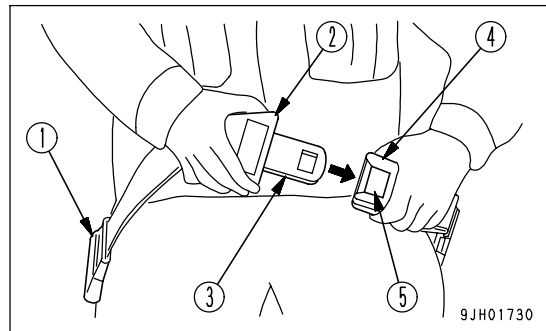

### Removing Belt

Press button (5) in buckle (4), and remove tongue (3) from buckle (4).

The belt is automatically wound in, hold grip (2) and return the belt slowly to wind-in device (1).

Operations Before Starting Engine

**WARNING**

Before starting the engine, check that the safety lock lever is securely at the LOCK position.

If the work equipment control lever is touched by accident when starting the engine, the work equipment may move unexpectedly and cause serious damage or personal injury.

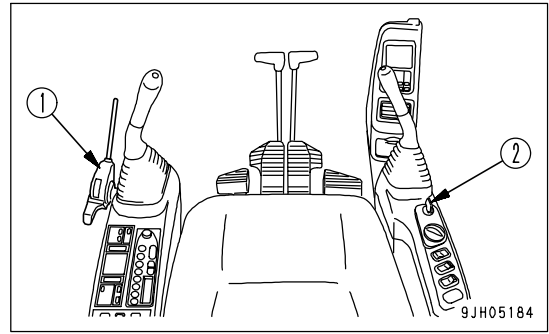

1. Check that safety lock lever (1) is at the LOCK position.
2. Check the position of each lever.  
Set control lever to the neutral position.

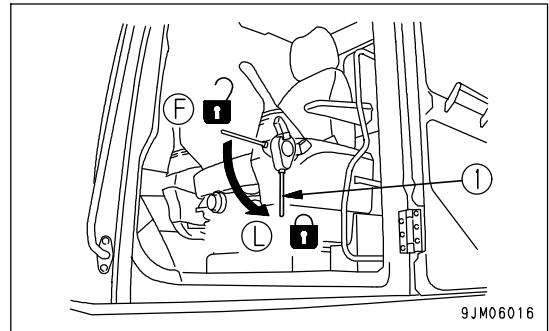

3. Insert the key in starting switch (2), turn the key to the ON position, then carry out the following checks.

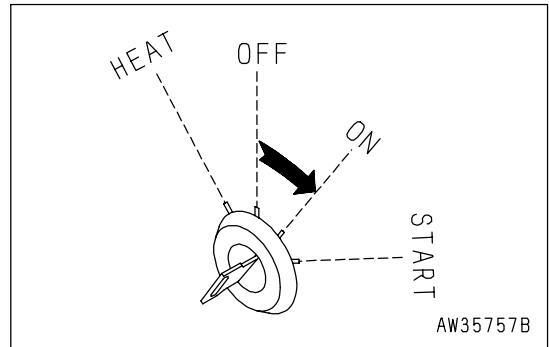

1) The buzzer sounds for approx. 1 second, and the following monitors and meters light up for approx. 3 seconds.

- Radiator coolant level monitor (4)
- Engine oil level monitor (5)
- Charge level monitor (6)
- Fuel level monitor (7)
- Engine coolant temperature monitor (8)
- Engine oil pressure monitor (9)
- Engine coolant temperature gauge (10)
- Fuel gauge (11)
- Air cleaner clogging monitor (12)

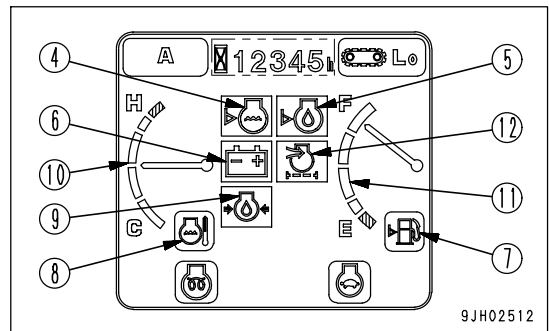

If the monitors do not light up or the buzzer does not sound, there is probably a failure in the monitor, so contact your Komatsu distributor for repairs.

2) After approx. 3 seconds, the screen switches to the working mode/travel speed display monitor. Then it switches to the normal screen.

- Fuel level monitor (7)
- Engine coolant temperature monitor (8)
- Engine coolant temperature gauge (10)
- Fuel gauge (11)
- Hydraulic oil temperature gauge (13)
- Hydraulic oil temperature monitor (14)

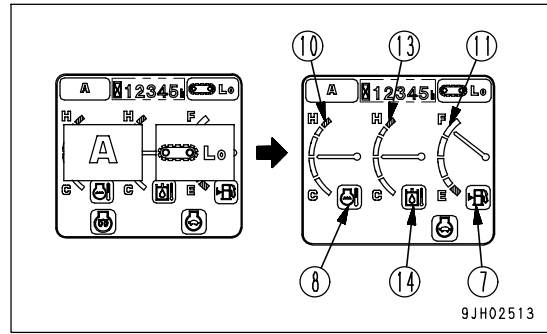

3) If the hydraulic oil temperature gauge goes out and caution lamp (15) stays lighted up red, perform inspection immediately for the item which is lighted up red.

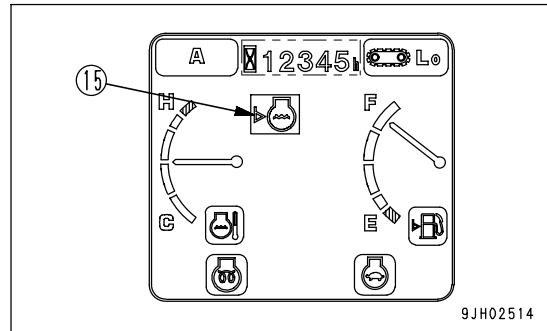

4) If there are any items where the maintenance time has passed, maintenance interval monitor (16) lights up for 30 seconds. Press maintenance switch (17), check the item, then perform maintenance immediately.

For details of the method of checking the maintenance interval, see "Maintenance Switch (PAGE 3-24)" in the Detailed controls and gauges.

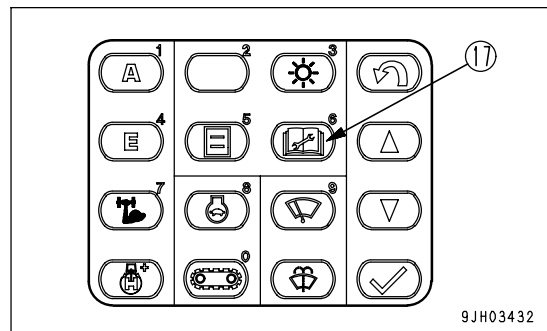
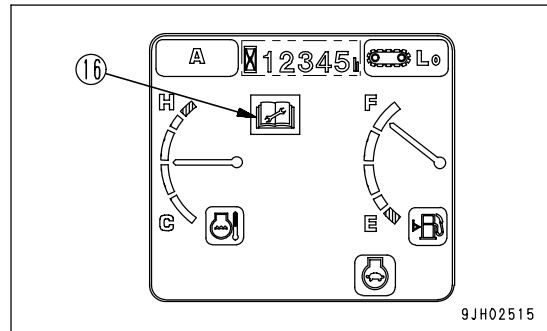

## STARTING ENGINE

### Normal Starting

#### WARNING

- Start the engine only after sitting down in the operator's seat.
- Do not attempt to start the engine by short-circuiting the engine starting circuit. Such an act may cause a serious bodily injury or fire.
- Check that there are no persons or obstacles in the surrounding area, then sound the horn and start the engine.
- Exhaust gas is toxic. When starting the engine in confined spaces, be particularly careful to ensure good ventilation.

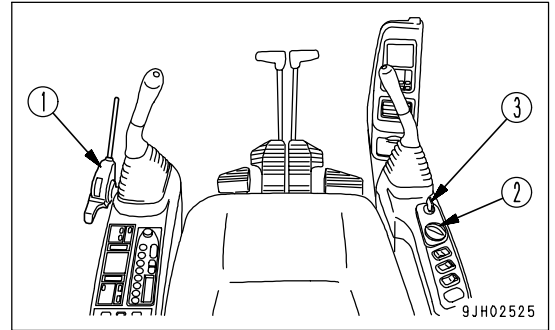

#### NOTICE

- Before starting the engine, check that the fuel control dial is at the low idle (MIN) position.  
If the fuel control dial is at the FULL position, the engine will accelerate suddenly and cause damage to the engine parts.
- Do not crank the starting motor continuously for more than 20 seconds.  
If the engine does not start, wait for at least 2 minutes before trying again.

#### REMARK

If the engine is stopped when it is not fully warmed up and it is started again a few minutes later, there may be a delay in the engine rotation during cranking. This is caused by fuel gas remaining inside the cylinder; it does not indicate any abnormality. In addition, even if this phenomenon occurs, there is no problem with the reliability or durability of the engine or other parts.

1. Check the safety lock lever (1) is at the LOCK position. If the safety lock lever is in the FREE position, the engine does not start.

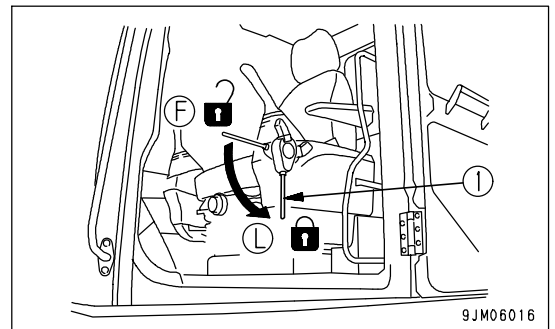

2. Set fuel control dial (2) at the low idle (MIN) position.  
If it is at the high idle (MAX) position, always change it to the low idle (MIN) position.

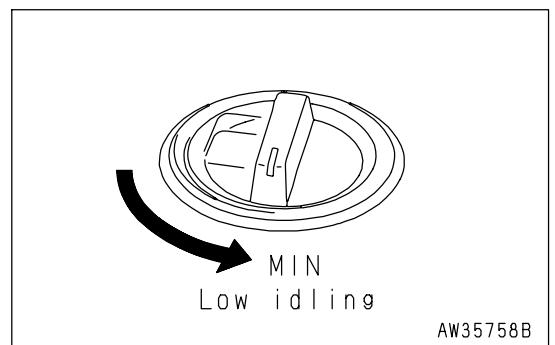



3. Turn the key in starting switch (3) to the START position. The engine will start.

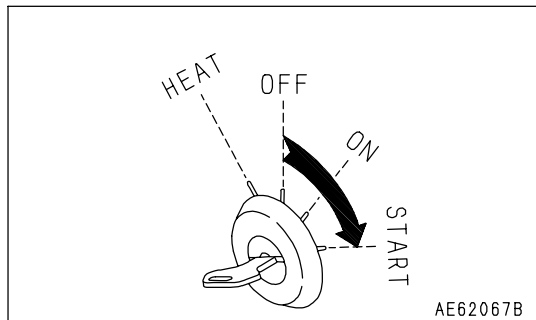

4. When the engine starts, release the key in starting switch (3). The key will return automatically to the ON position.

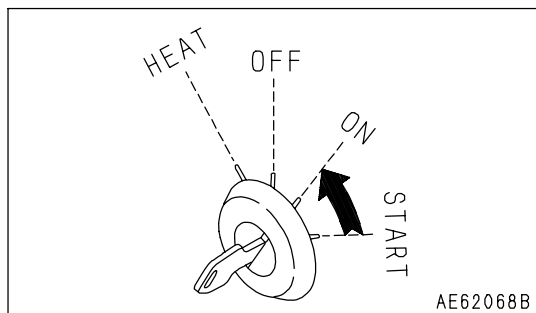

5. Even after the engine is started, do not touch the work equipment control levers and the travel pedals, while the engine hydraulic pressure monitor lamp is still lighted.

**NOTICE**

If the engine oil pressure monitor does not go out even after 4 to 5 seconds have passed, stop the engine immediately. Check the oil level, check for leakage of oil, and take the necessary action.

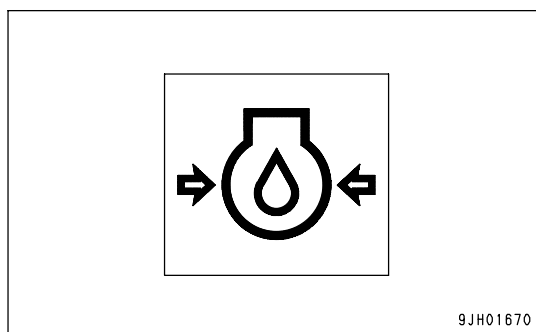

## Starting Engine in Cold Weather

**WARNING**

- Start the engine only after sitting down in the operator's seat.
- Do not attempt to start the engine by short-circuiting the engine starting circuit. Such an act may cause a serious bodily injury or fire.
- Check that there are no persons or obstacles in the surrounding area, then sound the horn and start the engine.
- Never use starting aid fluids as they may cause explosions.
- Exhaust gas is toxic. When starting the engine in confined spaces, be particularly careful to ensure good ventilation.

**NOTICE**

- Before starting the engine, check that fuel control dial (2) is at the low idle (MIN) position.  
If the fuel control dial is at the FULL position, the engine will accelerate suddenly and cause damage to the engine parts, set it to an intermediate or low speed position.
- Do not keep the starting motor rotating continuously for more than 20 seconds.  
If the engine fails to start, wait for about 2 minutes and repeat from Step 2.

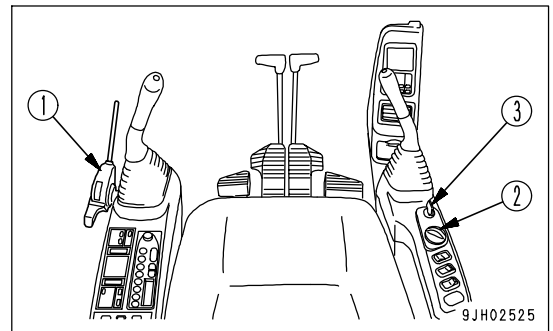

When starting in low temperatures, do as follows.

1. Check the safety lock lever (1) is at the LOCK position. If the safety lock lever is in the FREE position, the engine does not start.

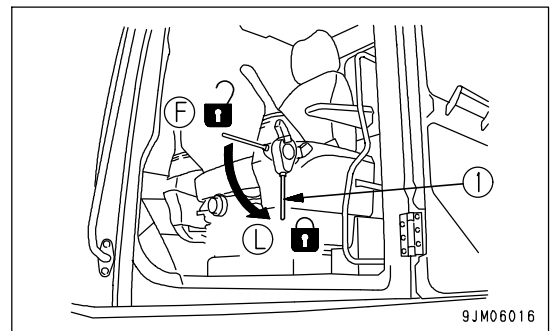

2. Set fuel control dial (2) at a low idle (MIN) position.  
Do not set fuel control dial (2) at the high idle (MAX) position.

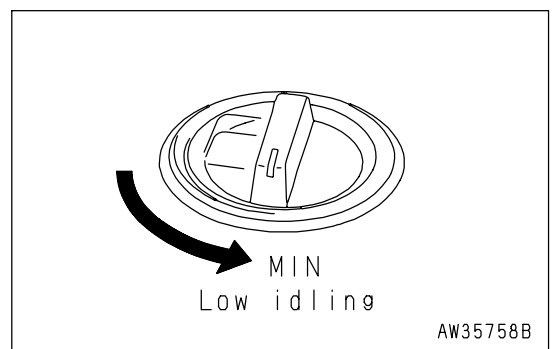

3. Hold the key in starting switch (3) at the HEAT position, and check that preheating monitor (4) lights up.  
After about 30 seconds, preheating monitor lamp (4) will flash to indicate that preheating is finished.

**REMARK**

- The monitors and gauges will light up also when the key is turned to the HEAT position, but this is not a problem.
- If the temperature is low, the monitor screen may become dark or it may take time for the display to appear, but this is not a problem.

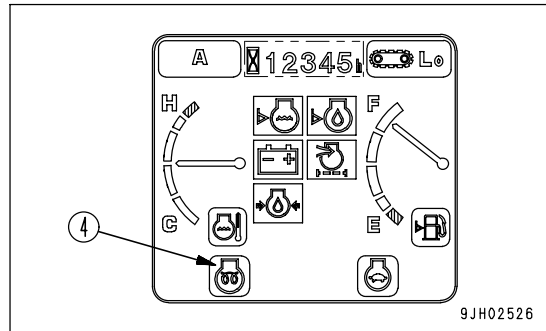
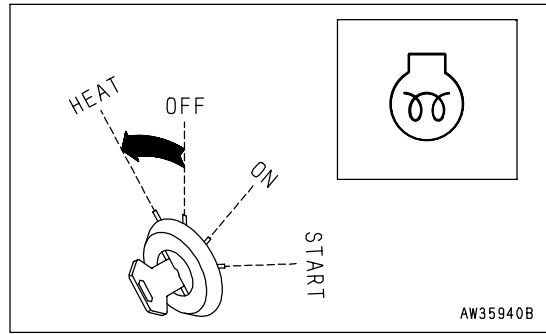

4. When preheating monitor (4) goes out, turn the key in starting switch (3) to the START position to start the engine.

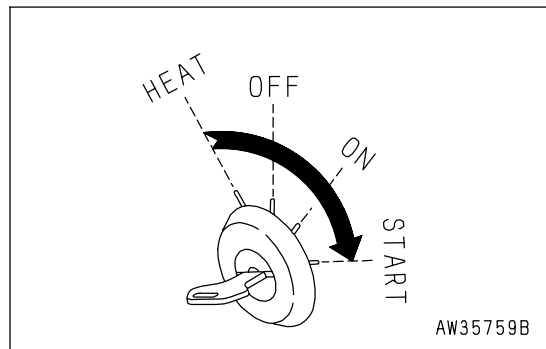

5. When the engine starts, release the key in starting switch (3). The key will return automatically to the ON position.

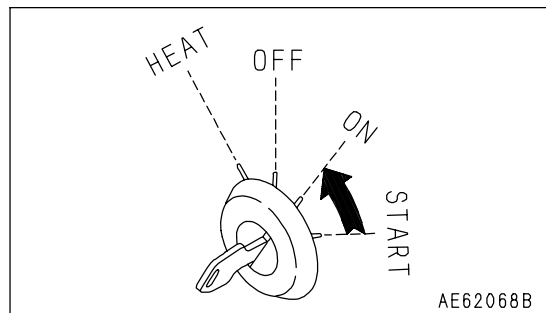

6. After starting the engine, do not touch the work equipment control lever or travel pedal while the engine oil pressure monitor lamp is lighted up.

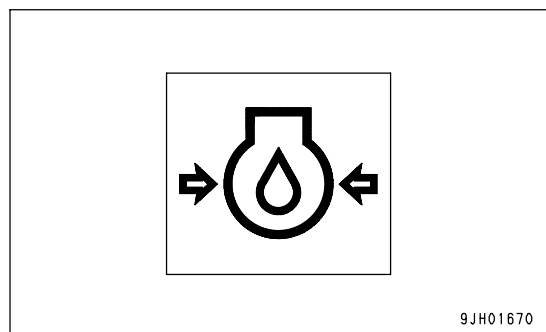

## AFTER STARTING ENGINE



### WARNING

- If there has been any Emergency stop, abnormal actuation or trouble, turn the starting switch key to the OFF position.
- If the work equipment is operated without sufficiently warming the machine up, response of the work equipment to movement of the control lever will be slow, and the work equipment may not respond as the operator desires, so always perform the warming-up operation. Particularly in cold areas, be sure the warming-up operation is completed.

## Warming-up Operation

### NOTICE

- When the hydraulic oil is at a low temperature, do not perform operations or move the levers suddenly. Always perform the warming-up operation. This will help extend the machine life.  
Do not suddenly accelerate the engine before the warming-up operation is completed.
- Do not run the engine at low or high idle continuously for more than 20 minutes. This will cause oil leaks from the turbocharger oil supply piping. If it is necessary to run the engine at idle, apply a load from time to time or run the engine at a mid-range speed.

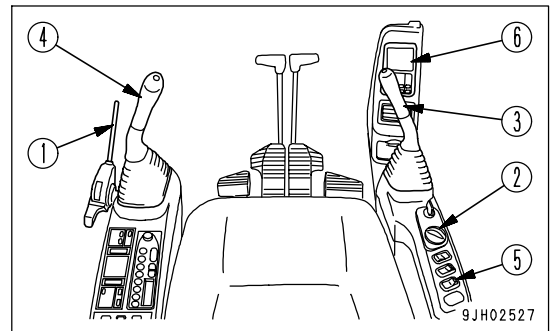

### REMARK

If the hydraulic oil temperature is low, the hydraulic oil temperature monitor display will be white.

After the engine starts, do not start operating the machine immediately. First, carry out the following operations and checks.

1. Set fuel control dial (2) to a point midway between low idling (MIN) and full throttle (MAX), and run the engine at a mid-range speed under no load until the engine water temperature monitor enters the green display.

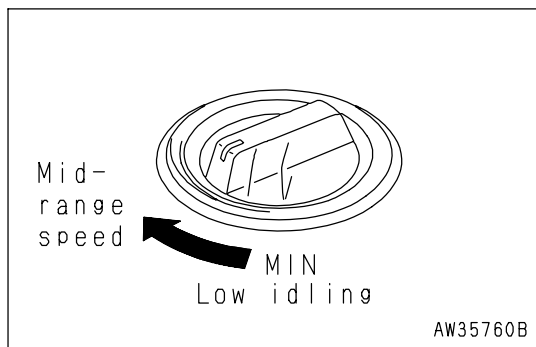

2. Set safety lock lever (1) to the FREE position and raise the bucket from the ground.

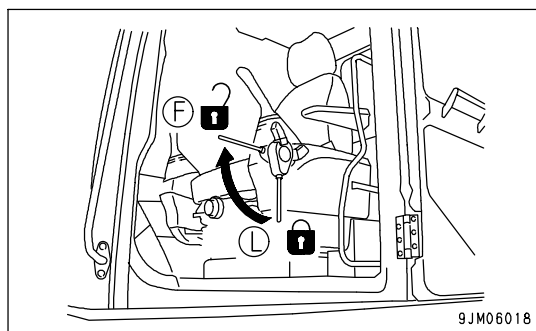

3. Operate bucket control lever (3) and arm control lever (4) slowly to move the bucket cylinder and arm cylinder to the end of the stroke.
4. Operate the bucket for 30 seconds and the arm for 30 seconds in turn fully for 5 minutes.

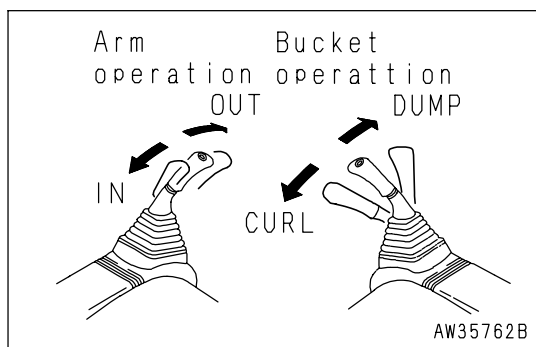

**NOTICE**

When the work equipment is retracted, take care that it does not interfere with the machine body or ground.

5. After performing the warming-up operation, check and be sure all the gauges on machine monitor (6) and the caution lamps are in the following conditions:

- Radiator coolant level monitor (7): OFF
- Engine oil level monitor (8): OFF
- Charge level monitor (9): OFF
- Fuel level monitor (10): Green display
- Engine coolant temperature monitor (11): Green display
- Engine oil pressure monitor (12): OFF
- Engine coolant temperature gauge (13): Indicator in black range
- Fuel gauge (14): Indicator in black range
- Engine pre-heating monitor (15): OFF
- Air cleaner clogging monitor (16): OFF
- Hydraulic oil temperature gauge (17): Indicator in black range
- Hydraulic oil temperature monitor (18): Green display

6. Check for abnormal exhaust gas color, noise, or vibration. If any problem is found, contact your Komatsu distributor.

7. If air cleaner clogging monitor (16) lights up, clean or replace the element immediately.

For details of the method of cleaning the element, see "CHECK, CLEAN AND REPLACE AIR CLEANER ELEMENT (PAGE 4-19)".

8. Use working mode selector switch (19) on machine monitor (6) to select the working mode to be used.

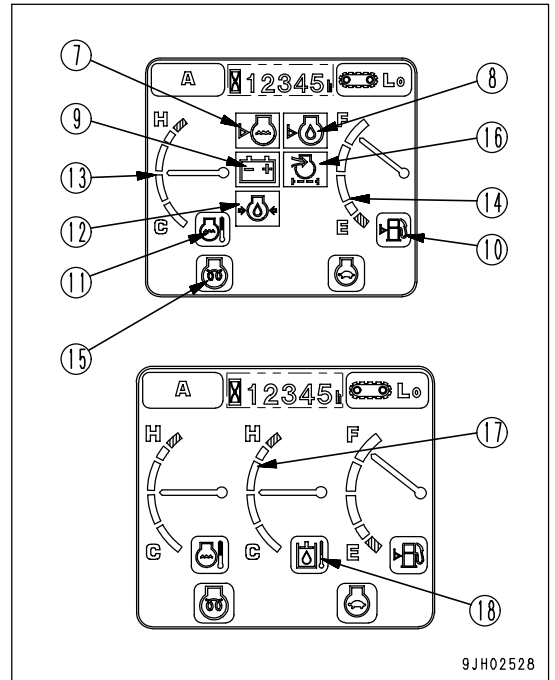

9JH02528

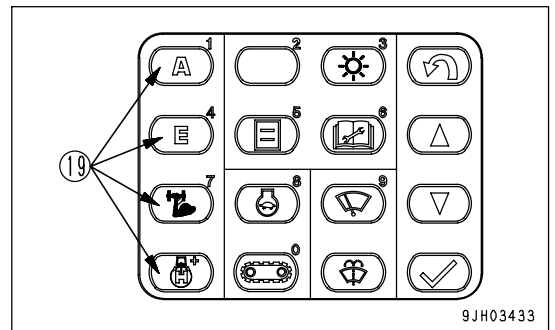

9JH03433

Working mode monitor display

1) A mode

For heavy-load operations

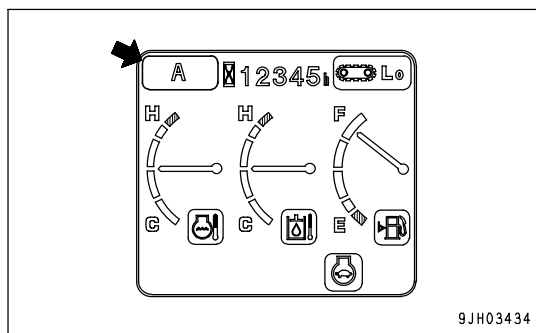

2) E mode

For operations with emphasis on fuel economy

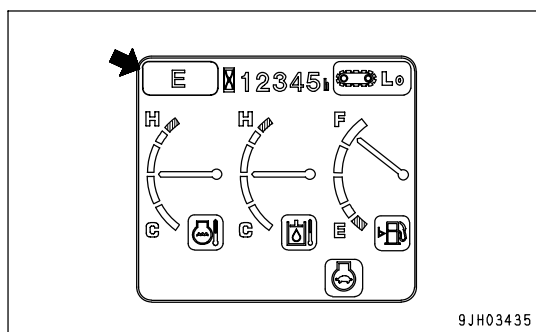

3) Heavy-duty lift

Boom lifting power increased when raising boom independently

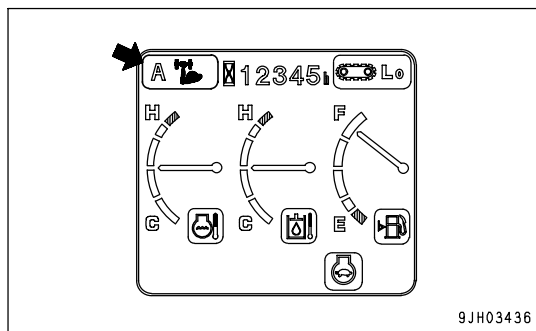

4) Swing priority mode

Priority given to swing when operating boom and swing simultaneously

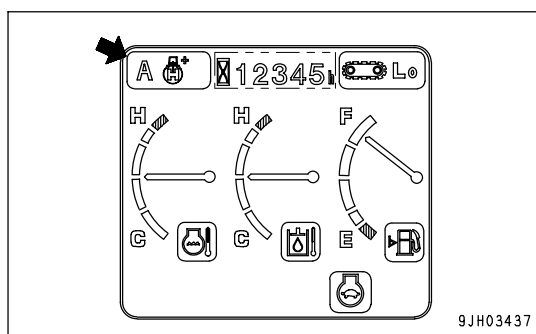

**In Cold Weather Areas**

(AUTOMATIC WARMING-UP OPERATION)

When starting the engine in cold areas, carry out the automatic warming-up operation after starting the engine.

When the engine is started, if the engine water temperature is low (below 30°C (86°F), the warming-up operation is performed automatically.

The automatic warming-up operation is canceled if the engine coolant temperature reaches the specified temperature (30°C (86°F) or if the warming-up operation continues for 10 minutes. If the engine coolant or hydraulic oil temperatures are low after 10 minutes, continue to warm the engine up as follows:

**NOTICE**

- Do not suddenly accelerate the engine before the warming-up operation is completed.  
Do not run the engine at low or high idle continuously for more than 20 minutes. This will cause oil leaks from the turbocharger oil supply piping. If it is necessary to run the engine at idle, apply a load from time to time or run the engine at a mid-range speed.
- Never perform operations or operate the control levers when the hydraulic oil is still a low temperature. Always continue the warming-up operation until the hydraulic oil temperature monitor display is green. This will extend the service life of the machine.

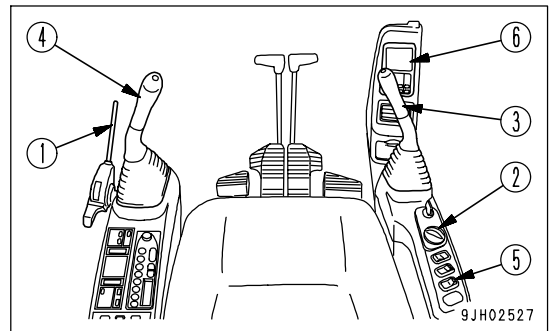

**REMARK**

If the hydraulic oil temperature is low, the hydraulic oil temperature monitor display will be white.

1. Turn fuel control dial (2) to the medium speed position.

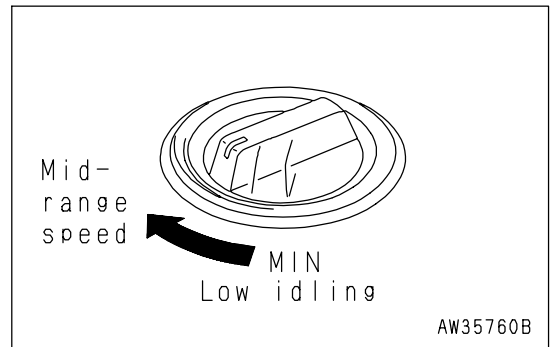

2. Set safety lock lever (1) to the FREE position and raise the bucket from the ground.

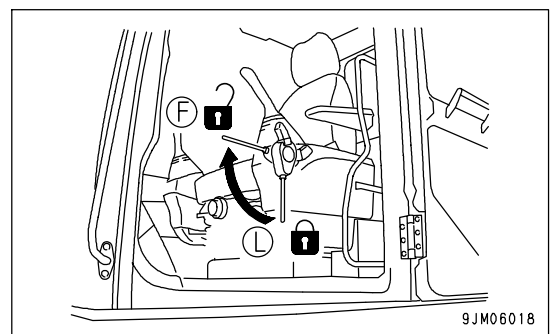



3. Operate bucket control lever (3) and arm control lever (4) slowly to move the bucket cylinder and arm cylinder to the end of the stroke.
4. Operate the bucket for 30 seconds and the arm for 30 seconds in turn fully for 5 minutes.

**NOTICE**

When the work equipment is retracted, take care that it does not interfere with the machine body or ground.

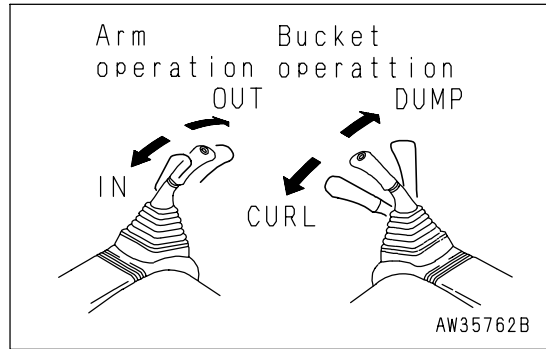

5. After the warming-up operation is completed, check that each gauge and monitor lamp is in the following condition:

- Radiator coolant level monitor (7): OFF
- Engine oil level monitor (8): OFF
- Charge level monitor (9): OFF
- Fuel level monitor (10): Green display
- Engine coolant temperature monitor (11): Green display
- Engine oil pressure monitor (12): OFF
- Engine coolant temperature gauge (13): Indicator in black range
- Fuel gauge (14): Indicator in black range
- Engine pre-heating monitor (15): OFF
- Air cleaner clogging monitor (16): OFF
- Hydraulic oil temperature gauge (17): Indicator in black range
- Hydraulic oil temperature monitor (18): Green display

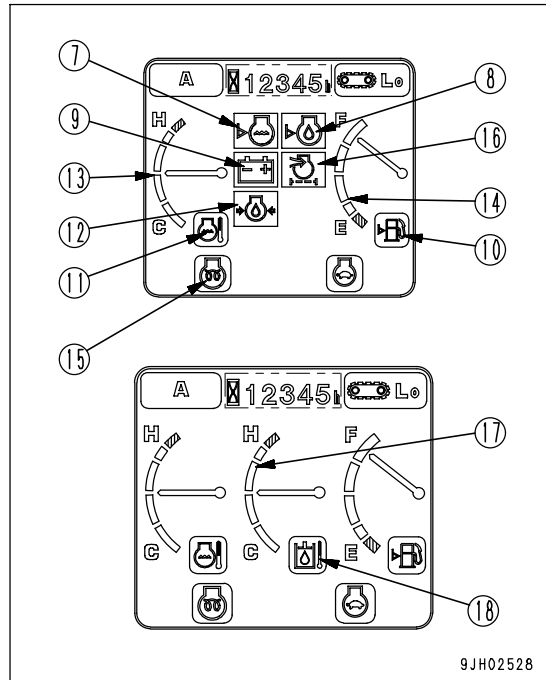

6. Check for abnormal exhaust gas color, noise, or vibration. If any problem is found, contact your Komatsu distributor.

7. If air cleaner clogging monitor (16) lights up, clean or replace the element immediately.

For details of the method of cleaning the element, see "CHECK, CLEAN AND REPLACE AIR CLEANER ELEMENT (PAGE 4-19)".

8. Turn fuel control dial (2) to the full speed (MAX) position and carry out the operation in Step 6. for 3 to 5 minutes.
9. Repeat the following operation 3 - 5 times and operate slowly.

- |                       |                   |
|-----------------------|-------------------|
| Boom operation        | RAISE ↔ LOWER     |
| Arm operation         | IN ↔ OUT          |
| Bucket operation      | CURL ↔ DUMP       |
| Swing operation       | LEFT ↔ RIGHT      |
| Travel (Lo) operation | FORWARD ↔ REVERSE |

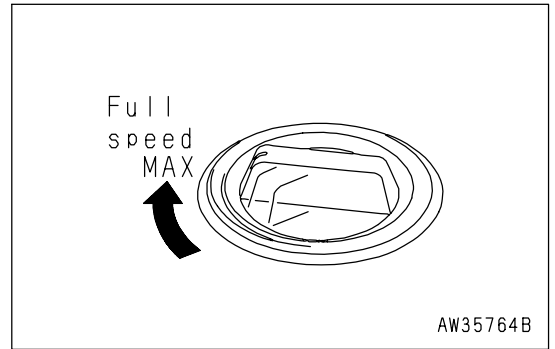

**REMARK**

If the above operation is not carried out, then there may be a delay in response when starting or stopping the actuation of the travel, swing, or work equipment.

10. Use working mode selector switch (19) on machine monitor (6) to select the working mode to be used.

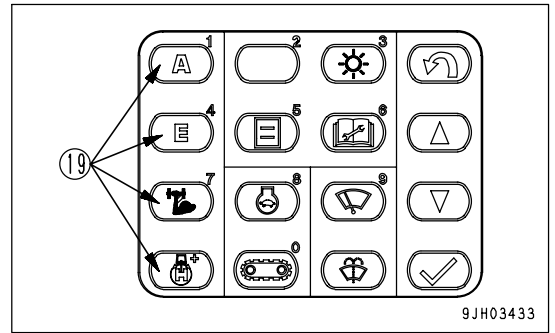

Working mode monitor display

- 1) A mode  
For heavy-load operations

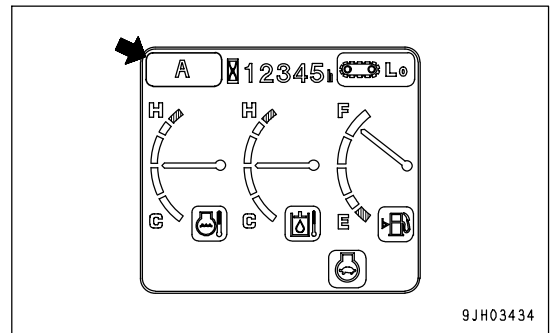

- 2) E mode  
For operations with emphasis on fuel economy

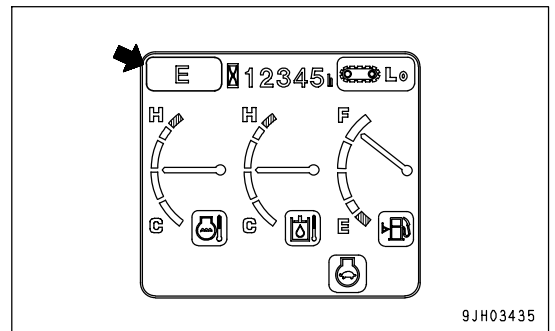

3) Heavy-duty lift

Boom lifting power increased when raising boom independently

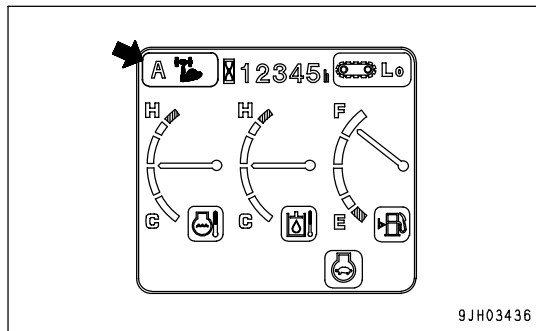

4) Swing priority mode

Priority given to swing when operating boom and swing simultaneously

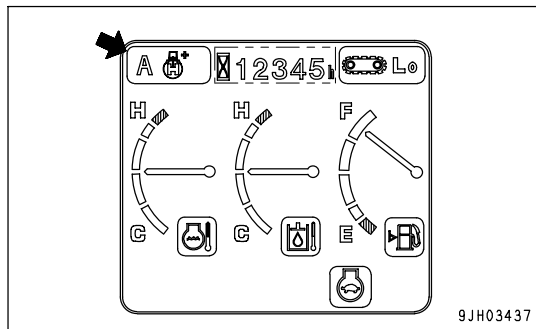

**NOTICE**

**Canceling automatic warm-up operation**

If it becomes necessary in an emergency to cancel the automatic warm-up operation or to lower the engine speed to low idle, do as follows.

- 1] Turn fuel control dial (2) to the full speed (MAX) position and hold it for 3 seconds.

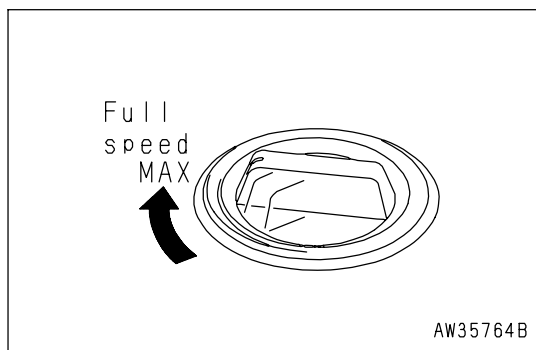

- 2] When fuel control dial (2) is returned to the low idle (MIN) position, the engine speed will drop.

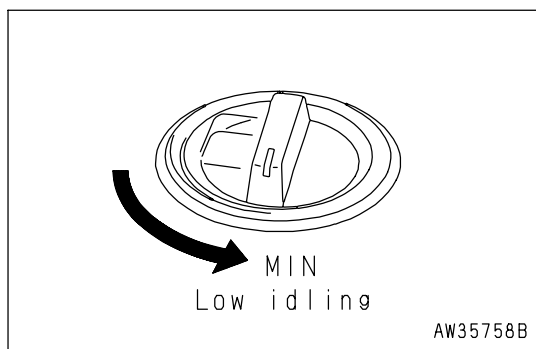

## STOPPING THE ENGINE

### NOTICE

If the engine is stopped abruptly, service life of component parts of the engine may be considerably reduced. Do not stop the engine abruptly except in an emergency. If the engine has overheated, do not try to stop it abruptly but run it at medium speed to allow it to cool down gradually, and then stop it.

1. Run the engine at low idle for about 5 minutes to cool down gradually.
2. Turn the key in starting switch (1) to the OFF position and stop the engine.
3. Remove the key from starting switch (1).

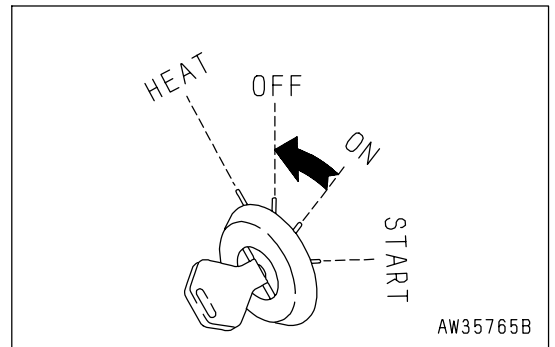
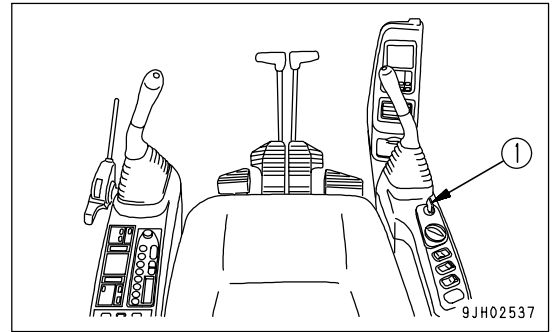

## MACHINE OPERATION

### Preparations for Moving the Machine

**! WARNING**

- Before operating the steering levers, check the direction of the track frame.  
If the sprocket is at the front, the operation of the travel levers is reversed.
- When moving the machine, check that the area around the machine is safe, and always sound the horn before moving.
- Do not allow anyone in the area around the machine.
- Remove all obstacles from the travel path of the machine.
- The rear of the machine is a blind spot, be extremely careful when traveling in reverse.
- If the lever is moved inside the deceleration range, engine speed will rise suddenly. Operate the levers carefully.
- For machines equipped with a travel alarm, check that the warning equipment works properly.

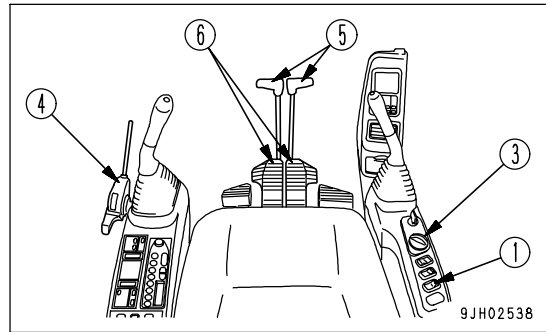

1. Set swing lock switch (1) to the ON (actuated) position and confirm that swing lock monitor lamp (2) lights up.

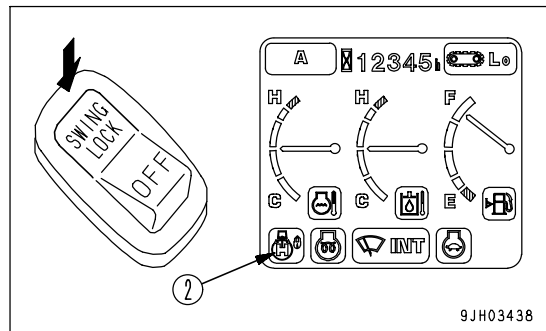

2. Turn fuel control dial (3) towards the full speed position to increase the engine speed.

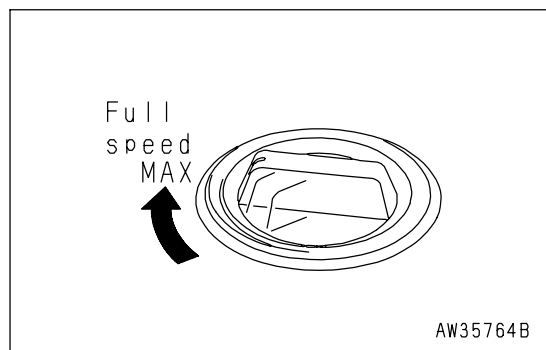

### Moving Machine Forward

1. Set safety lock lever (4) in the FREE position, fold the work equipment, and raise it 40 to 50 cm (16 to 20 in) from the ground.

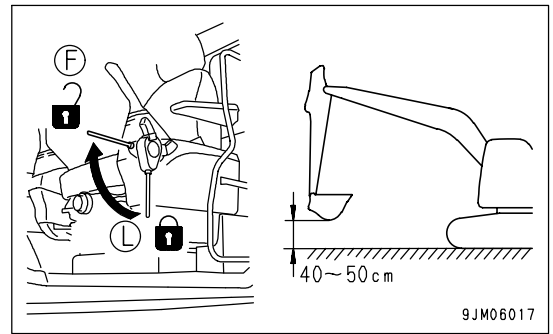

2. Operate the right and left travel levers (5), or the right or left travel pedals (6) as follows:

- When sprocket (A) is at the rear of the machine:  
Slowly push the levers (5) forward, or slowly depress the front part of the pedals (6) to move the machine forward.

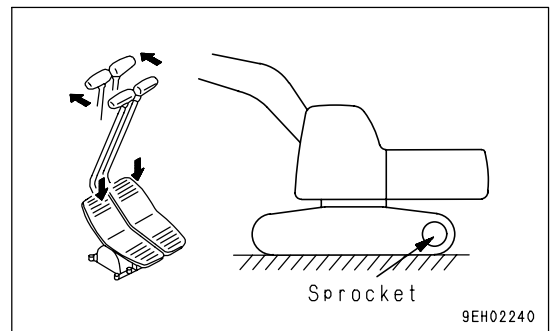

- When sprocket (A) is at the front of the machine:  
Slowly pull the levers (5) backward, or slowly depress the rear part of the pedals (6) to move the machine forward.

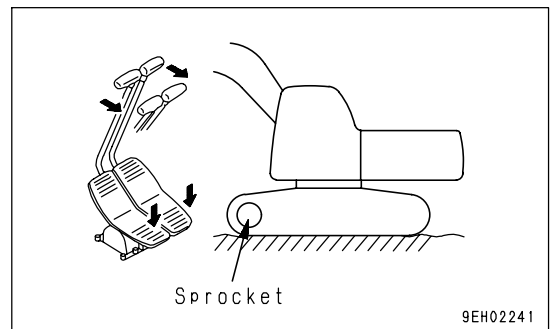

3. For machines equipped with a travel alarm, check that the alarm sounds. If the alarm does not sound, contact your Komatsu distributor for repairs.

### REMARK

In cold temperatures, if the machine travel speed is not normal, thoroughly perform the warming-up operation. In addition, if the undercarriage is clogged with mud and the machine travel speed is not normal, remove the soil and mud from the undercarriage.

### Moving Machine Backward

1. Set safety lock lever (4) in the FREE position, fold the work equipment, and raise it 40 to 50 cm (16 to 20 in) from the ground.

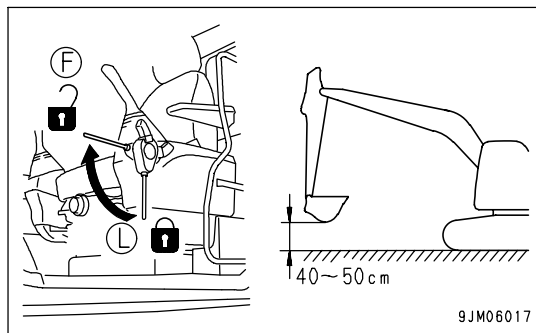

2. Operate the right and left travel levers (5), or the right or left travel pedals (6) as follows:

- When sprocket (A) is at the rear of the machine:  
Slowly pull the levers (5) backward, or slowly depress the rear part of the pedals (6) to move the machine backward.

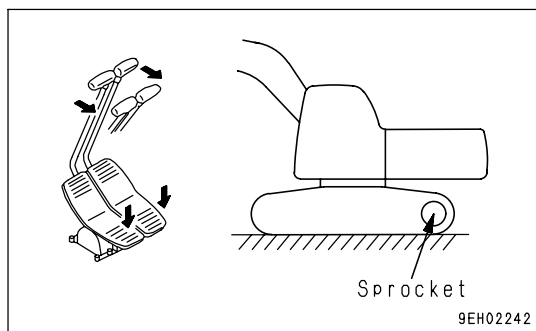

- When sprocket (A) is at the front of the machine:  
Slowly push the levers (5) forward, or slowly depress the front part of the pedals (6) to move the machine backward.

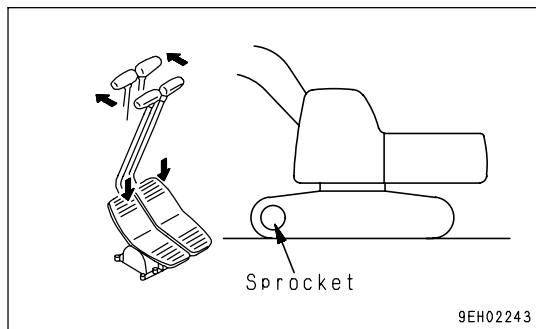

3. For machines equipped with a travel alarm, check that the alarm sounds. If the alarm does not sound, contact your Komatsu distributor for repairs.

## Stopping Machine

Avoid stopping suddenly. Give yourself ample room when stopping.

1. Put the left and right travel levers (1) in the neutral position, then stop the machine.

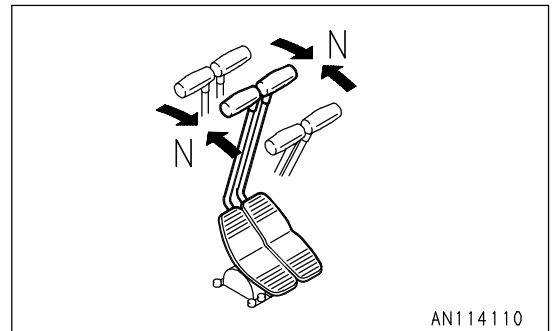
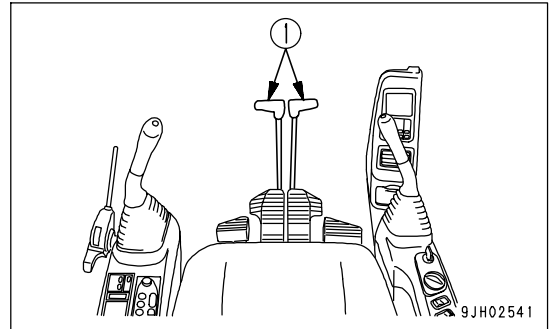



## STEERING THE MACHINE

### Steering

 **WARNING**

Before operating the travel levers, check the direction of the track frame (the position of the sprocket). If the sprocket is at the rear, the machine moves in the reverse direction to the operation of the travel levers.

Use the travel levers to change direction.  
 Avoid sudden changes of direction as much as possible.  
 Especially when performing counter-rotation (spin turn), stop the machine before turning.  
 Operate two travel levers (1) as follows.

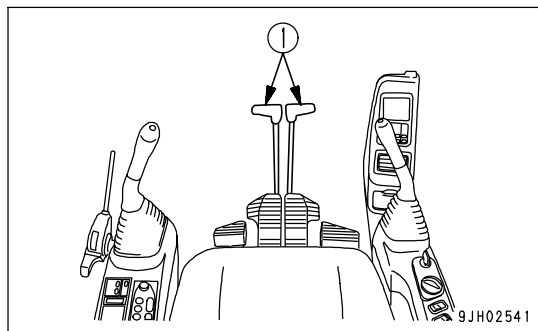

### Steering the Machine when Stopped

When turning to the left:  
 Push the right travel lever forward to turn to the left when traveling forward; and pull it back to turn left when traveling in reverse.

**REMARK**  
 When turning to the right, operate the left travel lever in the same way.

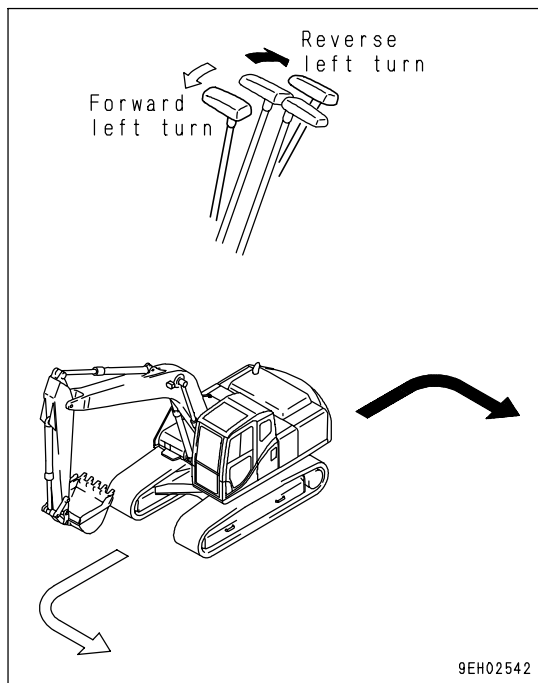

**Changing Direction of the Machine**

When turning to the left:

If the left travel lever is returned to the neutral position, the machine will turn to the left.

**REMARK**

When turning to the right, operate the right travel lever in the same way.

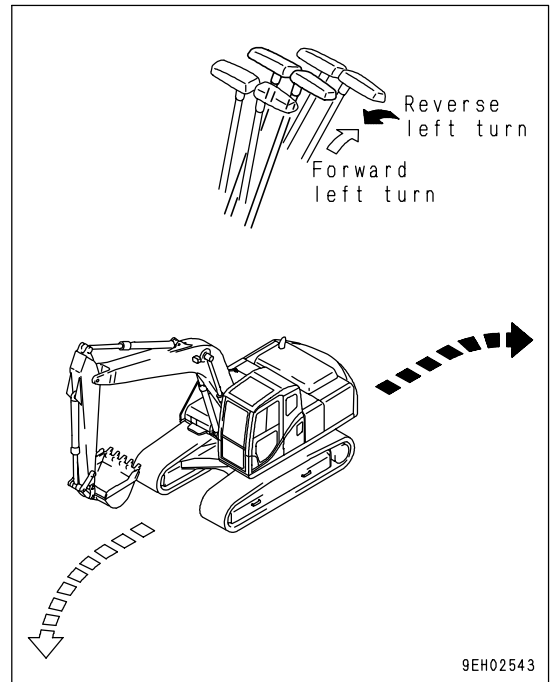

**Counter-rotation Turn (Spin Turn)**

When using counter-rotation (spin turn) to turn left, pull the left travel lever back and push the right travel lever forward.

**REMARK**

When using counter-rotation to turn right, pull the right travel lever back and push the left travel lever forward.

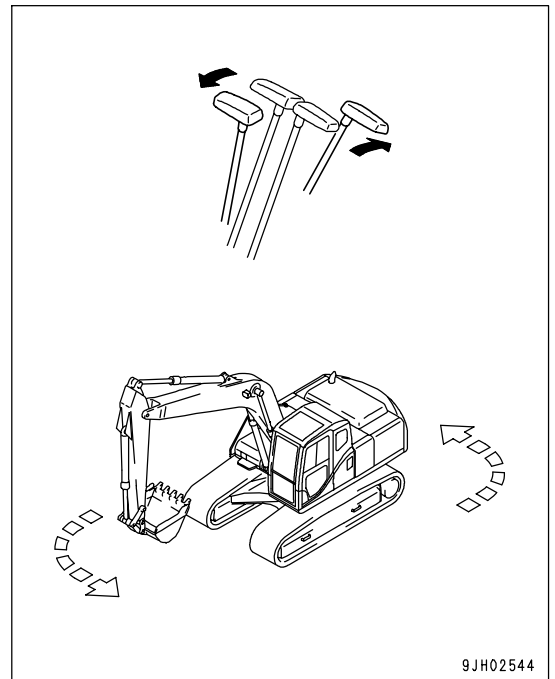

## SWINGING



### WARNING

The tail of the machine extends outside the tracks. Before operating the swing, check that the area around the machine is safe.

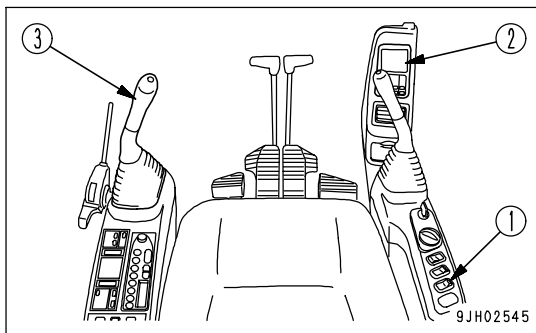

1. Before starting the swing operation, turn swing lock switch (1) OFF and check that swing lock monitor (2) has gone out.

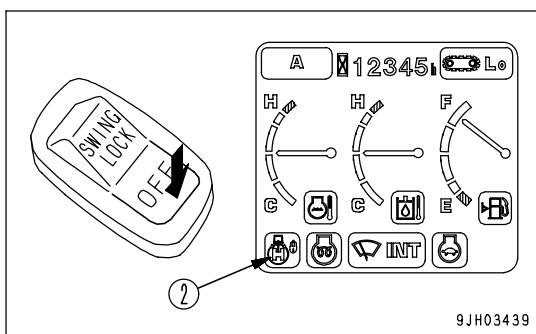

2. Operate left work equipment control lever (3) to swing the upper structure.

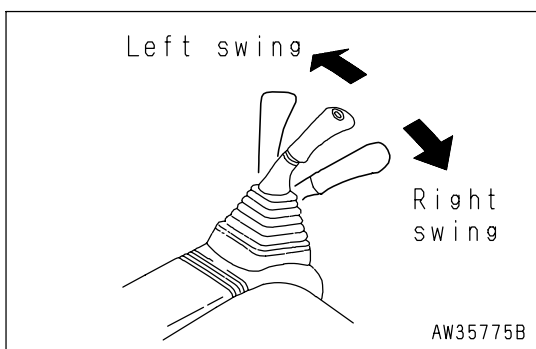

3. When not using the swing, turn swing lock switch (1) ON. Check that swing lock monitor (2) lights up.

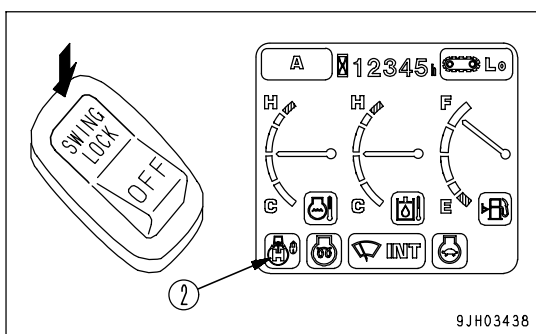

## WORK EQUIPMENT CONTROLS AND OPERATIONS

**WARNING**

- If the lever is operated when the engine speed has been lowered by the auto-deceleration function, the engine speed will suddenly rise, so operate the levers carefully.

The work equipment is operated by the left and right work equipment control levers. The left work equipment control lever operates the arm and swing, and the right work equipment control lever operates the boom and bucket.

The movements of the lever and work equipment are as shown in the diagrams on the right. When the levers are released, they automatically return to the neutral position and the work equipment is held in place.

- If the work equipment control levers are returned to the neutral position when the machine is stopped, even if the fuel control dial is set to FULL, the auto-deceleration mechanism will act to reduce the engine speed to a mid-range speed.

**REMARK**

With this machine, an accumulator is installed in the operating circuit, if less than 15 seconds has passed since the engine was stopped, when the starting switch is turned to the ON position even with the engine stopped, it is possible to operate the levers to lower work equipment to the ground.

In addition, this operation can also be used to release the remaining pressure in the hydraulic cylinder circuit or to lower the boom after the machine has been loaded onto a trailer.

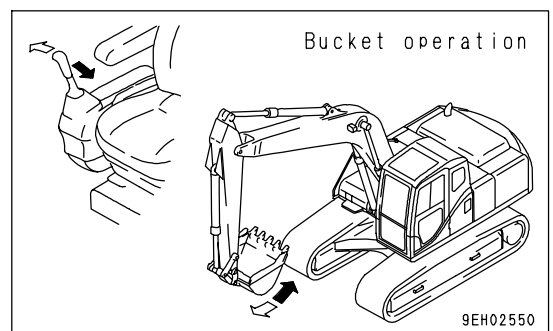
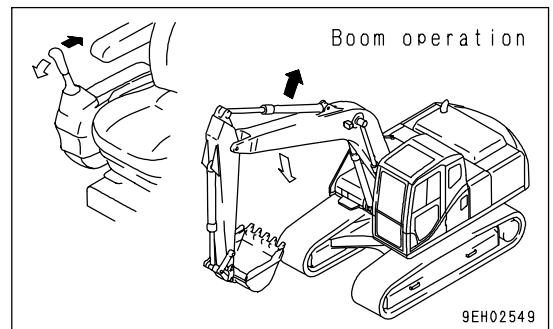
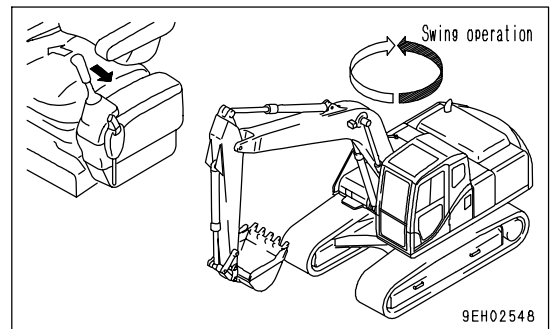
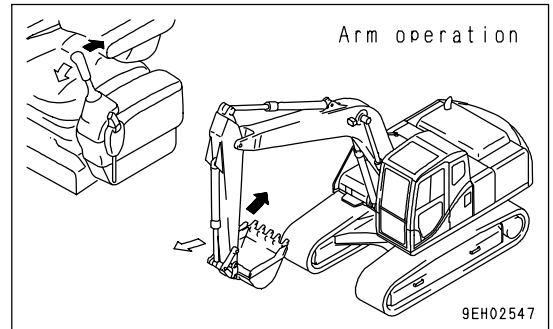

## WORKING MODE

### Working Mode

The mode selector switch can be used to switch the mode to match operating conditions and purpose, thereby enabling work to be performed efficiently.

Make effective use of each mode as follows.

When the starting switch is turned to the ON position, the working mode is set to A mode (digging).

Use the working mode switch to set the mode to the most efficient mode to match the type of work.

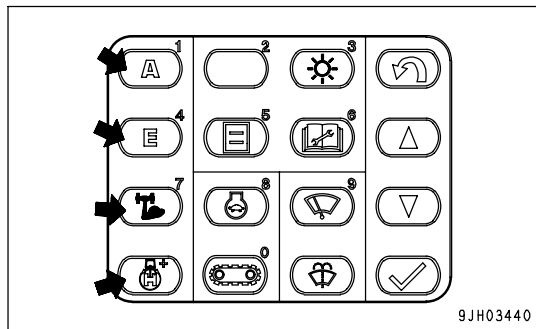

| Working mode        | Applicable operations  |
|---------------------|--|
| A mode              | Normal digging, loading operations<br>(Operations with emphasis on productivity)                             |
| E mode              | Normal digging, loading operations<br>(operation with emphasis on fuel economy)                              |
| Heavy-duty lift     | Normal digging, loading operations<br>(boom lifting power increased when raising boom independently)         |
| Swing priority mode | Normal digging, loading operations<br>(priority given to swing when operating boom and swing simultaneously) |

## PROHIBITED OPERATIONS



### WARNING

- If the lever is operated when the engine speed has been lowered by the auto-deceleration function, the engine speed will suddenly rise, so operate the levers carefully.

#### Operations Using Swing Force

Do not use the swing force to compact soil or break objects. This is not only dangerous, but will also drastically reduce the life of the machine.

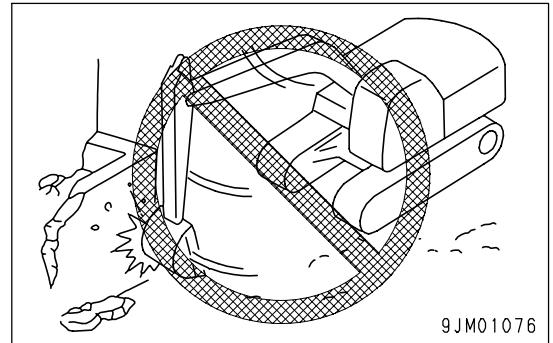

#### Operations Using Travel Force

Do not dig the bucket into the ground and use the travel force to carry out excavation. This will damage the machine or work equipment.

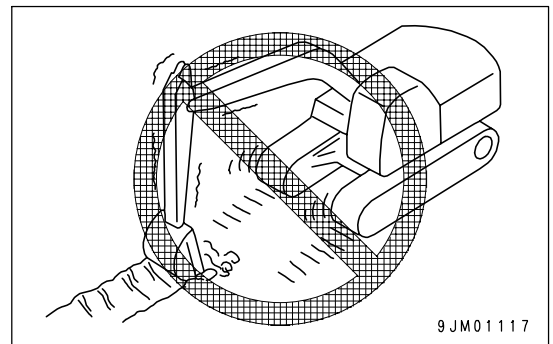

#### Prohibition of Operations Using Hydraulic Cylinders to Stroke Ends

If the work equipment is used with the cylinder rod operated to its stroke end, and given impact by some external force, the hydraulic cylinders will be damaged, causing personal injury. Avoid operations with the hydraulic cylinder fully retracted or fully extended.

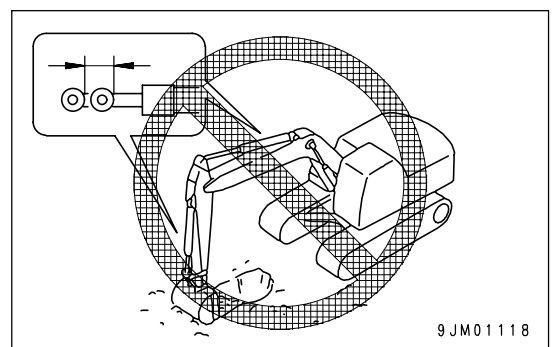

**Operations Using Bucket Dropping Force**

Do not use the dropping force of the machine for digging, or use the dropping force of the bucket as a pickaxe, breaker, or pile driver. This will drastically reduce the life of the machine.

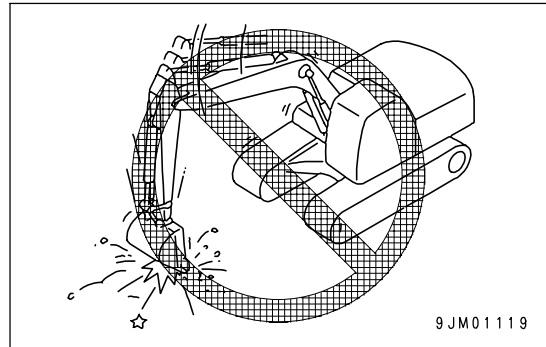

**Operations Using Machine Dropping Force**

Do not use the dropping force of the machine for digging.

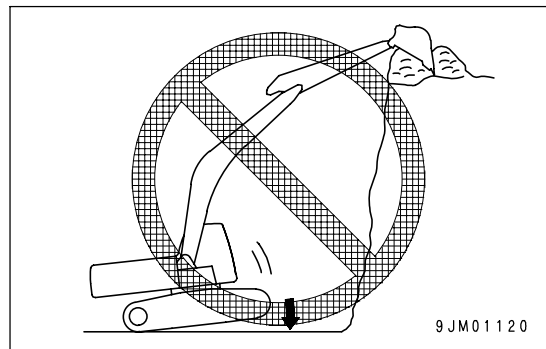

**Digging Hard Rocky Ground**

Do not attempt to directly excavate hard rocky ground with the work equipment. It is better to excavate it after breaking up by some other means. This will not only save the machine from damage but will make for better economy.

**Sudden Lever Shifting High Speed Travel**

- (1) Never carry out sudden lever shifting as this may cause sudden starting.
- (2) Avoid sudden lever shifting from forward to reverse (or from reverse to forward).
- (3) Avoid sudden lever shifting change such as sudden stopping from near top speed (lever release operation).

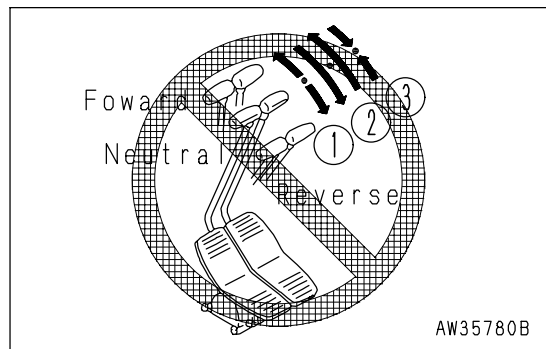

## GENERAL OPERATION INFORMATION

### Traveling

Traveling over boulders, tree stumps, or other obstacles will cause a big shock to the chassis (and in particular to the tracks), and this will cause damage to the machine. For this reason, always remove any obstacles or travel around them, or take other steps to avoid traveling over such obstacles as far as possible.

If there is no way to avoid traveling over an obstacle, reduce the travel speed, keep the work equipment close to the ground, and try to travel so that the center of the track passes over the obstacle.

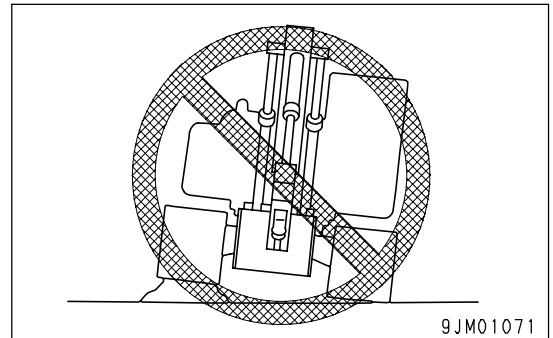

### High Speed Travel

On uneven roadbeds such as rock beds or uneven roads with large rocks, travel at Lo speed. When traveling at high speed, set the idler in the forward direction.

- To switch the travel speed, press travel speed selector switch (1). The travel speed is displayed as Lo, Mi, or Hi on the monitor display.

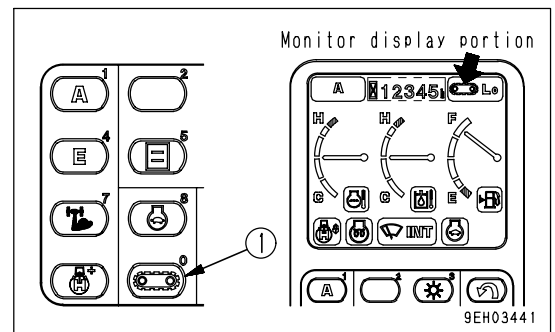

### Precautions when Carrying Out Operations Continually with the Work Equipment in the Same Posture

Precautions when carrying out operations continually with the work equipment in the same posture.

When operations are carried out continuously with the cylinder operated slightly, operate the cylinder occasionally by a large amount to ensure greasing of the work equipment pins. This will prevent loss of grease at the pins.



**Permissible Water Depth****NOTICE**

When driving the machine out of water, if the angle of the machine exceeds 15°, the rear of the upper structure will go under water, and water will be thrown up by the cooling fan. This may cause the fan to break.

Be extremely careful when driving the machine out of water.

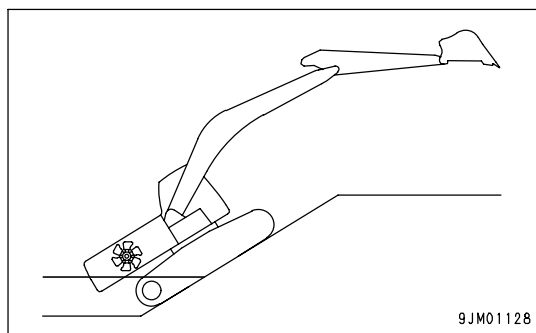

Do not drive the machine in water deeper than the center of carrier roller (1).

Supply grease to the parts which have been under water for a long time until the used grease is projected out of the bearings (around the bucket pin, in particular).

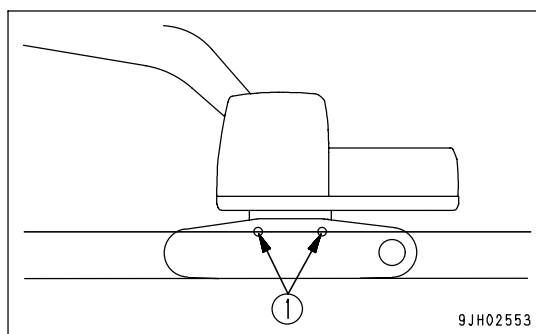

TRAVELING ON SLOPES

**! WARNING**

- Turning or operating the work equipment when working on slopes may cause the machine to lose its balance and turn over, so avoid such operations.  
It is particularly dangerous to swing downhill when the bucket is loaded. If such operations have to be carried out, pile soil to make a platform on the slope so that the machine can be kept horizontal when operating.
- Do not travel up or down steep slopes. There is danger that the machine may turn over.
- When traveling, raise the bucket approx. 20 to 30 cm (8 to 12 in) from the ground.  
Do not travel downhill in reverse.
- Never turn on slopes or travel across slopes.  
Always go down to a flat place to perform these operations. It may be longer, but it will ensure safety.
- Always operate or travel in such a way that it is possible to stop safely at any time if the machine slips or becomes unstable.
- When traveling uphill, if the shoes slip or it is impossible to travel uphill using only the force of the tracks, do not use the pulling force of the arm to help the machine travel uphill. There is danger that the machine may turn over.

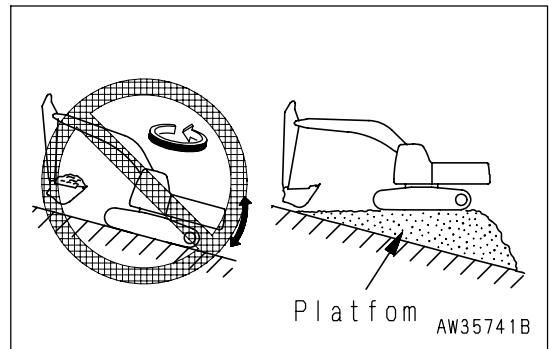
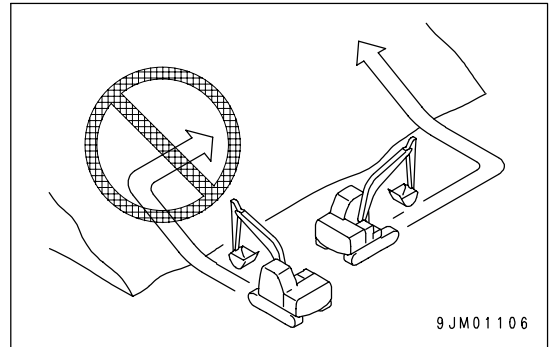

1. When traveling down steep hills, use the travel lever and fuel control lever to keep the travel speed low.  
When traveling down slopes of more than 15°, set the work equipment in the posture shown in the figure on the right, and lower the engine speed.

**REMARK**

Travel down hills with the sprocket side down.  
If the machine travels down with the sprocket side up, the track tends to become loose, and that can cause skipping pitches.

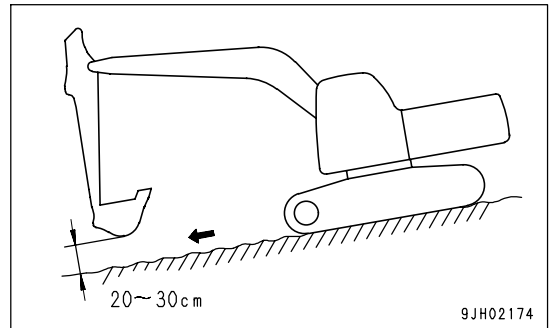

2. When traveling up a steep hill of more than 15°, set the work equipment to the posture shown in the diagram on the right.

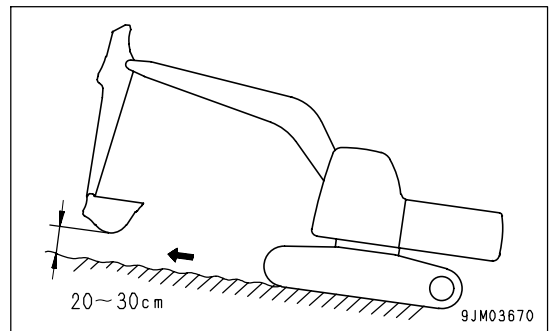

- When traveling up a steep slope, extend the work equipment to the front to improve the balance, keep the work equipment approximately 20 to 30 cm (8 to 12 in) above the ground, and travel at low speed.

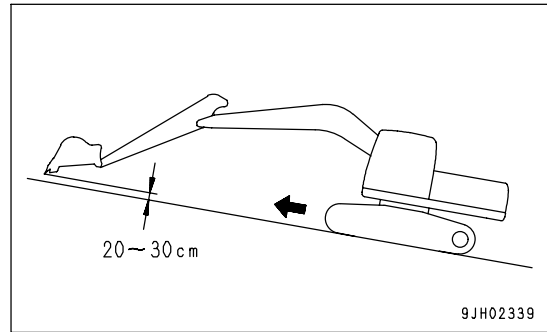

### Traveling Downhill

Put the travel lever in the neutral position. This will cause the brake to be automatically applied.

### Engine Stopped on Slope

If the engine stops when traveling uphill, move the travel levers to the neutral position, lower the bucket to the ground, stop the machine, then start the engine again.

### Cab Doors on Slope

- If the engine stops when the machine is on a slope, never use the left work equipment control lever to carry out swing operations. The upper structure will swing under its own weight.

## ESCAPE FROM MUD

Always operate carefully to avoid getting stuck in mud. If the machine does get stuck in mud, do as follows to get the machine out.

- Place the machine push-up switch at position (1). This will increase the pushing power of the boom and make it easier to escape.

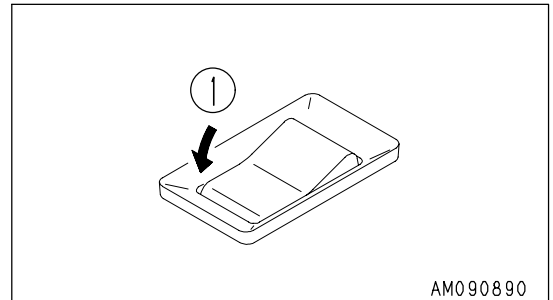

## Track on One Side Stuck

### NOTICE

When using the boom or arm to raise the machine, always have the bottom of the bucket in contact with the ground. The angle between the boom and arm should be 90° to 110°.

The same applies when using the bucket installed in the reverse direction.

When only one side is stuck in mud, use the bucket to raise the track, then lay boards or logs and drive the machine out.

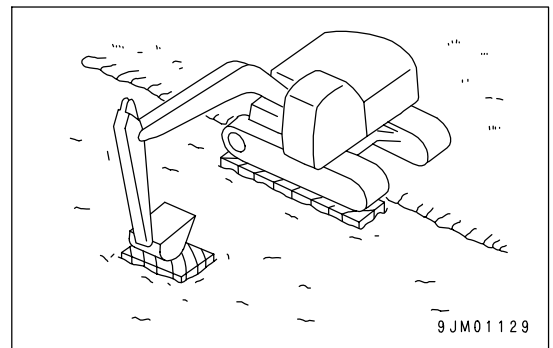

## Tracks on Both Sides Stuck

When the tracks on both sides are stuck in mud and they slip, making it impossible for the machine to move, lay boards or logs as explained above, and dig the bucket into the ground in front. Then pull in the arm as in normal digging operations and put the travel levers in the FORWARD position to pull the machine out.

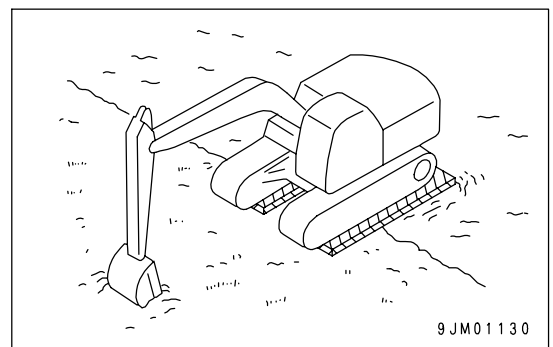

### RECOMMENDED APPLICATIONS

In addition to the following, it is possible to further increase the range of applications by using various attachments.

#### Backhoe Work

A backhoe is suitable for excavating areas that are lower than the machine.

When the condition of the machine is as shown in the diagram on the right (angle between [bucket cylinder and link] and [arm cylinder and arm] is 90°), the maximum excavation force is obtained from the pushing force of each cylinder.

When excavating, use this angle effectively to optimize your working efficiency.

The range for excavating with the arm is from a 45° angle away from the machine to a 30° angle towards the machine.

There may be some differences depending on the excavation depth, but try to stay within the above range rather than operating the cylinder to the end of its stroke.

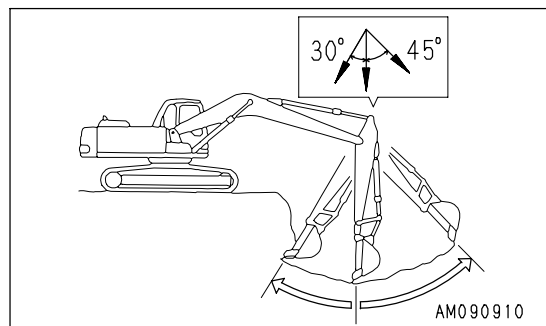
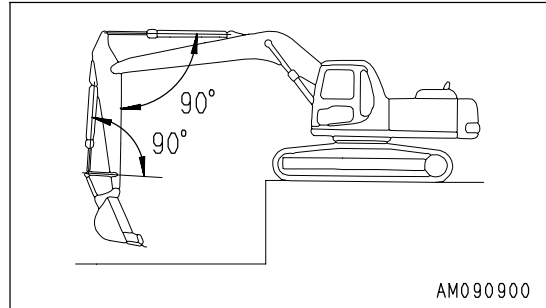

#### Ditching Work

Ditching work can be performed efficiently by attaching a bucket which matches the digging operation and then setting the tracks parallel to the line of the ditch to be excavated.

To excavate a wide ditch, first dig both sides and then finally remove the center portion.

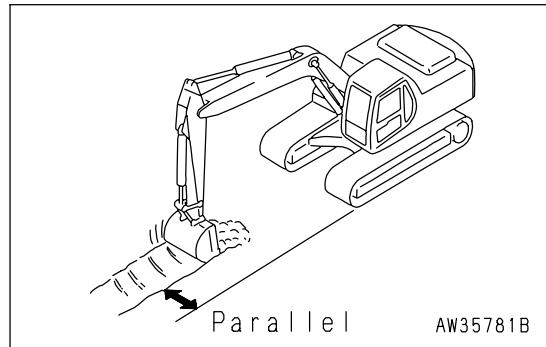

#### Loading Work

In places where the swing angle is narrow, work efficiency can be enhanced by locating the dump truck in a place easily visible to the operator.

Loading is easier and capacity greater if you begin from the front of the dump truck body than if loading is done from the side.

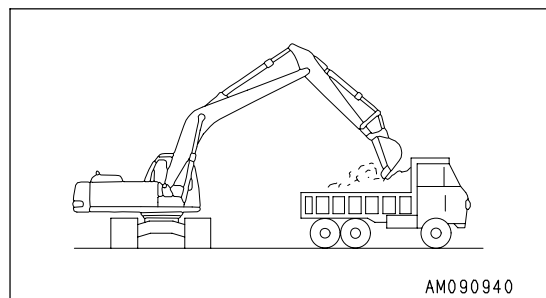

## BUCKET REPLACEMENT



### WARNING

- When pins are knocked in with a hammer, pieces of metal may fly and cause serious injury.  
When carrying out this operation, always wear goggles, hard hat, gloves, and other protective equipment.
- When the bucket is removed, place it in a stable condition.
- If pins are hit with a strong force, there is a hazard that the pin may fly out and injure people in the surrounding area. Make sure that there is no one in the surrounding area before starting the operation.
- When removing the pins, do not stand behind the bucket. In addition, be extremely careful not to put your foot under the bucket while standing at the side for the work.
- When removing or inserting pins, be extremely careful not to get your fingers caught.
- Never insert your fingers into the pin holes when aligning the holes.

Stop the machine on a firm and flat surface and do the work. When performing joint work, appoint a lead and follow that person's instructions and signals.

### Replacement

1. Place the bucket in contact with a flat surface.

#### NOTICE

When removing the bucket, set the bucket cylinder facing down as shown in the diagram in the right to prevent the front link from jumping up under the weight of the bucket cylinder.

#### REMARK

When removing the pins, place the bucket so that it is in light contact with the ground.

If the bucket is lowered strongly to the ground, the resistance will be increased and it will be difficult to remove the pins.

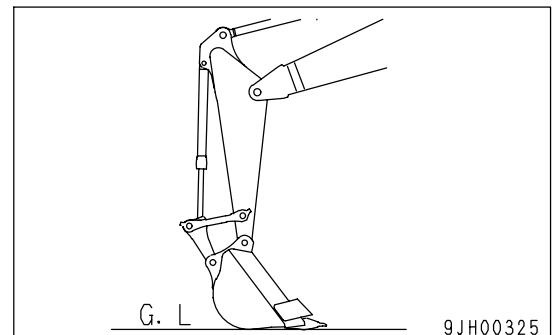

- Remove the stopper bolts and nuts, then remove pins (A) and (B), and remove the bucket.

**NOTICE**

After removing the pins, make sure that mud or sand does not get on them. Dust seals are fitted at both ends of the bushings, be careful not to damage them.

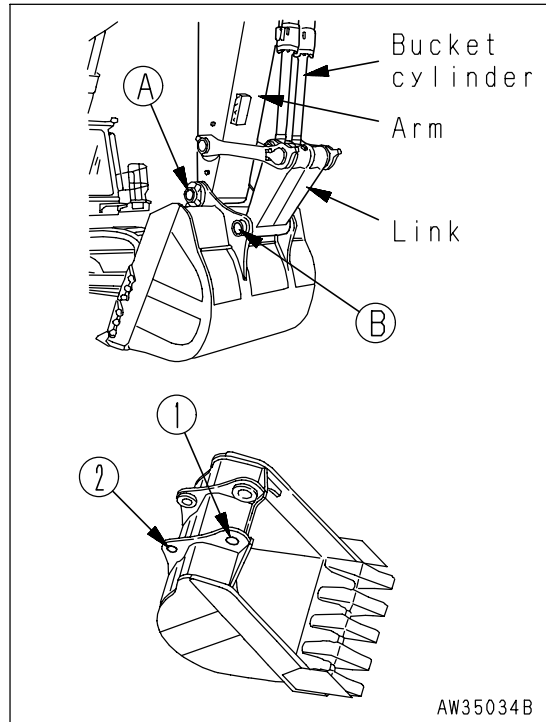

- Align the arm with holes (1) of the replacement bucket and the link with holes (2), then insert grease-coated pins (A) and (B) into hole (1) and hole (2) respectively.

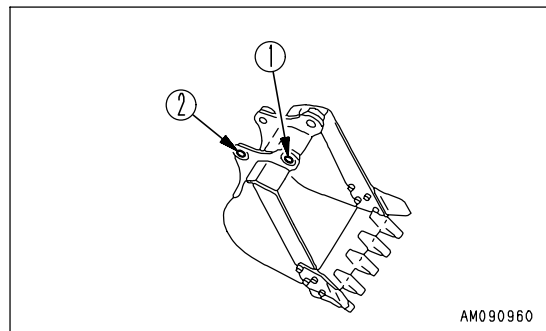

**REMARK**

- Carry out installation in the reverse order to removal.
- When installing the bucket, it is easy to damage the O-ring, so fit the O-ring to the arm in the position shown in the diagram on the right. After inserting the pin, fit the O-ring correctly in the groove.
- Install the stopper bolts and nuts for each pin, then grease the pin.

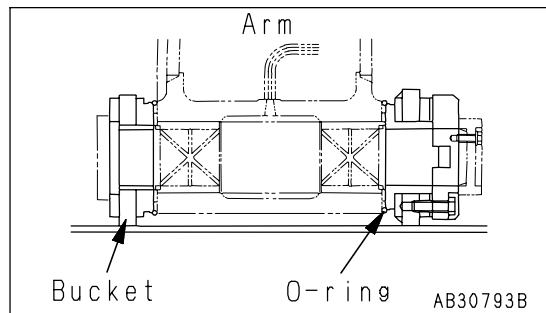

**PARKING MACHINE**

**⚠ WARNING**

- Avoid stopping suddenly. Give yourself ample room when stopping.
- When stopping the machine, select flat hard ground and avoid dangerous places. If it is unavoidably necessary to park the machine on a slope, insert blocks underneath the track shoes. As an additional safety measure, thrust the bucket into the ground.
- If the control lever is touched by accident, the work equipment or the machine may move suddenly, and this may lead to a serious accident. Before leaving the operator's compartment, always set the lock lever securely to LOCK position.

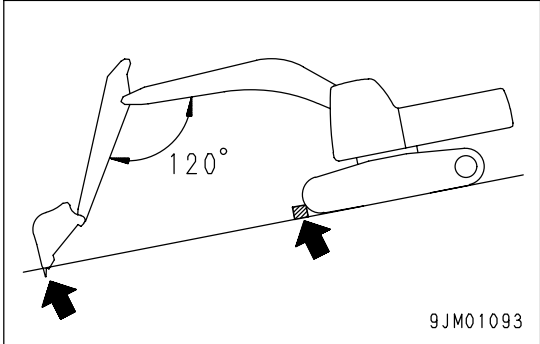

1. Put left and right travel levers (1) in the neutral position.  
The machine stops.

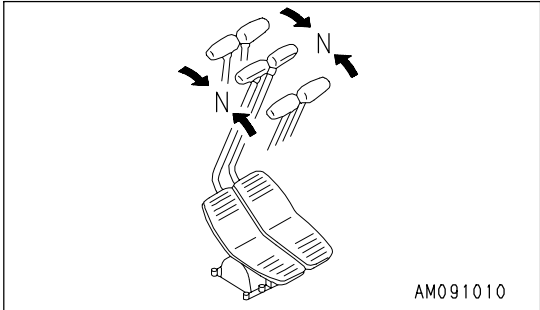
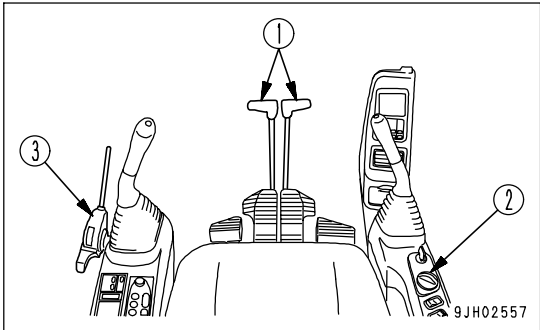

2. Turn fuel control dial (2) to lower the engine speed to low idle.

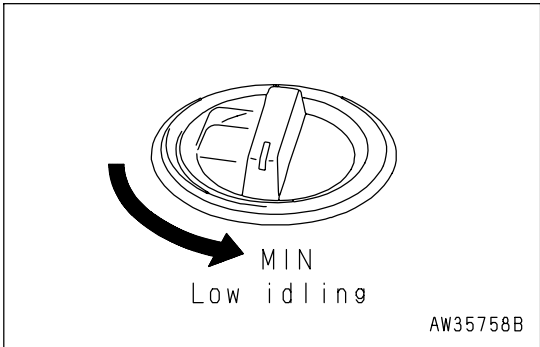



3. Lower the bucket horizontally until the bottom touches the ground.

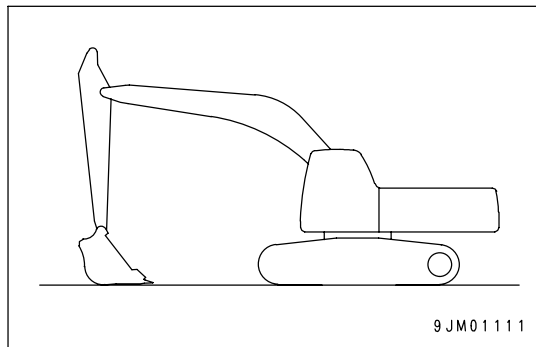

4. Set lock lever (3) in the LOCK position.

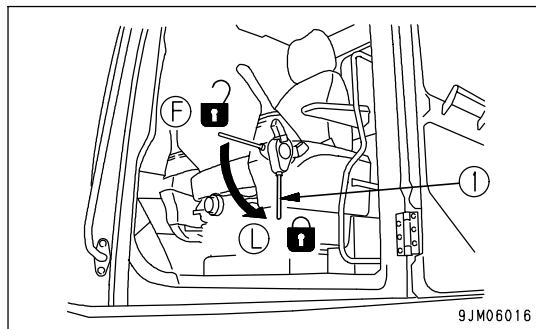

### CHECK AFTER SHUT OFF ENGINE

Check the engine coolant temperature, engine oil pressure, and fuel level on the machine monitor.

**REMARK**

After stopping the engine, if the starting switch is turned within approx. 10 seconds to the ON or START position to start the engine again, the monitor display is not reset, and the screen before the starting switch was turned OFF is displayed.

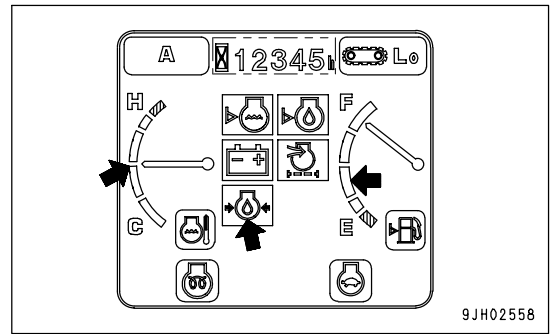

### MACHINE INSPECTION AFTER DAILY WORK

1. Walk around the machine and check the work equipment, machine exterior, and undercarriage, also check for any leakage of oil or coolant. If any problems are found, repair them.
2. Fill the fuel tank.
3. Check the engine compartment for paper and debris. Clean out any paper and debris to avoid a fire hazard.
4. Remove any mud affixed to the undercarriage.

### LOCKING

Always lock the following places.

- (1) Door of operator's cab  
Always remember to close the window.
- (2) Fuel tank filler port
- (3) Door of engine room [3 place]
- (4) Battery box cover
- (5) Left side door of the machine (pump room 1 place)
- (6) Tool box upper cover
- (7) Hydraulic tank filler port
- (8) Maintenance floor entrance

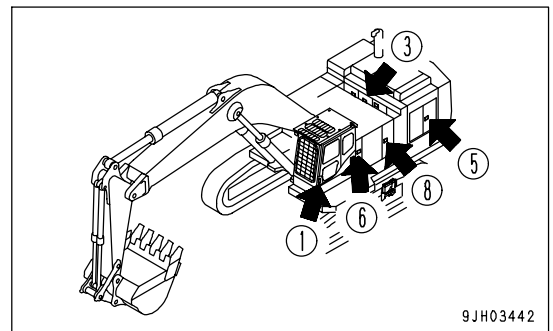

**REMARK**

Use the starting switch key to lock and unlock all these places.

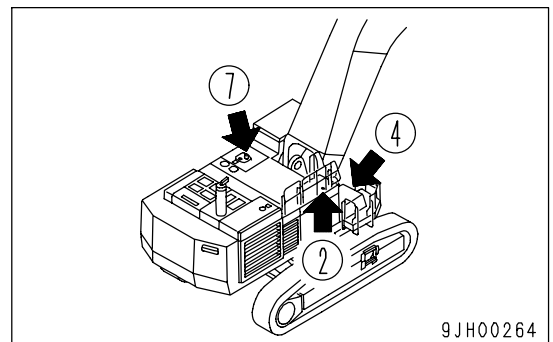

## TRANSPORTATION

When transporting the machine, observe all related laws and regulations, and be careful to assure safety.

### PRECAUTIONS FOR TRANSPORTATION



#### WARNING

This machine must be disassembled for transportation. When transporting the machine, please consult your Komatsu distributor.

### LIFTING MACHINE



#### WARNING

- Never perform lifting operations with any person on the machine.
- Always make sure that the wire rope (cable) used for lifting the machine is of ample strength for the weight of the machine.
- Never try to lift the machine in any posture other than the posture given in the procedure below.  
There is danger that the machine may lose its balance.
- When lifting the machine, pay careful attention to the center of gravity to maintain the balance.

When lifting the machine, perform the operation on flat ground as follows:

#### 1. Lifting machine

(Upper structure)

Fit wires to boom foot pins (1) and lifting (2) in the revolving frame, then lift the machine.

- The lifting load is 24.3 tons.

Pin diameter at lifting position : 160mm(6.30in)

(G):center of gravity.

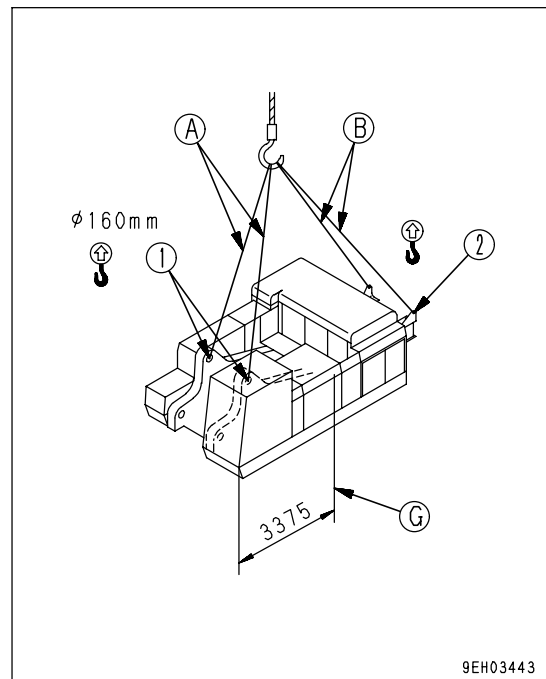

2. Combination of wire length

The length of the wire is the length from the pin and center of the hole.

- When using the following wire, use wire of more than the length given below.
- In addition, select a wire length that will bring the lifting position directly above the center of gravity of the machine.

|     | Unit       | Combination     |
|-----|------------|-----------------|
| (A) | mm (ft in) | 70,00 (22' 12") |
| (B) | mm (ft in) | 80,00 (26' 3")  |

3. After the machine comes off the ground, check the hook condition and the lifting posture, and then lift slowly.

**SHIPPING MACHINE INFORMATION**

**! WARNING**

- When loading the machine, choose firm level ground. Keep well away from the road shoulder.
- Run the engine at low speed and operate slowly.

After placing the machine on the specified position of the trailer, secure it according to the following procedure.

1. Secure control levers with the work equipment lock lever.

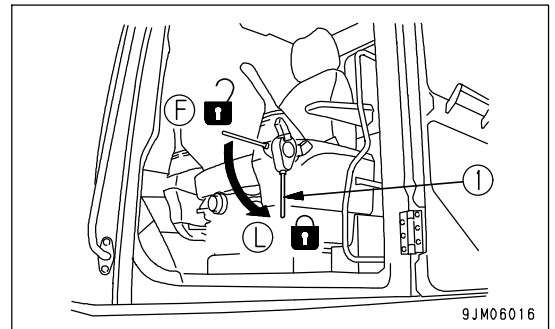

### TRANSPORTATION POSTURE

This machine can be divided into four units for transportation.

#### Four Units for Transportation

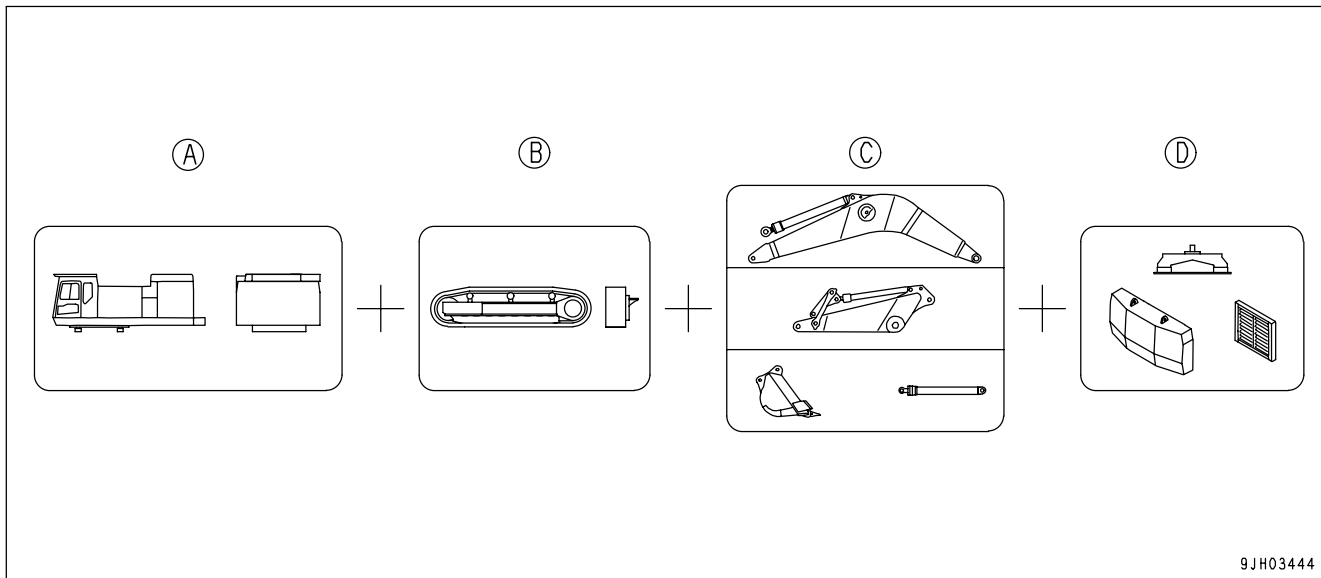

9JH03444

(A) Upper structure  
(B) Undercarriage

(C) Work equipment  
(D) Others

#### Posture for Each Unit

(dimensions in diagram are in mm.)

#### Upper Structure

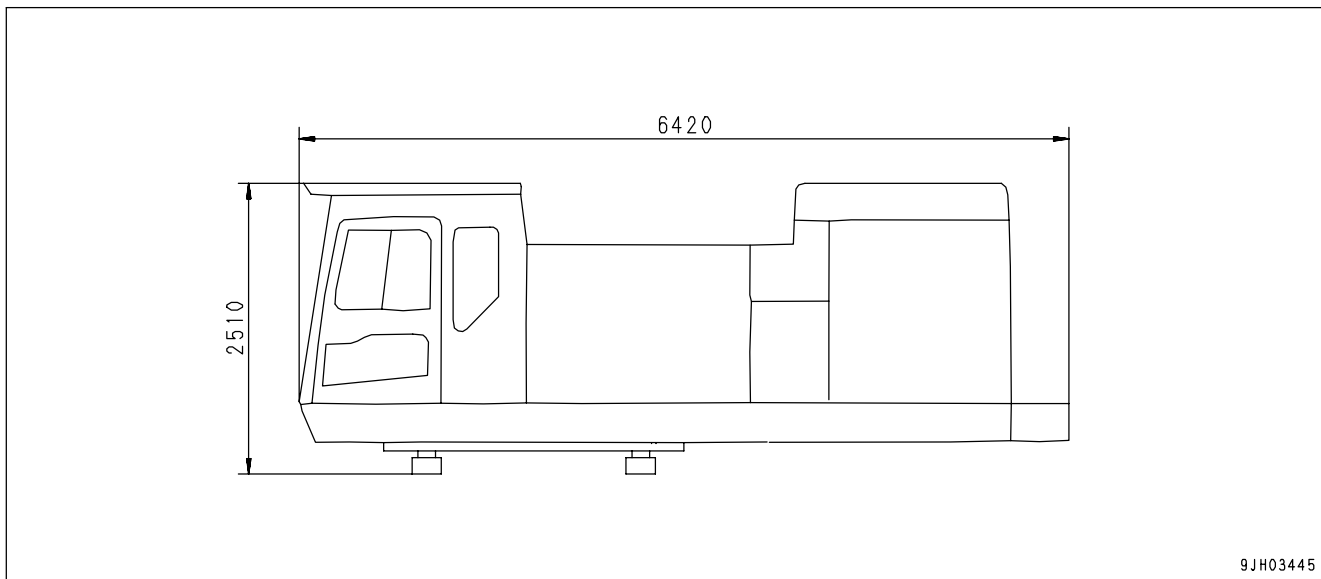

9JH03445

Secure the upper structure to the platform with a chain and block.

| Unit          |            | same for all models |
|---------------|------------|---------------------|
| Overall width | mm (ft in) | 3490 (11'5")        |
| Weight        | kg (lb)    | 24,300 (53,582)     |

Undercarriage

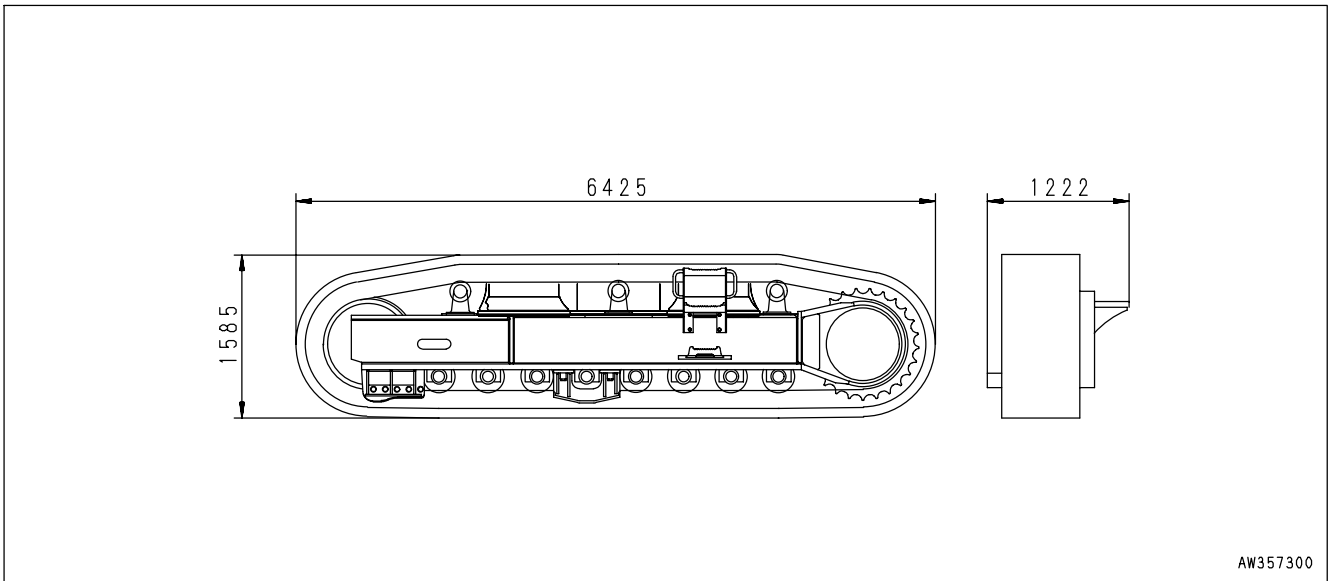

If there is a warning tag hanging on the work equipment control lever, do not start the engine.

|        |         |   |
|--------|---------|---|
| Unit   |         | same for all models                                   |
| Q'ty   | -       | 2   |
| Weight | kg (lb) | 30,500 (67,253 lb)<br>(15,250 X 2)<br>(33,626 lb X 2) |

Work Equipment

- Boom

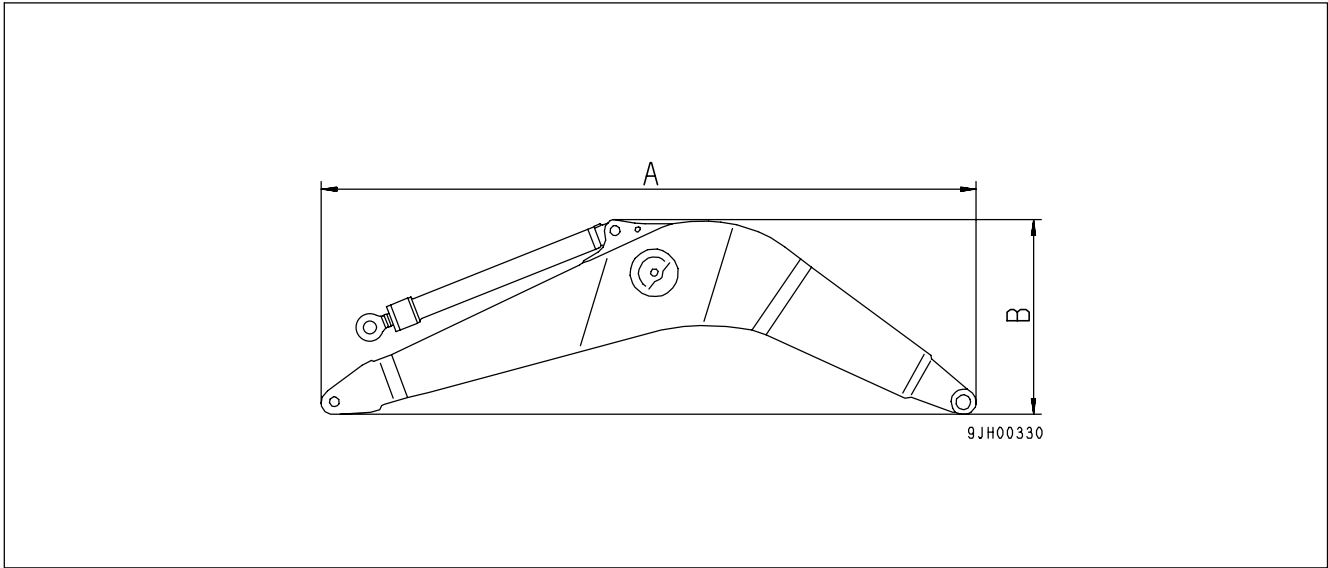

| Unit          |            | PC1250-7,<br>PC1250LC-7 | PC1250SP-7     |
|---------------|------------|-------------------------|----------------|
| A             | mm (ft in) | 9475 (31'1")            | 8170 (26'10")  |
| B             | mm (ft in) | 2894 (9'6")             | 3095 (10'2")   |
| Overall width | mm (ft in) | 1474 (4'10")            | 1474 (4'10")   |
| Weight        | kg (lb)    | 12700 (28,004)          | 12600 (27,783) |

- Arm

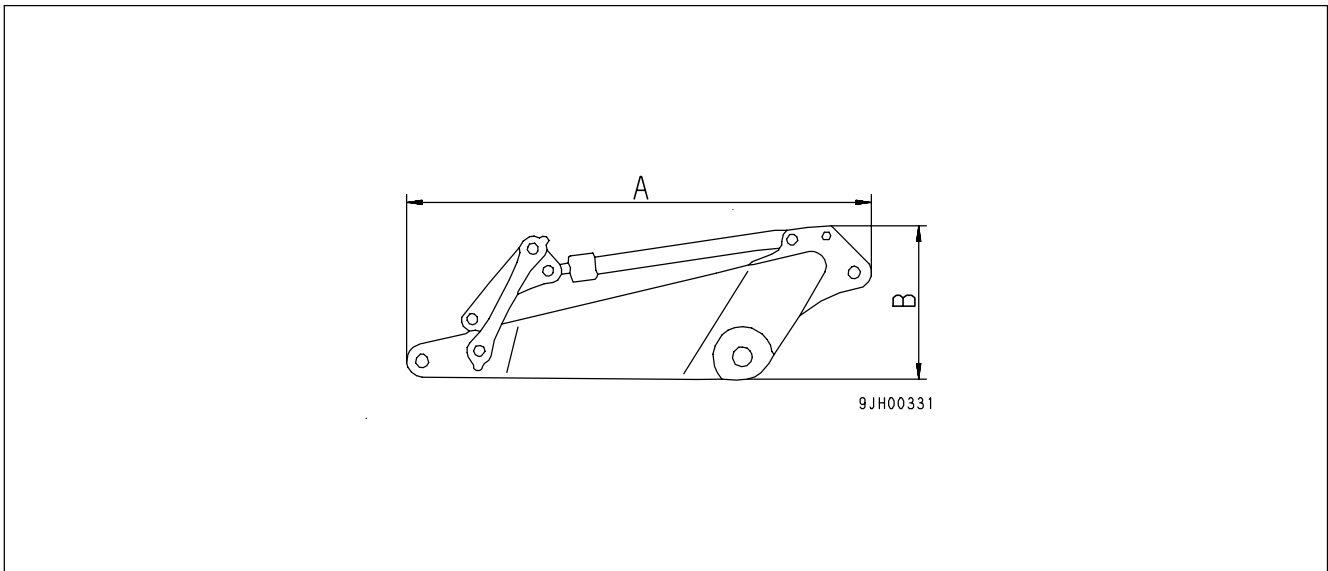

| Unit          |            | PC1250-7,<br>PC1250LC-7 | PC1250SP-7    |
|---------------|------------|-------------------------|---------------|
| A             | mm (ft in) | 4895 (16'1")            | 4914 (16'1")  |
| B             | mm (ft in) | 1626 (5'4")             | 1683 (5'6")   |
| Overall width | mm (ft in) | 890 (2'11")             | 890 (2'11")   |
| Weight        | kg (lb)    | 6200 (13,671)           | 6400 (14,112) |

- Bucket (except side cutter, shroud)

| Unit          |            | PC1250-7,<br>PC1250LC-7 | PC1250SP-7       |
|---------------|------------|-------------------------|------------------|
| A             | mm (ft in) | 2580 (8'6")             | 2527 (8'3")      |
| B             | mm (ft in) | 2276 (7'6")             | 2420 (7'11")     |
| Overall width | mm (ft in) | 2250 (7'5")             | 2520 (8'3")      |
| Weight        | kg (lb)    | 5100<br>(11,246)        | 6000<br>(13,230) |

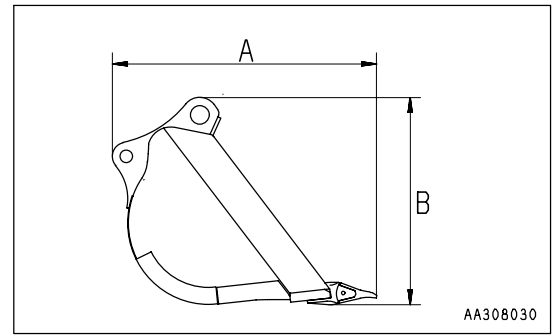

- Boom cylinder (same for all models)

| Unit   |            | same for all models                             |
|--------|------------|---|
| A      | mm (ft in) | 3810 (12'6")                                    |
| Weight | kg (lb)    | 2400 (5,292 lb)<br>(1200 X 2)<br>(2,646 lb X 2) |

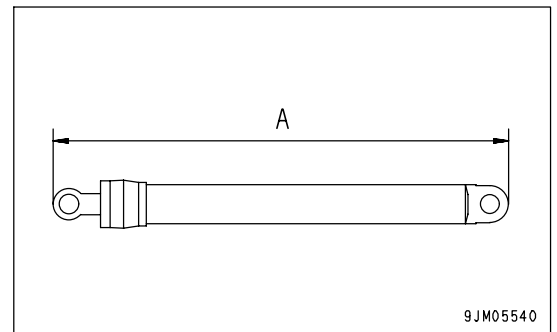



Others

- Center frame

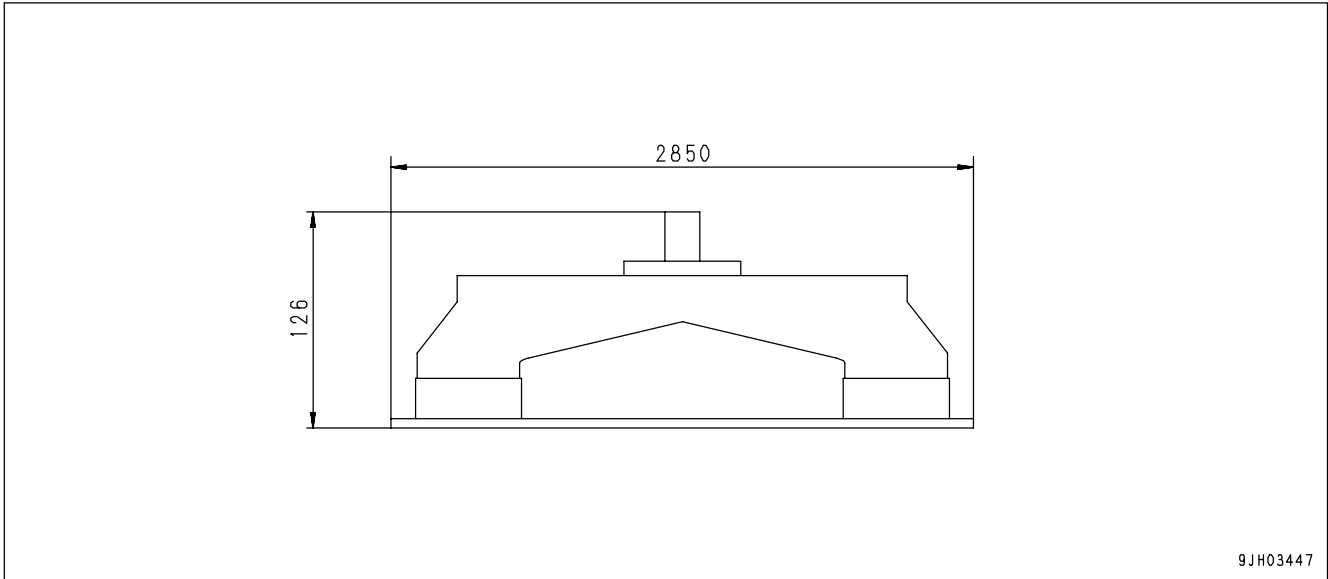

|        |         |                     |
|--------|---------|---------------------|
| Unit   |         | same for all models |
| Weight | kg (lb) | 9700 (21,389)       |

- Counterweight

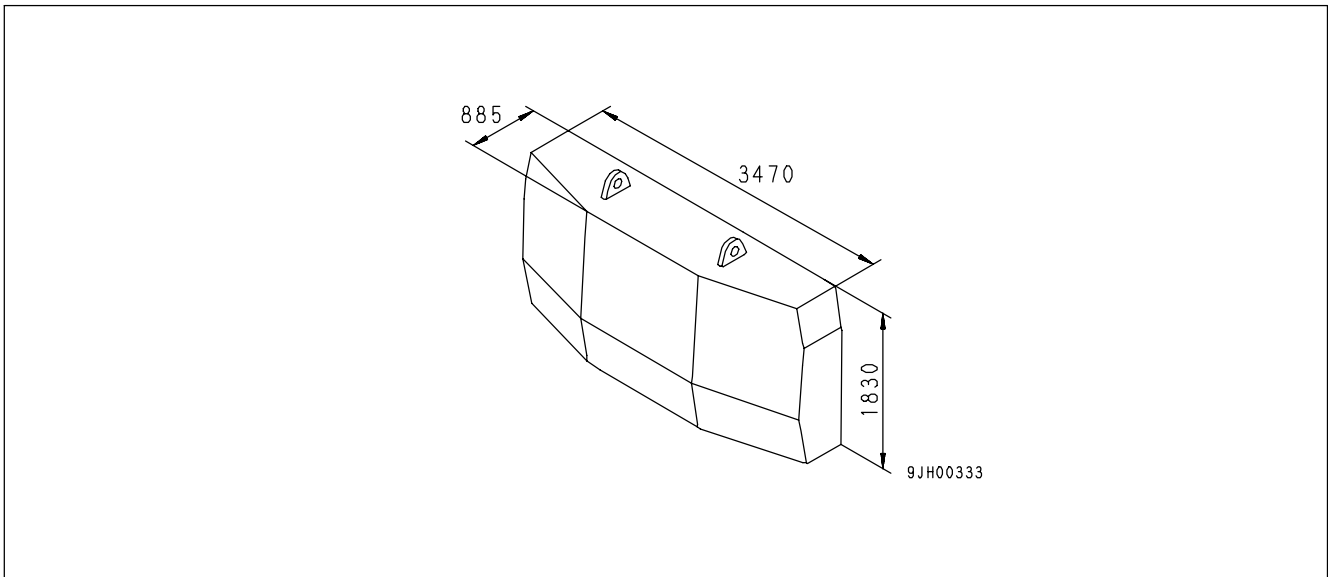

|        |         |                     |
|--------|---------|---------------------|
| Unit   |         | same for all models |
| Weight | kg (lb) | 18000 (39,690)      |

- Radiator duct (same for all models)

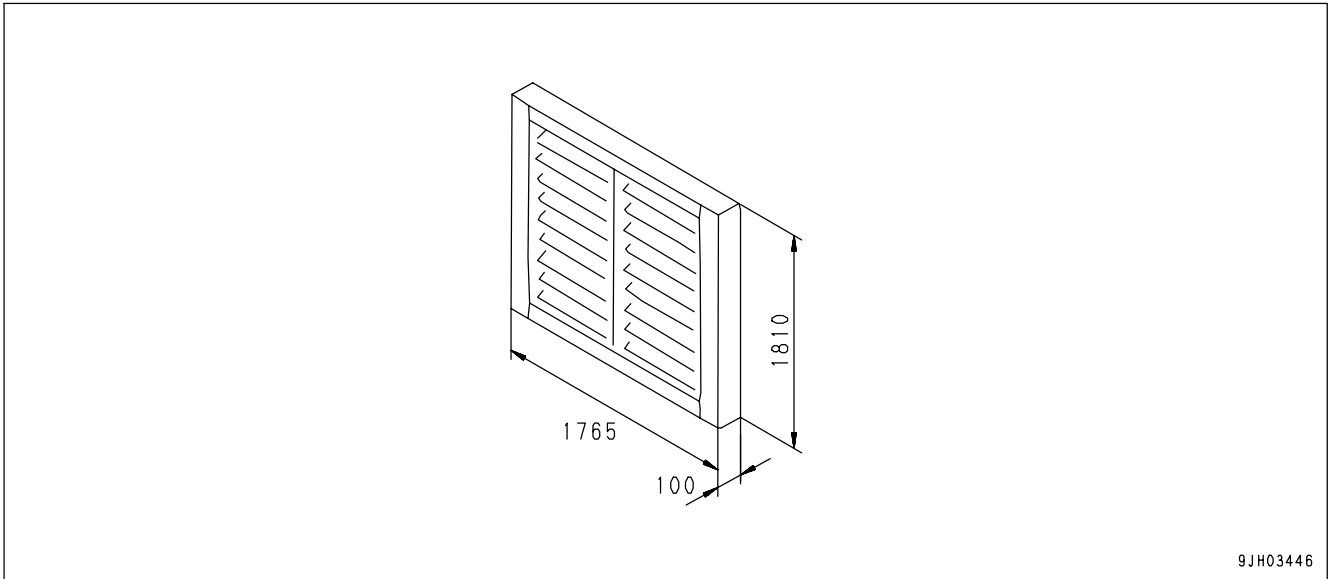

9JH03446

|        |         |                     |
|--------|---------|---------------------|
| Unit   |         | same for all models |
| Weight | kg (lb) | 80 (176)            |

- Catwalk (right) : (same for all models)

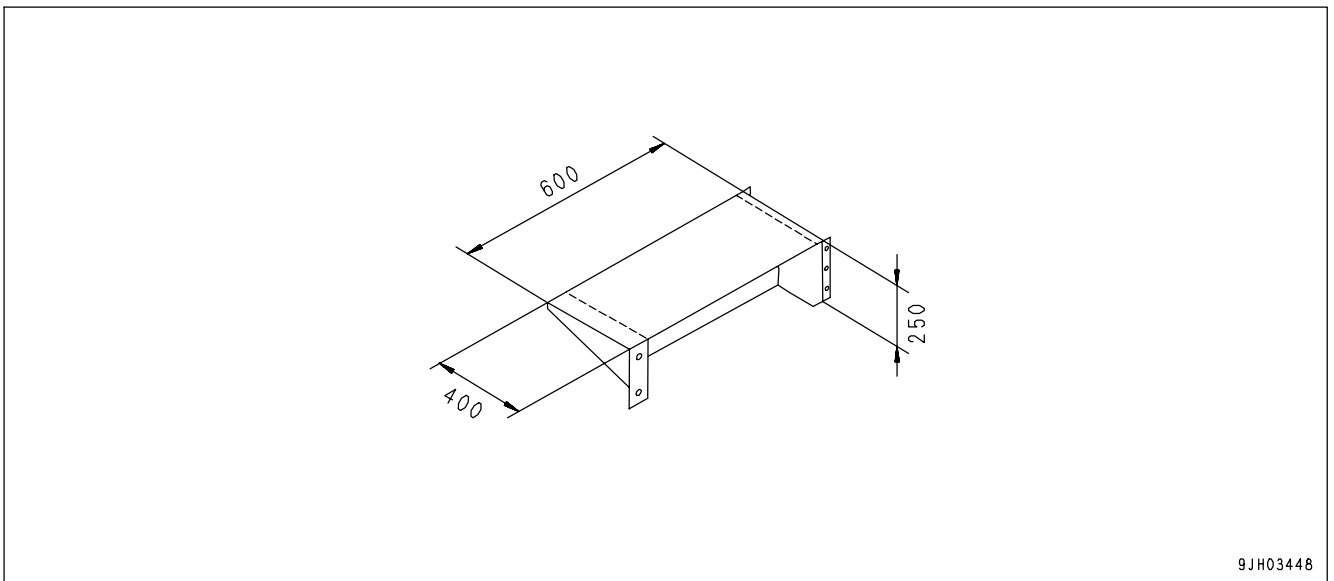

9JH03448

|        |         |                     |
|--------|---------|---------------------|
| Unit   |         | same for all models |
| Weight | kg (lb) | 17 (37.49)          |

- Catwalk (left, front) : (same for all models)

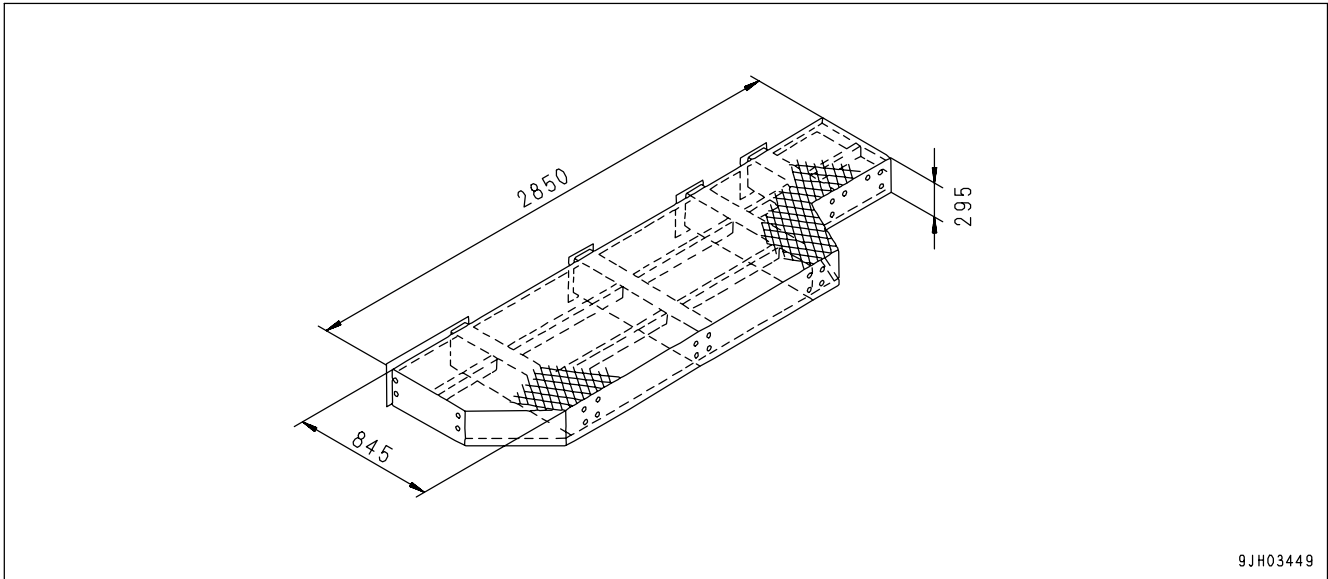

|        |         |                     |
|--------|---------|---------------------|
| Unit   |         | same for all models |
| Weight | kg (lb) | 150 (331)           |

- Catwalk (left, rear) : (same for all models)

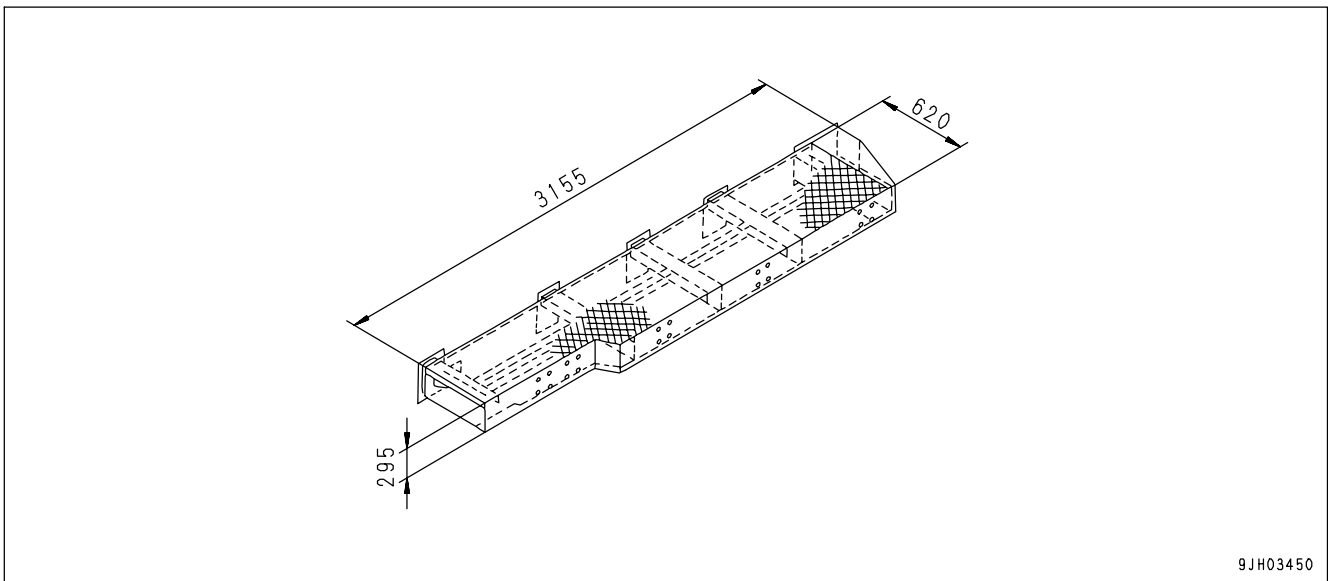

|        |         |                     |
|--------|---------|---------------------|
| Unit   |         | same for all models |
| Weight | kg (lb) | 160 (353)           |

## COLD WEATHER OPERATION

### COLD WEATHER OPERATION INFORMATION

If the temperature becomes low, it becomes difficult to start the engine, and the coolant may freeze, so do as follows.

#### Fuel and Lubricants

- Change to fuel and oil with low viscosity for all components. For details of the specified viscosity, see "LUBRICANTS, FUEL AND COOLANT SPECIFICATIONS (PAGE 4-10)".

#### Cooling System Coolant



### WARNING

- Antifreeze is toxic. Be careful not to get it into your eyes or on your skin. If it should get into your eyes or on your skin, wash it off with large amounts of fresh water and see a doctor at once.
- When changing the coolant or when handling coolant containing antifreeze that has been drained when repairing the radiator, please contact your Komatsu distributor or request a specialist company to carry out the operation. Antifreeze is toxic. Do not let it flow into drainage ditches or spray it onto the ground surface.
- Antifreeze is flammable. Do not bring any flame close. Do not smoke when handling antifreeze.

#### NOTICE

- Never use methanol, ethanol, or propanol-based antifreeze.
- Never use any water-leakage prevention agent or any antifreeze containing such an agent.
- Do not mix different types of antifreeze.

For details of the antifreeze mixture when changing the coolant, see "CLEAN INSIDE OF COOLING SYSTEM (PAGE 4-22)".

Use a Permanent Antifreeze (ethylene glycol mixed with corrosion inhibitor, antifoam agent, etc.) meeting the standard requirements as shown below. With permanent antifreeze, no change of coolant is required for a year. If it is doubtful that an available antifreeze meets the standard requirements, ask the supplier of that antifreeze for information.

Standard requirements for permanent antifreeze

- SAE J1034
- FEDERAL STANDARD O-A-548D

#### REMARK

In areas where permanent antifreeze is not available, it is possible to use antifreeze whose main component is ethylene glycol and does not contain any corrosion inhibitor. (Such antifreeze can be used for the winter season only.) However, in such a case, the coolant must be changed twice a year (spring and autumn), so use permanent antifreeze when possible.

### Battery

## WARNING

- The battery generates flammable gas. Do not bring fire or sparks near the battery.
- Battery electrolyte is dangerous. If it gets in your eyes or on your skin, wash it off with a large amount of water and consult a doctor.
- Battery electrolyte dissolves paint. If it gets on the bodywork, wash it off immediately with water.
- If the battery electrolyte is frozen, do not charge the battery or start the engine with a different power source. There is danger that the battery may explode.
- Battery electrolyte is toxic. Do not let it flow into drainage ditches or spray it on to the ground surface.

When the ambient temperature drops, the capacity of the battery will also drop. If the battery charge ratio is low, the battery electrolyte may freeze. Maintain the battery charge as close as possible to 100%. Insulate it against cold temperature to ensure the machine can be started easily the next morning.

### REMARK

Measure the specific gravity and calculate the charging rate from the following conversion table.

| Charging Rate (%) | Electrolyte Temperature | 20°C (68°F) | 0°C (32°F) | -10°C (14°F) | -20°C (-4°F) |
|-------------------|-------------------------|-------------|------------|--------------|--------------|
|                   | 100                     |             | 1.28       | 1.29         | 1.30         |
| 90                |                         | 1.26        | 1.27       | 1.28         | 1.29         |
| 80                |                         | 1.24        | 1.25       | 1.26         | 1.27         |
| 75                |                         | 1.23        | 1.24       | 1.25         | 1.26         |

- As the battery capacity drastically drops in low temperatures, cover or remove the battery from the machine, store the battery in a warm place, and install it again the next morning.
- If the electrolyte level is low, add distilled water in the morning before beginning work. Do not add water after the day's work to prevent diluted electrolyte in the battery from freezing during the night.

## AFTER DAILY WORK COMPLETION



### WARNING

Performing idle-running of the tracks is dangerous, stay well away from the tracks.

To prevent mud, water, or the undercarriage from freezing and making it impossible for the machine to move on the following morning, observe the following precautions.

- Remove all the mud and water from the machine body. In particular, wipe the hydraulic cylinder rods clean to prevent damage to the seal caused by mud, dirt, or drops of water on the rod from getting inside the seal.
- Park the machine on hard, dry ground.

If this is impossible, park the machine on boards.

The boards prevent the tracks from freezing to the ground, and allow the machine to be moved the next morning.

- Open the drain valve and drain any water collected in the fuel system to prevent it from freezing.
  - Fill the fuel tank to capacity. This minimizes moisture condensation in the tank when the temperature drops.
  - After operation in water or mud, remove water from undercarriage as described below to extend undercarriage service life.
1. Swing 90° with engine at low idle and bring the work equipment to the side of the track.
  2. Jack up the machine until the track is raised slightly from the ground. Rotate the track under no load. Repeat this procedure on both the left and right sides.

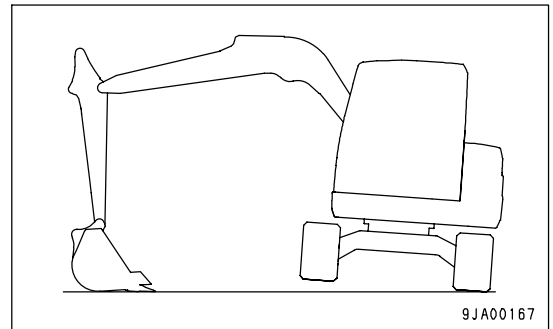

## AFTER COLD WEATHER SEASON

When the season changes and the weather becomes warmer, do as follows.

- Replace all fuel and oil with the specified fuel and oil.  
For details, see "LUBRICANTS, FUEL AND COOLANT SPECIFICATIONS (PAGE 4-10)".
- If for any reason permanent antifreeze cannot be used, and an ethylene glycol base antifreeze (winter, one season type) is used instead, or if no antifreeze is used, drain the cooling system completely. Thoroughly flush out the cooling system and fill it with fresh coolant.

## LONG TERM STORAGE

### BEFORE STORAGE

#### NOTICE

To protect the hydraulic cylinder piston rod while in storage, keep the work equipment in the posture shown at right.  
(This prevents rust from developing on the piston rod)

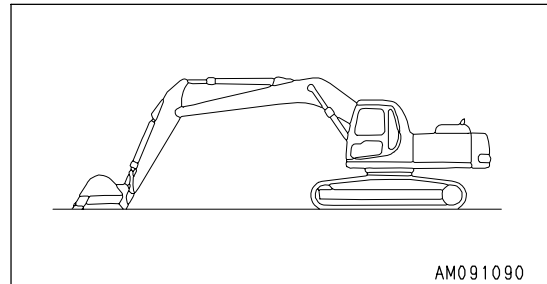

When putting the machine in storage for a long time, do as follows.

- Clean and wash all parts, then store the machine indoors. If the machine has to be stored outdoors, select level ground and cover the machine with canvas.
- Completely fill the fuel tank. This prevents moisture from collecting.
- Lubricate and change the oil before storage.
- Coat the exposed portion of the hydraulic cylinder piston rod with grease.
- Disconnect the negative terminals of the battery and cover it or remove it from the machine and store it separately.
- Lock each control lever and pedal with the safety lock lever and pedal lock.
- Set the stop valve to the LOCK position on machines ready for attachments. Install the blind plugs to the elbows.
- Set the selector valve on the machines which can install attachments to the "Where no attachment is mounted" position.

### DURING STORAGE



#### WARNING

If it is necessary to perform the rust-prevention operation while the machine is indoors, open the doors and windows to improve ventilation and prevent gas poisoning.

- During storage, operate and move the machine for a short distance once a month so that a new film of oil will coat moving parts. At the same time, also charge the battery.
- For machines equipped with an air conditioner, run the air conditioner.

### AFTER STORAGE

#### NOTICE

If the machine has been stored without carrying out the monthly rust-prevention operation, consult your Komatsu distributor before using it.

When using the machine after long-term storage, do as follows before using it.

- Wipe off the grease from the hydraulic cylinder rods.
- Add oil and grease at all lubrication points.
- When the machine is stored for a long period, moisture in the air will mix with the oil. Check the oil before and after starting the engine. If there is water in the oil, change all the oil.

**STARTING MACHINE AFTER LONG-TERM STORAGE**

When starting the engine after the machine has been in storage for a long time, perform the automatic warming-up operation.

If the engine is started according to the starting procedure for cold weather, the warming-up operation is performed automatically.

(For details, see "Starting Engine in Cold Weather (PAGE 3-89)" and "In Cold Weather Areas (PAGE 3-95)".)



## TROUBLES AND ACTIONS

### RUNNING OUT OF FUEL

When starting after running out of fuel, fill with fuel and bleed the air from the fuel system before starting.  
For details on bleeding the air, see "REPLACE FUEL FILTER CARTRIDGE (PAGE 4-54)".

### PHENOMENA THAT ARE NOT FAILURES

Note that the following phenomena are not failures:

- When the arm control lever is operated to the IN position and the work equipment is lowered under no load from a high position, the arm speed will drop momentarily when the arm is more or less at the vertical position.
- When the bucket control lever is operated to the CURL position and the work equipment is lowered under no load from a high position, the bucket speed will drop momentarily when the bucket teeth are more or less at the horizontal position.
- The bucket or arm will fluctuate by itself during heavy-duty digging operations.
- When starting or stopping the swing, noise will be emitted from the brake valve.
- When going down a steep slope at low speed, a noise will be emitted from the travel motor brake valve.

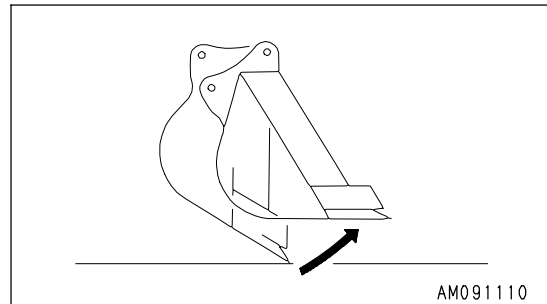
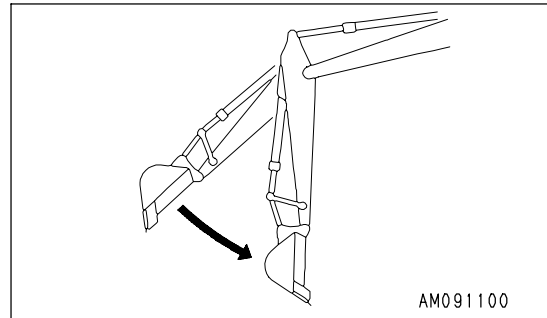

## TOWING THE MACHINE



### WARNING

- When towing the machine, use a wire rope that has ample strength for the weight of the machine that is being towed.
- Do not apply a sudden load to the wire rope.

If the machine sinks in mud and cannot get out under its own power, or if the drawbar pull of the excavator is being used to tow a heavy object, use a wire rope as shown in the diagram on the right.

Place pieces of wood between wire ropes and body to prevent damage to ropes and body.

At this time, never use the hole for light-weight towing.

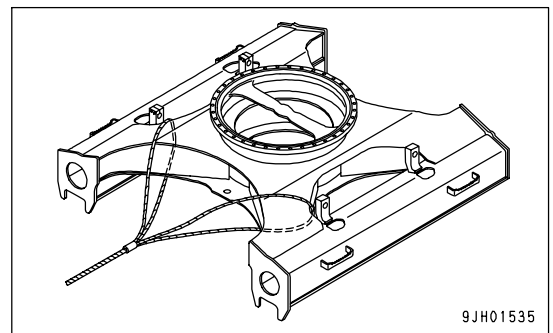
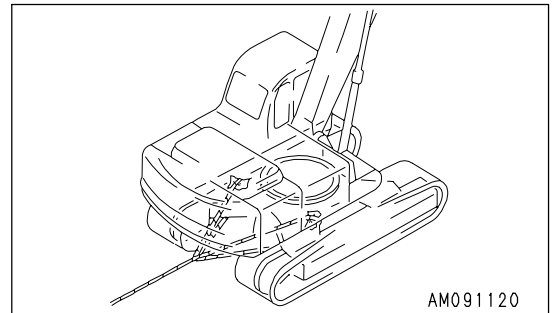

## SEVERE JOB CONDITION

- When carrying out digging operations in water, if the work equipment mounting pin goes into the water, carry out greasing every time the operation is carried out.
- For heavy-duty operations and deep digging, carry out greasing of the work equipment mounting pins every time before operation.

After greasing, operate the boom, arm and bucket several times, then grease again.

## DISCHARGED BATTERY



### WARNING

- It is dangerous to charge a battery when mounted on a machine. Make sure that it is dismantled before charging.
  - When checking or handling the battery, stop the engine and turn the starting switch key to the OFF position.
  - The battery generates hydrogen gas, so there is a hazard of explosion. Do not bring lighted cigarettes near the battery, or do anything that will cause sparks.
  - Battery electrolyte is dilute sulfuric acid, and it will attack your clothes and skin. If it gets on your clothes or on your skin, immediately wash it off with a large amount of water. If it gets in your eyes, wash it out with fresh water and consult a doctor.
  - When handling batteries, always wear safety glasses and rubber gloves.
  - When removing the battery, first disconnect the cable from the ground (normally the negative (-) terminal). When installing, install the positive (+) terminal first.
- If a tool touches the positive terminal and the chassis, there is danger that it will cause a spark, so be extremely careful.
- If the terminals are loose, there is danger that the defective contact may generate sparks that will cause an explosion.
  - When removing or installing the terminals, check which is the positive (+) terminal and which is the negative (-) terminal.

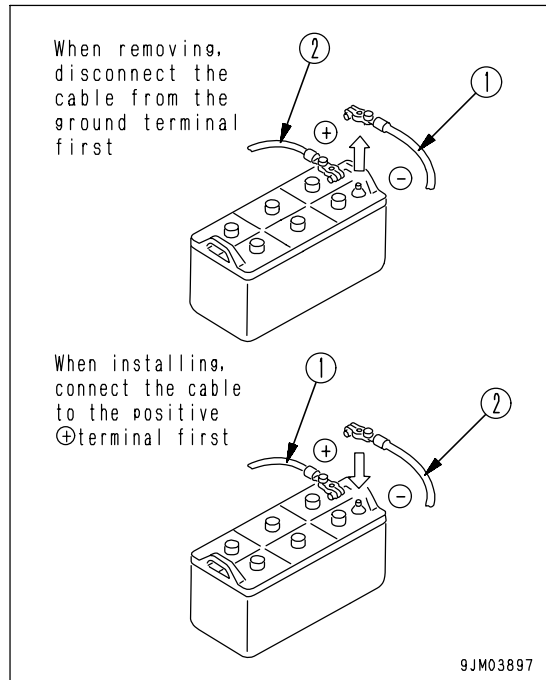

## Battery Removal and Installation

- Before removing the battery, remove the ground cable (normally connected to the negative (-) terminal).  
If any tool touches between the positive terminal and the chassis, there is a hazard of sparks being generated.
- When installing the battery, connect the ground cable last.
- When replacing the battery, fix the battery securely in position with the battery mounting clamp.  
Tightening torque of mounting bolt: 9.8 to 19.6 Nm (1.0 to 2.0 kgm, 7.2 to 14.5 lbf)

## Battery Charges

When charging the battery, if the battery is not handled correctly, there is a hazard that the battery may explode. Always follow the instructions of "DISCHARGED BATTERY (PAGE 3-138)" and the instruction manual accompanying the charger, and do as follows.

- Set the voltage of the charger to match the voltage of the battery to be charged. If the correct voltage is not selected, the charger may overheat and cause an explosion.
- Connect the positive (+) charger clip of the charger to the positive (+) terminal of the battery, then connect the negative (-) charger clip of the charger to the negative (-) terminal of the battery. Be sure to attach the clips securely.
- Set the charging current to 1/10 of the value of the rated battery capacity; when carrying out rapid charging, set it to less than the rated battery capacity.  
If the charger current is too high, the electrolyte will leak or dry up, and this may cause the battery to catch fire and explode.
- If the battery electrolyte is frozen, do not charge the battery or start the engine with a different power source. There is a danger that this will ignite the battery electrolyte and cause the battery to explode.
- Do not use or charge the battery if the battery electrolyte level is below the LOWER LEVEL line. This may cause an explosion. Check the battery electrolyte level periodically and add distilled water to bring the electrolyte level to the UPPER LEVEL line.

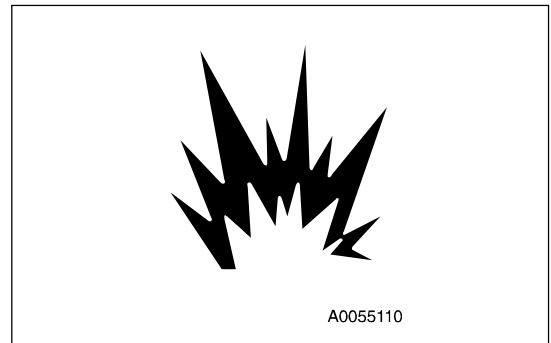

## Starting Engine with Booster Cables

When starting the engine with a booster cable, do as follows.

### Connecting and Disconnecting Booster Cables



## WARNING

- When connecting the cables, never contact the positive (+) and negative (-) terminals.
- When starting the engine with a booster cable, always wear safety glasses.
- Be careful not to let the normal machine and problem machine contact each other. This prevents sparks from generating near the battery which could ignite the hydrogen gas given off by the battery. If hydrogen gas explodes, it could cause serious injury.
- Be careful not to make a mistake when connecting a booster cable. In the last connection (to the upper structure frame), a spark will be caused, connect the cable to a spot as far away from the battery as possible. (Avoid the work equipment, however, because it is not a good conductor)
- When removing the booster cable, exercise good care so that the booster cable clips may not contact each other, or they contact the chassis.

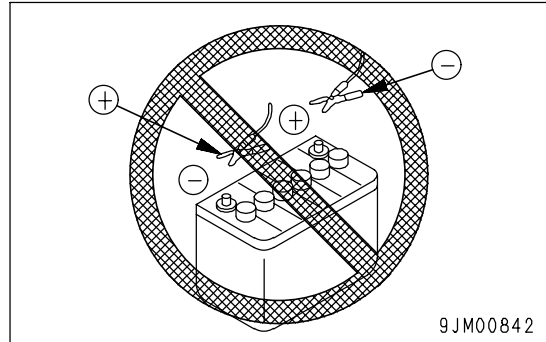

### NOTICE

- The starting system for this machine uses 24V. For the normal machine, also use a 24V battery.
- The size of the booster cable and clip should be suitable for the battery size.
- The battery of the normal machine must be the same capacity as that of the engine to be started.
- Check the cables and clips for damage or corrosion.
- Make sure that the cables and clips are firmly connected.
- Check that the safety lock levers and parking brake levers of both machine are in the LOCK position.
- Check that each lever is in the NEUTRAL position.

### Booster Cable Connection

Keep the starting switch of the normal machine and problem machine in the OFF position.

Connect the booster cable as follows, in the order of the numbers marked in the diagram.

1. Make sure the starting switches of the normal machine and problem machine are both at the OFF position.
2. Connect one clip of booster cable (A) to the positive (+) terminal of the problem machine.
3. Connect the other clip of booster cable (A) to the positive (+) terminal of the normal machine.
4. Connect one clip of booster cable (B) to the negative (-) terminal of the normal machine.
5. Connect the other clip of booster cable (B) to the upper structure frame of the problem machine.

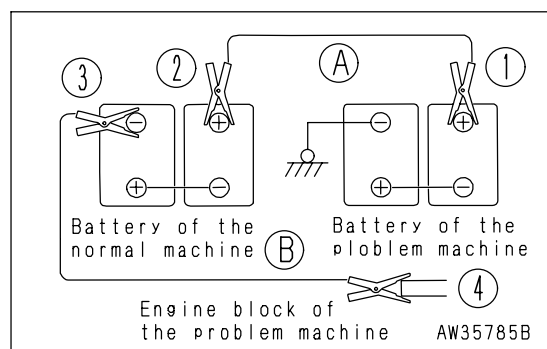

## Starting the Engine

**WARNING**

Always check that the safety lock lever is set to the LOCK position, regardless of whether the machine is working normally or has failed. Check also that all the control levers are in the HOLD or neutral position.

1. Make sure the clips are firmly connected to the battery terminals.
2. Start engine of the normal machine and run it at high idle speed.
3. Turn the starting switch of the problem machine to the START position and start the engine.  
If the engine doesn't start at first, try again after 2 minutes or so.

**Booster Cable Disconnection**

After the engine has started, disconnect the booster cables in the reverse of the order in which they were connected.

1. Remove one clip of booster cable (B) from the revolving frame of the problem machine.
2. Remove the other clip of booster cable (B) from the negative (-) terminal of the normal machine.
3. Remove one clip of booster cable (A) from the positive (+) terminal of the normal machine.
4. Remove the other clip of booster cable (A) from the positive (+) terminal of the problem machine.

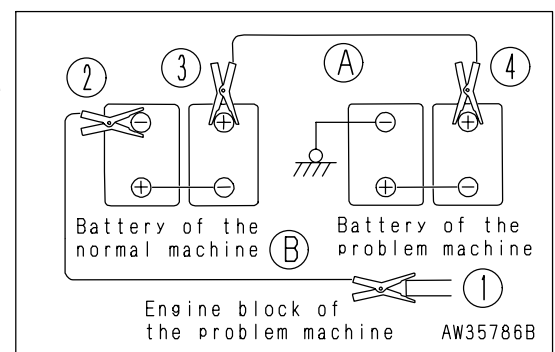

## OTHER TROUBLE

### Electrical System

- ( ): Always contact your Komatsu distributor when dealing with these items.
- In cases of problems or causes which are not listed below, contact your Komatsu distributor for repairs.

| Problem  | Main causes  | Remedy   |
|--|--|--|
| Lamp does not glow brightly even when the engine runs at high speed                            | <ul style="list-style-type: none"> <li>• Defective wiring, deterioration of battery</li> <li>• Loose fan belt</li> </ul>   | <ul style="list-style-type: none"> <li>( • Check, repair loose terminals, disconnections, replace battery)</li> <li>• Check fan belt tension, replace</li> </ul> |
| Lamp flickers while engine is running  |  |  |
| Charge level monitor does not go out even when engine is running                               | <ul style="list-style-type: none"> <li>• Defective alternator</li> <li>• Defective wiring</li> </ul>   | <ul style="list-style-type: none"> <li>( • Replace)</li> <li>( • Check, repair)</li> </ul>   |
| Abnormal noise is generated from alternator  | <ul style="list-style-type: none"> <li>• Defective alternator</li> </ul>   | <ul style="list-style-type: none"> <li>( • Replace)</li> </ul>   |
| Starting motor does not turn when starting switch is turned to ON                              | <ul style="list-style-type: none"> <li>• Defective wiring</li> <li>• Defective starting motor</li> <li>• Insufficient battery charge</li> </ul>                        | <ul style="list-style-type: none"> <li>( • Check, repair)</li> <li>( • Replace)</li> <li>• Charge</li> </ul>   |
| Pinion of starting motor keeps going and out   | <ul style="list-style-type: none"> <li>• Insufficient battery charge</li> <li>• Defective safety relay</li> </ul>  | <ul style="list-style-type: none"> <li>• Charge</li> <li>( • Replace)</li> </ul>   |
| Starting motor turns engine sluggishly   | <ul style="list-style-type: none"> <li>• Insufficient battery charge</li> <li>• Defective starting motor</li> </ul>  | <ul style="list-style-type: none"> <li>• Charge</li> <li>( • Replace)</li> </ul>   |
| Starting motor disengages before engine starts   | <ul style="list-style-type: none"> <li>• Defective wiring, defective ring gear pinion</li> <li>• Insufficient battery charge</li> </ul>                                | <ul style="list-style-type: none"> <li>( • Check, repair)</li> <li>• Charge</li> </ul>   |
| Engine pre-heating monitor does not light  | <ul style="list-style-type: none"> <li>• Defective wiring</li> <li>• Defective heater relay</li> <li>• Defective monitor</li> </ul>                                    | <ul style="list-style-type: none"> <li>( • Check, repair)</li> <li>( • Replace)</li> <li>( • Replace)</li> </ul>   |
| Oil pressure monitor does not light up when engine is stopped (starting switch at ON position) | <ul style="list-style-type: none"> <li>• Defective monitor</li> <li>• Defective caution lamp switch</li> </ul>   | <ul style="list-style-type: none"> <li>( • Replace)</li> <li>( • Replace)</li> </ul>   |
| Outside of electrical heater is not warm when touched by hand                                  | <ul style="list-style-type: none"> <li>• Defective wiring</li> <li>• Disconnection in electric heater</li> <li>• Defective operation of heater relay switch</li> </ul> | <ul style="list-style-type: none"> <li>( • Check, repair)</li> <li>( • Replace)</li> <li>( • Replace)</li> </ul>   |

**Chassis**

- ( ): Always contact your Komatsu distributor when dealing with these items.
- In cases of problems or causes which are not listed below, contact your Komatsu distributor for repairs.

| Problem   | Main causes   | Remedy   |
|---|---|--|
| Speed of travel, swing, boom, arm, bucket is slow | <ul style="list-style-type: none"> <li>• Lack of hydraulic oil</li> </ul>   | <ul style="list-style-type: none"> <li>• Add oil to specified level, see CHECK BEFORE STARTING</li> </ul>  |
| Pump generates abnormal noise (sucking in air)    | <ul style="list-style-type: none"> <li>• Clogged element in hydraulic tank strainer, lack of oil</li> </ul>                     | <ul style="list-style-type: none"> <li>• Clean, see EVERY 2000 HOURS SERVICE</li> </ul>  |
| Excessive rise in hydraulic oil temperature       | <ul style="list-style-type: none"> <li>• Loose fan belt</li> <li>• Dirty oil cooler</li> <li>• Lack of hydraulic oil</li> </ul> | <ul style="list-style-type: none"> <li>• Check fan belt tension, replace</li> <li>• Clean, see EVERY 500 HOURS SERVICE</li> <li>• Add oil to specified level, see CHECK BEFORE STARTING</li> </ul> |
| Track comes off                                   | <ul style="list-style-type: none"> <li>• Track too loose</li> </ul>   | <ul style="list-style-type: none"> <li>• Adjust track tension, see WHEN REQUIRED</li> </ul>  |
| Abnormal wear of sprocket                         |   |  |
| Boom rises slowly, does not rise                  | <ul style="list-style-type: none"> <li>• Lack of hydraulic oil</li> </ul>   | <ul style="list-style-type: none"> <li>• Add oil to specified level, CHECK BEFORE STARTING</li> </ul>  |
| Does not swing                                    | <ul style="list-style-type: none"> <li>• Swing lock switch still applied</li> </ul>   | <ul style="list-style-type: none"> <li>• Turn swing lock switch OFF</li> </ul>   |



## Engine

- ( ): Always contact your Komatsu distributor when dealing with these items.
- In cases of problems or causes which are not listed below, contact your Komatsu distributor for repairs.

| Problem  | Main causes   | Remedy  |
|--|---|---|
| Engine oil pressure monitor lights up                  | <ul style="list-style-type: none"> <li>• Engine oil pan oil level is low (sucking in air)</li> <li>• Clogged oil filter cartridge</li> <li>• Defective tightening of oil pipe, pipe joint, oil leakage from damaged point</li> <li>• Defective engine oil pressure sensor</li> <li>• Defective monitor</li> </ul>                   | <ul style="list-style-type: none"> <li>• Add oil to specified level, see CHECK BEFORE STARTING</li> <li>• Replace cartridge, see EVERY 500 HOURS SERVICE</li> <li>( • Check, repair)</li> <li>( • Replace sensor)</li> <li>( • Replace monitor)</li> </ul>  |
| Steam spurts out from top of radiator (pressure valve) | <ul style="list-style-type: none"> <li>• Coolant level low, leakage of water</li> <li>• Loose fan belt</li> <li>• Dirt or scale accumulated in cooling system</li> </ul>  | <ul style="list-style-type: none"> <li>• Check, add coolant, repair, see CHECK BEFORE STARTING</li> <li>• Check fan belt tension, adjust, replace</li> <li>• Change coolant, flush inside of cooling system, see WHEN REQUIRED</li> </ul>   |
| Radiator coolant level monitor lights up               | <ul style="list-style-type: none"> <li>• Clogged radiator fins or damaged fins</li> <li>• Defective thermostat</li> <li>• Loose radiator filler cap (high-altitude operations)</li> <li>• Defective water level sensor</li> <li>• Defective monitor</li> </ul>  | <ul style="list-style-type: none"> <li>• Clean or repair, see EVERY 500 HOURS SERVICE</li> <li>( • Replace thermostat)</li> <li>• Tighten cap or replace packing</li> <li>( • Replace sensor)</li> <li>( • Replace monitor)</li> </ul>  |
| Engine does not start when starting motor is turned    | <ul style="list-style-type: none"> <li>• Lack of fuel</li> <li>• Air in fuel system</li> <li>• Defective fuel injection pump or defective nozzle</li> <li>• Starting motor cranks engine sluggishly</li> <li>• Engine pre-heating monitor does not light up</li> <li>• Defective compression (effective valve clearance)</li> </ul> | <ul style="list-style-type: none"> <li>• Add fuel, see CHECK BEFORE STARTING</li> <li>• Repair place where air is sucked in, see EVERY 500 HOURS SERVICE</li> <li>( • Replace pump or nozzle)</li> <li>• See ELECTRICAL SYSTEM</li> <li>• See ELECTRICAL SYSTEM</li> <li>( • Adjust valve clearance)</li> </ul> |
| Exhaust gas is white or blue                           | <ul style="list-style-type: none"> <li>• Too much oil in oil pan</li> <li>• Improper fuel</li> </ul>  | <ul style="list-style-type: none"> <li>• Set oil to specified level, see CHECK BEFORE STARTING</li> <li>• Change to specified fuel</li> </ul>   |
| Exhaust gas occasionally turns black                   | <ul style="list-style-type: none"> <li>• Clogged air cleaner element</li> <li>• Defective nozzle</li> <li>• Defective compression</li> <li>• Defective turbocharger</li> </ul>  | <ul style="list-style-type: none"> <li>• Clean or replace, see WHEN REQUIRED</li> <li>( • Replace nozzle)</li> <li>( • See defective compression above)</li> <li>( • Clean or replace turbocharger)</li> </ul>  |
| Combustion noise occasionally make breathing sound     | <ul style="list-style-type: none"> <li>• Defective nozzle</li> </ul>  | <ul style="list-style-type: none"> <li>( • Replace nozzle)</li> </ul>   |

| Problem  | Main causes  | Remedy   |
|--|--|--|
| Abnormal noise generated<br>(combustion or mechanical) | <ul style="list-style-type: none"><li>• Low-grade fuel being used</li><li>• Overheating</li><br/><li>• Damage inside muffler</li><li>• Excessive valve clearance</li></ul> | <ul style="list-style-type: none"><li>• Change to specified fuel</li><li>• Refer to "Radiator coolant level monitor lights up" as above</li><li>( • Replace muffler)</li><li>( • Adjust valve clearance)</li></ul> |

## Electronic Control System

If an error code appears on the machine monitor display (normally displays TIME), follow the countermeasure table as shown below in the self-diagnosis.

### Machine Monitoring System

| Monitor display  | Error mode   | Remedy  |
|--|--|---|
| E02  | Error in pump control system                                       | When emergency pump drive switch is up, normal operations become normal, but carry out inspection immediately. (*)  |
| E03  | Error in swing brake system  | Turn the swing holding brake release switch is up to release the brake. When applying the swing brake, operate it manually with the swing lock switch. Depending on the cause of the problem, it may not be possible to release it. In any case, have it inspected immediately. (*) |
| E10  | Error in fuel line and swing sensor system (engine stop)           | Have inspection carried out immediately.  |
| E11  | Error in engine controller system (engine protection, output down) | Move machine to a safe posture, and carry out inspection immediately.   |
| E14  | Error in throttle system   | Move machine to a safe posture, and carry out inspection immediately.   |
| E15  | Error in sensor and engine controller power source                 | It is possible to carry out normal driving operations, but have inspection carried out immediately.   |
| E0E  | Network error  | Move machine to a safe posture, and carry out inspection immediately.   |
| In the case where the monitor will not display error codes and work equipment operation and swing operation cannot be carried out. |  | Have inspection carried out immediately.  |

(\*): For details of the method of handling the emergency pump drive switch and swing holding brake cancel switch, see "SWITCHES (PAGE 3-29)".

**Point of Contact to Telephone when Error Occurs**

If an error screen is displayed on the monitor, the screen changes as follows each time input confirmation switch (1) is pressed.

Error screen -> screen A -> screen B -> screen C -> error screen  
Check the point of contact telephone number on screen B.

**REMARK**

If the point of contact telephone number has not been registered, screen B is not displayed.

If it is necessary to register the point of contact telephone number, ask your Komatsu distributor to register it.

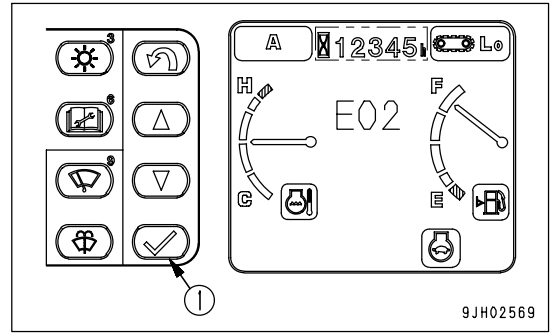

9JH02569

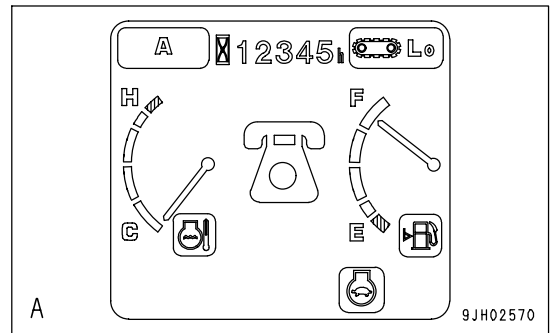

A

9JH02570

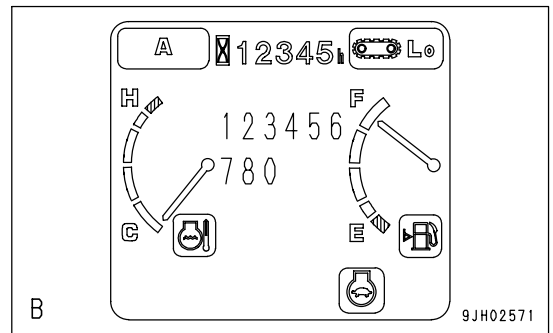

B

9JH02571

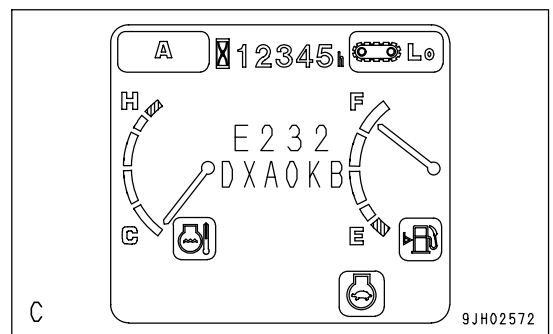

C

9JH02572



# MAINTENANCE

## **WARNING**

Please read and make sure that you understand the SAFETY section before reading this section.

---

## MAINTENANCE INFORMATION

Do not perform any inspection and maintenance operation that is not found in this manual.

### Service Meter Reading

Check the service meter reading every day to see if the time has come for any necessary maintenance to be performed.

### Komatsu Genuine Replacement Parts

Use Komatsu genuine parts specified in the Parts Book as replacement parts.

### Komatsu Genuine Lubricants

For lubrication of the machine, use the Komatsu genuine lubricants. Moreover use oil of the specified viscosity according to the ambient temperature.

### Windshield Washer Fluid

Use automobile window washer fluid, and be careful not to let any dirt get into it.

### Fresh and Clean Lubricants

Use clean oil and grease. Also, keep the containers of the oil and grease clean. Keep foreign materials away from oil and grease.

### Check Drained Oil and Used Filter

After oil is changed or filters are replaced, check the old oil and filters for metal particles and foreign materials. If large quantity of metal particles or foreign materials are found, always report to the person in charge, and carry out suitable action.

### Fuel Strainer

If your machine is equipped with a fuel strainer, do not remove it while fueling.

### Welding Instructions

- Turn off the engine starting switch.
- Do not apply more than 200 V continuously.
- Connect grounding cable within 1 m (3.3 ft) of the area to be welded. If grounding cable is connected near instruments, connectors, etc., the instruments may malfunction.
- If a seal or bearing happens to come between the part being welded and grounding point, change the grounding point to avoid such parts.
- Do not use the area around the work equipment pins or the hydraulic cylinders as the grounding point.

### Do not Drop Things Inside Machine

- When opening inspection windows or the oil filler port of the tank to carry out inspection, be careful not to drop nuts, bolts, or tools inside the machine.  
If such things are dropped inside the machine, it may cause damage and/or malfunction of the machine, and will lead to failure. If you drop anything inside the machine, always remove it immediately.
- Do not put unnecessary things in your pockets. Carry only things which are necessary for inspection.

### Dusty Jobsite

When working at dusty worksites, do as follows:

- Check the clogging of the air cleaner more frequently with the dust indicator. Clean the air cleaner element more frequently.
- Clean the radiator core frequently to avoid clogging.

- Clean and replace the fuel filter frequently.
- Clean electrical components, especially the starting motor and alternator, to avoid accumulation of dust.
- When inspecting or changing the oil, move the machine to a place that is free of dust to prevent dirt from getting into the oil.

### **Avoid Mixing Lubricants**

If a different brand or grade of oil has to be added, drain the old oil and replace all the oil with the new brand or grade of oil. Never mix different brand or grade of oil.

### **Locking the Inspection Covers**

Lock inspection cover securely into position with the lock bar. If inspection or maintenance is performed with inspection cover not locked in position, there is a danger that it may be suddenly blow shut by the wind and cause injury to the worker.

### **Hydraulic System - Air Bleeding**

When hydraulic equipment has been repaired or replaced, or the hydraulic piping has been removed and installed again, the air must be bled from the circuit. For details, see "BLEEDING AIR FROM HYDRAULIC SYSTEM (PAGE 4-37)".

### **Hydraulic Hose Installation**

- When removing parts at locations where there are O-rings or gasket seals, clean the mounting surface, and replace with new parts.  
When doing this, be careful not to forget to assemble the O-rings and gaskets.
- When installing the hoses, do not twist them or bend them sharply. If they are installed so, their service life will be shortened extremely and they may be damaged.

### **Checks After Inspection and Maintenance Works**

If you forget to perform the checks after inspection and maintenance, unexpected problems may occur, and this may lead to serious injury or property damage. Always do the following:

- Checks after operation (with engine stopped)
  - Have any inspection and maintenance points been forgotten?
  - Have all inspection and maintenance items been performed correctly?
  - Have any tools or parts been dropped inside the machine? It is particularly dangerous if parts are dropped inside the machine and get caught in the lever linkage mechanism.
  - Are there any leakage of coolant or oil? Have all nuts and bolts been tightened?
- Checks when operating engine
  - For details of the checks when operating the engine, see "TWO WORKERS FOR MAINTENANCE WHEN ENGINE IS RUNNING (PAGE 2-34)" and pay careful attention to safety.
  - Are the inspection and maintenance items working properly?
  - Is there any leakage of fuel or oil when the engine speed is raised?



## OUTLINE OF SERVICE

### HANDLING OIL, FUEL, COOLANT, AND PERFORMING OIL CLINIC

#### Oil

- The engine and hydraulic equipment are used under extremely severe conditions (high temperature, high-pressure), so the oil deteriorates as time passes.  
Always use the recommended oil in the list given in the Operation and Maintenance Manual that matches the grade, maximum temperature, and minimum temperature.  
Even if the oil is not dirty, always change the oil at the specified interval.
- Never mix oils of different grades or brands.
- Oil corresponds to blood in the human body, so always be careful when handling it to prevent any impurities (water, metal particles, dirt, etc.) from getting in.  
Take particular care not to let any impurities get in when adding oil.  
The majority of problems with machines are caused by the entry of such impurities.
- Always add the specified amount of oil.  
Having too much oil or too little oil are both causes of problems.
- When changing the oil, always replace the related filters at the same time.
- If the oil in the work equipment is not clear, there is probably water or air getting into the circuit. In such cases, please contact your Komatsu distributor.
- We recommend periodic performance of the oil clinic to ensure that you always know the condition of the machine. Please contact your Komatsu distributor for details of the oil clinic.

## Fuel

- The fuel pump is a precision instrument, and if fuel containing water or dirt is used, it cannot work properly.
- Be extremely careful not to let impurities get in when storing or adding fuel.
- Always use the fuel specified in the Operation and Maintenance Manual.  
Fuel may congeal, depending on the temperature, when it is used (particularly in low temperature below -15°C (5°F)). It is necessary to change to the fuel that is suitable for the temperature.
- To prevent the moisture in the air from condensing and forming water inside the fuel tank, always fill the fuel tank after completing the day's work.
- Before starting the engine, or when 10 minutes have passed after adding fuel, drain the sediment and water from the fuel tank.
- If the engine runs out of fuel, or if the filters have been replaced, it is necessary to bleed the air from the circuit.
- If there is any foreign material in the fuel tank, wash the tank and fuel system.

## NOTICE

**Always use diesel oil for the fuel.**

**To ensure good fuel consumption characteristics and exhaust gas characteristics, the engine mounted on this machine uses an electronically controlled high-pressure fuel injection device. This device requires high precision parts and lubrication, so if low viscosity fuel with low lubricating ability is used, the durability may drop markedly.**

## Cooling System Coolant

- The coolant is diluted for use, so always use distilled water or tap water (soft water) when diluting the coolant. Natural water, such as river water or well water (hard water), contains large amounts of minerals (calcium or magnesium) and will cause scale to form inside the engine and the radiator. Once scale forms, it is difficult to remove, and it will cause deficient heat exchange, leading to overheating. To prevent this, we recommend the use of water with a maximum overall hardness of 100 ppm (mg/ℓ) when diluting the coolant.
- When using antifreeze, always observe the precautions given in the Operation and Maintenance Manual.
- Komatsu machines are supplied with Komatsu original anti-freeze in the coolant when the machine is shipped. This anti-freeze is effective in preventing corrosion of the cooling system.  
The anti-freeze can be used continuously for two years or 4000 hours. Therefore, it can be used as it is even in hot areas.
- Antifreeze is flammable, so be extremely careful not to expose it to flame or fire.
- The proportion of anti-freeze to water differs according to the ambient temperature.  
For details of the mixing proportions, see "CLEAN INSIDE OF COOLING SYSTEM (PAGE 4-22)".
- If the engine overheats, wait for the engine to cool before adding coolant.
- If the coolant level is low, it will cause overheating, and will also cause problems with corrosion due to air entering the coolant.

## Grease

- Grease is used to prevent seizure and noises at the joints.
- Construction equipment operates under severe conditions. Always use the recommended grease listed in this Operation and Maintenance Manual that matches the ambient temperature, and observe the change intervals strictly.
- The nipples not included in the MAINTENANCE section are nipples used when overhauling, so they do not need grease.  
If any part becomes stiff or generates noise after being used for a long time, grease it.
- Always wipe off all of the old grease that is pushed out when greasing.  
Be particularly careful to wipe off the old grease in places where sand or dirt sticking in the grease would cause wear of the rotating parts.

## Oil and Fuel Storage

- Keep indoors to prevent any water, dirt, or other impurities from getting in.
- When keeping drum cans for a long period, put the drum on its side so that the filler port of the drums is at the side to prevent moisture from being sucked in.  
If drums have to be stored outside, cover them with a waterproof sheet or take other measures to protect them.
- To prevent any change in quality during long-term storage, be sure to use in the order of first in - first out (use the oldest oil or fuel first).

## Filters

- Filters are extremely important safety parts. They prevent impurities in the fuel and air circuits from entering important equipment and causing problems.  
Replace all filters periodically. For details, see the Operation and Maintenance Manual.  
However, when working in severe conditions, replace the filters at shorter intervals according to the oil and fuel (sulfur content) being used.
- Never try to clean the filters (cartridge type) and use them again. Always replace with new filters.
- When replacing oil filters, check if any metal particles are attached to the old filter. If any metal particles are found, contact your Komatsu distributor.
- Do not open packs of spare filters until just before they are to be used.
- Always use Komatsu genuine filters.

## Carrying Out KOWA (Komatsu Oil Wear Analysis)

The oil clinic samples the oil periodically and analyzes it. This is a preventive maintenance service, which provides early discovery of abnormal parts and wear of the drive parts of the machine. This then makes it possible to ensure prevention of failures and reduction in downtime.

Komatsu's long years of experience and rich supply of accumulated data make it possible to accurately determine the condition of your machine. This enables us to locate the problems and to recommend suitable and timely repair methods.

The oil clinic charges the customer only the actual costs, and provides an immediate report of the results of the analysis and recommendations for action to take. This low-cost service can save you high costs and inconvenience in the future, so we strongly recommend you to avail yourself of this service.

**KOWA Analysis Items**

- Measurement of density of metal wear particles

This uses an ICP (Inductively Coupled Plasma) analyzer to measure the density of iron, copper, and other metal wear particles in the oil.

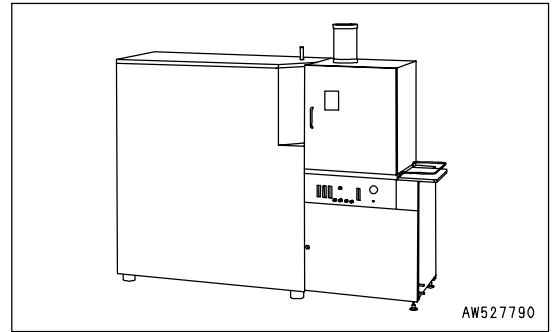

- Measurement of quantity of particles

This uses a PQI (Particle Quantifier Index) measurer to measure the quantity of iron particles of 5µm or more, enabling early detection of failures.

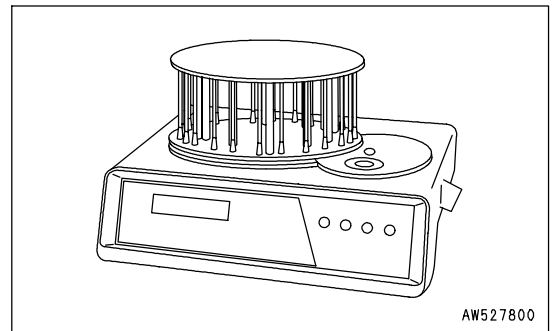

- Others

Measurements are made of items such as the ratio of water in the oil, density of the antifreeze coolant, ratio of fuel in the oil, and dynamic viscosity, enabling a highly precise diagnosis of the machine's health.

**Oil Sampling**

- Sampling interval
  - 250 hours: Engine
  - 500 hours: Other components
  
- Precautions when sampling
  - Make sure that the oil is well mixed before sampling.
  - Perform sampling at regular fixed intervals.
  - Do not perform sampling on rainy or windy days when water or dust can get into the oil.

For further details of KOWA, please contact your Komatsu distributor.

**ELECTRIC SYSTEM MAINTENANCE**

- It is extremely dangerous if the electrical equipment becomes wet or the covering of the wiring is damaged. This will cause an electrical short circuit and may lead to malfunction of the machine. Do not wash the inside of the operator's cab with water. When washing the machine, be careful not to let water get into the electrical components.
- Service relating to the electric system is checking fan belt tension, checking damage or wear to the fan belt and checking battery fluid level.
- Never install any electric components other than those specified by Komatsu.
- External electro-magnetic interference may cause malfunction of the control system controller, before installing a radio receiver or other wireless equipment, contact your Komatsu distributor.
- When working at the seashore, carefully clean the electric system to prevent corrosion.
- When installing electrical equipment, connect it to the special power source connector.  
Do not connect the optional power source to the fuse, starting switch, or battery relay.

## WEAR PARTS

Replace wear parts such as the filter element or air cleaner element at the time of periodic maintenance or before they reach the wear limit. The wear parts should be replaced correctly in order to ensure more economic use of the machine. When replacing parts, always use Komatsu genuine parts.

As a result of our continuous efforts to improve product quality, the part number may change, so inform your Komatsu distributor of the machine serial number and check for the latest part number when ordering parts.

### WEAR PARTS LIST

The parts in parentheses are to be replaced at the same time.

| Item                    | Part No.   | Part Name  | Q'ty                    | Replacement frequency    |
|-------------------------|--|--|-------------------------|--------------------------|
| Hydraulic oil filter    | 07063-51383<br>(07000-15210)                                       | Element<br>(O-ring)  | 2<br>(2)                | Every 500 hours service  |
| Pilot filter            | 424-16-11140   | Element  | 1                       | Every 500 hours service  |
| Drain filter            | 21N-60-12210   | Element  | 1                       | Every 500 hours service  |
| Engine oil filter       | 600-211-1231   | Element  | 2                       | Every 500 hours service  |
| Fuel filter             | 600-311-3111   | Cartridge  | 2                       | Every 500 hours service  |
| Corrosion resistor      | 600-411-1171   | Cartridge  | 1                       | Every 1000 hours service |
| Hydraulic tank breather | 285-62-17320<br>(20Y-60-21470)                                     | Element<br>(Element)   | 1<br>(1)                | Every 1000 hours service |
| Air cleaner             | 600-185-6100<br>(600-184-1671)                                     | Outer element assembly<br>(O-ring)   | 1<br>(1)                | -                        |
| Line filter             | 21N-62-31221<br>(07000-12055)<br>(07000-12070)<br>(07001-02070)    | Element<br>(O-ring)<br>(O-ring)<br>(Backup ring)                                 | 3<br>(3)<br>(3)<br>(3)  | -                        |
| Bucket                  | 21N-72-14290<br>(21N-72-14330)                                     | Horizontal pin type<br>Tooth<br>(Pin)  | 5<br>(5)                | -                        |
|                         | 21N-72-34150<br>(21N-72-34180)                                     | Vertical pin type<br>Tooth<br>(Pin)  | 5<br>(5)                |                          |
|                         | 21N-70-14180<br>21N-70-14190<br>(21N-09-11121)<br>(21N-09-11131)   | Side cutter type<br>Side cutter (left)<br>Side cutter (right)<br>(Bolt)<br>(Nut) | 1<br>1<br>(12)<br>(12)  | -                        |
|                         | 427-70-13611<br>(21N-939-3330)<br>(209-939-7110)<br>(209-939-7120) | Side shroud type<br>Side shroud<br>(Pin)<br>(Shim)<br>(Shim)                     | 4<br>(8)<br>(16)<br>(8) |                          |

# LUBRICANTS, FUEL AND COOLANT SPECIFICATIONS

| RESERVOIR            | KIND OF FLUID    | AMBIENT TEMPERATURE |            |            |         |          |                |          |           |               |  |
|----------------------|------------------|---------------------|------------|------------|---------|----------|----------------|----------|-----------|---------------|--|
|                      |                  | -22<br>-30          | -4<br>-20  | 14<br>-10  | 32<br>0 | 50<br>10 | 68<br>20       | 86<br>30 | 104<br>40 | 122°F<br>50°C |  |
| Engine oil pan       |                  |                     |            |            |         |          | SAE 30         |          |           |               |  |
|                      |                  |                     |            |            | SAE 10W |          |                |          |           |               |  |
|                      |                  |                     |            | SAE 10W-30 |         |          |                |          |           |               |  |
|                      |                  |                     | SAE 15W-40 |            |         |          |                |          |           |               |  |
| P.T.O case           | Engine oil       |                     |            |            |         |          | SAE 30         |          |           |               |  |
| Swing machinery case |                  |                     | SAE 10W    |            |         |          |                |          |           |               |  |
| Final drive case     |                  | SAE 30              |            |            |         |          |                |          |           |               |  |
| Hydraulic system     |                  | SAE 10W             |            |            |         |          |                |          |           |               |  |
|                      |                  | SAE 10W-30          |            |            |         |          |                |          |           |               |  |
|                      |                  | SAE 15W-40          |            |            |         |          |                |          |           |               |  |
| Fuel tank            | Diesel fuel (*2) |                     |            |            |         |          | ASTM D975 No.2 |          |           |               |  |
|                      |                  |                     | *1         |            |         |          |                |          |           |               |  |
| Grease fitting       | Grease           | NLGI No.2           |            |            |         |          |                |          |           |               |  |
| Cooling system       | Water            | Add antifreeze      |            |            |         |          |                |          |           |               |  |

| Reservoir |        | Engine oil pan | P.T.O case | Swing machinery case (Front & rear) | Final drive case (each) | Hydraulic system | Fuel tank | Cooling system |
|-----------|--------|----------------|------------|-------------------------------------|-------------------------|------------------|-----------|----------------|
| Capacity  | Liters | 68             | 13.5       | 24.3                                | 22                      | 800              | 1360      | 140            |
|           | US gal | 17.97          | 3.57       | 6.42                                | 5.81                    | 211.36           | 359.31    | 36.99          |
| Refill    | Liters | 55.5           | 13.5       | 24.3                                | 22                      | 670              | -         | -              |
|           | US gal | 14.66          | 3.57       | 6.42                                | 5.81                    | 177.01           | -         | -              |

**REMARK**

- When fuel sulphur content is less than 0.5%, change oil in the oil pan according to the periodic maintenance hours described in this manual.  
Change oil according to the following table if fuel sulfur content is above 0.5%.
- When starting the engine with an atmospheric temperature of lower than 0°C (32°F), be sure to use engine oil of SAE10W, SAE10W-30 and SAE15W-40, even though the atmospheric temperature goes up to 10°C (50° F) more or less during the day.
- Use API classification CD as engine oil and if API classification CC, reduce the engine oil change interval to half.
- There is no problem if single grade oil is mixed with multigrade oil (SAE10W-30, 15W-40), but be sure to add single grade oil that matches the temperature range in the table.
- We recommend Komatsu genuine oil which has been specifically formulated and approved for use in engine and hydraulic work equipment applications.

Specified capacity: Total amount of oil including oil for components and oil in piping.

Refill capacity: Amount of oil needed to refill system during normal inspection and maintenance.

ASTM: American Society of Testing and Material

SAE: Society of Automotive Engineers

API: American Petroleum Institute

| Fuel sulfur content | Engine oil change interval |
|---------------------|----------------------------|
| 0.5 to 1.0%         | 1/2 of regular interval    |
| Above 1.0%          | 1/4 of regular interval    |



| No. | Supplier        | Engine Oil<br>[CD or CE]<br>SAE10W, 30, 40<br>10W30, 15W40<br>(The 15W40 oil<br>marked * is CE.) | Gear Oil<br>[GL-4 or GL-5]<br>SAE80, 90, 140 | Grease<br>[Lithium-Base]<br>NLGI No.2               | Anti-freeze<br>Coolant<br>[Ethylene Glycol<br>Base]<br>Permanent Type |
|-----|-----------------|--|--|---|---|
| 1   | KOMATSU         | EO10-CD<br>EO30-CD<br>EO10-30CD<br>EO15-40CD   | GO90<br>GO140                                | G2-LI<br>G2-LI-S                                    | AF-ACL<br>AF-PTL<br>AF-PT(Winter, one<br>season type)                 |
| 2   | AGIP            | Diesel sigma S<br>super dieselmulti-<br>grade<br>*Sigma turbo                                    | Rotra MP                                     | GR MU/EP  | -   |
| 3   | AMOCO           | *Amoco 300   | Multi-purpose gear<br>oil                    | PYKON premium<br>grease                             | -   |
| 4   | ARCO            | *Arcofleet S3 plus   | Arco HD gear oil                             | Litholine HEP 2<br>Arco EP moly D                   | -   |
| 5   | BP              | Vanellus C3  | Gear oil EP<br>Hypogear EP                   | Energrease LS-EP2                                   | Antifreeze  |
| 6   | CALTEX          | *RPM delo 400<br>RPM delo 450  | Universal thuban<br>Universal thuban EP      | Marfak all purpose 2<br>Ultra-duty grease 2         | AF engine coolant   |
| 7   | CASTROL         | *Turbomax<br>*RX super<br>CRD  | EP<br>EPX<br>Hypoy<br>Hypoy B<br>Hypoy C     | MS3<br>Spheerol EPL2                                | Anti-freeze   |
| 8   | CHEVRON         | *Delo 400  | Universal gear                               | Ultra-duty grease 2                                 | -   |
| 9   | CONOCO          | *Fleet motor oil   | Universal gear<br>lubricant                  | Super-sta grease                                    | -   |
| 10  | ELF             | Multiperformance 3C<br>Performance 3C  | -  | Tranself EP<br>Tranself EP type 2                   | Glacelf   |
| 11  | EXXON<br>(ESSO) | Essolube D3<br>*Essolube XD-3<br>*Essolube XD-3 Extra<br>*Esso heavy duty<br>Exxon heavy duty    | Gear oil GP<br>Gear oil GX                   | Beacon EP2  | All season coolant  |
| 12  | GULF            | Super duty motor oil<br>*Super duty plus   | Multi-purpose gear<br>lubricant              | Gulfcrown EP2<br>Gulfcrown EP special               | Antifeeze and<br>coolant  |
| 13  | MOBIL           | Delvac 1300<br>*Delvac super<br>10W-30, 15W-40   | Mobilube GX<br>Mobilube HD                   | Mobilux EP2<br>Mobilgease 77<br>Mobilgrease special | -   |

| No. | Supplier      | Engine Oil<br>[CD or CE]<br>SAE10W, 30, 40<br>10W30, 15W40<br>(The 15W40 oil<br>marked * is CE.) | Gear Oil<br>[GL-4 or GL-5]<br>SAE80, 90, 140 | Grease<br>[Lithium-Base]<br>NLGI No.2                             | Anti-freeze<br>Coolant<br>[Ethylene Glycol<br>Base]<br>Permanent Type |
|-----|---------------|--|--|---|---|
| 14  | PENNZOIL      | *Supreme duty<br>fleet motor oil   | Multi-purpose 4092<br>Multi-purpose 4140     | Multi-purpose white<br>grease 705<br>707L White-bearing<br>grease | Anti-freeze and<br>summer coolant                                     |
| 15  | PETROFIN<br>A | FINA kappa TD  | FINA potonic N<br>FINA potonic NE            | FINA marson EPL2  | FINA tamidor  |
| 16  | SHELL         | Rimura X   | Spirax EP<br>Spirax heavy duty               | Albania EP grease   | -   |
| 17  | SUN           | -  | Sunoco GL5<br>gear oil                       | Sunoco ultra prestige<br>2EP<br>Sun prestige 742                  | Sunoco antifreeze<br>and summer<br>coolant                            |
| 18  | TEXACO        | *Ursa super plus<br>Ursa premium   | Multigear                                    | Multifak EP2<br>Starplex 2  | Coda 2055 startex<br>antifreeze coolant                               |
| 19  | TOTAL         | Rubia S<br>*Rubia X  | Total EP<br>Total Transmission<br>TM         | Multis EP2  | Antigal/antifreeze  |
| 20  | UNION         | *Guardol   | MP gear lube LS                              | Unoba EP  | -   |
| 21  | VEEDOL        | *Turbostar<br>*Diesel star<br>MDC  | Multigear<br>Multigear B<br>Multigear C      | -   | Antifreeze  |

# TIGHTENING TORQUE SPECIFICATIONS

## TIGHTENING TORQUE LIST



If nuts, bolts, or other parts are not tightened to the specified torque, it will cause looseness or damage to the tightened parts, and this will cause failure of the machine or problems with operation.

Always pay careful attention when tightening parts.

Unless otherwise specified, tighten the metric nuts and bolts to the torque shown in the table below. If it is necessary to replace any nut or bolt, always use a Komatsu genuine part of the same size as the part that was replaced.

| Thread diameter of bolt (a)(mm) | Width across flats (b)(mm) | Tightning torque [Nm (kgm)] |                             |
|---------------------------------|----------------------------|-----------------------------|-----------------------------|
|                                 |                            | Target value                | Permissible range           |
| 6                               | 10                         | 13.2 (1.35)                 | 11.8 - 14.7 (1.2 - 1.5)     |
| 8                               | 13                         | 31 (3.2)                    | 27 - 34 (2.8 - 3.5)         |
| 10                              | 17                         | 66 (6.7)                    | 59 - 74 (6.0 - 7.5)         |
| 12                              | 19                         | 113 (11.5)                  | 98 - 123 (10.0 - 12.5)      |
| 14                              | 22                         | 177 (18.0)                  | 157 - 196 (16.0 - 20.0)     |
| 16                              | 24                         | 279 (28.5)                  | 245 - 309 (25.0 - 31.5)     |
| 18                              | 27                         | 382 (39.0)                  | 343 - 425 (35.0 - 43.5)     |
| 20                              | 30                         | 549 (56.0)                  | 490 - 608 (50.0 - 62.0)     |
| 22                              | 32                         | 745 (76.0)                  | 662 - 829 (67.5 - 84.5)     |
| 24                              | 36                         | 927 (94.5)                  | 824 - 1030 (84.0 - 105.0)   |
| 27                              | 41                         | 1320 (135.0)                | 1180 - 1470 (120.0 - 150.0) |
| 30                              | 46                         | 1720 (175.0)                | 1520 - 1910 (155.0 - 195.0) |
| 33                              | 50                         | 2210 (225.0)                | 1960 - 2450 (200.0 - 250.0) |
| 36                              | 55                         | 2750 (280.0)                | 2450 - 3040 (250.0 - 310.0) |
| 39                              | 60                         | 3280 (335.0)                | 2890 - 3630 (295.0 - 370.0) |
| 42                              | 65                         | 3830 (390.0)                | 3430 - 4220 (350.0 - 430.0) |

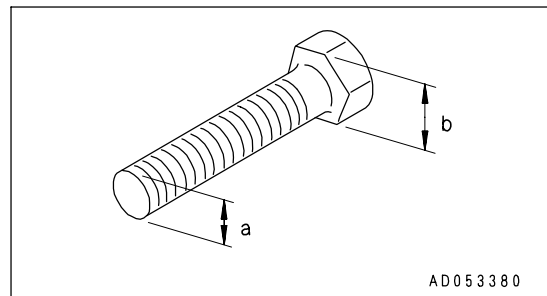

- Apply the following table for Hydraulic Hose.

| Thread diameter a (mm) | Width across flat b(mm) | Tightening torque [Nm (kgm)] |                         |
|------------------------|-------------------------|------------------------------|-------------------------|
|                        |                         | Target value                 | Permissible range       |
| 9/16 -18UNF            | 19                      | 44 (4.5)                     | 35 - 54 (3.5 - 5.5)     |
| 11/16 -16UN            | 22                      | 74 (7.5)                     | 54 - 93 (5.5 - 9.5)     |
| 13/16 -16UN            | 27                      | 103 (10.5)                   | 84 - 132 (8.5 - 13.5)   |
| 1 -14UNS               | 32                      | 157 (16.0)                   | 128 - 186 (13.0 - 19.0) |
| 1-3/16 -12UN           | 36                      | 216 (22.0)                   | 177 - 245 (18.0 - 25.0) |
| *1-7/16-12UN -2B       | 41                      | 215 (22)                     | 176 - 234 (18 - 24)     |

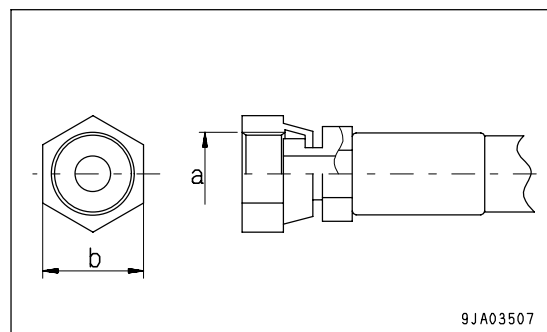

- The torques marked \* indicate the tightening torques for the hoses at the top of the swivel joint.

## SAFETY CRITICAL PARTS

To ensure safety at all times when operating or driving the machine, the user of the machine must always carry out periodic maintenance. In addition, to further improve safety, the parts in the safety-critical parts list on the next page must also be replaced at the specified interval. These parts are particularly closely connected to safety and fire prevention, so please contact your Komatsu distributor to have them replaced.

Material quality of these parts can change as time passes and they are likely to wear out or deteriorate. However, it is difficult to determine the extent of wear or deterioration at the time of periodic maintenance. Hence, it is required to replace them with new ones regardless of their condition after a certain period of usage. This is important to ensure that these parts maintain their full performance at all times.

Furthermore, should anything abnormal be found on any of these parts, replace it with a new one even if the periodic replacement time for the part has not yet arrived.

If any of the hose clamps show deterioration like deformation or cracking, replace the clamps at the same time as the hoses.

Also perform the following checks with hydraulic hoses which need to be replaced periodically. Tighten all loose clamps and replace defective hoses, as required.

When replacing hoses, always replace O-rings, gaskets, and other such parts at the same time.

Have your Komatsu distributor replace the critical parts.

Check the hydraulic and fuel hoses when performing the following periodic inspections.

### SAFETY CRITICAL PARTS LIST

| No. | Safety critical parts for periodic replacement | Q'ty | Replacement interval                                |
|-----|--|------|---|
| 1   | Fuel hose (fuel tank - fuel strainer)          | 1    | Every 2 years or 4000 hours, whichever comes sooner |
| 2   | Fuel hose (fuel strainer - fuel filter)        | 1    |   |
| 3   | Fuel return hose ( engine - fuel cooler)       | 1    |   |
| 4   | Fuel return hose (fuel cooler - fuel tank)     | 1    |   |
| 5   | No.1 pump outlet hose                          | 2    |   |
| 6   | No.2 pump outlet branch hose                   | 2    |   |
| 7   | No.2 pump outlet hose                          | 2    |   |
| 8   | No.3 pump outlet hose                          | 2    |   |
| 9   | No.3 pump outlet branch hose                   | 2    |   |
| 10  | No. 3 pump relay hose                          | 1    |   |
| 11  | Left 5-spool inlet branch hose                 | 1    |   |
| 12  | Right 4-spool inlet branch hose                | 1    |   |
| 13  | No.1 and No.2 pump relay hose                  | 2    |   |
| 14  | Heater hose (engine - heater)                  | 2    |   |
| 15  | Hydraulic pump suction hose                    | 4    |   |
| 16  | Swing line hose                                | 4    |   |
| 17  | Boom cylinder line hose (B/H)                  | 4    |   |
| 18  | Arm cylinder line hose (B/H)                   | 7    |   |
| 19  | Bucket cylinder line hose (B/H)                | 7    |   |
| 20  | Seat belt                                      | 1    | Every 3 years                                       |

# MAINTENANCE SCHEDULE

## MAINTENANCE SCHEDULE CHART

### INITIAL 100 HOURS MAINTENANCE (ONLY AFTER THE FIRST 100 HOURS)

CLEAN STRAINER OF PTO LUBRICATING OIL FILTER ----- 4- 64

### INITIAL 500 HOURS MAINTENANCE (ONLY AFTER THE FIRST 500 HOURS)

CHANGE OIL IN SWING MACHINERY CASE ----- 4- 69

CHANGE OIL IN PTO CASE ----- 4- 70

CHANGE OIL IN FINAL DRIVE CASE ----- 4- 78

### WHEN REQUIRED

CHECK, CLEAN AND REPLACE AIR CLEANER ELEMENT ----- 4- 19

CLEAN INSIDE OF COOLING SYSTEM ----- 4- 22

CHECK AND TIGHTEN TRACK SHOE BOLTS ----- 4- 25

CHECK AND ADJUST TRACK TENSION ----- 4- 26

CHECK ELECTRICAL INTAKE AIR HEATER ----- 4- 28

REPLACE BUCKET TEETH (VERTICAL PIN TYPE) ----- 4- 29

REPLACE BUCKET TEETH (HORIZONTAL PIN TYPE) ----- 4- 32

ADJUST BUCKET CLEARANCE ----- 4- 33

CHECK WINDOW WASHER FLUID LEVEL, ADD FLUID ----- 4- 34

CHECK AND MAINTENANCE AIR CONDITIONER ----- 4- 35

CLEAN LINE FILTER, REMOVE DIRT ----- 4- 36

BLEEDING AIR FROM HYDRAULIC SYSTEM ----- 4- 37

METHOD FOR RELEASING INTERNAL PRESSURE IN HYDRAULIC CIRCUIT ----- 4- 40

CHECK NITROGEN GAS CHARGE PRESSURE IN ACCUMULATOR (CONTROL CIRCUIT) ----- 4- 41

### CHECKS BEFORE STARTING

#### EVERY 10 HOURS MAINTENANCE

LUBRICATING ----- 4- 43

#### EVERY 100 HOURS MAINTENANCE

LUBRICATING SWING CIRCLE ----- 4- 45

#### EVERY 250 HOURS MAINTENANCE

CHECK OIL LEVEL IN FINAL DRIVE CASE, ADD OIL ----- 4- 46

CHECK LEVEL OF BATTERY ELECTROLYTE ----- 4- 47

LUBRICATING AFTER COOLER FAN MOUNT ----- 4- 50

CHECK AND TIGHTEN TRACK FRAME AND AXLE CONNECTING BOLTS ----- 4- 50

CHECK ALTERNATOR DRIVE BELT TENSION, ADJUST ----- 4- 51

CHECK AIR CONDITIONER COMPRESSOR BELT TENSION, ADJUST (ONLY FOR MACHINES  
EQUIPPED WITH AIR CONDITIONER) ----- 4- 52

**EVERY 500 HOURS MAINTENANCE**

|   |       |
|---|-------|
| REPLACE FUEL FILTER CARTRIDGE .....   | 4- 54 |
| CHECK SWING PINION GREASE LEVEL, ADD GREASE .....   | 4- 56 |
| CLEAN HYDRAULIC TANK STRAINER AND RETURN STRAINER .....   | 4- 57 |
| REPLACE HYDRAULIC OIL FILTER ELEMENT .....  | 4- 59 |
| CLEAN AND INSPECT RADIATOR FINS, OIL COOLER FINS, AFTER COOLER FINS, FUEL<br>COOLER FINS, AND CONDENSER FINS (ONLY MACHINES EQUIPPED WITH AIR CONDITIONER) -- | 4- 60 |
| CLEAN INTERNAL AND EXTERNAL AIR FILTERS OF AIR CONDITIONER .....  | 4- 61 |
| REPLACE PILOT FILTER ELEMENT .....  | 4- 63 |
| CLEAN STRAINER OF PTO LUBRICATING OIL FILTER.....   | 4- 64 |
| CHECK WEAR OF FAN BELT, REPLACE, ADJUST .....   | 4- 65 |
| REPLACE DRAIN FILTER CARTRIDGE .....  | 4- 66 |
| CHANGE OIL IN ENGINE OIL PAN, REPLACE ENGINE OIL FILTER CARTRIDGE .....   | 4- 67 |

**EVERY 1000 HOURS MAINTENANCE**

|  |       |
|--|-------|
| CHANGE OIL IN SWING MACHINERY CASE .....                       | 4- 69 |
| CHANGE OIL IN PTO CASE .....                                   | 4- 70 |
| CHECK ALL TIGHTENING PARTS OF TURBOCHARGER .....               | 4- 70 |
| REPLACE CORROSION RESISTOR CARTRIDGE .....                     | 4- 71 |
| LUBRICATING FAN PULLEY ASSEMBLY, TENSION PULLEY ASSEMBLY ..... | 4- 72 |
| REPLACE HYDRAULIC TANK BREATHER FILTER ELEMENT .....           | 4- 73 |
| CHECK FUEL STRAINER, CLEAN .....                               | 4- 74 |
| CHECK WELDED STRUCTURE .....                                   | 4- 75 |

**EVERY 2000 HOURS MAINTENANCE**

|  |       |
|--|-------|
| CHANGE OIL IN FINAL DRIVE CASE .....         | 4- 78 |
| CLEAN ENGINE BREATHER .....                  | 4- 79 |
| CHECK PLAY TURBOCHARGER ROTOR .....          | 4- 79 |
| CLEAN, CHECK TURBOCHARGER .....              | 4- 79 |
| CHECK ALTERNATOR, STARTING MOTOR .....       | 4- 79 |
| CHECK ENGINE VALVE CLEARANCE, ADJUST .....   | 4- 79 |
| CHECK ENGINE INJECTOR SET LOAD, ADJUST ..... | 4- 79 |

**EVERY 4000 HOURS MAINTENANCE**

|   |       |
|---|-------|
| CHECK WATER PUMP .....                    | 4- 80 |
| CHECK VIBRATION DAMPER .....              | 4- 80 |
| CHECK FAN PULLEY AND TENSION PULLEY ..... | 4- 80 |
| CHECK AIR COMPRESSOR, ADJUST .....        | 4- 80 |

**EVERY 5000 HOURS MAINTENANCE**

|  |       |
|--|-------|
| CHANGE OIL IN HYDRAULIC TANK, CLEAN STRAINER ..... | 4- 81 |
|--|-------|

## MAINTENANCE PROCEDURE

### INITIAL 100 HOURS MAINTENANCE (ONLY AFTER THE FIRST 100 HOURS)

Perform the following maintenance only after the first 100 hours.

- Clean strainer of PTO lubricating oil filter

For details of the method of maintaining, see EVERY 500 HOURS MAINTENANCE.

### INITIAL 500 HOURS MAINTENANCE (ONLY AFTER THE FIRST 500 HOURS)

Carry out the following maintenance only after the first 500 hours of operation on new machines.

- Change oil in swing machinery case
- Change oil in PTO case
- Change oil in final drive case

Special tools are needed for inspection and maintenance, so contact your Komatsu distributor.

For details of the method of replacing or maintaining, see EVERY 1000 HOURS and EVERY 2000 HOURS SERVICE.

**WHEN REQUIRED**

**CHECK, CLEAN AND REPLACE AIR CLEANER ELEMENT**

**⚠ WARNING**

- When using compressed air, there is danger of dirt flying and causing personal injury. Always wear protective glasses, dust mask, or other protective equipment.
- When removing the outer element from the air cleaner body, it is dangerous to pull it out by force. When working in high places or where the foothold is poor, be careful not to fall because of the reaction when pulling out the outer element.

**Checking**

If air cleaner clogging monitor (1) of the monitor panel flashes, clean the air cleaner element.

**Replacing**

- Replacing element, O-ring
  - If one year has passed since installing the element or if air cleaner clogging monitor (1) on the monitor panel flashes immediately after the element is cleaned, replace the outer element, inner element, and O-ring.

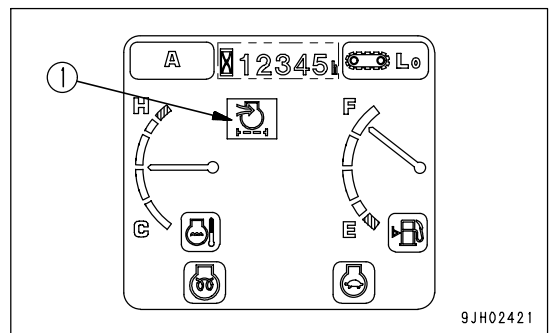

**REMARK**

Dust indicator (4) gives a guideline for the cleaning interval for the air cleaner element. If the yellow piston on the inside overlaps the red zone on the outside circumference of dust indicator (4), it is time to clean the element.

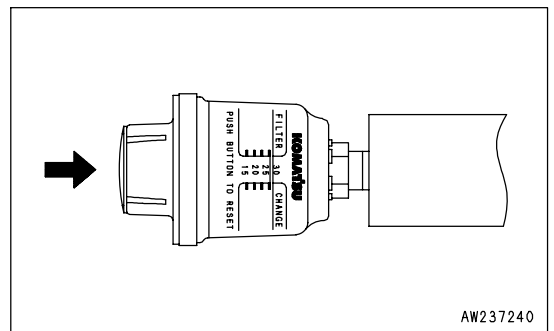
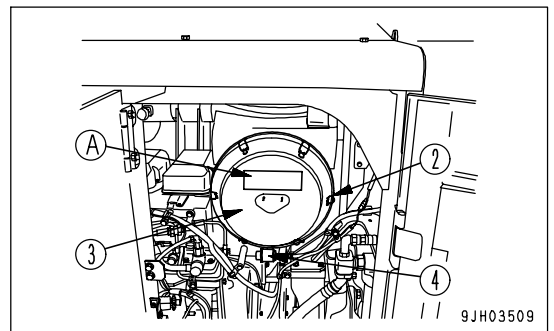

**NOTICE**

- Do not clean the air cleaner element until the air cleaner clogging monitor on the monitor panel light up. If the element is cleaned frequently before the air cleaner clogging monitor light up, the air cleaner will not be able to display its performance fully, and the cleaning efficiency will also go down. In addition, during the cleaning operation, more dirt stuck to the element will fall inside the inner element.
- If inspection, cleaning, or maintenance is carried out with the engine running, dirt will enter the engine and cause damage to the engine. Always stop the engine before carrying out these operations.



**Cleaning Outer Element**

1. Open the right door of the machine, remove 6 hooks (2), then remove cover (3).

**NOTICE**

Before and after cleaning the element, do not leave or keep it in direct sunlight.

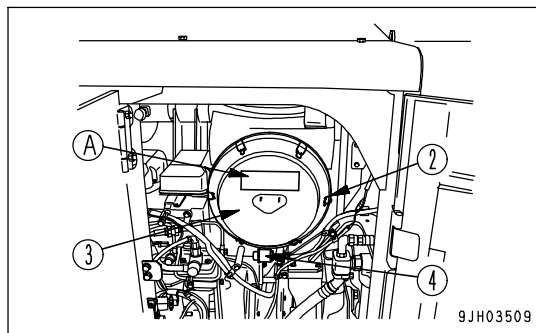

2. Hold the outer element, rock it lightly up and down and to the left and right, and rotate the element to the left and right to pull it out.

**NOTICE**

- Never remove the inner element. It will allow dirt to enter and cause failure of the engine.
- Do not use a screwdriver or any other tool.

3. After removing the outer element, cover the air connector inside the air cleaner body with a clean cloth or tape to prevent dirt or dust from entering.

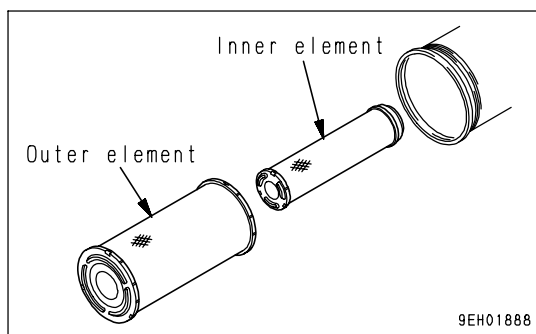

4. Wipe off or brush off the dirt stuck to cover (3) and the inside of the air cleaner body.

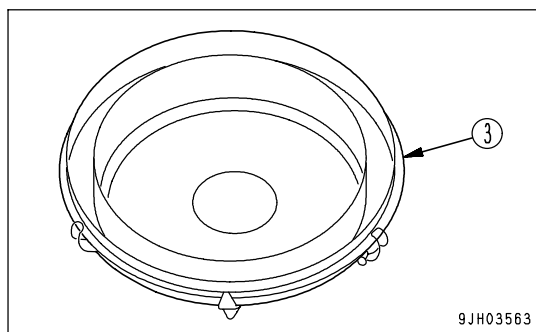
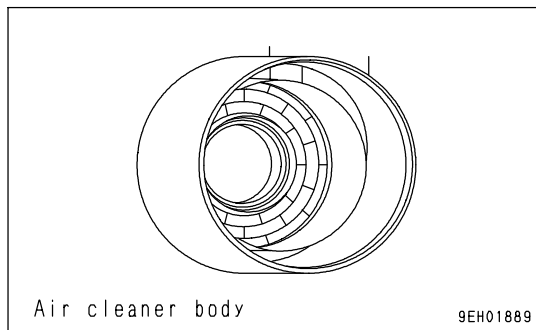

5. Direct dry compressed air (less than 0.69 MPa (7 kg/cm<sup>2</sup>, 99.4 PSI)) to the outer element from inside along its folds, then direct it from outside along its folds and again from inside.

- 1) Remove one seal from the element whenever the element has been cleaned.
- 2) Replace the outer element which has been cleaned 6 times repeatedly or used throughout a year. Replace the inner element at the same time.

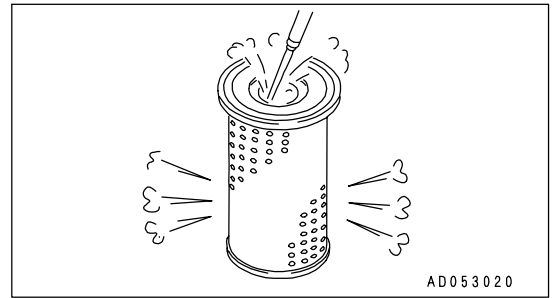

- 3) Replace both inner and outer elements when the air cleaner clogging monitor (1) lights up soon after installing the cleaned outer element even though it has not been cleaned 6 times.
- 4) Check that there is no play in the inner element. If any play is found, push it in properly.
- 5) When replacing the element, stick on seal (A) packed in the same box as the element. Stick the seal in the position shown in the diagram on the right.

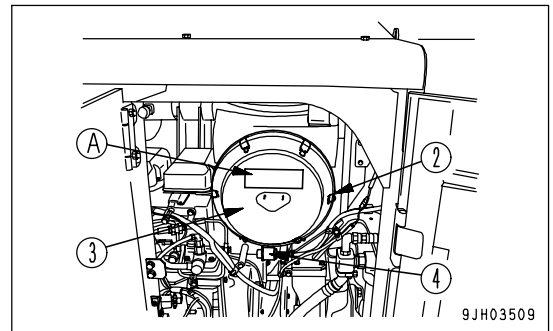

6. Remove the cloth or tape cover installed in Step 3.
7. If small holes or thinner parts are found on the element when it is checked by shining a light through it after cleaning, replace the element.

**NOTICE**

- When cleaning the element, do not hit or beat it against anything.
- Do not use an element whose folds or gasket or seal are damaged.

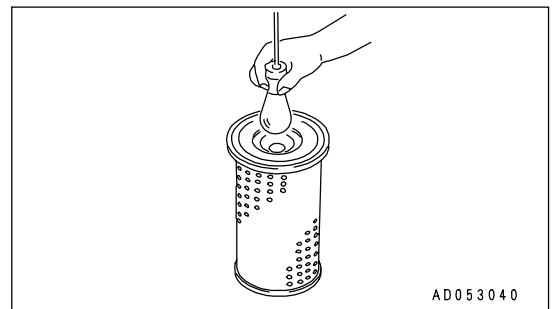

**Replacing Inner Element**

1. First remove the outer element, and then remove the inner element.
2. Cover the air connector side (outlet side) with a clean cloth or tape.
3. Clean the air cleaner body interior, then remove the cover installed in Step 2.
4. Fit a new inner element to the connector and tighten it with nuts.  
Do not clean and reinstall a inner element.
5. Install the outer element and the cover.
6. After replacing the element, push the dust indicator button to reset it. The yellow piston will return to its original position.

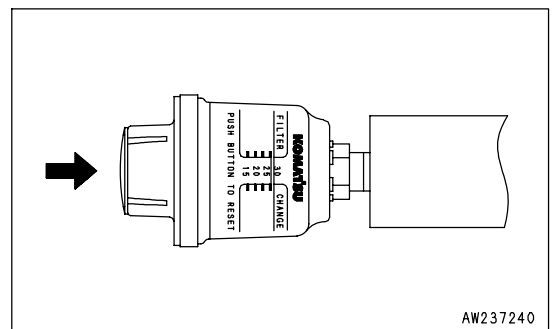

**CLEAN INSIDE OF COOLING SYSTEM**



- Immediately after the engine is stopped, the coolant is at a high temperature and the radiator is under high internal pressure. If the cap is removed to drain the coolant in this condition, there is a hazard of burns. Wait for the temperature to go down, then turn the cap slowly to release the pressure before removing it.
- Cleaning is carried out with the engine running. When standing up or leaving the operator's seat, set the lock lever to the LOCK position.
- For details of starting the engine, see "BEFORE STARTING ENGINE (PAGE 3-69)" and "STARTING ENGINE (PAGE 3-87)" in the OPERATION section.
- There is danger of touching the fan if the undercover is left removed.  
Never enter behind the machine when the engine is running.

Clean the inside of the cooling system, change the coolant and replace the corrosion resistor according to the table below.

| Kind of coolant  | Cleaning inside of cooling system and changing coolant                                 | Replacing corrosion resistor  |
|--|--|---|
| Permanent type antifreeze (All season type)  | Every year (autumn) or every 2000 hours, whichever comes first                         | Every 1000 hours and when cleaning the inside of the cooling system and when changing coolant |
| Non permanent type antifreeze containing ethylene glycol (winter, one season type) | Every 6 months (spring, autumn) (Drain antifreeze in spring, add antifreeze in autumn) |   |
| When not using antifreeze  | Every 6 months or every 1000 hours, whichever come first                               |   |

Stop the machine on level ground when cleaning or changing the coolant.

Use a permanent type of antifreeze.

If, for some reason, it is impossible to use permanent type antifreeze, use an antifreeze containing ethylene glycol. Super Coolant (AF-ACL) has an anti-corrosion effect as well as an antifreeze effect.

The ratio of antifreeze to water depends on the ambient temperature, but to obtain the corrosion resistance effect, a minimum ratio of 30% by volume is necessary.

When deciding the ratio of antifreeze to water, check the lowest temperature in the past, and decide from the mixing rate table given below.

It is actually better to estimate a temperature about 10°C (18°F) lower when deciding the mixing rate.

**Mixing rate of water and antifreeze**

| Min. atmospheric temperature | °C     | -10   | -15   | -20   | -25   | -30   | -35   | -40   |
|------------------------------|--------|-------|-------|-------|-------|-------|-------|-------|
|                              | °F     | 14    | 5     | -4    | -13   | -22   | -31   | -40   |
| Amount of antifreeze         | liter  | 42    | 50.4  | 57.4  | 64.4  | 70    | 75.6  | 81.2  |
|                              | US gal | 11.10 | 13.32 | 15.17 | 17.01 | 18.49 | 17.97 | 21.45 |
| Amount of water              | liter  | 98    | 89.6  | 82.6  | 75.6  | 70    | 64.4  | 58.8  |
|                              | US gal | 25.89 | 23.67 | 21.82 | 19.97 | 18.49 | 17.01 | 15.53 |
| Proportion by volume (%)     |        | 30    | 36    | 41    | 46    | 50    | 54    | 58    |

 **WARNING**

Antifreeze coolant is flammable, so keep it away from flame.

Antifreeze coolant is toxic. When removing the drain plug, be careful not to get water containing antifreeze coolant on you. If it gets in your eyes, flush your eyes with large amount of fresh water and see a doctor at once.

Use city water for the coolant.

If river water, well water or other such water supply must be used, contact your Komatsu distributor.

We recommend use of an antifreeze density gauge to control the mixing proportions.

- Prepare a container to catch drained coolant: Min 140 liters (36.99 US gal) capacity.
1. Stop the engine, close valve (1) on corrosion resistor (2).

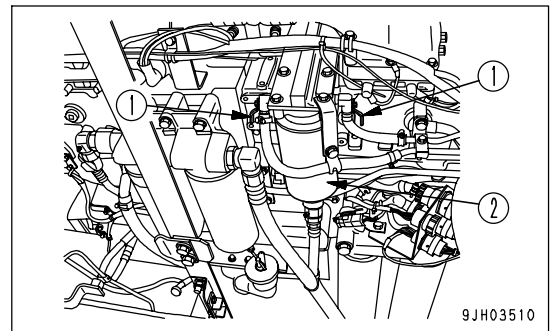

9JH03510

2. Turn radiator cap (3) slowly to remove it.

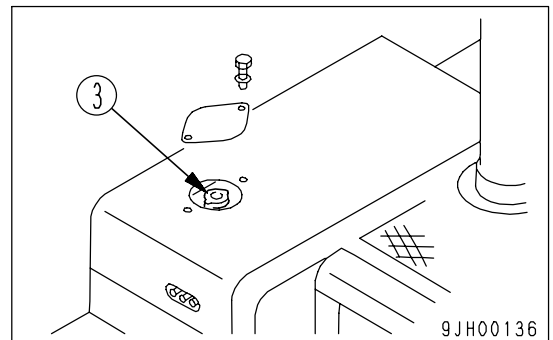

9JH00136

3. Remove the under cover (4), then set a container to catch the coolant under drain valves (5) and (6). Open drain valve (5) at the bottom of the radiator to drain the water. Open drain valve (6) at the cylinder block to drain the water.
4. After draining the water, tighten drain valves (5) and (6), and fill with tap water. When the radiator is full, start the engine and run at low idling. Keep the engine running at low idling for 10 minutes until the water temperature reaches more than 90°C (194°F).
5. Stop the engine, open drain valves (5) and (6), and drain the water.
6. After draining the water, clean the radiator with detergent. For the cleaning method, follow the instruction of detergent.
7. Close drain valves (5) and (6).
8. Replace the corrosion resistor, and open valve (1). For details of the method for replacing the corrosion resistor cartridge, see "REPLACE CORROSION RESISTOR CARTRIDGE (PAGE 4-71)".

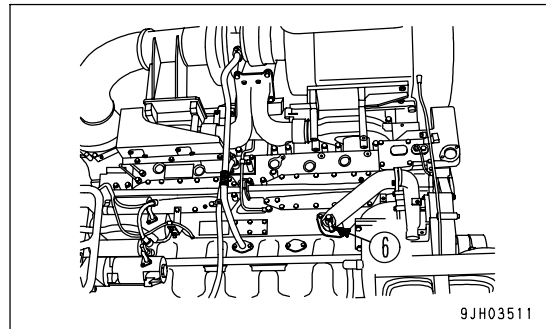
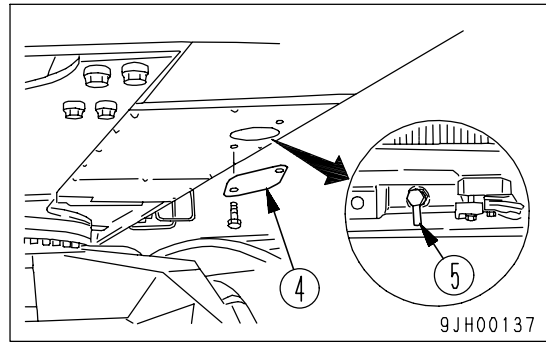

9. Install undercovers (4).
10. Add water through the water filler up to the filler port.
11. To remove air in the cooling system, run the engine for 5 minutes at low idle, then for 5 minutes at high idle. (While doing this, leave the radiator cap removed.)
12. After draining off the cooling water of reserve tank (7), clean the inside of the reserve tank and refill the water between FULL and LOW level.
13. Stop the engine and tighten the cap. Check the coolant level, and add water if the level is low.

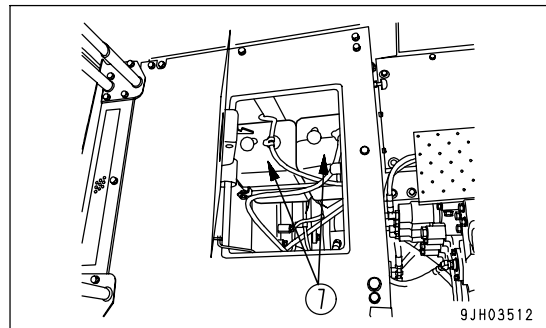

**CHECK AND TIGHTEN TRACK SHOE BOLTS**

If the machine is used with track shoe bolts (1) loose, they will break, so tighten any loose bolts immediately.

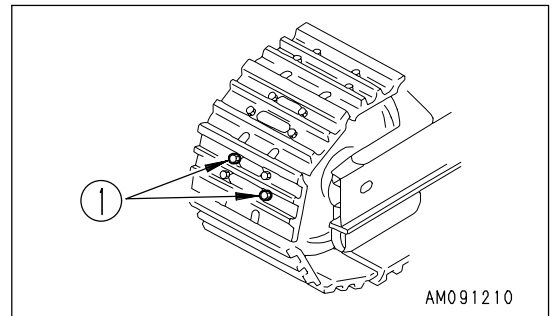

**Tightening**

1. First, tighten to a tightening torque of  $1372 \pm 137.2$  Nm ( $140 \pm 14$  kgm,  $1,012.6 \pm 101.3$  lbf), then check that the nut and shoe are in tight contact with the link mating surface.
2. After checking, further tighten to the tightening torque of  $150^\circ \pm 10^\circ$ .

**Order for Tightening**

Tighten the bolts in the order shown in the diagram on the right. After tightening, check that the nut and shoe are in close contact with the link mating surface.

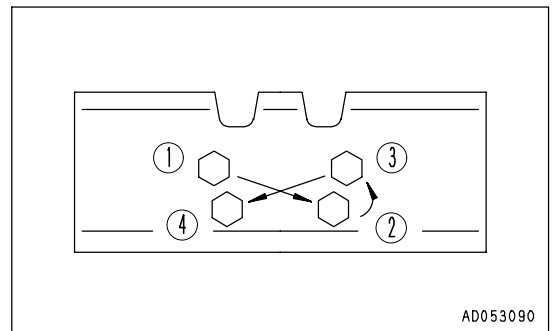

## CHECK AND ADJUST TRACK TENSION



### WARNING

- For details of starting the engine and operating the work equipment, see "BEFORE STARTING ENGINE (PAGE 3-69)", "STARTING ENGINE (PAGE 3-87)", "AFTER STARTING ENGINE (PAGE 3-91)", and "WORK EQUIPMENT CONTROLS AND OPERATIONS (PAGE 3-107)" in the OPERATION section.

The wear of the pins and bushings on the undercarriage will vary with the working conditions and type of soil, so inspect the track tension frequently in order to maintain the standard tension.

Stop the machine on firm, horizontal ground when carrying out the inspection and maintenance.

### Checking

1. Run the engine at low idle, then move the machine forward for a distance equal to the track length on ground, and slowly stop the machine.
2. Place wooden bar (3) on top of the track from No. 2 roller (1) to No. 3 roller (2).
3. Measure the maximum deflection between bottom surface of the wooden bar and top surface of the track shoe. Deflection "a" should be 10 - 30 mm (0.4 - 1.2 in).

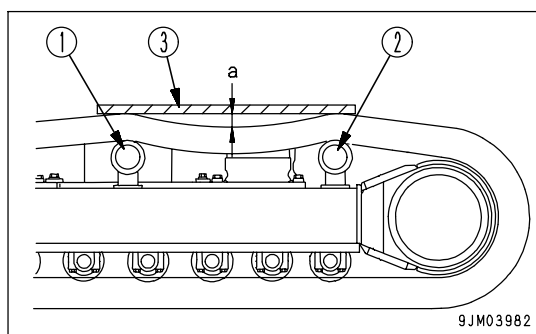

Adjustment

**! WARNING**

There is danger of plug (1) flying out under the high internal pressure of the grease. Never loosen plug (1) more than 1 turn. Never loosen any part other than plug (1). Never put your face in the mounting direction of plug (1).

If the track tension cannot be loosened with the procedure given here, please contact your Komatsu distributor.

**Increasing Track Tension**

Prepare a grease pump.

1. Pump in grease through valve (1) using a grease gun.
2. To check that the tension is correct, move the machine slowly forward and in reverse.
3. Check the track tension again, and if the tension is not correct, adjust it again.

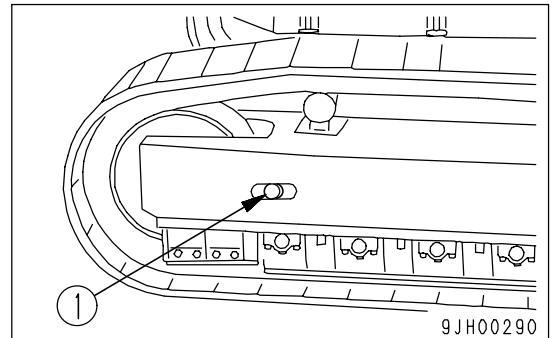

4. Continue to pump in grease until (A) becomes 200 mm (7.9 in). If the tension is still loose, the pin and bushing are excessively worn, so they must be either turned or replaced. Please contact your Komatsu distributor.

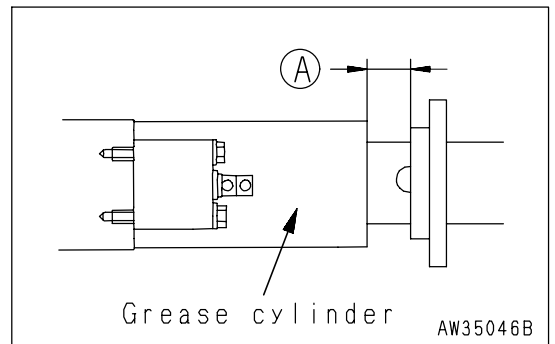



**Loosening Track Tension****WARNING**

It is extremely dangerous to release the grease by any method except the procedure given below.  
If track tension is not relieved by this procedure, contact your Komatsu distributor for repairs.

1. Loosen plug (1) gradually to release the grease.
2. Turn plug (1) a maximum of one turn.
3. If the grease does not come out smoothly, move the machine forwards and backwards a short distance.
4. Tighten plug (1).
5. To check that the correct tension has been achieved, move the machine backwards and forwards.
6. Check the track tension again, and if the tension is not correct, adjust it again.

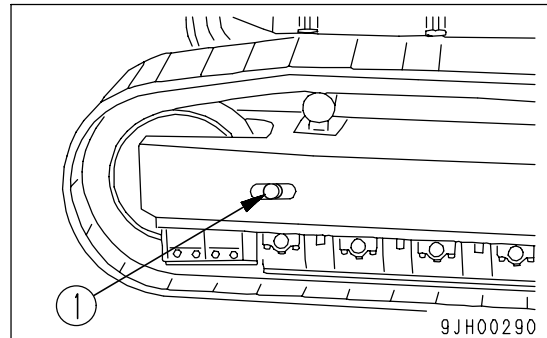
**CHECK ELECTRICAL INTAKE AIR HEATER**

Before the start of the cold season (once a year), contact your Komatsu distributor to have the electrical intake air heater repaired or checked for dirt or disconnections.

Remove the electrical intake air heater from the engine intake manifold, and check it for possible disconnections and dirt.

When inspecting and replacing the electrical intake air heater, replace the gasket with new one.

**REPLACE BUCKET TEETH (VERTICAL PIN TYPE)**

- Replace the bucket tooth before it wears down to the adapter.
- When replacing the bucket teeth, do not replace only both sides with new parts. If both sides only are replaced with new parts, the bucket will easily deform.

**WARNING**

- It is extremely dangerous if the work equipment moves unexpectedly when the teeth are being replaced.  
Set the work equipment in a stable condition, stop the engine, then set safety lock lever (1) securely to the LOCK position.
- The pin must be hit strongly to remove it, so there is danger of the pin flying out. Make sure that there is no person in the surrounding area before removing the pin.
- There is danger of broken pieces flying during the replacement operation, so always wear protective glasses, gloves, and other protective equipment.

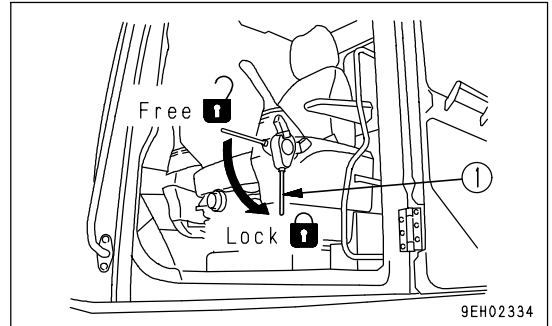

1. Prepare the replacement tooth, tools, and jig.

- (1) Pin
- (2) Tooth
- (3) Hammer
- (4) Pin removal jig
- (5) Adapter (welded to bucket)

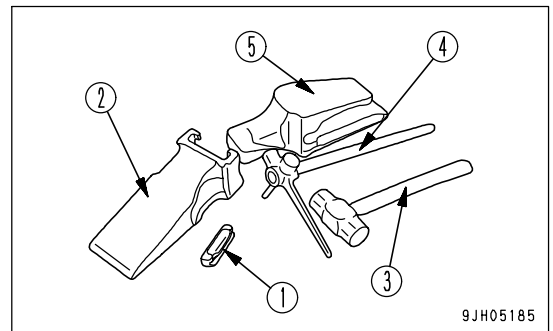

2. Set a block under the bottom face of the bucket so that pin (1) can be removed. Turn the starting switch to the ON position within 15 seconds after stopping the engine, operate the control levers fully, check that the work equipment is stable, then set the safety lock lever to the LOCK position. Set so that the bottom face of the bucket is horizontal.

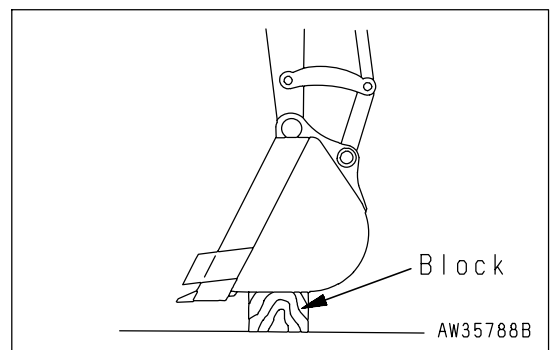

3. Put the short part of pin removal jig (4) in contact with the top surface of pin (1), then hit it with hammer (3).

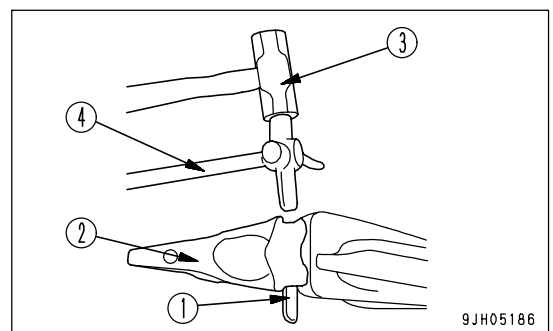

4. When the short part of pin removal jig (4) enters fully, put the long part in contact with pin (2) and remove the pin.

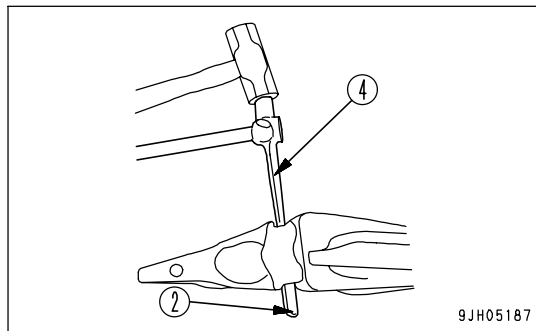

5. Turn tooth (2) counterclockwise and remove it from adapter (5).

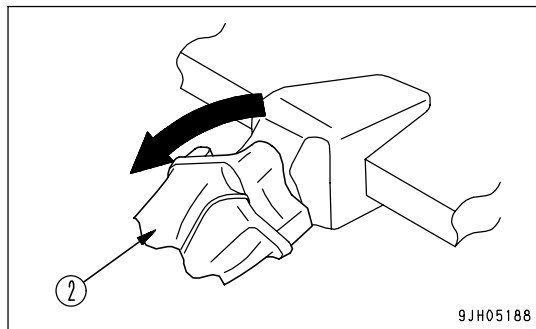

6. Clean the tip insertion portion of adapter (5). If there is any mud, sand, or gravel stuck to it, the tooth will not enter properly, and it will be impossible to knock in the pin.

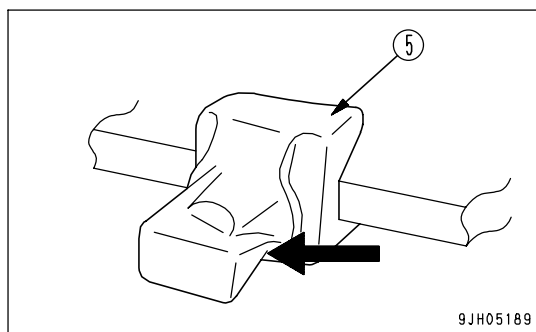

7. Turn replacement tooth (2) clockwise and gradually insert it into adapter (5). Continue to insert it until the tooth contacts the tip of the adapter.

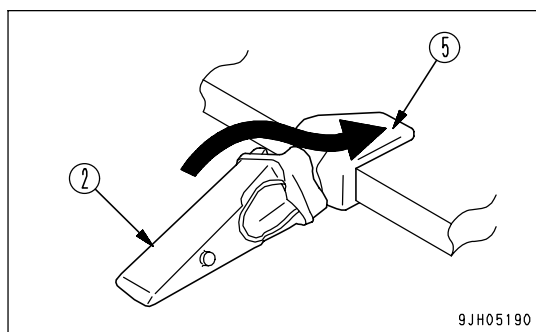

8. When tooth (2) is pushed securely into the nose of adapter (5), check the direction of pin (1) and insert it.

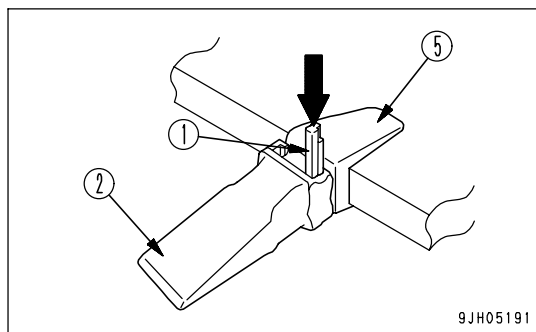

9. Hit pin (1) with the hammer and knock it in until it is level with the end of the ears of tooth (2).

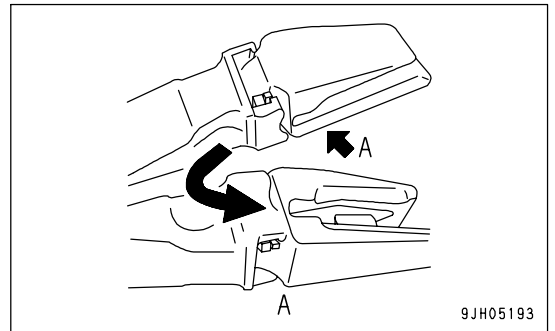
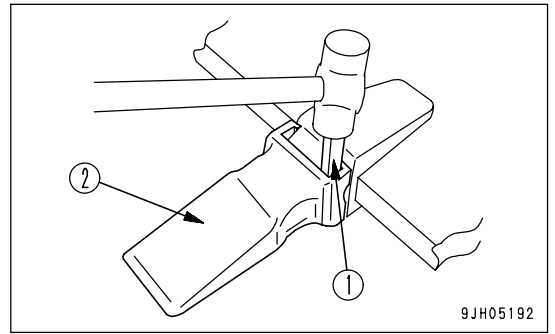

### REPLACE BUCKET TEETH (HORIZONTAL PIN TYPE)

Replace the teeth before the wear reaches the adapter.



#### WARNING

- It is dangerous if the work equipment moves by mistake when the teeth are being replaced.  
Set the work equipment in a stable condition, then stop the engine and set the lock lever securely to the LOCK position.
- The pins can be knocked out only with strong force, so there is a hazard that the pin may fly out. Check that there is no one in the surrounding area.
- There is a hazard that fragments will fly during the replacement work, so always wear protective equipment like safety glasses and gloves.

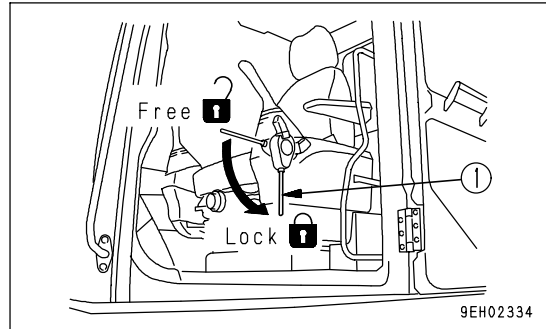

1. Place a block under the bucket bottom so that the pin (1) of tooth (2) can be knocked out with a hammer. Set so that the bottom face of the bucket is horizontal.

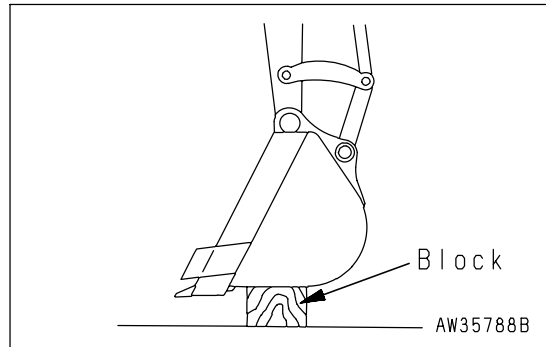

2. Place a bar on the head of pin (1), hit the bar with a hammer to knock out the pin, then remove tooth (2).

#### REMARK

- If the bucket teeth cannot be safely removed by this method, have your Komatsu distributor replace the bucket teeth.

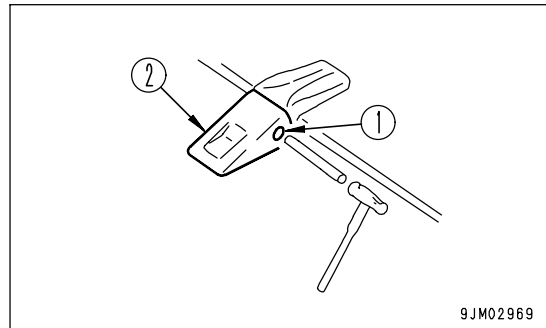

3. Clean the mounting face. Fit a new tooth (2) in the adapter, push in pin (1) partially by hand, then lock it with a hammer to install the tooth to the bucket.

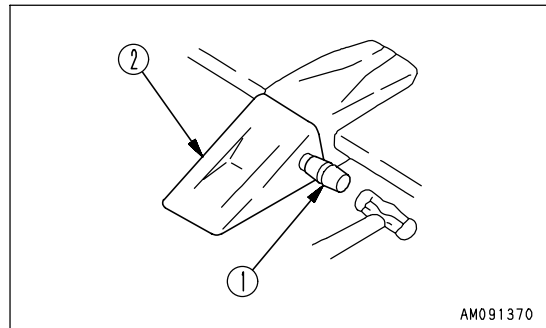

**ADJUST BUCKET CLEARANCE**

**WARNING**

It is dangerous if the work equipment is mistakenly moved when adjusting the bucket clearance.

Set the work equipment in a stable condition, stop the engine, then set safety lock lever (1) securely to the LOCK position.

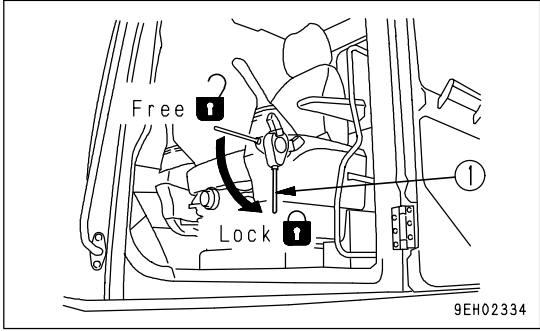

If there is excessive free play on the coupling section of the bucket and arm, adjust the bucket clearance in the following manner.

1. Set the work equipment in the position shown in the diagram on the right, then stop the engine and set the lock lever to the LOCK position (L).
2. Loosen 3 bolts (2), 6 bolts (3), plate (1) and plate (5).
3. Take out shims (4) equivalent in size to free play (a).

Thickness of shim (4) is 0.5 mm or 1.0 mm (0.02 or 0.04 in).

When free play (a) is less than a thickness of shim, do not compress the shims by tightening bolt (2).

4. Tighten 3 bolts (2) and 6 bolts (3).

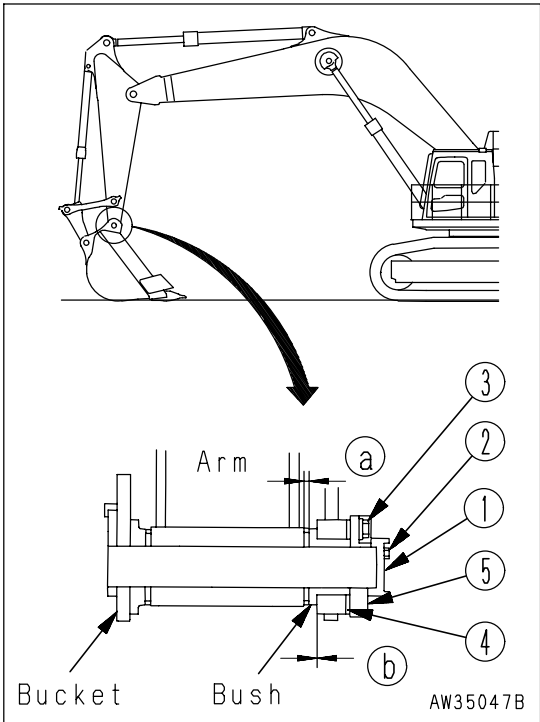

With this adjustment, clearance (b) becomes larger, but play (a) is removed.

**CHECK WINDOW WASHER FLUID LEVEL, ADD FLUID**

If there is air in the window washer fluid, check the level of the fluid in window washer tank (1). Add automobile window washer fluid if necessary.

When adding fluid, be careful not to let any dust get in.

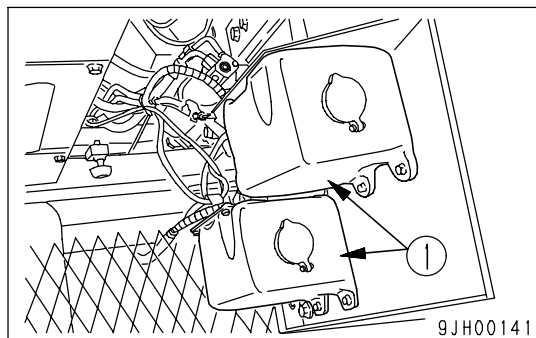

**Mixture Ratio of Pure Washer Fluid and Water**

The proportion differs according to the ambient temperature, so dilute the washer fluid with water to the following proportions before adding.

| Operation area and season       | Mixture ratio                       | Freezing temperature |
|---------------------------------|-------------------------------------|----------------------|
| Normal                          | Pure washer fluid<br>1/3: water 2/3 | - 10°C (14°F)        |
| Winter in cold region           | Pure washer fluid<br>1/2: water 1/2 | - 20°C (- 4°F)       |
| Winter in extremely cold region | Pure washer fluid                   | - 30°C (- 22°F)      |

There are two types depending on the freezing temperature:

-10°C (14°F) (general use) and -30°C (-22°F) (cold area use), select according to the area and season.

**CHECK AND MAINTENANCE AIR CONDITIONER**

(Only for machines equipped with an air conditioner)

**Check Level of Refrigerant (gas)**

 **WARNING**

If the refrigerant used in the air conditioner gets into your eyes or on your hands, it may cause loss of sight or frostbite. Do not touch the refrigerant. Never loosen any part of the refrigerant circuit.

Do not bring any flame close to any point where the refrigerant gas is leaking.

If there is a lack of refrigerant (gas), the cooling performance will be poor. When operating the air conditioner at high speed with the engine at full throttle, use the receiver sight glass (inspection window) to check the condition of the refrigerant gas (R134a) flowing in the refrigerant circuit.

- No bubbles in refrigerant flow: Suitable
- Some bubbles in flow  
(bubbles pass continuously): Lack of refrigerant
- Colorless, transparent: No refrigerant

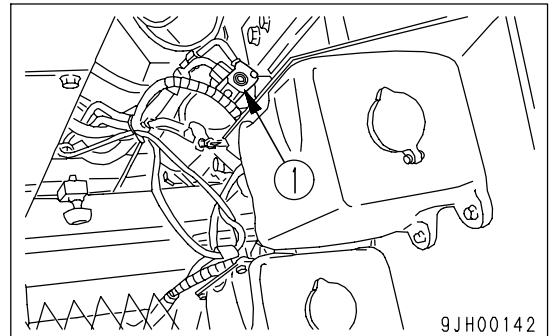

**REMARK**

When there are bubbles, the refrigerant gas level is low, so contact your Komatsu distributors to have refrigerant added. If the air conditioner is run with the refrigerant gas level low, it will cause damage to the compressor.

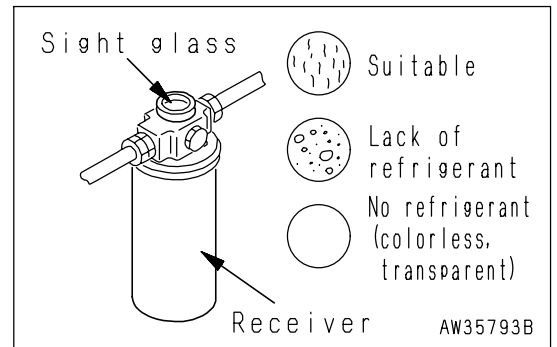

**Inspection During Off Season**

Even during the off-season, operate the air conditioner for 3 to 5 minutes once a month to maintain the oil film at all parts of the compressor.

**Inspection and Maintenance Items**

| Check, maintenance items  | Content of check, maintenance  | Guideline for maintenance interval |
|---------------------------|--|------------------------------------|
| Refrigerant (gas)         | Charge amount  | Twice a year (spring, autumn)      |
| Air conditioner condenser | Clogged fins   | Every 500 hours                    |
| Compressor                | Operating condition  | Every 4000 hours                   |
| V-belt                    | Damage, tension  | Every 250 hours                    |
| Blower motor, fan         | Operating condition<br>(does it make abnormal noise?)                                      | When required                      |
| Control mechanism         | Operating condition (does it function normally?)   | When required                      |
| Piping mounts             | Mounting condition, looseness at tightening or connecting portions, leakage of gas, damage | When required                      |



**CLEAN LINE FILTER, REMOVE DIRT**

If there is any abnormality in the pump or other hydraulic equipment, remove the dirt from inside the line filter as follows.

Before removing the line filter, release the pressure inside the hydraulic circuit. For details, see "METHOD FOR RELEASING INTERNAL PRESSURE IN HYDRAULIC CIRCUIT (PAGE 4-40)".

1. Remove plug (2).
2. Using a bolt (Ø10) in filter (1), remove the filter.
3. Wash the filter.

When washing the filter, clean off all dirt stuck to the side face of the case.

When assembling the case again, replace O-rings (4) and (5) and backup ring (3).

Tightening torque of cover:  $107.9 \pm 9.8 \text{ Nm}$   
 ( $11 \pm 1 \text{ kgm}$  ,  $79 \pm 7 \text{ lbft}$ )

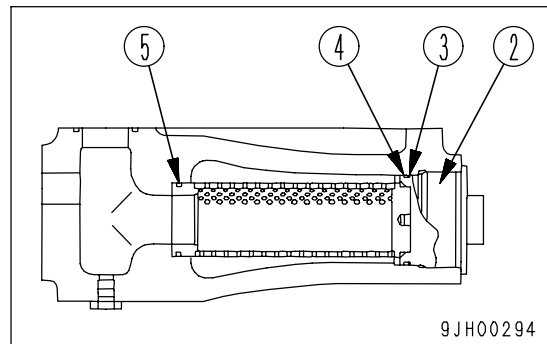
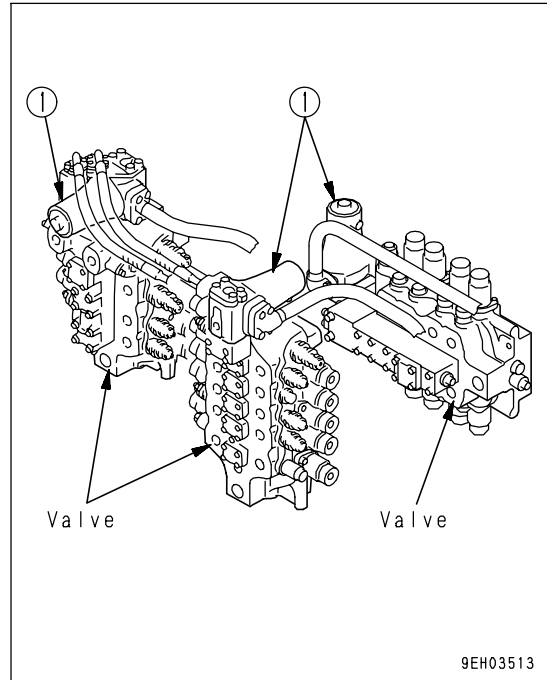

After assembling the line filter again, bleed the air. For details, see "BLEEDING AIR FROM HYDRAULIC SYSTEM (PAGE 4-37)".

**BLEEDING AIR FROM HYDRAULIC SYSTEM**

For details, see "STARTING ENGINE (PAGE 3-87)". If it is necessary to refer to the items for starting the engine, moving the machine off, steering, or stopping, see the OPERATION section.

**NOTICE**

- Bleed the air as follows.
  1. Pump (work equipment, swing)
  2. Work equipment circuit
- Run the engine at less than 1000 rpm, and operate the cylinders slowly.
- Do not suddenly stop and cause the cylinder pressure to rise or operate to the end of the stroke.
- When operating the cylinder for the first stroke (extending and retracting), operate particularly slowly.
- When operating the cylinder for the first stroke, there is a large amount of air inside the circuit, so the work equipment will not move for at least 10 seconds. Be careful not to operate the lever to the end of the stroke.
- Use clean oil of NAS7 class or above when filling the pump. Be sure to use a clean oil can.

Bleed the air from the various components in the order below (1 - 5).

1. Bleeding air from pump
  - 1) Loosen air bleeder (1) and check that oil oozes out from the air bleeder.

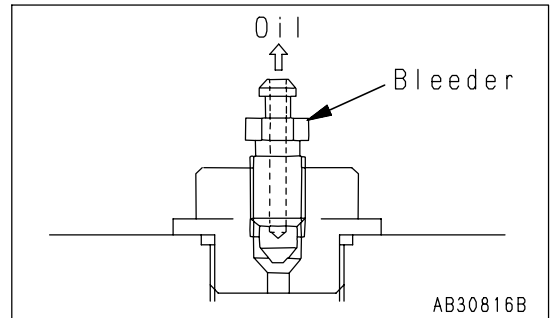

- 2) If no oil oozes out, remove the drain hose from the pump case, and add hydraulic oil through drain port (2) to fill the pump case. Oil will come out when the drain hose is removed, so secure the hose mouthpiece at a position higher than the level of the oil in the hydraulic tank.
- 3) After completing the air bleed operation, tighten air bleeder (1) and install the drain hose.

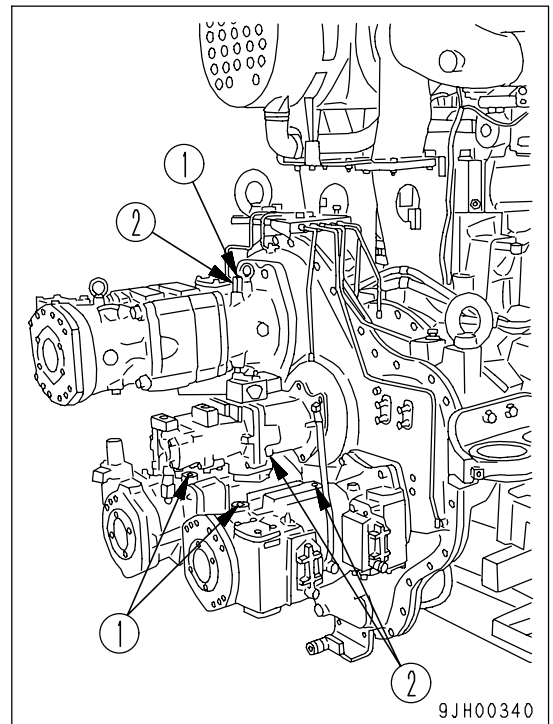

**NOTICE**

If the drain hose is installed first, oil will spurt out from plug (1) hole. If the pump is operated without filling the pump case with hydraulic oil, abnormal heat will be generated and this may cause premature damage to the pump.

2. Starting engine

Start the engine according to "STARTING ENGINE (PAGE 3-87)" keep running the engine at low idle for 10 minutes, and carry out the following procedure.

3. Bleeding air from cylinders

- 1) Run the engine at low idle, and extend and retract each cylinder 4 to 5 times, taking care that a cylinder is not moved to the end of its stroke. (Stop the cylinder approx. 100 mm (3.9 in) short of its stroke end)
- 2) Next, operate each cylinder 3 to 4 times to the end of its stroke.
- 3) Finally, operate each cylinder 4 to 5 times to the end of its stroke to completely remove the air.

**NOTICE**

If the engine is run at high speed immediately after startup or a cylinder is pushed up to its stroke end, air taken inside the cylinder may cause damage to the piston packing.

4. Bleeding air from swing motor (bleed the air only when the oil inside the swing motor case has been drained)

- 1) Run the engine at low idling, remove air hose (1), and check that oil oozes out from air hose (1).

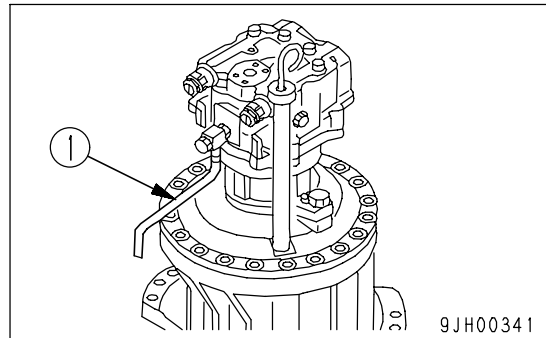

**NOTICE**

Do not operate the swing under any circumstances.

- 2) If the oil does not ooze out, stop the engine, remove air hose (1), then fill the motor case with hydraulic oil.

- 3) After completion of bleeding air, install air hose (1).
- 4) Run the engine at low idle, and slowly swing the upper structure at least 2 times uniformly to the left and right.

**NOTICE**

If the air is not bled from the swing motor, the motor bearings may be damaged.

5. Bleeding air from attachment (when installed)

If an attachment has been installed, run the engine at low idling and operate the attachment pedal repeatedly (approx. 10 times) until the air has been bled from the attachment and circuit.

**NOTICE**

- If the method of bleeding the air from the attachment itself is specified by the manufacturer, bleed the air according to the specified procedure.
- After completing the air bleeding operation, stop the engine, and leave the machine for 5 minutes before starting operations. This will remove the air bubbles in the oil inside the hydraulic cylinders.
- Check that there is no leakage of oil and wipe off any oil that has been spilled.

6. Bleeding air from travel motor circuit

If the piping has been removed from the travel motor circuit, bleed the air after reassembling. To bleed the air, run the engine at low idling and do as follows.

- 1) Start the engine and run at low idling.
- 2) Remove travel motor cover (1), then loosen air bleed plug (2) one turn.

**NOTICE**

**Do not loosen plug (2) more than one turn.**

- 3) Carry out fine operation of the travel lever and set to FORWARD and REVERSE 4 - 5 times.
- 4) When no more cloudy white oil comes out from air bleed plug (2), tighten air bleed plug (2).
- 5) Install the travel motor cover.

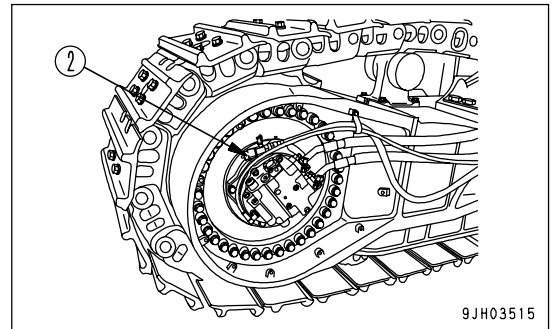
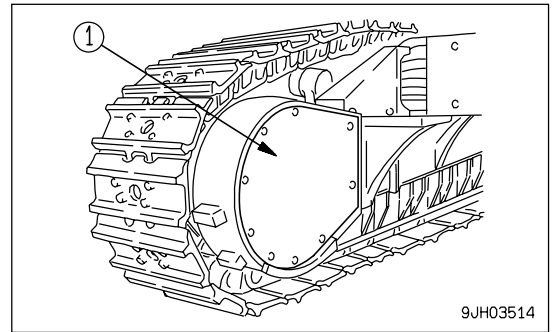

## METHOD FOR RELEASING INTERNAL PRESSURE IN HYDRAULIC CIRCUIT

### RELEASING PRESSURE FROM WORK EQUIPMENT CIRCUIT, SWING CIRCUIT, TRAVEL CIRCUIT

#### **WARNING**

- The hydraulic system is always under internal pressure, so when inspecting or replacing the piping or hoses, always release the pressure in the circuit before starting. If the pressure is not released, high pressure oil may spurt out and cause serious personal injury.
- The parts and oil are at high temperature after the engine is stopped, and may cause serious burns. Wait for the temperature to go down before starting the operation.
- When the oil filler cap is removed, oil may spurt out, so turn the cap slowly to release the pressure before removing the cap.

1. Stop the machine on firm horizontal ground, lower the work equipment to the ground as shown in the diagram on the right, then stop the engine.
  - Set the lock lever at the FREE position.
2. Operate each work equipment control lever to the full stroke within 5 - 6 seconds after stopping the engine.
  - Leave the starting switch at the ON position.
3. Remove the cap of the hydraulic tank.
4. Start the engine, run for approx. 10 seconds, then stop the engine again.
  - Do not run the engine at more than 1000 rpm.
  - Set the work equipment control levers to the HOLD position.
5. Operate each work equipment control lever to the full stroke within 5 - 6 seconds after stopping the engine.
  - Repeat Steps 4 - 5 three times.

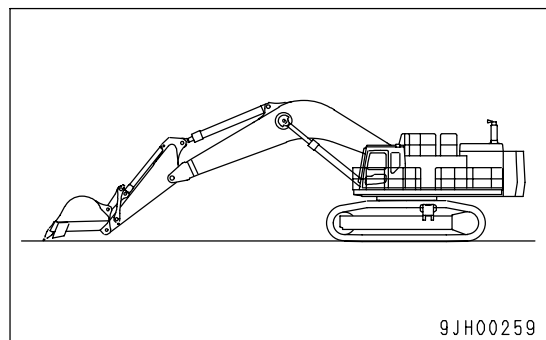

### RELEASING PRESSURE IN ACCUMULATOR CIRCUIT

After stopping the engine, set lock lever (1) to the FREE position, then operate each work equipment control lever 3 - 4 times to the end of the stroke. After 1 minute, the internal pressure will be relieved.

- Do not loosen any piping until at least 1 minute has passed after relieving the internal pressure.

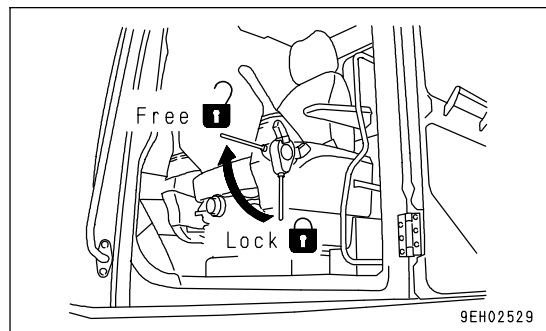

## CHECK NITROGEN GAS CHARGE PRESSURE IN ACCUMULATOR (control circuit)

### NOTICE

If the nitrogen gas charge pressure in the accumulator is low and operations are continued, it will become impossible to release the remaining pressure inside the hydraulic circuit if a failure occurs on the machine.

Check the nitrogen gas charge pressure as follows.

1. Set the work equipment to maximum reach as shown in the diagram on the right.

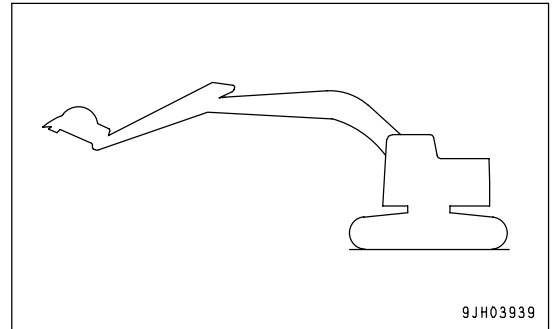

2. Stop the engine and carry out the LOWER operation for the boom.
3. Check that the tip of the bucket drops at least 1 m (3 ft).

If the tip of the bucket drops less than 1 m (3 ft), the charge pressure inside the accumulator is low, so contact your Komatsu distributor.

**CHECK BEFORE STARTING**

For details of the following items, see "Checks Before Starting (PAGE 3-71)" in the OPERATION section.

- Check coolant level, add coolant
- Check oil level in engine oil pan, add oil
- Check Fuel Level, Add Fuel
- Check oil level in hydraulic tank, add oil
- Check oil level in swing machinery case, add oil
- Check oil level in PTO case, add oil
- Check air cleaner for clogging
- Check working lamp switch
- Check electric wiring
- Check function of horn
- Drain Water And Sediment From Fuel Tank

**EVERY 10 HOURS MAINTENANCE**

**LUBRICATING**

1. Set to the greasing posture below, lower the work equipment to the ground, then stop the engine.
2. Using a grease pump, pump in grease through the grease fittings shown by arrows.
3. After greasing, wipe off any old grease that was pushed out.

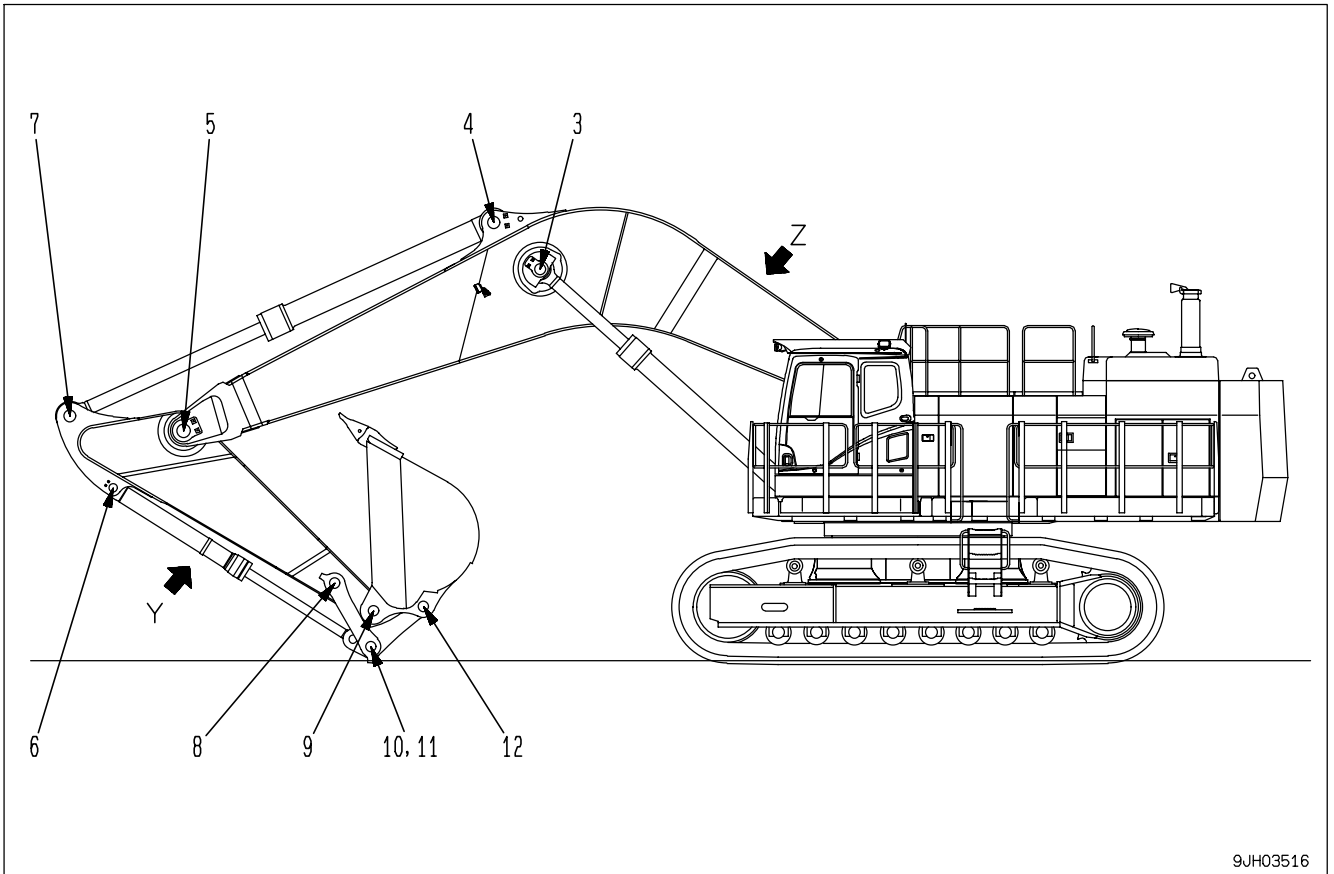

9JH03516

(1) Boom cylinder foot pin (2 places)

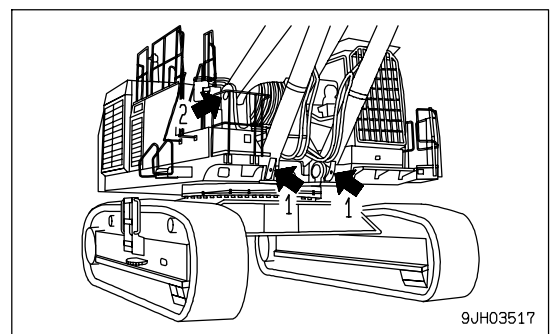

9JH03517



- (2) Boom foot pin (2 places)
- (3) Boom cylinder rod end pin (2 places)
- (4) Arm cylinder foot pin (1 place)

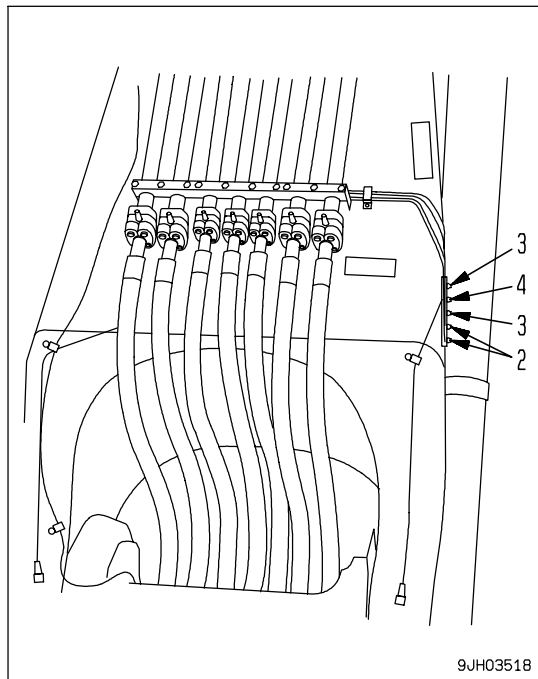

- (5) Boom - Arm coupling pin (1 place)
- (6) Bucket cylinder foot pin (2 point)
- (7) Arm cylinder rod pin (1 place)
- (8) Arm - Link coupling pin (1 place)
- (9) Arm-Bucket coupling pin (2 point)
- (10) Link coupling pin (1 point)
- (11) Bucket cylinder rod end pin (2 point)
- (12) Bucket-Link coupling pin (1 place)

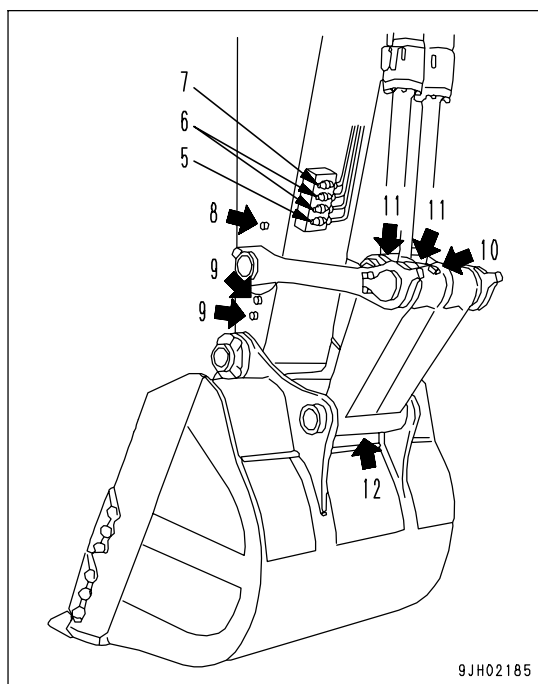

## EVERY 100 HOURS MAINTENANCE

Maintenance for every 10 hours service should be carried out at the same time.

### LUBRICATING SWING CIRCLE

(4 points)

1. Lower the work equipment to the ground.
2. Using a grease pump, pump in grease through the grease fittings shown by arrows.
3. After greasing, wipe off any old grease that was pushed out.

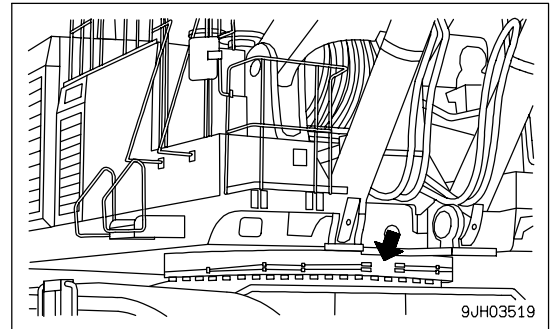

### EVERY 250 HOURS MAINTENANCE

Maintenance for every 10 hours service should be carried out at the same time.

### CHECK OIL LEVEL IN FINAL DRIVE CASE, ADD OIL

 **WARNING**

- The parts and oil are at high temperature immediately after the engine is stopped, and may cause serious burns. Wait for the temperature to go down before starting the operation.
- If there is still pressure remaining inside the case, the oil or plug may fly out. Loosen the plug slowly to release the pressure.

- Prepare a handle.
  1. Set the TOP mark at the top, with the UP mark and plug (P) perpendicular to the ground surface.
  2. Using a handle, remove plug (F) and check that the oil level is within a range of 10 mm (0.4 in) below the bottom edge of the plug hole.
  3. If the oil level is low, check again. Install plug (F), operate the travel lever, travel in FORWARD or REVERSE, and rotate the sprocket one turn. Perform inspection for Procedure 2 again.
  4. If the oil level is low, add engine oil through plug hole (F) until the oil overflows from plug hole (F).
  5. After checking, install plug (F).

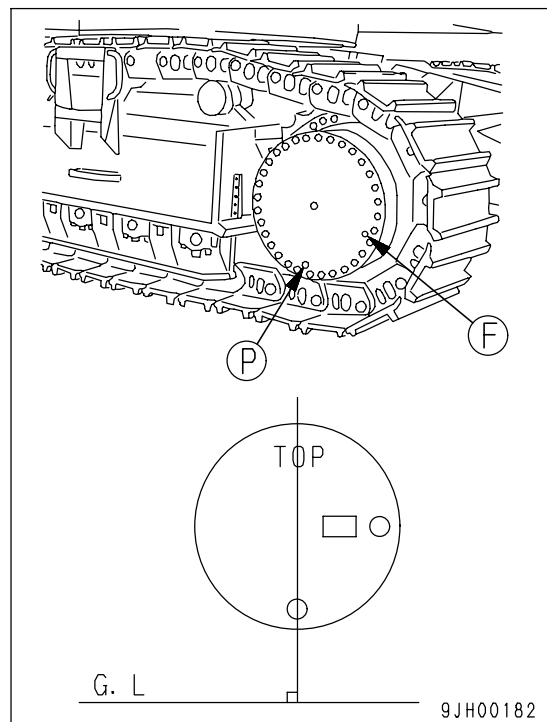

## CHECK LEVEL OF BATTERY ELECTROLYTE

Carry out this procedure before operating the machine.



### WARNING

- Do not use the battery if the battery electrolyte level is below the LOWER LEVEL line. This will accelerate deterioration of the inside of the battery and reduce the service life of the battery. In addition, it may cause an explosion.
- The battery generates flammable gas and there is danger of explosion, do not bring fire or sparks near the battery.
- Battery electrolyte is dangerous. If it gets in your eyes or on your skin, wash it off with a large amount of water and consult a doctor.
- When adding distilled water to the battery, do not allow the battery electrolyte to go above the UPPER LEVEL line. If the electrolyte level is too high, it may leak and cause damage to the paint surface or corrode other parts.

### NOTICE

If there is a fear that the battery water may freeze after refilling with purified water (e.g. commercially available replenishment water for a battery), do the replenishment before the day's work on the next day.

Inspect the battery electrolyte level at least once a month and follow the basic safety procedures given below. Open cover (1) at the rear left side of the machine. The batteries are installed at (A) part.

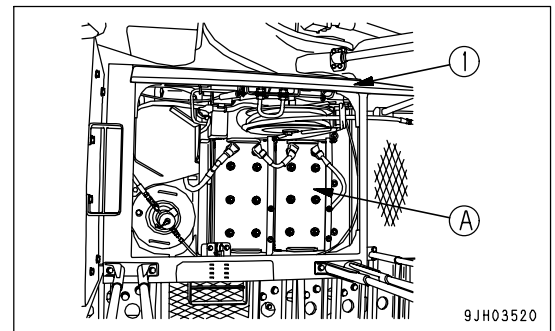

**When Checking Electrolyte Level from Side of Battery**

If it is possible to check the electrolyte level from the side of the battery, check as follows.

1. Use a wet cloth to clean the area around the electrolyte level lines and check that the electrolyte level is between the UPPER LEVEL (U.L.) and LOWER LEVEL (L.L.) lines.  
If the battery is wiped with a dry cloth, static electricity may cause a fire or explosion.

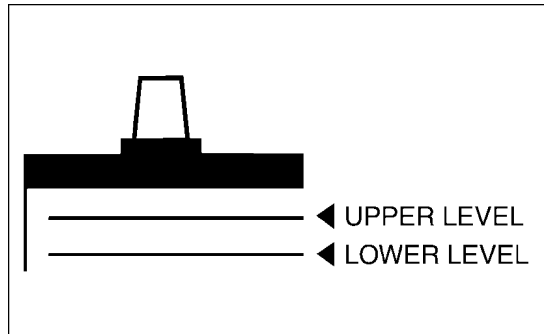

2. If the electrolyte level is below the midway point between the U.L and L.L lines, remove cap (1) and add distilled water to the U.L line.
3. After adding distilled water, tighten cap (1) securely.

**REMARK**

If distilled water is added to above the U.L. line, use a syringe to lower the level to the U.L. line. Neutralize the removed fluid with baking soda (sodium bicarbonate), then flush it away with a large amount of water or consult your Komatsu distributor or battery maker.

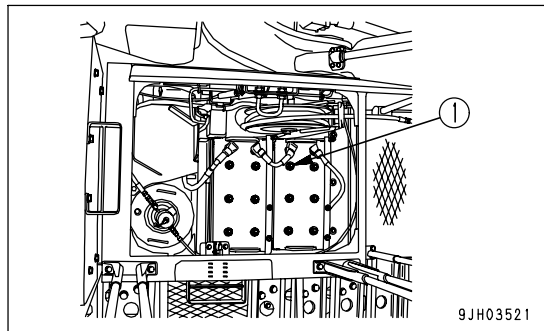

**When it is Impossible to Check Electrolyte Level from Side of Battery**

If it is impossible to check the electrolyte level from the side of the battery, or there is no display of the UPPER LEVEL line on the side of the battery, check as follows.

1. Remove cap (1) at the top of the battery, look through the water filler port, and check the electrolyte surface. If the electrolyte does not reach the sleeve, add distilled water so that the level reaches the bottom of the sleeve (UPPER LEVEL line) without fail.

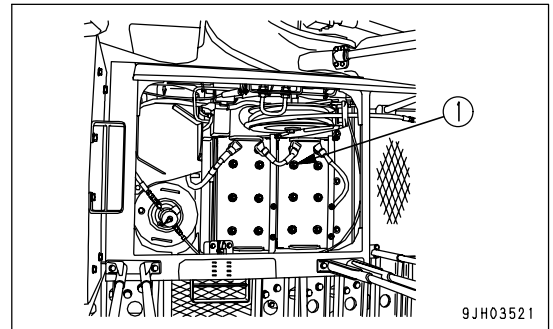

Use the diagram below for reference, and check if the electrolyte reaches the bottom of the sleeve.

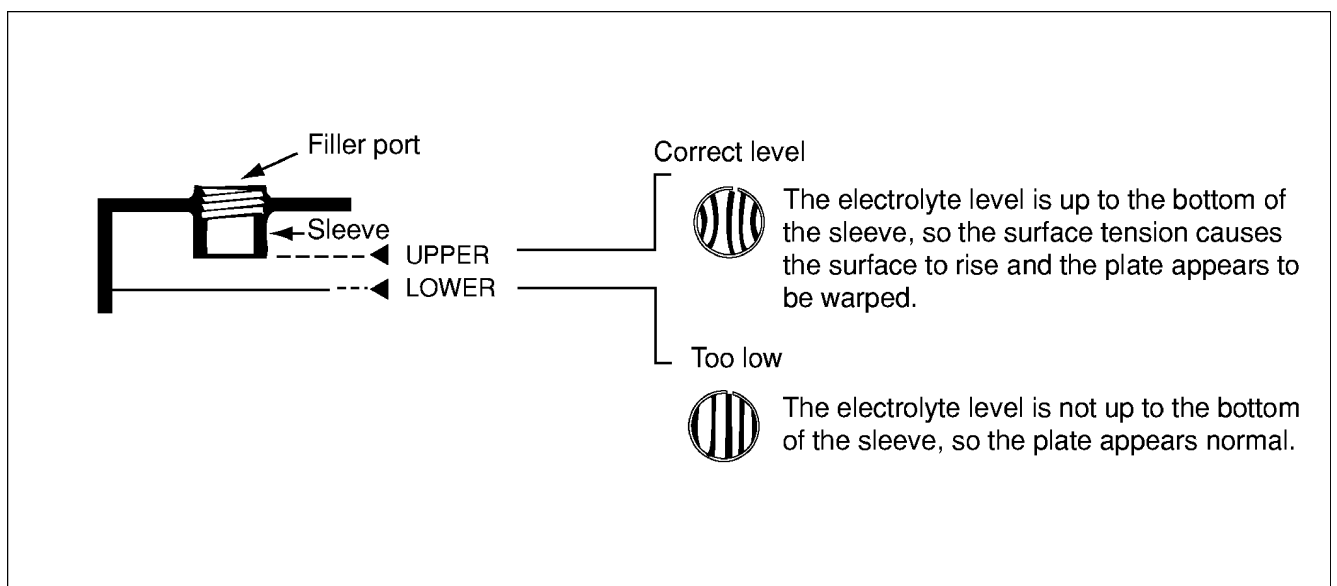

2. After adding distilled water, tighten cap (1) securely.

**REMARK**

If water is added to above the bottom tip of the sleeve, use a pipette to remove electrolyte. Neutralize the removed electrolyte with sodium bicarbonate, then flush it away with a large amount of water. If necessary, contact your Komatsu distributor or your battery maker.

**When it is Possible to Use Indicator to Check Electrolyte Level**

If it is possible to use an indicator to check the electrolyte level, follow the instructions given.

**LUBRICATING AFTERCOOLER FAN MOUNT**

(1 place)

1. Using a grease pump, pump in grease through the grease fittings shown by arrows.
2. After greasing, wipe off any old grease that was pushed out.

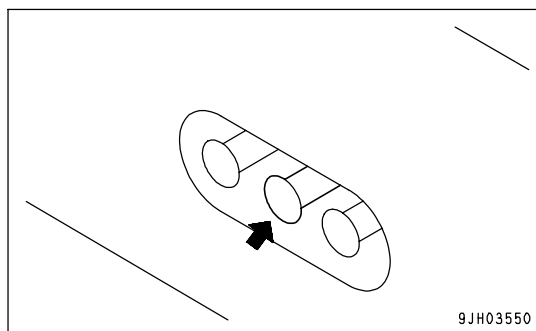
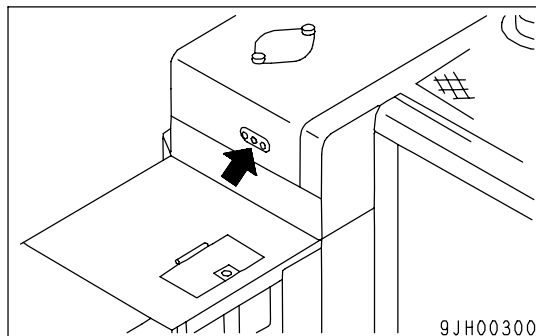

**CHECK AND TIGHTEN TRACK FRAME AND AXLE CONNECTING BOLTS**

Bolts (1) connecting the track frame and axle will break if they remain loose, so loose bolts must always be retightened.

- Tightening torque: 3260 ± 370 Nm (333 ± 38 kgm, 2410 ± 275 lbft)

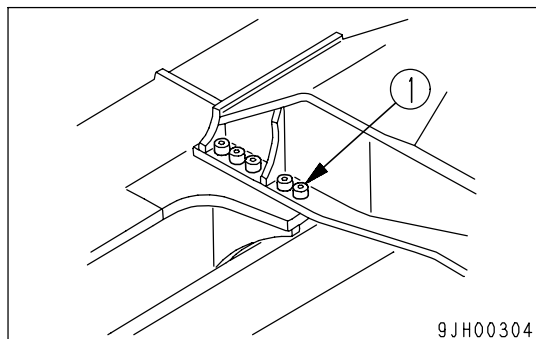

## CHECK ALTERNATOR DRIVE BELT TENSION, ADJUST

### Checking

The standard deflection for the drive belt is 15 mm (0.59 in) when pressed with a thumb [at approx. 58.8 N (approx. 6 kg)] at a point midway between the drive pulley and alternator pulley.

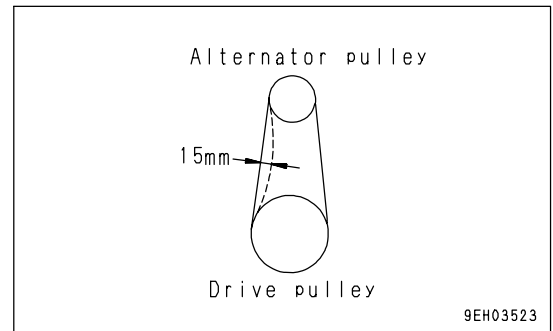

### Adjustment

1. Insert a bar between alternator (6) and the cylinder block to hold alternator (6) in position.

When holding in position, put a wooden block between the bar and alternator (6) to prevent damage to alternator (6).

2. Loosen the bolts and nuts in the order (1) to (5), and move alternator (6).

- Adjust the belt tension with nut (5) as follows:  
TIGHTEN to INCREASE tension  
LOOSEN to DECREASE tension

3. After adjusting the belt, tighten the bolts and nuts in the order (5) to (1) (the opposite order from loosening). Finally, tighten nut (5).

- Check each pulley for damage, wear of the V-groove, and wear of the V-belt. Check in particular that the V-belt does not contact the bottom of the V-groove.
- If the V-belt is elongated and there is no more allowance for adjustment, or if the belt is cracked or cut, replace the belt.
- When the V-belt has been replaced, adjust again after running for 1 hour.

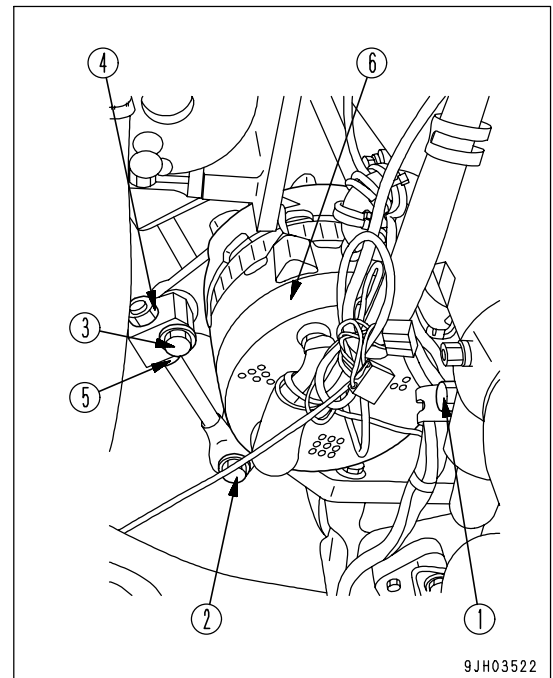



### CHECK AIR CONDITIONER COMPRESSOR BELT TENSION, ADJUST

**Checking**

1. Remove bolts (2), (3) and (4), then remove cover (1).
2. The standard deflection for the drive belt is approx. 16 mm (59 in) when pressed with a thumb [at approx. 58.8 N (approx. 6 kg)] at a point midway between the drive pulley and air conditioner compressor pulley.

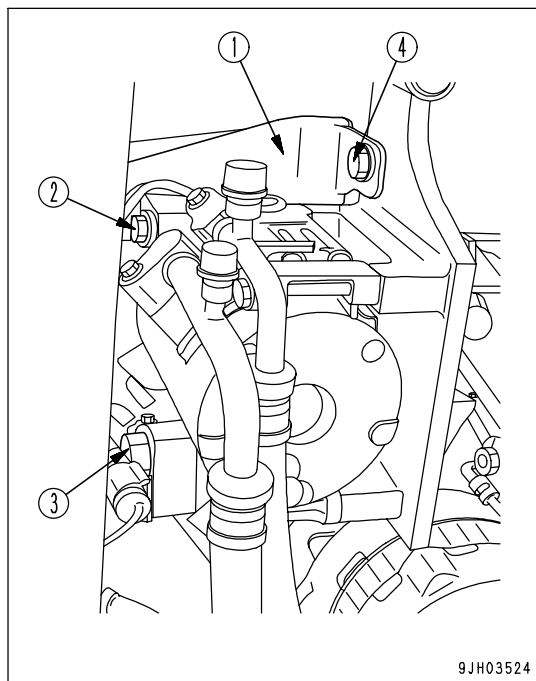

9JH03524

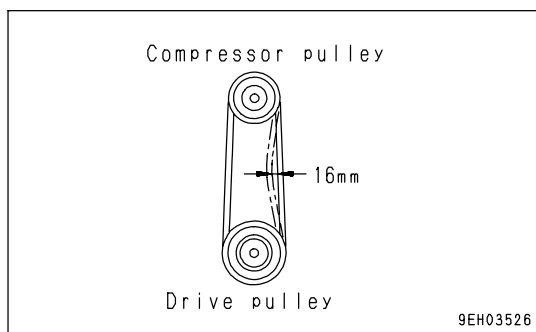

9EH03526

**Adjustment**

1. Loosen the bolts and nuts in the order (5) to (9), and move compressor.
  - Adjust the belt tension with nut (9) as follows:  
 TIGHTEN to INCREASE tension  
 LOOSEN to DECREASE tension
2. After adjusting the belt, tighten the bolts and nuts in the order (5) to (8) (the opposite order from loosening). Finally, tighten nut (8).
  - Check each pulley for damage, wear of the V-groove, and wear of the V-belt. Check in particular that the V-belt does not contact the bottom of the V-groove.
  - If the V-belt is elongated and there is no more allowance for adjustment, or if the belt is cracked or cut, replace the belt.
  - When the V-belt has been replaced, adjust again after running for 1 hour.
3. Install cover (1).

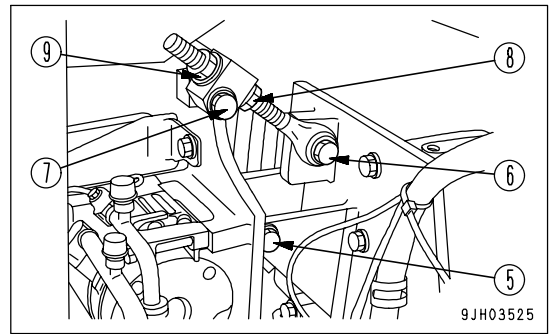

## EVERY 500 HOURS MAINTENANCE

Maintenance for every 10, 100, and 250 hours of service should be performed at the same time.

### REPLACE FUEL FILTER CARTRIDGE

#### WARNING

- After the engine has been operated, all parts are at high temperature, so do not replace the filter immediately. Wait for all parts to cool down before starting the operation.
- High pressure is generated inside the engine fuel piping system when the engine is running. When replacing the filter, wait for at least 30 seconds after stopping the engine to let the internal pressure go down before replacing the filter.
- Do not bring any fire or flame close.

#### NOTICE

- Genuine Komatsu fuel filter cartridges use a special filter that has highly efficient filtering ability. When replacing the filter cartridge, always use a genuine Komatsu part.
- The HPI fuel injection system used on this machine consists of more precise parts than the conventional injection pump and nozzle.

If any part other than a genuine Komatsu filter cartridge is used, dust or dirt may get in and cause problems with the injection system. Always avoid using substitute parts.

- When carrying out inspection or maintenance of the fuel system, pay more attention than normal to the entry of dirt. If dirt is stuck to any part, use fuel to wash it off completely.

- Container to catch the oil
  - Prepare a filter wrench
1. Set the container to catch the fuel under the filter cartridge.
    - The fuel filter is found by opening the engine side cover on the left of the machine.

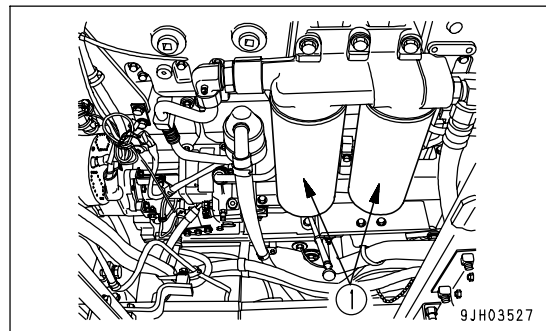

2. Close fuel supply valve (2) at the bottom of the fuel tank at the rear of the machine.
3. Using a filter wrench, turn filter cartridge (1) counterclockwise on remove it.
4. Clean the filter holder, fill the new filter cartridge with clean fuel, coat the packing surface thinly with oil, then install to the filter holder.

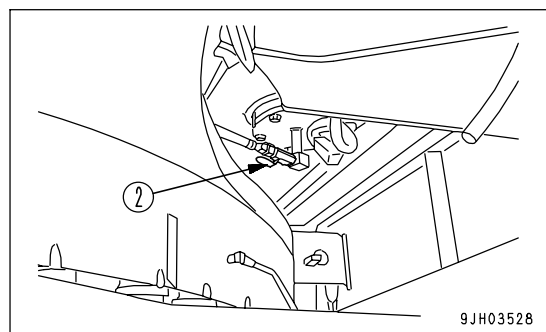

#### NOTICE

When filling with fuel, use clean fuel and be careful not to let any dirt or dust get in. In particular, the center area is the clean side, so be careful not to let dirt or dust get in.

5. When installing, tighten until the packing surface contacts the seal surface of the filter holder, then tighten it up 1/2 to 3/4 of a turn.

If the filter cartridge is tightened too far, the packing will be damaged and this will lead to leakage of fuel. If the filter cartridge is too loose, fuel will also leak from the packing, so always tighten to the correct amount.

6. With this machine, it is unnecessary to bleed the air. After carrying out the operations in Steps 1 - 5, turn the starting switch to the START position and start the engine.

**NOTICE**

Do not crank the starting motor continuously for more than 20 seconds. If the engine does not start, wait for at least two minutes before trying to start again.

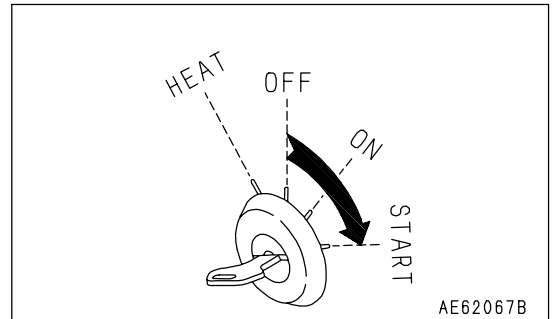

**REMARK**

If the fuel piping has been removed, bleed the air also from the injection pump air bleed valve.

**CHECK SWING PINION GREASE LEVEL, ADD GREASE**

- Prepare a scale.
- 1. Remove bolts (1) (4 bolts) on the top of the revolving frame and remove cover (2).

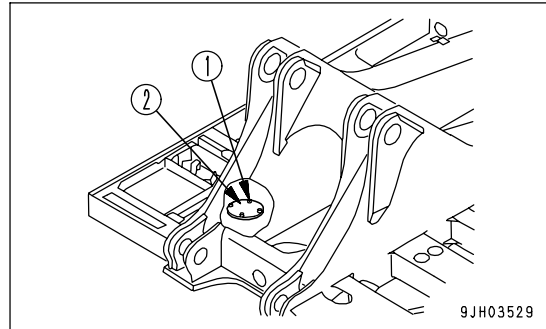

- 2. Insert a scale into the grease and check that the depth of the grease is approx. 36 mm (1.4 in). Add grease if necessary. Insert the scale in the position shown in the diagram on the right when measuring.

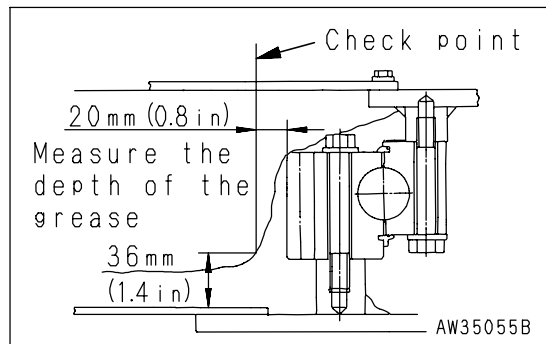

If the grease is particularly milky due to ingress of water, etc., then remove bolts (3) and cover (4) from the bottom of the track frame and remove the grease. Replace all of the grease with new grease.

The total amount of grease is 55 liters (49.5 kg) (14.5 US gal) (109 lb)).

- 3. Install cover (2) with bolts (1).

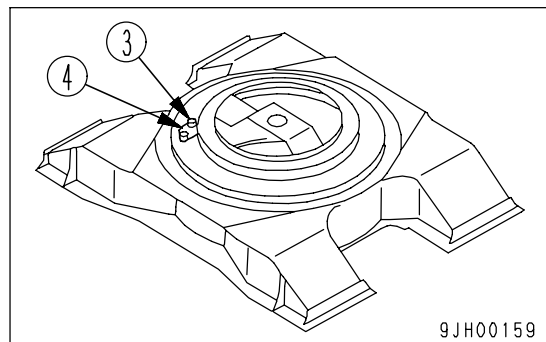

**CLEAN HYDRAULIC TANK STRAINER AND RETURN STRAINER**

**! WARNING**

- After the engine is stopped, the parts and oil are at high temperature, so there is danger of burns. Wait for the temperature to go down before starting the operation.
- When the cap of the oil filler port is removed, oil may spurt out, so turn it slowly to release the internal pressure, then remove it carefully.
- When removing cover (1), the cover may fly off under the force of spring (2), so loosen the 4 bolts slowly.

**Clean Hydraulic Tank Strainer**

1. Remove cap (F) from the oil filler port at the top of the hydraulic tank.
2. Remove cover (1) and lift up the top of rod (3) from above to take out spring (2) and strainer (4).
3. Remove any dirt stuck to strainer (4), then wash it in flushing oil. If strainer (4) is damaged, replace it with a new part.
4. When installing, check that the O-ring at the bottom of strainer (4) is not out of place or twisted, then coat the surface of the O-ring with grease, insert it on to tank protrusion (5), and install.
5. Install cover (1) with bolts.

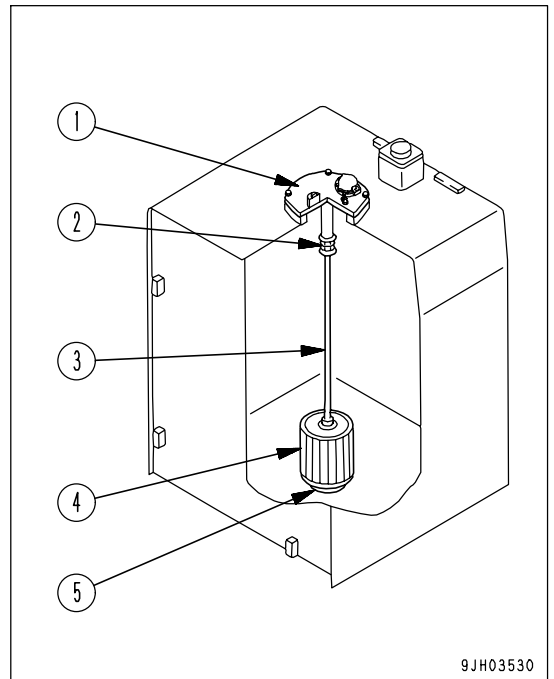
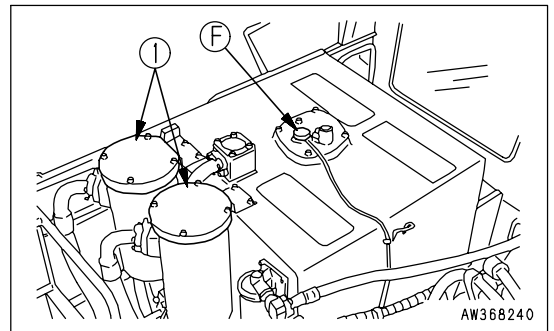

**Clean Return Strainer**

1. Remove (4) mounting bolts (1) of the return strainer holder cover at the top of the hydraulic tank, then remove return filter holder cover (2).
2. Remove strainer (3).
3. Remove any dirt stuck to strainer (3), then wash it with flushing oil. If the strainer is damaged, replace it with a new part.
4. Insert strainer (3), hold it down with return strainer holder cover (2), set it in position, then tighten bolts (1).

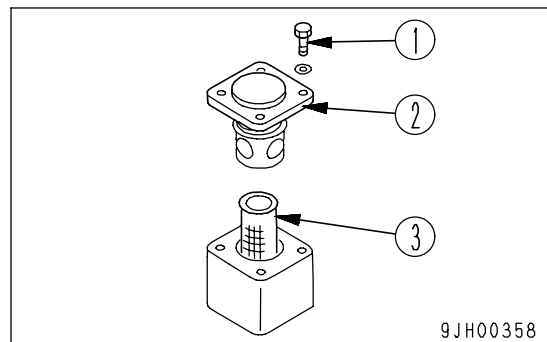
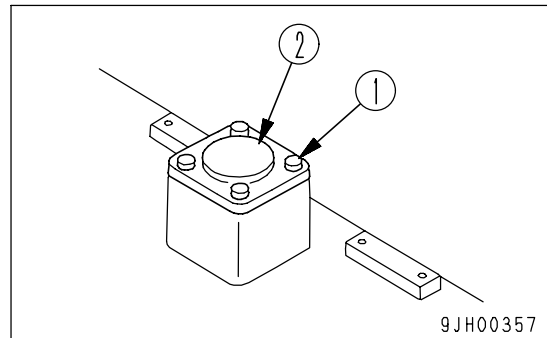

REPLACE HYDRAULIC OIL FILTER ELEMENT

**! WARNING**

- The parts and oil are at high temperature immediately after the engine is stopped, and may cause burns. Wait for the temperature to go down before starting the work.
- When removing the oil filler cap, turn it slowly to release the internal pressure, then remove it.

1. Remove the cap from oil filler (F), and release the internal pressure.
2. Loosen 4 bolts, then remove cover (1).  
When doing this, the cover may fly out under the force of spring (2), hold the cover down when removing the bolts.
3. After removing spring (2), valve (3) and strainer (5), take out element (4).
  - If there are metal particles or foreign material inside strainer (5), contact your Komatsu distributor.
4. Clean the removed parts in flushing oil.
5. Install the new element in the place where old element (4) was installed.
6. Set valve (3), strainer (5) and spring (2) on top of the element.
7. Set cover (1) in position, push it down by hand, and install the cover with the mounting bolts.
8. Install the cap of oil filler port (F).
9. To bleed the air, start the engine according to "STARTING ENGINE (PAGE 3-87)" and run the engine at low idle for 10 minutes.
10. Stop the engine.

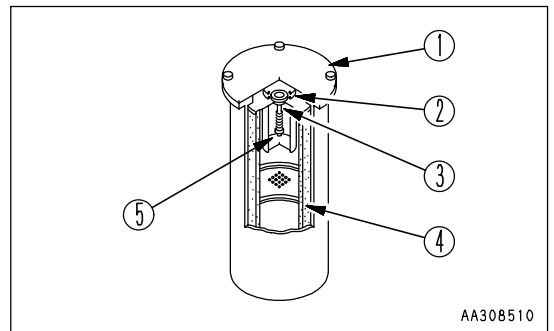
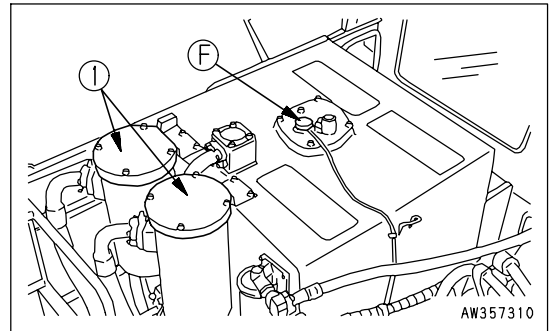

**REMARK**

Operate the machine after halting for more than 5 minutes to eliminate bubbles in the oil inside the tank.

11. Check for oil leakage and wipe off any spilled oil.



**CLEAN AND INSPECT RADIATOR FINS, OIL COOLER FINS, AFTERCOOLER FINS, FUEL COOLER FINS, AND AIR CONDITIONER CONDENSER FINS (only machines equipped with air conditioner)**

**! WARNING**

If compressed air, high-pressure water, or steam hits your body directly or dirt is sent flying by the compressed air, high-pressure water, or steam, there is danger of personal injury. Always wear protective glasses, dust mask, and other protective equipment.

**NOTICE**

When using compressed air, use from a distance to prevent damage to the fins.

In particular, with the fuel cooler and aftercooler, blow with compressed air at an angle of 45° with the nozzle at a distance of at least 300 mm (11.8 in).

Never blow the compressed air at right angles to the core. If the fins are damaged, it may cause coolant leakage or overheating. On dusty jobsites, check the fins daily, irrespective of the maintenance interval.

1. Open ducts (1) and (2) at the rear on the right side of the machine.

Remove 3 bolts (3) to open duct (1) and 2 bolts (4) to open duct (2).

2. Blow off mud, dust or leaves clogging the radiator fins (E), oil cooler fins (D), fuel cooler fins (B) and after cooler fins (C) using compressed air.

At the same time, clean the net in front of the oil cooler. Clean the condenser fins (A) on machines equipped with air conditioner.

Steam or water may be used instead of compressed air.

3. Check the rubber hose. Replace with a new one if the hose is found to have cracks or to be hardened by aging.

Also, check hose clamps for looseness.

After cooler hose clamp tightening torque:  $9.81 \pm 0.49 \text{ Nm}$  ( $1.0 \pm 0.05 \text{ kgm}$  ,  $7.2 \pm 0.36 \text{ lbf}$ )

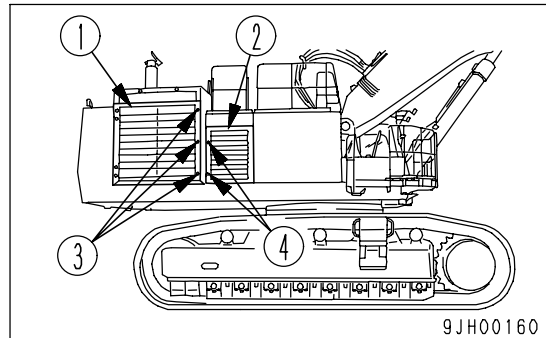

9JH00160

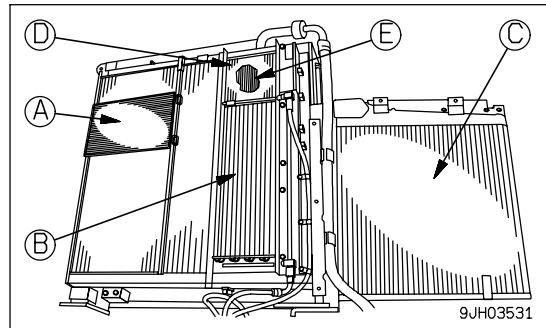

9JH03531

**CLEAN AIR CONDITIONER FRESH/RECIRC FILTERS**

**! WARNING**

If compressed air scattered around dust and debris, there is danger of injury. Always wear protective equipment such as protective glasses and mask.

**NOTICE**

As a guideline, the filters should be cleaned every 500 hours, but on dusty jobsites, clean the filters more frequently.

**REMARK**

If the filter becomes clogged, the air flow will be reduced, and there will be an abnormal noise from the air conditioner unit.

**Cleaning Recirculated Air Filter**

1. Remove wing bolts (1) from the inspection window at the bottom rear left on the inside of the operator's cab, then take out the recirculated air filter.
2. Clean the filter with compressed air. If there is oil on the filter, or if the filter is extremely dirty, wash it in a neutral agent. After rinsing it in water, dry it thoroughly before using it again. If the clogging of the filter cannot be removed by blowing with air or washing in water, replace the filter with a new part.

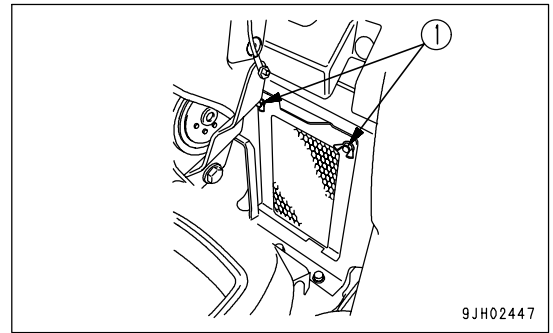

9JH02447

**Cleaning Fresh Air Filter**

1. Pull up the lock release lever (1) under the door release lever to release the lock.

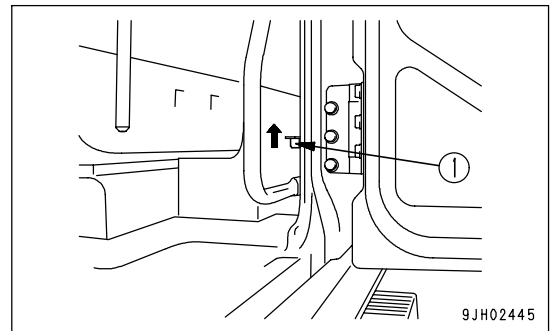

9JH02445

2. Open cover (2) at the bottom left of the operator's cab by hand, pull out filter case (3) from the inside, then remove the filter.

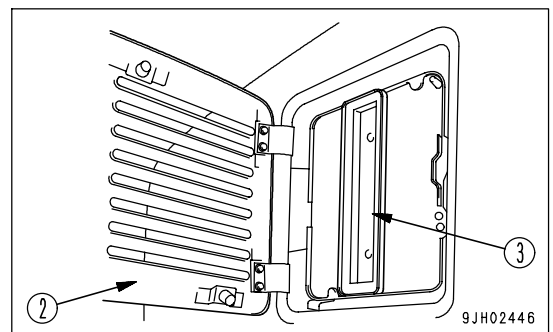

9JH02446

3. Clean the filter with compressed air. If there is oil on the filter, or if the filter is extremely dirty, wash it in a neutral agent. After rinsing it in water, dry it thoroughly before using it again.  
If the clogging of the filter cannot be removed by blowing with air or washing in water, replace the filter with a new part.
4. After cleaning, insert the filter in filter case (3) again, open the cover at the bottom left of the operator's cab by hand, return the filter case to its original position, then close the cover. When doing this, check that the lock is applied.

REPLACE PILOT FILTER ELEMENT

 **WARNING**

After the engine is stopped, the parts and oil are at high temperature, so there is danger of burns. Wait for the temperature to go down before starting the operation.

1. Set a container under drain plug (1) to catch the oil.
  2. Loosen bolt (2), then remove filter case (3).
  3. Remove element (4).
  4. Tighten drain plug (1).
  5. Insert a new element, then install filter case (3) and tighten bolt (2).
  6. Tighten bolt (2).
- Tightening torque: 65 to 88 Nm (6.6 to 9.0 kgm, 48 to 65 lbft)

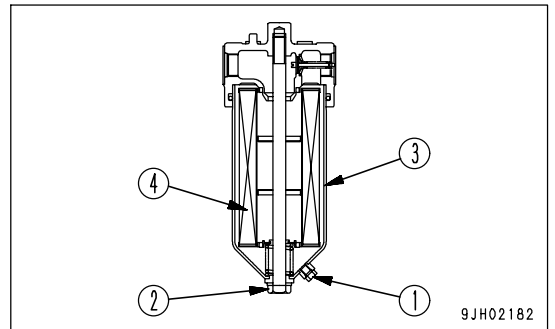
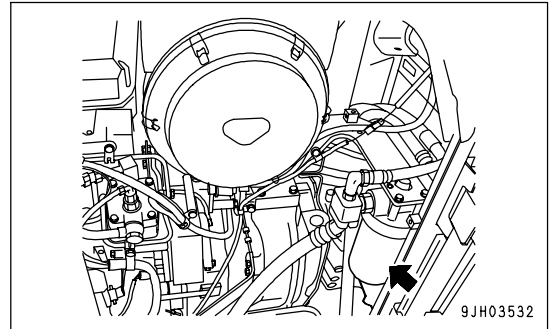

**CLEAN STRAINER OF PTO LUBRICATING OIL FILTER****WARNING**

- The parts and oil are at high temperature after the engine is stopped, and may cause serious burns. Wait for the temperature to go down before cleaning the engine breather.
- When using compressed air, there is a hazard that dirt may be blown up and cause serious injury. Always use safety glasses, dust mask, or other protective equipment.

1. Open the cover at the rear left of the machine, then remove filter case (1).
2. Take out the strainer, remove any dirt stuck to the strainer, then wash it in flushing oil.  
If the strainer is damaged, replace it with a new part.
3. Install the strainer and filter case (1).

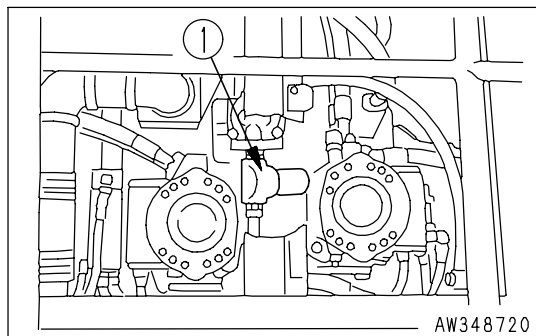

## CHECK WEAR OF FAN BELT, REPLACE, ADJUST

### Checking

Check the V-belt and when the following conditions exist, replace the V-belt:

- When the V-belt makes contact with the bottom of the groove in each pulley.
- When the V-belt is worn, and its surface is lower than the outer diameter of the pulley.
- When cracking and peeling of the V-belt occurs.

### Replace

1. Loosen locknut (1), then loosen adjustment screw (2) and move them to bracket (3).

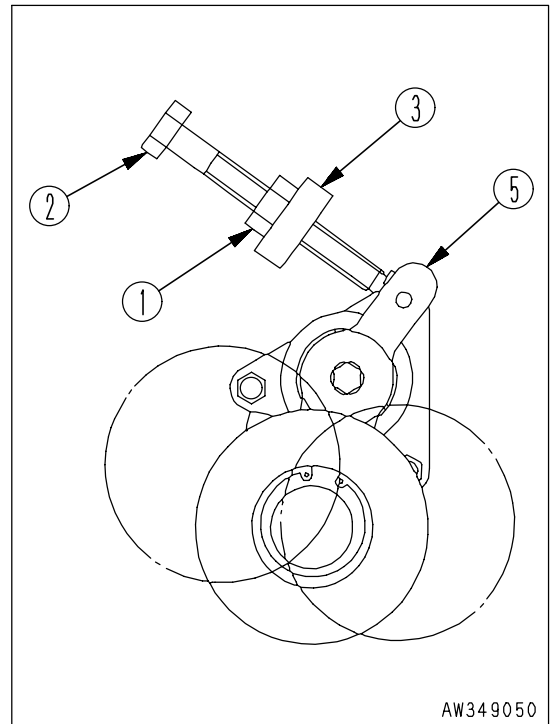

2. Insert a bar (length approx. 50 cm (20 in)) in hole (4) (Ø18 mm (0.71 in)) of the tension pulley bracket, then pull strongly to the front.
3. The spring will extend and the tension pulley will move to the inside, so remove the old belts and replace them with new belts.  
Always replace the V-belts as a set (3 belts).

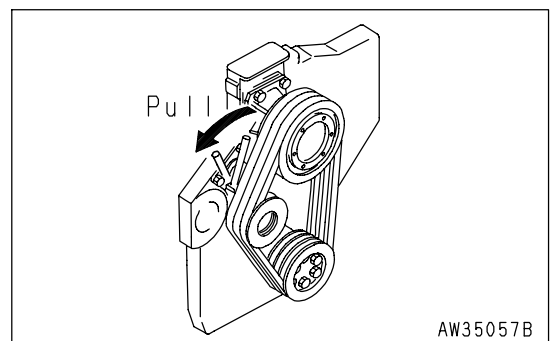
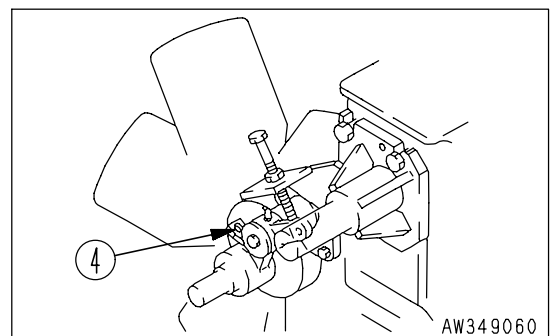

**Adjustment**

1. Tighten adjustment screw (2) to bring the tip of the adjustment screw into contact with tension pulley lever (5), then tighten the adjustment screw a further 180° and secure with locknut (1).
  2. If wear is a gap between the tip of adjustment screw (2) and tension pulley lever (5) during operations, repeat Step 1 to adjust again.
- If there is any squealing from the fan belt, adjust in the same way.

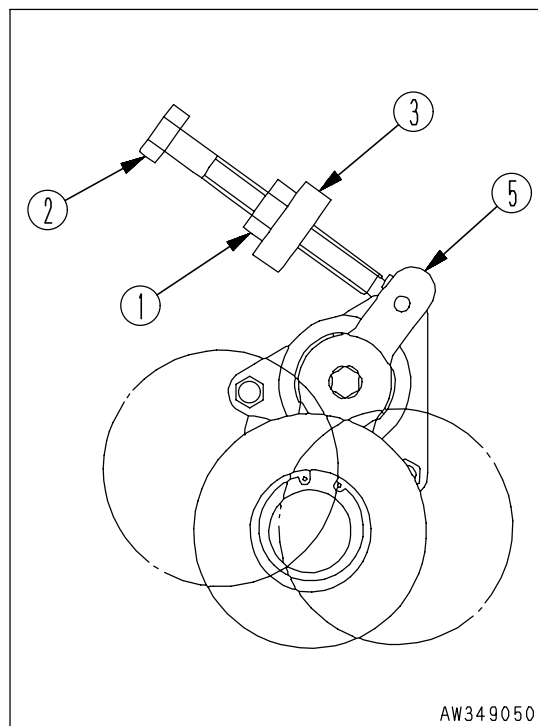

**REPLACE DRAIN FILTER CARTRIDGE**

1. Using a filter wrench, turn the filter cartridge (1) to the left to remove it.
  2. Fill the new filter cartridge with hydraulic oil, coat the packing surface with oil, then install it.
- When installing it, bring the packing surface into contact with the seal surface of the filter holder, then tighten a further 1/2 - 3/4 turns.

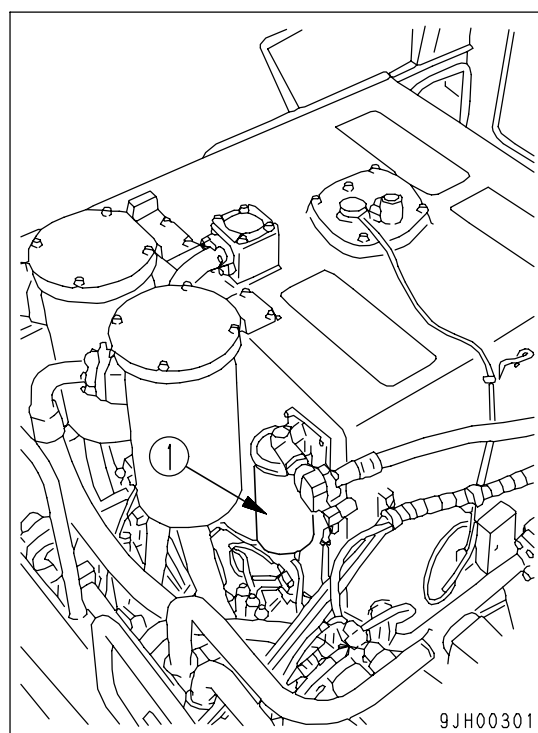

**CHANGE OIL IN ENGINE OIL PAN, REPLACE ENGINE OIL FILTER CARTRIDGE**

**! WARNING**

Parts and oil are at high temperature immediately after the engine is stopped and may cause serious burns. Wait for the oil temperature to go down before performing this operation.

- Refill capacity: 51 liters (13.5 US gal)
- Prepare a filter wrench

1. Remove the 2 bolts of undercover (1) under the engine, then open the undercover.

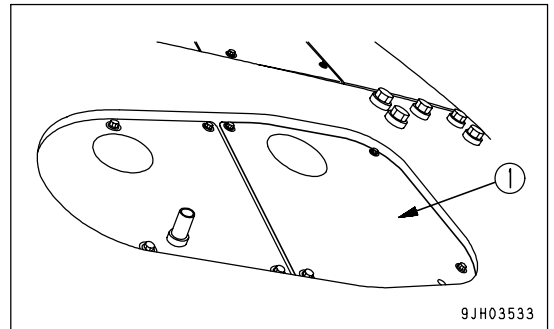

2. Set the container immediately under drain valve (2) at the bottom of the engine to catch the oil.

3. Install drain hose (4) (Part No: 21N-98-31490) to drain valve (2).

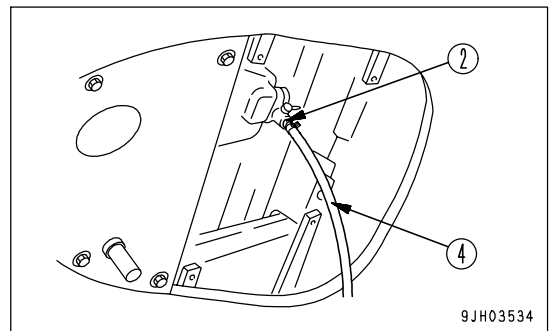

4. Lower lever (3) of the drain valve slowly to avoid getting oil on yourself, and drain the oil. After draining the oil, raise the lever to close the valve.

- Never loosen plug (a). Even if it is not loosened, the oil will come out when the lever is operated.

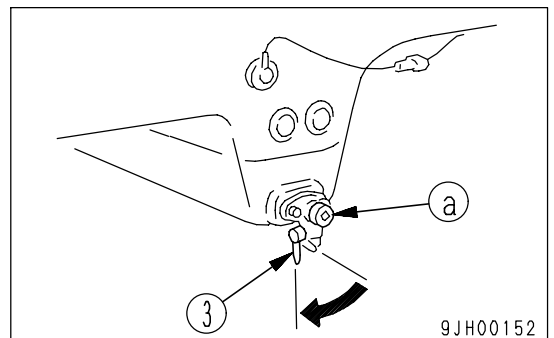



5. Open the front cover of the engine hood, use a filter wrench from the top of the engine, turn filter cartridge (4) to the left, and remove it. A large amount of oil will come out immediately after the engine is stopped, so wait for 10 minutes after the engine is stopped before draining the oil.
6. Clean the filter holder, fill the new filter cartridge with clean oil, coat the thread and packing surface of the new filter cartridge with clean oil (or coat it thinly with grease), then install it to the filter holder.

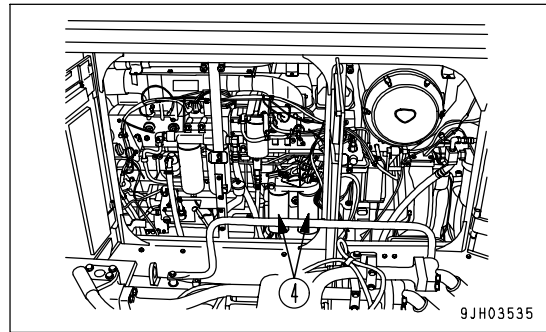

**REMARK**

Check that there is no old packing stuck to the filter holder. If there is any old packing stuck to the filter, it will cause leakage of oil.

7. When installing, bring the packing surface into contact with the seal surface of the filter holder, then tighten a further 3/4 - 1 turn.
8. After replacing the filter cartridge, add oil through oil filler port (F) so that the oil level is between the H and L marks on dipstick (G).
9. Run the engine for a short time at low idling, then stop the engine. Check that the oil level gauge is between the H and L marks. For details, see "Check Oil Level in Engine Oil Pan, Add Oil (PAGE 3-73)".

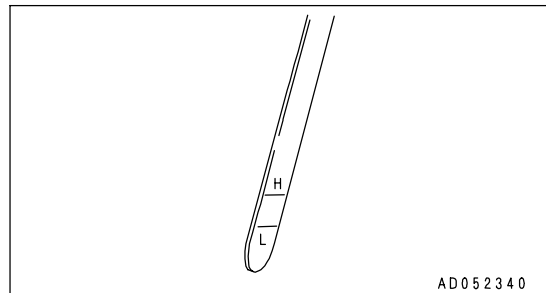
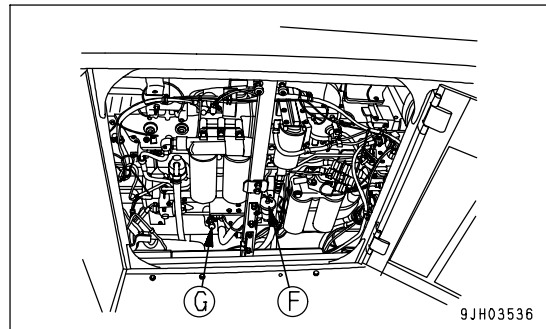

### EVERY 1000 HOURS MAINTENANCE

Maintenance for every 10, 100, 250, and 500 hours of service should be performed at the same time.

### CHANGE OIL IN SWING MACHINERY CASE

 **WARNING**

Parts and oil are at high temperature immediately after the engine is stopped and may cause serious burns. Wait for the oil temperature to go down before performing this operation.

- Refill capacity: 48.6 liters (12.84 US gal) (24.3 liters X 2 (6.42 US gal X 2))

1. Set a container under drain hose under the machine body to catch the oil.
2. Loosen drain valve (P) under the machine body, drain the oil, then tighten the drain plug again.
3. Remove dipstick (G) and air bleed plug (1) (remove air bleed plug (1) only when supplying oil to the front machinery), then add the replacement amount of oil through dipstick guide (F).
4. After filling with oil, install air bleed plug (1) of the front machinery.
5. Wipe off the oil on the dipstick with a cloth.
6. Fully insert dipstick (G) into filler pipe (F), then remove it.

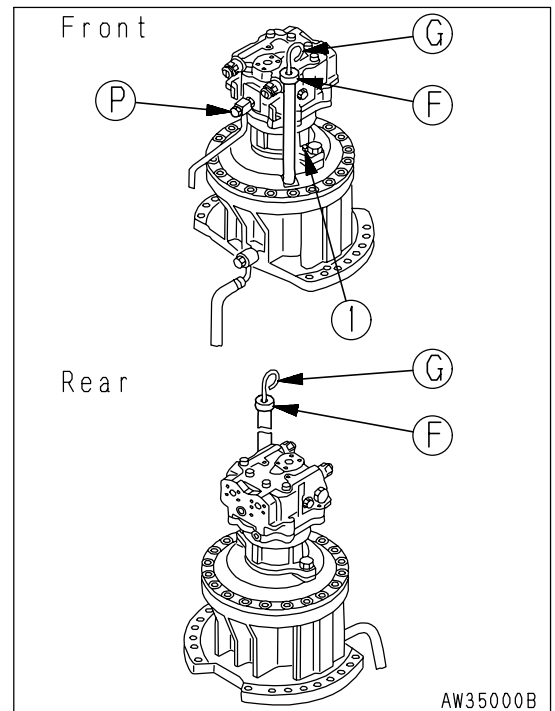

7. The oil level should be between H and L marks on the dipstick (G). If the oil does not reach the L mark, add oil through oil filler port (F).
8. If the oil is above the H mark, drain the excess engine oil from drain valve (P), and check the oil level again.
9. Immediately after changing the oil, oil level is variable. So operate for one hour, then check the oil level again.

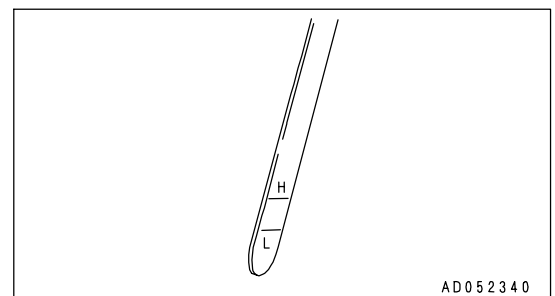

## CHANGE OIL IN PTO CASE



### WARNING

Parts and oil are at high temperature immediately after the engine is stopped and may cause serious burns. Wait for the oil temperature to go down before performing this operation.

### NOTICE

Park the machine on flat ground and stop the engine. After waiting for more than 30 minutes after stopping the engine, check the oil level.

- Refill capacity: 13.5 liters (3.57 US gal)

1. Open the oil filler for the engine oil, remove drain plug (1), then install drain hose (3) (Part No. : 21N-98-31490), then loosen valve (2) and drain the oil. After draining the oil, tighten drain plug (1) and valve (2).

Tightening torque:  $68.6 \pm 9.8 \text{ Nm}$  ( $7 \pm 1 \text{ kgm}$ ,  $50.6 \pm 7.2 \text{ lbft}$ )

Be careful not to loosen the drain valve too much or to deform the stopper pin inside the valve.

2. Refill the specified quantity of oil through oil filler (F).

### NOTICE

If excess oil is supplied, drain it to the specified amount to avoid overheating.

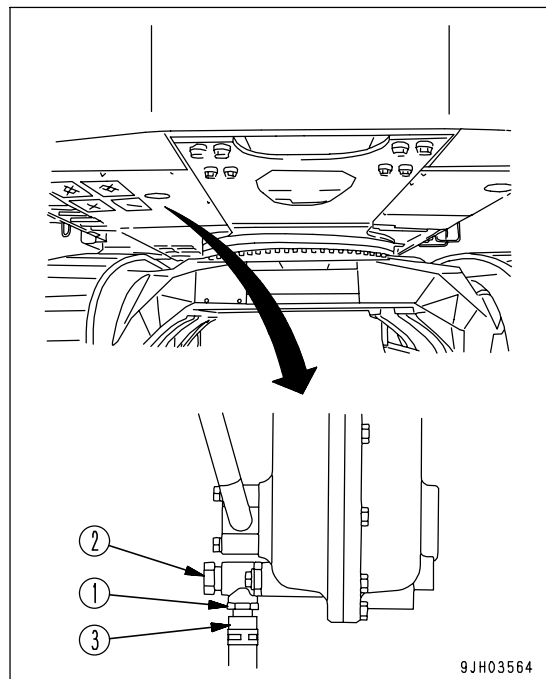

9JH03564

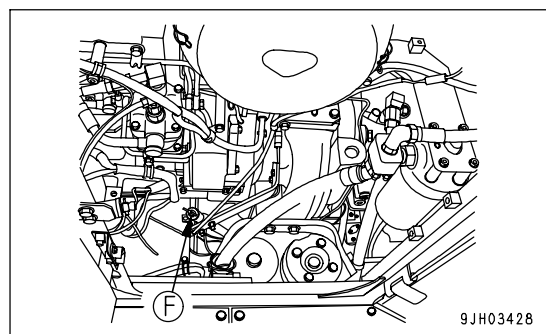

9JH03428

## CHECK ALL TIGHTENING PARTS OF TURBOCHARGER

Please contact your Komatsu distributor to have the tightening portions checked.

**REPLACE CORROSION RESISTOR CARTRIDGE**

**⚠ WARNING**

If the engine has been operated, all parts will be at a high temperature, so never try to replace the cartridge immediately after stopping the engine. Always wait for the engine and other parts to cool down.

- Container to catch drained coolant
- Prepare a filter wrench for fuel filter element.

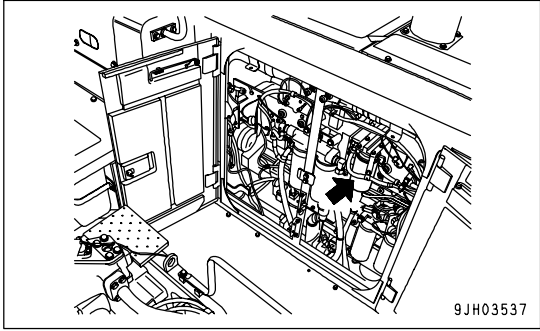

1. Tighten 2 valves (1).
2. Set a container to catch the coolant under the cartridge.
3. Using a filter wrench, remove cartridge (2).
4. Clean the filter holder, coat the packing surface and thread of the new cartridge with oil, then install it to the filter holder.
5. When installing, tighten until the packing surface contacts the seal surface of the filter holder, then tighten it up 2/3 of a turn. If the filter cartridge is tightened too far, the packing will be damaged and this will lead to leakage of coolant. If the filter cartridge is too loose, coolant will also leak from the packing, so always tighten to the correct amount.
6. Open valves (1) (2 places).
7. After replacing the cartridge, start the engine and check for any coolant leakage from the filter seal surface. If there is any leakage, check if the cartridge is tightened properly.

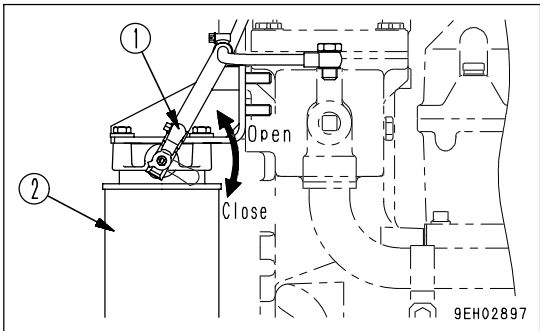
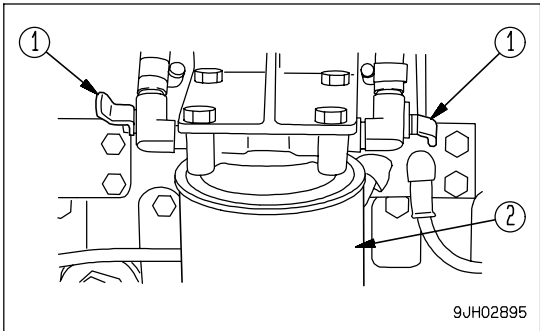

**LUBRICATING FAN PULLEY ASSEMBLY, TENSION PULLEY ASSEMBLY**

Add grease through the fittings marked by arrows.

- (1) Fan pulley assembly (1 point)
- (2) Tension pulley assembly (1 point)

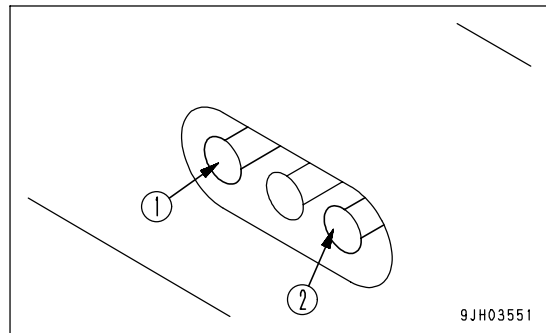
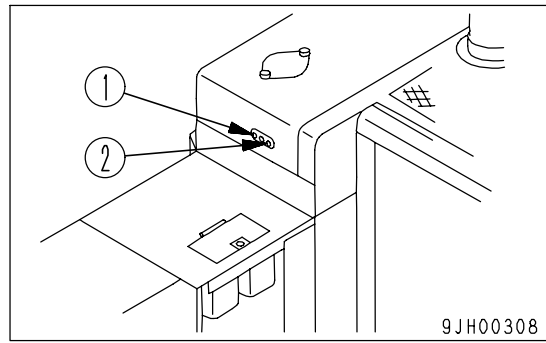

REPLACE HYDRAULIC TANK BREATHER FILTER ELEMENT

**! WARNING**

- The parts and oil are at high temperature immediately after the engine is stopped, and may cause burns. Wait for the temperature to go down before starting the work.
- When removing the oil filler cap, turn it slowly to release the internal pressure, then remove it.

1. After removing snap ring (2) of breather assembly (1), take out cover (3).
2. Replace filter element (4) with a new element.
3. Install cover (3) and snap ring (2).

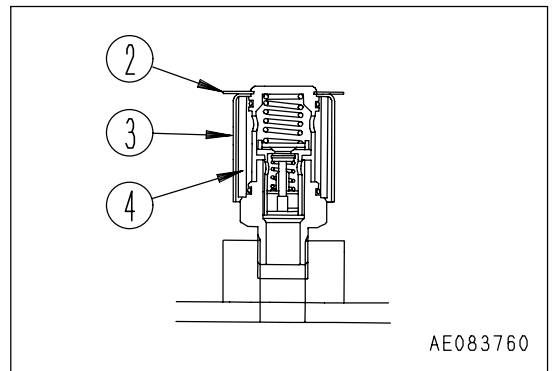
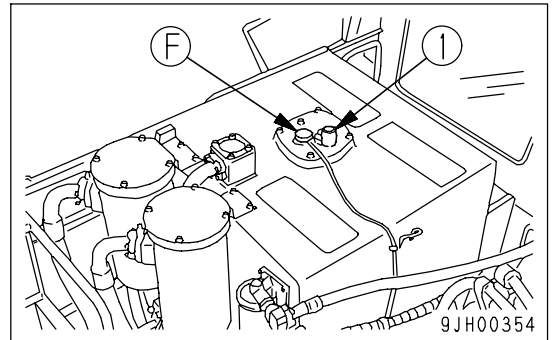

4. Remove cap assembly (F) of the filler port, then replace element (1) inside the cap.

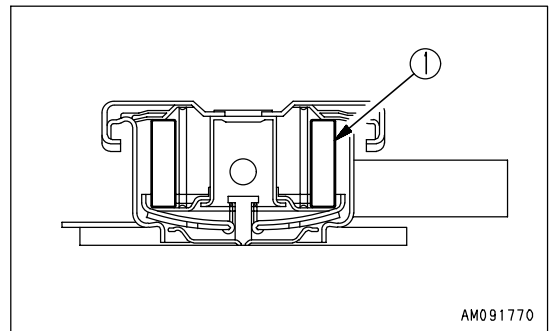

**CHECK FUEL STRAINER, CLEAN**

1. Close fuel supply valve (1) at the bottom of the fuel tank.
2. Remove undercover (2) on the inside rear of the fuel tank.

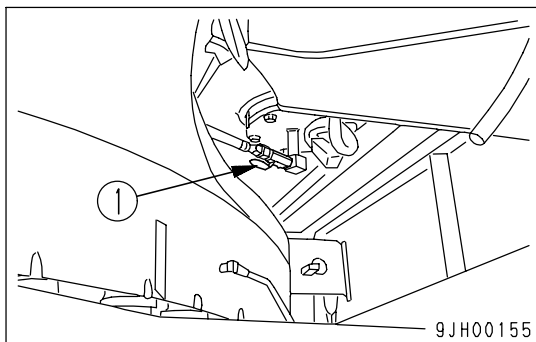

3. Remove filter case (3).
4. Take out the strainer, clean off dirt clung to it, and wash it in clean light oil or diesel oil.  
If the strainer is damaged, replace it with a new one.
5. Install the strainer and filter case (1).

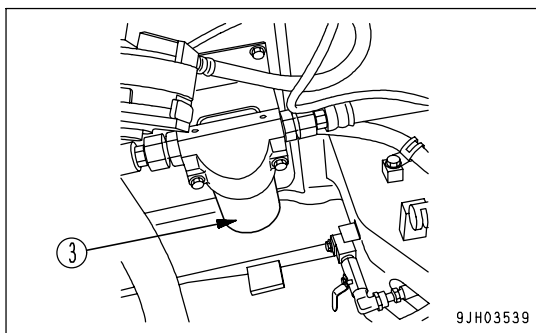
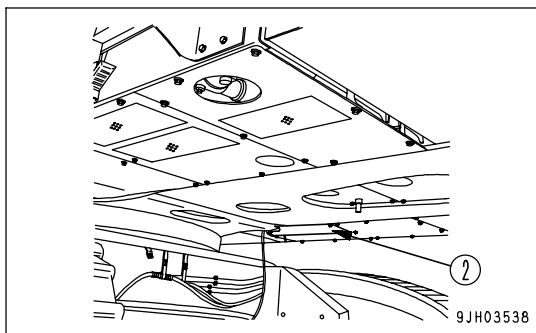

### CHECK WELDED STRUCTURE

(Color check)

Cracks in welded structures can be seen easily with a color check. Check the revolving frame, center frame, boom, and arm every 1000 hours.

In particular, carry out a color check on the important check points (marked with a circle).

The procedure for the color check is as follows.

1. Prepare the materials needed for the color check. (Detergent, penetrating agent, developing solution)
  2. Spray with detergent and wash to remove all the dirt and oil from the place to be checked.
  3. After washing, dry the area, then spray with penetrating agent and leave for 5 - 20 minutes.
  4. Spray with detergent, then clean the surface with a cloth.
  5. Clean the surface again, then spray with developing solution.
  6. Leave for 15 - 20 minutes, then check visually for cracks.
  7. If there are any cracks, carry out the repair procedure to repair.
- If there are any cracks, color can be seen.

- Revolving frame

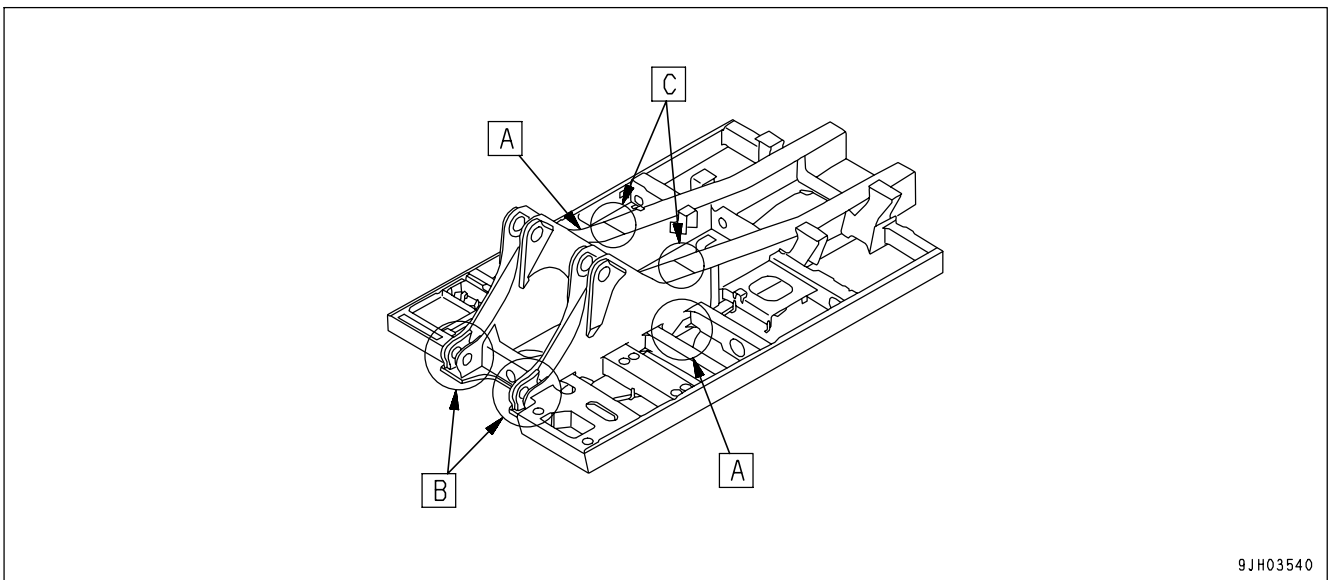

9JH03540

- Center frame

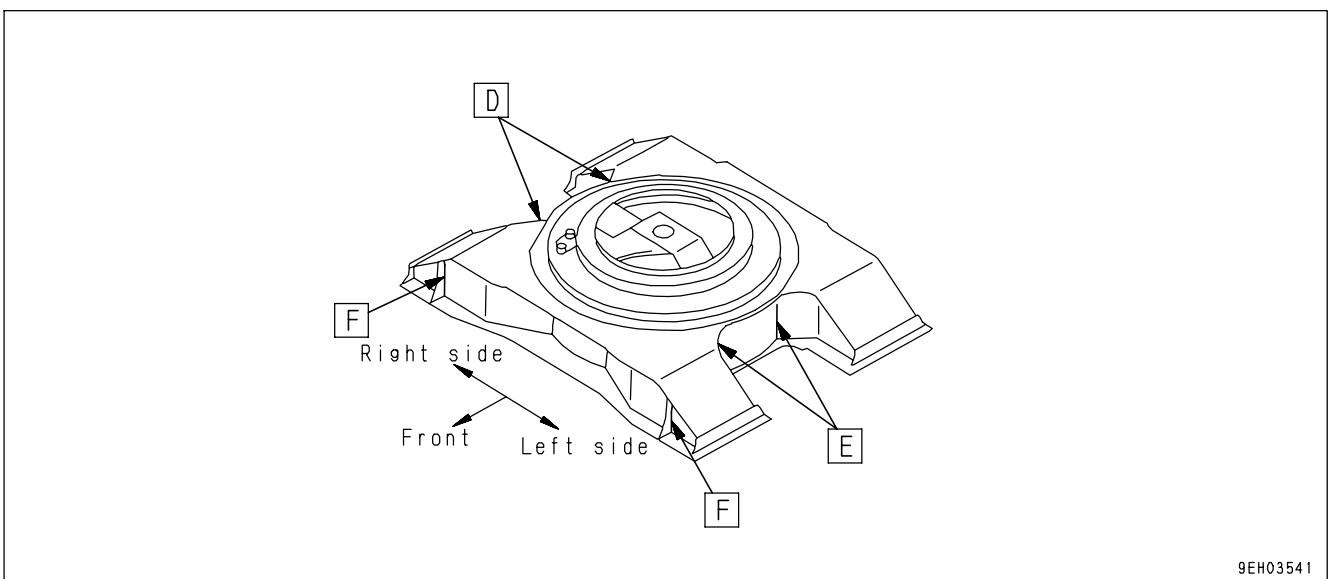

9EH03541



• Boom

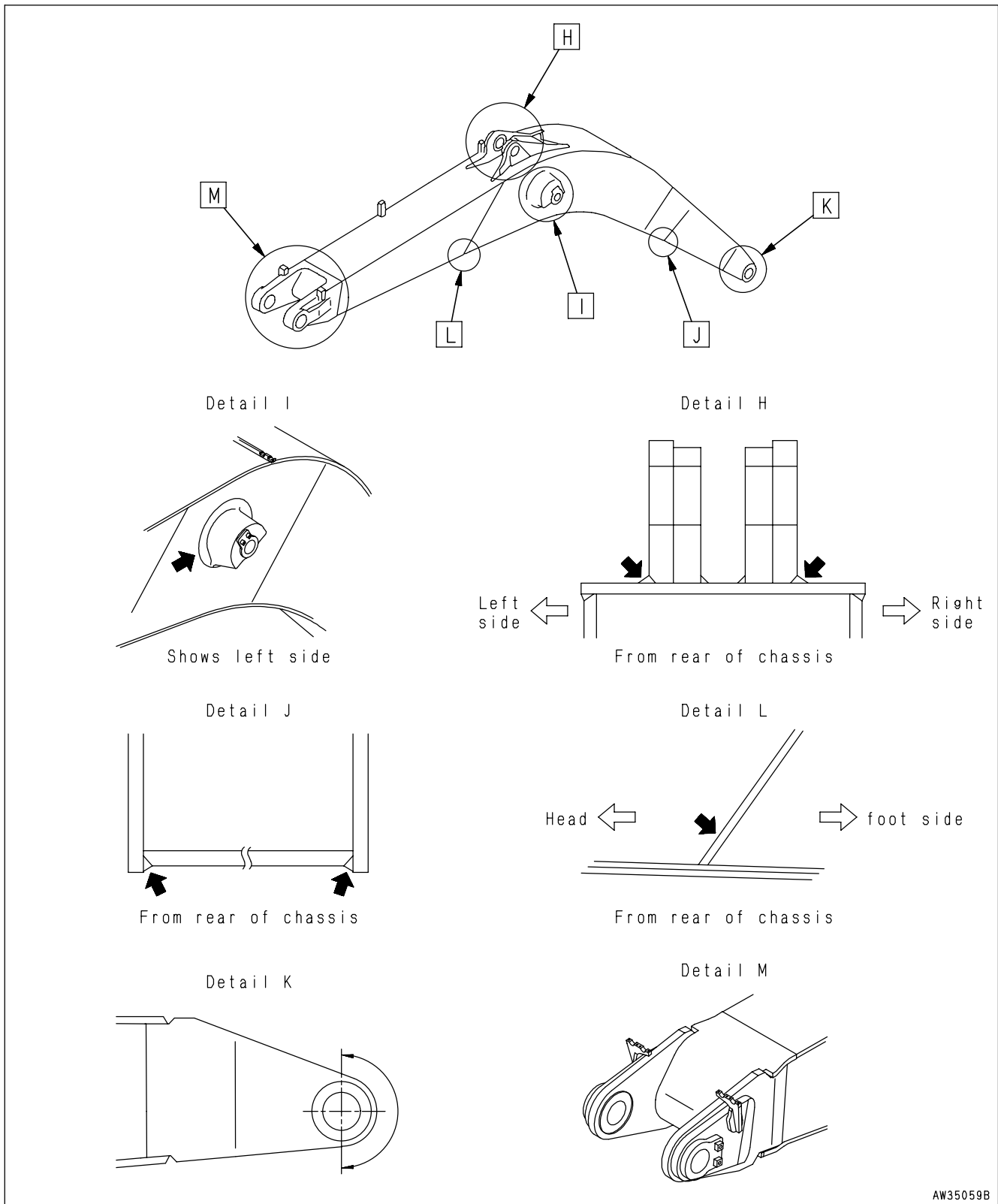

• Arm

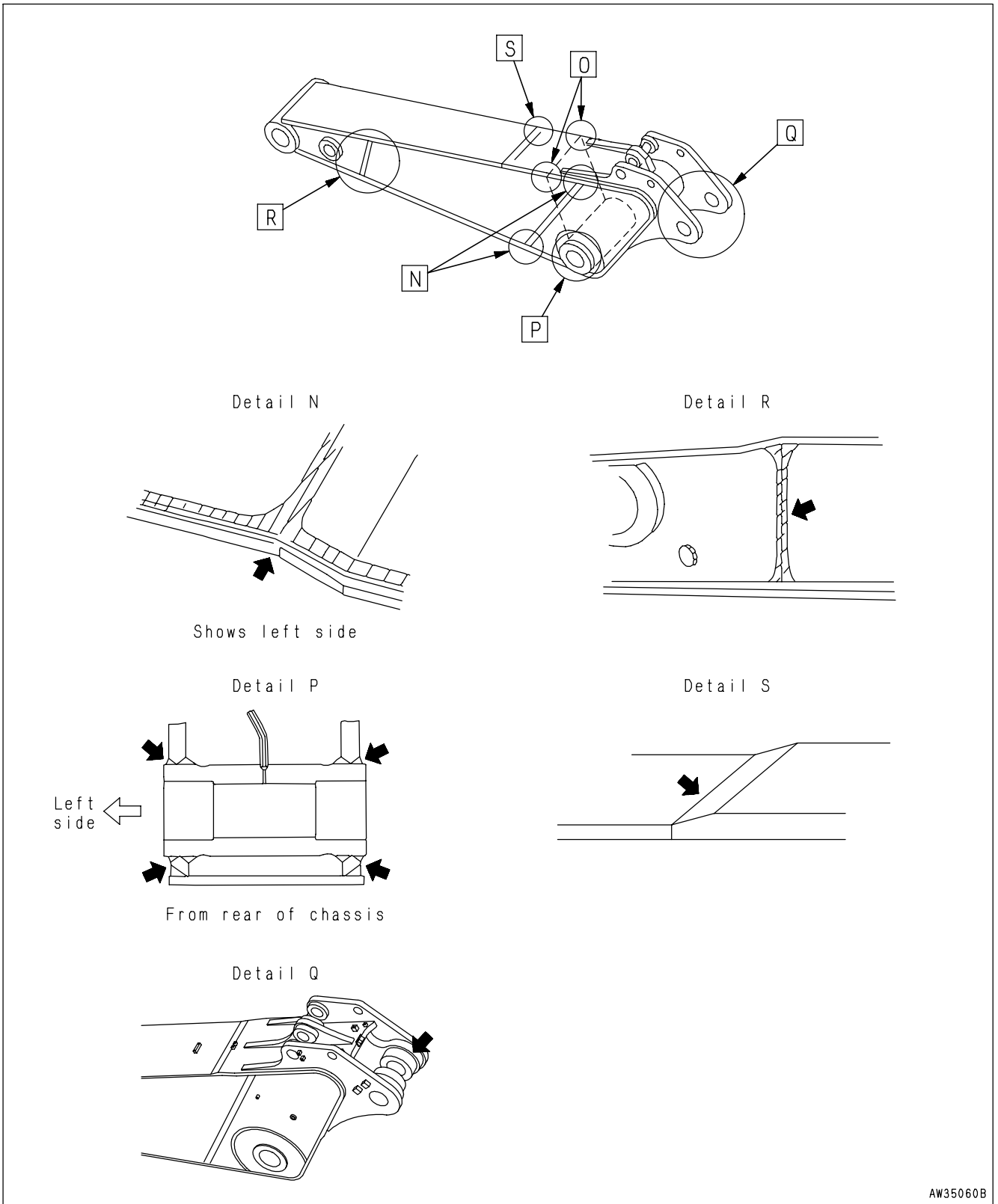

### EVERY 2000 HOURS MAINTENANCE

Maintenance for every 10, 100, 250, 500, and 1000 hours of service should be performed at the same time.

### CHANGE OIL IN FINAL DRIVE CASE

**WARNING**

- The parts and oil are at high temperature immediately after the engine is stopped, and may cause serious burns. Wait for the temperature to go down before starting the operation.
- If there is still pressure remaining inside the case, the oil or plug may fly out. Loosen the plug slowly to release the pressure.

- Refill capacity: each 22 liters (5.8 US gal)
  - Refill capacity: Left, right 22 liters (5.8 US gal) each
  - Prepare a handle.
1. Set the TOP mark at the top, with the TOP mark and plug (P) perpendicular to the ground surface.
  2. Set a container under plug (P) to catch the oil.
  3. Remove plugs (P) and (F) with the handle and drain the oil.

**REMARK**

Check the O-rings in the plugs for damage. If necessary, replace with new ones.

4. Tighten plug (P).
  5. Add oil through the hole of plug (F).
  6. When the oil overflows from the hole of plug (F), install plug (F).
- Tightening torque of plugs (P) and (F) :  
 93.1 - 122.5 Nm (9.5 - 12.5 kgm, 68.7 - 90.4 lbft)

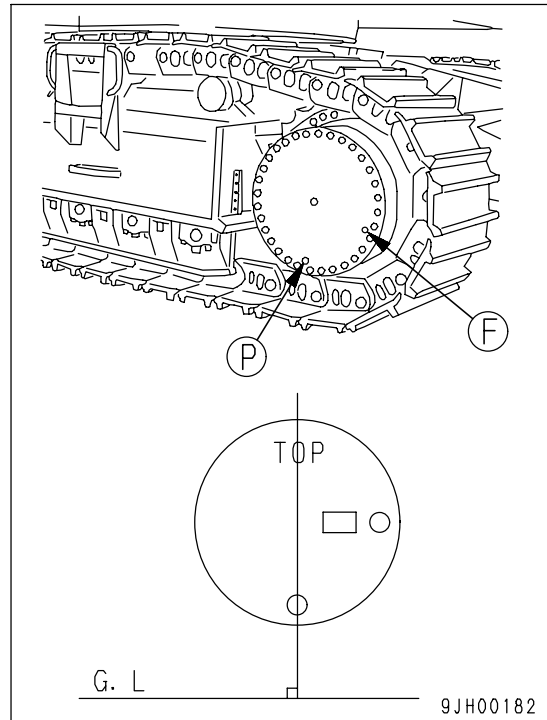

**CLEAN ENGINE BREATHER**

1. Loosen clamp (1), then remove the hose.
2. Remove bolt (2), then remove breather (3).
3. Wash the whole breather in diesel oil or flushing oil, then blow it dry with compressed air.
4. Replace the breather O-ring with a new part, coat with engine oil, and install it.  
Check the breather hose, and if there is any oil sludge on the inside, replace it with a new hose.

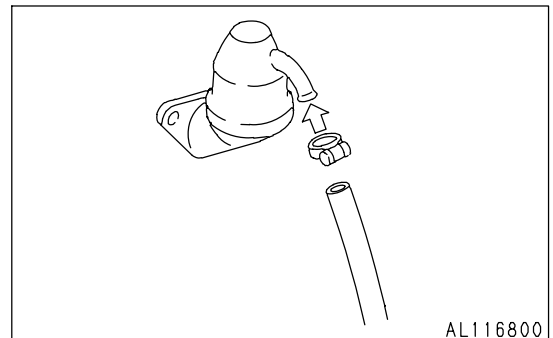
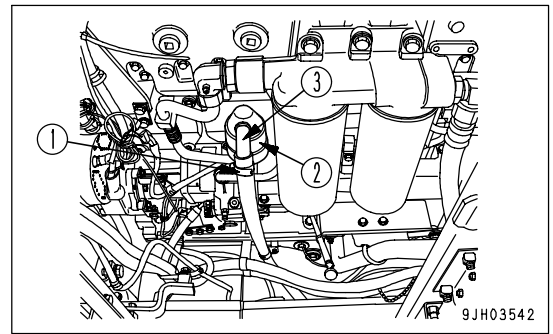

**CLEAN, CHECK TURBOCHARGER**

Contact your Komatsu distributor for cleaning or inspection.

**CHECK PLAY TURBOCHARGER ROTOR**

Please contact your Komatsu distributor to have the rotor play checked.

**CHECK ALTERNATOR, STARTING MOTOR**

The brushes may be worn, or the bearing may have run out of grease, so contact your Komatsu distributor for inspection or repair.

When the engine is frequently started, ask for inspection every 1000 hours or every 6 months, whichever comes sooner.

**CHECK ENGINE VALVE CLEARANCE, ADJUST**

Special tools are needed for inspection and maintenance, so contact your Komatsu distributor.

**CHECK ENGINE INJECTOR SET LOAD, ADJUST**

(ONLY AFTER THE 2000 HOURS)

As special tool is required for checking and adjusting the parts, request Komatsu distributor for service.

**EVERY 4000 HOURS MAINTENANCE**

Maintenance for every 10, 100, 250, 500, 1000, and 2000 hours of service should be performed at the same time.

**CHECK WATER PUMP**

Check that there is no oil leakage, water leakage, or clogging of the drain hole (1). If any abnormality is found, contact your Komatsu distributor for disassembly and repair or replacement.

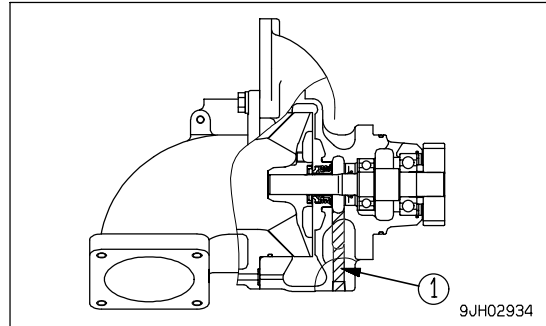

9JH02934

**CHECK VIBRATION DAMPER**

Check that there are no cracks or peeling in the outside surface of the vibration damper (1).

If any cracks or peeling are found, contact your Komatsu distributor to have the parts replaced.

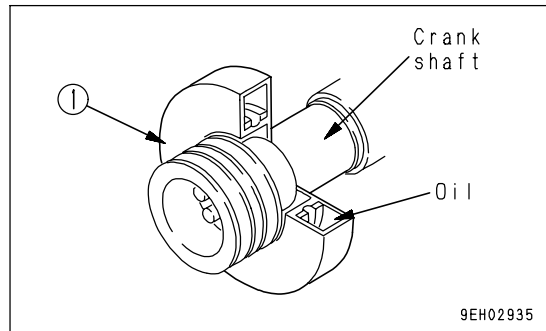

9EH02935

**CHECK FAN PULLEY AND TENSION PULLEY**

Check the pulley for play and leakage of grease. If there is any abnormality, please contact your Komatsu distributor for disassembly and repair or replacement.

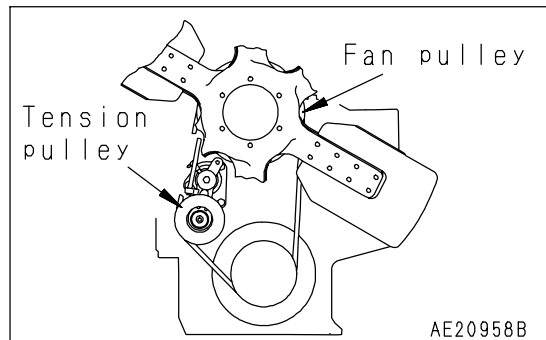

AE20958B

**CHECK AIR COMPRESSOR, ADJUST**

As special tool is required for checking and adjusting the parts, request Komatsu distributor for service.

### EVERY 5000 HOURS MAINTENANCE

Maintenance for every 10, 100, 250, 500, 1000, and 2000 hours of service should be performed at the same time.

### CHANGE OIL IN HYDRAULIC TANK, CLEAN STRAINER

 **WARNING**

- The parts and oil are at high temperature immediately after the engine is stopped, and may cause burns. Wait for the temperature to go down before starting the work.
- When removing the oil filler cap, turn it slowly to release the internal pressure, then remove it.

- Refill capacity: 670 liters (177.01 US gal)
  - Prepare a handle for socket wrench set
1. Swing the upper structure so that the drain plug under the hydraulic tank will be between both tracks.
  2. Retract the arm and bucket cylinders, then lower the boom and put the teeth in contact with the ground.
  3. Set the safety lock lever to the LOCK position and stop the engine.

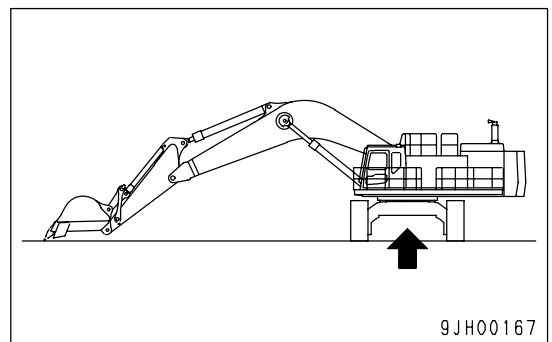

4. Remove the cap of oil filler (F) at the top of the hydraulic tank.

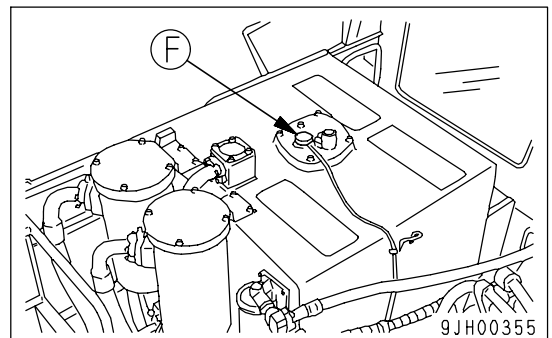

5. Set the container to catch the oil under the drain plug at the bottom of the chassis. Remove drain plug (P1), then loosen plug (P2) and drain the oil. After draining the oil, tighten drain plugs (P1) and (P2).

Tightening torque:  $70 \pm 10 \text{ Nm}$  ( $7 \pm 1 \text{ kgm}$ ,  $50 \pm 7 \text{ lbf}$ )

When loosening drain plug (P2) be careful not to get oil on yourself.

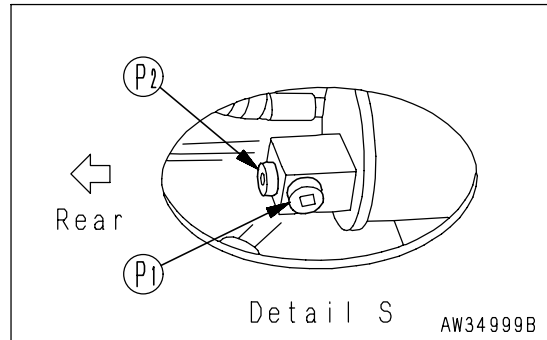
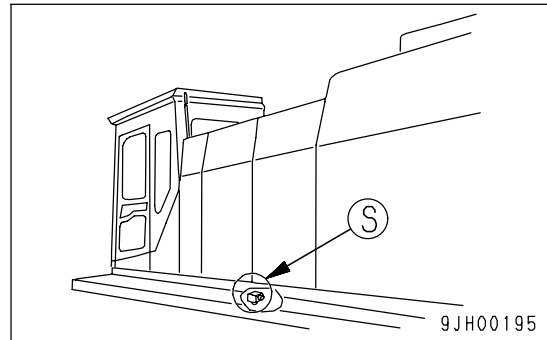

6. Remove 4 bolts, then remove cover (4). When doing this, cover (4) may fly off because of the force of spring (5), so keep the cover pushed down when removing the bolts.

7. Hold the top of rod (6) and pull up to remove spring (5) and strainer (7).

8. Remove any dirt stuck to strainer (7), then wash in clean diesel oil or flushing oil. If strainer (7) is broken, replace it with a new part.

9. When installing, insert strainer (7) into protruding part (8) of the tank, and assemble.

10. Fill with the specified amount of oil through oil filler port (F). Check that the oil level is within the correct range on the sight gauge.

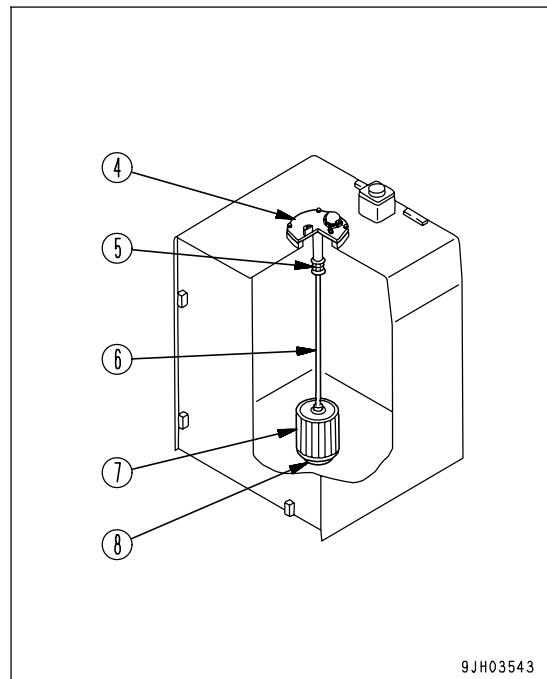

11. Bleed the air from the circuit after cleaning or replacing the filter element or strainer, or after changing the oil.

# **SPECIFICATIONS**



# SPECIFICATIONS

| Item                        | Unit                   | PC1250-7                        | PC1250SP-7        | PC1250LC-7       |
|-----------------------------|------------------------|---------------------------------|-------------------|------------------|
| Operating weight            | kg (lb)                | 108,700 (239,684)               | 109,500 (241,448) | 113,200 (249,60) |
| Bucket capacity             | m <sup>3</sup> (cu.yd) | 5.2 (6.8)                       | 6.7 (8.8)         | 5.2 (6.8)        |
| Name of engine              | -                      | KOMATSU SAA6D170E diesel engine |                   |                  |
| Engine horsepower           | KW(HP)/rpm             | 485(651)/1,800                  |                   |                  |
| A Overall length            | mm (ft in)             | 16,020 (52'7")                  | 14,790 (48'6")    | 16,020 (52'7")   |
| B Overall height            | mm (ft in)             | 6,040 (19'10")                  | 6,265 (20'7")     | 6,040 (19'10")   |
| C Overall width             | mm (ft in)             | 5,355 (17'7")                   | 5,355 (17'7")     | 5,355 (17'7")    |
| D Track width               | mm (ft in)             | 700 (2'4")                      | 700 (2'4")        | 700 (2'4")       |
| E Height of cab             | mm (ft in)             | 4,120 (13'6")                   | 4,120 (13'6")     | 4,120 (13'6")    |
| F Radius of upper structure | mm (ft in)             | 4,870 (15'12")                  | 4,870 (15'12")    | 4,870 (15'12")   |
| G Length of track           | mm (ft in)             | 6,425 (21'1")                   | 6,425 (21'1")     | 7,400 (24'3")    |
| H Tumbler center distance   | mm (ft in)             | 4,995 (16'5")                   | 4,995 (16'5")     | 5,970 (19'7")    |
| I Min. ground clearance     | mm (ft in)             | 990 (3'3")                      | 990 (3'3")        | 990 (3'3")       |
| Travel speed (Lo/Hi)        | km/h (MPH)             | 2.1/3.2 (1.3/2.0)               |                   |                  |
| Swing speed                 | rpm                    | 5.5                             |                   |                  |

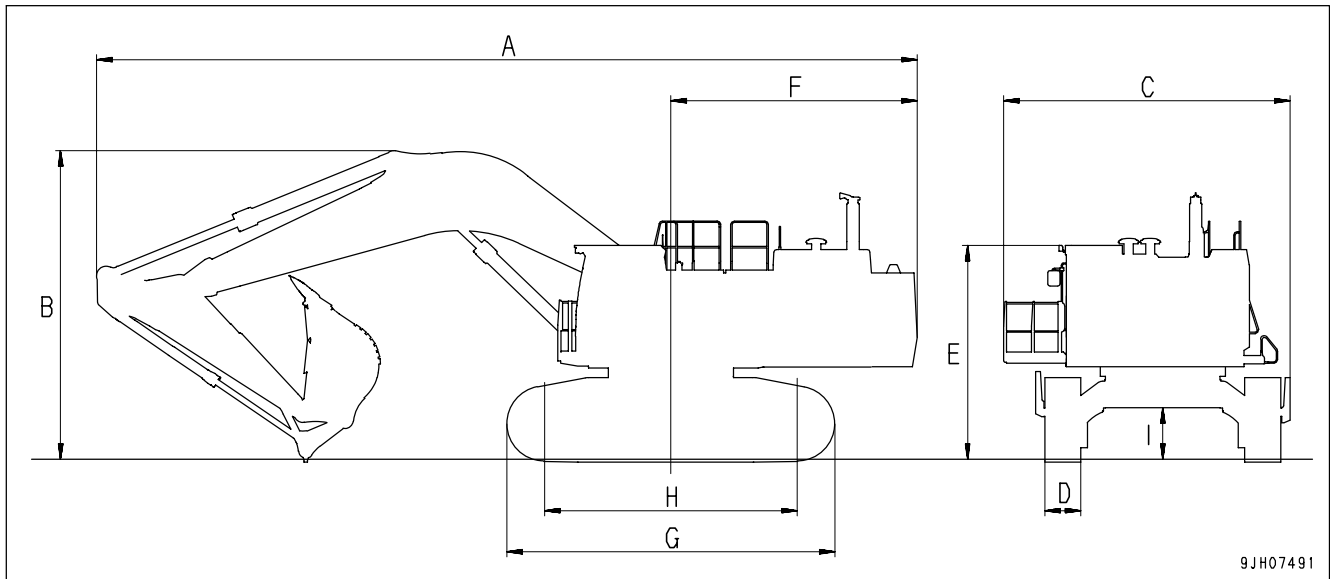

9JH07491

|   | Working ranges             | Unit       | PC1250-7        | PC1250SP-7      | PC1250LC-7      |
|---|----------------------------|------------|-----------------|-----------------|-----------------|
| A | Max. digging reach         | mm (ft in) | 15,350 (50'4")  | 14,070 (46'2")  | 15,350 (50'4")  |
| B | Max. digging depth         | mm (ft in) | 9,350 (30'8")   | 7,900 (25'11")  | 9,350 (30'8")   |
| C | Max. digging height        | mm (ft in) | 13,400 (43'12") | 13,000 (42'8")  | 13,400 (43'12") |
| D | Max. vertical wall depth   | mm (ft in) | 7,610 (24'12")  | 5,025 (16'6")   | 7,610 (24'12")  |
| E | Max. dumping height        | mm (ft in) | 8,680 (28'6")   | 8,450 (27'9")   | 8,680 (28'6")   |
| F | Max. reach at ground level | mm (ft in) | 15,000 (49'3")  | 13,670 (44'10") | 15,000 (49'3")  |

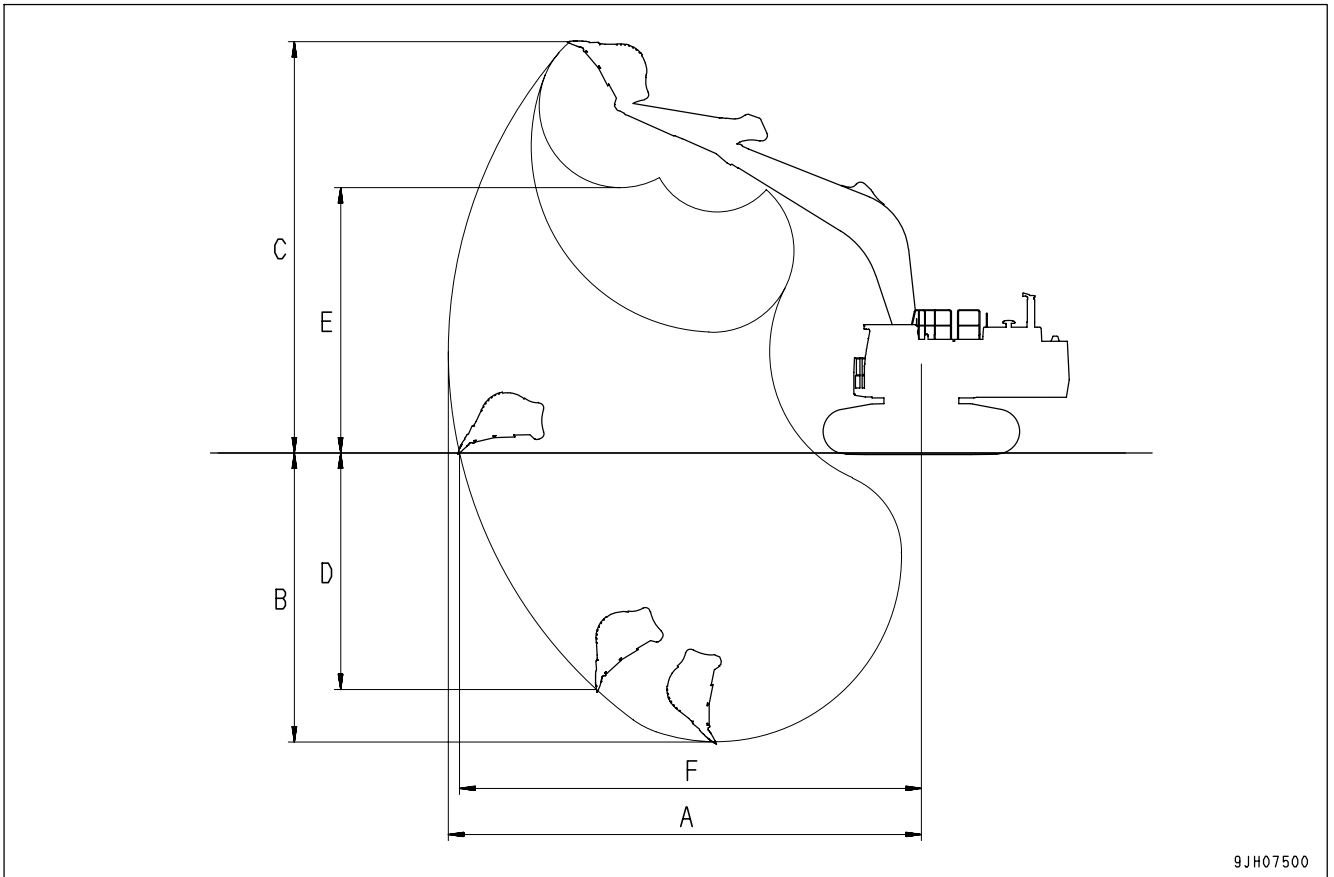



# ATTACHMENTS, OPTIONS

 **WARNING**

Please read and make sure that you understand the SAFETY section before reading this section.

---

## GENERAL PRECAUTIONS FOR SAFETY

When installing attachments or options to the machine, it is necessary to pay attention to safety. Please obey the following precautions strictly when selecting, installing, or using attachments or options.

### PRECAUTIONS WHEN SELECTING

- Please consult your Komatsu distributor before installing attachments or options to the machine. Depending on the type of attachment or option, it may be necessary to install a front guard, overhead guard, or other safety structure to the machine. There may also be problems of the attachment or option hitting the operator's cab.
- Install only attachments or options authorized by Komatsu. Komatsu cannot accept any responsibility for any accident, damage, or failure caused by the use of attachments or options not authorized by Komatsu.

### READ THE INSTRUCTION MANUAL THOROUGHLY

- Before installing or using any attachment or option, make sure that you thoroughly read and understand the instruction manuals for the machine and the attachment or option.
- If you lose the instruction manual or it is damaged, always obtain a new copy from the attachment manufacturer or your Komatsu distributor.

### PRECAUTIONS WHEN REMOVING OR INSTALLING

When removing or installing the attachment or option, obey the following precautions, and take care to ensure safety during the operation.

- Carry out the removal and installation operation on a flat, firm ground surface.
- When the operation is carried out by two or more workers, choose the leader and follow his instructions.
- Use a crane when handling heavy objects (more than 25 kg (55 lb)). (The crane must be operated by a qualified operator.)
- Never go under a load raised by the crane.
- Do not carry out operations with the load kept raised by the crane. Always use a stand to prevent the load from falling.
- When removing a heavy part, consider the balance after it is removed. To prevent the machine from tipping over, set a support in position if necessary before removing the part.
- Before installing or after removing the attachment or option, set it in a stable condition to prevent it from falling over.
- For details of the removal or installation operation, please consult your Komatsu distributor.

### PRECAUTIONS WHEN USING

When long or heavy work equipment is installed, remember the following precautions. Before starting operations, move the machine to a safe place and carry out a test operation to make sure that you fully understand the movement, center of gravity, and working range of the machine.

- Do not swing the work equipment if the machine is at an angle. If the work equipment is swung with the machine at an angle, there is danger that the machine will tip over.
- Always maintain a safe distance from obstacles in the surrounding area when operating. If long work equipment is installed, the working range becomes larger.
- If heavy work equipment is installed, pay careful attention to the following precautions.
  - The swing overrun (the distance the work equipment moves before completely stopping after the swing brake is applied) will be greater. There is danger of hitting objects if the swing overrun is miscalculated, so allow extra space to the swing position when swinging.
  - The hydraulic drift of the work equipment (the amount of the work equipment moves down under its own weight when it is stopped in a raised position) also becomes greater. Do not stop the work equipment in a raised position; always lower it to the ground.
  - Do not swing, lower, or stop the work equipment suddenly. There is danger that the machine may tip over.
  - Do not suddenly extend or retract the boom cylinder. The shock may cause the machine to tip over.

# ATTACHMENT GUIDE



## WARNING

- Please read the instruction manual for the attachment and the sections of this manual related to attachments and options.
- When installing any attachment or option, there may be problems with safety, so please contact your Komatsu distributor before installing.
- Installing attachments or options without consulting your Komatsu distributor may not only cause problems with safety, but may also have an adverse effect on the operation of the machine and the life of the equipment.
- Any injuries, accidents, or damage resulting from the use of unauthorized attachments or options will not be the responsibility of Komatsu.

## COMBINATIONS OF WORK EQUIPMENT



## WARNING

Depending on the type or combination of work equipment, there is danger that the work equipment may hit the cab or machine body.

When using unfamiliar work equipment for the first time, check before starting if there is any danger of interference, and operate with caution.

Select the combination of boom, arm, and bucket from the combinations shown in the table below.

| Model          |                             | PC1250                 |            |              |                     |          | PC1250SP         | Bucket width [mm (in)]            |                                   |
|----------------|-----------------------------|------------------------|------------|--------------|---------------------|----------|------------------|-----------------------------------|-----------------------------------|
| Boom           |                             | Standard boom<br>9.1 m |            |              |                     |          | SP boom<br>7.8 m |                                   |                                   |
| Arm            |                             | Standard arm           | Strong arm | Semilong arm | Strong Semilong arm | Long arm | SP arm           | Excluding side cutter side shroud | Including side cutter side shroud |
| Work equipment | 3.4 <4.4>                   | -                      | -          | B            | -                   | A        | -                | 1,500<br>(59.1 in)                | 1,670<br>(65.8 in)                |
|                | 4.0 <5.2>                   | B                      | -          | A            | -                   | C        | -                | 1,710<br>(67.4 in)                | 1,880<br>(74.1 in)                |
|                | 5.0 <6.5>                   | A                      | -          | C            | -                   | -        | -                | 2,050<br>(80.8 in)                | 2,220<br>(87.5 in)                |
|                | 5.2 <6.8>                   | -                      | A          | -            | C                   | -        | -                | 2,050<br>(80.8 in)                | 2,110<br>(83.1 in)                |
|                | 5.2 <6.8><br>standard       | -                      | B          | -            | C                   | -        | -                | 2,050<br>(80.8 in)                | 2,110<br>(83.1 in)                |
|                | 6.7 <8.8>                   | -                      | -          | -            | -                   | -        | A                | 2,280<br>(89.8 in)                | 2,340<br>(92.2 in)                |
|                | 6.7 <8.8><br>wide<br>strong | -                      | -          | -            | -                   | -        | B                | 2,280<br>(89.8 in)                | 2,340<br>(92.2 in)                |

| Model          |                                 | PC1250LC               |              |                     |          | Bucket width [mm (in)]            |                                   |
|----------------|---------------------------------|------------------------|--------------|---------------------|----------|-----------------------------------|-----------------------------------|
| Boom           |                                 | Standard boom<br>9.1 m |              |                     |          |                                   |                                   |
| Arm            |                                 | Standard arm           | Semilong arm | Strong Semilong arm | Long arm | Excluding side cutter side shroud | Including side cutter side shroud |
| Work equipment | 3.4 <4.4>                       | -                      | B            | -                   | A        | 1,500<br>(59.1 in)                | 1,670<br>(65.8 in)                |
|                | 4.0 <5.2>                       | B                      | A            | -                   | C        | 1,710<br>(67.4 in)                | 1,880<br>(74.1 in)                |
|                | 5.0 <6.5>                       | A                      | C            | -                   | -        | 2,050<br>(80.8 in)                | 2,220<br>(87.5 in)                |
|                | 5.2 <6.8>                       | -                      | -            | C                   | -        | 2,050<br>(80.8 in)                | 2,110<br>(83.1 in)                |
|                | 5.2 <6.8><br>standard<br>strong | -                      | -            | C                   | -        | 2,050<br>(80.8 in)                | 2,110<br>(83.1 in)                |
|                | 6.7 <8.8>                       | -                      | -            | -                   | -        | 2,280<br>(89.8 in)                | 2,340<br>(92.2 in)                |
|                | 6.7 <8.8><br>wide<br>strong     | -                      | -            | -                   | -        | 2,280<br>(89.8 in)                | 2,340<br>(92.2 in)                |

(A): For standard operations (density up to 1.8 t/m<sup>3</sup> 3,000 lb/yb<sup>3</sup>)

(B): Possible to use only for heavy work (density up to 2.1 t/m<sup>3</sup> 3,500 lb/yb<sup>3</sup>)

(C): Possible to use only for light work (density up to 1.5 t/m<sup>3</sup> 2,500 lb/yb<sup>3</sup>)

- : Impossible to use

Working Range Diagram

|   | Working ranges                | Unit          | PC1250-7<br>Standard<br>arm | PC1250-7<br>Strong arm | PC1250-7<br>Semilong<br>arm | PC1250-7<br>Strong<br>Semilong arm | PC1250-7<br>Long arm | PC1250SP-7<br>SE arm |
|---|-------------------------------|---------------|-----------------------------|------------------------|-----------------------------|------------------------------------|----------------------|----------------------|
| A | Max. digging reach            | mm<br>(ft in) | 15,350<br>(50'4")           | 15,350<br>(50'4")      | 16,340<br>(53'7")           | 16,340<br>(53'7")                  | 17,450<br>(57'3")    | 14,070<br>(46'2")    |
| B | Max. digging depth            | mm<br>(ft in) | 9,350<br>(30'8")            | 9,350<br>(30'8")       | 10,440<br>(34'3")           | 10,440<br>(34'3")                  | 11,590<br>(38')      | 7,900<br>(25'11")    |
| C | Max. digging height           | mm<br>(ft in) | 13,400<br>(43'12")          | 13,400<br>(43'12")     | 13,490<br>(44'3")           | 13,490<br>(44'3")                  | 13,910<br>(45'8")    | 13,000<br>(42'8")    |
| D | Max. vertical wall<br>depth   | mm<br>(ft in) | 7,610<br>(24'12")           | 7,610<br>(24'12")      | 8,490<br>(27'10")           | 8,490<br>(27'10")                  | 9,480<br>(31'1")     | 5,025<br>(16'6")     |
| E | Max. dumping<br>height        | mm<br>(ft in) | 8,680<br>(28'6")            | 8,680<br>(28'6")       | 9,000<br>(29'6")            | 9,000<br>(29'6")                   | 9,440<br>(30'12")    | 8,450<br>(27'9")     |
| F | Max. reach at<br>ground level | mm<br>(ft in) | 15,000<br>(49'3")           | 15,000<br>(49'3")      | 16,000<br>(52'6")           | 16,000<br>(52'6")                  | 17,130<br>(56'2")    | 13,670<br>(44'10")   |

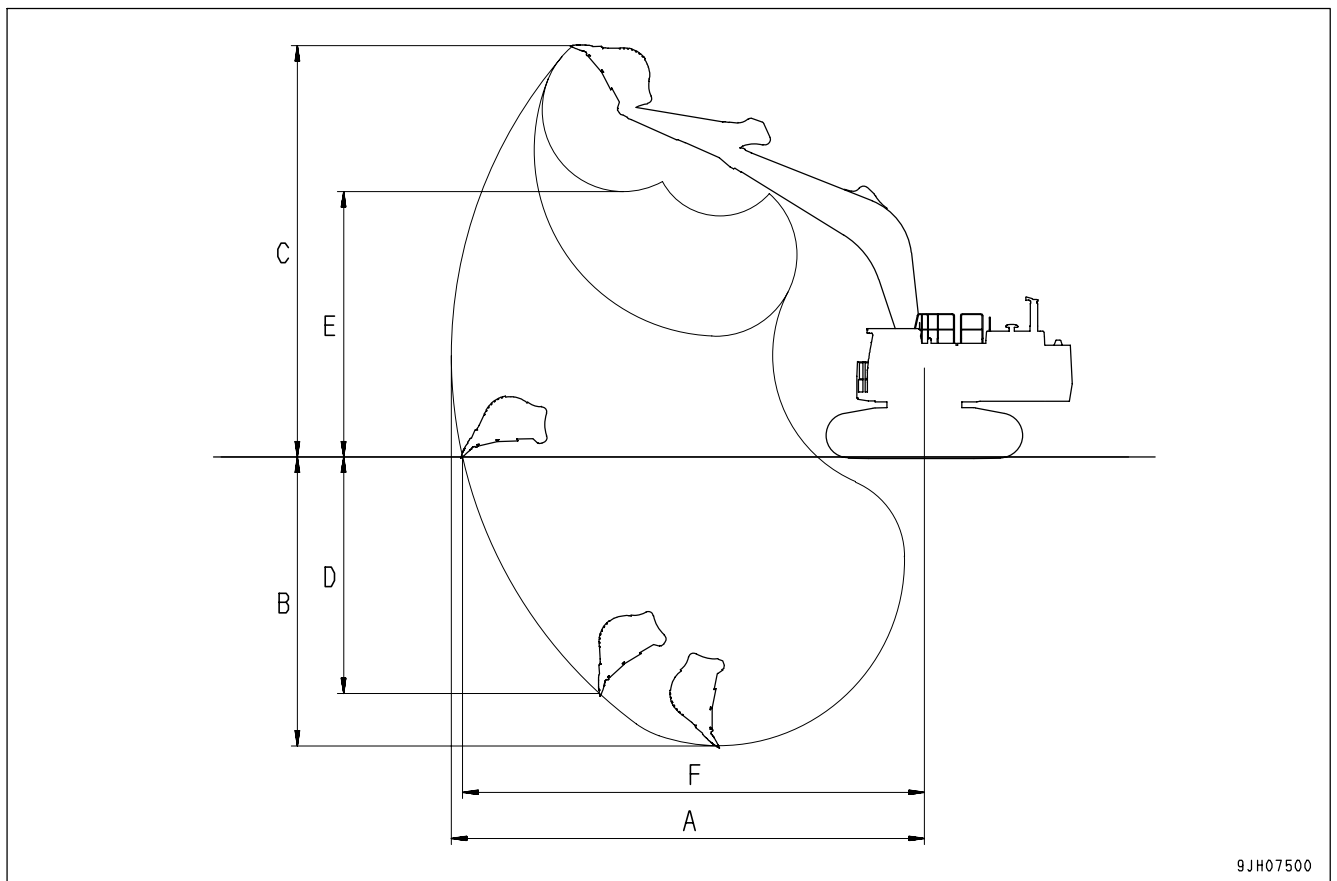



|   | Working ranges             | Unit          | PC1250LC-7<br>Standard arm | PC1250LC-7<br>Semilong arm | PC1250LC-7<br>Strong<br>Semilong arm | PC1250LC-7<br>Long arm |
|---|----------------------------|---------------|----------------------------|----------------------------|--------------------------------------|------------------------|
| A | Max. digging reach         | mm<br>(ft in) | 15,350<br>(50'4")          | 16,340<br>(53'7")          | 16,340<br>(53'7")                    | 17,450<br>(57'3")      |
| B | Max. digging depth         | mm<br>(ft in) | 9,350<br>(30'8")           | 10,440<br>(34'3")          | 10,440<br>(34'3")                    | 11,590<br>(38')        |
| C | Max. digging height        | mm<br>(ft in) | 13,400<br>(43'12")         | 13,490<br>(44'3")          | 13,490<br>(44'3")                    | 13,910<br>(45'8")      |
| D | Max. vertical wall depth   | mm<br>(ft in) | 7,610<br>(24'12")          | 8,490<br>(27'10")          | 8,490<br>(27'10")                    | 9,480<br>(31'1")       |
| E | Max. dumping height        | mm<br>(ft in) | 8,680<br>(28'6")           | 9,000<br>(29'6")           | 9,000<br>(29'6")                     | 9,440<br>(30'12")      |
| F | Max. reach at ground level | mm<br>(ft in) | 15,000<br>(49'3")          | 16,000<br>(52'6")          | 16,000<br>(52'6")                    | 17,130<br>(56'2")      |

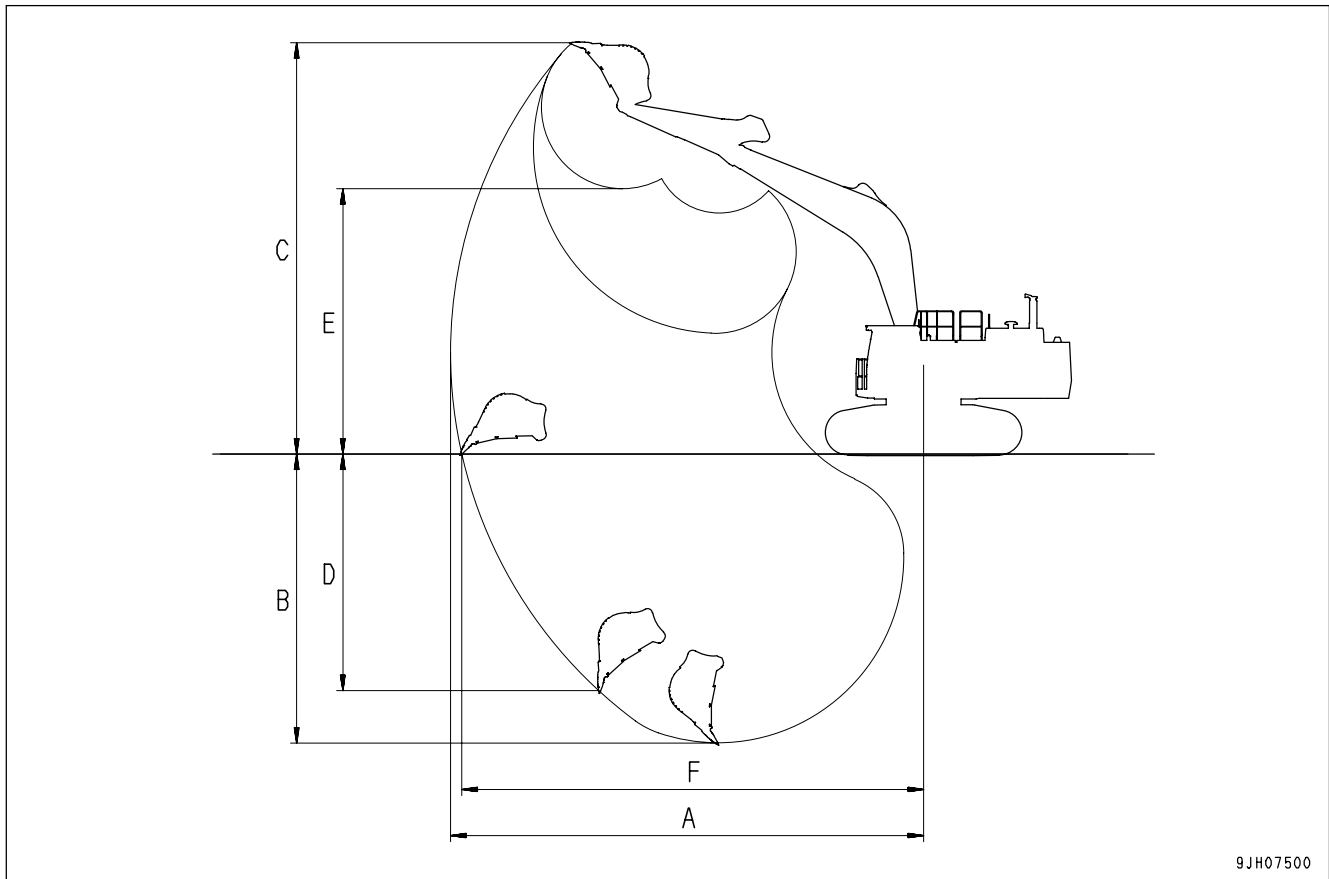

9JH07500

## SELECTION OF TRACK SHOES

Select the most suitable track shoe to match the operating conditions. Check the use in the table below, and select the shoe from the table on the next page.

| Category | Use                                  | Precautions when using   | Remarks  |
|----------|--------------------------------------|--|--|
| A        | Cocky ground, river bed, normal soil | Travel in Lo speed when traveling on rough ground with obstacles such as large boulders and fallen trees.  | Categories "B" are wide shoes, so there are restrictions on their use. Therefore, before using, check the restrictions and consider carefully the conditions of use before recommending a suitable shoe width. If necessary, give the customer guidance in their use.<br>When selecting the shoe width, select the narrowest shoe possible within the range that will give no problem with flotation and ground pressure. If a wider shoe than necessary is used, there will be a large load on the shoe, and this may lead to bending of the shoe, cracking of the links, breakage of the pins, loosening of the shoe bolts, or other problems. |
| B        | Normal soil, soft land               | <ul style="list-style-type: none"> <li>• Use only for ground where "B" sink and are impossible to use.</li> <li>• Cannot be used on rough ground where there are large obstacles such as boulders and fallen trees.</li> <li>• Travel in Hi speed only on flat ground; when it is impossible to avoid traveling over obstacles, lower the travel speed to approx. half of Lo speed.</li> </ul> |  |

| Shoe                     |                           | Double grouser shoe |                |               |                |                |
|--------------------------|---------------------------|---------------------|----------------|---------------|----------------|----------------|
| Model                    |                           | PC1250              |                | PC1250SP      | PC1250LC       |                |
| Shoe width               | mm (in)                   | 700 (27.6 in)       | 1000 (39.4 in) | 700 (27.6 in) | 1000 (39.4 in) | 1200 (47.3 in) |
| Overall width of crawler | mm (in)                   | 4600 (15'1")        | 4900 (16'1")   | 4600 (15'1")  | 4900 (16'1")   | 5100 (16'9")   |
| Ground pressure          | MPa (kg/cm <sup>2</sup> ) | 0.13 (1.35)         | 0.09 (0.96)    | 0.13 (1.36)   | 0.09 (0.88)    | 0.07 (0.74)    |
| category of use          |                           | A                   | B              | A             | B              | B              |

# AUTO-GREASING SYSTEM

## EXPLANATION OF COMPONENTS

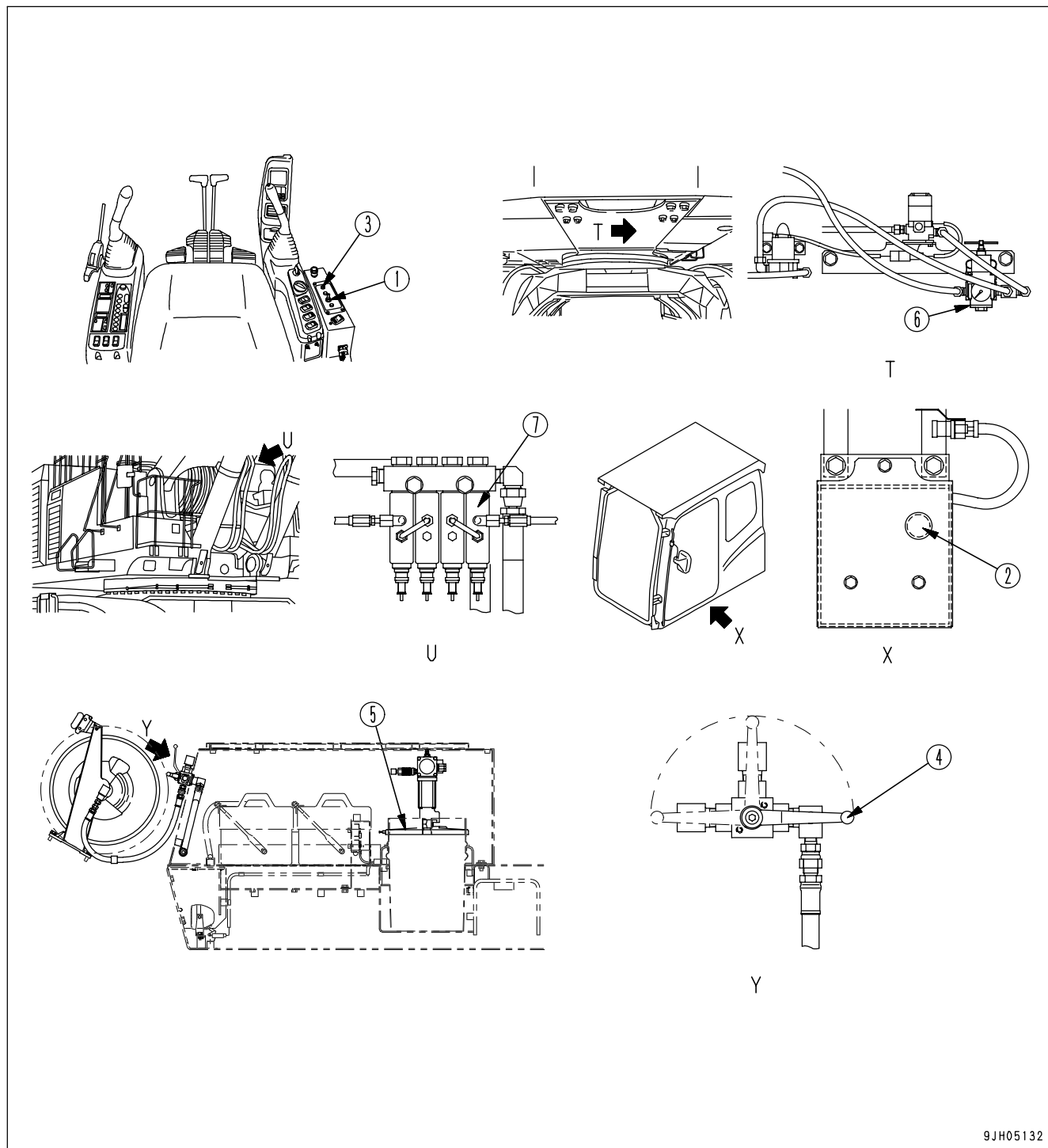

9JH05132

- (1) Auto-greasing switch
- (2) Interval adjustment dial
- (3) Warning lamp (red)
- (4) Auto-greasing/grease gun selector valve lever
- (5) Grease pump
- (6) Regulator
- (7) Injector

**Auto-greasing Switch**

This switch (1) actuates the greasing system.

- When this switch is set to the AUTO position, the lamp (green) lights up and the auto-greasing system starts to operate. If the auto-greasing switch is at AUTO when the machine starting switch is turned ON, the greasing system is actuated immediately.
- When the auto-greasing switch is set to the MANUAL position, the lamp (green) lights up and the auto-greasing system starts to operate regardless of the timer.
- When using the grease gun, set the auto-greasing switch to the MANUAL position. This position is also used when checking operation of the grease pump and when bleeding the air from the grease line.

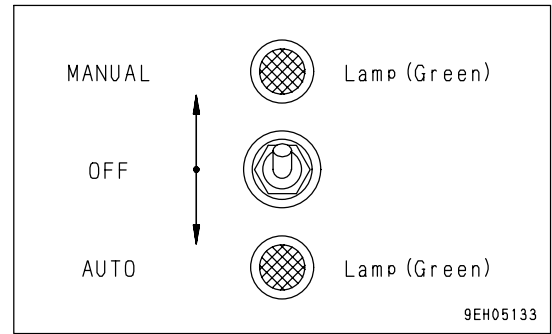

**Interval Adjustment Dial**

This dial (2) is used to adjust the greasing interval for auto-greasing. Remove the rubber cap; the adjustment dial is inside.

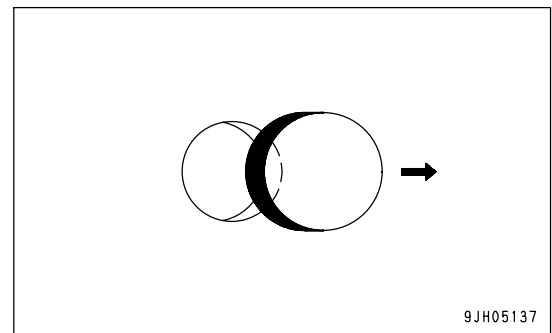

**Warning Lamp (red)**

This lamp (3) lights up when there is an abnormality in the auto-greasing system. The buzzer also sounds at the same time.

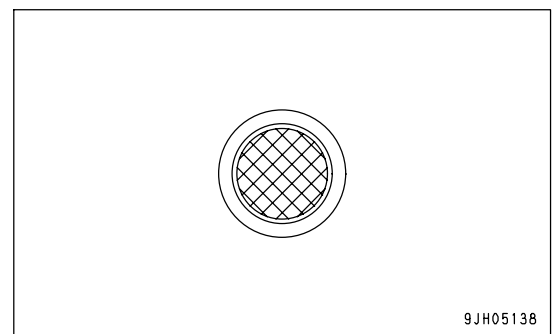

**Auto-greasing/Grease Gun Selector Valve Lever**

- This lever (4) is used to switch the flow of grease to the grease gun. When using the auto-greasing system, set it to the AUTO position (A); when using the grease gun, set it to the GREASE GUN position (B).
- After using the grease gun, always return the lever to the auto-greasing position.

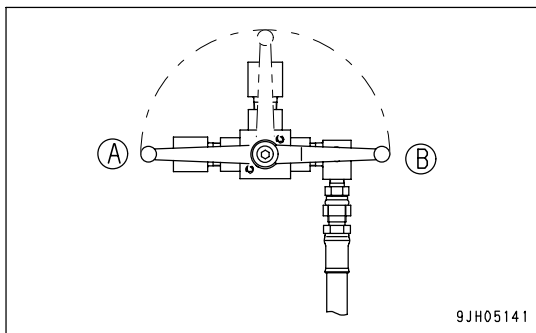

**Grease Pump**

- This pump (5) supplies the grease.
- For details of the method of handling the grease pump, see "GREASE PUMP (PAGE 3-65)".

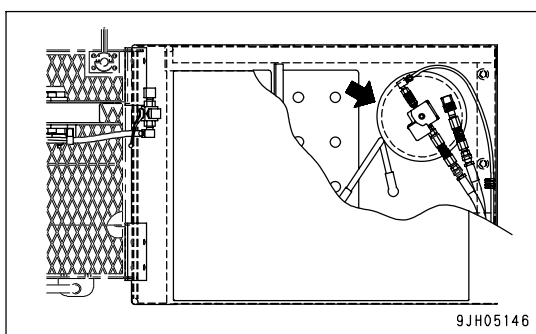

## Regulator



### WARNING

Do not raise the pressure in the regulator above a maximum of 0.49 MPa (5 kg/cm<sup>2</sup>). The pump pressure ratio is 50:1, so the grease pressure rises to 24.5 MPa (250 kg/cm<sup>2</sup>). If the system is used at above the specified pressure, there is danger that it may lead to a serious accident.

This regulator (6) adjusts and stabilizes the compressed air sent from the compressor to a suitable pressure.

- The regulator pressure is set to 0.44 MPa (4.5 kg/cm<sup>2</sup>) when the machine is shipped from the factory.

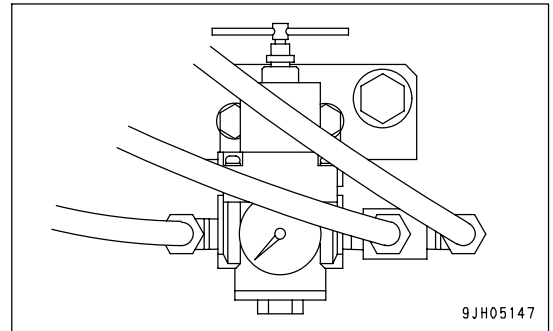

## Injector

This injector (7) supplies the grease sent from grease pump (5) to the greasing points.

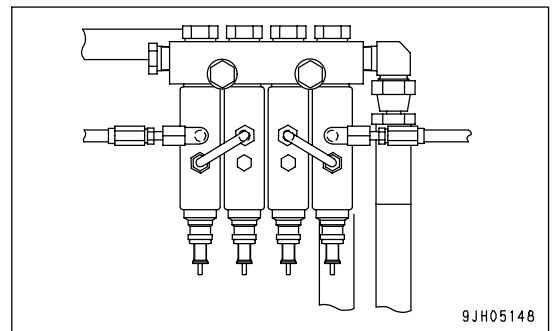

### Greasing Points for Auto-greasing System

**CAUTION**

- If there is an abnormality and the auto-greasing system does not function, supply the grease manually to greasing points (1) - (8). For details, see the INSPECTION AND MAINTENANCE section.
- Greasing points (9) - (13) are not included in the auto-greasing system, so supply the grease manually to these greasing points. For details, see the INSPECTION AND MAINTENANCE section.

The greasing points for the auto-greasing system are as follows.

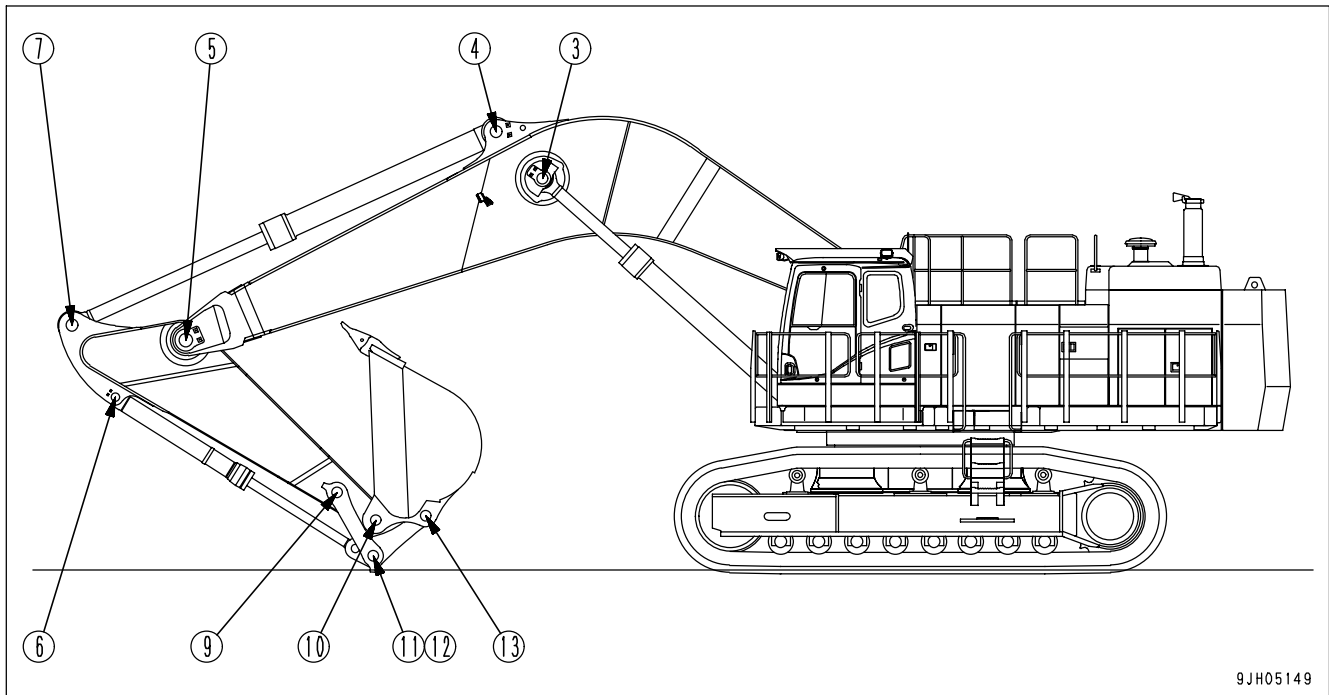

9JH05149

- (1) Boom cylinder foot pin (2 places)
- (2) Boom foot pin (2 places)
- (3) Boom cylinder rod pin (2 places)
- (4) Arm cylinder foot pin (1 place)
- (5) Boom-Arm coupling pin (1 place)
- (6) Bucket cylinder foot pin (2 places)
- (7) Arm cylinder rod pin (1 place)
- (8) Swing circle (4 places)

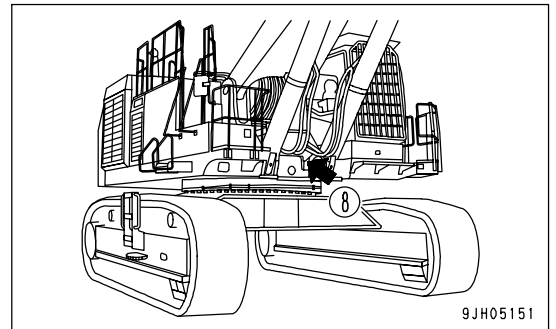
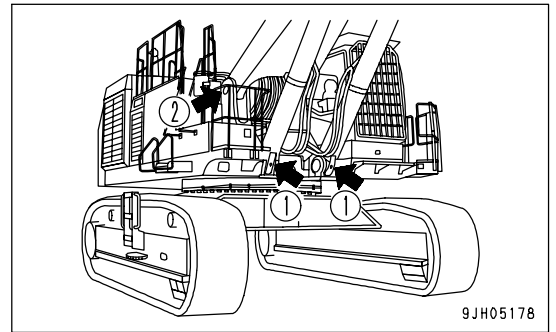



## OPERATION

### CHECK BEFORE STARTING OPERATIONS

- Check that there is ample grease in the grease pail in the grease pump inside the battery case. If the pump has run out of grease, replace the grease pail.
- Check that the grease pail is not dented or deformed.
- Check that the auto-greasing/grease gun selector valve lever inside the battery case is at the auto-greasing position (A).

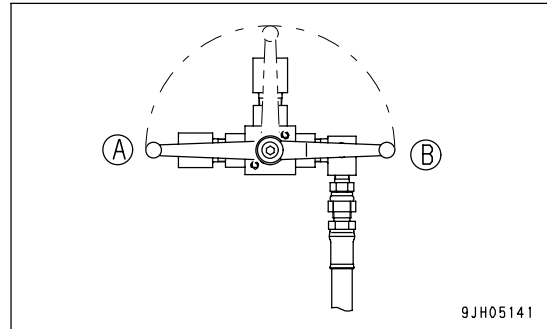

### OPERATING PROCEDURE FOR AUTO-GREASING SWITCH

- To operate the auto-greasing system, turn the machine starting switch ON, then operate the auto-greasing switch on the box on the side of the console on the right side of the operator's seat.

#### Operating With Auto-greasing Switch at Auto Position

- When the auto-greasing switch is set to the AUTO position, the lamp (green) lights up and the auto-greasing system starts to operate.
- When the machine starting switch is turned ON, if the auto-greasing switch is already at the AUTO position, the greasing operation will start immediately.

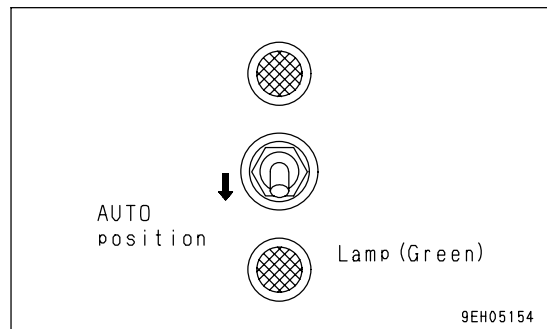

#### Operating With Auto-greasing Switch at Manual Position

- When the auto-greasing switch is set to the MANUAL position, the lamp (green) lights up and the auto-greasing system starts to operate regardless of the timer.
- When using the grease gun, set the auto-greasing switch to the MANUAL position. This position is also used when checking operation of the grease pump and when bleeding the air from the grease line.
- During manual operations, the auto-greasing system does not operate. After using the grease gun, always return the auto-greasing switch to the AUTO position.

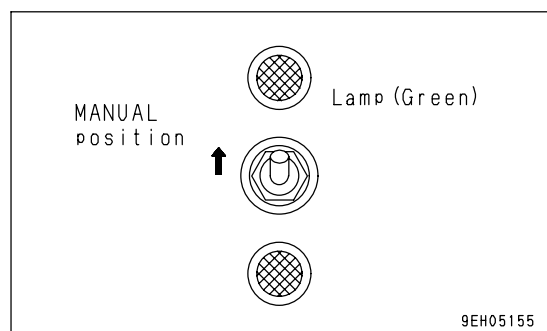

- Set the auto-greasing switch to the OFF position when it is necessary to stop the auto-greasing system, such as when the grease piping is broken or damaged.

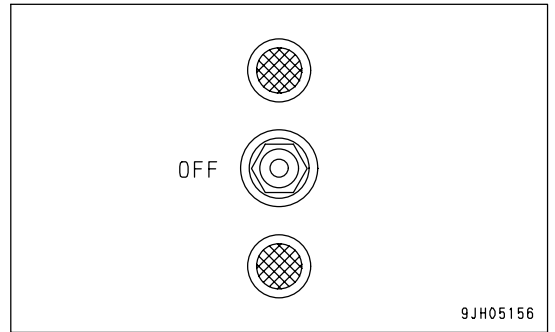

**METHOD OF ADJUSTING INTERVAL TIMER**



The setting of the interval timer differs according to the type of machine and the type of work. For this reason, it is necessary for the customer himself to set the interval timing to match the working condition of the machine.

- The interval timer is installed to control the greasing interval of the auto-greasing system.
- The greasing interval can be changed freely with the adjustment dial of the interval timer. The set interval has an error of about  $\pm 15\%$ , however (for both stopping and starting).

Examine: when timer is set to 20 minutes

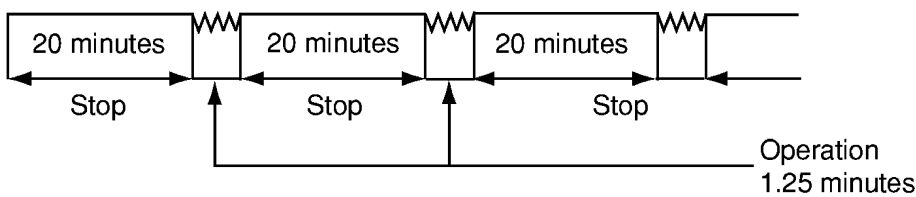

The greasing interval is set to 20 minutes when the machine is shipped from the factory.

**Adjustment procedure**

1. Remove rubber cap (1) on the front face of the timer box.  
The adjustment dial can be seen inside.

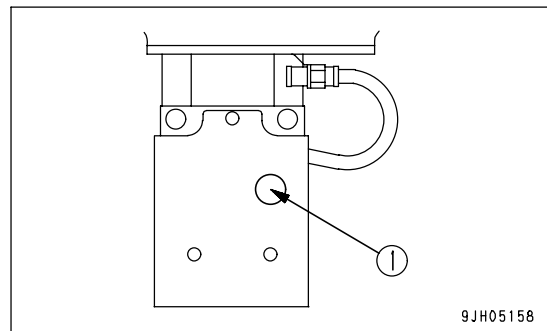

2. Using long-nosed pliers, turn the adjustment dial to set to the desired interval timing.
3. After adjusting, install cap (1).

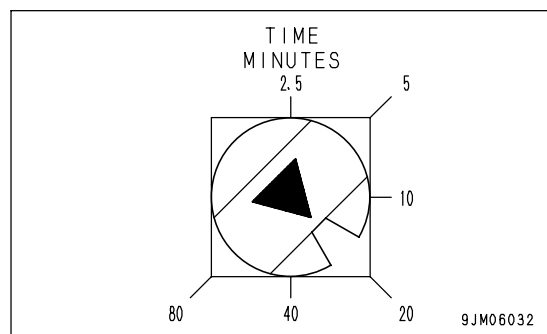

METHOD OF ADJUSTING INJECTOR DISCHARGE AMOUNT

**CAUTION**

The setting of the injector discharge amount differs according to the type of machine and the type of work. For this reason, it is necessary for the customer himself to set the injector discharge amount to match the working condition of the machine.

- The injector is operated by the pressure from the pump, and it feeds grease of the specified quantity to the bearing.
- To see if the injector works normally, check the operation of indicator pin (1) in its hard. If the injector is normal, the pin is retracted first. If the pump stops and the pressure is lost, the pin returns and it is reset for the next greasing.
- Although the injector can be overhauled and repaired, replace it with a spare one, if possible, when it has any trouble.

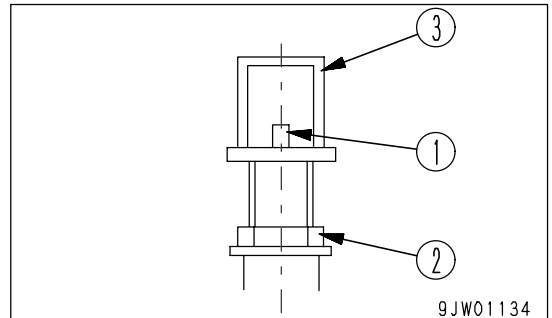

The injector discharge amount is set to the center position (0.7 cc/ST) when the machine is shipped from the factory.

Adjustment procedure

Adjust the discharge from the injector with adjustment screw (3) on its hard.

1. To reduce the discharge, loosen lock nut (2) and turn adjustment screw (3) clockwise. If the adjustment screw stops (at the stopper), the discharge is minimized.
2. If the adjustment screw is returned by 10 turns from the fully tightened position (minimum discharge) in 1] above, the discharge is maximized (1.3 cc/ST).
3. After adjusting the discharge from the injector, be sure to tighten lock nut (2).

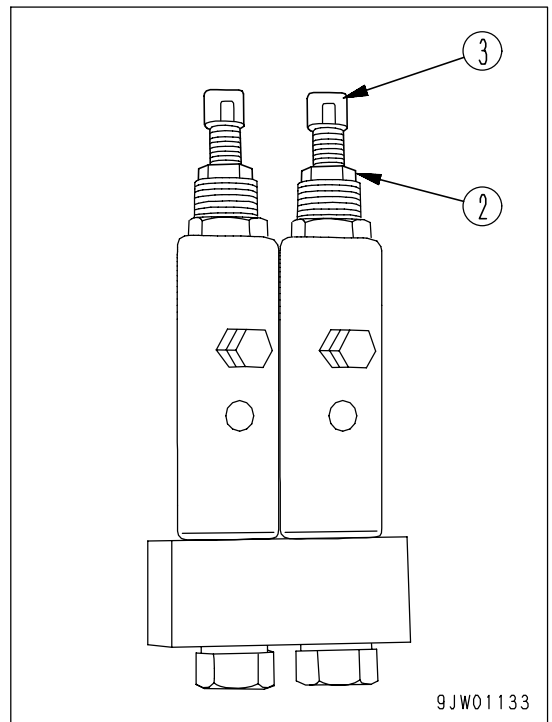

- Tightening torque for locknut (2): 19.6 to 24.5 Nm (2.0 to 2.5 kgm, 14.5 to 18.1 lbf)

|   | Discharge/time |
|---|----------------|
| Turn clockwise to stopper                             | 0.13 cc (Min)  |
| Turn counterclockwise by 10 turns from above position | 1.30 cc (Max)  |

### TROUBLESHOOTING

There is an auto-greasing warning lamp and injector actuation indicator at the position to inform of abnormalities in the auto-greasing system.

#### AUTO-GREASING WARNING LAMP (RED)

If there is any abnormality in the pressurization of the grease line, the buzzer sounds and the warning lamp (red) lights up.

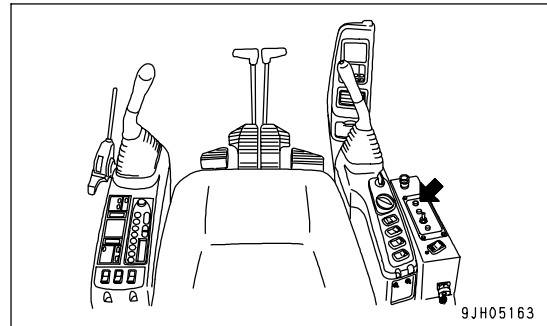

#### INJECTOR ACTION INDICATOR

The indicator pin moves up and down according to the increase or decrease in pressure in the grease line to inform the operator that grease is being supplied to the greasing points. If the grease is not being supplied normally, the indicator pin does not move even when the pressure increases or decreases, so it is possible to detect the abnormality.

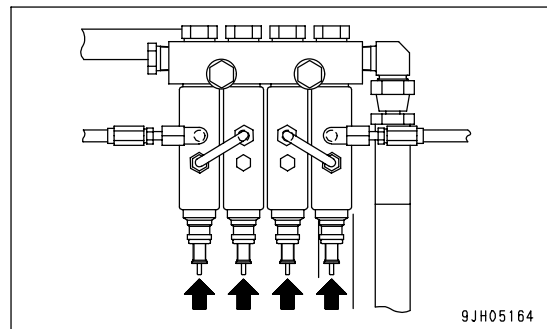

| Condition  | Main cause  | Action   |
|--|---|--|
| Auto-greasing warning lamp lights up (buzzer sounds) | <ul style="list-style-type: none"> <li>• Greasing system is being run with empty grease pail</li> <li>• Grease pail is deformed, so air is being sucked in without follower plate going down</li> <li>• Grease is leaking from grease piping (piping from pump to injector)</li> <li>• Grease is leaking from injector</li> <li>• Defective pressurization of pump</li> </ul> | <ul style="list-style-type: none"> <li>• Replace grease pail</li> <li>• Check, repair</li> <li>• Replace</li> <li>• Replace</li> </ul> |
| Injector actuation indicator does not work           | <ul style="list-style-type: none"> <li>• Defective injector</li> <li>• NLGI No. 2 or equivalent grease is being used in cold area</li> </ul>  | <ul style="list-style-type: none"> <li>• Replace</li> <li>• Change to grease for cold weather (NLGI No. 0 or equivalent)</li> </ul>    |

If any problem occurs where the cause is not listed in the above table, please contact your Komatsu distributor for repairs.

**MAINTENANCE**

**REPLACE GREASE PAIL**

**⚠ CAUTION**

- Do not use a grease pail if it is dented or deformed.  
Follower plate (2) will not come down, or air pockets will form, so the grease will not be sucked in.
- After using the pail, remove all grease that leaked or sprayed out.

If pail (1) runs out of grease, replace pail (1).  
 • Check that grease dose not leak from the piping between the pail (1) and follower plate (2).

**NOTICE**  
 Do not remove follower plate (2). If follower plate (2) is not used, pump (3) will be unable to suck up the grease even if there is still a large quantity of grease in the can.

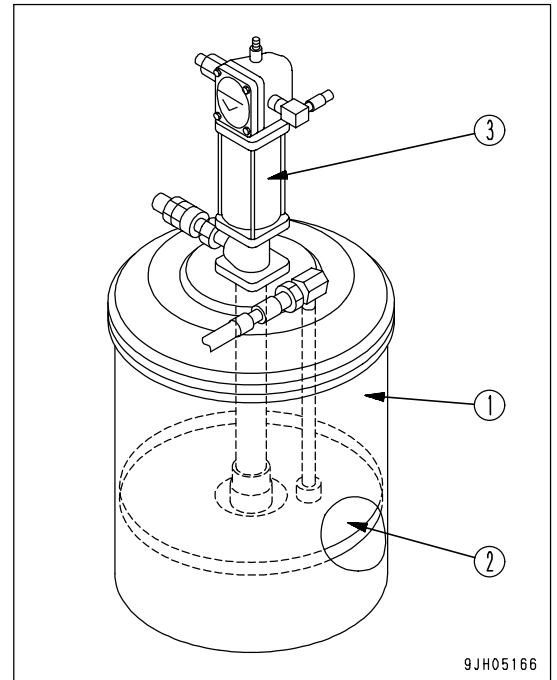

Select the grease to use from the following table to match the ambient temperature.

| KIND OF FLUID | AMBIENT TEMPERATURE |     |     |    |            |    |    |       |
|---------------|---------------------|-----|-----|----|------------|----|----|-------|
|               | -22                 | -4  | 14  | 32 | 50         | 68 | 86 | 104°F |
|               | -30                 | -20 | -10 | 0  | 10         | 20 | 30 | 40°C  |
| Grease        |                     |     |     |    | NLGI No. 2 |    |    |       |
|               | NLGI No. 0          |     |     |    | (*1)       |    |    |       |

\*1: If cold-weather grease (NLGI No. 0) is used in warm areas, some grease will drip from the tip of the work equipment pins, but there is no problem with the lubrication.

**PROCEDURE FOR BLEEDING AIR FROM GREASE LINE**



**WARNING**

There is no check device to prevent reverse flow in the service grease nipple installed to the injector. If you forget to tighten the cap, there is danger that high-pressure grease may spurt out when the grease pump is actuated.

Be sure not to forget to tighten the cap.

If the grease pump has been run empty or the grease piping has been disassembled and assembled again, and large amounts of air have got into the grease line, bleed the air from the grease line.

**NOTICE**

If air is left in the circuit, the grease pressure will not rise to the specified level or will take a long time to rise to the specified level, and the injector will not work normally.

Items to check

- Loosen the plug installed to each injector to bleed air from the main piping. This work shall be carry out by two persons.
- Start bleeding at the injector nearest the grease pump, then bleed at the other injectors in order.  
(Swing circle -> Boom cylinder bottom -> Boom -> Arm)
- Check that the auto-greasing/grease gun selector valve lever inside the battery case is at the auto-greasing position.

Method of bleeding air

1. Remove plug (2) from injector (1).
  - This plug (2) is installed to the manifold end of each end injector. If air must be bled from the main piping, remove this plug.
2. The other person should set the auto-greasing switch on the box on the side of the console on the right side of the operator's seat to the MANUAL position and operate the grease pump. For details of the method of operating the grease pump, see "OPERATION (PAGE 6-14)".
3. Discharge the air with the grease from the injector plug hole. (Often the grease becomes cloudy white because of the air.)
4. When normal grease comes out, set the auto-greasing switch to the OFF position and stop the grease pump.

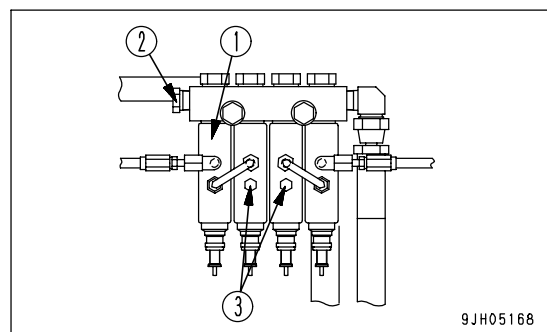

5. Tighten plug (2) of the injector to prevent the grease from leaking.

- Tightening torque of plug (2): 19.6 - 24.9 Nm (2.0 - 3.0 kgm, 14.5 - 21.7 lbft)

Carry out Steps 1 to 5 for every injector.

6. Remove cap (4) from service grease nipple (3) of the injector.

7. Operate the grease gun manually to fully charge all the branch lines with grease.

For details of the location of the injectors, see "Greasing Points for Auto-greasing System (PAGE 6-12)".

**REMARK**

If the auto-greasing system does not work properly and grease is not supplied, use the grease gun and carry out greasing manually from service grease nipple (3) installed to each injector.

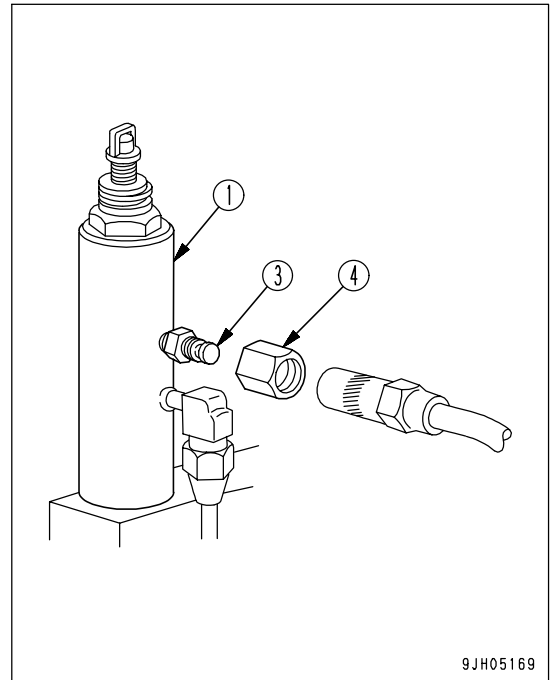

8. Tighten cap (4) of service grease nipple (3) of the injector.

- Tightening torque of cap (4): 3.92 to 5.88 Nm (0.4 to 0.6 kgm, 2.9 to 4.3lbft)
- There is no check device to prevent reverse flow in service grease nipple (3). If you forget to tighten cap (4), there is danger that high-pressure grease may spurt out when the grease pump is actuated. Be sure not to forget to tighten the cap.

9. After completing the operation in the Steps 1 to 8, set the auto-greasing switch on the box on the side of the console on the right side of the operator's seat to the AUTO position.

10. Turn the machine starting switch ON and check that indicator pin (5) of each injector is working properly. If the condition is normal, indicator pin (5) moves up and down in a piston movement.

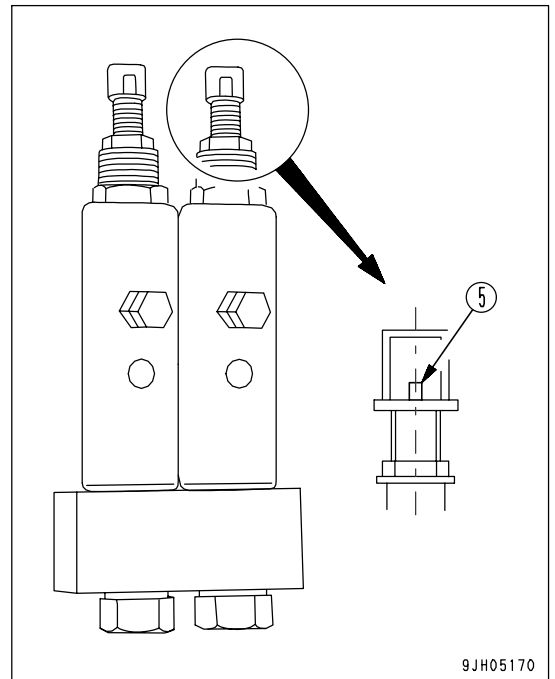



**INJECTOR POSITION IN AUTO-GREASING SYSTEM AND MANUAL GREASING**

**! WARNING**

There is no check device to prevent reverse flow in the service grease nipple installed to the injector. If you forget to tighten the cap, there is danger that high-pressure grease may spurt out when the grease pump is actuated.

Be sure not to forget to tighten the cap.

Injector (a) acts to send the grease supplied from the grease pump to each greasing point. If the auto-greasing system does not work properly and grease is not supplied, use the grease gun and carry out greasing manually from service grease nipple (b) installed to each injector.

- There is no check device to prevent reverse flow in service grease nipple (b). If you forget to tighten cap (c), there is danger that high-pressure grease may spurt out when the grease pump is actuated. Be sure not to forget to tighten the cap.

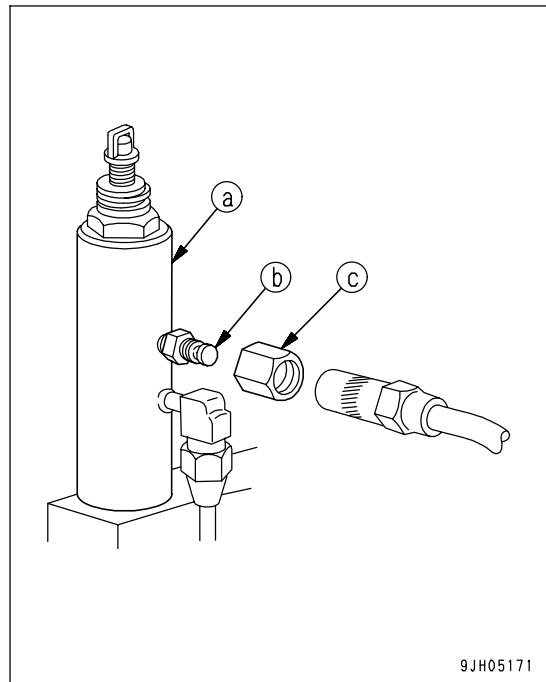

The locations of the service grease nipples for each injector are as follows.

- (1) Boom cylinder foot pin (right) (2 places)
- (2) Boom cylinder foot pin (left) (2 places)
- (3) Boom foot pin (right) (2 places)
- (4) Boom foot pin (left) (2 places)
- (5) Boom cylinder rod pin (right) (1 place)
- (6) Boom cylinder rod pin (left) (1 place)
- (7) Arm cylinder foot pin (right) (1 place)
- (8) Boom-arm connecting pin (2 places)
- (9) Bucket cylinder foot pin (right) (1 place)
- (10) Bucket cylinder foot pin (left) (1 place)
- (11) Arm cylinder rod pin (1 place)
- (12) Swing circle (4 places)

- When greasing places on top of the arm: boom-arm connecting pin (8), bucket cylinder foot pins (9) and (10), and arm cylinder rod pin (11), the greasing can be carried out manually from the central block.

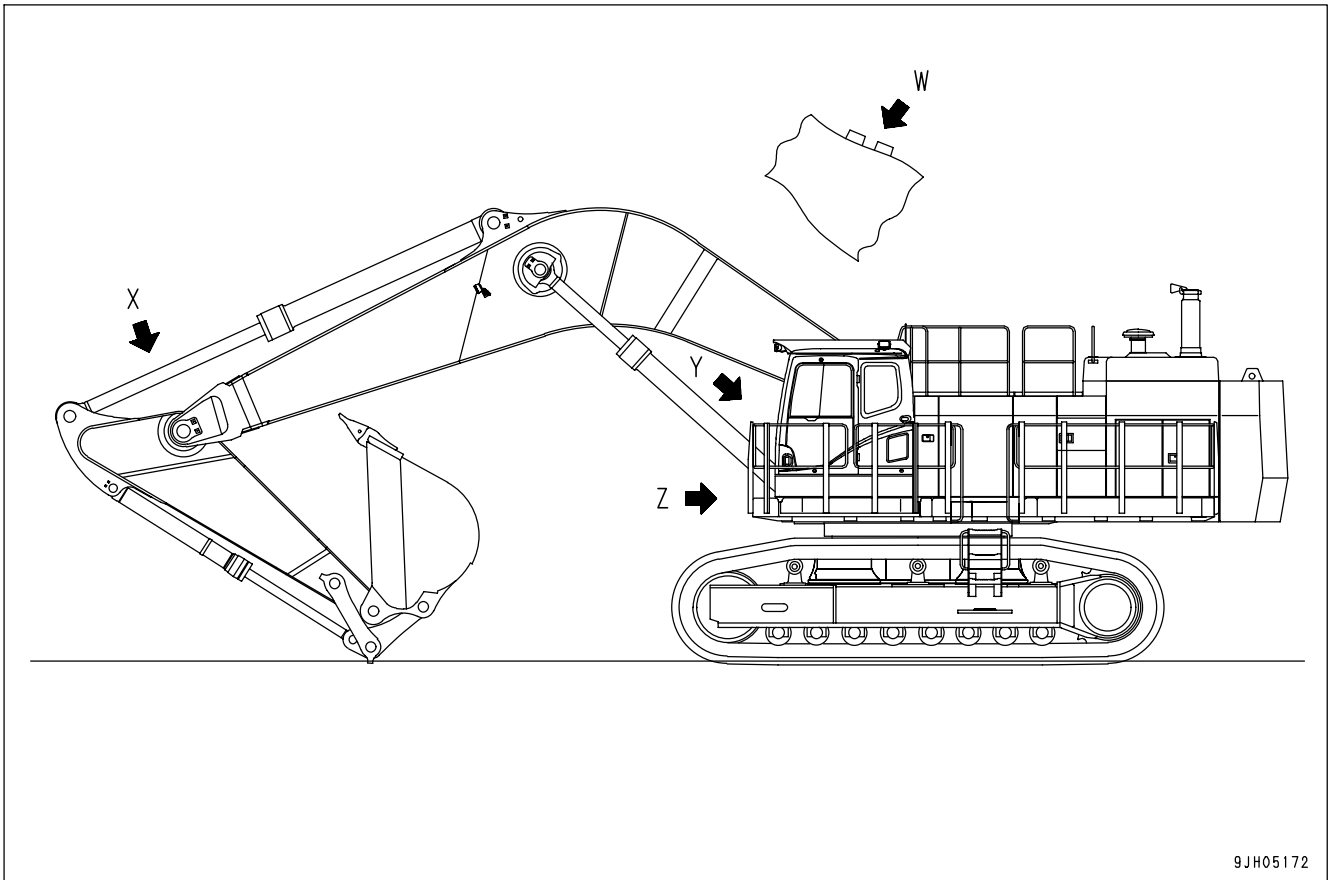

9JH05172

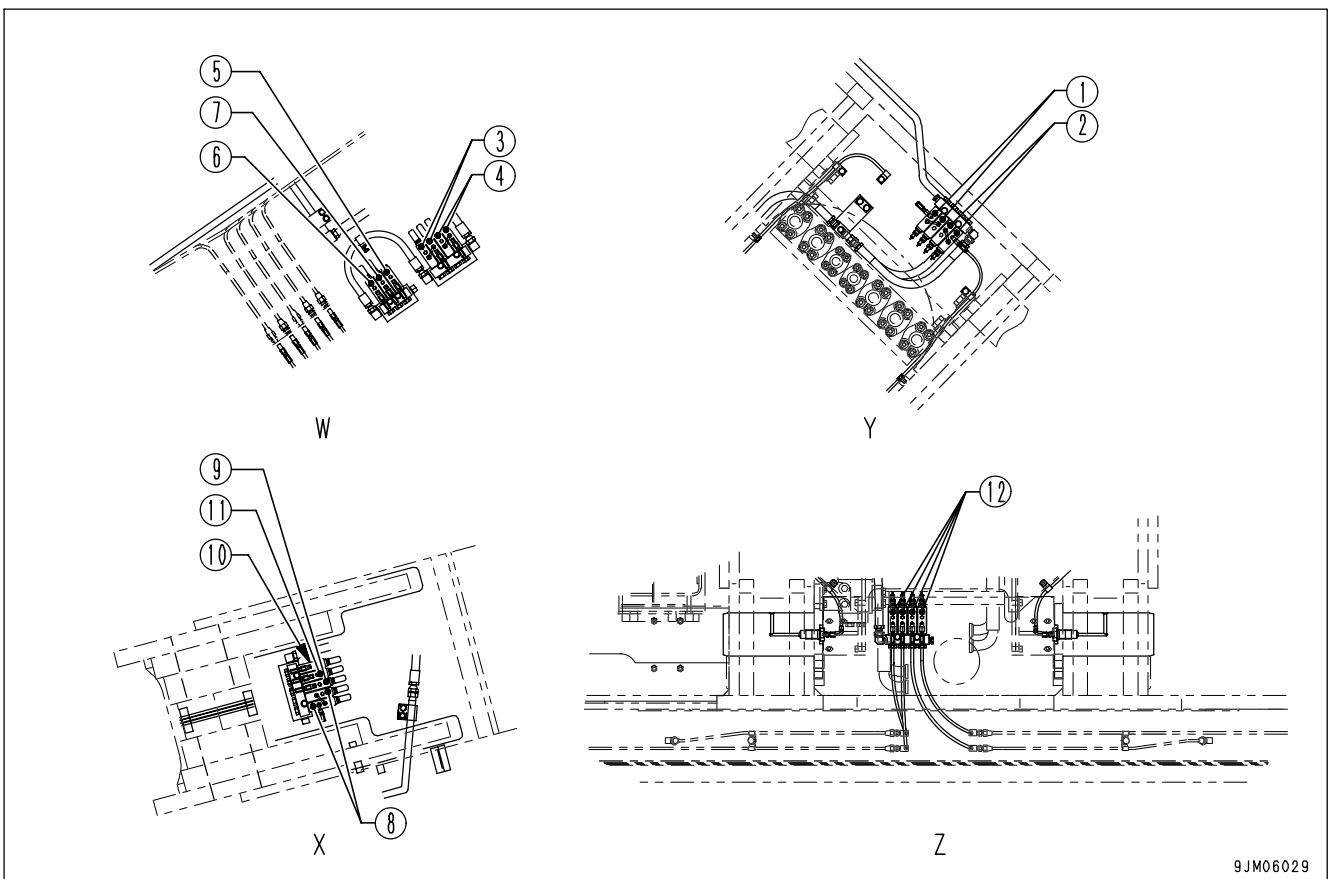

9JM06029

**EVERY 10 HOURS MAINTENANCE**

**Greasing Points not Including in Auto-greasing System**

1. Set to the greasing posture below, lower the work equipment to the ground, then stop the engine.
2. Using a grease pump, pump in grease through the grease fittings shown by arrows.
3. After greasing, wipe off any old grease that was pushed out.

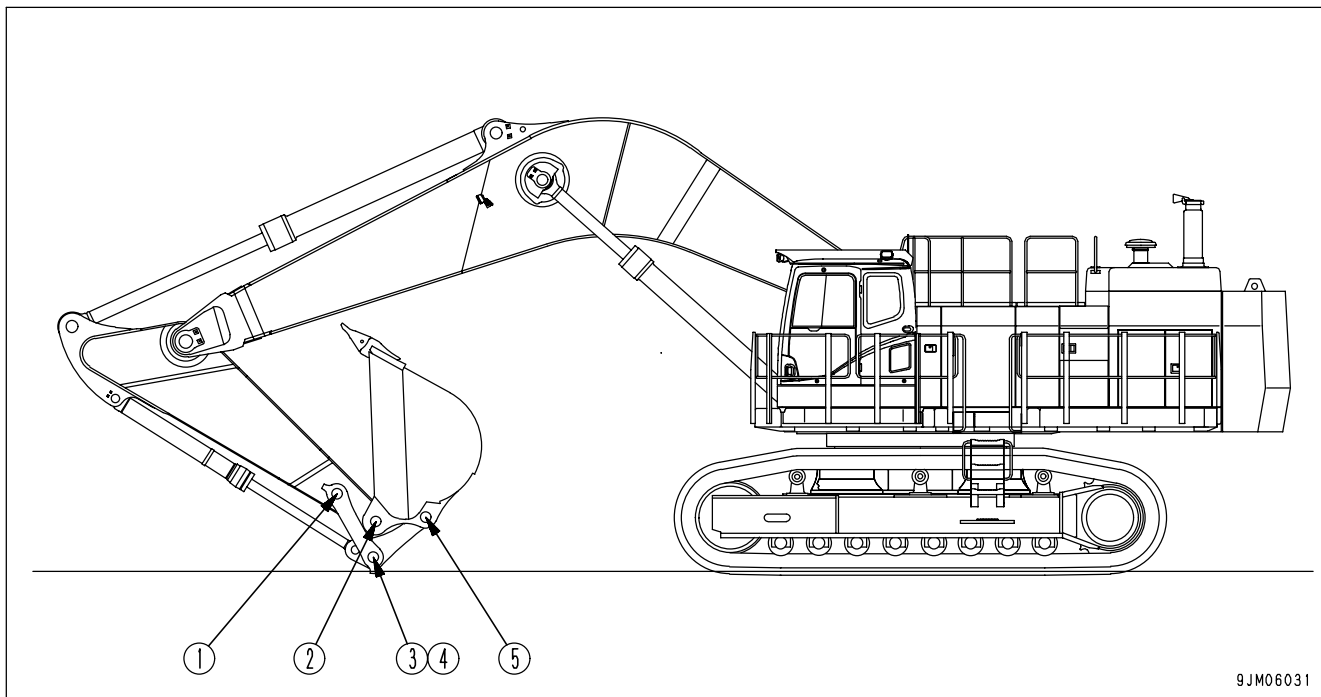

9JM06031

- (1) Arm-Link coupling pin (1 place)
- (2) Arm-Bucket coupling pin (2 places)
- (3) Link coupling pin (1 place)
- (4) Buket cylinder rod end pin (2 places)
- (5) Bucket-Link coupling pin (1 place)

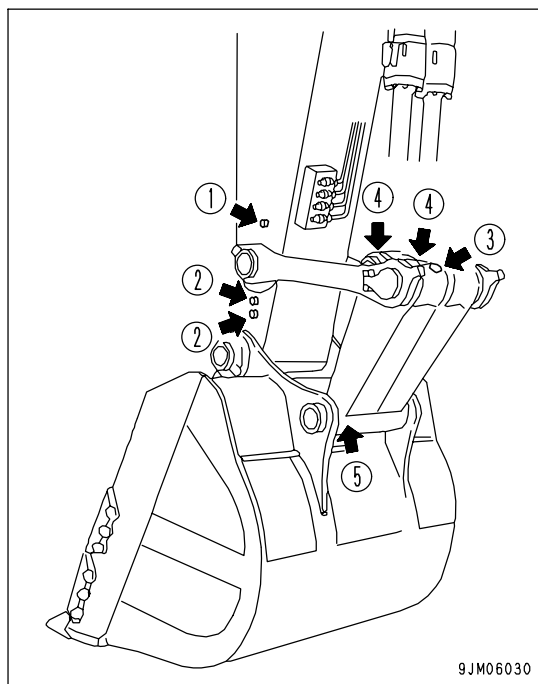

9JM06030

# LOADING SHOVEL

## **WARNING**

When using a loading shovel specification machine, the method for operation is different in some way from the standard machine. This section gives the explanation for the parts that are different.

---

## EXPLANATION OF COMPONENTS

### SWITCHES

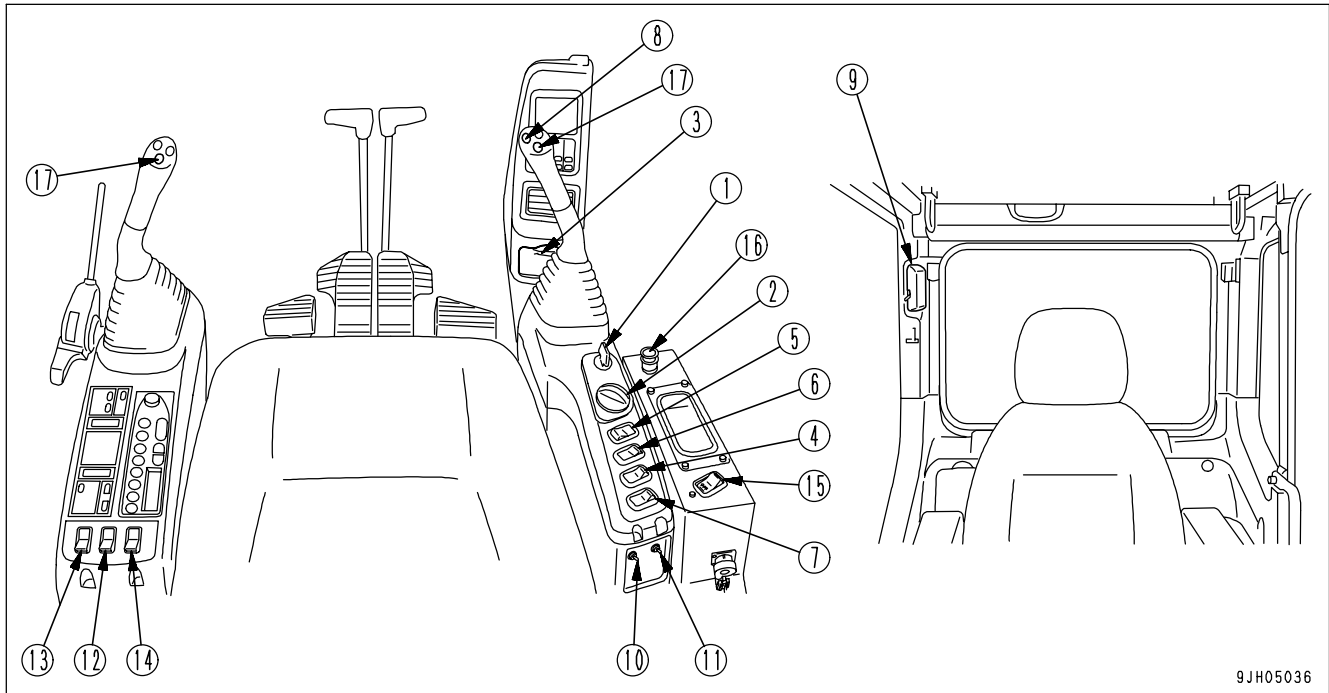

- |                                  |   |
|----------------------------------|---|
| (1) Starting switch              | (11) Swing holding brake release switch                                 |
| (2) Fuel control dial            | (12) Rotating lamp switch (if equipped)                                 |
| (3) Cigarette lighter            | (13) Lower wiper switch (machines equipped with fixed window cab)       |
| (4) Swing lock switch            | (14) Large capacity airflow air conditioner blower switch (if equipped) |
| (5) Lamp switch                  | (15) Boom shockless control switch                                      |
| (6) Alarm buzzer stops switch    | (16) Step light switch  |
| (7) Machine push-up switch       | (17) Bottom dump switch   |
| (8) Horn switch                  |   |
| (9) Room lamp switch             |   |
| (10) Emergency pump drive switch |   |

#### Starting Switch

#### Fuel Control Dial

(with Auto-deceleration System)

**Cigarette Lighter**

**Swing Lock Switch**

**Lamp Switch**

**Alarm Buzzer Stop Switch**

**Machine Push-up Switch**

**Horn Switch**

When the switch (8) at the tip of the right work equipment control lever is pressed, the horn will sound.

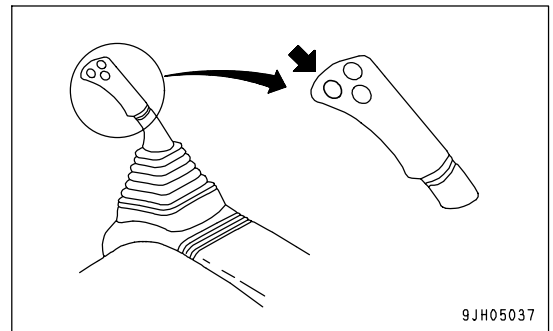

**Room Lamp Switch**

**Emergency Pump Drive Switch**

**Swing Parking Brake Release Switch**

**Rotating Lamp Switch**

**Lower Wiper Switch**

**Large Capacity Airflow Air Conditioner Blower Switch**

**Shackles Boom Control Switch**

**Step Light Switch**

**Bottom Dump Switch**

Use this switch (17) to open and close the front bucket.

If the button at the tip of the left work equipment control lever is depressed, the bucket will close.

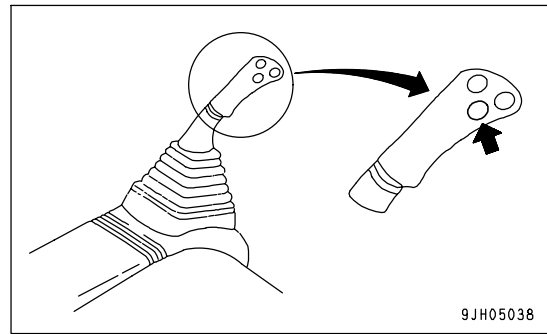

If the button at the tip of the right work equipment control lever is depressed, the front bucket will open.

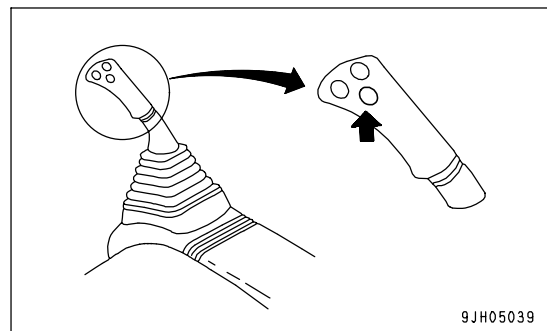

For explanation of switches (1) to (7) and (9) to (16), see "SWITCHES (PAGE 3-29)".

**FUSE****NOTICE**

Before replacing a fuse, be sure to turn off the starting switch.

**Fuse Capacities and Circuit Name**

| No.  | Fuse capacity | Name of circuit   |
|------|---------------|---|
| (1)  | 10A           | Prolix circuit  |
| (2)  | 10A           | Solenoid valve  |
| (3)  | 10A           | PPC hydraulic lock solenoid                             |
| (4)  | 20A           | Window washer, cigarette lighter                        |
| (5)  | 10A           | Horn, flash lamp light (if equipped), L/S (if equipped) |
| (6)  | 10A           | Auto-greasing system (if equipped)                      |
| (7)  | 10A           | Rotating lamp (if equipped)                             |
| (8)  | 10A           | L/S (if equipped)                                       |
| (9)  | 10A           | Radio   |
| (10) | 10A           | Spare   |
| (11) | 25A           | Air conditioner unit                                    |
| (12) | 20A           | VHMS (if equipped)                                      |
| (13) | 20A           | Spare   |
| (14) | 10A           | Optional power source (1)                               |
| (15) | 10A           | Optional power source (2), 12 V power port              |
| (16) | 10A           | Radio backup  |
| (17) | 10A           | Network pass (direct from battery)                      |
| (18) | 20A           | VHMS (direct from battery) (if equipped)                |
| (19) | 10A           | Room lamp   |
| (20) | 10A           | Step light  |

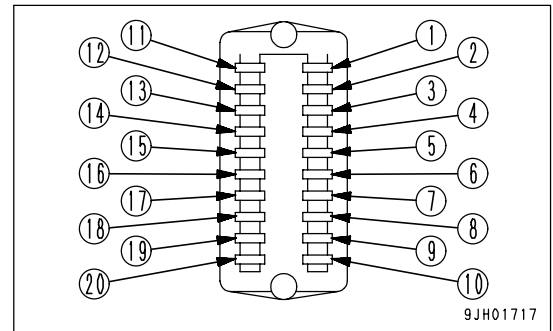



# OPERATIONS

## OPERATION OF WORK EQUIPMENT

### WARNING

- If the lever is operated in the deceleration range, the engine speed will suddenly rise. Operate the levers carefully.
- If the work equipment control levers are operated quickly, the engine speed will suddenly rise. Operate the levers carefully.

The work equipment is operated with the left work equipment control lever and right work equipment control lever. The left work equipment control lever operates the arm, swing, and bottom dump (CLOSE); the right work equipment control lever operates the boom, bucket, and bottom dump (OPEN).

The relationship between the operation of the lever and the movement of the work equipment is as shown in the diagram on the right.

When the lever is released, it returns to the HOLD position and the work equipment is held in position.

- If the work equipment control levers are returned to the neutral position when the machine is stopped, even if the fuel control dial is set to FULL, the auto-deceleration mechanism will act to reduce the engine speed to a mid-range speed.

### REMARK

If the key in the starting switch is turned ON within 15 seconds after stopping the engine, it is possible to lower the work equipment to the ground by operating the levers.

In addition, the levers can also be operated to release any remaining pressure inside the hydraulic cylinder circuit and to lower the boom after loading the machine on a trailer.

#### Arm operation

- (A): Arm OUT
- (B): Arm IN

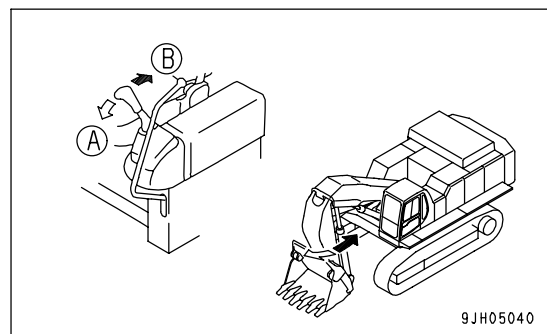

#### Swing operation

- (A): Left swing
- (B): Right swing

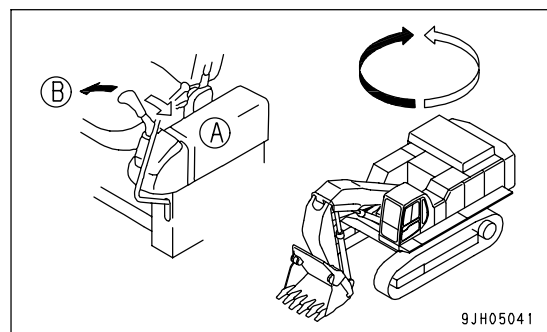

Boom operation

- (A): Boom RAISE
- (B): Boom LOWER

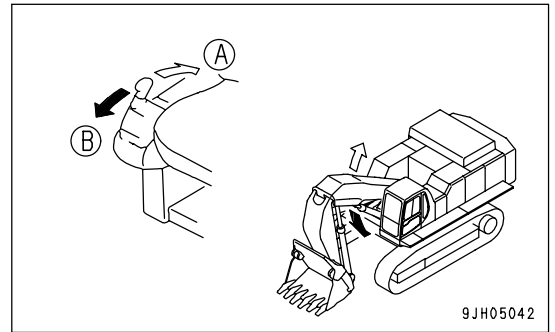

Bucket operation

- (A): Bucket DUMP
- (B): Bucket CURL

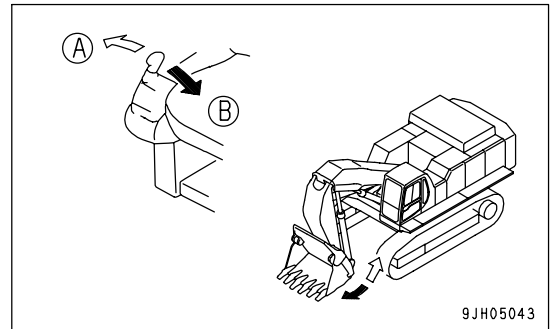

Bottom dump operation

- (A): OPEN
- (B): CLOSE

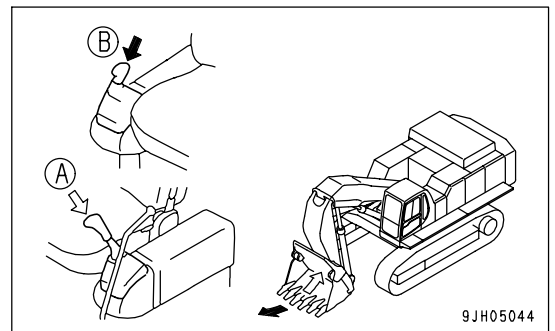

**PRECAUTIONS DURING OPERATION**

**! WARNING**

When the arm is pushed out to the front, the speed momentarily becomes slow around the vertical position of the arm.

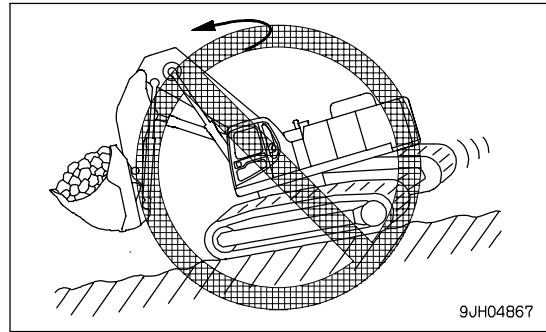

(A): Platform

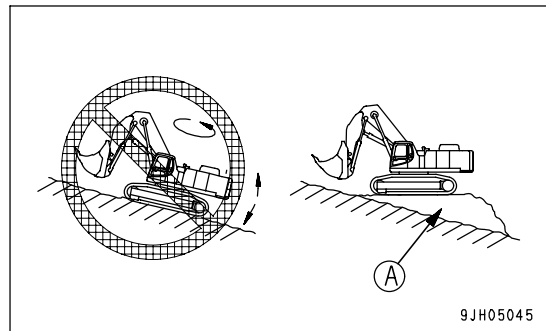

**It is Prohibited to Use the Swing Force for Operations.**  
Do not use bucket swing force to compact soil or break an earth wall, or do not dig the bucket teeth into the ground while swinging the bucket. Such a way of using the bucket can cause damage to the work equipment.

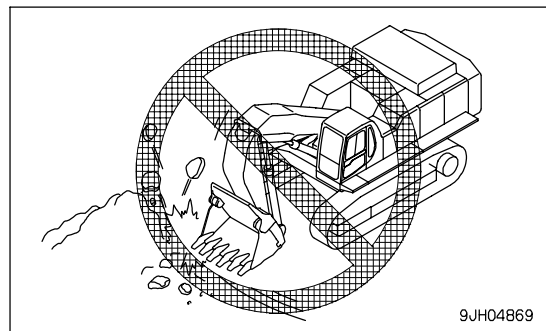

**It is Prohibited to Use the Travel Force for Operations.**  
Do not move off and excavate with the bucket left dug into the ground.

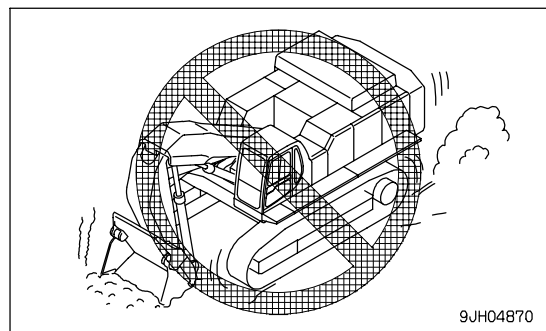

**Do not Carry Out Operations with the Hydraulic Cylinder at the End of its Stroke.**

If the cylinder is operated to the end of its stroke during operations, a large force will be brought to bear on the stopper inside the cylinder, and this will reduce the service life of the machine, so leave room (distance a) at the end of the stroke as far as possible.

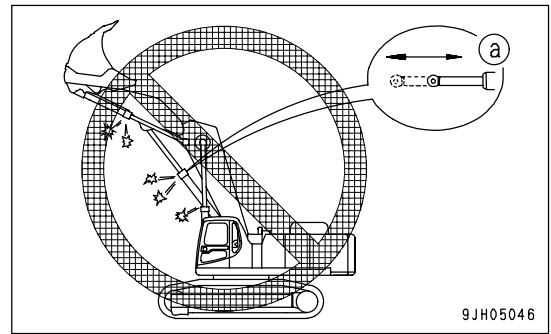
**It is Prohibited to Use the Dropping Force of the Bucket for Operations.**

Do not use the dropping force of the bucket as a pickaxe, breaker, or pile driver. This will bring excessive force to bear on the rear of the machine, and will not only damage the machine, but is also dangerous.

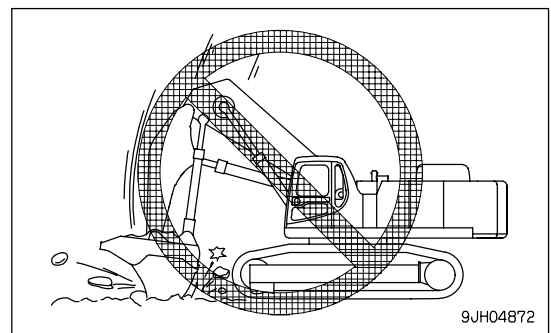
**Be Careful of Stability when Swinging.**

During swing operations, the stability of the machine differs to the front, rear, left and right, and there is danger that it may tip over.

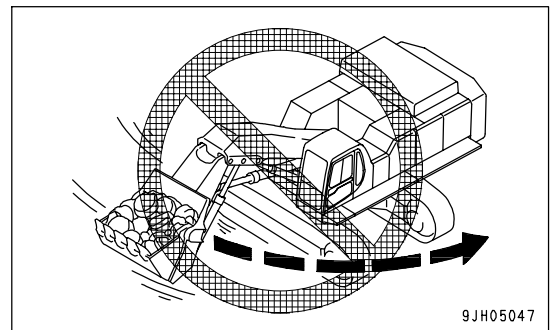
**It is Prohibited to Use the Tilt Operation for Digging.**

Do not set the teeth vertically when the bucket is pulled in, and then use the tilt operation to carry out digging.

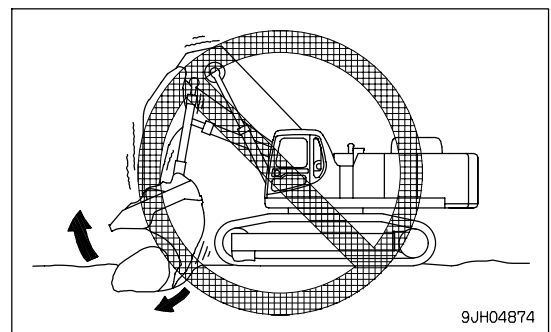

**It is Prohibited to Grip Rocks.**

Do not use the bottom dump bucket to grip rocks.

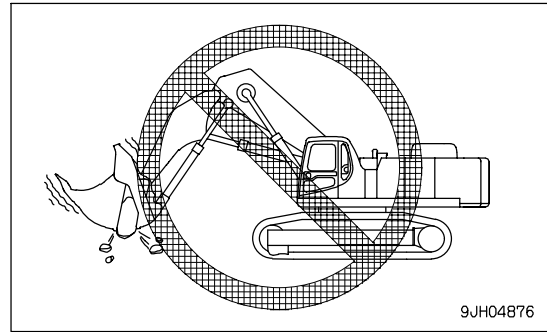

9JH04876

**It is Prohibited to Use the Bucket for Leaving Operations.**

Using the rear bucket to carry out leveling operations will bring an excessive force to bear on the work equipment, so do not use the rear bucket in this way.

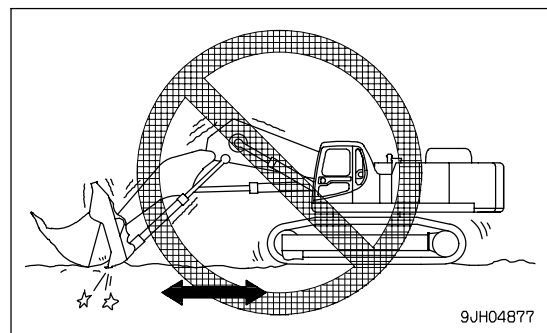

9JH04877

**Be Careful not to Spill the Load.**

When the bucket is fully loaded, do not raise the boom fully. If the boom is raised fully, the load will spill to the rear and cause danger to the operator.

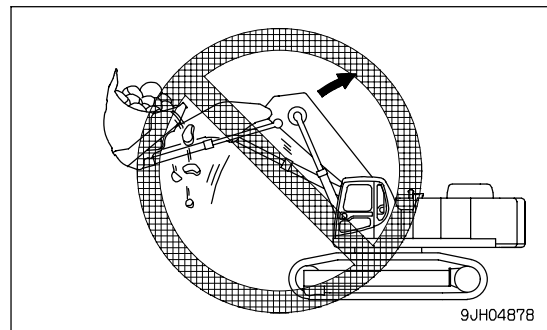

9JH04878

**Be Careful not to Hit the Undercarriage.**

If the upper structure is set diagonally to the track frame when carrying out digging operations, the work equipment will hit the track links.

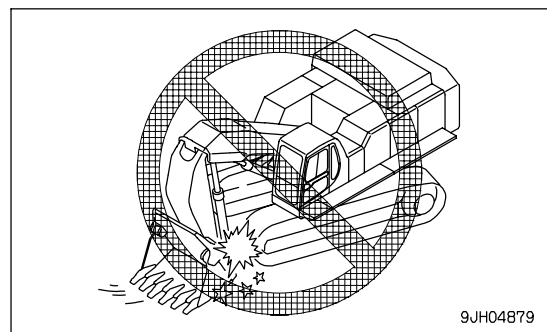

9JH04879

**Scraping-down Operations are Prohibited.**

Never use the front bucket of a bottom-dump bucket to scrap down rocks or soil.

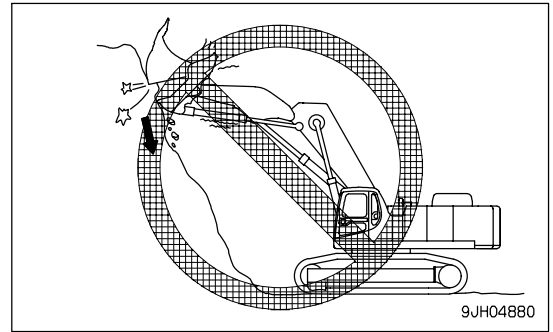
**Digging Rocky Ground**

Do not attempt to directly excavate hard rocky ground with the work equipment. It is better to excavate it after breaking up by some other means. This will not only save the machine from damage but will make for better economy.

**Phenomena that do not Indicate Failure**

Note that the following phenomena are not failures:

- When starting or stopping the swing, noise will be emitted from the brake valve.
- When going down a steep slope at low speed, a noise will be emitted from the travel motor.
- The arm may sometimes stop when the bucket teeth become more or less horizontal.

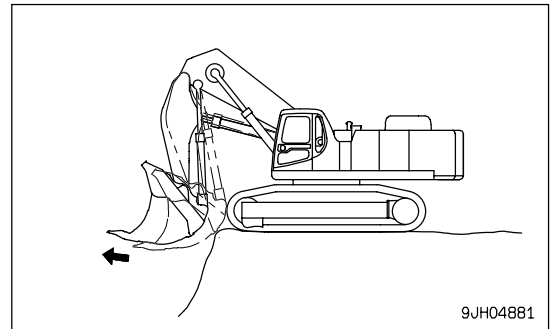

- The bottom dump of the bucket may sometimes stop at the bottom horizontal position when the bottom dump control lever changes from open to close.

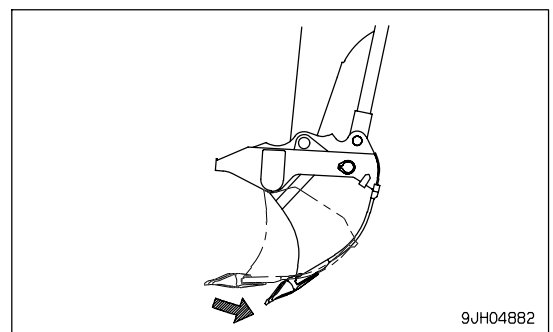

## EXCAVATOR WORK

In addition to the following, it is possible to further increase the range of applications by using various attachments.

### Shovel Work

This is suitable for digging a place which is higher than the machine's position. It is most efficient if the arm's digging angle is from vertical to 60° forward, and the arm cylinder is used effectively.

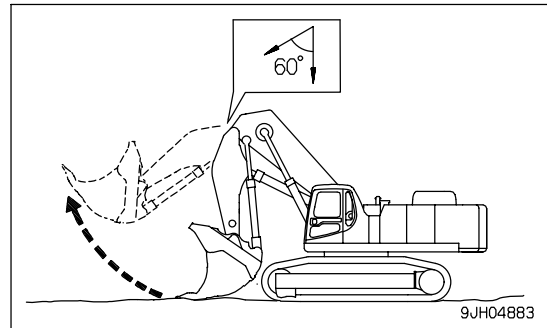

A simple method of seeing the angle of the bucket teeth to the ground surface is to use the teeth and the part of the rear bucket shown in the diagram on the right. Check that the part of the rear bucket is more or less parallel to the teeth.

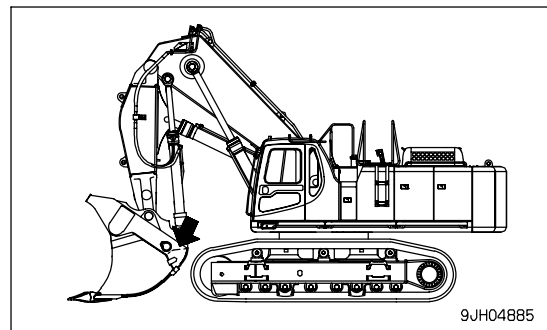

### Loading Work

In places where the swing angle is small, work efficiency can be enhanced by locating the dump truck in a place easily visible to the operator.

Loading is easier if the excavator is placed beside the dump truck for loading. This way means more earth can be loaded more effectively than by a loader working behind the truck.

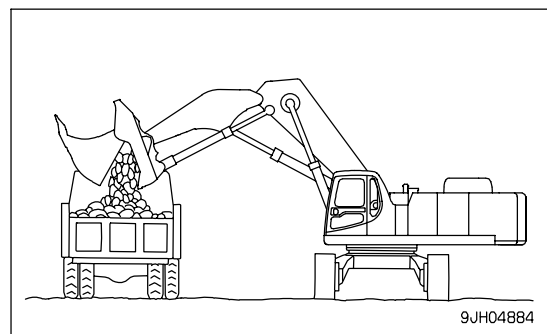

## PRECAUTIONS WHEN DISASSEMBLING MACHINE

### RELEASING PRESSURE

When disassembling the machine or removing the piping during inspection or maintenance, always release the pressure as follows.

#### Releasing Pressure from Work Equipment Circuit, Swing Circuit, Travel Circuit



### WARNING

- The hydraulic system is always under internal pressure, so when inspecting or replacing the piping or hoses, always release the pressure in the circuit before starting. If the pressure is not released, high pressure oil may spurt out and cause serious personal injury.
- The parts and oil are at high temperature after the engine is stopped, and may cause serious burns. Wait for the temperature to go down before starting the operation.
- When the oil filler cap is removed, oil may spurt out, so turn the cap slowly to release the pressure before removing the cap.

1. Stop the machine on firm horizontal ground, lower the work equipment to the ground as shown in the diagram on the right, then stop the engine.
  - Set the lock lever at the FREE position.

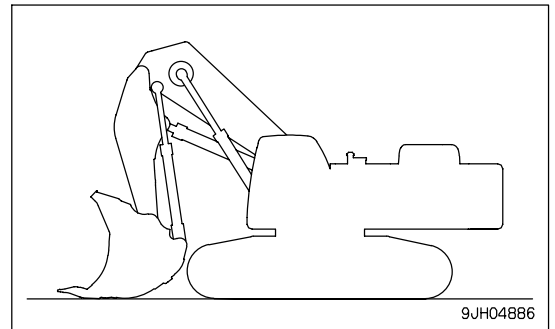

2. Operate each work equipment control lever to the full stroke within 5 - 6 seconds after stopping the engine.
  - Leave the starting switch at the ON position.
3. Remove the cap of the hydraulic tank.

4. Start the engine, run for approx. 10 seconds, then stop the engine again.
  - Do not run the engine at more than 1000 rpm.
  - Set the work equipment control levers to the HOLD position.

5. Operate each work equipment control lever to the full stroke within 5 - 6 seconds after stopping the engine.
  - Repeat Steps 4 - 5 three times.

#### Releasing Pressure in Accumulator Circuit

After stopping the engine, set lock lever (1) to the FREE position, then operate each work equipment control lever 3 - 4 times to the end of the stroke. After 1 minute, the internal pressure will be relieved.

- Do not loosen any piping until at least 1 minute has passed after relieving the internal pressure.

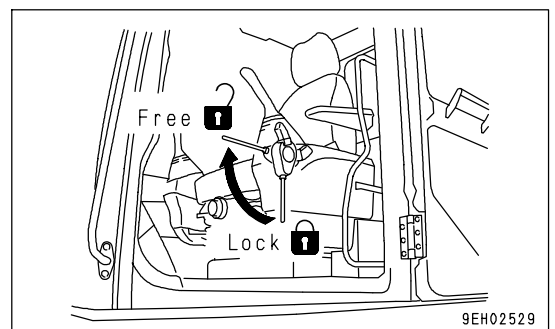



# TRANSPORTATION

## MACHINE CONFIGURATION FOR TRANSPORT

This machine can be divided into four units for transportation.

### Four Units for Transportation

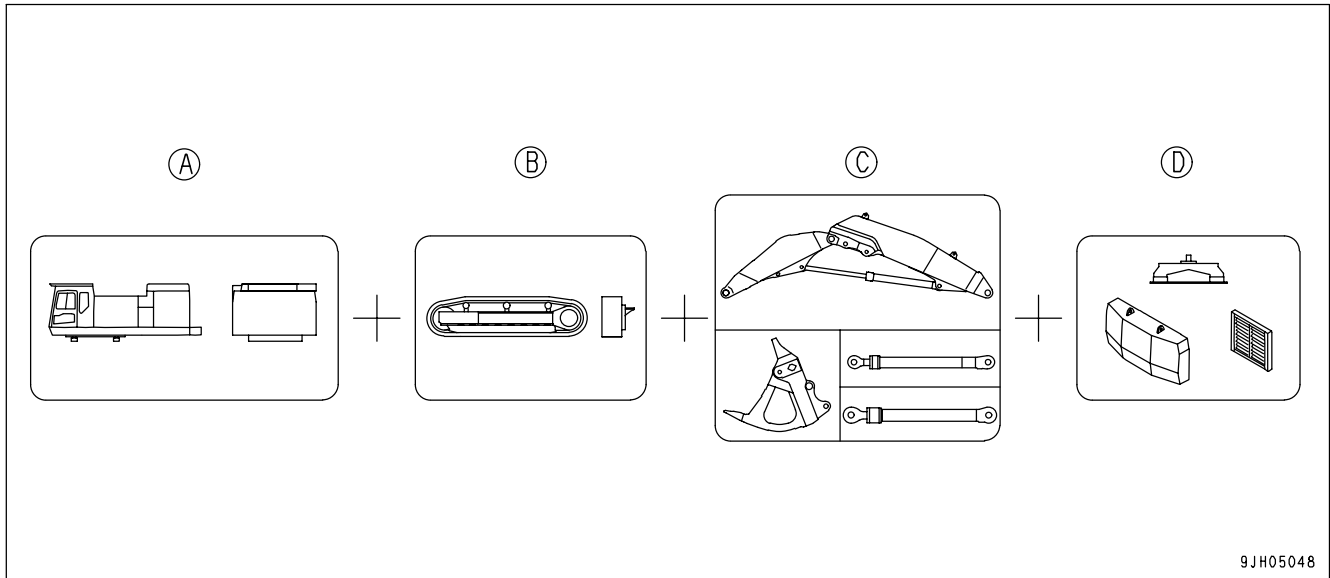

(A) Upper structure  
(B) Undercarriage

(C) Work equipment  
(D) Others

**Posture for Each unit**  
(dimensions in diagram are in mm.)

**Upper Structure**

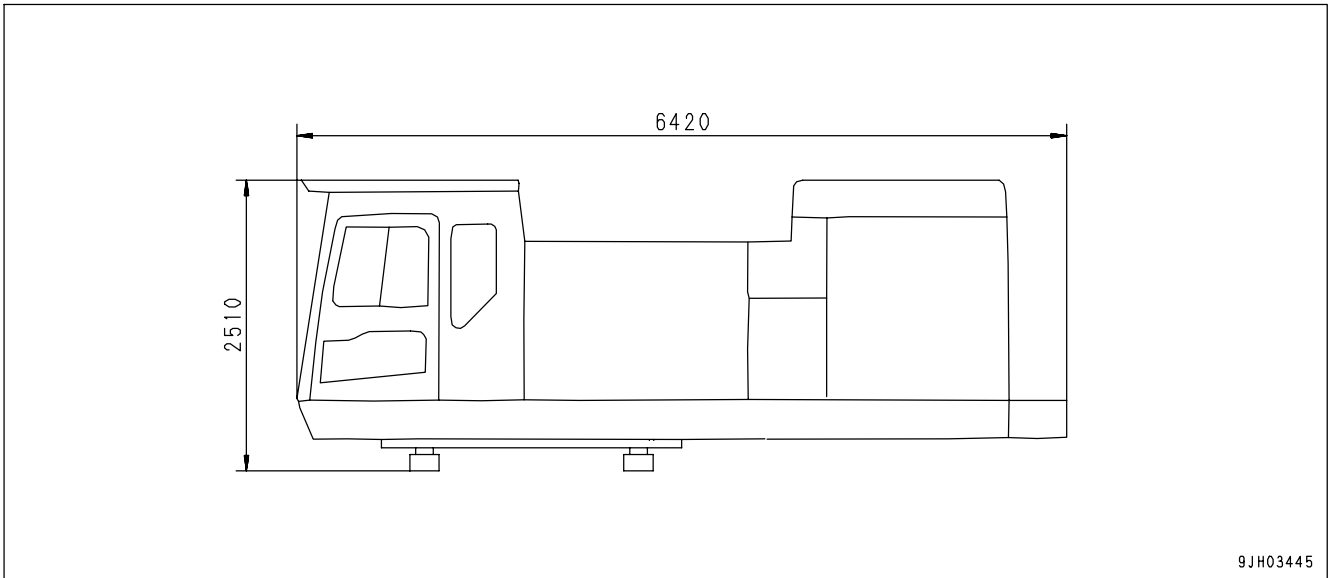

Secure the upper structure to the platform with a chain and block.

| Unit          |            | PC1250-7        |
|---------------|------------|-----------------|
| Overall width | mm (ft in) | 3490 (11'5")    |
| Weight        | kg (lb)    | 24,300 (53,582) |

**Undercarriage**

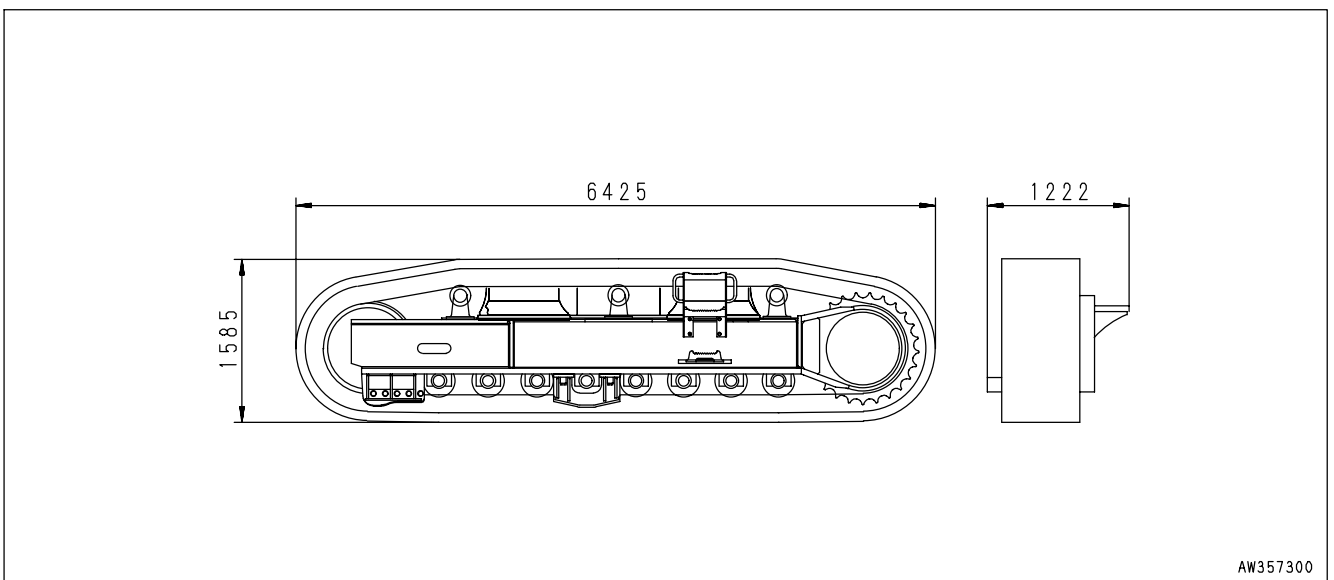

If there is a warning tag hanging on the work equipment control lever, do not start the engine.

| Unit   |         | PC1250-7  |
|--------|---------|---|
| Q'ty   | -       | 2   |
| Weight | kg (lb) | 30500 (67,253 lb)<br>(15250 X 2)<br>(33,626 lb X 2) |

**Work Equipment**

- Boom cylinder

|        |               |                                       |
|--------|---------------|---------------------------------------|
| Unit   |               | PC1250-7                              |
| A      | mm<br>(ft in) | 3520 (11'7")                          |
| Weight | kg (lb)       | 2160 (4762)<br>1080 X 2<br>(2381 X 2) |

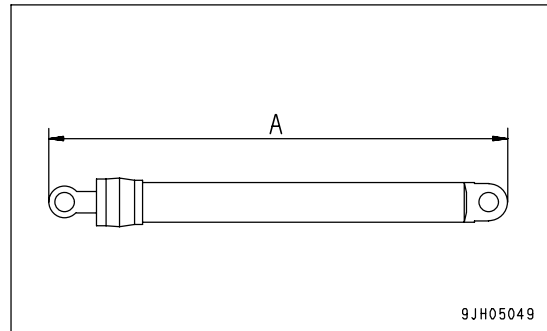

- Bucket cylinder

|        |               |                                      |
|--------|---------------|--------------------------------------|
| Unit   |               | PC1250-7                             |
| A      | mm<br>(ft in) | 3300 (10'10")                        |
| Weight | kg (lb)       | 1700 (3748)<br>850 X 2<br>(1874 X 2) |

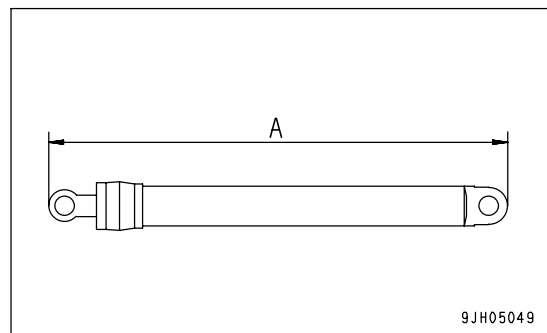

• Boom + Arm

|               |               |               |
|---------------|---------------|---------------|
| Unit          |               | PC1250-7      |
| A             | mm<br>(ft in) | 8730 (28'8")  |
| B             | mm<br>(ft in) | 2750 (9'7")   |
| Overall width | mm<br>(ft in) | 2000 (6'7")   |
| Weight        | kg (lb)       | 16000 (35275) |

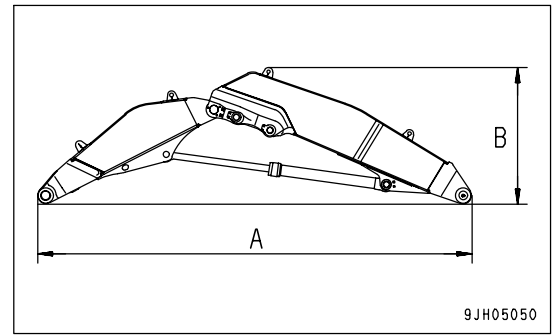

• Bucket

|               |               |              |
|---------------|---------------|--------------|
| Unit          |               | PC1250-7     |
| A             | mm<br>(ft in) | 3000 (9'11") |
| B             | mm<br>(ft in) | 2700 (8'10") |
| Overall width | mm<br>(ft in) | 2700 (8'10") |
| Weight        | kg (lb)       | 9300 (20503) |

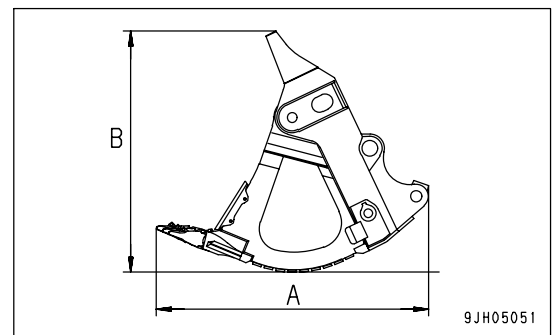

Others

- Center frame

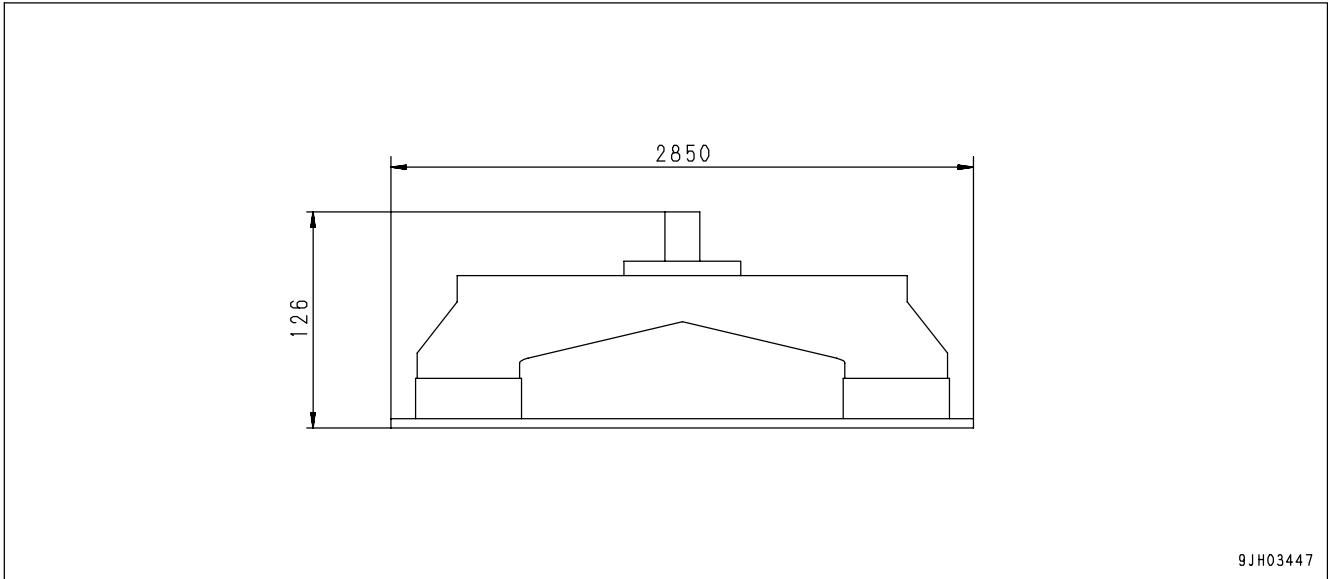

|                  |               |
|------------------|---------------|
| Unit             | PC1250-7      |
| Weight   kg (lb) | 9700 (21,389) |

- Counterweight

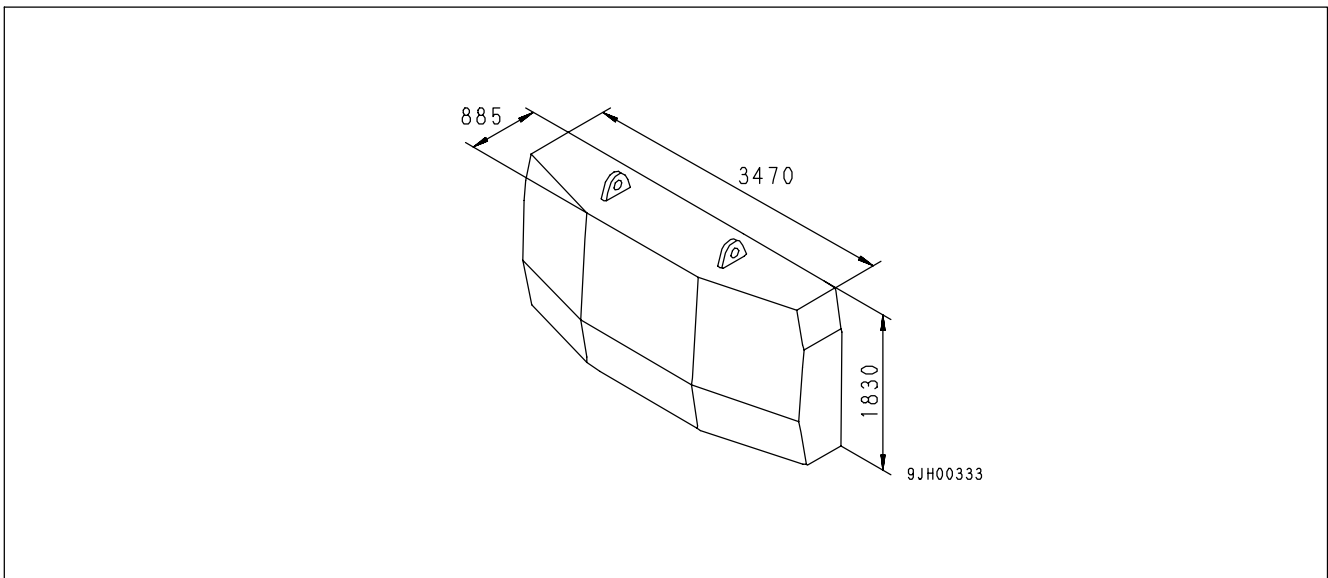

|                  |                |
|------------------|----------------|
| Unit             | PC1250-7       |
| Weight   kg (lb) | 18000 (39,690) |

- Radiator duct (same for all models)

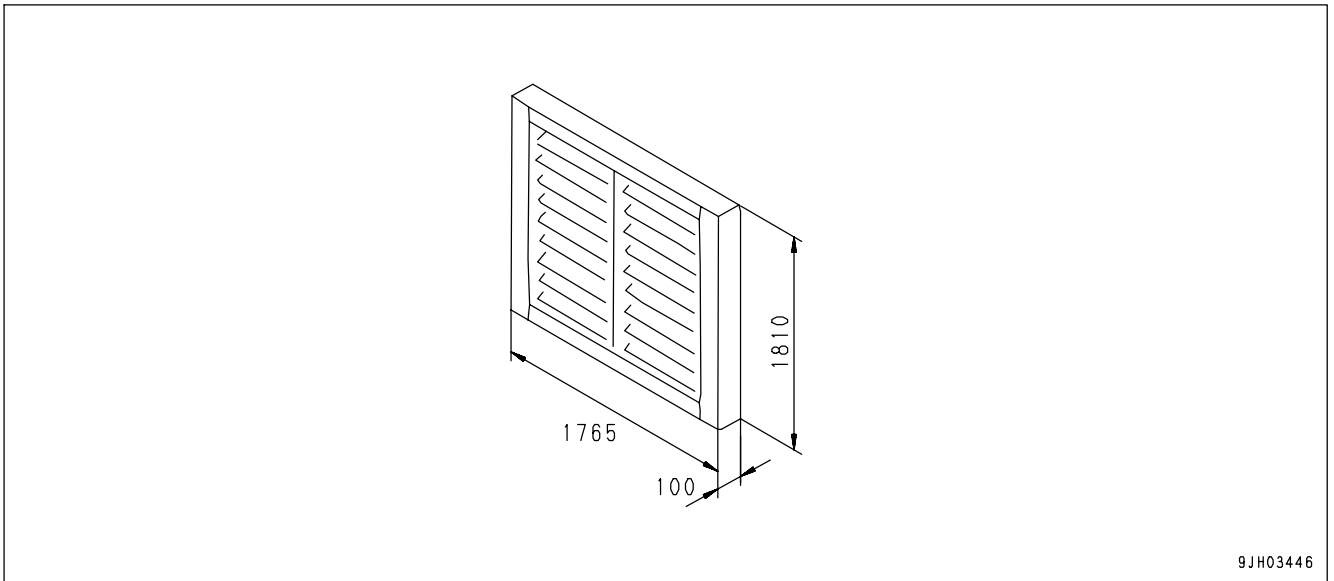

9JH03446

|                  |          |
|------------------|----------|
| Unit             | PC1250-7 |
| Weight   kg (lb) | 80 (176) |

- Catwalk (right) : (same for all models)

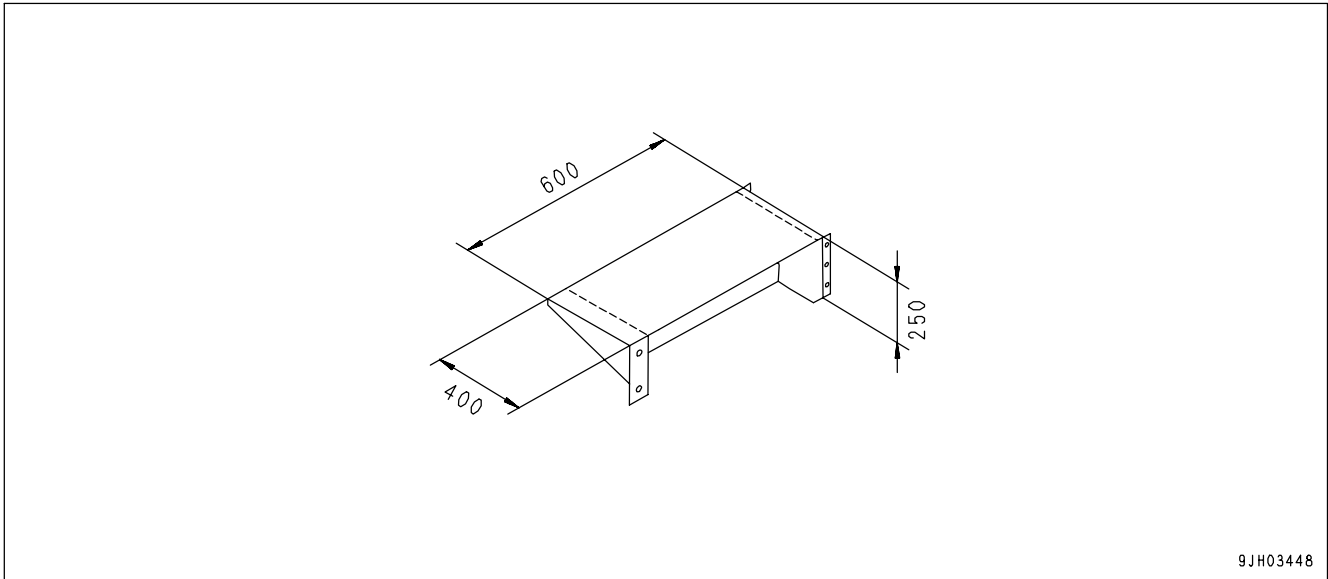

9JH03448

|                  |            |
|------------------|------------|
| Unit             | PC1250-7   |
| Weight   kg (lb) | 17 (37.49) |

- Catwalk (left, front) : (same for all models)

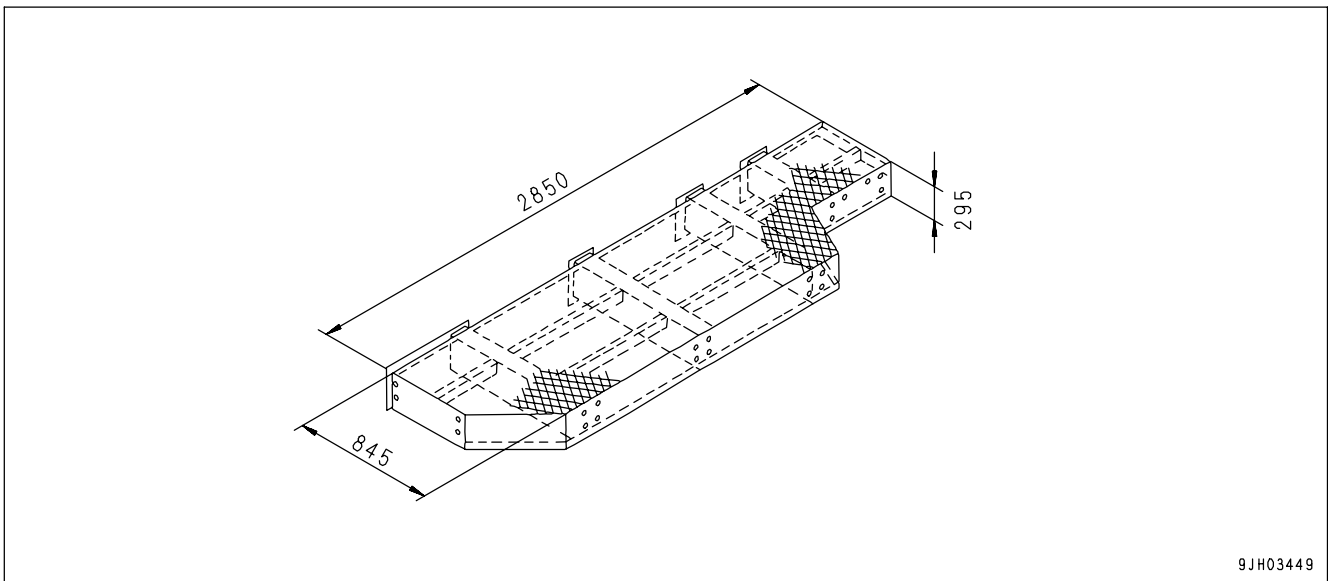

9JH03449

|                  |           |
|------------------|-----------|
| Unit             | PC1250-7  |
| Weight   kg (lb) | 150 (331) |

- Catwalk (left, rear) : (same for all models)

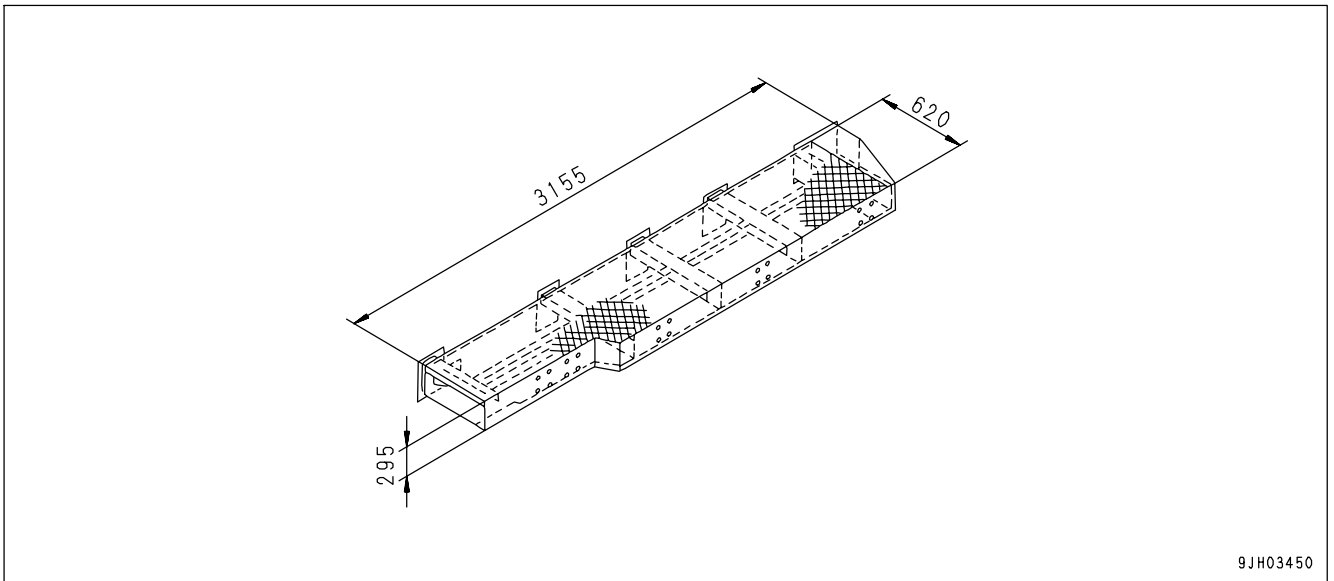

9JH03450

|                  |           |
|------------------|-----------|
| Unit             | PC1250-7  |
| Weight   kg (lb) | 160 (353) |



## WEAR PARTS

Replace wear parts such as the filter element or air cleaner element at the time of periodic maintenance or before they reach the wear limit. The wear parts should be replaced correctly in order to ensure more economic use of the machine. When replacing parts, always use Komatsu genuine parts.

As a result of our continuous efforts to improve product quality, the part number may change, so inform your Komatsu distributor of the machine serial number and check for the latest part number when ordering parts.

## WEAR PARTS LIST

The parts in parentheses are to be replaced at the same time.

| Item                    | Part No.   | Part Name  | Q'ty                   | Replacement frequency    |
|-------------------------|--|--|------------------------|--------------------------|
| Hydraulic oil filter    | 07063-51383<br>(07000-15210)                                     | Element<br>(O-ring)                              | 2<br>(2)               | Every 500 hours service  |
| Pilot filter            | 424-16-11140   | Element  | 1                      | Every 500 hours service  |
| Drain filter            | 21N-60-12210   | Cartridge  | 1                      | Every 500 hours service  |
| Engine oil filter       | 600-211-1231   | Cartridge  | 2                      | Every 500 hours service  |
| Fuel filter             | 600-311-3111   | Cartridge  | 2                      | Every 500 hours service  |
| Corrosion resistor      | 600-411-1171   | Cartridge  | 1                      | Every 1000 hours service |
| Hydraulic tank breather | 285-62-17320<br>(20Y-60-21470)                                   | Element<br>(Element)                             | 1<br>(1)               | Every 1000 hours service |
| Air cleaner             | 600-185-6100<br>(600-184-1671)                                   | Outer element assembly<br>(O-ring)               | 1<br>(1)               | -                        |
| Line filter             | 21N-62-31221<br>(07000-12055)<br>(07000-12070)<br>(07001-02070)  | Element<br>(O-ring)<br>(O-ring)<br>(Backup ring) | 3<br>(3)<br>(3)<br>(3) | -                        |
| Bucket                  | 21N-72-14290<br>(21N-72-14331)                                   | Horizontal pin type<br>Tooth<br>(Pin)            | 6<br>(6)               | -                        |
|                         | 427-70-13611<br>21N-939-3330<br>(209-939-7110)<br>(209-939-7120) | Side shroud<br>(Pin)<br>(Shim)<br>(Shim)         | 2<br>4<br>(8)<br>(4)   |                          |
|                         | 21N-72-34150<br>(21N-72-34180)                                   | Vertical pin type<br>Tooth<br>(Pin)              | 6<br>(6)               |                          |
|                         | 427-70-13611<br>21N-939-3330<br>(209-939-7110)<br>(209-939-7120) | Side shroud type<br>(Pin)<br>(Shim)<br>(Shim)    | 2<br>4<br>(8)<br>(4)   |                          |

# MAINTENANCE

## CHECK BEFORE STARTING

### Check Oil Level in Hydraulic Tank, Add Oil



## WARNING

If the oil filler cap is removed without releasing the internal pressure, oil will spurt out, so turn the oil filler cap slowly to release the internal pressure, then remove it carefully.

1. If work equipment is not in the condition shown in diagram on the right, start engine, run at low idle, retract the arm and bucket cylinders, then lower the boom, set bucket teeth in contact with the ground, and stop the engine.
2. Within 15 seconds after stopping the engine, turn starting switch to the ON position, and operate the control levers (work equipment, travel) in each direction to release the internal pressure.

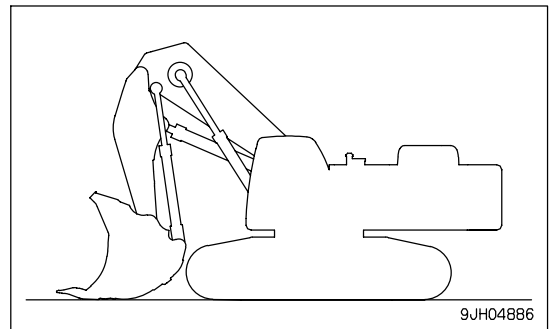

3. Check oil level gauge (G) at the rear of the hydraulic tank on the right side of the machine. The oil level should be within the specified range for that oil temperature. If the oil level is low, add oil.

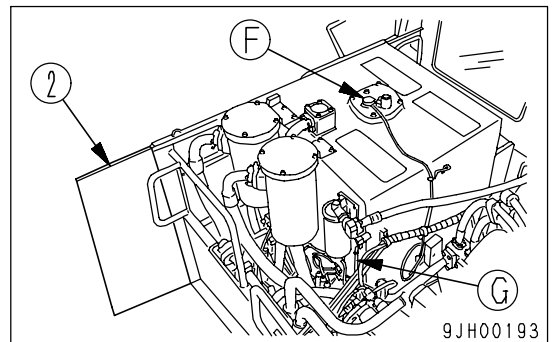

The proper way to check the hydraulic oil level is as follows.

- When the hydraulic oil is at normal temperature (15°C to 30°C), the oil level should be within the blue range of gauge label (a) in the diagram on the right.
- When the hydraulic oil is at high temperature (50°C to 80°C), the oil level should be within the red range of gauge label (b) in the diagram on the right.

4. If the level is below the correct line, add oil through filler port (F) at the top of the hydraulic tank.

### NOTICE

Do not add oil above the correct level. This may damage the hydraulic circuit and cause the oil to spurt out.

5. If oil is added to above the correct line, and drain the excess oil as follows.

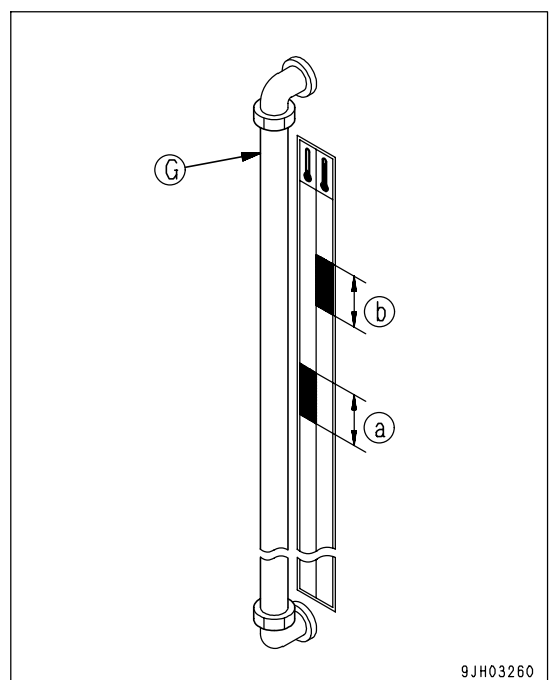



**WARNING**

If the oil is above the H level, stop the engine, wait for the hydraulic oil to cool down, then drain the excess oil from drain plug (P1). When draining the oil, loosen bottom drain plug (P1), then loosen the side drain plug (P2) and drain the oil. After draining the oil, tighten drain plugs (P1) and (P2).

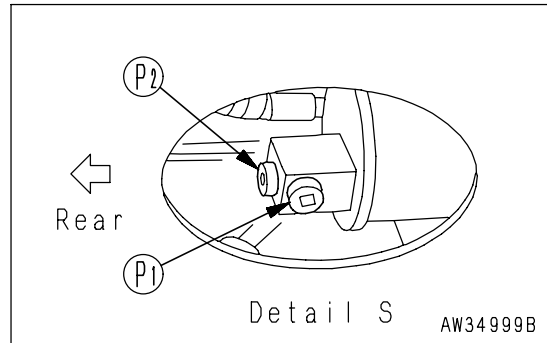
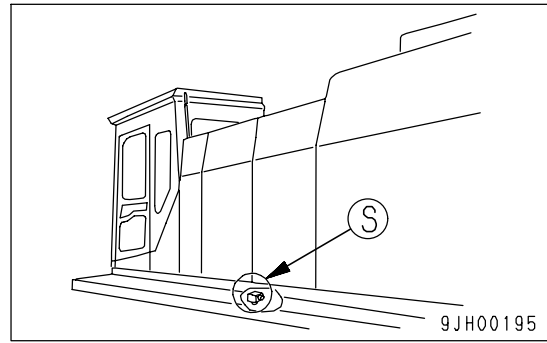

## EVERY 10 HOURS MAINTENANCE

### LUBRICATING

1. Set to the greasing posture below, lower the work equipment to the ground, then stop the engine.
2. Using a grease pump, pump in grease through the grease fittings shown by arrows.
3. After greasing, wipe off any old grease that was pushed out.

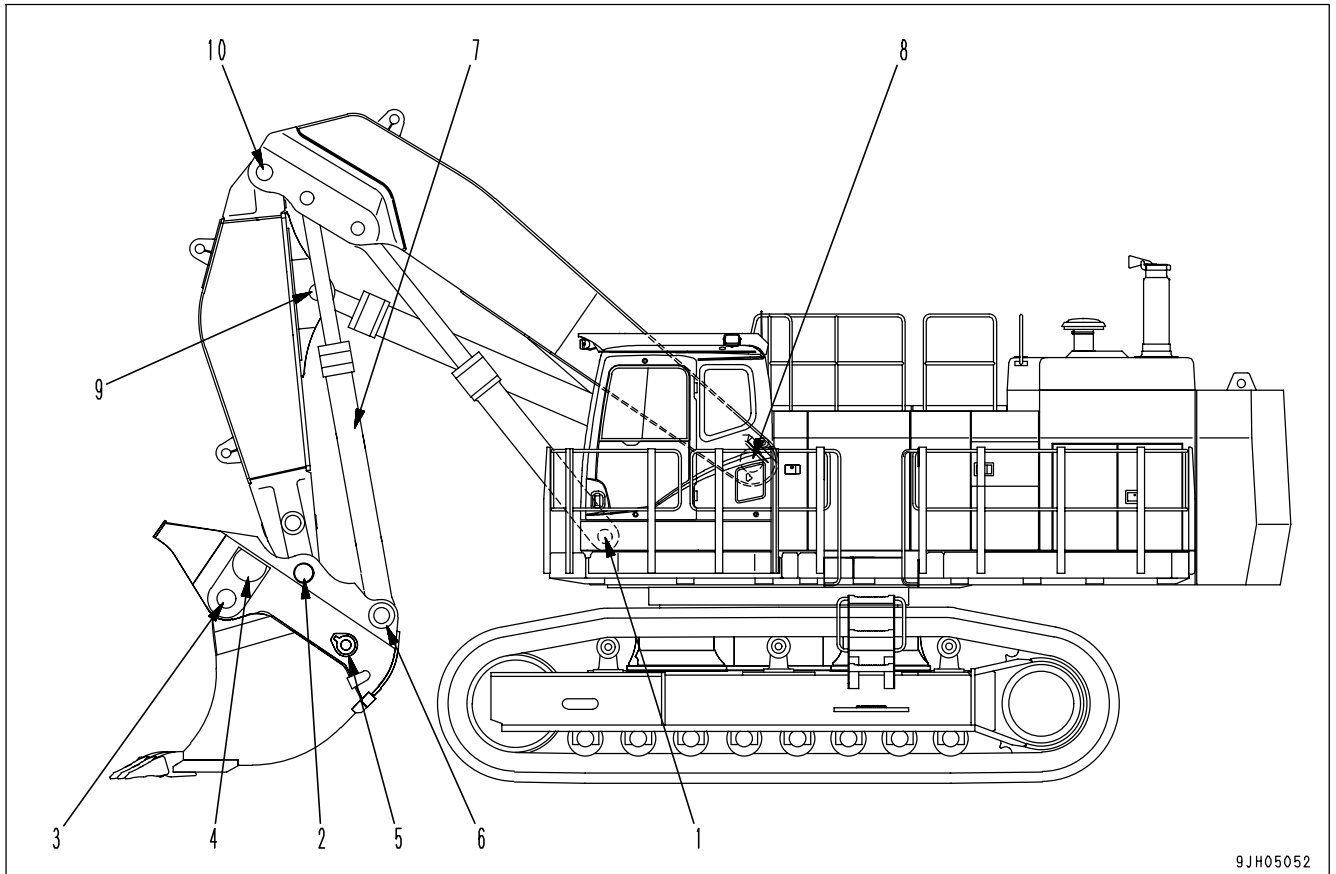

9JH05052

- (1) Boom cylinder foot pin (2 places)
- (2) Arm - Bucket coupling pin (2 place)
- (3) Bucket hinge pin (2 places)
- (4) Bottom dump cylinder rod end pin (2 places)
- (5) Bottom dump cylinder foot pin (2 places)
- (6) Bucket cylinder foot pin
- (7) Bucket cylinder rod end - Link coupling pin (4 places)
- (8) Boom centralized lubricating block (10 places)
  - Boom foot pin
  - Arm cylinder foot pin
  - Boom cylinder rod end pin
  - Bucket cylinder rod end pin
  - Boom - Arm coupling pin (Boom side)
- (9) Arm cylinder rod end pin (1 place)
- (10) Boom - Arm coupling pin (Arm side) (2 places)

### EVERY 5000 HOURS MAINTENANCE

Maintenance for every 10 hours service should be carried out at the same time.

#### CHANGE OIL IN HYDRAULIC TANK, CLEAN STRAINER

 **WARNING**

- The parts and oil are at high temperature immediately after the engine is stopped, and may cause burns. Wait for the temperature to go down before starting the work.
- When removing the oil filler cap, turn it slowly to release the internal pressure, then remove it.

- Refill capacity: 670 liters (177.01 US gal)
  - Prepare a handle for socket wrench set
1. Swing the upper structure so that the drain plug under the hydraulic tank will be between both tracks.
  2. Retract the arm and bucket cylinders, then lower the boom and put the teeth in contact with the ground.
  3. Set the safety lock lever to the LOCK position and stop the engine.

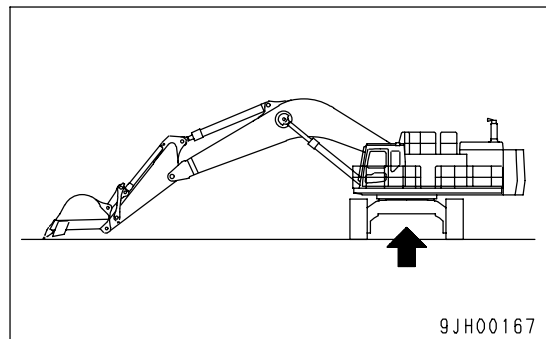

4. Remove the cap of oil filler (F) at the top of the hydraulic tank.

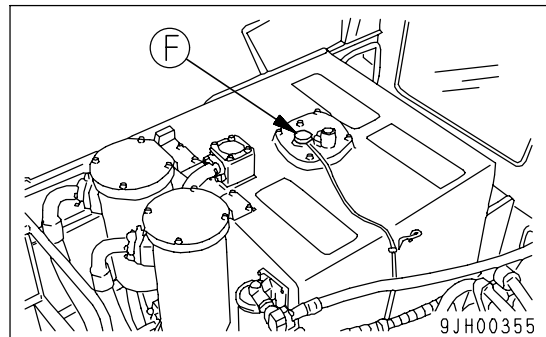

5. Set the container to catch the oil under the drain plug at the bottom of the chassis. Remove drain plug (P1), then loosen plug (P2) and drain the oil. After draining the oil, tighten drain plugs (P1) and (P2).

Tightening torque:  $70 \pm 10$  Nm ( $7 \pm 1$  kgm ,  $50 \pm 7$  lbft)

When loosening drain plug (P2) be careful not to get oil on yourself.

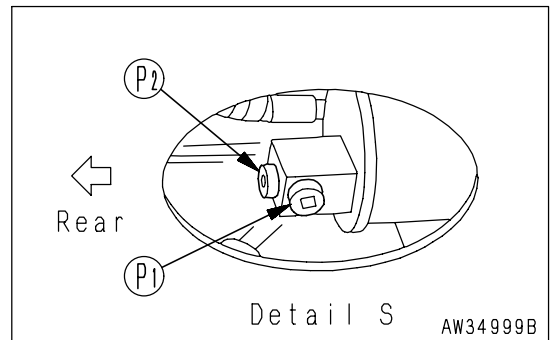
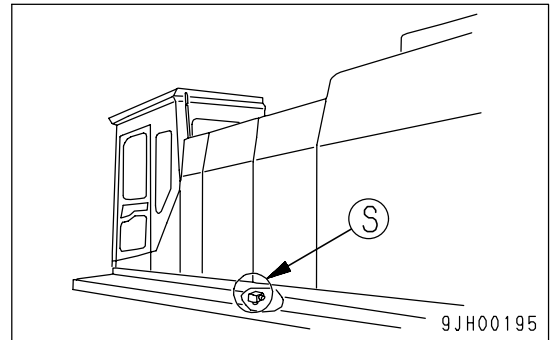

6. Remove 4 bolts, then remove cover (4). When doing this, cover (4) may fly off because of the force of spring (5), so keep the cover pushed down when removing the bolts.
7. Hold the top of rod (6) and pull up to remove spring (5) and strainer (7).
8. Remove any dirt stuck to strainer (7), then wash in clean diesel oil or flushing oil. If strainer (7) is broken, replace it with a new part.
9. When installing, insert strainer (7) into protruding part (8) of the tank, and assemble.
10. Fill with the specified amount of oil through oil filler port (F). Check that the oil level is within the correct range on the sight gauge.

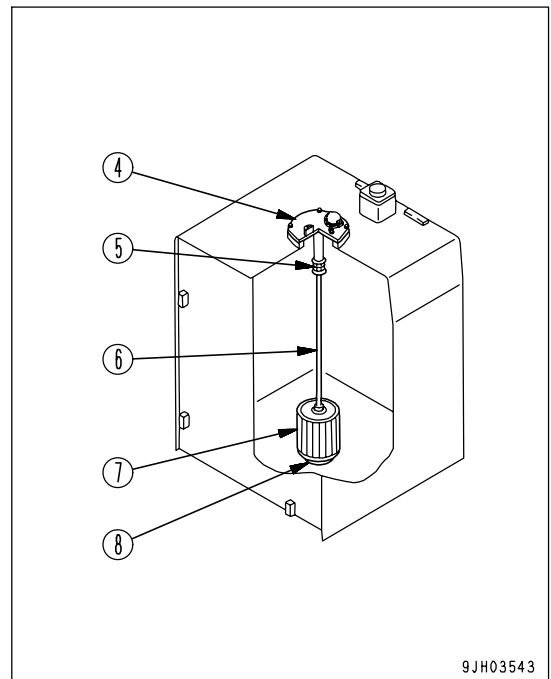

11. Bleed the air from the circuit after cleaning or replacing the filter element or strainer, or after changing the oil.

# SPECIFICATION

|   | Item                      | Unit                   | PC1250-7                        |
|---|---------------------------|------------------------|---------------------------------|
|   | Operating weight          | kg (lb)                | 110,000 (242,550)               |
|   | Bucket capacity           | m <sup>3</sup> (cu.yd) | 6.5 (8.5)                       |
|   | Name of engine            | -                      | KOMATSU SAA6D170E diesel engine |
|   | Engine horsepower         | KW(HP)/rpm             | 485 (651)/1,800                 |
| A | Overall length            | mm (ft in)             | 10,940 (35'11")                 |
| B | Overall height            | mm (ft in)             | 6,200 (20'4")                   |
| C | Overall width             | mm (ft in)             | 5,600 (18'4")                   |
| D | Track width               | mm (ft in)             | 700 (2'4")                      |
| E | Height of cab             | mm (ft in)             | 4,120 (13'6")                   |
| F | Radius of upper structure | mm (ft in)             | 4,870 (15'12")                  |
| G | Length of track           | mm (ft in)             | 6,425 (21'1")                   |
| H | Tumbler center distance   | mm (ft in)             | 4,995 (16'5")                   |
| I | Min. ground clearance     | mm (ft in)             | 990 (3'3")                      |
|   | Travel speed (Lo/Hi)      | km/h (MPH)             | 2.1/3.2 (1.3/2.0)               |
|   | Swing speed               | rpm                    | 5.5                             |

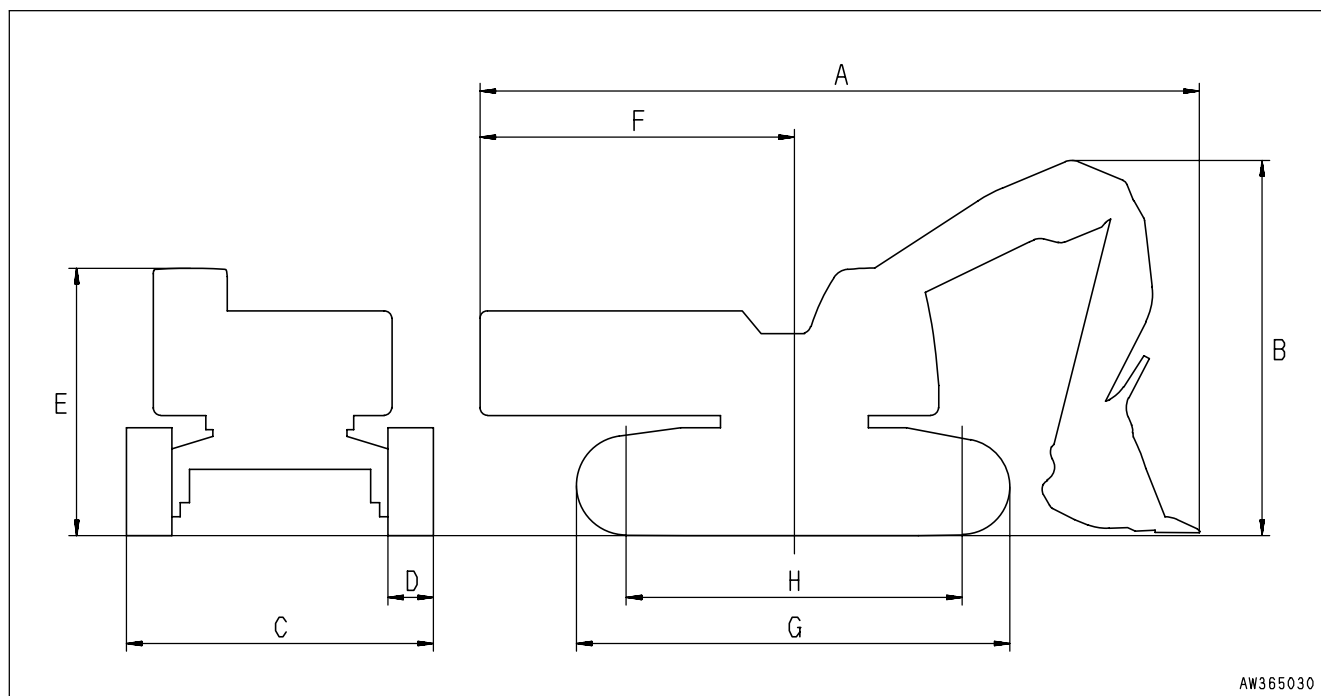

AW365030

## COMBINATION OF WORK EQUIPMENT



### WARNING

Depending on the type or combination of work equipment, there is danger that the work equipment may hit the cab or machine body.

When using unfamiliar work equipment for the first time, check before starting if there is any danger of interference, and operate with caution.

## COMBINATION OF WORK EQUIPMENT

Select the combination of boom, arm, and bucket from the combinations shown in the table below.

- For the dimensions of A to F, see the specifications shown in the working range diagram

|                   |   |     |                                |
|-------------------|---|-----|--------------------------------|
| Work<br>equipment | Boom  |     | 5.3 m (17'5")                  |
|                   | Arm   |     | 3.8 m (12'6")                  |
|                   | Bucket capacity                                     |     | 6.5 m <sup>3</sup> (8.5 cu.yd) |
|                   | Bucket width  |     | 2680 mm (8'10")                |
|                   | Loosen specific<br>gravity of soil to be<br>handled | 2.1 | ×                              |
|                   |   | 1.8 | ○                              |
| 1.5               |   | ○   |                                |



Working Range Diagram

|   | Working ranges                      | Unit       | PC1250-7 Loading shovel |
|---|-------------------------------------|------------|-------------------------|
|   |                                     |            | Without bucket link     |
| A | Max. digging radius                 | mm (ft in) | 11,400 (37'5")          |
| B | Max. digging reach at ground level  | mm (ft in) | 10,900 (35'9")          |
| C | Max. digging height                 | mm (ft in) | 12,330 (40'5")          |
| D | Max. digging depth                  | mm (ft in) | 3,650 (11'12")          |
| E | Min. digging reach at ground level  | mm (ft in) | 8,700 (28'7")           |
| F | Min. swing radius of work equipment | mm (ft in) | 4,480 (14'8")           |

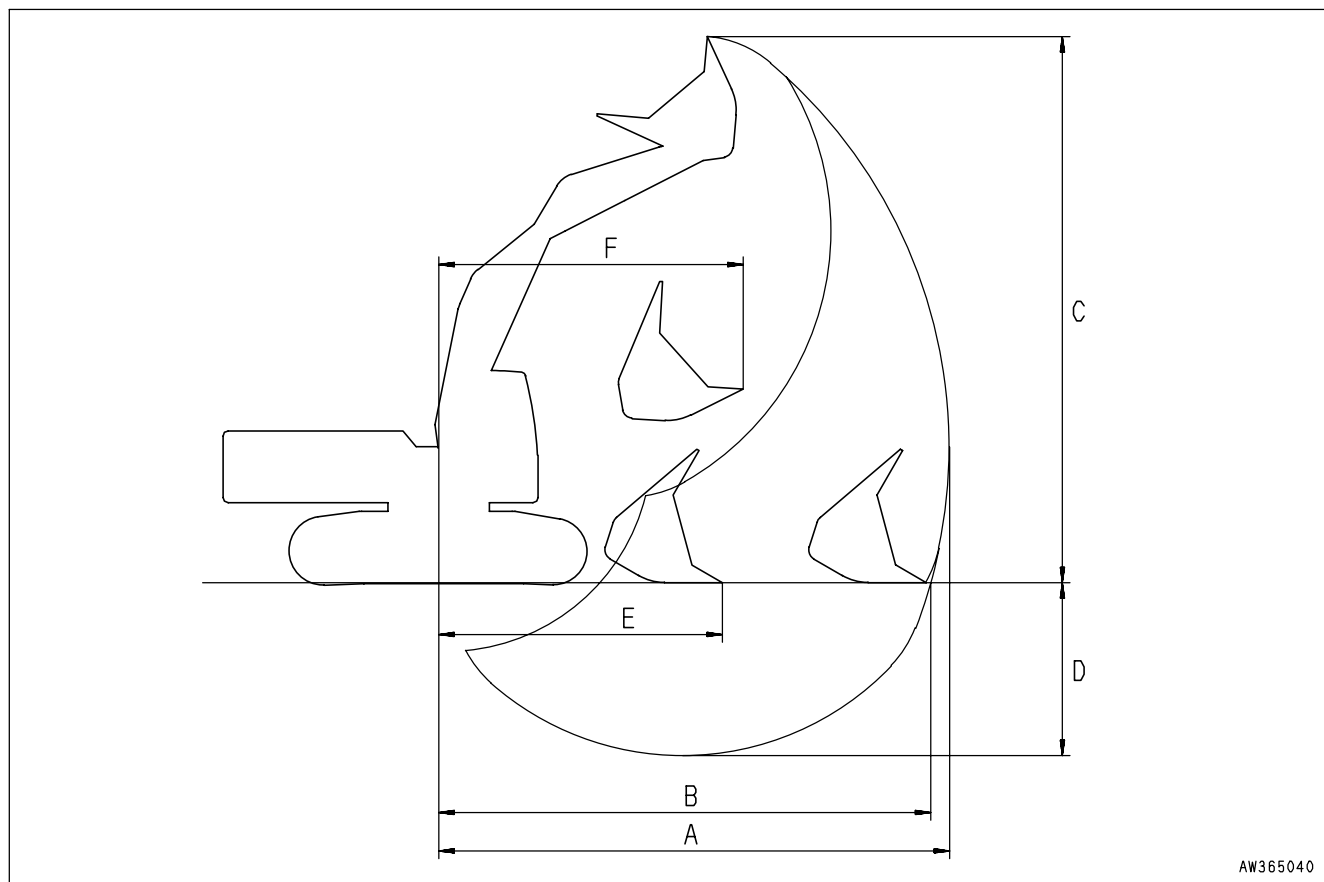

INDEX

|                                    |       |                                  |       |
|------------------------------------|-------|----------------------------------|-------|
| <A>                                |       | <F>                              |       |
| ACCUMULATOR .....                  | 3- 68 | FOREWORD .....                   | 1- 2  |
| AFTER STARTING ENGINE .....        | 3- 91 | FUSE .....                       | 3- 61 |
| AIR CONDITIONER CONTROLS .....     | 3- 41 | FUSE .....                       | 7- 5  |
| ASHTRAY .....                      | 3- 40 | <G>                              |       |
| ATTACHMENT GUIDE .....             | 6- 3  | GENERAL OPERATION                |       |
| AUTO-GREASING SYSTEM .....         | 6- 8  | INFORMATION .....                | 3-111 |
| AUXILIARY ELECTRIC POWER .....     | 3- 60 | GENERAL PRECAUTIONS .....        | 2- 12 |
| <B>                                |       | GENERAL PRECAUTIONS FOR          |       |
| BEFORE STARTING ENGINE .....       | 3- 69 | SAFETY .....                     | 6- 2  |
| BREAKING-IN THE NEW MACHINE .....  | 1- 7  | PRECAUTIONS WHEN REMOVING        |       |
| BUCKET REPLACEMENT .....           | 3-117 | OR INSTALLING .....              | 6- 2  |
| <C>                                |       | PRECAUTIONS WHEN SELECTING ..... | 6- 2  |
| CAP WITH LOCK .....                | 3- 38 | PRECAUTIONS WHEN USING .....     | 6- 2  |
| CHECK AFTER SHUT OFF ENGINE .....  | 3-121 | READ THE INSTRUCTION MANUAL      |       |
| CIRCUIT BREAKER .....              | 3- 62 | THOROUGHLY .....                 | 6- 2  |
| COLD WEATHER OPERATION .....       | 3-131 | GREASE PUMP .....                | 3- 65 |
| AFTER COLD WEATHER SEASON .....    | 3-133 | <H>                              |       |
| AFTER DAILY WORK COMPLETION .....  | 3-133 | HANDLING OIL, FUEL, COOLANT, AND |       |
| COLD WEATHER OPERATION             |       | PERFORMING OIL CLINIC .....      | 4- 4  |
| INFORMATION .....                  | 3-131 | HOT AND COOL BOX .....           | 3- 40 |
| COMBINATION OF WORK                |       | <I>                              |       |
| EQUIPMENT .....                    | 7- 29 | INTRODUCTION .....               | 1- 7  |
| COMBINATION OF WORK                |       | <L>                              |       |
| EQUIPMENT .....                    | 7- 29 | LIFTING MACHINE .....            | 3-122 |
| CONTROL LEVERS AND PEDALS .....    | 3- 35 | LOCKING .....                    | 3-121 |
| CONTROLLER .....                   | 3- 64 | LONG TERM STORAGE .....          | 3-134 |
| CONTROLS AND GAUGES .....          | 3- 3  | AFTER STORAGE .....              | 3-134 |
| <D>                                |       | BEFORE STORAGE .....             | 3-134 |
| DETAILED CONTROLS AND GAUGES ..... | 3- 5  | DURING STORAGE .....             | 3-134 |
| DIRECTIONS OF MACHINE .....        | 1- 7  | STARTING MACHINE AFTER           |       |
| DOOR LOCK .....                    | 3- 37 | LONG-TERM STORAGE .....          | 3-135 |
| <E>                                |       | LUBRICANTS, FUEL AND COOLANT     |       |
| ELECTRIC SYSTEM MAINTENANCE .....  | 4- 8  | SPECIFICATIONS .....             | 4- 10 |
| EMERGENCY EXIT FROM                |       | <M>                              |       |
| OPERATOR'S CAB .....               | 3- 37 | MACHINE INSPECTION AFTER DAILY   |       |
| ENGINE SERIAL NUMBER PLATE AND     |       | WORK .....                       | 3-121 |
| ITS LOCATION .....                 | 1- 8  | MACHINE OPERATION .....          | 3-100 |
| ESCAPE FROM MUD .....              | 3-115 | MACHINE OPERATIONS AND           |       |
| EXCAVATOR WORK .....               | 7- 12 | CONTROLS .....                   | 3- 69 |
| EXPLANATION OF COMPONENTS .....    | 7- 2  | MACHINE SERIAL NUMBER PLATE      |       |
|                                    |       | AND ITS LOCATION .....           | 1- 8  |

|                                   |       |                                    |       |
|-----------------------------------|-------|------------------------------------|-------|
| MACHINE VIEW ILLUSTRATIONS -----  | 3- 2  | DISASSEMBLING MACHINE -----        | 7- 13 |
| OVERALL MACHINE VIEW -----        | 3- 2  | RELEASING PRESSURE -----           | 7- 13 |
| MAGAZINE BOX -----                | 3- 40 | PRODUCT INFORMATION -----          | 1- 8  |
| MAINTENANCE -----                 | 7- 23 | PROHIBITED OPERATIONS -----        | 3-109 |
| CHECK BEFORE STARTING -----       | 7- 23 |                                    |       |
| EVERY 10 HOURS                    |       | <R>                                |       |
| MAINTENANCE -----                 | 7- 25 | RADIO -----                        | 3- 56 |
| EVERY 5000 HOURS                  |       | RECOMMENDED APPLICATIONS -----     | 3-116 |
| MAINTENANCE -----                 | 7- 26 |                                    |       |
| MAINTENANCE INFORMATION -----     | 4- 2  | <S>                                |       |
| MAINTENANCE PROCEDURE -----       | 4- 18 | SAFETY -----                       | 2- 2  |
| CHECK BEFORE STARTING -----       | 4- 42 | SAFETY CRITICAL PARTS -----        | 4- 15 |
| EVERY 10 HOURS                    |       | SAFETY CRITICAL PARTS LIST -----   | 4- 15 |
| MAINTENANCE -----                 | 4- 43 | SAFETY INFORMATION -----           | 1- 5  |
| EVERY 100 HOURS                   |       | SAFETY LABELS -----                | 2- 4  |
| MAINTENANCE -----                 | 4- 45 | SAFETY MACHINE OPERATION -----     | 2- 20 |
| EVERY 1000 HOURS                  |       | BATTERY -----                      | 2- 29 |
| MAINTENANCE -----                 | 4- 69 | OPERATION -----                    | 2- 22 |
| EVERY 2000 HOURS                  |       | TOWING -----                       | 2- 31 |
| MAINTENANCE -----                 | 4- 78 | TRANSPORTATION -----               | 2- 28 |
| EVERY 250 HOURS                   |       | SAFETY MAINTENANCE                 |       |
| MAINTENANCE -----                 | 4- 46 | INFORMATION -----                  | 2- 32 |
| EVERY 4000 HOURS                  |       | SERVICE METER LOCATION -----       | 1- 9  |
| MAINTENANCE -----                 | 4- 80 | SHIPPING MACHINE INFORMATION ----- | 3-123 |
| EVERY 500 HOURS                   |       | SPECIFICATION -----                | 7- 28 |
| MAINTENANCE -----                 | 4- 54 | STARTING ENGINE -----              | 3- 87 |
| EVERY 5000 HOURS                  |       | STEERING THE MACHINE -----         | 3-104 |
| MAINTENANCE -----                 | 4- 81 | STOPPING THE ENGINE -----          | 3- 99 |
| INITIAL 100 HOURS MAINTENANCE     |       | SWINGING -----                     | 3-106 |
| (ONLY AFTER THE FIRST 100         |       | SWITCHES -----                     | 3- 29 |
| HOURS) -----                      | 4- 18 | SWITCHES -----                     | 7- 2  |
| INITIAL 500 HOURS MAINTENANCE     |       |                                    |       |
| (ONLY AFTER THE FIRST 500         |       | <T>                                |       |
| HOURS) -----                      | 4- 18 | TIGHTENING TORQUE LIST -----       | 4- 14 |
| WHEN REQUIRED -----               | 4- 19 | TIGHTENING TORQUE                  |       |
| MAINTENANCE SCHEDULE -----        | 4- 16 | SPECIFICATIONS -----               | 4- 14 |
| MAINTENANCE SCHEDULE CHART ----   | 4- 16 | TOOL BOX -----                     | 3- 64 |
| MONITORING SYSTEM -----           | 3- 5  | TRANSPORTATION -----               | 3-122 |
|                                   |       | TRANSPORTATION -----               | 7- 14 |
| <O>                               |       | MACHINE CONFIGURATION FOR          |       |
| OPERATION OF WORK EQUIPMENT ----- | 7- 6  | TRANSPORT -----                    | 7- 14 |
| OPERATIONS -----                  | 7- 6  | TRANSPORTATION POSTURE -----       | 3-124 |
| OUTLINE OF SERVICE -----          | 4- 4  | TRAVELING ON SLOPES -----          | 3-113 |
|                                   |       | TROUBLES AND ACTIONS -----         | 3-136 |
| <P>                               |       | DISCHARGED BATTERY -----           | 3-138 |
| PARKING MACHINE -----             | 3-119 | OTHER TROUBLE -----                | 3-142 |
| PRECAUTIONS DURING OPERATION ---- | 7- 8  | PHENOMENA THAT ARE NOT             |       |
| PRECAUTIONS FOR                   |       | FAILURES -----                     | 3-136 |
| TRANSPORTATION -----              | 3-122 | RUNNING OUT OF FUEL -----          | 3-136 |
| PRECAUTIONS WHEN                  |       | SEVERE JOB CONDITION -----         | 3-137 |

## INDEX

---

TOWING THE MACHINE ----- 3-137

### <W>

WEAR PARTS ----- 4- 9

WEAR PARTS ----- 7- 22

WEAR PARTS LIST ----- 4- 9

WEAR PARTS LIST ----- 7- 22

WORK EQUIPMENT CONTROLS AND  
OPERATIONS ----- 3-107

WORKING MODE ----- 3-108

### <Y>

YOUR MACHINE SERIAL NUMBERS  
AND DISTRIBUTOR ----- 1- 10

PC1250-7, PC1250SP-7, PC1250LC-7 HYDRAULIC EXCAVATOR

---

Form No. TEN00291-00

©2008 KOMATSU  
All Rights Reserved  
Printed in Japan 02-08

---