

Operation & Maintenance Manual

WHEEL LOADER

WA430-6

SERIAL NUMBERS 65570 and up

ecot3

⚠ WARNING

Unsafe use of this machine may cause serious injury or death. Operators and maintenance personnel must read this manual before operating or maintaining this machine. This manual should be kept near the machine for reference and periodically reviewed by all personnel who will come into contact with it.

NOTICE

Komatsu has Operation & Maintenance Manuals written in some other languages. If a foreign language manual is necessary, contact your local distributor for availability.

KOMATSU

FOREWORD

CALIFORNIA

Proposition 65 Warning

Diesel engine exhaust and some of its constituents are known to the State of California to cause cancer, birth defects, and other reproductive harm.

CALIFORNIA

Proposition 65 Warning

Battery posts, terminals and related accessories contain lead and lead compounds, chemicals known to the State of California to cause cancer and birth defects or other reproductive harm.

Wash hands after handling.

BEFORE READING THIS MANUAL

This manual gives details of the operation and methods of inspection and maintenance for this machine that must be obeyed in order to use the machine safely. Most accidents are caused by the failure to follow fundamental safety rules for the operation and maintenance of machines.

Read, understand and follow all precautions and warnings in this manual and on the machine before performing operation and maintenance. Failure to do so may result in serious injury or death.

Komatsu cannot predict every circumstance that might involve a potential hazard when the machine is used. Therefore, the safety messages in this manual and on the machine may not include all possible safety precautions. If you carry out any operation, inspection, or maintenance under conditions that are not described in this manual, understand that it is your responsibility to take the necessary precautions to ensure safety. In no event should you or others engage in the prohibited uses or actions described in this manual. Improper operation and maintenance of the machine can be hazardous and could result in serious injury or death.

If you sell the machine, be sure to give this manual to the new owner together with the machine.

Always keep this Operation and Maintenance Manual in the location shown on the right so that all relevant personnel can read it at any time.

Storage location for the Operation and Maintenance Manual:
Pocket (1) at rear of operator's seat

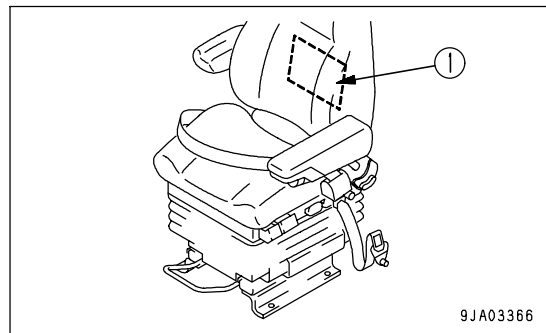

If this manual is lost or damaged, contact your distributor immediately to arrange for its replacement. For details regarding the machine serial No. you will need to provide your Komatsu distributor, see "TABLE TO ENTER SERIAL NO. AND DISTRIBUTOR (PAGE 1-7)".

This manual uses the international units (SI) for units of measurement. For reference, units that have been used in the past are given in ().

The explanations, values, and illustrations in this manual have been prepared based on the latest information available as of the date of its publication. Continuing improvements in the design of this machine may lead to additional changes that are not reflected in this manual. Consult Komatsu or your Komatsu distributor for the latest available information concerning your machine or with questions regarding information contained in this manual.

- The numbers in circles in the illustrations correspond to the numbers in () in the text.
(For example: ① → (1))



Komatsu delivers machines that comply with all applicable regulations and standards of the country to which it has been shipped. If this machine has been purchased in another country, it may lack certain safety devices and specifications that are necessary for use in your country. If there is any question about whether your product complies with the applicable standards and regulations of your country, consult Komatsu or your Komatsu distributor before operating the machine.

SAFETY INFORMATION

To enable you to use the machine safely, and to prevent injury to operators, service personnel or bystanders, the precautions and warnings included in this manual and the safety signs attached to the machine must always be followed.

To identify important safety messages in the manual and on the machine labels, the following signal words are used.

The "Safety Alert Symbol" identifies important safety messages on machines, in manuals, and elsewhere. When you see this symbol, be alert to the risk of personal injury or death. Follow the instructions in the safety message.

- | | |
|--|--|
|  DANGER | This signal word indicates an imminently hazardous situation which, if not avoided, will result in death or serious injury. |
|  WARNING | This signal word indicates a potentially hazardous situation which, if not avoided, could result in death or serious injury. |
|  CAUTION | This signal word indicates a potentially hazardous situation exists which, if not avoided, may result in minor or moderate injury. |

The following signal words are used to alert you to information that must be followed to avoid damage to the machine.

- | | |
|----------------|--|
| NOTICE | This precaution is given where the machine may be damaged or the service life reduced if the precaution is not followed. |
| REMARKS | This word is used for information that is useful to know. |

INTRODUCTION

USE OF MACHINE

This Komatsu machine is designed to be used mainly for the following work:

- Digging work
- Smoothing
- Pushing work
- Loading work

For details of the operating procedure, see "WORK POSSIBLE USING WHEEL LOADER (PAGE 3-141)".

FRONT/REAR, LEFT/RIGHT DIRECTIONS OF MACHINE

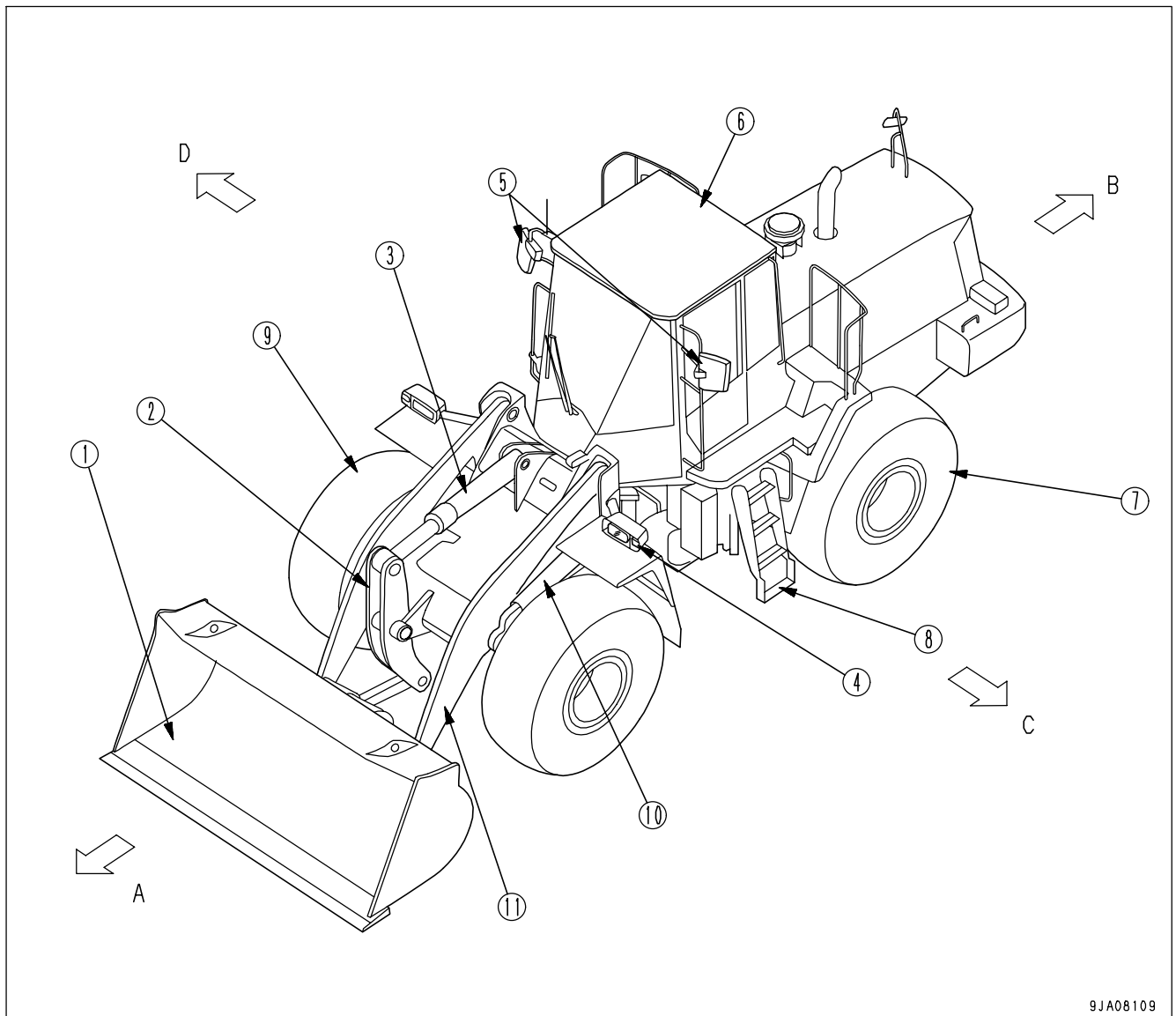

In this manual, the directions of the machine (front, rear, left, right) are determined according to the view from the operator's seat in the direction of travel (front) of the machine.

- | | |
|----------------------|--------------------|
| (1) Bucket | (7) Rear wheel |
| (2) Bell crank | (8) Step |
| (3) Bucket cylinder | (9) Front wheel |
| (4) Turn signal lamp | (10) Lift cylinder |
| (5) Mirror | (11) Lift arm |
| (6) ROPS cab | |
| (A) Front | (C) Left |
| (B) Rear | (D) Right |

VISIBILITY FROM OPERATOR'S SEAT

This machine complies with the visibility standard (ISO 5006).

This machine maintains a close visibility of a height of 1.5 m at a point 1 m away from the outside surface of the machine, and a visibility for a circumference of 12 m.

NECESSARY INFORMATION

When requesting service or ordering replacement parts, please inform your Komatsu distributor of the following items.

PRODUCT IDENTIFICATION NUMBER (PIN)/MACHINE SERIAL NO. PLATE

On the center right of the front frame.

The design of the nameplate differs according to the territory.

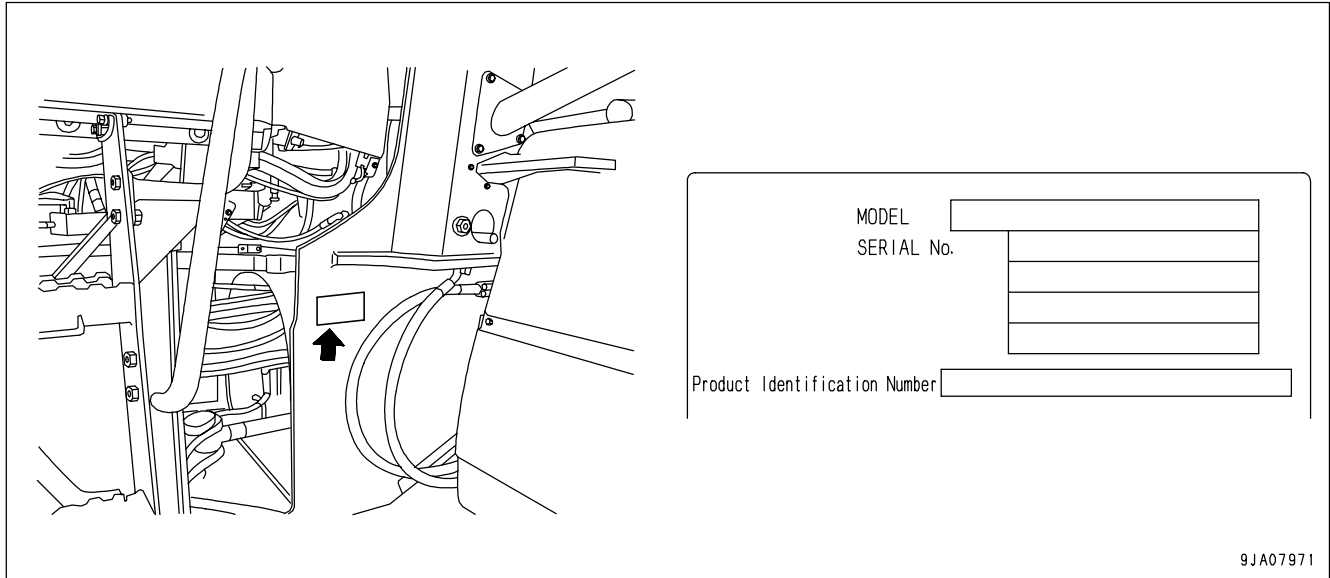

ENGINE SERIAL NO. PLATE

This is at the top at the rear of the engine on the right side of the machine.

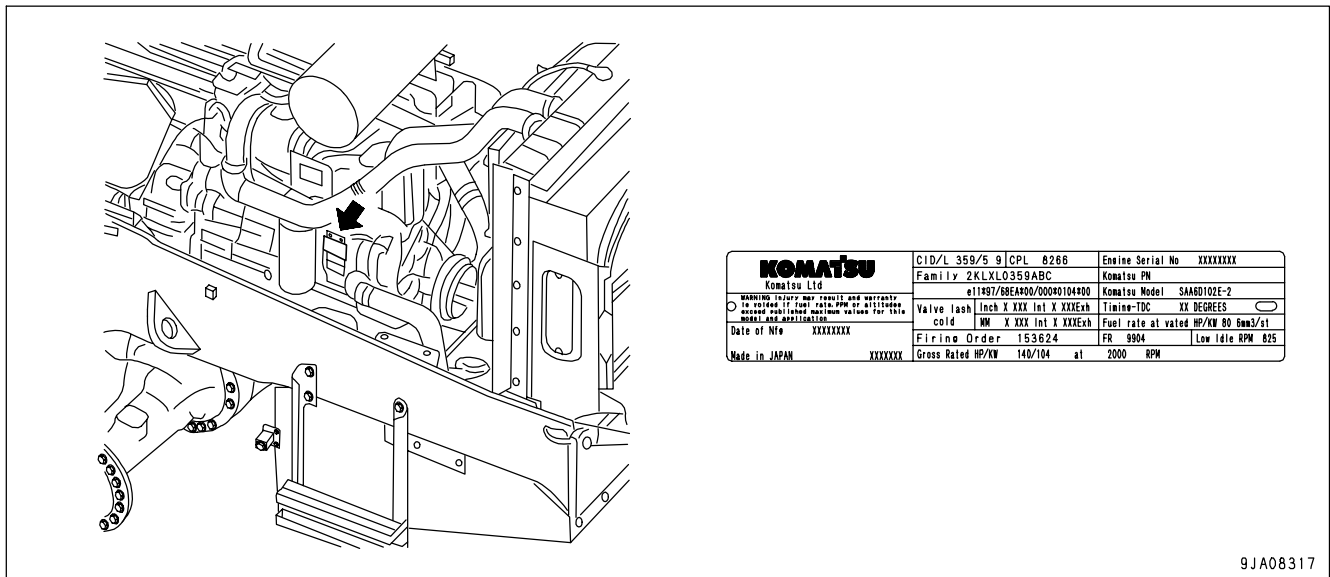

EPA: Environmental Protection Agency, U.S.A.

POSITION OF SERVICE METER

It is at the center bottom of the machine monitor.

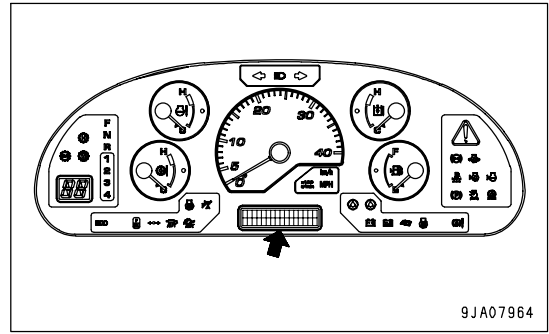

TABLE TO ENTER SERIAL NO. AND DISTRIBUTOR

Machine serial No.	
Engine serial No.	
Product identification number (PIN)	
Distributor name	
Address	-----

Service Personnel	-----
Phone/Fax	-----

CONTENTS

FOREWORD	1- 1
BEFORE READING THIS MANUAL	1- 2
SAFETY INFORMATION	1- 3
INTRODUCTION	1- 4
USE OF MACHINE	1- 4
FRONT/REAR, LEFT/RIGHT DIRECTIONS OF MACHINE	1- 5
VISIBILITY FROM OPERATOR'S SEAT	1- 5
NECESSARY INFORMATION	1- 6
PRODUCT IDENTIFICATION NUMBER (PIN)/MACHINE SERIAL NO. PLATE	1- 6
ENGINE SERIAL NO. PLATE	1- 6
POSITION OF SERVICE METER	1- 7
TABLE TO ENTER SERIAL NO. AND DISTRIBUTOR	1- 7
CONTENTS	1- 8
SAFETY	2- 1
SAFETY	2- 2
SAFETY LABELS	2- 5
LOCATION OF SAFETY LABELS	2- 5
SAFETY LABELS	2- 6
GENERAL PRECAUTIONS COMMON TO OPERATION AND MAINTENANCE	2- 13
PRECAUTIONS BEFORE STARTING OPERATION	2- 13
PREPARATIONS FOR SAFE OPERATION	2- 13
FIRE PREVENTION	2- 15
PRECAUTIONS WHEN GETTING ON OR OFF MACHINE	2- 16
DO NOT GET CAUGHT IN ARTICULATING PORTION	2- 19
PRECAUTIONS RELATED TO PROTECTIVE STRUCTURES	2- 19
UNAUTHORIZED MODIFICATION	2- 19
PRECAUTIONS RELATED TO ATTACHMENTS AND OPTIONS	2- 20
PRECAUTIONS WHEN RUNNING ENGINE INSIDE BUILDING	2- 20
PRECAUTIONS FOR OPERATION	2- 21
PRECAUTIONS FOR JOBSITE	2- 21
STARTING ENGINE	2- 23
OPERATION	2- 25
TRANSPORTATION	2- 32
TOWING	2- 33
PRECAUTIONS FOR MAINTENANCE	2- 34
PRECAUTIONS BEFORE STARTING INSPECTION AND MAINTENANCE	2- 34
PRECAUTIONS FOR INSPECTION AND MAINTENANCE	2- 39
TIRES	2- 44
OPERATION	3- 1
GENERAL VIEW	3- 2
GENERAL VIEW OF MACHINE	3- 2
GENERAL VIEW OF CONTROLS AND GAUGES	3- 3
EXPLANATION OF COMPONENTS	3- 6
MACHINE MONITOR	3- 6
SWITCHES	3- 39
CONTROL LEVERS, PEDALS	3- 53
STEERING TILT LOCK LEVER	3- 58
CAP WITH LOCK	3- 58
FRAME LOCK BAR	3- 60

TOWING PIN -----	3- 60
GREASE PUMP -----	3- 61
OPENING, CLOSING CAB DOORS, WINDOWS -----	3- 62
BACKUP ALARM -----	3- 66
FUSE -----	3- 67
SLOW BLOW FUSE -----	3- 68
POWER OUTLET -----	3- 69
AM/FM RADIO -----	3- 70
AM/FM RADIO-CASSETTE STEREO -----	3- 76
HANDLING AUTO AIR CONDITIONER -----	3- 84
AIR CONDITIONER -----	3- 91
HANDLING CAB WIPER -----	3- 98
OPERATION -----	3- 99
CHECK BEFORE STARTING ENGINE, ADJUST -----	3- 99
STARTING ENGINE -----	3-119
CHECKS AFTER STARTING ENGINE -----	3-123
OPERATIONS AND CHECKS AFTER STARTING ENGINE -----	3-124
STOPPING ENGINE -----	3-126
MOVING THE MACHINE (DIRECTIONAL, SPEED), STOPPING THE MACHINE -----	3-127
TURNING -----	3-136
OPERATION OF WORK EQUIPMENT -----	3-139
WORK POSSIBLE USING WHEEL LOADER -----	3-141
PRECAUTIONS FOR OPERATION -----	3-148
ADJUSTING WORK EQUIPMENT POSTURE -----	3-150
PARKING MACHINE -----	3-152
CHECKS AFTER COMPLETION OF OPERATION -----	3-154
LOCKING -----	3-155
HANDLING THE TIRES -----	3-156
TRANSPORTATION -----	3-158
TRANSPORTATION PROCEDURE -----	3-158
LOADING, UNLOADING WORK WITH TRAILERS -----	3-158
LIFTING MACHINE -----	3-162
COLD WEATHER OPERATION -----	3-164
PRECAUTIONS FOR LOW TEMPERATURE -----	3-164
PRECAUTIONS AFTER COMPLETION OF WORK -----	3-165
AFTER COLD WEATHER -----	3-165
LONG-TERM STORAGE -----	3-166
BEFORE STORAGE -----	3-166
DURING STORAGE -----	3-166
AFTER STORAGE -----	3-166
TROUBLESHOOTING -----	3-167
WHEN MACHINE RUNS OUT OF FUEL -----	3-167
METHOD OF TOWING MACHINE -----	3-167
IF BATTERY IS DISCHARGED -----	3-172
OTHER TROUBLE -----	3-175
MAINTENANCE -----	4- 1
GUIDES TO MAINTENANCE -----	4- 2
OUTLINES OF SERVICE -----	4- 4
HANDLING OIL, FUEL, COOLANT, AND PERFORMING OIL CLINIC -----	4- 4
OUTLINE OF ELECTRIC SYSTEM -----	4- 7

WEAR PARTS -----	4- 8
WEAR PARTS LIST -----	4- 8
RECOMMENDED FUEL, COOLANT, AND LUBRICANT -----	4- 9
USE OF FUEL, COOLANT AND LUBRICANTS ACCORDING TO AMBIENT TEMPERATURE -----	4- 10
RECOMMENDED BRANDS, RECOMMENDED QUALITY FOR PRODUCTS OTHER THAN KOMATSU GENUINE OIL -----	4- 11
STANDARD TIGHTENING TORQUES FOR BOLTS AND NUTS -----	4- 12
TORQUE LIST -----	4- 12
PERIODIC REPLACEMENT OF SAFETY CRITICAL PARTS -----	4- 13
MAINTENANCE SCHEDULE CHART -----	4- 15
MAINTENANCE SCHEDULE CHART -----	4- 15
SERVICE PROCEDURE -----	4- 17
INITIAL 10 HOURS SERVICE (SERVICE FOR FIRST 50 HOURS ON NEW MACHINE) -----	4- 17
INITIAL 250 HOURS SERVICE -----	4- 17
INITIAL 1000 HOURS SERVICE -----	4- 17
WHEN REQUIRED -----	4- 18
CHECK BEFORE STARTING -----	4- 39
EVERY 50 HOURS SERVICE -----	4- 40
EVERY 100 HOURS SERVICE -----	4- 41
EVERY 250 HOURS SERVICE -----	4- 43
EVERY 500 HOURS SERVICE -----	4- 49
EVERY 1000 HOURS SERVICE -----	4- 53
EVERY 2000 HOURS SERVICE -----	4- 58
EVERY 4000 HOURS SERVICE -----	4- 64
EVERY 8000 HOURS SERVICE -----	4- 67
SPECIFICATIONS -----	5- 1
SPECIFICATIONS -----	5- 2
ATTACHMENTS, OPTIONS -----	6- 1
SELECTING BUCKET AND TIRES -----	6- 2
HANDLING TORQUE CONVERTER LOCK-UP -----	6- 3
GENERAL LOCATIONS -----	6- 3
METHOD OF OPERATION -----	6- 5
WARNING/LIMIT FUNCTIONS FOR TRAVEL SPEED -----	6- 6
HANDLING JOYSTICK STEERING SYSTEM -----	6- 7
EXPLANATION OF COMPONENTS -----	6- 7
STRUCTURE AND FUNCTION OF JOYSTICK STEERING -----	6- 11
GETTING IN OR OUT OF OPERATOR'S CAB -----	6- 12
SEAT ADJUSTMENT -----	6- 13
ADJUSTMENT OF JOYSTICK CONSOLE -----	6- 15
OPERATION USING JOYSTICK LEVER AND OPERATION USING STEERING WHEEL -----	6- 16
PRECAUTIONS FOR STEERING WITH JOYSTICK -----	6- 17
OPERATION METHOD OF JOYSTICK STEERING SYSTEM -----	6- 17
HANDLING MULTI FUNCTION MONO-LEVER -----	6- 20
EXPLANATION OF COMPONENTS -----	6- 20
USING FNR SWITCH TO CHANGE BETWEEN FORWARD AND REVERSE -----	6- 25
HANDLING MACHINES EQUIPPED WITH KOMTRAX -----	6- 27
BASIC PRECAUTIONS -----	6- 27
INDEX -----	7- 1

SAFETY

WARNING

Please read and make sure that you fully understand the precautions described in this manual and the safety labels on the machine. When operating or servicing the machine, always follow these precautions strictly.

SAFETY

SAFETY LABELS	2- 5
LOCATION OF SAFETY LABELS	2- 5
SAFETY LABELS	2- 6
GENERAL PRECAUTIONS COMMON TO OPERATION AND MAINTENANCE	2- 13
PRECAUTIONS BEFORE STARTING OPERATION	2- 13
ENSURING SAFE OPERATION	2- 13
UNDERSTANDING THE MACHINE	2- 13
PREPARATIONS FOR SAFE OPERATION	2- 13
PRECAUTIONS REGARDING SAFETY-RELATED EQUIPMENT	2- 13
INSPECTING MACHINE	2- 13
WEAR WELL-FITTING CLOTHES AND PROTECTIVE EQUIPMENT	2- 13
KEEP MACHINE CLEAN	2- 14
PRECAUTIONS INSIDE OPERATOR'S COMPARTMENT	2- 14
PROVIDE FIRE EXTINGUISHER AND FIRST AID KIT	2- 14
IF ANY PROBLEM IS FOUND	2- 14
FIRE PREVENTION	2- 15
ACTION IF FIRE OCCURS	2- 15
PRECAUTIONS TO PREVENT FIRE	2- 15
PRECAUTIONS WHEN GETTING ON OR OFF MACHINE	2- 16
USE HANDRAILS AND STEPS WHEN GETTING ON OR OFF MACHINE	2- 16
NO JUMPING ON OR OFF MACHINE	2- 16
NO PEOPLE ON ATTACHMENTS	2- 16
PRECAUTIONS WHEN STANDING UP FROM OPERATOR'S SEAT	2- 17
PRECAUTIONS WHEN LEAVING MACHINE	2- 18
EMERGENCY EXIT FROM OPERATOR'S CAB	2- 18
PRECAUTIONS WHEN CLEANING CAB GLASS	2- 18
DO NOT GET CAUGHT IN ARTICULATING PORTION	2- 19
PRECAUTIONS RELATED TO PROTECTIVE STRUCTURES	2- 19
UNAUTHORIZED MODIFICATION	2- 19
PRECAUTIONS RELATED TO ATTACHMENTS AND OPTIONS	2- 20
PRECAUTIONS WHEN RUNNING ENGINE INSIDE BUILDING	2- 20

PRECAUTIONS FOR OPERATION	2- 21
PRECAUTIONS FOR JOBSITE	2- 21
INVESTIGATE AND CONFIRM JOBSITE CONDITIONS	2- 21
WORKING ON LOOSE GROUND	2- 21
DO NOT GO CLOSE TO HIGH-VOLTAGE CABLES	2- 22
ENSURE GOOD VISIBILITY	2- 22
CHECKING SIGNS AND SIGNALMAN'S SIGNALS	2- 22
BEWARE OF ASBESTOS DUST	2- 23
STARTING ENGINE	2- 23
USE WARNING TAGS	2- 23
INSPECTION AND MAINTENANCE BEFORE STARTING ENGINE	2- 24
PRECAUTIONS WHEN STARTING ENGINE	2- 24
PRECAUTIONS IN COLD AREAS	2- 24
STARTING WITH BOOSTER CABLES	2- 25
OPERATION	2- 25
CHECKS BEFORE OPERATION	2- 25
PRECAUTIONS WHEN TRAVELING IN FORWARD OR REVERSE	2- 26
PRECAUTIONS WHEN TRAVELING	2- 27
TRAVELING ON SLOPES	2- 28
METHOD OF USING BRAKES	2- 28
PRECAUTIONS WHEN OPERATING	2- 29
PROHIBITED OPERATIONS	2- 30
TRAVELING ON SNOW-COVERED OR FROZEN SURFACES	2- 30
PARKING MACHINE	2- 31
TRANSPORTATION	2- 32
LOADING AND UNLOADING	2- 32
TOWING	2- 33
PRECAUTIONS WHEN TOWING	2- 33

PRECAUTIONS FOR MAINTENANCE	2- 34
PRECAUTIONS BEFORE STARTING INSPECTION AND MAINTENANCE	2- 34
DISPLAY WARNING TAG DURING INSPECTION AND MAINTENANCE	2- 34
KEEP WORKPLACE CLEAN AND TIDY	2- 34
SELECT SUITABLE PLACE FOR INSPECTION AND MAINTENANCE	2- 34
ONLY AUTHORIZED PERSONNEL	2- 34
APPOINT LEADER WHEN WORKING WITH OTHERS	2- 34
STOP ENGINE BEFORE CARRYING OUT INSPECTION AND MAINTENANCE	2- 35
TWO WORKERS FOR MAINTENANCE WHEN ENGINE IS RUNNING	2- 37
TURNING E.C.S.S. SWITCH OFF BEFORE CARRYING OUT INSPECTION AND MAINTENANCE ..	2- 37
INSTALLING, REMOVING, OR STORING ATTACHMENTS	2- 38
PRECAUTIONS WHEN WORKING AT HIGH PLACES	2- 38
PRECAUTIONS WHEN WORKING UNDER MACHINE OR WORK EQUIPMENT	2- 38
PROPER TOOLS	2- 38
PRECAUTIONS FOR INSPECTION AND MAINTENANCE	2- 39
PRECAUTIONS WHEN WELDING	2- 39
HANDLING BATTERY	2- 39
PRECAUTIONS WHEN USING HAMMER	2- 40
PRECAUTIONS WITH HIGH-TEMPERATURE COOLANT	2- 40
PRECAUTIONS WITH HIGH-TEMPERATURE OIL	2- 40
PRECAUTIONS WITH HIGH-PRESSURE OIL	2- 41
PRECAUTIONS WITH HIGH-PRESSURE FUEL	2- 41
HANDLING HIGH-PRESSURE HOSES AND PIPING	2- 41
NOISE	2- 41
HANDLING ACCUMULATOR AND GAS SPRING	2- 42
PRECAUTIONS WITH COMPRESSED AIR	2- 42
MAINTENANCE OF AIR CONDITIONER	2- 42
DISPOSING OF WASTE MATERIALS	2- 42
METHOD OF SELECTING WINDOW WASHER FLUID	2- 42
PERIODIC REPLACEMENT OF SAFETY CRITICAL PARTS	2- 43
TIRES	2- 44
HANDLING TIRES	2- 44
PRECAUTIONS WHEN STORING TIRES	2- 45

SAFETY LABELS

The following safety labels are used on this machine. Be sure that you fully understand the correct position and content of these safety labels.

To ensure that the content of these safety labels can be read properly, be sure that they are in the correct place and always keep them clean. When cleaning them, use soap and water. Do not use organic solvents or gasoline. These may cause the safety labels to peel off.

If the safety labels are damaged or lost, or cannot be read, replace them with new parts. For details of the part numbers, see this manual or check on the actual part, and order the new part from your Komatsu distributor.

There are also other labels in addition to the safety labels. Handle these labels in the same way.

LOCATION OF SAFETY LABELS

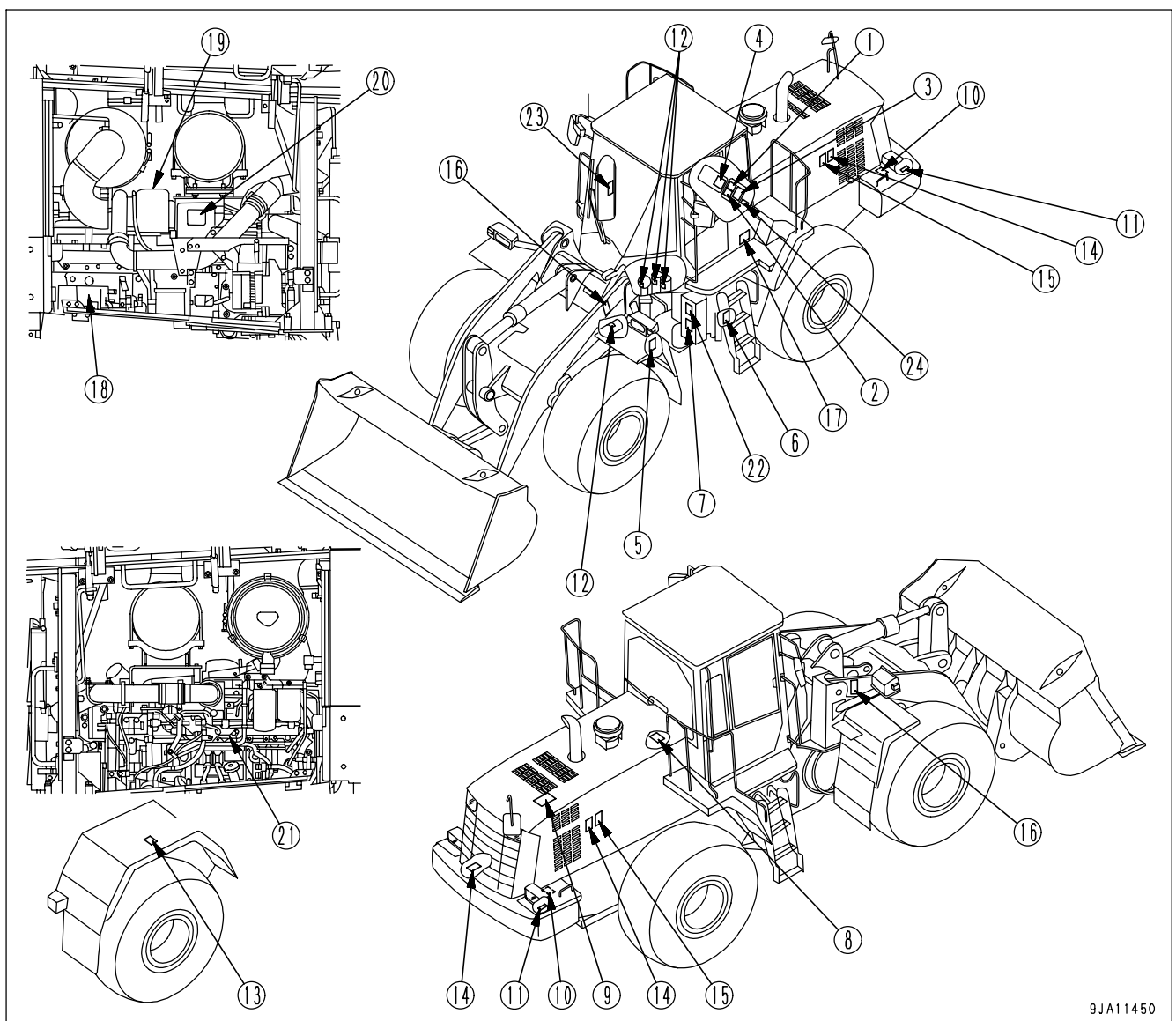

9JA11450

SAFETY LABELS

(1) Caution before starting (09651-03001)



(2) Caution for leaving the operator's seat (09654-03001)

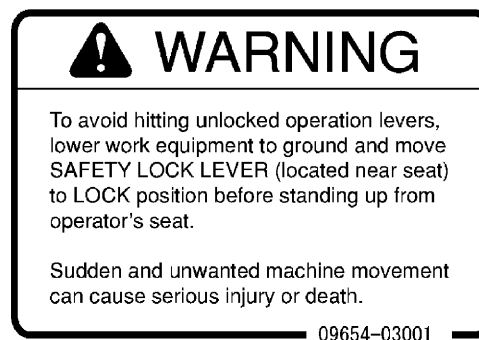

(3) Caution when traveling in reverse

Please request part No. 423-93-41150 for this safety label.

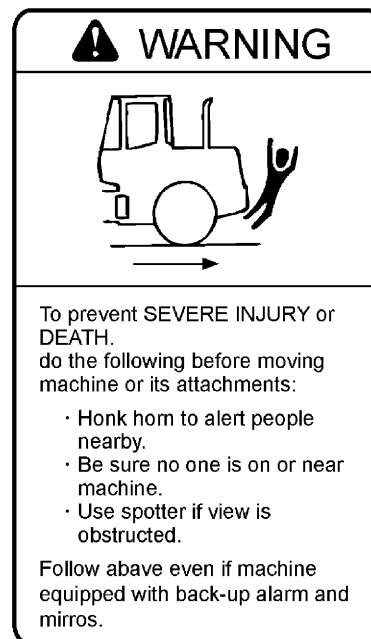

(4) Caution for going close to electric cables (09801-13001)



⚠ DANGER

Hazardous voltage hazard
 Serious injury or death can occur if machine or attachments are not kept safe distance away from electric lines

VOLTAGE	SAFE DISTANCE
LOW VOLTAGE	100V 200V 6,600V
SPECIAL HIGH VOLTAGE	22,000V
	66,000V
	154,000V
	187,000V
	275,000V
500,000V	

09801-13001

(5) Caution to keep away from movable parts (09162-23000)

⚠ DANGER

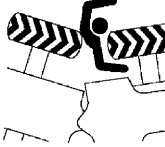

Crush Hazard. Can cause severe injury or death.

When machine is being operated, never place yourself in articulated area of machine.

09162-23000

(6) Caution for frame lock bar (09161-23000)

⚠ WARNING

If safety bar is unlocked, machine can jackknife unexpectedly when it is being transported or hoisted.

Jackknifing can cause serious injury or death to bystanders.

- Always lock safety bar when machine is being transported or hoisted.
- If necessary, lock safety bar during servicing or maintenance.

09161-23000

- (7) Caution when canceling parking brake emergency
(423-93-41311)

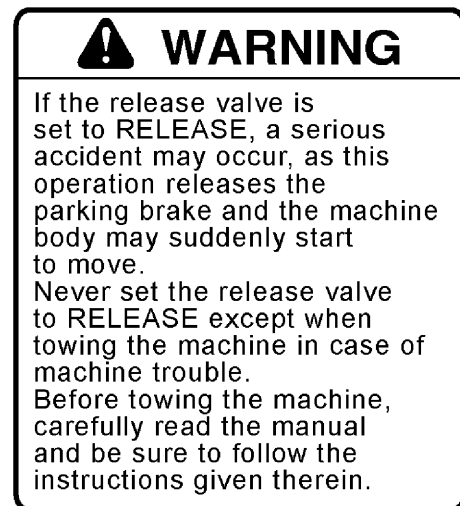

- (8) Warning for hot cooling water (09668-03001)



- (9) Caution when oil is at high temperature (09653-03001)



- (10) Caution when handling battery cable (09808-03000)

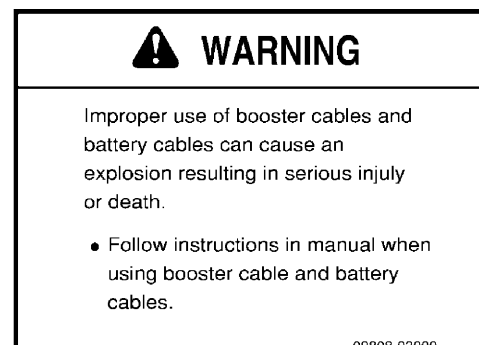

(11) Caution when handling battery (09664-30010)

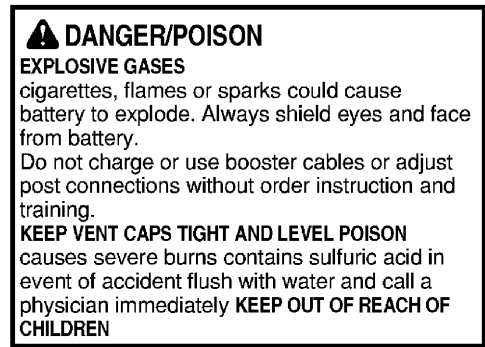

(12) Explosion hazard (09659-53000)



(13) Do not climb on fender (09805-03000)
(Machines with equipped with rear full fender)



(14) "Do not open when engine is running" sign
(09667-03001)

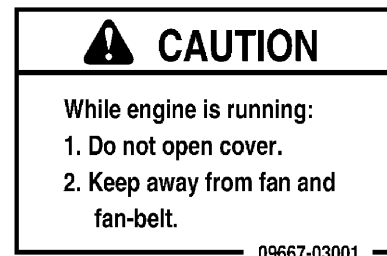

(15) "Do not come near machine" sign (09812-13000)



(16) "Do not go under work equipment" sign (09807-C0883)



Sign indicates a crush hazard from falling off of working device.

Keep away when the working device is raised.

(17) "Do not modify ROPS" sign (09620-A2000)

KOMATSU ROPS/FOPS CERTIFICATION			
This protective structure complies with the standard provided that it is properly equipped on a machine which mass is less than the specified maximum mass.			
MODEL	ROPS : ISO 2471:1994, SAE J150, J471, MSY03	FOPS : ISO 2449:1992	FOPS LEVEL No. <input type="text"/>
SERIAL No.	WACHINE MODEL	MAX. MASS	kg (Lb)
<p>WARNING</p> <ul style="list-style-type: none"> ● If any modification is applied to the ROPS or FOPS, it may affect the strength and may not comply with the standard. Consult Komatsu Distributor before altering. ● ROPS or FOPS may provide less protection if it has been structurally damaged or involved roll-over. Consult Komatsu Distributor in that case. ● Always wear seat belt when moving. 			
Komatsu Ltd. 2-3-8 Akasaka, Minato-ku, Tokyo, Japan 09620 A2000			

(18) Jump start prohibited (09842-A0481)



Start the engine only after sitting down in the operator's seat.

Do not attempt to start the engine by short-circuiting the engine starting circuit. Such an act may cause a serious bodily injury or fire.

(19) Caution for high temperature turbocharger (09817-A0753)



Sign indicates a burn hazard from touching heated parts, such as engine, motor, or muffler during or right after operation. Never touch when hot.

(20) Caution for high temperature exhaust pipe (09817-A0753)



Sign indicates a burn hazard from touching heated parts, such as engine, motor, or muffler during or right after operation. Never touch when hot.

(21) Caution for common rail high pressure (6754-71-1991)

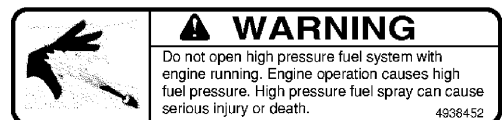

(22) Parking brake emergency cancel valve (423-93-41311)

Emergency Releasing Method of Parking Brake

Releasing method:

- (1) In driver's cab: Set the starting switch to OFF position.
- (2) Turn the lock nut of the release valve counterclockwise to loosen it, and turn the grip counterclockwise to release the valve.
- (3) In driver's cab: Set the starting switch to ON position.
- (4) Set the parking brake switch to ON position once, and then set it to OFF position.

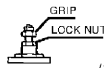

Normal condition:
Turn the grip of the release valve clockwise to close the valve (screw torque: 19.6Nm) and fix it with the lock nut (screw torque: 19.6Nm) GRIP

(23) Escape (425-93-51110)

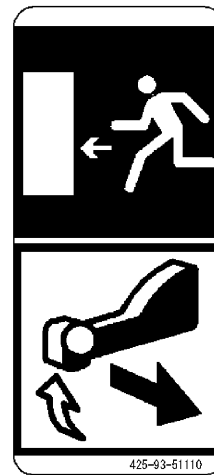

(24) Caution blast site (09845-00480)
(only when equipped with KOMTRAX)

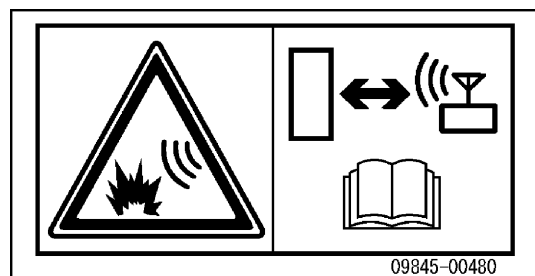

Sign indicates an explosion hazard caused by active radio transmitter at a blast zone.

Keep machine at a safe distance from a blast zone and detonator.

GENERAL PRECAUTIONS COMMON TO OPERATION AND MAINTENANCE

Mistakes in operation, inspection, or maintenance may result in serious personal injury or death. Before carrying out operation, inspection, or maintenance, always read this manual and the safety labels on the machine carefully and obey the warnings.

PRECAUTIONS BEFORE STARTING OPERATION

ENSURING SAFE OPERATION

- Only trained and authorized personnel can operate and maintain the machine.
- Follow all safety, precautions, and instructions in this manual when operating or performing inspection or maintenance on the machine.
- If you are not feeling well, or if you are under the influence of alcohol or medication, your ability to safely operate or repair your machine may be severely impaired, putting yourself and everyone else on your job site in danger.
- When working with another operator or with the person on the worksite traffic duty, discuss the content of the operation beforehand and use the determined signals when carrying out the operation.

UNDERSTANDING THE MACHINE

Before operating the machine, read this manual thoroughly. If there are any places in this manual that you do not understand, ask the person in charge of safety to give an explanation.

PREPARATIONS FOR SAFE OPERATION

PRECAUTIONS REGARDING SAFETY-RELATED EQUIPMENT

- Be sure that all guards, covers and mirrors are in their proper position. Have guards and covers repaired immediately if they are damaged.
- Understand the method of use of safety features and use them properly.
- Never remove any safety features. Always keep them in good operating condition.

INSPECTING MACHINE

Check the machine before starting operations. If any abnormality is found, do not operate the machine until repairs of the problem location have been completed.

WEAR WELL-FITTING CLOTHES AND PROTECTIVE EQUIPMENT

- Do not wear loose clothes or any accessories. If these catch on the control levers or protruding parts, there is danger that it may cause the machine to move unexpectedly.
- Always wear a hard hat and safety shoes. If the nature of the work requires it, wear safety glasses, mask, gloves, ear plugs, and safety belt when operating or maintaining the machine.
- If you have long hair and it hangs out from your hard hat, there is a hazard that it may get caught up in the machine, so tie your hair up and be careful not to let it get caught.
- Check that all protective equipment functions properly before using it.

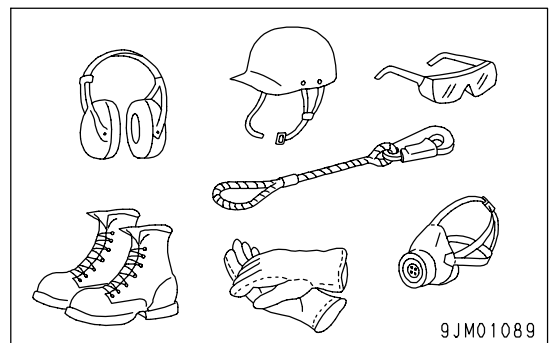

KEEP MACHINE CLEAN

- If you get on or off the machine or carry out inspection and maintenance when the machine is dirty with mud or oil, there is a hazard that you will slip and fall. Wipe off any mud or oil from the machine. Always keep the machine clean.
- If water gets into the electrical system, there is a hazard that it will cause malfunctions or misoperation. If there is any misoperation, there is danger that the machine may move unexpectedly and cause serious personal injury or death. When washing the machine with water or steam, do not allow the water or steam to come into direct contact with electrical components.

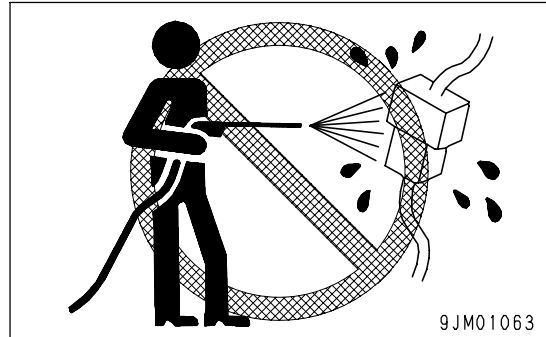
**PRECAUTIONS INSIDE OPERATOR'S COMPARTMENT**

- When entering the operator's compartment, always remove all mud and oil from the soles of your shoes. If you operate the pedal with mud or oil affixed to your shoes, your foot may slip and this may cause a serious accident.
- Do not leave tools or a machine parts lying around inside the operator's compartment. If tools or parts get into the control devices, it may obstruct operation and cause the machine to move unexpectedly, resulting in serious personal injury or death.
- Do not stick suction pads to the window glass. Suction pads act as a lens and may cause fire.
- Do not use a cell phone when driving or operating the machine. This may lead to mistakes in operation, which could cause serious personal injury or death.
- Never bring any dangerous objects such as flammable or explosive items into the operator's compartment.

PROVIDE FIRE EXTINGUISHER AND FIRST AID KIT

Always follow the precautions below to prepare for action if any injury or fire should occur.

- Be sure that fire extinguishers have been provided and read the labels to ensure that you know how to use them in emergencies.
- Carry out periodic inspection and maintenance to ensure that the fire extinguisher can always be used.
- Provide a first aid kit in the storage point. Carry out periodic checks and add to the contents if necessary.

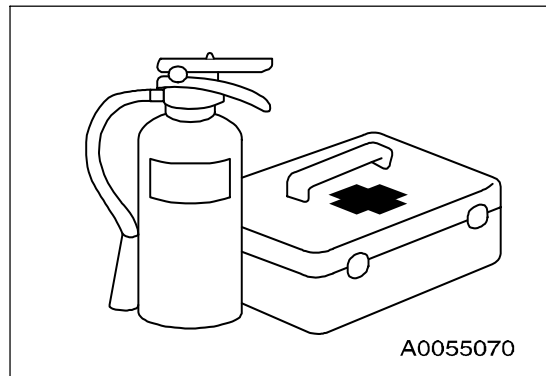
**IF ANY PROBLEM IS FOUND**

If you find any problems in the machine during operation or maintenance (noise, vibration, smell, incorrect gauges, smoke, oil leakage, etc., or any abnormal display on the warning devices or monitor), report to the person in charge and have the necessary action taken. Do not operate the machine until the problem has been corrected.

FIRE PREVENTION

ACTION IF FIRE OCCURS

- Turn the start switch OFF to stop the engine.
- Use the handrails and steps to get off the machine.
- Do not jump off the machine. There is the danger of falling and suffering serious injury.

PRECAUTIONS TO PREVENT FIRE

• Fire caused by fuel, oil, COOLANT or window washer fluid

Do not bring any flame or fire close to flammable substances such as fuel, oil, COOLANT or window washer fluid. There is danger that they may catch fire. To prevent fire, always observe the following:

- Do not smoke or use any flame near fuel or other flammable substances.
- Stop the engine before adding fuel.
- Do not leave the machine when adding fuel or oil.
- Tighten all fuel and oil caps securely.
- Be careful not to spill fuel on overheated surfaces or on parts of the electrical system.
- After adding fuel or oil, wipe up any spilled fuel or oil.
- Put greasy rags and other flammable materials into a safe container to maintain safety at the workplace.
- When washing parts with oil, use a non-flammable oil. Do not use diesel oil or gasoline. There is danger that they may catch fire.
- Do not weld or use a cutting torch to cut any pipes or tubes that contain flammable liquids.
- Determine well-ventilated areas for storing oil and fuel. Keep the oil and fuel in the determined place and do not allow unauthorized persons to enter.
- When carrying out grinding or welding work on the machine, move any flammable materials to a safe place before starting.

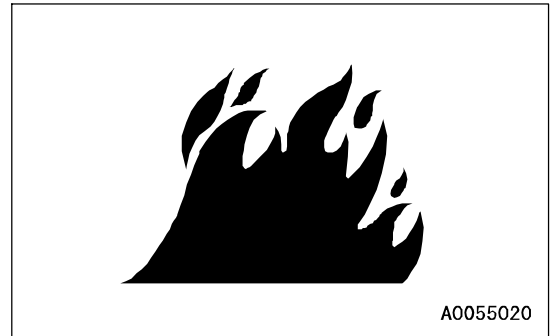

• Fire caused by accumulation of flammable material.

Remove any dry leaves, chips, pieces of paper, coal dust, or any other flammable materials accumulated or affixed around the engine, exhaust manifold, muffler, or battery, or inside the undercovers.

• Fire coming from electric wiring

Short circuits in the electrical system can cause fire. To prevent fire, always observe the following.

- Keep all electric wiring connections clean and securely tightened.
- Check the wiring every day for looseness or damage. Tighten any loose connectors or wiring clamps. Repair or replace any damaged wiring.

• Fire coming from piping

Check that all the hose and tube clamps, guards, and cushions are securely fixed in position.

If they are loose, they may vibrate during operation and rub against other parts. There is danger that this may lead to damage to the hoses and cause high-pressure oil to spurt out, leading to fire, serious personal injury or death.

- **Explosion caused by lighting equipment**

- When checking fuel, oil, battery electrolyte, or coolant, always use lighting with anti-explosion specifications.
- When taking the electrical power for the lighting from the machine itself, follow the instructions in this manual.

PRECAUTIONS WHEN GETTING ON OR OFF MACHINE

USE HANDRAILS AND STEPS WHEN GETTING ON OR OFF MACHINE

To prevent personal injury caused by slipping or falling off the machine, always do as follows.

- Use the handrails and steps marked by arrows in the diagram on the right when getting on or off the machine.

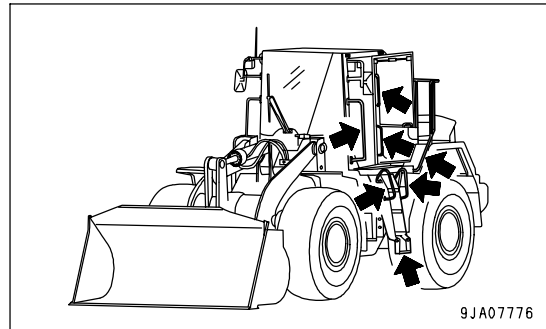

- Always face the machine and maintain at least three-point contact (both feet and one hand, or both hands and one foot) with the handrail and steps to ensure that you support yourself.

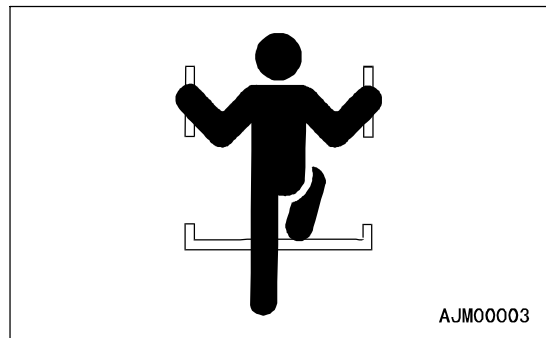

- Before getting on or off the machine, check the handrails and steps, and if there is any oil, grease, or mud on them, wipe it off immediately. In addition, repair any damage and tighten any loose bolts.
- Do not grip the control levers and work equipment lock lever when getting on or off the machine.
- Never climb on the engine hood or covers where there are no non-slip pads.
- Never move from the step at the rear of the machine or the step at the side of the cab to stand on top of the tire.
- Do not get on or off the machine while holding tools in your hand.

NO JUMPING ON OR OFF MACHINE

- Never jump on or off the machine. Never get on or off a moving machine.
- If the machine starts to move when there is no operator on the machine, do not jump on to the machine and try to stop it.

NO PEOPLE ON ATTACHMENTS

Never let anyone ride on the work equipment or other attachments. There is a hazard of falling and suffering serious personal injury or death.

PRECAUTIONS WHEN STANDING UP FROM OPERATOR'S SEAT

Before standing up from the operator's seat, such as when adjusting the position of the seat, always lower the work equipment completely to the ground, set work equipment lock lever (1) to the lock position (L), set parking brake switch (2) to the ON position (A), and stop the engine.

If the control levers are touched by mistake, the machine may suddenly move and cause serious personal injury or death.

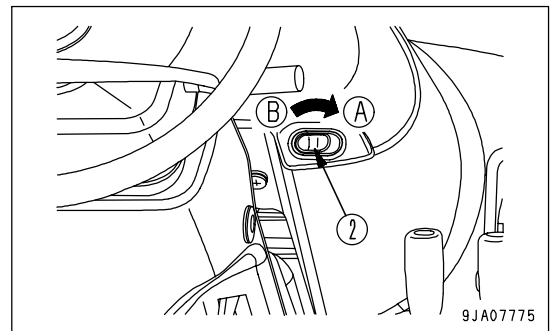
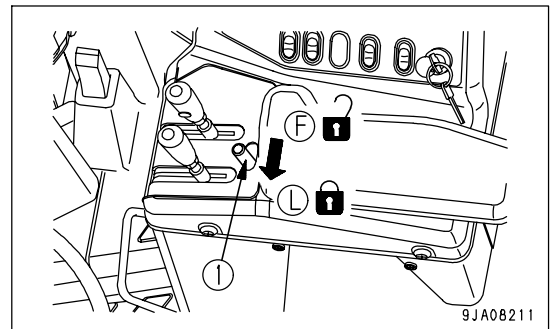
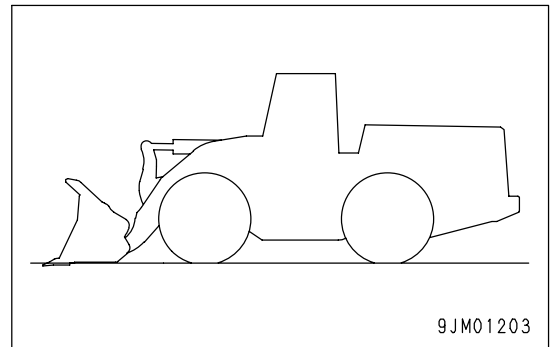

PRECAUTIONS WHEN LEAVING MACHINE

If the proper procedures are not taken when parking the machine, the machine may suddenly move off by itself, and this may lead to serious personal injury or death. Always do the following.

- When leaving the machine, always lower the work equipment completely to the ground, set work equipment lock lever (1) to the lock position (L), set parking brake switch (2) to the ON position (A), and stop the engine.

In addition, lock all parts, always take the key with you, and leave it in the specified place.

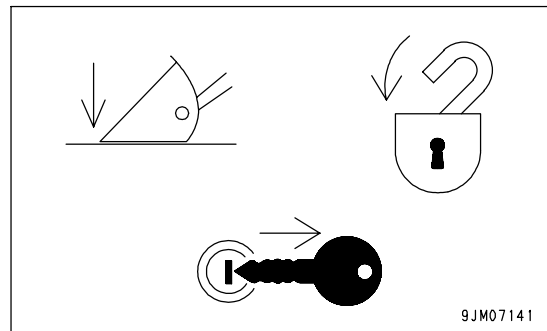
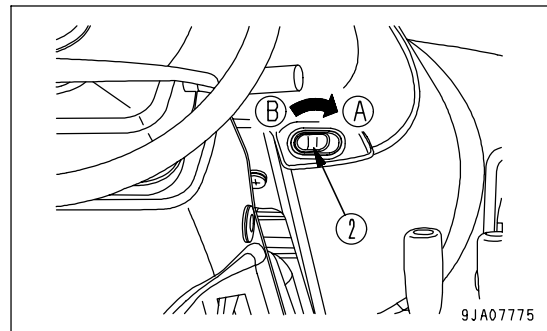
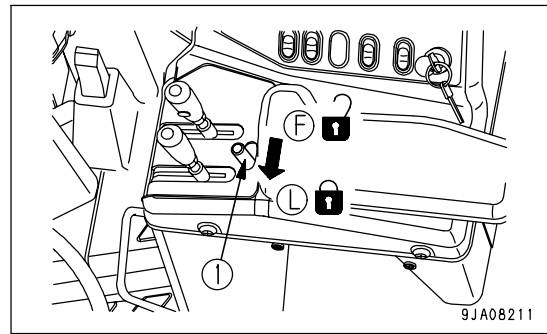
**EMERGENCY EXIT FROM OPERATOR'S CAB**

On machines fitted with a cab, a door is installed on the left side and an emergency escape door is installed on the right side. If the door on the left side does not open, escape from the emergency door on the right side.

PRECAUTIONS WHEN CLEANING CAB GLASS

Always keep the cab glass clean to ensure good visibility when operating.

When cleaning the front glass, pay careful attention to the safety of your footing on the platform on the left or right of the operator's cab or on the step on the front fender so as not to fall off the machine.

For cab glass cleaning procedures, see "WALK-AROUND CHECK (PAGE 3-99)" in this manual.

DO NOT GET CAUGHT IN ARTICULATING PORTION

- If the clearance at the articulating portion changes and you get caught in it, you will suffer serious personal injury or death. Do not allow anyone to come inside the articulation range.
- The clearance in the area around the work equipment changes according to the movement of the link. If you get caught, you will suffer serious personal injury or death. Do not allow anyone to come close to any rotating or extending/retracting portion.

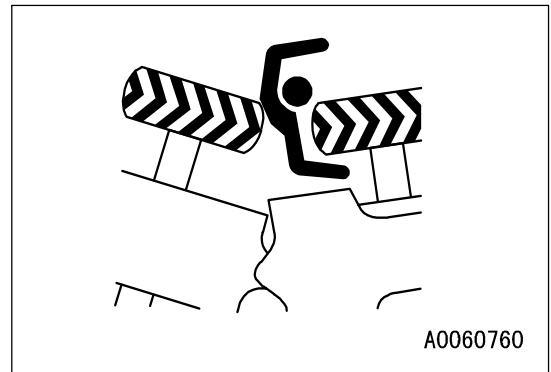

PRECAUTIONS RELATED TO PROTECTIVE STRUCTURES

The operator's compartment is equipped with a structure (such as ROPS, FOPS) to protect the operator by absorbing the impact energy. As for the machine equipped with ROPS, if the machine weight (mass) exceeds the certified value (shown on the ROLL-OVER PROTECTIVE STRUCTURE (ROPS) CERTIFICATION plate), ROPS will not be able to fulfill its function. Do not increase machine weight beyond the certified value by modifying the machine or by installing attachments to the machine. Also, if the function of the protective equipment is impeded, the protective equipment will not be able to protect the operator, and the operator may suffer injury or death. Always observe the following.

- If the machine is equipped with a protective structure, do not remove the protective structure and carry out operations without it.
- If the protective structure is welded, or holes are drilled in it, or it is modified in any other way, its strength may drop. Consult your Komatsu distributor before carrying out any modifications.
- If the protective structure is damaged or deformed by falling objects or by rolling over, its strength will be reduced and it will not be able to fulfill its function properly. In such cases, always contact your Komatsu distributor for advice on the method of repair.
- Even if the protective structure is installed, always fasten your seat belt properly when operating the machine. If you do not fasten your seatbelt properly, it cannot display its effect.

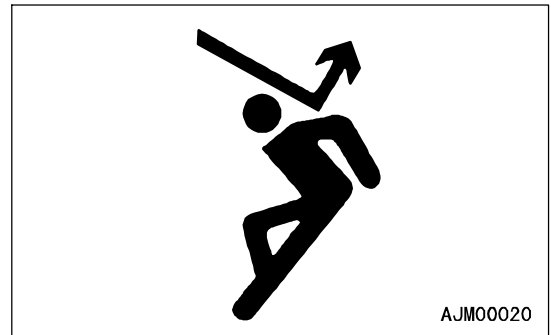

UNAUTHORIZED MODIFICATION

- Komatsu will not be responsible for any injuries, accidents, product failures or other property damages resulting from modifications made without authorization from Komatsu.
- Any modification made without authorization from Komatsu can create hazards. Before making a modification, consult your Komatsu distributor.

PRECAUTIONS RELATED TO ATTACHMENTS AND OPTIONS

- Any injuries, accidents, product failures or other property damages resulting from the use of unauthorized attachments or parts will not be the responsibility of Komatsu.
- When installing optional parts or attachments, there may be problems with safety or legal restrictions. Therefore contact your Komatsu distributor for advice.
- When installing and using optional attachments, read the instruction manual for the attachment, and the general information related to attachments in this manual.

PRECAUTIONS WHEN RUNNING ENGINE INSIDE BUILDING

The engine exhaust gas contains substances that may damage your health or even cause death. Start or operate the engine in a place where there is good ventilation. If the engine or machine must be operated inside a building or under ground, where the ventilation is poor, take steps to ensure that the engine exhaust gas is removed and that ample fresh air is brought in.

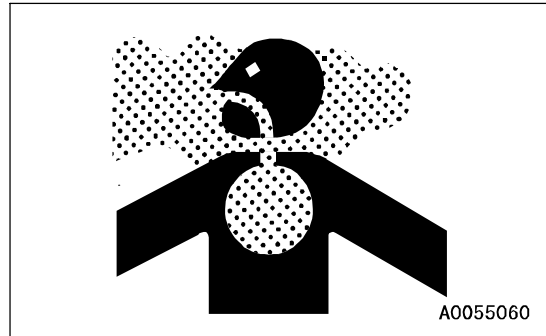

PRECAUTIONS FOR OPERATION

PRECAUTIONS FOR JOBSITE

INVESTIGATE AND CONFIRM JOBSITE CONDITIONS

On the jobsite, there are various hidden dangers that may lead to personal injury or death. Before starting operations, always check the following to confirm that there is no danger on the jobsite.

- When carrying out operations near combustible materials such as thatched roofs, dry leaves or dry grass, there is a hazard of fire, so be careful when operating.
- Check the terrain and condition of the ground at the worksite, and determine the safest method of operation. Do not operate where there is a hazard of landslides or falling rocks.
- If water lines, gas lines, or high-voltage electrical lines may be buried under the worksite, contact each utility and identify their locations. Be careful not to sever or damage any of these lines.
- Take necessary measures to prevent any unauthorized person from entering the operating area.
- In particular, if you need to operate on a road, protect pedestrian and cars by designating a person for worksite traffic duty or by installing fences around the worksite.
- When traveling or operating in water or on soft ground, check the water depth, speed of the current, bedrock, and shape of the ground beforehand and avoid any place that will obstruct travel.
- Maintain the travel path on the jobsite so that there is no obstruction to travel operations.

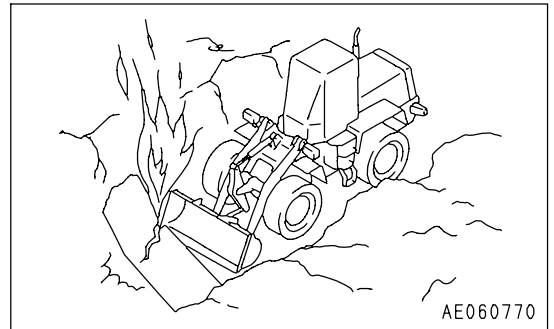

WORKING ON LOOSE GROUND

- Avoid traveling or operating your machine too close to the edge of cliffs, overhangs, and deep ditches. The ground may be weak in such areas. If the ground should collapse under the weight or vibration of the machine, there is a hazard that the machine may fall or tip over. Remember that the soil after heavy rain or blasting or after earthquakes is weak in these areas.
- When working on embankments or near excavated ditches, there is a hazard that the weight and vibration of the machine will cause the soil to collapse. Before starting operations, take steps to ensure that the ground is safe and to prevent the machine from rolling over or falling.

DO NOT GO CLOSE TO HIGH-VOLTAGE CABLES

Do not travel or operate the machine near electric cables. There is a hazard of electric shock, which may cause serious personal injury or death. On jobsites where the machine may go close to electric cables, always do as follows.

- Before starting work near electric cables, inform the local power company of the work to be performed, and ask them to take the necessary action.

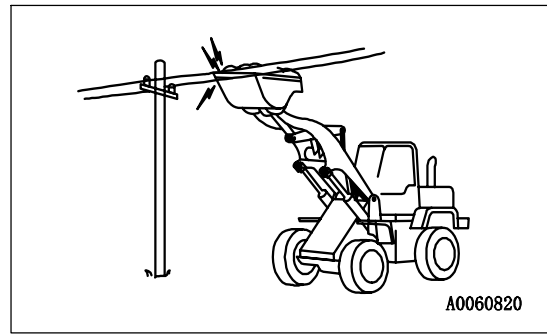

- Even going close to high-voltage cables can cause electric shock, which may cause serious burns or even death. Always maintain a safe distance (see the table on the right) between the machine and the electric cable. Check with the local power company about safe operating procedure before starting operations.
 - To prepare for any possible emergencies, wear rubber shoes and gloves. Lay a rubber sheet on top of the seat, and be careful not to touch the chassis with any exposed part of your body.
 - Use a signalman to give warning if the machine approaches too close to the electric cables.
 - When carrying out operations near high voltage cables, do not let anyone near the machine.
 - If the machine should come too close or touch the electric cable, to prevent electric shock, the operator should not leave the operator's compartment until it has been confirmed that the electricity has been shut off.
- Also, do not let anyone near the machine.

Voltage of Cables	Safety Distance
100V - 200V	Over 2 m (7 ft)
6,600V	Over 2 m (7 ft)
22,000V	Over 3 m (10 ft)
66,000V	Over 4 m (14 ft)
154,000V	Over 5 m (17 ft)
187,000V	Over 6 m (20 ft)
275,000V	Over 7 m (23 ft)
500,000V	Over 11 m (36 ft)

ENSURE GOOD VISIBILITY

This machine is equipped with mirrors to ensure good visibility, but even then there are places that cannot be seen from the operator's seat, so be careful when operating.

When traveling or carrying out operations in places with poor visibility, it is impossible to check for obstacles in the area around the machine and to check the condition of the jobsite. This leads to danger of serious personal injury or death. When traveling or carrying out operations in places with poor visibility, always observe the following.

- Position a signalman if there are areas where the visibility is not good.
- Only one signalman should give signals.
- When working in dark places, turn on the working lamp and front lamps installed to the machine, and set up additional lighting in the work area if necessary.
- Stop operations if the visibility is poor, such as in mist, snow, rain, or dust.
- When checking the mirrors installed to the machine, remove all dirt and adjust the angle of the mirror to ensure good visibility.

CHECKING SIGNS AND SIGNALMAN'S SIGNALS

- Set up signs to inform of road shoulders and soft ground. If the visibility is not good, position a signalman if necessary. Operators should pay careful attention to the signs and follow the instructions from the signalman.
- Only one signalman should give signals.
- Make sure that all workers understand the meaning of all signals and signs before starting work.

BEWARE OF ASBESTOS DUST

Asbestos dust in the air can cause lung cancer if it is inhaled. There is danger of inhaling asbestos when working on jobsites handling demolition work or work handling industrial waste. Always observe the following.

- Spray water to keep down the dust.
- Do not use compressed air.
- If there is danger that there may be asbestos dust in the air, always operate the machine from an upwind position, and make sure that all workers operate on the upwind side.
- All workers should use anti-dust masks.
- Do not allow other persons to approach during the operation.
- Always observe the rules and regulations for the work site and environmental standards.

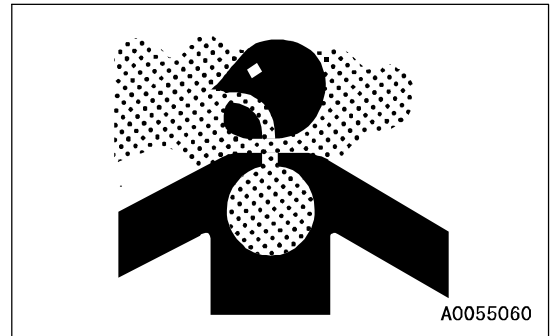

This machine does not use asbestos, but there is a danger that imitation parts may contain asbestos, so always use genuine Komatsu parts.

STARTING ENGINE**WARNING TAG**

If there is any "DANGER! Do NOT operate!" warning tag displayed, it means that someone is carrying out inspection and maintenance of the machine. If the warning sign is ignored and the machine is operated, there is danger that the person carrying out inspection or maintenance may be caught in the rotating parts or moving parts and suffer serious personal injury or death. Do not start the engine or touch the levers.

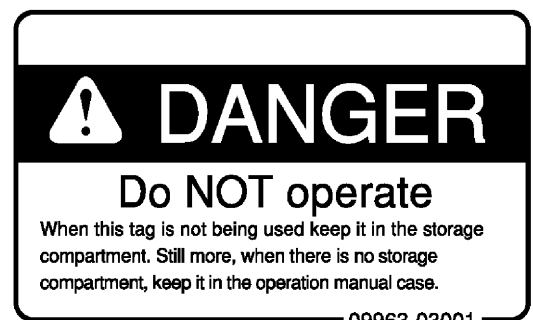
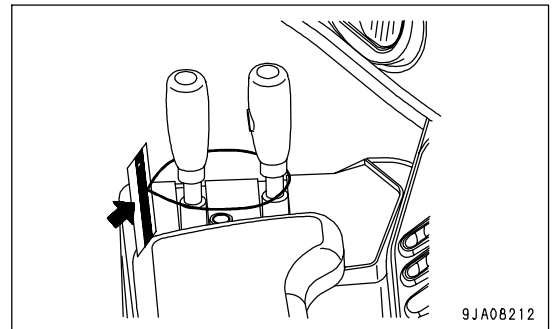

INSPECTION AND MAINTENANCE BEFORE STARTING ENGINE

Carry out the following checks before starting the engine at the beginning of the day's work to ensure that there is no problem with the operation of the machine. If this inspection is not carried out properly problems may occur with the operation of the machine, and there is danger that this may lead to serious personal injury or death.

- Remove all dirt from the surface of the window glass to ensure a good view.
- "WALK-AROUND CHECK (PAGE 3-99)" is surely executed.
- Remove all dirt from the surface of the lens of the front lamps, working lamps, and rear combination lamp, and check that they light up correctly.
- Check the coolant level, fuel level, and oil level in engine oil pan, check for clogging of the air cleaner, and check for damage to the electric wiring.
- Check that there is no mud or dust accumulated around the movable parts of the accelerator pedal or brake pedal, and check that the pedals work properly.
- Adjust the operator's seat to a position where it is easy to carry out operations, and check that there is no damage or wear to the seat belt or mounting clamps.
- Check that the gauges work properly, check the angle of the mirror, and check that the control levers are all at the Neutral position.
- Before starting up the engine, check that the work equipment lock lever is in the LOCK position.
- Adjust the mirrors so that the rear of the machine can be seen clearly from the operator's seat. See "ADJUSTING MIRRORS (PAGE 3-116)".
- Check that there are no persons or obstacles above, below, or in the area around the machine.
- Check that the parking brake switch is at the ON position.
- Check that frame lock lever (1) is securely fixed at FREE position(F).

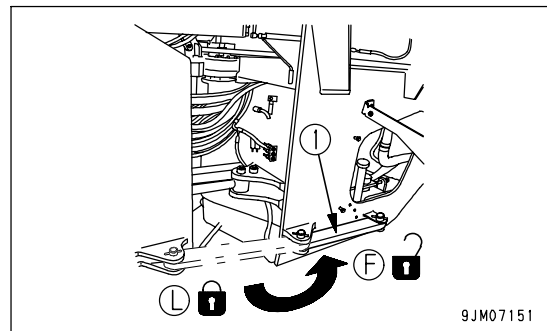
**PRECAUTIONS WHEN STARTING ENGINE**

- Start and operate the machine only while seated.
- When starting the engine, sound the horn as a warning.
- Do not allow anyone apart from the operator to ride on the machine.
- Do not attempt to start the engine by short-circuiting the engine starting circuit. This may cause fire, serious personal injury or death.
- Check that the backup alarm (alarm buzzer when machine travels in reverse) works properly.

PRECAUTIONS IN COLD AREAS

- Carry out the warming-up operation thoroughly. If the machine is not thoroughly warmed up before the control levers are operated, the reaction of the machine will be slow, and this may lead to unexpected accidents.
- If the battery electrolyte is frozen, do not charge the battery or start the engine with a different power source. There is a hazard that this will ignite the battery and cause the battery to explode. Before charging or starting the engine with a different power source, melt the battery electrolyte and check that there is no leakage of electrolyte before starting.

STARTING WITH BOOSTER CABLES

If any mistake is made in the method of connecting the booster cables, it may cause the battery to explode, so always do as follows.

- Always wear safety goggles and rubber gloves when starting the engine with booster cable.
- When connecting a normal machine to a problem machine with booster cables, always use a normal machine with the same battery voltage as the problem machine.
- When starting with a booster cable, carry out the starting operation with two workers (one worker sitting in the operator's seat and the other working with the battery).
- When starting from another machine, do not allow the two machines to touch.
- When connecting the booster cables, turn the starting switch to the OFF position for both the normal machine and problem machine. There is a hazard that the machine will move when the power is connected.
- Be sure to connect the positive (+) cable first when installing the booster cables. Disconnect the negative (-) cable (ground side) first when removing them.
- When removing the booster cables, be careful not to let the booster cable clips touch each other or to let the clips touch the machine.
- For details of the starting procedure when using booster cables, see "STARTING ENGINE WITH BOOSTER CABLE (PAGE 3-173)" in the OPERATION section.

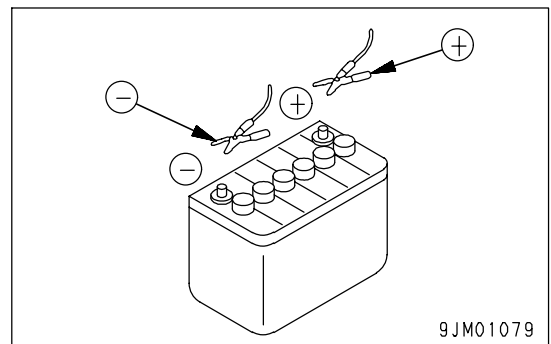
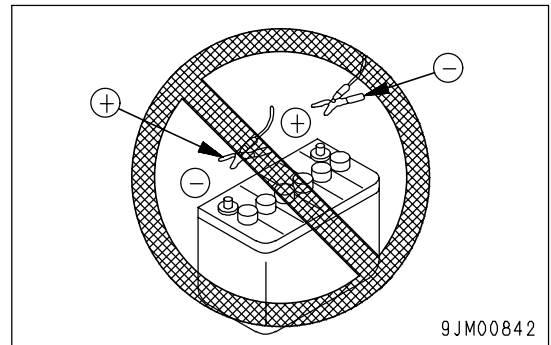
**OPERATION****CHECKS BEFORE OPERATION**

If the checks before starting are not carried out properly, the machine will be unable to display its full performance, and there is also danger that it may lead to serious personal injury or death.

When carrying out the checks, move the machine to a wide area where there are no obstructions, and pay careful attention to the surrounding area. Do not allow anyone near the machine.

- Always wear the seatbelt. There is danger that you may be thrown out of the operator's seat and suffer serious injury when the brakes are applied suddenly.
- Check the operation of travel, steering and brake systems, and work equipment control system.
- Check for any problem in the sound of the machine, vibration, heat, smell, or gauges; check also that there is no leakage of oil or fuel.
- If any problem is found, carry out repairs immediately.

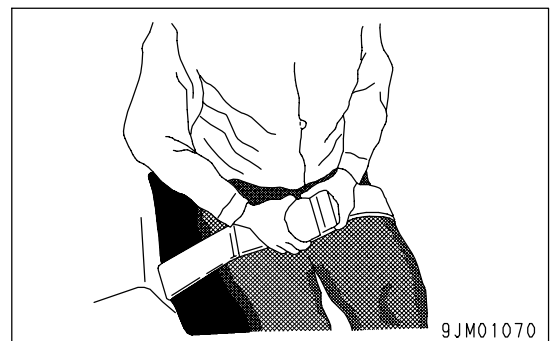

- Before driving the machine or starting operations, check that frame lock bar (1) is securely fixed at the FREE position.

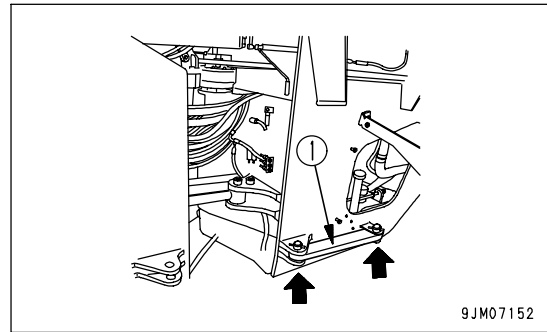

9JM07152

PRECAUTIONS WHEN TRAVELING IN FORWARD OR REVERSE

- Lock the cab door and windows securely, both when they are open and when they are closed.
- Do not allow anyone apart from the operator to ride on the machine.
- If there are any persons in the area around the machine, there is danger that they may be hit or caught by the machine, and this may lead to serious personal injury or death. Always observe the following before traveling.
 - Always operate the machine only when seated.
 - Before moving off, check again that there is no person or obstruction in the surrounding area.
 - Before moving, sound the horn to warn people in the surrounding area.
 - Check that the backup alarm (alarm buzzer when machine travels in reverse) works properly.
 - If there is an area to the rear of the machine which cannot be seen, position a signalman.

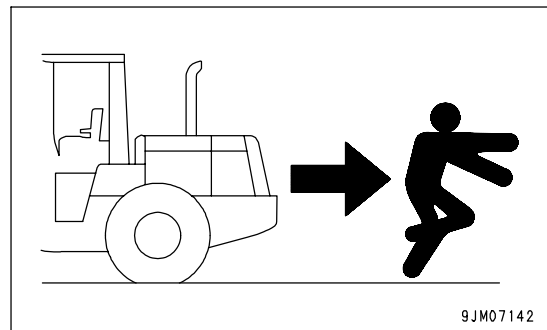

9JM07142

Always be sure to carry out the above precautions even when the machine is equipped with mirrors.

PRECAUTIONS WHEN TRAVELING

- Never turn the key in the starting switch to the OFF position. It is dangerous if the engine stops when the machine is traveling, because the steering becomes heavy. There is danger that this will cause misoperation of the steering wheel and may lead to serious personal injury or death. If the engine stops, depress the brake pedal immediately to stop the machine.
- When traveling or carrying out operations, always keep a safe distance from people, structures, or other machines to avoid coming into contact with them.
- When traveling on level ground, keep the work equipment at height (A) 40 to 50 cm (16 to 20 in) from the ground. If the work equipment is not sufficiently raised from the ground, there is danger that the work equipment will contact the ground and cause the machine to tip over.

When traveling, do not operate the work equipment control levers. If the work equipment control levers have to be operated, stop the machine first, then operate the levers.

- Avoid traveling over obstacles when possible. If the machine has to travel over an obstacle, keep the work equipment close to the ground and travel at low speed. There is more danger of the machine tipping over to the left or right than tipping over to the front or rear, so do not travel over obstacles which make the machine tilt strongly to the left or right sides.
 - When traveling on rough ground, travel at low speed and do not operate the steering suddenly. There is danger that the machine may turn over. The work equipment may hit the ground surface and cause the machine to lose its balance, or may damage the machine or structures in the area.
 - When using the machine, to prevent personal injury caused by damage to the work equipment or by the machine overturning due to overloading, do not exceed the permitted performance of the machine or the maximum permitted load for the structure of the machine.
 - When passing over bridges or structures, check first that the structure is strong enough to support the weight of the machine.
 - When operating in tunnels, under bridges, under electric wires, or other places where the height is limited, operate slowly and be extremely careful not to let the machine body or work equipment hit anything.
 - If you drive the machine at high speed continuously for a long time, the tires will overheat and the internal pressure will become abnormally high. This may cause the tires to burst. If a tire bursts, it produces a large destructive force, and this may cause serious injury or death.
- If you are going to travel continuously, please consult your Komatsu distributor.
- When the machine is traveling on flat ground or down a slope, NEVER set the directional lever to the Neutral position. Always set it to a transmission speed range.
 - If the transmission is at neutral, the engine brakes will not work and the steering wheel will become heavy, so this creates a dangerous situation.
 - It may also cause damage to the transmission or other parts of the power train, and this may lead to serious personal injury or death.

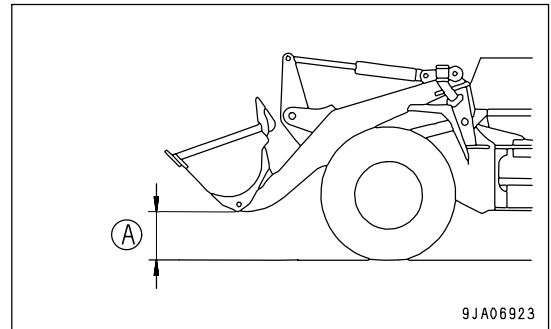

TRAVELING ON SLOPES

To prevent the machine from tipping over or slipping to the side, always do as follows.

- Keep the work equipment at height (A) 20 - 30 cm (8 - 12 in) above the ground so that it can be lowered immediately to the ground to stop the machine in case of emergency.

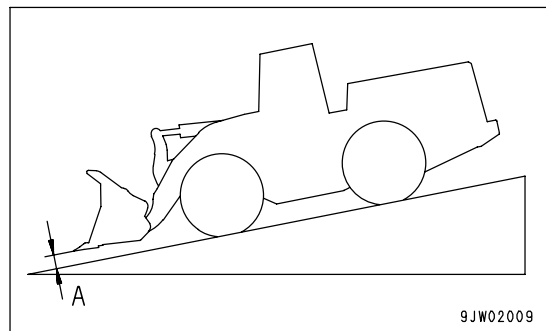
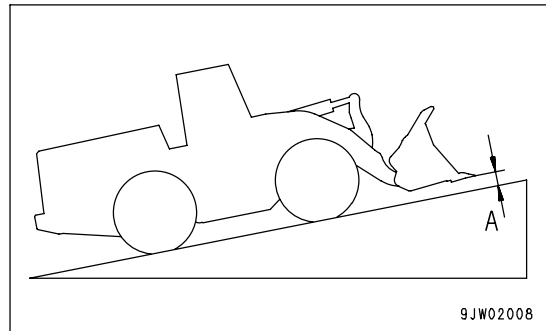

- Always travel straight up or down a slope. Traveling at an angle or across the slope is extremely dangerous.
- Do not turn on slopes or travel across slopes. Always go down to a flat place to change the position of the machine, then travel on to the slope again.

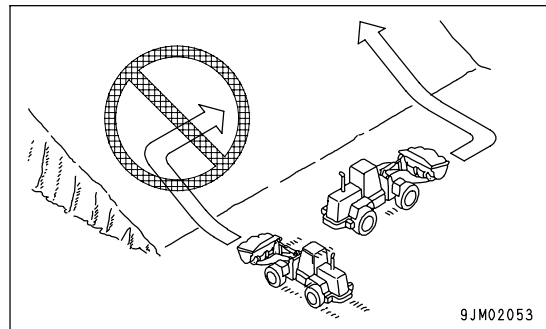

- Travel on grass, fallen leaves, or wet steel plates with low speed. Even with slight slopes there is a hazard that the machine may slip.
- If the engine stops, depress the brake pedal immediately, lower the bucket to the ground, and apply the parking brake to stop the machine.
- When traveling downhill, never shift gear or place the transmission at neutral. It is dangerous not to use the braking force of the engine. Always place the transmission in a low gear before starting to travel downhill.
- When traveling downhill, travel slowly. If necessary, use the braking force of the engine together with the brake pedal to control the travel speed.
- When traveling up or down hills with a loaded bucket, always travel with the bucket facing uphill. If the machine travels with the bucket facing downhill, there is danger that the machine may tip over.

METHOD OF USING BRAKES

- When the machine is traveling, do not rest your foot on the brake pedal. If you travel with your foot resting on the pedal, the brake will always be applied, and this will cause the brakes to overheat and fail.
- Do not depress the brake pedal repeatedly if not necessary.
- When traveling downhill, use the braking force of the engine, and always use the right brake pedal at the same time.
- Set to the lock-up and use the braking force of the engine.

PRECAUTIONS WHEN OPERATING

- When using the machine, to prevent personal injury caused by damage to the work equipment or by the machine overturning due to overloading, do not exceed the permitted performance of the machine or the maximum permitted load for the structure of the machine.
- If the engine cannot be started again after it has stopped, immediately operate the work equipment control levers to lower the work equipment to the ground. (After the engine stops, the accumulator allows the work equipment to be operated for a limited time.)
- Be careful not to approach too close to the edge of cliffs. When making embankments or landfills, or when dropping soil over a cliff, dump one pile, then use the next pile of soil to push the first pile.
- The load suddenly becomes lighter when the soil is pushed over a cliff or when the machine reaches the top of a slope. When this happens, there is danger that the travel speed will suddenly increase, so be sure to reduce the speed.
- When the bucket is fully loaded, never start, turn, or stop the machine suddenly. There is danger of the machine turning over.

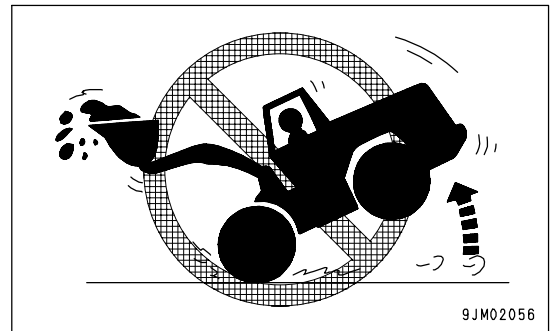

- When handling unstable loads, such as round or cylindrical objects, or piled sheets, if the work equipment is raised high, there is danger that the load may fall on top of the operator's compartment and cause serious injury or death.
- When handling unstable loads, be careful not to raise the work equipment too high or tip the bucket back too much.
- If the work equipment is suddenly lowered or suddenly stopped, the reaction may cause the machine to tip over. Particularly when carrying a load, be sure to operate the work equipment carefully.
- When operating in tunnels, under bridges, under electric wires, or other places where the height is limited, be extremely careful not to let the machine body or work equipment hit anything.
- To prevent accidents caused by hitting other objects, always operate the machine at a speed which is safe for operation, particular in confined spaces, indoors, and in places where there are other machines.

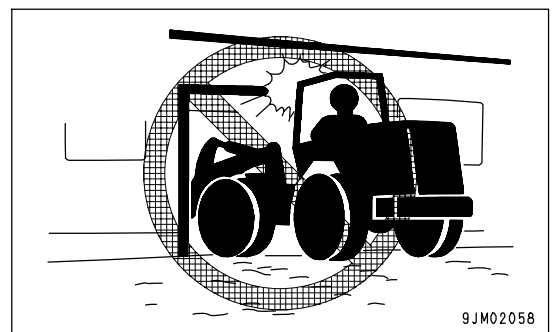
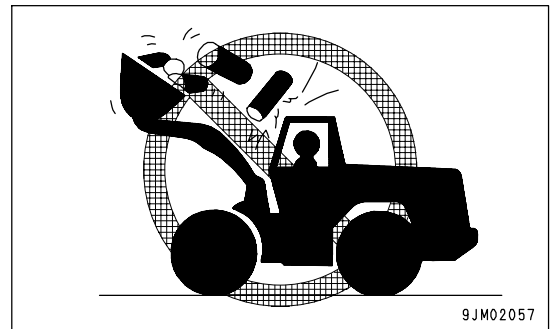

PROHIBITED OPERATIONS

If the machine rolls over or falls, or the ground at the working point collapses, it may lead to serious personal injury or death. Always observe the following precautions.

- Do not excavate the work face under an overhangs. There is danger that the work face will collapse.
- When digging, never thrust the bucket into a load at an angle. This will bring an excessive load to bear on the machine and will reduce the service life of the machine.
- It is dangerous to apply drive force when excavating a rock face. In addition, an excessive load will be brought to bear on the machine and this will cause damage to the machine.
- Never carry out digging operations on a downhill slope. An excessive load will be brought to bear on the machine and this will cause damage to the machine.
- Do not use the bucket or lift arm for crane operations. There is danger that the machine will tip over and that the load will fall.

- Do not pass the bucket over the head of other workers or over the operator's seat of dump trucks or other hauling equipment. The load may spill or the bucket may hit the dump truck and cause serious personal injury or death.

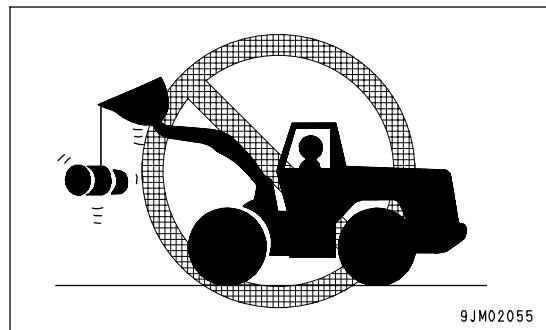
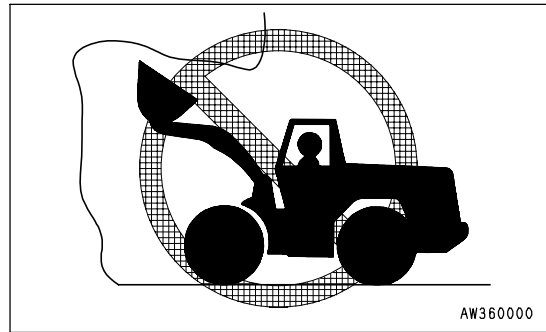

TRAVELING ON SNOW-COVERED OR FROZEN SURFACES

- Snow-covered or frozen surfaces are slippery, so be extremely careful when traveling or operating the machine, and do not operate the levers suddenly. Even a slight slope may cause the machine to slip, so be particularly careful when working on slopes.
- With frozen ground surfaces, the ground becomes soft when the temperature rises, and this may cause the machine to tip over or make it impossible for the machine to escape.
- When traveling on snow-covered roads, always fit tire chains.
- If the machine enters deep snow, there is a hazard that it may tip over or become buried in the snow. Be careful not to leave the road shoulder or to get trapped in a snow drift.
- When clearing snow, the road shoulder and objects placed beside the road are buried in the snow and cannot be seen. There is a hazard of the machine tipping over or hitting covered objects, so always carry out operations carefully.
- When traveling on snow-covered slopes, never apply the foot brake suddenly. Reduce the speed and use the engine as a brake while applying the foot brake intermittently (depress the brake intermittently several times). If necessary, lower the work equipment to the ground to stop the machine.

PARKING MACHINE

- Park the machine on firm, level ground.
- Select a place where there is no hazard of landslides, falling rocks, or flooding.
- Lower the work equipment completely to the ground.

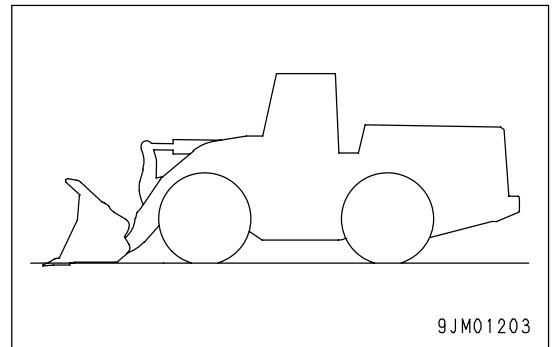

- When leaving the machine, set work equipment lock lever (1) to the LOCK position (L) and parking brake switch (2) to the ON position (A), and stop the engine.
- Always close the operator's cab door, and use the key to lock all the equipment in order to prevent any unauthorized person from moving the machine. Always remove the key, take it with you, and leave it in the specified place.

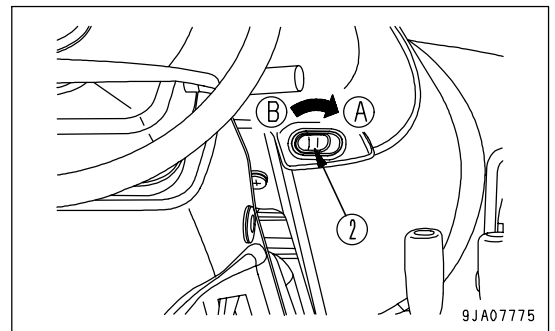
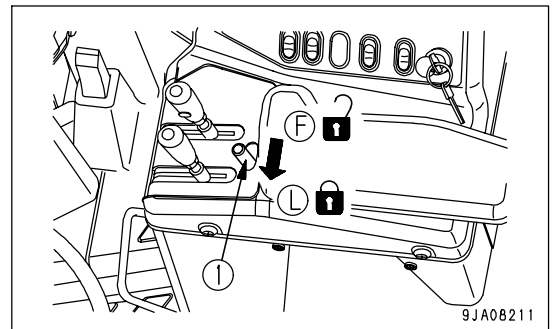

- If it is necessary to park the machine on a slope, set blocks under the wheels to prevent the machine from moving.

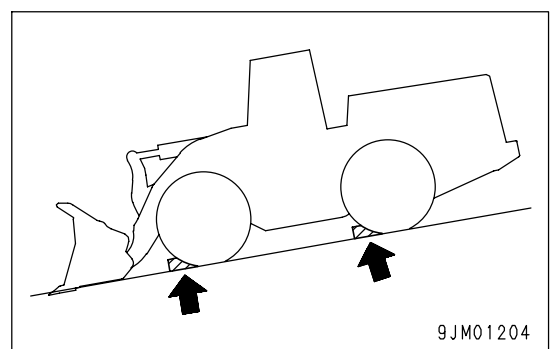

TRANSPORTATION

When the machine is transported on a trailer, there is danger of serious personal injury or death during transportation. Always do as follows.

- Always check the machine dimensions carefully. Depending on the work equipment installed, the machine weight, transportation height, and overall length may differ.
- Check beforehand that all bridges and other structures on the transportation route are strong enough to withstand the combined weight of the transporter and the machine being transported.
- The machine can be divided into parts for transportation, so when transporting the machine, please contact your Komatsu distributor to have the work carried out.
- Lock the frame with the frame lock bar to prevent the machine from articulating.
- Fit chains to the front frame and the rear frame to hold the machine securely in position.
- For details of the procedure for transporting the machine, see "TRANSPORTATION (PAGE 3-158)".

LOADING AND UNLOADING

When loading or unloading the machine, mistaken operation may bring the hazard of the machine tipping over or falling, so particular care is necessary. Always do as follows.

- Perform loading and unloading on firm, level ground only. Maintain a safe distance from the edge of the road or cliff.
 - Always use ramps of adequate strength. Be sure that the ramps are wide, long, and thick enough to provide a safe loading slope. Take suitable steps to prevent the ramps from moving out of position or coming off.
 - Be sure the ramp surface is clean and free of grease, oil, ice and loose materials. Remove dirt from the tire of the machine. On a rainy day, in particular, be extremely careful since the ramp surface is slippery.
 - Run the engine at low idling and drive the machine slowly at low speed.
 - Never correct your steering on the ramps. If necessary, drive off the ramps, correct the direction, then enter the ramps again.
 - When loading or unloading to an embankment or platform, make sure that it has suitable width, strength, and grade.
 - For machines equipped with a cab, always lock the door after boarding the machine. If this is not done, the door may suddenly open during transportation.
- Refer to "TRANSPORTATION (PAGE 3-158)".

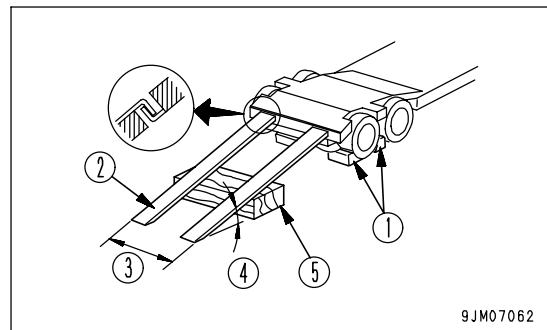

- (1) Blocks
- (2) Ramp
- (3) Width of ramps: Same width as tires
- (4) Angle of ramps: Max. 15°
- (5) Block

TOWING

PRECAUTIONS WHEN TOWING

Always use the correct towing equipment and towing method. Any mistake in the selection of the wire rope or towing bar or in the method of towing a disabled machine may lead to serious personal injury or death.

For details of the procedure for towing, see the "METHOD OF TOWING MACHINE (PAGE 3-167)"

- Always confirm that the wire rope or drawbar used for towing has ample strength for the weight of the machine being towed.
- Never use a wire rope which has cut strands (A), reduced diameter (B), or kinks (C). There is danger that the rope may break during the towing operation.
- Always wear leather gloves when handling wire rope.
- Never tow a machine on a slope.
- During the towing operation, never stand between the towing machine and the machine being towed.

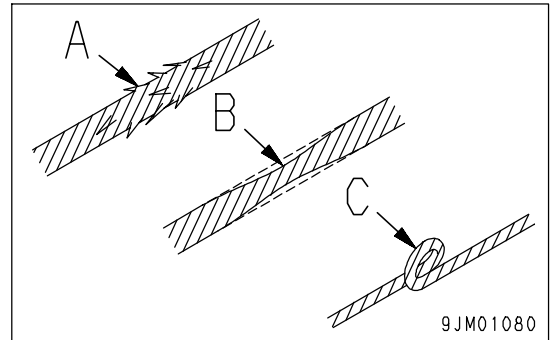

PRECAUTIONS FOR MAINTENANCE

PRECAUTIONS BEFORE STARTING INSPECTION AND MAINTENANCE

DISPLAY WARNING TAG DURING INSPECTION AND MAINTENANCE

If there is any "DANGER! Do NOT operate!" warning tag displayed, it means that someone is carrying out inspection and maintenance of the machine. If the warning sign is ignored and the machine is operated, there is danger that the person carrying out inspection or maintenance may be caught in the rotating parts or moving parts and suffer serious personal injury or death. Do not start the engine or touch the levers.

- If necessary, put up signs around the machine also.

Warning tag part number: 09963-03001

When not using this warning tag, keep it in the toolbox.

If there is no toolbox, keep it in the pocket for the Operation and Maintenance Manual

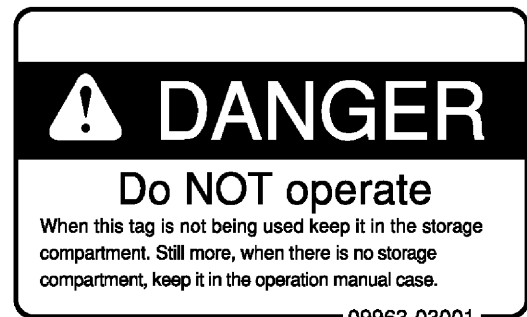
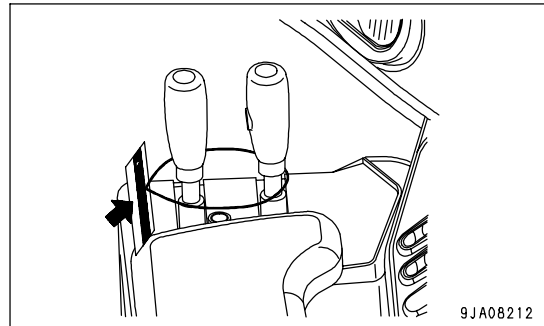

KEEP WORKPLACE CLEAN AND TIDY

Do not leave hammers or other tools lying around in the work place. Wipe up all grease, oil, or other substances that will cause you to slip. Always keep the work place clean the tidy to enable you to carry out operations safely. If the work place is not kept clean and tidy, there is the danger that you will trip, slip, or fall over and injure yourself.

SELECT SUITABLE PLACE FOR INSPECTION AND MAINTENANCE

- Stop the machine on firm, level ground.
- Select a place where there is no hazard of landslides, falling rocks, or flooding.

ONLY AUTHORIZED PERSONNEL

Do not allow any unauthorized personnel into the area when servicing the machine. If necessary, employ a guard.

APPOINT LEADER WHEN WORKING WITH OTHERS

- When repairing the machine or when removing and installing the work equipment, appoint a leader and follow his instructions during the operation.

STOP ENGINE BEFORE CARRYING OUT INSPECTION AND MAINTENANCE

- Lower the work equipment completely to the ground and stop the engine before performing any inspection and maintenance.

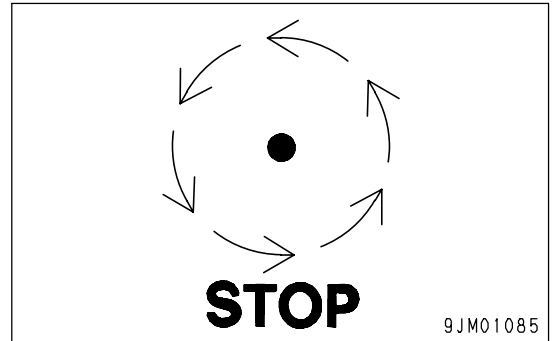

- After stopping the engine, turn the starting switch to the ON position, operate work equipment control lever (1) fully in the RAISE and LOWER directions 2 or 3 times to release the remaining pressure in the hydraulic circuit, then set work equipment lock lever (2) to LOCK position (L). After releasing the remaining pressure in the hydraulic circuit, turn the starting switch to the OFF position.

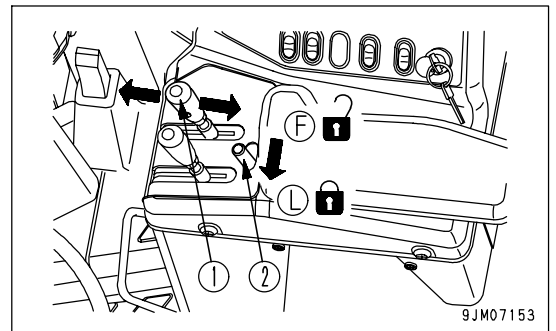

- Set parking brake switch (3) to the ON position (A) to apply the parking brake, then put blocks in front of and behind the tires to prevent the machine from moving.

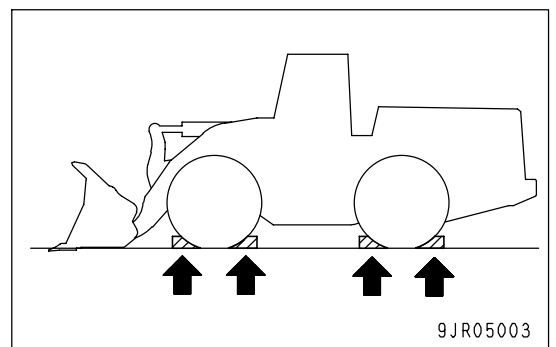
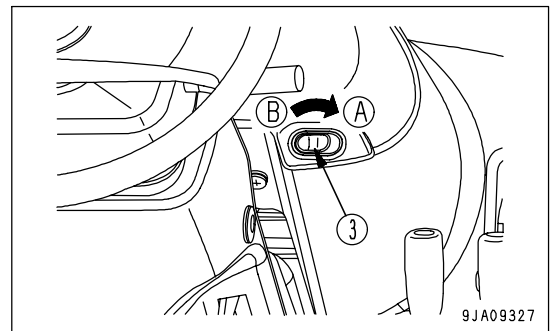

- Set frame lock bar (4) to lock position (L) to lock the front and rear frames.

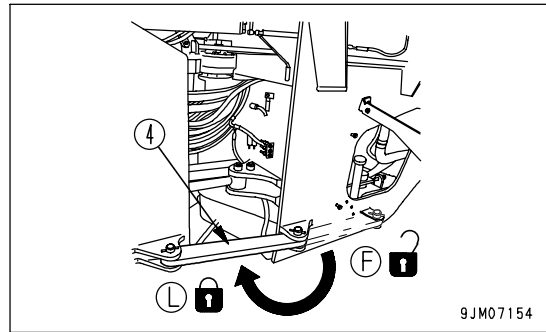

TWO WORKERS FOR MAINTENANCE WHEN ENGINE IS RUNNING

To prevent personal injury, do not carry out maintenance with the engine running. If maintenance must be carried out with the engine running, carry out the operation with at least two workers and do as follows.

- One worker must always sit in the operator's seat and be ready to stop the engine at any time. All workers must maintain contact with the other workers.
- When carrying out operations near the fan, fan belt, or other rotating parts, there is a hazard of being caught in the parts, so be careful not to come close.
- Never drop or insert tools or other objects into the fan, fan belt, or other rotating parts. There is danger that they may contact the rotating parts and break or be sent flying.

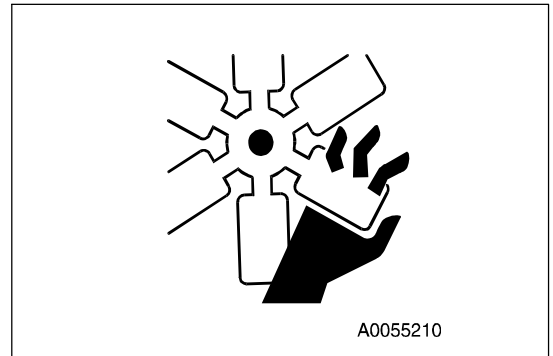

- Lower the work equipment completely to the ground, then set work equipment lock lever (1) to lock position (L) to prevent the machine from moving.

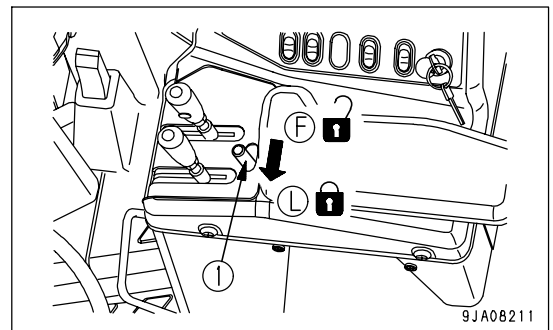

- Set parking brake switch(2) to ON position(A) and put blocks under the tires to prevent the machine from moving
- Be careful not to touch the control levers or steering equipment. If the control levers must be operated, always give a signal to your partner and have your partner withdraw to a safe place.

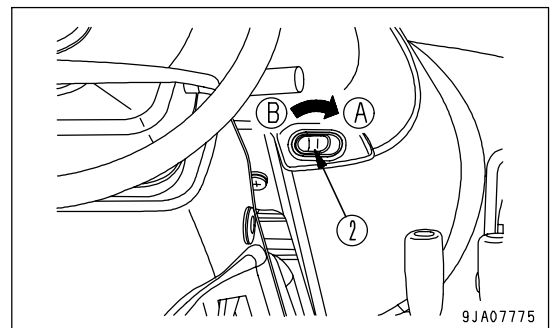
**TURNING E.C.S.S. SWITCH OFF BEFORE CARRYING OUT INSPECTION AND MAINTENANCE**

Lower the bucket to the ground, turn the E.C.S.S. switch OFF, and stop the engine before starting inspection or maintenance. NEVER turn the switch ON during inspection or maintenance.

INSTALLING, REMOVING, OR STORING ATTACHMENTS

- Appoint a leader before starting removal or installation operations for attachments.
- Place attachments that have been removed from the machine in a stable condition so that they do not fall. And take steps to prevent unauthorized persons from entering the storage area.



PRECAUTIONS WHEN WORKING AT HIGH PLACES

When working at high places, use a step ladder or other stand to ensure that the work can be carried out safely.

PRECAUTIONS WHEN WORKING UNDER MACHINE OR WORK EQUIPMENT

- Make sure the hoists or jacks you use are in good repair and strong enough to handle the weight of the component. Never use jacks at places where the machine is damaged, bent, or twisted. Never use frayed, twisted or pinched wire rope. Never use bent or distorted hooks.

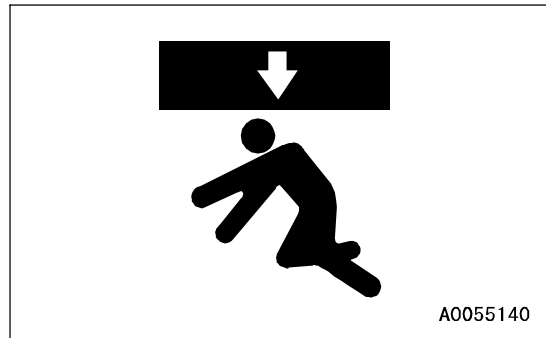

A0055140

- If it is necessary to raise the work equipment or a component and then go under it to carry out inspection or maintenance, support the work equipment or component securely with blocks and stands (1) strong enough to support the weight of the work equipment or component.

If the work equipment or component are not supported, there is a hazard that they may come down and that this may lead to serious personal injury or death.

- Never use concrete blocks for supports. They can collapse under even light loads.

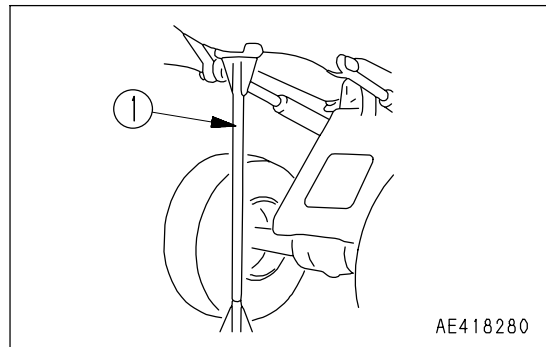

AE418280

PROPER TOOLS

Use only tools suited to the task and be sure to use the tools correctly. Using damaged, deformed, or low quality tools, or making improper use of the tools may cause serious personal injury.

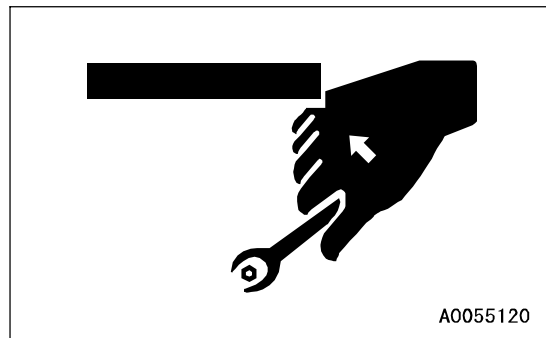

A0055120

PRECAUTIONS FOR INSPECTION AND MAINTENANCE

PRECAUTIONS WHEN WELDING

Welding operations must always be carried out by a qualified welder and in a place equipped with proper equipment. There is a hazard of gas, fire, or electrocution when carrying out welding, so never allow any unqualified personnel to carry out welding.

HANDLING BATTERY

Before inspecting or handling the battery, turn the key in the starting switch to the OFF position.

- **Danger of battery exploding**

When the battery is being charged, flammable hydrogen gas is generated and may explode. In addition, the battery electrolyte includes dilute sulphuric acid. Any mistake in handling may cause serious personal injury, explosion, or fire, so always observe the following.

- Do not use or charge the battery if the battery electrolyte is below the LOWER LEVEL mark. This will cause explosion. Always carry out periodic inspection of the battery electrolyte level, and add distilled water (or commercially available battery filler solution) to the UPPER LEVEL mark.
- Do not smoke or bring any flame close to the battery.
- Hydrogen gas is generated when the battery is being charged, so remove the battery from the machine, take it to a well-ventilated place, remove the battery caps, then carry out the charging.
- After charging, tighten the battery caps securely.

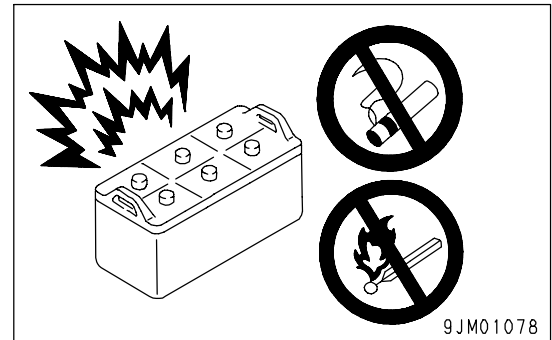

- **Danger from dilute sulphuric acid**

When the battery is being charged, flammable hydrogen gas is generated and may explode. In addition, the battery electrolyte includes dilute sulphuric acid. Any mistake in handling may cause serious personal injury, explosion, or fire, so always observe the following.

- When handling the battery, always wear protective goggles and rubber gloves.
- If battery electrolyte gets into your eyes, immediately wash your eyes with large amounts of fresh water. After that, get medical attention immediately.
- If battery electrolyte gets on your clothes or skin, wash it off immediately with large amounts of water.

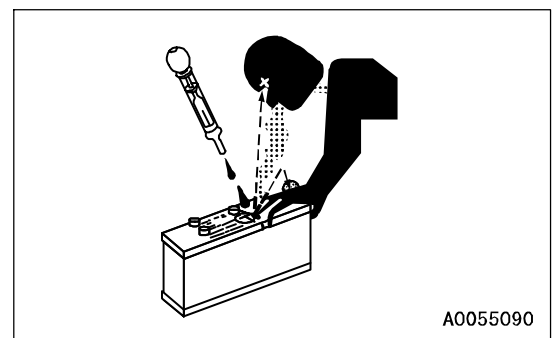

- **Removing battery cables**

Before repairing the electrical system or carrying out electric welding, turn the starting switch OFF. Wait for approx. 1 minute, then remove the negative (-) battery cable to stop the flow of electricity.

• Danger of sparks

There is hazard that sparks will be generated, so always observe the following.

- Do not let tools or other metal objects make any contact between the battery cables. Do not leave tools lying around near the battery.
- When removing the battery cables, remove the ground cable (negative (-) cable) first. When installing, connect the positive (+) cable first, then connect the ground. Tighten the battery cable terminals securely.
- Secure the battery firmly in the specified position.

PRECAUTIONS WHEN USING HAMMER

When using a hammer, pins may fly out or metal particles may be scattered. This may lead to serious personal injury or death. Always do as follows.

- When hitting pins or bucket teeth, there is a hazard that broken pieces might be sent flying and injure people in the surrounding area. Always check that there is no one in the surrounding area.
- If hard metal parts such as pins, bucket teeth, cutting edges, or bearings are hit with a hammer, there is a hazard that pieces might be scattered and cause serious personal injury or death. Always wear safety glasses and gloves.
- If the pin is hit with strong force, there is a hazard that it may fly out and injure people in the surrounding area. Do not allow anyone to enter the surrounding area.

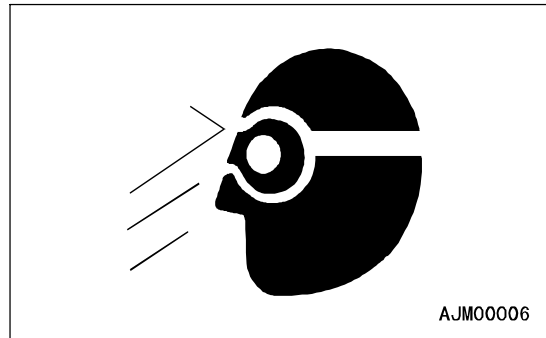

PRECAUTIONS WITH HIGH-TEMPERATURE COOLANT

To prevent burns from boiling water or steam spurting out when checking or draining the coolant, wait for the coolant to cool down to a temperature where the radiator cap can be touched by hand. Then loosen the cap slowly to release the pressure inside the radiator, and remove the cap.

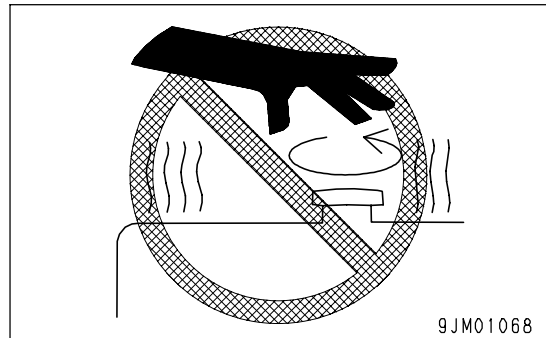

PRECAUTIONS WITH HIGH-TEMPERATURE OIL

To prevent burns from hot oil spurting out or from touching high-temperature parts when checking or draining the oil, wait for the oil to cool down to a temperature where the cap or plug can be touched by hand. Then loosen the cap or plug slowly to release the internal pressure and remove the cap or plug.

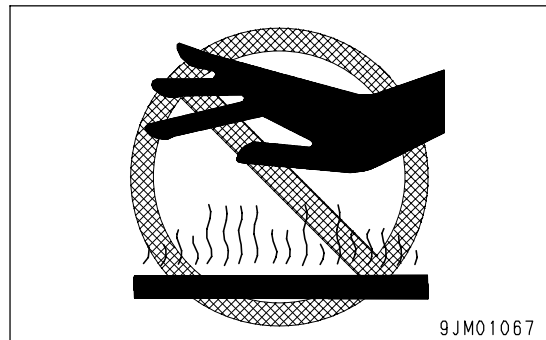

PRECAUTIONS WITH HIGH-PRESSURE OIL

The hydraulic system is always under internal pressure. In addition, the fuel piping is also under internal pressure when the engine is running and immediately after the engine is stopped. When carrying out inspection or replacement of the piping or hoses, check that the internal pressure in the circuit has been released. If this is not done, it may lead to serious personal injury or death. Always do as follows.

- Do not carry out inspection or replacement work with the circuit under pressure.
Always release the pressure before starting. For details, see "STOP ENGINE BEFORE CARRYING OUT INSPECTION AND MAINTENANCE (PAGE 2-35)".
- If there is any leakage from the piping or hoses, the surrounding area will be wet, so check for cracks in the piping and hoses and for swelling in the hoses.
When carry out inspection, wear safety glasses and leather gloves.
- There is a hazard that high-pressure oil leaking from small holes may penetrate your skin or cause loss of sight if it contacts your skin or eyes directly. If you are hit by a jet of high-pressure oil and suffer injury to your skin or eyes, wash the place with clean water, and consult a doctor immediately for medical attention.
- The pressure in the E.C.S.S. circuit is stored by an accumulator.
Do not remove the E.C.S.S. piping or components.
If it is necessary to remove them, please ask your Komatsu distributor to carry out the removal operation.

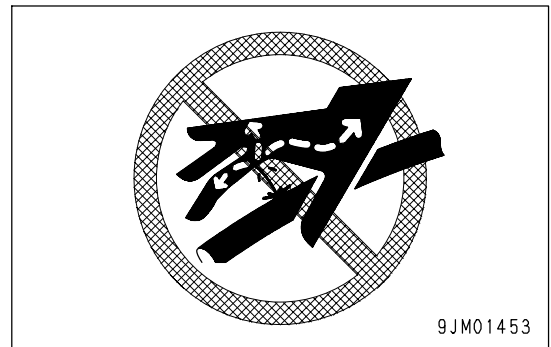
**PRECAUTIONS WITH HIGH-PRESSURE FUEL**

When the engine is running, high-pressure is generated in the engine fuel piping. When carrying out inspection or maintenance of the fuel piping system, stop the engine and wait for at least 30 seconds to allow the internal pressure to go down before starting the operation.

HANDLING HIGH-PRESSURE HOSES AND PIPING

- If oil or fuel leaks from high-pressure hoses or piping, it may cause fire or misoperation, and lead to serious personal injury, or death. If the hose or piping mounts are loose or oil or fuel is found to be leaking from the mount, stop operations and tighten to the specified torque.
If any damaged or deformed hoses or piping are found, please consult your Komatsu distributor.

Replace the hose if any of the following problems are found.

- Damaged hose or deformed hydraulic fitting.
- Frayed or cut covering or exposed reinforcement wire layer.
- Covering swollen in places.
- Twisted or crushed movable portion.
- Foreign material embedded in covering.

NOISE

When carrying out maintenance of the engine and you are exposed to noise for long periods of time, wear ear covers or ear plugs while working.

If the noise from the machine is too loud, it may cause temporary or permanent hearing problems.

HANDLING ACCUMULATOR AND GAS SPRING

This machine is equipped with an accumulator. Even after the engine has been stopped, it is possible to operate the work equipment control lever in the LOWER direction for a short time to allow the work equipment to go down under its own weight.

After stopping the engine, set the work equipment lock lever to the LOCK position and turn the parking brake switch ON.

The accumulator and gas spring are charged with high-pressure nitrogen gas. If the accumulator is handled mistakenly, it may cause an explosion that could lead to serious personal injury or death. For this reason, always observe the following precautions.

- Do not disassemble the accumulator.
- Do not bring it near flame or dispose of it in fire.
- Do not make holes in it, weld it, or use a cutting torch.
- Do not hit or roll the accumulator, or subject it to any impact.
- When disposing of the accumulator, the gas must be released.
Please contact your Komatsu distributor to have this work performed.



PRECAUTIONS WITH COMPRESSED AIR

- When carrying out cleaning with compressed air, there is a hazard of serious personal injury caused by flying dust or particles.
- When using compressed air to clean the filter element or radiator, wear safety glasses, anti-dust mask, gloves, and other protective equipment.

MAINTENANCE OF AIR CONDITIONER

- If air conditioner refrigerant gets into your eyes, it may cause loss of sight; if it contacts your skin, it may cause frostbite. Never loosen any parts of the cooling circuit.

DISPOSING OF WASTE MATERIALS

To prevent pollution, pay careful attention to the method of disposing of waste materials.

- Always put oil drained from your machine in containers. Never drain oil directly onto the ground or dump into the sewage system, rivers, the sea, or lakes.
- Obey appropriate laws and regulations when disposing of harmful objects such as oil, fuel, coolant, solvent, filters, and batteries.

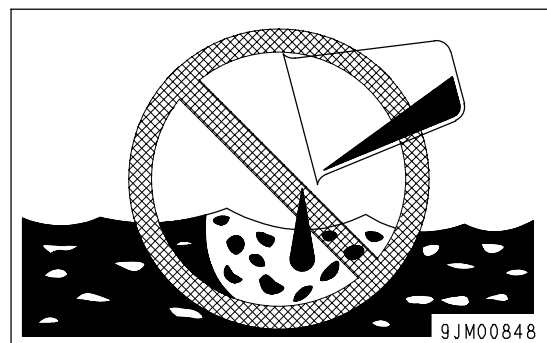

METHOD OF SELECTING WINDOW WASHER FLUID

Use an ethyl alcohol base washer liquid.

Methyl alcohol base washer liquid may irritate your eyes, so do not use it.

PERIODIC REPLACEMENT OF SAFETY CRITICAL PARTS

- To enable this machine to be used safely for a long period, always carry out periodic replacement of safety critical parts that have a particularly close relation to safety, such as hoses and the seatbelt.
For details of the replacement of safety critical parts, see "PERIODIC REPLACEMENT OF SAFETY CRITICAL PARTS (PAGE 4-13)".
- The material of these components naturally changes over time, and repeated use causes deterioration, wear, and fatigue. As a result, there is a hazard that these components may fail and cause serious personal injury or death. It is difficult to judge the remaining life of these components from external inspection or the feeling when operating, so always replace them at the specified interval.
- Replace or repair safety-critical parts if any defect is found, even when they have not reached the specified replacement time.

TIRES

HANDLING TIRES

If tires or rims are handled mistakenly, there is danger that the tire may explode or be damaged, or that the rim may fly off and cause serious personal injury or death.

To maintain safety, always do as follows.

- Maintenance, disassembly, repair, and assembly of the tires and rims requires special equipment and special technology, so always ask your Komatsu distributor to carry out these operations.
- Always use the tires specified by Komatsu and maintain the specified inflation pressure.

Suitable tire inflation pressure: see "HANDLING THE TIRES (PAGE 3-156)"

- When pumping up the tires, check that no other person is standing near the tire, and install an air chuck with a clip that can be secured to the air valve.

To prevent the tire inflation pressure from becoming too high, measure the pressure from time to time with an air gauge while pumping up the tire.

- If the tire pressure goes down abnormally or the rim parts do not fit the tire, there is a problem with the tire or rim parts. Always contact your Komatsu distributor for repairs.
- If the rim parts are not fitted properly when the tire is being pumped up, there is danger that the rim parts may fly off, so set up a protective fence around the tire, and do not stand directly in front of the rim. Stand beside the tread when pumping up the tire.
- Do not adjust the tire inflation pressure immediately after traveling at high speed or carrying out operations under heavy load.
- Never carry out welding or light a fire near the tire.
- Always release all pressure from a single tire or from both tires of a dual assembly prior to removing any rim components.
- Before removing the tire from the machine for repairs, remove the valve partially to release the air from the tire, then remove the tire.

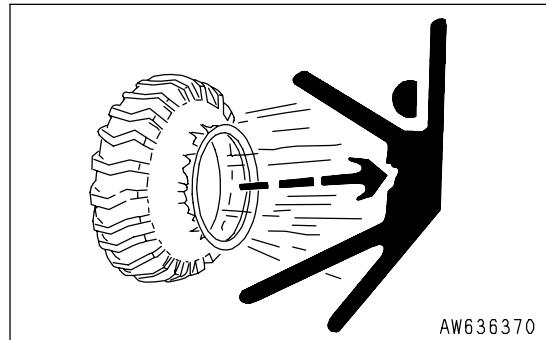

AW636370

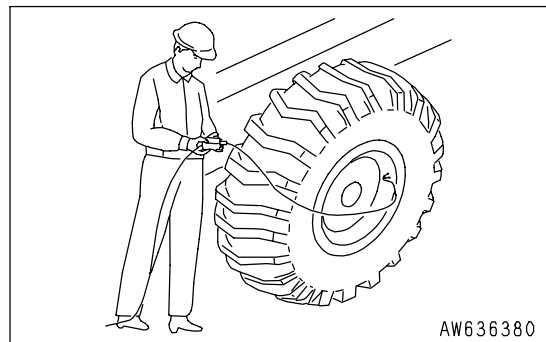

AW636380

PRECAUTIONS WHEN STORING TIRES

Tires for construction equipment are extremely heavy, it may lead to serious personal injury or death. To maintain safety, always do as follows.

- As a basic rule, store the tires in a warehouse which unauthorized persons cannot enter.
If the tires must be stored outside, always erect a fence and put up "No Entry" signs.
- Stand the tire on level ground at angle (A) of 60° - 70° and fit blocks (1) securely so that the tire cannot roll or fall over if any person should touch it. Do not lay the tire on its side. This will deform the tire.
- If the tire should fall over, do not attempt to stop it. Get out of the way quickly.

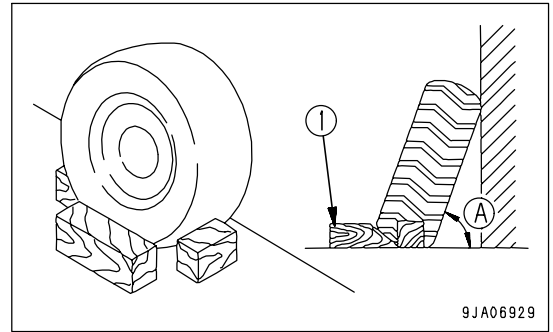

OPERATION

WARNING

Please read and make sure that you understand the SAFETY section before reading this section.

GENERAL VIEW

GENERAL VIEW OF MACHINE

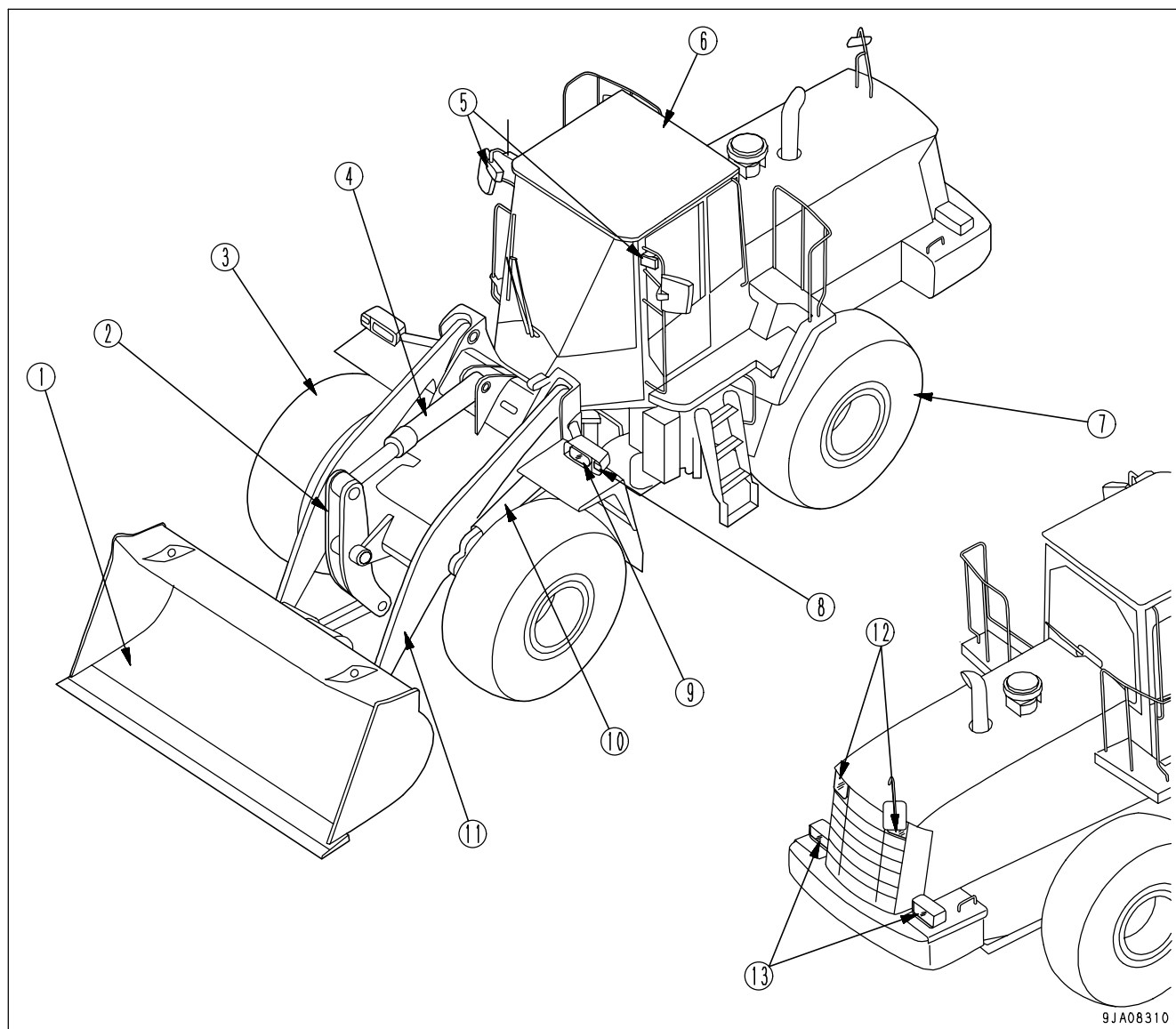

9JA08310

- | | |
|------------------------|----------------------------|
| (1) Bucket | (8) Turn signal lamp |
| (2) Bell crank | (9) Head lamp |
| (3) Front wheel | (10) Lift cylinder |
| (4) Bucket cylinder | (11) Lift arm |
| (5) Front working lamp | (12) Rear working lamp |
| (6) ROPS cab | (13) Rear combination lamp |
| (7) Rear wheel | |

GENERAL VIEW OF CONTROLS AND GAUGES

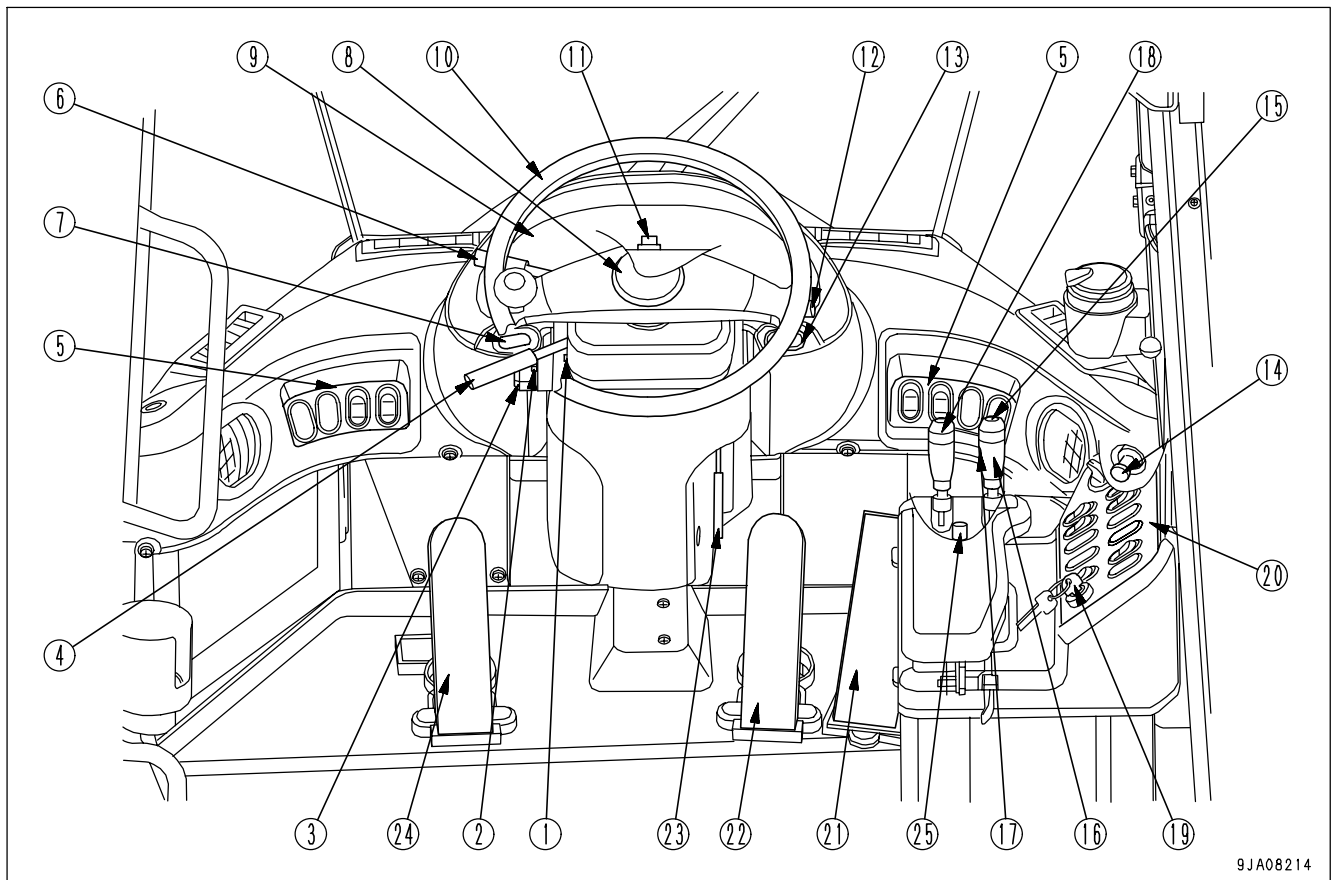

9JA08214

- | | |
|---|--------------------------------|
| (1) Gearshift lever stopper | (13) Parking brake switch |
| (2) Rear wiper switch | (14) Cigarette lighter |
| (3) Front wiper switch | (15) Kickdown switch |
| (4) Gearshift lever | (16) Lift arm control lever |
| (5) Front switch panel | (17) Hold switch |
| (6) Directional lever | (18) Bucket control lever |
| (7) E.C.S.S.
(electronic controlled suspension system)
switch | (19) Starting switch |
| (8) Horn button | (20) Right switch panel |
| (9) Machine monitor | (21) Accelerator pedal |
| (10) Steering wheel | (22) Right brake pedal |
| (11) Hazard lamp switch | (23) Steering tilt lock lever |
| (12) Lamp switch | (24) Left brake pedal |
| (12) Turn signal lever | (25) Work equipment lock lever |
| (12) Dimmer switch | |

MACHINE MONITOR

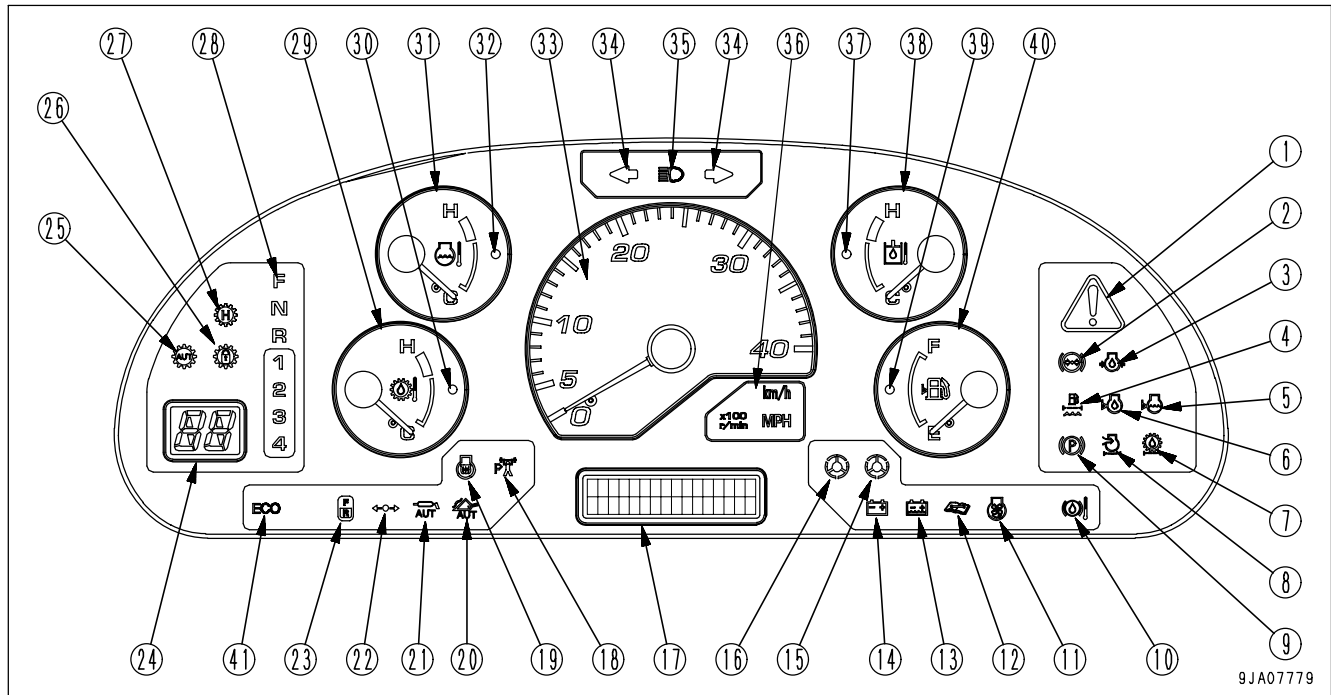

9JA07779

- (1) Central warning lamp
- (2) Brake oil pressure caution lamp
- (3) Engine oil pressure caution lamp
- (4) Water separator caution lamp
- (5) Radiator coolant level caution lamp
- (6) Engine oil level caution lamp
- (7) Transmission oil filter clogging caution lamp
- (8) Air cleaner clogging caution lamp
(Machines equipped with KOMTRAX)
- (9) Parking brake pilot lamp
- (10) Brake oil temperature caution lamp
- (11) Cooling fan reverse rotation pilot lamp
- (12) Maintenance caution lamp
- (13) Battery electrolyte level caution lamp
(if equipped)
- (14) Battery charge circuit caution lamp
- (15) Steering oil pressure caution lamp (if equipped)
- (16) Emergency steering pilot lamp (if equipped)
- (17) Character display portion
- (18) Power mode pilot lamp (P mode)
- (19) Preheating pilot lamp
- (20) Semi auto digging pilot lamp (if equipped)
- (21) Auto-greasing pilot lamp (if equipped)
- (22) Joystick pilot lamp (if equipped)
- (23) Directional selector pilot lamp
- (24) Shift indicator
- (25) Auto-shift pilot lamp
- (26) Torque converter lockup pilot lamp (if equipped)
- (27) Shift hold pilot lamp
- (28) Shift lever position pilot lamp
- (29) Torque converter oil temperature gauge
- (30) Torque converter oil temperature caution lamp
- (31) Engine coolant temperature gauge
- (32) Engine coolant temperature caution lamp
- (33) Speedometer
- (34) Turn signal pilot lamp
- (35) Head lamp high beam pilot lamp
- (36) Meter display pilot lamp
- (37) Hydraulic oil temperature caution lamp
- (38) Hydraulic oil temperature gauge
- (39) Fuel level caution lamp
- (40) Fuel gauge
- (41) Economy operation display lamp

SWITCH PANEL

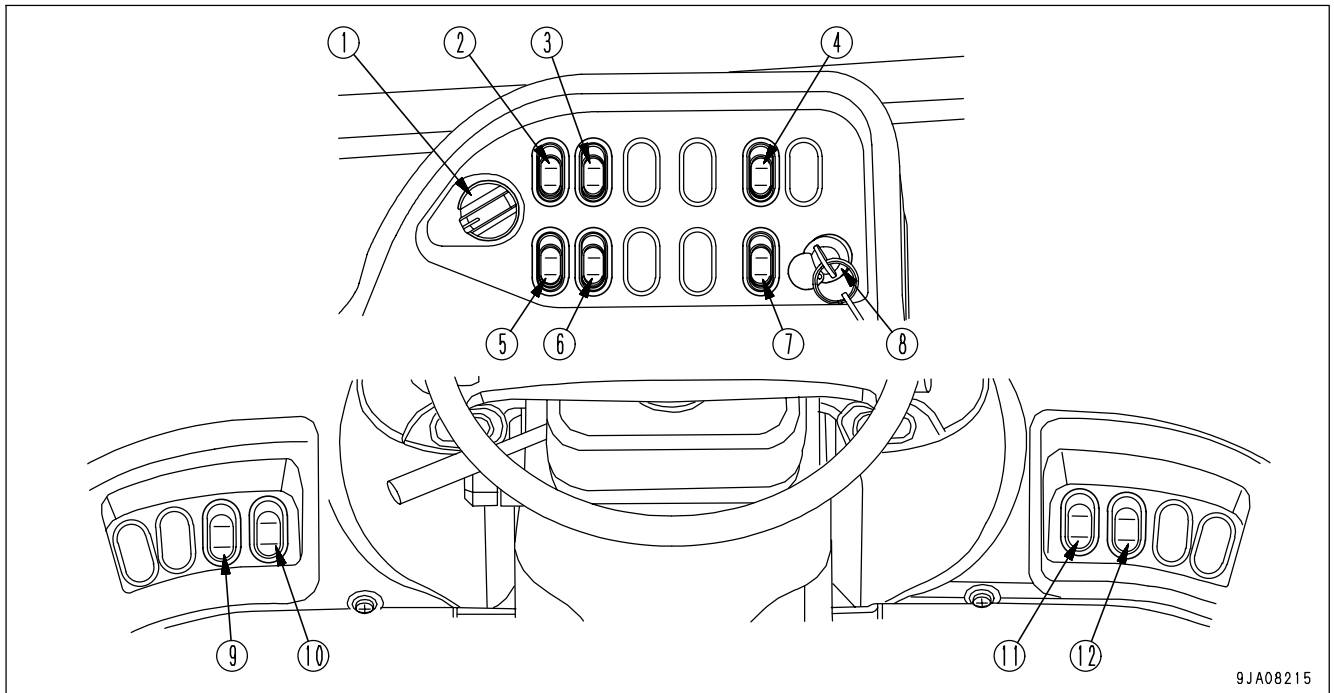

9JA08215

Right switch panel

- (1) Transmission shift mode selector switch
- (2) Transmission cut-off switch
- (3) Transmission cut-off set switch
- (4) Emergency steering switch
(if equipped)
- (5) Power mode selector switch
- (6) Torque converter lock-up switch
(if equipped)
- (7) Cooling fan reverse rotation switch
- (8) Starting switch

Front switch panel

- (9) Machine monitor mode selector switch 1
- (10) Machine monitor mode selector switch 2
- (11) Front working lamp switch
- (12) Rear working lamp switch

EXPLANATION OF COMPONENTS

The following is an explanation of devices needed for operating the machine.

To perform suitable operations correctly and safely, it is important to completely understand methods of operating the equipment, and the meanings of the displays.

MACHINE MONITOR

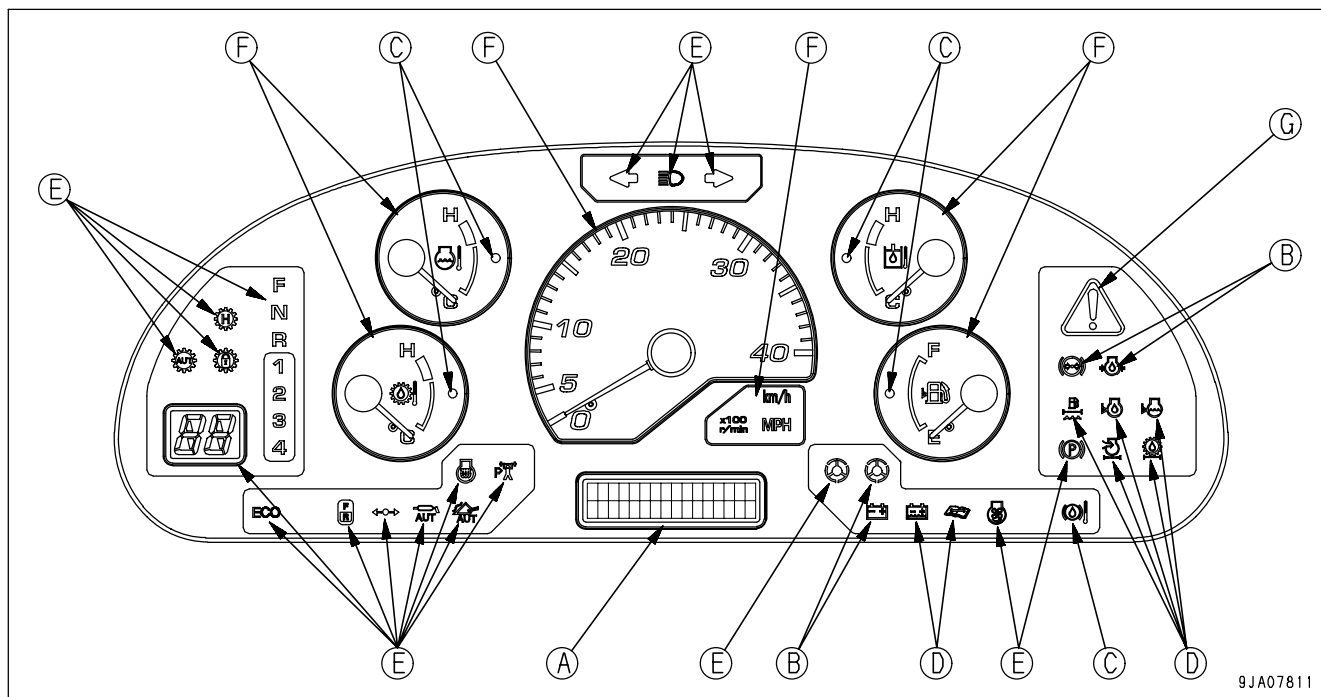

- | | |
|--------------------------------------|---------------------------|
| (A) Character display | (E) Pilot display portion |
| (B) Emergency stop items | (F) Meter display portion |
| (C) Caution items | (G) Central warning lamp |
| (D) Inspection and maintenance items | |

NOTICE

When turning the starting switch to the ON position before starting the engine, the central warning lamp, caution lamps, and pilot lamps light up for 2 seconds to check the system.

- After the alarm buzzer sounds for 2 seconds, it goes off if the condition is normal.
- The shift indicator display shows "88" for 2 seconds.
- The indicator gauges and meters are actuated after the above system check is completed.
- The character display shows "KOMATSU" for 3 seconds.
- If the lamps do not light up, there is probably a failure or disconnection, so contact your Komatsu distributor for inspection.

TYPES OF WARNING

If an abnormality occurs on the machine, or if any switch or lever is operated accidentally, the monitor display and buzzer give a warning to inform the operator.

Following are the types of warning depending on the level of danger.

REMARK

For details of action codes " E03 - E01", see "ACTION CODE DISPLAY (PAGE 3-9)" in the OPERATION Section.

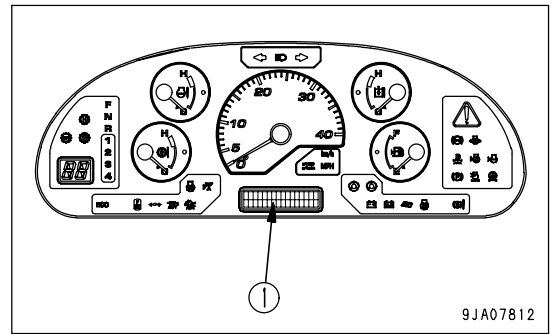

EMERGENCY STOP

This warning is given if there is a serious failure that affects the normal operation of the machine or if the setting is incorrect.

The central warning lamp on the monitor and the caution lamp for the location of the abnormality light up. At the same time, the alarm buzzer sounds and action code "E03" is displayed on character display (1).

CAUTION

This warning is given if the coolant or lubricating oil overheat.

The central warning lamp on the monitor and the individual caution lamps light up. At the same time, the alarm buzzer sounds and action code "E02" is displayed on character display (1).

MISTAKEN OPERATION

This warning is given if any switch or lever is operated mistakenly.

The central warning lamp on the monitor lights up and the alarm buzzer sounds at the same time.

INSPECTION AND MAINTENANCE

This warning is given if it is necessary to inspect and maintain wear parts, or if it is necessary to check the oil or coolant level.

The individual caution lamp on the monitor lights up. At the same time, action code "E01" is displayed on character display (1).

With this warning, the central warning lamp does not light up and the alarm buzzer does not sound.

CENTRAL WARNING LAMP

This display (1) lights up if any emergency stop item, caution item, or mistaken operation of any switch or lever occurs. At the same time the alarm buzzer sounds.

Check the display content and perform the specified action for that item.

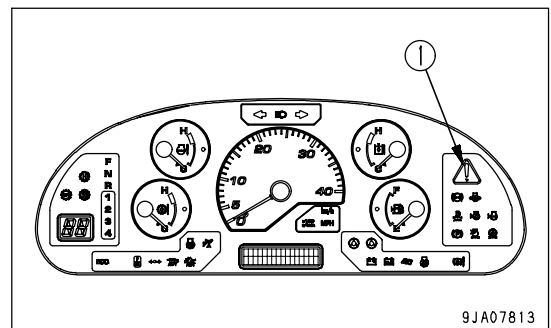

CHARACTER DISPLAY PORTION

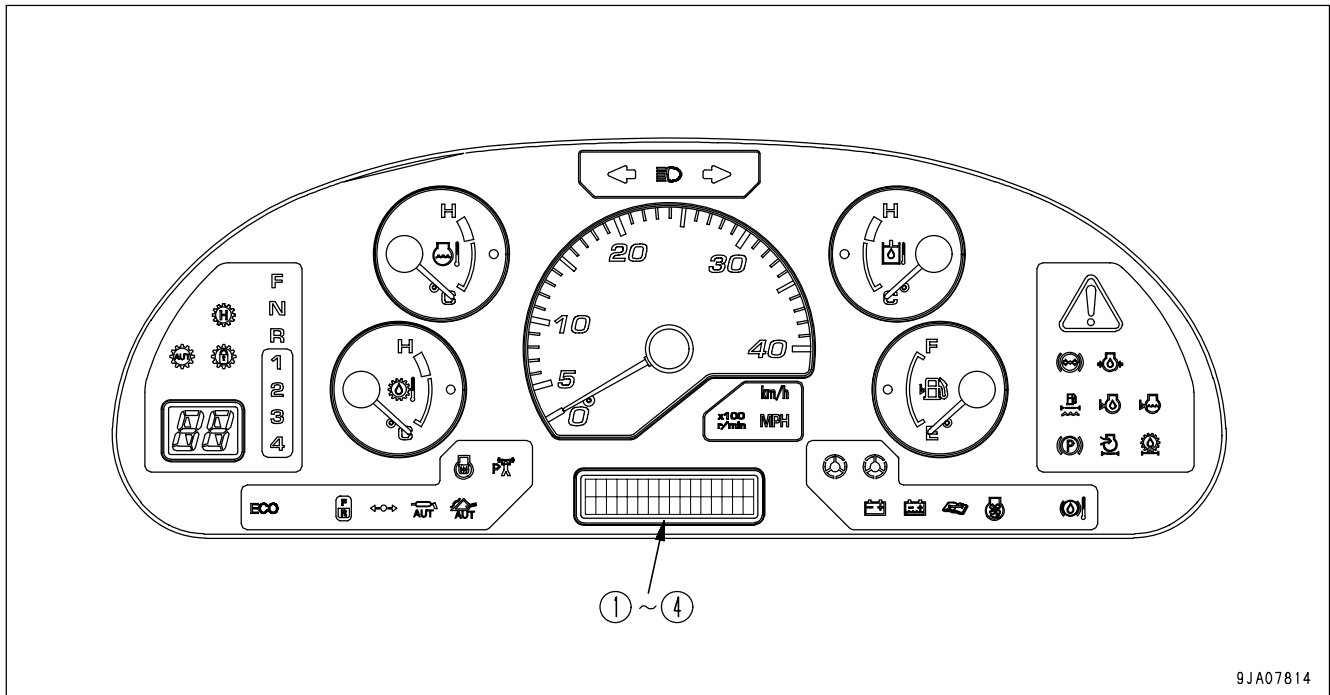

9JA07814

- (1) Service meter
- (2) Action code display
- (3) Failure code display
- (4) Filter, oil replacement time display

Normally, the service meter is displayed on the character display.
 If the machine has failed, if there has been an excessive load on the machine, or if inspection and maintenance are necessary, an action code is displayed to recommend suitable action.
 When the time for replacing the filter or changing the oil is reached, the filter or oil to be replaced is displayed.

NOTICE

Information regarding the failure of the machine or maintenance is displayed on the character display when the starting switch is at the ON position. Check the display to confirm that there is no abnormality before starting to travel.

SERVICE METER

This display (1) shows the total number of hours that the machine has been working.
 If the engine is running, the service meter advances even if the machine is not being operated.
 The service meter advances 1 for every hour of operation, regardless of the engine speed.
 Even if the starting switch is OFF, the service meter is displayed on the top line if the top (◇) portion of the machine monitor mode selector switch 1 is kept pressed.

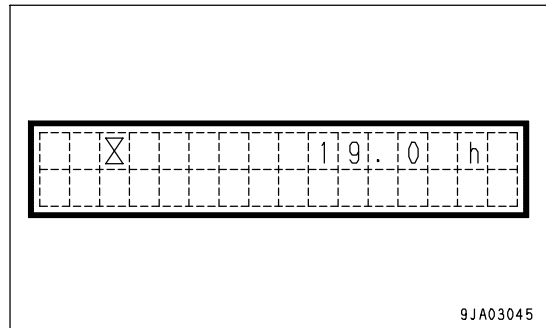

9JA03045

NOTICE

When the starting switch is at the OFF position, if the service meter is displayed even though the top (◇) of machine monitor mode selector switch 1 is not being pressed, there is probably a failure in the machine, so please contact your Komatsu distributor for inspection.

ACTION CODE DISPLAY



If action code E03 is displayed, stop the machine immediately and check the failure code. For details, see "FAILURE CODE DISPLAY (PAGE 3-11)".

Inform your Komatsu distributor of the failure code and ask for repairs.

If there is a failure on the machine, if it is necessary to change the method of operation, or if inspection or maintenance must be carried out, action code E01, E02, or E03 is displayed on the character display in display portion (2).

If different failures occur at the same time, the action code for the more serious problem is displayed.

The level of seriousness is as follows, starting with the most serious: E03, E02, E01.

In the case of action codes E02, and E03, the alarm buzzer sounds intermittently and the central warning lamp lights up.

If action codes E01, E02, or E03 are displayed on the character display, stop operations, check the content of the display, and take the following action.

E03: When this code is displayed, stop the machine immediately, check the failure code, and contact your Komatsu distributor for repairs.

REMARK

- "E03" is displayed on the top line of the character display and "CHECK RIGHT NOW" and "CALL" are displayed in turn on the bottom line for 3 seconds each.
- The telephone number is displayed to the right of "CALL". If no telephone number has been set, the display is blank. For details of the method of inputting the telephone number, see Section "INPUT METHOD FOR TELEPHONE NUMBER (PAGE 3-34)".

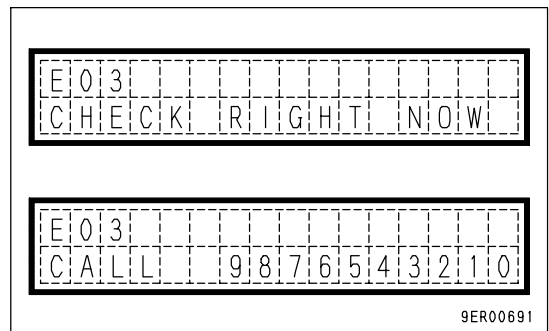

E02: If this code is displayed, stop the machine and run the engine under no load at a mid-range speed.

If an action code is still displayed after taking the necessary action, check the failure code and contact your Komatsu distributor for repairs.

REMARK

The top line of the character display displays "E02" and the bottom line displays the condition of the machine related to overheating.

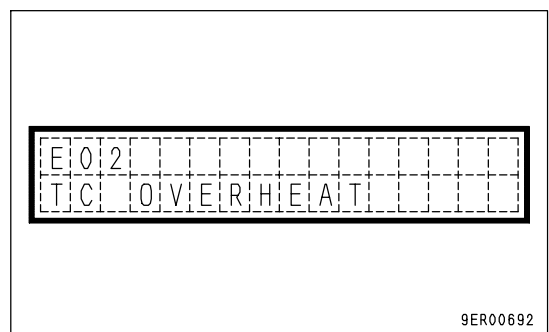

E01: When a failure occurs in the mechanical system, such as a drop in the level of the engine coolant, the maintenance location is displayed. If the maintenance caution lamp lights up at the same time, inspect and perform maintenance of the item indicated after completion of the day's work or when changing shifts. If "MAINTENANCE" is displayed together with E01, check the failure code and ask for repairs to be carried out.

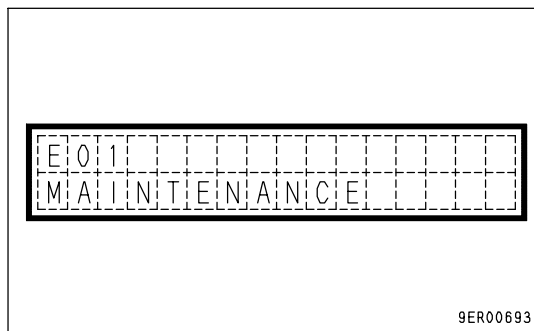
**REMARK**

"E01" is displayed on the top line of the character display and "MAINTENANCE" or the part of the machine requiring inspection, filling of fluid, or replacement is displayed on the bottom line.

FAILURE CODE DISPLAY

If an action code is displayed on the character display, check the failure code according to the failure code display method given below.

When contacting your Komatsu distributor to request repairs, inform your distributor of the failure code.

Method of displaying failure code

1. If an action code is displayed on the character display of display portion (3), press the top (>) of machine monitor mode selector switch 2 (A).

The action code will change to the failure code.

- The failure code is displayed with the first 6 digits on the left of the top line of the character display.
- The code displayed after the space on the right side of the failure code indicates the controller that detected the failure code.
- The component causing the failure is displayed on the bottom line of the character display.

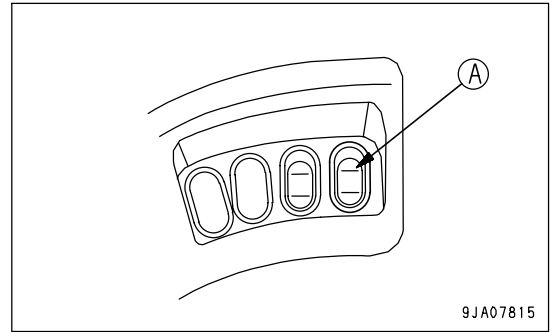

Top right code	Controller detecting failure code
MON	Machine monitor
TM	Transmission controller
WRK	Work equipment controller (if equipped)
ENG	Engine controller

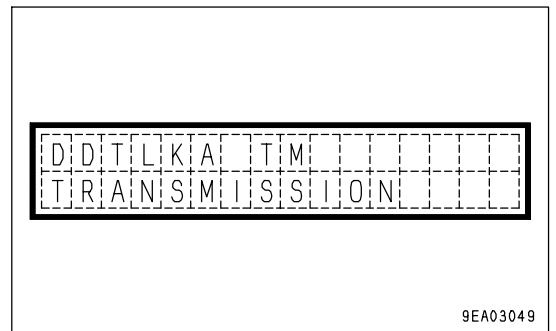

2. Press the top (>) of machine monitor mode selector switch 2 (A) again.

If the condition is normal, the service meter is displayed for several seconds, then the display returns to the action code.

If more than one failure has occurred at the same time, the next failure code is displayed.

FILTER, OIL REPLACEMENT TIME DISPLAY

After completion of the system check and when the starting switch is in the ON position, if any filter or oil item is approaching the replacement time, this display (4) shows the item for approx. 30 seconds. When this happens, the maintenance caution lamp also flashes or lights up.

After replacing the filter or changing the oil, reset the time for replacement. For details, see "RESET METHOD FOR FILTER, OIL REPLACEMENT TIME (PAGE 3-33)".

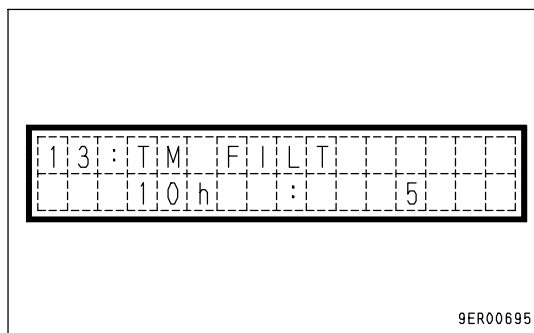
**REMARK**

- The top line of the character display shows the ID No. and item name for the item needing replacement; the bottom line shows the time remaining until replacement and the total number of times the replacement has been carried out.
- If the replacement time has already passed, a minus (-) sign appears before the time.
- After the display has been given for 30 seconds, it does not appear again until the starting switch is turned to the ON position.
- The message in the illustration above is not shown on the character display if an action code is being displayed.
- If there are two or more items to be displayed, the display changes repeatedly every three seconds. If there are more than 10 items, all the items are displayed once each, then the display returns to the normal display.
- The display appears when there is 30 hours remaining until the filter or oil replacement time. If the replacement time has passed, a minus (-) sign appears before the time for the first 30 hours. When more than 30 hours have passed, the display is no longer given.
- The maintenance caution lamp flashes as the replacement time approaches, and after the replacement time has passed, it lights up.

Items for display of filter, oil replacement time

Item	Replacement interval(H)	Character display	ID number
Engine oil	500	ENG OIL	01
Engine oil filter	500	ENG FILT	02
Fuel pre-filter	500	FUEL P FILT	41
Fuel filter	1000	FUEL FILT	03
Transmission oil	1000	TM OIL	12
Transmission oil filter	1000	TM FILT	13
Hydraulic filter	2000	HYD FILT	04
Hydraulic tank breather element	2000	HYD BREATH	05
Hydraulic oil	2000	HYD OIL	10
Axle oil	2000	AXLE OIL	15

REMARK

See the section below for details of the procedure for replacing the filter and oil.

- Engine oil
"CHANGE OIL IN ENGINE OIL PAN, REPLACE ENGINE OIL FILTER CARTRIDGE (PAGE 4-49)"
- Engine oil filter
"CHANGE OIL IN ENGINE OIL PAN, REPLACE ENGINE OIL FILTER CARTRIDGE (PAGE 4-49)"
- Fuel pre-filter
"REPLACE FUEL PRE-FILTER CARTRIDGE (PAGE 4-50)"
- Fuel main filter
"REPLACE FUEL MAIN FILTER CARTRIDGE (PAGE 4-53)"
- Transmission oil
"CHANGE OIL IN TRANSMISSION CASE AND TRANSMISSION OIL FILTER CARTRIDGE, CLEAN STRAINER (PAGE 4-55)"
- Transmission oil filter
"CHANGE OIL IN TRANSMISSION CASE AND TRANSMISSION OIL FILTER CARTRIDGE, CLEAN STRAINER (PAGE 4-55)"
- Hydraulic oil filter
"CHANGE OIL IN HYDRAULIC TANK, REPLACE HYDRAULIC FILTER ELEMENT (PAGE 4-58)"
- Hydraulic tank breather element
"REPLACE HYDRAULIC TANK BREATHER ELEMENT (PAGE 4-60)"
- Hydraulic oil
"CHANGE OIL IN HYDRAULIC TANK, REPLACE HYDRAULIC FILTER ELEMENT (PAGE 4-58)"
- Axle oil
"CHANGE AXLE OIL (PAGE 4-61)"

EMERGENCY STOP ITEMS

CAUTION

If these lamps light up and the buzzer sounds, stop operations immediately and carry out inspection and maintenance of the applicable location.

If any abnormality is found in the emergency stop items, the alarm buzzer will sound intermittently, and the lamp for the location of the abnormality and the central warning lamp will light up.

At the same time, the top line of the character display displays "E03" and the bottom line displays "CHECK RIGHT NOW" and "CALL" alternately for 3 seconds each, so stop the machine immediately in a safe place, stop the engine, and carry out inspection.

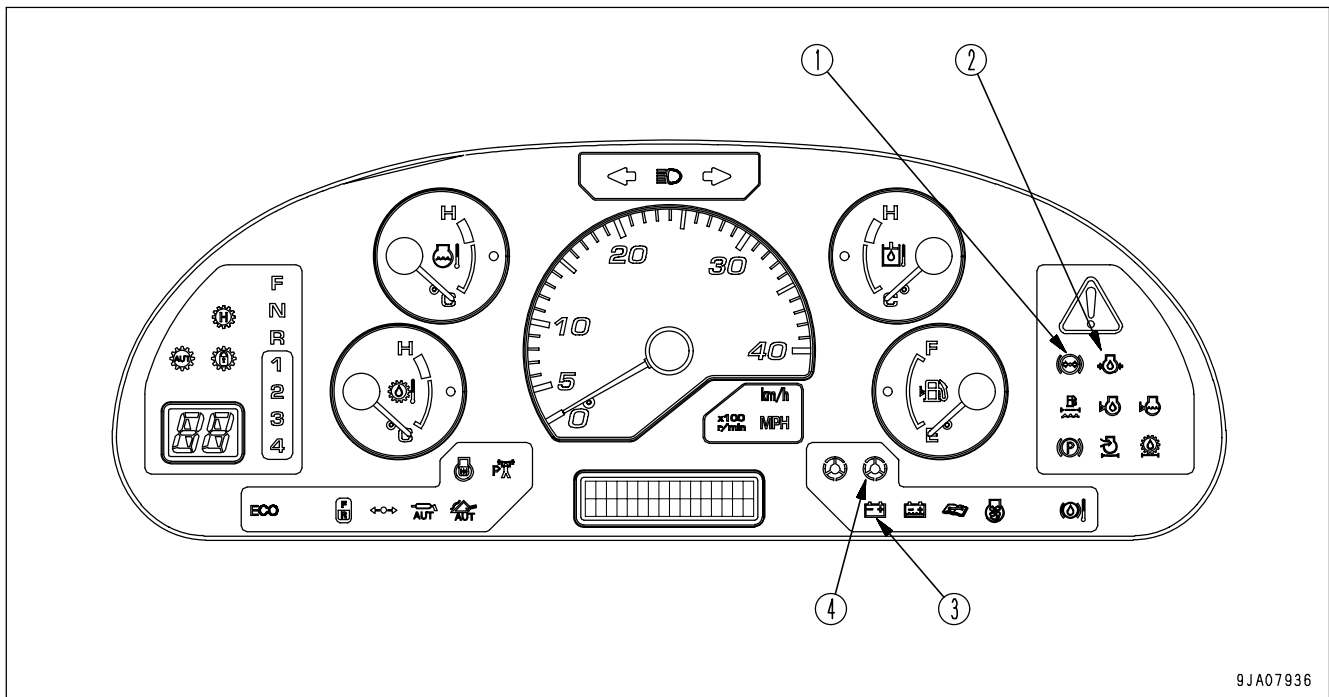

9JA07936

- (1) Brake oil pressure caution lamp
- (2) Engine oil pressure caution lamp
- (3) Battery charge circuit caution lamp
- (4) Steering oil pressure caution lamp (if equipped)

BRAKE OIL PRESSURE CAUTION LAMP

This lamp (1) lights up when the brake oil pressure goes below the specified value.

During checks before starting (when the starting switch is turned to the ON position but the engine is not started), the brake circuit is not actuated while the engine is stopped, so the brake oil pressure caution lamp and central warning lamp do not light up and the alarm buzzer does not sound.

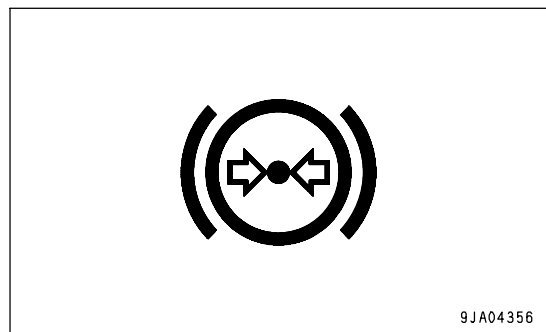

9JA04356

During operation (engine running)

If the brake oil pressure goes down during operation, the brake oil pressure caution lamp and central warning lamp light up and the alarm buzzer sounds intermittently.

At the same time, the top line of the character display displays "E03" and the bottom line displays "CHECK RIGHT NOW" and "CALL" alternately for 3 seconds each, so stop the machine immediately in a safe place, stop the engine, and carry out inspection.

If the brake oil pressure caution lamp lights up, the footbrake may not work. Keep the parking brake applied to prevent the machine from moving.

In addition, when the accumulator is being charged immediately after starting the engine, the brake oil pressure caution lamp will light up, but the central warning lamp remains OFF and the alarm buzzer does not sound.

Keep the parking brake applied to prevent the machine from moving until the brake pressure becomes normal and the brake oil pressure caution lamp goes out.

ENGINE OIL PRESSURE CAUTION LAMP

This lamp (2) lights up to warn the operator that the engine lubricating oil pressure has dropped.

During checks before starting (when the starting switch is turned to the ON position but the engine is not started), this monitor does not light up.

During operation (engine running)

If the engine lubricating oil pressure goes down during operation, the engine lubricating oil pressure caution lamp and central warning lamp light up and the alarm buzzer sounds intermittently.

At the same time, the top line of the character display displays "E03" and the bottom line displays "CHECK RIGHT NOW" and "CALL" alternately for 3 seconds each, so stop the machine immediately in a safe place, stop the engine, and carry out inspection.

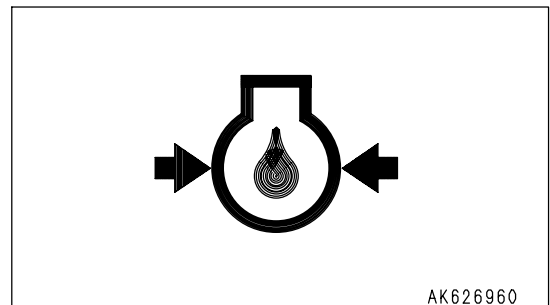

BATTERY CHARGE CIRCUIT CAUTION LAMP

This lamp (3) lights up when the engine is running to warn the operator that an abnormality has occurred in the charging circuit.

During checks before starting (when the starting switch is turned to the ON position but the engine is not started), this monitor does not light up.

During operation (engine running)

If an abnormality occurs in the charging circuit during operation, the battery charge circuit caution lamp and central warning lamp light up and the alarm buzzer sounds intermittently.

At the same time, the top line of the character display displays "E03" and the bottom line displays "CHECK RIGHT NOW" and "CALL" alternately for 3 seconds each, so stop the machine immediately in a safe place, stop the engine, and carry out inspection.

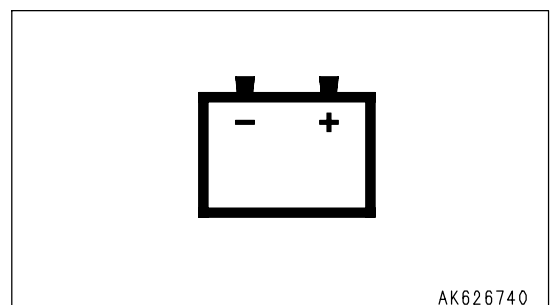

STEERING OIL PRESSURE CAUTION LAMP

(If equipped)

(Red)

This lamp (4) lights up to warn the operator that the steering oil pressure has dropped.

During checks before starting (when the starting switch is turned to the ON position but the engine is not started), this monitor does not light up.

However, it lights up during the self-check of the emergency steering.

During operation (engine running)

If the steering oil pressure goes down during operation, the steering oil pressure caution lamp and central warning lamp light up and the alarm buzzer sounds intermittently.

At the same time, the top line of the character display displays "E03" and the bottom line displays "CHECK RIGHT NOW" and "CALL" alternately for 3 seconds each, so stop the machine immediately in a safe place, stop the engine, and carry out inspection.

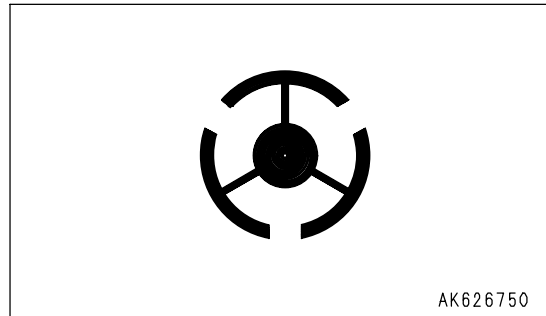

CAUTION ITEMS

! CAUTION

If these lamps light up, stop operations quickly and carry out the following action.

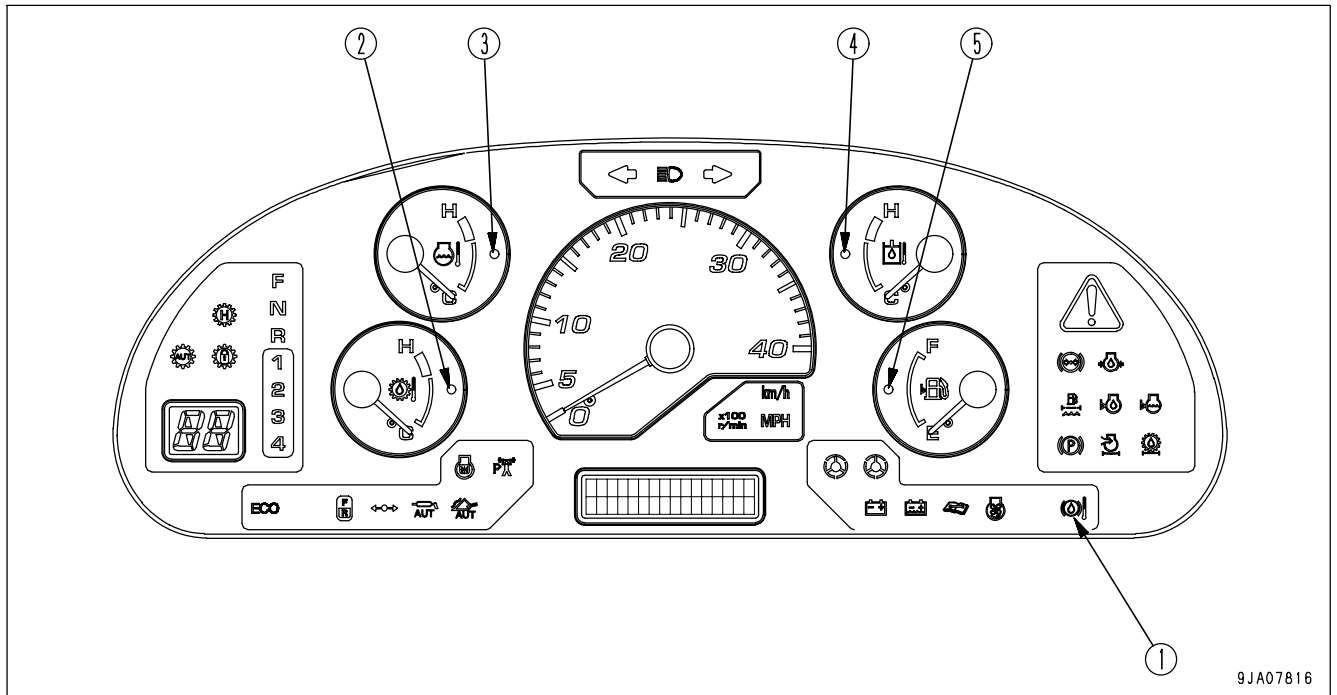

9JA07816

- | | |
|---|--|
| (1) Brake oil temperature caution lamp | (4) Hydraulic oil temperature caution lamp |
| (2) Torque converter oil temperature caution lamp | (5) Fuel level caution lamp |
| (3) Engine coolant temperature caution lamp | |

BRAKE OIL TEMPERATURE CAUTION LAMP

This lamp (1) lights up to warn the operator that the brake oil temperature has risen.

During checks before starting (when the starting switch is turned to the ON position but the engine is not started), this monitor does not light up.

During operation (engine running)

In continuous heavy-duty operations or when traveling long distances downhill where the brake is used frequently, the brake oil temperature becomes high. The brake oil temperature caution lamp and central warning lamp light up and the alarm buzzer sounds intermittently.

At the same time, the top line of the character display displays "E02" and the bottom line displays "BRAKE OVERHEAT", so take the following action.

1. Release the accelerator pedal and move the gearshift lever down one range to reduce the travel speed.
2. Avoid using the brake.
 - 1) Do not keep the brake pedal depressed continuously; use the brake only intermittently.
 - 2) Set the transmission cut-off switch to the ON position when carrying out operations.

If use of the brake is reduced for a short time in the way recommended above, the brake oil temperature will go down and the caution lamp will go out.

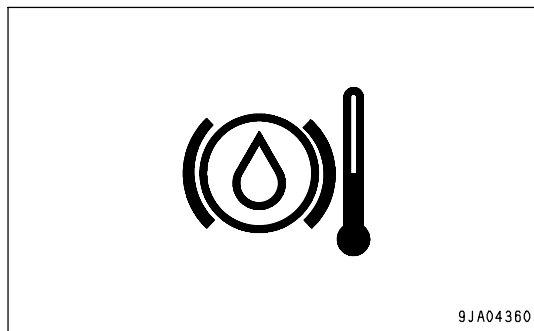
**TORQUE CONVERTER OIL TEMPERATURE CAUTION LAMP**

This lamp (2) lights up to warn the operator that the torque converter oil temperature has risen.

During checks before starting (when the starting switch is turned to the ON position but the engine is not started), this monitor does not light up.

During operation (engine running)

If the torque converter oil temperature rises, the torque converter oil temperature caution lamp only will light up.

If the oil temperature rises further, the central warning lamp will light up and the alarm buzzer will sound intermittently.

At the same time, "E02" is displayed on the top line of the character display and "TC OVERHEAT" is displayed on the bottom line. Stop the machine and run the engine under no load at a mid-range speed until the lamp goes out.

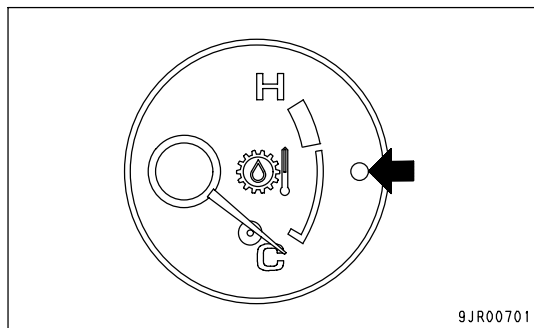

ENGINE COOLANT TEMPERATURE CAUTION LAMP

This lamp (3) warns the operator that the engine coolant temperature has risen.

During checks before starting (when the starting switch is turned to the ON position but the engine is not started), this monitor does not light up.

During operation (engine running)

If the engine coolant temperature rises, only the engine coolant water temperature caution lamp will light up.

If the coolant temperature rises further, the central warning lamp will light up and the alarm buzzer will sound intermittently.

At the same time as the central warning lamp lights up, the top line of the character display displays "E02" and the bottom line displays "ENGINE OVERHEAT", so stop the machine and run the engine under no load at a mid-range speed until the lamp goes out.

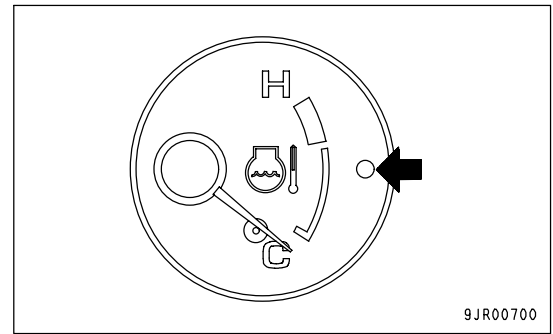
**HYDRAULIC OIL TEMPERATURE CAUTION LAMP**

This lamp (4) lights up to warn the operator that the hydraulic oil temperature has risen.

During checks before starting (when the starting switch is turned to the ON position but the engine is not started), this monitor does not light up.

During operation (engine running)

If the hydraulic oil temperature rises, the hydraulic oil temperature caution lamp, the central warning lamp will light up, and the alarm buzzer will sound intermittently.

At the same time, "E02" is displayed on the top line of the character display and "HYD OVERHEAT" is displayed on the bottom line. Stop the machine and run the engine under no load at a mid-range speed until the lamp goes out.

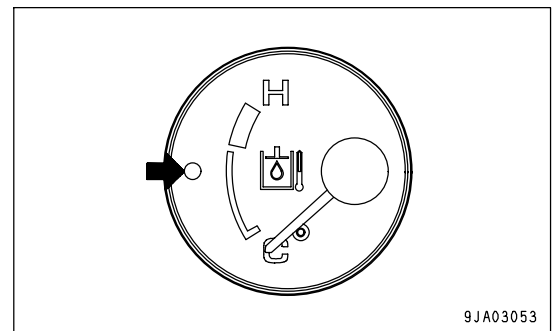
**FUEL LEVEL CAUTION LAMP**

This lamp (5) lights up if the amount of fuel remaining in the fuel tank goes below 35 liters (9.25 US gal).

If it lights up, check and add fuel and as soon as possible.

REMARK

Even if the caution lamp lights up, action code "E02" is not displayed on the character display.

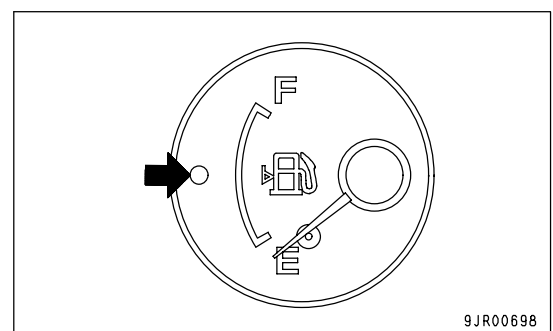

INSPECTION AND MAINTENANCE ITEMS

CAUTION

If these lamps light up, stop operations quickly and carry out the following action.

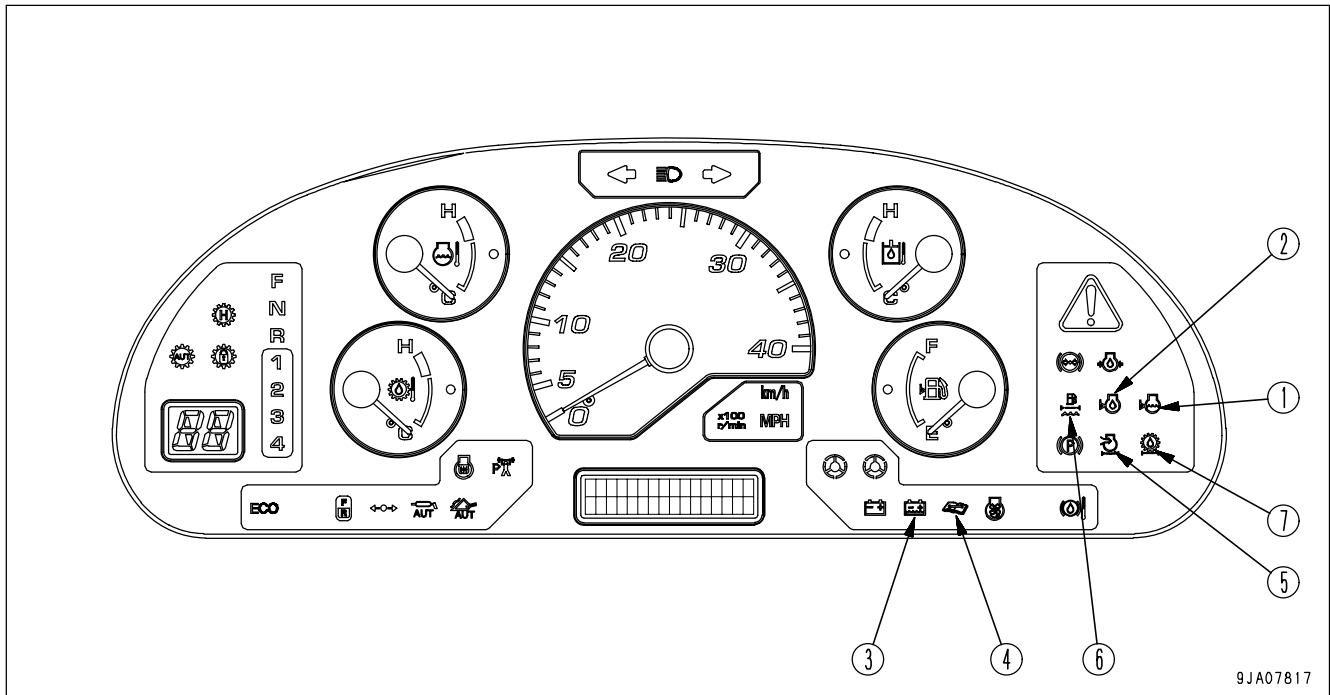

- (1) Radiator coolant level caution lamp
- (2) Engine oil level caution lamp
- (3) Battery electrolyte level caution lamp(if equipped)
- (4) Maintenance caution lamp
- (5) Air cleaner clogging caution lamp
(Machines equipped with KOMTRAX)
- (6) Water separator caution lamp
- (7) Transmission oil filter clogging caution lamp

RADIATOR COOLANT LEVEL CAUTION LAMP

This lamp (1) lights up to warn the operator that the coolant level in the radiator has gone down.

During checks before starting (when the starting switch is turned to the ON position but the engine is not started), this monitor lights up if the coolant level in the radiator is low.

At the same time, the top line of the character display displays "E01" and the bottom line displays "COOLANT LOW", so check the water level in the radiator and add water.

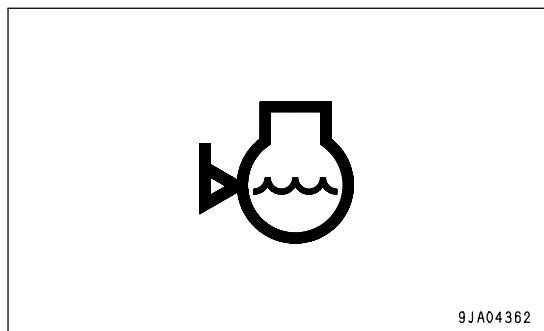

During operation (engine running)

If the coolant level in the radiator becomes too low, the radiator coolant level caution lamp will light up.

At the same time, the top line of the character display displays "E01" and the bottom line displays "COOLANT LOW", so stop the engine, check the water level in the radiator, and add water.

ENGINE OIL LEVEL CAUTION LAMP

This lamp (2) lights up to warn the operator that the oil level in the engine oil pan has gone down.

During checks before starting (when the starting switch is turned to the ON position but the engine is not started), this monitor lights up if the oil level in the engine oil pan is low.

At the same time, the top line of the character display displays "E01" and the bottom line displays "COOLANT LOW", so do not start the engine. Check the oil level in the engine oil pan and add oil.

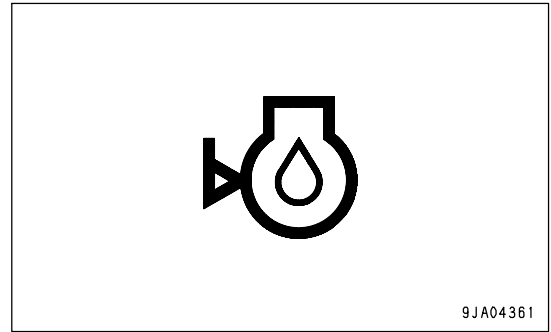
**REMARK**

During checks before starting, if the engine is started with the engine oil level caution lamp lighted up, the lamp will stay lighted up.

Stop the engine, check the oil level in the engine oil pan, and add oil.

BATTERY ELECTROLYTE LEVEL CAUTION LAMP

(If equipped)

This lamp (3) is not used.

MAINTENANCE CAUTION LAMP

If the caution lamp lights up, repair the problem as soon as possible. If this is left as it is, it will lead to failure.

When the time for oil change is reached, this lamp (4) flashes or lights up for approx. 30 seconds after completion of the system check when the starting switch is at the ON position.

REMARK

The maintenance caution lamp flashes when there are less than 30 hours to the replacement time, and after the replacement time has passed, it stays on.

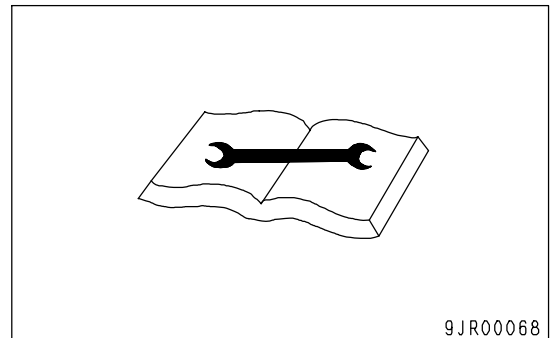

For details of the items covered by filter and oil replacement, see "FILTER, OIL REPLACEMENT TIME DISPLAY (PAGE 3-12)".

After replacing the filter or changing the oil, reset time for the replacement. For details, see "RESET METHOD FOR FILTER, OIL REPLACEMENT TIME (PAGE 3-33)".

AIR CLEANER CLOGGING CAUTION LAMP

(Machines equipped with KOMTRAX)

This lamp (5) lights up if the air cleaner element becomes clogged when the engine is running.

During checks before starting (when the starting switch is turned to the ON position but the engine is not started), this monitor does not light up.

During operation (engine running)

The lamp lights up if the air cleaner element becomes clogged.

At the same time, the top line of the character display displays "E01" and the bottom line displays "AIR FILTER", so stop the engine and clean or replace the element.

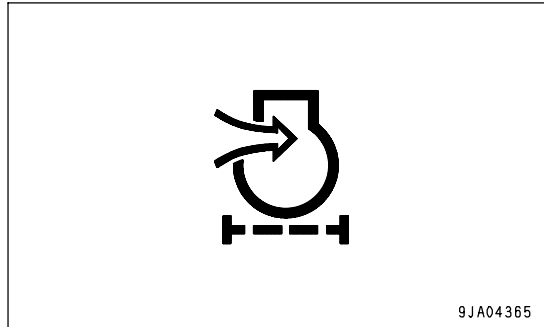
**REMARK**

It is possible to check the condition of clogging of the air cleaner with the dust indicator installed at the side of the air cleaner.

WATER SEPARATOR CAUTION LAMP

This lamp (6) lights up if water accumulates in the water separator installed to the fuel pre-filter.

If it lights up, check the pre-filter. For details, see "REPLACE FUEL PRE-FILTER CARTRIDGE (PAGE 4-50)"

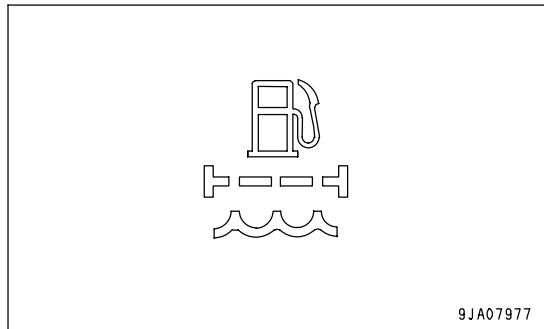
**TRANSMISSION OIL FILTER CLOGGING CAUTION LAMP**

This lamp (7) is not used.

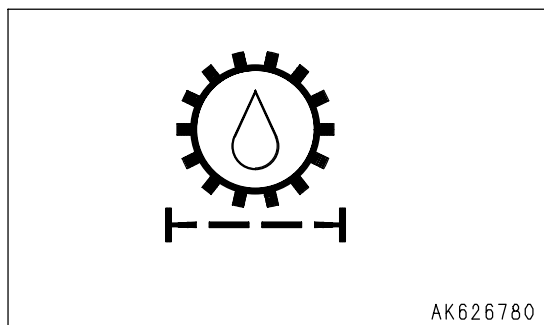

PILOT DISPLAY PORTION

When the starting switch is ON, the pilot display lights up when the display items are functioning.

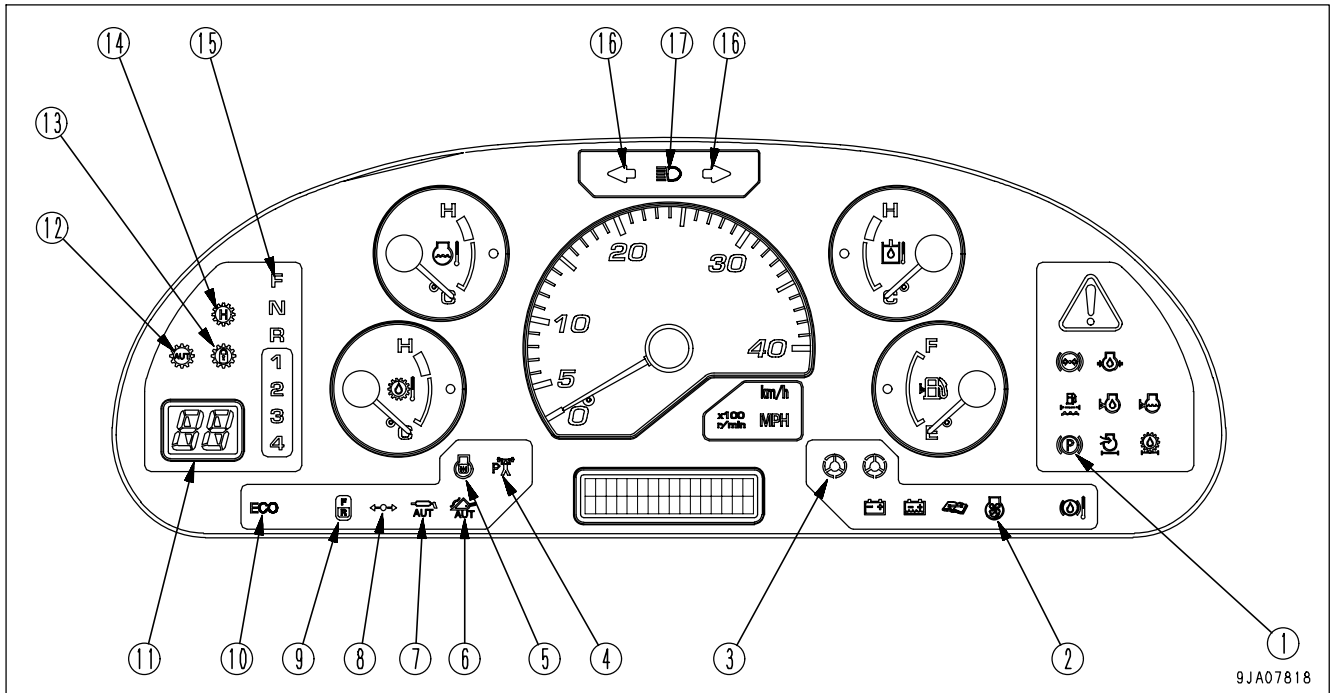

- (1) Parking brake pilot lamp
- (2) Cooling fan reverse rotation pilot lamp
- (3) Emergency steering pilot lamp (if equipped)
- (4) Power mode pilot lamp (P mode)
- (5) Preheating pilot lamp
- (6) Semi auto digging pilot lamp (if equipped)
- (7) Auto-greasing pilot lamp (if equipped)
- (8) Joystick pilot lamp (if equipped)
- (9) Directional selector pilot lamp
- (10) Economy operation display lamp
- (11) Shift indicator
- (12) Auto-shift pilot lamp
- (13) Torque converter lock-up pilot lamp (if equipped)
- (14) Shift hold pilot lamp
- (15) Shift lever position pilot lamp
- (16) Turn signal pilot lamp
- (17) Head lamp high beam pilot lamp

PARKING BRAKE PILOT LAMP

This lamp (1) lights up when the parking brake is applied.

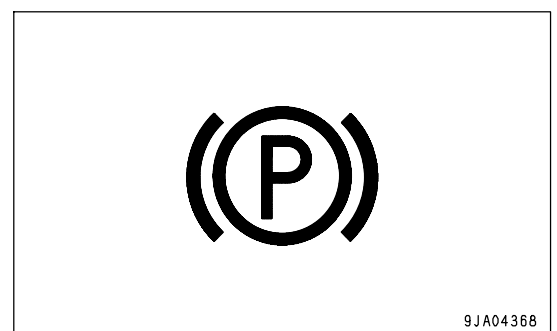

COOLING FAN REVERSE ROTATION PILOT LAMP

This lamp (2) lights up when the direction of rotation of the cooling fan is reversed.

At the same time, "COOLING FAN REVERSE" is displayed on the character display.

For details of the method of operation, see "COOLING FAN REVERSE ROTATION SWITCH (PAGE 3-50)".

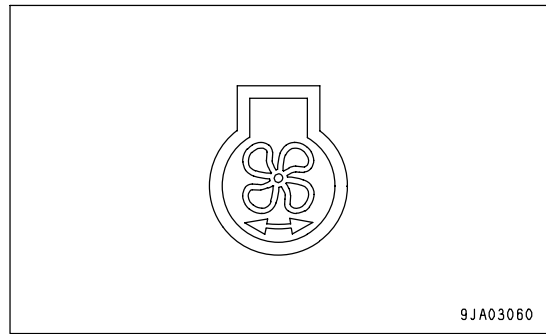
**EMERGENCY STEERING PILOT LAMP**

(If equipped)

(Green)

This lamp (3) lights up when the emergency steering is being actuated.

If the engine stops when the machine is traveling or an abnormality occurs in the steering oil pressure circuit, and the machine is traveling at a speed of more than 2 km/h (1.2 MPH), the emergency steering is automatically actuated and the lamp lights up.

If the lamp lights up, move the machine immediately to a safe place, stop the engine, and check the condition.

In addition, the lamp flashes if the emergency steering is actuated continuously for one minute.

At the same time, "E02 EMR S/T OVERRUN" is displayed on the character display, so move the machine immediately to a safe place, stop the engine, and check the condition.

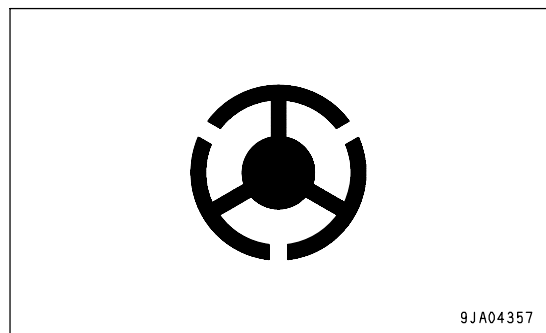

There is an emergency steering self-check function. For details, see "EMERGENCY STEERING SELF-CHECK FUNCTION (PAGE 3-138)" in the OPERATION section.

POWER MODE PILOT LAMP (P MODE)

This lamp (4) lights up when the P mode is selected.

Use the power mode selector switch to select the P mode.

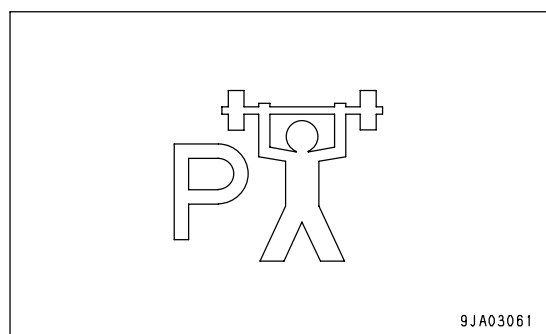

PREHEATING PILOT LAMP

This lamp (5) lights up when the engine preheating electric heater is actuated.

In cold weather, when the starting switch is turned to the ON position, this lamp lights up. It goes out when preheating is completed.

The preheating time differs according to the ambient temperature.

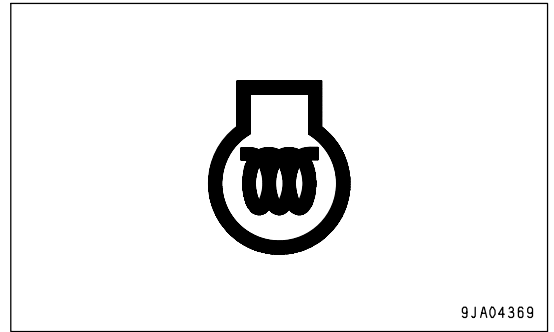

SEMI AUTO DIGGING PILOT LAMP

(If equipped)

This lamp (6) is not active.

AUTO-GREASING PILOT LAMP

(If equipped)

This lamp (7) is not used.

JOYSTICK PILOT LAMP

(If equipped)

This lamp (8) lights up when the joystick ON/OFF switch is at the ON position and the joystick console is tilted to the front.

For details, see "HANDLING JOYSTICK STEERING SYSTEM (PAGE 6-7)" in the ATTACHMENTS, OPTIONS Section.

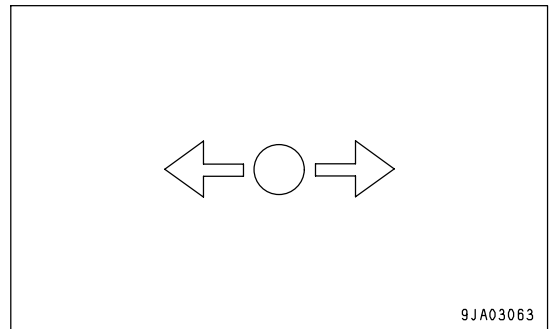

DIRECTIONAL SELECTOR PILOT LAMP

This lamp (9) is not used.

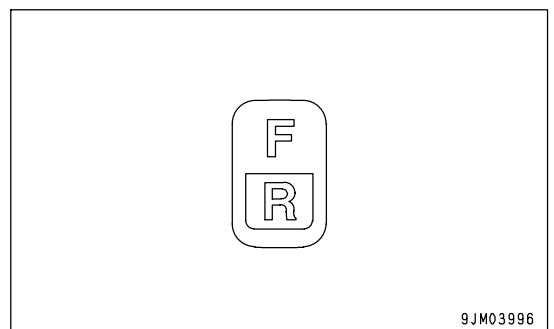

ECONOMY OPERATION DISPLAY LAMP

This lamp (10) lights up when the economy mode is used.

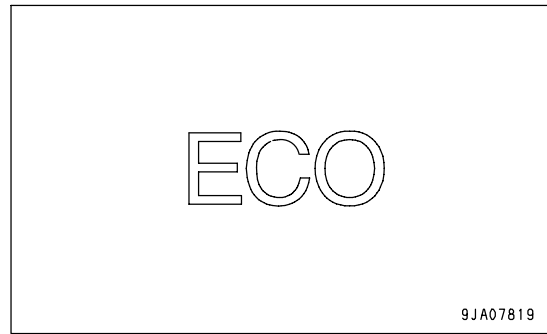
**SHIFT INDICATOR**

This monitor (11) indicates the transmission gear range (actual travel speed range).

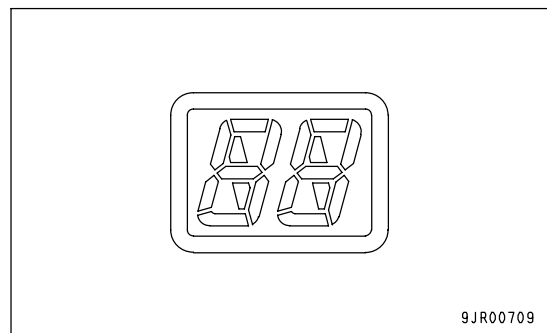
**AUTO-SHIFT PILOT LAMP**

This lamp (12) lights up when the auto-shift function is selected. Use the transmission shift mode selector switch to select the shift mode.

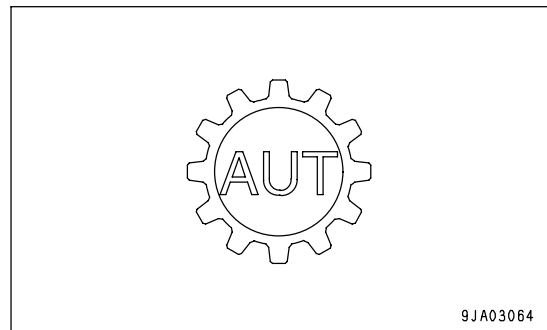
**TORQUE CONVERTER LOCK-UP PILOT LAMP**

(If equipped)

For details, see "HANDLING TORQUE CONVERTER LOCK-UP (PAGE 6-3)" in the ATTACHMENTS, OPTIONS section.

SHIFT HOLD PILOT LAMP

This lamp (14) lights up when the shift hold is actuated.

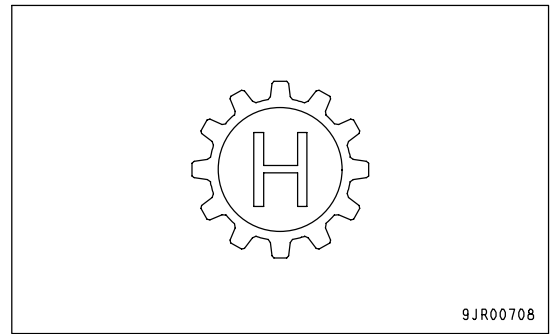

SHIFT LEVER POSITION PILOT LAMP

This lamp (15) displays the transmission position of the gearshift lever.

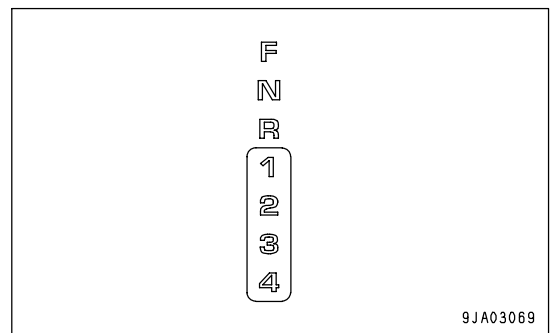

TURN SIGNAL PILOT LAMP

This lamp (16) flashes at the same time as the turn signal lamp flashes.

REMARK

If there is a disconnection in the turn signal lamp, the flashing interval becomes shorter.

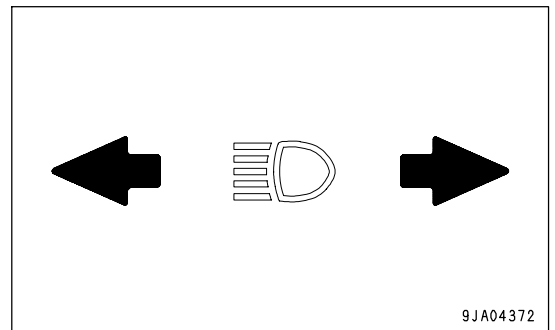

HEAD LAMP HIGH BEAM PILOT LAMP

This lamp (17) lights up when the head lamps are set to high beam.

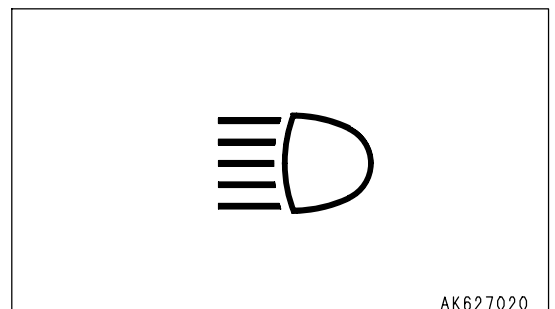

METER DISPLAY PORTION

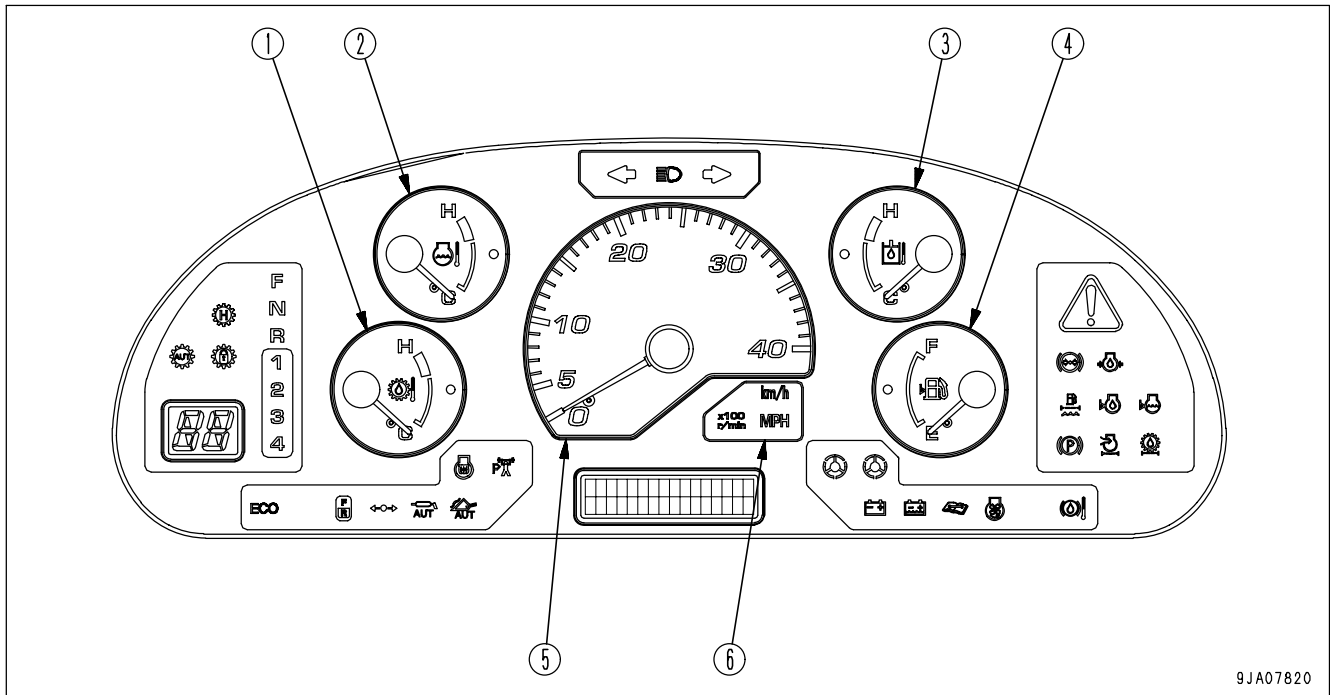

9JA07820

- (1) Torque converter oil temperature gauge
- (2) Engine coolant temperature gauge
- (3) Hydraulic oil temperature gauge
- (4) Fuel gauge
- (5) Speedometer
- (6) Meter display pilot lamp

TORQUE CONVERTER OIL TEMPERATURE GAUGE

This meter (1) indicates the torque converter oil temperature.

It should be in white range (A) during operations.

If it enters red range (B) during operations, caution lamp (C) inside the torque converter oil temperature gauge will light up. At the same time, the central warning lamp lights up and the alarm buzzer sounds intermittently. In addition, "E02" is displayed on the top line of the character display and "TC OVERHEAT" is displayed on the bottom line.

Run the engine under no load at a mid-range speed and wait until the indicator goes down to white range (A).

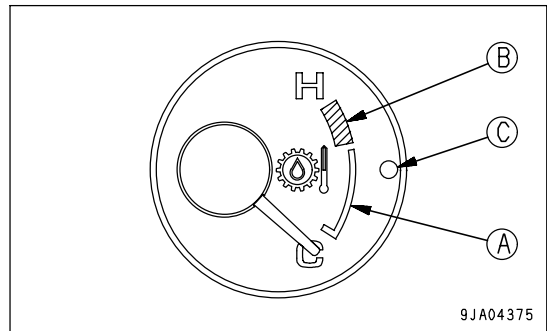

9JA04375

ENGINE COOLANT TEMPERATURE GAUGE

This meter (2) indicates the engine coolant temperature. During normal operations, the indicator should be in the white range (A). If the indicator enters red range (B) during operations, caution lamp (C) inside the engine coolant temperature gauge lights up. At the same time, the central warning lamp lights up and the alarm buzzer sounds. In addition, the top line of the character display displays "E02" and the bottom line displays "ENGINE OVERHEAT". Run the engine at a midrange speed under no load and wait for the indicator to return to the white range (A).

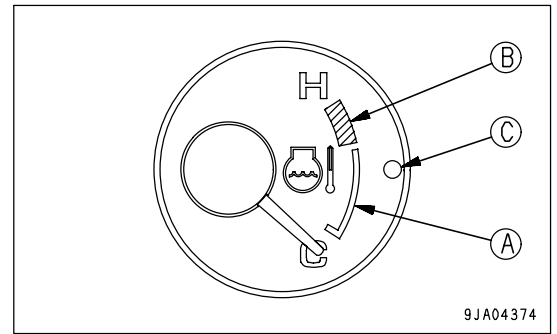

HYDRAULIC OIL TEMPERATURE GAUGE

This meter (3) indicates the hydraulic oil temperature. It should be in white range (A) during operations. If it enters red range (B) during operations, caution lamp (C) inside the hydraulic oil temperature gauge will light up. At the same time, the central warning lamp lights up and the alarm buzzer sounds intermittently. In addition, "E02" is displayed on the top line of the character display and "HYD OVERHEAT" is displayed on the bottom line. Run the engine under no load at a mid-range speed and wait until the indicator goes down to white range (A).

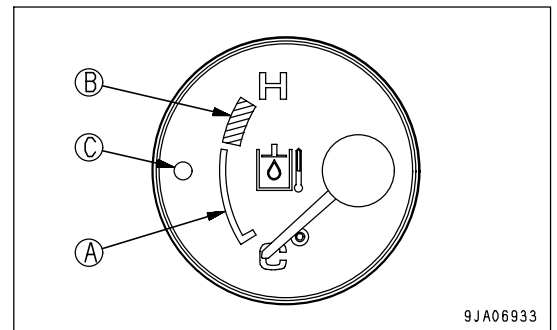

FUEL GAUGE

This meter (4) indicates the amount of fuel remaining in the fuel tank. F: Full tank E: Fuel level is low When the remaining amount of fuel goes below 35 liters (9.25 US gal), caution lamp (A) inside the fuel gauge lights up. If it lights up, check and add fuel.

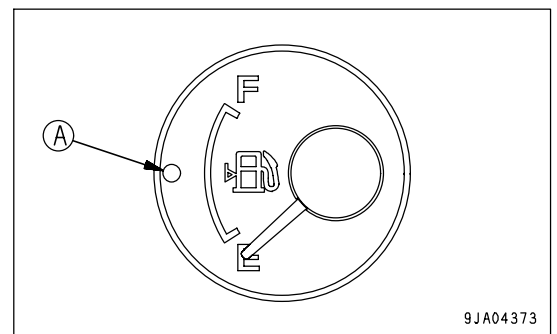

SPEEDOMETER

This meter (5) indicates the travel speed of the machine. The display unit is indicated on meter display pilot lamp (6). It is also possible to display the engine speed by switching meter (5). If you wish to switch between the speedometer and tachometer, please contact your Komatsu distributor to have it switched.

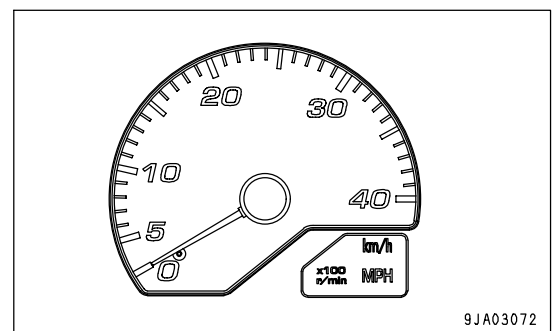

METER DISPLAY PILOT LAMP

This lamp (6) displays the unit for the travel speed or engine tachometer.

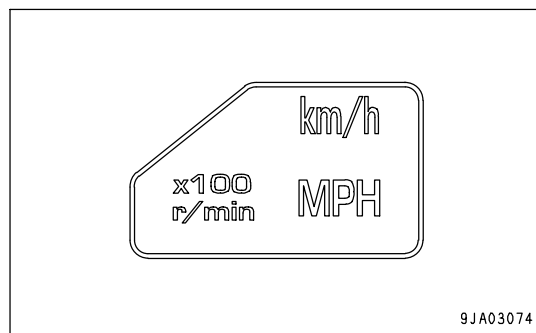

OTHER FUNCTIONS OF MACHINE MONITOR

The machine monitor also has the following functions.

Odometer, filter/oil replacement time reset, telephone number input, language selection, monitor brightness adjustment

Overall menu

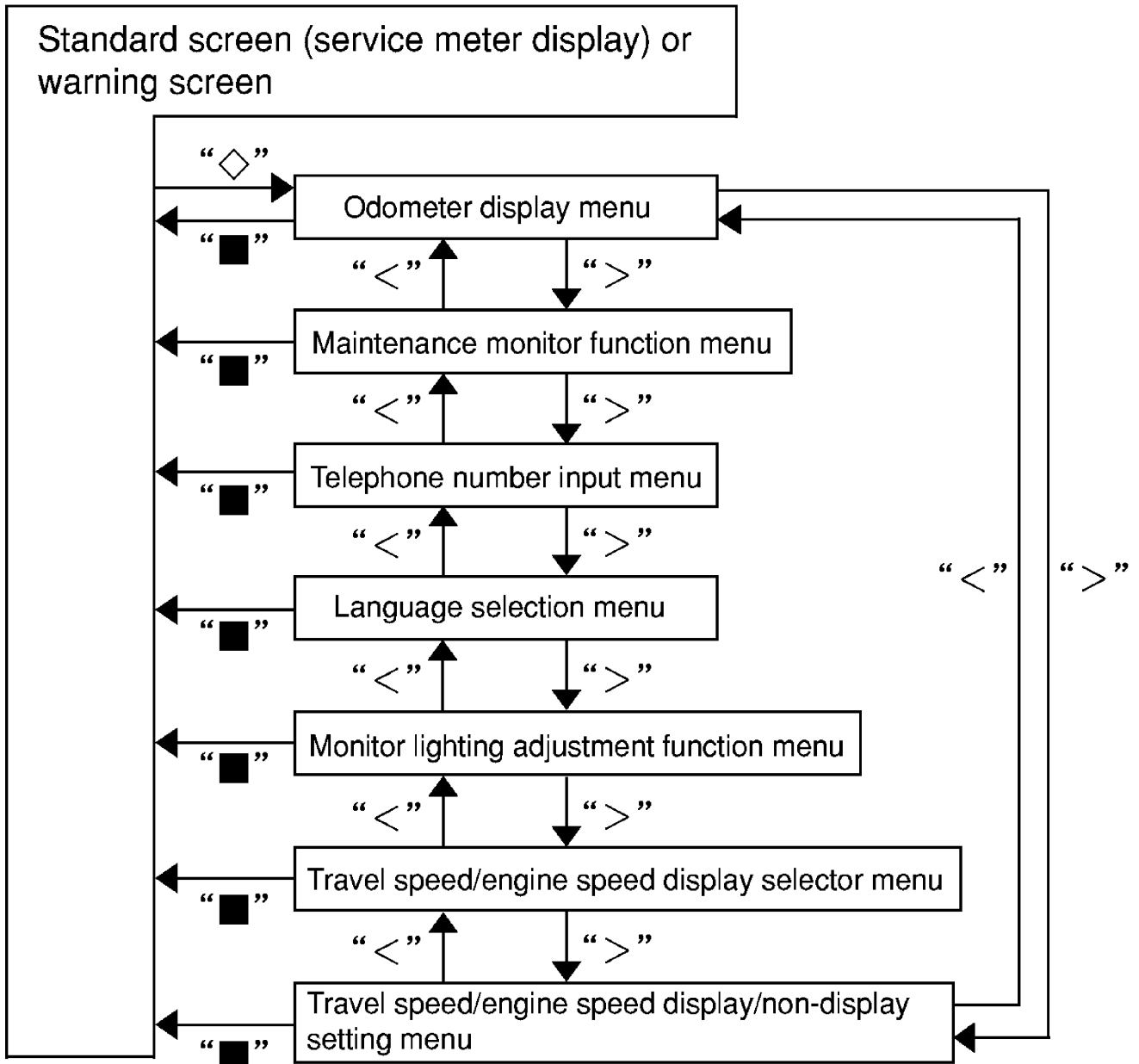

Standard screen

(service meter display)

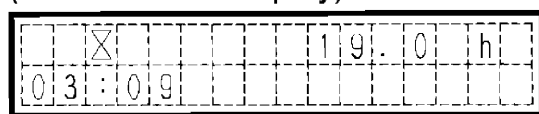

Odometer display menu

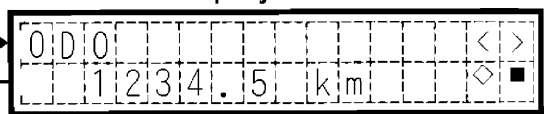

- ◊、■ : Machine monitor mode selector switch 1
- >、< : Machine monitor mode selector switch 2

METHOD OF DISPLAYING ODOMETER

Use this when checking the total distance that the machine has traveled.

1. Check that the character display is displaying the service meter or an action code. If there is any other display, turn the starting switch OFF, then turn the starting switch ON again and wait for the service meter display or action code display to appear.
2. Press the (◊) of machine monitor mode selector switch 1. It displays the odometer.
3. When completing the operation, press (■) of machine monitor mode selector switch 1 or turn the starting switch OFF.

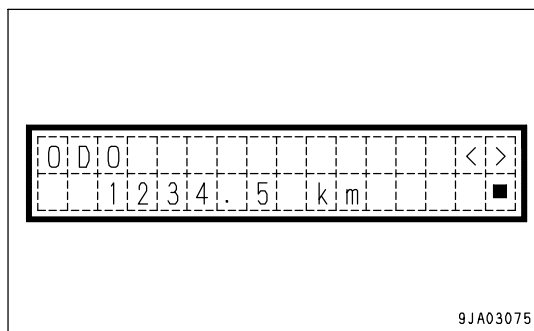

RESET METHOD FOR FILTER, OIL REPLACEMENT TIME

The filter and oil replacement time is displayed on the character display, so if the filter and oil have been replaced, reset the filter and oil change time.

1. Press the (◇) of machine monitor mode selector switch 1, and display the odometer.
2. Press (>) or (<) of machine monitor mode selector switch 2 and display "MAINTENANCE MONITOR".

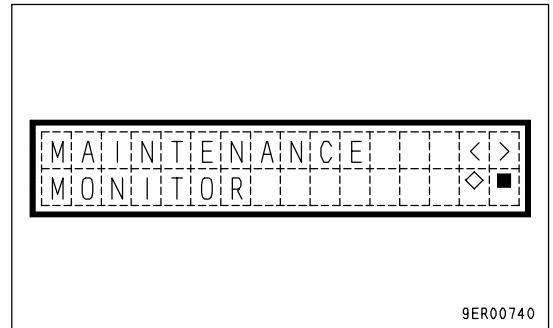

3. Press the (◇) of machine monitor mode selector switch 1. It will change to the display in the diagram on the right. The bottom line shows two items: the replacement time on the left and the total number of times the item has been replaced on the right.
4. Press the (>) or (<) of machine monitor mode selector switch 2 to display the item (filter or oil) which has reached the replacement time.

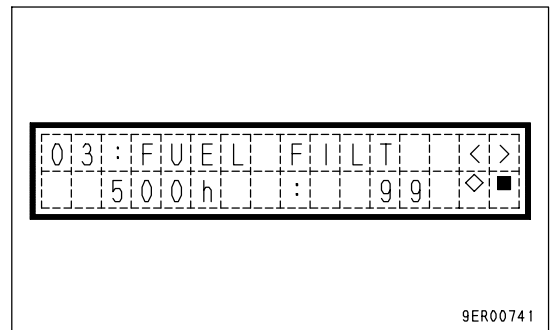

5. Press the (◇) of machine monitor mode selector switch 1. It will change to the display in the diagram on the right. The top line shows [Reset] and [Item to be reset] in turn.
6. When resetting the replacement time, press (>) or (<) of machine monitor mode selector switch 2, align the cursor with "YES", then press (■) of machine monitor mode selector switch 1. It will reset and return to the previous screen. To abort, align the cursor with "NO", then press (■) of machine monitor mode selector switch 1.

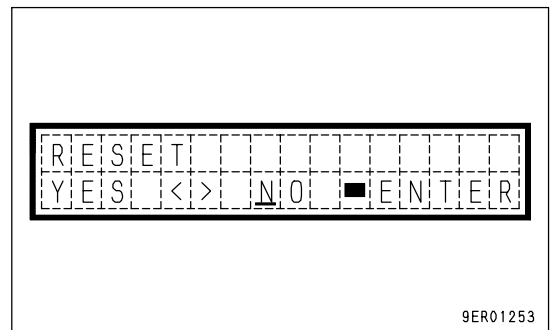

7. When resetting the replacement time for another item, use the procedure in Step 4. After completing, press (■) of machine monitor mode selector switch 1 twice or turn the starting switch OFF.

INPUT METHOD FOR TELEPHONE NUMBER

It is possible to display the telephone number on the right side of "CALL" displayed on the character display when action code "E03" is generated.

- 1. Press the (◇) of machine monitor mode selector switch 1, and display the odometer.
- 2. Press (>) or (<) of machine monitor mode selector switch 2 and display "TEL".

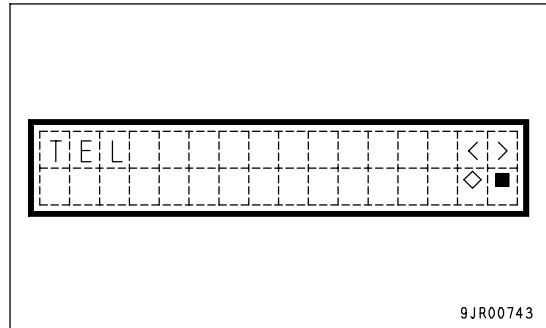

- 3. Press (◇) of machine monitor mode selector switch 1. It will change to the display in the diagram on the right.

Once the telephone number is input, the input number will be displayed next time.

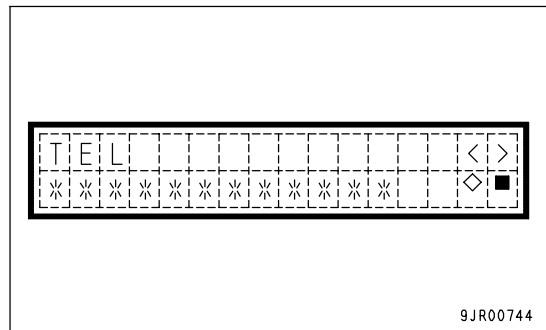

- 4. Up to 12 digits can be displayed for the telephone number. Input from the first digits.
The cursor is displayed at the input position. Press (>) or (<) of machine monitor mode selector switch 2 and display "0 to 9". To leave a blank, select "*".
When the input value is decided, press (◇) of machine monitor mode selector switch 1. The cursor will move to the next position.
- 5. Repeat the procedure in Step 4 until the last digit. At the last digit, press (◇) of machine monitor mode selector switch 1 to return to the previous screen.
If there is a mistake in the input or the input is to be stopped, press (■) of machine monitor mode selector switch 1 to return to the previous screen.
- 6. When completing the operation, press (■) of machine monitor mode selector switch 1 twice or turn the starting switch OFF.

METHOD FOR SELECTING LANGUAGE

Use this when switching the language displayed on the character display.

The following explanation is for when English is set as the language for the character display.

1. Press the (◇) of machine monitor mode selector switch 1, and display the odometer.
2. Press part (>) or (<) of machine monitor mode selector switch 2 to display "LANGUAGE".

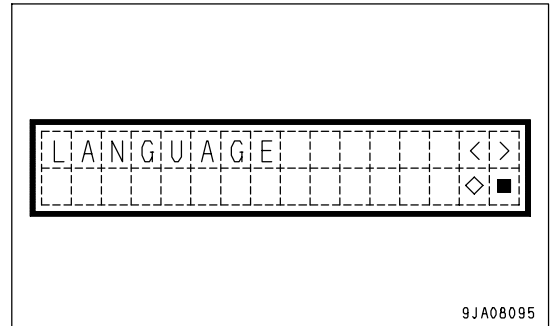

3. Press the (◇) of machine monitor mode selector switch 1. The presently selected language is displayed.
4. Press (>) or (<) of machine monitor mode selector switch 2 and select the language.

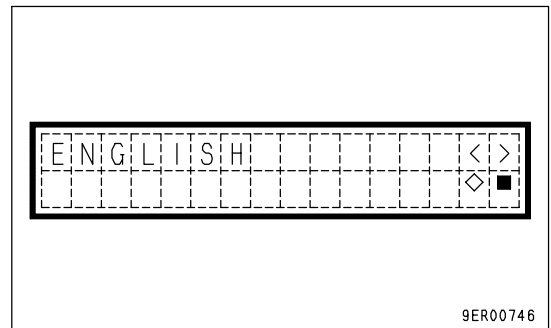

The available languages are English, Japanese, German, French, Italian, Spanish, and Swedish.

5. After selecting the language, press the (◇) of machine monitor mode selector switch 1.
 - To confirm, set the cursor at "YES", then press the (■) of machine monitor mode selector switch 1. The language will be selected and the screen will return to the previous screen.
 - To abort, set the cursor at "NO", then press the (■) of machine monitor mode selector switch 1.
6. When completing the operation, press (■) of machine monitor mode selector switch 1 twice or turn the starting switch OFF.

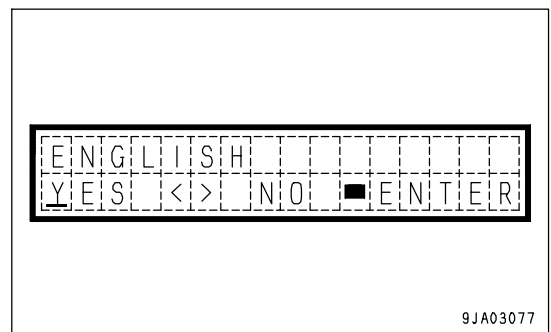

METHOD OF ADJUSTING MONITOR BRIGHTNESS

Do as follows to adjust the brightness of the monitor.

- 1. Press the (◇) of machine monitor mode selector switch 1, and display the odometer.
- 2. Press (>) or (<) of machine monitor mode selector switch 2 and display "BRIGHTNESS ADJUST".

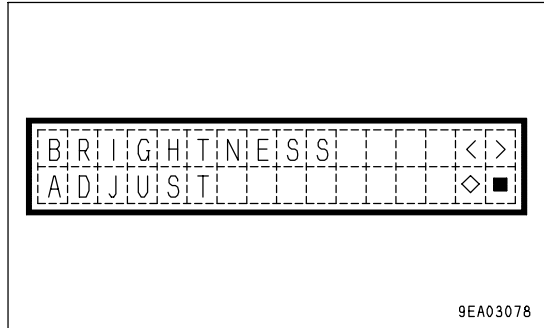

- 3. Press the (◇) of machine monitor mode selector switch 1. "MONITOR PANEL" will be displayed on the bottom line and it will be possible to adjust the brightness of the monitor.

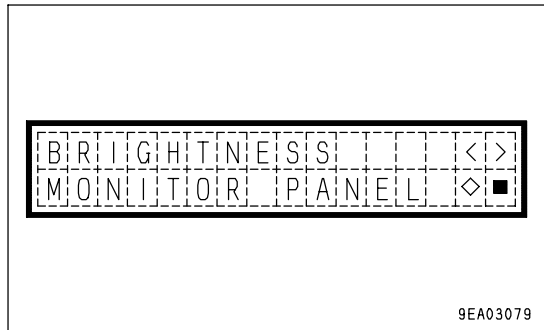

The brightness can be adjusted for the overall monitor or for the liquid crystal display only.
 To adjust only the brightness of the liquid crystal display, press the (>) or (<) of machine monitor mode selector switch 2 to switch the display to "LCD PANEL".

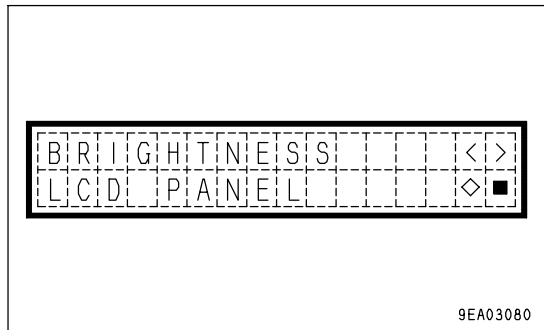

- 4. Press the (◇) of machine monitor mode selector switch 1. The screen will change to the display shown on the right and it will be possible to adjust the brightness.
- 5. Press the (>) or (<) of machine monitor mode selector switch 2 to select a level between L and H (available range: 7 stages).
- 6. After selecting the brightness, press the (■) of machine monitor mode selector switch 1. The brightness will be selected and the screen will return to the previous screen.
- 7. When completing the operation, press (■) of machine monitor mode selector switch 1 twice or turn the starting switch OFF.

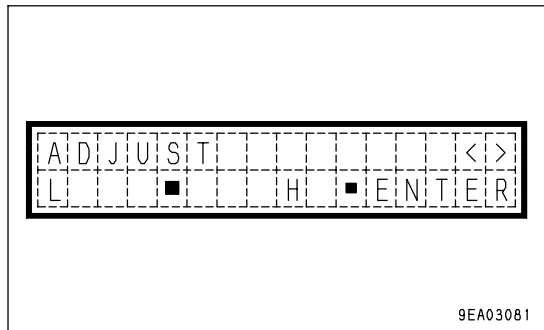

METHOD OF SWITCHING TRAVEL SPEED/ENGINE SPEED DISPLAY

Use this when switching between the travel speed (km/h, MPH) and the engine speed display.

1. Press the (◇) portion of the machine monitor mode selector switch 1 to display "ODO" (odometer).

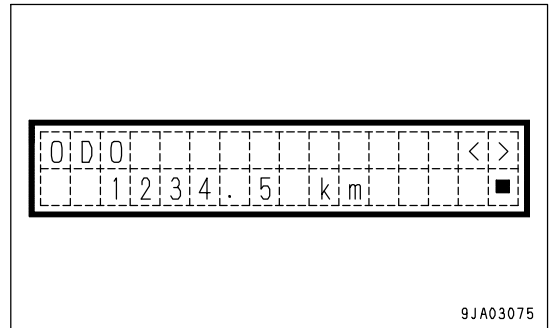

2. Press the (>) or (<) of the machine monitor mode selector switch 2 to display "SELECT SPEED" or "SELECT r/min".

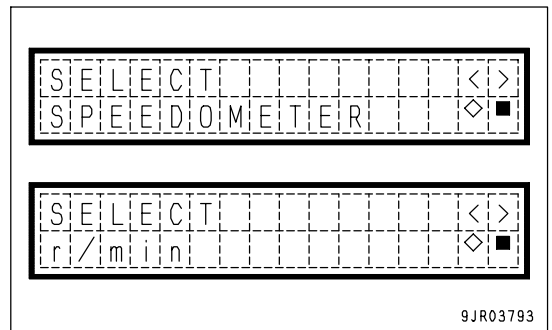

3. Press the (◇) portion of the machine monitor mode selector switch 1.
The display changes and returns to the service meter display.

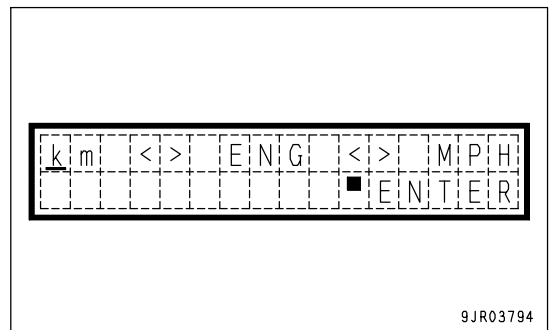

METHOD OF SWITCHING TRAVEL SPEED/ENGINE SPEED DISPLAY/NON-DISPLAY

Use the following method to display the travel speed or engine speed or to have no display on the character display.

- 1. Press the (<>) portion of the machine monitor mode selector switch 1 to display "ODO" (odometer).

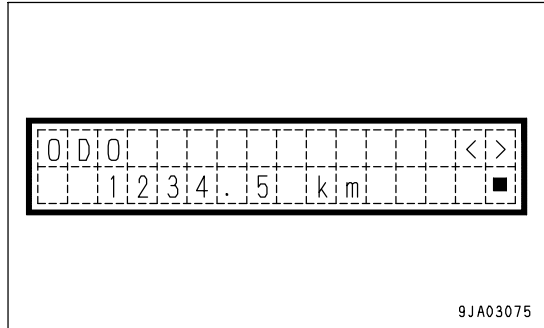

- 2. Press the (>) or (<) of the machine monitor mode selector switch 2 to display "rpm ON → OFF" or "km/h ON → OFF".
To set to no display for the travel speed or engine speed on the character display, display "rpm OFF → ON" or "km/h OFF → ON".

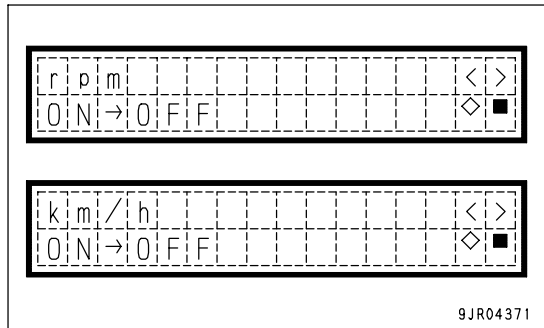

- 3. Press the (<>) of the machine monitor mode selector switch 1. The item that was being displayed changes to non-display, and the item that was not displayed, is displayed, and the screen returns to the service meter display.

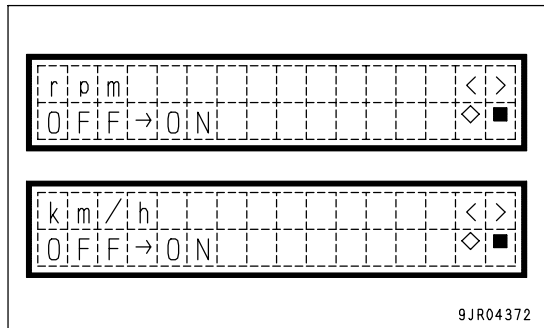

SWITCHES

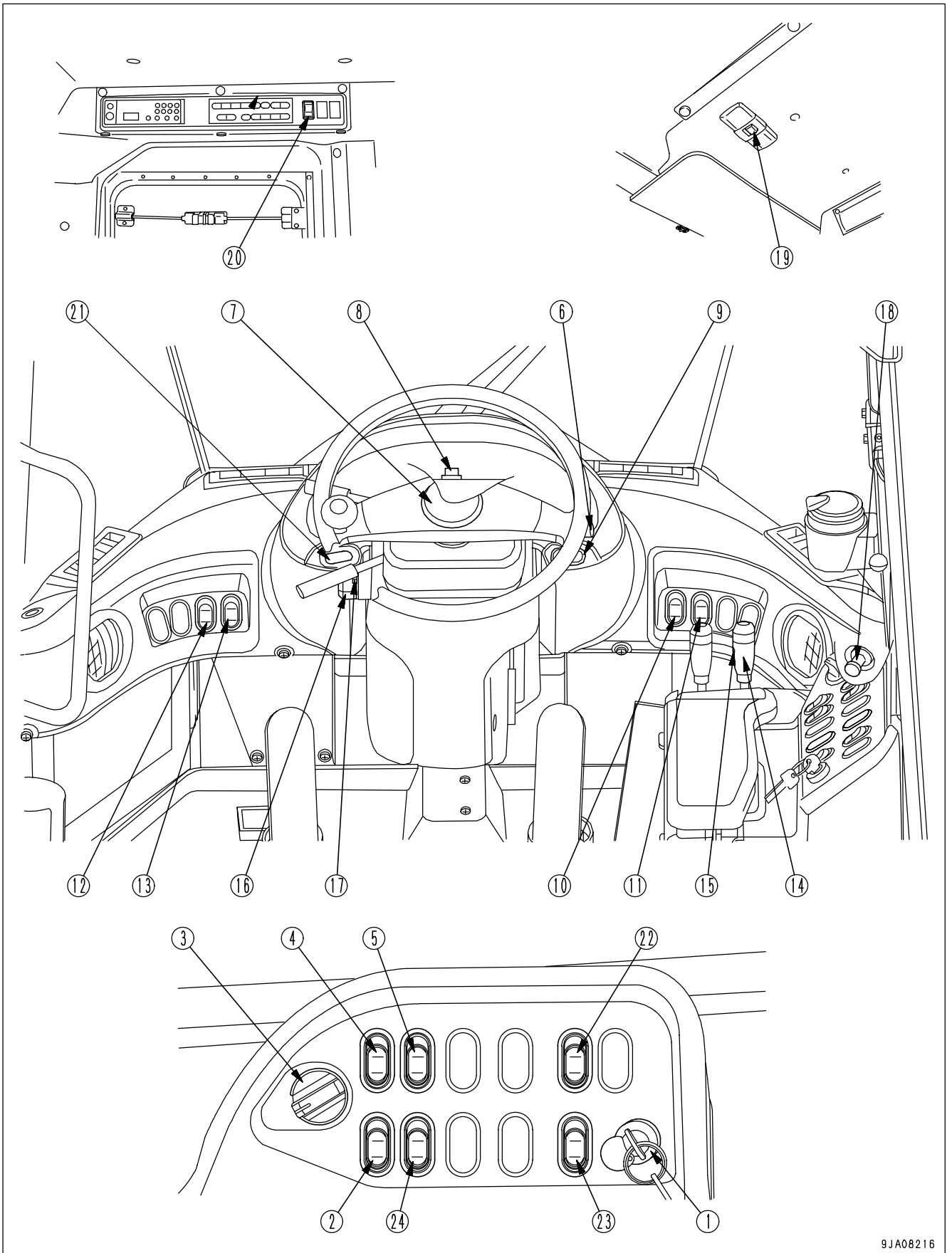

9JA08216

- | | |
|---|--|
| (1) Starting switch | (13) Machine monitor mode selector switch 2 |
| (2) Power mode selector switch | (14) Kickdown switch |
| (3) Transmission shift mode selector switch | (15) Hold switch |
| (4) Transmission cut-off switch | (16) Front wiper switch |
| (5) Transmission cut-off set switch | (17) Rear wiper switch |
| (6) Lamp switch | (18) Cigarette lighter |
| (6) Turn signal lever | (19) Room lamp switch |
| (6) Dimmer switch | (20) Rear heated wire glass switch |
| (7) Horn button | (21) E.C.S.S. (electronic controlled suspension system) switch |
| (8) Hazard lamp switch | (22) Emergency steering switch (if equipped) |
| (9) Parking brake switch | (23) Cooling fan reverse rotation switch |
| (10) Front working lamp switch | (24) Torque converter lock-up switch (if equipped) |
| (11) Rear working lamp switch | |
| (12) Machine monitor mode selector switch 1 | |

STARTING SWITCH

This switch (1) is used to start or stop the engine.

(A): OFF position

It is possible to insert and remove the starting switch key, all the electric system switches are turned off, and the engine stops. In addition, the parking brake is automatically applied.

(B): ON position

In this position, electric current flows in the charging and lamp circuits.

Keep the starting switch key at the ON position while the engine is running.

If the ambient temperature is low, when the engine is started, the preheating pilot lamp will light up automatically and preheating will start.

The preheating time differs according to the ambient temperature when the engine is started.

If the preheating pilot lamp lights up, wait for it to go out, then turn the key to the START position.

(C): START position

This is the position to start the engine. Hold the key at this position while cranking the engine. Release the key immediately after the engine has been started. The key will return to ON position (B) when released

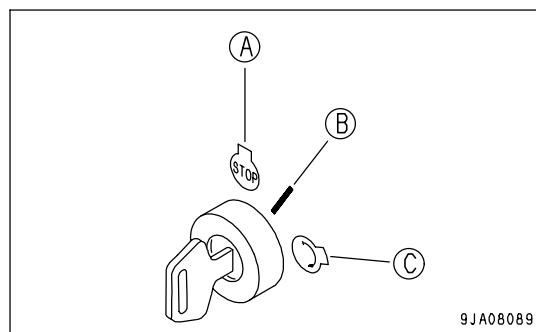

POWER MODE SELECTOR SWITCH

This switch (2) can be used to switch the engine output to match the purpose of the operation.

When the P mode is selected, the power mode pilot lamp (P mode) on the machine monitor lights up.

Position (a): E mode (engine output low); operations with emphasis on fuel economy, such as operations on level ground where a maximum output is not needed

Position (b): P mode (engine output high); operations with emphasis on productivity

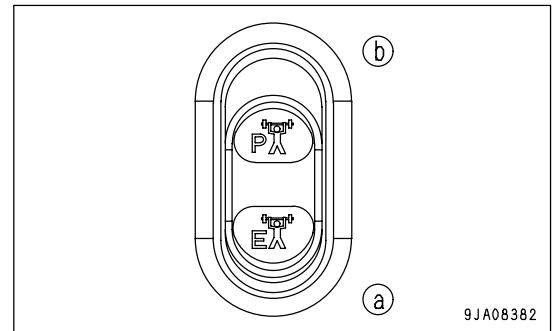
**REMARK**

- To carry out operations with effective fuel consumption, normally set to the E mode. The maximum engine speed is set lower than in the P mode, but except for hard operations such as heavy-duty digging of rock, it can display ample power and can also display good fuel consumption. Furthermore, by pressing the accelerator pedal lightly, it is possible to reduce the fuel consumption.
- Set to the P mode when carrying out heavy-duty digging operations of rock or operations where the speed is required, or when traveling at high speed on flat ground or on slopes.

TRANSMISSION SHIFT MODE SELECTOR SWITCH

This switch (3) is used to change the shift point when the AUTO SHIFT/MANUAL selector switch has been switched to auto shift.

At each of the L, H positions, the system switches to auto shift and the auto shift pilot lamp on the machine monitor lights up. Normally, set to auto shift.

MANUAL position: System is set to manual shift and speed range is a position selected by gearshift lever

L position: Travel speed when shifting up is low (flat ground, normal travel)

H position: Travel speed when shifting up is high (traveling uphill, traveling at high speed)

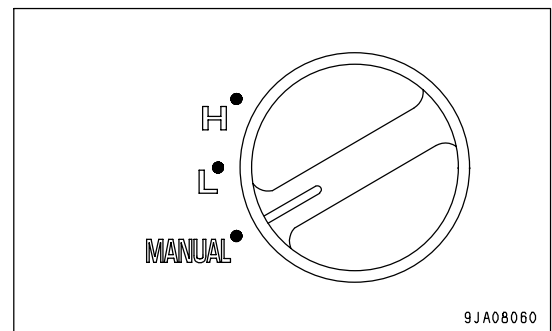

If it is set to the L position when the work is mainly operations on flat ground, it is possible to shift up when the engine speed is low. This is effective in reducing fuel consumption.

REMARK

For details of the manual shift, see "MANUAL SHIFT (PAGE 3-53)".

For details of the auto-shift, see "AUTOMATIC SHIFT (PAGE 3-54)".

TRANSMISSION CUT-OFF SWITCH

! WARNING

When starting the machine off up a hill, turn the transmission cut-off switch to the OFF position, depress the brake pedal, then gradually depress the accelerator pedal and release the brake slowly to allow the machine to start off. This makes it possible to prevent the machine from rolling back.

Press this switch (4) to turn on and off the transmission cut-off system.

When the switch is pressed, the pilot lamp lights up and the system is turned ON. The transmission is shifted to neutral at the adjusted brake pedal depression position.

Normally, keep the switch at the ON position.

For details of the method of adjusting the cut-off position, see "ADJUSTING TRANSMISSION CUT-OFF POSITION (PAGE 3-135)" in the STOPPING MACHINE section.

Position (a): OFF

The brake pedal acts in the normal way for the brake.

Position (b): ON

In addition to acting in the normal way for the brake, the brake pedal returns the transmission to Neutral at the same time.

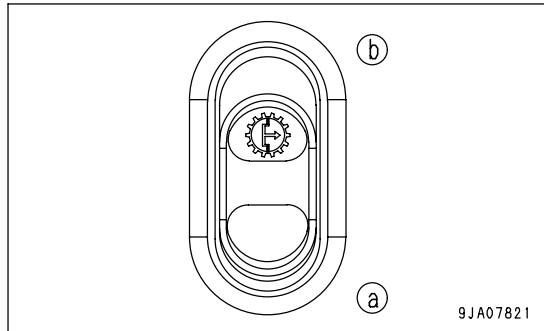

REMARK

The brake pedal position where the cut-off system is actuated can be adjusted by using the transmission cut-off set switch on the right switch panel.

TRANSMISSION CUT-OFF SET SWITCH

! CAUTION

Apply the parking brake before adjusting the transmission cut-off position.

Turn this switch (5) ON to adjust the brake pedal position where the transmission is automatically shifted to Neutral.

Position (a): ON

Cut-off position can be adjusted

When the switch is released, it automatically returns to its original position.

For details of the method of adjusting the cut-off position, see "ADJUSTING TRANSMISSION CUT-OFF POSITION (PAGE 3-135)" in the STOPPING MACHINE section.

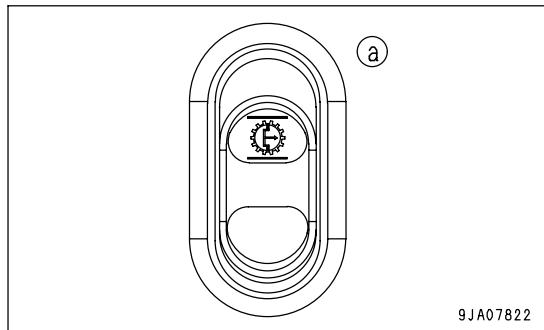

LAMP SWITCH

This switch (6) is used to light up the front lamps, side clearance lamps, tail lamps, and instrument panel.

Position (a): OFF

Position (b): Side clearance lamps, tail lamps, and instrument panel light up

Position (c): Head lamps light up in addition to lamps at (b) position

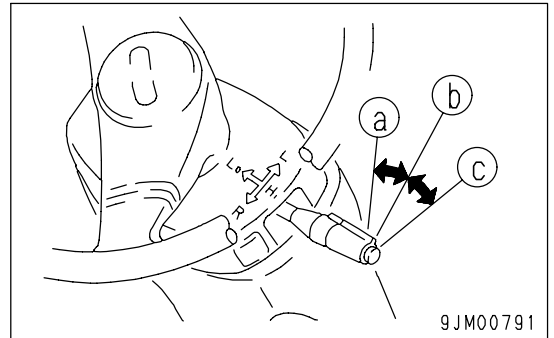

REMARK

The lamp switch can be operated regardless of the position of the lever.

TURN SIGNAL LEVER

This lever (6) is used to operate the turn signal lamp.

(L) position: LEFT TURN (Push lever FORWARD.)

(N) position: OFF

(R) position: RIGHT TURN (Pull lever BACK.)

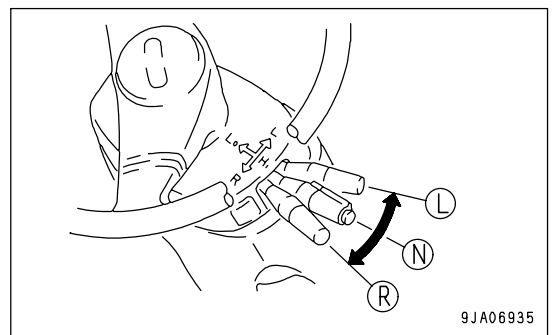

REMARK

- When the lever is operated, the turn signal pilot lamp also flashes.
- When the steering wheel is turned back, the lever automatically returns to its original position. If it does not return, return it manually.

DIMMER SWITCH

This switch (6) is used to switch the head lamps between high beam and low beam.

Position (L): Low beam

Position (H): High beam

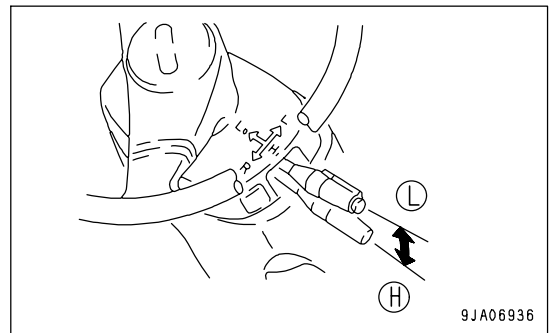

HORN BUTTON

When the horn button (7) in the center of the steering wheel is pressed, the horn will sound.

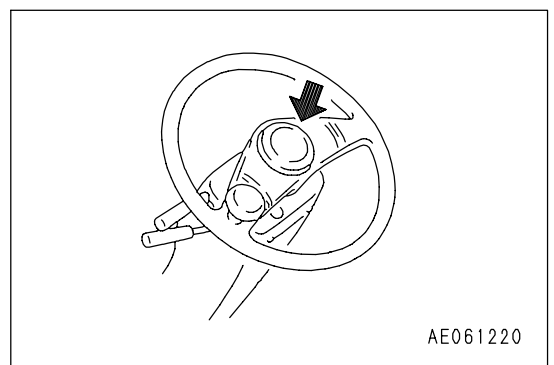

HAZARD LAMP SWITCH

**WARNING**

Use the hazard lamp only in emergencies. Using the hazard lamp when traveling may cause confusion for other machine operators.

This switch (8) is used in emergencies, such as when the machine breaks down and has to be parked on the road.

Position (A): Turn signal lamps, turn signal pilot lamp flash, and pilot lamp (C) lights up at same time.

Position (B): Lamps are OFF.

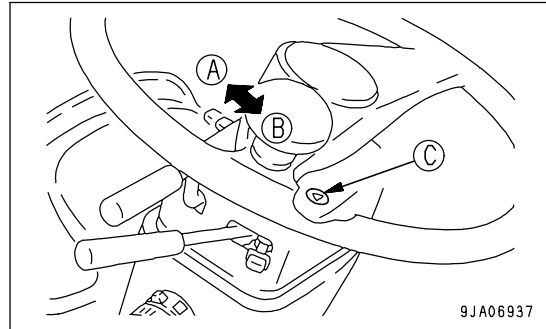

PARKING BRAKE SWITCH

**WARNING**

Always apply the parking brake when leaving the machine or when parking it.

Even if the parking brake switch is turned ON, there is danger until the parking brake pilot lamp lights up, so keep the brake pedal depressed.

NOTICE

- Do not use the parking brake switch to apply the brake when traveling except in emergencies. The parking brake may be damaged, resulting in a serious accident. Stop the machine first, then apply the parking brake.
- If the parking brake has to be used as an emergency brake when the machine is traveling at high speed, ask your Komatsu distributor to carry out inspection to check that there is no damage to the parking brake.

This switch (9) operates the parking brake.

Position (A): ON

The parking brake is applied, and the parking brake pilot lamp lights up.

Position (B): OFF

The parking brake is released.

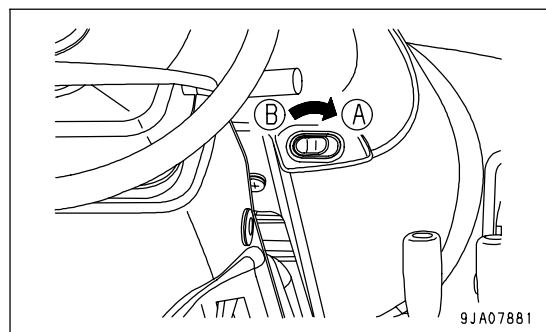

REMARK

- When the parking brake is applied, the machine will not move off even if the directional lever is operated.
- If the directional lever is placed at the F or R position with the parking brake still applied, the central warning lamp will light up and the buzzer will sound.
- Before starting the engine, turn the parking brake switch ON.

FRONT WORKING LAMP SWITCH**WARNING**

Always turn the working lamp off before traveling on public roads.

This switch (10) is used to light up the front working lamp.

Position (a): Working lamp lights up

Position (b): Working lamp goes out

If position (a) is pressed, the pilot lamp will light up and the working lamp circuit will be switched ON.

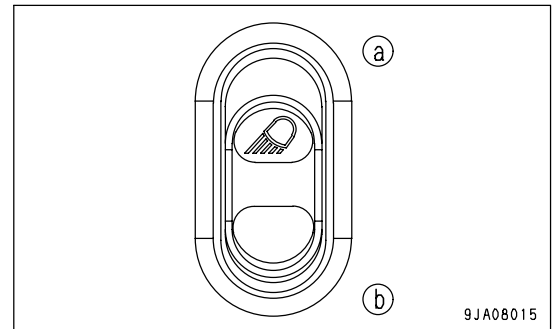
**REAR WORKING LAMP SWITCH****WARNING**

Always turn the working lamp off before traveling on public roads.

This switch (11) is used to light up the rear working lamp.

Position (a): Working lamp lights up

Position (b): Working lamp goes out

If position (a) is pressed, the pilot lamp will light up and the working lamp circuit will be switched ON.

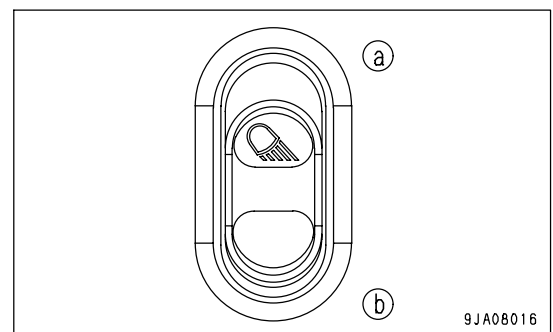
**MACHINE MONITOR MODE SELECTOR SWITCH 1**

This switch (12) is used to switch the function of the character display.

When the switch is released, it automatically returns to its original position.

The basic operation is as follows.

Position (◇):

Press here to select (confirm) each mode or operation

Position (■):

Press here to cancel each mode or operation

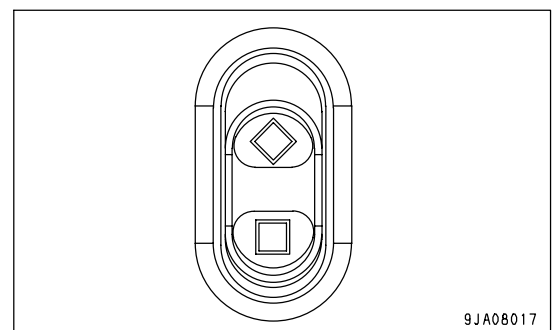

MACHINE MONITOR MODE SELECTOR SWITCH 2

This switch (13) is used to switch the function of the character display.

When the switch is released, it automatically returns to its original position.

The basic operation is as follows.

Position (>): Press here to go on to the next screen, or to move the cursor forward, or to increase the number when entering numerals

Position (<): Press here to go back to the previous screen, or to move the cursor back, or to reduce the number when entering numerals

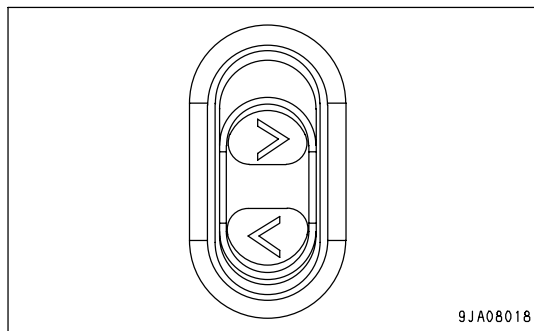
**KICKDOWN SWITCH**

When the gear shift lever is at F2, if switch (14) at the head of the lift arm control lever is pressed, the transmission will shift down one range.

Use this when you need to increase the drawbar pull in digging operations.

When the transmission shift range is in FORWARD 1st (F1) and the power mode selector switch is at E mode, if switch (14) is pressed, it is possible to switch to P mode.

Use this function during scraping-up operations or during digging operations when it is desired to further increase the lifting force.

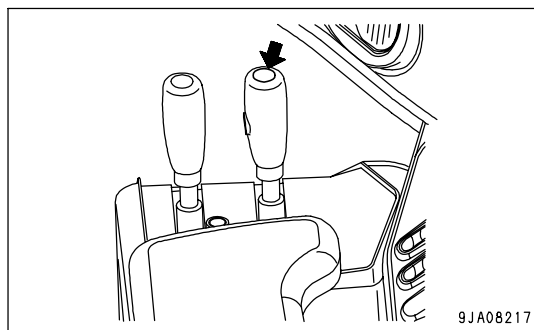

When using E mode

2nd E mode → 1st E mode → 1st P mode

When using P mode

2nd P mode → 1st P mode

If the transmission is in auto-shift, and the travel speed is below 10.5 km/h (6.5 MPH) in any speed range when traveling in either forward or in reverse, the kick-down switch is actuated and it is possible to shift down to 1st.

This makes it easy to carry out load and carry operations.

Even if the travel speed is more than 10.5 km/h (6.5MPH), this switch can be used to shift the transmission down. Each time the kick-down switch is pressed, the speed range will shift down one range at a time (F4 -> F3 -> F2).

REMARK

- When canceling the kick-down, operate the directional lever. In manual shift, the kick-down can be canceled by operating the gearshift lever to any position other than 2nd. It is also possible to cancel the kick-down by turning the starting switch OFF.
- In auto-shift, if the travel speed becomes high after the kick-down, the gear will be shifted up by the auto-shift.
- In auto-shift, when traveling at more than 18 km/h (11.2 MPH) in 3rd or at more than 28 km/h (17.4 MPH) in 4th, even if the kick-down switch is pressed, the transmission will not shift down. This is to prevent overrun of the engine.

HOLD SWITCH

To fix the speed range when traveling in automatic transmission, press switch (15) at the side of the lift arm control lever knob. The transmission will be fixed in the speed range displayed on shift indicator (A) on the machine monitor and shift hold pilot lamp (B) will light up.

When the switch is pressed again, the display goes out.

Use this function to select the desired speed range when traveling up or down hills or when carrying out operations such as grading.

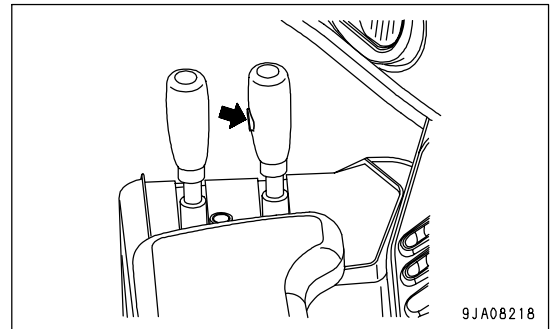

REMARK

When canceling the shift hold, operate the directional lever or gearshift lever or operate the transmission shift mode selector switch to MANUAL. It is also possible to cancel the hold shift by turning the starting switch OFF.

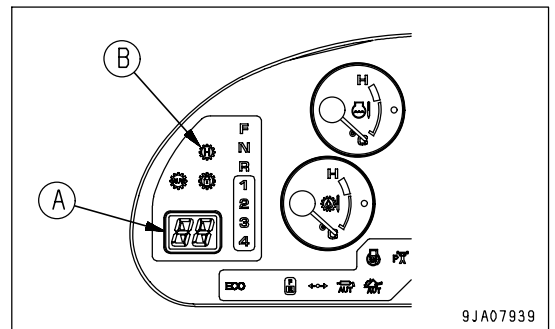

FRONT WIPER SWITCH

When rotary switch (E) of this switch (16) is turned, the front wiper will move.

If push button (F) is pressed, washer liquid will be sprayed out onto the front glass while the button is being pressed.

It is possible to check the position of the switch in display window (G).

- Position (A): (OFF) Stop
- Position (B): (INT) Intermittent wiper
- Position (C): Low-speed wiper
- Position (D): High-speed wiper

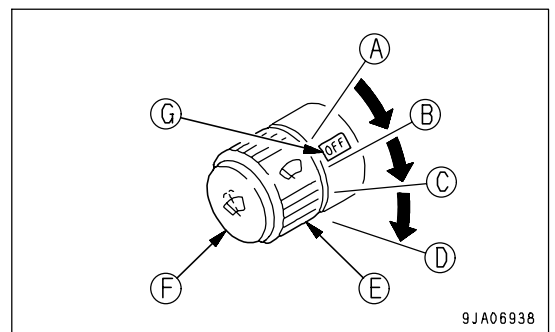

REAR WIPER SWITCH

When lever (E) of this switch (17) is turned, the rear wiper will move.

Position (A): Washer liquid is sprayed out

Position (B): OFF

Position (C): Wiper is operated

Position (D): Washer liquid is sprayed out, wiper is operated

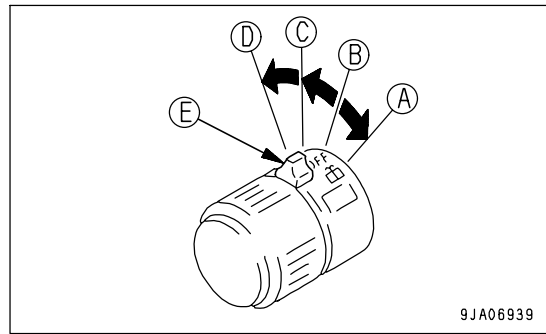

9JA06939

CIGARETTE LIGHTER

This is used to light cigarettes.

After cigarette lighter (18) is pushed in, it will return to its original position after a few seconds, so pull it out and light your cigarette.

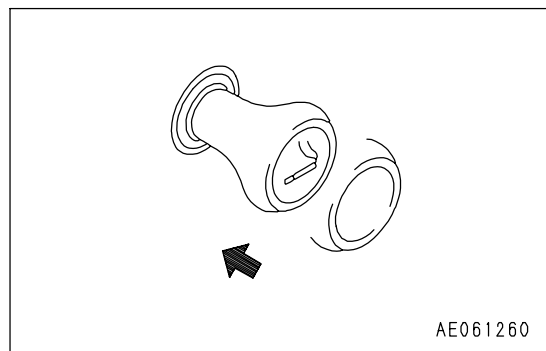

AE061260

ROOM LAMP SWITCH

This switch (19) is used to light up the room lamp.

Position (A): OFF

Position (B): Lights up when cab door is opened

Position (C): ON

REMARK

- The room lamp lights up even when the starting switch is OFF, so when leaving the operator's compartment, turn the switch to position (A) or (B).
- When operating with the cab door fully open, set the switch to position (A).

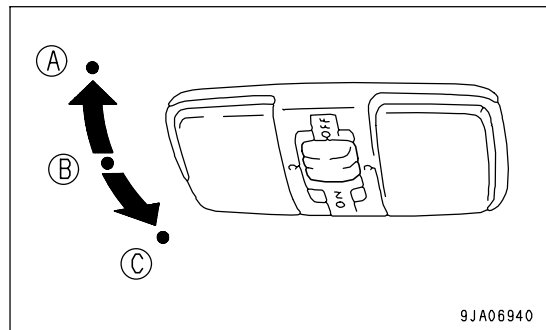

9JA06940

REAR HEATED WIRE GLASS SWITCH

When this switch (20) is pressed, electric current flows through the heated wire glass at the rear and the mist is removed from the glass.

Position (a): ON (removes mist from glass)

Position (b): OFF

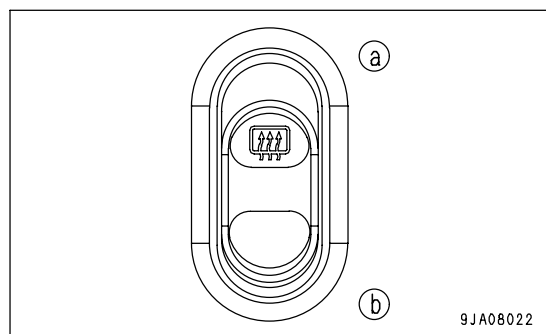

9JA08022

E.C.S.S. (ELECTRONIC CONTROLLED SUSPENSION SYSTEM) SWITCH**WARNING**

- If the machine is traveling or the work equipment is raised, the moment the E.C.S.S. switch is turned ON, the work equipment will move.
- If operations are carried out with the E.C.S.S. switch at the ON position, the moment the E.C.S.S. is actuated, the work equipment may move.
- Never turn the E.C.S.S. switch ON during inspection or maintenance. The work equipment will move and this will create a dangerous situation.

NOTICE

- Always stop the machine and lower the work equipment to the ground before operating the E.C.S.S. switch.
- When carrying out inspection and maintenance, first lower the work equipment to the ground, then turn the E.C.S.S. switch OFF before starting the inspection and maintenance operation.
- When carrying out leveling work, turn the E.C.S.S. switch OFF.

This switch (21) is used to turn the E.C.S.S. ON and OFF.

Position (a): ON

The pilot lamp lights up and the E.C.S.S. is actuated.

Position (b): OFF

The E.C.S.S. is not actuated.

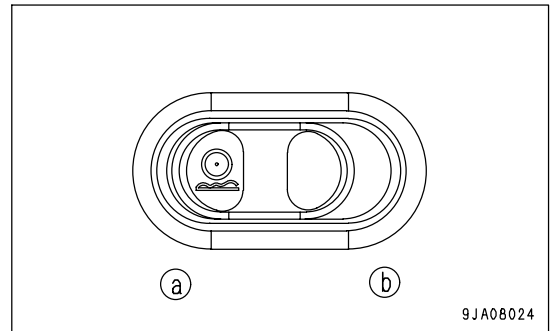
**REMARK**

- The E.C.S.S. is a device that uses the hydraulic spring effect of an accumulator to absorb the vibration of the chassis during travel and allows the machine to travel smoothly and at high speed.
- When traveling in 1st, the E.C.S.S. is not actuated.
- When the speed range is 2nd to 4th, and the travel speed becomes more than 5 km/h (3.1 MPH), the E.C.S.S. is automatically actuated; when the travel speed goes below 3 km/h (1.9 MPH), it is automatically disengaged.

EMERGENCY STEERING SWITCH

(If equipped)

This switch (22) is the manual control switch for the emergency steering.

Even when the engine has stopped, steering operations are made possible by pressing this switch.

Position (a): ON

The pilot lamp inside the switch and the emergency steering pilot lamp on the machine monitor light up and it becomes possible to operate the steering.

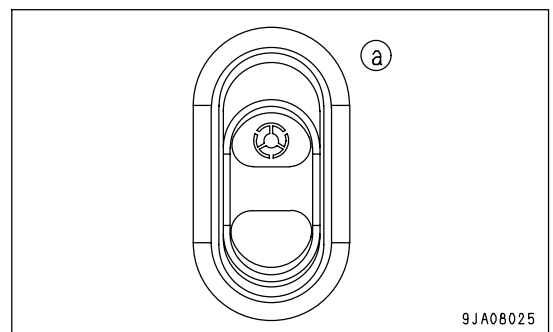

When the switch is released, it automatically returns to its original position.

Actuate the emergency steering only in cases of emergency or when checking the function.

The time for operating the emergency steering continuously is a maximum of 60 seconds. When using the emergency steering, travel at a speed of less than 5 km/h (3.1 MPH). For details, see "EMERGENCY STEERING (PAGE 3-137)" in the OPERATION section.

COOLING FAN REVERSE ROTATION SWITCH

This switch (23) is used to rotate the cooling fan in the reverse direction when cleaning the radiator.

Position (a): Manual reverse rotation switch ON

When the fan is rotating in the normal direction, if the switch is pressed once, the fan will rotate in reverse; if the switch is pressed again, the fan will rotate in the normal direction. When the fan is rotating in the reverse direction, the cooling fan reverse rotation pilot lamp on the machine monitor lights up. For details of the procedure when cleaning, see "CLEAN RADIATOR FINS AND COOLER FINS (PAGE 4-27)".

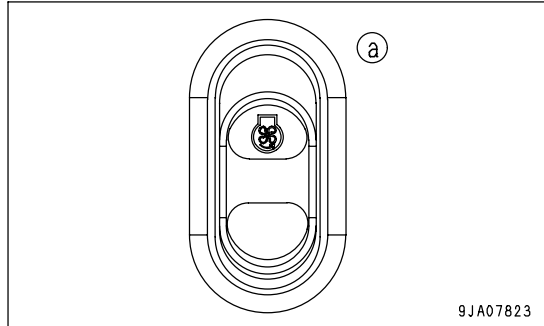

Run the engine at idling when operating the switch.

REMARK

- When the direction of rotation of the fan switches, the reverse rotation pilot lamp flashes.

COOLING FAN AUTO REVERSE ROTATION SWITCH

(If equipped)

This switch (23) is used to rotate the cooling fan in the reverse direction when cleaning the radiator.

Position (a): Auto reverse rotation function ON

The fan automatically rotates in reverse for 2 minutes every 2 hours.

The pilot lamp inside the switch and the cooling fan reverse rotation pilot lamp on the machine monitor light up.

Position (b): Manual reverse rotation switch ON

When the fan is rotating in the normal direction, if the switch is pressed once, the fan will rotate in reverse; if the switch is pressed again, the fan will rotate in the normal direction. When the fan is rotating in the reverse direction, the cooling fan reverse rotation pilot lamp on the machine monitor lights up. Reverse rotation continues for approx. 10 minutes after the switch is pressed. For details of the procedure when cleaning, see "CLEAN RADIATOR FINS AND COOLER FINS (PAGE 4-27)".

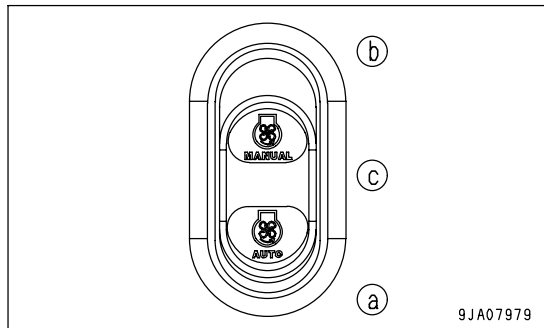

Position (c): Neutral (OFF)

The cooling fan is constantly set to normal rotation.

Run the engine at idling when operating the switch.

REMARK

- When the fan rotation direction is switched, the reverse rotation pilot lamp flashes.
- To protect the machine, the fan rotation direction may not change when the fan is operating under high load or in low temperatures. (For details, see Conditions for switching fan rotation.)
- When the engine is stopped, the fan rotation direction returns to the normal direction.
- If the switch is set to position (b) (manual reverse rotation ON), the switch will return to position (c) (Neutral) when the switch is released.
Even if position (b) of the switch is not kept pressed, the fan will rotate in the reverse direction for a fixed time, so there is no need to keep the switch pressed at position (b).
- During reverse rotation of the fan, if the engine cooling water, hydraulic oil, or torque converter oil overheat (the caution lamp for the oil temperature gauge on the machine monitor lights up), the reverse rotation of the fan is forcibly stopped and the fan switches to rotation in the normal direction.
- It is possible to adjust the following of the automatic reverse rotation functions:
Cycle fan automatic reverse rotation (Standard: 2 hours)
Continuous time fan automatic reverse rotation (Standard: 2 minutes)
Please ask your Komatsu distributor to carry out the adjustment

Conditions for switching fan rotation**When using manual reverse rotation function****Switching from normal rotation to reverse rotation**

The fan will switch from normal rotation to reverse rotation only if all the following conditions are fulfilled.

If the direction is switched, the cooling fan reverse rotation pilot lamp on the machine monitor will change from flashing and will stay lighted up.

If all the conditions are not fulfilled, the fan direction will not change.

If the direction is not switched, the cooling fan reverse rotation pilot lamp on the machine monitor will continue to flash.

Conditions

- Portion (b) of the cooling fan automatic reverse rotation switch is pressed once.
- The engine speed is between Lo and 1200 rpm.
- The engine water temperature is less than 90°C (194°F). (The indicator on the engine water temperature gauge is below horizontal)
- The hydraulic oil temperature is less than 90°C (194°F). (The indicator on the hydraulic oil temperature gauge is below horizontal)
- The torque converter oil temperature is below 100°C (212°F). (The indicator on the torque converter oil temperature gauge is below horizontal)
- At least 30 seconds have passed after the engine was started.

Switching from reverse rotation to normal rotation

The fan will switch from reverse rotation to normal rotation if any of the following conditions are fulfilled.

If the direction is switched, the cooling fan reverse rotation pilot lamp on the machine monitor will change as follows: Lighted up -> flashing -> OFF.

If none of the conditions are fulfilled, the fan direction will not change.

If the direction is not switched, the cooling fan reverse rotation pilot lamp on the machine monitor will change from being lighted up to flashing and will continue to flash.

Conditions

- More than 10 minutes have passed after the fan started to rotate in reverse and the engine speed has dropped to less than 1200 rpm.
- When portion (b) of the cooling fan automatic reverse rotation switch is pressed again when the fan is rotating in reverse, and the engine speed has dropped to less than 1200 rpm.

When using automatic reverse rotation function

Switching from normal rotation to reverse rotation

The fan will switch from normal rotation to reverse rotation only if all the following conditions are fulfilled.

If the direction is switched, the cooling fan reverse rotation pilot lamp on the machine monitor will change from flashing and will stay lighted up.

If all the conditions are not fulfilled, the fan direction will not change.

If the direction is not switched, the cooling fan reverse rotation pilot lamp on the machine monitor will change from OFF to flashing and will continue to flash.

Conditions

- The cooling fan automatic reverse rotation switch is at position (a).
- The engine water temperature is less than 90°C (194°F). (The indicator on the engine water temperature gauge is below horizontal)
- The hydraulic oil temperature is less than 90°C (194°F). (The indicator on the hydraulic oil temperature gauge is below horizontal)
- The torque converter oil temperature is below 100°C (212°F). (The indicator on the torque converter oil temperature gauge is below horizontal)
- At least 30 seconds have passed after the engine was started.
- The set time for switching has passed.

Switching from reverse rotation to normal rotation

The fan will switch from reverse rotation to normal rotation if both of the following conditions are fulfilled.

If the direction is switched, the cooling fan reverse rotation pilot lamp on the machine monitor will change as follows: Lighted up -> flashing -> OFF.

If neither of the conditions are fulfilled, the fan direction will not change.

If the direction is not switched, the cooling fan reverse rotation pilot lamp on the machine monitor will change from being lighted up to flashing and will continue to flash.

Conditions

- When the cooling fan automatic reverse rotation switch is set to any position other than portion (a) when the fan is rotating in reverse, and the hydraulic oil temperature has gone above 50°C (122°F) (the indicator on the hydraulic oil temperature gauge is in the green range).
- When the continuous time for fan automatic reverse rotation has passed and the hydraulic oil temperature has gone above 50°C (122°F) (the indicator on the hydraulic oil temperature gauge is in the green range).

TORQUE CONVERTER LOCK-UP SWITCH

(If equipped)

For details of the torque converter lock-up, see "HANDLING TORQUE CONVERTER LOCK-UP (PAGE 6-3)" in the ATTACHMENTS, OPTIONS section.

CONTROL LEVERS, PEDALS

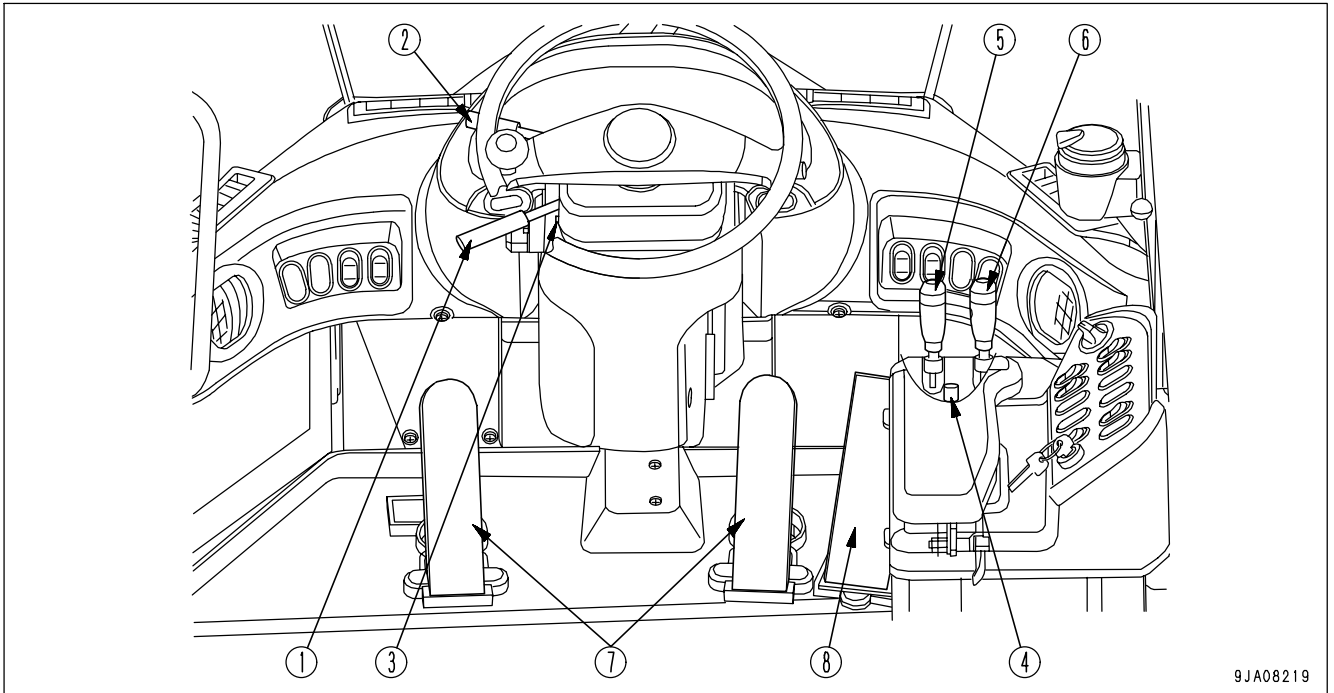

- | | |
|-------------------------------|----------------------------|
| (1) Gearshift lever | (5) Bucket control lever |
| (2) Directional lever | (6) Lift arm control lever |
| (3) Gearshift lever stopper | (7) Brake pedal |
| (4) Work equipment lock lever | (8) Accelerator pedal |

GEARSHIFT LEVER

This lever (1) changes the speed range of the transmission.

MANUAL SHIFT

This machine has a 4-FORWARD, 4-REVERSE speed transmission.

Place the gearshift lever in a suitable position to obtain the desired speed range.

1st and 2nd speeds are used for working.

3rd and 4th speeds are used for traveling.

However, when the gearshift lever stopper is being used, it is impossible to shift to 3rd or 4th. Disengage the gearshift lever stopper before trying to shift gear.

Position (a): 1st

Position (b): 2nd

Position (c): 3rd

Position (d): 4th

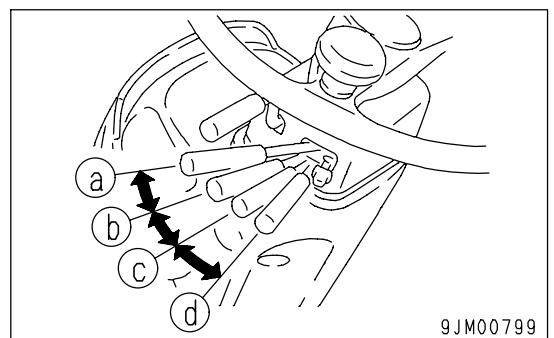

REMARK

The lever length can be set to 3 levels (positions (A), (B), and (C)). For adjustment, consult your Komatsu distributor. (The lever is installed to position (B) when delivered.)

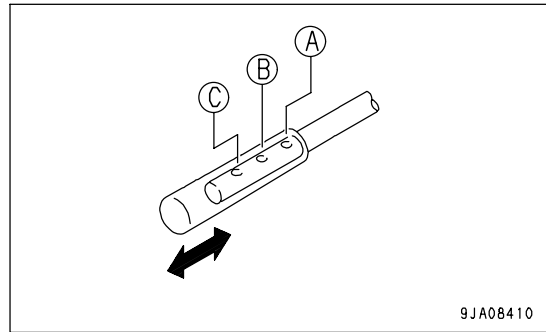

9JA08410

AUTOMATIC SHIFT

Automatic gear shifting can be carried out in the 2nd through 4th speed range of the four forward and reverse speeds depending on the travel conditions.

- Position (a): 1st
- Position (b): 2nd
- Position (c): 3rd
- Position (d): 4th

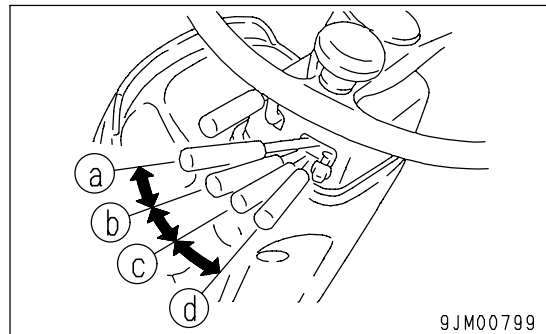

9JM00799

The range of speeds during automatic gear shifting is determined by the position of the gearshift lever as shown in the chart on the right.

Gear shift lever positions	Speed range
2nd	2nd
3rd	2nd <-> 3rd
4th	2nd <-> 3rd <-> 4th

REMARK

- The 1st position for the gearshift lever fixes the transmission in 1st. There is no automatic shifting of the transmission.
- When shifting down from 2nd to 1st, press the kick-down switch on the lift arm control lever.
- If the transmission is in auto-shift and the travel speed is below 10.5 km/h (6.5 MPH) in any speed range when traveling in either forward or in reverse, the kick-down switch is actuated and makes it possible to shift down to 1st. This makes it easy to carry out load and carry operations.
- Even if the travel speed is more than 10.5 km/h (6.5 MPH), this switch can be used to shift the transmission down. Each time the kick-down switch is pressed, the speed range will shift down one range at a time (when in 4th: F4 -> F3 -> F2; when in 3rd: F3 -> F2).

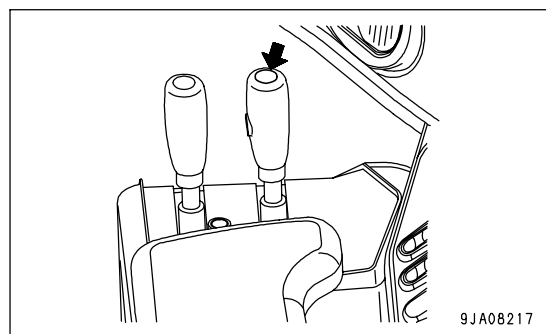

9JA08217

To set to the desired speed range when traveling uphill or downhill, or when carrying out grading, do as follows.

- When fixing the speed range
Press the HOLD switch on the lift arm control lever.
The speed range is fixed at the speed range displayed on the transmission indicator on the machine monitor.
- When shifting up or down from set speed range
Shift gear with the gearshift lever.

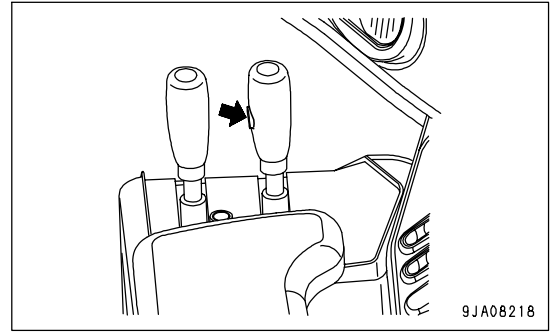

REMARK

When the transmission has been shifted down from 2nd to 1st with the kickdown switch, it will shift up from 1st to 2nd when the travel speed increases.

DIRECTIONAL LEVER

This lever (2) is used to switch the direction of travel of the machine between forward and reverse.

When starting the engine, if the directional lever is not at the N position, the engine will not start.

In this case, the central warning lamp will light up and the buzzer will sound.

Return the gearshift lever to the N position and start the engine.

Position (F): Forward

Position (N): Neutral

Position (R): Reverse

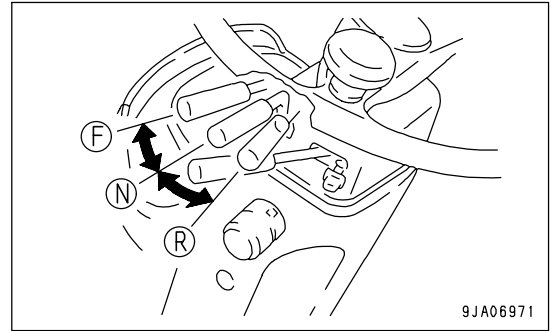

REMARK

The lever length can be set to 2 levels (positions (A), (B)). For adjustment, consult your Komatsu distributor.

(The lever is installed to position (A) when delivered.)

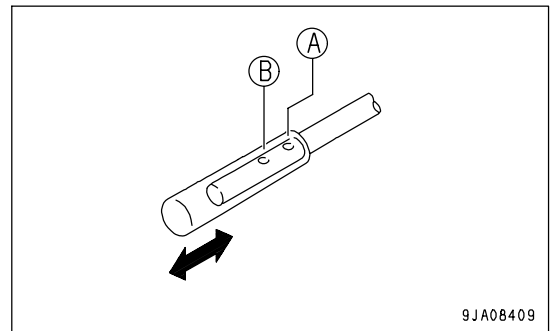

GEARSHIFT LEVER STOPPER

This stopper (3) prevents the gearshift lever from entering the 3rd or 4th positions when working.

Position (a): Stopper actuated.

Position (b): Stopper released.

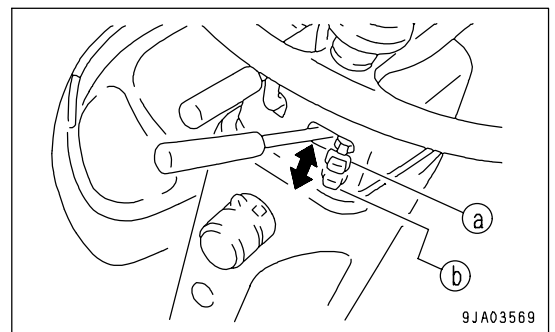

WORK EQUIPMENT LOCK LEVER

! WARNING

- Before standing up from the operator's seat, set the work equipment lock lever securely to the LOCK position. If the work equipment lock lever is not at the LOCK position, and work equipment control lever(A) is touched by mistake, it may lead to a serious accident.
- If the work equipment lock lever is not placed securely at the LOCK position, the work equipment may move, and this may lead to a serious accident or personal injury. Check that the lever is in the position shown in the diagram.
- When operating the work equipment lock lever, check that work equipment control lever(A) is at the HOLD position.
- When operating the work equipment lock lever, be careful not to touch work equipment control lever(A).

This lever (4) is used to lock the work equipment control levers and prevent operation of the work equipment. Pull the work equipment lock lever towards the center of the machine to set it to LOCK position (L).

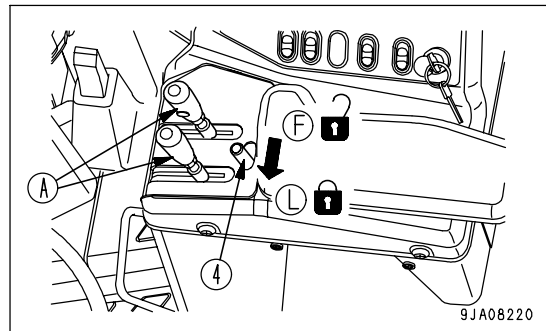

BUCKET CONTROL LEVER

This lever (5) operates the bucket.

Position (a): TILT

When the bucket control lever is pulled further from the TILT position, the lever is stopped in this position until the bucket reaches the preset position of the positioner, and the lever is returned to the HOLD position.

Position (b): HOLD

The bucket is kept in the same position.

Position (c): DUMP

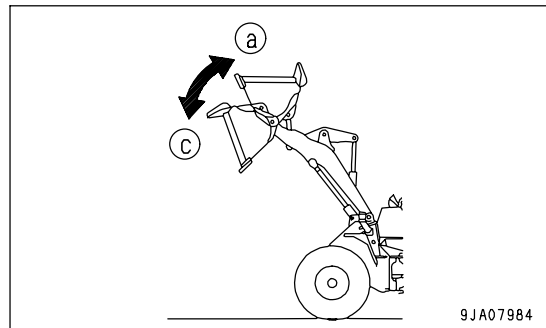
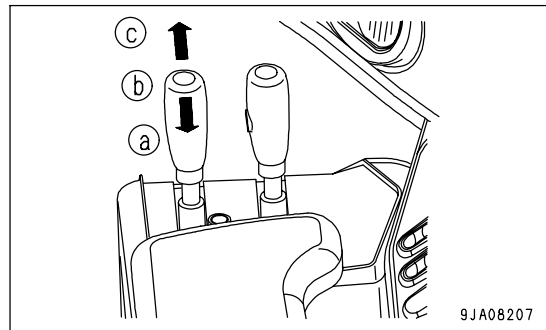

LIFT ARM CONTROL LEVER

This lever (6) is used to operate the lift arm.

NOTICE

Do not use the FLOAT position when lowering the bucket. Use the FLOAT position when leveling, see "LEVELING OPERATIONS (PAGE 3-145)".

Position (a): RAISE

When the lift arm control lever is pulled further from the RAISE position, the lever is stopped in this position until the lift arm reaches the preset position of the kickout, and the lever is returned to the HOLD position.

Position (b): HOLD

The lift arm is kept in the same position.

Position (c): LOWER

Position (d): FLOAT

The lift arm moves freely under external force.

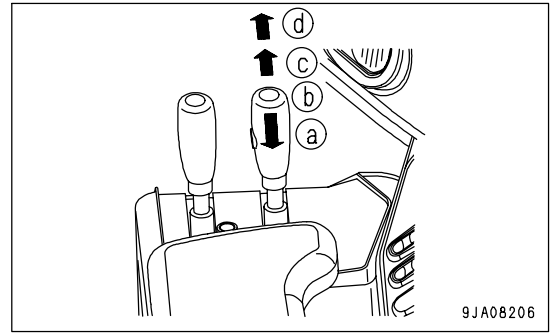

9JA08206

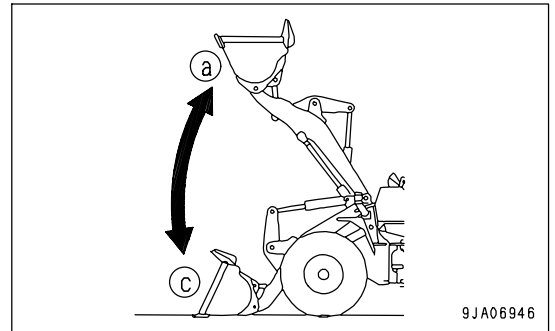

9JA06946

BRAKE PEDAL

! WARNING

- When traveling downhill, always use the right brake pedal, and use the braking force of the engine together with the brake.
- Do not use the brake pedal repeatedly more than necessary. If the brake is used too frequently, the brake will overheat. If this happens, the brakes will not work, so this may lead to a serious accident.
- Do not put your foot on this pedal unless necessary.

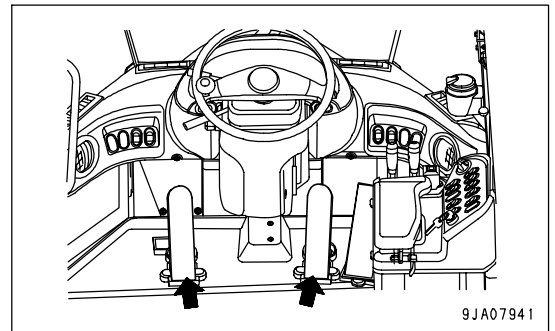

9JA07941

These pedals (7) operate the brakes.

RIGHT AND LEFT BRAKE PEDAL

The right brake pedal operates the wheel brakes.

Use the right brake pedal for normal braking operations.

When the transmission cut-off switch is at the ON position, the brakes are applied, and the transmission is returned to Neutral at the same time.

When the transmission cut-off switch is at the OFF position, the brakes are applied, but the transmission is not returned to Neutral.

REMARK

When using the brake and accelerator together to reduce the machine travel speed or to stop the machine while carrying out operations, set the transmission cut-off switch to the ON position and use the brake pedal.

ACCELERATOR PEDAL

This pedal (8) controls the engine speed and output. The engine speed can be freely controlled between low idle and full speed.

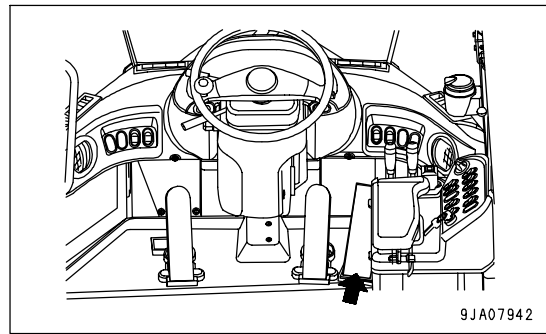

STEERING TILT LOCK LEVER



Stop the machine before adjusting the tilt of the steering wheel. If this operation (adjustment) is carried out while the machine is moving, it may lead to a serious accident or personal injury.

This lever is used to hold the steering wheel in position.
 (F) FREE position: Steering wheel can be moved to front, rear, up, and down
 (L) LOCK position: Steering wheel is held in position
 The adjustment amounts are as follows.

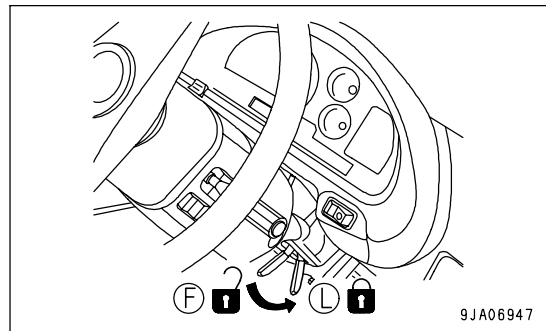

Up-down movement	When at 0 mm (0 in)	When moved up to 40 mm (1.6 in)
Tilt amount	0 - 105 mm (0 - 4.1 in)	0 - 130 mm (0 - 5.1 in)

CAP WITH LOCK

The fuel tank filler port and the hydraulic tank filler port are equipped with locks. Use the starting switch key to open and close the cap.

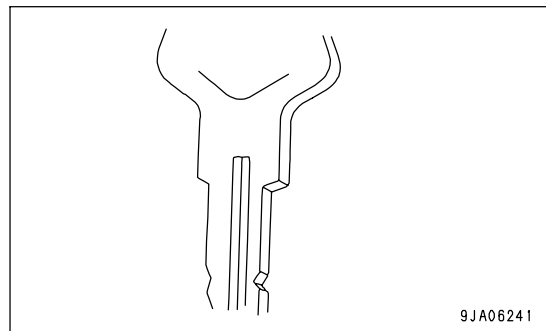

METHOD OF OPENING AND CLOSING CAP WITH LOCK (FOR THE FUEL TANK FILLER PORT)

TO OPEN THE CAP

1. Insert the key into the key slot.
2. Turn the key clockwise, align the key groove with mark (1) on the cap, then open the cap.
Position (A): OPEN
Position (B): LOCK

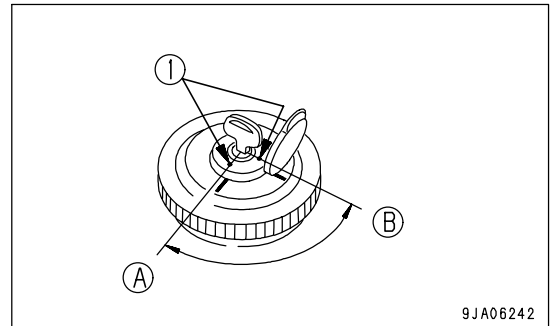

TO LOCK THE CAP

1. Turn the cap until tight, then insert the key into the key slot.
2. Turn the starting switch key to LOCK position (B), then remove the key.

METHOD OF OPENING AND CLOSING CAP WITH LOCK (FOR THE HYDRAULIC TANK FILLER PORT)

TO OPEN THE CAP

1. Insert the key into the key slot.
2. Turn the starting switch key counterclockwise and bring the rotor groove in line with the aligning mark (1) on the cap. Turn the cap slowly until a "clicking" sound is made. This releases the lock and allows the cap to be opened.
Position (A): OPEN
Position (B): LOCK

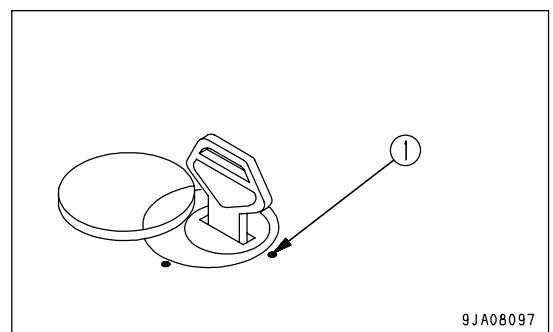
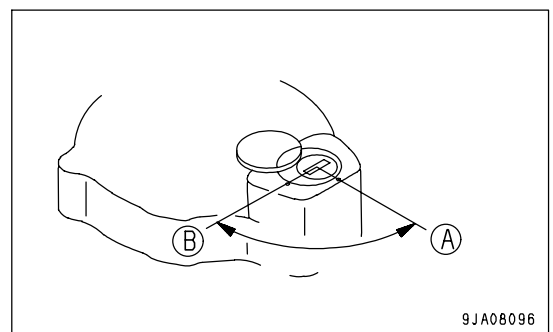

TO LOCK THE CAP

1. Screw the cap into place.
2. Turn the starting switch key to LOCK position (B), then remove the key.

FRAME LOCK BAR



WARNING

- When carrying out maintenance or transporting the machine, always set the frame lock bar to the LOCK position.
- Always remove the frame lock bar for travel operations. If it is not removed, the steering wheel cannot be used for steering, and this may lead to serious damage or injury.

This is a device used to lock the front and rear frames during maintenance or when transporting the machine. It prevents the front and rear frames from articulating.

(L) LOCK position: Front and rear frames are locked and machine cannot articulate. Set to this position when carrying out inspection and maintenance.

(F) FREE position: Set to this position for normal operations.

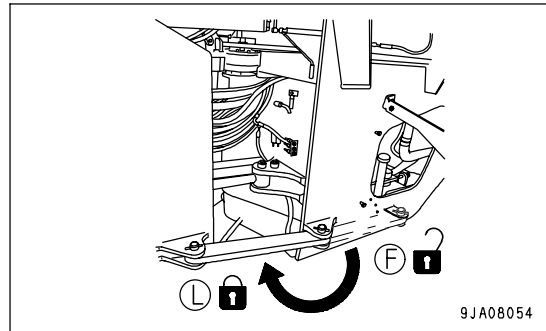

TOWING PIN

1. Insert towing pin (1) into hole (2) in the counterweight.

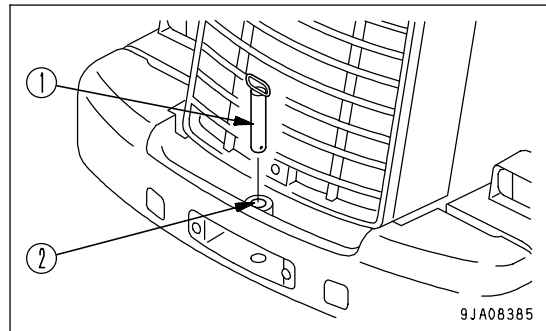

2. Use linch pin (3) to set so that the towing pin does not come out.

Reverse this operation to remove the pin.

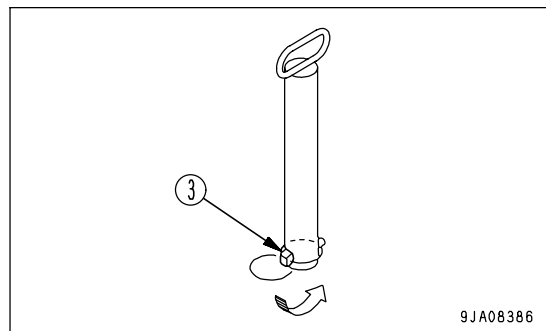

GREASE PUMP

The grease pump is installed in the holder on the left radiator side of the engine bulkhead at the rear of the machine. After using it, wipe off the grease from its outside and install it in position. Insert the grease pump in the holder and fix it with the rubber band. Hitch the tail chain of the grease pump to the hook at the bottom of the holder.

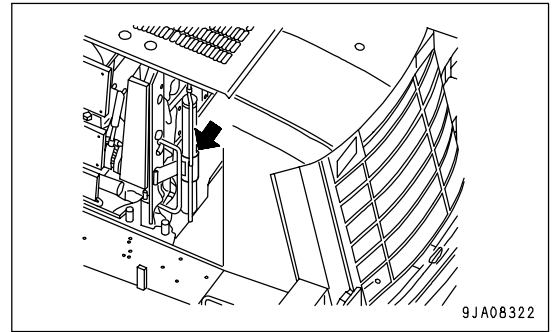

OPENING, CLOSING CAB DOORS, WINDOWS



CAUTION

- Always check that the cab door is locked, both when it is open and when it is closed.
- Always stop the machine on level ground before opening or closing the door.
Avoid opening or closing the door on a slope. There is danger that the operating effort may suddenly change.
- When opening or closing the door, always use door handle and knob.
- Be careful not to get your hands caught by the front pillar or center pillar.
- When there is any person inside the cab, always call out a warning before opening or closing the door.

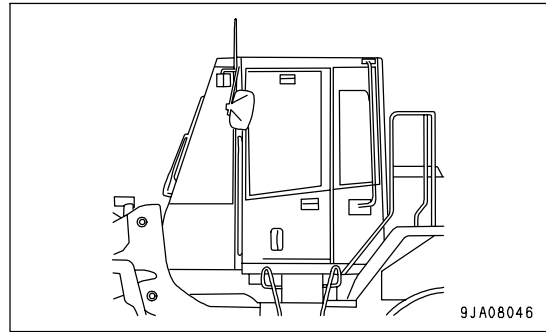

LEFT DOOR OF CAB

DOOR HANDLE

1. If the door has not been locked with the key, it is possible to pull door handle (1) and open the door fully.

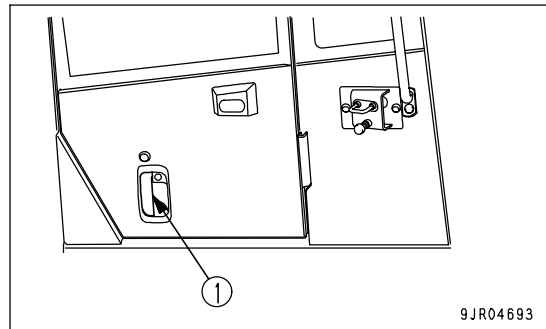

DOOR OPEN KNOB

1. When door open knob (2) is pulled, it is possible to open the door fully. It is possible to open the door in this way even when the door is locked with the key.

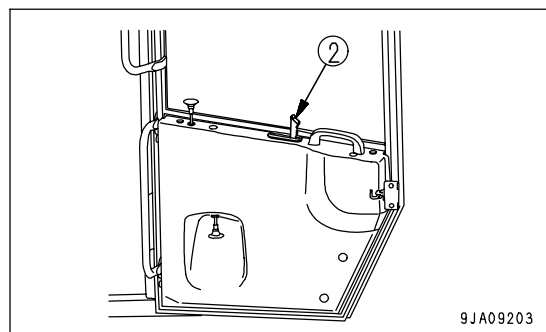

DOOR OPEN LOCK

When getting in or out of the operator's compartment, or when operating with the door open, use this lock to hold the door in position.

1. Push the door against catch (1) to lock it in position.
2. When attaching the door in position, lock it firmly to the catch.
3. When getting on or off the machine, hold the handrail on the inside.

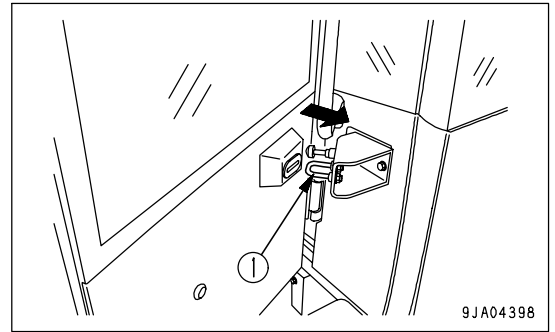

4. When closing the door from the operator's seat, push knob (2) to release the catch.
5. When closing the door after getting off the machine, pull knob (3) to release the catch.

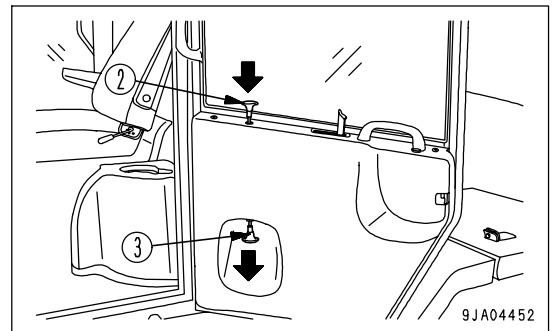

CAB SLIDING WINDOW LOCK RELEASE KNOB (LEFT, RIGHT)

Use this knob when you want to move the glass in the window of the door up or down to open or close it.

Grip lock release knob (1), release the lock, then move the glass down to a lower lock position. Release lock release knob (1).

When the glass is moved down, there are 3 stages for lock position (A).

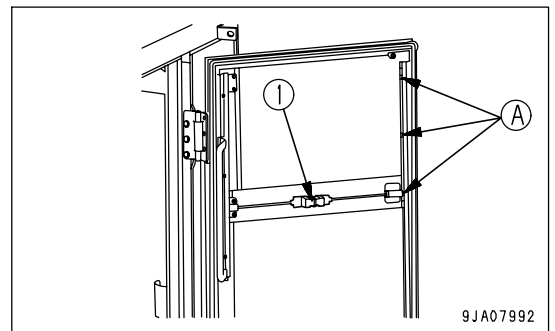

OPEN LOCK KNOB FOR CAB EMERGENCY ESCAPE DOOR

CAUTION

- The door on the right side of the cab is provided as an emergency escape door for use when it is impossible to exit from the door on the left side. Do not use it as the door for normal entry and exit from the cab.
- Never operate the machine with the door open to around 90 degrees. The door may extend beyond the maximum width of the machine or it may suddenly close if the brakes are applied. This is extremely dangerous, so never operate the machine in this condition.
- Operate the machine with the door on the right side fully closed (lock) or partially opened (quarter lock).

Use this to fix the door on the right side at the open or closed position.

1. When open lock knob (1) is pushed down securely, the lock is applied.
When using the air conditioner or heater, carry out operations with the knob in this position.

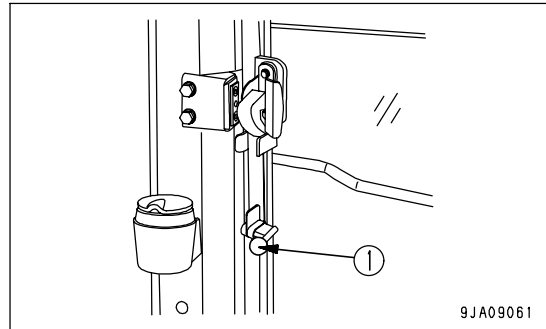

2. If open lock knob (1) is lifted up, the door on the right will partially open (quarter lock).
When taking in outside air on the right side, carry out operations with the window in this position.

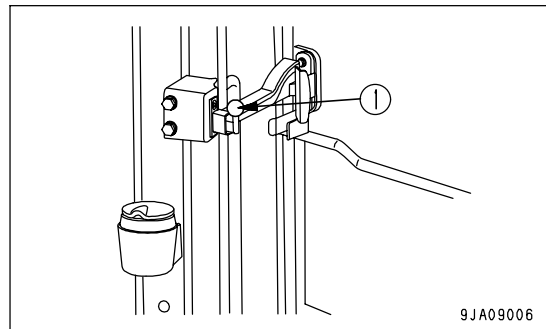

METHOD OF RELEASING A LOCK IN AN EMERGENCY

If the door on the left side of the cab will not open, or it is dangerous to get on or off the machine from the door on the left side, release the open lock of the door on the right, open the door fully, then use it to leave the operator's cab.

1. Lift open lock knob (1) up.

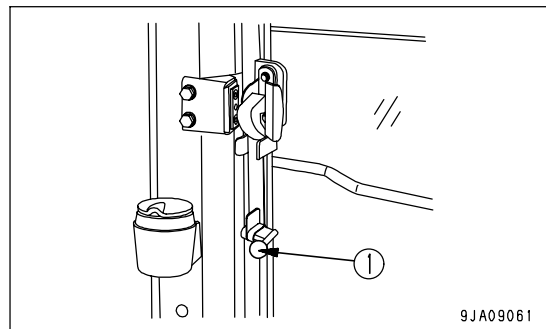

2. Grip open lock knob (1) and pull it towards the rear of the machine.

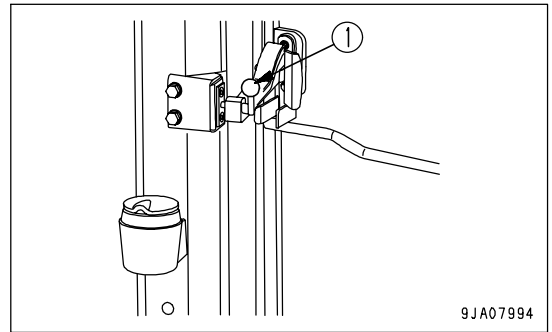

3. Remove the open lock guide rail from the window pillar guide to free the right window lock.

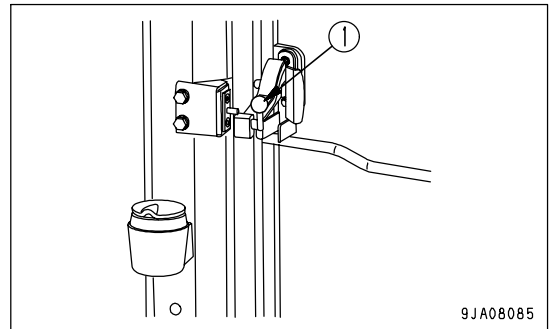

4. Open the right door fully and escape from the cab.

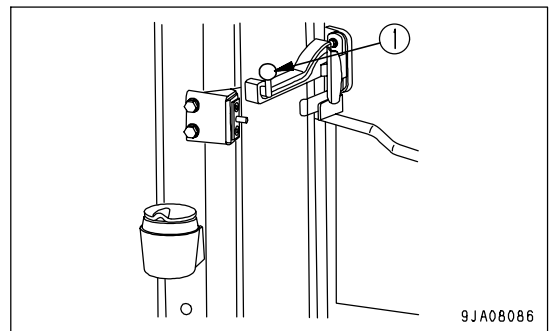

To return the open lock to its original position, hold open lock knob (1) by hand and pull it gradually to align the open lock guide rail with the guide, then push the open lock knob to the front. Check that the rail is completely fitted into the guide, then push open lock knob (1) down to set it securely to the LOCK position.

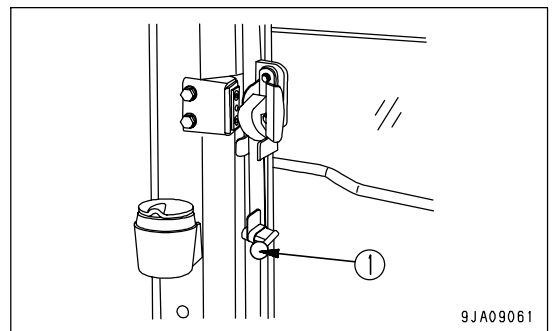

NOTICE

If you do not hold open lock knob (1) with your hand when closing the door, the plastic portion of the lock lever and pin (2) of the cab side will hit each other, and this may cause the plastic portion to break. Always hold open lock knob (1) with your hand when closing the door.

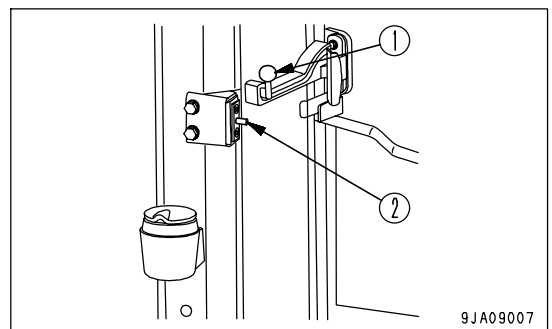

BACKUP ALARM

This sounds an alarm when the directional lever is set to the R position. It is used to warn people behind the machine that the machine will travel in reverse.

FUSE

NOTICE

Before replacing a fuse, be sure to turn off the starting switch.

The fuses protect the electrical equipment and wiring from burning out.

If the fuse becomes corroded, or white powder can be seen, or the fuse is loose in the fuse holder, replace the fuse.

Replace the fuse with another of the same capacity.

Inside rear console box

Loosen knob (1) at two places, then remove cover (2). The fuse boxes are A and B.

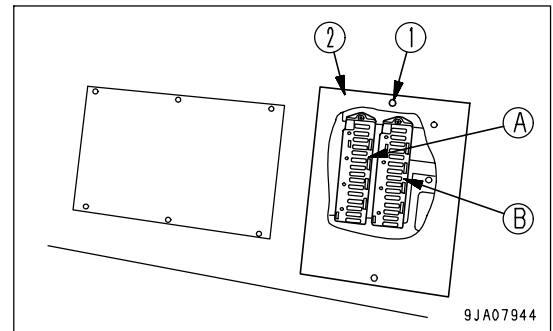

FUSE CAPACITY AND NAME OF CIRCUIT

FUSE BOX A

No.	Fuse capacity	Name of circuit
(1)	10A	Left front lamp
(2)	10A	Right front lamp
(3)	10A	Left clearance lamp
(4)	10A	Right clearance lamp
(5)	20A	Main lamp circuit
(6)	10A	Instrument panel B Load meter printer (if equipped)
(7)	5A	Air conditioner B (if equipped)
(8)	20A	Air conditioner A (if equipped)
(9)	20A	Wiper, washer
(10)	10A	Backup lamp, brake lamp
(11)	10A	Work equipment positioner, Work equipment controller A (if equipped)
(12)	5A	Emergency steering (if equipped)
(13)	5A	Parking brake
(14)	10A	Transmission control A
(15)	10A	Horn

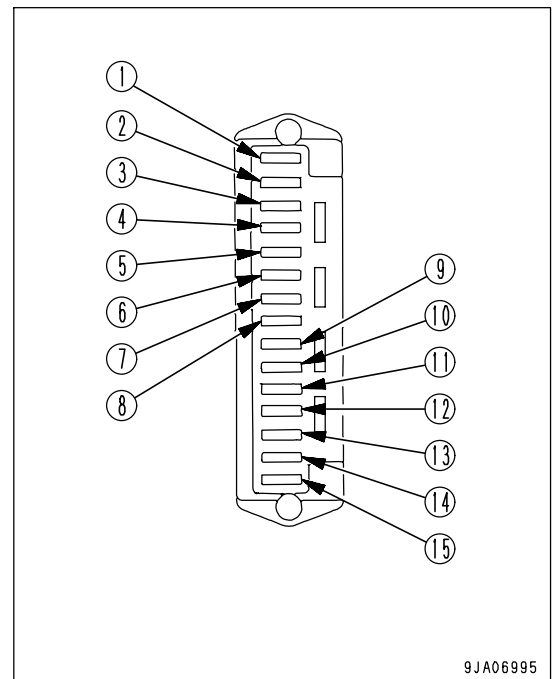

FUSE BOX B

No.	Fuse capacity	Name of circuit
(1)	5A	Engine control B
(2)	20A	Rear heated wire glass
(3)	10A	Air suspension seat (if equipped)
(4)	20A	Yellow rotating lamp(if equipped)
(5)	10A	Turn signal indicator
(6)	20A	Car radio, cigarette lighter, 12V power source (if equipped)
(7)	10A	Rear working lamp
(8)	10A	Front working lamp
(9)	10A	Spare 1
(10)	30A	Engine control A
(11)	5A	Transmission control B, Work equipment controler B (if equipped)
(12)	10A	Room lamp
(13)	10A	Instrument panel A, KOMTRAX (if equipped)
(14)	10A	Hazard lamp
(15)	20A	Starting switch

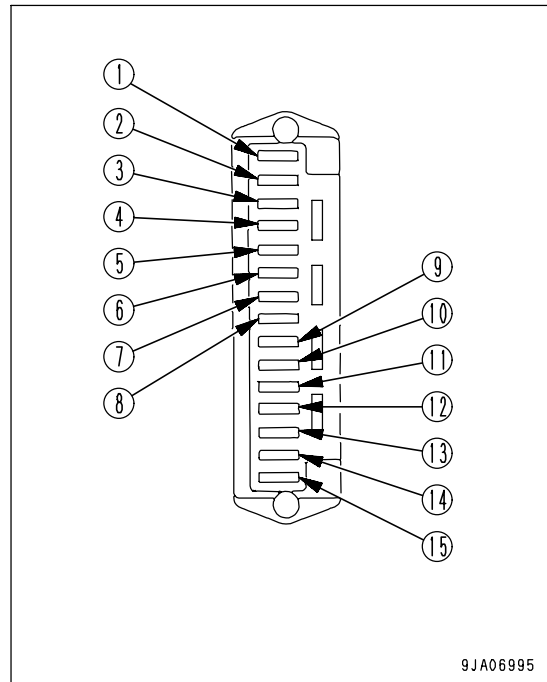

SLOW BLOW FUSE

If the power does not come on when the starting switch is turned to the ON position, there is probably a disconnection in the slow blow fuse, so inspect and replace it.

The slow blow fuse is on the left side of the machine at the side of the engine.

SLOW BLOW FUSE

- (1)50A: Permanent power source
- (2)50A: Main power A
- (3)50A: Main power B
- (4)120A: Charging circuit
- (5)120A: Heater relay (electrical intake air heater)

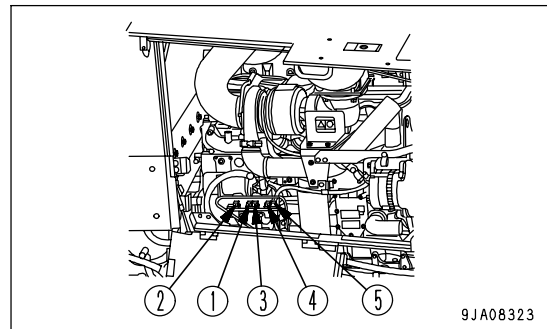

POWER OUTLET

NOTICE

- There are two power sources: 12V and 24V
Check the voltage of the electrical equipment and select the appropriate power source.
Mistaken use, such as using 24V as the power source for 12V equipment, will cause failure of the equipment.
- When using the electric power source, do not install any equipment which will exceed the maximum amperage.

When cigarette lighter (1) is removed, the lighter socket can be used as a 24V power source.

Maximum amperage: 9A (216W)

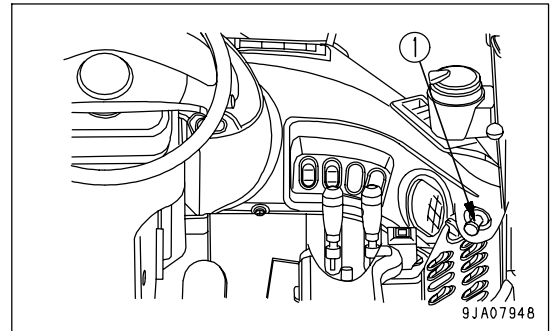

Electric power source (2) can be used as a 12V power source.

Maximum amperage: 10A (120W)

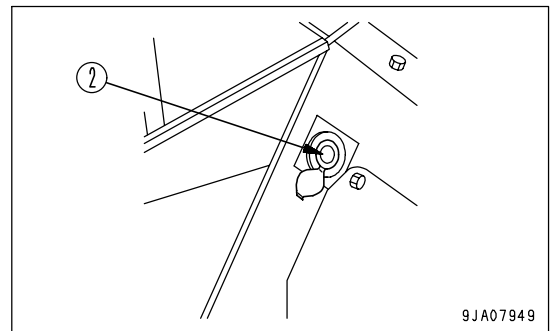

AM/FM RADIO

(If equipped)

EXPLANATION OF COMPONENTS

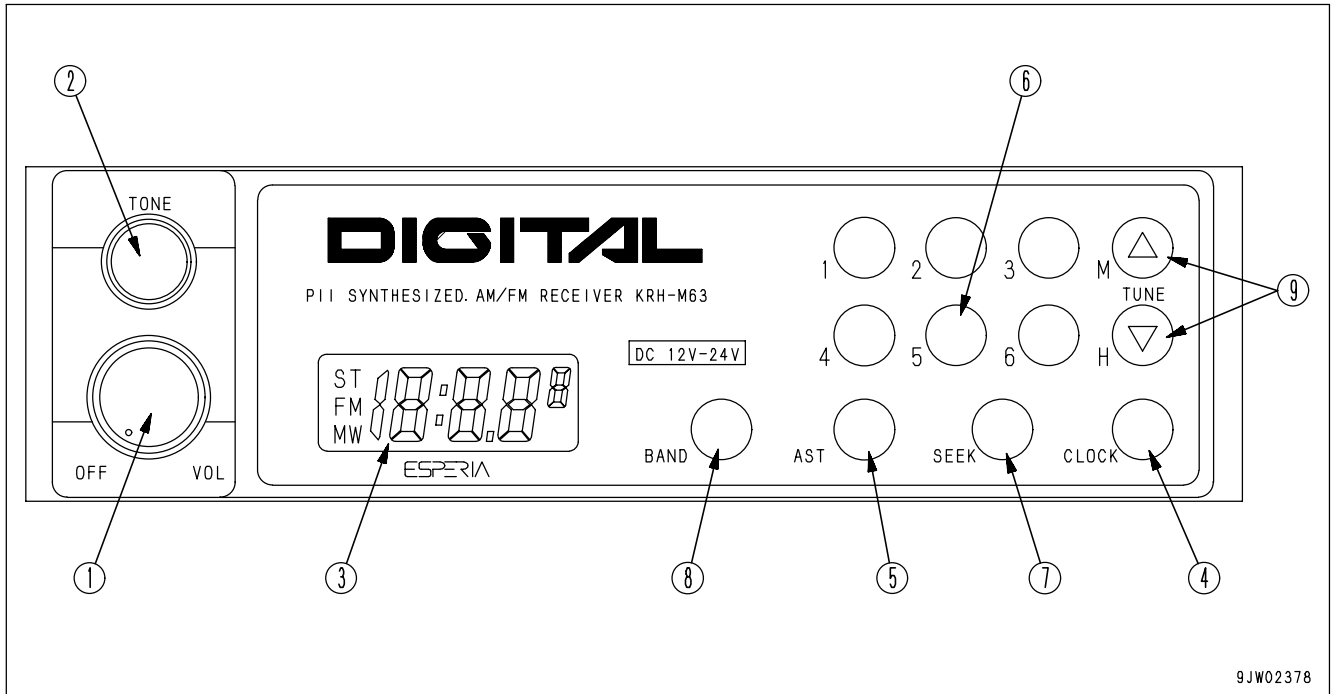

9JW02378

- | | |
|---------------------------------------|--------------------------|
| (1) Power switch/Volume | (6) Preset switch |
| (2) Tone control knob | (7) Seek |
| (3) Display | (8) Band selector switch |
| (4) Clock button/Displaying frequency | (9) Tuning switch |
| (5) AST | |

POWER SWITCH/VOLUME

When this switch (1) is turned to the right, it clicks and the power is turned on. If it is turned further, the speaker volume is adjusted.

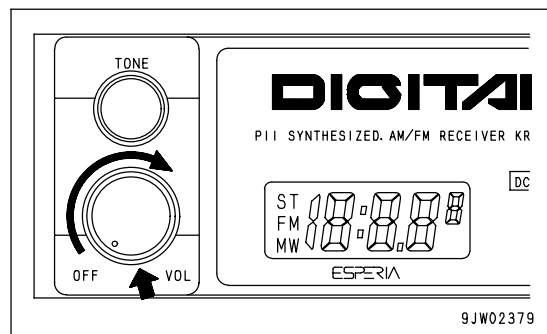

9JW02379

TONE CONTROL KNOB

If this knob (2) is turned to the right, the high tone is emphasized;
if it is turned to the left, the high tone is reduced.

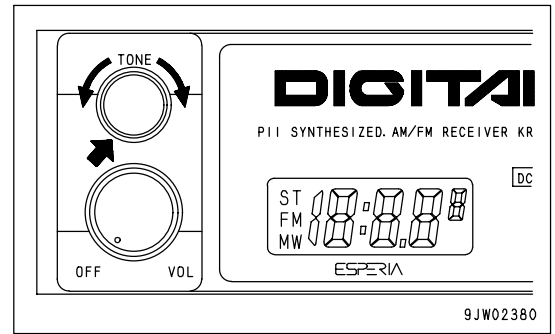

DISPLAY

This display (3) shows the radio reception frequency and the operating mode.

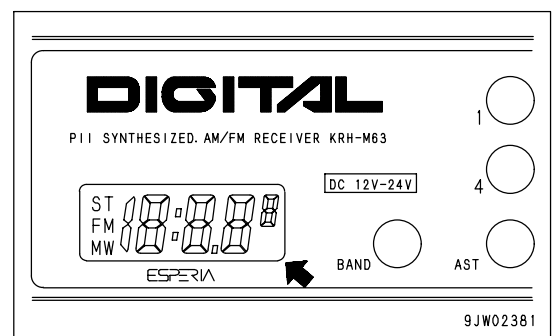

CLOCK BUTTON/DISPLAYING FREQUENCY

When this button (4) is pressed, the display changes to the time.
If it is pressed again, it displays the frequency.

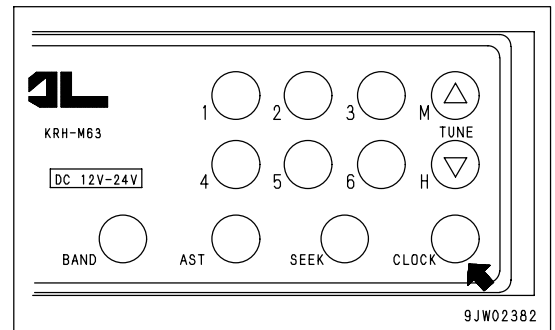

AST

When this button (5) is pressed, the preset stations are called up in turn.

When the desired broadcasting station is reached, press the button again to stop it.

If the button is kept pressed continuously for 2 seconds, it is set to auto memory.

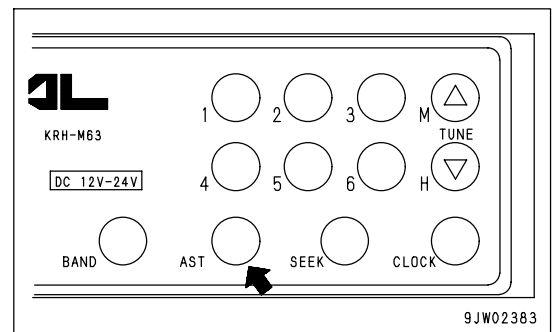

PRESET SWITCH

With this switch (6), each button can be preset to one station each for FM and MW (AM). (For details of the method of presetting, see Section "METHOD OF PRESETTING STATION (PAGE 3-74)".)

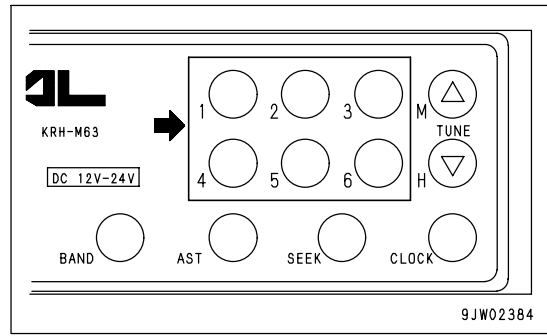

SEEK

When this switch (7) ("SEEK") is pressed, it automatically searches for stations that can be received, and when it receives a station, it stops.

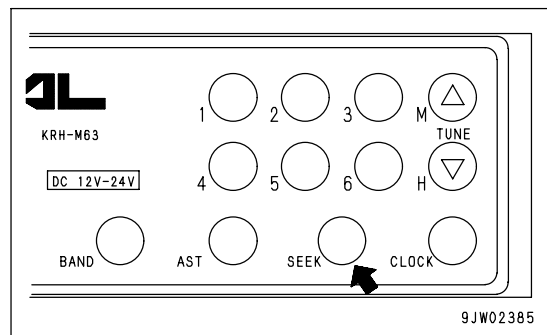

BAND SELECTOR SWITCH

When this switch (8) ("BAND") is pressed, the band is switched between FM and MW (AM).

The reception band and frequency are displayed on the display.

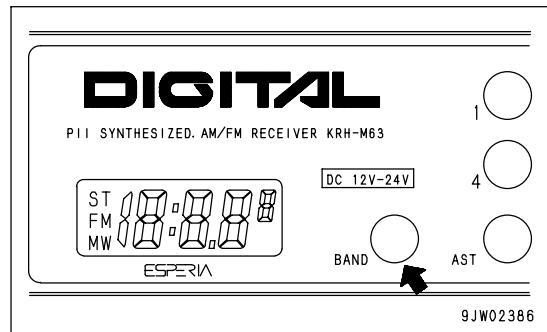

TUNING SWITCH

When the "TUNE" button Δ of switch (9) is pressed, the frequency goes up; when the ∇ button is pressed, the frequency goes down. If it is kept pressed, the frequency changes continuously.

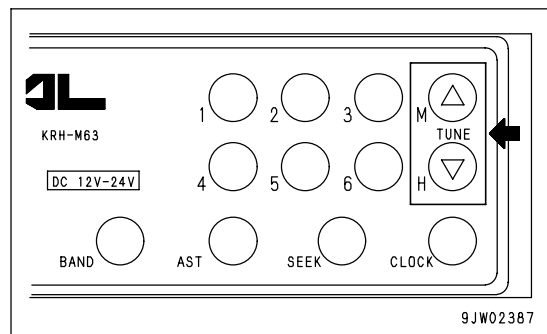

METHOD OF OPERATION

LISTENING TO RADIO

1. Turn radio power switch (1) ON.
2. "BAND" switch (2) is used to select MW (AM) or FM.
3. Use the preset switch or tuning switch (3) to select the station.
4. Adjust the volume and tone as desired.
5. To turn the radio OFF, turn VOL knob (1) to the left until a click is heard.

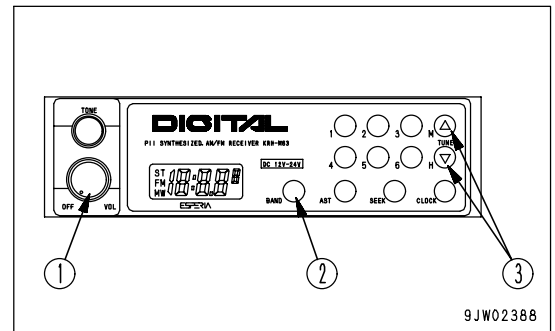

METHOD FOR SELECTING STATION AUTOMATICALLY

When the "SEEK" switch is pressed, it moves up to higher frequencies and when it finds a station that can be received, it stops automatically.

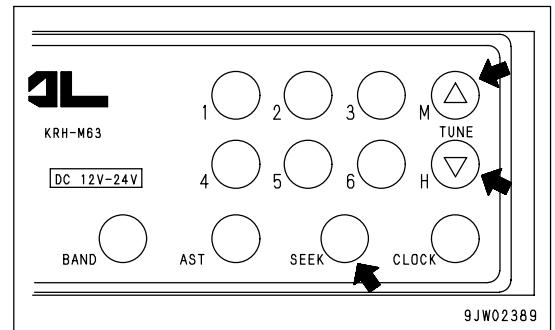

METHOD FOR SELECTING STATION MANUALLY

When the TUNE button Δ is pressed, the frequency goes up; when the ∇ button is pressed, the frequency goes down. If it is kept pressed, the frequency changes continuously.

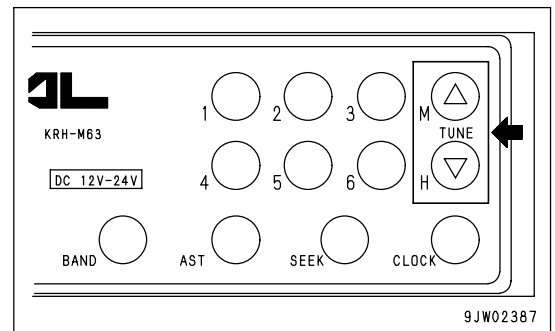

METHOD OF PRESETTING STATION

1. Select the desired preset station.

Use the "BAND" button to select MW (AM) or FM, and use the "TUNE" button to select the frequency of the broadcasting station.

2. Decide the number of the button to be preset, and keep it pressed for 2 seconds. The number of the button will be displayed and the presetting is completed.

3. Repeat Steps 1 to 2 to preset other broadcasting stations.

- To change the setting of a preset switch to another station, repeat Steps 1 to 2.
- If the battery is replaced or the power is switched off, all the preset settings are deleted. Carry out the presetting operation again.
- It is possible to preset 6 AM (MW) stations and 6 FM stations.

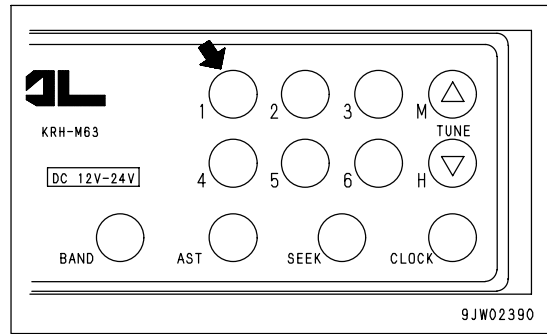

METHOD OF USING AUTO MEMORY

If the "AST" button is pressed for 2 seconds, the broadcasting stations that can be received in the area are called up in turn, and the broadcasting stations are automatically saved in the preset memory.

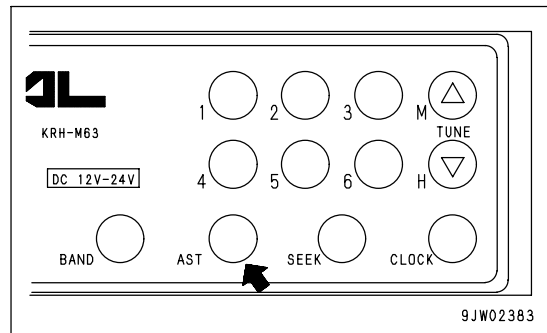

AUTOMATIC SWITCHING OF MONAURAL/STEREO RECEPTION

If the reception of the FM stereo broadcast being received is weak (when you are far from the broadcasting station or are surrounded by hills), the radio is automatically switched from stereo to monaural to reduce the interference. When the stereo broadcast becomes stronger, it automatically switches back to stereo broadcasting.

METHOD OF SETTING TIME

1. Turn radio power (1) ON. If the display (2) is set to a frequency, press TIME button (3) to display the time.
2. With TIME button (3) kept pressed:
 - Press Δ button (4) to set the minutes.
 - Press ∇ button (5) to set the hours.

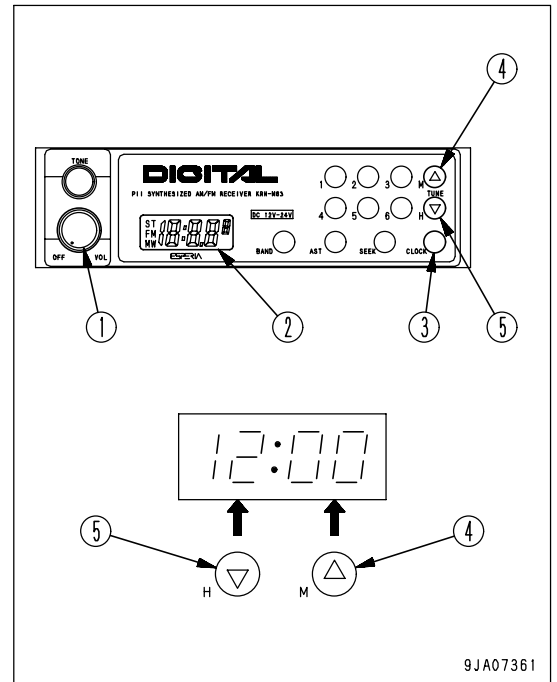

PRECAUTIONS WHEN USING

- Stow the antenna when traveling in places with low overhead clearance.
- To ensure safety, always keep the sound to a level where it is possible to hear outside sounds during operation.
- If water gets into the speaker case or radio, it may lead to an unexpected failure, so be careful not to get water on the equipment.
- Do not wipe the scales or buttons with solvent such as benzene or thinner. Wipe with a dry soft cloth. If the dirt cannot be removed easily, soak the cloth with alcohol.

AM/FM RADIO-CASSETTE STEREO

(If equipped)

EXPLANATION OF COMPONENTS

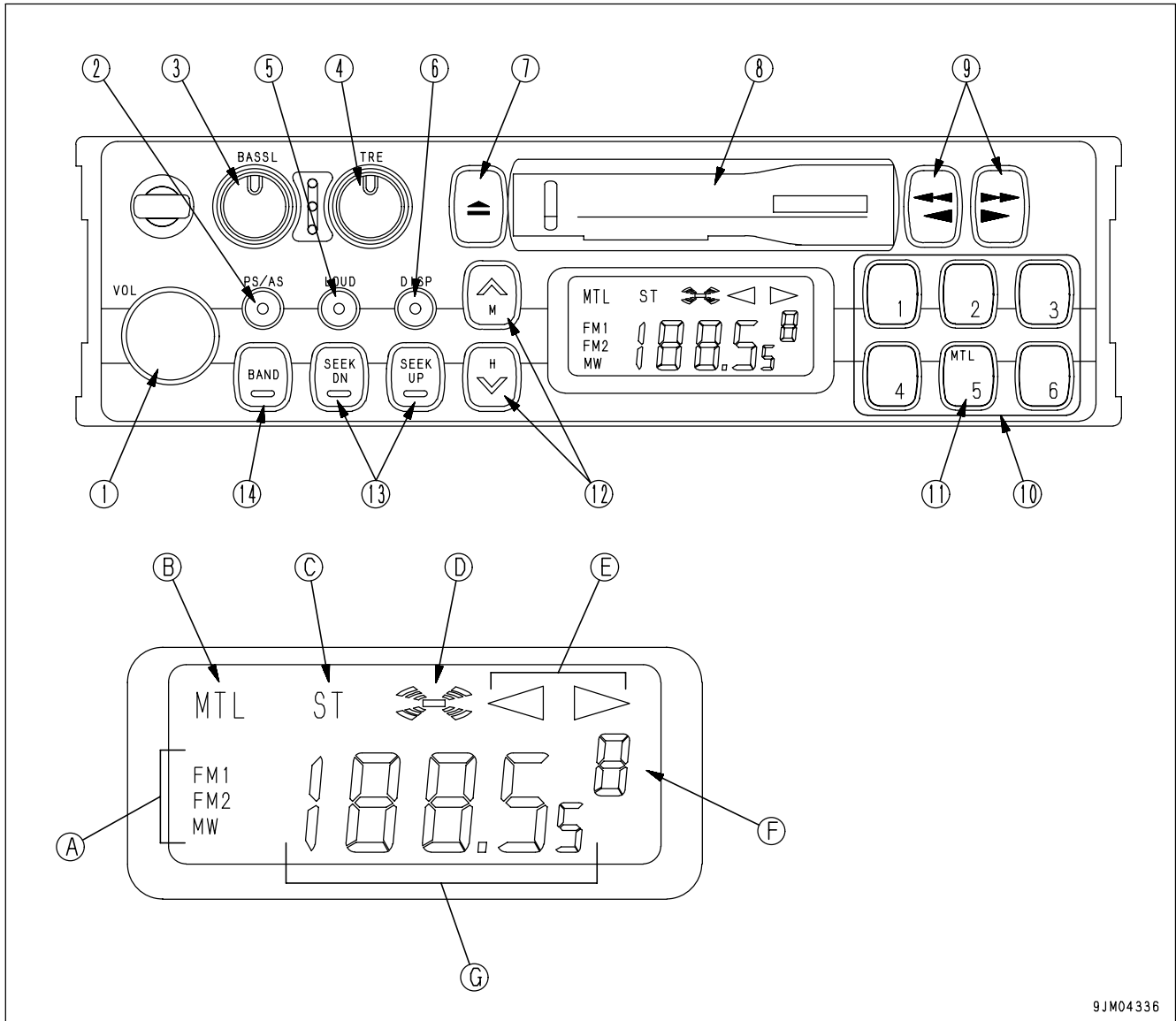

9JM04336

- (1) Power switch/volume
- (2) Auto-store/preset scan button
- (3) Bass control knob
- (4) Treble control knob
- (5) Loudness button
- (6) Time/radio display selector button
- (7) Tape eject button
- (8) Cassette door
- (9) Fast forward, rewind buttons
- (10) Preset buttons
- (11) Metal tape button
- (12) Manual tuning buttons
- (13) Seek tuning buttons
- (14) Band selector button

- (A) Band display
- (B) Metal tape display
- (C) FM stereo reception display
- (D) Loudness display
- (E) Tape direction display
- (F) Preset channel display
- (G) Time/frequency display

POWER SWITCH/VOLUME

Turn this knob (1) to the right until it clicks to turn the power on.
Turn it further to increase the volume.

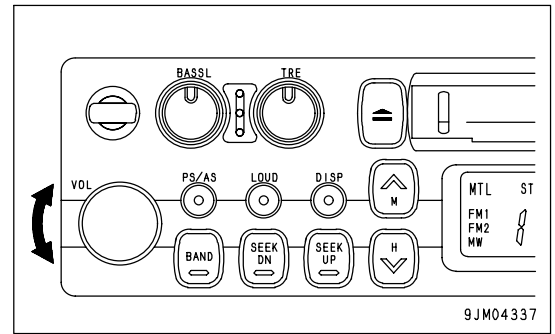

AUTO-STORE/PRESET SCAN BUTTON

Use this button (2) to actuate the preset scan and auto-store functions.

- Auto-store
Each time this button is pressed for more than 2 seconds while in radio reception, this auto-store function automatically starts to search for the desired station within a receivable band, and memorize the frequency in the preset memory. During this scanning process, the frequency shown in the right side of display continues to change. This indicates that each frequency is memorized in the auto-store.

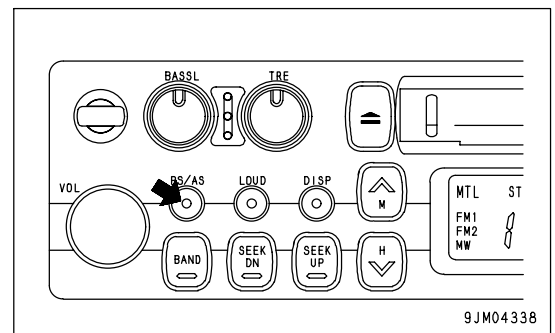

REMARK

The auto-store function cannot be used when the channel display is flashing.

When the display is flashing, the preset scan function is being used.

- Preset scan
If this button is pressed for less than 0.5 second while in radio reception, programs from the six preset stations in the same band will be broadcast one after another for 5 seconds each, starting from No. 1 through No. 6 stations consecutively.
When the desired station is found, press the button again. This stops the preset scan tuning process and switches to ordinary broadcasting. The same process will be repeated continuously until the button is pressed again.

BASS CONTROL KNOB

Turn this button (3) to the left to reduce the low tones; turn it to the right to emphasize the low tones.

Direction (a): Low tone reduced

Direction (b): Low tone emphasized

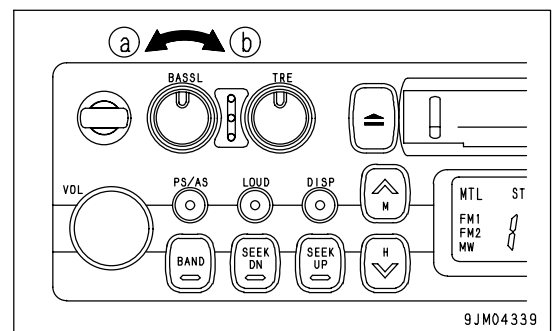

TREBLE CONTROL KNOB

Turn this button (4) to the left to reduce the low tones; turn it to the right to emphasize the high tones.

Direction (a): High tone reduced

Direction (b): High tone emphasized

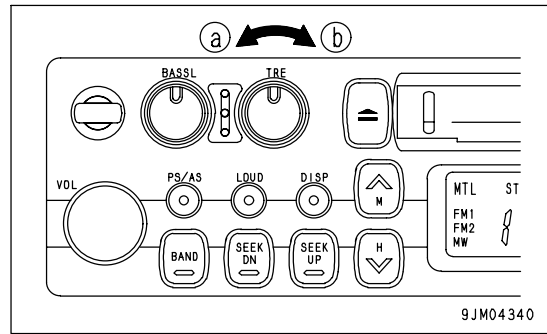

LOUDNESS BUTTON

This button (5) is used when playing at low volume. It makes it possible to hear more easily by emphasizing the low tone when the low tones are weak.

Push button: Actuated (ON)

Push button again: Canceled (OFF)

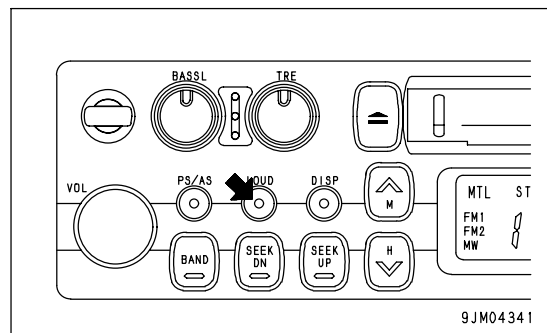

TIME/RADIO DISPLAY SELECTOR BUTTON

This button (6) is used to switch between the "Radio/tape display" and the "Time display".

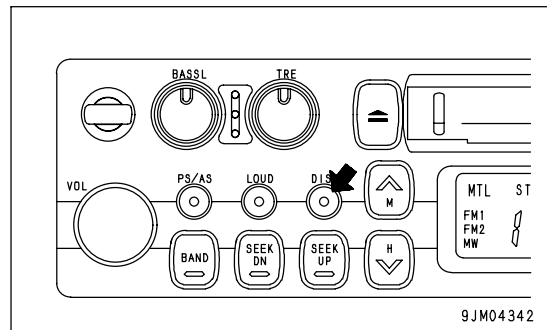

• Correcting the time

Press the button to set the time display.

(A) Correcting hour:

Keep the DISP button pressed and press the bottom (H) of the TUNING button to correct the hour.

(B) Correcting minute:

Keep the DISP button pressed and press the top (M) of the TUNING button to correct the minute.

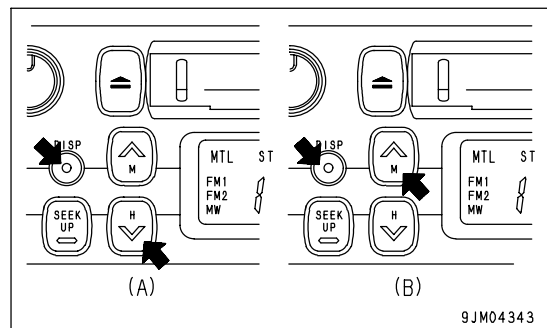

TAPE EJECT BUTTON

This button (7) is used to stop the tape and to eject the cassette. When this button is pressed, the tape is ejected and the radio plays.

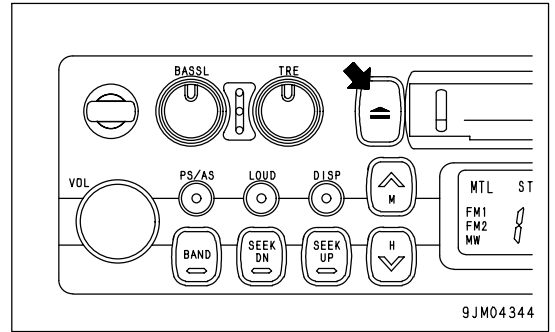

CASSETTE DOOR

Set the cassette with the exposed portion of the tape on the right side and insert it through the cassette door (8).

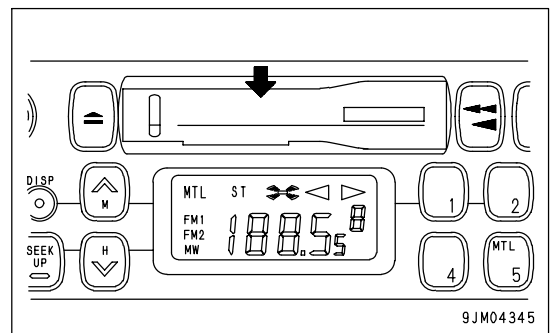

FAST-FORWARD, REWIND BUTTONS

These buttons (9) are used to fast-forward or rewind the tape.

- Fast-forward/rewind

If you press the button pointing in the same direction as the lighted arrow indicating the direction of play, the tape will be fast-forwarded; if you press the button pointing in the opposite direction, the tape will rewind.

To stop the tape, lightly press the button that is not locked. The fast-forward or rewind operation will be canceled.

If the fast-forward and rewind buttons are pressed at the same time, the tape will change sides.

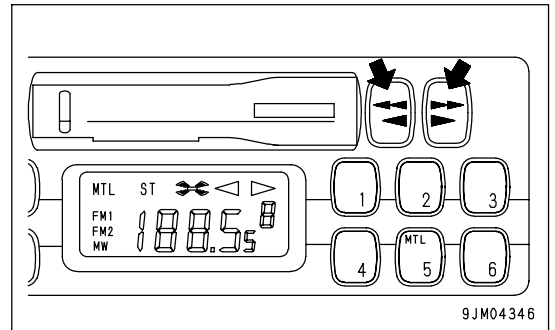

PRESET BUTTONS

These buttons (10) are used to call up the broadcast station frequencies preset in memory for each of buttons No. 1 to No. 6. It is possible to preset 18 stations (FM: 12; AM: 6) with these buttons.

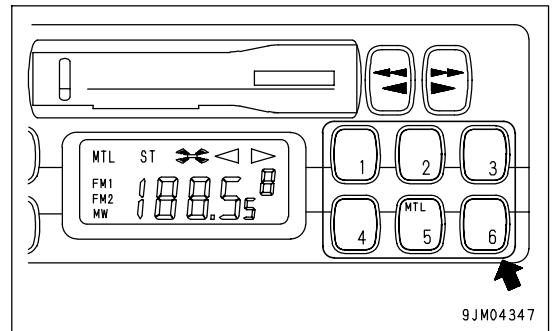

METAL TAPE BUTTON

(used also for preset button No. 5)

This button (11) is used when playing a metal or chrome tape. This button is also used for preset button No. 5. When it is pressed, "MTL" appears on the display.

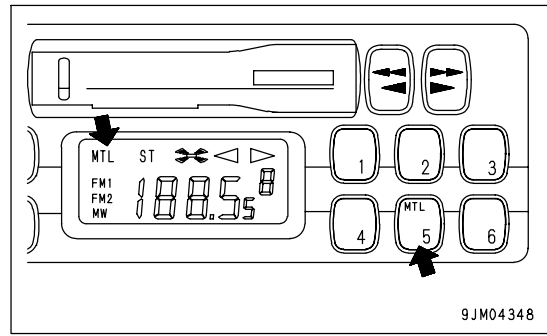

MANUAL TUNING BUTTONS

These buttons (12) are used for manual tuning.

When "TUN ^" button is pressed, the frequency goes up; when "TUN v" button is pressed, the frequency goes down. If the button is pressed down and held, the frequency will change continuously.

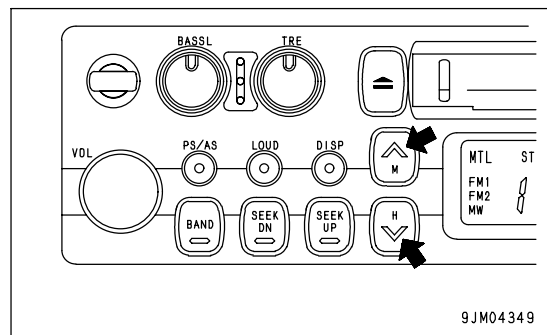

SEEK TUNING BUTTONS

These buttons (13) are used to seek tuning.

When the "SEEK UP" button is pressed, the search automatically goes up; when the "SEEK DN" button is pressed, the search automatically goes down.

When the next station that can be received is found, it automatically stops.

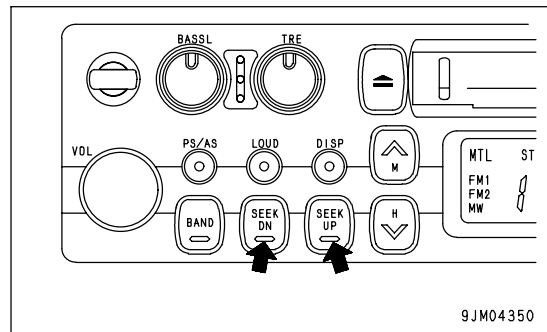

BAND SELECTOR BUTTON

When this button (14) is pressed, the band is switched between FM1, FM2, and MW (AM). The band is shown on the display.

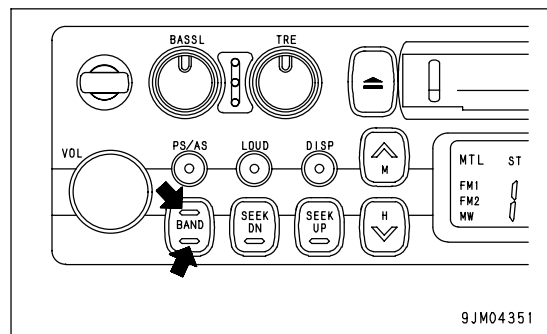

METHOD OF OPERATION

METHOD OF SETTING PRESET BUTTONS

It is possible to preset 6 MW (AM) stations and 12 FM stations (FM1: 6 stations, FM2: 6 stations).

REMARK

If you are playing the cassette, press the tape eject button to stop the tape.

METHOD OF AUTO PRESET

1. Use band selector button (1) to select MW (AM), FM1 or FM2.
2. Press auto-store/preset scan button (2) for less than 0.5 second.
3. The preset scan tuning function automatically searches for the desired station within the same band and can memorize as many as 6 stations in the preset memory.

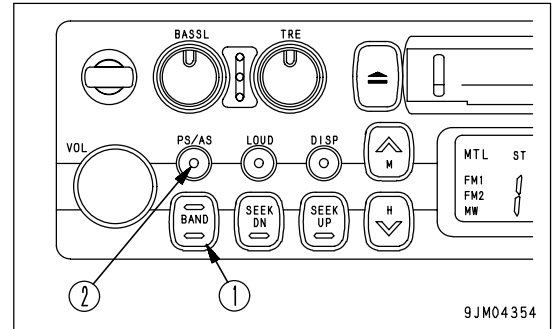

METHOD OF MANUAL PRESET

1. Use band selector button (1) to select MW (AM), FM1 or FM2.
2. Press manual tuning buttons (2) or seek tuning buttons (3).
3. Press preset button (4) of the number to be preset for 2 seconds while the frequency display is being shown on the display. (The preset channel and frequency are displayed and the presetting is completed).
4. Repeat the steps explained in Item 2 and 3 above to preset other stations to the subsequent numbers.
5. If you want to preset a station in the other bands, follow the steps explained in Item 1 through 4 above.

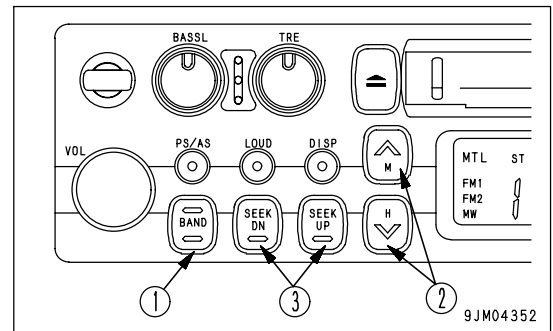

REMARK

- Also, use Steps 2 and 3 when changing the setting of a preset switch to another station.
- When the power is disconnected, such as when the battery is replaced, all the settings are deleted, so preset the stations again.

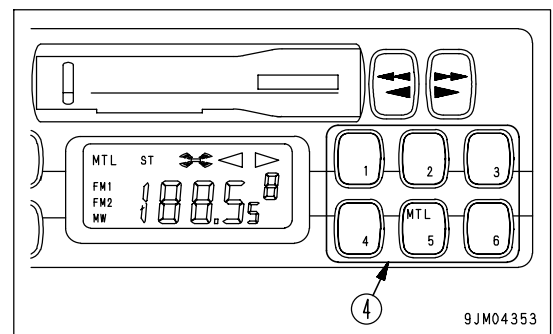

LISTENING TO RADIO

1. Turn the starting switch ON, then turn power switch (1) ON.
2. Use band selector button (2) to select MW (AM), FM1 or FM2.
3. Select the station with the preset buttons (3).

REMARK

In case you do not promptly remember the number assigned to a certain preset station, press auto-store/preset scan button (4) for less than 0.5 second. The preset 6 stations will broadcast one after another for 5 seconds each. When the desired station broadcasts, press the button again and scan tuning stops.

4. If you want to tune in to a station that is not preset, use either seek tuning button (5) or manual tuning button (6).
5. Adjust the volume, balance, and tone as desired.
6. When turning the radio OFF, turn power switch (1) to the left until it clicks.

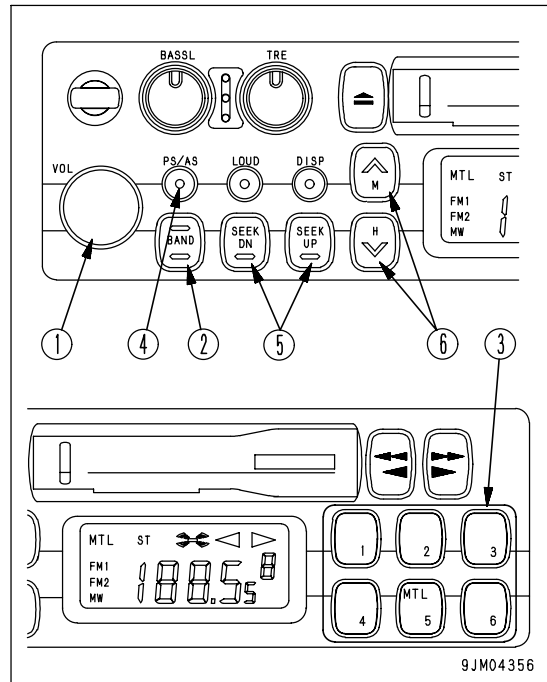

REMARK

- To switch to the radio when listening to a cassette, press the cassette eject button to stop the tape.
- If you insert a cassette when listening to the radio, the tape will start to play.

LISTENING TO CASSETTE TAPE

1. Turn the starting switch ON, then turn power switch (1) ON.
2. Set the cassette with the exposed portion of the tape on the right side and push it past the cassette door. The tape will automatically start playing.

If the arrow indicating the direction of play is pointing to the right, the top side is being played; if the arrow is pointing to the left, the bottom side is being played.

When the tape reaches the end, it is automatically reversed and the other side starts to play.

3. When finished with the tape, press the cassette eject button to eject the tape and automatically switch to the radio.

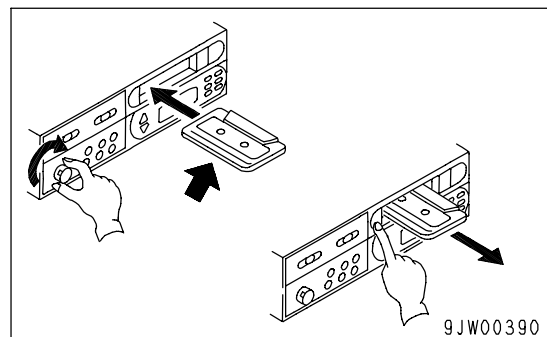
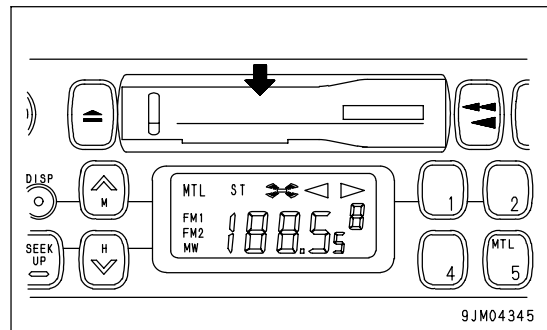

REVERSING TAPE

When listening to the tape, press both FAST FORWARD, REWIND buttons (A) and (B) at the same time lightly.

When this is done, the tape direction display will be reversed.

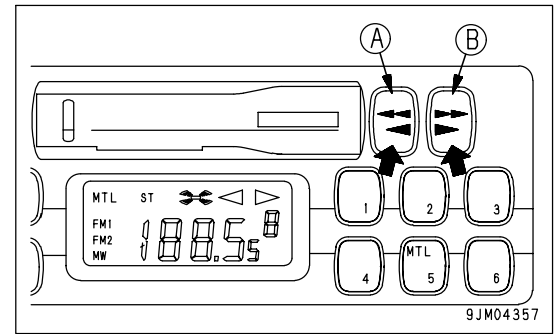
**PRECAUTIONS WHEN USING****WARNING**

- If a voltage greater than the specified voltage is input, it may cause fire, electrocution, or other failure. Never input any voltage other than the specified voltage.
- Places inside the radio are under high voltage. Do not remove the cover.
- Do not carry out any modifications. This may cause fire, electrocution, or other failure.
- If the sound cannot be heard, nothing is displayed, or any other problem occurs, turn off the power switch and ask your Komatsu distributor to make repairs without delay.

- Stow the antenna when traveling in places with low overhead clearance.
- To ensure safety during operations, keep the volume at a level where it is possible to hear other machines.
- If water gets inside the speaker case or radio (auto tuning), it may cause a serious problem, take care not to let water get in these items.
- Do not wipe the scales or buttons with solvent such as benzene or thinner. Wipe with a dry soft cloth. If the dirt cannot be removed easily, soak the cloth with alcohol.

NOTICE**Handling cassette tape**

- Clean the tape head approx. once a month with a commercially available head cleaning tape.
- Do not leave the tape any place where it is exposed to direct sunlight, any place that is excessively dusty, or any place where there is a magnetic field.
- Do not use 120-minute tapes. The tape is thin and it easily gets caught up inside the machine.
- If the tape is slack, it easily gets caught up inside the machine. Use a pencil to wind in the tape to remove any slack.
- Do not use any cassette tape if the label has started to come off. It may cause defective rotation, or it may be impossible to get the tape out of the machine.

HANDLING AUTO AIR CONDITIONER

By taking fresh air into the cab through a filter, it is possible to raise the pressure inside the cab. This makes it possible to provide a pleasant working environment even on dusty jobsites.

NAMES AND FUNCTIONS OF ITEMS ON CONTROL PANEL

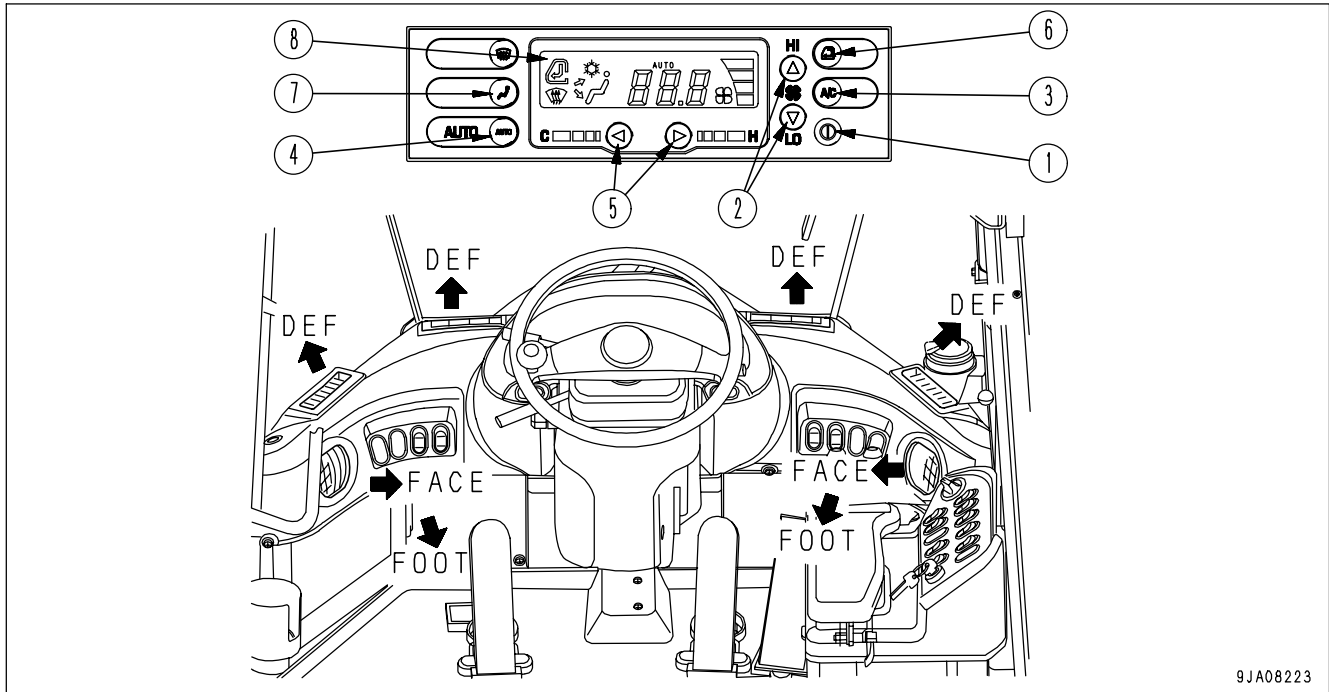

9JA08223

- | | |
|----------------------------|----------------------------------|
| (1) Main power switch | (5) Temperature control switch |
| (2) Fan switch | (6) FRESH/RECIRC selector switch |
| (3) Air conditioner switch | (7) Mode selector switch |
| (4) Auto switch | (8) Display monitor |

MAIN POWER SWITCH

Use the switch (1) to turn the main power of the air conditioner ON/OFF.

When the switch is pressed, display monitor (A) lights up. The fan begins operation.

When the switch is pressed again, the air conditioner is turned OFF and the display monitor goes out. The fan stops.

(When the switch is turned ON, the setting displayed is the same as when the air conditioner was turned OFF.)

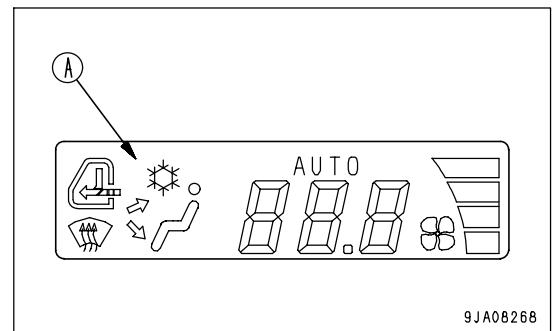
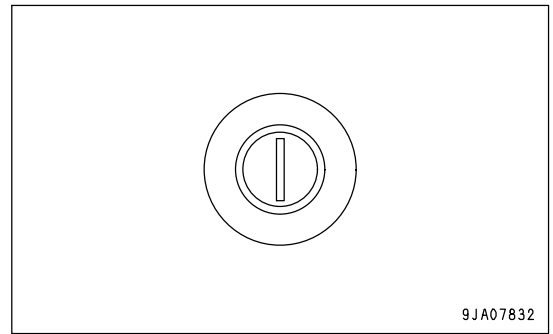

FAN SWITCH

Use this switch (2) to adjust the air flow from the fan.

The air flow can be adjusted to 4 levels.

When this switch (A) is pressed, the air flow increases; when switch (B) is pressed, the air flow decreases.

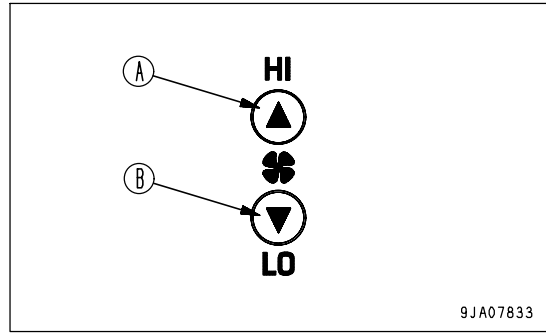

9JA07833

The setting for the air flow is displayed on the display monitor.

A: Monitor display

B: Air flow

a: Air flow "Lo"

b: Air flow "M1"

c: Air flow "M2"

d: Air flow "Hi"

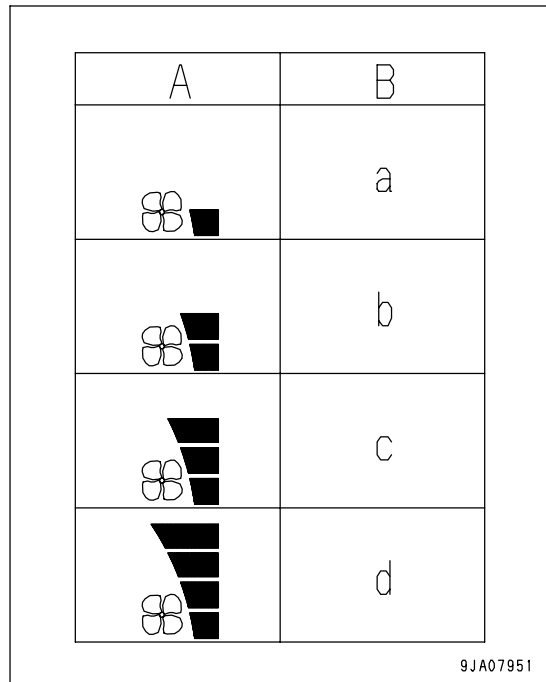

9JA07951

AIR CONDITIONER SWITCH

Use this switch (3) to start and stop the cooling or dehumidifying heating function.

When the main power switch is ON, if the air conditioner switch is pressed, the air conditioner is turned ON and (A) is displayed on the display monitor.

If the switch is pressed again, the switch is turned OFF and display monitor (A) goes out.

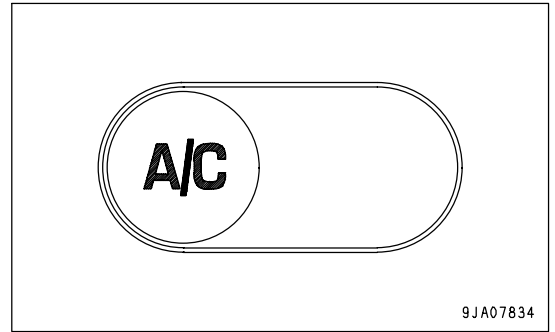

9JA07834

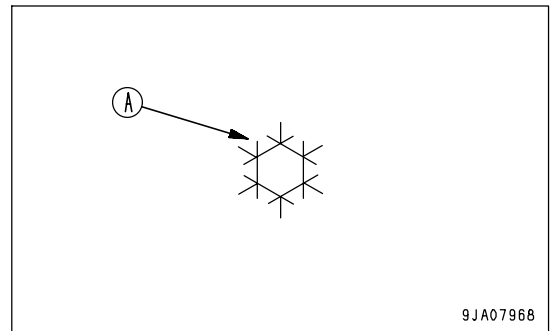

9JA07968

AUTO SWITCH

Use this switch (4) for automatic operation of the air conditioner (actuation of the cooling and dehumidifying/heating functions, stopping operation).

When the main power switch is turned ON and the AUTO air conditioner switch is pressed, the air conditioner is turned ON and the display monitor shows "AUTO".

If the switch is pressed again, the air conditioner is turned OFF and the "AUTO" sign on the display monitor goes out.

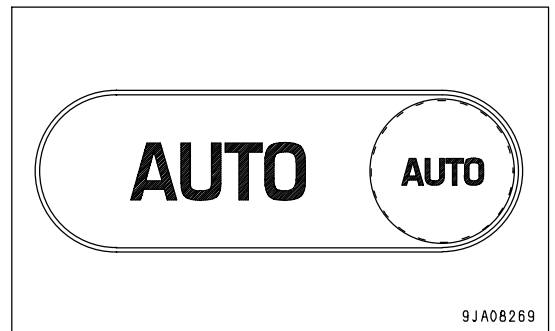

9JA08269

TEMPERATURE CONTROL SWITCH

Use this switch (5) to adjust the temperature between low temperature and high temperature.

When switch (A) is pressed, the temperature of the air blowing out becomes higher; when switch (B) is pressed, the temperature of the air blowing out becomes lower.

The set temperature is displayed on the display monitor.

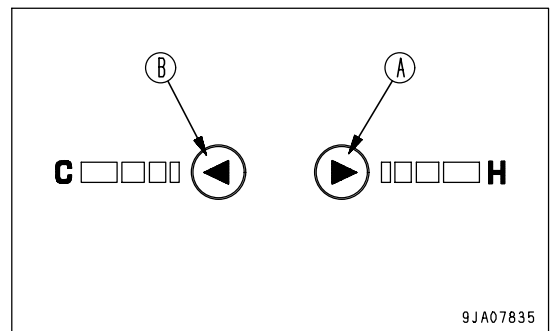

9JA07835

RECIRC/FRESH SELECTOR SWITCH

Use this switch (6) to switch between recirculation of the air inside the cab and intake of fresh air from outside.

When this switch is pressed, recirculation of inside air is selected and (A) lights up on the display monitor.

If the switch is pressed again, intake of fresh air is selected and (B) lights up on the display monitor.

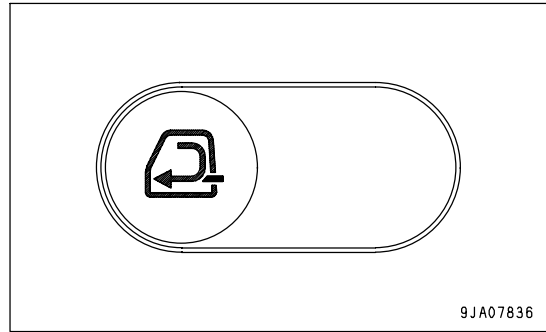
**Recirculation of air inside cab**

Only the air inside the cab is circulated. Use this setting when carrying out quick cooling or heating of the cab or when the outside air is dirty.

Intake of fresh air from outside

Air from the outside is taken into the cab. Use this setting when taking in fresh air from outside or when removing the mist from the windows.

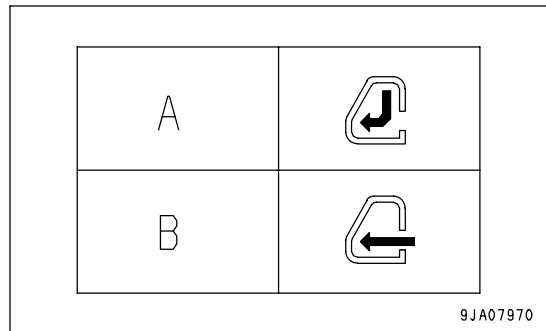

CONTROL METHOD

COOLING OPERATION

1. Press main power switch (1) of the air conditioner to turn the power ON.
2. Press fan switch (2) and set the air flow to "Hi".
3. Press temperature control switch (3) to set to the desired temperature.
4. Press air conditioner switch (4) to turn the air conditioner switch ON.
5. Press RECIRC/FRESH selector switch (5) to select RECIRC.
6. Press mode selector switch (6) to set the vents to FACE.
7. When the temperature inside the cab goes down, use the temperature control switch and the fan switch to set to the desired temperature.
8. When the AUTO switch is pressed, the temperature and location of the vents are automatically selected.

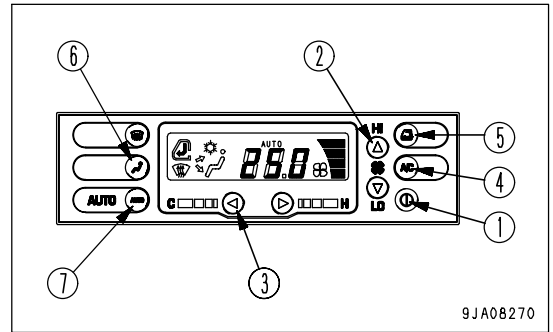

REMARK

Note that if the temperature control switch is pressed to set the temperature to the lowest position, and the air conditioner is run for a long time with the air flow at "Lo", in rare cases, the evaporator may freeze. If it freezes and no cold air comes out, turn the air conditioner switch OFF, raise the temperature setting, run for a short time with the air flow at "Hi", then turn the air conditioner switch ON again.

HEATING OPERATION

1. Press main power switch (1) of the air conditioner to turn the power ON.
2. Press fan switch (2) and set the air flow to "Hi".
3. Press temperature control switch (3) to set to the desired temperature.
4. Press RECIRC/FRESH selector switch (4) to select FRESH.
5. Press mode selector switch (5) to set the vents to FOOT.
6. When the temperature inside the cab goes up, use the temperature control switch and the fan switch to set to the desired temperature.
7. When the AUTO switch is pressed, the temperature and location of the vents are automatically selected.

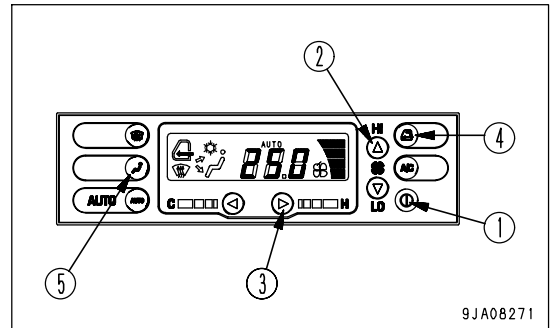

REMARK

The heating uses the heat from the engine cooling water, so it is effective only when the cooling water is hot.

DRYING-HEATING AND DEMISTING OPERATION

1. Press main power switch (1) of the air conditioner to turn the power ON.
2. Press fan switch (2) and set the air flow to the desired setting.
3. Press temperature control switch (3) and set to the desired temperature.
4. Press RECIRC/FRESH selector switch (4) to select FRESH.
5. Press air conditioner switch (5) to turn the air conditioner ON.

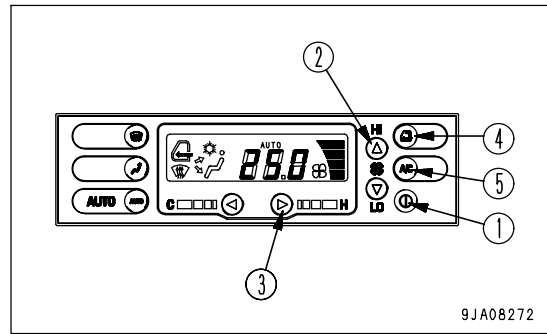
**REMARK**

When the outside temperature is below 0°C (32°F), the air conditioner (compressor) may not operate.

PRECAUTIONS WHEN USING

- To prevent any excessive load on the engine or compressor, use the air conditioner when the engine is running.
- If the machine is used in places where there is dust or bad smell, recirculate the air inside the cab when using the air conditioner.
- To prevent leakage of refrigerant from the air conditioner cooling circuit, run the air conditioner for several minutes 2 or 3 times a month, even during the off-season. If the machine is left for a long time when the refrigerant is leaking, rust will form on the inside and this will cause failure.
- To protect your health, do not make the inside of the cab too cool and do not let the cold air flow contact your skin directly for long periods.
Ventilate the cab from time to time.
- If the temperature inside the cab is high, open the door or window to let the hot air escape and let fresh air in before starting operation of the air conditioner.

INSPECTION AND MAINTENANCE

- When carrying out inspection and maintenance of the air conditioner, follow the table given in "CHECK AIR CONDITIONER (PAGE 4-34)".
- To allow the air conditioner to show its full performance and provide a comfortable environment, have inspection and maintenance carried out periodically.

When adding refrigerant or carrying out other maintenance, special tools and instruments are needed, so ask your Komatsu distributor to carry out inspection and repair.

AIR CONDITIONER

(If equipped)

By taking fresh air into the cab through a filter, it is possible to raise the pressure inside the cab. This makes it possible to provide a pleasant working environment even on dusty jobsites.

GENERAL LOCATIONS AND FUNCTION OF CONTROL PANEL

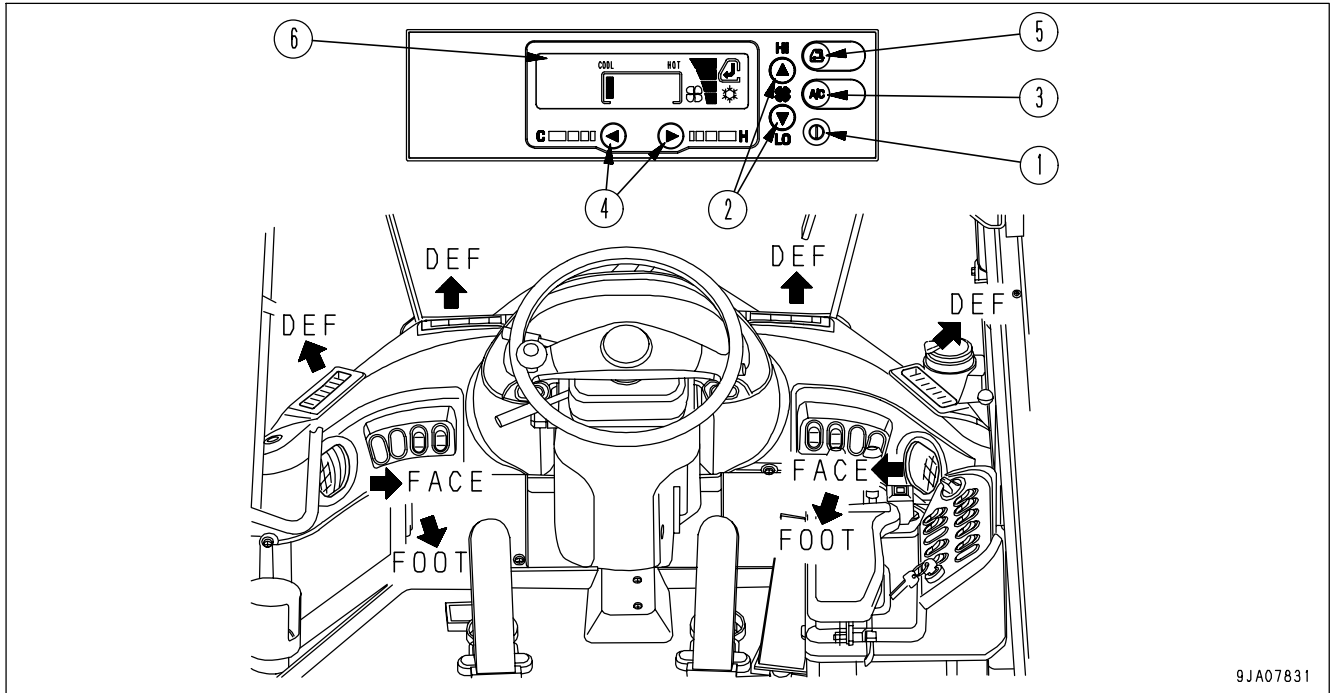

- | | |
|----------------------------|----------------------------------|
| (1) Main power switch | (4) Temperature control switch |
| (2) Fan switch | (5) FRESH/RECIRC selector switch |
| (3) Air conditioner switch | (6) Display monitor |

9JA07831

MAIN POWER SWITCH

Use the switch (1) to turn the main power of the air conditioner ON/OFF.

When the switch is pressed, display monitor (A) lights up. The fan begins operation.

When the switch is pressed again, the air conditioner is turned OFF and the display monitor goes out. The fan stops.

(When the switch is turned ON, the setting displayed is the same as when the air conditioner was turned OFF.)

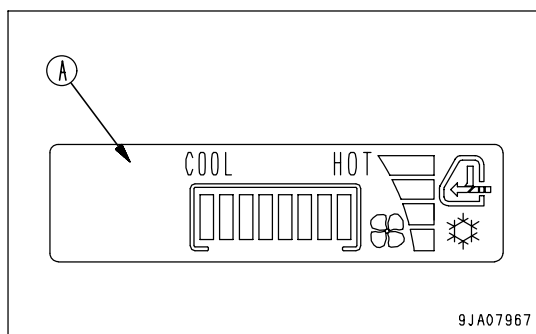
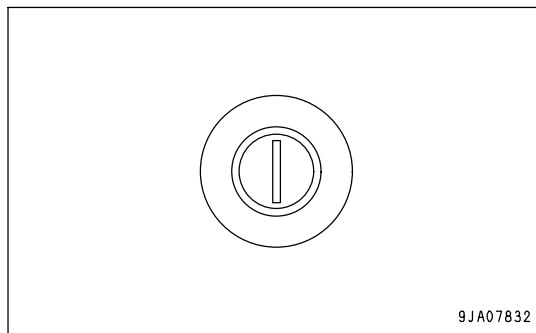

FAN SWITCH

Use this switch (2) to adjust the air flow from the fan.

The air flow can be adjusted to 4 levels.

When this switch (A) is pressed, the air flow increases; when switch (B) is pressed, the air flow decreases.

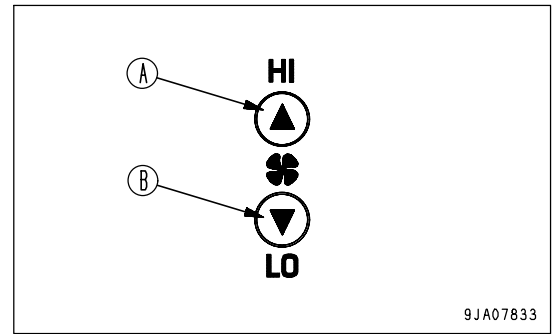

9JA07833

The setting for the air flow is displayed on the display monitor.

A: Monitor display

B: Air flow

a: Air flow "Lo"

b: Air flow "M1"

c: Air flow "M2"

d: Air flow "Hi"

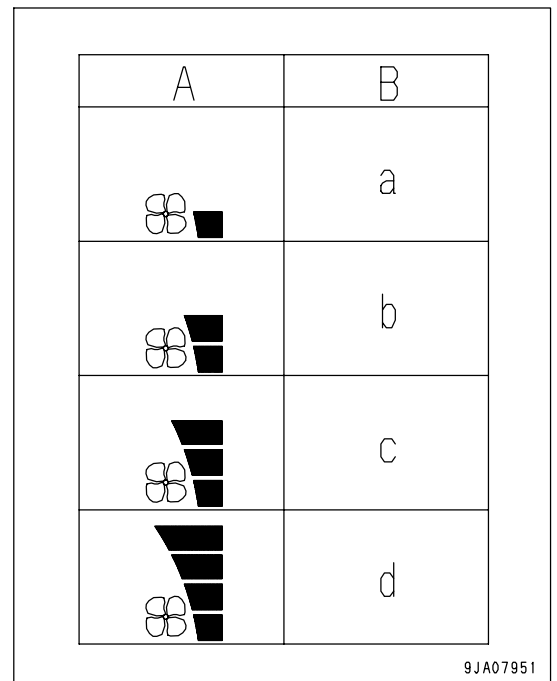

9JA07951

AIR CONDITIONER SWITCH

Use this switch (3) to start and stop the cooling or dehumidifying heating function.

When the main power switch is ON, if the air conditioner switch is pressed, the air conditioner is turned ON and (A) is displayed on the display monitor.

If the switch is pressed again, the switch is turned OFF and display monitor (A) goes out.

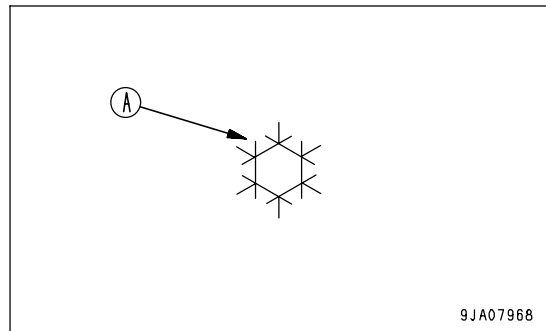
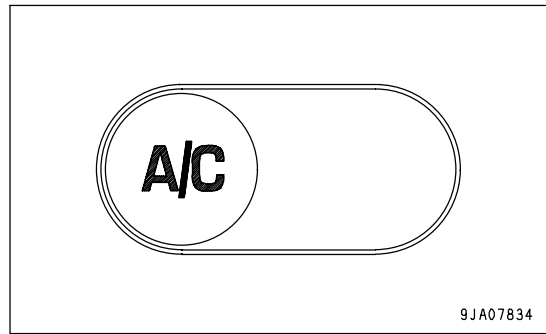

TEMPERATURE CONTROL SWITCH

Use this switch (4) to adjust the temperature between low temperature and high temperature.

When switch (A) is pressed, the temperature of the air blowing out becomes higher; when switch (B) is pressed, the temperature of the air blowing out becomes lower.

The setting (C) for the temperature is displayed on the display monitor.

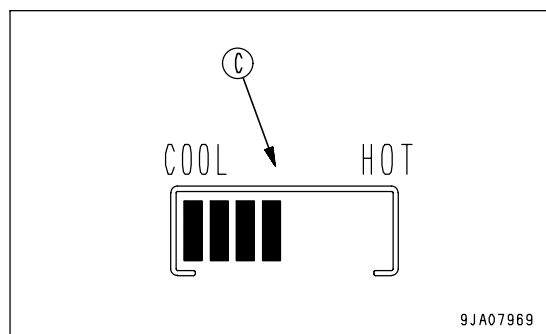
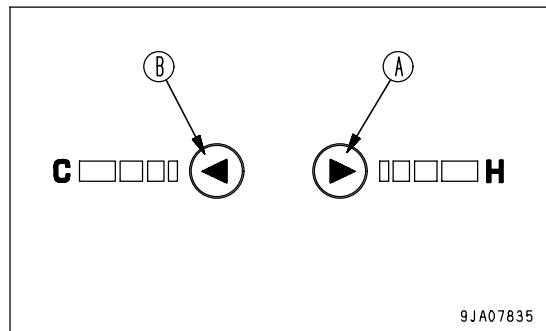

FRESH/RECIRC SELECTOR SWITCH

Use this switch (5) to switch between recirculation of the air inside the cab and intake of fresh air from outside.

When this switch is pressed, recirculation of inside air is selected and (A) lights up on the display monitor.

If the switch is pressed again, intake of fresh air is selected and (B) lights up on the display monitor.

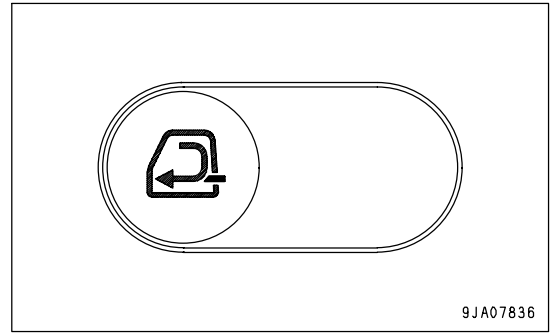

9JA07836

Recirculation of air inside cab

Only the air inside the cab is circulated. Use this setting when carrying out quick cooling or heating of the cab or when the outside air is dirty.

Intake of fresh air from outside

Air from the outside is taken into the cab. Use this setting when taking in fresh air from outside or when removing the mist from the windows.

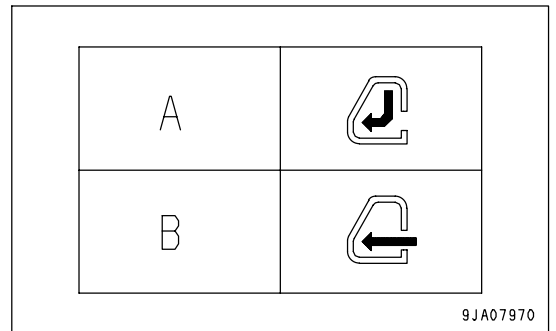

9JA07970

METHOD OF OPERATION

COOLING OPERATION

1. Press main power switch (1) of the air conditioner to turn the power ON.
2. Press fan switch (2) and set the air flow to "Hi".
3. Press temperature control switch (3) and set the display monitor to COOL (A).
4. Press air conditioner switch (4) to turn the air conditioner switch ON.
5. Press RECIRC/FRESH selector switch (5) to select RECIRC.
6. When the temperature inside the cab goes down, use the temperature control switch and the fan switch to set to the desired temperature.

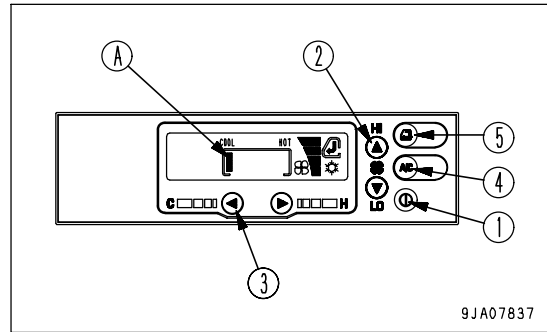

REMARK

If the temperature control switch is pressed to set the display monitor to COOL (A) and the air conditioner is run with the air flow at "Lo" for a long period, there is a slight risk that the evaporator will freeze. If it freezes and no cold air comes out, turn the air conditioner switch OFF, raise the temperature setting, run the air conditioner with the air flow at "Hi " for a short time, then turn the air conditioner switch ON again.

HEATING OPERATION

1. Press main power switch (1) of the air conditioner to turn the power ON.
2. Press fan switch (2) and set the air flow to "Hi".
3. Press temperature control switch (3) and set the display monitor to HOT (A).
4. Press RECIRC/FRESH selector switch (4) to select FRESH.
5. When the temperature inside the cab goes up, use the temperature control switch and the fan switch to set to the desired temperature.

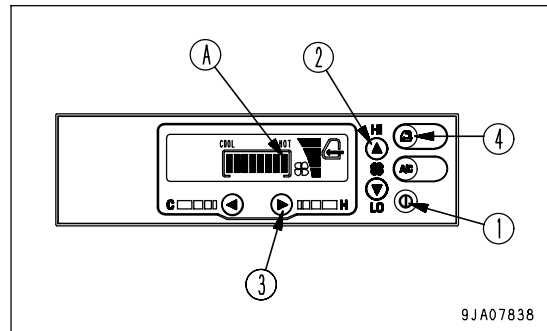

REMARK

The heating uses the heat from the engine cooling water, so it is effective only when the cooling water is hot.

DRYING-HEATING AND DEMISTING OPERATION

1. Press main power switch (1) of the air conditioner to turn the power ON.
2. Press fan switch (2) and set the air flow to the desired setting.
3. Press temperature control switch (3) and set to the desired temperature.
4. Press RECIRC/FRESH selector switch (4) to select FRESH.
5. Press air conditioner switch (5) to turn the air conditioner ON.

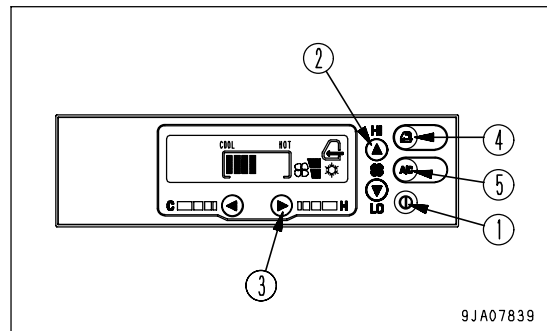

REMARK

When the outside temperature is below 0°C (32°F), the air conditioner (compressor) may not operate.

PRECAUTIONS WHEN USING

- To prevent any excessive load on the engine or compressor, use the air conditioner when the engine is running.
- If the machine is used in places where there is dust or bad smell, recirculate the air inside the cab when using the air conditioner.
- To prevent leakage of refrigerant from the air conditioner cooling circuit, run the air conditioner for several minutes 2 or 3 times a month, even during the off-season. If the machine is left for a long time when the refrigerant is leaking, rust will form on the inside and this will cause failure.
- To protect your health, do not make the inside of the cab too cool and do not let the cold air flow contact your skin directly for long periods.
Ventilate the cab from time to time.
- If the temperature inside the cab is high, open the door or window to let the hot air escape and let fresh air in before starting operation of the air conditioner.

PRECAUTIONS FOR INSPECTION AND MAINTENANCE

- When carrying out inspection and maintenance of the air conditioner, follow the table given in "CHECK AIR CONDITIONER (PAGE 4-34)".
- To allow the air conditioner to show its full performance and provide a comfortable environment, have inspection and maintenance carried out periodically.
When adding refrigerant or carrying out other maintenance, special tools and instruments are needed, so ask your Komatsu distributor to carry out inspection and repair.

COOL BOX

(If equipped)

When the cooling is being used, this can be used for keeping drinks and other things cool.

When the heating is being used, it can be used to keep things warm.

Do not use the cool box for things which smell or leak water or break easily.

Do not use it as a holder for tools or other small objects.

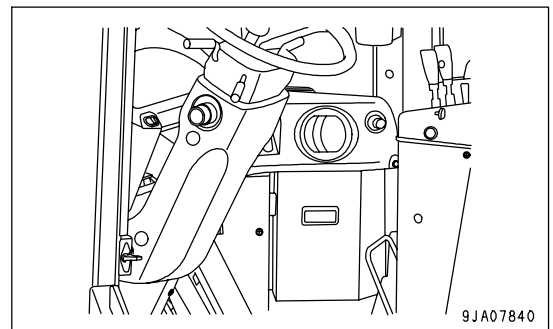

HANDLING CAB WIPER

PREVENTING DAMAGE TO WIPER ARM BRACKET

NOTICE

When angling the wiper arm (1) to the front, check that the wiper blade is hanging free.

When angling the wiper arm (1) to the front, such as when wiping the glass clean, if the wiper arm (1) is angled with the wiper blade (2) locked to the arm (the bottom of the blade is caught on the arm), abnormal force is brought to bear on the mounting bracket and the bracket may break.

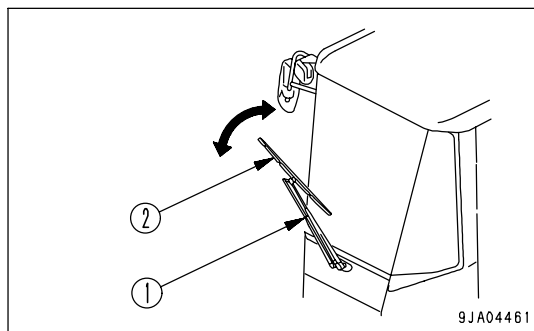

OPERATION

CHECK BEFORE STARTING ENGINE, ADJUST

WALK-AROUND CHECK

Before starting the engine, check the area around and under the machine, check for loose nuts and bolts, damage to any parts, leakage of oil, fuel, or coolant, and check the condition of the work equipment and hydraulic systems. Check for looseness or play in electric wiring and check that there is no dust accumulated around high-temperature parts.



WARNING

Remove any flammable materials from around the battery, engine, muffler, turbocharger, or other high temperature engine parts. Leakage of fuel or oil will cause the machine to catch fire. Check carefully, be sure to repair any problem, or contact your Komatsu distributor.

If the machine is at an angle, reposition it level before checking.

Perform the following inspections and cleaning every day before starting engine for the day's work.

1. Check for damage, wear, play in work equipment, cylinders, linkage and hoses.
Check that there are no cracks, excessive wear, or play in the work equipment, cylinders, linkage, or hoses. If any abnormality is found, repair it.
2. Remove dirt and dust from around engine, battery and radiator.
Check if there is any dirt or dust accumulated around the engine or radiator. Also check if there is any flammable material (dead leaves, twigs, etc.) accumulated around the battery or high temperature engine parts, such as the engine muffler or turbocharger. Remove all such dirt or flammable material.
3. Check for coolant or oil leakage around the engine.
Check that there is no oil leakage from the engine or coolant leakage from the cooling system. If any problem is found, repair it.
4. Check for leakage from fuel line.
Check that there is no leakage of fuel or damage to the hoses and tubes. If any problem is found, carry out repairs.
5. Check for leakage of oil from transmission case, axle, hydraulic tank, hoses, joints.
Check that there is no oil leakage. If any abnormality is found, repair the leakage.
6. Check for oil leakage from the brake line.
Check that there is no oil leakage or damage to the hoses and tubes. If any problem is found, repair the oil leakage and repair or replace the damaged parts.
7. Check for damaged or worn tires, wheels, and wheel hub bolts and nuts, check for loose wheel hub bolts and nuts.
Check for cracks or peeling of the tires and for cracks or wear to the wheels (side rim, rim base, lock ring). Tighten any loose wheel hub bolts or nuts. If any abnormality is found, repair or replace the part.
If any valve caps are missing, install new caps.

8. Check for damage and loose bolts on the handrail and steps.

Repair any damage and tighten any loose bolts.

9. Check for damage to gauges, lamps on the instrument panel and loose bolts.

Check for damage to the panel, gauges and lamps. If any problem is found, replace the parts. Clean off any dirt on the surface. Tighten any loose bolts.

10. Check for loose air cleaner mounting bolts.

Check for the loose bolts. If loose, tighten them.

11. Check for loose battery terminals.

Tighten any loose terminal.

Tightening torque for portion A: 5.9 to 9.8 Nm (0.6 to 1.0 kgm)

Tightening torque for portion B: 11.8 to 19.6 Nm (1.2 to 2.0 kgm)

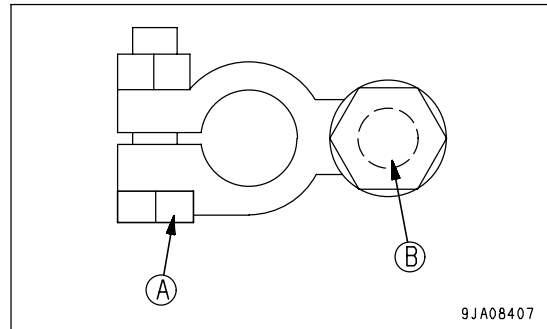

12. Check for damage to the seat belt and mounting clamps.

! WARNING

- Before fitting the seat belt, check that there is no problem in the belt mount bracket or mounting belt. If it is worn or damaged, replace the seat belt.
- Even if there are no signs of damage, replace belts in accordance with the following schedule:
5 years after the date of seat belt manufacture, or every 3 years after the start of actual usage, whichever date comes first.
- Always wear the seat belt during operations.
- Fit the seat belt so that it is not twisted.

REMARK

The date of seat belt manufacture attached to the seat belt is the start of the 5-year period. It is not the start of the 3-year period of actual usage.

REMARK

The date of manufacture of the seat belt is marked on the belt at the place indicated by the arrow in the diagram on the right.

Check that there are no loose bolts on the equipment mounting the seat belt to the machine, and tighten if necessary.

Tightening torque: 24.5 ± 4.9 Nm (2.5 ± 0.5 kgm, 18.1 ± 3.6 lbft)

If the belt is damaged or fluff is starting to form, or if there is any damage or deformation of the seat belt holders, replace the seat belt.

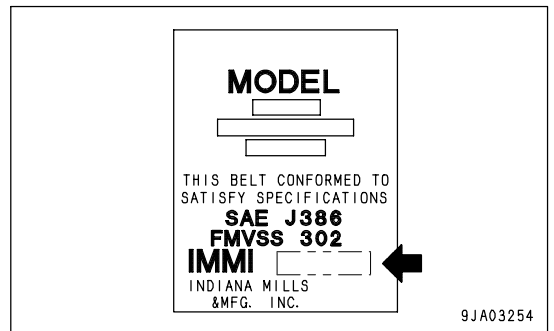
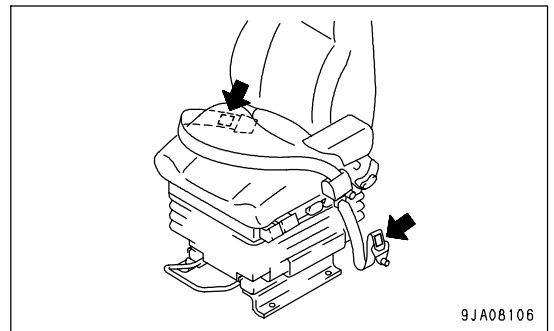

13. Clean cab window.

Clean the cab window to ensure good visibility when operating the machine.

It is extremely dangerous to cross from the side of the cab to the step on the front fender. Always articulate the machine fully to the side, then cross on that side from the side of the cab to the step. When crossing, grip the handrail on top of the cab and pay careful attention to the safety of your footing on the platform on the left or right to move to the step on the front fender.

In addition, when carrying out the cleaning operation, use the handrail on top of the cab and the step on the front fender, and always maintain at least three-point contact (both feet and one hand) with the handrail and steps to ensure that you support yourself.

Clean the cab glass only on the side to which the machine is articulated.

When cleaning the glass on the other side, articulate the machine in the opposite direction before starting.

14. Inspect tires.

**WARNING**

If worn or damaged tires are used, they may burst and cause serious injury or death.

To ensure safety, do not use the following tires.

Wear:

- Tires with a tread grooves of less than 15% of that of a new tire
- Tires with extreme uneven wear or with stepped-type wear

Damage:

- Tires with damage that has reached the cords (1), or with cracks in the rubber
- Tires with cut or pulled cords (1)
- Tires with peeled (separated) surface
- Tires with damaged bead (2)
- Leaking or improperly repaired tubeless tires
- Deteriorated, deformed or abnormally damaged tires, which do not seem usable

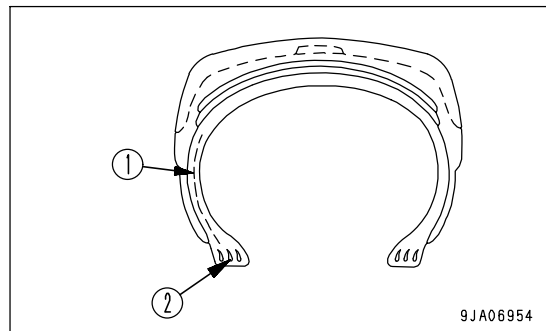

9JA06954

15. Inspect rims.

**WARNING**

Check the rims (wheels) to confirm that there is no deformation of the ring, or damage caused by corrosion, or cracks.

In particular, check the side ring, lock ring, and rim flange thoroughly.

If any problem is found, replace the part.

CHECK BEFORE STARTING

Always perform the procedures in this section before starting the engine each day.

CHECK MACHINE MONITOR

1. Turn starting switch to the ON position (B).

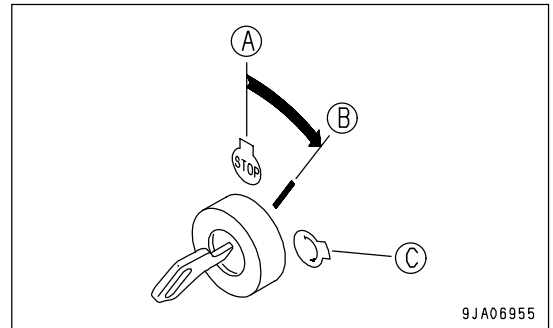

2. Check that all the monitors, gauges, and the central warning lamp light up for approx. 2 seconds, and that the alarm buzzer sounds for approx. 2 seconds.

If the lamps do not light up, there is probably a failure or disconnection. Contact your Komatsu distributor for inspection.

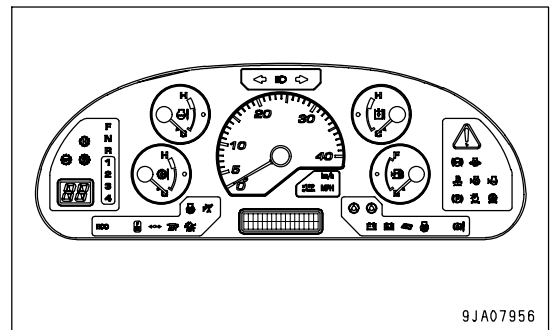

CHECK COOLANT LEVEL, ADD COOLANT

! WARNING

- Do not open the radiator cap unless necessary. When checking the coolant, always wait for the engine to cool down and check the sub-tank.
- Immediately after the engine is stopped, the coolant is at a high temperature and the radiator is under high internal pressure. If the cap is removed to check the coolant level in this condition, there is a hazard of burns. Wait for the temperature to go down, then turn the cap slowly to release the pressure and remove it carefully.

! CAUTION

When adding coolant, use the step and handrail provided. Support your body securely.

1. Open cover (1) of the platform on the right side of the machine.
2. Check that the coolant level is between the FULL and LOW marks on radiator sub-tank (2). If the coolant level is low, add coolant through the coolant filler of sub-tank (2) to the FULL level.
3. After adding coolant, tighten the cap securely.
4. If the sub-tank becomes empty, there is probably coolant leakage. After checking, repair any abnormality immediately. If no abnormality is found, check the level of the water in the radiator. If it is low, add COOLANT of the same density in radiator according to the COOLANT density table in "CLEAN INSIDE OF COOLING SYSTEM (PAGE 4-21)", then add COOLANT to the sub-tank.

If the volume of coolant added is more than usual, check for possible leakage.
Confirm that there is no oil in the coolant.

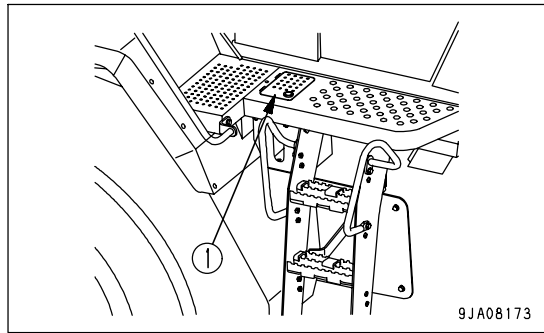

9JA08173

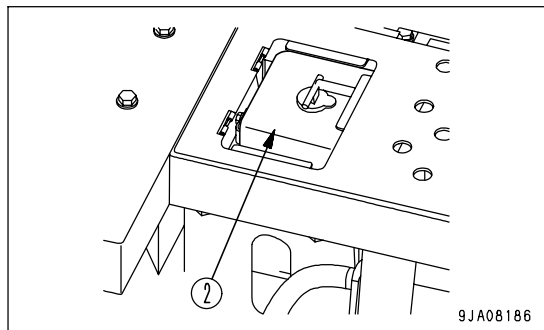

9JA08186

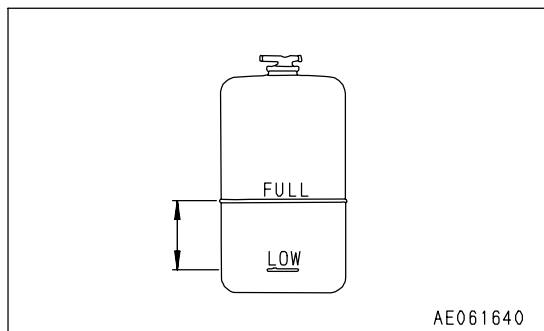

AE061640

CHECK OIL LEVEL IN ENGINE OIL PAN, ADD OIL

**WARNING**

Parts and oil are at high temperature immediately after the engine is stopped and may cause serious burns. Wait for the oil temperature to go down before performing this operation.

1. Open the inspection cover of the right side at the rear of the machine.
2. Take out the dipstick (G) and wipe off the oil with cloth.
3. Fully insert dipstick (G) into filler pipe, then remove it.
4. The oil level should be between the H and L marks on dipstick (G).
If the oil level is below the L mark, add oil through oil filler port (F).
5. If the oil is above the H mark, drain the excess oil from drain plug (P), and check the oil level again.
6. If the oil level is correct, tighten oil filler cap (F) securely and close the inspection window.

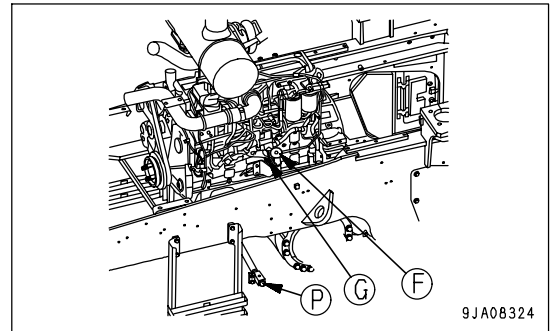
**REMARK**

- Wait for at least 15 minutes, after stopping the engine, before checking the oil level.
- If the machine is at an angle, make it horizontal before checking.

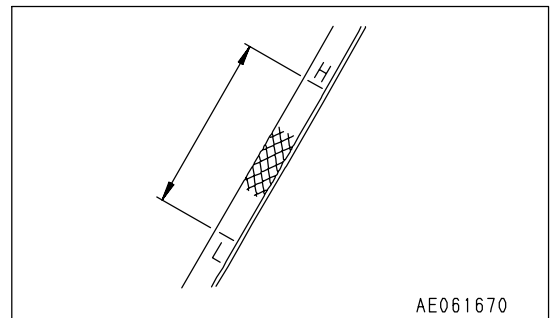

CHECK WATER SEPARATOR

**WARNING**

- Each part of the engine is still highly heated immediately after the engine is stopped. Do not attempt to drain cooling water or remove the filter element cup.
- High pressure is generated inside the engine fuel piping, while the engine is running. Wait for more than 30 seconds after the engine stop for the engine to sufficiently cool down. Then start with draining cooling water or removing the filter element cup.
- Do not bring fire close.

Check water separator, drain water and sediment.

1. Open the engine side cover on the right side of the machine.
The water separator (1) forms one unit with the fuel pre-filter, and is at the bottom.

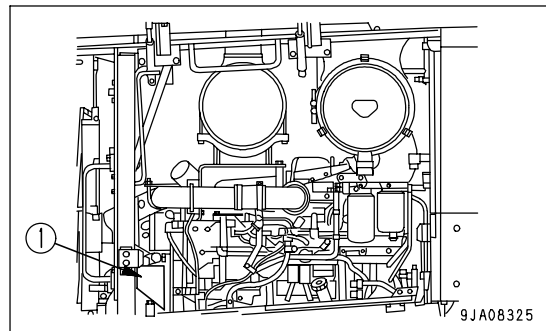

2. It is possible to judge the condition of water and sediment through transparent cap (3). If water or sediment is accumulated, set a container under drain hose (4) to collect the discharged water.
3. Loosen plug (2) and drain the water.
4. Tighten plug (2) as soon as fuel starts to be discharged from drain hose (4).
(Tightening torque: 0.2 - 0.45 Nm {0.02 - 0.046 kgm})

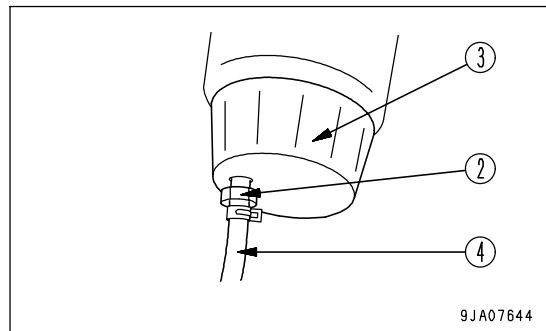

5. On this machine, sensor is installed to detect if water is accumulated at the bottom of the fuel pre-filter.
If water separator caution lamp on the machine monitor lights up, carry out the above Steps 1 - 4 to drain the water.

REMARK

If plug (2) is stiff, coat O-ring (5) of plug (2) with grease.

- 1) Set a fuel container under drain hose (4).
- 2) Loosen plug (2), then drain all the sediment together with the fuel from drain hose (4).
- 3) Check that nothing comes out from drain hose (4), then remove plug (2).
- 4) Coat O-ring portion (5) with a suitable amount of grease. When doing this, be careful not to let the grease get on the drain valve water drain port (a) or the plug thread.
- 5) Screw in plug (2) by hand until it contacts the bottom.
- 6) Remove the fuel container.

- If transparent cap (3) is dirty and the contents cannot be easily seen, clean transparent cap (3) when replacing the filter.
- When washing, if plug (2) is removed, coat the O-ring with grease, then tighten by hand until it contacts the bottom.

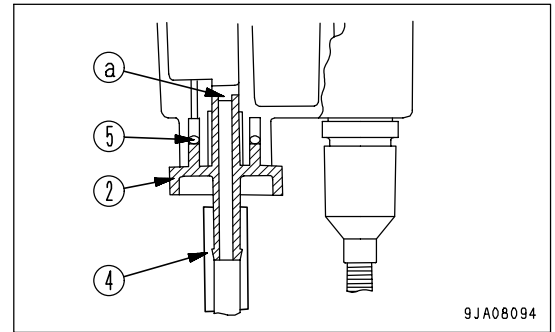

9JA08094

CHECK AIR CLEANER

**WARNING**

- If inspection, cleaning, or maintenance is carried out with the engine running, dirt will get into the engine and damage it. Always stop the engine before carrying out these operations.
- When using compressed air, there is danger that dirt may be blown around and cause serious injury. Always use protective glasses, dust mask, and other protective equipment.

1. Open the engine side cover on the right side of the chassis.
2. If the yellow piston in the display portion of dust indicator (1) installed to the air cleaner enters the red range (7.5 kPa), clean the element.
3. After cleaning, press the button of the dust indicator to reset it.
4. If the yellow piston enters the red range (7.5 kPa) soon after the dust indicator is reset, it is necessary to replace the element. For details of the procedure for replacing the element, see "REPLACING ELEMENT (PAGE 4-20)".

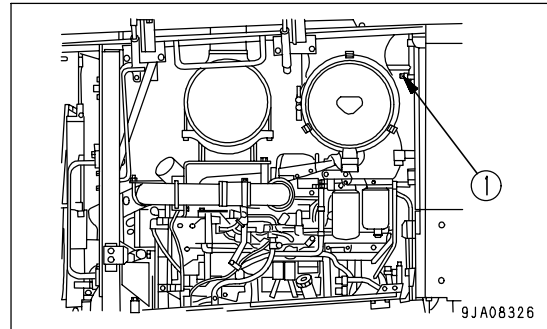
**ELECTRIC AIR CLEANER CLOGGING SENSOR**

(Machines equipped with KOMTRAX)

If the yellow piston in the display portion of dust indicator (1) enters the red range (7.5 kPa), or air cleaner clogging caution lamp (2) on the machine monitor lights up, clean the air cleaner element.

NOTICE

Do not clean at the element until the air cleaner clogging caution lamp lights up.

If the element is cleaned frequently before the air cleaner becomes clogged, the air cleaner will not be able to provide its expected performance and the cleaning efficiency will become poor.

In addition, dirt stuck to the element will drop inside the inner element more frequently during the cleaning operation.

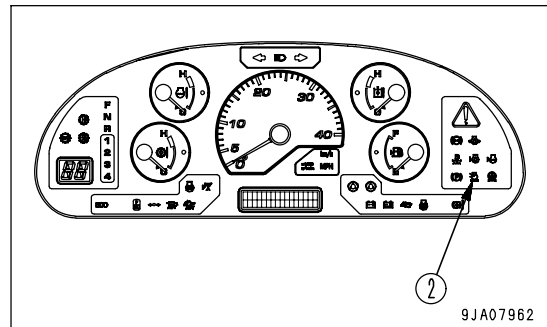

CHECK FUEL LEVEL, ADD FUEL

! WARNING

When filling with fuel, do not add any more fuel after the fuel supply has automatically stopped. If too much fuel is added, there is danger that the fuel may expand because of the rise in the ambient temperature and cause the fuel to overflow.

Spilled fuel may cause fire, so always wipe off any spilled fuel completely.

Fuel is highly flammable and a dangerous substance, so do not bring any fire or flame close.

NOTICE

If the engine has stopped because it has run out of fuel, it is necessary to bleed all the air from the circuit before starting again. For details of the procedure for bleeding air, see "PROCEDURE FOR BLEEDING AIR (PAGE 4-54)".

Be careful not to let the engine run out of fuel.

If the engine has run out of fuel, the air bleeding procedure can be carried out more quickly if the fuel tank is full.

1. Turn the engine starting switch to the ON position (B) and check the fuel level with fuel level gauge (G).
After checking, turn the switch back to the OFF position (A).

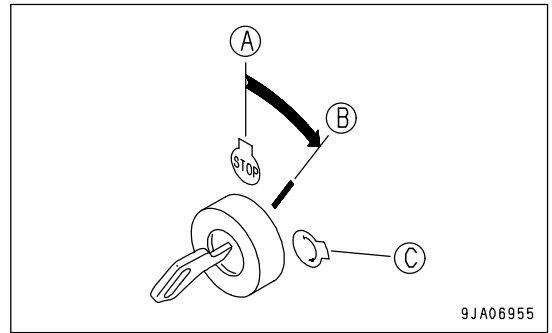

9JA06955

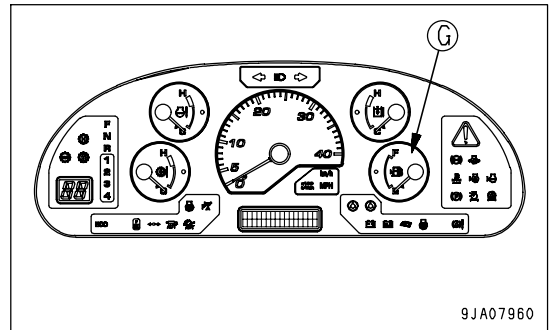

9JA07960

2. After completing the operation, open filler cover (1) on the right side of the machine, add fuel through fuel filler port (F) to fill the tank.
Do not add any more fuel after the tank is filled.
For details of the method for opening and closing the cap, see "CAP WITH LOCK (PAGE 3-58)".
3. After adding the fuel, tighten the caps securely.

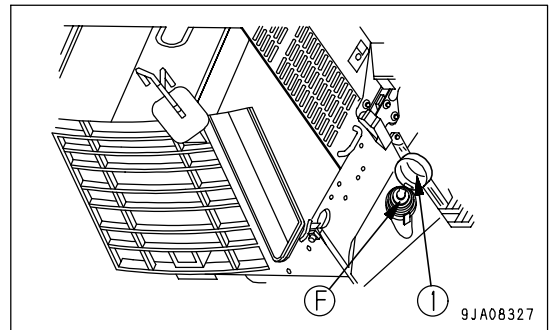

9JA08327

Fuel tank capacity: 325 liters (85.87 US gal)

CHECK ELECTRIC WIRING**WARNING**

- If the fuses frequently blow or if there are traces of short circuits in the electrical wiring, locate the cause and immediately perform repairs, or contact your Komatsu distributor for repairs.
- Keep the top surface of the battery clean and check the breather hole in the battery cap. If it is clogged with dirt or dust, wash the battery cap to clean the breather hole.

Check that the fuses are not damaged, that the fuses are of the correct capacity, and that there are no signs of short circuits or disconnections in the electric wiring. Check also that there are no loose terminals or connectors. Tighten any loose parts.

In particular, check the wiring of the battery, starting motor, and alternator.

Be also sure to check that there is no flammable material accumulated around the battery. Remove any such flammable material.

Please consult your Komatsu distributor about the repairs and causes of problems.

CHECK INFLATION PRESSURE OF TIRES

Measure the inflation pressure with a tire pressure gauge, while the tires are cool, before starting work.

Check for damage or wear to the tires and the rims. Check for loose wheel hub nuts (bolts).

The appropriate inflation pressure differs according to the type of work. See Section "HANDLING THE TIRES (PAGE 3-156)" for details.

CHECK CONDITION OF WINDOW WASHER SPRAY

Operate the window washer and check that the washer fluid is sprayed out properly.

- If the fluid does not spray out properly, clean the washer nozzle with a safety pin or thin wire.
- If the condition is still not improved, please ask your Komatsu distributor to carry out inspection and repair.

CHECK WIPING EFFICIENCY OF WIPER

Operate the wiper and check that it wipes the window properly under each operating speed: Intermittent, low speed, high speed.

- Operate the window washer to make the glass wet when checking.
- If the wiping condition is poor, it is necessary to clean the surface of the glass or replace the rubber wiper blade.
- If the condition is still not improved, please ask your Komatsu distributor to carry out inspection and repair.

CHECK HORN

Operate the horn switch and check that the horn sounds.

If there is any abnormality, please ask your Komatsu distributor to carry out inspection and repair.

CHECK DEFROSTER FUNCTION

- Operate the air conditioner and check that the air blows out properly onto the front glass.
If there is any abnormality, please ask your Komatsu distributor to carry out inspection and repair.
- Operate the rear heated wire glass switch and check that the rear glass surface is heated properly.
If there is any abnormality, please ask your Komatsu distributor to carry out inspection and repair.

CHECK LOCKS

Check that all places can be locked properly.

(For details of the locations that can be locked, see "LOCKING (PAGE 3-155)".)

If any abnormality is found, please ask your Komatsu distributor to carry out inspection and repair.

CHECK EMERGENCY EXIT

Operate the knob for opening and closing the emergency exit, and check that it works properly. If any abnormality is found, please ask your Komatsu distributor to carry out inspection and repair.

ADJUSTMENT**SEAT ADJUSTMENT****WARNING**

When adjusting the position of the operator's seat, always set the work equipment lock lever to the LOCK position to prevent any accidental contact with the control levers.

- Always adjust the operator's seat before starting each operation or when the operators change shift.
- When adjusting the seat, put your back against the backrest and adjust to a position where the brake pedal can be fully depressed.

LUMBAR SUPPORT TYPE SEAT**NOTICE**

- When pulling up levers (2) and (3), be careful not to pull up the switch box at the front by mistake. There is danger that the switch box may be damaged.
- When the left armrest is at the raised position, do not push down on the tip of the armrest with your hand to support your weight. There is danger that the armrest mount may be damaged.

Adjustments (E), (J), and (K) use the air compressor built into the seat, so turn the engine starting switch to the ON position when carrying out the adjustment.

(A) Fore-and-aft adjustment

Pull lever (1) up, set the seat to the desired position, then release the lever.

Amount of adjustment: 180 mm (7.1 in)
(10 mm (0.4 in) x 18 stages)

(B) Adjusting seat angle

Move lever (2) up and apply your weight to the rear of the seat. The seat will tilt to the rear.

Move lever (3) up and apply your weight to the front of the seat. The seat will tilt to the front.

Amount of adjustment: 24 degrees (front and rear tilt: 3 stages each)

(C) Adjusting height of seat

Move levers (2) and (3) up and move the seat up or down to the desired position.

These levers are also used for adjusting the seat angle, so adjust the seat angle to set the seat to the desired height.

Amount of adjustment: 65 mm (2.6 in)

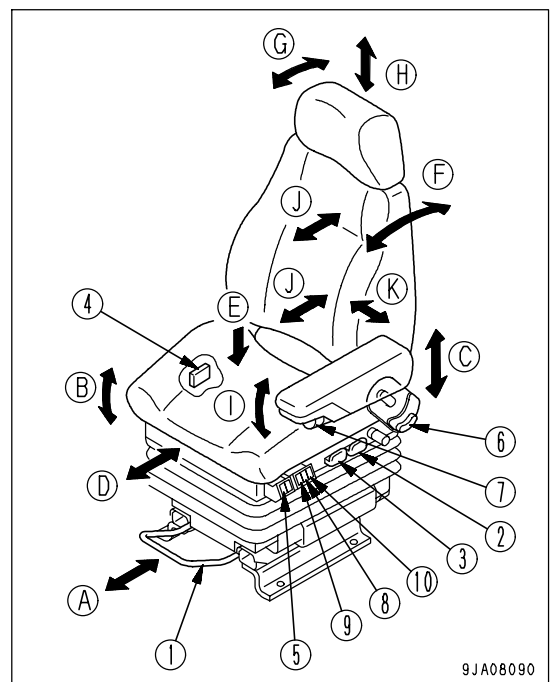

9JA08090

(D) Adjusting fore-and-aft position of seat cushion

Push in lever (4), set the seat cushion to the desired position, then release the lever.

Amount of adjustment: 60 mm (2.4 in)

(E) Setting seat for weight

Sit on the seat, raise your body slightly, then operate switch (5) to adjust the strength of the suspension.

Amount of adjustment: 50 - 130 kg (110 - 287 lb)(target)

When + is pressed: Suspension becomes stronger

When - is pressed: Suspension becomes weaker

(F) Adjusting reclining angle

Move lever (6) up and move the backrest to the front or rear.

Push your back against the backrest when carrying out this adjustment. If your back is not pressing against the backrest, the backrest may suddenly spring forward.

Amount of adjustment: Front tilt: Free

Rear tilt: 40 degrees (2 degrees x 20 stages)

(G) Adjusting headrest angle (if equipped)

Rotate the headrest to the front or rear.

Amount of adjustment:

Front tilt: 13 degrees

Rear tilt: 13 degrees

(H) Adjusting headrest height (if equipped)

Move the headrest up or down.

Amount of adjustment: 80 mm (3.2 in)

(I) Adjusting armrest angle

Rotate the knob (7) and adjust the angle of the armrest.

Amount of adjustment: 73 degrees (front: 54 degrees; rear: 19 degrees)

If the armrest is turned, it will spring up.

(J) Lumbar support

Operate switch (8) to give a suitable tension to the lower lumbar region.

Operate switch (9) to give a suitable tension to the upper lumbar region.

When + is pressed: Tension becomes stronger

When - is pressed: Tension becomes weaker

(K) Side support

Operate switch (10) to give a suitable tension to the left and right lumbar region.

When + is pressed: Tension becomes stronger

When - is pressed: Tension becomes weaker

REMOVAL AND INSTALLATION OF HEADREST**REMOVAL**

If the headrest is not needed, remove it as follows.

1. Pull up the headrest to the position where it stops.
2. From the top of the seat back, turn stopper (1) (under the material at the top of the seat) of the headrest bar on one side in the direction of the arrow, and pull up the headrest.
When stopper (1) is turned, it will come out of groove (2).
3. Turn stopper (1) on the other side in the direction of the arrow, and pull up the headrest.
When both stoppers (1) come out of groove (2), the headrest can be removed.

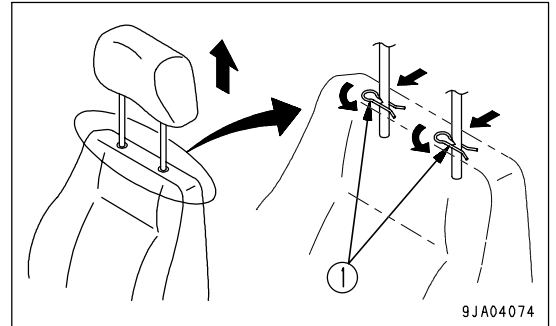
**INSTALLATION**

1. Insert the bars into the holes in the top of the seat and push down.

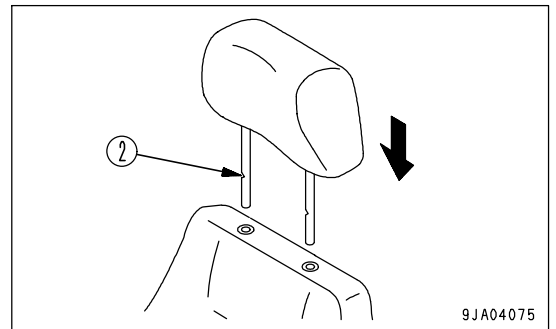

ADJUST SEAT BELT

Always wear the seat belt.

WARNING

- Before fastening the seat belt, check that there is no abnormality in the belt-mounting bracket or mounting of the belt. If the belt is worn or damaged, replace it.
- Even if there are no signs of damage, replace belts in accordance with the following schedule:
5 years after the date of seat belt manufacture, or every 3 years after the start of actual usage, whichever date comes first.
- Fasten the seat belt before starting operations.
- Always wear the seat belt during operations.
- Make sure that the left and right belts are not twisted when fastening the seat belt.

REMARK

The date of seat belt manufacture attached to the seat belt is the start of the 5-year period. It is not the start of the 3-year period of actual usage.

FASTENING AND REMOVING BELT

Fasten the belt so that it is tight without being too tight.

1. Sit on the seat, depress the brake pedal fully, and adjust the seat so that your back is pressed against the backrest.
2. After adjusting the seat position, adjust tether belt (1). Tense the tether belt and install it when there is no one sitting on the seat.
3. Sit on the seat, hold buckle (2) and tongue (3) with your left and right hands, insert tongue (3) into buckle (2), then pull the belt to check that it is securely locked.

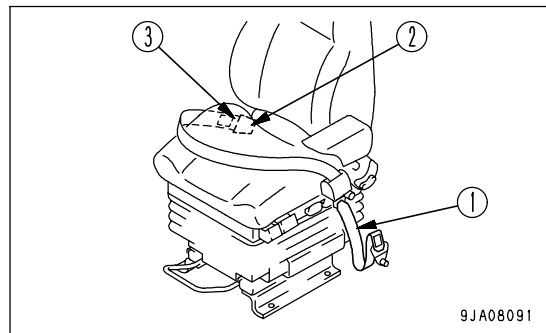

4. When removing the belt, press the red button in buckle (2) to free the belt.
Fasten the belt along your body without kinking it. Adjust the lengths of the belt on both the buckle and the tongue sides so that the buckle is located at the front, mid-point of your body.

ADJUST BELT LENGTH

To make belt shorter: Pull the free end of the tether belt.

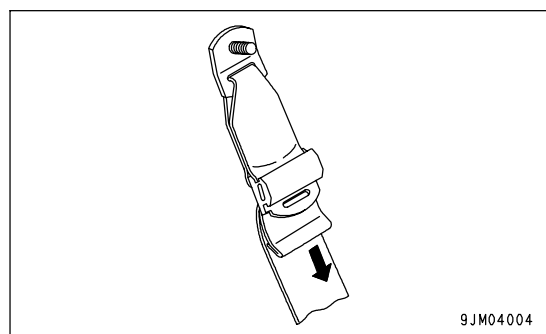

To make belt longer: Set the fixed end of the tether belt at 90 degrees to the holder, and pull.

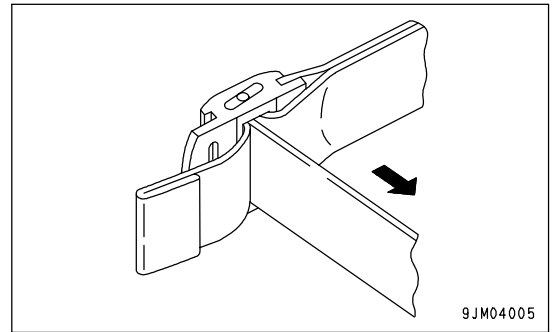

ADJUST LEVER STAND

⚠ WARNING

When adjusting the lever stand, check that the work equipment lock lever is securely at the LOCK position. If it is not at the LOCK position, and the work equipment control levers are touched by accident when adjusting the lever stand, the work equipment may suddenly move and cause serious personal injury.

ADJUST HEIGHT AND ANGLE OF ARMREST

The height and angle of armrest (1) can be adjusted by loosen lock lever (2).

Height adjustment amount: 30 mm

Angle adjustment amount: 44 degrees

REMARK

Set lock lever (2) to the FREE position (F). The lock lever is loosened.

Hold the armrest at the desired position and move the lock lever to the LOCK position (L) to secure the armrest in position.

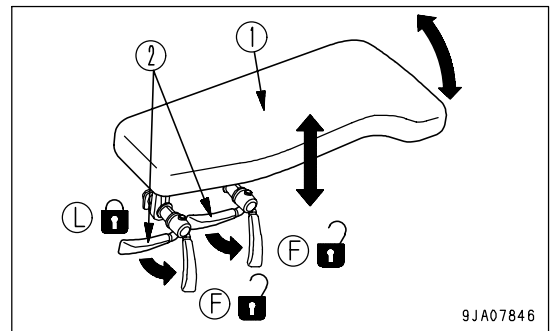

ADJUST LEVER STAND FORWARD AND BACKWARD

Pull lever (3) up with your left hand, grip armrest (1) with your right-hand and move it to the front or rear, then release lever (3).

Amount of adjustment: 180 mm

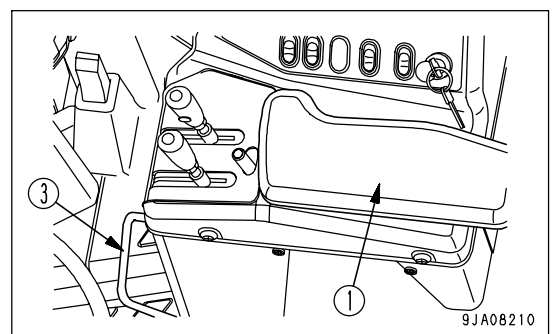

ADJUSTING MIRRORS



WARNING

Be sure to adjust the mirrors before starting work. If they are not adjusted properly, you cannot secure the visibility and may be injured or may injure someone seriously.

Mirrors A, B

Loosen bolt (1) of the mirror, then adjust the mirror to a position which gives the best view from the operator's seat of the blind spot at the left and right sides at the rear of the machine.

- When installing the mirror, adjust so that it is possible to see any person (or any object of a height of 1 m (3 ft 3 in) and diameter of 30 cm (11.8 in)) at the rear left or right of the machine.

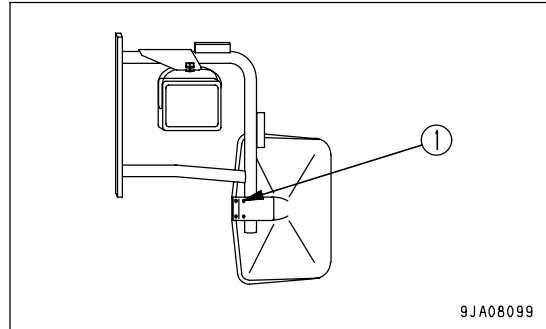

Mirrors C

Adjust so that it is possible to see the ground around the machine at a range of 1 m (3 ft 3 in) from the operator's seat.

- If the movement of the mirror is stiff when adjusting it, loosen bolt (2) of the mirror.

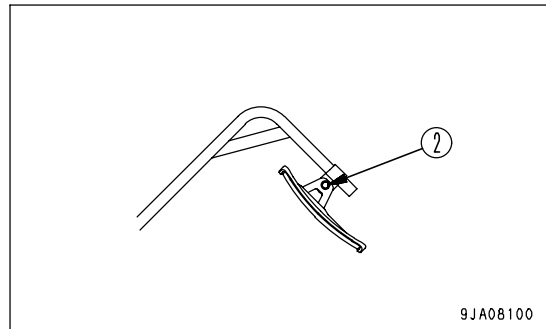

Install the mirrors at the position and dimensions shown in the diagram. The values below are reference values for the range of visibility.

- Range of view (left): 2500 mm (8 ft 2 in)
- Range of view (right): 2500 mm (8 ft 2 in)
- Mirror A: Must be possible to see hatched portion (A)
- Mirror B: Must be possible to see hatched portion (B)
- Mirror C: Must be possible to see hatched portion (C)

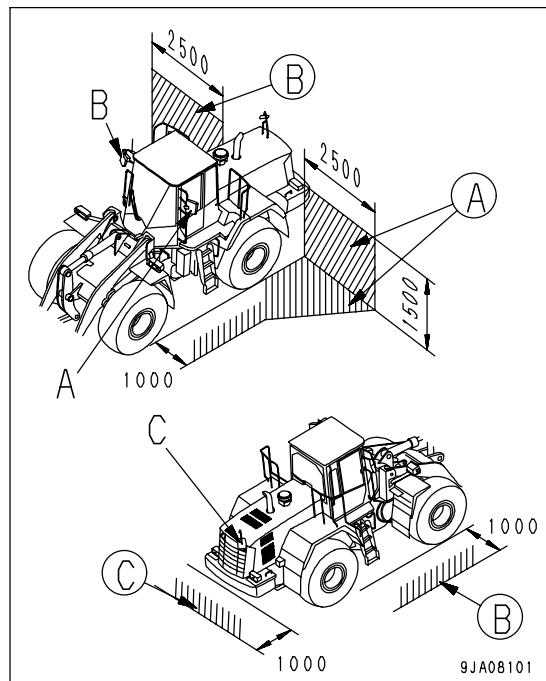

NOTICE

- Tighten the mirror mounting bolts securely that they will not be loosened and the mirrors will not come off.

Tightening torque

Mirrors A, B :2.0 to 2.5Nm{0.2 to 0.25 kgm}

Mirrors C :8.8 to 9.8Nm{0.9 to 1.0 kgm}

- If the tightening torque cannot be controlled, ask your Komatsu distributor for tightening the bolts.

OPERATIONS AND CHECKS BEFORE STARTING ENGINE

**WARNING**

When starting the engine, check that the work equipment lock lever are placed securely at the LOCK position. If the work equipment control lever is touched by accident when the engine is started, the work equipment may move unexpectedly and cause serious injury or damage.

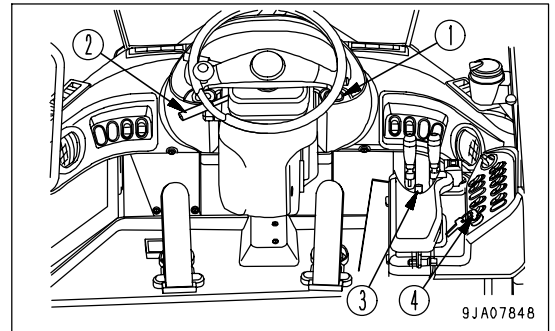

1. Check that parking brake switch (1) is at the ON position (A).

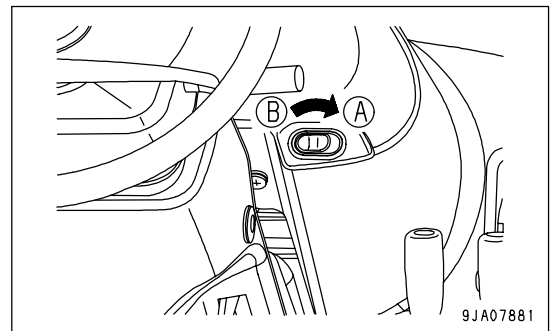

2. Check that directional lever (2) is at the Neutral position (N).

REMARK

If directional lever is not set to the Neutral position (N), the engine will not start.

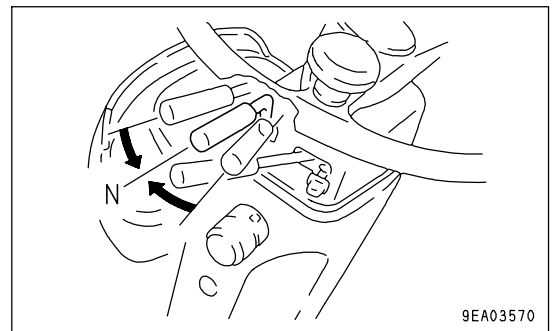

3. Check that the bucket is completely lowered to the ground.
If it is not completely lowered, lower the bucket to the ground as follows.

- 1) Check that the work equipment control lever is at the HOLD position, then set the work equipment lock lever to the FREE position.
- 2) Operate the work equipment control lever to lower the bucket to the ground.
- 3) Check that the work equipment control lever is at the HOLD position, then set the work equipment lock lever to the LOCK position.

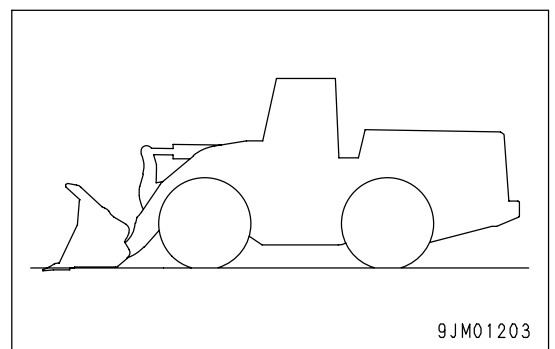

4. Check that work equipment lock lever (3) is at the LOCK position (L).

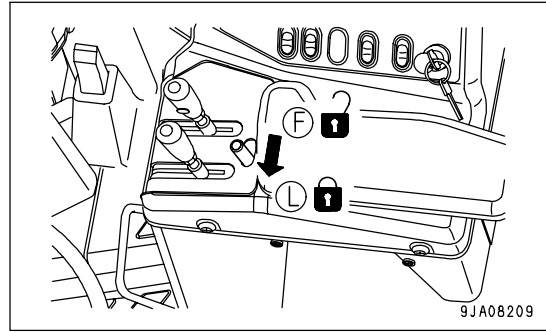

5. Insert the key in starting switch (4), turn the key to the ON position (B), and check that the machine monitor system works.

When the starting switch is turned to the ON position before starting the engine, monitors, gauges, and central warning lamp light up for approx. 2 seconds, and the alarm buzzer sounds for approx. 2 sec.

If any monitor does not light up, there is probably a failure or disconnection. Contact your Komatsu distributor for inspection.

In addition, after all the monitors, gauges, and central warning lamp light up, a self check is carried out to check that the emergency steering function works properly. For details, see "EMERGENCY STEERING SELF-CHECK FUNCTION (PAGE 3-138)" in the OPERATION section.

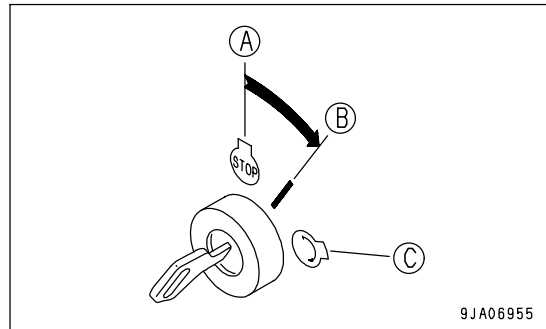

STARTING ENGINE

NORMAL STARTING

WARNING

- Sit down in the operator's seat before starting the engine.
- Do not attempt to start the engine by short-circuiting the engine starting circuit. Such an act may cause serious bodily injury or fire.
- Check that there are no persons or obstacles in the surrounding area, then sound the horn and start the engine.
- Exhaust gas is toxic. When starting the engine in confined spaces, be particularly careful to ensure good ventilation.

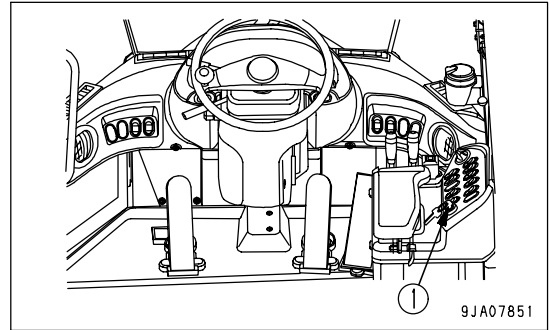

NOTICE

- Do not accelerate the engine suddenly before completing the warming-up operation.
- Do not keep the starting motor rotating continuously for more than 20 seconds.
- If the engine does not start, wait for at least 2 minutes before trying to start the engine again.

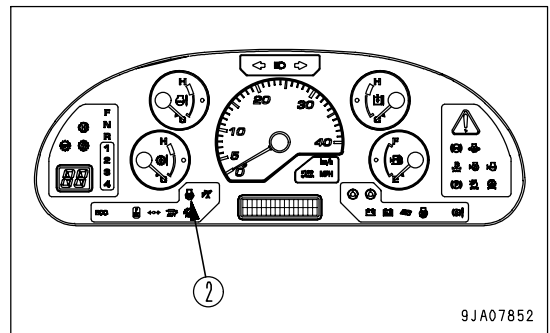

This machine is equipped with an engine automatic preheating device that functions to start the engine preheating automatically.

If the ambient temperature is low, the preheating monitor will light up when the key in starting switch (1) is turned to the ON position to inform the operator that preheating has been started automatically.

1. Turn the key in starting switch (1) to ON position (B).

If the ambient temperature is low, the preheating pilot lamp (2) lights up and automatic preheating is carried out. Keep the key in starting switch (1) at the ON position until the preheating pilot lamp (2) goes out.

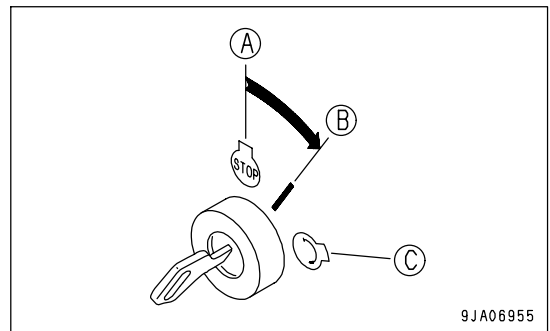

The time that the preheating pilot lamp (2) stays lighted up depends on the ambient temperature as shown in the table on the right.

Ambient temperature	Lighting time
-2 °C to -28 °C (28.4 °F to -18.4 °F)	5 seconds to 45 seconds
-28 °C or less (-18.4 °F or less)	45 seconds

- If the preheating pilot lamp (2) does not light up, or it lights up and then goes out to inform that the engine preheating has been completed, turn the key in starting switch (1) to the START position (C).

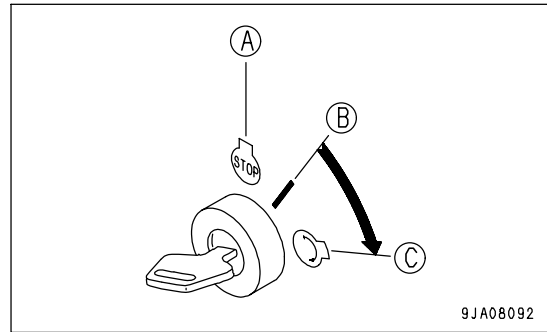

- The starting motor will continue to turn and the engine will start.
Keep the key in starting switch (1) at the START position (C) to keep the starting motor running until the engine starts.

REMARK

In low temperatures, to ensure lubrication of the engine and to improve the durability, no fuel is supplied to the engine for 3 seconds after the key in starting switch (1) is turned to the START position (C), so the engine will not start during this time.

Therefore, keep the key in starting switch (1) at the START position (C) to keep the starting motor running until the engine starts.

- After the engine starts, release the key in starting switch (1).
The key will automatically return to the ON position (B).

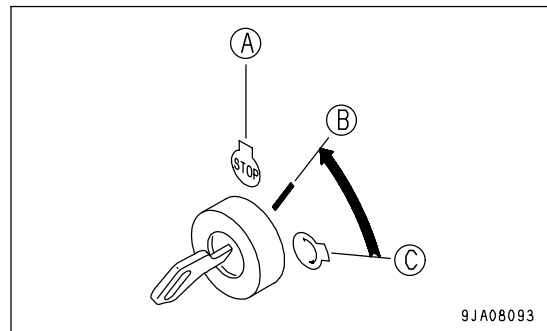

STARTING IN COLD WEATHER

WARNING

- Sit down in the operator's seat before starting the engine.
- Do not attempt to start the engine by short-circuiting the engine starting circuit. Such an act may cause serious bodily injury or fire.
- Check that there are no persons or obstacles in the surrounding area, then sound the horn and start the engine.
- Exhaust gas is toxic. When starting the engine in confined spaces, be particularly careful to ensure good ventilation.

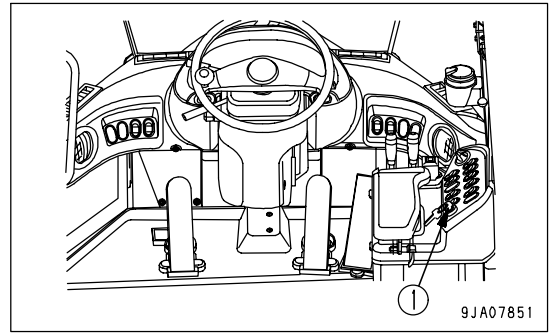

NOTICE

- Do not suddenly accelerate the engine before the warming-up operation is completed.

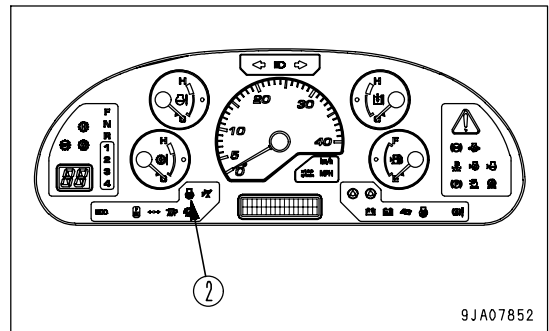

When starting the engine after the machine has been left for more than half a day in temperatures near -20°C, it will take time for the engine to achieve complete combustion, so operate the starting switch as follows.

1. Turn the key in starting switch (1) to ON position (B).

If the ambient temperature is low, the preheating pilot lamp (2) lights up and automatic preheating is carried out. Keep the key in starting switch (1) at the ON position until the preheating pilot lamp (2) goes out.

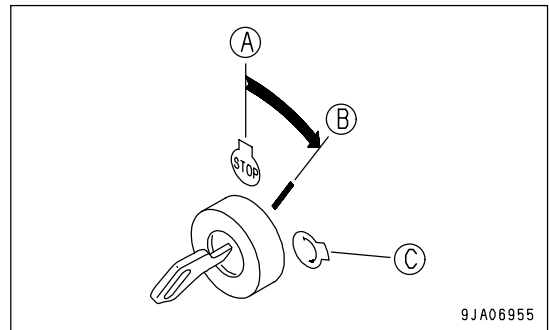

The time that the preheating pilot lamp (2) stays lighted up depends on the ambient temperature as shown in the table on the right.

Ambient temperature	Lighting time
-2 °C to -28 °C (28.4 °F to -18.4 °F)	5 seconds to 45 seconds
-28 °C or less (-18.4 °F or less)	45 seconds

2. When preheating pilot lamp (2) goes out, turn the key in starting switch (1) to the START position (C).
Keep the key in starting switch (1) at the START position (C) to keep the starting motor running until the engine starts.
3. The starting motor will continue to turn and the engine will start.

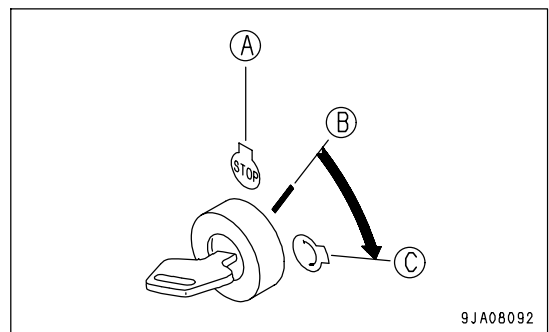

- 4. Method of starting engine in temperatures of approx. -20°C (-4°F).
 - 1) Keep the engine starting motor running for the max. 20 seconds, holding the key of engine starting switch (1) in the START position (C), until the engine starts up.
 - 2) If the engine fails to start up even after running the engine starting motor for about 20 seconds, stop the engine starting motor once (release the engine starting switch (1) key), and try the same process again after a pause for a minute or so.
 - 3) If the engine still fails to start up after the second attempt, try the same process for the third time after a pause for a minute or so.

- 5. When the engine has started up and the engine speed rises, release the key of engine starting switch (1). The key will automatically return to the ON position (B).

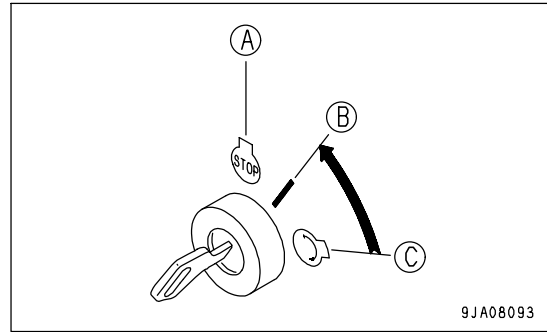

AUTOMATIC WARMING-UP OPERATION

After starting the engine, if the engine water temperature is below 20 °C, the automatic warming-up operation (engine speed: 1000 rpm) is carried out, and is cancelled when the engine water temperature goes above 30 °C. (Engine speed: 850 rpm)

- (X) :Engine speed (rpm)
- (Y) :Water temperature (°C)

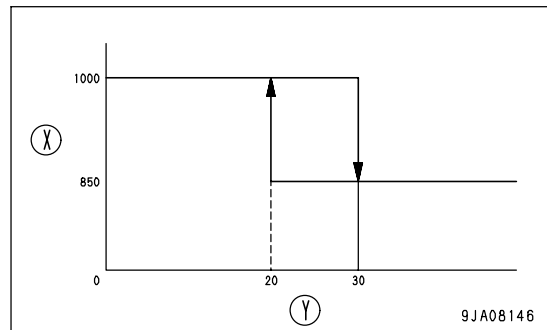

CHECKS AFTER STARTING ENGINE

CHECK PARKING BRAKE

Check that the parking brake works properly.

If there is any abnormality in the operation of the parking brake or the brake does not provide the proper braking effect, please contact your Komatsu distributor for adjustment.

CHECK BRAKE PEDAL

Set to the machine on level ground with no obstacles in the surrounding area, then drive the machine slowly forward and in reverse and check the braking effect of the brakes.

If there is any abnormality in the operation of the brakes, please ask your Komatsu distributor to carry out adjustment.

CHECK TRAVEL OF BRAKE PEDAL

Depress the brake pedal fully and check the distance from the floor. Check that the pedal is not too close to the floor and that there is no abnormal feeling when operating the brake pedal.

If any abnormality is found, please ask your Komatsu distributor to carry out adjustments.

CHECK FOR EASE OF STARTING ENGINE, ABNORMAL NOISE

When starting the engine, check that the engine causes no abnormal noise and that it starts up easily and smoothly. Check also that there is no abnormal noise when the engine is idling or when the revolution rises slightly.

- When there is an abnormal noise at the engine startup and if that condition continues, the engine may be damaged. In that case, ask your Komatsu distributor to check the engine as soon as possible.

CHECK ENGINE AT LOW SPEED AND WHEN ACCELERATING

Check that there is no irregularity in the engine speed and that the engine does not suddenly stop when the machine is stopped during normal travel.

Check also that the engine accelerates smoothly when the accelerator pedal is depressed.

- Carry out the inspection in a safe place and check that there is no one in the surrounding area.
- If the condition at low speed or when accelerating is extremely poor and that condition continues, there is danger that the engine may be damaged, that the operating feeling may become strange, that the braking effect may deteriorate, or that an unexpected accident may happen, so please ask your Komatsu distributor to carry out repairs as soon as possible.

CHECK LOCATION OF ABNORMALITIES FROM PREVIOUS DAYS

Check the places where problems occurred when using the machine on previous days.

If any abnormality is found, please contact your Komatsu distributor for inspection and repair.

OPERATIONS AND CHECKS AFTER STARTING ENGINE



WARNING

- If there has been any abnormal actuation or trouble, turn the starting switch key to the OFF position.
- If the work equipment is operated without warming the machine up sufficiently, the response of the work equipment to the movement of the control lever will be slow and the work equipment may not respond as the operator desires, so always carry out the warming-up operation. Particularly in cold areas, be sure to carry out the warm-up operation completely.

BREAKING-IN THE MACHINE



CAUTION

Your Komatsu machine has been thoroughly adjusted and tested before shipment. However, operating the machine under severe conditions at the beginning can adversely affect the performance and shorten the machine life.

Be sure to break-in the machine for the initial 100 hours (as indicated by the service meter).

During break-in operations, follow the precautions described in this manual.

- Idle the engine for 5 minutes after starting it up.
- Avoid operation with heavy loads or at high speeds.
- Immediately after starting the engine, avoid sudden starts, sudden acceleration, unnecessary sudden stops, and sudden changes in direction.

NORMAL OPERATION

After the engine starts, do not start operating the machine immediately. First, carry out the following operations and checks.

NOTICE

Do not suddenly accelerate the engine before the warming-up operation is completed.

Do not run the engine at low idle or high idle continuously for more than 20 minutes.

If it is necessary to run the engine at idle, apply a load from time to time or run the engine at a mid-range speed.

1. Depress accelerator pedal (1) lightly and run the engine with no load at midrange speed for about 5 minutes.

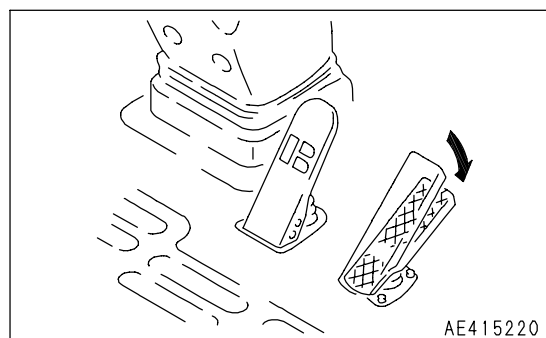
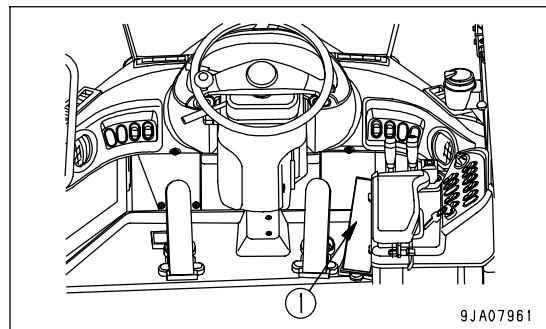

To warm up the hydraulic oil in cold areas, do as follows.

2. After carrying out the warming-up operation, check that the engine rotation is smooth, then set the work equipment lock lever to the FREE position (F).
3. Operate the bucket control lever to the TILT position (A) and return it to the HOLD position (B) repeatedly to warm up the hydraulic oil.

Relieve the circuit at the TILT position (A) for a maximum of 10 sec.

This brings the oil to the relief pressure and makes it quicker warm up the oil.

4. Slowly operate the steering wheel to the left and the right about 10 times to warm up the hydraulic oil inside the steering valve.

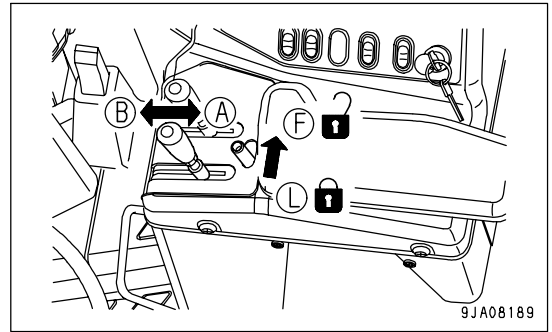

WARNING

If the steering wheel is operated and stopped while the oil temperature is low, there may be a time lag before the machine stops turning. In this case, use the frame lock bar to ensure safety, and perform the warm-up operation in a wide place. Do not relieve the hydraulic oil in the circuit continuously for more than 5 seconds.

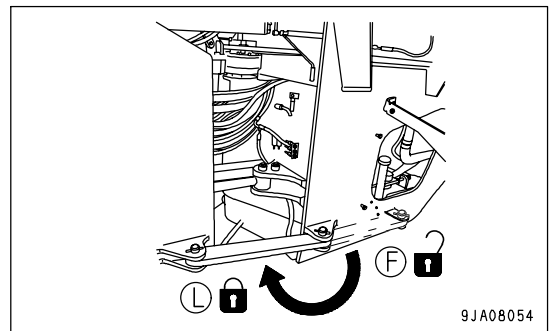

NOTICE

Turn the steering wheel a little and stop in that position. Confirm that the machine turns by an angle equivalent to the amount that the steering wheel is turned.

5. After carrying out the warming-up operation, check that the gauges and caution lamps are normal. If there is any abnormality, carry out maintenance or repair. Run the engine under a light load until engine water temperature gauge (2) and torque converter oil temperature gauge (3) are in the green range.
6. Check for abnormal exhaust gas color, noise, or vibration. If any problem is found, contact your Komatsu distributor.

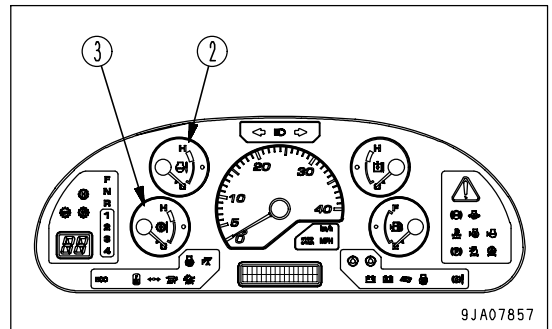

REMARK

The rotating speed of the cooling fan differs according to the following conditions, but this does not indicate any abnormality.

The cooling fan speed increases when the hydraulic oil temperature, engine coolant temperature, or transmission oil temperature are high.

However, when the cooling fan is rotating in reverse, it rotates at a fixed speed proportional to the engine speed, regardless of any oil or coolant temperature.

STOPPING ENGINE

NOTICE

If the engine is abruptly stopped before it has cooled down, engine life may be greatly shortened. Consequently, do not abruptly stop the engine apart from an emergency.

In particular, if the engine has overheated, do not abruptly stop it but run it at medium speed to allow it to cool gradually, then stop it.

1. Run the engine at low idle for about 5 minutes to cool down gradually.
2. Turn the key of starting switch (1) to the OFF position (A) to stop the engine.
3. Remove the key from starting switch (1).

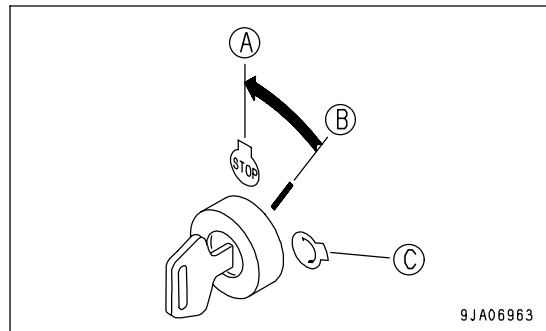
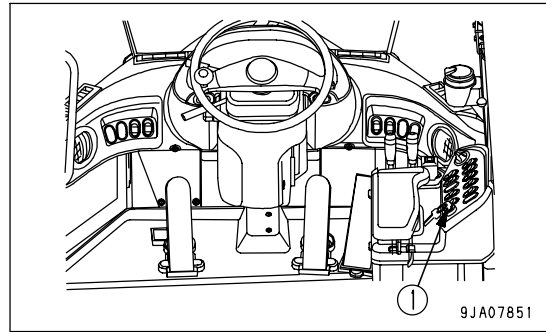

MOVING THE MACHINE (DIRECTIONAL, SPEED), STOPPING THE MACHINE



WARNING

- Always remove the frame lock bar for travel operations. If it is not removed, the steering wheel cannot be used for steering, and this may lead to serious damage or injury.
- When moving the machine off, check that the area around the machine is safe, then sound the horn before starting.
- Do not allow people to get near the machine.
- Clear the machine's travel path of any obstacle.
- Pay a particular attention to the blind spot at the rear of the machine, when traveling the machine in reverse.
- When starting the machine off up a slope, set the transmission cut-off switch to the OFF position, depress the left brake pedal. Then depress the accelerator pedal and gradually release the brake pedal to start the machine off. This makes it possible to prevent the machine from rolling back.

MOVING THE MACHINE

1. Check that caution lamp (1) is not lighted up.

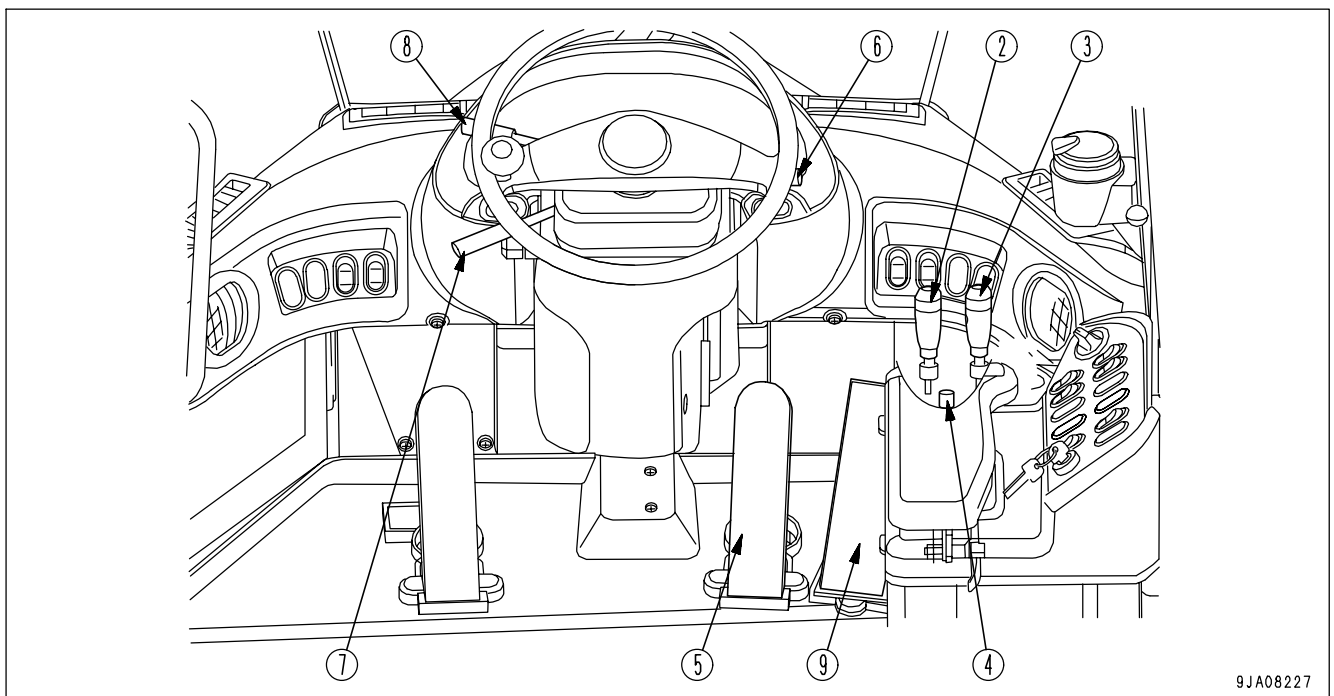
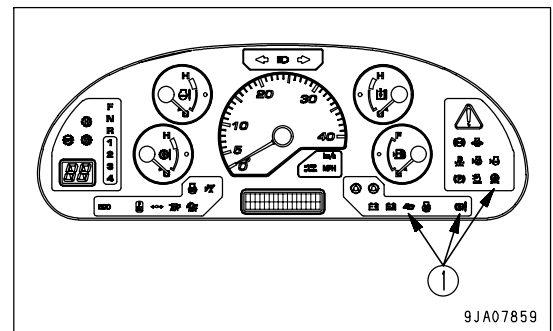

2. Check that the bucket control lever (2) and lift arm control lever (3) is at the HOLD position, then set the work equipment lock lever (4) to the FREE position (F).

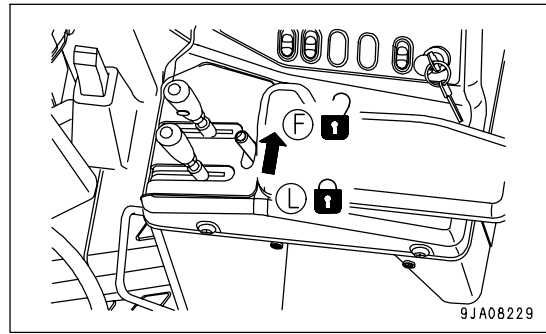

3. Operate lift arm control lever (3) to set the work equipment to the travel posture shown in the diagram on the right.
(A): 40 - 50 cm (16 - 20 in)

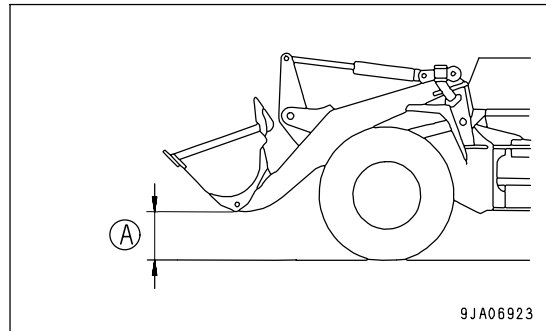

4. Depress right brake pedal (5) and turn parking brake switch (6) to the OFF position (B) to release the parking brake.
Keep right brake pedal (5) depressed.

REMARK

If the parking brake is still actuated when parking brake switch (6) is at the OFF position (B), turn the parking brake switch ON position (A), then turn it OFF position (B) again.

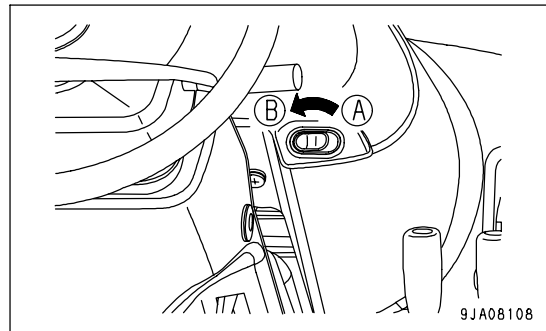

5. Set gearshift lever (7) to the desired position.

- Position (a): 1st
- Position (b): 2nd
- Position (c): 3rd
- Position (d): 4th

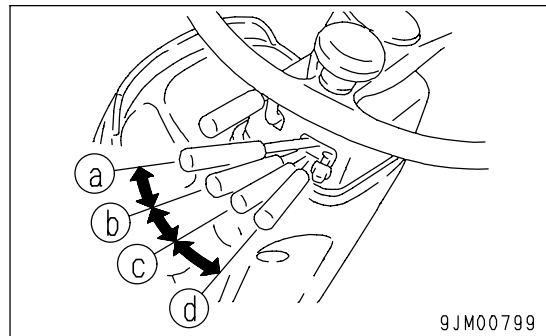

6. Set directional lever (8) to the desired position.

- Position (F): Forward
- Position (N): Neutral
- Position (R): Reverse

- Check that the backup alarm sounds when the directional lever is set to REVERSE. If the backup alarm does not sound, please contact your Komatsu distributor for repairs.

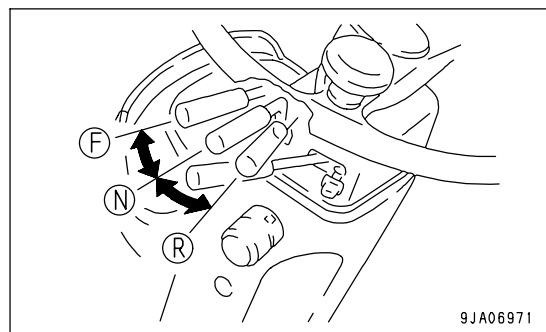

7. Release right brake pedal (5), then depress accelerator pedal (9) to move the machine off.

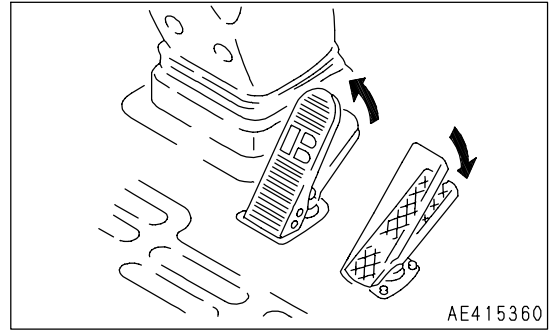

REMARK

When moving the machine off on a hill, turn transmission cut-off switch (10) OFF, depress left brake pedal (11), operate the gearshift lever to the low speed range, then depress accelerator pedal (9) and gradually release left brake pedal (11) to let the machine move off. This makes it possible to prevent the machine from rolling back.

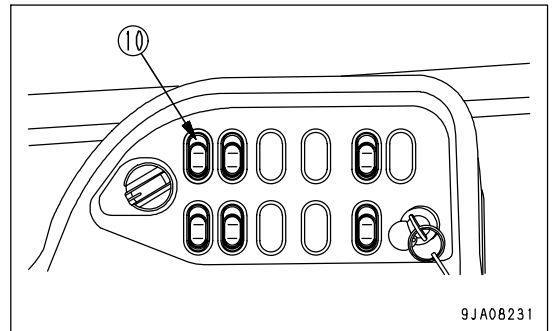
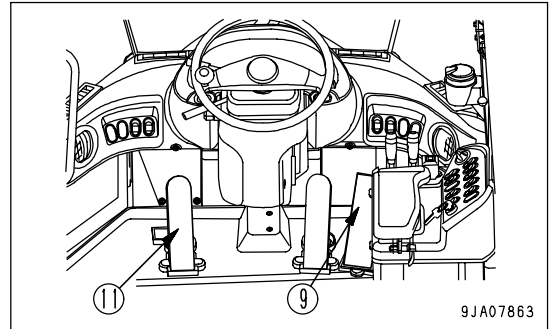

CHANGING GEAR SPEED

**WARNING**

When traveling at high speed, do not shift gear suddenly. Use the brake to reduce the travel speed before shifting gear.

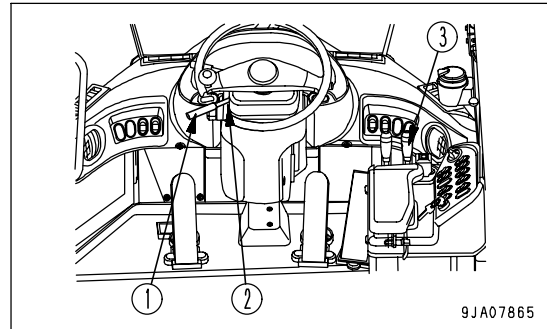

Shift gear as follows.

Move the gearshift lever (1) to the desired position to shift gear.

When carrying out digging or loading operations, the operation is carried out in 1st or 2nd, so use the gearshift lever stopper (2).

Position (a): 1st

Position (b): 2nd

Position (c): 3rd

Position (d): 4th

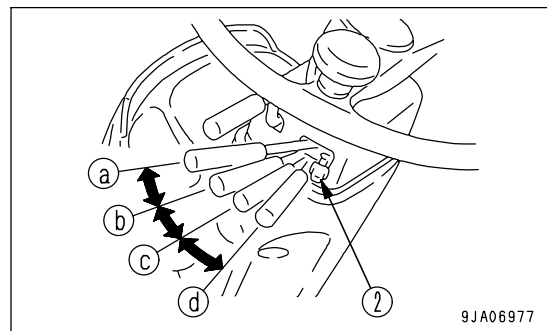
**REMARK**

- If the gearshift lever is operated slowly or is stopped between gear positions, the central warning lamp may light up and the alarm buzzer may sound. In this case, there is no failure, but try to operate the gearshift lever so that the gearshifting is completed within 2 seconds.
- This machine is equipped with kickdown switch (3). When traveling in 2nd, if kickdown switch (3) is pressed, the transmission shifts down to 1st.

For operations carried out in 1st and 2nd, such as digging and loading, we recommend the use of the kickdown switch. For details of the method of use, see Section KICKDOWN SWITCH (PAGE 3-46).

- This machine is equipped with an auto-shift system that automatically shifts the gear. For details of the method of use, see "TRANSMISSION SHIFT MODE SELECTOR SWITCH (PAGE 3-41)" and "AUTOMATIC SHIFT (PAGE 3-54)".

- When the machine is traveling at high speed, if the gear shift lever is shifted down to a lower speed, such as 4th <-> 3rd or 4th <-> 2nd, with the accelerator still depressed, the transmission is not shifted down. This is to prevent the engine from overrunning.

In this case, the central warning lamp lights up and the alarm buzzer sounds. At the same time, "OVERRUN PROTECT" is displayed on the bottom line.

If the alarm buzzer sounds, release the accelerator pedal immediately and depress the brake pedal to reduce speed, then carry out the gearshift operation.

CHANGING DIRECTION

⚠ WARNING

- When changing direction between FORWARD and REVERSE, check that the new direction of travel is safe. There is a blind spot behind the machine, so be particularly careful when changing direction to travel in reverse.
- Do not switch between FORWARD and REVERSE when traveling at high speed.
When switching between FORWARD and REVERSE, depress the brake to reduce the travel speed sufficiently, then change the direction of travel. (Max.speed for changing direction: 13 km/h (8.1 MPH))

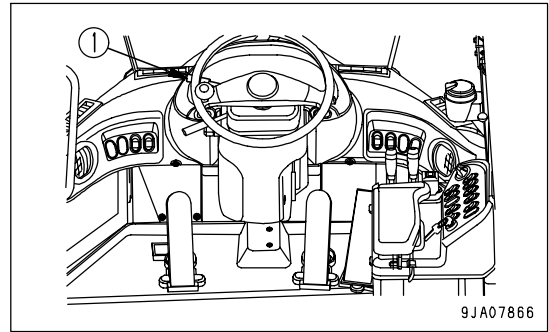

There is no need to stop the machine even when switching between FORWARD and REVERSE.

Place directional lever (1) in the desired position.

Position (F): Forward

Position (N): Neutral

Position (R): Reverse

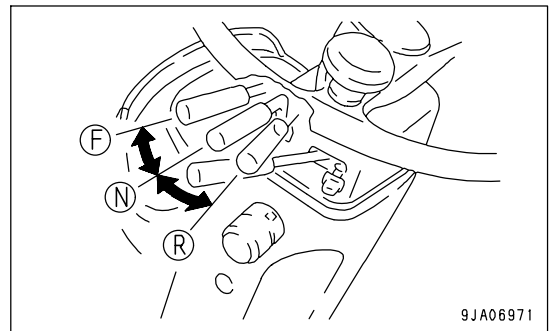

- Check that the backup alarm sounds when the directional lever is set to REVERSE. If the backup alarm does not sound, please contact your Komatsu distributor for repairs.

REMARK

If the directional lever is operated slowly or is stopped midway between the forward and reverse directions, "E01 MAINTENANCE" may be displayed on the character display. In this case, there is no failure, but try to operate the directional lever so that the change in direction is completed within 2 seconds.

If an attempt is made to switch the direction between FORWARD and REVERSE while traveling at high speed (when using 3rd or 4th), if the travel speed and engine speed are in ranges (A) or (B) in the chart, the central warning lamp will light up and the alarm buzzer will sound.

At the same time, "OVERRUN PROTECT" is displayed on the bottom line of the character display.

If the alarm buzzer sounds, depress the brake pedal immediately to reduce speed, then operate the directional lever to switch between FORWARD and REVERSE.

(X): Travel speed (km/h)

(Y): Engine speed (rpm)

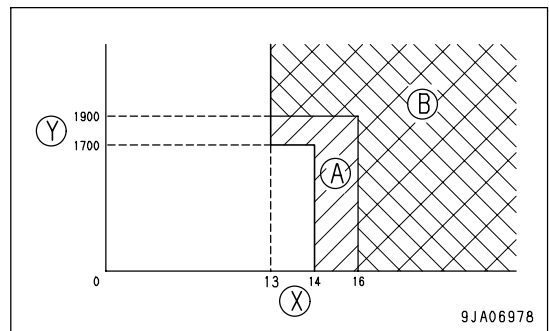

WHEN USING AUTO-SHIFT

If an attempt is made to switch the direction between forward and reverse when the auto-shift is ON, normally, the gearshift range will switch F3 -> R2, F4 -> R2, or R3 -> F2, R4 -> F2 to make it possible to move the machine off quickly.

However, if an attempt is made to shift between forward and reverse when the machine is traveling at high speed, such as shown in ranges (A) or (B) in the chart, the central warning lamp will light up and the buzzer will sound.

At the same time, "OVERRUN PROTECT" is displayed on the bottom line of the character display.

If the alarm buzzer sounds, depress the brake pedal immediately to reduce speed, then operate the directional lever to switch between FORWARD and REVERSE.

In particular, if an attempt is made to switch between forward and reverse in range (B), the speed range will not shifted to 2nd, but will switch F3 -> R3, F4 -> R4, or R3 -> F3, R4 -> F4. As a result, the reduction in speed will be less than in range (A), so care is necessary.

STOPPING THE MACHINE

**WARNING**

- Avoid stopping suddenly. Give yourself ample room when stopping.
- Even if the parking brake switch is turned ON, there is danger until the parking brake pilot lamp lights up, so keep the brake pedal depressed.

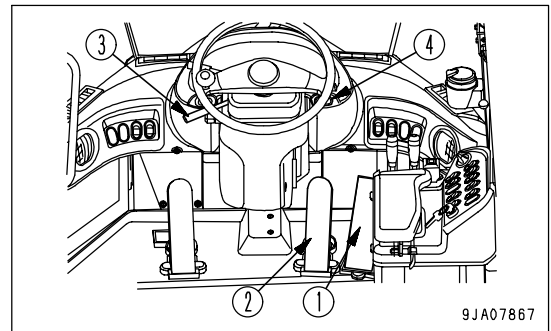

9JA07867

NOTICE

Never use the parking brake switch to brake the machine when traveling except in an emergency. Apply the parking brake only after the machine has stopped.

1. Release accelerator pedal (1), then depress brake pedal (2) to stop the machine.

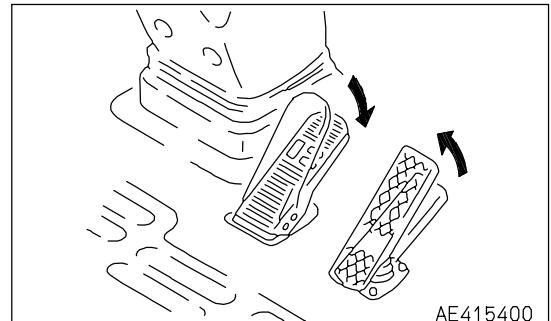

AE415400

2. Place directional lever (3) in Neutral position (N).

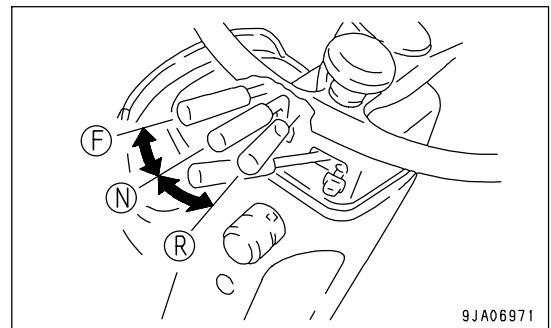

9JA06971

3. Set parking brake switch (4) to the ON position (A) to apply the parking brake.

REMARK

When the parking brake is applied, the transmission is automatically returned to neutral.

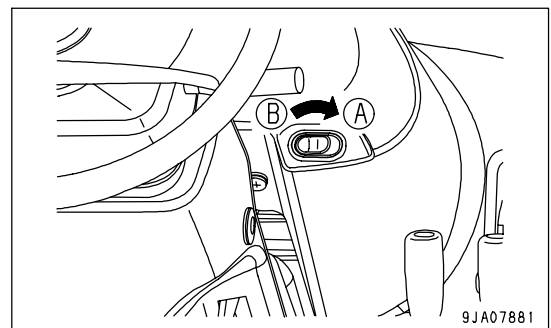

9JA07881

TRANSMISSION CUT-OFF FUNCTION

When the transmission cut-off switch is turned ON, the pilot lamp lights up and the following transmission cut-off function is actuated.

Position (a): OFF

Position (b): ON

When the brake pedal is depressed, the brakes are actuated and the transmission is returned to Neutral when the brake pedal is depressed to the set position.

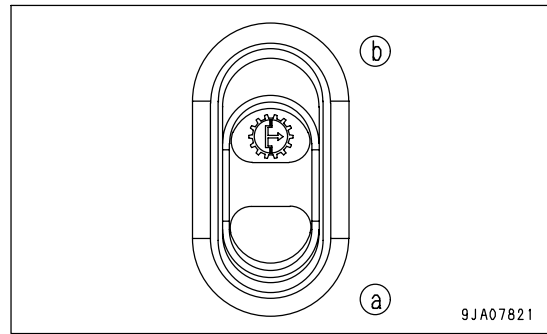

REMARK

- For details of the method of adjusting the set position for the amount that the brake pedal is depressed, see "ADJUSTING TRANSMISSION CUT-OFF POSITION (PAGE 3-135)".
- To match the following type of work, adjust the set position to cut off the transmission at a smaller or larger angle.
- When carrying out scooping-up work, lower the brake pedal depression position for the cut-off (transmission shifted to neutral). In this setting, the transmission driving force is cut at a point where there is ample braking force, so this prevents the machine from slipping down.

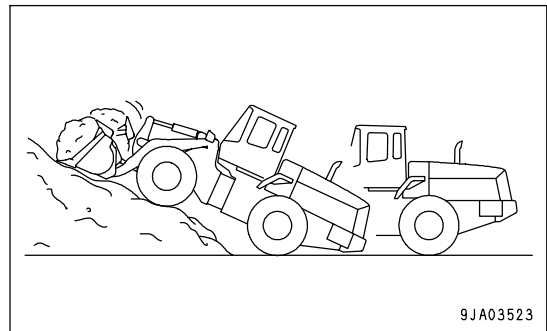

- When approaching dump trucks during loading operations, raise the brake pedal depression position for the cut-off (transmission shifted to neutral). In this setting, the fine control of the braking immediately before dumping the load can be carried out with the brake only, so this makes it easy to control and allows the machine to be brought to a soft stop.

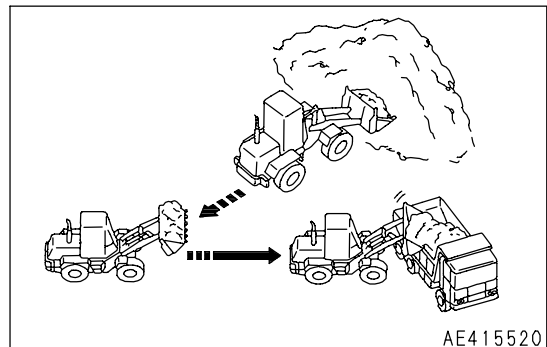

ADJUSTING TRANSMISSION CUT-OFF POSITION



CAUTION

Apply the parking brake before adjusting the transmission cut-off position.

Adjust the amount that the brake pedal is depressed for the set position to return the transmission to Neutral.

1. Start the engine with starting switch (1), then set parking brake switch (2) to the ON position.
2. Set transmission cut-off switch (3) to the ON position.
3. Depress brake pedal (4) and adjust the set position to return the transmission to Neutral.

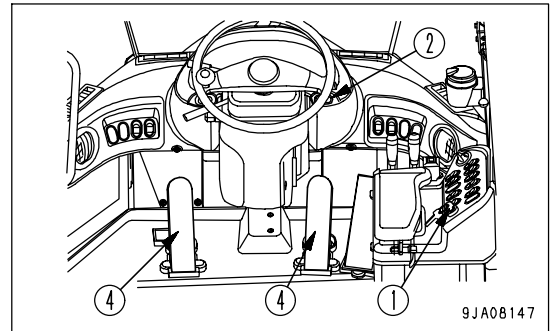

4. Press transmission cut-off set switch (5), then release it. When the switch is released, the buzzer will sound with a repeated short sound, and the cut-off position is set.

Method of canceling cut-off position

5. After the buzzer sounds in Step 4 of the adjustment procedure, the transmission cut-off switch flashes for 2 seconds. While it is flashing, press transmission cut-off set switch (5) again and release it.
6. The buzzer will sound with a long sound and the adjusted cut-off position is canceled.

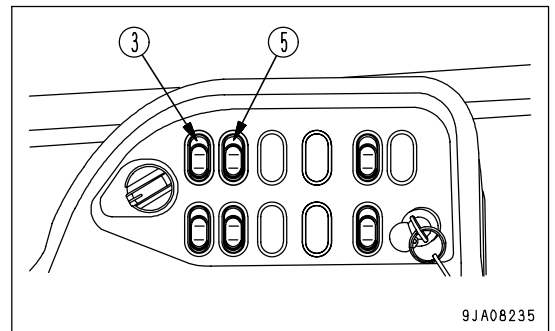

STOPPING WHEN TRANSMISSION CUT-OFF IS ON

When the transmission cut-off switch is ON, if the brake pedal is depressed, the transmission is returned to Neutral when the brake pedal is depressed to the set position.

REMARK

When the transmission cut-off switch is OFF, the transmission is not returned to Neutral.

TURNING



WARNING

- Operating the steering wheel suddenly at high speed or operating the steering wheel on steep slopes is dangerous. Do not operate the steering wheel in such situations.
- If the engine stops when the machine is traveling, the emergency steering is actuated. Note that this system is only for steering in emergencies, so never stop the engine.

It is particularly dangerous if the engine stops when the machine is traveling on slopes, so never let the engine stop when traveling on slopes.

If the engine stops, stop the machine immediately at a safe place.

When traveling, use steering wheel (1) to turn the machine.

With this machine, the front frame is joined to the rear frame at the center of the machine by the center pin. The front and rear frames bend at this point, and the rear wheels follow in the same track as the front wheels when turning.

Turn the steering wheel lightly to follow the machine as it turns.

NOTICE

When the steering wheel is turned fully, if it reaches the end of its stroke, do not try to turn it further.

Check that there is a play of 50 to 100 mm (2.0 to 3.9 in) in the steering wheel. Check also that the steering works properly. If any abnormality is found, please contact your Komatsu distributor for inspection.

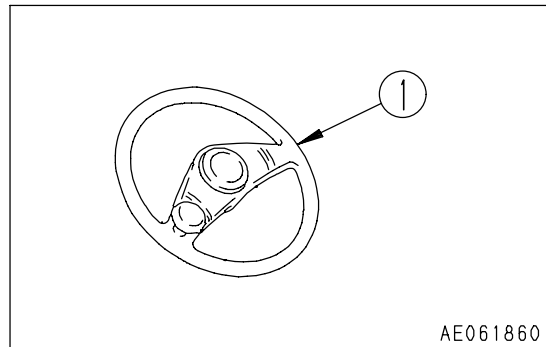

EMERGENCY STEERING

(If equipped)

CAUTION

- Never actuate the emergency steering except during emergencies or when checking the function.
- The emergency steering can be used continuously for a maximum of 60 seconds. Operating it continuously for more than 60 seconds may damage the system.
- When using the emergency steering, travel at less than 5 km/h (3.1 MPH).
- If the steering becomes heavy, keep the emergency steering switch pressed, move the machine immediately to a safe place, then stop the machine.

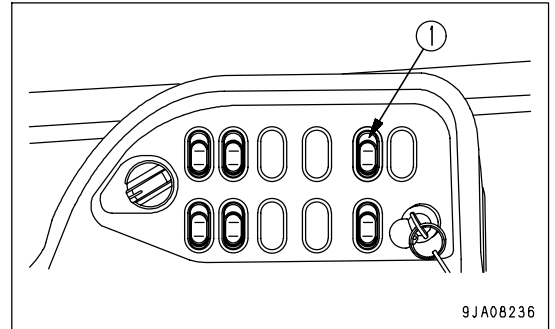

During emergencies or when stopping the engine to check the function, press emergency steering switch (1). Emergency steering pilot lamp (green) (2) will light up and the steering can be operated.

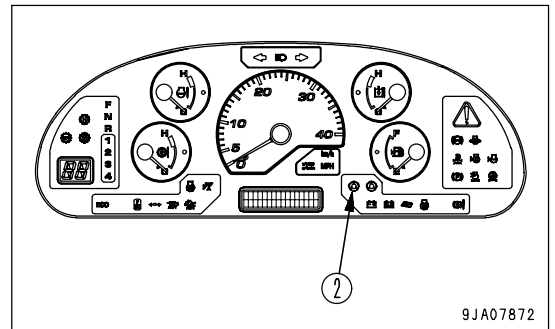

Emergency steering pilot lamp (green) (2) lights up to inform the operator that the emergency steering system has been actuated.

The emergency steering system is provided to enable the machine to be steered under the following conditions.

- The starting switch is at the ON position.
- The steering oil pressure is low or there is no pressure.

(When the engine has stopped or there is a failure in the steering oil pressure pump, etc.)

When the starting switch is turned to the ON position, the emergency steering automatically carries out a self check for 3 seconds. For details, see "EMERGENCY STEERING SELF-CHECK FUNCTION (PAGE 3-138)".

When the emergency steering controller detects lack of oil pressure in the steering system, steering oil pressure caution lamp (red) (3) and central warning lamp (4) light up, and the alarm buzzer sounds intermittently.

When this happens, if the machine is traveling at a speed of more than 2 km/h (1.2 MPH), the electric pump motor is automatically actuated and emergency steering pilot lamp (green) (2) lights up. Steering oil pressure caution lamp (red) (3) lights up to inform the operator that there is a failure in the steering system.

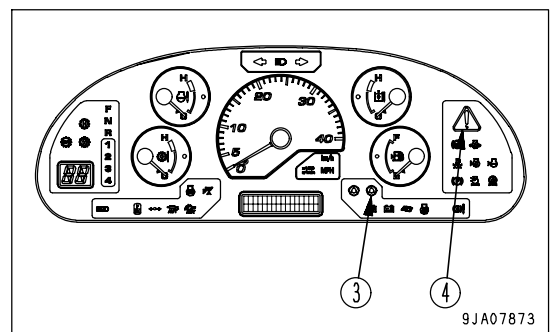

If steering oil pressure caution lamp (red) (3) lights up, move the machine immediately to a safe place and stop it. Locate the cause and do not operate the machine until it has been repaired.

REMARK

If any function of the oil pressure system is used when the engine is running at low speed, steering oil pressure caution lamp (red) (3) may light up for a moment, but if the lamp goes out again soon, there is no problem.

When the emergency steering controller detects that the oil pressure in the steering circuit has been restored, the actuation of the emergency steering system is stopped.

On machines equipped with an emergency steering function, the emergency steering switch is installed at the position shown in the diagram (1).

EMERGENCY STEERING SELF-CHECK FUNCTION

When the starting switch is turned ON, the emergency steering is automatically actuated for approx. 3 seconds to check that the emergency steering is functioning properly.

When this happens, steering oil pressure caution lamp (red) (1) and emergency steering pilot lamp (green) (2) light up.

If the steering oil pressure caution lamp (red) or emergency steering pilot lamp (green) do not light up, there is an abnormality, so please ask your Komatsu distributor to carry out inspection.

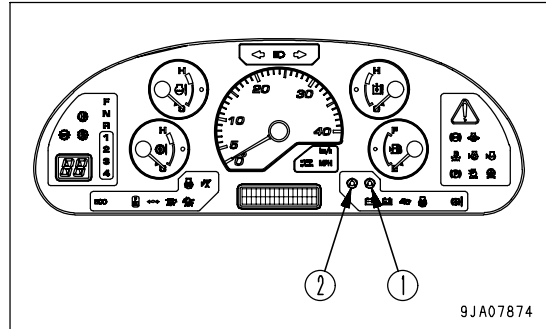

CAUTION

If the machine is steered during the steering self-check, it may move.
Do not steer the machine during the steering self-check.

The emergency steering function check is not carried out in the following cases.

- If the starting switch is turned ON, turned OFF again without starting the engine, and is then turned ON again.
- If the starting switch is turned ON again immediately after stopping the engine when the steering oil pressure has not gone down completely.
- If the engine is being preheated.

If the engine is being preheated.

When preheating is being carried out, the emergency steering self-check function is not actuated.

To check the emergency steering function, press the emergency steering switch after completing the warming-up operation.

OPERATION OF WORK EQUIPMENT

Lift arm control lever (1) and bucket control lever (2) can be used to operate the lift arm and bucket as follows.

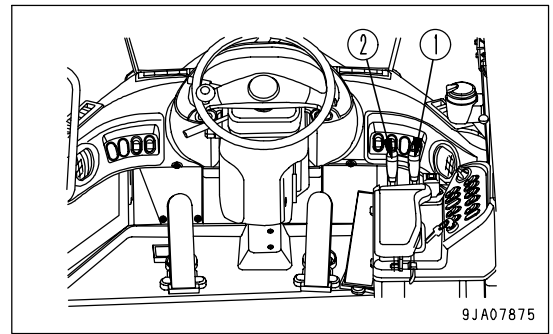

LIFT ARM CONTROL LEVER

NOTICE

Do not use the FLOAT position when lowering the bucket. Use the FLOAT position when leveling, see "LEVELING OPERATIONS (PAGE 3-145)".

Position (a): RAISE

When the lift arm control lever is pulled further from the RAISE position, the lever is stopped in this position until the lift arm reaches the preset position of the kickout, and the lever is returned to the HOLD position.

Position (b): HOLD

The lift arm is kept in the same position.

Position (c): LOWER

Position (d): FLOAT

The lift arm moves freely under external force.

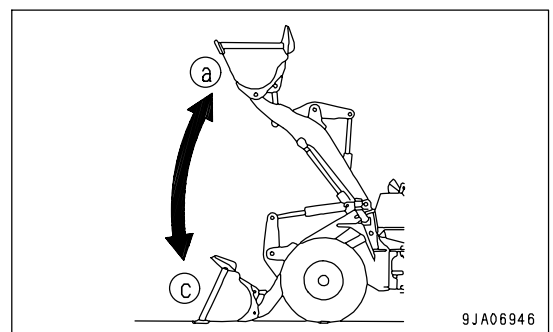
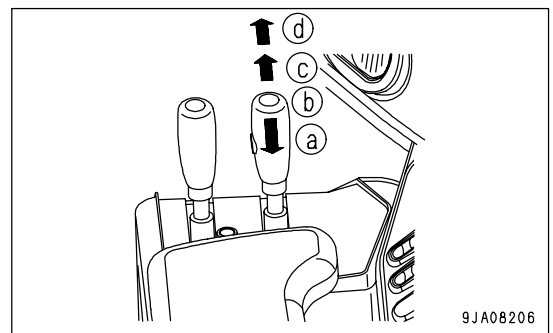

BUCKET CONTROL LEVER

Position (a): TILT

When the bucket control lever is pulled further from the TILT position, the lever is stopped in this position until the bucket reaches the preset position of the positioner, and the lever is returned to the HOLD position.

Position (b): HOLD

The bucket is kept in the same position.

Position (c): DUMP

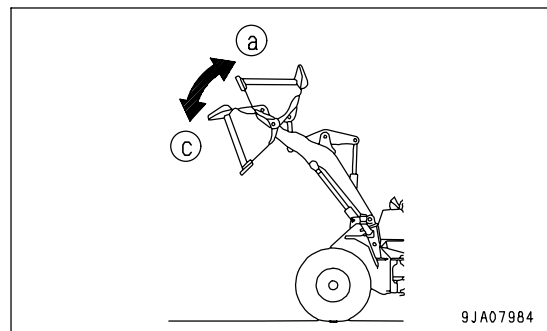
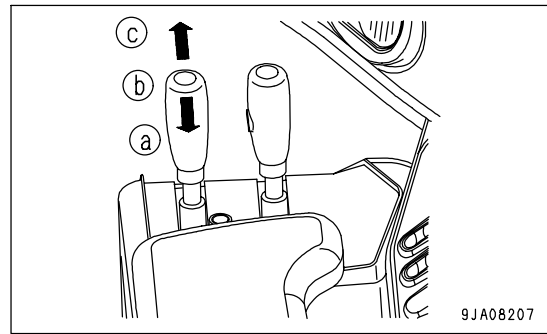

WORK POSSIBLE USING WHEEL LOADER

In addition to the following, it is possible to further increase the range of applications by using various attachments.

DIGGING OPERATIONS



WARNING

- Never carry out digging or scooping operations with the machine articulated. There is danger that the machine may tip over.
- When the machine is traveling or the work equipment is raised, the moment that the E.C.S.S. switch is turned ON, the work equipment will move.
- If operations are carried out with the E.C.S.S. switch left at the ON position, the moment that the travel damper is actuated, the work equipment will move.

NOTICE

If the tires slip, the tire life will be reduced, so do not allow the tires to slip during operation.

LOADING PILED SOIL OR BLASTED ROCK

- When loading piled soil or blasted rock, drive the machine forward as follows to load. To prevent cutting of the tires caused by the tires slipping, be careful of the following points during the operation.
 - Always keep the operating jobsite flat, and remove any fallen rocks.
 - When working with stockpiles, operate the machine in 1st or 2nd gear; when loading blasted rock operate the machine in 1st gear.

1. When driving the machine forward and lowering the bucket, stop the bucket at height (A) approx. 30 cm (12 in) from the ground, then lower it slowly.

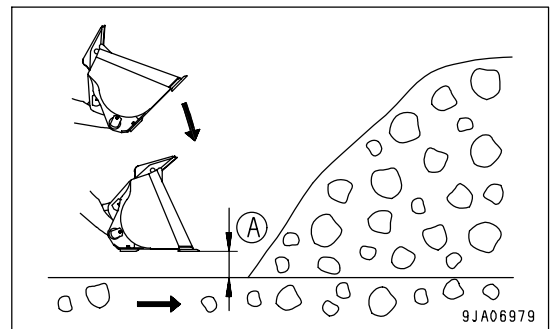

REMARK

If the bucket hits the ground, the front tires will come off the ground, and the tires will slip.

2. Shift down immediately in front of the material to be loaded. When completing the shift down, depress the accelerator pedal at the same time and thrust the bucket into the material.

REMARK

To reduce fuel consumption, depress the accelerator pedal the minimum possible amount. If it is depressed fully, the fuel consumption will increase, but there will be no increase in the amount loaded.

3. When the material is in a stockpile, keep the cutting edge of the bucket horizontal; when loading blasted rock, have the bucket tilting slightly down.

Be careful not to get blasted rock under the bucket. This will make the front tires come off the ground and slip. Try to keep the load in the center of the bucket; if the load is on one side of the bucket, the load will be unbalanced.

- Stock pile

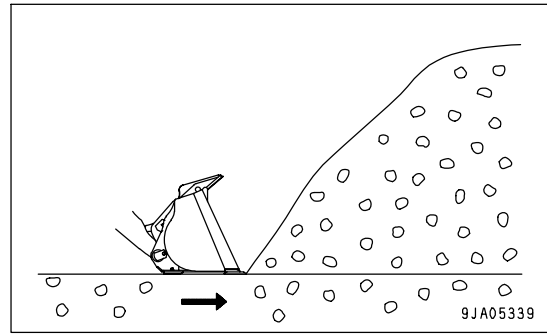

- Blasted rock

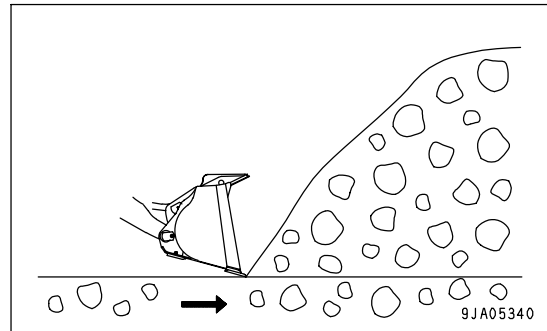

4. At the same time as thrusting the bucket into the material, raise the lift arm to prevent the bucket from going in too far. By raising the lift arm, ample traction will be produced by the front tires.

REMARK

If the bucket is thrust too much and the lift arm stops rising or the machine stops moving forward, release the accelerator pedal a little. Proper operation of the accelerator pedal for each type of the soil is effective for saving of fuel and prevention of wear of the tires.

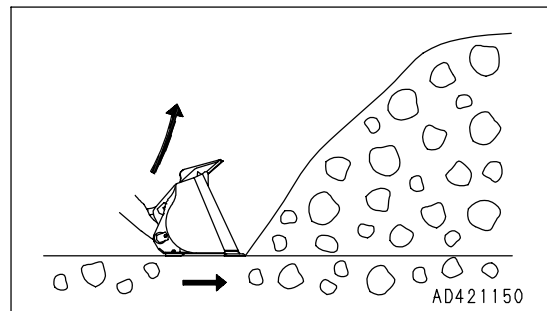

5. Check that there is enough material loaded into the bucket, then operate the bucket control lever to tilt the bucket and load the bucket fully.

REMARK

If the bucket edge is moved up and down while pushing in the bucket and digging, the front tires will come off the ground and this will cause the tires to slip.

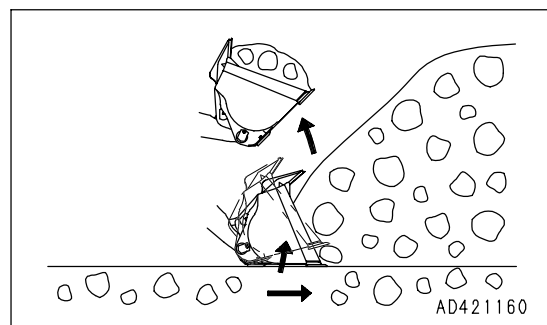

6. If there is too much material loaded in the bucket, dump and tilt the bucket quickly to remove the excessive load. This prevents spillage of the load during hauling.

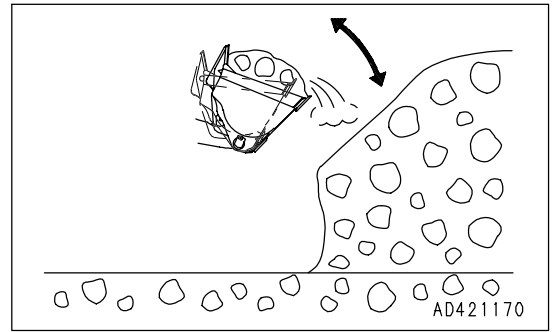

DIGGING AND LOADING ON LEVEL GROUND

- When digging and loading on level ground, set the bucket edge facing down slightly as follows and drive the machine forward. Always be careful not to load the bucket on one side and cause an unbalanced load. This operation should be carried out in 1st gear.

**CAUTION**

Do not set the bucket facing down more than 20 degrees.

1. Set the edge of the bucket facing slightly down.

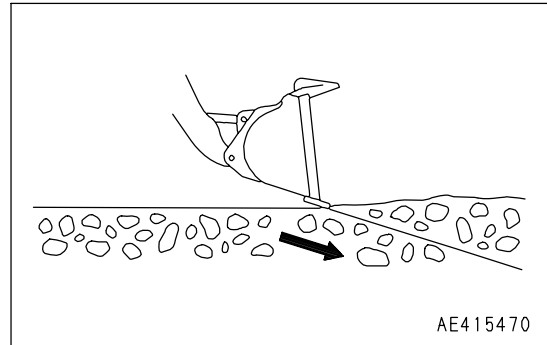

2. Drive the machine forward and operate the lift arm control lever forward to cut a thin layer of the surface each time when excavating the soil.

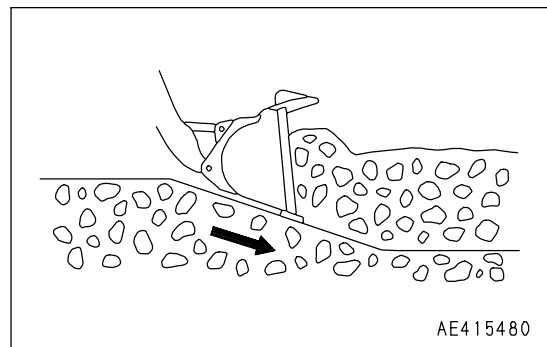

3. Operate the lift arm control lever slightly up and down to reduce the resistance when driving the machine forward.

When digging with the bucket, avoid imposing the digging force on one side of the bucket.

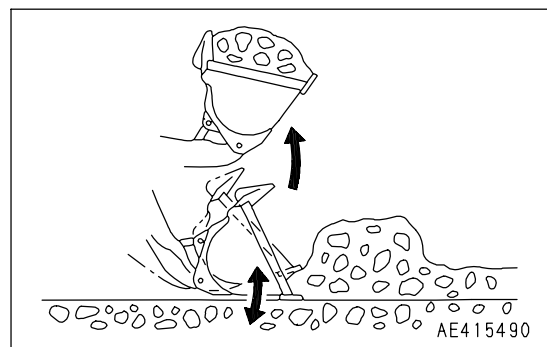

LEVELING OPERATIONS

NOTICE

- Always operate the machine in reverse when carrying out leveling operations.

If it is necessary to carry out leveling operations when traveling forward, do not set the bucket-dump angle to more than 20 degrees.

- Turn the E.C.S.S. switch (if equipped) OFF when carrying out leveling operations.

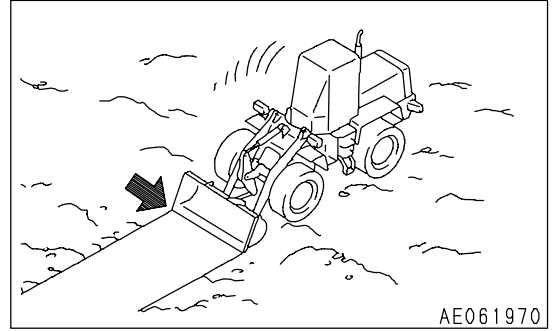

1. Scoop soil into the bucket. Move the machine backward while spreading soil from the bucket little by little.
2. Go over the spread soil with the bucket teeth touching the ground and level the ground by back-dragging.
3. Scoop some more soil into the bucket, put the lift arm control lever in FLOAT position, level the bucket at ground level, and smooth the ground by moving backward.

PUSHING OPERATION



CAUTION

Never set the bucket to the DUMP position when carrying out pushing operation.

When carrying out pushing operations, set the bottom of the bucket parallel to the ground surface.

LOAD AND CARRY OPERATIONS



WARNING

- When carrying a load, lower the bucket to lower the center of gravity when traveling.
- When the machine is traveling or the work equipment is raised, the moment that the E.C.S.S. switch is turned ON, the work equipment will move.
- If operations are carried out with the E.C.S.S. switch left at the ON position, the moment that the travel damper is actuated, the work equipment will move.

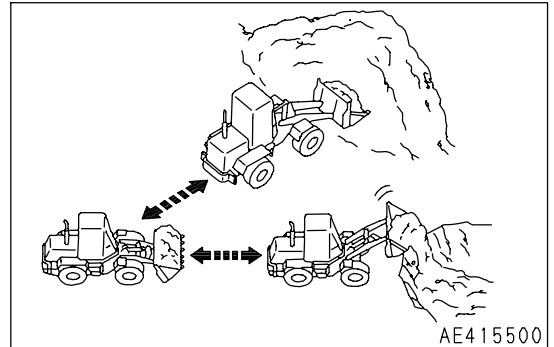

The load and carry method for wheel loaders consists of a cycle of scooping -> hauling -> loading (into a hopper, truck, etc.).

Always keep the travel path properly maintained.

When using the load and carry method, see "PRECAUTIONS FOR USING LOAD AND CARRY METHOD (PAGE 3-157)".

LOADING OPERATIONS

Select the method of operation which will give the minimum amount of turning and travel in order to provide the most efficient method for the jobsite.



WARNING

- Always keep the jobsite flat, and do not operate the steering wheel suddenly or apply the brakes suddenly when the lift arm is raised with a loaded bucket. This is dangerous.
- Never thrust the bucket in when traveling at high speed (when loading soil or crushed rock). This is dangerous.
- When the machine is traveling or the work equipment is raised, the moment that the E.C.S.S. switch is turned ON, the work equipment will move.
- If operations are carried out with the E.C.S.S. switch left at the ON position, the moment that the travel damper is actuated, the work equipment will move.

NOTICE

- If the tires slip, the tire life will be reduced, so do not allow the tires to slip during operation.
- Avoid excessive bucket shaking.

CROSS DRIVE LOADING

Always set the wheel loader facing at a right angle to the stockpile. After digging in and scooping up the load, drive the machine straight back in reverse, then bring the dump truck in between the stock pile and the wheel loader.

This method requires the least time for loading, and is extremely effective in reducing the cycle time.

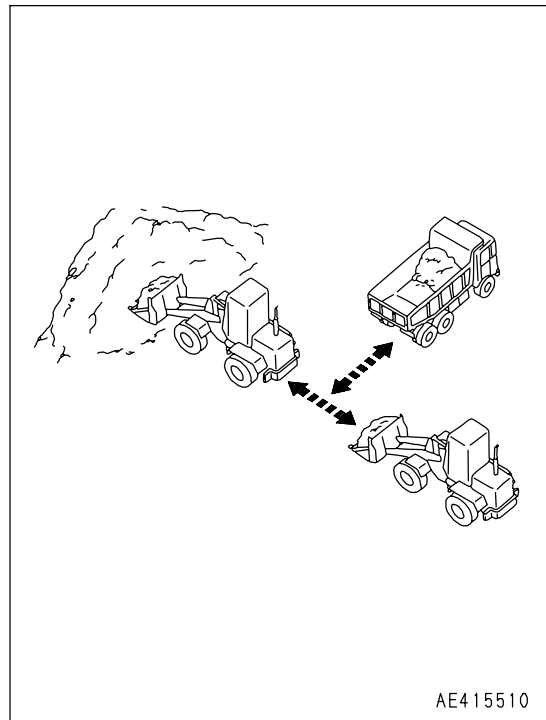

V-SHAPE LOADING

Position the dump truck so that the direction of approach of the wheel loader is approx. 60 degrees from the direction of approach to the stockpile. After loading the bucket, drive the wheel loader in reverse, then turn it to face the dump truck and travel forward to load the dump truck.

The smaller the turning angle of the wheel loader is, the more efficient the operation becomes.

When loading a full bucket and raising it to the maximum height, first shake the bucket to stabilize the load before raising the bucket. This will prevent the load from spilling to the rear.

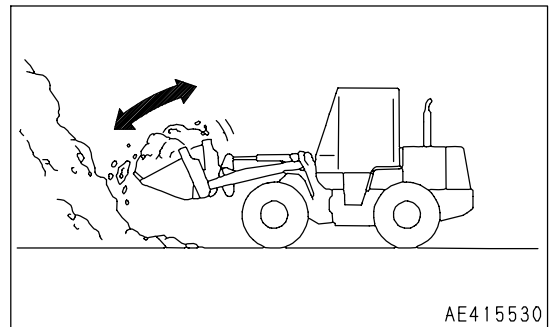
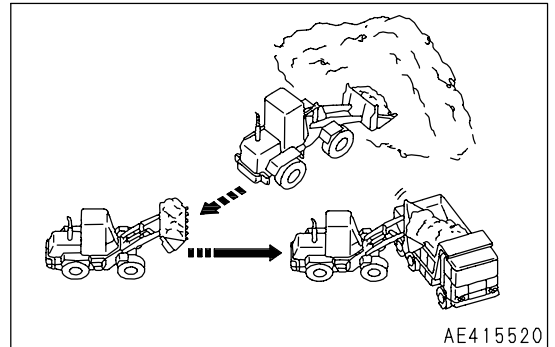
**PRECAUTIONS WHEN PILING UP LOADS**

When forming products into a pile, be careful not to let the rear counterweight come into contact with the ground. Do not set the bucket to the DUMP position when piling-up loads.

REMARK

- When using the transmission cut-off function, lower the cut-off position so that cut-off function is actuated, when the brake pedal is deeply depressed, while ensuring ample braking force.

PRECAUTIONS FOR OPERATION

PERMISSIBLE WATER DEPTH

When working in water or on swampy ground, do not let the water come above the bottom of the axle housing (1).

After finishing the operation, wash and check the lubricating points.

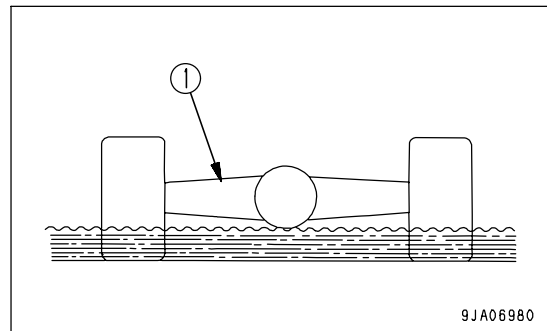

IF WHEEL BRAKE DOES NOT WORK

If the machine is not stopped by depressing the brake pedal, use the parking brake to stop the machine.

NOTICE

If the parking brake has been used as an emergency brake, contact your Komatsu distributor to have the parking brake checked for any abnormality.

PRECAUTIONS WHEN DRIVING UP OR DOWN SLOPES

LOWER THE CENTER OF GRAVITY WHEN TURNING

When turning on slopes, lower the work equipment to lower the center of gravity before turning. It is dangerous to turn the machine suddenly on slopes.

BRAKING ON DOWNHILL SLOPE

If the footbrake is used frequently when traveling downhill, the brake will overheat and may be damaged. Place the gearshift lever at a low speed range and use the braking force of the engine when traveling downhill.

Use the right brake pedal for braking.

If the brakes are used excessively, the brake oil temperature caution lamp may light up and the alarm buzzer may sound intermittently. For details of the necessary action to take, see "BRAKE OIL TEMPERATURE CAUTION LAMP (PAGE 3-18)" in EXPLANATION OF COMPONENTS.

If the speed range selected by the gearshift lever is not correct, the torque converter oil may overheat. If this happens, shift down one gear range and reduce the oil temperature.

If the oil temperature does not return to the white range even when the gearshift lever is at 1st, stop the machine, return the directional lever to the N position, and run the engine at a mid-range speed until the gauge returns to the white range.

IF ENGINE STOPS

If the engine stops on a slope, apply the parking brake immediately, and lower the work equipment to the ground and stop the machine. Then put the directional lever in neutral position, and start the engine again.

PRECAUTIONS WHEN DRIVING MACHINE

When the machine travels at high speed for a long distance, the tires become extremely hot. This causes early wear of the tires and should be avoided as much as possible. If the machine must be driven for a long distance, take the following precautions.

- Follow the regulations related to this machine, and drive carefully.
- Before driving the machine, carry out the checks before starting.
- The most suitable tire pressure, travel speed, or tire type differ according to the condition of the travel surface. Contact your Komatsu distributor or tire dealer for information.
- The following is a guide to suitable tire pressures and speeds when traveling on a paved surface with standard tires. (23.5-25-16PR(L3))

Tire pressure

Front wheel: 350 kPa (3.5 kg/cm², 49.8 PSI)

Rear wheel: 310 kPa (3.1 kg/cm², 44.0 PSI)

Speed: 14 km/h (8.7 MPH)

- Check the tire pressure before starting, when the tire is cool.
- After traveling for one hour, stop the machine for 30 minutes and check the tires and all parts for any abnormality. Check the oil level and coolant level also.

When stopping the machine in extremely cold areas, do as follows.

To prevent the radiator water temperature from rising suddenly, do not suddenly stop the engine. Gradually cool the radiator water down before stopping the engine.

- Always travel with the bucket empty.
- Never put "calcium chloride" or "dry ballast" in the tires when traveling.

PRECAUTIONS REGARDING BRAKE FUNCTION

When traveling long distances continuously downhill, the frequency of using the brake may increase. As a result, depending on the weight of the machine and the grade of the slope, the machine's braking capacity may be exceeded and the brakes may overheat.

The table below shows a guideline of the values for this machine.

Machine weight (t)	Slope grade (%)	Braking capacity limit	
		Average travel speed limit (km/h (MPH))	Downhill distance limit (continuous)(km)
18.1 to 20.1 (unloaded)	10	40 (24.9)	2.6
	20	17 (10.6)	0.9
23.7 to 25.7 (loaded)	10	37 (23.0)	2.1
	20	12 (7.5)	0.7

If the braking capacity limit is exceeded, a forced cooling system for the brakes is needed, so please consult your Komatsu distributor.

ADJUSTING WORK EQUIPMENT POSTURE

WARNING

- Stop the machine on flat ground and put blocks in front of and behind the tires.
- Set the parking brake switch to the ON position (A) to apply the parking brake.
- Set the frame lock bar to LOCK position (L) to lock the front and rear frames.
- Always attach a warning sign to the work equipment control levers.
- Do not go under the work equipment when the arm is raised.

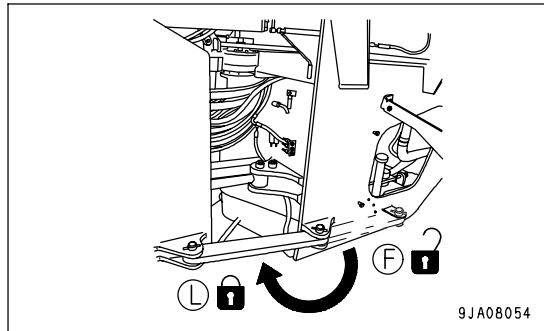
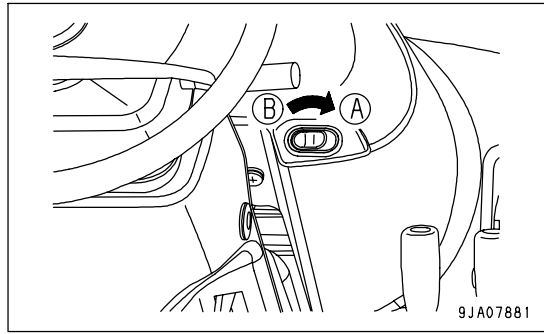

The boom kickout makes it possible to set the bucket so that it automatically stops at the desired lifting height (lift arm higher than horizontal) and the bucket positioner makes it possible to set the bucket so that it automatically stops at the desired digging angle. The setting can be adjusted to match the working conditions.

ADJUSTING BOOM KICKOUT

1. Raise the bucket to the desired position, return the lift arm control lever to the HOLD position, set the work equipment lock lever to the LOCK position, then stop the engine.
2. Loosen two bolts (1), and adjust plate (2) so that the bottom edge is in line with the center of the sensing surface of proximity switch (3). Then tighten the bolts to hold the plate in position.
3. Loosen two nuts (4) to make a clearance of 3 to 5 mm (0.118 to 0.197 in) between plate (2) and the sensing surface of proximity switch (3). Then tighten the nuts to hold in position. Tightening torque: 17.2 ± 2.5 Nm (1.75 ± 0.25 kgm, 12.7 ± 1.8 lbft)

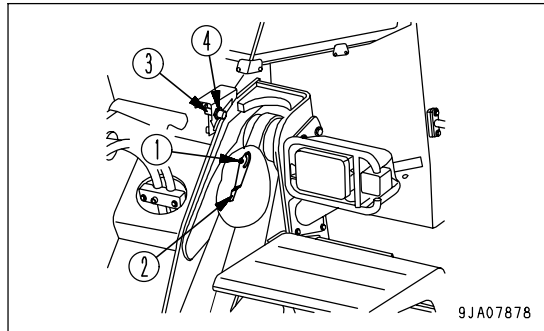

4. After adjusting, start the engine and operate the lift arm control lever. Check that the lever is automatically returned to HOLD when the bucket reaches the desired height.

ADJUSTING BUCKET POSITIONER

1. Lower the bucket to the ground, set it to the desired digging angle, return the bucket control lever to the HOLD position, set the work equipment lock lever to the LOCK position, then stop the engine.
2. Loosen 2 bolts (1), adjust the position of mounting bracket (4) of the proximity switch so that the rear tip of bar (2) is in line with the center of the sensing surface of proximity switch (3), then tighten bolts to hold the bracket in position.
3. Loosen 2 bolts (5), adjust so that the clearance between bar (2) and support (6) is 0.5 to 2 mm (0.020 to 0.079 in), then tighten bolts (5) to hold in position.
4. Loosen 2 nuts (7), adjust so that the clearance between bar (2) and the sensing surface of proximity switch (3) is 3 to 5 mm (0.118 to 0.197 in), then tighten the nuts to hold in position.
Tightening torque: 17.2 ± 2.5 Nm (1.75 ± 0.25 kgm, 12.7 ± 1.8 lbft)
5. After adjusting, start the engine and raise the lift arm. Operate the bucket control lever to the DUMP position, then operate it to the TILT BACK position and check that the lever is automatically returned to the HOLD position when the bucket reaches the desired digging angle.

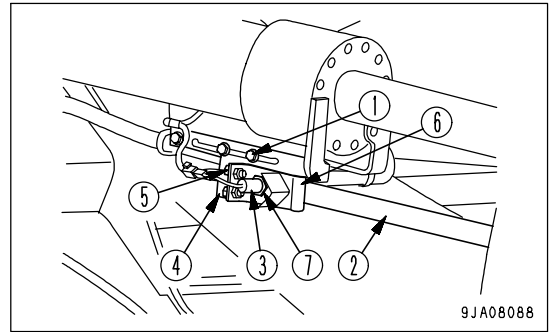

BUCKET LEVEL INDICATOR

(A) and (B) at the top rear of the bucket are the level indicators. They check the bucket angle during operations.

(A): Parallel with cutting edge

(B): 90 degrees to cutting edge

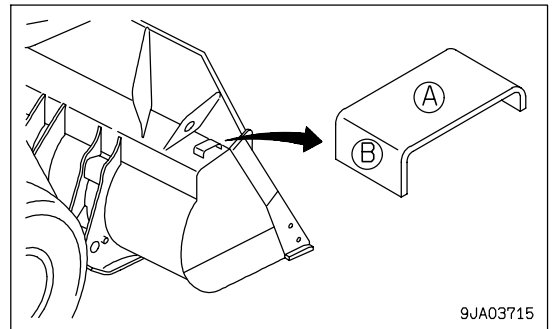

PARKING MACHINE

WARNING

- Avoid stopping suddenly. Give yourself ample room when stopping.
- Do not park the machine on slopes.
If the machine has to be parked on a slope, set it facing directly down the slope, then dig the bucket into the ground and put blocks under the tires to prevent the machine from moving.
- If the control lever is touched by accident, the work equipment or the machine may move suddenly, and this may lead to a serious accident. Before leaving the operator's compartment, always set the work equipment lock lever securely to the LOCK position.
- Even if the parking brake switch is turned ON, there is danger until the parking brake pilot lamp lights up, so keep the brake pedal depressed.

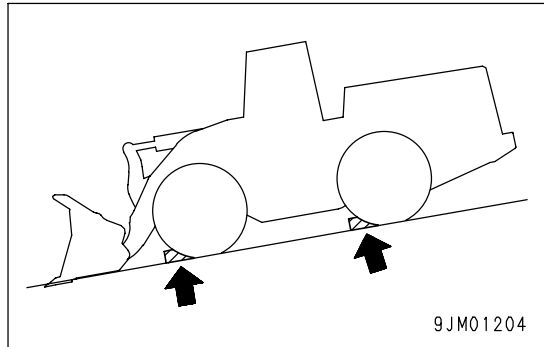

NOTICE

Never use the parking brake switch to brake the machine when traveling except in an emergency. Apply the parking brake only after the machine has stopped.

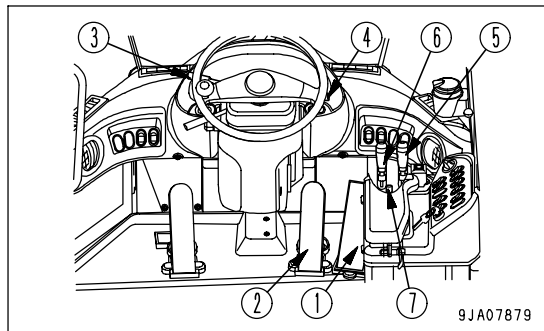

1. Release accelerator pedal (1), then depress brake pedal (2) to stop the machine.

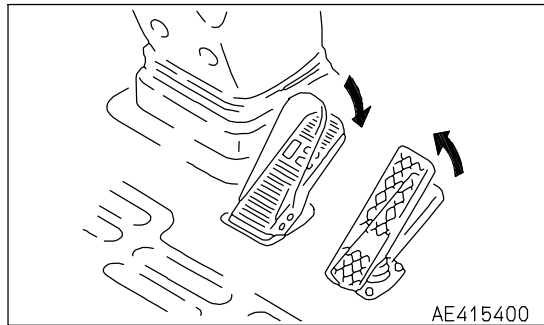

2. Place directional lever (3) in Neutral position (N).

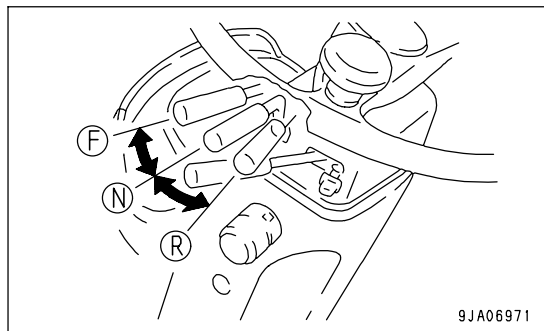

- Set parking brake switch (4) to the ON position (A) to apply the parking brake.

NOTICE

When the parking brake is applied, the transmission is automatically returned to neutral.

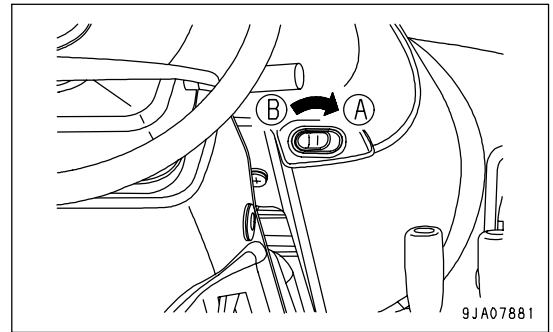

- Operate lift arm control lever (5) to lower the bucket to the ground.

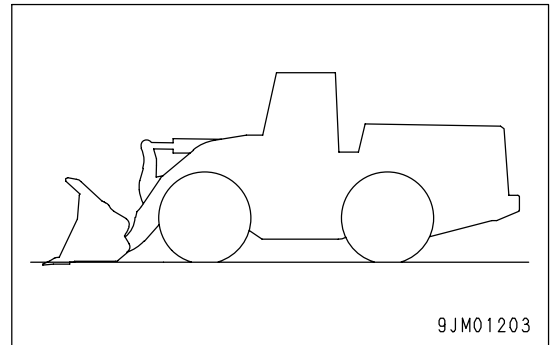

- Check that the lift arm control lever (5) and bucket control lever (6) is at the HOLD position, then set the work equipment lock lever (7) to the LOCK position (L).

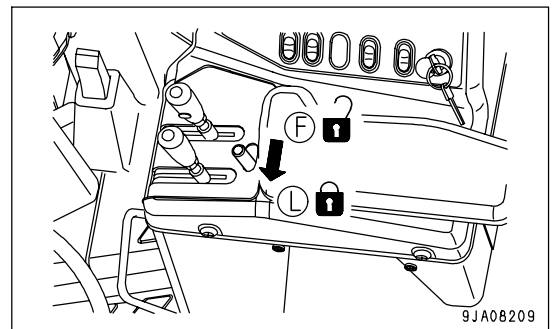

CHECKS AFTER COMPLETION OF OPERATION

BEFORE STOPPING ENGINE

Check the engine water temperature, engine oil pressure, torque converter oil temperature, and fuel level with the machine monitor.

If the engine has overheated, do not stop it suddenly. Run the engine at a midrange speed to allow the engine to cool down before stopping it.

AFTER STOPPING ENGINE

1. Walk around the machine and check the work equipment, bodywork, and undercarriage, and check also for oil and water leakage.
2. Fill the fuel tank.
3. Check the engine compartment for paper and debris. Clean out any paper and debris to avoid a fire hazard.
4. Remove any mud affixed to the undercarriage.

LOCKING

Always lock the following parts.

- (1) Fuel tank filler cap
- (2) Engine side panel (2 points)
- (3) Cab door
- (4) Hydraulic tank
- (5) Rear grille
- (6) Air conditioner fresh air filter
- (7) Transmission filter cover

REMARK

The starting switch key is used also for locks (1) to (7).

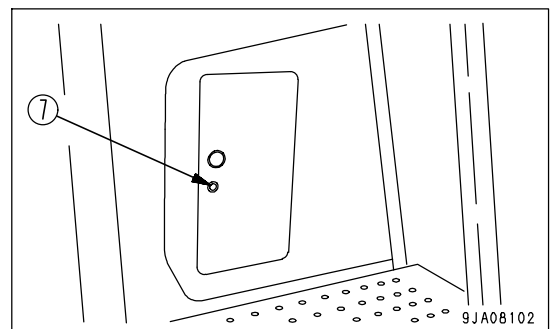
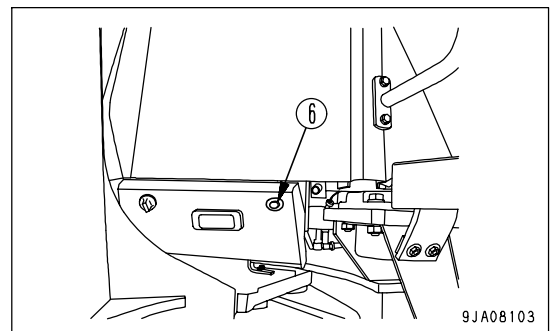
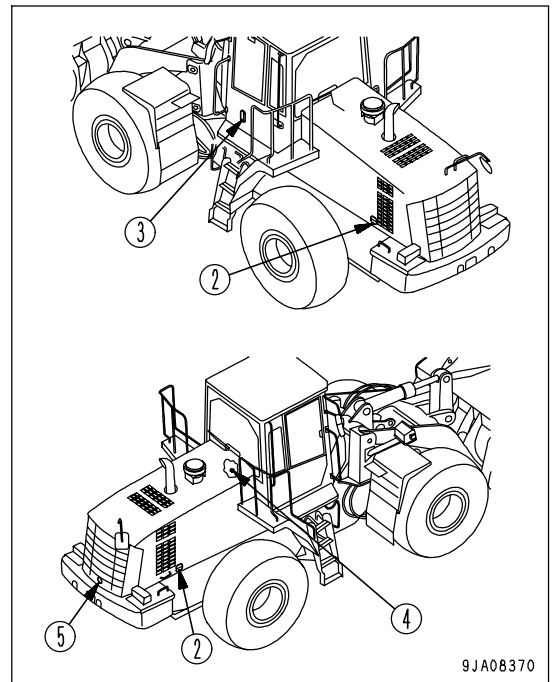
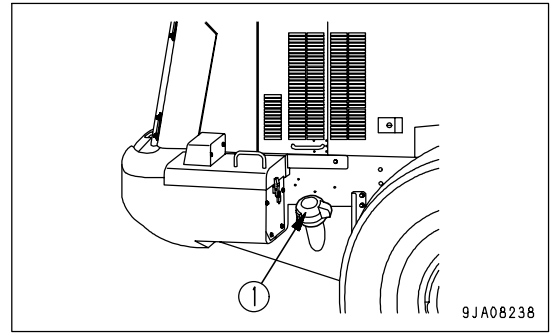

HANDLING THE TIRES

PRECAUTIONS WHEN HANDLING TIRES



If a tire has reached any of the following service limits, there is danger that the tire may burst or cause an accident, so to ensure safety, replace it with a new tire.

- **Service limits for wear**
 - When the remaining depth of the grooves on construction equipment tires (at a point approx. 1/4 of the tread width) is 15% of the groove depth on a new tire.
 - When the tire shows marked uneven wear, stepped wear or other abnormal wear, or when the cord layer is exposed.
- **Service limits for damage**
 - When there is external damage extending to the cord or when the cord is broken
 - When the cord is cut or there is dragging
 - When the tire is peeling (there is separation)
 - When the bead is damaged
 - For tubeless tires, when there is air leakage or improper repair
- Do not install a tire protector (mesh chain) to the rear tires.

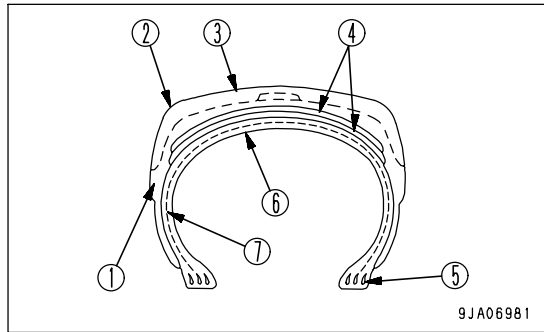

- (1) Side wall
- (2) Shoulder
- (3) Tread
- (4) Breaker or belt (cord layer)
- (5) Bead
- (6) Inner liner
- (7) Carcass

Please contact your Komatsu distributor when replacing the tires. It is dangerous to jack up the machine without taking due care.

TIRE PRESSURE

Measure the tire pressure before starting operations, when the tires are cool. If the tire inflation pressure is too low, there will be overload; if it is too high, it will cause tire cuts and shock burst. To prevent these problems, adjust the tire inflation pressure according to the table on the next page.
 Deflection ratio = $(H - h) / H \times 100$

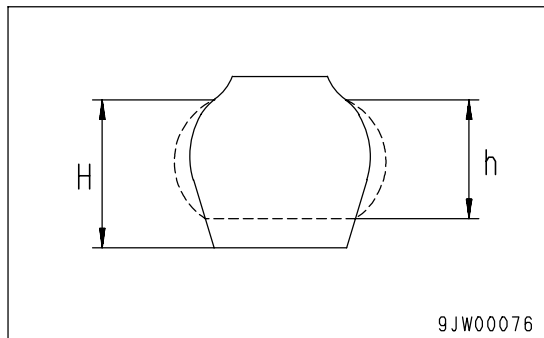

As a guideline that can be checked visibly, the deflection ratio of the front tire (deflection/free height) is as follows.
 When carrying normal load (lift arm horizontal): Approx. 15 to 25 %
 When digging (rear wheels off ground): Approx. 25 to 35 %

When checking the tire inflation pressure, check also for small scratches or peeling of the tire, for nails or pieces of metal which may cause punctures, and for any abnormal wear.

Clearing fallen stones and rocks from the operating area and maintaining the surface will extend the tire life and give improved economy.

- For operations on normal road surfaces, rock digging operations: High end of range in air pressure chart
- Stockpile operations on soft ground: Average pressure in air pressure chart
- Operations on sand (operations not using much digging force): Low end of range in air pressure chart

If the deflection of the tire is excessive, raise the inflation pressure within the limits given in the table to give a suitable deflection (see deflection ratio).

Tire size (Pattern)	H Free height (mm)	Inflation pressure [kPa(kgf/cm ² , PSI)]			When shipped from factory
		Soft ground (sandy ground)	Normal road		
			Stockpile	Stockpile	
23.5-25-16PR (L3: Rock) (Standard)	424(BS) 423(TOYO)	240 - 360 (2.4 - 3.6, 34.1 - 51.1)	240 - 360 (2.4 - 3.6, 34.1 - 51.1)	240 - 360 (2.4 - 3.6, 34.1 - 51.1)	Front tire: 350 (3.5, 49.8) Rear tire: 310 (3.1, 44.0)
23.5-25-20PR (L3: Rock) (if equipped)					
23.5-25-16PR (L2: Traction) (if equipped)	434(BS) 422(TOYO)				
23.5-25-20PR (L2: Traction) (if equipped)					

Stockpile operations mean the loading of sand and other loose materials.

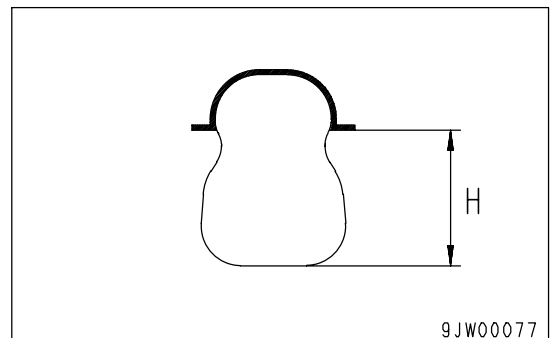

PRECAUTIONS FOR USING LOAD AND CARRY METHOD

When traveling continuously with load and carry operations, choose the correct tires to match the operating conditions, or choose the operating conditions to match the tires. If this is not done, the tires will be damaged, so contact your Komatsu distributor or tire dealer when selecting tires.

TRANSPORTATION

When transporting the machine, observe all related laws and regulations, and be careful to assure safety.

TRANSPORTATION PROCEDURE

When transporting the machine, choose the optimum transportation method in reference to the weight and dimensions shown in "SPECIFICATIONS (PAGE 5-2)". Note that machine specifications (weight and dimensions) vary depending on the kind of tire and bucket.

LOADING, UNLOADING WORK WITH TRAILERS

WARNING

- When loading or unloading the machine, run the engine at low speed, travel at low speed, and operate slowly.
- When loading or unloading the machine, stop the trailer on firm level ground.
In addition, keep well away from the road shoulder.
- Use ramps of ample width, length, thickness, and strength, and install them securely at an angle of less than 15°.
When using an embankment, compact the fill soil thoroughly and make sure that the slope face does not collapse.
- Remove the mud stuck to the undercarriage to prevent the machine from slipping to the side on the ramps.
In addition, remove any water, snow, ice, grease, or oil from the ramps.
- Never change direction on the ramps. There is danger that the machine may tip over.
If it is necessary to change direction, return to the ground surface or the trailer platform, correct the direction, and start again.
- The position of the center of gravity of the machine will change suddenly at the connection of the ramp and trailer, and there is danger of the machine losing its balance. Always drive slowly over this point.

When loading or unloading, always use ramps or a platform. Proceed as follows.

LOADING

1. Load and unload on firm level ground only.
Maintain a safe distance from the edge of a road.
2. Apply the brakes on the trailer securely and insert blocks (1) under the tires to hold the trailer in position.
Set the distance (3) between ramps (2) to match the distance between the left and right tires, and make angle (4) of the ramps a maximum of 15°.
If ramps (2) sag appreciably under the weight of the machine, put wooden block (5) under the ramps to support them.
3. Determine the direction of the ramp, then slowly load the machine.
4. Load the machine correctly in the specified position on the trailer.

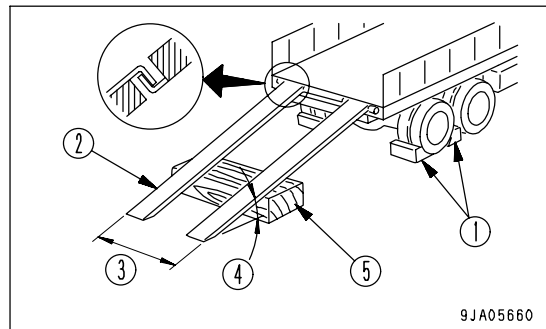

SECURING MACHINE

Load the machine onto a trailer as follows:

1. Lower the work equipment slowly.
2. Check that the work equipment control lever is at the HOLD position, then set the work equipment lock lever to the LOCK position (L).

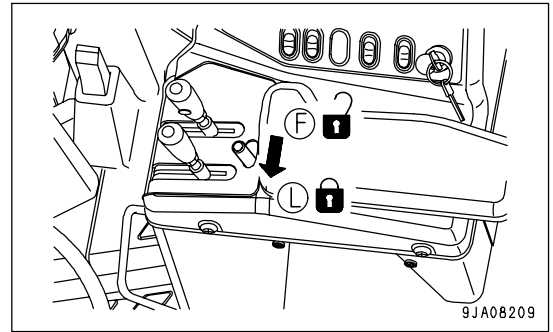

3. Set the parking brake switch to ON position (A) to apply the parking brake securely.
4. Turn the starting switch to the OFF position and stop the engine.
Remove the key from the starting switch.

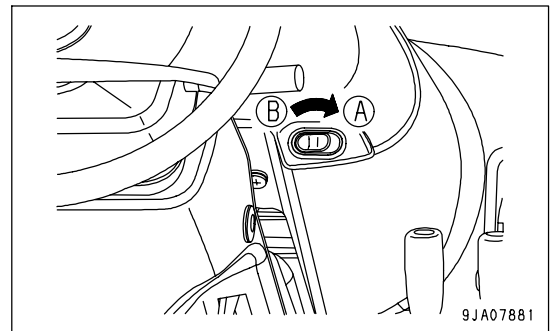

5. Set the frame lock bar to the LOCK position (L) to lock the front frame and rear frame.

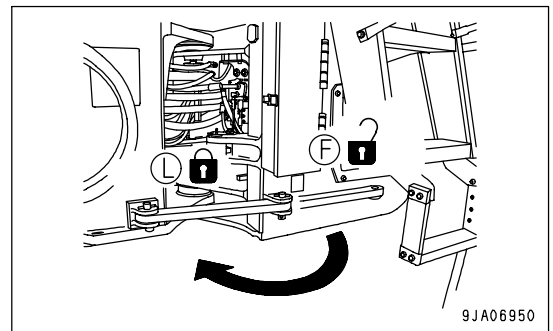

6. Put blocks in front and behind the wheels, and secure the machine with chains or wire rope to prevent the machine from moving during transportation.

In particular, attach the machine securely to prevent it from slipping sideways.

Fastening positions

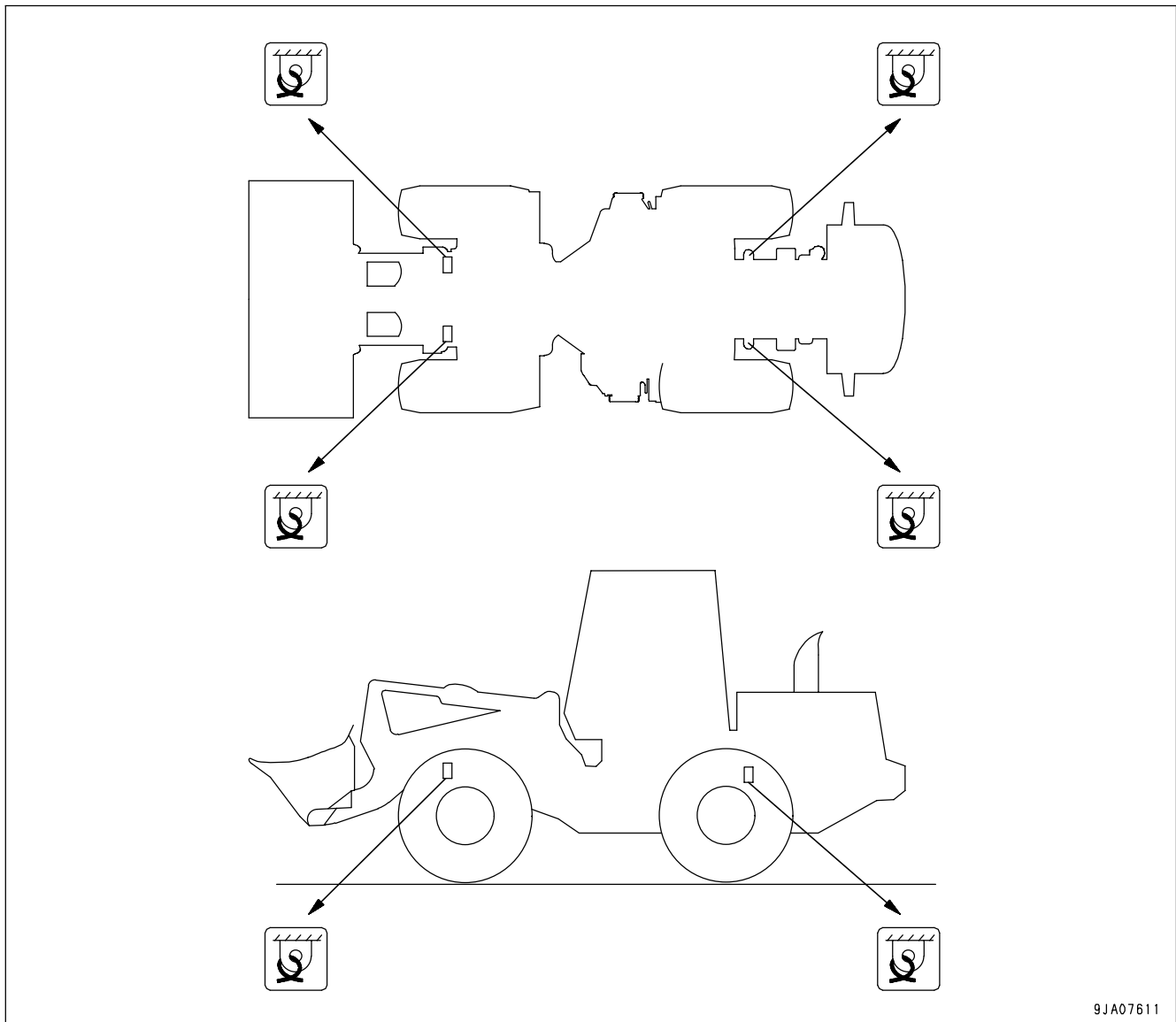

9JA07611

7. Stow the antenna away.

UNLOADING

1. Load and unload on firm level ground only. Maintain a safe distance from the edge of a road.

2. Apply the brakes on the trailer securely and insert blocks (1) under the tires to hold the trailer in position.

Set the distance (3) between ramps (2) to match the distance between the left and right tires, and make angle (4) of the ramps a maximum of 15°.

If ramps (2) sag appreciably under the weight of the machine, put wooden block (5) under the ramps to support them.

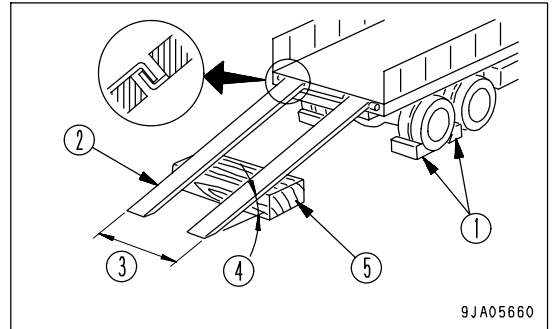

3. Remove the chains and wire ropes fastening the machine.

4. Set the frame lock bar to FREE position (F).

5. Start the engine.

Warm the engine up fully.

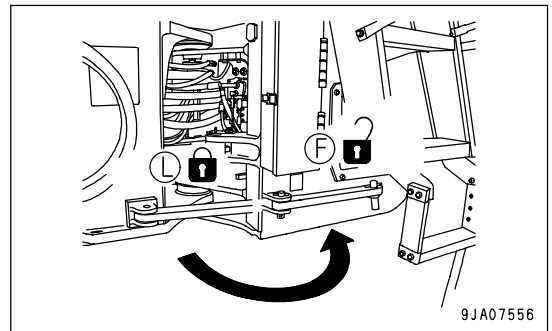

6. Check that the work equipment control lever is at the HOLD position, then set the work equipment lock lever to the FREE position (F).

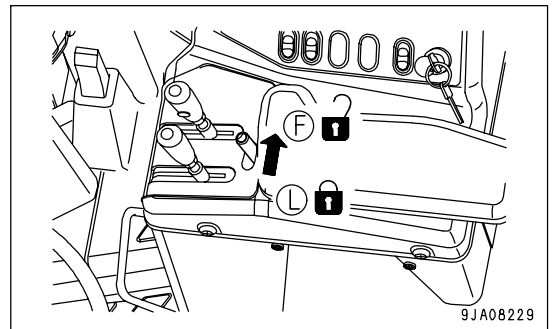

7. Set the parking brake switch to OFF position (B) to cancel the parking brake.

8. Determine the direction of the ramps, then drive the machine slowly down the ramps to unload the machine.

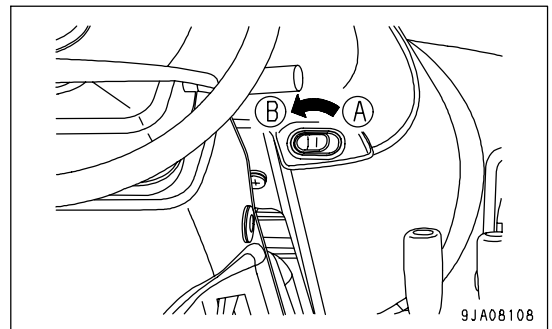

LIFTING MACHINE

WARNING

- The person using the crane to carry out lifting operations must be a qualified crane operator.
- Never carry out lifting operations if any person is on the machine being lifted.
- Always use a wire rope that has ample strength for the weight of the machine being lifted.
- Keep the machine horizontal when lifting it.
- When carrying out lifting operations, do as follows to prevent the machine from moving unexpectedly.
 - Set the parking brake switch to the ON position.
 - Set the work equipment lock lever to the LOCK position.
 - Set the frame lock bar to the LOCK position.
- Never enter the area under or around a raised machine.
- There is danger of the machine losing its balance.
 - Use the procedure below to set the machine in the proper posture and use the lifting equipment when lifting the machine.

NOTICE

This method of lifting applies to the standard specification machine.

The method of lifting differs according to the attachments and options installed.

For details of the procedure for machines that are not the standard specification, please consult your Komatsu distributor.

For weight, see "SPECIFICATIONS (PAGE 5-2)".

LIFTING PROCEDURE

Lifting position

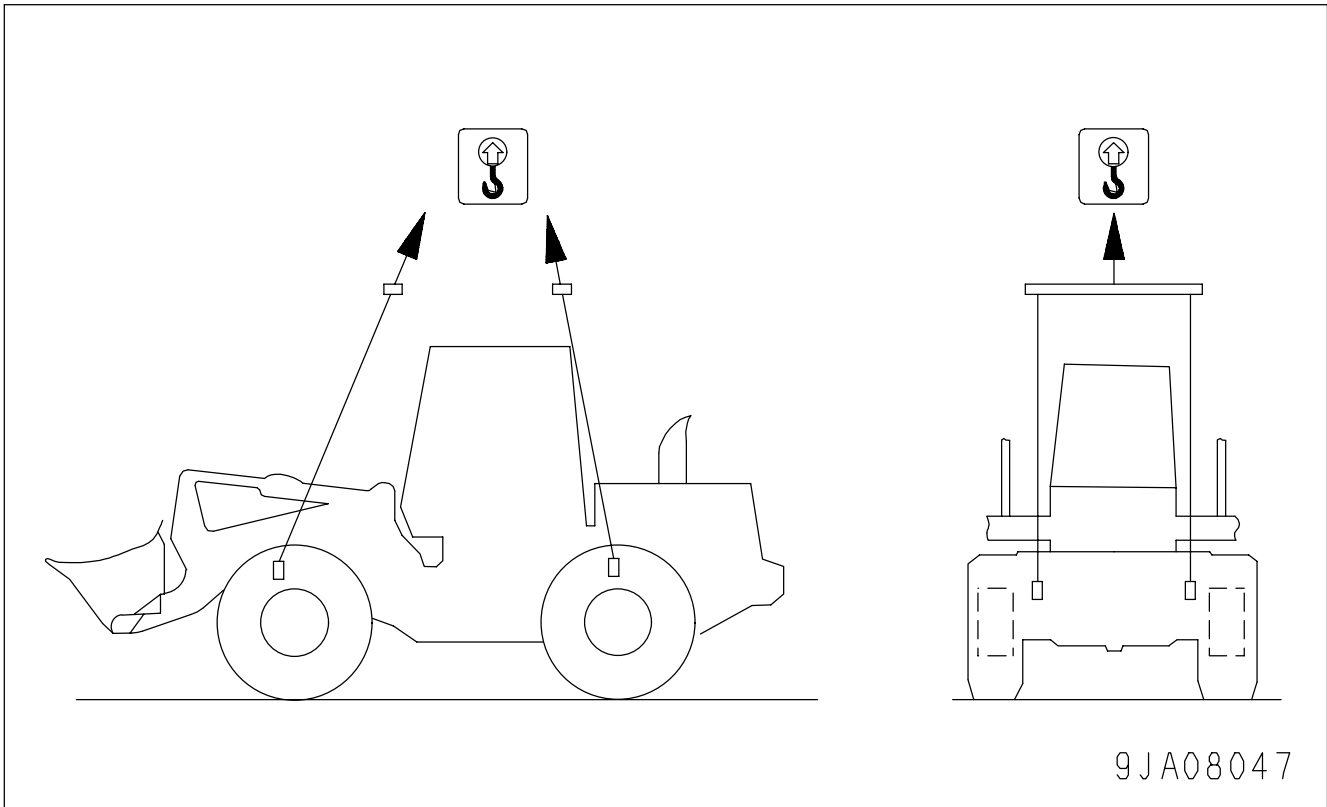

The machine can be lifted only if it has hook mark labels.

When lifting the machine, stop the machine on level ground and do as follows.

1. Start the engine, make sure that the machine is horizontal, then set the work equipment to the travel posture.

For details, see "MOVING THE MACHINE (PAGE 3-127)".

(A): 40 - 50 cm (16 - 20 in)

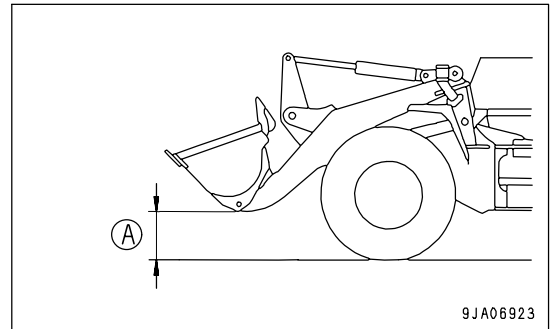

2. Check that the work equipment control lever is at the HOLD position, then set the work equipment lock lever to the LOCK position (L).

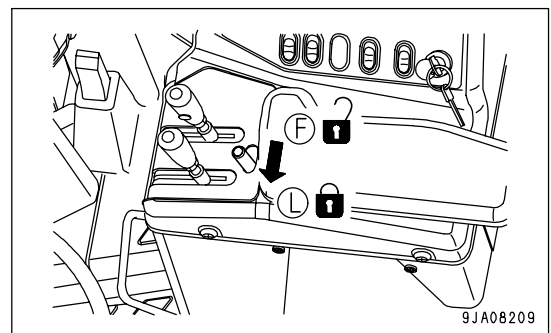

3. Stop the engine, check that the area around the operator's compartment is safe, then set the frame lock bar to the LOCK position (L) to prevent the front frame and rear frame from articulating.

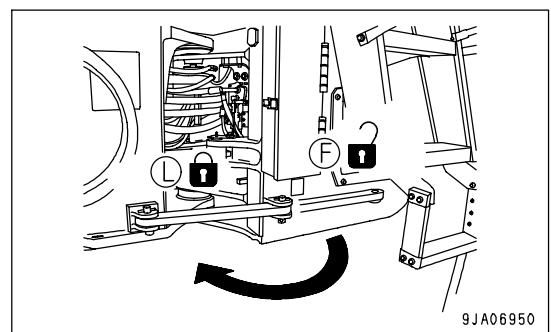

4. Use wire ropes and slings that match the weight of the machine, and wind the wire rope and fix it to the lifting points as shown in the figure.

NOTICE

- Use protectors, etc. so that the wire ropes will not be broken at sharp edges or narrow places.
 - Use threaders and bars having sufficient width so that the slings and wire ropes will not touch the machine.
 - For machines equipped with a rear full fender, remove the rear full fender before carrying out the operation.
5. Before lifting up the machine, set the slings and float the machine to 100 mm - 200 mm above the ground. Make sure that the wire ropes are not slack and the machine is kept horizontally, and then lift up the machine slowly.

COLD WEATHER OPERATION

PRECAUTIONS FOR LOW TEMPERATURE

If the temperature becomes low, it becomes difficult to start the engine, and the coolant may freeze, so do as follows.

FUEL AND LUBRICANTS

Change to fuel and oil with low viscosity for all components.

For details of the specified viscosity, see "RECOMMENDED FUEL, COOLANT, AND LUBRICANT (PAGE 4-9)".

COOLANT



WARNING

- COOLANT is toxic. Be careful not to get it into your eyes or on your skin. If it should get into your eyes or on your skin, wash it off with large amounts of fresh water and see a doctor at once.
- When changing the coolant or when handling the coolant containing COOLANT that has been drained during repair of radiator, please contact your Komatsu distributor or request a specialist company to carry out the operation. COOLANT is toxic. Do not let it flow into drainage ditches or spray it onto the ground surface.

NOTICE

Please use Komatsu genuine SUPERCOOLANT (AF-NAC) for the COOLANT. As a basic rule, we do not recommend the use of any COOLANT other than SUPERCOOLANT (AF-NAC).

COOLANT is already diluted with distilled water, so it is not flammable.

For details of the density of COOLANT and the interval for changing the coolant, see "CLEAN INSIDE OF COOLING SYSTEM (PAGE 4-21)".

BATTERY

 **WARNING**

- The battery generates flammable gas. Do not bring fire or sparks near the battery.
- Battery electrolyte is dangerous. If it gets in your eyes or on your skin, wash it off with a large amount of water and consult a doctor.
- Battery electrolyte dissolves paint. If it gets on the bodywork, wash it off immediately with water.
- If the battery electrolyte is frozen, do not charge the battery or start the engine with a different power source. There is danger that the battery may explode.
- Battery electrolyte is toxic. Do not let it flow into drainage ditches or spray it on to the ground surface.

When the ambient temperature drops, the capacity of the battery will also drop. If the battery charge ratio is low, the battery electrolyte may freeze. Maintain the battery charge as close as possible to 100%. Insulate it against cold temperature to ensure the machine can be started easily the next morning.

REMARK

Measure the specific gravity and calculate the charging rate from the following conversion table.

Electrolyte Temperature	20°C (68°F)	0°C (32°F)	-10°C (14°F)	-20°C (-4°F)
Charging Rate (%)				
100	1.28	1.29	1.30	1.31
90	1.26	1.27	1.28	1.29
80	1.24	1.25	1.26	1.27
75	1.23	1.24	1.25	1.26

- As the battery capacity drastically drops in low temperatures, cover or remove the battery from the machine, store the battery in a warm place, and install it again the next morning.
- If the electrolyte level is low, add distilled water in the morning before beginning work. Do not add water after the day's work to prevent diluted electrolyte in the battery from freezing during the night.

PRECAUTIONS AFTER COMPLETION OF WORK

To prevent mud, water, or the undercarriage from freezing and making it impossible for the machine to move on the following morning, observe the following precautions.

- Remove all the mud and water from the machine body. In particular, wipe the hydraulic cylinder rods clean to prevent damage to the seal caused by mud, dirt, or drops of water on the rod from getting inside the seal.
- Park the machine on hard, dry ground.
If this is impossible, park the machine on boards.
The boards prevent the tracks from freezing to the ground, and allow the machine to be moved the next morning.
- Open the drain valve and drain any water collected in the fuel system to prevent it from freezing.
- Fill the fuel tank to capacity. This minimizes moisture condensation in the tank when the temperature drops.

AFTER COLD WEATHER

When the season changes and the weather becomes warmer, do as follows.

- Replace all fuel and oil with fuel and oil of the specified viscosity. For details, see "RECOMMENDED FUEL, COOLANT, AND LUBRICANT (PAGE 4-9)".

LONG-TERM STORAGE

BEFORE STORAGE

When keeping in long-term storage (more than one month), store as follows.

- Clean and wash all parts, then store the machine indoors. If the machine has to be stored outdoors, select level ground and cover the machine with a sheet.
- Completely fill the fuel tank. This prevents moisture from collecting.
- Lubricate and change the oil before storage.
- Coat the exposed portion of the hydraulic cylinder piston rod with grease.
- Disconnect the negative terminals of the battery and cover it or remove it from the machine and store it separately.
- Set the lock lever to the LOCK position to prevent the machine from moving.
- To prevent rust, fill with COOLANT to give a density of at least 30% for the engine coolant.

DURING STORAGE



WARNING

If it is necessary to perform the rust-prevention operation while the machine is indoors, open the doors and windows to improve ventilation and prevent gas poisoning.

- During storage, operate and move the machine for a short distance once a month so that a new film of oil will coat moving parts. At the same time, also charge the battery.
- When operating the work equipment, wipe off all the grease from the hydraulic cylinder rods.
- If the machine is equipped with an air conditioner, operate the air conditioner for 3 to 5 minutes once a month to lubricate all parts of the air conditioner compressor. Always run the engine at low idle when doing this. In addition, check the refrigerant level twice a year.

AFTER STORAGE

NOTICE

If the machine has been stored without carrying out the monthly rust-prevention operation, consult your Komatsu distributor before using it.

When using the machine after long-term storage, do as follows before using it.

- Wipe off the grease from the hydraulic cylinder rods.
- Add oil and grease at all lubrication points.
- When the machine is stored for a long period, moisture in the air will mix with the oil. Check the oil before and after starting the engine. If there is water in the oil, change all the oil.
- Check that there is no rust on the engine pulley and no abnormality in the belt.
If there is excessive rust on the belt contact surface of the pulley, remove it with a wire brush.

TROUBLESHOOTING

WHEN MACHINE RUNS OUT OF FUEL



WARNING

When starting the engine again, check carefully that the area around the engine is safe before cranking the engine.

When starting the engine again after running out of fuel, fill with fuel, then bleed the air from the fuel system before starting the engine.

For details of bleeding the air, see "PROCEDURE FOR BLEEDING AIR (PAGE 4-52)".

METHOD OF TOWING MACHINE



WARNING

Serious injury or death could result if there is any mistake in the selection of wire rope or method of towing a disabled machine.

- Always be sure to check carefully that the capacity of the wire rope used for towing is ample for the weight of the towed machine.
- Never use a wire rope which has cut strands (A), reduced diameter (B), or kinks (C). There is danger that the rope may break during the towing operation.
- Always wear leather gloves when handling wire rope.
- Never tow a machine on a slope.
- During the towing operation, never stand between the towing machine and the machine being towed.
- Move the machine slowly and be sure not to apply any sudden load on the wire rope.
- If there is a failure in the brake line, the brakes cannot be used, so be extremely careful when towing.

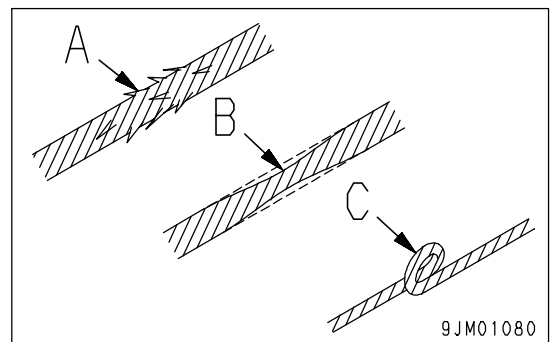

NOTICE

- Only tow the machine for a short distances, such as to a place for inspection or maintenance. The machine must not be towed for long distances.
- For details of the permissible towing load for this machine, see Section "SPECIFICATIONS (PAGE 5-2)".
- For details of the procedure for towing a machine when it has broken down, please contact your Komatsu distributor.

This machine must not be towed except in emergencies. When towing the machine, take the following precautions.

- Before releasing the brakes, put blocks under the wheels to prevent the machine from moving. If the wheels are not blocked, the machine may suddenly move.
- When towing a machine, tow it at a low speed of less than 2 km/h (1.2 MPH), and for a distance of a few meters to a place where repairs can be carried out. The machine should be towed only in emergencies. If the machine must be moved long distances, use a transporter.
- If it is impossible to operate the steering and brakes of the machine being towed, do not let anyone ride on the machine.
- Keep the angle of the towrope as small as possible. Keep the angle between the centerlines of the two machines to within 30 degrees.

- The towing machine should normally be of the same class as the machine being towed. Check that the towing machine and towed machine both have ample braking power and that the towing machine has ample rimpull to control both machines on the slopes or on the tow road.
- When towing a machine downhill, it may be necessary to connect another machine to the rear of the machine being towed in order to provide ample rimpull and braking power. This makes it possible to prevent the machine from losing control.
- Towing may be carried out under various differing conditions, so it is impossible to determine beforehand the requirements for towing. Towing on flat horizontal roads will require the minimum rimpull, while towing on slopes or on uneven road surfaces will require the maximum rim pull.
- Connect a wire rope to the part indicated with the arrow in the diagram at right.

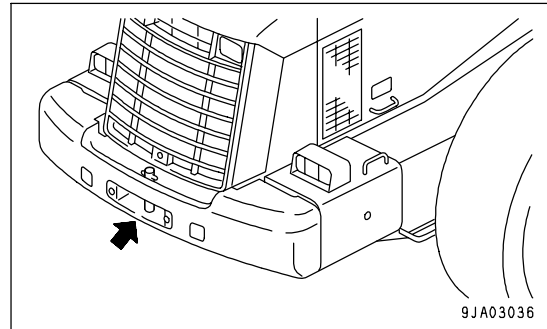

WHEN ENGINE CAN BE USED

- If the transmission and steering wheel can be operated, and the engine is running, it is possible to tow the machine out of mud or to move it for a short distance to the edge of the road.
- The operator should sit on the machine being towed and operate the steering in the direction that the machine is towed.

WHEN ENGINE CANNOT BE USED

When towing a machine with the engine stopped, use the following procedure.

1. The transmission oil does not lubricate the system, so remove the front and rear drive shafts. If necessary, block the tires to prevent the machine from moving.
2. The steering cannot be operated, so remove the steering cylinder.
Even if the brakes are in good condition, the brakes can only be used a limited number of times. There is no change in the operating force for the brake pedal, but the braking force is reduced each time the pedal is depressed.
3. Connect the towing equipment securely. When carrying out towing operations, use two machines of at least the same class as the machine being towed. Connect one machine each to the front and rear of the machine being towed, then remove the blocks from the tires and tow the machine.
4. Parking brake
The parking brake cannot be turned OFF. To release the parking brake, do as follows.

RELEASING PARKING BRAKE



WARNING

- When releasing the parking brake, stop the machine on level ground and check that the surrounding area is safe. If it is necessary to release the brake on a slope in an emergency, block the tires before starting the operation.
- If the parking brake is released, the brake cannot be used, so check the safety carefully when moving the machine.

If the engine will not run for some reason, use the following methods to release the parking brake and tow the machine.

METHOD OF RELEASING BRAKE BY USING EMERGENCY PARKING BRAKE CANCEL SWITCH



CAUTION

When the parking brake switch is at the OFF position and the emergency parking brake release valve is opened, the parking brake is released immediately.

In this condition, even if you feel danger and try to stop the machine, the parking brake will not be applied immediately even if you close the emergency parking brake release valve.

If the pressure in the brake accumulator is high, do as follows.

1. Turn the starting switch to the OFF position (A).

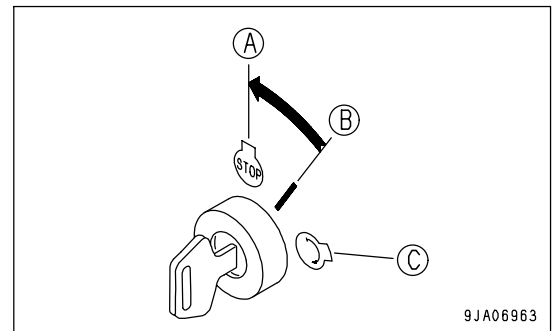

2. Turn locknut (1) of the release valve counterclockwise, then turn grip (2) counterclockwise to open the release valve.

REMARK

The relief valve is located on the left front portion inside the rear frame and secured to the accumulator mounting bracket.

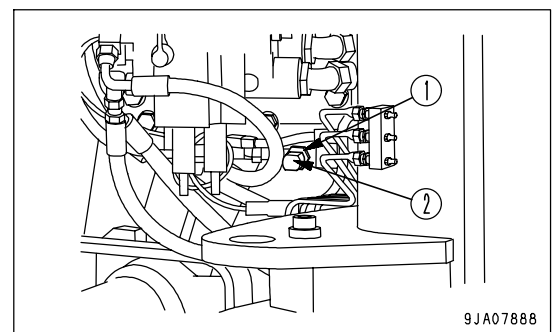

3. Turn starting switch to the ON position (B).

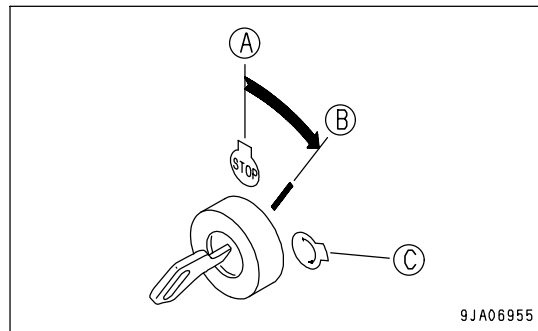

4. Move the parking brake switch to the ON (A) position (actuated), then move it to the OFF (B) position (released). The parking brake is released.

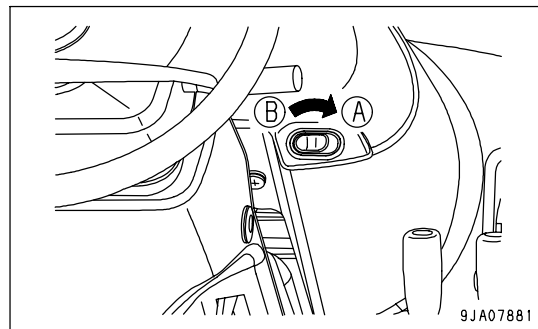

5. To restore the function of the parking brake, turn grip (2) of the release valve clockwise to close the release valve, then turn locknut (1) clockwise to lock it.

Tightening torque

Grip (2): 20 ± 5 Nm (2.0 ± 0.5 kgm, 14.5 ± 3.6 lbft)

Locknut (1): 20 ± 5 Nm (2.0 ± 0.5 kgm, 14.5 ± 3.6 lbft)

6. Move the parking brake switch to the ON (a) position. The parking brake is applied.

To release the parking brake again, repeat the procedure in Steps 1 to 4.

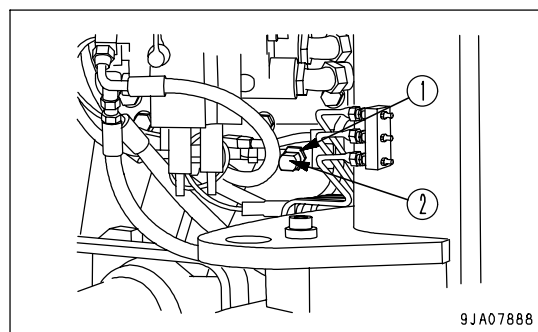

REMARK

If the brake accumulator pressure is low, the parking brake warning lamp may not go out and the alarm buzzer may sound (a long continuous sound). If this happens, release the brake. For details, see "METHOD OF RELEASING WITH ADJUSTMENT SCREW (PAGE 3-170)"

METHOD OF RELEASING WITH ADJUSTMENT SCREW

If the brake accumulator pressure is low, do as follows.

1. Loosen bolt (2) and adjustment screw (1) at 3 places (A, B, C) at the front of the transmission case.

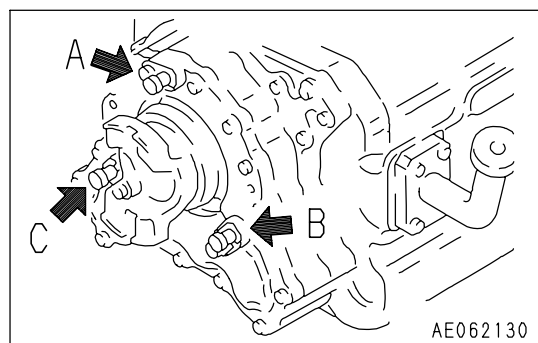

2. Rotate lock plate (3) to release the lock, then tighten adjustment screw (1) until it stops.
3. If this operation is carried out at the same time at A, B, and C, the parking brake can be released.

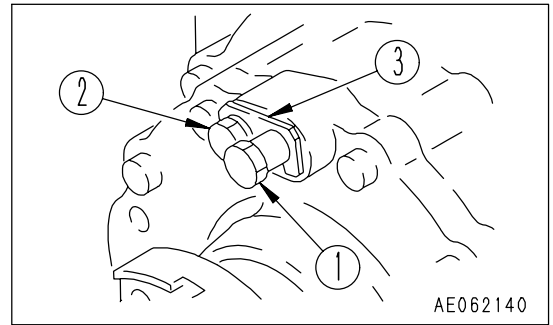

EMERGENCY TRAVEL OPERATION

The normal gear shifting operation is carried out by electric signals. If there should be a failure in the electrical system and the machine does not move, please contact your Komatsu distributor to have the machine moved.

NOTICE

Always request your Komatsu distributor to carry out the emergency travel operation.

IF BATTERY IS DISCHARGED



WARNING

- It is dangerous to charge a battery when installed on a machine. Make sure that it is removed before charging.
- When checking or handling the battery, stop the engine and turn the starting switch key to the OFF position.
- The battery generates hydrogen gas, so there is a hazard of explosion. Do not bring lighted cigarettes near the battery, or do anything that will cause sparks.
- Battery electrolyte is dilute sulfuric acid, and it will attack your clothes and skin. If it gets on your clothes or on your skin, immediately wash it off with a large amount of water. If it gets in your eyes, wash it out with fresh water and consult a doctor.
- When handling batteries, always wear safety glasses and rubber gloves.
- When removing the battery, first disconnect the cable from the ground (normally the negative (-) terminal). When installing, install the positive (+) terminal first.
If a tool touches the positive terminal and the chassis, there is danger that it will cause a spark, so be extremely careful.
- If the terminals are loose, there is danger that the defective contact may generate sparks that will cause an explosion.
- When removing or installing the terminals, check which is the positive (+) terminal and which is the negative (-) terminal.

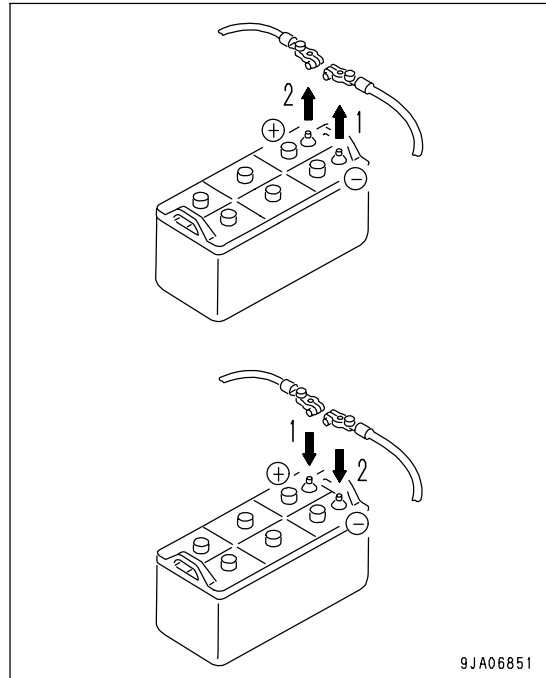

9JA06851

REMOVAL AND INSTALLATION OF BATTERY

1. Before removing battery, remove the ground cable (normally connected to the negative (-) terminal). If any tool touches between the positive terminal and the chassis, there is danger of sparks being generated. Loosen the nuts of the terminal and remove the wires from the battery.
2. After installing the battery, fix it with the battery hold down.
Tightening torque: 2 to 2.9 Nm
(0.2 to 0.3 kgm, 1.4 to 2.2 lbft)
3. When installing the battery, connect the ground cable last.
Insert the hole of the terminal on the battery and tighten the nut.
Tightening torque: 5.9 to 9.8 Nm
(0.6 to 1.0 kgm, 4.3 to 7.2 lbft)

REMARK

The batteries are on both sides at the rear of the machine. The battery used for the ground is on the left side of the machine.

PRECAUTIONS FOR CHARGING BATTERY

When charging the battery, if the battery is not handled correctly, there is danger that the battery may explode. Always follow the instructions in "BATTERY (PAGE 3-165)" and the instruction manual accompanying the charger, and do as follows.

- Do not use or charge the battery if the battery electrolyte level is below the LOWER LEVEL line. This may cause an explosion. Check the battery electrolyte level periodically and add distilled water to bring the electrolyte level to the UPPER LEVEL line.
- Set the voltage of the charger to match the voltage of the battery to be charged. If the correct voltage is not selected, the charger may overheat and cause an explosion.
- Connect the positive (+) charger clip of the charger to the positive (+) terminal of the battery, then connect the negative (-) charger clip of the charger to the negative (-) terminal of the battery. Be sure to attach the clips securely.
- Set the charging current to 1/10 of the value of the rated battery capacity; when carrying out rapid charging, set it to less than the rated battery capacity.
If the charger current is too high, the electrolyte will leak or dry up, and this may cause the battery to catch fire and explode.
- If the battery electrolyte is frozen, do not charge the battery or start the engine with a different power source. There is a danger that this will ignite the battery electrolyte and cause the battery to explode.

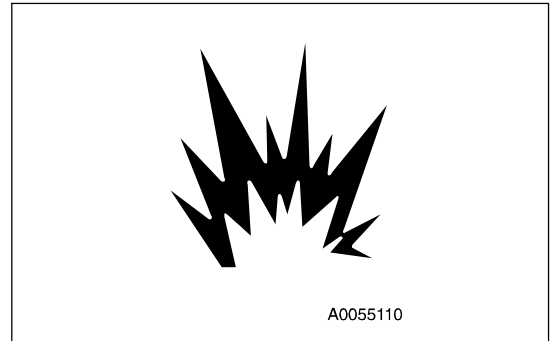

STARTING ENGINE WITH BOOSTER CABLE

When starting the engine with a booster cable, do as follows.

PRECAUTIONS WHEN CONNECTING AND DISCONNECTING BOOSTER CABLE

WARNING

- When connecting the cables, never contact the positive (+) and negative (-) terminals.
- When starting the engine with a booster cable, wear safety glasses and rubber gloves.
- Be careful not to let the normal machine and problem machine contact each other. This prevents sparks from generating near the battery which could ignite the hydrogen gas given off by the battery.
- Make sure that there is no mistake in the booster cable connections. The final connection is to the engine block of the problem machine, but sparks will be generated when this is done, so connect to a place as far as possible from the battery.
- When disconnecting the booster cable, take care not to bring the clips in contact with each other or with the machine body.

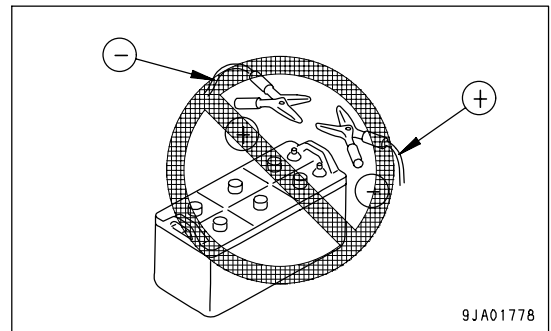

NOTICE

- The size of the booster cable and clip should be suitable for the battery size.
- The battery of the normal machine must be the same capacity as that of the engine to be started.
- Check the cables and clips for damage or corrosion.
- Make sure that the cables and clips are firmly connected.
- Check that the work equipment lock levers and parking brake levers of both machines are in the LOCK position.
- Check that each lever is in the NEUTRAL position.

CONNECTING THE BOOSTER CABLE

Keep the starting switch of the normal machine and problem machine in the OFF position.

Connect the booster cable as follows, in the order of the numbers marked in the diagram.

1. Connect the clip of booster cable (A) to the positive (+) terminal of battery (C) on the problem machine.
2. Connect the clip at the other end of booster cable (A) to the positive (+) terminal of battery (D) on the normal machine.
3. Connect the clip of booster cable (B) to the negative (-) terminal of battery (D) on the normal machine.
4. Connect the clip at the other end of booster cable (B) to engine block (E) on the problem machine.

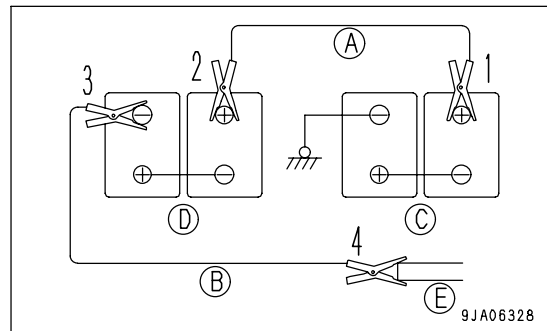

STARTING ENGINE



WARNING

Always check that the work equipment lock lever is set to the LOCK position, regardless of whether the machine is working normally or has failed. Check also that all the control levers are in the HOLD or NEUTRAL position.

1. Make sure the clips are firmly connected to the battery terminals.
2. Start engine of the normal machine and run it at high idle speed.
3. Turn the starting switch of the problem machine to the START position and start the engine.
If the engine doesn't start at first, wait for at least 2 minutes before trying again.

DISCONNECTING THE BOOSTER CABLE

After the engine has started, disconnect the booster cables in the reverse of the order in which they were connected.

1. Remove the clip of booster cable (B) from engine block (E) on the problem machine.
2. Remove the clip of booster cable (B) from the negative (-) terminal of battery (D) on the normal machine.
3. Remove the clip of booster cable (A) from the positive (+) terminal of battery (D) on the normal machine.
4. Remove the clip of booster cable (A) from the positive (+) terminal of battery (C) on the problem machine.

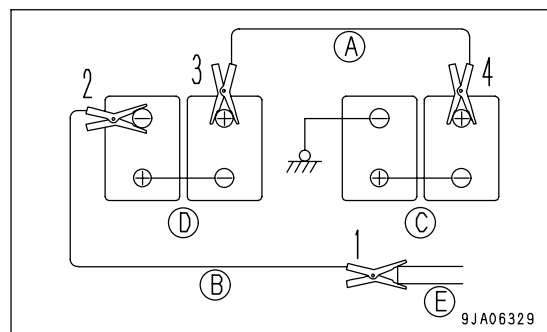

OTHER TROUBLE

ELECTRICAL SYSTEM

- (): Always contact your Komatsu distributor when dealing with these items.
- In cases of problems or causes which are not listed below, contact your Komatsu distributor for repairs.

Problem	Main causes	Remedy
Lamp does not glow brightly even when the engine runs at high speed Lamp flickers while engine is running	<ul style="list-style-type: none"> • Defective wiring • Defective adjustment of belt tension 	<ul style="list-style-type: none"> (• Check, repair loose terminals, disconnections) • Adjust alternator belt tension For details, see EVERY 250 HOURS SERVICE
Even when the engine is rotating, the battery charge circuit caution lamp does not go out	<ul style="list-style-type: none"> • Defective alternator • Defective wiring • Defective adjustment of alternator belt tension 	<ul style="list-style-type: none"> (• Replace) (• Check, repair) • Adjust alternator belt tension For details, see EVERY 250 HOURS SERVICE
Abnormal noise is generated from alternator	<ul style="list-style-type: none"> • Defective alternator 	<ul style="list-style-type: none"> (• Replace)
Starting motor does not turn when starting switch is turned to ON	<ul style="list-style-type: none"> • Defective wiring • Insufficient battery charge 	<ul style="list-style-type: none"> (• Check, repair) • Charge
Pinion of starting motor keeps going in and out	<ul style="list-style-type: none"> • Insufficient battery charge 	<ul style="list-style-type: none"> • Charge
Starting motor turns engine sluggishly	<ul style="list-style-type: none"> • Insufficient battery charge • Defective starting motor 	<ul style="list-style-type: none"> • Charge (• Replace)
Starting motor disengages before engine starts	<ul style="list-style-type: none"> • Defective wiring • Insufficient battery charge 	<ul style="list-style-type: none"> (• Check, repair) • Charge
Preheating pilot lamp does not light up	<ul style="list-style-type: none"> • Defective wiring • Defective heater relay, heater controller, temperature sensor • Defective preheating pilot lamp 	<ul style="list-style-type: none"> (• Check, repair) (• Replace) (• Replace)
Even when engine is stopped, battery charge circuit caution lamp does not light up (starting switch at ON position)	<ul style="list-style-type: none"> • Defective wiring • Defective monitor 	<ul style="list-style-type: none"> (• Check, repair) (• Replace)

CHASSIS

- (): Always contact your Komatsu distributor when dealing with these items.
- In cases of problems or causes which are not listed below, contact your Komatsu distributor for repairs.

Problem	Main causes	Remedy
Transmission		
Engine is running but machine does not move	<ul style="list-style-type: none"> • Parking brake is applied • Directional lever is not shifted properly • Lack of oil in transmission case 	<ul style="list-style-type: none"> • Release parking brake • Shift lever properly • Add oil to specified level. See WHEN REQUIRED
Even when engine is run at full throttle, machine only move slowly and lacks power	<ul style="list-style-type: none"> • Lack of oil in transmission case • Screen is clogged 	<ul style="list-style-type: none"> • Add oil to specified level. See WHEN REQUIRED (• Disassemble, clean)
Oil overheats	<ul style="list-style-type: none"> • Too much oil or too little oil in transmission case • Machine is not traveling in correct speed range • Torque converter is stalled for long periods • Engine is overheating 	<ul style="list-style-type: none"> • Add or drain oil to specified level. See WHEN REQUIRED • Place in correct speed range • Reduce stall time (• Check engine)
Noise generated	<ul style="list-style-type: none"> • Lack of oil in transmission case 	<ul style="list-style-type: none"> • Add oil to specified level. See WHEN REQUIRED
Axle		
Noise generated	<ul style="list-style-type: none"> • Lack of oil • Improper oil used (for machines with limited-slip differential) 	<ul style="list-style-type: none"> • Add oil to specified level. See WHEN REQUIRED • Change to specified oil
Brake		
Brake is not applied when pedal is depressed	<ul style="list-style-type: none"> • Disc has reached wear limit • Lack of oil in hydraulic tank • Air in brake line 	<ul style="list-style-type: none"> (• Replace disc) • Add oil to specified level. See EVERY 100 HOURS • Bleed air
Brake drags or remains applied	<ul style="list-style-type: none"> • Vent hole of brake valve is clogged 	<ul style="list-style-type: none"> • Clean
Brakes squeal	<ul style="list-style-type: none"> • Disc is worn • Large amount of water in axle oil • Deteriorated axle oil due to overuse of brake 	<ul style="list-style-type: none"> (• Replace disc) • Change axle oil • Change axle oil

Problem	Main causes	Remedy
Steering		
Steering wheel is heavy	<ul style="list-style-type: none"> • Lack of oil in hydraulic tank 	<ul style="list-style-type: none"> • Add oil to specified level. See EVERY 100 HOURS SERVICE
Steering wheel is loose	<ul style="list-style-type: none"> • Play in steering cylinder pin • Lack of oil in hydraulic tank 	<ul style="list-style-type: none"> • Grease bearing or replace pin and bushing where there is play • Add oil to specified level. See EVERY 100 HOURS SERVICE
Parking brake		
Braking effect is poor	<ul style="list-style-type: none"> • Disc is worn 	(• Replace disc)
Brake drags or remains applied	<ul style="list-style-type: none"> • Lack of oil in transmission case • Screen is clogged 	<ul style="list-style-type: none"> • Add oil to specified level. See WHEN REQUIRED (• Disassemble and clean)
Hydraulic system		
Lack of lifting power for bucket	<ul style="list-style-type: none"> • Lack of oil in hydraulic tank 	<ul style="list-style-type: none"> • Add oil to specified level. See EVERY 100 HOURS SERVICE
Bucket takes time to rise	<ul style="list-style-type: none"> • Clogged hydraulic tank filter 	<ul style="list-style-type: none"> • Replace filter. See EVERY 2000 HOURS SERVICE
Excessive bubbles in oil	<ul style="list-style-type: none"> • Low quality oil being used • Lack of oil in hydraulic tank • Air in oil line 	<ul style="list-style-type: none"> • Replace with good quality oil • Add oil to specified level. See EVERY 100 HOURS SERVICE • Bleed air. See EVERY 2000 HOURS SERVICE
Hydraulic pressure is low	<ul style="list-style-type: none"> • Lack of oil in hydraulic tank causes pump to suck in air 	<ul style="list-style-type: none"> • Add oil to specified level. See EVERY 100 HOURS SERVICE Then bleed air. See EVERY 2000 HOURS SERVICE
Movement of cylinder is irregular	<ul style="list-style-type: none"> • Lack of oil in hydraulic tank 	<ul style="list-style-type: none"> • Add oil to specified level. See EVERY 100 HOURS SERVICE

ENGINE

- (): Always contact your Komatsu distributor when dealing with these items.
- In cases of problems or causes which are not listed below, contact your Komatsu distributor for repairs.

Problem	Main causes	Remedy
Engine oil pressure caution lamp lights up	<ul style="list-style-type: none"> • Low engine oil pan oil level (sucking in air) • Clogged oil filter cartridge • Defective tightening of oil pipe joint, oil leakage from damaged part • Defective monitor 	<ul style="list-style-type: none"> • Add oil to specified level, see CHECK BEFORE STARTING • Replace cartridge, see EVERY 500 HOURS SERVICE (• Check, repair) (• Replace)
Steam is emitted from top part of radiator (pressure valve) Engine water temperature gauge is in red range Engine cooling water temperature caution lamp lights up	<ul style="list-style-type: none"> • Low cooling water level, water leakage • Defective fan pump or motor • Dirt or scale accumulated in cooling system • Clogged radiator fin or damaged fin • Defective thermostat • Defective thermostat seal • Loose radiator filler cap (high altitude operation) • Defective monitor 	<ul style="list-style-type: none"> • Check, add cooling water, repair, see WHEN REQUIRED (• Check, repair) • Change cooling water, clean inside of cooling system, see WHEN REQUIRED • Clean or repair, see WHEN REQUIRED (• Replace thermostat) (• Replace thermostat seal) • Tighten cap or replace packing (• Replace)
Engine water temperature gauge is in white range	<ul style="list-style-type: none"> • Defective thermostat • Defective monitor 	<ul style="list-style-type: none"> (• Replace thermostat) (• Replace)
Engine does not start when starting motor is turned	<ul style="list-style-type: none"> • Lack of fuel • Air in fuel system • No fuel in fuel filter • Defective injection pump or injector • Starting motor cranks engine too slowly • Starting motor does not turn • Preheating pilot lamp does not light up • Defective valve clearance (Defective compression) 	<ul style="list-style-type: none"> • Add fuel, see CHECK BEFORE STARTING • Repair place where air is sucked in • Fuel filter with fuel. See EVERY 500 HOURS SERVICE (• Replace pump or injector) • See ELECTRICAL SYSTEM • See ELECTRICAL SYSTEM • See ELECTRICAL SYSTEM (• Adjust valve clearance)
Exhaust gas is white or blue	<ul style="list-style-type: none"> • Too much oil in oil pan • Improper fuel 	<ul style="list-style-type: none"> • Add oil to specified level, see CHECK BEFORE STARTING • Change to specified fuel

Problem	Main causes	Remedy
Exhaust gas occasionally turns black	<ul style="list-style-type: none"> • Clogged air cleaner element • Defective injector • Defective compression • Defective turbocharger 	<ul style="list-style-type: none"> • Clean or replace, see WHEN REQUIRED (• Replace injector) (• See defective compression above) (• Clean or replace turbocharger)
Combustion noise occasionally makes breathing sound	<ul style="list-style-type: none"> • Defective nozzle 	<ul style="list-style-type: none"> (• Replace nozzle)
Abnormal noise generated (combustion or mechanical)	<ul style="list-style-type: none"> • Low grade fuel being used • Overheating • Damage inside muffler • Excessive valve clearance 	<ul style="list-style-type: none"> • Change to specified fuel • Refer to "Water temperature gauge is in red range" as above (• Replace muffler) (• Adjust valve clearance)

MAINTENANCE

WARNING

Please read and make sure that you understand the SAFETY section before reading this section.

GUIDES TO MAINTENANCE

Do not perform any inspection and maintenance operation that is not found in this manual.

CHECK SERVICE METER:

Check the service meter reading every day to see if the time has come for any necessary maintenance to be performed.

KOMATSU GENUINE REPLACEMENT PARTS:

Use Komatsu genuine parts specified in the Parts Book as replacement parts.

KOMATSU GENUINE OILS:

For lubrication of the machine, use the Komatsu genuine lubricants. Moreover use oil of the specified viscosity according to the ambient temperature.

ALWAYS USE CLEAN WASHER FLUID:

Use automobile window washer fluid, and be careful not to let any dirt get into it.

ALWAYS USE CLEAN OIL AND GREASE:

Use clean oil and grease. Also, keep the containers of the oil and grease clean. Keep foreign materials away from oil and grease.

CHECKING FOR FOREIGN MATERIALS IN DRAINED OIL AND ON FILTERS:

After oil is changed or filters are replaced, check the old oil and filters for metal particles and foreign materials. If large quantity of metal particles or foreign materials are found, always report to the person in charge, and carry out suitable action.

FUEL STRAINER:

Do not remove the strainer from the filler port when adding fuel.

WELDING INSTRUCTIONS:

- Cut off power. Wait for approx. one minute after turning off the engine starting switch key, and then disconnect the negative (-) terminal of the battery.
- Do not apply more than 200 V continuously.
- Connect grounding cable within 1 m (3.3 ft) of the area to be welded. If grounding cable is connected near instruments, connectors, etc., the instruments may malfunction.
- If a seal or bearing happens to come between the part being welded and grounding point, change the grounding point to avoid such parts.
- Do not use the area around the work equipment pins or the hydraulic cylinders as the grounding point.

DO NOT DROP THINGS INSIDE MACHINE:

- When opening inspection windows or the oil filler port of the tank to carry out inspection, be careful not to drop nuts, bolts, or tools inside the machine.
If such things are dropped inside the machine, it may cause damage and/or malfunction of the machine, and will lead to failure. If you drop anything inside the machine, always remove it immediately.
- Do not put unnecessary things in your pockets. Carry only things which are necessary for inspection.

DUSTY WORKSITES:

When working at dusty worksites, do as follows:

- Clean the radiator core frequently to avoid clogging.
- Clean and replace the fuel filter frequently.
- Clean electrical components, especially the starting motor and alternator, to avoid accumulation of dust.
- When inspecting or changing the oil, move the machine to a place that is free of dust to prevent dirt from getting into the oil.

AVOID MIXING OIL:

If a different brand or grade of oil has to be added, drain the old oil and replace all the oil with the new brand or grade of oil. Never mix different brand or grade of oil.

LOCKING INSPECTION COVERS:

Lock inspection cover securely into position with the lock bar. If inspection or maintenance is performed with inspection cover not locked in position, there is a danger that it may be suddenly blow shut by the wind and cause injury to the worker.

BLEEDING AIR FROM HYDRAULIC CIRCUIT:

If the hydraulic oil equipments have been repaired or replaced and if the hydraulic hoses, pipes, etc. have been disconnected, it is necessary to bleed air from the circuit. See "CHANGE OIL IN HYDRAULIC TANK, REPLACE HYDRAULIC FILTER ELEMENT (PAGE 4-58)".

PRECAUTIONS WHEN INSTALLING HYDRAULIC HOSES:

- When removing parts at locations where there are O-rings or gasket seals, clean the mounting surface, and replace with new parts.
When doing this, be careful not to forget to assemble the O-rings and gaskets.
- When installing the hoses, do not twist them or bend them sharply. If they are installed so, their service life will be shortened extremely and they may be damaged.

CHECKS AFTER INSPECTION AND MAINTENANCE:

If you forget to perform the checks after inspection and maintenance, unexpected problems may occur, and this may lead to serious injury or property damage. Always do the following:

- Checks after operation (with engine stopped)
 - Have any inspection and maintenance points been forgotten?
 - Have all inspection and maintenance items been performed correctly?
 - Have any tools or parts been dropped inside the machine? It is particularly dangerous if parts are dropped inside the machine and get caught in the lever linkage mechanism.
 - Are there any leakage of coolant or oil? Have all nuts and bolts been tightened?
- Check when the engine is running
 - See "TWO WORKERS FOR MAINTENANCE WHEN ENGINE IS RUNNING (PAGE 2-37)" in the section on safety for checking when the engine is running. Pay attention to safety.
 - Check if the inspected and maintenance area is operating normally.
 - Increase the engine speed to check for fuel and oil leakage.

OUTLINES OF SERVICE

- Always use Komatsu genuine parts for replacement parts, grease or oil.
- When changing the oil or adding oil, do not mix different types of oil. When changing the type of oil, drain all the old oil and fill completely with the new oil. Always replace the filter at the same time. (There is no problem if the small amount of oil remaining in the piping mixes with the new oil.)
- Unless otherwise specified, when the machine is shipped from the factory, it is filled with the oil and coolant listed in the table below.

item	type
Engine oil pan	Engine oil EO15W40-DH (Komatsu genuine parts)
Transmission case	Power train oil TO10 (Komatsu genuine parts)
Hydraulic oil system	Power train oil TO10 (Komatsu genuine parts)
Axle	Axle oil AXO80 (Komatsu genuine parts)
Radiator	SUPERCOOLANT (AF-NAC) (Komatsu genuine parts) (density: 30% or above)

HANDLING OIL, FUEL, COOLANT, AND PERFORMING OIL CLINIC

OIL

- Oil is used in the engine and hydraulic equipment under extremely severe conditions (high temperature, high pressure), and deteriorates with use.
Always use oil that matches the grade and maximum and minimum ambient temperatures recommended in the Operation and Maintenance Manual. Even if the oil is not dirty, always change the oil at the specified interval.
- Oil corresponds to blood in the human body, always be careful when handling it to prevent any impurities (water, metal particles, dirt, etc.) from getting in.
The majority of problems with the machine are caused by the entry of such impurities.
Take particular care not to let any impurities get in when storing or adding oil.
- Never mix oils of different grades or brands.
- Always add the specified amount of oil.
Having too much oil or too little oil are both causes of problems.
- If the oil in the work equipment is not clear, there is probably water or air getting into the circuit. In such cases, please contact your Komatsu distributor.
- When changing the oil, always replace the related filters at the same time.
- We recommend you have an analysis made of the oil periodically to check the condition of the machine. For those who wish to use this service, please contact your Komatsu distributor.
- When using commercially available oil, it may be necessary to reduce the oil change interval.
We recommend that you use the Komatsu oil clinic to carry out a detailed checks of the characteristics of the oil.

FUEL

- To prevent the moisture in the air from condensing and forming water inside the fuel tank, always fill the fuel tank after completing the day's work.
- The fuel pump is a precision instrument, and if fuel containing water or dirt is used, it cannot work properly.
- Be extremely careful not to let impurities get in when storing or adding fuel.
- Always use the fuel specified for the temperature in the Operation and Maintenance Manual.
 - If the fuel is used at temperatures lower than the specified temperature (particularly at temperatures below -15 °C (5°F), the fuel will solidify.
 - If the fuel is used at temperatures higher than the specified temperature, the viscosity will drop, and this may result in problems such as a drop in output.
- Before starting the engine, or when 10 minutes have passed after adding fuel, drain the sediment and water from the fuel tank.
- If the engine runs out of fuel, or if the filters have been replaced, it is necessary to bleed the air from the circuit.

NOTICE

Always use diesel oil for the fuel.

To ensure good fuel consumption characteristics and exhaust gas characteristics, the engine mounted on this machine uses an electronically controlled high-pressure fuel injection device. This device requires high precision parts and lubrication, so if low viscosity fuel with low lubricating ability is used, the durability may drop markedly.

COOLANT AND WATER FOR DILUTION

- Komatsu genuine SUPERCOOLANT (AF-NAC) has the important function of preventing corrosion as well as preventing freezing.

Even in the areas where freezing is not an issue, the use of antifreeze COOLANT is essential.

Komatsu machines are supplied with Komatsu SUPERCOOLANT (AF-NAC). SUPERCOOLANT (AF-NAC) has excellent anticorrosion, antifreeze and cooling properties and can be used continuously for two years or 4000 hours.

As a basic rule, we do not recommend the use of any COOLANT other than SUPERCOOLANT (AF-NAC). If you use another COOLANT, it may cause serious problems, such as corrosion of the engine and aluminum parts of the cooling system.
- When using antifreeze, always observe the precautions given in the Operation and Maintenance Manual.
- COOLANT is already diluted with distilled water, so it is not flammable.
- The density used for the COOLANT differs according to the ambient temperature.

For details of the density of the COOLANT, see "CLEAN INSIDE OF COOLING SYSTEM (PAGE 4-21)".

Even in the areas where it is not considered necessary to prevent freezing, always use COOLANT with a density of over 30% in order to prevent corrosion of the cooling system.

COOLANT is diluted with distilled water that does not contain any ions or water-hardening substances. Never dilute the COOLANT with ordinary water.
- If the engine overheats, wait for the engine to cool before adding coolant.
- If the coolant level is low, it will cause overheating, and will also cause problems with corrosion due to air entering the coolant.

GREASE

- Grease is used to prevent seizure and noises at the joints.
- This construction equipment is used under heavy-duty conditions. Always use the recommended grease and follow the change intervals and recommended ambient temperatures given in this Operation and Maintenance Manual.
- Grease fittings not included in the maintenance section are grease fittings for overhaul, so they do not need grease.
If any part becomes stiff after being used for long time, add grease.
- Always wipe off all of the old grease that is pushed out when greasing.
Be particularly careful to wipe off the old grease in places where sand or dirt sticking in the grease would cause wear of the rotating parts.

CARRYING OUT KOWA (Komatsu Oil Wear Analysis)

KOWA is a maintenance service that makes it possible to prevent machine failures and downtime. With KOWA, the oil is periodically sampled and analyzed. This enables early detection of wear of the machine drive parts and other problems.

We strongly recommend you to use this service. The oil analysis is carried out at actual cost, so the cost is low, and the results of the analysis are reported together with recommendations which will reduce repair costs and machine downtime.

KOWA ANALYSIS ITEMS

- Measurement of density of metal wear particles
This uses an ICP (Inductively Coupled Plasma) analyzer to measure the density of iron, copper, and other metal wear particles in the oil.

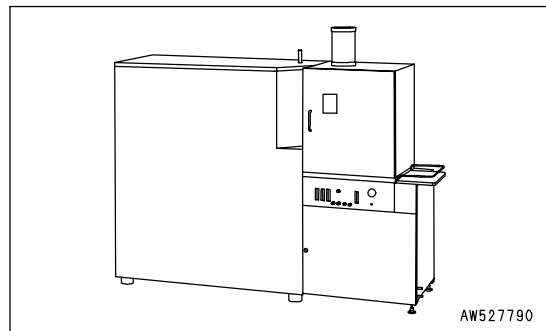

- Measurement of quantity of particles
This uses a PQI (Particle Quantifier Index) measurer to measure the quantity of iron particles of 5µm or more, enabling early detection of failures.

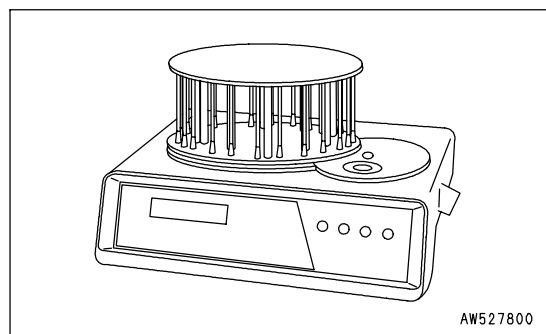

- Others
Measurements are made of items such as the ratio of water in the oil, density of the COOLANT, ratio of fuel in the oil, and dynamic viscosity, enabling a highly precise diagnosis of the machine's health.

OIL SAMPLING

- Sampling interval
 - 250 hours: Engine
 - 500 hours: Other components
- Precautions when sampling
 - Make sure that the oil is well mixed before sampling.
 - Perform sampling at regular fixed intervals.
 - Do not perform sampling on rainy or windy days when water or dust can get into the oil.

For further details of KOWA, please contact your Komatsu distributor.

STORING OIL AND FUEL

- Keep indoors to prevent any water, dirt, or other impurities from getting in.
- When keeping drum cans for a long period, put the drum on its side so that the filler port of the drums is at the side to prevent moisture from being sucked in.
If drums have to be stored outside, cover them with a waterproof sheet or take other measures to protect them.
- To prevent any change in quality during long-term storage, be sure to use in the order of first in - first out (use the oldest oil or fuel first).

FILTERS

- Filters are extremely important safety parts. They prevent impurities in the fuel and air circuits from entering important equipment and causing problems.
Replace all filters periodically. For details, see the Operation and Maintenance Manual.
However, when working in severe conditions, replace the filters at shorter intervals according to the oil and fuel (sulfur content) being used.
- Never try to clean the filters (cartridge type) and use them again. Always replace with new filters.
- When replacing oil filters, check if any metal particles are attached to the old filter. If any metal particles are found, contact your Komatsu distributor.
- Do not open packs of spare filters until just before they are to be used.
- Always use Komatsu genuine filters.

OUTLINE OF ELECTRIC SYSTEM

- It is extremely dangerous if the electrical equipment becomes wet or the covering of the wiring is damaged. This will cause an electrical short circuit and may lead to malfunction of the machine. Do not wash the inside of the operator's cab with water. When washing the machine, be careful not to let water get into the electrical components.
- Service relating to the electric system is checking fan belt tension, checking damage or wear to the fan belt and checking battery fluid level.
- Never install any electric components other than those specified by Komatsu.
- External electro-magnetic interference may cause malfunction of the control system controller, before installing a radio receiver or other wireless equipment, contact your Komatsu distributor.
- When working at the seashore, carefully clean the electric system to prevent corrosion.
- The optional power source must never be connected to the fuse, starting switch, or battery relay.

WEAR PARTS

Replace wear parts such as the filter element or air cleaner element at the time of periodic maintenance or before they reach the wear limit. The wear parts should be replaced correctly in order to ensure more economic use of the machine. When replacing parts, always use Komatsu genuine parts.

As a result of our continuous efforts to improve product quality, the part number may change, so inform your Komatsu distributor of the machine serial number and check for the latest part number when ordering parts.

WEAR PARTS LIST

The parts in parentheses are to be replaced at the same time.

Item	Part No.	Part Name	Q'ty	Replacement frequency	
Engine oil filter	6742-01-4540	Cartridge	1	EVERY 500 HOURS	
Fuel main filter	6754-71-6130	Cartridge	1	EVERY 1000 HOURS	
Fuel pre-filter	600-319-3610	Cartridge	1	EVERY 500 HOURS	
Transmission oil filter	714-07-28712	Cartridge	1	EVERY 1000 HOURS	
Transmission strainer	56D-15-19310 (07000-15085)	Strainer (O-ring)	1 (1)	- EVERY 1000 HOURS	
Hydraulic filter	14X-60-31150 (07002-15234)	Element (O-ring)	1 (1)	EVERY 2000 HOURS	
Hydraulic tank breather	423-60-35421	Element	1	EVERY 2000 HOURS	
Hydraulic oil strainer	22B-60-11160	Strainer		-	
Air cleaner	600-185-5100	Element ass'y	1	-	
Air conditioner filter	Fresh	426-07-32441	Element	1	EVERY 2000 HOURS
	Recirc	426-07-32441	Element	1	EVERY 2000 HOURS
PPC accumulator	425-62-23750 (07002-12034)	Accumulator (O-ring)	1	EVERY 4000 HOURS	
Bolt on cutting edge	Standard type	424-815-2210	Center edge	1	-
		424-815-2220	Side edge	2	
		(02090-11485)	(Bolt)	(14)	
	(02290-11422)	(Nut)	(14)		
	(01643-32260)	(Washer)	(14)		
	Long life type	424-T79-2210	Center edge	2	
		424-T79-2220	Side edge	2	
		(02090-11485)	(Bolt)	(14)	
		(02290-11422)	(Nut)	(14)	
(01643-32260)	(Washer)	(14)			
Segment type	421-838-1110	Center edge	7		
	421-838-1120	Side edge	2		
	(02091-11600)	(Bolt)	(16)		
	(02290-11625)	(Nut)	(16)		
(01643-22460)	(Washer)	(16)			

RECOMMENDED FUEL, COOLANT, AND LUBRICANT

- Komatsu genuine oils are adjusted to maintain the reliability and durability of Komatsu construction equipment and components.

In order to keep your machine in the best conditioner for long periods of time, it is essential to follow the instructions in this Operation and Maintenance Manual.

- Failure to follow these recommendations may result in shortened life or excess wear of the engine, power train, cooling system, and/or other components.
- Commercially available lubricant additives may be good for the machine, but they may also cause harm. Komatsu does not recommend any commercially available lubricant additive.
- Use the oil recommended according to the ambient temperature in the chart below.
- Specified capacity means the total amount of oil including the oil in the tank and the piping. Refill capacity means the amount of oil needed to refill the system during inspection and maintenance.
- When starting the engine in temperatures below 0°C (32°F), be sure to use the recommended multi-grade oil, even if the ambient temperature may become higher during the course of the day.
- If the machine is operated at a temperature below -20°C (-4°F), a separate device is needed, so consult your Komatsu distributor.
- When the fuel sulfur content is less than 0.5%, change the engine oil according to the period inspection table given in this Operation and Maintenance Manual.

If the fuel sulfur content is more than 0.5%, change the oil according to the following table.

Sulfur content (%)	Oil change interval
Less than 0.5	500 hours
0.5 - 1.0	250 hours
1.0 and up	Not recommendable (*)

* If these fuels are used, there is danger that serious trouble may occur because of early deterioration of the engine oil or early wear of the internal parts of the engine. If the local situation makes it necessary to use these fuels, always remember the following.

- 1) Be sure to check Total Basic Number (TBN) of oil frequently by TBN handy checker etc., and change oil based on the result.
- 2) Always be aware that oil change interval is extremely shorter than standard.
- 3) Be sure to carry out periodic engine inspection by distributor's expert since change interval of periodic replacement parts and overhaul interval are also shorter.

USE OF FUEL, COOLANT AND LUBRICANTS ACCORDING TO AMBIENT TEMPERATURE

Reservoir	Fluid Type	Ambient Temperature									Recommended Komatsu Fluids
		-22 -30	-4 -20	14 -10	32 0	50 10	68 20	86 30	104 40	122 °F 50 °C	
Engine Oil Pan	Engine oil	(Note.1)									Komatsu EOS0W30
		(Note.1)									Komatsu EOS5W40
		(Note.1)									Komatsu EO10W30-DH
		(Note.1)									Komatsu EO15W40-DH
		(Note.1)									Komatsu EO30-DH
Transmission case	Power train oil (Note.2)	(Note.1)									TO10
Hydraulic System	Power train oil	(Note.1)									TO10
	Hydraulic oil	(Note.1)									HO46-HM
	Engine oil	(Note.1)									Komatsu EO10W30-DH
		(Note.1)									Komatsu EO15W40-DH
Axle	Axle oil (Note.3)	(Note.1)									AXO80
	Power train oil (Note.4)	(Note.1)									TO50
Pin / Bushing Grease fitting	Hyper grease (Note.5)	(Note.1)									G2-T, G2-TE
	Lithium EP grease	(Note.1)									G2-LI
Cooling system	SUPERCOOLANT (AF-NAC) (Note.6)	(Note.1)									AF-NAC
Fuel tank	Diesel fuel	(Note.1)									ASTM Grade No.1-D S15 ASTM Grade No.1-D S500
		(Note.1)									ASTM Grade No.2-D S15 ASTM Grade No.2-D S500

AJA00833

Reservoir		Engine oil pan	Transmission case	Hydraulic system	Axle		Cooling system	Fuel tank
					Front	Rear		
Capacity	Liters	32	62	200	49	40	34	325
	US gal	8.5	16.4	52.8	12.9	10.6	9.0	85.9
Specified	Liters	30	54	139	49	40	-	-
	US gal	7.9	14.3	36.7	12.9	10.6	-	-

NOTICE

Always use diesel oil for the fuel.

To ensure good fuel consumption characteristics and exhaust gas characteristics, the engine mounted on this machine uses an electronically controlled high-pressure fuel injection device. This device requires high precision parts and lubrication, so if low viscosity fuel with low lubricating ability is used, the durability may drop markedly.

Note 1: HTHS (High-Temperature High-Shear Viscosity 150°C), specified by ASTM D4741 must be equal to or higher than 3.5 mPa·S. Komatsu EOS0W30 and EOS5W40 are the most suitable oils.

Note 2: Powertrain oil has different properties from engine oil. Be sure to use the recommended oils.

Note .3: Axle oil AXO80 has the function of preventing squealing from the brakes and LSD (Limited Slip Differential). If only AXO80 is recommended, use Komatsu genuine AXO80 or equivalent.

Note .4: When the ambient temperature is higher than 45°C (113°F) and the machine operation hour is longer than 12 hours/day, then the use of TO50 instead of AXO80 is recommended. Squealing of the brakes may occur with TO50, but there is no problem with the brake performance or durability. For machines with LSD, use AXO80 regardless of the ambient temperature. Do not use TO50.

Note .5: Hyper grease (G2-T, G2-TE) has a high performance. When it is necessary to improve the lubricating ability of the grease in order to prevent squeaking of pins and bushings, the use of G2-T or G2-TE is recommended.

Note 6: COOLANT

- 1) Komatsu genuine SUPERCOOLANT (AF-NAC) has the important function of preventing corrosion as well as preventing freezing. Even in the areas where freezing is not an issue, the use of antifreeze COOLANT is essential. Komatsu machines are supplied with SUPERCOOLANT (AF-NAC). SUPERCOOLANT (AF-NAC) has excellent anticorrosion, antifreeze and cooling properties and can be used continuously for two years or 4000 hours. SUPERCOOLANT (AF-NAC) is strongly recommended wherever available.
- 2) For details of the density of the COOLANT, see "CLEAN INSIDE OF COOLING SYSTEM (PAGE 4-21)". COOLANT is supplied already diluted. In this case, add the pre-diluted fluid to keep the tank full. (Never dilute the COOLANT with ordinary water.)
- 3) To maintain the anticorrosion properties of COOLANT, always keep the density of COOLANT between 30% and 68%.

RECOMMENDED BRANDS, RECOMMENDED QUALITY FOR PRODUCTS OTHER THAN KOMATSU GENUINE OIL

When using commercially available oils other than Komatsu genuine oil, consult your Komatsu distributor.

STANDARD TIGHTENING TORQUES FOR BOLTS AND NUTS

TORQUE LIST



If nuts, bolts, or other parts are not tightened to the specified torque, it will cause looseness or damage to the tightened parts, and this will cause failure of the machine or problems with operation.

Always pay careful attention when tightening parts.

Unless otherwise specified, tighten the metric nuts and bolts to the torque shown in the table below. If it is necessary to replace any nut or bolt, always use a Komatsu genuine part of the same size as the part that was replaced.

Thread diameter of bolt (a)(mm)	Width across flats (b)(mm)	Tightening torque					
		Target value			Service limit		
		Nm	kgm	lbft	Nm	kgm	lbft
6	10	13.2	1.35	9.8	11.8-14.7	1.2-1.5	8.7-10.8
8	13	31	3.2	23.1	27-34	2.8-3.5	20.3-25.3
10	17	66	6.7	48.5	59-74	6.0-7.5	43.4-54.2
12	19	113	11.5	83.2	98-123	10.0-12.5	72.3-90.4
14	22	172	17.5	126.6	153-190	15.5-19.5	112.1-141
16	24	260	26.5	191.7	235-285	23.5-29.5	170.0-213.4
18	27	360	37	267.6	320-400	33.0-41.0	238.7-296.6
20	30	510	52.3	378.3	455-565	46.5-58.0	336.3-419.5
22	32	688	70.3	508.5	610-765	62.5-78.0	452.1-564.2
24	36	883	90	651	785-980	80.0-100.0	578.6-723.3
27	41	1295	132.5	958.4	1150-1440	118.0-147.0	853.5-1063.3
30	46	1720	175.0	1265.8	1520-1910	155.0-195.0	1121.1-1410.4
33	50	2210	225.0	1627.4	1960-2450	200.0-250.0	1446.6-1808.3
36	55	2750	280.0	2025.2	2450-3040	250.0-310.0	1808.3-2242.2
39	60	3280	335.0	2423.1	2890-3630	295.0-370.0	2133.7-2676.2

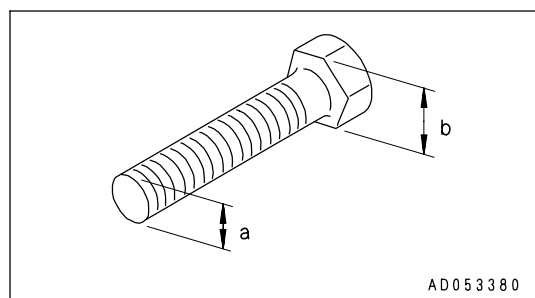

Apply the following table for Hydraulic Hose.

Nominal - No. of threads (a)	Width across flats (b) (mm)	Tightening torque					
		Target value			Permissible range		
		Nm	kgm	lbft	Nm	kgm	lbft
9/16 -18UNF	19	44	4.5	32.5	35 - 63	3.5 - 6.5	25.3 - 47.0
11/16 -16UN	22	74	7.5	54.2	54 - 93	5.5 - 9.5	39.8 - 68.7
13/16 -16UN	27	103	10.5	75.9	84 - 132	8.5 - 13.5	61.5 - 97.6
1 -14UNS	32	157	16.0	115.7	128 - 186	13.0 - 19.0	94.0 - 137.4
13/16 -12UN	36	216	22.0	159.1	177 - 245	18.0 - 25.0	130.2 - 180.8

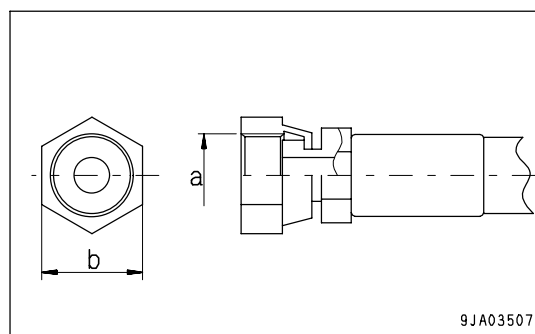

PERIODIC REPLACEMENT OF SAFETY CRITICAL PARTS

For using the machine safely for an extended period of time, you must periodically replace the safety critical and fire prevention-related parts listed in the table of important parts.

Material quality of these parts can change as time passes and they are likely to wear out or deteriorate. However, it is difficult to determine the extent of wear or deterioration at the time of periodic maintenance. Hence, it is required to replace them with new ones regardless of their condition after a certain period of usage. This is important to ensure that these parts maintain their full performance at all times.

Furthermore, should anything abnormal be found on any of these parts, replace it with a new one even if the periodic replacement time for the part has not yet arrived.

If any of the hose clamps show deterioration like deformation or cracking, replace the clamps at the same time as the hoses.

Also perform the following checks with hydraulic hoses which need to be replaced periodically. Tighten all loose clamps and replace defective hoses, as required.

When replacing hoses, always replace O-rings, gaskets, and other such parts at the same time.

Have your Komatsu distributor replace the critical parts.

No.	Safety critical parts	Q'ty	Replacement interval
1	Fuel hose (fuel tank - fuel pre-filter)	1	Every 2 years or 4000 hours, whichever comes sooner
2	Fuel hose (fuel pre-filter - supply pump)	1	
3	Fuel hose (supply pump - fuel main filter)	1	
4	Fuel hose (fuel main filter - supply pump)	1	
5	Fuel hose (supply pump - common rail overflow)	1	
6	Fuel hose (engine - fuel tank)	1	
7	Steering hose (pump - steering valve)	2	
8	Steering hose (steering valve - steering cylinder)	6	
9	Steering hose (steering valve - hydraulic tank)	2	
10	Steering hose (steering valve - hydraulic tank: seal drain circuit)	2	
11	Steering hose (steering valve - pump: LS)	1	
12	Brake hose (pump - charge valve)	1	
13	Brake hose (charge valve - hydraulic tank)	2	
14	Brake hose (charge valve - accumulator)	2	
15	Brake hose (accumulator - brake valve)	2	
16	Brake hose (brake valve - front axle)	3	
17	Brake hose (brake valve - rear axle)	2	
18	Brake hose (brake valve - hydraulic tank)	1	
19	Brake hose (accumulator - emergency release valve)	1	
20	Brake hose (emergency release valve - transmission valve)	1	
21	Transmission hose (pump - transmission valve)	1	
22	Transmission hose (transmission valve - transmission filter)	1	
23	Transmission hose (transmission filter - transmission main valve)	1	
24	Transmission hose (transmission - torque converter cooler)	1	
25	Transmission hose (torque converter cooler - transmission)	1	
26	Accumulator (for PPC)	1	
27	Alarm	2	
28	Engine high-pressure piping clamp	1set	Every 8000 hours
29	Fuel spray prevention cap	1set	
30	Seat belt	1	Every 3 years after beginning to use or 5 years after manufacturing of seat belt, whichever comes sooner

MAINTENANCE SCHEDULE CHART

MAINTENANCE SCHEDULE CHART

INITIAL 10 HOURS SERVICE (SERVICE FOR FIRST 50 HOURS ON NEW MACHINE)

LUBRICATING 4- 48

INITIAL 250 HOURS SERVICE (ONLY AFTER THE FIRST 250 HOURS)

CHANGE TRANSMISSION OIL FILTER CARTRIDGE 4- 55

REPLACE HYDRAULIC TANK FILTER ELEMENT 4- 58

INITIAL 1000 HOURS SERVICE (ONLY AFTER THE FIRST 1000 HOURS)

CHECK ENGINE VALVE CLEARANCE, ADJUST 4- 63

WHEN REQUIRED

CLEAN, REPLACE AIR CLEANER ELEMENT 4- 18

CLEAN INSIDE OF COOLING SYSTEM 4- 21

CHECK TRANSMISSION OIL LEVEL, ADD OIL 4- 24

CHECK AXLE OIL LEVEL, ADD OIL 4- 25

CLEAN AXLE CASE BREATHER 4- 26

CLEAN AIR CONDITIONER CONDENSER 4- 26

CHECK WINDOW WASHING FLUID LEVEL, ADD FLUID 4- 27

CLEAN RADIATOR FINS AND COOLER FINS 4- 27

TURN, REPLACE BOLT-ON CUTTING EDGE 4- 31

REPLACE BUCKET TEETH 4- 32

CHECK AIR CONDITIONER 4- 34

REPLACE SLOW BLOW FUSE 4- 35

CHECKING FUNCTION OF ACCUMULATOR 4- 36

SELECTION AND INSPECTION OF TIRES 4- 37

CHECK BEFORE STARTING

EVERY 50 HOURS SERVICE

DRAIN WATER, SEDIMENT FROM FUEL TANK 4- 40

EVERY 100 HOURS SERVICE

LUBRICATE REAR AXLE PIVOT PIN 4- 41

CHECK OIL LEVEL IN HYDRAULIC TANK, ADD OIL 4- 41

CLEAN ELEMENT IN AIR CONDITIONER FRESH AIR FILTER 4- 42

EVERY 250 HOURS SERVICE

CHECK BATTERY ELECTROLYTE LEVEL 4- 43

CHECK PARKING BRAKE 4- 44

CHECK AIR CONDITIONER COMPRESSOR BELT TENSION, ADJUST 4- 45

CHECK FOR LOOSE WHEEL HUB BOLTS, TIGHTEN 4- 46

CLEAN ELEMENT IN AIR CONDITIONER RECIRCULATION FILTER 4- 46

CHECKING FUNCTION OF ACCUMULATOR 4- 47

LUBRICATING 4- 48

EVERY 500 HOURS SERVICE

CHANGE OIL IN ENGINE OIL PAN, REPLACE ENGINE OIL FILTER CARTRIDGE ----- 4- 49
 REPLACE FUEL PRE-FILTER CARTRIDGE ----- 4- 50

EVERY 1000 HOURS SERVICE

REPLACE FUEL MAIN FILTER CARTRIDGE ----- 4- 53
 CHANGE OIL IN TRANSMISSION CASE AND TRANSMISSION OIL FILTER CARTRIDGE, CLEAN STRAINER ----- 4- 55
 CLEAN TRANSMISSION CASE BREATHER ----- 4- 56
 LUBRICATING ----- 4- 56
 CHECK OF ENGINE AIR INTAKE PIPING CLAMPS FOR LOOSENESS ----- 4- 57
 CHECK ALTERNATOR DRIVING BELT TENSION AND REPLACEMENT ----- 4- 57

EVERY 2000 HOURS SERVICE

CHANGE OIL IN HYDRAULIC TANK, REPLACE HYDRAULIC FILTER ELEMENT ----- 4- 58
 REPLACE HYDRAULIC TANK BREATHER ELEMENT ----- 4- 60
 CHANGE AXLE OIL(*) ----- 4- 61
 REPLACE ELEMENT IN AIR CONDITIONER RECIRCULATION AIR FILTER, FRESH AIR FILTER ---- 4- 61
 CHECK BRAKE DISC WEAR ----- 4- 62
 CHECKING FUNCTION OF ACCUMULATOR ----- 4- 63
 CHECK ALTERNATOR ----- 4- 63
 CHECK ENGINE VALVE CLEARANCE, ADJUST ----- 4- 63
 CHECK VIBRATION DAMPER ----- 4- 63

*: The interval of 2000 hours for changing the axle oil is for standard operations. If the brake is used frequently or the brakes make a sound, change the oil after a shorter interval.

EVERY 4000 HOURS SERVICE

LUBRICATING ----- 4- 64
 CHECK WATER PUMP ----- 4- 65
 CHECK STARTING MOTOR ----- 4- 65
 CHECK AIR CONDITIONER COMPRESSOR, ADJUST ----- 4- 65
 CHECK FOR LOOSE ENGINE HIGH-PRESSURE PIPING CLAMPS, HARDENING OF RUBBER ----- 4- 66
 CHECKING FOR MISSING FUEL SPRAY PREVENTION CAP, HARDENING OF RUBBER ----- 4- 66

EVERY 8000 HOURS SERVICE

REPLACE HIGH-PRESSURE PIPING CLAMP ----- 4- 67
 REPLACE FUEL SPRAY PREVENTION CAP ----- 4- 67

SERVICE PROCEDURE

INITIAL 10 HOURS SERVICE (SERVICE FOR FIRST 50 HOURS ON NEW MACHINE)

Carry out the following maintenance every 10 hours for the first 50 hours of operation of a new machine.

- Lubricating

For details of the method of replacing or maintaining, see the section on EVERY 250 HOURS SERVICE.

INITIAL 250 HOURS SERVICE

Perform the following maintenance only after the first 250 hours.

- Change transmission oil filter cartridge
- Replace hydraulic tank filter element

For details of the method of replacing or maintaining, see the section on EVERY 1000 HOURS and 2000 HOURS SERVICE.

INITIAL 1000 HOURS SERVICE

Carry out the following maintenance only after the first 1000 hours.

- Check engine valve clearance, adjust

For details of the method of replacing or maintaining, see the section on EVERY 2000 HOURS SERVICE.

WHEN REQUIRED

CLEAN, REPLACE AIR CLEANER ELEMENT



WARNING

- If inspection, cleaning, or maintenance is carried out with the engine running, dirt will get into the engine and damage it. Always stop the engine before carrying out these operations.
- When using compressed air, there is danger that dirt may be blown around and cause serious injury. Always use protective glasses, dust mask, and other protective equipment.

For inspection method, see "CHECK AIR CLEANER (PAGE 3-108)".

When the yellow piston of the dust indicator enters the red range (7.5 kPa) or the air cleaner clogging caution lamp of the machine monitor lights up, clean the air cleaner element.

CLEANING OUTER ELEMENT

1. Open the engine side cover on the right side of the chassis.
2. Remove three clips (1), then remove cover (2).

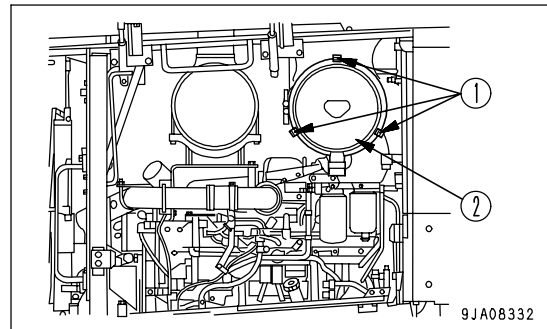

NOTICE

Never remove inner element (4). If it is removed, dust will enter and cause engine trouble.

3. Remove outer element (3).

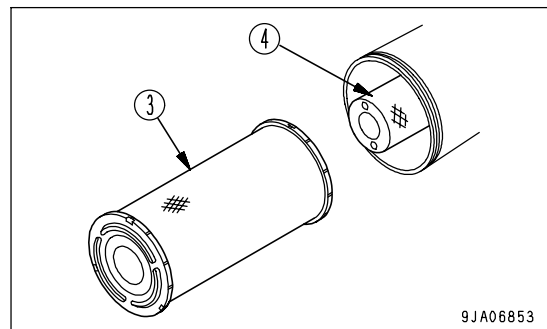

4. Clean the interior of the air cleaner body, cover (2) and evacuator valve (5).

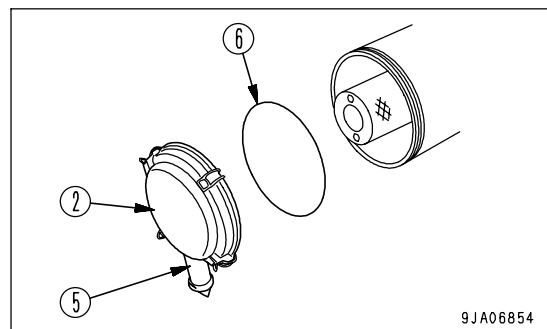

NOTICE

The inner element must not be used again even after cleaning. When replacing the outer element, replace the inner element at the same time.

5. Direct dry compressed air (less than 0.2 MPa (2.1 kg/cm², 30.0 PSI)) to the outer element from inside along its folds, then direct it from outside along its folds and again from inside.

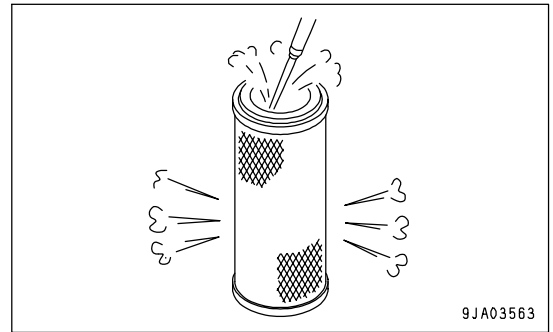

6. If small holes or thinner parts are found on the element when it is checked by shining a light through it after cleaning, replace the element.

NOTICE

When cleaning the element, do not hit or beat it against anything. Do not use an element whose folds, gasket or seal are damaged.

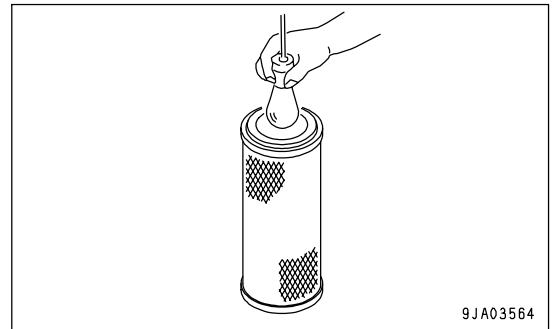

! CAUTION

When installing the cover (2), check O-ring (6) and replace it if there are any scratches or damage.

7. Set the cleaned outer element in position, then secure cover (2) with mounting clips (1).
8. Press the dust indicator button to return the yellow piston to its original position.

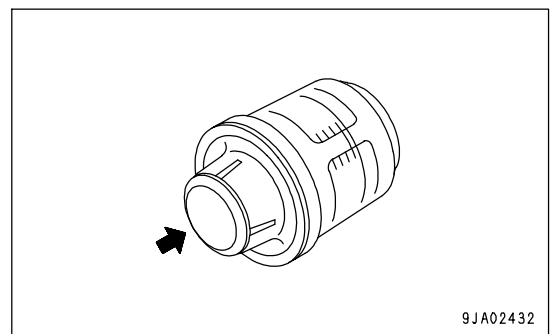

9. Close the engine side cover on the right side of the machine. After cleaning, if the air cleaner clogging caution lamp lights up immediately or the yellow piston reaches the red line (7.5 kPa), replace the inner and outer elements.

REPLACING ELEMENT

1. Open the engine side cover on the right side of the chassis.
2. Remove three clips (1), then remove cover (2).

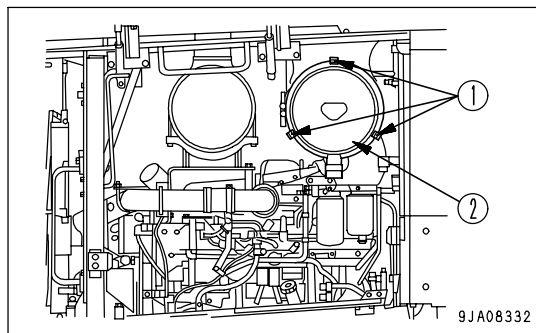

3. Remove outer element (3).
Do not remove inner element (4) at this time, however.

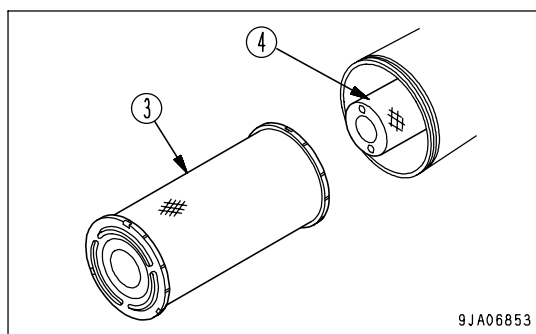

4. Clean the inside of the air cleaner body and dust cup.

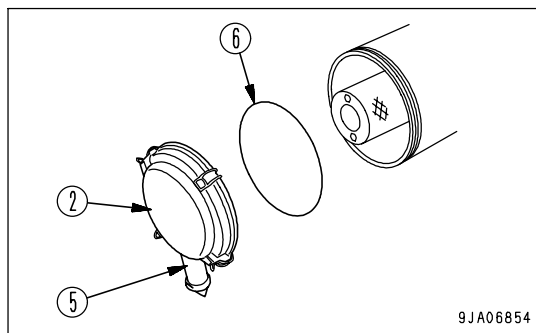

5. Remove inner element (4), then install a new inner element immediately.
6. Fit new outer element (3), replace O-ring (6) with a new part, install cover (2), then secure with clips (1).
7. Press the dust indicator button to return the yellow piston to its original position.

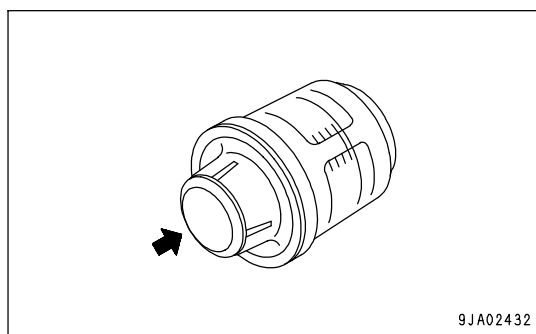

8. Close the engine side cover on the right side of the machine.

CLEAN INSIDE OF COOLING SYSTEM

 **WARNING**

- Immediately after the engine is stopped, the engine coolant is hot and the pressure inside the radiator is high. Removing the cap and draining the water under this condition could cause burns. Allow the engine to cool down, then turn the cap slowly to release the pressure.
- Start the engine and flush the system. Before standing up or leaving the operator's seat, set the work equipment lock lever to the LOCK position.
- For details of starting the engine, see "CHECK BEFORE STARTING ENGINE, ADJUST (PAGE 3-99)" and "STARTING ENGINE (PAGE 3-119)" in the OPERATION section of the Operation and Maintenance Manual.
- When the undercover is removed, there is danger of touching the fan.
Never enter the rear of the machine when the engine is running.

Clean the inside of the cooling system, change the coolant according to the table below.

Coolant	Interval for cleaning inside of cooling system and changing antifreeze coolant
Komatsu genuine SUPERCOOLANT (AF-NAC)	Every two years or every 4000 hours whichever comes first

Stop the machine on level ground when cleaning or changing the coolant.

Komatsu genuine SUPERCOOLANT (AF-NAC) has the important function of preventing corrosion as well as preventing freezing. Even in the areas where freezing is not an issue, the use of antifreeze COOLANT is essential. Komatsu machines are supplied with SUPERCOOLANT (AF-NAC). SUPERCOOLANT (AF-NAC) has excellent anticorrosion, antifreeze and cooling properties and can be used continuously for two years or 4000 hours. As a basic rule, we do not recommend the use of any COOLANT other than SUPERCOOLANT (AF-NAC). If you use another COOLANT, it may cause serious problems, such as corrosion of the engine and aluminum parts of the cooling system.

To maintain the anticorrosion properties of COOLANT, always keep the density of COOLANT between 30% and 68%.

When selecting COOLANT, investigate the lowest temperature in the past and decide the density for the COOLANT from the COOLANT density table below. When actually deciding the density for the COOLANT, set it about 10°C (18°F) below lowest temperature. The density must be over 30% at least. If the density of obtained COOLANT is higher than the necessary density for lowest temperature, dilute it with adequate distilled water, and then fill it into the tank.

If there is any unclear point, please contact your Komatsu distributor.

Coolant density table

Minimum Temp	°C	Above -10	-15	-20	-25	-30	-35	-40	-45	-50
	°F	Above 14	5	-4	-13	-22	-31	-40	-49	-58
Concentration (%)		30	36	41	46	50	54	58	61	64

! WARNING

- **COOLANT is toxic. When open the drain valve, be careful not to get coolant on you.**
If it gets in your eyes, flush your eyes with large amount of fresh water and see a doctor at once.
- **When changing the coolant or when handling the coolant containing COOLANT that has been drained during repair of radiator, please contact your Komatsu distributor or request a specialist company to carry out the operation. COOLANT is toxic. Do not let it flow into drainage ditches or spray it onto the ground surface.**

COOLANT is already diluted with distilled water, so it is not flammable. (For details of the distilled water, see "COOLANT AND WATER FOR DILUTION (PAGE 4-5)"). Check the density with a COOLANT tester. Prepare a container whose capacity is larger than the specified coolant volume to catch drained coolant. Prepare a hose to use when filling with coolant.

1. Stop the machine in a horizontal place.
2. Stop the engine.
3. Check that the coolant temperature has gone down enough to make it possible to touch the radiator cap surface by hand, then turn radiator cap (1) slowly until it contacts the stopper to release the pressure.
4. Following this, push radiator cap (1), turn it until it contacts the stopper, then remove it.

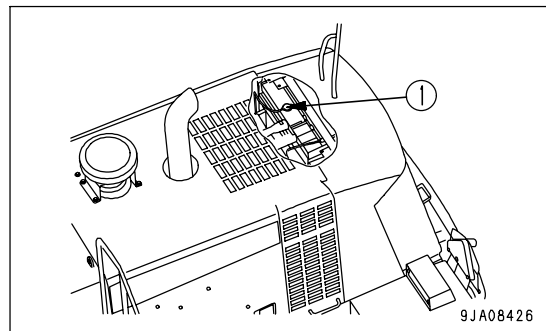

5. Set a container in position to catch the coolant, then open drain valve (2) at the left side of the fuel tank.
6. After draining the water, close drain valve (2) and fill with city water.
7. When the radiator is full, start the engine, and run it at low idle. Keep the engine running at low idle for 10 minutes until the coolant temperature reaches more than 90°C (194°F).
8. Stop the engine, open drain valve (2), drain the water, then tighten the drain valve again.

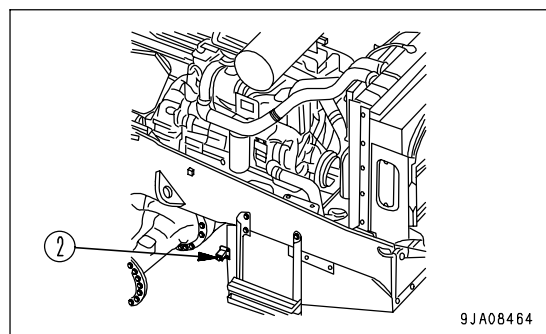

9. After draining the water, clean the cooling system with cleaning agent.
For the cleaning method, see the instructions for the cleaning agent.
10. Add coolant through the water filler port up to the mouth of the port. For details of the COOLANT density, see "COOLANT DENSITY TABLE".
11. To bleed the air from the cooling system, run the engine at low idle for 5 minutes, and for a further 5 minutes at high idle. (When doing this, leave the radiator cap off.)

- 12. After draining off the coolant of sub tank (3), clean the inside of the sub tank and refill the water between FULL and LOW level.
- 13. Stop the engine, wait for approximately 3 minutes, add coolant up to the mouth of the filler port, and tighten the cap.

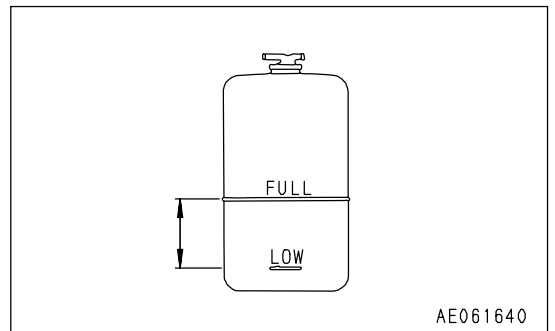
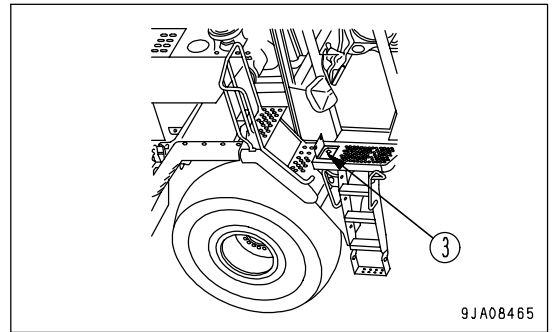

CHECK TRANSMISSION OIL LEVEL, ADD OIL

**WARNING**

The parts and oil are at high temperature immediately after the engine is stopped, and may cause burns. Wait for the temperature to go down before starting the work.

Carry out this procedure if there is any sign of oil on the transmission case, or if there is oil mixed with the cooling water.

1. Start the engine and run it for at least 5 minutes.
2. Open the cap of oil filler port (F), remove dipstick (G), and wipe the oil off with a cloth.
3. Fully insert dipstick (G) into filler pipe, then remove it.

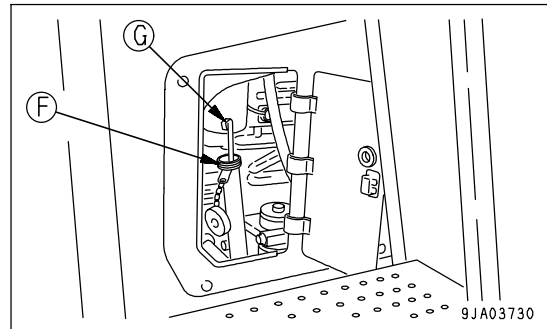

4. The oil level should be between the H and L marks on dipstick (G).
If the oil level is below the L mark, add oil through oil filler port (F).

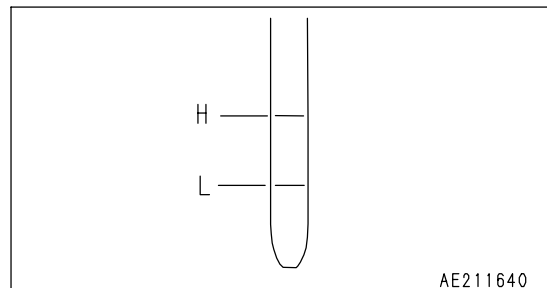

5. If the oil is above the H mark, drain the excess oil from drain plug (P), and check the oil level again.
6. If the oil level is correct, insert dipstick (G) in the dipstick guide, then tighten the cap.

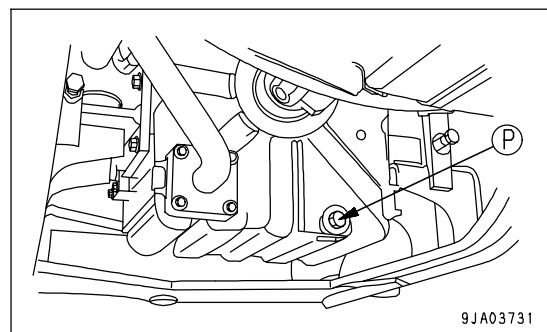

CHECK AXLE OIL LEVEL, ADD OIL

! WARNING

- When checking the oil level, apply the parking brake and secure the front and rear frames with the frame lock bar.
- After stopping the engine, the parts and oil are at a high temperature. Wait for the temperature to go down before starting the operation.

Perform this procedure if there is any sign of oil on the axle case.
 Inspect the machine on a horizontal surface.
 (If the road surface is at an angle, the oil level cannot be checked correctly.)

- A: Front B: Rear

1. Stop the engine and remove oil level plug (1).

REMARK

Remove the mud and dirt from around plug (1), then remove the plug.

2. With cloth, wipe off any oil adhering to the oil level gauge attached to plug (1).

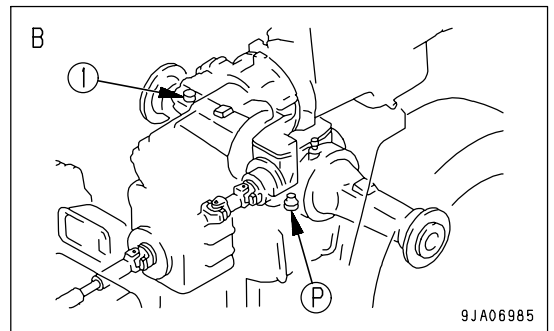
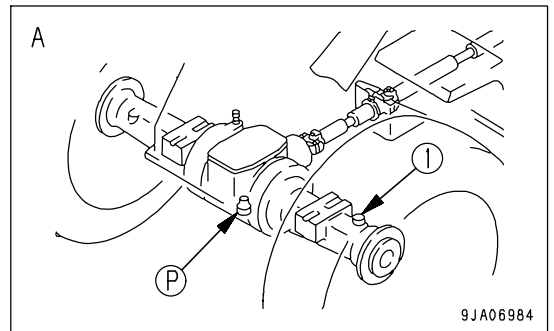

3. Set the oil level gauge (G) as shown in the right diagram.
 - (2): Axle
 - (3): Spot facing face)
4. The oil level should be between the two lines (H) and (L) on the oil level gauge.
 - If the oil is below the (L) line, add axle oil through oil filler port (F).

REMARK

For axles with ASD (Limited-Slip Differential), the brand of lubricating oil is different. Use the specified lubricating oil.

5. If the oil level is above the (H) line, drain the excess oil through drain plug (P), then check the oil level again.
6. If the oil level is correct, install plug (1).
 - Tightening torque: 127 to 177 Nm (13 to 18 kgm, 94.0 to 130.2 lbf)

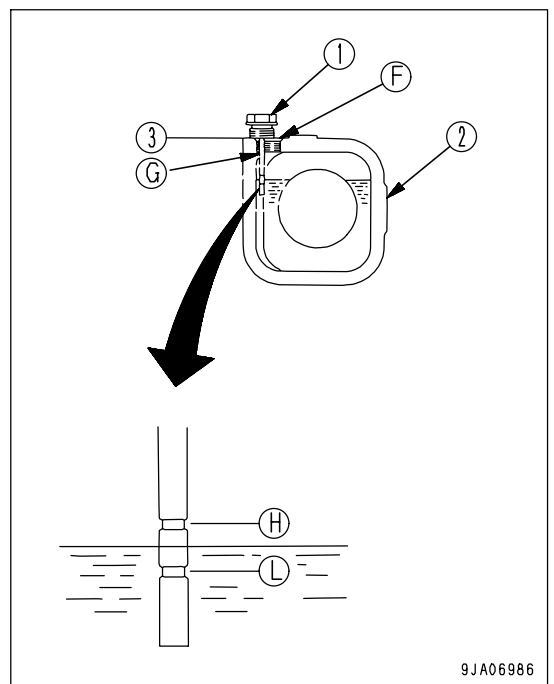

CLEAN AXLE CASE BREATHER



WARNING

When cleaning the axle breather, apply the parking brake and secure the front and rear frames with the frame lock bar.

- A: Front B: Rear

Remove all mud and dirt from around the breather with a brush. After removing the mud or dirt from around the breather, remove the breather, immerse it in cleaning fluid and clean it. When cleaning the breather, clean the breathers at two places (front and rear). After removing the breather, take steps to prevent dirt or dust from entering the mount.

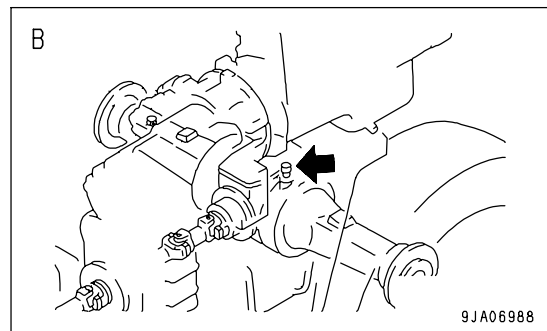
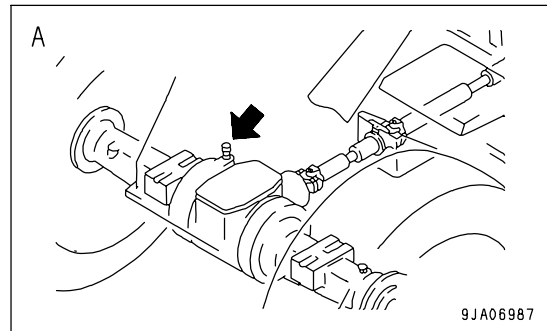

CLEAN AIR CONDITIONER CONDENSER



WARNING

- Do not wash the condenser with a steam cleaner. There is danger that the condenser could overheat.
- If high-pressure water hits your body directly or dirt is sent flying, there is danger of personal injury. Always wear protective glasses, dust mask, and other protective equipment.

If there is mud or dust on the air conditioner condenser, clean it with water.

If the water pressure is too high, the fins may get deformed. When washing with a high pressure washing machine, apply the water from a reasonable distance.

WASHING METHOD

Open the engine side cover on the left of the machine and wash the top of condenser (1) with water.

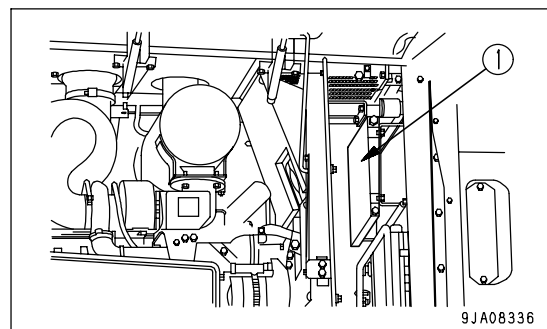

CHECK WINDOW WASHING FLUID LEVEL, ADD FLUID

Check the washing fluid levels in washer tank (1). When the fluid has run low, add automotive window washing fluid.

Be careful not to let dust get into the fluid.

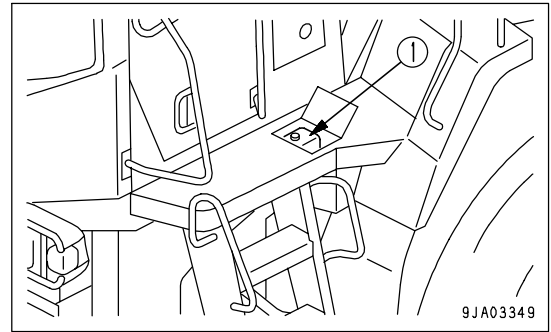

CLEAN RADIATOR FINS AND COOLER FINS

! WARNING

- Never open the engine side cover when the engine is running. Stop the engine completely before starting the cleaning operation.
- If compressed air, pressurized water, or steam hits your body directly, or causes dirt to fly, it may lead to personal injury. Always wear safety glasses, dust mask, or other protective equipment.

Clean the radiator fins if any mud or dirt is stuck to the radiator.

CLEAN FINS BY ROTATING COOLING FAN IN REVERSE

NOTICE

When rotating the fan in reverse, be careful of flying dust, and be careful not to let any cloth get caught in the fan.

Dust may rise, so check that there is no one in the surrounding area when rotating the fan in reverse.

On jobsites where it is easy for dirt to stick to the radiator or cooler, turn cooling fan reverse rotation switch (1) ON to rotate the fan in reverse. This will blow off the dirt and dust stuck to the radiator or cooler, and can extend the cleaning interval.

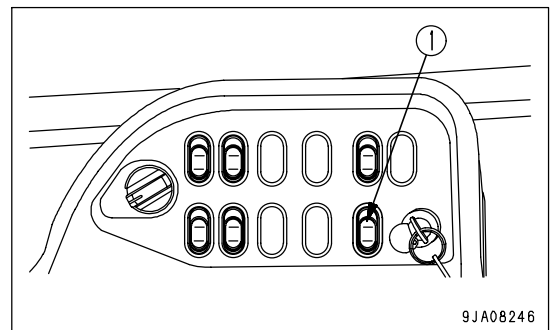

MANUAL FAN REVERSING METHOD

NOTICE

- Never rotate the fan in reverse by hand when carrying out the operation.
- Before operating the fan reverse rotation switch, run the engine at low idling.

1. Set the directional lever to the Neutral position.
2. Set the parking brake switch to the ON position to apply the parking brake.
3. Run the engine at low idling.
4. Press position (a) (manual reverse rotation ON) of cooling fan reverse rotation switch (1).

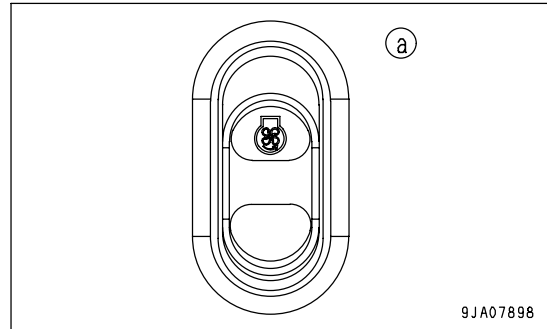

5. After the cooling fan reverse rotation pilot lamp on the machine monitor flashes, check that it lights up. At the same time, "COOLING FAN REVERSE" is displayed on the character display and the fan is set to rotate in reverse.

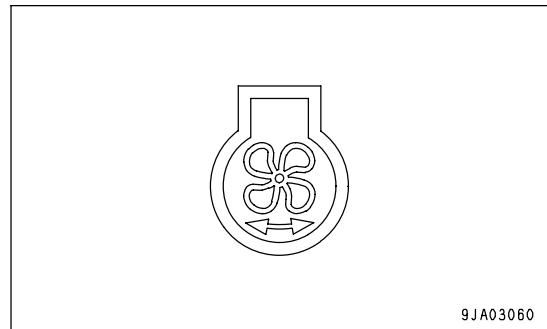

6. Run the engine at high idling.
 - Select the time for running the engine at high idle as follows according to the condition of clogging.
 - Normal clogging: 1 to 2 minutes
 - Excessive clogging: 2 to 3 minutes
7. When the cleaning is completed, run the engine at low idling.
8. Press position (a) (manual reverse rotation ON) of cooling fan reverse rotation switch (1).

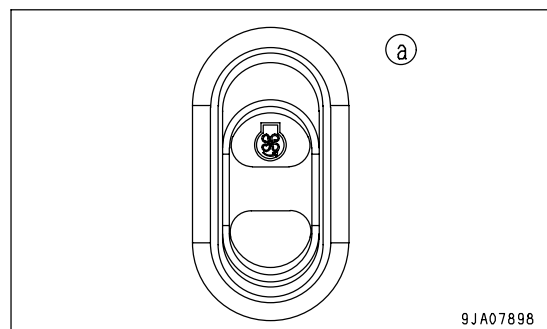

9. After the cooling fan reverse rotation pilot lamp on the machine monitor flashes, check that it goes out. The fan is set to rotate in the normal direction.

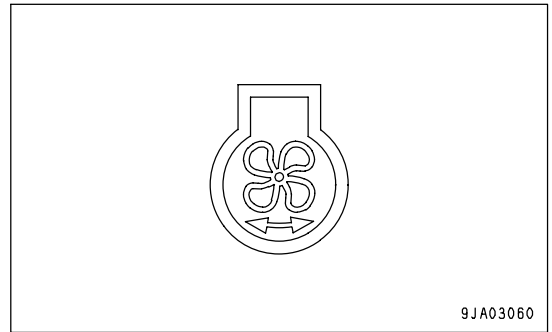

10. Run the engine at low idling for approx. 10 seconds.

AUTOMATIC FAN REVERSING METHOD

(If equipped)

1. Run the engine at low idling.
2. Press position (a) (auto reverse rotation ON) of cooling fan reverse rotation switch (1).
3. Check that pilot lamp inside of the switch and the cooling fan reverse rotation pilot lamp on the machine monitor light up. The fan automatically rotates in reverse for 2 minutes every 2 hours.

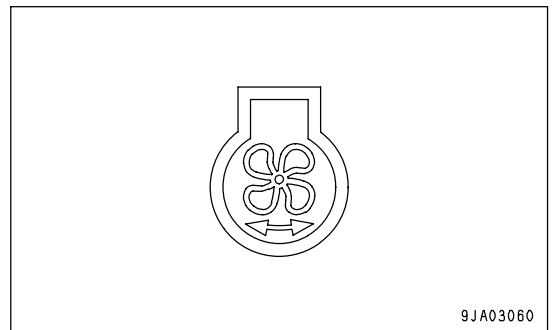
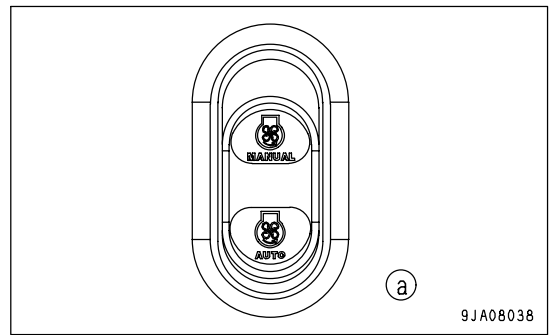

CLEAN FINS WITH COMPRESSED AIR

Insert the jet nozzle through the gap between the radiator, oil cooler, aftercooler (1) and air conditioner condenser (2) to clean the fins.

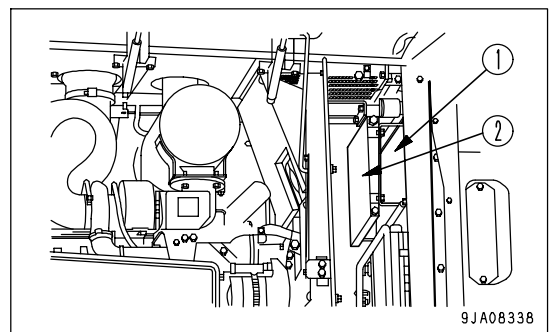

When cleaning the face behind the radiator, or oil cooler, and aftercooler (1), remove bolt (4) and plate (3), then insert the jet nozzle through the opening to clean the fins.

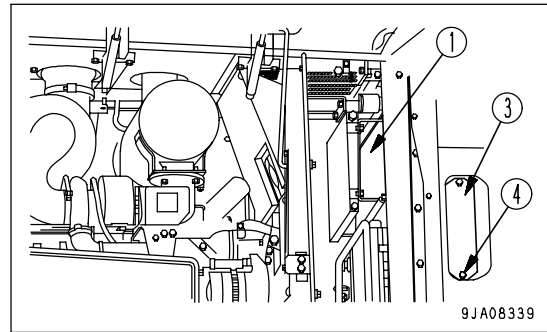

Steam or water can be used instead of compressed air. But, make sure to keep a reasonable distance when performing washing with powerful steam (high-pressure washing) to heat exchange devices (radiator, cooler). If steam washing (high pressure washing) is performed from point-blank distance, fins inside the heat exchange device may deform which will cause clogging or damage on early stage.

Examine the rubber hoses, and if any hose is cracked or deteriorated, replace it. Check also that there are no loose hose clamps.

TURN, REPLACE BOLT-ON CUTTING EDGE

! WARNING

It is dangerous if the work equipment moves by mistake during the turning or replacement operation. Set the work equipment in a stable condition, stop the engine, then set the work equipment lock lever securely to the LOCK position.

Turn or replace the cutting edge before the wear reaches the edge of the bucket.

1. Raise the bucket to a suitable height, then put blocks (A) under the bucket to prevent the bucket from coming down. Raise the bucket so that the bottom surface of the bucket is horizontal.
2. Remove nuts and bolts (1), then remove cutting edge (2).
3. Clean the mounting surface of cutting edge (2).
4. Turn cutting edge (2) and install it to the bucket. When turning the edge, install it to the opposite side (left edge to right side, right edge to left side).

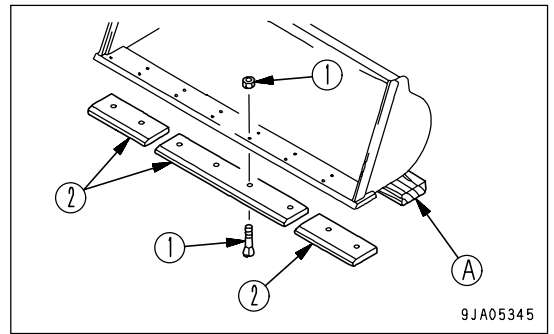

- If both sides of the cutting edge are worn, replace with a new part.
- If the wear extends to the mounting surface, repair the mounting surface before installing the cutting edge.
5. Tighten nuts and bolts (1) uniformly so that there is no gap between the bucket and cutting edge. Tightening torque for mounting bolt: $745 \pm 108 \text{ Nm}$ ($76 \pm 11 \text{ kgm}$, $549.7 \pm 79.6 \text{ lbft}$)
 6. Tighten the mounting bolts again after operating for several hours.

REPLACE BUCKET TEETH

ONE-PIECE TOOTH

(If equipped)

When the bucket teeth are worn, replace them as follows.

1. Raise the bucket to a suitable height, then put blocks (A) under the bucket to prevent the bucket from coming down.

Raise the bucket so that the bottom surface of the bucket is horizontal.

2. Remove the bolt and nuts (1) and (2), then remove bucket tooth (3).
3. Clean the installation surface of bucket tooth (3).
4. Install new teeth to the bucket.

When doing this, insert shims so that there is no clearance between the teeth and the top surface of the bucket.

Continue to add shims until it becomes impossible to add a 0.5 mm (0.02 in) shim.

If the mounting surface is worn, correct the mounting surface before installing the teeth.

5. To prevent any gap from forming between the teeth and tip of the bucket, tighten bolts and nuts (1) and (2) temporarily, then hit the tip of the teeth with a hammer.

Tightening torque of mounting bolt (1): 637 ± 853 Nm (65 ± 87 kgm, 470.1 ± 629.3 lbft)

(2): 618 Nm (63 kgm, 455.7 lbft)

6. After operating the machine for a few hours, tighten the mounting bolts again.

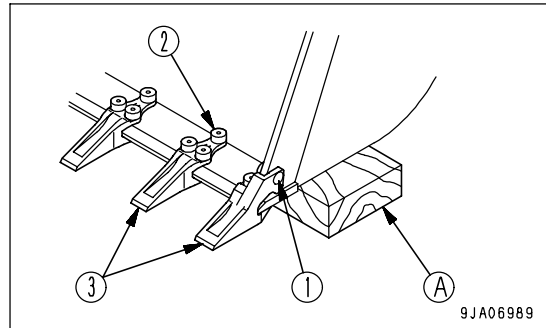

BUCKET WITH TIP TOOTH

! WARNING

- If the pin is hit out with strong force, there is danger that the pin may fly out. Check that there is no one in the surrounding area.
- There is danger of pieces flying during the replacement operation, so always wear protective clothing, such as safety glasses and gloves.

Replace the teeth before they wear down as far as the adapter.

1. Raise the bucket to a suitable height, then put blocks (A) under the bucket to prevent the bucket from coming down. Raise the bucket so that the bottom surface of the bucket is horizontal.

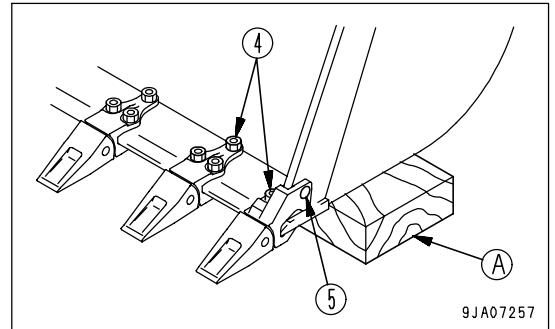

2. Remove pin (2) installed to the bucket, then remove tooth (1). Put a rod (slightly narrower than the pin) in contact with the hatched portion (either left or right) and tap pin (2) out to the opposite side.

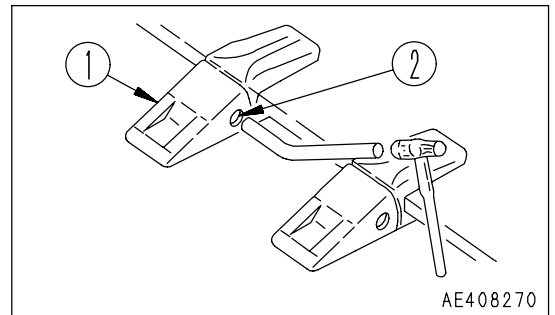

3. Fit new tooth (1) in adapter (3), push in pin (2) partially by hand, then knock it in with a hammer.
4. After operating the machine for a few hours, check that the pin does not come out.

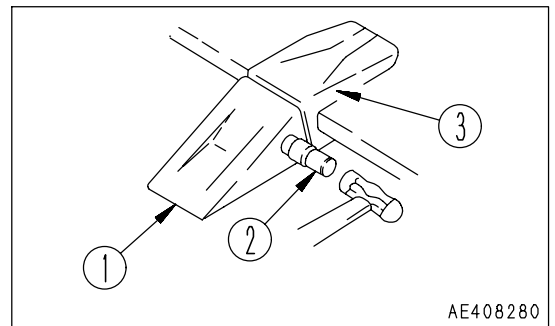

5. If mounting bolts (4) or (5) of adapter (3) are loose, tighten them.
 Tightening torque of mounting bolt (4): 637 ± 853 Nm (65 ± 87 kgm, 470.1 ± 629.3 lbf)
 (5): 618 Nm (63 kgm, 455.7 lbf)

CHECK AIR CONDITIONER

CHECK LEVEL OF REFRIGERANT (GAS)



If the refrigerant used in the air conditioner gets into your eyes or on your hands, it may cause loss of sight or frostbite. Do not touch the refrigerant. Never loosen any part of the refrigerant circuit. Do not bring any flame close to any point where the refrigerant gas is leaking.

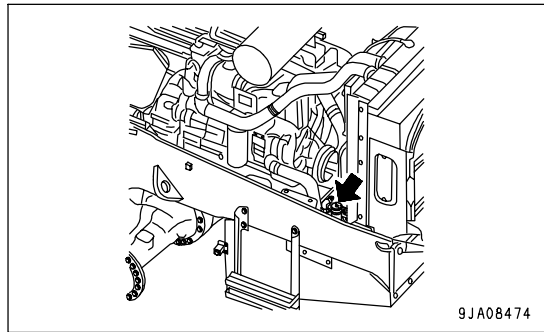

9JA08474

1. Start the engine and set the engine speed to approx. 1500 rpm.
2. Press main power switch (1) of the air conditioner to turn the power ON.
3. Press fan switch (2) and set the air flow to "Hi".
4. Press temperature control switch (3) and set the display monitor to COOL (A).
5. Open the door and window fully.
6. Press air conditioner switch (4) to turn the air conditioner switch ON.
7. Use sight glass (6) (inspection window) of receiver drier (5) to check the condition of the refrigerant gas (freon 134a) flowing in the refrigerant circuit.

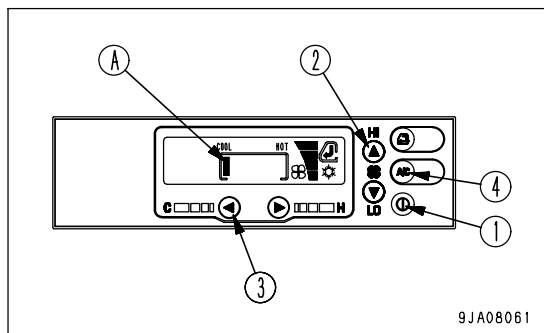

9JA08061

A: Quantity of refrigerant

B: Condition of sight glass

a: Proper: After air conditioner switch is turned ON, few bubbles are seen and refrigerant becomes milk-white and then becomes pale milk-white.

b: Insufficient refrigerant: After air conditioner switch is turned ON, bubbles are seen continuously.

X: Condition of refrigerant flow

Y: Condition of sight glass

x: There are bubbles: Gas and liquid of refrigerant are mixed.

y: There are not bubbles: All refrigerant is liquefied and transparent.

z: Refrigerant is milk-white: Oil and refrigerant are separated from each other and their mixture is pale milk-white.

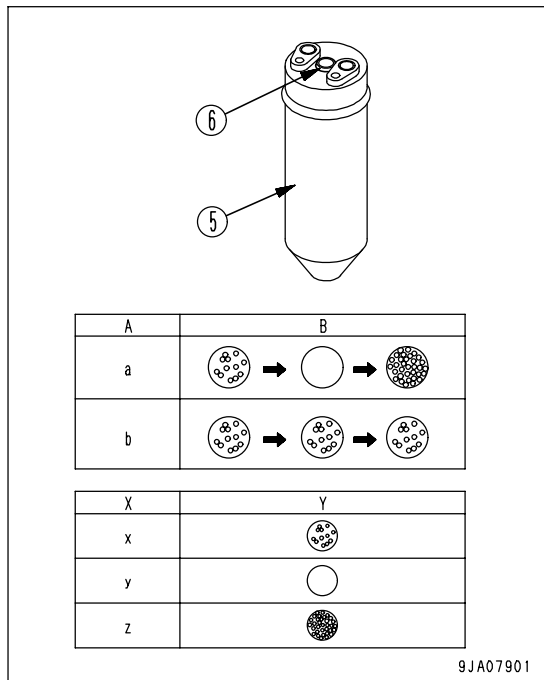

9JA07901

MAINTENANCE AND INSPECTION AND TIME TO EXECUTE THEM

Inspection location	Item to check for	Maintenance interval		
		Check before operating	6 months	Replacement interval
Filter	Clogging, dirt	Carry out check	-	2 years
Condenser	Clogging, dirt	Carry out check	-	-
Belt	Looseness, damage	Carry out check	-	2 years
Refrigerant gas	Amount	-	Carry out check	-
Piping	Looseness, damage, leakage	-	Carry out check	-
Receiver drier	-	-	-	2 years

REPLACE SLOW BLOW FUSE

NOTICE

- Always turn the power OFF when replacing the slow blow fuse (turn the starting switch to the OFF position).
- Always replace the slow blow fuse with a fuse of the same capacity.

1. Turn the starting switch to the OFF position (A).
2. Remove the slow blow fuse box from the chassis.

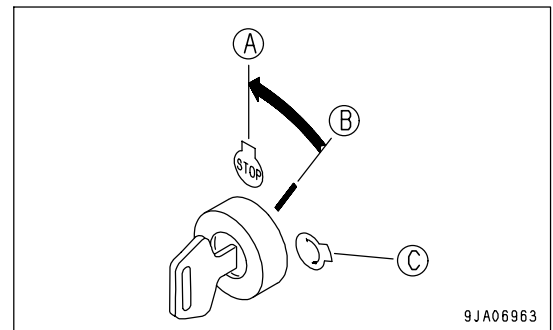

3. Open covers (1), (2), and (3) of the slow blow fuse box. Covers (2) and (3) can be removed easily by using protrusion (A) on the body as a fulcrum and levering the catch of the cover with a flat-headed screwdriver to release it.
4. Loosen screws (4) and (5), and remove. When screws (4) and (5) are removed, slow blow fuse (6) will also come off together with electric wiring (7) and (8).
5. Using screws (4) and (5), install a new slow blow fuse together with electric wiring (7) and (8) to the slow blow fuse box, then close covers (1), (2), and (3).
6. Install the slow blow fuse box to the chassis.

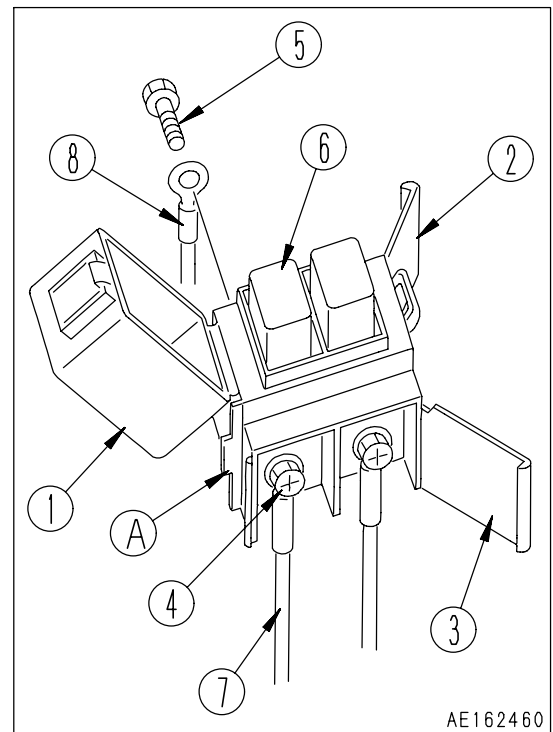

CHECKING FUNCTION OF ACCUMULATOR

For details of handling the accumulator, see Section "HANDLING ACCUMULATOR AND GAS SPRING (PAGE 2-42)".

ACCUMULATOR FOR TRAVEL DAMPER

When the travel damper switch is ON, the hydraulic spring effect of the accumulator absorbs the up-and-down motion of the machine during travel and reduces the swaying.

Drive the machine and compare the up-and-down movement of the machine during travel when the travel damper switch is ON and when it is OFF.

If there is no change in the up-and-down movement of the machine, the gas pressure in the accumulator has probably dropped.

Please contact your Komatsu distributor to have the accumulator inspected.

REMARK

Carry out the inspection with the speed range set to 2 - 4, with the machine traveling at a speed of at least 5 km/h. If the speed range is 1st or the machine is traveling at a speed of less than 5 km/h, the E.C.S.S. will not be actuated even if the E.C.S.S. switch is turned ON.

ACCUMULATOR FOR BRAKE DAMPER

When the brake pedal is depressed, the hydraulic spring effect of the accumulator actuates the brake smoothly.

If any change is felt in the smoothness of the brake operation during daily operations, the gas pressure in the accumulator has probably dropped.

Please contact your Komatsu distributor to have the accumulator inspected.

REMARK

Even if there is any change in the smoothness, there is no drop in the braking force or brake performance.

SELECTION AND INSPECTION OF TIRES

! WARNING

If a tire or a rim is handled improperly, the tire may burst or may be damaged and the rim may be broken and scattered, and that can cause serious injury or death.

- Since maintenance, disassembly, repair and assembly of the tires and rims require special equipment and skill, be sure to ask a tire repair shop to do the work.
- Do not heat or weld the rim to which the tire is installed. Do not make a fire near the tire.

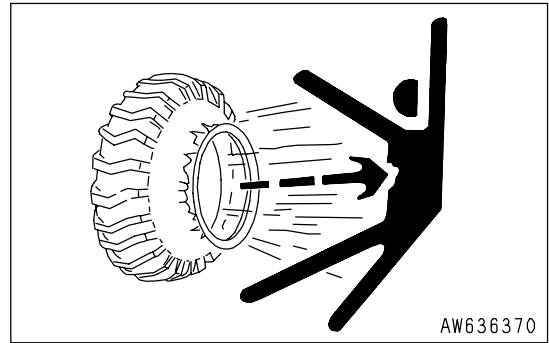

SELECTION OF TIRES

! WARNING

Select the tires according to the conditions of use and the weight of the attachments on the machine. Use only specified tires and inflate them to the specified pressure.

Select the tires according to the conditions of use and the weight of the attachments of the machine. Use the following table.

Since the travel speed indicated on the speedometer varies with the tire size, consult your Komatsu distributor when using optional tires.

		Tire size	Maximum load [kg (lb)]
Standard	Front and Rear	23.5-25-16PR	9,095 (20,051)

CHECK INFLATION PRESSURE OF TIRES

WARNING

When inflating a tire, check that no one will enter the working area. Use an air chuck which has a clip and which can be fixed to the air valve.

- While inflating the tire, check the inflation pressure occasionally so that it will not rise too high.
- If the rim is not fitted normally, it may be broken and scattered while the tire is inflated. To ensure safety, place a guard around the tire and do not work in front of the rim but work on the tread side of the tire.
- Abnormal drop of inflation pressure and abnormal fitting of the rim indicate trouble in the tire or rim. In this case, be sure to ask a tire repair shop to carry out repairs.
- Be sure to observe the specified inflation pressure.
- Do not adjust the inflation pressure of the tires just after high-speed travel or heavy-duty work.

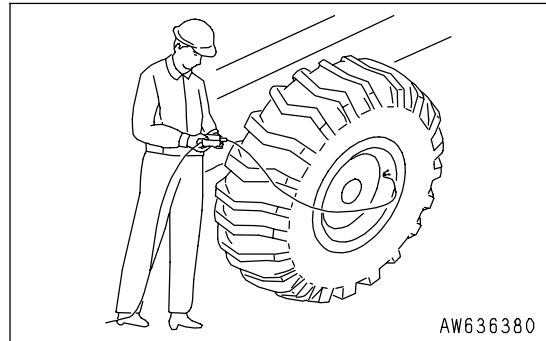

CHECK

Measure the inflation pressure with a tire pressure gauge, while the tires are cool, before starting work.

INFLATION OF TIRES

Adjust the inflation pressure properly.

When inflating a tire, use an air chuck which can be fixed to the air valve of the tire as shown in the figure. Do not work in front of the rim but work on the tread side of the tire.

The proper inflation pressure is shown below.

	Tire size	Inflation pressure
Standard	23.5-25-16PR	Front Tire: 350 kPa (3.5kgf/cm ² , 49.3 PSI) Rear Tire: 310 kPa (3.1kgf/cm ² , 43.5 PSI)

NOTICE

The optimum inflation pressure differs according to the type of work. For details, see "HANDLING THE TIRES (PAGE 3-156)".

CHECK BEFORE STARTING

For the following items, see "CHECK BEFORE STARTING (PAGE 3-103)".

- Check machine monitor
- Check coolant level, add coolant
- Check oil level in engine oil pan, add oil
- Check water separator
- Check air cleaner
- Check fuel level, add fuel
- Check electric wiring
- Check inflation pressure of tires
- Check window washer spray condition
- Check wiping efficiency of wiper
- Check horn
- Check defroster function
- Check locks
- Check emergency exit

EVERY 50 HOURS SERVICE**DRAIN WATER, SEDIMENT FROM FUEL TANK**

Loosen valve (1) on the right side of the tank so that the sediment and water will be drained together with fuel.

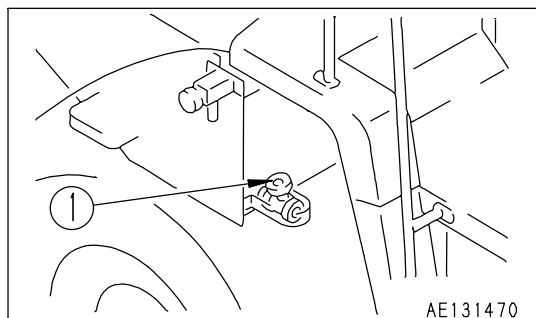

EVERY 100 HOURS SERVICE

Maintenance for every 50 hours service should be carried out at the same time.

LUBRICATE REAR AXLE PIVOT PIN

(3 places)

1. Using a grease pump, pump in grease through the grease fittings marked by the arrows.
2. After greasing, wipe off any old grease that was pushed out.

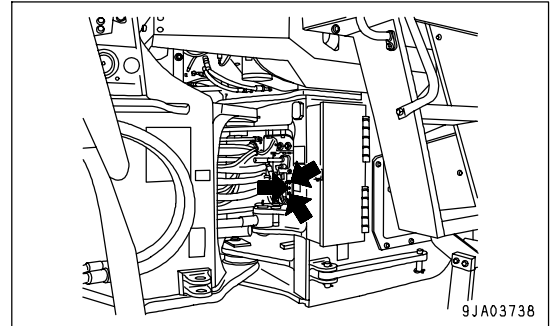

CHECK OIL LEVEL IN HYDRAULIC TANK, ADD OIL



WARNING

- The parts and oil are at high temperature immediately after the engine is stopped, and may cause burns. Wait for the temperature to go down before starting the work.
- When removing the oil filler cap, turn it slowly to release the internal pressure, then remove it.

1. Lower the bucket horizontally to the ground and stop the engine. Wait for 5 minutes, then check sight gauge (G). The oil level should be between the H and L marks.

NOTICE

If the oil has been added to above H level, stop the engine and wait for the hydraulic oil to cool down, then drain the excess oil from the drain plug. If the oil is above H level, it will damage the hydraulic circuit or cause the oil to spurt out.

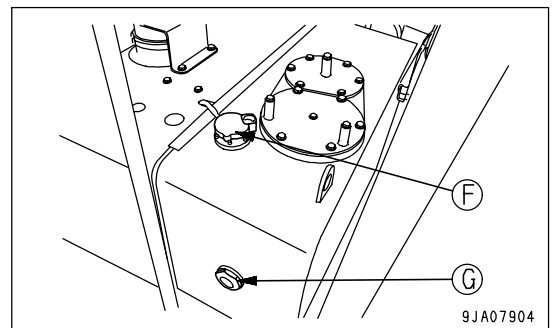

2. If the level is below the L mark, add oil through oil filler (F).

CLEAN ELEMENT IN AIR CONDITIONER FRESH AIR FILTER



WARNING

If compressed air scattered around dust and debris, there is danger of injury. Always wear protective equipment such as protective glasses and mask.

If the air conditioner has been used, the air filter should be cleaned.

Stop the air conditioner before cleaning the element.

Articulate the machine fully to the right before replacing the air filter element.

1. Insert the starting key into key slot (1), release the lock, loosen knob (2), and open cover (3).

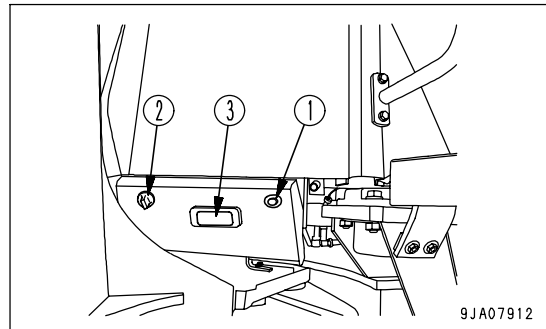

2. Take out element (4) and clean it.
3. Blow dry compressed air (less than 0.2 MPa (2.1 kg/cm², 30.0 PSI)) from the inside of the element along its folds. Then blow the compressed air from the outside along the folds, and again from the inside.
Replace the filter with a new part if the clogging cannot be removed with compressed air, or if it has been used for 1 year.
4. After cleaning, return filter (4) to its original position and close the cover. Use the starting switch key to lock the cover. Do not forget to remove the starting switch key.

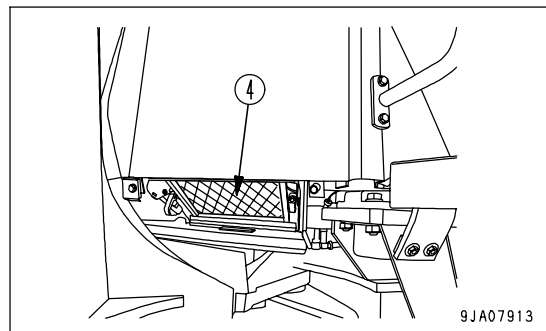

REMARK

If the filter becomes clogged, the air flow will be reduced, and there will be an abnormal noise from the air conditioner unit.

EVERY 250 HOURS SERVICE

Maintenance for every 50 and 100 hours service should be carried out at the same time.

CHECK BATTERY ELECTROLYTE LEVEL

Carry out this procedure before operating the machine.

WARNING

- Do not use the battery if the battery electrolyte level is below the LOWER LEVEL line. This will accelerate deterioration of the inside of the battery and reduce the service life of the battery. In addition, it may cause an explosion.
- The battery generates flammable gas and there is danger of explosion, do not bring fire or sparks near the battery.
- Battery electrolyte is dangerous. If it gets in your eyes or on your skin, wash it off with a large amount of water and consult a doctor.
- When adding distilled water to the battery, do not allow the battery electrolyte to go above the UPPER LEVEL line. If the electrolyte level is too high, it may leak and cause damage to the paint surface or corrode other parts.

NOTICE

If there is a fear that the battery water may freeze after refilling with purified water (e.g. commercially available replenishment water for a battery), do the replenishment before the day's work on the next day.

Inspect the battery electrolyte level at least once a month and follow the basic safety procedures given below.

WHEN CHECKING ELECTROLYTE LEVEL FROM SIDE OF BATTERY

If it is possible to check the electrolyte level from the side of the battery, check as follows.

1. Open the cover of the battery box.

There are two battery boxes: One on each side at the rear of the machine.

2. Use a wet cloth to clean the area around the electrolyte level lines and check that the electrolyte level is between the UPPER LEVEL (U.L.) and LOWER LEVEL (L.L.) lines.

If the battery is wiped with a dry cloth, static electricity may cause a fire or explosion.

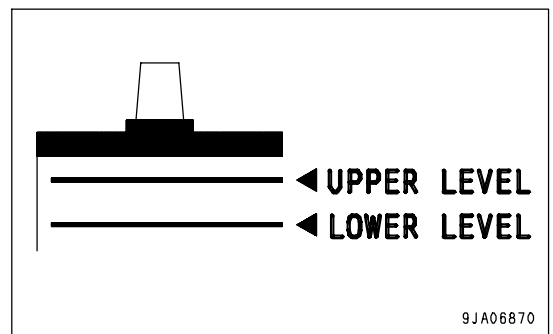

3. If the electrolyte level is below the midway point between the UPPER LEVEL (U.L.) and LOWER LEVEL (L.L.) lines, remove cap (1) and add distilled water to the U.L. line.

4. If distilled water has been added to any cell of cap (1), add distilled water also to the other cells.

5. Clean the vents of the battery caps, then close the caps securely.

Keep the top of the battery clean and wipe it with a wet cloth.

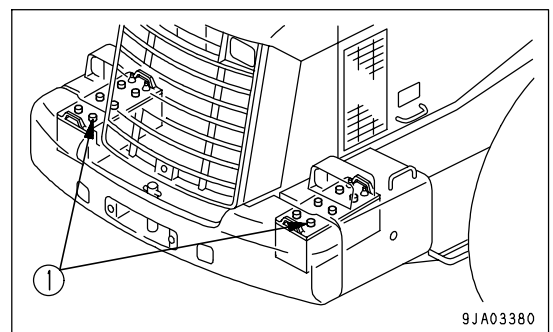

REMARK

If distilled water is added to above the UPPER LEVEL (U.L.) line, use a syringe to lower the level to the UPPER LEVEL (U.L.) line. Neutralize the removed fluid with baking soda (sodium bicarbonate), then flush it away with a large amount of water or consult your Komatsu distributor or battery maker.

WHEN IT IS IMPOSSIBLE TO CHECK ELECTROLYTE LEVEL FROM SIDE OF BATTERY

If it is impossible to check the electrolyte level from the side of the battery, or there is no display of the UPPER LEVEL line on the side of the battery, check as follows.

1. Open the cover of the battery box.

There are two battery boxes: One on each side at the rear of the machine.

2. Remove cap (1) at the top of the battery, look through the water filler port (2), and check the electrolyte surface. If the electrolyte does not reach the sleeve (3), add distilled water so that the level reaches the bottom of the sleeve (UPPER LEVEL line) without fail.

- (A) Suitable level: Electrolyte level is up to bottom of sleeve, so surface tension causes electrolyte surface to bulge and poles appear bent.
- (B) Low: Electrolyte level is not up to bottom of sleeve, so poles appear straight and not bent.

3. If distilled water has been added to any cell of cap (1), add distilled water also to the other cells.

4. After adding distilled water, tighten cap (1) securely.

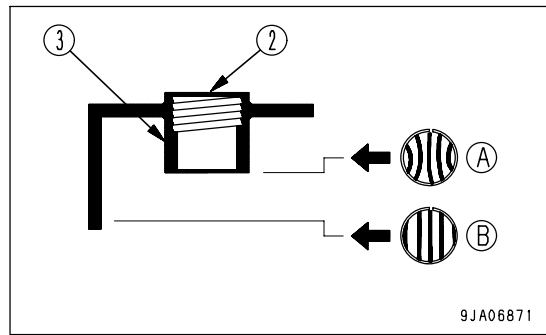
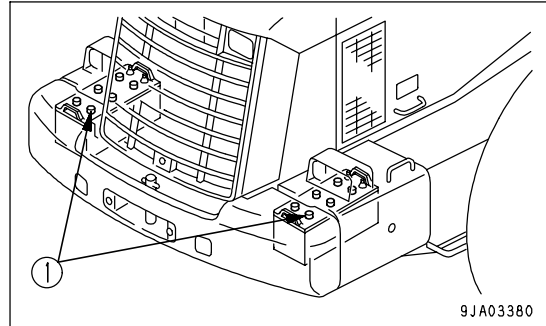
**REMARK**

If water is added to above the bottom tip of the sleeve, use a pipette to remove electrolyte. Neutralize the removed electrolyte with sodium bicarbonate, then flush it away with a large amount of water. If necessary, contact your Komatsu distributor or your battery maker.

WHEN IT IS POSSIBLE TO USE INDICATOR TO CHECK ELECTROLYTE LEVEL

If it is possible to use an indicator to check the electrolyte level, follow the instructions given.

CHECK PARKING BRAKE

1. Stop the machine on a dry slope (downhill slope), set the parking brake switch to the ON position (A), and check that the brake holds the machine in that position.
2. If any problem is found, please contact your Komatsu distributor.

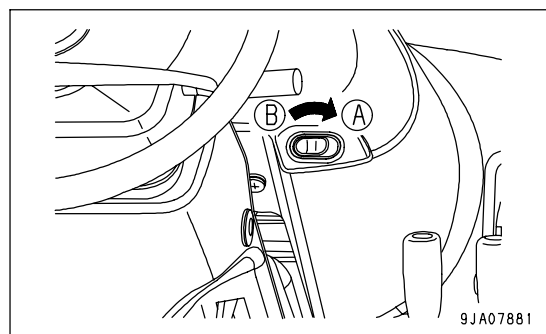

CHECK AIR CONDITIONER COMPRESSOR BELT TENSION, ADJUST

CHECKING

The standard deflection between the air conditioner compressor pulley and crank pulley when pressed with a thumb (approx. 98 N (10 kg)) should be approx. 11 to 15 mm (0.4 to 0.6 in).

When a belt tension gauge is used, the standard tension is within a range of 353 to 530 N (36 to 54 kg).

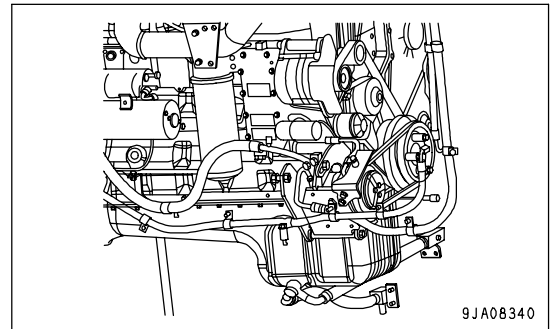

CHECK WHEN CHANGING THE V-BELT

The standard deflection between the air conditioner compressor pulley and fan pulley when pressed with a thumb (approx. 98 N (10 kg)) should be approx. 8 to 11.5 mm (0.315 to 0.5 in).

When a belt tension gauge is used, the standard tension is within a range of 530 to 745 N (54 to 76 kg).

REMARK

When the belt has been replaced with a new part, a high tension is necessary, so the initial tension is in the value given above.

ADJUSTING

1. Loosen bolt (1), then loosen the locknut of bolt (2), tighten bolt (2), and move compressor (3) to adjust.
2. Tighten bolt (1) and the locknut of bolt (2) to hold the compressor (3) in position.

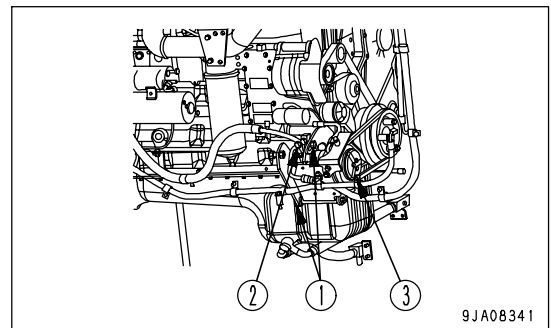

NOTICE

- Check each pulley for damage, wear of the V-groove, and wear of the V-belt. In particular, be sure to check that the V-belt is not touching the bottom of the V-groove.
- In case any of the following occurs, ask the Komatsu distributor in your territory to replace the belts with new ones.
 - The fan belt has elongated, leaving little allowance for adjustment.
 - A cut or crack is found on the belt.
 - Slipping or creaking sound is heard coming from the belt.
- When the new V-belt is set, readjust it after one hour of operation.

CHECK FOR LOOSE WHEEL HUB BOLTS, TIGHTEN

If wheel hub nuts (1) are loose, tire wear will be increased and accidents may be caused.

1. Check for loose nuts, and tighten if necessary.

When checking for loose nuts, always turn the nuts in the direction of tightening to check.

Tightening torque: 825 to 1030 Nm

(84 to 105 kgm, 607.6 to 759.9 lbft)

2. If any stud bolt is broken, replace all the stud bolts for that wheel.

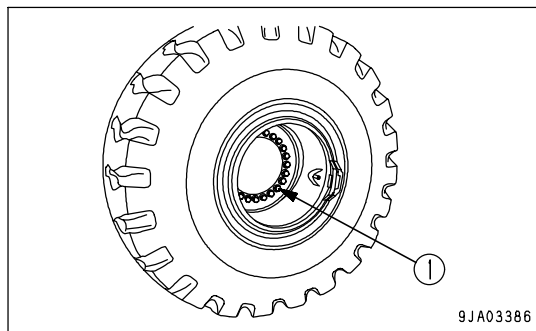

9JA03386

CLEAN ELEMENT IN AIR CONDITIONER RECIRCULATION FILTER

1. Loosen knob (1), then remove filter inspection cover (2).

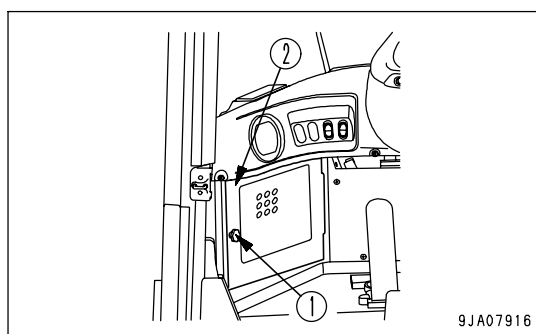

9JA07916

2. Remove filter (3) in the direction shown by the arrow.
3. Use compressed air to clean the recirculated air filter in the same way as for the fresh air filter.
Replace the filter with a new part if the clogging cannot be removed with compressed air, or if it has been used for 1 year.

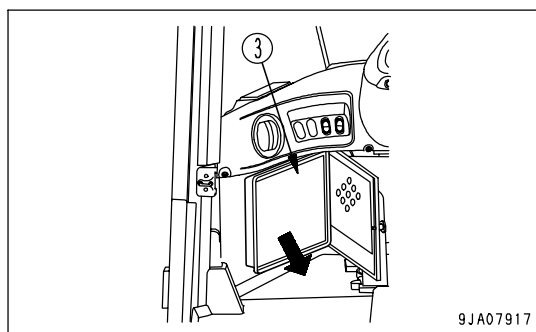

9JA07917

REMARK

If the filter becomes clogged, the air flow will be reduced, and there will be an abnormal noise from the air conditioner unit.

CHECKING FUNCTION OF ACCUMULATOR

For details of handling the accumulator, see Section "HANDLING ACCUMULATOR AND GAS SPRING (PAGE 2-42)".

BRAKE ACCUMULATOR

If the engine stops when the machine is traveling, the oil pressure in the accumulator can be used to apply the brake as an emergency measure.

1. Stop the machine on level ground and lower the work equipment completely to the ground.
2. Apply the parking brake.
3. Start the engine, run it at a mid-range speed for 1 minute, then stop the engine.
4. Turn the starting switch key to the ON position and depress the brake pedal repeatedly.
 - If the brake oil pressure caution lamp does not light up even when the brake is depressed 6 times, the gas pressure in the accumulator is normal.
 - If the brake oil pressure caution lamp lights up when the brake has been depressed 5 or less times, the gas pressure in the accumulator has probably dropped. Please contact your Komatsu distributor to have the accumulator inspected.

REMARK

Carry out the check within 5 minutes after stopping the engine. If the machine is left with the engine stopped, the accumulator pressure will drop and it will be impossible to check the cause of the problem.

LUBRICATING

1. Using a grease pump, pump in grease through the grease fittings marked by the arrows.
2. After greasing, wipe off any old grease that was pushed out.

NOTICE

When working on jobsites where heavy-duty operations are frequent or when working continuously for more than eight hours, shorten the lubrication interval and carry out lubrication more frequently.
 For the initial 50 hours, carry out lubrication every 10 hours.

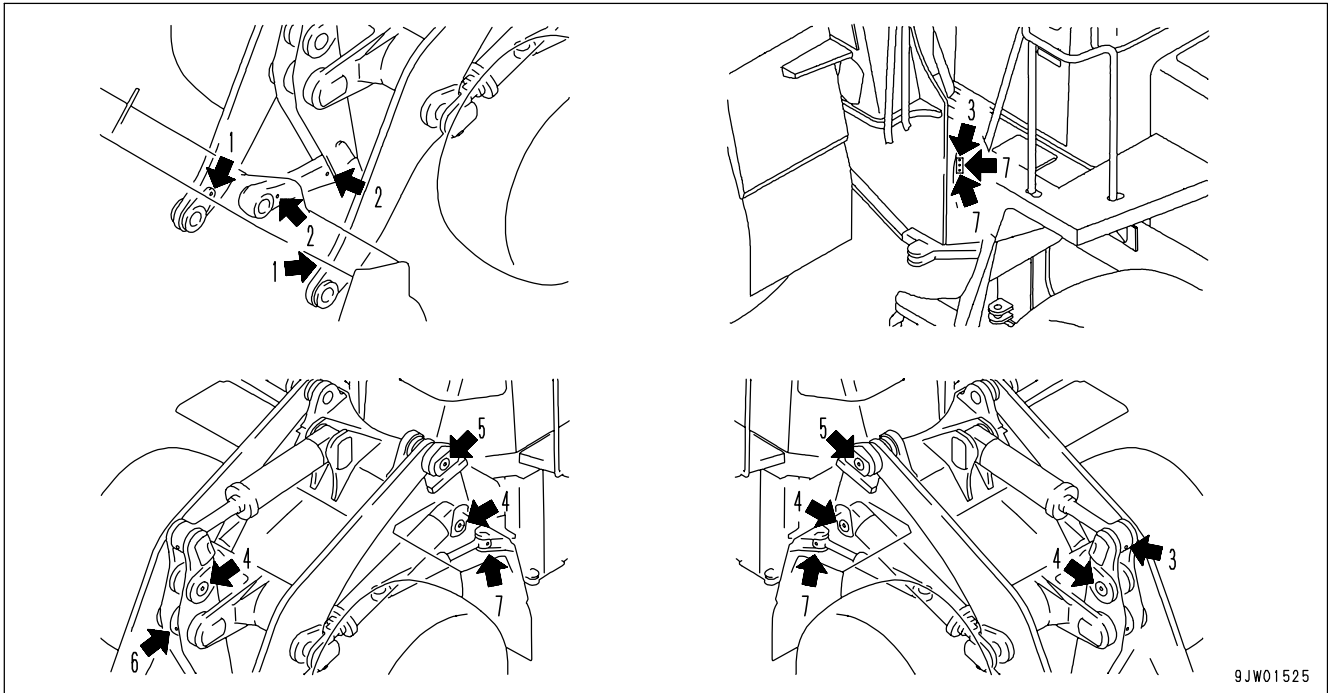

- | | |
|----------------------------------|--------------------------------------|
| (1) Bucket pin (2 places) | (5) Lift arm pivot pin (2 places) |
| (2) Bucket link pin (2 places) | (6) Bell crank pin (1 place) |
| (3) Dump cylinder pin (2 places) | (7) Steering cylinder pin (4 places) |
| (4) Lift cylinder pin (4 places) | |

When carrying out greasing of bucket pin (1), lift arm pivot pin (5), and bell crank pin (6), set the work equipment to the following posture.

Lower the bucket to the ground and set it horizontally.

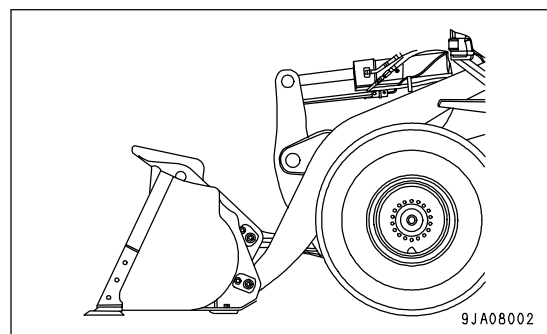

EVERY 500 HOURS SERVICE

Maintenance for every 50, 100 and 250 hours service should be carried out at the same time.

CHANGE OIL IN ENGINE OIL PAN, REPLACE ENGINE OIL FILTER CARTRIDGE

! WARNING

- The parts and oil are at high temperature immediately after the engine is stopped, and may cause burns. Wait for the temperature to go down before starting the work.
- When removing the oil filler cap, turn it slowly to release the internal pressure, then remove it.

- Refill capacity: 30 liters (7.93 US gal)
- Prepare a filter wrench

1. Open the engine side cover on the right side of the chassis.
2. Open oil filler (F).
3. Place a container to catch the oil under drain plug (P).
4. Loosen drain plug (P), and drain the oil.
5. Check the drained oil, and if there are excessive metal particles or foreign material, please contact your Komatsu distributor.
6. Install drain plug (P).

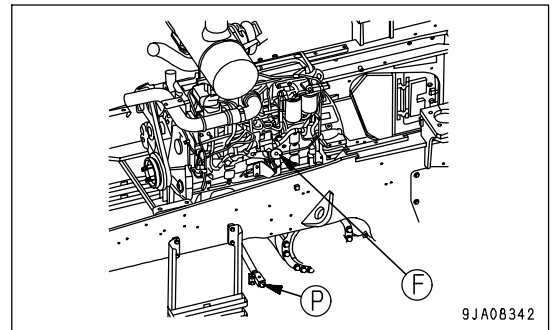

7. Open the engine side cover on the left side of the chassis.
8. Using the filter wrench, turn filter cartridge (1) counterclockwise to remove it.

In particular, if this operation is carried out immediately after stopping the engine, a large amount of oil will come out, so wait for 10 minutes before starting the operation.

9. Clean the filter holder, fill the new filter cartridge with engine oil, then coat the seal and thread of the filter cartridge with engine oil (or coat thinly with grease) and install.
10. When installing the seal, tighten it so its surface comes into contact with the filter holder, then tighten another 3/4 turn.
11. After replacing the filter cartridge, add oil through oil filler (F) until the oil level is between the H and L marks on the dipstick (G).
12. Run the engine at idle for short time, then stop the engine, and check that the oil is between the H and L marks on the dipstick. For details, see "CHECK OIL LEVEL IN ENGINE OIL PAN, ADD OIL (PAGE 3-105)".

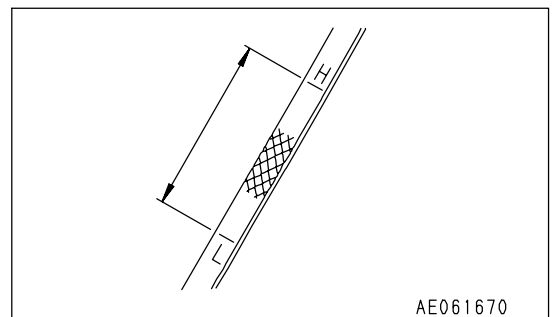
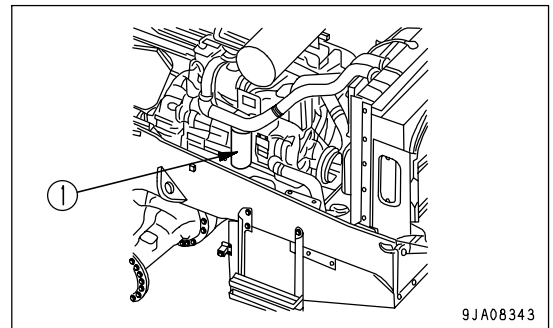

REPLACE FUEL PRE-FILTER CARTRIDGE



WARNING

- After the engine has been operated, all parts are at high temperature, so do not replace the filter immediately. Wait for all parts to cool down before starting the operation.
- High pressure is generated inside the engine fuel piping system when the engine is running. When replacing the filter, wait for at least 30 seconds after stopping the engine to let the internal pressure go down before replacing the filter.
- Do not bring any fire or flame close.

NOTICE

- Genuine Komatsu fuel filter cartridges use a special filter that has highly efficient filtering ability. When replacing the filter cartridge, always use a genuine Komatsu part.
- The common rail fuel injection system used on this machine consists of more precise parts than the conventional injection pump and nozzle. If any part other than a genuine Komatsu filter cartridge is used, dust or dirt may get in and cause problems with the injection system. Always avoid using substitute parts.
- When carrying out inspection or maintenance of the fuel system, pay more attention than normal to the entry of dirt. If dirt is stuck to any part, use fuel to wash it off completely.
- Prepare a filter wrench

1. Open the engine side cover on the right side of the chassis.
2. The fuel pre-filter forms one unit with the water separator and is at the rear of the engine.
3. Remove connector (1).

After removing the connector, cover the connector terminals with a vinyl bag or tape to protect them and prevent them from becoming dirty.

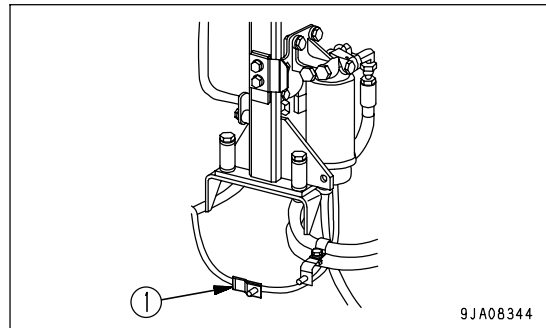

9JA08344

4. Set the container to catch the fuel under the filter cartridge.

5. Using a filter wrench, turn filter cartridge (2) counterclockwise on remove it.
6. Take water separator cup (3) installed to the bottom of the cartridge and turn it to the left to remove it. (This cup is used again. If it is damaged, replace it with a new part.)
7. Install cup (3) to the bottom of the new fuel pre-filter cartridge. When doing this, always replace the seal ring with a new part. Tightening torque for cup: 10 Nm {1.0 kgm}
When replacing the seal ring, coat the surface with clean fuel before installing it.
8. Check that drain plug (4) at the bottom of cup (3) of the fuel pre-filter is tightened securely. Tightening torque: 0.2 - 0.45 Nm {0.02 - 0.046 kgm}
9. Clean the filter holder.

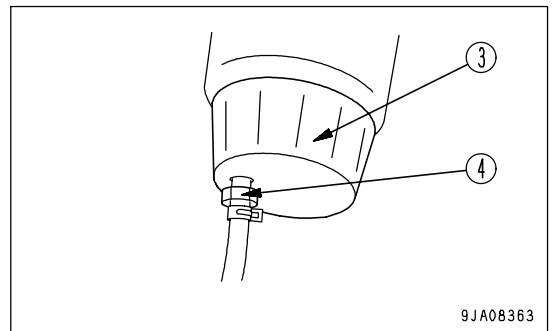
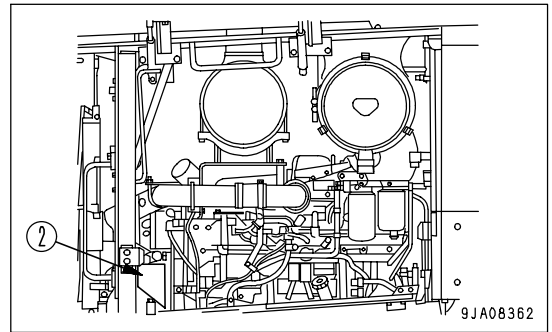

NOTICE

When filling the filter cartridge with fuel, carry out the filling operation with cap (A) fitted.

Cap (A) acts to prevent the entry of dirt or dust into the filter cartridge.

10. Fill the filter cartridge with clean fuel through the 8 small holes (B) in the new filter cartridge.
11. Coat the packing surface of the filter cartridge with oil.

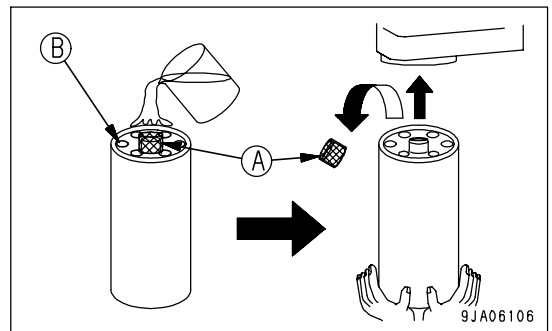

12. Remove filter cartridge cap (A) and install to the filter holder.
13. When installing, tighten until the packing surface contacts the seal surface of the filter holder, then tighten it 3/4 of a turn.
If the filter cartridge is tightened too far, the packing will be damaged and this will lead to leakage of fuel. If the filter cartridge is too loose, fuel will also leak from the packing, so always tighten the correct amount.
 - When tightening with a filter wrench, be extremely careful not to dent or damage the filter.
14. Connect connector (1).
15. When replacing the fuel main filter cartridge (EVERY 1000 HOURS), see "REPLACE FUEL MAIN FILTER CARTRIDGE (PAGE 4-53)" for details and bleed the air after replacing the cartridge.
Note: Do not put any fuel in the main filter cartridge.
16. Start the engine, check that there is no leakage of fuel from the filter seal surface or water separator mounting surface, then run for approx. 10 minutes at low idling.

PROCEDURE FOR BLEEDING AIR

1. Fill the fuel tank with fuel.
2. Insert the key in the starting switch and turn it to ON position (B).

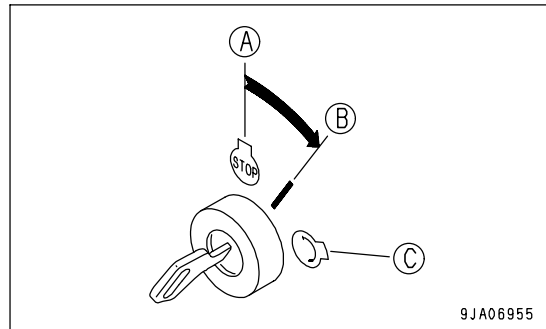

3. Hold the key at the ON position (B) for 30 seconds, then return it to OFF position (A) and wait for 10 seconds.
4. Repeat the operations in Step 2 and Step 3 four times.

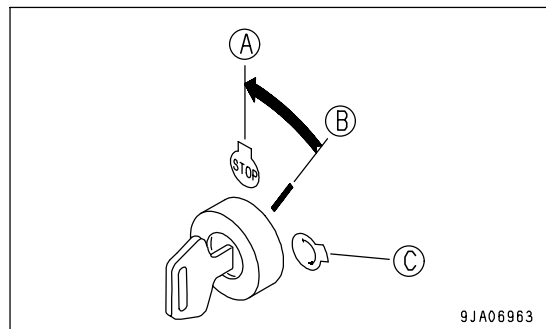

5. Crank the engine with the starting motor (starting rotation of starting motor) and start the engine.
 - When the engine is cranked, the air is automatically bled from the high-pressure circuit.
 - If the engine does not start, the air has probably not been bled properly from the low-pressure circuit. Repeat the procedure from Step 1.
 - If the engine is operated with air remaining in the fuel circuit, an error (CA449, CA559) may be generated in the fuel system.
If this happens, keep the throttle at Lo after starting the engine and run the engine continuously for approx. 3 minutes.
When the air is bled and the engine rotation becomes stabilized, the error display will go out.

EVERY 1000 HOURS SERVICE

Maintenance for every 50, 100, 250 and 500 hours service should be carried out at the same time.

REPLACE FUEL MAIN FILTER CARTRIDGE

⚠ WARNING

- After the engine has been operated, all parts are at high temperature, so do not replace the filter immediately. Wait for all parts to cool down before starting the operation.
- High pressure is generated inside the engine fuel piping system when the engine is running. When replacing the filter, wait for at least 30 seconds after stopping the engine to let the internal pressure go down before replacing the filter.
- Do not bring any fire or flame close.

NOTICE

- Genuine Komatsu fuel filter cartridges use a special filter that has highly efficient filtering ability. When replacing the filter cartridge, always use a genuine Komatsu part.
- The common rail fuel injection system used on this machine consists of more precise parts than the conventional injection pump and nozzle. If any part other than a genuine Komatsu filter cartridge is used, dust or dirt may get in and cause problems with the injection system. Always avoid using substitute parts.
- When carrying out inspection or maintenance of the fuel system, pay more attention than normal to the entry of dirt. If dirt is stuck to any part, use fuel to wash it off completely.

- Prepare a filter wrench

1. Open the engine side cover on the right side of the chassis.
2. Set the container to catch the fuel under the filter cartridge.
3. Using a filter wrench, turn filter cartridge (1) counterclockwise on remove it.
4. Clean the filter holder.

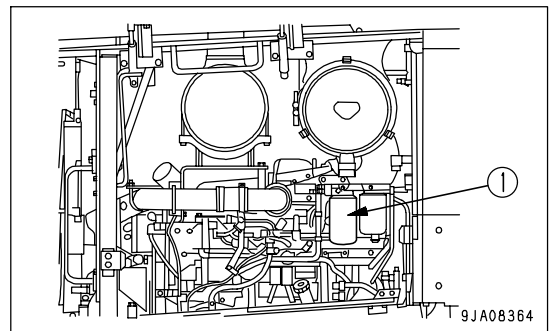

NOTICE

Do not fill the filter cartridge with fuel.

Cap (A) is installed to prevent dirt from entering the inside of the filter cartridge.

5. Coat the packing surface of the filter cartridge with oil.

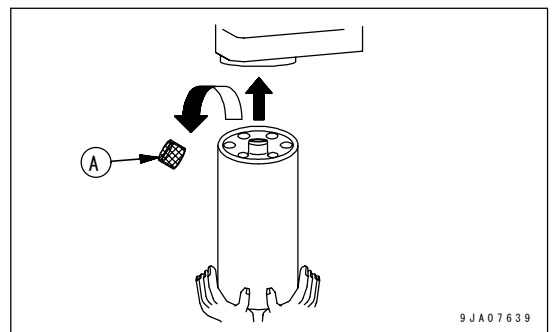

6. Remove filter cartridge cap (A) and install to the filter holder.

7. When installing, tighten until the packing surface contacts the seal surface of the filter holder, then tighten it 3/4 of a turn.
If the filter cartridge is tightened too far, the packing will be damaged and this will lead to leakage of fuel. If the filter cartridge is too loose, fuel will also leak from the packing, so always tighten the correct amount.
8. After completing replacement of fuel filter cartridge (1), bleed the air from the system. For details, see "PROCEDURE FOR BLEEDING AIR (PAGE 4-54)".
9. After completing the air bleeding, start the engine and check that there is no leakage of fuel from the filter seal surface. If there is any leakage, check the tightening condition of the filter cartridge. If there is still fuel leakage, repeat Steps 1 - 3 to remove the filter cartridge, then check the packing surface for damage or embedded dirt. If any damage or embedded dirt is found, replace the cartridge with a new part and repeat Steps 4 - 8 to install it.

PROCEDURE FOR BLEEDING AIR

1. Fill the fuel tank with fuel.
2. Insert the key in the starting switch and turn it to ON position (B).

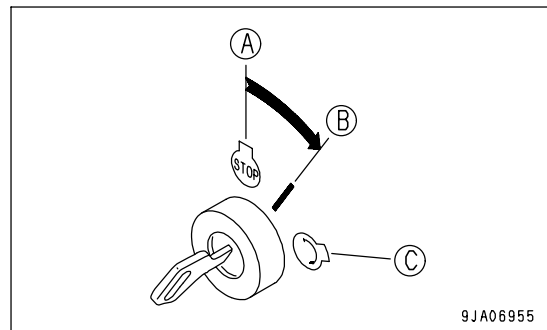

3. Hold the key at the ON position (B) for 30 seconds, then return it to OFF position (A) and wait for 10 seconds.
4. Repeat the operations in Step 2 and Step 3 four times.

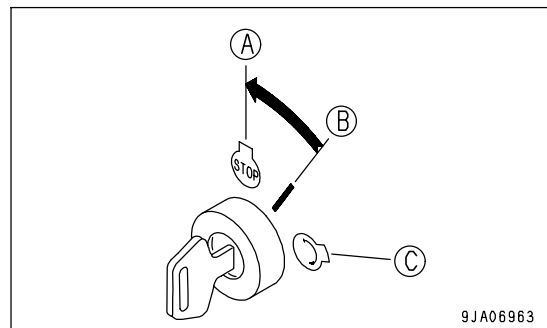

5. Crank the engine with the starting motor (starting rotation of starting motor) and start the engine.
 - When the engine is cranked, the air is automatically bled from the high-pressure circuit.
 - If the engine does not start, the air has probably not been bled properly from the low-pressure circuit. Repeat the procedure from Step 1.
 - If the engine is operated with air remaining in the fuel circuit, an error (CA449, CA559) may be generated in the fuel system.
If this happens, keep the throttle at Lo after starting the engine and run the engine continuously for approx. 3 minutes.
When the air is bled and the engine rotation becomes stabilized, the error display will go out.

CHANGE OIL IN TRANSMISSION CASE AND TRANSMISSION OIL FILTER CARTRIDGE, CLEAN STRAINER

WARNING

- The parts and oil are at high temperature immediately after the engine is stopped, and may cause burns. Wait for the temperature to go down before starting the work.
- When removing the oil filler cap, turn it slowly to release the internal pressure, then remove it.

- Refill capacity: 54 liters (14.27 US gal)
- Prepare a filter wrench

1. Set a container to catch the oil under drain plug (P), then remove drain plug (P) and drain the oil.
To prevent the oil from pouring out suddenly, loosen drain plug (P) and remove it gradually.
2. After draining the oil, install drain plug (P).
Tightening torque: 68.6 ± 9.8 Nm (7.0 ± 1.0 kgm, 50.6 ± 7.2 lbf)
3. Set a container to catch the oil under the transmission filter.

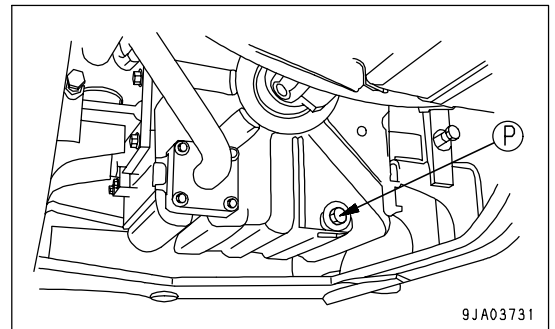

4. Remove drain plug (1) of the transmission filter, drain the oil, then tighten the plug again.
5. Using a filter wrench, turn filter cartridge (2) to the left to remove it.
6. Clean in the filter holder, coat the seal surface and thread of the new filter cartridge with engine oil, then install it.
7. When the seal surface comes into contact with the filter holder, tighten a further 2/5 turns with the filter wrench.

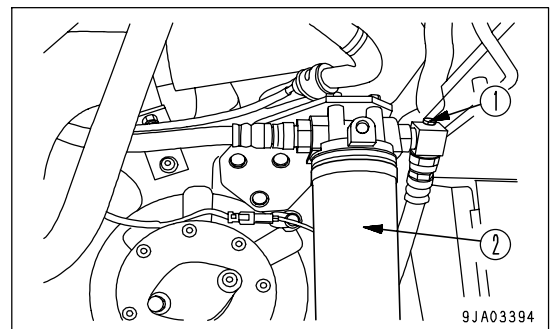

8. Remove 4 bolts (3), move tube (4), then remove strainer (5).
9. Remove any dirt stuck to strainer (5), then wash it in clean diesel fuel or flushing oil. If strainer (5) is damaged, replace it with a new part.
10. Install strainer (5) in the case.
Replace the O-ring of tube (4) with a new part, then install tube (4).

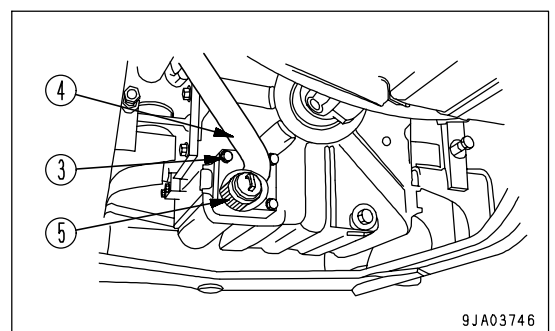

11. Refill the specified quantity of oil through oil filler (F).
12. After filling with oil, check that the oil is at the specified level.
For details, see "CHECK TRANSMISSION OIL LEVEL, ADD OIL (PAGE 4-24)".
13. Check that there is no leakage of oil from the transmission case or oil filter.

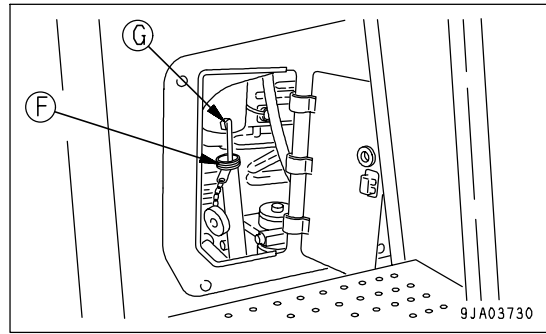

CLEAN TRANSMISSION CASE BREATHER

1. Loosen bolt (1) and remove cover (2).
2. Remove all dirt and mud from around the breather, then remove breather (3), soak it in flushing fluid, and wash it.
After removing the breather, take steps to prevent dirt or dust from entering the mount.

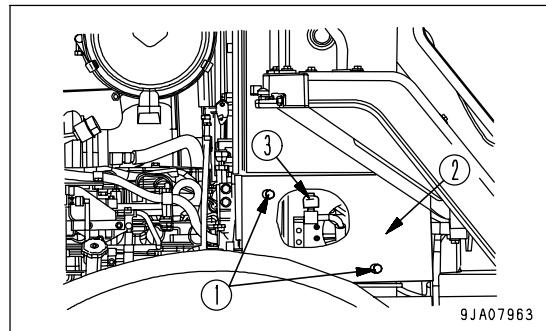

LUBRICATING

1. Using a grease pump, pump in grease through the grease fittings marked by the arrows.
2. After greasing, wipe off any old grease that was pushed out.

(1) Center hinge pin (2 places)

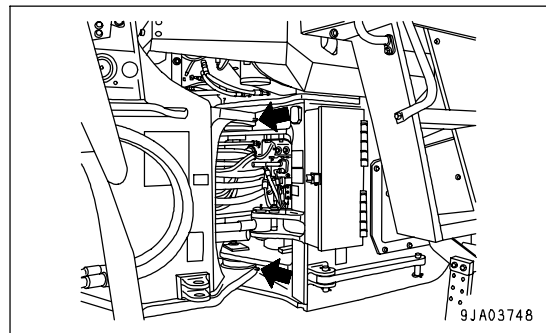

(2) Drive shaft center support (1 place)

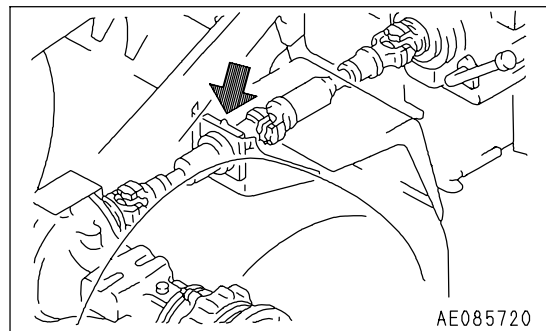

CHECK OF ENGINE AIR INTAKE PIPING CLAMPS FOR LOOSENESS

Please ask your Komatsu distributor to check the tightening of the clamps between the air cleaner - turbocharger - aftercooler - engine.

CHECK ALTERNATOR DRIVING BELT TENSION AND REPLACEMENT

Since inspection and replacement of the fan belt requires special tools, contact your Komatsu distributor.

REMARK

The machine is equipped with an auto tensioner, so there is no need to adjust the tension.

If the alternator drive belt is in the following condition, the belt must be replaced. Please ask your Komatsu distributor to replace the belt.

- When horizontal scratch (1) crosses vertical scratch (2)
- When there are tears (3) in part of the belt

In case (4) where there are horizontal scratches only, there is no need to replace the belt.

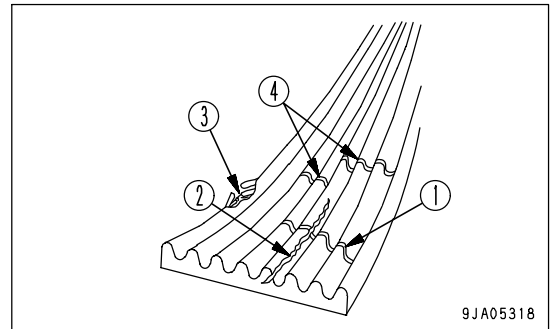

EVERY 2000 HOURS SERVICE

Maintenance for every 50, 100, 250, 500 and 1000 hours service should be carried out at the same time.

CHANGE OIL IN HYDRAULIC TANK, REPLACE HYDRAULIC FILTER ELEMENT**WARNING**

- The parts and oil are at high temperature immediately after the engine is stopped, and may cause burns. Wait for the temperature to go down before starting the work.
- When removing the oil filler cap, turn it slowly to release the internal pressure, then remove it.

- Refill capacity: 139 liters (36.72 US gal)

1. Lower the bucket horizontally to the ground and apply the parking brake, then stop the engine.
2. Remove oil filler cap (F).

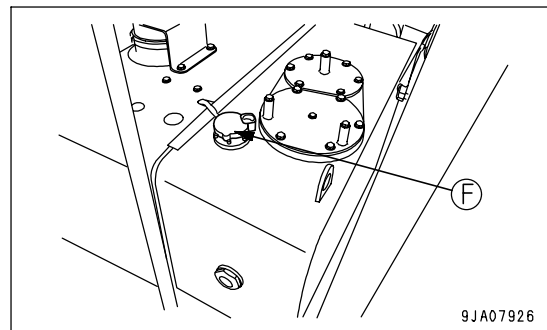

3. Set a container to catch the oil under drain plug (2).
4. Remove drain plug (2).
5. Loosen drain valve (3), then gradually pull it out to drain the oil.
6. After draining the oil, close drain valve (3), install and tighten drain plug (2).

Tightening torque

Drain plug (2): 68.6 ± 9.8 Nm (7.0 ± 1.0 kgm, 50.6 ± 7.2 lbft)

Drain valve (3): 63.7 ± 14.7 Nm (6.5 ± 1.5 kgm, 47.0 ± 10.8 lbft)

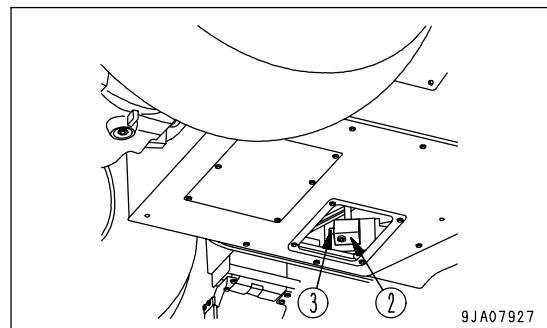

7. Remove mounting bolt (5) of filter cover (4) at the top of the tank, then remove the cover.
When doing this, the cover may fly off under the force of spring (6), so keep the cover pressed down when removing the bolts.
8. Remove spring (6) and bypass valve (7), then take out element (8).
9. Check that there is no foreign material inside the tank, then clean it.
10. Install new element (8), then set bypass valve (7), spring (6), and cover (4) on the tank.
When doing this, check the cover O-ring. If it is damaged or deteriorated, replace it.

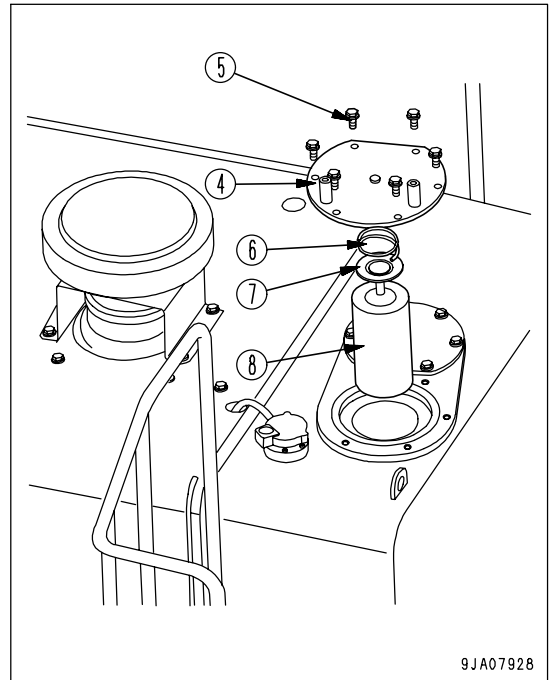

11. Remove 6 bolts (10), then remove cover (9).
12. Pull the top of rod (11) from the top and remove strainer (12).
13. Remove any dirt stuck to strainer (12), then wash it in flushing oil. If strainer (12) is damaged, replace it with a new part.

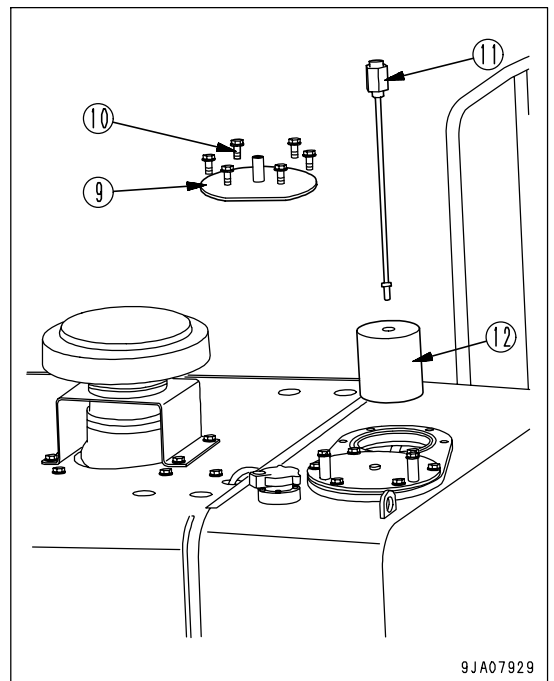

14. When installing the cover bolts, push down the cover and tighten the bolts evenly.
15. Add engine oil through oil filler port (F) to the specified level, then install cap (F).
16. Check that the hydraulic oil is at the standard level. For details, see "CHECK OIL LEVEL IN HYDRAULIC TANK, ADD OIL (PAGE 4-41)".
17. Run the engine at low idle, and extend and retract the steering, bucket, and lift arm cylinders 4 to 5 times. Be careful not to operate the cylinder to the end of its stroke (stop approx. 100 mm (3.9 in) before the end of stroke).

NOTICE

If the engine is run at high speed immediately after startup or a cylinder is pushed up to its stroke end, air taken inside the cylinder may cause damage to the piston packing.

18. Next, operate the steering, bucket, and lift arm cylinders fully 3 - 4 times, then stop the engine and loosen air bleed plug (13). After bleeding the air from the hydraulic tank, tighten plug (13). Keep the engine running at low idling when bleeding the air.
19. Check that the hydraulic oil is at the standard level. For details, see "CHECK OIL LEVEL IN HYDRAULIC TANK, ADD OIL (PAGE 4-41)".

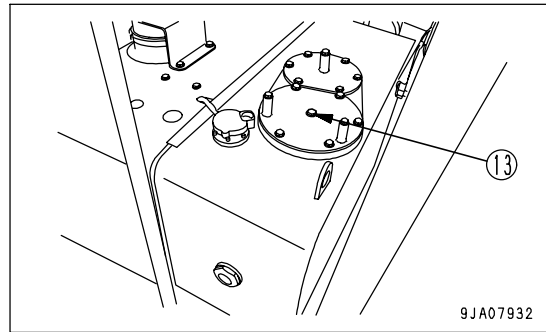

20. Next, raise the engine speed, repeat the air bleeding procedure in Step 18, and continue the operation until no more air comes out from plug (13).
21. After bleeding the air, tighten plug (13).
Tightening torque: $11.3 \pm 1.5 \text{ Nm}$ ($1.15 \pm 0.15 \text{ kgm}$, $8.3 \pm 1.1 \text{ lbf}$)
22. Check that the hydraulic oil is at the standard level. For details, see "CHECK OIL LEVEL IN HYDRAULIC TANK, ADD OIL (PAGE 4-41)".
23. Check that there is no leakage of oil from the filter cover mount.

REPLACE HYDRAULIC TANK BREATHER ELEMENT

! WARNING

- The parts and oil are at high temperature immediately after the engine is stopped, and may cause burns. Wait for the temperature to go down before starting the work.
- When removing the oil filler cap, turn it slowly to release the internal pressure, then remove it.

1. Before removing the breather, wipe off all the dirt from around the breather.
2. Remove the cap of oil filler (F).
3. Remove breather (1) built into the cap.
4. Replace the filter element (2) built into the breather with a new part, then install breather (1) to the cap.
5. Tighten the cap of oil filler (F).

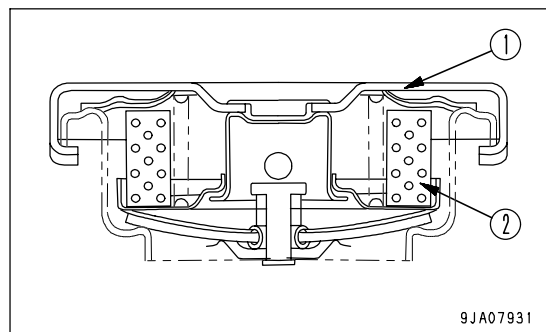
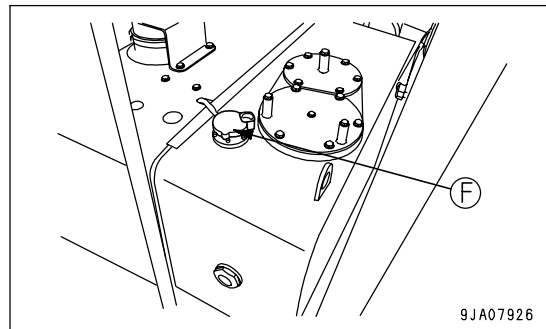

CHANGE AXLE OIL

! WARNING

- When changing the oil, apply the parking brake and secure the front and rear frames with the frame lock bar.
- After the engine is stopped, the parts and oil are at high temperature, and may cause burns. Wait for the temperature to go down before starting the operation.
- When the plug is removed, oil may spurt out, so turn it slowly to release the internal pressure, then remove it carefully.

- Refill capacity
 Front: 49 liters (12.95 US gal)
 Rear: 40 liters (10.57 US gal)

- A: Front B: Rear

1. Set a container to catch the oil under drain plug (P).
2. Remove front and rear oil filler plugs (1), then remove drain plug (P) to drain the oil.

REMARK

Remove the mud and dirt from around plug (1), then remove the plug.

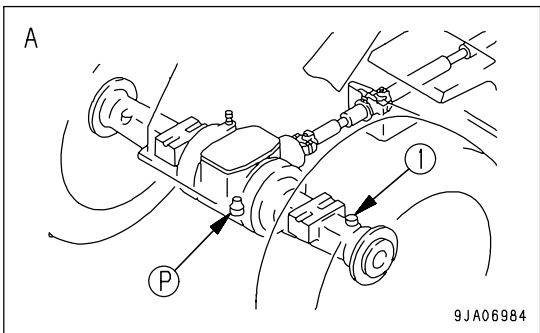

3. After draining the oil, clean drain plug (P) and install it again.
4. Add oil through plug hole (1) at the refill level.

REMARK

Be sure to use the only specified lubricating oil for the axle with the ASD (Anti-Slip Differential).

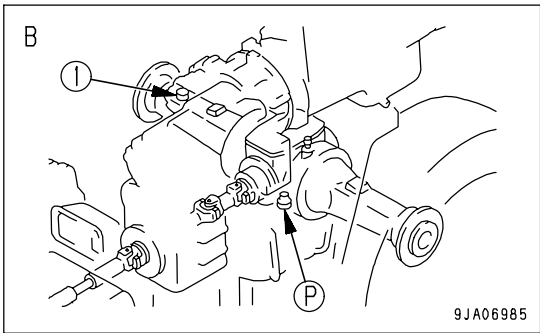

5. After adding oil, check at level plug (1) that the oil is at the specified level. For details, see "CHECK AXLE OIL LEVEL, ADD OIL (PAGE 4-25)".

REMARK

For operations where the brake is used frequently, change the axle oil at shorter intervals.

REPLACE ELEMENT IN AIR CONDITIONER RECIRCULATION AIR FILTER, FRESH AIR FILTER

Remove both the recirculation air filter and fresh air filter in the same way as when cleaning, and replace them with new parts.

For details of cleaning the recirculation air filter, see "CLEAN ELEMENT IN AIR CONDITIONER RECIRCULATION FILTER (PAGE 4-46)".

For details of cleaning the fresh air filter, see "CLEAN ELEMENT IN AIR CONDITIONER FRESH AIR FILTER (PAGE 4-42)".

CHECK BRAKE DISC WEAR

**WARNING**

- When checking the brake disc wear, apply the parking brake and secure the front and rear frames with the frame lock bar.
- Make sure that the brake oil temperature is less than 60°C (140°F) before checking the brake wear.
- If the disc is near the wear limit, carry out inspection at shorter intervals, regardless of the specified inspection interval.

When checking the brake disc for wear, there are 4 places (front axle and rear axle, left and right), so use the same procedure to check all 4 places.

1. Remove cap nut (1).

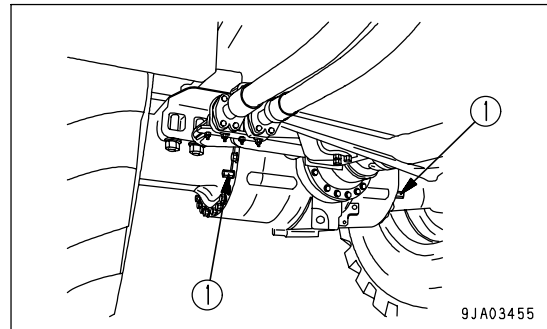

2. Depress the brake pedal and push in rod (2) fully.
3. Amount of wear (A) is the amount that end face (C) of the rod protrudes from end face (D) of the guide. Measure the amount of protrusion.

Permitted wear limit (B) of the disc is the point where groove (E) of the rod is in line with end face (D) of the guide.

When this point is reached, please ask your Komatsu distributor to carry out inspection and replacement of parts.

- If the disc is near the wear limit, carry out inspection at shorter intervals, regardless of the specified inspection interval.

4. Install cap nut (1).

Tightening torque: 29.4 to 39.2 Nm (3.0 to 4.0 kgm, 21.7 to 28.9 lbft)

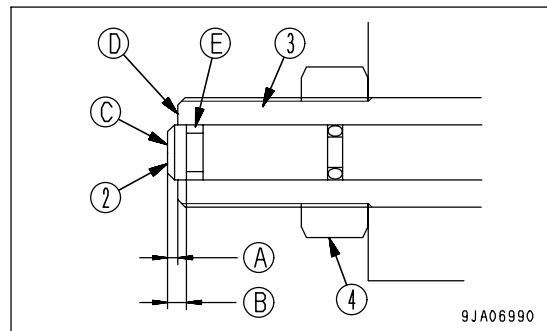
**REMARK**

- On new machines, the position of the guide is adjusted so that the end face of rod (2) comes to the end face of guide (3). For this reason, do not loosen locknut (4) except when replacing the disc.
- Carry out the operation with two workers: one worker depresses the brake pedal and the other worker pushes in rod (2).

CHECKING FUNCTION OF ACCUMULATOR

For details of handling the accumulator, see Section "HANDLING ACCUMULATOR AND GAS SPRING (PAGE 2-42)".

PPC ACCUMULATOR

If the engine stops with the work equipment raised, and it is impossible to start the engine again, it is possible as an emergency measure to actuate the valve with the oil pressure stored in the accumulator and lower the work equipment to the ground.

1. Apply the parking brake.
2. Raise the work equipment to the maximum height, then operate the lift arm control lever to HOLD position (b).
3. Stop the engine.
4. Leave the work equipment lock lever in the FREE position.
5. Check that the area around the machine is safe, then operate the lift arm control lever to FLOAT position (d) and lower the work equipment to a point 1 m above the ground.
6. When the lift arm comes to the 1 m position, return the lift arm control lever to LOWER position (c), and lower the work equipment slowly to the ground.

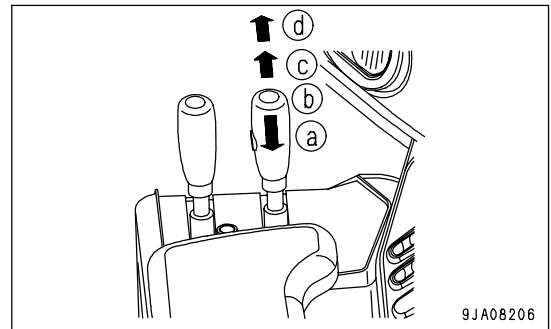

REMARK

Carry out the check within 2 minutes after stopping the engine. If the machine is left with the engine stopped, the accumulator pressure will drop and it will be impossible to check the cause of the problem.

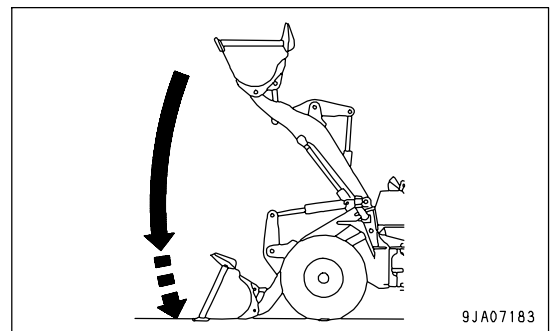

If the work equipment stops while it is moving, the gas pressure in the accumulator has probably dropped. Please contact your Komatsu distributor to have the accumulator inspected. Replace the accumulator every 4000 hours or every 2 years.

CHECK ALTERNATOR

Contact your Komatsu distributor to have the alternator checked.

If the engine is started frequently, have this inspection carried out every 1000 hours.

CHECK ENGINE VALVE CLEARANCE, ADJUST

As special tool is required for removing and adjusting the parts, request your Komatsu distributor for service.

CHECK VIBRATION DAMPER

Check that there are no cracks or peeling in the outside surface of the rubber.

If any cracks or peeling are found, contact your Komatsu distributor to have the parts replaced.

EVERY 4000 HOURS SERVICE

Maintenance for every 50, 100, 250, 500, 1000 and 2000 hours service should be carried out at the same time.

LUBRICATING

Carry out the greasing once every two years, regardless of whether the 4000 hour interval has passed.

1. Using a grease pump, apply grease through the grease fittings marked by arrows.
2. After greasing, wipe off any old grease that was pushed out.
3. When lubricating, stop the drive shaft so that the grease fitting of center drive shaft spline (1) will be as shown in the figure and supply grease from under the machine.

At this time, the grease fitting is at the position indicated by the arrow at the circle below seen from the rear of the machine.

(1) Center drive shaft spline (1 place)

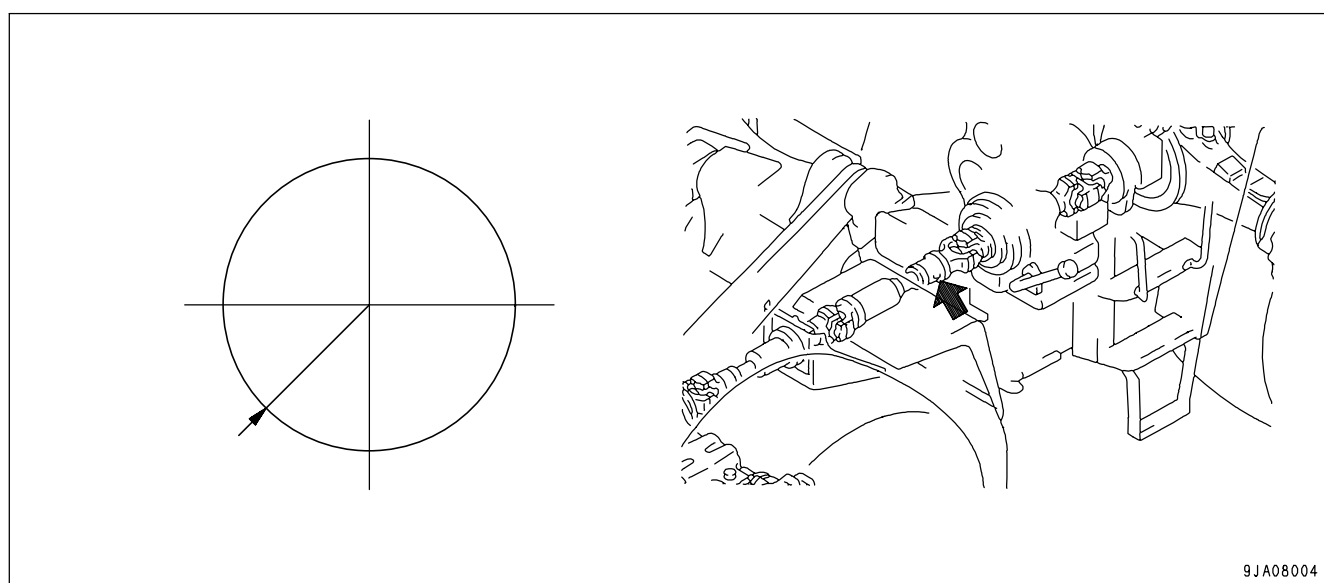

View from rear of machine

(2) Front drive shaft (2 places)

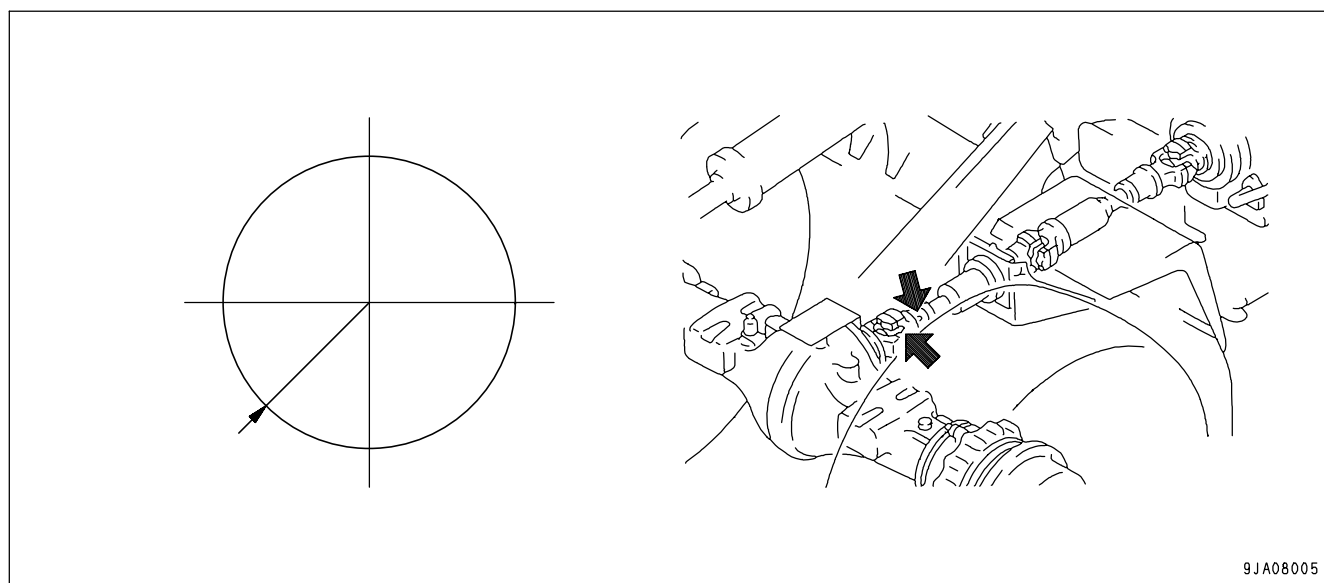

View from rear of machine

(3) Rear drive shaft (2 places)

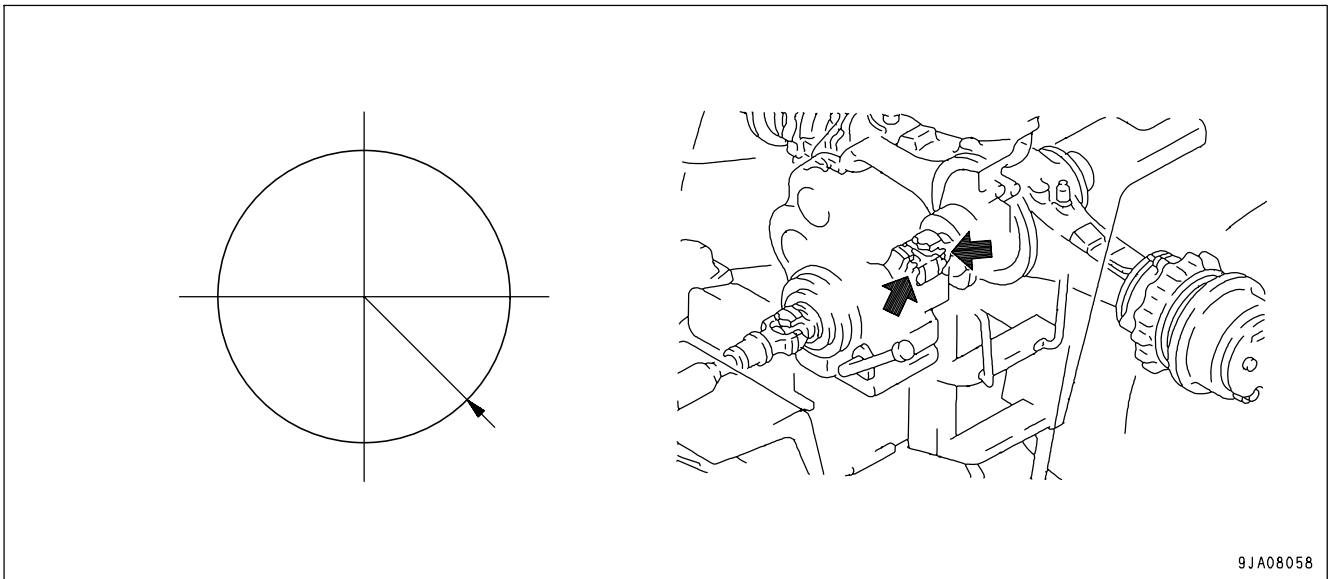

View from rear of machine

(4) Center drive shaft (2 places)

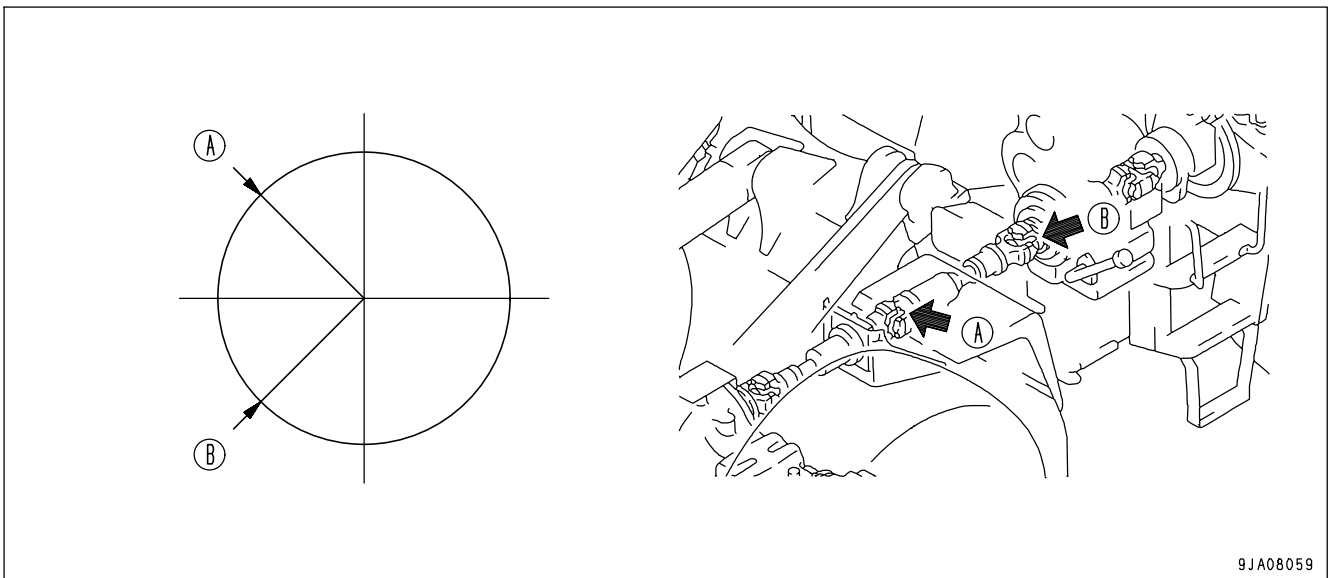

View from rear of machine

CHECK WATER PUMP

Check the water pump and its relative parts for water leak, and if anything abnormal is found, call on your Komatsu distributor for repairs or replacement.

CHECK STARTING MOTOR

Contact your Komatsu distributor to have the starting motor checked.
If the engine is started frequently, have this inspection carried out every 1000 hours.

CHECK AIR CONDITIONER COMPRESSOR, ADJUST

As special tool is required for checking and adjusting the parts, request Komatsu distributor for service.

CHECK FOR LOOSE ENGINE HIGH-PRESSURE PIPING CLAMPS, HARDENING OF RUBBER

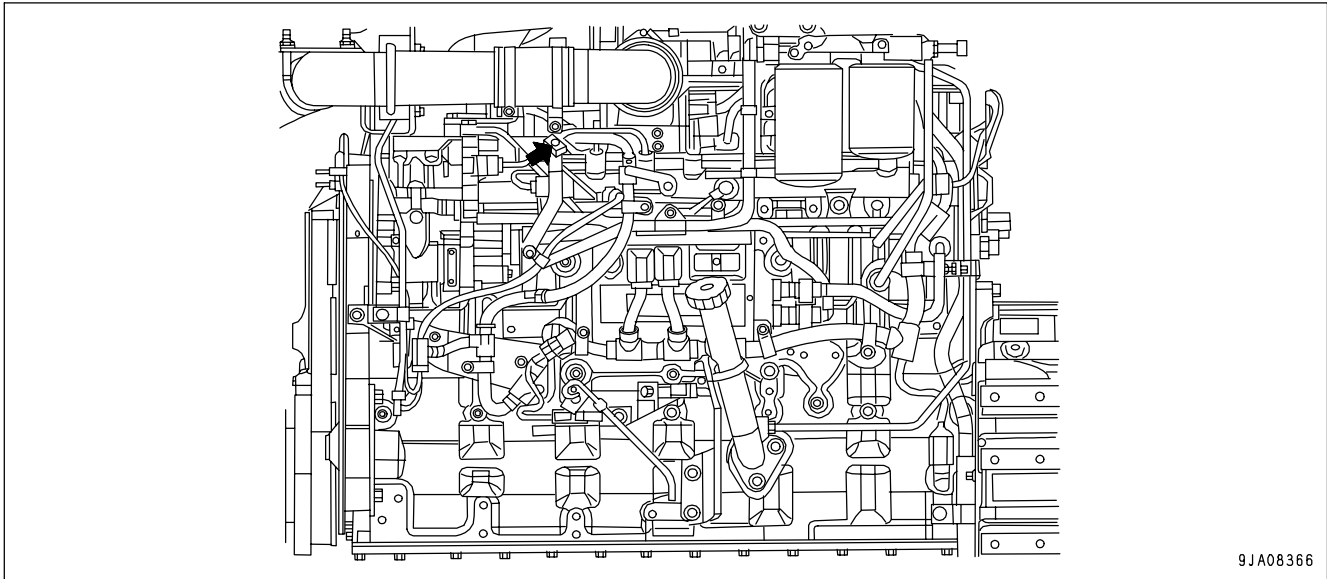

9JA08366

Check visually and touch by hand to check that there is no hardening of the rubber and no loose bolts of the mounting clamps (1 places) for the high-pressure piping between the supply pump and the common rail. If there are any problems, the parts must be replaced. In this case, please ask your Komatsu distributor to carry out replacement.

CHECKING FOR MISSING FUEL SPRAY PREVENTION CAP, HARDENING OF RUBBER

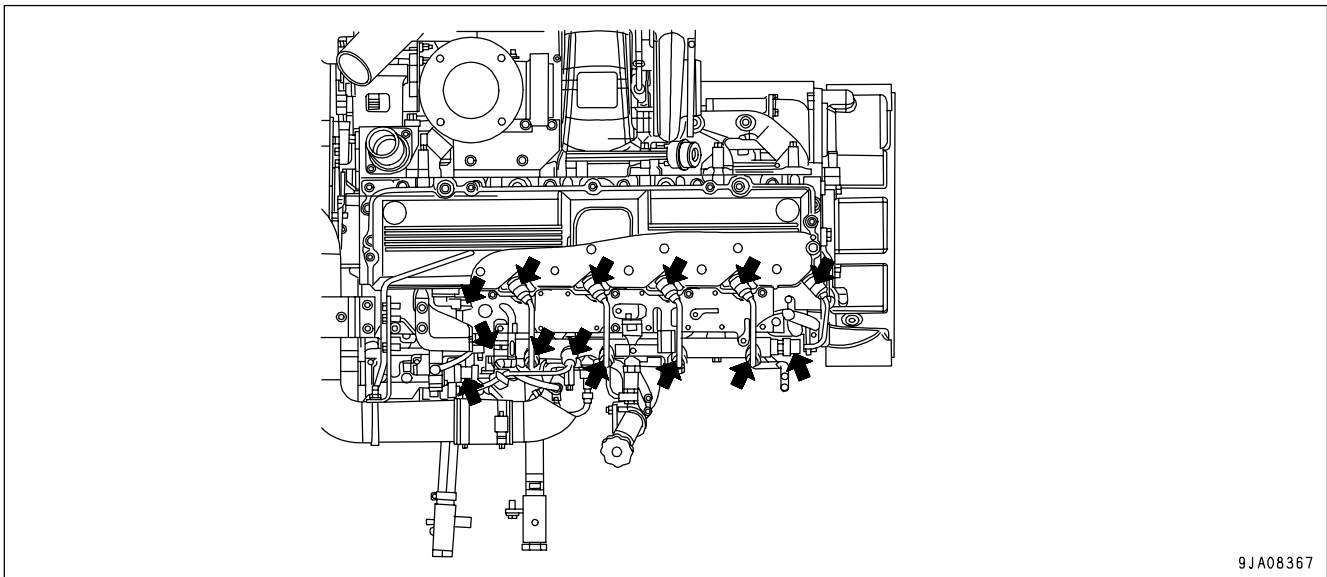

9JA08367

The fuel spray prevention caps (14 places) on the fuel injection piping and both ends of the high-pressure piping act to prevent the fuel from coming into contact with high-temperature parts of the engine and causing a fire if the fuel should leak or spray out. Check visually and touch by hand to check that there are no missing caps, loose bolts or hardening of the rubber. If there are any problems, the parts must be replaced. In this case, please ask your Komatsu distributor to carry out replacement.

EVERY 8000 HOURS SERVICE

Maintenance for every 50, 250, 500, 1000, 2000 and 4000 hours service should be carried out at the same time.

REPLACE HIGH-PRESSURE PIPING CLAMP

Contact your Komatsu distributor to have the engine high-pressure clamps replaced.

REPLACE FUEL SPRAY PREVENTION CAP

Contact your Komatsu distributor to have the fuel spray prevention cap replaced.

SPECIFICATIONS

SPECIFICATIONS

(Machines fitted with 23.5-25-16PR (L3) tires)

Item		Unit	WA430-6 standard specification machine (when using POWER mode)	
Machine weight (with bolt on cutting edge)		kg (lb)	18,290 (40,329)	
Normal load		kg (lb)	5,600 (12,348)	
Bucket capacity	Heaped	m ³ (cu.yd)	3.5 (4.6)	
Engine model		-	Komatsu SAA6D114E-3	
Flywheel horse power		kW (HP)/rpm	172 (231)/2,100	
A	Overall length	mm (ft in)	8,310 (27' 3")	
B	Overall height	mm (ft in)	3,390 (11' 1")	
C	Max.dimension when shaking bucket	mm (ft in)	5,710 (18' 9")	
D	Overall width	mm (ft in)	2,820 (9' 3")	
E	Min. ground clearance	mm (ft in)	455 (1' 6")	
F	Bucket width	mm (ft in)	3,050 (10' 0")	
G	Clearance	Cutting edge [BOC tip]	mm (ft in)	3,105 (10' 2") [3,015 (9' 11")]
H	Reach	Cutting edge [BOC tip]	mm (ft in)	1,150 (3' 9") [1,195 (3' 11")]
I	Dump angle	degrees	49	
	Min. turning radius	Out of chassis	mm (ft in)	7,230 (23' 9") [7,270 (23' 10")]
		Center of out side tire	mm (ft in)	6,335 (20' 9")
Permissible towing load		kN (kg)	116 (11,800)	
Travel speed	Forward	1st	km/h (MPH)	7.0 (4.3)
		2nd	km/h (MPH)	12.3 (7.6)
		3rd	km/h (MPH)	21.6 (13.4)
		4th	km/h (MPH)	37.2 (23.1)
	Reverse	1st	km/h (MPH)	7.6 (4.7)
		2nd	km/h (MPH)	12.9 (8.0)
		3rd	km/h (MPH)	23.0 (14.3)
		4th	km/h (MPH)	37.2 (23.1)

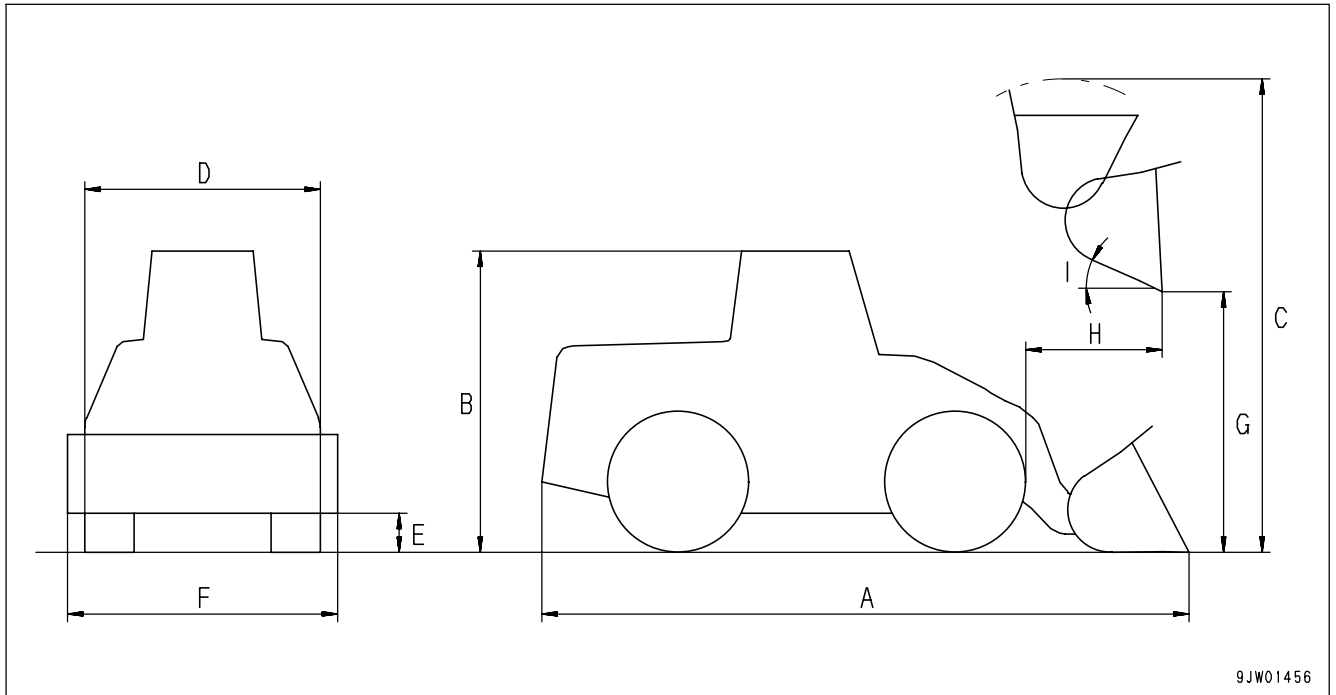

9JW01456

ATTACHMENTS, OPTIONS

 **WARNING**

Please read and make sure that you understand the SAFETY section before reading this section.

SELECTING BUCKET AND TIRES

Select the most suitable bucket and tires for the type of work and the ground conditions on the jobsite.

Type of work	Bucket	Ground conditions	Tire
Loading products	Stockpile bucket (with bolt-on cutting edge) (3.5 m ³ (4.6 cu.yd))	General ground conditions	23.5-25-16PR (L3 Rock)
		Leveled ground	23.5-25-16PR (L2 Traction)
Loading and carrying products	Stockpile bucket (with teeth) (3.3 m ³ (4.3 cu.yd)) Light material bucket (with bolt-on cutting edge) (4.6 m ³ (6.0 cu.yd))	Soft ground	23.5-25-16PR (L2 Traction)
		General ground conditions	23.5-25-20PR (L3 Rock)
Loading crushed rock	Excavating bucket (with segment edge) (3.1 m ³ (4.1 cu.yd))	Soft ground	23.5-25-16PR (L3 Rock)
		Ground with many light rocks	23.5-25-12PR (L3 Rock)
		Soft ground with many light rocks	23.5-25-12PR (L3 Rock)
		General ground conditions	23.5-25-20PR (L3 Rock)

BOC indicates a bolt-on type cutting edge.

The displayed travel speed changes according to the tire size, so when installing optional tires, please contact your Komatsu distributor.

HANDLING TORQUE CONVERTER LOCK-UP



WARNING

When traveling down slopes of a grade of more than 6°, never depress the accelerator pedal fully, regardless of whether the torque converter lock-up switch is ON or OFF. It is extremely dangerous to drive too fast.

The travel speed shown in this section is the value when the tire size is 23.5-25. The travel speed is subject to the using condition and road condition.

NOTICE

To prevent overrunning when traveling at high speed in the following cases, do not shift down gear.

- When traveling in F3 at a speed of more than 18.0 km/h (11.2 MPH), do not shift down to F2.
- When traveling in F4 at a speed of more than 28 km/h (17.4 MPH), do not shift down to F3.

When the actual speed range is 3rd or 4th in either FORWARD or REVERSE, the torque converter lock-up function is actuated according to the travel speed and sets to direct drive.

To prevent overrun, the lock-up is automatically canceled to prevent the travel speed from going above 40 km/h (24.9 MPH).

GENERAL LOCATIONS

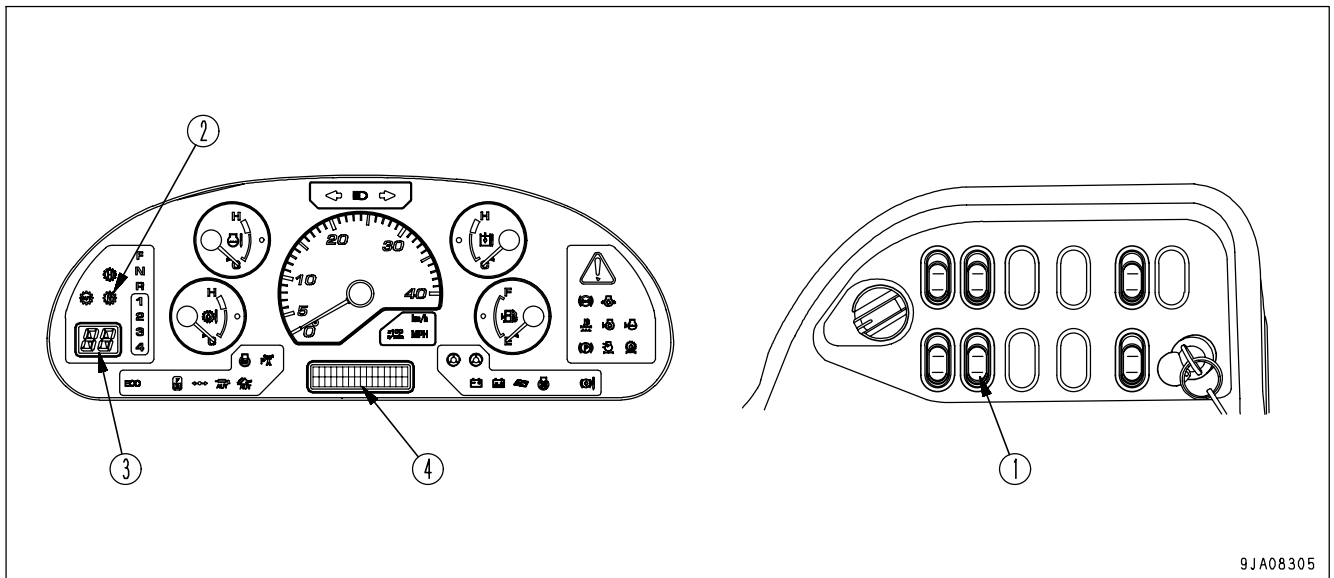

9JA08305

- | | |
|---|---|
| (1) Torque converter lock-up switch | (3) Shift indicator (displays actual speed range) |
| (2) Torque converter lock-up pilot lamp | (4) Character display |

TORQUE CONVERTER LOCK-UP SWITCH

This switch (1) is the control switch for the torque converter lock-up function.

Position (a): ON

The pilot lamp inside the switch lights up and the lock-up is actuated according to the travel speed.

While the lock-up is engaged, the lock-up pilot lamp on the machine monitor lights up.

Position (b): OFF

The lock-up does not function.

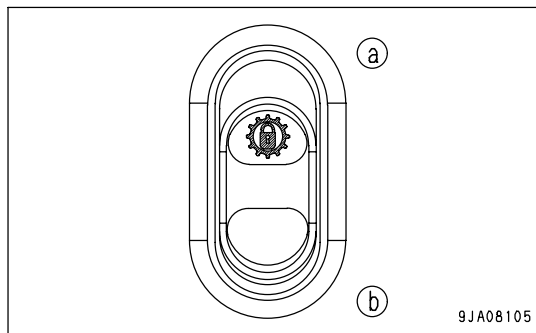
**TORQUE CONVERTER LOCK-UP PILOT LAMP**

This monitor (2) lights up when the torque converter lock-up is engaged and the transmission actually enters direct drive.

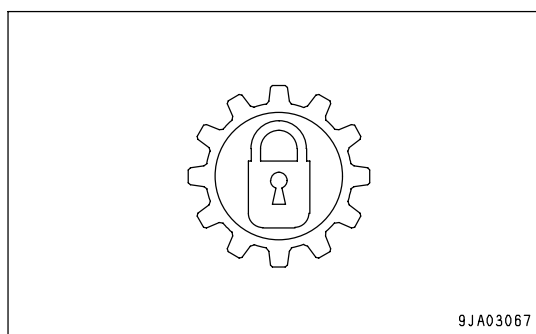

For details of (3) and (4), see "SHIFT INDICATOR (PAGE 3-26)" and "ACTION CODE DISPLAY (PAGE 3-9)" in the section on the machine monitor in the OPERATION section.

METHOD OF OPERATION

1. Press the top (a) of the torque converter lock-up switch to turn it ON.

The pilot lamp inside the switch lights up.

2. When the actual speed range is 3rd or 4th in either FORWARD or REVERSE, the torque converter lock-up function is actuated according to the travel speed and sets to direct drive.

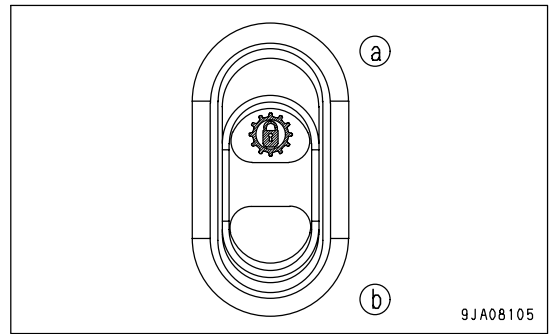

REMARK

When the gearshift lever is at 4th in auto-shift mode, the lock-up is not actuated if the actual speed range is 3rd. The lock-up is actuated only when the actual speed range is 4th.

When the lock-up is actually actuated, the lock-up pilot lamp on the machine monitor lights up.

3. To cancel the lock-up, press the bottom (b) of the torque converter lock-up switch to turn it OFF.

The lock-up is canceled.

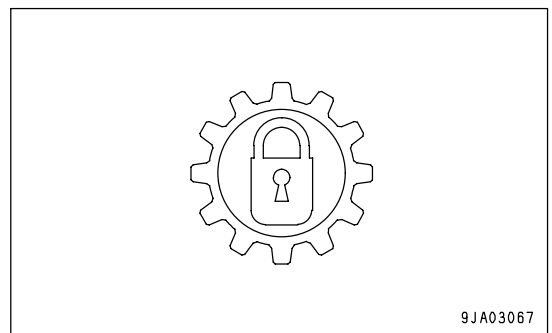

The travel speed for actuation and cancellation of the lock-up is as shown below.

Lock-up \ Speed range	FORWARD travel speed (km/h (MPH))		REVERSE travel speed (km/h (MPH))	
	Actuated	Canceled	Actuated	Canceled
3rd	11 to 13 (6.8 to 8.1)	10 to 12 (6.2 to 7.5)	12 to 14 (7.5 to 8.7)	11 to 13 (6.8 to 8.1)
4th	19 to 22 (11.8 to 13.7)	18 to 21 (11.2 to 13.0)	20 to 23 (12.4 to 14.3)	19 to 22 (11.8 to 13.7)

WARNING/LIMIT FUNCTIONS FOR TRAVEL SPEED**TRAVEL SPEED WARNING FUNCTION**

(This functions even when the torque converter lock-up switch is OFF.)

When the travel speed goes above 40.0 km/h (24.9 MPH), the central warning lamp lights up and the alarm buzzer sounds.

At the same time, "OVERRUN PROTECT" is displayed on the character display.

If the alarm buzzer sounds, depress the brake immediately to slow the machine down.

When the travel speed goes below 39.5 km/h (24.5 MPH), the alarm buzzer stops.

TRAVEL SPEED LIMIT FUNCTION

(This functions only when the torque converter lock-up switch is ON.)

To prevent the travel speed from going above 40.0 km/h (24.9 MPH), the lock-up is automatically canceled.

The lock-up cancel continues until the travel speed goes below 38.0 km/h {23.6 MPH}.

HANDLING JOYSTICK STEERING SYSTEM

To enable you to use the joystick steering safely and efficiently, please read the following before using it.

EXPLANATION OF COMPONENTS

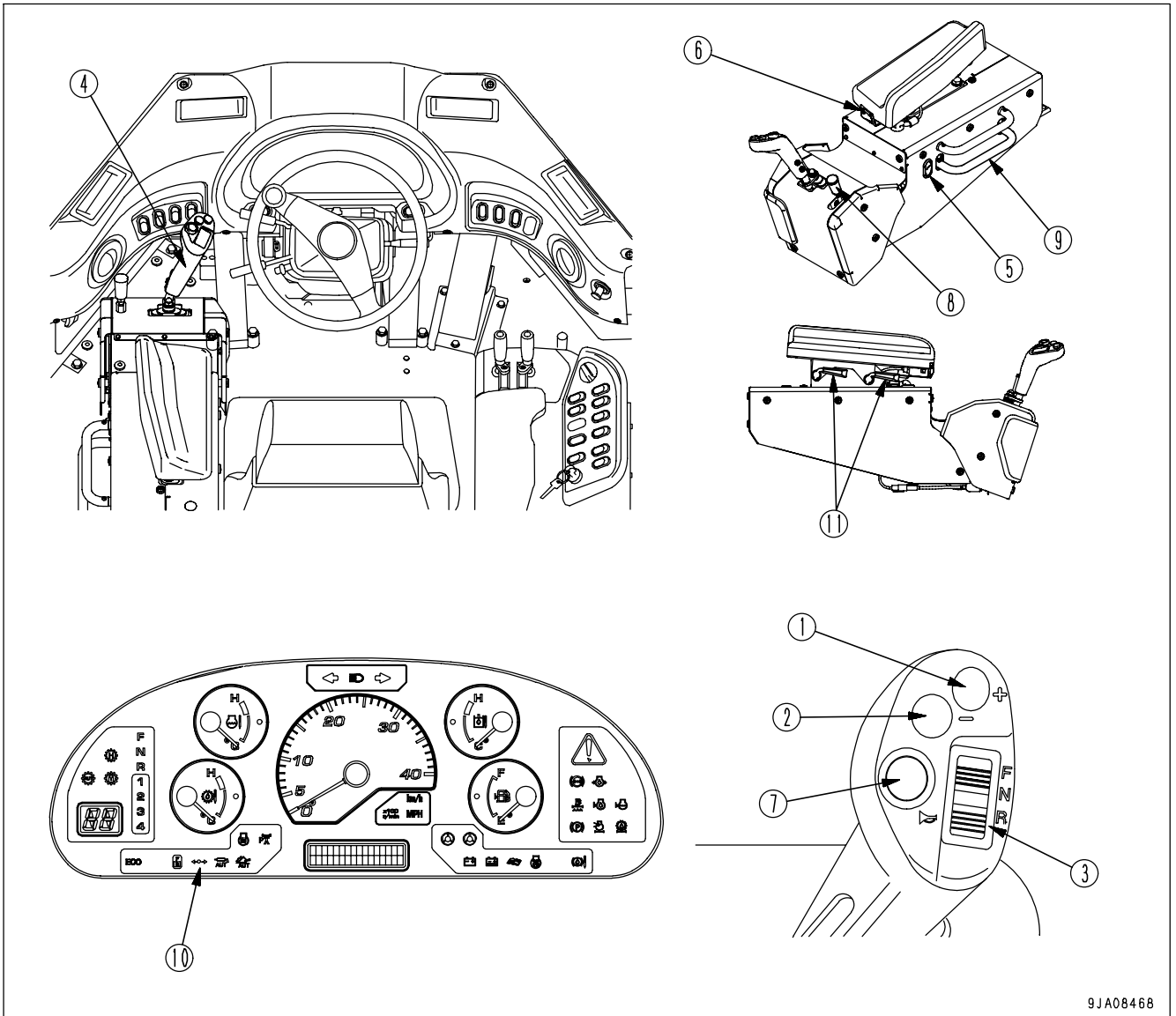

9JA08468

- | | |
|---------------------------------|---|
| (1) Shift up switch | (7) Horn switch |
| (2) Shift down switch | (8) Console tilt lever |
| (3) Directional selector switch | (9) Console fore-and-aft adjustment lever |
| (4) Joystick steering lever | (10) Joystick pilot lamp |
| (5) Joystick ON/OFF switch | (11) Armrest adjustment lever |
| (6) HI/LOW selector switch | |

SHIFT UP, SHIFT DOWN SWITCHES

These switches (1) and (2) are used to shift up or down in the manual shift mode.

Press (1): Shift up

Press (2): Shift down

These switches are not used in the auto shift mode.

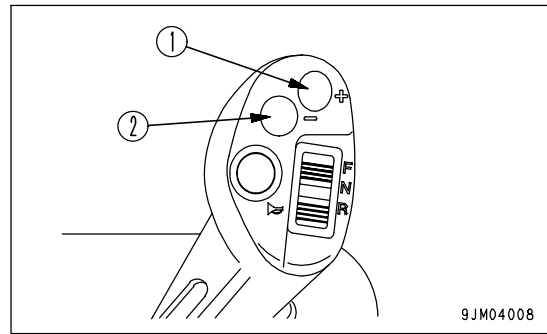

9JM04008

DIRECTIONAL SELECTOR SWITCH

This directional selector switch (3) on the head of the joystick steering lever is used to switch the transmission between forward and reverse.

(F) position: FORWARD

(N) position: NEUTRAL

(R) position: REVERSE

In the manual shift mode, use the shift up and shift down switches on the head of the joystick steering lever to shift the speed range.

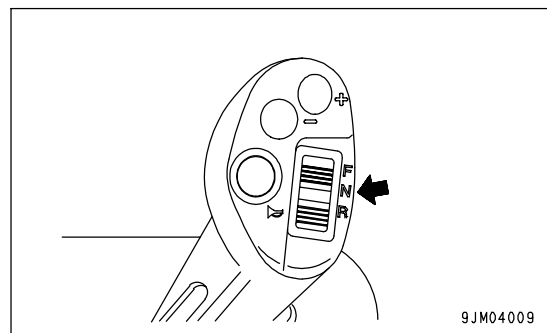

9JM04009

JOYSTICK STEERING LEVER

Use this lever (4) to steer the machine to the left or right.

When traveling, operate this lever in the direction to turn the machine.

(a): Left turn

(b): Right turn

(N): Neutral

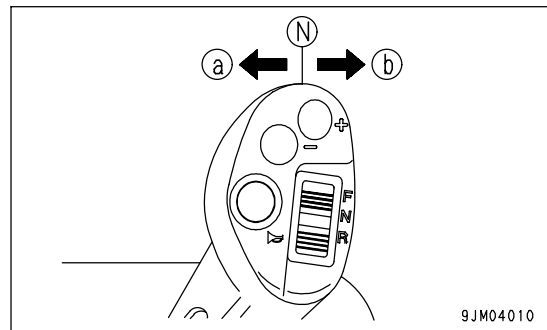

9JM04010

JOYSTICK ON/OFF SWITCH

Use this switch (5) to switch the joystick steering ON/OFF.

Position (a): ON (possible to steer with joystick)

Position (b): OFF (impossible to steer with joystick)

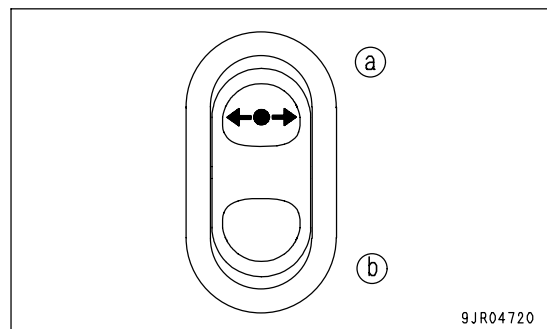

9JR04720

HI/LOW SELECTOR SWITCH

This switch (6) is used to switch the steering speed between HIGH and LOW.

Position (a): HI

The articulating speed of the machine is high in relationship to the operation of the joystick, so this setting is suitable for comparatively fast cycle times.

Position (b): LOW

The articulating speed of the machine is low in relationship to the operation of the joystick, so this setting is suitable for operations loading loose materials and materials that easily spill.

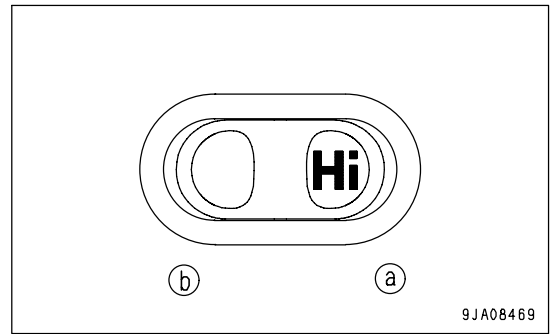

HORN SWITCH

Press this switch (7) at the top of the joystick to sound the horn. By using this switch, it is possible to sound the horn without taking your hand off the joystick.

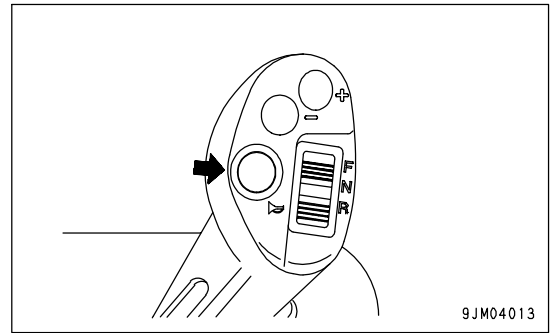

CONSOLE TILT LEVER

Push this lever (8) to the front to release the tilt lock for the joystick console lever portion, then tilt the console.

Position (a): Joystick steering system is actuated

Position (b): Joystick steering system is not actuated (system is turned OFF)

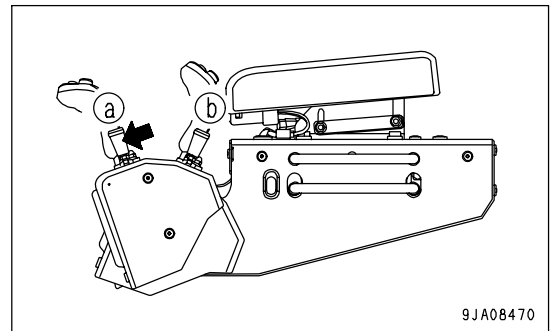

CONSOLE FORE-AND-AFT ADJUSTMENT LEVER

Use this lever (9) when sliding the whole joystick console to the front or rear. For details, see "ADJUSTMENT OF JOYSTICK CONSOLE (PAGE 6-15)".

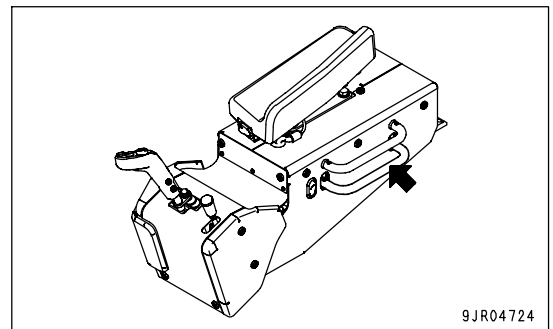

JOYSTICK PILOT LAMP

This lamp (10) lights up when the joystick ON/OFF switch is at the ON position and the joystick console is moved to the front to make it possible to use the joystick.

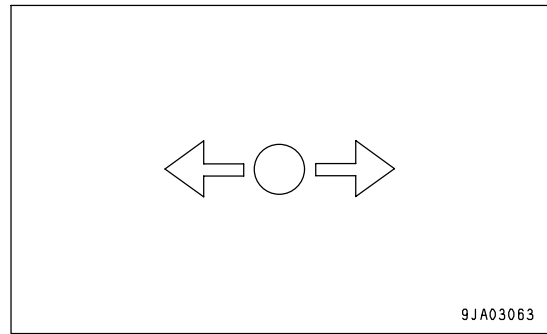
**ARMREST ADJUSTMENT LEVER**

Pull this lever (12) to adjust the height of the armrest within range (a) of 26 mm (1.0 in).

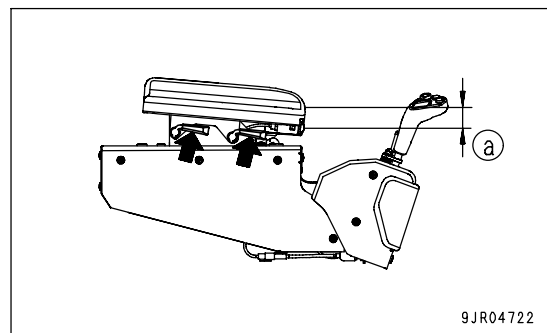

It is possible to adjust the angle within range (b) of approx. 7°.

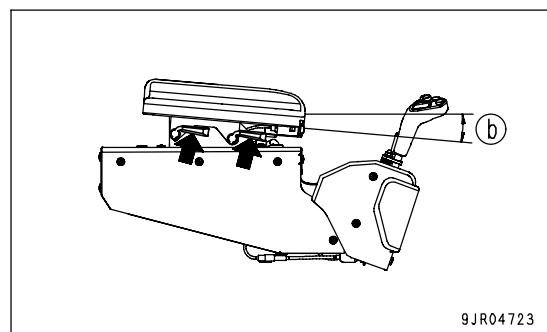

STRUCTURE AND FUNCTION OF JOYSTICK STEERING

- The joystick steering system is a system used to steer wheel loaders with a lever instead of a steering wheel.

The joystick enables steering with small, light movements, and helps to reduce operator fatigue.

When joystick ON/OFF switch (1) is turned ON, it becomes possible to operate the steering with the joystick. Before turning this switch (1) ON, adjust the position of the joystick console and check that there is no play in the console.

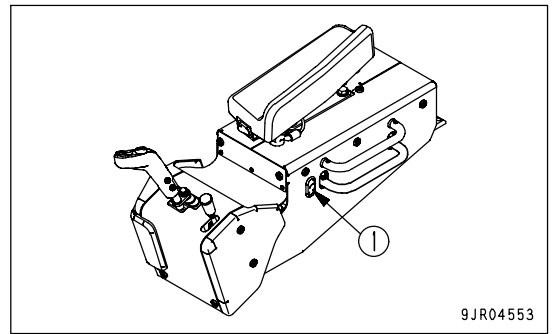

When the joystick steering is in use, the joystick pilot lamp on the machine monitor lights up.

- On machines equipped with the joystick steering system, it is possible to use joystick ON/OFF switch (1) to select the steering and transmission operation method as shown in the table below. The differences between operation using the joystick and operation using the steering wheel are as follows.

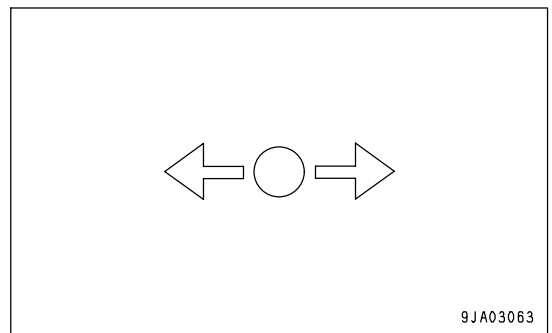

Selection		Operation using joystick		Operation using steering wheel	
Joystick ON/OFF switch		ON		OFF	
Steering		Steering using joystick (steering with steering wheel is also possible)		Steering using steering wheel	
Transmission	Changing direction	Operation using directional selector switch at top of joystick		Operation using transmission directinal lever	
	Transmission auto shift/manual shift selector switch	Manual	Auto (L,H)	Manual	Auto (L,H)
	Selection of speed range	Speed range selection using shift up, shift down switches at top of joystick*	Automatic gearshifting according to travel speed	Operation using gearshift lever	Automatic gearshifting according to travel speed
		1st - 3rd	2nd - 3rd	1st - 4th	2nd - 4th

*: Does not shift up above speed range of gearshift lever.

GETTING IN OR OUT OF OPERATOR'S CAB



WARNING

Before getting in or out of the operator's cab, turn the joystick ON/OFF switch to the OFF position, then grip console fore-and-aft adjustment lever (A) and slide the joystick console fully to the rear.

When the console fore-and-aft adjustment lever is gripped, the joystick console lever portion moves together and tilts to the rear, the joystick steering system power is turned OFF, and the joystick becomes inactive.

To make it easier to get in or out of the operator's cab, the joystick console can slide 220 mm to the front and rear.

1. When not using joystick

When not using the joystick, always turn the joystick ON/OFF switch (1) to the OFF position, push lever (B) to the front, and tilt the joystick console lever portion to the rear.

The electric power is turned OFF and the joystick steering system becomes inactive.

2. When using joystick

When operating the machine, push lever (B) to the front, tilt the joystick console lever portion to the front, and set joystick ON/OFF switch (1) to the ON position.

The electric power is turned ON and the joystick steering becomes active.

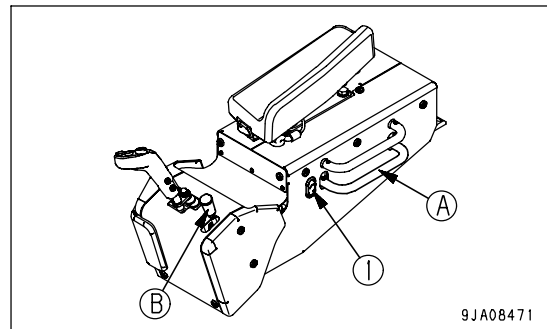

9JA08471

SEAT ADJUSTMENT

**WARNING**

- When adjusting the operator's seat, stop the machine in a safe place before starting the operation.
- Adjust the seat before starting operations for the day or when changing operators.
- When adjusting the seat, put your back against the backrest and adjust to a position where the brake pedal can be fully depressed.

An air compressor built into the seat is used for adjustment (C) and (D), so turn the engine starting switch to the ON position before starting the adjustment.

NOTICE

There is danger of damage to the air compressor, so do not keep lever (3) operated continuously for more than 1 minute.

(A) Fore-and-aft adjustment

Move lever (1) up and move the seat to the desired position and release the lever.

Fore-and-aft adjustment: 210 mm (10 mm x 21 stages)
(8.3 in (0.4 in) x 21 stages)

(B) Adjusting seat angle

Move lever (2) up, move the seat cushion at the front up or down to set to the desired position, then release the lever.

Amount of adjustment
Forward tilt: 3 degrees
Rear tilt: 11 degrees

(C) Adjusting seat height

The seat height adjustment uses an air system, and it can be adjusted steplessly.

When adjusting the height, pull lever (3) up fully or push it down fully (when pulling it up, pull it until a click is felt). When the seat is set at the desired height, release the lever. If the lever is kept pulled up, the position where the seat does not rise any further is the maximum height. When the seat reaches the maximum height, the suspension automatically goes down slightly to secure the amount of movement of the lever.

If the operator raises his body from the seat or changes the amount of weight applied to the seat during adjustment, the air in the suspension may be discharged.

Amount of adjustment: 80 mm (3.2 in)

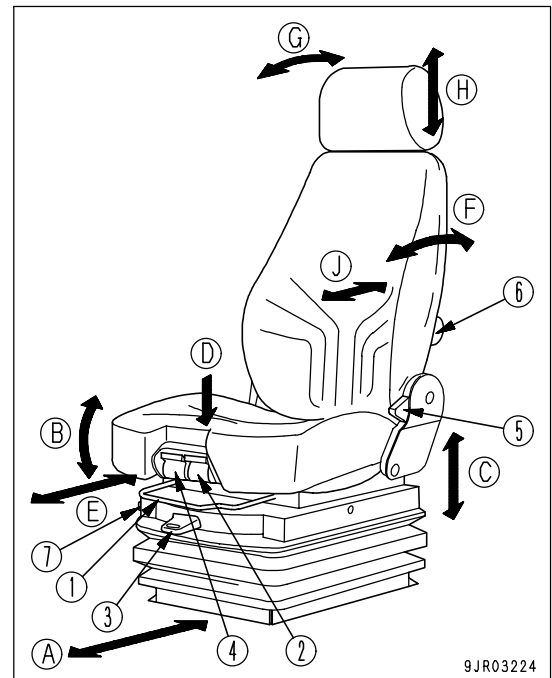

9JR03224

REMARK

If the lever is operated in the RAISE direction from the maximum height, the compressor may continue to operate for approx. 8 seconds, but this does not indicate any abnormality with the seat.

If this happens, the compressor will stop automatically after approx. 8 seconds. The compressor will also stop if the height control lever is operated in the LOWER direction.

(D) Setting seat for weight

Pull lever (3) up fully (pull it until a click can be felt). When the lever is released, the weight adjustment is carried out automatically. To ensure that the weight adjustment is carried out correctly, the operator should sit in the normal operating position when operating the lever. If the operator raises his body from the seat or changes the amount of weight applied to the seat during adjustment, the air in the suspension may be discharged.

When operators change shifts, the new operator should pull lever (3) up fully (pull it until a click it is felt). When the lever is released, the weight adjustment is carried out automatically.

If lever (3) is pulled lightly, the weight adjustment starts, but always pull the lever up fully (pull it until a click is felt) before releasing it.

REMARK

- When making initial adjustment or when adjusting the weight settings when operators change shifts, set the damping force of the suspension damper to the soft setting (for details, see "Adjusting hardness of suspension damper"), then adjust it to match the operator's weight. If the damping force of the suspension damper is left set to the hard setting and the height of the seat is adjusted, even if the height is raised, the seat may go down. If the seat goes down, set the damping force of the suspension damper to the soft setting, lower the seat, then adjust the weight again. After completing adjustment of the weight and height, set the damping force of the suspension damper to the desired strength.
- To protect the operator, the suspension must be adjusted to match the operator's weight. Adjust the weight before starting operations.
- When adjusting, do not remove your weight from the seat or change the load in any other way. If this is done, the air may be released from the suspension's seat.

(E) Fore-and-aft adjustment of seat cushion

Operate lever (4) up, set the seat cushion to the desired position, then release the lever.

Fore-and-aft adjustment: 60 mm (2.4 in)

(F) Adjusting reclining angle

Operate lever (5) up and move the back cushion to the front or rear.

But your back firmly against the seat back when carrying out this adjustment. If you move your back away from the seat back, the seat back may suddenly spring forward.

Amount of adjustment

Forward tilt: 10 degrees (over 10 degrees is free)

Rear tilt: 36 degrees

NOTICE

If the seat back is reclined too far, the seat back may hit the rear glass, so use it in a position where it does not contact the glass.

(G) Adjusting headrest angle

Rotate the backrest to the front or rear and set to the desired angle.

Amount of adjustment: 38 degrees

(H) Adjusting headrest height

Move the headrest up or down and set to the desired height.

Amount of adjustment: 100 mm (3.9 in)

(J) Lumbar support

Turn the knob (6) to the right or left to give the suitable amount of lumbar support.

(K) Adjusting hardness of suspension damper

Operate knob (7) to adjust the strength of the suspension damper. Turn knob (7) towards the front of the seat (a) to make the damping force harder; turn it towards the rear of the seat (b) to make the damping force softer.

Amount of adjustment: 5 stages

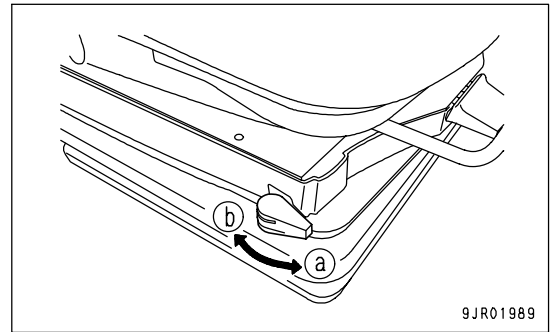
**ADJUSTMENT OF JOYSTICK CONSOLE****WARNING**

- Stop the machine on level ground in a safe place when carrying out the adjustment.
- Carry out the adjustment before starting operations or when changing operator shifts.
- Put your back against the backrest of the operator's seat and adjust the seat so that it is possible to depress the brake fully, then adjust the console.

Grip console fore-and-aft adjustment lever (1) and adjust the position of the joystick console to the front or rear.

If you grip the console fore-and-aft adjustment lever (1), lever portion (2) of the joystick console automatically tilts to the rear.

Maximum slide to rear when getting on or off: 220 mm (8.7 in)

Fore-and-aft adjustment when operating joystick: 160 mm (6.3 in)

(16 mm (0.6 in) x 10 stages)

When using the joystick, adjust the fore-and-aft position, then push console tilt lever (3) to the front and tilt lever portion (2) fully from the rear to the front.

After doing this, set the joystick ON/OFF switch to the ON position.

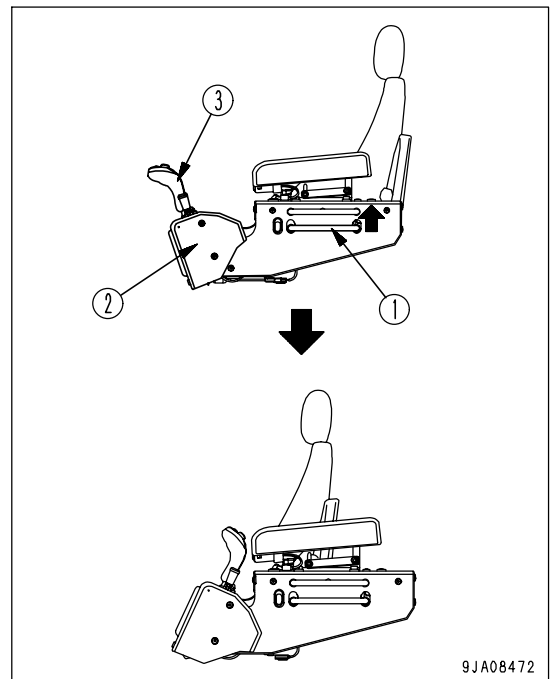

OPERATION USING JOYSTICK LEVER AND OPERATION USING STEERING WHEEL



CAUTION

- Set the joystick lever to the Neutral position when starting the engine.
- If the directional lever and joystick directional selector switch are not at the neutral position, the neutral interlock circuit makes it impossible to switch the transmission directional control (when the joystick ON/OFF switch is ON, it is switched from the directional lever to the joystick directional selector switch; when the joystick ON/OFF switch is OFF, it is switched from the joystick directional selector switch to the directional lever.)
- Do not use the joystick when traveling on public roads.
- When traveling on public roads, turn the joystick ON/OFF switch to the OFF position, then tilt the joystick console lever portion to the rear.
- When the engine is running, if the joystick lever is touched by accident, there is danger that it may cause the machine to articulate unexpectedly. To avoid this, if the machine is not being operated, always move the joystick ON/OFF switch to the OFF position and tilt the joystick console lever portion to the rear.

Select joystick operation or steering wheel operation according to the work.

- Steering using joystick

This is suited for continuous loading operations on jobsites with ample space where the loading operation can be carried out with a comparatively relaxed cycle time.

Because operations can be carried out with a small movements and light operating effort, this is also suitable for reducing operator fatigue when operating continuously.

- When the joystick is being actuated, the transmission will not enter 4th.
- Steering using steering wheel

This provides excellent fine control and ability to travel straight, so it is suitable for travel between jobsites and for load and carry operations. In addition, it is also suitable for short cycle loading operations because the upper part of the operator's body is supported by the steering wheel when frequently switching between FORWARD and REVERSE. Always use the steering wheel when driving the machine on public roads.



WARNING

Use the joystick only when carrying out continuous loading operations. Never use the joystick when traveling on public roads or when carrying out load and carry operations.

PRECAUTIONS FOR STEERING WITH JOYSTICK



WARNING

- When using the joystick lever to operate the steering and transmission, if the operation of the machine does not match the operation performed by the operator and the warning lamp lights up, do as follows.
Change to use of the steering wheel if necessary, apply the brakes immediately, turn the joystick ON/OFF switch OFF, operate the steering wheel and the directional lever to move the machine to a safe place, then stop the machine.
- Before starting the operation of the machine again, find out and repair the troubled part and confirm that the function is normal. For the troubleshooting and repair, please contact your Komatsu distributor.
- Never operate the machine before it is repaired completely.

- When the joystick ON/OFF switch is turned OFF, if the directional selector switch and directional lever are not at the N position, the neutral interlock circuit is actuated, the central warning lamp lights up, and the alarm buzzer sounds.
Return the directional selector switch and directional lever to the N position.
- If the electric circuit of the joystick steering system or transmission control system has trouble, the central caution lamp (Red) on the left side of the machine monitor flashes to notify the trouble to the operator.
Since both steering system and transmission are set in the respective neutral positions, turn off the joystick ON/OFF switch, then drive the machine with the steering wheel and the directional lever.

OPERATION METHOD OF JOYSTICK STEERING SYSTEM



WARNING

- It is dangerous to turn the machine suddenly at high speed, or to turn on steep hills. Do not operate the steering in such conditions.
- When turning, the articulation stops at the position where the steering wheel is turned to, but if the joystick is held in the tilted position, the body will articulate fully.
- The feeling when operating the steering with the joystick is different from when operating with the steering wheel, so be extremely careful until you have become used to operating the joystick.
- When the joystick ON/OFF switch is at the ON position, if the directional lever is operated to F or R, the machine will travel in forward or reverse according to the operation of the directional lever, regardless of the position of the directional selector switch on the head of the joystick lever. Priority is given to the operation of the directional lever, so be careful when operating.
- When this is done, the central warning lamp lights up and the alarm buzzer sounds.
- Set the directional lever and directional selector switch on the head of the joystick to the N position.

Check the adjustment and operation before starting the engine. For details, see "CHECK BEFORE STARTING ENGINE, ADJUST (PAGE 3-99)".

1. When starting the engine, check that the joystick lever is at the N position, that the transmission directional lever is at the N position, and that the surrounding area is safe.

REMARK

Under the following conditions, a warning may be given when the engine is started.

- If the directional selector switch on the joystick is at F or R, the joystick pilot lamp flashes, the central warning lamp lights up, and the alarm buzzer sounds.

In this condition, the engine will not start, so set the directional selector switch to N.

- If the joystick is not at the N position, the joystick pilot lamp flashes, the central warning lamp lights up, and the alarm buzzer sounds.

In this condition, the engine will not start, so set the joystick to the N position.

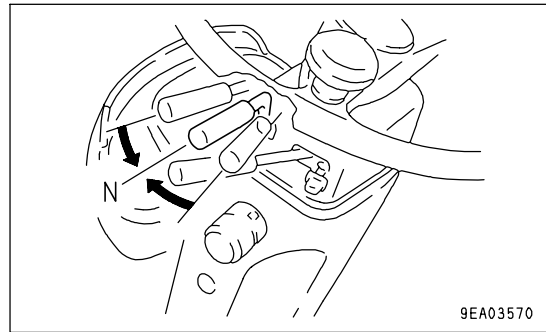

2. When using the joystick, set the joystick ON/OFF switch to position (a) to activate the joystick steering system.

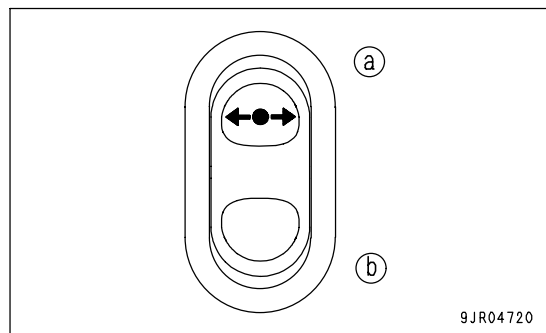

3. Operate the joystick in direction (b) to turn the machine to the right; operate it in direction (a) to turn the machine to the left. The greater the angle of operation, the faster the articulating speed becomes.

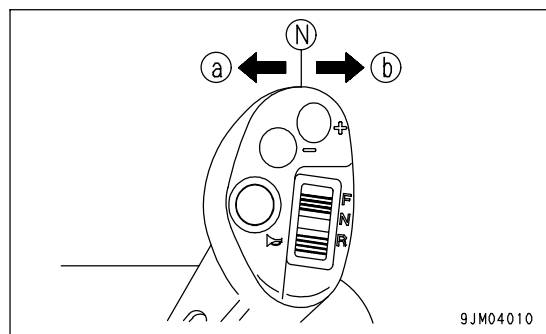

4. It is possible to switch the articulating speed with the HI/LOW selector switch. Select the speed to match the operation.

5. When the machine has articulated to the desired angle, return the joystick to the N position. The joystick will return automatically to the N position.

6. To return the direction of travel of the machine so that it travels in a straight line, operate the joystick in the opposite direction from the N position (for example, when the machine is articulated to the right, operate the joystick to the left).

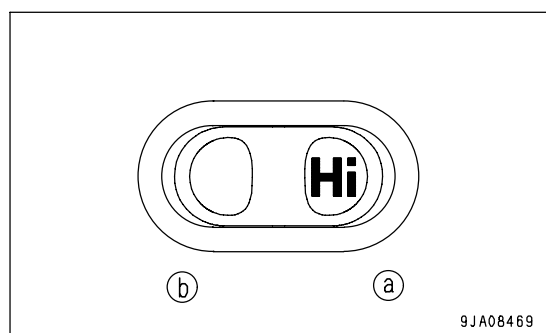

7. Use the directional selector switch at the top of the joystick lever to set the transmission to the direction of travel.

- N position: NEUTRAL
- F position: FORWARD
- R position: REVERSE

If the position of the directional lever and the directional selector switch are different, the joystick pilot lamp flashes, the warning lamp lights up, and the alarm buzzer sounds. In this condition, the machine moves to the front or rear according to the position of the directional lever. Place the directional lever at the N position.

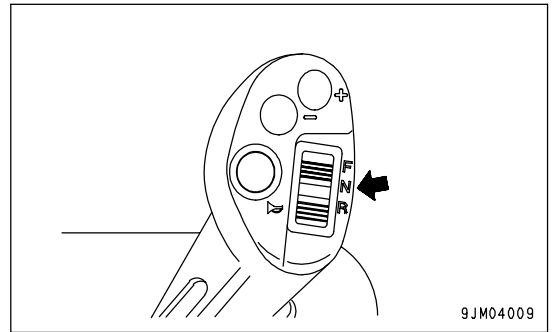

8. When the shift mode is in manual, use shift up switch (1) and shift down switch (2) on the joystick lever to shift the travel speed range.

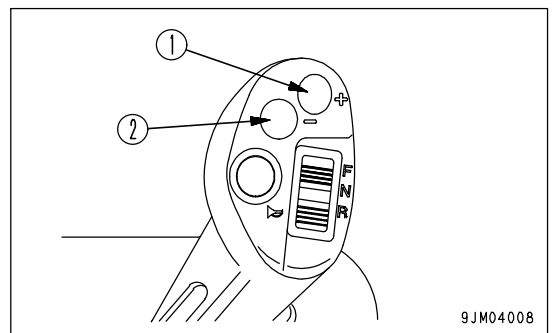

9. When not using the joystick, set the joystick ON/OFF switch to position (b).
The activation of the joystick is cancelled.

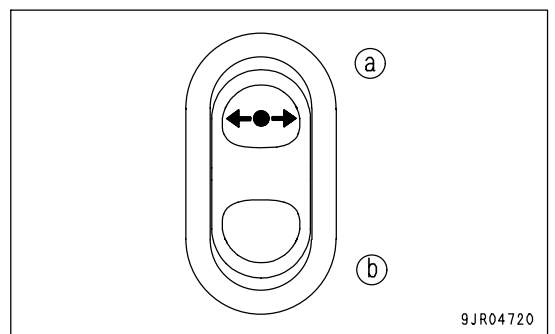

HANDLING MULTI FUNCTION MONO-LEVER

EXPLANATION OF COMPONENTS

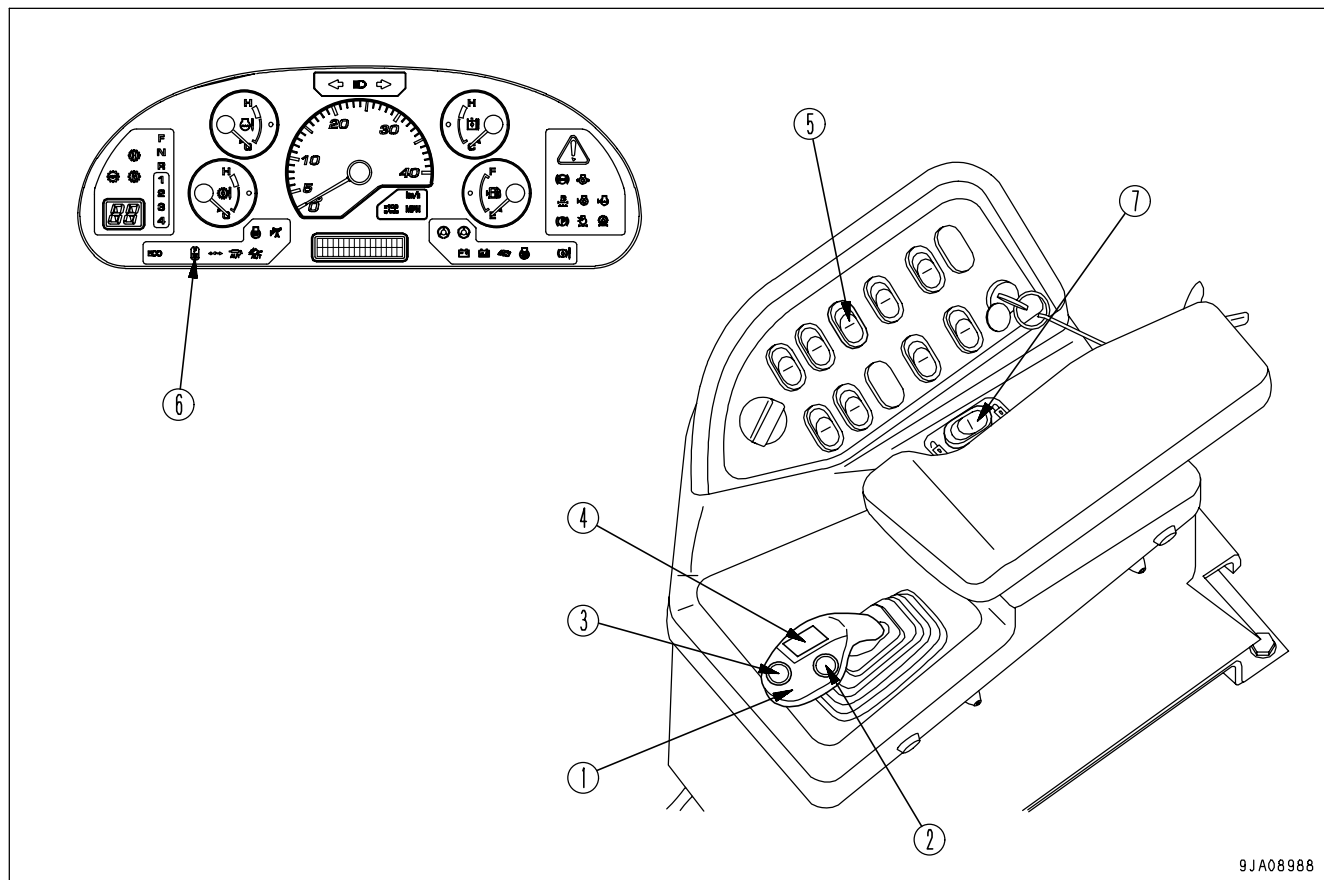

9JA08988

- (1) Work equipment lever
- (2) Kickdown switch
- (3) Hold switch
- (4) FNR switch
- (5) Directional selector switch actuation switch
- (6) Directional selector pilot lamp
- (7) Work equipment lock switch

WORK EQUIPMENT LEVER

This lever (1) is used to control the lift arm and bucket.

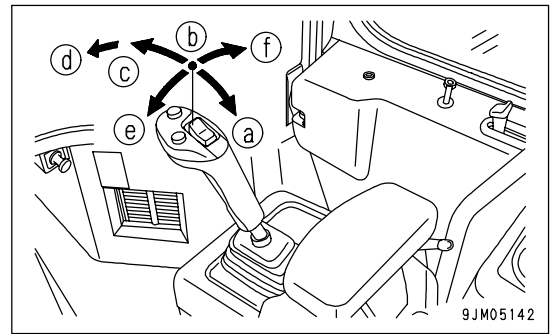

LIFT ARM OPERATION

NOTICE

Do not use the FLOAT position when lowering the bucket. Use the FLOAT position when leveling, see "LEVELING OPERATIONS (PAGE 3-145)".

Position (a): RAISE

When the work equipment control lever is pulled further beyond the RAISE position, the lever is stopped in this position until the lift arm reaches the preset position of the kickout, and the lever is returned to the HOLD position.

Position (b): HOLD

The lift arm is kept in the same position.

Position (c): LOWER

Position (d): FLOAT

The lift arm moves freely under external force.

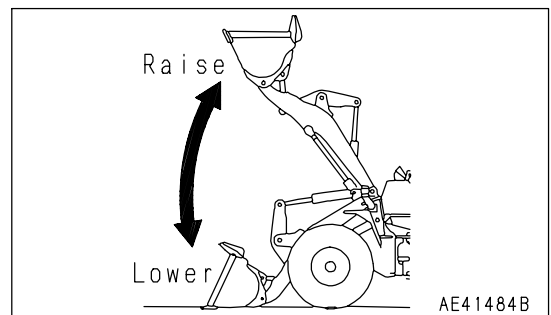

BUCKET OPERATION

Position (e): TILT

When the work equipment control lever is pulled further beyond the TILT position, the lever is stopped in this position until the bucket reaches the preset position of the positioner, and the lever is returned to the HOLD position.

Position (b): HOLD

The bucket is kept in the same position.

Position (f): DUMP

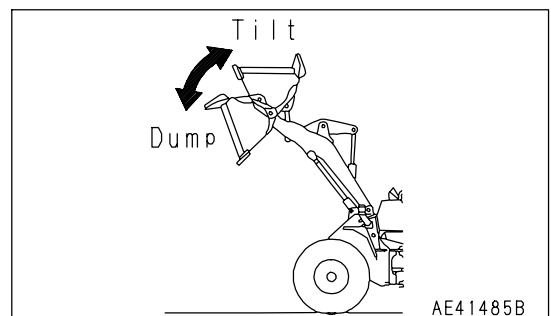

KICKDOWN SWITCH

When the gearshift lever is in 2nd, if switch (2) is pressed, the transmission will shift down to 1st.

Use this when you need to increase the drawbar pull in digging operations.

If the transmission is in auto-shift, and the travel speed is below 10.5 km/h (6.5 MPH) in any speed range when traveling in either forward or in reverse, the kick-down switch is actuated and it is possible to shift down to 1st.

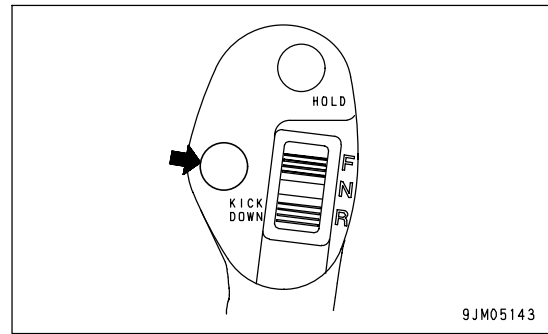

This makes it easy to carry out load and carry operations.

Even if the travel speed is more than 10.5 km/h (6.5MPH), this switch can be used to shift the transmission down. Each time the kick-down switch is pressed, the speed range will shift down one range at a time (F4 -> F3 -> F2). When the torque converter is in the lock-up condition (if equipped), the lock-up is canceled.

REMARK

- When canceling the kick-down, operate the directional lever or the FNR switch. In manual shift, it can be canceled by operating the speed lever to any position other than 2nd. It is also possible to cancel the kick-down by turning the starting switch OFF.
- In auto-shift, if the travel speed becomes high after the kick-down, the gear will be shifted up by the auto-shift.
- In auto-shift, when traveling at more than 18 km/h (11.2 MPH) in 3rd or at more than 28 km/h (17.4 MPH) in 4th, even if the kick-down switch is pressed, the transmission will not shift down. This is to prevent overrun of the engine.

HOLD SWITCH

To fix the speed range when traveling in automatic transmission, press this switch (3). The transmission will be fixed in the speed range displayed on shift indicator (A) on the machine monitor and shift hold pilot lamp (B) will light up.

When the switch is pressed again, the display goes out.

Use this function to select the desired speed range when traveling up or down hills or when carrying out operations such as grading.

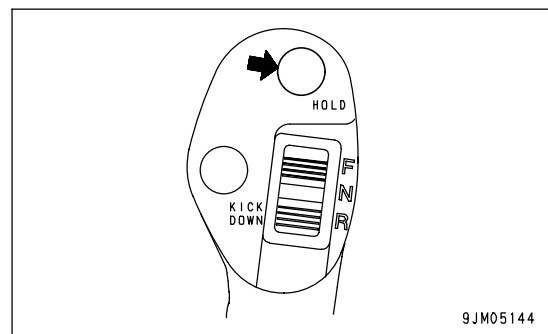

REMARK

- When the torque converter is in the lock-up condition (if equipped), the transmission cannot be fixed.
- When canceling the shift hold, operate the directional lever or the FNR switch. It can also be canceled by operating the speed lever and by switching the shift/manual selector switch to MANUAL. It is also possible to cancel the shift hold by turning the starting switch OFF.

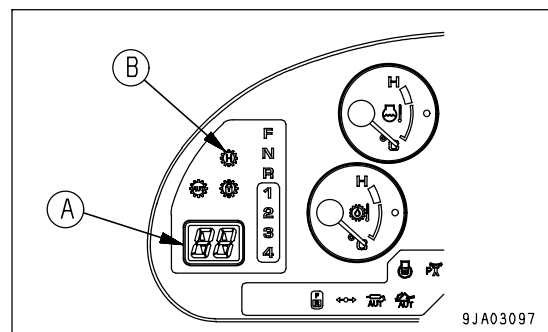

FNR SWITCH

This switch (4) is used to change the direction of travel of the machine.

Position (F): FORWARD

Position (N): Neutral

Position (R): REVERSE

Before operating this switch, check that the condition is as follows.

- Directional lever is at N
- Directional selector switch actuation switch is at ON

If the condition is not as above, the switch will not work.

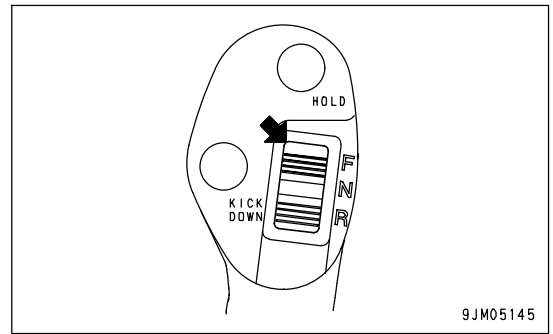

DIRECTIONAL SELECTOR SWITCH ACTUATION SWITCH

When this switch (5) is pressed, the FNR switch on the head of the multi-function lever is activated.

Position (a): ON

The pilot lamp inside the switch and the directional selection pilot lamp on the machine monitor light up, and the FNR switch is activated.

Position (b): OFF

The FNR switch is not activated.

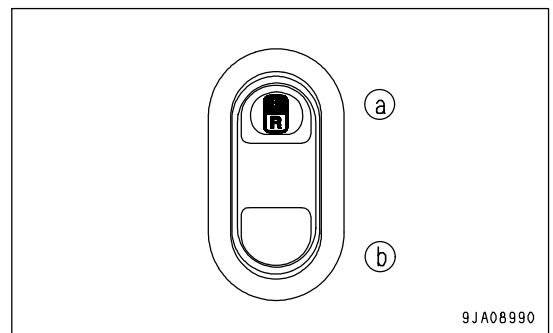

DIRECTIONAL SELECTOR PILOT LAMP

This monitor (6) lights up when the directional selector switch actuation switch on the right switch panel is turned ON. It indicates that it is possible to operate the travel direction of the machine with the FNR switch on the head of the multi-function lever.

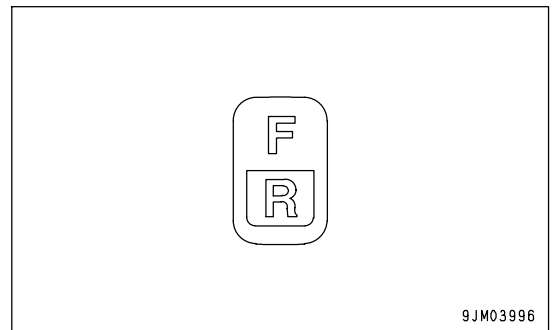

WORK EQUIPMENT LOCK SWITCH



WARNING

- Before standing up from the operator's seat, set the work equipment lock switch securely to the LOCK position. If the work equipment lock switch is not at the LOCK position, and work equipment control lever(1) is touched by mistake, it may lead to a serious accident.
- If the work equipment lock switch is not placed securely at the LOCK position, the work equipment may move, and this may lead to a serious accident or personal injury. Check that the lever is in the position shown in the diagram.
- When operating the work equipment lock switch, check that work equipment control lever(1) is at the HOLD position.
- When operating the work equipment lock switch, be careful not to touch work equipment control lever(1).

Use this switch (7) to switch the work equipment lock system between LOCK and FREE.

Position (a): LOCK

Position (b): FREE

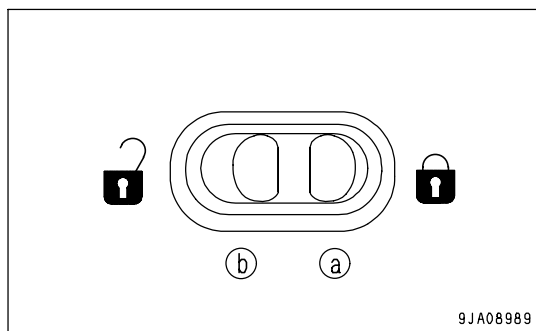

USING FNR SWITCH TO CHANGE BETWEEN FORWARD AND REVERSE



WARNING

- When changing direction between FORWARD and REVERSE, check that the new direction of travel is safe. There is a blind spot behind the machine, so be particularly careful when changing direction to travel in reverse.
- When the directional selector switch actuation switch is at the ON position, if the directional lever is operated to F or R, the machine will travel in forward or reverse according to the operation of the directional lever, regardless of the position of the FNR switch on the head of the multi-function lever. Priority is given to the operation of the directional lever, so be careful when operating.
- Do not switch between FORWARD and REVERSE when traveling at high speed. When switching between FORWARD and REVERSE, depress the brake to reduce the travel speed sufficiently, then change the direction of travel. (Max.speed for changing direction: 10.5 km/h (6.5 MPH))

1. Place the directional lever at the N position.

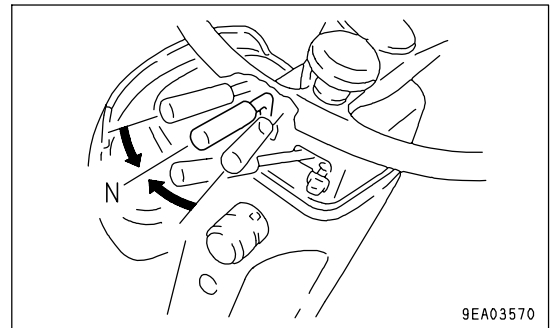

2. Turn on directional selector switch on the right side of switching panel that enables directional selection.

Position (a): ON

Position (b): OFF

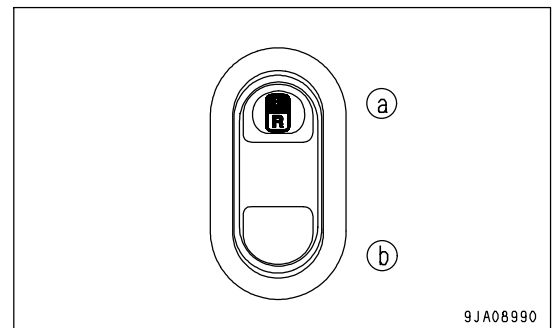

The pilot lamp inside the switch and the directional selection pilot lamp on the machine monitor light up, and the FNR switch is activated.

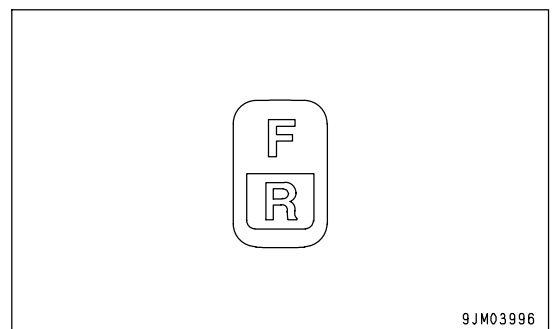

3. Push the FNR switch on the head of the multi-function lever to the desired position.

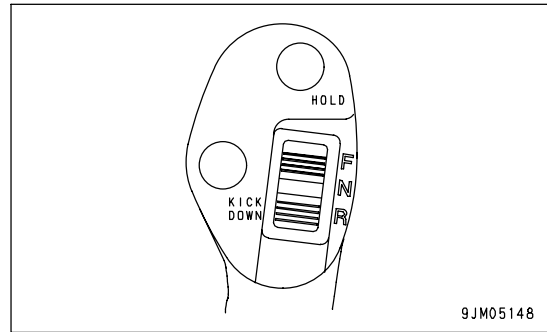

If the directional selector pilot lamp on the machine monitor flashes, the switch or the lever is in one of the following conditions.

- When the directional selector switch actuation switch is at the OFF position, if the FNR switch is operated to F (or R):
The pilot lamp flashes, and at the same time, the central warning lamp lights up and the alarm buzzer sounds.
Set the FNR switch to the N position.
- When the engine is started, if the directional selector switch is at the ON position and the directional lever is at N, and the FNR switch is operated to F (or R):
The pilot lamp flashes, and at the same time, the central warning lamp lights up and the alarm buzzer sounds.
Set the FNR switch to the N position.
- If the directional selector switch is at the ON position and the FNR switch is operated to F (or R):
The pilot lamp flashes, and at the same time, the central warning lamp lights up and the alarm buzzer sounds.
In this condition, the machine will travel in forward or reverse according to the operation of the directional lever.
Set the directional lever and the FNR switch on the head of the multi-function lever to the N position.

HANDLING MACHINES EQUIPPED WITH KOMTRAX

- KOMTRAX is a machine management system that uses wireless communications.
- A contract with your Komatsu distributor is necessary before the KOMTRAX system can be used. Any customers desiring to use the KOMTRAX system should consult their Komatsu distributor.
- The KOMTRAX equipment is a wireless device using radio waves, so it is necessary to obtain authorization and conform to the laws of the country or territory where the machine equipped with KOMTRAX is being used. Always contact your Komatsu distributor before selling or exporting any machine equipped with KOMTRAX.
- When selling or exporting the machine or at other times when your Komatsu distributor considers it necessary, it may be necessary for your Komatsu distributor to remove the KOMTRAX equipment or to carry out action to stop communications.
- If you do not obey the above precautions, neither Komatsu nor your Komatsu distributor can take any responsibility for any problem that is caused or for any loss that results.

BASIC PRECAUTIONS



WARNING

- Never disassemble, repair, modify, or move the communications terminal, antenna, or cables. This may cause failure or fire on the KOMTRAX equipment or the machine itself. (Your Komatsu distributor will carry out removal and installation of KOMTRAX.)
- Do not allow cables or cords to become caught; do not damage or pull cables or cords by force. Short circuits or disconnected wires may cause failure or fire on the KOMTRAX equipment or the machine itself.
- For anyone wearing a pacemaker, make sure that the communications antenna is at least 22 cm (8.7 in) from the pacemaker. The radio waves may have an adverse effect on the operation of the pacemaker.
- Near the blasting jobsite, there may be a danger of unexpected explosion due to use of interactive wireless communication device of KOMTRAX and resulting serious personal injury. Make sure to operate the machine away from the blasting jobsite. If you have to operate the machine within 12 m (39 ft 4 in) from the blasting jobsite or the remote blasting device, ask your Komatsu distributor to disconnect power source cable of KOMTRAX in advance.

If there are any restriction or law of the territory or country where the machine equipped with this device is used, such restriction or law has a priority than this warning.

KOMTRAX specifications are as follows.

Rated horsepower: 5 - 10 W

Operating frequency: 148 - 150 MHz

NOTICE

- Even when the key in the starting switch of the KOMTRAX system is at the OFF position, a small amount of electric power is consumed. When putting the machine into long-term storage, take the action given in "LONG-TERM STORAGE (PAGE 3-166)".
- Please contact your Komatsu distributor before installing a top guard or other attachment that covers the cab roof.
- Be careful not to get water on the communications terminal or wiring.

REMARK

- The KOMTRAX system uses wireless communications, so it cannot be used inside tunnels, underground, inside buildings, or in mountain areas where radio waves cannot be received. Even when the machine is outside, it cannot be used in areas where the radio signal is weak or in areas outside the wireless communication service area.
- There is absolutely no need to inspect or operate the KOMTRAX communications terminal, but if any abnormality is found, please consult your Komatsu distributor.

INDEX

<A>		PRECAUTIONS WHEN RUNNING	
ADJUSTING WORK EQUIPMENT		ENGINE INSIDE BUILDING -----	2- 20
POSTURE -----	3-150	PREPARATIONS FOR SAFE	
AIR CONDITIONER -----	3- 91	OPERATION -----	2- 13
AM/FM RADIO -----	3- 70	UNAUTHORIZED MODIFICATION -----	2- 19
AM/FM RADIO-CASSETTE STEREO -----	3- 76	GENERAL VIEW -----	3- 2
		GENERAL VIEW OF CONTROLS AND	
BACKUP ALARM -----	3- 66	GAUGES -----	3- 3
BEFORE READING THIS MANUAL -----	1- 2	GENERAL VIEW OF MACHINE -----	3- 2
<C>		GREASE PUMP -----	3- 61
CAP WITH LOCK -----	3- 58	GUIDES TO MAINTENANCE -----	4- 2
CHECK BEFORE STARTING ENGINE,		<H>	
ADJUST -----	3- 99	HANDLING AUTO AIR CONDITIONER -----	3- 84
CHECKS AFTER COMPLETION OF		HANDLING CAB WIPER -----	3- 98
OPERATION -----	3-154	HANDLING JOYSTICK STEERING	
COLD WEATHER OPERATION -----	3-164	SYSTEM -----	6- 7
AFTER COLD WEATHER -----	3-165	ADJUSTMENT OF JOYSTICK	
PRECAUTIONS AFTER		CONSOLE -----	6- 15
COMPLETION OF WORK -----	3-165	EXPLANATION OF COMPONENTS -----	6- 7
PRECAUTIONS FOR LOW		GETTING IN OR OUT OF	
TEMPERATURE -----	3-164	OPERATOR'S CAB -----	6- 12
CONTROL LEVERS, PEDALS -----	3- 53	OPERATION METHOD OF JOYSTICK	
<E>		STEERING SYSTEM -----	6- 17
ENGINE SERIAL NO. PLATE -----	1- 6	OPERATION USING JOYSTICK	
EXPLANATION OF COMPONENTS -----	3- 6	LEVER AND OPERATION USING	
<F>		STEERING WHEEL -----	6- 16
FRAME LOCK BAR -----	3- 60	PRECAUTIONS FOR STEERING	
FUSE -----	3- 67	WITH JOYSTICK -----	6- 17
<G>		SEAT ADJUSTMENT -----	6- 13
GENERAL PRECAUTIONS COMMON		STRUCTURE AND FUNCTION OF	
TO OPERATION AND MAINTENANCE ----	2- 13	JOYSTICK STEERING -----	6- 11
DO NOT GET CAUGHT IN		HANDLING MACHINES EQUIPPED	
ARTICULATING PORTION -----	2- 19	WITH KOMTRAX -----	6- 27
FIRE PREVENTION -----	2- 15	BASIC PRECAUTIONS -----	6- 27
PRECAUTIONS BEFORE STARTING		HANDLING MULTI FUNCTION	
OPERATION -----	2- 13	MONO-LEVER -----	6- 20
PRECAUTIONS RELATED TO		EXPLANATION OF COMPONENTS -----	6- 20
ATTACHMENTS AND OPTIONS -----	2- 20	USING FNR SWITCH TO CHANGE	
PRECAUTIONS RELATED TO		BETWEEN FORWARD AND	
PROTECTIVE STRUCTURES -----	2- 19	REVERSE -----	6- 25
PRECAUTIONS WHEN GETTING ON		HANDLING OIL, FUEL, COOLANT, AND	
OR OFF MACHINE -----	2- 16	PERFORMING OIL CLINIC -----	4- 4
		HANDLING THE TIRES -----	3-156
		HANDLING TORQUE CONVERTER	
		LOCK-UP -----	6- 3
		GENERAL LOCATIONS -----	6- 3

METHOD OF OPERATION -----	6- 5	PRECAUTIONS FOR MAINTENANCE -----	2- 34
WARNING/LIMIT FUNCTIONS FOR TRAVEL SPEED -----	6- 6	PRECAUTIONS BEFORE STARTING INSPECTION AND MAINTENANCE -----	2- 34
<I>		PRECAUTIONS FOR INSPECTION AND MAINTENANCE -----	2- 39
INTRODUCTION -----	1- 4	TIRES -----	2- 44
FRONT/REAR, LEFT/RIGHT DIRECTIONS OF MACHINE -----	1- 5	PRECAUTIONS FOR OPERATION -----	2- 21
USE OF MACHINE -----	1- 4	OPERATION -----	2- 25
VISIBILITY FROM OPERATOR'S SEAT -----	1- 5	PRECAUTIONS FOR JOBSITE -----	2- 21
<L>		STARTING ENGINE -----	2- 23
LIFTING MACHINE -----	3-162	TOWING -----	2- 33
LOADING, UNLOADING WORK WITH TRAILERS -----	3-158	TRANSPORTATION -----	2- 32
LOCKING -----	3-155	PRECAUTIONS FOR OPERATION -----	3-148
LONG-TERM STORAGE -----	3-166	PRODUCT IDENTIFICATION NUMBER (PIN)/MACHINE SERIAL NO. PLATE -----	1- 6
AFTER STORAGE -----	3-166	<R>	
BEFORE STORAGE -----	3-166	RECOMMENDED FUEL, COOLANT, AND LUBRICANT -----	4- 9
DURING STORAGE -----	3-166	RECOMMENDED BRANDS, RECOMMENDED QUALITY FOR PRODUCTS OTHER THAN KOMATSU GENUINE OIL -----	4- 11
<M>		USE OF FUEL, COOLANT AND LUBRICANTS ACCORDING TO AMBIENT TEMPERATURE -----	4- 10
MACHINE MONITOR -----	3- 6	<S>	
MAINTENANCE SCHEDULE CHART -----	4- 15	SAFETY -----	2- 2
MOVING THE MACHINE (DIRECTIONAL, SPEED), STOPPING THE MACHINE -----	3-127	SAFETY INFORMATION -----	1- 3
<N>		SAFETY LABELS -----	2- 5
NECESSARY INFORMATION -----	1- 6	LOCATION OF SAFETY LABELS -----	2- 5
<O>		SAFETY LABELS -----	2- 6
OPENING, CLOSING CAB DOORS, WINDOWS -----	3- 62	SELECTING BUCKET AND TIRES -----	6- 2
OPERATION -----	3- 99	SERVICE PROCEDURE -----	4- 17
OPERATION OF WORK EQUIPMENT -----	3-139	CHECK BEFORE STARTING -----	4- 39
OPERATIONS AND CHECKS AFTER STARTING ENGINE -----	3-124	EVERY 100 HOURS SERVICE -----	4- 41
OUTLINE OF ELECTRIC SYSTEM -----	4- 7	EVERY 1000 HOURS SERVICE -----	4- 53
OUTLINES OF SERVICE -----	4- 4	EVERY 2000 HOURS SERVICE -----	4- 58
<P>		EVERY 250 HOURS SERVICE -----	4- 43
PARKING MACHINE -----	3-152	EVERY 4000 HOURS SERVICE -----	4- 64
PERIODIC REPLACEMENT OF SAFETY CRITICAL PARTS -----	4- 13	EVERY 50 HOURS SERVICE -----	4- 40
POSITION OF SERVICE METER -----	1- 7	EVERY 500 HOURS SERVICE -----	4- 49
POWER OUTLET -----	3- 69	EVERY 8000 HOURS SERVICE -----	4- 67
		INITIAL 250 HOURS SERVICE -----	4- 17
		WHEN REQUIRED -----	4- 18
		SLOW BLOW FUSE -----	3- 68
		SPECIFICATIONS -----	5- 2
		STANDARD TIGHTENING TORQUES FOR BOLTS AND NUTS -----	4- 12

INDEX

STARTING ENGINE -----	3-119
STEERING TILT LOCK LEVER -----	3- 58
STOPPING ENGINE -----	3-126
SWITCHES -----	3- 39

<T>

TABLE TO ENTER SERIAL NO. AND

DISTRIBUTOR -----	1- 7
TORQUE LIST -----	4- 12
TOWING PIN -----	3- 60
TRANSPORTATION -----	3-158
TRANSPORTATION PROCEDURE -----	3-158
TROUBLESHOOTING -----	3-167
IF BATTERY IS DISCHARGED -----	3-172
METHOD OF TOWING MACHINE -----	3-167
OTHER TROUBLE -----	3-175
WHEN MACHINE RUNS OUT OF FUEL -----	3-167
TURNING -----	3-136

<W>

WEAR PARTS -----	4- 8
WEAR PARTS LIST -----	4- 8
WORK POSSIBLE USING WHEEL LOADER -----	3-141

WA430-6 WHEEL LOADER

Form No. TEN00489-01

©2011 KOMATSU
All Rights Reserved
Printed in Japan 02-11
