

Operation & Maintenance Manual

UEAM003601

PC130-7K

HYDRAULIC EXCAVATOR

SERIAL NUMBER PC130-7K - 70001 and up



WARNING

Unsafe use of this machine may cause serious injury or death. Operators and maintenance personnel must read this manual before operating or maintaining this machine. This manual should be kept inside the cab for reference and periodically reviewed by all personnel who will come into contact with the machine.

KOMATSU

FOREWORD

FOREWORD

This manual provides rules and guidelines which will help you use this machine safely and effectively. The precautions in this manual must be followed at all times when performing operation and maintenance. Most accidents are caused by the failure to follow fundamental safety rules for the operation and maintenance of machines. Accidents can be prevented by knowing beforehand conditions that may cause a hazard when performing operation and maintenance.

WARNING

Operators and maintenance personnel must always do as follows before beginning operation or maintenance.

Always be sure to read and understand this manual thoroughly before performing operation and maintenance.

Read the safety messages given in this manual and the safety labels affixed to the machine thoroughly and be sure that you understand them fully.

Keep this manual at the storage location for the Operation and Maintenance Manual given below, and have all personnel read it periodically.

If this manual has been lost or has become dirty and cannot be read, request a replacement manual immediately from Komatsu or your Komatsu distributor.

If you sell the machine, be sure to give this manual to the new owners together with the machine.

Komatsu delivers machines that comply with all applicable regulations and standards of the country to which it has been shipped. If this machine has been purchased in another country or purchased from someone in another country, it may lack certain safety devices and specifications that are necessary for use in your country. If there is any question about whether your product complies with the applicable standards and regulations of your country, consult Komatsu or your Komatsu distributor before operating the machine.

Storage location for the Operation and Maintenance Manual:

magazine box on the left side of the operator's seat.

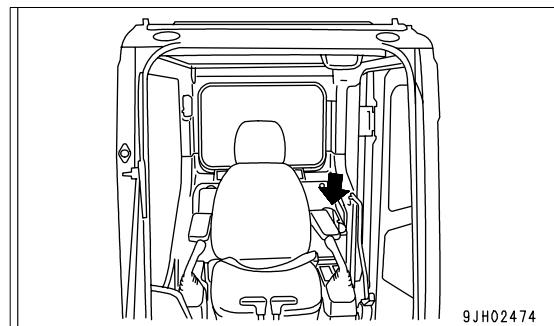

SAFETY INFORMATION

To enable you to use this machine safely, safety precautions and labels are given in this manual and affixed to the machine to give explanations of situations involving potential hazards and of the methods of avoiding such situations.

Signal words

The following signal words are used to inform you that there is a potential hazardous situation that may lead to personal injury or damage.

In this manual and on machine labels, the following signal words are used to express the potential level of hazard.



Indicates an imminently hazardous situation which, if not avoided, will result in death or serious injury.



Indicates a potentially hazardous situation which, if not avoided, could result in death or serious injury.



Indicates a potentially hazardous situation which, if not avoided, may result in minor or moderate injury. This word is used also to alert against unsafe practices that may cause property damage.

Example of safety message using signal word



**When standing up from the operator's seat, always place the safety lock lever in the LOCK position.
If you accidentally touch the control levers when they are not locked, this may cause a serious injury or death.**

Other signal words

In addition to the above, the following signal words are used to indicate precautions that should be followed to protect the machine or to give information that is useful to know.

NOTICE This word is used for precautions that must be taken to avoid actions which could shorten the life of the machine.

REMARKS This word is used for information that is useful to know.

q Safety labels

Safety labels are affixed to the machine to inform the operator or maintenance worker on the spot when carrying out operation or maintenance of the machine that may involve hazard.

This machine uses “Safety labels using words” and “Safety labels using pictograms” to indicate safety procedures.

Example of safety label using words

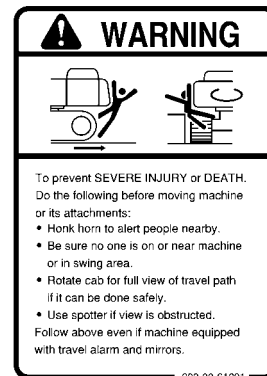

Part No.

Safety labels using pictogram

Safety pictograms use a picture to express a level of hazardous condition equivalent to the signal word. These safety pictograms use pictures in order to let the operator or maintenance worker understand the level and type of hazardous condition at all times.

Safety pictograms show the type of hazardous condition at the top or left side, and the method of avoiding the hazardous condition at the bottom or right side. In addition, the type of hazardous condition is displayed inside a triangle and the method of avoiding the hazardous condition is shown inside a circle.



Part No.

Komatsu cannot predict every circumstance that might involve a potential hazard in operation and maintenance. Therefore, the safety messages in this manual and on the machine may not include all possible safety precautions.

If any procedures or actions not specifically recommended or allowed in this manual are used, it is your responsibility to take the necessary steps to ensure safety.

In no event should you engage in prohibited uses or actions described in this manual.

The explanations, values, and illustrations in this manual were prepared based on the latest information available at that time. Continuing improvements in the design of this machine can lead to changes in detail which may not be reflected in this manual. Consult Komatsu or your Komatsu distributor for the latest available information of your machine or for questions regarding information in this manual.

The numbers in circles in the illustrations correspond to the numbers in () in the text. (For example: ① -> (1))

NOISE

- q Sound pressure level at the operator's station, measured according to ISO6396 (Dynamic test method, simulated working cycle).

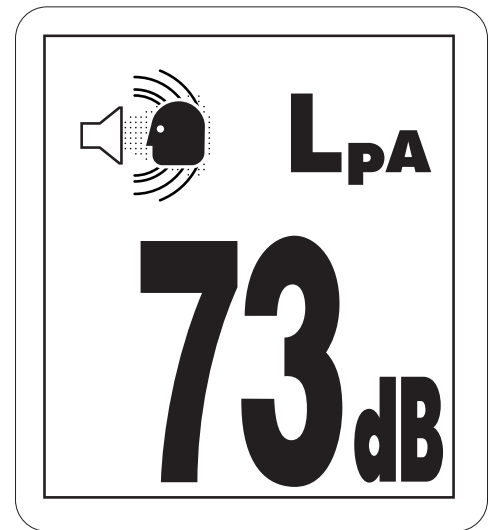

- q Sound power level emitted. This is the guaranteed value as specified in the European directive 2000/14/EC

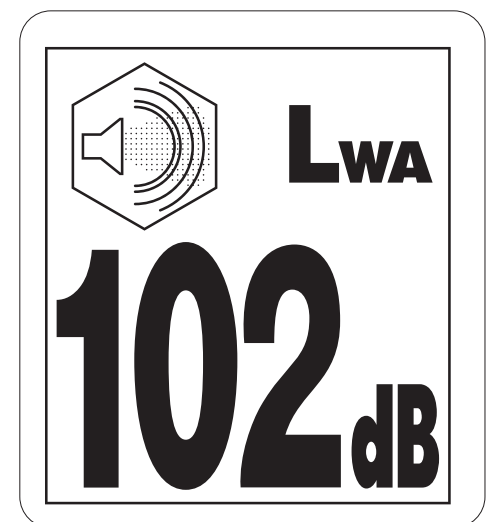

VIBRATION

The weighted root mean square acceleration value to which the operator's arms are subjected does not exceed 2.5 m/s^2
The weighted root mean square acceleration value to which the operator's body is subjected does not exceed 0.5 m/s^2
These results were obtained by accelerometers during trench digging.

INTRODUCTION

This Komatsu machine is designed to be used mainly for the following work:

- Digging work
- Leveling work
- Ditching work
- Loading work
- Demolition work

See the section "RECOMMENDED APPLICATIONS (3-98)" for further details.

DIRECTIONS OF MACHINE

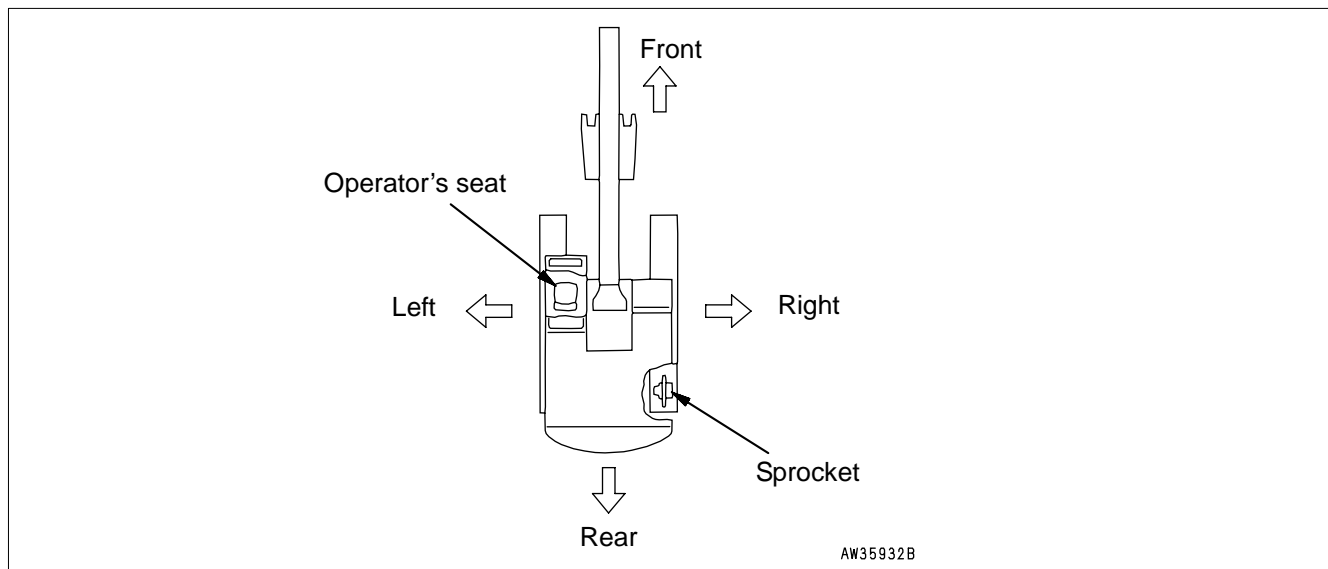

In this manual, the terms front, rear, left, and right refer to the travel direction as seen from the operator's seat when the operator's seat is facing the front and the sprocket is at the rear of the machine.

BREAKING-IN THE NEW MACHINE

NOTICE

Your Komatsu machine has been thoroughly adjusted and tested before shipment from the factory. However, operating the machine under full load before breaking the machine in can adversely affect the performance and shorten the machine life.

Be sure to break in the machine for the initial 100 hours (as indicated on the service meter).

Make sure that you fully understand the content of this manual, and pay careful attention to the following points when breaking in the machine.

- Run the engine at idling for 15 seconds after starting it. During this time, do not operate the control levers or fuel control dial.
- Idle the engine for 5 minutes after starting it up.
- Avoid operation with heavy loads or at high speeds.
- Immediately after starting the engine, avoid sudden starts, sudden acceleration, unnecessary sudden stops, and sudden changes in direction.

PRODUCT INFORMATION

When requesting service or ordering replacement parts, please inform your Komatsu distributor of the following items.

PRODUCT IDENTIFICATION NUMBER (PIN)/MACHINE SERIAL NO. PLATE

On the bottom right of the operator's cab

The design of the nameplate differs according to the territory.

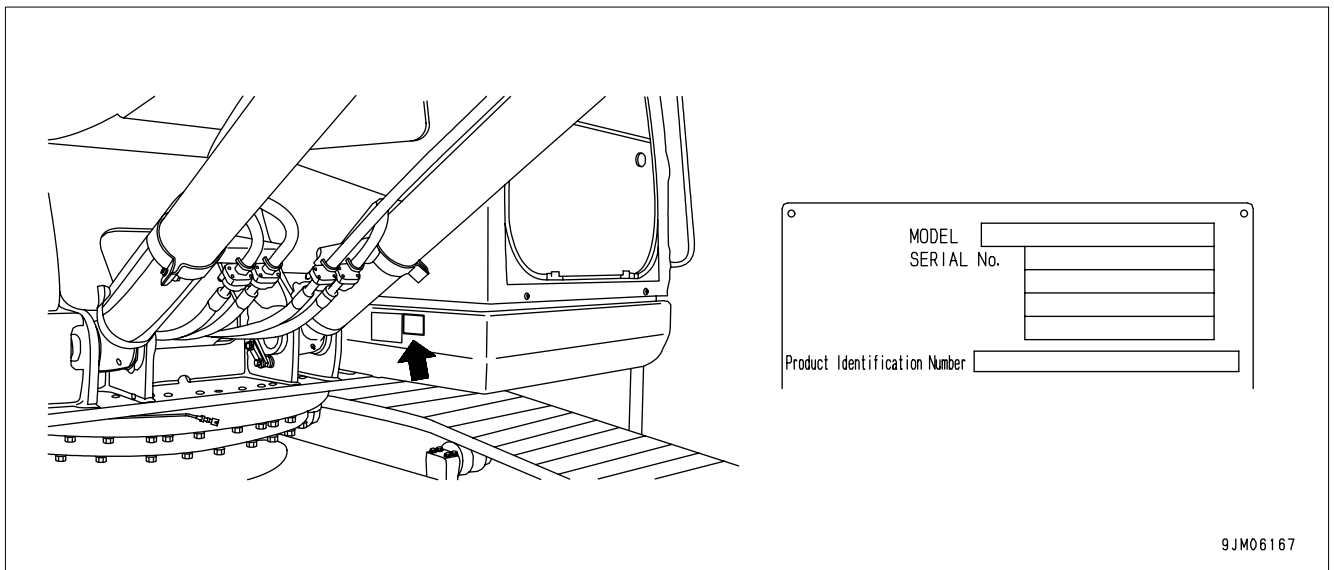

ENGINE SERIAL NUMBER PLATE AND ITS LOCATION

On the upper side of the engine cylinder head cover.

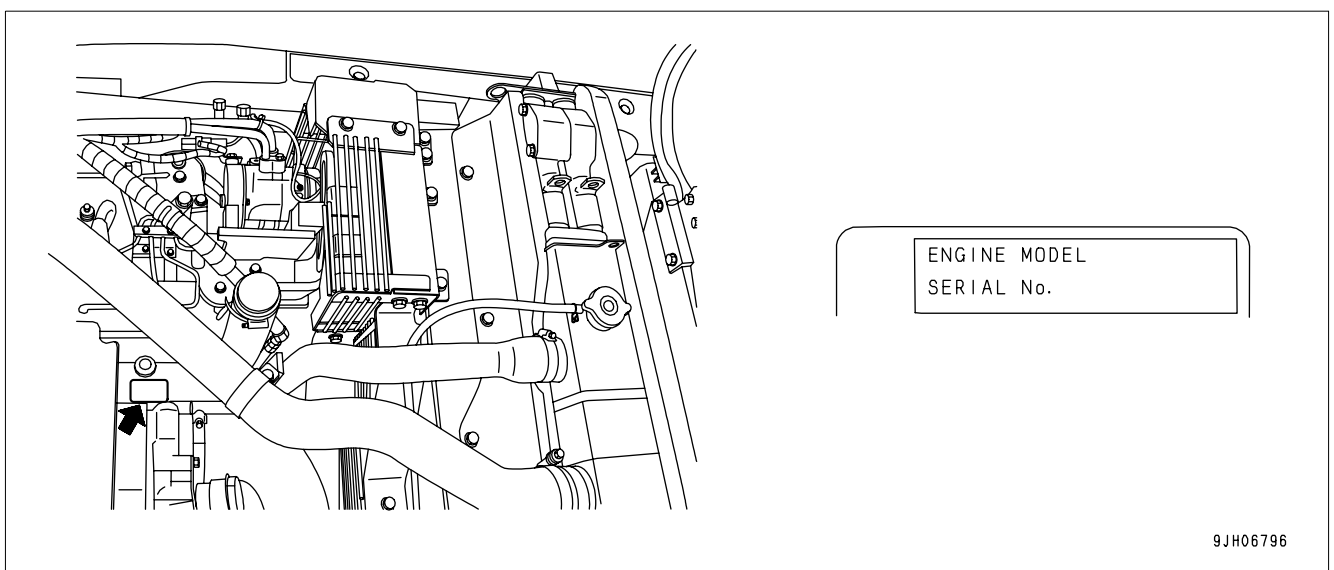

EPA: Environmental Protection Agency, U.S.A.

SERVICE METER LOCATION

On top of the machine monitor

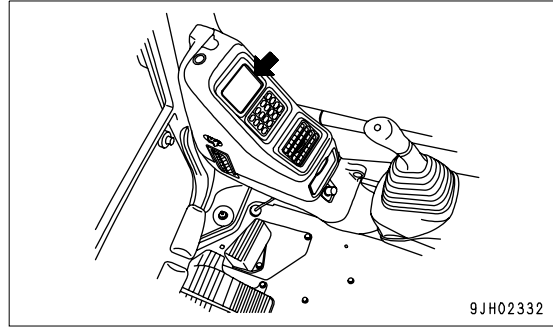

YOUR MACHINE SERIAL NUMBERS AND DISTRIBUTOR

Machine serial No.

Engine serial No.

Product Identification Number

Manufacturers name:	KOMATSU UK Ltd.
Address:	Durham Road Birtley Chester-Le street County Durham DH32QX United Kingdom

Distributor
Address

Phone

Service personnel for your
machine:

MACHINE SERIAL NUMBER PLATE

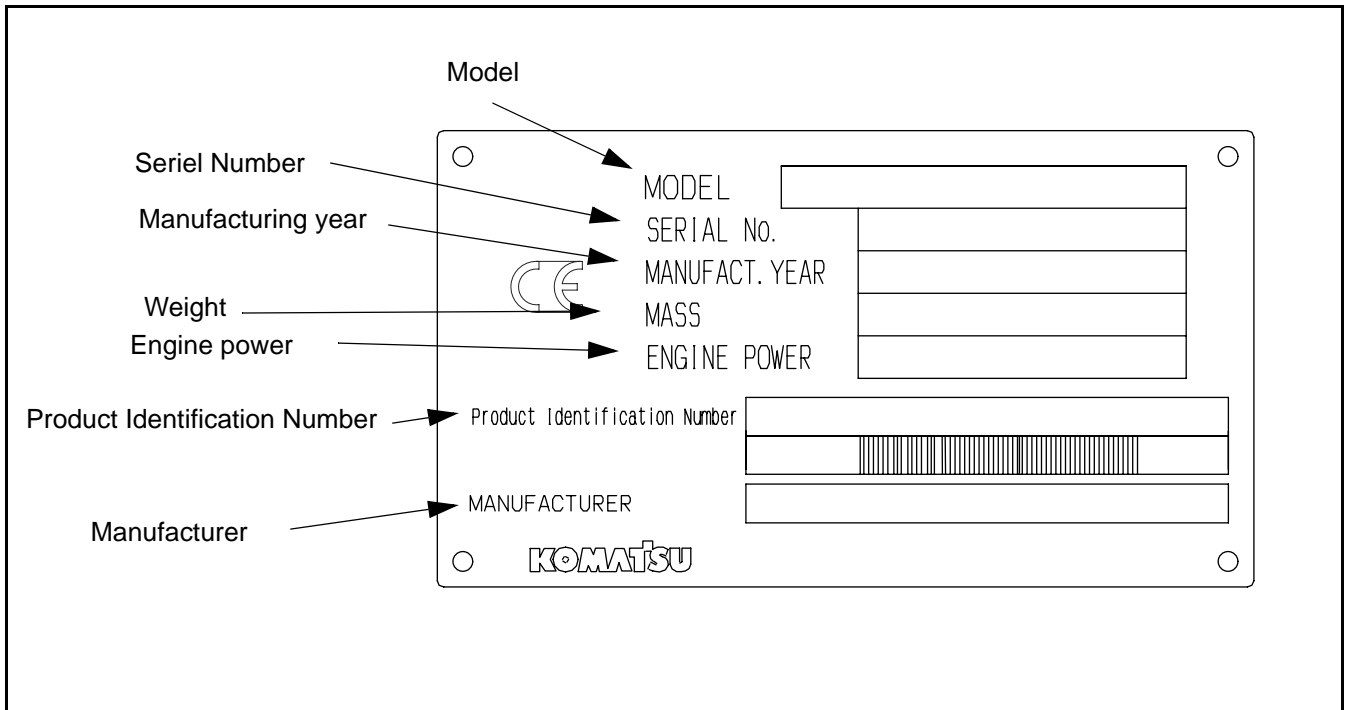

CONTENTS

FOREWORD

FOREWORD 1-2

SAFETY INFORMATION 1-3

 NOISE q-5

 VIBRATION q-5

INTRODUCTION 1-6

 DIRECTIONS OF MACHINE 1-6

 BREAKING-IN THE NEW MACHINE 1-6

PRODUCT INFORMATION 1-7

 PRODUCT IDENTIFICATION NUMBER (PIN)/MACHINE SERIAL NO. PLATE 1-7

 ENGINE SERIAL NUMBER PLATE AND ITS LOCATION 1-7

 SERVICE METER LOCATION 1-8

 YOUR MACHINE SERIAL NUMBERS AND DISTRIBUTOR 1-8

 MACHINE SERIAL NUMBER PLATE 1-9

SAFETY

SAFETY INFORMATION 2-2

SAFETY LABELS 2-4

 LOCATION OF SAFETY LABELS 2-4

 SAFETY LABELS 2-5

SAFETY INFORMATION 2-12

SAFETY MACHINE OPERATION 2-21

 STARTING ENGINE 2-21

 OPERATION 2-23

 TRANSPORTATION 2-30

 BATTERY 2-31

 TOWING 2-33

 LIFTING OBJECTS WITH BUCKET 2-34

SAFETY MAINTENANCE INFORMATION 2-36

OPERATION

MACHINE VIEW ILLUSTRATIONS 3-2

 OVERALL MACHINE VIEW 3-2

 CONTROLS AND GAUGES 3-3

DETAILED CONTROLS AND GAUGES	3-4
MONITORING SYSTEM.....	3-4
Basic Check Monitors.....	3-5
Caution Monitors.....	3-7
Emergency Monitors.....	3-9
Meter Display Portion.....	3-11
Monitor Switches Portion.....	3-14
SWITCHES.....	3-17
CONTROL LEVERS AND PEDALS.....	3-23
SUN ROOF.....	3-26
WINDSHIELD.....	3-26
EMERGENCY EXIT FROM OPERATOR'S CAB.....	3-31
DOOR LOCK.....	3-31
CAP WITH LOCK.....	3-32
HOT AND COOL BOX.....	3-34
MAGAZINE BOX.....	3-34
ASHTRAY.....	3-34
AIR CONDITIONER CONTROLS.....	3-35
Air Conditioner Control Panel.....	3-35
Method of Operation.....	3-40
Use Air Conditioner with Care.....	3-46
Inspection and maintenance of Air Conditioner Equipped Machine.....	3-46
Other Functions.....	3-47
CAB RADIO CASSETTE.....	3-48
Controls of Radio cassette.....	3-48
Precautions when Using.....	3-48
AUXILIARY ELECTRIC POWER.....	3-49
24V power source.....	3-49
12V power source.....	3-49
FUSE.....	3-49
FUSIBLE LINK.....	3-50
CONTROLLERS.....	3-51
TOOL BOX.....	3-51
GREASE GUN HOLDER.....	3-51
HANDLING GREASE GUN.....	3-52
REFUELLING PUMP.....	3-53
ACCUMULATOR.....	3-55
Releasing Hydraulic Pressure with Accumulator.....	3-55
MACHINE OPERATIONS AND CONTROLS	3-56
BEFORE STARTING ENGINE.....	3-56
Walk-around Checks.....	3-56
Checks Before Starting.....	3-58
Adjustment.....	3-64
Seat Belt.....	3-67
Operations Before Starting Engine.....	3-68
STARTING ENGINE.....	3-70
Normal Starting.....	3-70

CONTENTS

Starting Engine in Cold Weather 3-72

AFTER STARTING ENGINE 3-74

 Warming-up Operation 3-74

 In Cold Weather Areas 3-77

STOPPING THE ENGINE 3-81

MACHINE OPERATION 3-82

 Preparations for Moving the Machine Off 3-82

 Moving Machine Forward 3-83

 Moving Machine Backward 3-84

 Stopping Machine 3-85

STEERING THE MACHINE 3-86

 Steering 3-86

SWINGING 3-88

WORK EQUIPMENT CONTROLS AND OPERATIONS 3-89

WORKING MODE 3-91

PROHIBITED OPERATIONS 3-92

GENERAL OPERATION INFORMATION 3-94

TRAVELING ON SLOPES 3-95

ESCAPE FROM MUD 3-97

 Stuck One Side of Track 3-97

 Stuck Both Sides of Tracks 3-97

RECOMMENDED APPLICATIONS 3-98

 Backhoe Work 3-98

 Shovel Work 3-98

 Ditching Work 3-98

 Loading Work 3-99

BUCKET REPLACEMENT AND INVERSION 3-100

 Replacement 3-100

 Inversion 3-101

PARKING MACHINE 3-102

CHECK AFTER SHUT OFF ENGINE 3-103

MACHINE INSPECTION AFTER DAILY WORK 3-104

LOCKING 3-104

OVERLOAD WARNING DEVICE 3-104

TRANSPORTATION 3-105

TRANSPORTATION PROCEDURE 3-105

LOADING AND UNLOADING WITH TRAILER 3-106

 Loading 3-107

 Securing Machine 3-109

 Unloading 3-111

LIFTING MACHINE 3-113

COLD WEATHER OPERATION 3-114

COLD WEATHER OPERATION INFORMATION 3-114

 Fuel and Lubricants 3-114

 Cooling System Coolant 3-114

 Battery 3-115

AFTER DAILY WORK COMPLETION.....	3-116
AFTER COLD WEATHER SEASON	3-116
LONG TERM STORAGE	3-117
BEFORE STORAGE.....	3-117
DURING STORAGE	3-117
AFTER STORAGE.....	3-118
STARTING MACHINE AFTER LONG-TERM STORAGE	3-118
TROUBLES AND ACTIONS	3-119
RUNNING OUT OF FUEL	3-119
PHENOMENA THAT ARE NOT FAILURES.....	3-119
TOWING THE MACHINE	3-120
LIGHTWEIGHT TOWING HOLE	3-120
SEVERE JOB CONDITION	3-121
DISCHARGED BATTERY	3-122
Battery Removal and Installation	3-122
Battery Charges.....	3-123
Starting Engine with Booster Cables	3-124
OTHER TROUBLE	3-126
Electrical System	3-126
Chassis.....	3-127
Engine.....	3-128
Electronic Control System	3-130

MAINTENANCE

MAINTENANCE INFORMATION	4-2
LUBRICANTS, COOLANT AND FILTERS	4-5
HANDLING OIL, FUEL, COOLANT, AND PERFORMING OIL CLINIC	4-5
Oil	4-5
Fuel.....	4-5
Cooling System Coolant	4-6
Grease	4-6
Carrying Out KOWA (Komatsu Oil Wear Analysis)	4-7
Oil and Fuel Storage.....	4-8
Filters	4-8
ELECTRIC SYSTEM MAINTENANCE	4-8
WEAR PARTS	4-9
WEAR PARTS LIST.....	4-9
LUBRICANTS, FUEL AND COOLANT SPECIFICATIONS	4-10
PROPER SELECTION	4-10
TIGHTENING TORQUE SPECIFICATIONS	4-14
TIGHTENING TORQUE LIST.....	4-14

CONTENTS

SAFETY CRITICAL PARTS	4-15
SAFETY CRITICAL PARTS LIST	4-15
MAINTENANCE SCHEDULE	4-16
MAINTENANCE SCHEDULE CHART	4-16
MAINTENANCE INTERVAL FOR HYDRAULIC BREAKER.....	4-18
MAINTENANCE PROCEDURE	4-19
INITIAL 250 HOURS MAINTENANCE (ONLY AFTER THE FIRST 250 HOURS)	4-19
INITIAL 1000 HOURS MAINTENANCE (ONLY AFTER THE FIRST 1000 HOURS)	4-19
WHEN REQUIRED	4-20
CHECK, CLEAN AND REPLACE AIR CLEANER ELEMENT	4-20
CLEAN INSIDE OF COOLING SYSTEM	4-25
CHECK AND TIGHTEN TRACK SHOE BOLTS.....	4-28
CHECK AND ADJUST TRACK TENSION.....	4-29
CHECK ELECTRICAL INTAKE AIR HEATER	4-31
REPLACE BUCKET TEETH (VERTICAL PIN TYPE)	4-32
REPLACE BUCKET TEETH (HORIZONTAL PIN TYPE).....	4-35
ADJUST BUCKET CLEARANCE	4-36
CHECK WINDOW WASHER FLUID LEVEL, ADD FLUID	4-37
CHECK AND ADJUST AIR CONDITIONER.....	4-38
WASH WASHABLE FLOOR.....	4-39
BLEEDING AIR FROM HYDRAULIC SYSTEM.....	4-43
METHOD FOR RELEASING INTERNAL PRESSURE IN HYDRAULIC CIRCUIT.....	4-46
CHECK NITROGEN GAS CHARGE PRESSURE IN ACCUMULATOR (control circuit).....	4-46
CHECK BEFORE STARTING	4-47
EVERY 100 HOURS MAINTENANCE.....	4-48
LUBRICATING.....	4-48
CHECK SWING MACHINERY CASE OIL, ADD OIL.....	4-50
EVERY 250 HOURS MAINTENANCE.....	4-51
CHECK OIL LEVEL IN FINAL DRIVE CASE, ADD OIL	4-51
CHECK LEVEL OF BATTERY ELECTROLYTE	4-52
EVERY 500 HOURS MAINTENANCE.....	4-55
REPLACE FUEL FILTER CARTRIDGE	4-55
CHANGE OIL IN ENGINE OIL PAN, REPLACE ENGINE OIL FILTER CARTRIDGE	4-56
CHECK SWING PINION GREASE LEVEL, ADD GREASE	4-57
LUBRICATE SWING CIRCLE	4-57
Radiator Core and Fins - Check/Clean.....	4-58
CLEAN AIR CONDITIONER FRESH/RECIRC FILTERS	4-59
REPLACE HYDRAULIC OIL FILTER ELEMENT	4-61
REPLACE BREATHER ELEMENT IN HYDRAULIC TANK.....	4-62
CHECK AND ADJUST COOLING FAN BELT TENSION	4-63
CHECK, ADJUST AIR CONDITIONER COMPRESSOR BELT TENSION	4-64
EVERY 1000 HOURS MAINTENANCE.....	4-65
CHANGE OIL IN SWING MACHINERY CASE.....	4-65
CHANGE OIL IN FINAL DRIVE CASE	4-66
CHECK ALL TIGHTENING PARTS OF TURBOCHARGER	4-66
CHECK PLAY TURBOCHARGER ROTOR.....	4-66

CHECK NITROGEN GAS CHARGE PRESSURE IN ACCUMULATOR (for breaker)	4-66
EVERY 2000 HOURS MAINTENANCE.....	4-67
CHECK PTO GEAR CASE, ADD OIL	4-67
CLEAN HYDRAULIC TANK STRAINER	4-68
CLEAN, CHECK TURBOCHARGER.....	4-68
CHECK ALTERNATOR, STARTING MOTOR	4-68
CHECK ENGINE VALVE CLEARANCE, ADJUST	4-68
EVERY 4000 HOURS MAINTENENCE.....	4-69
CHECK WATER PUMP	4-69
EVERY 5000 HOURS MAINTENANCE.....	4-70
CHANGE OIL IN HYDRAULIC TANK.....	4-70

SPECIFICATIONS

SPECIFICATIONS	5-2
EXPLANATION OF LIFTING CAPACITY CHART (PC130-7K 1- PC BOOM)	5-4
EXPLANATION OF LIFTING CAPACITY CHART (PC130-7K 2-PC BOOM)	5-5

ATTACHMENTS AND OPTIONS

GENERAL PRECAUTIONS FOR SAFETY	6-2
PRECAUTIONS WHEN SELECTING.....	6-2
READ THE INSTRUCTION MANUAL THOROUGHLY	6-2
PRECAUTIONS WHEN REMOVING OR INSTALLING	6-2
PRECAUTIONS WHEN USING.....	6-3
BUCKET WITH HOOK	6-4
HOOK CONDITION	6-4
PROHIBITED OPERATIONS	6-4
MACHINE READY FOR ATTACHMENT	6-5
LOCATIONS	6-5
HYDRAULIC CIRCUIT.....	6-8
Hydraulic Circuit Connection	6-8
ATTACHMENT REMOVAL AND INSTALLATION.....	6-9
Attachment Removal	6-9
Attachment Installation	6-9
ATTACHMENT OPERATIONS.....	6-11
When Using Breaker.....	6-11
When Using General Attachment Such as Crusher	6-12
ACCUMULATOR	6-13
Hydraulic System - Pressure Release	6-13
LONG TERM STORAGE	6-14
SPECIFICATIONS	6-14
ATTACHMENT GUIDE	6-15

CONTENTS

OTHER ATTACHMENTS	6-15
ATTACHMENT COMBINATIONS.....	6-16
TRACK SHOES SELECTION.....	6-17
BUCKET TEETH SELECTION	6-18
Teeth Selection.....	6-18
Selection Guide for Horizontal or Vertical Pin Type Tooth	6-18
HANDLING OF RUBBER PAD SHOE AND ROAD LINER	6-19
Working Environment	6-19
Working Conditions.....	6-19
Storage, Protection	6-20
Extent of Damage to Rubber	6-20
Check Road Liner	6-20
Replace Road Liner	6-20
RECOMMENDED ATTACHMENT OPERATIONS.....	6-21
HYDRAULIC BREAKER	6-21
2-PC BOOM.....	6-26
FEATURES OF 2-PIECE BOOM & ARM	6-26
OPERATION.....	6-27
BEFORE STORAGE POSTURE WHEN LEAVING MACHINE.....	6-27
TESTING AND ADJUSTING	6-29
PERODIC MAINTENANCE-29	
TRANSPORTATION.....	6-30

INDEX

COLOPHON

SAFETY



WARNING

Please be sure that you fully understand this manual and the precautions described in this manual and the safety labels on the machine. When operating or servicing the machine, always follow these precautions strictly.

SAFETY INFORMATION

SAFETY LABELS..... 2-4
 LOCATION OF SAFETY LABELS 2-4
 SAFETY LABELS..... 2-5

SAFETY INFORMATION

Safety Rules..... 2-12
 If Abnormalities are Found 2-12
 Working Wear and Personal Protective Items 2-12
 Fire Extinguisher and First Aid Kit..... 2-12
 Safety Equipment..... 2-13
 Keep Machine Clean..... 2-13
 Keep Operator's Compartment Clean 2-13
 Leaving Operator's Seat with Lock 2-13
 Handrails and Steps..... 2-14
 Mounting and Dismounting 2-15
 No Persons on Attachments 2-15
 Burn Prevention 2-15
 Fire Prevention and Explosion Prevention 2-16
 Action If Fire Occurs..... 2-17
 Windshield Washer Fluid 2-17
 Falling Objects, Flying Objects and Intruding Objects Prevention 2-17
 Attachment Installation..... 2-17
 Attachment Combinations 2-18
 Cab Widow Glasses..... 2-18
 Unauthorized Modifications 2-18
 Safety at Jobsite..... 2-18
 Working on Loose Ground 2-18
 Distance to High Voltage Cables 2-19
 Ensure Good Visibility 2-19
 Ventilation for Enclosed Area..... 2-19
 Signalman's Signal and Signs..... 2-20
 Emergency Exit from Operator's Cab 2-20
 Asbestos Dust Hazard Prevention 2-20

SAFETY MACHINE OPERATION	2-21
STARTING ENGINE	2-21
Checks before starting engine	2-21
Safety rules for starting engine	2-21
Starting engine in cold weather.....	2-22
OPERATION.....	2-23
Checks before operation.....	2-23
Safety rules for changing machine directions	2-24
Safety rules for traveling	2-25
Traveling on slopes.....	2-26
Operations on slopes.....	2-27
Prohibited operations.....	2-27
Operations on snow	2-29
Parking machine	2-29
TRANSPORTATION.....	2-30
Loading and unloading	2-30
Shipping the machine	2-30
BATTERY	2-31
Battery hazard prevention.....	2-31
Starting engine with booster cables	2-32
TOWING	2-33
Safety rules for towing	2-33
LIFTING OBJECTS WITH BUCKET.....	2-34
Lifting work using bucket with hook	2-34
Safety rules for lifting objects.....	2-34
SAFETY MAINTENANCE INFORMATION.....	2-36
Warning tag.....	2-36
Keep work place clean and tidy	2-36
Appoint leader when working with others	2-36
Stop engine before carrying out maintenance	2-37
Two workers for maintenance when engine is running.....	2-37
Proper tools.....	2-38
Accumulator	2-38
Personnel.....	2-38
Attachments	2-39
Work under the machine.....	2-39
Noise.....	2-39
When using hammer.....	2-39
Welding works.....	2-39
Removing battery terminals	2-40
Safety first when using high-pressure grease to adjust track tension.....	2-40
Do not disassemble recoil springs	2-40
Safety rules for high-pressure oil	2-41
Safety handling high-pressure hoses.....	2-41
Waste materials	2-41
Air conditioner maintenance	2-42
Compressed air.....	2-42
Periodic replacement of safety critical parts	2-42

SAFETY LABELS

The following warning signs and safety labels are used on this machine.

- Be sure that you fully understand the correct position and content of labels.
- To ensure that the content of labels can be read properly, be sure that they are in the correct place and always keep them clean. When cleaning them, do not use organic solvents or gasoline. These may cause the labels to peel off.
- There are also other labels in addition to the warning signs and safety labels. Handle those labels in the same way.
- If the labels are damaged, lost, or cannot be read properly, replace them with new ones. For details of the part numbers for the labels, see this manual or the actual label, and place an order with Komatsu distributor.

LOCATION OF SAFETY LABELS

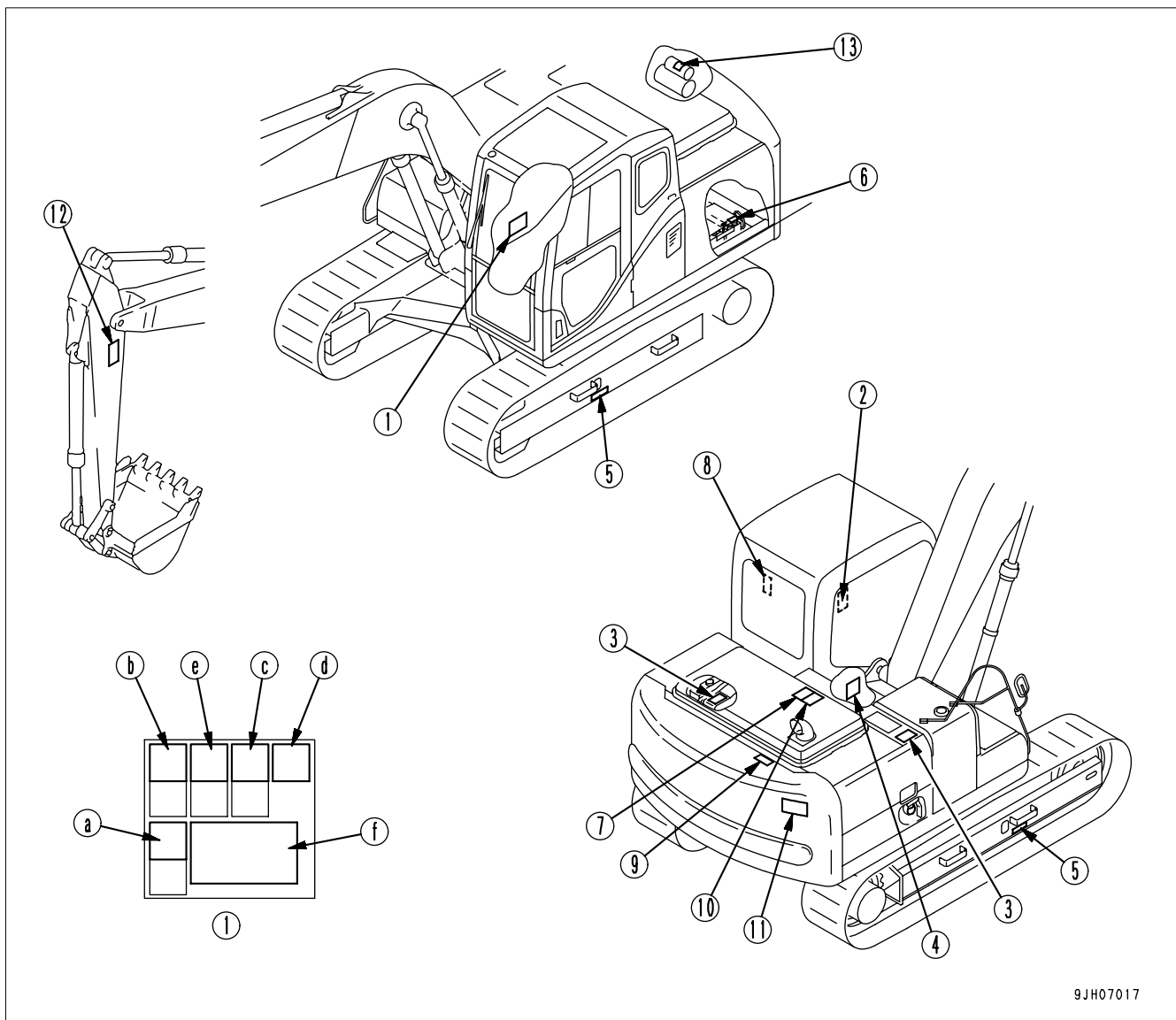

9JH07017

SAFETY LABELS

(1) (207-00-K1951)

- q Warnings for operation, inspection and maintenance.
- q Improper operation and maintenance can cause serious injury or death.
- q Read the manual and labels before operation and maintenance.
Follow instructions and warnings in manual and in labels on machine.

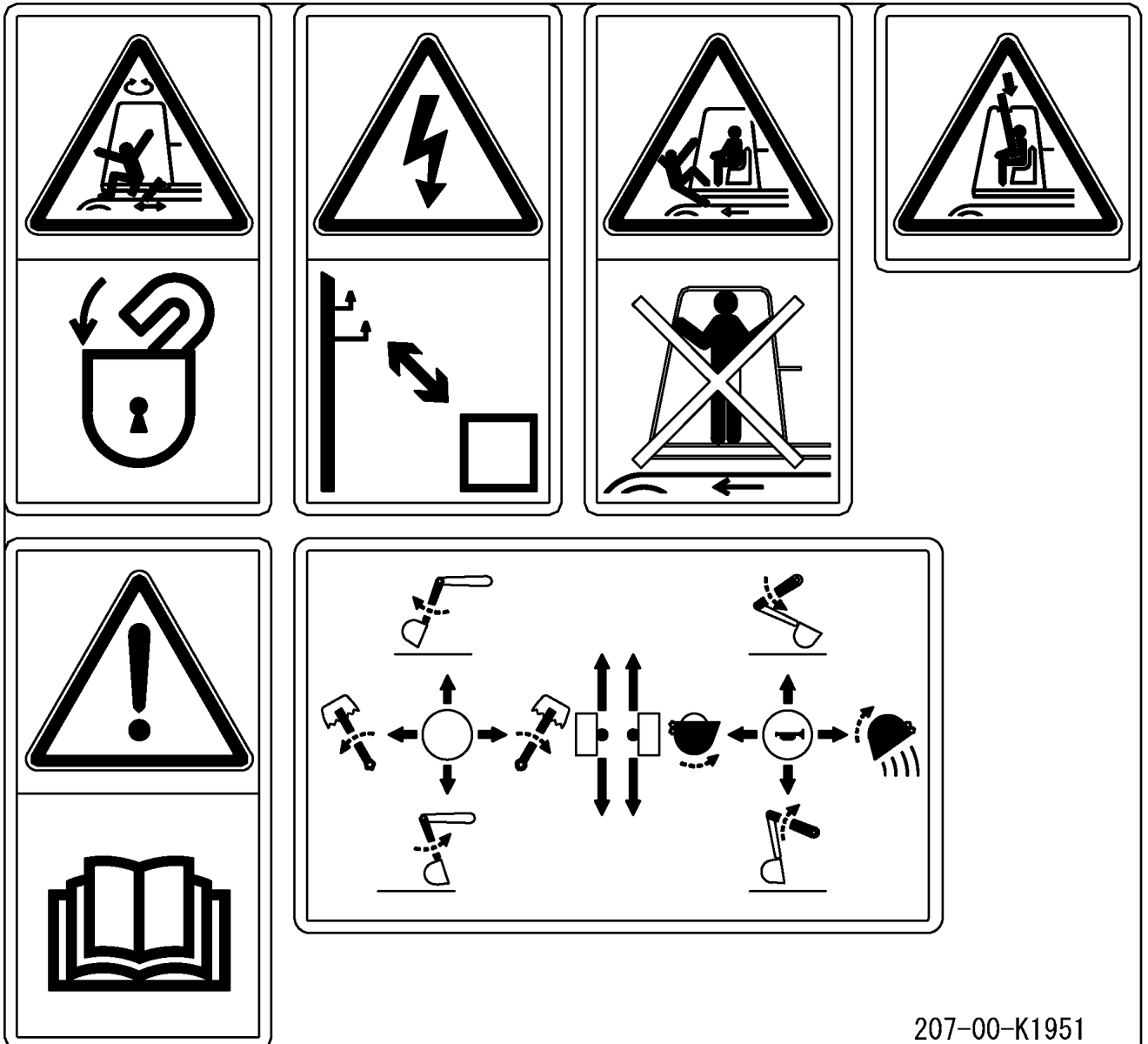

(a) Keep the manual in machine cab near operator.

If this manual is lost, please contact your Komatsu distributor for a replacement.

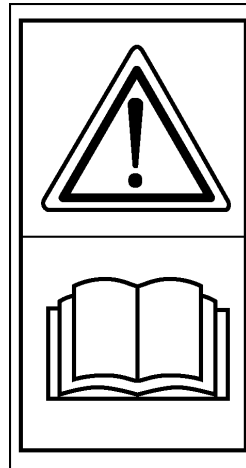

(b) Always apply lock when leaving operator's seat.



(c) WARNING - No passengers

No passengers allowed to ride on machine while it is moving.



(d) WARNING - DANGER OF FALLING OBJECTS

Do not operate where a danger of falling objects exists.

Consult your dealer for fitting of FOPS protections.



(e) HAZARDOUS - Voltage hazard

Serious injury or death can occur if machine or attachments are not kept safe distance away from electric lines.

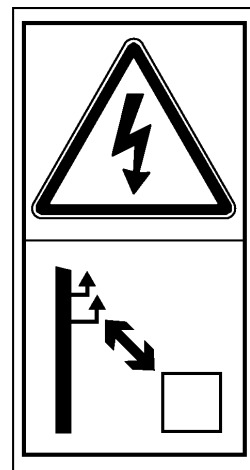

(f) Control levers operational function diagram.

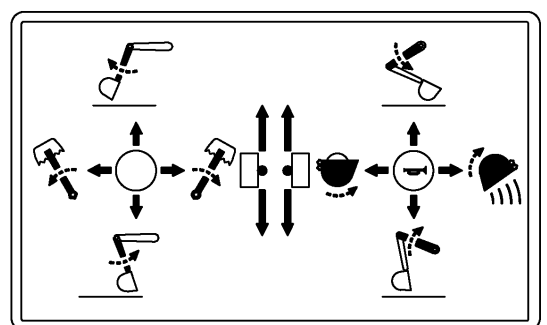

(2) Precautions when stowing front window (09803-A0481)

- q When the front window is stowed, there is the hazard that it will fall.
- q Always lock the front window securely at the stowed position.



(3) Precautions for high-temperature coolant, hydraulic oil (09653-A0481)

- q Never remove the cap when the engine is at operating (high) temperature. Steam or high temperature oil blowing up from the radiator or hydraulic tank, will cause personal injury and/or burns.
- q Never remove the radiator cap or hydraulic tank oil filler when cooling water or hydraulic oil is at high temperature.



(4) Precautions when handling accumulator (09659-A057B)

- q There is the hazard of explosion causing injury.
- q Do not disassemble the accumulator, make holes in it, weld it cut it, hit it, roll it or bring it near flame

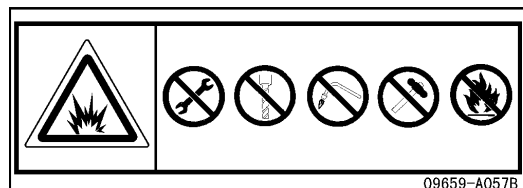

(5) Precautions when adjusting track tension (09657-A0881)

- q Sign indicates a hazard of flying plug from track adjuster that could cause injury.
- q Read manual and adjusting track for safe and proper handling.

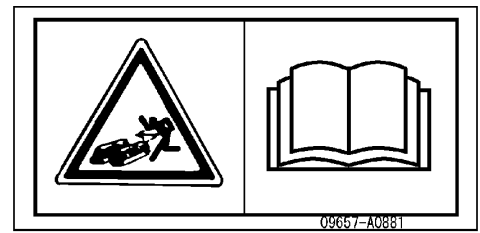

(6) Precautions when handling cable (203-00-71130)

- q Sign indicates an electric hazard from handling the cable.
- q Read manual for safe and proper handling.

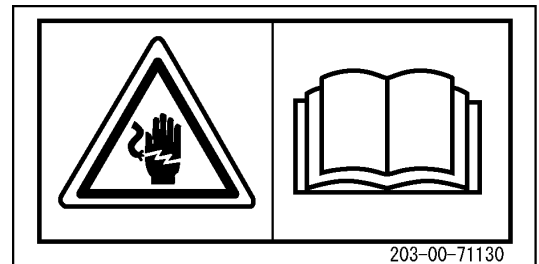

(7) Stopping rotation for inspection and maintenance (09667-A0481)

- q Sign indicates a hazard of rotating parts, such as belt.
- q Turn off before inspection and maintenance.

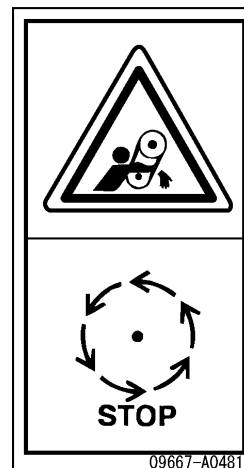

(8) Explanation of method for emergency escape
(20Y-00-K2220)

EMERGENCY EXIT

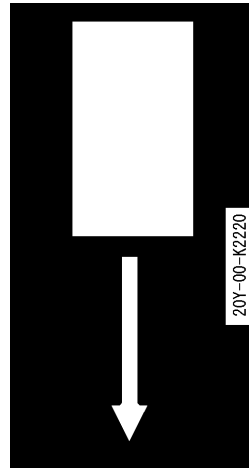

EMERGENCY EXIT

(9) Caution against falling (09805-A0881)

- q Sign indicates a hazard of falling off down.
- q Do not go close to the edge of the machine by mistake.



(10) Caution against falling (09805-C0481)

- q Sign indicates a hazard of falling.

- q Do not step here!

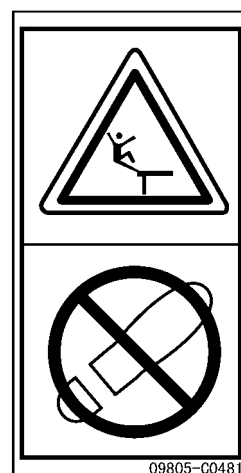

(11) Prohibited to enter swing radius (20E-00-K1150)

- q Sign indicates a crush hazard by rotation of upper structure of the machine.
- q Keep away from swinging area of the machine.



(12) Precautions for operation (20E-00-K1140)

- q Sign indicates a hazard of being hit by the working device of the machine.
- q Keep away from machine during operation.



(13) Prohibition of jump start (09842-A0481)

- q Start the engine only after sitting down in the operator's seat.
- q Do not attempt to start the engine by short-circuiting the engine starting circuit. Such an act may cause a serious bodily injury or fire.



SAFETY INFORMATION

SAFETY RULES

- q Only trained and authorized personnel can operate and maintain the machine.
- q Follow all safety rules, precautions and instructions when operating or performing maintenance on the machine.
- q If you are under the influence of alcohol or medication, your ability to safely operate or repair your machine may be severely impaired putting yourself and everyone else on your jobsite in danger.
- q When working with another operator or with a person on worksite traffic duty, be sure that all personnel understand all hand signals that are to be used.

IF ABNORMALITIES ARE FOUND

If you find any abnormality in the machine during operation or maintenance (noise, vibration, smell, incorrect gauges, smoke, oil leakage, etc., or any abnormal display on the warning devices or monitor), report to the person in charge and have the necessary action taken. Do not operate the machine until the abnormality has been corrected.

WORKING WEAR AND PERSONAL PROTECTIVE ITEMS

- q Do not wear loose clothing and accessories. There is a hazard that they may catch on control levers or other protruding parts.
- q If you have long hair and it hangs out from your hard hat, there is a hazard that it may get caught up in the machine, so tie your hair up and be careful not to let it get caught.
- q Always wear a hard hat and safety shoes. If the nature of the work requires it, wear safety glasses, mask, gloves, ear plugs, and safety belt when operating or maintaining the machine.
- q Check that all protective equipment functions properly before using it.

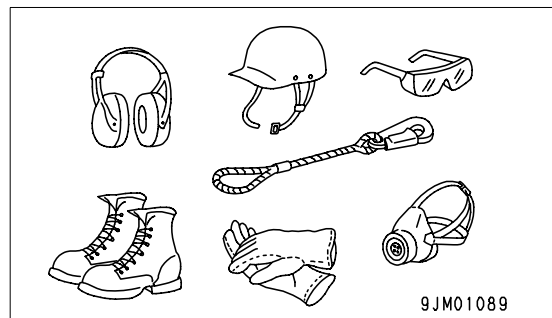

FIRE EXTINGUISHER AND FIRST AID KIT

Always follow the precautions below to prepare for action if any injury or fire should occur.

- q Be sure that fire extinguishers have been provided and read the labels to ensure that you know how to use them in emergencies.
- q Carry out periodic inspection and maintenance to ensure that the fire extinguisher can always be used.
- q Provide a first aid kit at the storage point. Carry out periodic checks and add to the contents if necessary.

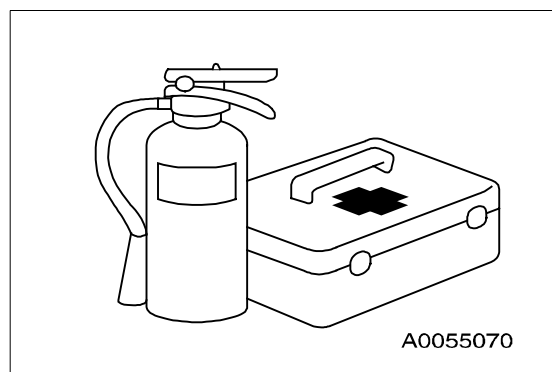

SAFETY EQUIPMENT

- q Be sure that all guards and covers are in their proper position. Have guards and covers repaired immediately if they are damaged.
- q Understand the method of use of safety features and use them properly.
- q Never remove any safety features. Always keep them in good operating condition.

KEEP MACHINE CLEAN

- q If water gets into the electrical system, there is a hazard that it will cause malfunctions or misoperation. Do not use water or steam to wash the electrical system (sensors, connectors).
- q If inspection and maintenance is carried out when the machine is still dirty with mud or oil, there is a hazard that you will slip and fall, or that dirt or mud will get into your eyes. Always keep the machine clean.

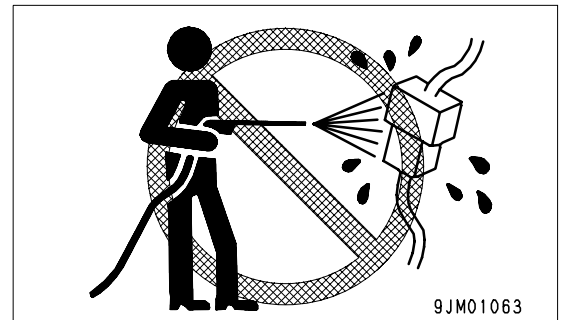
**KEEP OPERATOR'S COMPARTMENT CLEAN**

- q When entering the operator's compartment, always remove all mud and oil from the soles of your shoes. If you operate the pedal with mud or oil affixed to your shoes, your foot may slip and this may cause a serious accident.
- q Do not leave parts or tools lying around the operator's compartment.
- q Do not stick suction pads to the window glass. Suction pads act as a lens and may cause fire.
- q Do not use cellular telephones inside the operator's compartment when driving or operating the machine.
- q Never bring any dangerous objects such as flammable or explosive items into the operator's compartment.

LEAVING OPERATOR'S SEAT WITH LOCK

- q Before standing up from the operator's seat (such as when opening or closing the front window or roof window, or when removing or installing the bottom window, or when adjusting the operator's seat), lower the work equipment completely to the ground, set safety lock lever (1) securely to the LOCK position (L), then stop the engine. If you accidentally touch the levers when they are not locked, there is a hazard that the machine may suddenly move and cause serious injury or property damage.

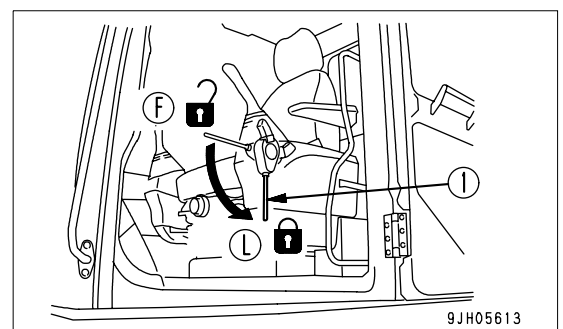

- q When leaving the machine, always lower the work equipment completely to the ground, set safety lock lever (1) securely to the LOCK position, then stop the engine. Use the key to lock all the equipment. Always remove the key, take it with you, and keep it in the specified place.

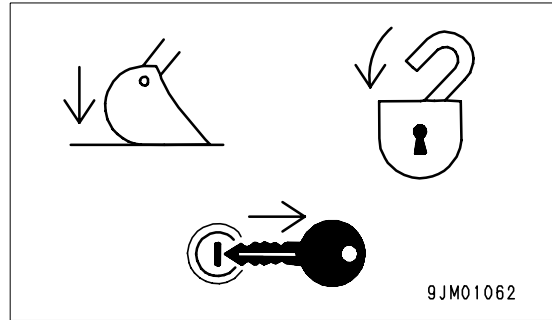

HANDRAILS AND STEPS

To prevent personal injury caused by slipping or falling off the machine, always do as follows.

- q Use the handrails and steps marked by arrows in the diagram on the right when getting on or off the machine.

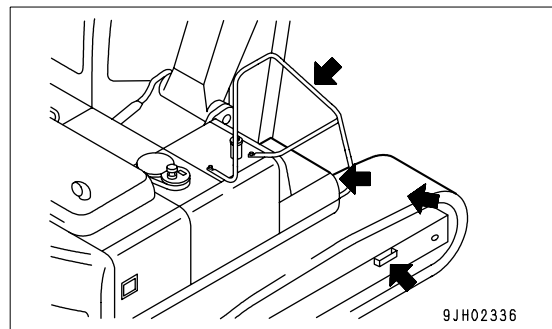
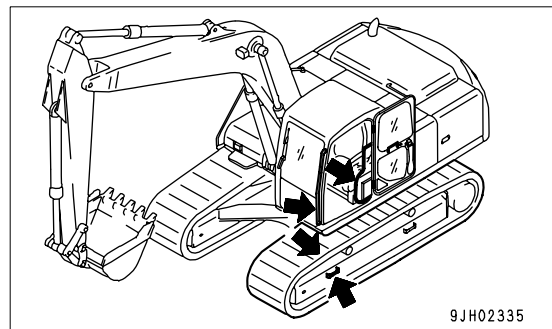

- q To ensure safety, always face the machine and maintain three-point contact (both feet and one hand, or both hands and one foot) with the handrails and steps (including the track shoe) to ensure that you support yourself.
- q Do not grip the control levers when getting on or off the machine.
- q Never climb on the engine hood or covers where there are no non-slip pads.
- q Before getting on or off the machine, check the handrails and steps (including the track shoe). If there is any oil, grease, or mud on the handrails or steps (including the track shoe), wipe it off immediately. Always keep these parts clean. Repair any damage and tighten any loose bolts.
- q Do not get on or off the machine while holding tools in your hand.

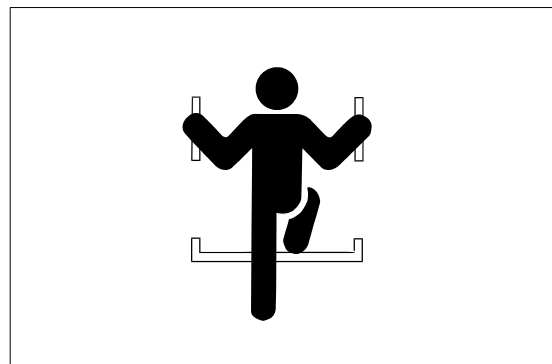

MOUNTING AND DISMOUNTING

- q Never jump on or off the machine. Never get on or off a moving machine.
- q If the machine starts to move when there is no operator on the machine, do not jump on to the machine and try to stop it.

NO PERSONS ON ATTACHMENTS

Never let anyone ride on the work equipment, or other attachments. There is a hazard of falling and suffering serious injury.

BURN PREVENTION

Hot coolant

- q To prevent burns from hot water or steam spurting out when checking or draining the coolant, wait for the water to cool to a temperature where it is possible to touch the radiator cap by hand before starting the operation. Even when the coolant has cooled down, loosen the cap slowly to relieve the pressure inside the radiator before removing the cap.

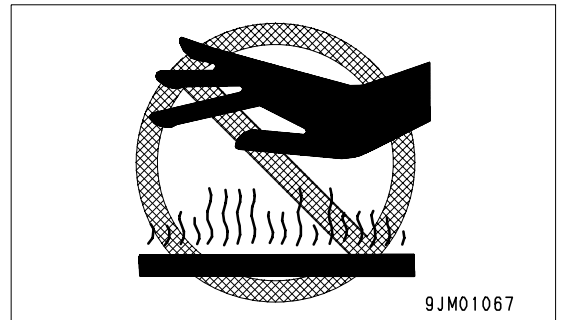

Hot oil

- q To prevent burns from hot oil spurting out when checking or draining the oil, wait for the oil to cool to at temperature where it is possible to touch the cap or plug by hand before starting the operation. Even when the oil has cooled down, loosen the cap or plug slowly to relieve the internal pressure before removing the cap or plug.

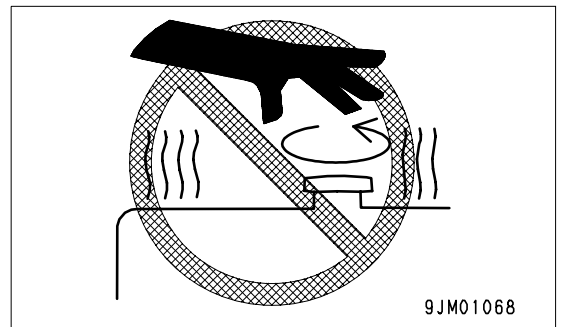

FIRE PREVENTION AND EXPLOSION PREVENTION**q Fire caused by fuel or oil**

Fuel, oil, antifreeze, and window washer liquid are particularly flammable and can be hazardous. To prevent fire, always observe the following:

- q Do not smoke or use any flame near fuel or oil.
- q Stop the engine before refueling.
- q Do not leave the machine while adding fuel or oil.
- q Tighten all fuel and oil caps securely.
- q Do not spill fuel on overheated surfaces or on parts of the electrical system.
- q Use well-ventilated areas for adding or storing oil and fuel.
- q Keep oil and fuel in the determined place and do not allow unauthorized persons to enter.
- q After adding fuel or oil, wipe up any spilled fuel or oil.
- q When carrying out grinding or welding work on the chassis, move any flammable materials to a safe place before starting.
- q When washing parts with oil, use a non-flammable oil. Diesel oil and gasoline may catch fire, so do not use them.
- q Put greasy rags and other flammable materials into a safe container to maintain safety at the work place.
- q Do not weld or use a cutting torch to cut any pipes or tubes that contain flammable liquids.

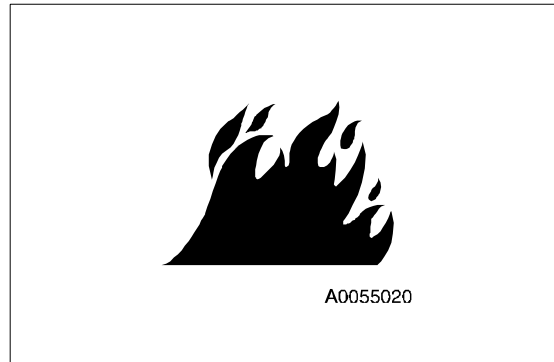
**q Fire caused by accumulation of flammable material.**

Remove any dry leaves, chips, pieces of paper, dust, or any other flammable materials accumulated or affixed around the engine, exhaust manifold, muffler, or battery, or inside the undercovers.

q Fire coming from electric wiring

Short circuits in the electrical system can cause fire.

- q Always keep electric wiring connections clean and securely tightened.
- q Check the wiring every day for looseness or damage. Tighten any loose connectors or wiring clamps. Repair or replace any damaged wiring.

q Fire coming from hydraulic line

Check that all the hose and tube clamps, guards, and cushions are securely fixed in position.

If they are loose, they may vibrate during operation and rub against other parts. This may lead to damage to the hoses, and cause high-pressure oil to spurt out, leading to fire damage or serious injury.

q **Explosion caused by lighting equipment**

- q When checking fuel, oil, battery electrolyte, window washer fluid, or coolant, always use lighting with anti-explosion specifications. If such lighting equipment is not used, there is danger of explosion that may cause serious injury.
- q When taking the electrical power for the lighting from the machine itself, follow the instructions in this manual.

ACTION IF FIRE OCCURS

If a fire occurs, escape from the machine as follows.

- q Turn the start switch OFF to stop the engine.
- q Use the handrails and steps to get off the machine.

WINDSHIELD WASHER FLUID

Use an ethyl alcohol base washer liquid.

Methyl alcohol base washer liquid may irritate your eyes, so do not use it.

FALLING OBJECTS, FLYING OBJECTS AND INTRUDING OBJECTS PREVENTION

On jobsites where there is a hazard that falling objects, flying objects, or intruding objects may hit or enter the operator's cab, consider the operating conditions and install the necessary guards to protect the operator.

- q When carrying out demolition or breaker operations, install a front guard and use a laminated coating sheet on the front glass.
- q When working in mines or quarries where there is a hazard of falling rock, install FOPS (Falling Objects Protective Structure) and a front guard, and use a laminated coating sheet on the front glass.
- q When carrying out the above operations, always close the front window. In addition, always ensure that bystanders are a safe distance away and are not in hazard from falling or flying objects.
- q The above recommendations assume that the conditions are for standard operations, but it may be necessary to add additional guards according to the operating conditions on the jobsite. Always contact your Komatsu distributor for advice.

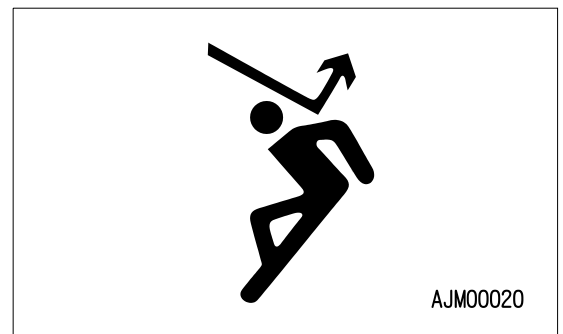
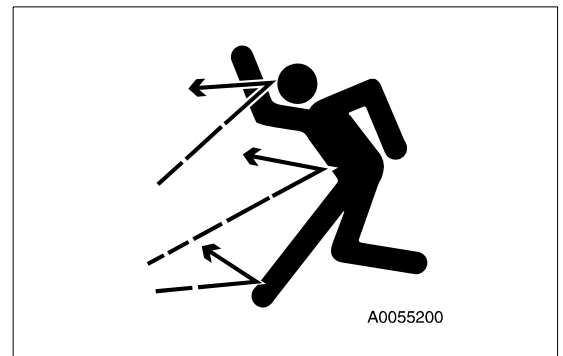

ATTACHMENT INSTALLATION

- q When installing optional parts or attachments, there may be problems with safety or legal restrictions. Therefore contact your Komatsu distributor for advice.
- q Any injuries, accidents, or product failures resulting from the use of unauthorized attachments or parts will not be the responsibility of Komatsu.
- q When installing and using optional attachments, read the instruction manual for the attachment, and the general information related to attachments in this manual.

ATTACHMENT COMBINATIONS

Depending on the type or combination of work equipment, there is a hazard that the work equipment may hit the cab or other parts of the machine. Before using unfamiliar work equipment, check if there is any hazard of interference, and operate with caution.

CAB WINDOW GLASSES

- If the cab glass on the work equipment side is broken, there is a hazard that the work equipment may contact the operator's body directly. Stop operation immediately and replace the glass.
- The ceiling window is made of organic glass (polycarbonate), and as such it is apt to break easily when receiving damage on the surface, thereby deteriorating its protective characteristic. If there is a crack or damage caused by a fallen rock, or when any sign of them is noticed, replace it with a new window.

UNAUTHORIZED MODIFICATIONS

Any modification made without authorization from Komatsu can create hazards. Before making a modification, consult your Komatsu distributor.

- Komatsu will not be responsible for any injuries, accidents, product failures or other property damages resulting from modifications made without authorization from Komatsu.

SAFETY AT JOBSITE

Before starting operations, thoroughly check the area for any unusual conditions that could be dangerous.

- When carrying out operations near combustible materials such as thatched roofs, dry leaves or dry grass, there is a hazard of fire, so be careful when operating.
- Check the terrain and condition of the ground at the worksite, and determine the safest method of operation. Do not carry out operations at places where there is a hazard of landslides or falling rocks.
- If water lines, gas lines, or high-voltage electrical lines may be buried under the worksite, contact each utility and identify their locations. Be careful not to sever or damage any of these lines.
- Take action to prevent unauthorized people from approaching the jobsite.

When working on public roads, position flagmen and erect barriers to ensure the safety of passing traffic and pedestrians.

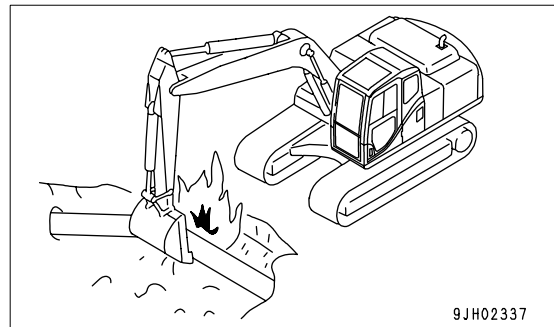

- When traveling or operating in shallow water or on soft ground, check the shape and condition of the bedrock, and the depth and speed of flow of the water before starting operations.

WORKING ON LOOSE GROUND

- Avoid traveling or operating your machine too close to the edge of cliffs, overhangs, and deep ditches. The ground may be weak in such areas. If the ground should collapse under the weight or vibration of the machine, there is a hazard that the machine may fall or tip over. Remember that the soil after heavy rain or blasting or after earthquakes is weak in these areas.
- When working on embankments or near excavated ditches, there is a hazard that the weight and vibration of the machine will cause the soil to collapse. Before starting operations, take steps to ensure that the ground is safe and to prevent the machine from rolling over or falling.

DISTANCE TO HIGH VOLTAGE CABLES

Do not travel or operate the machine near electric cables. There is a hazard of electric shock, which may cause serious injury or property damage. On jobsites where the machine may go close to electric cables, always do as follows.

- q Before starting work near electric cables, inform the local power company of the work to be performed, and ask them to take the necessary action.
 - q Even going close to high-voltage cables can cause electric shock, which may cause serious burns or even death. Always maintain a safe distance (see the table on the right) between the machine and the electric cable. Check with the local power company about safe operating procedure before starting operations.
 - q To prepare for any possible emergencies, wear rubber shoes and gloves. Lay a rubber sheet on top of the seat, and be careful not to touch the chassis with any exposed part of your body.
 - q Use a signalman to give warning if the machine approaches too close to the electric cables.
 - q When carrying out operations near high voltage cables, do not let anyone come close to the machine.
 - q If the machine should come too close or touch the electric cable, to prevent electric shock, the operator should not leave the operator's compartment until it has been confirmed that the electricity has been shut off.
- Also, do not let anyone come close to the machine.

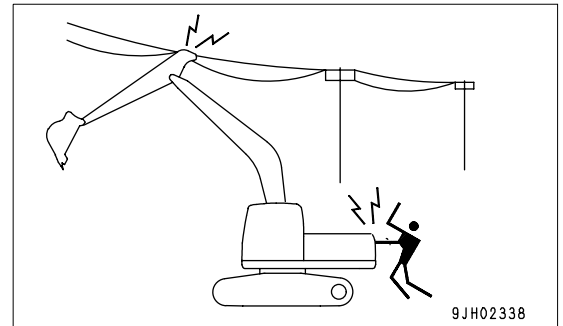

Voltage of Cables	Safety Distance
100 V - 200 V	Over 2 m
6,600 V	Over 2 m
22,000 V	Over 3 m
66,000 V	Over 4 m
154,000 V	Over 5 m
187,000 V	Over 6 m
275,000 V	Over 7 m
500,000 V	Over 11 m

ENSURE GOOD VISIBILITY

- q Check for any persons or obstacles in the area around the machine and check the conditions of the jobsite to ensure that operations and travel can be carried out safely. Always do as follows.
 - q When working in dark places, turn on the working lamp and front lamps installed to the machine, and set up additional lighting in the work area if necessary.
 - q Stop operations if the visibility is poor, such as in mist, snow, rain, or dust.

VENTILATION FOR ENCLOSED AREA

Exhaust fumes from the engine can kill.

- q If it is necessary to start the engine within an enclosed area, or when handling fuel, flushing oil, or paint, open the doors and windows to ensure that adequate ventilation is provided to prevent gas poisoning.

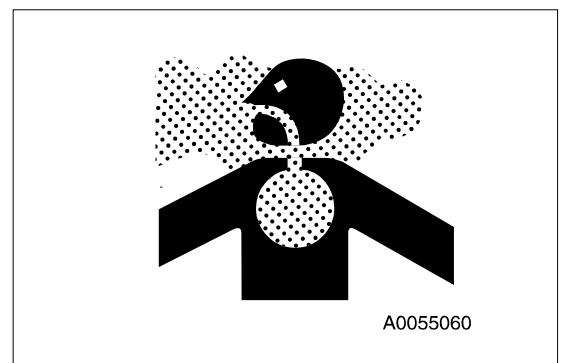

SIGNALMAN'S SIGNAL AND SIGNS

- q Set up signs to inform of road shoulders and soft ground. If the visibility is not good, position a signalman if necessary. Operators should pay careful attention to the signs and follow the instructions from the signalman.
- q Only one signalman should give signals.
- q Make sure that all workers understand the meaning of all signals and signs before starting work.

EMERGENCY EXIT FROM OPERATOR'S CAB

If for some reason, the cab door does not open, use the rear window as an emergency escape. For details, see Section "EMERGENCY EXIT FROM OPERATOR'S CAB (3-31)" in this manual.

ASBESTOS DUST HAZARD PREVENTION

Asbestos dust in the air can cause lung cancer if it is inhaled. There is danger of inhaling asbestos when working on jobsites handling demolition work or work handling industrial waste. Always observe the following.

- q Spray water to keep down the dust when cleaning. Do not use compressed air for cleaning.
- q If there is danger that there may be asbestos dust in the air, always operate the machine from an upwind position. All workers should use an approved respirator.

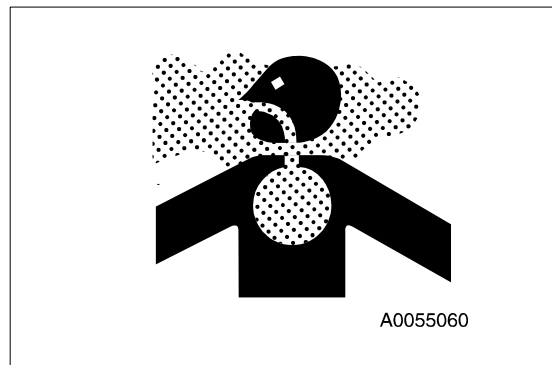

- q Do not allow other persons to approach during the operation.
- q Always observe the rules and regulations for the work site and environmental standards.

This machine does not use asbestos, but there is a danger that imitation parts may contain asbestos, so always use genuine Komatsu parts.

SAFETY MACHINE OPERATION

STARTING ENGINE

If there is a warning tag hanging from the work equipment control lever, do not start the engine or touch the levers .

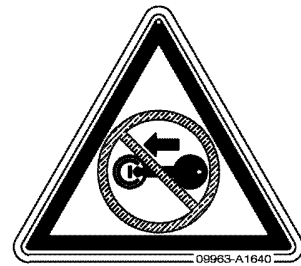
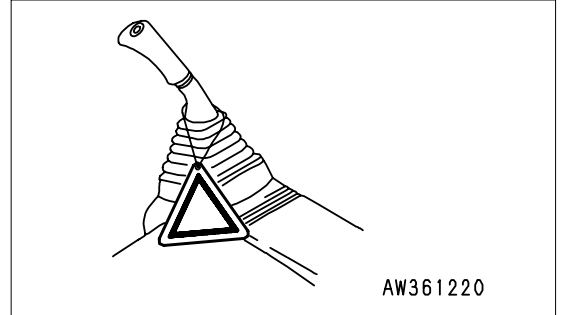

CHECKS BEFORE STARTING ENGINE

Carry out the following checks before starting the engine at the beginning of the day's work.

- q Remove all dirt from the surface of the window glass to ensure a good view.
- q Remove all dirt from the surface of the lens of the front lamps and working lamps, and check that they light up correctly.
- q Check the coolant level, fuel level, and oil level in engine oil pan, check for clogging of the air cleaner, and check for damage to the electric wiring.
- q Adjust the operator's seat to a position where it is easy to carry out operations, and check that there is no damage or wear to the seat belt or mounting clamps.
- q Check that the gauges work properly, check the angle of the lights and working lamps, and check that the control levers are all at the neutral position.
- q Before starting the engine, make sure that the safety lock lever is in the LOCK position.
- q Adjust the mirrors so that the rear of the machine can be seen clearly from the operator's seat.
When adjusting, see "Rearview Mirrors (3-66)".
- q Check that there are no persons or obstacles above, below, or in the area around the machine.

SAFETY RULES FOR STARTING ENGINE

- q Start and operate the machine only while seated.
- q Do not attempt to start the engine by short-circuiting the engine starting circuit. Such an act may cause a serious bodily injury or fire.
- q When starting the engine, sound the horn as a warning.

- q Do not allow anyone apart from the operator to ride on the machine.

STARTING ENGINE IN COLD WEATHER

- q Carry out the warming-up operation thoroughly. If the machine is not thoroughly warmed up before the control levers are operated, the reaction of the machine will be slow, and this may lead to unexpected accidents.
- q If the battery electrolyte is frozen, do not charge the battery or start the engine with a different power source. There is a hazard that this will ignite the battery and cause the battery to explode.

Before charging or starting the engine with a different power source, melt the battery electrolyte and check that there is no leakage of electrolyte before starting.

OPERATION

CHECKS BEFORE OPERATION

When carrying out the checks, move the machine to a wide area where there are no obstructions, and operate slowly. Do not allow anyone near the machine.

- q Always fasten your seat belt.
- q Check that the movement of the machine matches the display on the control pattern card. If it does not match, replace it immediately with the correct control pattern card.
- q Check the operation of the gauges and equipment, and check the operation of the bucket, arm, boom, travel system, swing system, and steering system.
- q Check for any abnormality in the sound of the machine, vibration, heat, smell, or gauges; check also that there is no leakage of oil or fuel.
- q If any abnormality is found, carry out repairs immediately.

SAFETY RULES FOR CHANGING MACHINE DIRECTIONS

- q Before traveling, position the upper structure so that the sprocket (1) is at the rear of the operator's cab. If the sprocket (1) is at the front of the operator's cab, the machine makes a movement reverse to the control lever movement (for example, forward becomes reverse, and left becomes right). Be careful to avoid such a reverse movement of the machine.
- q Before travelling, check again that there is no one in the surrounding area, and that there are no obstacles.
- q Before travelling, sound the horn to warn people in the area.
- q Always operate the machine only when seated.
- q Do not allow anyone apart from the operator to ride on the machine.
- q Check that the travel alarm (if equipped) works properly.
- q Always lock the door and windows of the operator's compartment in position (open or closed).

On jobsites where there is a hazard of flying objects or of objects entering the operator's compartment, check that the door and windows are securely closed.

- q If there is an area to the rear of the machine which cannot be seen, position a signal person. Take special care not to hit other machines or people when turning or swinging the machine.

Always be sure to carry out the above precautions even when the machine is equipped with mirrors.

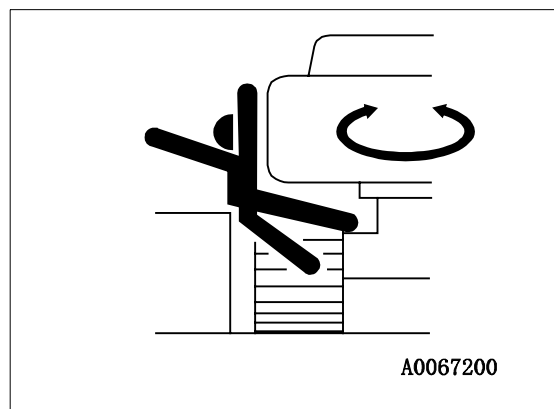
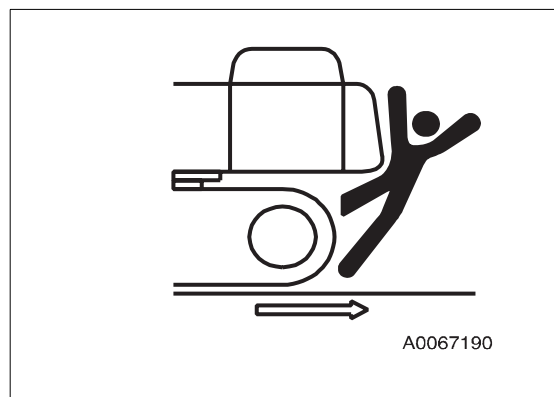
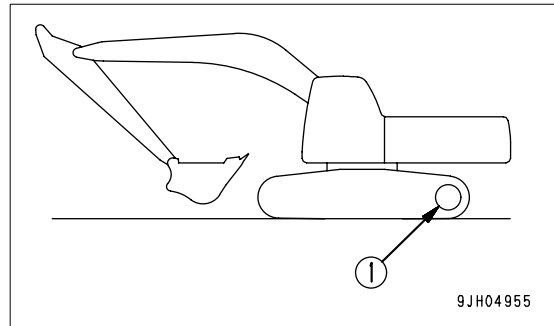

SAFETY RULES FOR TRAVELING

- q When traveling on flat ground, keep the work equipment 40 to 50 cm high above the ground.
- q When traveling on rough ground, travel at low speed and do not operate the steering suddenly. There is danger that the machine may turn over. The work equipment may hit the ground surface and cause the machine to lose its balance, or may damage the machine or structures in the area.
- q When traveling on rough ground or steep slopes, if the machine is equipped with auto-deceleration, always turn the auto-deceleration switch OFF (cancel).
- q Avoid traveling over obstacles when possible. If the machine has to travel over an obstacle, keep the work equipment close to the ground and travel at low speed. Never travel over obstacles which make the machine tilt strongly to one side.
- q When traveling or carrying out operations, always keep a safe distance from people, structures, or other machines to avoid coming into contact with them.
- q When passing over bridges or structures, check first that the structure is strong enough to support the weight of the machine. When traveling on public roads, check first with the relevant authorities and follow their instructions.
- q When operating in tunnels, under bridges, under electric wires, or other places where the height is limited, operate slowly and be extremely careful not to let the work equipment hit anything.

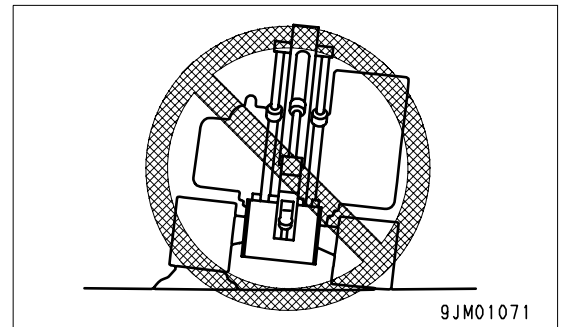
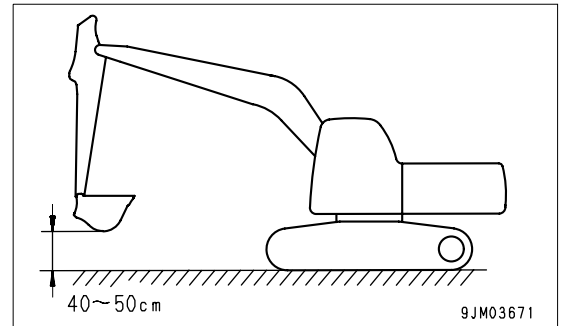

TRAVELING ON SLOPES

To prevent the machine from tipping over or slipping to the side, always do as follows.

- Keep the work equipment approx. 20 to 30 cm above the ground. In case of emergency, lower the work equipment to the ground immediately to help stop the machine.

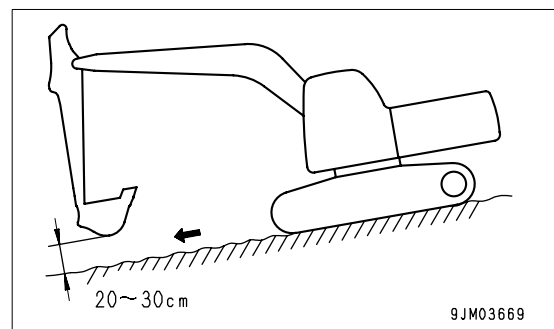
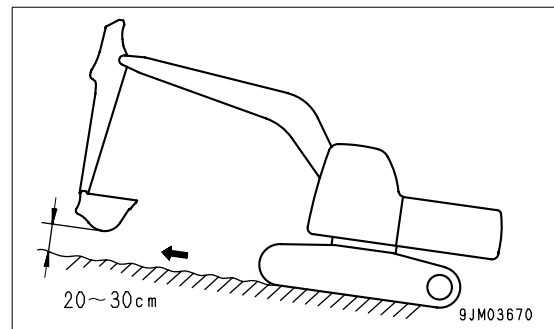

- When travel up slopes, set the operator's cab facing uphill, when travel down slopes, set the operator's cab facing downhill. Always check the firmness of the ground under the front of the machine when traveling.
- When traveling up a steep slope, extend the work equipment to the front to improve the balance, keep the work equipment approximately 20 to 30 cm above the ground, and travel at low speed.
- When traveling downhill, lower the engine speed, keep the travel lever close to the neutral position, and travel at low speed.

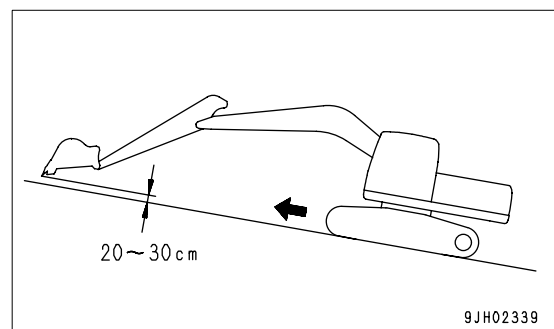

- Always travel straight up or down a slope. Traveling at an angle or across the slope is extremely dangerous.
- Do not turn on slopes or travel across slopes. Always go down to a flat place to change the position of the machine, then travel on to the slope again.
- Travel on grass, fallen leaves, or wet steel plates with low speed. Even with slight slopes there is a hazard that the machine may slip.
- If the engine stops when the machine is traveling on a slope, move the control levers immediately to the neutral position and start the engine again.

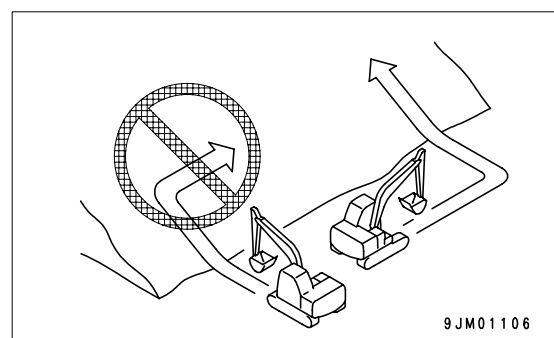

OPERATIONS ON SLOPES

- q When working on slopes, there is a hazard that the machine may lose its balance and turn over when the swing or work equipment are operated. This may lead to serious injury or property damage, so always provide a stable place when carrying out these operations, and operate carefully.
- q Do not swing the work equipment from the uphill side to the downhill side when the bucket is loaded. This operation is dangerous, and may cause the machine to tip over.
- q If the machine has to be used on a slope, pile the soil to make a platform (A) that will keep the machine as horizontal as possible.

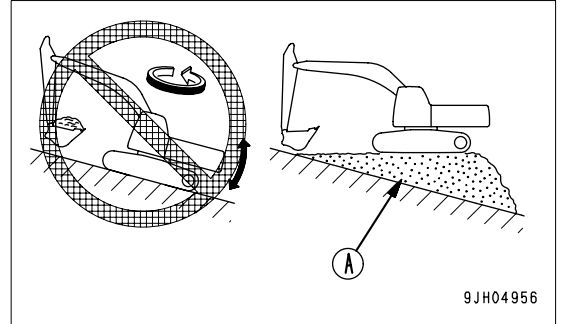

PROHIBITED OPERATIONS

- q Never dig the work face under an overhang. There is a hazard that rocks may fall or that the overhang may collapse and fall on top of the machine.

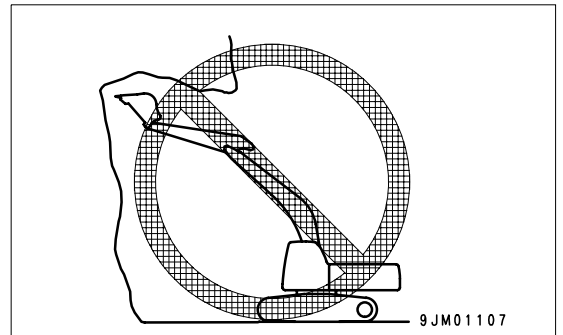

- q Do not excavate too deeply under the front of the machine. The ground under the machine may collapse and cause the machine to fall.

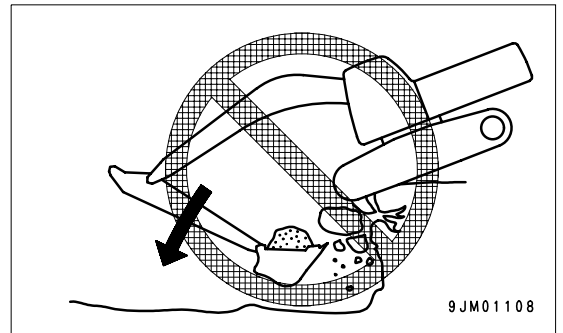

- q To make it easier to escape if there is any problem, set the tracks at right angles to the road shoulder or cliff with the sprocket at the rear when carrying out operations.

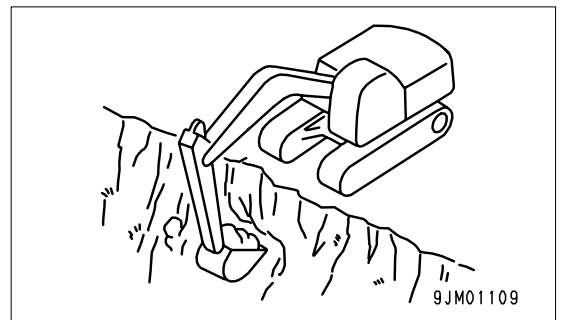

- q Do not carry out demolition work under the machine. There is a hazard that the machine may become unstable and tip over.
- q When working on or from the top of buildings or other structures, check the strength and the structure before starting operations. There is a hazard of the building collapsing and causing serious injury or damage.

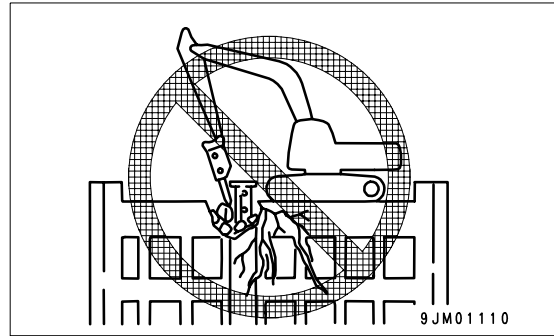

- q When carrying out demolition work, do not carry out demolition above your head. There is a hazard of broken parts falling or of the building collapsing and causing serious injury or property damage.

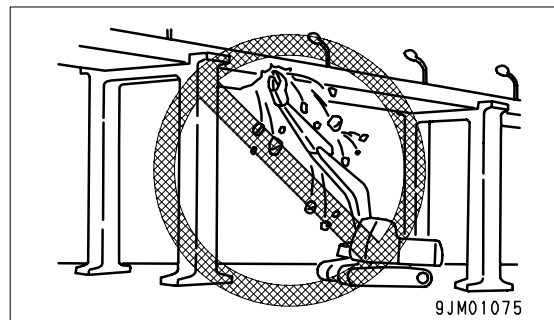

- q Do not use the impact force of the work equipment for breaking work. There is a hazard of damage to the work equipment, or a hazard of serious personal injury being caused by flying pieces of broken materials, or of the machine tipping over due to reaction from the impact.
- q Generally speaking, the machine is more liable to overturn when the work equipment is at the side than when it is at the front or rear.

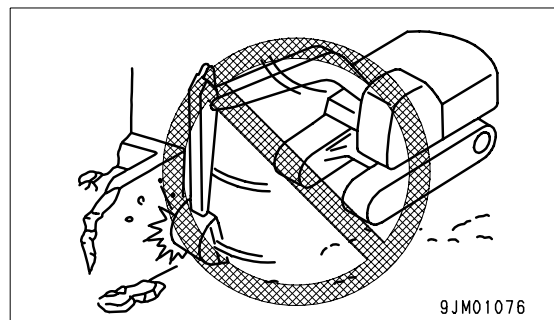

- q When using a breaker or other heavy work equipment, there is a hazard of the machine losing its balance and tipping over. When operating on flat ground as well as on slopes.
 - q Do not suddenly lower, swing, or stop the work equipment.
 - q Do not suddenly extend or retract the boom cylinder. There is a hazard that impact will cause the machine to tip over.
- q Do not pass the bucket over the head of other workers or over the operator's seat of dump trucks or other hauling equipment. The load may spill or the bucket may hit the dump truck and cause serious injury or property damage.

OPERATIONS ON SNOW

- q Snow-covered or frozen surfaces are slippery, so be extremely careful when traveling or operating the machine, and do not operate the levers suddenly. Even a slight slope may cause the machine to slip, so be particularly careful when working on slopes.
- q With frozen ground surfaces, the ground becomes soft when the temperature rises, and this may cause the machine to tip over.
- q If the machine enters deep snow, there is a hazard that it may tip over or become buried in the snow. Be careful not to leave the road shoulder or to get trapped in a snow drift.
- q When clearing snow, the road shoulder and objects placed beside the road are buried in the snow and cannot be seen. There is a hazard of the machine tipping over or hitting covered objects, so always carry out operations carefully.

PARKING MACHINE

- q Park the machine on firm, level ground.
- q Select a place where there is no hazard of falling rocks or landslides, or of flooding if the land is low.
- q Lower the work equipment completely to the ground.

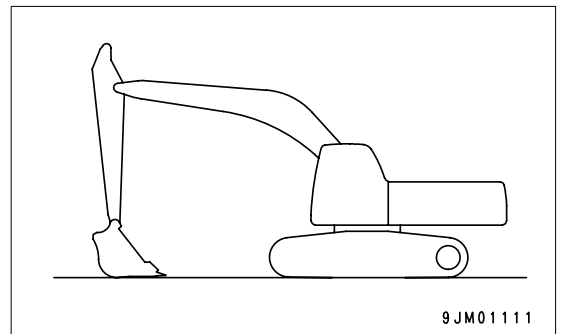

- q When leaving the machine, set safety lock lever (1) to the LOCK position (L), then stop the engine.
- q Always close the operator's cab door, and use the key to lock all the equipment in order to prevent any unauthorized person from moving the machine. Always remove the key, take it with you, and leave it in the specified place.
- q If it is necessary to park the machine on a slope, always do as follows.

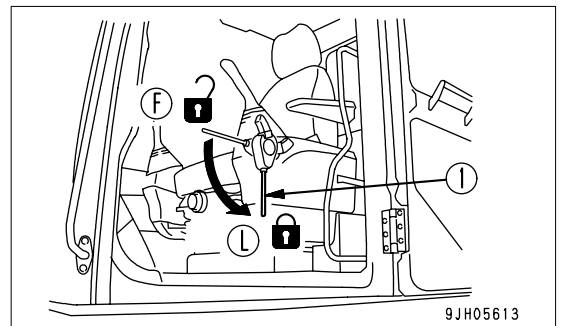

- q Set the bucket on the downhill side, then dig it into the ground.
- q Put blocks under the tracks to prevent the machine from moving.

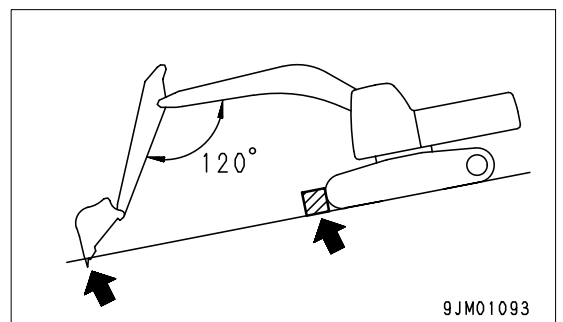

TRANSPORTATION

The machine can be divided into parts for transportation, so when transporting the machine, please contact your Komatsu distributor to have the work carried out.

LOADING AND UNLOADING

When loading or unloading the machine, mistaken operation may bring the hazard of the machine tipping over or falling, so particular care is necessary. Always do as follows.

- q Perform loading and unloading on firm, level ground only. Maintain a safe distance from the edge of the road or cliff.
- q Never use the work equipment to load or unload the machine. There is danger that the machine may fall or tip over.
- q Always use ramps of adequate strength. Be sure that the ramps are wide, long, and thick enough to provide a safe loading slope. Take suitable steps to prevent the ramps from moving out of position or coming off.
- q Be sure the ramp surface is clean and free of grease, oil, ice and loose materials. Remove dirt from machine-tracks. On a rainy day, in particular, be extremely careful since the ramp surface is slippery.
- q Turn the auto-decelerator switch OFF (auto-deceleration function released).
- q Run the engine at low speed and travel slowly.
- q When on the ramps, do not touch any other parts.
- q Never correct your steering on the ramps. If necessary, drive off the ramps, correct the direction, then enter the ramps again.
- q The center of gravity of the machine will change suddenly at the joint between the ramps and the track or trailer, and there is danger of the machine losing its balance. Travel slowly over this point.
- q When loading or unloading to an embankment or platform, make sure that it has suitable width, strength, and grade.
- q When swinging the upper structure on the trailer, the trailer is unstable, so pull in the work equipment and swing slowly. And turn swing lock switch ON to apply swing lock after loading machine.
- q For machines equipped with a cab, always lock the door after boarding the machine. If this is not done, the door may suddenly open during transportation.

Refer to "TRANSPORTATION (3-105)".

SHIPPING THE MACHINE

When shipping the machine on a trailer, do as follows.

- q The weight, transportation height, and overall length of the machine differ according to the work equipment, so be sure to confirm the dimensions.
- q When passing over bridges or structures on private land, check first that the structure is strong enough to support the weight of the machine. When traveling on public roads, check first with the relevant authorities and follow their instructions.
- q For details of the shipping procedure, see "TRANSPORTATION (3-105)" in the OPERATION section.

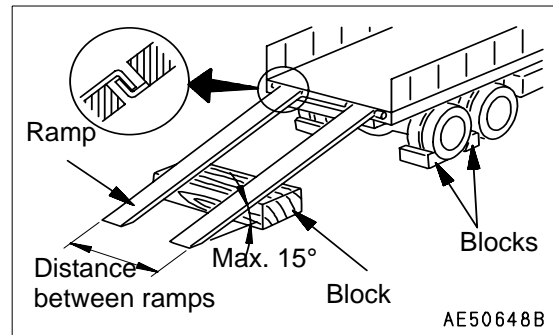

BATTERY

BATTERY HAZARD PREVENTION

Battery electrolyte contains sulphuric acid, and batteries generate flammable hydrogen gas, which may explode. Mistaken handling can lead to serious injury or fire. For this reason, always observe the following precautions.

- q Do not use or charge the battery if the battery electrolyte level is below the LOWER LEVEL line. This may cause an explosion. Always check the battery electrolyte level periodically and add distilled water to bring the electrolyte level to the UPPER LEVEL line.
- q When working with batteries, always wear safety glasses and rubber gloves.
- q Never smoke or use any flame near the battery.

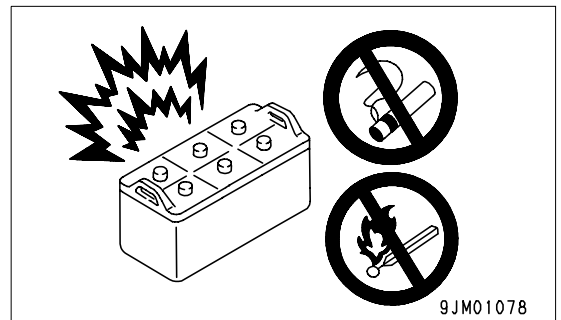

- q If you spill acid on your clothes or skin, immediately flush the area with large amount of water.
- q If acid gets into your eyes, flush them immediately with large amount of water and seek medical attention.

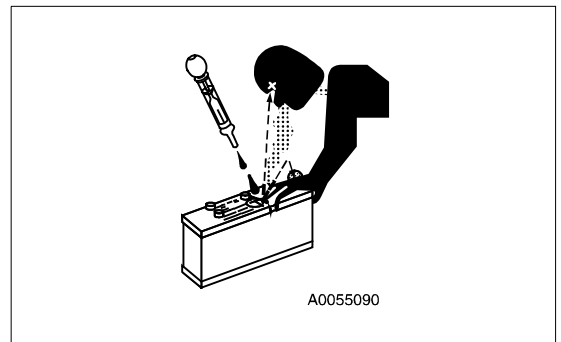

- q Before working with batteries, turn the starting switch to the OFF position.

As there is a hazard that sparks will be generated, always do as follows.

- q Do not let tools or other metal objects make any contact between the battery terminals. Do not leave tools or other metal objects lying around near the battery.
- q Always disconnect the negative (-) terminal (ground side) first when removing the battery; when installing the battery, connect the positive (+) terminal first, and connect the ground last. Tighten the battery terminals securely.
- q Flammable hydrogen gas is generated when the battery is charged, so remove the battery from the chassis, take it to a well-ventilated place, and remove the battery caps before charging it.
- q Tighten the battery caps securely.
- q Install the battery securely to the determined place.

STARTING ENGINE WITH BOOSTER CABLES

If any mistake is made in the method of connecting the booster cables, it may cause the battery to explode, so always do as follows.

- q When starting with a booster cable, carry out the starting operation with two workers (one worker sitting in the operator's seat and the other working with the battery).
- q When starting from another machine, do not allow the two machines to touch.
- q When connecting the booster cables, turn the starting switch OFF for both the normal machine and problem machine. There is a hazard that the machine will move when the power is connected.
- q Be sure to connect the positive (+) cable first when installing the booster cables. Disconnect the negative (-) cable (ground side) first when removing them.
- q When removing the booster cables, be careful not to let the booster cable clips touch each other or to let the clips touch the machine.
- q Always wear safety goggles and rubber gloves when starting the engine with booster cables.
- q When connecting a normal machine to a problem machine with booster cables, always use a normal machine with the same battery voltage as the problem machine.
- q For details of the starting procedure when using booster cables, see "Starting Engine with Booster Cables (3-124)" in the OPERATION section.

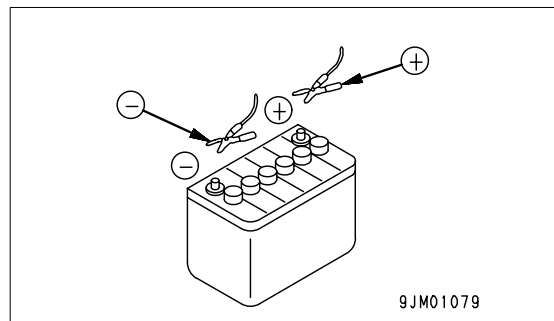
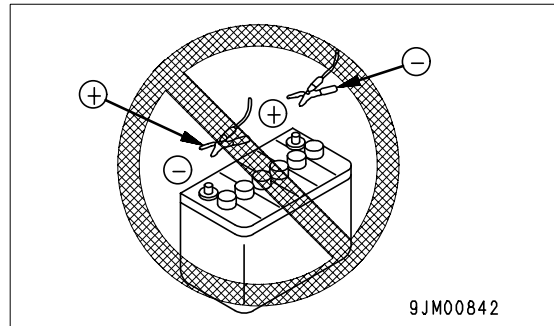

TOWING

SAFETY RULES FOR TOWING

Serious injury or death could result if a disabled machine is towed incorrectly or if there is a mistake in the selection or inspection of the wire rope.

For towing, see "TOWING THE MACHINE (3-120)".

- q Always wear leather gloves when handling wire rope.
- q Fix the wire rope to the track frame.
- q During the towing operation, never stand between the towing machine and the machine being towed.
- q Never tow a machine on a slope.

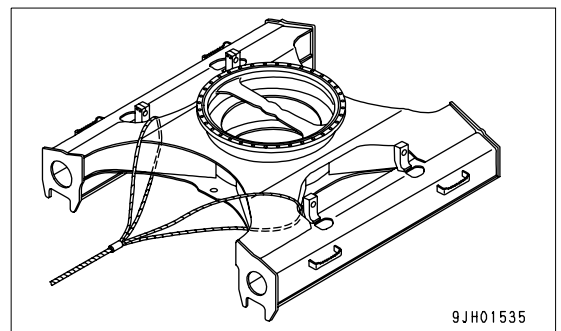
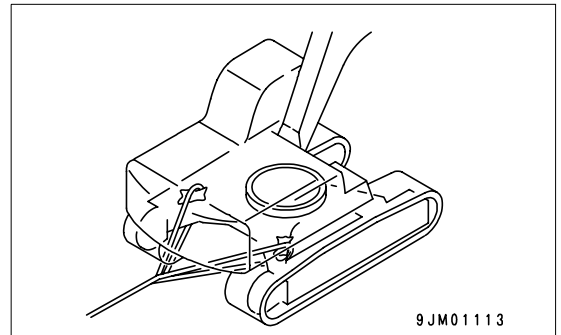

- q Never use a wire rope which has cut strands (A), reduced diameter (B), or kinks (C). There is danger that the rope may break during the towing operation.

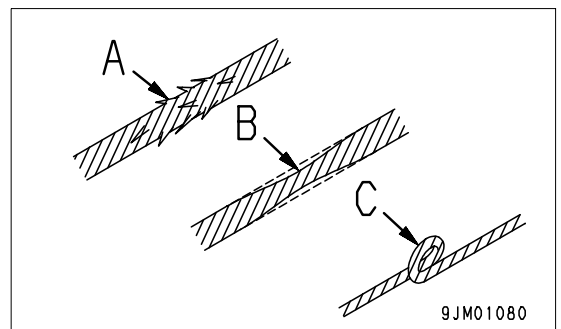

LIFTING OBJECTS WITH BUCKET

As a basic rule it is prohibited to carry out operations lifting objects with this standard specification machine.

LIFTING WORK USING BUCKET WITH HOOK

As a basic rule, it is prohibited to carry out lifting operations. However, if the work fulfils the specified conditions and only if it fulfils the specified conditions, it is permitted to carry out lifting operations using a bucket with a hook.

SAFETY RULES FOR LIFTING OBJECTS

- q Do not carry out lifting work on slopes, soft ground, or other places where the machine is not stable.
- q Use wire rope that conforms to the specified standard.
- q Do not exceed the specified lifting load.

For details of the maximum lifting load permitted for this machine, see "BUCKET WITH HOOK (6-4)".

- q It is dangerous if a raised load hits any person or structure. When operating the swing or work equipment, always check carefully that the surrounding area is safe.
- q Do not operate the swing or work equipment suddenly. There is danger that it will cause the load to sway.
- q Do not use 2 machines to cooperate to lift the same load. This is dangerous.
- q Do not leave the operator's seat when there is a raised load.
- q With lifting operations, the machine is unstable and there is high risk of the machine tipping over, so avoid carrying out lifting operations as far as possible. Lifting operations are particularly dangerous on slopes or in places where the ground surface is uneven.

If it is necessary to travel with a raised load, always obey the following precautions to completely ensure safety in the surrounding area.

- q The ground surface must be flat. Never travel with a raised load on an uneven surface. If the travel path is not flat and horizontal, level the ground surface to make it flat.
- q Never travel with a raised load on soft ground. The track will sink into the ground surface and there is danger that the machine may become unstable and tip over.
- q Make the length of the rope as short as possible, make the working radius also as small as possible, and travel with the load carried at a maximum of 10 cm above the ground. To prevent the machine from tipping over, always be prepared to lower the load to the ground at any moment.
- q Travel slowly, and avoid starting or stopping suddenly or carrying out any action that will cause the load to swing. Use a guide rope or carry out other measures to prevent the load from swinging, and travel at slow speed.
- q Never operate the swing or work equipment when traveling with a raised load.

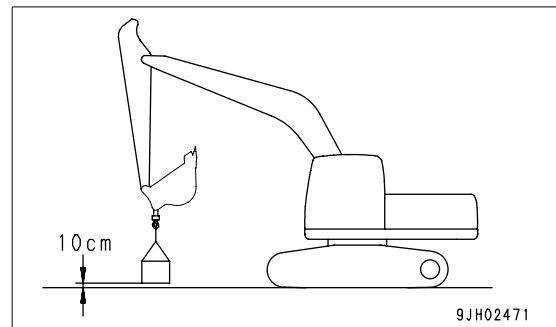

- q Do not use the work equipment or swing to pull the load in any direction. There is danger that the hook may break and the load come off, causing the work equipment to move suddenly and cause personal injury.

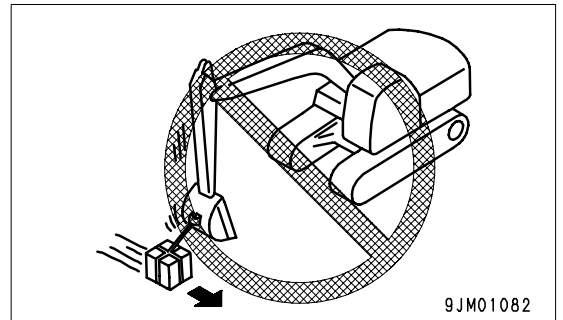
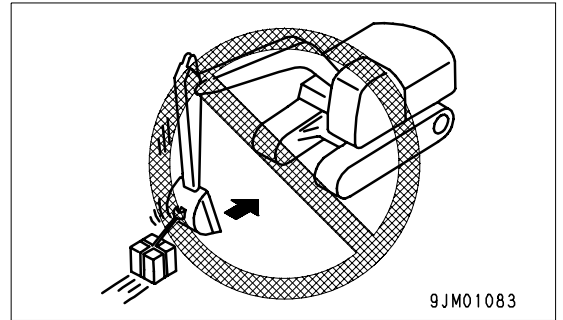

SAFETY MAINTENANCE INFORMATION

WARNING TAG

- q Always attach the "DO NOT OPERATE" warning tag to the work equipment control lever in the operator's cab to alert others that you are performing service or maintenance on the machine.

Attach additional warning tags around the machine if necessary.

Warning tag Part No. 09963-A1640

- q North America specified
- q Always attach the "DO NOT OPERATE" warning tag to the work equipment control lever in the operator's cab to alert others that you are performing service or maintenance on the machine.

Attach additional warning tags around the machine if necessary.

Warning tag Part No. 09963-03000

Keep this warning tag in the tool box while it is not used. If there is not the tool box, keep the tag in the operation manual pocket, as the magazine box.

- q If others start the engine, or touch or operate the work equipment control lever while you are performing service or maintenance, you could suffer serious injury or property damage.

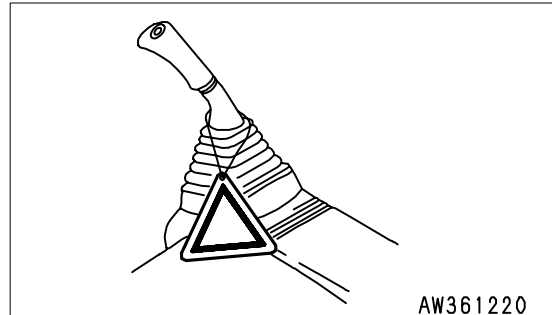

KEEP WORK PLACE CLEAN AND TIDY

- q Do not leave hammers or other tools lying around in the work place. Wipe up all grease, oil, or other substances that will cause you to slip. Always keep the work place clean and tidy to enable you to carry out operations safely.

If the work place is not kept clean and tidy, there is the danger that you will trip, slip, or fall over and injure yourself.

- q When cleaning the ceiling window which is made of organic glass (polycarbonate), use tap water and avoid use of organic solvents for cleaning. An organic solvent like benzene, toluene or methanol can invite a chemical reaction like dissolution and decomposition on the window glass, deteriorating polycarbonate in use.

APPOINT LEADER WHEN WORKING WITH OTHERS

- q When repairing the machine or when removing and installing the work equipment, appoint a leader and follow his instructions during the operation.

STOP ENGINE BEFORE CARRYING OUT MAINTENANCE

- q Stop the machine on firm, level ground.
- q Select a place where there is no hazard of falling rocks or landslides, or of flooding if the land is low.
- q Lower the work equipment completely to the ground and stop the engine.
- q Turn the starting switch to the ON position. Operate the work equipment control lever back and forth, left and right at the full stroke 2 to 3 times to eliminate the remaining internal pressure in the hydraulic circuit, and then push up safety lock lever (1) to the LOCK position (L).

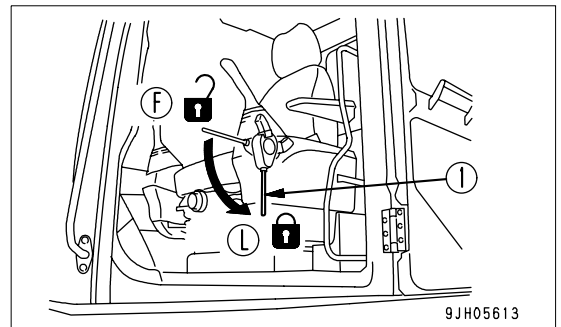
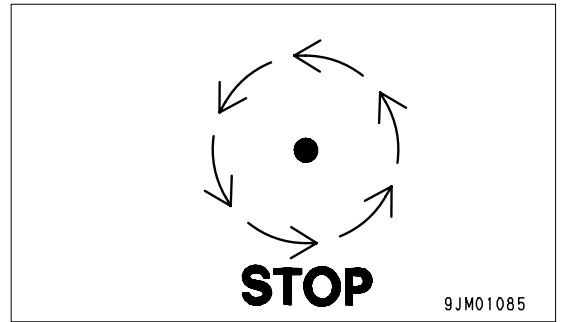

- q Put blocks under the track to prevent the machine from moving.

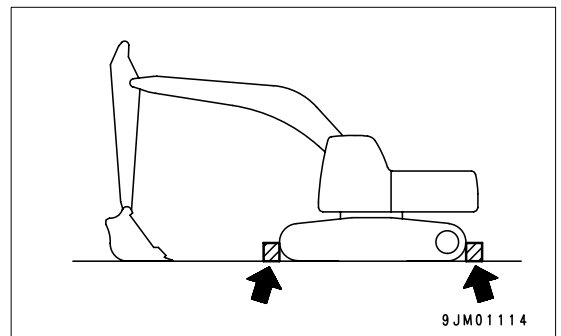
**TWO WORKERS FOR MAINTENANCE WHEN ENGINE IS RUNNING**

To prevent injury, do not carry out maintenance with the engine running. If maintenance must be carried out with the engine running, carry out the operation with at least two workers and do as follows.

- q One worker must always sit in the operator's seat and be ready to stop the engine at any time. All workers must maintain contact with the other workers.

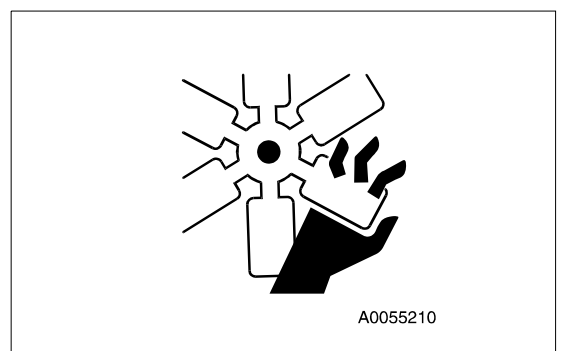

- q Set safety lock lever (1) to the LOCK position (L) to prevent the work equipment from moving.
- q When carrying out operations near the fan, fan belt, or other rotating parts, there is a hazard of being caught in the parts, so be careful not to come close.
- q Do not touch any control levers. If any control lever must be operated, give a signal to the other workers to warn them to move to a safe place.
- q Never drop or insert tools or other objects into the fan or fan belt. Parts may break or be sent flying.

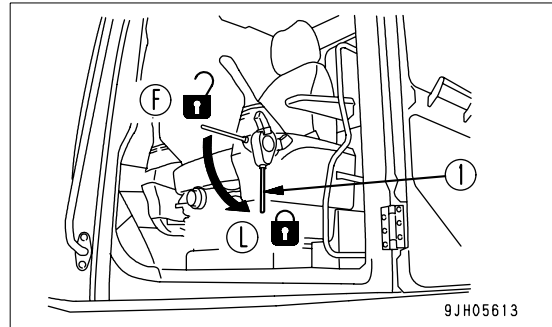

PROPER TOOLS

Use only tools suited to the task and be sure to use the tools correctly. Using damaged, low quality, faulty, makeshift tools or improper use of the tools could cause serious personal injury.

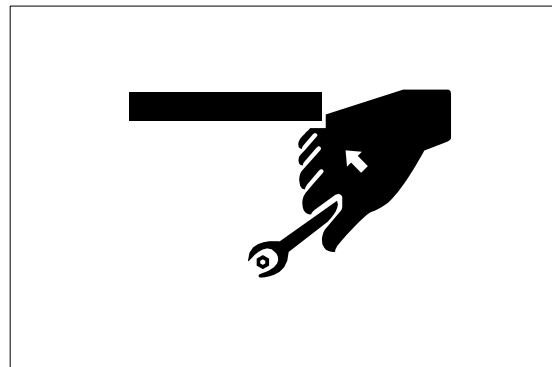

ACCUMULATOR

The accumulator is charged with high-pressure nitrogen gas. When handling the accumulator, careless procedure may cause an explosion which could lead to serious injury or property damage. For this reason, always observe the following precautions.

- q Do not disassemble the accumulator.
- q Do not bring it near flame or dispose of it in fire.
- q Do not make holes in it, weld it, or use a cutting torch.
- q Do not hit or roll the accumulator, or subject it to any impact.
- q When disposing of the accumulator, the gas must be released. Please contact your Komatsu distributor to have this work performed.



PERSONNEL

Only authorized personnel can service and repair the machine. Do not allow unauthorized personnel into the area. If necessary, employ an observer.

ATTACHMENTS

- q Appoint a leader before starting removal or installation operations for attachments.
- q Place attachments that have been removed from the machine in a stable condition so that they do not fall. And take steps to prevent unauthorized persons from entering the storage area.



WORK UNDER THE MACHINE

- q If it is necessary to go under the work equipment or the machine to carry out service and maintenance, support the work equipment and machine securely with blocks and stands strong enough to support the weight of the work equipment and machine.
- q It is extremely dangerous to work under the machine if the track shoes are lifted off the ground and the machine is supported only with the work equipment. If any of the control levers is touched by accident, or there is damage occurring to the hydraulic piping, the work equipment or the machine will suddenly drop. This is extremely dangerous. Never work under the work equipment or the machine.



NOISE

When carrying out maintenance of the engine and you are exposed to noise for long periods of time, wear ear covers or ear plugs while working.

If the noise from the machine is too loud, it may cause temporary or permanent hearing problems.

WHEN USING HAMMER

When using a hammer, pins may fly out or metal particles may be scattered. This may lead to serious injury. Always do as follows.

- q If hard metal parts such as pins, bucket teeth, cutting edges, or bearings are hit with a hammer, there is a hazard that pieces might be scattered and cause injury. Always wear safety goggles and gloves.
- q When hitting pins or bucket teeth, there is a hazard that broken pieces might be sent flying and injure people in the surrounding area. Always check that there is no one in the surrounding area.

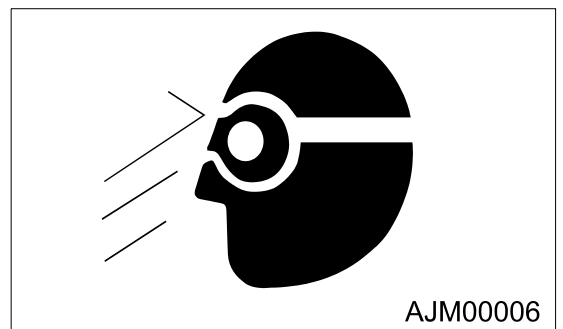

- q There is a hazard that the pin hit with strong force may fly out and injure people in the surrounding area.

WELDING WORKS

Welding operations must always be carried out by a qualified welder and in a place equipped with proper equipment. There is a hazard of gas, fire, or electrocution when carrying out welding, so never allow any unqualified personnel to carry out welding.

REMOVING BATTERY TERMINALS

When repairing the electrical system or when carrying out electrical welding, remove the negative (-) terminal of the battery to prevent the flow of current.

SAFETY FIRST WHEN USING HIGH-PRESSURE GREASE TO ADJUST TRACK TENSION

- q Grease is pumped into the track tension adjustment system under high pressure.

If the specified procedure for maintenance is not followed when making adjustment, grease drain plug (1) may fly out and cause serious injury or property damage.

- q When loosening grease drain plug (1) to loosen the track tension, never loosen it more than one turn. Loosen the grease drain plug slowly.
- q Never put your face, hands, feet, or any other part of your body close to grease drain plug (1).

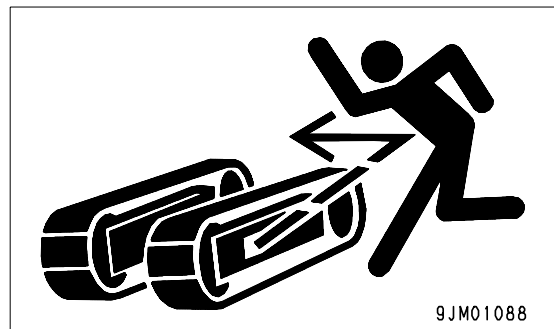
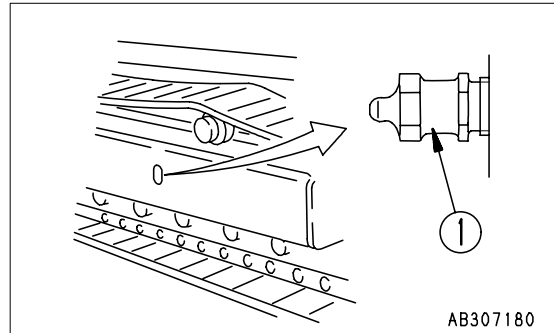

DO NOT DISASSEMBLE RECOIL SPRINGS

Never attempt to disassemble the recoils spring assembly. It contains a spring under high pressure which serves as a shock absorber for the idler. If it is disassembled by mistake, the spring will fly out and cause serious injury. When it becomes necessary to disassemble it, ask your Komatsu distributor to do the work.

SAFETY RULES FOR HIGH-PRESSURE OIL

The hydraulic system is always under internal pressure. When inspecting or replacing piping or hoses, always check that the pressure in the hydraulic circuit has been released. If the circuit is still under pressure, it will lead to serious injury, so always do as follows.

- q For details of the method of releasing the pressure, see “METHOD FOR RELEASING INTERNAL PRESSURE IN HYDRAULIC CIRCUIT (4-46)”. If the circuit is still under pressure, do not carry out any inspection or replacement operation.
- q If there is any leakage from the piping or hoses, the surrounding area will be wet, so check for cracks in the piping and hoses and for swelling in the hoses.

When carry out inspection, wear safety glasses and leather gloves.

- q There is a hazard that high-pressure oil leaking from small holes may penetrate your skin or cause blindness if it contacts your eyes directly. If you are hit by a jet of high-pressure oil and suffer injury to your skin or eyes, wash the place with clean water, and consult a doctor immediately for medical attention.

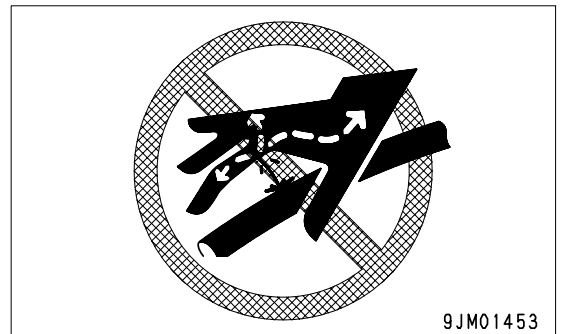

SAFETY HANDLING HIGH-PRESSURE HOSES

- q If oil or fuel leaks from high-pressure hoses, it may cause fire or defective operation, which may lead to serious injury. If any loose bolts are found, stop work and tighten to the specified torque. If any damaged hoses are found, stop operations immediately and contact your Komatsu distributor.

Replace the hose if any of the following problems are found.

- q Damaged or leaking hydraulic fitting.
- q Frayed or cut covering or exposed reinforcement wire layer.
- q Covering swollen in places.
- q Twisted or crushed movable portion.
- q Foreign material embedded in covering.

WASTE MATERIALS

To prevent pollution, pay careful attention to the method of disposing of waste materials.

- q Always put oil drained from your machine in containers. Never drain oil directly onto the ground or dump into the sewage system, rivers, the sea, or lakes.
- q Obey appropriate laws and regulations when disposing of harmful objects such as oil, fuel, coolant, solvent, filters, and batteries.

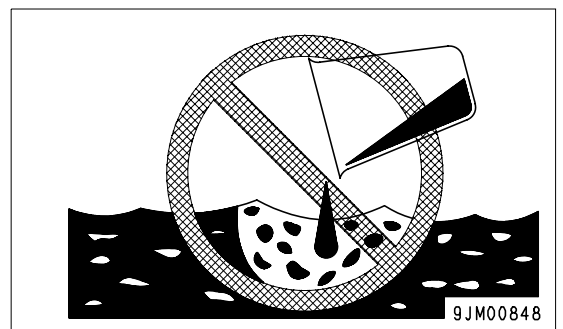

AIR CONDITIONER MAINTENANCE

If air conditioner refrigerant gets into your eyes, it may cause blindness; if it touches your skin, it may cause frostbite.

Never touch refrigerant.

COMPRESSED AIR

- When carrying out cleaning with compressed air, there is a hazard of serious injury caused by flying particles.
- When using compressed air to clean elements or the radiator, always wear safety goggles, dust mask, gloves, and other protective equipment.

PERIODIC REPLACEMENT OF SAFETY CRITICAL PARTS

- To enable the machine to be used safely for long periods, be particularly careful to periodically replace the seatbelt, hoses, and other parts which have a close relationship to safety.

See Replacing critical parts: SAFETY CRITICAL PARTS (4-15)

- The material of these components naturally changes over time, and repeated use causes deterioration, wear, and fatigue. As a result, there is a hazard that these components may fail and cause serious injury or death. It is difficult to judge the remaining life of these components from external inspection or the feeling when operating, so always replace them at the specified interval.
- Replace or repair safety-critical parts if any defect is found, even when they have not reached the time specified interval.

OPERATION



WARNING

Please read and make sure that you understand the safety volume before reading this section.

MACHINE VIEW ILLUSTRATIONS

OVERALL MACHINE VIEW

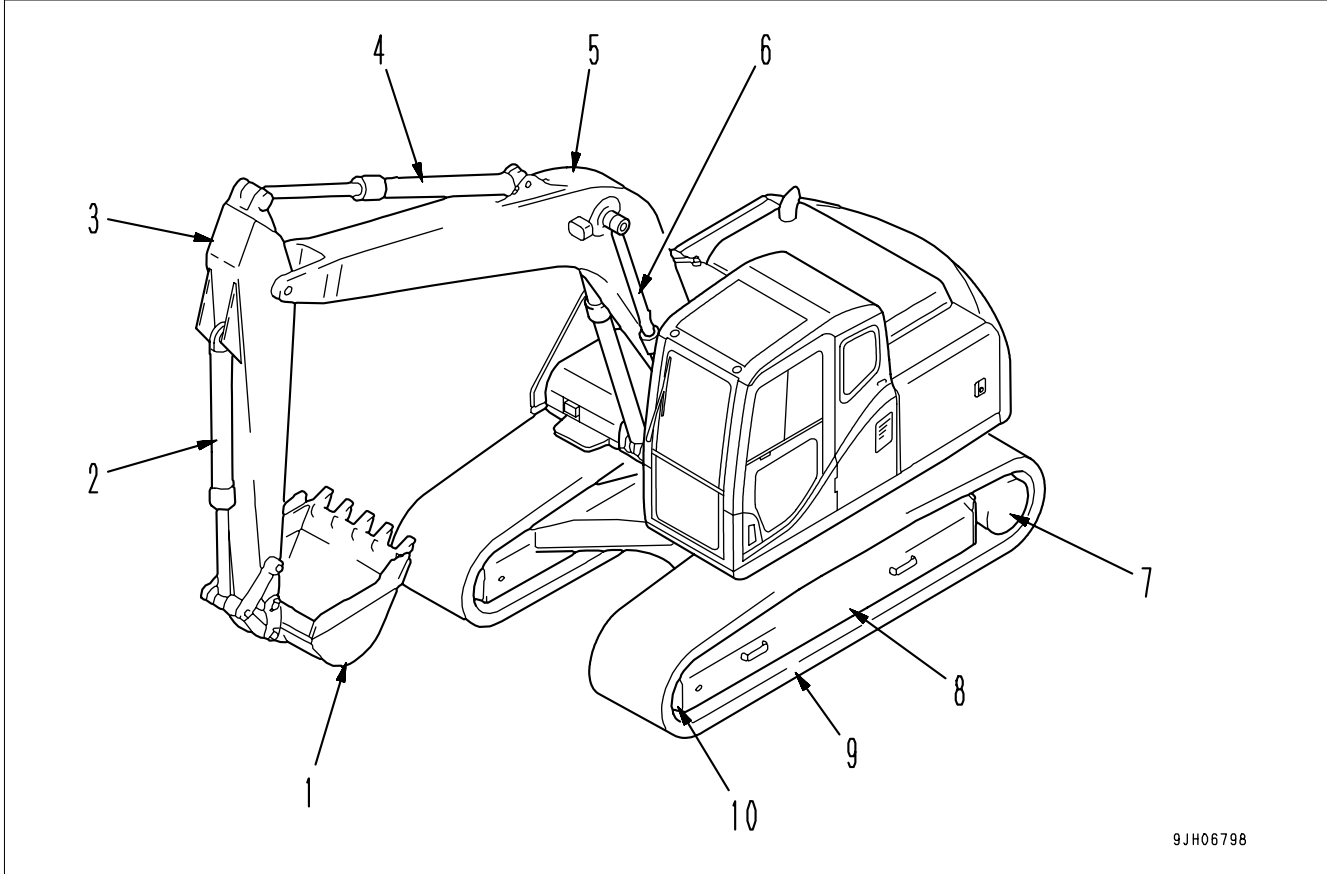

9JH06798

- | | |
|---------------------|-------------------|
| (1) Bucket | (6) Boom cylinder |
| (2) Bucket cylinder | (7) Sprocket |
| (3) Arm | (8) Track frame |
| (4) Arm cylinder | (9) Track shoe |
| (5) Boom | (10) Idler |

CONTROLS AND GAUGES

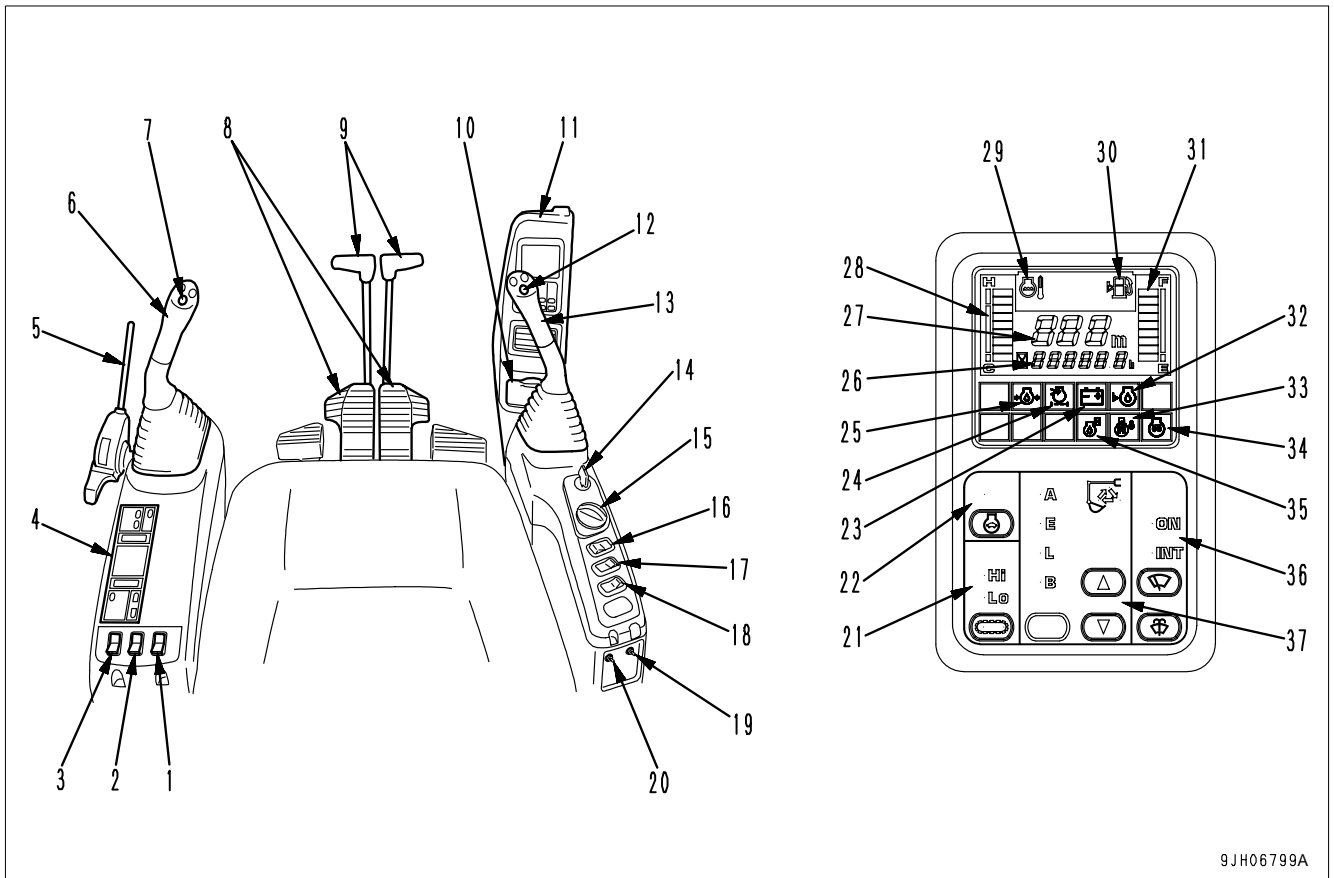

9JH06799A

- | | |
|-----------------------------------------------|-----------------------------------------|
| (1) Heated operator seat switch (if equipped) | (20) Pump drive Emergency switch |
| (2) Rotating lamp switch (if equipped) | (21) Travel speed selector switch |
| (3) Lower wiper switch (if equipped) | (22) Auto-deceleration switch |
| (4) Air conditioner control switch | (23) Charge level monitor |
| (5) Safety lock lever | (24) Air cleaner clogging monitor |
| (6) Left work equipment control lever | (25) Engine oil pressure monitor |
| (7) Knob switch | (26) Service meter |
| (8) Travel pedals | (27) Display (for failure display) |
| (9) Travel levers | (28) Engine coolant temperature gauge |
| (10) Cigarette lighter | (29) Engine coolant temperature monitor |
| (11) Machine monitor | (30) Fuel level monitor |
| (12) Horn switch | (31) Fuel gauge |
| (13) Right work equipment control lever | (32) Engine oil temperature monitor |
| (14) Starting switch | (33) Swing lock monitor |
| (15) Fuel control dial | (34) Engine pre-heating monitor |
| (16) Lamp switch | (35) Engine oil change monitor |
| (17) Alarm buzzer stop switch | (36) Wiper switch |
| (18) Swing lock switch | (37) Working mode selector switch |
| (19) Swing holding brake release switch | |

DETAILED CONTROLS AND GAUGES

The following is an explanation of the devices needed for operating the machine.

To perform suitable operations correctly and safely, it is important to completely understand the methods of operating equipment and meanings of the displays.

MONITORING SYSTEM

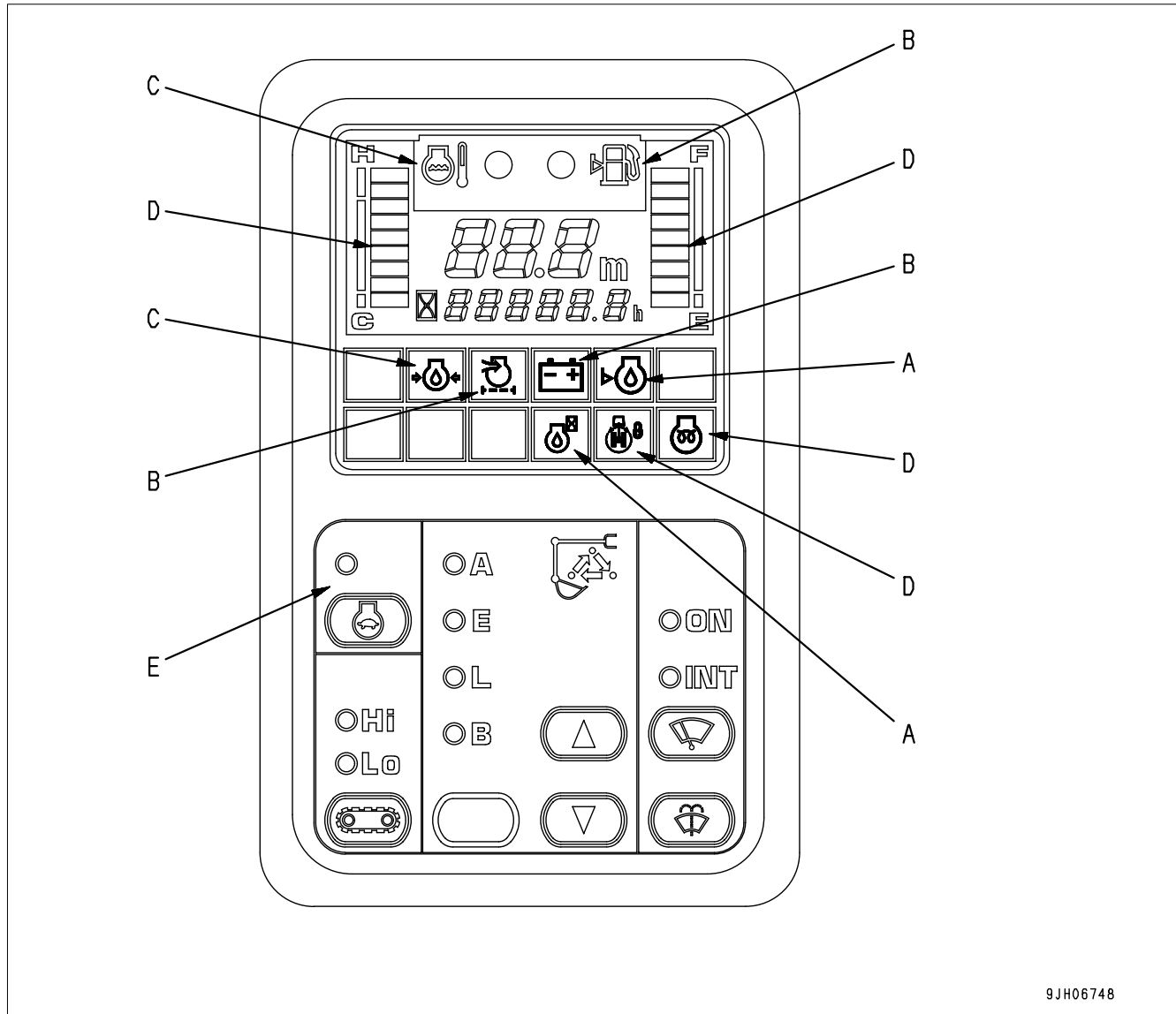

9JH06748

- A: Basic check monitors
- B: Caution monitors
- C: Emergency monitors

- D: Meter Display Portion
- E: Monitor switches portion

Basic Check Monitors

⚠ CAUTION

These monitors DO NOT ensure that the machine is in good condition. When performing checks before starting (daily checks), do not simply rely on the monitors. Always dismount the machine and check each item directly.

This displays the basic items that should be checked before starting the engine.

If there is any abnormality, the appropriate monitor lamp will flash.

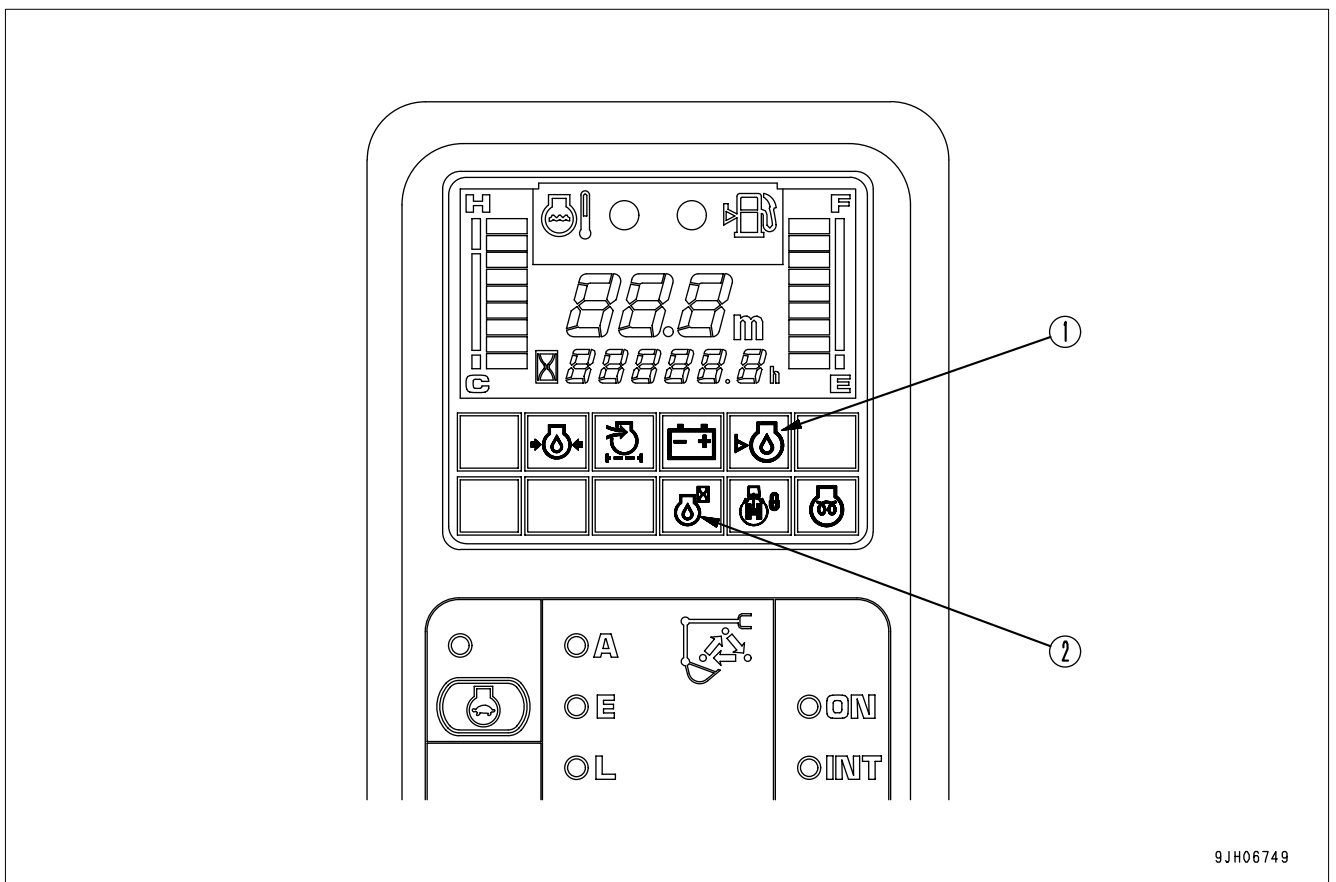

9JH06749

A (1) Engine oil temperature monitor

A (2) Engine oil change monitor (only if equipped)

Engine Oil Level Monitor

This monitor (1) lights up to warn the operator that the oil level in the engine oil pan has gone down.

If the monitor lamp flashes, check the oil level in the engine oil pan, and add oil.

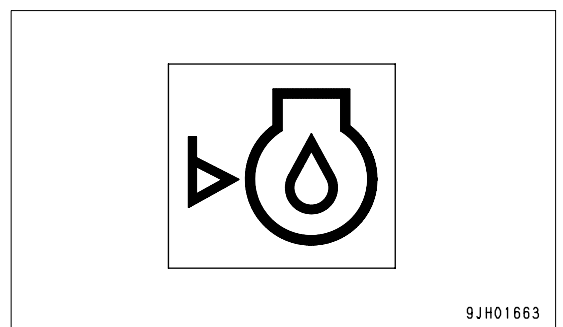

9JH01663

Engine Oil Change Monitor (Only if Equipped)

This monitor (2) warns the operator that the set time for the engine oil change has passed.

If the set time (125, 250, 500 H) passes after the engine oil is replaced, this lamp lights up. If the lamp lights up, change the engine oil.

When you want to change the oil replacement interval, consult Komatsu Ltd. or its distributor.

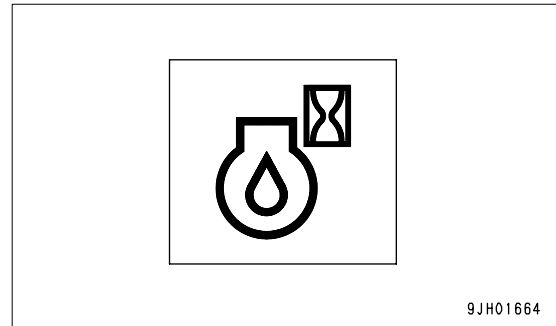

Caution Monitors

⚠ CAUTION
If the warning monitor flashes, check the problem point as soon as possible and carry out maintenance. Failure to repair the problem will lead to failure of the machine.

These are items which need to be observed while the engine is running. If any abnormality occurs, items which need to be repaired as soon as possible are displayed.

If there is any abnormality, the appropriate monitor lamp will flash to indicate the location of the abnormality.

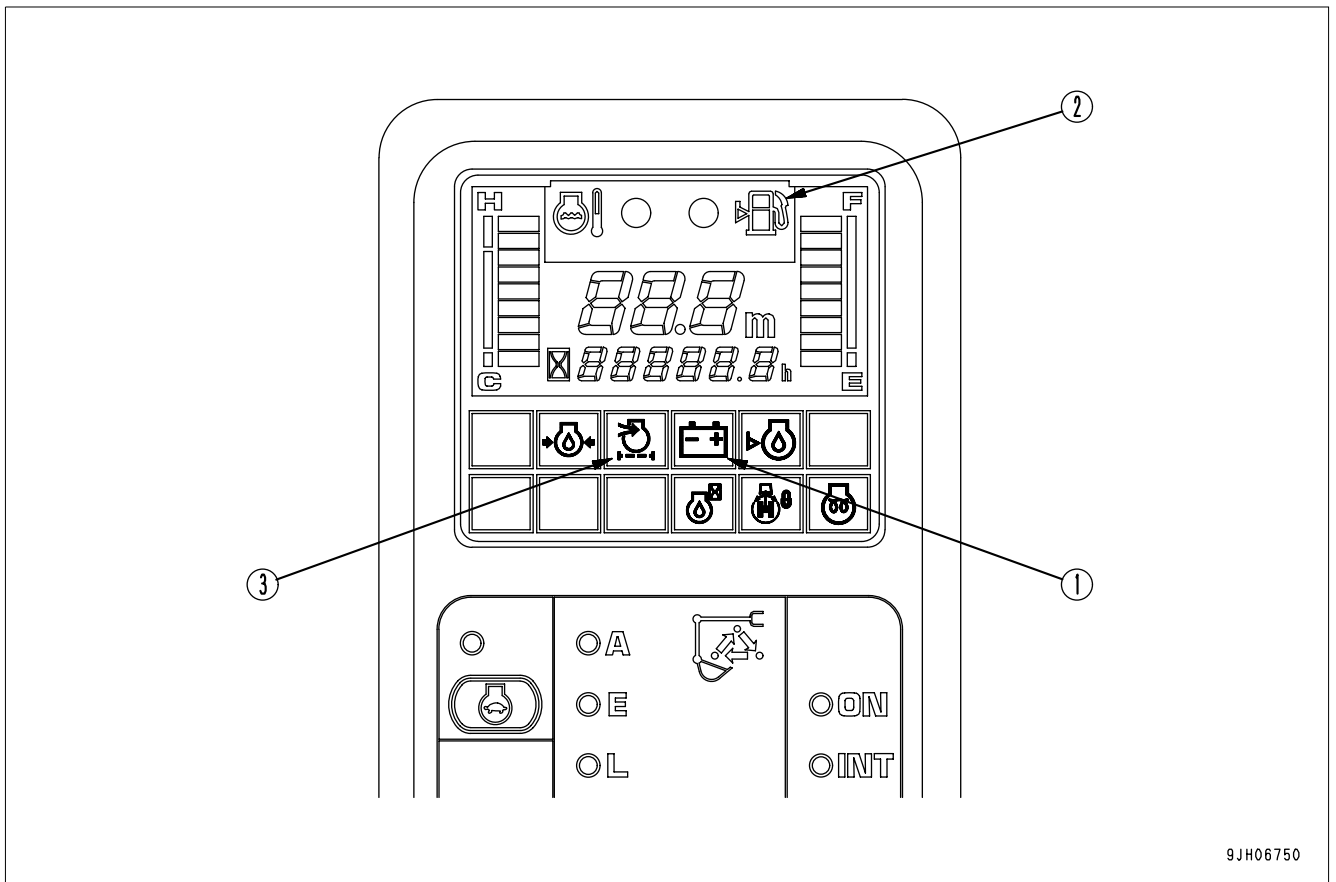

9JH06750

- B (1) Charge level monitor
- B (2) Fuel level monitor

- B (3) Air cleaner clogging monitor

Charge Level Monitor

This monitor (1) flashes if the battery is not being properly charged when the engine is running.

If it flashes, check the V-belt for looseness. If any abnormality is found, take the action given in "OTHER TROUBLE (3-126)".

REMARK

When the starting switch is at ON, the lamp stays lighted up. After the engine starts, it goes out.

When the starting switch is ON, and the engine is started or stopped, the lamp may light up momentarily and the buzzer may sound, but this does not indicate any abnormality.

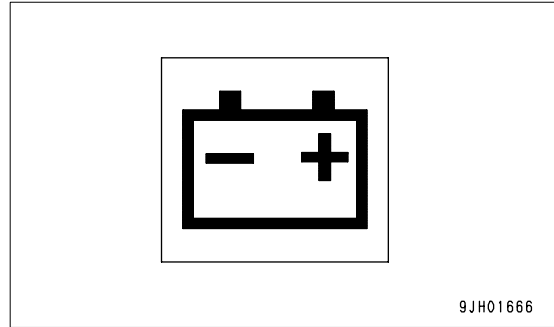

Fuel Level Monitor

This monitor (2) warns against the reduced fuel level in the fuel tank.

When the remaining oil level drops to approx. 46 liters, this monitor flashes, so add fuel as soon as possible.

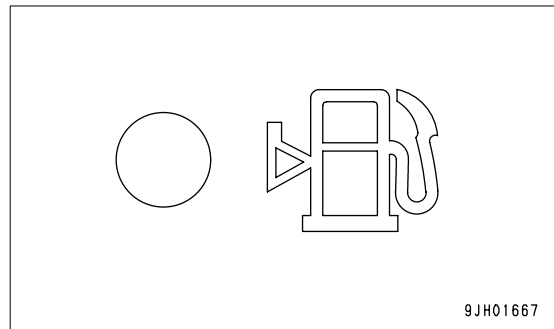

Air Cleaner Clogging Monitor

This monitor (3) warns that the air cleaner is clogged.

If the monitor lamp flashes, stop the engine, then inspect and clean the air cleaner.

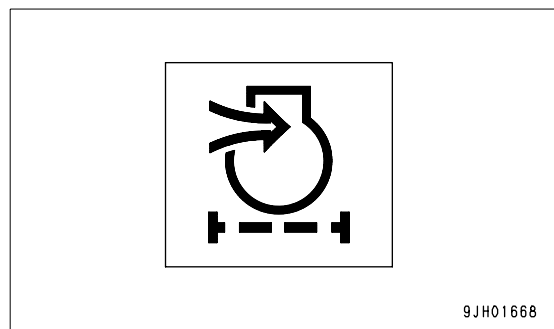

Emergency Monitors

⚠ CAUTION

If the monitor lights up red, stop the engine immediately or run at low idle, check applicable location, then perform necessary actions.

These items should be observed while the engine is running. If there is an abnormality, monitor for the abnormal location lights up red and buzzer sounds, so perform action immediately.

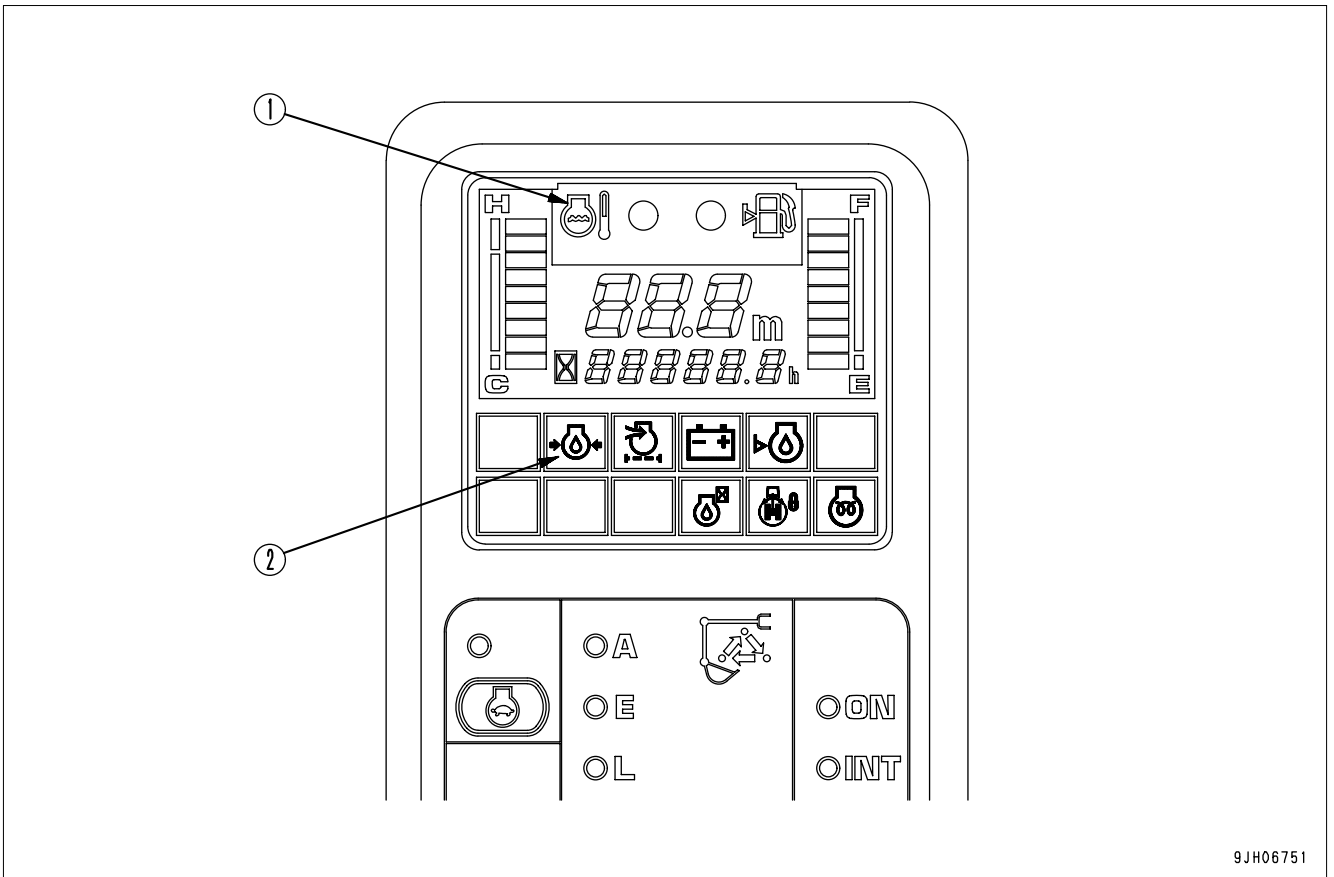

9JH06751

C (1) Engine coolant temperature monitor

C (2) Engine oil pressure monitor

Engine Coolant Temperature Monitor

This monitor (1) serves to warn against abnormal rise of the engine coolant temperature.

If the temperature of the engine cooling water becomes abnormally high, the monitor lamp flashes, and the overheat prevention system is automatically actuated to reduce the engine speed.

Stop operations and run the engine at low idling until the engine water temperature gauge enters the green range.

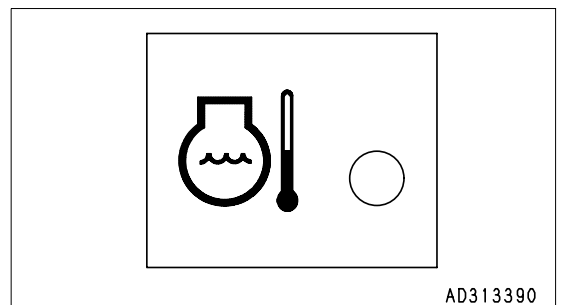

AD313390

Engine Oil Pressure Monitor

If the engine lubricating pressure is below the normal value, this monitor (2) flashes. If it flashes, stop the engine, and check the oil level in the oil pan and lubricating system.

REMARK

When the starting switch is ON, the lamp is always lighted up. After the engine starts, it goes out. When the engine is started, the buzzer may sound momentarily, but this does not indicate any abnormality.

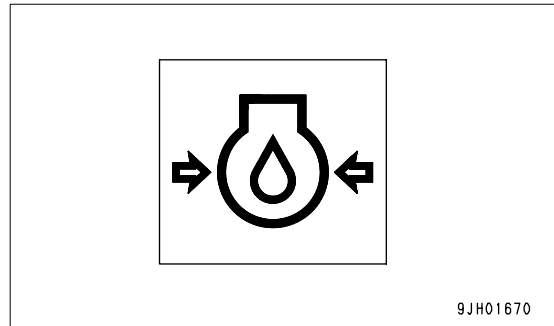

Meter Display Portion

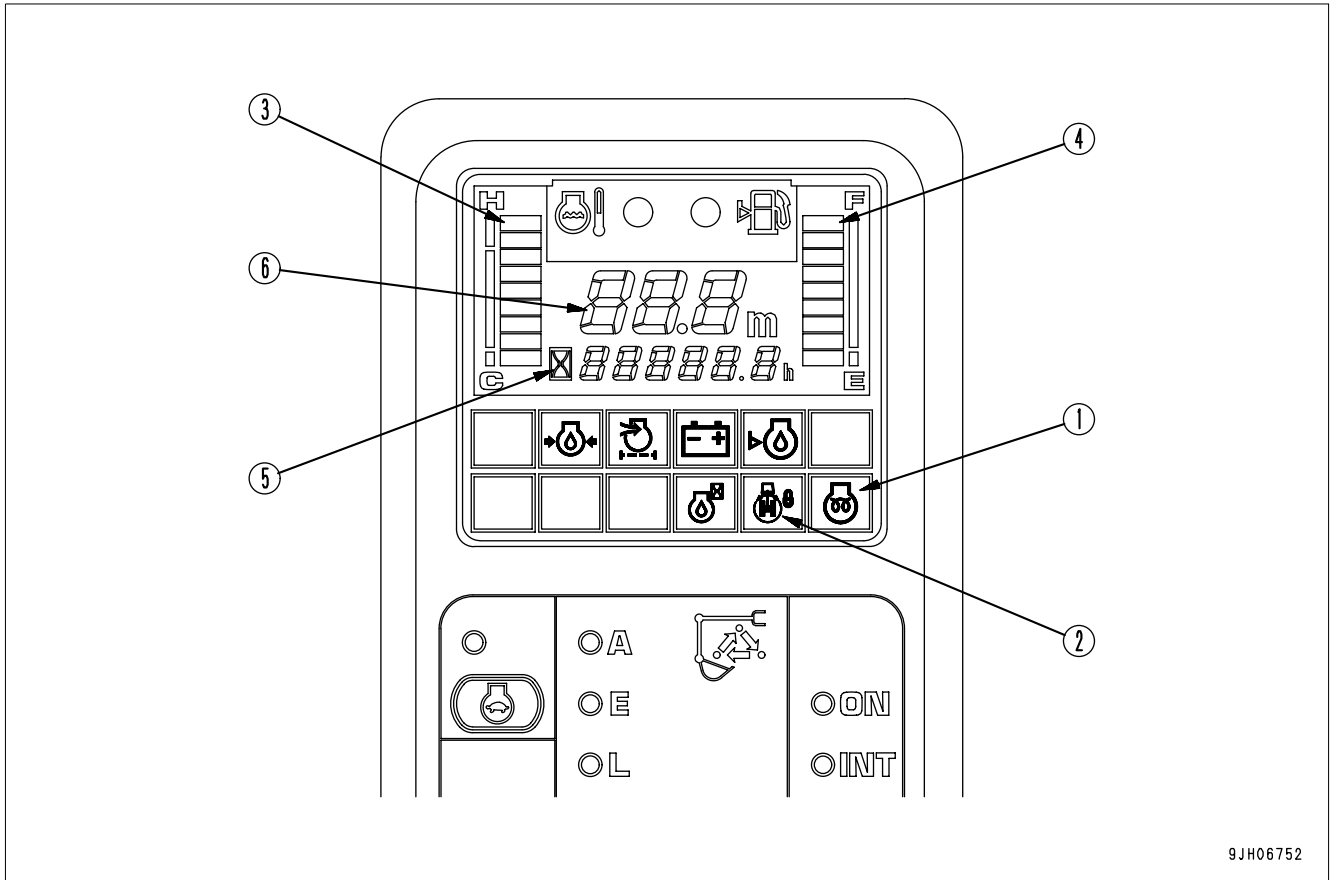

9JH06752

- D (1) Engine pre-heating monitor
- D (2) Swing lock monitor
- D (3) Engine coolant temperature gauge
- D (4) Fuel gauge
- D (5) Service meter
- D (6) Display

Pilot Display

When ignition switch is ON, the pilot display lights up when display items are functioning.

Engine Pre-heating Monitor

This monitor (1) indicates the pre-heating time required when starting the engine at an ambient temperature below 0°C.

The monitor lamp lights up when the engine starting switch is turned to the HEAT position and begins to flash after about 30 seconds to show that the pre-heating is completed. (The monitor lamp will go off after about 10 seconds)

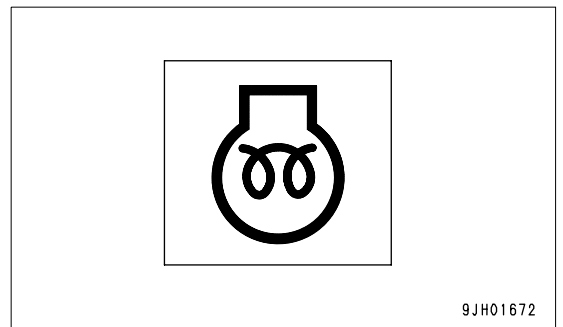

9JH01672

Swing Lock Monitor

This monitor (2) informs the operator that the swing lock is being actuated.

Actuated: Lights up

When the swing lock switch is turned ON (ACTUATED), the monitor lamp lights up.

When the swing holding brake release switch is turned on, this monitor lamp flashes.

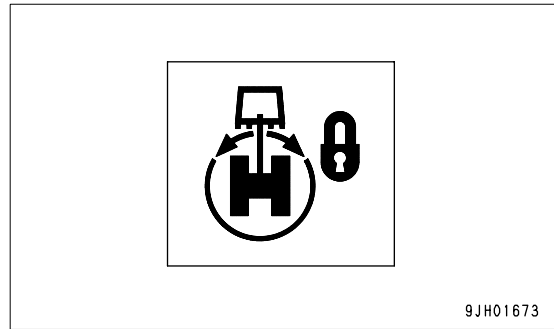

REMARK

The swing motor is equipped with a disc brake that mechanically stops the rotation. When the swing lock monitor lamp is lighted up, the brake remains applied.

Gauges and Meter

Engine Coolant Temperature Gauge

This gauge (3) indicates the engine cooling water temperature.

If the temperature is normal during operation, the green range will light up.

If the red range lights up during operation, the overheat prevention system will be actuated.

The overheat prevention system acts as follows.

Red range (A) lights up: Engine water temperature monitor lamp (C) flashes.

Red range (B) lights up: Engine speed drops to low idling, engine water temperature monitor lamp (C) flashes, and alarm buzzer sounds at same time.

The overheat prevention system works until the temperature enters the green range.

When red range (A) has lighted up, if the fuel control dial is set to low idling after the engine water temperature drops, the display is canceled.

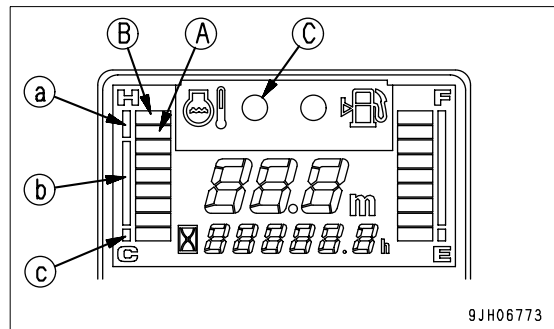

(a): Red range

(b): Green range

(c): White range

Fuel Gauge

This meter (4) shows the amount of fuel in the fuel tank.

The green range should light up during operations.

If only the red range lights up during operations, there is less than 46 liters of fuel remaining, so check and add fuel.

Red range (A) lights up: Fuel gauge monitor lamp (B) flashes.

After the starting switch is turned to the ON position, the correct level is not displayed for a short time, but this does not indicate any abnormality.

When the engine is stopped, turn the starting switch ON and check that each item and the meters light up.

(a): Red range

(b): Green range

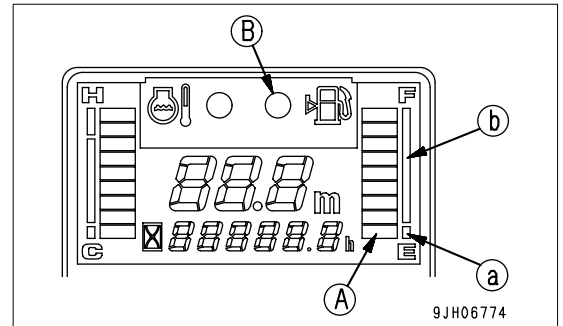

Service Meter

This monitor (5) displays the total amount of time that the machine has been operated.

Use the time display to set the maintenance intervals. If the engine is running, even if the machine is not moving, the service meter advances. The service meter advances by 1 for every hour that the engine is running, regardless of the engine speed.

Display

This display (5) shows the service meter. If any abnormality occurs, (6) indicates the content of the failure.

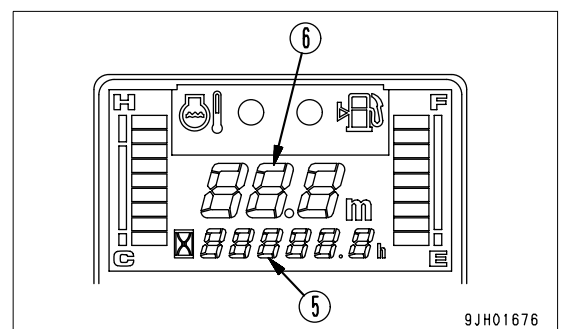
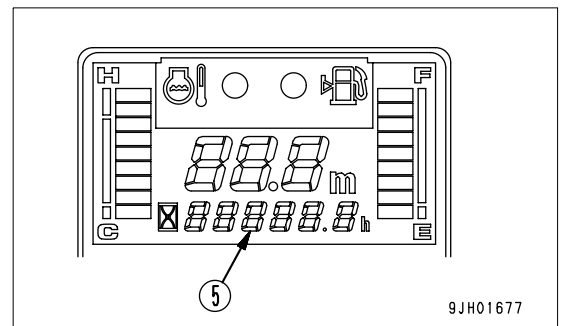

REMARK

If the machine has a fault, error information appears while the starting switch is ON. The monitor flashes and displays all error information sequentially.

Monitor display	Failure mode
E02	Error in pump control system
E03	Error in swing brake system
E05	Error in governor system
E06	Error in electrical system

If any of the above displays flashes, see “Electronic Control System (3-130)”.

Monitor Switches Portion

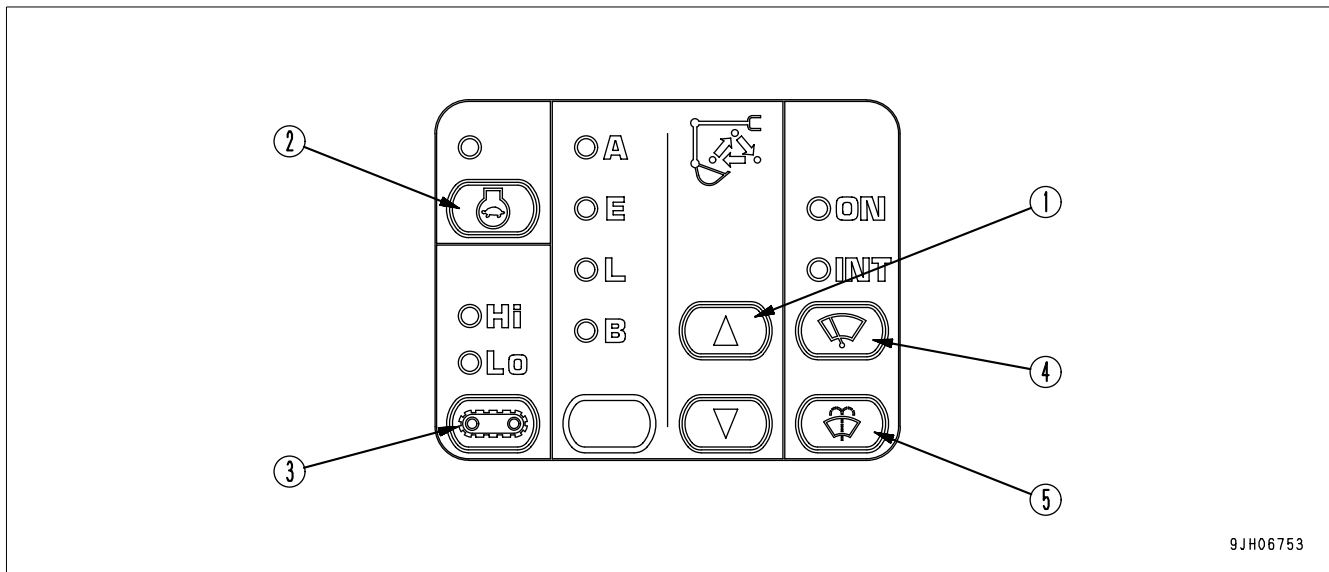

9JH06753

- E (1) Working mode selector switches (basic switches)
- E (2) Auto-deceleration switch (selection switch)
- E (3) Travel speed selector switch
- E (4) Wiper switch
- E (5) Window washer switch

Working Mode Selector Switch (Basic Switch)

This switch (1) is used to set the movement and force of the work equipment. Selecting the mode to match the type of operation makes operations easier.

A lights up: Heavy-duty operations

E lights up: Operations emphasizing economy in fuel consumption

L lights up: Fine control operations (when positioning work equipment exactly)

B lights up: Breaker operations

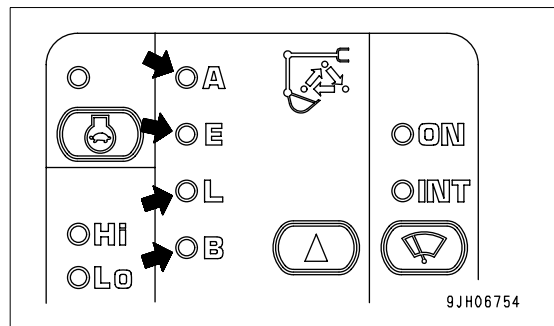

9JH06754

- q When the engine is started, the mode is set by default to A mode. Each time the switch is pressed, the next mode is selected.
- q If it is desired to have the working mode set to start automatically in E, L, or B mode (default options setting), please ask your Komatsu distributor to change the setting.

NOTICE

Do not use A mode when using a breaker. Otherwise the breaker will likely be damaged.

Auto-deceleration Switch (Selection Switch)

This switch (2) acts to activate the function that automatically lowers the engine speed and reduces fuel consumption when the control levers are at neutral.

Auto-deceleration lights up: Auto-deceleration is actuated

Auto-deceleration goes out: Auto-deceleration is canceled

Each time the switch is pressed, the auto-deceleration is actuated or canceled.

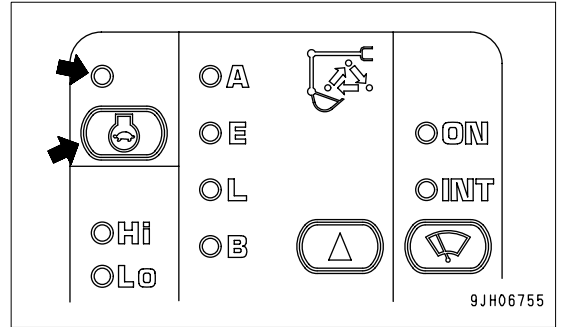

Travel Speed Selector Switch

⚠ WARNING

- q When loading on or unloading from a trailer, always travel at low speed (with the travel speed selector switch put at the Lo position). Never operate the travel speed selector switch during the loading or unloading operation.
- q If the travel speed is switched between Hi and Lo when the machine is traveling, the machine may deviate to one side, even when traveling in a straight line. Stop the machine before switching the travel speed.

This switch (3) is used to switch the travel speed between two levels (high and low).

Lo lights up: Low speed

Hi lights up: High speed

When the engine is started, the speed is automatically set to Lo.

When traveling in Hi, if more travel power is needed, such as on soft ground or traveling uphill, the transmission automatically switches to low speed (Lo), so there is no need to operate the switch. The monitor display stays at Hi.

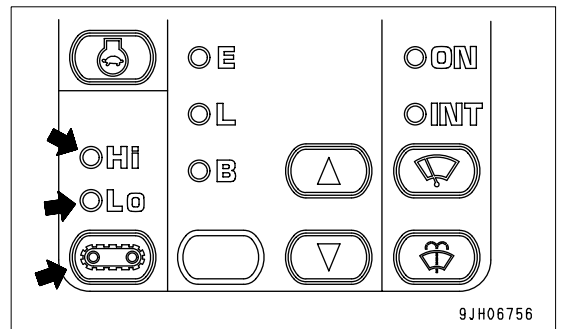

Wiper Switch

This switch (4) actuates the front window wiper.

ON lights up: The wiper works continuously.

INT lights up: The wiper works intermittently.

OFF: The wiper stops.

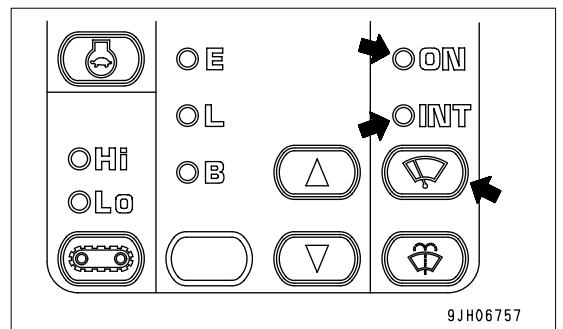

Window Washer Switch

This switch (5) is kept continuously pressed, window washer fluid is sprayed out on the front glass. When the switch is released, the spray stops.

- q If switch (5) is kept pressed when the wiper is stopped, the window washer fluid will spray out, and at the same time, the wiper will be actuated continuously. When switch (5) is released, the wiper will continue to operate for 2 cycles, then stop.
- q If the wiper is moving intermittently and switch (5) is kept pressed, window washer fluid will spray out, and at the same time, the wiper will be actuated continuously. When switch (5) is released, the wiper will continue to operate for 2 cycles, then return to intermittent operation.

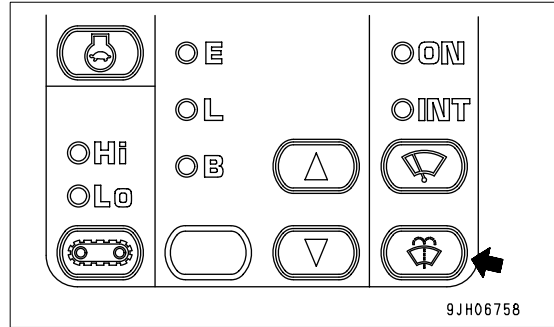

SWITCHES

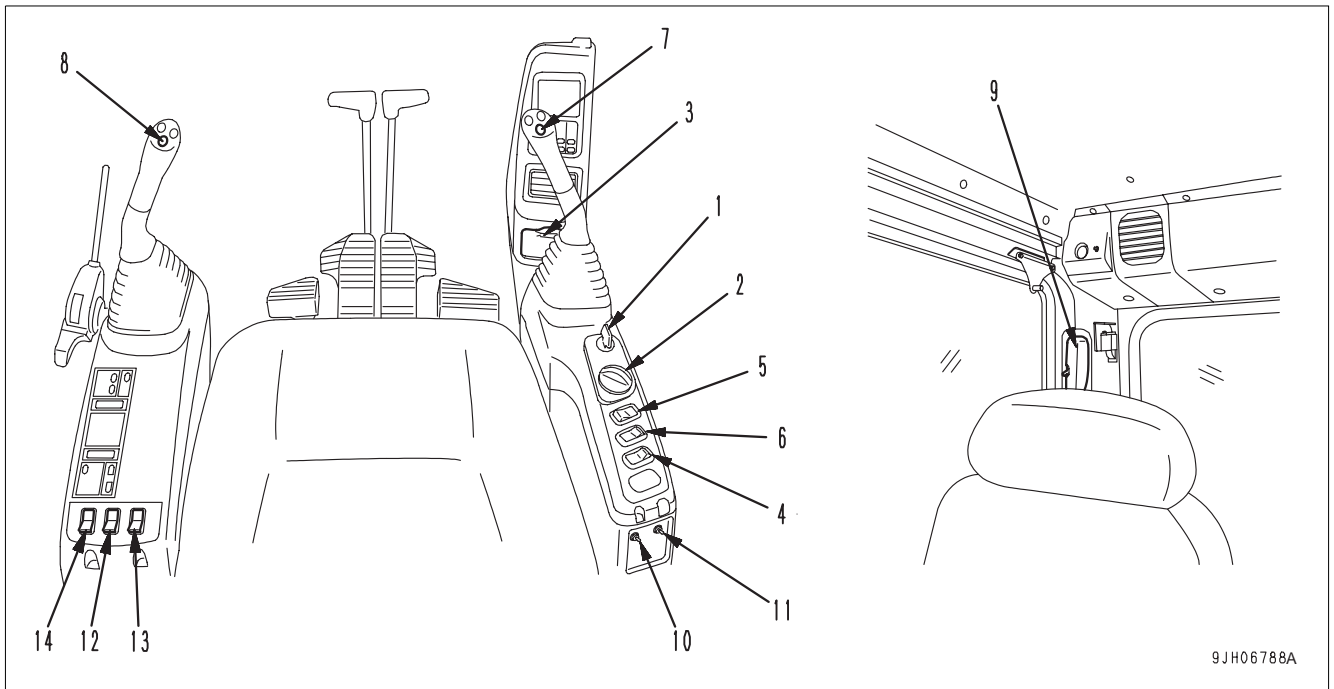

- | | |
|------------------------------|------------------------------------------------|
| (1) Starting switch | (8) Knob switch |
| (2) Fuel control dial | (9) Room lamp switch |
| (3) Cigarette lighter | (10) Pump drive Emergency switch |
| (4) Swing lock switch | (11) Swing holding brake release switch |
| (5) Lamp switch | (12) Rotating lamp switch (if equipped) |
| (6) Alarm buzzer stop switch | (13) Heated operator seat switch (if equipped) |
| (7) Horn switch | (14) Lower wiper switch (if equipped) |

Starting Switch

This switch (1) is used to start or stop the engine.

(A): OFF position

The key can be inserted or withdrawn. The switches for the electric system except the room lamp, are all turned off and the engine is stopped.

(B): ON position

Electric current flows in the charging and lamp circuits. Keep the starting switch key at the ON position while the engine is running.

(C): START position

This is the engine-start position. Keep the key at this position during cranking. Immediately after starting the engine, release the key. It will automatically return to the ON position (B).

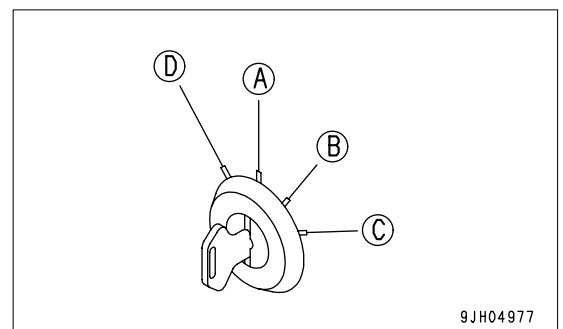

(D): HEAT position

Set to this position when starting the engine in cold weather.

When the key is set to HEAT position (D), the preheating monitor lights up. Keep the key at the HEAT position until the preheating monitor flashes. When the preheating monitor flashes, release the key immediately. (The flashing will stop after approx. 10 seconds.) When the key is released, it will return to OFF position (A), so turn it immediately to START position (C) and start the engine.

Fuel Control Dial

This dial (2) adjusts the engine speed and output.

- (a) Low idling (MIN): Turned fully to the left
- (b) Full speed (MAX): Turned fully to the right

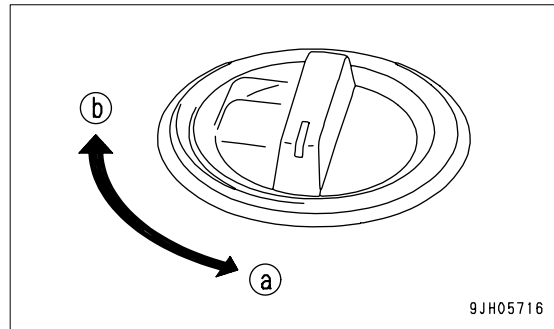

Cigarette Lighter

This switch (3) is used to light cigarettes. To use, push the lighter in. After a few seconds it will spring back.

Pull out the lighter and light your cigarette.

By removing the cigarette lighter, the socket is available as a power source for the yellow flashing lamp. Max. current is 3.5 A (85 W).

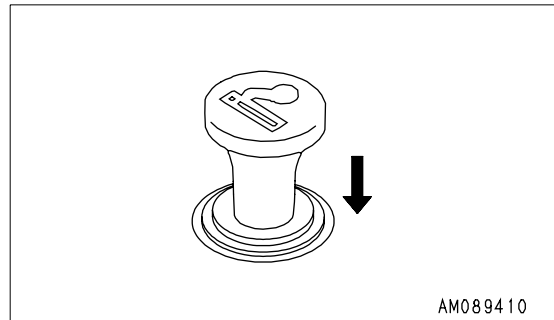

Swing Lock Switch

! WARNING

- q When not using the swing operation, e.g. in traveling, put the swing lock switch to the OFF position.
- q On slopes, even when the swing lock switch is at the ON position, the weight of the work equipment may cause the upper structure to swing if the swing control lever is operated in the downhill direction.

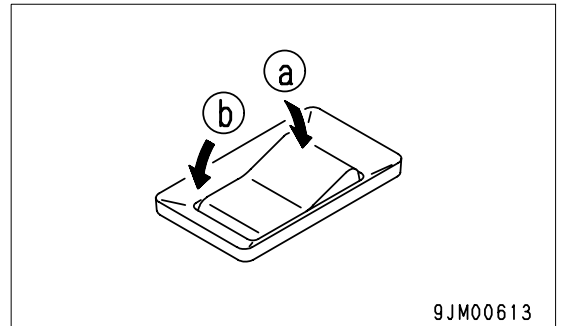

Switch (4) is used to lock the upper structure so it will not swing.

(a) ON position: The swing lock is always applied, and the upper structure will not swing even if the swing is operated. In this condition, the swing lock lamp lights up.

(b) OFF position: The swing lock is applied only when the swing control lever is in the neutral position, and released when operating the swing control lever. The swing lock is actuated in 7 seconds after putting the swing control lever in the neutral position.

Lamp Switch

This switch (5) is used to light up the front lamps, working lamp, additional lamp at the top front of the cab, rear lamp, and monitor lighting.

- (a) ON: Lamps light up
- (b) OFF: Lamps go off

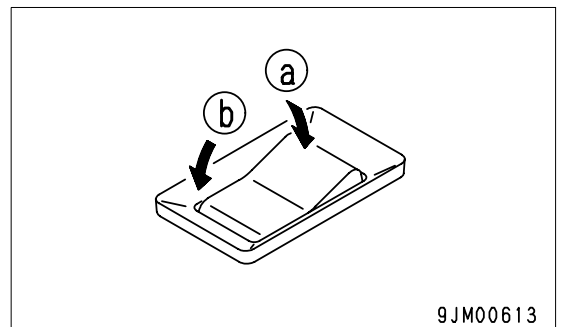

Alarm Buzzer Stop Switch

This switch (6) is used (when the engine is running) to stop the alarm buzzer when it has sounded to warn of an abnormality in a warning item.

REMARK

This switch (6) is an automatic return switch. For this reason, if the switch is pressed to the ON in position (a) and released, it will return to stop position (b), but this is not an abnormality.

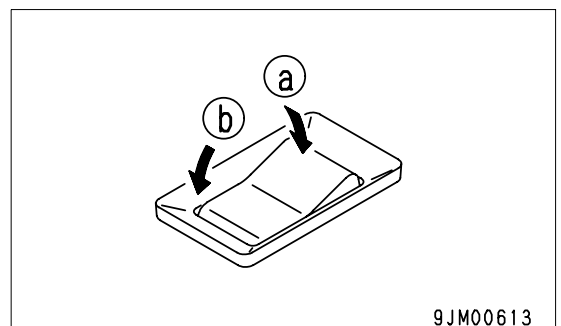

Horn Switch

When the button (7) at the tip of the right work equipment control lever is pressed, the horn will sound.

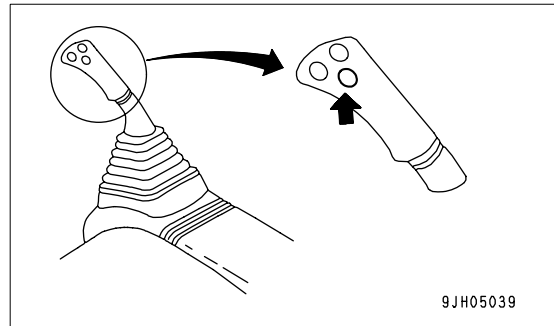

Knob Switch

Use knob switch (8) on the left work equipment control lever to activate the one-touch power max./slow-down function.

Press the switch and keep it pressed until the power max. function is canceled.

In A mode or E mode, the power max. function is actuated for a maximum of 8.5 seconds.

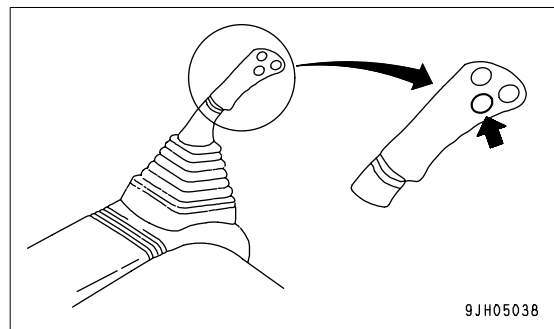

Room Lamp Switch

NOTICE

It is possible to turn on the room lamp even when the starting switch is at the OFF position, so be careful not to forget to turn it off.

Use this switch (9) to light up the room lamp.

Position (a) ON: Lights up

Position (b) OFF: Goes out

The room lamp lights up even when the starting switch is at the OFF position.

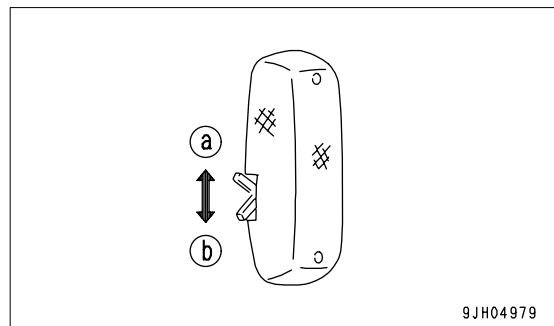

Pump Drive Emergency Switch

NOTICE

The emergency pump driving switch is provided to make it possible to carry out work for a short time when there is a failure in pump control system. It is necessary to repair the abnormal location as soon as possible.

This switch (10) is used when there is an abnormality in the pump control system (when the display shows "E02"). It makes it possible to carry out operations for a short time.

- (a) When there is abnormality: Move switch up
- (b) When condition is normal: Move switch down
- If the display shows "E02", move this switch up to make it possible to carry out operations.

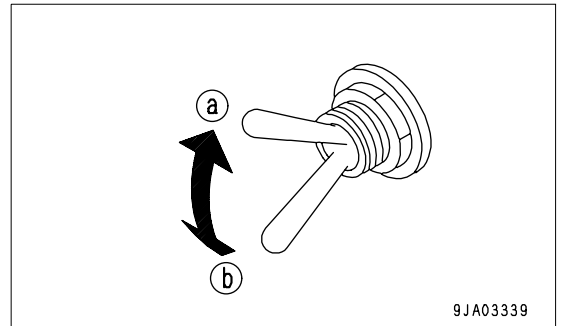

Swing Holding Brake Release Switch

NOTICE

This switch makes it possible to carry out swing operations for a short time even when there is an abnormality in the swing brake system. Do not use this switch except in emergencies. Repair the abnormality as soon as possible.

This switch (11) is used when there is an abnormality in the swing holding brake system (when the display shows "E03"). It makes it possible to carry out swing operations for a short time.

- (a) When there is abnormality: Move switch up
- (b) When condition is normal: Leave switch down
- If the display shows "E03", move this switch up to make it possible to carry out swing operations.

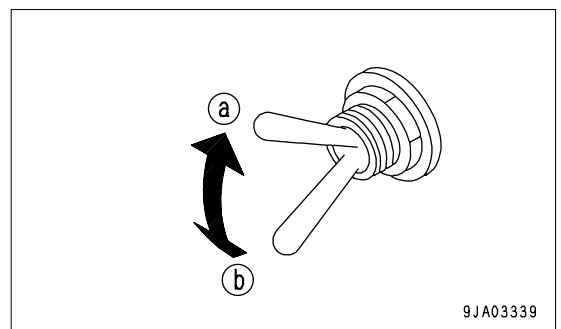

Rotating Lamp Switch (If Equipped)

This switch (12) is used to light up the yellow rotating lamp on top of the cab.

- (a) ON: Lamps light up
- (b) OFF: Lamps go off

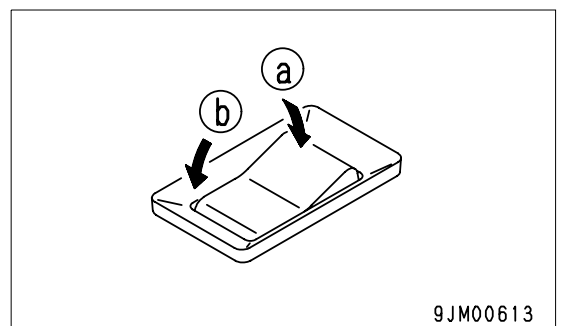

Heated operator seat switch

(if equipped)

This switch (13) is used to switch on the heated seat.

(a) ON: seat heated

(b) OFF: seat not heated

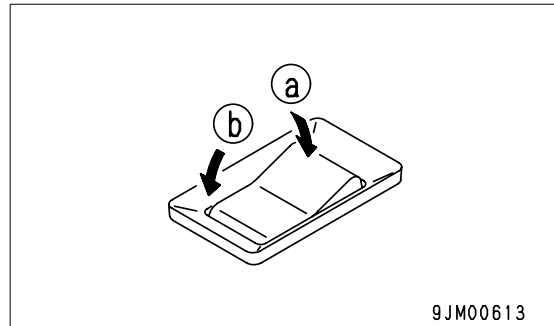

9JM00613

Lower Wiper Switch

(if equipped)

This switch (14) activates the front lower wiper.

(a) ON: wiper moves continuously

(b) OFF: wiper stops

NB. Do not operate with front lower screen removed.

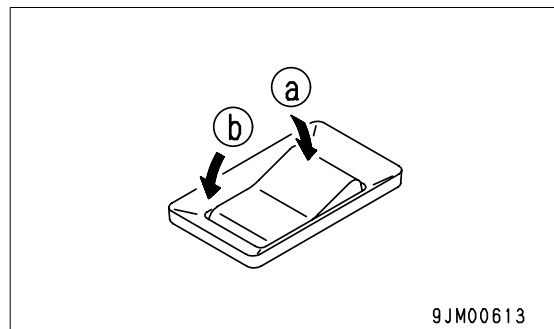

9JM00613

CONTROL LEVERS AND PEDALS

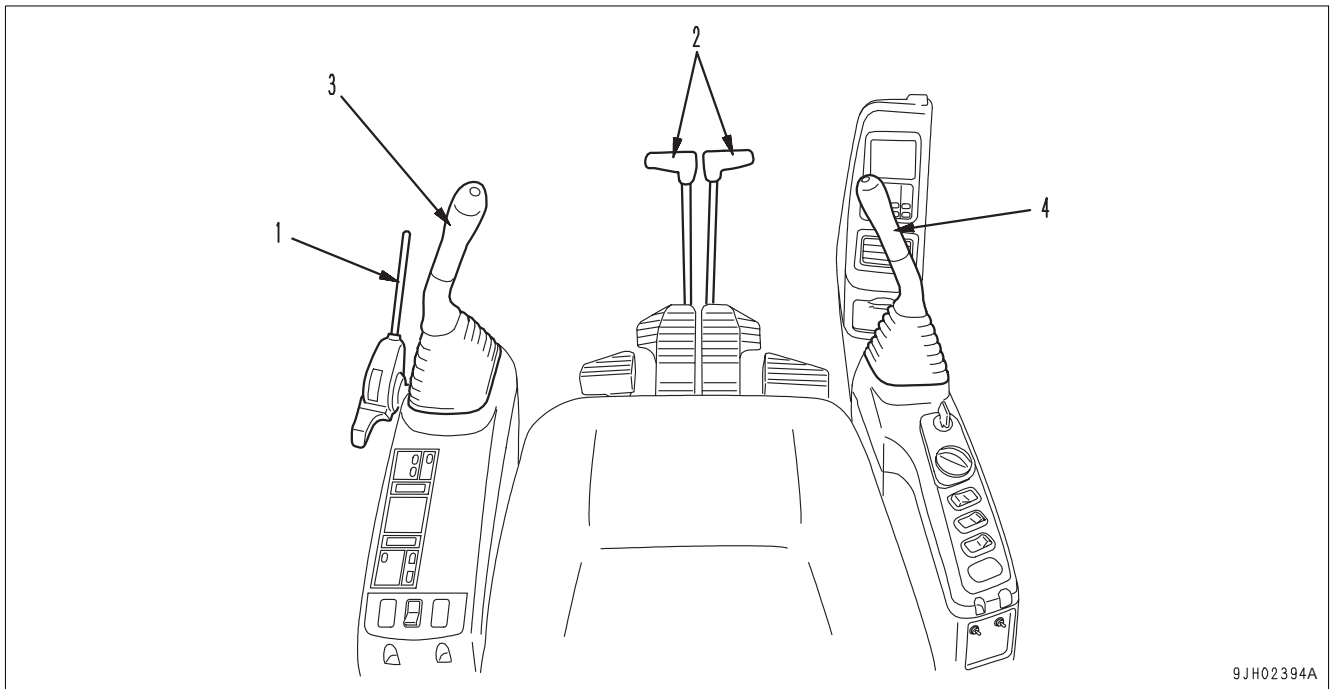

9JH02394A

- | | |
|------------------------------------------------------------------|---------------------------------------------------------------------------|
| (1) Safety lock lever | (3) Left work equipment control lever
(with auto-deceleration system) |
| (2) Travel levers
(with a pedal and auto-deceleration system) | (4) Right work equipment control lever
(with auto-deceleration system) |

Safety Lock Lever

 **WARNING**

- q When leaving the operator's compartment, set the safety lock lever (1) securely to the LOCK position (L). If the safety lock lever is not at the LOCK position (L) and the control levers are touched by mistake, it may lead to serious personal injury.
- q Check that the condition of the lever (1) is as shown in the diagram.
- q When pulling or pushing the safety lock (1) lever up, be careful not to touch the work equipment control lever.

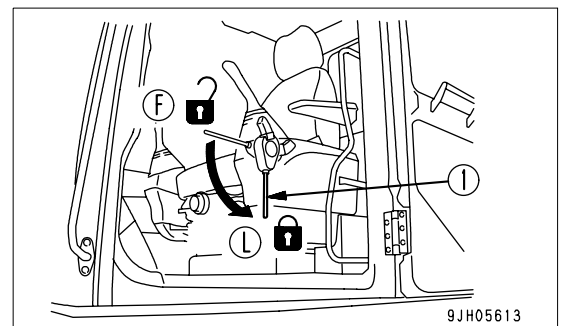

9JH05613

This lever (1) is a device to lock the work equipment, swing, travel, and attachment (if equipped) control levers.

Push the lever (1) down to apply the lock.

This lock lever is a hydraulic lock, so even if it is in the lock position (L), the work equipment control lever and travel lever will move, but the work equipment, travel motor, and swing motor will not work.

Travel Levers

⚠ WARNING

- q Do not rest your foot on the pedal during operations. If the pedal is depressed by mistake, the machine may suddenly move and cause a serious accident. Be extremely careful when operating the pedal for travel or steering operations. When you are not using the pedal, do not rest your foot on it.
- q If the track frame is facing the rear, the direction of travel operations will be reversed when the travel lever is operated. (The machine will travel forward when operated in reverse, and in reverse when operated forward; the left and right directions will also be reversed.)
- q When operating the travel levers, check if the track frame is facing the front or the rear. (If the sprocket is at the rear, the track frame is facing the front.)

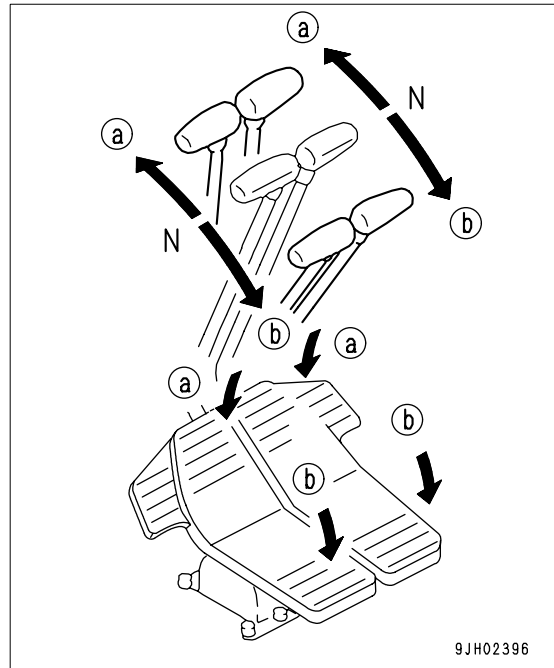

Lever (2) is used to change the direction of travel between forward and reverse. () shows the pedal operation.

(a) FORWARD: The lever is pushed forward

(The pedal is angled forward)

(b) REVERSE: The lever is pulled back

(The pedal is angled back)

N (Neutral): The machine stops

REMARK

Machines equipped with travel alarm (If equipped)

If the lever is shifted to the advance or reverse position from the neutral position, the alarm sounds to warn that the machine is starting to advance.

Work Equipment Control Lever

This Left work equipment control lever (3) is used to operate the arm and upper structure.

Arm operation

- (a) Arm OUT
- (b) Arm IN

Swing operation

- (c) Swing to right
- (d) Swing to left

N (Neutral) : The upper structure and arm are held in position and do not move.

This Right work equipment control lever (4) is used to operate the boom and bucket.

Boom operation

- (a) RAISE
- (b) LOWER

Bucket operation

- (c) DUMP
- (d) CURL

N (Neutral) : The boom and bucket are held in position and do not move.

REMARK

The engine speed for all control levers (travel, work equipment, attachment) is changed as follows by the auto-deceleration mechanism.

- q When the travel lever and work equipment control levers are at the neutral position, even if the fuel control dial is above midrange speed, the engine speed will go down to a midrange speed. If one of these levers is operated, the engine speed will rise to the speed set by the fuel control dial.
- q If all the control levers are at the neutral position, the engine speed goes down approx. 100 rpm, then after approx. 4 seconds, the engine speed goes down to the deceleration speed (approx. 1400 rpm).

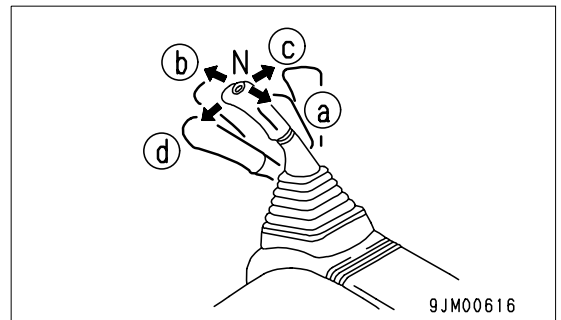
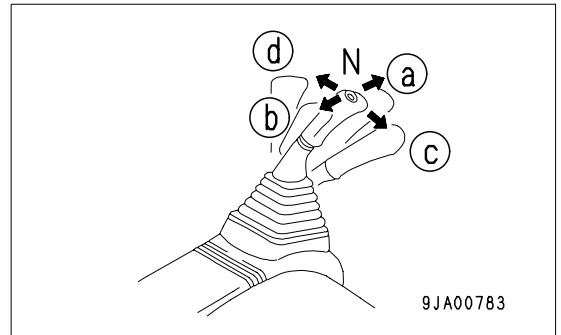

SUN ROOF

WARNING

When leaving the operator's seat, set the safety lock lever securely to the LOCK position (L).

If the safety lock lever (1) is at the FREE position (F) and the control lever is touched by mistake, this may lead to a serious accident.

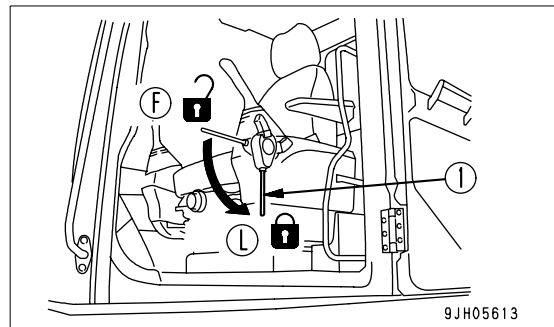

Opening

1. Set safety lock lever (1) securely to the LOCK position.
2. Check for any ceiling window movement by pulling lock knob (A) located on front side, then push up and open the ceiling window grasping grip (B).

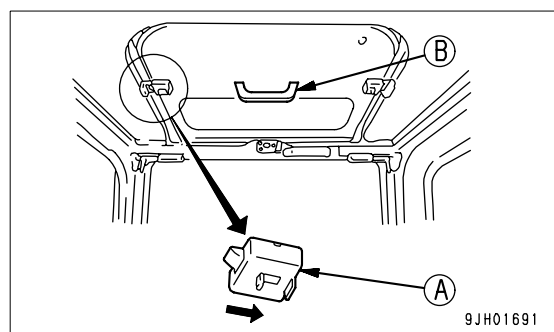

Closing

Grip handle (B), then lower the sun roof and apply lock (A). If the lock does not click into position, open the sun roof and pull it down again.

WINDSHIELD

WARNING

q When opening or closing the front window, bottom window, or door, always set the safety lock lever (1) to the LOCK position (L).

If the control levers are not locked and they are touched by accident, this may lead to a serious accident.

q When opening or closing the window at the front of the cab, stop the machine on horizontal ground, lower the work equipment completely to the ground, stop the engine, then carry out the operation.

q When opening the front window, hold the grip securely with both hands, pull up, and do not let go until the automatic lock catch is locked.

q When closing the front window, the window will move quicker under its own weight. Hold the grips securely with both hands when closing it.

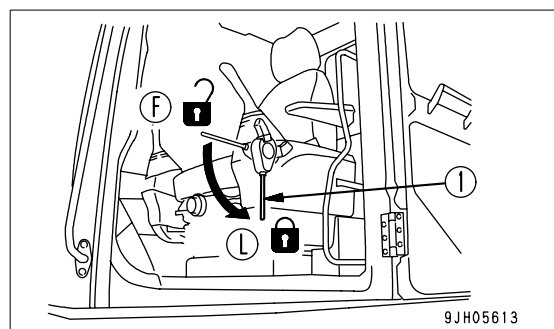

It is possible to stow (pull up) the front window in the roof of the operator's compartment.

Opening

1. Stop the machine on level ground, lower the work equipment completely to the ground, then stop the engine.
2. Set the safety lock lever securely to the LOCK position (L).

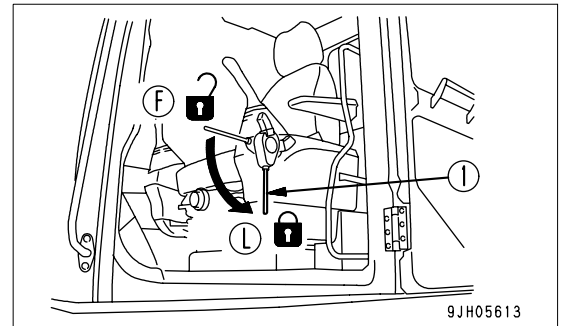

3. Check that the wiper blade is stowed in the right stay.

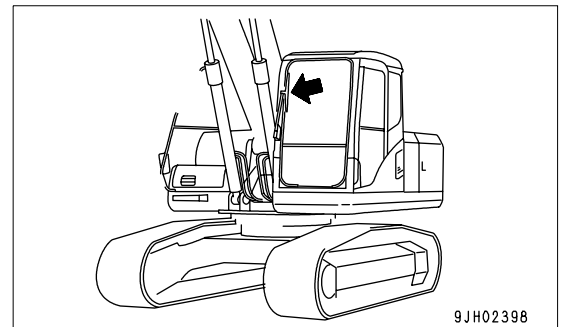

4. Grip handles (A) at the top right and left of the front window, and pull lock lever (B) toward yourself to release the lock at the top of the front window. The top of the front window will come out.

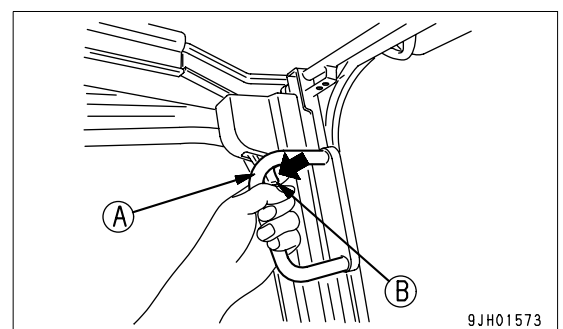
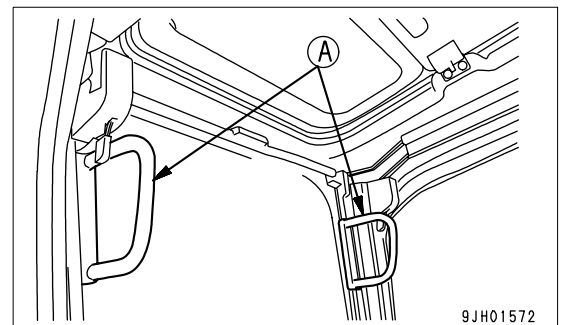

5. Hold lower knob (C) with your left hand from inside the operator's cab, and with your right hand, grip top knob (D), pull it up, and push it against lock catch (E) at the rear of the cab securely to lock the window.

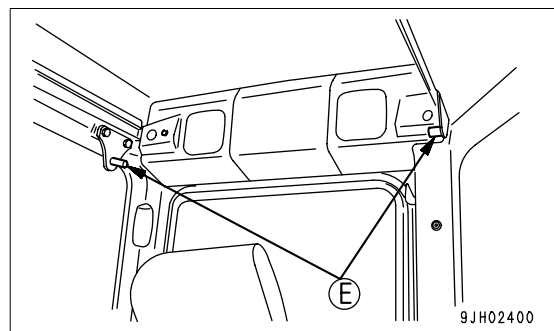
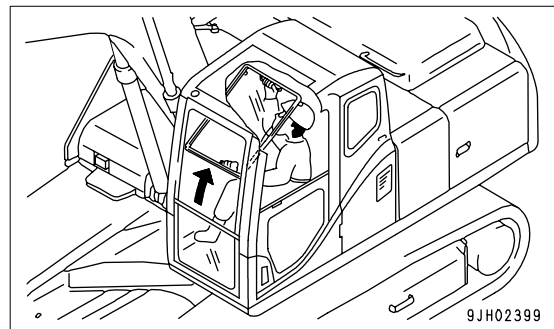
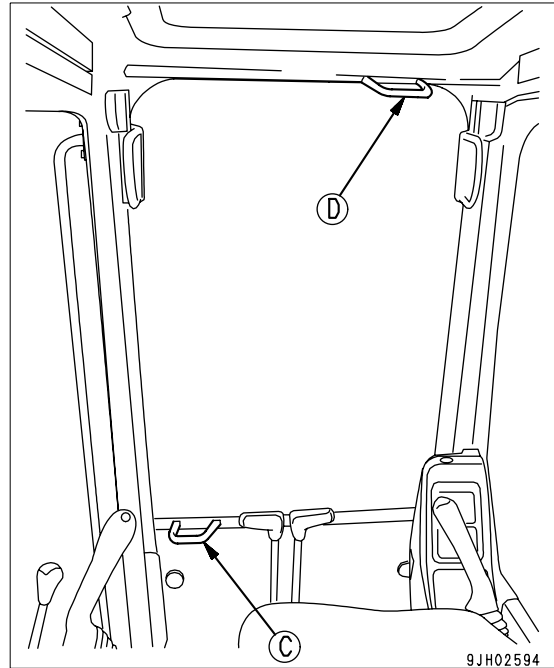

6. Check that lock lever (B) is securely at the LOCK position.
 - q The lock is engaged if the arrow on lock case (F) matches the position of the arrow on lock lever (B). Check visually.
 - q If the arrow on lock case (F) does not match the position of the arrow on lock lever (B), the lock is not engaged. Repeat the operation in Step 5 to engage the lock.

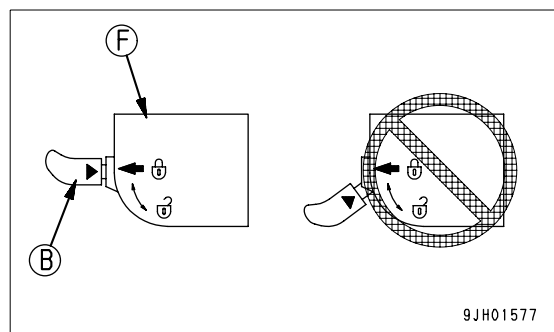

Closing

 **WARNING**

When closing the window, lower it slowly and be careful not to get your hand caught.

1. Stop the machine on level ground, lower the work equipment completely to the ground, then stop the engine.
2. Set the safety lock lever securely to the LOCK position (L).

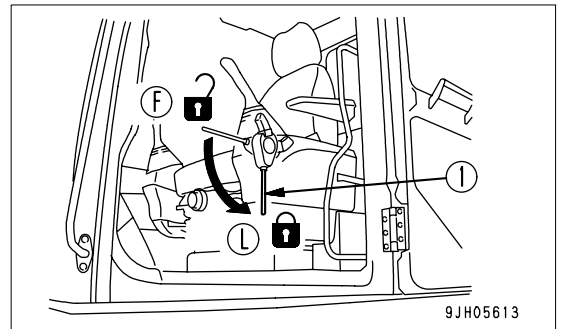

3. Grip left and right handles (A), and pull down lock lever (B) to release the lock.

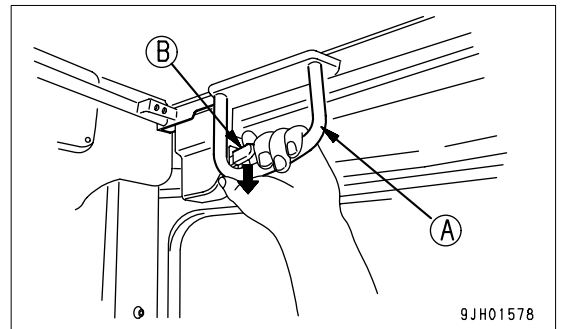

4. Grip handle (C) at the bottom of the front window with your left hand and handle (D) at the top with your right hand, push to the front, then lower slowly.

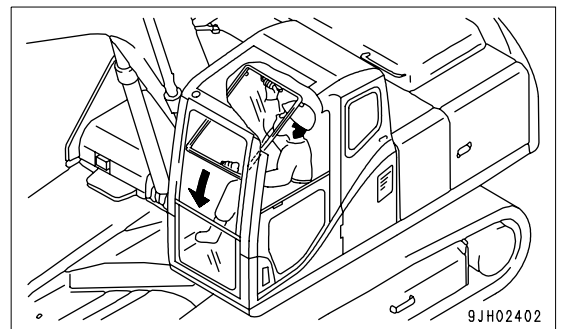
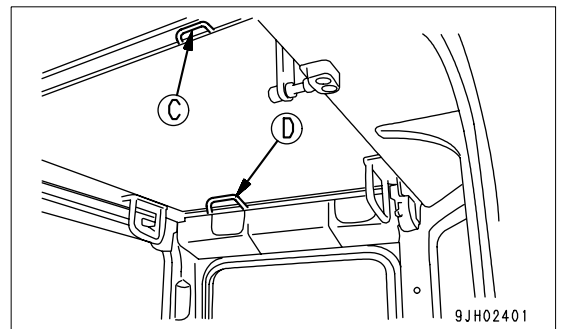

5. When the bottom of the window reaches the top of the bottom window, push the top of the window to the front to push it against left and right lock catches (G) and engage the lock.

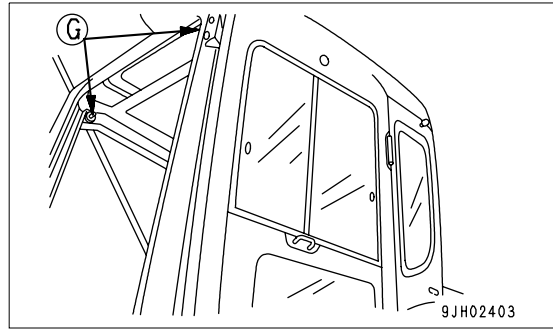

6. Check that lock lever (B) is securely at the LOCK position.
 - q The lock is engaged if the arrow on lock case (F) matches the position of the arrow on lock lever (B). Check visually.
 - q If the arrow on lock case (F) does not match the position of the arrow on lock lever (B), the lock is not engaged. Repeat the operation in Step 5 to engage the lock.

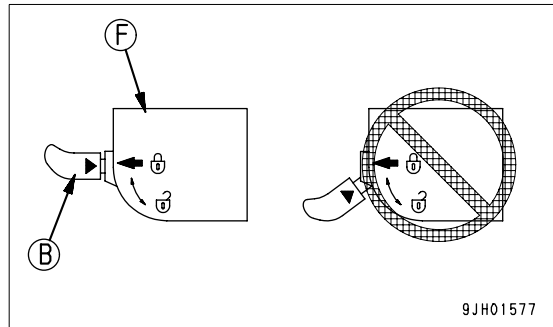

Removing Lower Windshield

1. Open the front window, then hold grip (A), pull up, and remove the bottom window.

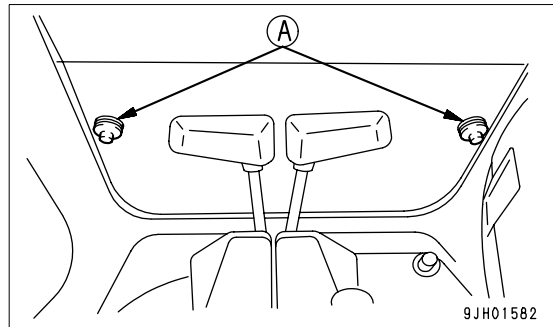

2. After removing the bottom window, store it at the rear of the operator's cab and lock it securely with left and right locks (B).

- q When removing, always hold the glass with one hand and release the lock with the other hand.

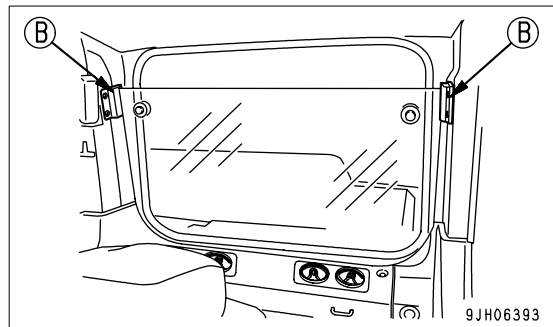

EMERGENCY EXIT FROM OPERATOR'S CAB

- q If for some reason, the cab door does not open, remove the rear window and use it as an emergency escape.
- q Remove the rear window as follows.
 1. Pull ring (1) and completely remove seal (2) from the rubber core.

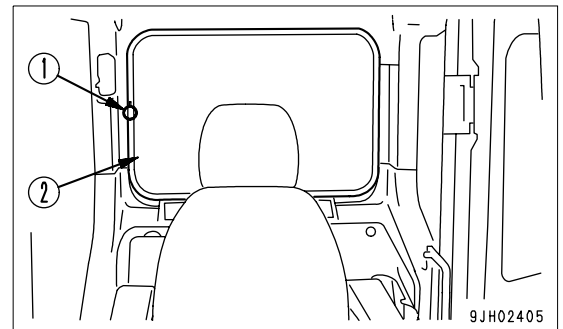

2. When the corner of the front window glass is pushed strongly, it can be removed to the outside.
 - q Do not remove the rear window except when using it as an emergency exit.

DOOR LOCK

WARNING

- q Before releasing the door lock, always stop the machine on flat ground.
- q Never release the door lock on a slope. The door may suddenly close and cause injury.
- q When releasing the door lock, do not extend your body or hands outside the machine and do not put your hands on the door frame. The door may suddenly close and cause injury.

Use the door lock to fix the door in position after opening it.

1. Push the door against catch (1) to lock it in position.
2. When closing the door, push down the lever (2) on the left of the operator's seat to release the catch.
3. When attaching the door in position, lock it firmly to the catch.

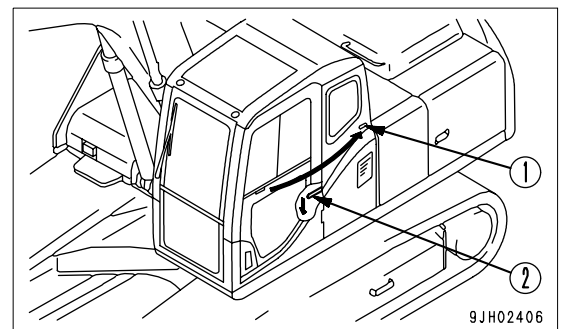

CAP WITH LOCK

Use the starting key to open and close the locks on the caps and covers.

For details of the locations of the caps and covers with locks, see "LOCKING (3-104)".

Insert the key as far as it will go to the shoulder. If the key is turned before it is inserted all the way, it may break.

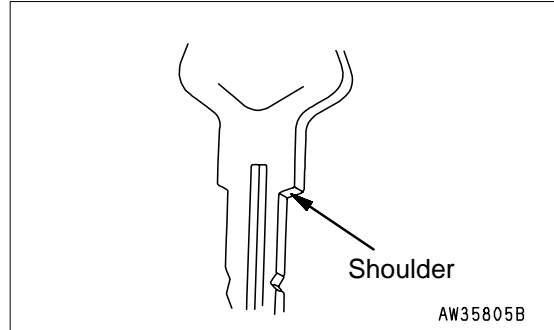

Opening and Closing Caps with Lock

Opening the Cap

1. Insert the key into the key slot.
2. Turn the key clockwise (counterclockwise for type B), align the key groove with counter mark (3) on the cap, then open the cap.

(1): Open

(2): Lock

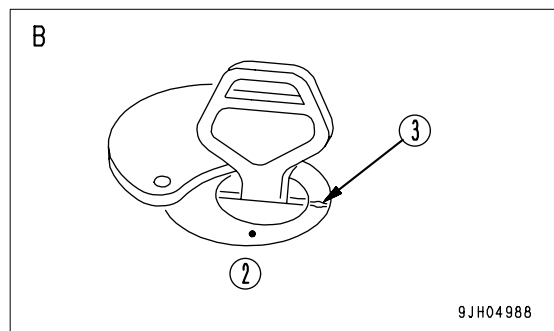
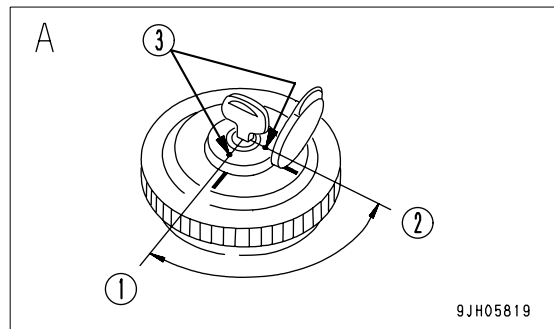

Locking the Cap

1. Turn the cap until tight, then insert the key into the key slot.
2. Turn the starting switch key counterclockwise (clockwise for the B type) and remove the key.

Opening and Closing Cover with Lock**Opening the Cover (Locked Cover)**

1. Insert the key into the key slot.
2. Turn the key counterclockwise and open the cover by pulling the cover grip.

(A): Open

(B): Lock

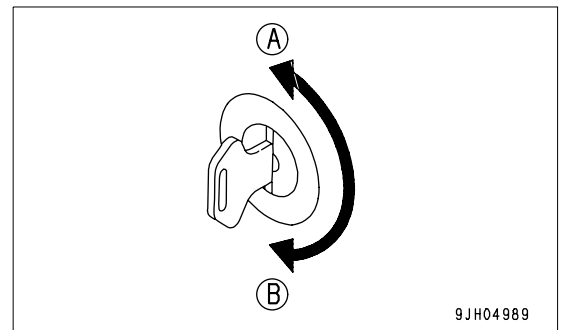
**Locking the Cover**

1. Close the cover and insert the key into the key slot.
2. Turn the key clockwise and take the key out.

HOT AND COOL BOX

This is on the right side at the rear of the operator's seat. It is interconnected with the air conditioner: it stays warm when the heating is used, and stays cool when the cooling is used.

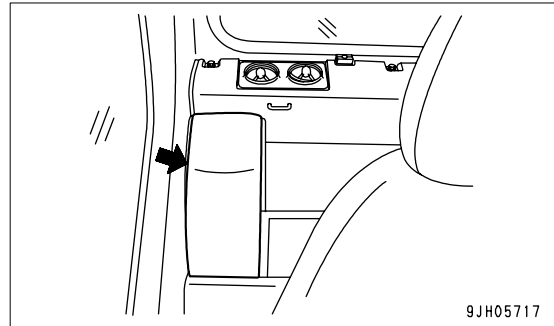

9JH05717

MAGAZINE BOX

(The cup holder is provided separately at the front of the magazine box.)

This is on the left side of the operator's seat.

Keep the Operation and Maintenance Manual in this box so that it can be taken out and read whenever necessary.

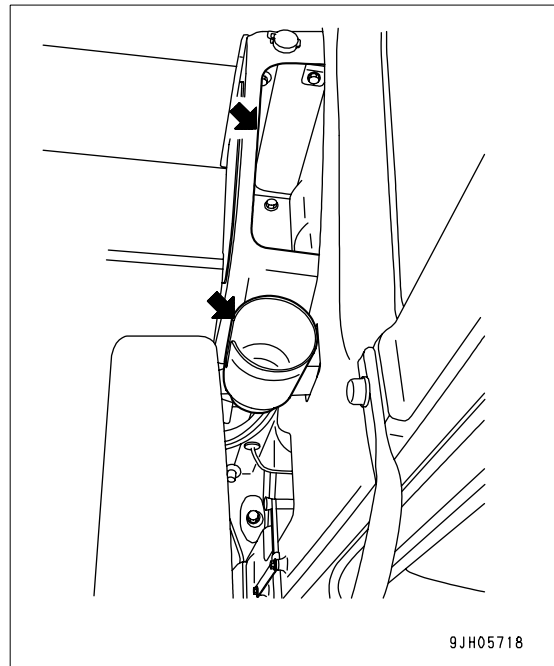

9JH05718

ASHTRAY

This is under the machine monitor at the front right of the operator's compartment.

Always make sure that you extinguish your cigarette, then put it in the ashtray and close the lid.

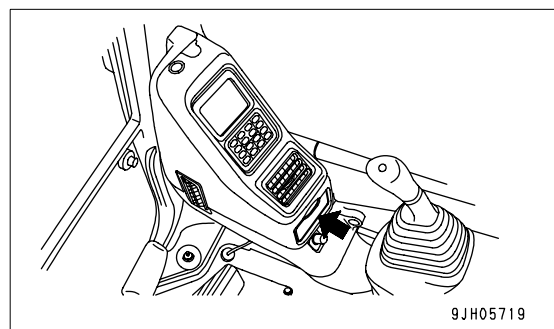

9JH05719

AIR CONDITIONER CONTROLS

Air Conditioner Control Panel

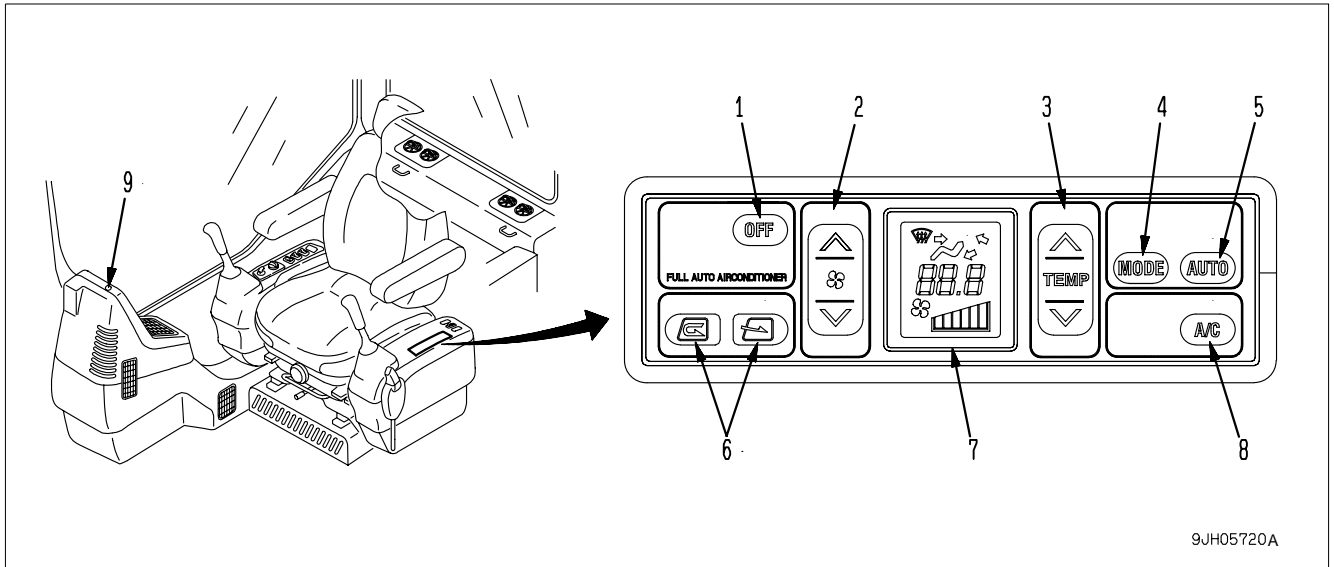

9JH05720A

- | | |
|--------------------------------|----------------------------------|
| (1) OFF switch | (6) FRESH/RECIRC selector switch |
| (2) Fan switch | (7) Display monitor |
| (3) Temperature control switch | (8) Air conditioner switch |
| (4) Vent selector switch | (9) Sunlight sensor |
| (5) Auto switch | |

OFF Switch

Switch (1) is used to stop the fan and air conditioner.

- q When OFF switch (1) is pressed, the set temperature and air flow displayed on monitor (7), the lamps above auto switch (5), and air conditioner (8) go out, and operation stops.

REMARK

When switch (1) is turned to the OFF position, the lamp above FRESH/RECIRC selector switch (6) does not go out, but this is not an abnormality.



9JH02411

Fan Switch

This switch (2) is used to adjust the air flow.

The air flow can be adjusted to six levels.

- q Press the ^ switch to increase the air flow; press the v switch to reduce the air flow.
- q During auto operation, the air flow is automatically adjusted.

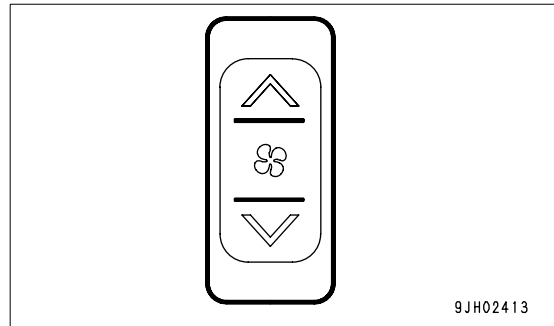

A: Liquid crystal display

B: Air flow

- a: Air flow "low"
- b: Air flow "medium 1"
- c: Air flow "medium 2"
- d: Air flow "medium 3"
- e: Air flow "medium 4"
- f: Air flow "high"

A	B
	a
	b
	c
	d
	e
	f

Temperature Control Switch

This switch (3) is used to control the temperature inside the cab. The temperature can be set between 18°C and 32°C.

- q Press the ^ switch to raise the set temperature; press the v switch to lower the set temperature.
- q The temperature is generally set at 25°C.
- q The temperature can be set in stages of 0.5°C.

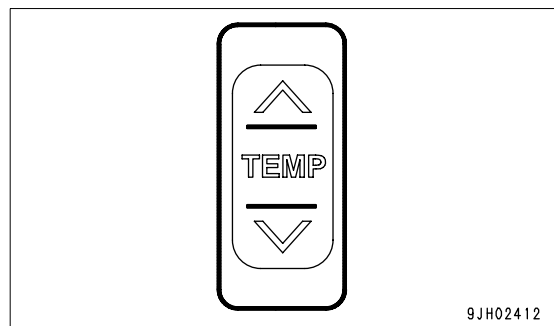

<Monitor display and the function>

Monitor display (°C)	Set temperature
18.0	Max. cooling
18.5 to 31.5	Adjusts temperature inside cab to set temperature
32.0	Max. heating

REMARK

If the mode is set to auto mode and the temperature setting is set to 18.0 °C and 32.0 °C, the air flow from the fan is always set to HIGH and does not change even when the set temperature is reached.

Vent Selector Switch

This switch (4) is used to select the vents.

- q When switch (4) is pressed, the display on monitor display (7) switches and air blows out from the vents displayed.
- q During automatic operation, the vents are automatically selected.

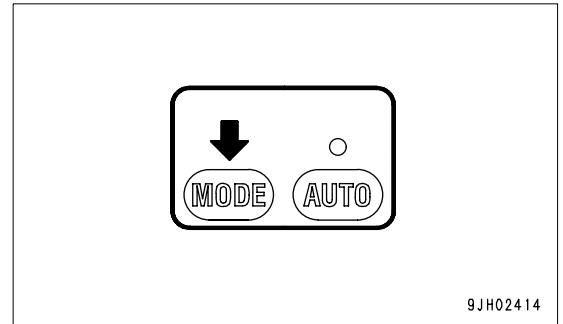

- (A): Rear vents (4 places)
- (B): Face vent (1 place)
- (C): Foot vent (1 place)
- (D1): Front window vent (1 place)
- (D2): Front window vent (1 place)

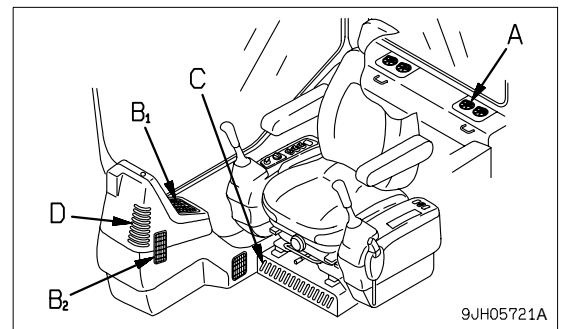

Liquid crystal display	Vent mode	Vent				Remarks
		(A)	(B)	(C)	(D)	
	Front and rear vents (including defroster vent)		○			Cannot be selected for automatic operation
	Front, rear and foot vents (including defroster vent)	○	○			-
	Foot vent		○	○		-
				○		
	Front , foot vents (including defroster vent)			○	○	Cannot be selected for automatic operation
	Front vents (including defroster vent)				○	Cannot be selected for automatic operation

Note 1: Air blows out from vents marked ○

Note 2: The defroster vents can be opened or closed manually with the vent lever.

Auto Switch

With this switch (5), the air flow, vents, and air source (RECIRC/FRESH) are automatically selected according to the set temperature.

- q When auto switch (5) is pressed, the lamp at the top of the auto switch lights up.
- q Normally, press this switch, then use temperature control switch (3) to set the temperature, and run the air conditioner under automatic control.
- q When the control is switched from automatic operation to manual operation, it is possible to operate the switch to change the air flow, vents, and air source (RECIRC/FRESH). When the manual control is used, the lamp at the top of the auto switch goes out.

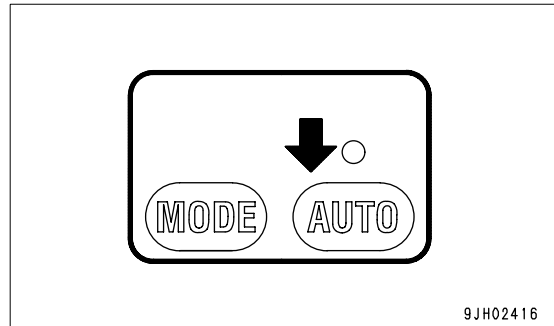

9JH02416

REMARK

When Auto Mode is selected, if the set temperature is set to 18.0 °C and 32.0 °C, the air flow is always set to High, but this is not an abnormality.

FRESH/RECIRC Selector Switch

This switch (6) is used to switch the air source between recirculation of the air inside the cab and intake of air from the outside.

- q When switch (6) is pressed, the lamp at the top of the selector switch lights up to show that air is being blown out.
- q During automatic operation, the selection of inside air (RECIRC) and outside air (FRESH) is carried out automatically.

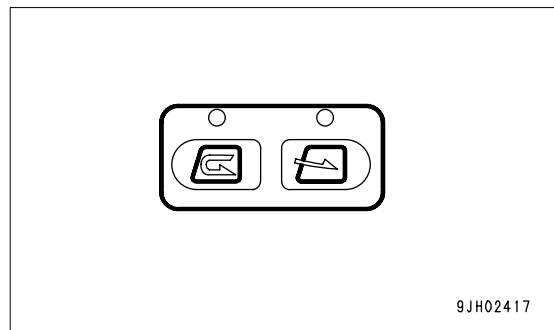

9JH02417

RECIRC	The outside air is shut off and only the air inside the cab is circulated. Use this position to carry out rapid cooling of the cab or when the outside air is dirty.
FRESH	Outside air is taken into the cab. Use this position to take in fresh air or when carrying out demisting.

Display Monitor

Monitor (7) displays the status of temperature setting (a), air flow (b), and vents (c).

- q When OFF switch (1) is pressed, the display of temperature setting (a) and air flow (b) goes out, and operation stops.

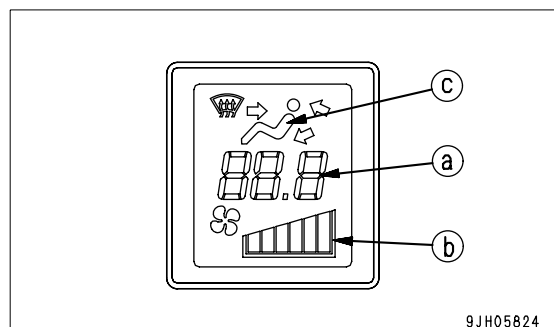

9JH05824

Air Conditioner Switch

This switch (8) is used to turn the air conditioner (cooling, dehumidifying, heating) ON or OFF.

- q When the fan is acutated (the display monitor shows (b)) and air conditioner switch (8) is pressed, the air conditioner is switched ON, the lamp at the top of the air conditioner switch lights up, and the air conditioner starts. When it is pressed again to the OFF position, the lamp at the top of the air conditioner switch goes out.
- q The air conditioner cannot be operated while the fan is stopped.

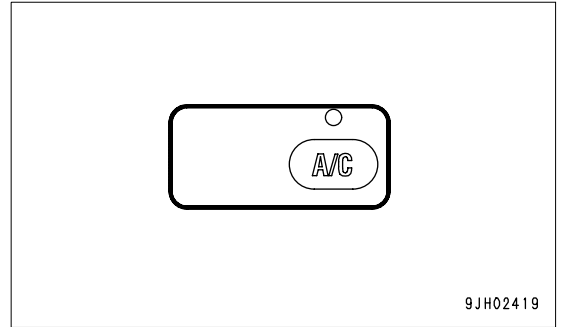

Sunlight Sensor

This sensor (9) automatically adjusts the flow of air from the vents to match the strength of the sun's rays. In addition, it automatically detects changes in the temperature inside the cab caused by changes in the strength of the sun's rays beforehand and automatically adjusts the temperature.

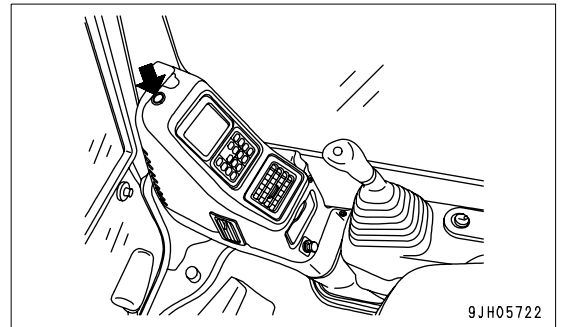

Method of Operation

The air conditioner can be operated automatically or manually. Select the method of operation as desired.

Automatic Operation

1. Turn auto switch (5) ON.
 - q The lamp at the top of switch (5) lights up.
 - q The set temperature (a) and air flow (b) are displayed on the monitor.

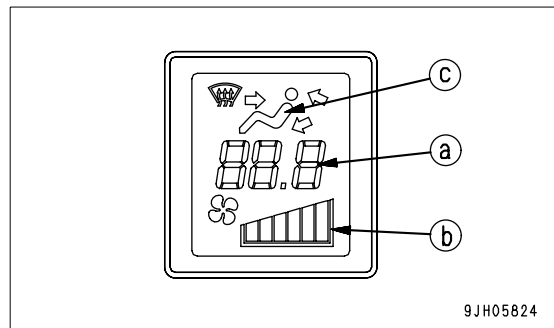
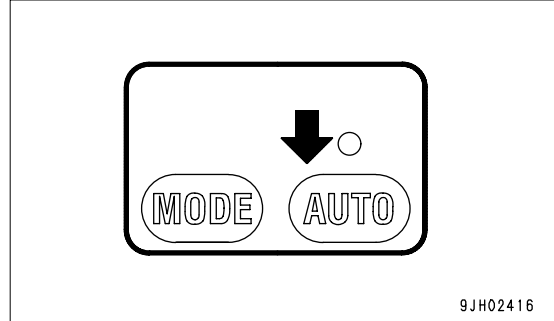

2. Use temperature set switch (3) to set to the desired temperature. The air flow, combination of vents, and selection of fresh or recirculated air is automatically selected according to the set temperature, and the air conditioner is operated automatically to provide the set temperature.

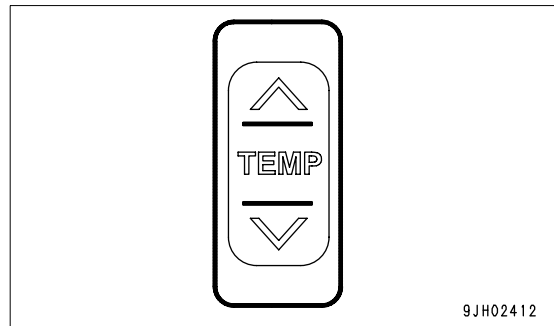

REMARK

When vent display monitor (c) displays (d) or (e), and engine coolant temperature is low, the air flow is automatically limited to prevent cold air from blowing out.

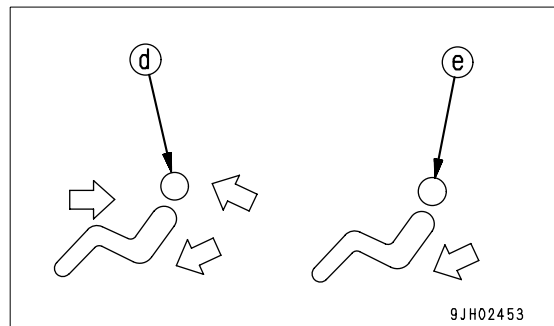

Stopping Automatic Operation

Press OFF switch (1). The displays for temperature setting (a) and air flow (b) on monitor (7), and lamps above auto switch (5) and air conditioner switch (8) go out, the operation stops.



Manual Operation

1. Press fan switch (2) and adjust the air flow. When doing this, check that temperature setting (a) and air flow (b) are displayed on monitor (7).

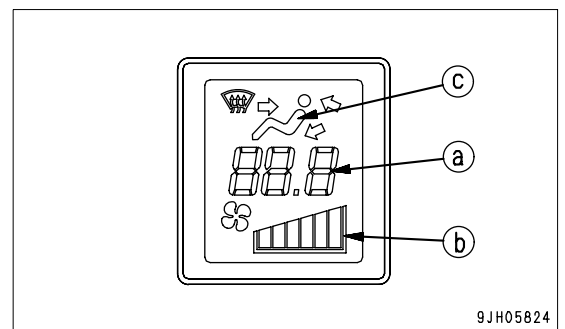
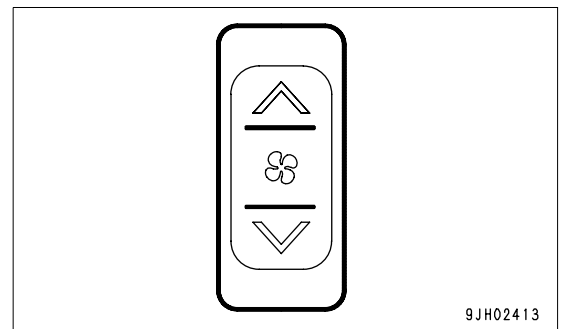

2. Turn air conditioner switch (8) ON. Check that the lamp at the top of the air conditioner switch lights up.

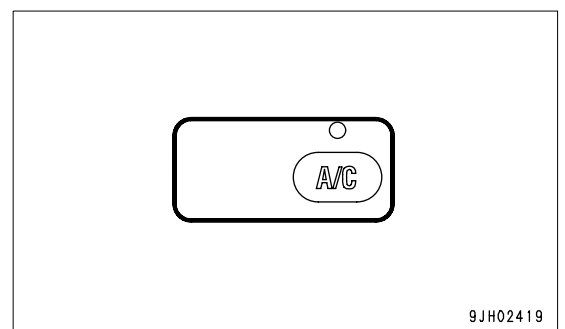

- 3. Press temperature setting switch (3) and adjust temperature inside the cab.

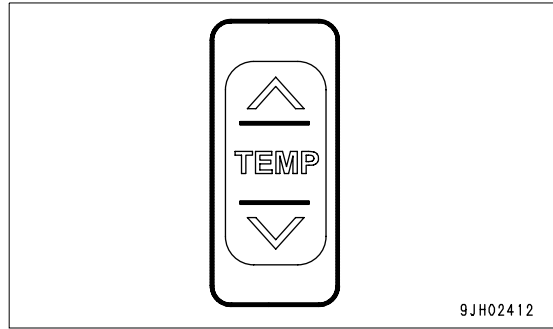

- 4. Press vent selector switch (4) and select the desired vents.
When this is done, the display for vent (c) of the display monitor changes according to the selection.

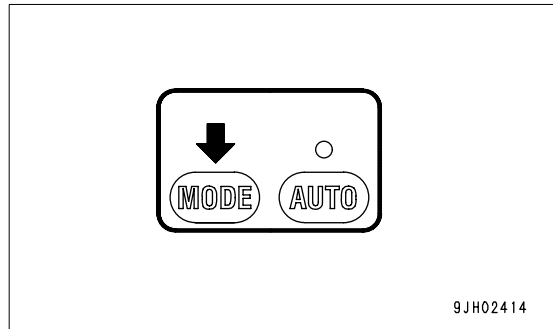

- 5. Press RECIRC/FRESH selector switch (6) and select recirculation of the air inside the cab (RECIRC) or intake of fresh air from outside (FRESH).

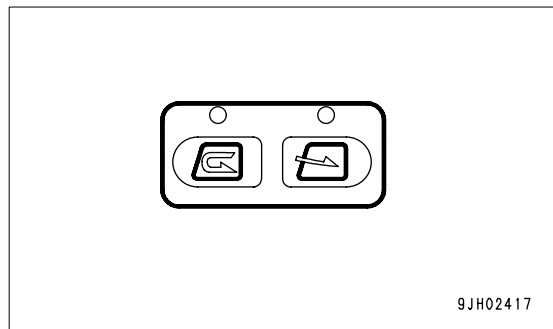
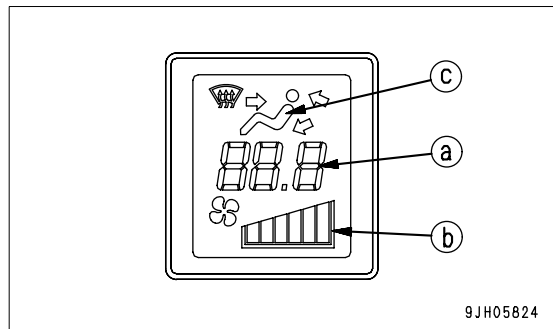

Stopping Manual Operation

Press OFF switch (1). The displays for temperature setting (a) and air flow (b) on monitor (7), and lamps above auto switch (5) and air conditioner switch (8) go out, the operation stops.



Operation with Cold Air to Face and Warm Air to Feet

To operate with cold air blowing to the face and warm air blowing to the feet, set as follows.

1. Press fan switch (2) and adjust the air flow. When doing this, check that temperature setting (a) and air flow (b) are displayed on monitor (7).

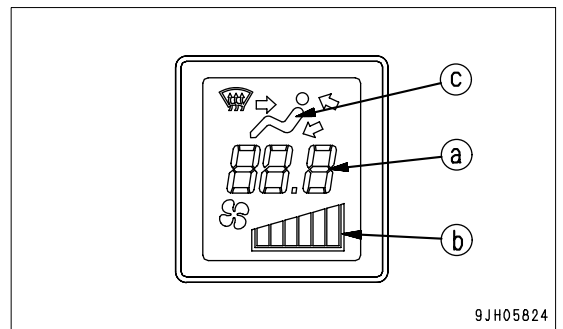
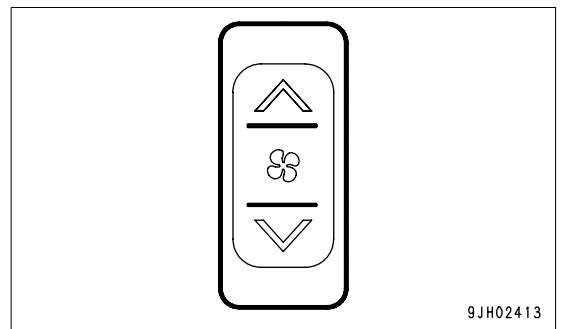

2. Press vent selector switch (4) and set the vent display on the display monitor to the display shown in the diagram on the right.

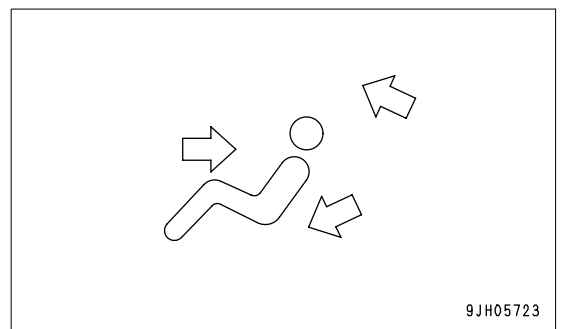

- 3. Turn air conditioner switch (8) ON. Check that the lamp at the top of the air conditioner switch lights up.

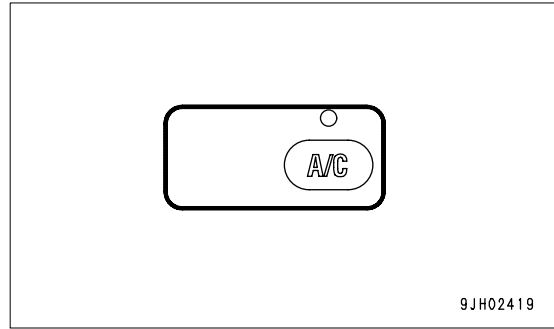

- 4. Adjust fan switch (2), temperature setting switch (3) and FRESH/RECIRC selector switch (6) to the desired positions.

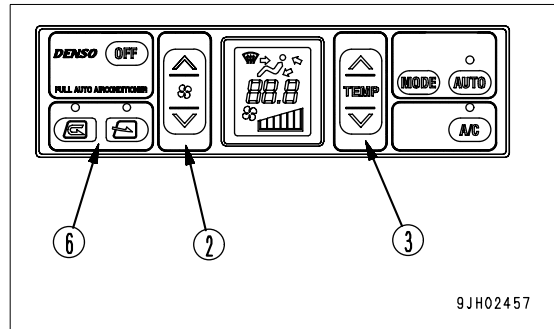

Defroster Operation

- 1. Press fan switch (2) and adjust the air flow. When doing this, check that temperature setting (a) and air flow (b) are displayed on monitor (7).

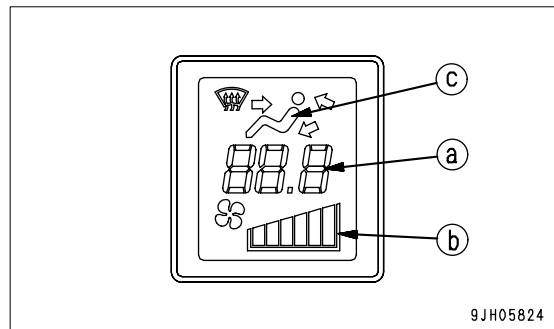
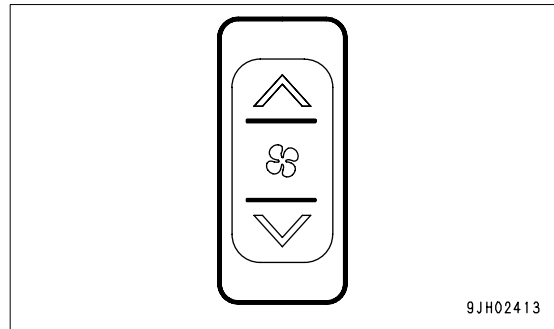

- Press vent selector switch (4) and set the vent display on the display monitor (C) to the display shown in (f) or (g) in the diagram on the right.

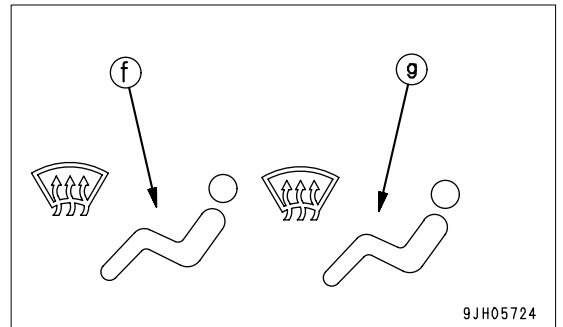
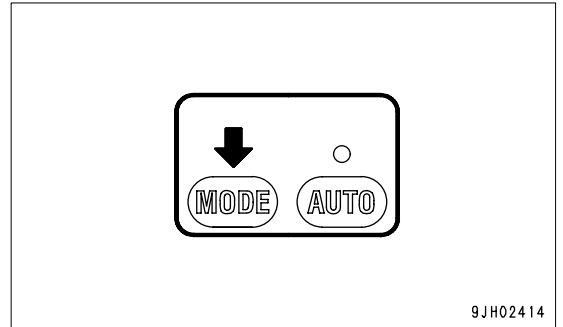

- Press FRESH/RECIRC selector switch (6) and set it to take in fresh air.

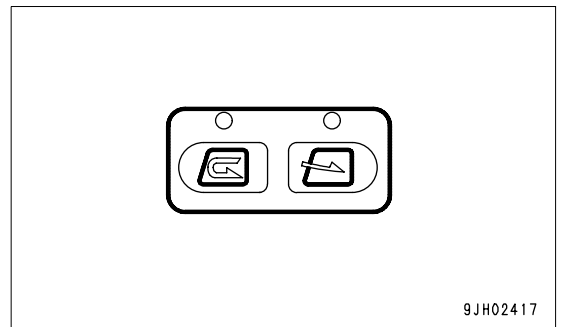

- Press temperature setting switch (3) and set temperature on the display (7) monitor to maximum heating.

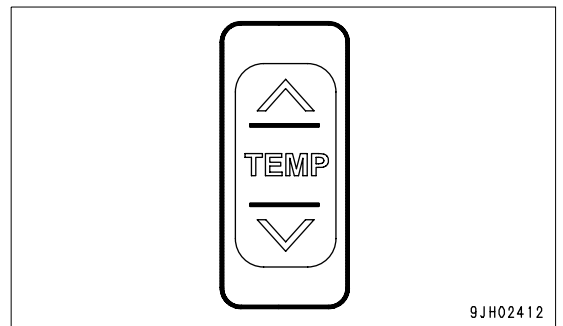

- Adjust vents (A), (B1), and (B2) so that the air blows onto the window glass.

(Vents (C) and (D) are fixed and cannot be adjusted.)

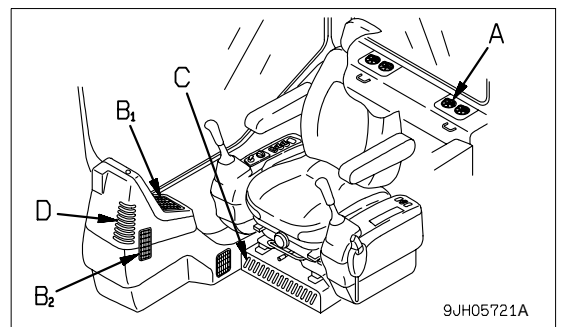

When operating in the rainy season or when it is desired to remove the mist from the window glass or to dehumidify the air, turn air conditioner switch (8) ON.

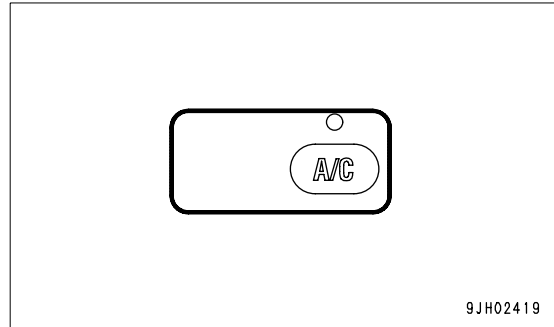

Use Air Conditioner with Care

NOTICE

- q When running the air conditioner, always start with the engine running at low speed. Never start the air conditioner when the engine is running at high speed. It will cause failure of the air conditioner.
- q If water gets into the control panel or sunlight sensor, it may lead to unexpected failure, so be careful not to let water get on these parts. In addition, never bring any flame near these parts.
- q For the auto function of the air conditioner to work properly, always keep the sunlight sensor clean and do not leave anything around the sunlight sensor that may interfere with its sensor function.

Ventilation

- q If you smoke when the cooler is on, the smoke may start to hurt your eyes, so open the window and turn the lever to FRESH for a while to remove the smoke while continuing the cooling.
- q When running the air conditioner for a long time, turn the lever to the FRESH position once an hour to carry out ventilation and cooling.

Temperature Control

When the cooler is on, set the temperature so that it feels slightly cool when entering the cab (5 or 6 °C) lower than the outside temperature). This temperature difference is considered to be the most suitable for your health, so always be careful to adjust the temperature properly.

Inspection and maintenance of Air Conditioner Equipped Machine

Inspection and maintenance of air conditioner (if equipped)

When carrying out inspection and maintenance of the air conditioner, follow the procedure given in the chart in "CHECK AND ADJUST AIR CONDITIONER (4-38),CHECK, ADJUST AIR CONDITIONER COMPRESSOR BELT TENSION (4-64),CLEAN AIR CONDITIONER FRESH/RECIRC FILTERS (4-59)".

Other Functions

Self-diagnostic Function

It is possible to perform troubleshooting of various sensors and equipment used on the air conditioner.

1. Turn the starting switch key to the ON (B) position.
2. Press OFF switch (1). The temperature setting and air flow display on the liquid crystal display portion go out and operation stops.
3. If the “√” and “^” parts of temperature setting switch (3) are kept pressed at the same time for at least 3 seconds, the troubleshooting mode is displayed on the liquid crystal display portion.

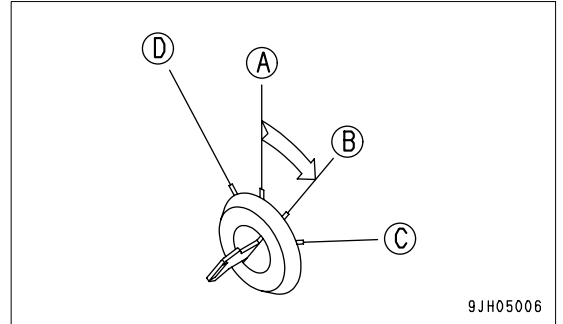

<Monitor display and failure mode>

Display	Failure mode
E--	No failure
E11	Disconnection in recirculated air sensor
E12	Short circuit in recirculated air sensor
E13	Disconnection in fresh air sensor
E14	Short circuit in fresh air sensor
E15	Disconnection in water temperature sensor
E16	Short circuit in water temperature sensor
E18	Short circuit in sunlight sensor
E21	Disconnection in vent sensor
E22	Short circuit in vent sensor
E43	Abnormality in vent damper
E44	Abnormality in air mix damper
E45	Abnormality in FRESH/RECIRC air damper
E51	Abnormality in refrigerant pressure

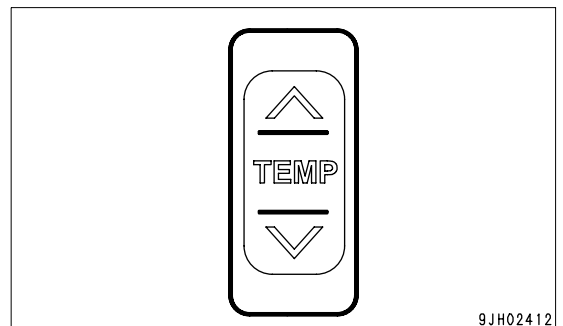

- q When more than one failure is detected, press the “√” or “^” portion of temperature setting switch (3) to display the failures in turn.
- q After completing the troubleshooting, press OFF switch (1) again to return to the normal display.

If any abnormality is detected by the self-diagnostic function, ask your Komatsu distributor to carry out inspection and repair.

Function to Switch Set Temperature Display Between Fahrenheit and Celsius

It is possible to switch the set temperature display between °F and °C.

If the “∨” and “∧” portions of temperature setting switch (3) are pressed at the same time for more than 5 seconds while the fan is running, the temperature display will switch between °F and °C.

(Note that the unit is not displayed.)

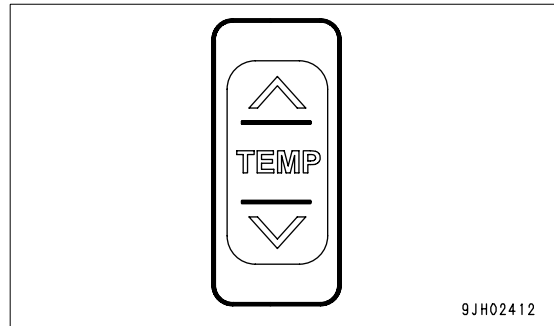

	Liquid crystal display range
°C	18.0 to 32.0
°F	63 to 91

CAB RADIO CASSETTE

(if equipped)

Refer to the separate operation manual for radio cassette.

REMARK

Ensure radio is switched off when leaving the machine for long periods to prevent draining of battery charge.

Controls of Radio cassette

Antenna

NOTICE

Before transporting the machine or putting it inside a building, stored the antenna to prevent any interference.

Stow the antenna as follows.

1. Loosen antenna mounting bolt (1) and store the antenna at position (A).
2. After storing the antenna, tighten bolt (1).

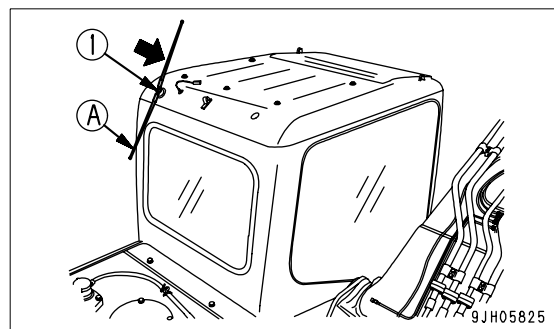

Precautions when Using

- To ensure safety, always keep the sound to a level where it is possible to hear outside sounds during operation.
- If water gets into the speaker case or radio, it may lead to an unexpected failure, so be careful not to get water on the equipment.
- Do not wipe the scales or buttons with benzene, thinner, or any other solvent. Wipe with a soft dry cloth. Use a cloth soaked in alcohol if the equipment is extremely dirty.
- When the battery is replaced, the settings for the preset buttons are all cleared, so set them again.

AUXILIARY ELECTRIC POWER

24V power source

NOTICE

Do not use this as the power source for 12 V equipment.

Pull out the connector plug for taking out electric power from the rear side of the panel.

Maximum usable electric power is 85 W (24 V x 3.5 A).

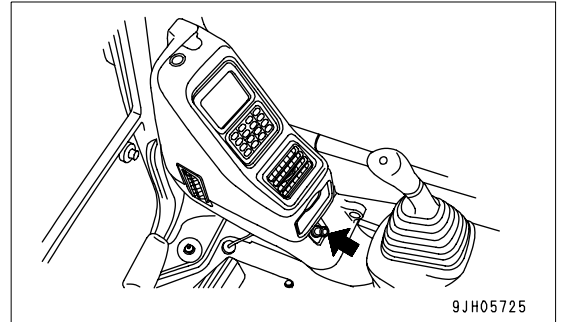

12V power source

(if equipped)

This power source can be used up to a capacity of 60W (12V x 5A).

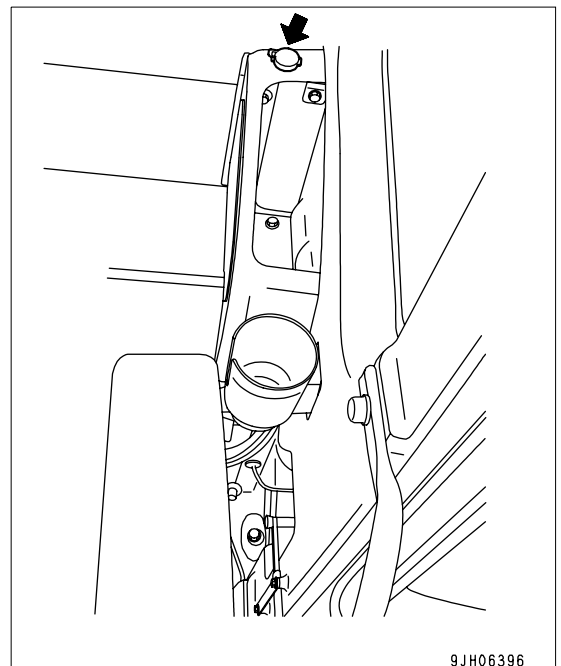

FUSE

NOTICE

Before replacing a fuse, be sure to turn off the starting switch.

The fuses protect the electrical equipment and wiring from burning out.

If the fuse becomes corroded, or white powder can be seen, or the fuse is loose in the fuse holder, replace the fuse.

Replace the fuse with another of the same capacity.

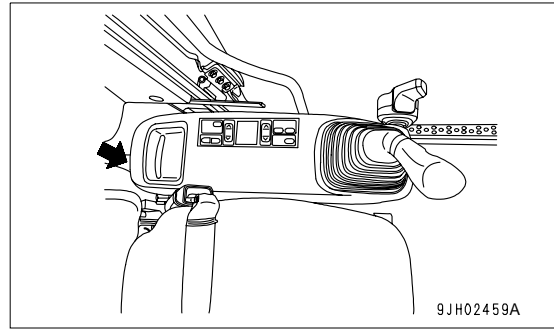

Fuse Capacities and Circuit Names

No.	Fuse	Circuit name
(1)	10A	Controller
(2)	20A	Solenoid valve
(3)	10A	PPC oil pressure lock solenoid
(4)	10A	Window washer, Cigarette lighter
(5)	10A	Right knob switch, horn
(6)	10A	Lower wiper
(7)	10A	Revolving warning lamp
(8)	25A	Working lamp
(9)	10A	Left knob switch
(10)	10A	Refuelling pump
(11)	20A	Air conditioner unit
(12)	20A	Monitors, Wiper monitor
(13)	20A	Light, Light relay drive
(14)	10A	OPT power supply (1)
(15)	10A	OPT power supply (2)
(16)	10A	Radio backup, 12V power supply
(17)	10A	Monitor (normal power source)
(18)	10A	Starting switch
(19)	10A	Room lamp
(20)	10A	Spare fuse

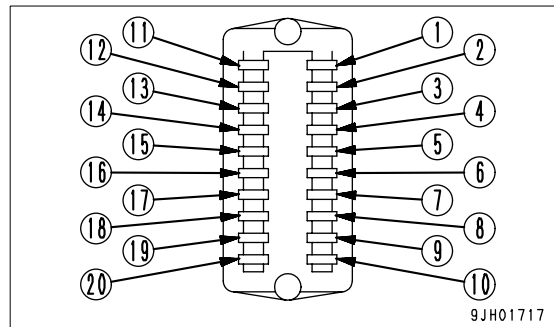

FUSIBLE LINK

If the starting motor does not work when the starting switch is turned ON, the wire type fusible link (1) (2 places) is probably broken, so open the battery box cover on the right side of the machine, then check and replace.

REMARK

A fusible link refers to the large-sized fuse wiring installed in the high current flow portion of the circuit to protect electrical components and wiring from burning, in the same way as an ordinary fuse.

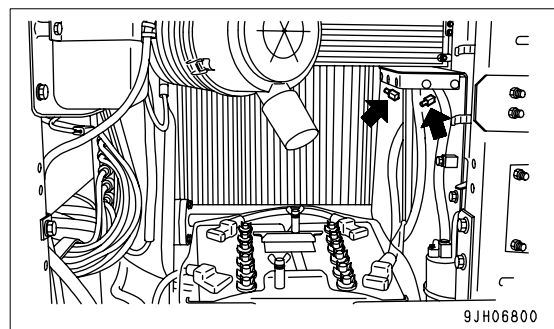

CONTROLLERS

controller installed.

NOTICE

- q Be careful not to get water, mud, or juice on the controller. This will cause failure.

- q If any abnormality occurs in the controller, do not disassemble it yourself. Contact your Komatsu distributor for repairs.

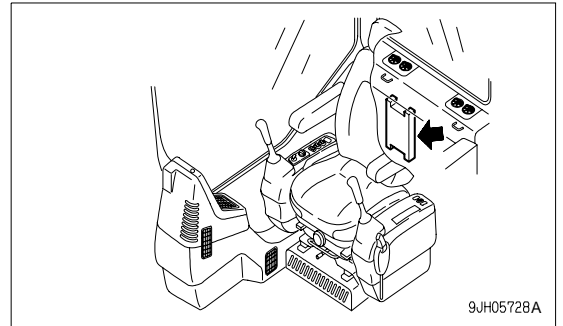

TOOL BOX

This is used for keeping the tools.

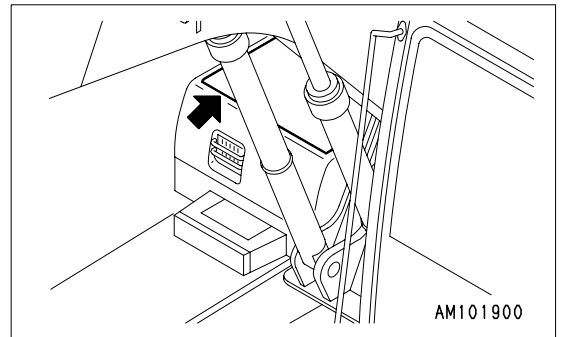

GREASE GUN HOLDER

This is inside the battery room door on the left side of the machine.

When not using the grease gun, fit it in this holder.

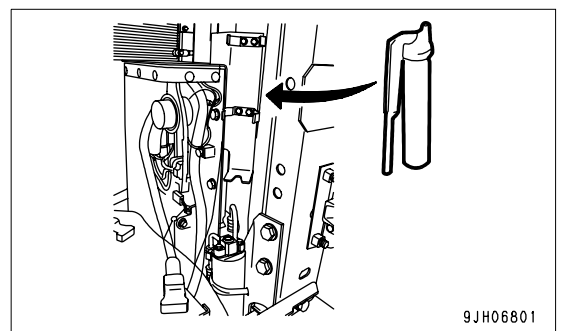

HANDLING GREASE GUN

When using the Komatsu genuine greasing gun, follow the procedure given below.

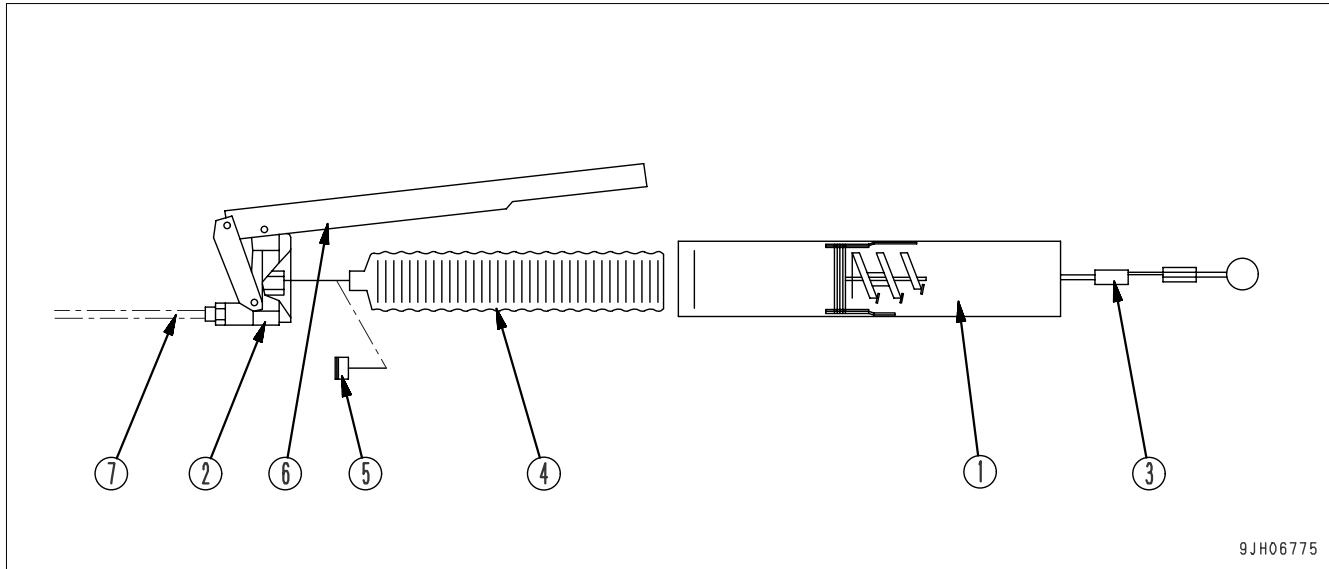

1. Pull chain (3) and lock it in the groove of grease cylinder (1).
2. Twist grease cylinder (1) back and remove it from body (2).
3. Remove cap (5) of grease cartridge (4), then screw it into body (2).

NOTICE

When not using grease cartridge (4), charge grease cylinder (1) directly with grease. When doing this, be careful not to let air or dirt get into the grease cylinder.

4. Install grease cylinder (1) to body (2).
5. Release the lock of chain (3), then stow inside grease cylinder (1).
6. Pump lever (6) up and down and 2 or 3 times and check that grease comes out from the tip of nozzle (7).

REMARK

When using grease cylinder (1) directly charged with grease, the grease may not come out easily even when the lever is operated. This problem is caused by an air pocket in the grease, so loosen grease cylinder (1) 1 or 2 turns to release the air.

REFUELLING PUMP

Safety

- q Do not bring fire or sparks near fuel - smoking is prohibited.
- q In event of ingested fuel - do not induce vomiting. Drink large quantity of milk or water and seek medical attention.
- q Skin protection - wear protective gloves when dispensing fuel. Plastic gloves conforming to EN388 cat: 2 are recommended.
- q Attendance - transfer of fuel must always take place under the supervision of the operator.
- q Location for refuelling: Ensure that refuelling takes place away from hazardous areas.

Procedure

1. When the machine is operated on sites with no fuel container and pump, the machine may be refuelled, using the refuelling pump, from fuel barrels.
2. The refuelling pump is located in the tool box at the front right hand side of the machine.
3. Stop the machine engine.
4. Open the cap on the foot valve by unscrewing fully.
5. Check strainer on the fuel hose end is clean.
6. Place the fuel hose into the fuel barrel, ensuring that the foot valve is placed at the bottom of the barrel.
7. Open the cap on top of the tank.
8. Switch on the pump.
9. Check that the pump primes properly (should prime within 1 minute). If it does not, stop the pump and check that the strainer is clean and hose is immersed in the fuel.
10. When the level indicator (1) shows the tank to be full, stop the pump. Take care not to allow fuel to overflow from the tank.
11. Close the cap on the foot valve by screwing fully.
12. Replace the hose and the tank cap.

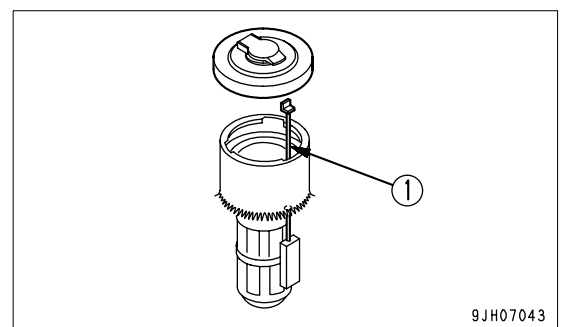
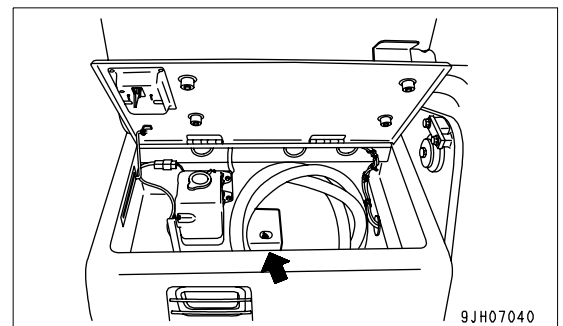
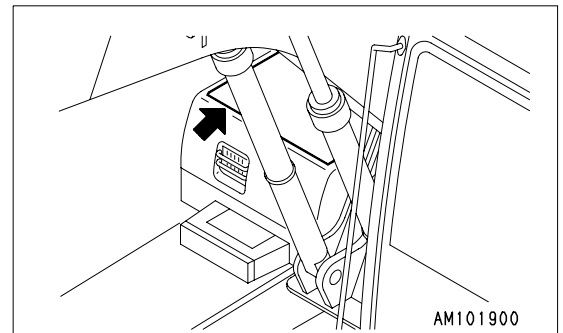

REMARK

The pump is protected by a fuse. If pump fails to function, check fuse (10A).

Do not allow the pump to run dry, as this will overheat the motor. If the barrel is emptied during the refuelling stop the pump immediatly.

The maxium permitted running time for the pump is 30 minutes. The tank should be full well within this time. Do not allow the pump to run for longer than this as damage will occur to the motor.

Maintenance

Weekly: Clean the suction filter.

Monthly: Check hose joints, electrical cables and clean the pump body of impurities.

Storage: If the pump is not to be used for a period, ensure that fuel is sprayed into the motor housing every two weeks to prevent risk of rusting to the rotor.

ACCUMULATOR

WARNING

The accumulator is charged with high-pressure nitrogen gas, so mistaken operation may cause an explosion which will lead to serious injury or damage. When handling the accumulator, always do as follows. The pressure in the control circuit cannot be completely removed. When removing the hydraulic equipment, do not stand in the direction that the oil spurts out when carrying out the operation.

Loosen the bolts slowly.

Do not disassemble the accumulator.

Do not bring it near flame or dispose of it in fire.

Do not make holes in it or weld it.

Do not hit it, roll it, or subject it to any impact.

When disposing of the accumulator, the gas must be released. Please contact your Komatsu distributor to have this work carried out.

This machine is equipped with an accumulator in the control circuit. The accumulator is a device to store oil pressure for the control circuit, and when it is installed, the control circuit can be actuated for a short time even after the engine is stopped. Due to this device, the work equipment lowers under its own weight, if the control lever is moved in the lowering direction.

The accumulator is installed to the position shown in the diagram on the right.

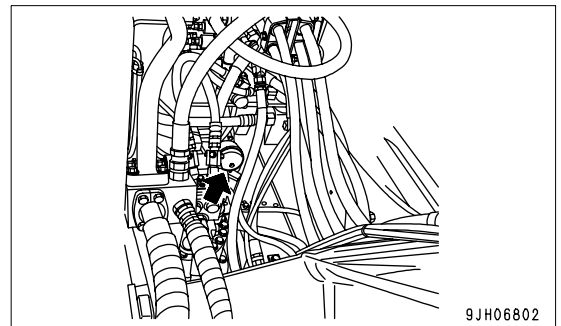

Releasing Hydraulic Pressure with Accumulator

1. Place the work equipment on the ground. Close the crusher attachment jaws, etc.
2. Stop the engine.
3. Turn the starting switch to the ON position.
4. Move the safety lock lever to the free position. Move the work equipment control lever and the attachment control pedal to full stroke back and forth, right and left so as to release the pressure in the control circuit.
5. Move the safety lock lever to the lock position. Lock the control lever and attachment control pedal.
6. Turn the key in starting switch to the OFF position.

MACHINE OPERATIONS AND CONTROLS

BEFORE STARTING ENGINE

Walk-around Checks

Before starting the engine, look around the machine and under the machine to check for loose nuts or bolts, or leakage of oil, fuel, or coolant, and check the condition of the work equipment and hydraulic system. Check also for loose wiring, play, and accumulation of dust in places which reach high temperatures.

WARNING

Remove any flammable materials from around the battery or engine muffler, turbocharger, or other high temperature engine parts. Leakage of fuel or oil will cause the machine to catch fire. Check carefully, and be sure to repair any abnormalities, or please contact your Komatsu distributor.

Carry out the following inspections and cleaning every day before starting the engine for the day's work.

1. Check for damage, wear, play in work equipment, cylinders, linkage, hoses
Check that there are no cracks, excessive wear, or play in the work equipment, cylinders, linkage, or hose. If any abnormality is found, repair it.
2. Remove the dirt from around the engine, battery, and radiator.
Check that there is no dirt accumulated around the engine or radiator. Check also that there is no flammable material (dry leaves, twigs, etc.) around the battery, engine muffler, turbocharger, or other high temperature parts of the engine. If any dirt or flammable materials are found, remove them.
3. Check for leakage of water or oil around engine
Check that there is no leakage of oil from the engine or leakage of coolant from the cooling system. If any abnormality is found, repair it.
4. Check for oil leakage from hydraulic equipment, hydraulic tank, hoses, joints
Check that there is no oil leakage. If any abnormality is found, repair the place where the oil is leaking.
5. Check the undercarriage (track, sprocket, idler, guard) for damage, wear, loose bolts, or leakage of oil from rollers.
If any abnormality is found, repair it.
6. Check for abnormality in handrails, steps, loose bolts.
If any abnormality is found, repair it. Tighten any loose bolts.

7. Check for abnormality in gauges, monitor.

Check that there is no abnormality in the gauges and monitor in the operator's cab. If any abnormality is found, replace the parts. Clean off any dirt on the surface.

8. Clean, check rear view mirror

Check that there is no damage to the rear view mirror. If it is damaged, replace it with a new mirror. Clean the surface of the mirror and adjust the angle so that the area at the rear can be seen from the operator's seat.

9. Seat belt and mounting clamps

Check that there is no abnormality in the seat belt or mounting clamps. If there is any damage, replace with new parts.

10. Check bucket with hook (if equipped) for damage.

Check that there is no damage to the hook, guide, or hook mount. If any abnormality is found, please contact your Komatsu distributor for repair.

Checks Before Starting

Always check the items in this section before starting the engine each day.

Check Coolant Level, Add Coolant

WARNING

- q Do not open the radiator cap unless necessary. When checking the coolant, always wait for the engine to cool down and check the sub tank.
- q Immediately after the engine is stopped, the coolant is at a high temperature and the radiator is under high internal pressure. If the cap is removed to check the coolant level in this condition, there is a hazard of burns. Wait for the temperature to go down, then turn the cap slowly to release the pressure before removing it.

1. Open the door at the rear left of the machine, and check if the cooling water in sub-tank (1) (shown in the diagram on the right) is between the FULL and LOW marks. If the water level is low, add water to the FULL level through the filler port of sub-tank (1).
2. After adding coolant, tighten the cap securely.
3. If the sub tank is empty, there is probably leakage of water. After inspecting, repair any abnormality immediately. If there is no abnormality, check the water level in the radiator. If the water level is low, add water to the radiator, then fill the reserve tank (1).

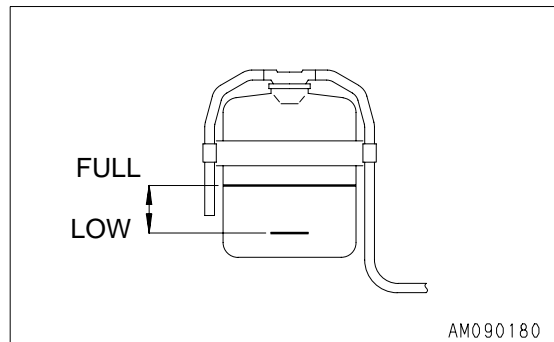
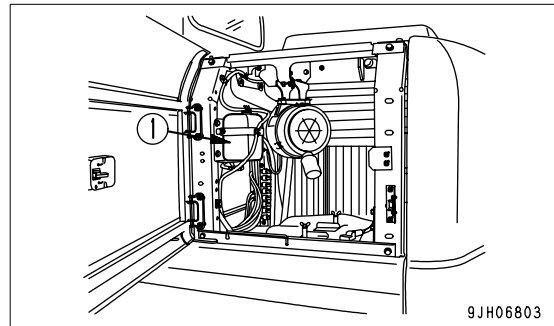

Check Oil Level in Engine Oil Pan, Add Oil **WARNING**

Engine parts and oil are at high temperature immediately after the engine is stopped, and will cause serious burns. Wait for the temperature to cool down before starting the operation.

1. Open the engine hood on the machine.
2. Remove dipstick (G), and wipe the oil off with a cloth.
3. Completely insert dipstick (G) into the oil filler pipe, then remove it and check the oil level.
4. The oil level should be between the H and L marks on dipstick (G).

If the oil level is below the L mark, add engine oil through oil filler (F).

5. If the oil is above the H line, open drain valve (P) at the bottom of the engine oil pan, drain the excess engine oil, then check the oil level again.
6. If the oil level is correct, tighten the oil filler cap securely and close the engine hood.

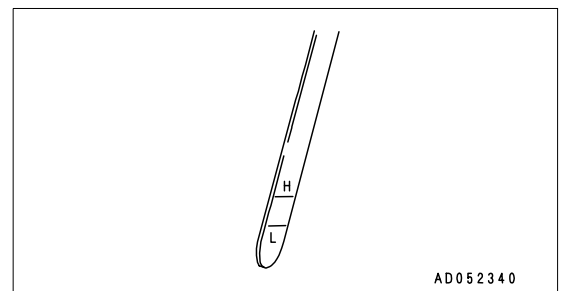
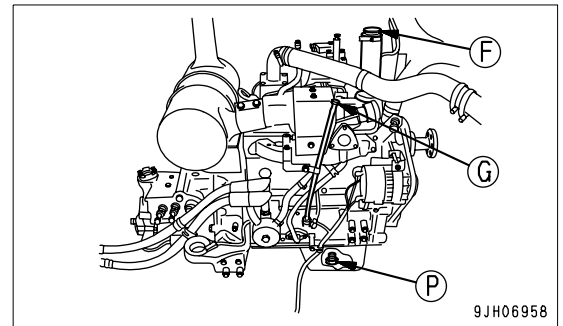
**REMARK**

When checking the oil level after the engine has been operated, wait for at least 15 minutes after stopping the engine before checking.

If the machine is at an angle, make it horizontal before checking.

Check Fuel Level, Add Fuel

⚠ WARNING

When adding fuel, never let the fuel overflow. This may cause a fire. If any fuel is spilled, wipe it up completely. Never bring flames near fuel because it is highly flammable and dangerous.

1. Open fuel filler cap (F) of the fuel tank.
2. If fuel filler cap (F) is opened, float gauge (G) rises to the fuel level. Check that the fuel tank is full. Check the fuel level visually and with float gauge (G).
3. If the fuel tank is not full, supply fuel through the fuel filler until float gauge (G) rises to the maximum position.
 - Fuel tank capacity: 240 liters
 - Position of tip of float gauge (G) when tank is full: Approx. 50 mm from top surface of fuel tank
4. After adding fuel, push float gauge (G) straight down with fuel filler cap (F). Be careful not to get float gauge (G) caught in the tab of fuel filler cap (F), and tighten fuel filler cap (F) securely.

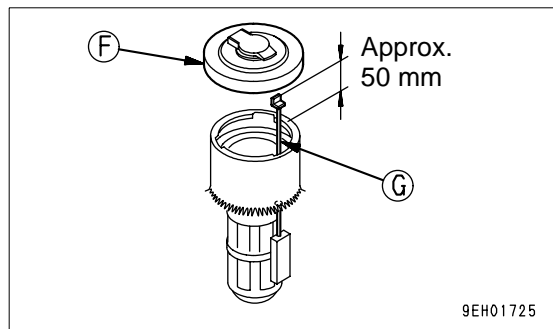
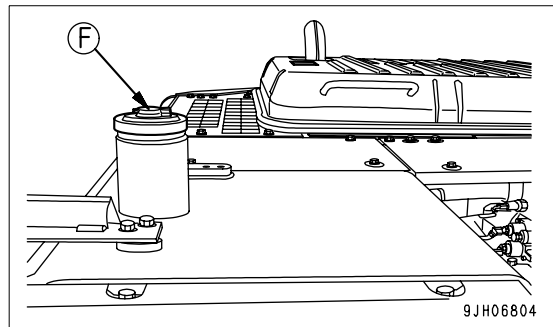
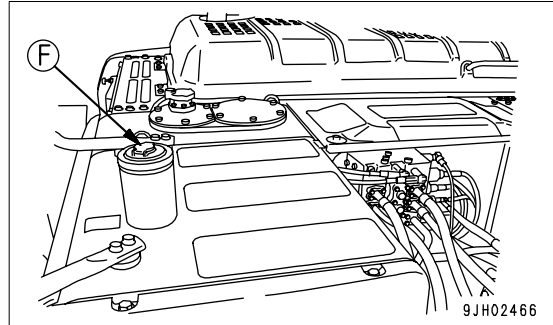

REMARK

If breather hole (1) in the cap is clogged, the pressure in the tank will drop and fuel will not flow. Clean the hole from time to time.

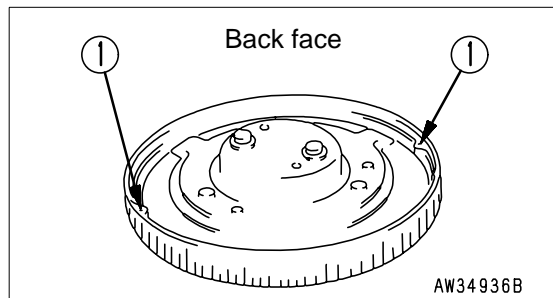

Drain Water And Sediment from Fuel Tank

1. Set a container under the drain valve (1) to catch the fuel when it is drained.
2. Open drain valve (1) at the rear of the fuel tank and drain the water and sediment accumulated at the bottom of the tank.
3. When no more water and sediment comes out with the fuel, close drain valve (1).

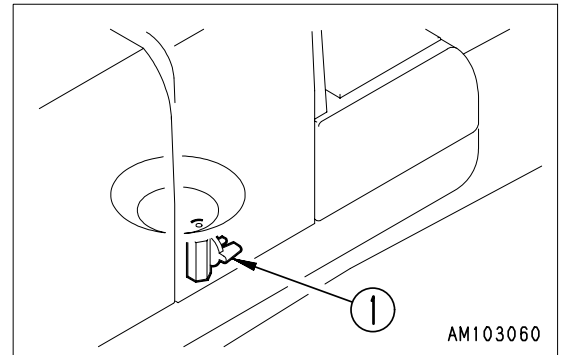

Check for Water and Sediment in Water Separator, Drain Water

1. Open the pump room door on the right side of the machine.
2. Inspect the water separator, and check if the ring inside has risen to the marked line.
3. If the ring has risen to the marked line, carry out the procedure from Step 4.
4. Prepare a container to catch the drained fuel and set it under the water separator.
5. Close fuel valve (6) at the inlet port of the water separator.
6. Remove air bleed plug (5) at the top of the water separator.
7. Loosen drain valve (1) at the bottom of the water separator, and drain the water and sediment into the container.
8. Loosen ring nut (2), then remove filter case (3).
9. Remove element (4) from the separator base.
10. Wash element (4) and filter case (3) in clean diesel oil.
11. Check element (4) and replace it if it is damaged.
12. When installing element (4), perform Steps 5 and 9 in the opposite order.

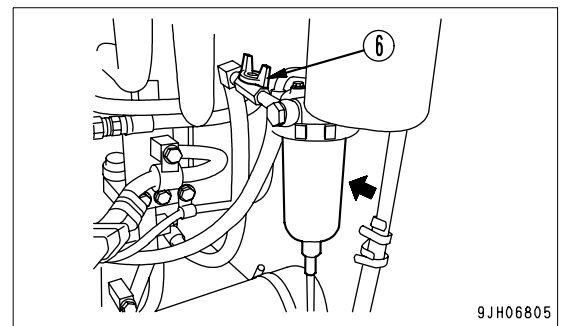

13. Loosen air bleed plug (5) then Fill filter case (3) with fuel. When the fuel comes out from air bleed plug (5), tighten air bleed plug (5).

Tightening torque of ring nut (2):

$40 \pm 3 \text{ N}\cdot\text{m}$ ($4.1 \pm 0.3 \text{ kgf}\cdot\text{m}$)

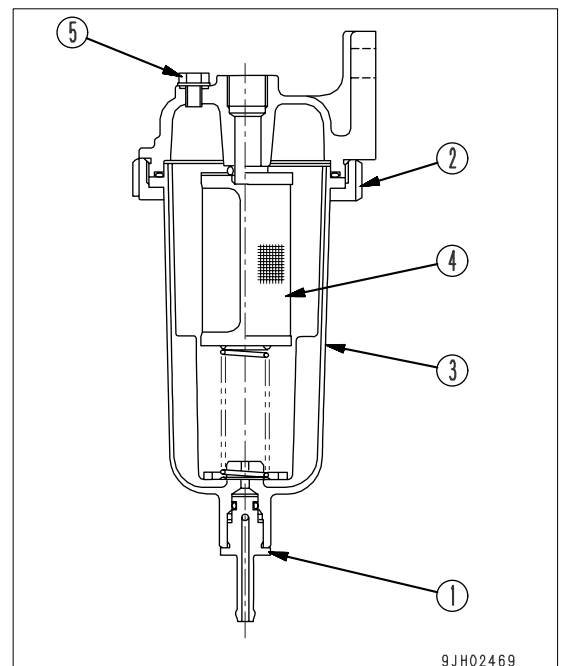

Check Oil Level in Hydraulic Tank, Add Oil

⚠ WARNING

When removing the oil filler cap, oil may spurt out, so turn the cap slowly to release the internal pressure before removing the cap.

1. If the work equipment is not in the condition shown in the diagram on the right, start the engine, run the engine at low speed, retract the arm and bucket cylinder rods fully, then lower the boom, set the bucket teeth in contact with the ground, and stop the engine.
2. Within 15 seconds after stopping the engine, move each control lever (for work equipment and travel) to the full stroke in all directions to release the internal pressure.
3. Check sight gauge (G) from the right window installed to the operator's compartment. The oil level should be between the H and L lines.

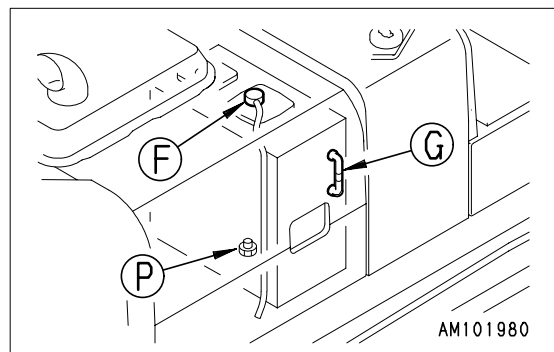
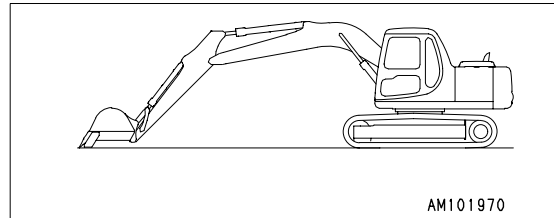

NOTICE

Do not add oil above the H line. This will damage the hydraulic circuit or cause the oil to spurt out. If oil has been added to above the H level, stop the engine and wait for the hydraulic oil to cool down, then drain the excess oil from drain plug (P).

4. If the oil level is below the L line, add oil through oil filler (F) at the top of the hydraulic tank.

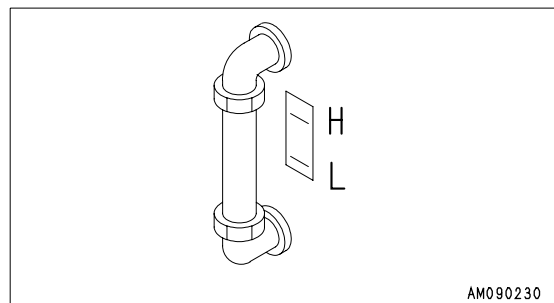

REMARK

The oil level will vary depending upon the oil temperature. Accordingly, use the following as a guide:
 Before starting operation: Between H and L levels (Oil temperature 10 to 30°C)
 Normal operation: around H level (Oil temperature 50 to 80°C)

Check Working Lamp Switch

Turn the lamp switch to the ON position and check that the working lamp light up.

If the lamps do not light up, there is probably a broken bulb or disconnection in the wiring, so contact your Komatsu distributor for repairs.

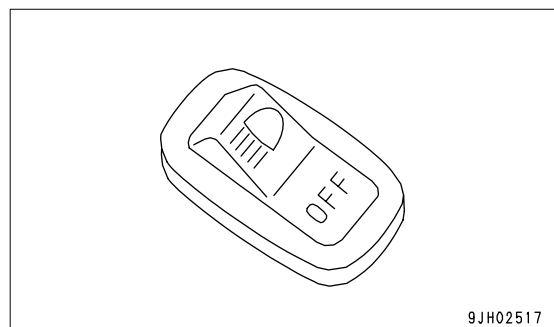

Check Electric Wiring



CAUTION

If fuses are frequently blown or if there are traces of short-circuiting on the electrical wiring, promptly ask your Komatsu distributor to locate the cause and make the repair.

Keep the top surface of the battery clean and check the breather hole in the battery cap. If it is clogged with dirt or dust, wash the battery cap to clear the breather hole.

Check that there is no damage to the fuses; that fuses of the specified capacity are used; that there is no disconnection or trace of short-circuiting on the electric wiring and no damage to the covering. Check also that there is no loosened terminals. If any, tighten them.

Moreover, pay particular attention to the electric wiring when checking the battery, engine starting motor and alternator.

Be sure to check that there is no inflammable material accumulated around the battery. If present, remove it as soon as possible.

Check Function of Horn

1. Turn the starting switch to the ON position.
2. Confirm that the horn sounds immediately when the horn button is pressed.

If the horn does not sound, please contact your Komatsu distributor for repair.

Adjustment

Seat Adjustment

⚠ WARNING

When adjusting the position of the operator's seat, always set the safety lock lever to the LOCK position to prevent any accidental contact with the control levers.

- Always adjust the operator's seat before starting each operation or when the operators change shift.
- Adjust the seat so that the control levers and switchis can be operated freely and easily with the operator back against the backrest.

(A) Fore-and-aft adjustment

Pull lever (1) up, set the seat to the desired position, then release the lever.

Fore-and-aft adjustment: 160 mm (16 stages)

(B) Adjusting reclining

NOTICE

The seat can be reclined to a large angle when the seat is pushed fully forward, but the reclining angle is reduced when the seat is moved back, so when moving the seat to the rear, return the seat back to its original position.

Pull up lever (2) and set the seat back to a position which is comfortable for operation, then release the lever.

Sit with your back against the seat back when adjusting. If your back is not touching the seat back, the seat back may suddenly move forward.

(C) Adjusting seat tilt

- Forward tilt

Push lever (3) up to adjust the angle of the front of the seat. (4 stages)

- To raise the angle at the front of the seat, keep the lever pushed up and apply your weight to the rear of the seat.
- To lower the angle at the front of the seat, keep the lever pushed up and apply your weight to the front of the seat.

- Rear tilt

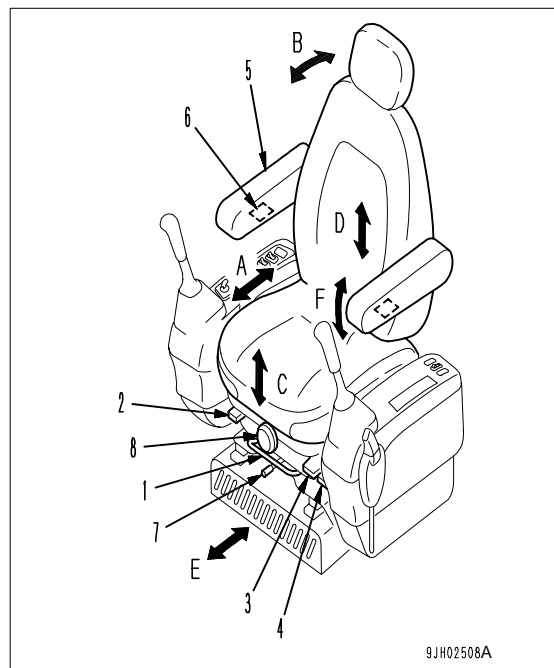

9JH02508A

Pull lever (4) up to adjust the angle of the rear of the seat. (4 stages)

q To raise the angle at the rear of the seat, keep the lever (3) pulled up and stand up slightly to remove your weight from the seat.

q To lower the angle at the rear of the seat, keep the lever (3) pulled up and apply your weight to the

Amount of tilt: Up 13°, down 13°

q Adjusting seat height

It is possible to move the seat up or down by combining adjustments forward tilt and rear tilt.

After setting the forward tilt or rear tilt to the desired height, operate the opposite part to set the seat horizontal then secure in position.

Height adjustment: 60 mm

(D) Adjusting armrest angle

Armrest (5) can be made to spring up by hand approx. 90°.

In addition, by turning the bottom (6) of the armrest by hand it is possible to make fine vertical adjustments of the armrest angle.

Armrest adjustment angle: 25°.

REMARK

If the seat back is tipped to the front without raising the armrest(5), the armrest will rise automatically.

(E) Overall fore-and-aft adjustment of seat

Move lever (7) to right, set to the desired position, then release the lever. In this case, the operator's seat, left and right control levers, and safety lock lever all slide together.

Fore-and-aft adjustment: 180 mm (9 stages)

(F) Adjusting suspension (if equipped)

Turn knob (8) to the right to make the suspension harder, or to the left to make the suspension softer. Adjust the reading of the dial to match the operator's weight and select the optimum suspension.

REMARK

To obtain the optimum adjustment, turn the knob (8) so that the indicator of the weight display (kg) in the transparent portion of knob (8) is the same as the operator's weight.

Rearview Mirrors

Loosen nut (1) and bolt (2) mounting the mirror, and adjust to the position which gives the best view from the operator's seat of the blind spot to the left and right sides at the rear of the machine.

- q Adjust the mirror mount so that it is possible to see people (or objects with a height of 1 m or a diameter of 30 cm) at the rear left and right of the machine
- q Install the mirror to the dimensions listed in the table below. Recognition areas are also shown in the table for reference.

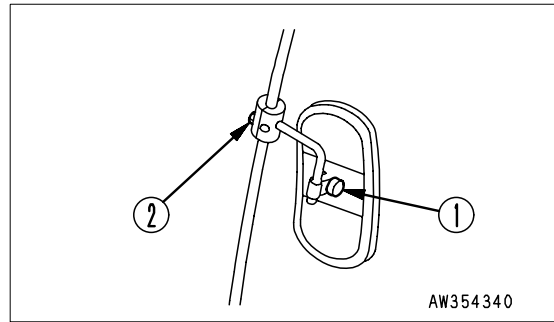

Mounting position X: 25 mm

Area of visibility Y (right): 1050 mm

Area of visibility Z (left): 1500 mm

Mirror A : Must be able to see hatched area (A)

Mirror B : Must be able to see hatched area (B)

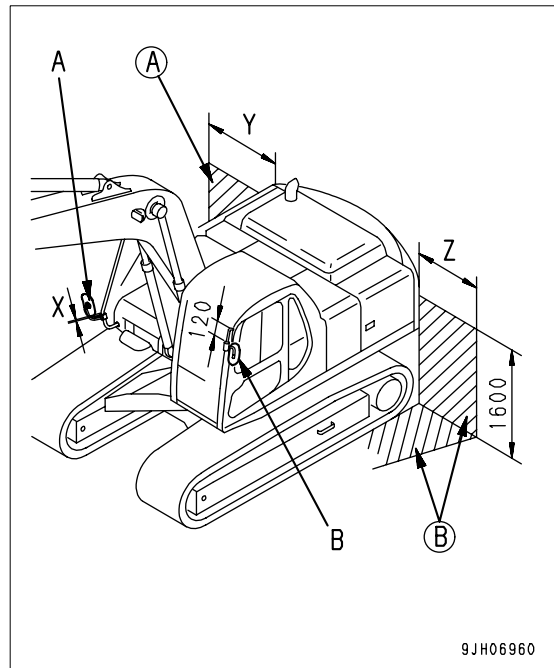

Seat Belt

WARNING

- q Before fitting the seat belt, check that there is no abnormality in the belt mount bracket or mounting belt. If it is worn or damaged, replace the seat belt.
- q Even if no abnormality can be seen in the belt, replace the seat belt every 3 years. The date of manufacture of the belt is shown on the back of the belt.
- q Always wear the seat belt during operations.
- q Fit the seat belt so that it is not twisted.

Fastening and Removing

This seat belt has a wind-in device, so it is not necessary to adjust the length.

Fastening Seat Belt

Hold grip (2) and pull the belt out from wind-in device (1), check that the belt is not twisted, then insert tongue (3) into buckle (4) securely.

When doing this, pull the belt lightly to check that it is properly locked.

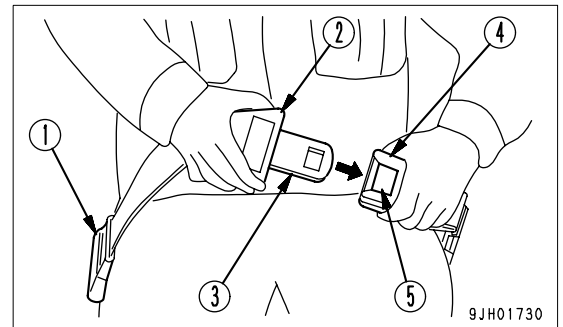

Removing Belt

Press button (5) in buckle (4), and remove tongue (3) from buckle (4).

The belt is automatically wound in, so hold grip (2) and return the belt slowly to wind-in device (1).

REMARK

For machines with a suspension seat, adjust the position of the seat, then adjust tether belt (1). Install the tether belt so that it is tensed when no one is sitting in the seat. (Only machines equipped with suspension seat)

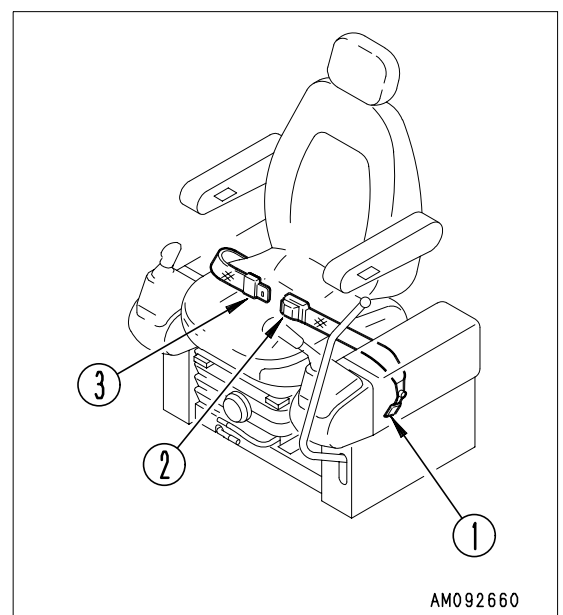

Operations Before Starting Engine

⚠ WARNING

When starting the engine, check that the safety lock lever is securely at the LOCK position (L). If the control levers are not locked and they are touched by accident when starting the engine, the work equipment may move unexpectedly, and this may lead to a serious accident.

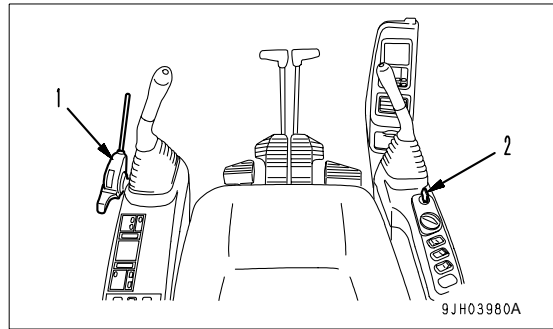

1. Check that safety lock lever (1) is at the LOCK position (L).
2. Check the position of each levers.
Set the control lever to the neutral position.
3. Insert the key in starting switch (2), turn the key to the ON position (B), then carry out the following checks.

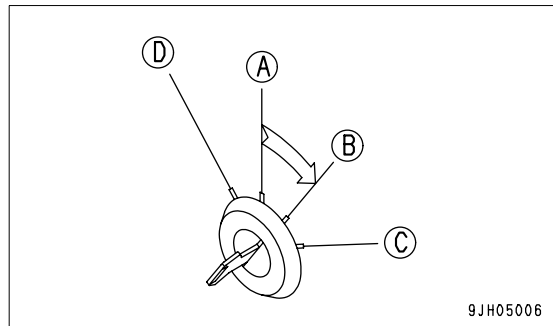
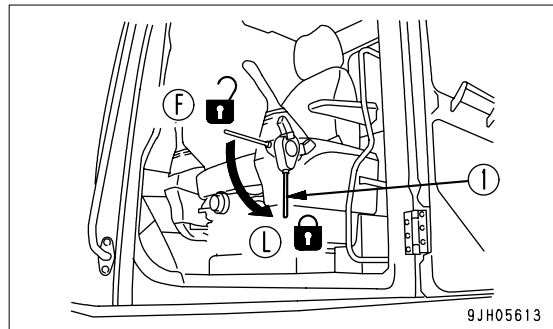

4. The buzzer will sound for approx. 1 sec, and the following monitors and gauges will light up for approx. 3 sec.

- q Engine oil temperature monitor (3)
- q Charge level monitor (4)
- q Fuel level monitor (5)
- q Engine coolant temperature monitor (6)
- q Engine oil pressure monitor (7)
- q Engine coolant temperature gauge (8)
- q Fuel gauge (9)
- q Pre-heating monitor (10)
- q Air cleaner clogging monitor (11)
- q Swing lock monitor (12)
- q Engine oil support monitor (13)

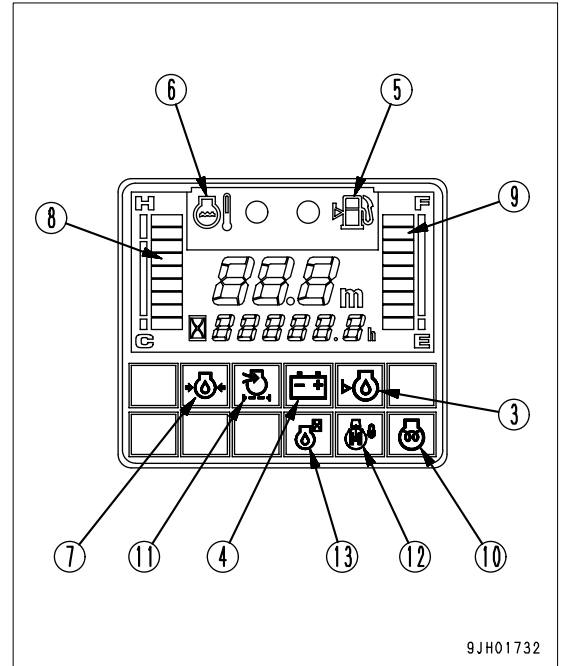

If the monitors or gauges do not light up or the buzzer does not sound, there is probably a blown bulb or disconnection, so please contact your Komatsu distributor for repair.

After approx. 3 seconds, the following monitors and gauges will stay lighted up; the other monitors and gauges will go out.

- q Charge level monitor (4)
- q Engine oil pressure monitor (7)
- q Engine coolant temperature gauge (8)
- q Fuel gauge (9)

STARTING ENGINE

Normal Starting

⚠ WARNING

- q Start the engine only after sitting down in the operator's seat.
- q Do not attempt to start the engine by short-circuiting the engine starting circuit. Such an act may cause serious bodily injury or fire.
- q Check that there are no persons or obstacles in the surrounding area, then sound the horn and start the engine.
- q Exhaust gas is toxic. When starting the engine in confined spaces, be particularly careful to ensure good ventilation.

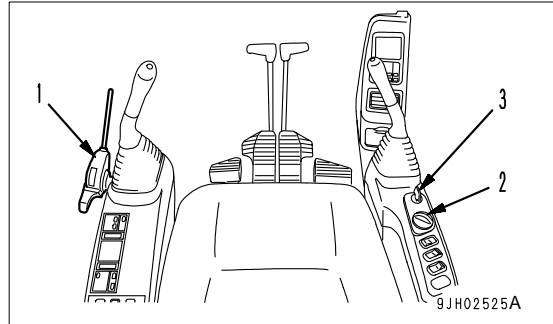

NOTICE

- q Before starting the engine, check that the fuel control dial is at the low idling (MIN) position. If the fuel control dial is at the FULL position, the engine will accelerate suddenly and cause damage to the engine parts.
- q Do not crank the starting motor continuously for more than 20 seconds. If the engine does not start, wait for at least 2 minutes before trying again.

1. Check the safety lock lever (1) is at the LOCK position (L). If the safety lock lever is in the FREE position (F), the engine does not start.

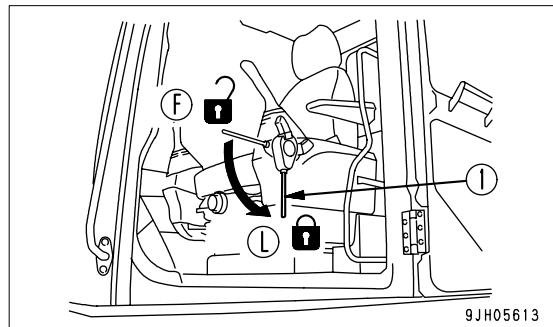

2. Set fuel control dial (2) at the low idling (MIN) position. If it is at the high idling (MAX) position, always change it to the low idling (MIN) position.

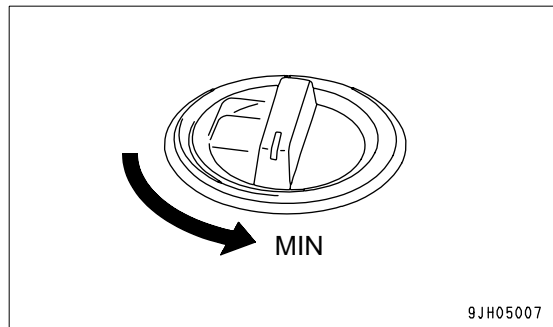

- Turn the key in starting switch (3) to the START position (C). The engine will start.

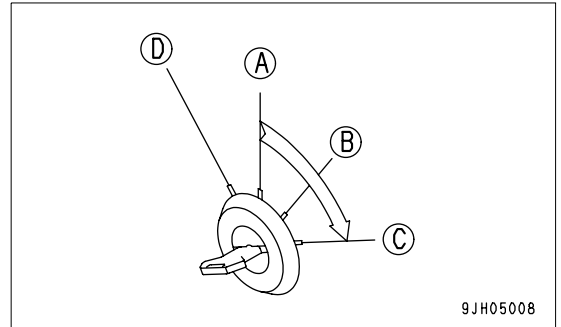

- After the engine starts, release the key in starting switch (3). The key will automatically return to the ON position (B).

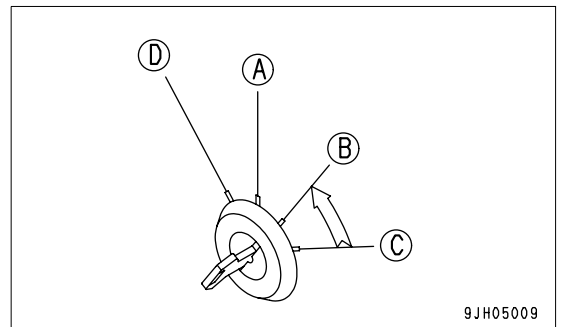

- Even after the engine is started, do not touch the work equipment control levers and the travel pedals, while the engine hydraulic pressure monitor lamp is still lighted.

NOTICE

If the engine oil pressure monitor does not go out even after 4 to 5 seconds have passed, stop the engine immediately. Check the oil level, check for leakage of oil, and take the necessary action.

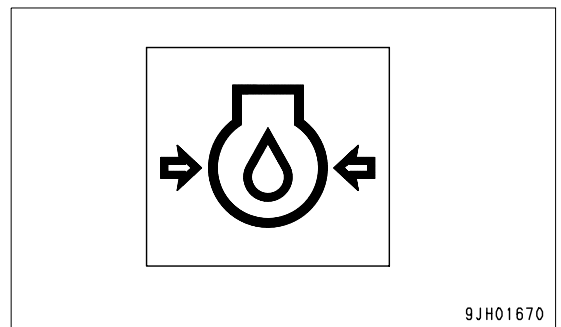

Starting Engine in Cold Weather

⚠ WARNING

- q Start the engine only after sitting down in the operator's seat.
- q Do not attempt to start the engine by short-circuiting the engine starting circuit. Such an act may cause a serious bodily injury or fire.
- q Check that there are no persons or obstacles in the surrounding area, then sound the horn and start the engine.
- q Never use starting aid fluids as they may cause explosions.
- q Exhaust gas is toxic. When starting the engine in confined spaces, be particularly careful to ensure good ventilation.

NOTICE

- q Before starting the engine, check that fuel control dial (2) is at the low idling (MIN) position. If the fuel control dial is at the FULL position, the engine will accelerate suddenly and cause damage to the engine parts, so set it to an intermediate or low speed position.
- q Do not keep the starting motor rotating continuously for more than 20 seconds. If the engine fails to start, wait for about 2 minutes and repeat from Step 2.

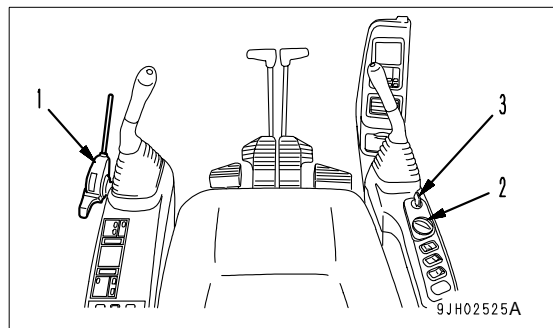

When starting in low temperatures, do as follows.

1. Check the safety lock lever (1) is at the LOCK position (L). If the safety lock lever is in the FREE position (F), the engine does not start.

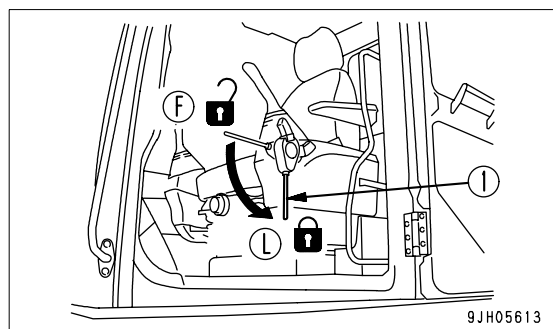

2. Set fuel control dial (2) at a low idling (MIN) position. Do not set fuel control dial (2) at the high idling (MAX) position.

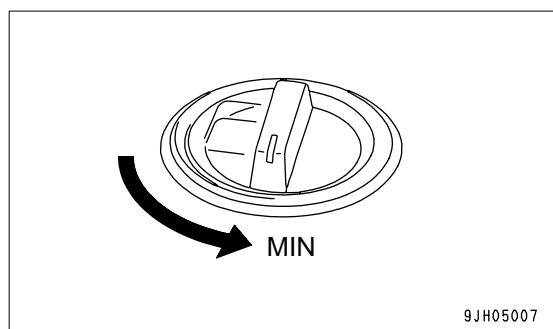

- Hold the key in starting switch (3) at the HEAT position (D), and check that preheating monitor (4) lights up. After about 30 seconds, preheating monitor lamp (4) will flash to indicate that preheating is finished.

(The flashing will stop after approx. 10 seconds.)

REMARK

The monitors and gauges will light up also when the key is turned to the HEAT position, but this is not an abnormality. If the temperature is low, the monitor screen may become dark or it may take time for the display to appear, but this is not an abnormality.

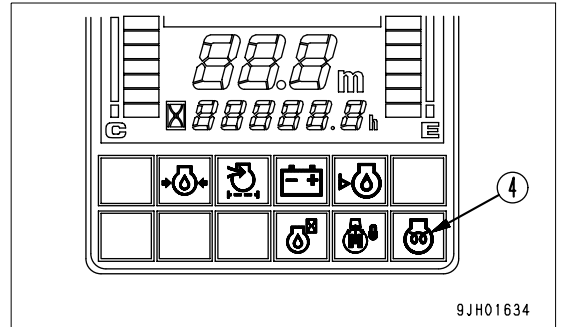
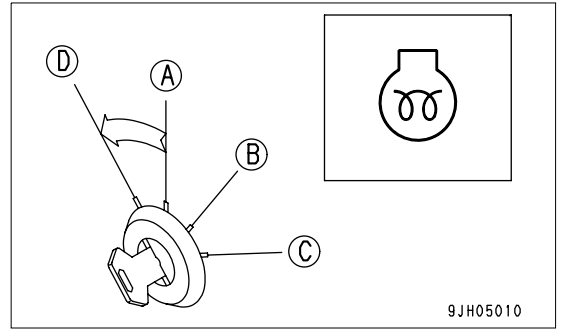

- When preheating monitor (4) flashes, turn the key in starting switch (3) to the START position (C) to start the engine.

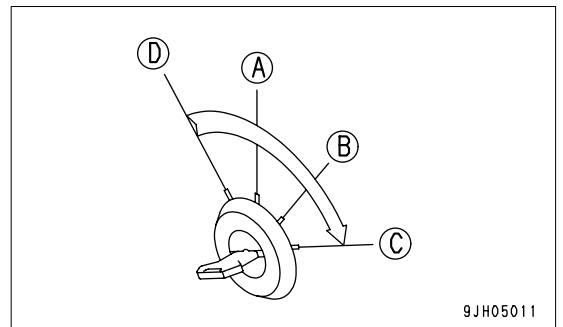

- After the engine starts, release the key in starting switch (3). The key will automatically return to the ON position (B).

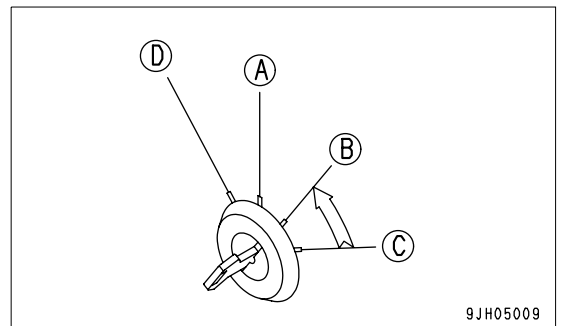

- After starting the engine, do not touch the work equipment control lever or travel pedal while the engine oil pressure monitor lamp is lighted up.

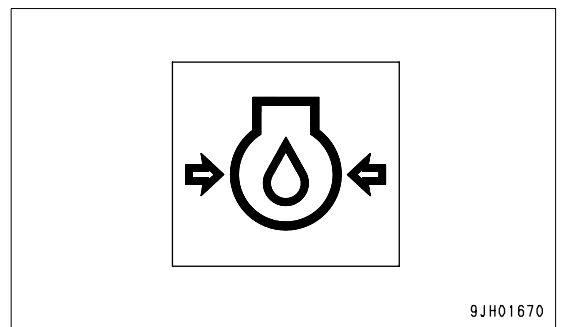

AFTER STARTING ENGINE

WARNING

- q If any trouble occurs, such as sudden stopping or abnormal operation, turn the starting switch to the OFF position.
- q If the work equipment is operated without carrying out the warming-up operation properly, the reaction of the work equipment to the operation of the control lever will be slow and the work equipment may not move as the operator intends. To prevent such problems, always be sure to carry out the warming-up operation fully. In cold weather particularly, be extremely careful to carry out the warming-up operation fully.

Warming-up Operation

NOTICE

- q When the hydraulic oil is at a low temperature, do not carry out operations or move the levers suddenly. Always carry out the warming-up operation. This will help to extend the machine life. Do not suddenly accelerate the engine before the warming-up operation is completed.
- q Do not run the engine at low idling or high idling continuously for more than 20 minutes. This will cause leakage of oil from the turbocharger oil supply piping. If it is necessary to run the engine at idling, apply a load from time to time or run the engine at a mid-range speed.

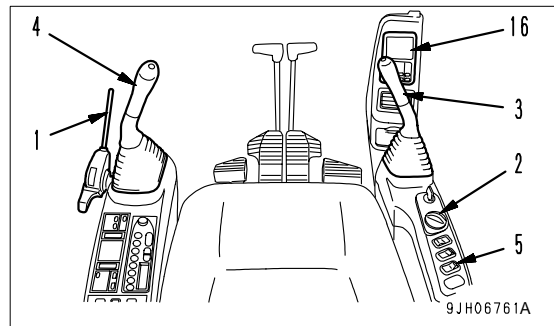

REMARK

If the engine water temperature is above 30°C, to protect the turbocharger, the engine speed does not rise for 2 seconds after starting, even if the fuel control dial is turned.

If the hydraulic oil temperature is low, the hydraulic oil temperature monitor display will be white.

After starting the engine, do not immediately start operations. First, carry out the following operations and checks.

1. Turn fuel control dial (2) to center position (a) between the low idling (MIN) and high idling (MAX) positions and run the engine at a mid-range speed under no load until the engine water temperature monitor gives a green display.

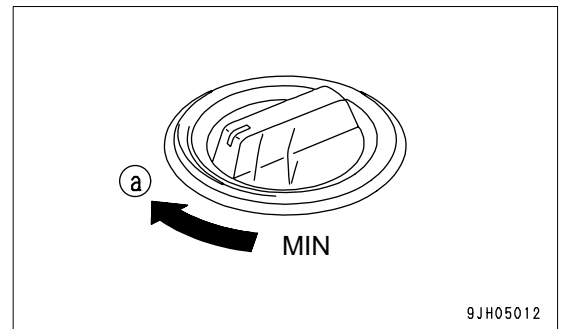

2. Set safety lock lever (1) to the FREE position (F) and raise the bucket from the ground.

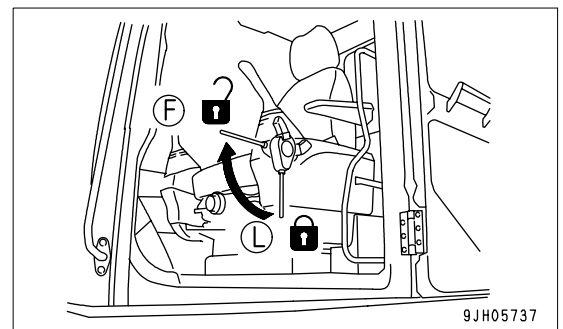

3. Operate bucket control lever (3) and arm control lever (4) slowly to move the bucket cylinder and arm cylinder to the end of the stroke.

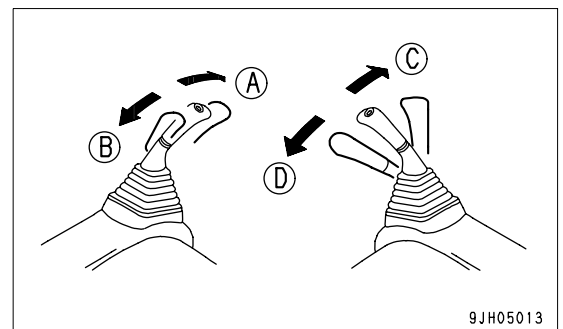

4. Operate the bucket for 30 seconds and the arm for 30 seconds in turn fully for 5 minutes.

- (A): Arm is pushed out
- (B): Arm is pulled in
- (C): Bucket is pushed out
- (D): Bucket is pulled in

REMARK

If the swing lock switch (5) is set to the ON (actuated) position and swing control lever (4) is operated at full stroke, oil temperature rise can be increased earlier.

- (E): Left swing
- (F): Right swing

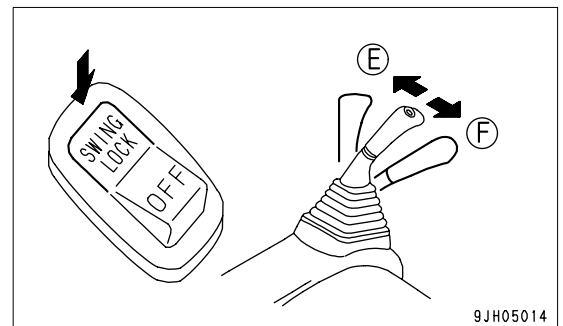

NOTICE

When the work equipment is retracted, take care that it does not interfere with the machine body or ground.

5. After carrying out the warming-up operation, check that each gauge and monitor lamp is in the following condition.
 - q Engine oil temperature monitor (6): Is it lighted up?
 - q Charge level monitor (7): Is it lighted up?
 - q Fuel level monitor (8): Is it lighted up?
 - q Engine water temperature monitor (9): OFF
 - q Engine oil pressure monitor (10): Is it lighted up?
 - q Engine coolant temperature gauge (11): Is it in green range?
 - q Fuel gauge (12): Is it in green range?
 - q Air cleaner clogging monitor (13): Is it lighted up?
 - q Engine oil support monitor (14): Is it lighted up?
 - q Engine pre-heating monitor (15): Is it lighted up?
6. Check that there is no abnormal exhaust gas color, noise or vibration. If any abnormality is found, contact your Komatsu distributor.
7. If air cleaner clogging monitor (13) is lighted up, clean or replace the element immediately.

For details of the method of cleaning the element, see "CHECK, CLEAN AND REPLACE AIR CLEANER ELEMENT (4-20)".

8. Use the working mode switch on monitor panel (16) to select the working mode to be used.

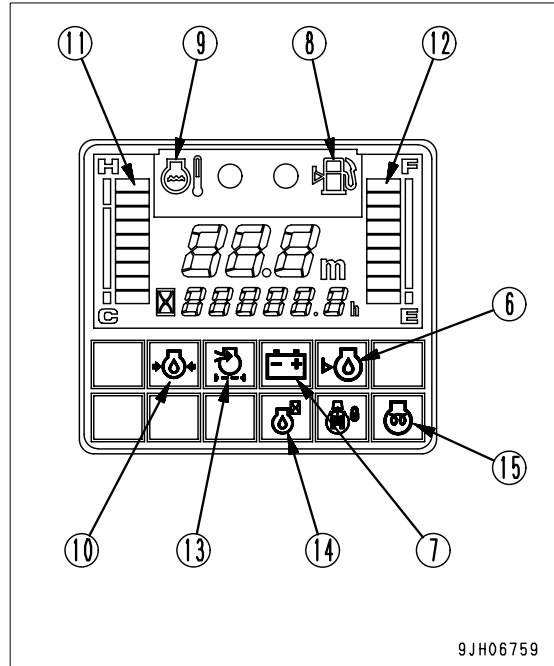

9JH06759

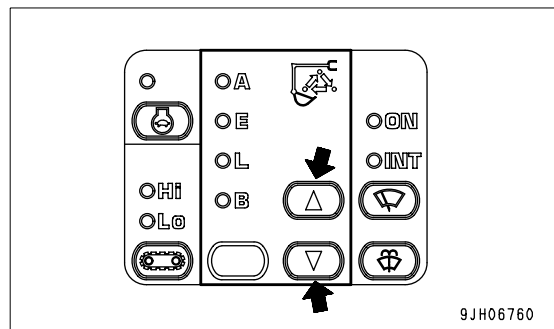

9JH06760

In Cold Weather Areas

(AUTOMATIC WARMING-UP OPERATION)

This machine is equipped with an automatic warming-up device.

When the engine is started, if the engine water temperature is low (below 30 °C), the warming-up operation is carried out automatically.

The automatic warming-up operation is canceled if the engine water temperature reaches the specified temperature (30 °C) or if the warming-up operation is continued for 10 minutes. If the engine water temperature or hydraulic oil temperature are low after the automatic warming-up operation, warm the engine up further as follows.

NOTICE

- q **Do not suddenly accelerate the engine before the warming-up operation is completed. Do not run the engine at low idling or high idling continuously for more than 20 minutes. This will cause leakage of oil from the turbocharger oil supply piping. If it is necessary to run the engine at idling, apply a load from time to time or run the engine at a mid-range speed.**
- q **Never carry out operations or operate the levers suddenly when the hydraulic oil is still at low temperature. Always continue the warming-up operation until the work equipment monitor display is green. This will extend the service life of the machine.**

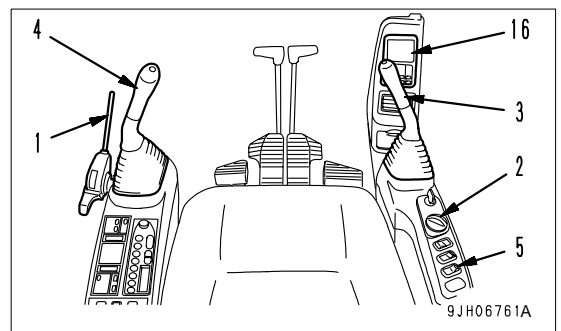

1. Turn fuel control dial (2) to the low idling (MIN) position and run the engine under no load until the engine water temperature monitor gives a green display.
2. To raise the hydraulic oil temperature quickly, use the operating mode switch on the machine monitor to set to A mode (heavy-duty operation mode).

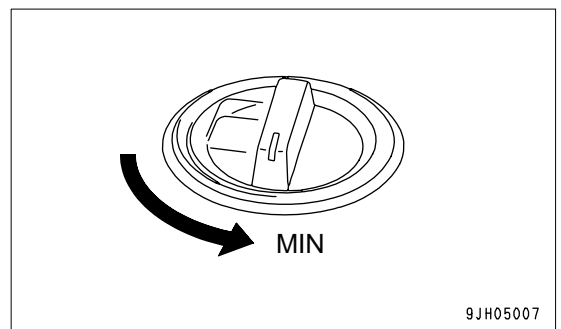

3. Turn fuel control dial (2) to the medium speed position (a).

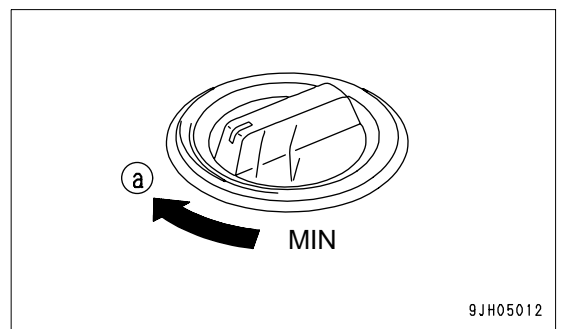

4. Set safety lock lever (1) to the FREE position (F) and raise the bucket from the ground.

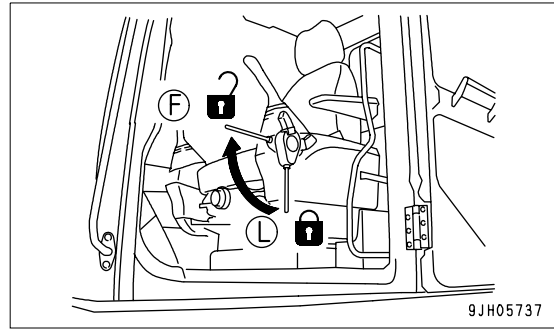

5. Operate bucket control lever (3) and arm control lever (4) slowly to move the bucket cylinder and arm cylinder to the end of the stroke.
6. Operate the bucket for 30 seconds and the arm for 30 seconds in turn fully for 5 minutes.

- (A): Arm is pushed out
- (B): Arm is pulled in
- (C): Bucket is pushed out
- (D): Bucket is pulled in

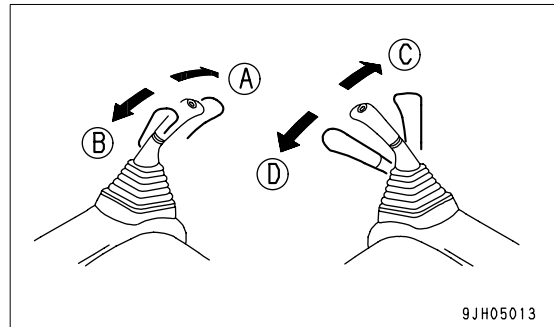

REMARK

If the swing lock switch (5) is set to the ON (actuated) position and swing control lever (4) is operated at full stroke, oil temperature rise can be increased earlier.

- (E): Left swing
- (F): Right swing

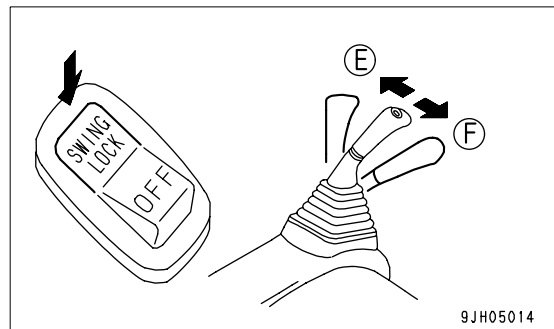

NOTICE

When the work equipment is retracted, take care that it does not interfere with the machine body or ground.

7. After carrying out the warming-up operation, check that each gauge and monitor lamp is in the following condition.
 - q Engine oil temperature monitor (6): Is it lighted up?
 - q Charge level monitor (7): Is it lighted up?
 - q Fuel level monitor (8): Is it lighted up?
 - q Engine water temperature monitor (9): OFF
 - q Engine oil pressure monitor (10): Is it lighted up?
 - q Engine coolant temperature gauge (11): Is it in green range?
 - q Fuel gauge (12): Is it in green range?
 - q Air cleaner clogging monitor (13): Is it lighted up?
 - q Engine oil support monitor (14): Is it lighted up?
 - q Engine pre-heating monitor (15): Is it lighted up?
8. Check that there is no abnormal exhaust gas color, noise or vibration. If any abnormality is found, contact your Komatsu distributor.
9. If air cleaner clogging monitor (13) is lighted up, clean or replace the element immediately.

For details of the method of cleaning the element, see "CHECK, CLEAN AND REPLACE AIR CLEANER ELEMENT (4-20)".
10. Turn fuel control dial (2) to the full speed (MAX) position and carry out the operation in Step 4. for 3 to 5 minutes.
11. Repeat the following operation 3 - 5 times and operate slowly.

- | | |
|-----------------------|-------------------|
| Boom operation | RAISE ↔ LOWER |
| Arm operation | IN ↔ OUT |
| Bucket operation | CURL ↔ DUMP |
| Swing operation | LEFT ↔ RIGHT |
| Travel (Lo) operation | FORWARD ↔ REVERSE |

REMARK

If the above operation is not carried out, then may be a delay in response when starting or stopping the actuation of the travel, swing, or work equipment.

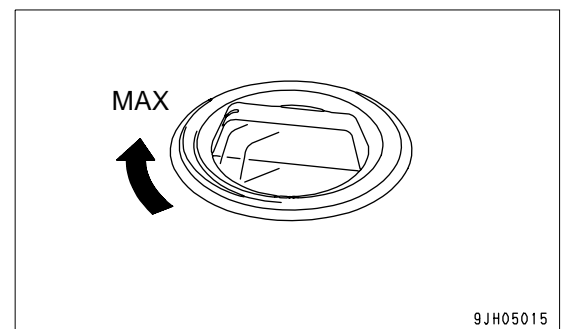
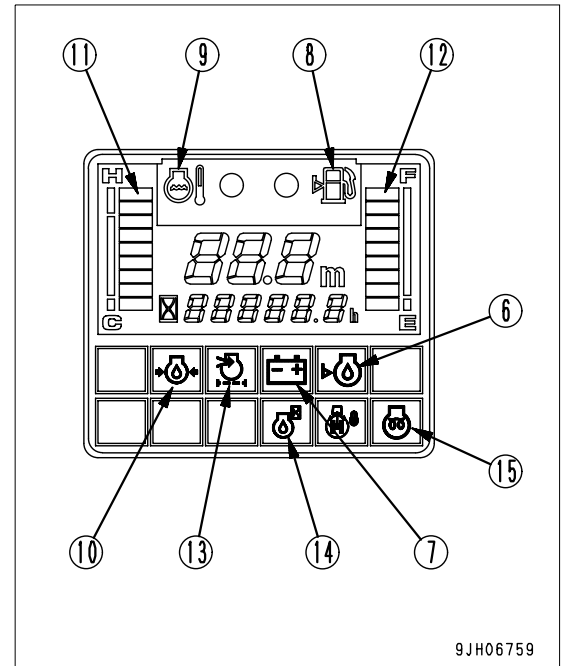

12. Use the working mode switch on monitor panel (16) to select the working mode to be used.

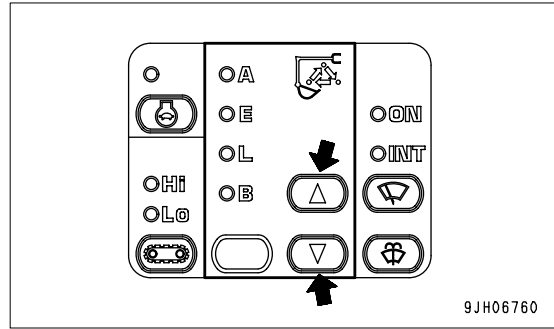

NOTICE

Canceling automatic warming-up operation

If it becomes necessary in an emergency to cancel the automatic warming-up operation or to lower the engine speed to low idling, do as follows.

13. Turn fuel control dial (2) to the full speed (MAX) position and hold it for 3 seconds.

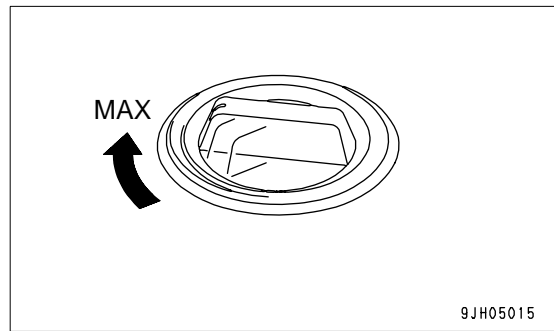

14. When fuel control dial (2) is returned to the low idling (MIN) position, the engine speed will drop.

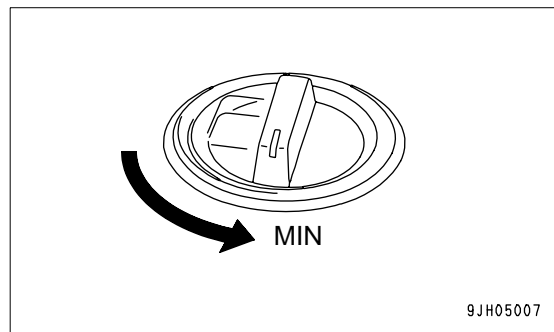

STOPPING THE ENGINE

NOTICE

If the engine is stopped abruptly, service life of component parts of the engine may be considerably reduced. Hence do not stop the engine abruptly except in an emergency. If the engine has overheated, do not try to stop it abruptly but run it at medium speed to allow it to cool down gradually, and then stop it.

1. Run the engine at low idling for about 5 minutes to cool down gradually.
2. Turn the key in starting switch (1) to the OFF position (A) and stop the engine.
3. Remove the key from starting switch (1).

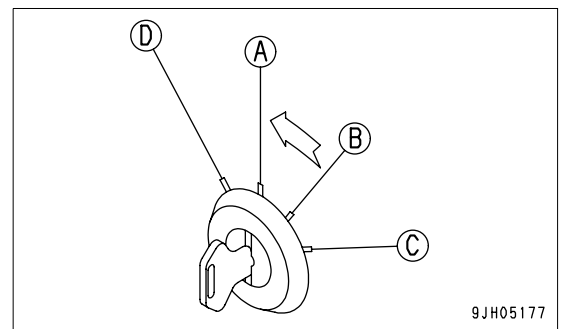
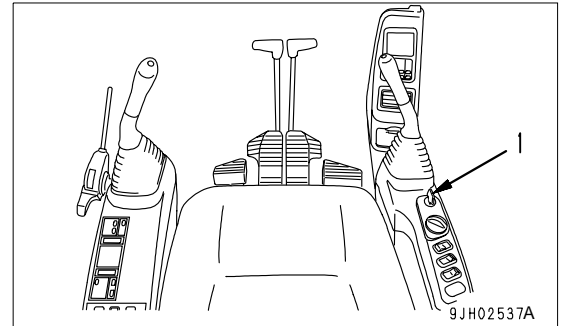

MACHINE OPERATION

Preparations for Moving the Machine Off

WARNING

- q Before operating the steering levers, check the direction of the track frame.
If the sprocket is at the front, the operation of the travel levers is reversed.
- q When moving off, check that the area around the machine is safe, and sound the horn before moving.
- q Do not allow anyone in the area around the machine.
- q Remove all obstacles from the travel path of the machine.
- q The rear of the machine is a blind spot, so be particularly careful when travel in reverse.
- q If the lever is moved inside the deceleration range, engine speed will rise suddenly. Operate the levers carefully.
- q For machines equipped with a travel alarm (if equipped), check that the warning equipment works properly.

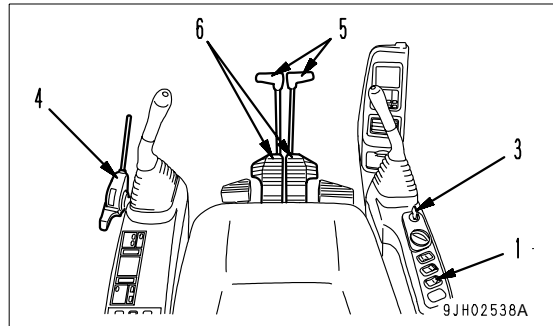

1. Set swing lock switch (1) to the ON (actuated) position and confirm that swing lock monitor lamp (2) lights up.

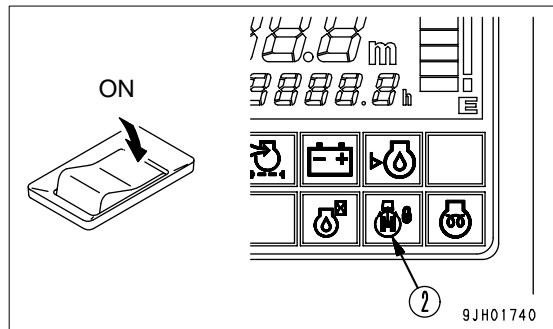

2. Turn fuel control dial (3) towards the full speed position to increase the engine speed.

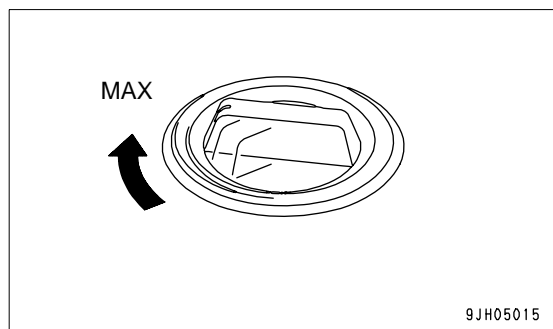

Moving Machine Forward

1. Set safety lock lever (4) in the FREE position (F), fold the work equipment, and raise it 40 to 50 cm from the ground.

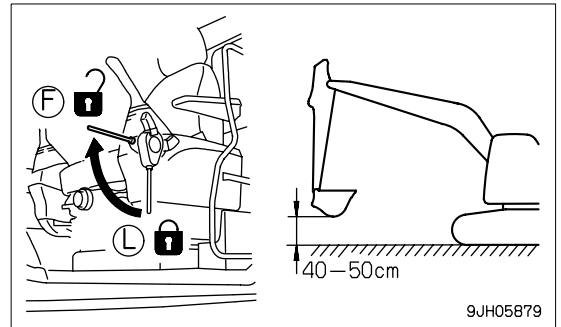

2. Operate right and left travel levers (5) or right and left travel pedals (6) as follows.

- When the sprocket (A) is at the rear of the machine

Push levers (5) forward slowly or depress the front part of pedals (6) slowly to move the machine off.

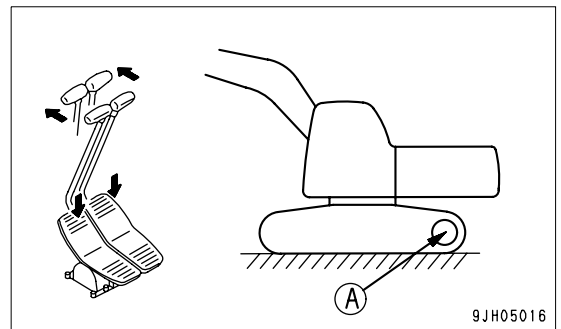

- When the sprocket (A) is at the front of the machine

Pull levers (5) backward slowly or depress the rear part of pedals (6) slowly to move the machine off.

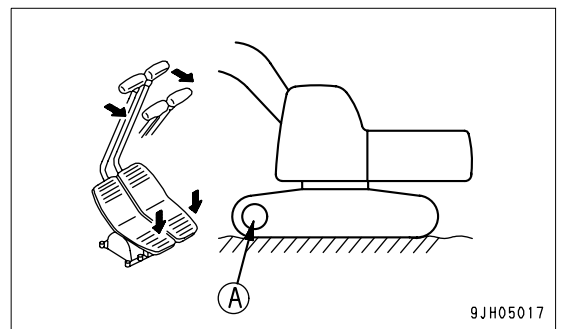

3. For machines equipped with a travel alarm (if equipped), check that the alarm sounds. If the alarm does not sound, please contact your Komatsu distributor for repair.

REMARK

In cold temperatures, if the machine travel speed is not normal, carry out the warming-up operation thoroughly. In addition, if the undercarriage is clogged with mud and the machine travel speed is not normal, remove the soil and mud from the undercarriage.

Moving Machine Backward

1. Set safety lock lever (4) in the FREE position (F), fold the work equipment, and raise it 40 to 50 cm from the ground.

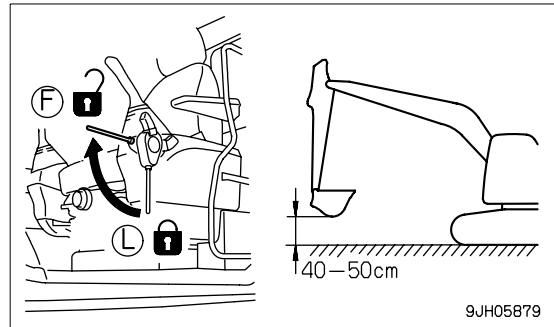

2. Operate right and left travel levers (5) or right and left travel pedals (6) as follows.

- c) When the sprocket (A) is at the rear of the machine

Pull levers (5) backward slowly or depress the rear part of pedals (6) to move the machine off.

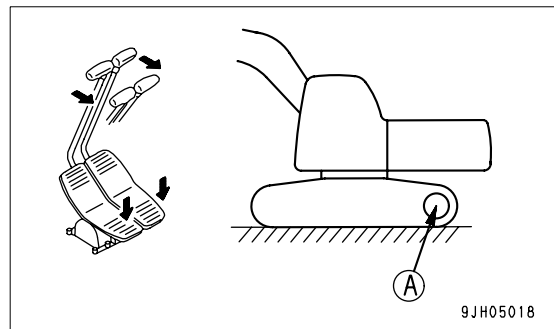

- c) When the sprocket (A) is at the front of the machine

Push levers (5) forward slowly or depress the front part of pedals (6) to move the machine off.

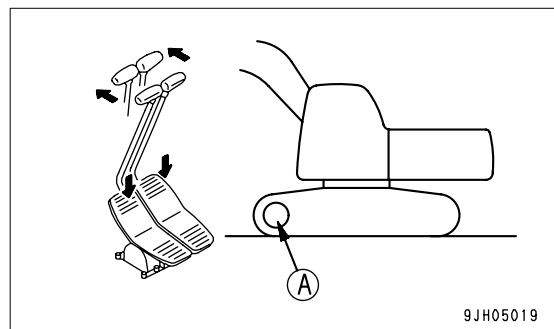

3. For machines equipped with a travel alarm (if equipped), check that the alarm sounds. If the alarm does not sound, please contact your Komatsu distributor for repair.

Stopping Machine

Avoid stopping suddenly. Give yourself ample room when stopping.

1. Put the left and right travel levers (1) in the neutral position, then stop the machine.

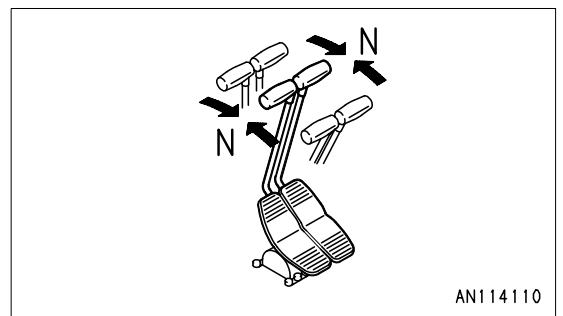
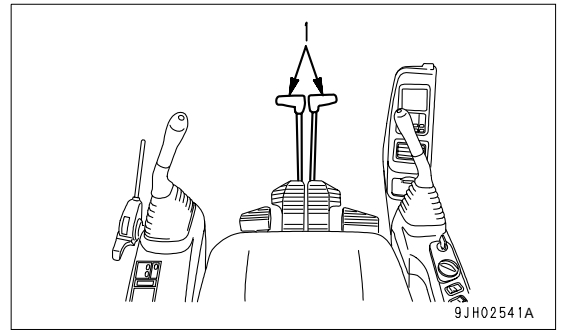

STEERING THE MACHINE

Steering

WARNING

Before operating the travel levers, check the direction of the track frame (the position of the sprocket). If the sprocket is at the rear, the machine moves in the reverse direction to the operation of the travel levers.

Use the travel levers to change direction.

Avoid sudden changes of direction as far as possible. In particular, when carrying out counter-rotation (spin turn), stop the machine first before turning.

Operate two travel levers (1) as follows.

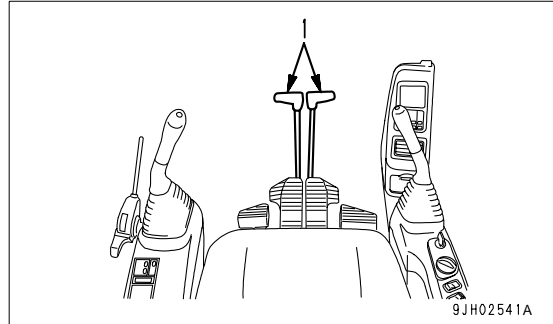

Steering the Machine when Stopped

When turning to the left:

Push the right travel lever forward to turn to the left when traveling forward; and pull it back to turn left when traveling in reverse.

(A): Forward left turn

(B): Reverse left turn

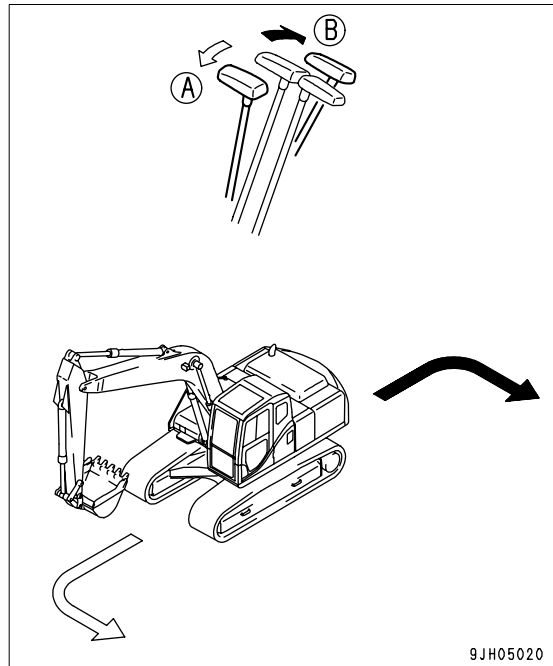

REMARK

When turning to the right, operate the left travel lever in the same way.

Changing Direction of the Machine

When turning to the left:

If the left travel lever is returned to the neutral position, the machine will turn to the left.

(A): Forward left turn

(B): Reverse left turn

REMARK

When turning to the right, operate the right travel lever in the same way.

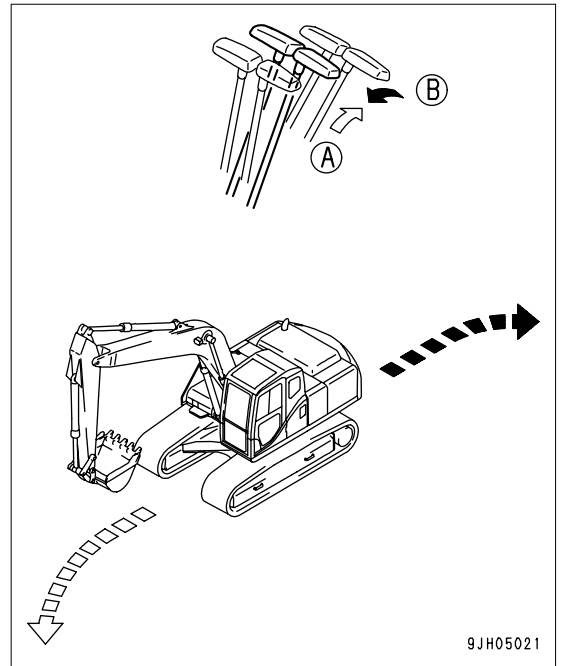

Counter-rotation Turn (Spin Turn)

When using counter-rotation (spin turn) to turn left, pull the left travel lever back and push the right travel lever forward.

REMARK

When using counter-rotation to turn right, pull the right travel lever back and push the left travel lever forward.

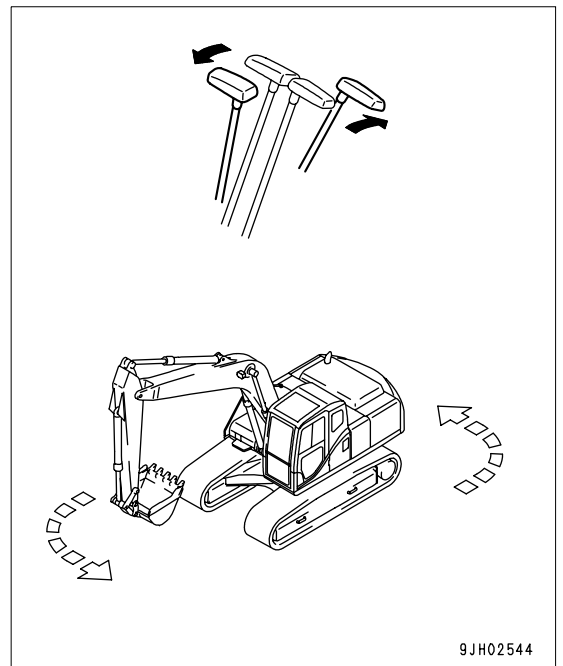

SWINGING

WARNING

The tail of the machine extends outside the tracks. Before operating the swing, check that the area around the machine is safe.

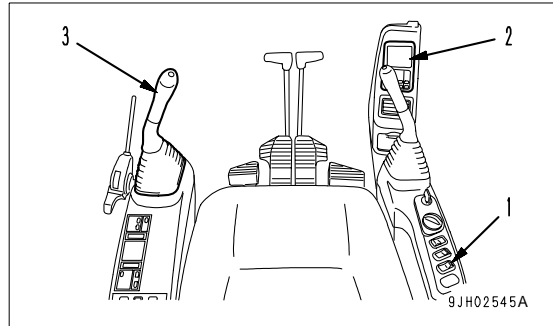

1. Before starting the swing operation, turn swing lock switch (1) OFF and check that swing lock monitor (2) has gone out.

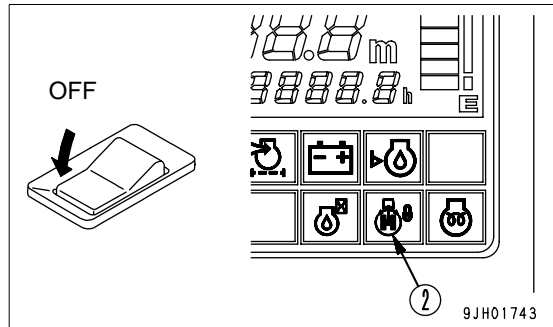

2. Operate left work equipment control lever (3) to swing the upper structure.

(A): Left swing

(B): Right swing

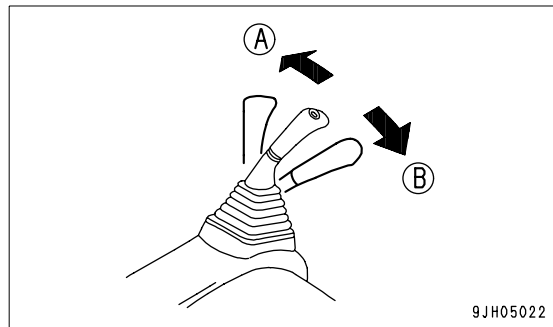

3. When not using the swing, turn swing lock switch (1) ON. Check that swing lock monitor (2) lights up.

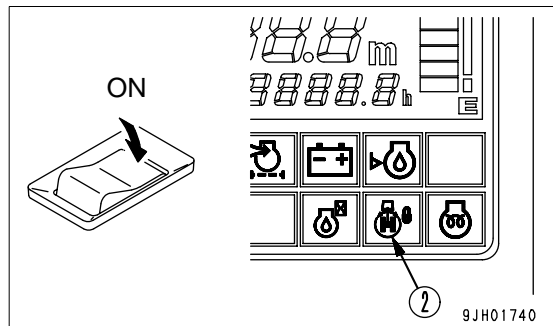

WORK EQUIPMENT CONTROLS AND OPERATIONS

WARNING

If the lever is operated when the engine speed has been lowered by the auto-deceleration function, the engine speed will suddenly rise, so operate the levers carefully.

Use the control levers to operate the work equipment.

Note that when the levers are released, they return to the HOLD position and the work equipment is held in that position.

The work equipment is operated by the left and right work equipment control levers. The left work equipment control lever operates the arm and swing, and the right work equipment control lever operates the boom and bucket.

The movements of the lever and work equipment are as shown in the diagrams on the right. When the levers are released, they automatically return to the neutral position and the work equipment is held in place.

- If the work equipment control levers are returned to the neutral position when the machine is stopped, even if the fuel control dial is set to FULL, the auto-deceleration mechanism will act to reduce the engine speed to a mid-range speed.

REMARK

With this machine, an accumulator is installed in the operating circuit, so if less than 15 seconds has passed since the engine was stopped, when the starting switch is turned to the ON position even when the engine is stopped, it is possible to operate the levers to lower the work equipment to the ground.

In addition, this operation can also be used to release the remaining pressure in the hydraulic cylinder circuit or to lower the boom after the machine has been loaded onto a trailer.

Arm operation

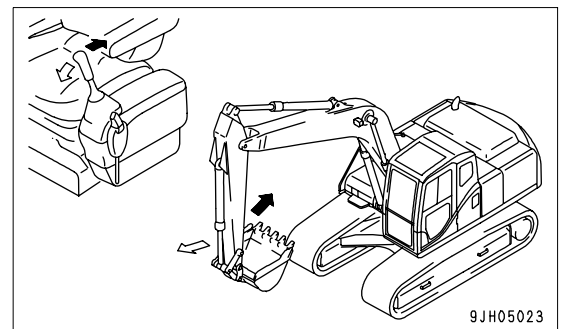

Swing operation

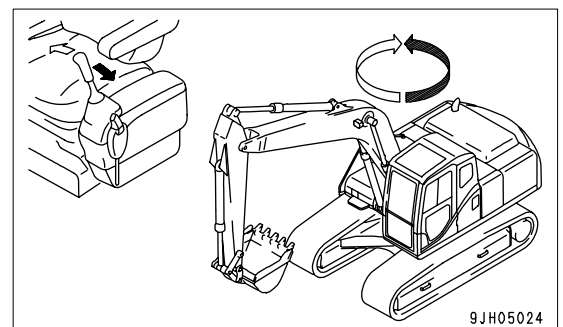

Boom operation

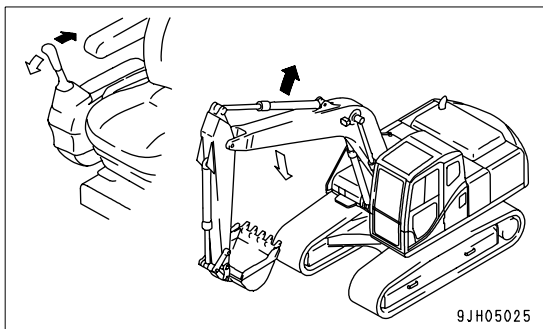

Bucket operation

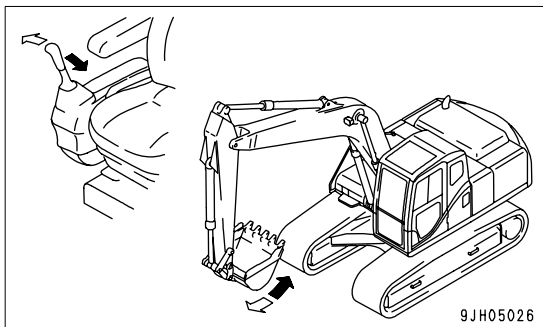

WORKING MODE

Working Mode

The mode selector switch can be used to switch the mode to match the operating conditions and purpose, thereby enabling work to be carried out efficiently.

Make effective use of each mode as follows.

When the starting switch is turned ON, the working mode is set to A mode (digging).

Use the working mode switch to set the mode to the most efficient mode to match the type of work.

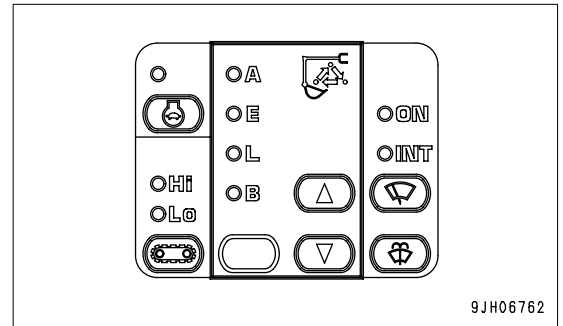

Working mode	Applicable operations
A mode	Normal digging, loading operations (Operations with emphasis on productivity)
E mode	Normal digging, loading operations (Operations with emphasis on fuel consumption)
L mode	When positioning work equipment exactly (fine-control operations)
B mode	Breaker operations

NOTICE

Breaker operations must be carried out in B mode. If they are carried out in any mode other than B mode, the hydraulic equipment will be damaged.

One-Touch Power Max. Switch

The one-touch power max. Switch can be used during operations to increase the power. Make effective use of this function whenever necessary in combination with the working mode.

- q Press the left knob switch and keep it pressed. The power is increased as long as the switch is being pressed. However, the increased power is automatically canceled after 8.5 seconds.
- q This function is not actuated when the working mode is set to L mode or B mode.

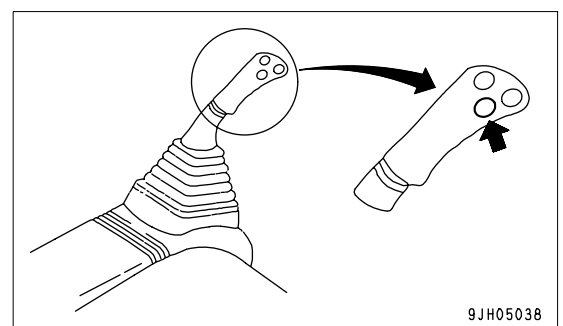

PROHIBITED OPERATIONS

WARNING

- q If it is necessary to operate the work equipment control lever when the machine is traveling, stop the machine, then operate the control lever.
- q If any lever is operated when the auto-deceleration is being actuated, the engine speed will suddenly increase, so be careful when operating.

Operations Using Swing Force

Do not use the swing force to compact soil or break objects. This is not only dangerous, but will also markedly reduce the life of the machine.

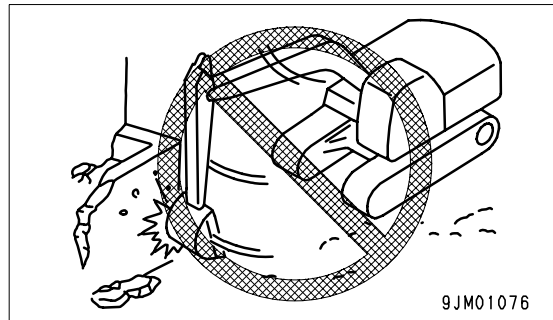

Operations Using Travel Force

Do not dig the bucket into the ground and use the travel force to carry out excavation. This will damage the machine or work equipment.

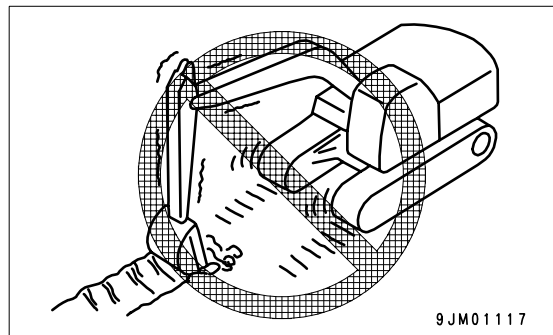

Prohibition of Operations Using Hydraulic Cylinders to Stroke Ends

If the work equipment is used with the cylinder rod operated to its stroke end, and given impact by some external force, the hydraulic cylinders will be damaged, causing personal injury. Avoid operations with the hydraulic cylinder fully retracted or fully extended.

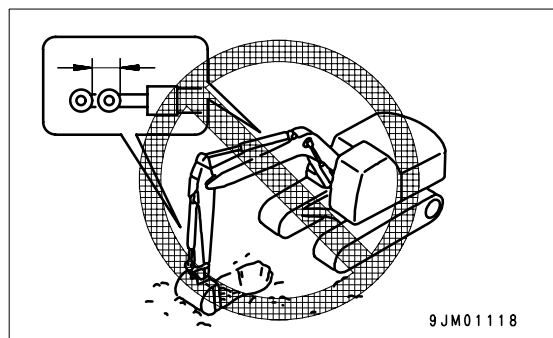

Operations Using Bucket Dropping Force

Do not use the dropping force of the machine for digging, or use the dropping force of the bucket as a pickaxe, breaker, or pile driver. This will markedly reduce the life of the machine.

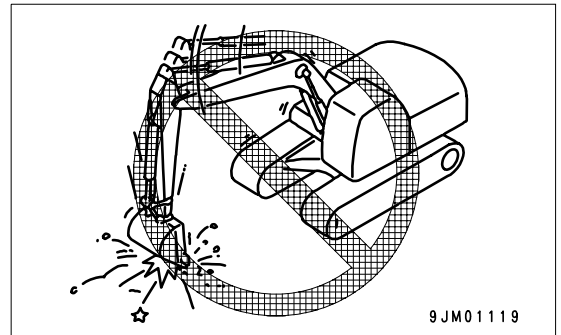

Operations Using Machine Dropping Force

Do not use the dropping force of the machine for digging.

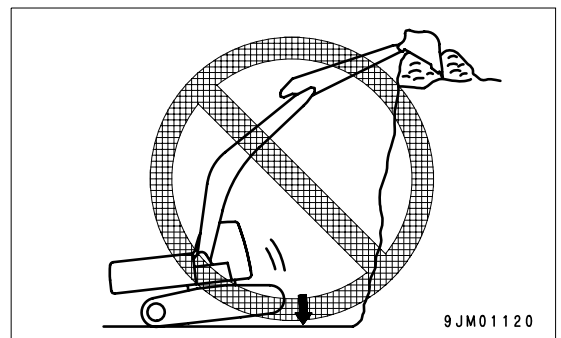

Digging Hard Rocky Ground

Do not attempt to directly excavate hard rocky ground with the work equipment. It is better to excavate it after breaking up by some other means. This will not only save the machine from damage but make for better economy.

Sudden Lever Shifting High Speed Travel

- (1) Never carry out sudden lever shifting as this may cause sudden starting.
- (2) Avoid sudden lever shifting from forward (A) to reverse (B) (or from reverse (B) to forward (A)).
- (3) Avoid sudden lever shifting change such as sudden stopping from near top speed (lever release operation).

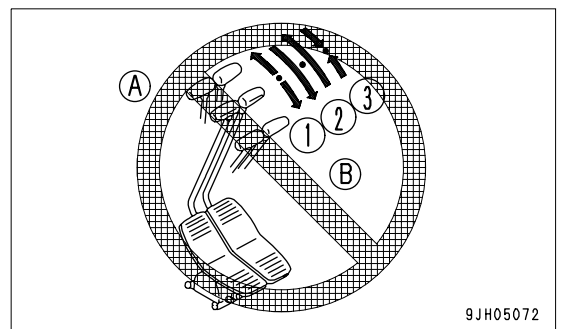

GENERAL OPERATION INFORMATION

Traveling

Traveling over boulders, tree stumps, or other obstacles will cause a big shock to the chassis (and in particular to the tracks), and this will cause damage to the machine. For this reason, always remove any obstacles or travel around them, or take other steps to avoid traveling over such obstacles as far as possible.

If there is no way to avoid traveling over an obstacle, reduce the travel speed, keep the work equipment close to the ground, and try to travel so that the center of the track passes over the obstacle.

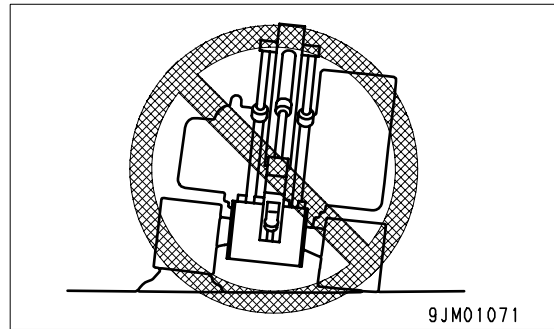

High Speed Travel

On uneven roadbeds, such as rockbed or uneven roads with large rocks, travel at low speed. When traveling at high speed, set the idler at the front of the machine.

- Press travel speed selector switch (1) to select the travel speed.

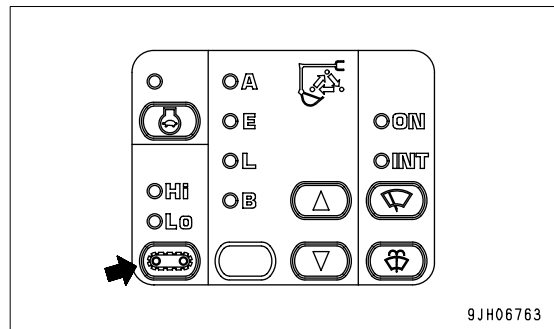

Permissible Water Depth

NOTICE

When driving the machine out of water, if the angle of the machine exceeds 15°C, the rear of the upper structure will go under water, and water will be thrown up by the radiator fan. This may cause the fan to break.

Be extremely careful when driving the machine out of water.

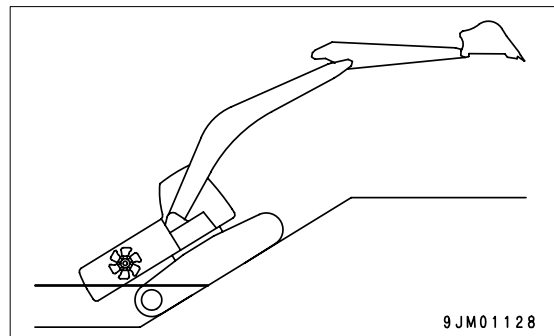

Do not drive the machine in water deeper than of the center of carrier roller (1).

Supply grease to the parts which have been under water for a long time until the used grease is projected out of the bearings (around the bucket pin, in particular).

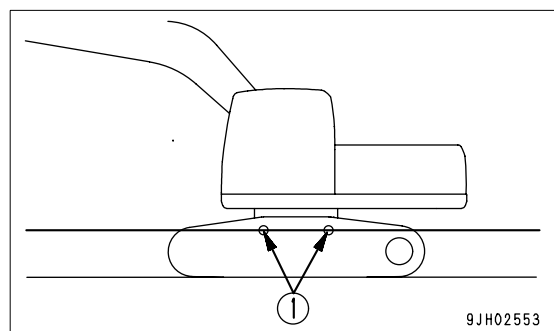

TRAVELING ON SLOPES

WARNING

- q Turning or operating the work equipment when working on slopes may cause the machine to lose its balance and turn over, so avoid such operations. It is particularly dangerous to swing downhill when the bucket is loaded. If such operations have to be carried out, pile soil to make a platform (A) on the slope so that the machine can be kept horizontal when operating.
- q Do not travel up or down steep slopes. There is danger that the machine may turn over.
- q When traveling, raise the bucket approx. 20 to 30 cm from the ground. Do not travel downhill in reverse.
- q Never turn on slopes or travel across slopes. Always go down to a flat place to perform these operations. It may be longer, but it will ensure safety.
- q Always operate or travel in such a way that it is possible to stop safely at any time if the machine slips or becomes unstable.
- q When traveling uphill, if the shoes slip or it is impossible to travel uphill using only the force of the tracks, do not use the pulling force of the arm to help the machine travel uphill. There is danger that the machine may turn over.

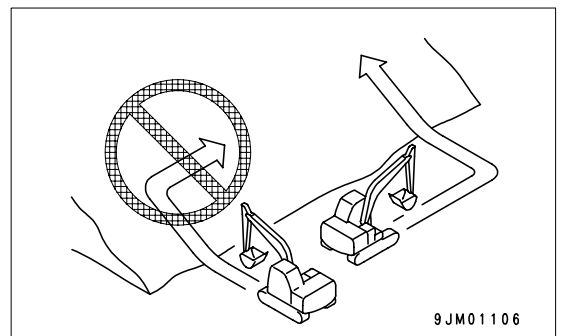
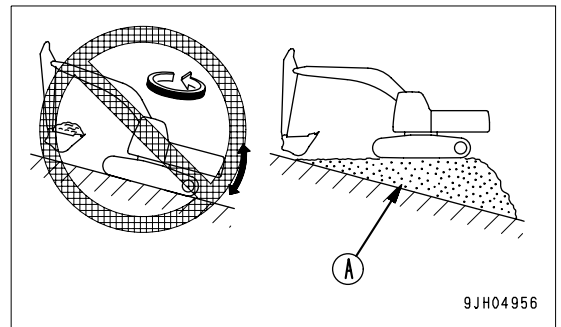

1. When traveling down steep hills, use the travel lever and fuel control dial to keep the travel speed low. When traveling down a steep hill of more than 15°, set the work equipment to the posture shown in the diagram on the right, and lower the engine speed.

REMARK

Travel down hills with the sprocket side down. If the machine travels down with the sprocket side up, the track tends to become loose, and that can cause skipping pitches.

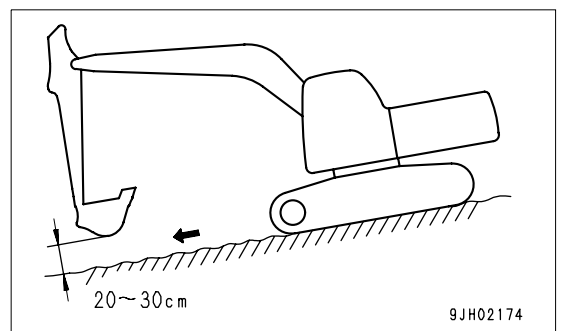

2. When traveling up a steep hill of more than 15°, set the work equipment to the posture shown in the diagram on the right.

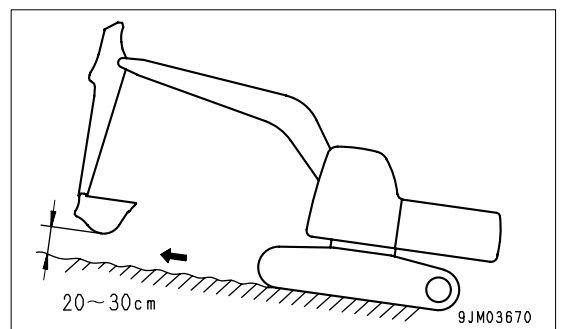

- When traveling up a steep slope, extend the work equipment to the front to improve the balance, keep the work equipment approximately 20 to 30 cm above the ground, and travel at low speed.

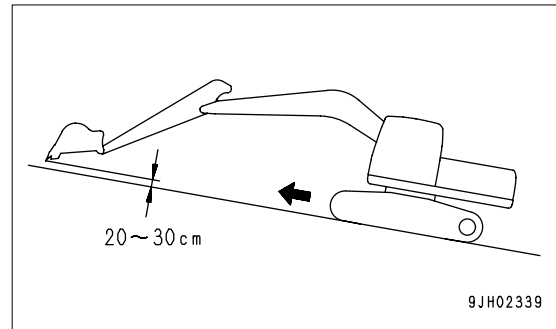

Traveling Downhill

Put the travel lever in the neutral position. This will cause the brake to be automatically applied.

Engine Stopped on Slope

If the engine stops when traveling uphill, move the travel levers to the neutral position, lower the bucket to the ground, stop the machine, then start the engine again.

Cab Doors on Slope

- If the engine stops when the machine is on a slope, never use the left work equipment control lever to carry out swing operations. The upper structure will swing under its own weight.
- Do not open or close the door when the machine is on a slope. The operating effort may suddenly change. Always keep the door locked in position when it is open and when it is closed.

ESCAPE FROM MUD

Always operate carefully to avoid getting affixed in mud. If the machine does get affixed in mud, do as follows to get the machine out.

Stuck One Side of Track

NOTICE

When using the boom or arm to raise the machine, always have the bottom of the bucket in contact with the ground. The angle between the boom and arm should be 90° to 110°.

The same applies when using the bucket installed in the reverse direction.

When only one side is affixed in mud, use the bucket to raise the track, then lay boards or logs and drive the machine out.

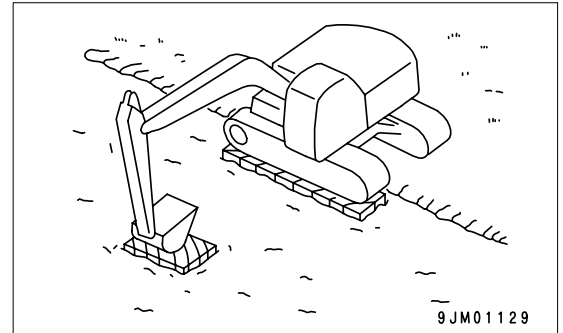

Stuck Both Sides of Tracks

When the tracks on both sides are stuck in mud and they slip, making it impossible for the machine to move, lay boards or logs as explained above, and dig the bucket into the ground in front. Then pull in the arm as in normal digging operations and put the travel levers in the FORWARD position to pull the machine out.

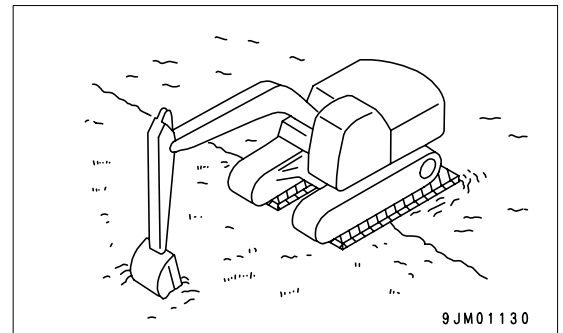

RECOMMENDED APPLICATIONS

In addition to the following, it is possible to further increase the range of applications by using various attachments.

Backhoe Work

A backhoe is suitable for excavating areas that are lower than the machine.

When the condition of the machine is as shown in the diagram on the right (angle between [bucket cylinder and link] and [arm cylinder and arm] is 90°), the maximum excavation force is obtained from the pushing force of each cylinder.

When excavating, use this angle effectively to optimize your working efficiency.

The range for excavating with the arm is from a 45° angle away from the machine to a 30° angle towards the machine.

There may be some differences depending on the excavation depth, but try to stay within the above range rather than operating the cylinder to the end of its stroke.

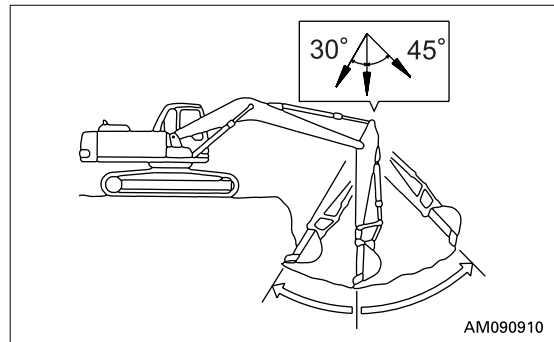
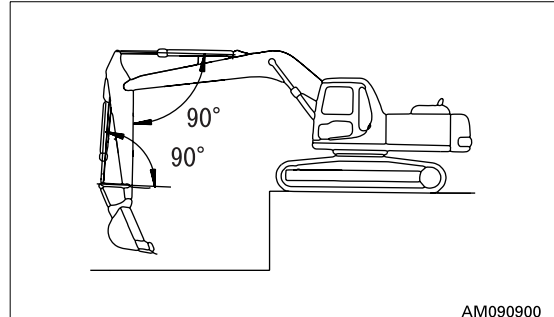

Shovel Work

A shovel is suitable for excavating at a position higher than the machine. Shovel work is performed by attaching the bucket in the reverse direction.

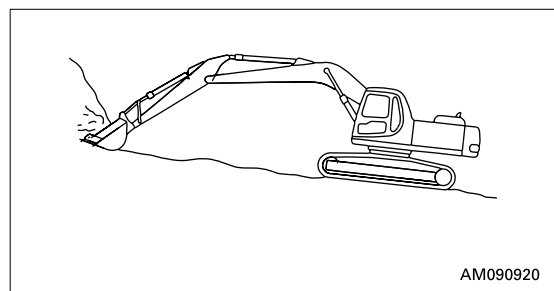

Ditching Work

Ditching work can be performed efficiently by attaching a bucket which matches the digging operation and then setting the tracks parallel to the line of the ditch to be excavated.

To excavate a wide ditch, first dig both sides and then finally remove the center portion.

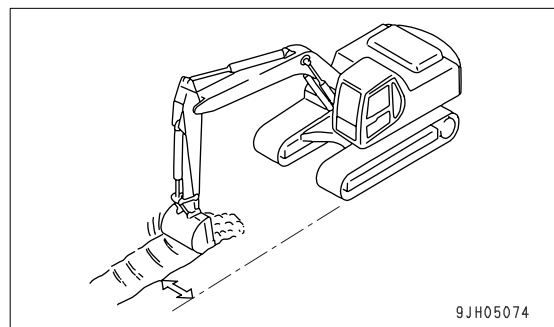

Loading Work

In places where the swing angle is small, work efficiency can be enhanced by locating the dump truck in a place easily visible to the operator.

Loading is easier and capacity greater if you begin from the front of the dump truck body than if loading is done from the side.

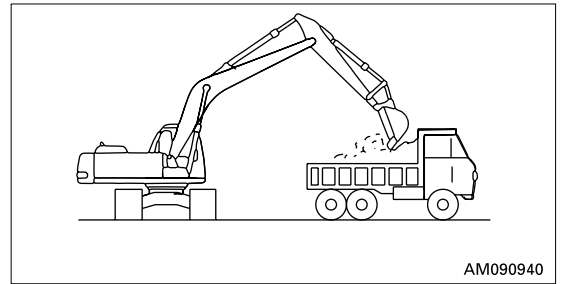

BUCKET REPLACEMENT AND INVERSION

WARNING

- q When pins are knocked in with a hammer, pieces of metal may fly and cause serious injury. When carrying out this operation, always wear goggles, hard hat, gloves, and other protective equipment.
- q When the bucket is removed, place it in a stable condition.
- q If pins are hit with a strong force, there is a hazard that the pin may fly out and injure people in the surrounding area. Make sure that there is no one in the surrounding area before starting the operation.
- q When removing the pins, do not stand behind the bucket. In addition, be extremely careful not to put your foot under the bucket while standing at the side for the work.
- q When removing or inserting pins, be extremely careful not to get your fingers caught.
- q Never insert your fingers into the pin holes when aligning the holes.

Stop the machine on a firm and flat surface and do the work. When performing joint work, appoint a conductor and follow that person's instructions and signals.

Replacement

1. Place the bucket in contact with a flat surface.

REMARK

When removing the pins, place the bucket so that it is in light contact with the ground.

If the bucket is lowered strongly to the ground, the resistance will be increased and it will be difficult to remove the pins.

NOTICE

After removing the pins, make sure that mud or sand does not get on them. Dust seals are fitted at both ends of the bushings, so be careful not to damage them.

2. Remove the double nut of the stopper bolt for arm pin (A) and link pin (B), remove the bolt, pull out arm pin (A) and link pin (B), and then remove the bucket.
3. Align the arm (5) with holes (1) of the replacement bucket and the link (6) with holes (2), then insert grease-coated pins (A) and (B) into hole (1) and hole (2) respectively.

REMARK

Carry out installation in the reverse order to removal.

When installing the bucket, the O-rings are easily damaged, so fit the O-rings on the boss of the arm end as shown in the diagram. When knocking the pin, move the O-ring down to the regular groove.

4. Install the stopper bolts and nuts for each pin, then grease the pin.

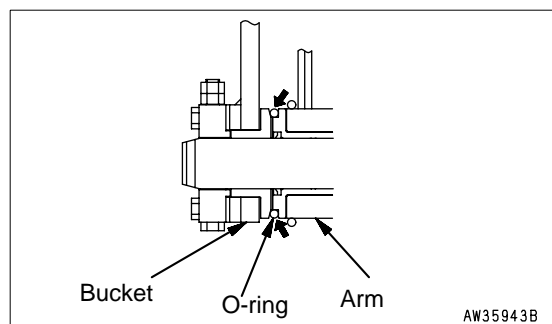
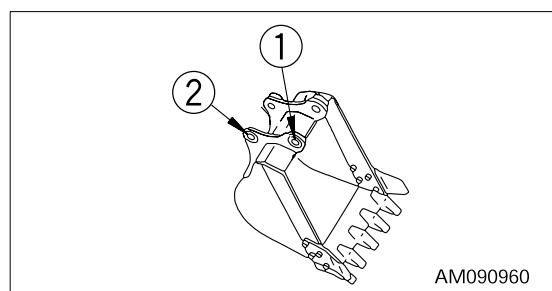
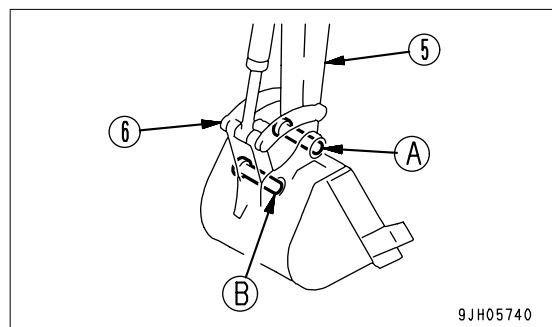

Inversion

1. Place the bucket in contact with a flat surface.

REMARK

When removing the pins, place the bucket so that it is in light contact with the ground.

If the bucket is lowered strongly to the ground, the resistance will be increased and it will be difficult to remove the pins.

NOTICE

After removing the pins, make sure that mud or sand does not get on them. Dust seals are fitted at both ends of the bushings, so be careful not to damage them.

2. Remove the double nut of the stopper bolt for arm pin (A) and link pin (B), remove the bolt, pull out arm pin (A) and link pin (B), and then remove the bucket.
3. Turn the removed bucket. After turning the bucket, align the arm with link mounting hole (1), then align the link with arm mounting hole (2) and install.
4. Align the arm with holes (1) of the replacement bucket and the link with holes (2), then insert grease-coated pins (A) and (B) into hole (1) and hole (2) respectively.

REMARK

Install the O-ring into retaining hole (1) of the arm and bucket. When installing the bucket, the O-rings are easily damaged, so fit the O-rings on the boss of the arm end as shown in the diagram on the right. When knocking in the pins, move the O-ring down to the regular groove.

5. Install the stopper bolts and nuts for each pin, then grease the pin.

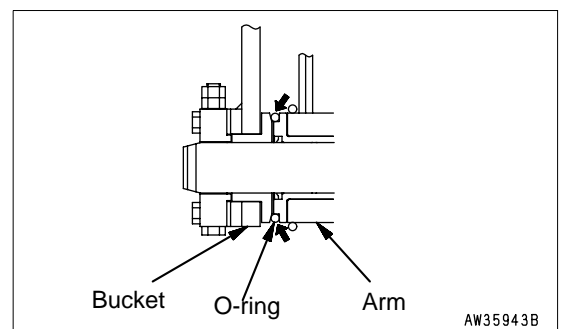
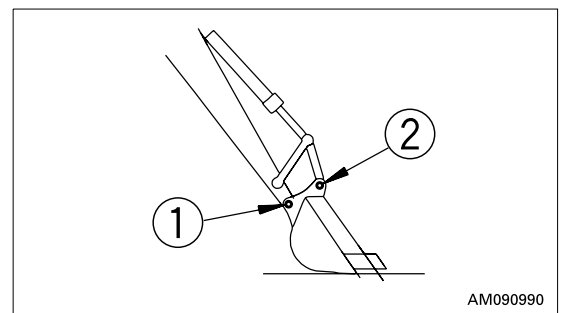
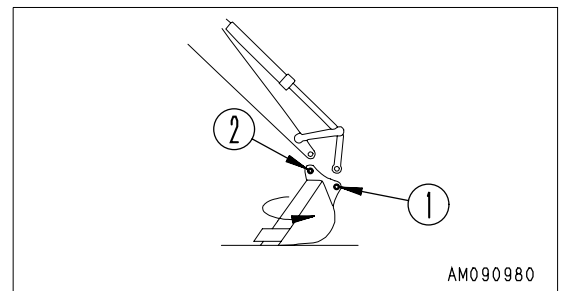
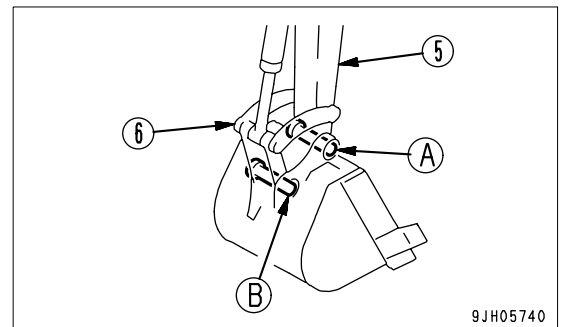

PARKING MACHINE

WARNING

- q Avoid stopping suddenly. Give yourself ample room when stopping.
- q When stopping the machine, select flat hard ground and avoid dangerous places. If it is unavoidably necessary to park the machine on a slope, insert blocks underneath the track shoes. As an additional safety measure, thrust the bucket into the ground.
- q If the control lever is touched by accident, the work equipment or the machine may move suddenly, and this may lead to a serious accident. Before leaving the operator's compartment, always set the safety lock lever securely to LOCK position.

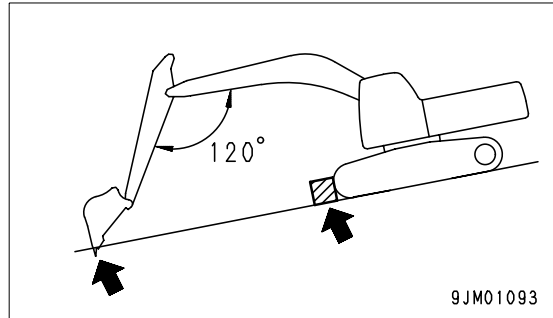

1. Put left and right travel levers (1) in the neutral position.
The machine stops.

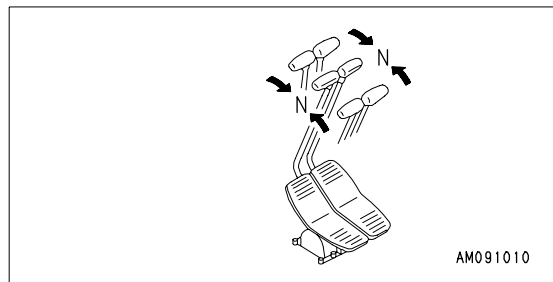
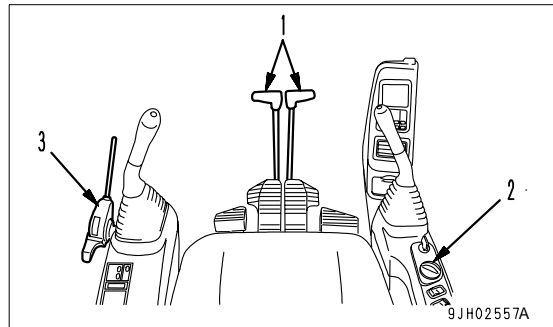

2. Turn fuel control dial (2) to lower the engine speed to low idling.

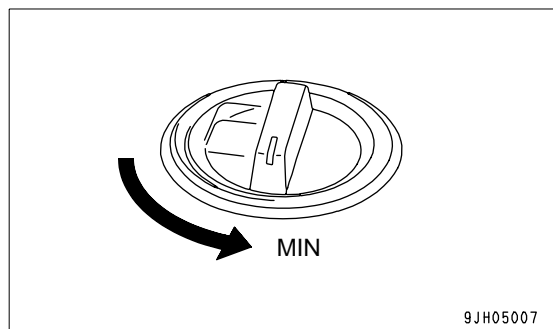

- Lower the bucket horizontally until the bottom touches the ground.

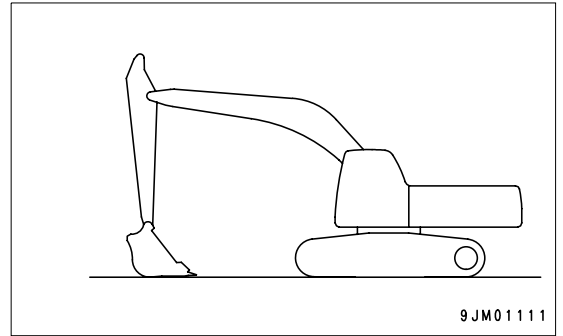

- Set safety lock lever (3) in the LOCK position.

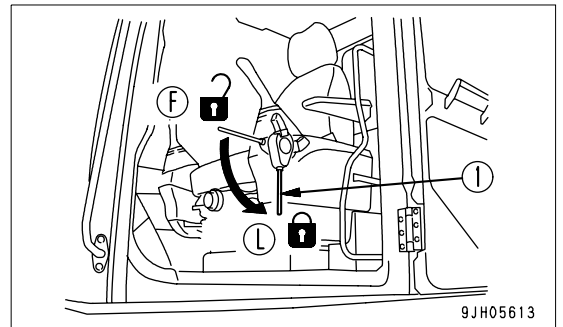

- Stop the engine. For details of the procedure for stopping the engine, see "STOPPING THE ENGINE (3-81)".

CHECK AFTER SHUT OFF ENGINE

Use the machine monitor to check engine water temperature (1), engine oil pressure (2), and fuel level (3).

REMARK

After stopping the engine, if the starting switch is turned within approx. 10 seconds to the ON or START position to start the engine again, the monitor display is not reset, and the screen before the starting switch was turned OFF is displayed.

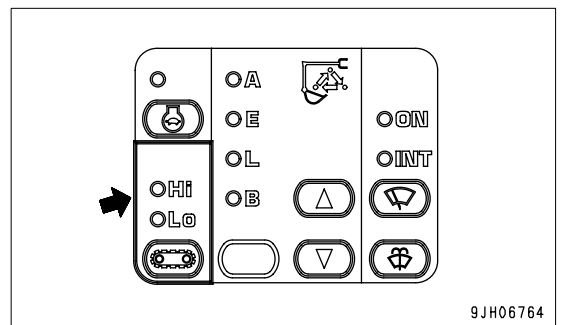
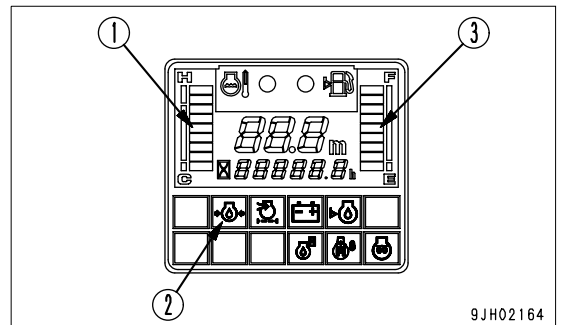

MACHINE INSPECTION AFTER DAILY WORK

1. Walk around the machine and check the work equipment, machine exterior, and undercarriage, also check for any leakage of oil or coolant. If any abnormalities are found, repair them.
2. Fill the fuel tank.
3. Check the engine compartment for paper and debris. Clean out any paper and debris to avoid a fire hazard.
4. Remove any mud affixed to the undercarriage.

LOCKING

Always lock the following places.

- (1) Operator's cab door
 - Always close the window.
- (2) Fuel tank filler port
- (3) Engine hood
- (4) Toolbox cover
- (5) Left side door of the machine
- (6) Right side door of the machine

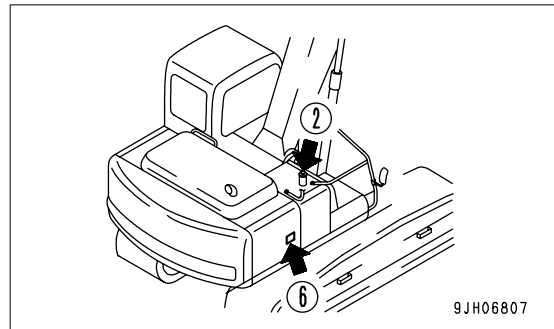
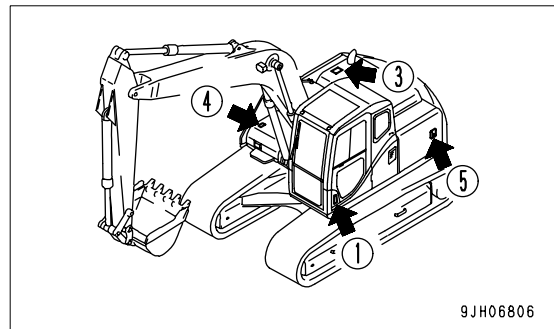

REMARK

Use the starting switch key to open and close all these places.

OVERLOAD WARNING DEVICE

Excavators are provided with this device to warn the operator about tipping over while lifting loads. A buzzer will sound when the machine is in L mode and the machine nears its lifting capacity.

REMARK

1. Only conduct lifting operations in L mode as the overload warning system is only active in this mode.
2. When the load comes close to the lifting capacity, the buzzer sounds and monitor (1) lights up.

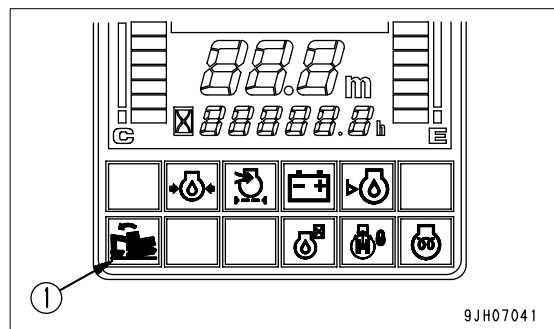

TRANSPORTATION

When transporting the machine, observe all related laws and regulations, and be careful to assure safety.

TRANSPORTATION PROCEDURE

As a basic rule, transport the machine by trailer.

Select the trailer to match the weight and dimensions given in "SPECIFICATIONS (5-2)".

Note that the value for the weight and transportation dimensions given in SPECIFICATIONS may differ according to the type of shoe or type of arm or other attachments.

LOADING AND UNLOADING WITH TRAILER

WARNING

- q Always turn the auto-deceleration switch OFF (cancel) during loading and unloading operations.
If the auto-deceleration switch is left ON, the machine may suddenly start moving.
- q When loading or unloading the machine on a trailer, always travel at low speed. Do not operate the travel speed selector switch.
- q Run the engine at low idling, set to low speed, and operate the machine slowly when loading or unloading.
- q Do not carry out loading or unloading operations during the automatic warming-up operation.
If the automatic warming-up operation is canceled before completion, the travel speed may suddenly change.
- q Select firm, level ground when loading or unloading the machine.
Maintain a safe distance from the edge of the road.
- q Use ramps with ample width, length, thickness, and strength and install them at a maximum slope of 15°. When using piled soil, compact the piled soil fully and prevent the slope face from collapsing.
- q Remove all mud and dirt from the machine tracks before starting in order to prevent the machine from slipping on the ramps.
Be sure that the ramp surface is clean and free of water, snow, grease, oil, or ice.
- q Never correct your steering on the ramps. There is a hazard that the machine may turn over.
If necessary, drive off the ramps, correct the direction, then enter the ramps again.
- q It is dangerous to use the work equipment for loading and unloading operations.
- q When on the ramps, do not operate any lever except the travel lever.
- q The center of gravity of the machine will change suddenly at the joint between the ramps and the track or trailer, and there is a hazard of the machine losing its balance. Travel slowly over this point.
- q When swinging the upper structure on the trailer, the trailer is unstable, so pull in the work equipment and swing slowly.

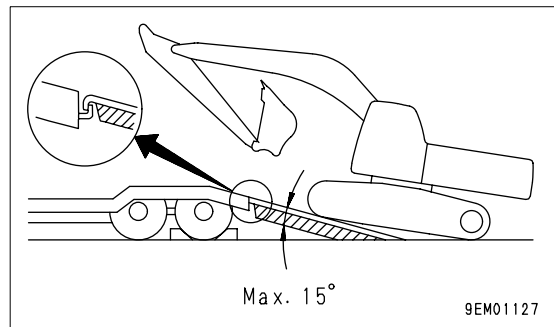
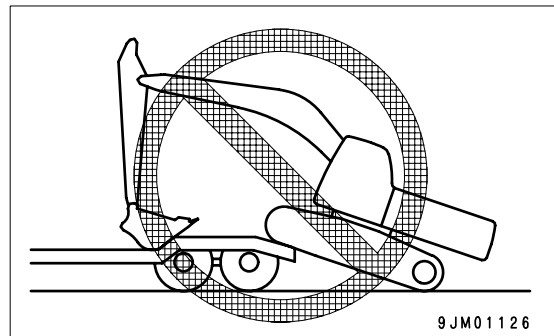

When loading or unloading, always use ramps or a platform and carry out the operation as follows.

Loading

1. Load and unload on firm level ground only.
 Maintain a safe distance from the edge of a road.
2. Properly apply the brakes on the trailer and put blocks under the tires to ensure that the trailer does not move.
 Make the slope of the ramps a maximum of 15°.

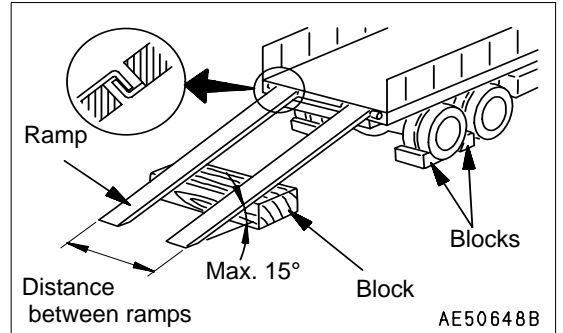

3. Set the travel speed switch to the Lo position.

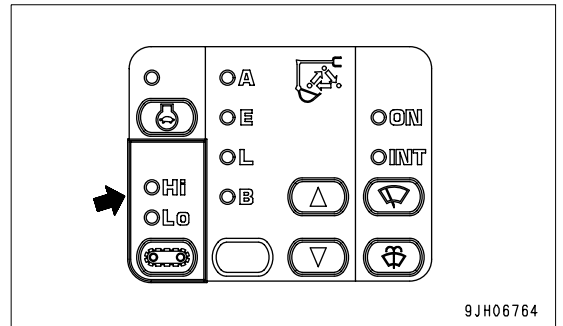

4. Turn auto-deceleration switch (1) OFF and operate the fuel control dial to set the engine speed to low idling.

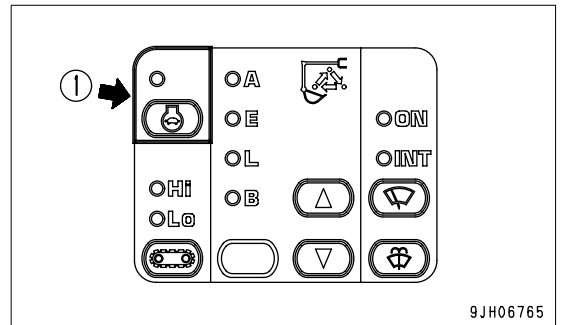

5. Turn the swing lock switch ON to apply the swing lock.

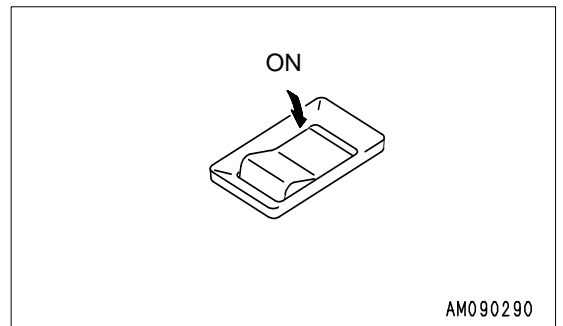

6. If the machine is equipped with work equipment, set the work equipment at the front, and travel forward to load it; if it has no work equipment, travel in reverse to load it.

Follow instructions and signals of a conductor particularly when traveling in reverse.

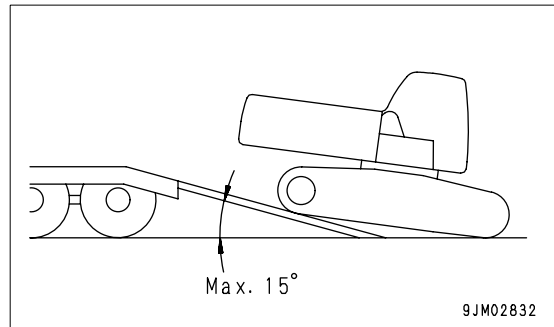
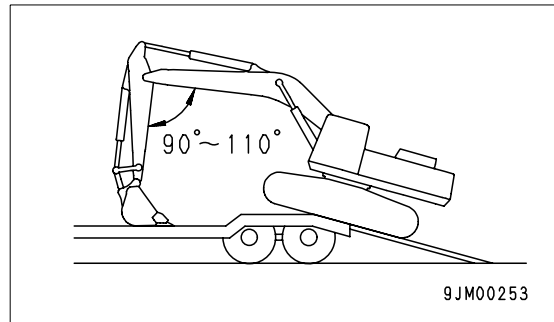

7. Before moving onto the ramps, make sure that the machine is positioned in a straight line with the ramps and that the centerline of the machine matches that of the trailer.

Align the direction of travel with the ramps and travel slowly.

Lower the work equipment as far as possible without causing interference.

When on the ramps, operate only the travel lever. Do not operate any other lever.

8. When the machine travels over the rear wheels of the trailer, it becomes unstable, so drive slowly and carefully. (Never operate the steering.)
9. At the moment the machine passes the rear wheels, it tilts forward, so be careful not to let the work equipment hit the trailer body. Drive the machine forward to the specified position, then stop the machine.
10. Turn the swing lock switch OFF to release the swing lock, then swing the upper structure slowly 180°.
11. Stop the machine at the specified position on the trailer.
12. Turn the swing lock switch ON to lock the swing lock.

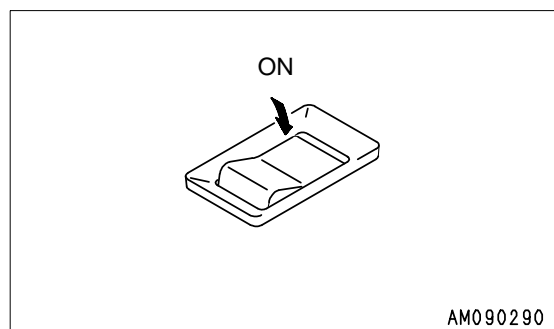
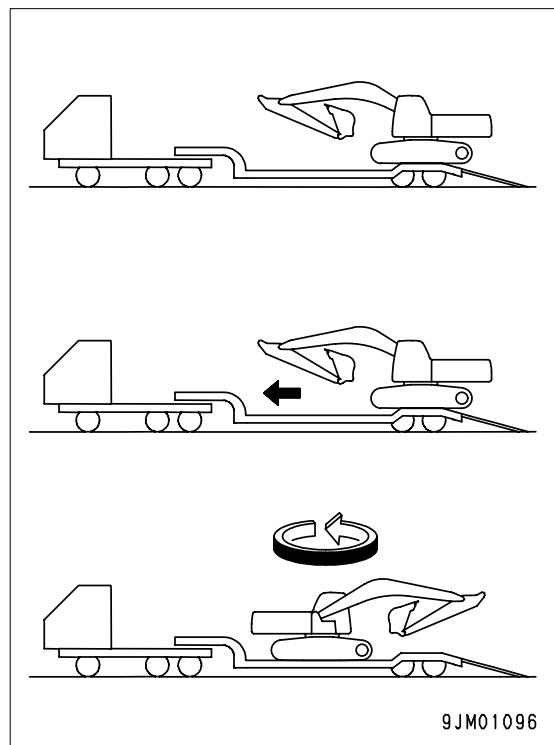

Securing Machine

NOTICE

- q **Stow the car radio antenna. In addition, remove the mirrors. Tie the removed parts securely to the trailer.**
- q **To prevent damage to the bucket cylinder during transportation, fit a wooden block at one end of the bucket cylinder to prevent it from touching the floor.**

Load the machine onto a trailer as follows:

1. Extend the bucket and arm cylinders fully, then lower the boom slowly.
2. Stop the engine, then remove the key from the starting switch.
3. Secure control levers with the safety lock lever.
4. After removing the outer element, cover with a clean cloth or tape to prevent dirt or dust from sticking to the inner element.
5. Place blocks under both ends of the tracks to prevent the machine from moving during transportation, and secure the machine with chains or wire rope of suitable strength.
Be particularly careful to secure the machine in position so it does not slip to the side.

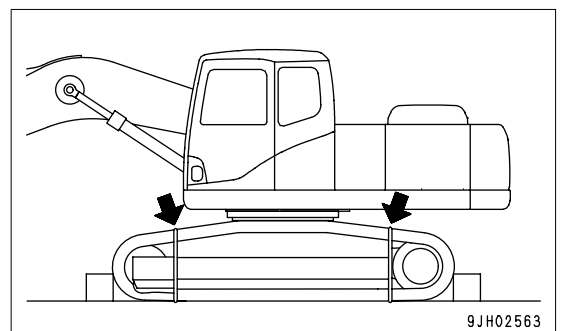
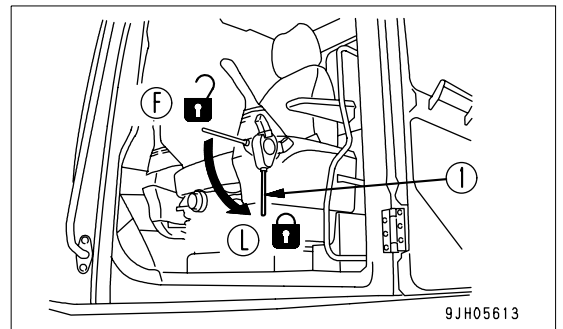
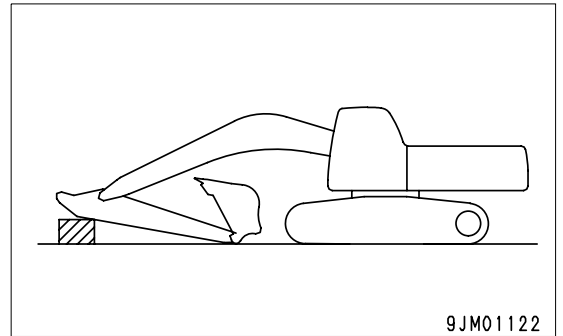

Rearview Mirrors

The mirrors are at the positions shown in the diagram on the right.

If they are damaged, or are to be removed for shipment, or are to be installed again, use the following procedure.

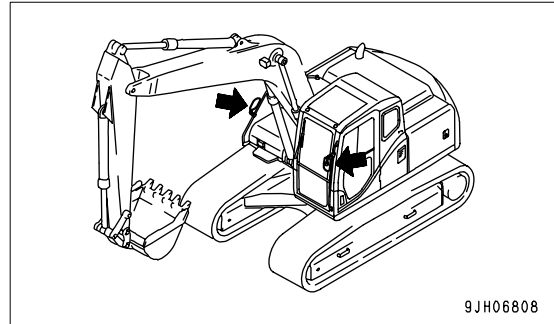

Removal

1. Loosen locknut (2) of mirror (1), then remove mirror (1) from support (3).
2. Loosen bolt (4) and remove support (3) and clamp (5) from the handrail.

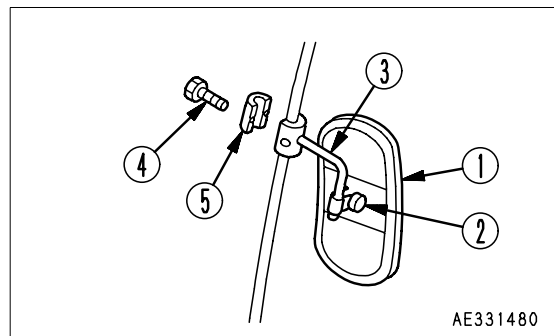

Installation

1. Install support (3) and clamp (5) to the handrail, then tighten with bolt (4).
2. Install mirror (1) to support (3), then tighten locknut (2).

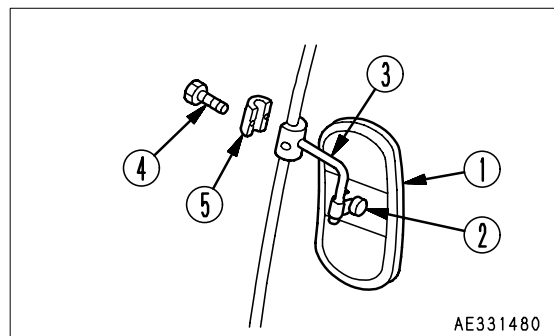

Unloading

1. Load and unload on firm level ground only. Maintain a safe distance from the edge of a road.

2. Properly apply the brakes on the trailer and put blocks under the tires to ensure that the trailer does not move.

Make the slope of the ramps a maximum of 15°.

3. Remove the chains and wire ropes fastening the machine.

4. Start the engine.

Warm the engine up fully.

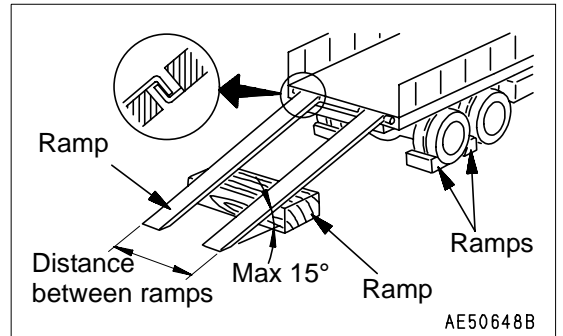

5. Set the safety lock lever to FREE position (F).

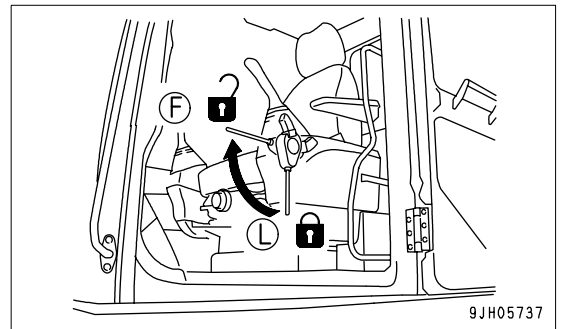

6. Set the travel speed selector switch to the LOW position.

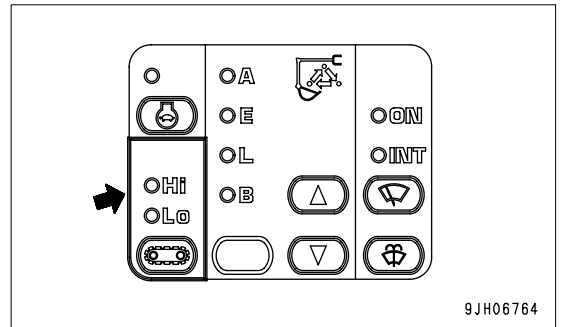

7. Turn auto-deceleration switch (1) OFF and operate the fuel control dial to set the engine speed to low idling.

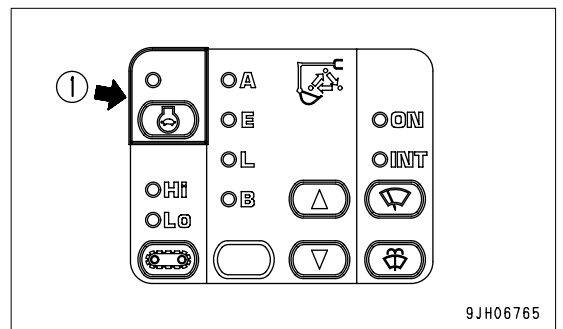

8. Turn the swing lock switch OFF to release the swing lock.
 - c) When the swing lock switch is turned OFF, display monitor (4) goes off.

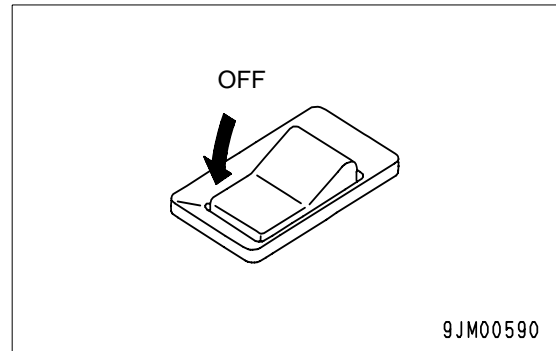

9. Raise the work equipment, pull in the arm under the boom, then move the machine slowly.
10. When the machine is horizontal on top of the rear wheels of the trailer, stop the machine.

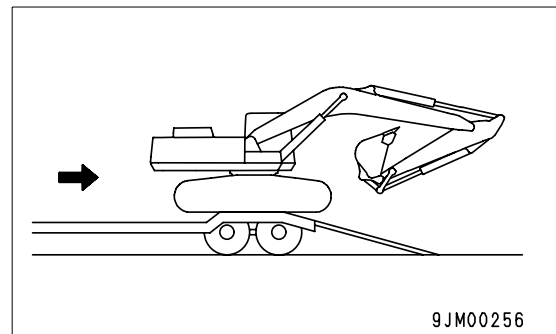

11. When moving from the rear of the trailer on to the ramps, set the angle of the arm and boom to 90° to 110° , lower the bucket to the ground, then move the machine slowly.

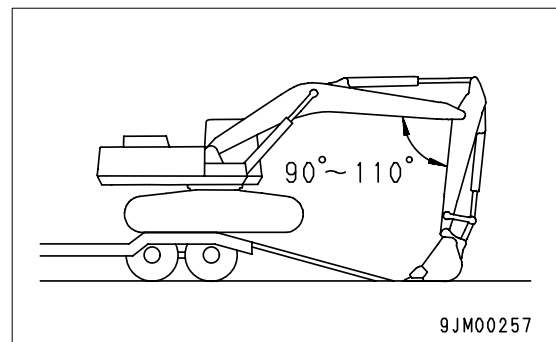

12. When moving down the ramps, operate the boom and arm slowly to lower the machine carefully until it is completely off the ramps.

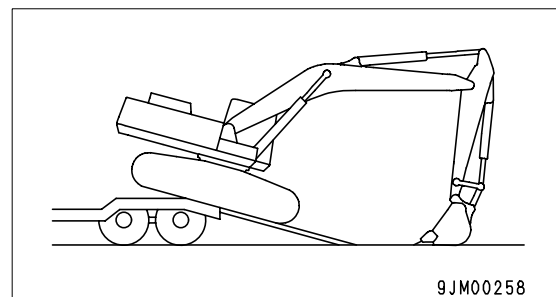

LIFTING MACHINE

 **WARNING**

- q **Never carry out the lifting operation with any person on the machine.**
- q **Always make sure that the wire rope used for lifting the machine is of ample strength for the weight of the machine.**
- q **Never try to lift the machine in any posture other than the posture given in the procedure below. There is danger that the machine may lose its balance.**
- q **When lifting the machine, pay careful attention to the center of gravity to maintain the balance.**

When lifting the machine, carry out the operation on flat ground as follows.

1. Start the engine and set the work equipment to the posture shown in the diagram on the right (boom raised to maximum height, arm and bucket pulled in fully). Set with the upper structure facing straight to the front. (Idler end)

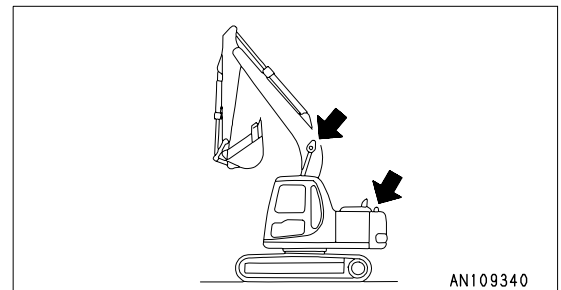

2. Set safety lock lever (1) securely to LOCK position (L).
3. Stop the engine, check that there is nothing around the operator's compartment, then get off the machine. Close the cab door and front glass securely.
4. Install shackles to the hooks at the top of the counterweight and boom, then fit wire rope.

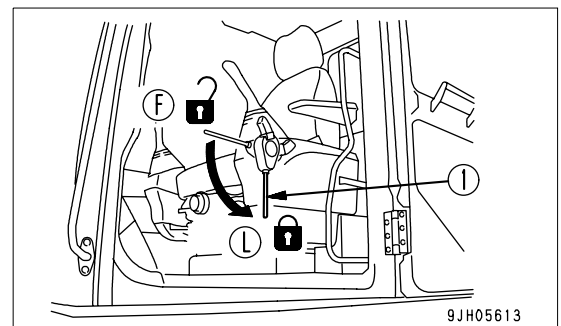

5. Raise so that the length and lifting angle of the wire rope are as shown in the diagram on the right.

(A): Min. 1.1 m

(B): Min. 3 m

(C): Max. 20°

(D): Max. 33°

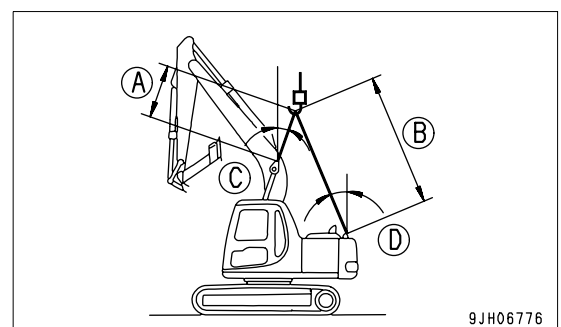

6. When raising, check that the posture does not change because of leakage of oil from the hydraulic circuit at the boom cylinder head end.
7. When the machine comes off the ground, stop and check the balance of the machine carefully. When the machine is stable, raise it slowly.

COLD WEATHER OPERATION

COLD WEATHER OPERATION INFORMATION

If the temperature becomes low, it becomes difficult to start the engine, and the coolant may freeze, so do as follows.

Fuel and Lubricants

Change the fuel and oil for each component to those of lower viscosity. For the specific viscosity, see "LUBRICANTS, FUEL AND COOLANT SPECIFICATIONS (4-10)".

Cooling System Coolant

WARNING

- q Antifreeze is toxic. Be careful not to get it into your eyes or on your skin. If it should get into your eyes or on your skin, wash it off with large amounts of fresh water and see a doctor at once.
- q When changing the coolant or when handling coolant containing antifreeze that has been drained when repairing the radiator, please contact your Komatsu distributor. Antifreeze is toxic, so do not let it flow into drainage ditches or spray it on to the ground surface.
- q Antifreeze is flammable, so do not bring any flame close. Do not smoke when handling antifreeze.

NOTICE

- q Never use methanol, ethanol, or propanol-based antifreeze.
- q Never use any water-leakage prevention agent or any antifreeze containing such an agent.
- q Do not mix different types of antifreeze.

For details of the antifreeze mixture when changing the coolant, see "CLEAN INSIDE OF COOLING SYSTEM (4-25)".

Use a Permanent Antifreeze (ethylene glycol mixed with corrosion inhibitor, antifoam agent, etc.) meeting the standard requirements as shown below. With permanent antifreeze, no change of coolant is required for a year. If it is doubtful that an available antifreeze meets the standard requirements, ask the supplier of that antifreeze for information.

Standard requirements for permanent antifreeze

- q SAE J1034
- q FEDERAL STANDARD O-A-548D

REMARK

In areas where permanent antifreeze is not available, it is possible to use antifreeze whose main component is ethylene glycol and does not contain any corrosion inhibitor. (Such antifreeze can be used for the winter season only.) However, in such a case, the coolant must be changed twice a year (spring and fall), so use permanent antifreeze when possible.

Battery

WARNING

- q The battery generates flammable gas, so do not bring fire or sparks near the battery.
- q Battery electrolyte is dangerous. If it gets in your eyes or on your skin, wash it off with a large amount of water and consult a doctor.
- q Battery electrolyte dissolves paint. If it gets on the bodywork, wash it off immediately with water.
- q If the battery electrolyte is frozen, do not charge the battery or start the engine with a different power source. There is danger that the battery may explode.
- q Battery electrolyte is toxic, so do not let it flow into drainage ditches or spray it on to the ground surface.

When the ambient temperature drops, the capacity of the battery will also drop. If the battery charge ratio is low, the battery electrolyte may freeze. Maintain the battery charge as close as possible to 100%, and insulate it against cold temperature so that the machine can be started easily the next morning.

REMARK

Measure the specific gravity and calculate the rate of charge from the following conversion table.

Charging Rate (%)	Temperature (°C)			
	20	0	-10	-20
100	1.28	1.29	1.30	1.31
90	1.26	1.27	1.28	1.29
80	1.24	1.25	1.26	1.27
75	1.23	1.24	1.25	1.26

- q As the battery capacity drops markedly in low temperatures, cover the battery or remove it from the machine, keep it in a warm place, and install it again the next morning.
- q If the electrolyte level is low, add distilled water in the morning before beginning work. Do not add the water after the day's work so as to prevent fluid in the battery from freezing during the night.

AFTER DAILY WORK COMPLETION

WARNING

Performing idle-running of the tracks is dangerous, so stay well away from the tracks.

To prevent mud, water, or the undercarriage from freezing and making it impossible for the machine to move on the following morning, always observe the following precautions.

- q Remove all the mud and water from the machine body. In particular, wipe the hydraulic cylinder rod clean to prevent damage to the seal caused by mud or dirt on the rod surface getting inside the seal together with drops of water.
- q Park the machine on hard, dry ground.
If this is impossible, park the machine on wooden boards.
The boards help protect the tracks from being frozen in soil so the machine can move next morning.
- q Open the drain valve and drain any water collected in the fuel system to prevent it from freezing.
- q Fill the fuel tank to the full in order to prevent moisture from forming dew in the tank room, as the ambient temperature goes down.
- q After operation in water or mud, remove water from undercarriage as described below to extend undercarriage service life.
 1. Swing 90° with engine at low idling and bring the work equipment to the side of the track.
 2. Jack up the machine until the track is raised slightly from the ground. Rotate the track under no load. Repeat this procedure on both the left and right sides.

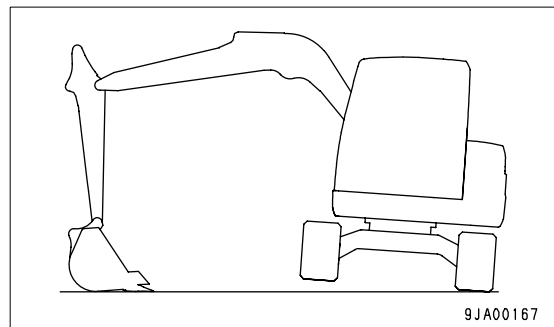

AFTER COLD WEATHER SEASON

When season changes and the weather becomes warmer, do as follows.

- q Replace the fuel and oil for all parts with oil of the viscosity specified.
For details, see “LUBRICANTS, FUEL AND COOLANT SPECIFICATIONS (4-10)“.
- q If for any reason permanent antifreeze cannot be used, and an ethylene glycol base antifreeze (winter, one season type) is used instead, or if no antifreeze is used, drain the cooling system completely, then clean out the inside of the cooling system thoroughly, and fill with fresh coolant.

LONG TERM STORAGE

BEFORE STORAGE

NOTICE

To protect the hydraulic cylinder piston rod while in storage, keep the work equipment in the posture shown at right.

(This prevents rust from developing on the piston rod)

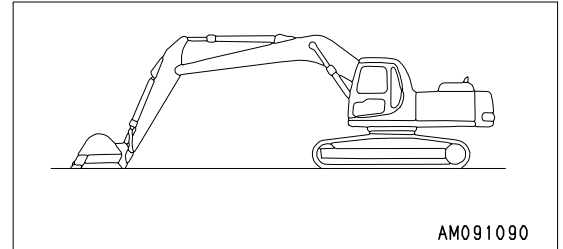

When putting the machine in storage for a long time, do as follows.

- q Clean and wash all parts, then store the machine indoors. If the machine has to be stored outdoors, select level ground and cover the machine with canvas.
- q Completely fill the fuel tank, lubricate and change the oil before storage.
- q Apply a thin coat of grease to the metal surface of the hydraulic piston rods.
- q Disconnect the negative terminals of the battery and cover it or remove it from the machine and store it separately.
- q Lock each control lever and pedal with the safety lock lever and pedal lock.
- q Set the stop valve to the LOCK position on machines ready for attachments. Install the blind plugs to the elbows.
- q Set the selector valve on the machines which can install attachments to the “Where no attachment is mounted” position.

DURING STORAGE

WARNING

When it is necessary to perform the rust-preventive operation while the machine is indoors, open the doors and windows to improve ventilation and prevent gas poisoning.

- q During storage, always operate the machine once a month so that a new film of oil will be coated over movable parts and component surfaces. At the same time, also charge the battery.
- q For machines equipped with an air conditioner, run the air conditioner.
- q Rotate the tracks.

AFTER STORAGE

NOTICE

If the machine has been stored without the monthly rust prevention operation, consult your Komatsu distributor for service.

When using the machine after long-term storage, do as follows before using it.

- Wipe off the grease from the hydraulic cylinder rods.
- Add oil and grease at all lubrication points.
- When the machine is stored for a long period, moisture in the air can contaminate the oil over time. Check the oil for presence of water before and after starting the engine. If there is water in the oil, change the oil.

STARTING MACHINE AFTER LONG-TERM STORAGE

When starting the engine after the machine has been in storage for a long time, carry out the automatic warming-up operation.

If the engine is started according to the starting procedure for cold weather, the warming-up operation is carried out automatically.

(For details, see Section "Starting Engine in Cold Weather (3-72)" and Section "In Cold Weather Areas (3-77)")

TROUBLES AND ACTIONS

RUNNING OUT OF FUEL

When starting after running out of fuel, fill with fuel and bleed the air from the fuel system before starting.

For details of bleeding the air, see "REPLACE FUEL FILTER CARTRIDGE (4-55)".

PHENOMENA THAT ARE NOT FAILURES

Note that the following phenomena are not failures:

- q When the arm control lever is operated to the IN position and the work equipment is lowered under no load from a high position, the arm speed will drop momentarily when the arm is more or less at the vertical position.

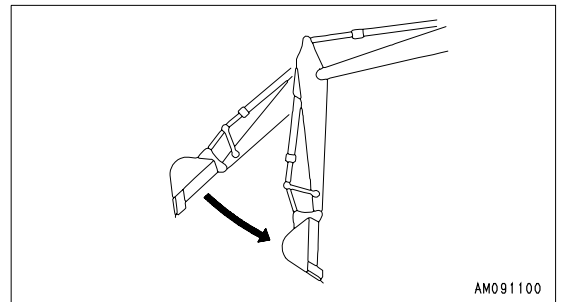

- q When the bucket control lever is operated to the CURL position and the work equipment is lowered under no load from a high position, the bucket speed will drop momentarily when the bucket teeth are more or less at the horizontal position.
- q The bucket or arm will fluctuate by itself during heavy-duty digging operations.

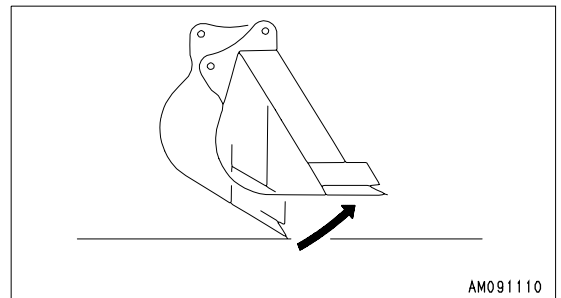

- q When starting or stopping the swing, noise will be emitted from the brake valve.
- q When going down a steep slope at low speed, a noise will be emitted from the travel motor brake valve.

TOWING THE MACHINE

WARNING

- q When towing the machine, use a wire rope that has ample strength for the weight of the machine that is being towed.
- q Do not apply a sudden load to the wire rope.

If the machine sinks in mud and cannot get out under its own power, or if the drawbar pull of the excavator is being used to tow a heavy object, use a wire rope as shown in the diagram on the right.

Place pieces of wood between wire ropes and body to prevent damage to ropes and body.

At this time, never use the hole for light-weight towing.

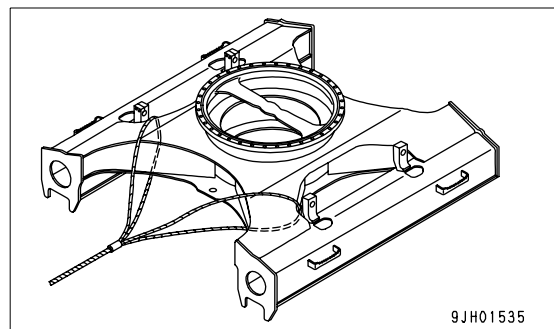
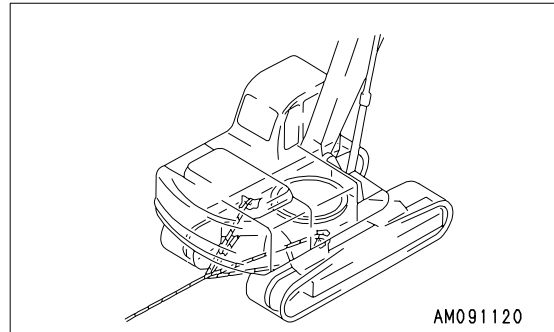

LIGHTWEIGHT TOWING HOLE

WARNING

- q The shackle must always be used.
- q Hold the rope level and direct it straight to the track frame.
- q Move the machine slowly in the Lo mode.

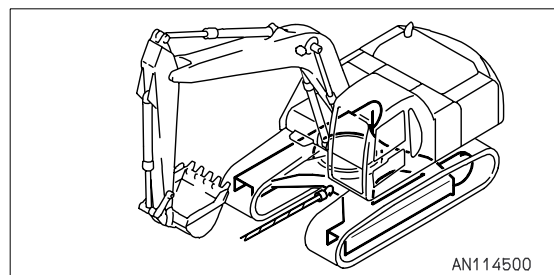

There is a hole in the track frame to fit the shackle when towing light objects.

Permissible towing weight: Max. 39,200 N (4,000 kgf)

SEVERE JOB CONDITION

- q When carrying out digging operations in water, if the work equipment mounting pin goes into the water, carry out greasing every time the operation is carried out.
- q For heavy-duty operations and deep digging, carry out greasing of the work equipment mounting pins every time before operation.

After greasing, operate the boom, arm and bucket several times, then grease again.

DISCHARGED BATTERY

WARNING

- q It is dangerous to charge a battery when mounted on a machine. Make sure that it is dismantled before charging.
- q When checking or handling the battery, stop the engine and turn the starting switch key to the OFF position.
- q The battery generates hydrogen gas, so there is a hazard of explosion. Do not bring lighted cigarettes near the battery, or do anything that will cause sparks.
- q Battery electrolyte is dilute sulphuric acid, and it will attack your clothes and skin. If it gets on your clothes or on your skin, immediately wash it off with a large amount of water. If it gets in your eyes, wash it out with fresh water and consult a doctor.
- q When handling batteries, always wear protective goggles and rubber gloves.
- q When removing the battery, first disconnect the cable from the ground (normally the negative (-) terminal). When installing, install the positive (+) terminal first. If a tool touches the positive terminal and the chassis, there is danger that it will cause a spark, so be extremely careful.
- q If the terminals are loose, there is danger that the defective contact may generate sparks that will cause an explosion. Terminals should be connected firmly.
- q When removing or installing the terminals, check which is the positive (+) terminal and which is the negative (-) terminal.

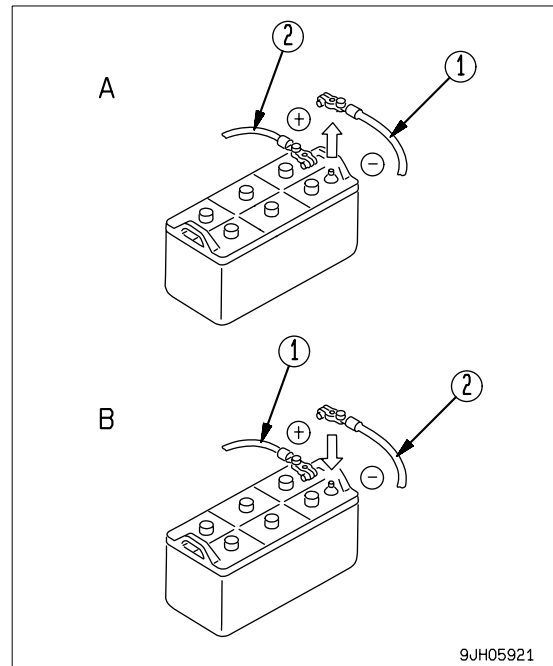

9JH05921

Battery Removal and Installation

- q Before removing the battery, remove the ground cable (normally connected to the negative (-) terminal).
If any tool touches between the positive terminal and the chassis, there is a hazard of sparks being generated.
- q When installing the battery, connect the ground cable last.
- q When replacing the battery, secure it with battery fitting.
Tightening torque: Tightening battery terminal: 9.8 to 14.7 N·m (1 to 1.5 kgf·m)

Battery Charges

When charging the battery, if the battery is not handled correctly, there is a hazard that the battery may explode. Always follow the instructions of "DISCHARGED BATTERY (3-122)" and the instruction manual accompanying the charger, and do as follows.

- q Set the voltage of the charger to match the voltage of the battery to be charged. If the correct voltage is not selected, the charger may overheat and cause an explosion.
- q Connect the positive (+) charger clip of the charger to the positive (+) terminal of the battery, then connect the negative (-) charger clip of the charger to the negative (-) terminal of the battery. Be sure to fix the clips securely.
- q Set the charging current to 1/10 of the value of the rated battery capacity; when carrying out rapid charging, set it to less than the rated battery capacity.

If the charger current is too high, the electrolyte will leak or dry up, and this may cause the battery to catch fire and explode.
- q If the battery electrolyte is frozen, do not charge the battery or start the engine with a different power source. There is a hazard that this will ignite the battery electrolyte and cause the battery to explode.
- q Do not use or charge the battery if the battery electrolyte level is below the LOWER LEVEL line. This may cause an explosion. Always check the battery electrolyte level periodically and add distilled water to bring the electrolyte level to the UPPER LEVEL line.

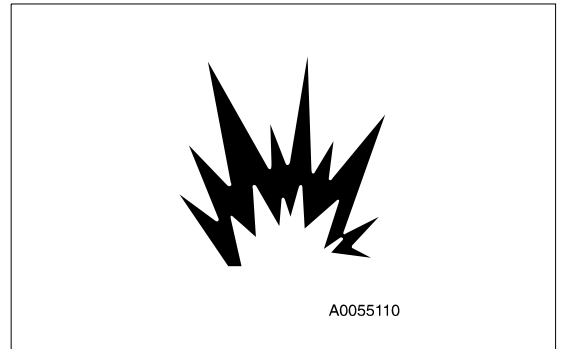

Starting Engine with Booster Cables

When starting the engine with a booster cable, do as follows:

Connecting and Disconnecting Booster Cables

WARNING

- q When connecting the cables, never contact the positive (+) and negative (-) terminals.
- q When starting the engine with a booster cable, always wear safety glasses.
- q Be careful not to let the normal machine and problem machine contact each other. This prevents sparks from generating near the battery which could ignite the hydrogen gas given off by the battery. If hydrogen gas explodes, it could cause serious injury.
- q Be careful not to make a mistake when connecting a booster cable. In the last connection (to the upper structure frame), a spark will be caused, so connect the cable to a spot as far away from the battery as possible. (Avoid the work equipment, however, because it is not a good conductor)
- q When removing the booster cable, exercise good care so that the booster cable clips may not contact each other, or they contact the chassis.

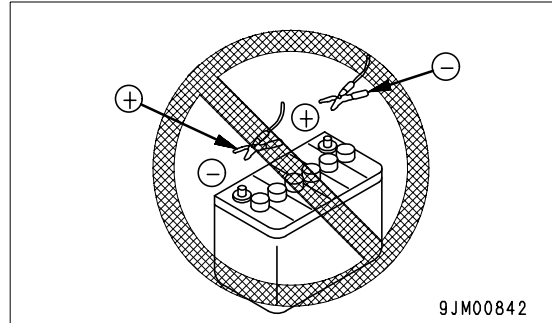

NOTICE

- q The starting system for this machine uses 24V. For the normal machine, also use a 24V battery.
- q The size of the booster cable and clip should be suitable for the battery size.
- q The battery of the normal machine must be the same capacity as that of the engine to be started.
- q Check the cables and clips for damage or corrosion.
- q Make sure that the cables and clips are firmly connected.
- q Check that the safety lock levers and parking brake levers of both machine are in the LOCK position.
- q Check that each lever is in the NEUTRAL position.

Booster Cable Connection

Keep the starting switch of the normal machine and problem machine in the OFF position.

Connect the booster cable as follows, in the order of the numbers marked in the diagram.

1. Connect one clip of booster cable (A) to the positive (+) terminal of the problem machine.
2. Connect the other clip of booster cable (A) to the positive (+) terminal of the normal machine.

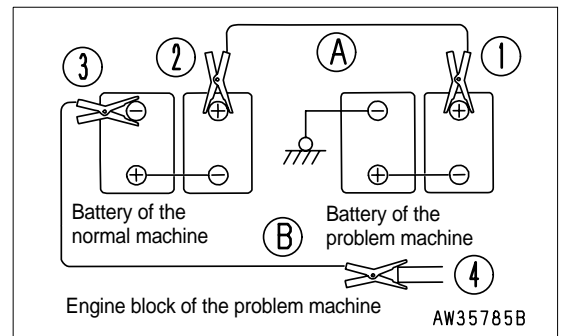

3. Connect one clip of booster cable (B) to the negative (-) terminal of the normal machine.
4. Connect the other clip of booster cable (B) to the revolving frame of the problem machine.

Starting the Engine

WARNING

Always check that the safety lock lever is set to the LOCK position, regardless of whether the machine is working normally or has failed. Check also that all the control levers are in the HOLD or neutral position.

1. Make sure the clips are firmly connected to the battery terminals.
2. Start the engine of the normal machine and keep it running at high idle.
3. Turn the starting switch of the problem machine to the START position and start the engine.

If the engine doesn't start at first, try again after 2 minutes or so.

Booster Cable Disconnection

After the engine has started, disconnect the booster cables in reverse order of connection.

1. Remove one clip of booster cable (B) from the revolving frame of the problem machine.
2. Remove the other clip of booster cable (B) from the negative (-) terminal of the normal machine.
3. Remove one clip of booster cable (A) from the positive (+) terminal of the normal machine.
4. Remove the other clip of booster cable (A) from the positive (+) terminal of the problem machine.

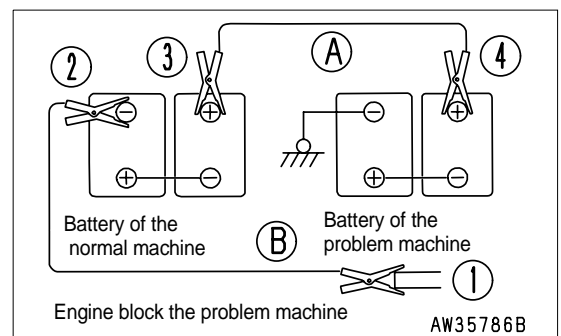

OTHER TROUBLE

Electrical System

□ (): Always contact your Komatsu distributor when dealing with these items.

□ In cases of abnormalities or causes which are not listed below, contact your Komatsu distributor for repairs.

Problem	Main causes	Remedy
Lamp does not glow brightly even when the engine runs at high speed	•Defective wiring, deterioraion of battery	(•Check, repair loose terminals, disconnections, replace battery)
Lamp flickers while engine is running	•Loose fan belt	•Check fan belt tension, replace
Charge level monitor does not go out even when engine is running	•Defective alternator •Defectivr wiring	(•Replace) (•Check, repair)
Abnormal noise is generated from alternator	•Defective alternator	(•Replace)
Starting motor does not turn when starting switch is turned to ON	•Defective wiring •Defective starting motor •Insufficient battery charge	(•Check, repair) (•Replace) •Charge
Pinion of starting motor keeps going and out	•Insufficient battery charge •Defective safety relay	•Charge (•Replace)
Starting motor turns engine sluggishly	•Insufficient battery charge •Defective starting motor	•Charge (•Replace)
Starting motor disengages before engine starts	•Defective wiring, defective ring gear pinion •Insufficient battery charge	(•Check, repair) •Charge
Pre-heating monitor does not light	•Defective wiring •Defective heater relay •Defective monitor	(•Check, repair) (•Replace) (•Replace)
Oil pressure monitor does not light up when engine is stopped (starting switch at ON position)	•Defective monitor •Defective caution lamp switch	(•Replace) (•Replace)
Outside of electrical heater is not warm when touched by hand	•Defective wiring •Disconnection in electric heater •Defective operation of heater relay switch	(•Check, repair) (•Replace) (•Replace)

Chassis

q (): Always contact your Komatsu distributor when dealing with these items.

q In cases of abnormalities or causes which are not listed below, contact your Komatsu distributor for repairs.

Problem	Main causes	Remedy
Speed of travel, swing, boom, arm, bucket is slow	•Lack of hydraulic oil	•Add oil to specified level, see CHECK BEFORE STARTING
Pump generates abnormal noise (sucking in air)	•Clogged element in hydraulic tank strainer, lack of oil	•Clean, see EVERY 2000 HOURS SERVICE
Excessive rise in hydraulic oil temperature	•Loose fan belt •Dirty oil cooler •Lack of hydraulic oil	•Check fan belt tension, replace •Clean, see EVERY 500 HOURS SERVICE •Add oil to specified level, see CHECK BEFORE STARTING
Track comes off Abnormal wear of sprocket	•Track too loose	•Adjust track tension, see WHEN REQUIRED
Bucket rises slowly, does not rise	•Lack of hydraulic oil	•Add oil to specified level, CHECK BEFORE STARTING
Does not swing	•Swing lock switch still applied	•Turn swing lock switch OFF

Engine

q (): Always contact your Komatsu distributor when dealing with these items.

q In cases of abnormalities or causes which are not listed below, contact your Komatsu distributor for repairs.

Problem	Main causes	Remedy
Engine oil pressure monitor lights up	<ul style="list-style-type: none"> •Engine oil pan oil level is low (sucking in air) •Clogged oil filter cartridge •Defective tightening of oil pipe, pipe joint, oil leakage from damaged point •Defective engine oil pressure sensor •Defective monitor 	<ul style="list-style-type: none"> •Add oil to specified level, see CHECK BEFORE STARTING •Replace cartridge, see EVERY 500 HOURS SERVICE (•Check, repair) (•Replace sensor) (•Replace monitor)
Steam spurts out from top of radiator (pressure valve)	<ul style="list-style-type: none"> •Cooling water level low, leakage of water •Loose fan belt 	<ul style="list-style-type: none"> •Check, add water, repair, see CHECK BEFORE STARTING •Check fan belt tension, adjust, replace
Radiator water level monitor lights up	<ul style="list-style-type: none"> •Dirt or scale accumulated in cooling system •Clogged radiator fins or damaged fins •Defective thermostat •Loose radiator filler cap (high-altitude operations) •Defective water level sensor •Defective monitor 	<ul style="list-style-type: none"> •Change coolant, flush inside of cooling system, see WHEN REQUIRED •Clean or repair, see EVERY 500 HOURS SERVICE (•Replace thermostat) •Tighten cap or replace packing (•Replace sensor) (•Replace monitor)
Engine does not start when starting motor is turned	<ul style="list-style-type: none"> •Lack of fuel •Air in fuel system •Defective fuel injection pump or defective nozzle •Starting motor cranks engine sluggishly •Preheating monitor does not light up •Defective compression •Defective valve clearance 	<ul style="list-style-type: none"> •Add fuel, see CHECK BEFORE STARTING •Repair place where air is sucked in, see EVERY 500 HOURS SERVICE (•Replace pump or nozzle) •See ELECTRICAL SYSTEM •See ELECTRICAL SYSTEM (•Adjust valve clearance)
Exhaust gas is white or blue	<ul style="list-style-type: none"> •Too much oil in oil pan •Improper fuel 	<ul style="list-style-type: none"> •Set oil to specified level, see CHECK BEFORE STARTING •Change to specified fuel
Exhaust gas occasionally turns black	<ul style="list-style-type: none"> •Clogged air cleaner element •Defective nozzle •Defective compression •Defective turbocharger 	<ul style="list-style-type: none"> •Clean or replace, see WHEN REQUIRED (•Replace nozzle) (•See defective compression above) •Clean or replace turbocharger
Combustion noise occasionally make breathing sound	<ul style="list-style-type: none"> •Defective nozzle 	<ul style="list-style-type: none"> (•Replace nozzle)

Problem	Main causes	Remedy
Abnormal noise generated (combustion or mechanical)	<ul style="list-style-type: none">•Low-grade fuel being used•Overheating •Damage inside muffler•Excessive valve clearance	<ul style="list-style-type: none">•Change to specified fuel•Refer to "Radiator water level monitor lights up" as above•Replace muffler(•Adjust valve clearance)

Electronic Control System

When the user code is shown on the display portion of the machine monitor, take the respective measures shown in the self-diagnosis chart below.

Machine Monitoring System

Monitor display	Failure mode	Action
E02	Error in pump control system	When emergency pump drive switch is moved up, normal operations are possible, but have inspection carried out immediately. (*)
E03	Error in swing brake system	Move swing holding brake release switch up to release brake. When applying swing brake, operate swing lock switch manually. Depending on cause of failure, it may be impossible to release brake. In any case, have inspection carried out immediately. (*)
E05	Error in governor system	Governor controller does not work. Operate governor lever manually. To secure at FULL position, there is a hole in the bracket to install the lock bolt. In this case, have inspection carried out immediately.
When no user code is displayed but work equipment and swing cannot be operated		Have inspection carried out immediately.

(*) For details of the method of handling the emergency pump drive switch and swing holding brake cancel switch, see SWITCHES (3-17).

MAINTENANCE



WARNING

Please read and make sure that you understand the safety volume before reading this section.

MAINTENANCE INFORMATION

Do not carry out any inspection and maintenance operation that is not found in this manual.

Service Meter Reading

Check the service meter reading every day to see if the time has come for any necessary maintenance to be performed.

Komatsu Genuine Replacement Parts

Use Komatsu genuine parts specified in the Parts Book as replacement parts.

Komatsu Genuine Lubricants

Use Komatsu genuine oils and grease. Choose oils and grease with proper viscosities specified for ambient temperature.

Windshield Washer Fluid

Use automobile window washer fluid, and be careful not to let any dirt get into it.

Fresh and Clean Lubricants

Use clean oil and grease. Also, keep the containers of the oil and grease clean. Keep foreign materials away from oil and grease.

Check Drained Oil and Used Filter

After oil is changed or filters are replaced, check the old oil and filters for metal particles and foreign materials. If large quantity of metal particles or foreign materials are found, always report to the person in charge, and carry out suitable action.

Fuel Strainer

If your machine is equipped with a fuel strainer, do not remove it while fueling.

Welding Instructions

- Turn off the engine ignition switch.
- Do not apply more than 200 V continuously.
- Connect grounding cable within 1 m of the area to be welded. If grounding cable is connected near instruments, connectors, etc., the instruments may malfunction.
- If a seal or bearing happens to come between the part being welded and grounding point, change the the grounding point to avoid such parts.
- Do not use the area around the work equipment pins or the hydraulic cylinders as the grounding point.

Do not Drop Things Inside Machine

- When opening inspection windows or the oil filler port of the tank to carry out inspection, be careful not to drop nuts, bolts, or tools inside the machine.

If such things are dropped inside the machine, it may cause damage and/or malfunction of the machine, and will lead to failure. If you drop anything inside the machine, always remove it immediately.

- Do not put unnecessary things in your pockets. Carry only things which are necessary for inspection.

Dusty Jobsite

When working at dusty worksites, do as follows:

- q Inspect the air cleaner clogging monitor frequently to see if the air cleaner is clogged.
Clean the air cleaner element at a shorter interval than specified.
- q Clean the radiator core frequently to avoid clogging.
- q Clean and replace the fuel filter frequently.
- q Clean electrical components, especially the starting motor and alternator, to avoid accumulation of dust.
- q When inspecting or changing the oil, move the machine to a place that is free of dust to prevent dirt from getting into the oil.

Avoid Mixing Lubricants

If a different brand or grade of oil has to be added, drain the old oil and replace all the oil with the new brand or grade of oil. Never mix different brand or grade of oil.

Locking the Inspection Covers

Lock inspection cover securely into position with the lock bar. If inspection or maintenance is performed with inspection cover not locked in position, there is a hazard that it may suddenly be blown shut by the wind and cause injury to the worker.

Hydraulic System - Air Bleeding

When hydraulic equipment has been repaired or replaced, or the hydraulic piping has been removed and installed again, the air must be bled from the circuit. For details, see "BLEEDING AIR FROM HYDRAULIC SYSTEM (4-43)".

Hydraulic Hose Installation

- q When removing parts at locations where there are O-rings or gasket seals, clean the mounting surface, and replace with new parts.
When doing this, be careful not to forget to assemble the O-rings and gaskets.
- q When installing the hoses, do not twist or bend them into loops with a small radius.
This will cause damage to the hose and drastically reduce its service life.

Checks After Inspection and Maintenance Works

If you forget to perform the checks after inspection and maintenance, unexpected problems may occur, and this may lead to serious injury or property damage. Always do the following:

- q Checks after operation (with engine stopped)
 - q Have any inspection and maintenance points been forgotten?
 - q Have all inspection and maintenance items been performed correctly?
 - q Have any tools or parts been dropped inside the machine? It is particularly dangerous if parts are dropped inside the machine and get caught in the lever linkage mechanism.
 - q Is there any coolant or oil leaks?
Have all nuts and bolts been tightened?
- q Checks when operating engine
 - q For details of the checks when operating the engine, see "TWO WORKERS FOR MAINTENANCE WHEN ENGINE IS RUNNING (2-37)" and pay careful attention to safety.
 - q Are the inspection and maintenance items working properly?
 - q Is there any leakage of fuel or oil when the engine speed is raised?

LUBRICANTS, COOLANT AND FILTERS

HANDLING OIL, FUEL, COOLANT, AND PERFORMING OIL CLINIC

Oil

- q The engine and hydraulic equipment are used under extremely severe conditions (high temperature, high-pressure), so the oil deteriorates as time passes.

Always use the recommended oil in the list given in the Operation and Maintenance Manual that matches the grade, maximum temperature, and minimum temperature.

Even if the oil is not dirty, always change the oil at the specified interval.

- q Oil corresponds to blood in the human body, so always be careful when handling it to prevent any impurities (water, metal particles, dirt, etc.) from getting in.

The majority of problems with machines are caused by the entry of such impurities.

Take particular care not to let any impurities get in when storing or adding oil.

- q Never mix oils of different grades or brands.

- q Always add the specified amount of oil.

Having too much oil or too little oil are both causes of problems.

- q If the oil in the work equipment is not clear, there is probably water or air getting into the circuit. In such cases, please contact your Komatsu distributor.

- q When changing the oil, always replace the related filters at the same time.

- q We recommend periodic performance of the oil clinic to ensure that you always know the condition of the machine. Please contact your Komatsu distributor for details of the oil clinic.

- q When using commercially available oil, it may be necessary to reduce the oil change interval. For this reason, we recommend use of the Komatsu oil clinic.

Fuel

- q The fuel pump is a precision instrument, and if fuel containing water or dirt is used, it cannot work properly.

- q Be extremely careful not to let impurities get in when storing or adding fuel.

- q Always use the fuel specified in the Operation and Maintenance Manual.

Fuel may congeal depending on the temperature when it is used (particularly in low temperature below -15°C). It is necessary to use the fuel that is suitable for the temperature.

- q To prevent the moisture in the air from condensing and forming water inside the fuel tank, always fill the fuel tank after completing the day's work.

- q Before starting the engine, or when 10 minutes have passed after adding fuel, drain the sediment and water from the fuel tank.

- q If the engine runs out of fuel, or if the filters have been replaced, it is necessary to bleed the air from the circuit.

Cooling System Coolant

- q River water contains large amount of calcium and other impurities, so if it is used, scale will stick to the engine and radiator, and this will cause defective heat exchange and overheating.

Do not use water that is not suitable for drinking.

- q When using antifreeze, always observe the precautions given in the Operation and Maintenance Manual.
- q Komatsu machines are supplied with Komatsu original anti-freeze in the coolant when the machine is shipped.

This anti-freeze is effective in preventing corrosion of the cooling system.

The anti-freeze can be used continuously for two years or 4000 hours. Therefore, it can be used as it is even in hot areas.

- q Antifreeze is flammable, so be extremely careful not to expose it to flame or fire.
- q The proportion of anti-freeze to water differs according to the ambient temperature.
For details of the mixing proportions, see "CLEAN INSIDE OF COOLING SYSTEM (4-25)".
- q If the engine overheats, wait for the engine to cool before adding coolant.

- q If the coolant level is low, it will cause overheating and will also cause problems with corrosion from the air in the coolant.

Grease

- q Grease is used to prevent twisting and noise at the joints.
- q This construction equipment is used under heavy-duty conditions. Always use the recommended grease and follow the change intervals and recommended ambient temperatures given in this Operation and Maintenance Manual.
- q The nipples not included in the MAINTENANCE section are nipples used when overhauling, so they do not need grease.

If any part becomes stiff or generates noise after being used for a long time, grease it.

- q Always wipe off all of the old grease that is pushed out when greasing.

Be particularly careful to wipe off the old grease in places where sand or dirt sticking in the grease would cause wear of the rotating parts.

Carrying Out KOWA (Komatsu Oil Wear Analysis)

The oil clinic samples the oil periodically and analyzes it. This is a preventive maintenance service, which provides early discovery of abnormal parts and wear of the drive parts of the machine. This then makes it possible to ensure prevention of failures and reduction in downtime.

Komatsu's long years of experience and rich supply of accumulated data make it possible to accurately determine the condition of your machine. This enables us to locate the problems and to recommend suitable and timely repair methods.

The oil clinic charges the customer only the actual costs, and provides an immediate report of the results of the analysis and recommendations for action to take. This low-cost service can save you high costs and inconvenience in the future, so we strongly recommend you to avail yourself of this service.

KOWA Analysis Items

- q Analysis of metal wear particles

This uses an ICP (Inductively Coupled Plasma) analyzer to measure the density of metal wear particles in the oil.

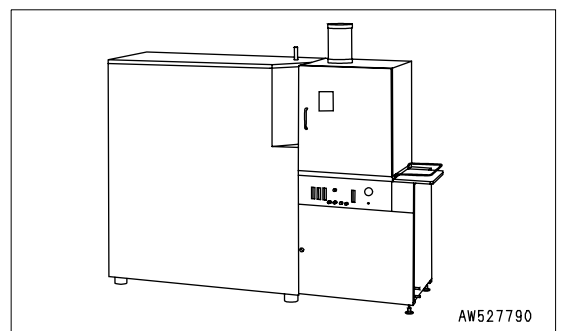

- q Measurement of particle quantity

This uses a PQI (Particle Quantifier Index) machine to measure the quantity of large iron particles in the oil.

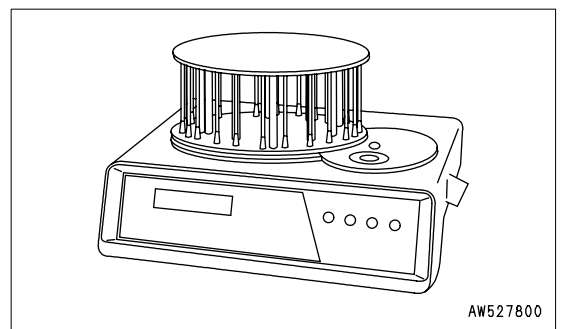

- q Others

Measurements are made of items such as the ratio of water or fuel in the oil, and the dynamic viscosity.

Oil Sampling

- q Sampling interval

250 hours: Engine

500 hours: Other components

- q Precautions when sampling

- q Make sure that the oil is well mixed before sampling.

- q Carry out sampling regularly at fixed intervals.

- q Do not carry out sampling on rainy or windy days when water or dust can get into the oil.

For further details of KOWA, please contact your Komatsu distributor.

Oil and Fuel Storage

- q Keep indoors to prevent any water, dirt, or other impurities from getting in.
- q When keeping drum cans for a long period, put the drum on its side so that the filler port of the drums is at the side to prevent moisture from being sucked in.

If drums have to be stored outside, cover them with a waterproof sheet or take other measures to protect them.

- q To prevent any change in quality during long-term storage, be sure to use in the order of first in - first out (use the oldest oil or fuel first).

Filters

- q Filters are extremely important safety parts. They prevent impurities in the fuel and air circuits from entering important equipment and causing problems.

Replace all filters periodically. For details, see the Operation and Maintenance Manual.

However, when working in severe conditions, replace the filters at shorter intervals according to the oil and fuel (sulfur content) being used.

- q Never try to clean the filters (cartridge type) and use them again. Always replace with new filters.
- q When replacing oil filters, check if any metal particles are affixed to the old filter. If any metal particles are found, contact your Komatsu distributor.
- q Do not open packs of spare filters until just before they are to be used.
- q Use of Komatsu genuine filter elements is strongly recommended.

ELECTRIC SYSTEM MAINTENANCE

- q It is extremely dangerous if the electrical equipment becomes wet or the covering of the wiring is damaged. This will cause an electrical short circuit and may lead to malfunction of the machine. Do not wash the inside of the operator's cab with water. When washing the machine, be careful not to let water get into the electrical components.
- q Service relating to the electric system is checking fan belt tension, checking damage or wear to the fan belt and checking battery fluid level.
- q Never install any electric components other than those specified by Komatsu.
- q External electro-magnetic interference may cause malfunction of the control system controller, so before installing a radio receiver or other wireless equipment, please contact your Komatsu distributor.
- q When working at the seashore, carefully clean the electric system to prevent corrosion.
- q When installing an operator's cab cooler or any other electrical equipment, connect it to an independent power source connector. The optional power source must never be connected to the fuse, starting switch, or battery relay.

WEAR PARTS

Replace wear parts such as the filter element or air cleaner element at the time of periodic maintenance or before they reach the wear limit. The wear parts should be replaced correctly in order to ensure more economic use of the machine. When replacing parts, always use Komatsu genuine parts.

As a result of our continuous efforts to improve product quality, the part number may change, so inform your Komatsu distributor of the machine serial number and check for the latest part number when ordering parts.

WEAR PARTS LIST

The parts in parentheses are to be replaced at the same time.

Item	Part No.	Part Name	Q'ty	Change interval
Engine oil filter	600-211-2110	Cartridge	1	Every 500 hours
Hydraulic oil filter	203-60-61230 (07000-15155)	Element (O-ring)	1 (1)	Every 500 hours
Fuel filter	600-311-7460	Cartridge	1	Every 500 hours
Hydraulic tank breather	20Y-60-21470	Element	1	Every 500 hours
Air cleaner	600-185-2100	Element assembly	1	-
Electric heater	6136-11-4820	Gasket	2	-
Bucket	205-70-74272 (205-70-74281) (205-70-74291)	Vertical pin type Tooth (Pin) (Lock)	4 (4) (4)	-
	205-70-19570 (09244-02496)	Horizontal pin type Tooth (Pin)	4 (4)	
	202-70-63161 202-70-63171 (208-32-11231) (01803-02228)	Side cutter type cutter (left) cutter (right) (Bolt) (Nut)	1 1 (8) (8)	

LUBRICANTS, FUEL AND COOLANT SPECIFICATIONS

PROPER SELECTION

Reservoir	Kind of fluid	AMBIENT TEMPERATURE		Type
		Min	Max	
Engine oil pan	Engine oil	0°C	40°C	SAE 30
Swing machinery case		-20° C	10° C	SAE 10W
Final drive case (each)		-15 °C	50° C	SAE 15W-40
P.T.O. case		-20° C	40° C	SAE 10W-30
Hydraulic system		-20° C	40° C	SAE 30
		-20° C	40° C	SAE 10W-30
		-15° C	50° C	SAE 15W-40
Fuel tank	Diesel fuel	-10° C	40° C	ASTM D975 No. 2
		-30° C	-10° C	ASTM D975 No. 1 (for winter use)
Cooling sytem	Water	Add antifreeze		
Grease fitting	Grease	-30° C	40° C	NLGI No. 2

*1: ASTM D975 No.1

		Engine Oil pan	Swing machinery case	Final drive case (Each of right and left)	PTO gear case	Hydraulic oil system	Fuel tank	Cooling system
Specified oil amount	Liters	11.5	2.5	2.5	0.75	145	247	13.4
Refill oil amount	Liters	11	2.5	2.5	-	90	-	-

REMARK

When fuel sulphur content is less than 0.5%, change oil in the oil pan according to the periodic maintenance hours described in this manual.

Change oil according to the following table if fuel sulphur content is above 0.5%.

When starting the engine with an atmospheric temperature of lower than 0°C, be sure to use engine oil of SAE10W, SAE10W-30 and SAE15W-40, even though the atmospheric temperature goes up to 10°C more or less during the day.

Use API classification CD as engine oil and if API classification CC, reduce the engine oil change interval to half.

There is no problem if single grade oil is mixed with multigrade oil (SAE10W-30, 15W-40), but be sure to add single grade oil that matches the temperature range in the table.

We recommend Komatsu genuine oil which has been specifically formulated and approved for use in engine and hydraulic work equipment applications.

Specified capacity: Total amount of oil including oil for components and oil in piping.

Refill capacity: Amount of oil needed to refill system during normal inspection and maintenance.

ASTM: American Society of Testing and Material

SAE: Society of Automotive Engineers

API: American Petroleum Institute

Fuel sulphur content	Change interval of oil in engine oil pan
0.5 to 1.0%	1/2 of regular interval
Above 1.0%	1/4 of regular interval

No.	Supplier	Engine Oil [CD or CE] SAE10W, 30, 40 10W30, 15W40 (The 15W40 oil marked * is CE.)	Gear Oil [GL-4 or GL-5] SAE80, 90, 140	Grease [Lithium-Base] NLGI No.2	Anti-freeze Coolant [Ethylene Glycol Base] Permanent Type
1	KOMATSU	EO10-CD EO30-CD EO10-30CD EO15-40CD	GO90 GO140	G2-LI G2-LI-S	AF-ACL AF-PTL AF-PT(Winter, one season type)
2	AGIP	Diesel sigma S super dieselmulti- grade *Sigma turbo	Rotra MP	GR MU/EP	-
3	AMOCO	*Amoco 300	Multi-purpose gear oil	PYKON premium grease	-
4	ARCO	*Arcofleet S3 plus	Arco HD gear oil	Litholine HEP 2 Arco EP moly D	-
5	BP	Vanellus C3	Gear oil EP Hypogear EP	Energrease LS-EP2	Antifreeze
6	CALTEX	*RPM delo 400 RPM delo 450	Universal thuban Universal thuban EP	Marfak all purpose 2 Ultra-duty grease 2	AF engine coolant
7	CASTROL	*Turbomax *RX super CRD	EP EPX Hypoy Hypoy B Hypoy C	MS3 Spheerol EPL2	Anti-freeze
8	CHEVRON	*Delo 400	Universal gear	Ultra-duty grease 2	-
9	CONOCO	*Fleet motor oil	Universal gear lubricant	Super-sta grease	-
10	ELF	Multiperformance 3C Performance 3C	-	Tranself EP Tranself EP type 2	Glacelf
11	EXXON (ESSO)	Essolube D3 *Essolube XD-3 *Essolube XD-3 Extra *Esso heavy duty Exxon heavy duty	Gear oil GP Gear oil GX	Beacon EP2	All season coolant
12	GULF	Super duty motor oil *Super duty plus	Multi-purpose gear lubricant	Gulfcrown EP2 Gulfcrown EP special	Antifeeze and cool- ant
13	MOBIL	Delvac 1300 *Delvac super 10W-30, 15W-40	Mobilube GX Mobilube HD	Mobilux EP2 Mobilgease 77 Mobilgrease special	-

No.	Supplier	Engine Oil [CD or CE] SAE10W, 30, 40 10W30, 15W40 (The 15W40 oil marked * is CE.)	Gear Oil [GL-4 or GL-5] SAE80, 90, 140	Grease [Lithium-Base] NLGI No.2	Anti-freeze Coolant [Ethylene Glycol Base] Permanent Type
14	PENNZOIL	*Superme duty fleet motor oil	Multi-purpose 4092 Multi-purpose 4140	Multi-purpose white grease 705 707L White-bearing grease	Anti-freeze and summer coolant
15	PETRO- FINE	FINA kappa TD	FINA potonic N FINA potonic NE	FINA marson EPL2	FINA tamidor
16	SHELL	Rimura X	Spirax EP Spirax heavy duty	Albania EP grease	-
17	SUN	-	Sunoco GL5 gear oil	Sunoco ultra prestige 2EP Sun prestige 742	Sunoco antifreeze and summer cool- ant
18	TEXACO	*Ursa super plus Ursa premium	Multigear	Multifak EP2 Starplex 2	Coda 2055 startex antifreeze coolant
19	TOTAL	Rubia S *Rubia X	Total EP Total Transmission TM	Multis EP2	Antigal/antifreeze
20	UNION	*Guardol	MP gear lube LS	Unoba EP	-
21	VEEDOL	*Turbostar *Diesel star MDC	Multigear Multigear B Multigear C	-	Antifreeze

TIGHTENING TORQUE SPECIFICATIONS

TIGHTENING TORQUE LIST

⚠ CAUTION

If nuts, bolts, or other parts are not tightened to the specified torque, it will cause looseness or damage to the tightened parts, and this will cause failure of the machine or problems with operation. Always pay careful attention when tightening parts.

Unless otherwise specified, tighten the metric nuts and bolts to the torque shown in the table below.

If it is necessary to replace any nut or bolt, always use a Komatsu genuine part of the same size as the part that was replaced.

Thread diameter of bolt (a)(mm)	Width across flats (b)(mm)	Tightening torque			
		Target value		Service limit	
		N·m	kgf·m	N·m	kgf·m
6	10	13.2	1.35	11.8-14.7	1.2-1.5
8	13	31	3.2	27-34	2.8-3.5
10	17	66	6.7	59-74	6.0-7.5
12	19	113	11.5	98-123	10.0-12.5
14	22	172	17.5	153-190	15.5-19.5
16	24	260	26.5	235-285	23.5-29.5
18	27	360	37	320-400	33.0-41.0
20	30	510	52.3	455-565	46.5-58.0
22	32	688	70.3	610-765	62.5-78.0
24	36	883	90	785-980	80.0-100.0
27	41	1295	132.5	1150-1440	118.0-147.0
30	46	1720	175.0	1520-1910	155.0-195.0
33	50	2210	225.0	1960-2450	200.0-250.0
36	55	2750	280.0	2450-3040	250.0-310.0
39	60	3280	335.0	2890-3630	295.0-370.0

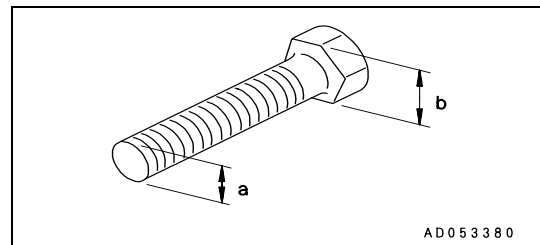

q Apply the following table for Hydraulic Hose.

Hose nominal number	Width across flat a(mm)	Tightening torque			
		Target valve		Service limit	
		N·m	kgf·m	N·m	kgf·m
02	19	44	4.5	35-63	3.5-6.5
03	22	74	7.5	54-93	5.5-9.5
	24	78	8.0	59-98	6.0-10.0
04	27	103	10.5	84-132	8.5-13.5
05	32	157	16.0	128-186	13.0-19.0
06	36	216	22.0	177-245	18.0-25.0

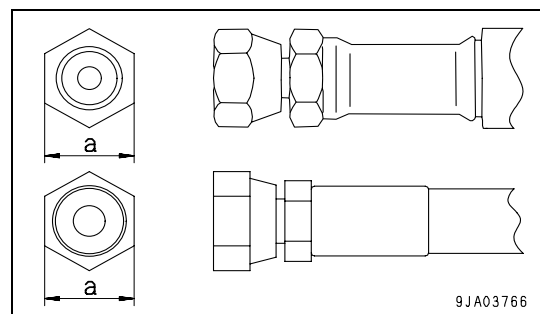

SAFETY CRITICAL PARTS

For using the machine safely for an extended period of time, you are required to periodically replace the safety (critical and fire prevention) related parts listed in the table of important parts on the following page.

Material quality of these parts can change as time passes and they are likely to wear out or deteriorate. However, it is difficult to determine the extent of wear or deterioration at the time of periodic maintenance. Hence, it is required to replace them with new ones regardless of their condition after a certain period of usage. This is important to ensure that these parts maintain their full performance at all times.

Furthermore, should anything abnormal be found on any of these parts, replace it with a new one even if the periodic replacement time for the part has not yet arrived.

If any of the hose clamps show deterioration like deformation or cracking, replace the clamps at the same time as the hoses.

Also perform the following checks with hydraulic hoses which need to be replaced periodically. Tighten all loose clamps and replace defective hoses, as required.

When replacing hoses, always replace O-rings, gaskets, and other such parts at the same time.

Have your Komatsu distributor replace the critical parts.

SAFETY CRITICAL PARTS LIST

No.	Safety critical parts for periodic replacement	Q'ty	Replacement interval
1	Fuel hose (Fuel tank - Water separator)	1	Every 2 years or 4000 hours, whichever comes sooner
2	Fuel hose (Water separator - Fuel pump)	1	
3	Fuel return hose (Fuel injection pump - Fuel tank)	1	
4	Spill hose (Engine output connector - Fuel tank)	1	
5	Pump outlet hose (Pump - Control valve)	2	
6	Work equipment hose (Boom cylinder inlet)	4	
7	Work equipment hose (Bucket cylinder line - Boom foot section)	2	
8	Work equipment hose (Bucket cylinder inlet)	2	
9	Work equipment hose (Arm cylinder line - Boom foot section)	2	
10	Work equipment hose (Arm cylinder inlet)	2	
11	Additional attachment line hose (Boom foot section)	2	
12	Additional attachment line hose (Boom top section)	2	
13	Swing line hose (Swing motor inlet)	2	
14	Main suction hose	1	
15	Heater hose	2	
16	Travel line hose (Control valve - Swivel joint)	4	
17	Travel line hose (Swivel joint - Travel motor)	4	
18	Seat belt	1	Every 3 years

MAINTENANCE SCHEDULE

If the machine is equipped with a hydraulic breaker, the maintenance schedule for some parts will be different. For details, see "MAINTENANCE INTERVAL FOR HYDRAULIC BREAKER (4-18)" to confirm the correct maintenance schedule when carrying out maintenance.

MAINTENANCE SCHEDULE CHART

INITIAL 250 HOURS MAINTENANCE (ONLY AFTER THE FIRST 250 HOURS)

REPLACE FUEL FILTER CARTRIDGE..... 4-55

INITIAL 1000 HOURS MAINTENANCE (ONLY AFTER THE FIRST 1000 HOURS)

CHECK ENGINE VALVE CLEARANCE, ADJUST 4-19

WHEN REQUIRED

CHECK, CLEAN AND REPLACE AIR CLEANER ELEMENT 4-20
 CLEAN INSIDE OF COOLING SYSTEM 4-25
 CHECK AND TIGHTEN TRACK SHOE BOLTS 4-28
 CHECK AND ADJUST TRACK TENSION 4-29
 CHECK ELECTRICAL INTAKE AIR HEATER 4-31
 REPLACE BUCKET TEETH (VERTICAL PIN TYPE) 4-32
 REPLACE BUCKET TEETH (HORIZONTAL PIN TYPE) 4-35
 ADJUST BUCKET CLEARANCE 4-36
 CHECK WINDOW WASHER FLUID LEVEL, ADD FLUID 4-37
 CHECK AND ADJUST AIR CONDITIONER (ONLY MACHINES EQUIPPED WITH AIRCONDITIONER) 4-38
 WASHING WASHABLE FLOOR 4-39
 BLEEDING AIR FROM HYDRAULIC SYSTEM 4-43
 METHOD FOR RELEASING INTERNAL PRESSURE IN HYDRAULIC CIRCUIT 4-46
 CHECK NITROGEN GAS CHARGE PRESSURE IN ACCUMULATOR (control circuit) 4-46

CHECKS BEFORE STARTING

EVERY 100 HOURS MAINTENANCE

LUBRICATING 4-48
 CHECK SWING MACHINERY CASE OIL, ADD OIL 4-50

EVERY 250 HOURS MAINTENANCE

CHECK OIL LEVEL IN FINAL DRIVE CASE, ADD OIL 4-51
 CHECK LEVEL OF BATTERY ELECTROLYTE 4-52

EVERY 500 HOURS MAINTENANCE

REPLACE FUEL FILTER CARTRIDGE..... 4-55
 CHANGE OIL IN ENGINE OIL PAN, REPLACE ENGINE OIL FILTER CARTRIDGE 4-56
 CHECK SWING PINION GREASE LEVEL, ADD GREASE 4-57
 LUBRICATE SWING CIRCLE..... 4-57
 CLEAN, CHECK RADIATOR FINS, OIL COOLER FINS, AFTERCOOLER FINS, CONDENSER FINS
 (ONLY MACHINES EQUIPPED WITH AIR CONDITIONER) 4-58
 CLEAN ATR CONDITIONER FRESH/RECIRC FILTERS 4-59
 REPLACE HYDRAULIC OIL FILTER ELEMENT 4-61
 REPLACE BREATHER ELEMENT IN HYDRAULIC TANK..... 4-62
 CHECK AND ADJUST COOLING FAN BELT TENSION 4-63
 CHECK AND ADJUST AIR CONDITIONER COMPRESSOR BELT TENSION..... 4-64

EVERY 1000 HOURS MAINTENANCE

CHANGE OIL IN SWING MACHINERY CASE 4-65
 CHANGE OIL IN FINAL DRIVE CASE 4-66
 CHECK ALL TIGHTENING PARTS OF TURBOCHARGER 4-66
 CHECK PLAY TURBOCHARGER ROTOR..... 4-66
 CHECK NITROGEN GAS CHARGE PRESSURE IN ACCUMULATOR (for breaker)..... 4-66

EVERY 2000 HOURS MAINTENANCE

CHECK PTO GEAR CASE, ADD OIL..... 4-67
 CLEAN HYDRAULIC OIL TANK STRAINER..... 4-68
 CLEAN, CHECK TURBOCHARGER 4-68
 CHECK ALTERNATOR, STARTING MOTOR..... 4-68
 CHECK ENGINE VALVE CLEARANCE, ADJUST 4-68

EVERY 4000 HOURS MAINTENANCE

CHECK WATER PUMP 4-69

EVERY 5000 HOURS MAINTENANCE

CHANGE OIL IN HYDRAULIC TANK..... 4-70

MAINTENANCE INTERVAL FOR HYDRAULIC BREAKER

For machine equipped with a hydraulic breaker, the hydraulic oil deteriorates faster than for normal bucket digging operations, so set the maintenance intervals as follows.

REPLACE HYDRAULIC OIL FILTER ELEMENT

q On new machines, replace the element after the first 100 to 150 hours, then carry out further replacement of the element according to the table on the right.

1. Replacement interval for hydraulic oil
2. Hydraulic filter element
3. Additional filter element

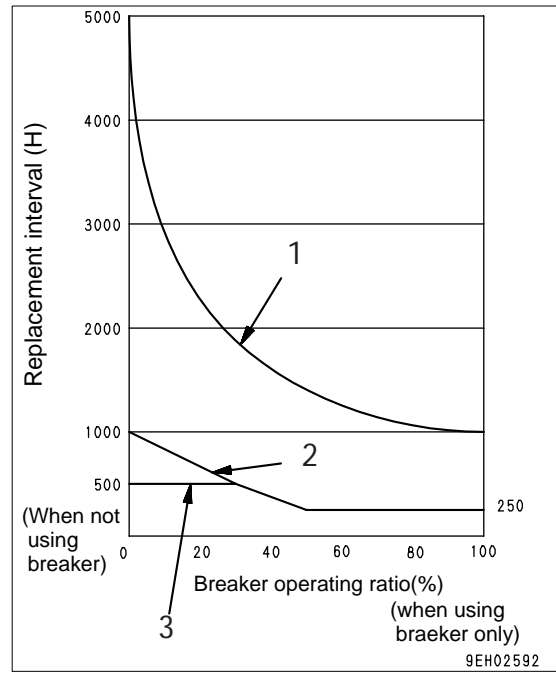

CHANGE OIL IN HYDRAULIC TANK

q Change the oil according to the table on the right.

REPLACE ADDITIONAL FILTER ELEMENT FOR BREAKER

q Use a guideline of 250 hours for use of the breaker (operating ratio for the breaker: 50 % or more), and replace the element according to the table on the right.

MAINTENANCE PROCEDURE

INITIAL 250 HOURS MAINTENANCE (ONLY AFTER THE FIRST 250 HOURS)

Carry out the following maintenance only after the first 250 hours of operation on new machines.

- Replace fuel filter cartridge

For details of the method of replacing or maintaining, see the section on EVERY 500 HOURS SERVICE.

INITIAL 1000 HOURS MAINTENANCE (ONLY AFTER THE FIRST 1000 HOURS)

Carry out the following maintenance only after the first 1000 hours of operation on new machines.

- CHECK ENGINE VALVE CLEARANCE, ADJUST

Special tools are needed for inspection and maintenance, so contact your Komatsu distributor.

For details of the method of replacing or maintaining, see the section on EVERY 2000 HOURS SERVICE.

WHEN REQUIRED

CHECK, CLEAN AND REPLACE AIR CLEANER ELEMENT

WARNING

- q When using compressed air, there is danger of dirt flying and causing personal injury. Always wear protective glasses, dust mask, or other protective equipment.
- q When removing the outer element from the air cleaner body, it is dangerous to pull it out by force. When working at high places or where the foothold is poor, be careful not to fall because of the reaction when pulling out the outer element.

Checking

If air cleaner clogging monitor (1) of the monitor panel flashes, clean the air cleaner element.

NOTICE

- q Do not clean the air cleaner element until the air cleaner clogging monitor on the monitor panel flashes. If the element is cleaned frequently before the clogging monitor flashes, the air cleaner will not be able to display its performance fully, and the cleaning efficiency will also go down. In addition, during the cleaning operation, more dirt stuck to the element will fall inside the inner element.
- q If inspection, cleaning, or maintenance is carried out with the engine running, dirt will enter the engine and cause damage to the engine. Always stop the engine before carrying out these operations.

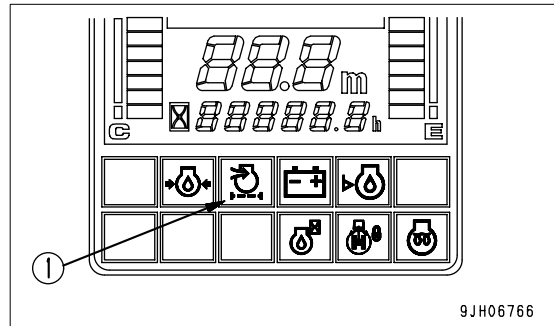

Cleaning or Replacing Outer Element

1. Open the battery room door on the left side of the machine, remove clips (2) at 3 places, then take out cover (3).

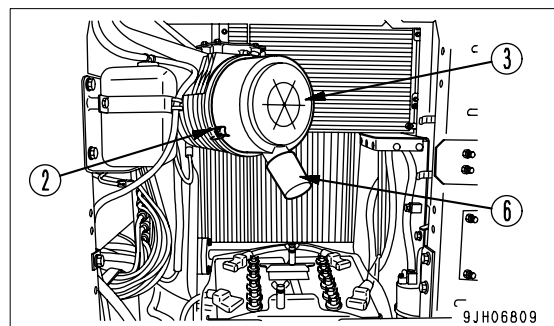

NOTICE

Never remove inner element (5). If it is removed, dust will enter and cause engine trouble.

2. Remove outer element (4).

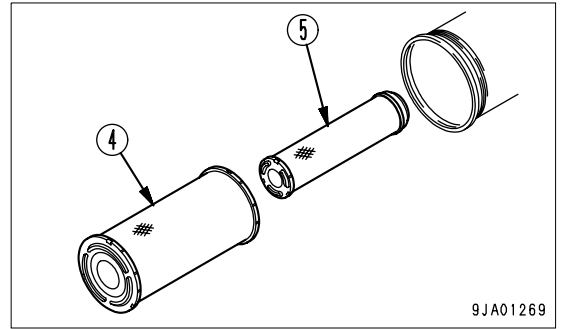

NOTICE

When cleaning cover (3), do not remove evacuator valve (6).

3. Clean the inside of the air cleaner body and the cover (3).

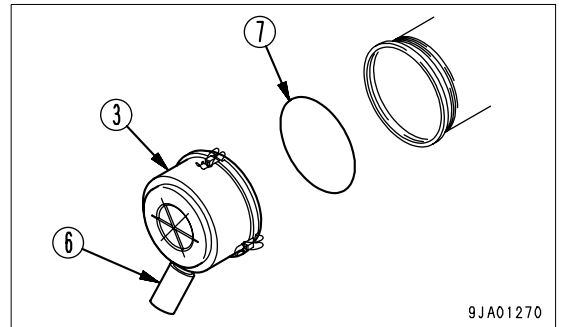

NOTICE

The inner element must not be used again even after its cleaning. When replacing the outer element, replace the outer element at the same time.

4. Direct dry compressed air (Max. 0.69 MPa (7 kgf/cm²)) from the inside of the outer element along its folds. Then direct the compressed air from the outside along the folds, and again from the inside.
5. Replace any outer element, which has been cleaned 6 times or used for one year. Replace the inner element at the same time.
6. Replace both inner and outer elements when the dust indicator red piston appears soon after installing the cleaned outer element even though it has not been cleaned 6 times.
7. Remove one seal from the element whenever the element has been cleaned.

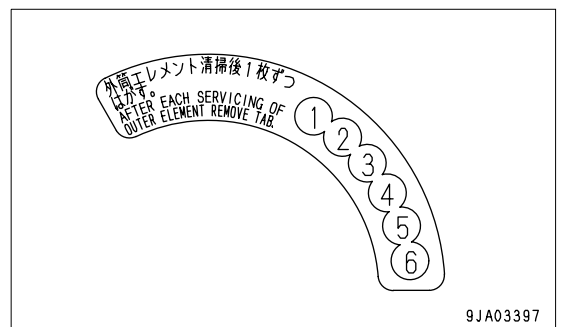
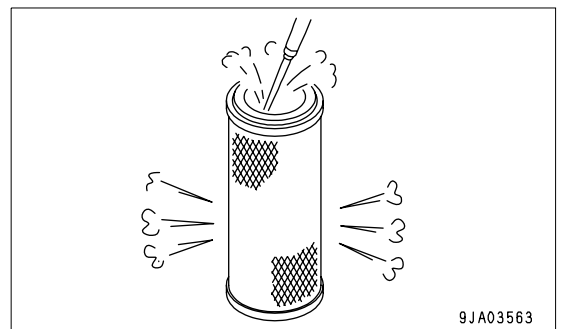

8. If small holes or thinner parts are found on the element when it is checked by shining a light through it after cleaning, replace the element.

NOTICE

When cleaning the element, do not hit it or beat it against something.

Do not use an element whose folds or gasket or seal are damaged.

Wrap unused element and store them in a dry place.

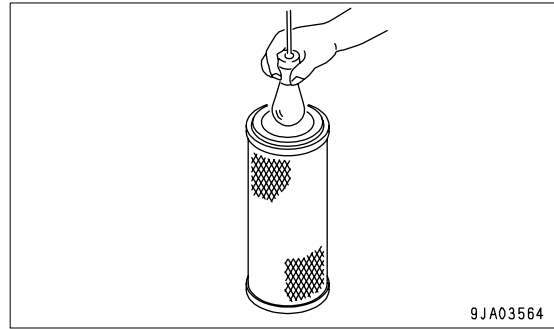
**⚠ CAUTION**

When installing the cover (3), check O-ring (7) and replace it if there are any scratches or damage.

9. Set the cleaned outer element in position, then secure cover (3) with mounting clips (2).
10. Remove evacuator valve (6) and blow with compressed air to clean.
After cleaning, install evacuator valve (6) again.

Install Air Cleaner Element

1. Open the battery room door on the left side of the machine, remove clips (2) at 3 places, then take out cover (3).

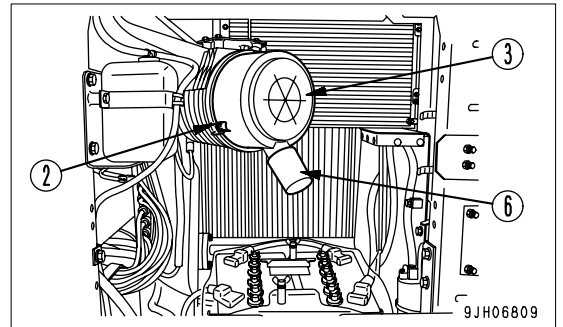

2. Remove outer element (4).
Do not remove inner element (5) at this time, however.

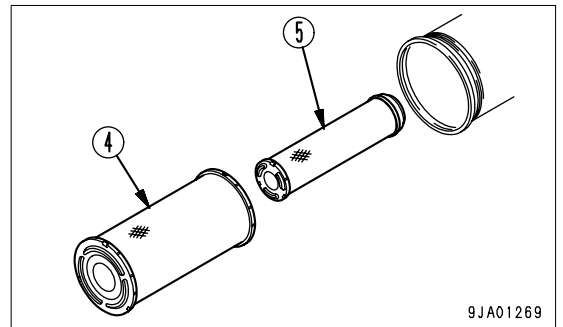

NOTICE
When cleaning cover (3), do not remove evacuator valve (6).

3. Clean the inside of the air cleaner body and the cover (3).

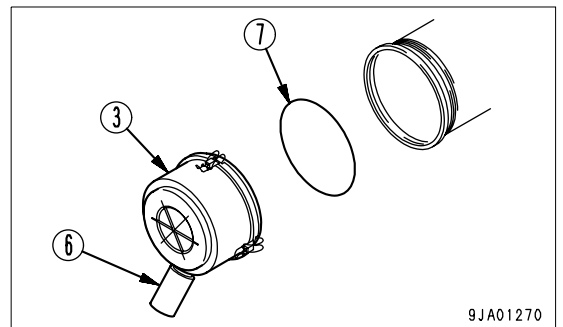

4. Remove inner element (5), then install a new inner element immediately.

CAUTION
When installing the cover (3), check O-ring (7) and replace it if there are any scratches or damage.

5. Set the cleaned outer element in position, then secure cover (3) with mounting clips (2).
6. Replace the seal attached to cover (3) with new one.

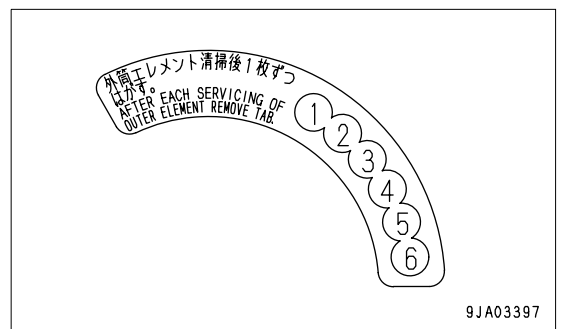

Replacing Inner Element

1. First remove the outer element, and then remove the inner element.
2. Cover the air connector side (outlet side) with a clean cloth or tape.
3. Clean the air cleaner body interior, then remove the cover from the air intake port in Step 2.
4. Install the new inner element to the connector, then install the outer element.

NOTICE

The inner element must not be used again even after its cleaning. When replacing the outer element, replace the outer element at the same time.

5. Set the outer element in position, then lock cover (3) with hooks (2).

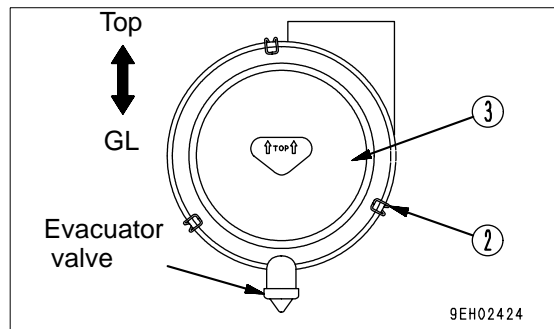
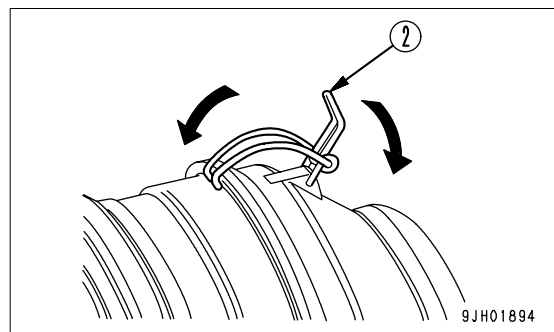

CLEAN INSIDE OF COOLING SYSTEM

 WARNING

- q **Immediately** after the engine is stopped, the coolant is at a high temperature and the radiator is under high internal pressure. If the cap is removed to drain the coolant in this condition, there is a hazard of burns. Wait for the temperature to go down, then turn the cap slowly to release the pressure before removing it.
- q **Cleaning is carried out with the engine running. When standing up or leaving the operator's seat, set the safety lock lever to the LOCK position.**
- q **For details of starting the engine, see “BEFORE STARTING ENGINE (3-56)” and “STARTING ENGINE (3-70)” in the OPERATION section.**
- q **There is danger of touching the fan if the undercover is left removed. Never enter behind the machine when the engine is running.**

Clean the inside of the cooling system, change the coolant and replace the corrosion resistor according to the table below.

Kind of coolant	Cleaning inside of cooling system and changing coolant
Permanent type antifreeze (All season type)	Every year (autumn) or every 2000 hours whichever comes first
Non-permanent type antifreeze containing ethylene glycol (winter, one season type)	Every 6 months (spring and autumn) (Drain antifreeze in spring, add antifreeze in autumn)
When not using antifreeze	Every 6 months or every 1000 hours whichever comes first

Stop the machine on level ground when cleaning or changing the coolant.

Use a permanent type of antifreeze.

If, for some reason, it is impossible to use permanent type antifreeze, use an antifreeze containing ethylene glycol.

Super Coolant (AF-ACL) has an anti-corrosion effect as well as an antifreeze effect.

The ratio of antifreeze to water depends on the ambient temperature, but to obtain the corrosion resistance effect, a minimum ratio of 30% by volume is necessary.

When deciding the ratio of antifreeze to water, check the lowest temperature in the past, and decide from the mixing rate table given below.

It is actually better to estimate a temperature about 10°C lower when deciding the mixing rate.

Mixing rate of water and antifreeze

Min. atmospheric temperature	°C	Above -10	-15	-20	-25	-30
Amount of antifreeze	liters	4.0	4.8	5.5	6.2	6.7
Amount of water	liters	9.4	8.6	7.9	7.2	6.7
Volume ratio (%)		30	36	41	46	50

⚠ WARNING

Antifreeze is flammable, so keep it away from flame.
Antifreeze is toxic. When removing the drain plug, be careful not to get water containing antifreeze on you. If it gets in your eyes, flush your eyes with large amount of fresh water and see a doctor at once.

Use city water for the coolant.

If river water, well water or other such water supply must be used, contact your Komatsu distributor.

We recommend use of an antifreeze density gauge to control the mixing proportions.

Prepare a container with a capacity of at least 13.4 liters to catch the drained coolant.

1. Remove undercover (1).

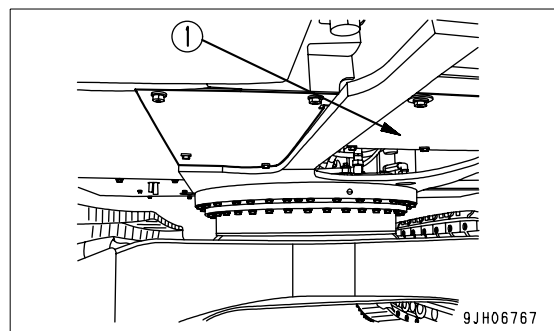

2. Turn radiator cap (2) slowly and remove it.

3. Set a container to catch the drained coolant under drain valve (3) and drain plug (4). Remove drain hose (5) at the bottom of the radiator from clip (6), let it hang perpendicularly to the container, then open drain valve (3) and drain the coolant. Remove drain plug (4) from the cylinder block also to drain the coolant.

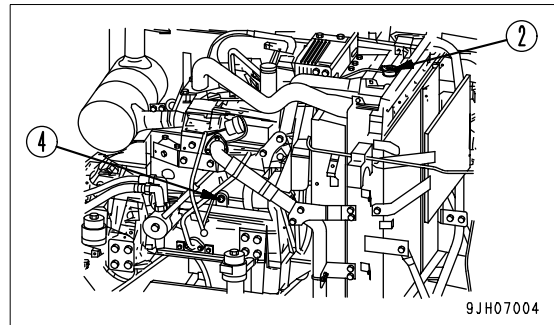

4. After draining the coolant, close drain valve (3) and drain plug (4), and fill with tap water. When the radiator is full of water, start the engine, run at low idling, raise the water temperature to above 90 °C, and run for approx. 10 minutes.

5. Stop the engine, open drain valve (3) and drain plug (4), and drain the coolant.

6. After draining the water, clean the radiator with detergent.

For the cleaning method, follow the instruction of detergent.

7. Close drain valve (3), then wind sealing tape around drain plug (4) and close it.

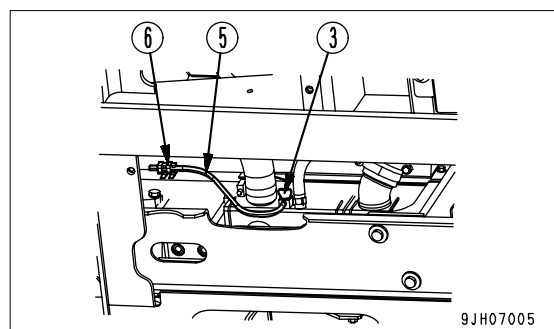

8. After securing drain hose (5) with clip (6), install undercover (1).

9. Add water through the water filler up to the filler port.

10. To bleed the air from the coolant, run at low idling for 5 minutes, then run for a further 5 minutes at high idling. (When doing this, leave radiator cap (2) off.)
11. Drain the coolant from sub tank (7), wash the inside of the sub tank, then add water to between the FULL and LOW marks.
12. Stop the engine, wait for 3 minutes, then add tap water to near the water filler port, and close radiator cap (2).

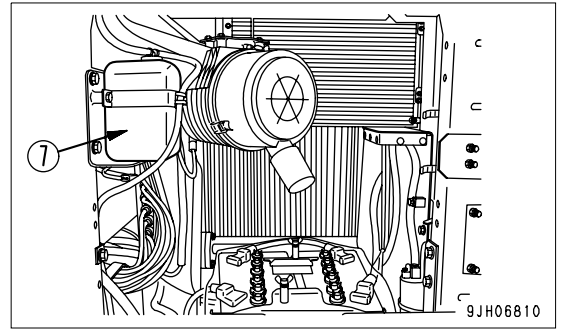

CHECK AND TIGHTEN TRACK SHOE BOLTS

(Machine equipped with steel shoes, road liners)

If the machine is used with track shoe bolts (1) loose, they will break, so tighten any loose bolts immediately.

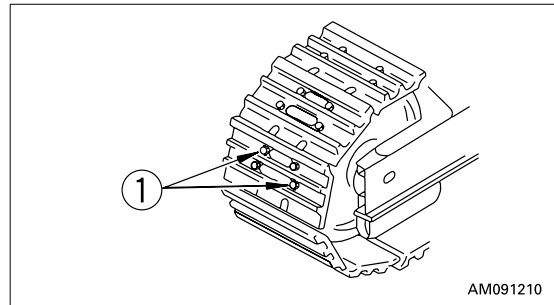

Tightening

1. First, tighten to the initial tightening torque of 196 ± 19.6 N·m (20 ± 2 kgf·m), then check that the nut and shoe are in tight contact with the link mating face.
2. After checking, tighten each shoe by the additional tightening angle.

Type of shoe	Initial tightening torque N·m (kgf·m)	Additional tightening angle
Triple shoe Flat shoe	196 ± 20 (20 ± 2)	$90^\circ \pm 10^\circ$
Swamp shoe	196 ± 20 (20 ± 2)	$120^\circ \pm 10^\circ$
Road liner	147 ± 10 (15 ± 1)	$50^\circ \pm 5^\circ$

Order for Tightening

Tighten the bolts in the order shown in the diagram on the right. After tightening, check that the nut and shoe are in close contact with the link mating surface.

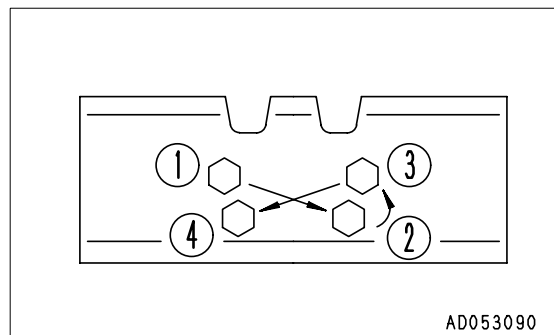

CHECK AND ADJUST TRACK TENSION

⚠ WARNING

For details of starting the engine and operating the work equipment, see “BEFORE STARTING ENGINE (3-56)”, “STARTING ENGINE (3-70)”, “AFTER STARTING ENGINE (3-74)”, and “WORK EQUIPMENT CONTROLS AND OPERATIONS (3-89)” in the OPERATION section.

Wear on pins and bushings of the undercarriage will vary with working conditions and a type of soil, so inspect the track tension every now and then in order to maintain the standard tension.

For carrying out inspection and adjustment of track shoes, park the machine on the flat and solid ground.

Checking

1. Run the engine at low idling, then travel the machine forward for a distance equal to the track length on ground and stop the machine slowly.
2. Put on the track shoe straight wooden bar (3) which stretches from idler (1) to upper carrier roller (2).
3. Measure the maximum deflection between the bottom surface of the wooden bar and the top surface of the track shoe.

Deflection “a” should be 10 to 30 mm.

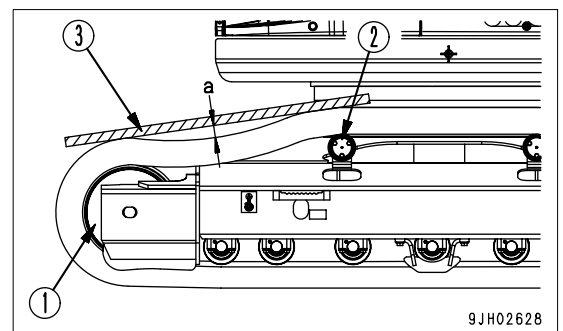

9JH02628

If the track tension is not at the standard value, adjust it in the following manner.

Adjustment

! WARNING

Grease inside the adjusting mechanism is under high pressure. Grease coming from plug (1) under pressure can penetrate the body, causing injury or death. For this reason, do not loosen plug (1) more than one turn. Do not loosen any part other than plug (1). Furthermore, do not bring your face in front of the plug (1). If the track tension is not relieved by this procedure, please contact your Komatsu distributor for repairs.

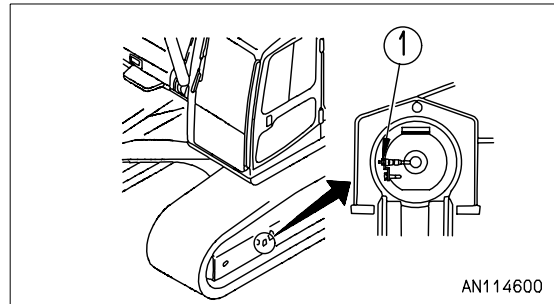

Increasing Track Tension

Prepare a grease gun.

1. Pump in grease through grease fitting (2) with a grease gun. (Grease fitting (2) forms one part with plug (1).)
2. To check if the tension is correct, run the engine at low idling, move the machine slowly forward (by an amount equal to the length of track on ground), then stop the machine.
3. Check the track tension again, and if the tension is not correct, adjust it again.
4. Continue to pump in grease until dimension S becomes zero (0). If the tension is still loose, the pin and bushing are excessively worn, so they must be either turned or replaced. Please contact your Komatsu distributor for repairs.

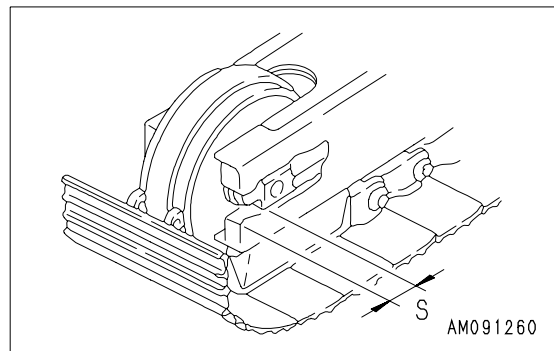
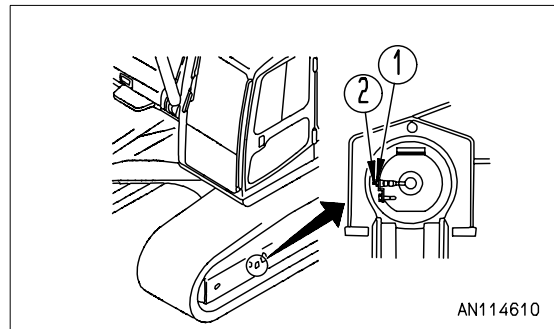

Loosening Track Tension

WARNING

It is extremely dangerous to release the grease by any method except the procedure given below. If the track tension is not relieved by this procedure, please contact your Komatsu distributor for repairs.

1. Loosen plug (1) gradually to release the grease.
2. When loosening plug (1), turn it a maximum of one turn.
3. If the grease does not come out smoothly, move the machine forwards and backwards a short distance.
4. Tighten plug (1).
5. To check if the tension is correct, run the engine at low idling, move the machine slowly forward (by an amount equal to the length of track on ground), then stop the machine.
6. Check the track tension again, and if the tension is not correct, adjust it again.

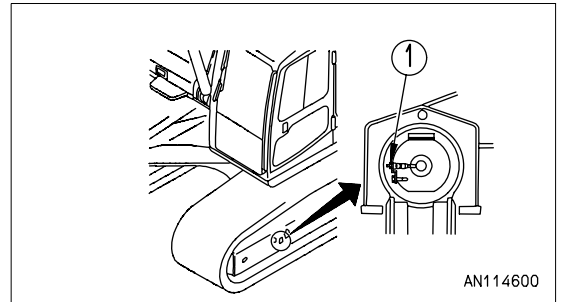

CHECK ELECTRICAL INTAKE AIR HEATER

Before the start of the cold season (once a year), contact your Komatsu distributor to have the electrical intake air heater checked for dirt or disconnections.

REPLACE BUCKET TEETH (VERTICAL PIN TYPE)

Replace the bucket teeth before the adapter starts to wear.

⚠ WARNING

- q It is dangerous if the work equipment is mistakenly moved when replacing the teeth. Set the work equipment in a stable condition, stop the engine, then set safety lock lever (1) securely to the LOCK position (L).
- q As the locking pin is knocked out with force, there is danger that the pin may fly out. Check that there is no one near the machine.
- q Broken pieces may fly during the replacement operation, so always wear safety glasses, gloves, or other protective equipment.

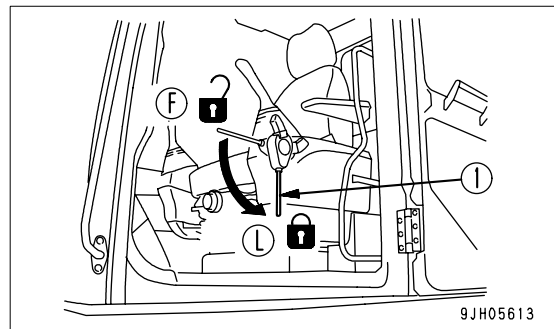

1. To make it possible to knock out the pin of tooth (1), put block (5) under the bottom of the bucket, and set so that the bottom surface of the bucket is horizontal.

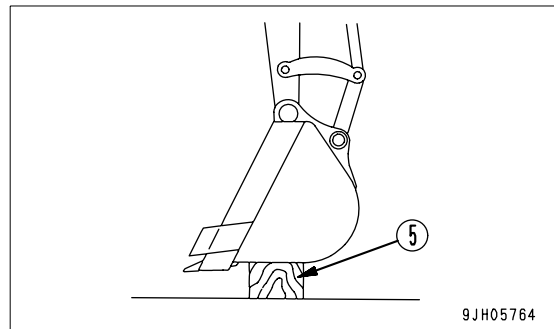

- 2. Use a hammer and drift to knock out lock pin (2). (If the drift is set against rubber pin lock (3) when it is hit, the rubber pin lock may break. Set it against the back of the pin.)
- 3. After removing lock pin (2) and rubber pin lock (3), check them.

If lock pin (2) and rubber pin lock (3) are used in the condition below, it will cause tooth (1) to come off during operation. Always replace them with new parts.

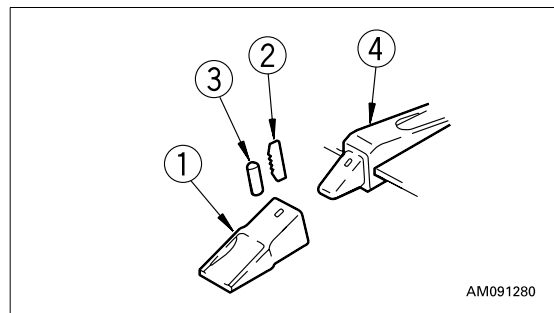

q Lock pin (2) is too short.

Dimension (B) is less than 1/3 A when lock pin (2) is aligned at bottom surface (C).

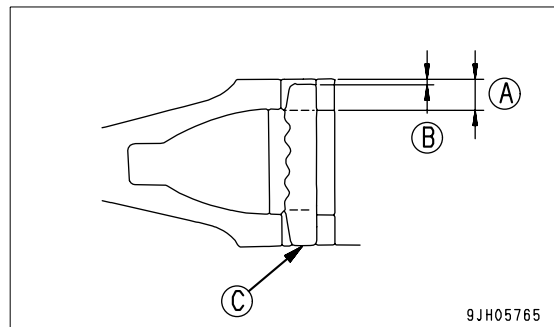

- q Rubber (6) of the rubber pin lock is cut and the steel ball is about to come out.

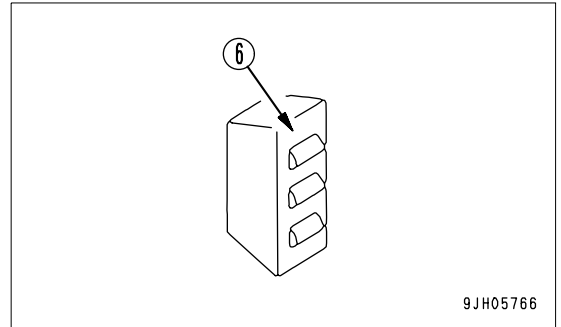

- q Steel ball (7) sinks in when it is pushed by hand.

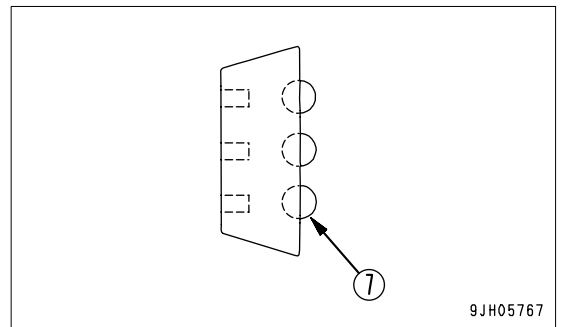

- Clean the surface of adapter (4) and remove the soil with a knife.
- Hit rubber pin lock (3) by hand or with a metal hammer and push it into the hole in adapter (4).

When doing this, be careful not to let rubber pin lock (3) fly out from the surface of adapter (4).

- Clean the inside surface of tooth (1), then install to adapter (4). If there is any mud stuck to it or any protrusion, tooth (1) will not fit properly in adapter (4) and the fitting contact will be poor.

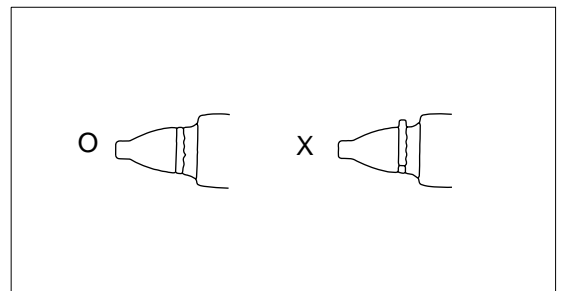

- Fit teeth (1) to adapter (4), and confirm that when the pointer is pressed strongly, the rear face of the hole for the pin of the teeth is at the same level as the rear face of the hole for the pin of the adapter.

If the rear face of the pin hole of tooth (1) protrudes in front of the rear face of the pin hole of adapter (4), do not knock the pin in.

If this happens, there is something (C) preventing the tooth (1) from fitting completely in adapter (4), so locate the problem and remove the obstruction. When tooth (1) fits completely in adapter (4), knock in lock pin (2).

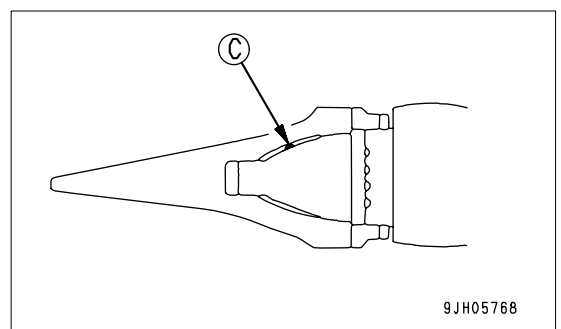

8. Insert lock pin (2) in the pin hole in the tooth (1), and knock it in so that the top surface of lock pin (2) is the same height as the surface of tooth (1).
9. After replacing the bucket tooth, always check as follows.
 - 1) After lock pin (2) is completely knocked in, check that it is secured in position at tooth (1) and the surface.
 - 2) After knocking in the lock pin (2) from one direction, tap it back lightly in the opposite direction.
 - 3) Tap the tip of tooth (1) from the top and bottom, and the side face from the left and right.
 - 4) Rubber pin lock (3) and lock pin (2) must be as shown in the diagram on the right.

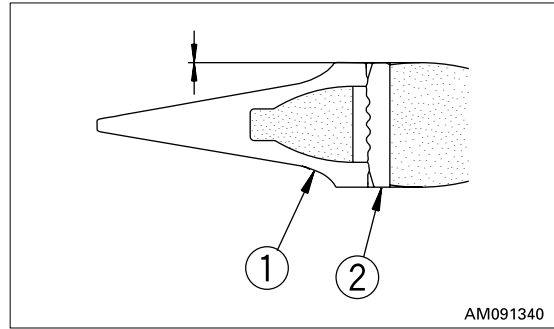

REMARK

If the tooth is turned, the wear will become uniform. This will extend the service life of the tooth and reduce the frequency of replacement. When replacing the tooth, replace the rubber pin lock and lock pin with new parts at the same time. This will prevent the tooth from falling out.

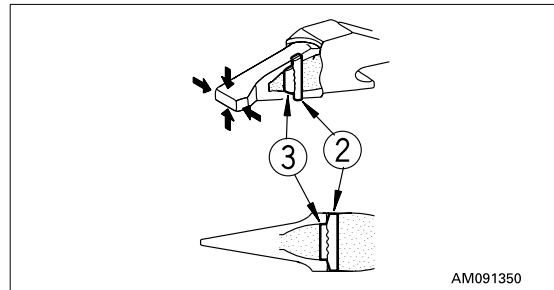

REPLACE BUCKET TEETH (HORIZONTAL PIN TYPE)

Replace the teeth before the wear reaches the adapter.

! WARNING

- q It is dangerous if the work equipment is mistakenly moved when replacing the teeth. Set the work equipment in a stable condition, stop the engine, then set safety lock lever (1) securely to the LOCK position (L).
- q As the locking pin is knocked out with force, there is danger that the pin may fly out. Check that there is no one near the machine.
- q Broken pieces may fly during the replacement operation, so always wear safety glasses, gloves, or other protective equipment.

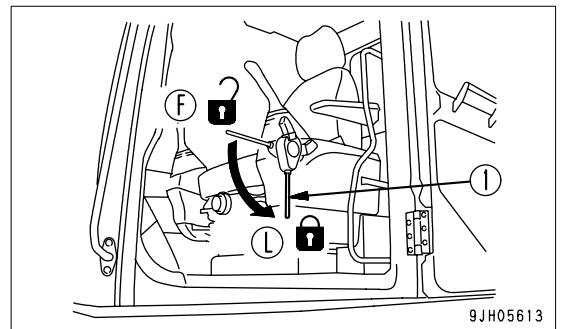

1. To make it possible to knock out the pin (1) of tooth (2), put block (5) under the bottom of the bucket, and set so that the bottom surface of the bucket is horizontal.

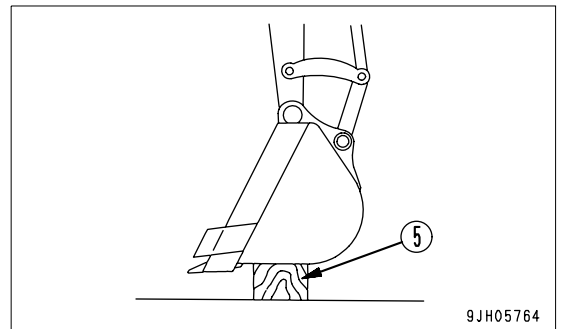

2. Place a bar on the head of pin (1), hit the bar with a hammer to knock out the pin, then remove tooth (2).

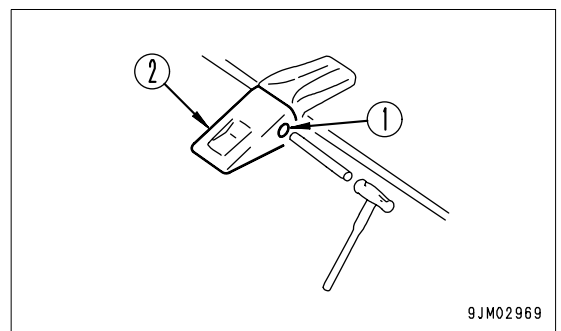

REMARK

If it cannot be removed by this method, for safety reasons, always contact your Komatsu distributor to have the replacement carried out.

3. Clean the mounting face. Fit a new tooth (2) in the adapter, push in pin (1) partially by hand, then lock it with a hammer to install the tooth to the bucket.

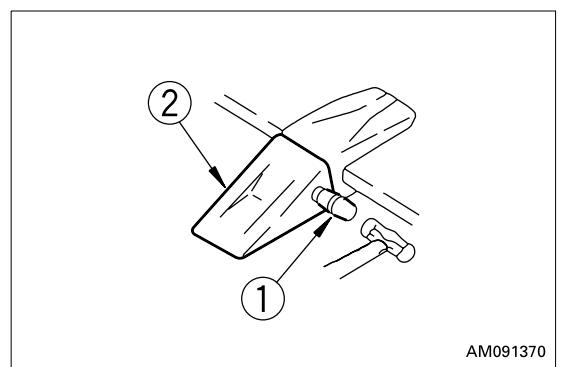

ADJUST BUCKET CLEARANCE

⚠ WARNING

It is dangerous if the work equipment is mistakenly moved when adjusting the bucket clearance.

Set the work equipment in a stable condition, stop the engine, then set safety lock lever (1) securely to the LOCK position (L).

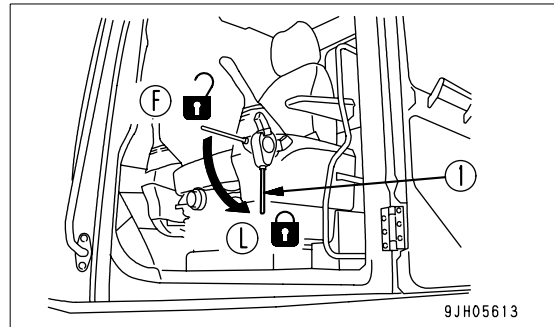

1. Set the work equipment to the position shown in the diagram on the right, then stop the engine and set the lock lever to the LOCK position.

2. Shift O-ring (1) of the linkage and measure the amount of play "a".

Measurement is easier if you move the bucket to one side or the other so all the play can be measured in one place. (In the diagram this is on the left-hand side)

Use a gap (clearance) gauge for easy and accurate measurement.

3. Loosen 4 plate mounting bolts (2) and loosen plate (3).

4. Remove shim (4) corresponding to the amount of play "a" measured above.

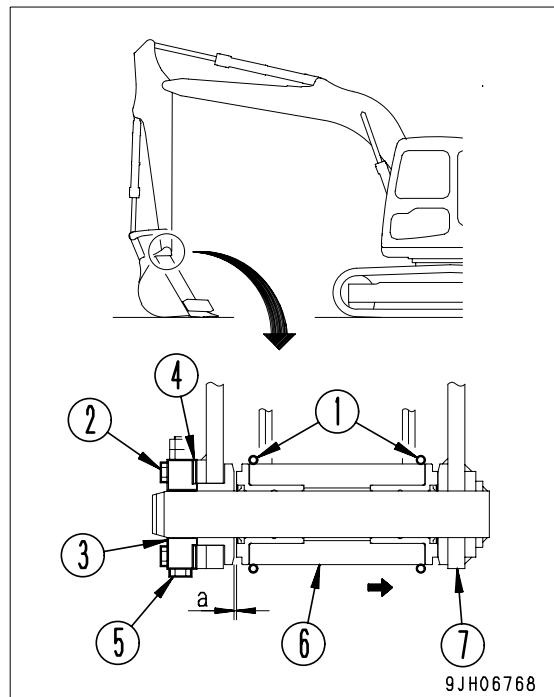

[Example]

In the case of play of 3 mm, remove two 1.0 mm shims and one 0.5 mm shim. Play becomes 0.5 mm. For shim (4), two types of 1.0 mm and 0.5 mm are used.

When play "a" is smaller than one shim, do not carry out any maintenance.

5. Tighten the four bolts (2).

If the bolts (2) are too stiff to tighten, pull out pin stopper bolt (5) for easier tightening.

(6): Arm

(7): Bucket

CHECK WINDOW WASHER FLUID LEVEL, ADD FLUID

If there is air in the window washer fluid, check the level of the fluid in window washer tank (1). Add automobile window washer fluid if necessary.

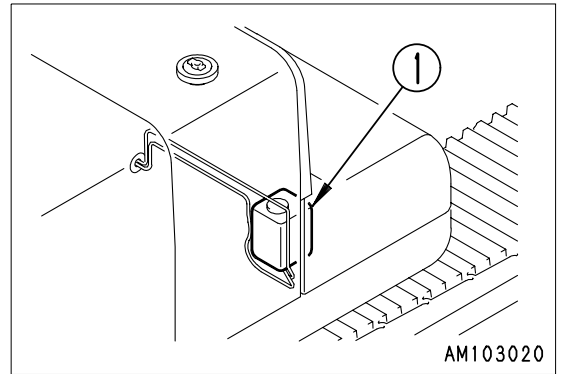

When adding fluid, be careful not to let any dust get in.

Mixture Ratio of Pure Washer Fluid and Water

The proportion differs according to the ambient temperature, so dilute the washer fluid with water to the following proportions before adding.

Area, season	Proportions	Freezing temperature
Normal	Washer fluid 1/3: water 2/3	-10°C
Winter in cold area	Washer fluid 1/2 : water 1/2	-20°C
Winter in extremely cold area	Pure washer fluid	-30°C

There are two types depending on the freezing temperature:

-10°C (general use) and -30°C (cold area use), so select according to the area and season.

CHECK AND ADJUST AIR CONDITIONER

Check Level of Refrigerant (gas)

WARNING

If the refrigerant used in the cooler gets into your eyes or on your hands, it may cause loss of sight or frostbite. Do not touch the refrigerant. Never loosen any part of the refrigerant circuit. Do not bring any flame close to any point where the refrigerant gas is leaking.

If the level of the refrigerant (gas) is low, the cooling effect will be reduced. Run the engine at high idling, and check the flow of the refrigerant gas (freon 134a) in the refrigerant circuit through the sight glass (2) (inspection window) of the receiver (1) when the cooler is running at high speed.

- (A) No bubbles in refrigerant flow: Suitable
- (B) Some bubbles in flow (bubbles pass continuously): Lack of refrigerant
- (C) Colorless, transparent: No refrigerant

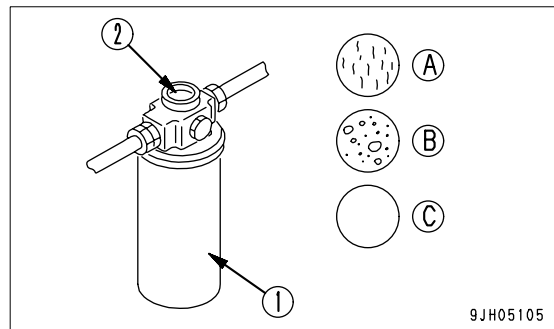
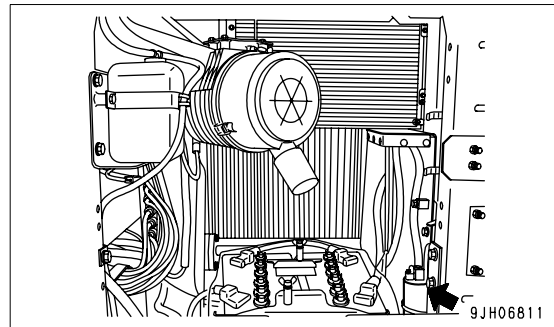

REMARK

When there are bubbles, the refrigerant gas level is low, so contact your refrigerant dealer to have refrigerant added. If the air conditioner is run with the refrigerant gas level low, it will cause damage to the compressor.

Inspection During Off Season

Even during the off-season, operate the air conditioner for 3 to 5 minutes once a month to maintain the oil film at all parts of the compressor.

Inspection and Maintenance Items

Check, maintenance items	Content of check, maintenance	Guideline for maintenance interval
Refrigerant (gas)	Charge amount	Twice a year (spring, autumn)
Condenser	Clogged fins	Every 500 hours
Compressor	Operating condition	Every 4000 hours
V-belt	Damage, tension	Every 250 hours
Blower motor, fan	Operating condition (does it when required make abnormal noise?)	When required
Control mechanism	Operating condition (does it function normally?)	When required
Piping mounts	Mounting condition, looseness at tightening or connecting portions, leakage of gas, damage	When required

WASH WASHABLE FLOOR**WARNING**

- q When setting the machine at an angle, use strong blocks to stabilize the machine and be extremely careful when carrying out the operation.
- q If the control levers are touched by mistake, the work equipment or machine may suddenly move, and this may lead to a serious accident. Always set the safety lock lever securely to the LOCK position before standing up from the operator's seat.
- q When setting the machine at an angle, use strong blocks to stabilize the machine and be extremely careful when carrying out the operation.
- q If the control levers are touched by mistake, the work equipment or machine may suddenly move, and this may lead to a serious accident. Always set the safety lock lever securely to the LOCK position before standing up from the operator's seat.

NOTICE

- q When carrying out this operation, be careful not to get water on the monitor and connectors inside the operator's cab.
- q Never spray water above the pedestal of the operator's seat (2).
- q If any water splashes on the surrounding equipment, be sure to wipe it off.

With the washable floor, it is possible to flush out the dirt on the cab floor directly with water.

Washing Washable Floor Mat

1. Stop the machine on horizontal ground, lower the bucket to the ground, and then stop the engine.
2. When washing the floor mat, use a brush to remove the dust, or direct the water onto the mat and wash it with a brush.

Method of Washing

1. Set the machine at an angle.
For details, see “Method of Setting Machine at Angle (4-42)”
2. Swing the upper structure slowly so that water drain holes (3) in the cab floor are at a low position.

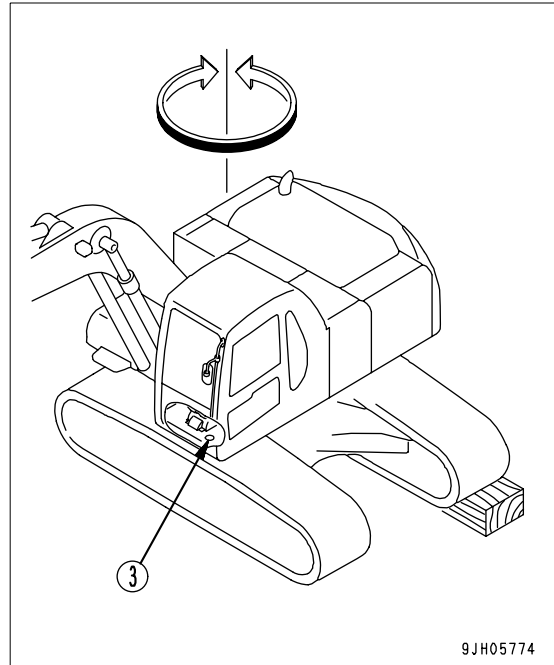

3. Lower the work equipment to the ground and set the machine in a stable condition.

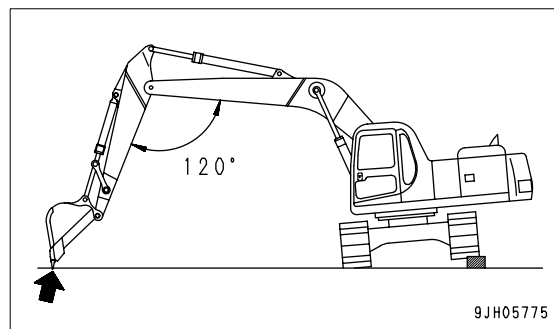

4. Set safety lock lever (1) to LOCK position (L) and stop the engine.
5. Remove the floor mat holder plate (4).
6. Remove the floor mat.
7. Remove the cap from water drain port (3).

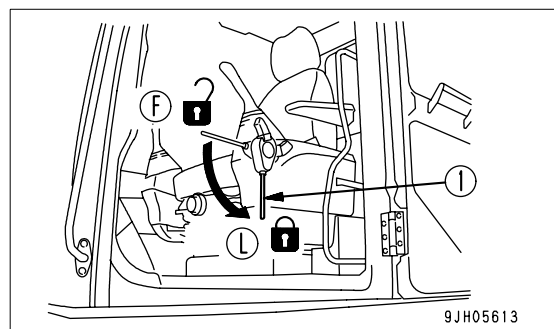

8. Flush out the dirt on the floor directly with water through water drain port (3).

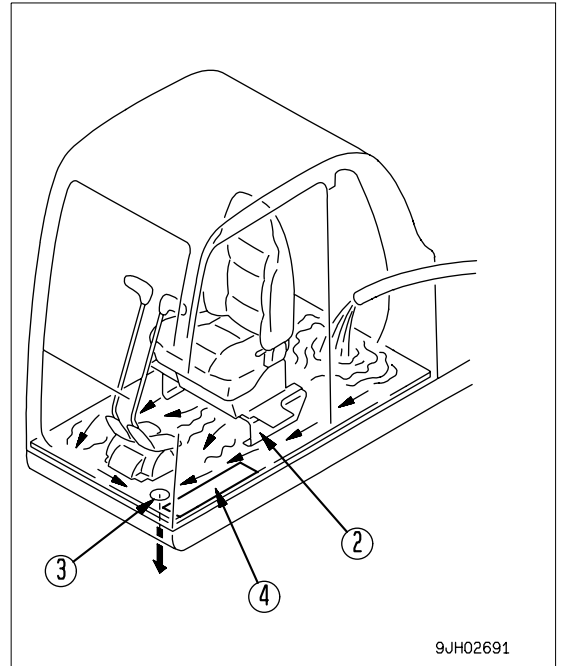

9. After completing the washing operation, install the cap in water drain port (3).
10. Fit the floor mat, then secure it with floor mat holder plate (4).

Method of Setting Machine at Angle

Method Using Slope

! WARNING

Select a solid and smooth slope.

Always put blocks under the track to prevent the machine from moving, and dig the work equipment into the ground.

1. Stop the machine so that the work equipment is on the downhill side.
2. Put blocks under the track and dig the work equipment into the ground.

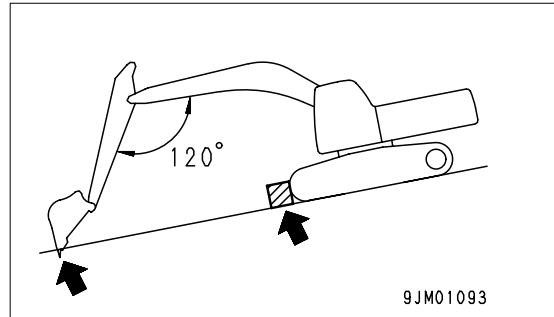

Method Using Block

! WARNING

Select a firm flat place.

Put strong blocks under the undercarriage to stabilize the machine and be extremely careful when carrying out the operation.

1. Raise the chassis with the boom and arm.
When doing this, operate the levers slowly.
2. Insert block (5) under the raised track to make the machine stable.

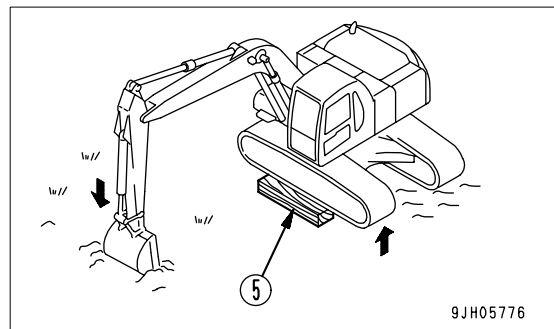

3. Raise the boom slowly and lower the machine.
When doing this, check that the machine is always stable.

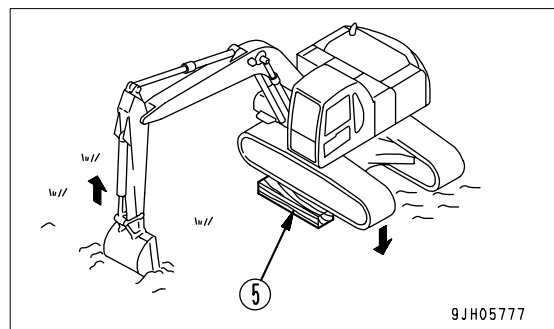

BLEEDING AIR FROM HYDRAULIC SYSTEM

For details, see “STARTING ENGINE (3-70)“. If it is necessary to refer to the items for starting the engine, moving the machine off, steering, or stopping, see the OPERATION section.

1. Bleeding air from pump
2. Loosen air bleed plug (1) and check that oil oozes out from the air bleeder.
3. If the oil does not ooze out, remove the drain hose from the hydraulic pump case and fill the pump case completely with hydraulic oil through drain port (2).

Hold the removed hose firmly, keeping the mouthpiece higher than the oil level in the hydraulic tank so that oil will not spill out of the hose.

4. After completing the air bleed operation, tighten air bleed plug (1) and install the drain hose.

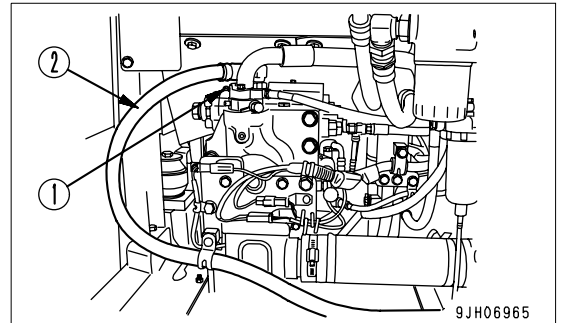

NOTICE

If the drain hose is installed first, oil will spurt out from plug hole (1).

If the pump is operated without filling the pump case with hydraulic oil, abnormal heat will be generated and this may cause an unexpected damage to the pump.

5. Starting engine

Start the engine, referring to “STARTING ENGINE (3-70)“.

Run the engine at low idling for 10 minutes after starting, then start operations.

6. Bleeding air from cylinders
7. Run the engine at low idling, and extend and retract each cylinder 4 to 5 times, taking care so that a cylinder may not be brought up to its stroke end. (Stop the cylinder approx. 100 mm short of its stroke end)
8. Next, operate each cylinder 3 to 4 times to the end of its stroke.
9. Finally, operate each cylinder 4 to 5 times to the end of its stroke to completely remove the air.

NOTICE

If the engine is run at high speed immediately after startup or a cylinder is pushed up to its stroke end, air taken inside the cylinder may cause damage to the piston packing.

10. Bleeding air from swing motor
(only after draining oil from swing motor case)
11. Run the engine at low idling, Loosen air bleeding plug (1) and check that oil oozes out from air bleeding plug (1).

NOTICE

When doing this, do not operate the swing.

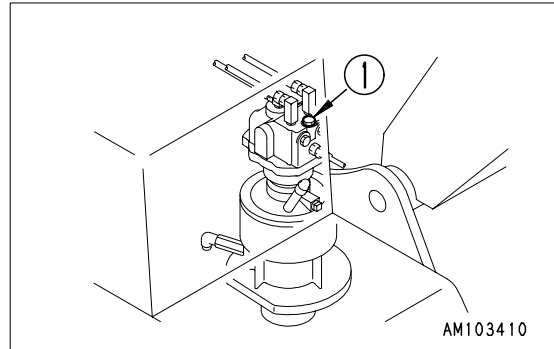

12. If no oil oozes out, stop the engine, remove air bleeding plug (1), then fill the motor case with hydraulic oil.
13. After completing the air bleed operation, tighten air bleeding plug (1).
14. Run the engine at low idling and slowly swing at least two times uniformly to the left and right. This will automatically bleed the air.

NOTICE

- Ⓚ **If the air is not bled from the swing motor, the motor bearings may be damaged.**
- Ⓚ **When replacing the travel motor safety valve, please contact your Komatsu distributor to have it replaced and to have the air bled.**

15. Bleeding air from travel motor

(Bleed the air only when the oil inside the travel motor case has been drained.)

16. Run the engine at low idling, remove hose (1) from port C, then when the oil has flowed out, tighten it again.
17. Run the engine at low idling and swing the work equipment 90° to bring it to the side of the track.
18. Jack up the machine until the track is raised slightly from the ground. Rotate the track under no load for 2 minutes.

Repeat this procedure on both the left and right sides, and rotate the track equally both forward and in reverse.

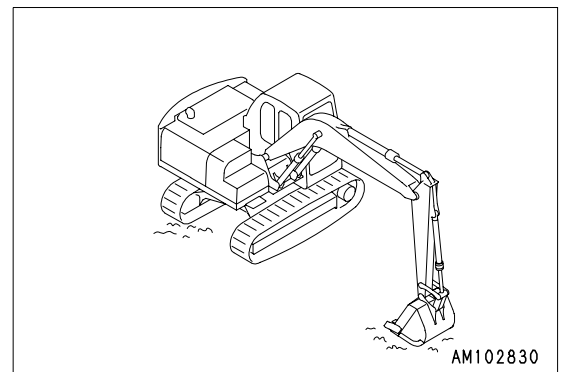
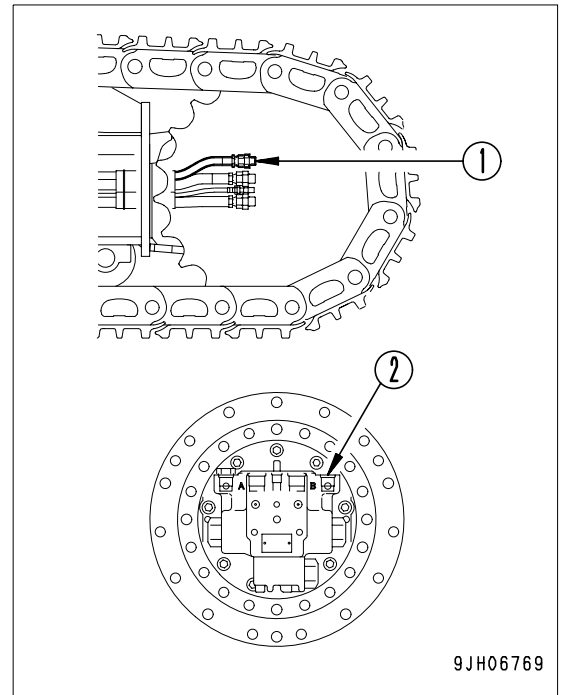

19. Bleeding air from attachment (when installed)

If a breaker or other attachment has been installed, run the engine at low idling and operate the attachment pedal repeatedly (approx. 10 times) until the air has been bled from the attachment circuit.

NOTICE

- q If the method of bleeding the air from the attachment itself is specified by the manufacturer, bleed the air according to the specified procedure.
- q After completing the air bleeding operation, stop the engine, and leave the machine for 5 minutes before starting operations. This will remove the air bubbles in the oil inside the hydraulic cylinders.
- q Check that there is no leakage of oil and wipe off any oil that has been spilled.
- q After completing the air bleeding operation, inspect the oil level, and if the oil level is low, add oil.

METHOD FOR RELEASING INTERNAL PRESSURE IN HYDRAULIC CIRCUIT

⚠ WARNING

- q The hydraulic system is always under internal pressure, so when inspecting or replacing the piping or hoses, always release the pressure in the circuit before starting. If the pressure is not released, high pressure oil may spurt out and cause serious personal injury.
- q The parts and oil are at high temperature after the engine is stopped, and may cause serious burns. Wait for the temperature to go down before starting the operation.
- q When the oil filler cap is removed, oil may spurt out, so turn the cap slowly to release the pressure before removing the cap.

1. Stop the machine on firm level ground.

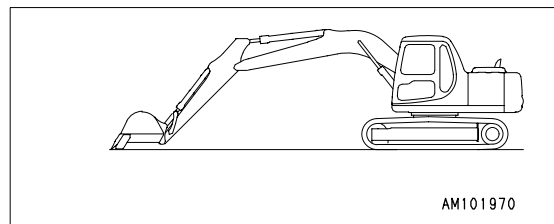

2. Within 15 seconds after stopping the engine, operate all the control levers (work equipment, travel) fully in each direction to release the internal pressure.

3. Remove cover (1) on top of the hydraulic tank.

4. Loosen oil filler cap (F) at the top of the hydraulic tank slowly to release the internal pressure.

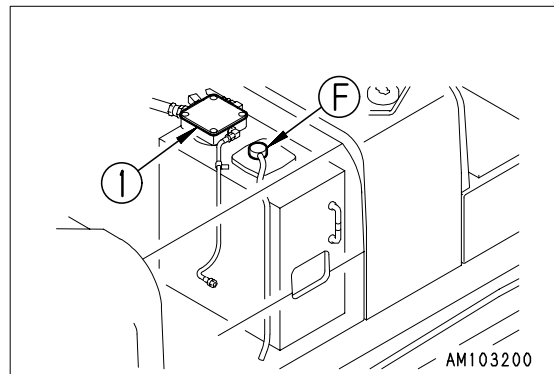

CHECK NITROGEN GAS CHARGE PRESSURE IN ACCUMULATOR (control circuit)

NOTICE

If the nitrogen gas charge pressure in the accumulator is low and operations are continued, it will become impossible to release the remaining pressure inside the hydraulic circuit in a failure occurs on the machine.

Check the nitrogen gas charge pressure as follows.

- 1. Set the work equipment to maximum reach as shown in the diagram on the right.
- 2. Stop the engine and carry out the LOWER operation for the boom.
- 3. Check that the tip of the bucket drops at least 1m.

If the tip of the bucket drops less than 1m, the charge pressure inside the accumulator is low, so please contact your Komatsu distributor.

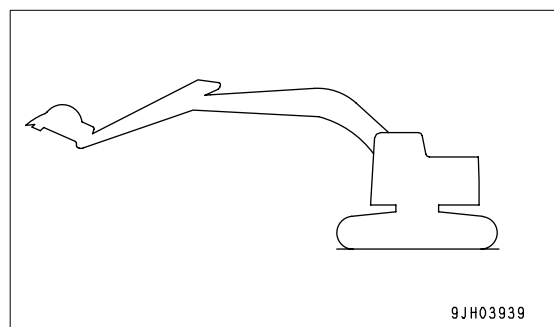

CHECK BEFORE STARTING

For details of the following items, see "Checks Before Starting (3-58)" in the OPERATION section.

- q Check coolant level, add coolant
- q Check oil level in engine oil pan, add oil
- q Check fuel level, add fuel
- q Drain water and sediment from fuel tank
- q Check for water and sediment in water separator, drain water
- q Check oil level in hydraulic tank, add oil
- q Check working lamp switch
- q Check electric wiring
- q Check function of horn

EVERY 100 HOURS MAINTENANCE

LUBRICATING

NOTICE

- q Carry out lubrication for lubrication points 1-7 every 10 hours for the initial 100 hours on new machines.
 - q After carrying out digging operations in water, always lubricate the pins that were under water.
1. Set to the greasing posture below, lower the work equipment completely to the ground, and stop the engine. (For the 3.0 m arm, greasing posture (5C) is different. See REMARK on the next page for details.)
 2. Using a grease pump, pump in grease through the grease fittings shown by arrows.
 3. After greasing, wipe off any old grease that was pushed out.

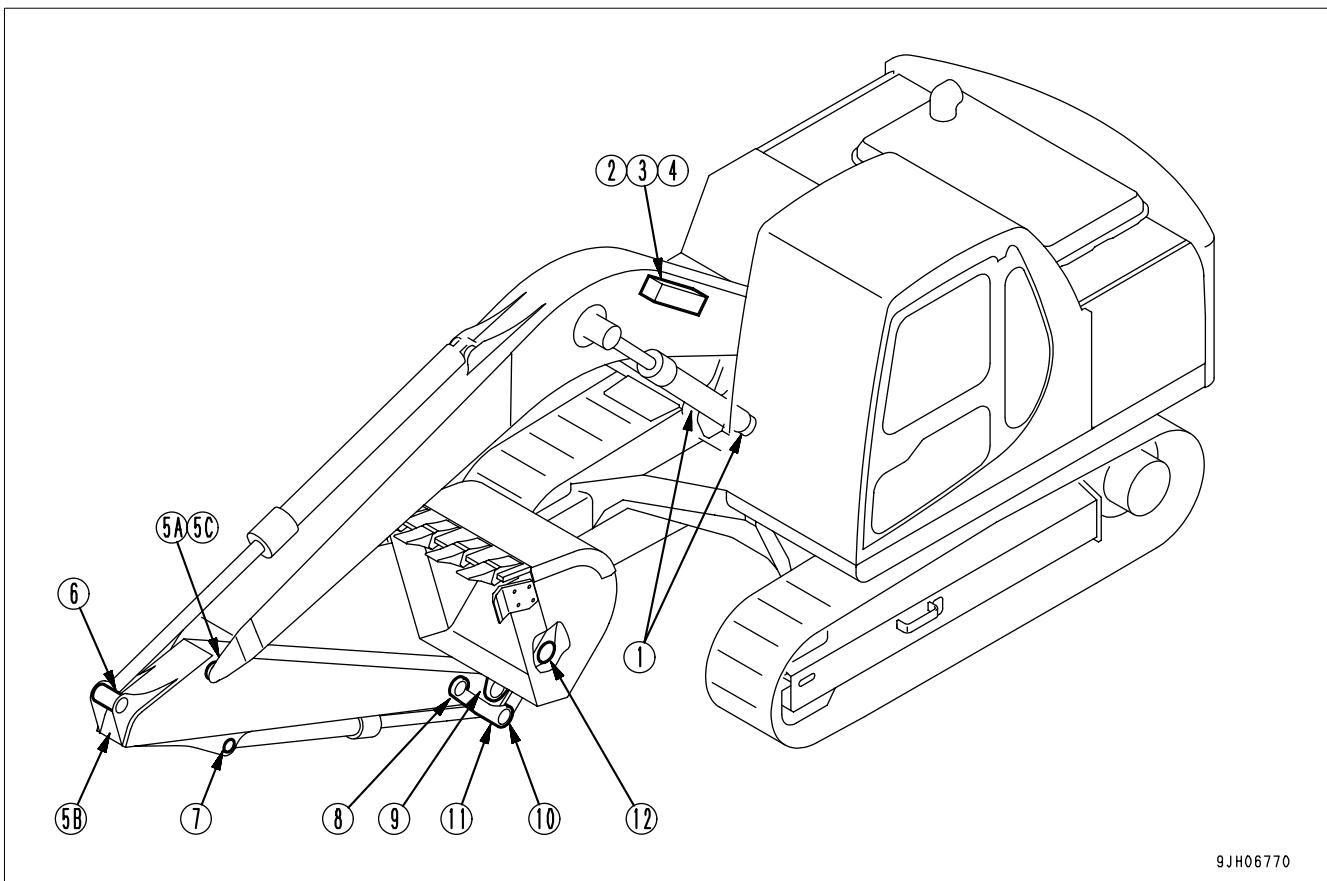

9JH06770

(1) Boom cylinder foot pin (2 places)

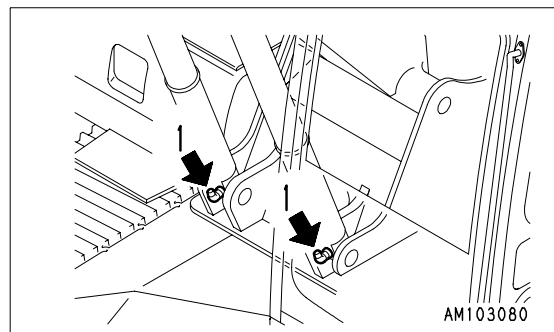

- (2) Boom foot pin (2 places)
- (3) Boom cylinder rod end pin (2 places)
- (4) Arm cylinder foot pin (1 place)

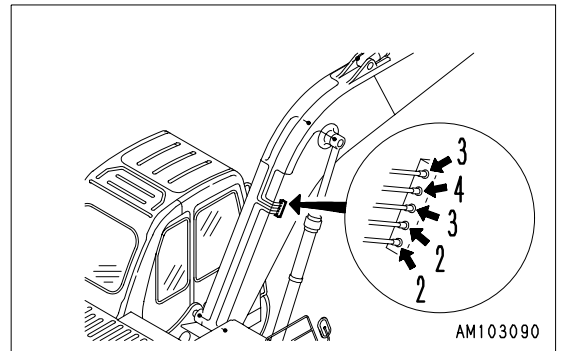

- (5A) Boom-arm connecting pin (2.1 m arm) (1 place)
- (5B) Boom-arm connecting pin (2.5 m arm) (1 place)
- (5C) Boom-arm connecting pin (3.0 m arm) (1 place)
- (6) Arm cylinder rod end pin (1 place)
- (7) Bucket cylinder foot pin (1 place)

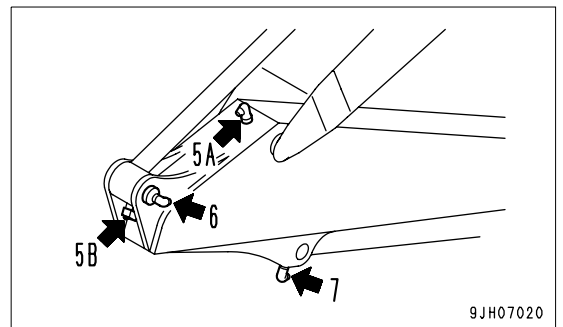

REMARK

The greasing point for the boom-arm connecting pin differs according to the length of the arm. When carrying out greasing of (5C) boom-arm connecting pin (3.0 m arm), set to the posture shown in the diagram on the right.

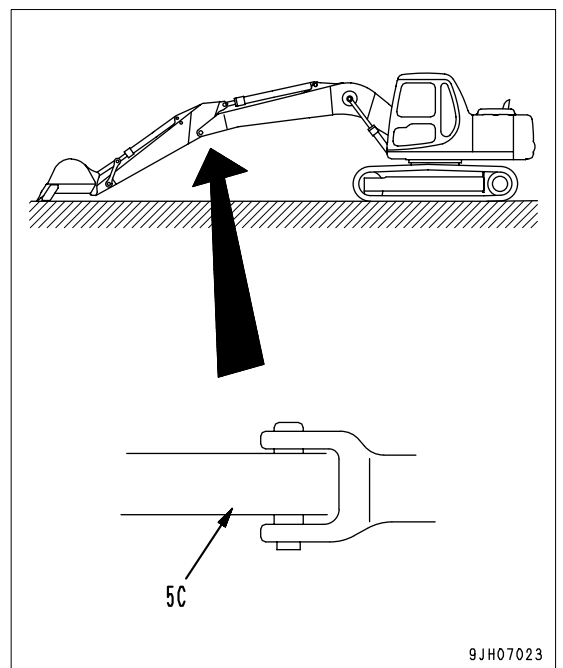

- (8) Arm-Link coupling pin (1 place)
- (9) Arm-Bucket coupling pin (1 place)

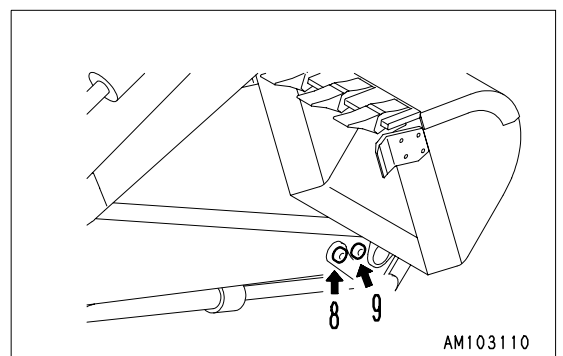

- (10) Link coupling pin (2 places)
- (11) Bucket cylinder rod end pin (1 place)
- (12) Bucket-Link coupling pin (2 places)

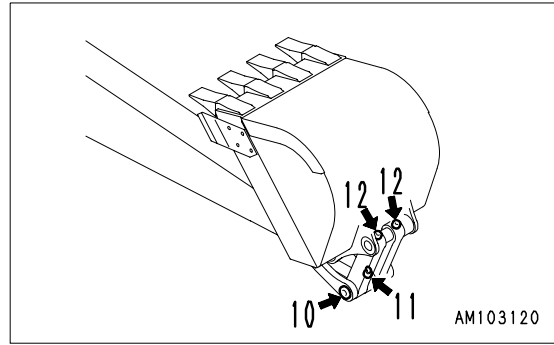

CHECK SWING MACHINERY CASE OIL, ADD OIL

⚠ WARNING

Engine parts and oil are at high temperature immediately after the engine is stopped, and will cause serious burns. Wait for the temperature to cool down before starting the operation.

1. Remove dipstick (G) and wipe the oil from the dipstick with a cloth.
2. Insert dipstick (G) fully in the guide.
3. When dipstick (G) is pulled out, if the oil level is between the H and L marks of the gauge, oil level is proper.
4. If the oil does not reach the L mark on dipstick (G), add engine oil through dipstick insertion hole (F).

When refilling, remove bleeding plug (1).

5. If the oil level exceeds the H mark on the dipstick, loosen drain valve (P) to drain the excess oil.
6. After checking oil level or adding oil, insert the dipstick into the hole and install air bleeding plug (1).

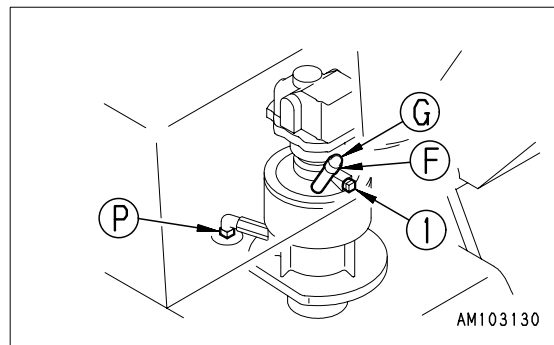

EVERY 250 HOURS MAINTENANCE

CHECK OIL LEVEL IN FINAL DRIVE CASE, ADD OIL

⚠ WARNING

- q The parts and oil are at high temperature immediately after the engine is stopped, and may cause serious burns. Wait for the temperature to go down before starting the operation.
- q If there is still pressure remaining inside the case, the oil or plug may fly out. Loosen the plug slowly to release the pressure.

- q Prepare a hexagon wrench
 1. Set so that plug (F) is at the top, with plug (F) and plug (P) perpendicular to the ground.
 2. Using a hexagonal wrench, remove plug (F) and check that the oil level is within a range from the bottom of the plug hole to a point 10 mm below it.
 3. If the oil level is too low, install plug (F), operate the travel levers, and drive forward or in reverse to rotate the sprocket one turn. Then repeat Step 2 to check again.
 4. If the oil level is low, add engine oil through plug hole (F) until the oil overflows from plug hole (P).
 5. After checking, install plug (F).

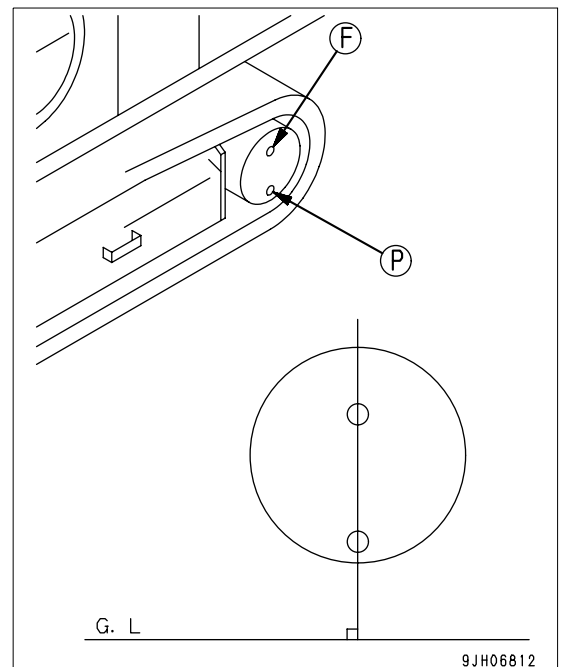

CHECK LEVEL OF BATTERY ELECTROLYTE

Carry out this check before operating the machine.

⚠ WARNING

- q Do not use the battery if the battery electrolyte level is below the LOWER LEVEL line. This will accelerate deterioration of the inside of the battery and reduce the service life of the battery. In addition, it may also cause an explosion.
- q The battery generates flammable gas and there is danger of explosion, so do not bring fire or sparks near the battery.
- q Battery electrolyte is dangerous. If it gets in your eyes or on your skin, wash it off with a large amount of water and consult a doctor.
- q When adding distilled water to the battery, do not allow the battery electrolyte to go above the UPPER LEVEL line. If the electrolyte level is too high, it may leak and cause damage to the paint surface or corrode other parts.

NOTICE

When adding distilled water in cold weather, add it before starting operations in the morning to prevent the electrolyte from freezing.

Inspect the battery electrolyte level at least once a month and follow the basic safety procedures given below.

1. Open the battery room door on the left side of the machine, then remove cover (1).

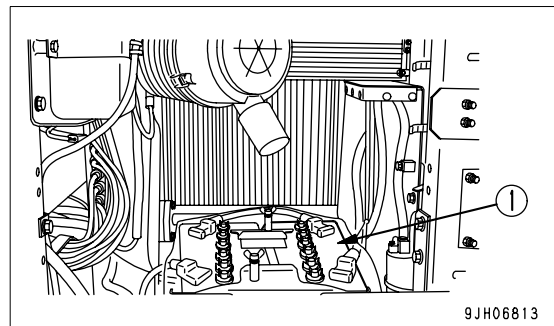

When Checking Electrolyte Level from Side of Battery

If it is possible to check the electrolyte level from the side of the battery, check as follows.

1. Use a wet cloth to clean the area around the electrolyte level lines and check that the electrolyte level is between the UPPER LEVEL (U.L.) and LOWER LEVEL (L.L.) lines.

If the battery is wiped with a dry cloth, static electricity may cause a fire or explosion.

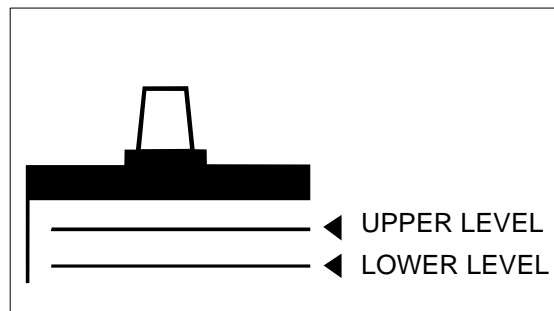

2. If the electrolyte has dropped more than half way between the U.L and L.L range, remove cap (2) immediately and add distilled water (such as commercially available distilled water for batteries) up to the U. L line.
3. After adding distilled water, tighten cap (2) securely.

REMARK

If distilled water is added to above the U.L. line, use a syringe to lower the level to the U.L. line. Neutralize the removed fluid with baking soda (sodium bicarbonate), then flush it away with a large amount of water or consult your Komatsu distributor or battery maker.

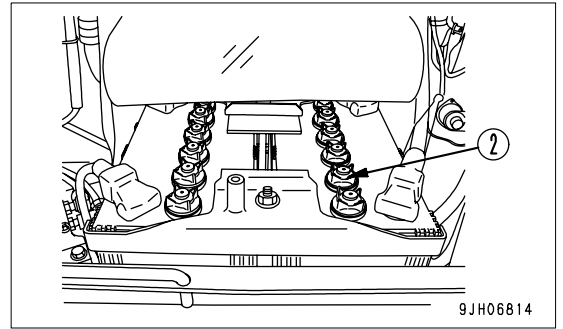

When it is Impossible to Check Electrolyte Level from Side of Battery

If it is impossible to check the electrolyte level from the side of the battery, or there is no display of the UPPER LEVEL line on the side of the battery, check as follows.

1. Remove cap (1) at the top of the battery, look through the water filler port, and check the electrolyte surface. If the electrolyte does not reach the sleeve, add distilled water so that the level reaches the bottom of the sleeve (UPPER LEVEL line) without fail.

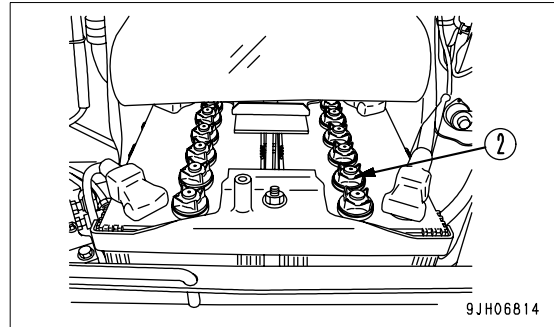

Use the diagram below for reference, and check if the electrolyte reaches the bottom of the sleeve.

A	<p>Correct level The electrolyte level is up to the bottom of the sleeve, so the surface tension causes the surface to rise and the plate appears to be warped.</p>
B	<p>Too low (level) The electrolyte level is not up to the bottom of the sleeve, so the plate appears to be normal.</p>

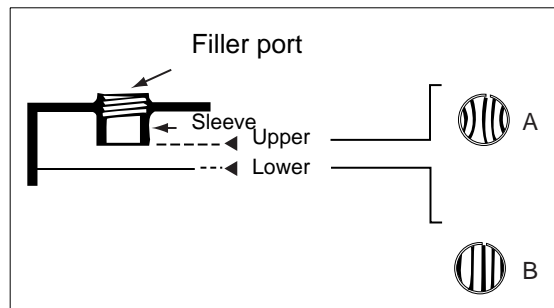

2. After adding distilled water, tighten cap (1) securely.

REMARK

If distilled water is added to above the bottom of the sleeve, use a syringe to lower the level to the bottom of the sleeve. Neutralize the removed fluid with baking soda (sodium bicarbonate), then flush it away with a large amount of water or consult your Komatsu distributor or battery maker.

When it is Possible to Use Indicator to Check Electrolyte Level

If it is possible to use an indicator to check the electrolyte level, follow the instructions given.

EVERY 500 HOURS MAINTENANCE

Maintenance for every 100 and 250 hours should be carried out at the same time.

REPLACE FUEL FILTER CARTRIDGE



WARNING

- q The parts are at high temperature immediately after the engine has been operated. Wait for all parts to cool down before replacing the filter.
- q Do not bring fire or sparks near the fuel.

Prepare a filter wrench and a container to catch the fuel.

1. Set the container to catch the fuel under the filter cartridge.
2. Using a filter wrench, turn filter cartridge (1) counterclockwise to remove it.
3. Clean the filter holder, fill a new filter cartridge with clean fuel, coat the packing surface with engine oil, then install it to the filter holder.
4. When installing, screw in cartridge until seal comes in contact with sealing surface, then tighten approx. an additional 1/2 turn.

If the filter cartridge is tightened too far, the packing will be damaged and this will lead to leakage of fuel. If the filter cartridge is too loose, fuel will also leak from the packing, so always tighten to the correct amount.

5. After replacing the fuel filter cartridge, bleed the air from the system.

Bleed the air as follows.

6. Fill the fuel tank with fuel (to the position where the float is at the highest position).
7. After replacing filter cartridge (1), loosen plug (2).
8. Loosen the knob of feed pump (3) and pump it up and down until no more bubbles come out with the fuel from plug (2).
9. Tighten plug (2).

Always use a Komatsu genuine part for the filter cartridge.

After replacing the filter cartridge, start the engine, and check that there is no leakage of fuel from the filter seal surface.

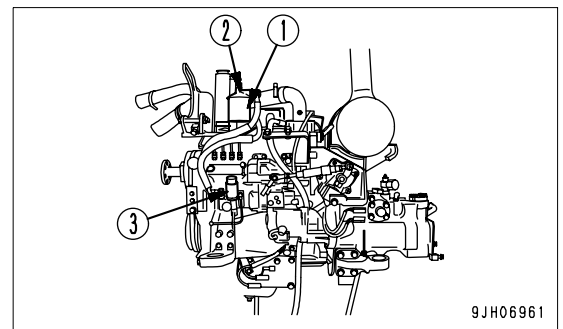

CHANGE OIL IN ENGINE OIL PAN, REPLACE ENGINE OIL FILTER CARTRIDGE

⚠ WARNING

Engine parts and oil are at high temperature immediately after the engine is stopped, and will cause serious burns. Wait for the temperature to cool down before starting the operation.

- q Refill oil amount: 11 liters
- q Filter wrench

1. Remove the undercover inspection cover directly under drain valve (P) under the machine, then set a container in position under it to catch the drained oil.
2. Taking care not to get oil over yourself, open drain valve (P) and drain the oil.
3. Close drain valve (P).
4. Open the engine hood. Using the filter wrench from the upper side of the engine, turn filter cartridge (1) counter-clockwise to remove it.

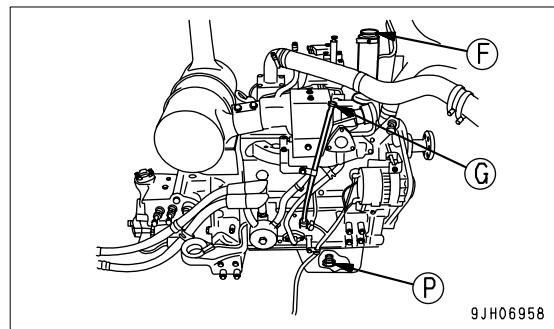

In particular, if this operation is carried out immediately after stopping the engine, a large amount of oil will come out, so wait for 10 minutes before starting the operation.

5. Clean the filter holder, fill the new filter cartridge with clean engine oil, coat the thread and packing surface of the new filter cartridge with clean engine oil (or coat it thinly with grease), then install it to the filter holder.

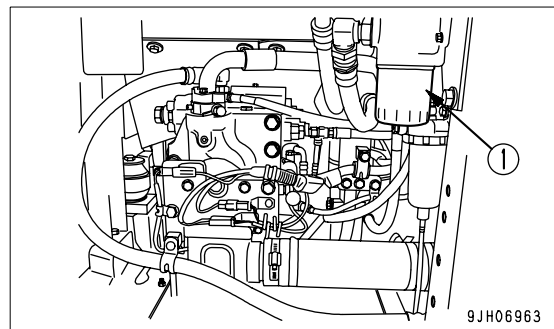

REMARK

Check that there is no old packing affixed to the filter holder. If there is any old packing affixed to the filter, it will cause leakage of oil.

6. When installing, tighten until the packing surface contacts the filter holder, then tighten a further 3/4 turn.
7. After replacing the filter cartridge, add engine oil through oil filler port (F) so that the oil level is between the H and L marks on dipstick (G).
8. Run the engine at idling for a short time, then stop the engine, and check that the oil level is between the H and L marks on the dipstick. For details, see "Check Oil Level in Engine Oil Pan, Add Oil (3-59)".

CHECK SWING PINION GREASE LEVEL, ADD GREASE

- c) Prepare a scale.
- 1. Remove bolts (1) (2 bolts) on the top of the revolving frame and remove cover (2).
- 2. Insert the scale into the grease and check that the grease passing through the pinion has a height of at least 16 mm. If the level is low, add grease.
- 3. Check if the grease is milky white. If it is milky white, it is necessary to change the grease. Please contact your Komatsu distributor.

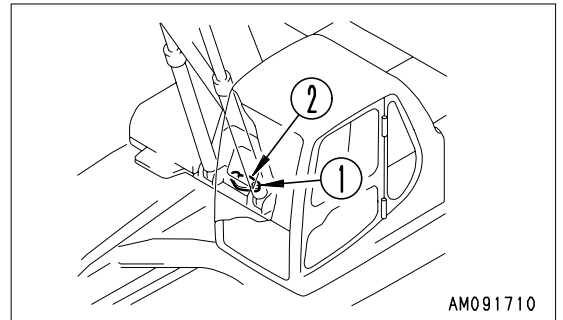

Total amount of grease: 9.1 liters [8.3 kg]

- 4. Install cover (2) with bolts (1).

LUBRICATE SWING CIRCLE

- 1. Lower the work equipment to the ground.
- 2. Using a grease pump, pump in grease through the grease fittings shown by arrows.
- 3. After greasing, wipe off any old grease that was pushed out.

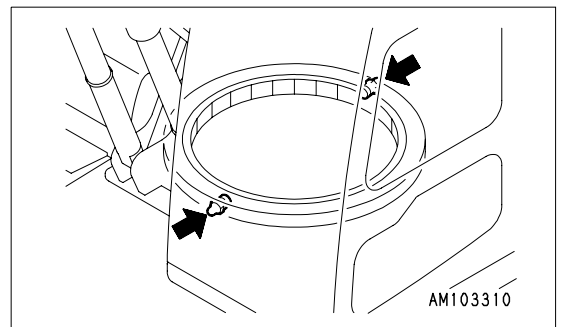

Radiator Core and Fins - Check/Clean

⚠ WARNING

If compressed air, high-pressure water, or steam hit your body directly, or they cause dirt or dust to be blown up, there is a hazard of serious injury. Always use safety glasses, dust mask, or other protective equipment.

NOTICE

When use the compressed air, keep a distance from air nozzle, to prevents damage to the fins. To prevent damage to the fins, apply compressed air from and appropriate distance. Damaged fins may cause water leakage or overheating. In a dusty site, check the fins daily, irrespective of the maintenance interval.

1. Open the engine hood.
2. Loosen screw (3) and pull up net (2).
3. Clean net (2). (it is to be installed again, as instructed in the step 8.)
4. Remove 3 bolts (4) on the engine side, then remove cover (5).
5. Check the front face and rear face of oil cooler fins (6), radiator fins (7), aftercooler fins (8), and condenser fins (9). If any mud, dirt, or leaves are stuck to the fins, blow them off with compressed air.

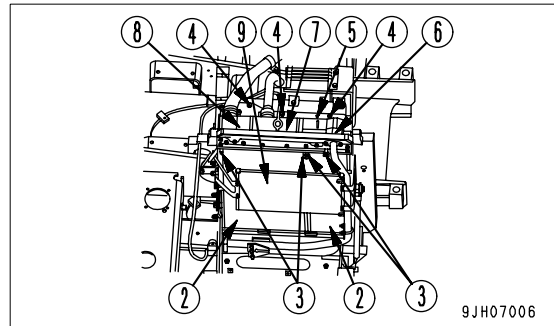

It is also possible to use steam or water instead of compressed air.

6. Check the rubber hose. Replace with a new one, if the hose is found to have cracks or to be hardened by aging.

Further, check the hose cramps for looseness.

7. Remove undercover (1), then clean out the mud, dirt, or leaves that were blown off in the cleaning operation.
8. Push in cleaned net (2) back to the original place and secure it with screw (3).
9. Install cover (5) with 3 bolts (4).
10. Install undercover (1).

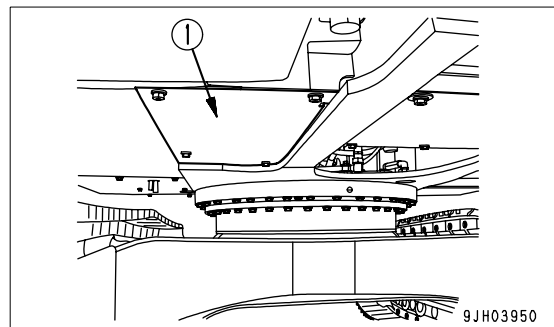

CLEAN AIR CONDITIONER FRESH/RECIRC FILTERS

⚠ WARNING

If compressed air is used, there is danger that dirt may fly and cause personal injury. Always wear safety glasses, dust mask, and other protective equipment.

NOTICE

As a guideline, the filters should be cleaned every 500 hours, but on dusty jobsites, clean the filters more frequently.

REMARK

If the filter becomes clogged, the air flow will be reduced, and there will be an abnormal noise from the air conditioner unit.

Cleaning Reticulated Air Filter

1. Remove wing bolts (1) from the inspection window at the bottom rear left on the inside of the operator's cab, then take out the recirculated air filter.
2. Clean the filter with compressed air. If there is oil on the filter, or if the filter is extremely dirty, wash it in a neutral agent. After rinsing it in water, dry it thoroughly before using it again.

If the clogging of the filter cannot be removed by blowing with air or washing in water, replace the filter with a new part every year.

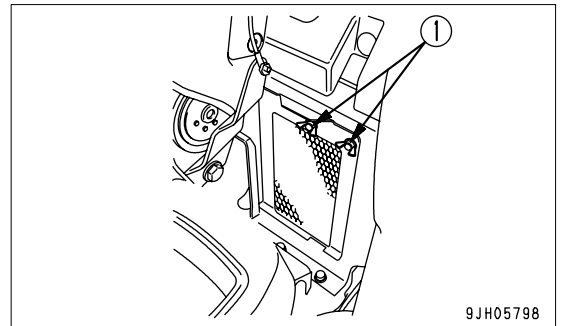

Cleaning Fresh Air Filter

1. Use the starting key to open cover (2) at the rear left of the operator's cab, then open cover (2) by hand and remove filter (3) inside the cover.

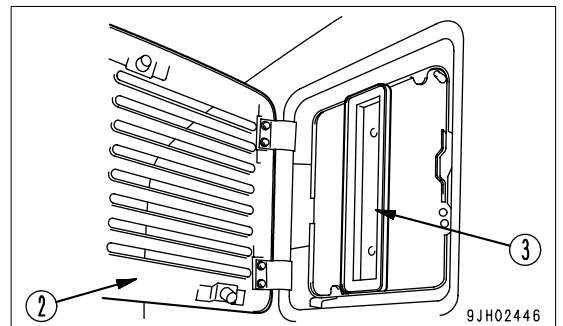

2. Clean the filter with compressed air. If there is oil on the filter, or if the filter is extremely dirty, wash it in a neutral agent. After rinsing it in water, dry it thoroughly before using it again.

If the clogging of the filter cannot be removed by blowing with air or washing in water, replace the filter with a new part every year.

3. After cleaning, return filter (3) to its original position and close the cover. Use the starting key to lock the cover. Do not forget to remove the starting key.

REMARK

The FRESH filter must be installed facing in the correct direction. When installing, insert the long (L) end of filter (3) into the filter case first. If the short (S) end is installed first, cover (2) will not close.

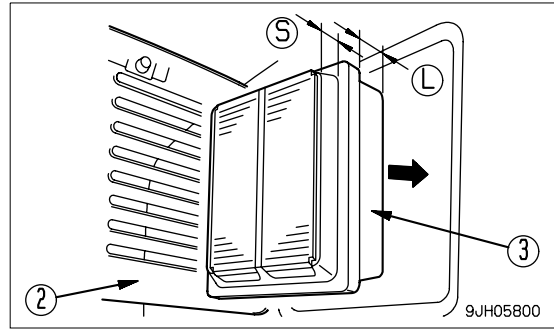

REPLACE HYDRAULIC OIL FILTER ELEMENT

⚠ WARNING
 When the oil filler cap is removed, oil may spurt out, so turn the cap slowly to release the pressure before removing the cap.

NOTICE

If the machine is equipped with a hydraulic breaker, the hydraulic oil will deteriorate much faster than during normal bucket operations. For details, see “MAINTENANCE INTERVAL FOR HYDRAULIC BREAKER (4-18)” when carrying out maintenance.

1. Remove the cover at the top of the hydraulic tank.
2. Remove the cap from oil filler (F), and release the internal pressure.
3. Loosen 4 bolts, then remove cover (1).
 When doing this, the cover may fly out under the force of spring (2), so hold the cover down when removing the bolts.
4. After removing spring (2) and valve (3), take out element (4).
5. Clean the removed parts in diesel oil.
6. Install the new element in the place where old element (4) was installed.
7. Set valve (3) and spring (2) on top of the element.
8. Set cover (1) in position, push it down by hand, and install the cover with the mousing bolts.
9. Install the oil filler cap, then install the cover at the top of the hydraulic tank.
10. To bleed the air, start the engine according to “STARTING ENGINE (3-70)” and run the engine at low idling for 10 minutes.
11. Stop the engine.

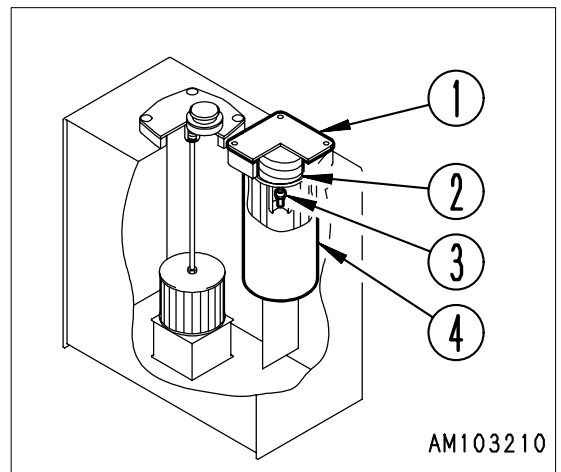
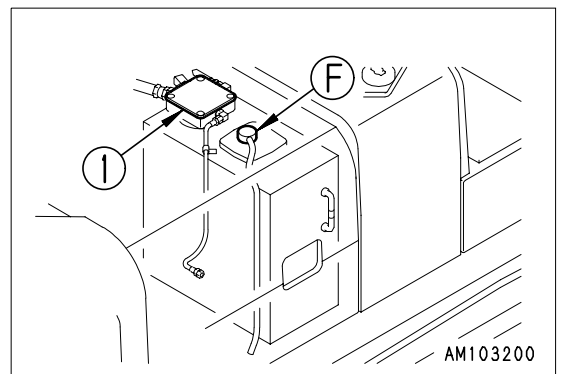

REMARK

Wait for at least 5 minutes after stopping the engine to eliminate bubbles in the oil inside the tank.

12. Check for oil leakage and wipe off any spilled oil.

REPLACE BREATHER ELEMENT IN HYDRAULIC TANK**⚠ WARNING**

- q The parts and oil are at high temperature after the engine is stopped, and may cause burns. Wait for the temperature to go down before starting the work.
- q When removing the oil filler cap, turn it slowly to release the internal pressure, then remove it.

1. Remove the cap of oil filler (F) at the top of the hydraulic tank.

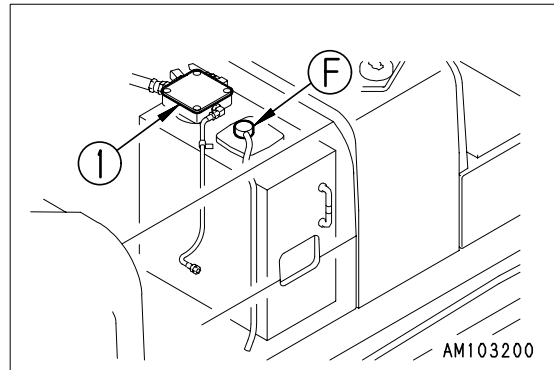

2. Replace element (1) inside the cap.

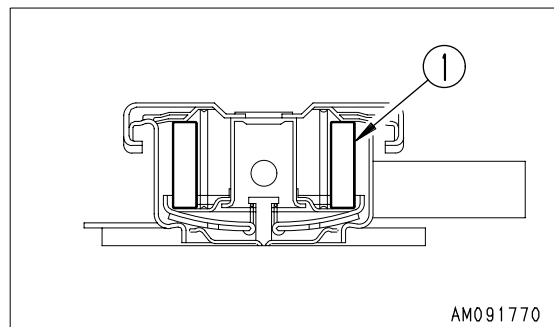

CHECK AND ADJUST COOLING FAN BELT TENSION

Checking

Deflection (a) should be 6 to 10 mm at a point midway between the alternator pulley and fan pulley when pressed with a finger force of approx. 58.8 N (6 kgf).

(A): Alternator pulley

(B): Fan pulley

(C): Crankshaft pulley

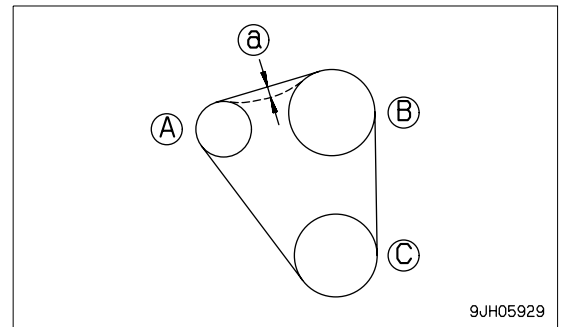

Adjustment

1. Loosen bolts and nuts (2) and (3).
2. Loosen locknut (4) and move alternator (1) with adjustment bolt (5) so that the deflection of the belt is 6 to 10 mm when pressed with a finger force of approx. 58.8 N (6 kgf).
3. Tighten locknut (4) and bolts and nuts (2) and (3) to hold alternator (1) in position.

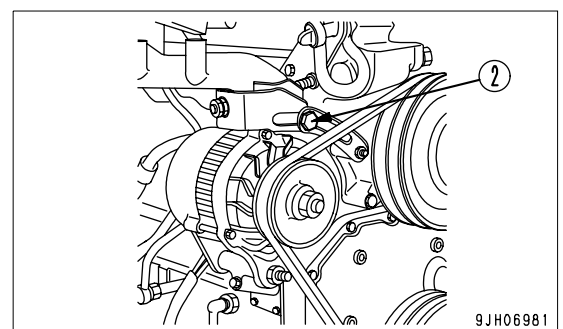
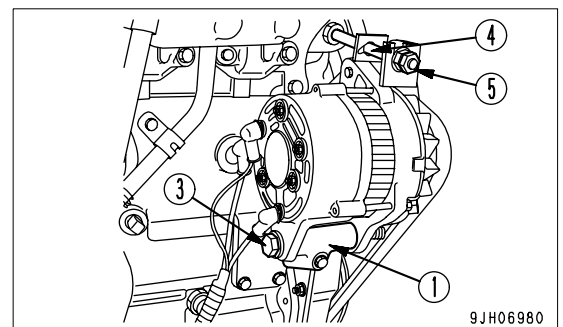

4. Check for damage to the pulleys, and wear of the V-groove and V-belt. Be particularly careful to check that the V-belt is not in contact with the bottom of the V-groove.
5. If the belt has elongated and there is no more allowance for adjustment, or if the belt is cut or cracked, replace the belt.
6. After replacing the V-belt, operate for one hour, then adjust again.

CHECK, ADJUST AIR CONDITIONER COMPRESSOR BELT TENSION

Checking

Deflection (a) should be 6 to 10 mm at a point midway between the fan pulley and compressor pulley when pressed with a finger force of approx. 58.8 N (6 kgf).

(A): Compressor pulley

(B): Fan pulley

(C): Crankshaft pulley

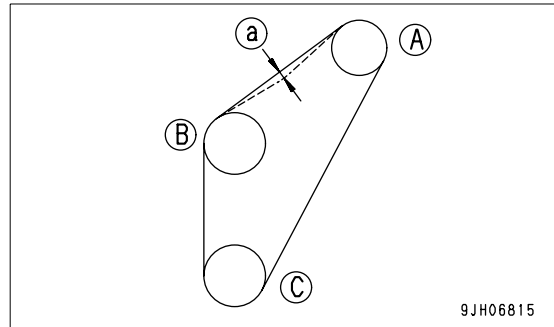

Adjustment

1. Loosen bolts (1) and (2).

- Bracket (4) holds the compressor in place. When bolts (1) and (2) are loosened, bracket (4) moves with the securing position of bolt (2) as a fulcrum.

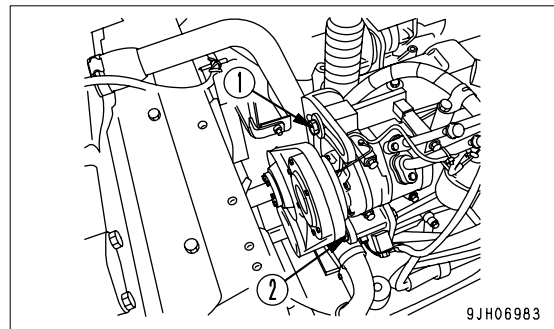

2. Loosen bolt (1) and bolts (2), then move compressor (3) to adjust.

3. When the position of the compressor is determined, tighten bolts (1) and (2) to hold it in position.

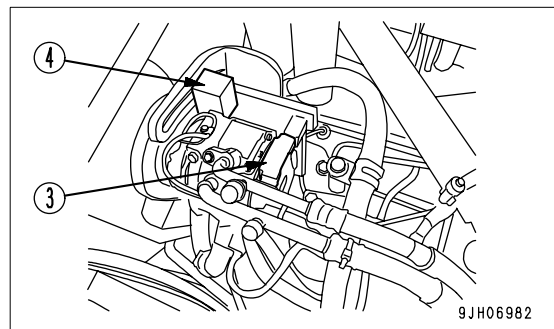

4. Check for damage to the pulleys, and wear of the V-groove and V-belt. Be particularly careful to check that the V-belt is not in contact with the bottom of the V-groove.

5. If the belt has elongated and there is no more allowance for adjustment, or if the belt is cut or cracked, replace the belt.

6. After replacing the V-belt, operate for one hour, then adjust again.

EVERY 1000 HOURS MAINTENANCE

Carry out the EVERY 100 HOURS MAINTENANCE, EVERY 250 HOURS MAINTENANCE, and EVERY 500 HOURS MAINTENANCE at the same time.

CHANGE OIL IN SWING MACHINERY CASE

WARNING

Engine parts and oil are at high temperature immediately after the engine is stopped, and will cause serious burns. Wait for the temperature to cool down before starting the operation.

q Refill capacity: 2.5 liters

1. Set an oil container under drain valve (P) at the bottom of the machine.
2. Remove drain plug (P) under the machine, drain the oil, then tighten the drain plug.

Tightening torque for drain plug:

98.1 to 186 N·m (10 to 19 kgf·m).

3. Remove dipstick (G) and air bleeding plug (1), then add the specified amount of engine oil through filler port (F) of the dipstick guide.
4. After adding oil, install air bleed plug (1).
5. Wipe off the oil on the dipstick with a cloth.
6. Completely insert dipstick (G) into the oil filler pipe, then remove it and check the oil level.
7. The oil level should be between H and L marks on the dipstick (G). If the oil does not reach the L mark, add engine oil through oil filler port (F).
8. If the oil level is above the L mark, drain the excess engine oil from drain plug (P), then check the oil level again.

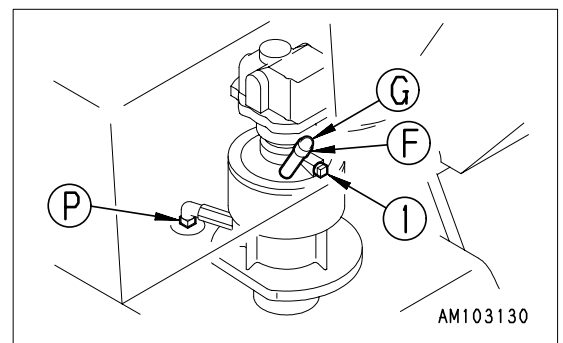

CHANGE OIL IN FINAL DRIVE CASE

⚠ WARNING

- q The parts and oil are at high temperature immediately after the engine is stopped, and may cause serious burns. Wait for the temperature to go down before starting the operation.
- q If there is still pressure remaining inside the case, the oil or plug may fly out. Loosen the plug slowly to release the pressure.

- q Refill capacity (each): 2.5 liters
 - q Prepare a handle.
 - q Prepare a hexagon wrench
1. Set plug (F) at the top, with plug (F) and plug (P) perpendicular to the ground surface.
 2. Set a container under plug (P) to catch the oil.
 3. Remove plugs (P) and (F) with the hexagon wrench and drain the oil.
 4. Tighten plug (P).
 5. Add engine oil through the hole of plug (F).

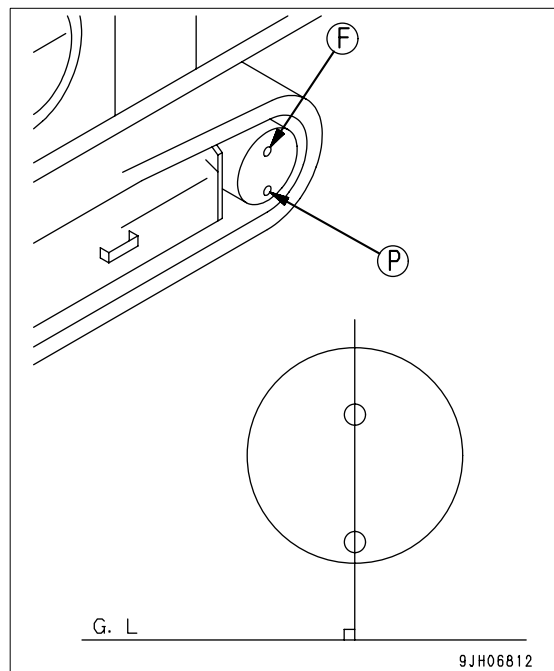

CHECK ALL TIGHTENING PARTS OF TURBOCHARGER

Contact your Komatsu distributor to have the tightening portions checked.

CHECK PLAY TURBOCHARGER ROTOR

Contact your Komatsu distributor to have the rotor play checked.

CHECK NITROGEN GAS CHARGE PRESSURE IN ACCUMULATOR (for breaker)

(If equipped)

A special tool is needed for inspecting and charging with nitrogen gas.

Please ask your Komatsu distributor.

EVERY 2000 HOURS MAINTENANCE

Carry out the periodic maintenance work of every 100, 250, 500 and 1000 hours of operation at the same time.

CHECK PTO GEAR CASE, ADD OIL

 **WARNING**

Engine parts and oil are at high temperature immediately after the engine is stopped, and will cause serious burns. Wait for the temperature to cool down before starting the operation.

1. Swing the upper structure so that the PTO gear case is in the middle between the left and right tracks.

Stop the engine and set the safety lock lever to the LOCK position.

2. Remove the cover under the right side of the machine.

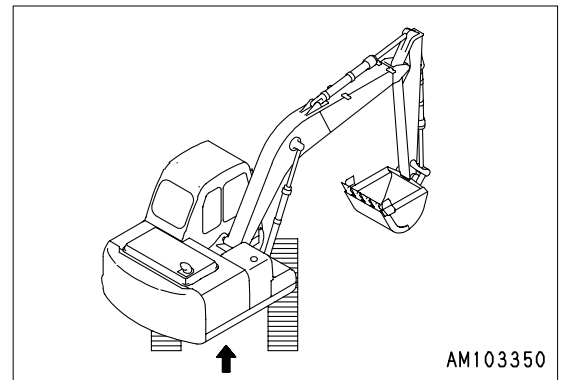

3. Remove plug (G) and check that the oil level is near the bottom edge of the plug hole. If the oil level is low, remove plug (F) and add oil through the hole of plug (F) until the oil is up to the bottom edge of the hole of plug (G).

4. Install plugs (G) and (F).

5. Install the cover.

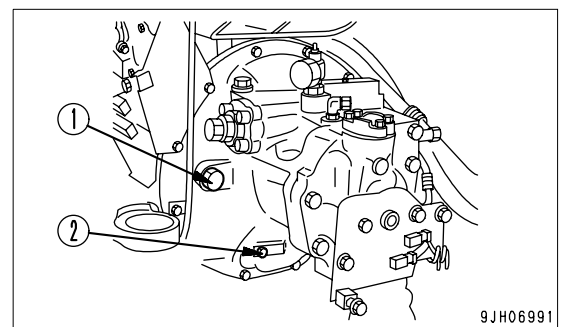

CLEAN HYDRAULIC TANK STRAINER**⚠ WARNING**

- q The parts and oil are at high temperature after the engine is stopped, and may cause burns. Wait for the temperature to go down before starting the work.
- q When removing the oil filler cap, turn it slowly to release the internal pressure, then remove it.

1. Remove 4 bolts, then remove cover (1). When doing this, cover (1) may fly off because of the force of spring (2), so keep the cover pushed down when removing the bolts.
2. Hold the top of rod (3) and pull up to remove spring (2) and strainer (4).
3. Remove any dirt stuck to strainer (4), then wash it in clean diesel oil or flushing oil. If strainer (4) is damaged, replace it with a new part.
4. When installing, insert strainer (4) into protruding part (5) of the tank, and assemble.
5. Install cover (1) with bolts.

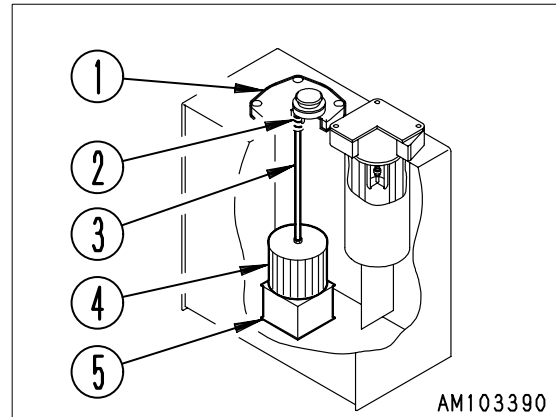
**CLEAN, CHECK TURBOCHARGER**

Contact your Komatsu distributor for cleaning and inspection.

CHECK ALTERNATOR, STARTING MOTOR

The brushes may be worn or the bearing may have run out of grease, contact your Komatsu distributor for inspection and repairs.

If the engine is started frequently, have this inspection carried out every 1000 hours.

CHECK ENGINE VALVE CLEARANCE, ADJUST

Special tools are needed for inspection and maintenance, please contact your Komatsu distributor.

EVERY 4000 HOURS MAINTENANCE

Carry out the EVERY 100 HOURS MAINTENANCE, EVERY 250 HOURS MAINTENANCE, EVERY 500 HOURS MAINTENANCE, EVERY 1000 HOURS MAINTENANCE, and EVERY 2000 HOURS MAINTENANCE at the same time.

CHECK WATER PUMP

Check that there is no play in the pulley, leakage of oil or water, or clogging of the drain hole. If any abnormality is found, please contact your Komatsu distributor for repairs or replacement.

EVERY 5000 HOURS MAINTENANCE

Carry out the periodic maintenance work of every 100, 250, 500 and 1000 hours of operation at the same time.

CHANGE OIL IN HYDRAULIC TANK

WARNING

- q The parts and oil are at high temperature after the engine is stopped, and may cause burns. Wait for the temperature to go down before starting the work.
- q When removing the oil filler cap, turn it slowly to release the internal pressure, then remove it.

NOTICE

If the machine is equipped with a hydraulic breaker, the hydraulic oil will deteriorate much faster than during normal bucket operations. For details, see “MAINTENANCE INTERVAL FOR HYDRAULIC BREAKER (4-18)” when carrying out maintenance.

- q Refill oil amount: 19 liters
 - q Prepare a handle (for the socket wrench).
1. Swing so that the drain plug at the bottom of the hydraulic tank is in the middle between the left and right tracks.
 2. Retract the arm and bucket cylinders, then lower the boom and put the teeth in contact with the ground.
 3. Set the safety lock lever to the LOCK position and stop the engine.

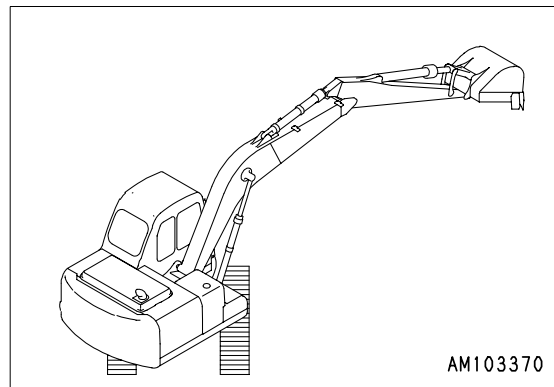

4. Remove the cover over the hydraulic tank and remove the cap of oil filler (F).
5. Set a container direct under the drain plug located on the machine's underside to catch oil that is drained. Remove drain plug (P) and drain the oil. Check an O-ring installed to Plug (P), and if it has a scratch or damage, replace it with new one. After draining the oil, tighten drain plug (P).

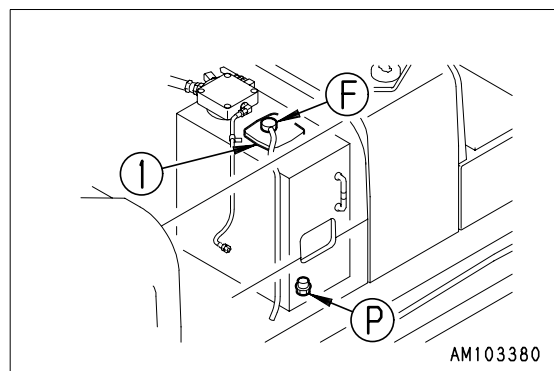

- q The specified tightening torque is $68.6 \pm 9.81 \text{ N}\cdot\text{m}$ ($7 \pm 1 \text{ kgf}\cdot\text{m}$)
- q Take care not to get oil on yourself when you remove drain plug (P).

6. Add the specified amount of new and clean engine oil (for hydraulic system) through oil filler port (F). Check that the oil level is between H and L on the sight gauge.

For details of oil level check, see “Check Oil Level in Hydraulic Tank, Add Oil (3-62)”.

SPECIFICATIONS

SPECIFICATIONS

	Item	Unit	PC130-7
	Operating weight	kg	12,300
	Bucket capacity	m ³	0.5
	Name of engine	-	Komatsu SAA4D95LE-3 diesel engine
	Rated horsepower of engine	kW (HP)/rpm	66.2 (88.7)/2,200
A	Overall length	mm	7,595
B	Overall height	mm	-
C	Overall width	mm	2,490
D	Track shoe width	mm	500
E	Height of cab	mm	2,810
F	Radius of upper structure	mm	2,190
G	Overall length of track	mm	3,610
H	Tumbler center distance	mm	2,880
	Min. ground clearance	mm	400
	Traveling speed (Low/High)	km/h	2.7/5.5
	Swing speed	rpm	11

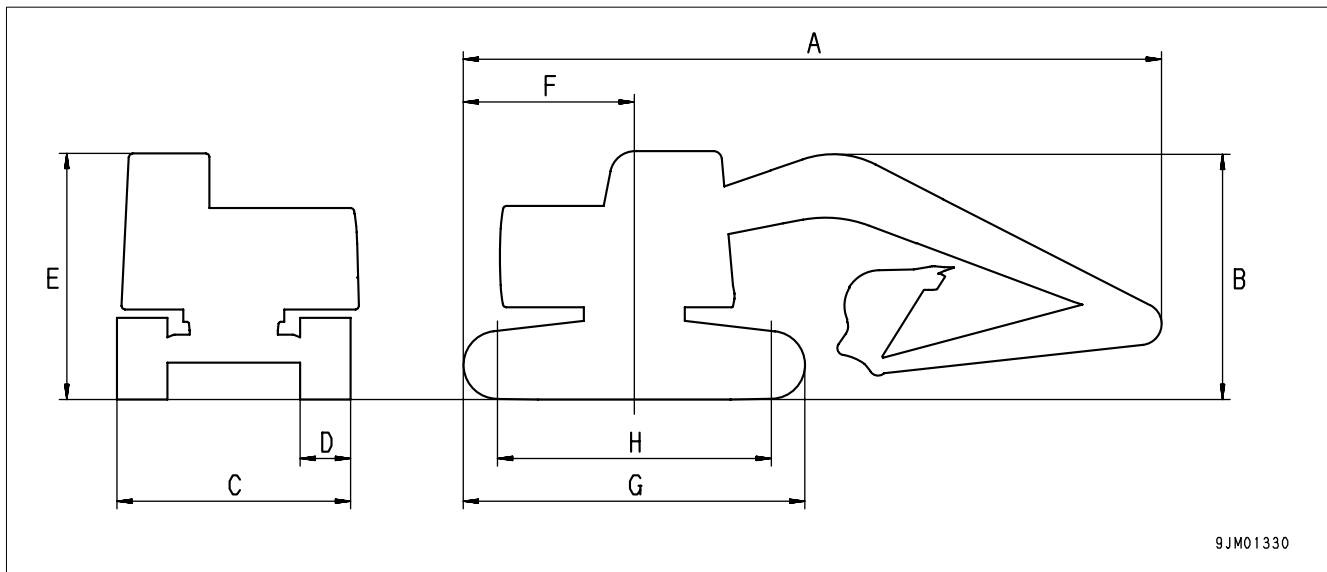

PC130-7K WORKING RANGE (1-pc boom)

	Working ranges	Unit	PC130-7
A	Max. digging reach	mm	8,290
B	Max. digging depth	mm	5,520
C	Max. digging height	mm	8,610
D	Max. vertical wall digging depth	mm	4,940
E	Max. dumping height	mm	6,170
F	Min. dump height	mm	-
G	Max. digging reached at ground level	mm	8,170

PC130-7 WORKING RANGE (2-pc boom)

ARM LENGTH	Unit	2100m	2500m
A. Max. digging height	mm	8580	8830
B. Max. dumping height	mm	8210	6470
C. Max. digging depth	mm	5520	5920
D. Max. vertical wall digging depth	mm	4450	4820
E. Max. digging depth of cut for 2.44 m level	mm	5400	5780
F. Max. digging reach	mm	8130	8510
G. Max. digging reach at ground level	mm	8000	8390
H. Min swing radius	mm	2580	2620

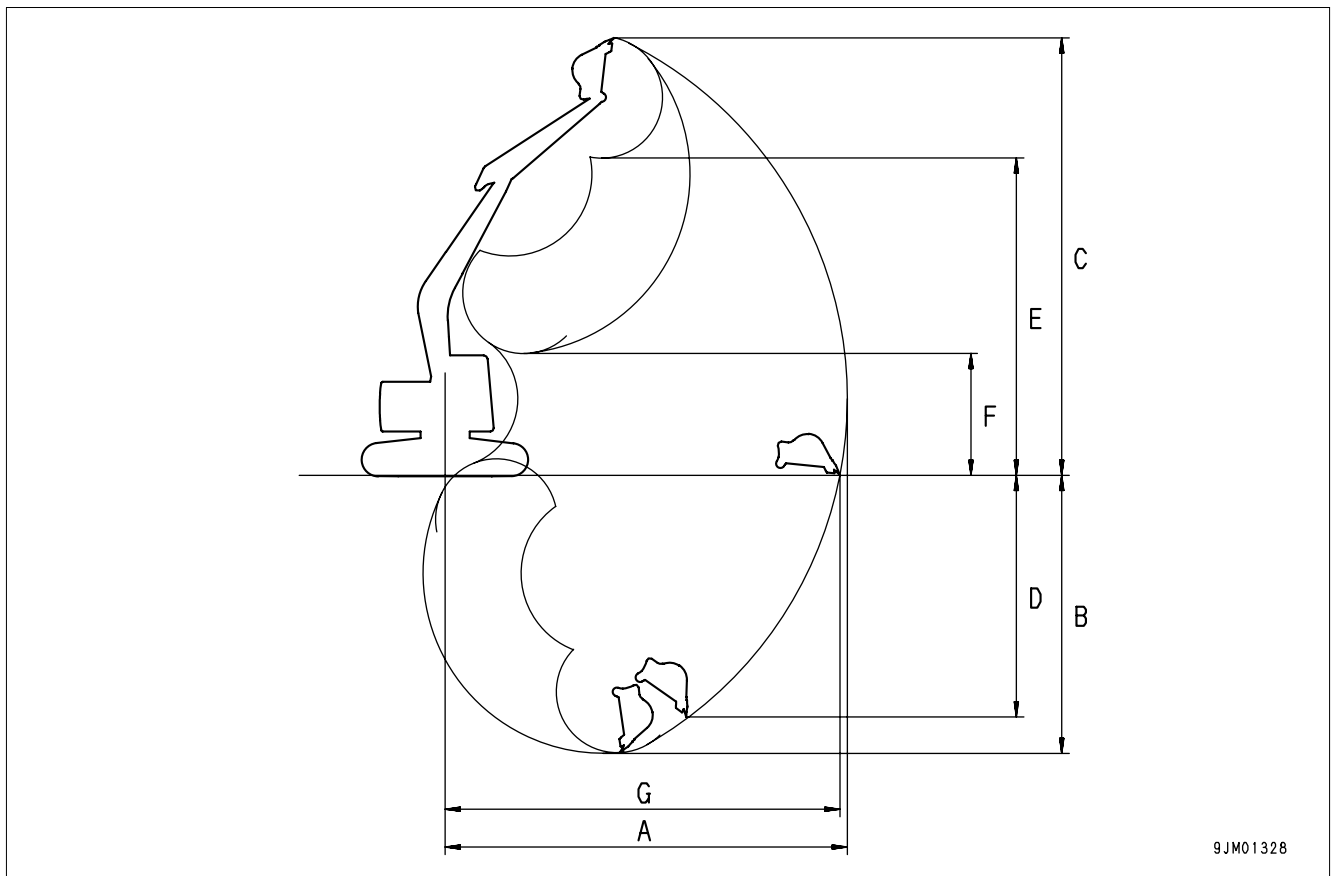

EXPLANATION OF LIFTING CAPACITY CHART (PC130-7K 1- PC BOOM)

LEGEND

- A : Reach from swing centre
- B : Bucket hook height
- OF : Lifting capacity (rating overfront)
- OS : Lifting capacity (rating overside)

LEGEND

- (1) Position of lifting point
- (2) Arm length:
- (3) Boom length
- (4) Hydraulic pressure: 37.3 MPa

WORKING CONDITIONS:

- WITH BUCKET (0.53m³ CECE).(469 kg)°
- IF OBJECT HANDLING IS PERFORMED WITH OTHER TOOL INSTALLED, THE WEIGHT DIFFERENCE OF THE TOOL SHALL BE DEDUCTED FROM THE VALUES OF THIS TABLE.
- WITH FULLY EXTENDED BUCKET CYLINDER.
- ON A COMPACT HORIZONTAL LEVEL GROUND.

WITH 700 mm WIDTH SHOE.

Loads do not exceed 87% of hydraulic capacity or 75% of tipping capacity (* load limited by hydraulic capacity rather than tipping)

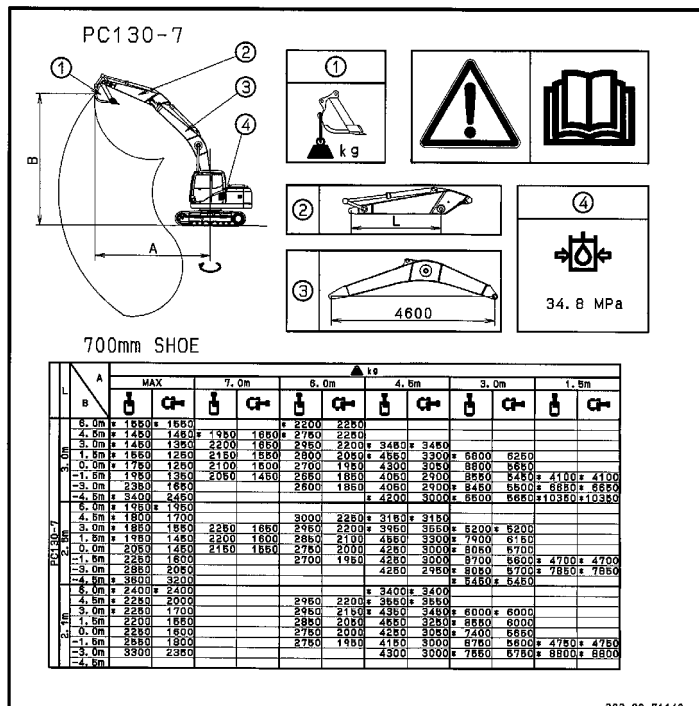

Arm	Height	MAX		7.5m		6.0m		4.5m		3.0m		1.5m	
		OF	OS	OF	OS	OF	OS	OF	OS	OF	OS	OF	OS
3.0m	6.0m	*1550	*1550			*2200	2250						
	4.5m	*1450	1450	*1950	1650	*2750	2250						
	3.0m	*1450	1350	2200	1650	2950	2200	*3450	*3450				
	1.5m	*1550	1250	2150	1550	2800	2050	*4550	3300	*6800	6250		
	0.0m	*1750	1250	2100	1500	2700	1950	4300	3050	8800	5650		
	-1.5m	1950	1350	2050	1450	2650	1850	4050	2900	8550	5450	*4100	*4100
	-3.0m	2350	1650			2600	1850	4050	2900	*8450	5500	*6650	*6650
	-4.5m	*3400	2450					*4200	3000	*6500	5650	*10350	*10350
2.5	6.0m	*1950	*1950										
	4.5m	*1800	1700			3000	2250	*3150	*3150				
	3.0m	*1850	1550	2250	1650	2950	2200	*3950	3550	*5200	*5200		
	1.5m	*1950	1450	2200	1600	2850	2100	4550	3300	*7900	6150		
	0.0m	2050	1450	2150	1550	2750	2000	4250	3000	*8050	5700		
	-1.5m	2250	1600			2700	1950	4250	3000	8700	5600	*4700	*4700
	-3.0m	2850	2050					4250	2950	*8050	5700	*7850	*7850
	-4.5m	*3600	3200							*5450	*5450		
2.1	6.0m	*2400	*2400					*3400	*3400				
	4.5m	*2250	2000			2950	2200	*3550	*3550				
	3.0m	*2250	1700			2950	2150	*4350	3450	*6000	*6000		
	1.5m	2200	1550			2850	2050	4550	3250	*8550	6000		
	0.0m	2250	1600			2750	2000	4250	3050	*7400	5650		
	-1.5m	2550	1800			2750	1950	4150	3000	8750	5600	*4750	*4750
	-3.0m	3300	2350					4300	3000	*7550	5750	*8800	*8800
	-4.5m												

EXPLANATION OF LIFTING CAPACITY CHART (PC130-7K 2-PC BOOM)

LEGEND

A : Reach from swing centre
 B : Bucket hook height

OF : Lifting capacity (rating overfront)
 OS : Lifting capacity (rating overside)

LEGEND

- (1) Position of lifting point
- (2) Arm length:
- (3) Boom length
- (4) Hydraulic pressure: 34.8 MPa

WORKING CONDITIONS:

- q WITH BUCKET (0.53m³ CECE).(469 kg)
- q IF OBJECT HANDLING IS PERFORMED WITH OTHER TOOL INSTALLED, THE WEIGHT DIFFERENCE OF THE TOOL SHALL BE DEDUCTED FROM THE VALUES OF THIS TABLE.

- q WITH FULLY EXTENDED BUCKET CYLINDER.
- q ON A COMPACT HORIZONTAL LEVEL GROUND.

PC130-7 with 700mm width shoe

Loads do not exceed 87% of hydraulic capacity or 75% of tipping capacity (* load limited by hydraulic capacity rather than tipping)

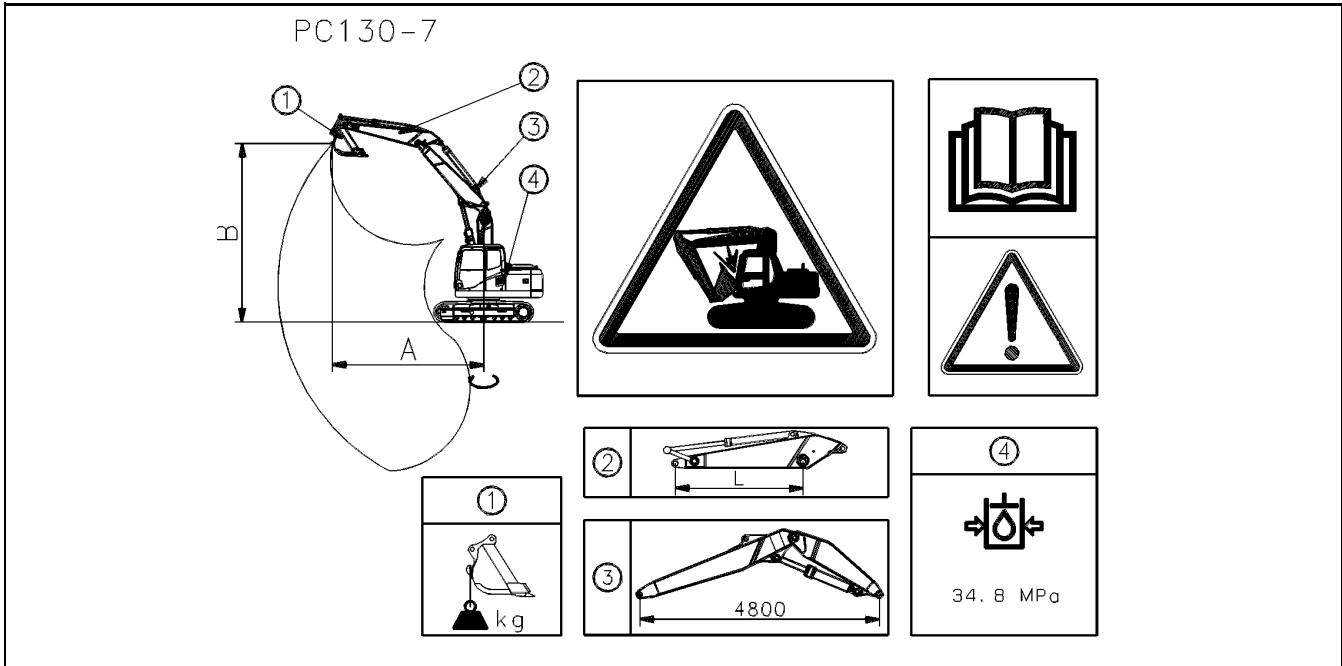

Model	Arm	Height	MAX		7.0m		6.0m		4.5m		3.0m		1.5m	
			OF	OS	OF	OS	OF	OS	OF	OS	OF	OS	OF	OS
PC130-7K 2 pc boom	3.0m	6.0m	*1600	*1600			*2550	2150						
		4.5m	*1500	1300	2300	1550	*2650	2150						
		3.0m	*1450	1100	2250	1500	*3000	2050	*3400	3350				
		1.5m	*1550	1050	2200	1450	2850	1900	*4500	3050				
		0.0m	1650	1050	2100	1350	2700	1750	4300	2800	*6100	5200		
		-1.5m	1800	1150	2050	1300	2600	1700	4100	2650	*7150	4950	*3100	*3100
		-3.0m	2150	1350			2600	1650	4100	2600	*8350	4950	*5600	*5600
		-4.5m	*2950	1950					4150	2650	*6600	5150		
	2.5m	6.0m	*2050	2000			*2450	2100						
		4.5m	*1900	1550			*3000	2100	*3100	*3100				
		3.0m	*1850	1300	2250	1550	3000	2050	*3900	3350	*5300	*5300		
		1.5m	1850	1200	2200	1450	2850	1900	4600	3050				
		0.0m	1900	1250	2150	1400	2750	1800	4300	2800	*5450	5200		
		-1.5m	2100	1350	2100	1400	2700	1750	4200	2700	*7700	5100	*3550	*3550
		-3.0m	2550	1650			2700	1750	4200	2700	*7950	5150	*6700	*6700
		-4.5m												
	2.1m	6.0m	*2500	2300					*3200	*3200				
		4.5m	*2300	1700			3050	2100	*3450	*3450				
		3.0m	2200	1450	2250	1500	2950	2000	*4250	3250	*6100	*6100		
		1.5m	2050	1350	2200	1450	2850	1900	4550	3000				
		0.0m	2100	1350	2150	1400	2750	1800	4300	2800	*4800	*4800		
		-1.5m	2300	1500			2700	1750	4200	2700	*8100	5100	*3800	*3800
		-3.0m	2900	1950					4250	2750	*7500	5200		
		-4.5m												

ATTACHMENTS AND OPTIONS



WARNING

Please read and make sure that you understand the safety volume before reading this section.

GENERAL PRECAUTIONS FOR SAFETY

When installing attachments or options to the machine, it is necessary to pay attention to safety. Please obey the following precautions strictly when selecting, installing, or using attachments or options.

PRECAUTIONS WHEN SELECTING

- Please consult your Komatsu distributor before installing attachments or options to the machine. Depending on the type of attachment or option, it may be necessary to install a front guard, overhead guard, or other safety structure to the machine. There may also be problems of the attachment or option hitting the operator's cab.
- Install only attachments or options authorized by Komatsu. Komatsu cannot accept any responsibility for any accident, damage, or failure caused by the use of attachments or options not authorized by Komatsu.

READ THE INSTRUCTION MANUAL THOROUGHLY

- Before installing or using any attachment or option, make sure that you thoroughly read and understand the instruction manuals for the machine and the attachment or option.
- If you lose the instruction manual or it is damaged, always obtain a new copy from the attachment manufacturer or your Komatsu distributor.

PRECAUTIONS WHEN REMOVING OR INSTALLING

When removing or installing the attachment or option, obey the following precautions, and take care to ensure safety during the operation.

- Carry out the removal and installation operation on a flat, firm ground surface.
- When the operation is carried out by two or more workers, choose the leader and follow his instructions.
- Use a crane when handling heavy objects (more than 25 kg). (The crane must be operated by a qualified operator.)
- Never go under a load raised by the crane.
- Do not carry out operations with the load kept raised by the crane. Always use a stand to prevent the load from falling.
- When removing a heavy part, consider the balance after it is removed. To prevent the machine from tipping over, set a support in position if necessary before removing the part.
- Before installing or after removing the attachment or option, set it in a stable condition to prevent it from falling over.
- For details of the removal or installation operation, please consult your Komatsu distributor.

PRECAUTIONS WHEN USING

When long or heavy work equipment is installed, remember the following precautions. Before starting operations, move the machine to a safe place and carry out a test operation to make sure that you fully understand the movement, center of gravity, and working range of the machine.

- q Do not swing the work equipment if the machine is at an angle. If the work equipment is swung with the machine at an angle, there is danger that the machine will tip over.
- q Always maintain a safe distance from obstacles in the surrounding area when operating. If long work equipment is installed, the working range becomes larger.
- q If heavy work equipment is installed, pay careful attention to the following precautions.
 - q The swing overrun (the distance the work equipment moves before completely stopping after the swing brake is applied) will be greater. There is danger of hitting objects if the swing overrun is miscalculated, so allow extra space to the swing position when swinging.
 - q The hydraulic drift of the work equipment (the amount of the work equipment moves down under its own weight when it is stopped in a raised position) also becomes greater. Do not stop the work equipment in a raised position; always lower it to the ground.
 - q Do not swing, lower, or stop the work equipment suddenly. There is danger that the machine may tip over.
 - q Do not suddenly extend or retract the boom cylinder. The shock may cause the machine to tip over.

BUCKET WITH HOOK

HOOK CONDITION

Check that there is no damage to the hook, stopper, or hook mount. If there is any abnormality, contact your Komatsu distributor.

PROHIBITED OPERATIONS

Operations with Care

- During lifting operations, reduce the engine speed and carry out the operation in L mode.
- Depending on the operating posture, there is danger that the wire or ring may come off the hook. To prevent this, pay careful attention to the angle of the hook.
- Never travel the machine while lifting a load.
- If the bucket with hook is turned and used for operations, it will hit the arm during dumping operations, so be careful when using it.
- If you are planning to newly install a hook, contact your Komatsu distributor.

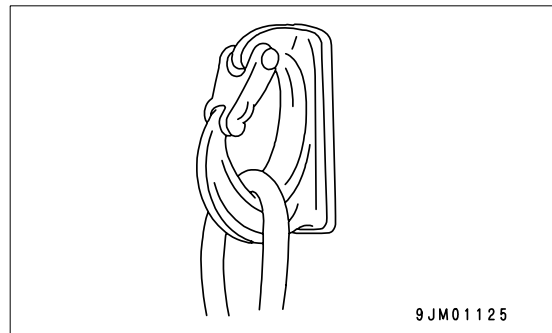
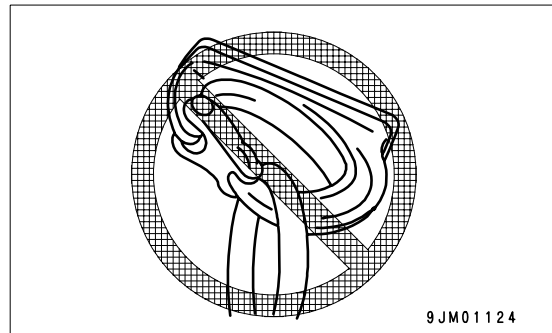

MACHINE READY FOR ATTACHMENT

LOCATIONS

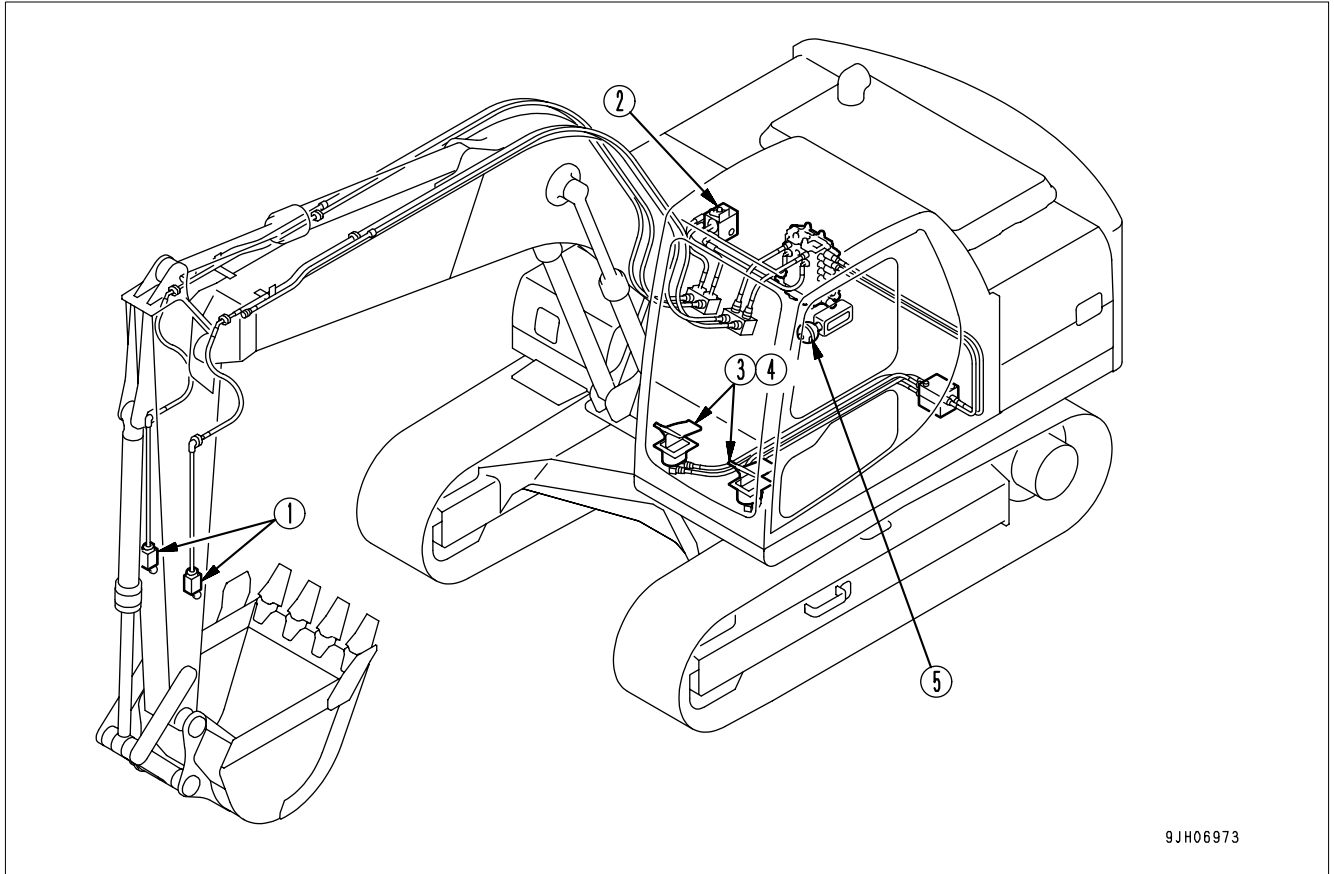

- (1) Stop valve
- (2) Selector valve
- (3) Attachment control valve

- (4) Lock pin
- (5) Accumulator (for control circuit)

Stop Valve

This valve (1) stops the flow of the hydraulic oil.

(a) FREE : Hydraulic oil flows.

(b) LOCK : Hydraulic oil stops.

When removing or installing attachments, set this valve to the LOCK position.

Always remove this lever and keep it in storage unless it is being used for switching the oil flow.

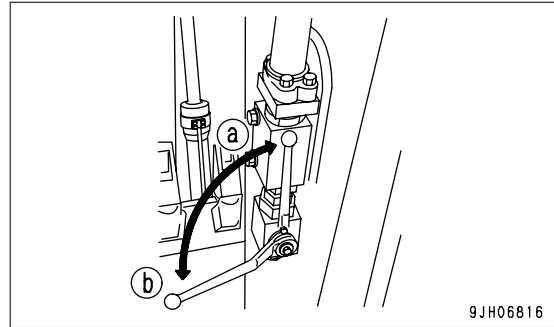

9JH06816

REMARK

If groove (A) is facing in the direction shown in the diagram on the right, it is in the lock position.

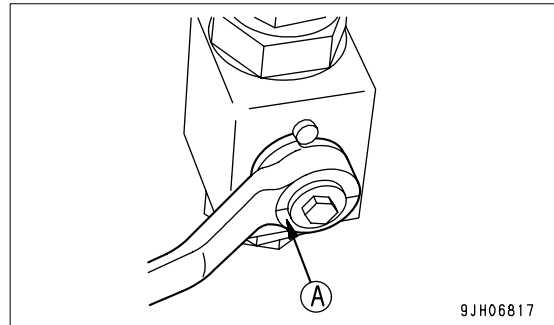

9JH06817

Selector Valve

NOTICE

Stop the engine and lower the work equipment and chassis to the ground to set in a stable position before carrying out the operation.

Switch the position of valve (2) to match the type of attachment. Use a wrench to turn the rotor of the selector valve to the appropriate position. A sticker using arrows to indicate the direction of the ports is fixed to the head of the rotor.

This valve (2) selector the flow of the hydraulic oil.

Position (a): When using breaker

Position (b): When using general attachment (crusher, etc.)

After changing the position of the valve, lock it in position with stopper bar (1).

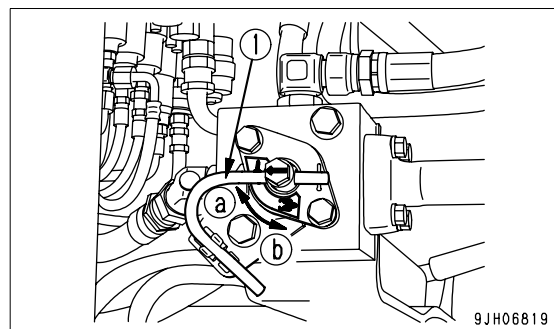

9JH06819

Attachment Control Pedal

⚠ WARNING

Do not carry out operations with your foot on the pedal. If the pedal is depressed by mistake, the attachment may suddenly move and cause a serious accident. Lock the pedal with the lock pin when you are not operating the attachment.

This pedal (3) is used to operate the attachment.

(a): Pedal for attachment system 1

(b): Pedal for attachment system 2 (when installed)

Right pedal (a) is used to operate the breaker.

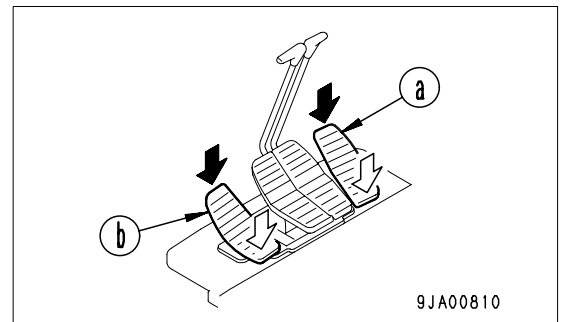

Lock Pin

This pin (4) is used to lock the control pedal.

Position (a): Lock

Position (b): Pedal half-stroke position (when using slide arm or other attachment with small oil flow)

Position (c): Pedal full-stroke position (when using crusher, power ripper, or other attachment with large oil flow)

ⓘ When using the breaker, select B mode on the monitor and set the pedal to position (c).

When not using the attachment, set the lock pin to position (a).

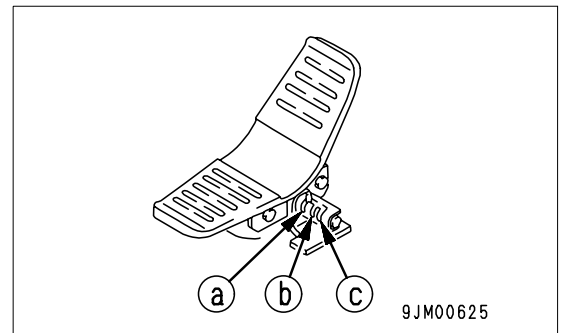

Accumulator (for Control Circuit)

⚠ WARNING

The accumulator is charged with high-pressure nitrogen gas, and it is extremely dangerous if it is handled mistakenly.

For details of handling, see "ACCUMULATOR (6-13)".

This accumulator (8) is installed to release the remaining pressure in the attachment circuit after the engine is stopped. Normally, do not touch it.

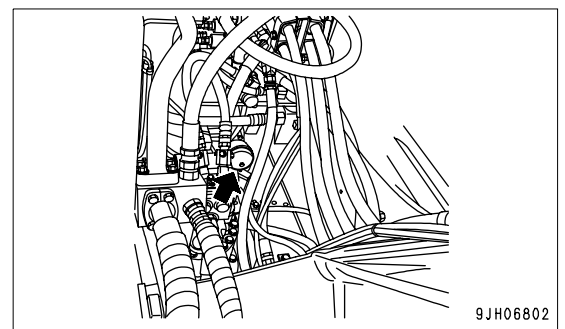

HYDRAULIC CIRCUIT

Hydraulic Circuit Connection

When connecting the attachment, connect the hydraulic circuit as follows.

One Line Attachment

1. Check that the stop valve is at the LOCK position, then remove plug (1).

Be careful not to lose or damage the removed parts.

2. Connect the piping for the attachment provided by the attachment maker.

The dimensions on the stopper valve side are as indicated at right. For those on the attachment side, confer with each manufacturer of attachment and determine.

3. After connecting the piping, bleed the air from the circuit.
4. Start the engine, referring to "STARTING ENGINE (3-70)", and run it at low idling for the subsequent 10 minutes. Then proceed to the next work.
5. Run the engine at low idling until the air in the attachment circuit is completely removed, then operate the attachment pedal repeatedly (approx. 10 times) to bleed the air.

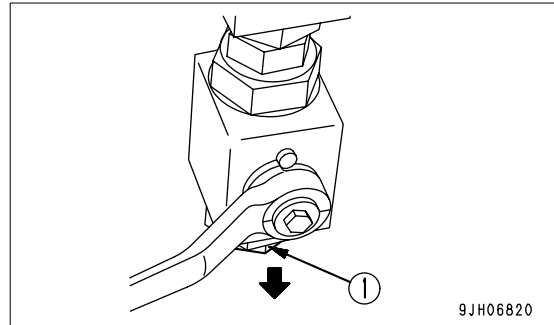

9JH06820

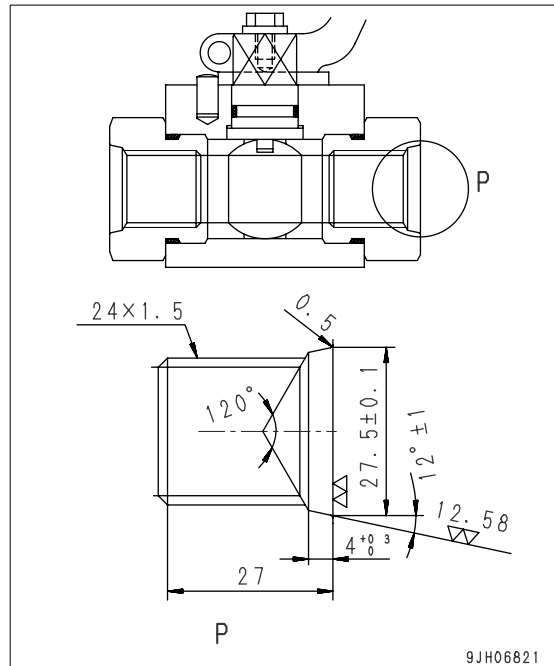

9JH06821

NOTICE

If the attachment maker specifies an air bleeding procedure for the attachment itself, follow the specified procedure to bleed the air.

6. After completing the bleeding of the air, stop the engine, and wait for at least 5 minutes before starting operations. This will release the bubbles in the oil inside the tank.
7. Check that there is no oil leakage, and wipe off any oil that has been spilled.

ATTACHMENT REMOVAL AND INSTALLATION

Attachment Removal

1. Lower the attachment to the ground and stop the engine.
2. After stopping the engine, operate each control lever and attachment control pedal to the front and rear, and left and right 2 or 3 times to the end of its stroke to release the remaining pressure inside the hydraulic circuit.
3. After checking that the oil temperature is low, rotate the rotor of the stop valve (installed to the side face of the arm) for the inlet and outlet port piping to the Lock position.
4. Remove the hoses on the attachment side. Install the plugs to the two outlets.

The plugs are used to prevent the attachment from incorrect operation caused by mixing in of foreign matter. After the plugs are correctly installed, store the attachment.

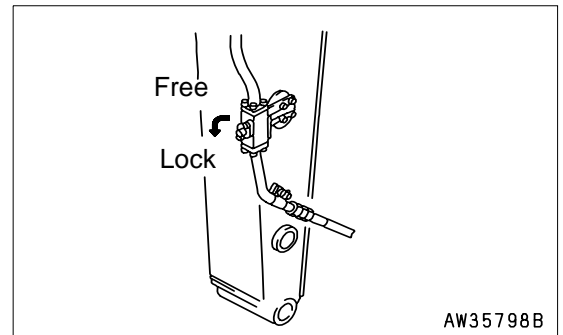

5. Pull out the mounting pins (2 places), remove the attachment, then install the bucket.

For details of the procedure for installing the bucket, see "BUCKET REPLACEMENT AND INVERSION (3-100)".

6. After installing the bucket, check the oil level in the hydraulic tank.

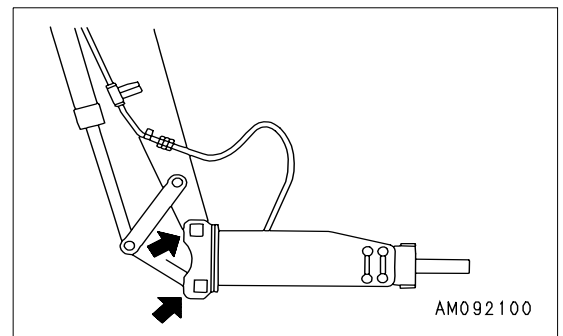

Attachment Installation

1. Remove the bucket.

For bucket dismounting procedure, see "BUCKET REPLACEMENT AND INVERSION (3-100)".

2. Place the attachment in a horizontal position, then install to the arm with pin (A) and then pin (B).
3. After installing the attachment, stop the engine. Then operate each control lever and attachment control pedal to the front and rear, and left and right 2 or 3 times to the end of its stroke to release the remaining pressure inside the hydraulic circuit.

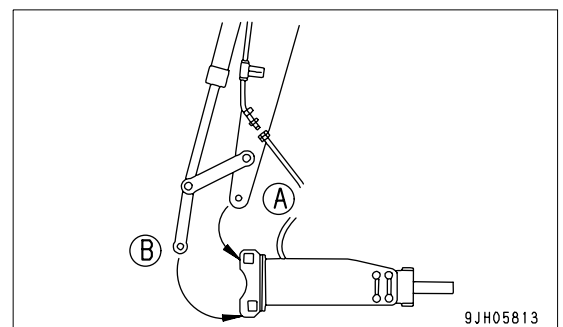

4. After confirming low oil temperature, remove the plug from the outlet and inlet port respectively.

Take care that no dust, mud etc. adheres to the hose mousepiece portions.

If O-ring is damaged, replace it with a new one.

5. Turn the rotor of the stop valves installed to the inlet and outlet piping at the side of the arm to the FREE position.
6. After installing the attachment, check the oil level in the hydraulic tank.

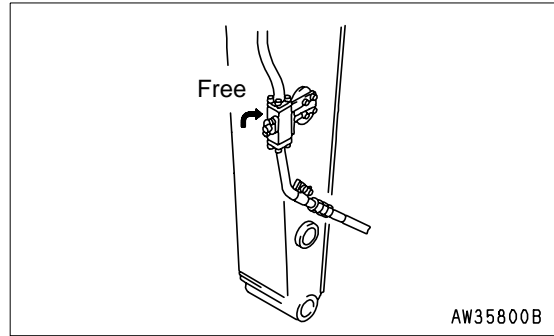

ATTACHMENT OPERATIONS

⚠ WARNING

- q Do not rest the foot on the pedal and depress it, when the auto deceleration switch is in ON position. The engine speed rises all of sudden and the attachment will move suddenly and cause serious damage or injury.
- q Do not put your foot on the pedal except when operating the pedal. If rest your foot on the pedal during operations, and it is depressed by accident, the attachment may move suddenly and cause serious damage or injury.

Operate the attachment as follows.

When Using Breaker**NOTICE**

Always use B mode for breaker operations. If any other mode (A, E, L) is used, the hydraulic equipment may be damaged.

Set the lock pin to the Free position and depress the front of the right pedal to operate the breaker.

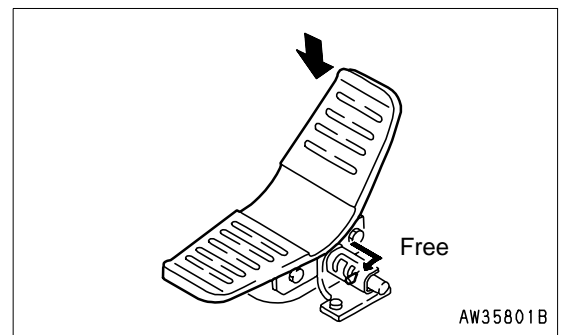

Set the working mode to B mode.

Precautions when using

- q Check that the stopper valve is in the FREE position.
- q Check that the selector valve is in the position for using the breaker.
- q Check that stopper bar (1) for the selector valve spool is installed at the breaker position.
For details of the oil flow, see "HYDRAULIC CIRCUIT (6-8)".

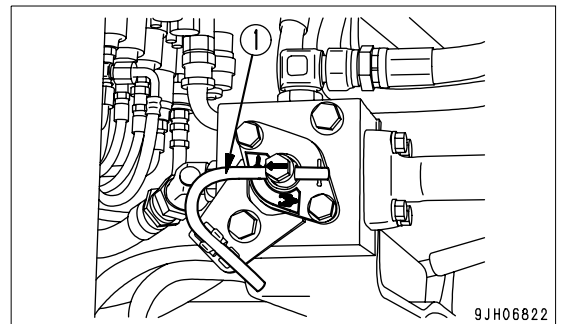

- q For details of other precautions when handling the breaker, see the instruction manual provided by the breaker manufacturer.
- q Compared with normal operations, the deterioration of the hydraulic oil is much more rapid when carrying out breaker operations, so change the oil and replace the element at shorter intervals than normal.
For details, see "MAINTENANCE INTERVAL FOR HYDRAULIC BREAKER (4-18)".

When Using General Attachment Such as Crusher

When the lock pin is set at the FREE position and the front or rear of the pedal is depressed, the attachment is actuated.

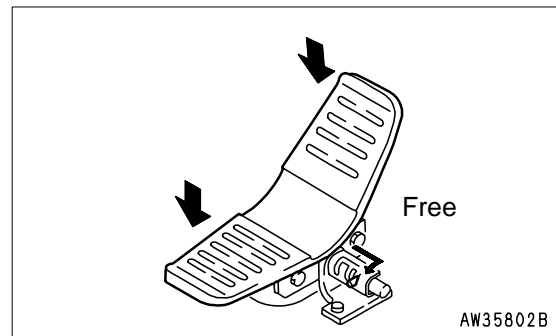

Precautions when using

- q Check that the stopper valve is in the FREE position.
- q Check that the selector valve is in the position for using the general attachment such as crusher.
- q Check that stopper bar (1) for the selector valve spool is installed at the crusher (general attachment) position. For details of the oil flow, see "HYDRAULIC CIRCUIT (6-8)".

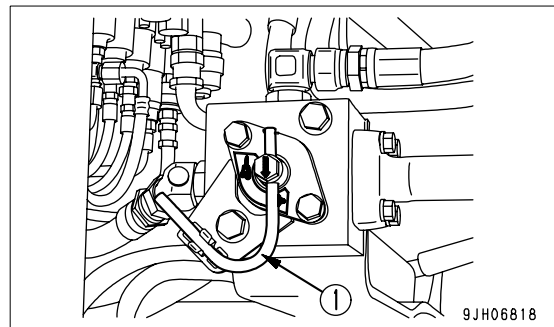

- q For details of other precautions when handling the breaker, read and use correctly the instruction manual provided by the breaker manufacturer.

ACCUMULATOR

WARNING

The accumulator is charged with high-pressure nitrogen gas, so mistaken operation may cause an explosion which will lead to serious injury or damage. When handling the accumulator, always do as follows. The pressure in the control circuit cannot be completely removed. When removing the hydraulic equipment, do not stand in the direction that the oil spurts out when carrying out the operation.

Loosen the bolts slowly.

Do not disassemble the accumulator.

Do not bring it near flame or dispose of it in fire.

Do not make holes in it or weld it.

Do not hit it, roll it, or subject it to any impact.

When disposing of the accumulator, the gas must be released. Please contact your Komatsu distributor to have this work carried out.

NOTICE

If the nitrogen gas charge pressure in the accumulator drops, it will be impossible to bleed the remaining pressure in the hydraulic circuit after the engine is stopped. In addition, if operations continue to be carried out when the nitrogen gas charge pressure is low, it may lead to failure of the hydraulic circuit or the machine.

For details, see "CHECK NITROGEN GAS CHARGE PRESSURE IN ACCUMULATOR (control circuit) (4-46)".

This machine is equipped with an accumulator in the control circuit. The accumulator is a device to store oil pressure for the control circuit, and when it is installed, the control circuit can be actuated for a short time even after the engine is stopped. Due to this device, the work equipment lowers under its own weight, if the control lever is moved in the lowering direction.

The accumulator is installed to the position shown in the diagram on the right.

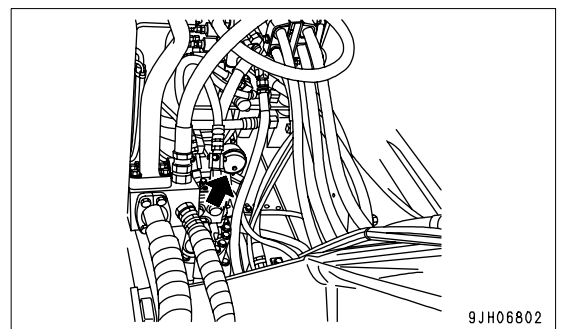

Hydraulic System - Pressure Release

1. Place the work equipment on the ground. Close the crusher attachment jaws, etc.
2. Stop the engine.
3. Move the safety lock lever to the free position. Move the work equipment control lever and the attachment control pedal to full stroke back and forth, right and left so as to release the pressure in the control circuit.
4. Move the safety lock lever to the lock position. Lock the control lever and attachment control pedal.

LONG TERM STORAGE

If the equipment is not to be used for a long time, do as follows.

- Set the stop valve in the LOCK condition.
- Install the plug and O-rings to the valves.
- Set the selector valve to position (b): Position when using general attachment (crusher, etc.)
- Insert the pedal lock pin in the Lock position.

If there is no breaker or general attachment installed, operating the pedal may cause overheating and other problems.

SPECIFICATIONS

Hydraulic specifications

- Oil flow

Pedal lock pin position	A mode	E mode	B mode
(b): Half	100 l/min	90 l/min	-
(c): Free	200 l/min	180 l/min	125 l/min

- Cracking pressure of service valve safety valve: 17.20 MPa (175 kgf/cm²)

ATTACHMENT GUIDE

⚠ WARNING

- q Please read the instruction manual for the attachment and the sections of this manual related to attachments and options.
- q When installing any attachment or option, there may be problems with safety, so please contact your Komatsu distributor before installing.
- q Installing attachments or options without consulting your Komatsu distributor may not only cause problems with safety, but may also have an adverse effect on the operation of the machine and the life of the equipment.
- q Any injuries, accidents, or damage resulting from the use of unauthorized attachments or options will not be the responsibility of Komatsu.

OTHER ATTACHMENTS

Bucket capacities

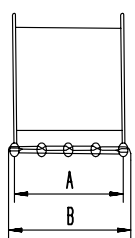

Width		Capacities (ltr)
A (MM)	B (MM)	
450	500	235/220
500	550	275/255
550	600	315/290
600	650	350/325
650	700	390/360
700	750	430/395
750	800	470/425
800	850	510/460
850	950	590/530
900	950	590/530
950	1000	630/570
1000	1050	675/605
1050	1100	715/640
1100	1150	755/675
1150	1200	795/710
1200	1250	840/745

Bucket portion

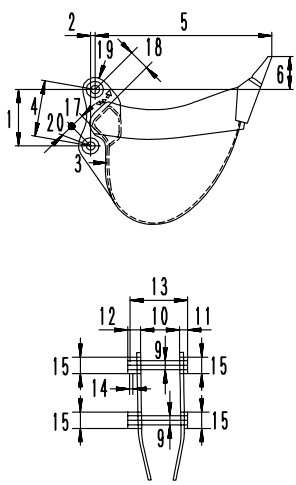

No.	
1	373
2	38
3	95.8°
4	374.9
5	1197
6	222
9	60
10	260
11	50
12	85
13	380
14	18
15	110
17	101.5
18	138
19	85
20	85

9JH06786

Track shoes	Triple grouser shoe width 700 mm Triple grouser shoe width 600 mm
Head guard	In place where there is danger of falling rocks, always install the head guard to protect the operator.

- q Various other optional parts, such as track frame center guard, arm holding valve, additional front lamps, rear lamps, and travel alarm are available, so please contact your Komatsu distributor.

ATTACHMENT COMBINATIONS

This table lists the combination of attachments which can be installed to the standard arm, short arm and long arm.

REMARK

When a long arm is installed, if the bucket is pulled in fully to the front of the machine it may hit the chassis; when digging at an angle, the bucket may hit the undercarriage, so be careful when carrying out these operations.

Bucket and arm combination

Bucket capacity (heaped)		Width		Weight (Without side cutters)	No.of teeth	Arm		
SAE, PCSA	CECE	Without side cutters	With side cutters			2.1 m	2.5 m	3.0 m
0.24	0.22	450 mm	575 mm	314 kg	3	○	○	○
0.28	0.26	550 mm	675 mm	339 kg	3	○	○	○
0.35	0.33	600 mm	775 mm	367 kg	3	○	○	○
0.47	0.43	750 mm	875 mm	419 kg	4	○	○	□
0.59	0.53	900 mm	1025 mm	469 kg	4	○	□	E
0.68	0.61	1000 mm	1125 mm	497 kg	4	□	E	-

These charts based on over-side stability with fully loaded bucket at maximum reach.

Please consult your dealer for the bucket range available in your region.

○: Material weight up to 1.8 t/m³

□: Material weight up to 1.5 t/m³

E : Material weight up to 1.2 t/m³

-: Not for use

TRACK SHOES SELECTION

Select the most suitable track shoe to match the operating conditions.

Selection

Check the category from the uses in the table below, then select the shoes from the table below that.

- q Category of use B and C are the wide shoe, so there are limits on the use. Check the precautions for use, examine the conditions of use thoroughly, and use the optimum shoes for the situation.
- q When selecting the shoe width, choose the narrowest shoes possible to bring the machine within the range where there is no problem regarding the machine flotation and ground contact pressure. If wider shoes than necessary are used, the load on the track shoe will increase, so this may cause problems such as bending of the shoe, cracking of the link, damage of the pin, and looseness of the shoe bolts.

Category	Use	Precautions when using
A	Rocky ground, riverbeds, normal soil	<ul style="list-style-type: none"> •On rough ground where there are large obstacles such as boulders or fallen trees, travel at Lo speed.
B	Normal soil, soft ground	<ul style="list-style-type: none"> •These shoes cannot be used on rough ground where there are large obstacles such as boulders or fallen trees. •Travel at Hi speed only on flat ground, and if it is impossible to avoid going over obstacles, shift down and travel at half speed in Lo.
C	Extremely soft ground (swamp)	<ul style="list-style-type: none"> •Use these shoes only in places where the machine sinks and it is impossible to use A or B. •These shoes cannot be used on rough ground where there are large obstacles such as boulders or fallen trees. •Travel at Hi speed only on flat ground, and if it is impossible to avoid going over obstacles, shift down and travel at half speed in Lo.
D	Paved road surface	<ul style="list-style-type: none"> •To protect rubber shoes, always follow the precautions given in HANDLING ROAD LINER.

PC130-7		
	Specifications	Category
Standard	500 mm Triple	A
Option	500 mm Road liner (rubber pad type)	D
Option	600 mm Triple	B
Option	700 mm Triple	C

BUCKET TEETH SELECTION

Depending on the working conditions, there is danger that an adapter and teeth may break, so select from the vertical pin and horizontal pin teeth to give teeth that are suitable for the purpose.

While the standard teeth of both vertical and horizontal pin types may be used widely, the following kinds of teeth are recommended depending on the working conditions.

Teeth Selection

Vertical Pin Type Tooth

General digging: Digging and loading normal soil, such as sand, gravel, clay, etc.

Light-duty digging: digging and loading dry and loose sandy soil, or muddy soil.

Loading: loading of dry and loose earth.

Horizontal Pin Type Tooth

Heavy-duty digging: Digging and hammering work on hard soil, soil with rocks, scraping or other heavy-duty work

□ The heavy-duty bucket is of a horizontal pin type and as such, use it for heavy duty-digging.

Long-life Tooth

□ Jobsites where long wear life is demanded, such as when loading hard rocks.

□ Jobsites where no penetration is needed, such as when working with crushed rocks after blasting or ripping.

□ Jobsites where heavy-duty operations are carried out, such as hitting or pulling up rocks with the tips of the teeth.

Self-sharpening Tooth

□ Jobsites demanding penetration such as digging and loading sandy or clayey soil.

Selection Guide for Horizontal or Vertical Pin Type Tooth

			Applicable Work Site			
			Rock	Crushed stone	Clayey soil, Decompressed weathered granite	Sand
Work Contents	Heavy ↑ ↓ Light	Digging with hammering work	Horizontal pin type teeth		Vertical pin type teeth	
		Scraping down	Horizontal pin type teeth		Vertical pin type teeth	
	General excavation	Vertical pin type teeth				
	Loading	Vertical pin type teeth				

HANDLING OF RUBBER PAD SHOE AND ROAD LINER

Be sure to observe the following instructions, when using a machine equipped with rubber pad shoes or Road Liner.

Working Environment

- q Use a machine equipped with rubber pad shoes or Road Liner mainly for jobs on the paved roads. If used otherwise, breakage or chipping will occur on the rubber and the service life will be considerably reduced.

Particularly the following jobsites must be avoided.

- q Jobsite strewn with crushed concrete or on sand
- q Jobsite with protruding edged objects like steel bar, glass and the like
- q Jobsite on rocky terrain or in a river with many rocks A ride over a concrete road shoulder or above all the tip of sheet piles driven into the ground must be avoided.
- q Be careful of machine skidding on the road covered with water, ice, snow or gravel. Pay special attention when unloading a machine from a truck.
- q Use a machine equipped with rubber pad shoes or Road Liner in the ambient temperature range of -25°C to 65°C due to the properties of rubber.

Working Conditions

- q A job using the undercarriage as a fulcrum, side digging job, digging job on a slope and a job requiring frequent steering, as shown in the picture, cause an excessive load on the rubber and there is danger that it may be damaged.
- q Durability of rubber pad shoes may not be covered with warranty, if a special work equipment is mounted.

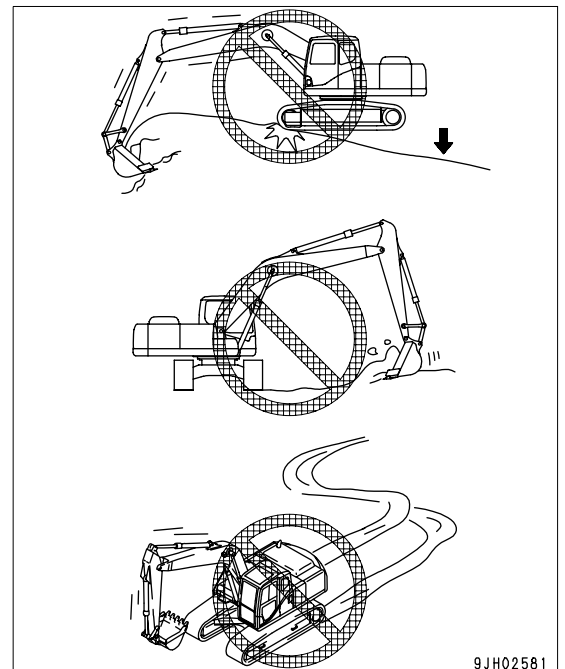

Storage, Protection

- Take care that no oil or grease sticks to the rubber. If it does, wipe it off immediately.
- Install rubber pad shoes and Road Liner corresponding to the number of the links. If there is any missing pad or liner, the rubber will be greatly deformed and damaged.
- If rubber pad shoes or Road Liner has to be stored for a long period, keep it indoors to avoid direct sunlight and rain.

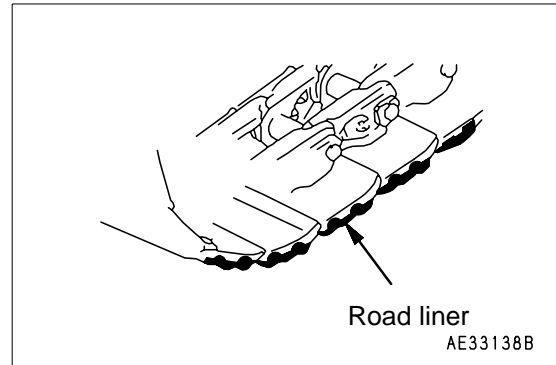

Extent of Damage to Rubber

- When traveling on a concrete pavement, rubber may stick to the road surface, leaving a dark track behind. It is the time for replacement.

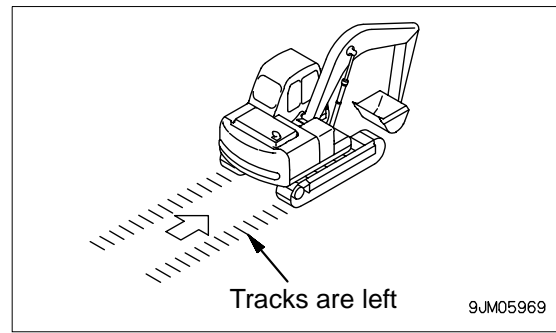

- The rubber is still usable, even if it does not look in good shape with part of the rubber chipped or cuts developed on the surface, so long as damage has not developed all over the shoe or it does not damage a road surface.

Check Road Liner

If the road liner are in the following condition, they must be repaired or replaced, so please contact your Komatsu distributor for repair or replacement.

Height of Lug

- If lug height "a" is reduced by wear, the drawer pull will drop. If "a" is less than 5 mm, replace with a new part.

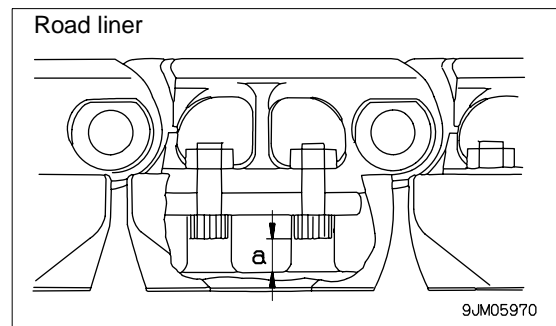

Replace Road Liner

- When all the road liners of the machine need to be replaced, ask your Komatsu distributor to replace them.
- When replacing only part of the road liner, use the special road liner removal tool. Please order the tool from your Komatsu distributor.

RECOMMENDED ATTACHMENT OPERATIONS

Below described are instructions which must be followed without fail when doing the work using a hydraulic excavator equipped with an attachment.

NOTICE

Select the optimum model of attachment for a hydraulic excavator on which it is to be mounted. Depending on machine models of hydraulic excavator, the kind of attachments or the model of specific attachments that can be mounted will vary. Hence, consult your Komatsu distributor for the selection of optimum attachments.

HYDRAULIC BREAKER

Main Applications

- q Crushed rock
- q Demolition work
- q Road construction

This attachment can be used for a wide range of applications including demolition of buildings, breaking up road surfaces or slag, tunnel work, rock crushing and breaking operations in quarries.

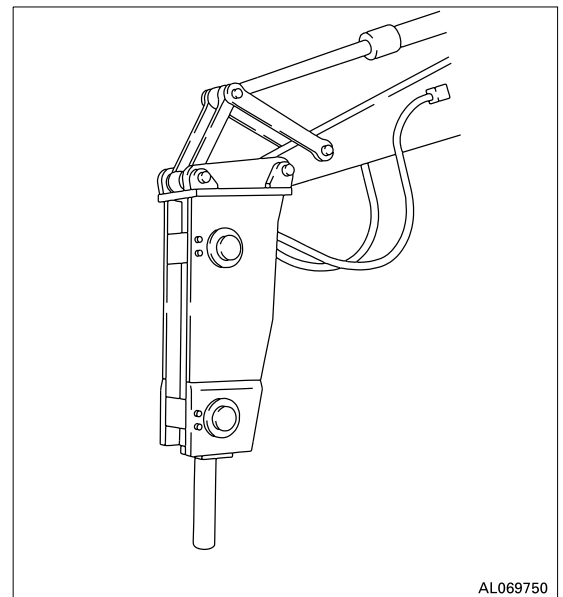

Keep the chisel pushed perpendicularly against the impact surface when carrying out breaking operations.

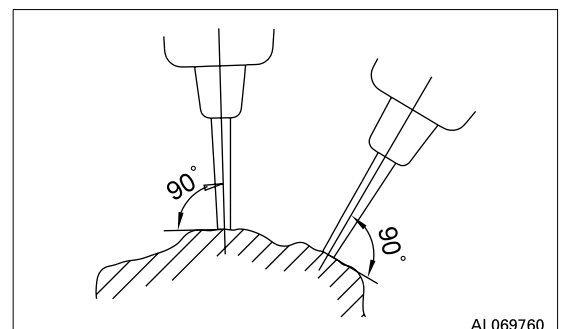

When applying impact, push the chisel against the impact surface and operate so that the chassis rises approx. 5 cm off the ground. Do not let the machine come further off the ground than this amount.

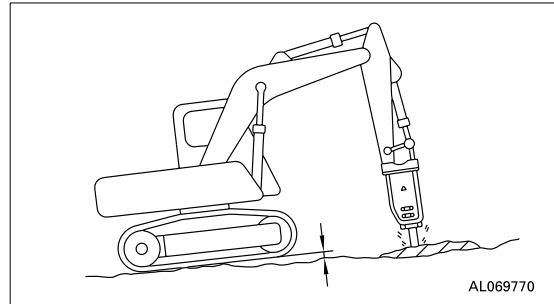

When applying continuous impact to the same impact surface, if the chisel does not penetrate or break the surface within 1 minute, change the point of impact and carry out breaking operations closer to the edge.

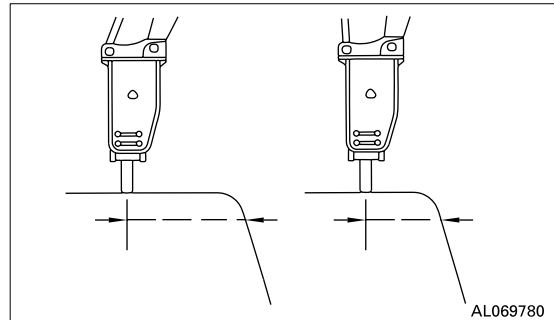

The direction of penetration of the chisel and the direction of the breaker body will gradually move out of line with each other, so always adjust the bucket cylinder to keep them aligned.

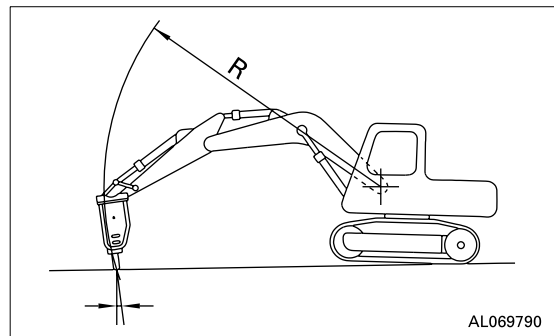

Always keep the chisel pressed against the impact surface properly to prevent using the impact force when there is no resistance.

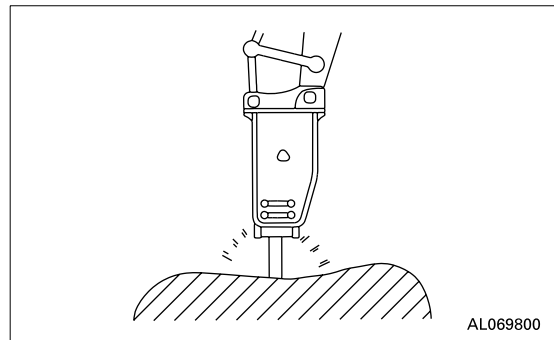

Prohibited Works

To ensure that the machine has a long life, and to ensure that operations are carried out in safety, do not operate the machine in any of the following ways.

- q Do not operate all cylinders to the end of their strokes. Always leave approx. 5 cm to spare.

Using the mount to gather in pieces of rock

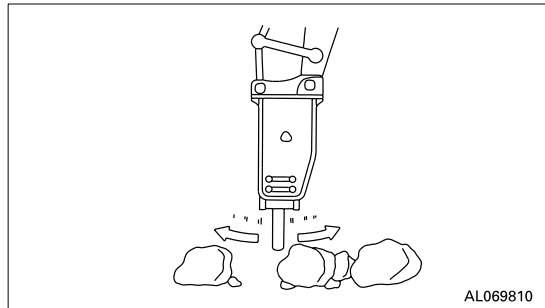

Operations using the swing force

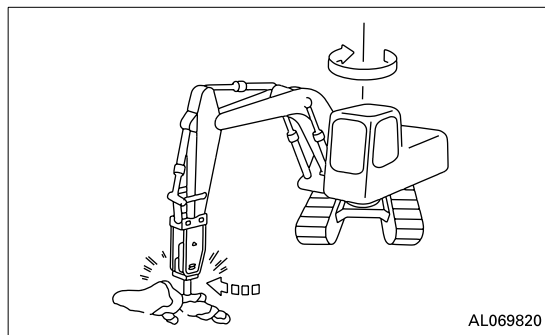

Moving the chisel while carrying out impacting operations

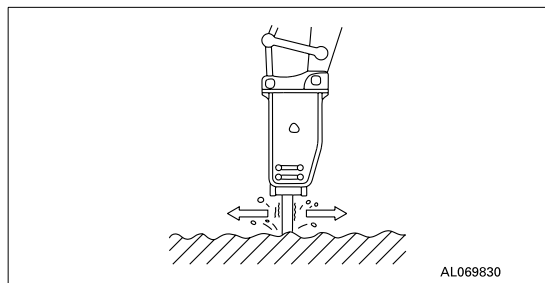

Holding the chisel horizontal or pointed up when carrying out impacting operations

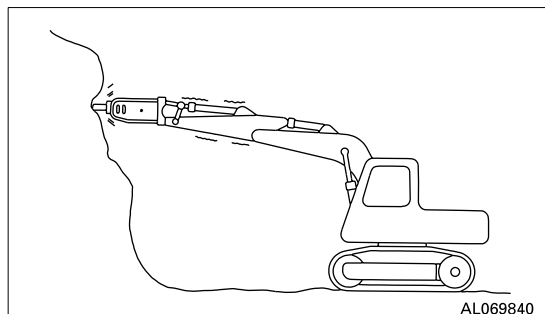

Twisting the chisel when it has penetrated the rock

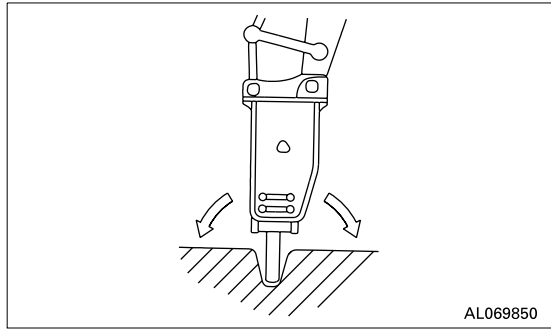

Pecking operations

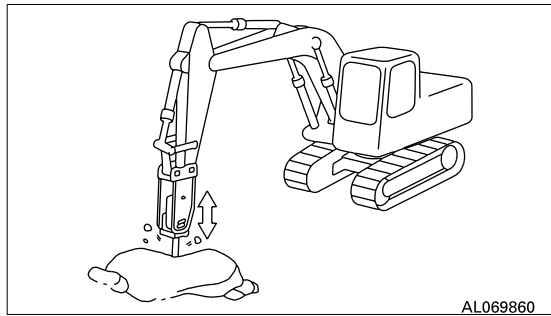

Extending the bucket cylinder fully and thrusting to raise the machine off the ground

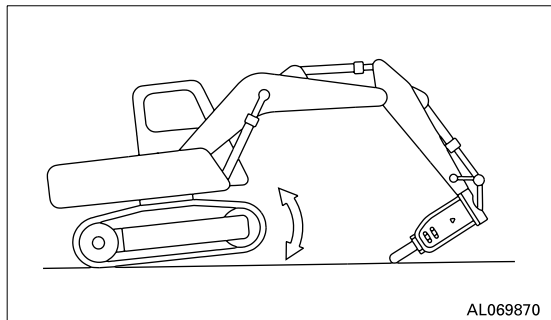

Greasing

Supply grease in the correct position.

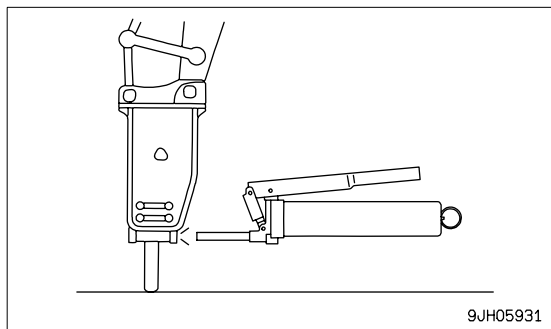

NOTICE

If the breaker is greased in an improper posture, it is filled with more grease than necessary. As a result, soil and sand will enter the hydraulic circuit and can damage the hydraulic components, while the breaker is in use. Therefore, be sure to grease the breaker, holding it in the right posture.

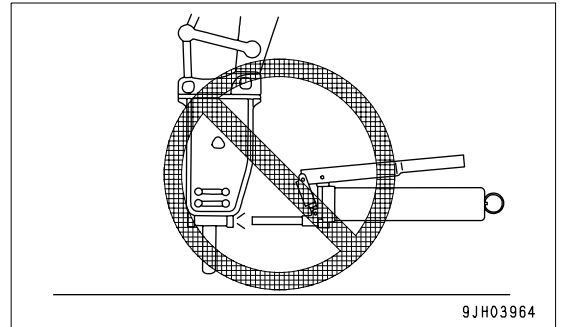
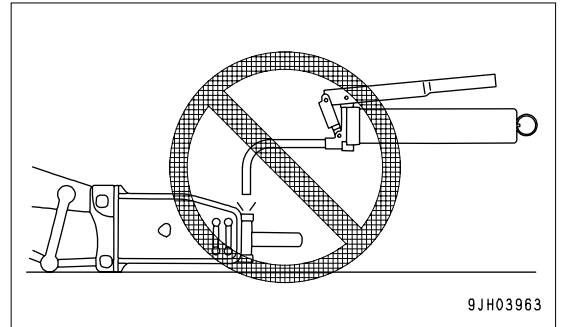

2-PC BOOM

6

FEATURES OF 2-PIECE BOOM & ARM

This sketch shows format of two piece boom machine, including location of grease points (For 1st and 2nd booms only).

For starting procedure, refer to OPERATION (4-1)

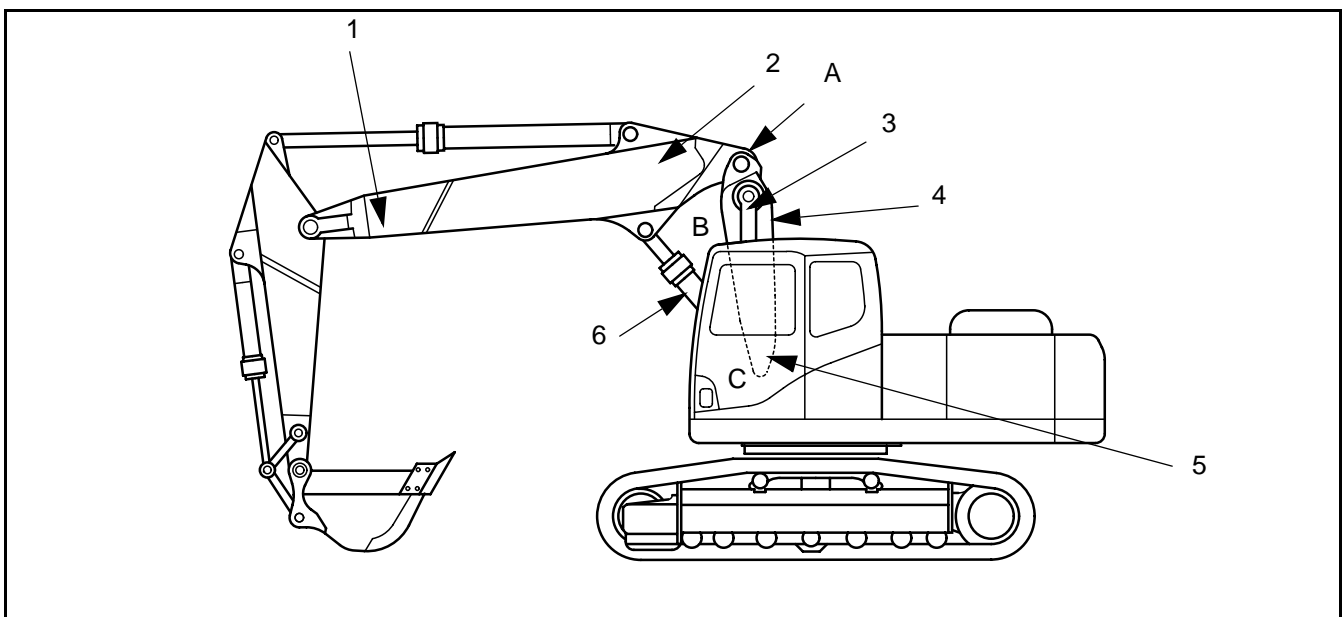

- | | | | |
|----|---------------------------------------------------------|----|------------------------------------------------------------------------|
| 1. | Side of arm.
1 grease point located here for joint D | 4. | First boom |
| 2. | Second boom | 5. | Top of boom foot
5 grease points located here for joints A, B and C |
| 3. | First boom raise cylinder | 6. | Second boom adjust cylinder |

OPERATION

Explanation of Devices

2 piece boom control pedal.

The control pedal to the left of the travel levers controls two functions on a 2-Piece Boom machine:

The pedal controls the operation of the second boom adjust cylinder. Pressing down on the front of the pedal pushes the second boom away from the cab, pressing down on the rear of the pedal pulls the second boom towards the cab.

- 1 2 Piece boom control pedal

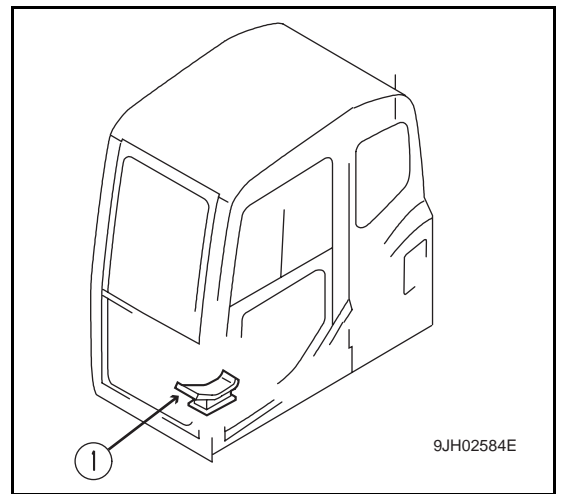

- A Extend 2nd boom raise cylinder
- B Retract 2 nd boom raise cilinder

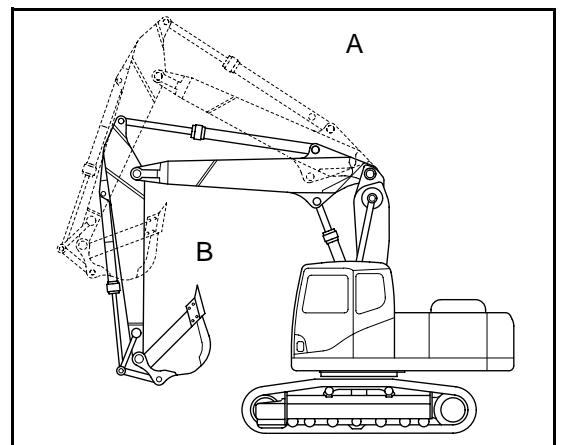

- A Press the rear of the pedal
- B Press the front of the pedal

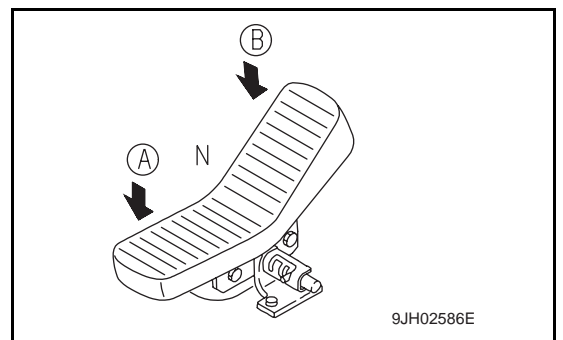

BEFORE STORAGE POSTURE WHEN LEAVING MACHINE

When leaving the operator's compartment, put the machine in the following posture for reasons of safety.

1. When leaving the machine for a long time see ,LONG TERM STORAGE (3-117) for instructions on correct preparation of machine for long term storage.

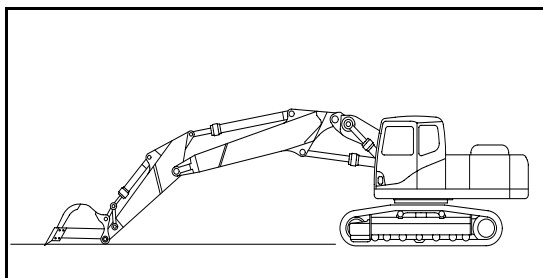

2. When leaving the machine for a short time.

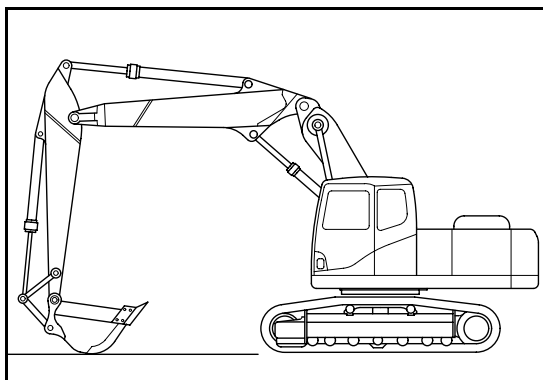

TESTING AND ADJUSTING

INSPECTION AND MAINTENANCE

To use the machine safely, and to prevent failures before they occur, always carry out checks before starting and periodic maintenance.

The locations for periodic inspection are as shown in the diagram below.

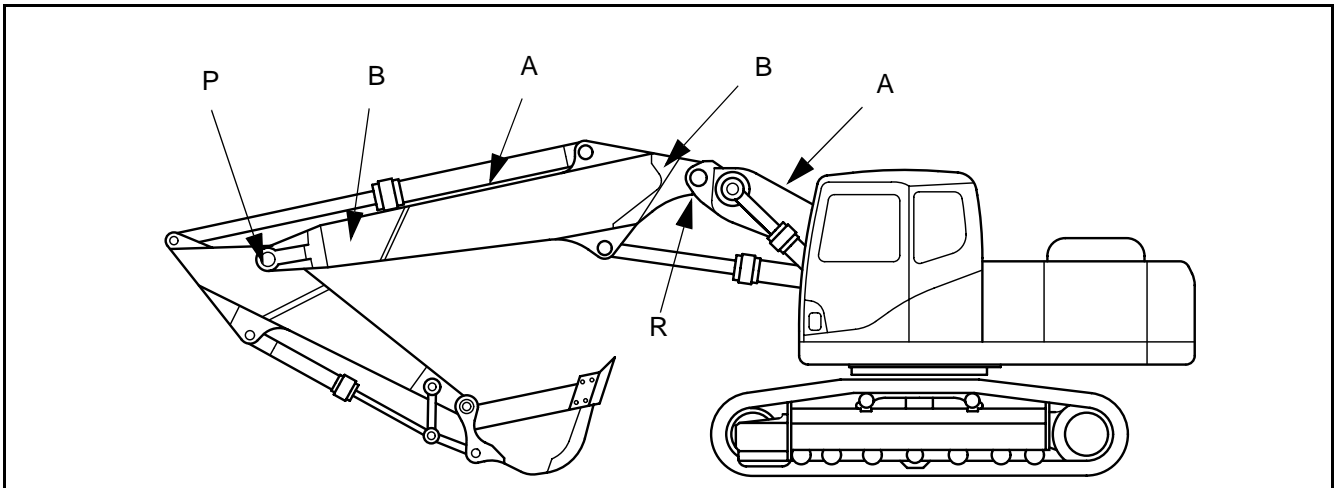

- A Cracks at end of weld (checks before starting).
- P R Play, wear of pins (every 1000 Hours).
- B Furrows in base metal (checks before starting).

NOTICE

If any abnormality is found during inspection, please contact your Komatsu distributor.

For details of inspection and maintenance items for the chassis other than those listed above, MAINTENANCE (4-1)

PERODIC MAINTENANCE

- q Changing the hydraulic oil

When changing the hydraulic oil, set the work equipment in the posture shown below.

- q Hydraulic oil capacity for the 2-piece boom machine is litres.
- q Periodic maintenance required is the same as mono-boom machine.

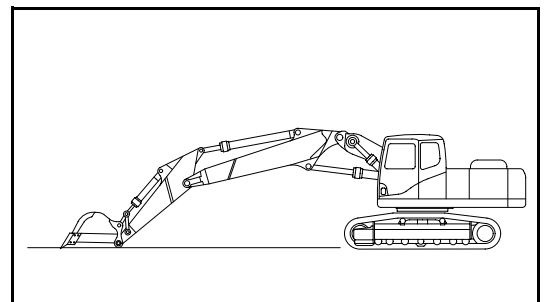

TRANSPORTATION

PROCEDURE FOR LOADING ON TO TRAILER

q Loading and unloading procedure.

Refer to TRANSPORTATION (3-105) for correct procedure for loading and unloading of machine.

(2-piece boom machine is same as mono-boom machine)

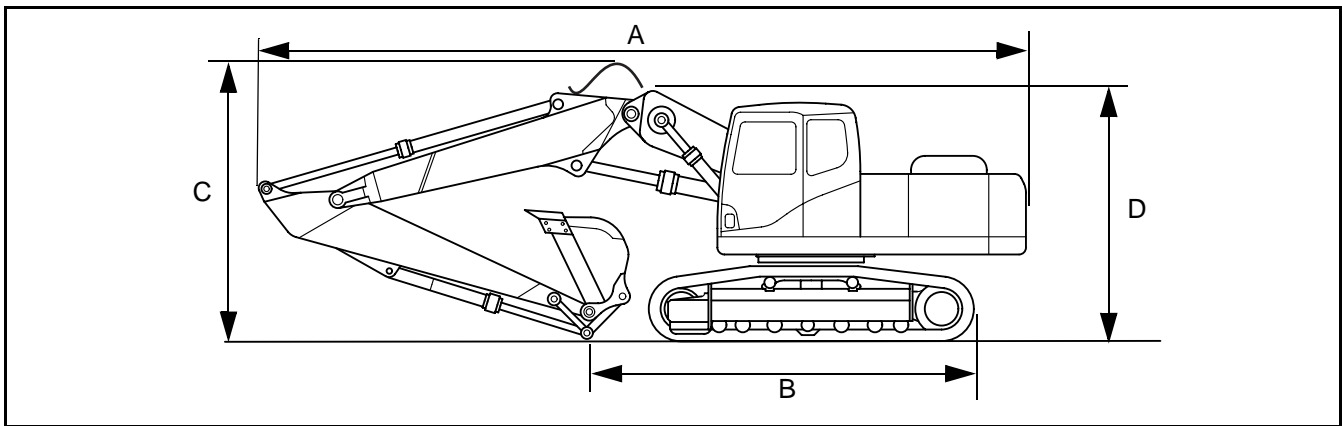

For transportation dimensions, refer to the below mentioned table.

	Arm	2100 mm	2500 mm
PC130-7K	A		
	B		
	C		
	D		

INDEX

INDEX

<A>

Accumulator	3-55
Air Conditioner Controls	3-35
Ashtray	3-34
Attachment Guide	6-15
Attachment Combinations	6-16
Bucket Teeth Selection.....	6-18
Handling of rubber pad shoe and road liner	6-19
Other attachments	6-15
Track Shoes Selection.....	6-17
Auxiliary Electric Power.....	3-49

Breaking-In The New Machine.....	1-6
Bucket Replacement and Inversion	3-100
Bucket with Hook	6-4
Hook Condition	6-4
Prohibited Operations.....	6-4

<C>

Cab Radio Cassette	3-48
Cap with Lock.....	3-32
Cold Weather Operation	3-114
After Cold Weather Season.....	3-116
After Daily Work Completion	3-116
Cold Weather Operation Information.....	3-114
Control Levers and Pedals.....	3-23
Controllers.....	3-51
Controls and Gauges	3-3

<D>

Detailed Controls and Gauges	3-4
Direction of Machine	1-6
Door Lock.....	3-31

<E>

Electric System Maintenance.....	4-8
Emergency Exit from OperatorsCab'	3-31
Engine After Starting	3-74
Engine Before Starting.....	3-56
Engine Serial No. Plate and Its Location.....	1-7
Engine, Check After Shut Off	3-103
Engine, Starting.....	3-70
Engine, Stopping the.....	3-81
Escape from Mud	3-97

<F>

Forward	1-2
Fuse	3-49

Fusible Link.....	3-50
-------------------	------

<G>

General Operation Information	3-94
General Precautions for Safety.....	6-2
Precautions when Removing or Installing	6-2
Precautions when Selecting.....	6-2
Precautions when Using	6-3
Read the Instruction Manual Thoroughly	6-2
Grease Gun Holder.....	3-51

<H>

Handling Grease Gun	3-52
Handling Oil, Fuel, Coolant, and Performing Oil Clinic	4-5
Hot and cool box.....	3-34

<I>

Introduction	1-6
--------------------	-----

<L>

Locking	3-104
Long term storage.....	3-117
After Storage	3-118
Before Storage	3-117
During Storage	3-117
Starting machine after long-term storage.....	3-118
Lubricants, Coolant and Filters	4-5
Lubricants, Fuel and Coolant Specifications.....	4-10
Proper Selection.....	4-10

<M>

Machine Inspection After Daily Work.....	3-104
Machine Operation	3-82
Machine Operations and Controls	3-56
Machine Ready for Attachment	6-5
Accumulator	6-13
Attachment Operations	6-11
Attachment Removal and Installation.....	6-9
Hydraulic Circuit.....	6-8
Locations.....	6-5
Long term storage	6-14
Specifications	6-14
Machine View Illustrations	3-2
Machine, Steering the.....	3-86
Magazine Box	3-34
Maintenance Information	4-2
Maintenance Procedure.....	4-19
Check before starting	4-47

Every 100 hours4-48
 Every 1000 hours4-65
 Every 2000 hours4-67
 Every 250 hours4-51
 Every 4000 hours4-69
 Every 500 hours4-55
 Every 5000 hours4-70
 Initial 250 hours (First 250 hours only)4-19
 When Required.....4-20
 Maintenance Schedule.....4-16
 Maintenance Interval for Hydraulic Breaker4-18
 Maintenance Schedule Chart4-16
 Monitoring System3-4

<O>

Overall Machine View3-2
 Overload warning device.....3-104

<P>

Parking Machine3-102
 Product Identification Number (PIN)/Machine Serial
 No. Plate1-7
 Product Information1-7
 Prohibited Operations3-92

<R>

Recommended Applications3-98
 Recommended Attachment Operations6-21
 Hydraulic Breaker6-21
 Refuelling pump3-53

<S>

Safety Critical Parts.....4-15
 Safety Critical Parts List4-15
 Safety Information1-3,2-2,2-12
 Safety Labels2-4
 Location of Safety Labels2-4
 Safety Labels.....2-5
 Safety Machine Operation.....2-21
 Battery2-31
 Lifting Objects with Bucket2-34
 Operation2-23
 Starting Engine2-21
 Towing2-33
 Transportation2-30
 Safety Maintenance Information2-36
 Service Meter Location1-8
 Specifications5-2
 Sun Roof3-26
 Swinging.....3-88
 Switches.....3-17

<T>

Tightening Torque Specifications4-14
 Tightening Torque List.....4-14

Tool Box.....3-51
 Transportation.....3-105
 Lifting Machine3-113
 Loading and Unloading with Trailer.....3-106
 Transportation Procedure3-105
 Traveling on Slopes3-95
 Troubles and Actions3-119
 Battery, Discharged.....3-122
 Lightweight Towing Hole3-120
 Other Trouble3-126
 Phenomena that are not failures3-119
 Running Out of Fuel3-119
 Severe Job Condition3-121
 Towing the Machine3-120

<W>

Wear Parts4-9
 Wear Parts List.....4-9
 Windshield3-26
 Work Equipment Controls and Operations3-89
 Working Mode.....3-91

<Y>

Your Machine Serial Numbers And Distributor1-8

COLOPHON

PC130-7 GALEO HYDRAULIC EXCAVATOR

Form No. UEAM003601

© 2004 KOMATSU
All Rights Reserve
Printed in Belgium 04-07
