

Service Manual

Buses

Group **37**

Release **01**

Multiplex electrical system Version 2
Wiring Diagram

B12B, DH12E
chassie nr 145005-145639



VOLVO

Foreword

The information in this manual is based on present design in

september, 2010

The products are under continuous development. This may effect the correctness of the information in this manual. If the differences are significant, new editions of this manual will be released to cover the changes.

Volvo Bus Corporation

Göteborg, Sweden

Order number:

17083

© Volvo Bus Corporation, Göteborg, Sweden

All rights reserved. No part of this publication may be reproduced, stored in retrieval system, or transmitted in any forms by any means, electronic, mechanical, photocopying, recording or otherwise, without the prior written permission of Volvo Bus Corporation.

Engineering Release Notice (ERN)	Location	Change Description	A = Added U = Deleted	W = Was	Date	Modification Count
		See DCN				

WIRING DIAGRAM INDEX, B7, B9, B12

NAME	DESCRIPTION	PAGE	NAME	DESCRIPTION	PAGE
AA	IGNITION AND STARTING SYSTEM	03	DO	VOITH DIWA5 ARTIC	39
AA2	BATS-D	04			
AB	POWER SUPPLY	05	EO	EBS, ELECTRONIC BRAKE SYSTEM	40
AB2	POWER SUPPLY	06	EP	EBS, ELECTRONIC BRAKE SYSTEM	41
AC	START ENGINE AND ALTERNATORS	07	EX	PARKING BRAKE RELEASE	42
AD	STARTER MOTOR AND ALTERNATORS FOR MD7	08	FA	ECS, AIR SUSPENSION	43
AE	STARTER MOTOR AND ALTERNATORS FOR R9L, R9TL, B9R	09	FB	ECS, AIR SUSPENSION	44
AF	STARTER MOTOR AND ALTERNATORS MD12	10	FC	AMECU	45
AG	START/STOP SWITCHES REAR	11	FO	ELECTRONIC STEERED AXLE	46
AH	STARTER MOTOR AND ALTERNATOR FOR R9S	12			
			GA	LCM, REAR LIGHTS	47
BA	VECU, VEHICLE ECU	13	GB	LCM, FRONT LIGHTS	48
BB	BBM, BODY BUILDER MODULE	14	GC	LCM, REAR LIGHTS	49
BC	BBM, BODY BUILDER MODULE	15	GD	LCM, ARTIC LIGHTS PULLER	50
BD	FIRE ALARM	16	GE	LCM, BI-XENON LIGHT	51
BE	LKS/DAS-SYSTEM	17	GF	LCM, BIARTIC LIGHTS	52
			GM	WIPER, WASHER	53
CA	EECU D9B, ENGINE	18	GN	LCM, XENON LIGHT RELAY	54
CB	EECU G9A, ENGINE	19			
CC	EECU D12D, ENGINE	20	IS	HORN SWM, STEERING WHEEL MODULE	55
CD	EECU CUMMINS CNG	21	IU	AUDIO	56
CE	EMS CUMMINS CNG	22			
CF	CONVERTER CUMMINS CNG	23	LA	HUBNER ECU 1 ST TURNTABLE	57
CG	FTM, FUEL TANK MONITOR	24	LB	HUBNER ECU 2 ND TURNTABLE	58
CH	ESI CONTROL UNIT	25			
CL	BIO, BUS I/O	26	NA	BIC, BUS INSTRUMENT CLUSTER	59
CM	EECU DH12E, ENGINE	27	NB	TACHOGRAPH	60
CN	EECU D7E, ENGINE	28	NC	DYNAFLEET, ALCOLOCK	61
CO	OILMASTER	29	ND	FMS 200, FLEET MANAGEMENT SYSTEM	62
CP	BIC AND RV165	30	NE	FMS 200 GATEWAY, FLEET MANAGEMENT SYSTEM	63
CU	UDS, UREA DOSING SYSTEM	31	NF	VDV, INSTRUMENT CLUSTER	64
CV	CAN SAE 1939_7	32	NG	VDV, INSTRUMENT CLUSTER	65
DA	G8-EGS	33	XC	CAN SAE 1939	66
DB	ECOMAT4 ZF	34	XD	CAN SAE 1587	67
DC	VOITH DIWA5	35	XE	CAN SAE 1587 UDS	68
DD	ECOLIFE ZF	36			
DM	RECU, RETARDER	37	ZC	GROUND	69
DN	I-SHIFT	38			

VOLUME NO	CONTENT	PAGES
01	WIRING DIAGRAM	1-69
02	BILL OF MATERIAL/COMPONENT LIST	1-72

<p>The copying, distribution and utilization of this document as well as the communication of its contents to others without expressed authorization is prohibited. Offenders will be held liable for payment of damages. All rights reserved in the event of the grant of a patent, utility model or ornamental design registration.</p>	Document Title WIRING DIAGRAM B7, B9, B12			
	Document Type PRODUCT SCHEMATIC			
	Owner Domain: Document Prefix			
	Document No 20904123	Issue Index 10	Volume No 01(02)	Page No 1(69)



ABREVIATIONS

AC	Air Condition	IJ	Inlet Jet
Acp	Accelerator Pedal	Ind	Indicator
AI	Analogue Input	Inj	Injection
Amb	Ambient	JK	Jack-knife
AO	Analogue Output	KL	Key Line
ARC	Air Regeneration Control	L	Low
BHSA	Brake Hill Start Aid	LCP	Light Control Panel
Brk	Brake	LDI	Low Digital Input
Buf	Buffered	LDO	Low Digital Output
C	Closing	LS	Low Side
CampL	Campaign Lights	Nd	Needle
Cent	Centering	O	Output
Ctrl	Control	OV	Overflow
Cyl	Cylinder	OP	Opening
Dash	Dashboard	PCV	Pressure Control Valve
Deliv	Delivery	Plo	Plough
DI	Digital Input	PR	Pressure Regulator
Diag	Diagnostic	Pres	Pressure
Dir	Direction	Pos	Position
Dis	Disable	PWM	Pulse Width Modulation
DO	Digital Output	Rad	Radiator
DRL_RMC	Daytime Running Light/Reduced Mode Control	RAI	Resistance Analogue Input
EACC	Electric Air Compressor Control	Red	Reductor
ECB	VBC, Engine Compressor Brake	Rel	Relay
ECU	Electronic Control Unit	Req	Request
ECU_GND	External Ground	RES	Input for Sensors with Variable Resistance
EGR	Exhaust Recirculation, valve	Ret	Retarder
EMT	Exhaust Manifold Temperature	Sen	Sensor
Eng	Engine	Sign	Signal
EPG	Exhaust Pressure Governor	Sno	Snow
ES	Engine Synchronization	Sp	Speed
ETCC	Exhaust Temperature Catalytic Converter	St	Start
Ext	External	Stp	Stop
GND	Signal Ground	SV	Supply Voltage
H	High	Sw	Switch
Haz	Hazard	Temp	Temperature
HDI	High Digital Input	Tor	Torque
HDO	High Digital Output	UBat	Feed Directly from Battery
HLa	HeadLamps	VEB	Volvo Engine Brake
HS	High Side	Veh	Vehicle
Hyd	Hydraulic		

VOLVO

Volvo Bus Corporation

Document Title

WIRING DIAGRAM

Document Type

PRODUCT SCHEMATIC

Document No

20904123

Issue Index

10

Volume No

01(02)

Page No

2(69)

IGNITION AND STARTING SYSTEM

WIRING DIAGRAM AA

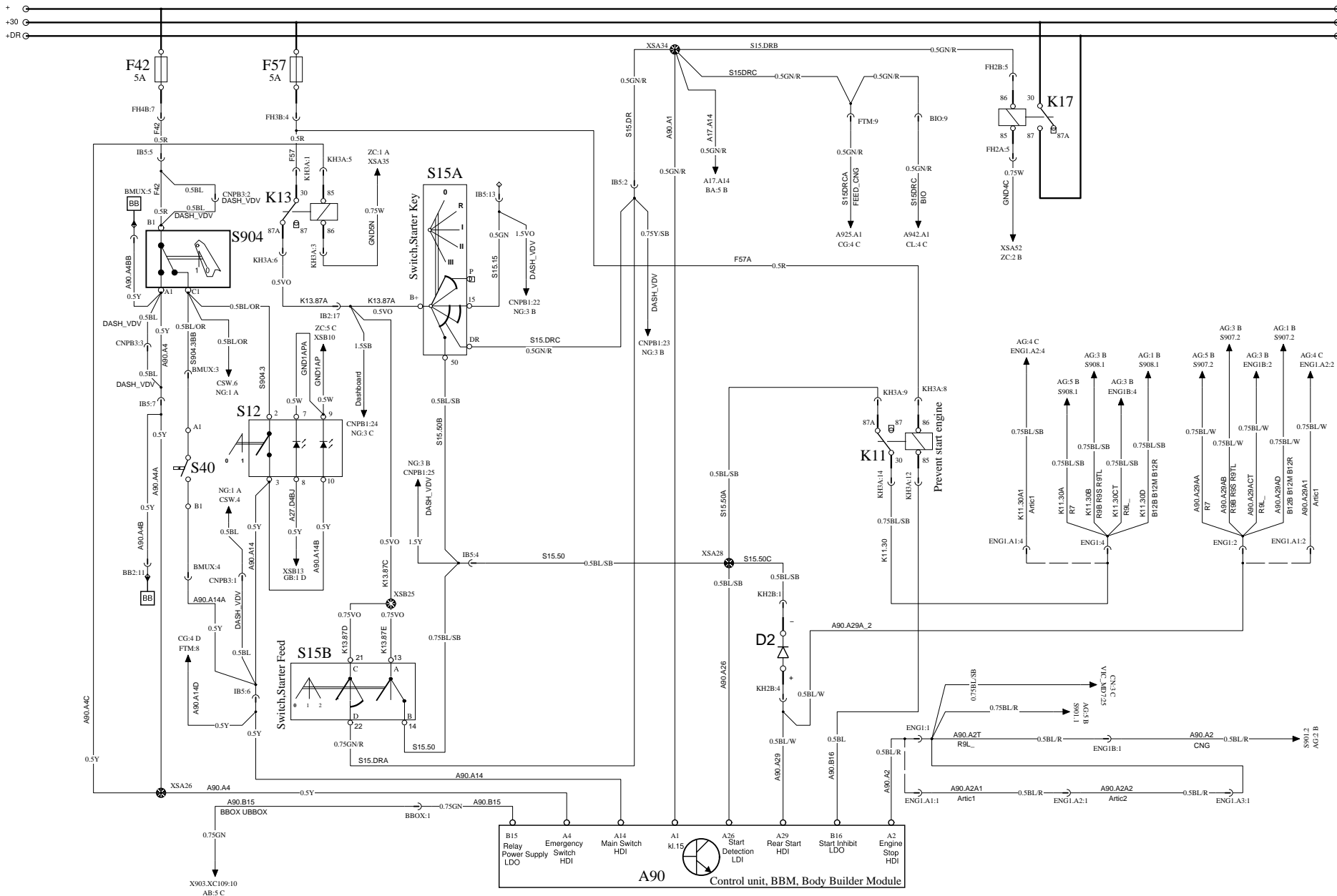

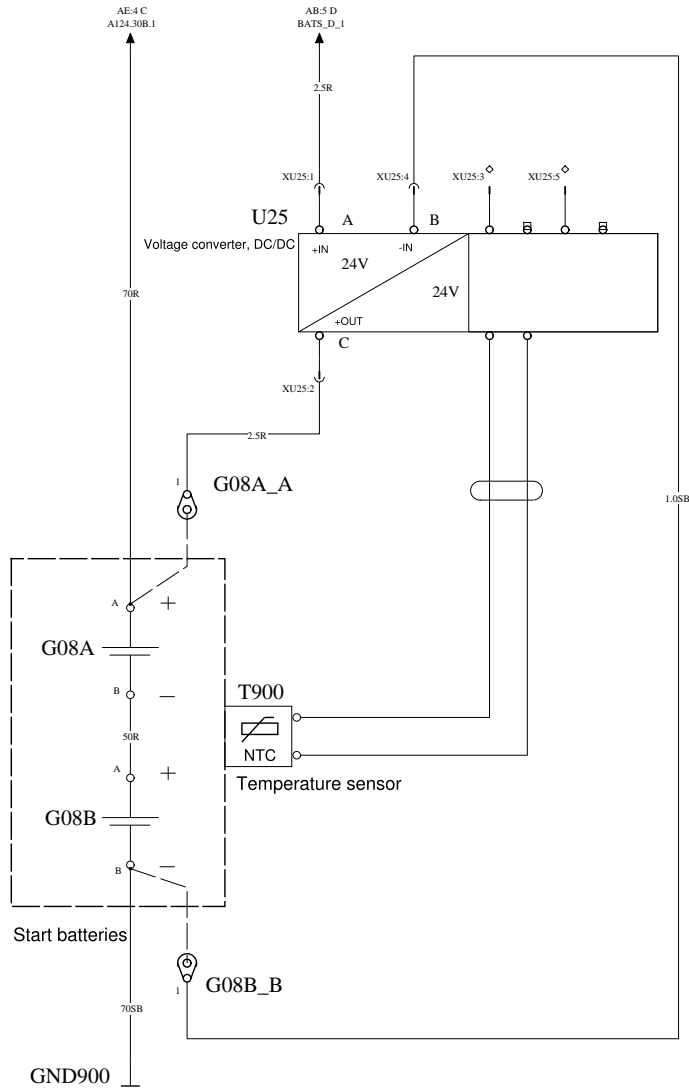

POWER SUPPLY

WIRING DIAGRAM AB2

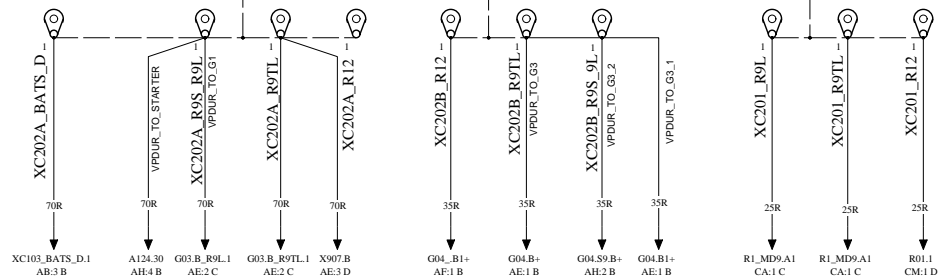
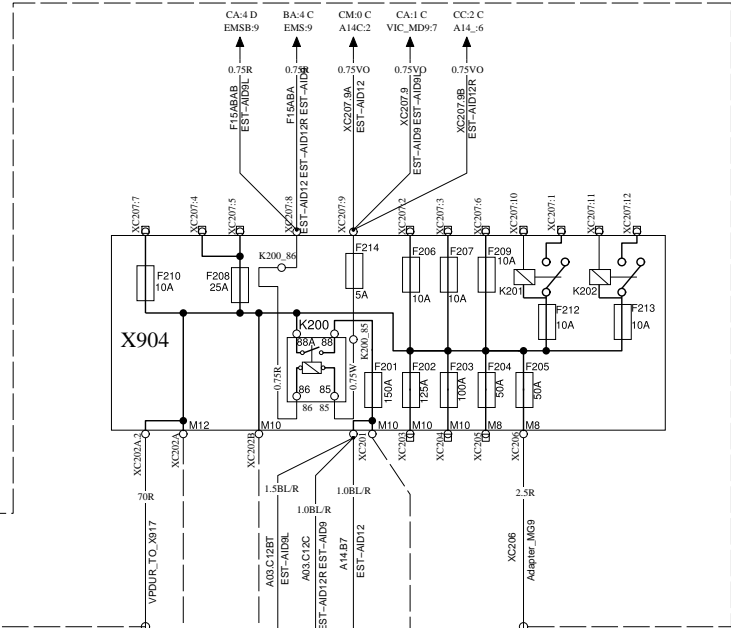
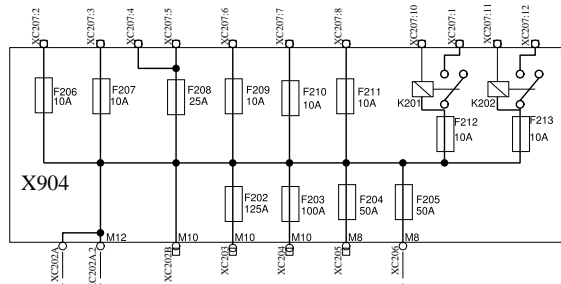
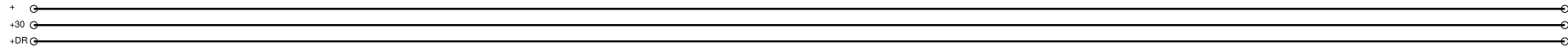

B9/B12 U RELAY

B9/B12

START ENGINE AND ALTERNATORS

WIRING DIAGRAM AC

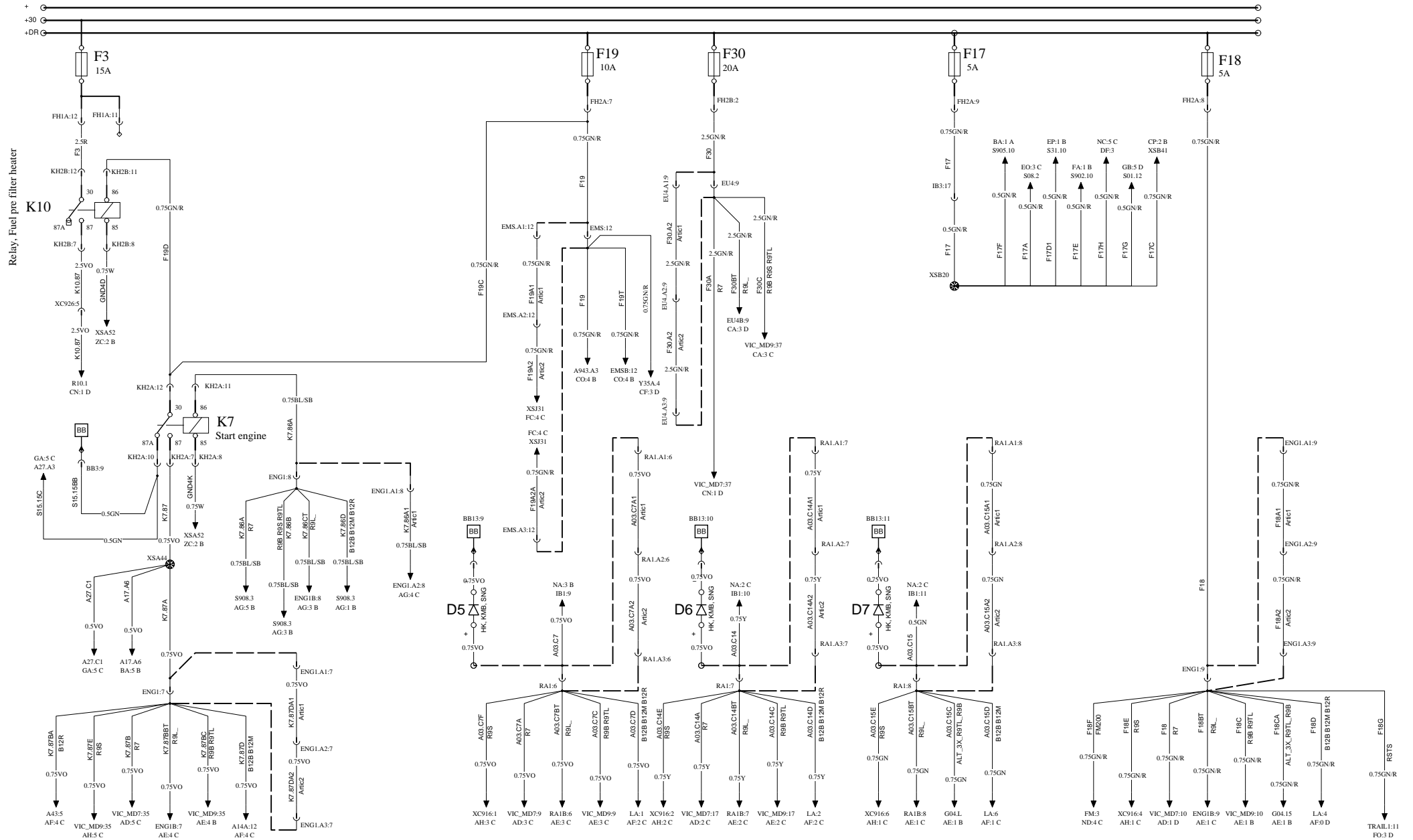

STARTER MOTOR AND ALTERNATORS FOR MD7

WIRING DIAGRAM AD

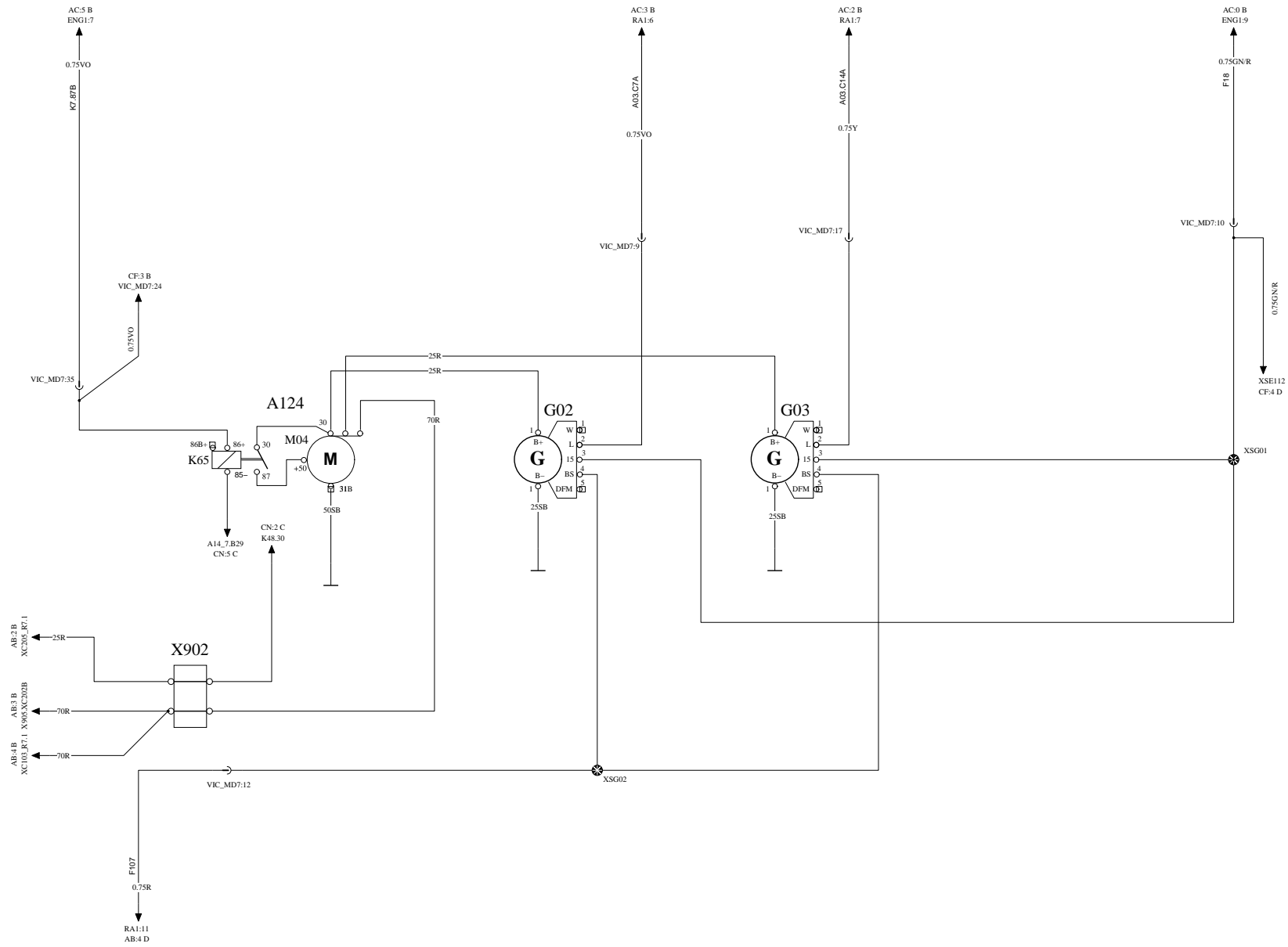

STARTER MOTOR AND ALTERNATORS FOR R9L, R9TL, B9R

WIRING DIAGRAM AE

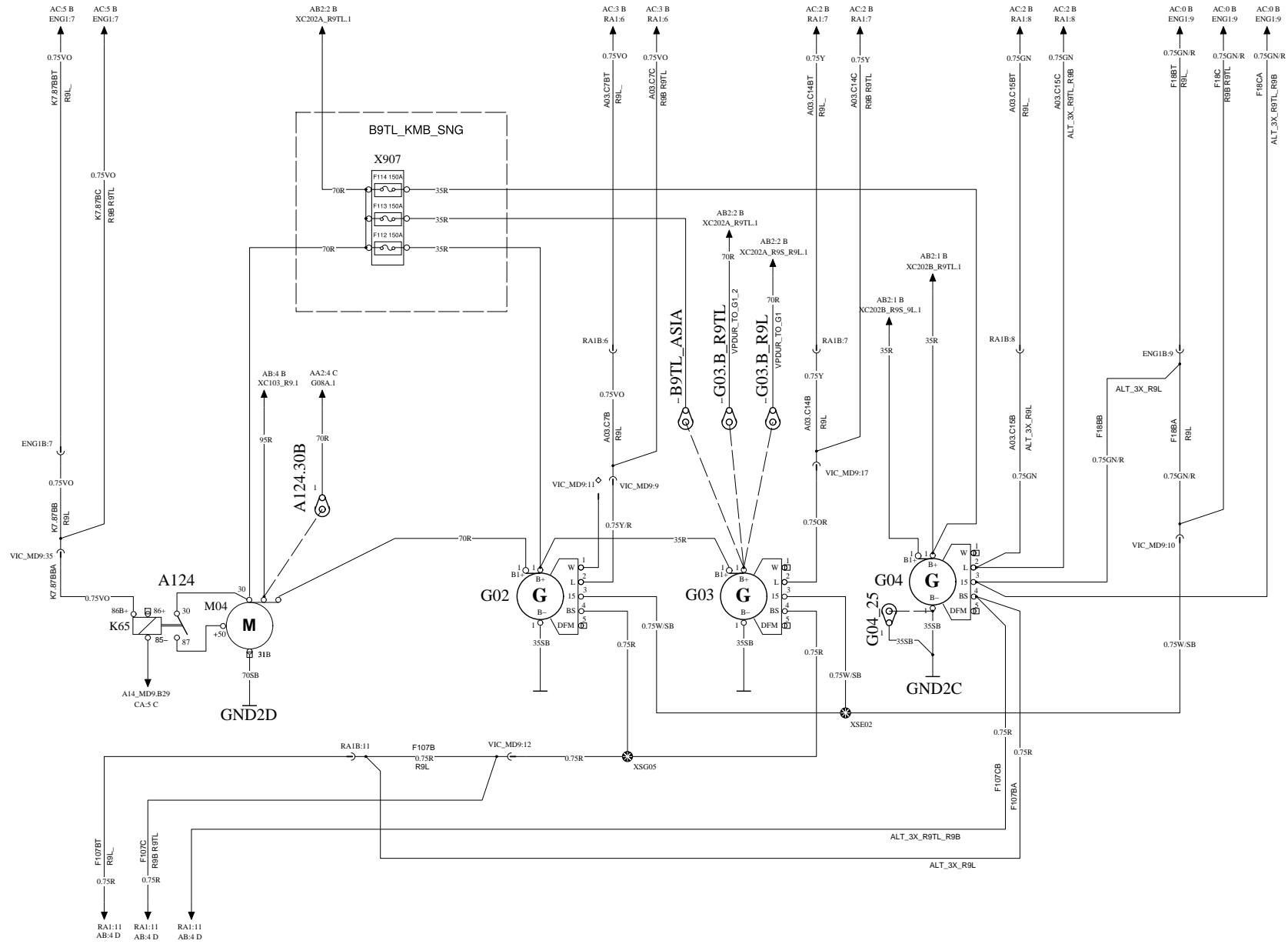

STARTER MOTOR AND ALTERNATORS FOR MD12

WIRING DIAGRAM AF

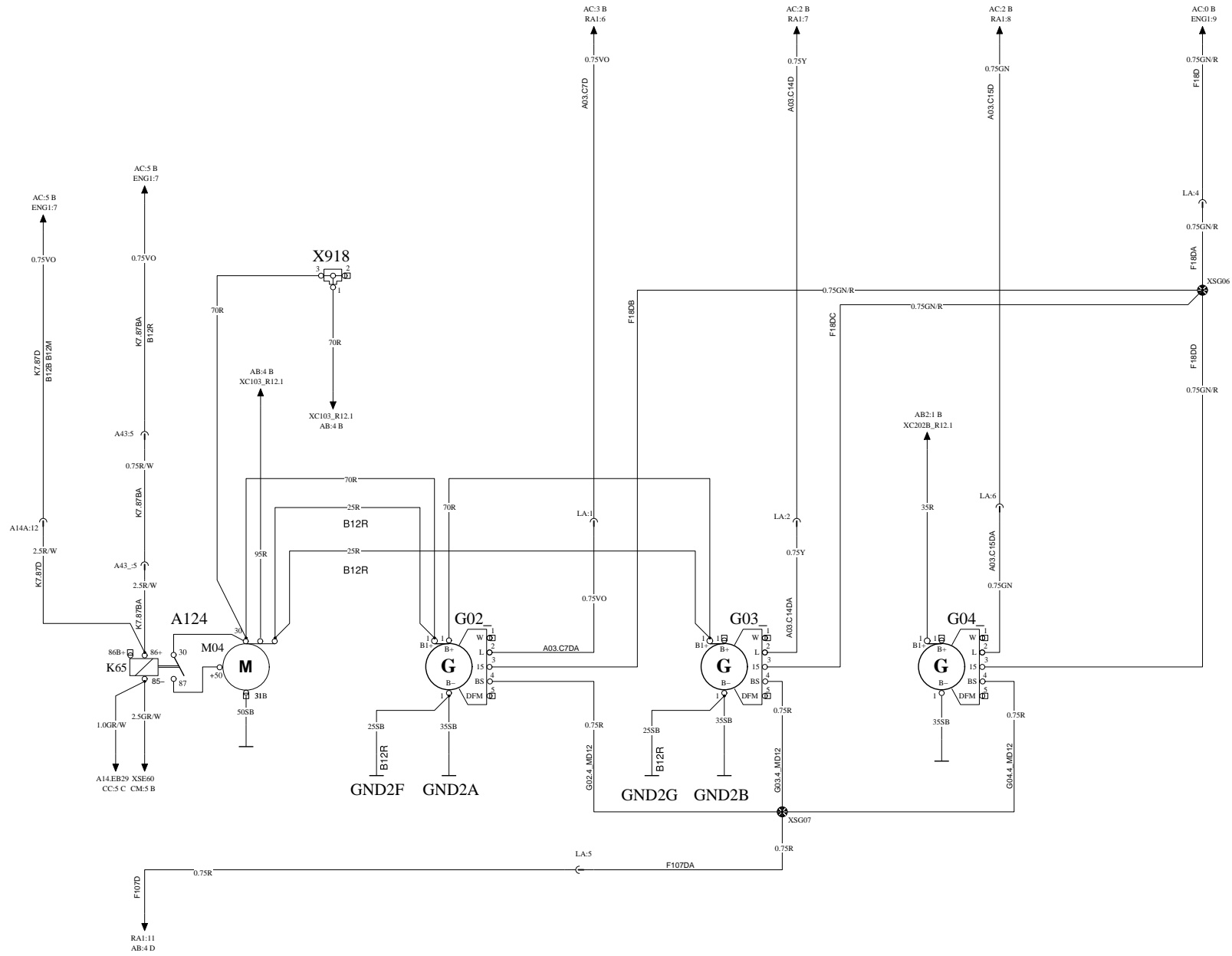

START/STOP SWITCHES REAR

WIRING DIAGRAM AG

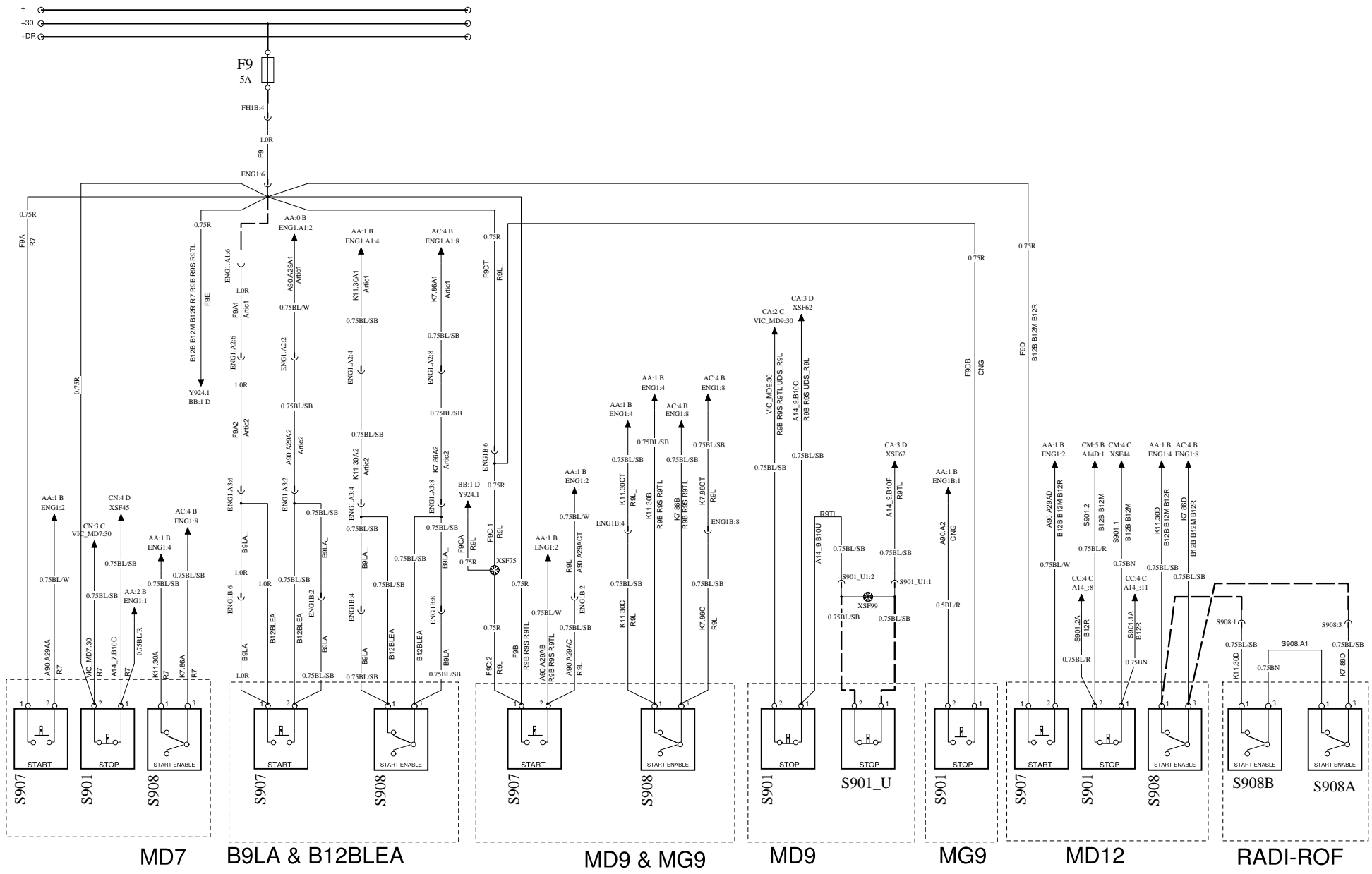

VECU

VEHICLE ECU

WIRING DIAGRAM BA

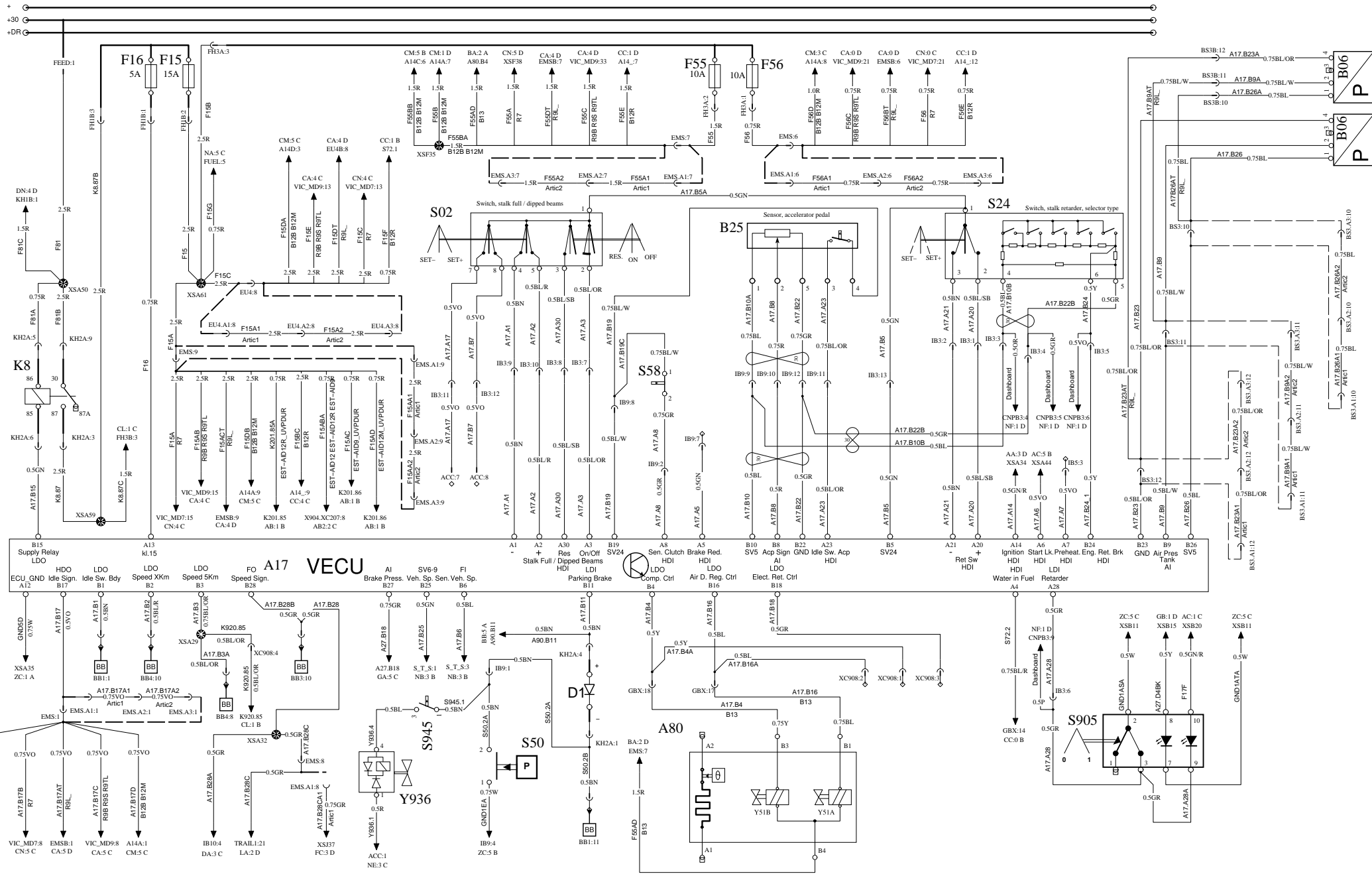

BODY BUILDER MODULE WIRING DIAGRAM BB

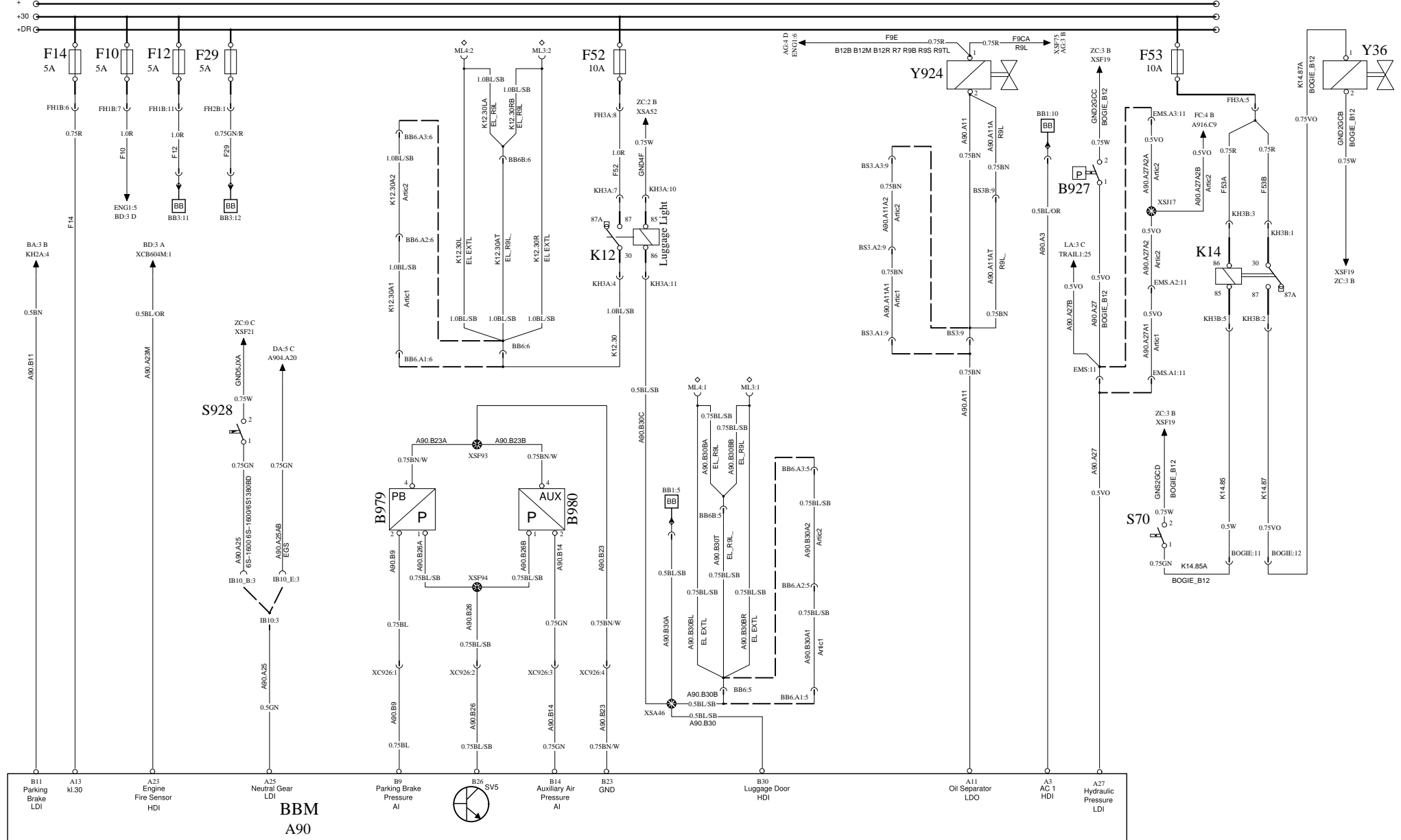

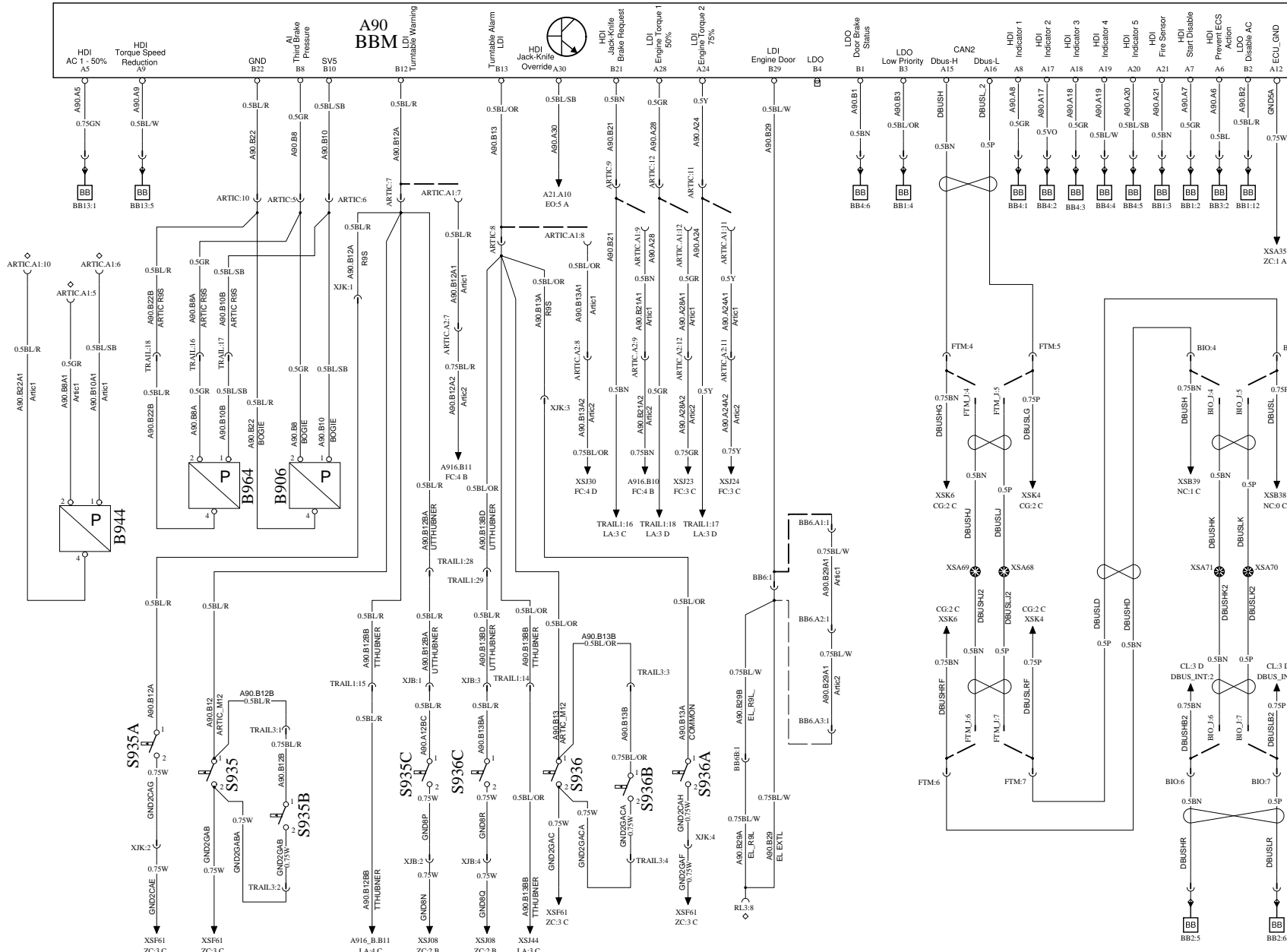

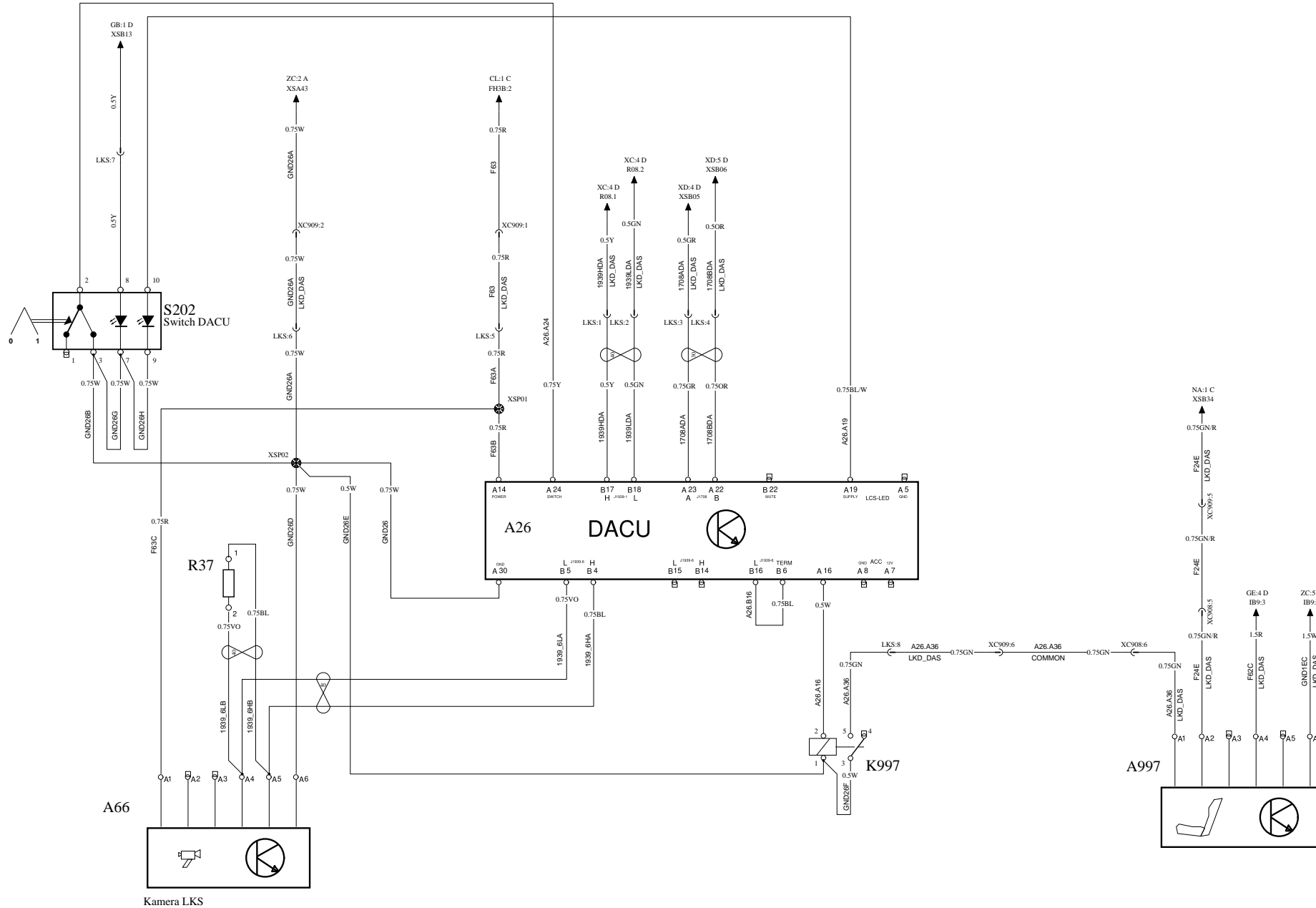

EECU D9B

WIRING DIAGRAM CA

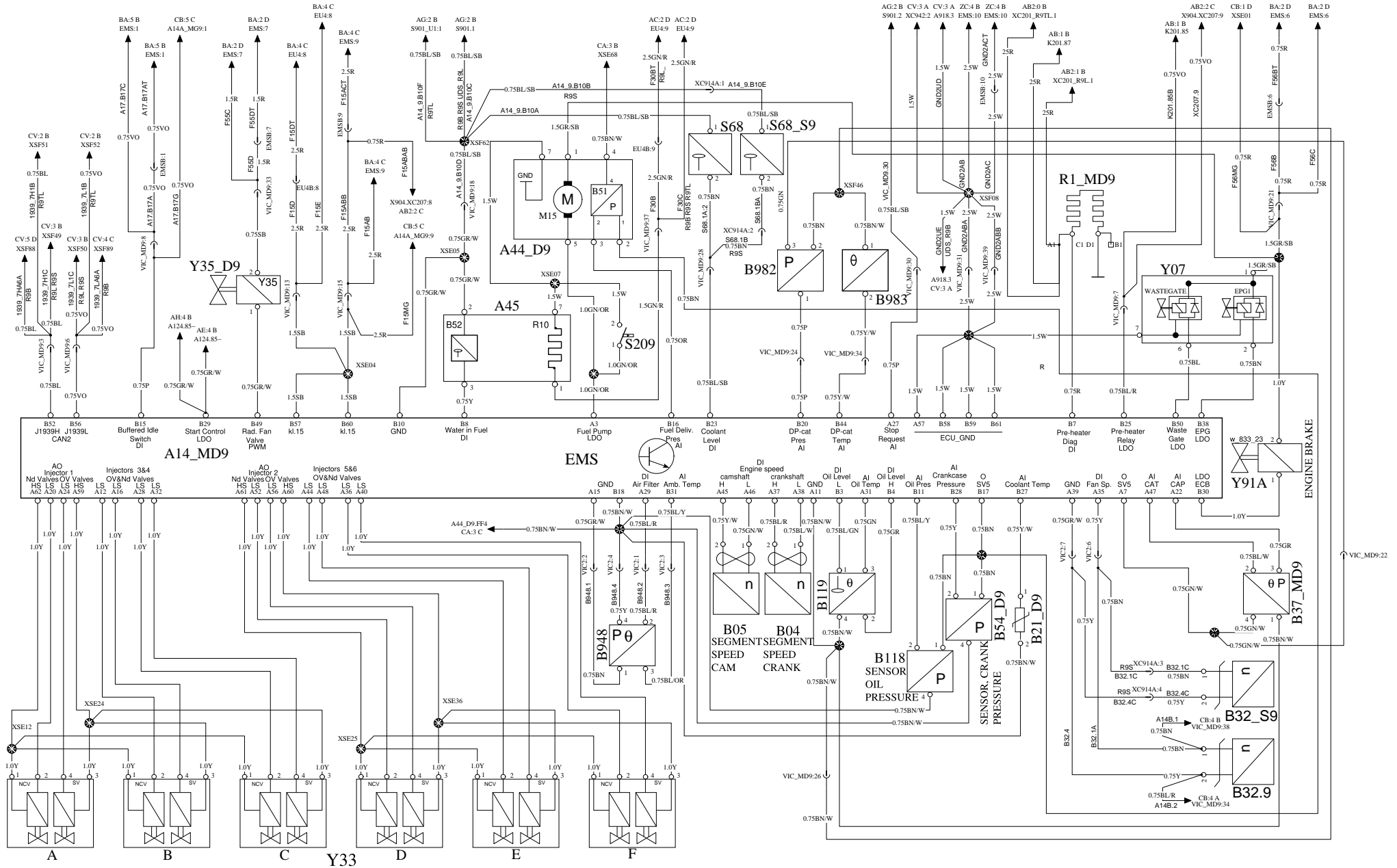

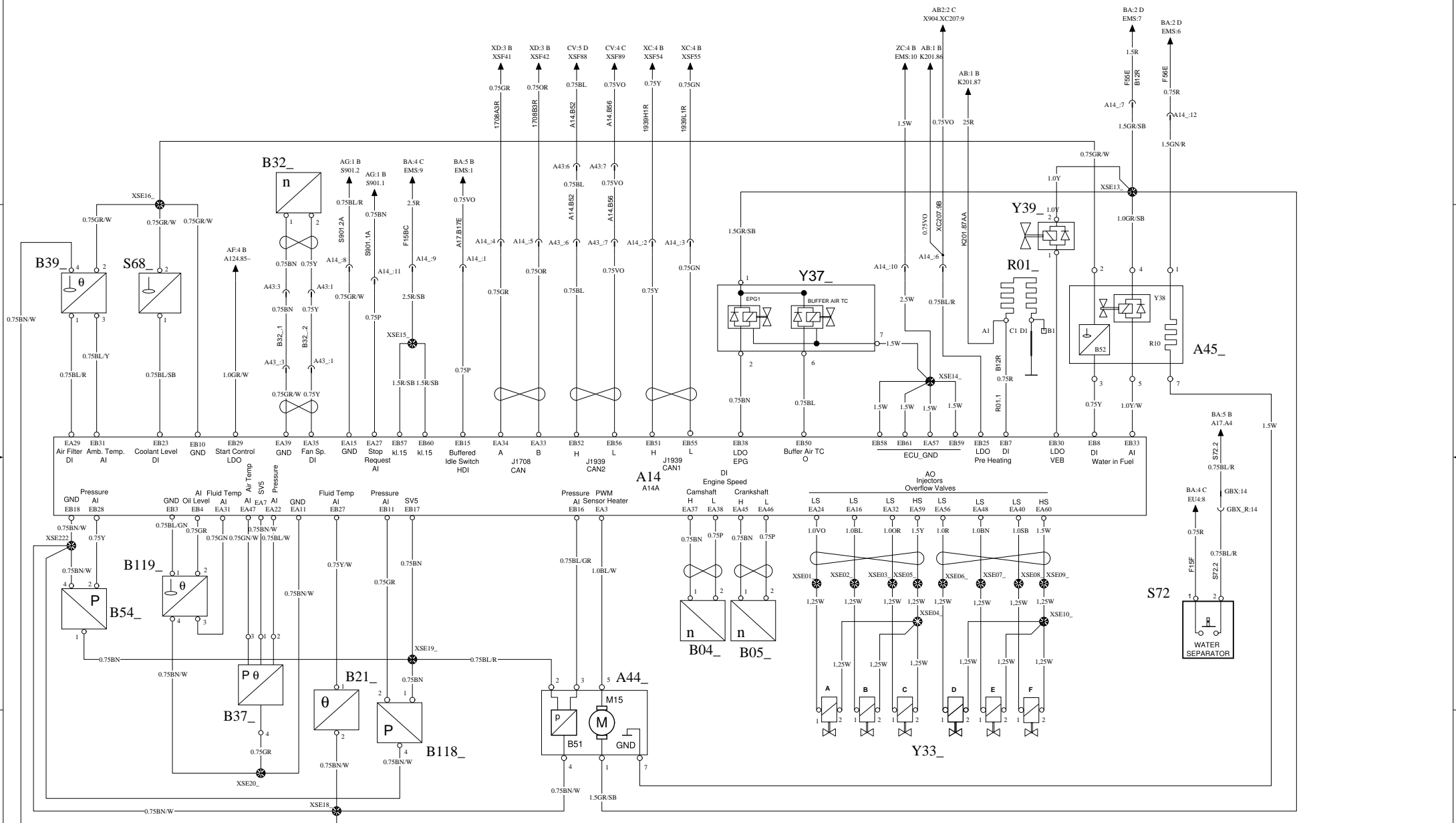

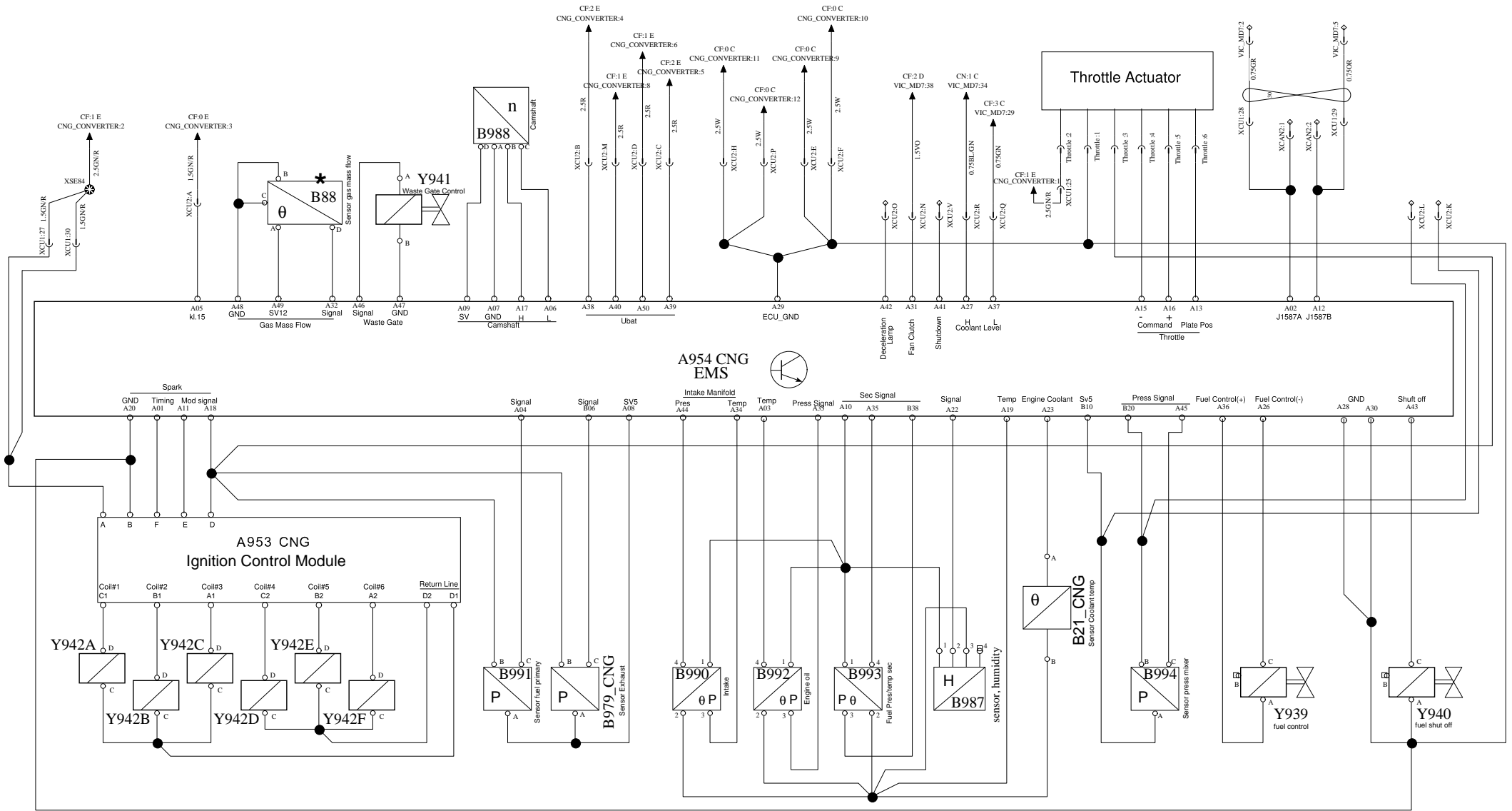

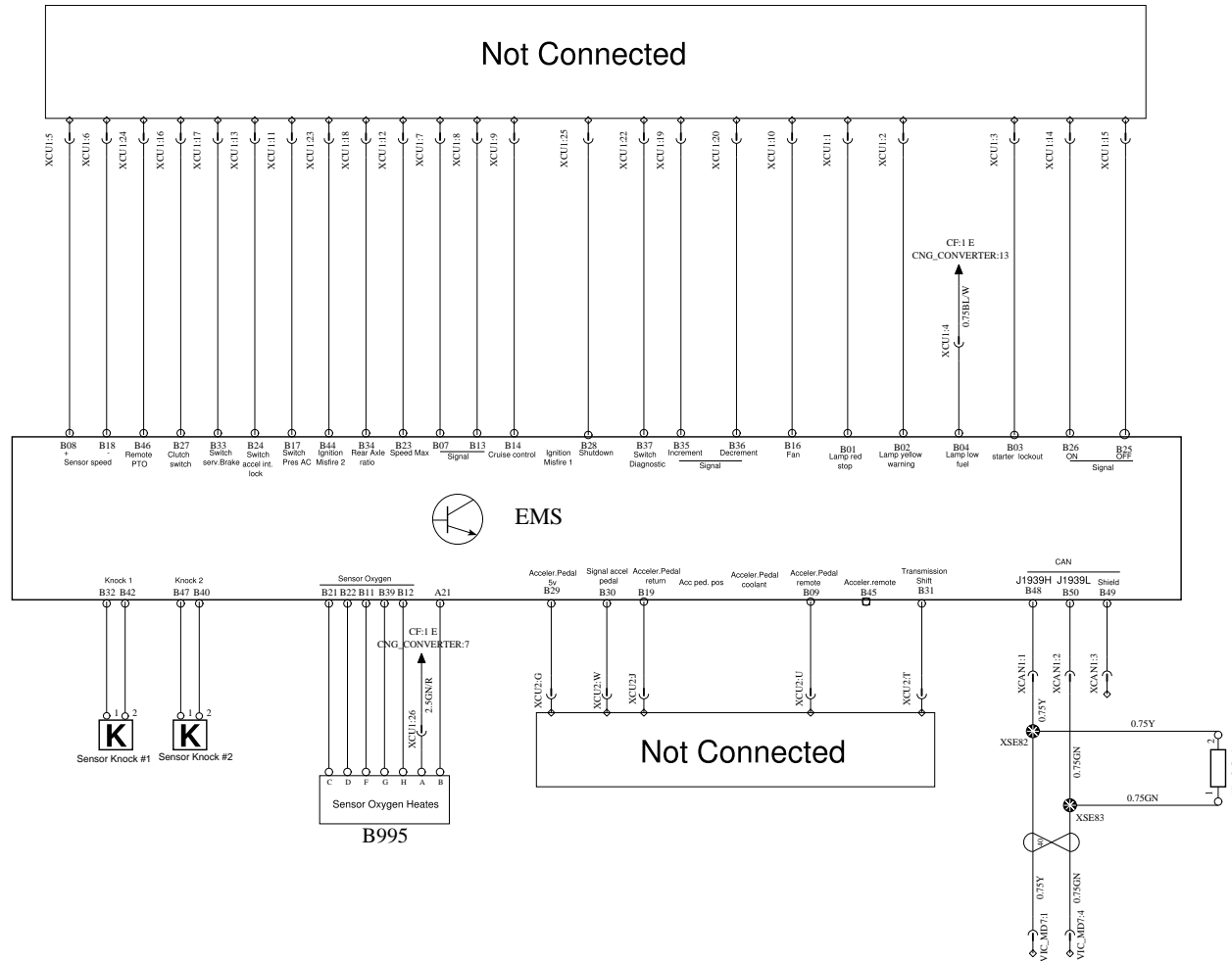

CONVERTER CUMMINS CNG

WIRING DIAGRAM CF

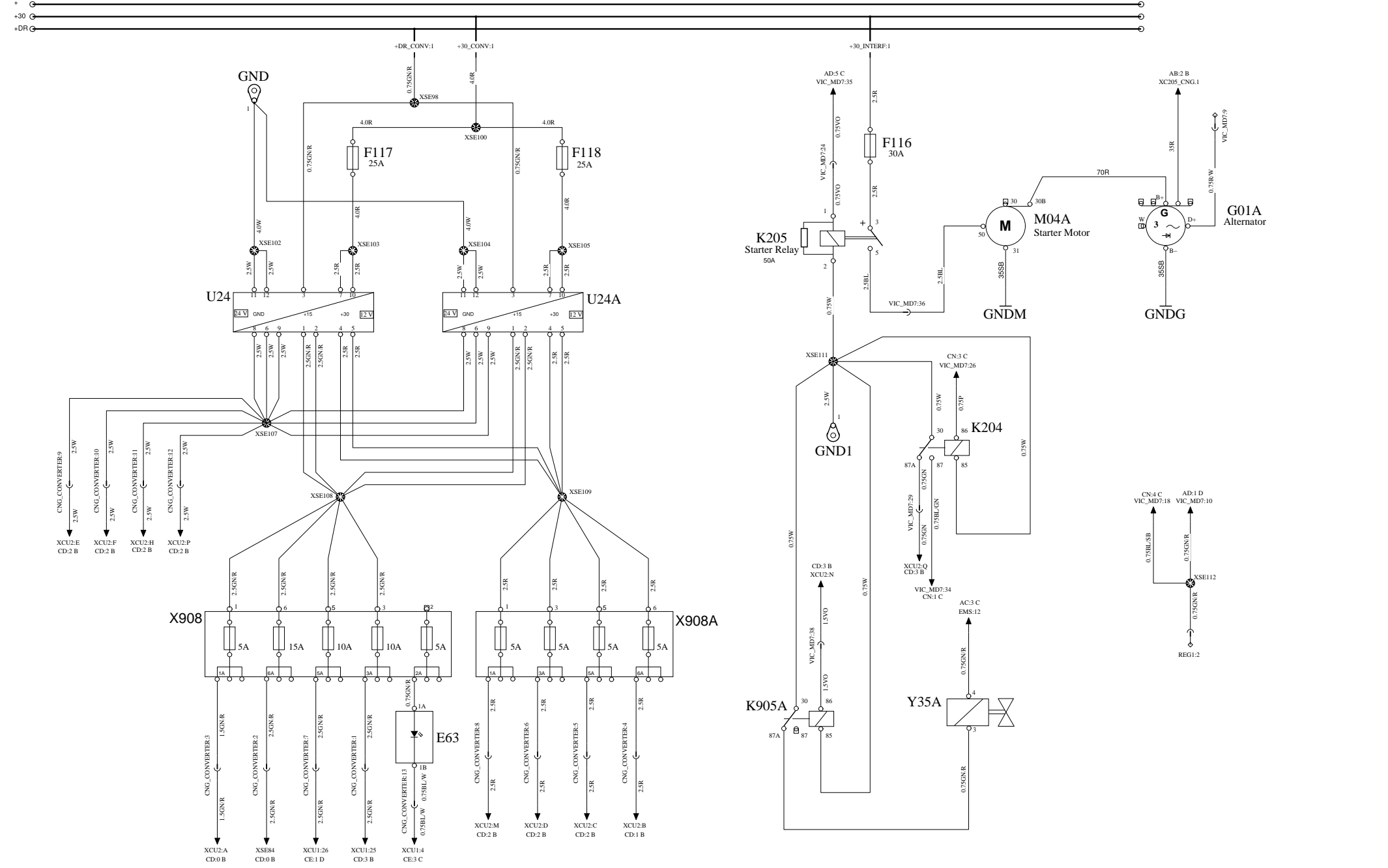

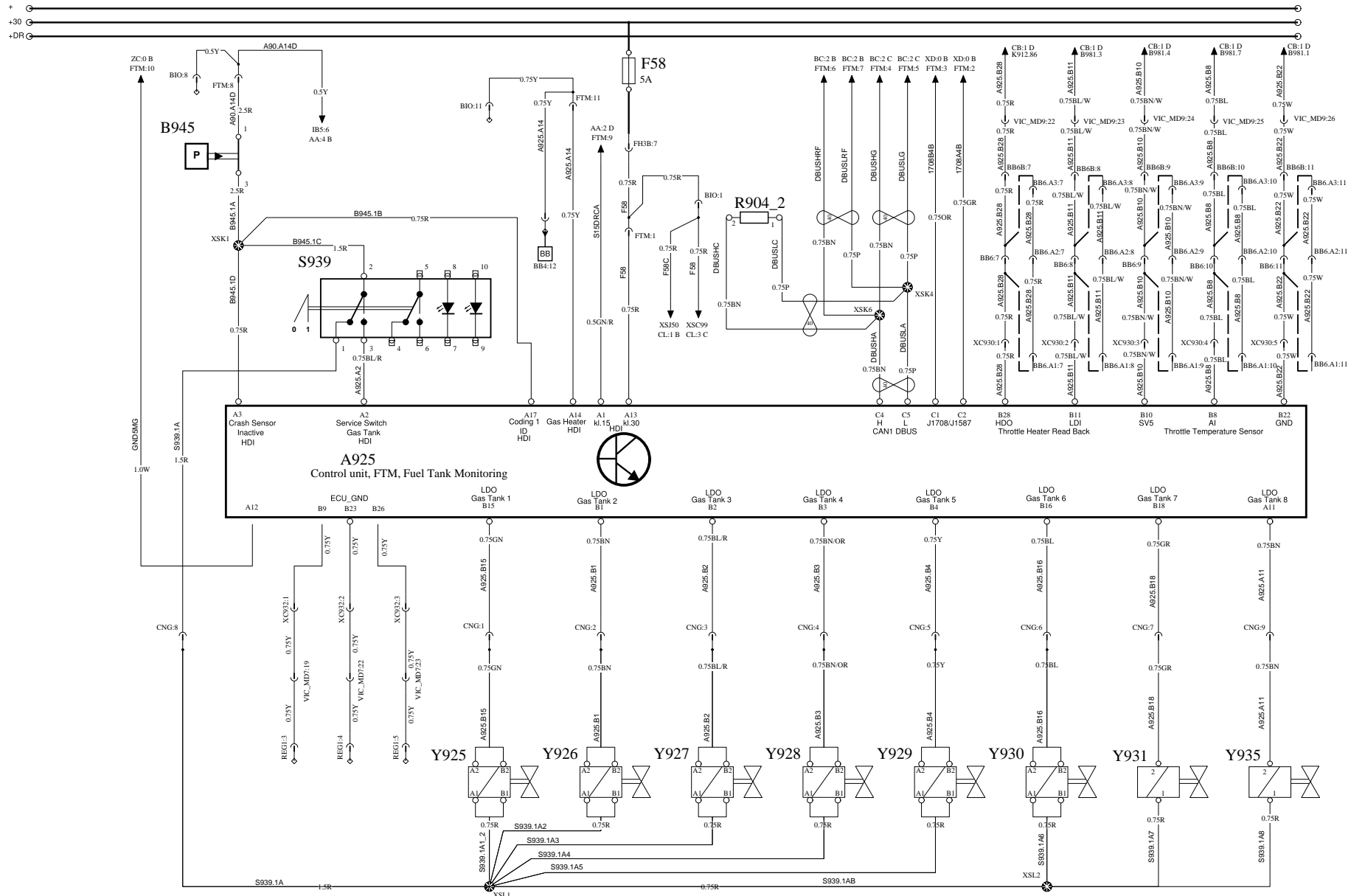

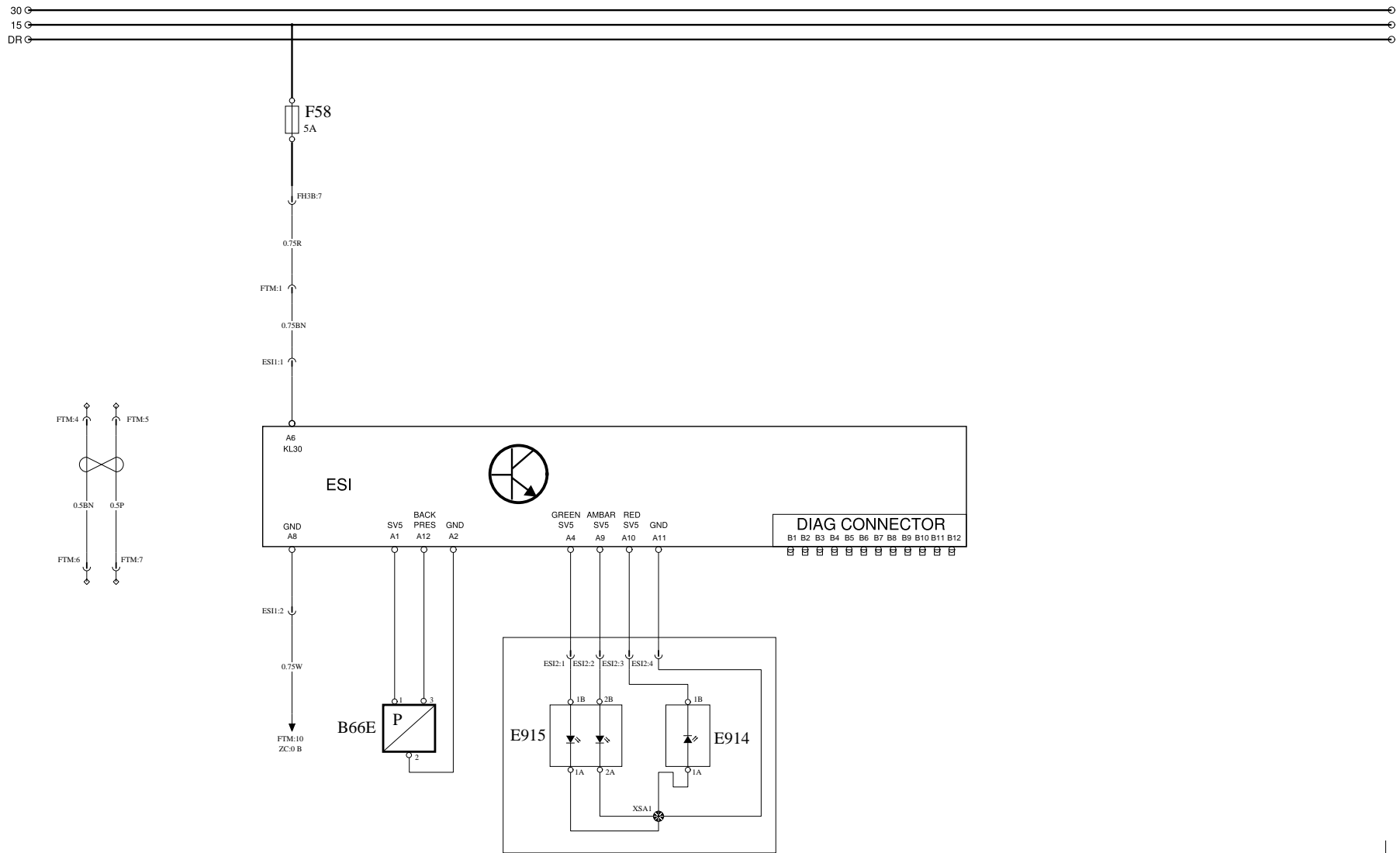

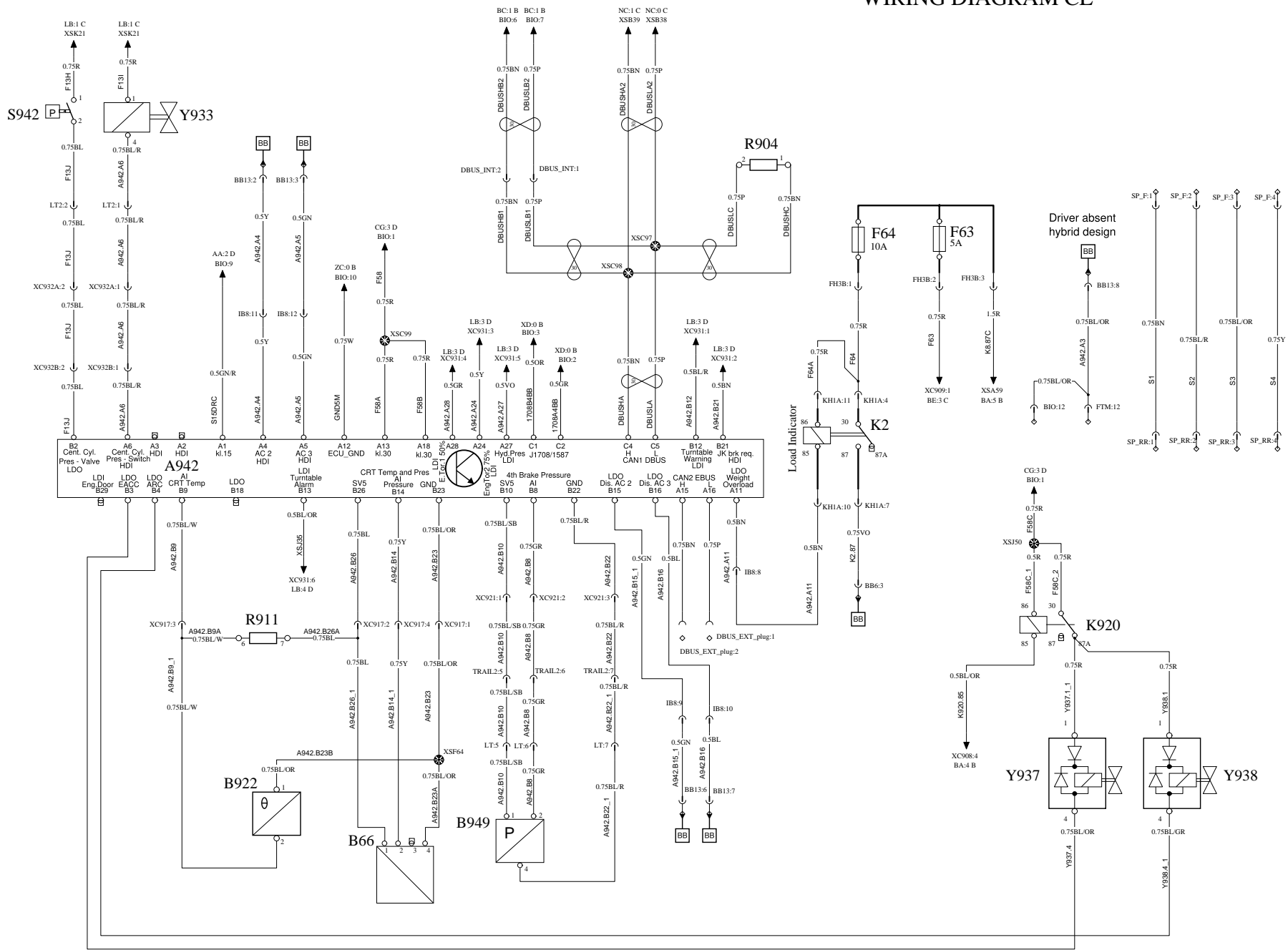

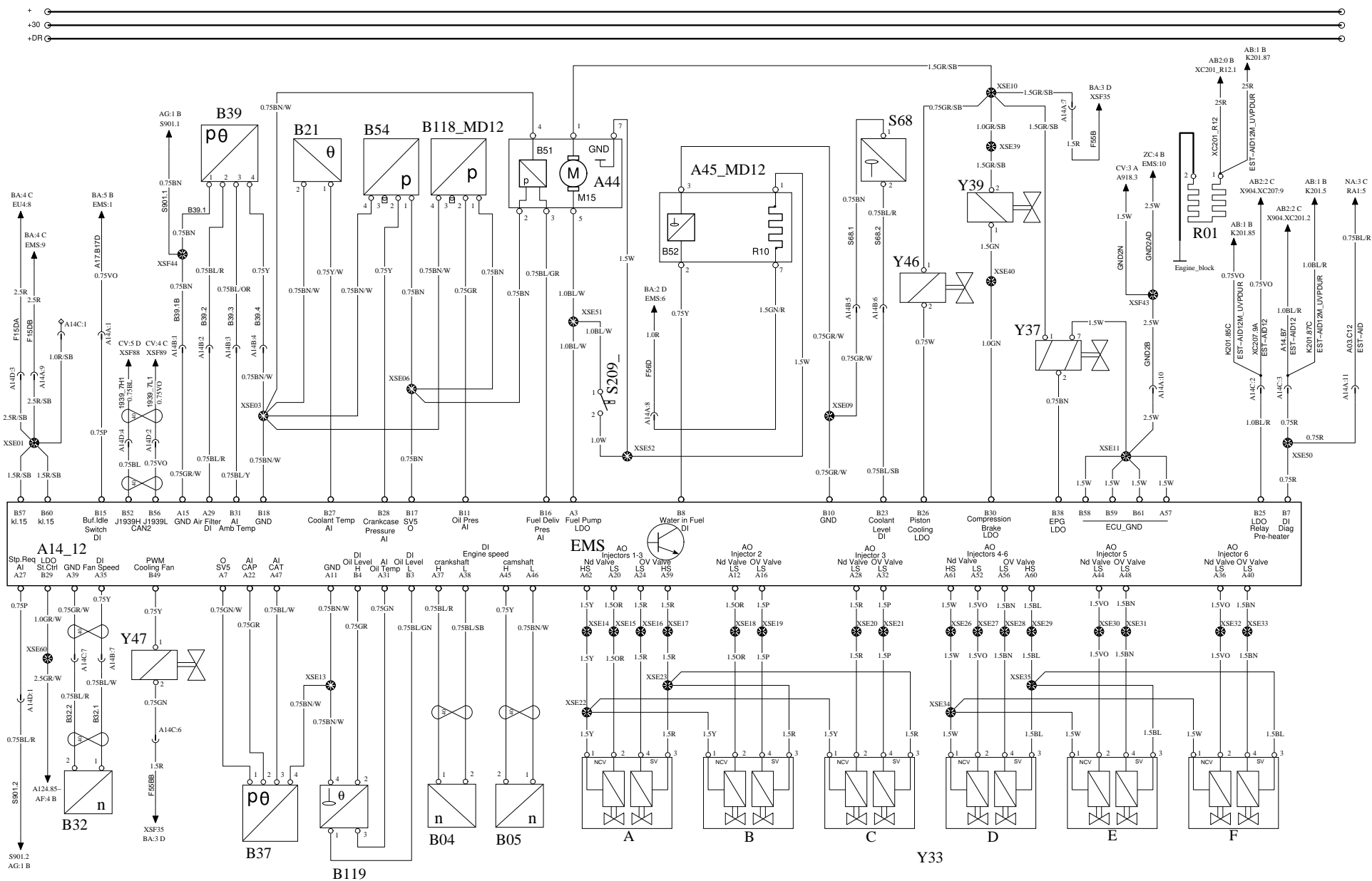

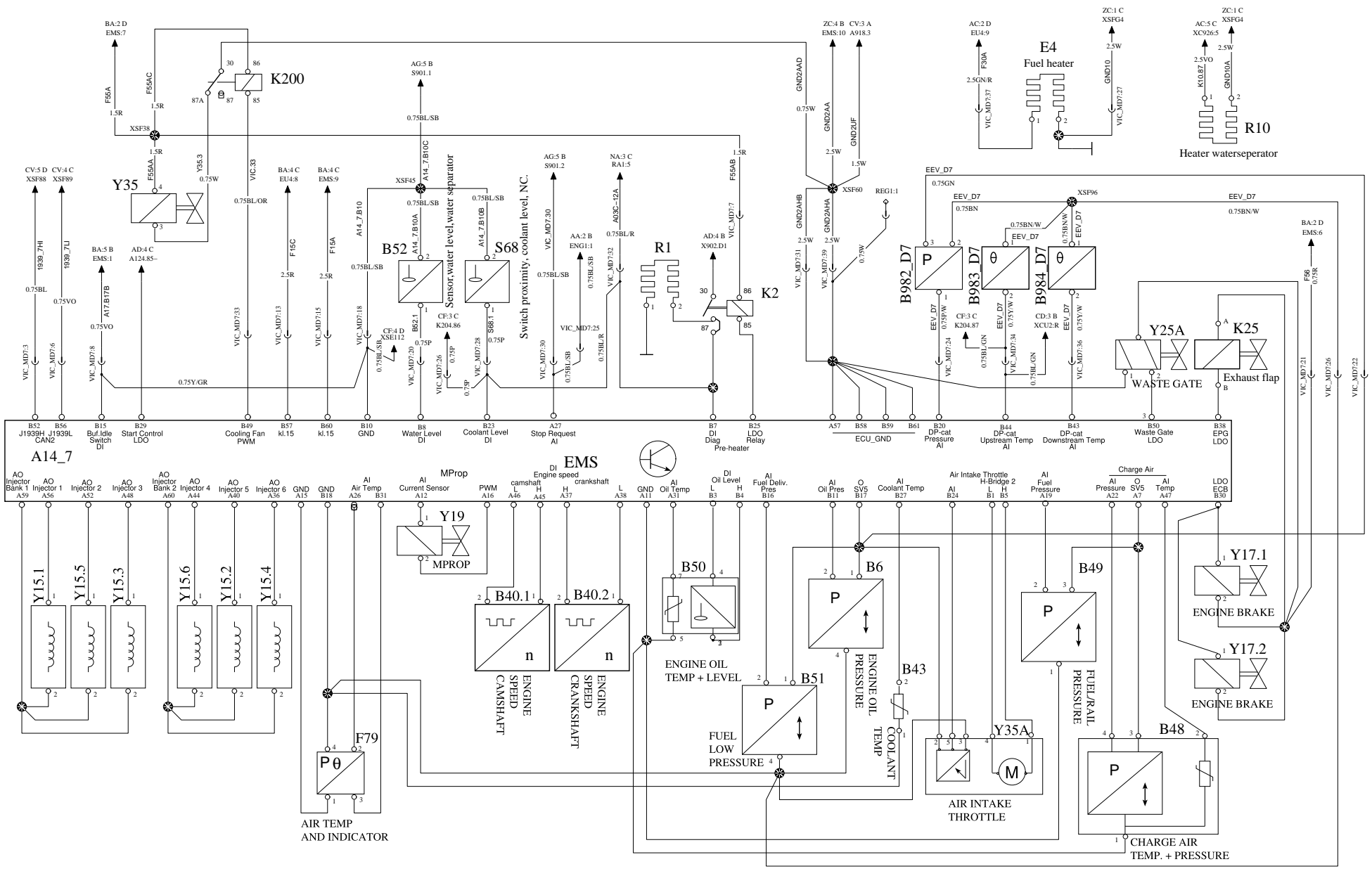

OILMASTER

WIRING DIAGRAM CO

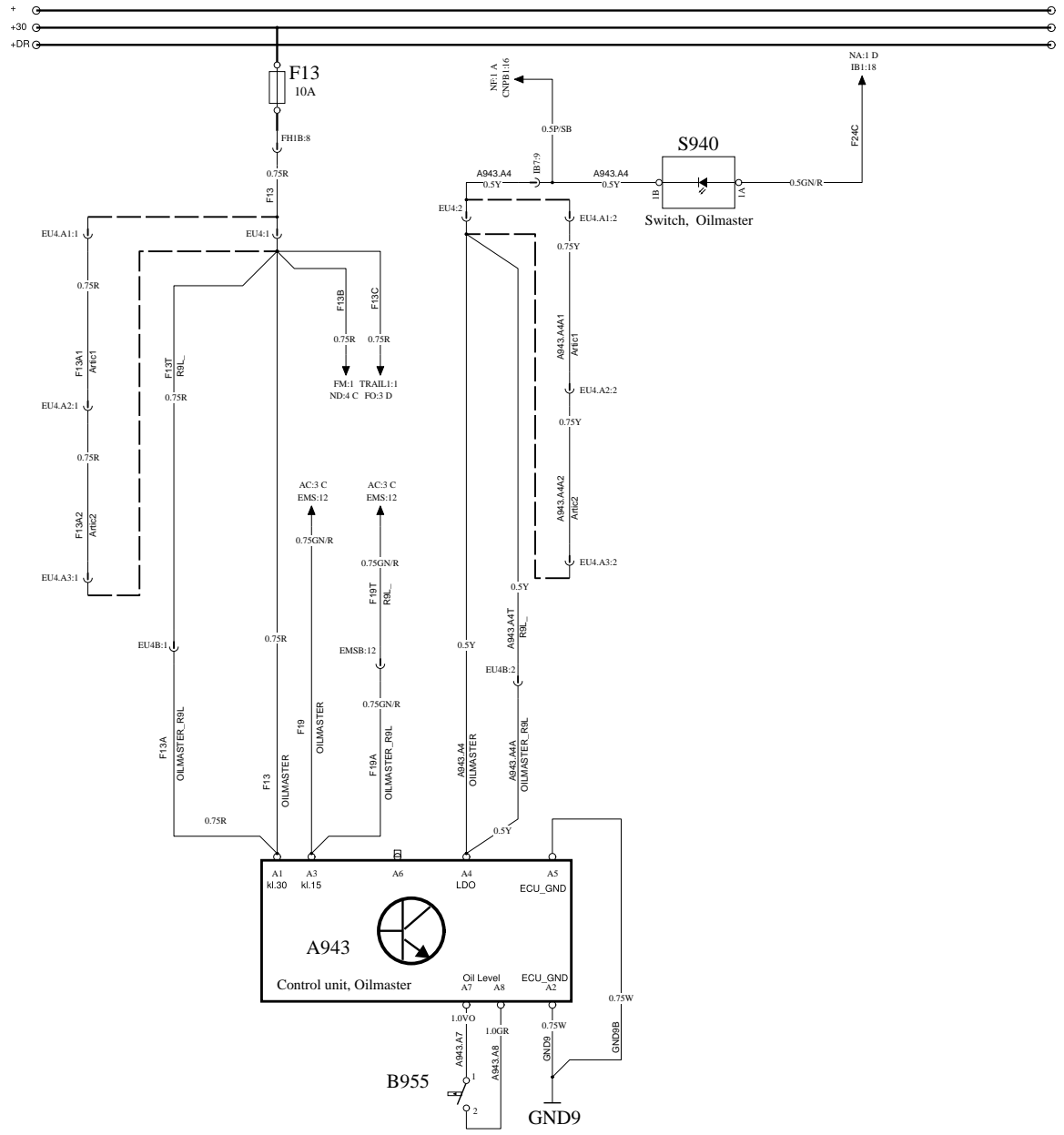

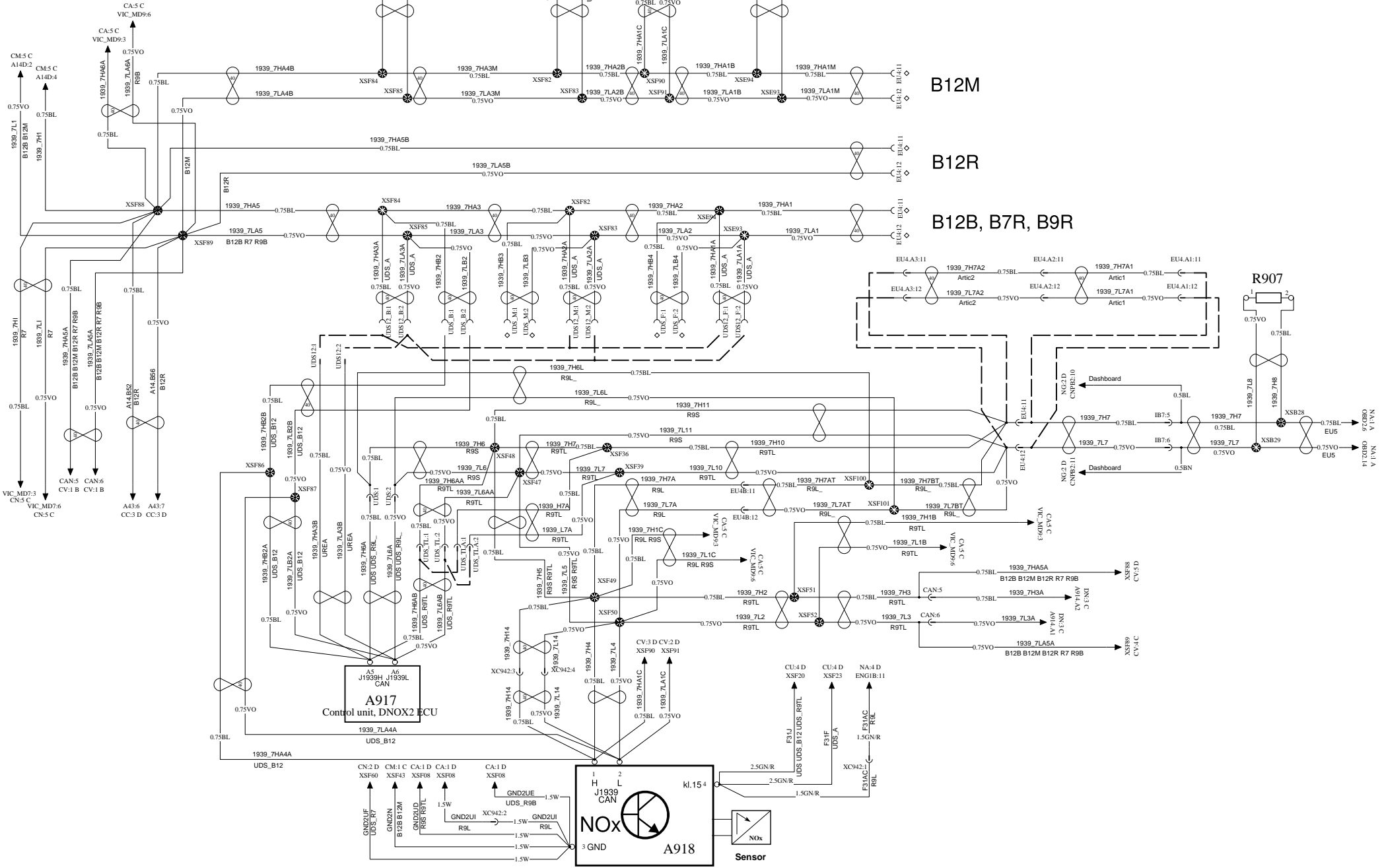

B12M

B12R

B12B, B7R, B9R

R907

A917 Control unit, DNOX2 ECU



G8-EGS

WIRING DIAGRAM DA

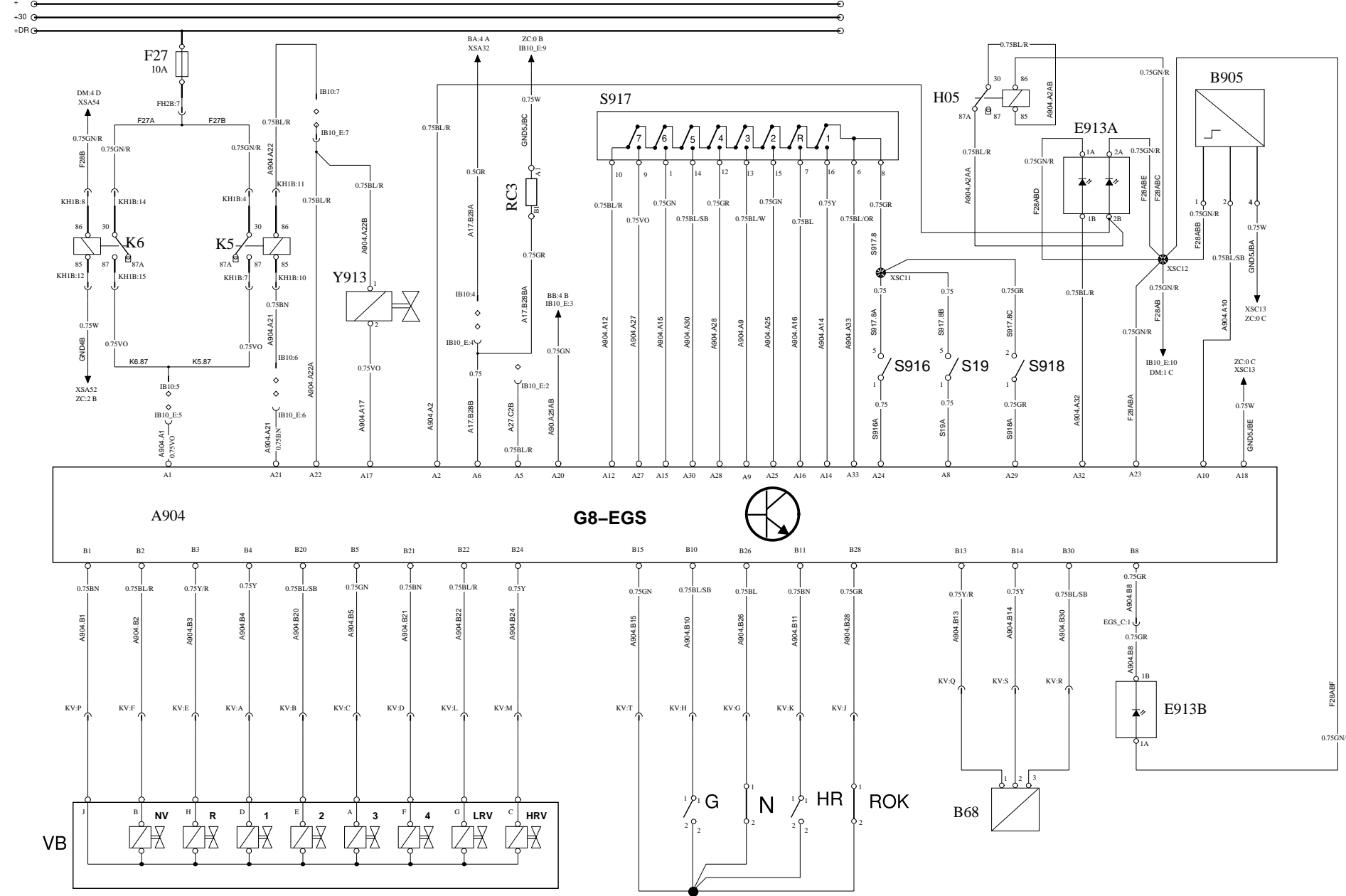

ECOMAT4 ZF

WIRING DIAGRAM DB

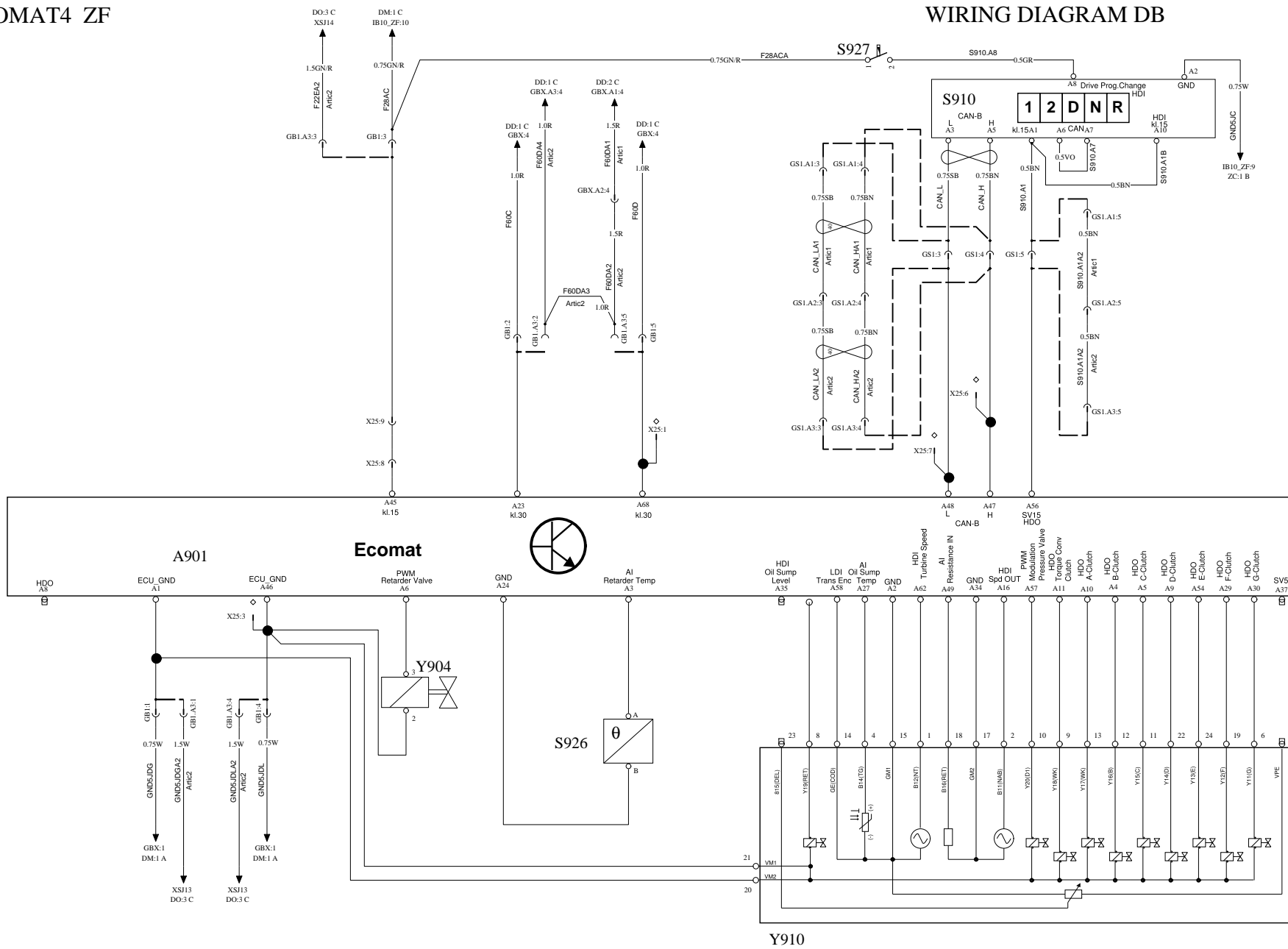

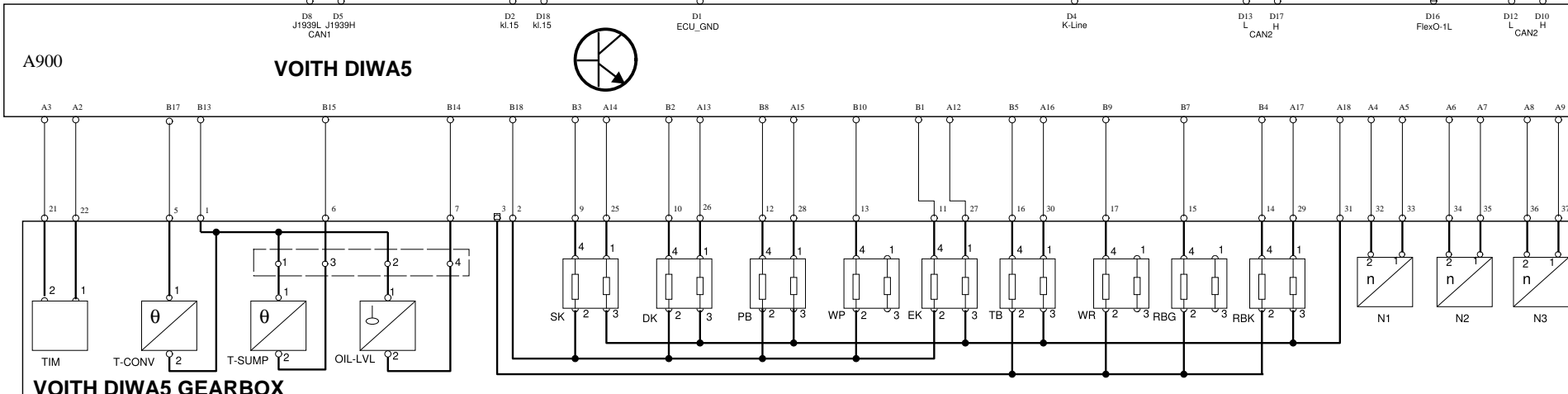
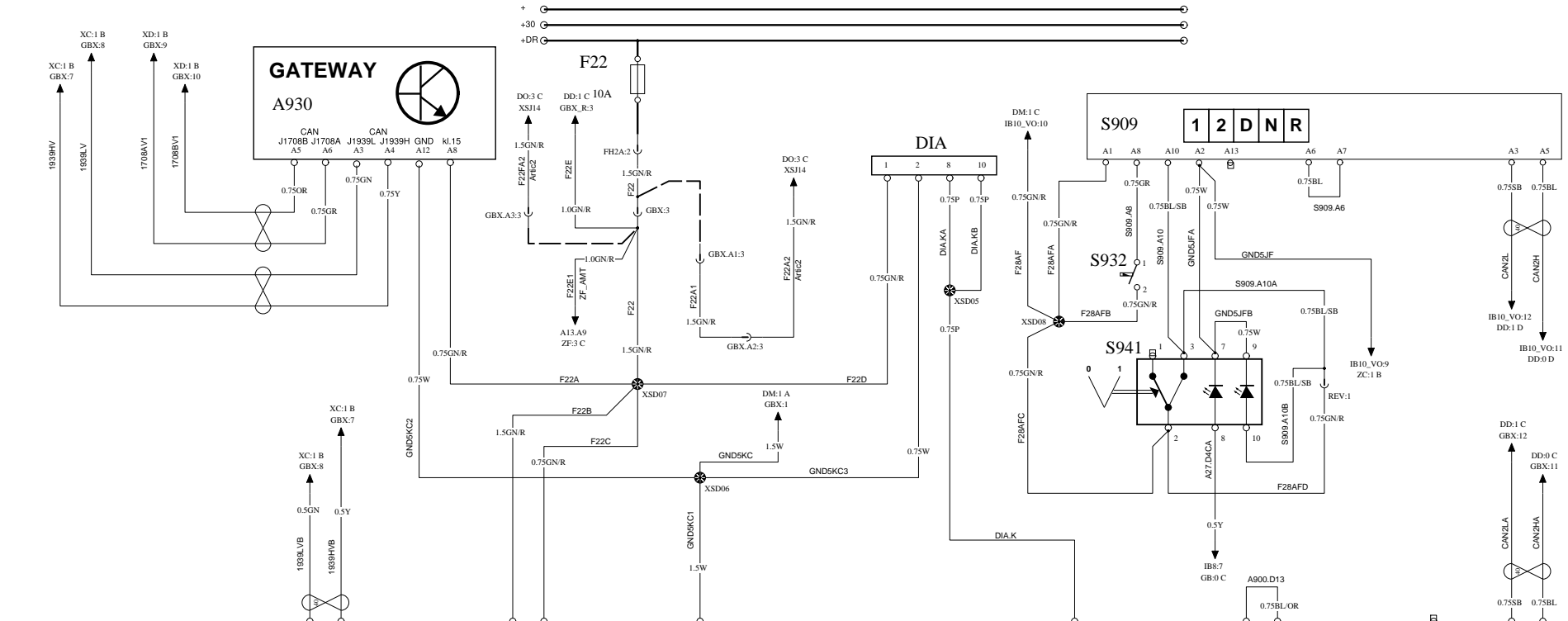

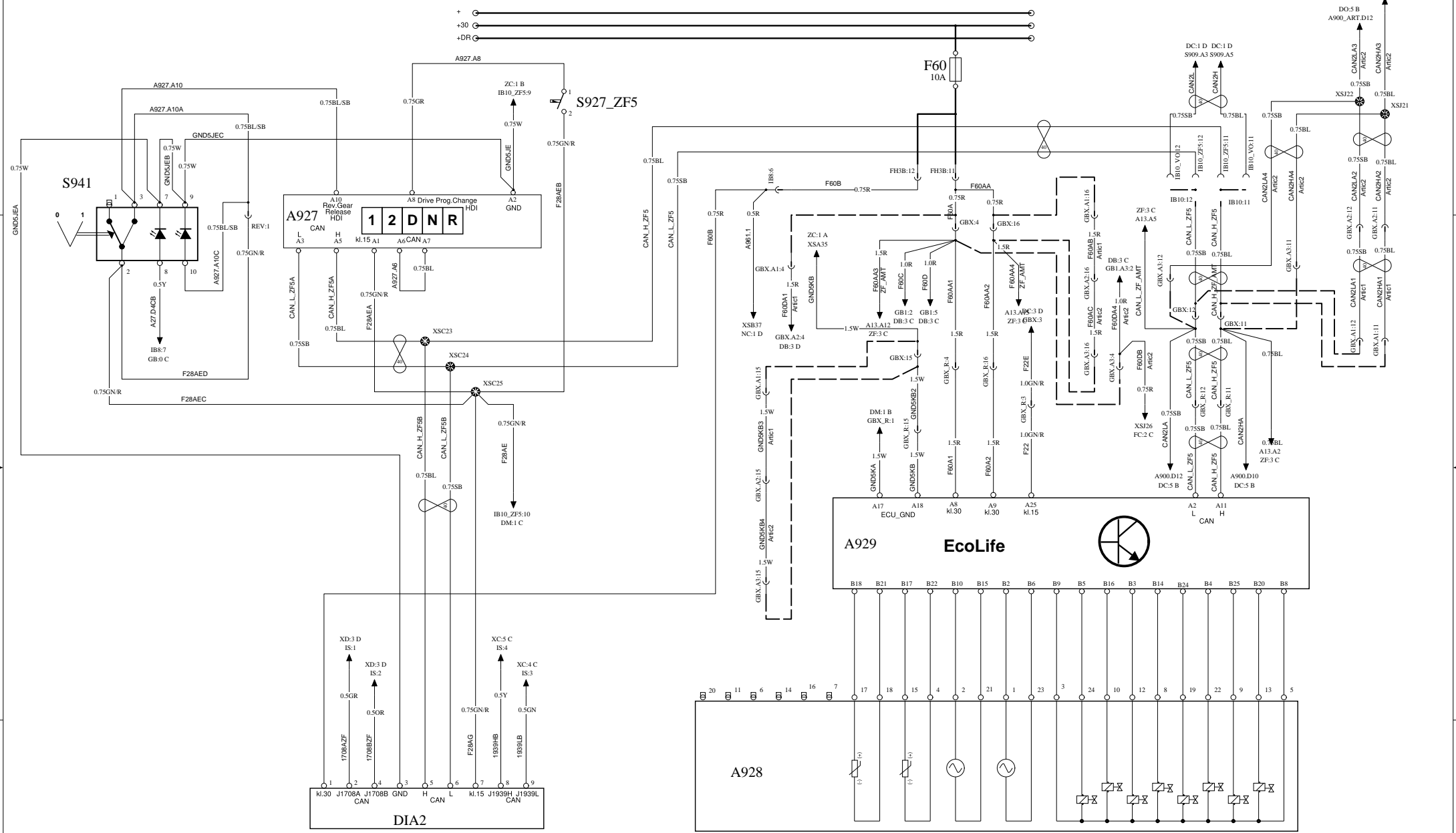

RETARDER

WIRING DIAGRAM DM

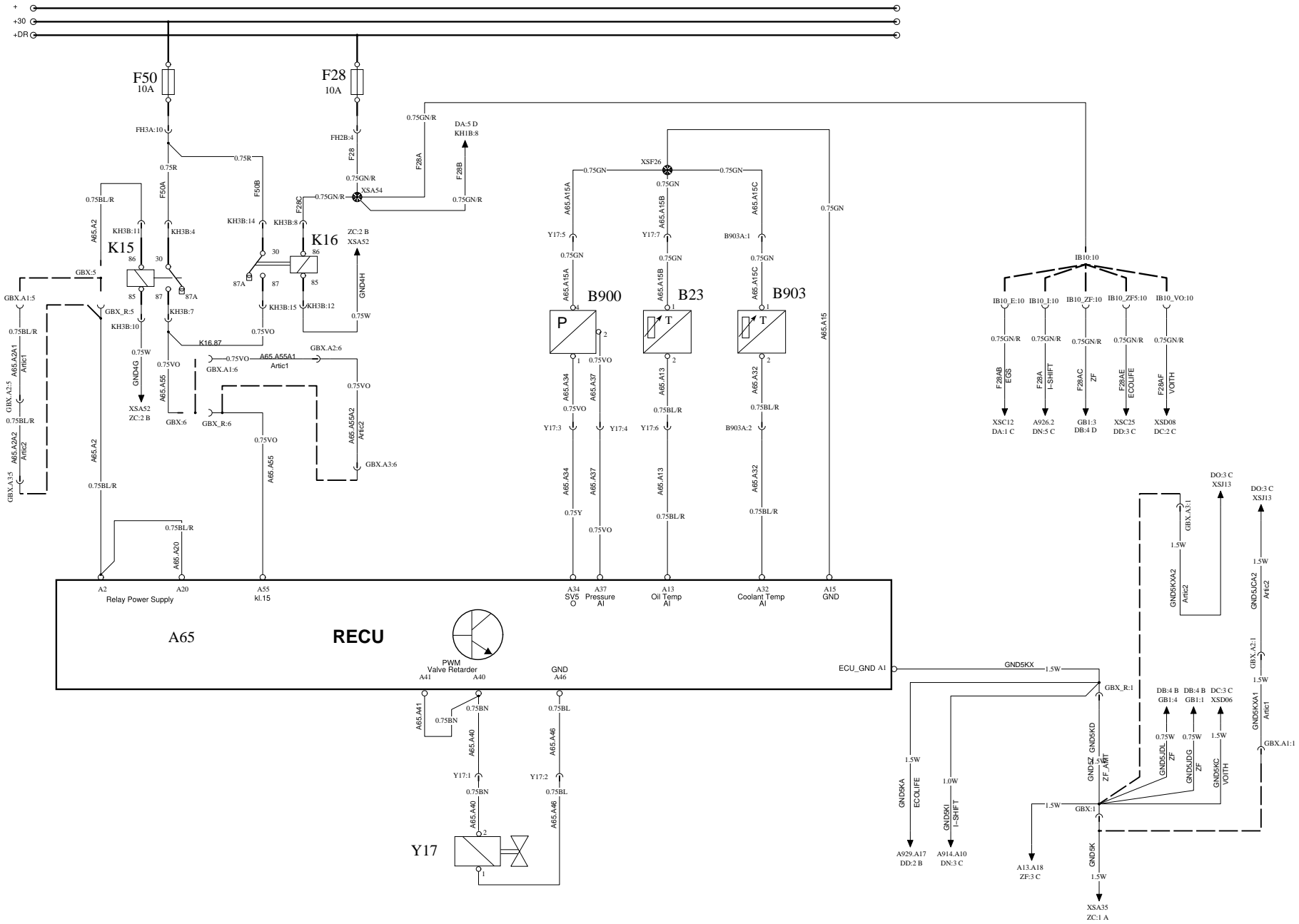

I-SHIFT

WIRING DIAGRAM DN

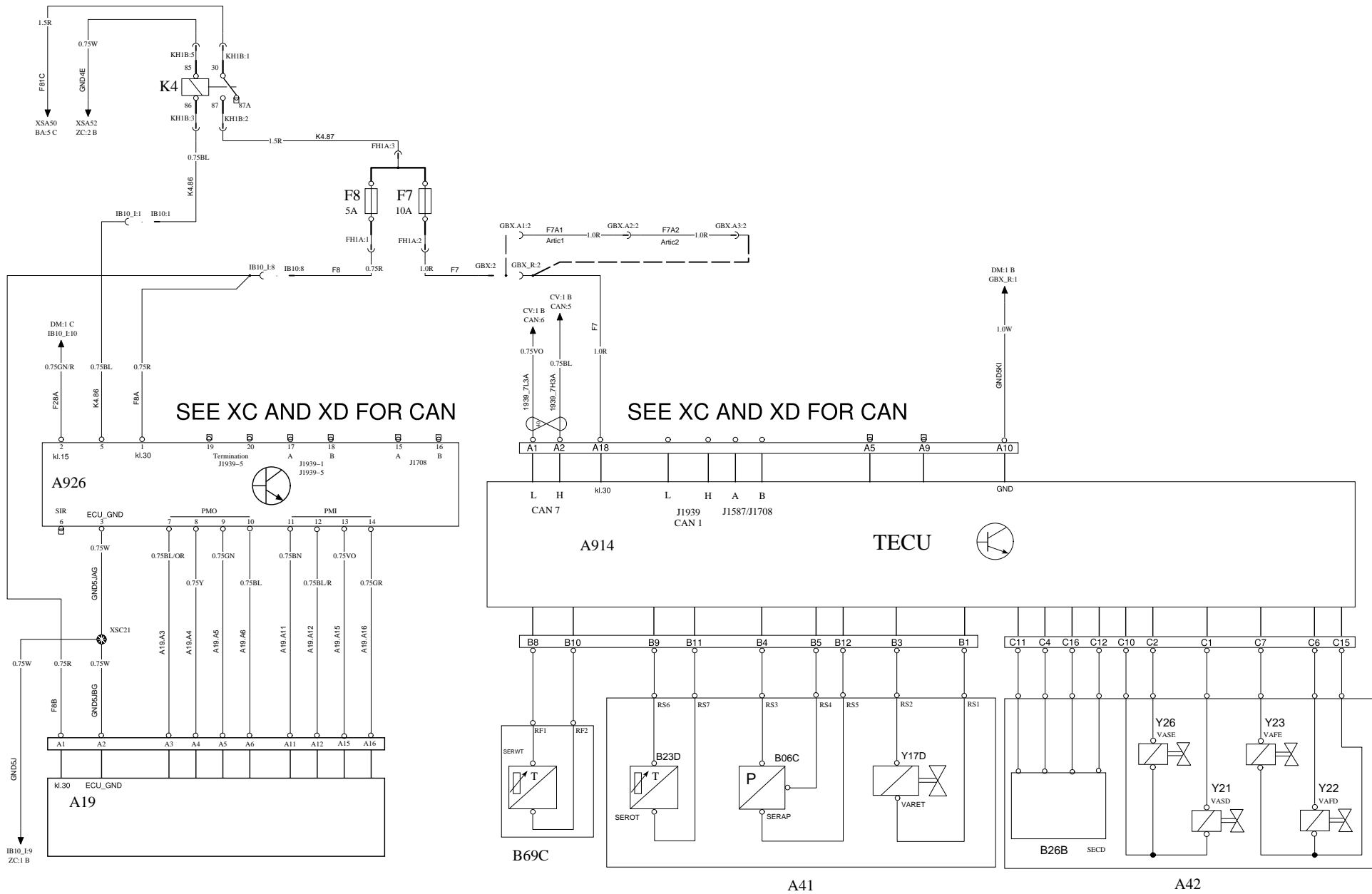

VOITH DIWA5 ARTIC

WIRING DIAGRAM DO

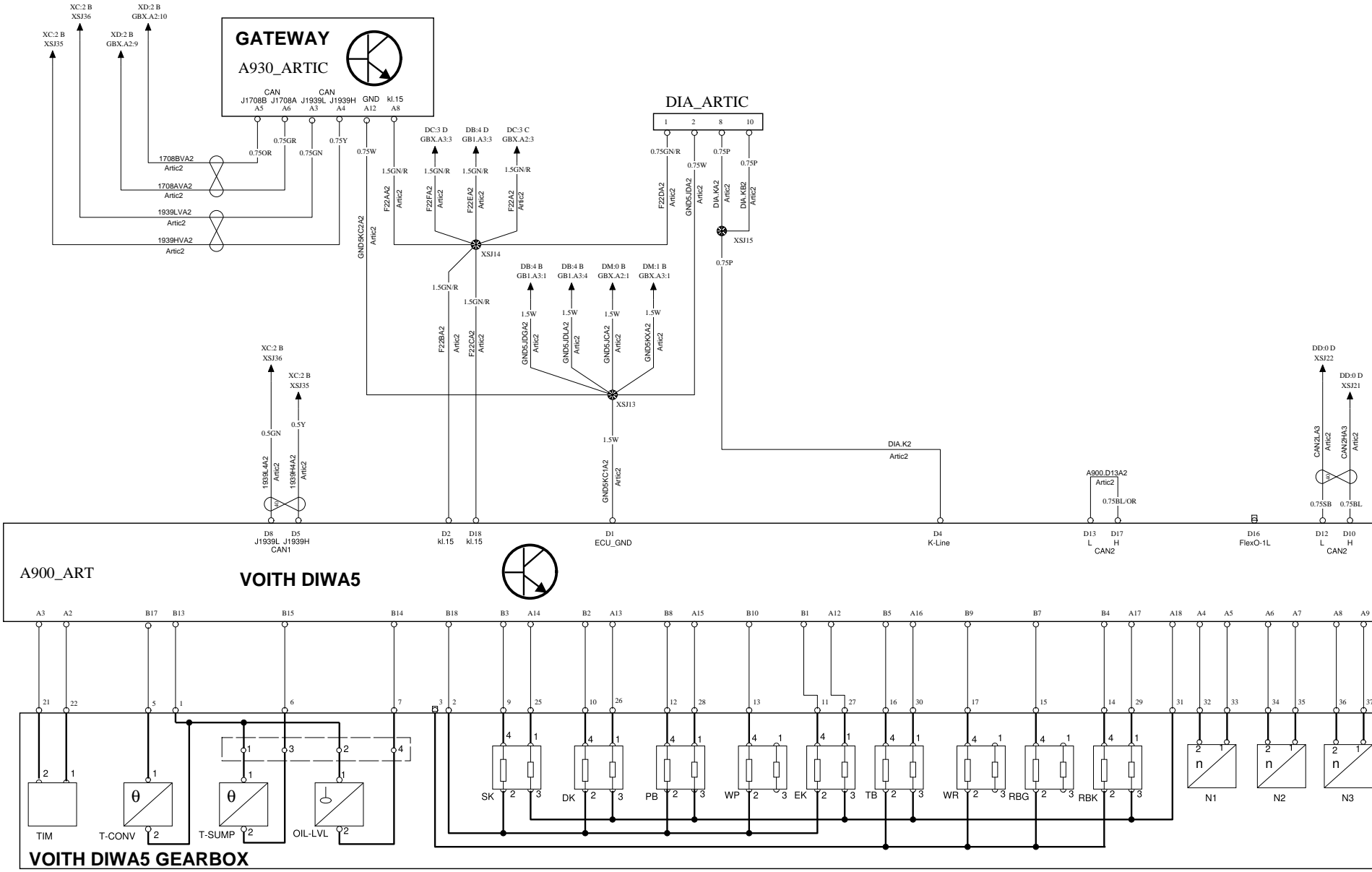

EBS

WIRING DIAGRAM EO

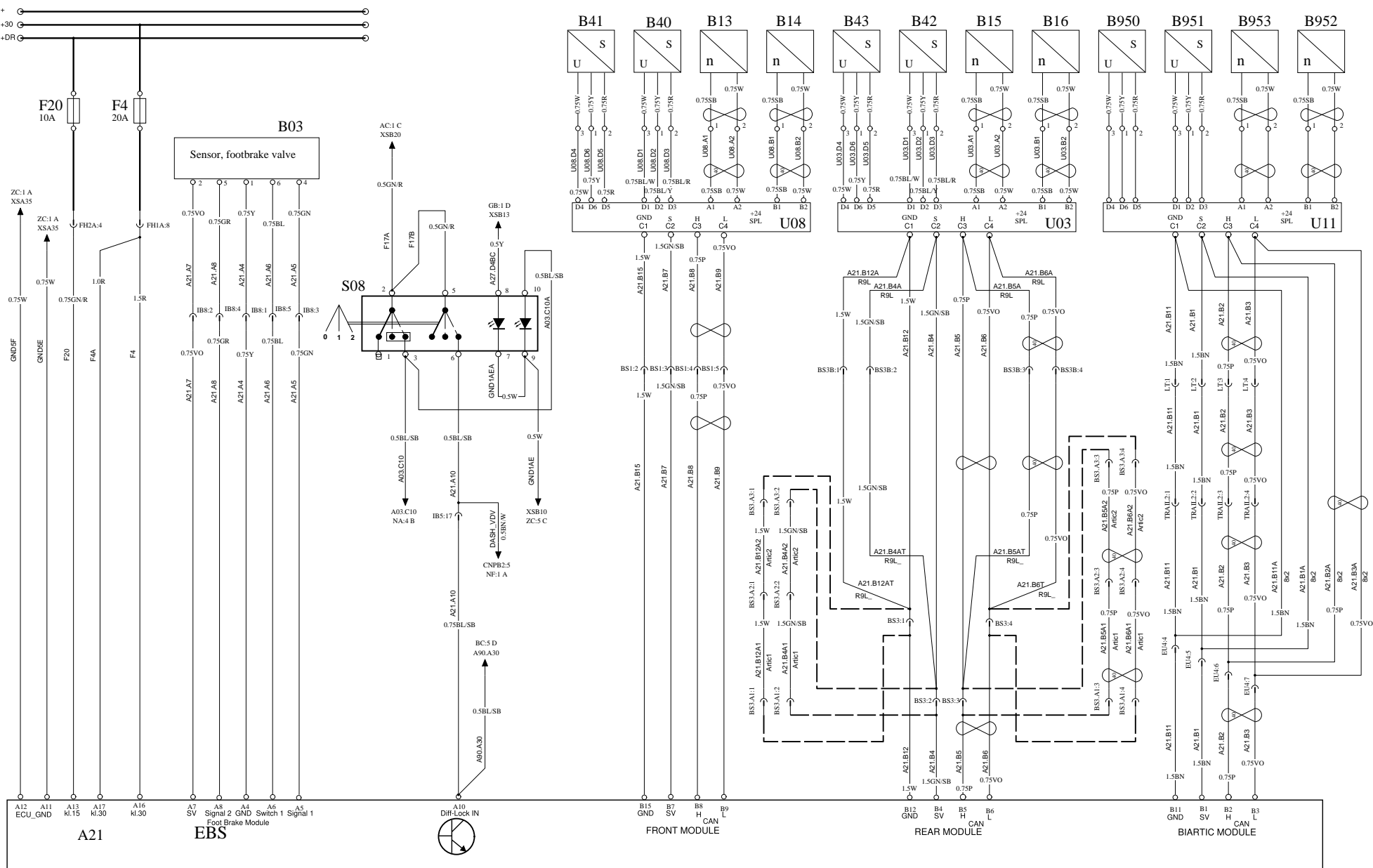

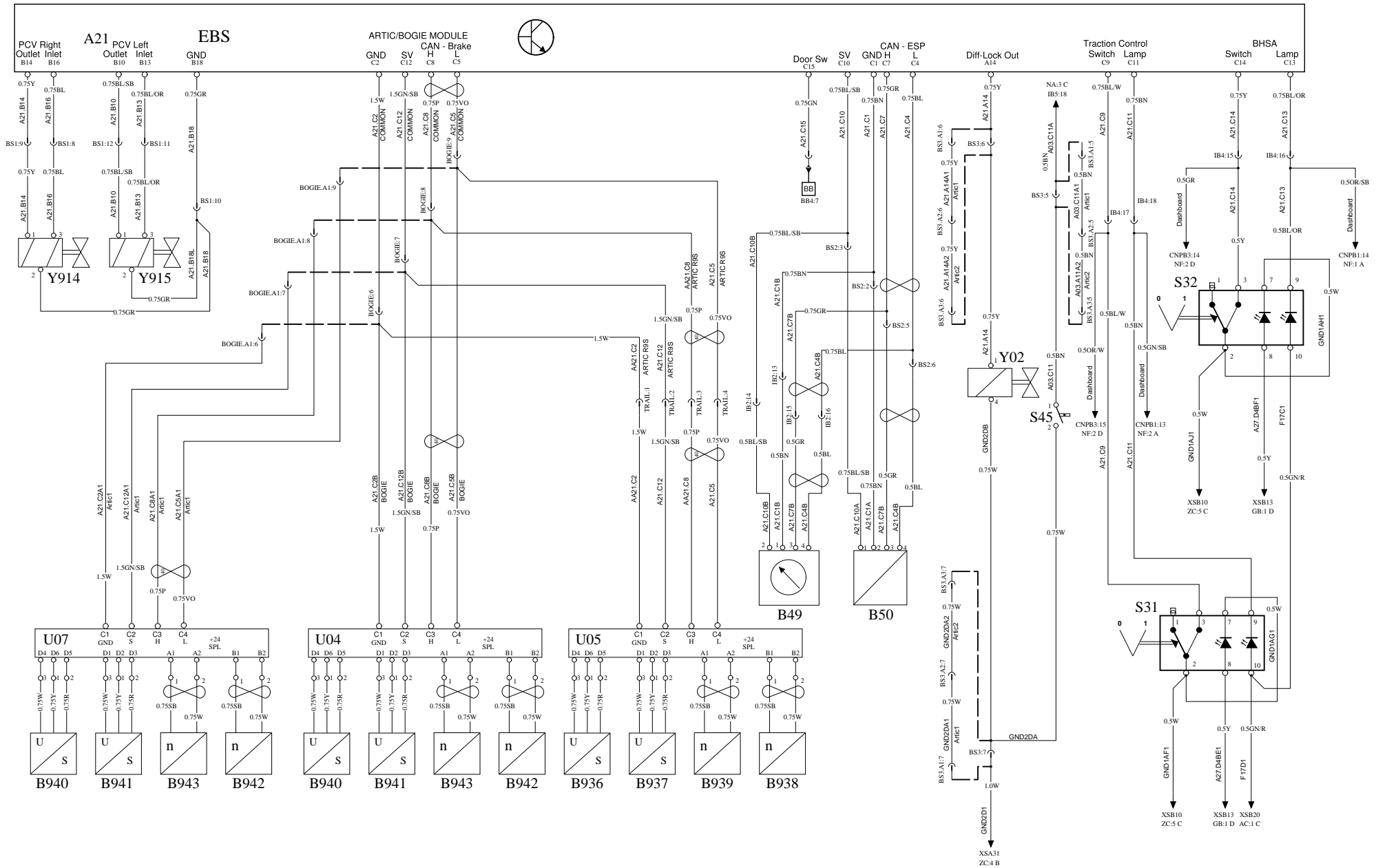

PARKING BRAKE RELEASE

WIRING DIAGRAM EX

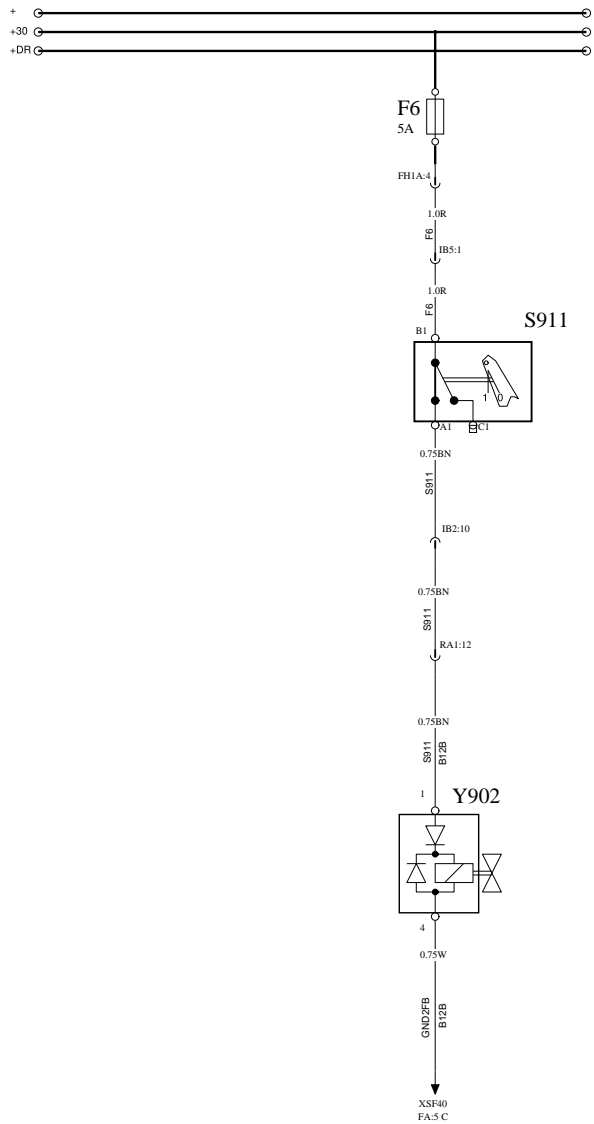

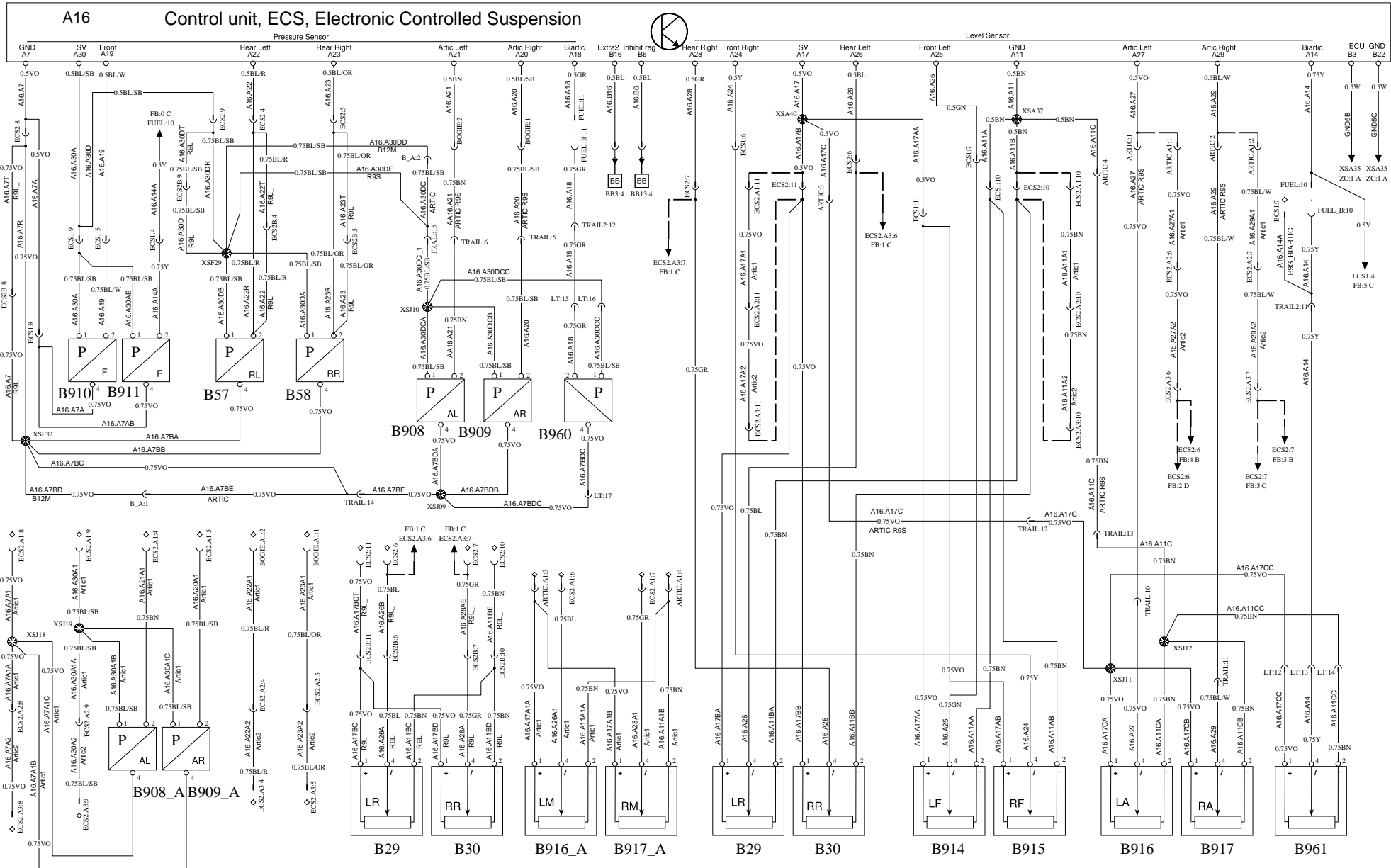

ELECTRONIC STEERED AXLE

WIRING DIAGRAM FO

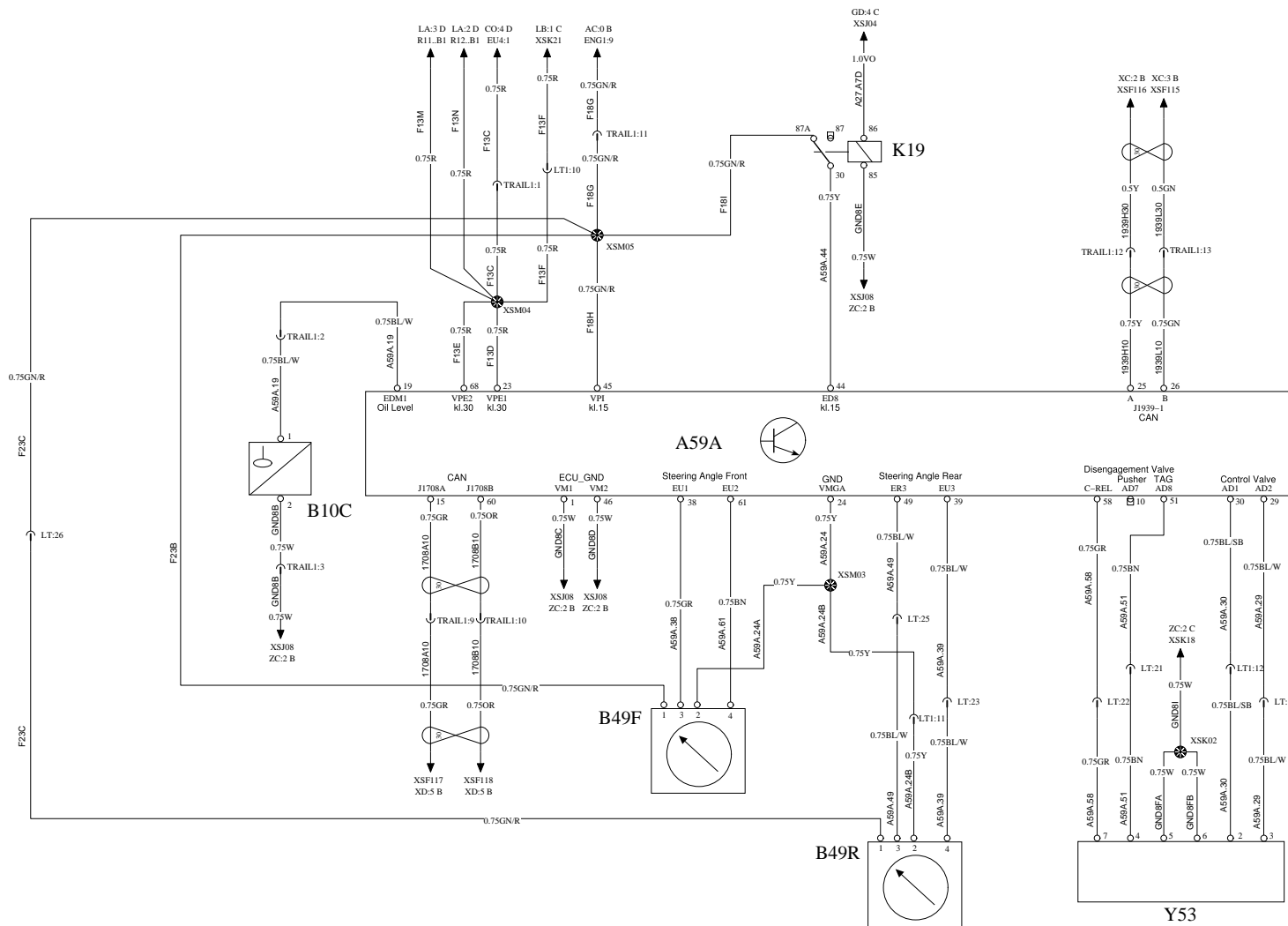

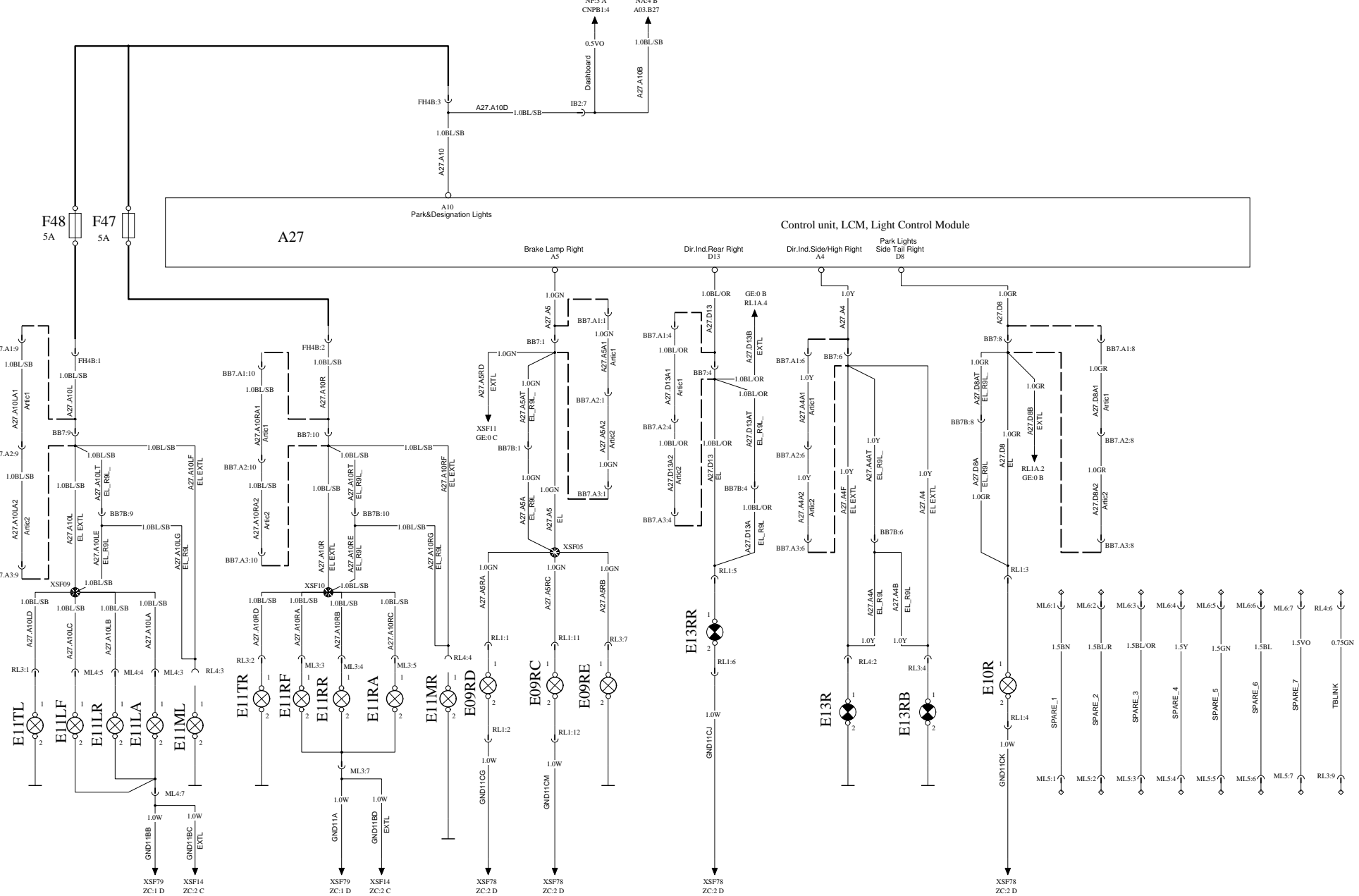

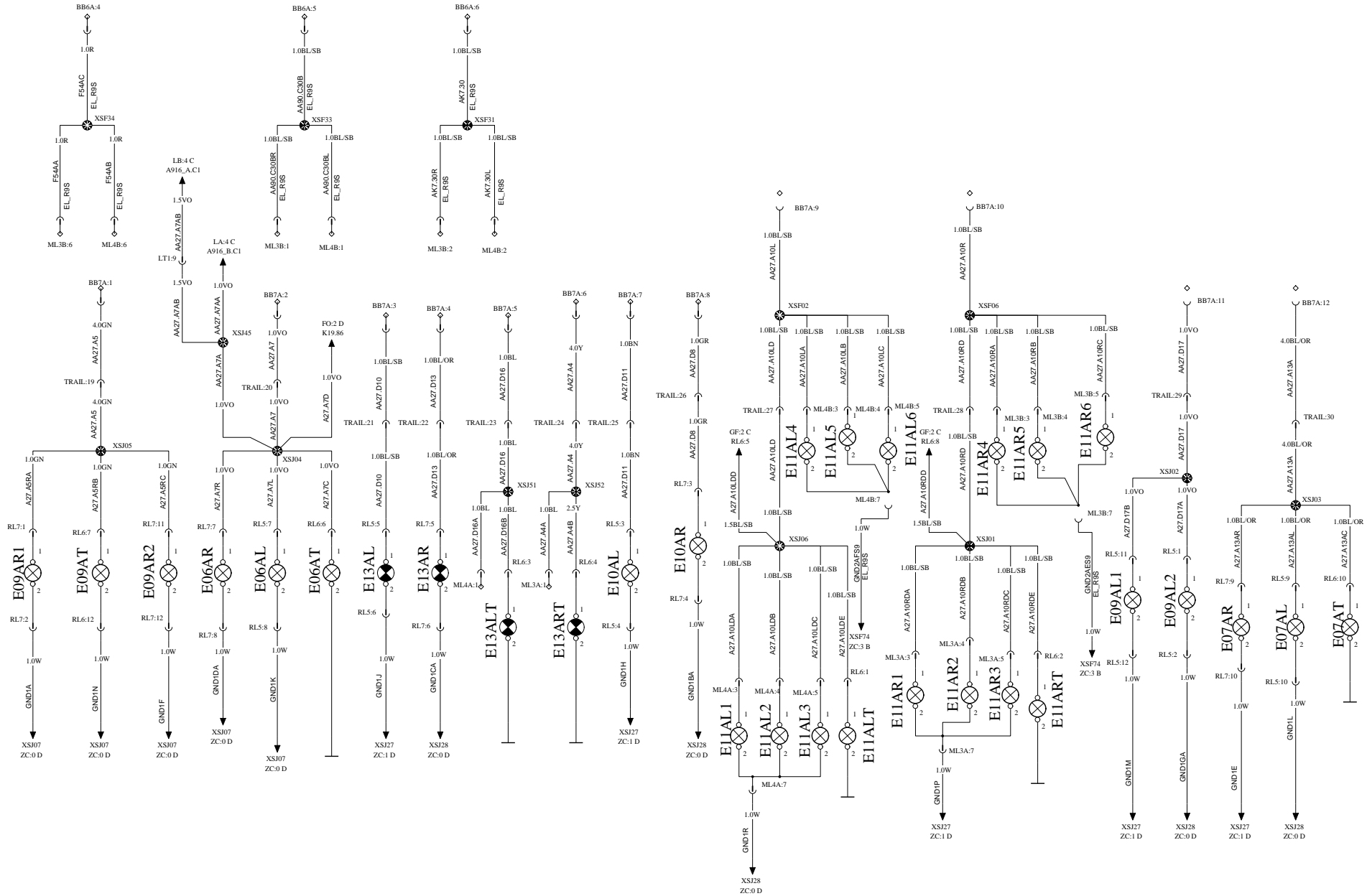

WIPER, WASHER

WIRING DIAGRAM GM

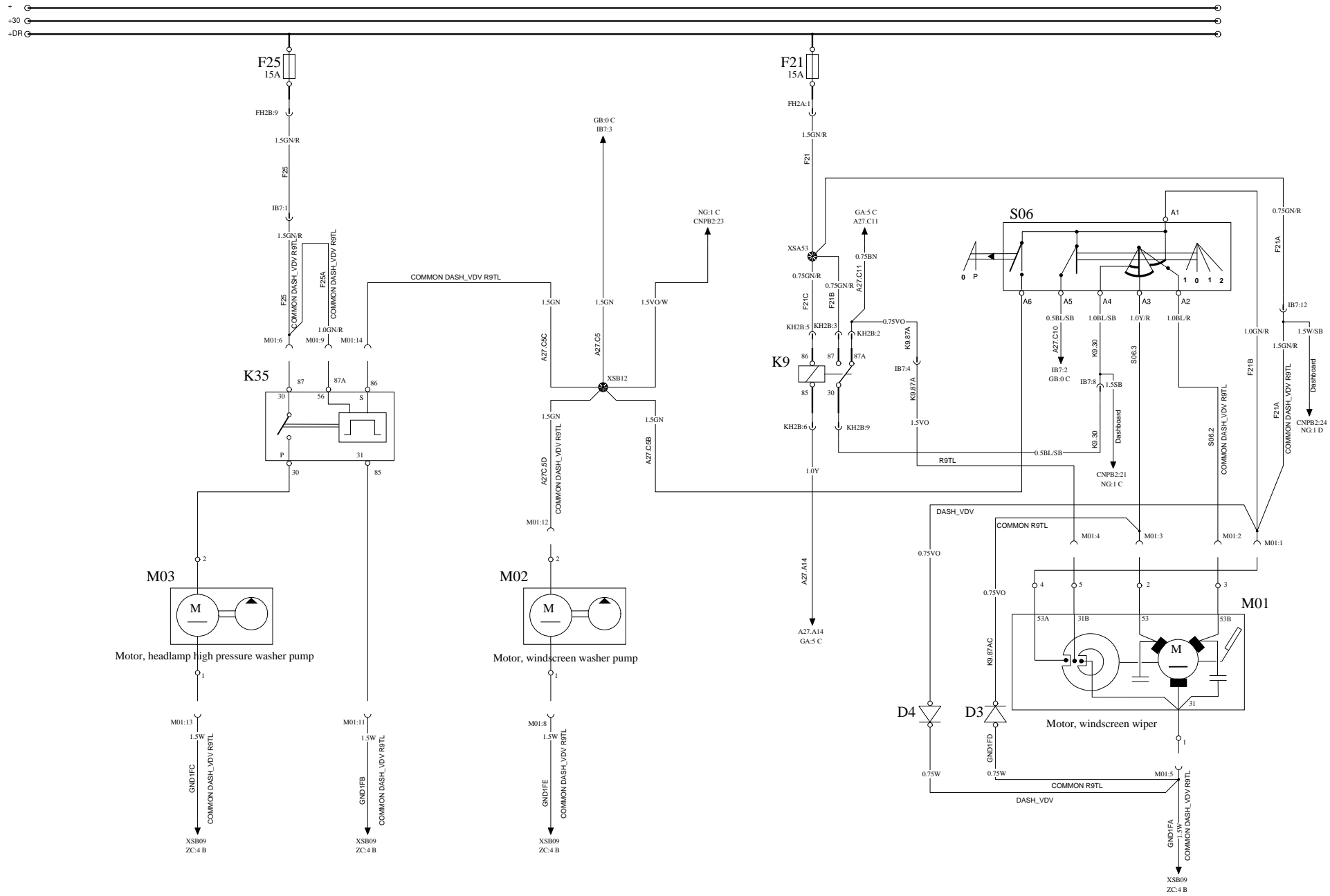

LCM XENON LIGHT RELAY WIRING DIAGRAM GN

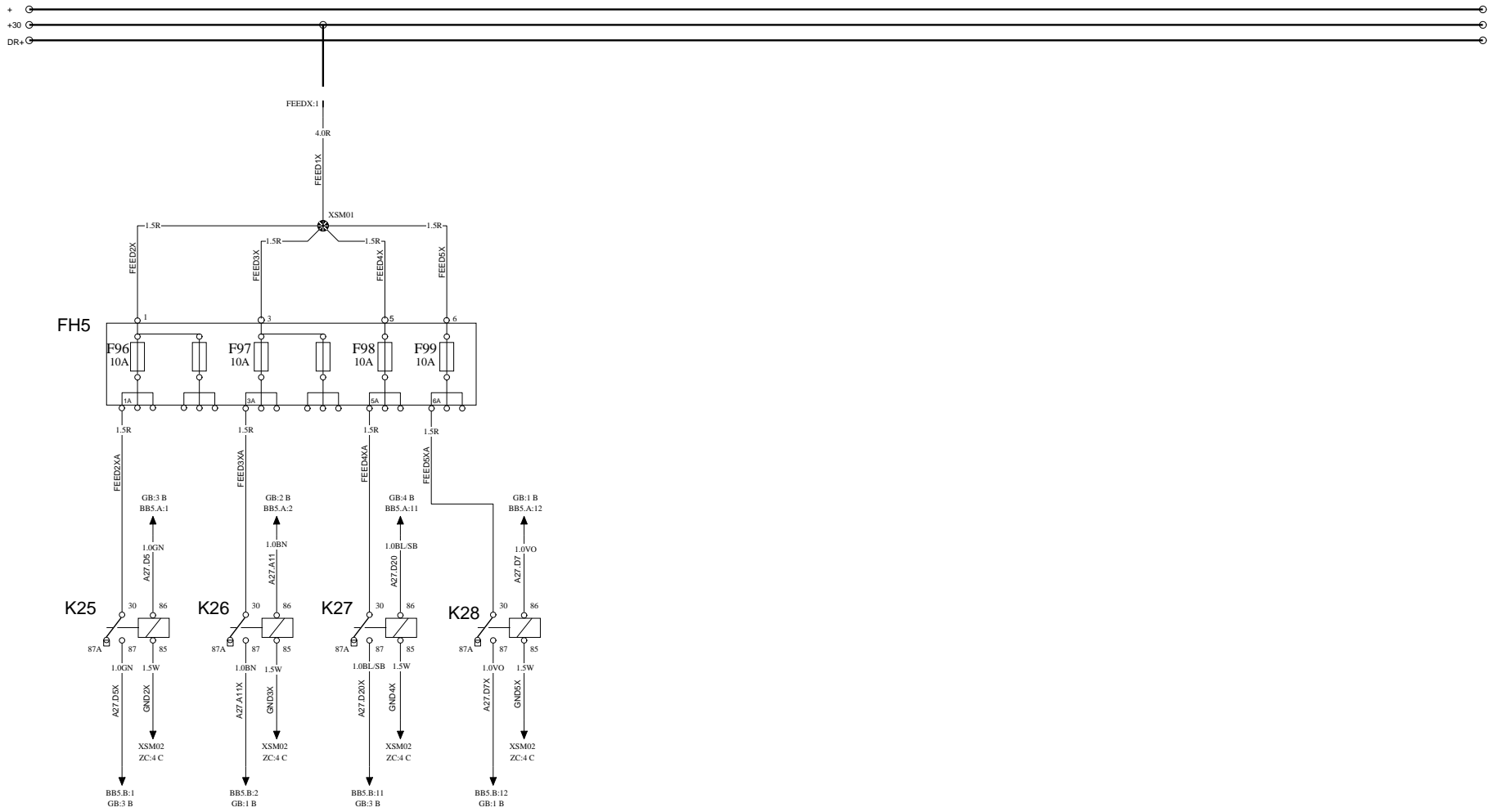

VOLVO
Volvo Bus Corporation

Document title
WIRING DIAGRAM GN
Document type
PRODUCT SCHEMATIC

Document No

20904123

Issue

10

Volume

01(02)

Page

54(69)

AUDIO

WIRING DIAGRAM IU

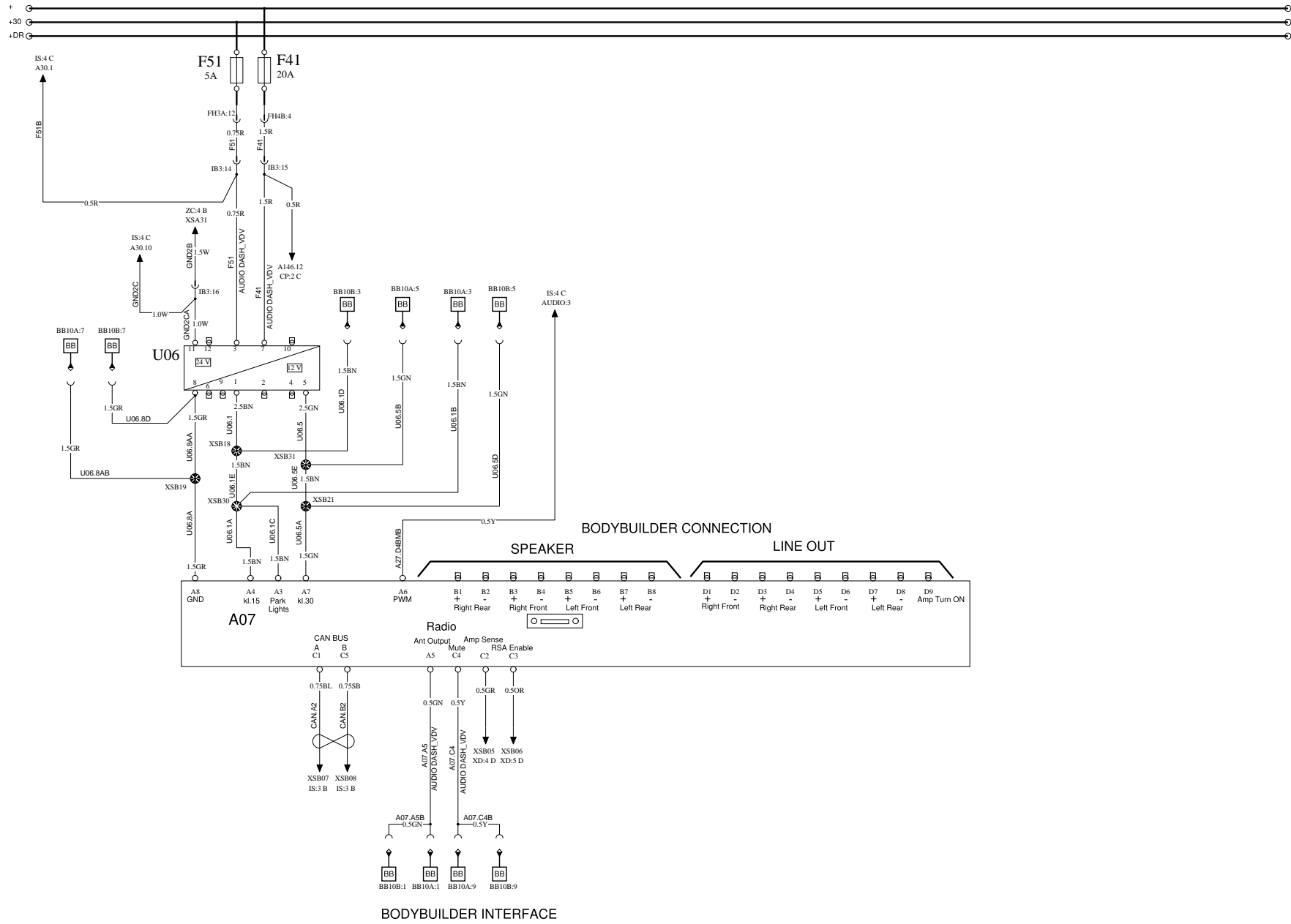

BUS INSTRUMENT CLUSTER BIC2

WIRING DIAGRAM NA

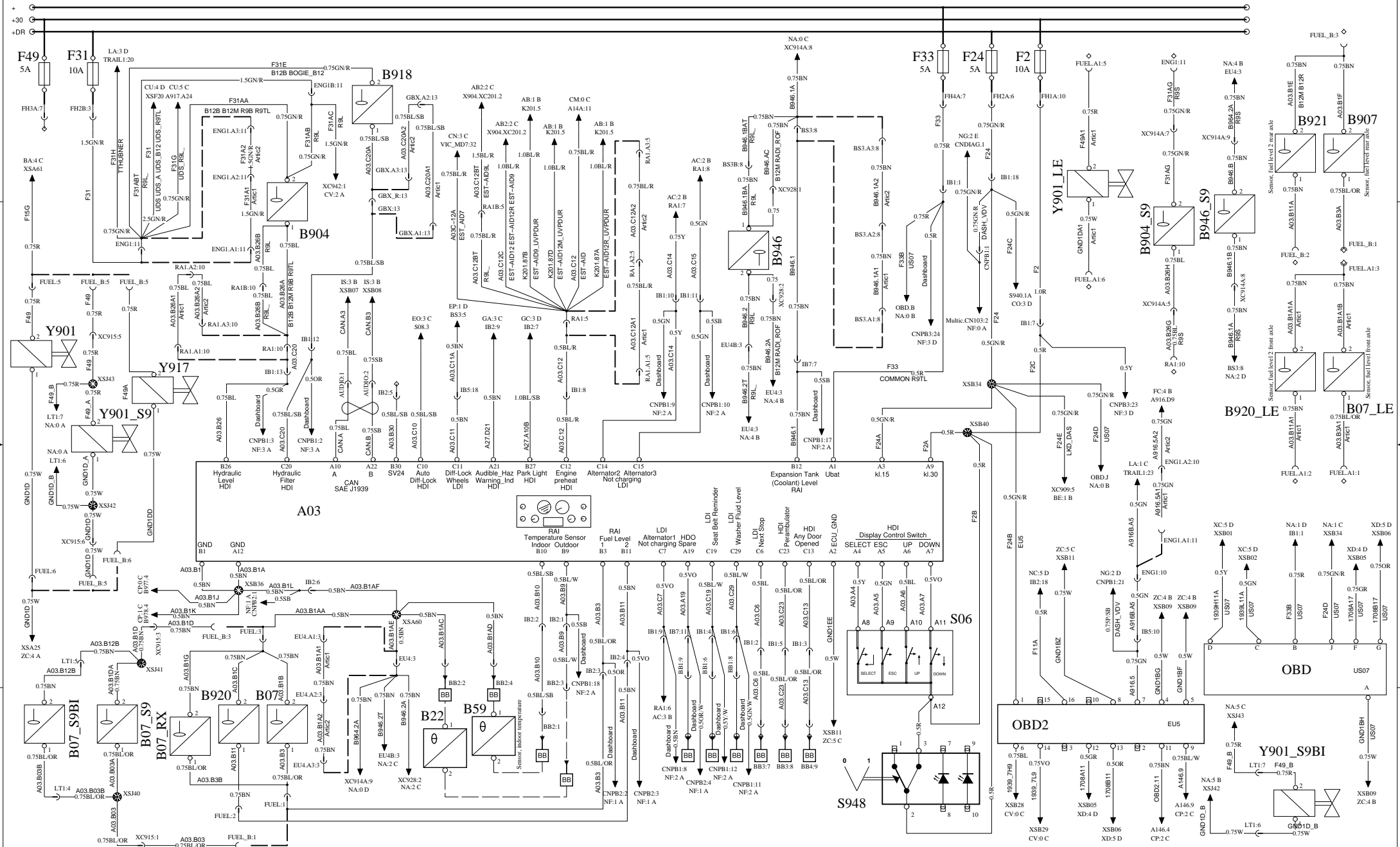

Document title
WIRING DIAGRAM NA
Document type
PRODUCT SCHEMATIC

Document No	Issue	Volume	Page
20904123	10	01(02)	59(69)

TACHOGRAPH

WIRING DIAGRAM NB

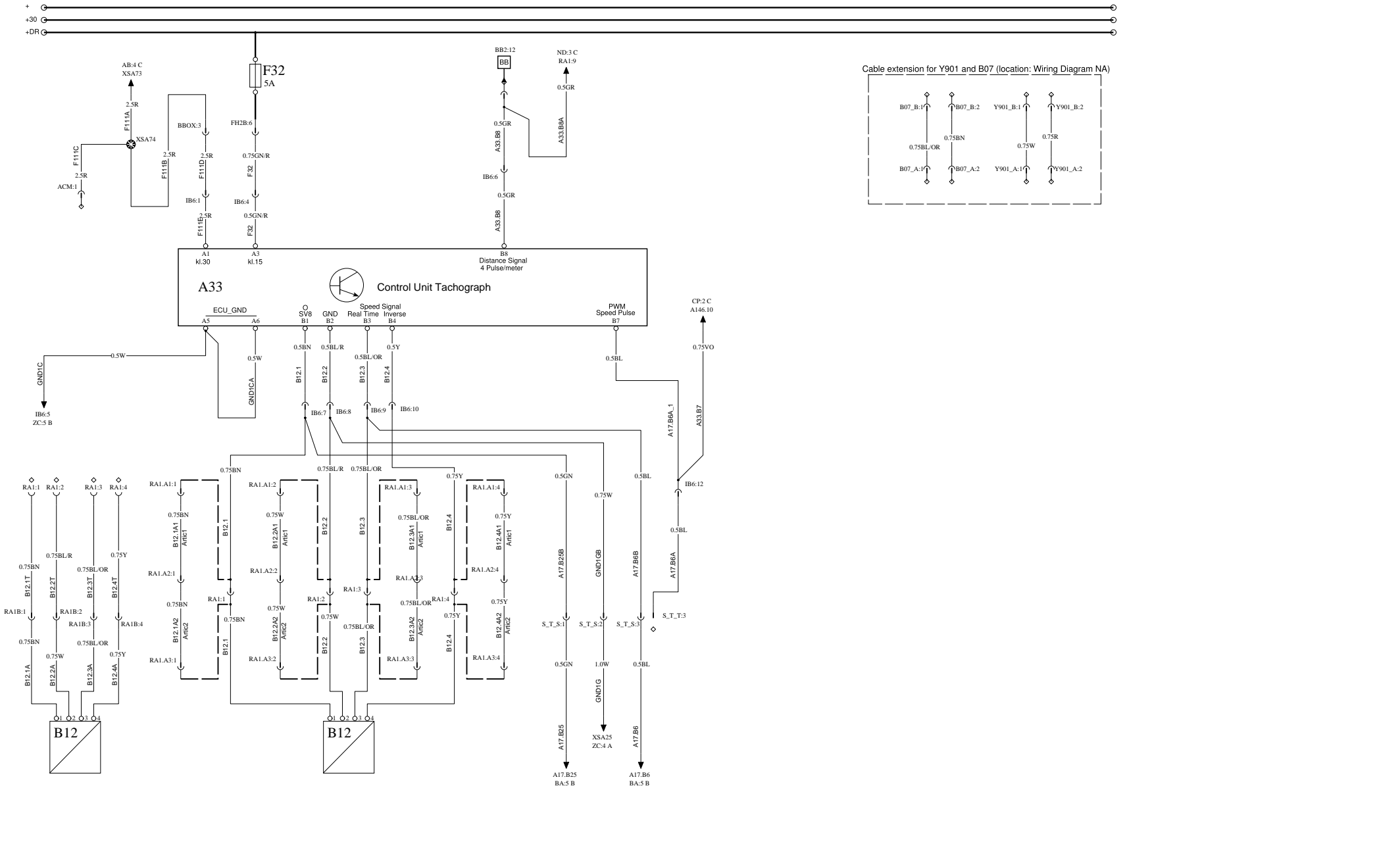

Cable extension for Y901 and B07 (location: Wiring Diagram NA)

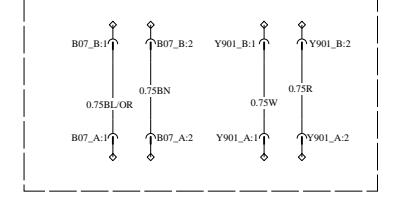

Document title WIRING DIAGRAM NB	Document No 20904123	Issue 10	Volume 01(02)	Page 60(69)
Document type PRODUCT SCHEMATIC				

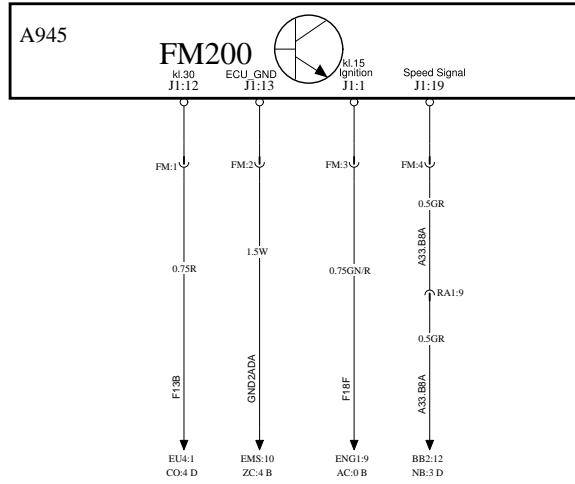

FMS GATEWAY

WIRING DIAGRAM NE

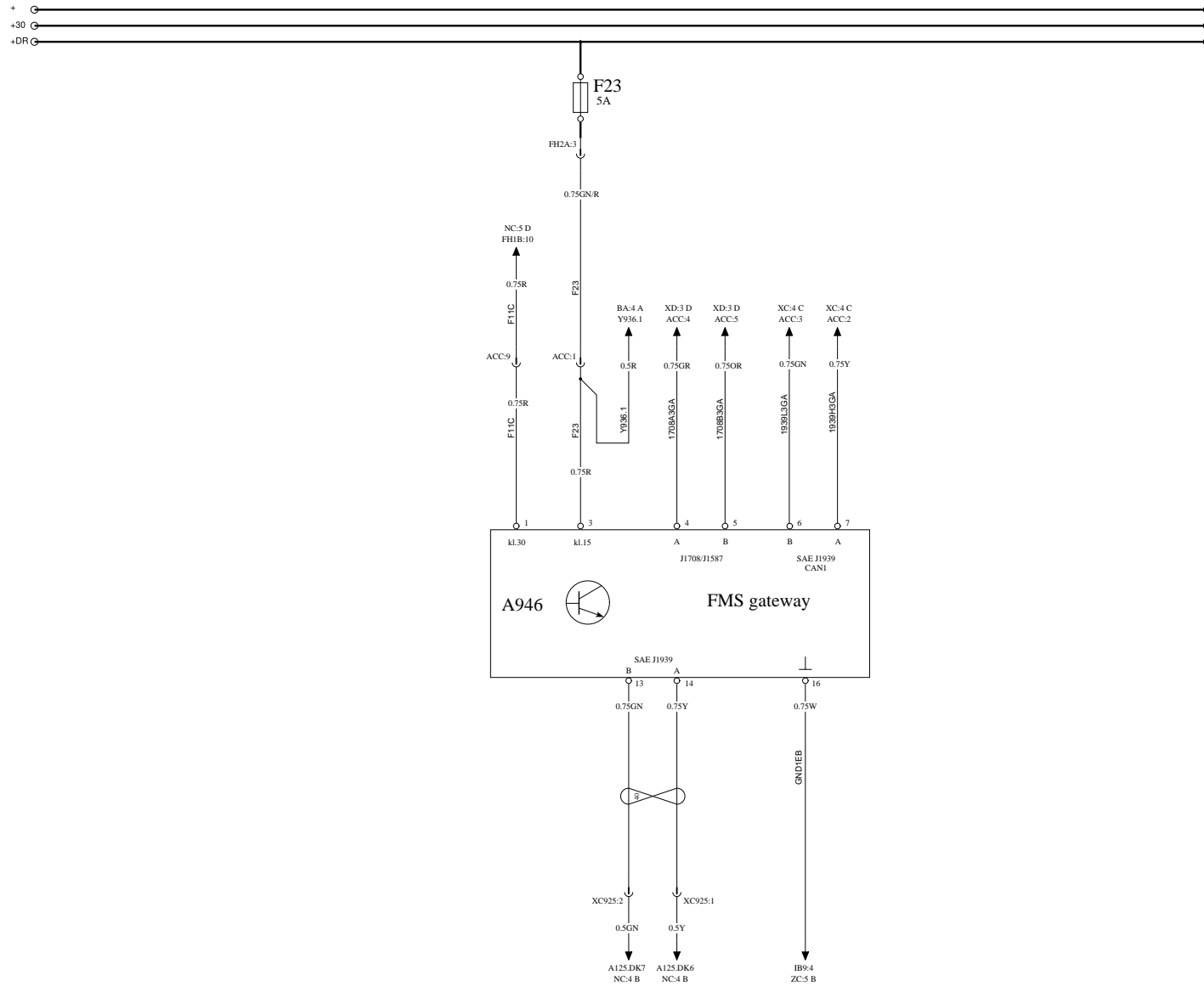

VDV, INSTRUMENT CLUSTER

WIRING DIAGRAM NG

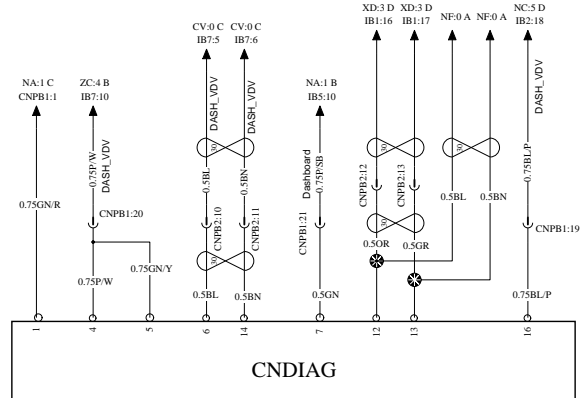
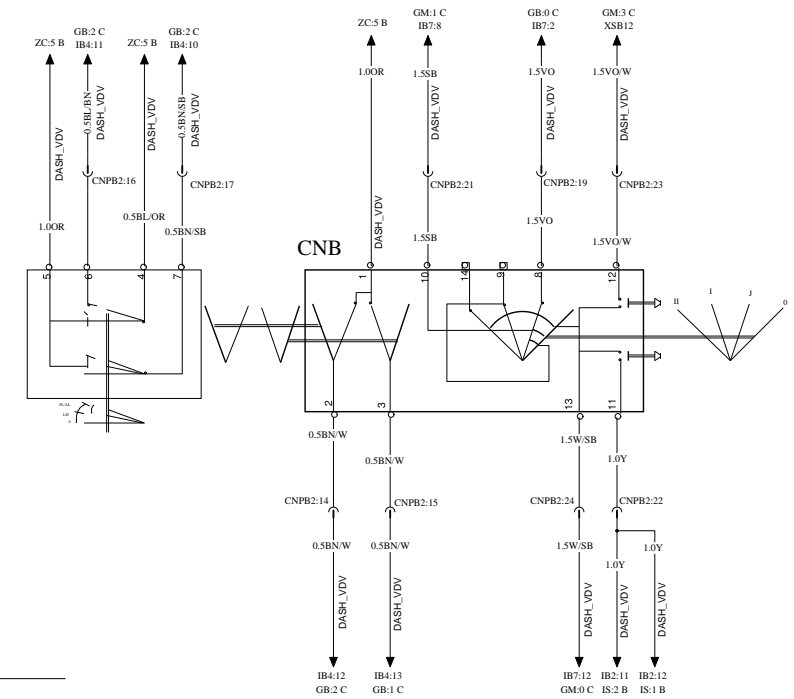
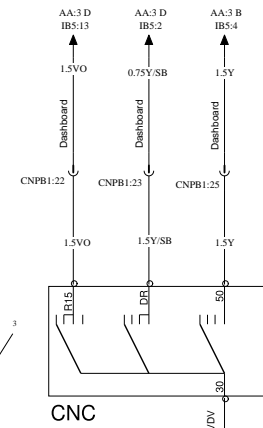
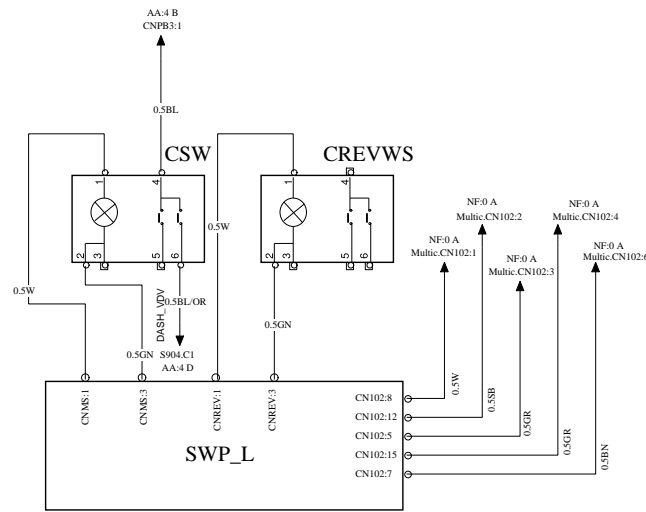
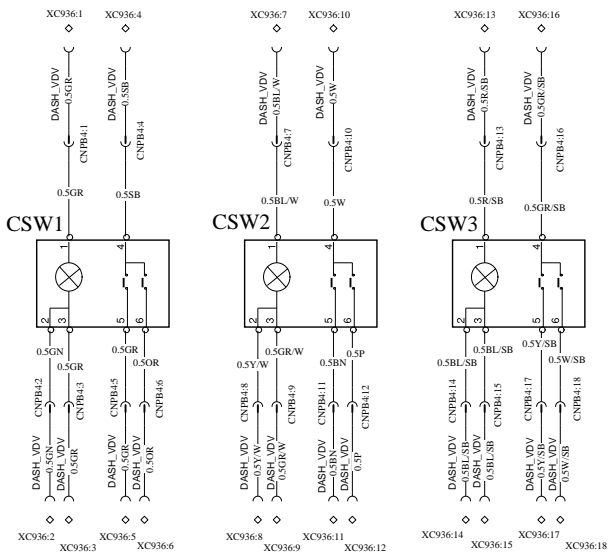

Volvo Bus Corporation

Document title
WIRING DIAGRAM
Document type
PRODUCT SCHEMATIC

Document No	Issue	Volume	Page
20904123	10	01(02)	65(69)

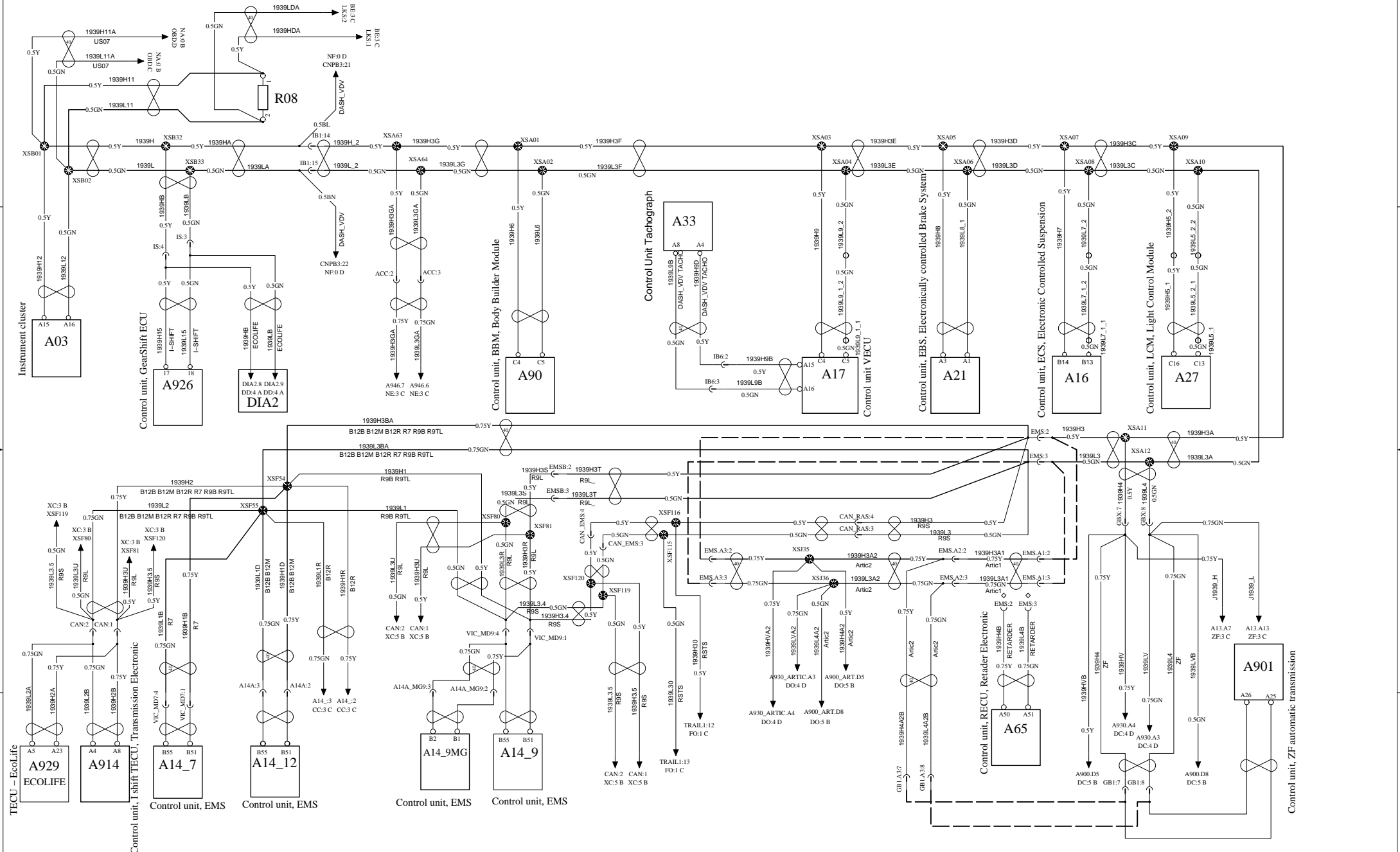

 Volvo Bus Corporation	Document title WIRING DIAGRAM XC	Document No 20904123	Issue 10	Volume 01(02)	Page 66(69)
	Document type PRODUCT SCHEMATIC				

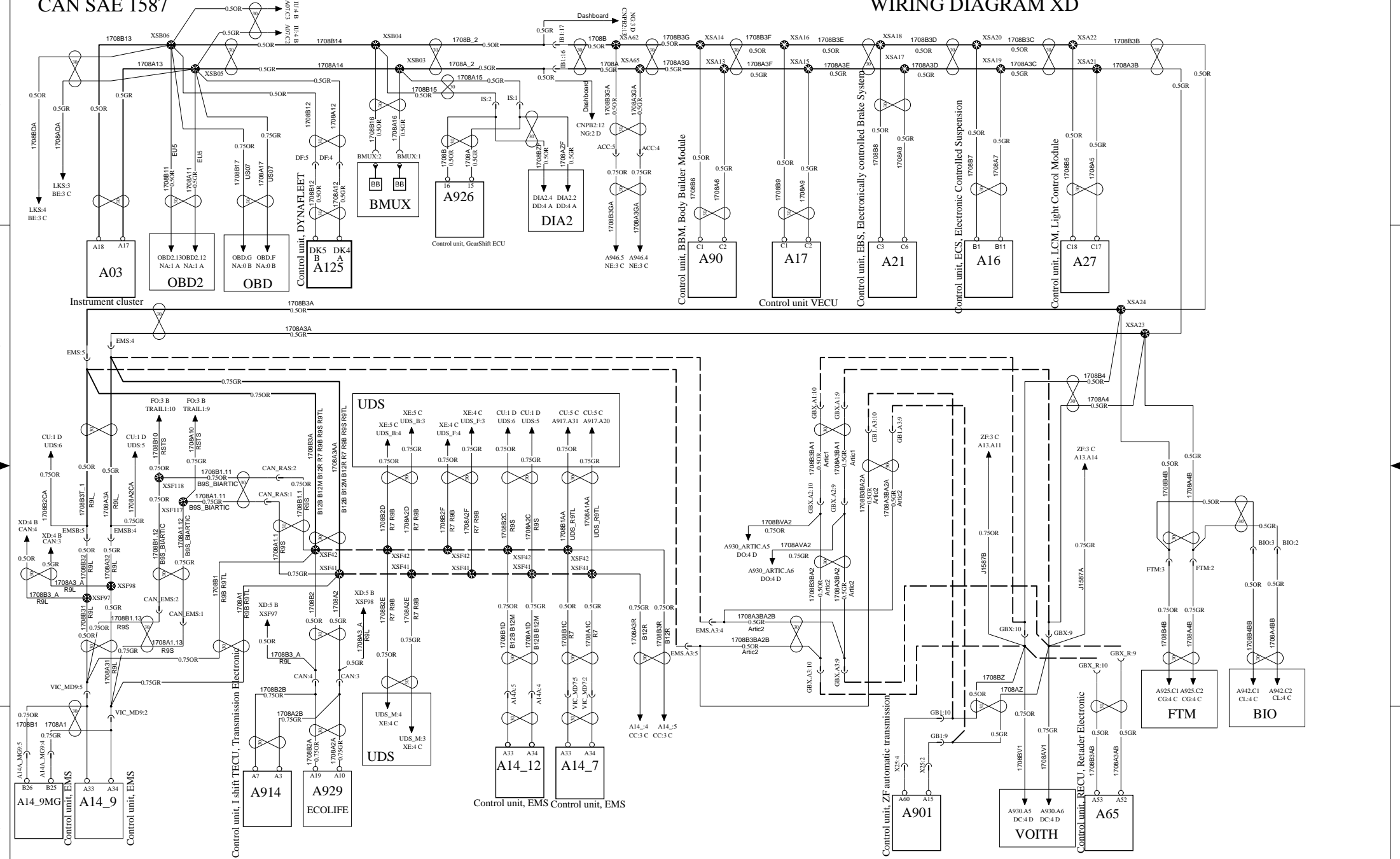

More component placement information, see:	2
Symbol explanations	4
Placement of intermediate connector pieces and control units on the chassis	6
Placement of sensors and actuators on the chassis.....	6
1 (driver environment)	10
Electrical distribut.unit, chassis.....	37
Relay.....	40
Fuses.....	42
Intermediate connector pieces	46
Control units	52
Diagnostic connector.....	61
Electrical distribution units	63

More component placement information, see:



Language	Function group	Title
Arabic	300	تانوكمل اعضو
Brazilian/Portuguese	300	Localização do componente
Canadian/French	300	Emplacement des composants
Chinese (simple.)	300	部件位置
Chinese (trad)	300	部件位置
Czech	300	Umístění komponenty
German	300	Platzierung der Bauteile
Danish	300	Komponentplacering
English	300	Component placement
Spanish	300	Colocación del componente
Estonian	300	Komponentide asukoht
Finnish	300	Komponenttien sijoittaminen
French	300	Emplacement des composants
Greece	300	Τοποθέτηση εξαρτήματος
Hungarian	300	Alkatrész-elhelyezés
Indonesian	300	Penggantian komponen

See also, 300, Component placement, Description, Design and function

The reader is advised that printed copies are uncontrolled.

Component Placement





Volvo Bus Corporation

Farsi/Persian	300	هعطق نداد اج
Hebrew	300	מוקמב החנה, ביכר
Italian	300	Posizionamento dei componenti.
Japanese	300	コンポーネント配置
Korean	300	구성부품 배치
Lithuanian	300	Komponento išdėstymas
Latvian	300	Daļu izvietojums
Mexican/Spanish	300	Colocación de componente
Dutch	300	Lokatie van componenten
Norwegian	300	Komponentplassering
Polish	300	Rozmieszczenie komponentów
Portuguese	300	Colocação de componentes
Romanian	300	Plasare componentă
Russian	300	Размещение компонентов
Serbian	300	Raspored komponenti
Slovak	300	Umiestnenie komponentu
Slovenian	300	Zamenjava sestavnih delov
Swedish	300	Komponentplacering
Thai	300	การติดตั้งอุปกรณ์
Turkish	300	Parça deęiřtirme
American/English	300	Component Placement

See also, 300, Component placement, Description, Design and function

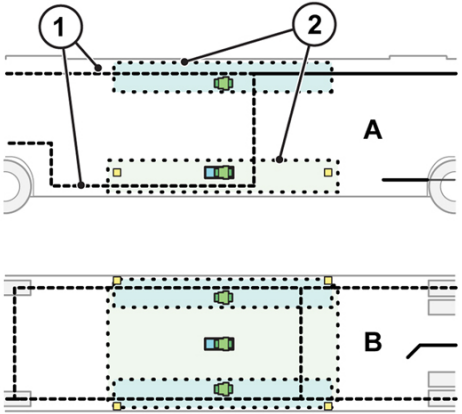

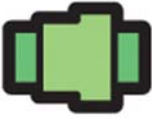

The reader is advised that printed copies are uncontrolled.

Symbol explanations

Symbol	Explanations
	<p>A: View from side</p> <p>B: View from above</p> <p>1: Alternative cable routing</p> <p>2: Area marked with light colour and dashed lines. The area shows where a control unit and /or a connector piece can be located</p>
	<p>Symbol for electrical distribution unit</p>
	<p>Symbol for intermediate connector piece</p>
	<p>Symbol for intermediate connector piece in grey to show that it is placed behind a component (e.g. the engine).</p>

See also, 300, Component placement, Description, Design and function

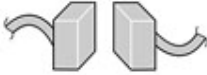
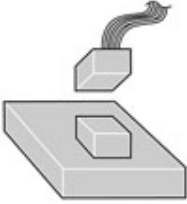
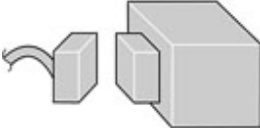
The reader is advised that printed copies are uncontrolled.

	<p>Symbol for control unit</p>
	<p>Symbol for intermediate connector piece in grey to show that it is placed behind a component (e.g. the engine).</p>
	<p>Symbol for intermediate connector piece that is shown where another illustration is missing.</p>
	<p>Symbol for control unit that is shown where another illustration is missing.</p>
	<p>Symbol for sensor/actuator that is shown where another illustration is missing.</p>
	<p>Symbol for branching point</p>
	<p>Symbol for branching point in grey to show that it is placed behind a component (e.g. the electrical distribution unit).</p>

Placement of intermediate connector pieces and control units on the chassis

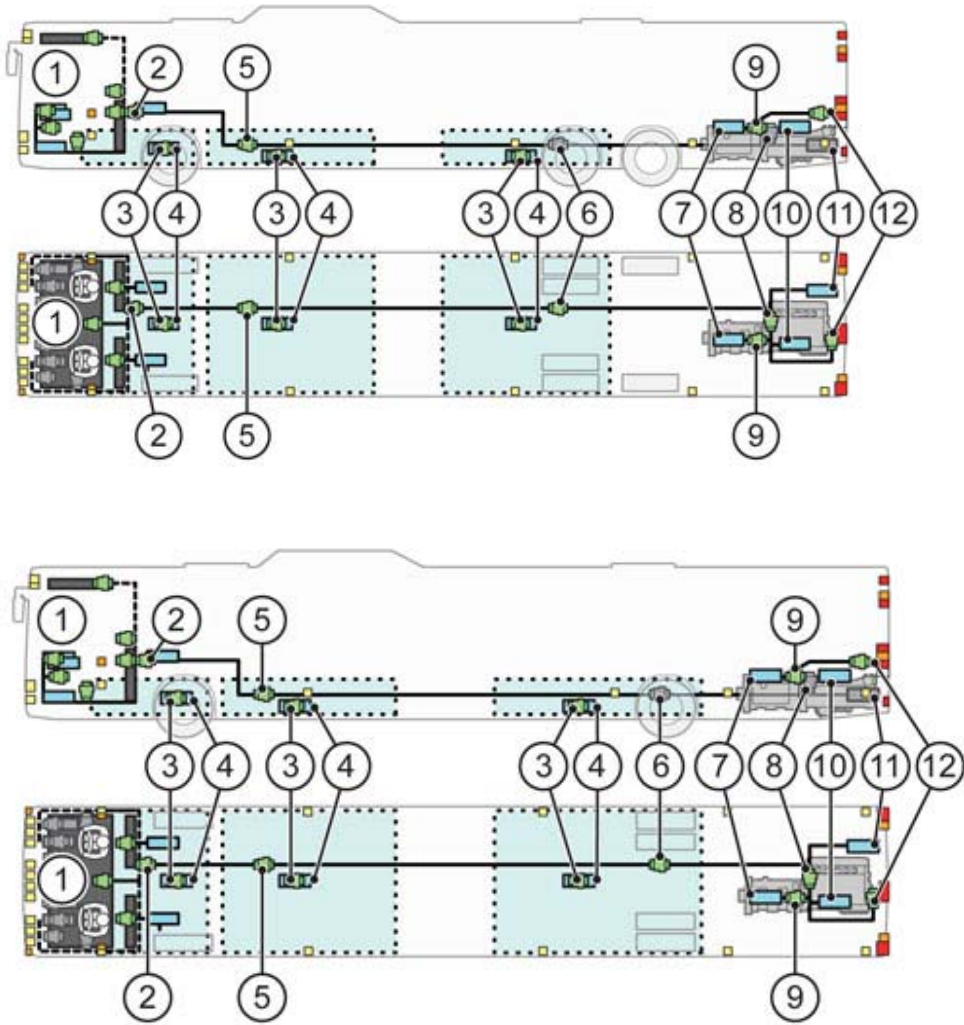

See also, 300, Component placement, Description, Design and function

The reader is advised that printed copies are uncontrolled.

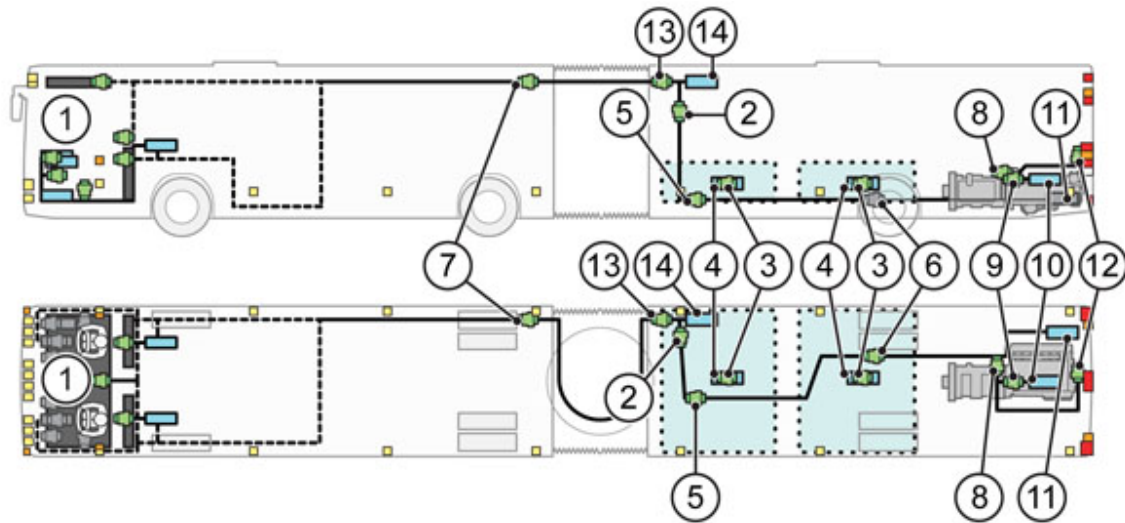

The illustrations show in principle how the chassis cabling is routed and where the intermediate connector pieces, control units and electrical distribution units are located. If the vehicle is not built by a Volvo body builder, then the cabling to the lamps is probably routed in another way than shown in the illustration. The dashed lines show alternative cable routings.

[Symbol explanations](#)

Note: For naming of components, see wiring diagram.

Placement	Components named according to wiring diagram
1 (driver environment)	A27 (LCM), A21 (EBS), A16 (ECS), A90 (BBM), A17 (VECU), A943 (BIO), A946 (FMS), A65 (RECU), A125 (Dynafleet), K1-K17, K25-K28, F1-F64, FH5 (F96, F97, F98, F99), U06, IB10_B, IB10_E, BB5.A, BB10B, BB11, XC925, ACC, BBOX , XC921 , XC917, XC927, EMS, ENG1, ARTIC, BOGIE , RA1, ECS2, BS3, FUEL, EU4, ECS1, BS1, BS2, FH1A – FH4A , FH1B – FH4B, KH1A - KH3A, KH1B - KH3B, S_TS, S_T_T , XC922, BB13, FTM , XC926, XC930, BB8, BB11, XK2, XK1, IS, GB1, IB1 – IB5, BB7, BB6, GBX, GS1, ARTIC, BOGIE, IB6 – IB10, BB1 – BB5, A03 (BIC), A07 (Radio), A33 (TACHO), OBD2 , BMUX, A30 (SWM), X25, AUDIO, DF, BB10A, A926 (GSECU), A900 (Voith TECU), A901 (ZF ECOMAT TECU), A65 (RECU)
2	UDS_F
3	R905A, R906A, R907A, R908, R909A, R910A
4	A917 (DECU)

See also, 300, Component placement, Description, Design and function

The reader is advised that printed copies are uncontrolled.

5	UDS_M
6	UDS_B
7	A914 (TECU)
7 (B12BLEA/articulated bus)	BB7.A2, BS3.A2, FUEL.A2
	BB6.A2, ECS2.A2, EU4.A2
	GBX.A2
	EMS.A2, BOGIE.A2
	ENG1.A2, ARTIC.A2
	RA1.A2
	GS1.A2
8	CAN
9	A14A
	A14B, A14C, A14D
10	A14 (EECU)
11	A918 (NOx ECU)
12	LA
13	BB7.A3, BS3.A3, FUEL.A3
	BB6.A3, ECS2.A3, EU4.A3

See also, 300, Component placement, Description, Design and function

The reader is advised that printed copies are uncontrolled.

	GBX.A3
	EMS.A3
	ENG1.A3
	RA1.A3
	RL4
	GS1.A3
14	A916
Left side rear (Volvo body)	RL2, RL5, RL8
	RL2A
Right side rear (Volvo body)	RL1, RL7, RL10
	RL1A
Rear, often located towards the centre (Volvo body)	RL3

Placement of sensors and actuators on the chassis

B12B 4x2



The illustration shows where the chassis components are located in a B12B 4x2. The table contains the designations and coordinates for components on the chassis.

B12B 6x2



The illustration shows where the chassis components are located in a B12B 6x2. The table contains the designations and coordinates for components on the chassis.

B12BLEA

See also, 300, Component placement, Description, Design and function

The reader is advised that printed copies are uncontrolled.

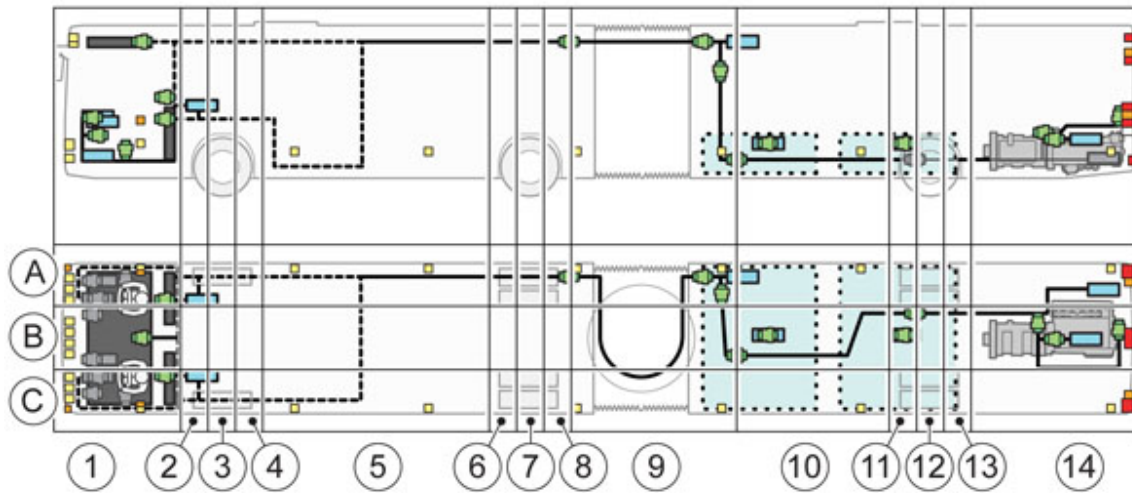

The illustration shows where the chassis components are located in a B12BLEA. The table contains the designations and coordinates for components on the chassis.

List of components

Component	Description	Placement
A03	Instrument (BIC)	1 – C
A07	Radio	1 - C
A08	GPS receiver	1 – B
A14	Engine control unit (EECU)	B12B 4x2:10 – B
		B12B 6x2:12 – B
		B12BLEA:14 – B
A16	Control unit, air suspension (ECS)	1 electrical distribution unit
A17	Vehicle control unit (VECU)	1 electrical distribution unit
A19	Control unit gear selector (GECU)	1 – C

See also, 300, Component placement, Description, Design and function

The reader is advised that printed copies are uncontrolled.

Component Placement

Volvo Bus Corporation

Component	Description	Placement
A21	Control unit brake system (EBS)	1 electrical distribution unit
A22	Dynafleet	1 – C
A23	Fuel monitoring system (FMS)	1 electrical distribution unit
A27	Control unit lighting (LCM)	1 electrical distribution unit
A30	Control unit steering wheel buttons (SWM)	1 electrical distribution unit
A33	Tachograph	1 – C
A41	Components transmission B23, B06, Y17	B12B: 9 – B
		B12B 6x2: 11 – B
		B12B LEA: 14 – B
A42	Components transmission B26, Y21, Y22, Y23, Y26	B12B: 9 – B
		B12B 6x2: 11 – B
		B12B LEA: 14 – B
A44	Fuel pump	B12B 4x2:10 – B
		B12B 6x2:12 – B
		B12BLEA:14 – B
A45	Water separator fuel	B12B 4x2:10 – B
		B12B 6x2:12 – B

See also, 300, Component placement, Description, Design and function

The reader is advised that printed copies are uncontrolled.

Component Placement

Volvo Bus Corporation

Component	Description	Placement
		B12BLEA:14 – B
A65	Control unit compact retarder (RECU)	1 electrical distribution unit/B12B 4x2:10 – B
		1 electrical distribution unit/B12B 6x2:12 – B
		1 electrical distribution unit/B12BLEA :14 – B
A90	Control unit body builder (BBM)	1 electrical distribution unit
A105	Dynafleet (SIB)	1 – C
A900	Control unit gearbox VOITH	1 – C / 1 electrical distribution unit
A901	Control unit gearbox ZF	1 – C / 1 electrical distribution unit
A904	Control unit gearbox (EGS)	1 – C
A914	Control unit gearbox (TECU)	B12B: 9 – B
		B12B 6x2: 11 – B
		B12B LEA: 14 – B
B03	Sensor, brake pedal	1 – C
B04	Sensor, engine speed crankshaft	B12B 4x2:10 – B
		B12B 6x2:12 – B
		B12BLEA:14 – B

See also, 300, Component placement, Description, Design and function

The reader is advised that printed copies are uncontrolled.

Component Placement**Volvo Bus Corporation**

Component	Description	Placement
B05	Sensor, engine speed camshaft	B12B 4x2:10 – B
		B12B 6x2:12 – B
		B12BLEA:14 – B
B06	Pressure sensor, wet tank	B12B: 8 – B
		B12B 6x2: 8 – B
		B12B LEA: 13 – B
B07A	Fuel level sensor, front axle	B12B 4x2:10 – B
		B12B 6x2:12 – B
		B12BLEA:14 – B
B10	Oil level sensor	B12B 4x2:10 – B
		B12B 6x2:12 – B
		B12BLEA:14 – B
B12	Speed sensor, speedometer and tachograph	B12B: 9 – B
		B12B 6x2: 11 – B
		B12B LEA: 14 – B
B13	Wheel speed sensor, left front	3 – C
B14	Wheel speed sensor, right front	3 — A

See also, 300, Component placement, Description, Design and function

The reader is advised that printed copies are uncontrolled.

Component Placement**Volvo Bus Corporation**

Component	Description	Placement
B15	Wheel speed sensor, left drive wheel	B12B: 7 – C
		B12B 6x2: 7 – C
		B12B LEA: 12– C
B16	Wheel speed sensor, right drive wheel	B12B: 10 – A
		B12B 6x2: 7 – A
		B12B LEA: 12 – A
B21	Temperature sensor coolant temperature	B12B 4x2:10 – B
		B12B 6x2:12 – B
		B12BLEA:14 – B
B22	Temperature sensor, outside temperature	1 – C
B23	Temperature sensor oil temperature, retarder	B12B: 9 – B
		B12B 6x2: 11 – B
		B12B LEA: 14 – B
B25	Accelerator pedal	1 – C
B29	Level sensor air suspension, left front	B12B: 6 – C
		B12B 6x2: 6 – C
		B12BLEA: 11 – C

See also, 300, Component placement, Description, Design and function

15

The reader is advised that printed copies are uncontrolled.

Component Placement**Volvo Bus Corporation**

Component	Description	Placement
B30	Level sensor air suspension, right rear	B12B: 6 – A
		B12B 6x2: 6 – A
		B12B LEA: 11 – A
B32	Speed sensor cooling fan engine	B12B 4x2:10 – C
		B12B 6x2:12 – C
		B12BLEA:14 – C
B37	Sensor charge air temperature and charge pressure	B12B 4x2:10 – B
		B12B 6x2:12 – B
		B12BLEA:14 – B
B38	Sensor oil temperature and oil pressure	B12B 4x2:10 – B
		B12B 6x2:12 – B
		B12BLEA:14 – B
B39	Sensor air filter temperature and air filter pressure	B12B 4x2:10 – B
		B12B 6x2:12 – B
		B12BLEA:14 – B
B40	Wear sensor for brakes, left front wheel	3 – C
B41	Wear sensor for brakes, right front wheel	3 — A

See also, 300, Component placement, Description, Design and function

16

The reader is advised that printed copies are uncontrolled.

Component Placement**Volvo Bus Corporation**

Component	Description	Placement
B42	Wear sensor for brakes, left drive wheel	B12B: 7 – C
		B12B 6x2: 7 – C
		B12B LEA: 12 – C
B43	Wear sensor for brakes, right drive wheel	B12B: 7 – A
		B12B 6x2: 7 – A
		B12B LEA: 12 – A
B49	Sensor steering lock	1 – C
B50	Sensor skid angle	4 – B
B51	Pressure sensor fuel pressure	B12B 4x2:10 – B
		B12B 6x2:12 – B
		B12BLEA:14 – B
B54	Pressure sensor crankcase pressure	B12B 4x2:10 – B
		B12B 6x2:12 – B
		B12BLEA:14 – B
B57	Pressure sensor air suspension, left rear	B12B: 6 – B
		B12B 6x2: 11 – B
		B12B LEA: 11 – B

See also, 300, Component placement, Description, Design and function

17

The reader is advised that printed copies are uncontrolled.

Component Placement**Volvo Bus Corporation**

Component	Description	Placement
B58	Pressure sensor air suspension, right rear	B12B: 6 – B
		B12B 6x2: 11 – B
		B12B LEA: 11 – B
B59	Temperature sensor, inside temperature	1 – C
B68	Speed sensor output shaft transmission	B12B: 9 – B
		B12B 6x2: 11 – B
		B12B LEA: 14 – B
B68C	Temperature sensor, coolant retarder	B12B: 9 – B
		B12B 6x2: 11 – B
		B12B LEA: 14 – B
B900	Pressure sensor retarder, manual gearbox	B12B: 9 – B
		B12B 6x2: 11 – B
		B12B LEA: 14 – B
B903	Temperature sensor coolant retarder, manual gearbox	B12B: 9 – B
		B12B 6x2: 11 – B
		B12B LEA: 14 – B
B904	Level sensor, hydraulic oil	B12B: 7 – B

See also, 300, Component placement, Description, Design and function

18

The reader is advised that printed copies are uncontrolled.

Component Placement**Volvo Bus Corporation**

Component	Description	Placement
		B12B 6x2: 7 – B
		B12B LEA: 12 – B
B905	Position sensor, clutch pedal	1 – C
B907	Level sensor fuel level rear axle	B12B: 5 – A/C
		B12B 6x2: 5 – A/C
		B12B LEA: 10 – A/C
B914	Level sensor air suspension, left front	3 – B
B915	Level sensor air suspension, right front	3 – B
B916	Level sensor air suspension, left	B12B LEA: 7 – C
B917	Level sensor air suspension, right	B12B LEA: 7 – A
B920	Fuel sensor 2, front axle	4 – B
B921	Fuel sensor 2, rear axle	B12B: 5 – A/C
		B12B 6x2: 5 – A/C
		B12B LEA: 10 – A/C
B925	Temperature sensor, fire alarm	B12B 4x2:10 – B
		B12B 6x2:12 – B
		B12BLEA:14 – B

See also, 300, Component placement, Description, Design and function

19

The reader is advised that printed copies are uncontrolled.

Component Placement**Volvo Bus Corporation**

Component	Description	Placement
B925A	Temperature sensor, fire alarm	B12B 4x2:10 – B
		B12B 6x2:12 – B
		B12BLEA:14 – B
B925B	Temperature sensor, fire alarm	B12B 4x2:10 – B
		B12B 6x2:12 – B
		B12BLEA:14 – B
B925C	Temperature sensor, fire alarm	B12B 4x2:10 – B
		B12B 6x2:12 – B
		B12BLEA:14 – B
B926	Temperature sensor 2, fire alarm	B12B 4x2:10 – B
		B12B 6x2:12 – B
		B12BLEA:14 – B
B935	Level sensor coolant engine	B12B 4x2:10 – C
		B12B 6x2:12 – C
		B12BLEA:14 – C
B936	Sensor, wear warning right wheel, articulated bus A/B	B12B LEA: 7 – A
B937	Sensor, wear warning left wheel, articulated bus A/B	B12B LEA: 7 – C

See also, 300, Component placement, Description, Design and function

20

The reader is advised that printed copies are uncontrolled.

Component Placement**Volvo Bus Corporation**

Component	Description	Placement
B938	Wheel speed sensor, right wheel, articulated bus A/B	B12B LEA: 7 – A
B940	Wheel speed sensor, left wheel, articulated bus A/B	B12B LEA: 7 – C
E06AL	Reversing light left, articulated bus	B12B LEA: 14 – C
E06AR	Reversing light right, articulated bus	B12B LEA: 14 – A
E06L	Reversing light, left	B12B 4x2:10 – C
		B12B 6x2:12 – C
		B12BLEA:14 – C
E06LA	Extra reversing light, left	B12B 4x2:10 – C
		B12B 6x2:12 – C
		B12BLEA:14 – C
E06R	Reversing light, right	B12B 4x2:10 – A
		B12B 6x2:12 – A
		B12BLEA:14 – A
E07AL	Fog light left, articulated bus	B12B LEA: 14 – C
E07AR	Fog light right, articulated bus	B12B LEA: 7 – A
E07L	Fog light, left front	1 – C
E07LR	Fog light, left rear	B12B 4x2:10 – C

See also, 300, Component placement, Description, Design and function

21

The reader is advised that printed copies are uncontrolled.

Component Placement**Volvo Bus Corporation**

Component	Description	Placement
		B12B 6x2:12 – C
		B12BLEA:14 – C
E07R	Fog light, right front	1 – A
E07RR	Fog light, right rear	B12B 4x2:10 – C
		B12B 6x2:12 – C
		B12BLEA:14 – C
E09AL1	Brake light, left, articulated bus	B12B LEA: 14 – C
E09AL2	Brake light, left, articulated bus	B12B LEA: 14 – C
E09AR1	Brake light, right, articulated bus	B12B LEA: 14 – A
E09AR2	Brake light, right, articulated bus	B12B LEA: 14 – A
E09AT	Brake light, trailer, articulated bus	B12B LEA: 14 – B
E09LA	Brake light, left	B12B 4x2:10 – C
		B12B 6x2:12 – C
		B12BLEA:14 – C
E09LB	Brake light, left	B12B 4x2:10 – C
		B12B 6x2:12 – C
		B12BLEA:14 – C

See also, 300, Component placement, Description, Design and function

22

The reader is advised that printed copies are uncontrolled.

Component Placement**Volvo Bus Corporation**

Component	Description	Placement
E09RA	Brake light, extra	B12B 4x2:10 – C
		B12B 6x2:12 – C
		B12BLEA:14 – C
E09RC	Brake light, right	B12B 4x2:10 – A
		B12B 6x2:12 – A
		B12BLEA:14 – A
E09RD	Brake light, right rear	B12B 4x2:10 – A
		B12B 6x2:12 – A
		B12BLEA:14 – A
E09RE	Brake light, left centre	B12B 4x2:10 – A
		B12B 6x2:12 – A
		B12BLEA:14 – A
E11LF	Side position light, left front	1 – C
E11LR	Side position light, left rear	B12B 4x2:10 – C
		B12B 6x2:12 – C
		B12BLEA:14 – C
E11ML	Side position light, centre left	4 – C

See also, 300, Component placement, Description, Design and function

23

The reader is advised that printed copies are uncontrolled.

Component Placement**Volvo Bus Corporation**

Component	Description	Placement
E11MR	Side position light, centre right	B12B: 5 – A
		B12B 6x2: 5 – A
		B12B LEA: 10 – A
E11RF	Side position light, right front	1 – A
E11RR	Side position light, right rear	B12B 4x2:10 – A
		B12B 6x2:12 – A
		B12BLEA:14 – A
E13AL	Direction indicator, left, articulated bus	B12B 4x2:10 – C
		B12B 6x2:12 – C
		B12BLEA:14 – C
E13AR	Direction indicator, right, articulated bus	B12B 4x2:10 – C
		B12B 6x2:12 – C
		B12BLEA:14 – C
E13ART	Direction indicator, right trailer, articulated bus	B12B 4x2:10 – A
		B12B 6x2:12 – A
		B12BLEA:14 – A
E13L	Direction indicator, left	1 – C

See also, 300, Component placement, Description, Design and function

24

The reader is advised that printed copies are uncontrolled.

Component Placement**Volvo Bus Corporation**

Component	Description	Placement
E13LA	Direction indicator, left	1 – C
E13LR	Direction indicator, left rear	B12B 4x2:10 – C
		B12B 6x2:12 – C
		B12BLEA:14 – C
E13R	Direction indicator, right	1 – A
E13RB	Direction indicator, right	B12B 4x2:10 – A
		B12B 6x2:12 – A
		B12BLEA:14 – A
E13RF	Direction indicator, right rear	B12B 4x2:10 – A
		B12B 6x2:12 – A
		B12BLEA:14 – A
E913A	Diagnostics lamp gearbox EGS	1 – C
E913B	Diagnostics lamp gearbox EGS	1 – C
F42	Fuse emergency switch, main switch	1 – C
F80	Main fuse battery B+	1 – C
F81	Main fuse, main current 30+	1 – C
F93	Fuse alternator	1 – C

See also, 300, Component placement, Description, Design and function

25

The reader is advised that printed copies are uncontrolled.

Component Placement**Volvo Bus Corporation**

Component	Description	Placement
FUSE	Fuse preheating engine	B12B 4x2:10 – B
		B12B 6x2:12 – B
		B12BLEA:14 – B
G01	Battery	1 – C
G01B	Battery	1 – C
G02	Alternator 1	B12B 4x2:10 – B
		B12B 6x2:12 – B
		B12BLEA:14 – B
G03	Alternator 2	B12B 4x2:10 – B
		B12B 6x2:12 – B
		B12BLEA:14 – B
G04	Alternator 4	B12B 4x2:10 – B
		B12B 6x2:12 – B
		B12BLEA:14 – B
H02	Horn	1 – A/B/C
H05	Buzzer	1 – A/C
K35	Disconnection of headlamp washers	1 – C

See also, 300, Component placement, Description, Design and function

26

The reader is advised that printed copies are uncontrolled.

Component Placement**Volvo Bus Corporation**

Component	Description	Placement
M01	Windscreen wiper motor	1 – B
M02	Motor windscreen washer	1 – B
M03	Motor headlamp washers	1 – A/C
M04	Starter motor	B12B 4x2:10 – B
		B12B 6x2:12 – B
		B12BLEA:14 – B
R01	Preheating element, engine	B12B 4x2:10 – B
		B12B 6x2:12 – B
		B12BLEA:14 – B
R06	Preheating element, fuel filter	B12B 4x2:10 – C
		B12B 6x2:12 – C
		B12BLEA:14 – C
R08	Termination resistor SAE J1939	1 – C
S01	Light switch, lighting	1 – C
S02	Stalk direction indicators	1 – C
S06	Stalk windscreen wiper	1 – C
S07	Switch, engine brake	1 – C

See also, 300, Component placement, Description, Design and function

27

The reader is advised that printed copies are uncontrolled.

Component Placement**Volvo Bus Corporation**

Component	Description	Placement
S08	Switch differential lock rear wheels	1 – C
S11	Switch 6x2-lift	1 – C
S12	Main switch	1 – C
S14A	Switch horn	1 – C
S14B	Switch horn	1 – C
S15A	Starter key, key position	1 – C
S15B	Starter key, supply	1 – C
S16	Switch compressed air horns	1 – C
S19	Switch, accessories	1 – C
S24	Stalk retarder	1 – C
S31	Switch traction control (TCS)	1 – C
S32	Switch brake holding	1 – C
S34	Steering wheel buttons	1 – C
S40	Switch battery main switch	1 – C
S41	Battery main switch	1 – C
S45	Contact for engaged differential lock	1 – C
S50	Press contact, parking brake	1 – C

See also, 300, Component placement, Description, Design and function

28

The reader is advised that printed copies are uncontrolled.

Component Placement**Volvo Bus Corporation**

Component	Description	Placement
S58	Switch contact disengaging	1 – C
S68	Temperature sensor, coolant	B12B 4x2:10 – C
		B12B 6x2:12 – C
		B12BLEA:14 – C
S70	Position switch, flow sensor servo steering	B12B 4x2:10 – B
		B12B 6x2:12 – B
		B12BLEA:14 – B
S77	Switch emergency call	1 – C
S902	Switch level retention	1 – C
S904	Switch emergency stop	1 – C
S905	Switch retarder	1 – C
S906	Switch preheating	1 – C
S909	Gear selector VOITH	1 – C
S910	Gear selector Ecomat	1 – C
S913	Contact reversing light	1 – C
S915	Switch kneeling	1 – C
S916	Switch failure EGS	1 – C

See also, 300, Component placement, Description, Design and function

29

The reader is advised that printed copies are uncontrolled.

Component Placement**Volvo Bus Corporation**

Component	Description	Placement
S917	Gear selector EGS	1 – C
S918	Switch extra gear EGS	1 – C
S926	Oil temperature, retarder	B12B: 9 – B
		B12B 6x2: 11 – B
		B12B LEA: 14 – B
S927	Switch alternative gear program ZF	1 – C
S928	Switch, neutral gear, manual gearbox	1 – C
S932	Switch alternative gear change program VOITH	1 – C
S935	Sensor, warning critical angle turntable	1 – C
S938	Switch engine stop rear side	1 – C
U03	Modulator EBS, drive wheel	B12B: 6 – B
		B12B 6x2: 6 – B
		B12B LEA: 11 – B
U08	Modulator EBS, front	4 – B
X09	Slide ring horn	5 – B
Y02	Solenoid valve for differential lock	B12B: 7 – B
		B12B 6x2: 7 – B

See also, 300, Component placement, Description, Design and function

30

The reader is advised that printed copies are uncontrolled.

Component Placement**Volvo Bus Corporation**

Component	Description	Placement
		B12B LEA: 12 – B
Y07	Solenoid valve EPG	B12B 4x2:10 – B
		B12B 6x2:12 – B
		B12BLEA:14 – B
Y17	Solenoid valve retarder, manual gearbox	B12B: 9 – B
		B12B 6x2: 11 – B
		B12B LEA: 14 – B
Y25	Solenoid valve assembly for ECS, rear	B12B: 6 – B
		B12B 6x2: 6 – B
		B12B LEA: 11 – B
Y37	Solenoid valve EPG	B12B 4x2:10 – B
		B12B 6x2:12 – B
		B12BLEA:14 – B
Y39	Solenoid valve, VEB	B12B 4x2:10 – B
		B12B 6x2:12 – B
		B12BLEA:14 – B
Y40	Solenoid valve block ECS, forward	4 – B

See also, 300, Component placement, Description, Design and function

31

The reader is advised that printed copies are uncontrolled.

Component Placement**Volvo Bus Corporation**

Component	Description	Placement
Y47	Solenoid valve pump, hydraulic oil fan	B12B 4x2:10 – B
		B12B 6x2:12 – B
		B12BLEA:14 – B
Y72	Solenoid valve, horn	1 – C
Y901	Solenoid valve for fuel shut-off	2 – B
Y904	Valve retarder, ZF	1 – C
Y905	Accumulator valve, ZF	1 – C
Y910	Operation valve retarder, ZF	1 – C
Y913	Solenoid valve, gear prohibited	B12B 4x2: 9 – B
		B12B 6x2: 11 – B
		B12B LEA: 14 – B
Y924	Solenoid valve oil separator	B12B 4x2:10 – B
		B12B 6x2:12 – B
		B12BLEA:14 – B

See also, 300, Component placement, Description, Design and function

32

The reader is advised that printed copies are uncontrolled.

1 (driver environment)

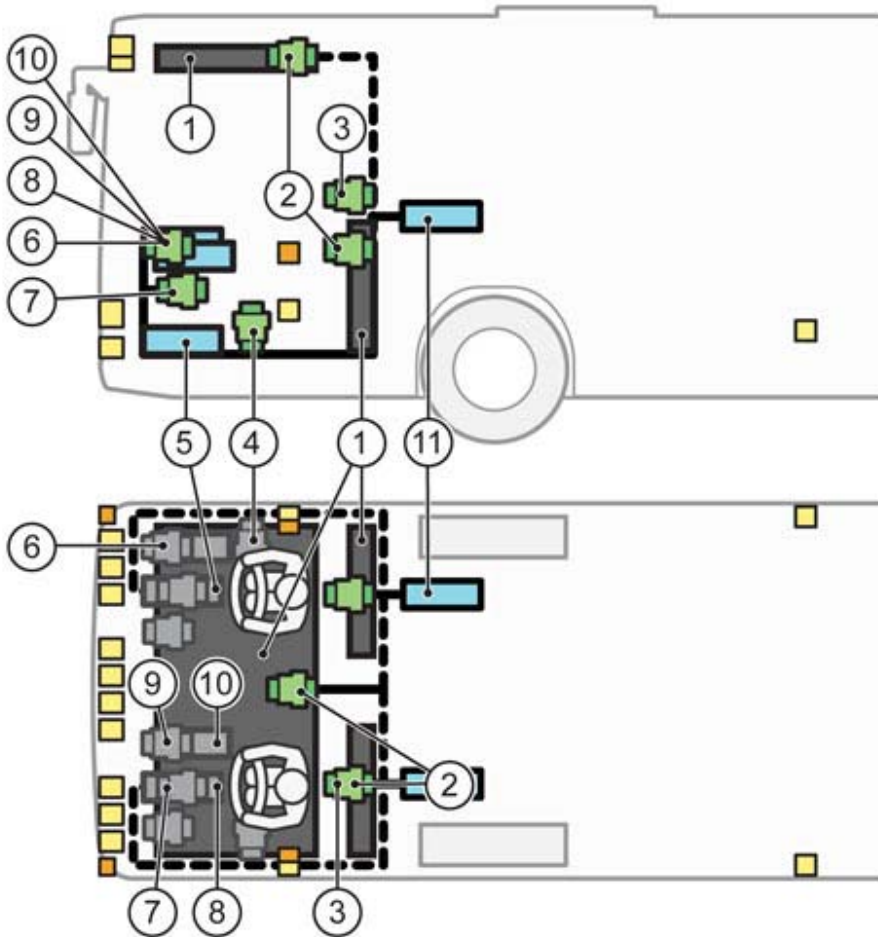

The illustration shows in principle how the chassis cabling is routed and where the intermediate connector pieces, control units and electrical distribution units are located. The dashed lines show alternative cable routings. The illustration is used for both right-hand drive and left-hand drive vehicles, where of certain components are drawn in two places.

Note: The table includes components that the vehicle is not equipped with.

Placement	Components named according to wiring diagram
1	A16 (ECS)
	A17 (VECU)

See also, 300, Component placement, Description, Design and function

The reader is advised that printed copies are uncontrolled.

	A21 (EBS)
	A27 (LCM)
	A65 (RECU)
	A90 (BBM)
	A125 (Dynafleet)
	A943 (BIO)
	A946 (FMS)
	K1– K17, K25 – K28
	F1 – F64, F96 – F99, F90A, F90B
	FH1A, FH1B
	FH2A, FH2B
	FH3A, FH3B, FH4A, FH4B
	U06
	S_T_S, S_T_T
2	ACC, BB10B, XC937, DEV-CAN
	ARTIC, BB1, BS1, ENG1, IB10
	BB2, BOGIE, BS2, IB9, EMS
	BB3, ECS1, IB8, RA1

See also, 300, Component placement, Description, Design and function

The reader is advised that printed copies are uncontrolled.

	BB4, BB6, BB6A, BB6B, ECS2, EU4, IB7
	BB5, BB5A, BB5B, BS3, FUEL, IB6, BB7
	IB1
	IB2
	GBX, IB3
	IB4
	IB5
	BB11, BBOX
	BB13
	FTM, KH2A, KH2B, GS1, XC933
	GB1
	IS, XC925, SP_F, SP_RR
	KH1A, KH1B, KH3A, KH3B
	RL4 (B6R/B7R, B9R, B12M, B12B)
	XC917, XC921, XC935, XK2
3	X25
4	BMUX
5	A30 (SWM)

See also, 300, Component placement, Description, Design and function

The reader is advised that printed copies are uncontrolled.

6	DF
7	OBD2
8	A03 (BIC)
	A07 (Radio)
	A33 (TACHO)
9	AUDIO, BB10A
	BB10A
10	A926 (GSECU)
11	A900 (Voith TECU)
	A901 (ZF ECOMAT TECU)
Left front	FL2
	FL2A
Right front	FL3
	FL3A

Electrical distribut.unit, chassis

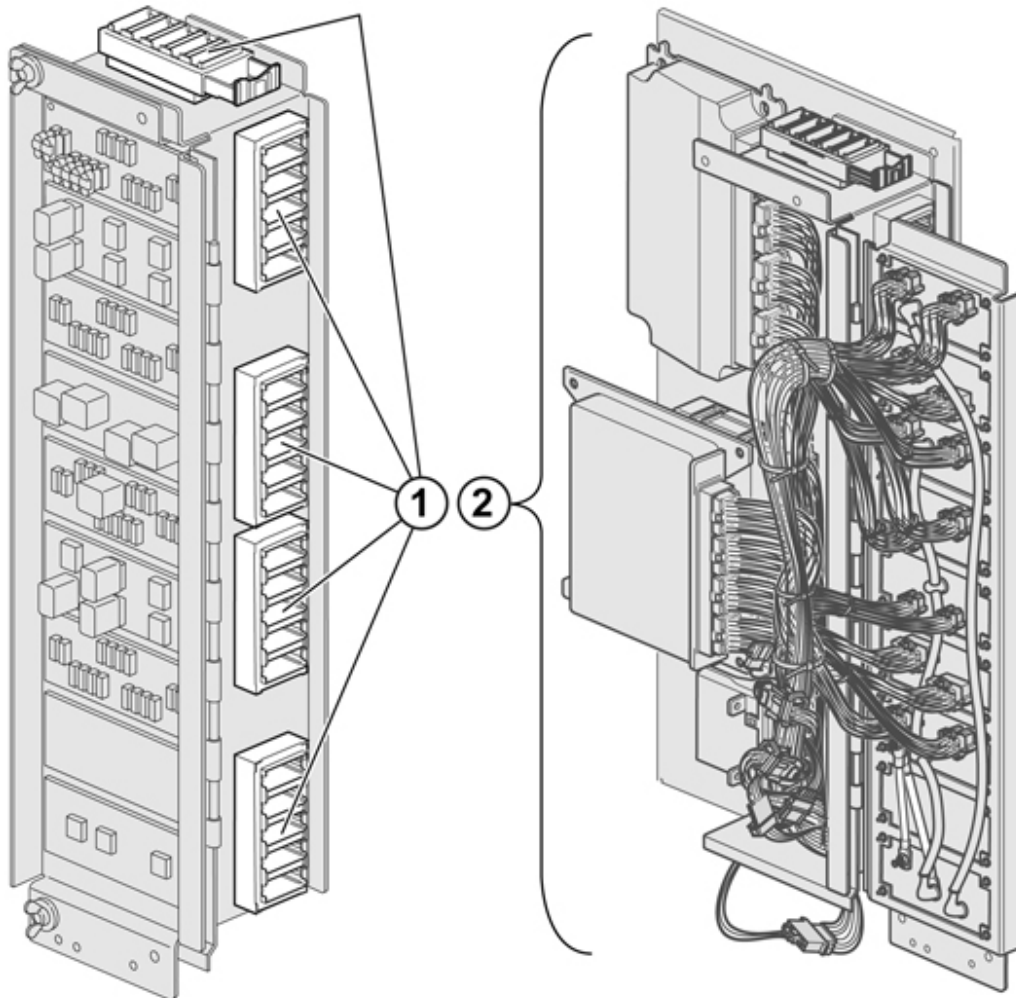

Note: The table includes components that the vehicle is not equipped with.

Placement	Components named according to wiring diagram
1	ARTIC, BB1, BS1, ENG1, IB10
	BB2, BOGIE, BS2, IB9, EMS
	BB3, ECS1, IB8, RA1

See also, 300, Component placement, Description, Design and function

The reader is advised that printed copies are uncontrolled.

	BB4, BB6, BB6A, BB6B, ECS2, EU4, IB7
	BB5, BB5A, BB5B, BS3, FUEL, IB6, BB7
	IB1
	IB2
	GBX, IB3
	IB4
	IB5
2	A16 (ECS)
	A17 (VECU)
	A21 (EBS)
	A27 (LCM)
	A65 (RECU)
	A90 (BBM)
	A125 (Dynafleet)
	A943 (BIO)
	A946 (FMS)
	K1– K17, K25 – K28
	F1 – F64, F96 – F99, F90A, F90B

See also, 300, Component placement, Description, Design and function

The reader is advised that printed copies are uncontrolled.

FH1A, FH1B
FH2A, FH2B
FH3A, FH3B, FH4A, FH4B
U06
BB11, BBOX
BB13
FTM, KH2A, KH2B, GS1, XC933
GB1
IS, XC925, SP_F, SP_RR
KH1A, KH1B, KH3A, KH3B
RL4 (B6R/B7R, B9R, B12M, B12B)
XC917, XC921, XC935, XK2
ACC, BB10B, XC937
S_T_S, S_T_T

Relay

The placement of the relays in the electrical distribution unit is described below.

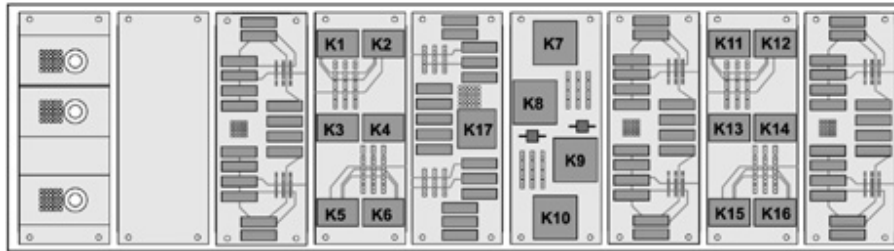

Relay	Designation
K1	—
K2	Overload indicator (option)
K3	ECS (air suspension control unit)
K4 ₁	TECU (gearbox control unit), GECU (gear selector control unit), gearbox I-Shift
K5 ₁	EGS manual gearbox
K6 ₁	EGS manual gearbox
K7	Starter motor
K8 ₁	VECU (vehicle control unit), EECU (motor control unit)
K9	Wiper motor intermittent relay
K10	Inverting relay, neutral signal (only automatic gearboxes)
K11	Start inhibit relay
K12	Stowage compartment lighting
K13	Emergency cut-out
K14 ₁	Bogie axle

See also, 300, Component placement, Description, Design and function

The reader is advised that printed copies are uncontrolled.

K15 ¹	RECU (retarder control unit)
K16 ¹	RECU (retarder control unit)
K17	Ignition relay (+15)

¹ Dependent on variant

Fuses

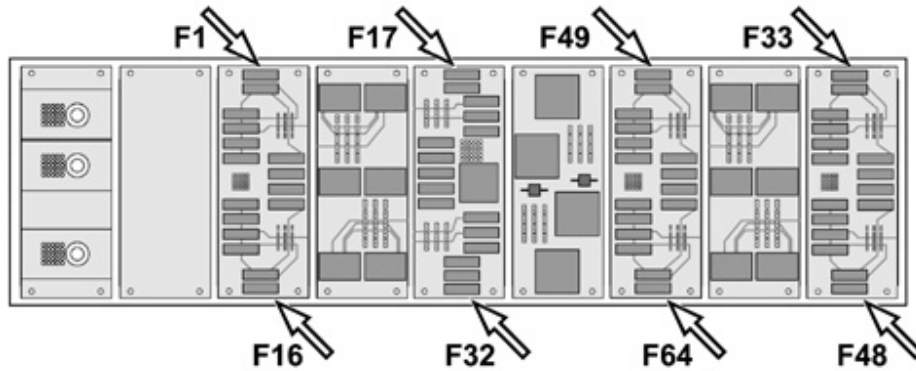

Fuse	Rating	Designation
F1	5 A	ECS (air suspension control unit)
F2	10 A	BIC (instrument panel), lamp check switch
F3	15 A	Starting signal, starter motor
F4	20 A	EBS (brake control unit)
F5	5 A	Horn
F6	5 A	Emergency parking brake release
F7 ₁	15 A	TECU (transmission electronic control unit), gearbox I-shift
F8 ₁	5 A	GECU (gear selection control unit) I-shift
F9	5 A	Start switch, engine compartment
F10	5 A	Fire Alarm
F11 ₁	10 A	Dynafleet (option)
F12	5 A	Supply, main switch (+30) to body-builder outlet
F13	10 A	Automatic oil filling (option)
F14	5 A	BBM (Body Builder Module)
F15	15 A	EECU (Engine Electronic Control Unit), control valve, cooling fan
F16	5 A	VECU (Vehicle Electronic Control Unit)

See also, 300, Component placement, Description, Design and function

The reader is advised that printed copies are uncontrolled.

Fuse	Rating	Designation
F17	5 A	Lighting, level control switch
F18	5 A	Alternator 1, 2, 3
F19 ¹	10 A	Control unit, turntable
F20	10 A	EBS (brake control unit)
F21	15 A	Wiper motor, windscreen
F22 ¹	5 A	TECU (Transmission Electronic Control Unit), Voith automatic transmission
F24	5 A	BIC (instrument)
F25	15 A	Wiper motor, headlights
F26	5 A	ECS (air suspension control unit)
F27 ¹	10 A	EGS manual gearbox
F28 ¹	10 A	RECU (Retarder Electronic Control Unit)
F29	5 A	Supply, ignition (+15) to body-builder outlet
F30 ¹	5 A	Fuel heater (D7E engine)
F31 ¹	10 A	Hydraulic oil level, SCR (control unit exhaust cleaning)
F32 ¹	5 A	Tachograph
F33	5 A	BIC (instrument)
F34 ¹	10 A	Tachograph
F35	25 A	LCM (external lighting control unit)
F36	25 A	LCM (external lighting control unit)
F37	25 A	LCM (external lighting control unit)
F38	5 A	Inverted +15
F39	25 A	SCR (control unit exhaust cleaning)

See also, 300, Component placement, Description, Design and function

The reader is advised that printed copies are uncontrolled.

Fuse	Rating	Designation
F41	20 A	Radio
F42	5 A	Main switch
F44	25 A	LCM (external lighting control unit)
F45	25 A	LCM (external lighting control unit)
F46	25 A	LCM (external lighting control unit)
F47	5 A	Side position light, right
F48	5 A	Side position light, left
F49	5 A	Fuel shut-off valve
F50 ¹	10 A	RECU (Retarder Electronic Control Unit)
F51	5 A	Radio
F52 ¹	10 A	Stowage compartment lighting
F53 ¹	5 A	Trailing axle, water separator heater
F54 ¹	5 A	Engine/luggage compartment door
F55 ¹	10 A	Engine brake, cooling fan solenoid valve, pre-heater relay
F56 ¹	10 A	Engine brake
F57	5 A	Supply, ignition lock
F58 ¹	5 A	Control unit, tank valves (only gas buses)
F60 ¹	10 A	TECU (Transmission Electronic Control Unit), Voith automatic transmission
F61 ¹	10 A	Stowage compartment lighting
F62 ¹	5 A	Sleeping bunk lighting
F63	5 A	Starter motor
F64 ¹	10 A	Indicates overload

See also, 300, Component placement, Description, Design and function

The reader is advised that printed copies are uncontrolled.

¹ Dependent on variant.

Note: The table includes components that the vehicle is not equipped with. When there is no illustration for a component, a symbol illustration is shown. More adapters than those stated can fit the connector pieces.

Intermediate connector pieces

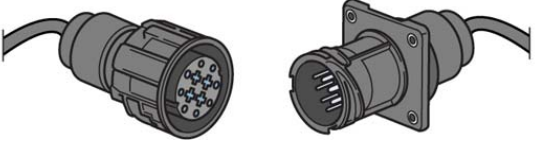
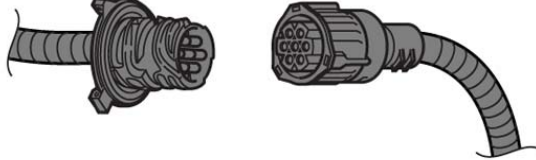
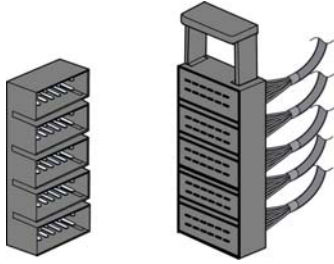
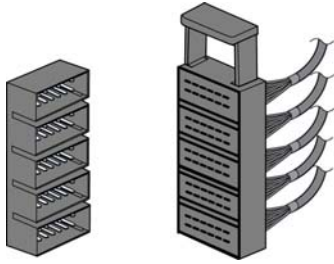
Wiring diagram designation, component/connector piece	Illustration	Adapter	Index in breakout box
A14_, A14A, FL2, FL3, LT1, MEDA, RL1, RL2, RL3, RL5, RL6, RL7, TRAIL2, UDS, XC914A		9998563	1 – 12
A14B, A14C, A14D, A43, BMUX, CAN, FL2A, FL3A, LA, ML1, ML2, ML3, ML3B, ML4, ML4A, ML4B, ML5, ML6, ML7, RL1A, RL2A, RL4, TRAIL3, VIC2, XC915, XC916, XC931, Y17		88890053	1– 7
ARTIC, BB1, BS1, IB10		9990805 or 88890116	1 – 12
ENG1, ENG1B		9990008, 9990805 or 88890116	– or 1 – 12
BB2, BOGIE, BS2, IB9		9990805 or 88890116	13 – 24 or 19 – 30 (88890116)
EMS, EMSB		9990008, 9990805 or 88890116	– or 19 – 30 (88890116)

See also, 300, Component placement, Description, Design and function

The reader is advised that printed copies are uncontrolled.

Component Placement

Volvo Bus Corporation

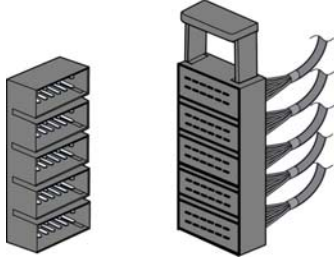
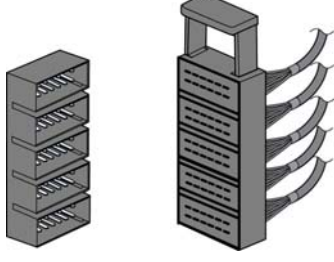
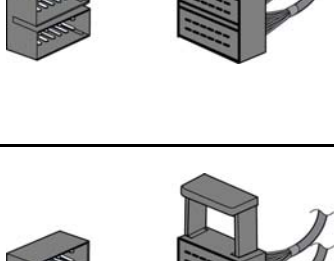
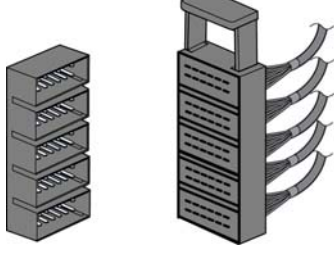
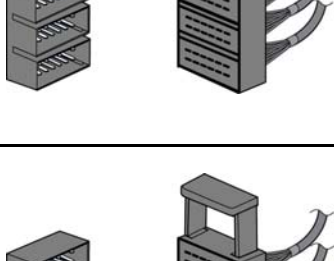
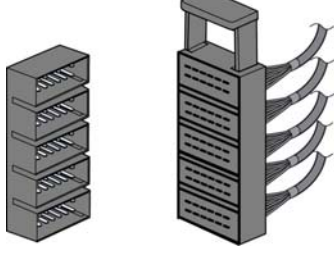
BB3, ECS1, IB8, RA1, RA1B		9990805 or 88890116	25 – 36 or 37 – 48 (88890116)
BB4, ECS2, ECS2B, EU4, IB7		9990805 or 88890116	37 – 48 or 55 – 62 plus 1 – 10 (88890116)
BB6, BB6A, BB6B		9990008 , 9990805 or 88890116	– or 55 – 62 plus 1 – 4 (88890116)
BB5, BB5.A, BB5.B, BS3, BS3B, FUEL, IB6		9990805 or 88890116	49 – 60
BB7, BB7A, BB7B		9990008 , 9990805 or 88890116	– or 11 – 22 (88890116)
IB1		9990008 or 88890116	– or 11 – 28 (88890116)

See also, 300, Component placement, Description, Design and function

The reader is advised that printed copies are uncontrolled.

Component Placement

Volvo Bus Corporation

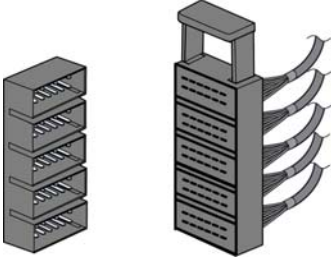
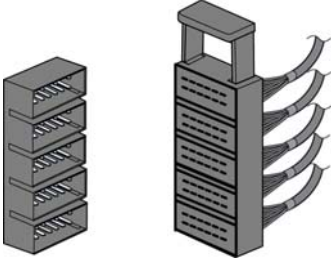
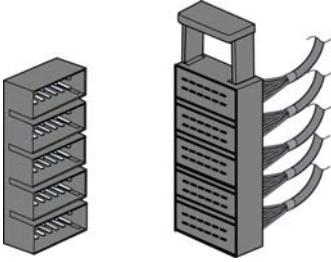
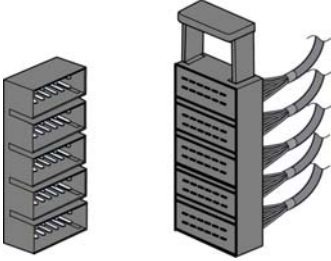
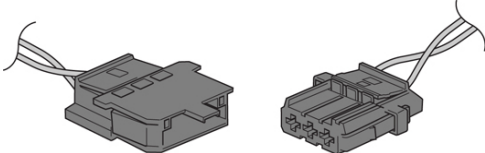



<p>IB2</p>		<p>9990008 or 88890116</p>	<p>— or 55 – 62, 1–10 (88890116)</p>
<p>GBX, IB3</p>		<p>9990008 or 88890116</p>	<p>— or 37 – 54 (88890116)</p>
<p>IB4</p>		<p>9990008 or 88890116</p>	<p>— or 19 – 36 (88890116)</p>
<p>IB5</p>		<p>9990008 or 88890116</p>	<p>— or 1 – 18 (88890116)</p>
<p>AUDIO, BB11, BB8, BBOX, RL, XC927, BBOX, S_T_S, S_T_T, XC922</p>		<p>9990008</p>	<p>—</p>

See also, 300, Component placement, Description, Design and function

The reader is advised that printed copies are uncontrolled.

Component Placement

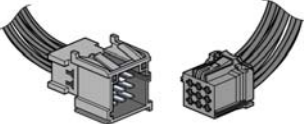
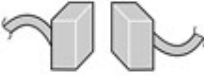
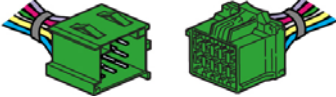
Volvo Bus Corporation





<p>B_A, B930T, IS, LT2, R905A, R905B, R906A, R906B, R906C, R908A, R908B, R908C, R910A, R910B, R910C, S901_U1, S908, SP_F, SP_RR, UDS, XC925, XC932A, XC934, XJK</p>		<p>88890039</p>	<p>1 – 4</p>
<p>KH1A, KH1B, KH3A, KH3B</p>		<p>9998596</p>	<p>18 – 32</p>
<p>ACC, BB10A, BB10B, DEV-CAN, FH2A, FH2B, XC937</p>		<p>9998596</p>	<p>33 – 41</p>
<p>XC917, XC921, XC935, XK2</p>		<p>9998596</p>	<p>42 – 47</p>
<p>CNG, DF, EU4B, FH1A, FH3A, FH3B, FH4A, FH4B, FTM, GS1, KH2A, KH2B, XC926, XC930, XC933</p>		<p>9998596</p>	<p>49 – 60</p>
<p>FM</p>			
<p>LT_, TRAIL, TRAIL1</p>		<p>9990090</p>	<p>1 – 31</p>

See also, 300, Component placement, Description, Design and function

The reader is advised that printed copies are uncontrolled.

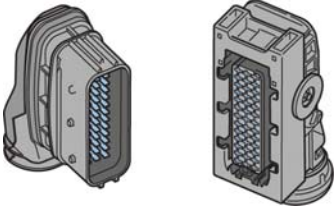
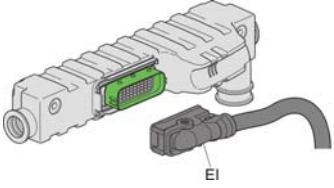
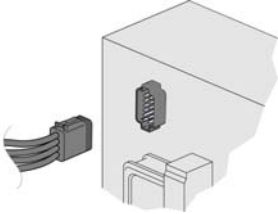
Component Placement

Volvo Bus Corporation

REV			
VIC/EI (D7E), MED, XC941		88890025	1 – 39
VIC/EI		88890025	1 – 39
X904.XC207		9990008	—
BB13			
GB1			
X25			
DPF			

See also, 300, Component placement, Description, Design and function

The reader is advised that printed copies are uncontrolled.

Component Placement

Volvo Bus Corporation

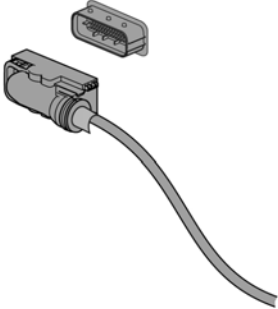
XC940		9990014	1 – 62
-------	---	-------------------------	--------

Note: The table includes components that the vehicle is not equipped with. The illustrations show examples of the components' appearance. When there is no illustration for a component, a symbol illustration is shown. More adapters than those stated can fit the connector pieces.

See also, 300, Component placement, Description, Design and function

The reader is advised that printed copies are uncontrolled.

Control units

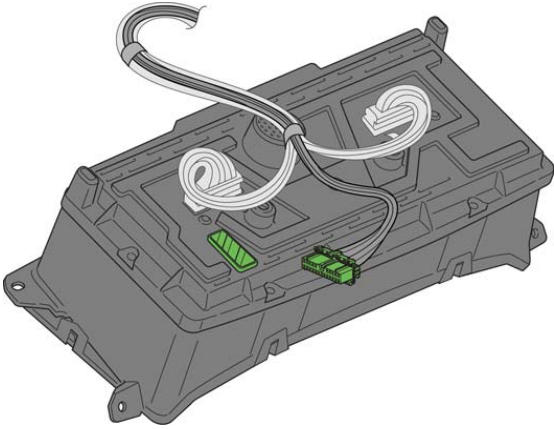
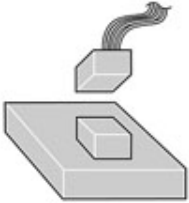
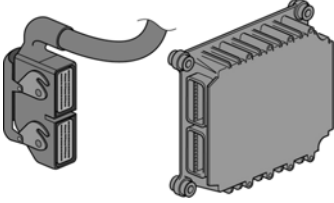
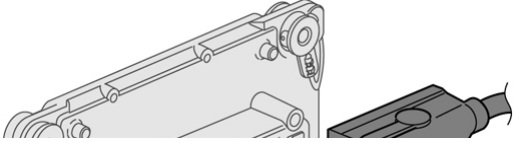
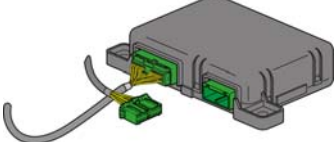
Wiring diagram designation, component/connector piece	Illustration	Adapter	Index in breakout box
A03.A		9998533	31 – 52
A03.B		9813194	1 – 30
A03.C		9998533	1 – 30
A07.A			
A07.B			
A07.C			
A14.A (EMS1)		9998505	1 – 36
A14.B (EMS1)		9998505	1 – 36
A14.A (EMS2)		9990014	1 – 62
A14.B (EMS2)		9990014	1 – 62
A16.A		9813194	1 – 30
A16.B		9998533	31 – 52

See also, 300, Component placement, Description, Design and function

The reader is advised that printed copies are uncontrolled.

Component Placement

Volvo Bus Corporation

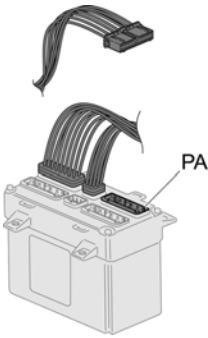
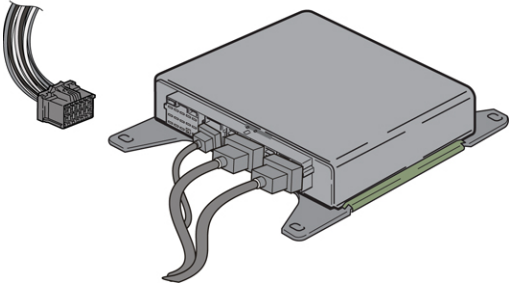
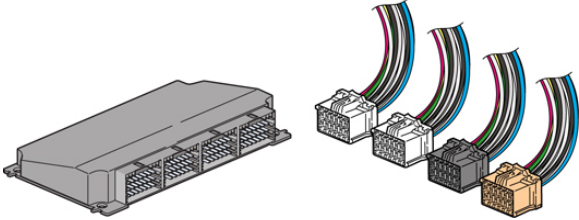
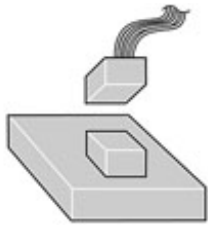
A17.A		9813194	1 – 30
A17.B		9998533	1 – 30
A17.C		9998604	26 – 30
A21.A		9998596	1 – 17
A21.B		9990025	1 – 18
A21.C		9998596	18 – 32
A21.D		—	—
A27.A		9990025	19 – 39
A27.B		9990025	1 – 18
A27.C		9990025	1 – 18
A27.D		9990025	19 – 39
A30		9813194	47 – 56

See also, 300, Component placement, Description, Design and function

The reader is advised that printed copies are uncontrolled.

Component Placement

Volvo Bus Corporation

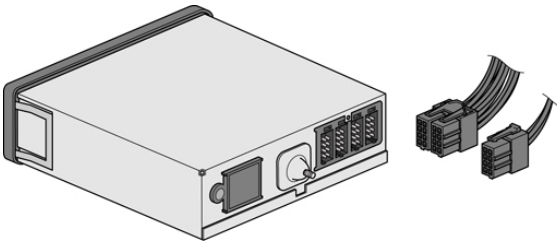
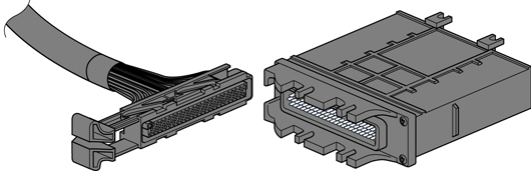
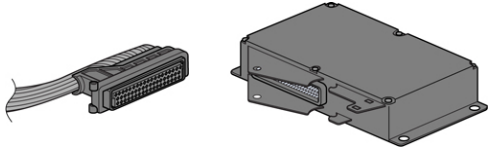
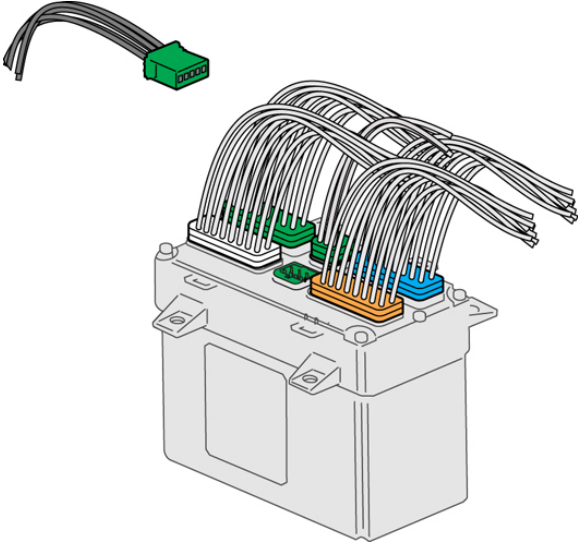

A33.A		9990008	—
A33.B		9990008	—
A33.C		9990008	—
A33.D		9990008	—
A59A		9990155	1 – 62, 1 – 6
A65		9998543	1 – 55
A90.A		9998533	1 – 30
A90.B		9813194	1 – 30
A90.C		9998604	26 – 30

See also, 300, Component placement, Description, Design and function

The reader is advised that printed copies are uncontrolled.

Component Placement

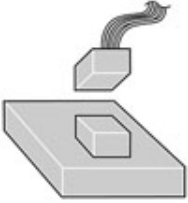
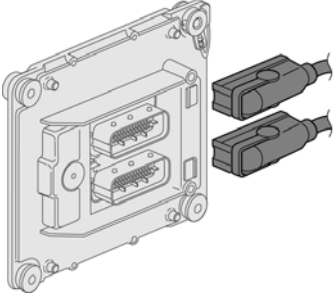
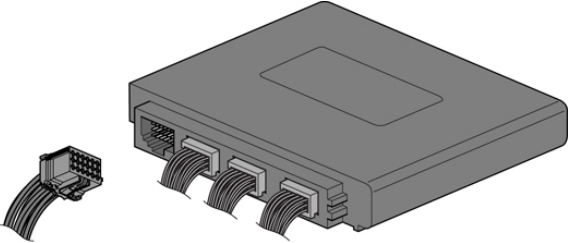
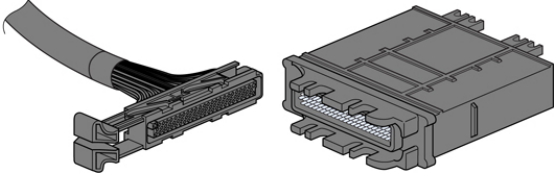
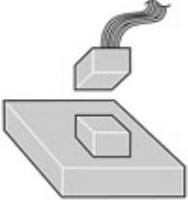
Volvo Bus Corporation

A125			
A141.A		9990014	1 – 62
A141.B		9990014	1 – 62
A900.A (VOITH)		9990025	1 – 18
A900.B (VOITH)		9990025	1 – 18
A900.C (VOITH)		9998596	18 – 32
A900.D (VOITH)		9990025	1 – 18
A901		9990155	1 – 61, 1 – 6
A904			
A914.A		9990041	1 – 20

See also, 300, Component placement, Description, Design and function

The reader is advised that printed copies are uncontrolled.

Component Placement

Volvo Bus Corporation

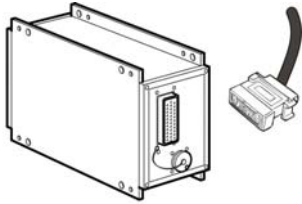
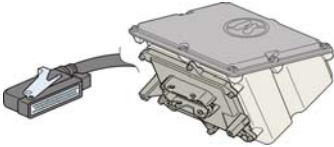
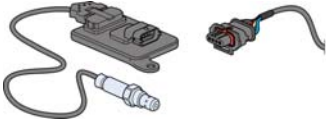
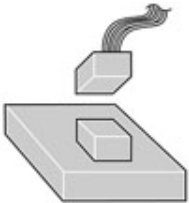
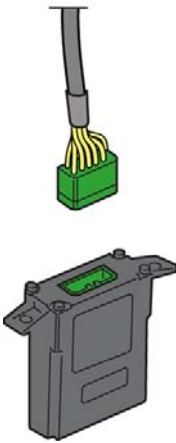
A914.B		9990041	1 – 20
A914.C		9990041	1 – 20
A916.A		9998996	1 – 29
A916.B		9998996	31 – 46
A916.C		9998996	31 – 46
A917		88890052	1 – 35
A918		9990216	1 – 4
A925.A		9813194	1 – 30
A925.B		9998533	1 – 30
A925.C		9998604	26 – 30
A926		9998533	31 – 52

See also, 300, Component placement, Description, Design and function

The reader is advised that printed copies are uncontrolled.

Component Placement

Volvo Bus Corporation

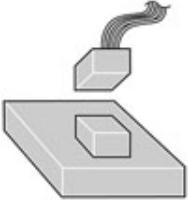
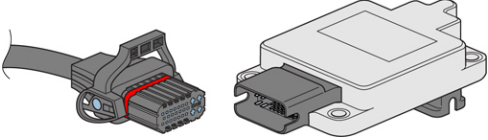
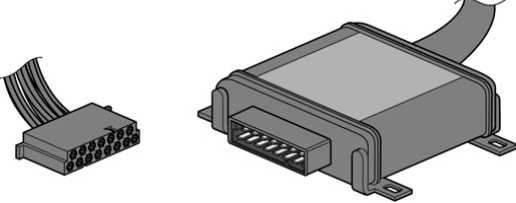
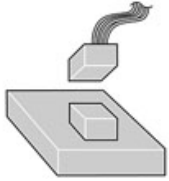
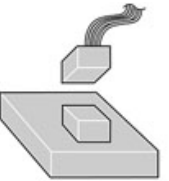
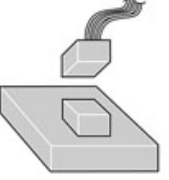
A927			
A929.A		88810020	1 – 25
A929.B		88810020	26 – 50
A930			
A942.A		9813194	1 – 30
A942.B		9998533	1 – 30
A942.C		9998604	26 – 30
A943			
A945			

See also, 300, Component placement, Description, Design and function

The reader is advised that printed copies are uncontrolled.

Component Placement

Volvo Bus Corporation

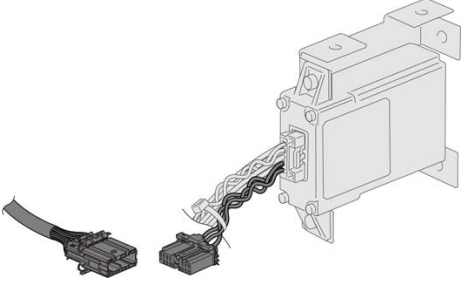
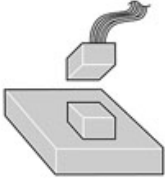
A946	 A technical drawing of a rectangular electronic component with mounting tabs on the top and bottom. A multi-wire cable is connected to the front of the component. To the left of the component, there is a separate cable with a connector.	9813194	31 – 46
A952	 A technical drawing showing a small rectangular component being inserted into a larger rectangular base. A cable is attached to the top of the small component.		

See also, 300, Component placement, Description, Design and function

The reader is advised that printed copies are uncontrolled.

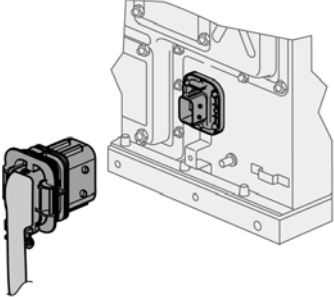
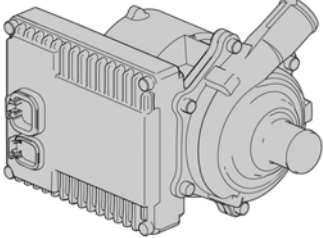
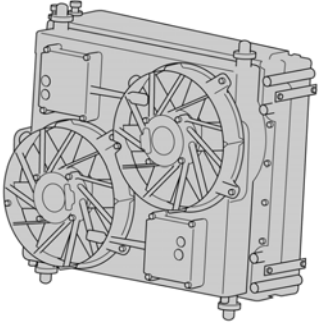
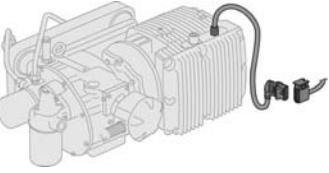
G07.A			
G07.B		88890093	1 – 15
M30, M33		9990008	—
M31, M32		9990008	—
M35, M36			

Component Placement

Volvo Bus Corporation

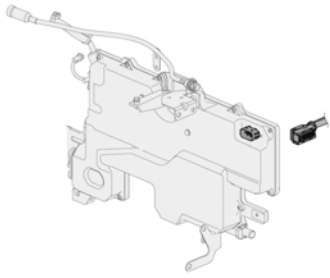
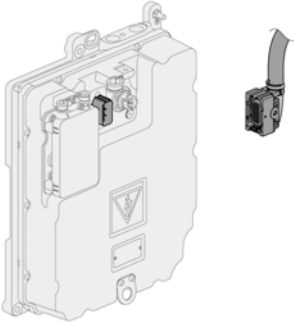
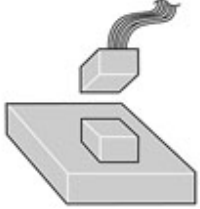
U23		88890094	1 – 21
U24		88890094	1 – 21
Y54		88890053	1 – 7

Note: The table includes components that the vehicle is not equipped with. More adapters than those stated can fit the connector pieces.

See also, 300, Component placement, Description, Design and function

The reader is advised that printed copies are uncontrolled.

Diagnostic connector

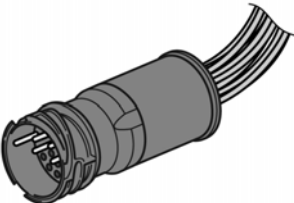
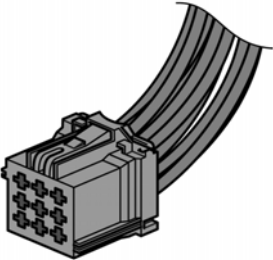
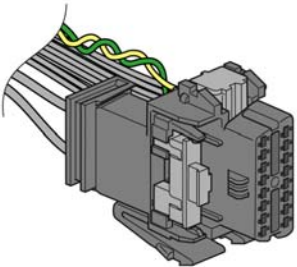
Wiring diagram designation, component/connector piece	Illustration	Adapter	Index in breakout box
DIA			
DIA2		9998596	33 – 41
DIA-16, OBD2		88890018 9998960	

See also, 300, Component placement, Description, Design and function

The reader is advised that printed copies are uncontrolled.

Component Placement

Volvo Bus Corporation

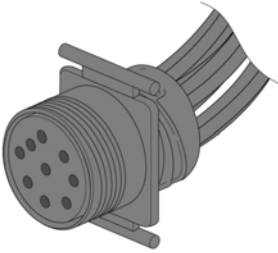
		9990137	
--	---	-------------------------	--

See also, 300, Component placement, Description, Design and function

The reader is advised that printed copies are uncontrolled.

Electrical distribution units

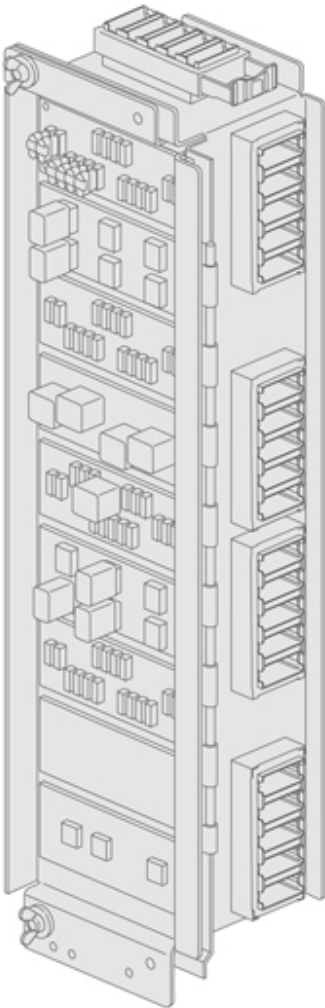
Wiring diagram designation, component/connector piece	Illustration
Electrical distribution unit	

See also, 300, Component placement, Description, Design and function

The reader is advised that printed copies are uncontrolled.

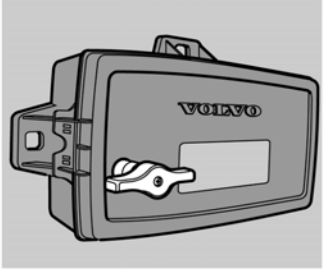
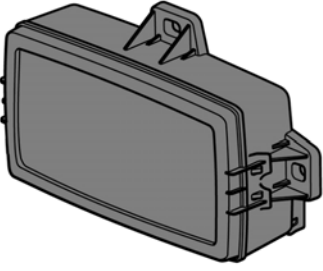
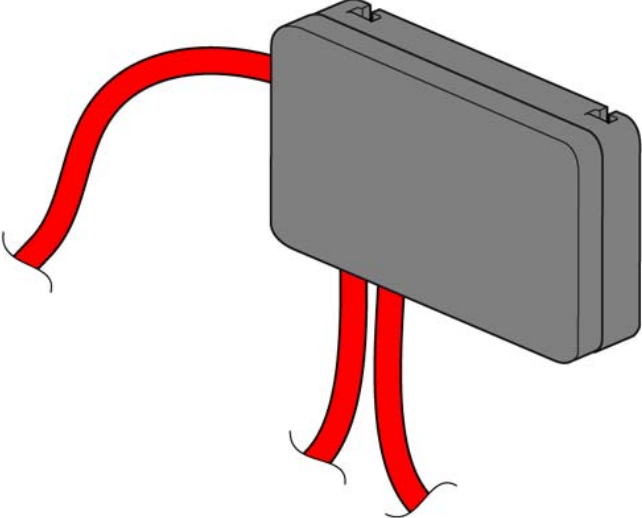
X903	 A grey, rectangular component box with a handle on top. The word "VOLVO" is printed on the front. A metal terminal is attached to the front face.
X904	 A grey, rectangular component box shown from a side perspective, highlighting its depth and the mounting tabs on the side.
X905	 A grey, rectangular component box with three red cables connected to it. One cable enters from the left side, and two cables exit from the bottom.

See also, 300, Component placement, Description, Design and function
The reader is advised that printed copies are uncontrolled.

BILL OF MATERIAL/COMPONENT LIST

Part Name	Description	Location	Part Type
A03	Instrument cluster	{NA 4 B} {XC 5 C} {XD 5 C} {CP 0 B}	componentSymbol
A07	Radio	{IU 4 B}	componentSymbol
A14	Control unit, EMS	{CC 5 C}	componentSymbol
A14_7	Control unit, EMS	{XC 5 A} {CN 5 C} {XD 3 A}	componentSymbol
A14_9	Control unit, EMS	{XC 3 A} {XD 5 A}	componentSymbol
A14_9MG	Control unit, EMS	{XC 3 A} {CB 5 C} {XD 5 A}	componentSymbol
A14_12	Control unit, EMS	{XC 4 A} {CM 5 C} {XD 3 A}	componentSymbol
A14_MD9	Control unit, EMS	{CA 5 C}	componentSymbol
A16	Control unit, ECS, Electronic Controlled Suspension	{FA 5 A} {XC 1 C} {XD 1 C} {FB 5 D}	componentSymbol
A17	Control unit VECU	{BA 5 B} {XC 2 C} {XD 2 C} {CP 2 D}	componentSymbol
A19	Control unit, GECU, gear selector ECU	{DN 5 B}	componentSymbol
A21	Control unit, EBS, Electronically controlled Brake System	{XC 1 C} {EO 5 A} {XD 2 C} {EP 5 D}	componentSymbol
A26	Control unite,ACC(Adaptive Cruise Control)	{BE 3 C}	componentSymbol
A27	Control unit, LCM, Light Control Module	{GA 5 C} {GB 5 C} {GC 5 D} {XD 2 D}	componentSymbol
A30	Control unite,SWM(Steering Wheel Module)	{IS 4 C}	componentSymbol
A33	Tachograph	{NB 4 C} {XC 4 C} {NC 4 B} {Wrong world, out of range.}	componentSymbol
A41	Control unit, Contains B23, B06 and Y17	{DN 3 B}	componentSymbol
A42	Control unit, Contains B26, Y21, Y22, Y23 and Y26	{DN 1 B}	componentSymbol
A44	Control unit, Body I/O Module 44	{CM 3 D}	componentSymbol
A44_	Control unit, Body I/O Module 44	{CC 3 B}	componentSymbol
A44_D9	Control unit, Fuel pump	{CA 3 C}	componentSymbol
A45	Body I/O Module 45	{CA 3 C}	componentSymbol
A45_	Control unit, Body I/O Module 45	{CC 1 C}	componentSymbol
A45_MD12	Control unit, Fuel water separator	{CM 3 D}	componentSymbol

VOLVO

Volvo Bus Corporation

Document Title

WIRING DIAGRAM

Document Type

PRODUCT SCHEMATIC

Document No

20904123

Issue Index

10

Volume No

02(02)

Page No

1(72)

Part Name	Description	Location	Part Type
A59A	Control unit, RAS ECU	{FO 3 C}	componentSymbol
A65	Control unit, RECU, Retarder Electronic	{DM 5 B} {XC 1 A} {XD 1 A}	componentSymbol
A66	Kamera LKS	{BE 5 A}	componentSymbol
A80	Control unit, Heated air dryer, electronically controlled	{BA 2 A}	componentSymbol
A90	Control unit, BBM, Body Builder Module	{BB 5 A} {XC 3 C} {AA 4 A} {XD 2 C} {BC 5 D}	componentSymbol
A124	Start Motor	{AD 4 C} {AE 4 B} {AF 4 B} {AH 4 B}	componentSymbol
A124.30B		{AE 4 C}	componentSymbol
A125	Control unit, DYNAFLEET	{NC 4 B} {XD 4 C}	componentSymbol
A146	Control Unit, RV165 Tracking System	{CP 2 C}	componentSymbol
A900	Control unit, Voith automatic transmission	{DC 5 B}	componentSymbol
A900_ART	Control unit, VOITH ECU, ARTIC	{DO 5 B}	componentSymbol
A901	Control unit, ZF automatic transmission	{DB 5 C} {XC 0 A} {XD 2 A}	componentSymbol
A904	Control unit, Volvo EGS gearbox	{DA 5 C}	componentSymbol
A914	Control unit, I shift TECU, Transmission Electronic	{XC 5 A} {DN 3 C} {XD 4 A}	componentSymbol
A916	Control unit, AMECU	{FC 4 B}	componentSymbol
A916_A	Control unit, AMECU	{LB 4 C}	componentSymbol
A916_B	Control unit, AMECU	{LA 4 C}	componentSymbol
A917	Control unit, DNOX2 ECU	{CU 5 C} {CV 4 B}	componentSymbol
A918	Control unit, NOx sensor	{CV 3 A}	componentSymbol
A925	Control unit, FTM, Fuel Tank Monitoring	{CG 4 C}	componentSymbol
A926	Control unit, GearShift ECU	{XC 5 C} {DN 5 C} {XD 3 D}	componentSymbol
A927	Control unit, GECU, Ecomat 5	{DD 4 D}	componentSymbol
A928	Control unit, Gearbox Ecomat 5	{DD 2 B}	componentSymbol
A929	TECU - EcoLife	{XC 5 A} {DD 2 B} {XD 4 A}	componentSymbol
A930	Control unit, Gateway DIVA5	{DC 4 D}	componentSymbol
A930_ARTIC	Control unit, Gateway DIWA5	{DO 4 D}	componentSymbol
A942	BIO - Bus I/O	{CL 4 C}	componentSymbol
A943	Control unit, Oilmaster	{CO 4 B}	componentSymbol
A945	Control unit, VDO FM200	{ND 4 D}	componentSymbol
A946	Control unit, Gateway FMS, Fleet management system	{NE 3 C}	componentSymbol
A953 CNG	Module Control Ignition,CNG	{CD 0 D}	componentSymbol
A954 CNG	EMS- Cummins-CNG	{CD 0 C}	componentSymbol
A961	Alcohol Interlock, ECU	{NC 1 C}	componentSymbol

VOLVO

Volvo Bus Corporation

Document Title

WIRING DIAGRAM

Document Type

PRODUCT SCHEMATIC

Document No

20904123

Issue Index

10

Volume No

02(02)

Page No

2(72)

Part Name	Description	Location	Part Type
A997		{BE 1 B}	componentSymbol
B03	Sensor, footbrake valve	{EO 4 D}	componentSymbol
B04	Sensor,engine speed,crankshaft	{CM 4 A}	componentSymbol
B04_	Sensor, engine speed crankshaft	{CC 3 B}	componentSymbol
B05	Sensor,engine speed,camshaft	{CM 3 A}	componentSymbol
B05_	Sensor, engine speed camshaft	{CC 2 B}	componentSymbol
B06	Sensor, air pressure, reservoir	{BA 0 D} {BA 0 D}	componentSymbol
B07	Sensor, fuel level	{NA 4 A}	componentSymbol
B07_LE	Sensor, fuel level front axle	{NA 0 C}	componentSymbol
B07_RX	Sensor, fuel level	{NA 4 A}	componentSymbol
B07_S9	Sensor, fuel level	{NA 5 A}	componentSymbol
B07_S9BI	Sensor, fuel level	{NA 5 A}	componentSymbol
B9TL_ASIA	Alternator2	{AE 2 C}	componentSymbol
B10C	Sensor, oil level (hydraulic steered axle, electric controlled)	{FO 4 C}	componentSymbol
B12	Sensor, tachograph/speedometer	{NB 5 A} {NB 4 A}	componentSymbol
B13	Sensor, wheel speed, lhs. 1:st front axle	{EO 2 D}	componentSymbol
B14	Sensor, wheel speed,rhs. 1:st front axle	{EO 2 D}	componentSymbol
B15	Sensor, wheel speed, lhs. 1st rear axle	{EO 1 D}	componentSymbol
B16	Sensor, wheel speed, rhs. 1:st rear axle	{EO 1 D}	componentSymbol
B21	Sensor,coolant temperature	{CM 4 D}	componentSymbol
B21_	Sensor, coolant temperature	{CC 4 B}	componentSymbol
B21_CNG		{CD 3 D}	componentSymbol
B21_D9	Sensor, coolant temperature	{CA 1 B}	componentSymbol
B22	Sensor, outdoor temperature	{NA 3 A}	componentSymbol
B23	Sensor,oil temperature,retarder	{DM 3 C}	componentSymbol
B25	Sensor, accelerator pedal	{BA 2 C}	componentSymbol
B29	Sensor, chassis level, lhs.rear axle	{FB 4 A} {FB 3 A}	componentSymbol
B30	Sensor, chassis level, rhs.rear axle	{FB 4 A} {FB 2 A}	componentSymbol
B32	Sensor,engine cooling fan speed	{CM 5 B}	componentSymbol
B32.9	Sensor, engine cooling fan speed	{CA 1 A}	componentSymbol
B32_	Sensor, engine cooling fan speed	{CC 4 C}	componentSymbol
B32_S9	Sensor, engine cooling fan speed	{CA 1 B}	componentSymbol
B37	Sensor,boots pressure and boots temperature	{CM 4 A}	componentSymbol
B37_	Sensor, boost pressure and temp	{CC 4 B}	componentSymbol
B37_MD9	Sensor, boost pressure and temp	{CA 0 B}	componentSymbol
B39	Sensor,air filter pressure and air filter temperature	{CM 4 D}	componentSymbol
B39_	Sensor, air filter pressure and temp	{CC 5 C}	componentSymbol
B40	Sensor, brake lining wear indicator, lhs.1:st front axle	{EO 3 D}	componentSymbol
B41	Seonsor, brake lining wear indicator, rhs. 1:st front axle	{EO 3 D}	componentSymbol
B42	Sensor, brake lining wear indicator,lhs. 1:st rear axle	{EO 2 D}	componentSymbol
B43	Sensor, brake lining wear indicator,rhs. 1:st rear axle	{EO 2 D}	componentSymbol
B48	Sensor, coolant pressure	{CN 1 B}	componentSymbol

VOLVO

Volvo Bus Corporation

Document Title

WIRING DIAGRAM

Document Type

PRODUCT SCHEMATIC

Document No

20904123

Issue Index

10

Volume No

02(02)

Page No

3(72)

Part Name	Description	Location	Part Type
B49	Sensor, steering angle	{EP 2 B}	componentSymbol
B49F	Sensor, steering angle, Front	{FO 3 B}	componentSymbol
B49R	Sensor, steering angle, Rear	{FO 2 B}	componentSymbol
B50	Sensor, yaw rate	{EP 2 B}	componentSymbol
B52	Sensor,water level,water separator	{CN 4 C}	componentSymbol
B54	Sensor, crankhouse pressure	{CM 4 D}	componentSymbol
B54_	Sensor, crankhouse pressure	{CC 5 B}	componentSymbol
B54_D9	Sensor, crankhouse pressure	{CA 1 B}	componentSymbol
B57	Sensor, air pressure, suspension bellows, lhs.rear	{FB 4 C}	componentSymbol
B58	Sensor, air pressur, suspension bellows, rhs.rear	{FB 4 C}	componentSymbol
B59	Sensor, indoor temperature	{NA 3 A}	componentSymbol
B66	Sensor pressure downstream SCRT	{CL 3 A}	componentSymbol
B66E		{CH 1 D}	componentSymbol
B68	Sensor,output shaft speed, gearbox	{DA 1 A}	componentSymbol
B69C	Sensor, coolant temperature, retarder	{DN 3 B}	componentSymbol
B88		{CD 0 B}	componentSymbol
B118	Sensor, Oil Pressure	{CB 2 B}	componentSymbol
B118.	Sensor, Oil pressure	{FC 3 A}	componentSymbol
		{LA 2 A}	
B118_	Sensor, oil pressure	{CC 4 A}	componentSymbol
B118_MD12	Sensor, oil pressure	{CM 3 D}	componentSymbol
B118A	Sensor, Oil pressure	{LB 2 A}	componentSymbol
B119	Sensor, oil level/temp	{CM 4 A}	componentSymbol
B119_	Sensor, oil level/temp	{CC 5 B}	componentSymbol
B900	Sensor, manuel gearbox retarder pressure	{DM 3 C}	componentSymbol
B903	Sensor, Man.gbx.retarder water temperature	{DM 2 C}	componentSymbol
B904	Sensor, hydraulic oil level	{NA 4 C}	componentSymbol
B904_S9	Sensor, Hydraulic oil level	{NA 0 C}	componentSymbol
B905	Sensor, Clutch pedal position inductive	{DA 1 D}	componentSymbol
B906	Sensor,Brake Press (6*2)	{BC 4 C}	componentSymbol
B907	Sensor, fuel level rear axle	{NA 0 D}	componentSymbol
B908	Sensor air press. ECS AL	{FB 4 C}	componentSymbol
B908_A	Sensor, air press. ECS AL	{FB 5 A}	componentSymbol
B909	Sensor air press. ECS AR	{FB 3 C}	componentSymbol
B909_A	Sensor, air press. ECS AR	{FB 5 A}	componentSymbol
B910	Sensor, airpressure ECS frot LHS	{FB 5 C}	componentSymbol
B911	Sensor, airpressure ECS front RHS	{FB 5 C}	componentSymbol
B914	Sensor, chassis level front axle LHS	{FB 2 A}	componentSymbol
B915	Sensor, chassis level front axle RHS	{FB 1 A}	componentSymbol
B916	Sensor, chassis level artic front axle LHS	{FB 1 A}	componentSymbol
B916_A	Sensor, chassis level artic axle LHS	{FB 3 A}	componentSymbol
B917	Sensor, chassis level artic front axle RHS	{FB 1 A}	componentSymbol
B917_A	Sensor, chassis level artic axle LHS	{FB 3 A}	componentSymbol
B918	Sensor, Hydraulic oil level	{NA 4 D}	componentSymbol
B920	Sensor, fuel level 2	{NA 4 A}	componentSymbol
B920_LE	Sensor, fuel level 2 front axle	{NA 0 C}	componentSymbol
B921	Sensor, fuel level 2 rear axle	{NA 0 D}	componentSymbol
B922	Sensor, temp.downstream SCRT	{CL 4 B}	componentSymbol
B923	Sensor, temp/level adblue SCRT	{CU 2 B}	componentSymbol

VOLVO

Volvo Bus Corporation

Document Title

WIRING DIAGRAM

Document Type

PRODUCT SCHEMATIC

Document No

20904123

Issue Index

10

Volume No

02(02)

Page No

4(72)

Part Name	Description	Location	Part Type
B927	Sensor, hydr.oil press	{BB 1 D}	componentSymbol
B930	Sensor, temp uppstream scrtr DNOX2	{CU 1 D} {CU 2 D} {CU 1 D}	componentSymbol
B936	Sensor, brake lining wear indicator Artic, A/B R	{EP 3 B}	componentSymbol
B937	Sensor, brake lining wear indicator Artic, A/B L	{EP 3 B}	componentSymbol
B938	Sensor, wheel speed Artic, A/B R	{EP 2 B}	componentSymbol
B939	Sensor, wheel speed Artic, A/B L	{EP 2 B}	componentSymbol
B940	Sensor, brake lining wear indicator, A/B R	{EP 5 B} {EP 4 B}	componentSymbol
B941	Sensor, brake lining wear indicator, A/B L	{EP 5 B} {EP 4 B}	componentSymbol
B942	Sensor, wheel speed, A/B R	{EP 4 B} {EP 3 B}	componentSymbol
B943	Sensor, wheel speed, A/B L	{EP 5 B} {EP 3 B}	componentSymbol
B944	Sensor, Trailer air brake pressure	{BC 5 C}	componentSymbol
B945	Sensor, Crash	{CG 4 D}	componentSymbol
B946	Sensor, coolant level	{NA 2 C}	componentSymbol
B946_S9	Sensor, coolant level	{NA 0 C}	componentSymbol
B948	Sensor, air filter pressure and temp	{CA 3 B}	componentSymbol
B949	Sensor, air brake pressure, 8x2 & Last trailer (biartic)	{CL 3 A}	componentSymbol
B950	Sensor, brake lining wear indicator Biartic, A/B R	{EO 1 D}	componentSymbol
B951	Sensor, brake lining wear indicator Biartic, A/B L	{EO 1 D}	componentSymbol
B952	Sensor, wheel speed Biartic, A/B R	{EO 0 D}	componentSymbol
B953	Sensor, wheel speed Biartic, A/B L	{EO 0 D}	componentSymbol
B954	Sensor, turntable angle	{FC 3 A} {LA 3 B}	componentSymbol
B954A	Sensor, turntable angle	{LB 3 B}	componentSymbol
B955	Sensor, oil level	{CO 4 A}	componentSymbol
B956	Sensor, drake pressure to AMEC, After Market Executive Committee	{FC 2 D}	componentSymbol
B960	Sensor, air Pressure ECS, Last Trailer, Biartic	{FB 3 C}	componentSymbol
B961	Sensor, chassi level last trailer (Biartic)	{FB 0 A}	componentSymbol
B964	Sensor, Trailer air brake pressure sensor2	{BC 4 C}	componentSymbol
B970	Sensor, Fire temp	{BD 1 C} {BD 1 C} {BD 2 C} {BD 4 C} {BD 4 C} {BD 2 C} {BD 2 C} {BD 5 C} {BD 5 C}	componentSymbol
B970_	Fire sensor, 110°C	{BD 3 C}	componentSymbol
B970C	Sensor, Fire temp	{BD 5 C}	componentSymbol

VOLVO

Volvo Bus Corporation

Document Title

WIRING DIAGRAM

Document Type

PRODUCT SCHEMATIC

Document No

20904123

Issue Index

10

Volume No

02(02)

Page No

5(72)

B971	Sensor, Fire temp	{BD 1 C} {BD 1 C} {BD 2 C} {BD 4 C} {BD 4 C} {BD 2 C} {BD 2 C} {BD 5 C} {BD 5 C}	componentSymbol
B971_	Fire Sensor, 110°C	{BD 3 C}	componentSymbol
B971C	Sensor, Fire temp	{BD 5 C}	componentSymbol
B972	Sensor, Fire temp	{BD 1 C} {BD 2 C} {BD 1 C} {BD 2 C} {BD 4 C} {BD 4 C} {BD 2 C} {BD 5 C} {BD 5 C}	componentSymbol
B972_	Fire Sensor, 110°C	{BD 3 C}	componentSymbol
B972C	Sensor, Fire temp	{BD 5 C}	componentSymbol
B973	Sensor, Fire temp	{BD 5 C}	componentSymbol
B973_	Fire Sensor, 150°C	{BD 3 B}	componentSymbol
B973C	Sensor, Fire temp	{BD 5 C}	componentSymbol
B974	Sensor, Fire temp	{BD 2 B} {BD 4 B} {BD 5 B}	componentSymbol
B974C	Sensor, Fire temp	{BD 5 C}	componentSymbol
B975	Sensor, Fire temp	{BD 4 B}	componentSymbol
B977	Sensor, brake pressure 1	{CP 0 C}	componentSymbol
B978	Sensor, brake pressure 2	{CP 1 C}	componentSymbol
B979	Sensor, Parking brake pressure	{BB 3 B}	componentSymbol
B979_CNG	Sensor, exhaust back pressure	{CD 1 E}	componentSymbol
B980	Sensor, Auxilliary pressure	{BB 3 B}	componentSymbol
B981	Sensor, Throttle heater MG9	{CB 1 D}	componentSymbol
B982	Sensor, DP-cat differential pressure	{CA 2 C}	componentSymbol
B982_D7	Sensor, DPF differential pressure	{CN 2 C}	componentSymbol
B983	Sensor, DP-cat temp	{CA 2 C}	componentSymbol
B983_D7	Sensor, temperature upstream catalyst	{CN 1 C}	componentSymbol
B984_D7	Sensor, temperature downstream catalyst	{CN 1 C}	componentSymbol
B985	Fire sensor	{BD 0 C}	componentSymbol
B986	Fire sensor	{BD 0 C}	componentSymbol
B987	sensor, humidity	{CD 3 D}	componentSymbol
B988	sensor, Camshaft	{CD 1 B}	componentSymbol
B990	Sensor, Intake Manifold press/temp	{CD 2 E}	componentSymbol
B991	Sensor, pressure primary fuel	{CD 1 E}	componentSymbol
B992	Sensor, temp/press Engine Oil	{CD 2 E}	componentSymbol
B993	Sensor, secondary temp/press Fuel	{CD 2 E}	componentSymbol
B994	Sensor, pressure Mixer Inlet	{CD 3 E}	componentSymbol
B995	Sensor, oxygen heater	{CE 1 D}	componentSymbol
CNB	VDV-dash	{NG 0 D}	componentSymbol
CNDIAG	VDV_dash	{NG 2 E}	componentSymbol

VOLVO

Volvo Bus Corporation

Document Title

WIRING DIAGRAM

Document Type

PRODUCT SCHEMATIC

Document No

20904123

Issue Index

10

Volume No

02(02)

Page No

6(72)

Part Name	Description	Location	Part Type
CREVWS	VDV dash	{NG 2 A}	componentSymbol
CSW	VDV_dash	{NG 1 A}	componentSymbol
CSW1		{NG 0 B}	componentSymbol
CSW2		{NG 0 B}	componentSymbol
CSW3	VDV dash	{NG 1 B}	componentSymbol
D1	Diode	{BA 3 B}	componentSymbol
D2	Diode	{AA 2 B}	componentSymbol
D3	Diode	{GM 1 B}	componentSymbol
D4	Diode	{GM 2 B}	componentSymbol
D5	Diode	{AC 3 B}	componentSymbol
D6	Diode	{AC 2 B}	componentSymbol
D7	Diode	{AC 2 B}	componentSymbol
DIA	Diagnostic connector	{DC 2 D}	componentSymbol
DIA2	Diagnostic connector for Ecomat 5	{DD 4 A}	componentSymbol
DIA_ARTIC	Diagnostic connector artic	{DO 3 D}	componentSymbol
E4	Fuel heater	{CN 1 D}	componentSymbol
E06AL	Reverse light(Left), Artic	{GD 4 B}	componentSymbol
E06AR	Reverse light(Right), Artic	{GD 4 B}	componentSymbol
E06AT	Reverse light(Triler), Artic	{GD 4 B}	componentSymbol
E06BL	Reverse light (Left), Biartic	{GF 4 C}	componentSymbol
E06BR	Reverse light (Right), Biartic	{GF 4 C}	componentSymbol
E06BT	Reverse light (Triler), Biartic	{GF 4 C}	componentSymbol
E06L	Reversing light left	{GA 1 A}	componentSymbol
E06LA	Reversing light left optional	{GA 1 A}	componentSymbol
E06R	Reversing light right	{GA 1 A}	componentSymbol
E07AL	Fog light(Left),Artic	{GD 0 B}	componentSymbol
E07AR	Fog light(Right), Artic	{GD 1 B}	componentSymbol
E07AT	Fog light,Trailer, Artic	{GD 0 B}	componentSymbol
E07BL	Fog light (Left), Biartic	{GF 0 C}	componentSymbol
E07BR	Fog light (Right), Biartic	{GF 0 C}	componentSymbol
E07BT	Fog light, Trailer, Biartic	{GF 0 C}	componentSymbol
E07L	Fog light left	{GB 2 B} {GE 3 B}	componentSymbol
E07LR	Fog light left rear	{GA 2 A} {GE 2 B}	componentSymbol
E07R	Fog light right	{GB 2 B} {GE 2 B}	componentSymbol
E07RR	Fog light right rear	{GA 2 A} {GE 1 B}	componentSymbol
E07X	Fog light, Extra	{GA 2 A}	componentSymbol
E09AL1	Brake light(left), Artic	{GD 1 B}	componentSymbol
E09AL2	Brake light(left), Artic	{GD 1 B}	componentSymbol
E09AR1	Brake light (Right), Artic	{GD 5 B}	componentSymbol
E09AR2	Brake light(Right), Artic	{GD 4 B}	componentSymbol
E09AT	Brake light, Centre(Artic ,Trailer)	{GD 5 B}	componentSymbol
E09BL1	Brake light (Left), Biartic	{GF 1 C}	componentSymbol
E09BL2	Brake light (Left), Biartic	{GF 1 C}	componentSymbol
E09BR1	Brake light (Right), Biartic	{GF 5 C}	componentSymbol
E09BR2	Brake light (Right), Biartic	{GF 5 C}	componentSymbol
E09BT	Brake light, Centre (Biartic, Trailer)	{GF 5 C}	componentSymbol
E09LA	Brake light left	{GA 3 A}	componentSymbol

VOLVO

Volvo Bus Corporation

Document Title

WIRING DIAGRAM

Document Type

PRODUCT SCHEMATIC

Document No

20904123

Issue Index

10

Volume No

02(02)

Page No

7(72)

Part Name	Description	Location	Part Type
E09LB	Brake light left	{GA 3 A}	componentSymbol
E09RC	Brake light right	{GC 3 B}	componentSymbol
E09RD	Brake light right(Rear)	{GC 3 B}	componentSymbol
E09RE	Brake light left, Centre	{GC 3 B}	componentSymbol
E10AL	Tail light(left),Artic	{GD 3 B}	componentSymbol
E10AR	Tail light(Right),Artic	{GD 3 B}	componentSymbol
E10BL	Tail light (Left), Biartic	{GF 3 C}	componentSymbol
E10BR	Tail light (Right), Biartic	{GF 3 C}	componentSymbol
E10L	Tail light left	{GA 5 A}	componentSymbol
E10LD	Tail light left	{GA 5 A}	componentSymbol
E10R	Tail light right	{GC 1 B}	componentSymbol
E11AL1	Side marker(Left)Artic	{GD 2 B}	componentSymbol
E11AL2	Side marker((Left),Artic	{GD 2 B}	componentSymbol
E11AL3	Side marker(Left),Artic	{GD 2 B}	componentSymbol
E11AL4	Side marker(Left),Artic	{GD 2 C}	componentSymbol
E11AL5	Side marker(Left),Artic	{GD 2 C}	componentSymbol
E11AL6	Side marker(Left),Artic	{GD 2 C}	componentSymbol
E11ALT	Position light, Left(Trailer),Artic	{GD 2 B}	componentSymbol
E11AR1	Side marker(Right),Artic	{GD 2 B}	componentSymbol
E11AR2	Side marker(Right),Artic	{GD 2 B}	componentSymbol
E11AR3	Side marker(Right),Artic	{GD 1 B}	componentSymbol
E11AR4	Side marker(Right),Artic	{GD 1 C}	componentSymbol
E11AR5	Side marker(Right),Artic	{GD 1 C}	componentSymbol
E11AR6	Side marker(Right),Artic	{GD 1 C}	componentSymbol
E11ART	Side marker(Right) ,trailer,Artic	{GD 1 B}	componentSymbol
E11BL1	Side marker (Left), Biartic	{GF 3 B}	componentSymbol
E11BL2	Side marker (Left), Biartic	{GF 2 B}	componentSymbol
E11BL3	Side marker (Left), Biartic	{GF 2 B}	componentSymbol
E11BLT	Position light, Left (Trailer), Biartic	{GF 2 B}	componentSymbol
E11BR1	Side marker (Right), Biartic	{GF 2 B}	componentSymbol
E11BR2	Side marker (Right), Biartic	{GF 2 B}	componentSymbol
E11BR3	Side marker (Right), Biartic	{GF 1 B}	componentSymbol
E11BRT	Side marker (Right), Trailer, Biartic	{GF 1 B}	componentSymbol
E11LA	Side marker light left	{GC 5 B}	componentSymbol
E11LF	Side marker light left front	{GC 5 B}	componentSymbol
E11LR	Side marker light left rear	{GC 5 B}	componentSymbol
E11ML	Side marker light middle left	{GC 4 B}	componentSymbol
E11MR	Side marker light middle right	{GC 3 B}	componentSymbol
E11RA	Side marker light right	{GC 4 B}	componentSymbol
E11RF	Side marker light right front	{GC 4 B}	componentSymbol
E11RR	Side marker light right rear	{GC 4 B}	componentSymbol
E11TL	Position Light,Left(Trailer)	{GC 5 B}	componentSymbol
E11TR	Position Light,Right(Trailer)	{GC 4 B}	componentSymbol
E13AL	Direction indicator (left),Artic	{GD 4 B}	componentSymbol
E13ALT	Direction indicator,Left(trailer),Artic	{GD 3 B}	componentSymbol
E13AR	Direction indicator,(Left),Artic	{GD 3 B}	componentSymbol
E13ART	Direction indicator,Right,(Artic)	{GD 3 B}	componentSymbol
E13BL	Direction indicator (Left), Biartic	{GF 4 C}	componentSymbol
E13BLT	Direction indicator, Left (Trailer), Biartic	{GF 3 C}	componentSymbol
E13BR	Direction indicator (Right), Biartic	{GF 4 C}	componentSymbol

VOLVO

Volvo Bus Corporation

Document Title

WIRING DIAGRAM

Document Type

PRODUCT SCHEMATIC

Document No

20904123

Issue Index

10

Volume No

02(02)

Page No

8(72)

Part Name	Description	Location	Part Type
E13BRT	Direction indicator, Right (Trailer), Biartic	{GF 3 C}	componentSymbol
E13L	Lamp direction indicator left	{GA 4 A}	componentSymbol
E13LA	Dir.indicator left	{GA 4 A}	componentSymbol
E13LR	Dir. indicator left rear	{GA 3 B}	componentSymbol
E13R	Dir. indicator right	{GC 2 B}	componentSymbol
E13RB	Dir.indicator right	{GC 2 B}	componentSymbol
E13RR	Dir. indicator right rear	{GC 2 B}	componentSymbol
E63	CNG Pressure Warning lamp	{CF 1 D}	componentSymbol
E913A	Lamp, EGS gearbox diagnostics	{DA 1 D}	componentSymbol
E913B	Lamp, EGS gearbox diagnostics	{DA 1 B}	componentSymbol
E914	CRT varnig lamp	{CH 2 D}	componentSymbol
E915	CRT alarm lamp	{CH 2 D}	componentSymbol
F1	Fuse, ECS, 5A	{FA 0 D}	componentSymbol
F2	Fuse, BIC2, 10A	{NA 1 D}	componentSymbol
F02		{CF 1 D}	componentSymbol
F3	Fuse, Fuel pre filter heater, 15A	{AC 5 D}	componentSymbol
F03		{CF 2 D}	componentSymbol
F4	Fuse, EBS, 20A	{EO 5 D}	componentSymbol
F5	Fuse, Horn, 5A	{IS 2 D}	componentSymbol
F6	Fuse, Emergency parking brake release, 5A	{EX 4 D}	componentSymbol
F7	Fuse, Gearbox ECU I-shift, 15A	{DN 4 D}	componentSymbol
F8	Fuse, Gear selector I-shift, 5A	{DN 4 D}	componentSymbol
F9	Fuse, Switchbox start/stop rear, 5A	{AG 4 D}	componentSymbol
F10	Fuse, Fire Alarm, 5A	{BB 5 D}	componentSymbol
F11	Fuse, Dynafleet, 10A	{NC 5 D}	componentSymbol
F12	Fuse, Body +30, 5A	{BB 4 D}	componentSymbol
F13	Fuse, Oilmaster 10A	{CO 4 D}	componentSymbol
F14	Fuse, BBM, 5A	{BB 5 D}	componentSymbol
F15	Fuse, EECU, 15A	{BA 4 D}	componentSymbol
F16	Fuse, VECU, 5A	{BA 4 D}	componentSymbol
F17	Fuse, Switch feed, 5A	{AC 1 D}	componentSymbol
F18	Fuse, Alternator, 5A	{AC 0 D}	componentSymbol
F19	Fuse, Hymer, 10A	{AC 3 D}	componentSymbol
F20	Fuse, EBS, 10A	{EO 5 D}	componentSymbol
F21	Fuse, Wiper washer, 15A	{GM 2 D}	componentSymbol
F22	Fuse, Diva 5, Ecolife, 10A	{DC 3 D}	componentSymbol
F23	Fuse, ACC, 5A	{NE 3 D}	componentSymbol
F24	Fuse, BIC2, 5A	{NA 1 D}	componentSymbol
F25	Fuse, Washer motor, 15A	{GM 4 D}	componentSymbol
F26	Fuse, ECS, 5A	{FA 0 D}	componentSymbol
F27	Fuse, G8-EGS, 10A	{DA 4 D}	componentSymbol
F28	Fuse, Retarder, 10A	{DM 4 D}	componentSymbol
F29	Fuse, Body +DR, 5A	{BB 4 D}	componentSymbol
F30	Fuse, Fuel heater MD7, 20A	{AC 2 D}	componentSymbol
F31	Fuse, Hydraulic oil, DNOX2, 10A	{NA 5 D}	componentSymbol
F32	Fuse, Tachograph, 5A	{NB 4 D}	componentSymbol
F33	Fuse, BIC2, 5A	{NA 1 D}	componentSymbol
F35	Fuse, LCM, 25A	{GA 5 D}	componentSymbol
F36	Fuse, LCM, 25A	{GA 4 D}	componentSymbol
F37	Fuse, LCM, 25A	{GA 3 D}	componentSymbol

VOLVO

Volvo Bus Corporation

Document Title

WIRING DIAGRAM

Document Type

PRODUCT SCHEMATIC

Document No

20904123

Issue Index

10

Volume No

02(02)

Page No

9(72)

Part Name	Description	Location	Part Type
F39	Fuse, DNOX2, 25A	{CU 5 D}	componentSymbol
F41	Fuse, Radio, 20A	{IU 4 D}	componentSymbol
F42	Fuse, Main switch, 5A	{AA 5 D}	componentSymbol
F44	Fuse, LCM, 25A	{GA 5 D}	componentSymbol
F45	Fuse, LCM, 25A	{GA 4 D}	componentSymbol
F46	Fuse, LCM, 25A	{GA 4 D}	componentSymbol
F47	Fuse, Side marker L, 5A	{GC 5 D}	componentSymbol
F48	Fuse, Side marker R, 5A	{GC 5 D}	componentSymbol
F49	Fuse, Fuel cut off valve, 5A	{NA 5 D}	componentSymbol
F50	Fuse, Retarder, 10A	{DM 4 D}	componentSymbol
F51	Fuse, Radio, 5A	{IU 4 D}	componentSymbol
F52	Fuse, Luggage light, 10A	{BB 3 D}	componentSymbol
F53	Fuse, Bogie valve, Heater waterseparator, 10A	{BB 0 D}	componentSymbol
F54	Fuse, Engine/Luggage hatch, 5A	{GA 3 D}	componentSymbol
F55	Fuse, Engine brake valve, Preheat relay, Fan speed clutch, 10A	{BA 2 D}	componentSymbol
F56	Fuse, Engine brake, 10A	{BA 2 D}	componentSymbol
F57	Fuse, Key switch, 5A	{AA 4 D}	componentSymbol
F58	Fuse, FTM, 5A	{CG 3 D} {CH 1 A}	componentSymbol
F60	Fuse, Ecolife, ZF4, 10A	{DD 1 D}	componentSymbol
F61	Fuse, Light luggage room, 10A	{GA 3 D}	componentSymbol
F62	Fuse, Light sleeping compartment, 20A	{GA 2 D}	componentSymbol
F63	Fuse, Starter motor control, 5A	{CL 1 D}	componentSymbol
F64	Fuse, Load Indicator 10A	{CL 2 C}	componentSymbol
F90A	Fuse, heated hose	{CU 1 B}	componentSymbol
F90B	Fuse, heated hose	{CU 1 B}	componentSymbol
F92	Fuse 150A, pre-heater	{AB 1 C}	componentSymbol
F96	Fuse, Xenon low beam L, 10A	{GN 5 C}	componentSymbol
F97	Fuse, Xenon low beam R, 10A	{GN 4 C}	componentSymbol
F98	Fuse, Xenon high beam L, 10A	{GN 4 C}	componentSymbol
F99	Fuse, Xenon high beam R, 10A	{GN 4 C}	componentSymbol
F116	Fuse, Starter Motor Signal CNG	{CF 3 A}	componentSymbol
F117	Fuse, CNG Converter	{CF 1 A}	componentSymbol
F118	Fuse, CNG Converter	{CF 2 A}	componentSymbol
FH5	Fuse house, Xenon light	{GN 5 C}	componentSymbol
FL2A	Front light, L	{GE 5 B}	componentSymbol
FL3A	Front light, R	{GE 3 B}	componentSymbol
G01	Battery	{AB 4 B}	componentSymbol
G01A	Alternator	{CF 4 B}	componentSymbol
G01B	Battery	{AB 4 B}	componentSymbol
G02	Alternator 1	{AD 3 C} {AE 3 B}	componentSymbol
G02.S9	Alternator 1	{AH 3 B}	componentSymbol
G02_	Alternator 1	{AF 3 B}	componentSymbol
G03	Alternator 2	{AD 2 C} {AE 2 B}	componentSymbol
G03.B_R9L	Alternator 2	{AE 2 C}	componentSymbol
G03.B_R9TL	Alternator 2	{AE 2 C}	componentSymbol
G03.S9	Alternator 2	{AH 3 B}	componentSymbol
G03_	Alternator 2	{AF 2 B}	componentSymbol

VOLVO

Volvo Bus Corporation

Document Title

WIRING DIAGRAM

Document Type

PRODUCT SCHEMATIC

Document No

20904123

Issue Index

10

Volume No

02(02)

Page No

10(72)

Part Name	Description	Location	Part Type
G04	Alternator 3	{AE 1 B}	componentSymbol
G04.S9	Alternator 3	{AH 2 B}	componentSymbol
G04_	Alternator 3	{AF 1 B}	componentSymbol
G04_25	Alternator 3	{AE 2 B}	componentSymbol
G08A	Battery	{AA2 4 C}	componentSymbol
G08A_A	Battery	{AA2 4 C}	componentSymbol
G08B	Battery	{AA2 4 B}	componentSymbol
G08B_B	Battery	{AA2 4 B}	componentSymbol
GND		{CF 0 A}	componentSymbol
GND1		{CF 3 C}	componentSymbol
GND1A		{ZC 2 A}	componentSymbol
GND1B		{ZC 3 A}	componentSymbol
GND1C		{ZC 2 A}	componentSymbol
GND1D		{ZC 0 A}	componentSymbol
GND1E		{ZC 0 C}	componentSymbol
GND2A		{AF 3 B}	componentSymbol
GND2B		{AF 2 B}	componentSymbol
GND2C		{AE 1 B}	componentSymbol
GND2D		{AE 4 B}	componentSymbol
GND2F		{AF 3 B}	componentSymbol
GND2G		{AF 2 B}	componentSymbol
GND6		{GB 5 B}	componentSymbol
GND6B		{ZC 4 C}	componentSymbol
GND8		{ZC 2 B}	componentSymbol
GND9		{CO 3 A}	componentSymbol
GND10		{ZC 1 C}	componentSymbol
GND11		{ZC 2 C}	componentSymbol
GND31A		{ZC 1 A}	componentSymbol
GND31B		{AB 4 A}	componentSymbol
GND70		{ZC 1 A}	componentSymbol
GND71		{ZC 0 A}	componentSymbol
GND72		{AH 4 B}	componentSymbol
GND73		{AH 2 B}	componentSymbol
GND74		{CU 1 A}	componentSymbol
GND75		{GA 0 C}	componentSymbol
GND76		{CB 1 D}	componentSymbol
GND77		{ZC 3 A}	componentSymbol
GND78		{ZC 3 A}	componentSymbol
GND900		{AA2 4 A}	componentSymbol
GND_ENGINEBLOCK		{ZC 1 A}	componentSymbol
GND_FRAME		{ZC 2 A}	componentSymbol
GNDG		{CF 4 B}	componentSymbol
GNDM		{CF 3 B}	componentSymbol
GNDX		{ZC 4 C}	componentSymbol
GS1	VDV_dash	{NF 3 D}	componentSymbol
GS2	VDV_dash	{NF 3 E}	componentSymbol
H01	Horn, air operated	{IS 2 C}	componentSymbol
H02	Horn	{IS 1 C}	componentSymbol
H05	Buzzer,H05	{DA 1 D}	componentSymbol
Interface_BOARD	VDV-dash	{NF 0 C}	componentSymbol

VOLVO

Volvo Bus Corporation

Document Title

WIRING DIAGRAM

Document Type

PRODUCT SCHEMATIC

Document No

20904123

Issue Index

10

Volume No

02(02)

Page No

11(72)

Part Name	Description	Location	Part Type
K2	Load Indicator	{CL 2 C}	componentSymbol
K02	Relay_Day_Light_Running	{GB 5 C}	componentSymbol
K3	ECS	{FA 0 B}	componentSymbol
K4	I-Shift/Voith	{DN 4 D}	componentSymbol
K5	EGS	{DA 4 D}	componentSymbol
K6	EGS	{DA 5 D}	componentSymbol
K7	Start engine	{AC 5 C}	componentSymbol
K8	VECU/EMS	{BA 5 C}	componentSymbol
K9	Wiper/Washer	{GM 2 C}	componentSymbol
K10	Relay, Fuel pre filter heater	{AC 5 D}	componentSymbol
K11	Prevent start engine	{AA 2 C}	componentSymbol
K12	Luggage Light	{BB 3 C}	componentSymbol
K13	Emergency switch relay	{AA 4 D}	componentSymbol
K14	Bogie	{BB 0 C}	componentSymbol
K15	RECU	{DM 4 C}	componentSymbol
K16	RECU	{DM 4 C}	componentSymbol
K17	Ignition +DR	{AA 1 D}	componentSymbol
K18	Hubner warning	{LA 4 C}	componentSymbol
K19	Hubner reverse signal	{FO 2 D}	componentSymbol
K21	Hubner warning	{LB 4 C}	componentSymbol
K25	Exhaust flap	{CN 1 C}	componentSymbol
K25X	Xenon light low beam left	{GN 5 B}	componentSymbol
K26X	Xenon light low beam right	{GN 4 B}	componentSymbol
K27X	Xenon light high beam left	{GN 4 B}	componentSymbol
K28X	Xenon light high beam right	{GN 3 B}	componentSymbol
K35	Relay, disconn headlight wash	{GM 4 C}	componentSymbol
K48	Relay Engine Preheating	{CN 2 C}	componentSymbol
K200	Relay engine preheat	{CN 4 D}	componentSymbol
K201	Relay, pre-heater	{AB 1 B}	componentSymbol
K204	Relay, coolant level	{CF 3 C}	componentSymbol
K205	Starter Relay	{CF 3 B}	componentSymbol
K902	Relay heated hose pressure line	{CU 3 B}	componentSymbol
K903	Relay heated hose backflow to pump line	{CU 3 B}	componentSymbol
K905A	Fan Clutch Relay	{CF 2 D}	componentSymbol
K906	Relay,Turntable failure	{FC 5 C}	componentSymbol
K908	Relay heated hose suction line	{CU 4 B}	componentSymbol
K909	Relay heated hose backflow to tank line	{CU 2 B}	componentSymbol
K911	Relay, DRL, Day Running Light	{GE 4 D}	componentSymbol
K912	Relay, Throttle heater MG9	{CB 1 D}	componentSymbol
K920		{CL 1 B}	componentSymbol
K997	Relay DACU Vibr. chair	{BE 2 A}	componentSymbol
M01	Motor, windscreen wiper	{GM 1 B}	componentSymbol
M02	Motor, windscreen washer pump	{GM 3 B}	componentSymbol
M03	Motor, headlamp high pressure washer pump	{GM 4 B}	componentSymbol
M04A	Starter Motor	{CF 3 B}	componentSymbol
Multic	VDV_dash	{NF 0 A}	componentSymbol
OBD	On Board Diagnostic	{NA 0 B}	componentSymbol
OBD2	On Board Diagnostic	{NA 1 A}	componentSymbol
OBD3	Diagnostic connector for HUBNER ECU.	{LB 1 C}	componentSymbol
R1	Heater engine preheat	{CN 3 C}	componentSymbol

VOLVO

Volvo Bus Corporation

Document Title

WIRING DIAGRAM

Document Type

PRODUCT SCHEMATIC

Document No

20904123

Issue Index

10

Volume No

02(02)

Page No

12(72)

Part Name	Description	Location	Part Type
R01	Heater, engine preheat	{CM 1 D}	componentSymbol
R01_	Heater, engine preheat	{CC 1 C}	componentSymbol
R1_MD9	Heater, engine preheat	{CA 1 C}	componentSymbol
R02	Heater, rear view mirror	{GB 5 C}	componentSymbol
R08	Resistor, CAN-bus Termination	{XC 4 D}	componentSymbol
R08A	Resistor, CAN-bus Termination	{CE 3 D}	componentSymbol
R10	Heater waterseparator	{CN 1 D}	componentSymbol
R10.	Pulldown for Brake signal	{FC 2 C}	componentSymbol
R10_	Pulldown for Brake signal	{LB 1 D}	componentSymbol
R11	Pulldown for E-Gas step 1 signal	{FC 3 C}	componentSymbol
R11.	Pulldown for E-Gas step 1 signal	{LA 3 D}	componentSymbol
R11_	Pulldown for E-Gas step 1 signal	{LB 2 D}	componentSymbol
R12	Pulldown for E-Gas step 2 signal	{FC 3 C}	componentSymbol
R12.	Pulldown for E-Gas step 2 signal	{LA 2 D}	componentSymbol
R12_	Pulldown for E-Gas step 2 signal	{LB 2 D}	componentSymbol
R37	Terminator 1939_6	{BE 4 B}	componentSymbol
R904	Resistor, DBUS Termination	{CL 2 D}	componentSymbol
R904_2	Resistor_DBUS	{CG 2 D}	componentSymbol
R905	Heated Hose Suction Line	{CU 4 B}	componentSymbol
R906	Heated Hose Pressure Line	{CU 4 B}	componentSymbol
R907	Resistor, CAN2 termination	{CV 0 C}	componentSymbol
R908	Heated Hose Backflow to tank DNOX2	{CU 2 B}	componentSymbol
R909	Heated Filter DNOX2	{CU 5 B}	componentSymbol
R910	Heated Hose Backflow to pump DNOX2	{CU 3 B}	componentSymbol
R911	Resistor, CRT diagnos	{CL 4 B}	componentSymbol
RC3	Pulldown for C3 signal	{DA 3 D}	componentSymbol
Rc3	Pulldown for C3 signal	{LB 2 D}	componentSymbol
rc3	Pulldown for C3 signal	{LA 2 D}	componentSymbol
RC3_HYM	Pulldown for C3 signal	{FC 3 D}	componentSymbol
RL1A	Rear light, R	{GE 0 B}	componentSymbol
RL2A	Rear light, L	{GE 1 B}	componentSymbol
S01	Switch, main lighting, selector type	{GB 5 D}	componentSymbol
S02	Switch, stalk full / dipped beams	{BA 3 D} {GB 2 D}	componentSymbol
S06	Switch, stalk windscreen wiper, selector type	{NA 2 B} {GM 1 D}	componentSymbol
S08	Switch,differential gear lock,rear wheels	{EO 3 C}	componentSymbol
S11	Switch, bogie lift, selector type	{FA 3 B}	componentSymbol
S12	Switch, battery main switch	{AA 4 C}	componentSymbol
S14A	Switch, push button, Air horn	{IS 2 A}	componentSymbol
S14B	Switch, push button, Air horn	{IS 1 A}	componentSymbol
S15A	Switch,Starter Key	{AA 3 D}	componentSymbol
S15B	Switch,Starter Feed	{AA 4 B}	componentSymbol
S16	Switch, push button, El. horn	{IS 1 A}	componentSymbol
S19	Switch,extra	{DA 2 C}	componentSymbol
S24	Switch, stalk retarder, selector type	{BA 1 D}	componentSymbol
S31	Switch, TCS, Traction Control System	{EP 1 B}	componentSymbol
S32	Switch, brake hold	{EP 1 C}	componentSymbol
S34	Switch unit, steering wheel push buttons	{IS 5 C}	componentSymbol
S40	Switch, battery main switch	{AA 5 C}	componentSymbol

VOLVO

Volvo Bus Corporation

Document Title

WIRING DIAGRAM

Document Type

PRODUCT SCHEMATIC

Document No

20904123

Issue Index

10

Volume No

02(02)

Page No

13(72)

Part Name	Description	Location	Part Type
S45	Switch, position differential gear lock indicator, rear wheels, NC. or NO.	{EP 1 C}	componentSymbol
S48	Pressure switch, brake light, NO.	{LB 2 D}	componentSymbol
S50	Switch, pressure parking brake indicator, NO	{BA 3 A}	componentSymbol
S58	Switch, position clutch pedal, NO.	{BA 2 C}	componentSymbol
S68	Switch proximity, coolant level, NC.	{CN 3 C} {CM 2 D} {CA 2 D}	componentSymbol
S68_	Switch proximity, coolant level, NC.	{CC 5 C}	componentSymbol
S68_S9	Switch proximity, coolant level, NC.	{CA 2 D}	componentSymbol
S70	Switch position , flow sensor, power-steering, NC	{BB 1 B}	componentSymbol
S72	Switch, water separator draining	{CC 1 B}	componentSymbol
S77	Switch, emergency call	{NC 3 C}	componentSymbol
S77A	Switch, emergency call	{CP 3 B}	componentSymbol
S202	Switch DACU	{BE 5 C}	componentSymbol
S209	Switch, fuel pump	{CA 3 C}	componentSymbol
S209_	Switch, fuel pump	{CM 3 C}	componentSymbol
S901	Switch, eng stop rear	{AG 1 B} {AG 5 B} {AG 2 B} {AG 2 B}	componentSymbol
S901_U	Switch, eng stop switch outside	{AG 2 B}	componentSymbol
S902	Switch, raise/lower	{FA 1 B}	componentSymbol
S904	Switch,emergency cut-out	{AA 4 D}	componentSymbol
S905	Switch,Retarder	{BA 1 A}	componentSymbol
S907	Switch, eng start rear	{AG 1 B} {AG 3 B} {AG 5 B} {AG 4 B}	componentSymbol
S908	Switch, eng start enable rear	{AG 4 B} {AG 1 B} {AG 3 B} {AG 5 B}	componentSymbol
S908A	Switch, eng start enable roof	{AG 0 B}	componentSymbol
S908B	Switch, eng start enable rear	{AG 0 B}	componentSymbol
S909	Switch group,Voith transmission gear selector	{DC 1 D}	componentSymbol
S910	Switch, group ecomat transmission gear selector	{DB 1 D}	componentSymbol
S911	Switch, EGG, Israel	{EX 3 C}	componentSymbol
S913	Switch, cl.cont/rev.l man.transm	{GA 1 D}	componentSymbol
S915	Switch,kneeling	{FA 3 C}	componentSymbol
S916	Switch, EGS fault diagnosis checking	{DA 2 C}	componentSymbol
S917	Switch, group EGS gear selector	{DA 3 D}	componentSymbol
S918	Switch, EGS extera gear	{DA 1 C}	componentSymbol
S925	Switch, Alcohol lock driver change indicator	{NC 2 D}	componentSymbol
S926	Switch, Ecomat transmission retarder oil temperature.	{DB 3 B}	componentSymbol
S927	Switch, alternative gearshift program,ZF	{DB 2 D}	componentSymbol
S927_ZF5	Switch, alternative gearshift program,ZF	{DD 3 D}	componentSymbol
S928	Switch, Position Neutral	{BB 4 C}	componentSymbol
S932	Switch, alternative gearshift program, Voith	{DC 2 C}	componentSymbol
S935	Switch, Jack knife warning	{BC 4 B}	componentSymbol

VOLVO

Volvo Bus Corporation

Document Title

WIRING DIAGRAM

Document Type

PRODUCT SCHEMATIC

Document No

20904123

Issue Index

10

Volume No

02(02)

Page No

14(72)

Part Name	Description	Location	Part Type
S935A	Switch, Jack knife warning	{BC 5 B}	componentSymbol
S935B	Switch, Jack knife warning (last trailer)	{BC 4 A}	componentSymbol
S935C	Jack-knife warning	{BC 4 B}	componentSymbol
S936	Switch, Jack knife stop	{BC 3 B}	componentSymbol
S936A	Switch, Jack knife stop	{BC 3 B}	componentSymbol
S936B	Switch, Jack knife stop (last trailer)	{BC 3 B}	componentSymbol
S936C	Jack-knife stop	{BC 4 B}	componentSymbol
S939	Switch, service gas system	{CG 4 C}	componentSymbol
S940	Switch, Oilmaster	{CO 3 D}	componentSymbol
S941	Switch, reverse gearselector	{DC 1 C} {DD 5 D}	componentSymbol
S942	Switch, ON/OFF RAS	{CL 5 D}	componentSymbol
S945	Switch, Steering wheel adjustment	{BA 3 B}	componentSymbol
S948	Switch, enable menu navigation	{NA 2 A}	componentSymbol
Sensor_7_VBC_97012_133		{CB 3 B}	componentSymbol
SWP_L	VDV_dash	{NG 1 B}	componentSymbol
SWP_R	VDV_dash	{NF 3 B}	componentSymbol
sym634_182	Fuse 12V Act. EMS2	{CF 1 D}	componentSymbol
sym636_182	Fuse 12V Fuel Pump	{CF 1 D}	componentSymbol
sym638_182	Fuse 12V Cool Fan	{CF 1 D}	componentSymbol
sym641_182	Fuse 12V Act. EMS2	{CF 2 D}	componentSymbol
sym642_182	Fuse 12V Fuel Pump	{CF 2 D}	componentSymbol
sym645_178		{CH 1 C}	componentSymbol
sym654_355	Fuse 12V EMS2	{CF 0 D}	componentSymbol
sym655_355	Fuse 12V I-shift	{CF 1 D}	componentSymbol
T900	Temperature Snsor NTC	{AA2 3 B}	componentSymbol
U03	Modulator, EBS, rear axle	{EO 2 C}	componentSymbol
U04	Modulator, EBS, 3:rd axle	{EP 4 B}	componentSymbol
U05	Modulator, EBS, trailer	{EP 3 B}	componentSymbol
U06	Voltage converter	{IU 4 C}	componentSymbol
U06_	Voltage converter	{CB 4 C}	componentSymbol
U07	Modulator, EBS,Bogie/Artic	{EP 5 B}	componentSymbol
U08	Modulator, EBS,front	{EO 3 C}	componentSymbol
U11	Modulator, EBS, last-trailer, biartic, 8x2	{EO 1 C}	componentSymbol
U12	Voltage converter, Bi-xenon	{GE 4 C}	componentSymbol
U24	Voltage converter, 600VDC/24VDC/12VDC	{CF 0 B}	componentSymbol
U24A	Voltage converter, 600VDC/24VDC/12VDC	{CF 1 B}	componentSymbol
U25	Voltage converter, DC/DC	{AA2 3 C}	componentSymbol
V03	Diod, Light	{GE 4 C}	componentSymbol
V04	Diod, Light	{GE 4 C}	componentSymbol
X09	Slip contact/Horne	{IS 1 B}	componentSymbol
X09_RX	Slip contact horn	{IS 1 B}	componentSymbol
X902	Power connection box MD7	{AD 4 B}	componentSymbol
X903	VPDU Front with main relay and main switch	{AB 5 C}	componentSymbol
X904	VPDU Rear with preheat relay	{AB2 2 C} {AB2 4 C}	componentSymbol
X905	VPDU Rear without preheat relay	{AB 3 B}	componentSymbol
X906	External charger outlet	{AB 5 B}	componentSymbol
X907	VPDU 3 Fuses	{AE 3 D}	componentSymbol
X908	Fuse Holder	{CF 0 D}	componentSymbol

VOLVO

Volvo Bus Corporation

Document Title

WIRING DIAGRAM

Document Type

PRODUCT SCHEMATIC

Document No

20904123

Issue Index

10

Volume No

02(02)

Page No

15(72)

Part Name	Description	Location	Part Type
X908A	Fuse Holder	{CF 1 D}	componentSymbol
X917	Power junction R9S	{AH 3 C}	componentSymbol
X918	Power connection box T	{AF 3 C}	componentSymbol
XC103_BATS_D		{AB 3 B}	componentSymbol
XC103_R7		{AB 4 B}	componentSymbol
XC103_R9		{AB 4 B}	componentSymbol
XC103_R12		{AB 4 B}	componentSymbol
XC201_R9L		{AB2 1 B}	componentSymbol
XC201_R9TL		{AB2 0 B}	componentSymbol
XC201_R12		{AB2 0 B}	componentSymbol
XC202A_BATS_D		{AB2 2 B}	componentSymbol
XC202A_R9S_R9L		{AB2 2 B}	componentSymbol
XC202A_R9TL		{AB2 2 B}	componentSymbol
XC202A_R12		{AB2 2 B}	componentSymbol
XC202B_R9S_9L		{AB2 1 B}	componentSymbol
XC202B_R9TL		{AB2 1 B}	componentSymbol
XC202B_R12		{AB2 1 B}	componentSymbol
XC205_CNG		{AB 2 B}	componentSymbol
XC205_R7		{AB 2 B}	componentSymbol
Y02	Solenoid valve, diff. lock, rear wheels	{EP 1 C}	componentSymbol
Y07	Solenoid valve, EPG (Exhaust Pressure Governor)	{CA 0 C}	componentSymbol
Y17	Solenoid valve, retarder	{DM 3 A}	componentSymbol
Y17.1	Solenoid valve, retarder	{CN 1 B}	componentSymbol
Y17.2	Solenoid valve, retarder	{CN 1 B}	componentSymbol
Y25	Solenoid valve unit, ECS, Rear axle	{FA 5 C}	componentSymbol
Y33	Solenoid valve, UI (Unit Injector)	{CM 3 B}	componentSymbol
Y33_	Solenoid valve, UI (Unit Injector)	{CC 2 B}	componentSymbol
Y35	Solenoid valve, engine cooling fan	{CN 5 D}	componentSymbol
Y35.1	Solenoid valve, engine cooling fan	{CB 2 C}	componentSymbol
Y35_D9	Solenoid valve, engine cooling fan	{CA 4 C}	componentSymbol
Y35A	Solenoid valve, engine cooling fan	{CF 3 D}	componentSymbol
Y36	Solenoid valve, Steerable axle, Bogie	{BB 0 D}	componentSymbol
Y37	Solenoid valve unit, engine brake/EPG	{CM 1 C}	componentSymbol
Y37_	Solenoid valve unit, engine brake / EPG (Exhaust pressure governor)	{CC 2 C}	componentSymbol
Y39	Solenoid valve, VEB (Volvo Engine Brake).	{CM 1 D}	componentSymbol
Y39_	Solenoid valve, VEB (Volvo Engine Brake).	{CC 1 C}	componentSymbol
Y40	Solenoid valve unit, ECS, Front axle	{FA 4 B}	componentSymbol
Y46	Solenoid valve, piston cooling	{CM 2 C}	componentSymbol
Y47	Solenoid valve, engine cooling fan	{CM 5 B}	componentSymbol
Y53	Control valve block, RAS	{FO 1 B}	componentSymbol
Y72	Solenoid valve, Horn	{IS 2 C}	componentSymbol
Y90	Solenoid valve, PWM Idle Valve	{CB 5 B}	componentSymbol
Y91A	Solenoid valve, Engine Break	{CA 0 C}	componentSymbol
Y900	solenoid valve unit, ECS, Bogie axle	{FA 2 C}	componentSymbol
Y901	Solenoid valve, fuel cut off valve front axle	{NA 5 C}	componentSymbol
Y901_LE	Solenoid valve, fuel cut off valve front axle	{NA 1 D}	componentSymbol
Y901_S9	Solenoid valve, fuel cut off valve front axle	{NA 5 B}	componentSymbol
Y901_S9BI	Solenoid valve, fuel cut off valve front axle	{NA 0 A}	componentSymbol

VOLVO

Volvo Bus Corporation

Document Title

WIRING DIAGRAM

Document Type

PRODUCT SCHEMATIC

Document No

20904123

Issue Index

10

Volume No

02(02)

Page No

16(72)

Part Name	Description	Location	Part Type
Y902	Solenoid valve, main EGG, Isreal	{EX 4 B}	componentSymbol
Y904	Solenoid valve, proportional, ecomat transmission retarder X8/Y1	{DB 4 B}	componentSymbol
Y910	Solenoid valve, internal transmission components X6/A4, Ecomat	{DB 2 B}	componentSymbol
Y911	Solenoid valve, inj SCRT	{CU 3 D} {CU 2 D} {CU 3 D}	componentSymbol
Y912	Solenoid valve, water heating SCRT	{CU 5 B}	componentSymbol
Y913	Solenoid valve, EGS	{DA 4 C}	componentSymbol
Y914	Solenoid valve, pressure control PCU/R	{EP 5 C}	componentSymbol
Y915	Solenoid valve, pressure control PCU/L	{EP 5 C}	componentSymbol
Y916	Solenoid valve unit, ECS, Artic Axle	{FA 2 C}	componentSymbol
Y916_A	Solenoid valve unit, ECS, Artic Axle	{FA 2 C}	componentSymbol
Y917	Solenoid valve, Fuel cut off valve rear axle	{NA 5 C}	componentSymbol
Y924	Solenoid,Oil seperator	{BB 1 D}	componentSymbol
Y925	Solenoid valve, gas tank1	{CG 3 B}	componentSymbol
Y926	Solenoid valve, gas tank2	{CG 3 B}	componentSymbol
Y927	Solenoid valve, gas tank3	{CG 3 B}	componentSymbol
Y928	Solenoid valve, gas tank4	{CG 2 B}	componentSymbol
Y929	Solenoid valve, gas tank5	{CG 2 B}	componentSymbol
Y930	Solenoid valve, gas tank6	{CG 1 B}	componentSymbol
Y931	Solenoid valve, gas tank7	{CG 1 B}	componentSymbol
Y932	Proportional valve, Hubner	{FC 2 A} {LA 2 B}	componentSymbol
Y932A	Proportional valve, Hubner	{LB 2 A}	componentSymbol
Y933	Solenoid valve, cylinder RAS	{CL 4 D}	componentSymbol
Y934	Solenoid valve unit, ECS, last trailer (Biartic)	{FA 3 C}	componentSymbol
Y935	Solenoid valve, gas tank8	{CG 1 B}	componentSymbol
Y936	Solenoid, Steering wheel adjustment	{BA 4 A}	componentSymbol
Y937	Solenoid valve, APBE 1	{CL 1 B}	componentSymbol
Y938	Solenoid valve, APBE 2	{CL 1 B}	componentSymbol
Y939	Valve control Fuel	{CD 4 D}	componentSymbol
Y940	Valve Fuel Shut Off	{CD 4 D}	componentSymbol
Y941	Valve, Waste Gate Control	{CD 1 B}	componentSymbol
Y942A	Valve,Ignition Coil A	{CD 0 D}	{CD 0 D}
Y942B	Valve, Ignition Coil B	{CD 0 D}	{CD 0 D}
Y942C	Valve, Ignition Coil C		{CD 1 D}
Y942D	Valve, Ignition Coil D		{CD 1 D}
Y942E	Valve, Ignition Coil E		global_terminal_connector
Y942F	Valve, Ignition Coil F		global_terminal_connector
earth18_82	Ground conn., steering column	{IS 1 A}	global_terminal_connector
earth23_94		{GA 4 A}	global_terminal_connector
earth26_98		{GD 3 B}	global_terminal_connector
earth26_133		{CB 0 B}	global_terminal_connector
earth27_98		{GD 3 B}	global_terminal_connector
earth27_133		{CB 0 B}	global_terminal_connector
earth28_94		{GC 3 B}	global_terminal_connector
earth28_98		{GD 4 B}	global_terminal_connector
earth28_133		{CB 0 B}	global_terminal_connector
earth29_94		{GC 2 B}	global_terminal_connector

VOLVO

Volvo Bus Corporation

Document Title

WIRING DIAGRAM

Document Type

PRODUCT SCHEMATIC

Document No

20904123

Issue Index

10

Volume No

02(02)

Page No

17(72)

Part Name	Description	Location	Part Type
earth29_98		{GD 2 A}	global_terminal_connector
earth29_133		{CB 1 B}	global_terminal_connector
earth30_133		{CB 1 B}	global_terminal_connector
earth31_98		{GA 2 A}	global_terminal_connector
earth31_105		{CN 3 C}	global_terminal_connector
earth31_113		{GC 4 B} {CC 1 C}	global_terminal_connector
earth32_98		{GA 1 A}	global_terminal_connector
earth32_105		{GA 3 B}	global_terminal_connector
earth32_133		{CB 1 B}	global_terminal_connector
earth33		{CA 1 C}	global_terminal_connector
earth33_66		{AD 2 B}	global_terminal_connector
earth33_98		{GC 4 B}	global_terminal_connector
earth33_105		{CN 1 D}	global_terminal_connector
earth34_98		{GC 5 B}	global_terminal_connector
earth35		{AE 3 B}	global_terminal_connector
earth35_98		{GD 1 A}	global_terminal_connector
earth36_98		{GD 0 B}	global_terminal_connector
earth37_48		{AD 4 B}	global_terminal_connector
earth38		{AE 2 B}	global_terminal_connector
earth38_48		{AD 3 B}	global_terminal_connector
earth38_72		{GA 4 A}	global_terminal_connector
earth39_72		{GC 2 B}	global_terminal_connector
earth39_114		{CB 0 C}	global_terminal_connector
earth40		{AF 4 B}	global_terminal_connector
earth40_245		{AH 3 B}	global_terminal_connector
earth42_72		{GC 3 A}	global_terminal_connector
earth42_245		{AH 3 B}	global_terminal_connector
earth43_331		{GF 3 B}	global_terminal_connector
earth44_331		{GF 3 B}	global_terminal_connector
earth45_331		{GF 4 B}	global_terminal_connector
earth46_331		{GF 2 B}	global_terminal_connector
earth47_331		{GF 0 B}	global_terminal_connector
earth49_331		{GF 1 B}	inline_connector
Engine_block	Grund	{CM 1 C}	inline_connector
+30:1		{AB 3 D}	inline_connector
+30_CONV:1		{CF 1 A}	inline_connector
+30_INTERF:1		{CF 3 A}	inline_connector
+B:1		{AB 5 D}	inline_connector
+DR_CONV:1		{CF 1 A}	inline_connector
30UA:1		{CU 1 B}	inline_connector
30UB:1		{CU 1 B}	inline_connector
A14_:1	Buffered Idle Switch	{CC 3 C}	inline_connector
A14_:2		{CC 3 C}	inline_connector
A14_:3		{CC 3 C}	inline_connector
A14_:4		{CC 3 C}	inline_connector
A14_:5		{CC 3 C}	inline_connector
A14_:6	Pre heating LDO	{CC 2 C}	inline_connector
A14_:7		{CC 1 D}	inline_connector
A14_:8	GND	{CC 4 C}	inline_connector

VOLVO

Volvo Bus Corporation

Document Title

WIRING DIAGRAM

Document Type

PRODUCT SCHEMATIC

Document No

20904123

Issue Index

10

Volume No

02(02)

Page No

18(72)

Part Name	Description	Location	Part Type
A14_:9		{CC 4 C}	inline_connector
A14_:10	ECU Gnd	{CC 2 C}	inline_connector
A14_:11	Stop Request	{CC 4 C}	inline_connector
A14_:12		{CC 1 D}	inline_connector
A14A:1		{CM 5 C}	inline_connector
A14A:2		{XC 4 B}	inline_connector
A14A:3		{XC 4 B}	inline_connector
A14A:4		{XD 3 B}	inline_connector
A14A:5		{XD 3 B}	inline_connector
A14A:7		{CM 1 D}	inline_connector
A14A:8		{CM 3 C}	inline_connector
A14A:9		{CM 5 C}	inline_connector
A14A:10		{CM 1 C}	inline_connector
A14A:11		{CM 0 C}	inline_connector
A14A:12		{AF 4 C}	inline_connector
A14A_MG9:1		{CB 5 C}	inline_connector
A14A_MG9:2		{XC 3 B}	inline_connector
A14A_MG9:3		{XC 3 B}	inline_connector
A14A_MG9:4		{XD 5 A}	inline_connector
A14A_MG9:5		{XD 5 A}	inline_connector
A14A_MG9:6		{CB 1 A}	inline_connector
A14A_MG9:7		{BD 1 C} {BD 4 C}	inline_connector
A14A_MG9:8		{BD 1 B} {BD 4 B}	inline_connector
A14A_MG9:9		{CB 5 C}	inline_connector
A14A_MG9:12		{CB 1 D}	inline_connector
A14B:1		{CM 4 C}	inline_connector
A14B:2		{CM 4 C}	inline_connector
A14B:3		{CM 4 C}	inline_connector
A14B:4		{CM 4 C}	inline_connector
A14B:5		{CM 2 C}	inline_connector
A14B:6		{CM 2 C}	inline_connector
A14B:7		{CM 5 B}	inline_connector
A14B_MG9:1		{CB 4 B}	inline_connector
A14B_MG9:2		{CB 4 A}	inline_connector
A14B_MG9:3		{CB 2 D}	inline_connector
A14B_MG9:4		{CB 2 C}	inline_connector
A14C:1		{CM 5 C}	inline_connector
A14C:2		{CM 0 C}	inline_connector
A14C:3		{CM 0 C}	inline_connector
A14C:4		{BD 1 B} {BD 2 B}	inline_connector
A14C:5		{BD 1 C} {BD 2 C}	inline_connector
A14C:6		{CM 5 B}	inline_connector
A14C:7		{CM 5 B}	inline_connector
A14D:1		{CM 5 B}	inline_connector
A14D:2		{CM 5 C}	inline_connector
A14D:3		{CM 5 C}	inline_connector
A14D:4		{CM 5 C}	inline_connector

VOLVO

Volvo Bus Corporation

Document Title

WIRING DIAGRAM

Document Type

PRODUCT SCHEMATIC

Document No

20904123

Issue Index

10

Volume No

02(02)

Page No

19(72)

Part Name	Description	Location	Part Type
A43:1		{CC 4 C}	inline_connector
A43:3		{CC 4 C}	inline_connector
A43:5		{AF 4 C}	inline_connector
A43:6		{CC 3 D}	inline_connector
A43:7		{CC 3 D}	inline_connector
A43_:1		{CC 4 C}	inline_connector
A43_:3		{CC 4 C}	inline_connector
A43_:5		{AF 4 B}	inline_connector
A43_:6		{CC 3 C}	inline_connector
A43_:7		{CC 3 C}	inline_connector
ACC:1		{NE 3 C}	inline_connector
ACC:2		{XC 4 C}	inline_connector
ACC:3		{XC 4 C}	inline_connector
ACC:4		{XD 3 D}	inline_connector
ACC:5		{XD 3 D}	inline_connector
ACC:6		{ZC 1 B}	inline_connector
ACC:7		{BA 3 B}	inline_connector
ACC:8		{BA 3 B}	inline_connector
ACC:9		{NE 3 C}	inline_connector
ACM:1		{NB 5 D}	inline_connector
ARTIC.A1:1	Level Sensor, Artic Left	{FB 1 D}	inline_connector
ARTIC.A1:2	Level Sensor, Artic Right	{FB 1 D}	inline_connector
ARTIC.A1:3		{FB 3 B}	inline_connector
ARTIC.A1:4		{FB 3 B}	inline_connector
ARTIC.A1:5		{BC 5 C}	inline_connector
ARTIC.A1:6		{BC 5 C}	inline_connector
ARTIC.A1:7	Turntable Warning	{BC 4 D}	inline_connector
ARTIC.A1:8	Turntable alarm	{BC 3 C}	inline_connector
ARTIC.A1:9	Jack-knife break request	{BC 3 C}	inline_connector
ARTIC.A1:10		{BC 5 C}	inline_connector
ARTIC.A1:11	Engine torque 2	{BC 3 C}	inline_connector
ARTIC.A1:12	Engine torque 1	{BC 3 C}	inline_connector
ARTIC.A2:7		{BC 4 C}	inline_connector
ARTIC.A2:8		{BC 3 C}	inline_connector
ARTIC.A2:9		{BC 3 C}	inline_connector
ARTIC.A2:11		{BC 3 C}	inline_connector
ARTIC.A2:12		{BC 3 C}	inline_connector
ARTIC:1		{FB 1 D}	inline_connector
ARTIC:2		{FB 1 D}	inline_connector
ARTIC:3		{FB 2 C}	inline_connector
ARTIC:4		{FB 1 D}	inline_connector
ARTIC:5		{BC 4 D}	inline_connector
ARTIC:6		{BC 4 D}	inline_connector
ARTIC:7		{BC 4 D}	inline_connector
ARTIC:8		{BC 3 C}	inline_connector
ARTIC:9		{BC 3 D}	inline_connector
ARTIC:10		{BC 4 D}	inline_connector
ARTIC:11		{BC 3 D}	inline_connector
ARTIC:12		{BC 3 D}	inline_connector
AUDIO:1		{NA 4 C}	inline_connector

VOLVO

Volvo Bus Corporation

Document Title

WIRING DIAGRAM

Document Type

PRODUCT SCHEMATIC

Document No

20904123

Issue Index

10

Volume No

02(02)

Page No

20(72)

Part Name	Description	Location	Part Type
AUDIO:2		{NA 4 C}	inline_connector
AUDIO:3		{IS 4 C}	inline_connector
B07_A:1		{NB 1 D}	inline_connector
B07_A:2		{NB 1 D}	inline_connector
B07_B:1		{NB 1 D}	inline_connector
B07_B:2		{NB 1 D}	inline_connector
B903A:1		{DM 2 C}	inline_connector
B903A:2		{DM 2 C}	inline_connector
B930T:1	Dosing Valve	{CU 2 C}	inline_connector
B930T:2	Dosing Valve	{CU 2 C}	inline_connector
B930T:3	Temp. sensor	{CU 1 C}	inline_connector
B930T:4		{CU 1 C}	inline_connector
B_A:1		{FB 5 B}	inline_connector
B_A:2		{FB 4 D}	inline_connector
BB1:1	Idle switch	{BA 5 B}	inline_connector
BB1:2	Start disable	{BC 1 D}	inline_connector
BB1:3	Fire alarm,body	{BC 1 D}	inline_connector
BB1:4	Low priority loads, relay	{BC 2 D}	inline_connector
BB1:5	Luggage hatch ,open	{BB 2 B}	inline_connector
BB1:6	Safety belt indicator	{NA 2 B}	inline_connector
BB1:8	Washer fluid low level	{NA 2 B}	inline_connector
BB1:9	Altenator charging	{NA 2 B}	inline_connector
BB1:10	AC 1	{BB 1 D}	inline_connector
BB1:11	Parking brake applied	{BA 3 A}	inline_connector
BB1:12	AC Disable	{BC 1 D}	inline_connector
BB2:1	Indoor temperator +	{NA 3 A}	inline_connector
BB2:2	Indoor temperature -	{NA 3 B}	inline_connector
BB2:3	Out door temperator +	{NA 3 B}	inline_connector
BB2:4	Out door temperatur-	{NA 3 B}	inline_connector
BB2:5	D-CAN H	{BC 1 A}	inline_connector
BB2:6	D-CAN L	{BC 1 A}	inline_connector
BB2:7	Horn(contacts steering wheelside)	{IS 1 B}	inline_connector
BB2:8	Horn supply	{IS 2 D}	inline_connector
BB2:9	Horn (contacts steer.wheel centre)	{IS 2 B}	inline_connector
BB2:10	Alarm	{GB 3 C}	inline_connector
BB2:11	Emergency switch	{AA 5 B}	inline_connector
BB2:12	Signal 4 pulses/meter C6	{NB 3 D}	inline_connector
BB3:1	Head lamps off	{GB 3 C}	inline_connector
BB3:2	Prevent ECS action	{BC 1 D}	inline_connector
BB3:3	Kneeling position	{FA 4 B}	inline_connector
BB3:4	Lowering Prodection	{FB 3 D}	inline_connector
BB3:5	Hazard warning lamps	{GB 2 C}	inline_connector
BB3:6	DRL Output	{GB 5 B}	inline_connector
BB3:7	Next stop indicator	{NA 2 A}	inline_connector
BB3:8	Pram indicator	{NA 2 A}	inline_connector
BB3:9	+15 Ignition	{AC 5 C}	inline_connector
BB3:10	Speed signal C3	{BA 4 B}	inline_connector
BB3:11	+30 main switch (fuse F12)	{BB 4 D}	inline_connector
BB3:12	+15 ignition(fuse F29)	{BB 4 D}	inline_connector
BB4:1	Glass heating	{BC 2 D}	inline_connector

VOLVO

Volvo Bus Corporation

Document Title

WIRING DIAGRAM

Document Type

PRODUCT SCHEMATIC

Document No

20904123

Issue Index

10

Volume No

02(02)

Page No

21(72)

Part Name	Description	Location	Part Type
BB4:2	Host call	{BC 2 D}	inline_connector
BB4:3	Toilet fluid level	{BC 1 D}	inline_connector
BB4:4	Toilet occupied	{BC 1 D}	inline_connector
BB4:5	Door failure	{BC 1 D}	inline_connector
BB4:6	Door brake, status	{BC 2 D}	inline_connector
BB4:7	Door brake,request	{EP 2 D}	inline_connector
BB4:8	Speed signal 5 km/h	{BA 4 B}	inline_connector
BB4:9	Any door open	{NA 2 A}	inline_connector
BB4:10	Speed signal X km/h	{BA 4 B}	inline_connector
BB4:11	Dimmer,dashboard illumination	{GB 0 C}	inline_connector
BB4:12	N/A	{CG 3 D}	inline_connector
BB5.A:1	dipped beam.Left	{GB 3 B}	inline_connector
BB5.A:2	Dipped beam.Right	{GB 2 B}	inline_connector
BB5.A:3	Direction indicator,front and side.Left	{GB 4 B}	inline_connector
BB5.A:4	Direction indicator,Front and side. Right	{GB 0 B}	inline_connector
BB5.A:5	Fog lamps,front	{GB 2 B}	inline_connector
BB5.A:6	Additional main beam	{GB 2 C}	inline_connector
BB5.A:7	End-outline maker,side marker,position lamps.Left	{GB 4 B}	inline_connector
BB5.A:8	End-outline marker,side marker, position lamps.Right	{GB 1 B}	inline_connector
BB5.A:9	Main beam 2. Left	{GB 3 B}	inline_connector
BB5.A:10	Main beam 2.Right	{GB 2 B}	inline_connector
BB5.A:11	Main beam 1.Left	{GB 4 B}	inline_connector
BB5.A:12	Main beam 1.Right	{GB 1 B}	inline_connector
BB5.B:1	dipped beam.Left	{GB 3 B}	inline_connector
BB5.B:2	Dipped beam.Right	{GB 1 B}	inline_connector
BB5.B:3	Direction indicator,front and side.Left	{GB 4 B}	inline_connector
BB5.B:4	Direction indicator,Front and side. Right	{GB 0 B}	inline_connector
BB5.B:5	Fog lamps,front	{GB 2 B}	inline_connector
BB5.B:6	Additional main beam	{GB 2 C}	inline_connector
BB5.B:7	End-outline maker,side marker,position lamps.Left	{GB 4 B}	inline_connector
BB5.B:8	End-outline marker,side marker, position lamps.Right	{GB 1 B}	inline_connector
BB5.B:9	Main beam 2. Left	{GB 3 B}	inline_connector
BB5.B:10	Main beam 2.Right	{GB 2 B}	inline_connector
BB5.B:11	Main beam 1.Left	{GB 3 B}	inline_connector
BB5.B:12	Main beam 1.Right	{GB 1 B}	inline_connector
BB5:1	dipped beam.Left	{GB 3 B}	inline_connector
BB5:2	Dipped beam.Right	{GB 1 B}	inline_connector
BB5:3	Direction indicator,front and side.Left	{GB 4 B}	inline_connector
BB5:4	Direction indicator,Front and side. Right	{GB 0 B}	inline_connector
BB5:5	Fog lamps,front	{GB 2 B}	inline_connector
BB5:6	Additional main beam	{GB 2 C}	inline_connector
BB5:7	End-outline maker,side marker,position lamps.Left	{GB 4 B}	inline_connector
BB5:8	End-outline marker,side marker, position lamps.Right	{GB 1 B}	inline_connector
BB5:9	Main beam 2. Left	{GB 3 B}	inline_connector
BB5:10	Main beam 2.Right	{GB 2 B}	inline_connector

VOLVO

Volvo Bus Corporation

Document Title

WIRING DIAGRAM

Document Type

PRODUCT SCHEMATIC

Document No

20904123

Issue Index

10

Volume No

02(02)

Page No

22(72)

Part Name	Description	Location	Part Type
BB5:11	Main beam 1.Left	{GB 3 B}	inline_connector
BB5:12	Main beam 1.Right	{GB 1 B}	inline_connector
BB6.A1:1		{BC 2 B}	inline_connector
BB6.A1:2		{GA 3 D}	inline_connector
BB6.A1:4		{GA 3 D}	inline_connector
BB6.A1:5		{BB 2 B}	inline_connector
BB6.A1:6		{BB 3 C}	inline_connector
BB6.A1:7		{CG 1 C}	inline_connector
BB6.A1:8		{CG 1 C}	inline_connector
BB6.A1:9		{CG 1 C}	inline_connector
BB6.A1:10		{CG 1 C}	inline_connector
BB6.A1:11		{CG 0 C}	inline_connector
BB6.A1:12		{GA 2 B}	inline_connector
BB6.A2:1		{BC 2 B}	inline_connector
BB6.A2:2		{GA 3 D}	inline_connector
BB6.A2:4		{GA 2 D}	inline_connector
BB6.A2:5		{BB 2 B}	inline_connector
BB6.A2:6		{BB 3 C}	inline_connector
BB6.A2:7		{CG 1 C}	inline_connector
BB6.A2:8		{CG 1 C}	inline_connector
BB6.A2:9		{CG 1 C}	inline_connector
BB6.A2:10		{CG 1 C}	inline_connector
BB6.A2:11		{CG 0 C}	inline_connector
BB6.A2:12		{GA 2 B}	inline_connector
BB6.A3:1		{BC 2 B}	inline_connector
BB6.A3:2		{GA 3 C}	inline_connector
BB6.A3:4		{GA 2 D}	inline_connector
BB6.A3:5		{BB 2 C}	inline_connector
BB6.A3:6		{BB 3 D}	inline_connector
BB6.A3:7		{CG 1 D}	inline_connector
BB6.A3:8		{CG 1 D}	inline_connector
BB6.A3:9		{CG 1 D}	inline_connector
BB6.A3:10		{CG 1 D}	inline_connector
BB6.A3:11		{CG 0 D}	inline_connector
BB6.A3:12		{GA 2 B}	inline_connector
BB6:1	Starter inhibitor, engine hatch	{BC 3 B}	inline_connector
BB6:2	N/A	{GA 3 D}	inline_connector
BB6:3	AC compressor 3	{CL 2 B}	inline_connector
BB6:4	+30 main swith(fuse F54)	{GA 3 D}	inline_connector
BB6:5	Luggage hatch, open	{BB 2 B}	inline_connector
BB6:6	Luggage compartment light	{BB 3 C}	inline_connector
BB6:7		{CG 1 C}	inline_connector
BB6:8		{CG 1 C}	inline_connector
BB6:9		{CG 1 C}	inline_connector
BB6:10		{CG 1 C}	inline_connector
BB6:11		{CG 0 C}	inline_connector
BB6:12	Reverse warning signal	{GA 2 B}	inline_connector
BB6A:4		{GD 5 D}	inline_connector
BB6A:5		{GD 4 D}	inline_connector
BB6A:6		{GD 3 D}	inline_connector

VOLVO

Volvo Bus Corporation

Document Title

WIRING DIAGRAM

Document Type

PRODUCT SCHEMATIC

Document No

20904123

Issue Index

10

Volume No

02(02)

Page No

23(72)

Part Name	Description	Location	Part Type
BB6B:1		{BC 3 B}	inline_connector
BB6B:2		{GA 3 C}	inline_connector
BB6B:4		{GA 3 C}	inline_connector
BB6B:5		{BB 2 B}	inline_connector
BB6B:6		{BB 3 D}	inline_connector
BB6B:7		{CG 1 D}	inline_connector
BB6B:8		{CG 1 D}	inline_connector
BB6B:9		{CG 1 D}	inline_connector
BB6B:10		{CG 1 D}	inline_connector
BB6B:11		{CG 0 D}	inline_connector
BB6B:12		{GA 2 B}	inline_connector
BB7.A1:1		{GC 3 C}	inline_connector
BB7.A1:2		{GA 1 B}	inline_connector
BB7.A1:3		{GA 4 B}	inline_connector
BB7.A1:4		{GC 3 C}	inline_connector
BB7.A1:5		{GA 4 B}	inline_connector
BB7.A1:6		{GC 2 C}	inline_connector
BB7.A1:7		{GA 5 B}	inline_connector
BB7.A1:8		{GC 1 C}	inline_connector
BB7.A1:9		{GC 5 C}	inline_connector
BB7.A1:10		{GC 4 C}	inline_connector
BB7.A1:11		{GA 3 B}	inline_connector
BB7.A1:12		{GA 2 B}	inline_connector
BB7.A2:1		{GC 3 C}	inline_connector
BB7.A2:2		{GA 1 B}	inline_connector
BB7.A2:3		{GA 4 B}	inline_connector
BB7.A2:4		{GC 3 C}	inline_connector
BB7.A2:5		{GA 4 B}	inline_connector
BB7.A2:6		{GC 2 C}	inline_connector
BB7.A2:7		{GA 5 B}	inline_connector
BB7.A2:8		{GC 1 C}	inline_connector
BB7.A2:9		{GC 5 C}	inline_connector
BB7.A2:10		{GC 4 C}	inline_connector
BB7.A2:11		{GA 3 B}	inline_connector
BB7.A2:12		{GA 2 B}	inline_connector
BB7.A3:1		{GC 3 C}	inline_connector
BB7.A3:2		{GA 1 B}	inline_connector
BB7.A3:3		{GA 4 B}	inline_connector
BB7.A3:4		{GC 3 B}	inline_connector
BB7.A3:5		{GA 4 B}	inline_connector
BB7.A3:6		{GC 2 B}	inline_connector
BB7.A3:7		{GA 5 B}	inline_connector
BB7.A3:8		{GC 1 B}	inline_connector
BB7.A3:9		{GC 5 B}	inline_connector
BB7.A3:10		{GC 4 B}	inline_connector
BB7.A3:11		{GA 3 B}	inline_connector
BB7.A3:12		{GA 2 B}	inline_connector
BB7:1	Stop lamp.Right	{GC 3 C}	inline_connector
BB7:2	Reversing lamps	{GA 1 B}	inline_connector
BB7:3	Direction indicator.Rear left	{GA 3 B}	inline_connector

 Volvo Bus Corporation	Document Title			
	WIRING DIAGRAM			
	Document Type			
PRODUCT SCHEMATIC				
Document No	Issue Index	Volume No	Page No	
20904123	10	02(02)	24(72)	

Part Name	Description	Location	Part Type
BB7:4	Direction indicator.Rear right	{GC 2 C}	inline_connector
BB7:5	Extra direction indicator.Left	{GA 4 B}	inline_connector
BB7:6	Extra direction indicator.Right	{GC 2 C}	inline_connector
BB7:7	Rear position lamps.Left	{GA 5 B}	inline_connector
BB7:8	Rear position lamp.Right	{GC 1 C}	inline_connector
BB7:9	End-outline marker,sidemarker lamps.Rear left	{GC 5 C}	inline_connector
BB7:10	End-outline marker,side marker lamps.Rear right	{GC 4 C}	inline_connector
BB7:11	Stop lamp,left and Category S3 stop lamps	{GA 3 B}	inline_connector
BB7:12	Fog lamps,Rear	{GA 2 B}	inline_connector
BB7_T:1	Rear position lamp.Right	{GA 1 D}	inline_connector
BB7_T:2	Rear position lamp.Right	{GA 1 D}	inline_connector
BB7_T:3	Rear position lamp.Right	{GA 1 D}	inline_connector
BB7_T:4	Rear position lamp.Right	{GA 1 D}	inline_connector
BB7_T:7	Rear position lamp.Right	{GA 0 D}	inline_connector
BB7_T:8	Rear position lamp.Right	{GA 1 D}	inline_connector
BB7_T:11	Rear position lamp.Right	{GA 1 D}	inline_connector
BB7A:1	Reversing lamps	{GD 5 C}	inline_connector
BB7A:2	Reversing lamps	{GD 4 C}	inline_connector
BB7A:3	Direction indicator.Rear left	{GD 4 C}	inline_connector
BB7A:4	Direction indicator.Rear right	{GD 3 C}	inline_connector
BB7A:5	Xtra direction indicator.Left	{GD 3 C}	inline_connector
BB7A:6	Extra direction indicator.Right	{GD 3 C}	inline_connector
BB7A:7	Rear position lamps.Left	{GD 3 C}	inline_connector
BB7A:8	Rear position lamps.Right	{GD 3 C}	inline_connector
BB7A:9	End-outline marker,sidemarker lamps.Rear left	{GD 2 D}	inline_connector
BB7A:10	End-outline marker,sidemarker lamps.Rear right	{GD 2 D}	inline_connector
BB7A:11	Stop lamps,left and Category S3 stop lamps	{GD 1 C}	inline_connector
BB7A:12	Fog lamps ,Rear	{GD 0 C}	inline_connector
BB7B:1	Stop lamp.Right	{GC 3 C}	inline_connector
BB7B:2	Reversing lamps	{GA 1 B}	inline_connector
BB7B:3	Direction indicator.Rear left	{GA 4 B}	inline_connector
BB7B:4	Stop lamp.Right	{GC 2 C}	inline_connector
BB7B:5	Direction indicator.Rear left	{GA 4 B}	inline_connector
BB7B:6	Direction indicator.Rear left	{GC 2 B}	inline_connector
BB7B:7	Direction indicator.Rear left	{GA 5 B}	inline_connector
BB7B:8	Stop lamp.Right	{GC 1 C}	inline_connector
BB7B:9	Direction indicator.Rear left	{GC 5 B}	inline_connector
BB7B:10	Direction indicator.Rear left	{GC 4 B}	inline_connector
BB7B:11	Direction indicator.Rear left	{GA 3 B}	inline_connector
BB7B:12	Direction indicator.Rear left	{GA 2 B}	inline_connector
BB8:1	End-outline marker lamp.Front left	{GB 4 A}	inline_connector
BB8:2	End-outline marker lamp.Front right	{GB 1 B}	inline_connector
BB8:3	Extra main beam	{GB 2 C}	inline_connector
BB10A:1	remote control of extra power amplifier(12V)	{IU 4 A}	inline_connector
BB10A:3	+15(12V)	{IU 3 C}	inline_connector
BB10A:5	+30(12V)	{IU 4 C}	inline_connector
BB10A:7	Ground	{IU 5 C}	inline_connector
BB10A:9	N/A	{IU 3 A}	inline_connector

VOLVO

Volvo Bus Corporation

Document Title

WIRING DIAGRAM

Document Type

PRODUCT SCHEMATIC

Document No

20904123

Issue Index

10

Volume No

02(02)

Page No

25(72)

Part Name	Description	Location	Part Type
BB10B:1	remote control of extra power amplifier (12V)	{IU 4 A}	inline_connector
BB10B:3	+15(12V)	{IU 4 C}	inline_connector
BB10B:5	+30(12V)	{IU 3 C}	inline_connector
BB10B:7	Ground	{IU 5 C}	inline_connector
BB10B:9	N/A	{IU 3 A}	inline_connector
BB11:1	Connected to RL:3	{GB 5 B}	inline_connector
BB13:1	AC 1 - 50%	{BC 5 D}	inline_connector
BB13:2	AC compressor 2	{CL 4 D}	inline_connector
BB13:3	AC compressor 3	{CL 4 D}	inline_connector
BB13:4	Lowering Protection	{FB 3 D}	inline_connector
BB13:5	TORQUE REDUCTION	{BC 5 D}	inline_connector
BB13:6	AC compressor 2	{CL 2 A}	inline_connector
BB13:7	AC compressor 3	{CL 2 A}	inline_connector
BB13:8		{CL 1 C}	inline_connector
BB13:9		{AC 3 B}	inline_connector
BB13:10		{AC 2 B}	inline_connector
BB13:11		{AC 2 B}	inline_connector
BBOX:1	Relay Power supply	{AA 4 A}	inline_connector
BBOX:2		{AB 4 C}	inline_connector
BBOX:3		{NB 4 D}	inline_connector
BFEED:1		{CU 5 D}	inline_connector
BIO:1		{CG 3 D}	inline_connector
BIO:2		{XD 0 B}	inline_connector
BIO:3		{XD 0 B}	inline_connector
BIO:4		{BC 1 C}	inline_connector
BIO:5		{BC 1 C}	inline_connector
BIO:6		{BC 1 B}	inline_connector
BIO:7		{BC 1 B}	inline_connector
BIO:8		{CG 4 D}	inline_connector
BIO:9		{AA 2 D}	inline_connector
BIO:10		{ZC 0 B}	inline_connector
BIO:11		{CG 3 D}	inline_connector
BIO:12		{CL 1 C}	inline_connector
BIO_J:4		{BC 1 C}	inline_connector
BIO_J:5		{BC 1 C}	inline_connector
BIO_J:6		{BC 1 B}	inline_connector
BIO_J:7		{BC 1 B}	inline_connector
BMUX:1		{XD 4 D}	inline_connector
BMUX:2		{XD 4 D}	inline_connector
BMUX:3	Externa main switch	{AA 5 C}	inline_connector
BMUX:4	Externa main switch	{AA 5 B}	inline_connector
BMUX:5		{AA 5 C}	inline_connector
BOGIE.A1:1		{FB 4 B}	inline_connector
BOGIE.A1:2		{FB 4 B}	inline_connector
BOGIE.A1:3		{FA 4 B}	inline_connector
BOGIE.A1:4		{FA 5 B}	inline_connector
BOGIE.A1:5		{FA 5 B}	inline_connector
BOGIE.A1:6		{EP 4 C}	inline_connector
BOGIE.A1:7		{EP 4 C}	inline_connector
BOGIE.A1:8		{EP 4 C}	inline_connector

VOLVO

Volvo Bus Corporation

Document Title

WIRING DIAGRAM

Document Type

PRODUCT SCHEMATIC

Document No

20904123

Issue Index

10

Volume No

02(02)

Page No

26(72)

Part Name	Description	Location	Part Type
BOGIE.A1:9		{EP 4 D}	inline_connector
BOGIE:1		{FB 3 D}	inline_connector
BOGIE:2		{FB 4 D}	inline_connector
BOGIE:3		{FA 1 B}	inline_connector
BOGIE:4		{FA 2 B}	inline_connector
BOGIE:5		{FA 3 B} {FA 2 B}	inline_connector
BOGIE:6		{EP 4 C}	inline_connector
BOGIE:7		{EP 4 C}	inline_connector
BOGIE:8		{EP 4 D}	inline_connector
BOGIE:9		{EP 3 D}	inline_connector
BOGIE:10		{ZC 3 B}	inline_connector
BOGIE:11		{BB 0 B}	inline_connector
BOGIE:12		{BB 0 B}	inline_connector
BS1:2		{EO 3 C}	inline_connector
BS1:3		{EO 3 C}	inline_connector
BS1:4		{EO 3 C}	inline_connector
BS1:5		{EO 2 C}	inline_connector
BS1:8		{EP 5 D}	inline_connector
BS1:9		{EP 5 D}	inline_connector
BS1:10		{EP 4 D}	inline_connector
BS1:11		{EP 5 D}	inline_connector
BS1:12		{EP 5 D}	inline_connector
BS2:2		{EP 2 C}	inline_connector
BS2:3		{EP 2 C}	inline_connector
BS2:5		{EP 2 C}	inline_connector
BS2:6		{EP 2 C}	inline_connector
BS3.A1:1		{EO 2 B}	inline_connector
BS3.A1:2		{EO 2 B}	inline_connector
BS3.A1:3		{EO 1 B}	inline_connector
BS3.A1:4		{EO 1 B}	inline_connector
BS3.A1:5		{EP 1 D}	inline_connector
BS3.A1:6		{EP 2 D}	inline_connector
BS3.A1:7		{EP 2 A}	inline_connector
BS3.A1:8		{NA 2 C}	inline_connector
BS3.A1:9		{BB 2 C}	inline_connector
BS3.A1:10		{BA 0 C}	inline_connector
BS3.A1:11		{BA 0 B}	inline_connector
BS3.A1:12		{BA 0 B}	inline_connector
BS3.A2:1		{EO 2 B}	inline_connector
BS3.A2:2		{EO 2 B}	inline_connector
BS3.A2:3		{EO 1 B}	inline_connector
BS3.A2:4		{EO 1 B}	inline_connector
BS3.A2:5		{EP 1 C}	inline_connector
BS3.A2:6		{EP 2 C}	inline_connector
BS3.A2:7		{EP 2 B}	inline_connector
BS3.A2:8		{NA 2 C}	inline_connector
BS3.A2:9		{BB 2 C}	inline_connector
BS3.A2:10		{BA 0 C}	inline_connector
BS3.A2:11		{BA 0 C}	inline_connector

VOLVO

Volvo Bus Corporation

Document Title

WIRING DIAGRAM

Document Type

PRODUCT SCHEMATIC

Document No

20904123

Issue Index

10

Volume No

02(02)

Page No

27(72)

Part Name	Description	Location	Part Type
BS3.A2:12		{BA 0 B}	inline_connector
BS3.A3:1		{EO 2 B}	inline_connector
BS3.A3:2		{EO 2 B}	inline_connector
BS3.A3:3		{EO 1 C}	inline_connector
BS3.A3:4		{EO 1 C}	inline_connector
BS3.A3:5		{EP 1 C}	inline_connector
BS3.A3:6		{EP 2 C}	inline_connector
BS3.A3:7		{EP 2 B}	inline_connector
BS3.A3:8		{NA 2 D}	inline_connector
BS3.A3:9		{BB 2 D}	inline_connector
BS3.A3:10		{BA 0 C}	inline_connector
BS3.A3:11		{BA 0 C}	inline_connector
BS3.A3:12		{BA 0 C}	inline_connector
BS3:1		{EO 2 B}	inline_connector
BS3:2		{EO 2 B}	inline_connector
BS3:3		{EO 2 B}	inline_connector
BS3:4		{EO 1 B}	inline_connector
BS3:5		{EP 1 D}	inline_connector
BS3:6		{EP 1 D}	inline_connector
BS3:7		{EP 1 A}	inline_connector
BS3:8		{NA 2 D}	inline_connector
BS3:9		{BB 1 C}	inline_connector
BS3:10		{BA 0 C}	inline_connector
BS3:11		{BA 0 C}	inline_connector
BS3:12		{BA 0 B}	inline_connector
BS3B:1		{EO 2 C}	inline_connector
BS3B:2		{EO 2 C}	inline_connector
BS3B:3		{EO 1 C}	inline_connector
BS3B:4		{EO 1 C}	inline_connector
BS3B:8		{NA 2 D}	inline_connector
BS3B:9		{BB 1 D}	inline_connector
BS3B:10		{BA 0 D}	inline_connector
BS3B:11		{BA 0 D}	inline_connector
BS3B:12		{BA 0 D}	inline_connector
CAN:1		{XC 5 B}	inline_connector
CAN:2		{XC 5 B}	inline_connector
CAN:3		{XD 4 B}	inline_connector
CAN:4		{XD 4 B}	inline_connector
CAN:5		{CV 1 B}	inline_connector
CAN:6		{CV 1 B}	inline_connector
CAN_EMS:1		{XD 5 B}	inline_connector
CAN_EMS:2		{XD 5 B}	inline_connector
CAN_EMS:3		{XC 3 B}	inline_connector
CAN_EMS:4		{XC 3 B}	inline_connector
CAN_RAS:1		{XD 4 B}	inline_connector
CAN_RAS:2		{XD 4 B}	inline_connector
CAN_RAS:3		{XC 2 B}	inline_connector
CAN_RAS:4		{XC 2 B}	inline_connector
CNG:1	Solenoid valve Tank CNG	{CG 3 B}	inline_connector
CNG:2	Solenoid valve Tank CNG	{CG 3 B}	inline_connector

VOLVO

Volvo Bus Corporation

Document Title

WIRING DIAGRAM

Document Type

PRODUCT SCHEMATIC

Document No

20904123

Issue Index

10

Volume No

02(02)

Page No

28(72)

Part Name	Description	Location	Part Type
CNG:3	Solenoid valve Tank CNG	{CG 3 B}	inline_connector
CNG:4	Solenoid valve Tank CNG	{CG 2 B}	inline_connector
CNG:5	Solenoid valve Tank CNG	{CG 2 B}	inline_connector
CNG:6	Solenoid valve Tank CNG	{CG 1 B}	inline_connector
CNG:7	Solenoid valve Tank CNG	{CG 1 B}	inline_connector
CNG:8	Solenoid valve Tank CNG	{CG 4 B}	inline_connector
CNG:9	Solenoid valve Tank CNG	{CG 1 B}	inline_connector
CNG_CONVERTER:1	Throttle actuator	{CF 1 E}	inline_connector
CNG_CONVERTER:2	Timing Ignition Control Module	{CF 1 E}	inline_connector
CNG_CONVERTER:3		{CF 0 E}	inline_connector
CNG_CONVERTER:4	EMS CNG Power Supply	{CF 2 E}	inline_connector
CNG_CONVERTER:5	EMS CNG Power Supply	{CF 2 E}	inline_connector
CNG_CONVERTER:6	EMS CNG Power Supply	{CF 1 E}	inline_connector
CNG_CONVERTER:7		{CF 1 E}	inline_connector
CNG_CONVERTER:8	EMS CNG Power Supply	{CF 1 E}	inline_connector
CNG_CONVERTER:9	CNG Converter Ground	{CF 0 C}	inline_connector
CNG_CONVERTER:10	CNG Converter Ground	{CF 0 C}	inline_connector
CNG_CONVERTER:11	CNG Converter Ground	{CF 0 C}	inline_connector
CNG_CONVERTER:12	CNG Converter Ground	{CF 0 C}	inline_connector
CNG_CONVERTER:13	CNG Led Warning	{CF 1 E}	inline_connector
CNPB1:1		{NA 1 C}	inline_connector
CNPB1:2		{NF 3 A}	inline_connector
CNPB1:3		{NF 3 A}	inline_connector
CNPB1:4		{NF 3 A}	inline_connector
CNPB1:5		{NF 3 A}	inline_connector
CNPB1:6		{NF 3 A}	inline_connector
CNPB1:7		{NF 2 A}	inline_connector
CNPB1:8		{NF 2 A}	inline_connector
CNPB1:9		{NF 2 A}	inline_connector
CNPB1:10		{NF 2 A}	inline_connector
CNPB1:11		{NF 2 A}	inline_connector
CNPB1:12		{NF 2 A}	inline_connector
CNPB1:13		{NF 2 A}	inline_connector
CNPB1:14		{NF 1 A}	inline_connector
CNPB1:15		{NF 1 A}	inline_connector
CNPB1:16		{NF 1 A}	inline_connector
CNPB1:17		{NF 2 A}	inline_connector
CNPB1:18		{NF 2 A}	inline_connector
CNPB1:19		{NG 3 D}	inline_connector
CNPB1:20		{NG 2 D}	inline_connector
CNPB1:21		{NG 2 D}	inline_connector
CNPB1:22		{NG 3 B}	inline_connector
CNPB1:23		{NG 3 B}	inline_connector
CNPB1:24		{NG 3 C}	inline_connector
CNPB1:25		{NG 3 B}	inline_connector
CNPB2:1		{NF 1 A}	inline_connector
CNPB2:2		{NF 1 A}	inline_connector
CNPB2:3		{NF 1 A}	inline_connector
CNPB2:4		{NF 1 A}	inline_connector
CNPB2:5		{NF 1 A}	inline_connector

VOLVO

Volvo Bus Corporation

Document Title

WIRING DIAGRAM

Document Type

PRODUCT SCHEMATIC

Document No

20904123

Issue Index

10

Volume No

02(02)

Page No

29(72)

Part Name	Description	Location	Part Type
CNPB2:6		{NF 1 C}	inline_connector
CNPB2:7		{NF 1 C}	inline_connector
CNPB2:8		{NF 1 C}	inline_connector
CNPB2:9		{NF 0 C}	inline_connector
CNPB2:10		{NG 2 D}	inline_connector
CNPB2:11		{NG 2 D}	inline_connector
CNPB2:12		{NG 2 D}	inline_connector
CNPB2:13		{NG 3 D}	inline_connector
CNPB2:14		{NG 0 D}	inline_connector
CNPB2:15		{NG 0 D}	inline_connector
CNPB2:16		{NG 0 C}	inline_connector
CNPB2:17		{NG 0 C}	inline_connector
CNPB2:19		{NG 1 C}	inline_connector
CNPB2:21		{NG 1 C}	inline_connector
CNPB2:22		{NG 1 D}	inline_connector
CNPB2:23		{NG 1 C}	inline_connector
CNPB2:24		{NG 1 D}	inline_connector
CNPB3:1		{AA 4 B}	inline_connector
CNPB3:2		{AA 4 D}	inline_connector
CNPB3:3	Externa main switch	{AA 5 C}	inline_connector
CNPB3:4		{NF 1 D}	inline_connector
CNPB3:5		{NF 1 D}	inline_connector
CNPB3:6		{NF 1 D}	inline_connector
CNPB3:7		{NF 1 C}	inline_connector
CNPB3:8		{NF 0 D}	inline_connector
CNPB3:9		{NF 1 D}	inline_connector
CNPB3:10		{NF 1 D}	inline_connector
CNPB3:11		{NF 1 D}	inline_connector
CNPB3:12		{NF 1 D}	inline_connector
CNPB3:13		{NF 2 D}	inline_connector
CNPB3:14		{NF 2 D}	inline_connector
CNPB3:15		{NF 2 D}	inline_connector
CNPB3:16		{NF 2 D}	inline_connector
CNPB3:17		{NF 2 D}	inline_connector
CNPB3:18		{NF 2 D}	inline_connector
CNPB3:19		{NF 2 D}	inline_connector
CNPB3:20		{NF 2 D}	inline_connector
CNPB3:21		{NF 0 D}	inline_connector
CNPB3:22		{NF 0 D}	inline_connector
CNPB3:23		{NF 3 D}	inline_connector
CNPB3:24		{NF 3 D}	inline_connector
CNPB3:25		{ZC 5 B}	inline_connector
CNPB4:1		{NG 0 A}	inline_connector
CNPB4:2		{NG 0 B}	inline_connector
CNPB4:3		{NG 0 B}	inline_connector
CNPB4:4		{NG 0 A}	inline_connector
CNPB4:5		{NG 0 B}	inline_connector
CNPB4:6		{NG 0 B}	inline_connector
CNPB4:7		{NG 0 A}	inline_connector
CNPB4:8		{NG 0 B}	inline_connector

VOLVO

Volvo Bus Corporation

Document Title

WIRING DIAGRAM

Document Type

PRODUCT SCHEMATIC

Document No

20904123

Issue Index

10

Volume No

02(02)

Page No

30(72)

Part Name	Description	Location	Part Type
CNPB4:9		{NG 0 B}	inline_connector
CNPB4:10		{NG 0 A}	inline_connector
CNPB4:11		{NG 0 B}	inline_connector
CNPB4:12		{NG 0 B}	inline_connector
CNPB4:13		{NG 1 A}	inline_connector
CNPB4:14		{NG 1 B}	inline_connector
CNPB4:15		{NG 1 B}	inline_connector
CNPB4:16		{NG 1 A}	inline_connector
CNPB4:17		{NG 1 B}	inline_connector
CNPB4:18		{NG 1 B}	inline_connector
CNPB4:19		{NF 0 A}	inline_connector
CNPB4:20		{NF 0 A}	inline_connector
DBUS_EXT_plug:1	CAN2 EBus L	{CL 2 B}	inline_connector
DBUS_EXT_plug:2	CAN2 EBus H	{CL 2 B}	inline_connector
DBUS_INT:1	CAN1 DBus L	{CL 3 D}	inline_connector
DBUS_INT:2	CAN1 DBus H	{CL 3 D}	inline_connector
DF:1		{NC 3 D}	inline_connector
DF:2	+30 Dynafleet	{NC 4 C}	inline_connector
DF:3	+DR Dynafleet	{NC 5 C}	inline_connector
DF:4		{XD 4 D}	inline_connector
DF:5		{XD 4 D}	inline_connector
DF:6	Assistance Button Dynafleet	{NC 4 D}	inline_connector
DF:11	GND Dynafleet	{NC 3 B}	inline_connector
ECS1:1	Solenoid valve Front, Left	{FA 4 B}	inline_connector
ECS1:2	Solenoid valve Front, Right	{FA 4 B}	inline_connector
ECS1:3	Solenoid valve Front, Central	{FA 4 B}	inline_connector
ECS1:4	Level Sensor, Biartic	{FB 5 C}	inline_connector
ECS1:5	Pressure Sensor, Front	{FB 5 C}	inline_connector
ECS1:6	Level Sensor, Front Right	{FB 2 D}	inline_connector
ECS1:7	Level Sensor, Front Left	{FB 0 C} {FB 2 D}	inline_connector
ECS1:8	ECS Pressure sensor Gnd	{FB 5 C}	inline_connector
ECS1:9		{FB 5 C}	inline_connector
ECS1:10	ECS Level Sensor Gnd	{FB 2 C}	inline_connector
ECS1:11		{FB 2 C}	inline_connector
ECS1:12	Solenoid valve Front, GND	{FA 4 C}	inline_connector
ECS2.A1:1		{FA 2 C}	inline_connector
ECS2.A1:2		{FA 2 C}	inline_connector
ECS2.A1:3		{FA 2 C}	inline_connector
ECS2.A1:4		{FB 5 B}	inline_connector
ECS2.A1:5		{FB 4 B}	inline_connector
ECS2.A1:6		{FB 3 B}	inline_connector
ECS2.A1:7		{FB 3 B}	inline_connector
ECS2.A1:8		{FB 5 B}	inline_connector
ECS2.A1:9		{FB 5 B}	inline_connector
ECS2.A1:10		{FB 1 C}	inline_connector
ECS2.A1:11		{FB 2 C}	inline_connector
ECS2.A1:12		{FA 4 D}	inline_connector
ECS2.A2:1		{FA 5 B}	inline_connector
ECS2.A2:2		{FA 4 B}	inline_connector

VOLVO

Volvo Bus Corporation

Document Title

WIRING DIAGRAM

Document Type

PRODUCT SCHEMATIC

Document No

20904123

Issue Index

10

Volume No

02(02)

Page No

31(72)

Part Name	Description	Location	Part Type
ECS2.A2:3		{FA 5 B}	inline_connector
ECS2.A2:4		{FB 4 B}	inline_connector
ECS2.A2:5		{FB 4 B}	inline_connector
ECS2.A2:6		{FB 1 C}	inline_connector
ECS2.A2:7		{FB 1 C}	inline_connector
ECS2.A2:8		{FB 5 B}	inline_connector
ECS2.A2:9		{FB 5 A}	inline_connector
ECS2.A2:10		{FB 1 C}	inline_connector
ECS2.A2:11		{FB 2 C}	inline_connector
ECS2.A2:12		{FA 4 D}	inline_connector
ECS2.A3:1		{FA 5 C}	inline_connector
ECS2.A3:2		{FA 4 C}	inline_connector
ECS2.A3:3		{FA 5 C}	inline_connector
ECS2.A3:4		{FB 4 A}	inline_connector
ECS2.A3:5		{FB 4 A}	inline_connector
ECS2.A3:6		{FB 1 C}	inline_connector
ECS2.A3:7		{FB 1 C}	inline_connector
ECS2.A3:8		{FB 5 A}	inline_connector
ECS2.A3:9		{FB 5 A}	inline_connector
ECS2.A3:10		{FB 1 C}	inline_connector
ECS2.A3:11		{FB 2 C}	inline_connector
ECS2.A3:12		{FA 4 D}	inline_connector
ECS2:1	Solenoid valve rear, Left	{FA 5 B}	inline_connector
ECS2:2	Solenoid valve rear, Right	{FA 4 B}	inline_connector
ECS2:3	Solenoid Valve rear, Central	{FA 5 B}	inline_connector
ECS2:4	Pressure sensor, rear left	{FB 4 D}	inline_connector
ECS2:5	Pressure sensor, Rear Right	{FB 4 D}	inline_connector
ECS2:6	Level Sensor, Rear Left	{FB 4 B} {FB 2 D}	inline_connector
ECS2:7	Level Sensor, rear Right	{FB 3 C} {FB 3 B}	inline_connector
ECS2:8	ECS Pressure Sensor Gnd	{FB 5 D}	inline_connector
ECS2:9		{FB 4 D}	inline_connector
ECS2:10	ECS Level Sensor Gnd	{FB 1 C} {FB 3 B}	inline_connector
ECS2:11		{FB 2 C} {FB 4 B}	inline_connector
ECS2:12	Solenoid valve Rear, GND	{FA 4 D}	inline_connector
ECS2B:1		{FA 5 C}	inline_connector
ECS2B:2		{FA 4 C}	inline_connector
ECS2B:3		{FA 5 C}	inline_connector
ECS2B:4		{FB 4 C}	inline_connector
ECS2B:5		{FB 4 C}	inline_connector
ECS2B:6		{FB 4 B}	inline_connector
ECS2B:7		{FB 3 B}	inline_connector
ECS2B:8		{FB 5 C}	inline_connector
ECS2B:9		{FB 5 C}	inline_connector
ECS2B:10		{FB 3 B}	inline_connector
ECS2B:11		{FB 4 B}	inline_connector
ECS2B:12		{FA 5 C}	inline_connector
EGS_C:1		{DA 1 B}	inline_connector

VOLVO

Volvo Bus Corporation

Document Title

WIRING DIAGRAM

Document Type

PRODUCT SCHEMATIC

Document No

20904123

Issue Index

10

Volume No

02(02)

Page No

32(72)

Part Name	Description	Location	Part Type
EMS.A1:1		{BA 5 B}	inline_connector
EMS.A1:2		{XC 1 B}	inline_connector
EMS.A1:3		{XC 1 B}	inline_connector
EMS.A1:6		{BA 2 D}	inline_connector
EMS.A1:7		{BA 2 D}	inline_connector
EMS.A1:8		{BA 4 A}	inline_connector
EMS.A1:9		{BA 3 C}	inline_connector
EMS.A1:10		{ZC 4 B}	inline_connector
EMS.A1:11		{BB 1 C}	inline_connector
EMS.A1:12		{AC 3 C}	inline_connector
EMS.A2:1		{BA 4 B}	inline_connector
EMS.A2:2		{XC 1 B}	inline_connector
EMS.A2:3		{XC 1 B}	inline_connector
EMS.A2:6		{BA 2 D}	inline_connector
EMS.A2:7		{BA 3 D}	inline_connector
EMS.A2:8		{FC 3 C}	inline_connector
EMS.A2:9		{BA 3 C}	inline_connector
EMS.A2:10		{ZC 4 C}	inline_connector
EMS.A2:11		{BB 1 C}	inline_connector
EMS.A2:12		{AC 3 C}	inline_connector
EMS.A3:1		{BA 4 B}	inline_connector
EMS.A3:2		{XC 2 B}	inline_connector
EMS.A3:3		{XC 2 B}	inline_connector
EMS.A3:4		{XD 2 B}	inline_connector
EMS.A3:5		{XD 2 B}	inline_connector
EMS.A3:6		{BA 1 D}	inline_connector
EMS.A3:7		{BA 3 D}	inline_connector
EMS.A3:9		{BA 3 B}	inline_connector
EMS.A3:10		{ZC 4 C}	inline_connector
EMS.A3:11		{BB 1 D}	inline_connector
EMS.A3:12		{AC 3 B}	inline_connector
EMS:1	Idle Signal, VECU	{BA 5 B}	inline_connector
EMS:2		{XC 1 B} {XC 1 C}	inline_connector
EMS:3		{XC 1 B} {XC 1 B}	inline_connector
EMS:4		{XD 5 C}	inline_connector
EMS:5		{XD 5 C}	inline_connector
EMS:6	+30, 10A	{BA 2 D}	inline_connector
EMS:7	+30, 10A	{BA 2 D}	inline_connector
EMS:8	Speed Signal, VECU	{BA 4 A}	inline_connector
EMS:9	+30, 15A	{BA 4 C}	inline_connector
EMS:10	GND	{ZC 4 B}	inline_connector
EMS:11	Hydraulic Pressure, BBM	{BB 1 C}	inline_connector
EMS:12	+DR, 10A	{AC 3 C}	inline_connector
EMSB:1		{CA 5 D}	inline_connector
EMSB:2		{XC 3 B}	inline_connector
EMSB:3		{XC 3 B}	inline_connector
EMSB:4		{XD 5 B}	inline_connector
EMSB:5		{XD 5 B}	inline_connector

VOLVO

Volvo Bus Corporation

Document Title

WIRING DIAGRAM

Document Type

PRODUCT SCHEMATIC

Document No

20904123

Issue Index

10

Volume No

02(02)

Page No

33(72)

Part Name	Description	Location	Part Type
EMSB:6		{CA 0 D}	inline_connector
EMSB:7		{CA 4 D}	inline_connector
EMSB:9		{CA 4 D}	inline_connector
EMSB:10		{CA 1 D}	inline_connector
EMSB:12		{CO 4 B}	inline_connector
ENG1.A1:1		{AA 2 A}	inline_connector
ENG1.A1:2		{AA 0 B}	inline_connector
ENG1.A1:3		{BD 2 A}	inline_connector
ENG1.A1:4		{AA 1 B}	inline_connector
ENG1.A1:5		{BD 2 D}	inline_connector
ENG1.A1:6		{AG 4 C}	inline_connector
ENG1.A1:7		{AC 4 B}	inline_connector
ENG1.A1:8		{AC 4 B}	inline_connector
ENG1.A1:9		{AC 0 C}	inline_connector
ENG1.A1:11		{NA 4 C} {NA 0 B}	inline_connector
ENG1.A1:12		{ZC 3 B}	inline_connector
ENG1.A2:1		{AA 1 A}	inline_connector
ENG1.A2:2		{AG 4 C}	inline_connector
ENG1.A2:3		{BD 2 A}	inline_connector
ENG1.A2:4		{AG 4 C}	inline_connector
ENG1.A2:5		{BD 2 D}	inline_connector
ENG1.A2:6		{AG 4 C}	inline_connector
ENG1.A2:7		{AC 4 A}	inline_connector
ENG1.A2:8		{AG 4 C}	inline_connector
ENG1.A2:9		{AC 0 B}	inline_connector
ENG1.A2:10		{NA 0 B}	inline_connector
ENG1.A2:11		{NA 4 D}	inline_connector
ENG1.A2:12		{ZC 3 B}	inline_connector
ENG1.A3:1		{AA 1 A}	inline_connector
ENG1.A3:2		{AG 4 B}	inline_connector
ENG1.A3:3		{BD 2 A}	inline_connector
ENG1.A3:4		{AG 4 B}	inline_connector
ENG1.A3:5		{BD 2 D}	inline_connector
ENG1.A3:6		{AG 4 B}	inline_connector
ENG1.A3:7		{AC 4 A}	inline_connector
ENG1.A3:8		{AG 4 B}	inline_connector
ENG1.A3:9		{AC 0 B}	inline_connector
ENG1.A3:11		{NA 4 D}	inline_connector
ENG1:1	Engine Stop	{AA 2 B}	inline_connector
ENG1:2	Rear Start	{AA 1 B}	inline_connector
ENG1:3	Fire sensor interface	{BD 3 A}	inline_connector
ENG1:4	Start Detection	{AA 1 B}	inline_connector
ENG1:5	Fire sensor interface	{BD 3 D}	inline_connector
ENG1:6	+30, 5A, Start/Stop switches Rear	{AG 4 D}	inline_connector
ENG1:7	Start Motor Signal	{AC 5 B}	inline_connector
ENG1:8	Start Engine Signal	{AC 4 B}	inline_connector
ENG1:9	+DR, 5A, Alternator Signal	{AC 0 B}	inline_connector
ENG1:10		{NA 1 B}	inline_connector

VOLVO

Volvo Bus Corporation

Document Title

WIRING DIAGRAM

Document Type

PRODUCT SCHEMATIC

Document No

20904123

Issue Index

10

Volume No

02(02)

Page No

34(72)

Part Name	Description	Location	Part Type
ENG1:11	+DR, 5A	{NA 0 D} {NA 5 C}	inline_connector
ENG1:12	GND	{ZC 3 B}	inline_connector
ENG1B:1		{AA 1 B}	inline_connector
ENG1B:2		{AG 4 B} {AG 3 B}	inline_connector
ENG1B:3		{BD 2 B} {BD 5 B}	inline_connector
ENG1B:4		{AG 4 B} {AG 3 B}	inline_connector
ENG1B:5		{BD 2 D} {BD 5 D}	inline_connector
ENG1B:6		{AG 4 B} {AG 3 C}	inline_connector
ENG1B:7		{AE 4 C}	inline_connector
ENG1B:8		{AG 4 B} {AG 3 B}	inline_connector
ENG1B:9		{AE 1 C}	inline_connector
ENG1B:11		{NA 4 D}	inline_connector
ESI1:1		{CH 1 C}	inline_connector
ESI1:2		{CH 1 D}	inline_connector
ESI2:1		{CH 2 D}	inline_connector
ESI2:2		{CH 2 D}	inline_connector
ESI2:3		{CH 2 D}	inline_connector
ESI2:4		{CH 2 D}	inline_connector
EU4.A1:1		{CO 5 D}	inline_connector
EU4.A1:2		{CO 3 D}	inline_connector
EU4.A1:3		{NA 4 B}	inline_connector
EU4.A1:8		{BA 4 C}	inline_connector
EU4.A1:9		{AC 3 D}	inline_connector
EU4.A1:10		{CU 5 D}	inline_connector
EU4.A1:11		{CV 0 C}	inline_connector
EU4.A1:12		{CV 0 C}	inline_connector
EU4.A2:1		{CO 5 C}	inline_connector
EU4.A2:2		{CO 3 C}	inline_connector
EU4.A2:3		{NA 4 A}	inline_connector
EU4.A2:8		{BA 4 C}	inline_connector
EU4.A2:9		{AC 3 C}	inline_connector
EU4.A2:10		{CU 4 D}	inline_connector
EU4.A2:11		{CV 1 C}	inline_connector
EU4.A2:12		{CV 1 C}	inline_connector
EU4.A3:1		{CO 5 C}	inline_connector
EU4.A3:2		{CO 3 C}	inline_connector
EU4.A3:3		{NA 4 A}	inline_connector
EU4.A3:8		{BA 3 C}	inline_connector
EU4.A3:9		{AC 3 C}	inline_connector
EU4.A3:10		{CU 5 D}	inline_connector
EU4.A3:11		{CV 2 C}	inline_connector
EU4.A3:12		{CV 2 C}	inline_connector
EU4:1	+30, 10A, Oilmaster	{CO 4 D}	inline_connector
EU4:2	LDO, Oilmaster	{CO 4 D}	inline_connector

VOLVO

Volvo Bus Corporation

Document Title

WIRING DIAGRAM

Document Type

PRODUCT SCHEMATIC

Document No

20904123

Issue Index

10

Volume No

02(02)

Page No

35(72)

Part Name	Description	Location	Part Type
EU4:3	GND BIC 2	{NA 4 B}	inline_connector
EU4:4	GND EBS Biartic Module	{EO 1 B}	inline_connector
EU4:5	SV EBS Biartic Module	{EO 1 B}	inline_connector
EU4:6	CAN H EBS Biartic Module	{EO 1 B}	inline_connector
EU4:7	CAN L EBS Biartic Module	{EO 0 B}	inline_connector
EU4:8	+30, 15A	{BA 4 C}	inline_connector
EU4:9	+DR, 20A	{AC 2 D}	inline_connector
EU4:10	SV DNOX2 ECU	{CU 5 D}	inline_connector
EU4:11		{CV 2 D} {CV 2 D} {CV 2 D} {CV 1 C}	inline_connector
EU4:12		{CV 2 D} {CV 2 D} {CV 2 C} {CV 1 C}	inline_connector
EU4B:1		{CO 5 B}	inline_connector
EU4B:2		{CO 4 B}	inline_connector
EU4B:3		{NA 2 C}	inline_connector
EU4B:8		{CA 4 D}	inline_connector
EU4B:9		{CA 3 D}	inline_connector
EU4B:11		{CV 2 B}	inline_connector
EU4B:12		{CV 2 B}	inline_connector
FEED:1		{BA 5 D}	inline_connector
FEEDX:1		{GN 4 D}	inline_connector
FH1A:1	+30, 5A, I-Shift	{DN 4 C}	inline_connector
FH1A:2	+30, 10A, I-Shift	{DN 4 C}	inline_connector
FH1A:3	+30	{DN 4 D}	inline_connector
FH1A:4	+30, 5A, Parking Break	{EX 4 D}	inline_connector
FH1A:6	+30, 5A, Horn	{IS 2 D}	inline_connector
FH1A:7	Power supply ECS	{FA 0 D}	inline_connector
FH1A:8	+30, 20A, EBS	{EO 5 D}	inline_connector
FH1A:10	+30, 10A BIC2	{NA 1 D}	inline_connector
FH1A:11		{AC 5 D}	inline_connector
FH1A:12		{AC 5 D}	inline_connector
FH1B:1		{BA 4 D}	inline_connector
FH1B:2		{BA 4 D}	inline_connector
FH1B:3		{BA 5 D}	inline_connector
FH1B:4		{AG 4 D}	inline_connector
FH1B:6		{BB 5 D}	inline_connector
FH1B:7		{BB 5 D}	inline_connector
FH1B:8		{CO 4 D}	inline_connector
FH1B:10		{NC 5 D}	inline_connector
FH1B:11		{BB 4 D}	inline_connector
FH2A:1		{GM 2 D}	inline_connector
FH2A:2		{DC 3 D}	inline_connector
FH2A:3		{NE 3 D}	inline_connector
FH2A:4		{EO 5 D}	inline_connector
FH2A:5		{AA 1 D}	inline_connector
FH2A:6		{NA 1 D}	inline_connector
FH2A:7		{AC 3 D}	inline_connector

VOLVO

Volvo Bus Corporation

Document Title

WIRING DIAGRAM

Document Type

PRODUCT SCHEMATIC

Document No

20904123

Issue Index

10

Volume No

02(02)

Page No

36(72)

Part Name	Description	Location	Part Type
FH2A:8		{AC 0 D}	inline_connector
FH2A:9		{AC 1 D}	inline_connector
FH2B:1		{BB 4 D}	inline_connector
FH2B:2		{AC 2 D}	inline_connector
FH2B:3		{NA 5 D}	inline_connector
FH2B:4		{DM 4 D}	inline_connector
FH2B:5		{AA 1 D}	inline_connector
FH2B:6		{NB 4 D}	inline_connector
FH2B:7		{DA 4 D}	inline_connector
FH2B:8		{FA 0 D}	inline_connector
FH2B:9		{GM 4 D}	inline_connector
FH3A:1		{BA 2 D}	inline_connector
FH3A:2		{BA 2 D}	inline_connector
FH3A:3		{BA 4 D}	inline_connector
FH3A:4		{GA 3 D}	inline_connector
FH3A:5		{BB 0 D}	inline_connector
FH3A:7		{NA 5 D}	inline_connector
FH3A:8		{BB 3 D}	inline_connector
FH3A:10		{DM 4 D}	inline_connector
FH3A:12		{IU 4 D}	inline_connector
FH3B:1		{CL 2 C}	inline_connector
FH3B:2		{CL 1 C}	inline_connector
FH3B:3		{CL 1 C}	inline_connector
FH3B:4		{AA 4 D}	inline_connector
FH3B:5		{GA 2 D}	inline_connector
FH3B:7		{CG 3 D} {CH 1 B}	inline_connector
FH3B:9		{GA 3 D}	inline_connector
FH3B:11		{DD 1 D}	inline_connector
FH3B:12		{DD 2 D}	inline_connector
FH4A:2		{CU 5 D}	inline_connector
FH4A:3		{CU 5 D}	inline_connector
FH4A:5		{GA 3 D}	inline_connector
FH4A:7		{NA 1 D}	inline_connector
FH4A:8		{GA 4 D}	inline_connector
FH4A:12		{GA 5 D}	inline_connector
FH4B:1		{GC 5 C}	inline_connector
FH4B:2		{GC 4 C}	inline_connector
FH4B:3		{GC 3 D}	inline_connector
FH4B:4		{IU 4 D}	inline_connector
FH4B:5		{GA 4 D}	inline_connector
FH4B:7		{AA 5 D}	inline_connector
FH4B:8		{GA 4 D}	inline_connector
FH4B:12		{GA 5 D}	inline_connector
FL2:1		{ZC 4 D}	inline_connector
FL2:2		{ZC 4 D}	inline_connector
FL2:3		{ZC 4 D}	inline_connector
FL2:4		{GB 3 A}	inline_connector
FL2:5		{GB 2 B}	inline_connector
FL2:6		{ZC 4 D}	inline_connector

VOLVO

Volvo Bus Corporation

Document Title

WIRING DIAGRAM

Document Type

PRODUCT SCHEMATIC

Document No

20904123

Issue Index

10

Volume No

02(02)

Page No

37(72)

Part Name	Description	Location	Part Type
FL2:7		{GB 4 A}	inline_connector
FL2:8		{GB 4 A}	inline_connector
FL2:9		{GB 3 A}	inline_connector
FL2:10		{GB 3 A}	inline_connector
FL2:11		{GB 5 C}	inline_connector
FL2:12		{ZC 4 D}	inline_connector
FL3:1		{ZC 5 D}	inline_connector
FL3:2		{ZC 5 D}	inline_connector
FL3:3		{ZC 5 D}	inline_connector
FL3:4		{GB 2 A}	inline_connector
FL3:5		{GB 2 B}	inline_connector
FL3:6		{ZC 5 D}	inline_connector
FL3:7		{GB 0 B}	inline_connector
FL3:8		{GB 1 A}	inline_connector
FL3:9		{GB 1 A}	inline_connector
FL3:10		{GB 1 A}	inline_connector
FL3:11		{GB 5 C}	inline_connector
FL3:12		{ZC 5 D}	inline_connector
FM:1	+30 FM 200	{ND 4 C}	inline_connector
FM:2	GND FM 200	{ND 4 C}	inline_connector
FM:3	+15 FM 200	{ND 4 C}	inline_connector
FM:4	Speed Signal	{ND 3 C}	inline_connector
FS1:1		{BD 0 C}	inline_connector
FS1:2		{BD 0 B}	inline_connector
FTM:1	+30 FTM	{CG 3 D} {CH 1 B}	inline_connector
FTM:2	CAN FTM	{XD 0 B}	inline_connector
FTM:3	CAN FTM	{XD 0 B}	inline_connector
FTM:4	CAN DBUS H FTM	{BC 2 C} {CH 0 C}	inline_connector
FTM:5	CAN DBUS L FTM	{BC 2 C} {CH 0 C}	inline_connector
FTM:6	CAN DBUS H FTM	{BC 2 B} {CH 0 C}	inline_connector
FTM:7	CAN DBUS L FTM	{BC 2 B} {CH 0 C}	inline_connector
FTM:8	Crash Sensor	{CG 4 D}	inline_connector
FTM:9	+15 FTM	{AA 2 D}	inline_connector
FTM:10	GND FTM	{ZC 0 B}	inline_connector
FTM:11	Gas Heater	{CG 3 D}	inline_connector
FTM:12		{CL 1 C}	inline_connector
FTM_J:4		{BC 2 C}	inline_connector
FTM_J:5		{BC 2 C}	inline_connector
FTM_J:6		{BC 2 B}	inline_connector
FTM_J:7		{BC 2 B}	inline_connector
FUEL.A1:1		{NA 0 B}	inline_connector
FUEL.A1:2		{NA 0 B}	inline_connector
FUEL.A1:3		{NA 0 C}	inline_connector
FUEL.A1:5		{NA 1 D}	inline_connector
FUEL.A1:6		{NA 1 C}	inline_connector
FUEL:1		{NA 4 A}	inline_connector

VOLVO

Volvo Bus Corporation

Document Title

WIRING DIAGRAM

Document Type

PRODUCT SCHEMATIC

Document No

20904123

Issue Index

10

Volume No

02(02)

Page No

38(72)

Part Name	Description	Location	Part Type
FUEL:2		{NA 4 A}	inline_connector
FUEL:3		{NA 4 B}	inline_connector
FUEL:5		{NA 5 C}	inline_connector
FUEL:6		{NA 5 B}	inline_connector
FUEL:7		{FA 3 B}	inline_connector
FUEL:8		{FA 3 B}	inline_connector
FUEL:9		{FA 3 B}	inline_connector
FUEL:10		{FB 0 C}	inline_connector
FUEL:11		{FB 3 D}	inline_connector
FUEL_B:1		{NA 0 C} {NA 4 A}	inline_connector
FUEL_B:2		{NA 0 C}	inline_connector
FUEL_B:3		{NA 0 D} {NA 4 B}	inline_connector
FUEL_B:5		{NA 5 C} {NA 5 B} {NA 5 C}	inline_connector
FUEL_B:6		{NA 5 B}	inline_connector
FUEL_B:7		{FA 3 B} {FA 3 B}	inline_connector
FUEL_B:8		{FA 3 B}	inline_connector
FUEL_B:9		{FA 3 B}	inline_connector
FUEL_B:10		{FB 0 C}	inline_connector
FUEL_B:11		{FB 3 D}	inline_connector
GB1.A3:1		{DB 4 B}	inline_connector
GB1.A3:2		{DB 3 C}	inline_connector
GB1.A3:3		{DB 4 D}	inline_connector
GB1.A3:4		{DB 4 B}	inline_connector
GB1.A3:5		{DB 3 C}	inline_connector
GB1.A3:7		{XC 2 A}	inline_connector
GB1.A3:8		{XC 1 A}	inline_connector
GB1.A3:9		{XD 2 C}	inline_connector
GB1.A3:10		{XD 2 C}	inline_connector
GB1:1	ECOMAT4 ECU GND	{DB 4 B}	inline_connector
GB1:2	+30 ECOMAT4 ECU	{DB 3 C}	inline_connector
GB1:3	+15 ECOMAT4	{DB 4 D}	inline_connector
GB1:4	ECOMAT4 ECU GND	{DB 4 B}	inline_connector
GB1:5	+30 ECOMAT4 ECU	{DB 3 C}	inline_connector
GB1:7	CAN	{XC 1 A}	inline_connector
GB1:8	CAN	{XC 1 A}	inline_connector
GB1:9	CAN	{XD 1 A}	inline_connector
GB1:10	CAN	{XD 1 A}	inline_connector
GBX.A1:1		{DM 0 B}	inline_connector
GBX.A1:2		{DN 3 C}	inline_connector
GBX.A1:3		{DC 3 C}	inline_connector
GBX.A1:4		{DD 2 C}	inline_connector
GBX.A1:5		{DM 5 C}	inline_connector
GBX.A1:6		{DM 4 C}	inline_connector
GBX.A1:9		{XD 2 C}	inline_connector
GBX.A1:10		{XD 2 C}	inline_connector
GBX.A1:11		{DD 0 C}	inline_connector

VOLVO

Volvo Bus Corporation

Document Title

WIRING DIAGRAM

Document Type

PRODUCT SCHEMATIC

Document No

20904123

Issue Index

10

Volume No

02(02)

Page No

39(72)

Part Name	Description	Location	Part Type
GBX.A1:12		{DD 0 C}	inline_connector
GBX.A1:13		{NA 3 C}	inline_connector
GBX.A1:15		{DD 2 C}	inline_connector
GBX.A1:16		{DD 1 D}	inline_connector
GBX.A2:1		{DM 0 B}	inline_connector
GBX.A2:2		{DN 3 C}	inline_connector
GBX.A2:3		{DC 3 C}	inline_connector
GBX.A2:4		{DB 3 D}	inline_connector
GBX.A2:5		{DM 5 C}	inline_connector
GBX.A2:6		{DM 4 C}	inline_connector
GBX.A2:9		{XD 2 B}	inline_connector
GBX.A2:10		{XD 2 B}	inline_connector
GBX.A2:11		{DD 0 C}	inline_connector
GBX.A2:12		{DD 0 C}	inline_connector
GBX.A2:13		{NA 4 D}	inline_connector
GBX.A2:15		{DD 2 B}	inline_connector
GBX.A2:16		{DD 1 C}	inline_connector
GBX.A3:1		{DM 1 B}	inline_connector
GBX.A3:2		{DN 2 C}	inline_connector
GBX.A3:3		{DC 3 D}	inline_connector
GBX.A3:4		{DD 1 C}	inline_connector
GBX.A3:5		{DM 5 C}	inline_connector
GBX.A3:6		{DM 4 C}	inline_connector
GBX.A3:9		{XD 2 B}	inline_connector
GBX.A3:10		{XD 2 B}	inline_connector
GBX.A3:11		{DD 0 C}	inline_connector
GBX.A3:12		{DD 1 C}	inline_connector
GBX.A3:13		{NA 4 D}	inline_connector
GBX.A3:15		{DD 2 B}	inline_connector
GBX.A3:16		{DD 1 C}	inline_connector
GBX:1		{DM 1 A}	inline_connector
GBX:2		{DN 3 C}	inline_connector
GBX:3		{DC 3 D}	inline_connector
GBX:4		{DD 1 C}	inline_connector
GBX:5		{DM 5 C}	inline_connector
GBX:6		{DM 4 C}	inline_connector
GBX:7		{XC 1 B}	inline_connector
GBX:8		{XC 1 B}	inline_connector
GBX:9		{XD 1 B}	inline_connector
GBX:10		{XD 1 B}	inline_connector
GBX:11		{DD 0 C}	inline_connector
GBX:12		{DD 1 C}	inline_connector
GBX:13		{NA 4 D}	inline_connector
GBX:14		{CC 0 B}	inline_connector
GBX:15		{DD 2 C}	inline_connector
GBX:16		{DD 1 C}	inline_connector
GBX:17		{BA 2 B}	inline_connector
GBX:18		{BA 2 B}	inline_connector
GBX_R:1		{DM 1 B}	inline_connector
GBX_R:2		{DN 3 C}	inline_connector

VOLVO

Volvo Bus Corporation

Document Title

WIRING DIAGRAM

Document Type

PRODUCT SCHEMATIC

Document No

20904123

Issue Index

10

Volume No

02(02)

Page No

40(72)

Part Name	Description	Location	Part Type
GBX_R:3		{DD 1 C}	inline_connector
GBX_R:4		{DD 1 C}	inline_connector
GBX_R:5		{DM 5 C}	inline_connector
GBX_R:6		{DM 4 C}	inline_connector
GBX_R:9		{XD 1 B}	inline_connector
GBX_R:10		{XD 1 B}	inline_connector
GBX_R:11		{DD 0 C}	inline_connector
GBX_R:12		{DD 1 C}	inline_connector
GBX_R:13		{NA 4 D}	inline_connector
GBX_R:14		{CC 0 B}	inline_connector
GBX_R:15		{DD 2 C}	inline_connector
GBX_R:16		{DD 1 C}	inline_connector
GND1UA:1		{CU 2 A}	inline_connector
GND1UB:1		{CU 2 A}	inline_connector
GS1.A1:3		{DB 2 D}	inline_connector
GS1.A1:4		{DB 2 D}	inline_connector
GS1.A1:5		{DB 1 D}	inline_connector
GS1.A2:3		{DB 2 C}	inline_connector
GS1.A2:4		{DB 2 C}	inline_connector
GS1.A2:5		{DB 1 C}	inline_connector
GS1.A3:3		{DB 2 C}	inline_connector
GS1.A3:4		{DB 2 C}	inline_connector
GS1.A3:5		{DB 1 C}	inline_connector
GS1:3		{DB 2 D}	inline_connector
GS1:4		{DB 1 D}	inline_connector
GS1:5		{DB 1 D}	inline_connector
IB1:1	Ubat 5A BIC2	{NA 1 D}	inline_connector
IB1:2	Next Stop	{NA 2 B}	inline_connector
IB1:3	Any Door Opened	{NA 2 B}	inline_connector
IB1:4	Seat belt reminder	{NA 2 B}	inline_connector
IB1:5	Perambulator	{NA 2 B}	inline_connector
IB1:6	Washer fluid level	{NA 2 B}	inline_connector
IB1:7	+30 10A BIC2	{NA 1 C}	inline_connector
IB1:8	Engine preheat	{NA 3 C}	inline_connector
IB1:9	Alternator1 Not Charging	{NA 3 B}	inline_connector
IB1:10	Alternator2 Not Charging	{NA 2 C}	inline_connector
IB1:11	Alternator3 Not Charging	{NA 2 C}	inline_connector
IB1:12	Hydraulic filter	{NA 4 C}	inline_connector
IB1:13	Hydraulic Level	{NA 4 C}	inline_connector
IB1:14	CAN	{XC 4 D}	inline_connector
IB1:15	CAN	{XC 4 D}	inline_connector
IB1:16	CAN	{XD 3 D}	inline_connector
IB1:17	CAN	{XD 3 D}	inline_connector
IB1:18	+15 5A BIC2	{NA 1 D}	inline_connector
IB2:1		{NA 3 B}	inline_connector
IB2:2		{NA 3 B}	inline_connector
IB2:3		{NA 3 B}	inline_connector
IB2:4		{NA 3 B}	inline_connector
IB2:5		{NA 4 C}	inline_connector
IB2:6		{NA 4 B}	inline_connector

VOLVO

Volvo Bus Corporation

Document Title

WIRING DIAGRAM

Document Type

PRODUCT SCHEMATIC

Document No

20904123

Issue Index

10

Volume No

02(02)

Page No

41(72)

Part Name	Description	Location	Part Type
IB2:7		{GC 3 D}	inline_connector
IB2:8		{ZC 5 B}	inline_connector
IB2:9		{GA 3 C}	inline_connector
IB2:10		{EX 4 C}	inline_connector
IB2:11		{IS 2 B}	inline_connector
IB2:12		{IS 1 B}	inline_connector
IB2:13		{EP 2 C}	inline_connector
IB2:14		{EP 2 C}	inline_connector
IB2:15		{EP 2 C}	inline_connector
IB2:16		{EP 2 C}	inline_connector
IB2:17		{AA 4 C}	inline_connector
IB2:18		{NC 5 D}	inline_connector
IB3:1		{BA 1 C}	inline_connector
IB3:2		{BA 1 C}	inline_connector
IB3:3		{BA 1 C}	inline_connector
IB3:4		{BA 1 C}	inline_connector
IB3:5		{BA 1 C}	inline_connector
IB3:6		{BA 1 B}	inline_connector
IB3:7		{BA 3 C}	inline_connector
IB3:8		{BA 3 C}	inline_connector
IB3:9		{BA 3 C}	inline_connector
IB3:10		{BA 3 C}	inline_connector
IB3:11		{BA 3 C}	inline_connector
IB3:12		{BA 3 C}	inline_connector
IB3:13		{BA 1 C}	inline_connector
IB3:14		{IU 4 D}	inline_connector
IB3:15		{IU 4 D}	inline_connector
IB3:16		{IU 4 C}	inline_connector
IB3:17		{AC 1 D}	inline_connector
IB3:18		{ZC 5 A}	inline_connector
IB4:1		{GB 3 C}	inline_connector
IB4:2		{GB 3 C}	inline_connector
IB4:3		{GB 4 C}	inline_connector
IB4:4		{GB 4 C}	inline_connector
IB4:5		{GB 4 C}	inline_connector
IB4:6		{GA 3 B}	inline_connector
IB4:7		{GB 2 B}	inline_connector
IB4:8		{GB 4 C}	inline_connector
IB4:9		{GB 4 C}	inline_connector
IB4:10		{GB 2 C}	inline_connector
IB4:11		{GB 2 C}	inline_connector
IB4:12		{GB 2 C}	inline_connector
IB4:13		{GB 1 C}	inline_connector
IB4:14		{GB 1 C}	inline_connector
IB4:15		{EP 0 D}	inline_connector
IB4:16		{EP 0 D}	inline_connector
IB4:17		{EP 1 C}	inline_connector
IB4:18		{EP 1 C}	inline_connector
IB5:1		{EX 4 C}	inline_connector
IB5:2		{AA 3 D}	inline_connector

VOLVO

Volvo Bus Corporation

Document Title

WIRING DIAGRAM

Document Type

PRODUCT SCHEMATIC

Document No

20904123

Issue Index

10

Volume No

02(02)

Page No

42(72)

Part Name	Description	Location	Part Type
IB5:3		{BA 1 B}	inline_connector
IB5:4		{AA 3 B}	inline_connector
IB5:5		{AA 5 D}	inline_connector
IB5:6		{AA 4 B}	inline_connector
IB5:7		{AA 5 C}	inline_connector
IB5:8		{FA 4 C}	inline_connector
IB5:9		{FA 2 B}	inline_connector
IB5:10		{NA 1 B}	inline_connector
IB5:11		{FA 3 C}	inline_connector
IB5:12		{FA 3 C}	inline_connector
IB5:13		{AA 3 D}	inline_connector
IB5:14		{FA 1 B}	inline_connector
IB5:15		{FA 1 B}	inline_connector
IB5:16		{FA 2 B}	inline_connector
IB5:17		{EO 3 B}	inline_connector
IB5:18		{NA 3 C}	inline_connector
IB6:1		{NB 4 D}	inline_connector
IB6:2		{XC 2 C}	inline_connector
IB6:3		{XC 2 C}	inline_connector
IB6:4		{NB 4 D}	inline_connector
IB6:5		{ZC 5 B}	inline_connector
IB6:6		{NB 3 D}	inline_connector
IB6:7		{NB 4 C}	inline_connector
IB6:8		{NB 4 C}	inline_connector
IB6:9		{NB 4 C}	inline_connector
IB6:10		{NB 4 C}	inline_connector
IB6:11		{CP 2 D}	inline_connector
IB6:12		{NB 2 B}	inline_connector
IB7:1		{GM 4 D}	inline_connector
IB7:2		{GB 0 C}	inline_connector
IB7:3		{GB 0 C}	inline_connector
IB7:4		{GM 2 C}	inline_connector
IB7:5		{CV 0 C}	inline_connector
IB7:6		{CV 0 C}	inline_connector
IB7:7		{NA 2 C}	inline_connector
IB7:8		{GM 1 C}	inline_connector
IB7:9		{CO 4 D}	inline_connector
IB7:10		{ZC 4 B}	inline_connector
IB7:11		{NA 2 B}	inline_connector
IB7:12		{GM 0 C}	inline_connector
IB8:1		{EO 4 C}	inline_connector
IB8:2		{EO 4 C}	inline_connector
IB8:3		{EO 4 C}	inline_connector
IB8:4		{EO 4 C}	inline_connector
IB8:5		{EO 4 C}	inline_connector
IB8:6		{DD 2 D}	inline_connector
IB8:7		{GB 0 C}	inline_connector
IB8:8		{CL 2 B}	inline_connector
IB8:9		{CL 2 B}	inline_connector
IB8:10		{CL 2 B}	inline_connector

VOLVO

Volvo Bus Corporation

Document Title

WIRING DIAGRAM

Document Type

PRODUCT SCHEMATIC

Document No

20904123

Issue Index

10

Volume No

02(02)

Page No

43(72)

Part Name	Description	Location	Part Type
IB8:11		{CL 4 C}	inline_connector
IB8:12		{CL 4 C}	inline_connector
IB9:1		{BA 3 B}	inline_connector
IB9:2		{BA 2 B}	inline_connector
IB9:3		{GE 4 D}	inline_connector
IB9:4		{ZC 5 B}	inline_connector
IB9:5		{GE 4 C}	inline_connector
IB9:6		{GA 0 B}	inline_connector
IB9:7		{BA 2 C}	inline_connector
IB9:8		{BA 3 C}	inline_connector
IB9:9		{BA 2 C}	inline_connector
IB9:10		{BA 2 C}	inline_connector
IB9:11		{BA 2 C}	inline_connector
IB9:12		{BA 2 C}	inline_connector
IB10:1		{DN 5 D}	inline_connector
IB10:2		{GA 1 C}	inline_connector
IB10:3		{BB 4 B}	inline_connector
IB10:4		{DA 3 C}	inline_connector
IB10:5		{DA 5 C}	inline_connector
IB10:6		{DA 4 C}	inline_connector
IB10:7		{DA 4 D}	inline_connector
IB10:8		{DN 4 C}	inline_connector
IB10:9		{ZC 1 B}	inline_connector
IB10:10		{DM 1 C}	inline_connector
IB10:11		{DD 0 D}	inline_connector
IB10:12		{DD 1 D}	inline_connector
IB10_B:2		{GA 1 C}	inline_connector
IB10_B:3		{BB 4 B}	inline_connector
IB10_B:9		{ZC 0 B}	inline_connector
IB10_E:2		{DA 3 C}	inline_connector
IB10_E:3		{BB 4 B}	inline_connector
IB10_E:4		{DA 3 C}	inline_connector
IB10_E:5		{DA 5 C}	inline_connector
IB10_E:6		{DA 4 C}	inline_connector
IB10_E:7		{DA 4 D}	inline_connector
IB10_E:9		{ZC 0 B}	inline_connector
IB10_E:10		{DM 1 C}	inline_connector
IB10_I:1		{DN 5 D}	inline_connector
IB10_I:8		{DN 4 C}	inline_connector
IB10_I:9		{ZC 1 B}	inline_connector
IB10_I:10		{DM 1 C}	inline_connector
IB10_VO:9		{ZC 1 B}	inline_connector
IB10_VO:10		{DM 1 C}	inline_connector
IB10_VO:11		{DD 0 D}	inline_connector
IB10_VO:12		{DD 1 D}	inline_connector
IB10_ZF5:9		{ZC 1 B}	inline_connector
IB10_ZF5:10		{DM 1 C}	inline_connector
IB10_ZF5:11		{DD 0 D}	inline_connector
IB10_ZF5:12		{DD 1 D}	inline_connector
IB10_ZF:9		{ZC 1 B}	inline_connector

VOLVO

Volvo Bus Corporation

Document Title

WIRING DIAGRAM

Document Type

PRODUCT SCHEMATIC

Document No

20904123

Issue Index

10

Volume No

02(02)

Page No

44(72)

Part Name	Description	Location	Part Type
IB10_ZF:10		{DM 1 C}	inline_connector
IS:1		{XD 3 D}	inline_connector
IS:2		{XD 3 D}	inline_connector
IS:3		{XC 4 C}	inline_connector
IS:4		{XC 5 C}	inline_connector
IS:5		{NE 4 B}	inline_connector
IS:6		{NE 4 B}	inline_connector
KH1A:1		{FA 0 B}	inline_connector
KH1A:2		{FA 0 B}	inline_connector
KH1A:3		{FA 0 B}	inline_connector
KH1A:4		{CL 2 C}	inline_connector
KH1A:5		{FA 0 B}	inline_connector
KH1A:7		{CL 2 C}	inline_connector
KH1A:10		{CL 2 C}	inline_connector
KH1A:11		{CL 2 C}	inline_connector
KH1B:1		{DN 4 D}	inline_connector
KH1B:2		{DN 4 D}	inline_connector
KH1B:3		{DN 4 D}	inline_connector
KH1B:4		{DA 4 D}	inline_connector
KH1B:5		{DN 4 D}	inline_connector
KH1B:7		{DA 4 C}	inline_connector
KH1B:8		{DA 5 D}	inline_connector
KH1B:10		{DA 4 C}	inline_connector
KH1B:11		{DA 4 D}	inline_connector
KH1B:12		{DA 5 C}	inline_connector
KH1B:14		{DA 5 D}	inline_connector
KH1B:15		{DA 5 C}	inline_connector
KH2A:1		{BA 3 A}	inline_connector
KH2A:3		{BA 5 C}	inline_connector
KH2A:4		{BA 3 B}	inline_connector
KH2A:5		{BA 5 C}	inline_connector
KH2A:6		{BA 5 C}	inline_connector
KH2A:7		{AC 5 C}	inline_connector
KH2A:8		{AC 4 C}	inline_connector
KH2A:9		{BA 5 C}	inline_connector
KH2A:10		{AC 5 C}	inline_connector
KH2A:11		{AC 4 C}	inline_connector
KH2A:12		{AC 5 C}	inline_connector
KH2B:1		{AA 2 B}	inline_connector
KH2B:2		{GM 2 C}	inline_connector
KH2B:3		{GM 2 C}	inline_connector
KH2B:4		{AA 2 B}	inline_connector
KH2B:5		{GM 2 C}	inline_connector
KH2B:6		{GM 2 C}	inline_connector
KH2B:7		{AC 5 C}	inline_connector
KH2B:8		{AC 5 C}	inline_connector
KH2B:9		{GM 2 C}	inline_connector
KH2B:11		{AC 5 D}	inline_connector
KH2B:12		{AC 5 D}	inline_connector
KH3A:1		{AA 4 D}	inline_connector

 Volvo Bus Corporation	Document Title			
	WIRING DIAGRAM			
	Document Type			
PRODUCT SCHEMATIC				
Document No	Issue Index	Volume No	Page No	
20904123	10	02(02)	45(72)	

Part Name	Description	Location	Part Type
KH3A:3		{AA 4 C}	inline_connector
KH3A:4		{BB 3 C}	inline_connector
KH3A:5		{AA 4 D}	inline_connector
KH3A:6		{AA 4 C}	inline_connector
KH3A:7		{BB 3 D}	inline_connector
KH3A:8		{AA 2 C}	inline_connector
KH3A:9		{AA 2 C}	inline_connector
KH3A:10		{BB 3 D}	inline_connector
KH3A:11		{BB 3 C}	inline_connector
KH3A:12		{AA 2 C}	inline_connector
KH3A:14		{AA 2 C}	inline_connector
KH3B:1		{BB 0 D}	inline_connector
KH3B:2		{BB 0 C}	inline_connector
KH3B:3		{BB 0 D}	inline_connector
KH3B:4		{DM 4 D}	inline_connector
KH3B:5		{BB 0 C}	inline_connector
KH3B:7		{DM 4 C}	inline_connector
KH3B:8		{DM 4 D}	inline_connector
KH3B:10		{DM 5 C}	inline_connector
KH3B:11		{DM 5 D}	inline_connector
KH3B:12		{DM 4 C}	inline_connector
KH3B:14		{DM 4 D}	inline_connector
KH3B:15		{DM 4 C}	inline_connector
KV:A		{DA 4 B}	inline_connector
KV:B		{DA 4 B}	inline_connector
KV:C		{DA 4 B}	inline_connector
KV:D		{DA 4 B}	inline_connector
KV:E		{DA 4 B}	inline_connector
KV:F		{DA 5 B}	inline_connector
KV:G		{DA 2 B}	inline_connector
KV:H		{DA 3 B}	inline_connector
KV:J		{DA 2 B}	inline_connector
KV:K		{DA 2 B}	inline_connector
KV:L		{DA 3 B}	inline_connector
KV:M		{DA 3 B}	inline_connector
KV:P		{DA 5 B}	inline_connector
KV:Q		{DA 2 B}	inline_connector
KV:R		{DA 1 B}	inline_connector
KV:S		{DA 1 B}	inline_connector
KV:T		{DA 3 B}	inline_connector
LA:1		{AF 2 C}	inline_connector
LA:2		{AF 2 C}	inline_connector
LA:4		{AF 0 D}	inline_connector
LA:5		{AF 2 A}	inline_connector
LA:6		{AF 1 C}	inline_connector
LKS:1		{BE 3 C}	inline_connector
LKS:2		{BE 3 C}	inline_connector
LKS:3		{BE 3 C}	inline_connector
LKS:4		{BE 3 C}	inline_connector
LKS:5		{BE 3 C}	inline_connector

VOLVO

Volvo Bus Corporation

Document Title

WIRING DIAGRAM

Document Type

PRODUCT SCHEMATIC

Document No

20904123

Issue Index

10

Volume No

02(02)

Page No

46(72)

Part Name	Description	Location	Part Type
LKS:6		{BE 4 C}	inline_connector
LKS:7		{BE 5 D}	inline_connector
LKS:8		{BE 2 B}	inline_connector
LT1:2		{LB 2 D}	inline_connector
LT1:3		{LB 4 C}	inline_connector
LT1:4		{NA 5 A}	inline_connector
LT1:5		{NA 5 B}	inline_connector
LT1:6		{NA 0 A}	inline_connector
LT1:7		{NA 0 A}	inline_connector
LT1:8		{LB 3 C}	inline_connector
LT1:9		{GD 4 C}	inline_connector
LT1:10		{FO 3 D}	inline_connector
LT1:11		{FO 2 B}	inline_connector
LT1:12		{FO 1 B}	inline_connector
LT2:1		{CL 4 D}	inline_connector
LT2:2		{CL 5 D}	inline_connector
LT:1		{EO 1 C}	inline_connector
LT:2		{EO 1 C}	inline_connector
LT:3		{EO 1 C}	inline_connector
LT:4		{EO 0 C}	inline_connector
LT:5		{CL 3 B}	inline_connector
LT:6		{CL 3 B}	inline_connector
LT:7		{CL 3 B}	inline_connector
LT:8		{FA 3 C}	inline_connector
LT:9		{FA 3 C}	inline_connector
LT:10		{FA 3 C}	inline_connector
LT:11		{FA 3 C}	inline_connector
LT:12		{FB 0 B}	inline_connector
LT:13		{FB 0 B}	inline_connector
LT:14		{FB 0 B}	inline_connector
LT:15		{FB 3 C}	inline_connector
LT:16		{FB 3 C}	inline_connector
LT:17		{FB 3 B}	inline_connector
LT:18		{FO 1 B}	inline_connector
LT:19		{ZC 2 C}	inline_connector
LT:20		{LB 3 C}	inline_connector
LT:21		{FO 1 B}	inline_connector
LT:22		{FO 1 B}	inline_connector
LT:23		{FO 2 B}	inline_connector
LT:25		{FO 2 B}	inline_connector
LT:26		{FO 4 C}	inline_connector
LT:27		{LB 3 C}	inline_connector
LT:28		{LB 3 C}	inline_connector
LT:29		{LB 3 C}	inline_connector
LT:30		{LB 3 D}	inline_connector
LT:31		{LB 2 D}	inline_connector
M01:1		{GM 0 B}	inline_connector
M01:2		{GM 0 B}	inline_connector
M01:3		{GM 1 B}	inline_connector
M01:4		{GM 1 B}	inline_connector

VOLVO

Volvo Bus Corporation

Document Title

WIRING DIAGRAM

Document Type

PRODUCT SCHEMATIC

Document No

20904123

Issue Index

10

Volume No

02(02)

Page No

47(72)

Part Name	Description	Location	Part Type
M01:5		{GM 1 A}	inline_connector
M01:6		{GM 4 C}	inline_connector
M01:8		{GM 3 B}	inline_connector
M01:9		{GM 4 C}	inline_connector
M01:11		{GM 4 B}	inline_connector
M01:12		{GM 3 B}	inline_connector
M01:13		{GM 4 B}	inline_connector
M01:14		{GM 4 C}	inline_connector
ML1:1		{GB 4 A}	inline_connector
ML1:2		{ZC 3 D} {ZC 4 D}	inline_connector
ML1:3		{GB 4 A} {GE 5 B}	inline_connector
ML1:4		{ZC 3 D} {ZC 4 D}	inline_connector
ML1:5		{GB 4 A} {GE 5 B}	inline_connector
ML1:6		{ZC 3 D} {ZC 4 D}	inline_connector
ML1:7		{GE 5 B}	inline_connector
ML2:1		{GB 0 B}	inline_connector
ML2:2		{ZC 3 D} {ZC 4 D}	inline_connector
ML2:3		{GB 1 A} {GE 3 B}	inline_connector
ML2:4		{ZC 3 D} {ZC 4 D}	inline_connector
ML2:5		{GB 1 A} {GE 3 B}	inline_connector
ML2:6		{ZC 3 D} {ZC 4 D}	inline_connector
ML2:7		{GE 3 B}	inline_connector
ML3:1		{BB 2 C}	inline_connector
ML3:2		{BB 3 D}	inline_connector
ML3:3		{GC 4 B}	inline_connector
ML3:4		{GC 4 B}	inline_connector
ML3:5		{GC 4 B}	inline_connector
ML3:6		{GA 3 C}	inline_connector
ML3:7		{GC 4 B}	inline_connector
ML3A:1		{GD 3 B}	inline_connector
ML3A:3		{GD 2 B}	inline_connector
ML3A:4		{GD 2 B}	inline_connector
ML3A:5		{GD 1 B}	inline_connector
ML3A:7		{GD 2 B}	inline_connector
ML3B:1		{GD 4 C}	inline_connector
ML3B:2		{GD 3 C}	inline_connector
ML3B:3		{GD 1 C}	inline_connector
ML3B:4		{GD 1 C}	inline_connector
ML3B:5		{GD 1 C}	inline_connector
ML3B:6		{GD 5 C}	inline_connector
ML3B:7		{GD 1 B}	inline_connector
ML4:1		{BB 2 C}	inline_connector

VOLVO

Volvo Bus Corporation

Document Title

WIRING DIAGRAM

Document Type

PRODUCT SCHEMATIC

Document No

20904123

Issue Index

10

Volume No

02(02)

Page No

48(72)

Part Name	Description	Location	Part Type
ML4:2		{BB 3 D}	inline_connector
ML4:3		{GC 5 B}	inline_connector
ML4:4		{GC 5 B}	inline_connector
ML4:5		{GC 5 B}	inline_connector
ML4:6		{GA 3 C}	inline_connector
ML4:7		{GC 5 A}	inline_connector
ML4A:1		{GD 3 B}	inline_connector
ML4A:3		{GD 2 B}	inline_connector
ML4A:4		{GD 2 B}	inline_connector
ML4A:5		{GD 2 B}	inline_connector
ML4A:7		{GD 2 A}	inline_connector
ML4B:1		{GD 4 C}	inline_connector
ML4B:2		{GD 3 C}	inline_connector
ML4B:3		{GD 2 C}	inline_connector
ML4B:4		{GD 2 C}	inline_connector
ML4B:5		{GD 2 C}	inline_connector
ML4B:6		{GD 5 C}	inline_connector
ML4B:7		{GD 2 B}	inline_connector
ML5:1		{GC 1 A}	inline_connector
ML5:2		{GC 1 A}	inline_connector
ML5:3		{GC 1 A}	inline_connector
ML5:4		{GC 1 A}	inline_connector
ML5:5		{GC 1 A}	inline_connector
ML5:6		{GC 0 A}	inline_connector
ML5:7		{GC 0 A}	inline_connector
ML6:1		{GC 1 B}	inline_connector
ML6:2		{GC 1 B}	inline_connector
ML6:3		{GC 1 B}	inline_connector
ML6:4		{GC 1 B}	inline_connector
ML6:5		{GC 1 B}	inline_connector
ML6:6		{GC 0 B}	inline_connector
ML6:7		{GC 0 B}	inline_connector
ML7:5		{GA 2 C}	inline_connector
ML7:6		{GA 2 C}	inline_connector
ML8:1		{GF 4 C}	inline_connector
ML8:3		{GF 2 B}	inline_connector
ML8:4		{GF 2 B}	inline_connector
ML8:5		{GF 1 B}	inline_connector
ML8:7		{GF 2 B}	inline_connector
ML9:1		{GF 4 C}	inline_connector
ML9:3		{GF 3 B}	inline_connector
ML9:4		{GF 2 B}	inline_connector
ML9:5		{GF 2 B}	inline_connector
ML9:7		{GF 3 B}	inline_connector
R905A:1		{CU 4 B}	inline_connector
R905A:2		{CU 4 B}	inline_connector
R905B:1		{CU 4 B}	inline_connector
R905B:2		{CU 4 B}	inline_connector
R905C:1		{CU 4 B}	inline_connector
R905C:2		{CU 4 B}	inline_connector

 <p>Volvo Bus Corporation</p>	Document Title			
	WIRING DIAGRAM			
	Document Type			
PRODUCT SCHEMATIC				
Document No	Issue Index	Volume No	Page No	
20904123	10	02(02)	49(72)	

Part Name	Description	Location	Part Type
R906A:1		{CU 4 B}	inline_connector
R906A:2		{CU 4 B}	inline_connector
R906B:1		{CU 4 B}	inline_connector
R906B:2		{CU 3 B}	inline_connector
R906C:1		{CU 3 B}	inline_connector
R906C:2		{CU 4 B}	inline_connector
R908A:1		{CU 2 B}	inline_connector
R908A:2		{CU 2 B}	inline_connector
R908B:1		{CU 2 B}	inline_connector
R908B:2		{CU 2 B}	inline_connector
R908C:1		{CU 2 B}	inline_connector
R908C:2		{CU 2 B}	inline_connector
R910A:1		{CU 3 B}	inline_connector
R910A:2		{CU 3 B}	inline_connector
R910B:1		{CU 3 B}	inline_connector
R910B:2		{CU 3 B}	inline_connector
R910C:1		{CU 3 B}	inline_connector
R910C:2		{CU 3 B}	inline_connector
RA1.A1:1		{NB 4 B}	inline_connector
RA1.A1:2		{NB 4 B}	inline_connector
RA1.A1:3		{NB 3 B}	inline_connector
RA1.A1:4		{NB 3 B}	inline_connector
RA1.A1:5		{NA 3 C}	inline_connector
RA1.A1:6		{AC 3 C}	inline_connector
RA1.A1:7		{AC 2 C}	inline_connector
RA1.A1:8		{AC 1 C}	inline_connector
RA1.A1:10		{NA 5 C}	inline_connector
RA1.A1:11		{AB 4 D}	inline_connector
RA1.A2:1		{NB 4 B}	inline_connector
RA1.A2:2		{NB 4 B}	inline_connector
RA1.A2:3		{NB 3 B}	inline_connector
RA1.A2:4		{NB 3 B}	inline_connector
RA1.A2:5		{NA 3 C}	inline_connector
RA1.A2:6		{AC 3 B}	inline_connector
RA1.A2:7		{AC 2 B}	inline_connector
RA1.A2:8		{AC 1 B}	inline_connector
RA1.A2:10		{NA 4 C}	inline_connector
RA1.A2:11		{AB 4 D}	inline_connector
RA1.A3:1		{NB 4 B}	inline_connector
RA1.A3:2		{NB 4 B}	inline_connector
RA1.A3:3		{NB 3 B}	inline_connector
RA1.A3:4		{NB 3 B}	inline_connector
RA1.A3:5		{NA 3 D}	inline_connector
RA1.A3:6		{AC 3 B}	inline_connector
RA1.A3:7		{AC 2 B}	inline_connector
RA1.A3:8		{AC 1 B}	inline_connector
RA1.A3:10		{NA 4 C}	inline_connector
RA1.A3:11		{AB 4 D}	inline_connector
RA1:1		{NB 5 B} {NB 4 B}	inline_connector

VOLVO

Volvo Bus Corporation

Document Title

WIRING DIAGRAM

Document Type

PRODUCT SCHEMATIC

Document No

20904123

Issue Index

10

Volume No

02(02)

Page No

50(72)

Part Name	Description	Location	Part Type
RA1:2		{NB 5 B} {NB 4 B}	inline_connector
RA1:3		{NB 5 B} {NB 4 B}	inline_connector
RA1:4		{NB 5 B} {NB 3 B}	inline_connector
RA1:5		{NA 3 C}	inline_connector
RA1:6		{AC 3 B}	inline_connector
RA1:7		{AC 2 B}	inline_connector
RA1:8		{AC 2 B}	inline_connector
RA1:9		{ND 3 C}	inline_connector
RA1:10		{NA 0 C} {NA 4 C}	inline_connector
RA1:11		{AB 4 D}	inline_connector
RA1:12		{EX 4 B}	inline_connector
RA1B:1		{NB 5 B}	inline_connector
RA1B:2		{NB 5 B}	inline_connector
RA1B:3		{NB 5 B}	inline_connector
RA1B:4		{NB 5 B}	inline_connector
RA1B:5		{NA 3 C}	inline_connector
RA1B:6		{AE 3 C}	inline_connector
RA1B:7		{AE 2 C}	inline_connector
RA1B:8		{AE 1 C}	inline_connector
RA1B:10		{NA 4 C}	inline_connector
RA1B:11		{AE 3 B}	inline_connector
REG1:1		{CN 2 D}	inline_connector
REG1:2		{CF 4 C}	inline_connector
REG1:3		{CG 4 B}	inline_connector
REG1:4		{CG 4 B}	inline_connector
REG1:5		{CG 4 B}	inline_connector
REV:1		{DC 1 C} {DD 4 D}	inline_connector
RL1:1		{GC 3 B}	inline_connector
RL1:2		{GC 3 B}	inline_connector
RL1:3		{GC 1 B}	inline_connector
RL1:4		{GC 1 B}	inline_connector
RL1:5		{GC 2 B}	inline_connector
RL1:6		{GC 2 B}	inline_connector
RL1:7		{GA 1 B}	inline_connector
RL1:8		{GA 1 A}	inline_connector
RL1:9		{GA 2 B}	inline_connector
RL1:10		{GA 2 A}	inline_connector
RL1:11		{GC 3 B}	inline_connector
RL1:12		{GC 3 B}	inline_connector
RL2:1		{GA 3 B}	inline_connector
RL2:2		{GA 3 A}	inline_connector
RL2:3		{GA 5 B}	inline_connector
RL2:4		{GA 5 A}	inline_connector
RL2:5		{GA 3 B}	inline_connector
RL2:6		{GA 3 A}	inline_connector
RL2:7		{GA 1 B}	inline_connector

VOLVO

Volvo Bus Corporation

Document Title

WIRING DIAGRAM

Document Type

PRODUCT SCHEMATIC

Document No

20904123

Issue Index

10

Volume No

02(02)

Page No

51(72)

Part Name	Description	Location	Part Type
RL2:8		{GA 1 A}	inline_connector
RL2:9		{GA 2 B}	inline_connector
RL2:10		{GA 2 A}	inline_connector
RL2:11		{GA 3 B}	inline_connector
RL2:12		{GA 3 A}	inline_connector
RL3:1		{GC 5 B}	inline_connector
RL3:2		{GC 4 B}	inline_connector
RL3:3		{GA 4 A}	inline_connector
RL3:4		{GC 2 B}	inline_connector
RL3:5		{GA 3 C}	inline_connector
RL3:6		{GA 1 B} {GE 1 C}	inline_connector
RL3:7		{GC 3 B} {GE 0 C}	inline_connector
RL3:8		{BC 3 A}	inline_connector
RL3:9		{GC 0 A}	inline_connector
RL3:10		{GA 2 B} {GE 2 B}	inline_connector
RL3:11		{GA 3 C}	inline_connector
RL3:12		{ZC 2 D} {ZC 2 D}	inline_connector
RL4:1		{GA 4 A}	inline_connector
RL4:2		{GC 2 B}	inline_connector
RL4:3		{GC 4 B}	inline_connector
RL4:4		{GC 3 B}	inline_connector
RL4:5		{GA 3 B}	inline_connector
RL4:6		{GC 0 B}	inline_connector
RL4:7		{GA 2 B}	inline_connector
RL5:1		{GD 1 B} {GF 1 C}	inline_connector
RL5:2		{GD 1 B} {GF 1 B}	inline_connector
RL5:3		{GD 3 B} {GF 3 C}	inline_connector
RL5:4		{GD 3 B} {GF 3 B}	inline_connector
RL5:5		{GD 4 B} {GF 4 C}	inline_connector
RL5:6		{GD 4 B} {GF 4 B}	inline_connector
RL5:7		{GD 4 B} {GF 4 C}	inline_connector
RL5:8		{GD 4 B} {GF 4 B}	inline_connector
RL5:9		{GD 0 B} {GF 0 C}	inline_connector
RL5:10		{GD 0 B} {GF 0 B}	inline_connector
RL5:11		{GD 1 B} {GF 1 C}	inline_connector
RL5:12		{GD 1 B} {GF 1 B}	inline_connector
RL6:1		{GD 2 B}	inline_connector

VOLVO

Volvo Bus Corporation

Document Title

WIRING DIAGRAM

Document Type

PRODUCT SCHEMATIC

Document No

20904123

Issue Index

10

Volume No

02(02)

Page No

52(72)

Part Name	Description	Location	Part Type
RL6:2		{GD 1 B}	inline_connector
RL6:3		{GD 3 B} {GF 3 C}	inline_connector
RL6:4		{GD 3 B} {GF 3 C}	inline_connector
RL6:5		{GF 2 C}	inline_connector
RL6:6		{GD 4 B} {GF 4 C}	inline_connector
RL6:7		{GD 5 B} {GF 5 C}	inline_connector
RL6:8		{GF 2 C}	inline_connector
RL6:9		{GF 2 A}	inline_connector
RL6:10		{GD 0 B} {GF 0 C}	inline_connector
RL6:11		{LA 1 C}	inline_connector
RL6:12		{GD 5 B} {GF 5 B}	inline_connector
RL7:1		{GD 5 B} {GF 5 C}	inline_connector
RL7:2		{GD 5 B} {GF 5 B}	inline_connector
RL7:3		{GD 3 B} {GF 3 C}	inline_connector
RL7:4		{GD 3 B} {GF 3 B}	inline_connector
RL7:5		{GD 3 B} {GF 4 C}	inline_connector
RL7:6		{GD 3 B} {GF 4 B}	inline_connector
RL7:7		{GD 4 B} {GF 4 C}	inline_connector
RL7:8		{GD 4 B} {GF 4 B}	inline_connector
RL7:9		{GD 1 B} {GF 0 C}	inline_connector
RL7:10		{GD 1 B} {GF 0 B}	inline_connector
RL7:11		{GD 4 B} {GF 5 C}	inline_connector
RL7:12		{GD 4 B} {GF 5 B}	inline_connector
RL8:1		{GF 1 C}	inline_connector
RL8:2		{GF 1 B}	inline_connector
RL8:3		{GF 3 C}	inline_connector
RL8:4		{GF 3 B}	inline_connector
RL8:5		{GF 4 C}	inline_connector
RL8:6		{GF 4 B}	inline_connector
RL8:7		{GF 4 C}	inline_connector
RL8:8		{GF 4 B}	inline_connector
RL8:9		{GF 0 C}	inline_connector
RL8:10		{GF 0 B}	inline_connector
RL8:11		{GF 1 C}	inline_connector
RL8:12		{GF 1 B}	inline_connector
RL9:1		{GF 2 B}	inline_connector

VOLVO

Volvo Bus Corporation

Document Title

WIRING DIAGRAM

Document Type

PRODUCT SCHEMATIC

Document No

20904123

Issue Index

10

Volume No

02(02)

Page No

53(72)

Part Name	Description	Location	Part Type
RL9:2		{GF 1 B}	inline_connector
RL9:3		{GF 3 C}	inline_connector
RL9:4		{GF 3 C}	inline_connector
RL9:6		{GF 4 C}	inline_connector
RL9:7		{GF 5 C}	inline_connector
RL9:10		{GF 0 C}	inline_connector
RL9:12		{GF 5 B}	inline_connector
RL10:1		{GF 5 C}	inline_connector
RL10:2		{GF 5 B}	inline_connector
RL10:3		{GF 3 C}	inline_connector
RL10:4		{GF 3 B}	inline_connector
RL10:5		{GF 4 C}	inline_connector
RL10:6		{GF 4 B}	inline_connector
RL10:7		{GF 4 C}	inline_connector
RL10:8		{GF 4 B}	inline_connector
RL10:9		{GF 0 C}	inline_connector
RL10:10		{GF 0 B}	inline_connector
RL10:11		{GF 5 C}	inline_connector
RL10:12		{GF 5 B}	inline_connector
RL:1		{GB 5 C}	inline_connector
RL:3		{GB 5 B}	inline_connector
RL_DA:1		{GB 5 B}	inline_connector
RL_DB:1		{GB 5 C}	inline_connector
S901_U1:1		{AG 2 B}	inline_connector
S901_U1:2		{AG 2 B}	inline_connector
S908:1		{AG 1 B}	inline_connector
S908:3		{AG 0 B}	inline_connector
S_T_S:1		{NB 3 B}	inline_connector
S_T_S:2		{NB 3 B}	inline_connector
S_T_S:3		{NB 3 B}	inline_connector
S_T_T:3		{NB 3 B}	inline_connector
SP_F:1		{CL 1 D}	inline_connector
SP_F:2		{CL 0 D}	inline_connector
SP_F:3		{CL 0 D}	inline_connector
SP_F:4		{CL 0 D}	inline_connector
SP_RR:1		{CL 1 C}	inline_connector
SP_RR:2		{CL 0 C}	inline_connector
SP_RR:3		{CL 0 C}	inline_connector
SP_RR:4		{CL 0 C}	inline_connector
Throttle :1		{CD 3 B}	inline_connector
Throttle :2		{CD 3 B}	inline_connector
Throttle :3		{CD 3 B}	inline_connector
Throttle :4		{CD 3 B}	inline_connector
Throttle :5		{CD 3 B}	inline_connector
Throttle :6		{CD 3 B}	inline_connector
TOW:1		{GA 0 C}	inline_connector
TOW:2		{GA 0 C}	inline_connector
TOW:3		{GA 1 C}	inline_connector
TOW:4		{GA 1 C}	inline_connector
TOW:5		{GA 1 C}	inline_connector

VOLVO

Volvo Bus Corporation

Document Title

WIRING DIAGRAM

Document Type

PRODUCT SCHEMATIC

Document No

20904123

Issue Index

10

Volume No

02(02)

Page No

54(72)

Part Name	Description	Location	Part Type
TOW:6		{GA 1 C}	inline_connector
TOW:7		{GA 1 C}	inline_connector
TRAIL1:1		{FO 3 D}	inline_connector
TRAIL1:2		{FO 4 C}	inline_connector
TRAIL1:3		{FO 4 B}	inline_connector
TRAIL1:4		{LB 3 C}	inline_connector
TRAIL1:5		{LB 3 C}	inline_connector
TRAIL1:6		{LB 3 D}	inline_connector
TRAIL1:7		{LB 3 D}	inline_connector
TRAIL1:8		{LB 3 C}	inline_connector
TRAIL1:9		{FO 3 B}	inline_connector
TRAIL1:10		{FO 3 B}	inline_connector
TRAIL1:11		{FO 3 D}	inline_connector
TRAIL1:12		{FO 1 C}	inline_connector
TRAIL1:13		{FO 1 C}	inline_connector
TRAIL1:14		{BC 3 B}	inline_connector
TRAIL1:15		{BC 4 B}	inline_connector
TRAIL1:16		{LA 3 C}	inline_connector
TRAIL1:17		{LA 3 D}	inline_connector
TRAIL1:18		{LA 3 D}	inline_connector
TRAIL1:20		{LA 3 D}	inline_connector
TRAIL1:21		{LA 2 D}	inline_connector
TRAIL1:22		{LB 4 D}	inline_connector
TRAIL1:23		{LA 1 C}	inline_connector
TRAIL1:25		{LA 3 C}	inline_connector
TRAIL1:28		{BC 4 B}	inline_connector
TRAIL1:29		{BC 4 B}	inline_connector
TRAIL2:1		{EO 1 B}	inline_connector
TRAIL2:2		{EO 1 B}	inline_connector
TRAIL2:3		{EO 1 B}	inline_connector
TRAIL2:4		{EO 0 B}	inline_connector
TRAIL2:5		{CL 3 B}	inline_connector
TRAIL2:6		{CL 3 B}	inline_connector
TRAIL2:7		{CL 3 B}	inline_connector
TRAIL2:8		{FA 3 B}	inline_connector
TRAIL2:9		{FA 3 B}	inline_connector
TRAIL2:10		{FA 3 B}	inline_connector
TRAIL2:11		{FB 0 C}	inline_connector
TRAIL2:12		{FB 3 C}	inline_connector
TRAIL3:1		{BC 4 B}	inline_connector
TRAIL3:2		{BC 4 A}	inline_connector
TRAIL3:3		{BC 3 B}	inline_connector
TRAIL3:4		{BC 3 A}	inline_connector
TRAIL:1		{EP 3 C}	inline_connector
TRAIL:2		{EP 3 C}	inline_connector
TRAIL:3		{EP 3 C}	inline_connector
TRAIL:4		{EP 2 C}	inline_connector
TRAIL:5		{FB 3 C}	inline_connector
TRAIL:6		{FB 4 C}	inline_connector
TRAIL:7		{FA 1 C}	inline_connector

VOLVO

Volvo Bus Corporation

Document Title

WIRING DIAGRAM

Document Type

PRODUCT SCHEMATIC

Document No

20904123

Issue Index

10

Volume No

02(02)

Page No

55(72)

Part Name	Description	Location	Part Type
TRAIL:8		{FA 2 C}	inline_connector
TRAIL:9		{FA 2 C}	inline_connector
TRAIL:10		{FB 1 B}	inline_connector
TRAIL:11		{FB 1 B}	inline_connector
TRAIL:12		{FB 1 B}	inline_connector
TRAIL:13		{FB 1 B}	inline_connector
TRAIL:14		{FB 4 B}	inline_connector
TRAIL:15		{FB 4 C}	inline_connector
TRAIL:16		{BC 5 C}	inline_connector
TRAIL:17		{BC 4 C}	inline_connector
TRAIL:18		{BC 5 C}	inline_connector
TRAIL:19		{GD 5 C}	inline_connector
TRAIL:20		{GD 4 C}	inline_connector
TRAIL:21		{GD 4 C}	inline_connector
TRAIL:22		{GD 3 C}	inline_connector
TRAIL:23		{GD 3 C}	inline_connector
TRAIL:24		{GD 3 C}	inline_connector
TRAIL:25		{GD 3 C}	inline_connector
TRAIL:26		{GD 3 C}	inline_connector
TRAIL:27		{GD 2 C}	inline_connector
TRAIL:28		{GD 2 C}	inline_connector
TRAIL:29		{GD 1 C}	inline_connector
TRAIL:30		{GD 0 C}	inline_connector
TRAIL:31		{FA 2 D}	inline_connector
UDS12:1		{CV 4 C}	inline_connector
UDS12:2		{CV 4 C}	inline_connector
UDS12:3		{CU 4 C}	inline_connector
UDS12:4		{CU 3 C}	inline_connector
UDS12:5		{XE 3 C}	inline_connector
UDS12:6		{XE 3 C}	inline_connector
UDS12:7		{CU 4 C}	inline_connector
UDS12:8		{CU 2 C}	inline_connector
UDS12:9		{CU 2 C}	inline_connector
UDS12:11		{CU 5 C}	inline_connector
UDS12:12		{CU 0 B}	inline_connector
UDS12_B:1		{CV 4 D} {CV 4 C}	inline_connector
UDS12_B:2		{CV 4 D} {CV 4 C}	inline_connector
UDS12_B:3		{CU 3 D}	inline_connector
UDS12_B:4		{CU 3 D}	inline_connector
UDS12_B:5		{XE 3 C}	inline_connector
UDS12_B:6		{XE 3 C}	inline_connector
UDS12_B:7		{CU 4 C}	inline_connector
UDS12_B:8		{CU 2 C}	inline_connector
UDS12_B:9		{CU 2 C}	inline_connector
UDS12_B:11		{CU 5 D}	inline_connector
UDS12_B:12		{CU 1 B}	inline_connector
UDS12_F:1		{CV 2 D} {CV 2 C}	inline_connector

VOLVO

Volvo Bus Corporation

Document Title

WIRING DIAGRAM

Document Type

PRODUCT SCHEMATIC

Document No

20904123

Issue Index

10

Volume No

02(02)

Page No

56(72)

Part Name	Description	Location	Part Type
UDS12_F:2		{CV 2 D} {CV 2 C}	inline_connector
UDS12_F:3		{CU 4 D}	inline_connector
UDS12_F:4		{CU 3 D}	inline_connector
UDS12_F:5		{XE 3 C}	inline_connector
UDS12_F:6		{XE 3 C}	inline_connector
UDS12_F:7		{CU 4 C}	inline_connector
UDS12_F:8		{CU 2 C}	inline_connector
UDS12_F:9		{CU 1 C}	inline_connector
UDS12_F:11		{CU 5 D}	inline_connector
UDS12_F:12		{CU 0 B}	inline_connector
UDS12_M:1		{CV 3 D} {CV 3 C}	inline_connector
UDS12_M:2		{CV 3 D} {CV 3 C}	inline_connector
UDS12_M:3		{CU 4 D}	inline_connector
UDS12_M:4		{CU 3 D}	inline_connector
UDS12_M:5		{XE 3 C}	inline_connector
UDS12_M:6		{XE 3 C}	inline_connector
UDS12_M:7		{CU 4 C}	inline_connector
UDS12_M:8		{CU 2 C}	inline_connector
UDS12_M:9		{CU 2 C}	inline_connector
UDS12_M:11		{CU 5 D}	inline_connector
UDS12_M:12		{CU 0 B}	inline_connector
UDS:1		{CV 4 B}	inline_connector
UDS:2		{CV 4 B}	inline_connector
UDS:5		{CU 1 D}	inline_connector
UDS:6		{CU 1 D}	inline_connector
UDS_B:1		{CV 3 C}	inline_connector
UDS_B:2		{CV 3 C}	inline_connector
UDS_B:3		{XE 5 C}	inline_connector
UDS_B:4		{XE 5 C}	inline_connector
UDS_F:1		{CV 3 C}	inline_connector
UDS_F:2		{CV 2 C}	inline_connector
UDS_F:3		{XE 4 C}	inline_connector
UDS_F:4		{XE 4 C}	inline_connector
UDS_M:1		{CV 3 C}	inline_connector
UDS_M:2		{CV 3 C}	inline_connector
UDS_M:3		{XE 4 C}	inline_connector
UDS_M:4		{XE 4 C}	inline_connector
UDS_TL:1		{CV 3 B}	inline_connector
UDS_TL:2		{CV 3 B}	inline_connector
UDS_TLA:1		{CV 3 B}	inline_connector
UDS_TLA:2		{CV 3 B}	inline_connector
VIC2:1		{CA 3 B}	inline_connector
VIC2:2		{CA 3 B}	inline_connector
VIC2:3		{CA 3 B}	inline_connector
VIC2:4		{CA 3 B}	inline_connector
VIC2:6		{CA 1 B}	inline_connector
VIC2:7		{CA 1 B}	inline_connector

VOLVO

Volvo Bus Corporation

Document Title

WIRING DIAGRAM

Document Type

PRODUCT SCHEMATIC

Document No

20904123

Issue Index

10

Volume No

02(02)

Page No

57(72)

Part Name	Description	Location	Part Type
VIC_MD7:1		{XC 4 A} {CE 3 E}	inline_connector
VIC_MD7:2		{XD 3 B} {CD 4 A}	inline_connector
VIC_MD7:3		{CN 5 C}	inline_connector
VIC_MD7:4		{XC 5 A} {CE 3 E}	inline_connector
VIC_MD7:5		{XD 3 B} {CD 4 A}	inline_connector
VIC_MD7:6		{CN 5 C}	inline_connector
VIC_MD7:7		{CN 2 D}	inline_connector
VIC_MD7:8		{CN 5 C}	inline_connector
VIC_MD7:9		{AD 3 C} {CF 4 A}	inline_connector
VIC_MD7:10		{AD 1 D}	inline_connector
VIC_MD7:12		{AD 4 B}	inline_connector
VIC_MD7:13		{CN 4 C}	inline_connector
VIC_MD7:14		{BD 5 D}	inline_connector
VIC_MD7:15		{CN 4 C}	inline_connector
VIC_MD7:16		{BD 5 B}	inline_connector
VIC_MD7:17		{AD 2 C}	inline_connector
VIC_MD7:18		{CN 4 C}	inline_connector
VIC_MD7:19		{CG 4 B}	inline_connector
VIC_MD7:20		{CN 4 C}	inline_connector
VIC_MD7:21		{CN 0 C} {CD 3 B}	inline_connector
VIC_MD7:22		{CN 0 C} {CG 4 B}	inline_connector
VIC_MD7:23		{CG 4 B}	inline_connector
VIC_MD7:24		{CN 2 C} {CF 3 B}	inline_connector
VIC_MD7:25		{CN 3 C}	inline_connector
VIC_MD7:26		{CN 3 C} {CN 0 C}	inline_connector
VIC_MD7:27		{CN 1 D}	inline_connector
VIC_MD7:28		{CN 3 C}	inline_connector
VIC_MD7:29		{CF 3 C}	inline_connector
VIC_MD7:30		{CN 3 C}	inline_connector
VIC_MD7:31		{CN 2 C}	inline_connector
VIC_MD7:32		{CN 3 C}	inline_connector
VIC_MD7:33		{CN 4 C}	inline_connector
VIC_MD7:34		{CN 1 C}	inline_connector
VIC_MD7:35		{AD 5 C}	inline_connector
VIC_MD7:36		{CN 1 C} {CF 3 B}	inline_connector
VIC_MD7:37		{CN 1 D}	inline_connector
VIC_MD7:38		{CF 2 D}	inline_connector
VIC_MD7:39		{CN 2 C}	inline_connector
VIC_MD9:1		{XC 3 B}	inline_connector
VIC_MD9:2		{XD 5 A}	inline_connector
VIC_MD9:3		{CA 5 C}	inline_connector
VIC_MD9:4		{XC 3 B}	inline_connector

VOLVO

Volvo Bus Corporation

Document Title

WIRING DIAGRAM

Document Type

PRODUCT SCHEMATIC

Document No

20904123

Issue Index

10

Volume No

02(02)

Page No

58(72)

Part Name	Description	Location	Part Type
VIC_MD9:5		{XD 5 B}	inline_connector
VIC_MD9:6		{CA 5 C}	inline_connector
VIC_MD9:7		{CA 1 C}	inline_connector
VIC_MD9:8		{CA 5 C}	inline_connector
VIC_MD9:9		{AE 3 C}	inline_connector
VIC_MD9:10		{AE 1 B}	inline_connector
VIC_MD9:11		{AE 3 C}	inline_connector
VIC_MD9:12		{AE 3 B}	inline_connector
VIC_MD9:13		{CA 4 C}	inline_connector
VIC_MD9:14		{BD 2 C} {BD 4 C} {BD 2 C} {BD 5 C}	inline_connector
VIC_MD9:15		{CA 4 C}	inline_connector
VIC_MD9:16		{BD 2 B} {BD 4 C} {BD 2 B} {BD 5 B}	inline_connector
VIC_MD9:17		{AE 2 C}	inline_connector
VIC_MD9:18		{CA 3 D}	inline_connector
VIC_MD9:21		{CA 0 D}	inline_connector
VIC_MD9:22		{CG 1 D} {CA 0 B}	inline_connector
VIC_MD9:23		{CG 1 D}	inline_connector
VIC_MD9:24		{CG 1 D} {CA 2 C}	inline_connector
VIC_MD9:25		{CG 1 D}	inline_connector
VIC_MD9:26		{CG 0 D} {CA 2 A}	inline_connector
VIC_MD9:28		{CA 2 C}	inline_connector
VIC_MD9:30		{CA 2 C}	inline_connector
VIC_MD9:31		{CA 1 C}	inline_connector
VIC_MD9:33		{CA 4 D}	inline_connector
VIC_MD9:34		{CB 4 A} {CA 2 C}	inline_connector
VIC_MD9:35		{AE 4 B} {AH 5 C}	inline_connector
VIC_MD9:37		{CA 3 C}	inline_connector
VIC_MD9:38		{CB 4 B}	inline_connector
VIC_MD9:39		{CA 1 C}	inline_connector
X25:1		{DB 3 C}	inline_connector
X25:2		{XD 1 A}	inline_connector
X25:3		{DB 4 B}	inline_connector
X25:4		{XD 2 A}	inline_connector
X25:6		{DB 1 C}	inline_connector
X25:7		{DB 2 C}	inline_connector
X25:8		{DB 4 C}	inline_connector
X25:9		{DB 4 C}	inline_connector
XC906:1		{AB 5 C}	inline_connector
XC906:2		{AB 4 C}	inline_connector
XC906:3		{AB 4 C}	inline_connector
XC906:4		{AB 4 C}	inline_connector

VOLVO

Volvo Bus Corporation

Document Title

WIRING DIAGRAM

Document Type

PRODUCT SCHEMATIC

Document No

20904123

Issue Index

10

Volume No

02(02)

Page No

59(72)

Part Name	Description	Location	Part Type
XC906:5		{AB 4 C}	inline_connector
XC906:6		{AB 4 C}	inline_connector
XC908:1		{BA 1 B}	inline_connector
XC908:2		{BA 2 B}	inline_connector
XC908:3		{BA 1 B}	inline_connector
XC908:4		{BA 4 B}	inline_connector
XC908:5		{BE 1 B}	inline_connector
XC908:6		{BE 1 B}	inline_connector
XC909:1		{BE 3 C}	inline_connector
XC909:2		{BE 4 C}	inline_connector
XC909:5		{BE 1 B}	inline_connector
XC909:6		{BE 2 B}	inline_connector
XC914A:1		{CA 2 D}	inline_connector
XC914A:2		{CA 2 C}	inline_connector
XC914A:3		{CA 1 B}	inline_connector
XC914A:4		{CA 1 B}	inline_connector
XC914A:5		{NA 0 C}	inline_connector
XC914A:7		{NA 0 D}	inline_connector
XC914A:8		{NA 0 C}	inline_connector
XC914A:9		{NA 0 D}	inline_connector
XC915:1		{NA 5 A}	inline_connector
XC915:3		{NA 5 B}	inline_connector
XC915:5		{NA 5 C}	inline_connector
XC915:6		{NA 5 B}	inline_connector
XC916:1		{AH 3 C}	inline_connector
XC916:2		{AH 2 C}	inline_connector
XC916:4		{AH 1 C}	inline_connector
XC916:5		{AH 4 B}	inline_connector
XC916:6		{AH 1 C}	inline_connector
XC917:1		{CL 3 B}	inline_connector
XC917:2		{CL 4 B}	inline_connector
XC917:3		{CL 4 B}	inline_connector
XC917:4		{CL 3 B}	inline_connector
XC920:1		{FC 2 C}	inline_connector
XC920:2		{FC 2 D}	inline_connector
XC921:1		{CL 3 B}	inline_connector
XC921:2		{CL 3 B}	inline_connector
XC921:3		{CL 3 B}	inline_connector
XC922:1		{GB 2 C}	inline_connector
XC922:3		{GB 1 C}	inline_connector
XC925:1		{NE 3 B}	inline_connector
XC925:2		{NE 3 B}	inline_connector
XC926:1		{BB 3 B}	inline_connector
XC926:2		{BB 3 B}	inline_connector
XC926:3		{BB 3 B}	inline_connector
XC926:4		{BB 3 B}	inline_connector
XC926:5		{AC 5 C}	inline_connector
XC927_1/2:1		{GE 5 C}	inline_connector
XC927_1/2:2		{GE 3 C}	inline_connector
XC927_1:1		{GE 5 D}	inline_connector

VOLVO

Volvo Bus Corporation

Document Title

WIRING DIAGRAM

Document Type

PRODUCT SCHEMATIC

Document No

20904123

Issue Index

10

Volume No

02(02)

Page No

60(72)

Part Name	Description	Location	Part Type
XC927_1:2		{GE 3 D}	inline_connector
XC927_2:1		{GE 5 D}	inline_connector
XC927_2:2		{GE 3 D}	inline_connector
XC928:1		{NA 2 D}	inline_connector
XC928:2		{NA 2 C}	inline_connector
XC930:1		{CG 1 C}	inline_connector
XC930:2		{CG 1 C}	inline_connector
XC930:3		{CG 1 C}	inline_connector
XC930:4		{CG 1 C}	inline_connector
XC930:5		{CG 0 C}	inline_connector
XC931:1		{LB 3 D}	inline_connector
XC931:2		{LB 3 D}	inline_connector
XC931:3		{LB 3 D}	inline_connector
XC931:4		{LB 3 D}	inline_connector
XC931:5		{LB 3 D}	inline_connector
XC931:6		{LB 4 D}	inline_connector
XC932:1		{CG 4 B}	inline_connector
XC932:2		{CG 4 B}	inline_connector
XC932:3		{CG 4 B}	inline_connector
XC932A:1		{CL 4 C}	inline_connector
XC932A:2		{CL 5 C}	inline_connector
XC932B:1		{CL 4 C}	inline_connector
XC932B:2		{CL 5 C}	inline_connector
XC935:1		{NF 1 C}	inline_connector
XC935:2		{NF 1 C}	inline_connector
XC935:3		{NF 1 C}	inline_connector
XC935:4		{NF 3 A}	inline_connector
XC935:5		{NF 2 A}	inline_connector
XC935:7		{NF 0 C}	inline_connector
XC935:8		{NF 1 C}	inline_connector
XC935:10		{NF 0 A}	inline_connector
XC935:12		{NF 0 A}	inline_connector
XC936:1		{NG 0 A}	inline_connector
XC936:2		{NG 0 B}	inline_connector
XC936:3		{NG 0 B}	inline_connector
XC936:4		{NG 0 A}	inline_connector
XC936:5		{NG 0 B}	inline_connector
XC936:6		{NG 0 B}	inline_connector
XC936:7		{NG 0 A}	inline_connector
XC936:8		{NG 0 B}	inline_connector
XC936:9		{NG 0 B}	inline_connector
XC936:10		{NG 0 A}	inline_connector
XC936:11		{NG 0 B}	inline_connector
XC936:12		{NG 0 B}	inline_connector
XC936:13		{NG 1 A}	inline_connector
XC936:14		{NG 1 B}	inline_connector
XC936:15		{NG 1 B}	inline_connector
XC936:16		{NG 1 A}	inline_connector
XC936:17		{NG 1 B}	inline_connector
XC936:18		{NG 1 B}	inline_connector

VOLVO

Volvo Bus Corporation

Document Title

WIRING DIAGRAM

Document Type

PRODUCT SCHEMATIC

Document No

20904123

Issue Index

10

Volume No

02(02)

Page No

61(72)

Part Name	Description	Location	Part Type
XC941:1		{NC 0 D}	inline_connector
XC941:3		{NC 0 D}	inline_connector
XC942:1		{CV 2 A}	inline_connector
XC942:2		{CV 3 A}	inline_connector
XC942:3		{CV 3 B}	inline_connector
XC942:4		{CV 3 B}	inline_connector
XC942:5		{CU 2 D}	inline_connector
XC942:6		{CU 2 D}	inline_connector
XC942:7		{CU 1 D}	inline_connector
XC942:8		{CU 1 D}	inline_connector
XCAN1:1		{CE 3 D}	inline_connector
XCAN1:2		{CE 3 D}	inline_connector
XCAN1:3		{CE 3 D}	inline_connector
XCAN2:1		{CD 4 B}	inline_connector
XCAN2:2		{CD 4 B}	inline_connector
XCB604M:1		{BD 3 A}	inline_connector
XCU1:1		{CE 2 B}	inline_connector
XCU1:2		{CE 3 B}	inline_connector
XCU1:3		{CE 3 B}	inline_connector
XCU1:4		{CE 3 C}	inline_connector
XCU1:5		{CE 1 B}	inline_connector
XCU1:6		{CE 1 B}	inline_connector
XCU1:7		{CE 1 B}	inline_connector
XCU1:8		{CE 2 B}	inline_connector
XCU1:9		{CE 2 B}	inline_connector
XCU1:10		{CE 2 B}	inline_connector
XCU1:11		{CE 1 B}	inline_connector
XCU1:12		{CE 1 B}	inline_connector
XCU1:13		{CE 1 B}	inline_connector
XCU1:14		{CE 3 B}	inline_connector
XCU1:15		{CE 3 B}	inline_connector
XCU1:16		{CE 1 B}	inline_connector
XCU1:17		{CE 1 B}	inline_connector
XCU1:18		{CE 1 B}	inline_connector
XCU1:19		{CE 2 B}	inline_connector
XCU1:20		{CE 2 B}	inline_connector
XCU1:22		{CE 2 B}	inline_connector
XCU1:23		{CE 1 B}	inline_connector
XCU1:24		{CE 1 B}	inline_connector
XCU1:25		{CD 3 B} {CE 2 B}	inline_connector
XCU1:26		{CE 1 D}	inline_connector
XCU1:27		{CD 0 B}	inline_connector
XCU1:28		{CD 4 B}	inline_connector
XCU1:29		{CD 4 B}	inline_connector
XCU1:30		{CD 0 B}	inline_connector
XCU2:A		{CD 0 B}	inline_connector
XCU2:B		{CD 1 B}	inline_connector
XCU2:C		{CD 2 B}	inline_connector
XCU2:D		{CD 2 B}	inline_connector

VOLVO

Volvo Bus Corporation

Document Title

WIRING DIAGRAM

Document Type

PRODUCT SCHEMATIC

Document No

20904123

Issue Index

10

Volume No

02(02)

Page No

62(72)

Part Name	Description	Location	Part Type
XCU2:E		{CD 2 B}	inline_connector
XCU2:F		{CD 2 B}	inline_connector
XCU2:G		{CE 2 D}	inline_connector
XCU2:H		{CD 2 B}	inline_connector
XCU2:J		{CE 2 D}	inline_connector
XCU2:K		{CD 4 B}	inline_connector
XCU2:L		{CD 4 B}	inline_connector
XCU2:M		{CD 2 B}	inline_connector
XCU2:N		{CD 3 B}	inline_connector
XCU2:O		{CD 2 B}	inline_connector
XCU2:P		{CD 2 B}	inline_connector
XCU2:Q		{CD 3 B}	inline_connector
XCU2:R		{CE 2 D}	inline_connector
XCU2:S		{CD 3 B}	inline_connector
XCU2:T		{CE 3 D}	inline_connector
XCU2:U		{CE 2 D}	inline_connector
XCU2:V		{CD 3 B}	inline_connector
XCU2:W		{CE 2 D}	inline_connector
XFSEN:1		{BD 5 C}	inline_connector
XFSEN:2		{BD 5 B}	inline_connector
XJB:1		{BC 4 B}	inline_connector
XJB:2		{BC 4 A}	inline_connector
XJB:3		{BC 4 B}	inline_connector
XJB:4		{BC 4 A}	inline_connector
XJK:1		{BC 4 C}	inline_connector
XJK:2		{BC 5 A}	inline_connector
XJK:3		{BC 3 C}	inline_connector
XJK:4		{BC 3 A}	inline_connector
XK2:5		{GA 2 C}	inline_connector
XK2:6		{GA 2 C}	inline_connector
XU25:1		{AA2 3 D}	inline_connector
XU25:2		{AA2 3 C}	inline_connector
XU25:3		{AA2 3 D}	inline_connector
XU25:4		{AA2 3 D}	inline_connector
XU25:5		{AA2 3 D}	inline_connector
Y17:1		{DM 3 A}	inline_connector
Y17:2		{DM 3 A}	inline_connector
Y17:3		{DM 3 C}	inline_connector
Y17:4		{DM 3 C}	inline_connector
Y17:5		{DM 3 C}	inline_connector
Y17:6		{DM 3 C}	inline_connector
Y17:7		{DM 3 C}	inline_connector
Y901_A:1		{NB 1 D}	inline_connector
Y901_A:2		{NB 1 D}	inline_connector
Y901_B:1		{NB 1 D}	physical_splice_connector
Y901_B:2		{NB 1 D}	physical_splice_connector
BATS_D_1		{AB 5 D}	physical_splice_connector
splice378_1852		{NG 2 D}	physical_splice_connector
splice379_1852		{NG 3 D}	physical_splice_connector
splice383_1632		{NF 1 C}	physical_splice_connector

VOLVO

Volvo Bus Corporation

Document Title

WIRING DIAGRAM

Document Type

PRODUCT SCHEMATIC

Document No

20904123

Issue Index

10

Volume No

02(02)

Page No

63(72)

Part Name	Description	Location	Part Type
splice384_1632		{NF 1 C}	physical_splice_connector
splice385_1632		{NF 0 C}	physical_splice_connector
splice386_1632		{NF 1 C}	physical_splice_connector
splice389_1768		{IS 2 C}	physical_splice_connector
splice391_1632		{ZC 5 B}	physical_splice_connector
splice391_1768		{IS 2 C}	physical_splice_connector
splice393_1632		{CN 1 B}	physical_splice_connector
splice440_130		{CN 1 D}	physical_splice_connector
XE1		{CB 5 C}	physical_splice_connector
XE5		{CB 3 D}	physical_splice_connector
XE8		{CB 1 C}	physical_splice_connector
XE10		{CB 1 A}	physical_splice_connector
XSA1		{CH 2 D}	physical_splice_connector
XSA01		{XC 3 D}	physical_splice_connector
XSA02		{XC 3 D}	physical_splice_connector
XSA03		{XC 2 D}	physical_splice_connector
XSA04		{XC 2 D}	physical_splice_connector
XSA05		{XC 1 D}	physical_splice_connector
XSA06		{XC 1 D}	physical_splice_connector
XSA07		{XC 1 D}	physical_splice_connector
XSA08		{XC 1 D}	physical_splice_connector
XSA09		{XC 0 D}	physical_splice_connector
XSA10		{XC 0 D}	physical_splice_connector
XSA11		{XC 1 C}	physical_splice_connector
XSA12		{XC 1 B}	physical_splice_connector
XSA13		{XD 2 D}	physical_splice_connector
XSA14		{XD 2 D}	physical_splice_connector
XSA15		{XD 2 D}	physical_splice_connector
XSA16		{XD 2 D}	physical_splice_connector
XSA17		{XD 2 D}	physical_splice_connector
XSA18		{XD 2 D}	physical_splice_connector
XSA19		{XD 1 D}	physical_splice_connector
XSA20		{XD 1 D}	physical_splice_connector
XSA21		{XD 1 D}	physical_splice_connector
XSA22		{XD 1 D}	physical_splice_connector
XSA23		{XD 1 C}	physical_splice_connector
XSA24		{XD 1 C}	physical_splice_connector
XSA25		{ZC 4 A}	physical_splice_connector
XSA26		{AA 5 A}	physical_splice_connector
XSA27		{FA 4 B}	physical_splice_connector
XSA28		{AA 3 B}	physical_splice_connector
XSA29		{BA 4 B}	physical_splice_connector
XSA31		{ZC 4 B}	physical_splice_connector
XSA32		{BA 4 A}	physical_splice_connector
XSA34		{AA 3 D}	physical_splice_connector
XSA35		{ZC 1 A}	physical_splice_connector
XSA37		{FB 1 D}	physical_splice_connector
XSA40		{FB 2 D}	physical_splice_connector
XSA43		{ZC 2 A}	physical_splice_connector
XSA44		{AC 5 B}	physical_splice_connector

VOLVO

Volvo Bus Corporation

Document Title

WIRING DIAGRAM

Document Type

PRODUCT SCHEMATIC

Document No

20904123

Issue Index

10

Volume No

02(02)

Page No

64(72)

Part Name	Description	Location	Part Type
XSA46		{BB 2 B}	physical_splice_connector
XSA50		{BA 5 C}	physical_splice_connector
XSA52		{ZC 2 B}	physical_splice_connector
XSA53		{GM 2 C}	physical_splice_connector
XSA54		{DM 4 D}	physical_splice_connector
XSA59		{BA 5 B}	physical_splice_connector
XSA60		{NA 4 B}	physical_splice_connector
XSA61		{BA 4 C}	physical_splice_connector
XSA62		{XD 3 D}	physical_splice_connector
XSA63		{XC 4 D}	physical_splice_connector
XSA64		{XC 4 D}	physical_splice_connector
XSA65		{XD 3 D}	physical_splice_connector
XSA68		{BC 2 B}	physical_splice_connector
XSA69		{BC 2 B}	physical_splice_connector
XSA70		{BC 1 B}	physical_splice_connector
XSA71		{BC 1 B}	physical_splice_connector
XSA72		{AB 5 C}	physical_splice_connector
XSA73		{AB 4 C}	physical_splice_connector
XSA74		{NB 5 D}	physical_splice_connector
XSB01		{XC 5 D}	physical_splice_connector
XSB02		{XC 5 D}	physical_splice_connector
XSB03		{XD 4 D}	physical_splice_connector
XSB04		{XD 4 D}	physical_splice_connector
XSB05		{XD 4 D}	physical_splice_connector
XSB06		{XD 5 D}	physical_splice_connector
XSB07		{IS 3 B}	physical_splice_connector
XSB08		{IS 3 B}	physical_splice_connector
XSB09		{ZC 4 B}	physical_splice_connector
XSB10		{ZC 5 C}	physical_splice_connector
XSB11		{ZC 5 C}	physical_splice_connector
XSB12		{GM 3 C}	physical_splice_connector
XSB13		{GB 1 D}	physical_splice_connector
XSB14		{ZC 5 C}	physical_splice_connector
XSB15		{GB 1 D}	physical_splice_connector
XSB16		{NE 3 B}	physical_splice_connector
XSB17		{NE 3 B}	physical_splice_connector
XSB18		{IU 4 C}	physical_splice_connector
XSB19		{IU 4 C}	physical_splice_connector
XSB20		{AC 1 C}	physical_splice_connector
XSB21		{IU 4 C}	physical_splice_connector
XSB22		{NC 3 C}	physical_splice_connector
XSB23		{NC 4 C}	physical_splice_connector
XSB24		{NC 5 C}	physical_splice_connector
XSB25		{AA 4 B}	physical_splice_connector
XSB26		{NC 3 B}	physical_splice_connector
XSB28		{CV 0 C}	physical_splice_connector
XSB29		{CV 0 C}	physical_splice_connector
XSB30		{IU 4 C}	physical_splice_connector
XSB31		{IU 4 C}	physical_splice_connector
XSB32		{XC 5 D}	physical_splice_connector

VOLVO

Volvo Bus Corporation

Document Title

WIRING DIAGRAM

Document Type

PRODUCT SCHEMATIC

Document No

20904123

Issue Index

10

Volume No

02(02)

Page No

65(72)

Part Name	Description	Location	Part Type
XSB33		{XC 4 D}	physical_splice_connector
XSB34		{NA 1 C}	physical_splice_connector
XSB36		{NA 4 B}	physical_splice_connector
XSB37		{NC 1 D}	physical_splice_connector
XSB38		{NC 0 C}	physical_splice_connector
XSB39		{NC 1 C}	physical_splice_connector
XSB40		{NA 1 C}	physical_splice_connector
XSB41		{CP 2 B}	physical_splice_connector
XSC01		{ZC 4 D}	physical_splice_connector
XSC02		{GE 3 C}	physical_splice_connector
XSC03		{GB 2 B}	physical_splice_connector
XSC04		{GE 5 C}	physical_splice_connector
XSC05		{GE 4 B}	physical_splice_connector
XSC06		{GE 3 C}	physical_splice_connector
XSC07		{ZC 4 D}	physical_splice_connector
XSC08		{GB 1 B}	physical_splice_connector
XSC09		{GB 4 B}	physical_splice_connector
XSC11		{DA 2 C}	physical_splice_connector
XSC12		{DA 1 C}	physical_splice_connector
XSC13		{ZC 0 C}	physical_splice_connector
XSC14		{ZC 4 C}	physical_splice_connector
XSC15		{ZC 4 D}	physical_splice_connector
XSC16		{GB 5 C}	physical_splice_connector
XSC17		{ZC 3 D}	physical_splice_connector
XSC18		{ZC 4 D}	physical_splice_connector
XSC21		{DN 5 B}	physical_splice_connector
XSC23		{DD 4 C}	physical_splice_connector
XSC24		{DD 3 C}	physical_splice_connector
XSC25		{DD 3 C}	physical_splice_connector
XSC97		{CL 2 D}	physical_splice_connector
XSC98		{CL 3 C}	physical_splice_connector
XSC99		{CL 3 C}	physical_splice_connector
XSD05		{DC 2 C}	physical_splice_connector
XSD06		{DC 3 C}	physical_splice_connector
XSD07		{DC 3 C}	physical_splice_connector
XSD08		{DC 2 C}	physical_splice_connector
XSE01		{CB 1 D} {CM 5 C}	physical_splice_connector
XSE01_	Unit injector cylinder 1 2 3	{CC 2 B}	physical_splice_connector
XSE02		{AE 2 B}	physical_splice_connector
XSE02_	Unit injector cylinder 1 2 3	{CC 2 B}	physical_splice_connector
XSE03		{CM 4 C}	physical_splice_connector
XSE03_	Unit injector cylinder 1 2 3	{CC 2 B}	physical_splice_connector
XSE04		{CA 4 C}	physical_splice_connector
XSE04_	Unit injector cylinder 1 2 3	{CC 2 B}	physical_splice_connector
XSE05		{CA 3 C}	physical_splice_connector
XSE05_	Unit injector cylinder 1 2 3	{CC 2 B}	physical_splice_connector
XSE06		{CM 4 C}	physical_splice_connector
XSE06_	Unit injector cylinder 1 2 3	{CC 2 B}	physical_splice_connector
XSE07		{CA 3 C}	physical_splice_connector

VOLVO

Volvo Bus Corporation

Document Title

WIRING DIAGRAM

Document Type

PRODUCT SCHEMATIC

Document No

20904123

Issue Index

10

Volume No

02(02)

Page No

66(72)

Part Name	Description	Location	Part Type
XSE07_	Unit injector cylider 1 2 3	{CC 1 B}	physical_splice_connector
XSE08		{CA 3 C}	physical_splice_connector
XSE08_	Unit injector cylider 1 2 3	{CC 1 B}	physical_splice_connector
XSE09		{CM 2 C}	physical_splice_connector
XSE09_	Unit injector cylider 1 2 3	{CC 1 B}	physical_splice_connector
XSE10		{CM 1 D}	physical_splice_connector
XSE10_	Unit injector cylider 4 5 6	{CC 1 B}	physical_splice_connector
XSE11		{CM 1 C}	physical_splice_connector
XSE12		{CA 5 A}	physical_splice_connector
XSE13		{CM 4 B}	physical_splice_connector
XSE13_		{CC 1 D}	physical_splice_connector
XSE14		{CM 3 B}	physical_splice_connector
XSE14_	GND	{CC 2 C}	physical_splice_connector
XSE15		{CM 3 B}	physical_splice_connector
XSE15_	+30 main switch (F15 15A)	{CC 4 C}	physical_splice_connector
XSE16		{CM 3 B}	physical_splice_connector
XSE16_		{CC 5 D}	physical_splice_connector
XSE17		{CM 3 B}	physical_splice_connector
XSE18		{CM 2 B}	physical_splice_connector
XSE18_	Ground for sensors	{CC 4 A}	physical_splice_connector
XSE19		{CM 2 B}	physical_splice_connector
XSE19_	Power supply 5V	{CC 4 B}	physical_splice_connector
XSE20		{CM 2 B}	physical_splice_connector
XSE20_		{CC 4 A}	physical_splice_connector
XSE21		{CM 2 B}	physical_splice_connector
XSE22		{CM 3 B}	physical_splice_connector
XSE23		{CM 3 B}	physical_splice_connector
XSE24		{CA 5 B}	physical_splice_connector
XSE25		{CA 4 A}	physical_splice_connector
XSE26		{CM 2 B}	physical_splice_connector
XSE27		{CM 2 B}	physical_splice_connector
XSE28		{CM 1 B}	physical_splice_connector
XSE29		{CM 1 B}	physical_splice_connector
XSE30		{CM 1 B}	physical_splice_connector
XSE31		{CM 1 B}	physical_splice_connector
XSE32		{CM 1 B}	physical_splice_connector
XSE33		{CM 1 B}	physical_splice_connector
XSE34		{CM 2 B}	physical_splice_connector
XSE35		{CM 1 B}	physical_splice_connector
XSE36		{CA 4 B}	physical_splice_connector
XSE39		{CM 1 D}	physical_splice_connector
XSE40		{CM 1 C}	physical_splice_connector
XSE41		{CN 2 C}	physical_splice_connector
XSE42		{CN 2 C}	physical_splice_connector
XSE43		{CN 0 B}	physical_splice_connector
XSE44		{CN 2 B}	physical_splice_connector
XSE45		{CN 3 B}	physical_splice_connector
XSE46		{CN 5 B}	physical_splice_connector
XSE47		{CN 5 B}	physical_splice_connector
XSE48		{CN 4 B}	physical_splice_connector

VOLVO

Volvo Bus Corporation

Document Title

WIRING DIAGRAM

Document Type

PRODUCT SCHEMATIC

Document No

20904123

Issue Index

10

Volume No

02(02)

Page No

67(72)

Part Name	Description	Location	Part Type
XSE49		{CN 2 A}	physical_splice_connector
XSE50		{CM 0 C}	physical_splice_connector
XSE51		{CM 3 C}	physical_splice_connector
XSE52		{CM 3 C}	physical_splice_connector
XSE53		{CB 2 D}	physical_splice_connector
XSE54		{CB 1 D}	physical_splice_connector
XSE55		{CB 4 C}	physical_splice_connector
XSE56		{CB 4 D}	physical_splice_connector
XSE57		{CB 4 A}	physical_splice_connector
XSE58		{CB 2 B}	physical_splice_connector
XSE59		{CB 2 B}	physical_splice_connector
XSE60		{CM 5 B}	physical_splice_connector
XSE61		{CA 0 C}	physical_splice_connector
XSE63		{CA 1 C}	physical_splice_connector
XSE68		{CA 3 B}	physical_splice_connector
XSE70		{CA 2 B}	physical_splice_connector
XSE71		{CA 1 B}	physical_splice_connector
XSE72		{CA 1 B}	physical_splice_connector
XSE82		{CE 3 D}	physical_splice_connector
XSE83		{CE 3 D}	physical_splice_connector
XSE84		{CD 0 B}	physical_splice_connector
XSE93		{CV 2 D}	physical_splice_connector
XSE94		{CV 2 C}	
XSE94		{CV 2 D}	physical_splice_connector
XSE94		{CV 2 D}	
XSE98		{CF 1 A}	physical_splice_connector
XSE100		{CF 1 A}	physical_splice_connector
XSE102		{CF 0 B}	physical_splice_connector
XSE103		{CF 1 B}	physical_splice_connector
XSE104		{CF 1 B}	physical_splice_connector
XSE105		{CF 2 B}	physical_splice_connector
XSE107		{CF 1 C}	physical_splice_connector
XSE108		{CF 1 C}	physical_splice_connector
XSE109		{CF 2 C}	physical_splice_connector
XSE111		{CF 3 C}	physical_splice_connector
XSE112		{CF 4 C}	physical_splice_connector
XSE222		{CC 5 B}	physical_splice_connector
XSF01		{GE 1 C}	physical_splice_connector
XSF02		{GD 2 C}	physical_splice_connector
XSF03		{GA 2 B}	physical_splice_connector
XSF04		{GA 1 B}	physical_splice_connector
XSF05		{GC 3 B}	physical_splice_connector
XSF06		{GD 2 C}	physical_splice_connector
XSF07		{ZC 2 D}	physical_splice_connector
XSF08		{CA 1 D}	physical_splice_connector
XSF09		{GC 5 B}	physical_splice_connector
XSF10		{GC 4 B}	physical_splice_connector
XSF11		{GE 0 C}	physical_splice_connector
XSF12		{GA 3 C}	physical_splice_connector
XSF13		{GE 2 C}	physical_splice_connector

VOLVO

Volvo Bus Corporation

Document Title

WIRING DIAGRAM

Document Type

PRODUCT SCHEMATIC

Document No

20904123

Issue Index

10

Volume No

02(02)

Page No

68(72)

Part Name	Description	Location	Part Type
XSF14		{ZC 2 C}	physical_splice_connector
XSF19		{ZC 3 B}	physical_splice_connector
XSF20		{CU 4 D}	physical_splice_connector
XSF21		{ZC 0 C}	physical_splice_connector
XSF22		{CU 4 D}	physical_splice_connector
XSF23		{CU 4 D}	physical_splice_connector
XSF26		{DM 3 D}	physical_splice_connector
XSF29		{FB 4 C}	physical_splice_connector
XSF31		{GD 3 D}	physical_splice_connector
XSF32		{FB 5 C}	physical_splice_connector
XSF33		{GD 4 D}	physical_splice_connector
XSF34		{GD 5 D}	physical_splice_connector
XSF35		{BA 3 D}	physical_splice_connector
XSF36		{CV 3 C}	physical_splice_connector
XSF37		{GA 3 B}	physical_splice_connector
XSF38		{CN 5 D}	physical_splice_connector
XSF39		{CV 3 B}	physical_splice_connector
XSF40		{FA 5 C}	physical_splice_connector
XSF41		{XD 3 B} {XD 4 B} {XD 4 B} {XD 3 B} {XD 3 B} {XE 3 D}	physical_splice_connector
XSF42		{XD 3 B} {XD 4 B} {XD 4 B} {XD 3 B} {XD 3 B} {XE 3 C}	physical_splice_connector
XSF43		{CM 1 C}	physical_splice_connector
XSF44		{CM 4 C}	physical_splice_connector
XSF45		{CN 4 D}	physical_splice_connector
XSF46		{CA 2 D}	physical_splice_connector
XSF47		{CV 3 B}	physical_splice_connector
XSF48		{CV 3 C}	physical_splice_connector
XSF49		{CV 3 B}	physical_splice_connector
XSF50		{CV 3 B}	physical_splice_connector
XSF51		{CV 2 B}	physical_splice_connector
XSF52		{CV 2 B}	physical_splice_connector
XSF54		{XC 4 B}	physical_splice_connector
XSF55		{XC 4 B}	physical_splice_connector
XSF60		{CN 2 D}	physical_splice_connector
XSF61		{ZC 3 C}	physical_splice_connector
XSF62		{CA 3 D}	physical_splice_connector
XSF64		{CL 3 B}	physical_splice_connector
XSF70		{CU 5 C}	physical_splice_connector
XSF71		{CU 1 B}	physical_splice_connector
XSF72		{CU 5 A}	physical_splice_connector
XSF73		{CU 5 A}	physical_splice_connector
XSF74		{ZC 3 B}	physical_splice_connector

VOLVO

Volvo Bus Corporation

Document Title

WIRING DIAGRAM

Document Type

PRODUCT SCHEMATIC

Document No

20904123

Issue Index

10

Volume No

02(02)

Page No

69(72)

Part Name	Description	Location	Part Type
XSF75		{AG 3 B}	physical_splice_connector
XSF76		{CU 5 C}	physical_splice_connector
XSF77		{ZC 3 D}	physical_splice_connector
XSF78		{ZC 2 D}	physical_splice_connector
XSF79		{ZC 1 D}	physical_splice_connector
XSF80		{XC 3 B}	physical_splice_connector
XSF81		{XC 3 B}	physical_splice_connector
XSF82		{CV 3 D}	physical_splice_connector
		{CV 3 D}	
XSF83		{CV 3 D}	physical_splice_connector
		{CV 3 C}	
XSF84		{CV 4 D}	physical_splice_connector
		{CV 4 D}	
XSF85		{CV 4 D}	physical_splice_connector
		{CV 4 C}	
XSF86		{CV 4 B}	physical_splice_connector
XSF87		{CV 4 B}	physical_splice_connector
XSF88		{CV 5 D}	physical_splice_connector
XSF89		{CV 4 C}	physical_splice_connector
XSF90		{CV 3 D}	physical_splice_connector
XSF91		{CV 2 D}	physical_splice_connector
XSF93		{BB 3 C}	physical_splice_connector
XSF94		{BB 3 B}	physical_splice_connector
XSF96		{CN 1 D}	physical_splice_connector
XSF97		{XD 5 B}	physical_splice_connector
XSF98		{XD 5 B}	physical_splice_connector
XSF99		{AG 2 B}	physical_splice_connector
XSF100		{CV 2 B}	physical_splice_connector
XSF101		{CV 2 B}	physical_splice_connector
XSF102		{CU 2 D}	physical_splice_connector
XSF103		{CU 2 D}	physical_splice_connector
XSF104		{CU 2 D}	physical_splice_connector
XSF105		{CU 2 D}	physical_splice_connector
XSF106		{CU 3 D}	physical_splice_connector
XSF107		{CU 3 D}	physical_splice_connector
XSF108		{CU 4 D}	physical_splice_connector
XSF109		{CU 3 D}	physical_splice_connector
XSF110		{CU 5 D}	physical_splice_connector
XSF111		{CU 5 D}	physical_splice_connector
XSF112		{CU 5 D}	physical_splice_connector
XSF113		{CU 1 A}	physical_splice_connector
XSF114		{CU 0 A}	physical_splice_connector
XSF115		{XC 3 B}	physical_splice_connector
XSF116		{XC 2 B}	physical_splice_connector
XSF117		{XD 5 B}	physical_splice_connector
XSF118		{XD 5 B}	physical_splice_connector
XSF119		{XC 3 B}	physical_splice_connector
XSF120		{XC 3 B}	physical_splice_connector
XSF121		{DM 1 B}	physical_splice_connector
XSFG4		{ZC 1 C}	physical_splice_connector
XSG01		{AD 1 C}	physical_splice_connector

VOLVO

Volvo Bus Corporation

Document Title

WIRING DIAGRAM

Document Type

PRODUCT SCHEMATIC

Document No

20904123

Issue Index

10

Volume No

02(02)

Page No

70(72)

Part Name	Description	Location	Part Type
XSG02		{AD 3 B}	physical_splice_connector
XSG03		{AH 3 B}	physical_splice_connector
XSG04		{AH 2 B}	physical_splice_connector
XSG05		{AE 3 B}	physical_splice_connector
XSG06		{AF 0 C}	physical_splice_connector
XSG07		{AF 2 B}	physical_splice_connector
XSG08		{CB 1 D}	physical_splice_connector
XSJ01		{GD 2 B}	physical_splice_connector
XSJ02		{GD 1 C}	physical_splice_connector
XSJ03		{GD 0 B}	physical_splice_connector
XSJ04		{GD 4 C}	physical_splice_connector
XSJ05		{GD 5 C}	physical_splice_connector
XSJ06		{GD 2 B}	physical_splice_connector
XSJ07		{ZC 0 D}	physical_splice_connector
XSJ08		{ZC 2 B}	physical_splice_connector
XSJ09		{FB 4 B}	physical_splice_connector
XSJ10		{FB 4 C}	physical_splice_connector
XSJ11		{FB 1 B}	physical_splice_connector
XSJ12		{FB 1 B}	physical_splice_connector
XSJ13		{DO 3 C}	physical_splice_connector
XSJ14		{DO 3 C}	physical_splice_connector
XSJ15		{DO 3 C}	physical_splice_connector
XSJ16		{GF 2 C}	physical_splice_connector
XSJ17		{BB 1 D}	physical_splice_connector
XSJ18		{FB 5 B}	physical_splice_connector
XSJ19		{FB 5 B}	physical_splice_connector
XSJ20		{FA 2 D}	physical_splice_connector
XSJ21		{DD 0 D}	physical_splice_connector
XSJ22		{DD 0 D}	physical_splice_connector
XSJ23		{FC 3 C}	physical_splice_connector
XSJ24		{FC 3 C}	physical_splice_connector
XSJ25		{FC 2 C}	physical_splice_connector
XSJ26		{FC 2 C} {FC 3 D}	physical_splice_connector
XSJ27		{ZC 1 D}	physical_splice_connector
XSJ28		{ZC 0 D}	physical_splice_connector
XSJ30		{FC 4 D}	physical_splice_connector
XSJ31		{FC 4 C}	physical_splice_connector
XSJ32		{FC 5 B}	physical_splice_connector
XSJ33		{GF 2 C}	physical_splice_connector
XSJ34		{ZC 4 B}	physical_splice_connector
XSJ35		{XC 2 B}	physical_splice_connector
XSJ36		{XC 2 B}	physical_splice_connector
XSJ37		{FC 3 D}	physical_splice_connector
XSJ40		{NA 5 A}	physical_splice_connector
XSJ41		{NA 5 B}	physical_splice_connector
XSJ42		{NA 5 B}	physical_splice_connector
XSJ43		{NA 5 C}	physical_splice_connector
XSJ44		{LA 3 C}	physical_splice_connector
XSJ45		{GD 4 C}	physical_splice_connector

VOLVO

Volvo Bus Corporation

Document Title

WIRING DIAGRAM

Document Type

PRODUCT SCHEMATIC

Document No

20904123

Issue Index

10

Volume No

02(02)

Page No

71(72)

Part Name	Description	Location	Part Type
XSJ46		{GF 2 B}	physical_splice_connector
XSJ47		{LA 3 D}	physical_splice_connector
XSJ48		{LA 3 D}	physical_splice_connector
XSJ50		{CL 1 B}	physical_splice_connector
XSJ51		{GD 3 B}	physical_splice_connector
XSJ52		{GD 3 B}	physical_splice_connector
XSK1		{CG 4 C}	physical_splice_connector
XSK02	GND	{FO 1 B}	physical_splice_connector
XSK4		{CG 2 C}	physical_splice_connector
XSK6		{CG 2 C}	physical_splice_connector
XSK06		{LA 3 D}	physical_splice_connector
XSK13		{LA 2 C}	physical_splice_connector
XSK15	+15 ignition	{LB 3 C}	physical_splice_connector
XSK16		{LB 2 C}	physical_splice_connector
XSK17		{LB 4 B}	physical_splice_connector
XSK18		{ZC 2 C}	physical_splice_connector
XSK19		{LB 2 C}	physical_splice_connector
XSK20		{LA 4 C}	physical_splice_connector
XSK21		{LB 1 C}	physical_splice_connector
XSK22		{GF 4 C}	physical_splice_connector
XSK23		{GF 4 C}	physical_splice_connector
XSK24		{LB 3 C}	physical_splice_connector
XSK25		{LB 3 C}	physical_splice_connector
XSL1		{CG 3 A}	physical_splice_connector
XSL2		{CG 1 A}	physical_splice_connector
XSL10		{CU 3 A}	physical_splice_connector
XSL11		{CU 3 A}	physical_splice_connector
XSL12		{CU 2 A}	physical_splice_connector
XSL13		{CU 2 A}	physical_splice_connector
XSM01		{GN 4 D}	physical_splice_connector
XSM02		{ZC 4 C}	physical_splice_connector
XSM03	Analogue ground sensors	{FO 2 B}	physical_splice_connector
XSM04	+30 main switch	{FO 3 C}	physical_splice_connector
XSM05	+15 ignition	{FO 3 C}	physical_splice_connector
XSP01		{BE 3 C}	
XSP02		{BE 4 C}	

VOLVO

Volvo Bus Corporation

Document Title

WIRING DIAGRAM

Document Type

PRODUCT SCHEMATIC

Document No

20904123

Issue Index

10

Volume No

02(02)

Page No

72(72)

TP 17083

English Sweden.

VOLVO

Volvo Bus Corporation

Göteborg, Sweden