

Service Manual

Buses

Group **37**

Release **01**

Multiplex electrical system Version 2
Wiring Diagram

B9R with D9B (chno 112690-115593)



Foreword

The information in this manual is based on present design in May 2006.

The products are under continuous development. This may effect the correctness of the information in this manual. If the differences are significant, new editions of this manual will be released to cover the changes.

Volvo Bus Corporation

Göteborg, Sweden

Order number: TP 17016

© 2006 Volvo Bus Corporation, Göteborg, Sweden

All rights reserved. No part of this publication may be reproduced, stored in retrieval system, or transmitted in any forms by any means, electronic, mechanical, photocopying, recording or otherwise, without the prior written permission of Volvo Bus Corporation.

Engineering Release Notice (ERN)	Location	Change Description	A = Added U = Deleted	W = Was	Document Release Status RELEASED
D-13277-72					Date 2006-05-17 Modification Count

WIRING DIAGRAM INDEX, B7, B9, B12

NAME	DESCRIPTION	PAGE	NAME	DESCRIPTION	PAGE
AA	IGNITION AND STARTING SYSTEM	02	DN	I-SHIFT	28
AB	POWER SUPPLY AND STARTER SYSTEM	03	DO	VOITH ARTIC	29
AC	STARTER AND ALTERNATOR	04			
AD	STARTER AND ALTERNATOR FOR MD7	05	EO	EBS	30
AE	STARTER AND ALTERNATOR FOR R9L, R9TL, R9B	06	EP	EBS	31
AF	STARTER AND ALTERNATOR FOR MD12	07			
AG	STAR/STOP SWITCHES REAR	08	FA	AIR SUSPENSION ECS	32
AH	STARTER AND ALTERNATOR R9S	09	FB	AIR SUSPENSION ECS	33
			FC	AMECU	34
BA	VEHICLE ECU	10			
BB	BBM	11	GA	LCM, REAR LIGHTS	35
BC	BBM	12	GB	LCM, FRONT LIGTHS	36
BD	FIRE ALARM	13	GC	LCM, REAR LIGHTS	37
			GD	LCM, ARTIC LIGHTS	38
CA	EECU D9B	14	GM	WIPER, WASHER	39
CB	EECU MG9	15			
CG	FTM	16	IS	SWM,SRS / HORN	40
CL	BIO	17	IU	AUDIO	41
CM	EECU D12E	18			
CN	EECU D7E	19	NA	BUS INSTRUMENT CLUSTER BIC2	42
CO	OILMASTER	20	NB	TACHOGRAPH	43
CU	DNOX2	21	NC	DYNAFLEET	44
CV	DNOX2	22	ND	FMS 200	45
DA	G8-EGS	23	XC	CAN SAE1939	46
DB	ECOMAT 4 ZF	24	XD	CAN SAE1587	47
DC	VOITH DIWA5	25			
DD	ECOLIFE ZF	26	ZC	GROUND	48
DM	RETARDER	27			

VOLUME NO	CONTENT	PAGES
01	WIRING DIAGRAM	1-48
02	BILL OF MATERIAL/COMPONENT LIST	1-50

The copying, distribution and utilization of this document as well as the communication of its contents to others without expressed authorization is prohibited. Offenders will be held liable for payment of damages. All rights reserved in the event of the grant of a patent, utility model or ornamental design registration.

Document Title
**WIRING DIAGRAM
B7, B9, B12**

VOLVO
Volvo Bus Corporation

Document Type
TECHNICAL REGULATION

Owner Domain: Document Prefix

Document No 20904123	Issue Index 02	Volume No 01(02)	Page No 1(48)
--------------------------------	--------------------------	---------------------	-------------------------

IGNITION AND STARTING SYSTEM

WIRING DIAGRAM AA

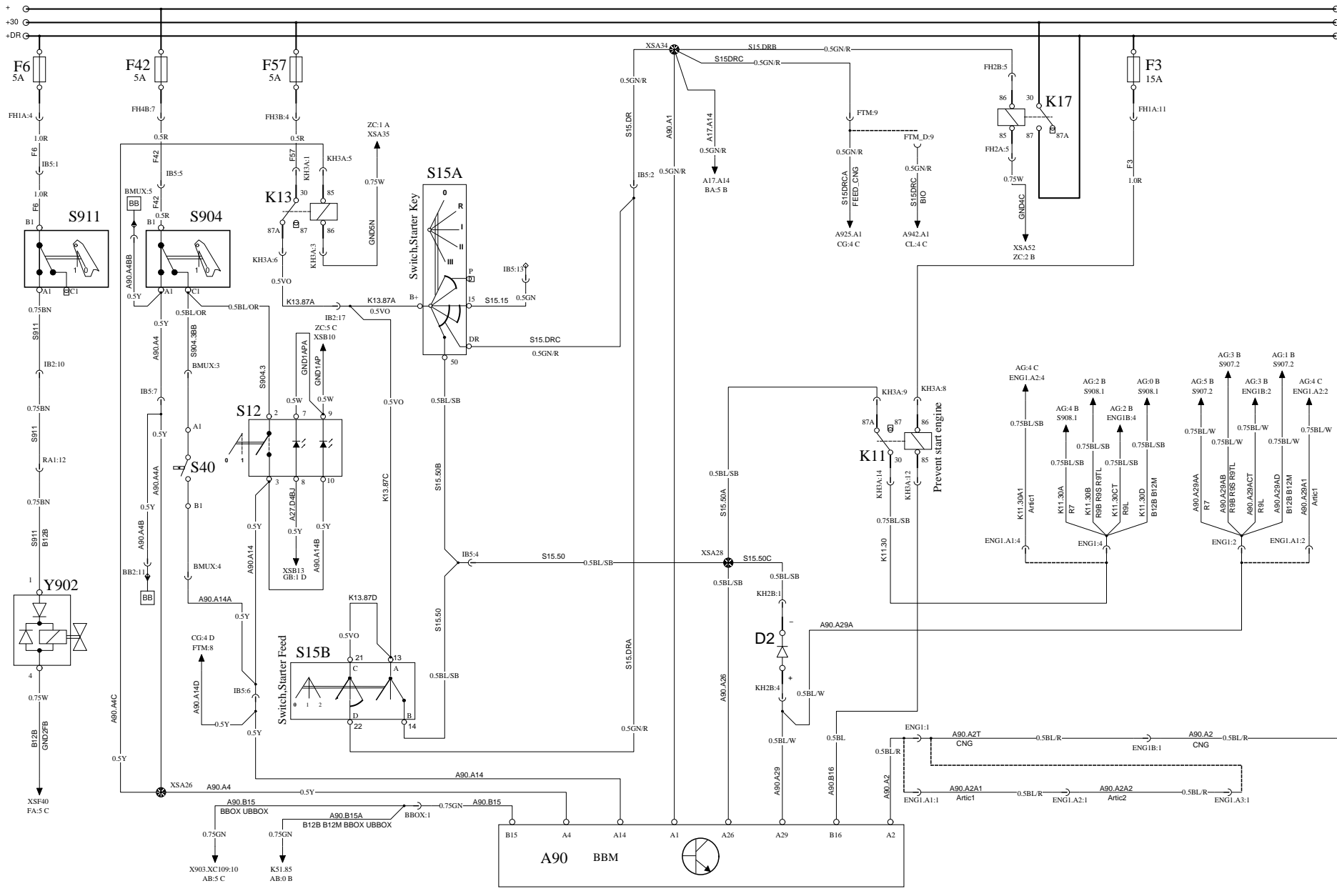

POWER SUPPLY

WIRING DIAGRAM AB

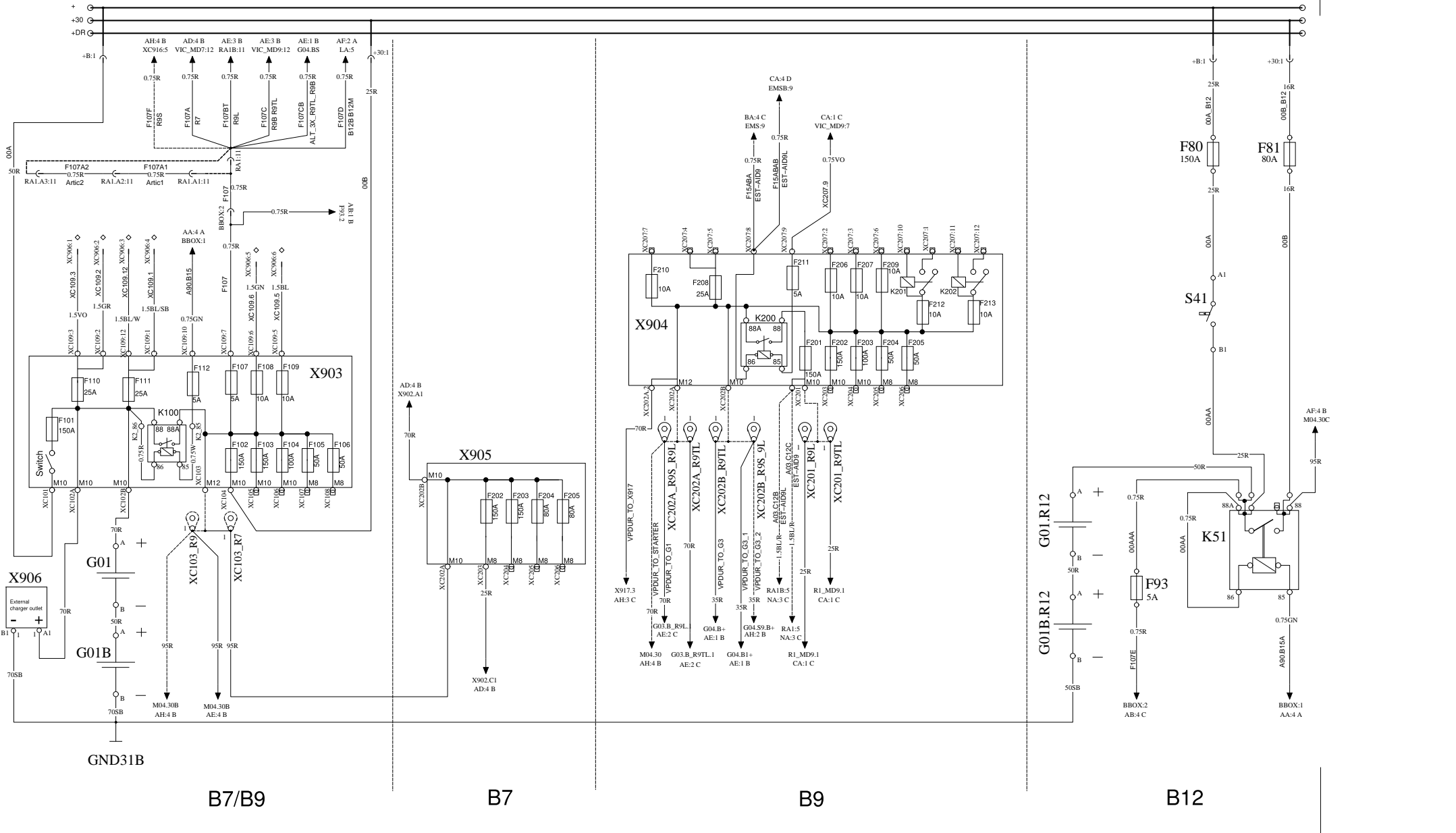

Volvo Bus Corporation

Document title
WIRING DIAGRAM AB
Document type
PRODUCT SCHEMATIC

Document No
20904123

Issue
02
Volume
01(02)
Page
03(48)

START ENGINE AND ALTERNATORS

WIRING DIAGRAM AC

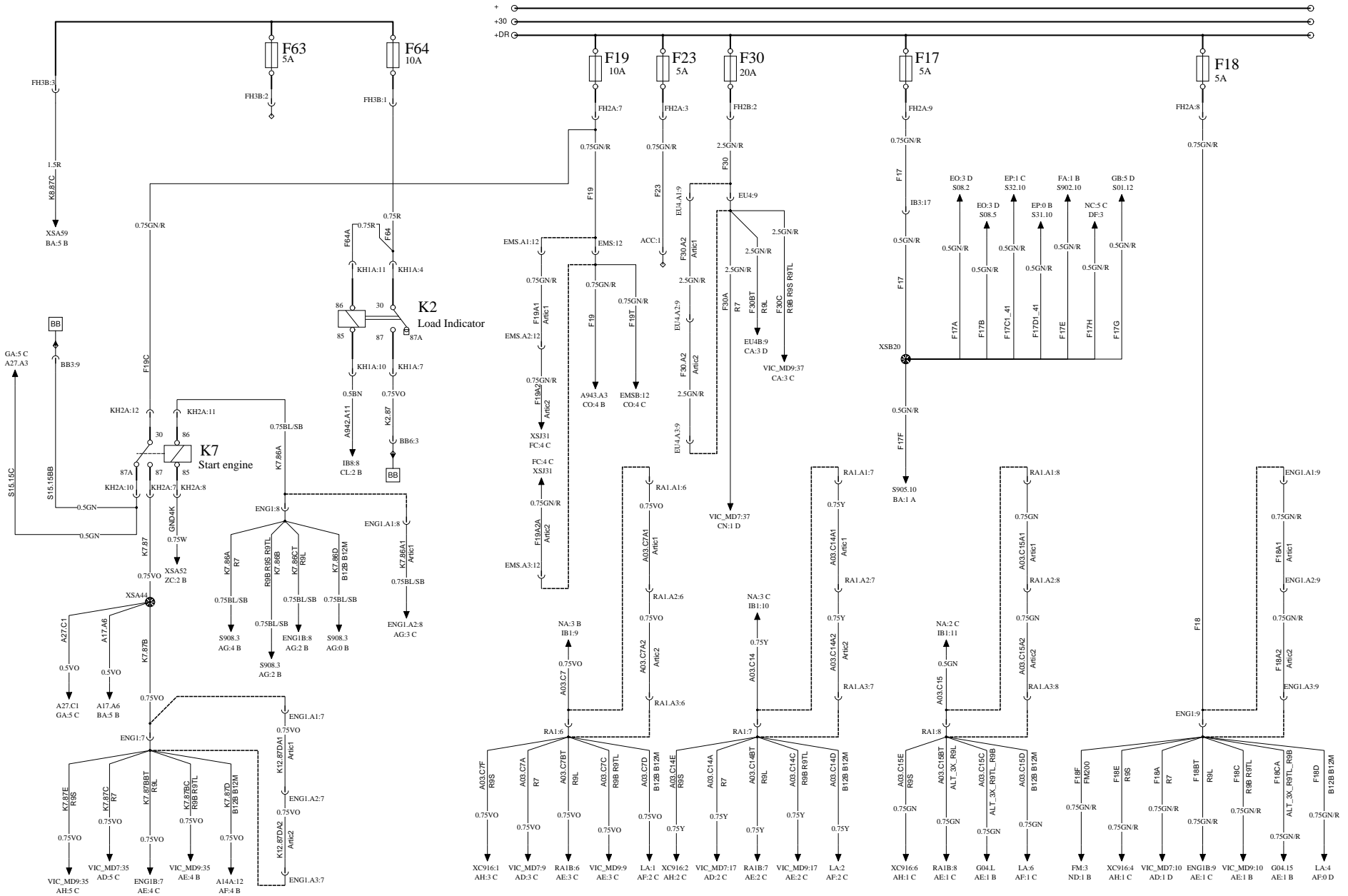

Volvo Bus Corporation

Document title
WIRING DIAGRAM AC

Document type
PRODUCT SCHEMATIC

Document No

20904123

Issue

02

Volume

01(02)

Page

04(48)

STARTER MOTOR AND ALTERNATORS FOR MD7

WIRING DIAGRAM AD

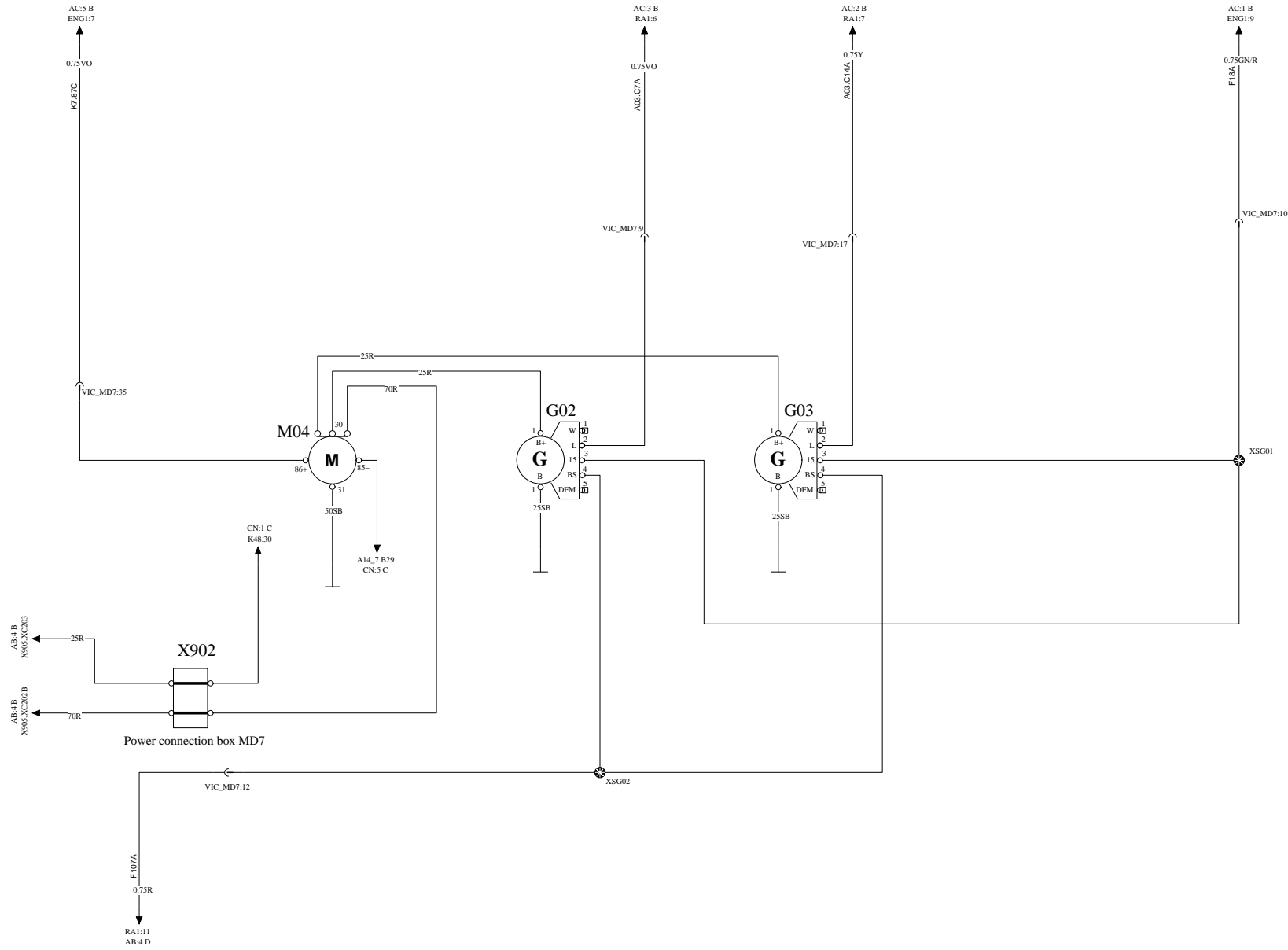

VOLVO

Volvo Bus Corporation

Document title
WIRING DIAGRAM AD
Document type
PRODUCT SCHEMATIC

Document No
20904123

Issue
02

Volume
01(02)

Page
05(48)

STARTER MOTOR AND ALTERNATORS FOR R9L, R9TL, B9R

WIRING DIAGRAM AE

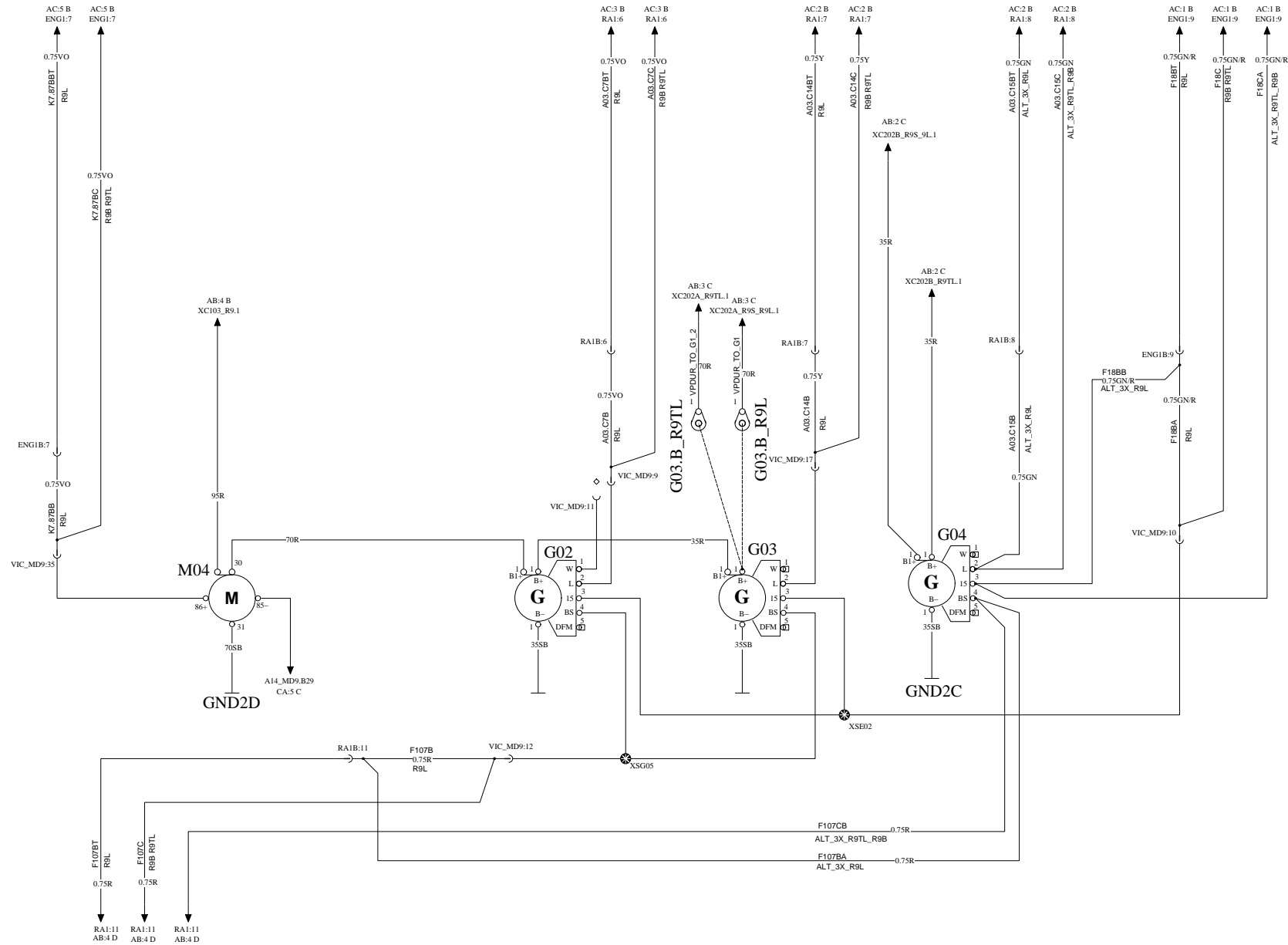

START/STOP SWITCHES REAR

WIRING DIAGRAM AG

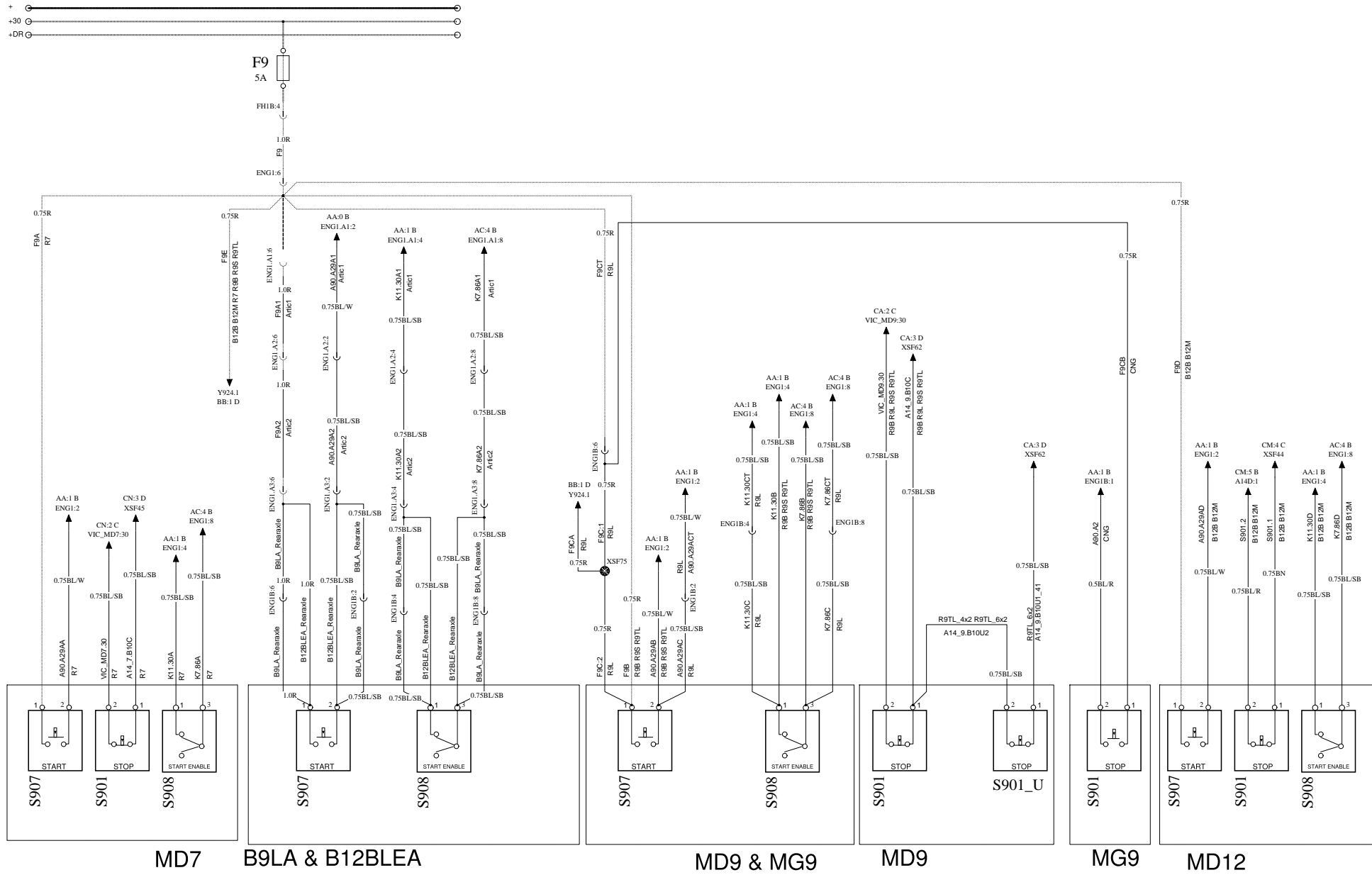

Volvo Bus Corporation

Document title
WIRING DIAGRAM AG

Document type
PRODUCT SCHEMATIC

Document No
20904123

Issue
02

Volume
01(02)

Page
08(48)

STARTER MOTOR AND ALTERNATOR FOR R9S

WIRING DIAGRAM AH

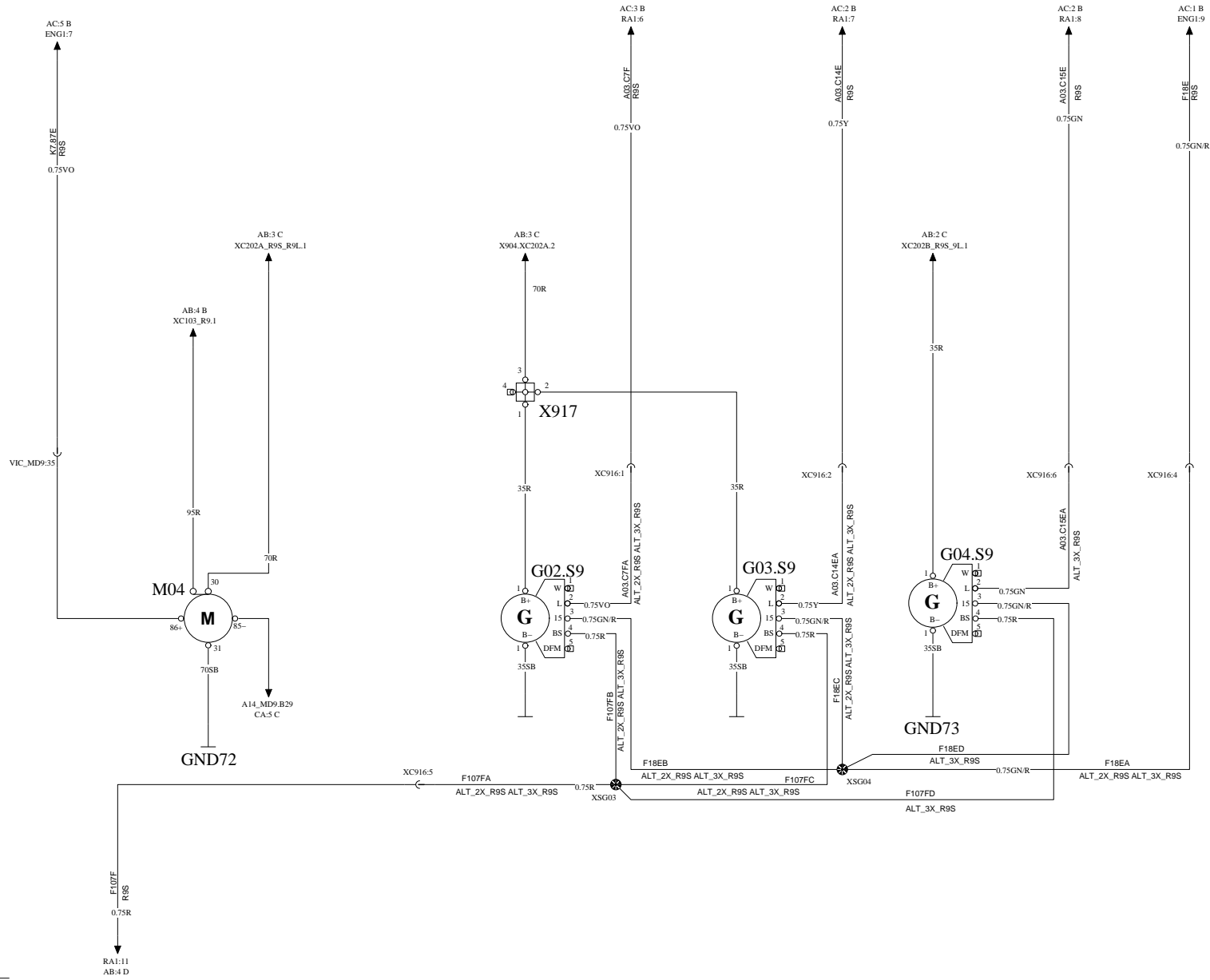

Volvo Bus Corporation

Document title
WIRING DIAGRAM AH
Document type
PRODUCT SCHEMATIC

Document No
20904123

Issue
02

Volume
01(02)

Page
09(48)

VEHICLE ECU

WIRING DIAGRAM BA

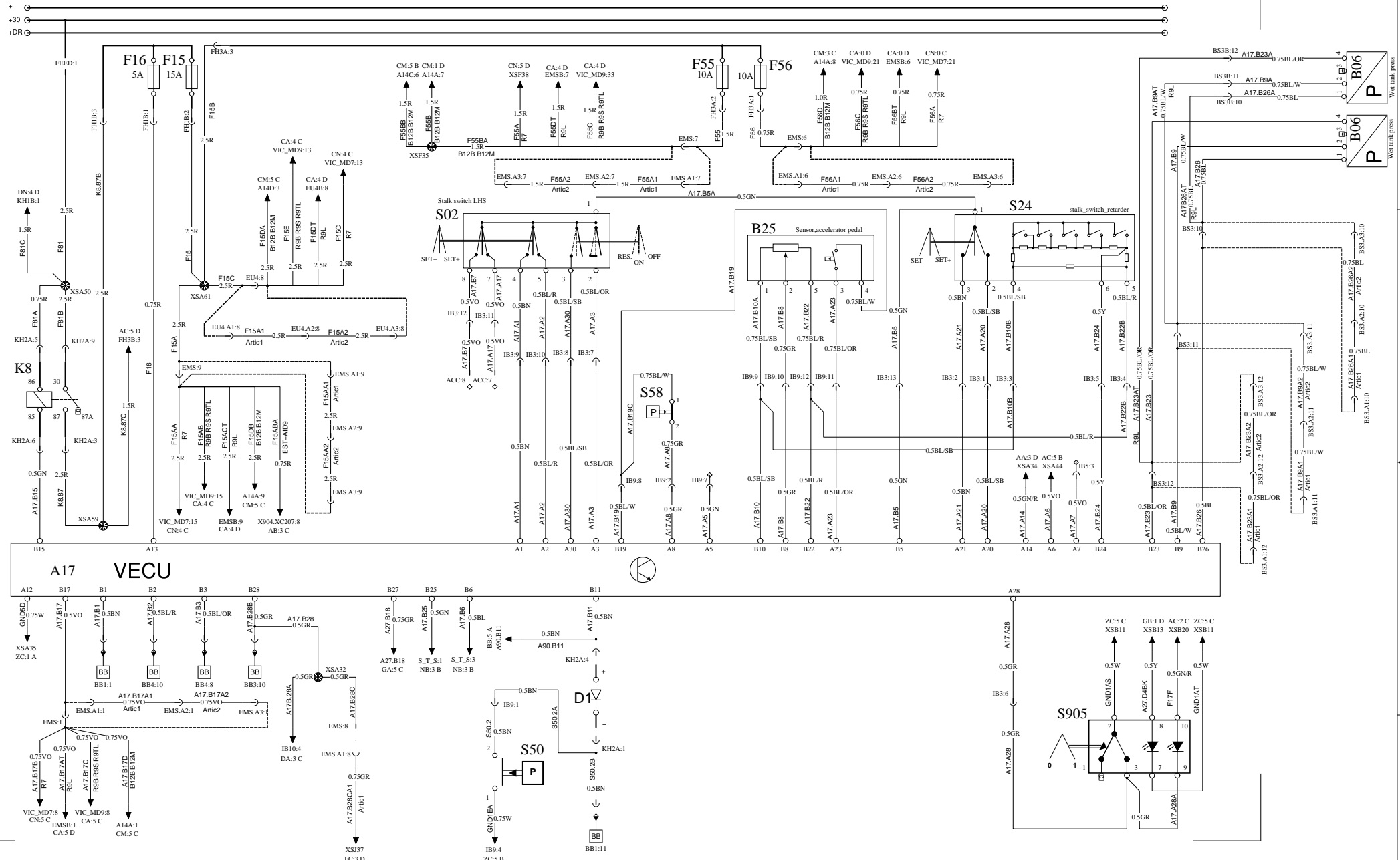

Volvo Bus Corporation

Document title
WIRING DIAGRAM BA

Document type
PRODUCT SCHEMATIC

Document No

20904123

Issue

02

Volume

01(02)

Page

10(48)

BBM WIRING DIAGRAM BB

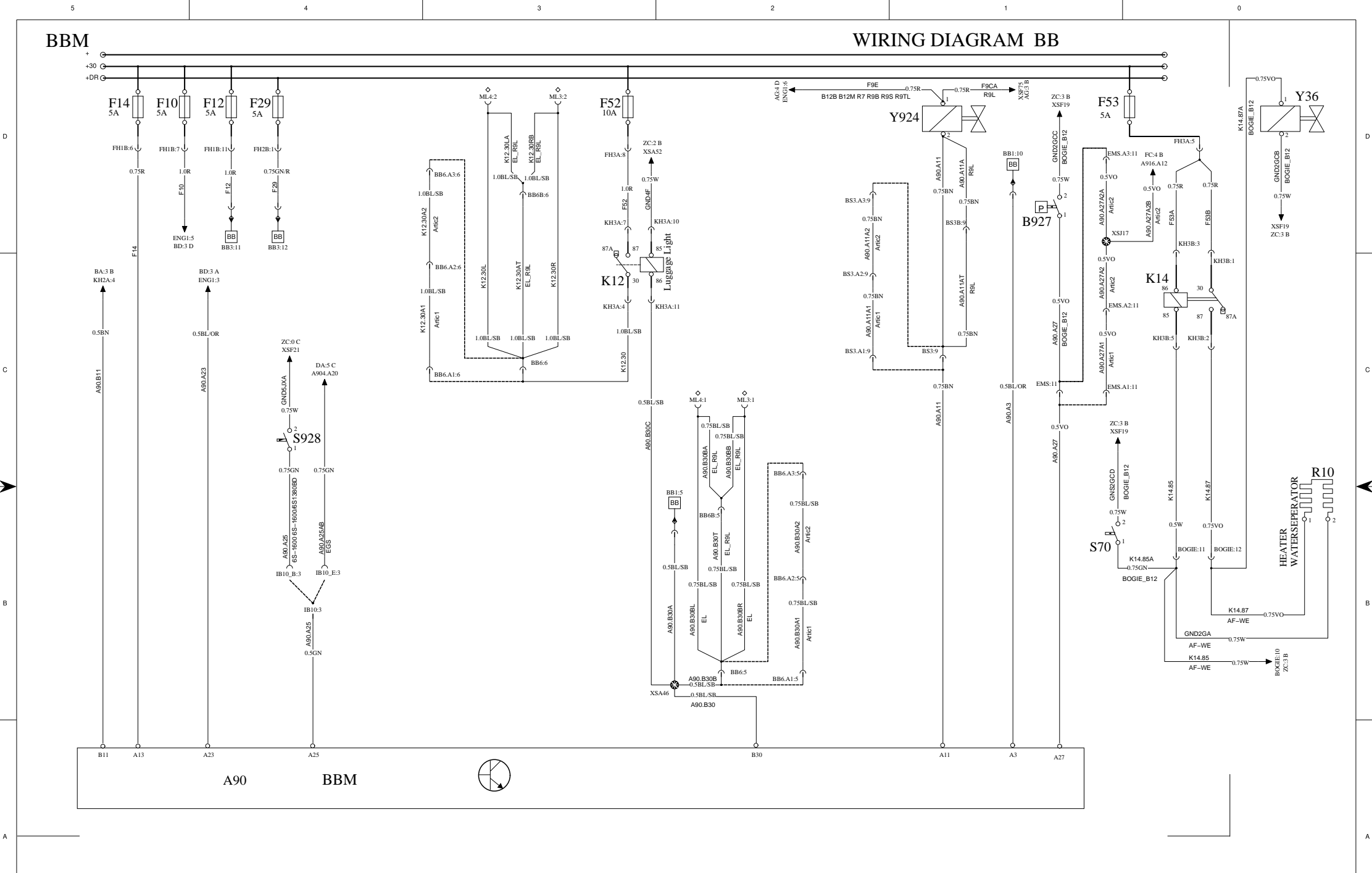

FIRE ALARM

WIRING DIAGRAM BD

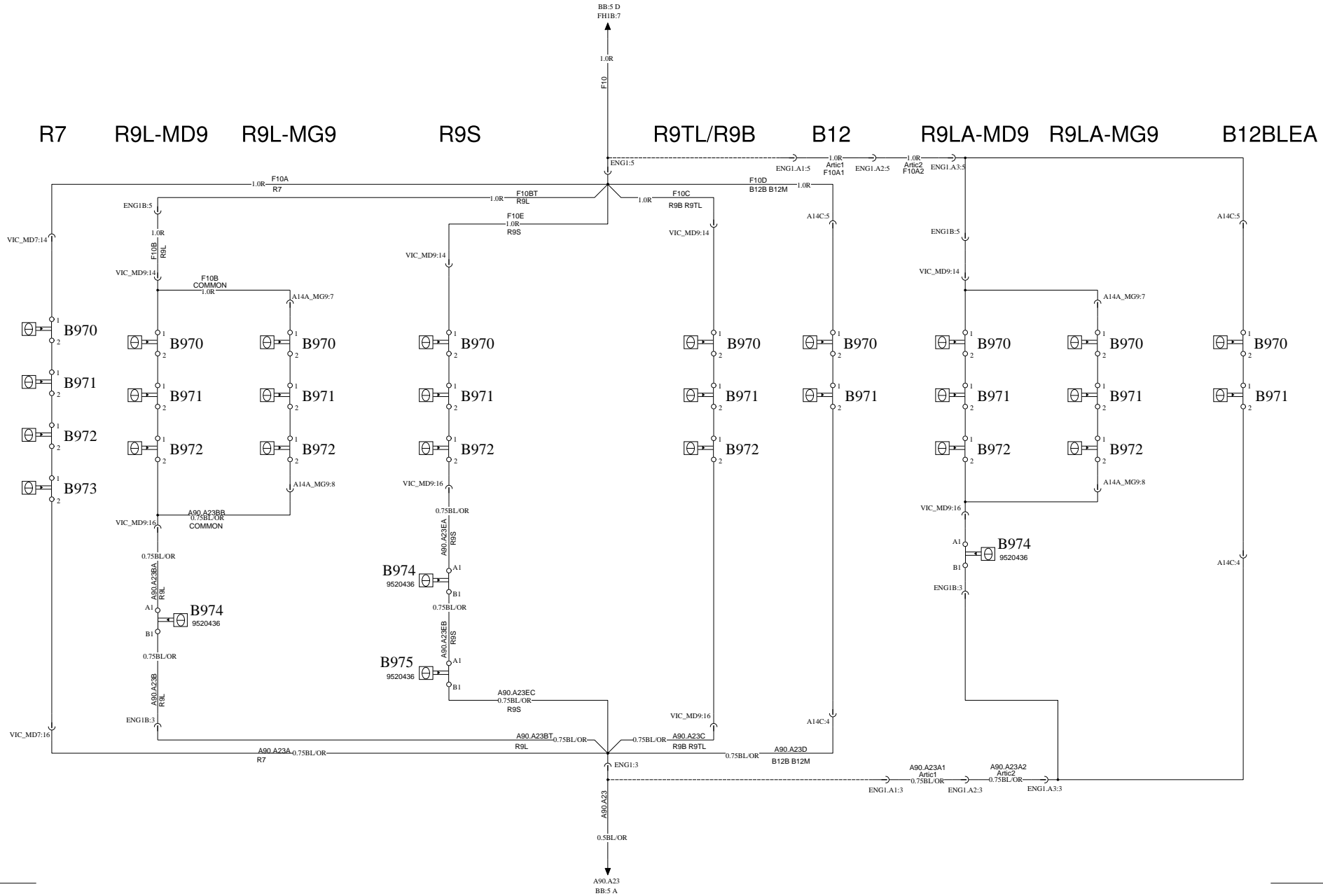

Volvo Bus Corporation

Document title
WIRING DIAGRAM BD
Document type
PRODUCT SCHEMATIC

Document No	Issue	Volume	Page
20904123	02	01(02)	13(48)

EECU D9B

WIRING DIAGRAM CA

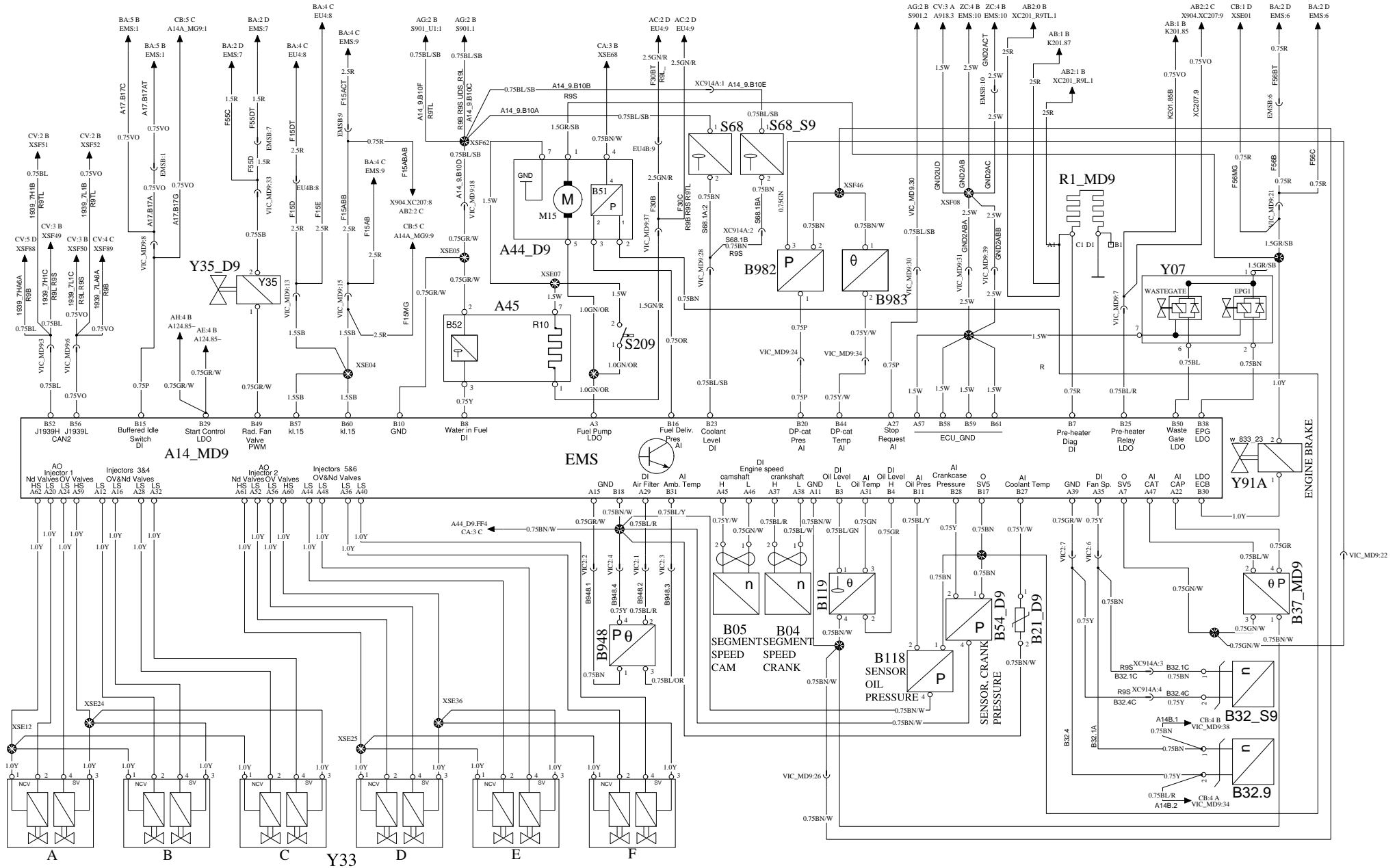

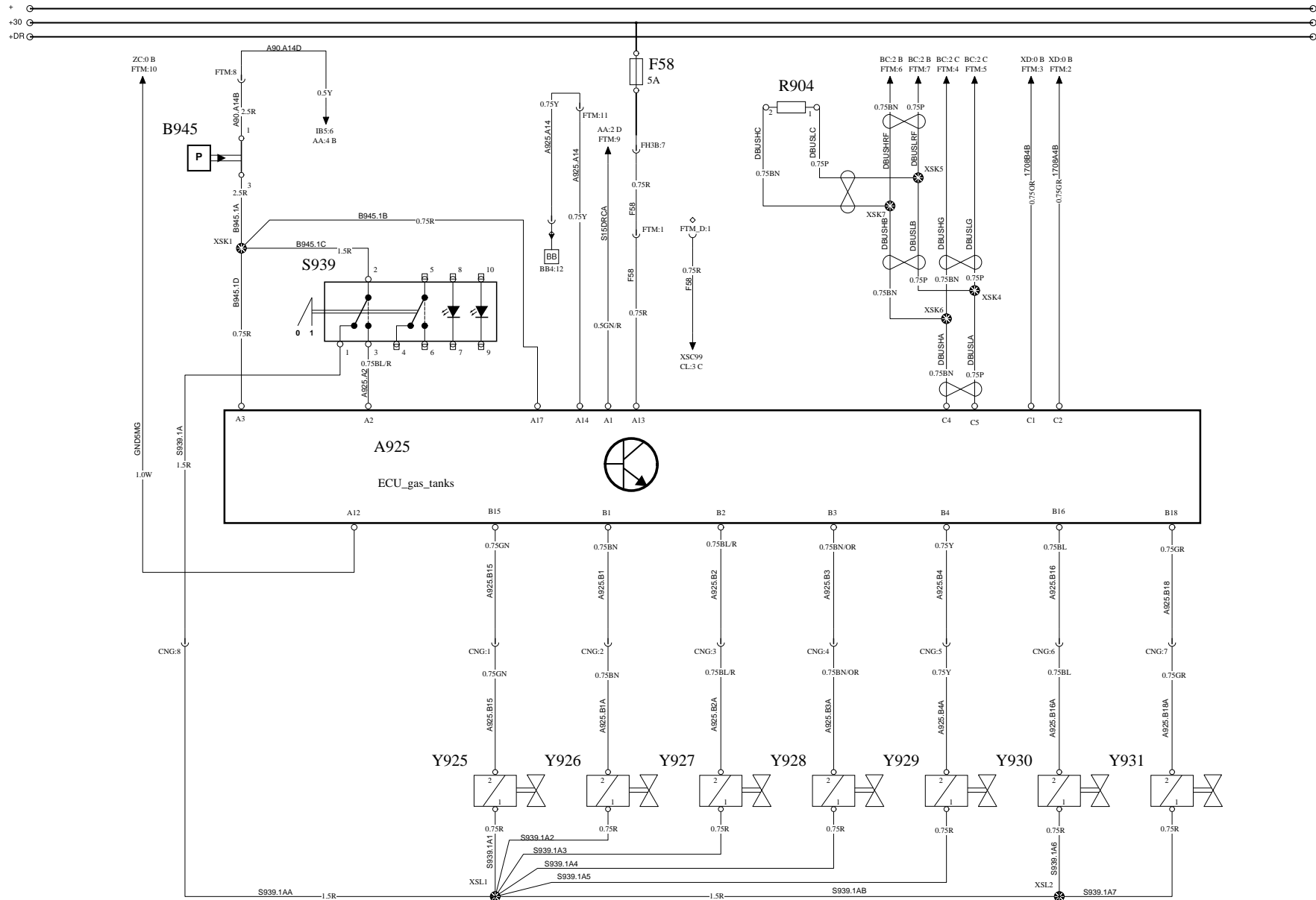

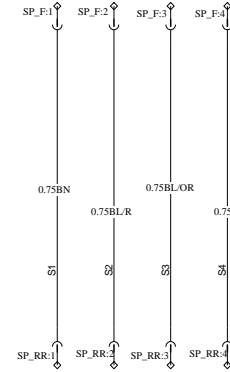
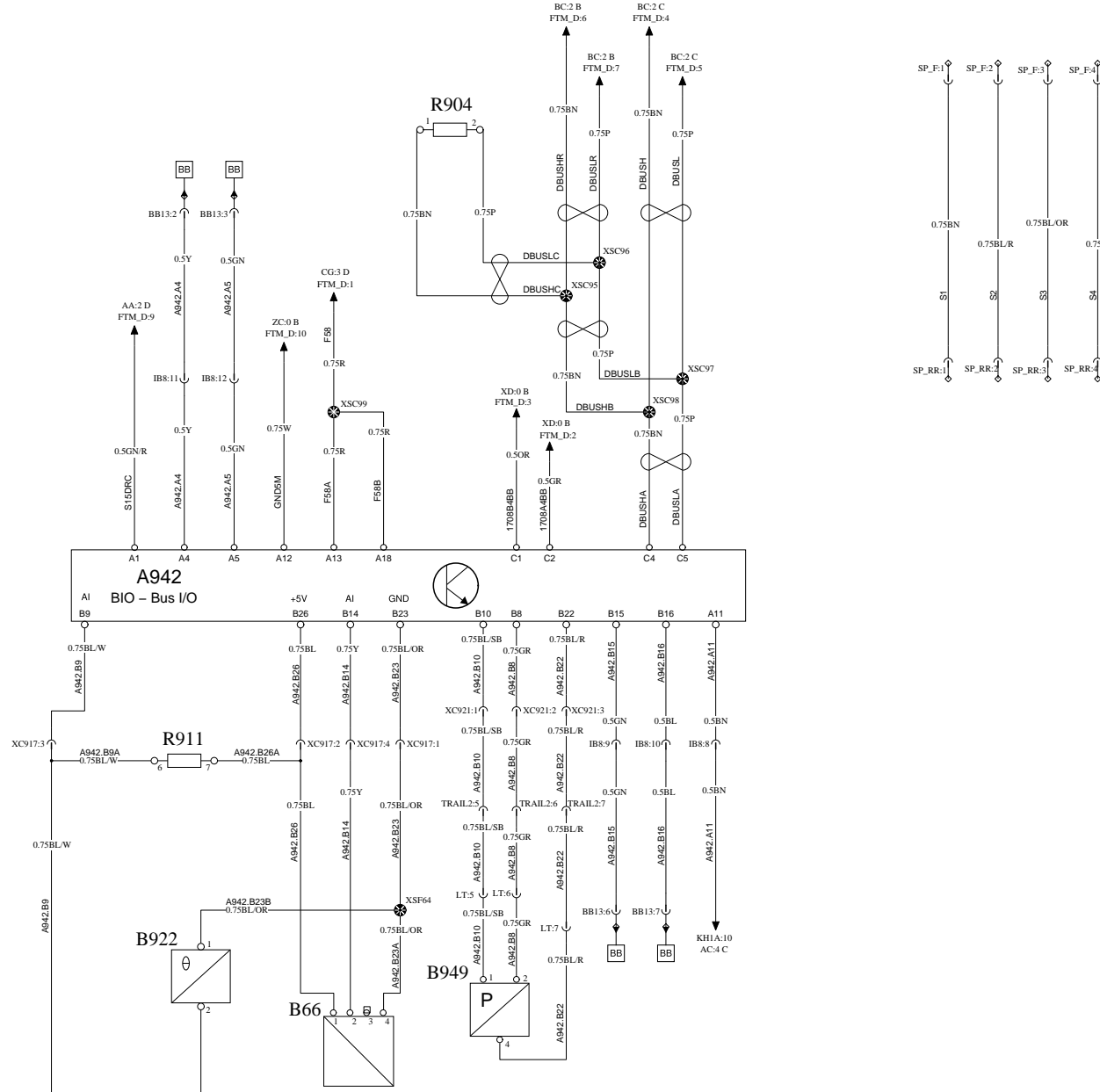

OILMASTER

WIRING DIAGRAM CO

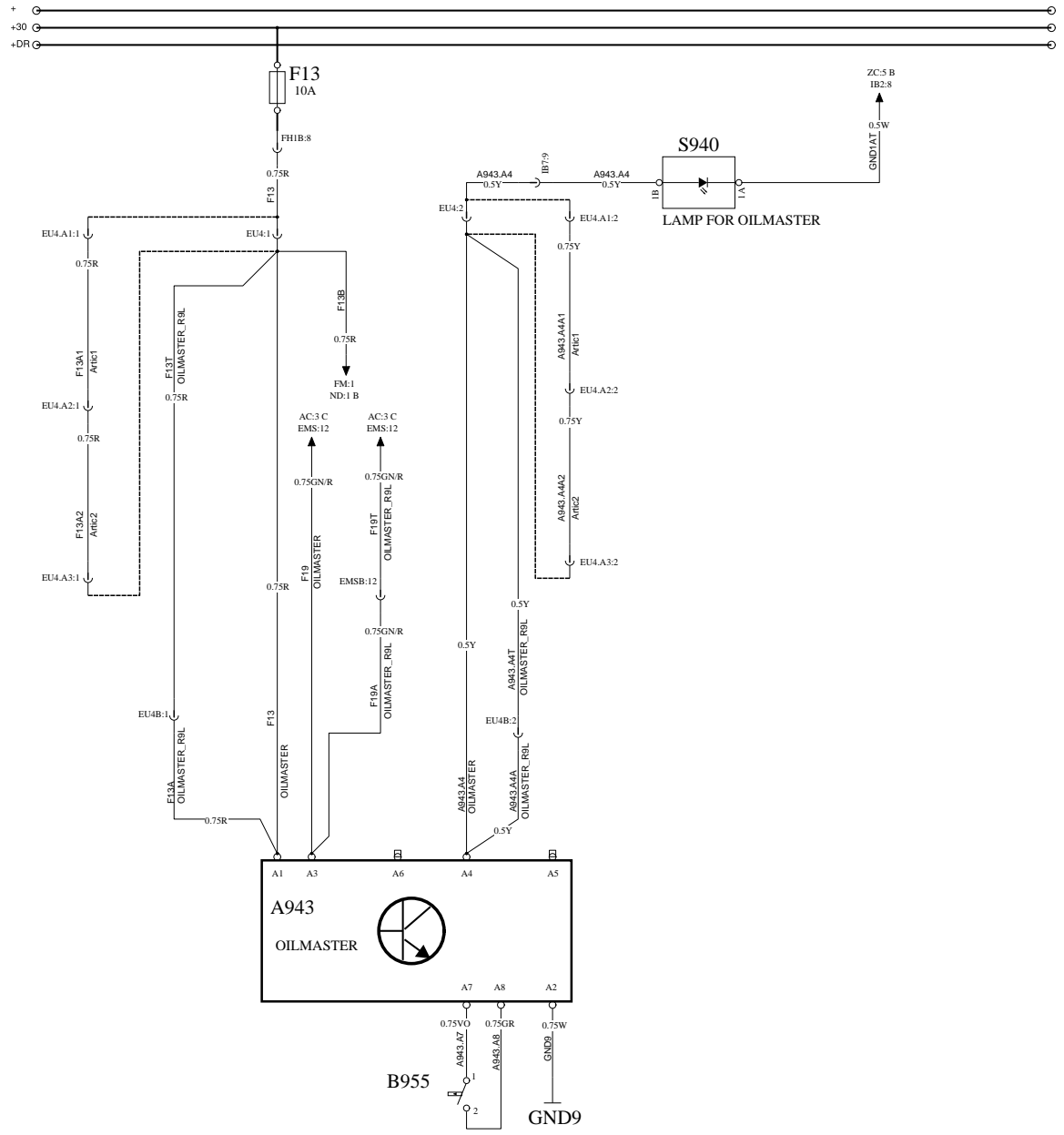

Volvo Bus Corporation

Document title
WIRING DIAGRAM CO

Document type
PRODUCT SCHEMATIC

Document No
20904123

Issue	Volume	Page
02	01(02)	20(48)

DNOX2

WIRING DIAGRAM CU

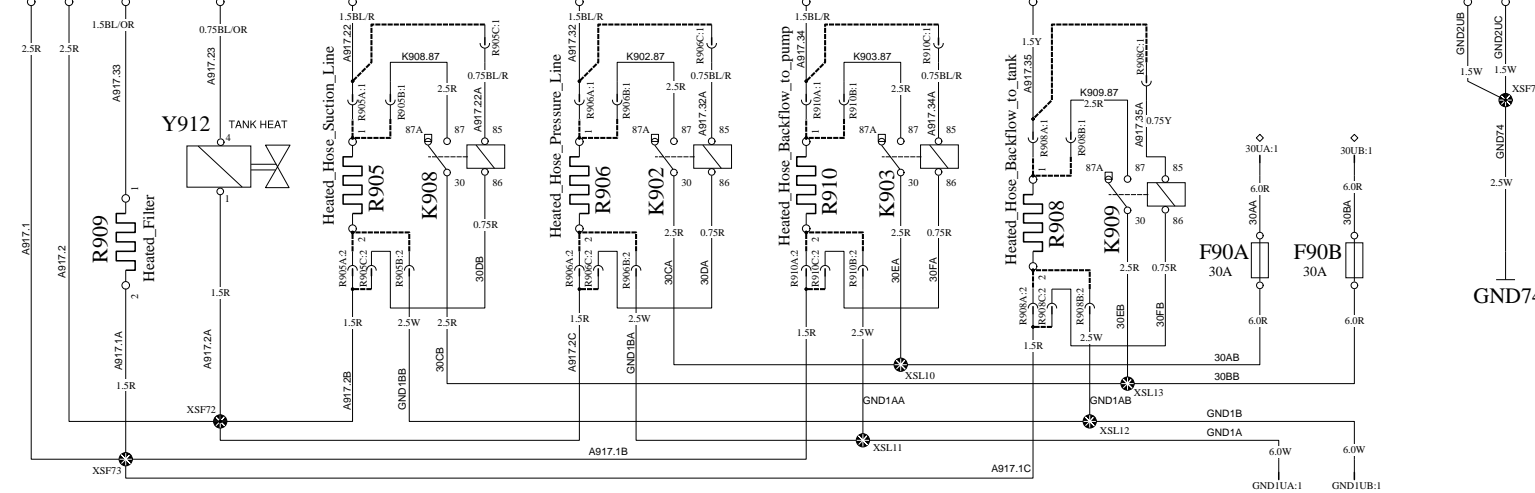
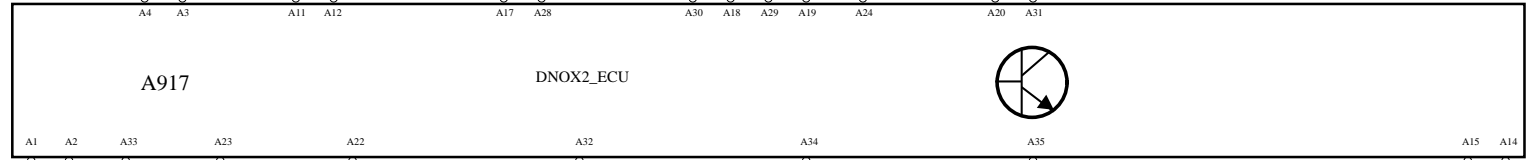
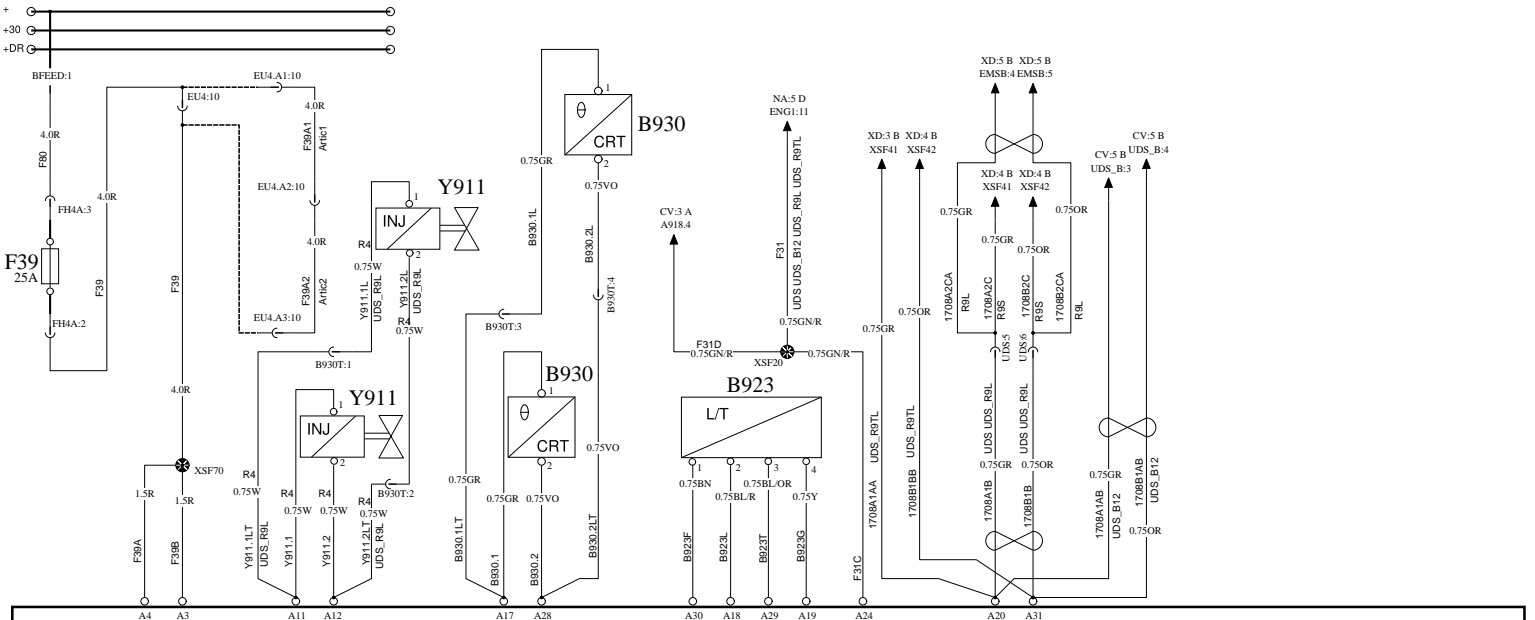

DNOX2

WIRING DIAGRAM CV

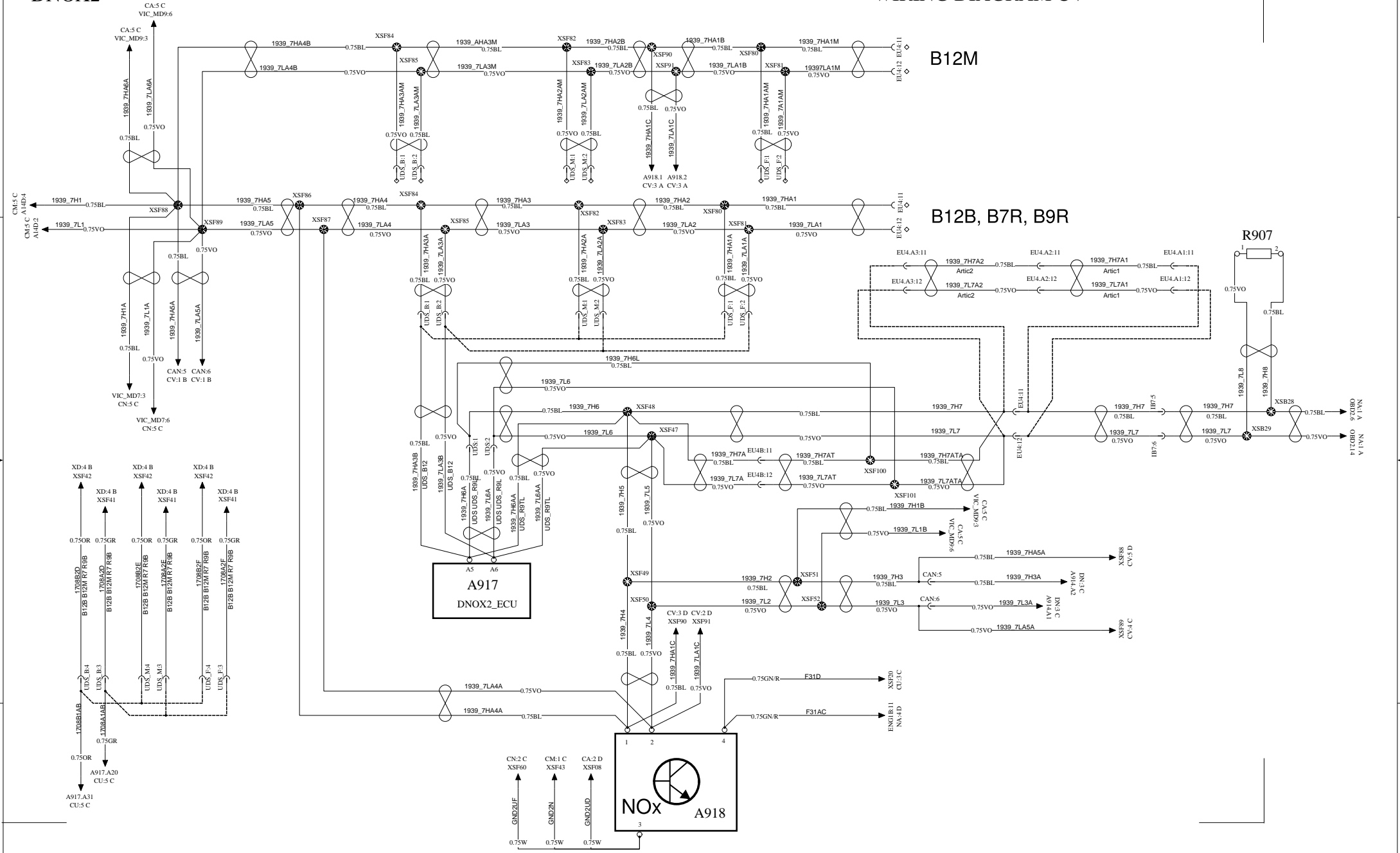

G8-EGS

WIRING DIAGRAM DA

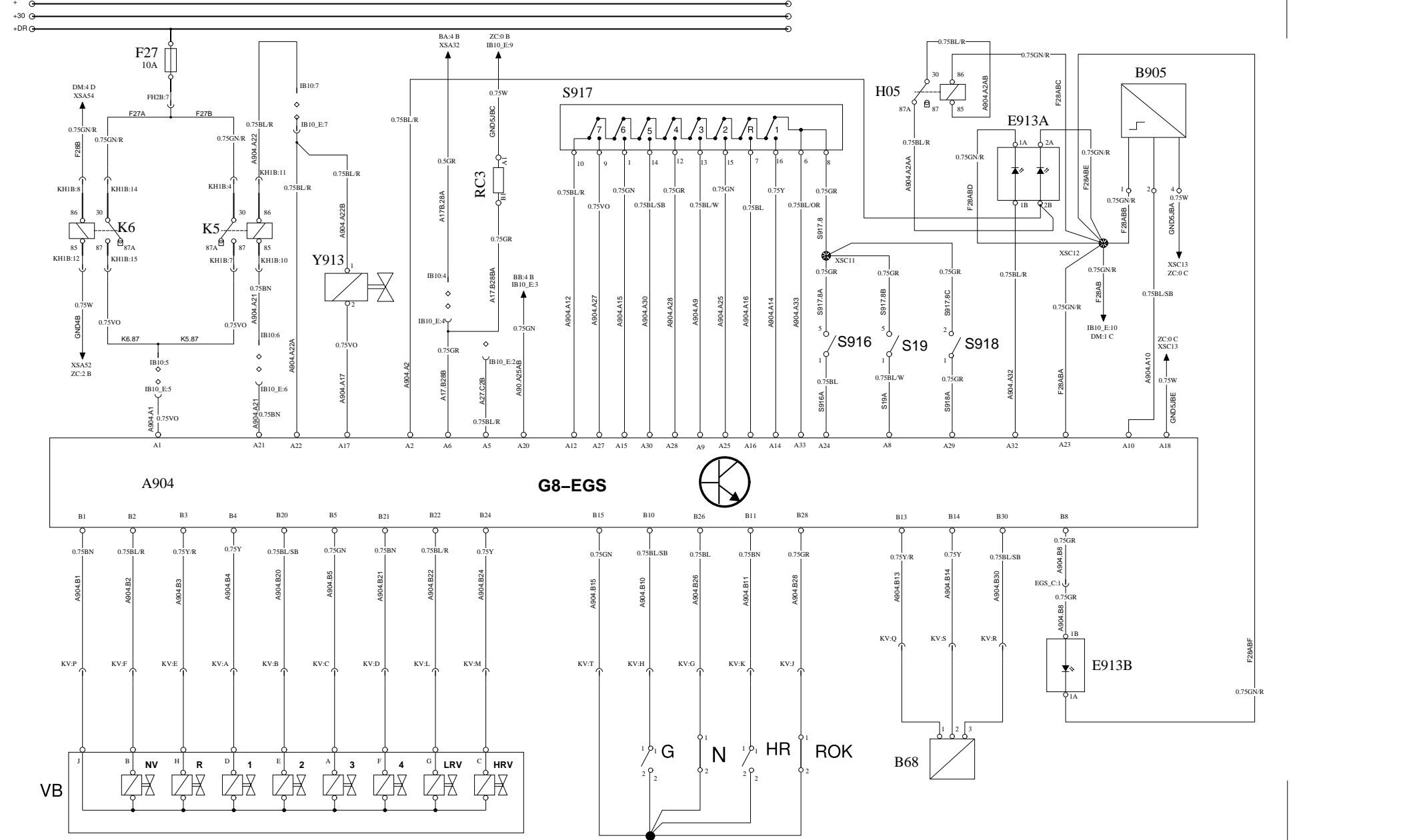

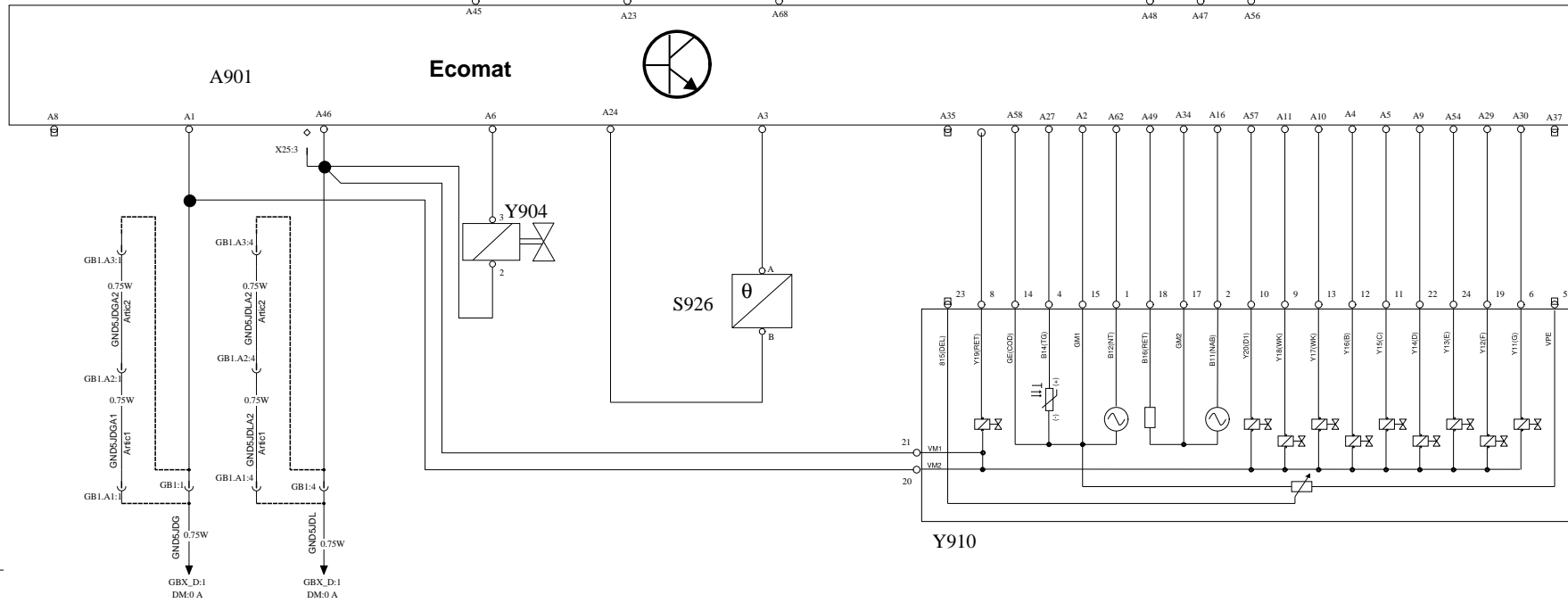
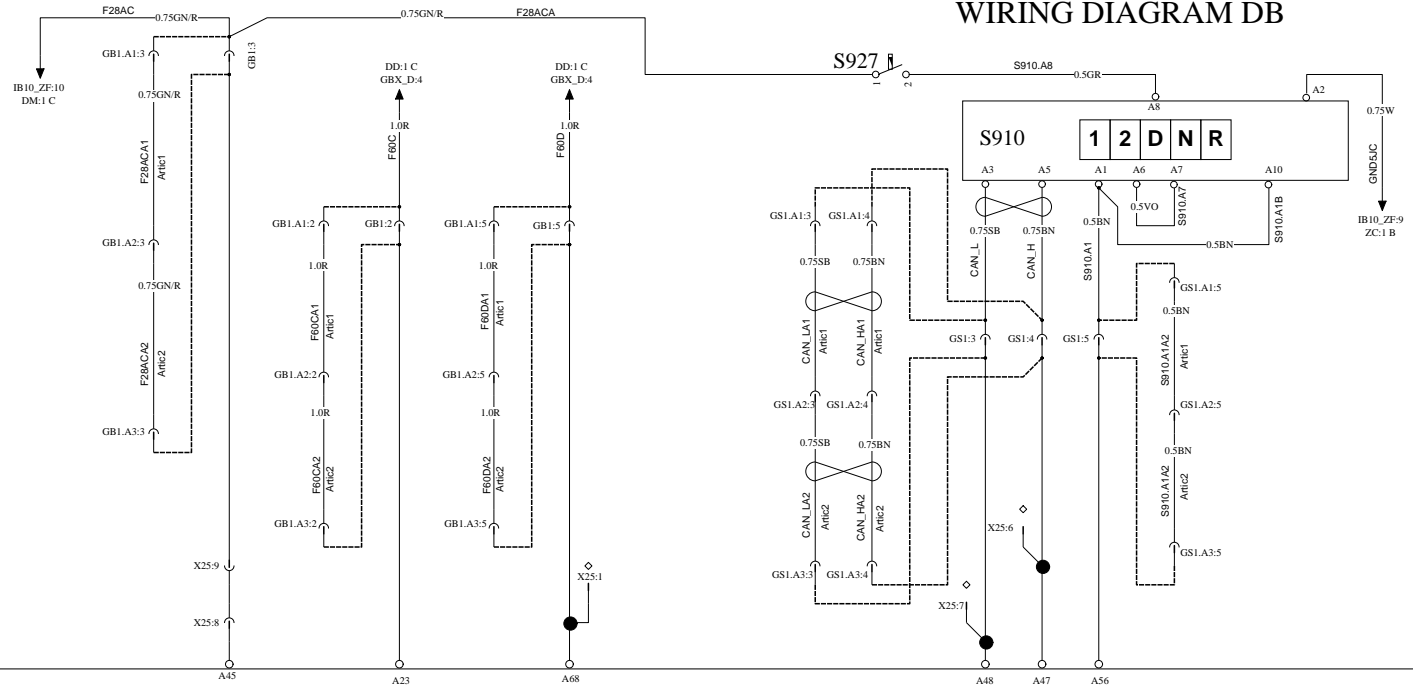

VOITH DIWA5

WIRING DIAGRAM DC

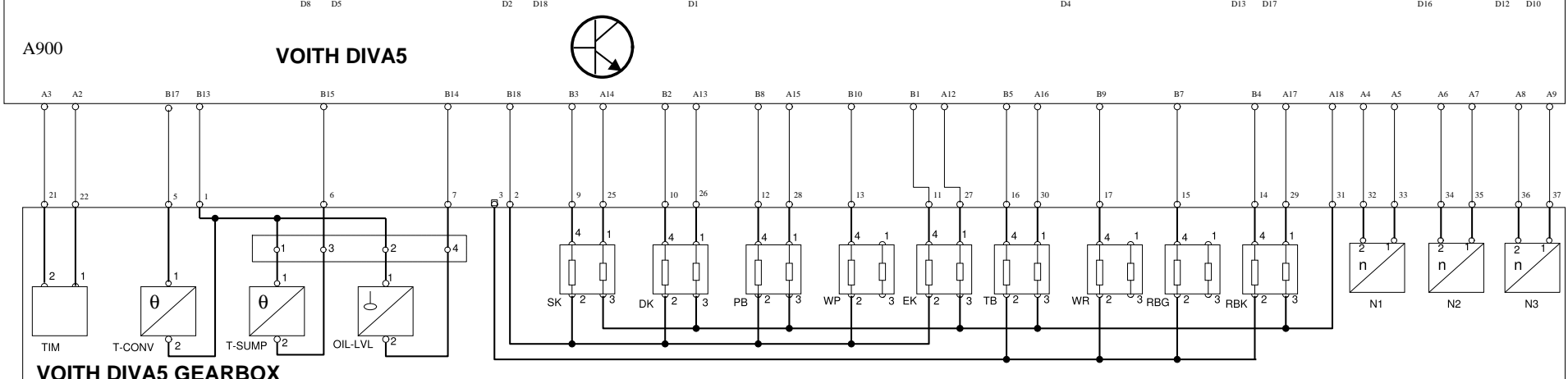
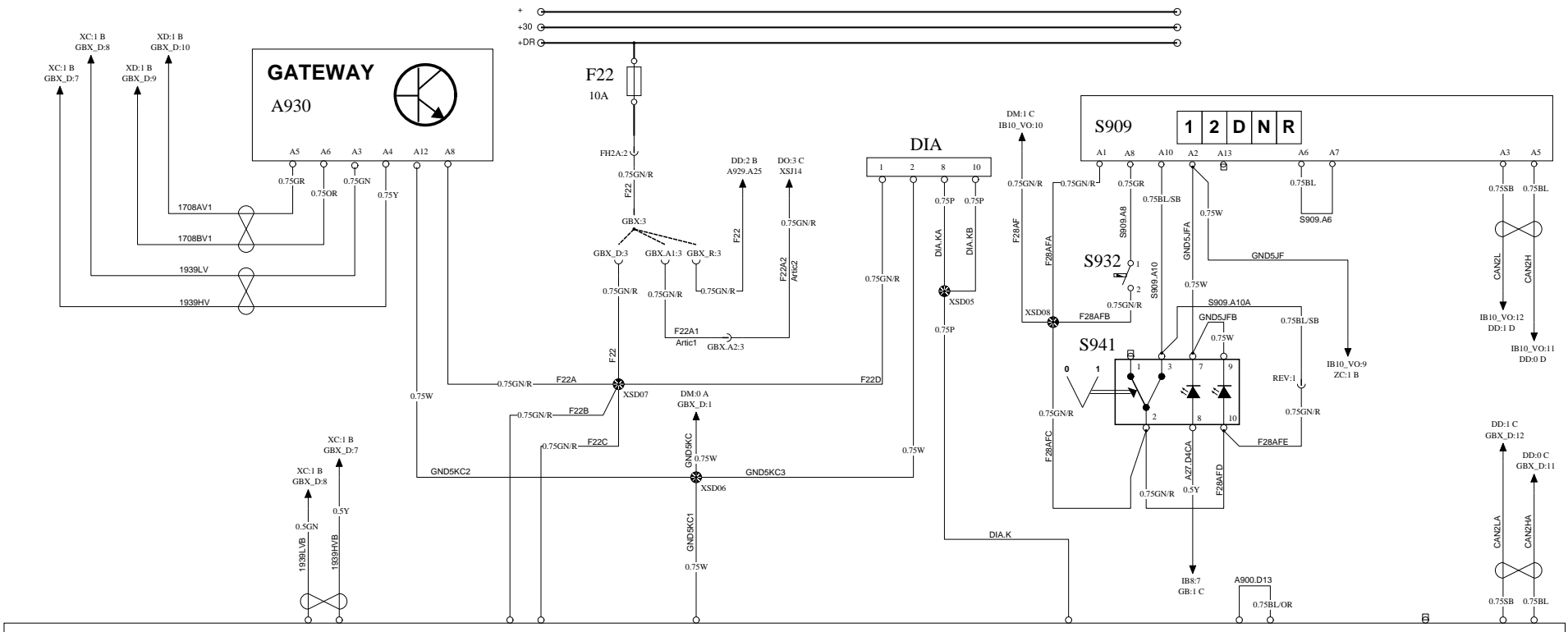

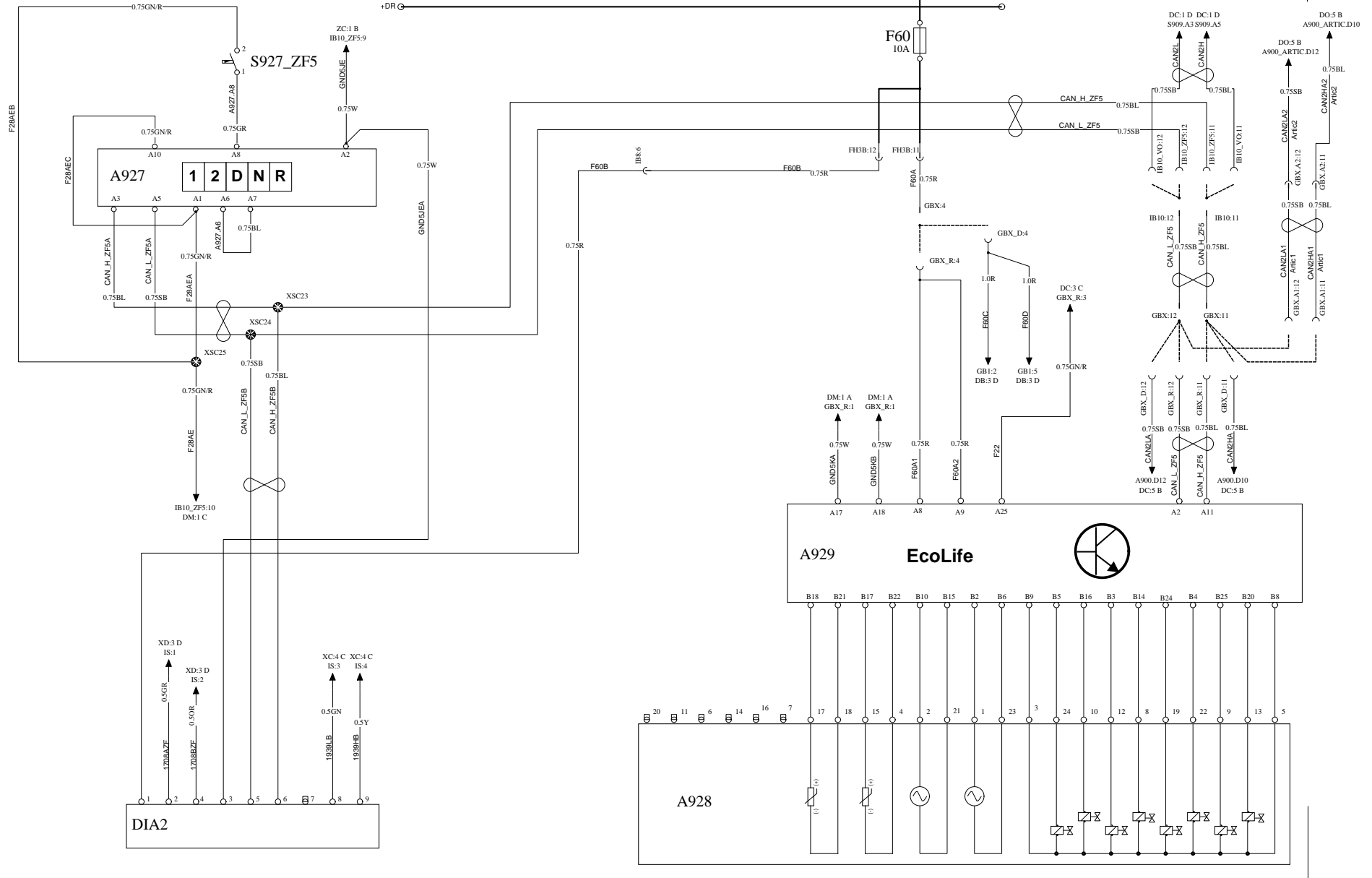
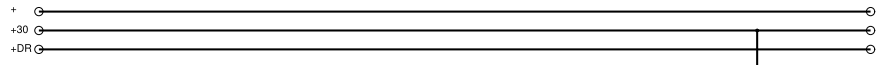

RETARDER

WIRING DIAGRAM DM

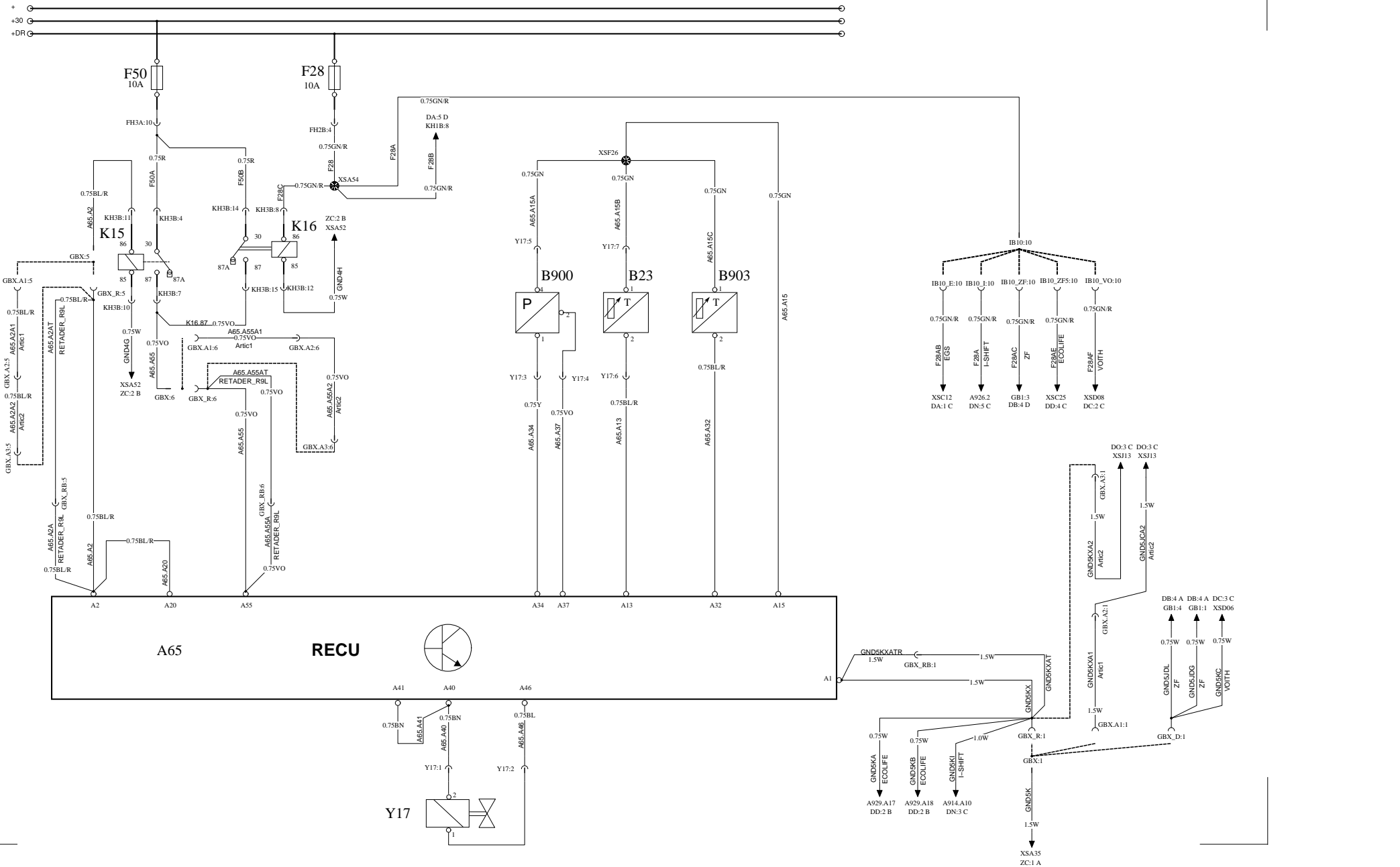

I-SHIFT

WIRING DIAGRAM DN

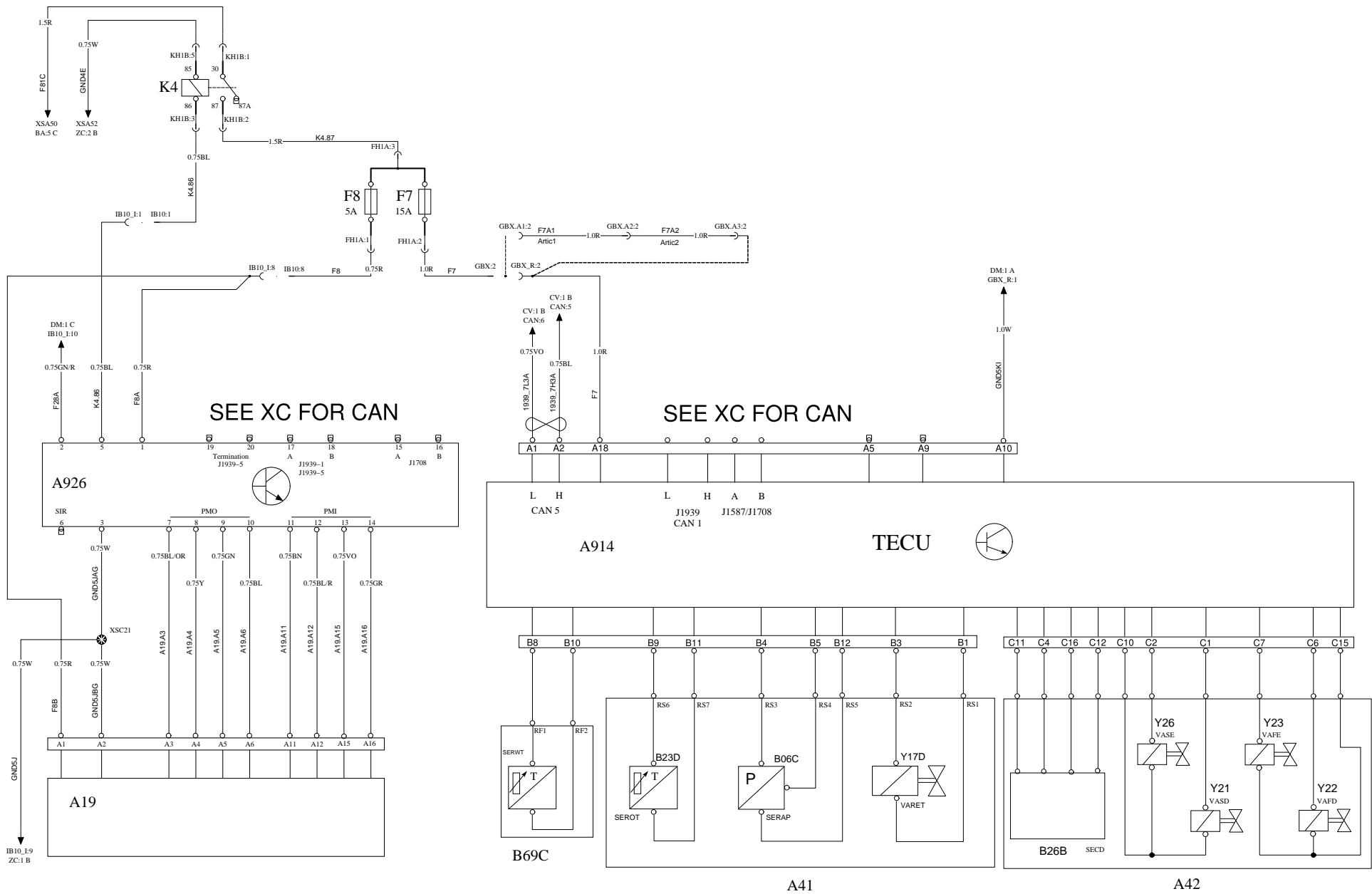

Volvo Bus Corporation

Document title
WIRING DIAGRAM DN

Document type
PRODUCT SCHEMATIC

Document No
20904123

Issue
02

Volume
01(02)

Page
28(48)

VOITH DIWA5 ARTIC

WIRING DIAGRAM DO

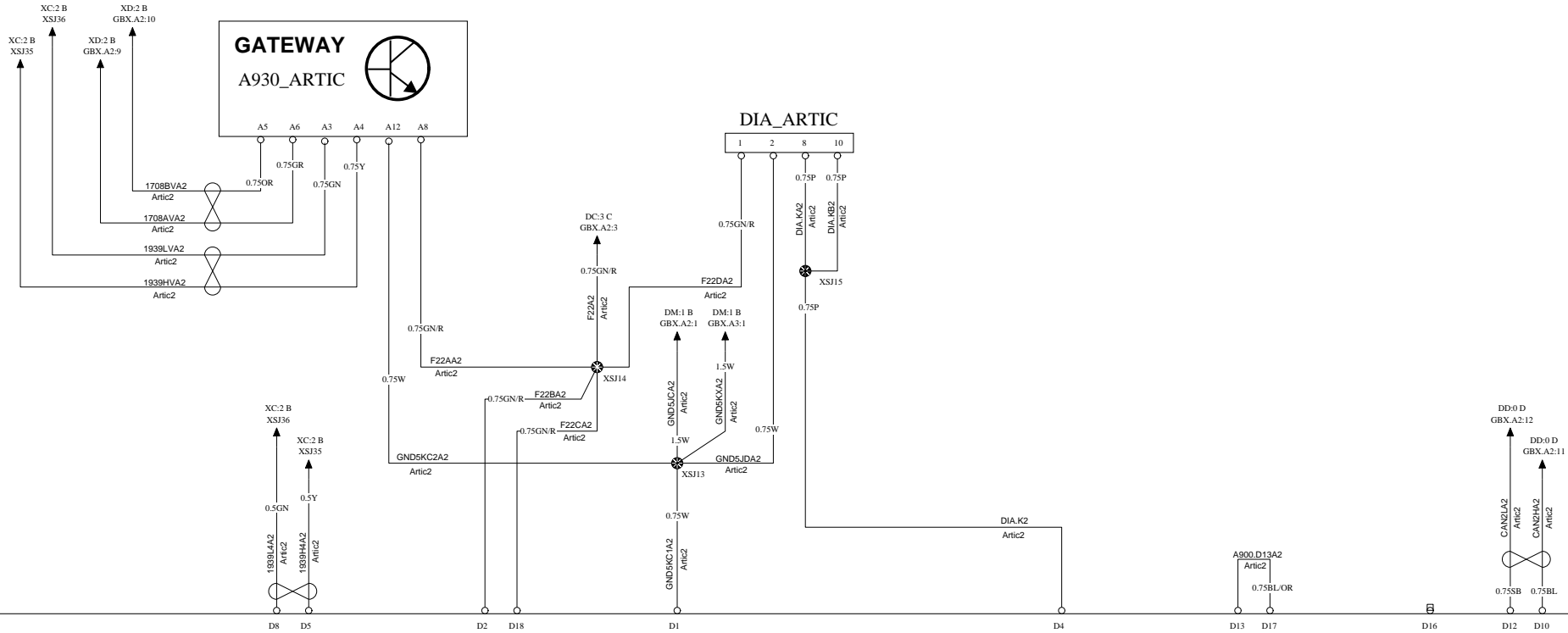

A900_ARTIC

VOITH DIVA5

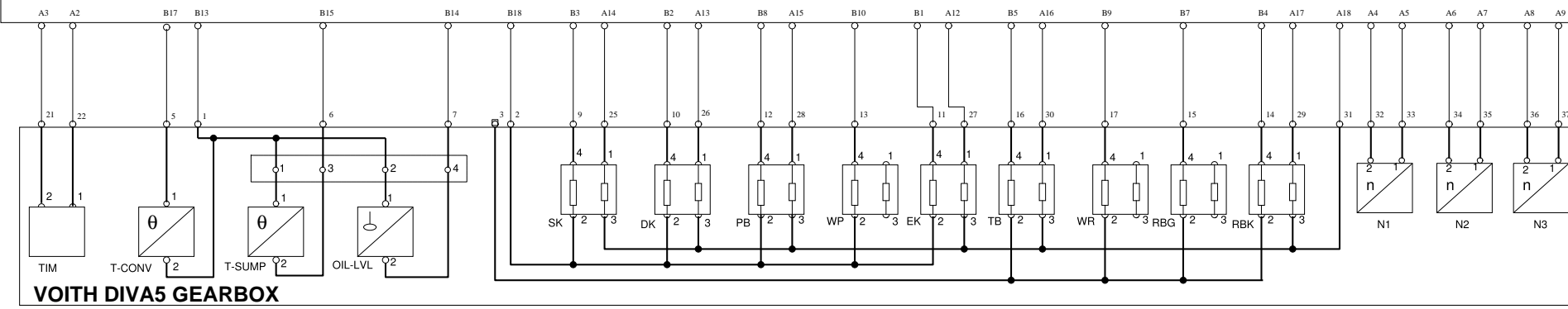

VOITH DIVA5 GEARBOX



Volvo Bus Corporation

Document title
WIRING DIAGRAM DO
Document type
PRODUCT SCHEMATIC

Document No
20904123

Issue
02
Volume
01(02)
Page
29(48)

EBS

WIRING DIAGRAM EO

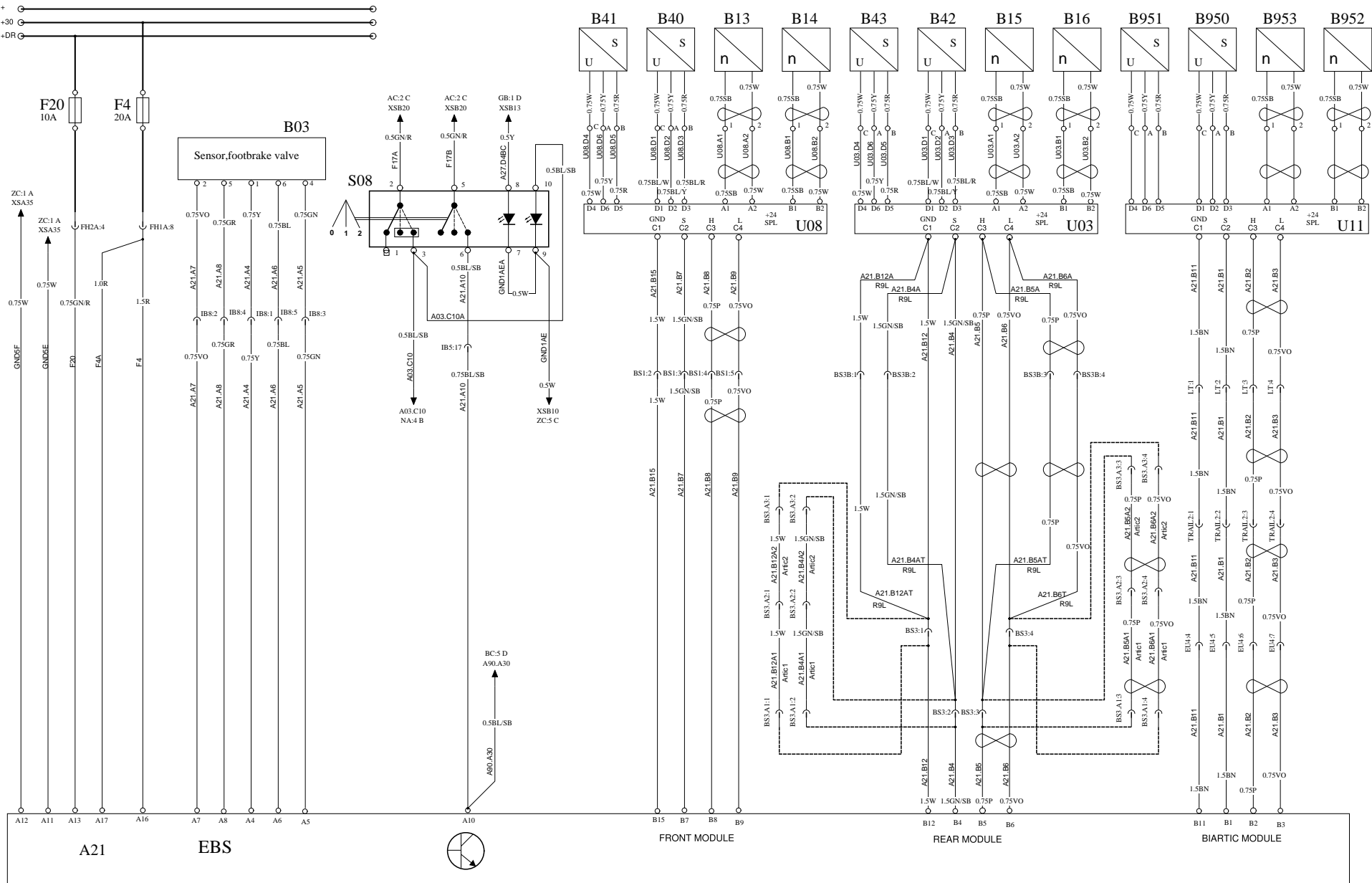

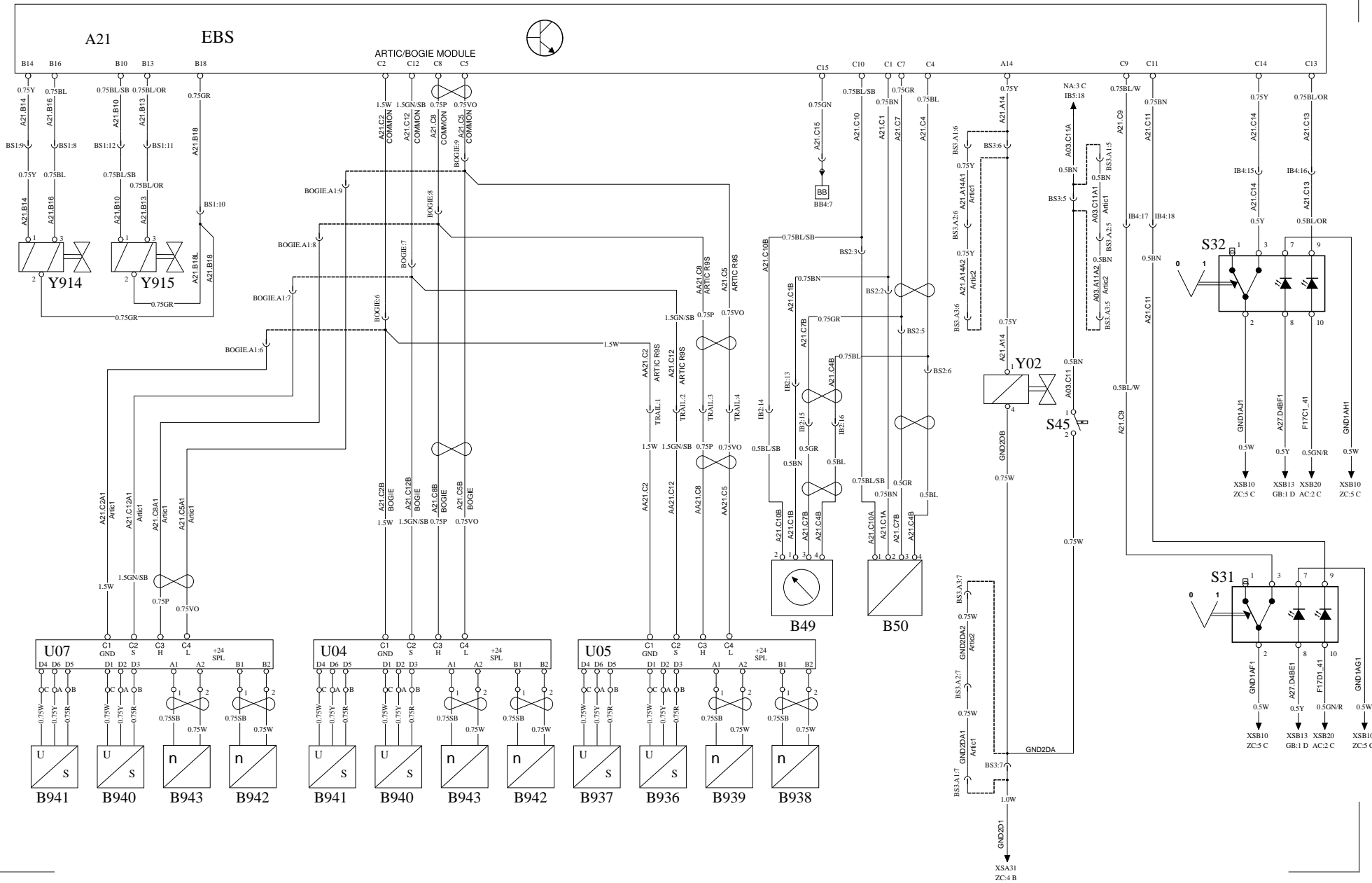

AIR SUSPENSION ECS

WIRING DIAGRAM FA

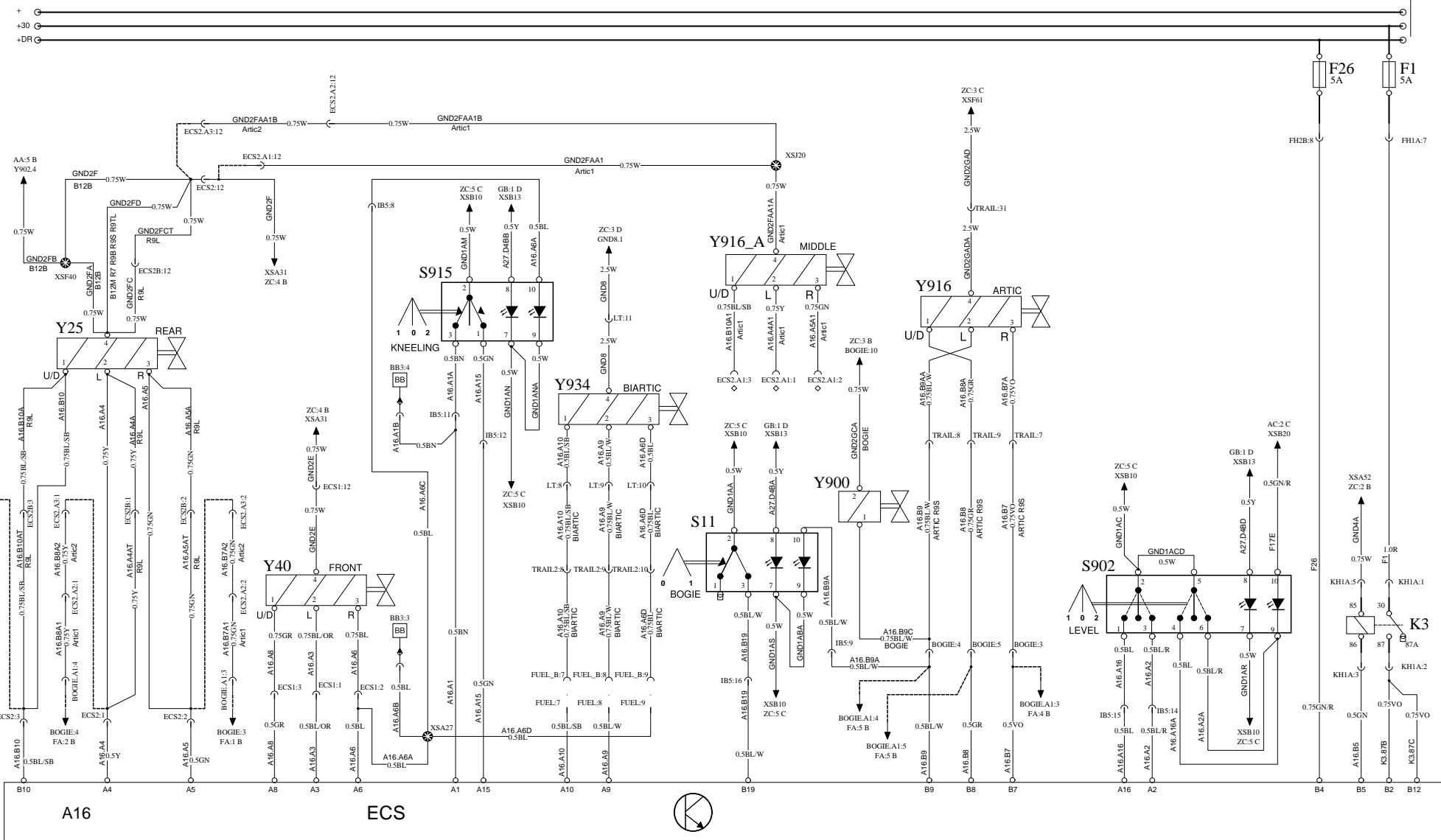

Document title WIRING DIAGRAM FA	Document No 20904123	Issue 02	Volume 01(02)	Page 32(48)
Document type PRODUCT SCHEMATIC				

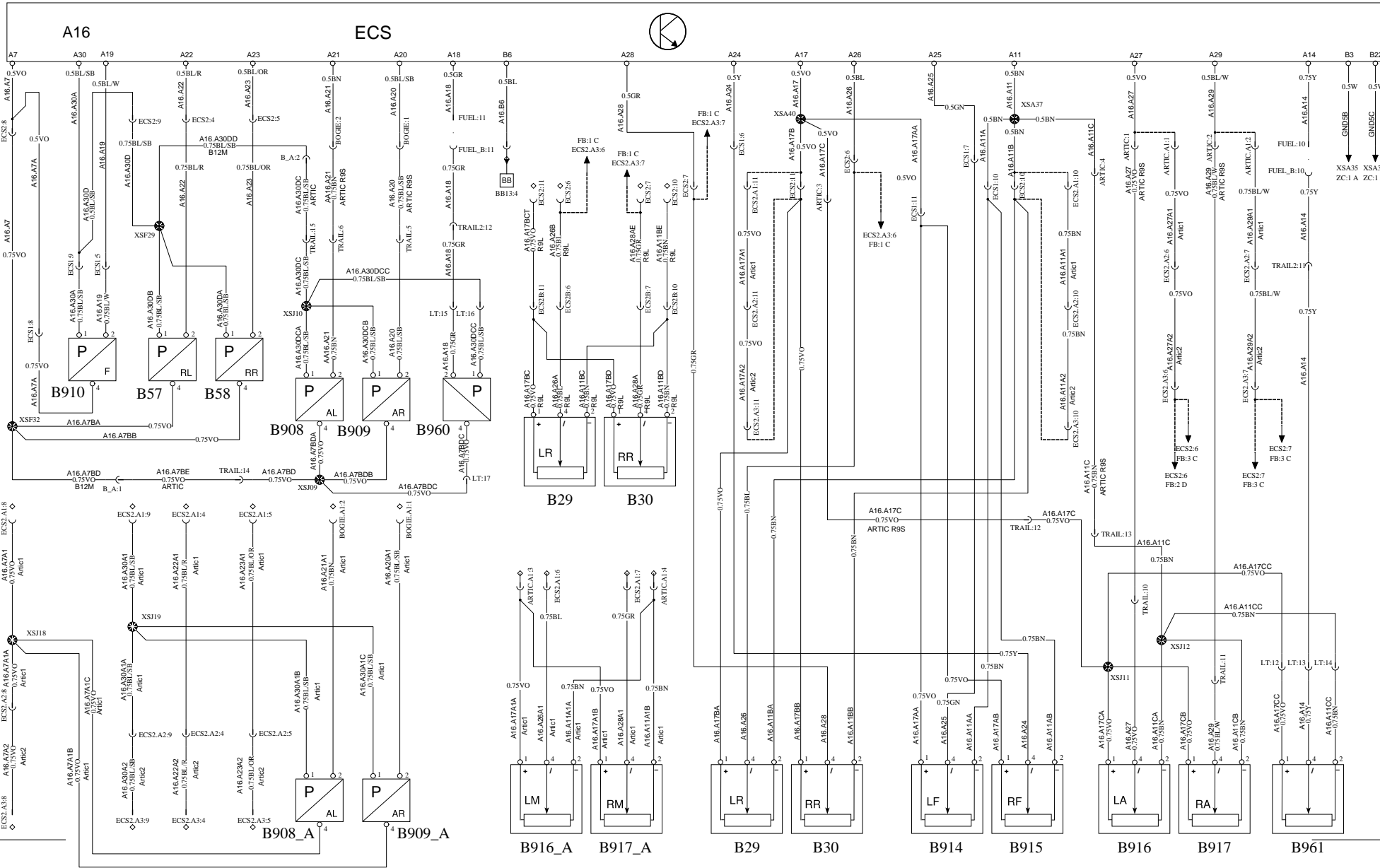

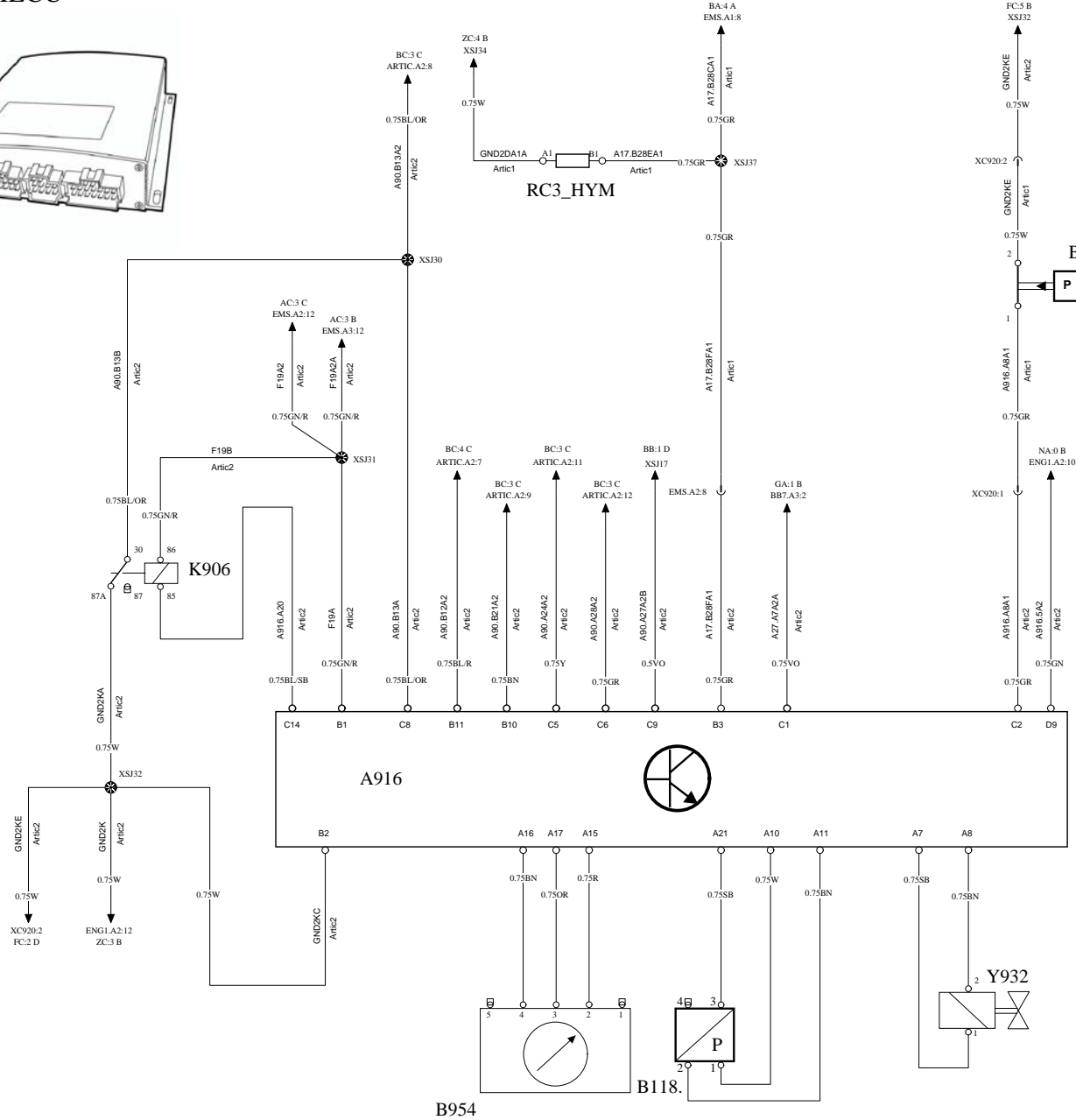
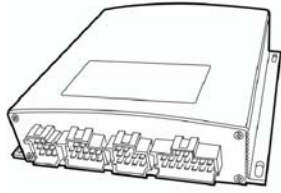

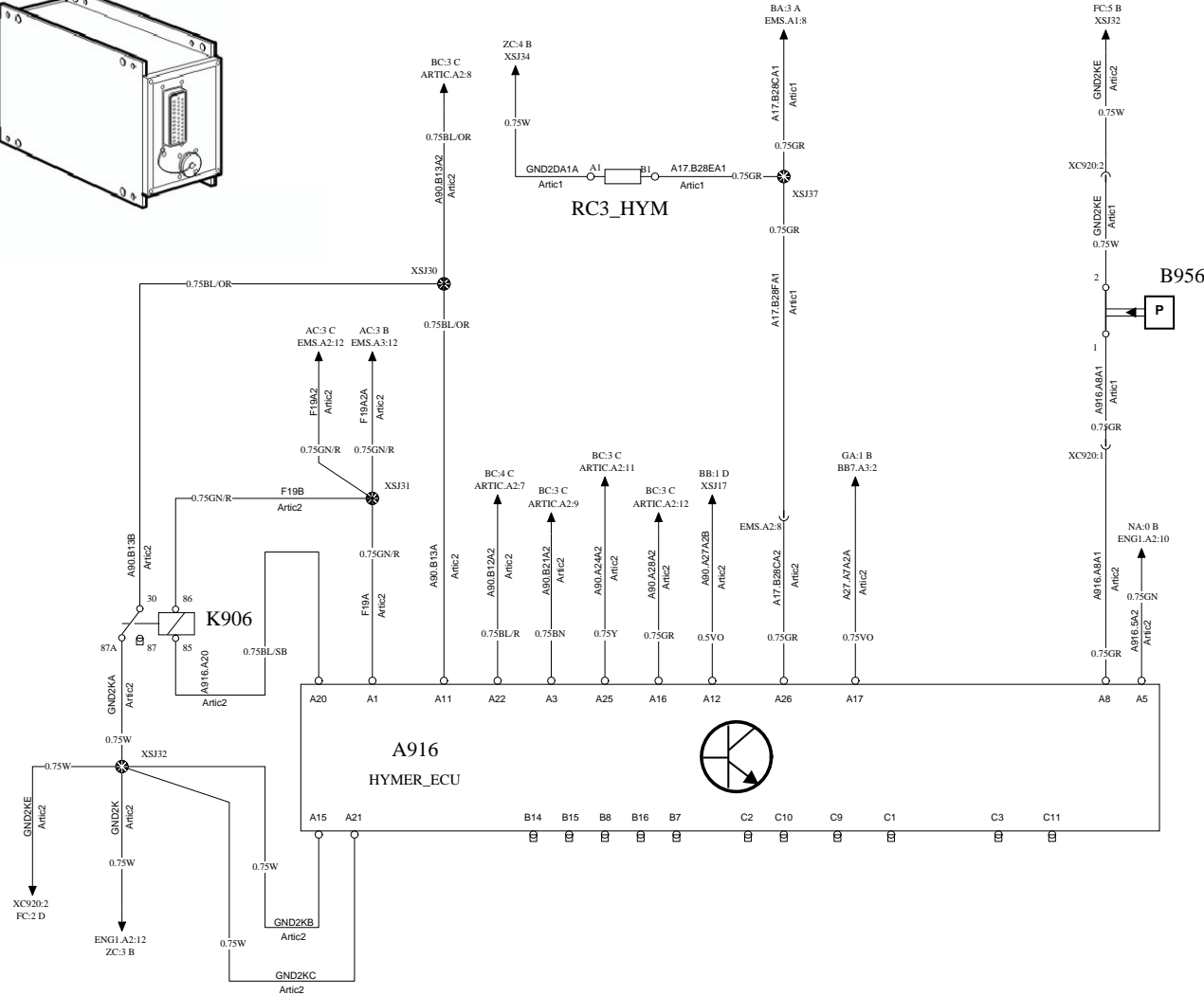
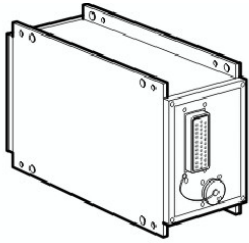

LCM

REAR LIGHTS

WIRING DIAGRAM GA

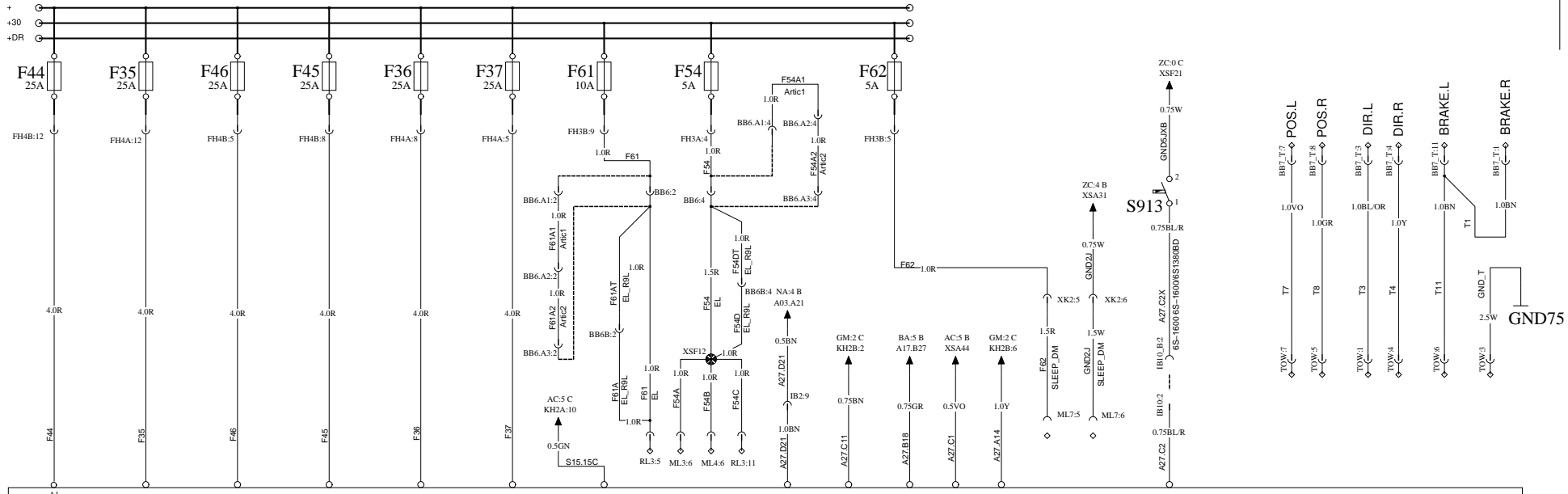

A27 LCM

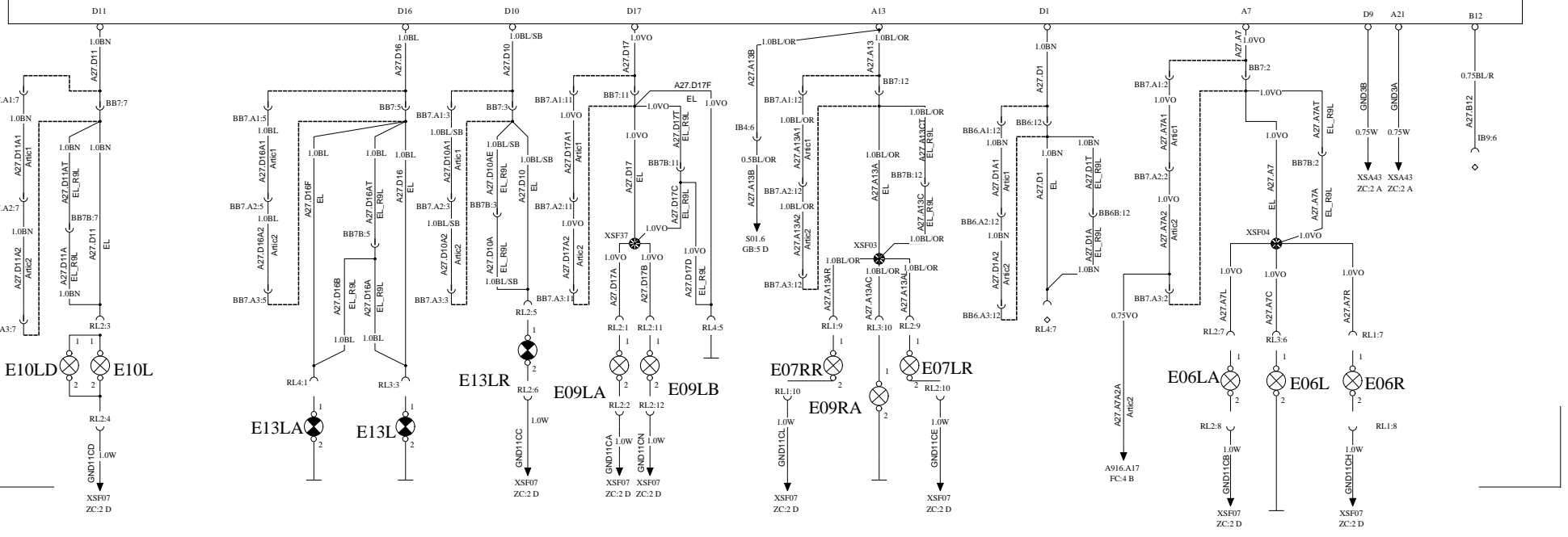

Volvo Bus Corporation

Document title WIRING DIAGRAM GA
Document type PRODUCT SCHEMATIC

Document No 20904123

Issue 02	Volume 01(02)	Page 35(48)
-------------	------------------	----------------

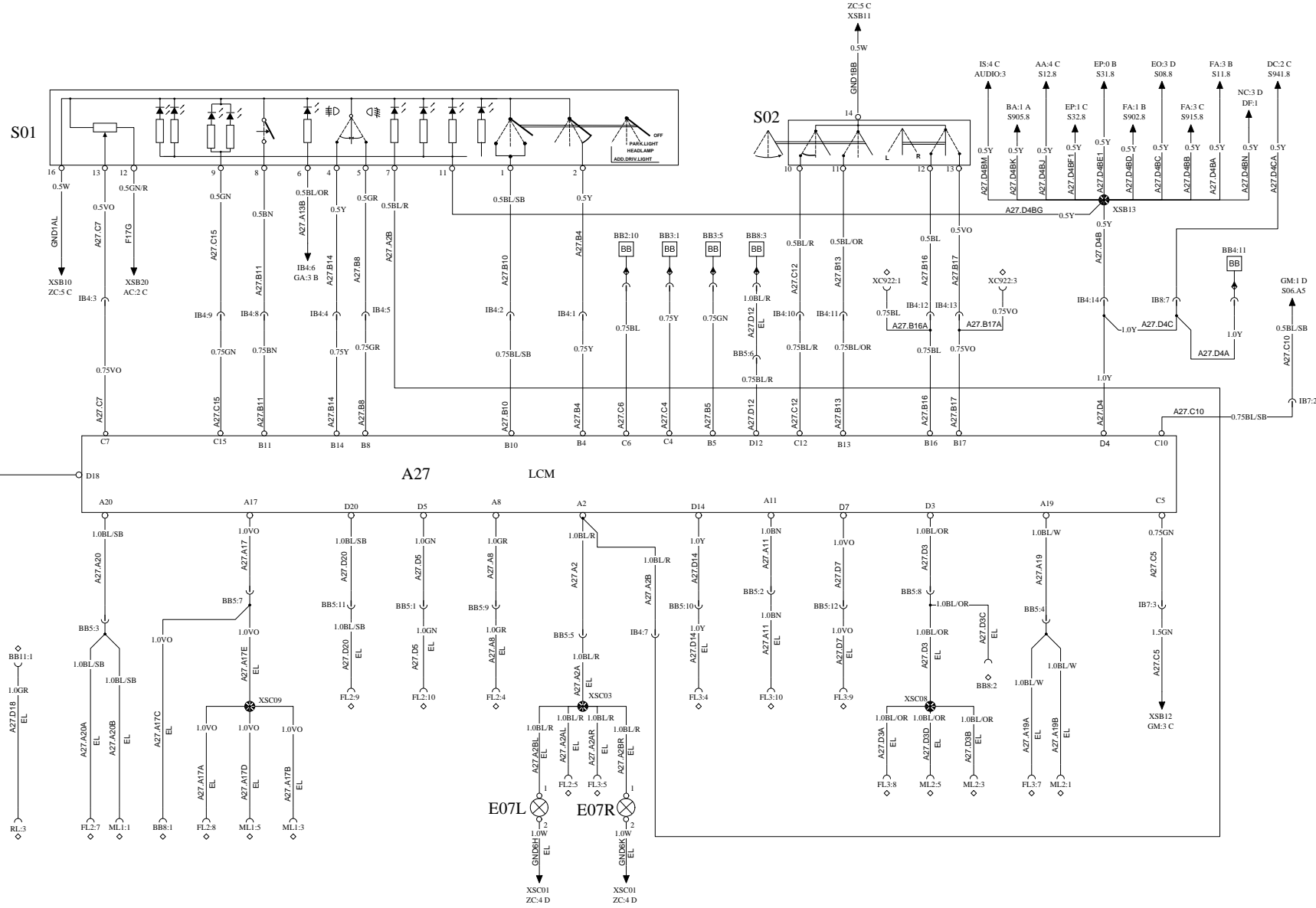

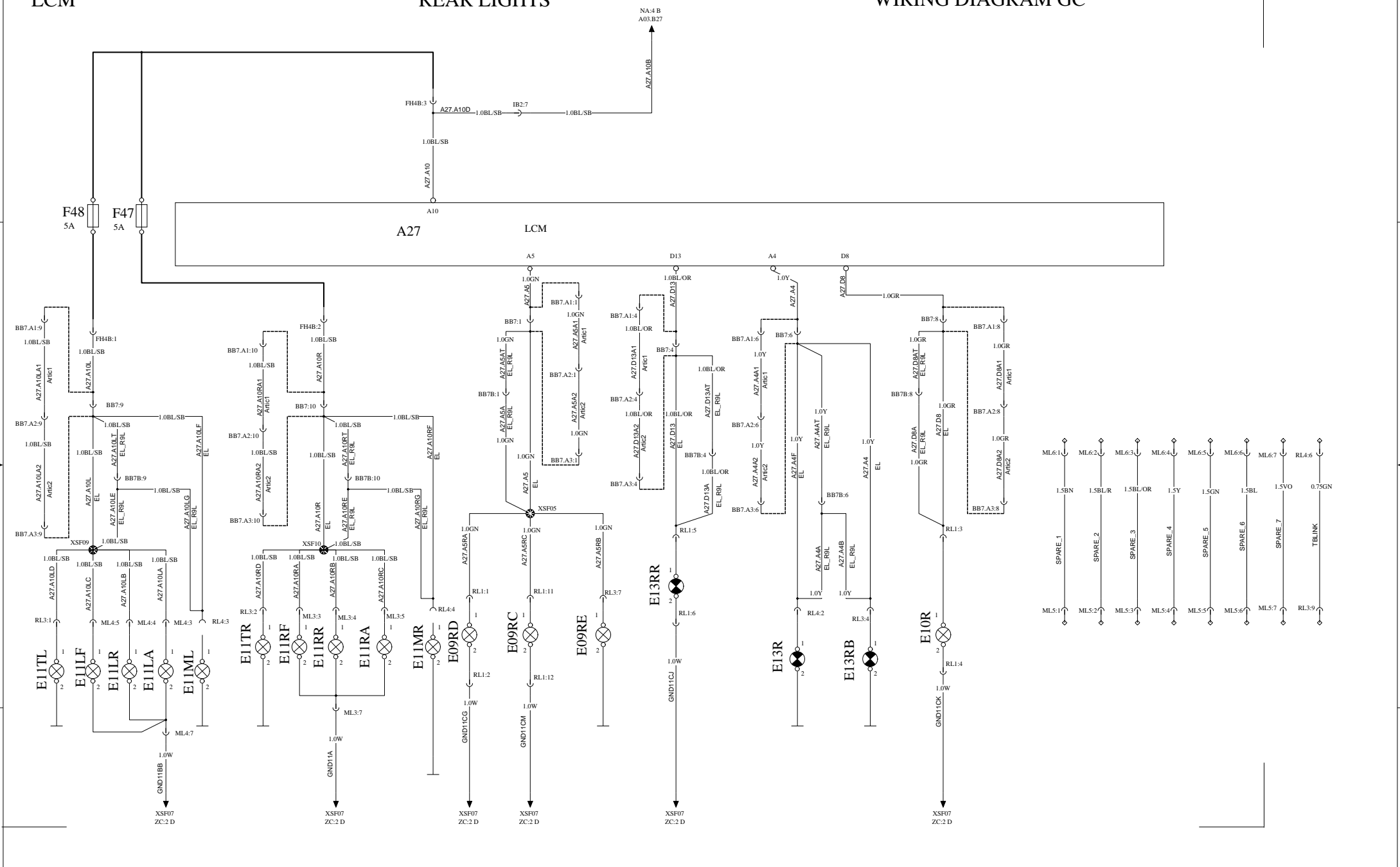

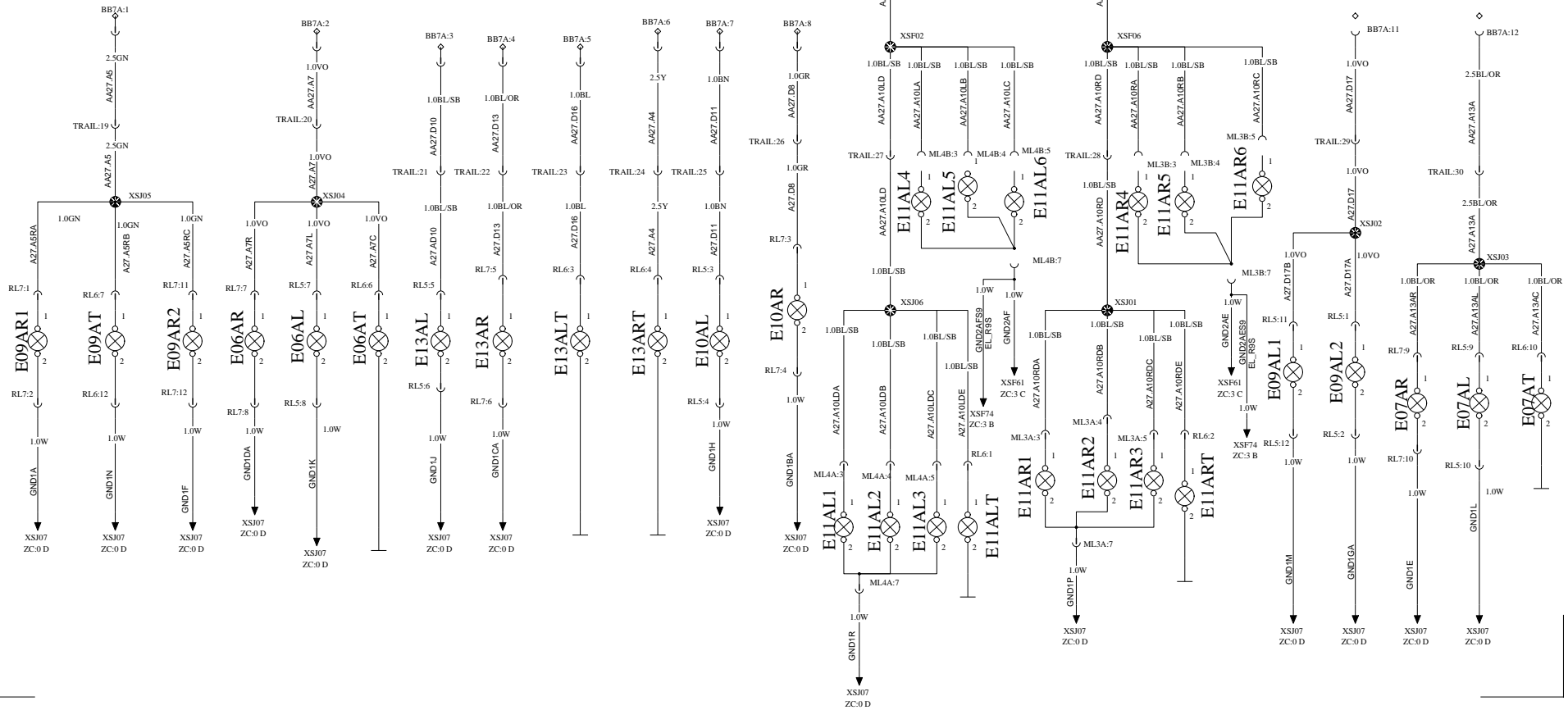
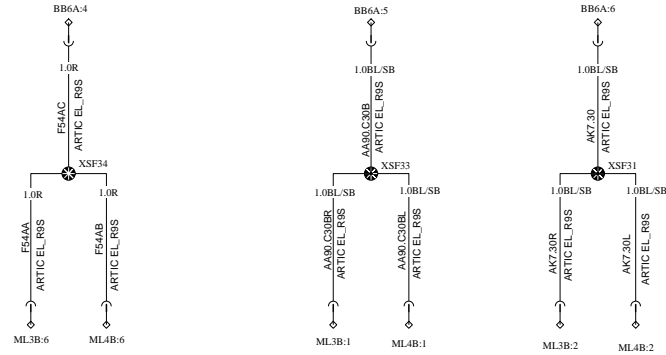

WIPER, WASHER

WIRING DIAGRAM GM

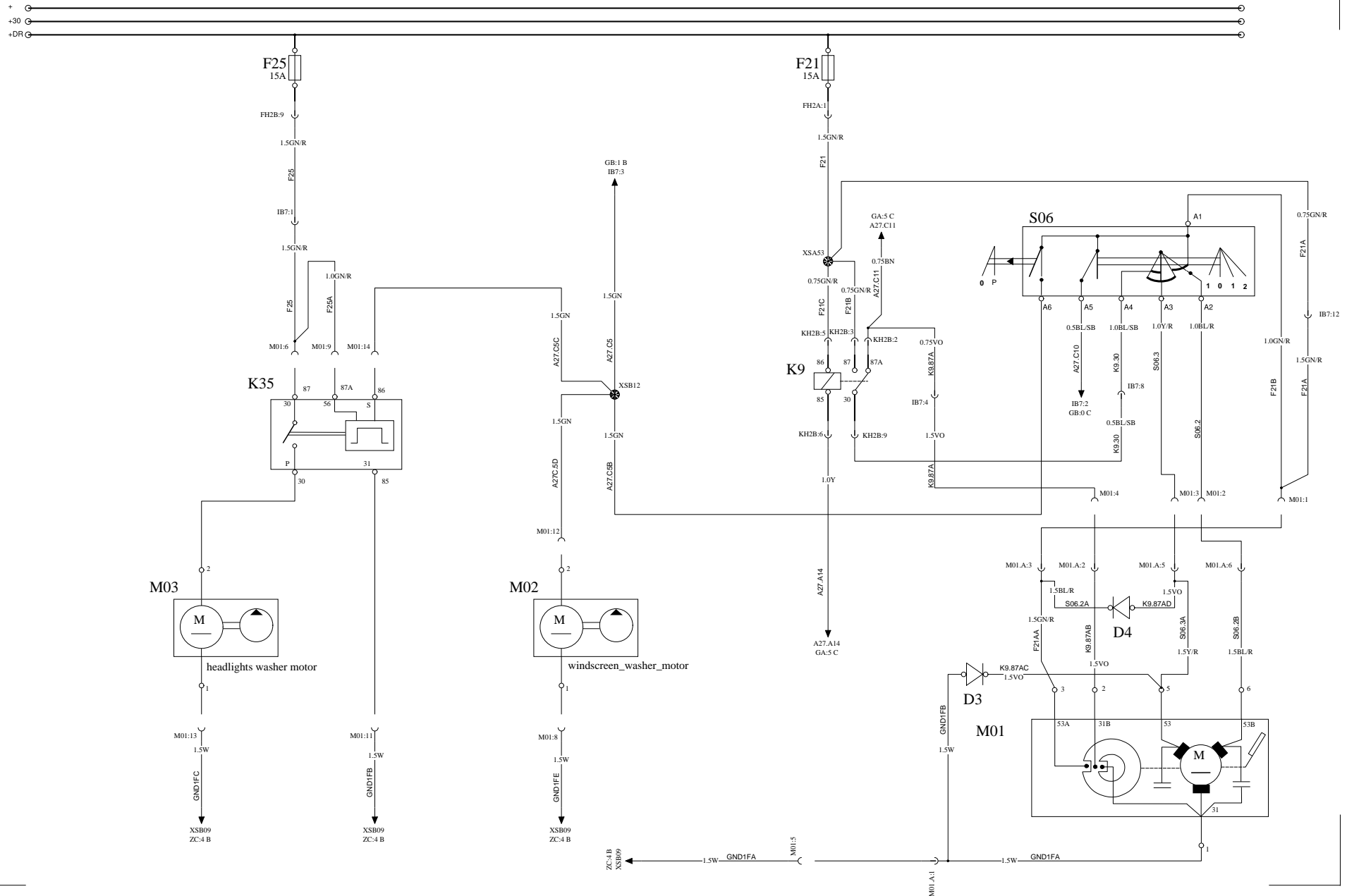

SWM,SRS/HORN

WIRING DIAGRAM IS

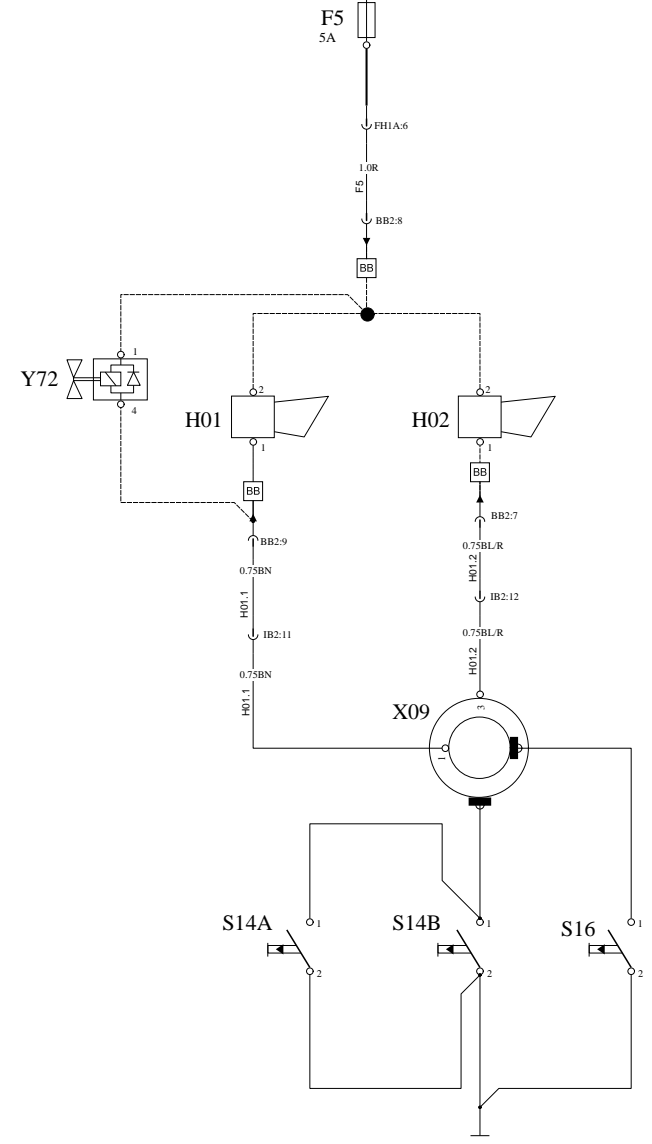
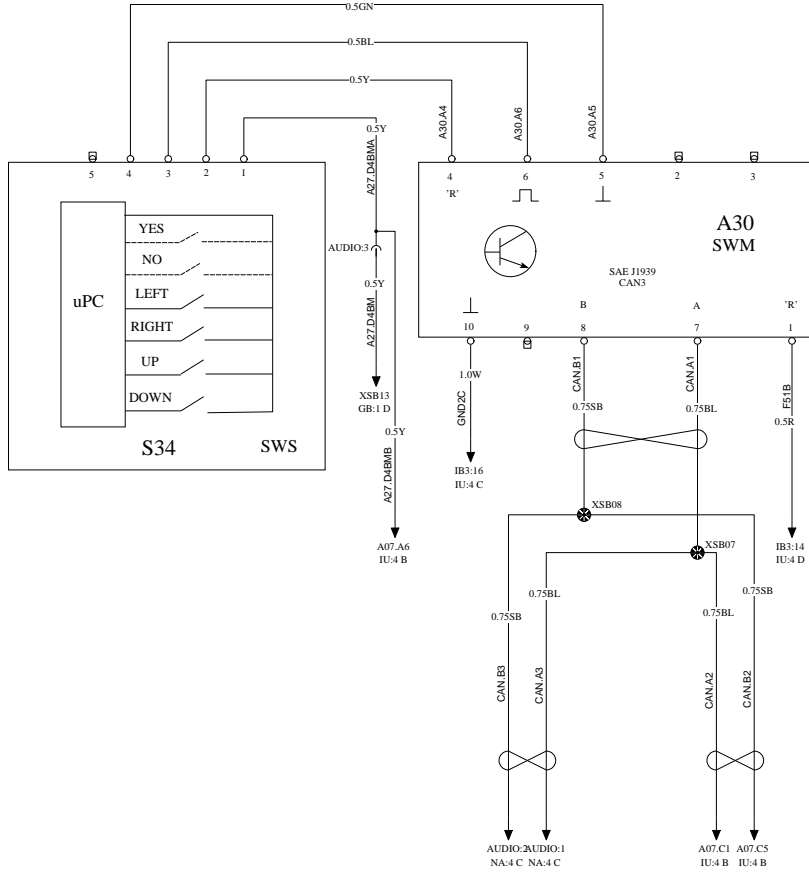
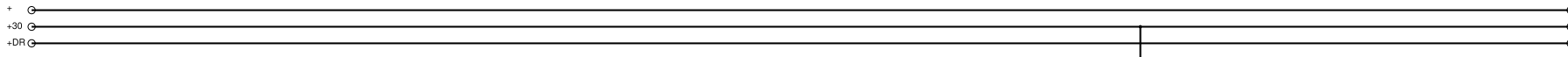

Volvo Bus Corporation

Document title
WIRING DIAGRAM IS
Document type
PRODUCT SCHEMATIC

Document No
20904123

Issue	Volume	Page
02	01(02)	40(48)

AUDIO

WIRING DIAGRAM IU

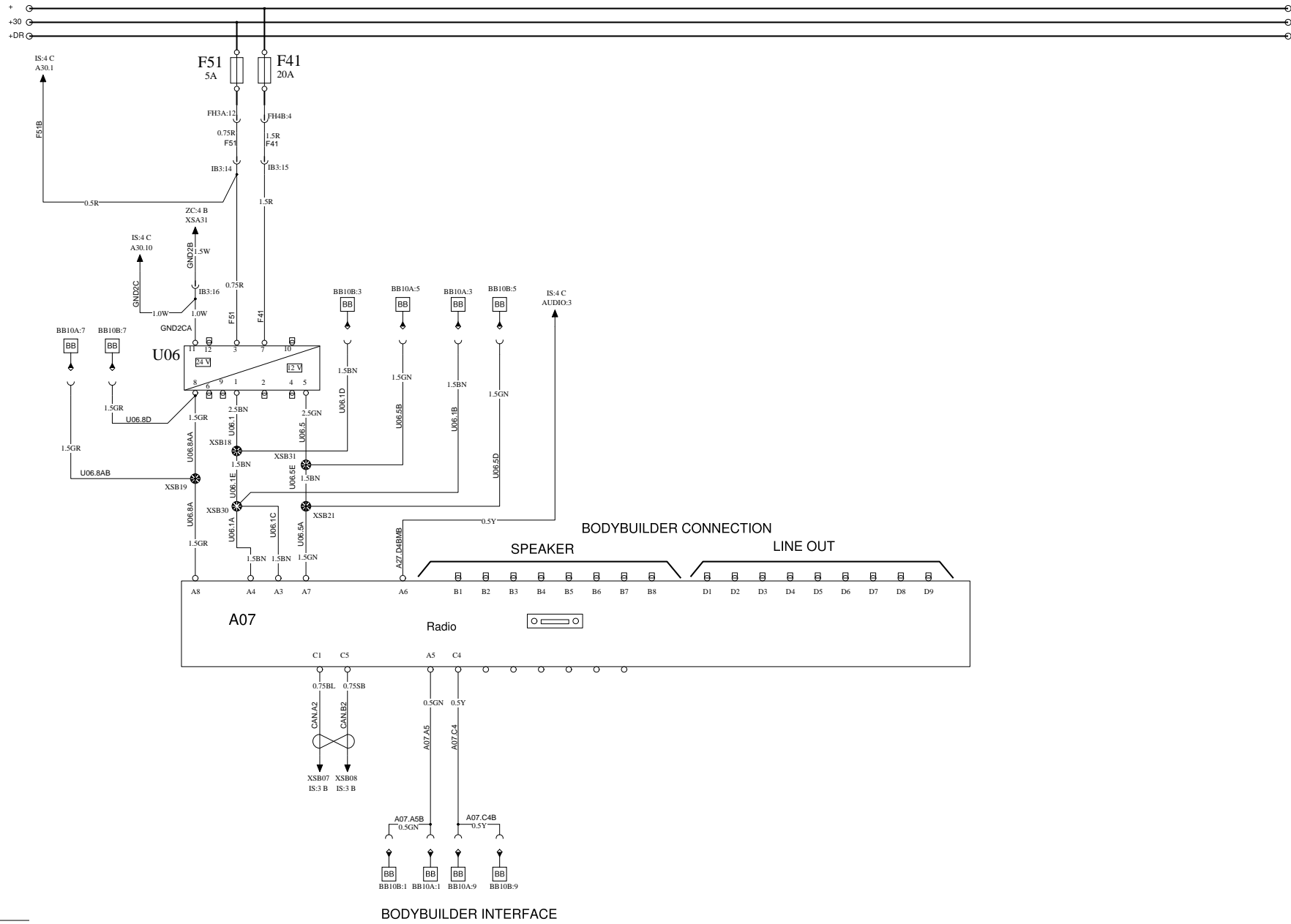

TACHOGRAPH

WIRING DIAGRAM NB

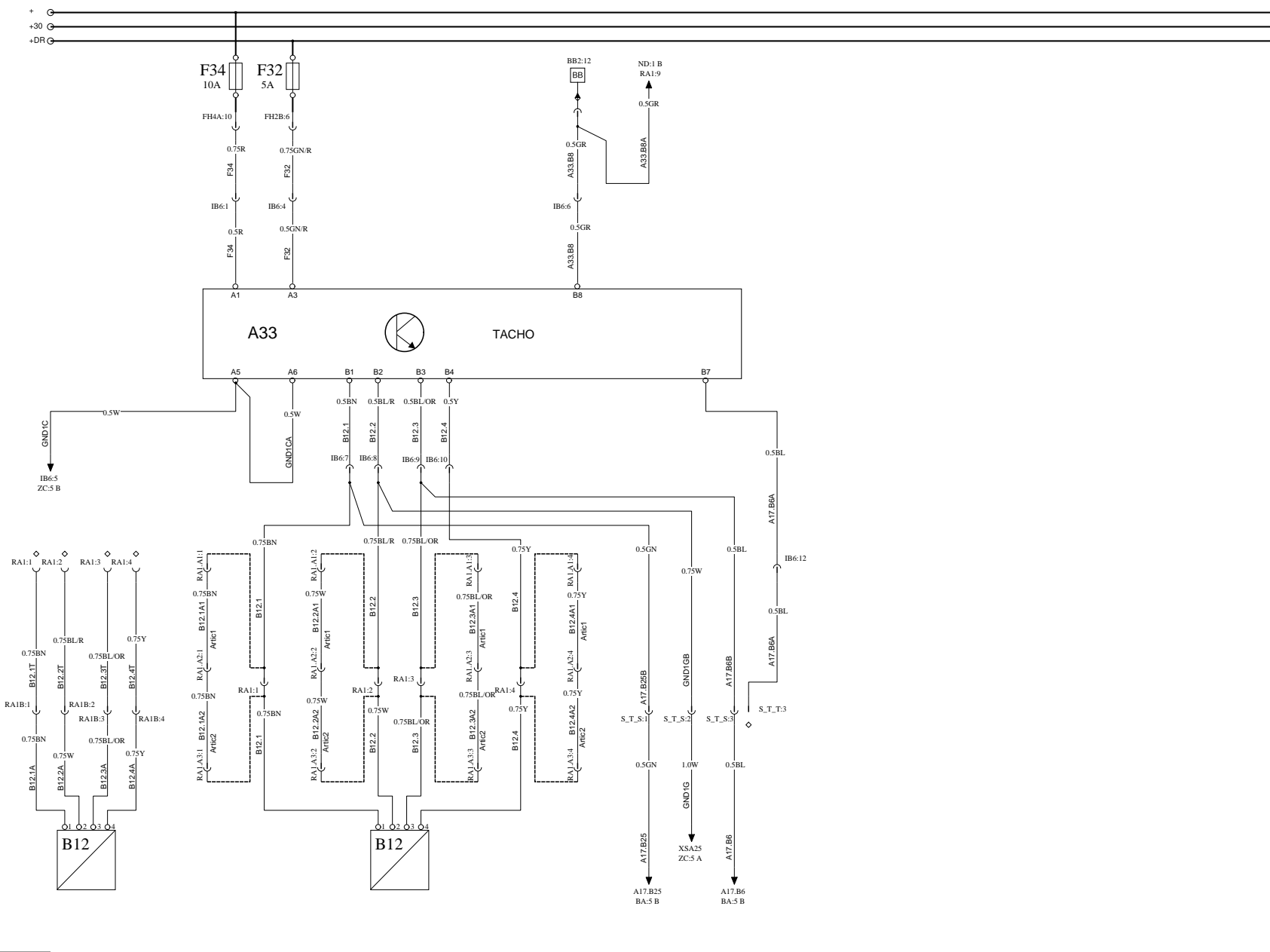

Volvo Bus Corporation

Document title
WIRING DIAGRAM NB
Document type
PRODUCT SCHEMATIC

Document No
20904123

Issue	Volume	Page
02	01(02)	43(48)

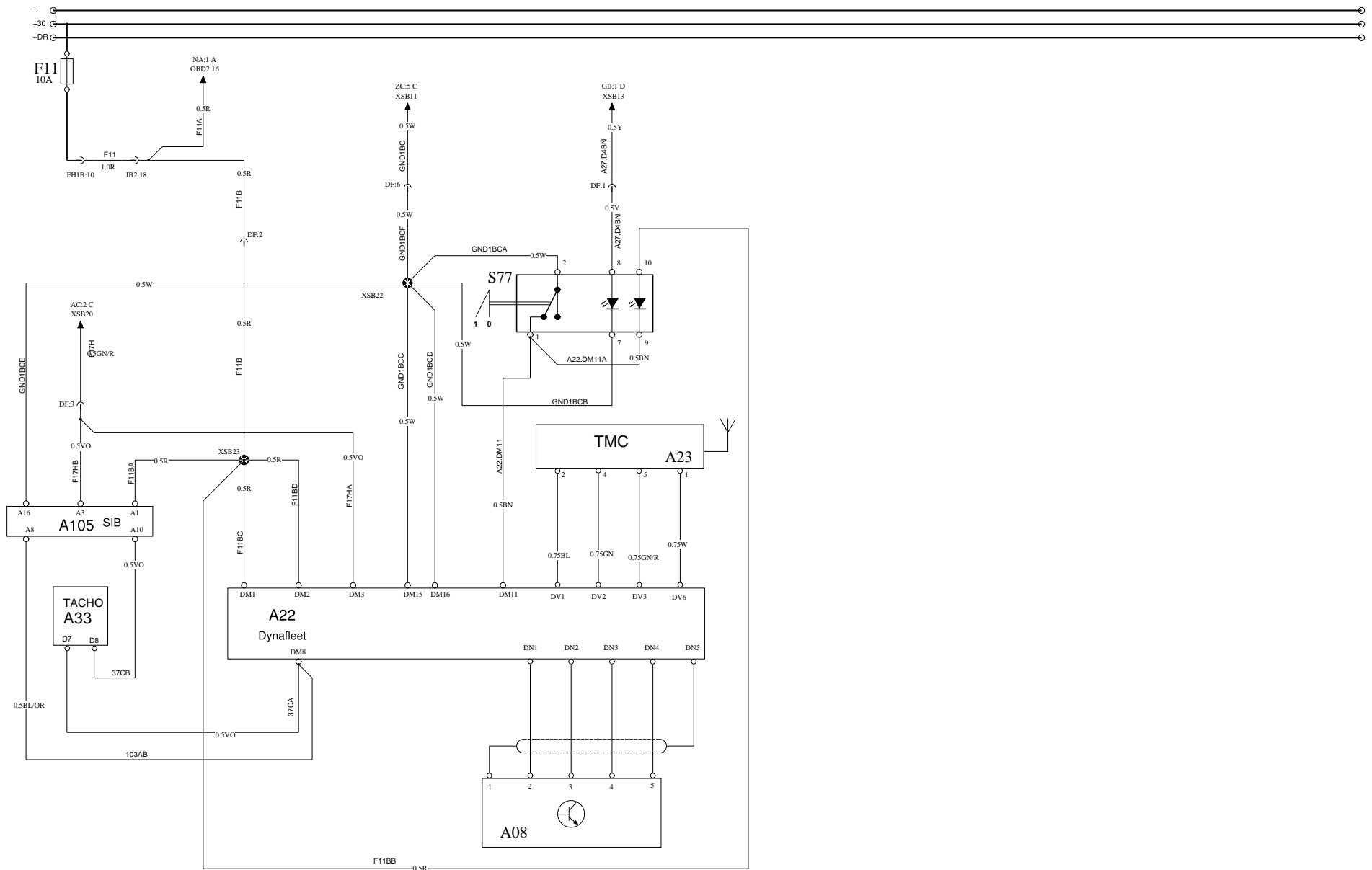

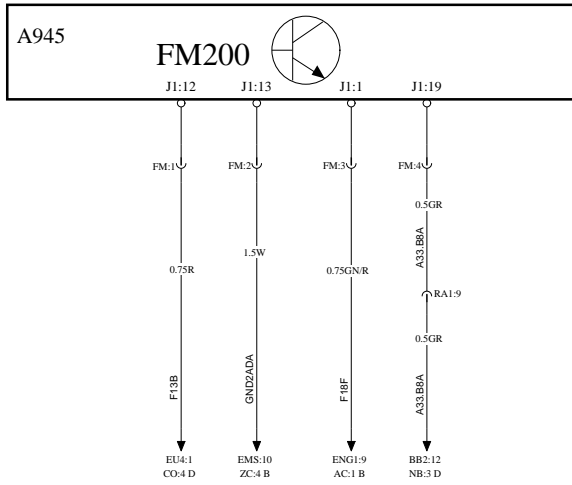

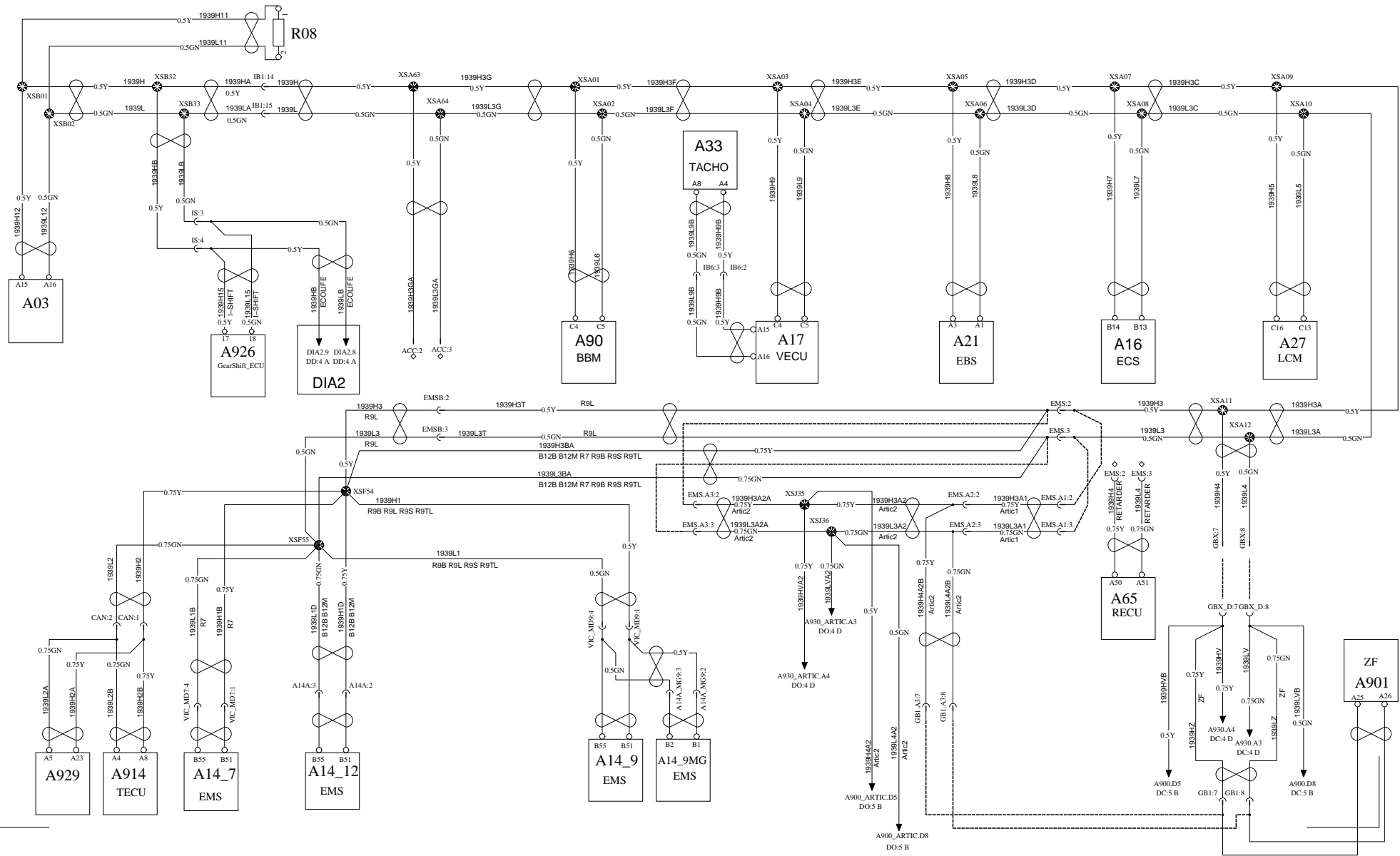

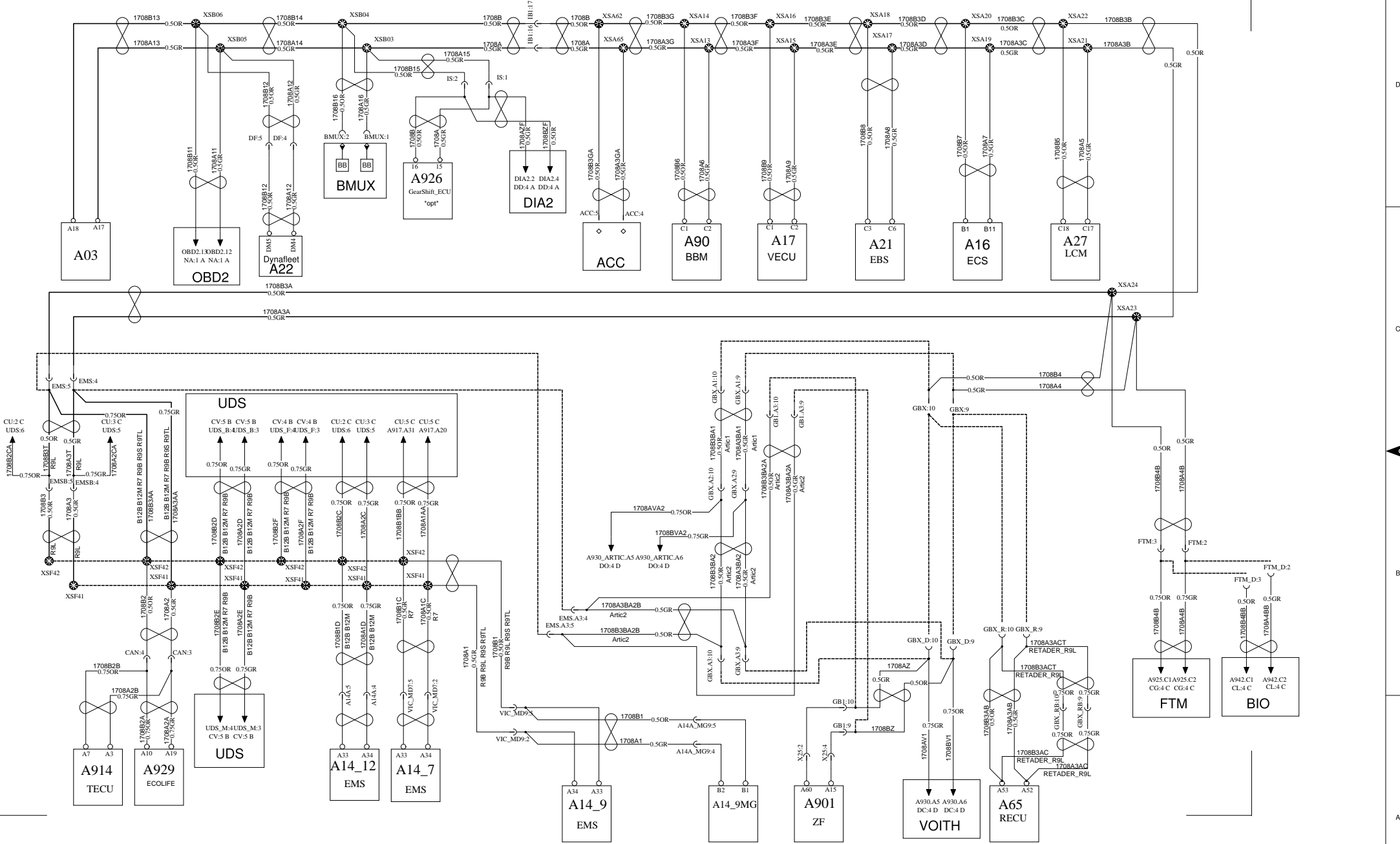

GROUND

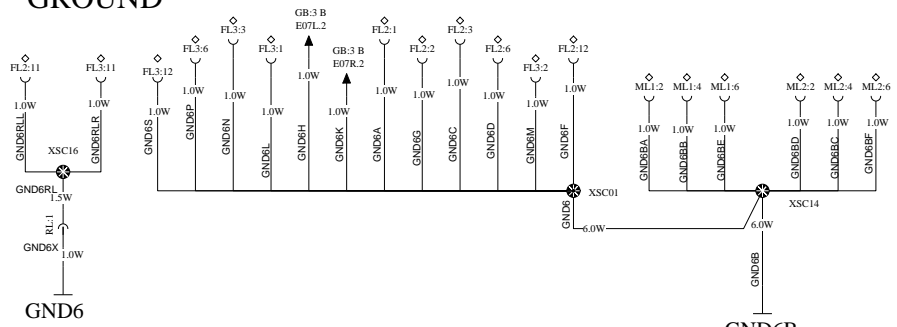

WIRING DIAGRAM ZC

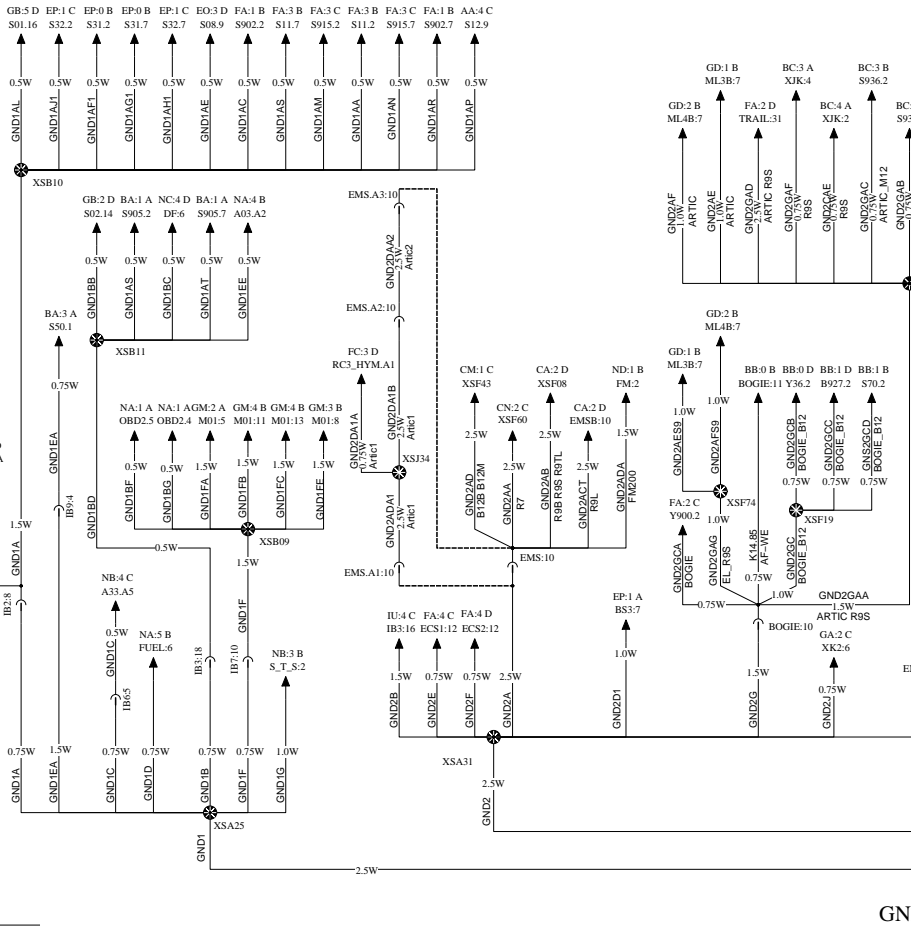
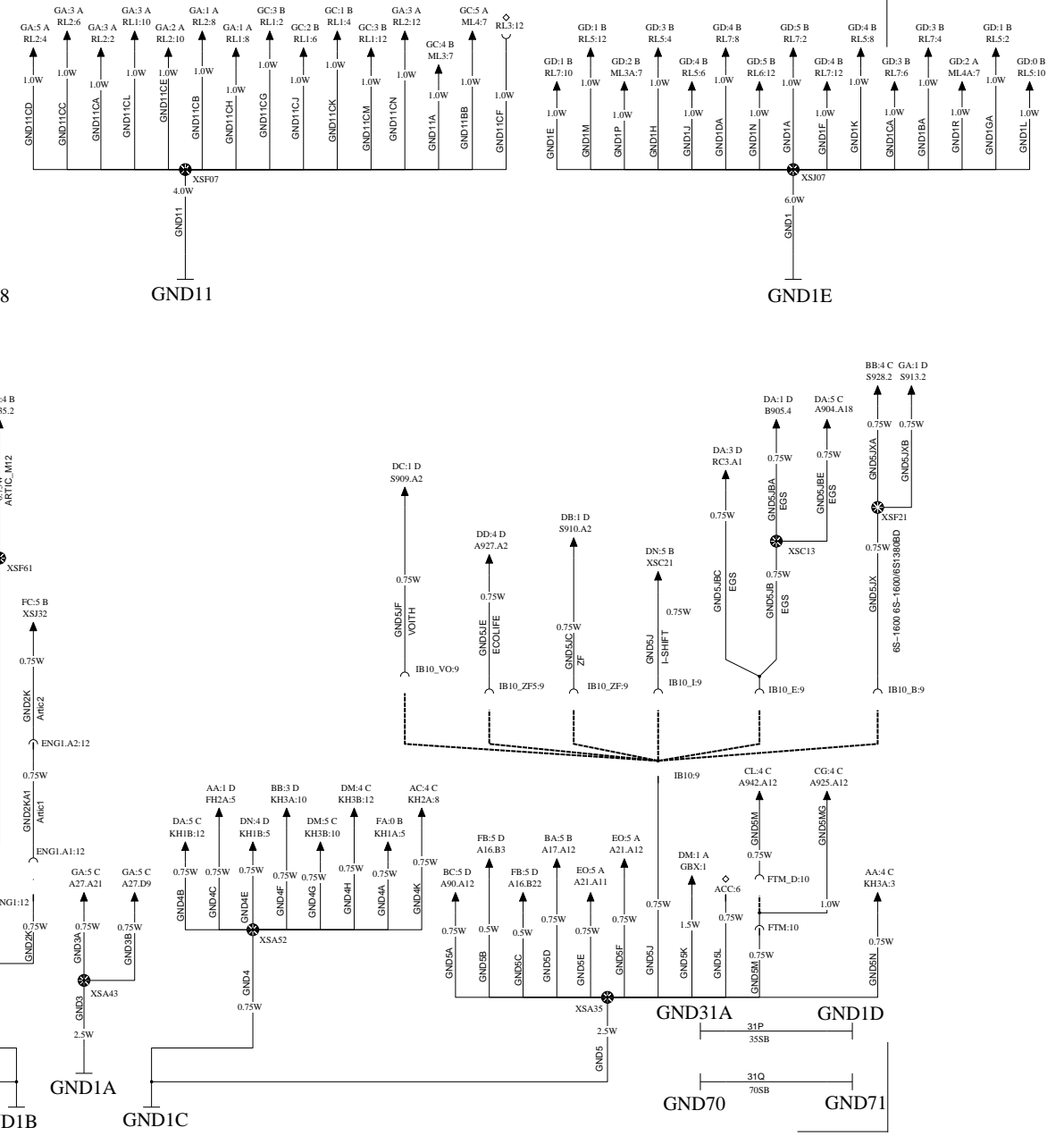

Volvo Bus Corporation

Document title WIRING DIAGRAM ZC	Document No 20904123	Issue 02	Volume 01(02)	Page 48(48)
Document type PRODUCT SCHEMATIC				

More component placement information, see:	2
Symbol explanations	4
Placement of intermediate connector pieces and control units on the chassis	6
Placement of intermediate connector pieces and control units on the chassis B9L articulated	8
1 (driver environment)	11
Electrical distribut.unit, chassis.....	15
Relay.....	18
Fuses.....	20
Intermediate connector pieces	24
Control units	30
Diagnostic connector.....	39
Electrical distribution units	41

More component placement information, see:

Language	Function group	Title
Arabic	300	تانوكمل اعضو
Brazilian/Portuguese	300	Localização do componente
Canadian/French	300	Emplacement des composants
Chinese (simple.)	300	部件位置
Chinese (trad)	300	部件位置
Czech	300	Umístění komponenty
German	300	Platzierung der Bauteile
Danish	300	Komponentplacering
English	300	Component placement
Spanish	300	Colocación del componente
Estonian	300	Komponentide asukoht
Finnish	300	Komponenttien sijoittaminen
French	300	Emplacement des composants
Greece	300	Τοποθέτηση εξαρτήματος
Hungarian	300	Alkatrész-elhelyezés
Indonesian	300	Penggantian komponen

See also, 300, Component placement, Description, Design and function

The reader is advised that printed copies are uncontrolled.

Component Placement





Volvo Bus Corporation

Farsi/Persian	300	هعطق نداد اج
Hebrew	300	מוקמב החנה, ביכר
Italian	300	Posizionamento dei componenti.
Japanese	300	コンポーネント配置
Korean	300	구성부품 배치
Lithuanian	300	Komponento išdėstymas
Latvian	300	Daļu izvietojums
Mexican/Spanish	300	Colocación de componente
Dutch	300	Lokatie van componenten
Norwegian	300	Komponentplassering
Polish	300	Rozmieszczenie komponentów
Portuguese	300	Colocação de componentes
Romanian	300	Plasare componentă
Russian	300	Размещение компонентов
Serbian	300	Raspored komponenti
Slovak	300	Umiestnenie komponentu
Slovenian	300	Zamenjava sestavnih delov
Swedish	300	Komponentplacering
Thai	300	การติดตั้งอุปกรณ์
Turkish	300	Parça deęiřtirme
American/English	300	Component Placement

See also, 300, Component placement, Description, Design and function

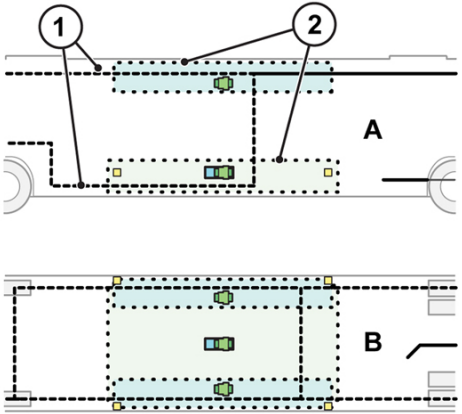



The reader is advised that printed copies are uncontrolled.

Symbol explanations

Symbol	Explanations
	<p>A: View from side</p> <p>B: View from above</p> <p>1: Alternative cable routing</p> <p>2: Area marked with light colour and dashed lines. The area shows where a control unit and /or a connector piece can be located</p>
	<p>Symbol for electrical distribution unit</p>
	<p>Symbol for intermediate connector piece</p>
	<p>Symbol for intermediate connector piece in grey to show that it is placed behind a component (e.g. the engine).</p>

See also, 300, Component placement, Description, Design and function

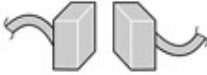
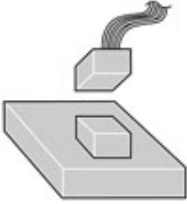
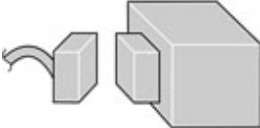
The reader is advised that printed copies are uncontrolled.

	<p>Symbol for control unit</p>
	<p>Symbol for intermediate connector piece in grey to show that it is placed behind a component (e.g. the engine).</p>
	<p>Symbol for intermediate connector piece that is shown where another illustration is missing.</p>
	<p>Symbol for control unit that is shown where another illustration is missing.</p>
	<p>Symbol for sensor/actuator that is shown where another illustration is missing.</p>
	<p>Symbol for branching point</p>
	<p>Symbol for branching point in grey to show that it is placed behind a component (e.g. the electrical distribution unit).</p>

Placement of intermediate connector pieces and control units on the chassis

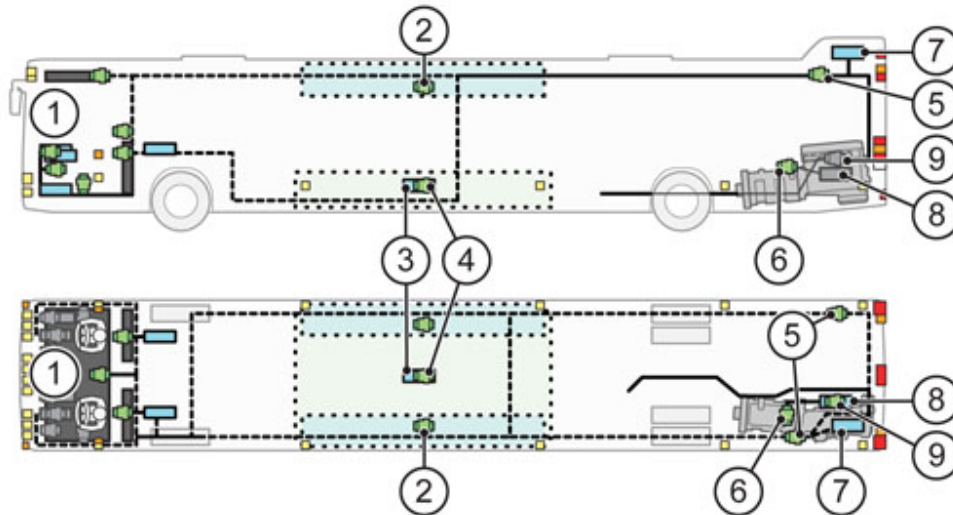

The illustration shows in principle how the chassis cabling is routed and where the intermediate connector pieces, control units and electrical distribution units are located. If the vehicle is not built by a Volvo body builder, then the cabling to the lamps is probably routed in another way than shown in the illustration. The dashed lines show alternative cable routings.

[Symbol explanations](#)

Note: For naming of components, see wiring diagram.

Placement	Components named according to wiring diagram
1 (driver environment)	A27 (LCM), A21 (EBS), A16 (ECS), A90 (BBM), A17 (VECU), A943 (BIO), A946 (FMS), A65 (RECU), A125 (Dynafleet), K1-K17, K25-K28, F1-F64, FH5 (F96, F97, F98, F99), U06, IB10_B, IB10_E, BB5.A, BB10B, BB11, XC925, ACC, BBOX, XC921, XC917, XC927, EMS, ENG1, ARTIC, BOGIE, RA1, ECS2, BS3, FUEL, EU4, ECS1, BS1, BS2, FH1A – FH4A, FH1B – FH4B, KH1A - KH3A, KH1B - KH3B, S_TS, S_T_T, XC922, BB13, FTM, XC926, XC930, BB8, BB11, XK2, XK1, IS, GB1, IB1 – IB5, BB7, BB6, GBX, GS1, ARTIC, BOGIE, IB6 – IB10, BB1 – BB5, A03 (BIC), A07 (Radio), A33 (TACHO), OBD2, BMUX, A30 (SWM), X25, AUDIO, DF, BB10A, A926 (GSECU), A900 (Voith TECU), A901 (ZF ECOMAT TECU), A65 (RECU)

See also, **300, Component placement, Description, Design and function**

The reader is advised that printed copies are uncontrolled.

Component Placement**Volvo Bus Corporation**

2	UDS
3	A917 (DECU)
4	R905A, R906A, R907A, R908, R909A, R910A
5	BB7B, BS3B
	BB6B, ECS2B
	EMSB
	ENG1B
	RA1B
	EU4B
	B930T
6	VIC2
7	A918 (NOx)
8	A14 (EECU)
9	VIC/EI
Left side rear (Volvo body)	RL2, RL5, RL8
Right side rear (Volvo body)	RL1, RL7, RL10
Rear, often located towards the centre (Volvo body)	RL3

See also, 300, Component placement, Description, Design and function

7

The reader is advised that printed copies are uncontrolled.

Placement of intermediate connector pieces and control units on the chassis B9L articulated

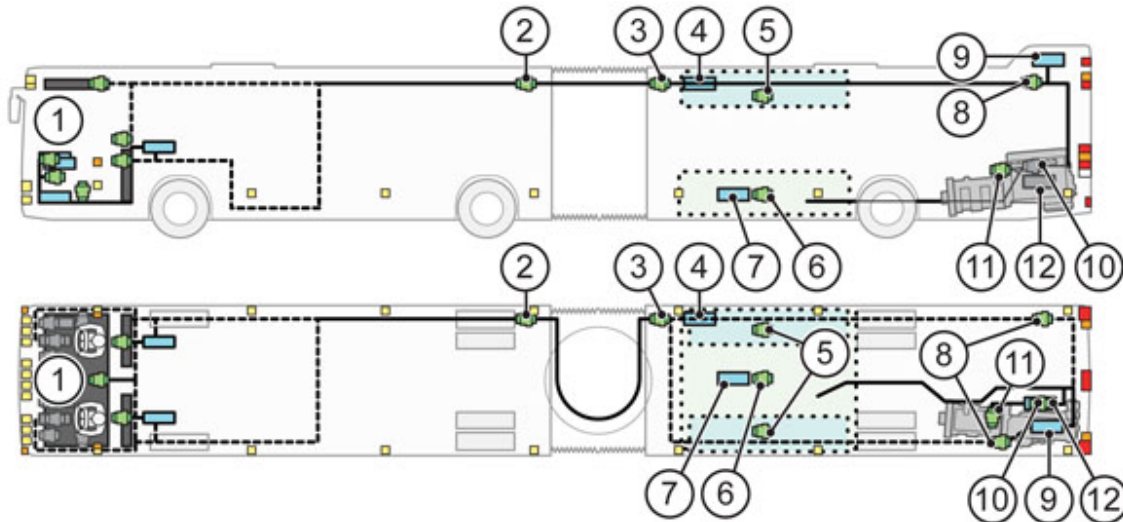

The illustration shows in principle how the chassis cabling is routed and where the intermediate connector pieces, control units and electrical distribution units are located. If the vehicle is not built by a Volvo body builder, then the cabling to the lamps is probably routed in another way than shown in the illustration. The dashed lines show alternative cable routings.

[Symbol explanations](#)

Note: For naming of components, see wiring diagram.

Placement	Components named according to wiring diagram
1 (driver environment)	A27 (LCM), A21 (EBS), A16 (ECS), A90 (BBM), A17 (VECU), A943 (BIO), A946 (FMS), A65 (RECU), A125 (Dynafleet), K1-K17, K25-K28, F1-F64, FH5 (F96, F97, F98, F99), U06, IB10_B, IB10_E, BB5.A, BB10B, BB11, XC925, ACC, BBOX, XC921, XC917, XC927, EMS, ENG1, ARTIC, BOGIE, RA1, ECS2, BS3, FUEL, EU4, ECS1, BS1, BS2, FH1A – FH4A, FH1B – FH4B, KH1A - KH3A, KH1B - KH3B, S_TS, S_T_T, XC922, BB13, FTM, XC926, XC930, BB8, BB11, XK2, XK1, IS, GB1, IB1 – IB5, BB7, BB6, GBX, GS1, ARTIC, BOGIE, IB6 – IB10, BB1 – BB5, A03 (BIC), A07 (Radio), A33 (TACHO), OBD2, BMUX, A30 (SWM), X25, AUDIO, DF, BB10A, A926 (GSECU), A900 (Voith TECU), A901 (ZF ECOMAT TECU), A65 (RECU)

See also, 300, Component placement, Description, Design and function

The reader is advised that printed copies are uncontrolled.

2	BB7.A2, BS3.A2, FUEL.A2
	BB6.A2, ECS2.A2, EU4.A2
	GBX.A2
	EMS.A2, BOGIE.A2
	ENG1.A2, ARTIC.A2
	RA1.A2
	GS1.A2
3	BB7.A3, BS3.A3, FUEL.A3
	BB6.A3, ECS2.A3, EU4.A3
	GBX.A3
	EMS.A3
	ENG1.A3
	RA1.A3
	GS1.A3
4	A916
	A900
	A901
5	UDS

See also, 300, Component placement, Description, Design and function

The reader is advised that printed copies are uncontrolled.

Component Placement**Volvo Bus Corporation**

6	R905A, R906A, R907A, R908, R909A, R910A
7	A917 (DECU)
8	BB7B, BS3B
	BB6B, ECS2B, EU4B
	GBXB
	EMSB
	ENG1B
	RA1B
9	A918
10	VIC/EI
11	VIC2
12	A14 (EECU)
Left side rear (Volvo body)	RL2, RL5, RL8
Right side rear (Volvo body)	RL1, RL7, RL10
Rear, often located towards the centre (Volvo body)	RL3

See also, 300, Component placement, Description, Design and function

10

The reader is advised that printed copies are uncontrolled.

1 (driver environment)

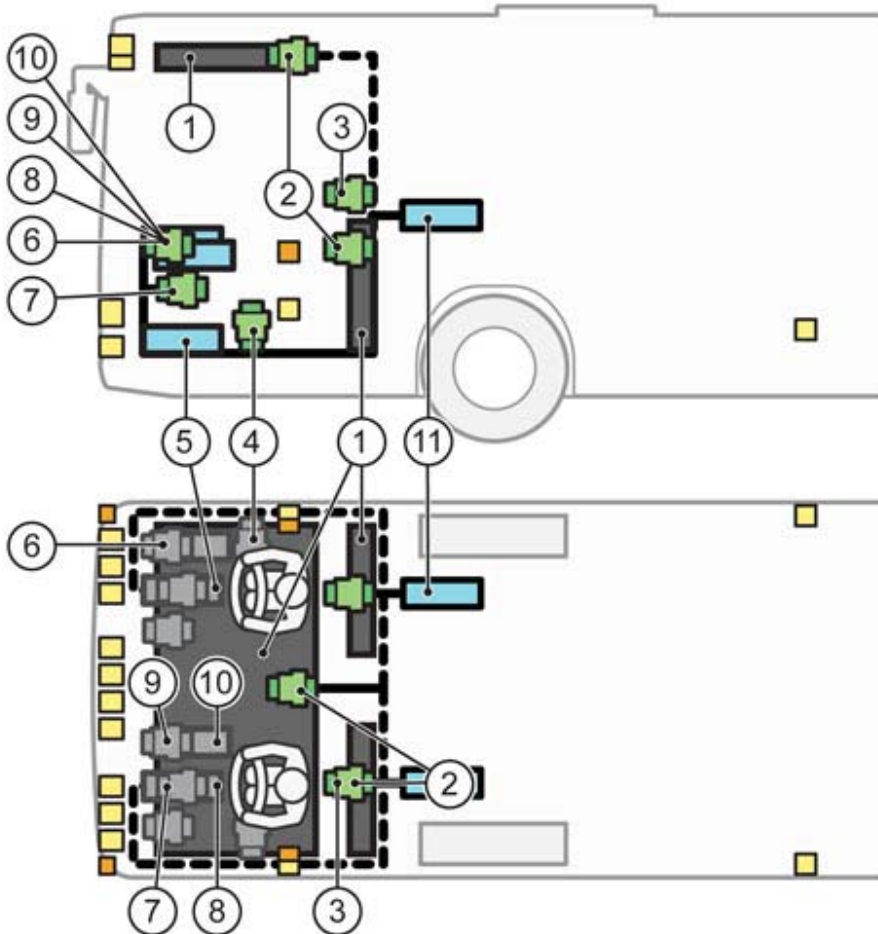

The illustration shows in principle how the chassis cabling is routed and where the intermediate connector pieces, control units and electrical distribution units are located. The dashed lines show alternative cable routings. The illustration is used for both right-hand drive and left-hand drive vehicles, where of certain components are drawn in two places.

Note: The table includes components that the vehicle is not equipped with.

Placement	Components named according to wiring diagram
1	A16 (ECS)
	A17 (VECU)

See also, 300, Component placement, Description, Design and function

The reader is advised that printed copies are uncontrolled.

	A21 (EBS)
	A27 (LCM)
	A65 (RECU)
	A90 (BBM)
	A125 (Dynafleet)
	A943 (BIO)
	A946 (FMS)
	K1– K17, K25 – K28
	F1 – F64, F96 – F99, F90A, F90B
	FH1A, FH1B
	FH2A, FH2B
	FH3A, FH3B, FH4A, FH4B
	U06
	S_T_S, S_T_T
2	ACC, BB10B, XC937, DEV-CAN
	ARTIC, BB1, BS1, ENG1, IB10
	BB2, BOGIE, BS2, IB9, EMS
	BB3, ECS1, IB8, RA1

See also, 300, Component placement, Description, Design and function

The reader is advised that printed copies are uncontrolled.

	BB4, BB6, BB6A, BB6B, ECS2, EU4, IB7
	BB5, BB5A, BB5B, BS3, FUEL, IB6, BB7
	IB1
	IB2
	GBX, IB3
	IB4
	IB5
	BB11, BBOX
	BB13
	FTM, KH2A, KH2B, GS1, XC933
	GB1
	IS, XC925, SP_F, SP_RR
	KH1A, KH1B, KH3A, KH3B
	RL4 (B6R/B7R, B9R, B12M, B12B)
	XC917, XC921, XC935, XK2
3	X25
4	BMUX
5	A30 (SWM)

Component Placement**Volvo Bus Corporation**

6	DF
7	OBD2
8	A03 (BIC)
	A07 (Radio)
	A33 (TACHO)
9	AUDIO, BB10A
	BB10A
10	A926 (GSECU)
11	A900 (Voith TECU)
	A901 (ZF ECOMAT TECU)
Left front	FL2
	FL2A
Right front	FL3
	FL3A

See also, 300, Component placement, Description, Design and function

14

The reader is advised that printed copies are uncontrolled.

Electrical distribut.unit, chassis

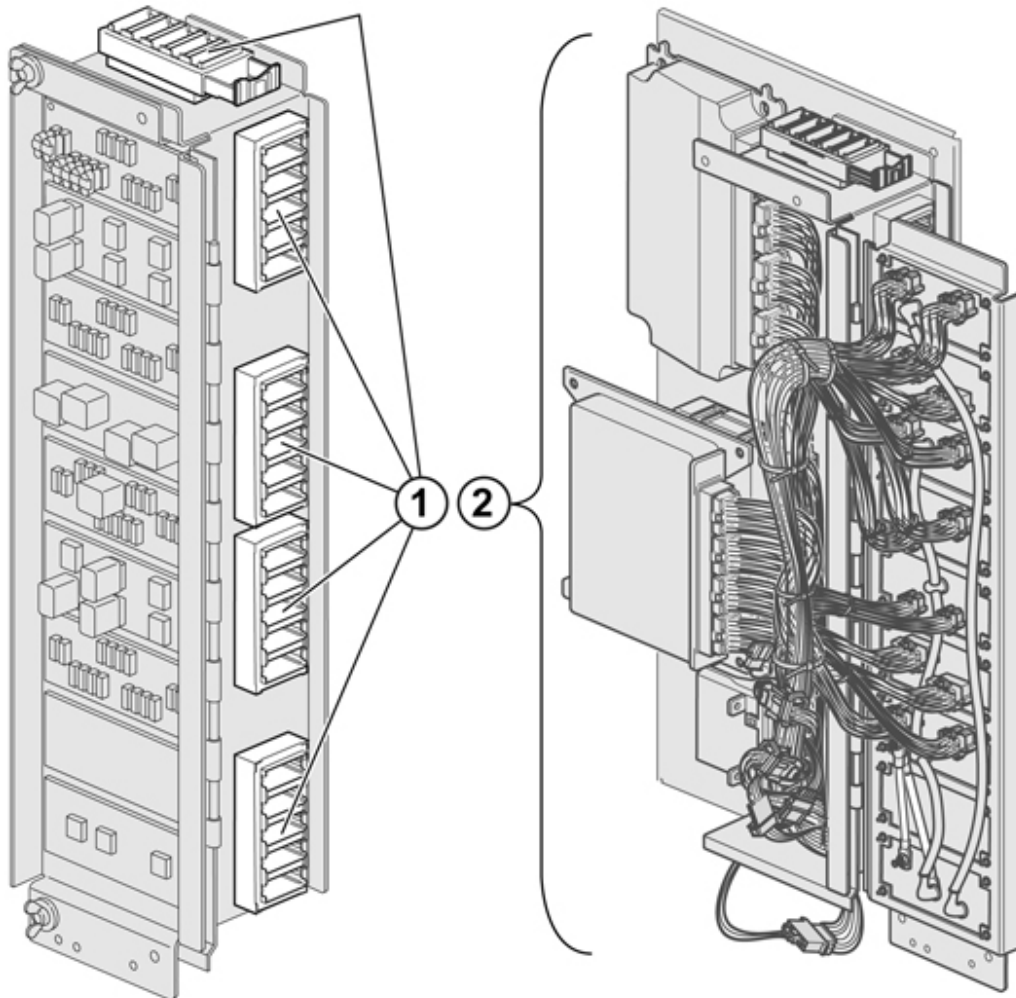

Note: The table includes components that the vehicle is not equipped with.

Placement	Components named according to wiring diagram
1	ARTIC, BB1, BS1, ENG1, IB10
	BB2, BOGIE, BS2, IB9, EMS
	BB3, ECS1, IB8, RA1

See also, 300, Component placement, Description, Design and function

The reader is advised that printed copies are uncontrolled.

	BB4, BB6, BB6A, BB6B, ECS2, EU4, IB7
	BB5, BB5A, BB5B, BS3, FUEL, IB6, BB7
	IB1
	IB2
	GBX, IB3
	IB4
	IB5
2	A16 (ECS)
	A17 (VECU)
	A21 (EBS)
	A27 (LCM)
	A65 (RECU)
	A90 (BBM)
	A125 (Dynafleet)
	A943 (BIO)
	A946 (FMS)
	K1– K17, K25 – K28
	F1 – F64, F96 – F99, F90A, F90B

See also, 300, Component placement, Description, Design and function

The reader is advised that printed copies are uncontrolled.

FH1A, FH1B
FH2A, FH2B
FH3A, FH3B, FH4A, FH4B
U06
BB11, BBOX
BB13
FTM, KH2A, KH2B, GS1, XC933
GB1
IS, XC925, SP_F, SP_RR
KH1A, KH1B, KH3A, KH3B
RL4 (B6R/B7R, B9R, B12M, B12B)
XC917, XC921, XC935, XK2
ACC, BB10B, XC937
S_T_S, S_T_T

Relay

The placement of the relays in the electrical distribution unit is described below.

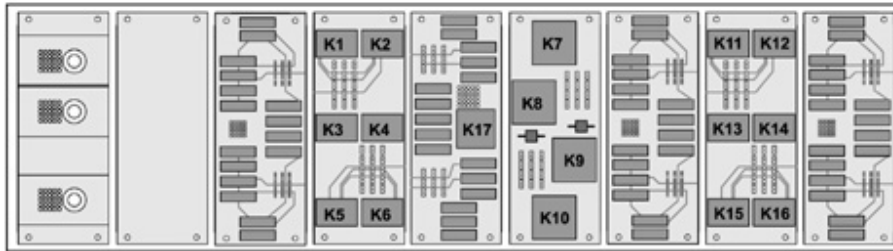

Relay	Designation
K1	—
K2	Overload indicator (option)
K3	ECS (air suspension control unit)
K4 ₁	TECU (gearbox control unit), GECU (gear selector control unit), gearbox I-Shift
K5 ₁	EGS manual gearbox
K6 ₁	EGS manual gearbox
K7	Starter motor
K8 ₁	VECU (vehicle control unit), EECU (motor control unit)
K9	Wiper motor intermittent relay
K10	Inverting relay, neutral signal (only automatic gearboxes)
K11	Start inhibit relay
K12	Stowage compartment lighting
K13	Emergency cut-out
K14 ₁	Bogie axle

See also, 300, Component placement, Description, Design and function

The reader is advised that printed copies are uncontrolled.

K15 ¹	RECU (retarder control unit)
K16 ¹	RECU (retarder control unit)
K17	Ignition relay (+15)

¹ Dependent on variant

Fuses

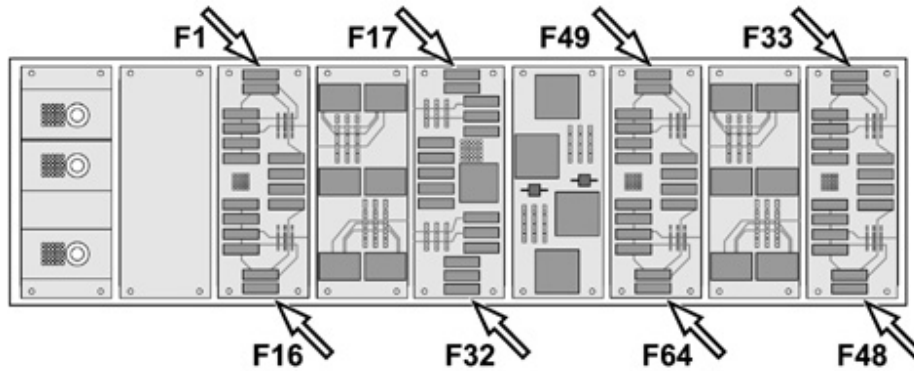

Fuse	Rating	Designation
F1	5 A	ECS (air suspension control unit)
F2	10 A	BIC (instrument panel), lamp check switch
F3	15 A	Starting signal, starter motor
F4	20 A	EBS (brake control unit)
F5	5 A	Horn
F6	5 A	Emergency parking brake release
F7 ₁	15 A	TECU (transmission electronic control unit), gearbox I-shift
F8 ₁	5 A	GECU (gear selection control unit) I-shift
F9	5 A	Start switch, engine compartment
F10	5 A	Fire Alarm
F11 ₁	10 A	Dynafleet (option)
F12	5 A	Supply, main switch (+30) to body-builder outlet
F13	10 A	Automatic oil filling (option)
F14	5 A	BBM (Body Builder Module)
F15	15 A	EECU (Engine Electronic Control Unit), control valve, cooling fan
F16	5 A	VECU (Vehicle Electronic Control Unit)

See also, 300, Component placement, Description, Design and function

The reader is advised that printed copies are uncontrolled.

Fuse	Rating	Designation
F17	5 A	Lighting, level control switch
F18	5 A	Alternator 1, 2, 3
F19 ¹	10 A	Control unit, turntable
F20	10 A	EBS (brake control unit)
F21	15 A	Wiper motor, windscreen
F22 ¹	5 A	TECU (Transmission Electronic Control Unit), Voith automatic transmission
F24	5 A	BIC (instrument)
F25	15 A	Wiper motor, headlights
F26	5 A	ECS (air suspension control unit)
F27 ¹	10 A	EGS manual gearbox
F28 ¹	10 A	RECU (Retarder Electronic Control Unit)
F29	5 A	Supply, ignition (+15) to body-builder outlet
F30 ¹	5 A	Fuel heater (D7E engine)
F31 ¹	10 A	Hydraulic oil level, SCR (control unit exhaust cleaning)
F32 ¹	5 A	Tachograph
F33	5 A	BIC (instrument)
F34 ¹	10 A	Tachograph
F35	25 A	LCM (external lighting control unit)
F36	25 A	LCM (external lighting control unit)
F37	25 A	LCM (external lighting control unit)
F38	5 A	Inverted +15
F39	25 A	SCR (control unit exhaust cleaning)

See also, 300, Component placement, Description, Design and function

The reader is advised that printed copies are uncontrolled.

Fuse	Rating	Designation
F41	20 A	Radio
F42	5 A	Main switch
F44	25 A	LCM (external lighting control unit)
F45	25 A	LCM (external lighting control unit)
F46	25 A	LCM (external lighting control unit)
F47	5 A	Side position light, right
F48	5 A	Side position light, left
F49	5 A	Fuel shut-off valve
F50 ¹	10 A	RECU (Retarder Electronic Control Unit)
F51	5 A	Radio
F52 ¹	10 A	Stowage compartment lighting
F53 ¹	5 A	Trailing axle, water separator heater
F54 ¹	5 A	Engine/luggage compartment door
F55 ¹	10 A	Engine brake, cooling fan solenoid valve, pre-heater relay
F56 ¹	10 A	Engine brake
F57	5 A	Supply, ignition lock
F58 ¹	5 A	Control unit, tank valves (only gas buses)
F60 ¹	10 A	TECU (Transmission Electronic Control Unit), Voith automatic transmission
F61 ¹	10 A	Stowage compartment lighting
F62 ¹	5 A	Sleeping bunk lighting
F63	5 A	Starter motor
F64 ¹	10 A	Indicates overload

See also, 300, Component placement, Description, Design and function

The reader is advised that printed copies are uncontrolled.

¹ Dependent on variant.

Note: The table includes components that the vehicle is not equipped with. When there is no illustration for a component, a symbol illustration is shown. More adapters than those stated can fit the connector pieces.

Intermediate connector pieces

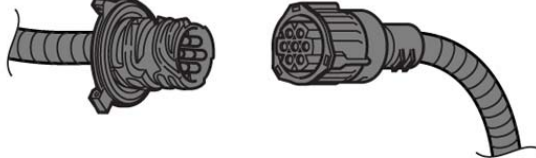
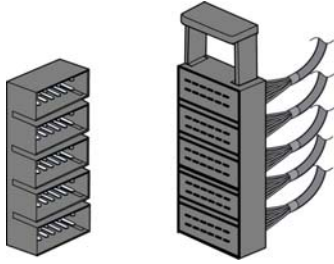
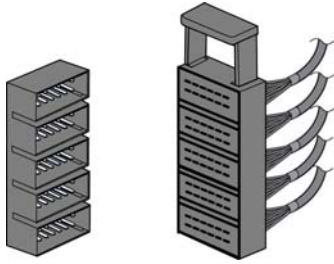
Wiring diagram designation, component/connector piece	Illustration	Adapter	Index in breakout box
A14_, A14A, FL2, FL3, LT1, MEDA, RL1, RL2, RL3, RL5, RL6, RL7, TRAIL2, UDS, XC914A		9998563	1 – 12
A14B, A14C, A14D, A43, BMUX, CAN, FL2A, FL3A, LA, ML1, ML2, ML3, ML3B, ML4, ML4A, ML4B, ML5, ML6, ML7, RL1A, RL2A, RL4, TRAIL3, VIC2, XC915, XC916, XC931, Y17		88890053	1– 7
ARTIC, BB1, BS1, IB10		9990805 or 88890116	1 – 12
ENG1, ENG1B		9990008 , 9990805 or 88890116	– or 1 – 12
BB2, BOGIE, BS2, IB9		9990805 or 88890116	13 – 24 or 19 – 30 (88890116)
EMS, EMSB		9990008 , 9990805 or 88890116	– or 19 – 30 (88890116)

See also, 300, Component placement, Description, Design and function

The reader is advised that printed copies are uncontrolled.

Component Placement

Volvo Bus Corporation

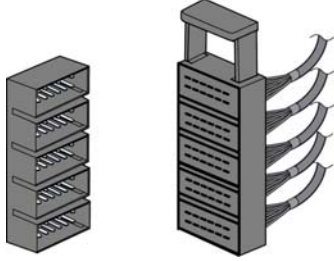
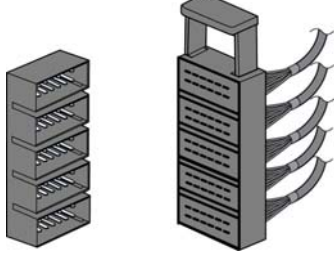
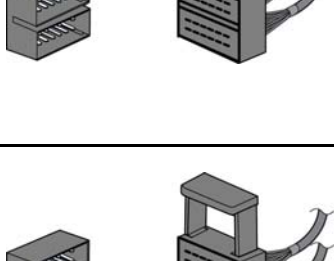
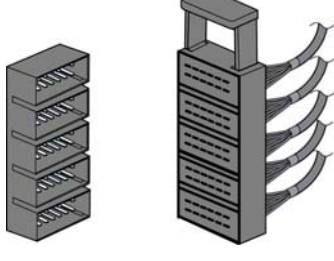
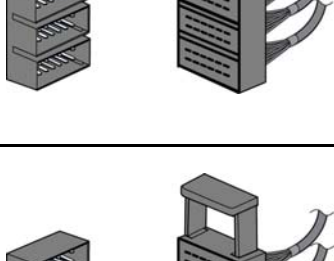
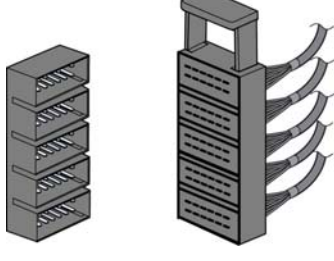
BB3, ECS1, IB8, RA1, RA1B		9990805 or 88890116	25 – 36 or 37 – 48 (88890116)
BB4, ECS2, ECS2B, EU4, IB7		9990805 or 88890116	37 – 48 or 55 – 62 plus 1 – 10 (88890116)
BB6, BB6A, BB6B		9990008 , 9990805 or 88890116	– or 55 – 62 plus 1 – 4 (88890116)
BB5, BB5.A, BB5.B, BS3, BS3B, FUEL, IB6		9990805 or 88890116	49 – 60
BB7, BB7A, BB7B		9990008 , 9990805 or 88890116	– or 11 – 22 (88890116)
IB1		9990008 or 88890116	– or 11 – 28 (88890116)

See also, 300, Component placement, Description, Design and function

The reader is advised that printed copies are uncontrolled.

Component Placement

Volvo Bus Corporation

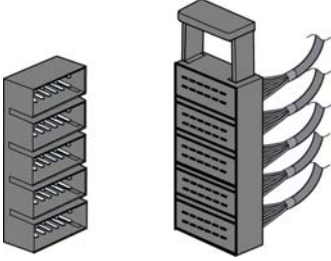
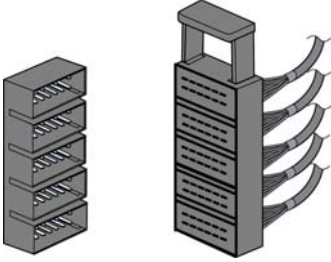
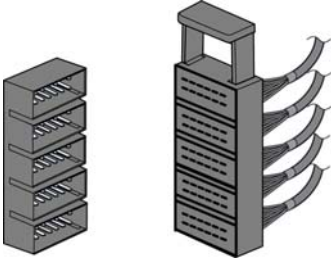
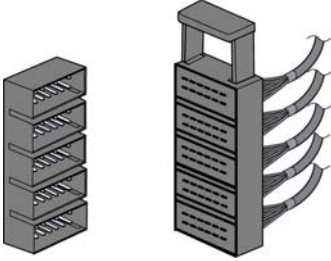
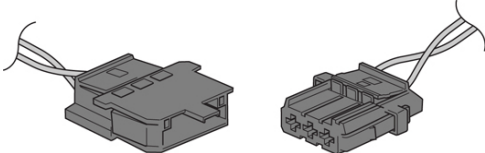



<p>IB2</p>		<p>9990008 or 88890116</p>	<p>— or 55 – 62, 1–10 (88890116)</p>
<p>GBX, IB3</p>		<p>9990008 or 88890116</p>	<p>— or 37 – 54 (88890116)</p>
<p>IB4</p>		<p>9990008 or 88890116</p>	<p>— or 19 – 36 (88890116)</p>
<p>IB5</p>		<p>9990008 or 88890116</p>	<p>— or 1 – 18 (88890116)</p>
<p>AUDIO, BB11, BB8, BBOX, RL, XC927, BBOX, S_T_S, S_T_T, XC922</p>		<p>9990008</p>	<p>—</p>

See also, 300, Component placement, Description, Design and function

The reader is advised that printed copies are uncontrolled.

Component Placement

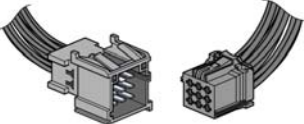
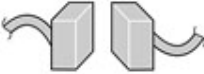
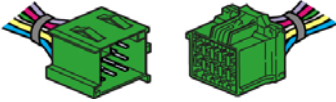
Volvo Bus Corporation





<p>B_A, B930T, IS, LT2, R905A, R905B, R906A, R906B, R906C, R908A, R908B, R908C, R910A, R910B, R910C, S901_U1, S908, SP_F, SP_RR, UDS, XC925, XC932A, XC934, XJK</p>		<p>88890039</p>	<p>1 – 4</p>
<p>KH1A, KH1B, KH3A, KH3B</p>		<p>9998596</p>	<p>18 – 32</p>
<p>ACC, BB10A, BB10B, DEV-CAN, FH2A, FH2B, XC937</p>		<p>9998596</p>	<p>33 – 41</p>
<p>XC917, XC921, XC935, XK2</p>		<p>9998596</p>	<p>42 – 47</p>
<p>CNG, DF, EU4B, FH1A, FH3A, FH3B, FH4A, FH4B, FTM, GS1, KH2A, KH2B, XC926, XC930, XC933</p>		<p>9998596</p>	<p>49 – 60</p>
<p>FM</p>			
<p>LT_, TRAIL, TRAIL1</p>		<p>9990090</p>	<p>1 – 31</p>

See also, 300, Component placement, Description, Design and function

The reader is advised that printed copies are uncontrolled.

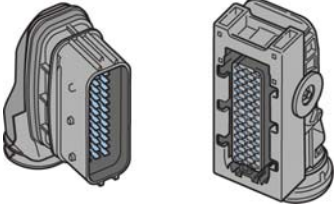
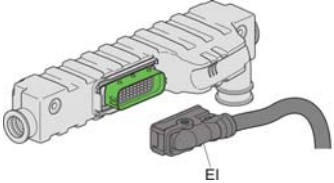
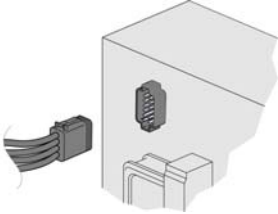
Component Placement

Volvo Bus Corporation

REV			
VIC/EI (D7E), MED, XC941		88890025	1 – 39
VIC/EI		88890025	1 – 39
X904.XC207		9990008	—
BB13			
GB1			
X25			
DPF			

See also, 300, Component placement, Description, Design and function

The reader is advised that printed copies are uncontrolled.

Component Placement

Volvo Bus Corporation

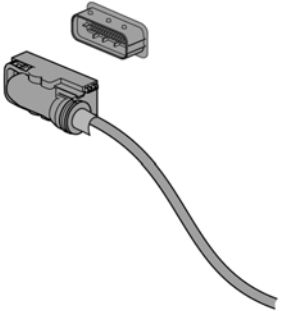
XC940		9990014	1 – 62
-------	---	-------------------------	--------

Note: The table includes components that the vehicle is not equipped with. The illustrations show examples of the components' appearance. When there is no illustration for a component, a symbol illustration is shown. More adapters than those stated can fit the connector pieces.

See also, 300, Component placement, Description, Design and function

The reader is advised that printed copies are uncontrolled.

Control units

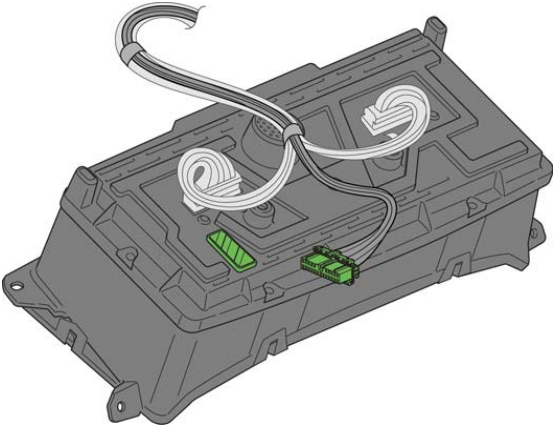
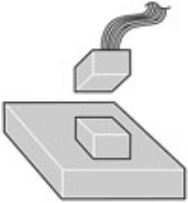
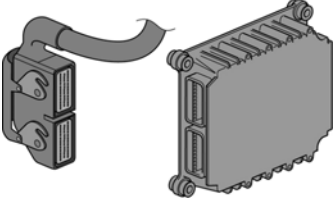
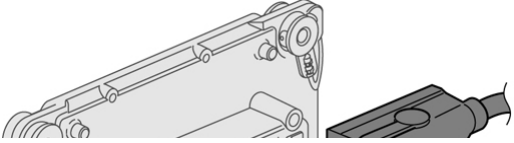
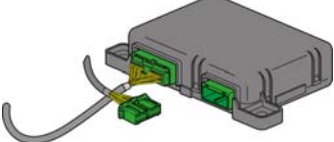
Wiring diagram designation, component/connector piece	Illustration	Adapter	Index in breakout box
A03.A		9998533	31 – 52
A03.B		9813194	1 – 30
A03.C		9998533	1 – 30
A07.A			
A07.B			
A07.C			
A14.A (EMS1)		9998505	1 – 36
A14.B (EMS1)		9998505	1 – 36
A14.A (EMS2)		9990014	1 – 62
A14.B (EMS2)		9990014	1 – 62
A16.A		9813194	1 – 30
A16.B		9998533	31 – 52

See also, 300, Component placement, Description, Design and function

The reader is advised that printed copies are uncontrolled.

Component Placement

Volvo Bus Corporation

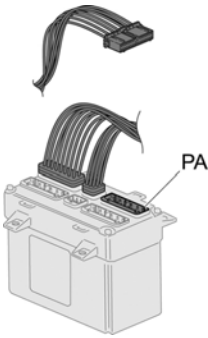
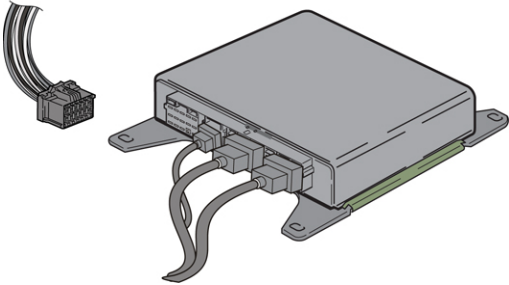
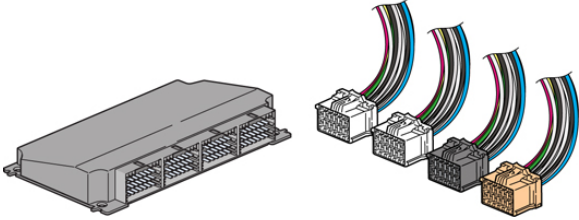
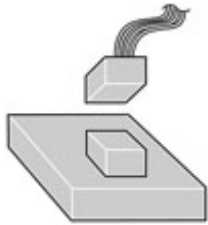
A17.A		9813194	1 – 30
A17.B		9998533	1 – 30
A17.C		9998604	26 – 30
A21.A		9998596	1 – 17
A21.B		9990025	1 – 18
A21.C		9998596	18 – 32
A21.D		—	—
A27.A		9990025	19 – 39
A27.B		9990025	1 – 18
A27.C		9990025	1 – 18
A27.D		9990025	19 – 39
A30		9813194	47 – 56

See also, 300, Component placement, Description, Design and function

The reader is advised that printed copies are uncontrolled.

Component Placement

Volvo Bus Corporation

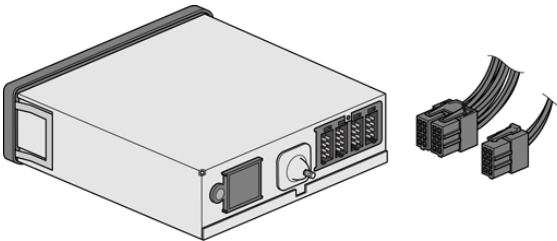
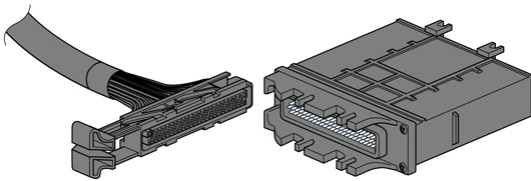
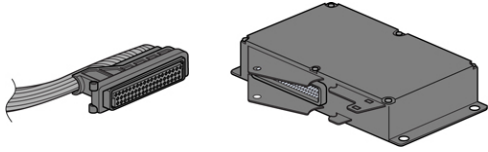
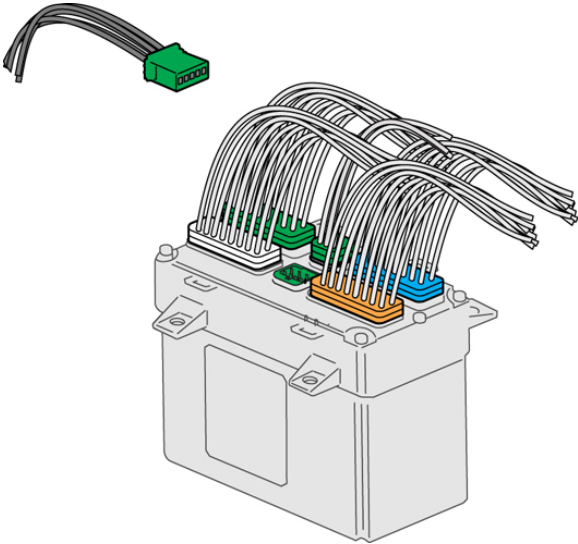

A33.A		9990008	—
A33.B		9990008	—
A33.C		9990008	—
A33.D		9990008	—
A59A		9990155	1 – 62, 1 – 6
A65		9998543	1 – 55
A90.A		9998533	1 – 30
A90.B		9813194	1 – 30
A90.C		9998604	26 – 30

See also, 300, Component placement, Description, Design and function

The reader is advised that printed copies are uncontrolled.

Component Placement

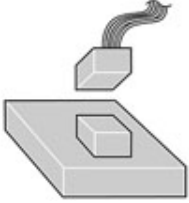
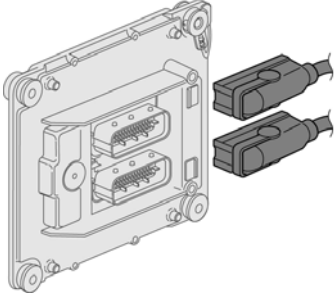
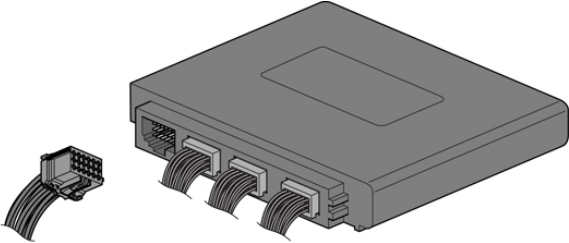
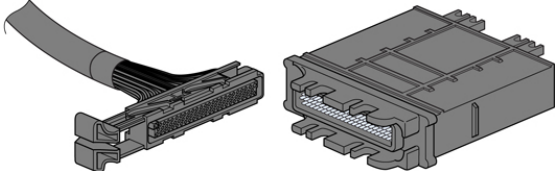
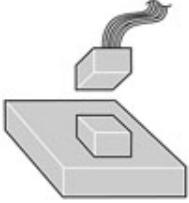
Volvo Bus Corporation

A125			
A141.A		9990014	1 – 62
A141.B		9990014	1 – 62
A900.A (VOITH)		9990025	1 – 18
A900.B (VOITH)		9990025	1 – 18
A900.C (VOITH)		9998596	18 – 32
A900.D (VOITH)		9990025	1 – 18
A901		9990155	1 – 61, 1 – 6
A904			
A914.A		9990041	1 – 20

See also, 300, Component placement, Description, Design and function

The reader is advised that printed copies are uncontrolled.

Component Placement

Volvo Bus Corporation

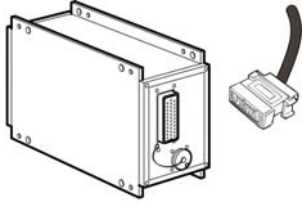
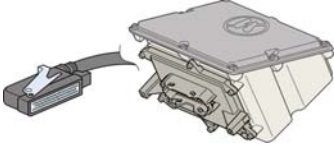
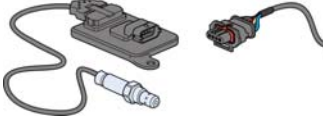
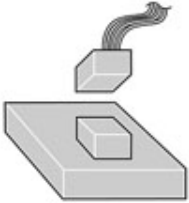
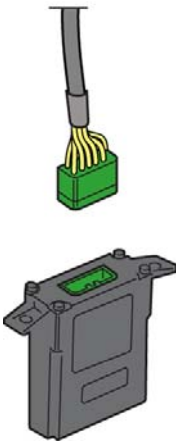
A914.B		9990041	1 – 20
A914.C		9990041	1 – 20
A916.A		9998996	1 – 29
A916.B		9998996	31 – 46
A916.C		9998996	31 – 46
A917		88890052	1 – 35
A918		9990216	1 – 4
A925.A		9813194	1 – 30
A925.B		9998533	1 – 30
A925.C		9998604	26 – 30
A926		9998533	31 – 52

See also, 300, Component placement, Description, Design and function

The reader is advised that printed copies are uncontrolled.

Component Placement

Volvo Bus Corporation

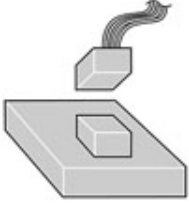
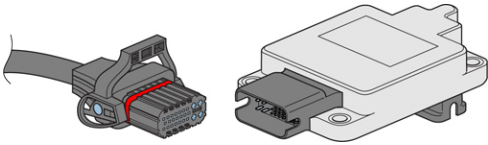
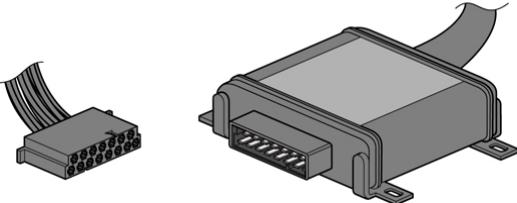
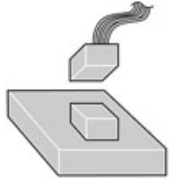
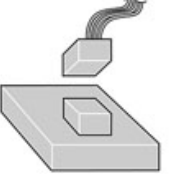
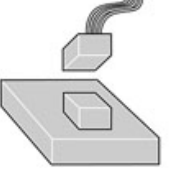
A927			
A929.A		88810020	1 – 25
A929.B		88810020	26 – 50
A930			
A942.A		9813194	1 – 30
A942.B		9998533	1 – 30
A942.C		9998604	26 – 30
A943			
A945			

See also, 300, Component placement, Description, Design and function

The reader is advised that printed copies are uncontrolled.

Component Placement

Volvo Bus Corporation

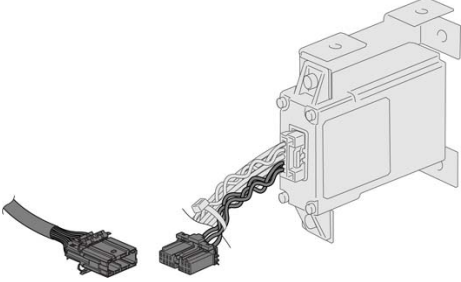
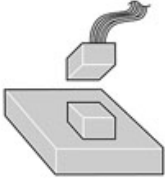
A946	 A technical drawing of a rectangular electronic component with two mounting tabs on top. A multi-wire cable is connected to the front of the component. To the left of the component, there is a separate cable with a connector, and another connector is shown being inserted into the component's front panel.	9813194	31 – 46
A952	 A technical drawing showing a small rectangular component being inserted into a larger rectangular base. The component has a small protrusion on its top surface.		

See also, 300, Component placement, Description, Design and function

The reader is advised that printed copies are uncontrolled.

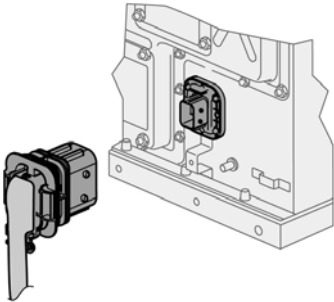
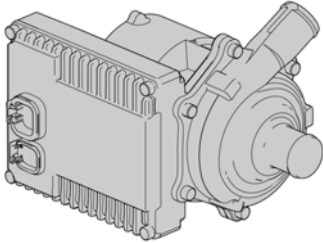
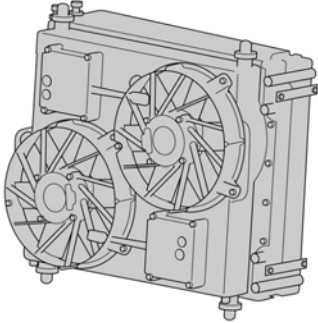
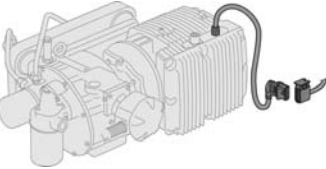
G07.A			
G07.B		88890093	1 – 15
M30, M33		9990008	–
M31, M32		9990008	–
M35, M36			

Component Placement

Volvo Bus Corporation

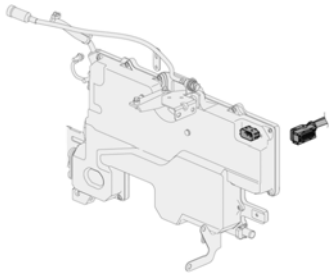
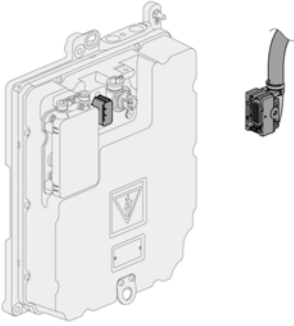
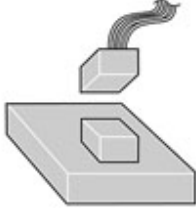
U23		88890094	1 – 21
U24		88890094	1 – 21
Y54		88890053	1 – 7

Note: The table includes components that the vehicle is not equipped with. More adapters than those stated can fit the connector pieces.

See also, 300, Component placement, Description, Design and function

The reader is advised that printed copies are uncontrolled.

Diagnostic connector

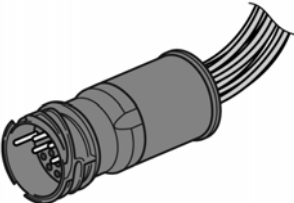
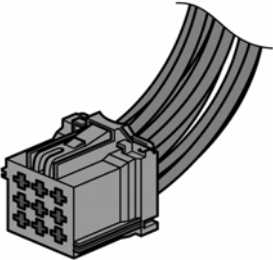
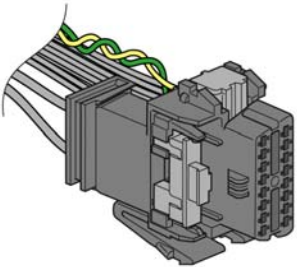
Wiring diagram designation, component/connector piece	Illustration	Adapter	Index in breakout box
DIA			
DIA2		9998596	33 – 41
DIA-16, OBD2		88890018 9998960	

See also, 300, Component placement, Description, Design and function

The reader is advised that printed copies are uncontrolled.

Component Placement

Volvo Bus Corporation

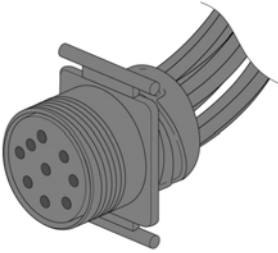
		9990137	
--	---	-------------------------	--

See also, 300, Component placement, Description, Design and function

The reader is advised that printed copies are uncontrolled.

Electrical distribution units

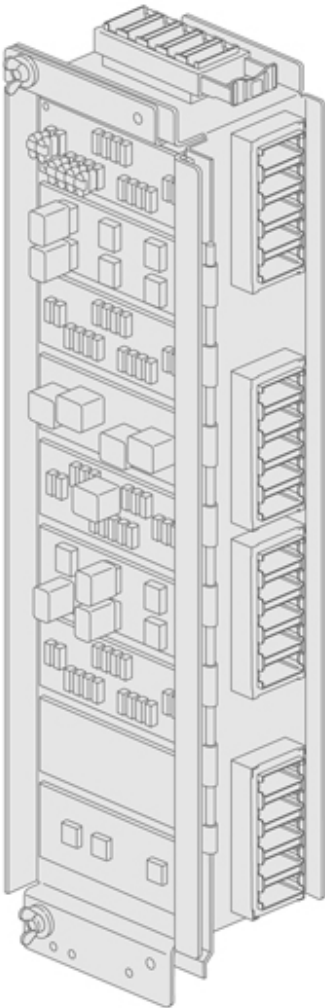
Wiring diagram designation, component/connector piece	Illustration
Electrical distribution unit	

See also, 300, Component placement, Description, Design and function

The reader is advised that printed copies are uncontrolled.

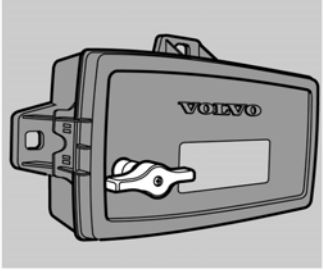
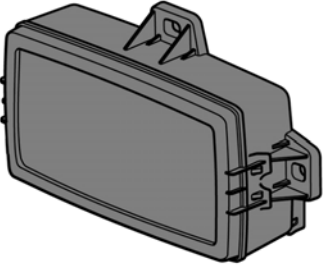
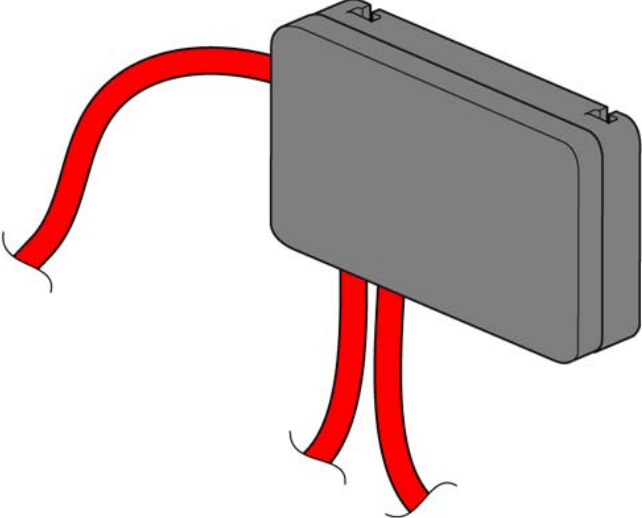
X903	 A grey, rectangular component box with a handle on top. The word "VOLVO" is printed on the front. A metal terminal is attached to the front face.
X904	 A grey, rectangular component box shown from a side perspective, highlighting its depth and the mounting tabs on the side.
X905	 A grey, rectangular component box with three red cables connected to it. One cable enters from the left side, and two cables exit from the bottom.

See also, 300, Component placement, Description, Design and function
The reader is advised that printed copies are uncontrolled.

Engineering Release Notice (ERN)	Location	Change Description	A = Added U = Deleted	W = Was	Document Release Status
D-13277-72					Date 2006-05-17 Modification Count

BILL OF MATERIAL/COMPONENT LIST

Part Name	Description	Location	Part Type
+30:1		{AB 0 D} {AB 4 D}	inline_connector
+B:1		{AB 0 D} {AB 5 D}	inline_connector
30UA:1		{CU 2 B}	inline_connector
30UB:1		{CU 2 B}	inline_connector
A03	BIC	{NA 4 B} {XC 5 C} {XD 5 C}	componentSymbol
A07	Radio	{IU 4 B}	componentSymbol
A08	Control unit GPS	{NC 3 A}	componentSymbol
A14A:1		{CM 5 C}	inline_connector
A14A:2		{XC 4 B}	inline_connector
A14A:3		{XC 4 B}	inline_connector
A14A:4		{XD 4 B}	inline_connector
A14A:5		{XD 4 B}	inline_connector
A14A:7		{CM 1 D}	inline_connector
A14A:8		{CM 3 C}	inline_connector
A14A:9		{CM 5 C}	inline_connector
A14A:10		{CM 1 C}	inline_connector
A14A:11		{CM 1 C}	inline_connector
A14A:12		{AF 4 B}	inline_connector
A14A_MG9:1		{CB 5 C}	inline_connector
A14A_MG9:2		{XC 3 B}	inline_connector
A14A_MG9:3		{XC 3 B}	inline_connector
A14A_MG9:4		{XD 2 A}	inline_connector
A14A_MG9:5		{XD 2 A}	inline_connector
A14A_MG9:6		{CB 1 A}	inline_connector
A14A_MG9:7		{BD 1 C} {BD 4 C}	inline_connector
A14A_MG9:8		{BD 1 C} {BD 4 C}	inline_connector
A14A_MG9:9		{CB 5 C}	inline_connector
A14A_MG9:10		{CB 1 D}	inline_connector
A14A_MG9:12		{CB 1 D}	inline_connector
A14B:1		{CM 4 C}	inline_connector
A14B:2		{CM 4 C}	inline_connector
A14B:3		{CM 4 C}	inline_connector
A14B:4		{CM 4 C}	inline_connector
A14B:5		{CM 2 C}	inline_connector
A14B:6		{CM 2 C}	inline_connector
A14B:7		{CM 5 B}	inline_connector

The copying, distribution and utilization of this document as well as the communication of its contents to others without expressed authorization is prohibited. Offenders will be held liable for payment of damages. All rights reserved in the event of the grant of a patent, utility model or ornamental design registration.

Document Title
WIRING DIAGRAM
B7, B9, B12



Document Type
TECHNICAL REGULATION

Owner Domain:Document Prefix

Document No 20904123	Issue Index 02	Volume No 02(02)	Page No 1(50)
--------------------------------	--------------------------	---------------------	-------------------------

Part Name	Description	Location	Part Type
A14B_MG9:1		{CB 4 B}	inline_connector
A14B_MG9:2		{CB 4 A}	inline_connector
A14B_MG9:3		{CB 2 D}	inline_connector
A14B_MG9:4		{CB 2 C}	inline_connector
A14C:1		{CM 0 D}	inline_connector
A14C:2		{CM 0 C}	inline_connector
A14C:3		{CM 0 C}	inline_connector
A14C:4		{BD 0 B} {BD 2 B}	inline_connector
A14C:5		{BD 0 D} {BD 2 D}	inline_connector
A14C:6		{CM 5 B}	inline_connector
A14C:7		{CM 5 B}	inline_connector
A14D:1		{CM 5 B}	inline_connector
A14D:2		{CM 5 C}	inline_connector
A14D:3		{CM 5 C}	inline_connector
A14D:4		{CM 5 C}	inline_connector
A14_7	EMS	{XC 4 A} {CN 5 C} {XD 3 A}	componentSymbol
A14_9	EMS	{XC 3 A} {XD 3 A}	componentSymbol
A14_9MG	EMS	{XC 3 A} {CB 5 C} {XD 2 A}	componentSymbol
A14_12	EMS	{XC 4 A} {CM 5 C} {XD 4 A}	componentSymbol
A14_MD9		{CA 5 C}	componentSymbol
A16	ECS	{FA 5 B} {XC 1 C} {XD 1 C} {FB 5 D}	componentSymbol
A17	VECU	{BA 5 B} {XC 2 C} {XD 2 C}	componentSymbol
A19	GECU	{DN 5 B}	componentSymbol
A21	EBS	{XC 2 C} {EO 5 A} {XD 2 C} {EP 5 D}	componentSymbol
A22	Dynafleet	{NC 4 B} {XD 4 C}	componentSymbol
A23	FMS	{NC 3 C}	componentSymbol
A27	LCM	{XC 0 C} {GA 5 C} {GB 4 C} {GC 4 C} {XD 1 C}	componentSymbol
A30	Control unite,SWM(Steering Wheel Module)	{IS 4 C}	componentSymbol

VOLVO

Volvo Bus Corporation

Document Title

WIRING DIAGRAM

Document Type

TECHNICAL REGULATION

Document No

20904123

Issue Index

02

Volume No

02(02)

Page No

2(50)

Part Name	Description	Location	Part Type
A33	TACHO	{NB 4 C} {XC 3 C} {NC 5 B}	componentSymbol
A41	Component group transmission.Contains B23,B06 and Y17.	{DN 3 B}	componentSymbol
A42	Component group transmission.Contains B26, Y21,Y22, Y23 and Y26.	{DN 1 B}	componentSymbol
A43	Body I/O Module 43	{CA 4 C}	componentSymbol
A43B		{CB 4 B}	componentSymbol
A44	Fuel_Pump	{CM 3 D}	componentSymbol
A45	Fuel_Water_Separator	{CA 3 C}	componentSymbol
A45_MD12		{CM 3 D}	componentSymbol
A65	RECU	{DM 5 B} {XC 1 B} {XD 1 A}	componentSymbol
A90	BBM	{BB 5 A} {XC 3 C} {AA 4 A} {XD 2 C} {BC 5 D}	componentSymbol
A105	SIB	{NC 5 B}	componentSymbol
A900	VOITH	{DC 5 B}	componentSymbol
A900_ARTIC		{DO 5 B}	componentSymbol
A901	ZF	{DB 5 C} {XC 0 A} {XD 2 A}	componentSymbol
A904	Volvo EGS gearbox control unit	{DA 5 C}	componentSymbol
A914	TECU	{XC 5 A} {DN 3 C} {XD 5 A}	componentSymbol
A916	HYMER_ECU	{FC 4 B}	componentSymbol
A917	DNOX2_ECU	{CU 5 C} {CV 3 B}	componentSymbol
A918	NOx-sensor	{CV 3 A}	componentSymbol
A925	ECU_gas_tanks	{CG 4 C}	componentSymbol
A926	GearShift_ECU	{XC 4 C} {DN 5 C} {XD 3 D}	componentSymbol
A927	GECU - Ecomat 5	{DD 4 D}	componentSymbol
A928	Gearbox Ecomat 5	{DD 2 B}	componentSymbol
A929	TECU - Ecomat 5	{XC 5 A} {DD 2 B} {XD 5 A}	componentSymbol
A930	Gateway DIVAS	{DC 4 D}	componentSymbol
A930_ARTIC		{DO 4 D}	componentSymbol
A942	BIO - Bus I/O	{CL 4 C}	componentSymbol
A943	OILMASTER	{CO 4 B}	componentSymbol
A945	Control unit, VDO FM200	{ND 0 A}	componentSymbol
ACC:1		{AC 3 C}	inline_connector
ACC:2		{XC 4 C}	inline_connector
ACC:3		{XC 4 C}	inline_connector
ACC:4		{XD 3 C}	inline_connector

VOLVO

Volvo Bus Corporation

Document Title

WIRING DIAGRAM

Document Type

TECHNICAL REGULATION

Document No

20904123

Issue Index

02

Volume No

02(02)

Page No

3(50)

Part Name	Description	Location	Part Type
ACC:5		{XD 3 C}	inline_connector
ACC:6		{ZC 1 B}	inline_connector
ACC:7		{BA 3 C}	inline_connector
ACC:8		{BA 3 C}	inline_connector
ARTIC.A1:1		{FB 1 D}	inline_connector
ARTIC.A1:2		{FB 1 D}	inline_connector
ARTIC.A1:3		{FB 3 B}	inline_connector
ARTIC.A1:4		{FB 3 B}	inline_connector
ARTIC.A1:5		{BC 5 B}	inline_connector
ARTIC.A1:6		{BC 5 B}	inline_connector
ARTIC.A1:7		{BC 4 D}	inline_connector
ARTIC.A1:8		{BC 3 C}	inline_connector
ARTIC.A1:9		{BC 3 C}	inline_connector
ARTIC.A1:10		{BC 5 B}	inline_connector
ARTIC.A1:11		{BC 3 C}	inline_connector
ARTIC.A1:12		{BC 3 C}	inline_connector
ARTIC.A2:7		{BC 4 C}	inline_connector
ARTIC.A2:8		{BC 3 C}	inline_connector
ARTIC.A2:9		{BC 3 C}	inline_connector
ARTIC.A2:11		{BC 3 C}	inline_connector
ARTIC.A2:12		{BC 3 C}	inline_connector
ARTIC:1		{FB 1 D}	inline_connector
ARTIC:2		{FB 1 D}	inline_connector
ARTIC:3		{FB 2 C}	inline_connector
ARTIC:4		{FB 1 D}	inline_connector
ARTIC:5		{BC 4 D}	inline_connector
ARTIC:6		{BC 4 D}	inline_connector
ARTIC:7		{BC 4 D}	inline_connector
ARTIC:8		{BC 3 C}	inline_connector
ARTIC:9		{BC 3 D}	inline_connector
ARTIC:10		{BC 4 D}	inline_connector
ARTIC:11		{BC 3 D}	inline_connector
ARTIC:12		{BC 3 D}	inline_connector
AUDIO:1		{NA 4 C}	inline_connector
AUDIO:2		{NA 4 C}	inline_connector
AUDIO:3		{IS 4 C}	inline_connector
B03	Sensor,footbrake valve	{EO 4 D}	componentSymbol
B04	Sensor,engine speed,crankshaft	{CM 4 A}	componentSymbol
B05	Sensor,engine speed,camshaft	{CM 3 A}	componentSymbol
B06	Wet tank press	{BA 0 D} {BA 0 D}	componentSymbol
B07	Sensor,fuel level front axle	{NA 4 A}	componentSymbol
B07_LE	Sensor,fuel level front axle	{NA 0 B}	componentSymbol
B07_S9		{NA 5 A}	componentSymbol
B12	Sensor,tachograph/speedometer	{NB 5 A} {NB 4 A}	componentSymbol
B13	Sensor,wheel speed, lhs. 1:st front axle	{EO 2 D}	componentSymbol
B14	Sensor,wheel speed, rhs. 1:st front axle	{EO 2 D}	componentSymbol
B15	Sensor,Wheel speed, lhs. 1:st driven rear axle	{EO 1 D}	componentSymbol
B16	Sensor,Wheel speed, rhs. 1:st driven rear axle	{EO 1 D}	componentSymbol
B21	Sensor,coolant temperature	{CM 4 D}	componentSymbol
B22	Sensor, outdoor temperature	{NA 3 A}	componentSymbol

VOLVO

Volvo Bus Corporation

Document Title

WIRING DIAGRAM

Document Type

TECHNICAL REGULATION

Document No

20904123

Issue Index

02

Volume No

02(02)

Page No

4(50)

Part Name	Description	Location	Part Type
B23	Sensor,oil temperature,retarder	{DM 3 C}	componentSymbol
B25	Sensor,accelerator pedal	{BA 2 C}	componentSymbol
B29	sensor chassis level rear axle LHS	{FB 3 C} {FB 3 A}	componentSymbol
B30	sensor chassis level rear axle RHS	{FB 3 C} {FB 2 A}	componentSymbol
B32	Sensor,engine cooling fan speed	{CM 5 B}	componentSymbol
B32.9		{CA 2 A}	componentSymbol
B32_S9		{CA 1 A}	componentSymbol
B37	Sensor,boots pressure and boots temperature	{CM 4 A}	componentSymbol
B37_MD9		{CA 1 B}	componentSymbol
B39	Sensor,air filter pressure and air filter temperature	{CM 4 D}	componentSymbol
B40	Sensor,brake lining wear indicator,lhs. 1:st front axle	{EO 3 D}	componentSymbol
B41	Sensor,brake lining wear indicator,rhs. 1:st front axle	{EO 3 D}	componentSymbol
B42	Sensor,brake lining wear indicator,lhs. 1:st driven rear axle	{EO 2 D}	componentSymbol
B43	Sensor,brake lining wear indicator,rhs.1:st driven rear axle	{EO 2 D}	componentSymbol
B48		{CN 1 B}	componentSymbol
B49	Sensor,steering angle	{EP 2 B}	componentSymbol
B50	Sensor,yaw-rate	{EP 2 B}	componentSymbol
B52	FUEL FILTER	{CN 3 C}	componentSymbol
B54	Sensor,pressure crankhouse	{CM 4 D}	componentSymbol
B57	Sensor,air pressure, suspension bellows,lhs.rear	{FB 5 C}	componentSymbol
B58	Sensor,air perssure,suspension bellow,rhs. rear	{FB 4 C}	componentSymbol
B59	Sensor, indoor temperature	{NA 3 A}	componentSymbol
B66		{CL 3 A}	componentSymbol
B68	Sensor,output shaft speed, gearbox	{DA 1 A}	componentSymbol
B69C	Sensor,coolant temperature, retarder	{DN 3 B}	componentSymbol
B118		{CB 2 B}	componentSymbol
B118_MD12		{CM 3 D}	componentSymbol
B119	Sensor_oil_level_and_oil_temp	{CM 4 A}	componentSymbol
B167		{CB 3 B}	componentSymbol
B900	Manual gearbox retarder pressre sensor	{DM 3 C}	componentSymbol
B903	Manuel gearbox retarder water temperature	{DM 2 C}	componentSymbol
B904	hydr_oil_level_sens	{NA 4 D}	componentSymbol
B904_S9		{NA 0 C}	componentSymbol
B905	Clutch pedal position inductive sensor	{DA 1 D}	componentSymbol
B906	Sensor,Brake Press (6*2)	{BC 4 A}	componentSymbol
B907	Sensor,fuel level rear axle	{NA 0 C}	componentSymbol
B908	sensor air press. ECS AL	{FB 4 C}	componentSymbol
B908_A	sensor air press. ECS AL	{FB 4 A}	componentSymbol
B909	sensor air press. ECS AR	{FB 4 C}	componentSymbol
B909_A	sensor air press. ECS AR	{FB 4 A}	componentSymbol
B910	sensor air press. ECS FL	{FB 5 C}	componentSymbol
B914	sensor chassis level front axle LHS	{FB 2 A}	componentSymbol
B915	sensor chassis level front axle RHS	{FB 1 A}	componentSymbol
B916	sensor chassis level artic axle LHS	{FB 1 A}	componentSymbol

VOLVO

Volvo Bus Corporation

Document Title

WIRING DIAGRAM

Document Type

TECHNICAL REGULATION

Document No

20904123

Issue Index

02

Volume No

02(02)

Page No

5(50)

Part Name	Description	Location	Part Type
B916_A	sensor chassis level artic axle LHS	{FB 3 A}	componentSymbol
B917	sensor chassis level artic axle LHS	{FB 1 A}	componentSymbol
B917_A	sensor chassis level artic axle LHS	{FB 3 A}	componentSymbol
B920	Sensor,fuel level 2 front axle	{NA 4 A}	componentSymbol
B920_LE	Sensor,fuel level 2 front axle	{NA 0 B}	componentSymbol
B921	Sensor,fuel level 2 rear axle	{NA 0 C}	componentSymbol
B922	Sensor_temp_downstream_scr_t_DNOX2	{CL 4 A}	componentSymbol
B923	Sensor_temp/level_adblue_tank_SCRT_DNOX2	{CU 3 C}	componentSymbol
B927	Sensor Hydr.oil press	{BB 1 D}	componentSymbol
B930	Sensor_temp_upstream_scr_t_DNOX2	{CU 4 D} {CU 4 C}	componentSymbol
B930T:1		{CU 4 C}	inline_connector
B930T:2		{CU 4 C}	inline_connector
B930T:3		{CU 4 D}	inline_connector
B930T:4		{CU 4 D}	inline_connector
B936	Sensor,brake lining wear indicator Artic, A/B R	{EP 3 B}	componentSymbol
B937	Sensor,brake lining wear indicator Artic, A/B L	{EP 3 B}	componentSymbol
B938	Sensor, wheel speed Artic, A/B R	{EP 2 B}	componentSymbol
B939	Sensor,wheel speed Artic, A/B L	{EP 2 B}	componentSymbol
B940	sensor_brake_lining_wear_ind_A/B_R	{EP 5 B} {EP 4 B}	componentSymbol
B941	sensor_brake_lining_wear_ind_A/B_L	{EP 5 B} {EP 4 B}	componentSymbol
B942	sensor_wheel_speed_A/B_R	{EP 4 B} {EP 3 B}	componentSymbol
B943	sensor_wheel_speed_A/B_L	{EP 5 B} {EP 3 B}	componentSymbol
B944	Trailer air brake pressure sensor	{BC 5 A}	componentSymbol
B945	Crash Sensor	{CG 4 D}	componentSymbol
B946	Sensor, coolant level	{NA 2 C}	componentSymbol
B946_S9		{NA 0 C}	componentSymbol
B948		{CA 4 B}	componentSymbol
B949	Last trailer air brake pressure sensor (biartic)	{CL 3 A}	componentSymbol
B950	Sensor,brake lining wear indicator Biartic, A/B R	{EO 1 D}	componentSymbol
B951	Sensor,brake lining wear indicator Biartic, A/B L	{EO 1 D}	componentSymbol
B952	Sensor, wheel speed Biartic, A/B R	{EO 0 D}	componentSymbol
B953	Sensor,wheel speed Biartic, A/B L	{EO 0 D}	componentSymbol
B955	OIL LEVEL SENSOR	{CO 4 A}	componentSymbol
B956	Brake pressure to AMEC	{FC 2 C}	componentSymbol
B960	Sensor, Air Pressure ECS, Last Trailer (Biartic)	{FB 3 C}	componentSymbol
B961	Sensor, chassi level last trailer (Biartic)	{FB 0 A}	componentSymbol
B964	TRAIL AIR BRAKE PRESSOR SENSOR2	{BC 4 A}	componentSymbol

VOLVO

Volvo Bus Corporation

Document Title

WIRING DIAGRAM

Document Type

TECHNICAL REGULATION

Document No

20904123

Issue Index

02

Volume No

02(02)

Page No

6(50)

Part Name	Description	Location	Part Type
B970		{BD 0 C} {BD 1 C} {BD 1 C} {BD 3 C} {BD 4 C} {BD 2 C} {BD 2 C} {BD 5 C} {BD 5 C}	componentSymbol
B971		{BD 0 C} {BD 1 C} {BD 1 C} {BD 3 C} {BD 4 C} {BD 2 C} {BD 2 C} {BD 5 C} {BD 5 C}	componentSymbol
B972		{BD 1 C} {BD 1 C} {BD 3 C} {BD 4 C} {BD 2 C} {BD 5 C} {BD 5 C}	componentSymbol
B973		{BD 5 C}	componentSymbol
B974		{BD 1 B} {BD 3 B} {BD 5 B}	componentSymbol
B975		{BD 3 B}	componentSymbol
BB1:1	Idle switch	{BA 5 B}	inline_connector
BB1:2	Start disable	{BC 1 D}	inline_connector
BB1:3	Fire alarm,body	{BC 1 D}	inline_connector
BB1:4	Low priority loads, relay	{BC 2 D}	inline_connector
BB1:5	Luggage hatch ,open	{BB 2 B}	inline_connector
BB1:6	Safety belt indicator	{NA 2 A}	inline_connector
BB1:8	Washer fluid low level	{NA 2 A}	inline_connector
BB1:9	Altenator charging	{NA 2 A}	inline_connector
BB1:10	AC 1	{BB 1 D}	inline_connector
BB1:11	Parking brake applied	{BA 3 A}	inline_connector
BB1:12	AC Disable	{BC 1 D}	inline_connector
BB2:1	Indoor temperator +	{NA 3 A}	inline_connector
BB2:2	Indoor temperature -	{NA 3 B}	inline_connector
BB2:3	Out door temperator +	{NA 3 A}	inline_connector
BB2:4	Out door temperatur-	{NA 3 B}	inline_connector
BB2:5	D-CAN H	{BC 2 B}	inline_connector
BB2:6	D-CAN L	{BC 2 B}	inline_connector
BB2:7	Horn(contacts steering wheelside)	{IS 1 C}	inline_connector
BB2:8	Horn supply	{IS 2 D}	inline_connector
BB2:9	Horn (contacts steer.wheel centre)	{IS 2 C}	inline_connector
BB2:10	Alarm	{GB 3 C}	inline_connector
BB2:11	Emergency switch	{AA 5 B}	inline_connector

VOLVO

Volvo Bus Corporation

Document Title

WIRING DIAGRAM

Document Type

TECHNICAL REGULATION

Document No

20904123

Issue Index

02

Volume No

02(02)

Page No

7(50)

Part Name	Description	Location	Part Type
BB2:12	Signal 4 pulses/meter C6	{NB 3 D}	inline_connector
BB3:1	Head lamps off	{GB 3 C}	inline_connector
BB3:2	Prevent ECS action	{BC 1 D}	inline_connector
BB3:3	Kneeling position	{FA 4 B}	inline_connector
BB3:4	Cancel kneeling	{FA 4 C}	inline_connector
BB3:5	Hazard warning lamps	{GB 2 C}	inline_connector
BB3:6	N/A	{GB 5 B}	inline_connector
BB3:7	Next stop indicator	{NA 2 A}	inline_connector
BB3:8	pram indicator	{NA 2 A}	inline_connector
BB3:9	N/A	{AC 5 C}	inline_connector
BB3:10	Speed signal C3	{BA 4 B}	inline_connector
BB3:11	+30 main switch (fuse F12)	{BB 4 D}	inline_connector
BB3:12	+15 ignition(fuse F29)	{BB 4 D}	inline_connector
BB4:1	Glass heating	{BC 2 D}	inline_connector
BB4:2	Host call	{BC 2 D}	inline_connector
BB4:3	Toilet fluid level	{BC 1 D}	inline_connector
BB4:4	Toilet occupied	{BC 1 D}	inline_connector
BB4:5	Door failure	{BC 1 D}	inline_connector
BB4:6	Door brake, status	{BC 2 D}	inline_connector
BB4:7	Door brake,request	{EP 2 D}	inline_connector
BB4:8	Speed signal 5 km/h	{BA 4 B}	inline_connector
BB4:9	Any door open	{NA 2 A}	inline_connector
BB4:10	Speed signal X km/h	{BA 4 B}	inline_connector
BB4:11	Dimmer,dashboard illumination	{GB 1 C}	inline_connector
BB4:12	N/A	{CG 3 D}	inline_connector
BB5:1	dipped beam.Left	{GB 3 B}	inline_connector
BB5:2	Dipped beam.Right	{GB 2 B}	inline_connector
BB5:3	Direction indicator,front and side.Left	{GB 4 B}	inline_connector
BB5:4	Direction indicator,Front and side. Right	{GB 1 B}	inline_connector
BB5:5	Fog lamps,front	{GB 3 B}	inline_connector
BB5:6	Additional main beam	{GB 2 C}	inline_connector
BB5:7	End-outline maker,side marker,position lamps.Left	{GB 4 B}	inline_connector
BB5:8	End-outline marker,side marker, position lamps.Right	{GB 2 B}	inline_connector
BB5:9	Main beam 2. Left	{GB 3 B}	inline_connector
BB5:10	Main beam 2.Right	{GB 2 B}	inline_connector
BB5:11	Main beam 1.Left	{GB 4 B}	inline_connector
BB5:12	Main beam 1.Right	{GB 2 B}	inline_connector
BB6.A1:1	Starter inhibitor, engine hatch	{BC 2 B}	inline_connector
BB6.A1:2		{GA 3 D}	inline_connector
BB6.A1:4		{GA 3 D}	inline_connector
BB6.A1:5		{BB 2 B}	inline_connector
BB6.A1:6		{BB 3 C}	inline_connector
BB6.A1:12		{GA 2 B}	inline_connector
BB6.A2:1	Starter inhibitor, engine hatch	{BC 2 B}	inline_connector
BB6.A2:2		{GA 3 D}	inline_connector
BB6.A2:4		{GA 2 D}	inline_connector
BB6.A2:5		{BB 2 B}	inline_connector
BB6.A2:6		{BB 3 C}	inline_connector
BB6.A2:12		{GA 2 B}	inline_connector
BB6.A3:1	Starter inhibitor, engine hatch	{BC 2 B}	inline_connector

VOLVO

Volvo Bus Corporation

Document Title

WIRING DIAGRAM

Document Type

TECHNICAL REGULATION

Document No

20904123

Issue Index

02

Volume No

02(02)

Page No

8(50)

Part Name	Description	Location	Part Type
BB6.A3:2		{GA 3 C}	inline_connector
BB6.A3:4		{GA 2 D}	inline_connector
BB6.A3:5		{BB 2 C}	inline_connector
BB6.A3:6		{BB 3 D}	inline_connector
BB6.A3:12		{GA 2 B}	inline_connector
BB6:1	Starter inhibitor, engine hatch	{BC 3 B}	inline_connector
BB6:2	N/A	{GA 3 D}	inline_connector
BB6:3	AC compressor 3	{AC 4 C}	inline_connector
BB6:4	+30 main swith(fuse F54)	{GA 3 D}	inline_connector
BB6:5	Luggage hatch, open	{BB 2 B}	inline_connector
BB6:6	Luggage compartment light	{BB 3 C}	inline_connector
BB6:12	Reverse warning signal	{GA 2 B}	inline_connector
BB6A:4	+30 main switch (switch F54)	{GD 5 D}	inline_connector
BB6A:5	Luggage hatch,open	{GD 4 D}	inline_connector
BB6A:6	Luggage compartment light	{GD 3 D}	inline_connector
BB6B:1	Starter inhibitor, engine hatch	{BC 3 B}	inline_connector
BB6B:2		{GA 3 C}	inline_connector
BB6B:4		{GA 3 C}	inline_connector
BB6B:5	Luggage hatch, open	{BB 2 B}	inline_connector
BB6B:6	Luggage hatch, open	{BB 3 D}	inline_connector
BB6B:12	Direction indicator.Rear left	{GA 2 B}	inline_connector
BB7.A1:1		{GC 3 C}	inline_connector
BB7.A1:2		{GA 1 B}	inline_connector
BB7.A1:3		{GA 4 B}	inline_connector
BB7.A1:4		{GC 3 C}	inline_connector
BB7.A1:5		{GA 4 B}	inline_connector
BB7.A1:6		{GC 2 C}	inline_connector
BB7.A1:7		{GA 5 B}	inline_connector
BB7.A1:8		{GC 1 C}	inline_connector
BB7.A1:9		{GC 5 C}	inline_connector
BB7.A1:10		{GC 4 C}	inline_connector
BB7.A1:11		{GA 3 B}	inline_connector
BB7.A1:12		{GA 3 B}	inline_connector
BB7.A2:1		{GC 3 C}	inline_connector
BB7.A2:2		{GA 1 B}	inline_connector
BB7.A2:3		{GA 4 B}	inline_connector
BB7.A2:4		{GC 3 C}	inline_connector
BB7.A2:5		{GA 4 B}	inline_connector
BB7.A2:6		{GC 2 C}	inline_connector
BB7.A2:7		{GA 5 B}	inline_connector
BB7.A2:8		{GC 1 C}	inline_connector
BB7.A2:9		{GC 5 C}	inline_connector
BB7.A2:10		{GC 4 C}	inline_connector
BB7.A2:11		{GA 3 B}	inline_connector
BB7.A2:12		{GA 3 B}	inline_connector
BB7.A3:1		{GC 3 C}	inline_connector
BB7.A3:2		{GA 1 B}	inline_connector
BB7.A3:3		{GA 4 B}	inline_connector
BB7.A3:4		{GC 3 B}	inline_connector
BB7.A3:5		{GA 4 B}	inline_connector
BB7.A3:6		{GC 2 B}	inline_connector

VOLVO

Volvo Bus Corporation

Document Title

WIRING DIAGRAM

Document Type

TECHNICAL REGULATION

Document No

20904123

Issue Index

02

Volume No

02(02)

Page No

9(50)

Part Name	Description	Location	Part Type
BB7.A3:7		{GA 5 B}	inline_connector
BB7.A3:8		{GC 1 B}	inline_connector
BB7.A3:9		{GC 5 B}	inline_connector
BB7.A3:10		{GC 4 B}	inline_connector
BB7.A3:11		{GA 3 B}	inline_connector
BB7.A3:12		{GA 3 B}	inline_connector
BB7:1	Stop lamp.Right	{GC 3 C}	inline_connector
BB7:2	Reversing lamps	{GA 1 B}	inline_connector
BB7:3	Direction indicator.Rear left	{GA 3 B}	inline_connector
BB7:4	Direction indicator.Rear right	{GC 2 C}	inline_connector
BB7:5	Extra direction indicator.Left	{GA 4 B}	inline_connector
BB7:6	Extra direction indicator.Right	{GC 2 C}	inline_connector
BB7:7	Rear position lamps.Left	{GA 5 B}	inline_connector
BB7:8	Rear position lamp.Right	{GC 1 C}	inline_connector
BB7:9	End-outline marker,sidemarkers lamps.Rear left	{GC 5 C}	inline_connector
BB7:10	End-outline marker,side marker lamps.Rear right	{GC 4 C}	inline_connector
BB7:11	Stop lamp,left and Category S3 stop lamps	{GA 3 B}	inline_connector
BB7:12	Fog lamps,Rear	{GA 2 B}	inline_connector
BB7A:1	Reversing lamps	{GD 5 C}	inline_connector
BB7A:2	Reversing lamps	{GD 4 C}	inline_connector
BB7A:3	Direction indicator.Rear left	{GD 4 C}	inline_connector
BB7A:4	Direction indicator.Rear right	{GD 3 C}	inline_connector
BB7A:5	Xtra direction indicator.Left	{GD 3 C}	inline_connector
BB7A:6	Extra direction indicator.Right	{GD 3 C}	inline_connector
BB7A:7	Rear position lamps.Left	{GD 3 C}	inline_connector
BB7A:8	Rear position lamps.Right	{GD 3 C}	inline_connector
BB7A:9	End-outline marker,sidemarkers lamps.Rear left	{GD 2 D}	inline_connector
BB7A:10	End-outline marker,sidemarkers lamps.Rear right	{GD 2 D}	inline_connector
BB7A:11	Stop lamps,left and Category S3 stop lamps	{GD 1 C}	inline_connector
BB7A:12	Fog lamps ,Rear	{GD 0 C}	inline_connector
BB7B:1	Stop lamp.Right	{GC 3 C}	inline_connector
BB7B:2	Reversing lamps	{GA 1 B}	inline_connector
BB7B:3	Direction indicator.Rear left	{GA 4 B}	inline_connector
BB7B:4	Stop lamp.Right	{GC 2 C}	inline_connector
BB7B:5	Direction indicator.Rear left	{GA 4 B}	inline_connector
BB7B:6	Direction indicator.Rear left	{GC 2 B}	inline_connector
BB7B:7	Direction indicator.Rear left	{GA 5 B}	inline_connector
BB7B:8	Stop lamp.Right	{GC 1 C}	inline_connector
BB7B:9	Direction indicator.Rear left	{GC 5 B}	inline_connector
BB7B:10	Direction indicator.Rear left	{GC 4 B}	inline_connector
BB7B:11	Direction indicator.Rear left	{GA 3 B}	inline_connector
BB7B:12	Direction indicator.Rear left	{GA 2 B}	inline_connector
BB7_T:1	Rear position lamp.Right	{GA 0 D}	inline_connector
BB7_T:3	Rear position lamp.Right	{GA 1 D}	inline_connector
BB7_T:4	Rear position lamp.Right	{GA 1 D}	inline_connector
BB7_T:7	Rear position lamp.Right	{GA 1 D}	inline_connector
BB7_T:8	Rear position lamp.Right	{GA 1 D}	inline_connector
BB7_T:11	Rear position lamp.Right	{GA 0 D}	inline_connector
BB8:1	End-outline marker lamp.Front left	{GB 4 A}	inline_connector
BB8:2	End-outline marker lamp.Front right	{GB 1 B}	inline_connector

VOLVO

Volvo Bus Corporation

Document Title

WIRING DIAGRAM

Document Type

TECHNICAL REGULATION

Document No

20904123

Issue Index

02

Volume No

02(02)

Page No

10(50)

Part Name	Description	Location	Part Type
BB8:3	Extra main beam	{GB 2 C}	inline_connector
BB10A:1	remote control of extra power amplifier(12V)	{IU 4 A}	inline_connector
BB10A:3	+15(12V)	{IU 3 C}	inline_connector
BB10A:5	+30(12V)	{IU 4 C}	inline_connector
BB10A:7	Ground	{IU 5 C}	inline_connector
BB10A:9	N/A	{IU 3 A}	inline_connector
BB10B:1	remote control of extra power amplifier (12V)	{IU 4 A}	inline_connector
BB10B:3	+15(12V)	{IU 4 C}	inline_connector
BB10B:5	+30(12V)	{IU 3 C}	inline_connector
BB10B:7	Ground	{IU 5 C}	inline_connector
BB10B:9	N/A	{IU 3 A}	inline_connector
BB11:1	Connected to RL:3	{GB 5 B}	inline_connector
BB13:1	AC 1 - 50%	{BC 5 D}	inline_connector
BB13:2	AC compressor 2	{CL 4 D}	inline_connector
BB13:3	AC compressor 3	{CL 4 D}	inline_connector
BB13:4		{FB 3 D}	inline_connector
BB13:5	TORQUE REDUCTION	{BC 5 D}	inline_connector
BB13:6	AC compressor 2	{CL 3 B}	inline_connector
BB13:7	AC compressor 3	{CL 2 B}	inline_connector
BBOX:1		{AA 4 A}	inline_connector
BBOX:2		{AB 4 C}	inline_connector
BFEED:1		{CU 5 D}	inline_connector
BMUX:1		{XD 4 D}	inline_connector
BMUX:2		{XD 4 D}	inline_connector
BMUX:3	Externa main switch	{AA 5 C}	inline_connector
BMUX:4	Externa main switch	{AA 5 B}	inline_connector
BMUX:5		{AA 5 C}	inline_connector
BOGIE.A1:1		{FB 4 B}	inline_connector
BOGIE.A1:2		{FB 4 B}	inline_connector
BOGIE.A1:3		{FA 4 B}	inline_connector
BOGIE.A1:4		{FA 5 B}	inline_connector
BOGIE.A1:5		{FA 5 B}	inline_connector
BOGIE.A1:6		{EP 4 C}	inline_connector
BOGIE.A1:7		{EP 4 C}	inline_connector
BOGIE.A1:8		{EP 4 C}	inline_connector
BOGIE.A1:9		{EP 4 D}	inline_connector
BOGIE:1		{FB 4 D}	inline_connector
BOGIE:2		{FB 4 D}	inline_connector
BOGIE:3		{FA 1 B}	inline_connector
BOGIE:4		{FA 2 B}	inline_connector
BOGIE:5		{FA 2 B}	inline_connector
BOGIE:6		{EP 4 C}	inline_connector
BOGIE:7		{EP 4 C}	inline_connector
BOGIE:8		{EP 4 D}	inline_connector
BOGIE:9		{EP 3 D}	inline_connector
BOGIE:10		{ZC 3 B}	inline_connector
BOGIE:11		{BB 0 B}	inline_connector
BOGIE:12		{BB 0 B}	inline_connector
BS1:2		{EO 3 C}	inline_connector
BS1:3		{EO 3 C}	inline_connector
BS1:4		{EO 3 C}	inline_connector

VOLVO

Volvo Bus Corporation

Document Title

WIRING DIAGRAM

Document Type

TECHNICAL REGULATION

Document No

20904123

Issue Index

02

Volume No

02(02)

Page No

11(50)

Part Name	Description	Location	Part Type
BS1:5		{EO 2 C}	inline_connector
BS1:8		{EP 5 D}	inline_connector
BS1:9		{EP 5 D}	inline_connector
BS1:10		{EP 4 D}	inline_connector
BS1:11		{EP 5 D}	inline_connector
BS1:12		{EP 5 D}	inline_connector
BS2:2		{EP 2 C}	inline_connector
BS2:3		{EP 2 C}	inline_connector
BS2:5		{EP 2 C}	inline_connector
BS2:6		{EP 2 C}	inline_connector
BS3.A1:1		{EO 2 B}	inline_connector
BS3.A1:2		{EO 2 B}	inline_connector
BS3.A1:3		{EO 1 B}	inline_connector
BS3.A1:4		{EO 1 B}	inline_connector
BS3.A1:5		{EP 1 D}	inline_connector
BS3.A1:6		{EP 2 D}	inline_connector
BS3.A1:7		{EP 2 A}	inline_connector
BS3.A1:8		{NA 2 C}	inline_connector
BS3.A1:9		{BB 2 C}	inline_connector
BS3.A1:10		{BA 0 C}	inline_connector
BS3.A1:11		{BA 0 B}	inline_connector
BS3.A1:12		{BA 0 B}	inline_connector
BS3.A2:1		{EO 2 B}	inline_connector
BS3.A2:2		{EO 2 B}	inline_connector
BS3.A2:3		{EO 1 B}	inline_connector
BS3.A2:4		{EO 1 B}	inline_connector
BS3.A2:5		{EP 1 C}	inline_connector
BS3.A2:6		{EP 2 C}	inline_connector
BS3.A2:7		{EP 2 B}	inline_connector
BS3.A2:8		{NA 2 C}	inline_connector
BS3.A2:9		{BB 2 C}	inline_connector
BS3.A2:10		{BA 0 C}	inline_connector
BS3.A2:11		{BA 0 C}	inline_connector
BS3.A2:12		{BA 0 B}	inline_connector
BS3.A3:1		{EO 2 B}	inline_connector
BS3.A3:2		{EO 2 B}	inline_connector
BS3.A3:3		{EO 1 C}	inline_connector
BS3.A3:4		{EO 1 C}	inline_connector
BS3.A3:5		{EP 1 C}	inline_connector
BS3.A3:6		{EP 2 C}	inline_connector
BS3.A3:7		{EP 2 B}	inline_connector
BS3.A3:8		{NA 2 D}	inline_connector
BS3.A3:9		{BB 2 D}	inline_connector
BS3.A3:10		{BA 0 C}	inline_connector
BS3.A3:11		{BA 0 C}	inline_connector
BS3.A3:12		{BA 0 C}	inline_connector
BS3:1		{EO 2 B}	inline_connector
BS3:2		{EO 2 B}	inline_connector
BS3:3		{EO 2 B}	inline_connector
BS3:4		{EO 1 B}	inline_connector
BS3:5		{EP 1 D}	inline_connector

VOLVO

Volvo Bus Corporation

Document Title

WIRING DIAGRAM

Document Type

TECHNICAL REGULATION

Document No

20904123

Issue Index

02

Volume No

02(02)

Page No

12(50)

Part Name	Description	Location	Part Type
BS3:6		{EP 1 D}	inline_connector
BS3:7		{EP 1 A}	inline_connector
BS3:8		{NA 2 D}	inline_connector
BS3:9		{BB 1 C}	inline_connector
BS3:10		{BA 0 C}	inline_connector
BS3:11		{BA 0 C}	inline_connector
BS3:12		{BA 0 B}	inline_connector
BS3B:1		{EO 2 C}	inline_connector
BS3B:2		{EO 2 C}	inline_connector
BS3B:3		{EO 1 C}	inline_connector
BS3B:4		{EO 1 C}	inline_connector
BS3B:8		{NA 2 D}	inline_connector
BS3B:9		{BB 1 D}	inline_connector
BS3B:10		{BA 0 D}	inline_connector
BS3B:11		{BA 0 D}	inline_connector
BS3B:12		{BA 0 D}	inline_connector
B_A:1		{FB 5 B}	inline_connector
B_A:2		{FB 4 D}	inline_connector
CAN:1		{XC 5 B}	inline_connector
CAN:2		{XC 5 B}	inline_connector
CAN:3		{XD 4 B}	inline_connector
CAN:4		{XD 5 B}	inline_connector
CAN:5		{CV 1 B}	inline_connector
CAN:6		{CV 1 B}	inline_connector
CNG:1		{CG 3 B}	inline_connector
CNG:2		{CG 3 B}	inline_connector
CNG:3		{CG 3 B}	inline_connector
CNG:4		{CG 2 B}	inline_connector
CNG:5		{CG 2 B}	inline_connector
CNG:6		{CG 1 B}	inline_connector
CNG:7		{CG 1 B}	inline_connector
CNG:8		{CG 4 B}	inline_connector
D1	Diod	{BA 3 B}	componentSymbol
D2	Diod	{AA 2 B}	componentSymbol
D3		{GM 1 B}	componentSymbol
D4		{GM 1 B}	componentSymbol
DF:1		{NC 3 D}	inline_connector
DF:2		{NC 4 C}	inline_connector
DF:3		{NC 5 C}	inline_connector
DF:4		{XD 4 D}	inline_connector
DF:5		{XD 4 D}	inline_connector
DF:6		{NC 4 D}	inline_connector
DIA		{DC 2 D}	componentSymbol
DIA2	Diagnostic connector for Ecomat 5	{DD 4 A}	componentSymbol
DIA_ARTIC		{DO 3 D}	componentSymbol
E4	Fuel heater	{CN 0 D}	componentSymbol
E06AL	Reverse Light(Left),Artic	{GD 4 B}	componentSymbol
E06AR	Reverse Light(Right),Artic	{GD 4 B}	componentSymbol
E06AT	Reverse Light(Triler),Artic	{GD 4 B}	componentSymbol
E06L	Reversing light left	{GA 1 A}	componentSymbol
E06LA	Reversing light left optional	{GA 1 A}	componentSymbol

VOLVO

Volvo Bus Corporation

Document Title

WIRING DIAGRAM

Document Type

TECHNICAL REGULATION

Document No

20904123

Issue Index

02

Volume No

02(02)

Page No

13(50)

Part Name	Description	Location	Part Type
E06R	Reversing light right	{GA 1 A}	componentSymbol
E07AL	Fog Light(Left),Artic	{GD 0 B}	componentSymbol
E07AR	Fog Light(Right),Artic	{GD 1 B}	componentSymbol
E07AT	Fog Light,Trailer,Artic	{GD 0 B}	componentSymbol
E07L	Fog light left	{GB 3 B}	componentSymbol
E07LR	Fog light left rear	{GA 2 A}	componentSymbol
E07R	Fog light right	{GB 3 B}	componentSymbol
E07RR	Fog light right rear	{GA 2 A}	componentSymbol
E09AL1	Brake Light(left),Artic	{GD 1 B}	componentSymbol
E09AL2	Brake Light(left),Artic	{GD 1 B}	componentSymbol
E09AR1	Brake Light (Right),Artic	{GD 5 B}	componentSymbol
E09AR2	Brake Light(Right),Artic	{GD 4 B}	componentSymbol
E09AT	Brake Light, Centre(Artic , Trailer)	{GD 5 B}	componentSymbol
E09LA	Brake light left	{GA 3 A}	componentSymbol
E09LB	Brake light left	{GA 3 A}	componentSymbol
E09RA	Brake light optional	{GA 2 A}	componentSymbol
E09RC	Brake light right	{GC 3 B}	componentSymbol
E09RD	Brake light right(Rear)	{GC 3 B}	componentSymbol
E09RE	Brake light left, Centre	{GC 3 B}	componentSymbol
E10AL	Tail Light(left),Artic	{GD 3 B}	componentSymbol
E10AR	Tail Light(Right),Artic	{GD 3 B}	componentSymbol
E10L	tail light left	{GA 5 A}	componentSymbol
E10LD	Tail light left	{GA 5 A}	componentSymbol
E10R	tail light right	{GC 1 B}	componentSymbol
E11AL1	Side marker(Left)Artic	{GD 2 B}	componentSymbol
E11AL2	Side marker((Left),Artic	{GD 2 B}	componentSymbol
E11AL3	Side marker(Left),Artic	{GD 2 B}	componentSymbol
E11AL4	Side marker(Left),Artic	{GD 2 C}	componentSymbol
E11AL5	Side marker(Left),Artic	{GD 2 C}	componentSymbol
E11AL6	Side marker(Left),Artic	{GD 2 C}	componentSymbol
E11ALT	Position Light,Left(Trailer),Artic	{GD 2 B}	componentSymbol
E11AR1	Side marker(Right),Artic	{GD 2 B}	componentSymbol
E11AR2	Side marker(Right),Artic	{GD 2 B}	componentSymbol
E11AR3	Side marker(Right),Artic	{GD 1 B}	componentSymbol
E11AR4	Side marker(Right),Artic	{GD 1 C}	componentSymbol
E11AR5	Side marker(Right),Artic	{GD 1 C}	componentSymbol
E11AR6	Side marker(Right),Artic	{GD 1 C}	componentSymbol
E11ART	Side marker(Right) ,trailer,Artic	{GD 1 B}	componentSymbol
E11LA		{GC 5 B}	componentSymbol
E11LF	Side marker light left front	{GC 5 B}	componentSymbol
E11LR	Side marker light left rear	{GC 5 B}	componentSymbol
E11ML	Side marker light middle left	{GC 4 B}	componentSymbol
E11MR	Side marker light middle right	{GC 3 B}	componentSymbol
E11RA		{GC 4 B}	componentSymbol
E11RF	Side marker light right front	{GC 4 B}	componentSymbol
E11RR	Side marker light right rear	{GC 4 B}	componentSymbol
E11TL	Position Light,Left(Trailer)	{GC 5 B}	componentSymbol
E11TR	Position Light,Right(Trailer)	{GC 4 B}	componentSymbol
E13AL	Direction indicator (left),Artic	{GD 4 B}	componentSymbol
E13ALT	Direction indicator, Left(trailer),Artic	{GD 3 B}	componentSymbol
E13AR	Direction indicator,(Left),Artic	{GD 3 B}	componentSymbol

VOLVO

Volvo Bus Corporation

Document Title

WIRING DIAGRAM

Document Type

TECHNICAL REGULATION

Document No

20904123

Issue Index

02

Volume No

02(02)

Page No

14(50)

Part Name	Description	Location	Part Type
E13ART	Direction indicator,Right,(Artic)	{GD 3 B}	componentSymbol
E13L	Lamp direction indicator left	{GA 4 A}	componentSymbol
E13LA	Dir.indicator left	{GA 4 A}	componentSymbol
E13LR	Dir. indicator left rear	{GA 3 B}	componentSymbol
E13R	Dir. indicator right	{GC 2 B}	componentSymbol
E13RB	Dir.indicator right	{GC 2 B}	componentSymbol
E13RR	Dir. indicator right rear	{GC 2 B}	componentSymbol
E913A	EGS gearbox diagnostics lamp	{DA 1 D}	componentSymbol
E913B	EGS gearbox diagnostics lamp	{DA 1 B}	componentSymbol
ECS1:1		{FA 4 B}	inline_connector
ECS1:2		{FA 4 B}	inline_connector
ECS1:3		{FA 4 B}	inline_connector
ECS1:5		{FB 5 C}	inline_connector
ECS1:6		{FB 2 D}	inline_connector
ECS1:7		{FB 2 D}	inline_connector
ECS1:8		{FB 5 C}	inline_connector
ECS1:9		{FB 5 C}	inline_connector
ECS1:10		{FB 2 C}	inline_connector
ECS1:11		{FB 2 C}	inline_connector
ECS1:12		{FA 4 C}	inline_connector
ECS2.A1:1		{FA 2 C}	inline_connector
ECS2.A1:2		{FA 2 C}	inline_connector
ECS2.A1:3		{FA 2 C}	inline_connector
ECS2.A1:4		{FB 5 B}	inline_connector
ECS2.A1:5		{FB 4 B}	inline_connector
ECS2.A1:6		{FB 3 B}	inline_connector
ECS2.A1:7		{FB 3 B}	inline_connector
ECS2.A1:8		{FB 5 B}	inline_connector
ECS2.A1:9		{FB 5 B}	inline_connector
ECS2.A1:10		{FB 1 C}	inline_connector
ECS2.A1:11		{FB 2 C}	inline_connector
ECS2.A1:12		{FA 4 D}	inline_connector
ECS2.A2:1		{FA 5 B}	inline_connector
ECS2.A2:2		{FA 4 B}	inline_connector
ECS2.A2:3		{FA 5 B}	inline_connector
ECS2.A2:4		{FB 5 A}	inline_connector
ECS2.A2:5		{FB 4 A}	inline_connector
ECS2.A2:6		{FB 1 C}	inline_connector
ECS2.A2:7		{FB 1 C}	inline_connector
ECS2.A2:8		{FB 5 B}	inline_connector
ECS2.A2:9		{FB 5 A}	inline_connector
ECS2.A2:10		{FB 1 C}	inline_connector
ECS2.A2:11		{FB 2 C}	inline_connector
ECS2.A2:12		{FA 4 D}	inline_connector
ECS2.A3:1		{FA 5 C}	inline_connector
ECS2.A3:2		{FA 4 C}	inline_connector
ECS2.A3:3		{FA 5 C}	inline_connector
ECS2.A3:4		{FB 5 A}	inline_connector
ECS2.A3:5		{FB 4 A}	inline_connector
ECS2.A3:6		{FB 1 C}	inline_connector
ECS2.A3:7		{FB 1 C}	inline_connector

VOLVO

Volvo Bus Corporation

Document Title

WIRING DIAGRAM

Document Type

TECHNICAL REGULATION

Document No

20904123

Issue Index

02

Volume No

02(02)

Page No

15(50)

Part Name	Description	Location	Part Type
ECS2.A3:8		{FB 5 A}	inline_connector
ECS2.A3:9		{FB 5 A}	inline_connector
ECS2.A3:10		{FB 1 C}	inline_connector
ECS2.A3:11		{FB 2 C}	inline_connector
ECS2.A3:12		{FA 4 D}	inline_connector
ECS2:1		{FA 5 B}	inline_connector
ECS2:2		{FA 4 B}	inline_connector
ECS2:3		{FA 5 B}	inline_connector
ECS2:4		{FB 5 D}	inline_connector
ECS2:5		{FB 4 D}	inline_connector
ECS2:6		{FB 3 C} {FB 2 D}	inline_connector
ECS2:7		{FB 3 C} {FB 3 C}	inline_connector
ECS2:8		{FB 5 D}	inline_connector
ECS2:9		{FB 5 D}	inline_connector
ECS2:10		{FB 1 C} {FB 3 C}	inline_connector
ECS2:11		{FB 2 C} {FB 3 C}	inline_connector
ECS2:12		{FA 4 D}	inline_connector
ECS2B:1		{FA 5 C}	inline_connector
ECS2B:2		{FA 4 C}	inline_connector
ECS2B:3		{FA 5 C}	inline_connector
ECS2B:6		{FB 3 C}	inline_connector
ECS2B:7		{FB 3 C}	inline_connector
ECS2B:10		{FB 3 C}	inline_connector
ECS2B:11		{FB 3 C}	inline_connector
ECS2B:12		{FA 5 C}	inline_connector
EGS_C:1		{DA 1 B}	inline_connector
EMS.A1:1		{BA 5 B}	inline_connector
EMS.A1:2		{XC 1 B}	inline_connector
EMS.A1:3		{XC 1 B}	inline_connector
EMS.A1:6		{BA 2 D}	inline_connector
EMS.A1:7		{BA 2 D}	inline_connector
EMS.A1:8	Parking Brake	{BA 4 A}	inline_connector
EMS.A1:9		{BA 4 C}	inline_connector
EMS.A1:10		{ZC 4 B}	inline_connector
EMS.A1:11	Luggage hatch, open	{BB 1 C}	inline_connector
EMS.A1:12		{AC 3 C}	inline_connector
EMS.A2:1		{BA 4 B}	inline_connector
EMS.A2:2		{XC 2 B}	inline_connector
EMS.A2:3		{XC 2 B}	inline_connector
EMS.A2:6		{BA 2 D}	inline_connector
EMS.A2:7		{BA 3 D}	inline_connector
EMS.A2:8		{FC 3 C}	inline_connector
EMS.A2:9		{BA 4 C}	inline_connector
EMS.A2:10		{ZC 4 C}	inline_connector
EMS.A2:11	Luggage hatch, open	{BB 1 C}	inline_connector
EMS.A2:12		{AC 3 C}	inline_connector
EMS.A3:1		{BA 4 B}	inline_connector
EMS.A3:2		{XC 3 B}	inline_connector

VOLVO

Volvo Bus Corporation

Document Title

WIRING DIAGRAM

Document Type

TECHNICAL REGULATION

Document No

20904123

Issue Index

02

Volume No

02(02)

Page No

16(50)

Part Name	Description	Location	Part Type
EMS.A3:3		{XC 3 B}	inline_connector
EMS.A3:4		{XD 3 B}	inline_connector
EMS.A3:5		{XD 3 B}	inline_connector
EMS.A3:6		{BA 1 D}	inline_connector
EMS.A3:7		{BA 3 D}	inline_connector
EMS.A3:9		{BA 4 B}	inline_connector
EMS.A3:10		{ZC 4 C}	inline_connector
EMS.A3:11	Luggage hatch, open	{BB 1 D}	inline_connector
EMS.A3:12		{AC 3 B}	inline_connector
EMS:1		{BA 5 B}	inline_connector
EMS:2		{XC 1 B} {XC 1 C}	inline_connector
EMS:3		{XC 1 B} {XC 1 B}	inline_connector
EMS:4		{XD 5 C}	inline_connector
EMS:5		{XD 5 C}	inline_connector
EMS:6		{BA 2 D}	inline_connector
EMS:7		{BA 2 D}	inline_connector
EMS:8	Parking Brake	{BA 4 A}	inline_connector
EMS:9		{BA 4 C}	inline_connector
EMS:10		{ZC 4 B}	inline_connector
EMS:11	Luggage hatch, open	{BB 1 C}	inline_connector
EMS:12		{AC 3 C}	inline_connector
EMSB:1		{CA 5 D}	inline_connector
EMSB:2		{XC 4 C}	inline_connector
EMSB:3		{XC 4 B}	inline_connector
EMSB:4		{XD 5 B}	inline_connector
EMSB:5		{XD 5 B}	inline_connector
EMSB:6		{CA 0 D}	inline_connector
EMSB:7		{CA 4 D}	inline_connector
EMSB:9		{CA 4 D}	inline_connector
EMSB:10		{CA 2 D}	inline_connector
EMSB:12		{CO 4 C}	inline_connector
ENG1.A1:1		{AA 2 A}	inline_connector
ENG1.A1:2		{AA 0 B}	inline_connector
ENG1.A1:3		{BD 2 A}	inline_connector
ENG1.A1:4		{AA 1 B}	inline_connector
ENG1.A1:5		{BD 2 D}	inline_connector
ENG1.A1:6		{AG 4 C}	inline_connector
ENG1.A1:7		{AC 4 B}	inline_connector
ENG1.A1:8		{AC 4 B}	inline_connector
ENG1.A1:9		{AC 0 C}	inline_connector
ENG1.A1:10		{NA 0 B}	inline_connector
ENG1.A1:11		{NA 4 D}	inline_connector
ENG1.A1:12		{ZC 3 B}	inline_connector
ENG1.A2:1		{AA 1 A}	inline_connector
ENG1.A2:2		{AG 4 C}	inline_connector
ENG1.A2:3		{BD 1 A}	inline_connector
ENG1.A2:4		{AG 4 C}	inline_connector
ENG1.A2:5		{BD 2 D}	inline_connector
ENG1.A2:6		{AG 4 C}	inline_connector
ENG1.A2:7		{AC 4 A}	inline_connector

VOLVO

Volvo Bus Corporation

Document Title

WIRING DIAGRAM

Document Type

TECHNICAL REGULATION

Document No

20904123

Issue Index

02

Volume No

02(02)

Page No

17(50)

Part Name	Description	Location	Part Type
ENG1.A2:8		{AG 3 C}	inline_connector
ENG1.A2:9		{AC 0 B}	inline_connector
ENG1.A2:10		{NA 0 B}	inline_connector
ENG1.A2:11		{NA 4 D}	inline_connector
ENG1.A2:12		{ZC 3 B}	inline_connector
ENG1.A3:1		{AA 1 A}	inline_connector
ENG1.A3:2		{AG 4 B}	inline_connector
ENG1.A3:3		{BD 1 A}	inline_connector
ENG1.A3:4		{AG 4 B}	inline_connector
ENG1.A3:5		{BD 2 D}	inline_connector
ENG1.A3:6		{AG 4 B}	inline_connector
ENG1.A3:7		{AC 4 A}	inline_connector
ENG1.A3:8		{AG 3 B}	inline_connector
ENG1.A3:9		{AC 0 B}	inline_connector
ENG1.A3:11		{NA 4 D}	inline_connector
ENG1:1		{AA 2 B}	inline_connector
ENG1:2		{AA 1 B}	inline_connector
ENG1:3		{BD 3 A}	inline_connector
ENG1:4		{AA 1 B}	inline_connector
ENG1:5		{BD 3 D}	inline_connector
ENG1:6		{AG 4 D}	inline_connector
ENG1:7		{AC 5 B}	inline_connector
ENG1:8		{AC 4 B}	inline_connector
ENG1:9		{AC 1 B}	inline_connector
ENG1:10		{NA 0 B}	inline_connector
ENG1:11		{NA 0 D} {NA 5 D}	inline_connector
ENG1:12		{ZC 3 B}	inline_connector
ENG1B:1		{AA 1 B}	inline_connector
ENG1B:2		{AG 4 B} {AG 3 B}	inline_connector
ENG1B:3		{BD 1 B} {BD 5 B}	inline_connector
ENG1B:4		{AG 4 B} {AG 2 B}	inline_connector
ENG1B:5		{BD 1 C} {BD 5 D}	inline_connector
ENG1B:6		{AG 4 B} {AG 3 C}	inline_connector
ENG1B:7		{AE 4 C}	inline_connector
ENG1B:8		{AG 3 B} {AG 2 B}	inline_connector
ENG1B:9		{AE 1 C}	inline_connector
ENG1B:11		{NA 4 D}	inline_connector
Engine_block	Grund	{CM 0 C}	global_terminal_connector
EU4.A1:1		{CO 5 D}	inline_connector
EU4.A1:2		{CO 3 D}	inline_connector
EU4.A1:3	Indoor temperature -	{NA 4 B}	inline_connector
EU4.A1:8		{BA 4 C}	inline_connector
EU4.A1:9		{AC 3 D}	inline_connector
EU4.A1:10		{CU 4 D}	inline_connector
EU4.A1:11		{CV 0 C}	inline_connector

VOLVO

Volvo Bus Corporation

Document Title

WIRING DIAGRAM

Document Type

TECHNICAL REGULATION

Document No

20904123

Issue Index

02

Volume No

02(02)

Page No

18(50)

Part Name	Description	Location	Part Type
EU4.A1:12		{CV 0 C}	inline_connector
EU4.A2:1		{CO 5 C}	inline_connector
EU4.A2:2		{CO 3 C}	inline_connector
EU4.A2:3	Indoor temperature -	{NA 4 A}	inline_connector
EU4.A2:8		{BA 4 C}	inline_connector
EU4.A2:9		{AC 3 C}	inline_connector
EU4.A2:10		{CU 4 D}	inline_connector
EU4.A2:11		{CV 1 C}	inline_connector
EU4.A2:12		{CV 1 C}	inline_connector
EU4.A3:1		{CO 5 C}	inline_connector
EU4.A3:2		{CO 3 C}	inline_connector
EU4.A3:3	Indoor temperature -	{NA 4 A}	inline_connector
EU4.A3:8		{BA 3 C}	inline_connector
EU4.A3:9		{AC 3 C}	inline_connector
EU4.A3:10		{CU 4 C}	inline_connector
EU4.A3:11		{CV 2 C}	inline_connector
EU4.A3:12		{CV 2 C}	inline_connector
EU4:1		{CO 4 D}	inline_connector
EU4:2		{CO 4 D}	inline_connector
EU4:3	Indoor temperature -	{NA 4 B}	inline_connector
EU4:4		{EO 1 B}	inline_connector
EU4:5		{EO 1 B}	inline_connector
EU4:6		{EO 1 B}	inline_connector
EU4:7		{EO 0 B}	inline_connector
EU4:8		{BA 4 C}	inline_connector
EU4:9		{AC 2 D}	inline_connector
EU4:10		{CU 5 D}	inline_connector
EU4:11		{CV 2 D} {CV 2 D} {CV 1 C}	inline_connector
EU4:12		{CV 2 D} {CV 2 C} {CV 1 C}	inline_connector
EU4B:1		{CO 5 B}	inline_connector
EU4B:2		{CO 4 B}	inline_connector
EU4B:3	Indoor temperature -	{NA 2 C}	inline_connector
EU4B:8		{CA 4 D}	inline_connector
EU4B:9		{CA 3 D}	inline_connector
EU4B:11		{CV 2 C}	inline_connector
EU4B:12		{CV 2 B}	inline_connector
F1	ECS, 5A	{FA 0 D}	componentSymbol
F2	BIC2,10A	{NA 1 D}	componentSymbol
F3	Starter motor,15A	{AA 1 D}	componentSymbol
F4	EBS,20A	{EO 5 D}	componentSymbol
F5	Horn,5A	{IS 2 D}	componentSymbol
F6	Emg. Parking brake release, 5A	{AA 5 D}	componentSymbol
F7	Gearbox ECU I-Shift, ZF4, 15A	{DN 4 D}	componentSymbol
F8	Gear selector ,I-Shift,5A	{DN 4 D}	componentSymbol
F9	Switchbox start/stop rear, 5A	{AG 4 D}	componentSymbol
F10	Fire Alarm,5A	{BB 5 D}	componentSymbol
F11	Dyna fleet,10A	{NC 5 D}	componentSymbol
F12	Body +30,5A	{BB 4 D}	componentSymbol

VOLVO

Volvo Bus Corporation

Document Title

WIRING DIAGRAM

Document Type

TECHNICAL REGULATION

Document No

20904123

Issue Index

02

Volume No

02(02)

Page No

19(50)

Part Name	Description	Location	Part Type
F13		{CO 4 D}	componentSymbol
F14	BBM,5A	{BB 5 D}	componentSymbol
F15	EECU,15A	{BA 4 D}	componentSymbol
F16	VECU,5A	{BA 4 D}	componentSymbol
F17	Switch feed,5A	{AC 2 D}	componentSymbol
F18	Alternature,5A	{AC 1 D}	componentSymbol
F19	Hymner / Pre-heat relay,10A	{AC 3 D}	componentSymbol
F20	EBS,10A	{EO 5 D}	componentSymbol
F21	Wiper,Washer,15A	{GM 2 D}	componentSymbol
F22	Diva 5, Ecolife, 10A	{DC 3 D}	componentSymbol
F23	ACC,5A	{AC 3 D}	componentSymbol
F24	BIC 2,5A	{NA 1 D}	componentSymbol
F25	Washer motor, 15A	{GM 4 D}	componentSymbol
F26	ECS,5A	{FA 0 D}	componentSymbol
F27	G8-EGS,10A	{DA 4 D}	componentSymbol
F28	Retarder,10A	{DM 4 D}	componentSymbol
F29	Body +DR, 5A	{BB 4 D}	componentSymbol
F30	Fuel heater DH7, 20A	{AC 2 D}	componentSymbol
F31	Hydraulic oil, DNOx2, 10A	{NA 5 D}	componentSymbol
F32	Tachograph,5A	{NB 4 D}	componentSymbol
F33	BIC 2,5A	{NA 1 D}	componentSymbol
F34	Tachograph,10A	{NB 4 D}	componentSymbol
F35	LCM ,25A	{GA 5 D}	componentSymbol
F36	LCM,25A	{GA 4 D}	componentSymbol
F37	LCM,25A	{GA 3 D}	componentSymbol
F39	DNOx2, 25A	{CU 5 D}	componentSymbol
F41	Radio,20A	{IU 4 D}	componentSymbol
F42	Maine Switch,5A	{AA 5 D}	componentSymbol
F44	LCM,25A	{GA 5 D}	componentSymbol
F45	LCM,25A	{GA 4 D}	componentSymbol
F46	LCM,25A	{GA 4 D}	componentSymbol
F47	Side marker L,5A	{GC 5 D}	componentSymbol
F48	Side marker R,5A	{GC 5 D}	componentSymbol
F49	Fuel cut off valve,5A	{NA 5 D}	componentSymbol
F50	Retarder,10A	{DM 4 D}	componentSymbol
F51	Radio,5A	{IU 4 D}	componentSymbol
F52	Luggage Light,10A	{BB 3 D}	componentSymbol
F53	Bogie Valve, Heater waterseperator, 5A	{BB 0 D}	componentSymbol
F54	Engine/Luggage hatch,5A	{GA 3 D}	componentSymbol
F55	Engine brake valve, Preheat relay, Fan speed clutch,10A	{BA 2 D}	componentSymbol
F56	Engine brake, 10A	{BA 2 D}	componentSymbol
F57	Key switch,5A	{AA 4 D}	componentSymbol
F58	FTM,5A	{CG 3 D}	componentSymbol
F60	Ecolife,10A	{DD 1 D}	componentSymbol
F61	Light, luggageroom,10A	{GA 3 D}	componentSymbol
F62	Light sleep department,5A	{GA 2 D}	componentSymbol
F63	Inverted starter motor, 5A	{AC 4 D}	componentSymbol
F64	Spare	{AC 4 D}	componentSymbol
F80	Fuse +	{AB 0 D}	componentSymbol
F81	Fuse +30	{AB 0 D}	componentSymbol
F90A		{CU 2 B}	componentSymbol

VOLVO

Volvo Bus Corporation

Document Title

WIRING DIAGRAM

Document Type

TECHNICAL REGULATION

Document No

20904123

Issue Index

02

Volume No

02(02)

Page No

20(50)

Part Name	Description	Location	Part Type
F90B		{CU 2 B}	componentSymbol
F93	Fuse,Alternator	{AB 1 B}	componentSymbol
FEED:1		{BA 5 D}	inline_connector
FH1A:1		{DN 4 C}	inline_connector
FH1A:2		{DN 4 C}	inline_connector
FH1A:3		{DN 4 D}	inline_connector
FH1A:4		{AA 5 D}	inline_connector
FH1A:6		{IS 2 D}	inline_connector
FH1A:7		{FA 0 D}	inline_connector
FH1A:8		{EO 5 D}	inline_connector
FH1A:10		{NA 1 D}	inline_connector
FH1A:11		{AA 1 D}	inline_connector
FH1B:1		{BA 4 D}	inline_connector
FH1B:2		{BA 4 D}	inline_connector
FH1B:3		{BA 5 D}	inline_connector
FH1B:4		{AG 4 D}	inline_connector
FH1B:6		{BB 5 D}	inline_connector
FH1B:7		{BB 5 D}	inline_connector
FH1B:8		{CO 4 D}	inline_connector
FH1B:10		{NC 5 D}	inline_connector
FH1B:11		{BB 4 D}	inline_connector
FH2A:1		{GM 2 D}	inline_connector
FH2A:2		{DC 3 D}	inline_connector
FH2A:3		{AC 3 D}	inline_connector
FH2A:4		{EO 5 D}	inline_connector
FH2A:5		{AA 1 D}	inline_connector
FH2A:6		{NA 1 D}	inline_connector
FH2A:7		{AC 3 D}	inline_connector
FH2A:8		{AC 1 D}	inline_connector
FH2A:9		{AC 2 D}	inline_connector
FH2B:1		{BB 4 D}	inline_connector
FH2B:2		{AC 2 D}	inline_connector
FH2B:3		{NA 5 D}	inline_connector
FH2B:4		{DM 4 D}	inline_connector
FH2B:5		{AA 1 D}	inline_connector
FH2B:6		{NB 4 D}	inline_connector
FH2B:7		{DA 4 D}	inline_connector
FH2B:8		{FA 0 D}	inline_connector
FH2B:9		{GM 4 D}	inline_connector
FH3A:1		{BA 2 D}	inline_connector
FH3A:2		{BA 2 D}	inline_connector
FH3A:3		{BA 4 D}	inline_connector
FH3A:4		{GA 3 D}	inline_connector
FH3A:5		{BB 0 D}	inline_connector
FH3A:7		{NA 5 D}	inline_connector
FH3A:8		{BB 3 D}	inline_connector
FH3A:10		{DM 4 D}	inline_connector
FH3A:12		{IU 4 D}	inline_connector
FH3B:1		{AC 4 D}	inline_connector
FH3B:2		{AC 4 D}	inline_connector
FH3B:3		{AC 5 D}	inline_connector

VOLVO

Volvo Bus Corporation

Document Title

WIRING DIAGRAM

Document Type

TECHNICAL REGULATION

Document No

20904123

Issue Index

02

Volume No

02(02)

Page No

21(50)

Part Name	Description	Location	Part Type
FH3B:4		{AA 4 D}	inline_connector
FH3B:5		{GA 2 D}	inline_connector
FH3B:7		{CG 3 D}	inline_connector
FH3B:9		{GA 3 D}	inline_connector
FH3B:11		{DD 1 D}	inline_connector
FH3B:12		{DD 2 D}	inline_connector
FH4A:2		{CU 5 C}	inline_connector
FH4A:3		{CU 5 D}	inline_connector
FH4A:5		{GA 3 D}	inline_connector
FH4A:7		{NA 1 D}	inline_connector
FH4A:8		{GA 4 D}	inline_connector
FH4A:10		{NB 4 D}	inline_connector
FH4A:12		{GA 5 D}	inline_connector
FH4B:1		{GC 5 C}	inline_connector
FH4B:2		{GC 4 C}	inline_connector
FH4B:3		{GC 3 D}	inline_connector
FH4B:4		{IU 4 D}	inline_connector
FH4B:5		{GA 4 D}	inline_connector
FH4B:7		{AA 5 D}	inline_connector
FH4B:8		{GA 4 D}	inline_connector
FH4B:12		{GA 5 D}	inline_connector
FL2:1		{ZC 4 D}	inline_connector
FL2:2		{ZC 4 D}	inline_connector
FL2:3		{ZC 4 D}	inline_connector
FL2:4		{GB 3 B}	inline_connector
FL2:5		{GB 3 B}	inline_connector
FL2:6		{ZC 4 D}	inline_connector
FL2:7		{GB 5 A}	inline_connector
FL2:8		{GB 4 A}	inline_connector
FL2:9		{GB 4 B}	inline_connector
FL2:10		{GB 3 B}	inline_connector
FL2:11		{ZC 5 D}	inline_connector
FL2:12		{ZC 4 D}	inline_connector
FL3:1		{ZC 4 D}	inline_connector
FL3:2		{ZC 4 D}	inline_connector
FL3:3		{ZC 5 D}	inline_connector
FL3:4		{GB 2 B}	inline_connector
FL3:5		{GB 3 B}	inline_connector
FL3:6		{ZC 5 D}	inline_connector
FL3:7		{GB 1 B}	inline_connector
FL3:8		{GB 2 B}	inline_connector
FL3:9		{GB 2 B}	inline_connector
FL3:10		{GB 2 B}	inline_connector
FL3:11		{ZC 5 D}	inline_connector
FL3:12		{ZC 5 D}	inline_connector
FM:1		{ND 1 B}	inline_connector
FM:2		{ND 1 B}	inline_connector
FM:3		{ND 1 B}	inline_connector
FM:4		{ND 1 B}	inline_connector
FTM:1		{CG 3 D}	inline_connector
FTM:2		{XD 0 B}	inline_connector

VOLVO

Volvo Bus Corporation

Document Title

WIRING DIAGRAM

Document Type

TECHNICAL REGULATION

Document No

20904123

Issue Index

02

Volume No

02(02)

Page No

22(50)

Part Name	Description	Location	Part Type
FTM:3		{XD 0 B}	inline_connector
FTM:4	Glass heating	{BC 2 C}	inline_connector
FTM:5	D-CAN L	{BC 2 C}	inline_connector
FTM:6	D-CAN H	{BC 2 B}	inline_connector
FTM:7	D-CAN L	{BC 2 B}	inline_connector
FTM:8		{CG 4 D}	inline_connector
FTM:9		{AA 2 D}	inline_connector
FTM:10		{ZC 0 B}	inline_connector
FTM:11		{CG 3 D}	inline_connector
FTM_D:1		{CG 3 D}	inline_connector
FTM_D:2		{XD 0 B}	inline_connector
FTM_D:3		{XD 0 B}	inline_connector
FTM_D:4	D-CAN L	{BC 2 C}	inline_connector
FTM_D:5	D-CAN L	{BC 2 C}	inline_connector
FTM_D:6	D-CAN H	{BC 2 B}	inline_connector
FTM_D:7	D-CAN H	{BC 2 B}	inline_connector
FTM_D:9		{AA 2 D}	inline_connector
FTM_D:10		{ZC 0 B}	inline_connector
FTM_J:4	D-CAN L	{BC 2 C}	inline_connector
FTM_J:5	D-CAN L	{BC 2 C}	inline_connector
FTM_J:6	D-CAN H	{BC 2 B}	inline_connector
FTM_J:7	D-CAN H	{BC 2 B}	inline_connector
FUEL.A1:1		{NA 0 B}	inline_connector
FUEL.A1:2		{NA 0 B}	inline_connector
FUEL.A1:3		{NA 0 C}	inline_connector
FUEL.A1:5		{NA 1 D}	inline_connector
FUEL.A1:6		{NA 1 C}	inline_connector
FUEL:1		{NA 4 A}	inline_connector
FUEL:2		{NA 4 A}	inline_connector
FUEL:3		{NA 4 B}	inline_connector
FUEL:5		{NA 5 C}	inline_connector
FUEL:6		{NA 5 B}	inline_connector
FUEL:7		{FA 3 B}	inline_connector
FUEL:8		{FA 3 B}	inline_connector
FUEL:9		{FA 3 B}	inline_connector
FUEL:10		{FB 0 D}	inline_connector
FUEL:11		{FB 4 D}	inline_connector
FUEL_A:1		{NA 4 A}	inline_connector
FUEL_A:3		{NA 4 B}	inline_connector
FUEL_A:5		{NA 5 C}	inline_connector
FUEL_A:6		{NA 5 B}	inline_connector
FUEL_B:1		{NA 0 C}	inline_connector
FUEL_B:2		{NA 0 C}	inline_connector
FUEL_B:3		{NA 0 D}	inline_connector
FUEL_B:5		{NA 5 C}	inline_connector
FUEL_B:6		{NA 5 B}	inline_connector
FUEL_B:7		{FA 3 B}	inline_connector
FUEL_B:8		{FA 3 B}	inline_connector
FUEL_B:9		{FA 3 B}	inline_connector
FUEL_B:10		{FB 0 D}	inline_connector
FUEL_B:11		{FB 4 D}	inline_connector

VOLVO

Volvo Bus Corporation

Document Title

WIRING DIAGRAM

Document Type

TECHNICAL REGULATION

Document No

20904123

Issue Index

02

Volume No

02(02)

Page No

23(50)

Part Name	Description	Location	Part Type
FUSE	Fuse,Engine preheating	{CM 0 D}	componentSymbol
G01	Battery	{AB 5 B}	componentSymbol
G01.R12		{AB 1 B}	componentSymbol
G01B	Battery	{AB 5 B}	componentSymbol
G01B.R12		{AB 1 B}	componentSymbol
G02	Alternator 1	{AD 3 C} {AE 3 B} {AF 3 B}	componentSymbol
G02.S9		{AH 3 B}	componentSymbol
G03	Alternator 2	{AD 2 C} {AE 2 B} {AF 2 B}	componentSymbol
G03.B_R9L		{AE 2 C}	componentSymbol
G03.B_R9TL		{AE 2 C}	componentSymbol
G03.S9		{AH 3 B}	componentSymbol
G04	Alternator 4	{AE 1 B} {AF 1 B}	componentSymbol
G04.S9		{AH 2 B}	componentSymbol
GB1.A1:1		{DB 5 A}	inline_connector
GB1.A1:2		{DB 3 D}	inline_connector
GB1.A1:3		{DB 4 D}	inline_connector
GB1.A1:4		{DB 4 A}	inline_connector
GB1.A1:5		{DB 3 D}	inline_connector
GB1.A2:1		{DB 5 B}	inline_connector
GB1.A2:2		{DB 3 C}	inline_connector
GB1.A2:3		{DB 4 D}	inline_connector
GB1.A2:4		{DB 4 B}	inline_connector
GB1.A2:5		{DB 3 C}	inline_connector
GB1.A3:1		{DB 5 B}	inline_connector
GB1.A3:2		{DB 3 C}	inline_connector
GB1.A3:3		{DB 4 C}	inline_connector
GB1.A3:4		{DB 4 B}	inline_connector
GB1.A3:5		{DB 3 C}	inline_connector
GB1.A3:7		{XC 2 A}	inline_connector
GB1.A3:8		{XC 2 A}	inline_connector
GB1.A3:9		{XD 2 C}	inline_connector
GB1.A3:10		{XD 2 C}	inline_connector
GB1:1		{DB 4 A}	inline_connector
GB1:2		{DB 3 D}	inline_connector
GB1:3		{DB 4 D}	inline_connector
GB1:4		{DB 4 A}	inline_connector
GB1:5		{DB 3 D}	inline_connector
GB1:7		{XC 1 A}	inline_connector
GB1:8		{XC 1 A}	inline_connector
GB1:9		{XD 2 A}	inline_connector
GB1:10		{XD 2 A}	inline_connector
GBX.A1:1		{DM 1 A}	inline_connector
GBX.A1:2		{DN 3 C}	inline_connector
GBX.A1:3		{DC 3 C}	inline_connector
GBX.A1:5		{DM 5 C}	inline_connector
GBX.A1:6		{DM 4 C}	inline_connector
GBX.A1:9		{XD 2 C}	inline_connector

VOLVO

Volvo Bus Corporation

Document Title

WIRING DIAGRAM

Document Type

TECHNICAL REGULATION

Document No

20904123

Issue Index

02

Volume No

02(02)

Page No

24(50)

Part Name	Description	Location	Part Type
GBX.A1:10		{XD 2 C}	inline_connector
GBX.A1:11		{DD 0 C}	inline_connector
GBX.A1:12		{DD 0 C}	inline_connector
GBX.A2:1		{DM 1 B}	inline_connector
GBX.A2:2		{DN 3 C}	inline_connector
GBX.A2:3		{DC 3 C}	inline_connector
GBX.A2:5		{DM 5 C}	inline_connector
GBX.A2:6		{DM 4 C}	inline_connector
GBX.A2:9		{XD 2 B}	inline_connector
GBX.A2:10		{XD 2 B}	inline_connector
GBX.A2:11		{DD 0 D}	inline_connector
GBX.A2:12		{DD 0 D}	inline_connector
GBX.A3:1		{DM 1 B}	inline_connector
GBX.A3:2		{DN 2 C}	inline_connector
GBX.A3:5		{DM 5 C}	inline_connector
GBX.A3:6		{DM 4 C}	inline_connector
GBX.A3:9		{XD 2 B}	inline_connector
GBX.A3:10		{XD 2 B}	inline_connector
GBX:1		{DM 1 A}	inline_connector
GBX:2		{DN 3 C}	inline_connector
GBX:3		{DC 3 D}	inline_connector
GBX:4		{DD 1 C}	inline_connector
GBX:5		{DM 5 C}	inline_connector
GBX:6		{DM 4 C}	inline_connector
GBX:7		{XC 1 B}	inline_connector
GBX:8		{XC 1 B}	inline_connector
GBX:9		{XD 1 C}	inline_connector
GBX:10		{XD 1 C}	inline_connector
GBX:11		{DD 0 C}	inline_connector
GBX:12		{DD 1 C}	inline_connector
GBX_D:1		{DM 0 A}	inline_connector
GBX_D:3		{DC 3 C}	inline_connector
GBX_D:4		{DD 1 C}	inline_connector
GBX_D:7		{XC 1 B}	inline_connector
GBX_D:8		{XC 1 B}	inline_connector
GBX_D:9		{XD 1 B}	inline_connector
GBX_D:10		{XD 1 B}	inline_connector
GBX_D:11		{DD 0 C}	inline_connector
GBX_D:12		{DD 1 C}	inline_connector
GBX_R:1		{DM 1 A}	inline_connector
GBX_R:2		{DN 3 C}	inline_connector
GBX_R:3		{DC 3 C}	inline_connector
GBX_R:4		{DD 1 C}	inline_connector
GBX_R:5		{DM 5 C}	inline_connector
GBX_R:6		{DM 4 C}	inline_connector
GBX_R:9		{XD 1 B}	inline_connector
GBX_R:10		{XD 1 B}	inline_connector
GBX_R:11		{DD 0 C}	inline_connector
GBX_R:12		{DD 1 C}	inline_connector
GBX_RB:1		{DM 1 B}	inline_connector
GBX_RB:5		{DM 5 B}	inline_connector

VOLVO

Volvo Bus Corporation

Document Title

WIRING DIAGRAM

Document Type

TECHNICAL REGULATION

Document No

20904123

Issue Index

02

Volume No

02(02)

Page No

25(50)

Part Name	Description	Location	Part Type
GBX_RB:6		{DM 4 B}	inline_connector
GBX_RB:9		{XD 1 A}	inline_connector
GBX_RB:10		{XD 1 A}	inline_connector
GND1A		{ZC 2 A}	componentSymbol
GND1B		{ZC 3 A}	componentSymbol
GND1C		{ZC 2 A}	componentSymbol
GND1D		{ZC 0 A}	componentSymbol
GND1E		{ZC 0 D}	componentSymbol
GND1UA:1		{CU 2 A}	inline_connector
GND1UB:1		{CU 2 A}	inline_connector
GND2A		{AF 3 B}	componentSymbol
GND2B		{AF 2 B}	componentSymbol
GND2C		{AE 1 B}	componentSymbol
GND2D		{AE 4 B}	componentSymbol
GND6		{ZC 5 D}	componentSymbol
GND6B		{ZC 3 D}	componentSymbol
GND8		{ZC 3 D}	componentSymbol
GND9		{CO 3 A}	componentSymbol
GND11		{ZC 2 D}	componentSymbol
GND31A		{ZC 1 A}	componentSymbol
GND31B		{AB 5 A}	componentSymbol
GND70		{ZC 1 A}	componentSymbol
GND71		{ZC 0 A}	componentSymbol
GND72		{AH 4 B}	componentSymbol
GND73		{AH 2 B}	componentSymbol
GND74		{CU 1 B}	componentSymbol
GND75	GND_term_for_Towing_WH	{GA 0 C}	componentSymbol
GS1.A1:3		{DB 2 D}	inline_connector
GS1.A1:4		{DB 2 D}	inline_connector
GS1.A1:5		{DB 1 D}	inline_connector
GS1.A2:3		{DB 2 C}	inline_connector
GS1.A2:4		{DB 2 C}	inline_connector
GS1.A2:5		{DB 1 C}	inline_connector
GS1.A3:3		{DB 2 C}	inline_connector
GS1.A3:4		{DB 2 C}	inline_connector
GS1.A3:5		{DB 1 C}	inline_connector
GS1:3		{DB 2 D}	inline_connector
GS1:4		{DB 1 D}	inline_connector
GS1:5		{DB 1 D}	inline_connector
H01	Air,Operated	{IS 2 C}	componentSymbol
H02	Diaphragm horn	{IS 1 C}	componentSymbol
H05	Buzzer,H05	{DA 1 D}	componentSymbol
IB1:1		{NA 2 C}	inline_connector
IB1:2		{NA 2 B}	inline_connector
IB1:3		{NA 2 B}	inline_connector
IB1:4		{NA 2 B}	inline_connector
IB1:5		{NA 2 B}	inline_connector
IB1:6		{NA 2 B}	inline_connector
IB1:7		{NA 1 C}	inline_connector
IB1:8		{NA 3 C}	inline_connector
IB1:9		{NA 3 B}	inline_connector

VOLVO

Volvo Bus Corporation

Document Title

WIRING DIAGRAM

Document Type

TECHNICAL REGULATION

Document No

20904123

Issue Index

02

Volume No

02(02)

Page No

26(50)

Part Name	Description	Location	Part Type
IB1:10		{NA 3 C}	inline_connector
IB1:11		{NA 2 C}	inline_connector
IB1:13		{NA 4 C}	inline_connector
IB1:14		{XC 4 D}	inline_connector
IB1:15		{XC 4 D}	inline_connector
IB1:16		{XD 3 D}	inline_connector
IB1:17		{XD 3 D}	inline_connector
IB1:18		{NA 1 C}	inline_connector
IB2:1		{NA 3 B}	inline_connector
IB2:2		{NA 3 B}	inline_connector
IB2:3		{NA 3 B}	inline_connector
IB2:4		{NA 3 B}	inline_connector
IB2:5		{NA 4 C}	inline_connector
IB2:6		{NA 4 B}	inline_connector
IB2:7		{GC 3 D}	inline_connector
IB2:8		{ZC 5 B}	inline_connector
IB2:9		{GA 3 C}	inline_connector
IB2:10		{AA 5 C}	inline_connector
IB2:11		{IS 2 B}	inline_connector
IB2:12		{IS 1 C}	inline_connector
IB2:13		{EP 2 C}	inline_connector
IB2:14		{EP 2 C}	inline_connector
IB2:15		{EP 2 C}	inline_connector
IB2:16		{EP 2 C}	inline_connector
IB2:17		{AA 4 C}	inline_connector
IB2:18		{NC 5 D}	inline_connector
IB3:1		{BA 1 C}	inline_connector
IB3:2		{BA 1 C}	inline_connector
IB3:3		{BA 1 C}	inline_connector
IB3:4		{BA 1 C}	inline_connector
IB3:5		{BA 1 C}	inline_connector
IB3:6		{BA 1 B}	inline_connector
IB3:7		{BA 3 C}	inline_connector
IB3:8		{BA 3 C}	inline_connector
IB3:9		{BA 3 C}	inline_connector
IB3:10		{BA 3 C}	inline_connector
IB3:11		{BA 3 C}	inline_connector
IB3:12		{BA 3 C}	inline_connector
IB3:13		{BA 1 C}	inline_connector
IB3:14		{IU 4 D}	inline_connector
IB3:15		{IU 4 D}	inline_connector
IB3:16		{IU 4 C}	inline_connector
IB3:17		{AC 2 D}	inline_connector
IB3:18		{ZC 5 B}	inline_connector
IB4:1		{GB 3 C}	inline_connector
IB4:2		{GB 3 C}	inline_connector
IB4:3		{GB 4 C}	inline_connector
IB4:4		{GB 4 C}	inline_connector
IB4:5		{GB 4 C}	inline_connector
IB4:6		{GA 3 B}	inline_connector
IB4:7		{GB 3 B}	inline_connector

VOLVO

Volvo Bus Corporation

Document Title

WIRING DIAGRAM

Document Type

TECHNICAL REGULATION

Document No

20904123

Issue Index

02

Volume No

02(02)

Page No

27(50)

Part Name	Description	Location	Part Type
IB4:8		{GB 4 C}	inline_connector
IB4:9		{GB 4 C}	inline_connector
IB4:10		{GB 2 C}	inline_connector
IB4:11		{GB 2 C}	inline_connector
IB4:12		{GB 2 C}	inline_connector
IB4:13		{GB 2 C}	inline_connector
IB4:14		{GB 1 C}	inline_connector
IB4:15		{EP 0 D}	inline_connector
IB4:16		{EP 0 D}	inline_connector
IB4:17		{EP 1 C}	inline_connector
IB4:18		{EP 1 C}	inline_connector
IB5:1		{AA 5 D}	inline_connector
IB5:2		{AA 3 D}	inline_connector
IB5:3		{BA 1 B}	inline_connector
IB5:4		{AA 3 B}	inline_connector
IB5:5		{AA 5 D}	inline_connector
IB5:6		{AA 4 B}	inline_connector
IB5:7		{AA 5 C}	inline_connector
IB5:8		{FA 4 D}	inline_connector
IB5:9		{FA 2 B}	inline_connector
IB5:10		{NA 0 B}	inline_connector
IB5:11		{FA 3 C}	inline_connector
IB5:12		{FA 3 C}	inline_connector
IB5:13		{AA 3 C}	inline_connector
IB5:14		{FA 1 B}	inline_connector
IB5:15		{FA 1 B}	inline_connector
IB5:16		{FA 2 B}	inline_connector
IB5:17		{EO 3 C}	inline_connector
IB5:18		{NA 3 C}	inline_connector
IB6:1		{NB 4 D}	inline_connector
IB6:2		{XC 2 C}	inline_connector
IB6:3		{XC 3 C}	inline_connector
IB6:4		{NB 4 D}	inline_connector
IB6:5		{ZC 5 B}	inline_connector
IB6:6		{NB 3 D}	inline_connector
IB6:7		{NB 4 C}	inline_connector
IB6:8		{NB 4 C}	inline_connector
IB6:9		{NB 4 C}	inline_connector
IB6:10		{NB 4 C}	inline_connector
IB6:12		{NB 2 B}	inline_connector
IB7:1		{GM 4 D}	inline_connector
IB7:2		{GB 0 C}	inline_connector
IB7:3		{GB 1 B}	inline_connector
IB7:4		{GM 2 C}	inline_connector
IB7:5		{CV 0 C}	inline_connector
IB7:6		{CV 0 C}	inline_connector
IB7:7		{NA 2 C}	inline_connector
IB7:8		{GM 1 C}	inline_connector
IB7:9		{CO 4 D}	inline_connector
IB7:10		{ZC 4 B}	inline_connector
IB7:12		{GM 0 C}	inline_connector

VOLVO

Volvo Bus Corporation

Document Title

WIRING DIAGRAM

Document Type

TECHNICAL REGULATION

Document No

20904123

Issue Index

02

Volume No

02(02)

Page No

28(50)

Part Name	Description	Location	Part Type
IB8:1		{EO 4 C}	inline_connector
IB8:2		{EO 4 C}	inline_connector
IB8:3		{EO 4 C}	inline_connector
IB8:4		{EO 4 C}	inline_connector
IB8:5		{EO 4 C}	inline_connector
IB8:6		{DD 2 D}	inline_connector
IB8:7		{GB 1 C}	inline_connector
IB8:8	AC compressor 3	{CL 2 B}	inline_connector
IB8:9	AC compressor 2	{CL 3 B}	inline_connector
IB8:10	AC compressor 3	{CL 2 B}	inline_connector
IB8:11	AC compressor 2	{CL 4 C}	inline_connector
IB8:12	AC compressor 3	{CL 4 C}	inline_connector
IB9:1		{BA 3 B}	inline_connector
IB9:2		{BA 2 B}	inline_connector
IB9:4		{ZC 5 B}	inline_connector
IB9:6		{GA 0 B}	inline_connector
IB9:7		{BA 2 B}	inline_connector
IB9:8		{BA 3 B}	inline_connector
IB9:9		{BA 2 C}	inline_connector
IB9:10		{BA 2 C}	inline_connector
IB9:11		{BA 2 C}	inline_connector
IB9:12		{BA 2 C}	inline_connector
IB10:1		{DN 5 D}	inline_connector
IB10:2		{GA 1 C}	inline_connector
IB10:3		{BB 4 B}	inline_connector
IB10:4		{DA 3 C}	inline_connector
IB10:5		{DA 5 C}	inline_connector
IB10:6		{DA 4 C}	inline_connector
IB10:7		{DA 4 D}	inline_connector
IB10:8		{DN 4 C}	inline_connector
IB10:9		{ZC 1 B}	inline_connector
IB10:10		{DM 1 C}	inline_connector
IB10:11		{DD 0 C}	inline_connector
IB10:12		{DD 1 C}	inline_connector
IB10_B:2		{GA 1 C}	inline_connector
IB10_B:3		{BB 4 B}	inline_connector
IB10_B:9		{ZC 0 B}	inline_connector
IB10_E:2		{DA 3 C}	inline_connector
IB10_E:3		{BB 4 B}	inline_connector
IB10_E:4		{DA 3 C}	inline_connector
IB10_E:5		{DA 5 C}	inline_connector
IB10_E:6		{DA 4 C}	inline_connector
IB10_E:7		{DA 4 D}	inline_connector
IB10_E:9		{ZC 0 B}	inline_connector
IB10_E:10		{DM 1 C}	inline_connector
IB10_I:1		{DN 5 D}	inline_connector
IB10_I:8		{DN 4 C}	inline_connector
IB10_I:9		{ZC 1 B}	inline_connector
IB10_I:10		{DM 1 C}	inline_connector
IB10_VO:9		{ZC 1 B}	inline_connector
IB10_VO:10		{DM 1 C}	inline_connector

VOLVO

Volvo Bus Corporation

Document Title

WIRING DIAGRAM

Document Type

TECHNICAL REGULATION

Document No

20904123

Issue Index

02

Volume No

02(02)

Page No

29(50)

Part Name	Description	Location	Part Type
IB10_VO:11		{DD 0 D}	inline_connector
IB10_VO:12		{DD 1 D}	inline_connector
IB10_ZF5:9		{ZC 1 B}	inline_connector
IB10_ZF5:10		{DM 1 C}	inline_connector
IB10_ZF5:11		{DD 0 D}	inline_connector
IB10_ZF5:12		{DD 1 D}	inline_connector
IB10_ZF:9		{ZC 1 B}	inline_connector
IB10_ZF:10		{DM 1 C}	inline_connector
IS:1		{XD 3 D}	inline_connector
IS:2		{XD 3 D}	inline_connector
IS:3		{XC 4 C}	inline_connector
IS:4		{XC 4 C}	inline_connector
K2	Load Indicator	{AC 4 C}	componentSymbol
K3	ECS	{FA 0 B}	componentSymbol
K4	I-Shift/Voith	{DN 4 D}	componentSymbol
K5	EGS	{DA 4 D}	componentSymbol
K6	EGS	{DA 5 D}	componentSymbol
K7	Start engine	{AC 5 C}	componentSymbol
K8	VECU/EMS	{BA 5 C}	componentSymbol
K9	Wiper/Washer	{GM 2 C}	componentSymbol
K11	Prevent start engine	{AA 2 C}	componentSymbol
K12	Luggage Light	{BB 3 C}	componentSymbol
K13		{AA 4 D}	componentSymbol
K14	Bogie	{BB 0 C}	componentSymbol
K15	RECU	{DM 4 C}	componentSymbol
K16	RECU	{DM 4 C}	componentSymbol
K17	Ignition +15	{AA 1 D}	componentSymbol
K25	EXHAUST FLAP	{CN 1 C}	componentSymbol
K35	relay_disconn_headlight_wash	{GM 4 C}	componentSymbol
K48	Relay Engine Preheating	{CN 1 C} {CM 0 D}	componentSymbol
K51	Power relay,battery main switch	{AB 0 B}	componentSymbol
K200		{CN 4 D}	componentSymbol
K902		{CU 3 B}	componentSymbol
K903		{CU 3 B}	componentSymbol
K906	Relay_Turntable_failure	{FC 5 C}	componentSymbol
K908		{CU 4 B}	componentSymbol
K909		{CU 2 B}	componentSymbol
KH1A:1		{FA 0 B}	inline_connector
KH1A:2		{FA 0 B}	inline_connector
KH1A:3		{FA 0 B}	inline_connector
KH1A:4		{AC 4 C}	inline_connector
KH1A:5		{FA 0 B}	inline_connector
KH1A:7		{AC 4 C}	inline_connector
KH1A:10		{AC 4 C}	inline_connector
KH1A:11		{AC 4 C}	inline_connector
KH1B:1		{DN 4 D}	inline_connector
KH1B:2		{DN 4 D}	inline_connector
KH1B:3		{DN 4 D}	inline_connector
KH1B:4		{DA 4 D}	inline_connector
KH1B:5		{DN 4 D}	inline_connector

VOLVO

Volvo Bus Corporation

Document Title

WIRING DIAGRAM

Document Type

TECHNICAL REGULATION

Document No

20904123

Issue Index

02

Volume No

02(02)

Page No

30(50)

Part Name	Description	Location	Part Type
KH1B:7		{DA 4 C}	inline_connector
KH1B:8		{DA 5 D}	inline_connector
KH1B:10		{DA 4 C}	inline_connector
KH1B:11		{DA 4 D}	inline_connector
KH1B:12		{DA 5 C}	inline_connector
KH1B:14		{DA 5 D}	inline_connector
KH1B:15		{DA 5 C}	inline_connector
KH2A:1		{BA 3 A}	inline_connector
KH2A:3		{BA 5 C}	inline_connector
KH2A:4		{BA 3 B}	inline_connector
KH2A:5		{BA 5 C}	inline_connector
KH2A:6		{BA 5 C}	inline_connector
KH2A:7		{AC 5 C}	inline_connector
KH2A:8		{AC 4 C}	inline_connector
KH2A:9		{BA 5 C}	inline_connector
KH2A:10		{AC 5 C}	inline_connector
KH2A:11		{AC 4 C}	inline_connector
KH2A:12		{AC 5 C}	inline_connector
KH2B:1		{AA 2 B}	inline_connector
KH2B:2		{GM 2 C}	inline_connector
KH2B:3		{GM 2 C}	inline_connector
KH2B:4		{AA 2 B}	inline_connector
KH2B:5		{GM 2 C}	inline_connector
KH2B:6		{GM 2 C}	inline_connector
KH2B:9		{GM 2 C}	inline_connector
KH3A:1		{AA 4 D}	inline_connector
KH3A:3		{AA 4 C}	inline_connector
KH3A:4		{BB 3 C}	inline_connector
KH3A:5		{AA 4 D}	inline_connector
KH3A:6		{AA 4 C}	inline_connector
KH3A:7		{BB 3 D}	inline_connector
KH3A:8		{AA 2 C}	inline_connector
KH3A:9		{AA 2 C}	inline_connector
KH3A:10		{BB 3 D}	inline_connector
KH3A:11		{BB 3 C}	inline_connector
KH3A:12		{AA 2 C}	inline_connector
KH3A:14		{AA 2 C}	inline_connector
KH3B:1		{BB 0 D}	inline_connector
KH3B:2		{BB 0 C}	inline_connector
KH3B:3		{BB 0 D}	inline_connector
KH3B:4		{DM 4 D}	inline_connector
KH3B:5		{BB 0 C}	inline_connector
KH3B:7		{DM 4 C}	inline_connector
KH3B:8		{DM 4 D}	inline_connector
KH3B:10		{DM 5 C}	inline_connector
KH3B:11		{DM 5 D}	inline_connector
KH3B:12		{DM 4 C}	inline_connector
KH3B:14		{DM 4 D}	inline_connector
KH3B:15		{DM 4 C}	inline_connector
KV:A		{DA 4 B}	inline_connector
KV:B		{DA 4 B}	inline_connector

VOLVO

Volvo Bus Corporation

Document Title

WIRING DIAGRAM

Document Type

TECHNICAL REGULATION

Document No

20904123

Issue Index

02

Volume No

02(02)

Page No

31(50)

Part Name	Description	Location	Part Type
KV:C		{DA 4 B}	inline_connector
KV:D		{DA 4 B}	inline_connector
KV:E		{DA 4 B}	inline_connector
KV:F		{DA 5 B}	inline_connector
KV:G		{DA 2 B}	inline_connector
KV:H		{DA 3 B}	inline_connector
KV:J		{DA 2 B}	inline_connector
KV:K		{DA 2 B}	inline_connector
KV:L		{DA 3 B}	inline_connector
KV:M		{DA 3 B}	inline_connector
KV:P		{DA 5 B}	inline_connector
KV:Q		{DA 2 B}	inline_connector
KV:R		{DA 1 B}	inline_connector
KV:S		{DA 1 B}	inline_connector
KV:T		{DA 3 B}	inline_connector
LA:1		{AF 2 C}	inline_connector
LA:2		{AF 2 C}	inline_connector
LA:4		{AF 0 D}	inline_connector
LA:5		{AF 2 A}	inline_connector
LA:6		{AF 1 C}	inline_connector
LT:1		{EO 1 C}	inline_connector
LT:2		{EO 1 C}	inline_connector
LT:3		{EO 1 C}	inline_connector
LT:4		{EO 0 C}	inline_connector
LT:5		{CL 3 B}	inline_connector
LT:6		{CL 3 B}	inline_connector
LT:7		{CL 3 A}	inline_connector
LT:8		{FA 3 C}	inline_connector
LT:9		{FA 3 C}	inline_connector
LT:10		{FA 3 C}	inline_connector
LT:11		{FA 3 C}	inline_connector
LT:12		{FB 0 B}	inline_connector
LT:13		{FB 0 B}	inline_connector
LT:14		{FB 0 B}	inline_connector
LT:15		{FB 4 C}	inline_connector
LT:16		{FB 3 C}	inline_connector
LT:17		{FB 3 B}	inline_connector
M01	Motor, windscreen wiper	{GM 1 B}	componentSymbol
M01.A:1		{GM 2 A}	inline_connector
M01.A:2		{GM 1 B}	inline_connector
M01.A:3		{GM 1 B}	inline_connector
M01.A:5		{GM 1 B}	inline_connector
M01.A:6		{GM 0 B}	inline_connector
M01:1		{GM 0 B}	inline_connector
M01:2		{GM 1 B}	inline_connector
M01:3		{GM 1 B}	inline_connector
M01:4		{GM 1 B}	inline_connector
M01:5		{GM 2 A}	inline_connector
M01:6		{GM 4 C}	inline_connector
M01:8		{GM 3 B}	inline_connector
M01:9		{GM 4 C}	inline_connector

VOLVO

Volvo Bus Corporation

Document Title

WIRING DIAGRAM

Document Type

TECHNICAL REGULATION

Document No

20904123

Issue Index

02

Volume No

02(02)

Page No

32(50)

Part Name	Description	Location	Part Type
M01:11		{GM 4 B}	inline_connector
M01:12		{GM 3 B}	inline_connector
M01:13		{GM 4 B}	inline_connector
M01:14		{GM 4 C}	inline_connector
M02	windscreen_washer_motor	{GM 3 B}	componentSymbol
M03	headlights washer motor	{GM 4 B}	componentSymbol
M04	starter motor	{AD 4 C} {AE 4 B} {AF 4 B} {AH 4 B}	componentSymbol
ML1:1		{GB 4 A}	inline_connector
ML1:2		{ZC 3 D}	inline_connector
ML1:3		{GB 4 A}	inline_connector
ML1:4		{ZC 3 D}	inline_connector
ML1:5		{GB 4 A}	inline_connector
ML1:6		{ZC 3 D}	inline_connector
ML2:1		{GB 1 B}	inline_connector
ML2:2		{ZC 3 D}	inline_connector
ML2:3		{GB 1 B}	inline_connector
ML2:4		{ZC 3 D}	inline_connector
ML2:5		{GB 2 B}	inline_connector
ML2:6		{ZC 3 D}	inline_connector
ML3:1		{BB 2 C}	inline_connector
ML3:2		{BB 3 D}	inline_connector
ML3:3		{GC 4 B}	inline_connector
ML3:4		{GC 4 B}	inline_connector
ML3:5		{GC 4 B}	inline_connector
ML3:6		{GA 3 C}	inline_connector
ML3:7		{GC 4 B}	inline_connector
ML3A:3		{GD 2 B}	inline_connector
ML3A:4		{GD 2 B}	inline_connector
ML3A:5		{GD 1 B}	inline_connector
ML3A:7		{GD 2 B}	inline_connector
ML3B:1		{GD 4 C}	inline_connector
ML3B:2		{GD 3 C}	inline_connector
ML3B:3		{GD 1 C}	inline_connector
ML3B:4		{GD 1 C}	inline_connector
ML3B:5		{GD 1 C}	inline_connector
ML3B:6		{GD 5 C}	inline_connector
ML3B:7		{GD 1 B}	inline_connector
ML4:1		{BB 2 C}	inline_connector
ML4:2		{BB 3 D}	inline_connector
ML4:3		{GC 5 B}	inline_connector
ML4:4		{GC 5 B}	inline_connector
ML4:5		{GC 5 B}	inline_connector
ML4:6		{GA 3 C}	inline_connector
ML4:7		{GC 5 A}	inline_connector
ML4A:3		{GD 2 B}	inline_connector
ML4A:4		{GD 2 B}	inline_connector
ML4A:5		{GD 2 B}	inline_connector
ML4A:7		{GD 2 A}	inline_connector
ML4B:1		{GD 4 C}	inline_connector

VOLVO

Volvo Bus Corporation

Document Title

WIRING DIAGRAM

Document Type

TECHNICAL REGULATION

Document No

20904123

Issue Index

02

Volume No

02(02)

Page No

33(50)

Part Name	Description	Location	Part Type
ML4B:2		{GD 3 C}	inline_connector
ML4B:3		{GD 2 C}	inline_connector
ML4B:4		{GD 2 C}	inline_connector
ML4B:5		{GD 2 C}	inline_connector
ML4B:6		{GD 5 C}	inline_connector
ML4B:7		{GD 2 B}	inline_connector
ML5:1	Rear position lamp.Right	{GC 1 B}	inline_connector
ML5:2	Rear position lamp.Right	{GC 1 B}	inline_connector
ML5:3	Rear position lamp.Right	{GC 1 B}	inline_connector
ML5:4	Rear position lamp.Right	{GC 0 B}	inline_connector
ML5:5	Rear position lamp.Right	{GC 0 B}	inline_connector
ML5:6	Rear position lamp.Right	{GC 0 B}	inline_connector
ML5:7	Rear position lamp.Right	{GC 0 B}	inline_connector
ML6:1	Rear position lamp.Right	{GC 1 C}	inline_connector
ML6:2	Rear position lamp.Right	{GC 1 C}	inline_connector
ML6:3	Rear position lamp.Right	{GC 1 C}	inline_connector
ML6:4	Rear position lamp.Right	{GC 0 C}	inline_connector
ML6:5	Rear position lamp.Right	{GC 0 C}	inline_connector
ML6:6	Rear position lamp.Right	{GC 0 C}	inline_connector
ML6:7	Rear position lamp.Right	{GC 0 C}	inline_connector
ML7:5		{GA 2 C}	inline_connector
ML7:6		{GA 2 C}	inline_connector
OBD2		{NA 1 A}	componentSymbol
R1		{CN 1 C}	componentSymbol
R01	Heater_Engine_Preheat	{CM 0 C}	componentSymbol
R1_MD9		{CA 1 C}	componentSymbol
R08	Termination resistor,CAN-bus	{XC 4 D}	componentSymbol
R10	HEATER WATERSEPERATOR	{BB 0 B}	componentSymbol
R904	Resistor_DBUS	{CL 3 D} {CG 2 D}	componentSymbol
R905	Heated_Hose_Suction_Line	{CU 4 B}	componentSymbol
R905A:1		{CU 4 B}	inline_connector
R905A:2		{CU 4 B}	inline_connector
R905B:1		{CU 4 B}	inline_connector
R905B:2		{CU 4 B}	inline_connector
R905C:1		{CU 4 B}	inline_connector
R905C:2		{CU 4 B}	inline_connector
R906	Heated_Hose_Pressure_Line	{CU 4 B}	componentSymbol
R906A:1		{CU 4 B}	inline_connector
R906A:2		{CU 4 B}	inline_connector
R906B:1		{CU 4 B}	inline_connector
R906B:2		{CU 3 B}	inline_connector
R906C:1		{CU 3 B}	inline_connector
R906C:2		{CU 4 B}	inline_connector
R907		{CV 0 C}	componentSymbol
R908	Heated_Hose_Backflow_to_tank	{CU 2 B}	componentSymbol
R908A:1		{CU 2 B}	inline_connector
R908A:2		{CU 2 B}	inline_connector
R908B:1		{CU 2 B}	inline_connector
R908B:2		{CU 2 B}	inline_connector
R908C:1		{CU 2 B}	inline_connector

VOLVO

Volvo Bus Corporation

Document Title

WIRING DIAGRAM

Document Type

TECHNICAL REGULATION

Document No

20904123

Issue Index

02

Volume No

02(02)

Page No

34(50)

Part Name	Description	Location	Part Type
R908C:2		{CU 2 B}	inline_connector
R909	Heated_Filter	{CU 5 B}	componentSymbol
R910	Heated_Hose_Backflow_to_pump	{CU 3 B}	componentSymbol
R910A:1		{CU 3 B}	inline_connector
R910A:2		{CU 3 B}	inline_connector
R910B:1		{CU 3 B}	inline_connector
R910B:2		{CU 3 B}	inline_connector
R910C:1		{CU 3 B}	inline_connector
R910C:2		{CU 3 B}	inline_connector
R911		{CL 4 B}	componentSymbol
RA1.A1:1		{NB 4 B}	inline_connector
RA1.A1:2		{NB 4 B}	inline_connector
RA1.A1:3		{NB 3 B}	inline_connector
RA1.A1:4		{NB 3 B}	inline_connector
RA1.A1:5		{NA 3 C}	inline_connector
RA1.A1:6		{AC 3 C}	inline_connector
RA1.A1:7		{AC 2 C}	inline_connector
RA1.A1:8		{AC 1 C}	inline_connector
RA1.A1:10		{NA 5 C}	inline_connector
RA1.A1:11		{AB 4 D}	inline_connector
RA1.A2:1		{NB 4 B}	inline_connector
RA1.A2:2		{NB 4 B}	inline_connector
RA1.A2:3		{NB 3 B}	inline_connector
RA1.A2:4		{NB 3 B}	inline_connector
RA1.A2:5		{NA 3 C}	inline_connector
RA1.A2:6		{AC 3 B}	inline_connector
RA1.A2:7		{AC 2 B}	inline_connector
RA1.A2:8		{AC 1 B}	inline_connector
RA1.A2:10		{NA 4 C}	inline_connector
RA1.A2:11		{AB 5 D}	inline_connector
RA1.A3:1		{NB 4 B}	inline_connector
RA1.A3:2		{NB 4 B}	inline_connector
RA1.A3:3		{NB 3 B}	inline_connector
RA1.A3:4		{NB 3 B}	inline_connector
RA1.A3:5		{NA 3 D}	inline_connector
RA1.A3:6		{AC 3 B}	inline_connector
RA1.A3:7		{AC 2 B}	inline_connector
RA1.A3:8		{AC 1 B}	inline_connector
RA1.A3:10		{NA 4 C}	inline_connector
RA1.A3:11		{AB 5 D}	inline_connector
RA1:1		{NB 5 B} {NB 4 B}	inline_connector
RA1:2		{NB 5 B} {NB 4 B}	inline_connector
RA1:3		{NB 5 B} {NB 4 B}	inline_connector
RA1:4		{NB 5 B} {NB 3 B}	inline_connector
RA1:5		{NA 3 C}	inline_connector
RA1:6		{AC 3 B}	inline_connector
RA1:7		{AC 2 B}	inline_connector
RA1:8		{AC 2 B}	inline_connector

VOLVO

Volvo Bus Corporation

Document Title

WIRING DIAGRAM

Document Type

TECHNICAL REGULATION

Document No

20904123

Issue Index

02

Volume No

02(02)

Page No

35(50)

Part Name	Description	Location	Part Type
RA1:9		{ND 1 B}	inline_connector
RA1:10		{NA 0 C} {NA 4 C}	inline_connector
RA1:11		{AB 4 D}	inline_connector
RA1:12		{AA 5 C}	inline_connector
RA1B:1		{NB 5 B}	inline_connector
RA1B:2		{NB 5 B}	inline_connector
RA1B:3		{NB 5 B}	inline_connector
RA1B:4		{NB 5 B}	inline_connector
RA1B:5		{NA 3 C}	inline_connector
RA1B:6		{AE 3 C}	inline_connector
RA1B:7		{AE 2 C}	inline_connector
RA1B:8		{AE 1 C}	inline_connector
RA1B:10		{NA 4 C}	inline_connector
RA1B:11		{AE 3 B}	inline_connector
RC3		{DA 3 D}	componentSymbol
RC3_HYM		{FC 3 D}	componentSymbol
REV:1		{DC 1 C}	inline_connector
RL1:1		{GC 3 B}	inline_connector
RL1:2		{GC 3 B}	inline_connector
RL1:3		{GC 1 B}	inline_connector
RL1:4		{GC 1 B}	inline_connector
RL1:5		{GC 2 B}	inline_connector
RL1:6		{GC 2 B}	inline_connector
RL1:7		{GA 1 B}	inline_connector
RL1:8		{GA 1 A}	inline_connector
RL1:9		{GA 2 B}	inline_connector
RL1:10		{GA 3 A}	inline_connector
RL1:11		{GC 3 B}	inline_connector
RL1:12		{GC 3 B}	inline_connector
RL2:1		{GA 3 B}	inline_connector
RL2:2		{GA 3 A}	inline_connector
RL2:3		{GA 5 B}	inline_connector
RL2:4		{GA 5 A}	inline_connector
RL2:5		{GA 3 B}	inline_connector
RL2:6		{GA 3 A}	inline_connector
RL2:7		{GA 1 B}	inline_connector
RL2:8		{GA 1 A}	inline_connector
RL2:9		{GA 2 B}	inline_connector
RL2:10		{GA 2 A}	inline_connector
RL2:11		{GA 3 B}	inline_connector
RL2:12		{GA 3 A}	inline_connector
RL3:1		{GC 5 B}	inline_connector
RL3:2		{GC 4 B}	inline_connector
RL3:3		{GA 4 A}	inline_connector
RL3:4		{GC 2 B}	inline_connector
RL3:5		{GA 3 C}	inline_connector
RL3:6		{GA 1 B}	inline_connector
RL3:7		{GC 3 B}	inline_connector
RL3:8		{BC 3 A}	inline_connector
RL3:9	Rear position lamp.Right	{GC 0 B}	inline_connector

VOLVO

Volvo Bus Corporation

Document Title

WIRING DIAGRAM

Document Type

TECHNICAL REGULATION

Document No

20904123

Issue Index

02

Volume No

02(02)

Page No

36(50)

Part Name	Description	Location	Part Type
RL3:10		{GA 2 B}	inline_connector
RL3:11		{GA 3 C}	inline_connector
RL3:12		{ZC 1 D}	inline_connector
RL4:1		{GA 4 A}	inline_connector
RL4:2		{GC 2 B}	inline_connector
RL4:3		{GC 4 B}	inline_connector
RL4:4		{GC 3 B}	inline_connector
RL4:5		{GA 3 B}	inline_connector
RL4:6	Rear position lamp.Right	{GC 0 C}	inline_connector
RL4:7		{GA 2 B}	inline_connector
RL5:1		{GD 1 B}	inline_connector
RL5:2		{GD 1 B}	inline_connector
RL5:3		{GD 3 B}	inline_connector
RL5:4		{GD 3 B}	inline_connector
RL5:5		{GD 4 B}	inline_connector
RL5:6		{GD 4 B}	inline_connector
RL5:7		{GD 4 B}	inline_connector
RL5:8		{GD 4 B}	inline_connector
RL5:9		{GD 0 B}	inline_connector
RL5:10		{GD 0 B}	inline_connector
RL5:11		{GD 1 B}	inline_connector
RL5:12		{GD 1 B}	inline_connector
RL6:1		{GD 2 B}	inline_connector
RL6:2		{GD 1 B}	inline_connector
RL6:3		{GD 3 B}	inline_connector
RL6:4		{GD 3 B}	inline_connector
RL6:6		{GD 4 B}	inline_connector
RL6:7		{GD 5 B}	inline_connector
RL6:10		{GD 0 B}	inline_connector
RL6:12		{GD 5 B}	inline_connector
RL7:1		{GD 5 B}	inline_connector
RL7:2		{GD 5 B}	inline_connector
RL7:3		{GD 3 B}	inline_connector
RL7:4		{GD 3 B}	inline_connector
RL7:5		{GD 3 B}	inline_connector
RL7:6		{GD 3 B}	inline_connector
RL7:7		{GD 4 B}	inline_connector
RL7:8		{GD 4 B}	inline_connector
RL7:9		{GD 1 B}	inline_connector
RL7:10		{GD 1 B}	inline_connector
RL7:11		{GD 4 B}	inline_connector
RL7:12		{GD 4 B}	inline_connector
RL:1		{ZC 5 D}	inline_connector
RL:3	N/A	{GB 5 A}	inline_connector
S01	Switch,main lighting,selector type	{GB 5 D}	componentSymbol
S02	Stalk switch LHS	{BA 3 D} {GB 2 D}	componentSymbol
S06	Stalk switch , windscreen wiper, selector type	{NA 2 B} {GM 1 D}	componentSymbol
S07	Engine_Brake_Switch	{CM 3 C}	componentSymbol
S08	Switch,differential gear lock,rear wheels	{EO 3 D}	componentSymbol
S11	switch bogie lift	{FA 3 B}	componentSymbol

VOLVO

Volvo Bus Corporation

Document Title

WIRING DIAGRAM

Document Type

TECHNICAL REGULATION

Document No

20904123

Issue Index

02

Volume No

02(02)

Page No

37(50)

Part Name	Description	Location	Part Type
S12	Main switch	{AA 4 C}	componentSymbol
S14A	Switch, push button, horn	{IS 2 B}	componentSymbol
S14B	Switch, push button, horn	{IS 1 B}	componentSymbol
S15A	Switch,Starter Key	{AA 3 D}	componentSymbol
S15B	Switch,Starter Feed	{AA 4 B}	componentSymbol
S16	Switch,push button,air horn	{IS 1 B}	componentSymbol
S19	Switch,extra	{DA 2 C}	componentSymbol
S24	stalk_switch_retarder	{BA 1 D}	componentSymbol
S31	TCS	{EP 0 B}	componentSymbol
S32	Brake hold	{EP 1 C}	componentSymbol
S34	Switch unit, steering wheel push buttons	{IS 5 C}	componentSymbol
S40	Switch, battery main switch	{AA 5 C}	componentSymbol
S41	Switch, battery main switch control	{AB 0 C}	componentSymbol
S45	Position switch,differential gear lock indicator,rear wheels,NC.or NO.	{EP 1 C}	componentSymbol
S50	Pressure switch, exhaust pressure governor,NC	{BA 3 A}	componentSymbol
S58	clutch_switch	{BA 2 C}	componentSymbol
S68	coolant_level	{CN 3 C} {CM 2 D} {CA 3 C}	componentSymbol
S68_S9		{CA 3 C}	componentSymbol
S70	Switch Hydr.oil ,Flow sensor	{BB 1 B}	componentSymbol
S77	Assistantnce call	{NC 3 C}	componentSymbol
S901	eng_stop_rear	{AG 0 B} {AG 5 B} {AG 2 B} {AG 1 B}	componentSymbol
S901_U	Eng_stop_switch_outside	{AG 1 B}	componentSymbol
S902	switch leveling	{FA 1 B}	componentSymbol
S904	Switch,emergency cut-out	{AA 4 D}	componentSymbol
S905	switch_retarder	{BA 1 A}	componentSymbol
S907	eng_start_rear	{AG 4 B} {AG 1 B} {AG 3 B} {AG 5 B}	componentSymbol
S908	eng_start_enable_rear	{AG 3 B} {AG 0 B} {AG 2 B} {AG 4 B}	componentSymbol
S909	Gear selector Voith	{DC 1 D}	componentSymbol
S910	Switch group, Ecomat transmission gear selector	{DB 1 D}	componentSymbol
S911	Switch,EGG	{AA 5 D}	componentSymbol
S913	Switch,cl.cont/rev.l man.transm	{GA 1 D}	componentSymbol
S915	switch kneeling	{FA 3 C}	componentSymbol
S916	Switch,Fault EGS	{DA 2 C}	componentSymbol
S917	Switch,Gear selector EGS	{DA 3 D}	componentSymbol
S918	Switch,EGS extra gear	{DA 1 C}	componentSymbol
S926	Ecomat_trans_ret_oil_temp_sens	{DB 3 B}	componentSymbol
S927	Switch,alternative gearshift program,ZF	{DB 2 D}	componentSymbol
S927_ZF5		{DD 4 D}	componentSymbol
S928	Switch_Position_Neutral	{BB 4 C}	componentSymbol

VOLVO

Volvo Bus Corporation

Document Title

WIRING DIAGRAM

Document Type

TECHNICAL REGULATION

Document No

20904123

Issue Index

02

Volume No

02(02)

Page No

38(50)

Part Name	Description	Location	Part Type
S932	Switch_alternativ gearshift program,Voiith	{DC 2 C}	componentSymbol
S935	Jack-knife warning	{BC 4 B}	componentSymbol
S935A		{BC 4 B}	componentSymbol
S935B	Jack-knife warning (last trailer)	{BC 4 A}	componentSymbol
S936	Jack-knife stop	{BC 3 B}	componentSymbol
S936A		{BC 3 B}	componentSymbol
S936B	Jack-knife stop (last trailer)	{BC 3 A}	componentSymbol
S939	Switch_service_gas_system	{CG 4 C}	componentSymbol
S940	LAMP FOR OILMASTER	{CO 3 D}	componentSymbol
S941	Reverse gearselector	{DC 2 C}	componentSymbol
SP_F:1	AC compressor 2	{CL 2 D}	inline_connector
SP_F:2	AC compressor 3	{CL 1 D}	inline_connector
SP_F:3	AC compressor 2	{CL 1 D}	inline_connector
SP_F:4	AC compressor 3	{CL 1 D}	inline_connector
SP_RR:1	AC compressor 2	{CL 2 C}	inline_connector
SP_RR:2	AC compressor 3	{CL 1 C}	inline_connector
SP_RR:3	AC compressor 2	{CL 1 C}	inline_connector
SP_RR:4	AC compressor 3	{CL 1 C}	inline_connector
S_T_S:1		{NB 3 B}	inline_connector
S_T_S:2		{NB 3 B}	inline_connector
S_T_S:3		{NB 3 B}	inline_connector
S_T_T:3		{NB 3 B}	inline_connector
TOW:1	Rear position lamp.Right	{GA 1 C}	inline_connector
TOW:3	Rear position lamp.Right	{GA 0 C}	inline_connector
TOW:4	Rear position lamp.Right	{GA 1 C}	inline_connector
TOW:5	Rear position lamp.Right	{GA 1 C}	inline_connector
TOW:6	Rear position lamp.Right	{GA 0 C}	inline_connector
TOW:7	Rear position lamp.Right	{GA 1 C}	inline_connector
TRAIL2:1		{EO 1 B}	inline_connector
TRAIL2:2		{EO 1 B}	inline_connector
TRAIL2:3		{EO 1 B}	inline_connector
TRAIL2:4		{EO 0 B}	inline_connector
TRAIL2:5		{CL 3 B}	inline_connector
TRAIL2:6		{CL 3 B}	inline_connector
TRAIL2:7		{CL 3 B}	inline_connector
TRAIL2:8		{FA 3 B}	inline_connector
TRAIL2:9		{FA 3 B}	inline_connector
TRAIL2:10		{FA 3 B}	inline_connector
TRAIL2:11		{FB 0 C}	inline_connector
TRAIL2:12		{FB 4 C}	inline_connector
TRAIL3:1		{BC 4 B}	inline_connector
TRAIL3:2		{BC 4 A}	inline_connector
TRAIL3:3		{BC 3 B}	inline_connector
TRAIL3:4		{BC 3 A}	inline_connector
TRAIL:1		{EP 3 C}	inline_connector
TRAIL:2		{EP 3 C}	inline_connector
TRAIL:3		{EP 3 C}	inline_connector
TRAIL:4		{EP 2 C}	inline_connector
TRAIL:5		{FB 4 C}	inline_connector
TRAIL:6		{FB 4 C}	inline_connector
TRAIL:7		{FA 1 C}	inline_connector

VOLVO

Volvo Bus Corporation

Document Title

WIRING DIAGRAM

Document Type

TECHNICAL REGULATION

Document No

20904123

Issue Index

02

Volume No

02(02)

Page No

39(50)

Part Name	Description	Location	Part Type
TRAIL:8		{FA 2 C}	inline_connector
TRAIL:9		{FA 2 C}	inline_connector
TRAIL:10		{FB 1 B}	inline_connector
TRAIL:11		{FB 1 B}	inline_connector
TRAIL:12		{FB 1 B}	inline_connector
TRAIL:13		{FB 1 B}	inline_connector
TRAIL:14		{FB 4 B}	inline_connector
TRAIL:15		{FB 4 C}	inline_connector
TRAIL:16		{BC 5 B}	inline_connector
TRAIL:17		{BC 4 B}	inline_connector
TRAIL:18		{BC 5 B}	inline_connector
TRAIL:19		{GD 5 C}	inline_connector
TRAIL:20		{GD 4 C}	inline_connector
TRAIL:21		{GD 4 C}	inline_connector
TRAIL:22		{GD 3 C}	inline_connector
TRAIL:23		{GD 3 C}	inline_connector
TRAIL:24		{GD 3 C}	inline_connector
TRAIL:25		{GD 3 C}	inline_connector
TRAIL:26		{GD 3 C}	inline_connector
TRAIL:27		{GD 2 C}	inline_connector
TRAIL:28		{GD 2 C}	inline_connector
TRAIL:29		{GD 1 C}	inline_connector
TRAIL:30		{GD 0 C}	inline_connector
TRAIL:31		{FA 2 D}	inline_connector
U03	Modulator,EBS,rear axle(drive axle)	{EO 2 C}	componentSymbol
U04	Modulator EBS, bogie	{EP 4 B}	componentSymbol
U05	Modulator EBS, trailer	{EP 3 B}	componentSymbol
U06	Voltage converter	{IU 4 C}	componentSymbol
U07	Modulator,EBS,Bogie/Artic	{EP 5 B}	componentSymbol
U08	Modulator,EBS,front	{EO 3 C}	componentSymbol
U11	Modulator,EBS, last-trailer, biartic	{EO 1 C}	componentSymbol
UDS:1		{CV 3 C}	inline_connector
UDS:2		{CV 3 C}	inline_connector
UDS:5		{CU 3 C}	inline_connector
UDS:6		{CU 2 C}	inline_connector
UDS_B:1		{CV 4 D} {CV 4 C}	inline_connector
UDS_B:2		{CV 4 D} {CV 3 C}	inline_connector
UDS_B:3		{CV 5 B}	inline_connector
UDS_B:4		{CV 5 B}	inline_connector
UDS_F:1		{CV 2 D} {CV 2 C}	inline_connector
UDS_F:2		{CV 2 D} {CV 2 C}	inline_connector
UDS_F:3		{CV 4 B}	inline_connector
UDS_F:4		{CV 4 B}	inline_connector
UDS_M:1		{CV 3 D} {CV 3 C}	inline_connector
UDS_M:2		{CV 3 D} {CV 3 C}	inline_connector
UDS_M:3		{CV 5 B}	inline_connector

VOLVO

Volvo Bus Corporation

Document Title

WIRING DIAGRAM

Document Type

TECHNICAL REGULATION

Document No

20904123

Issue Index

02

Volume No

02(02)

Page No

40(50)

Part Name	Description	Location	Part Type
UDS_M:4		{CV 5 B}	inline_connector
VIC2:1		{CA 4 B}	inline_connector
VIC2:2		{CA 4 B}	inline_connector
VIC2:3		{CA 4 B}	inline_connector
VIC2:4		{CA 4 B}	inline_connector
VIC2:6		{CA 2 B}	inline_connector
VIC2:7		{CA 2 B}	inline_connector
VIC_MD7:1		{XC 4 A}	inline_connector
VIC_MD7:2		{XD 3 B}	inline_connector
VIC_MD7:3		{CN 5 C}	inline_connector
VIC_MD7:4		{XC 4 A}	inline_connector
VIC_MD7:5		{XD 4 B}	inline_connector
VIC_MD7:6		{CN 5 C}	inline_connector
VIC_MD7:7		{CN 1 C}	inline_connector
VIC_MD7:8		{CN 5 C}	inline_connector
VIC_MD7:9		{AD 3 C}	inline_connector
VIC_MD7:10		{AD 1 D}	inline_connector
VIC_MD7:12		{AD 4 B}	inline_connector
VIC_MD7:13		{CN 4 C}	inline_connector
VIC_MD7:14		{BD 5 C}	inline_connector
VIC_MD7:15		{CN 4 C}	inline_connector
VIC_MD7:16		{BD 5 B}	inline_connector
VIC_MD7:17		{AD 2 C}	inline_connector
VIC_MD7:18		{CN 4 C}	inline_connector
VIC_MD7:20		{CN 3 C}	inline_connector
VIC_MD7:21		{CN 0 C}	inline_connector
VIC_MD7:28		{CN 3 C}	inline_connector
VIC_MD7:30		{CN 2 C}	inline_connector
VIC_MD7:31		{CN 2 C}	inline_connector
VIC_MD7:32		{CN 2 C}	inline_connector
VIC_MD7:33		{CN 4 C}	inline_connector
VIC_MD7:35		{AD 5 C}	inline_connector
VIC_MD7:37		{CN 1 D}	inline_connector
VIC_MD7:39		{CN 2 C}	inline_connector
VIC_MD9:1		{XC 3 B}	inline_connector
VIC_MD9:2		{XD 3 A}	inline_connector
VIC_MD9:3		{CA 5 C}	inline_connector
VIC_MD9:4		{XC 3 B}	inline_connector
VIC_MD9:5		{XD 3 A}	inline_connector
VIC_MD9:6		{CA 5 C}	inline_connector
VIC_MD9:7		{CA 1 C}	inline_connector
VIC_MD9:8		{CA 5 C}	inline_connector
VIC_MD9:9		{AE 3 C}	inline_connector
VIC_MD9:10		{AE 1 B}	inline_connector
VIC_MD9:11		{AE 3 C}	inline_connector
VIC_MD9:12		{AE 3 B}	inline_connector
VIC_MD9:13		{CA 4 C}	inline_connector
VIC_MD9:14		{BD 1 C} {BD 3 C} {BD 2 D} {BD 5 C}	inline_connector
VIC_MD9:15		{CA 4 C}	inline_connector

VOLVO

Volvo Bus Corporation

Document Title

WIRING DIAGRAM

Document Type

TECHNICAL REGULATION

Document No

20904123

Issue Index

02

Volume No

02(02)

Page No

41(50)

Part Name	Description	Location	Part Type
VIC_MD9:16		{BD 1 B} {BD 3 C} {BD 2 B} {BD 5 B}	inline_connector
VIC_MD9:17		{AE 2 C}	inline_connector
VIC_MD9:18		{CA 3 D}	inline_connector
VIC_MD9:21		{CA 0 D}	inline_connector
VIC_MD9:28		{CA 3 C}	inline_connector
VIC_MD9:30		{CA 2 C}	inline_connector
VIC_MD9:31		{CA 2 C}	inline_connector
VIC_MD9:33		{CA 4 D}	inline_connector
VIC_MD9:34		{CB 4 A}	inline_connector
VIC_MD9:35		{AE 4 B} {AH 5 C}	inline_connector
VIC_MD9:37		{CA 3 C}	inline_connector
VIC_MD9:38		{CB 4 B}	inline_connector
VIC_MD9:39		{CA 2 C}	inline_connector
X09	Slip contact/Horne	{IS 1 B}	componentSymbol
X14		{AF 3 C}	componentSymbol
X25:1		{DB 3 C}	inline_connector
X25:2		{XD 2 A}	inline_connector
X25:3		{DB 4 B}	inline_connector
X25:4		{XD 2 A}	inline_connector
X25:6		{DB 1 C}	inline_connector
X25:7		{DB 2 C}	inline_connector
X25:8		{DB 4 C}	inline_connector
X25:9		{DB 4 C}	inline_connector
X902	Power connection box MD7	{AD 4 B}	componentSymbol
X903	VPDU Front with main relay and main switch	{AB 5 C}	componentSymbol
X904	VPDU Rear with preheat relay	{AB 3 C}	componentSymbol
X905		{AB 4 B}	componentSymbol
X906	EXTERNAL CHARGER OUTLET	{AB 5 B}	componentSymbol
X917	POWER JUNCTION R9S	{AH 3 C}	componentSymbol
XC103_R7		{AB 4 B}	componentSymbol
XC103_R9		{AB 4 B}	componentSymbol
XC201_R9L		{AB 2 C}	componentSymbol
XC201_R9TL		{AB 2 C}	componentSymbol
XC202A_R9S_R9L		{AB 3 C}	componentSymbol
XC202A_R9TL		{AB 3 C}	componentSymbol
XC202B_R9S_9L		{AB 2 C}	componentSymbol
XC202B_R9TL		{AB 2 C}	componentSymbol
XC906:1		{AB 5 C}	inline_connector
XC906:2		{AB 5 C}	inline_connector
XC906:3		{AB 5 C}	inline_connector
XC906:4		{AB 5 C}	inline_connector
XC906:5		{AB 4 C}	inline_connector
XC906:6		{AB 4 C}	inline_connector
XC914A:1		{CA 3 D}	inline_connector
XC914A:2		{CA 3 C}	inline_connector
XC914A:3		{CA 1 B}	inline_connector
XC914A:4		{CA 1 A}	inline_connector
XC914A:5		{NA 0 C}	inline_connector

VOLVO

Volvo Bus Corporation

Document Title

WIRING DIAGRAM

Document Type

TECHNICAL REGULATION

Document No

20904123

Issue Index

02

Volume No

02(02)

Page No

42(50)

Part Name	Description	Location	Part Type
XC914A:7		{NA 0 D}	inline_connector
XC914A:8		{NA 0 C}	inline_connector
XC914A:9	Indoor temperature -	{NA 0 D}	inline_connector
XC915:1		{NA 5 A}	inline_connector
XC915:3		{NA 5 B}	inline_connector
XC915:5		{NA 5 C}	inline_connector
XC915:6		{NA 5 B}	inline_connector
XC916:1		{AH 3 C}	inline_connector
XC916:2		{AH 2 C}	inline_connector
XC916:4		{AH 1 C}	inline_connector
XC916:5		{AH 4 B}	inline_connector
XC916:6		{AH 1 C}	inline_connector
XC917:1		{CL 3 B}	inline_connector
XC917:2		{CL 3 B}	inline_connector
XC917:3		{CL 4 B}	inline_connector
XC917:4		{CL 3 B}	inline_connector
XC920:1		{FC 2 C}	inline_connector
XC920:2		{FC 2 D}	inline_connector
XC921:1		{CL 3 B}	inline_connector
XC921:2		{CL 3 B}	inline_connector
XC921:3		{CL 3 B}	inline_connector
XC922:1		{GB 2 C}	inline_connector
XC922:3		{GB 1 C}	inline_connector
XE1		{CB 5 C}	physical_splice_connector
XE5		{CB 3 D}	physical_splice_connector
XE8		{CB 1 C}	physical_splice_connector
XE10		{CB 1 A}	physical_splice_connector
XJK:1		{BC 4 C}	inline_connector
XJK:2		{BC 4 A}	inline_connector
XJK:3		{BC 3 C}	inline_connector
XJK:4		{BC 3 A}	inline_connector
XK2:5		{GA 2 C}	inline_connector
XK2:6		{GA 2 C}	inline_connector
XSA01		{XC 3 D}	physical_splice_connector
XSA02		{XC 3 D}	physical_splice_connector
XSA03		{XC 2 D}	physical_splice_connector
XSA04		{XC 2 D}	physical_splice_connector
XSA05		{XC 2 D}	physical_splice_connector
XSA06		{XC 2 D}	physical_splice_connector
XSA07		{XC 1 D}	physical_splice_connector
XSA08		{XC 1 D}	physical_splice_connector
XSA09		{XC 0 D}	physical_splice_connector
XSA10		{XC 0 D}	physical_splice_connector
XSA11		{XC 1 C}	physical_splice_connector
XSA12		{XC 1 B}	physical_splice_connector
XSA13		{XD 2 D}	physical_splice_connector
XSA14		{XD 2 D}	physical_splice_connector
XSA15		{XD 2 D}	physical_splice_connector
XSA16		{XD 2 D}	physical_splice_connector
XSA17		{XD 2 D}	physical_splice_connector
XSA18		{XD 2 D}	physical_splice_connector

VOLVO

Volvo Bus Corporation

Document Title

WIRING DIAGRAM

Document Type

TECHNICAL REGULATION

Document No

20904123

Issue Index

02

Volume No

02(02)

Page No

43(50)

Part Name	Description	Location	Part Type
XSA19		{XD 1 D}	physical_splice_connector
XSA20		{XD 1 D}	physical_splice_connector
XSA21		{XD 1 D}	physical_splice_connector
XSA22		{XD 1 D}	physical_splice_connector
XSA23		{XD 1 C}	physical_splice_connector
XSA24		{XD 1 C}	physical_splice_connector
XSA25		{ZC 5 A}	physical_splice_connector
XSA26		{AA 5 A}	physical_splice_connector
XSA27		{FA 4 B}	physical_splice_connector
XSA28		{AA 3 B}	physical_splice_connector
XSA31		{ZC 4 B}	physical_splice_connector
XSA32		{BA 4 B}	physical_splice_connector
XSA34		{AA 3 D}	physical_splice_connector
XSA35		{ZC 1 A}	physical_splice_connector
XSA37		{FB 1 D}	physical_splice_connector
XSA40		{FB 2 D}	physical_splice_connector
XSA43		{ZC 2 A}	physical_splice_connector
XSA44		{AC 5 B}	physical_splice_connector
XSA46		{BB 2 B}	physical_splice_connector
XSA50		{BA 5 C}	physical_splice_connector
XSA52		{ZC 2 B}	physical_splice_connector
XSA53		{GM 2 C}	physical_splice_connector
XSA54		{DM 4 D}	physical_splice_connector
XSA59		{BA 5 B}	physical_splice_connector
XSA60		{NA 4 B}	physical_splice_connector
XSA61		{BA 4 C}	physical_splice_connector
XSA62		{XD 3 D}	physical_splice_connector
XSA63		{XC 4 D}	physical_splice_connector
XSA64		{XC 4 D}	physical_splice_connector
XSA65		{XD 3 D}	physical_splice_connector
XSA68		{BC 2 C}	physical_splice_connector
XSA69		{BC 2 C}	physical_splice_connector
XSB01		{XC 5 D}	physical_splice_connector
XSB02		{XC 5 D}	physical_splice_connector
XSB03		{XD 4 D}	physical_splice_connector
XSB04		{XD 4 D}	physical_splice_connector
XSB05		{XD 4 D}	physical_splice_connector
XSB06		{XD 4 D}	physical_splice_connector
XSB07		{IS 3 B}	physical_splice_connector
XSB08		{IS 3 B}	physical_splice_connector
XSB09		{ZC 4 B}	physical_splice_connector
XSB10		{ZC 5 C}	physical_splice_connector
XSB11		{ZC 5 C}	physical_splice_connector
XSB12		{GM 3 C}	physical_splice_connector
XSB13		{GB 1 D}	physical_splice_connector
XSB18		{IU 4 C}	physical_splice_connector
XSB19		{IU 4 C}	physical_splice_connector
XSB20		{AC 2 C}	physical_splice_connector
XSB21		{IU 4 C}	physical_splice_connector
XSB22		{NC 4 C}	physical_splice_connector
XSB23		{NC 4 C}	physical_splice_connector

VOLVO

Volvo Bus Corporation

Document Title

WIRING DIAGRAM

Document Type

TECHNICAL REGULATION

Document No

20904123

Issue Index

02

Volume No

02(02)

Page No

44(50)

Part Name	Description	Location	Part Type
XSB28		{CV 0 C}	physical_splice_connector
XSB29		{CV 0 C}	physical_splice_connector
XSB30		{IU 4 C}	physical_splice_connector
XSB31		{IU 4 C}	physical_splice_connector
XSB32		{XC 5 D}	physical_splice_connector
XSB33		{XC 4 D}	physical_splice_connector
XSC01		{ZC 4 D}	physical_splice_connector
XSC03		{GB 3 B}	physical_splice_connector
XSC08		{GB 2 B}	physical_splice_connector
XSC09		{GB 4 B}	physical_splice_connector
XSC11		{DA 2 C}	physical_splice_connector
XSC12		{DA 1 C}	physical_splice_connector
XSC13		{ZC 0 C}	physical_splice_connector
XSC14		{ZC 3 D}	physical_splice_connector
XSC16		{ZC 5 D}	physical_splice_connector
XSC21		{DN 5 B}	physical_splice_connector
XSC23		{DD 4 C}	physical_splice_connector
XSC24		{DD 4 C}	physical_splice_connector
XSC25		{DD 4 C}	physical_splice_connector
XSC95		{CL 3 C}	physical_splice_connector
XSC96		{CL 3 C}	physical_splice_connector
XSC97		{CL 2 C}	physical_splice_connector
XSC98		{CL 2 C}	physical_splice_connector
XSC99		{CL 3 C}	physical_splice_connector
XSD05		{DC 2 C}	physical_splice_connector
XSD06		{DC 3 C}	physical_splice_connector
XSD07		{DC 3 C}	physical_splice_connector
XSD08		{DC 2 C}	physical_splice_connector
XSE01		{CB 1 D} {CM 5 C}	physical_splice_connector
XSE02		{AE 2 B}	physical_splice_connector
XSE03		{CM 4 C}	physical_splice_connector
XSE06		{CM 4 C}	physical_splice_connector
XSE09		{CM 2 C}	physical_splice_connector
XSE10		{CM 1 D}	physical_splice_connector
XSE11		{CM 1 C}	physical_splice_connector
XSE13		{CM 4 B}	physical_splice_connector
XSE14		{CM 3 B}	physical_splice_connector
XSE15		{CM 3 B}	physical_splice_connector
XSE16		{CM 3 B}	physical_splice_connector
XSE17		{CM 3 B}	physical_splice_connector
XSE18		{CM 2 B}	physical_splice_connector
XSE19		{CM 2 B}	physical_splice_connector
XSE20		{CM 2 B}	physical_splice_connector
XSE21		{CM 2 B}	physical_splice_connector
XSE22		{CM 3 B}	physical_splice_connector
XSE23		{CM 3 B}	physical_splice_connector
XSE26		{CM 2 B}	physical_splice_connector
XSE27		{CM 2 B}	physical_splice_connector
XSE28		{CM 1 B}	physical_splice_connector
XSE29		{CM 1 B}	physical_splice_connector

VOLVO

Volvo Bus Corporation

Document Title

WIRING DIAGRAM

Document Type

TECHNICAL REGULATION

Document No

20904123

Issue Index

02

Volume No

02(02)

Page No

45(50)

Part Name	Description	Location	Part Type
XSE30		{CM 1 B}	physical_splice_connector
XSE31		{CM 1 B}	physical_splice_connector
XSE32		{CM 1 B}	physical_splice_connector
XSE33		{CM 1 B}	physical_splice_connector
XSE34		{CM 2 B}	physical_splice_connector
XSE35		{CM 1 B}	physical_splice_connector
XSE39		{CM 1 D}	physical_splice_connector
XSE40		{CM 1 C}	physical_splice_connector
XSE41		{CN 2 C}	physical_splice_connector
XSE42		{CN 1 C}	physical_splice_connector
XSE43		{CN 0 B}	physical_splice_connector
XSE44		{CN 2 B}	physical_splice_connector
XSE45		{CN 3 B}	physical_splice_connector
XSE46		{CN 5 B}	physical_splice_connector
XSE47		{CN 5 B}	physical_splice_connector
XSE48		{CN 4 B}	physical_splice_connector
XSE49		{CN 2 A}	physical_splice_connector
XSE50		{CM 0 C}	physical_splice_connector
XSE51		{CM 3 C}	physical_splice_connector
XSE52		{CM 3 C}	physical_splice_connector
XSE53		{CB 2 D}	physical_splice_connector
XSE54		{CB 1 D}	physical_splice_connector
XSE55		{CB 4 C}	physical_splice_connector
XSE56		{CB 4 D}	physical_splice_connector
XSE57		{CB 4 A}	physical_splice_connector
XSE58		{CB 2 B}	physical_splice_connector
XSE59		{CB 2 B}	physical_splice_connector
XSE60		{CM 5 B}	physical_splice_connector
XSE61		{CA 0 C}	physical_splice_connector
XSE62		{CA 5 B}	physical_splice_connector
XSE63		{CA 2 C}	physical_splice_connector
XSE64		{CA 5 B}	physical_splice_connector
XSE65		{CA 3 C}	physical_splice_connector
XSE66		{CA 2 A}	physical_splice_connector
XSE67		{CA 5 B}	physical_splice_connector
XSE68		{CA 4 B}	physical_splice_connector
XSE69		{CA 5 B}	physical_splice_connector
XSE70		{CA 3 B}	physical_splice_connector
XSE71		{CA 2 B}	physical_splice_connector
XSF02		{GD 2 C}	physical_splice_connector
XSF03		{GA 2 B}	physical_splice_connector
XSF04		{GA 1 B}	physical_splice_connector
XSF05		{GC 3 B}	physical_splice_connector
XSF06		{GD 2 C}	physical_splice_connector
XSF07		{ZC 2 D}	physical_splice_connector
XSF08		{CA 2 D}	physical_splice_connector
XSF09		{GC 5 B}	physical_splice_connector
XSF10		{GC 4 B}	physical_splice_connector
XSF12		{GA 3 C}	physical_splice_connector
XSF19		{ZC 3 B}	physical_splice_connector
XSF20		{CU 3 C}	physical_splice_connector

VOLVO

Volvo Bus Corporation

Document Title

WIRING DIAGRAM

Document Type

TECHNICAL REGULATION

Document No

20904123

Issue Index

02

Volume No

02(02)

Page No

46(50)

Part Name	Description	Location	Part Type
XSF21		{ZC 0 C}	physical_splice_connector
XSF26		{DM 3 D}	physical_splice_connector
XSF29		{FB 5 C}	physical_splice_connector
XSF31		{GD 3 D}	physical_splice_connector
XSF32		{FB 5 C}	physical_splice_connector
XSF33		{GD 4 D}	physical_splice_connector
XSF34		{GD 5 D}	physical_splice_connector
XSF35		{BA 3 D}	physical_splice_connector
XSF37		{GA 3 B}	physical_splice_connector
XSF38		{CN 5 D}	physical_splice_connector
XSF40		{FA 5 C}	physical_splice_connector
XSF41		{XD 4 B} {XD 4 B} {XD 4 B} {XD 5 B} {XD 4 B} {XD 3 B}	physical_splice_connector
XSF42		{XD 4 B} {XD 4 B} {XD 5 B} {XD 5 B} {XD 4 B} {XD 4 B}	physical_splice_connector
XSF43		{CM 1 C}	physical_splice_connector
XSF44		{CM 4 C}	physical_splice_connector
XSF45		{CN 3 D}	physical_splice_connector
XSF47		{CV 3 C}	physical_splice_connector
XSF48		{CV 3 C}	physical_splice_connector
XSF49		{CV 3 B}	physical_splice_connector
XSF50		{CV 3 B}	physical_splice_connector
XSF51		{CV 2 B}	physical_splice_connector
XSF52		{CV 2 B}	physical_splice_connector
XSF54		{XC 4 B}	physical_splice_connector
XSF55		{XC 4 B}	physical_splice_connector
XSF60		{CN 2 C}	physical_splice_connector
XSF61		{ZC 3 C}	physical_splice_connector
XSF62		{CA 3 D}	physical_splice_connector
XSF64		{CL 3 B}	physical_splice_connector
XSF70		{CU 5 C}	physical_splice_connector
XSF71		{CU 1 B}	physical_splice_connector
XSF72		{CU 5 A}	physical_splice_connector
XSF73		{CU 5 A}	physical_splice_connector
XSF74		{ZC 3 B}	physical_splice_connector
XSF75		{AG 3 B}	physical_splice_connector
XSF80		{CV 2 D} {CV 2 D}	physical_splice_connector
XSF81		{CV 2 D} {CV 2 C}	physical_splice_connector
XSF82		{CV 3 D} {CV 3 D}	physical_splice_connector
XSF83		{CV 3 D} {CV 3 C}	physical_splice_connector

VOLVO

Volvo Bus Corporation

Document Title

WIRING DIAGRAM

Document Type

TECHNICAL REGULATION

Document No

20904123

Issue Index

02

Volume No

02(02)

Page No

47(50)

Part Name	Description	Location	Part Type
XSF84		{CV 4 D} {CV 4 D}	physical_splice_connector
XSF85		{CV 4 D} {CV 3 C}	physical_splice_connector
XSF86		{CV 4 D}	physical_splice_connector
XSF87		{CV 4 C}	physical_splice_connector
XSF88		{CV 5 D}	physical_splice_connector
XSF89		{CV 4 C}	physical_splice_connector
XSF90		{CV 3 D}	physical_splice_connector
XSF91		{CV 2 D}	physical_splice_connector
XSF100		{CV 2 C}	physical_splice_connector
XSF101		{CV 2 B}	physical_splice_connector
XSG01		{AD 1 C}	physical_splice_connector
XSG02		{AD 3 B}	physical_splice_connector
XSG03		{AH 3 B}	physical_splice_connector
XSG04		{AH 2 B}	physical_splice_connector
XSG05		{AE 3 B}	physical_splice_connector
XSG06		{AF 0 C}	physical_splice_connector
XSG07		{AF 2 B}	physical_splice_connector
XSJ01		{GD 2 B}	physical_splice_connector
XSJ02		{GD 1 C}	physical_splice_connector
XSJ03		{GD 0 B}	physical_splice_connector
XSJ04		{GD 4 C}	physical_splice_connector
XSJ05		{GD 5 C}	physical_splice_connector
XSJ06		{GD 2 B}	physical_splice_connector
XSJ07		{ZC 0 D}	physical_splice_connector
XSJ09		{FB 4 B}	physical_splice_connector
XSJ10		{FB 4 C}	physical_splice_connector
XSJ11		{FB 1 B}	physical_splice_connector
XSJ12		{FB 1 B}	physical_splice_connector
XSJ13		{DO 3 C}	physical_splice_connector
XSJ14		{DO 3 C}	physical_splice_connector
XSJ15		{DO 3 C}	physical_splice_connector
XSJ17		{BB 1 D}	physical_splice_connector
XSJ18		{FB 5 B}	physical_splice_connector
XSJ19		{FB 5 B}	physical_splice_connector
XSJ20		{FA 2 D}	physical_splice_connector
XSJ30		{FC 4 C}	physical_splice_connector
XSJ31		{FC 4 C}	physical_splice_connector
XSJ32		{FC 5 B}	physical_splice_connector
XSJ34		{ZC 4 B}	physical_splice_connector
XSJ35		{XC 2 B}	physical_splice_connector
XSJ36		{XC 2 B}	physical_splice_connector
XSJ37		{FC 3 D}	physical_splice_connector
XSK1		{CG 4 C}	physical_splice_connector
XSK4		{CG 2 C}	physical_splice_connector
XSK5		{CG 2 D}	physical_splice_connector
XSK6		{CG 2 C}	physical_splice_connector
XSK7		{CG 2 D}	physical_splice_connector
XSL1		{CG 3 A}	physical_splice_connector
XSL2		{CG 1 A}	physical_splice_connector
XSL10		{CU 3 A}	physical_splice_connector

VOLVO

Volvo Bus Corporation

Document Title

WIRING DIAGRAM

Document Type

TECHNICAL REGULATION

Document No

20904123

Issue Index

02

Volume No

02(02)

Page No

48(50)

Part Name	Description	Location	Part Type
XSL11		{CU 3 A}	physical_splice_connector
XSL12		{CU 2 A}	physical_splice_connector
XSL13		{CU 2 A}	physical_splice_connector
Y02	Solenoid valve,Differential lock,rear wheels	{EP 1 C}	componentSymbol
Y07	sol_valve_EPG	{CA 1 C}	componentSymbol
Y17	Solenoid valve,Retarder (manual gearbox)	{DM 3 A}	componentSymbol
Y17.1		{CN 1 B}	componentSymbol
Y17.2		{CN 1 B}	componentSymbol
Y17:1		{DM 3 A}	inline_connector
Y17:2		{DM 3 A}	inline_connector
Y17:3		{DM 3 C}	inline_connector
Y17:4		{DM 3 C}	inline_connector
Y17:5		{DM 3 C}	inline_connector
Y17:6		{DM 3 C}	inline_connector
Y17:7		{DM 3 C}	inline_connector
Y25	Solenoid valve unit, ECS, Rear axle	{FA 5 C}	componentSymbol
Y33	sol_valve_unit_injector	{CM 3 B}	componentSymbol
Y35		{CN 5 D}	componentSymbol
Y35.1		{CB 2 C}	componentSymbol
Y36	Solenoid valve,Steerable axle,Bogie	{BB 0 D}	componentSymbol
Y37	Solenoid valve unit, engine brake/EPG	{CM 1 C}	componentSymbol
Y39	Solenoid valve,Volvo Engine Brake(VEB)	{CM 1 D}	componentSymbol
Y40	Solenoid valve unit, ECS, Front axle	{FA 4 B}	componentSymbol
Y46	sol_valve_piston_cooling	{CM 2 C}	componentSymbol
Y47	sol_valve_engine_cooling_fan	{CM 5 B}	componentSymbol
Y72	Valve, Horn	{IS 2 C}	componentSymbol
Y90		{CB 5 B}	componentSymbol
Y91A		{CA 0 C}	componentSymbol
Y900	solenoid valve unit, ECS, Bogie axle	{FA 2 C}	componentSymbol
Y901	Fuel cut off valve front axle	{NA 5 B}	componentSymbol
Y901_LE		{NA 1 C}	componentSymbol
Y901_S9		{NA 5 B}	componentSymbol
Y902	Solenoid Valve,EGG	{AA 5 B}	componentSymbol
Y904	X9/Y1 Ecomat	{DB 4 B}	componentSymbol
Y910	X6/A4 Ecomat	{DB 2 B}	componentSymbol
Y911	sol_valve_inj_SCRT_DNOX2	{CU 4 D} {CU 4 C}	componentSymbol
Y912	sol_valve_adblue_tank_heating_SCRT_DNOX 2	{CU 5 B}	componentSymbol
Y913	Solenoid valve,EGS	{DA 4 C}	componentSymbol
Y914	Pressure control valve(PCU/R)	{EP 5 C}	componentSymbol
Y915	Pressure controll valve (PCU/R)	{EP 5 C}	componentSymbol
Y916	Solenoid valve unit, ECS, Artic Axle	{FA 2 C}	componentSymbol
Y916_A	Solenoid valve unit, ECS, Artic Axle	{FA 2 C}	componentSymbol
Y917	Fuel cut off valve rear axle	{NA 5 C}	componentSymbol
Y924	Solenoid,Oil seperator	{BB 1 D}	componentSymbol
Y925	Sol_valve_gas_tank1	{CG 3 B}	componentSymbol
Y926	Sol_valve_gas_tank2	{CG 3 B}	componentSymbol
Y927	Sol_valve_gas_tank3	{CG 3 B}	componentSymbol
Y928	Sol_valve_gas_tank4	{CG 2 B}	componentSymbol
Y929	Sol_valve_gas_tank5	{CG 2 B}	componentSymbol
Y930	Sol_valve_gas_tank6	{CG 1 B}	componentSymbol

VOLVO

Volvo Bus Corporation

Document Title

WIRING DIAGRAM

Document Type

TECHNICAL REGULATION

Document No

20904123

Issue Index

02

Volume No

02(02)

Page No

49(50)

Part Name	Description	Location	Part Type
Y931	Sol_valve_gas_tank7	{CG 1 B}	componentSymbol
Y934	Solenoid valve unit, ECS, last trailer (Biartic)	{FA 3 C}	componentSymbol

VOLVO

Volvo Bus Corporation

Document Title

WIRING DIAGRAM

Document Type

TECHNICAL REGULATION

Document No

20904123

Issue Index

02

Volume No

02(02)

Page No

50(50)

VOLVO

Volvo Bus Corporation

Göteborg, Sweden