

Service Manual

Buses

Group **37**

Release **01**

Multiplex electrical system Version 2
Wiring Diagram

B9R with D9B
Chassie nr 158809-162217



VOLVO

Foreword

The information in this manual is based on present design in

July, 2012

The products are under continuous development. This may effect the correctness of the information in this manual. If the differences are significant, new editions of this manual will be released to cover the changes.

Volvo Bus Corporation

Göteborg, Sweden

© Volvo Bus Corporation, Göteborg, Sweden

All rights reserved. No part of this publication may be reproduced, stored in retrieval system, or transmitted in any forms by any means, electronic, mechanical, photocopying, recording or otherwise, without the prior written permission of Volvo Bus Corporation.

| | | | | | |
|----------------------------------|----------|--------------------|--------------------------|---------|--|
| Engineering Release Notice (ERN) | Location | Change Description | A = Added U = Deleted | W = Was | Document Release Status RELEASED |
| | | See DCN | | | Date Modification Count |

WIRING DIAGRAM INDEX, B7, B9, B12

| NAME | DESCRIPTION | PAGE | | NAME | DESCRIPTION | PAGE |
|------|--|------|--|------|--------------------------------------|------|
| AA | IGNITION AND STARTING SYSTEM | 03 | | DN | I-SHIFT | 43 |
| AA2 | BATS-D | 04 | | DO | VOITH DIWA5 ARTIC | 44 |
| AB | POWER SUPPLY | 05 | | DP | ZF INTARDER | 45 |
| AB2 | POWER SUPPLY | 06 | | | | |
| | | | | DQ | VOITH RETARDER | 46 |
| AB3 | POWER SUPPLY | 07 | | EO | EBS | 47 |
| AC | START ENGINE AND ALTERNATORS | 08 | | EP | EBS | 48 |
| AD | STARTER MOTOR AND ALTERNATORS FOR MD7 | 09 | | EX | PARKING BRAKE RELEASE | 49 |
| AE | STARTER MOTOR AND ALTERNATORS FOR R9L, R9TL, B9R | 10 | | | | |
| AF | STARTER MOTOR AND ALTERNATORS MD12 | 11 | | FA | AIR SUSPENSION ECS | 50 |
| AG | START/STOP SWITCHES REAR | 12 | | FB | AIR SUSPENSION ECS | 51 |
| AH | STARTER MOTOR AND ALTERNATOR FOR R9S | 13 | | FC | AMECU | 52 |
| | | | | FO | ELECTRONIC STEERED AXLE | 53 |
| BA | VECU, VEHICLE ECU | 14 | | | | |
| BB | BBM, BODY BUILDER MODULE | 15 | | GA | LCM, REAR LIGHTS | 54 |
| BB2 | BBM, BODY BUILDER MODULE | 16 | | | | |
| BC | BBM, BODY BUILDER MODULE | 17 | | GB | LCM, FRONT LIGHTS | 55 |
| BD | FIRE ALARM | 18 | | GC | LCM, REAR LIGHTS | 56 |
| BE | LKS/DAS-SYSTEM | 19 | | GD | LCM, ARTIC LIGHTS PULLER | 57 |
| BF | DUST CAP INTERLOCK SENSOR | 20 | | GE | LCM, BI-XENON LIGHT | 58 |
| | | | | GF | LCM, BIARTIC LIGHTS | 59 |
| CA | EECU D9B | 21 | | GM | WIPER, WASHER | 60 |
| CA2 | ELECTRICAL COOLING FANS | 22 | | GN | LCM, XENON LIGHT RELAY | 61 |
| CB | EECU G9A | 23 | | | | |
| CC | EECU D12D | 24 | | IS | HORN SWM | 62 |
| CD | EECU CUMMINS CNG | 25 | | IU | AUDIO | 63 |
| CE | EMS CUMMINS CNG | 26 | | | | |
| CF | CONVERTER CUMMINS CNG | 27 | | LA | HUBNER ECU 1 ST TURNTABLE | 64 |
| CG | FTM | 28 | | LB | HUBNER ECU 2 ND TURNTABLE | 65 |
| CH | ESI CONTROL UNIT | 29 | | | | |
| CL | BIO | 30 | | NA | BUS INSTRUMENT CLUSTER, BIC2 | 66 |
| CM | EECU DH12E | 31 | | NB | TACHOGRAPH | 67 |
| CN | EECU D7E | 32 | | NC | DYNAFLEET, ALCOLOCK | 68 |
| CO | OILMASTER | 33 | | ND | FMS 200 | 69 |
| CP | BIC AND RTVW | 34 | | NE | FMS GATEWAY | 70 |
| CU | DNOX2 | 35 | | NF | VDV, INSTRUMENT CLUSTER | 71 |
| CV | CAN SAE 1939_7 | 36 | | NG | VDV, INSTRUMENT CLUSTER | 72 |
| | | | | | | |
| DA | G8-EGS | 37 | | XC | CAN SAE 1939 | 73 |
| DB | ECOMAT4 ZF | 38 | | XD | CAN SAE 1587 | 74 |
| DC | VOITH DIWA5 | 39 | | XE | CAN SAE 1587 UDS | 75 |
| DD | ECOLIFE ZF | 40 | | | | |
| DE | GEARBOX ZF-AMT | 41 | | ZC | GROUND | 76 |
| DM | RETARDER | 42 | | | | |

| VOLUME NO | CONTENT | PAGES |
|-----------|---------------------------------|-------|
| 01 | WIRING DIAGRAM | 1-76 |
| 02 | BILL OF MATERIAL/COMPONENT LIST | 1-76 |

The copying, distribution and utilization of this document as well as the communication of its contents to others without expressed authorization is prohibited. Offenders will be held liable for payment of damages. All rights reserved in the event of the grant of a patent, utility model or ornamental design registration.

Document Title
**WIRING DIAGRAM
B7, B9, B12**

VOLVO
Volvo Bus Corporation

Document Type
PRODUCT SCHEMATIC

Owner Domain: Document Prefix

| | | | |
|--------------------------------|--------------------------|----------------------------|-------------------------|
| Document No 20904123 | Issue Index 15 | Volume No 01(02) | Page No 1(76) |
|--------------------------------|--------------------------|----------------------------|-------------------------|

ABREVIATIONS

| | | | |
|----------------|--|-------------|--|
| AC | Air Condition | IJ | Inlet Jet |
| Acp | Accelerator Pedal | Ind | Indicator |
| AI | Analogue Input | Inj | Injection |
| Amb | Ambient | JK | Jack-knife |
| AO | Analogue Output | KL | Key Line |
| ARC | Air Regeneration Control | L | Low |
| BHSA | Brake Hill Start Aid | LCP | Light Control Panel |
| Brk | Brake | LDI | Low Digital Input |
| Buf | Buffered | LDO | Low Digital Output |
| C | Closing | LS | Low Side |
| CampL | Campaign Lights | Nd | Needle |
| Cent | Centering | O | Output |
| Ctrl | Control | OV | Overflow |
| Cyl | Cylinder | OP | Opening |
| Dash | Dashboard | PCV | Pressure Control Valve |
| Deliv | Delivery | Plo | Plough |
| DI | Digital Input | PR | Pressure Regulator |
| Diag | Diagnostic | Pres | Pressure |
| Dir | Direction | Pos | Position |
| Dis | Disable | PWM | Pulse Width Modulation |
| DO | Digital Output | Rad | Radiator |
| DRL_RMC | Daytime Running Light/Reduced Mode Control | RAI | Resistance Analogue Input |
| EACC | Electric Air Compressor Control | Red | Reductor |
| ECB | VBC, Engine Compressor Brake | Rel | Relay |
| ECU | Electronic Control Unit | Req | Request |
| ECU_GND | External Ground | RES | Input for Sensors with Variable Resistance |
| EGR | Exhaust Recirculation, valve | Ret | Retarder |
| EMT | Exhaust Manifold Temperature | Sen | Sensor |
| Eng | Engine | Sign | Signal |
| EPG | Exhaust Pressure Governor | Sno | Snow |
| ES | Engine Synchronization | Sp | Speed |
| ETCC | Exhaust Temperature Catalytic Converter | St | Start |
| Ext | External | Stp | Stop |
| GND | Signal Ground | SV | Supply Voltage |
| H | High | Sw | Switch |
| Haz | Hazard | Temp | Temperature |
| HDI | High Digital Input | Tor | Torque |
| HDO | High Digital Output | UBat | Feed Directly from Battery |
| HLa | HeadLamps | VEB | Volvo Engine Brake |
| HS | High Side | Veh | Vehicle |
| Hyd | Hydraulic | | |

VOLVO

Volvo Bus Corporation

Document Title

WIRING DIAGRAM

Document Type

PRODUCT SCHEMATIC

Document No

20904123

Issue Index

15

Volume No

01(02)

Page No

2(76)

IGNITION AND STARTING SYSTEM

WIRING DIAGRAM AA

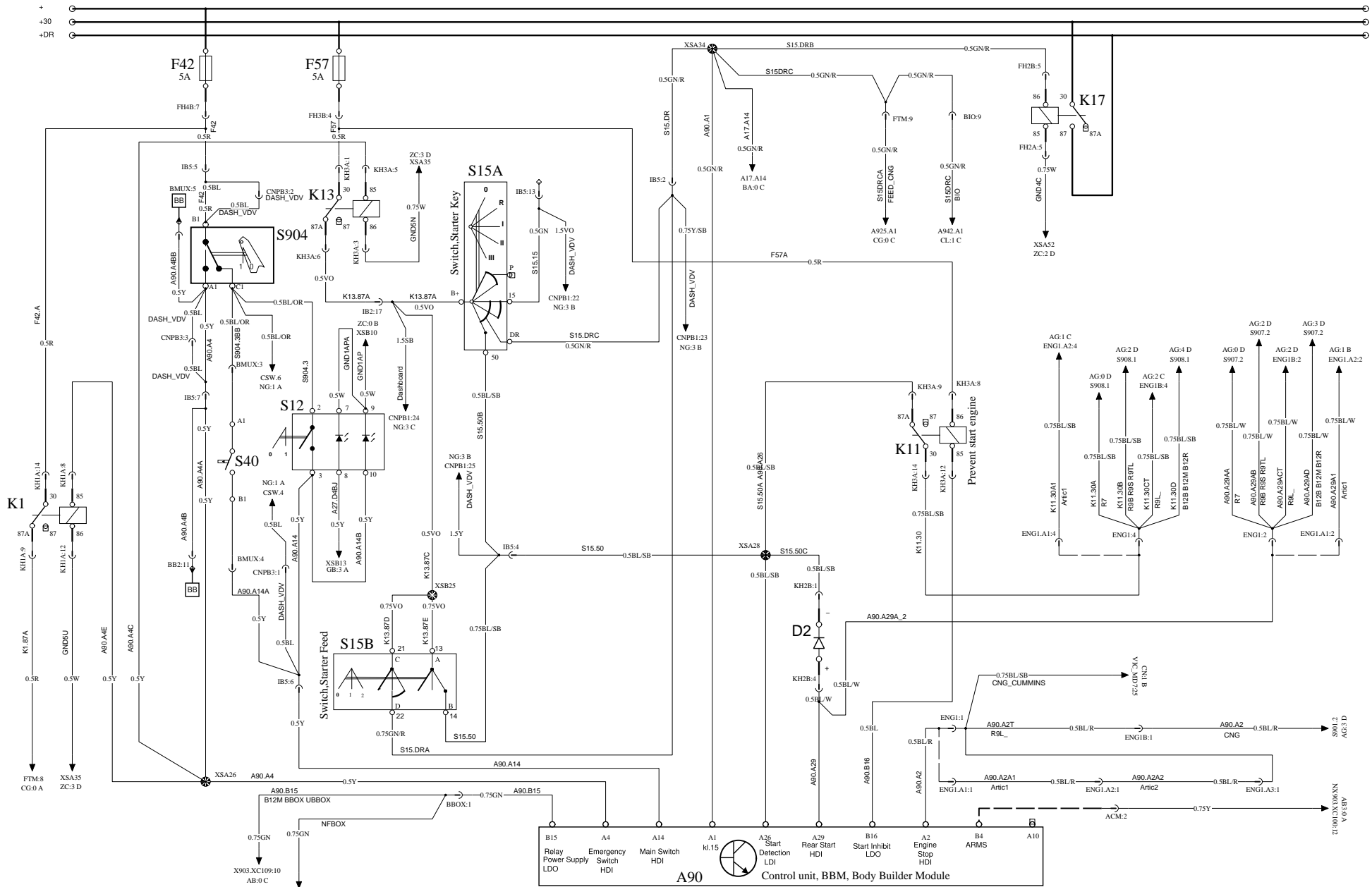

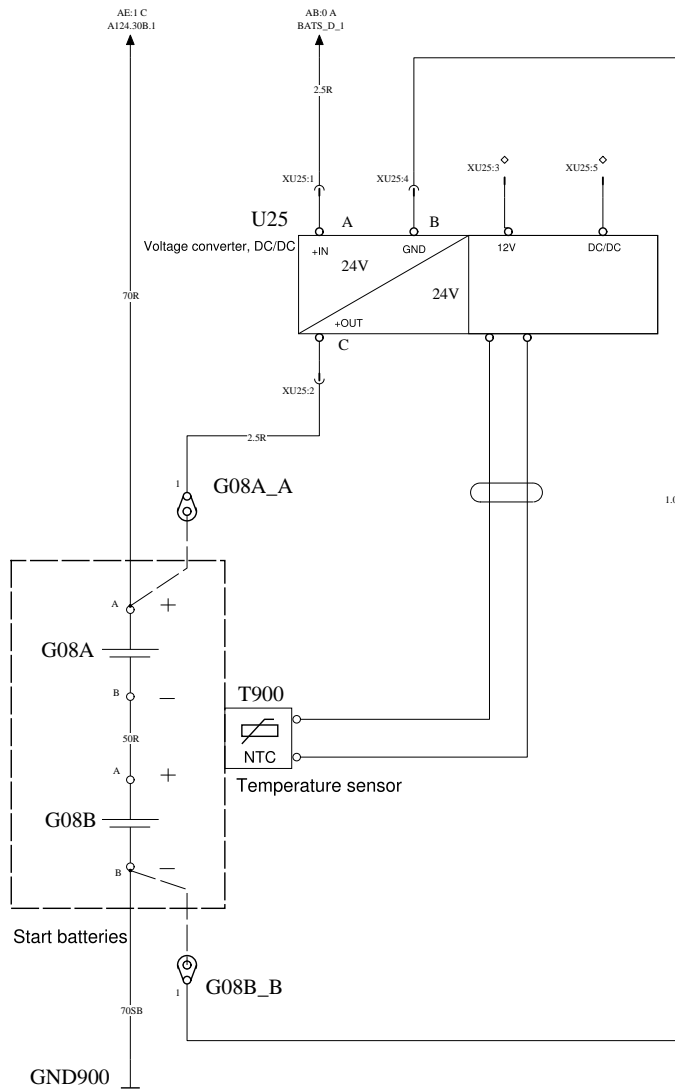

A

A

B

B

C

C

D

D

E

E

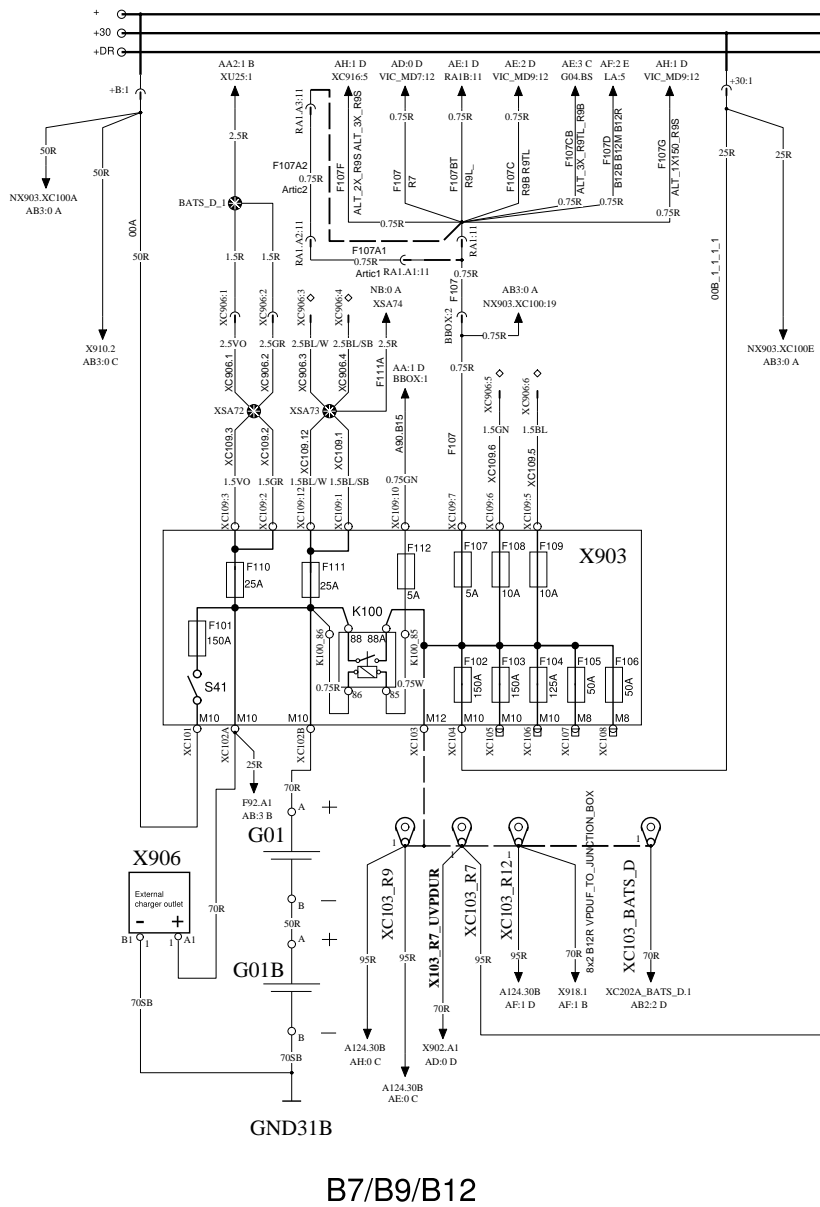

B7/B9/B12

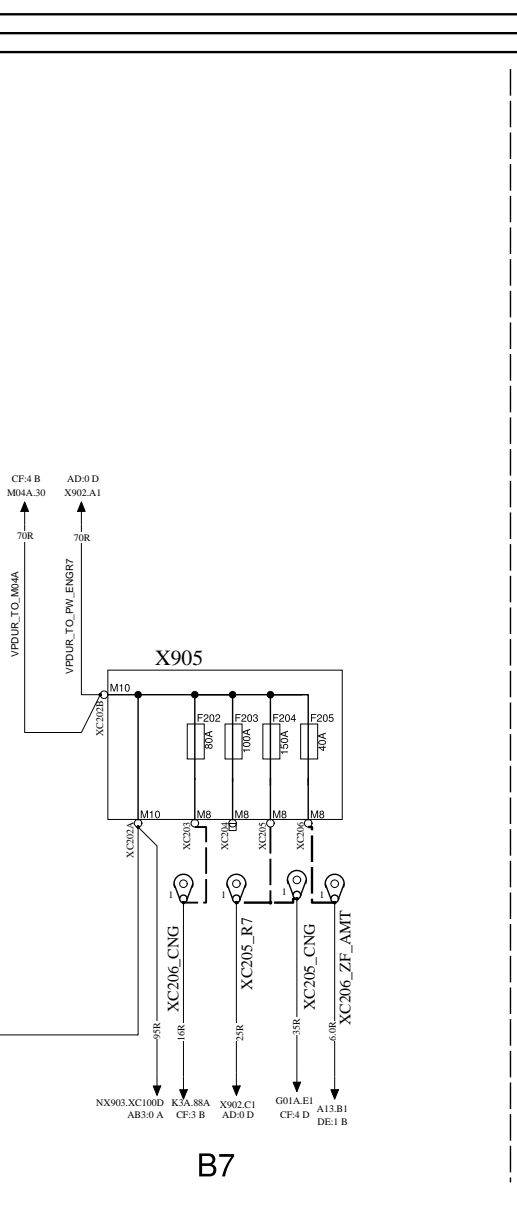

B7

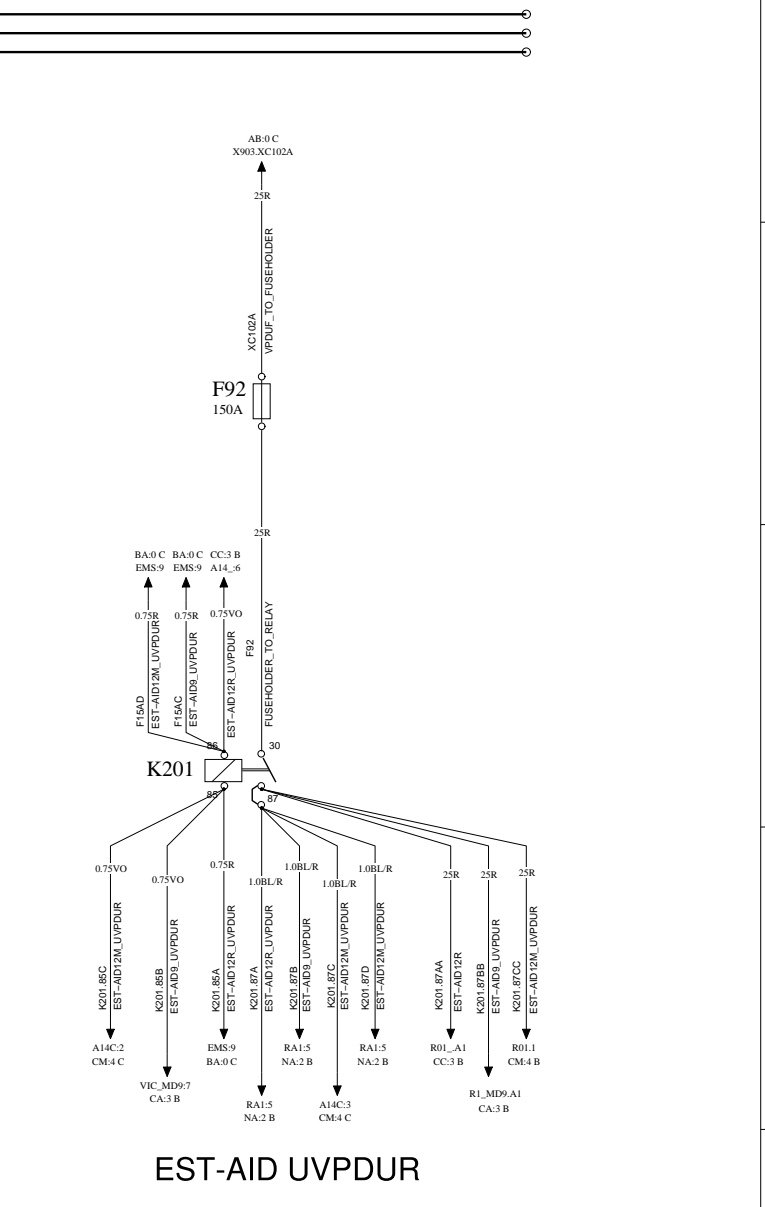

EST-AID UVDPUR

POWER SUPPLY

WIRING DIAGRAM AB2

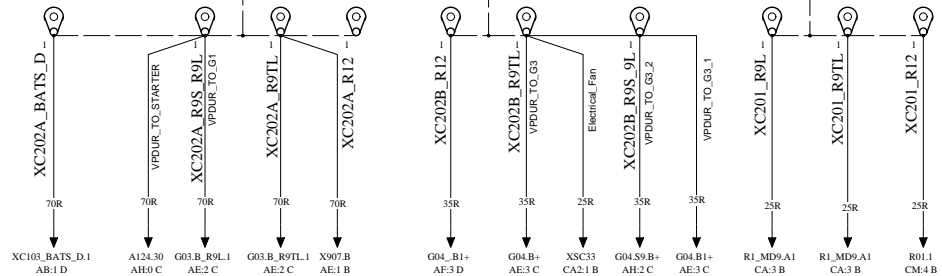
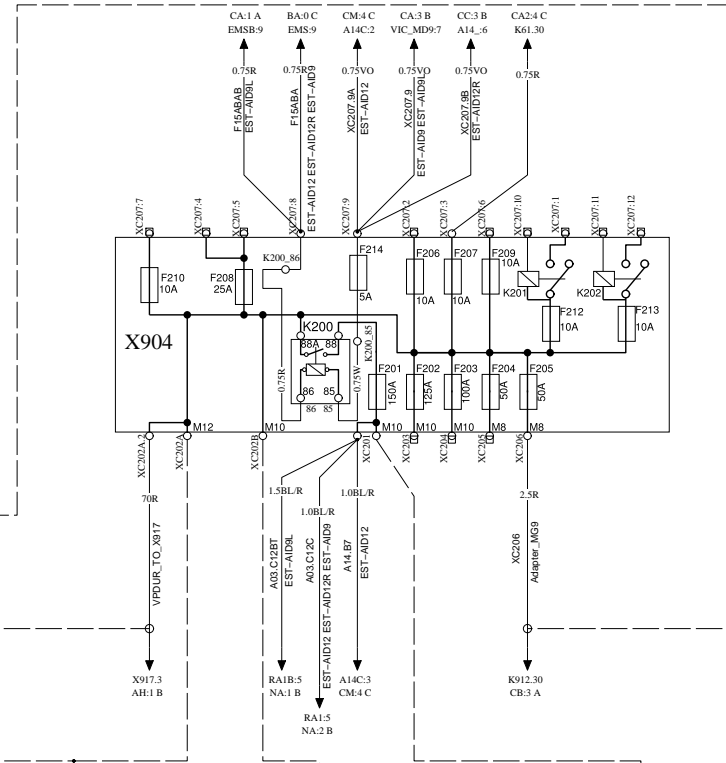
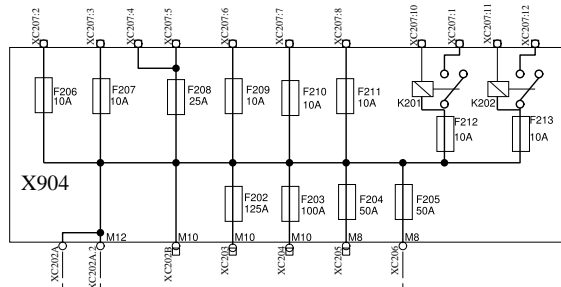
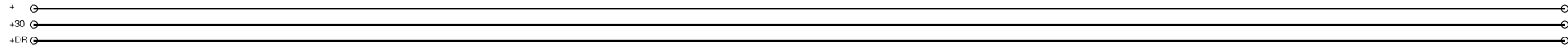

B9/B12 U RELAY

B9/B12

VPDUF

B7R

WIRING DIAGRAM AB3

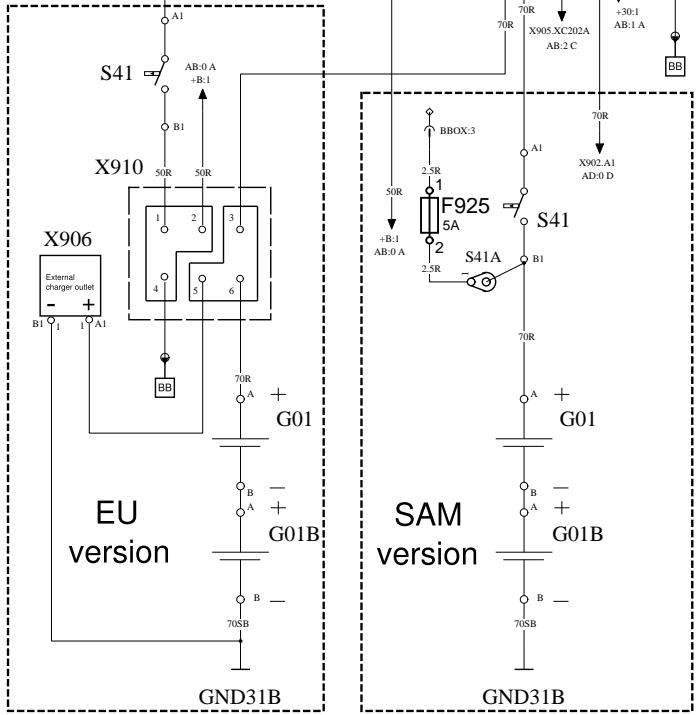
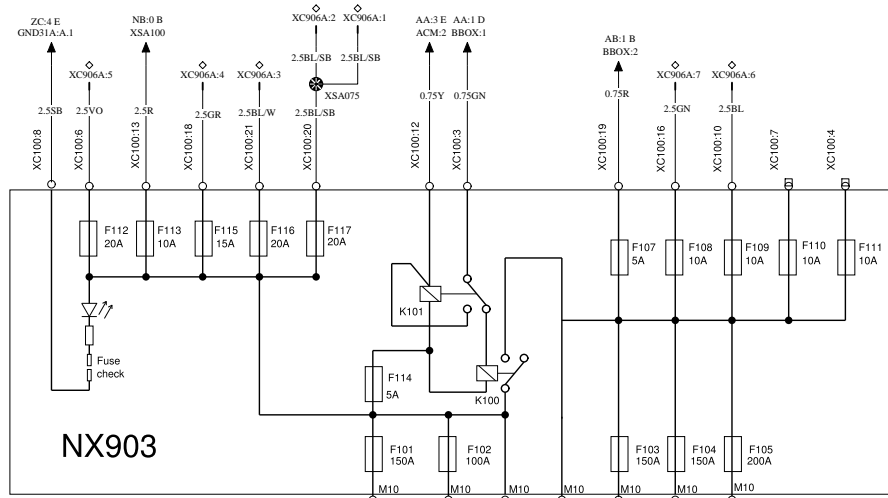

VOLVO

Volvo Bus Corporation

Document title
WIRING DIAGRAM AB3

Document type
PRODUCT SCHEMATIC

Document No

20904123

Issue

15

Volume

01(02)

Page

07(76)

START ENGINE AND ALTERNATORS

WIRING DIAGRAM AC

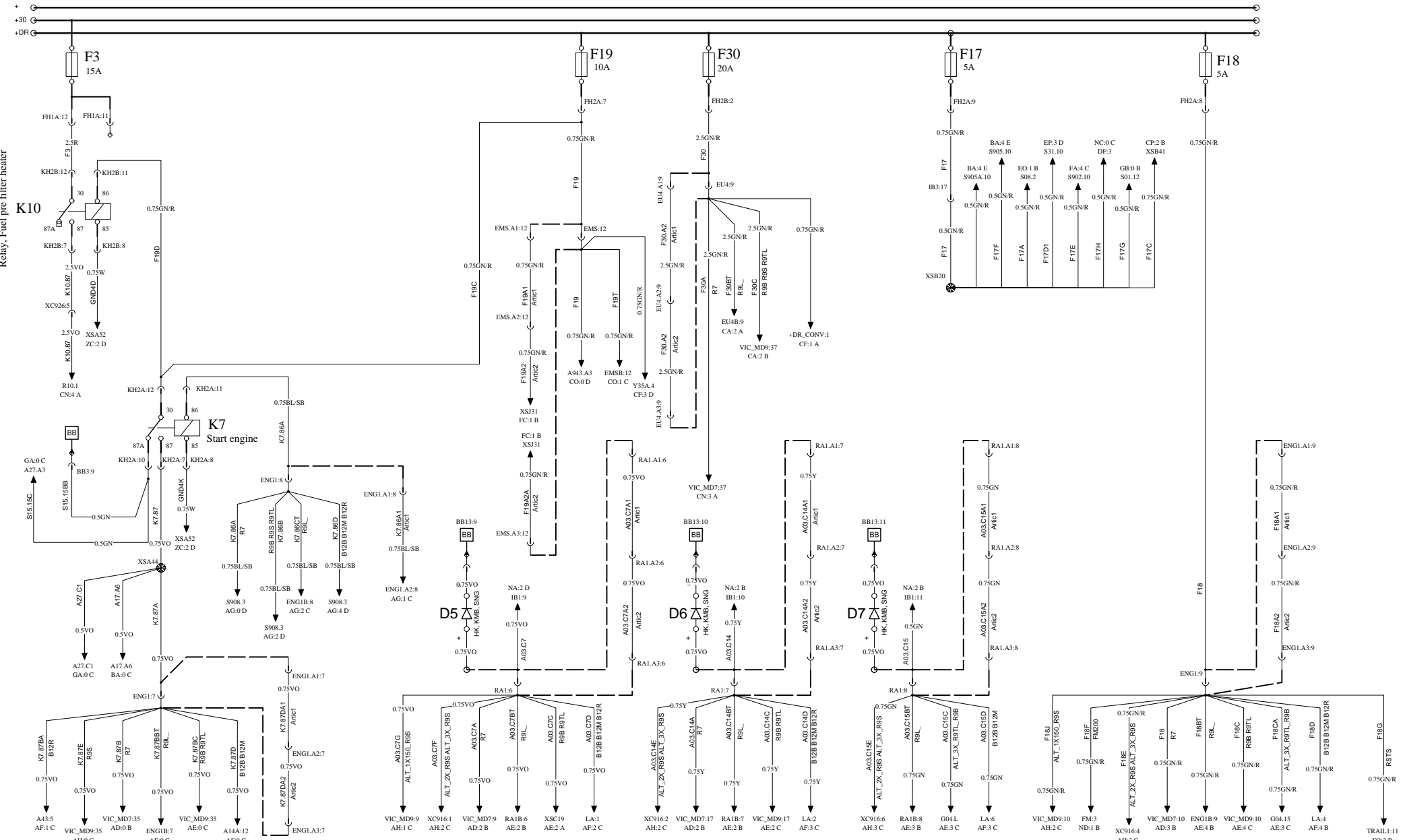

STARTER MOTOR AND ALTERNATORS FOR MD7

WIRING DIAGRAM AD

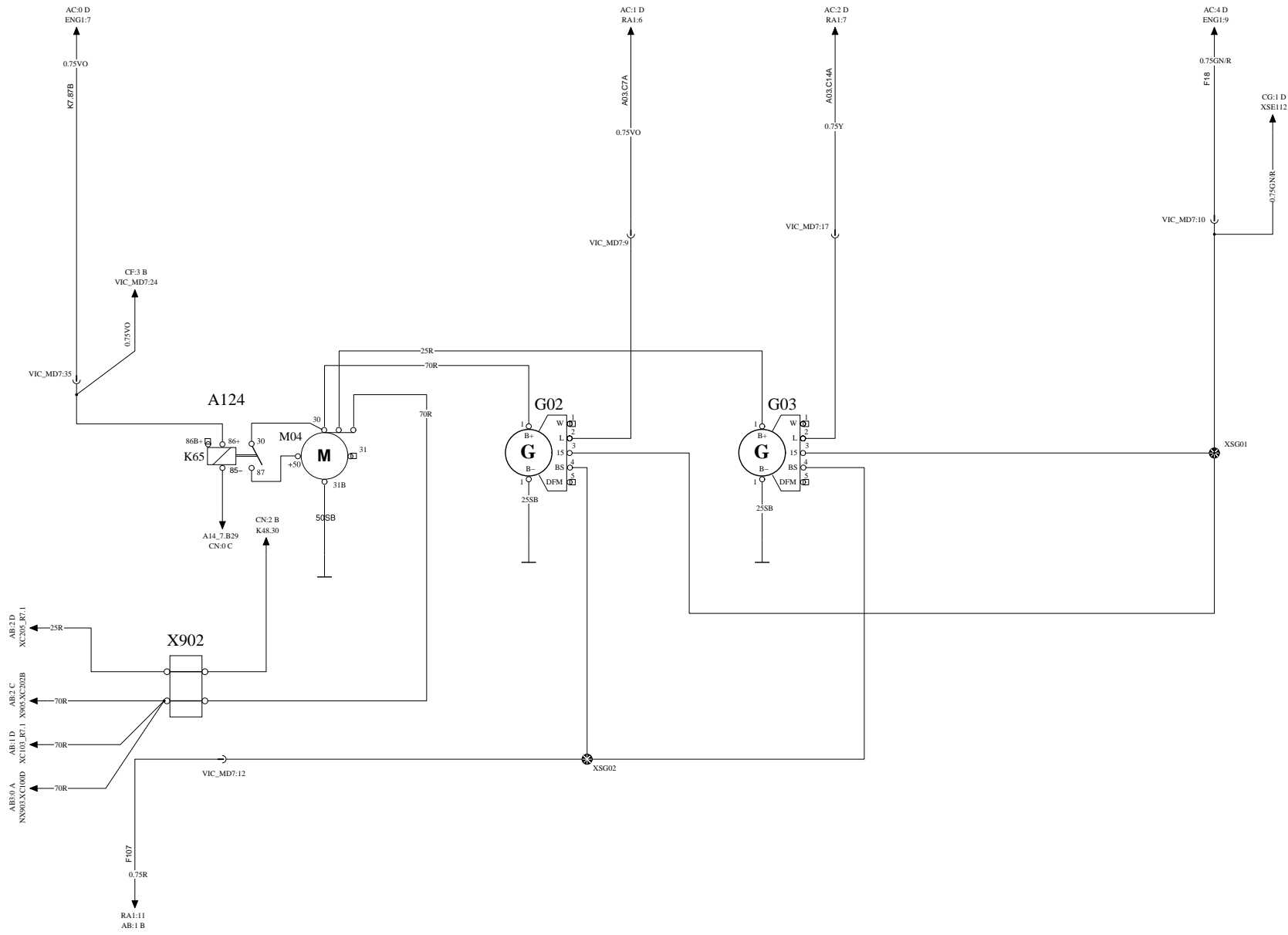

STARTER MOTOR AND ALTERNATORS FOR R9L, R9TL, B9R

WIRING DIAGRAM AE

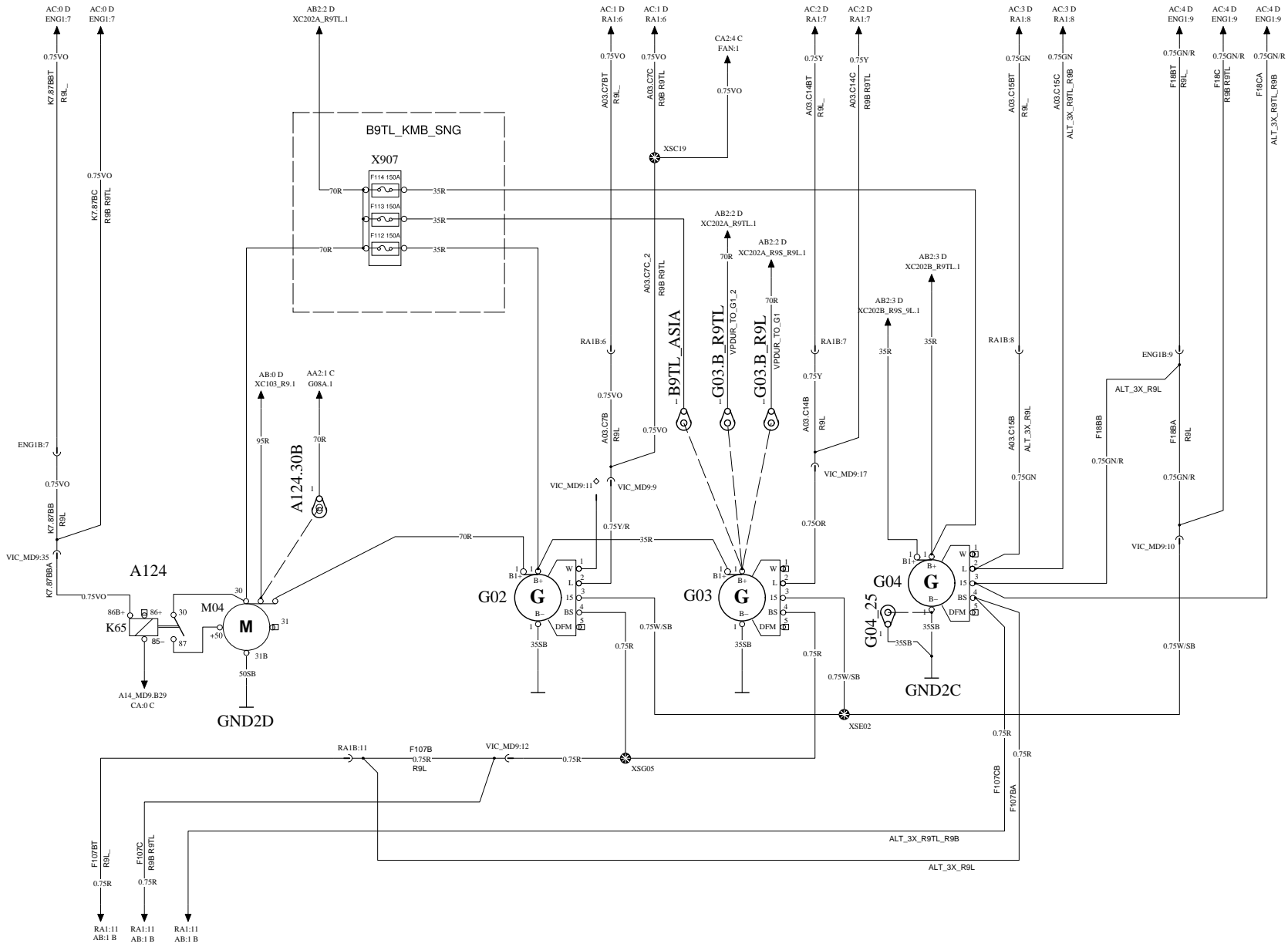

STARTER MOTOR AND ALTERNATORS FOR MD12

WIRING DIAGRAM AF

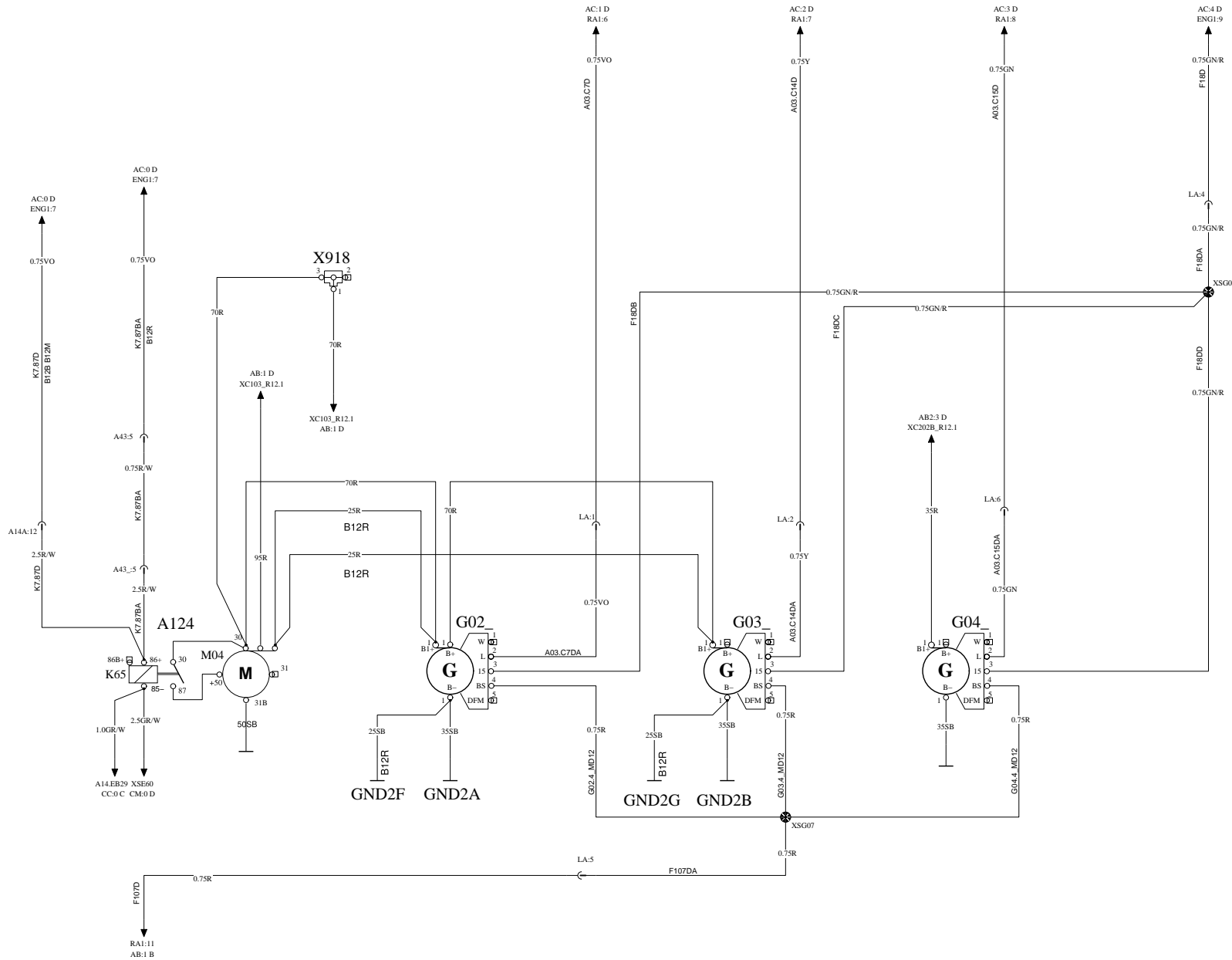

START/STOP SWITCHES REAR

WIRING DIAGRAM AG

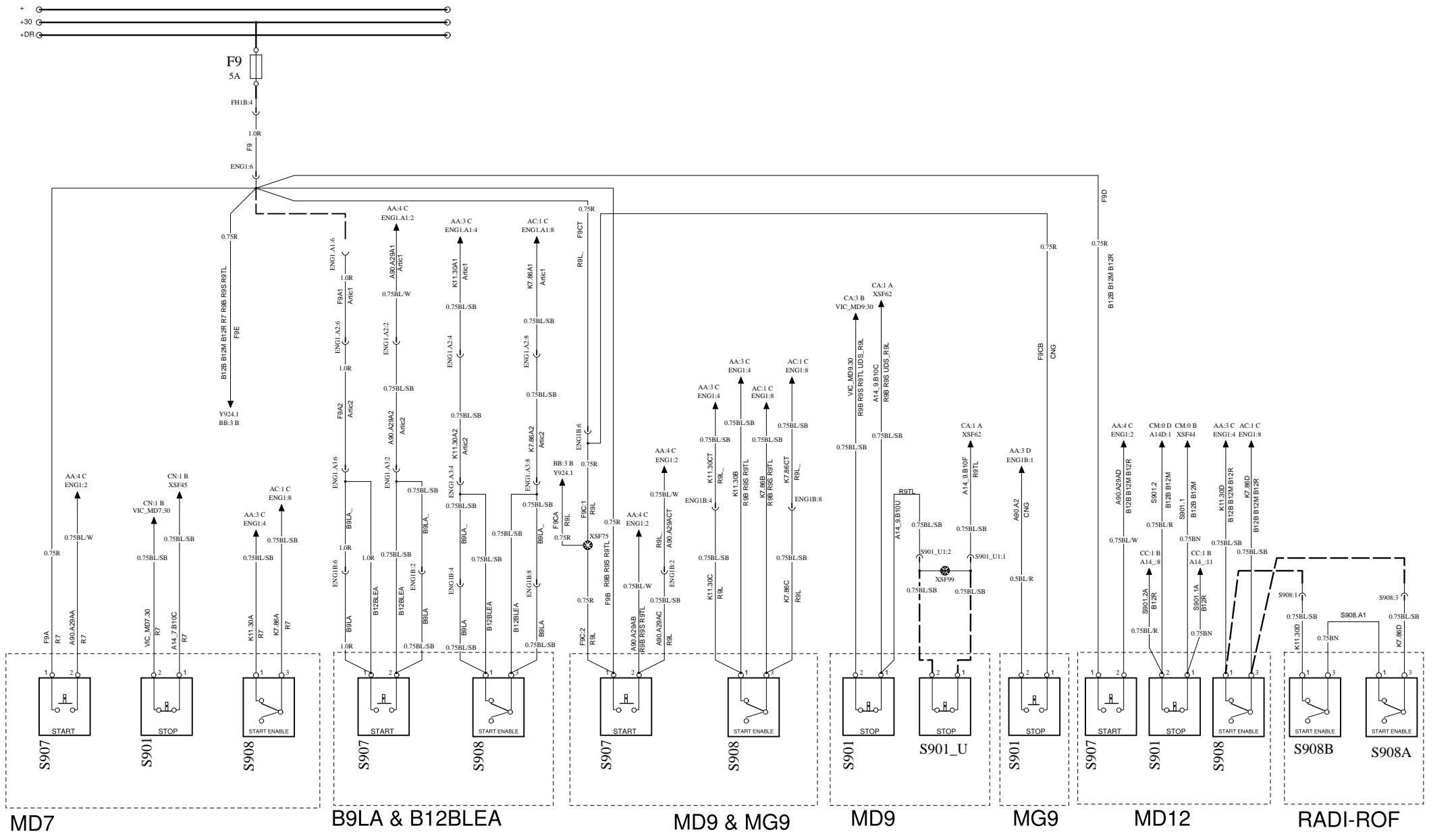

STARTER MOTOR AND ALTERNATOR FOR R9S

WIRING DIAGRAM AH

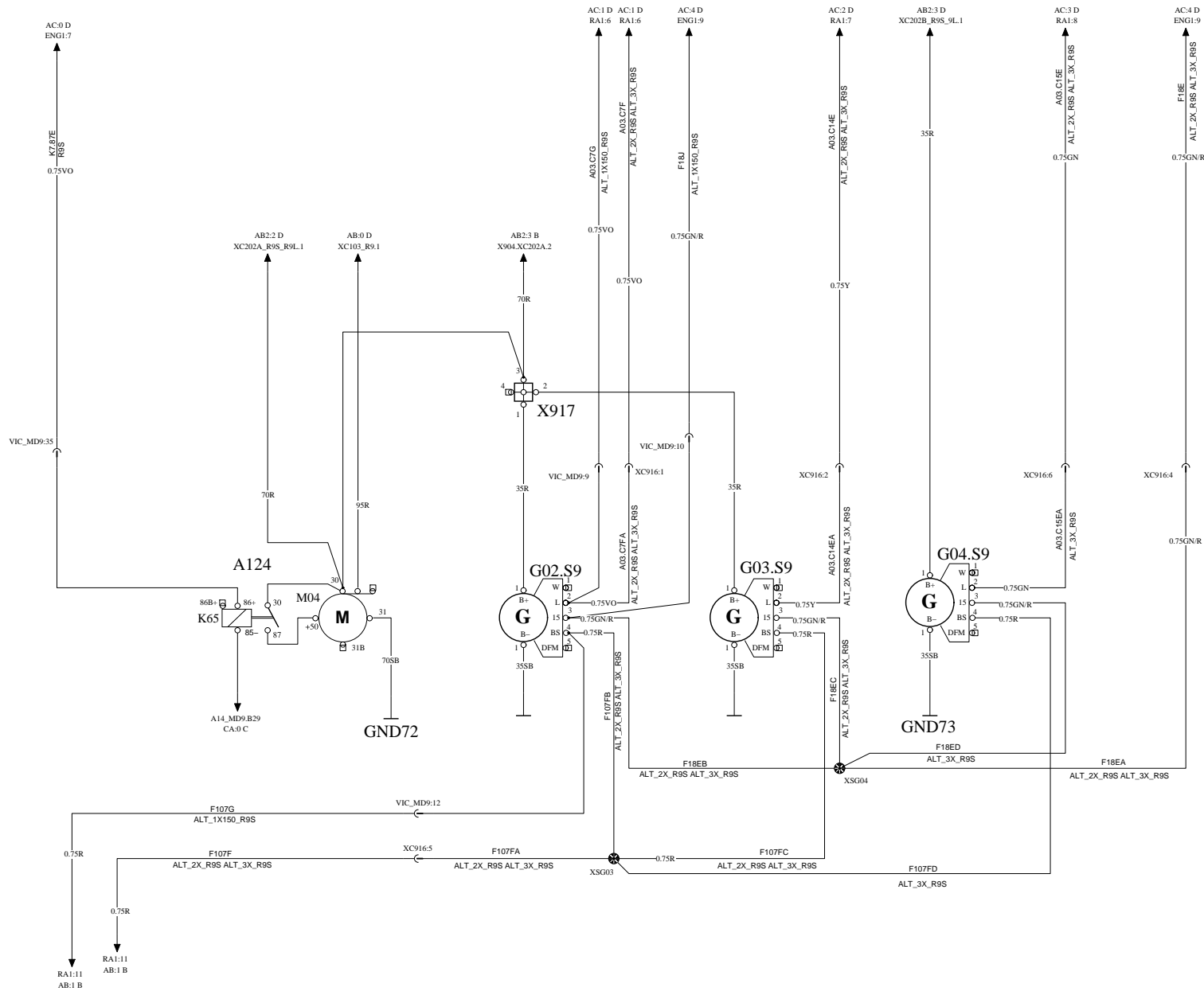

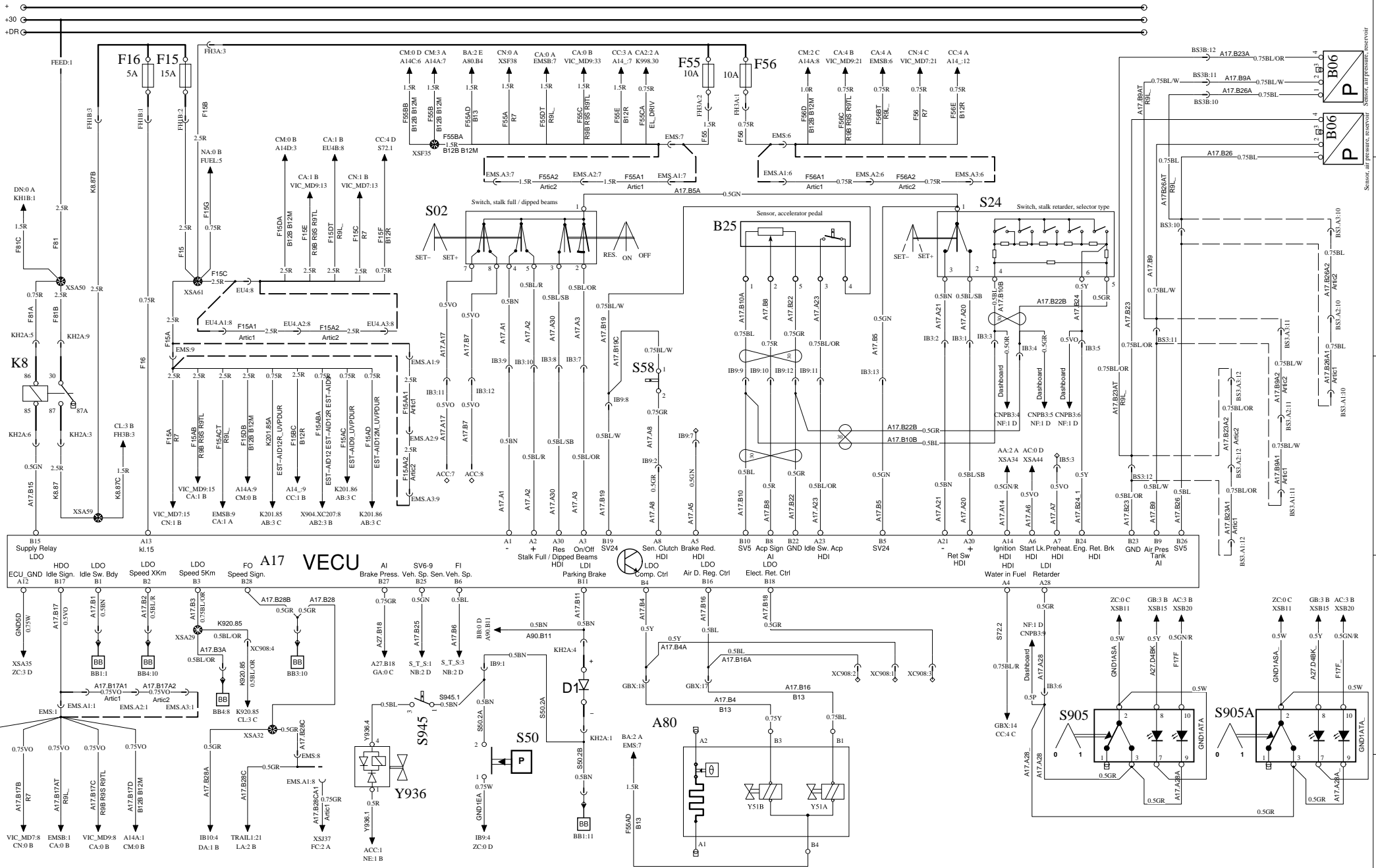

BODY BUILDER MODULE

WIRING DIAGRAM BB

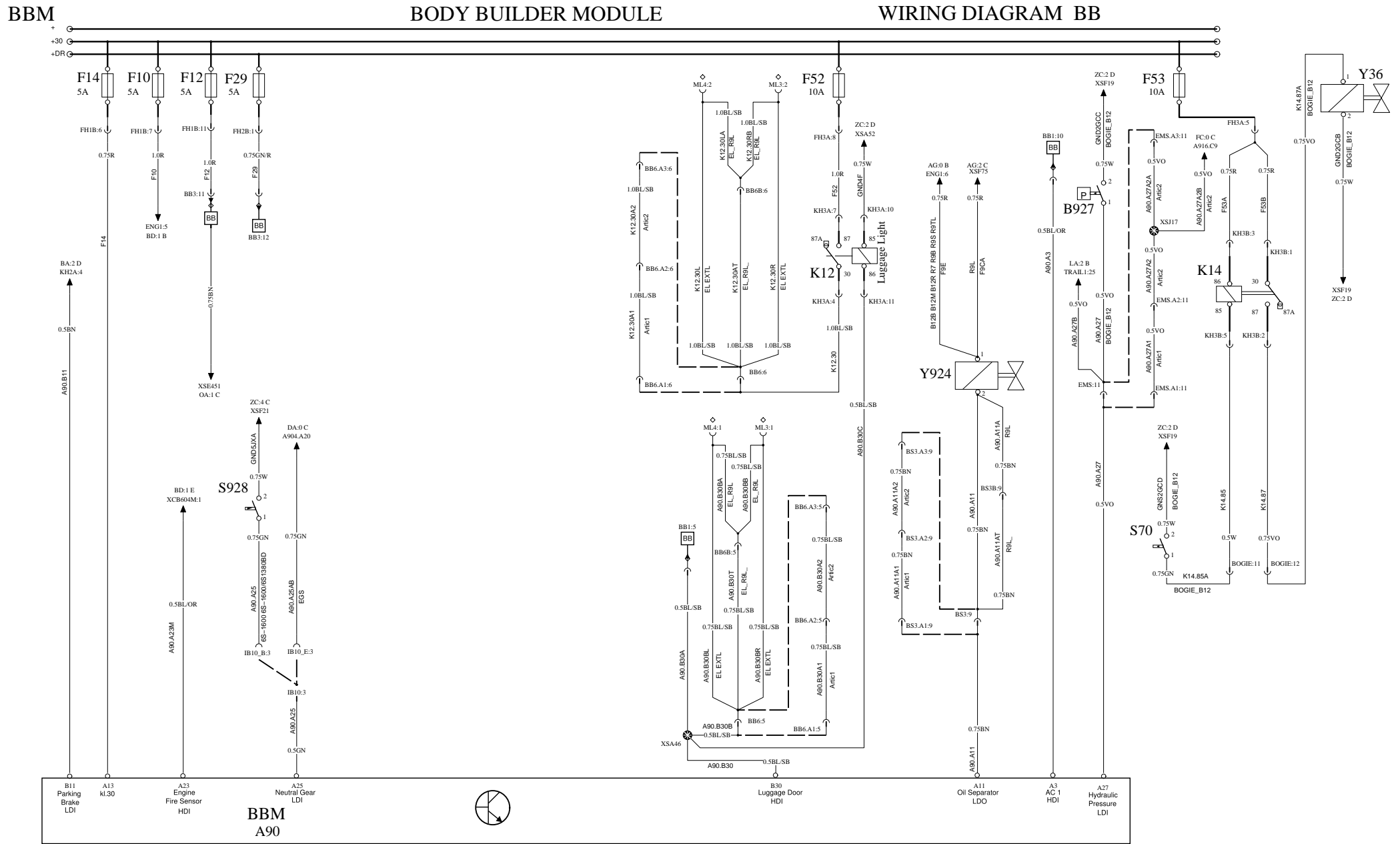

B9TL 6x2

B9S

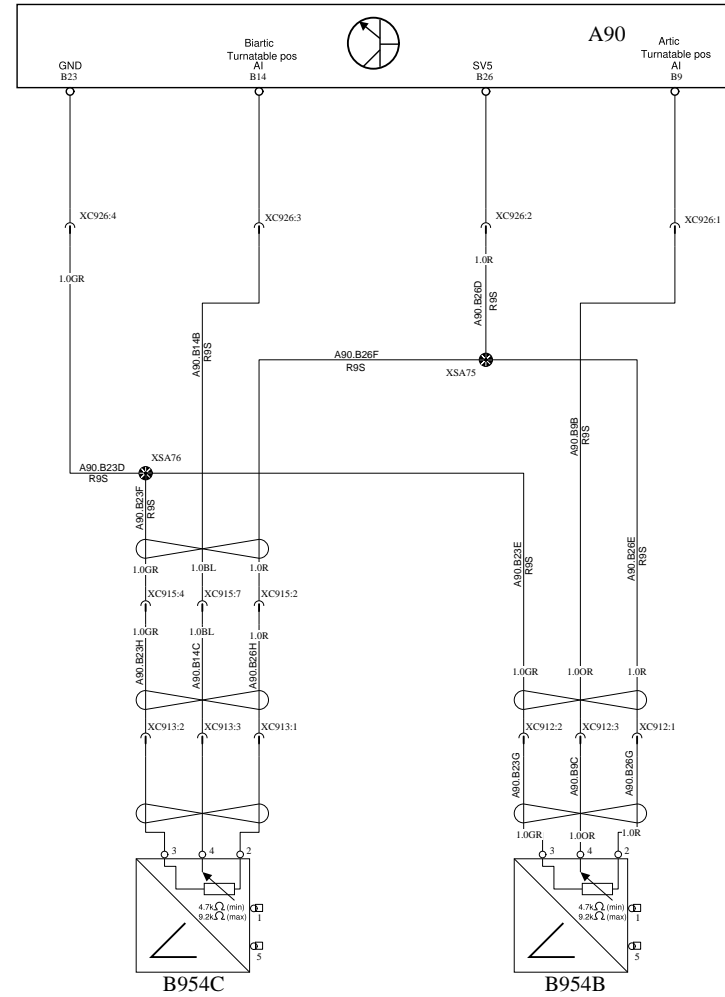
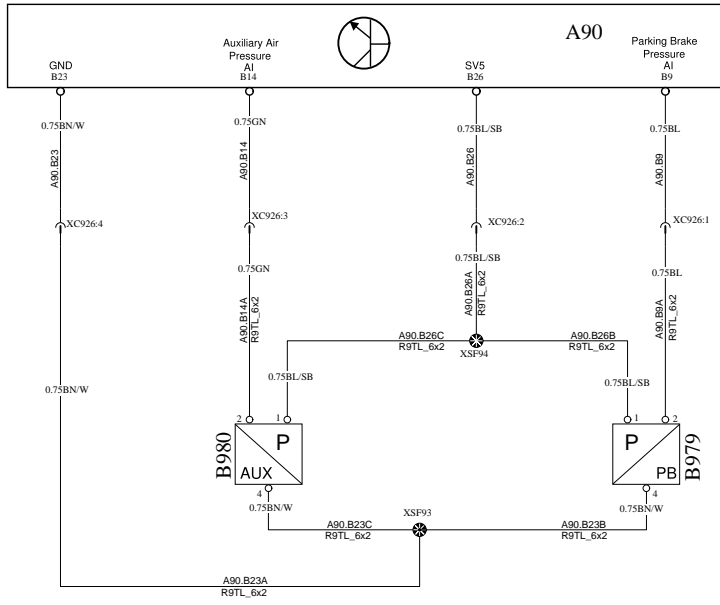

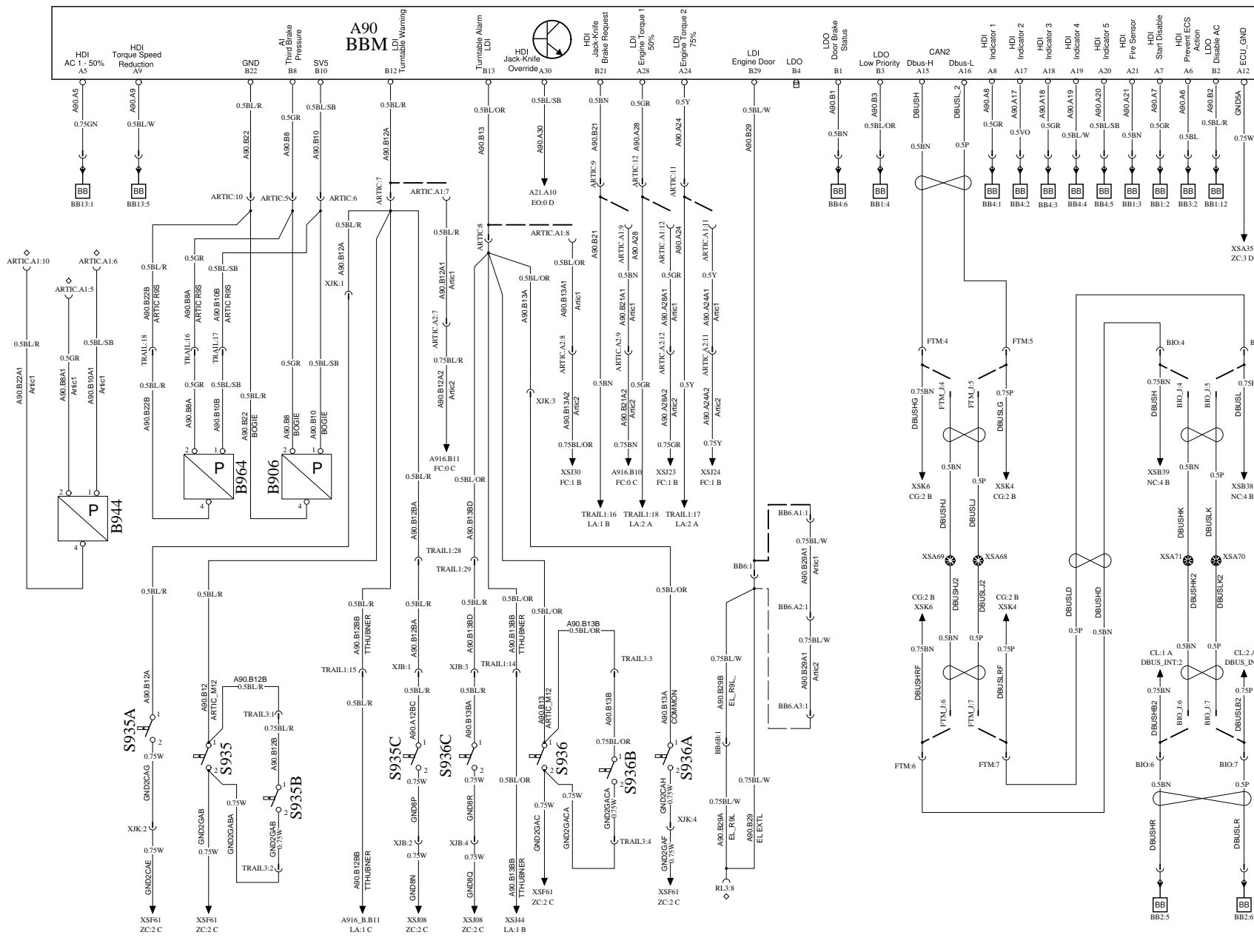

HK-SPEC
KMB-SPEC
SNG-SPEC

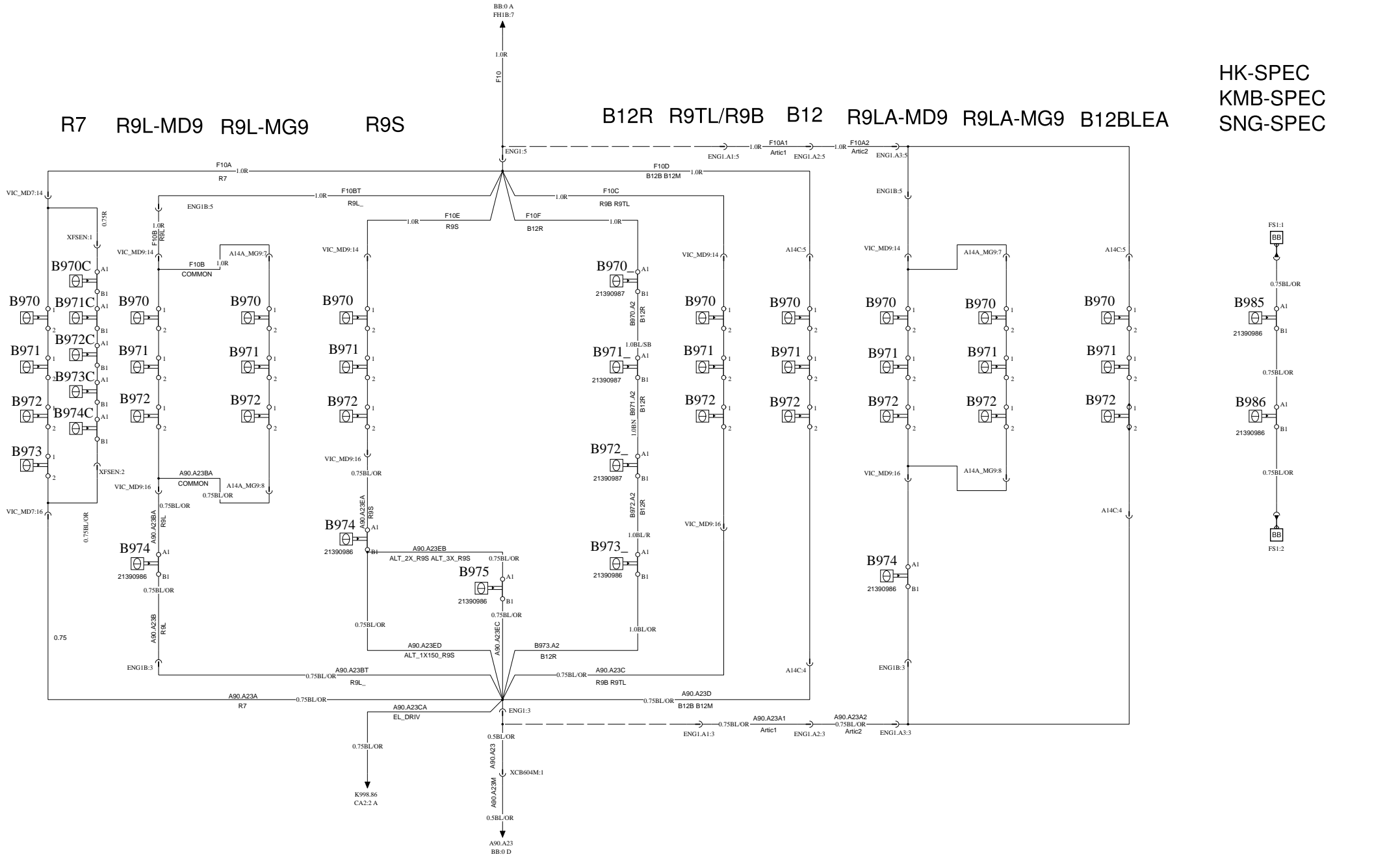

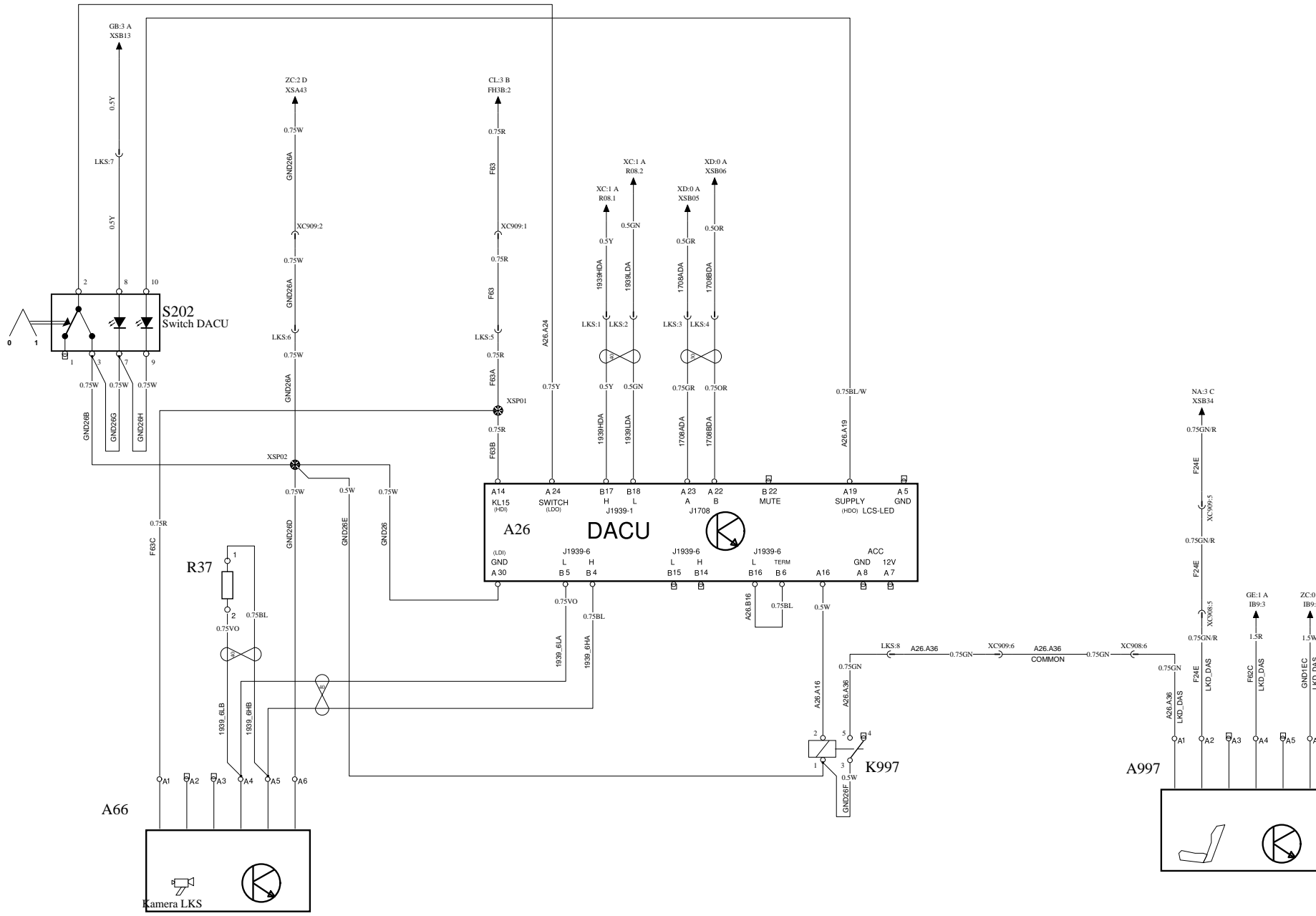

| | | | | | |
|--|-------------------------------------|------------------------------------|-----------------|----------------------|--------------------|
|  Volvo Bus Corporation | Document title WIRING DIAGRAM BE | Document No 20904123 | Issue 15 | Volume 01(02) | Page 19(76) |
| | Document type PRODUCT SCHEMATIC | | | | |

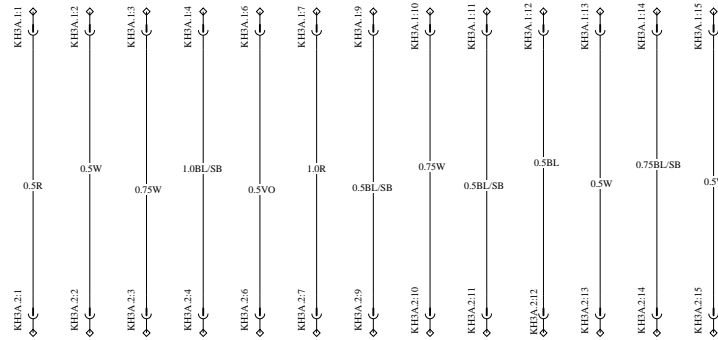
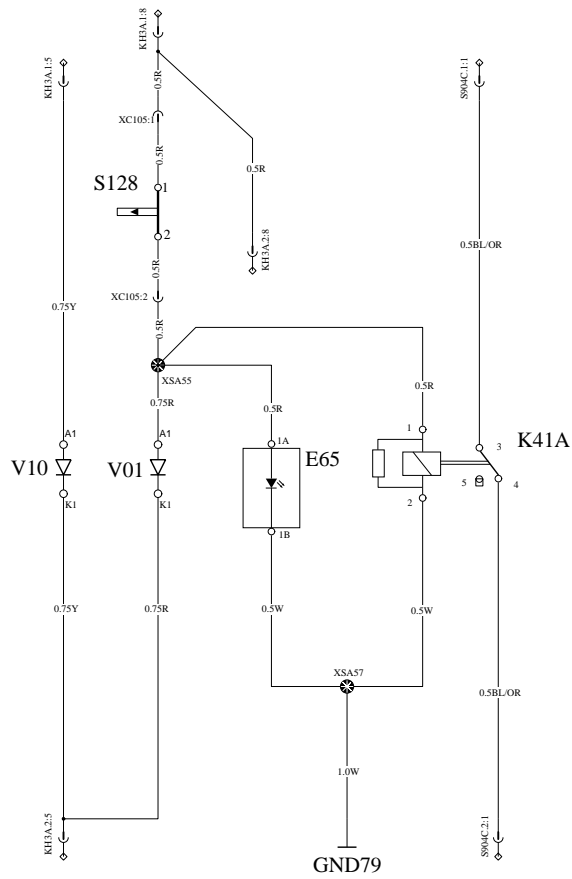

FOR INTERCONNECTIONS SEE SHEET AA

A

B

C

D

E

A

B

C

D

E

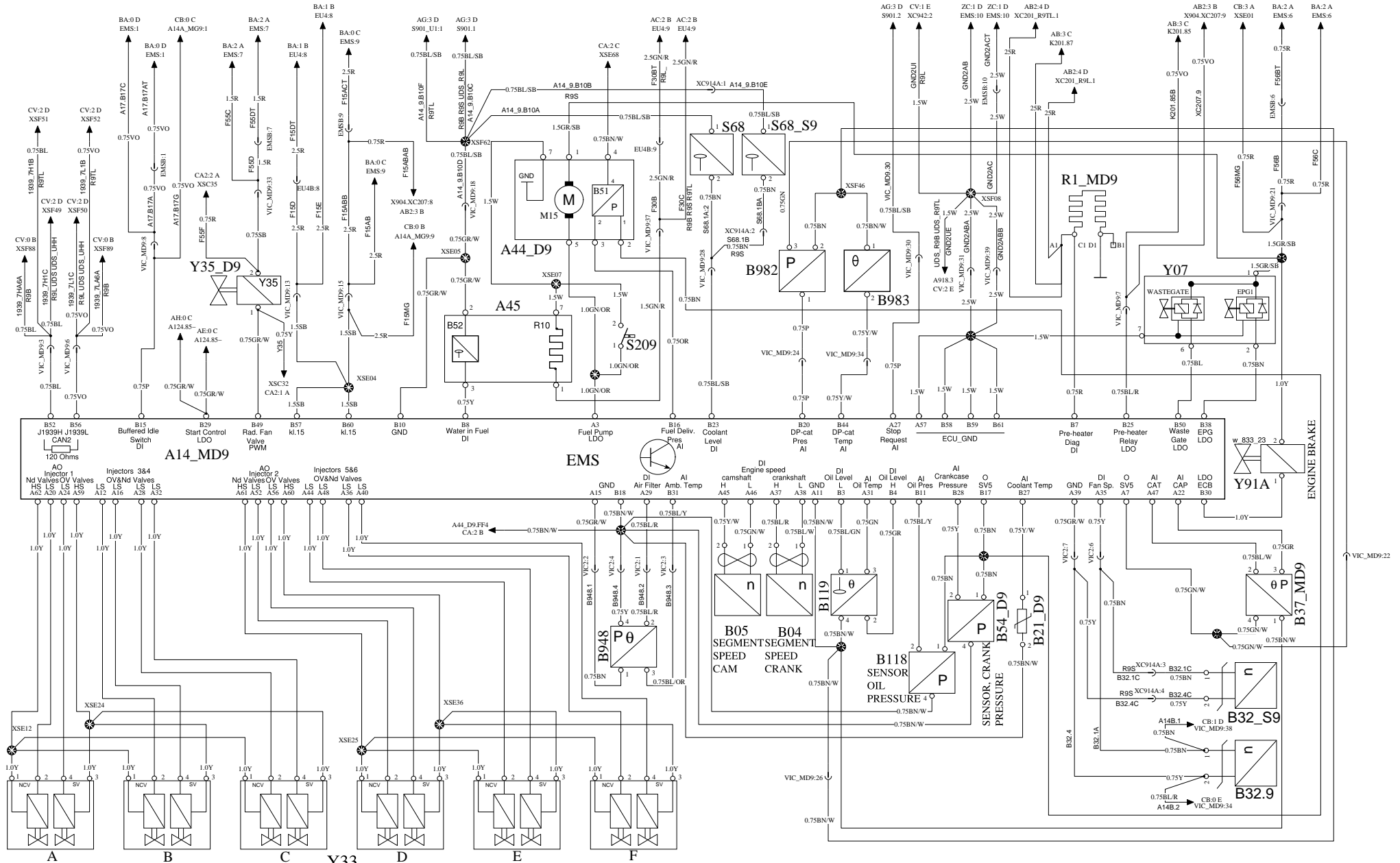

ELECTRIC COOLING FANS

B9TL

WIRING DIAGRAM CA2

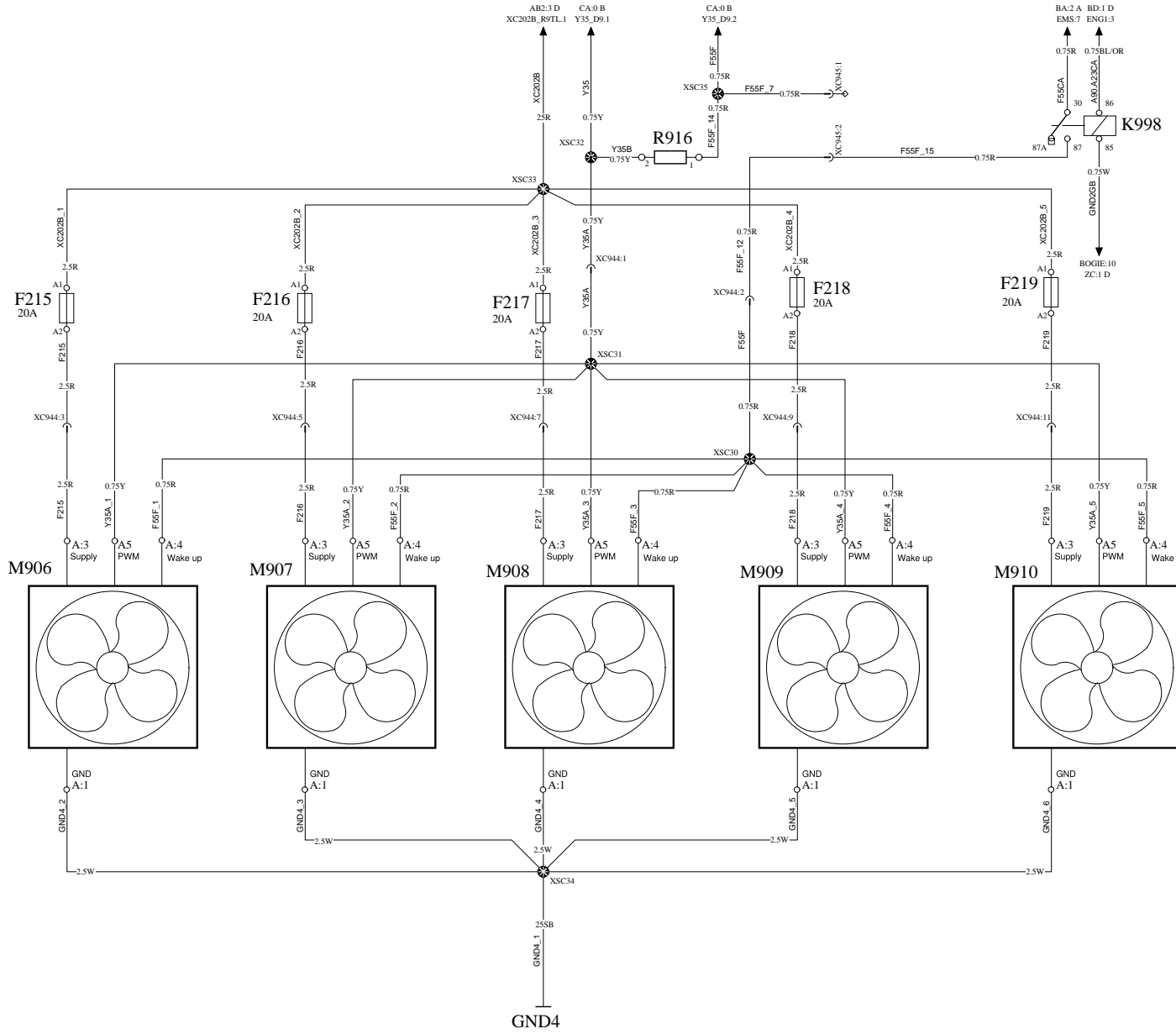

FAN REAR HATCH B9TL

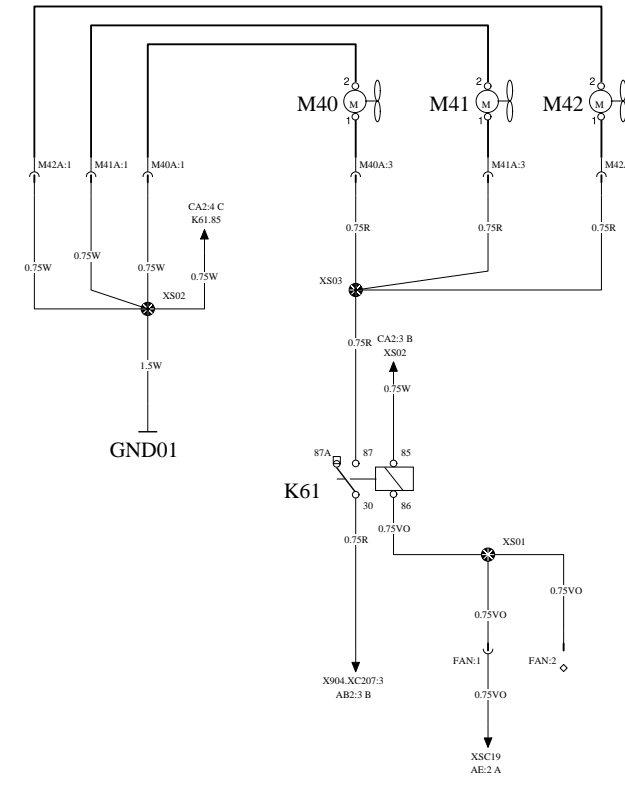

EECU G9A

WIRING DIAGRAM CB

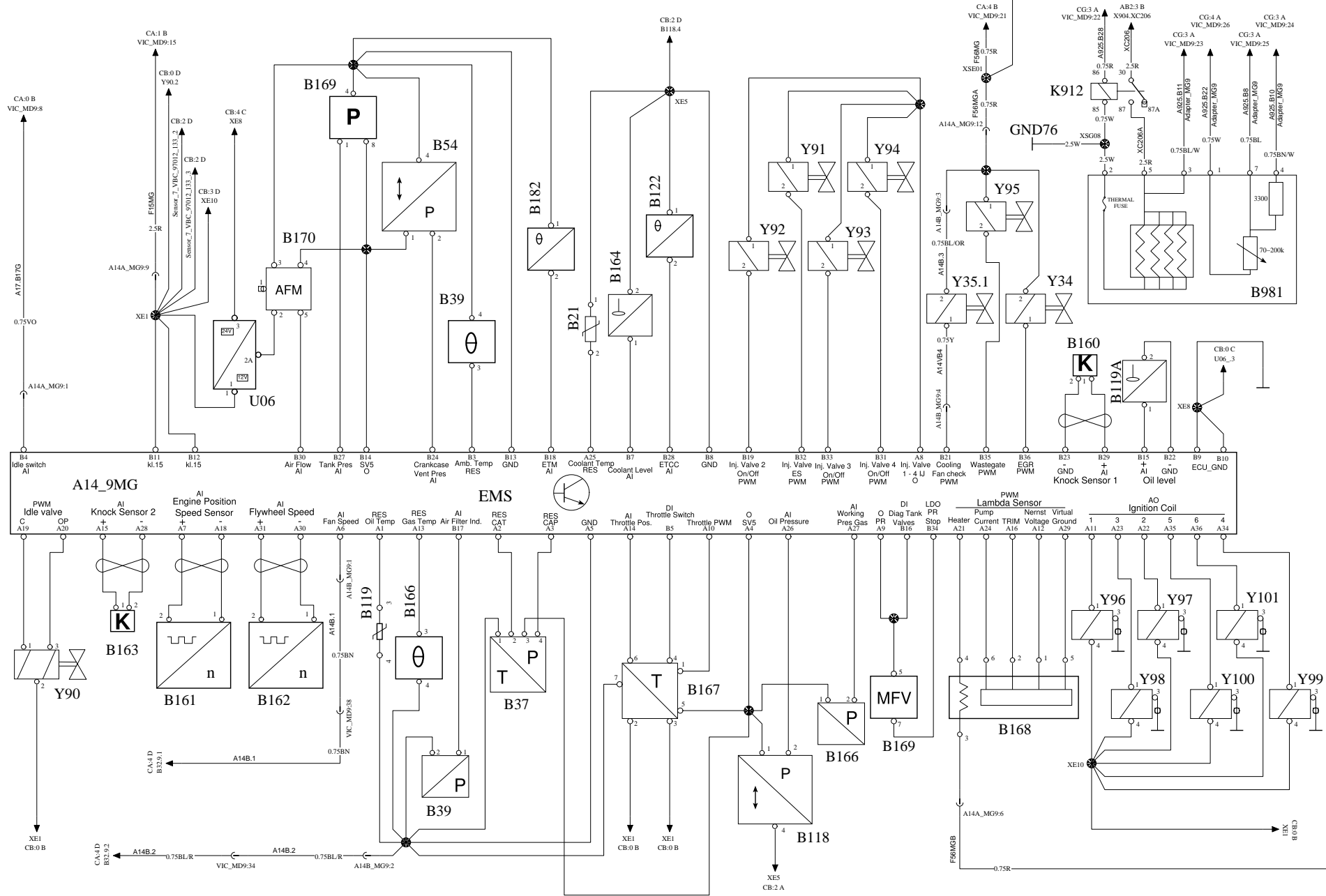

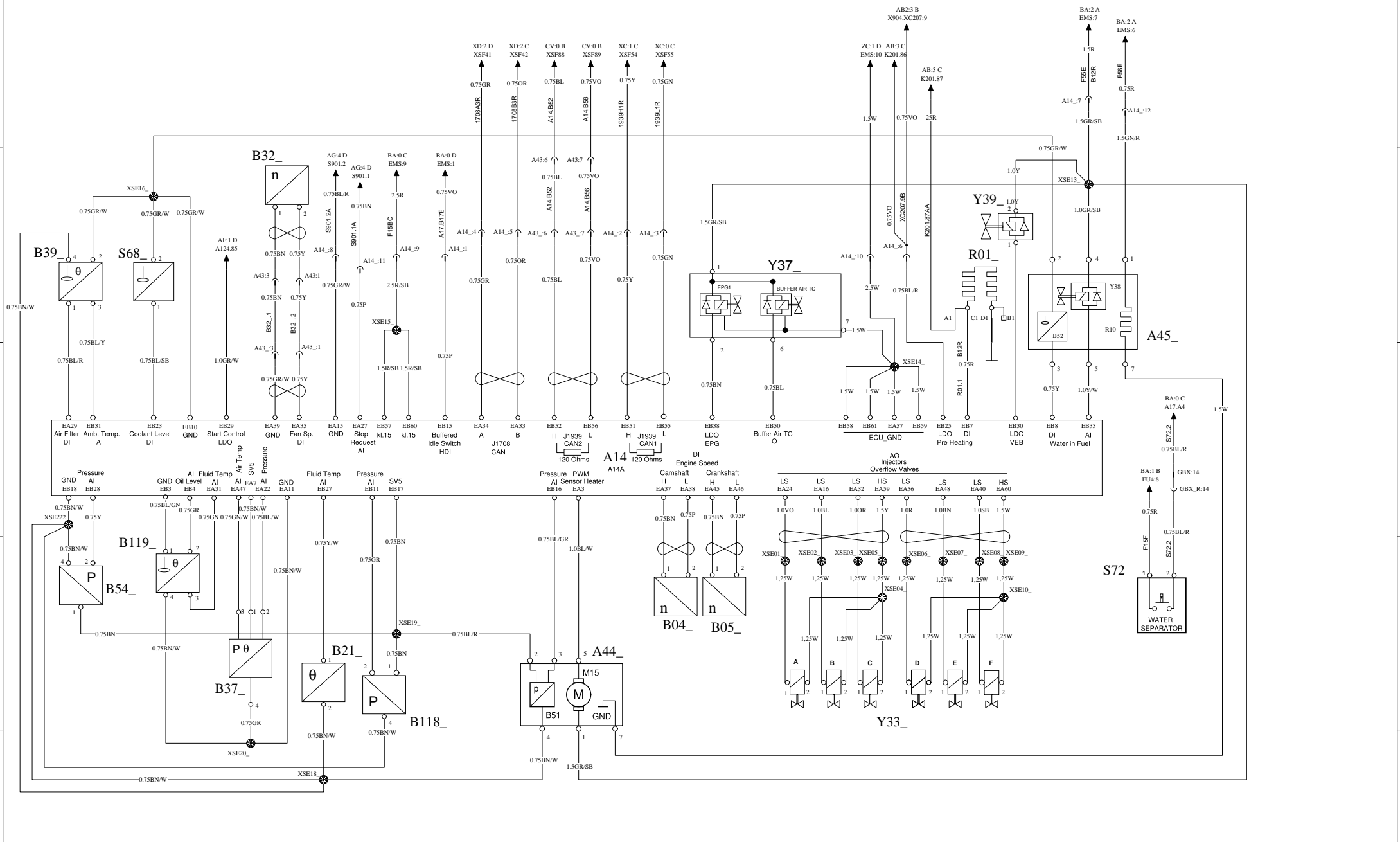

| | | | | | |
|--|-------------------------------------|------------------------------------|------------------------|-----------------------------|---------------------------|
|  Volvo Bus Corporation | Document title WIRING DIAGRAM CC | Document No 20904123 | Issue 15 | Volume 01(02) | Page 24(76) |
| | Document type PRODUCT SCHEMATIC | | | | |

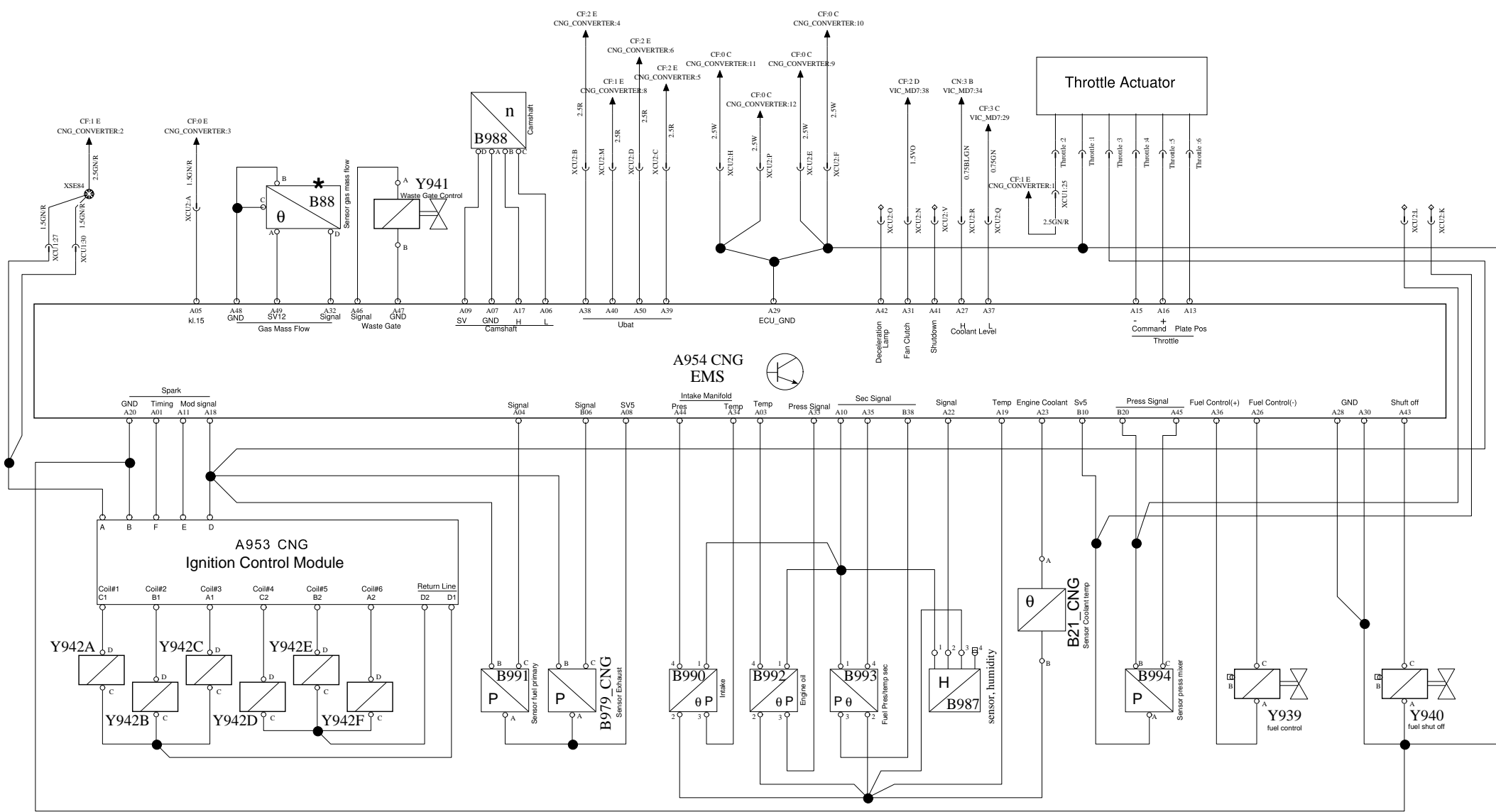

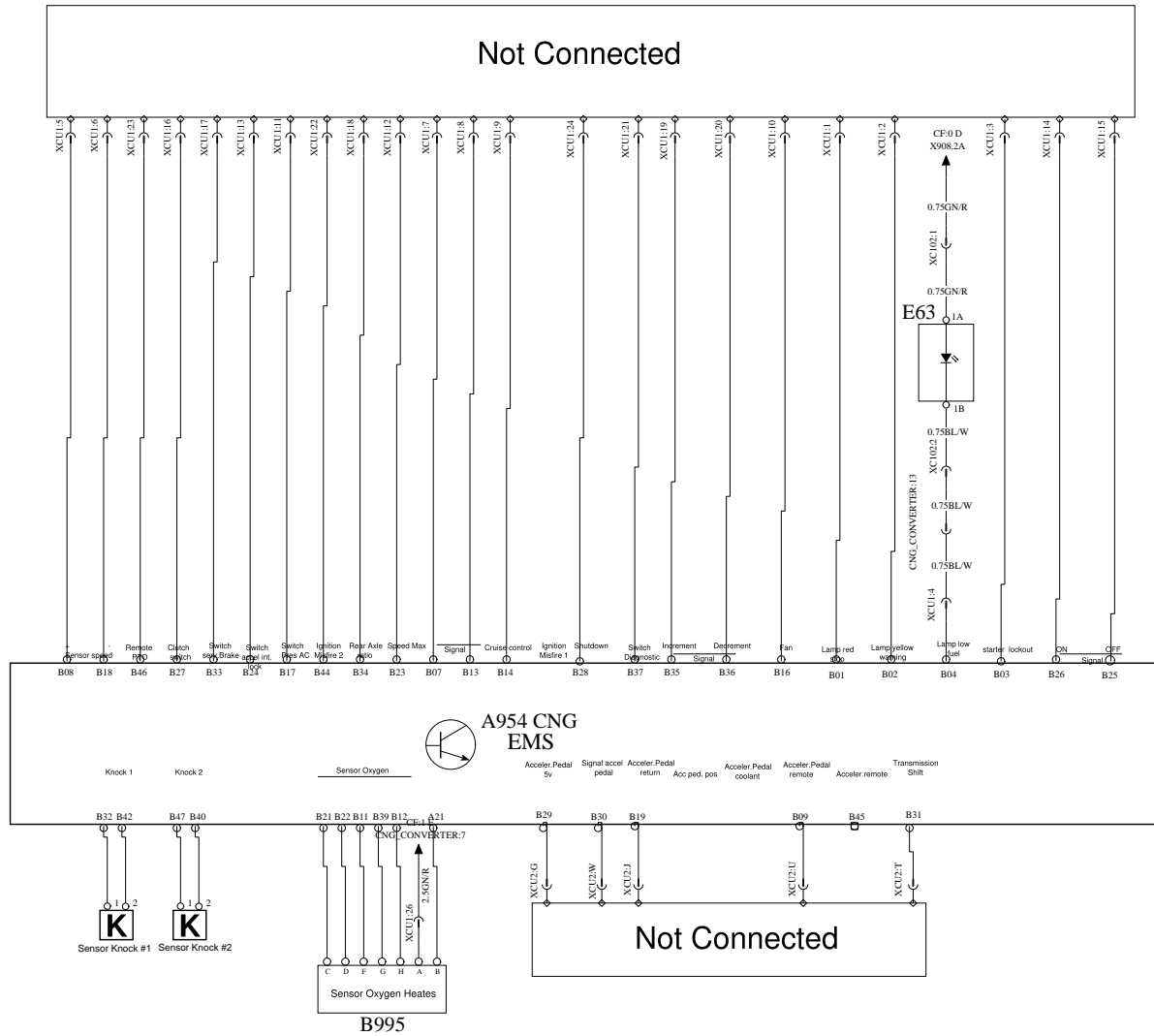

CONVERTER CUMMINS CNG

WIRING DIAGRAM CF

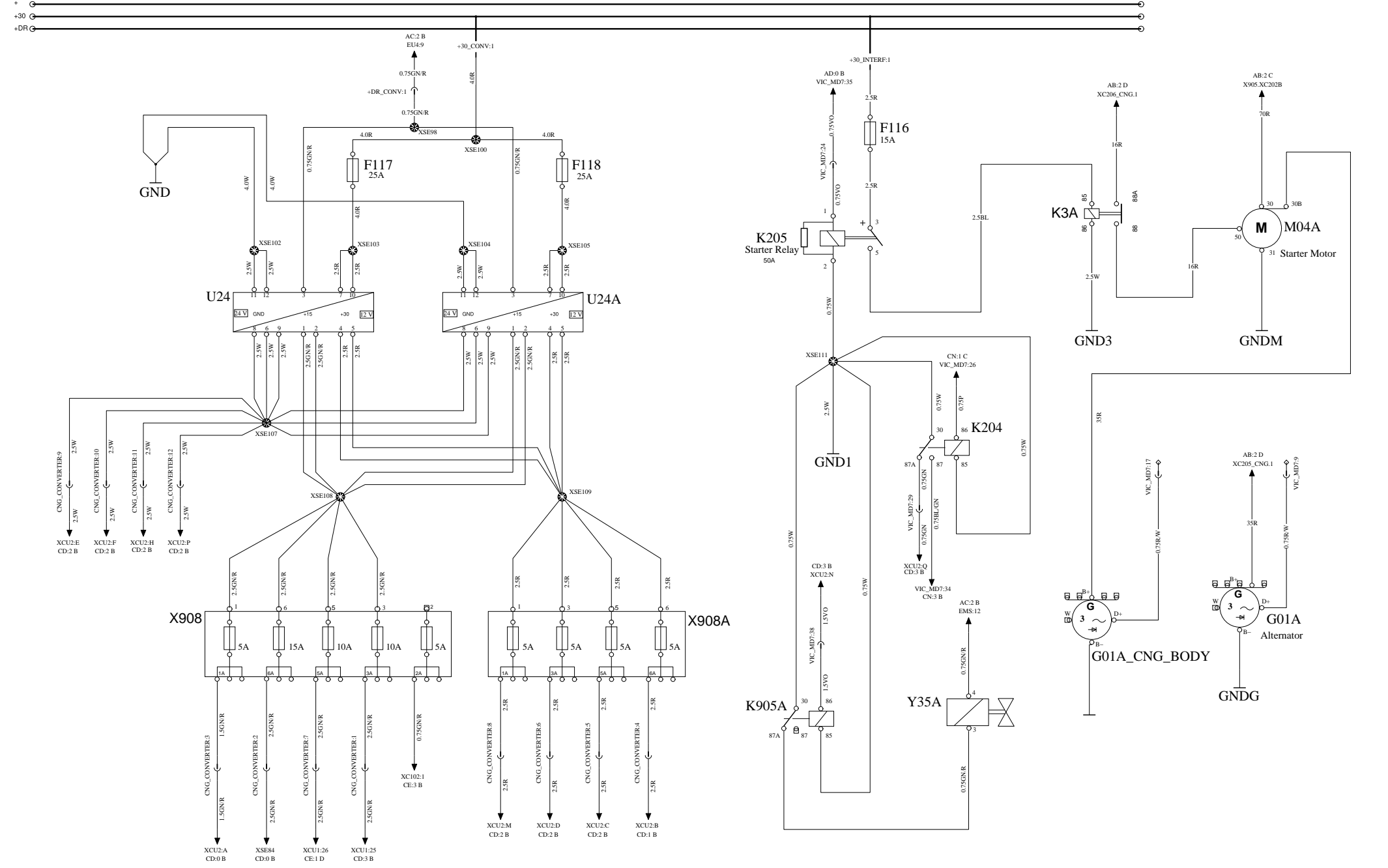

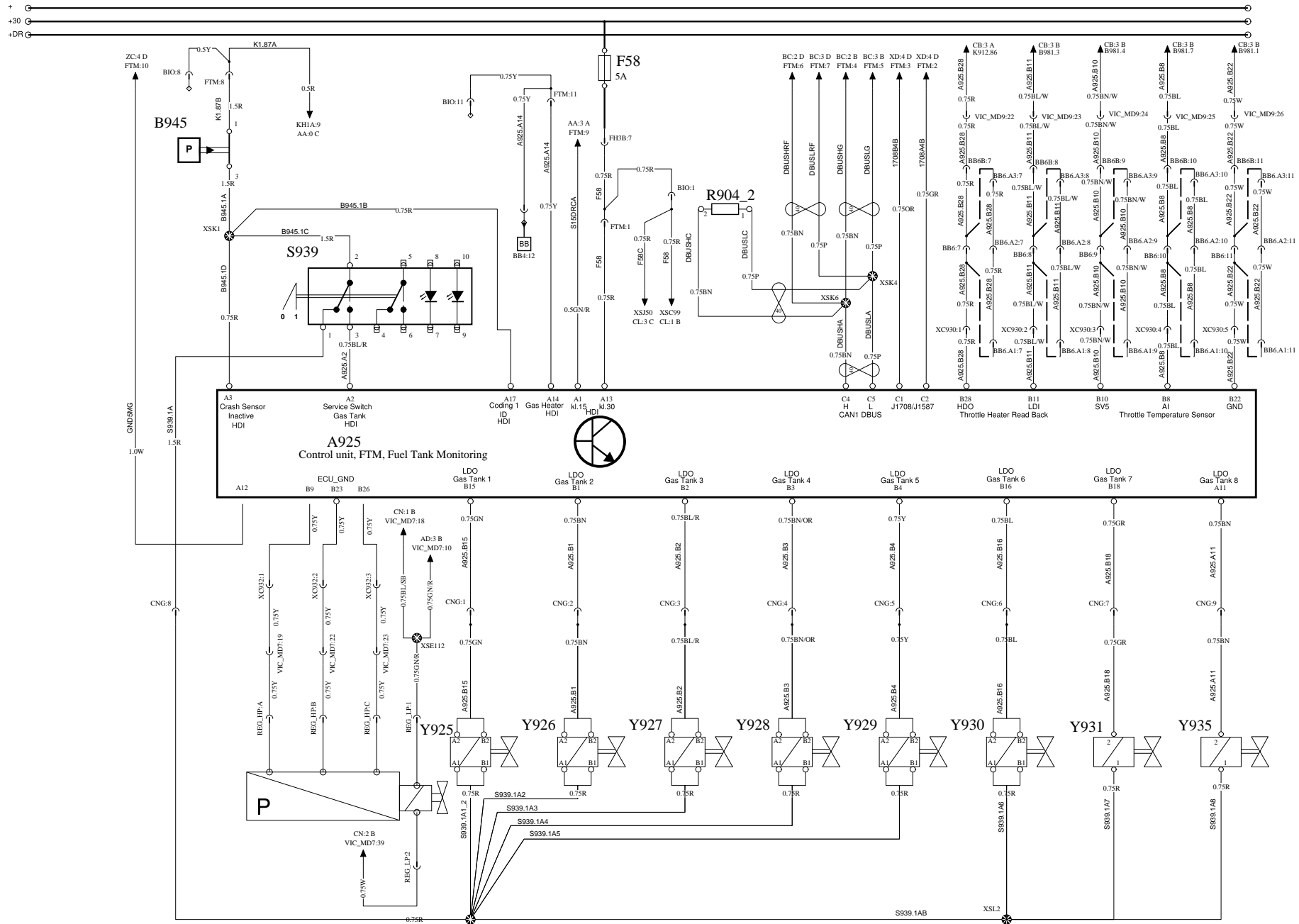

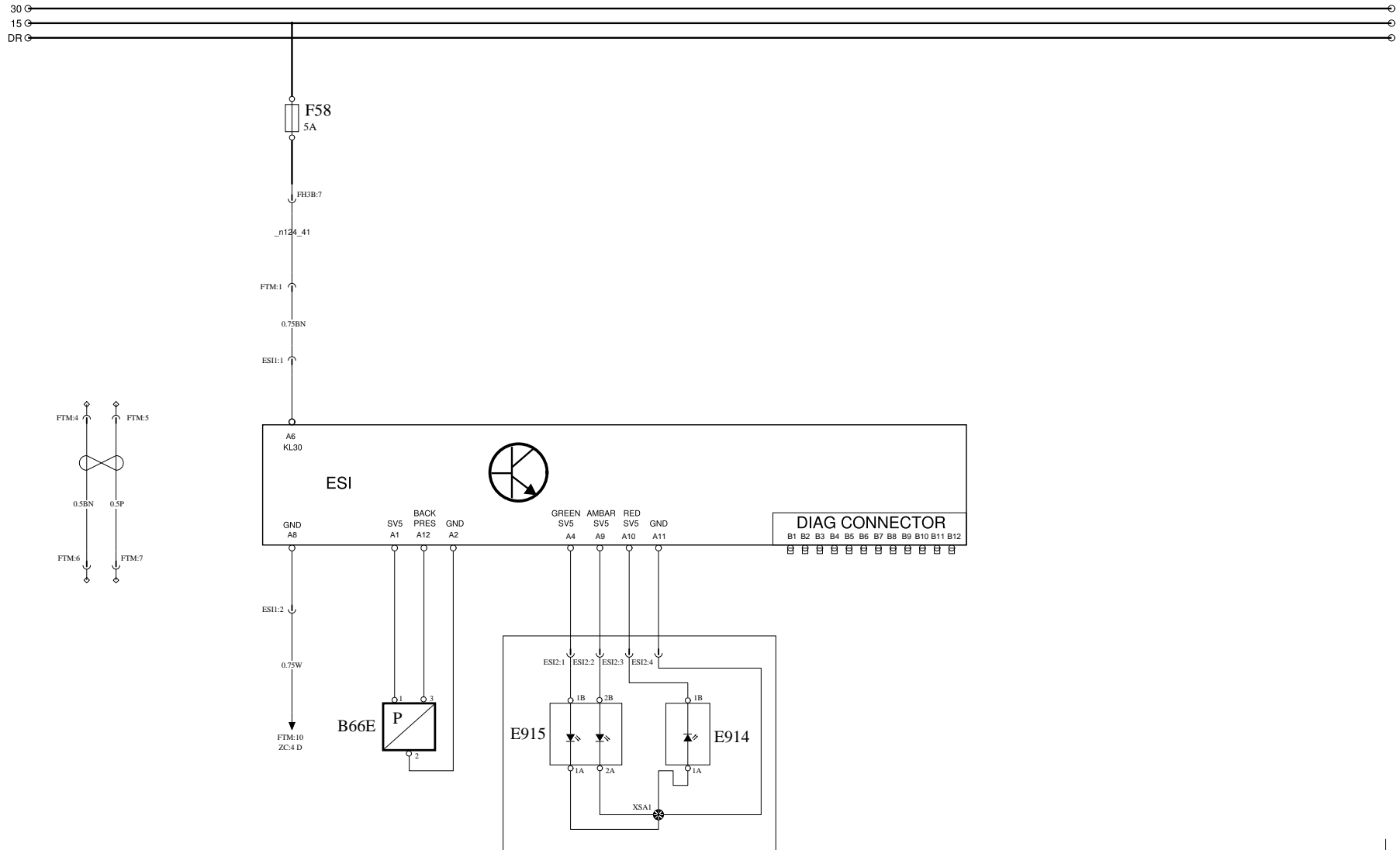

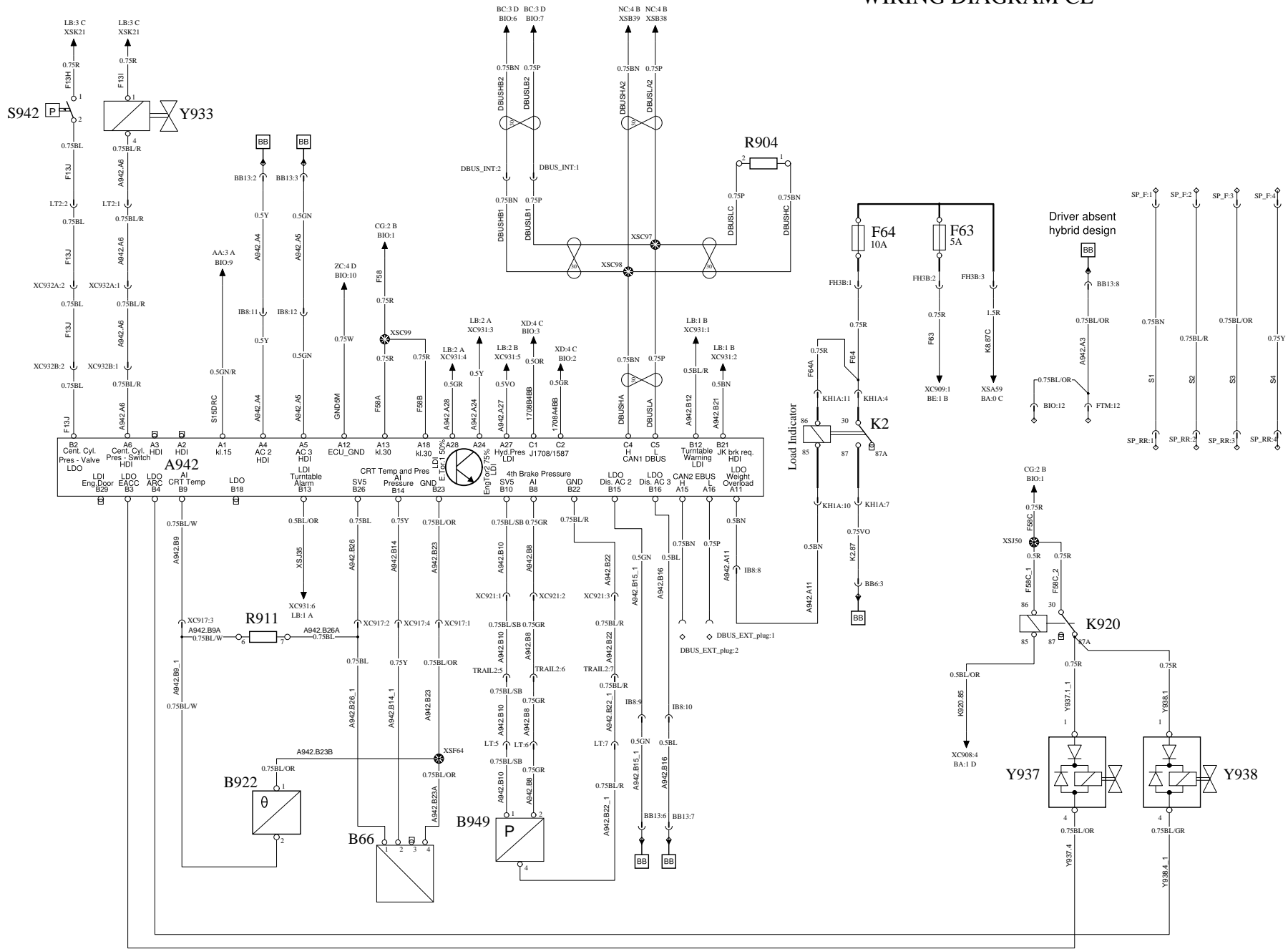

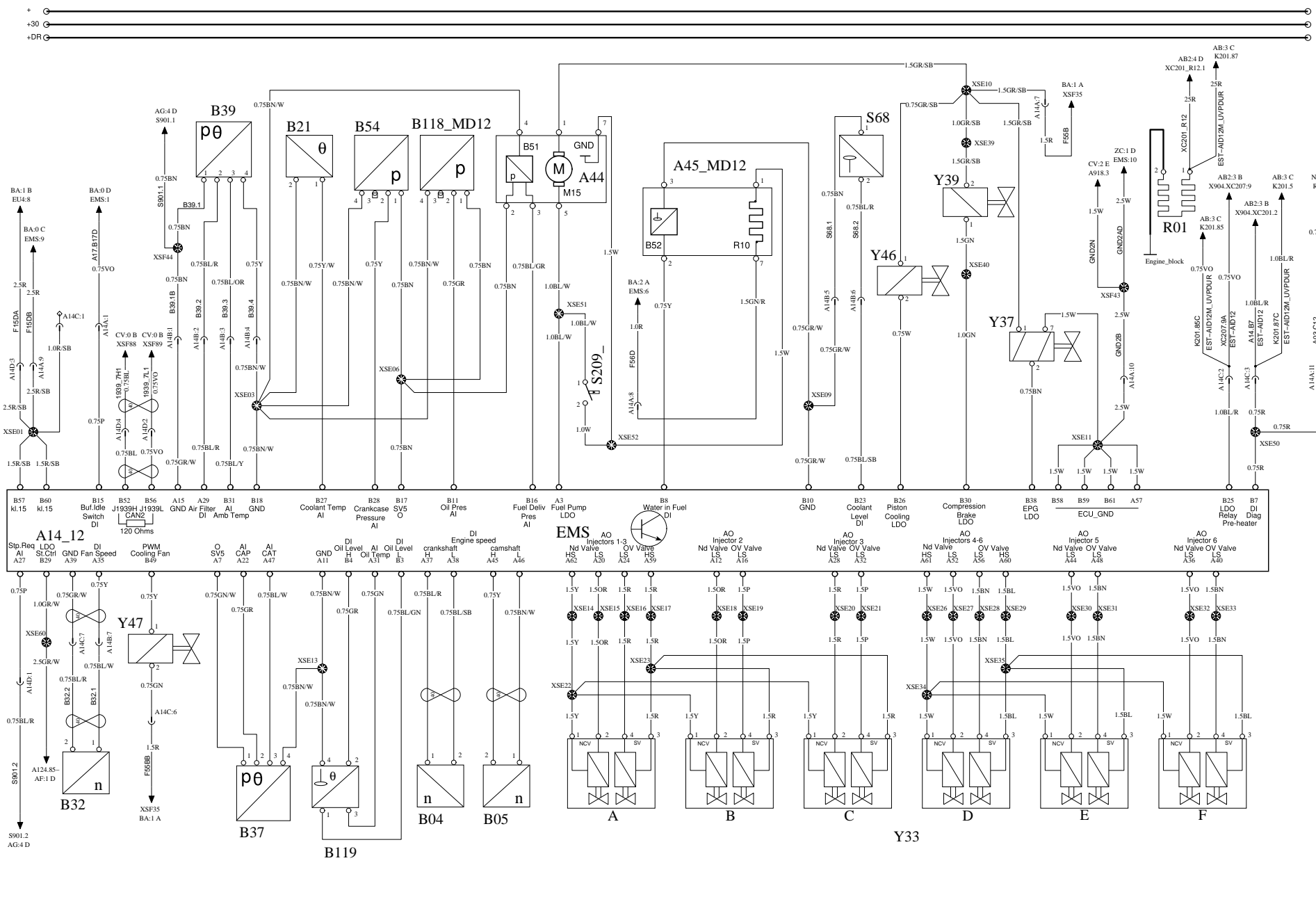

EECU D7E

WIRING DIAGRAM CN

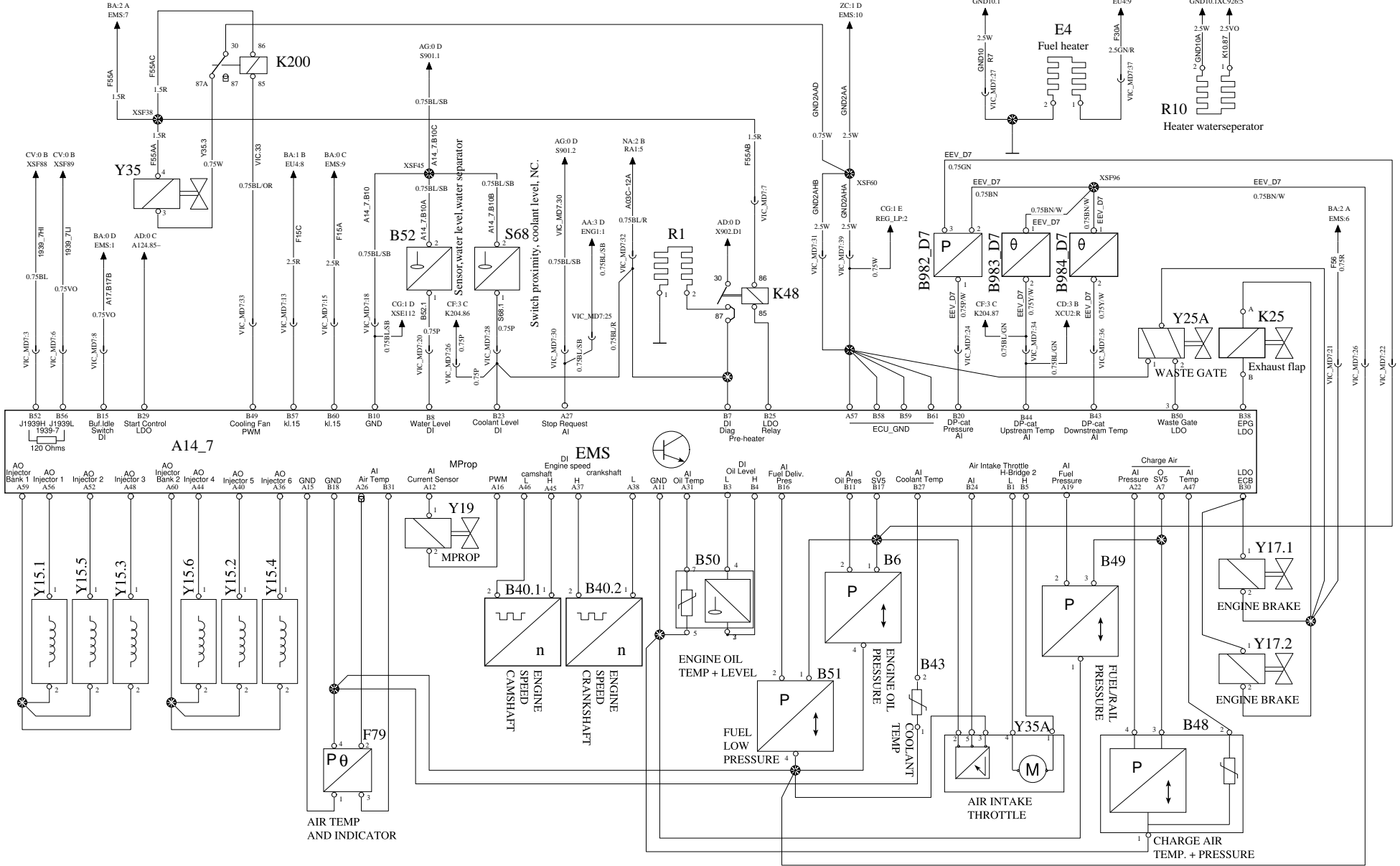

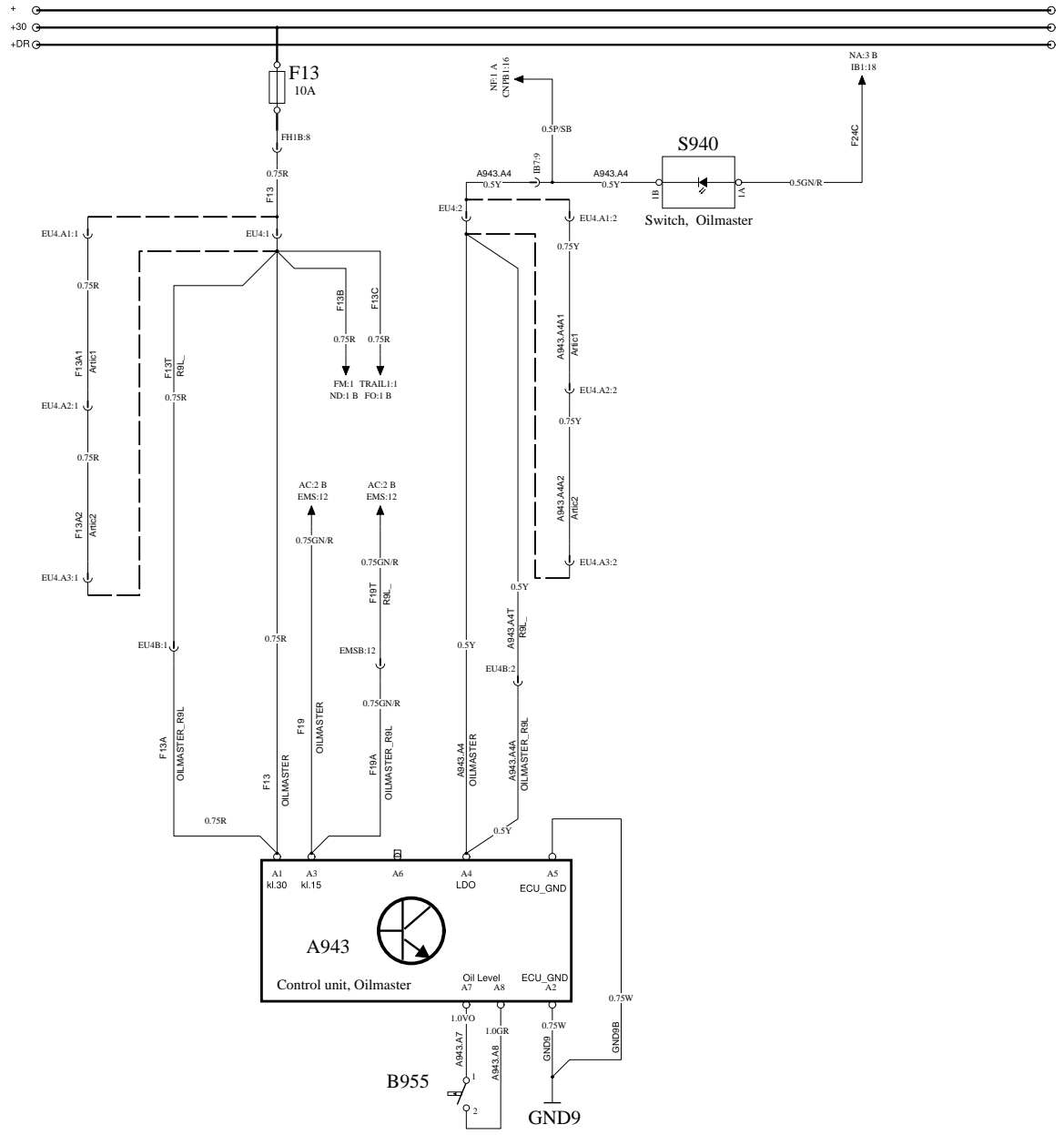

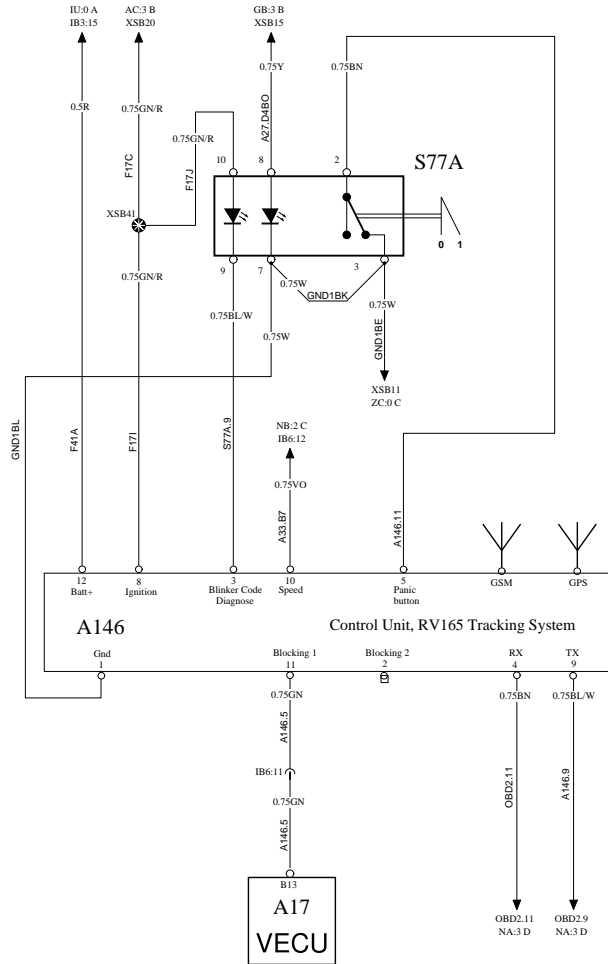
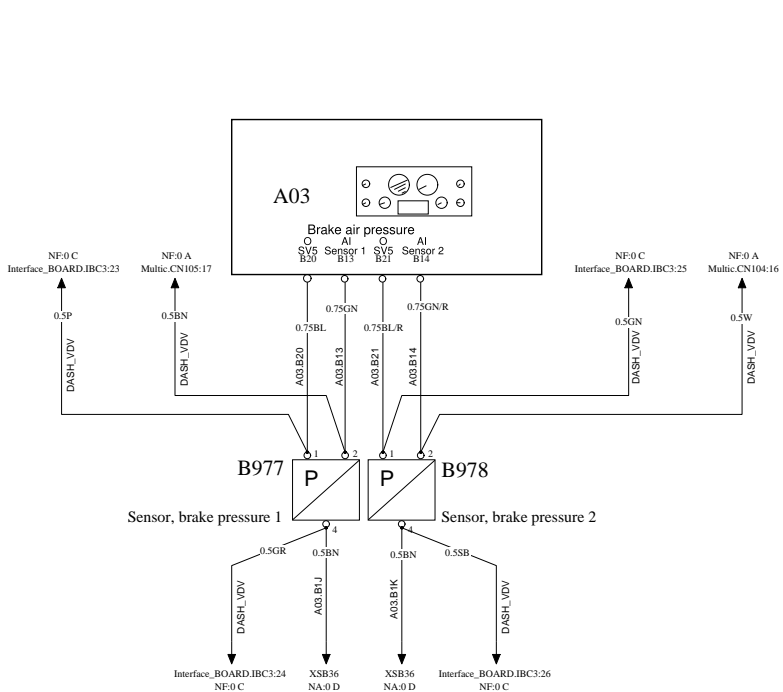

DNOX2

WIRING DIAGRAM CU

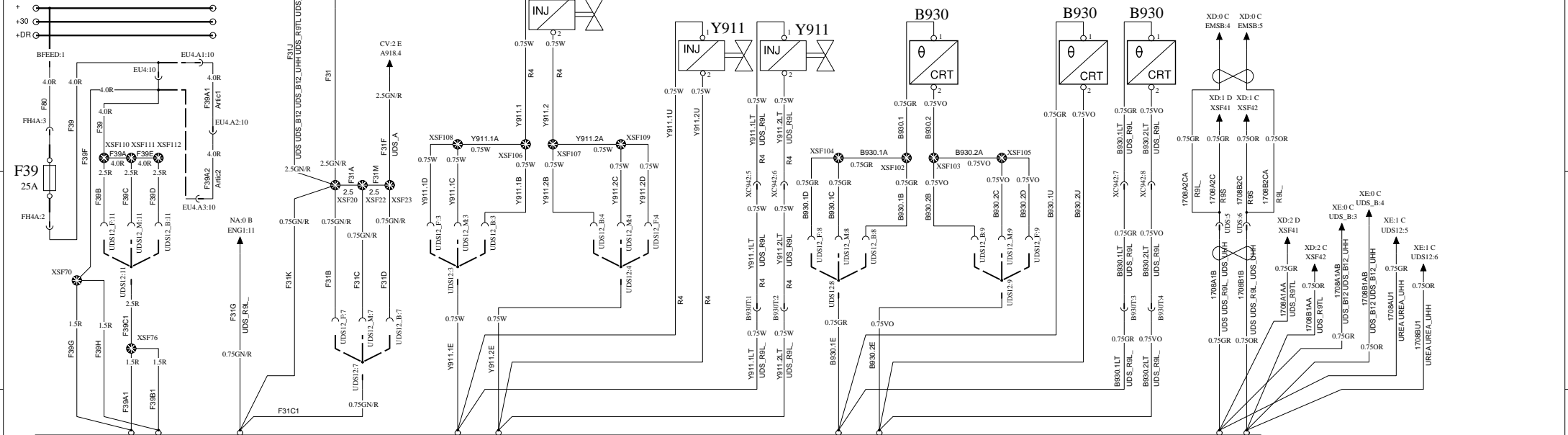

A917

Control unit, DNOX2 ECU

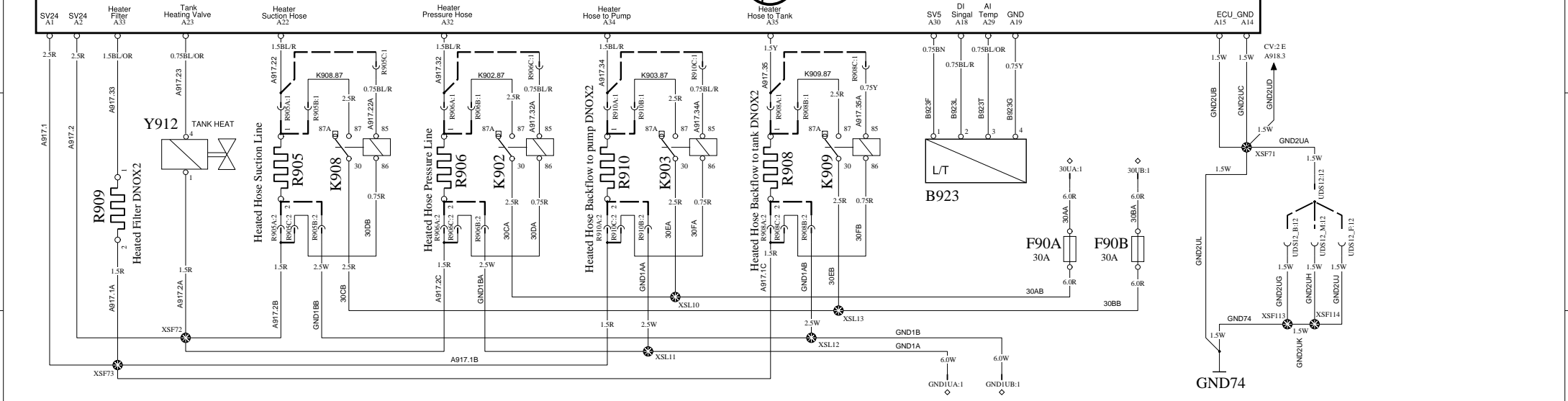

| | | | | | |
|---------------------------|---|-------------|-------|--------|--------|
| Volvo Bus Corporation | Document title | Document No | Issue | Volume | Page |
| | WIRING DIAGRAM CU Document type PRODUCT SCHEMATIC | 20904123 | 15 | 01(02) | 35(76) |

CAN SAE 1939_7

WIRING DIAGRAM CV

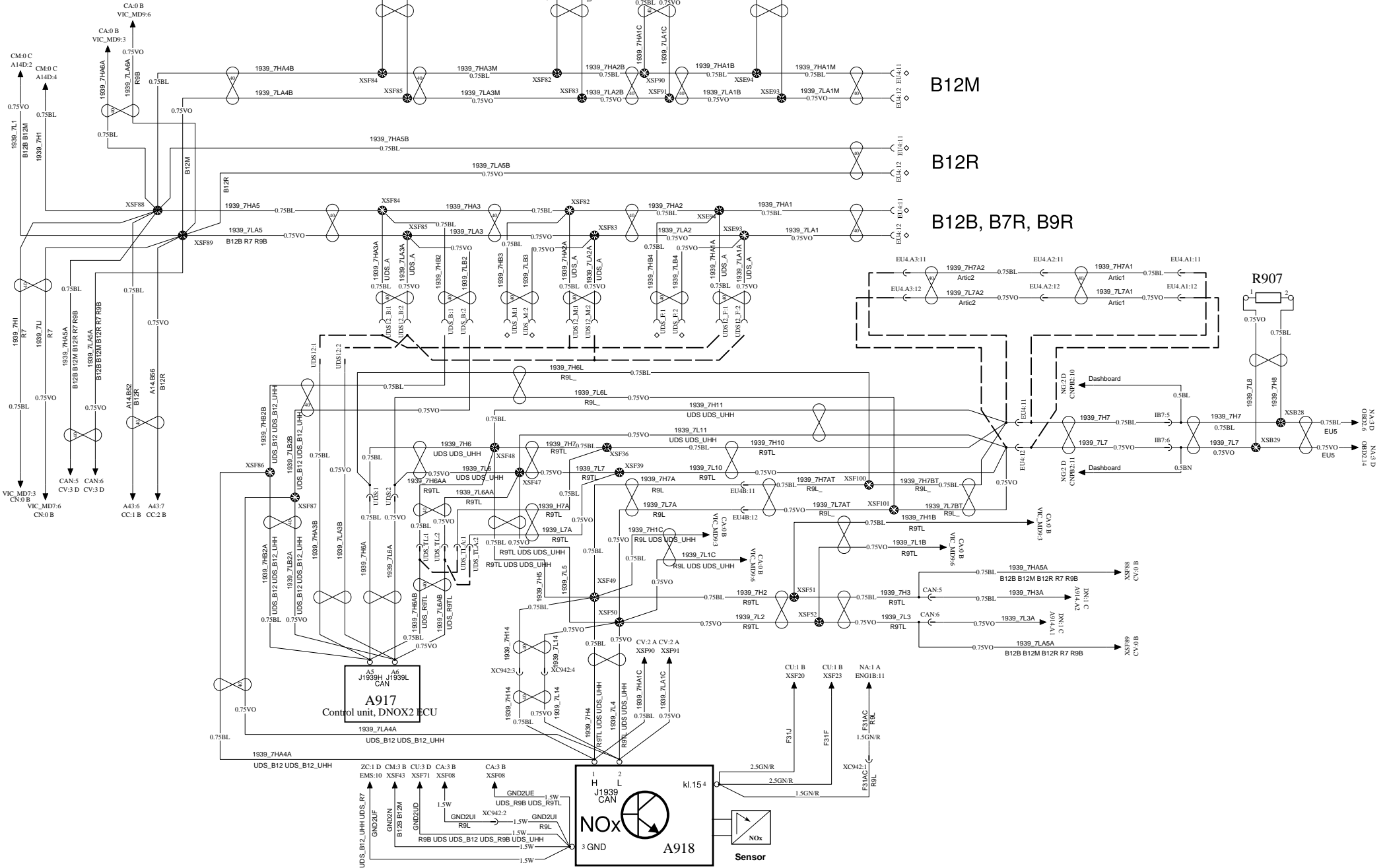

ECOMAT4 ZF

WIRING DIAGRAM DB

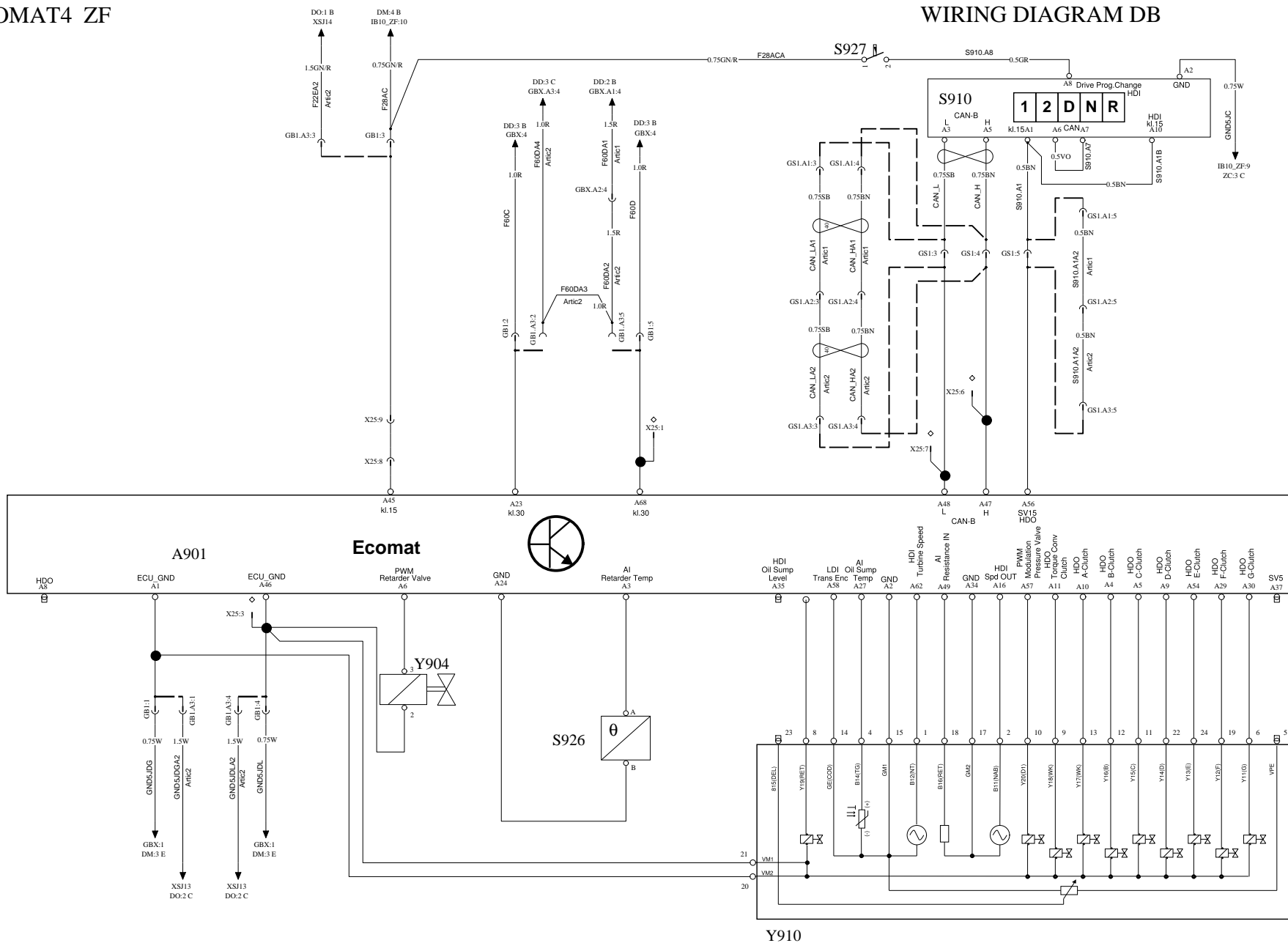

VOITH DIWA5

WIRING DIAGRAM DC

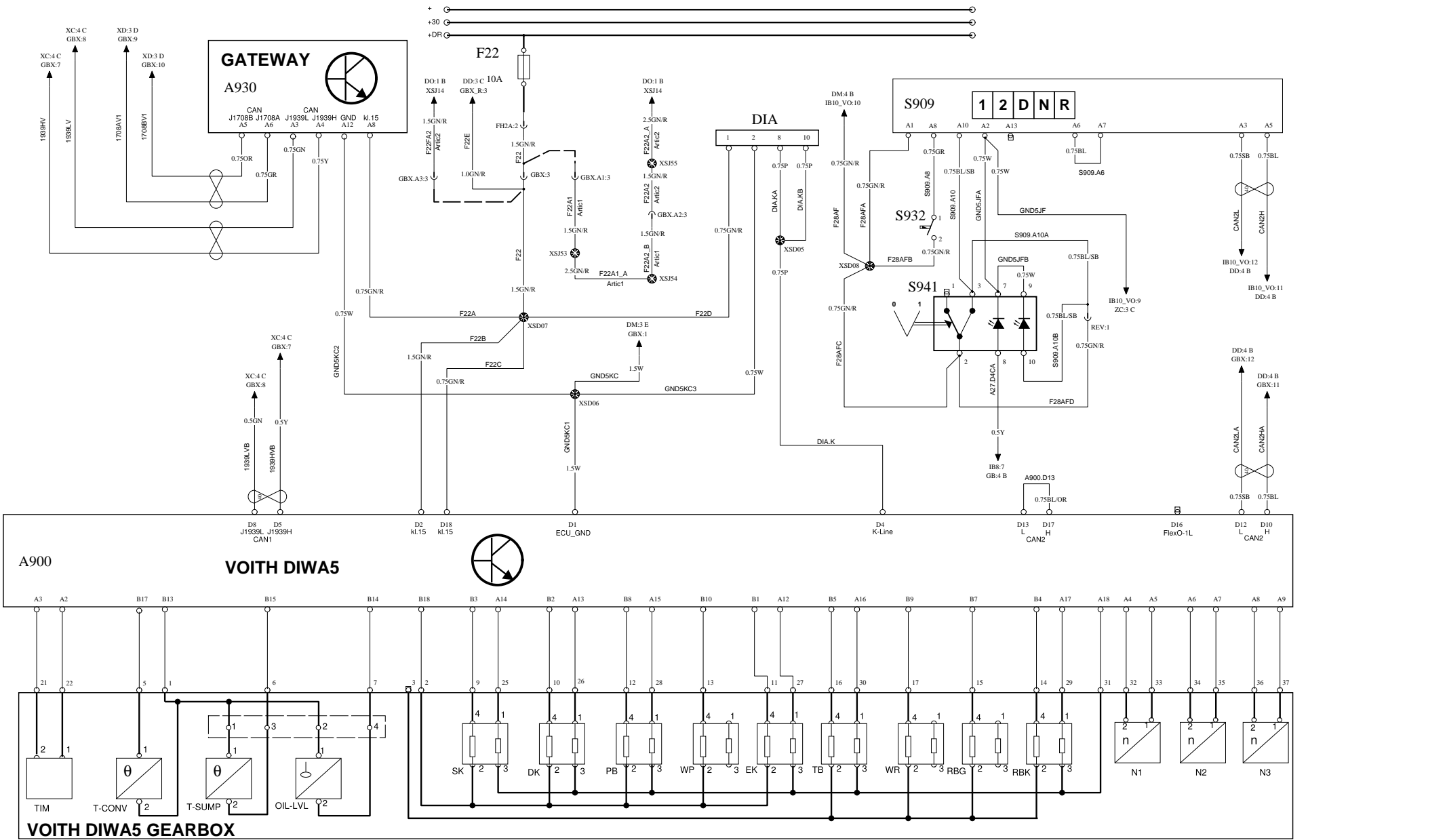

A

B

C

D

E

A

B

C

D

E

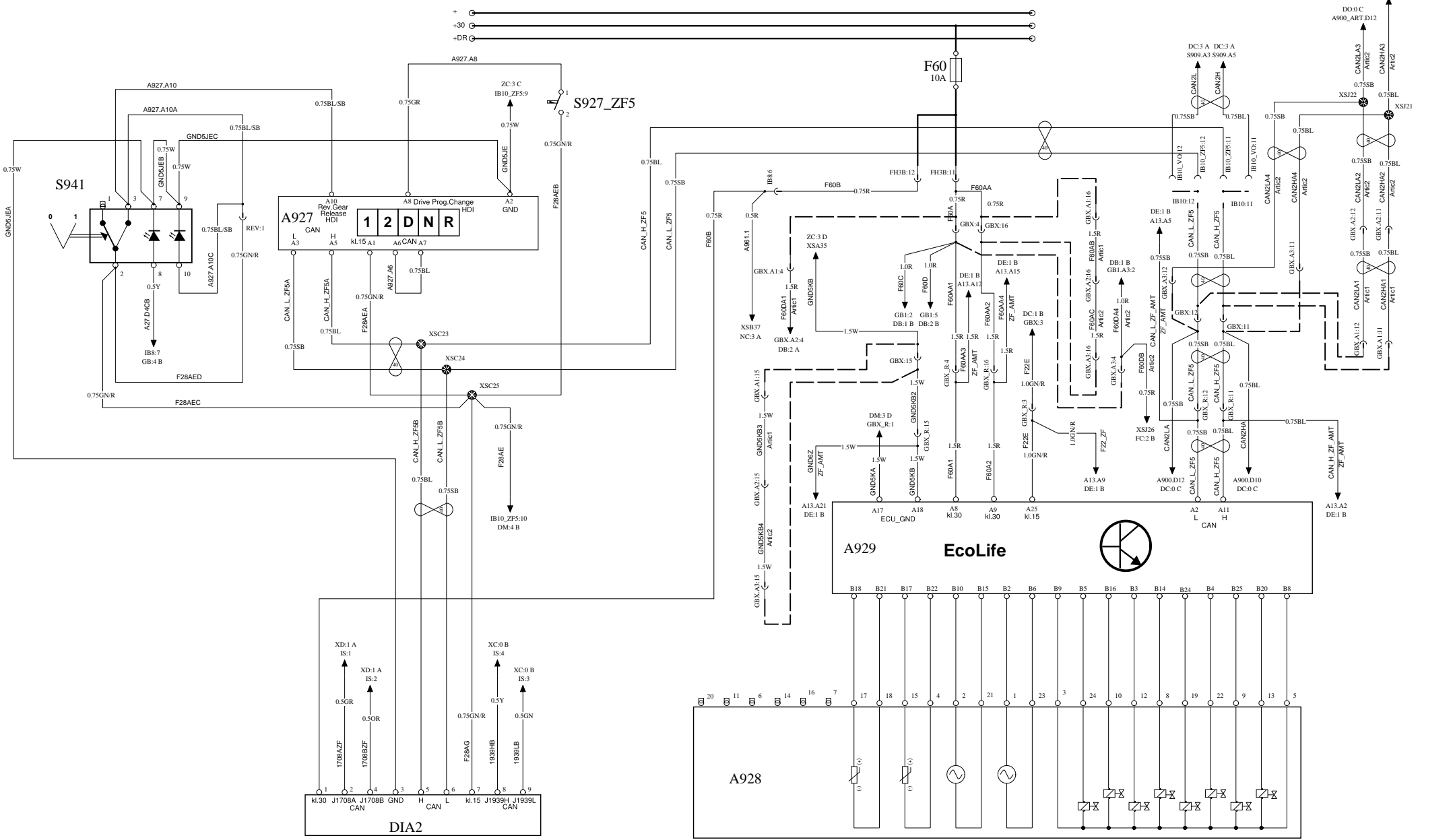

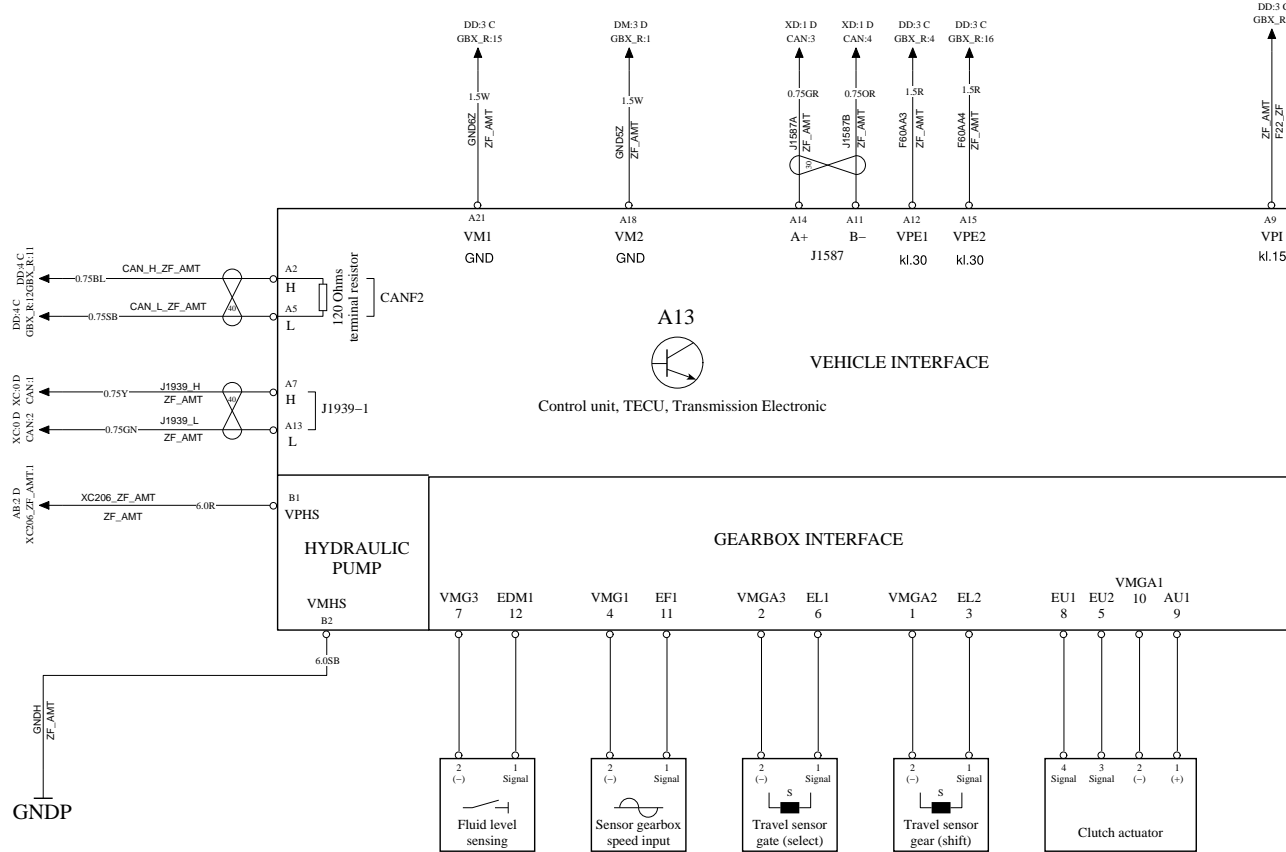

RETARDER

WIRING DIAGRAM DM

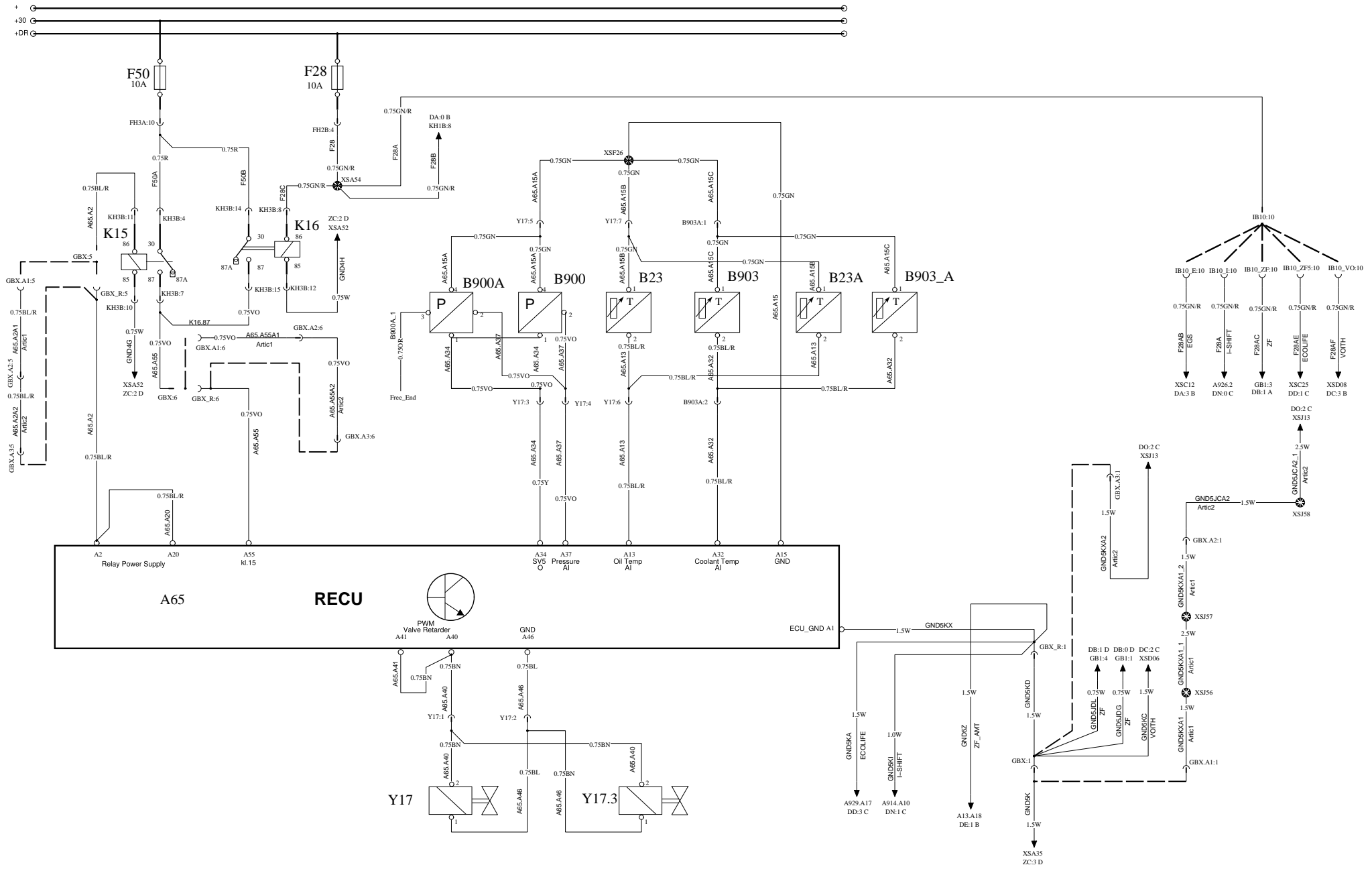

I-SHIFT

WIRING DIAGRAM DN

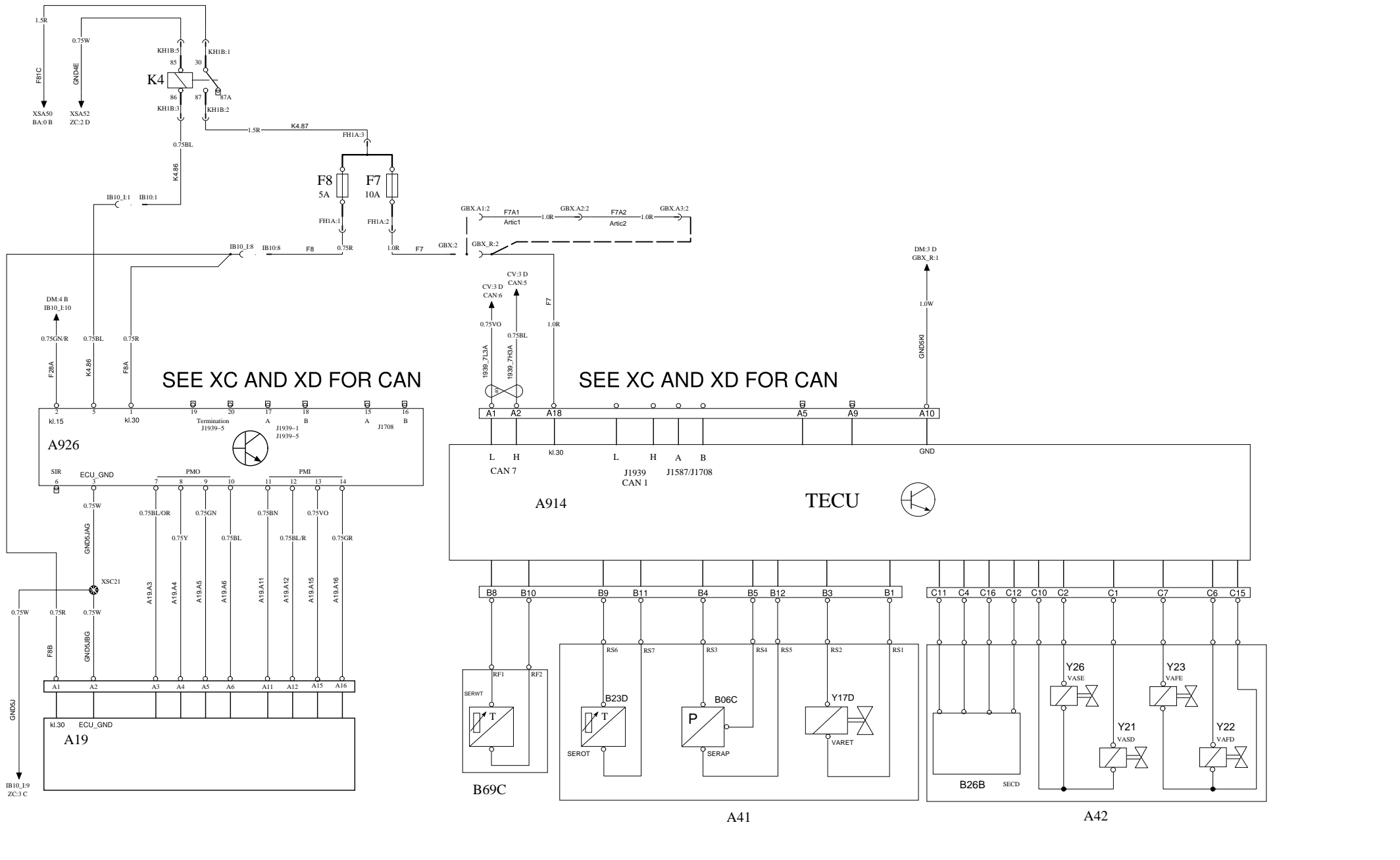

SEE XC AND XD FOR CAN

SEE XC AND XD FOR CAN

VOITH DIWA5 ARTIC

WIRING DIAGRAM DO

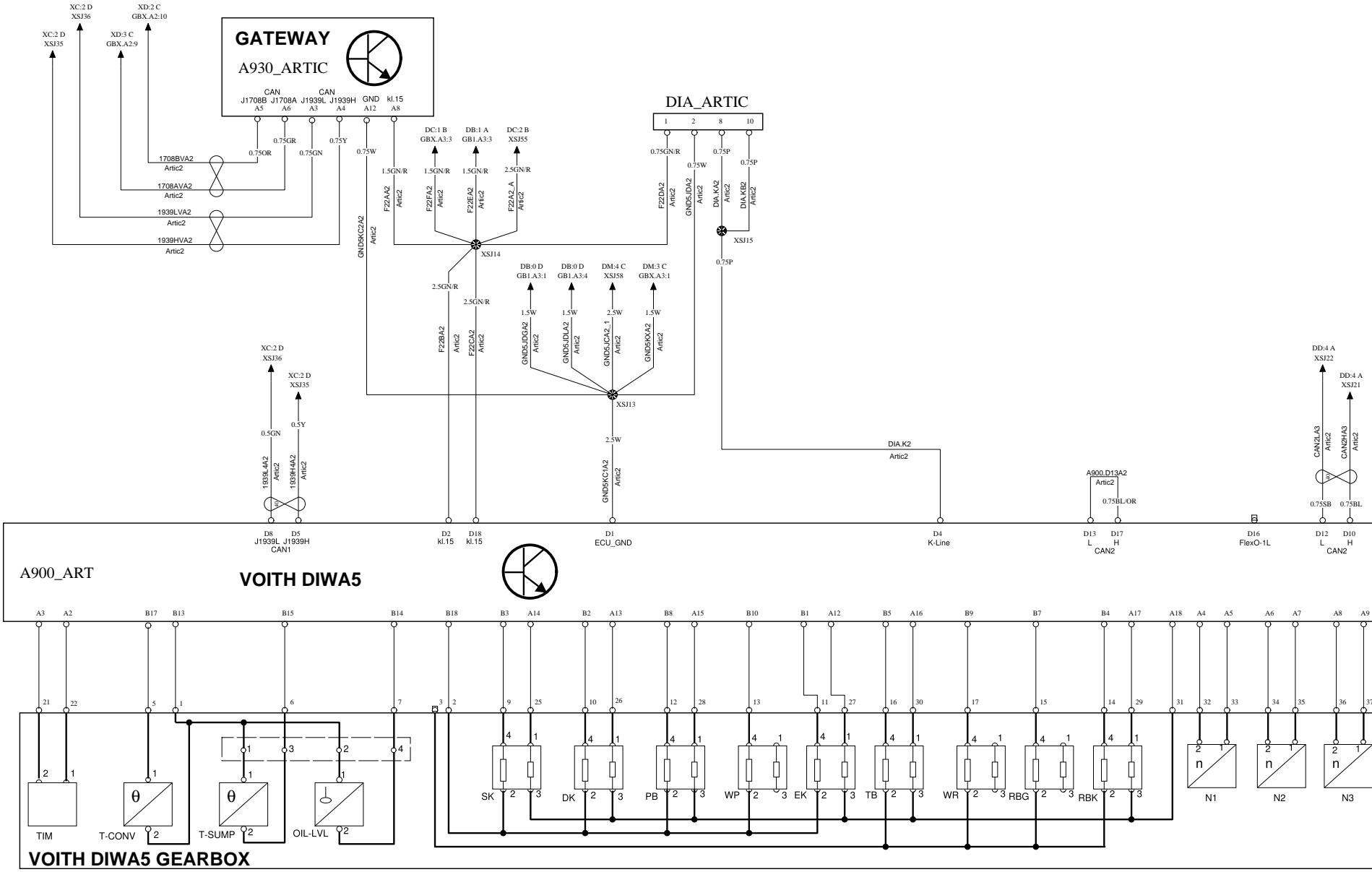

FOR WIRING CONNECTIONS SEE CONECTOR GBX PINOUT ON SHEET DD

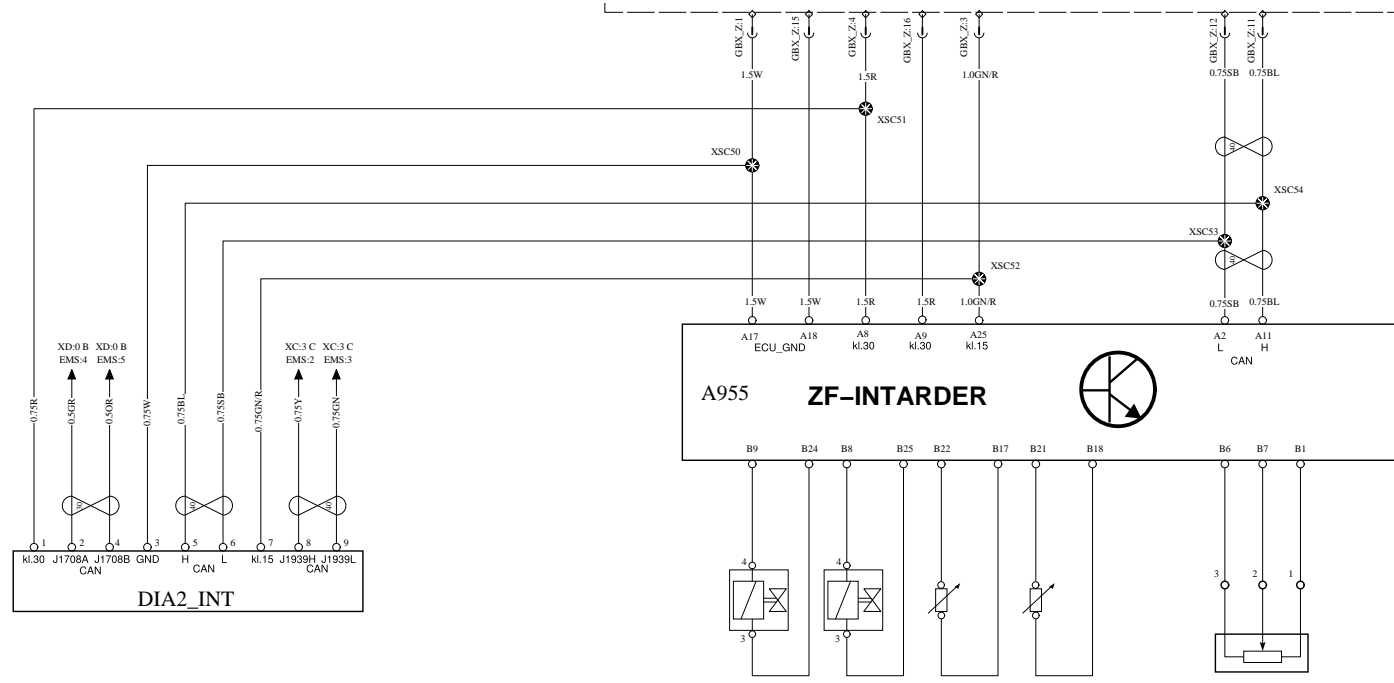

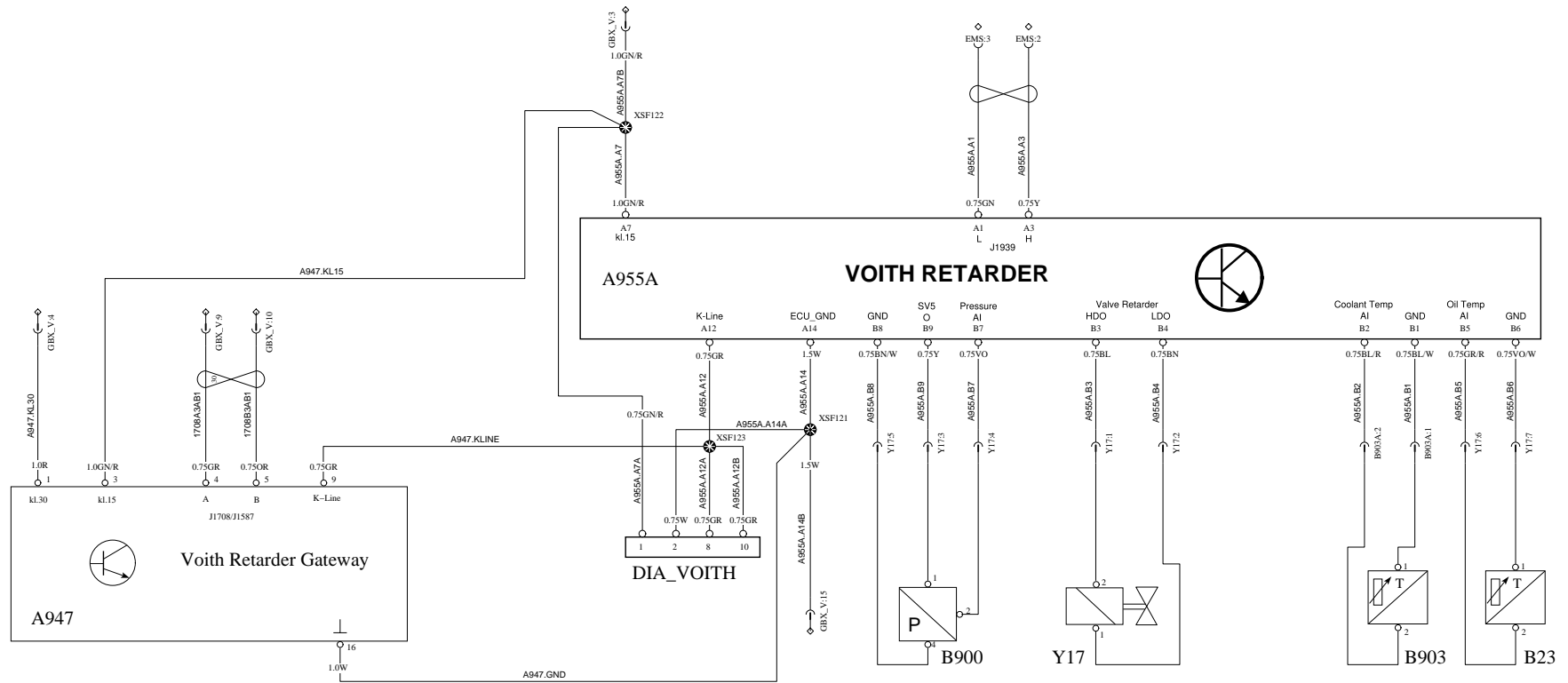

EBS

WIRING DIAGRAM EO

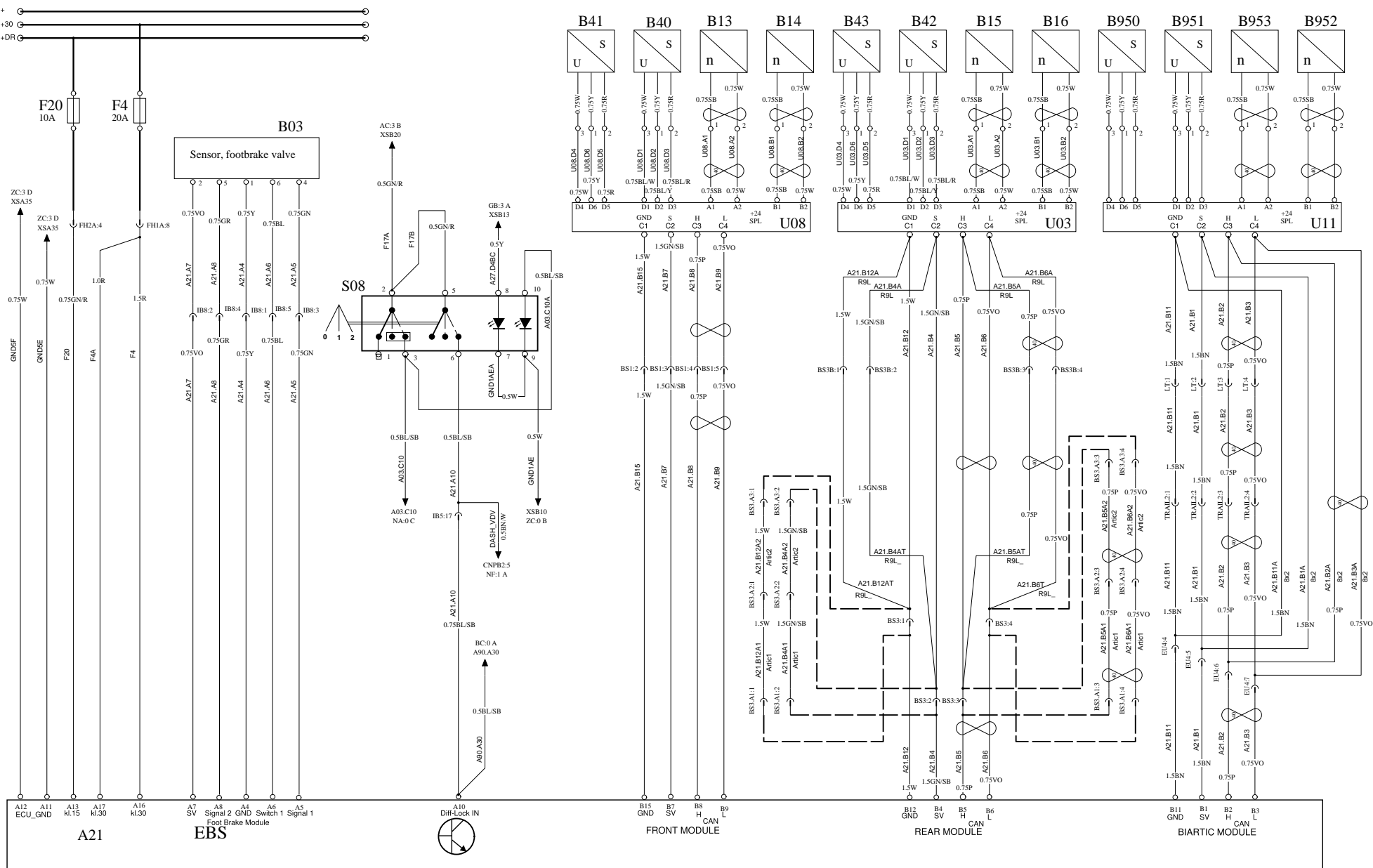

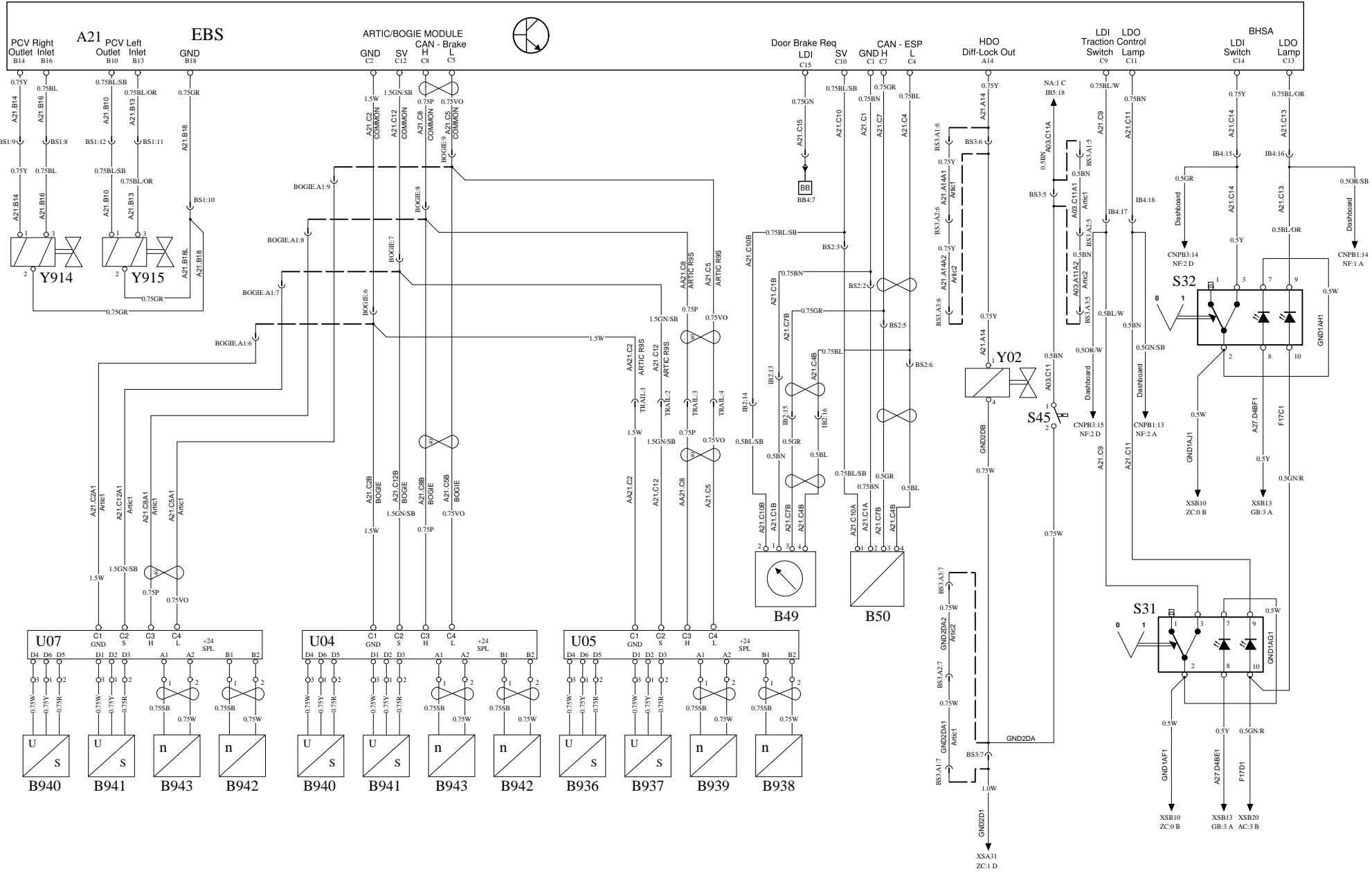

Volvo Bus Corporation

Document title
WIRING DIAGRAM EP
Document type
PRODUCT SCHEMATIC

Document No

20904123

Issue

15

Volume

01(02)

Page

48(76)

PARKING BRAKE RELEASE

WIRING DIAGRAM EX

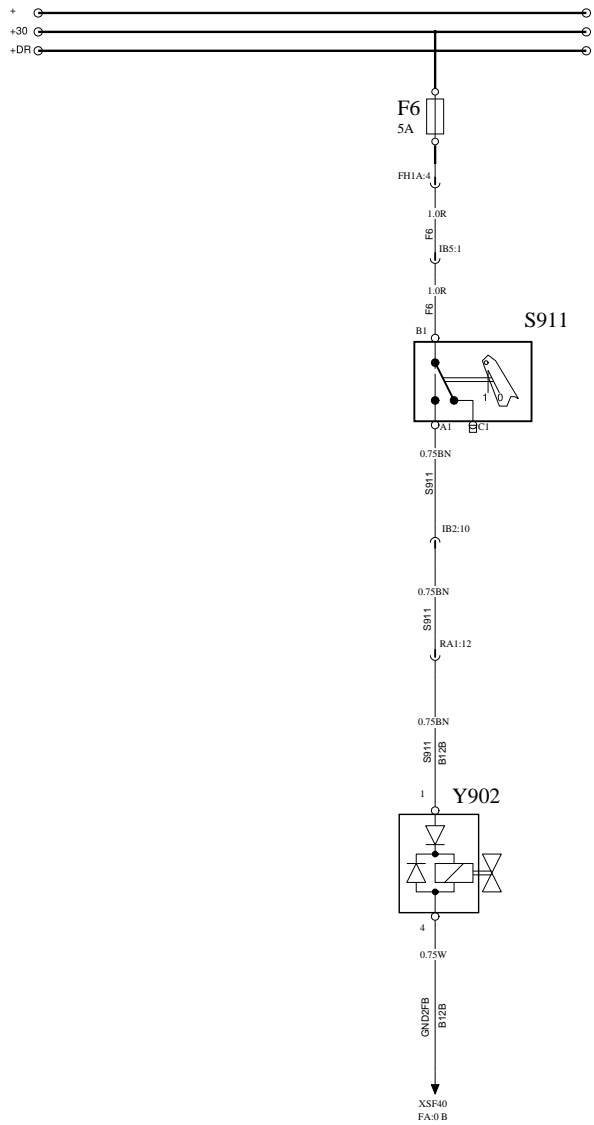

AIR SUSPENSION ECS

WIRING DIAGRAM FA

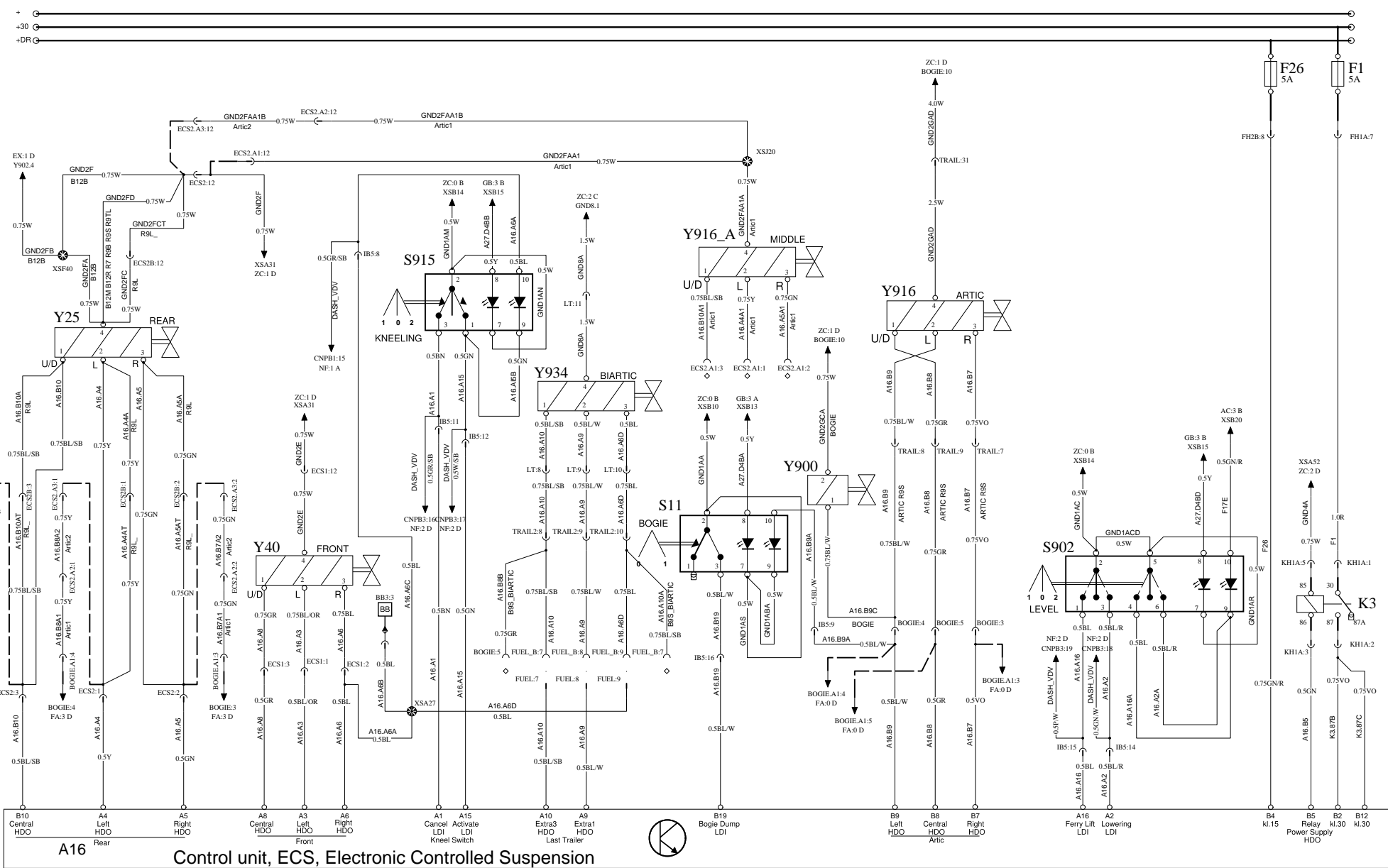

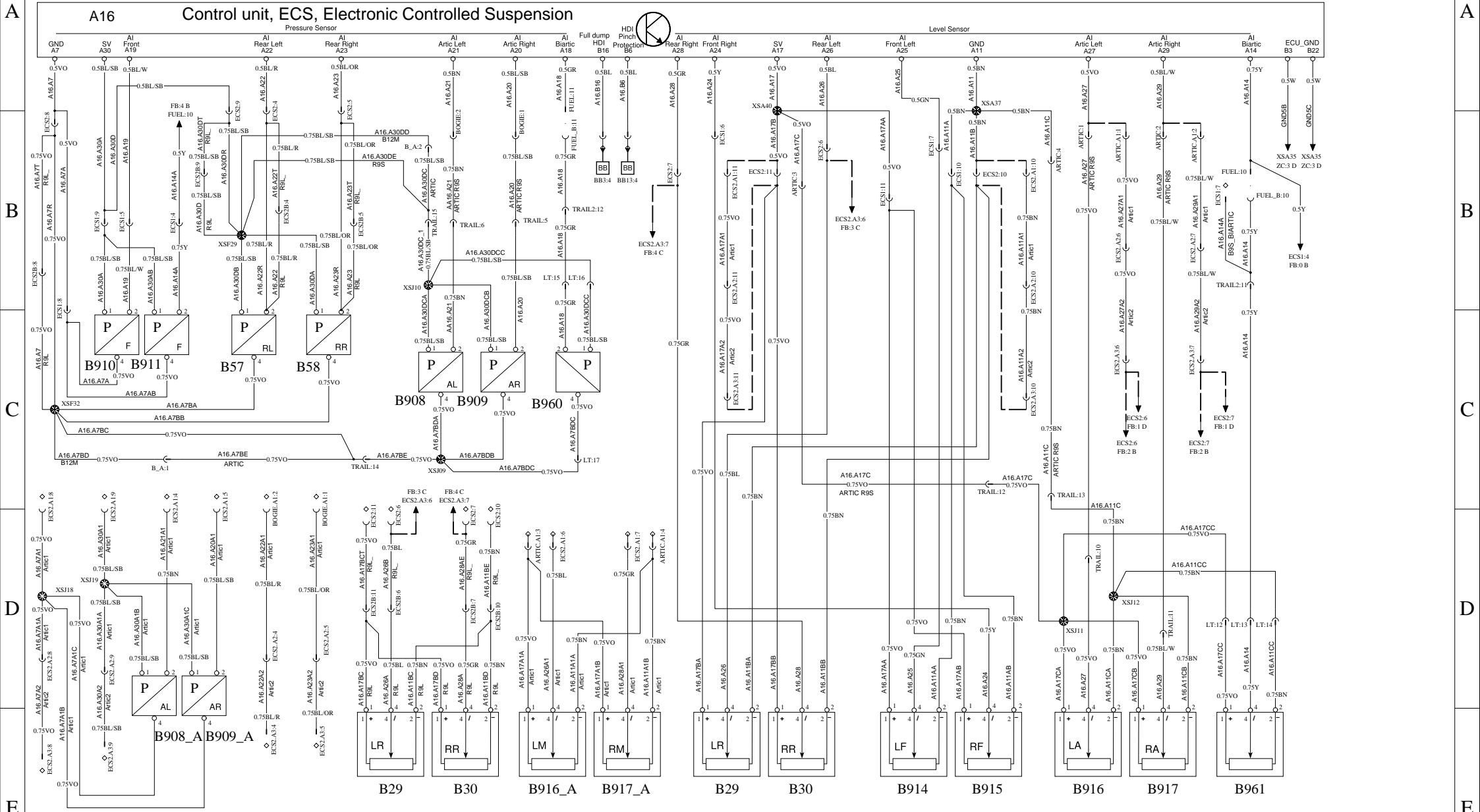

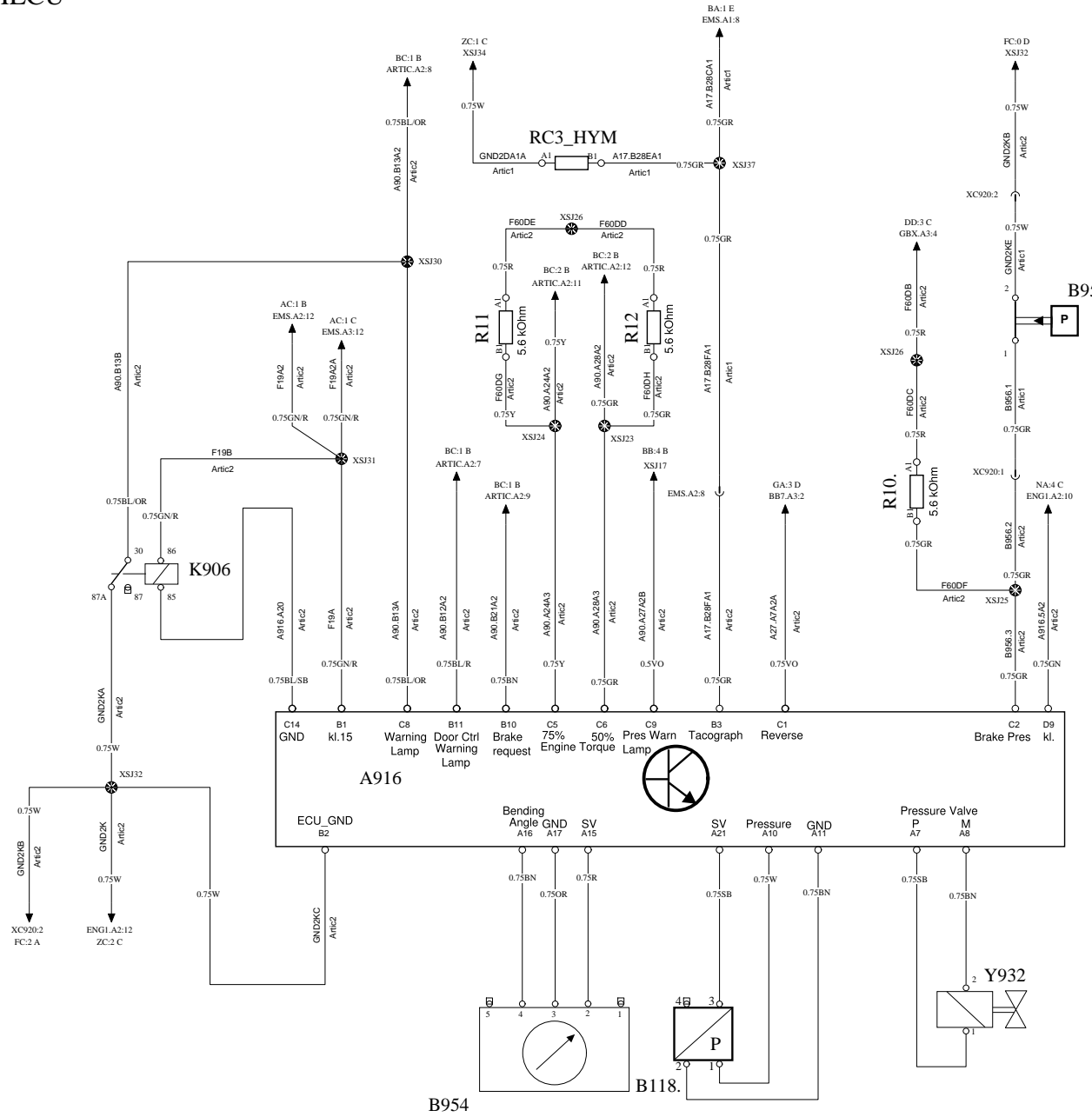

ELECTRONIC STEERED AXLE

WIRING DIAGRAM FO

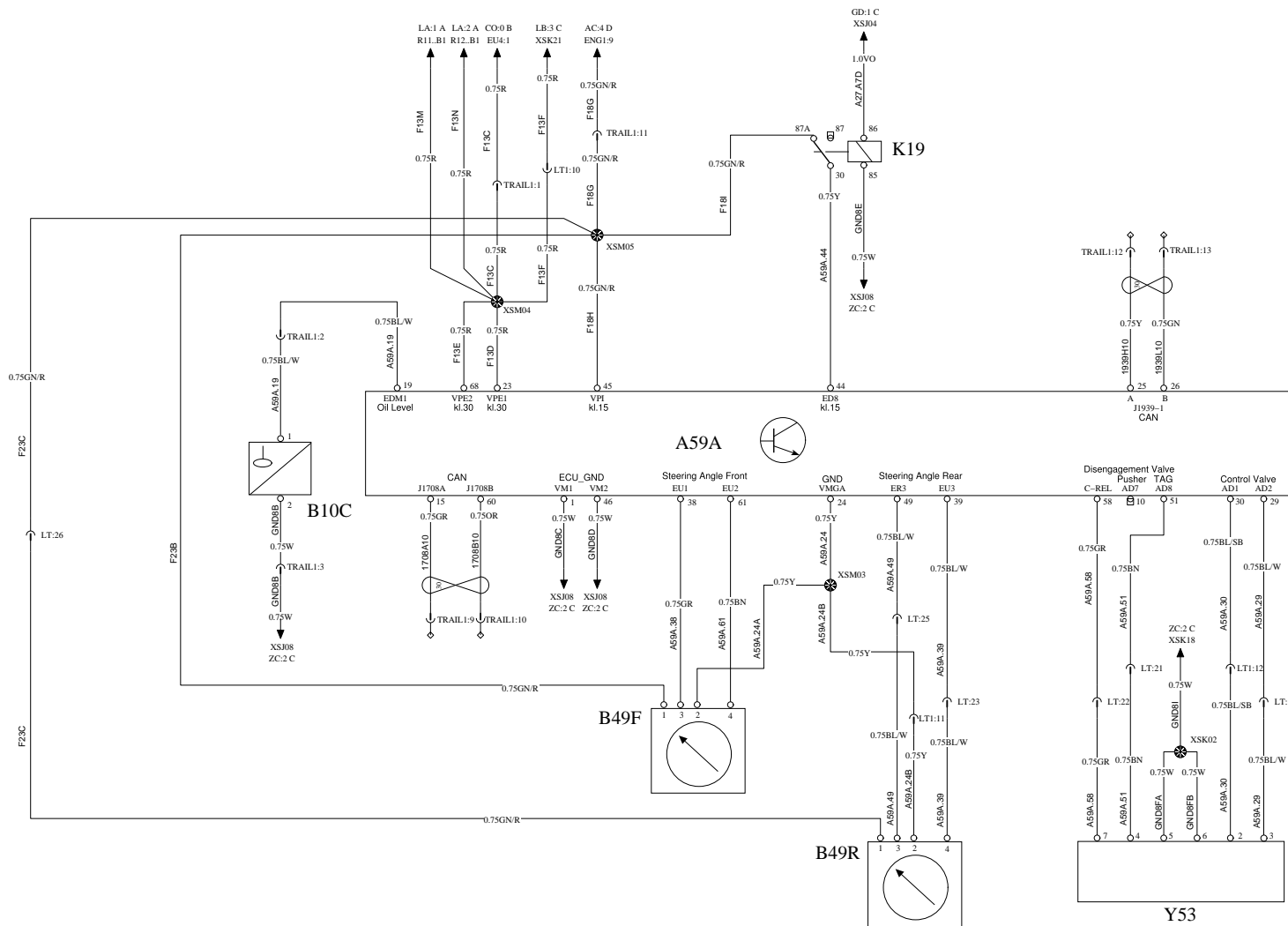

LCM

REAR LIGHTS

WIRING DIAGRAM GA

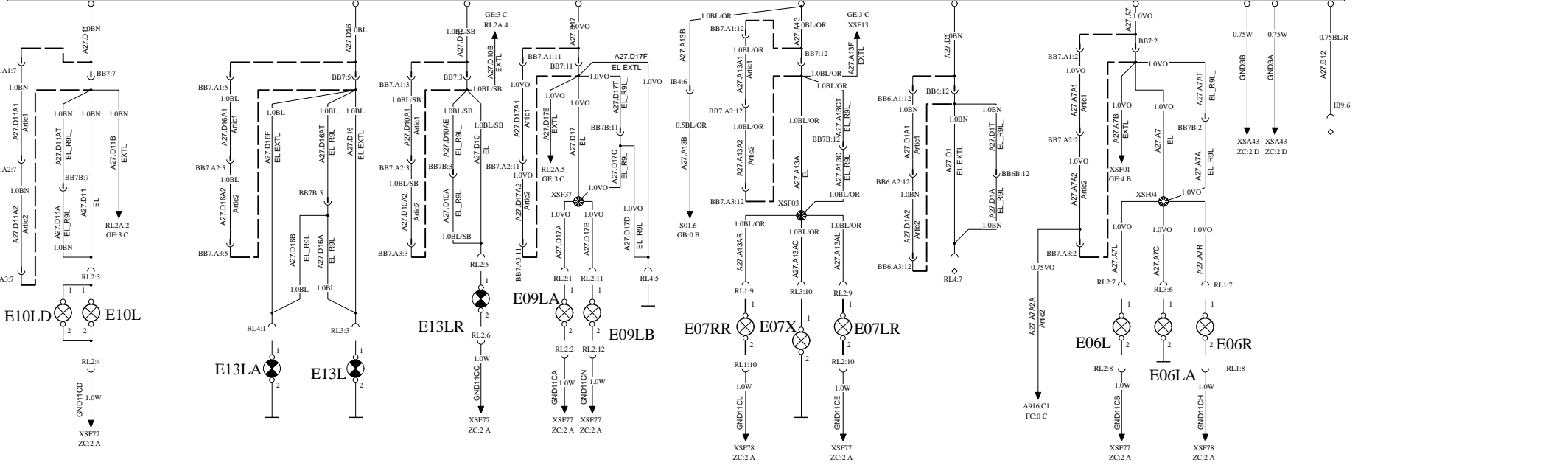
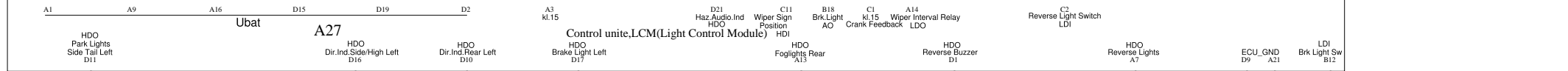
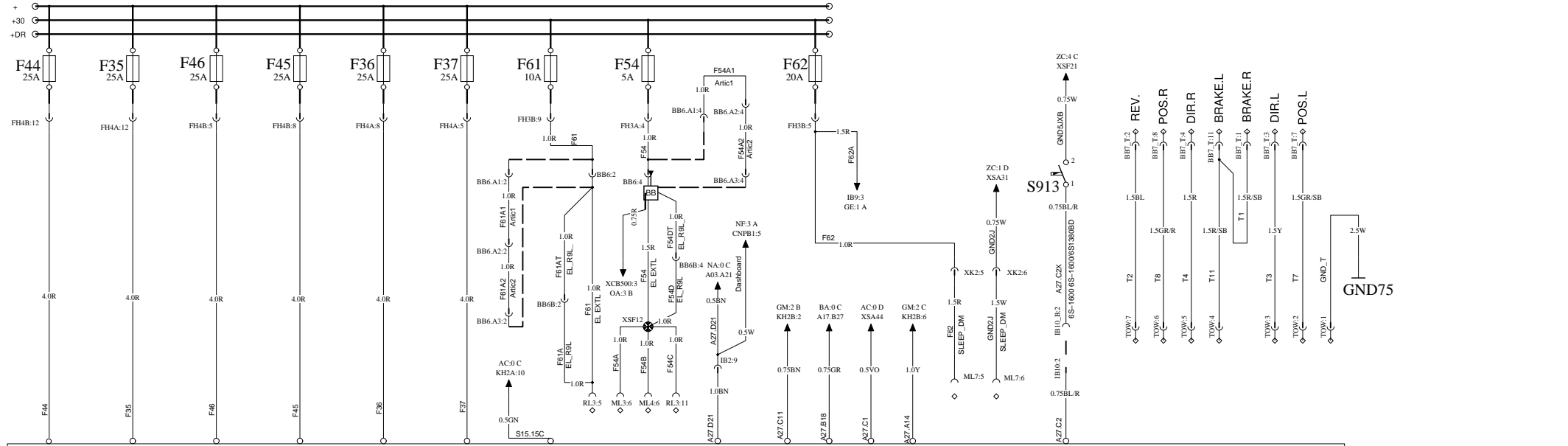

S01

S02

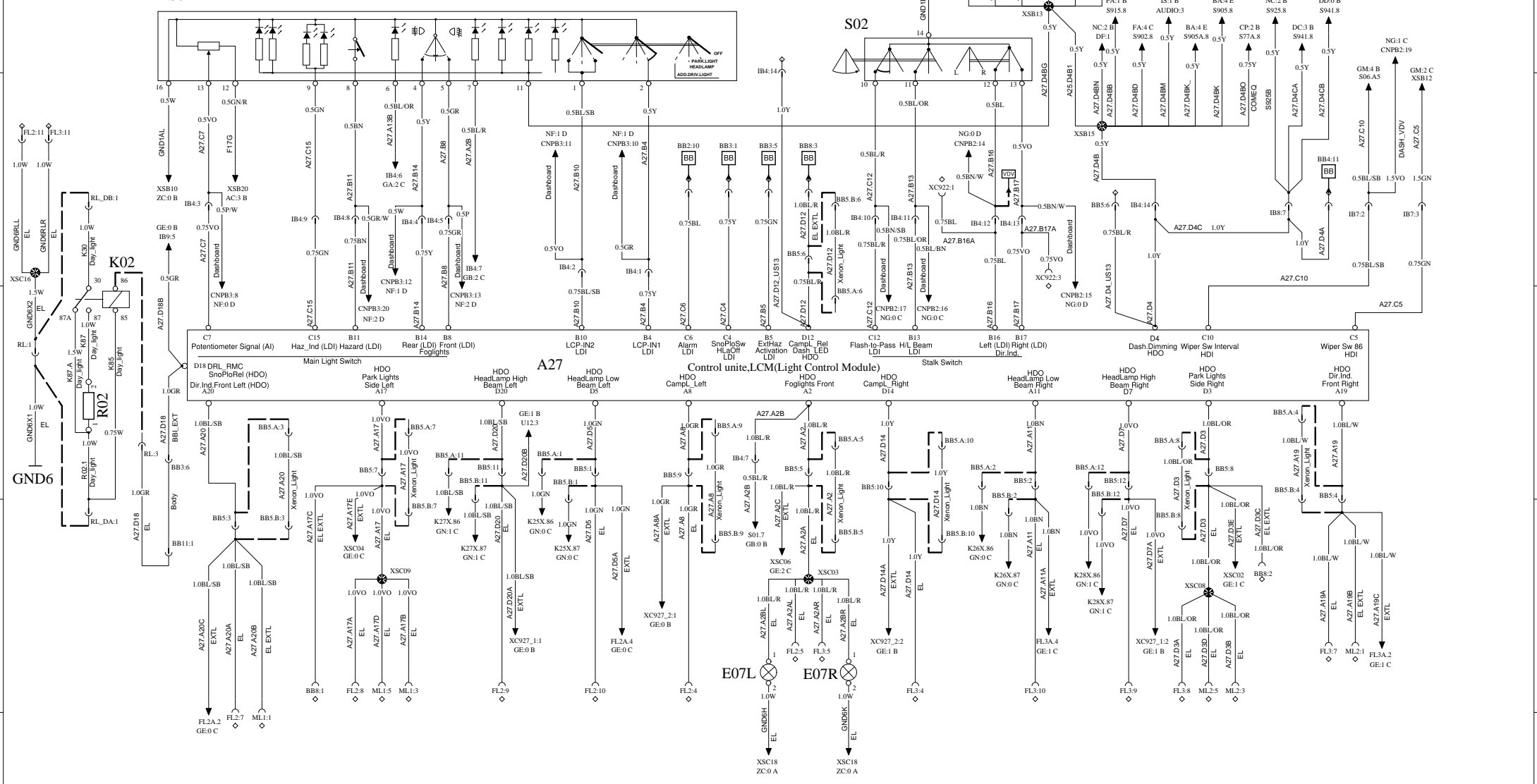

A B C D E

| | | | | | |
|---|-------------------------------------|--------------------------------|--------------------|-------------------------|-----------------------|
| <p>VOLVO Volvo Bus Corporation</p> | Document title WIRING DIAGRAM GB | Document No 20904123 | Issue 15 | Volume 01(02) | Page 55(76) |
| | Document type PRODUCT SCHEMATIC | | | | |

LCM REAR LIGHTS WIRING DIAGRAM GC

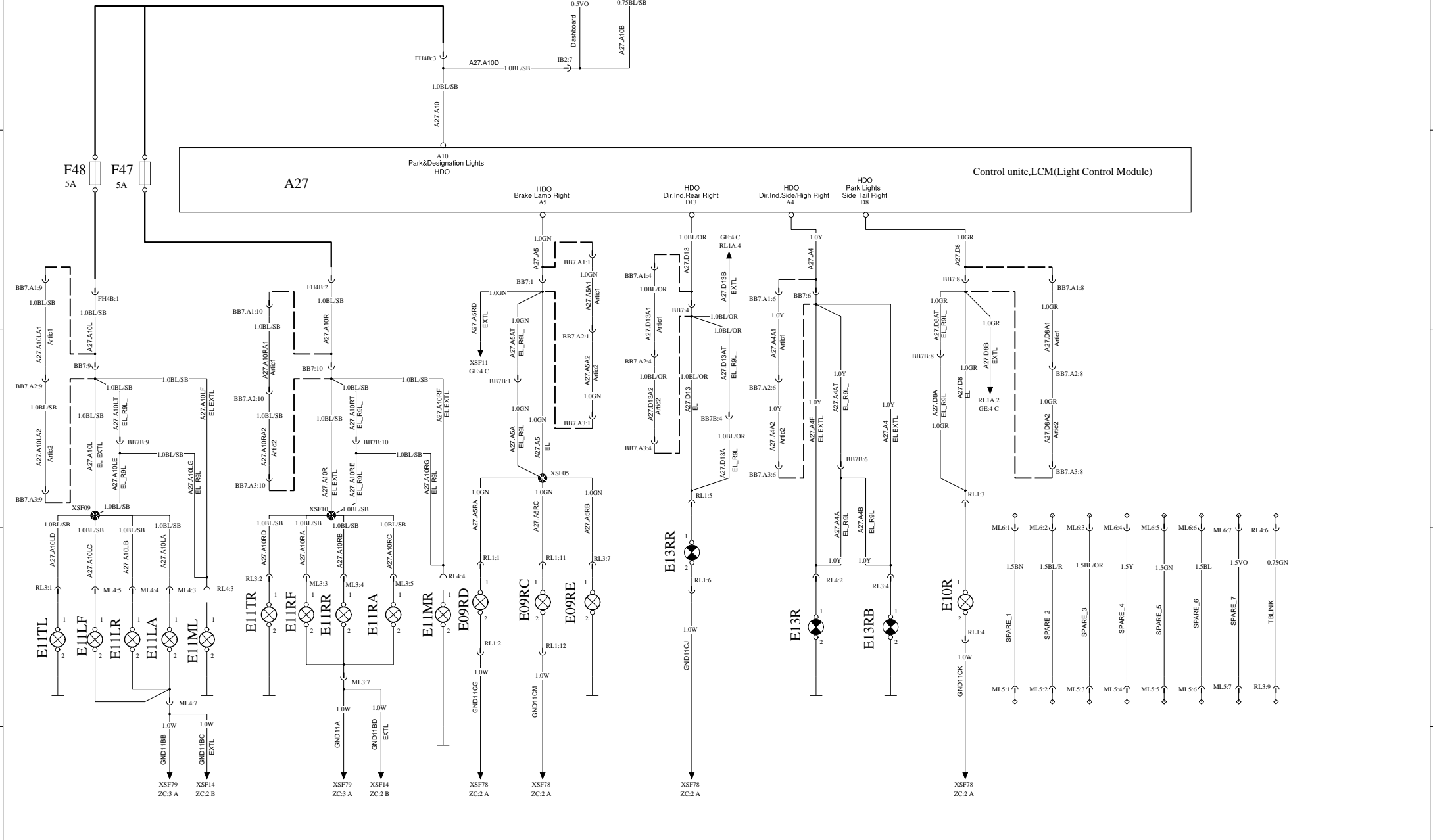

| | | | | | |
|---|-------------------------------------|-------------------------|-------------|------------------|----------------|
| <p>VOLVO Volvo Bus Corporation</p> | Document title WIRING DIAGRAM GC | Document No 20904123 | Issue 15 | Volume 01(02) | Page 56(76) |
| | Document type PRODUCT SCHEMATIC | | | | |

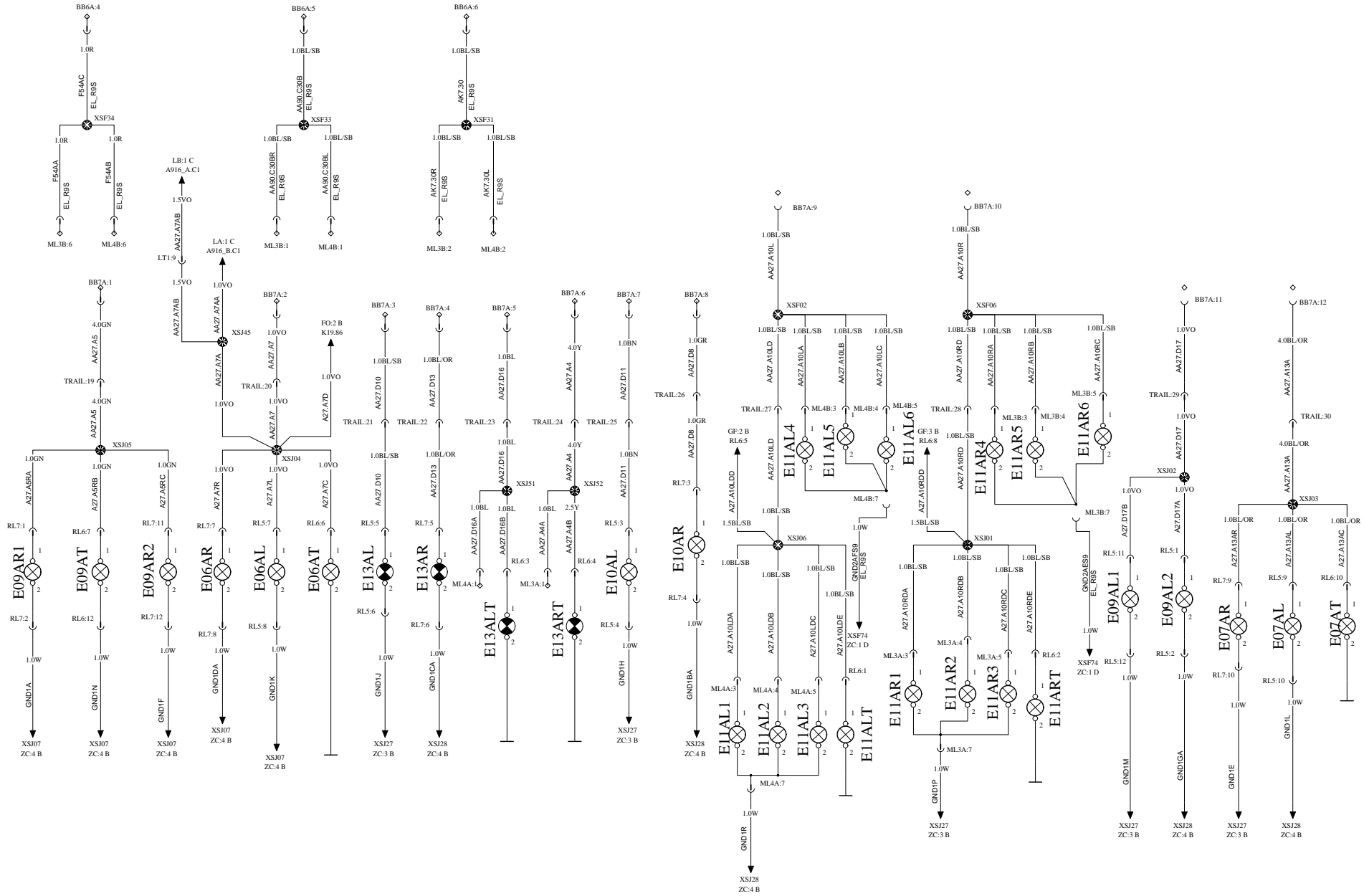

FRONT LIGHT

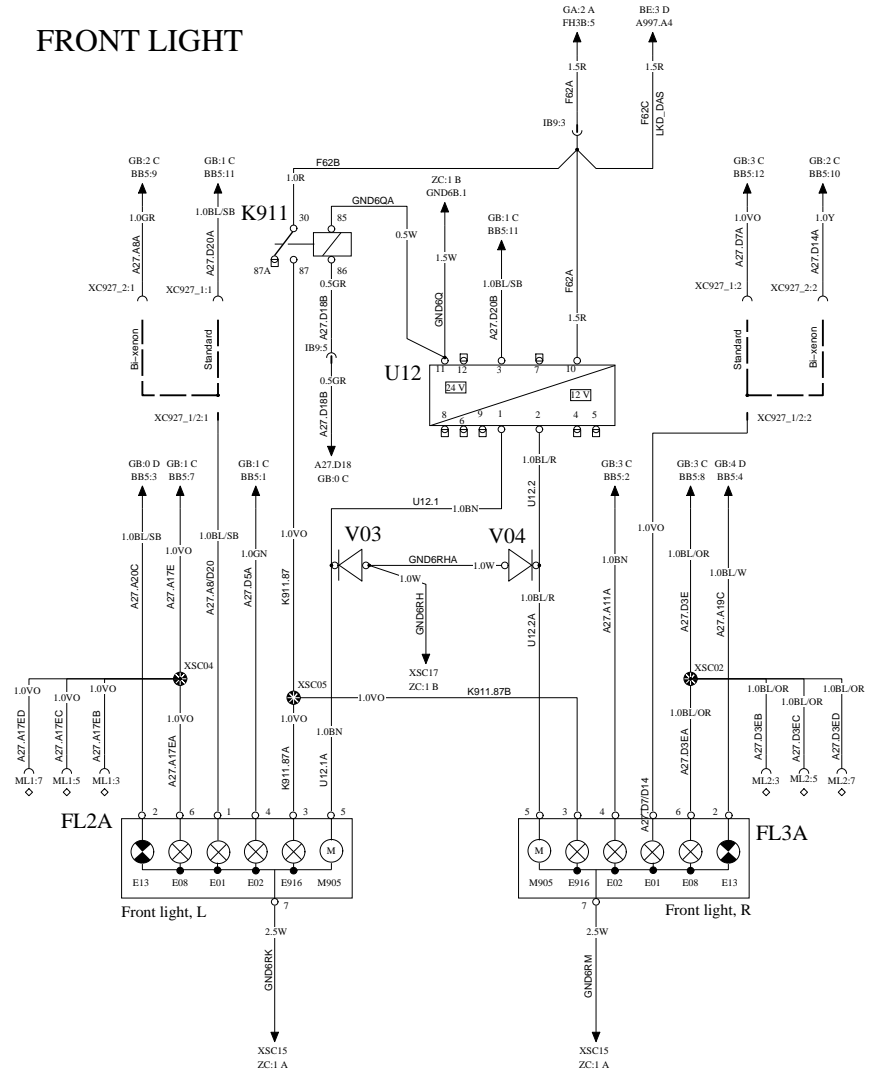

REAR LIGHT

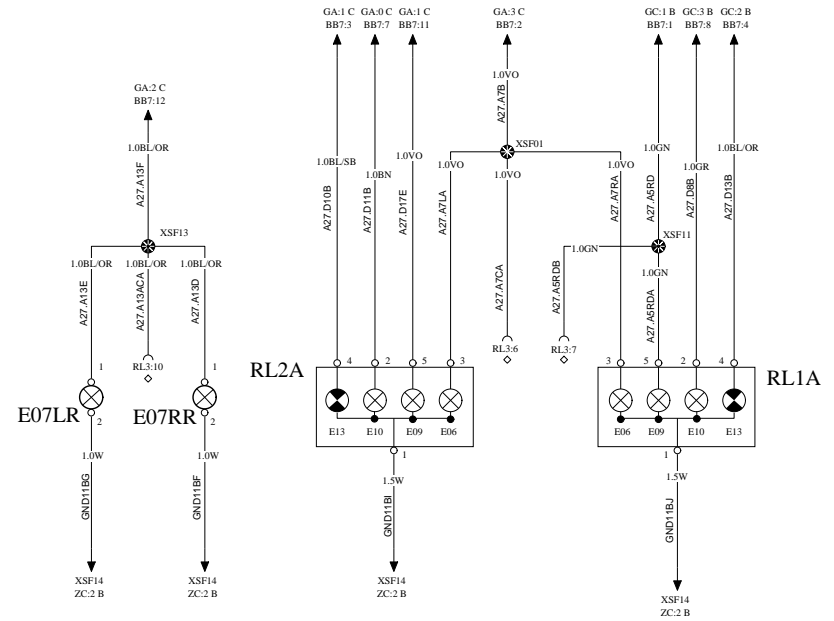

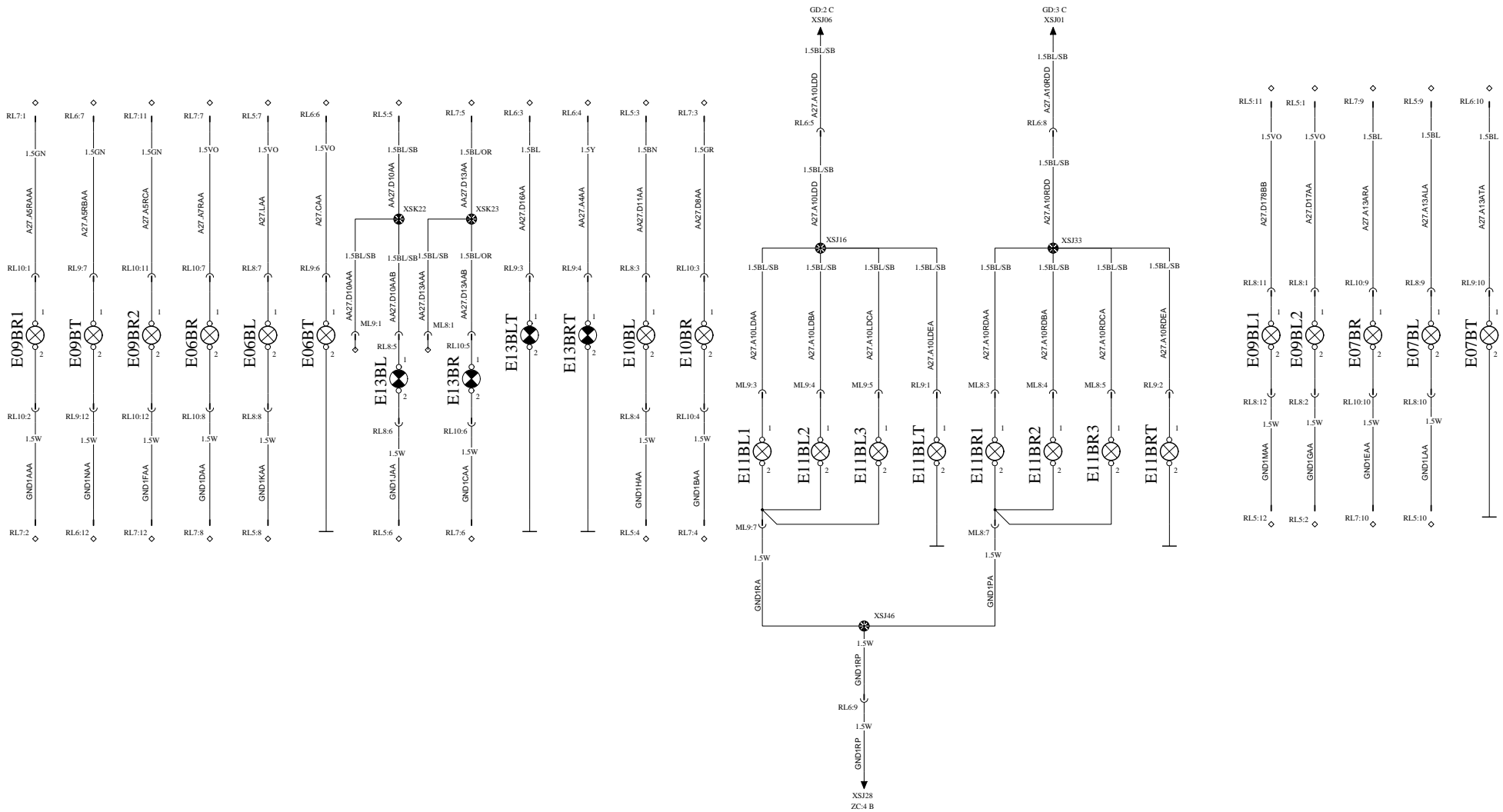

WIPER, WASHER

WIRING DIAGRAM GM

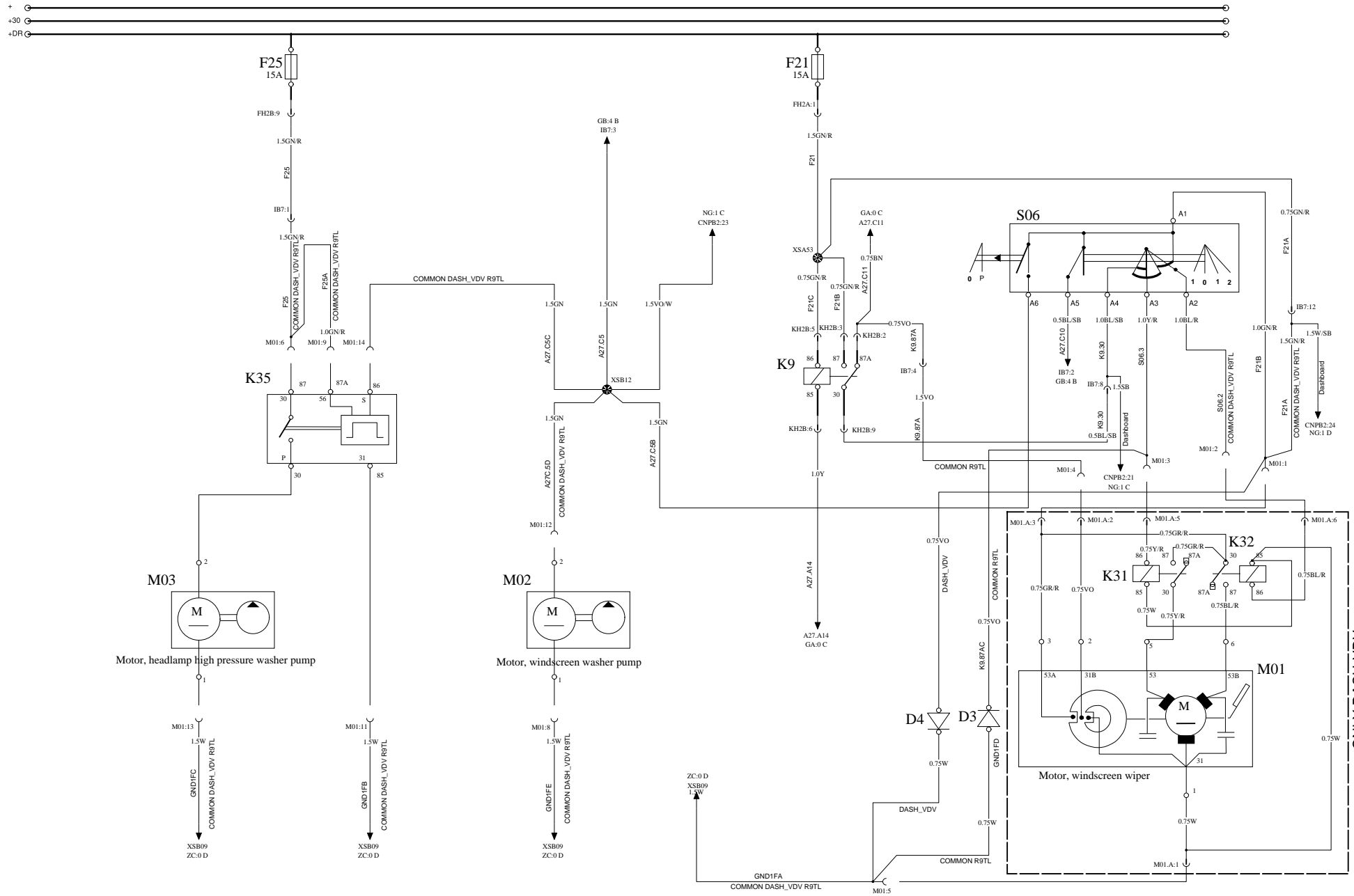

LCM XENON LIGHT RELAY WIRING DIAGRAM GN

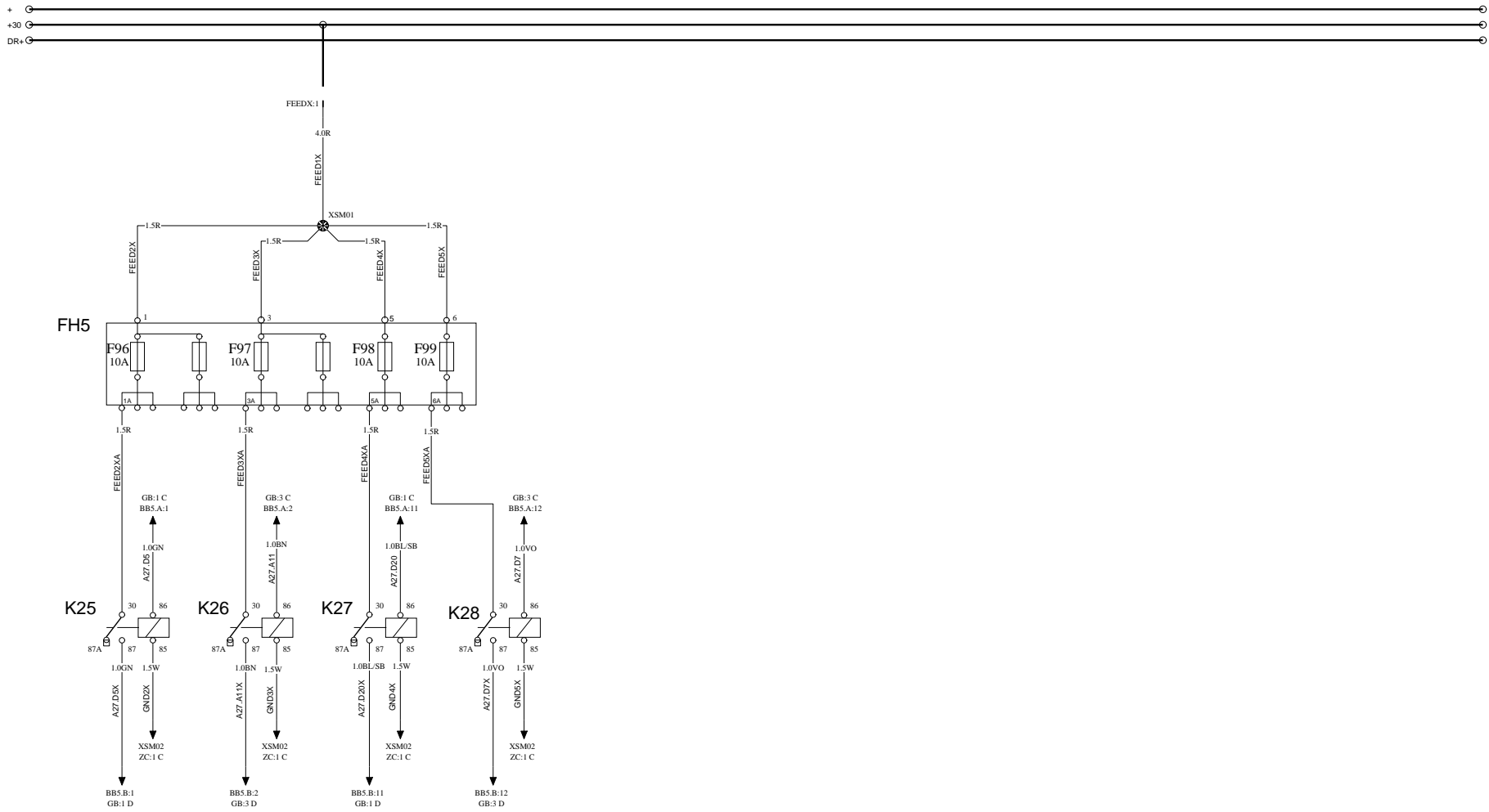

VOLVO
Volvo Bus Corporation

Document title
WIRING DIAGRAM GN
Document type
PRODUCT SCHEMATIC

Document No
20904123

Issue
15

Volume
01(02)

Page
61(76)

HORN, SWM

WIRING DIAGRAM IS

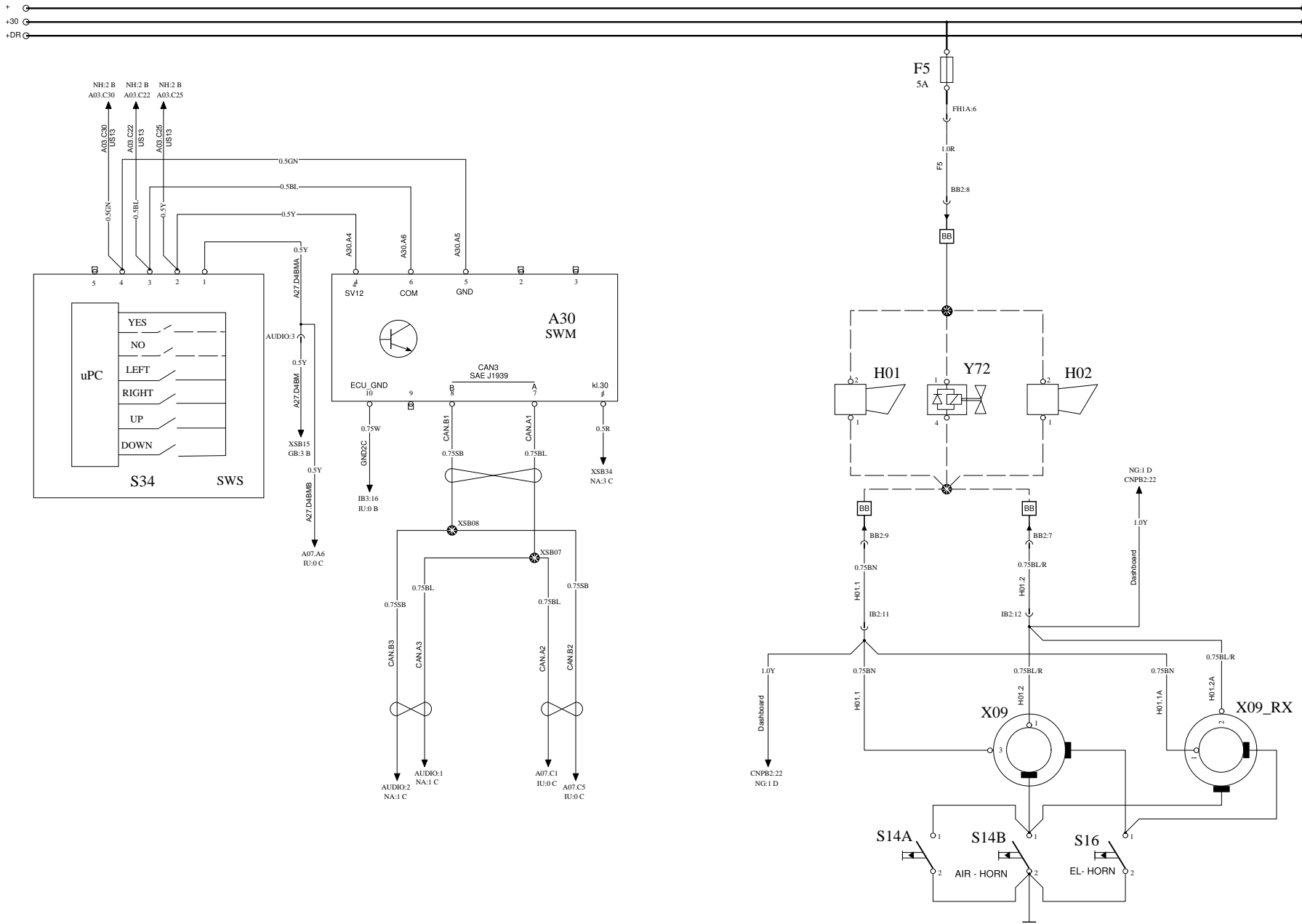

AUDIO

WIRING DIAGRAM IU

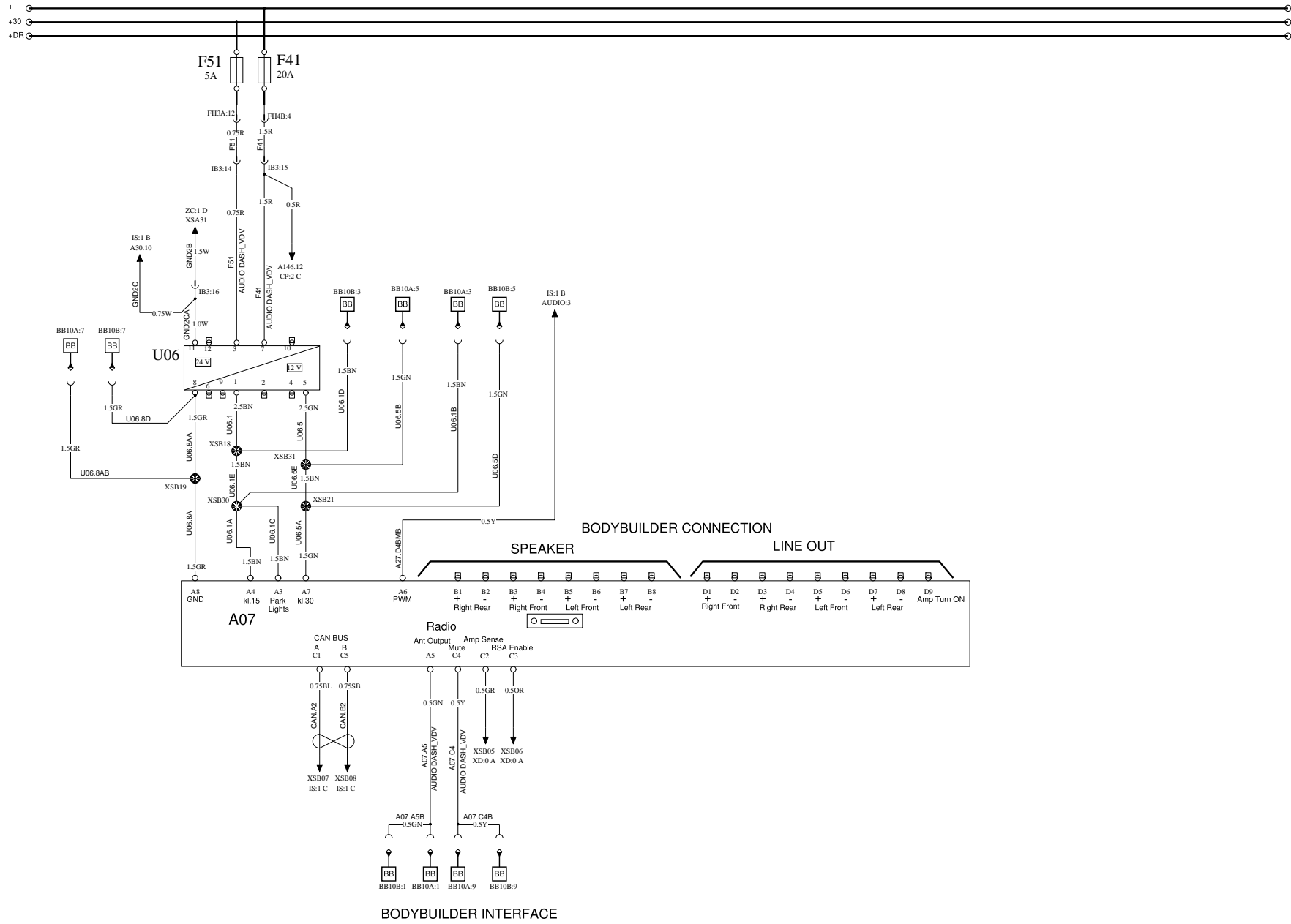

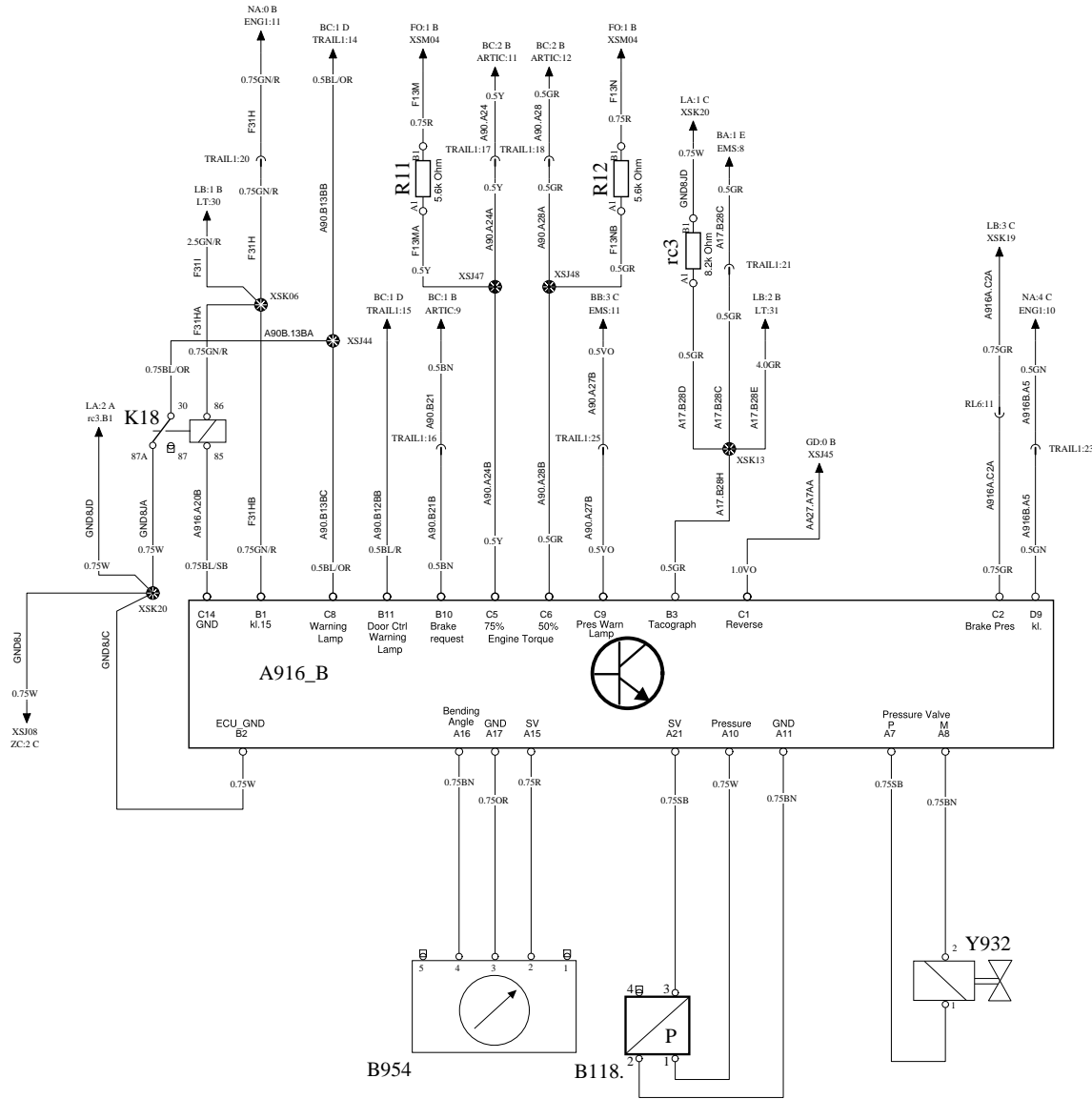

HUBNER ECU

2ND TURNTABLE

WIRING DIAGRAM LB

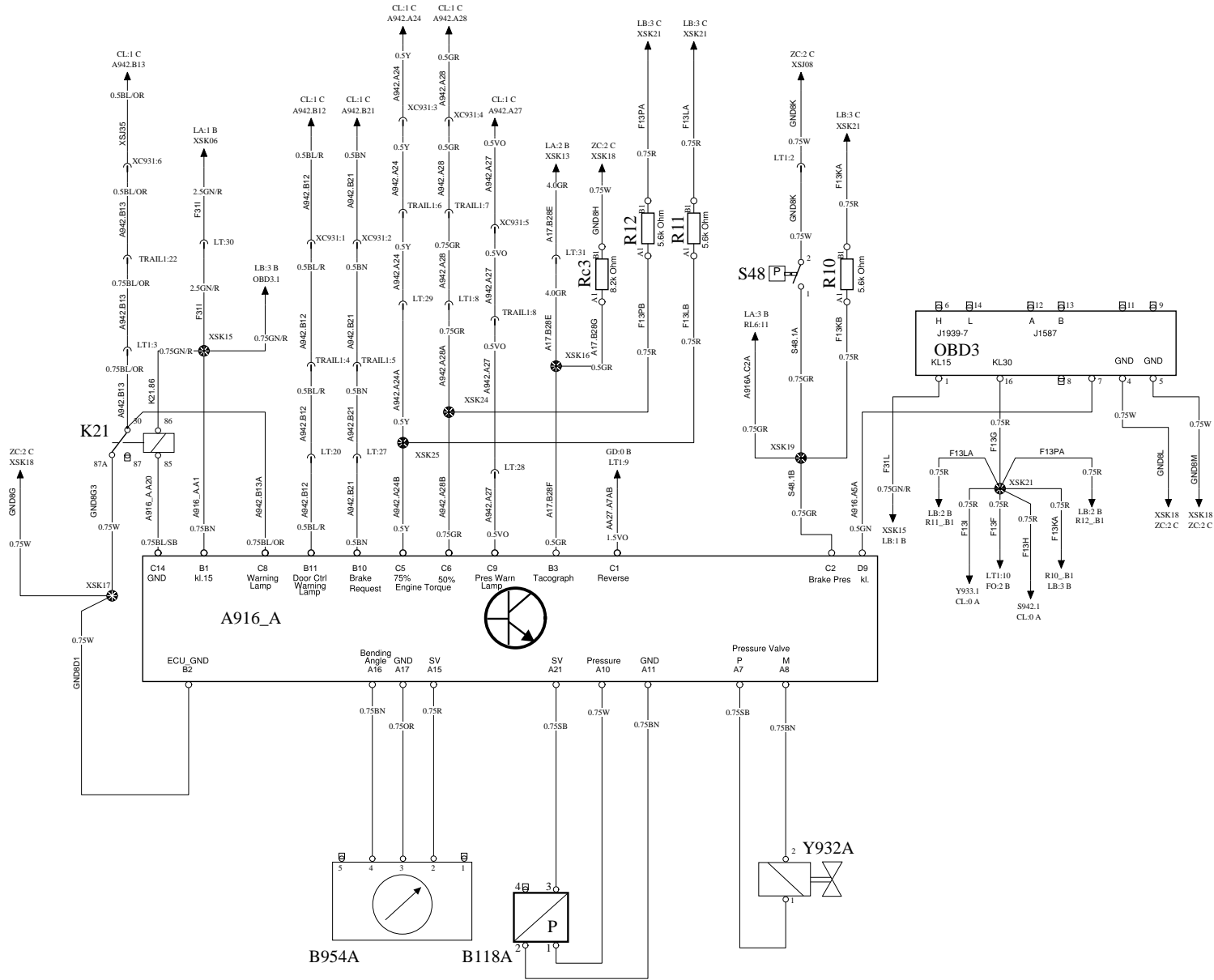

BUS INSTRUMENT CLUSTER BIC2

WIRING DIAGRAM NA

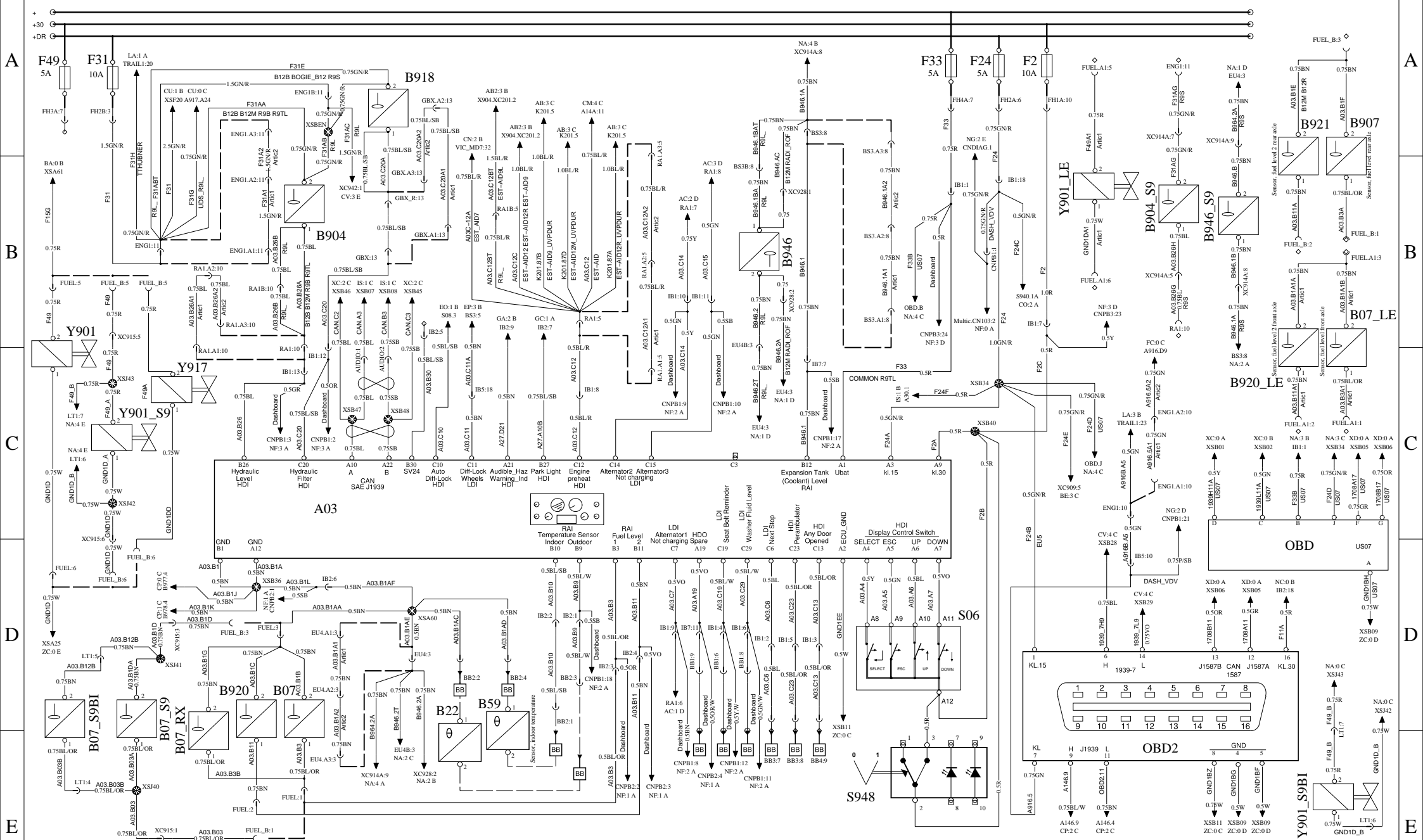

TACHOGRAPH

WIRING DIAGRAM NB

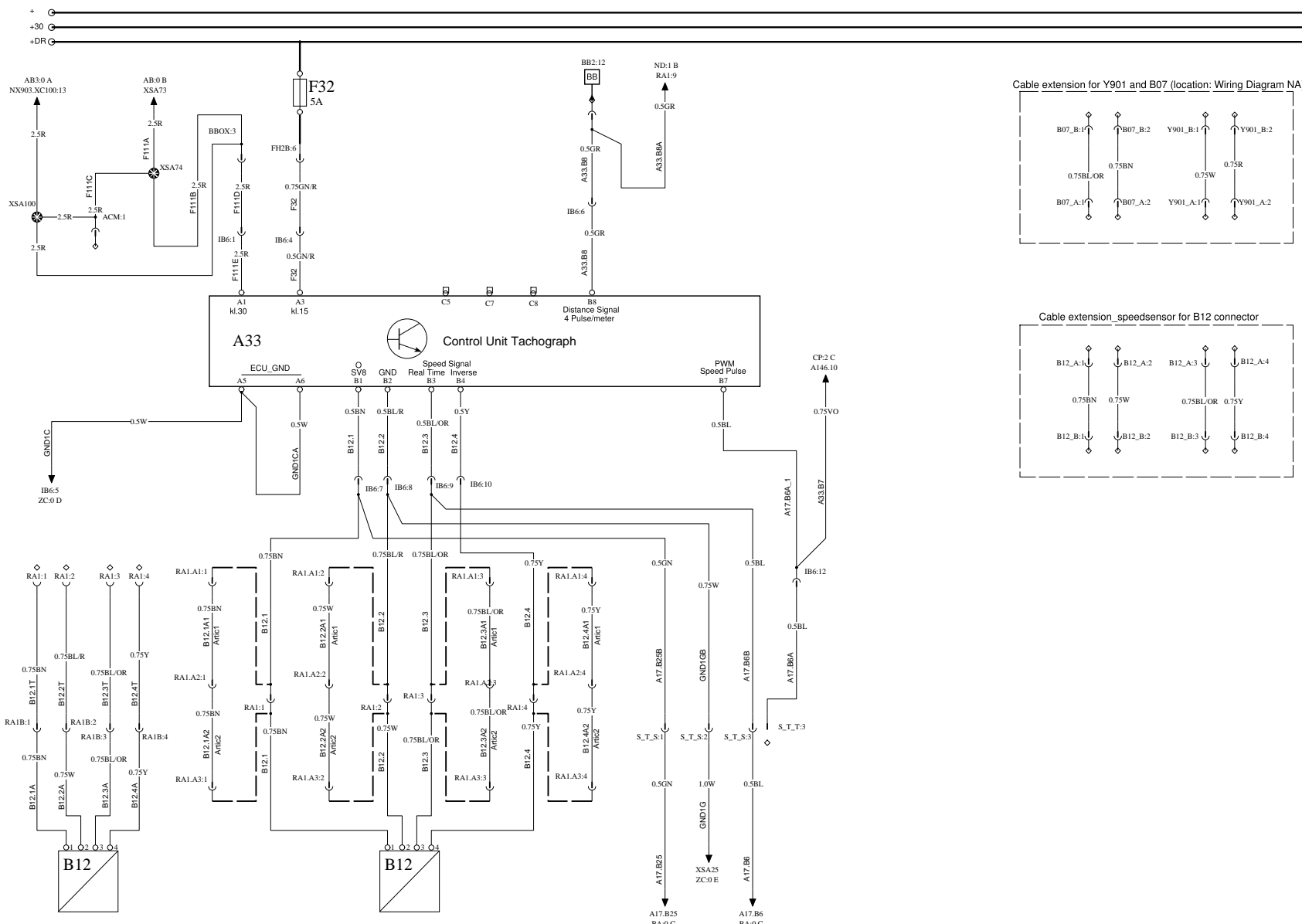

Cable extension for Y901 and B07 (location: Wiring Diagram NA)

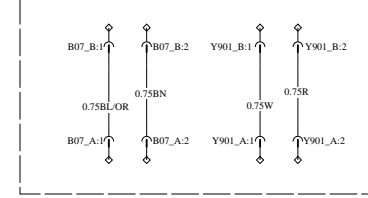

Cable extension_speedsensor for B12 connector

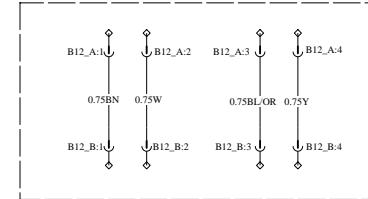

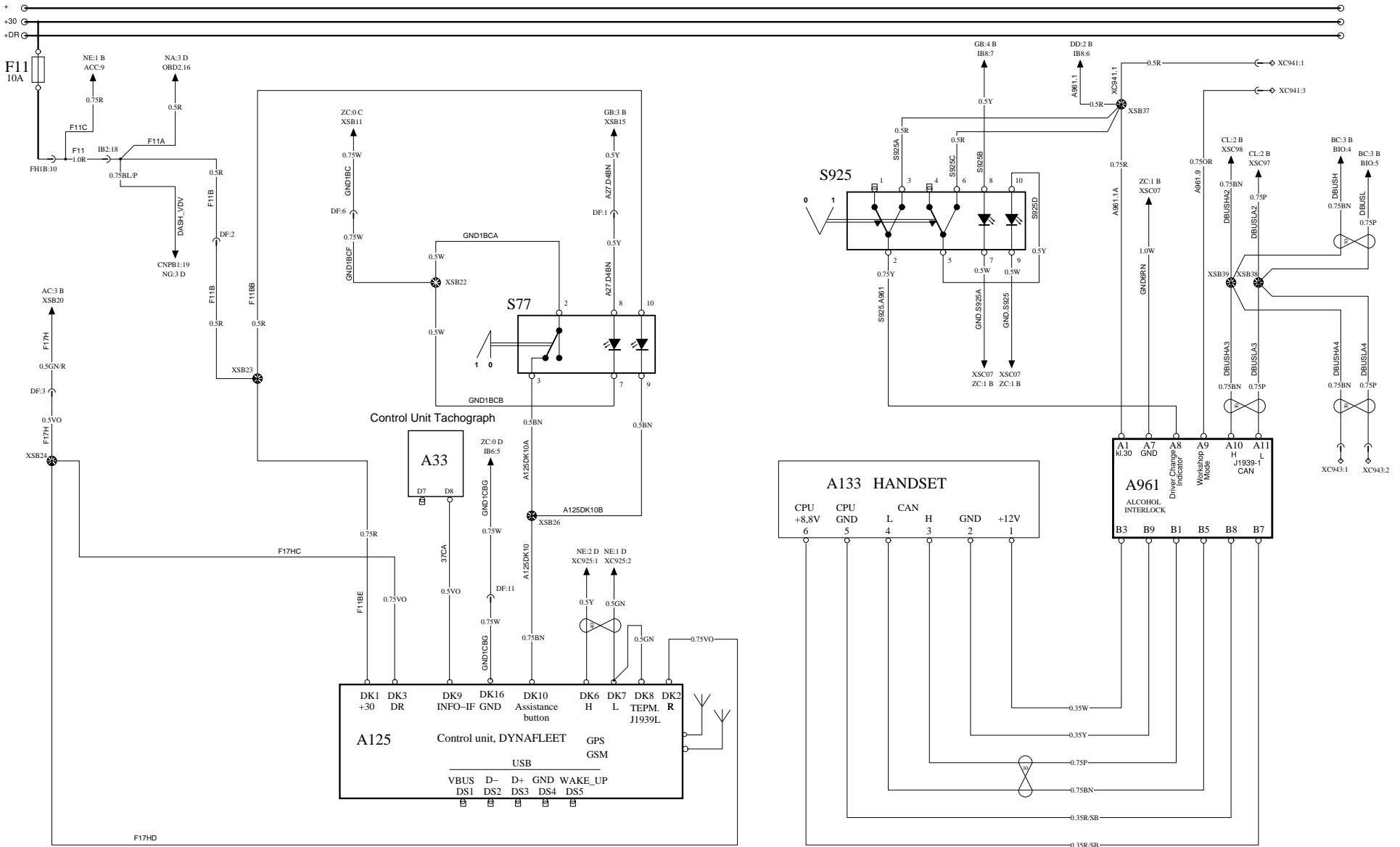

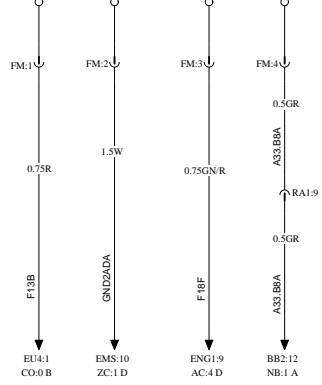
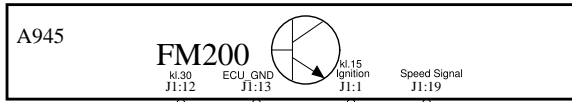

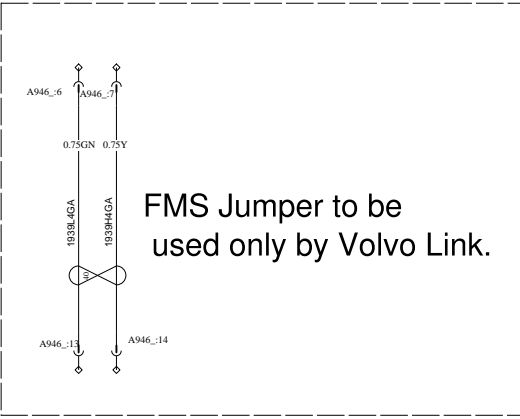
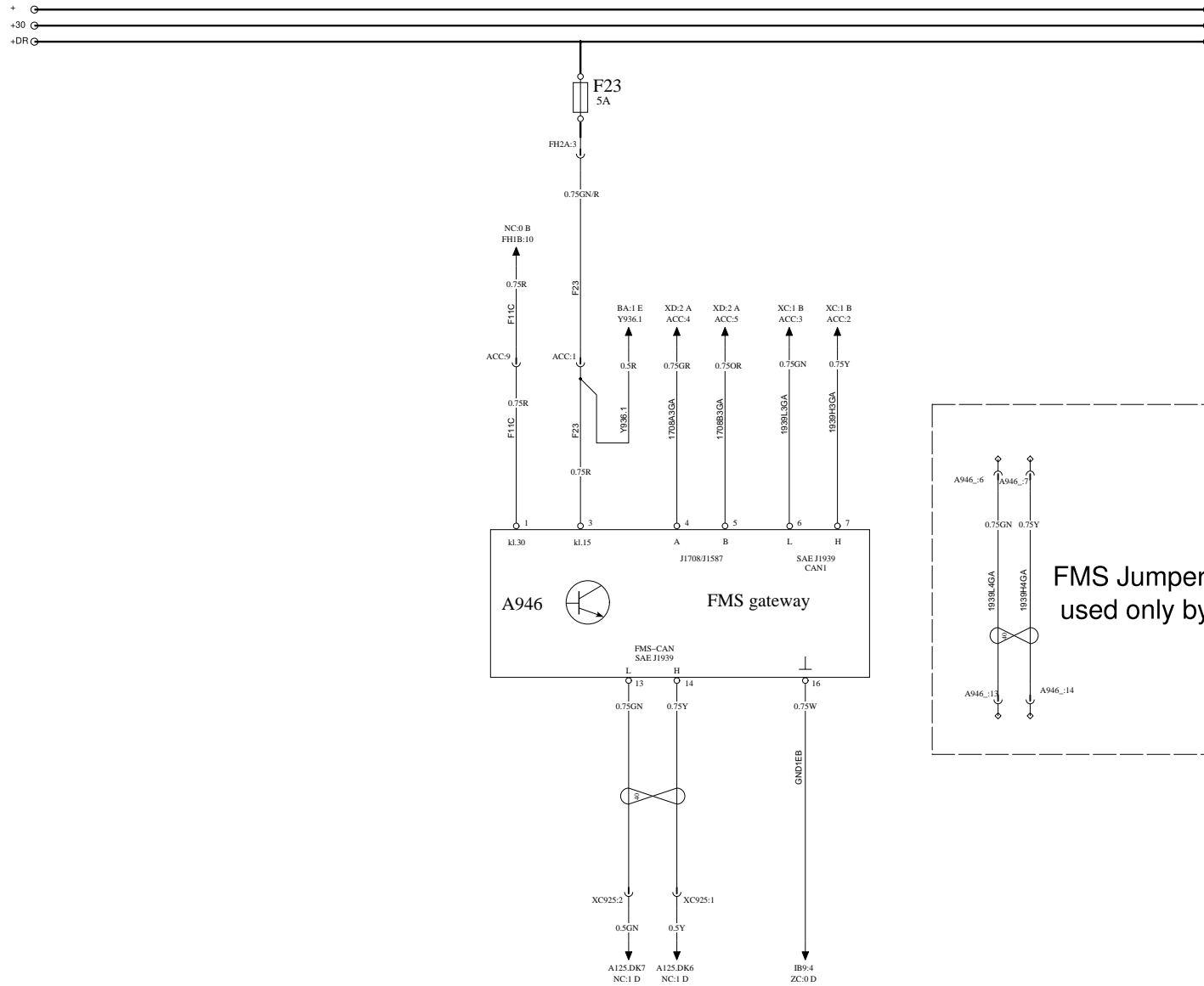

VDV, INSTRUMENT CLUSTER

WIRING DIAGRAM NF

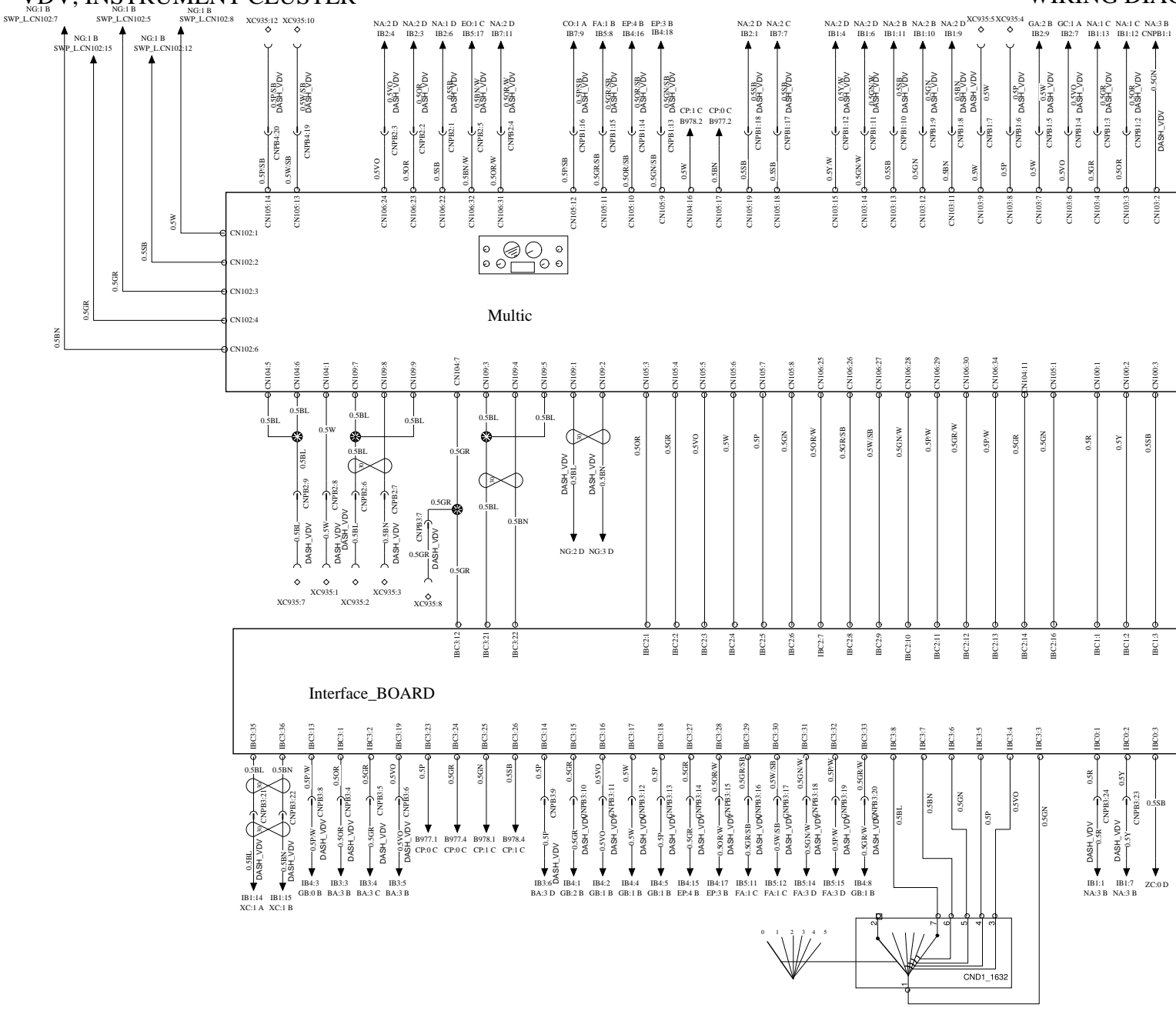

VDV, INSTRUMENT CLUSTER

WIRING DIAGRAM NG

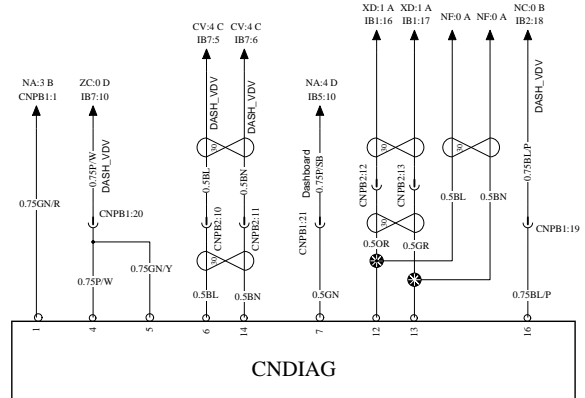
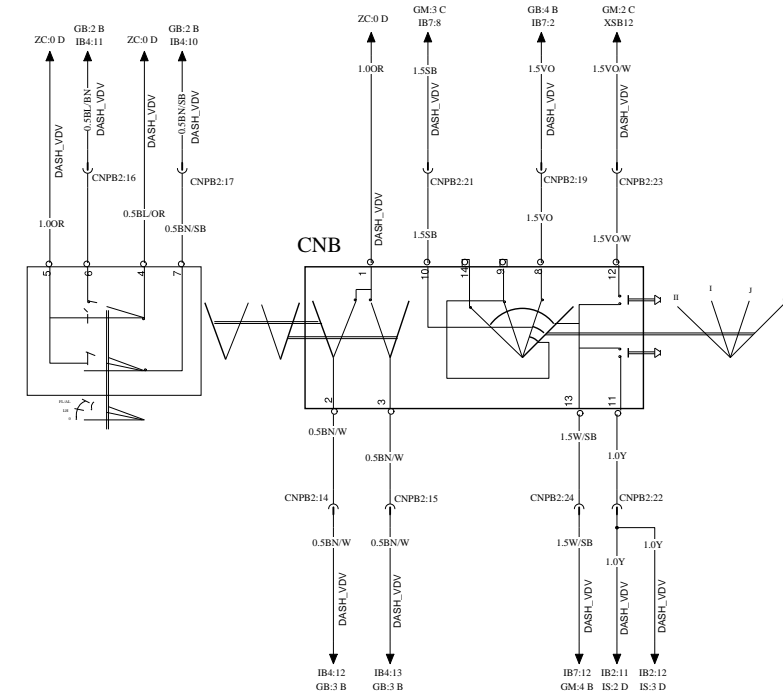
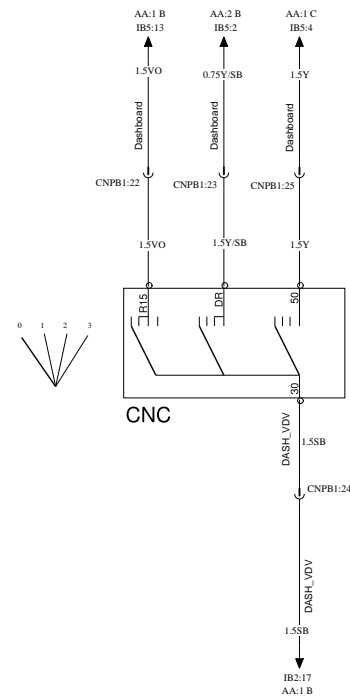
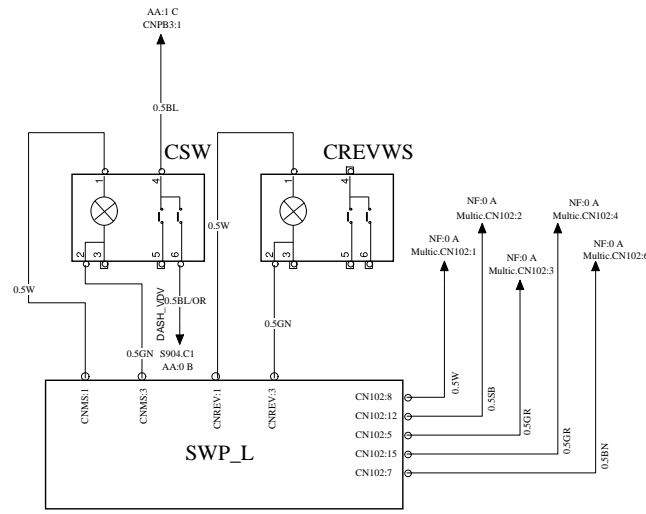
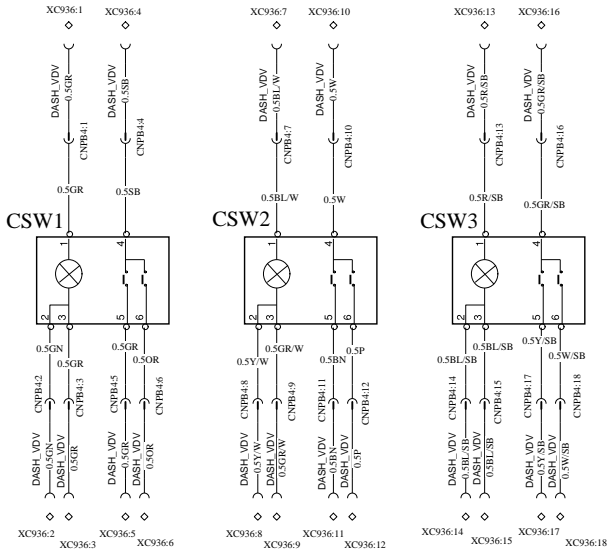

CAN SAE 1939

WIRING DIAGRAM XC

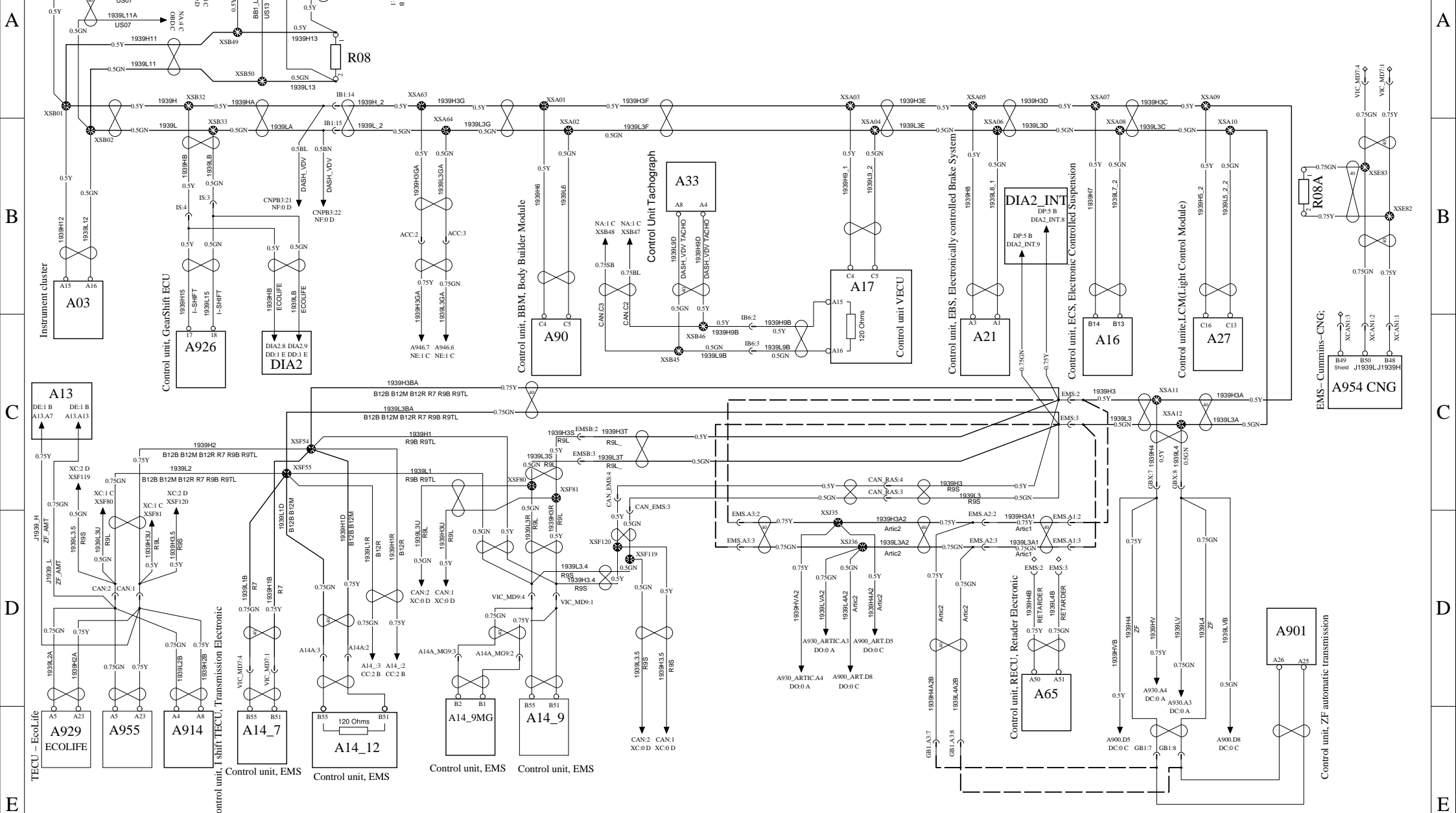

CAN SAE 1587

WIRING DIAGRAM XD

A

B

C

D

E

A

B

C

D

E

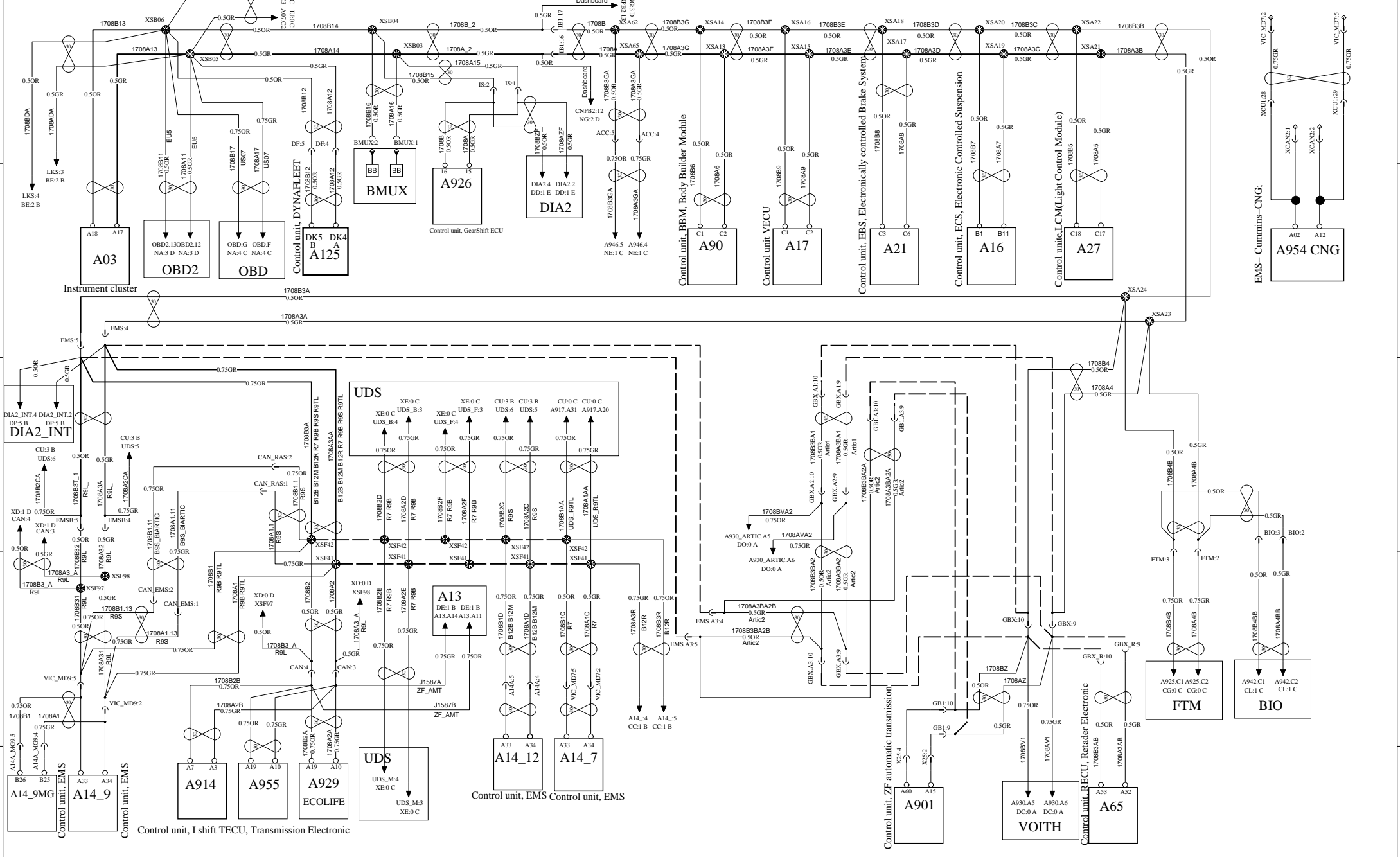

| | | | | | | |
|------------------------------|--|-------------------|-------------|-------|--------|--------|
| <p>Volvo Bus Corporation</p> | | Document title | Document No | Issue | Volume | Page |
| | | WIRING DIAGRAM XD | 20904123 | 15 | 01(02) | 74(76) |
| | | Document type | | | | |
| | | PRODUCT SCHEMATIC | | | | |

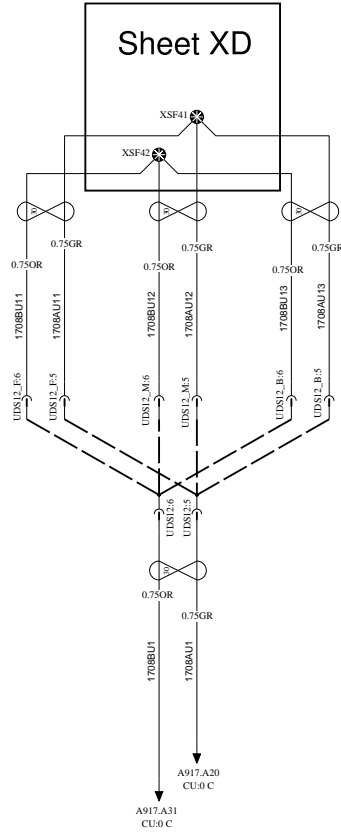
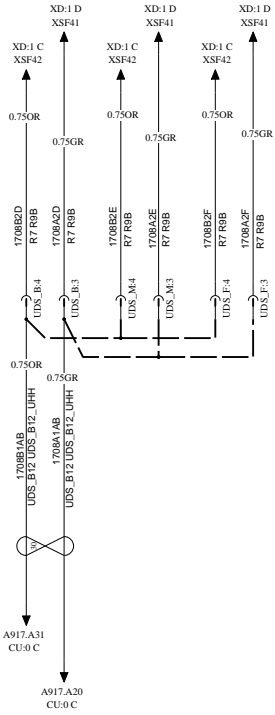

GROUND

WIRING DIAGRAM ZC

A

A

B

B

C

C

D

D

E

E

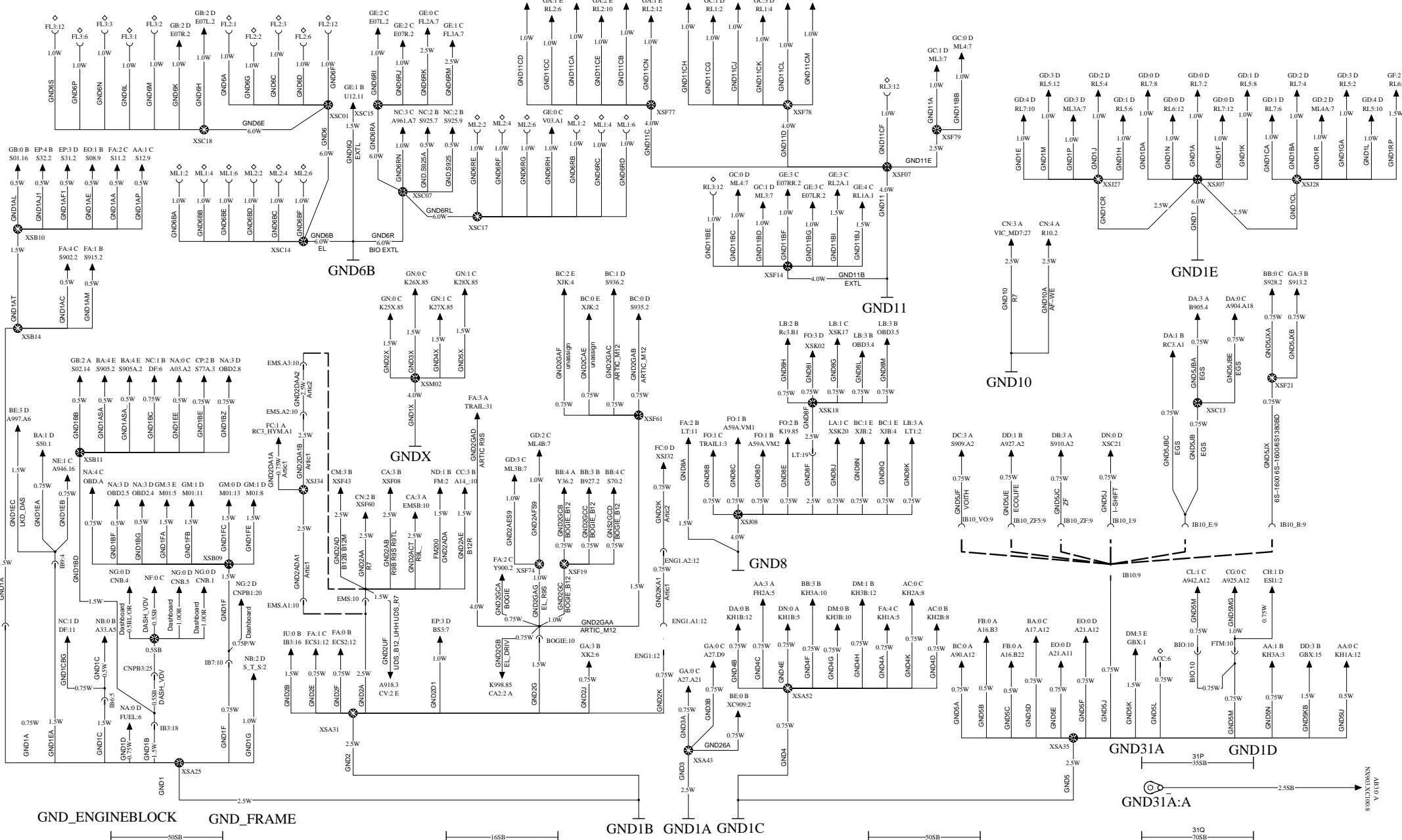

GND_ENGINEBLOCK GND_FRAME

GND77 GND78 GND1B GND1A GND1C

GND_FRAME GND_ENGINEBLOCK

GND70 GND71

| | | | | | |
|----------------------------------|----------|--------------------|--------------------------|---------|--|
| Engineering Release Notice (ERN) | Location | Change Description | A = Added D = Deleted | W = Was | Document Release Status RELEASED |
| D-14388-61 | | | | | Date 2010-05-21 Modification Count |

WIRING DIAGRAM P30-0472 MD9 EURO 4 VBC EEV min A

| Issue | Change Description | Date | By |
|-------|--|----------|----|
| 01 | <p>Initial release NEW WIRING DIAGRAM : P/N 21122242 (old P/N 21095738) We change the pinning of PCRT relative pressure signal: Signal from EI24 to EA19; to EB20</p> <p>+5V From EA7 to EB17 by move of the wire from EI22 to splice XE2, to splice XE6 (we delete the splice XE2)</p> <p>-5V from EA11 to EB18 by move of wire from EI26 to splice XE13, to EI26 to splice XE3</p> <p>We change the pinning of PCRT temp:</p> <p>-5V from EA11 to EB18 by Move of wire from E26 to splice XE13, to EI26 to splice XE3</p> | 07-07-23 | SV |
| 02 | We replace EI36 by EI34 on the schematic because of a mistake on the last release | 07-08-27 | SV |
| 03 | <p>Replace reference fire sensor 70351785 -> 21390986 Change color fire sensor wires OR -> R Change pinning of WIF and Priming Pump: EA3 become EB33 for WIF (A45, pin 5) EB33 become EA3 for Priming pump (A44, pin 5)</p> | 10-05-21 | CB |

The copying, distribution and utilization of this document as well as the communication of its contents to others without expressed authorization is prohibited. Offenders will be held liable for payment of damages. All rights reserved in the event of the grant of a patent, utility model or ornamental design registration.

Document Title
WIRING DIAGRAM
P304072
MD9 EURO 4 VBC EEV min A

VOLVO

Volvo Powertrain Corporation

Document Type
TECHNICAL REGULATION

Owner Domain: Document Prefix

| | | | |
|--------------------------------|--------------------------|------------------------|------------------------|
| Document No 21122242 | Issue Index 03 | Volume No 01 | Page No 1(4) |
|--------------------------------|--------------------------|------------------------|------------------------|

A

IVS CAN 1 J 1708 CAN 2

IB15 IB13 IB8 IB4 IB2 IB5 IB3 IB6

B32 AMBIENT AIR TEMP



IB26 IB22

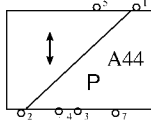

Component group engine. Contains B51 and M15

S209 Switch, Electrical fuel pump

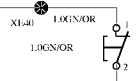

IB28

IB17 IB18

IB21

IB11 IB9 IB7

Sheet 2 of 4 B
R01 1-2a

B

LSB L5SB



B21 Sensor, coolant temperature, engine



B54 Sensor, pressure crankhouse



XE3 0.75BN/W

XE8 1.5W

Sheet 2 of 3 C
M04 SW1

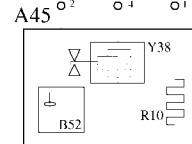

Y91A



Solenoid valve, EPG (Exhaust Pressure Governor)

Y07



B32 AIR FILTER INDICATOR



C

A14

A14

LSB L5SB 0.73P 0.75Y 0.75GN 0.75GR 0.75OR 0.75BL 0.75VO 1.0GN/OR

0.75YW 0.75BN/W

0.75Y 0.75BN

0.75OR 0.75GR/W

0.75BL/SB 0.75GR/W

0.75Y 0.75Y/W

1.5W

1.0W 0.75BN

0.75BL 1.5W

1.5W 1.5W

1.5W 1.5W

0.75BL/R 0.75R 0.75BL/R 0.75GR/W

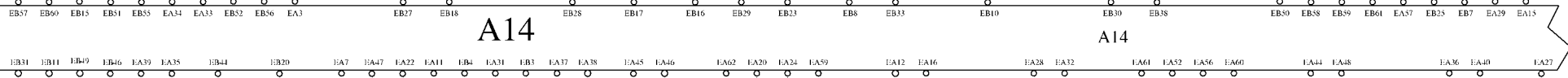

D

B118 Sensor, Oil pressure



B32 FAN SPEED



B37 Sensor, boost pressure and boost temperature



0.75BN/W



B119 Sensor, Oil level / temp



B04 Sensor, engine speed, crankshaft



B05 Sensor, engine speed, camshaft

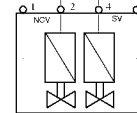

Y33G

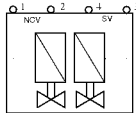

Y33H

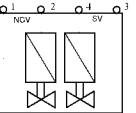

Y33I

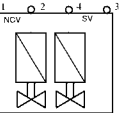

Y33J

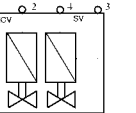

Y33K

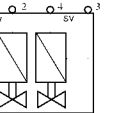

Y33L

E

sheet 0 C
A4-EB7
↑
0.75R

FEEDBACK PREHEATER
FOR EMS

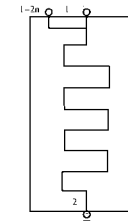

R01
Heater, engine preheat
PRESENT ON ENGINE
Air preheater
(option)

EMS

Et:35
↑
sheet 0 C
A4-EB29
0.75R/W 0.75GR/W

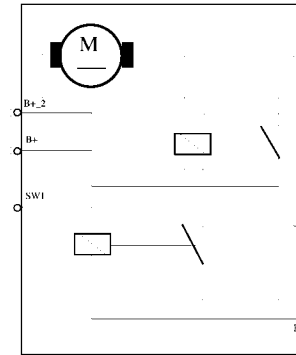

M04
Motor, starter motor

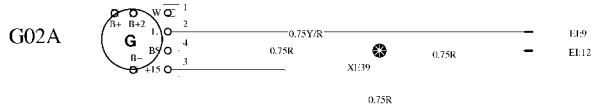

0.75W/SB

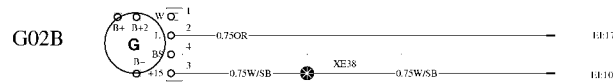

VBC VARIANT WITH
3 ALTERNATOR

+5V DPF SENSOR GROUND DPF SENSOR

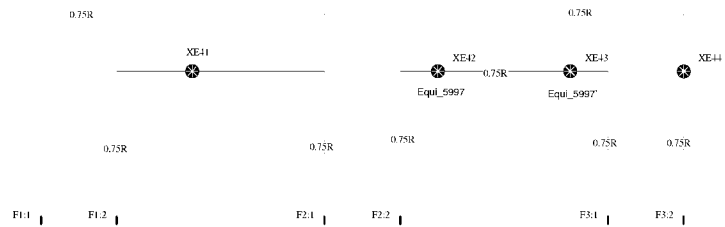

| REF | DESCRIPTIONS | DRAW LOCATION |
|------|---|-----------------------------|
| A14 | Control unit, EMS (Engine Management System) | {sheet 1 0 C} {sheet 2 0 C} |
| A43 | Component group engine Contains B32 and Y35 | {sheet 2 1 C} |
| A45 | Component group engine Contains B52, R06, Y38 | {sheet 1 2 B} |
| B04 | Sensor, engine speed, crankshaft | {sheet 1 1 E} |
| B05 | Sensor, engine speed, camshaft | {sheet 1 2 E} |
| B118 | Sensor, Oil pressure | {sheet 1 0 D} |
| B119 | Sensor, Oil level / temp | {sheet 1 1 E} |
| B21 | Sensor, Coolant temperature, engine | {sheet 1 1 B} |
| B32 | Sensor, engine cooling fan speed | {sheet 1 1 A} |
| B37 | Sensor, boost pressure and boost temperature | {sheet 1 1 D} |
| B52 | Sensor water level | {sheet 1 2 B} |
| B54 | Sensor, pressure crankhouse | {sheet 1 1 B} |
| G02A | Alternator 1 | {sheet 2 1 A} |
| G02B | Alternator 2 | {sheet 2 1 C} |
| M04 | Motor, starter motor | {sheet 2 3 C} |
| R01 | Heater, engine preheat | {sheet 2 4 B} |
| R06 | Heater, Fuel water separator | {sheet 1 2 B} |
| S209 | Switch, electrical fuel pump | {sheet 1 2 A} |
| Y07 | Solenoid valve, EPG (Exhaust Pressure Governor) | {sheet 1 3 B} |
| Y33G | Solenoid valve, UI (Unit Injector) | {sheet 1 2 D} |
| Y33H | Solenoid valve, UI (Unit Injector) | {sheet 1 2 D} |
| Y33I | Solenoid valve, UI (Unit Injector) | {sheet 1 3 D} |
| Y33J | Solenoid valve, UI (Unit Injector) | {sheet 1 3 D} |
| Y33K | Solenoid valve, UI (Unit Injector) | {sheet 1 3 D} |
| Y33L | Solenoid valve, UI (Unit Injector) | {sheet 1 4 D} |
| Y35 | Solenoid valve, engine cooling fan | {sheet 1 0 E} |
| Y38 | Solenoid valve, Fuel water separator | {sheet 1 2 B} |

VOLVO

Volvo Powertrain Corporation

Document Title

WIRING DIAGRAM

Document Type

TECHNICAL REGULATION

Document No

21122242

Issue Index

02

Volume No

01

Page No

4(4)

TELEMATICS

ITS4mobility

WIRING DIAGRAM TL

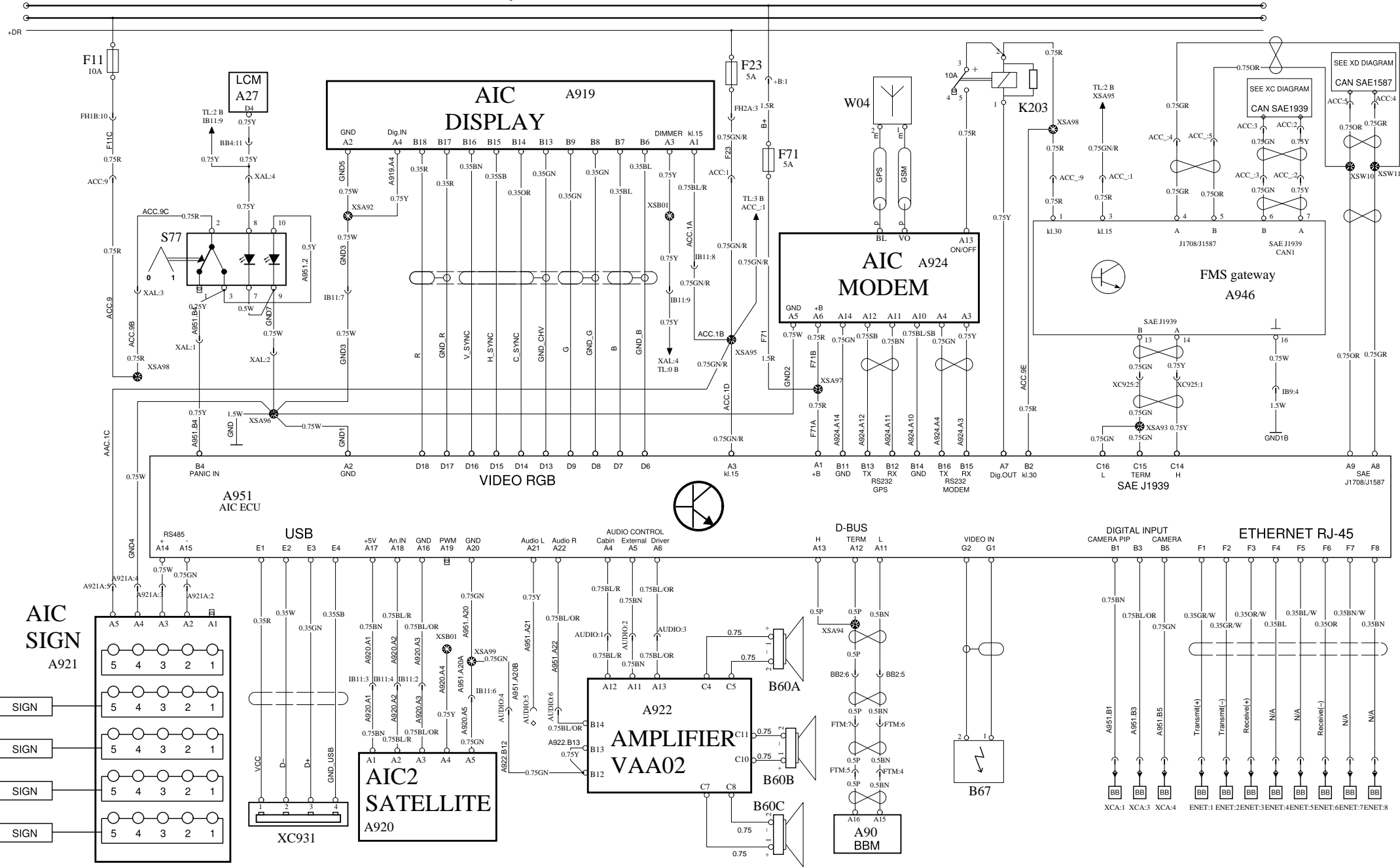

| | | | | | |
|----------------------------------|----------|--------------------|--------------------------|---------|----------------------------|
| Engineering Release Notice (ERN) | Location | Change Description | A = Added U = Deleted | W = Was | Document Release Status |
| | | See DCN | | | Date Modification Count |

BILL OF MATERIAL/COMPONENT LIST

| Part Name | Description | Location | Part Type |
|-----------|--|----------|------------------|
| +B:1 | B+ (+24V) | | inline_connector |
| A27 | Control unit, LCM(Light Control Module) | | componentSymbol |
| A90 | CECM Chassis Electronic Control Module | | componentSymbol |
| A919 | AIC, Advanced Information Center | | componentSymbol |
| A920 | AIC SATELLITE, Advanced Information Center Satellite | | componentSymbol |
| A921 | AIC SIGN UNIT, Advanced Information Center Sign Unit | | componentSymbol |
| A921A:2 | RS 485(-) | | inline_connector |
| A921A:3 | RS 485(+) | | inline_connector |
| A921A:4 | GND (LDO) | | inline_connector |
| A921A:5 | +30 main switch | | inline_connector |
| A922 | AIC AMPLIFIER, Advanced Information Center Amplifier | | componentSymbol |
| A924 | AIC MODEM, Advanced Information Center Modem | | componentSymbol |
| A946 | FMS GATEWAY | | componentSymbol |
| A951 | AIC ECU | | componentSymbol |
| AUDIO:1 | Cabin speakers Activate with a LDO signal (GND) | | inline_connector |
| AUDIO:2 | Speakers Activate with a LDO signal (GND) | | inline_connector |
| AUDIO:3 | Driver speaker Activate with a LDO signal (GND) | | inline_connector |
| AUDIO:4 | Audio GND | | inline_connector |
| AUDIO:5 | Audio L | | inline_connector |
| AUDIO:6 | Audio R | | inline_connector |
| B60A | External Speaker | | componentSymbol |
| B60B | Driver Speaker | | componentSymbol |
| B60C | Cabin Speaker | | componentSymbol |
| B67 | Rear view camera | | componentSymbol |
| BB2:5 | D-CAN H | | inline_connector |
| BB2:6 | D-CAN L | | inline_connector |
| BB4:11:1 | Dimmer, dashboard illumination | | inline_connector |
| ENET:1 | ETHERNET RJ45 connector | | inline_connector |
| ENET:2 | ETHERNET RJ45 connector | | inline_connector |
| ENET:3 | ETHERNET RJ45 connector | | inline_connector |
| ENET:4 | ETHERNET RJ45 connector | | inline_connector |
| ENET:5 | ETHERNET RJ45 connector | | inline_connector |
| ENET:6 | ETHERNET RJ45 connector | | inline_connector |
| ENET:7 | ETHERNET RJ45 connector | | inline_connector |
| ENET:8 | ETHERNET RJ45 connector | | inline_connector |
| F11 | +30 Fuse, 10A | | componentSymbol |
| F23 | +DR Fuse, 5A | | componentSymbol |

The copying, distribution and utilization of this document as well as the communication of its contents to others without expressed authorization is prohibited. Offenders will be held liable for payment of damages. All rights reserved in the event of the grant of a patent, utility model or ornamental design registration.

Document Title
WIRING DIAGRAM
TELEMATICS
ITS4mobility

VOLVO
Volvo Bus Corporation

Document Type
PRODUCT SCHEMATIC

Owner Domain: Document Prefix

| | | | |
|-----------------|-------------|---------------|-------------|
| Document No | Issue Index | Volume No | Page No |
| 21115832 | 09 | 02(02) | 1(2) |

| Part Name | Description | Location | Part Type |
|-----------|--|----------|------------------|
| F71 | +B Fuse, extra equipment ITS4mobility | | componentSymbol |
| GND | Ground | | componentSymbol |
| K203 | Relay, extra, modem ON/OFF | | componentSymbol |
| S77 | Switch, emergency call | | componentSymbol |
| W04 | Antenna ITS4mobility | | componentSymbol |
| XAL:1 | Alarm switch (Customer Adaptation HDI) | | inline_connector |
| XAL:2 | GND | | inline_connector |
| XAL:3 | +30 main switch | | inline_connector |
| XC925:1 | Can link FMS interface 1939H | | inline_connector |
| XC925:2 | Can link FMS interface 1939L | | inline_connector |
| XC931 | USB connection | | componentSymbol |
| XCA:1 | Customer Adaptation HDI | | inline_connector |
| XCA:3 | Customer Adaptation HDI | | inline_connector |
| XCA:4 | Customer Adaptation HDI | | inline_connector |

VOLVO

Volvo Bus Corporation

Document Title

WIRING DIAGRAM

Document Type

PRODUCT SCHEMATIC

Document No

21115832

Issue Index

09

Volume No

02(02)

Page No

2(2)

Foreword

The information in this manual is based on present design in March 2011.

The products are under continuous development. This may effect the correctness of the information in this manual. If the differences are significant, new editions of this manual will be released to cover the changes.

Volvo Bus Corporation

Göteborg, Sweden

Order number: TP 17073

© 2011 Volvo Bus Corporation, Göteborg, Sweden

All rights reserved. No part of this publication may be reproduced, stored in retrieval system, or transmitted in any forms by any means, electronic, mechanical, photocopying, recording or otherwise, without the prior written permission of Volvo Bus Corporation.

More component placement information, see:2
Symbol explanations4
Placement of intermediate connector pieces and control units on the chassis6
Placement of sensors and actuators on the chassis.....6
1 (driver environment)8
Electrical distribut.unit, chassis.....31
Relay.....34
Fuses.....36
Intermediate connector pieces40
Control units46
Diagnostic connector55
Electrical distribution units57

More component placement information, see:

| Language | Function group | Title |
|----------------------|----------------|-----------------------------|
| Arabic | 300 | تانوكمل اعضو |
| Brazilian/Portuguese | 300 | Localização do componente |
| Canadian/French | 300 | Emplacement des composants |
| Chinese (simple.) | 300 | 部件位置 |
| Chinese (trad) | 300 | 部件位置 |
| Czech | 300 | Umístění komponenty |
| German | 300 | Platzierung der Bauteile |
| Danish | 300 | Komponentplacering |
| English | 300 | Component placement |
| Spanish | 300 | Colocación del componente |
| Estonian | 300 | Komponentide asukoht |
| Finnish | 300 | Komponenttien sijoittaminen |
| French | 300 | Emplacement des composants |
| Greece | 300 | Τοποθέτηση εξαρτήματος |
| Hungarian | 300 | Alkatrész-elhelyezés |
| Indonesian | 300 | Penggantian komponen |

See also, 300, Component placement, Description, Design and function

The reader is advised that printed copies are uncontrolled.

Component Placement





Volvo Bus Corporation

| | | |
|------------------|-----|--------------------------------|
| Farsi/Persian | 300 | هعطق نداد اج |
| Hebrew | 300 | מוקמב החנה, ביכר |
| Italian | 300 | Posizionamento dei componenti. |
| Japanese | 300 | コンポーネント配置 |
| Korean | 300 | 구성부품 배치 |
| Lithuanian | 300 | Komponento išdėstymas |
| Latvian | 300 | Daļu izvietojums |
| Mexican/Spanish | 300 | Colocación de componente |
| Dutch | 300 | Lokatie van componenten |
| Norwegian | 300 | Komponentplassering |
| Polish | 300 | Rozmieszczenie komponentów |
| Portuguese | 300 | Colocação de componentes |
| Romanian | 300 | Plasare componentă |
| Russian | 300 | Размещение компонентов |
| Serbian | 300 | Raspored komponenti |
| Slovak | 300 | Umiestnenie komponentu |
| Slovenian | 300 | Zamenjava sestavnih delov |
| Swedish | 300 | Komponentplacering |
| Thai | 300 | การติดตั้งอุปกรณ์ |
| Turkish | 300 | Parça deęiřtirme |
| American/English | 300 | Component Placement |

See also, 300, Component placement, Description, Design and function

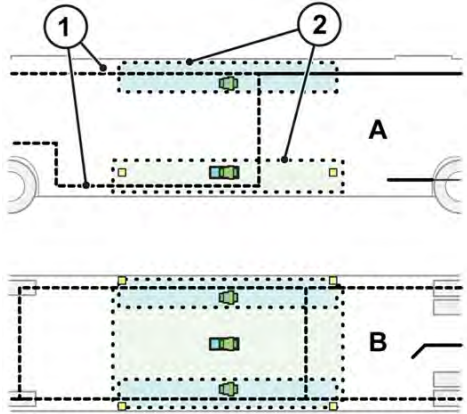



The reader is advised that printed copies are uncontrolled.

Symbol explanations

| Symbol | Explanations |
|---|---|
|  | <p>A: View from side</p> <p>B: View from above</p> <p>1: Alternative cable routing</p> <p>2: Area marked with light colour and dashed lines. The area shows where a control unit and /or a connector piece can be located</p> |
|  | <p>Symbol for electrical distribution unit</p> |
|  | <p>Symbol for intermediate connector piece</p> |
|  | <p>Symbol for intermediate connector piece in grey to show that it is placed behind a component (e.g. the engine).</p> |

See also, 300, Component placement, Description, Design and function

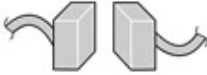
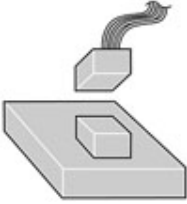
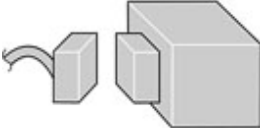
The reader is advised that printed copies are uncontrolled.

| | |
|---|---|
|  | <p>Symbol for control unit</p> |
|  | <p>Symbol for intermediate connector piece in grey to show that it is placed behind a component (e.g. the engine).</p> |
|  | <p>Symbol for intermediate connector piece that is shown where another illustration is missing.</p> |
|  | <p>Symbol for control unit that is shown where another illustration is missing.</p> |
|  | <p>Symbol for sensor/actuator that is shown where another illustration is missing.</p> |
|  | <p>Symbol for branching point</p> |
|  | <p>Symbol for branching point in grey to show that it is placed behind a component (e.g. the electrical distribution unit).</p> |

Placement of intermediate connector pieces and control units on the chassis

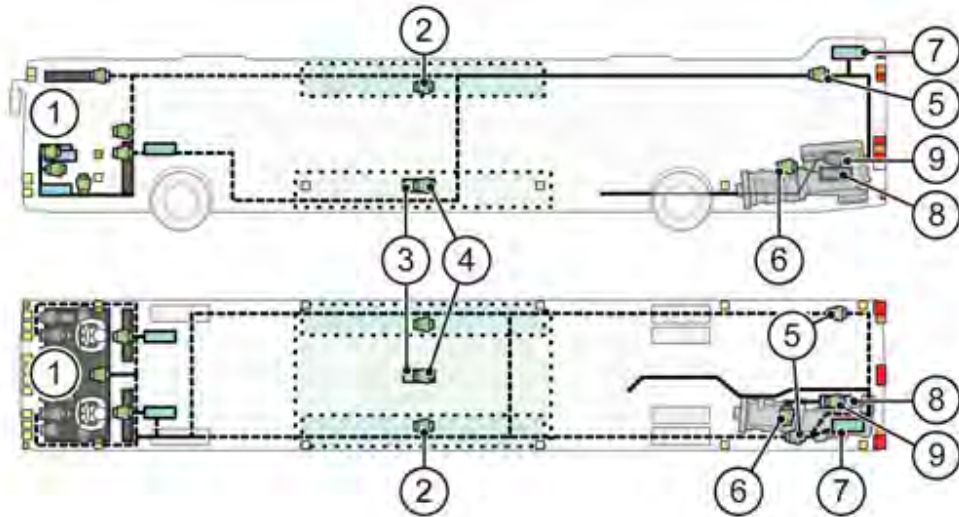

The illustration shows in principle how the chassis cabling is routed and where the intermediate connector pieces, control units and electrical distribution units are located. If the vehicle is not built by a Volvo body builder, then the cabling to the lamps is probably routed in another way than shown in the illustration. The dashed lines show alternative cable routings.

[Symbol explanations](#)

Note: For naming of components, see wiring diagram.

| Placement | Components named according to wiring diagram |
|--|--|
| 1 (driver environment) | A27 (LCM), A21 (EBS), A16 (ECS), A90 (BBM), A17 (VECU), A943 (BIO), A946 (FMS), A65 (RECU), A125 (Dynafleet), K1-K17, K25-K28, F1-F64, FH5 (F96, F97, F98, F99), U06, IB10_B, IB10_E, BB5.A, BB10B, BB11, XC925, ACC, BBOX , XC921 , XC917, XC927, EMS, ENG1, ARTIC, BOGIE , RA1, ECS2, BS3, FUEL, EU4, ECS1, BS1, BS2, FH1A – FH4A , FH1B – FH4B, KH1A - KH3A, KH1B - KH3B, S_TS, S_T_T , XC922, BB13, FTM , XC926, XC930, BB8, BB11, XK2, XK1, IS, GB1, IB1 – IB5, BB7, BB6, GBX, GS1, ARTIC, BOGIE, IB6 – IB10, BB1 – BB5, A03 (BIC), A07 (Radio), A33 (TACHO), OBD2 , BMUX, A30 (SWM), X25, AUDIO, DF, BB10A, A926 (GSECU), A900 (Voith TECU), A901 (ZF ECOMAT TECU), A65 (RECU) |

See also, 300, Component placement, Description, Design and function

The reader is advised that printed copies are uncontrolled.

Component Placement**Volvo Bus Corporation**

| | |
|--|---|
| 2 | UDS |
| 3 | A917 (DECU) |
| 4 | R905A, R906A, R907A, R908, R909A, R910A |
| 5 | BB7B, BS3B |
| | BB6B, ECS2B |
| | EMSB |
| | ENG1B |
| | RA1B |
| | EU4B |
| | B930T |
| 6 | VIC2 |
| 7 | A918 (NOx) |
| 8 | A14 (EECU) |
| 9 | VIC/EI |
| Left side rear (Volvo body) | RL2, RL5, RL8 |
| Right side rear (Volvo body) | RL1, RL7, RL10 |
| Rear, often located towards the centre (Volvo body) | RL3 |

See also, 300, Component placement, Description, Design and function

7

The reader is advised that printed copies are uncontrolled.

Placement of intermediate connector pieces and control units on the chassis B9L articulated

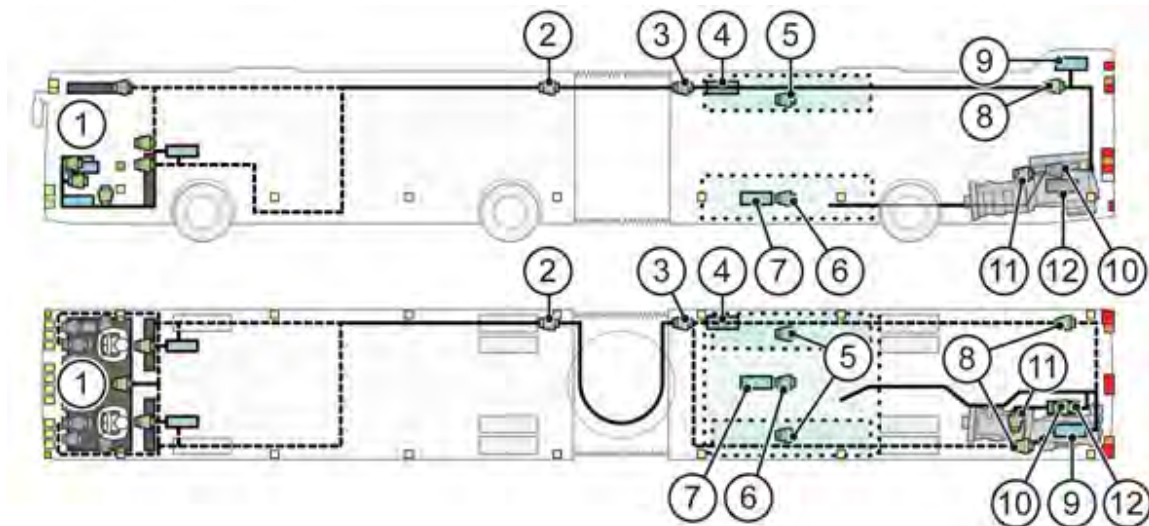

The illustration shows in principle how the chassis cabling is routed and where the intermediate connector pieces, control units and electrical distribution units are located. If the vehicle is not built by a Volvo body builder, then the cabling to the lamps is probably routed in another way than shown in the illustration. The dashed lines show alternative cable routings.

[Symbol explanations](#)

Note: For naming of components, see wiring diagram.

| Placement | Components named according to wiring diagram |
|--|---|
| 1 (driver environment) | A27 (LCM), A21 (EBS), A16 (ECS), A90 (BBM), A17 (VECU), A943 (BIO), A946 (FMS), A65 (RECU), A125 (Dynafleet), K1-K17, K25-K28, F1-F64, FH5 (F96, F97, F98, F99), U06, IB10_B, IB10_E, BB5.A, BB10B, BB11, XC925, ACC, BBOX, XC921, XC917, XC927, EMS, ENG1, ARTIC, BOGIE, RA1, ECS2, BS3, FUEL, EU4, ECS1, BS1, BS2, FH1A – FH4A, FH1B – FH4B, KH1A - KH3A, KH1B - KH3B, S_TS, S_T_T, XC922, BB13, FTM, XC926, XC930, BB8, BB11, XK2, XK1, IS, GB1, IB1 – IB5, BB7, BB6, GBX, GS1, ARTIC, BOGIE, IB6 – IB10, BB1 – BB5, A03 (BIC), A07 (Radio), A33 (TACHO), OBD2, BMUX, A30 (SWM), X25, AUDIO, DF, BB10A, A926 (GSECU), A900 (Voith TECU), A901 (ZF ECOMAT TECU), A65 (RECU) |

See also, 300, Component placement, Description, Design and function

The reader is advised that printed copies are uncontrolled.

| | |
|---|-------------------------|
| 2 | BB7.A2, BS3.A2, FUEL.A2 |
| | BB6.A2, ECS2.A2, EU4.A2 |
| | GBX.A2 |
| | EMS.A2, BOGIE.A2 |
| | ENG1.A2, ARTIC.A2 |
| | RA1.A2 |
| | GS1.A2 |
| 3 | BB7.A3, BS3.A3, FUEL.A3 |
| | BB6.A3, ECS2.A3, EU4.A3 |
| | GBX.A3 |
| | EMS.A3 |
| | ENG1.A3 |
| | RA1.A3 |
| | GS1.A3 |
| 4 | A916 |
| | A900 |
| | A901 |
| 5 | UDS |

See also, 300, Component placement, Description, Design and function

The reader is advised that printed copies are uncontrolled.

Component Placement**Volvo Bus Corporation**

| | |
|--|---|
| 6 | R905A, R906A, R907A, R908, R909A, R910A |
| 7 | A917 (DECU) |
| 8 | BB7B, BS3B |
| | BB6B, ECS2B, EU4B |
| | GBXB |
| | EMSB |
| | ENG1B |
| | RA1B |
| 9 | A918 |
| 10 | VIC/EI |
| 11 | VIC2 |
| 12 | A14 (EECU) |
| Left side rear (Volvo body) | RL2, RL5, RL8 |
| Right side rear (Volvo body) | RL1, RL7, RL10 |
| Rear, often located towards the centre (Volvo body) | RL3 |

See also, 300, Component placement, Description, Design and function

10

The reader is advised that printed copies are uncontrolled.

1 (driver environment)

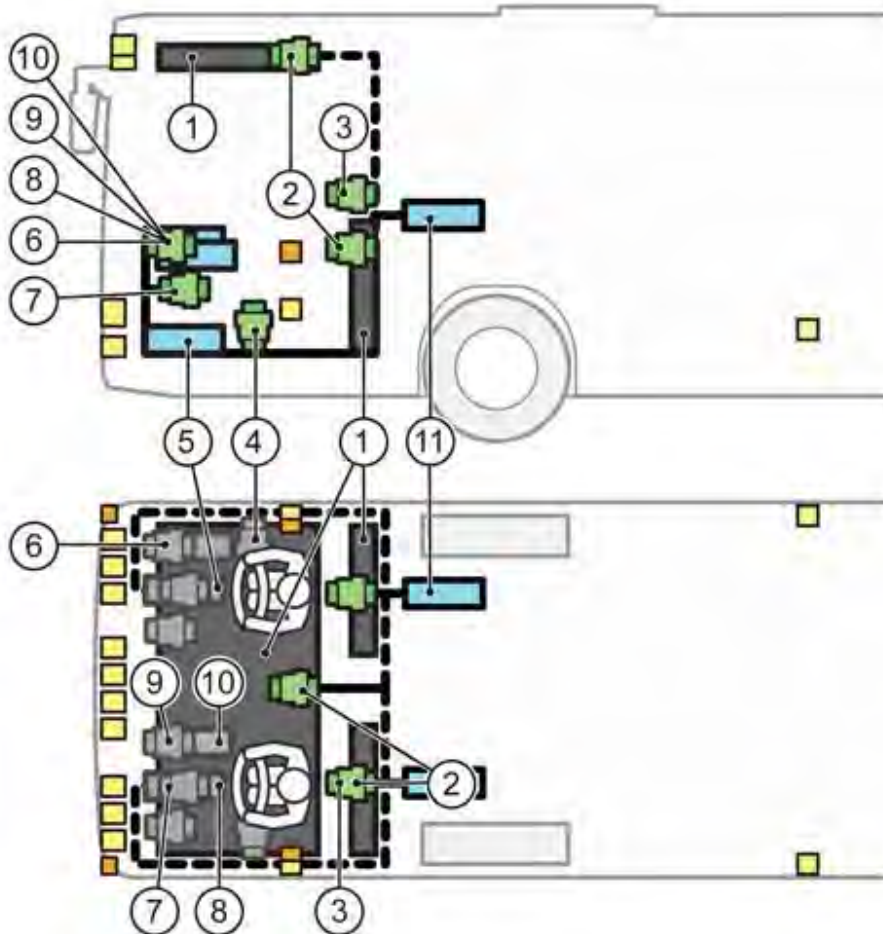

The illustration shows in principle how the chassis cabling is routed and where the intermediate connector pieces, control units and electrical distribution units are located. The dashed lines show alternative cable routings. The illustration is used for both right-hand drive and left-hand drive vehicles, where of certain components are drawn in two places.

Note: The table includes components that the vehicle is not equipped with.

| Placement | Components named according to wiring diagram |
|-----------|--|
| 1 | A16 (ECS) |
| | A17 (VECU) |

See also, 300, Component placement, Description, Design and function

The reader is advised that printed copies are uncontrolled.

| | |
|----------|---------------------------------|
| | A21 (EBS) |
| | A27 (LCM) |
| | A65 (RECU) |
| | A90 (BBM) |
| | A125 (Dynafleet) |
| | A943 (BIO) |
| | A946 (FMS) |
| | K1– K17, K25 – K28 |
| | F1 – F64, F96 – F99, F90A, F90B |
| | FH1A, FH1B |
| | FH2A, FH2B |
| | FH3A, FH3B, FH4A, FH4B |
| | U06 |
| | S_T_S, S_T_T |
| 2 | ACC, BB10B, XC937, DEV-CAN |
| | ARTIC, BB1, BS1, ENG1, IB10 |
| | BB2, BOGIE, BS2, IB9, EMS |
| | BB3, ECS1, IB8, RA1 |

See also, 300, Component placement, Description, Design and function

The reader is advised that printed copies are uncontrolled.

| | |
|----------|--------------------------------------|
| | BB4, BB6, BB6A, BB6B, ECS2, EU4, IB7 |
| | BB5, BB5A, BB5B, BS3, FUEL, IB6, BB7 |
| | IB1 |
| | IB2 |
| | GBX, IB3 |
| | IB4 |
| | IB5 |
| | BB11, BBOX |
| | BB13 |
| | FTM, KH2A, KH2B, GS1, XC933 |
| | GB1 |
| | IS, XC925, SP_F, SP_RR |
| | KH1A, KH1B, KH3A, KH3B |
| | RL4 (B6R/B7R, B9R, B12M, B12B) |
| | XC917, XC921, XC935, XK2 |
| 3 | X25 |
| 4 | BMUX |
| 5 | A30 (SWM) |

See also, 300, Component placement, Description, Design and function

The reader is advised that printed copies are uncontrolled.

Component Placement**Volvo Bus Corporation**

| | |
|-------------|-----------------------|
| 6 | DF |
| 7 | OBD2 |
| 8 | A03 (BIC) |
| | A07 (Radio) |
| | A33 (TACHO) |
| 9 | AUDIO, BB10A |
| | BB10A |
| 10 | A926 (GSECU) |
| 11 | A900 (Voith TECU) |
| | A901 (ZF ECOMAT TECU) |
| Left front | FL2 |
| | FL2A |
| Right front | FL3 |
| | FL3A |

See also, 300, Component placement, Description, Design and function

14

The reader is advised that printed copies are uncontrolled.

Electrical distribut.unit, chassis

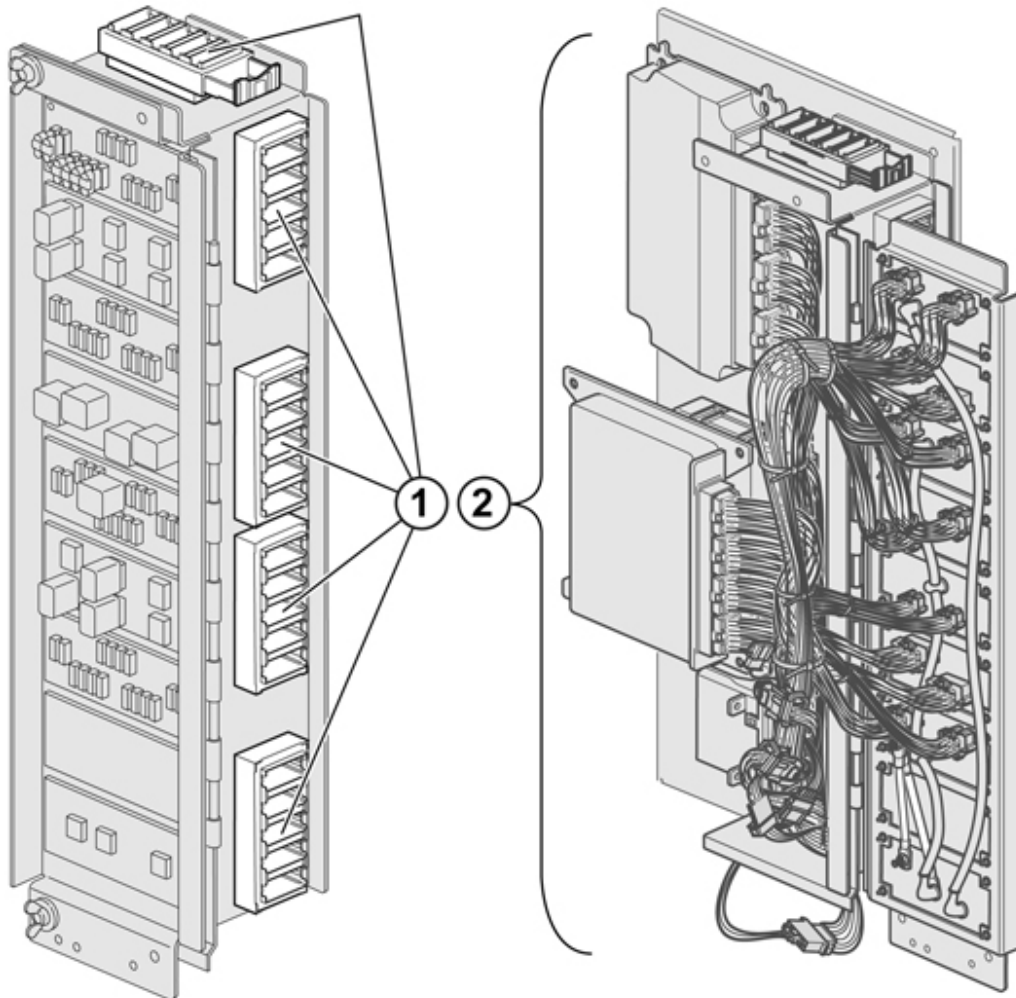

Note: The table includes components that the vehicle is not equipped with.

| Placement | Components named according to wiring diagram |
|-----------|--|
| 1 | ARTIC, BB1, BS1, ENG1, IB10 |
| | BB2, BOGIE, BS2, IB9, EMS |
| | BB3, ECS1, IB8, RA1 |

See also, 300, Component placement, Description, Design and function

The reader is advised that printed copies are uncontrolled.

| | |
|----------|--------------------------------------|
| | BB4, BB6, BB6A, BB6B, ECS2, EU4, IB7 |
| | BB5, BB5A, BB5B, BS3, FUEL, IB6, BB7 |
| | IB1 |
| | IB2 |
| | GBX, IB3 |
| | IB4 |
| | IB5 |
| 2 | A16 (ECS) |
| | A17 (VECU) |
| | A21 (EBS) |
| | A27 (LCM) |
| | A65 (RECU) |
| | A90 (BBM) |
| | A125 (Dynafleet) |
| | A943 (BIO) |
| | A946 (FMS) |
| | K1– K17, K25 – K28 |
| | F1 – F64, F96 – F99, F90A, F90B |

See also, 300, Component placement, Description, Design and function

The reader is advised that printed copies are uncontrolled.

| |
|--------------------------------|
| FH1A, FH1B |
| FH2A, FH2B |
| FH3A, FH3B, FH4A, FH4B |
| U06 |
| BB11, BBOX |
| BB13 |
| FTM, KH2A, KH2B, GS1, XC933 |
| GB1 |
| IS, XC925, SP_F, SP_RR |
| KH1A, KH1B, KH3A, KH3B |
| RL4 (B6R/B7R, B9R, B12M, B12B) |
| XC917, XC921, XC935, XK2 |
| ACC, BB10B, XC937 |
| S_T_S, S_T_T |

Relay

The placement of the relays in the electrical distribution unit is described below.

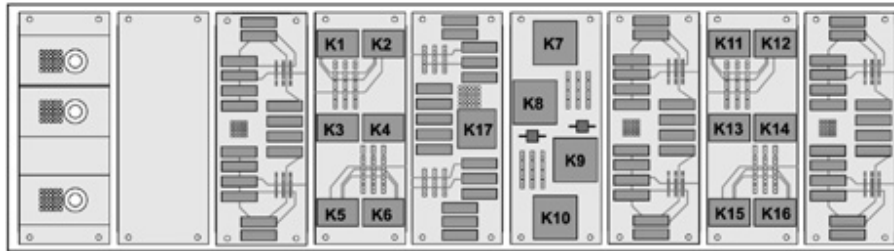

| Relay | Designation |
|------------------|---|
| K1 | — |
| K2 | Overload indicator (option) |
| K3 | ECS (air suspension control unit) |
| K4 ₁ | TECU (gearbox control unit), GECU (gear selector control unit), gearbox I-Shift |
| K5 ₁ | EGS manual gearbox |
| K6 ₁ | EGS manual gearbox |
| K7 | Starter motor |
| K8 ₁ | VECU (vehicle control unit), EECU (motor control unit) |
| K9 | Wiper motor intermittent relay |
| K10 | Inverting relay, neutral signal (only automatic gearboxes) |
| K11 | Start inhibit relay |
| K12 | Stowage compartment lighting |
| K13 | Emergency cut-out |
| K14 ₁ | Bogie axle |

See also, 300, Component placement, Description, Design and function

The reader is advised that printed copies are uncontrolled.

| | |
|------------------|------------------------------|
| K15 ¹ | RECU (retarder control unit) |
| K16 ¹ | RECU (retarder control unit) |
| K17 | Ignition relay (+15) |

¹ Dependent on variant

Fuses

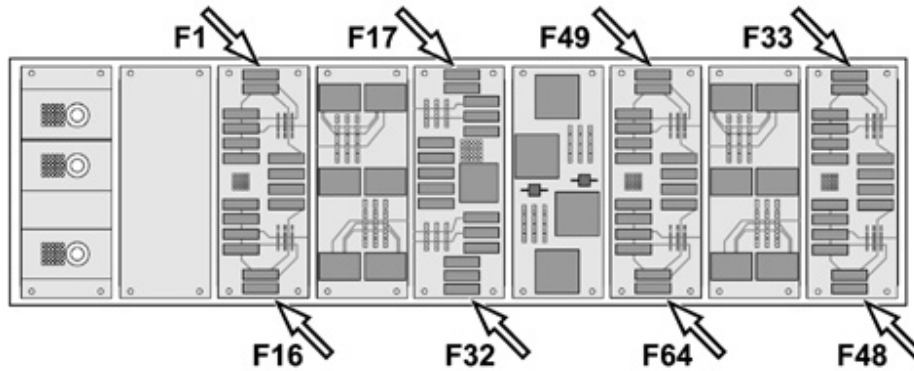

| Fuse | Rating | Designation |
|------------------|--------|---|
| F1 | 5 A | ECS (air suspension control unit) |
| F2 | 10 A | BIC (instrument panel), lamp check switch |
| F3 | 15 A | Starting signal, starter motor |
| F4 | 20 A | EBS (brake control unit) |
| F5 | 5 A | Horn |
| F6 | 5 A | Emergency parking brake release |
| F7 ₁ | 15 A | TECU (transmission electronic control unit), gearbox I-shift |
| F8 ₁ | 5 A | GECU (gear selection control unit) I-shift |
| F9 | 5 A | Start switch, engine compartment |
| F10 | 5 A | Fire Alarm |
| F11 ₁ | 10 A | Dynafleet (option) |
| F12 | 5 A | Supply, main switch (+30) to body-builder outlet |
| F13 | 10 A | Automatic oil filling (option) |
| F14 | 5 A | BBM (Body Builder Module) |
| F15 | 15 A | EECU (Engine Electronic Control Unit), control valve, cooling fan |
| F16 | 5 A | VECU (Vehicle Electronic Control Unit) |

See also, 300, Component placement, Description, Design and function

The reader is advised that printed copies are uncontrolled.

| Fuse | Rating | Designation |
|------------------|--------|---|
| F17 | 5 A | Lighting, level control switch |
| F18 | 5 A | Alternator 1, 2, 3 |
| F19 ¹ | 10 A | Control unit, turntable |
| F20 | 10 A | EBS (brake control unit) |
| F21 | 15 A | Wiper motor, windscreen |
| F22 ¹ | 5 A | TECU (Transmission Electronic Control Unit), Voith automatic transmission |
| F24 | 5 A | BIC (instrument) |
| F25 | 15 A | Wiper motor, headlights |
| F26 | 5 A | ECS (air suspension control unit) |
| F27 ¹ | 10 A | EGS manual gearbox |
| F28 ¹ | 10 A | RECU (Retarder Electronic Control Unit) |
| F29 | 5 A | Supply, ignition (+15) to body-builder outlet |
| F30 ¹ | 5 A | Fuel heater (D7E engine) |
| F31 ¹ | 10 A | Hydraulic oil level, SCR (control unit exhaust cleaning) |
| F32 ¹ | 5 A | Tachograph |
| F33 | 5 A | BIC (instrument) |
| F34 ¹ | 10 A | Tachograph |
| F35 | 25 A | LCM (external lighting control unit) |
| F36 | 25 A | LCM (external lighting control unit) |
| F37 | 25 A | LCM (external lighting control unit) |
| F38 | 5 A | Inverted +15 |
| F39 | 25 A | SCR (control unit exhaust cleaning) |

See also, 300, Component placement, Description, Design and function

The reader is advised that printed copies are uncontrolled.

| Fuse | Rating | Designation |
|------------------|---------------|---|
| F41 | 20 A | Radio |
| F42 | 5 A | Main switch |
| F44 | 25 A | LCM (external lighting control unit) |
| F45 | 25 A | LCM (external lighting control unit) |
| F46 | 25 A | LCM (external lighting control unit) |
| F47 | 5 A | Side position light, right |
| F48 | 5 A | Side position light, left |
| F49 | 5 A | Fuel shut-off valve |
| F50 ¹ | 10 A | RECU (Retarder Electronic Control Unit) |
| F51 | 5 A | Radio |
| F52 ¹ | 10 A | Stowage compartment lighting |
| F53 ¹ | 5 A | Trailing axle, water separator heater |
| F54 ¹ | 5 A | Engine/luggage compartment door |
| F55 ¹ | 10 A | Engine brake, cooling fan solenoid valve, pre-heater relay |
| F56 ¹ | 10 A | Engine brake |
| F57 | 5 A | Supply, ignition lock |
| F58 ¹ | 5 A | Control unit, tank valves (only gas buses) |
| F60 ¹ | 10 A | TECU (Transmission Electronic Control Unit), Voith automatic transmission |
| F61 ¹ | 10 A | Stowage compartment lighting |
| F62 ¹ | 5 A | Sleeping bunk lighting |
| F63 | 5 A | Starter motor |
| F64 ¹ | 10 A | Indicates overload |



See also, 300, Component placement, Description, Design and function

The reader is advised that printed copies are uncontrolled.

¹ Dependent on variant.

Note: The table includes components that the vehicle is not equipped with. When there is no illustration for a component, a symbol illustration is shown. More adapters than those stated can fit the connector pieces.

Intermediate connector pieces

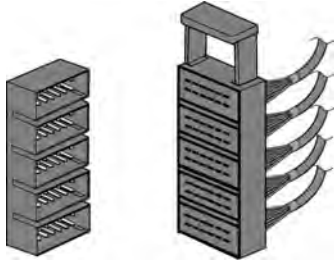
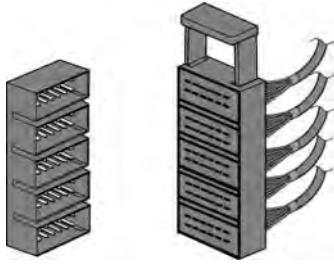
| Wiring diagram designation, component/connector piece | Illustration | Adapter | Index in breakout box |
|--|---|--|--|
| A14_, A14A, FL2, FL3, LT1, MEDA, RL1, RL2, RL3, RL5, RL6, RL7, TRAIL2, UDS, XC914A |  | 9998563 | 1 – 12 |
| A14B, A14C, A14D, A43, BMUX, CAN, FL2A, FL3A, LA, ML1, ML2, ML3, ML3B, ML4, ML4A, ML4B, ML5, ML6, ML7, RL1A, RL2A, RL4, TRAIL3, VIC2, XC915, XC916, XC931, Y17 |  | 88890053 | 1– 7 |
| ARTIC, BB1, BS1, IB10 |  | 9990805 or 88890116 | 1 – 12 |
| ENG1, ENG1B | | 9990008 , 9990805 or 88890116 | – or 1 – 12 |
| BB2, BOGIE, BS2, IB9 |  | 9990805 or 88890116 | 13 – 24 or 19 – 30 (88890116) |
| EMS, EMSB | | 9990008 , 9990805 or 88890116 | – or 19 – 30 (88890116) |

See also, **300, Component placement, Description, Design and function**

The reader is advised that printed copies are uncontrolled.

Component Placement

Volvo Bus Corporation

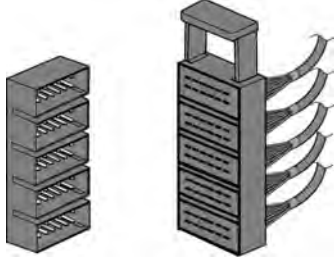
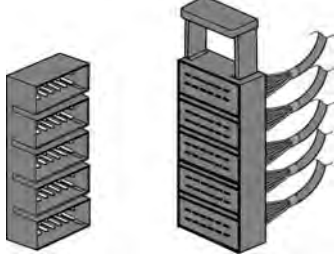
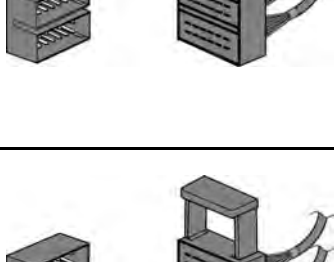
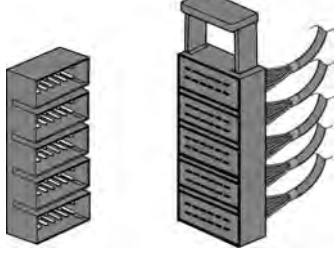
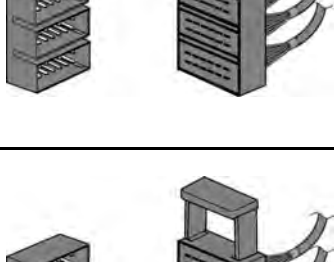
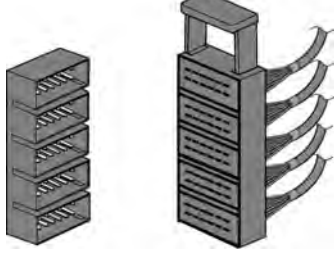
| | | | |
|---|---|--|--|
| BB3, ECS1, IB8, RA1, RA1B |  | 9990805 or 88890116 | 25 – 36 or 37 – 48 (88890116) |
| BB4, ECS2, ECS2B, EU4, IB7 |  | 9990805 or 88890116 | 37 – 48 or 55 – 62 plus 1 – 10 (88890116) |
| BB6, BB6A, BB6B |  | 9990008 , 9990805 or 88890116 | – or 55 – 62 plus 1 – 4 (88890116) |
| BB5, BB5.A, BB5.B, BS3, BS3B, FUEL, IB6 |  | 9990805 or 88890116 | 49 – 60 |
| BB7, BB7A, BB7B |  | 9990008 , 9990805 or 88890116 | – or 11 – 22 (88890116) |
| IB1 |  | 9990008 or 88890116 | – or 11 – 28 (88890116) |

See also, 300, Component placement, Description, Design and function

The reader is advised that printed copies are uncontrolled.

Component Placement

Volvo Bus Corporation

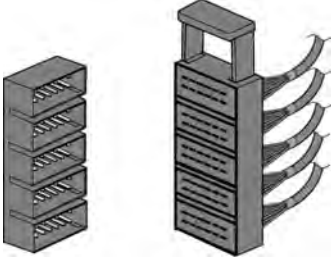
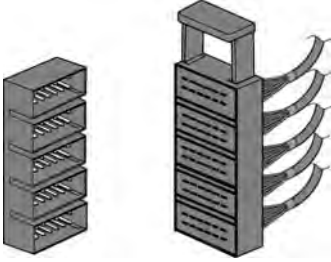
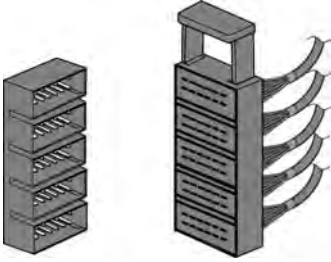
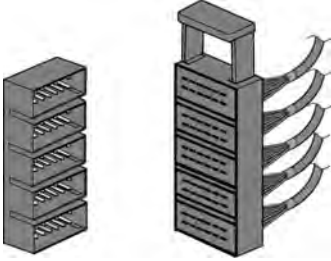
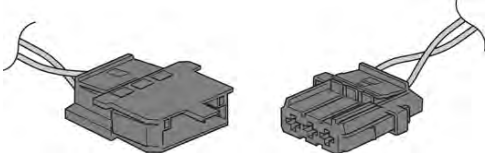



| | | | |
|---|---|--|--|
| <p>IB2</p> |  | <p>9990008 or 88890116</p> | <p>— or 55 – 62, 1–10 (88890116)</p> |
| <p>GBX, IB3</p> |  | <p>9990008 or 88890116</p> | <p>— or 37 – 54 (88890116)</p> |
| <p>IB4</p> |  | <p>9990008 or 88890116</p> | <p>— or 19 – 36 (88890116)</p> |
| <p>IB5</p> |  | <p>9990008 or 88890116</p> | <p>— or 1 – 18 (88890116)</p> |
| <p>AUDIO, BB11, BB8, BBOX, RL, XC927, BBOX, S_T_S, S_T_T, XC922</p> |  | <p>9990008</p> | <p>—</p> |

See also, 300, Component placement, Description, Design and function

The reader is advised that printed copies are uncontrolled.

Component Placement

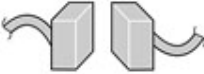
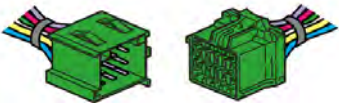
Volvo Bus Corporation





| | | | |
|---|---|---------------------------------|----------------|
| <p>B_A, B930T, IS, LT2, R905A, R905B, R906A, R906B, R906C, R908A, R908B, R908C, R910A, R910B, R910C, S901_U1, S908, SP_F, SP_RR, UDS, XC925, XC932A, XC934, XJK</p> |  | <p>88890039</p> | <p>1 – 4</p> |
| <p>KH1A, KH1B, KH3A, KH3B</p> |  | <p>9998596</p> | <p>18 – 32</p> |
| <p>ACC, BB10A, BB10B, DEV-CAN, FH2A, FH2B, XC937</p> |  | <p>9998596</p> | <p>33 – 41</p> |
| <p>XC917, XC921, XC935, XK2</p> |  | <p>9998596</p> | <p>42 – 47</p> |
| <p>CNG, DF, EU4B, FH1A, FH3A, FH3B, FH4A, FH4B, FTM, GS1, KH2A, KH2B, XC926, XC930, XC933</p> |  | <p>9998596</p> | <p>49 – 60</p> |
| <p>FM</p> |  | | |
| <p>LT_, TRAIL, TRAIL1</p> |  | <p>9990090</p> | <p>1 – 31</p> |

See also, 300, Component placement, Description, Design and function

The reader is advised that printed copies are uncontrolled.

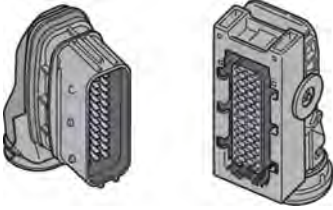
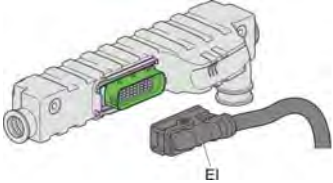
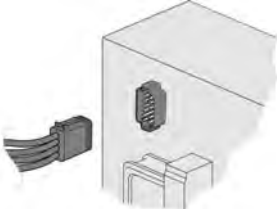
Component Placement

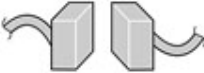
Volvo Bus Corporation

| | | | |
|--------------------------|---|--------------------------|--------|
| REV |  | | |
| VIC/EI (D7E), MED, XC941 |  | 88890025 | 1 – 39 |
| VIC/EI |  | 88890025 | 1 – 39 |
| X904.XC207 |  | 9990008 | — |
| BB13 |  | | |
| GB1 |  | | |
| X25 |  | | |
| DPF |  | | |

See also, 300, Component placement, Description, Design and function

The reader is advised that printed copies are uncontrolled.

Component Placement

Volvo Bus Corporation

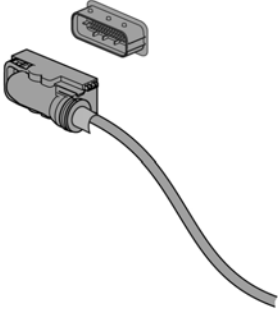
| | | | |
|-------|---|-------------------------|--------|
| XC940 |  | 9990014 | 1 – 62 |
|-------|---|-------------------------|--------|

Note: The table includes components that the vehicle is not equipped with. The illustrations show examples of the components' appearance. When there is no illustration for a component, a symbol illustration is shown. More adapters than those stated can fit the connector pieces.

See also, 300, Component placement, Description, Design and function

The reader is advised that printed copies are uncontrolled.

Control units

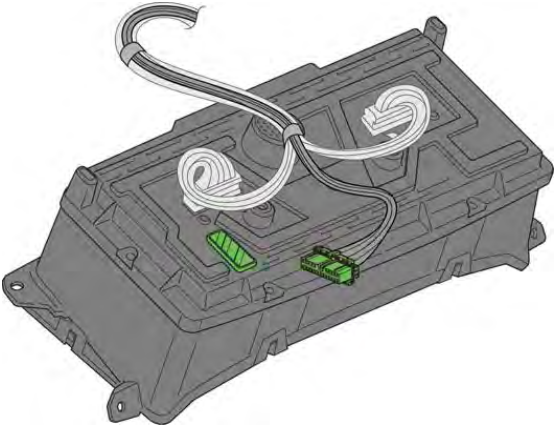
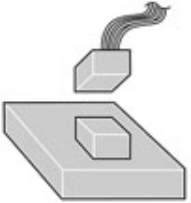
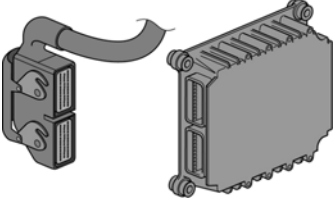
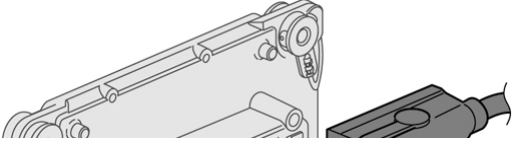
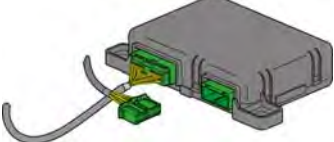
| Wiring diagram designation, component/connector piece | Illustration | Adapter | Index in breakout box |
|---|---|-------------------------|-----------------------|
| A03.A |  | 9998533 | 31 – 52 |
| A03.B | | 9813194 | 1 – 30 |
| A03.C | | 9998533 | 1 – 30 |
| A07.A |  | | |
| A07.B | | | |
| A07.C | | | |
| A14.A (EMS1) |  | 9998505 | 1 – 36 |
| A14.B (EMS1) | | 9998505 | 1 – 36 |
| A14.A (EMS2) |  | 9990014 | 1 – 62 |
| A14.B (EMS2) | | 9990014 | 1 – 62 |
| A16.A |  | 9813194 | 1 – 30 |
| A16.B | | 9998533 | 31 – 52 |

See also, 300, Component placement, Description, Design and function

The reader is advised that printed copies are uncontrolled.

Component Placement

Volvo Bus Corporation

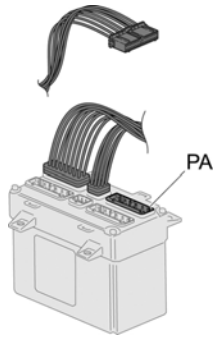
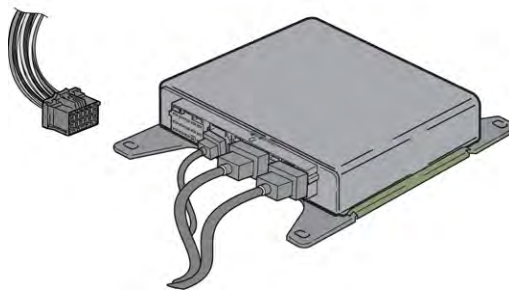
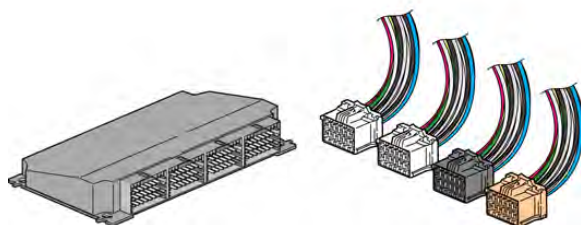
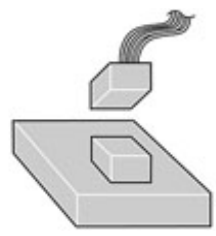
| | | | |
|-------|---|-------------------------|---------|
| A17.A |  | 9813194 | 1 – 30 |
| A17.B | | 9998533 | 1 – 30 |
| A17.C | | 9998604 | 26 – 30 |
| A21.A |  | 9998596 | 1 – 17 |
| A21.B | | 9990025 | 1 – 18 |
| A21.C | | 9998596 | 18 – 32 |
| A21.D | | — | — |
| A27.A |  | 9990025 | 19 – 39 |
| A27.B | | 9990025 | 1 – 18 |
| A27.C | | 9990025 | 1 – 18 |
| A27.D | | 9990025 | 19 – 39 |
| A30 |  | 9813194 | 47 – 56 |

See also, 300, Component placement, Description, Design and function

The reader is advised that printed copies are uncontrolled.

Component Placement

Volvo Bus Corporation

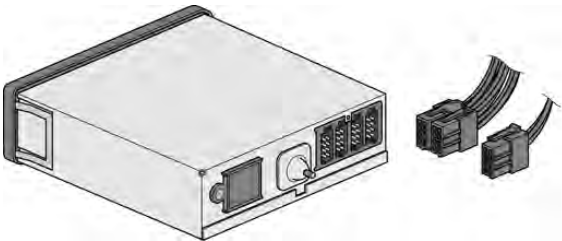
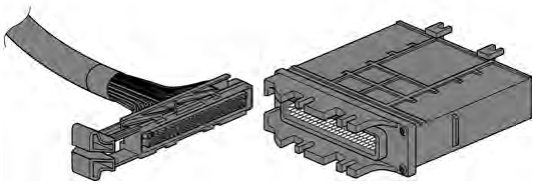
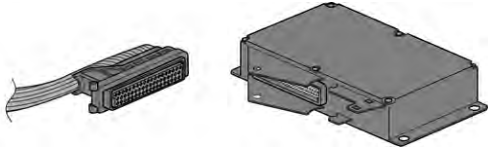
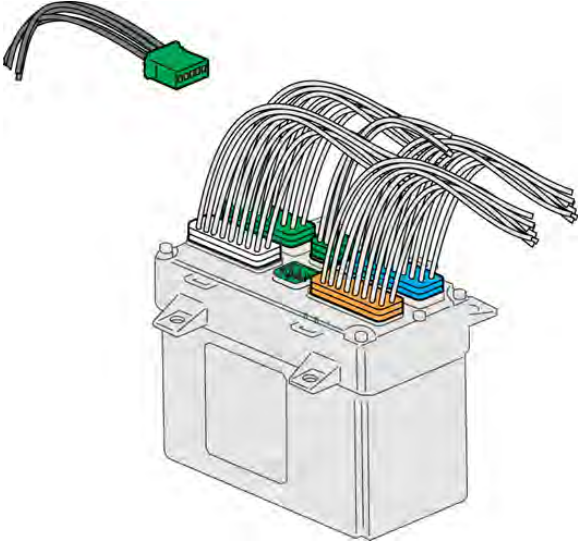

| | | | |
|-------|---|-------------------------|---------------|
| A33.A |  | 9990008 | — |
| A33.B | | 9990008 | — |
| A33.C | | 9990008 | — |
| A33.D | | 9990008 | — |
| A59A |  | 9990155 | 1 – 62, 1 – 6 |
| A65 |  | 9998543 | 1 – 55 |
| A90.A |  | 9998533 | 1 – 30 |
| A90.B | | 9813194 | 1 – 30 |
| A90.C | | 9998604 | 26 – 30 |

See also, 300, Component placement, Description, Design and function

The reader is advised that printed copies are uncontrolled.

Component Placement

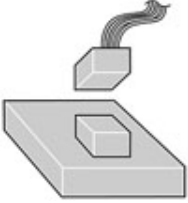
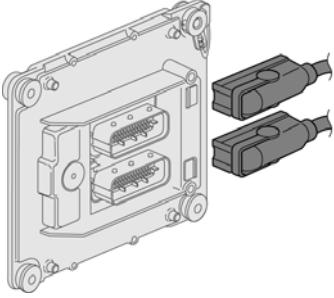
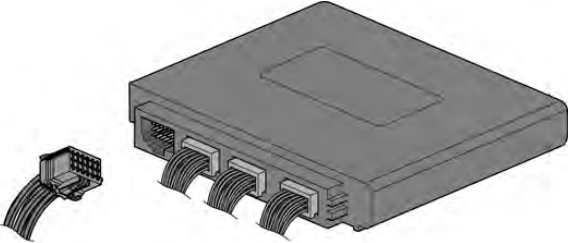
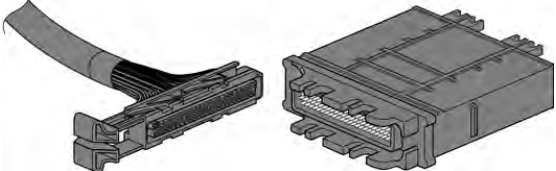
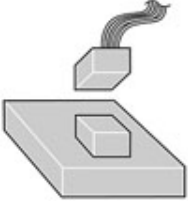
Volvo Bus Corporation



| | | | |
|----------------|---|-------------------------|---------------|
| A125 |  | | |
| A141.A |  | 9990014 | 1 – 62 |
| A141.B | | 9990014 | 1 – 62 |
| A900.A (VOITH) |  | 9990025 | 1 – 18 |
| A900.B (VOITH) | | 9990025 | 1 – 18 |
| A900.C (VOITH) | | 9998596 | 18 – 32 |
| A900.D (VOITH) | | 9990025 | 1 – 18 |
| A901 |  | 9990155 | 1 – 61, 1 – 6 |
| A904 |  | | |
| A914.A |  | 9990041 | 1 – 20 |

See also, 300, Component placement, Description, Design and function

The reader is advised that printed copies are uncontrolled.

Component Placement

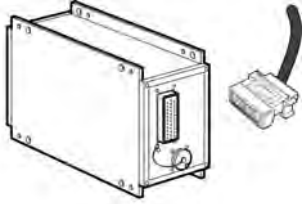
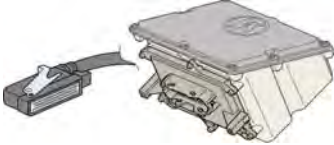
Volvo Bus Corporation

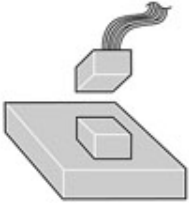
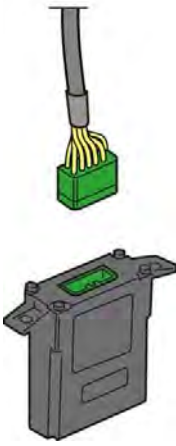
| | | | |
|--------|---|--------------------------|---------|
| A914.B | | 9990041 | 1 – 20 |
| A914.C | | 9990041 | 1 – 20 |
| A916.A |  | 9998996 | 1 – 29 |
| A916.B | | 9998996 | 31 – 46 |
| A916.C | | 9998996 | 31 – 46 |
| A917 |  | 88890052 | 1 – 35 |
| A918 |  | 9990216 | 1 – 4 |
| A925.A |  | 9813194 | 1 – 30 |
| A925.B | | 9998533 | 1 – 30 |
| A925.C | | 9998604 | 26 – 30 |
| A926 |  | 9998533 | 31 – 52 |

See also, 300, Component placement, Description, Design and function

The reader is advised that printed copies are uncontrolled.

Component Placement

Volvo Bus Corporation

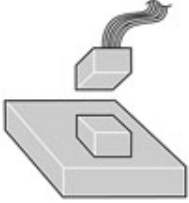
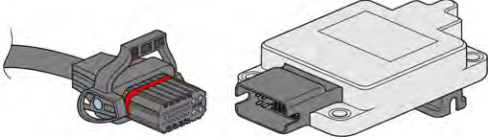
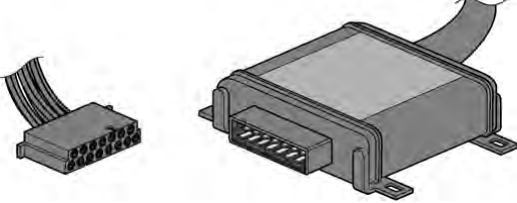
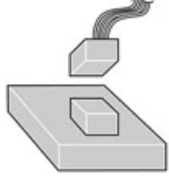
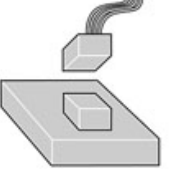
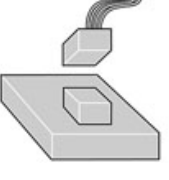
| | | | |
|--------|---|--------------------------|---------|
| A927 |  | | |
| A929.A |  | 88810020 | 1 – 25 |
| A929.B | | 88810020 | 26 – 50 |
| A930 |  | | |
| A942.A |  | 9813194 | 1 – 30 |
| A942.B | | 9998533 | 1 – 30 |
| A942.C | | 9998604 | 26 – 30 |
| A943 |  | | |
| A945 |  | | |

See also, 300, Component placement, Description, Design and function

The reader is advised that printed copies are uncontrolled.

Component Placement

Volvo Bus Corporation

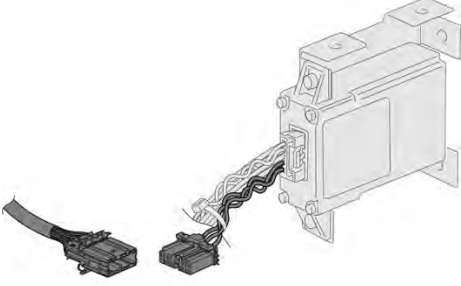
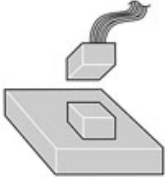
| | | | |
|------|---|-------------------------|---------|
| A946 |  A technical drawing of a rectangular electronic component with a multi-pin connector on the left side. A cable with several wires is connected to the component. The component has mounting tabs on the top and bottom. | 9813194 | 31 – 46 |
| A952 |  A technical drawing of a small, rectangular component with a multi-pin connector on the top side. It is shown being inserted into a larger rectangular base or housing. | | |

See also, 300, Component placement, Description, Design and function

The reader is advised that printed copies are uncontrolled.

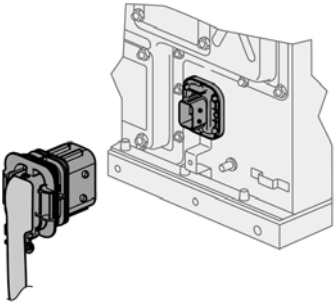
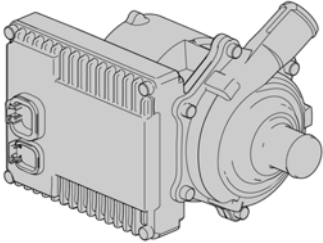
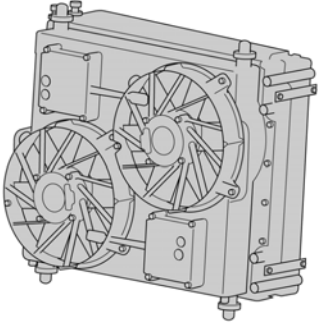
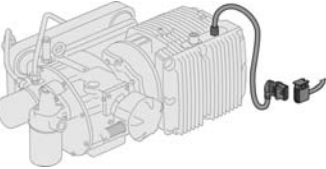
| | | | |
|----------|---|--------------------------|--------|
| G07.A | | | |
| G07.B |  | 88890093 | 1 – 15 |
| M30, M33 |  | 9990008 | – |
| M31, M32 |  | 9990008 | – |
| M35, M36 |  | | |

Component Placement

Volvo Bus Corporation

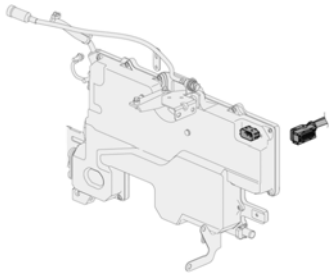
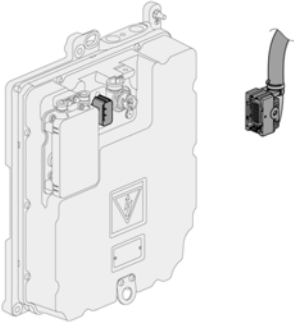
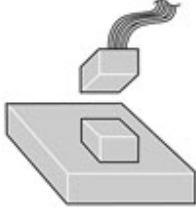
| | | | |
|-----|---|--------------------------|--------|
| U23 |  | 88890094 | 1 – 21 |
| U24 |  | 88890094 | 1 – 21 |
| Y54 |  | 88890053 | 1 – 7 |

Note: The table includes components that the vehicle is not equipped with. More adapters than those stated can fit the connector pieces.

See also, 300, Component placement, Description, Design and function

The reader is advised that printed copies are uncontrolled.

Diagnostic connector

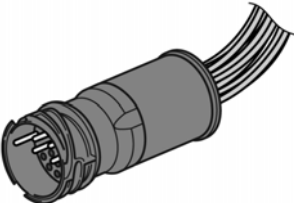
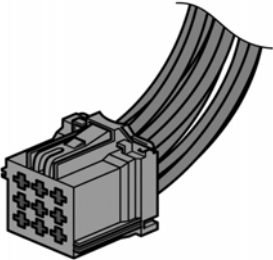
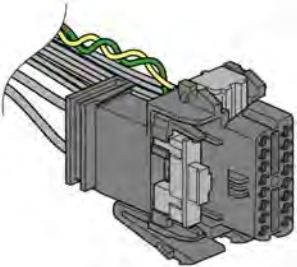
| Wiring diagram designation, component/connector piece | Illustration | Adapter | Index in breakout box |
|---|---|---|-----------------------|
| DIA |  | | |
| DIA2 |  | 9998596 | 33 – 41 |
| DIA-16, OBD2 |  | 88890018 9998960 | |

See also, 300, Component placement, Description, Design and function

The reader is advised that printed copies are uncontrolled.

Component Placement

Volvo Bus Corporation

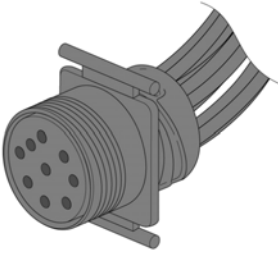
| | | | |
|--|---|-------------------------|--|
| |  | 9990137 | |
|--|---|-------------------------|--|

See also, 300, Component placement, Description, Design and function

The reader is advised that printed copies are uncontrolled.

Electrical distribution units

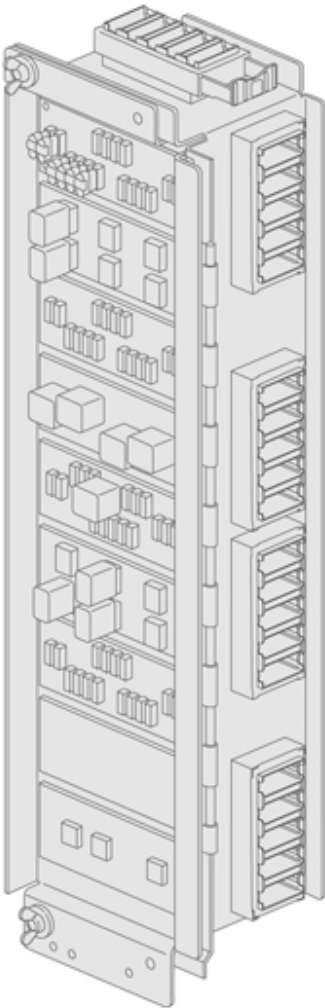
| Wiring diagram designation, component/connector piece | Illustration |
|---|--|
| Electrical distribution unit |  |

See also, 300, Component placement, Description, Design and function

The reader is advised that printed copies are uncontrolled.

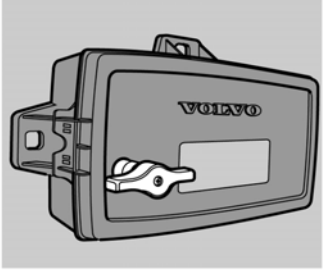
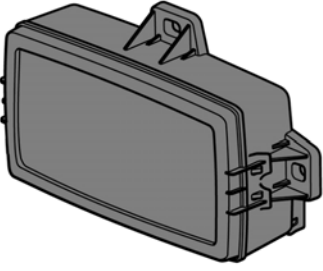
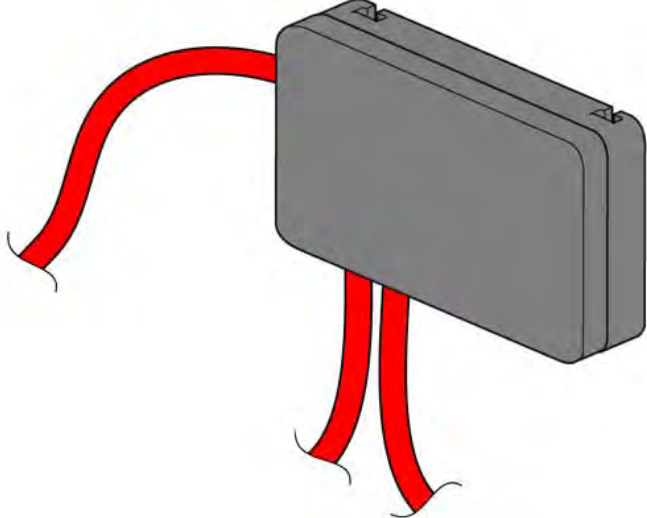
| | |
|------|---|
| X903 |  A grey, rectangular component box with a handle on top. The word "VOLVO" is printed on the front. A metal terminal is attached to the front panel. |
| X904 |  A grey, rectangular component box shown from a side perspective, highlighting its depth and the mounting tabs on the side. |
| X905 |  A grey, rectangular component box with three red cables connected to it. One cable enters from the left side, and two cables exit from the bottom. |

See also, 300, Component placement, Description, Design and function
The reader is advised that printed copies are uncontrolled.

BILL OF MATERIAL/COMPONENT LIST

| Part Name | Description | Location | Part Type |
|-----------|---|--|-----------------|
| A03 | Instrument cluster | {NA 0 C} {XC 0 B} {XD 0 B} {CP 0 B} | componentSymbol |
| A07 | Radio | {IU 0 C} | componentSymbol |
| A13 | Control unit, TECU, Transmission Electronic | {DE 1 B} | componentSymbol |
| A14 | Control unit, EMS | {CC 0 C} | componentSymbol |
| A14_7 | Control unit, EMS | {XC 0 E} {CN 0 C} {XD 2 D} | componentSymbol |
| A14_9 | Control unit, EMS | {XC 1 D} {XD 0 E} | componentSymbol |
| A14_9MG | Control unit, EMS | {XC 1 D} {CB 0 C} {XD 0 E} | componentSymbol |
| A14_12 | Control unit, EMS | {XC 1 E} {CM 0 C} {XD 1 D} | componentSymbol |
| A14_MD9 | Control unit, EMS | {CA 0 C} | componentSymbol |
| A16 | Control unit, ECS, Electronic Controlled Suspension | {FA 0 D} {XC 3 C} {XD 3 B} {FB 0 A} | componentSymbol |
| A17 | Control unit VECU | {BA 0 C} {XC 2 B} {XD 2 B} {CP 2 D} | componentSymbol |
| A19 | Control unit, GECU, gear selector ECU | {DN 0 D} | componentSymbol |
| A21 | Control unit, EBS, Electronically controlled Brake System | {XC 3 C} {EO 0 D} {XD 3 B} {EP 0 A} | componentSymbol |
| A26 | Control unite,ACC(Adaptive Cruise Control) | {BE 1 C} | componentSymbol |
| A27 | Control unite,LCM(Light Control Module) | {GA 0 C} {GB 0 C} {GC 0 B} {XC 4 C} {XD 2 B} | componentSymbol |
| A30 | Control unite,SWM(Steering Wheel Module) | {IS 1 B} | componentSymbol |
| A33 | Tachograph | {NB 0 B} {XC 0 B} {NC 2 C} | componentSymbol |
| A41 | Control unit, Contains B23, B06 and Y17 | {DN 2 D} | componentSymbol |
| A42 | Control unit, Contains B26, Y21, Y22, Y23 and Y26 | {DN 3 D} | componentSymbol |
| A44 | Control unit, Body I/O Module 44 | {CM 1 B} | componentSymbol |
| A44_ | Control unit, Body I/O Module 44 | {CC 1 D} | componentSymbol |
| A44_D9 | Control unit, Fuel pump | {CA 2 B} | componentSymbol |
| A45 | Body I/O Module 45 | {CA 1 C} | componentSymbol |
| A45_ | Control unit, Body I/O Module 45 | {CC 3 B} | componentSymbol |

VOLVO

Volvo Bus Corporation

Document Title

WIRING DIAGRAM

Document Type

PRODUCT SCHEMATIC

Document No

20904123

Issue Index

15

Volume No

02(02)

Page No

1(76)

| Part Name | Description | Location | Part Type |
|------------|--|--|-----------------|
| A45_MD12 | Control unit, Fuel water separator | {CM 2 B} | componentSymbol |
| A59A | Control unit, RAS ECU | {FO 1 B} | componentSymbol |
| A65 | Control unit, RECU, Retader Electronic | {DM 0 C} {XC 3 D} {XD 3 E} | componentSymbol |
| A66 | Kamera LKS | {BE 0 D} | componentSymbol |
| A80 | Control unit, Heated air dryer, electronically controlled | {BA 2 E} | componentSymbol |
| A90 | Control unit, BBM, Body Builder Module | {BB 0 D} {XC 1 C} {AA 1 E} {XD 2 B} {BC 0 A} {BB2 2 B} {BB2 4 B} | componentSymbol |
| A124 | Starter motor with relay | {AD 0 C} {AE 0 C} {AF 1 D} {AH 0 C} | componentSymbol |
| A124.30B | | {AE 1 C} | componentSymbol |
| A125 | Control unit, DYNAFLEET | {NC 1 D} {XD 1 B} | componentSymbol |
| A133 | | {NC 2 C} | componentSymbol |
| A146 | Control Unit, RV165 Tracking System | {CP 2 C} | componentSymbol |
| A900 | Control unit, Voith automatic transmission | {DC 0 C} | componentSymbol |
| A900_ART | Control unit, VOITH ECU, ARTIC | {DO 0 C} | componentSymbol |
| A901 | Control unit, ZF automatic transmission | {DB 0 C} {XC 4 D} {XD 3 E} | componentSymbol |
| A904 | Control unit, Volvo EGS gearbox | {DA 0 C} | componentSymbol |
| A914 | Control unit, I shift TECU, Transmission Electronic | {XC 0 E} {DN 1 C} {XD 0 E} | componentSymbol |
| A916 | Control unit, AMECU | {FC 0 C} | componentSymbol |
| A916_A | Control unit, AMECU | {LB 1 C} | componentSymbol |
| A916_B | Control unit, AMECU | {LA 1 C} | componentSymbol |
| A917 | Control unit, DNOX2 ECU | {CU 0 C} {CV 1 D} | componentSymbol |
| A918 | Control unit, NOx sensor | {CV 2 E} | componentSymbol |
| A925 | Control unit, FTM, Fuel Tank Monitoring | {CG 0 C} | componentSymbol |
| A926 | Control unit, GearShift ECU | {XC 0 C} {DN 0 C} {XD 1 B} | componentSymbol |
| A927 | Control unit, GECU, Ecomat 5 | {DD 1 B} | componentSymbol |
| A928 | Control unit, Gearbox Ecomat 5 | {DD 2 D} | componentSymbol |
| A929 | TECU - EcoLife | {XC 0 E} {DD 3 C} {XD 1 E} | componentSymbol |
| A930 | Control unit, Gateway DIVA5 | {DC 0 A} | componentSymbol |
| A930_ARTIC | Control unit, Gateway DIWA5 | {DO 0 A} | componentSymbol |
| A942 | BIO - Bus I/O | {CL 1 C} | componentSymbol |
| A943 | Control unit, Oilmaster | {CO 0 D} | componentSymbol |
| A945 | Control unit, VDO FM200 | {ND 0 A} | componentSymbol |

VOLVO

Volvo Bus Corporation

Document Title

WIRING DIAGRAM

Document Type

PRODUCT SCHEMATIC

Document No

20904123

Issue Index

15

Volume No

02(02)

Page No

2(76)

| Part Name | Description | Location | Part Type |
|-----------|---|--|-----------------|
| A946 | Control unit, Gateway FMS, Fleet management system | {NE 1 C} | componentSymbol |
| A947 | Control unit, Gateway Voith | {DQ 0 D} | componentSymbol |
| A953 CNG | Module Control Ignition,CNG | {CD 0 D} | componentSymbol |
| A954 CNG | EMS- Cummins-CNG | {XC 4 C} {XD 4 B} {CD 0 C} {CE 0 D} | componentSymbol |
| A955 | | {XC 0 E} {XD 0 E} {DP 3 B} | componentSymbol |
| A955A | Control unit, RETARDER VOITH ECU | {DQ 2 C} | componentSymbol |
| A961 | Alcohol Interlock, ECU | {NC 3 C} | componentSymbol |
| A997 | | {BE 3 D} | componentSymbol |
| B03 | Sensor, footbrake valve | {EO 0 B} | componentSymbol |
| B04 | Sensor,engine speed,crankshaft | {CA 2 D} {CM 1 D} | componentSymbol |
| B04_ | Sensor, engine speed crankshaft | {CC 2 D} | componentSymbol |
| B05 | Sensor,engine speed,camshaft | {CA 2 D} {CM 1 D} | componentSymbol |
| B05_ | Sensor, engine speed camshaft | {CC 2 D} | componentSymbol |
| B06 | Sensor, air pressure, reservoir | {BA 4 B} {BA 4 A} | componentSymbol |
| B06D | Sensor, air pressure, reservoir | {DN 2 D} | componentSymbol |
| B07 | Sensor, fuel level | {NA 1 E} | componentSymbol |
| B07_LE | Sensor, fuel level front axle | {NA 4 C} | componentSymbol |
| B07_RX | Sensor, fuel level | {NA 0 E} | componentSymbol |
| B07_S9 | Sensor, fuel level | {NA 0 E} | componentSymbol |
| B07_S9BI | Sensor, fuel level | {NA 0 E} | componentSymbol |
| B6 | Sensor, engine oil pressure | {CN 2 C} | componentSymbol |
| B9TL_ASIA | Alternator2 | {AE 2 C} | componentSymbol |
| B10C | Sensor, oil level (hydraulic steered axle, electric controlled) | {FO 1 C} | componentSymbol |
| B12 | Sensor, tachograph/speedometer | {NB 0 D} {NB 1 D} | componentSymbol |
| B13 | Sensor, wheel speed, lhs. 1:st front axle | {EO 2 A} | componentSymbol |
| B14 | Sensor, wheel speed,rhs. 1:st front axle | {EO 2 A} | componentSymbol |
| B15 | Sensor, wheel speed, lhs. 1st rear axle | {EO 3 A} | componentSymbol |
| B16 | Sensor, wheel speed, rhs. 1:st rear axle | {EO 3 A} | componentSymbol |
| B21 | Sensor,coolant temperature | {CB 1 B} {CM 1 B} | componentSymbol |
| B21_ | Sensor, coolant temperature | {CC 1 D} | componentSymbol |
| B21_CNG | | {CD 3 D} | componentSymbol |
| B21_D9 | Sensor, coolant temperature | {CA 3 D} | componentSymbol |
| B22 | Sensor, outdoor temperature | {NA 1 D} | componentSymbol |
| B23 | Sensor,oil temperature,retarder | {DM 2 B} {DQ 4 D} | componentSymbol |
| B23A | Sensor, oil temperature, retarder | {DM 2 B} | componentSymbol |
| B23D | Sensor, oil temperature, retarder | {DN 2 D} | componentSymbol |
| B25 | Sensor, accelerator pedal | {BA 2 B} | componentSymbol |
| B26D | | {DN 3 E} | componentSymbol |
| B29 | Sensor, chassis level, lhs.rear axle | {FB 1 E} {FB 2 E} | componentSymbol |

VOLVO

Volvo Bus Corporation

Document Title

WIRING DIAGRAM

Document Type

PRODUCT SCHEMATIC

Document No

20904123

Issue Index

15

Volume No

02(02)

Page No

3(76)

| Part Name | Description | Location | Part Type |
|-----------|--|----------------------------------|-----------------|
| B30 | Sensor, chassis level, rhs.rear axle | {FB 1 E} {FB 2 E} | componentSymbol |
| B32 | Sensor,engine cooling fan speed | {CM 0 D} | componentSymbol |
| B32.9 | Sensor, engine cooling fan speed | {CA 4 D} | componentSymbol |
| B32_ | Sensor, engine cooling fan speed | {CC 0 B} | componentSymbol |
| B32_S9 | Sensor, engine cooling fan speed | {CA 4 D} | componentSymbol |
| B37 | Sensor,boots pressure and boots temperature | {CB 1 D} {CM 0 D} | componentSymbol |
| B37_ | Sensor, boost pressure and temp | {CC 0 D} | componentSymbol |
| B37_MD9 | Sensor, boost pressure and temp | {CA 4 C} | componentSymbol |
| B39 | Sensor,air filter pressure and air filter temperature | {CB 1 B} {CB 1 E} {CM 0 B} | componentSymbol |
| B39_ | Sensor, air filter pressure and temp | {CC 0 B} | componentSymbol |
| B40 | Sensor, brake lining wear indicator, lhs.1:st front axle | {EO 2 A} | componentSymbol |
| B40.1 | Sensor, engine speed camshaft | {CN 1 D} | componentSymbol |
| B40.2 | Sensor, engine speed camshaft | {CN 2 D} | componentSymbol |
| B41 | Seansor, brake lining wear indicator, rhs. 1:st front axle | {EO 1 A} | componentSymbol |
| B42 | Sensor, brake lining wear indicator,lhs. 1:st rear axle | {EO 3 A} | componentSymbol |
| B43 | Sensor, brake lining wear indicator,rhs. 1:st rear axle | {CN 3 D} {EO 2 A} | componentSymbol |
| B48 | Sensor, coolant pressure | {CN 3 D} | componentSymbol |
| B49 | Sensor, steering angle | {CN 3 C} {EP 2 C} | componentSymbol |
| B49F | Sensor, steering angle, Front | {FO 2 D} | componentSymbol |
| B49R | Sensor, steering angle, Rear | {FO 2 D} | componentSymbol |
| B50 | Sensor, yaw rate | {CN 2 C} {EP 2 C} | componentSymbol |
| B51 | Sensor, Fuel Low pressure | {CN 2 D} | componentSymbol |
| B52 | Sensor,water level,water separator | {CN 1 B} | componentSymbol |
| B54 | Sensor, crankhouse pressure | {CB 1 A} {CM 1 B} | componentSymbol |
| B54_ | Sensor, crankhouse pressure | {CC 0 D} | componentSymbol |
| B54_D9 | Sensor, crankhouse pressure | {CA 3 D} | componentSymbol |
| B57 | Sensor, air pressure, suspension bellows, lhs.rear | {FB 0 C} | componentSymbol |
| B58 | Sensor, air pressur, suspension bellows, rhs.rear | {FB 1 C} | componentSymbol |
| B59 | Sensor, indoor temperature | {NA 1 D} | componentSymbol |
| B66 | Sensor pressure downstream SCRT | {CL 1 E} | componentSymbol |
| B66E | | {CH 1 D} | componentSymbol |
| B68 | Sensor,output shaft speed, gearbox | {DA 3 D} | componentSymbol |
| B69C | Sensor, coolant temperature, retarder | {DN 1 D} | componentSymbol |
| B88 | | {CD 0 B} | componentSymbol |
| B118 | Sensor, Oil Pressure | {CA 3 D} {CB 2 D} | componentSymbol |
| B118. | Sensor, Oil pressure | {FC 2 E} {LA 2 D} | componentSymbol |
| B118_ | Sensor, oil pressure | {CC 1 D} | componentSymbol |
| B118_MD12 | Sensor, oil pressure | {CM 1 B} | componentSymbol |

VOLVO

Volvo Bus Corporation

Document Title

WIRING DIAGRAM

Document Type

PRODUCT SCHEMATIC

Document No

20904123

Issue Index

15

Volume No

02(02)

Page No

4(76)

| Part Name | Description | Location | Part Type |
|-----------|--|----------------------------------|-----------------|
| B118A | Sensor, Oil pressure | {LB 2 E} | componentSymbol |
| B119 | Sensor, oil level/temp | {CA 2 D} {CB 1 D} {CM 1 D} | componentSymbol |
| B119_ | Sensor, oil level/temp | {CC 0 D} | componentSymbol |
| B119A | Sensor, oil level/temp | {CB 3 C} | componentSymbol |
| B122 | | {CB 2 B} | componentSymbol |
| B160 | | {CB 3 B} | componentSymbol |
| B161 | | {CB 0 D} | componentSymbol |
| B162 | | {CB 1 D} | componentSymbol |
| B163 | | {CB 0 D} | componentSymbol |
| B164 | | {CB 2 B} | componentSymbol |
| B166 | | {CB 1 D} {CB 2 D} | componentSymbol |
| B167 | | {CB 2 D} | componentSymbol |
| B168 | | {CB 3 D} | componentSymbol |
| B169 | | {CB 1 A} {CB 3 D} | componentSymbol |
| B170 | | {CB 1 B} | componentSymbol |
| B182 | | {CB 1 B} | componentSymbol |
| B900 | Sensor, manuel gearbox retarder pressure | {DM 2 B} {DQ 3 E} | componentSymbol |
| B900A | Automatic gearbox retarder pressure sensor | {DM 1 B} | componentSymbol |
| B903 | Sensor, Man.gbx.retarder water temperature | {DM 2 B} {DQ 4 D} | componentSymbol |
| B903_A | Sensor, Man.gbx.retarder water temperature | {DM 3 B} | componentSymbol |
| B904 | Sensor, hydraulic oil level | {NA 1 B} | componentSymbol |
| B904_S9 | Sensor, Hydraulic oil level | {NA 4 B} | componentSymbol |
| B905 | Sensor, Clutch pedal position inductive | {DA 3 A} | componentSymbol |
| B906 | Sensor, Brake Press (6*2) | {BC 1 C} | componentSymbol |
| B907 | Sensor, fuel level rear axle | {NA 4 B} | componentSymbol |
| B908 | Sensor air press. ECS AL | {FB 1 C} | componentSymbol |
| B908_A | Sensor, air press. ECS AL | {FB 0 D} | componentSymbol |
| B909 | Sensor air press. ECS AR | {FB 1 C} | componentSymbol |
| B909_A | Sensor, air press. ECS AR | {FB 0 D} | componentSymbol |
| B910 | Sensor, airpressure ECS frot LHS | {FB 0 C} | componentSymbol |
| B911 | Sensor, airpressure ECS front RHS | {FB 0 C} | componentSymbol |
| B914 | Sensor, chassis level front axle LHS | {FB 3 E} | componentSymbol |
| B915 | Sensor, chassis level front axle RHS | {FB 3 E} | componentSymbol |
| B916 | Sensor, chassis level artic front axle LHS | {FB 3 E} | componentSymbol |
| B916_A | Sensor, chassis level artic axle LHS | {FB 1 E} | componentSymbol |
| B917 | Sensor, chassis level artic front axle RHS | {FB 3 E} | componentSymbol |
| B917_A | Sensor, chassis level artic axle LHS | {FB 2 E} | componentSymbol |
| B918 | Sensor, Hydraulic oil level | {NA 1 A} | componentSymbol |
| B920 | Sensor, fuel level 2 | {NA 0 E} | componentSymbol |
| B920_LE | Sensor, fuel level 2 front axle | {NA 4 C} | componentSymbol |
| B921 | Sensor, fuel level 2 rear axle | {NA 4 B} | componentSymbol |
| B922 | Sensor, temp.downstream SCRT | {CL 1 D} | componentSymbol |
| B923 | Sensor, temp/level adblue SCRT | {CU 2 D} | componentSymbol |
| B927 | Sensor, hydr.oil press | {BB 3 B} | componentSymbol |

VOLVO

Volvo Bus Corporation

Document Title

WIRING DIAGRAM

Document Type

PRODUCT SCHEMATIC

Document No

20904123

Issue Index

15

Volume No

02(02)

Page No

5(76)

| Part Name | Description | Location | Part Type |
|-----------|--|--|-----------------|
| B930 | Sensor, temp uppstream scrt DNOX2 | {CU 3 A} {CU 2 A} {CU 3 A} | componentSymbol |
| B936 | Sensor, brake lining wear indicator Artic, A/B R | {EP 1 D} | componentSymbol |
| B937 | Sensor, brake lining wear indicator Artic, A/B L | {EP 2 D} | componentSymbol |
| B938 | Sensor, wheel speed Artic, A/B R | {EP 2 D} | componentSymbol |
| B939 | Sensor, wheel speed Artic, A/B L | {EP 2 D} | componentSymbol |
| B940 | Sensor, brake lining wear indicator, A/B R | {EP 0 D} {EP 1 D} | componentSymbol |
| B941 | Sensor, brake lining wear indicator, A/B L | {EP 0 D} {EP 1 D} | componentSymbol |
| B942 | Sensor, wheel speed, A/B R | {EP 0 D} {EP 1 D} | componentSymbol |
| B943 | Sensor, wheel speed, A/B L | {EP 0 D} {EP 1 D} | componentSymbol |
| B944 | Sensor, Trailer air brake pressure | {BC 0 C} | componentSymbol |
| B945 | Sensor, Crash | {CG 0 A} | componentSymbol |
| B946 | Sensor, coolant level | {NA 2 B} | componentSymbol |
| B946_S9 | Sensor, coolant level | {NA 4 B} | componentSymbol |
| B948 | Sensor, air filter pressure and temp | {CA 2 D} | componentSymbol |
| B949 | Senso, air brake pressure, 8x2 & Last trailer (biartic) | {CL 1 D} | componentSymbol |
| B950 | Sensor, brake lining wear indicator Biartic, A/B R | {EO 3 A} | componentSymbol |
| B951 | Sensor, brake lining wear indicator Biartic, A/B L | {EO 3 A} | componentSymbol |
| B952 | Sensor, wheel speed Biartic, A/B R | {EO 4 A} | componentSymbol |
| B953 | Sensor, wheel speed Biartic, A/B L | {EO 4 A} | componentSymbol |
| B954 | Sensor, turntable angle | {FC 1 D} {LA 2 D} | componentSymbol |
| B954A | Sensor, turntable angle | {LB 2 D} | componentSymbol |
| B954B | Sensor, turntable angle | {BB2 4 D} | componentSymbol |
| B954C | Sensor, turntable angle | {BB2 3 D} | componentSymbol |
| B955 | Sensor, oil level | {CO 1 E} | componentSymbol |
| B956 | Sensor, drake pressure to AMEC, After Market Executive Committee | {FC 2 B} | componentSymbol |
| B960 | Sensor, air Pressure ECS, Last Trailer, Biartic | {FB 1 C} | componentSymbol |
| B961 | Sensor, chassi level last trailer (Biartic) | {FB 4 E} | componentSymbol |
| B964 | Sensor, Trailer air brake pressure sensor2 | {BC 0 C} | componentSymbol |
| B970 | Sensor, Fire temp | {BD 4 B} {BD 3 B} {BD 3 B} {BD 1 B} {BD 0 B} {BD 2 B} {BD 2 B} {BD 0 B} {BD 0 B} | componentSymbol |
| B970_ | Fire sensor, 110°C | {BD 2 B} | componentSymbol |
| B970C | | {BD 0 B} | componentSymbol |

VOLVO

Volvo Bus Corporation

Document Title

WIRING DIAGRAM

Document Type

PRODUCT SCHEMATIC

Document No

20904123

Issue Index

15

Volume No

02(02)

Page No

6(76)

| Part Name | Description | Location | Part Type |
|-----------|---|--|-----------------|
| B971 | Sensor, Fire temp | {BD 4 C} {BD 3 C} {BD 3 C} {BD 1 C} {BD 0 C} {BD 2 C} {BD 2 C} {BD 0 C} {BD 0 C} | componentSymbol |
| B971_ | Fire Sensor, 110°C | {BD 2 C} | componentSymbol |
| B971C | | {BD 0 B} | componentSymbol |
| B972 | Sensor, Fire temp | {BD 4 C} {BD 2 C} {BD 3 C} {BD 3 C} {BD 1 C} {BD 0 C} {BD 2 C} {BD 0 C} {BD 0 C} | componentSymbol |
| B972_ | Fire Sensor, 110°C | {BD 2 C} | componentSymbol |
| B972C | | {BD 0 B} | componentSymbol |
| B973 | Sensor, Fire temp | {BD 0 C} | componentSymbol |
| B973_ | Fire Sensor, 150°C | {BD 2 D} | componentSymbol |
| B973C | | {BD 0 C} | componentSymbol |
| B974 | Sensor, Fire temp | {BD 3 D} {BD 1 C} {BD 0 D} | componentSymbol |
| B974C | | {BD 0 C} | componentSymbol |
| B975 | Sensor, Fire temp | {BD 1 D} | componentSymbol |
| B977 | Sensor, brake pressure 1 | {CP 0 C} | componentSymbol |
| B978 | Sensor, brake pressure 2 | {CP 1 C} | componentSymbol |
| B979 | Sensor, Parking brake pressure | {BB2 1 C} | componentSymbol |
| B979_CNG | | {CD 1 E} | componentSymbol |
| B980 | Sensor, Auxilliary pressure | {BB2 0 C} | componentSymbol |
| B981 | Sensor, Throttle heater MG9 | {CB 3 B} | componentSymbol |
| B982 | Sensor, DP-cat differential pressure | {CA 2 B} | componentSymbol |
| B982_D7 | Sensor, DPF differential pressure | {CN 3 B} | componentSymbol |
| B983 | Sensor, DP-cat temp | {CA 2 B} | componentSymbol |
| B983_D7 | Sensor, temperature upstream catalyst | {CN 3 B} | componentSymbol |
| B984_D7 | Sensor, temperature downstream catalyst | {CN 3 B} | componentSymbol |
| B985 | Fire sensor | {BD 4 B} | componentSymbol |
| B986 | Fire sensor | {BD 4 C} | componentSymbol |
| B987 | sensor, humidity | {CD 3 D} | componentSymbol |
| B988 | | {CD 1 B} | componentSymbol |
| B990 | Sensor,Intake Manifold press/temp | {CD 2 E} | componentSymbol |
| B991 | | {CD 1 E} | componentSymbol |
| B992 | Sensor,temp/press Engine Oil | {CD 2 E} | componentSymbol |
| B993 | Sensor, secondary temp/press Fuel | {CD 2 E} | componentSymbol |
| B994 | Sensor, pressure Mixer Inlet | {CD 3 E} | componentSymbol |
| B995 | | {CE 1 D} | componentSymbol |
| CNB | VDV-dash | {NG 0 D} | componentSymbol |
| CNC | | {NG 3 B} | componentSymbol |

VOLVO

Volvo Bus Corporation

Document Title

WIRING DIAGRAM

Document Type

PRODUCT SCHEMATIC

Document No

20904123

Issue Index

15

Volume No

02(02)

Page No

7(76)

| Part Name | Description | Location | Part Type |
|-----------|------------------------------------|----------------------|-----------------|
| CND1_1632 | | {NF 2 E} | componentSymbol |
| CNDIAG | VDV_dash | {NG 2 E} | componentSymbol |
| CREVWS | VDV_dash | {NG 2 A} | componentSymbol |
| CSW | VDV_dash | {NG 1 A} | componentSymbol |
| CSW1 | | {NG 0 B} | componentSymbol |
| CSW2 | | {NG 0 B} | componentSymbol |
| CSW3 | VDV_dash | {NG 1 B} | componentSymbol |
| D1 | Diod | {BA 2 D} | componentSymbol |
| D2 | Diod | {AA 2 D} | componentSymbol |
| D3 | Diod | {GM 3 D} | componentSymbol |
| D4 | Diod | {GM 3 D} | componentSymbol |
| D5 | HK, KMB, SNG | {AC 1 D} | componentSymbol |
| D6 | HK, KMB, SNG | {AC 2 D} | componentSymbol |
| D7 | HK, KMB, SNG | {AC 3 D} | componentSymbol |
| DIA | Diagnostic connector | {DC 2 B} | componentSymbol |
| DIA2 | Diagnostic connector for Ecomat 5 | {DD 1 E} | componentSymbol |
| DIA2_INT | | {DP 5 B} | componentSymbol |
| DIA_ARTIC | Diagnostic connector artic | {DO 2 A} | componentSymbol |
| DIA_VOITH | Diagnostic connector for Voith ECU | {DQ 2 D} | componentSymbol |
| E4 | Fuel heater | {CN 3 A} | componentSymbol |
| E01 | | {GE 0 D} {GE 1 D} | componentSymbol |
| E02 | | {GE 0 D} {GE 1 D} | componentSymbol |
| E06 | | {GE 3 C} {GE 4 C} | componentSymbol |
| E06AL | Reverse light(Left), Artic | {GD 1 C} | componentSymbol |
| E06AR | Reverse light(Right), Artic | {GD 0 C} | componentSymbol |
| E06AT | Reverse light(Triler), Artic | {GD 1 C} | componentSymbol |
| E06BL | Reverse light (Left), Biartic | {GF 0 C} | componentSymbol |
| E06BR | Reverse light (Right), Biartic | {GF 0 C} | componentSymbol |
| E06BT | Reverse light (Triler), Biartic | {GF 1 C} | componentSymbol |
| E06L | Reversing light left | {GA 3 D} | componentSymbol |
| E06LA | Reversing light left optional | {GA 3 D} | componentSymbol |
| E06R | Reversing light right | {GA 3 D} | componentSymbol |
| E07AL | Fog light(Left),Artic | {GD 4 D} | componentSymbol |
| E07AR | Fog light(Right), Artic | {GD 4 D} | componentSymbol |
| E07AT | Fog light,Trailer, Artic | {GD 4 D} | componentSymbol |
| E07BL | Fog light (Left), Biartic | {GF 4 C} | componentSymbol |
| E07BR | Fog light (Right), Biartic | {GF 4 C} | componentSymbol |
| E07BT | Fog light, Trailer, Biartic | {GF 4 C} | componentSymbol |
| E07L | Fog light left | {GB 2 D} {GE 2 C} | componentSymbol |
| E07LR | Fog light left rear | {GA 2 D} {GE 3 C} | componentSymbol |
| E07R | Fog light right | {GB 2 D} {GE 2 C} | componentSymbol |
| E07RR | Fog light right rear | {GA 2 D} {GE 3 C} | componentSymbol |
| E07X | Fog light, Extra | {GA 2 D} | componentSymbol |
| E08 | | {GE 0 D} {GE 1 D} | componentSymbol |

VOLVO

Volvo Bus Corporation

Document Title

WIRING DIAGRAM

Document Type

PRODUCT SCHEMATIC

Document No

20904123

Issue Index

15

Volume No

02(02)

Page No

8(76)

| Part Name | Description | Location | Part Type |
|-----------|---|----------------------|-----------------|
| E09 | | {GE 3 C} {GE 4 C} | componentSymbol |
| E09AL1 | Brake light(left), Artic | {GD 3 D} | componentSymbol |
| E09AL2 | Brake light(left), Artic | {GD 3 D} | componentSymbol |
| E09AR1 | Brake light (Right), Artic | {GD 0 C} | componentSymbol |
| E09AR2 | Brake light(Right), Artic | {GD 0 C} | componentSymbol |
| E09AT | Brake light, Centre(Artic ,Trailer) | {GD 0 C} | componentSymbol |
| E09BL1 | Brake light (Left), Biartic | {GF 3 C} | componentSymbol |
| E09BL2 | Brake light (Left), Biartic | {GF 3 C} | componentSymbol |
| E09BR1 | Brake light (Right), Biartic | {GF 0 C} | componentSymbol |
| E09BR2 | Brake light (Right), Biartic | {GF 0 C} | componentSymbol |
| E09BT | Brake light, Centre (Biartic, Trailer) | {GF 0 C} | componentSymbol |
| E09LA | Brake light left | {GA 1 D} | componentSymbol |
| E09LB | Brake light left | {GA 1 D} | componentSymbol |
| E09RC | Brake light right | {GC 1 D} | componentSymbol |
| E09RD | Brake light right(Rear) | {GC 1 D} | componentSymbol |
| E09RE | Brake light left, Centre | {GC 2 D} | componentSymbol |
| E10 | | {GE 3 C} {GE 4 C} | componentSymbol |
| E10AL | Tail light(left),Artic | {GD 2 C} | componentSymbol |
| E10AR | Tail light(Right),Artic | {GD 2 C} | componentSymbol |
| E10BL | Tail light (Left), Biartic | {GF 1 C} | componentSymbol |
| E10BR | Tail light (Right), Biartic | {GF 2 C} | componentSymbol |
| E10L | Tail light left | {GA 0 D} | componentSymbol |
| E10LD | Tail light left | {GA 0 D} | componentSymbol |
| E10R | Tail light right | {GC 3 D} | componentSymbol |
| E11AL1 | Side marker(Left)Artic | {GD 2 D} | componentSymbol |
| E11AL2 | Side marker((Left),Artic | {GD 2 D} | componentSymbol |
| E11AL3 | Side marker(Left),Artic | {GD 2 D} | componentSymbol |
| E11AL4 | Side marker(Left),Artic | {GD 2 C} | componentSymbol |
| E11AL5 | Side marker(Left),Artic | {GD 2 C} | componentSymbol |
| E11AL6 | Side marker(Left),Artic | {GD 2 C} | componentSymbol |
| E11ALT | Position light,Left(Trailer),Artic | {GD 2 D} | componentSymbol |
| E11AR1 | Side marker(Right),Artic | {GD 3 D} | componentSymbol |
| E11AR2 | Side marker(Right),Artic | {GD 3 D} | componentSymbol |
| E11AR3 | Side marker(Right),Artic | {GD 3 D} | componentSymbol |
| E11AR4 | Side marker(Right),Artic | {GD 3 C} | componentSymbol |
| E11AR5 | Side marker(Right),Artic | {GD 3 C} | componentSymbol |
| E11AR6 | Side marker(Right),Artic | {GD 3 C} | componentSymbol |
| E11ART | Side marker(Right) ,trailer,Artic | {GD 3 D} | componentSymbol |
| E11BL1 | Side marker (Left), Biartic | {GF 2 C} | componentSymbol |
| E11BL2 | Side marker (Left), Biartic | {GF 2 C} | componentSymbol |
| E11BL3 | Side marker (Left), Biartic | {GF 2 C} | componentSymbol |
| E11BLT | Position light, Left (Trailer), Biartic | {GF 2 C} | componentSymbol |
| E11BR1 | Side marker (Right), Biartic | {GF 3 C} | componentSymbol |
| E11BR2 | Side marker (Right), Biartic | {GF 3 C} | componentSymbol |
| E11BR3 | Side marker (Right), Biartic | {GF 3 C} | componentSymbol |
| E11BRT | Side marker (Right), Trailer, Biartic | {GF 3 C} | componentSymbol |
| E11LA | Side marker light left | {GC 0 D} | componentSymbol |
| E11LF | Side marker light left front | {GC 0 D} | componentSymbol |
| E11LR | Side marker light left rear | {GC 0 D} | componentSymbol |
| E11ML | Side marker light middle left | {GC 0 D} | componentSymbol |
| E11MR | Side marker light middle right | {GC 1 D} | componentSymbol |

VOLVO

Volvo Bus Corporation

Document Title

WIRING DIAGRAM

Document Type

PRODUCT SCHEMATIC

Document No

20904123

Issue Index

15

Volume No

02(02)

Page No

9(76)

| Part Name | Description | Location | Part Type |
|-----------|---|--|-----------------|
| E11RA | Side marker light right | {GC 1 D} | componentSymbol |
| E11RF | Side marker light right front | {GC 1 D} | componentSymbol |
| E11RR | Side marker light right rear | {GC 1 D} | componentSymbol |
| E11TL | Position Light,Left(Trailer) | {GC 0 D} | componentSymbol |
| E11TR | Position Light,Right(Trailer) | {GC 0 D} | componentSymbol |
| E13 | | {GE 0 D} {GE 1 D} {GE 3 C} {GE 4 C} | componentSymbol |
| E13AL | Direction indicator (left),Artic | {GD 1 C} | componentSymbol |
| E13ALT | Direction indicator,Left(trailer),Artic | {GD 1 D} | componentSymbol |
| E13AR | Direction indicator,(Left),Artic | {GD 1 C} | componentSymbol |
| E13ART | Direction indicator,Right,(Artic) | {GD 1 D} | componentSymbol |
| E13BL | Direction indicator (Left), Biartic | {GF 1 C} | componentSymbol |
| E13BLT | Direction indicator, Left (Trailer), Biartic | {GF 1 C} | componentSymbol |
| E13BR | Direction indicator (Right), Biartic | {GF 1 C} | componentSymbol |
| E13BRT | Direction indicator, Right (Trailer), Biartic | {GF 1 C} | componentSymbol |
| E13L | Lamp direction indicator left | {GA 1 E} | componentSymbol |
| E13LA | Dir.indicator left | {GA 0 E} | componentSymbol |
| E13LR | Dir. indicator left rear | {GA 1 D} | componentSymbol |
| E13R | Dir. indicator right | {GC 2 D} | componentSymbol |
| E13RB | Dir.indicator right | {GC 3 D} | componentSymbol |
| E13RR | Dir. indicator right rear | {GC 2 D} | componentSymbol |
| E63 | | {CE 3 B} | componentSymbol |
| E65 | | {BF 1 B} | componentSymbol |
| E913A | Lamp, EGS gearbox diagnostics | {DA 3 A} | componentSymbol |
| E913B | Lamp, EGS gearbox diagnostics | {DA 3 D} | componentSymbol |
| E914 | CRT varnig lamp | {CH 2 D} | componentSymbol |
| E915 | CRT alarm lamp | {CH 2 D} | componentSymbol |
| E916 | | {GE 0 D} {GE 1 D} | componentSymbol |
| ESI | | {CH 1 C} | componentSymbol |
| F1 | Fuse, ECS, 5A | {FA 4 A} | componentSymbol |
| F2 | Fuse, BIC2, 10A | {NA 3 A} | componentSymbol |
| F02 | | {CF 1 D} | componentSymbol |
| F3 | Fuse, Fuel pre filter heater, 15A | {AC 0 A} | componentSymbol |
| F03 | | {CF 2 D} | componentSymbol |
| F4 | Fuse, EBS, 20A | {EO 0 A} | componentSymbol |
| F5 | Fuse, Horn, 5A | {IS 3 A} | componentSymbol |
| F6 | Fuse, Emergency parking brake release, 5A | {EX 1 A} | componentSymbol |
| F7 | Fuse, Gearbox ECU I-shift, 15A | {DN 1 B} | componentSymbol |
| F8 | Fuse, Gear selector I-shift, 5A | {DN 1 B} | componentSymbol |
| F9 | Fuse, Switchbox start/stop rear, 5A | {AG 0 A} | componentSymbol |
| F10 | Fuse, Fire Alarm, 5A | {BB 0 A} | componentSymbol |
| F11 | Fuse, Dynafleet, 10A | {NC 0 A} | componentSymbol |
| F12 | Fuse, Body +30, 5A | {BB 0 A} | componentSymbol |
| F13 | Fuse, Oilmaster 10A | {CO 0 A} | componentSymbol |
| F14 | Fuse, BBM, 5A | {BB 0 A} | componentSymbol |
| F15 | Fuse, EECU, 15A | {BA 0 A} | componentSymbol |
| F16 | Fuse, VECU, 5A | {BA 0 A} | componentSymbol |
| F17 | Fuse, Switch feed, 5A | {AC 3 A} | componentSymbol |
| F18 | Fuse, Alternator, 5A | {AC 4 A} | componentSymbol |
| F19 | Fuse, Hymer, 10A | {AC 2 A} | componentSymbol |

VOLVO

Volvo Bus Corporation

Document Title

WIRING DIAGRAM

Document Type

PRODUCT SCHEMATIC

Document No

20904123

Issue Index

15

Volume No

02(02)

Page No

10(76)

| Part Name | Description | Location | Part Type |
|-----------|---|-----------------------|-----------------|
| F20 | Fuse, EBS, 10A | {EO 0 A} | componentSymbol |
| F21 | Fuse, Wiper washer, 15A | {GM 2 A} | componentSymbol |
| F22 | Fuse, Diva 5, Ecolife, 10A | {DC 1 A} | componentSymbol |
| F23 | Fuse, ACC, 5A | {NE 1 A} | componentSymbol |
| F24 | Fuse, BIC2, 5A | {NA 3 A} | componentSymbol |
| F25 | Fuse, Washer motor, 15A | {GM 1 A} | componentSymbol |
| F26 | Fuse, ECS, 5A | {FA 4 A} | componentSymbol |
| F27 | Fuse, G8-EGS, 10A | {DA 0 A} | componentSymbol |
| F28 | Fuse, Retarder, 10A | {DM 1 A} | componentSymbol |
| F29 | Fuse, Body +DR, 5A | {BB 0 A} | componentSymbol |
| F30 | Fuse, Fuel heater MD7, 20A | {AC 2 A} | componentSymbol |
| F31 | Fuse, Hydraulic oil, DNOX2, 10A | {NA 0 A} | componentSymbol |
| F32 | Fuse, Tachograph, 5A | {NB 0 A} | componentSymbol |
| F33 | Fuse, BIC2, 5A | {NA 3 A} | componentSymbol |
| F35 | Fuse, LCM, 25A | {GA 0 A} | componentSymbol |
| F36 | Fuse, LCM, 25A | {GA 1 A} | componentSymbol |
| F37 | Fuse, LCM, 25A | {GA 1 A} | componentSymbol |
| F39 | Fuse, DNOX2, 25A | {CU 0 A} | componentSymbol |
| F41 | Fuse, Radio, 20A | {IU 0 A} | componentSymbol |
| F42 | Fuse, Main switch, 5A | {AA 0 A} | componentSymbol |
| F44 | Fuse, LCM, 25A | {GA 0 A} | componentSymbol |
| F45 | Fuse, LCM, 25A | {GA 1 A} | componentSymbol |
| F46 | Fuse, LCM, 25A | {GA 0 A} | componentSymbol |
| F47 | Fuse, Side marker L, 5A | {GC 0 B} | componentSymbol |
| F48 | Fuse, Side marker R, 5A | {GC 0 B} | componentSymbol |
| F49 | Fuse, Fuel cut off valve, 5A | {NA 0 A} | componentSymbol |
| F50 | Fuse, Retarder, 10A | {DM 0 A} | componentSymbol |
| F51 | Fuse, Radio, 5A | {IU 0 A} | componentSymbol |
| F52 | Fuse, Luggage light, 10A | {BB 2 A} | componentSymbol |
| F53 | Fuse, Bogie valve, Heater waterseparator, 10A | {BB 4 A} | componentSymbol |
| F54 | Fuse, Engine/Luggage hatch, 5A | {GA 2 A} | componentSymbol |
| F55 | Fuse, Engine brake valve, Preheat relay, Fan speed clutch,10A | {BA 2 A} | componentSymbol |
| F56 | Fuse, Engine brake, 10A | {BA 2 A} | componentSymbol |
| F57 | Fuse, Key switch, 5A | {AA 1 A} | componentSymbol |
| F58 | Fuse, FTM, 5A | {CG 2 A} {CH 1 A} | componentSymbol |
| F60 | Fuse, Ecolife, ZF4, 10A | {DD 3 A} | componentSymbol |
| F61 | Fuse, Light luggage room, 10A | {GA 1 A} | componentSymbol |
| F62 | Fuse, Light sleeping compartment, 20A | {GA 2 A} | componentSymbol |
| F63 | Fuse, Starter motor control, 5A | {CL 3 B} | componentSymbol |
| F64 | Fuse, Load Indicator 10A | {CL 3 B} | componentSymbol |
| F79 | | {CN 1 D} | componentSymbol |
| F90A | Fuse, heated hose | {CU 3 D} | componentSymbol |
| F90B | Fuse, heated hose | {CU 3 D} | componentSymbol |
| F92 | Fuse 150A, pre-heater | {AB 3 B} | componentSymbol |
| F96 | Fuse, Xenon low beam L, 10A | {GN 0 B} | componentSymbol |
| F97 | Fuse, Xenon low beam R, 10A | {GN 0 B} | componentSymbol |
| F98 | Fuse, Xenon high beam L, 10A | {GN 1 B} | componentSymbol |
| F99 | Fuse, Xenon high beam R,10A | {GN 1 B} | componentSymbol |
| F101 | | {AB 0 C} {AB3 1 B} | componentSymbol |

VOLVO

Volvo Bus Corporation

Document Title

WIRING DIAGRAM

Document Type

PRODUCT SCHEMATIC

Document No

20904123

Issue Index

15

Volume No

02(02)

Page No

11(76)

| Part Name | Description | Location | Part Type |
|-----------|-----------------------------|------------------------------------|-----------------|
| F102 | | {AB 1 C} {AB3 1 B} | componentSymbol |
| F103 | | {AB 1 C} {AB3 1 B} | componentSymbol |
| F104 | | {AB 1 C} {AB3 1 B} | componentSymbol |
| F105 | | {AB 1 C} {AB3 2 B} | componentSymbol |
| F106 | Fuse, Fuse box spare, 50A | {AB 1 C} | componentSymbol |
| F107 | Fuse, Fuse box BBOX.2, 5A | {AB 1 C} {AB3 1 A} | componentSymbol |
| F108 | | {AB 1 C} {AB3 1 A} | componentSymbol |
| F109 | Fuse, Fuse box XC906.6, 10A | {AB 1 C} {AB3 2 A} | componentSymbol |
| F110 | | {AB 0 C} {AB3 2 A} | componentSymbol |
| F111 | | {AB 0 C} {AB3 2 A} | componentSymbol |
| F112 | | {AB 0 C} {AB3 0 A} {AE 1 B} | componentSymbol |
| F113 | | {AB3 0 A} {AE 1 B} | componentSymbol |
| F114 | | {AB3 1 B} {AE 1 B} | componentSymbol |
| F115 | | {AB3 0 A} | componentSymbol |
| F116 | | {CF 3 A} {AB3 0 A} | componentSymbol |
| F117 | | {CF 1 A} {AB3 0 A} | componentSymbol |
| F118 | | {CF 2 A} | componentSymbol |
| F201 | | {AB2 3 B} | componentSymbol |
| F202 | | {AB 2 C} {AB2 3 B} {AB2 1 B} | componentSymbol |
| F203 | | {AB 2 C} {AB2 3 B} {AB2 1 B} | componentSymbol |
| F204 | | {AB 2 C} {AB2 3 B} {AB2 1 B} | componentSymbol |
| F205 | | {AB 2 C} {AB2 3 B} {AB2 1 B} | componentSymbol |
| F206 | | {AB2 3 B} {AB2 0 B} | componentSymbol |
| F207 | | {AB2 3 B} {AB2 0 B} | componentSymbol |
| F208 | | {AB2 3 B} {AB2 1 B} | componentSymbol |
| F209 | | {AB2 3 B} {AB2 1 B} | componentSymbol |

VOLVO

Volvo Bus Corporation

Document Title

WIRING DIAGRAM

Document Type

PRODUCT SCHEMATIC

Document No

20904123

Issue Index

15

Volume No

02(02)

Page No

12(76)

| Part Name | Description | Location | Part Type |
|---------------|-------------------------|------------------------------------|-----------------|
| F210 | | {AB2 3 B} {AB2 1 B} | componentSymbol |
| F211 | | {AB2 1 B} | componentSymbol |
| F212 | | {AB2 4 B} {AB2 1 B} | componentSymbol |
| F213 | | {AB2 4 B} {AB2 1 B} | componentSymbol |
| F214 | | {AB2 3 B} | componentSymbol |
| F215 | Fuse, Electrical Fan 1 | {CA2 0 B} | componentSymbol |
| F216 | Fuse, Electrical Fan 2 | {CA2 0 B} | componentSymbol |
| F217 | Fuse, Electrical Fan 3 | {CA2 1 B} | componentSymbol |
| F218 | Fuse, Electrical Fan 4 | {CA2 2 B} | componentSymbol |
| F219 | Fuse, Electrical Fan 5 | {CA2 2 B} | componentSymbol |
| F925 | | {AB3 1 C} | componentSymbol |
| FH5 | Fuse house, Xenon light | {GN 0 B} | componentSymbol |
| FL2A | Front light, L | {GE 0 C} | componentSymbol |
| FL3A | Front light, R | {GE 1 C} | componentSymbol |
| G01 | Battery | {AB 0 C} {AB3 1 D} {AB3 0 D} | componentSymbol |
| G01A | Alternator | {CF 4 D} | componentSymbol |
| G01A_CNG_BODY | Alternator CNG | {CF 3 D} | componentSymbol |
| G01B | Battery | {AB 0 D} {AB3 1 D} {AB3 0 D} | componentSymbol |
| G02 | Alternator 1 | {AD 1 C} {AE 2 C} | componentSymbol |
| G02.S9 | Alternator 1 | {AH 1 C} | componentSymbol |
| G02_ | Alternator 1 | {AF 2 D} | componentSymbol |
| G03 | Alternator 2 | {AD 2 C} {AE 2 C} | componentSymbol |
| G03.B_R9L | Alternator 2 | {AE 2 C} | componentSymbol |
| G03.B_R9TL | Alternator 2 | {AE 2 C} | componentSymbol |
| G03.S9 | Alternator 2 | {AH 2 C} | componentSymbol |
| G03_ | Alternator 2 | {AF 2 D} | componentSymbol |
| G04 | Alternator 3 | {AE 3 C} | componentSymbol |
| G04.S9 | Alternator 3 | {AH 2 C} | componentSymbol |
| G04_ | Alternator 3 | {AF 3 D} | componentSymbol |
| G04_25 | Alternator 3 | {AE 3 C} | componentSymbol |
| G08A | Battery | {AA2 1 C} | componentSymbol |
| G08A_A | | {AA2 1 C} | componentSymbol |
| G08B | Battery | {AA2 1 D} | componentSymbol |
| G08B_B | | {AA2 1 D} | componentSymbol |
| G | | {DA 2 D} | componentSymbol |
| GND | | {CF 0 B} | componentSymbol |
| GND1 | | {CF 3 C} | componentSymbol |
| GND01 | Ground, Extra Fan B9TL | {CA2 3 C} | componentSymbol |
| GND1A | | {ZC 2 E} | componentSymbol |
| GND1B | | {ZC 2 E} | componentSymbol |
| GND1C | | {ZC 2 E} | componentSymbol |
| GND1D | | {ZC 4 E} | componentSymbol |
| GND1E | | {ZC 4 B} | componentSymbol |
| GND2A | | {AF 2 D} | componentSymbol |

VOLVO

Volvo Bus Corporation

Document Title

WIRING DIAGRAM

Document Type

PRODUCT SCHEMATIC

Document No

20904123

Issue Index

15

Volume No

02(02)

Page No

13(76)

| Part Name | Description | Location | Part Type |
|-----------------|-------------------------|------------------------------------|-----------------|
| GND2B | | {AF 2 D} | componentSymbol |
| GND2C | | {AE 3 D} | componentSymbol |
| GND2D | | {AE 1 D} | componentSymbol |
| GND2F | | {AF 1 D} | componentSymbol |
| GND2G | | {AF 2 D} | componentSymbol |
| GND3 | | {CF 3 B} | componentSymbol |
| GND4 | | {CA2 1 E} | componentSymbol |
| GND6 | | {GB 0 C} | componentSymbol |
| GND6B | | {ZC 1 B} | componentSymbol |
| GND8 | | {ZC 2 C} | componentSymbol |
| GND9 | | {CO 1 E} | componentSymbol |
| GND10 | | {ZC 3 B} | componentSymbol |
| GND11 | | {ZC 3 B} | componentSymbol |
| GND31A | | {ZC 4 E} | componentSymbol |
| GND31A:A | | {ZC 4 E} | componentSymbol |
| GND31B | | {AB 0 D} {AB3 1 E} {AB3 0 E} | componentSymbol |
| GND70 | | {ZC 4 E} | componentSymbol |
| GND71 | | {ZC 4 E} | componentSymbol |
| GND72 | | {AH 1 D} | componentSymbol |
| GND73 | | {AH 2 D} | componentSymbol |
| GND74 | | {CU 3 E} | componentSymbol |
| GND75 | | {GA 4 B} | componentSymbol |
| GND76 | | {CB 3 A} | componentSymbol |
| GND77 | | {ZC 1 E} | componentSymbol |
| GND78 | | {ZC 1 E} | componentSymbol |
| GND79 | | {BF 1 D} | componentSymbol |
| GND900 | | {AA2 1 D} | componentSymbol |
| GND_ENGINEBLOCK | | {ZC 0 E} {ZC 3 E} | componentSymbol |
| GND_FRAME | | {ZC 0 E} {ZC 3 E} | componentSymbol |
| GNDG | | {CF 4 D} | componentSymbol |
| GNDM | | {CF 4 B} | componentSymbol |
| GNDP | | {DE 0 D} | componentSymbol |
| GNDX | | {ZC 1 C} | componentSymbol |
| GS1 | VDV_dash | {NF 3 D} | componentSymbol |
| GS2 | VDV_dash | {NF 3 E} | componentSymbol |
| H01 | Horn, air operated | {IS 2 B} | componentSymbol |
| H02 | Horn | {IS 3 B} | componentSymbol |
| H05 | Buzzer,H05 | {DA 3 A} | componentSymbol |
| HR | | {DA 2 D} | componentSymbol |
| Interface_BOARD | VDV-dash | {NF 0 C} | componentSymbol |
| K1 | Relay, Inverted +DR | {AA 0 C} | componentSymbol |
| K2 | Load Indicator | {CL 3 C} | componentSymbol |
| K02 | Relay_Day_Light_Running | {GB 0 C} | componentSymbol |
| K3 | ECS | {FA 4 C} | componentSymbol |
| K3A | | {CF 3 B} | componentSymbol |
| K4 | I-Shift/Voith | {DN 0 A} | componentSymbol |
| K5 | EGS | {DA 0 B} | componentSymbol |
| K6 | EGS | {DA 0 B} | componentSymbol |
| K7 | Start engine | {AC 0 C} | componentSymbol |

VOLVO

Volvo Bus Corporation

Document Title

WIRING DIAGRAM

Document Type

PRODUCT SCHEMATIC

Document No

20904123

Issue Index

15

Volume No

02(02)

Page No

14(76)

| Part Name | Description | Location | Part Type |
|-----------|---|--|-----------------|
| K8 | VECU/EMS | {BA 0 C} | componentSymbol |
| K9 | Wiper/Washer | {GM 2 C} | componentSymbol |
| K10 | Relay, Fuel pre filter heater | {AC 0 B} | componentSymbol |
| K11 | Prevent start engine | {AA 3 C} | componentSymbol |
| K12 | Luggage Light | {BB 2 B} | componentSymbol |
| K13 | Emergency switch relay | {AA 1 B} | componentSymbol |
| K14 | Bogie | {BB 4 B} | componentSymbol |
| K15 | RECU | {DM 0 B} | componentSymbol |
| K16 | RECU | {DM 1 B} | componentSymbol |
| K17 | Ignition +DR | {AA 3 A} | componentSymbol |
| K18 | Hubner warning | {LA 1 B} | componentSymbol |
| K19 | Hubner reverse signal | {FO 2 B} | componentSymbol |
| K21 | Hubner warning | {LB 1 B} | componentSymbol |
| K25 | Exhaust flap | {CN 4 B} | componentSymbol |
| K25X | Xenon light low beam left | {GN 0 C} | componentSymbol |
| K26X | Xenon light low beam right | {GN 0 C} | componentSymbol |
| K27X | Xenon light high beam left | {GN 1 C} | componentSymbol |
| K28X | Xenon light high beam right | {GN 1 C} | componentSymbol |
| K31 | Relay, Wiper motor | {GM 4 D} | componentSymbol |
| K32 | Relay, wiper motor | {GM 4 C} | componentSymbol |
| K35 | Relay, disconn headlight wash | {GM 1 C} | componentSymbol |
| K41A | | {BF 1 B} | componentSymbol |
| K48 | Relay Engine Preheating | {CN 2 B} | componentSymbol |
| K61 | Relay, Extra Fan B9TL | {CA2 4 C} | componentSymbol |
| K65 | | {AD 0 C} {AE 0 C} {AF 1 D} {AH 0 C} | componentSymbol |
| K100 | | {AB 0 C} {AB3 0 A} | componentSymbol |
| K101 | | {AB3 1 B} | componentSymbol |
| K200 | Relay engine preheat | {AB2 3 B} {CN 0 A} | componentSymbol |
| K201 | Relay, pre-heater | {AB 3 C} {AB2 3 B} {AB2 1 B} | componentSymbol |
| K202 | | {AB2 4 B} {AB2 1 B} | componentSymbol |
| K204 | | {CF 3 C} | componentSymbol |
| K205 | Starter Relay | {CF 3 B} | componentSymbol |
| K902 | Relay heated hose pressure line | {CU 1 D} | componentSymbol |
| K903 | Relay heated hose backflow to pump line | {CU 2 D} | componentSymbol |
| K905A | Fan Clutch Relay | {CF 2 D} | componentSymbol |
| K906 | Relay, Turntable failure | {FC 0 C} | componentSymbol |
| K908 | Relay heated hose suction line | {CU 1 D} | componentSymbol |
| K909 | Relay heated hose backflow to tank line | {CU 2 D} | componentSymbol |
| K911 | Relay, DRL, Day Running Light | {GE 0 B} | componentSymbol |
| K912 | Relay, Throttle heater MG9 | {CB 3 A} | componentSymbol |
| K920 | | {CL 3 C} | componentSymbol |
| K997 | Relay DACU Vibr. chair | {BE 2 D} | componentSymbol |
| K998 | | {CA2 2 A} | componentSymbol |
| M01 | Motor, windscreen wiper | {GM 3 D} | componentSymbol |
| M02 | Motor, windscreen washer pump | {GM 1 C} | componentSymbol |

VOLVO

Volvo Bus Corporation

Document Title

WIRING DIAGRAM

Document Type

PRODUCT SCHEMATIC

Document No

20904123

Issue Index

15

Volume No

02(02)

Page No

15(76)

| Part Name | Description | Location | Part Type |
|-----------|---|--|-----------------|
| M03 | Motor, headlamp high pressure washer pump | {GM 0 C} | componentSymbol |
| M04 | Starter Motor | {AD 1 C} {AE 1 C} {AF 1 D} {AH 1 C} | componentSymbol |
| M04A | Starter Motor | {CF 4 B} | componentSymbol |
| M40 | Extra Fan B9TL | {CA2 4 B} | componentSymbol |
| M41 | Extra Fan B9TL, Rear Left Hatch | {CA2 4 B} | componentSymbol |
| M42 | Extra Fan B9TL, Rear Right Hatch | {CA2 4 B} | componentSymbol |
| M905 | | {GE 0 D} {GE 1 D} | componentSymbol |
| M906 | Motor, Engine Cooling Fan 1 | {CA2 0 C} | componentSymbol |
| M907 | Motor, Engine Cooling Fan 2 | {CA2 0 C} | componentSymbol |
| M908 | Motor, Engine Cooling Fan 3 | {CA2 1 C} | componentSymbol |
| M909 | Motor, Engine Cooling Fan 4 | {CA2 2 C} | componentSymbol |
| M910 | Motor, Engine Cooling Fan 5 | {CA2 2 C} | componentSymbol |
| Multic | VDV_dash | {NF 0 A} | componentSymbol |
| N | | {DA 2 D} | componentSymbol |
| NX903 | | {AB3 0 A} | componentSymbol |
| OBD | On Board Diagnostic | {NA 4 C} | componentSymbol |
| OBD2 | On Board Diagnostic | {NA 3 D} | componentSymbol |
| OBD3 | Diagnostic connector for HUBNER ECU. | {LB 3 B} | componentSymbol |
| R1 | Heater engine preheat | {CN 2 B} | componentSymbol |
| R01 | Heater, engine preheat | {CM 4 B} | componentSymbol |
| R01_ | Heater, engine preheat | {CC 3 B} | componentSymbol |
| R1_MD9 | Heater, engine preheat | {CA 3 B} | componentSymbol |
| R02 | Heater, rear view mirror | {GB 0 C} | componentSymbol |
| R08 | Resistor, CAN-bus Termination | {XC 1 A} | componentSymbol |
| R08A | | {XC 4 B} | componentSymbol |
| R10 | Heater waterseparator | {CN 4 A} | componentSymbol |
| R10. | Pulldown for Brake signal | {FC 2 C} | componentSymbol |
| R10_ | Pulldown for Brake signal | {LB 3 B} | componentSymbol |
| R11 | Pulldown for E-Gas step 1 signal | {FC 1 B} | componentSymbol |
| R11. | Pulldown for E-Gas step 1 signal | {LA 1 A} | componentSymbol |
| R11_ | Pulldown for E-Gas step 1 signal | {LB 2 B} | componentSymbol |
| R12 | Pulldown for E-Gas step 2 signal | {FC 1 B} | componentSymbol |
| R12. | Pulldown for E-Gas step 2 signal | {LA 2 A} | componentSymbol |
| R12_ | Pulldown for E-Gas step 2 signal | {LB 2 B} | componentSymbol |
| R37 | Terminator 1939_6 | {BE 0 C} | componentSymbol |
| R904 | Resistor, DBUS Termination | {CL 2 A} | componentSymbol |
| R904_2 | Resistor_DBUS | {CG 2 B} | componentSymbol |
| R905 | Heated Hose Suction Line | {CU 0 D} | componentSymbol |
| R906 | Heated Hose Pressure Line | {CU 1 D} | componentSymbol |
| R907 | Resistor, CAN2 termination | {CV 4 B} | componentSymbol |
| R908 | Heated Hose Backflow to tank DNOX2 | {CU 2 D} | componentSymbol |
| R909 | Heated Filter DNOX2 | {CU 0 D} | componentSymbol |
| R910 | Heated Hose Backflow to pump DNOX2 | {CU 1 D} | componentSymbol |
| R911 | Resistor, CRT diagnos | {CL 1 D} | componentSymbol |
| R916 | Resistor, polup electrical fan | {CA2 1 A} | componentSymbol |
| RC3 | Pulldown for C3 signal | {DA 1 B} | componentSymbol |
| Rc3 | Pulldown for C3 signal | {LB 2 B} | componentSymbol |
| rc3 | Pulldown for C3 signal | {LA 2 A} | componentSymbol |

VOLVO

Volvo Bus Corporation

Document Title

WIRING DIAGRAM

Document Type

PRODUCT SCHEMATIC

Document No

20904123

Issue Index

15

Volume No

02(02)

Page No

16(76)

| Part Name | Description | Location | Part Type |
|-----------|--|--|-----------------|
| RC3_HYM | Pulldown for C3 signal | {FC 1 A} | componentSymbol |
| RL1A | Rear light, R | {GE 4 C} | componentSymbol |
| RL2A | Rear light, L | {GE 3 C} | componentSymbol |
| ROK | | {DA 2 D} | |
| S01 | Switch, main lighting, selector type | {GB 0 B} | componentSymbol |
| S02 | Switch, stalk full / dipped beams | {BA 2 B} {GB 2 A} | componentSymbol |
| S06 | Switch, stalk windscreen wiper, selector type | {NA 2 D} {GM 4 B} | componentSymbol |
| S08 | Switch,differential gear lock,rear wheels | {EO 1 B} | componentSymbol |
| S11 | Switch, bogie lift, selector type | {FA 2 C} | componentSymbol |
| S12 | Switch, battery main switch | {AA 1 C} | componentSymbol |
| S14A | Switch, push button, Air horn | {IS 3 E} | componentSymbol |
| S14B | Switch, push button, Air horn | {IS 3 E} | componentSymbol |
| S15A | Switch,Starter Key | {AA 1 B} | componentSymbol |
| S15B | Switch,Starter Feed | {AA 1 D} | componentSymbol |
| S16 | Switch, push button, El. horn | {IS 3 E} | componentSymbol |
| S19 | Switch,extra | {DA 3 B} | componentSymbol |
| S24 | Switch, stalk retarder, selector type | {BA 3 B} | componentSymbol |
| S31 | Switch, TCS, Traction Control System | {EP 3 D} | componentSymbol |
| S32 | Switch, brake hold | {EP 4 B} | componentSymbol |
| S34 | Switch unit, steering wheel push buttons | {IS 0 B} | componentSymbol |
| S40 | Switch, battery main switch | {AA 0 C} | componentSymbol |
| S41 | Switch, battery main switch control | {AB3 1 C} {AB3 0 C} | componentSymbol |
| S41A | | {AB3 1 D} | componentSymbol |
| S45 | Switch, position differential gear lock indicator, rear wheels, NC. or NO. | {EP 3 C} | componentSymbol |
| S48 | Pressure switch, brake light, NO. | {LB 3 B} | componentSymbol |
| S50 | Switch, pressure parking brake indicator, NO | {BA 1 D} | componentSymbol |
| S58 | Switch, position clutch pedal, NO. | {BA 2 C} | componentSymbol |
| S68 | Switch proximity, coolant level, NC. | {CN 1 B} {CM 2 A} {CA 2 A} | componentSymbol |
| S68_ | Switch proximity, coolant level, NC. | {CC 0 B} | componentSymbol |
| S68_S9 | Switch proximity, coolant level, NC. | {CA 2 A} | componentSymbol |
| S70 | Switch position , flow sensor, power-steering, NC | {BB 4 C} | componentSymbol |
| S72 | Switch, water separator draining | {CC 4 D} | componentSymbol |
| S77 | Switch, emergency call | {NC 1 C} | componentSymbol |
| S77A | Switch, emergency call | {CP 2 B} | componentSymbol |
| S128 | | {BF 1 B} | componentSymbol |
| S202 | Switch DACU | {BE 0 B} | componentSymbol |
| S209 | Switch, fuel pump | {CA 2 B} | componentSymbol |
| S209_ | Switch, fuel pump | {CM 2 C} | componentSymbol |
| S901 | Switch, eng stop rear | {AG 4 D} {AG 0 D} {AG 3 D} {AG 3 D} | componentSymbol |
| S901_U | Switch, eng stop switch outside | {AG 3 D} | componentSymbol |
| S902 | Switch, raise/lower | {FA 4 C} | componentSymbol |
| S904 | Switch,emergency cut-out | {AA 0 B} | componentSymbol |

VOLVO

Volvo Bus Corporation

Document Title

WIRING DIAGRAM

Document Type

PRODUCT SCHEMATIC

Document No

20904123

Issue Index

15

Volume No

02(02)

Page No

17(76)

| Part Name | Description | Location | Part Type |
|-----------------|---|--|-----------------|
| S905 | Switch,Retarder | {BA 4 E} | componentSymbol |
| S905A | Switch, Retarder R9TL | {BA 4 E} | componentSymbol |
| S907 | Switch, eng start rear | {AG 3 D} {AG 2 D} {AG 0 D} {AG 1 D} | componentSymbol |
| S908 | Switch, eng start enable rear | {AG 1 D} {AG 4 D} {AG 2 D} {AG 0 D} | componentSymbol |
| S908A | Switch, eng start enable roof | {AG 4 D} | componentSymbol |
| S908B | Switch, eng start enable rear | {AG 4 D} | componentSymbol |
| S909 | Switch group,Voith transmission gear selector | {DC 3 A} | componentSymbol |
| S910 | Switch, group ecomat transmission gear selector | {DB 3 A} | componentSymbol |
| S911 | Switch, EGG, Israel | {EX 1 B} | componentSymbol |
| S913 | Switch, cl.cont/rev.l man.transm | {GA 3 B} | componentSymbol |
| S915 | Switch,kneeling | {FA 1 B} | componentSymbol |
| S916 | Switch, EGS fault diagnosis checking | {DA 2 B} | componentSymbol |
| S917 | Switch, group EGS gear selector | {DA 2 A} | componentSymbol |
| S918 | Switch, EGS extera gear | {DA 3 B} | componentSymbol |
| S925 | | {NC 2 B} | componentSymbol |
| S926 | Switch, Ecomat transmission retarder oil temperature. | {DB 2 D} | componentSymbol |
| S927 | Switch, alternative gearshift program,ZF | {DB 2 A} | componentSymbol |
| S927_ZF5 | Switch, alternative gearshift program,ZF | {DD 1 A} | componentSymbol |
| S928 | Switch, Position Neutral | {BB 0 C} | componentSymbol |
| S932 | Switch, alternative gearshift program, Voith | {DC 3 B} | componentSymbol |
| S935 | Switch, Jack knife warning | {BC 0 D} | componentSymbol |
| S935A | Switch, Jack knife warning | {BC 0 D} | componentSymbol |
| S935B | Switch, Jack knife warning (last trailer) | {BC 0 D} | componentSymbol |
| S935C | | {BC 1 D} | componentSymbol |
| S936 | Switch, Jack knife stop | {BC 1 D} | componentSymbol |
| S936A | Switch, Jack knife stop | {BC 2 D} | componentSymbol |
| S936B | Switch, Jack knife stop (last trailer) | {BC 1 D} | componentSymbol |
| S936C | | {BC 1 D} | componentSymbol |
| S939 | Switch, service gas system | {CG 1 B} | componentSymbol |
| S940 | Switch, Oilmaster | {CO 2 A} | componentSymbol |
| S941 | Switch, reverse gearselector | {DC 3 B} {DD 0 B} | componentSymbol |
| S942 | Switch, ON/OFF RAS | {CL 0 A} | componentSymbol |
| S945 | Switch, Steering wheel adjustment | {BA 1 D} | componentSymbol |
| S948 | Switch, enable menu navigation | {NA 3 E} | componentSymbol |
| Sensor Knock #1 | | {CE 1 D} | componentSymbol |
| Sensor Knock #2 | | {CE 1 D} | componentSymbol |
| SWP_L | VDV_dash | {NG 1 B} | componentSymbol |
| SWP_R | VDV_dash | {NF 3 B} | componentSymbol |
| T900 | | {AA2 1 C} | componentSymbol |
| U03 | Modulator, EBS, rear axle | {EO 3 B} | componentSymbol |
| U04 | Modulator, EBS, 3:rd axle | {EP 1 D} | componentSymbol |
| U05 | Modulator, EBS, trailer | {EP 2 D} | componentSymbol |

VOLVO

Volvo Bus Corporation

Document Title

WIRING DIAGRAM

Document Type

PRODUCT SCHEMATIC

Document No

20904123

Issue Index

15

Volume No

02(02)

Page No

18(76)

| Part Name | Description | Location | Part Type |
|----------------|---|------------------------|-----------------|
| U06 | Voltage converter | {IU 0 B} | componentSymbol |
| U06_ | Voltage converter | {CB 0 C} | componentSymbol |
| U07 | Modulator, EBS,Bogie/Artic | {EP 0 D} | componentSymbol |
| U08 | Modulator, EBS,front | {EO 2 B} | componentSymbol |
| U11 | Modulator, EBS, last-trailer, biartic, 8x2 | {EO 3 B} | componentSymbol |
| U12 | Voltage converter, Bi-xenon | {GE 1 B} | componentSymbol |
| U24 | Voltage converter, 600VDC/24VDC/12VDC | {CF 0 B} | componentSymbol |
| U24A | Voltage converter, 600VDC/24VDC/12VDC | {CF 1 B} | componentSymbol |
| U25 | Voltage converter, DC/DC | {AA2 2 B} | componentSymbol |
| V01 | Diode | {BF 1 C} | componentSymbol |
| V03 | Diod, Light | {GE 0 C} | componentSymbol |
| V04 | Diod, Light | {GE 1 C} | componentSymbol |
| V10 | | {BF 0 C} | componentSymbol |
| VB | | {DA 0 E} | componentSymbol |
| X09 | Slip contact/Horne | {IS 3 D} | componentSymbol |
| X09_RX | Slip contact horn | {IS 3 D} | componentSymbol |
| X902 | Power connection box MD7 | {AD 0 D} | componentSymbol |
| X903 | VPDU Front with main relay and main switch | {AB 0 C} | componentSymbol |
| X904 | VPDU Rear with preheat relay | {AB2 3 B} {AB2 0 B} | componentSymbol |
| X905 | VPDU Rear without preheat relay | {AB 2 C} | componentSymbol |
| X906 | External charger outlet | {AB 0 D} {AB3 0 D} | componentSymbol |
| X907 | VPDU 3 Fuses | {AE 1 B} | componentSymbol |
| X908 | Fuse Holder | {CF 0 D} | componentSymbol |
| X908A | Fuse Holder | {CF 1 D} | componentSymbol |
| X910 | Junction box battery/fuse box | {AB3 0 C} | componentSymbol |
| X917 | Power junction R9S | {AH 1 B} | componentSymbol |
| X918 | Power connection box T | {AF 1 B} | componentSymbol |
| XC103_BATS_D | | {AB 1 D} | componentSymbol |
| XC103_R7 | | {AB 1 D} | componentSymbol |
| XC103_R9 | | {AB 0 D} | componentSymbol |
| XC103_R12 | | {AB 1 D} | componentSymbol |
| XC201_R9L | | {AB2 4 D} | componentSymbol |
| XC201_R9TL | | {AB2 4 D} | componentSymbol |
| XC201_R12 | | {AB2 4 D} | componentSymbol |
| XC202A_BATS_D | | {AB2 2 D} | componentSymbol |
| XC202A_R9S_R9L | | {AB2 2 D} | componentSymbol |
| XC202A_R9TL | | {AB2 2 D} | componentSymbol |
| XC202A_R12 | | {AB2 3 D} | componentSymbol |
| XC202B_R9S_9L | | {AB2 3 D} | componentSymbol |
| XC202B_R9TL | | {AB2 3 D} | componentSymbol |
| XC202B_R12 | | {AB2 3 D} | componentSymbol |
| XC205_CNG | | {AB 2 D} | componentSymbol |
| XC205_R7 | | {AB 2 D} | componentSymbol |
| XC206_CNG | | {AB 2 D} | componentSymbol |
| XC206_ZF_AMT | | {AB 2 D} | componentSymbol |
| Y02 | Solenoid valve, diff. lock, rear wheels | {EP 3 C} | componentSymbol |
| Y07 | Solenoid valve, EPG (Exhaust Pressure Governor) | {CA 4 B} | componentSymbol |
| Y15.1 | | {CN 0 D} | componentSymbol |
| Y15.2 | | {CN 0 D} | componentSymbol |

VOLVO

Volvo Bus Corporation

Document Title

WIRING DIAGRAM

Document Type

PRODUCT SCHEMATIC

Document No

20904123

Issue Index

15

Volume No

02(02)

Page No

19(76)

| Part Name | Description | Location | Part Type |
|-----------|--|----------------------|-----------------|
| Y15.3 | | {CN 0 D} | componentSymbol |
| Y15.4 | | {CN 0 D} | componentSymbol |
| Y15.5 | | {CN 0 D} | componentSymbol |
| Y15.6 | | {CN 0 D} | componentSymbol |
| Y17 | Solenoid valve, retarder | {DM 1 E} {DQ 3 D} | componentSymbol |
| Y17.1 | Solenoid valve, retarder | {CN 4 D} | componentSymbol |
| Y17.2 | Solenoid valve, retarder | {CN 4 D} | componentSymbol |
| Y17.3 | Solenoid valve, retarder | {DM 2 E} | componentSymbol |
| Y17D | Solenoid valve, retarder | {DN 3 D} | componentSymbol |
| Y19 | | {CN 1 C} | componentSymbol |
| Y21 | | {DN 4 D} | componentSymbol |
| Y22 | | {DN 4 D} | componentSymbol |
| Y23 | | {DN 4 D} | componentSymbol |
| Y25 | Solenoid valve unit, ECS, Rear axle | {FA 0 B} | componentSymbol |
| Y26 | | {DN 3 D} | componentSymbol |
| Y33 | Solenoid valve, UI (Unit Injector) | {CA 1 E} {CM 1 D} | componentSymbol |
| Y33_ | Solenoid valve, UI (Unit Injector) | {CC 2 D} | componentSymbol |
| Y34 | | {CB 3 B} | componentSymbol |
| Y35 | Solenoid valve, engine cooling fan | {CN 0 B} | componentSymbol |
| Y35.1 | Solenoid valve, engine cooling fan | {CB 3 B} | componentSymbol |
| Y35_D9 | Solenoid valve, engine cooling fan | {CA 0 B} | componentSymbol |
| Y35A | Solenoid valve, engine cooling fan | {CF 3 D} {CN 3 D} | componentSymbol |
| Y36 | Solenoid valve, Steerable axle, Bogie | {BB 4 A} | componentSymbol |
| Y37 | Solenoid valve unit, engine brake/EPG | {CM 3 B} | componentSymbol |
| Y37_ | Solenoid valve unit, engine brake / EPG (Exhaust pressure governor) | {CC 2 B} | componentSymbol |
| Y39 | Solenoid valve, VEB (Volvo Engine Brake). | {CM 3 B} | componentSymbol |
| Y39_ | Solenoid valve, VEB (Volvo Engine Brake). | {CC 3 B} | componentSymbol |
| Y40 | Solenoid valve unit, ECS, Front axle | {FA 1 C} | componentSymbol |
| Y46 | Solenoid valve, piston cooling | {CM 3 B} | componentSymbol |
| Y47 | Solenoid valve, engine cooling fan | {CM 0 D} | componentSymbol |
| Y51A | | {BA 2 E} | componentSymbol |
| Y51B | | {BA 3 E} | componentSymbol |
| Y53 | Control valve block, RAS | {FO 3 D} | componentSymbol |
| Y72 | Solenoid valve, Horn | {IS 3 B} | componentSymbol |
| Y90 | | {CB 0 D} | componentSymbol |
| Y91 | | {CB 2 A} | componentSymbol |
| Y91A | | {CA 4 C} | componentSymbol |
| Y92 | | {CB 2 B} | componentSymbol |
| Y93 | | {CB 2 B} | componentSymbol |
| Y94 | | {CB 2 A} | componentSymbol |
| Y95 | | {CB 3 B} | componentSymbol |
| Y96 | | {CB 3 D} | componentSymbol |
| Y97 | | {CB 3 D} | componentSymbol |
| Y98 | | {CB 3 D} | componentSymbol |
| Y99 | | {CB 4 D} | componentSymbol |
| Y100 | | {CB 4 D} | componentSymbol |
| Y101 | | {CB 4 D} | componentSymbol |
| Y900 | solenoid valve unit, ECS, Bogie axle | {FA 2 C} | componentSymbol |
| Y901 | Solenoid valve, fuel cut off valve front axle | {NA 0 C} | componentSymbol |

VOLVO

Volvo Bus Corporation

Document Title

WIRING DIAGRAM

Document Type

PRODUCT SCHEMATIC

Document No

20904123

Issue Index

15

Volume No

02(02)

Page No

20(76)

| Part Name | Description | Location | Part Type |
|--------------|--|----------------------------------|---------------------------|
| Y901_LE | Solenoid valve, fuel cut off valve front axle | {NA 3 B} | componentSymbol |
| Y901_S9 | Solenoid valve, fuel cut off valve front axle | {NA 0 C} | componentSymbol |
| Y901_S9BI | Solenoid valve, fuel cut off valve front axle | {NA 4 E} | componentSymbol |
| Y902 | Solenoid valve, main EGG, Isreal | {EX 1 D} | componentSymbol |
| Y904 | Solenoid valve, proportional, ecomat transmission retarder X8/Y1 | {DB 1 D} | componentSymbol |
| Y910 | Solenoid valve, internal transmission components X6/A4, Ecomat | {DB 2 D} | componentSymbol |
| Y911 | Solenoid valve, inj SCRT | {CU 2 A} {CU 2 A} {CU 1 A} | componentSymbol |
| Y912 | Solenoid valve, water heating SCRT | {CU 0 D} | componentSymbol |
| Y913 | Solenoid valve, EGS | {DA 1 B} | componentSymbol |
| Y914 | Solenoid valve, pressure control PCU/R | {EP 0 B} | componentSymbol |
| Y915 | Solenoid valve, pressure control PCU/L | {EP 0 B} | componentSymbol |
| Y916 | Solenoid valve unit, ECS, Artic Axle | {FA 3 B} | componentSymbol |
| Y916_A | Solenoid valve unit, ECS, Artic Axle | {FA 2 B} | componentSymbol |
| Y917 | Solenoid valve, Fuel cut off valve rear axle | {NA 0 C} | componentSymbol |
| Y924 | Solenoid,Oil seperator | {BB 3 B} | componentSymbol |
| Y925 | Solenoid valve, gas tank1 | {CG 1 D} | componentSymbol |
| Y926 | Solenoid valve, gas tank2 | {CG 2 D} | componentSymbol |
| Y927 | Solenoid valve, gas tank3 | {CG 2 D} | componentSymbol |
| Y928 | Solenoid valve, gas tank4 | {CG 2 D} | componentSymbol |
| Y929 | Solenoid valve, gas tank5 | {CG 3 D} | componentSymbol |
| Y930 | Solenoid valve, gas tank6 | {CG 3 D} | componentSymbol |
| Y931 | Solenoid valve, gas tank7 | {CG 3 D} | componentSymbol |
| Y932 | Proportional valve, Hubner | {FC 2 E} {LA 3 D} | componentSymbol |
| Y932A | Proportional valve, Hubner | {LB 3 D} | componentSymbol |
| Y933 | Solenoid valve, cylinder RAS | {CL 0 A} | componentSymbol |
| Y934 | Solenoid valve unit, ECS, last trailer (Bartic) | {FA 2 B} | componentSymbol |
| Y935 | Solenoid valve, gas tank8 | {CG 4 D} | componentSymbol |
| Y936 | Solenoid, Steering wheel adjustment | {BA 1 E} | componentSymbol |
| Y937 | | {CL 3 D} | componentSymbol |
| Y938 | | {CL 4 D} | componentSymbol |
| Y939 | Valve control Fuel | {CD 4 D} | componentSymbol |
| Y940 | Valve Fuel Shut Off | {CD 4 D} | componentSymbol |
| Y941 | Valve, Waste Gate Control | {CD 1 B} | componentSymbol |
| Y942A | Valve,Ignition Coil A | {CD 0 D} | componentSymbol |
| Y942B | Valve, Ignition Coil B | {CD 0 D} | componentSymbol |
| Y942C | Valve, Ignition Coil C | {CD 0 D} | componentSymbol |
| Y942D | Valve, Ignition Coil D | {CD 0 D} | componentSymbol |
| Y942E | Valve, Ignition Coil E | {CD 1 D} | componentSymbol |
| Y942F | Valve, Ignition Coil F | {CD 1 D} | componentSymbol |
| BB3:11 | | {BB 0 B} | global_terminal_connector |
| BB6:4 | | {GA 2 B} | global_terminal_connector |
| Engine_block | Ground | {CM 3 B} | global_terminal_connector |
| Free_End | | {DM 1 C} | global_terminal_connector |
| +30:1 | | {AB 1 A} | inline_connector |
| +30_CONV:1 | | {CF 1 A} | inline_connector |
| +30_INTERF:1 | | {CF 3 A} | inline_connector |
| +B:1 | | {AB 0 A} | inline_connector |

VOLVO

Volvo Bus Corporation

Document Title

WIRING DIAGRAM

Document Type

PRODUCT SCHEMATIC

Document No

20904123

Issue Index

15

Volume No

02(02)

Page No

21(76)

| Part Name | Description | Location | Part Type |
|-------------|-------------|----------------------|------------------|
| +DR_CONV:1 | | {CF 1 A} | inline_connector |
| 30UA:1 | | {CU 3 D} | inline_connector |
| 30UB:1 | | {CU 3 D} | inline_connector |
| A14_:1 | | {CC 1 B} | inline_connector |
| A14_:2 | | {CC 2 B} | inline_connector |
| A14_:3 | | {CC 2 B} | inline_connector |
| A14_:4 | | {CC 1 B} | inline_connector |
| A14_:5 | | {CC 1 B} | inline_connector |
| A14_:6 | | {CC 3 B} | inline_connector |
| A14_:7 | | {CC 3 A} | inline_connector |
| A14_:8 | | {CC 1 B} | inline_connector |
| A14_:9 | | {CC 1 B} | inline_connector |
| A14_:10 | | {CC 3 B} | inline_connector |
| A14_:11 | | {CC 1 B} | inline_connector |
| A14_:12 | | {CC 4 A} | inline_connector |
| A14A:1 | | {CM 0 B} | inline_connector |
| A14A:2 | | {XC 1 D} | inline_connector |
| A14A:3 | | {XC 1 D} | inline_connector |
| A14A:4 | | {XD 1 D} | inline_connector |
| A14A:5 | | {XD 1 D} | inline_connector |
| A14A:7 | | {CM 3 A} | inline_connector |
| A14A:8 | | {CM 2 C} | inline_connector |
| A14A:9 | | {CM 0 B} | inline_connector |
| A14A:10 | | {CM 3 C} | inline_connector |
| A14A:11 | | {CM 4 C} | inline_connector |
| A14A:12 | | {AF 0 C} | inline_connector |
| A14A_MG9:1 | | {CB 0 C} | inline_connector |
| A14A_MG9:2 | | {XC 1 D} | inline_connector |
| A14A_MG9:3 | | {XC 1 D} | inline_connector |
| A14A_MG9:4 | | {XD 0 E} | inline_connector |
| A14A_MG9:5 | | {XD 0 E} | inline_connector |
| A14A_MG9:6 | | {CB 3 E} | inline_connector |
| A14A_MG9:7 | | {BD 3 B} {BD 0 B} | inline_connector |
| A14A_MG9:8 | | {BD 3 C} {BD 0 C} | inline_connector |
| A14A_MG9:9 | | {CB 0 B} | inline_connector |
| A14A_MG9:12 | | {CB 3 A} | inline_connector |
| A14B:1 | | {CM 0 B} | inline_connector |
| A14B:2 | | {CM 0 B} | inline_connector |
| A14B:3 | | {CM 0 B} | inline_connector |
| A14B:4 | | {CM 0 B} | inline_connector |
| A14B:5 | | {CM 2 B} | inline_connector |
| A14B:6 | | {CM 2 B} | inline_connector |
| A14B:7 | | {CM 0 D} | inline_connector |
| A14B_MG9:1 | | {CB 1 C} | inline_connector |
| A14B_MG9:2 | | {CB 1 E} | inline_connector |
| A14B_MG9:3 | | {CB 3 B} | inline_connector |
| A14B_MG9:4 | | {CB 3 C} | inline_connector |
| A14C:1 | | {CM 0 B} | inline_connector |
| A14C:2 | | {CM 4 C} | inline_connector |
| A14C:3 | | {CM 4 C} | inline_connector |

VOLVO

Volvo Bus Corporation

Document Title

WIRING DIAGRAM

Document Type

PRODUCT SCHEMATIC

Document No

20904123

Issue Index

15

Volume No

02(02)

Page No

22(76)

| Part Name | Description | Location | Part Type |
|-------------|-------------|----------------------|------------------|
| A14C:4 | | {BD 4 C} {BD 2 D} | inline_connector |
| A14C:5 | | {BD 4 B} {BD 2 B} | inline_connector |
| A14C:6 | | {CM 0 D} | inline_connector |
| A14C:7 | | {CM 0 D} | inline_connector |
| A14D:1 | | {CM 0 D} | inline_connector |
| A14D:2 | | {CM 0 C} | inline_connector |
| A14D:3 | | {CM 0 B} | inline_connector |
| A14D:4 | | {CM 0 C} | inline_connector |
| A43:1 | | {CC 1 B} | inline_connector |
| A43:3 | | {CC 0 B} | inline_connector |
| A43:5 | | {AF 1 C} | inline_connector |
| A43:6 | | {CC 1 B} | inline_connector |
| A43:7 | | {CC 2 B} | inline_connector |
| A43_:1 | | {CC 1 C} | inline_connector |
| A43_:3 | | {CC 0 C} | inline_connector |
| A43_:5 | | {AF 1 C} | inline_connector |
| A43_:6 | | {CC 1 B} | inline_connector |
| A43_:7 | | {CC 2 B} | inline_connector |
| A946_:6 | | {NE 2 C} | inline_connector |
| A946_:7 | | {NE 3 C} | inline_connector |
| A946_:13 | | {NE 2 D} | inline_connector |
| A946_:14 | | {NE 3 D} | inline_connector |
| ACC:1 | | {NE 1 B} | inline_connector |
| ACC:2 | | {XC 1 B} | inline_connector |
| ACC:3 | | {XC 1 B} | inline_connector |
| ACC:4 | | {XD 2 A} | inline_connector |
| ACC:5 | | {XD 2 A} | inline_connector |
| ACC:6 | | {ZC 4 D} | inline_connector |
| ACC:7 | | {BA 1 C} | inline_connector |
| ACC:8 | | {BA 1 C} | inline_connector |
| ACC:9 | | {NE 1 B} | inline_connector |
| ACM:1 | | {NB 0 B} | inline_connector |
| ACM:2 | | {AA 3 E} | inline_connector |
| ARTIC.A1:1 | | {FB 3 B} | inline_connector |
| ARTIC.A1:2 | | {FB 4 B} | inline_connector |
| ARTIC.A1:3 | | {FB 1 D} | inline_connector |
| ARTIC.A1:4 | | {FB 2 D} | inline_connector |
| ARTIC.A1:5 | | {BC 0 B} | inline_connector |
| ARTIC.A1:6 | | {BC 0 B} | inline_connector |
| ARTIC.A1:7 | | {BC 1 B} | inline_connector |
| ARTIC.A1:8 | | {BC 1 B} | inline_connector |
| ARTIC.A1:9 | | {BC 1 B} | inline_connector |
| ARTIC.A1:10 | | {BC 0 B} | inline_connector |
| ARTIC.A1:11 | | {BC 2 B} | inline_connector |
| ARTIC.A1:12 | | {BC 2 B} | inline_connector |
| ARTIC.A2:7 | | {BC 1 B} | inline_connector |
| ARTIC.A2:8 | | {BC 1 B} | inline_connector |
| ARTIC.A2:9 | | {BC 1 B} | inline_connector |
| ARTIC.A2:11 | | {BC 2 B} | inline_connector |
| ARTIC.A2:12 | | {BC 2 B} | inline_connector |
| ARTIC:1 | | {FB 3 B} | inline_connector |

VOLVO

Volvo Bus Corporation

Document Title

WIRING DIAGRAM

Document Type

PRODUCT SCHEMATIC

Document No

20904123

Issue Index

15

Volume No

02(02)

Page No

23(76)

| Part Name | Description | Location | Part Type |
|-----------|---------------------------|----------------------|------------------|
| ARTIC:2 | | {FB 3 B} | inline_connector |
| ARTIC:3 | | {FB 2 B} | inline_connector |
| ARTIC:4 | | {FB 3 B} | inline_connector |
| ARTIC:5 | | {BC 0 B} | inline_connector |
| ARTIC:6 | | {BC 1 B} | inline_connector |
| ARTIC:7 | | {BC 1 B} | inline_connector |
| ARTIC:8 | | {BC 1 B} | inline_connector |
| ARTIC:9 | | {BC 1 B} | inline_connector |
| ARTIC:10 | | {BC 0 B} | inline_connector |
| ARTIC:11 | | {BC 2 B} | inline_connector |
| ARTIC:12 | | {BC 2 B} | inline_connector |
| AUDIO:1 | | {NA 1 C} | inline_connector |
| AUDIO:2 | | {NA 1 C} | inline_connector |
| AUDIO:3 | | {IS 1 B} | inline_connector |
| B07_A:1 | | {NB 3 B} | inline_connector |
| B07_A:2 | | {NB 3 B} | inline_connector |
| B07_B:1 | | {NB 3 A} | inline_connector |
| B07_B:2 | | {NB 3 A} | inline_connector |
| B12_A:1 | | {NB 3 B} | inline_connector |
| B12_A:2 | | {NB 3 B} | inline_connector |
| B12_A:3 | | {NB 3 B} | inline_connector |
| B12_A:4 | | {NB 3 B} | inline_connector |
| B12_B:1 | | {NB 3 C} | inline_connector |
| B12_B:2 | | {NB 3 C} | inline_connector |
| B12_B:3 | | {NB 3 C} | inline_connector |
| B12_B:4 | | {NB 3 C} | inline_connector |
| B903A:1 | | {DM 2 B} {DQ 4 D} | inline_connector |
| B903A:2 | | {DM 2 C} {DQ 4 D} | inline_connector |
| B930T:1 | | {CU 2 B} | inline_connector |
| B930T:2 | | {CU 2 B} | inline_connector |
| B930T:3 | | {CU 3 B} | inline_connector |
| B930T:4 | | {CU 3 B} | inline_connector |
| B_A:1 | | {FB 0 C} | inline_connector |
| B_A:2 | | {FB 1 B} | inline_connector |
| BB1:1 | Idle switch | {BA 0 D} | inline_connector |
| BB1:2 | Start disable | {BC 3 B} | inline_connector |
| BB1:3 | Fire alarm, body | {BC 3 B} | inline_connector |
| BB1:4 | Low priority loads, relay | {BC 2 B} | inline_connector |
| BB1:5 | Luggage hatch ,open | {BB 2 C} | inline_connector |
| BB1:6 | Safety belt indicator | {NA 2 D} | inline_connector |
| BB1:8 | Washer fluid low level | {NA 2 D} | inline_connector |
| BB1:9 | Altenator charging | {NA 2 D} | inline_connector |
| BB1:10 | AC 1 | {BB 3 A} | inline_connector |
| BB1:11 | Parking brake applied | {BA 2 E} | inline_connector |
| BB1:12 | AC Disable | {BC 3 B} | inline_connector |
| BB2:1 | Indoor temperator + | {NA 1 D} | inline_connector |
| BB2:2 | Indoor temperature - | {NA 1 D} | inline_connector |
| BB2:3 | Out door temperator + | {NA 2 D} | inline_connector |
| BB2:4 | Out door temperatur- | {NA 1 D} | inline_connector |
| BB2:5 | D-CAN H | {BC 3 E} | inline_connector |
| BB2:6 | D-CAN L | {BC 3 E} | inline_connector |

VOLVO

Volvo Bus Corporation

Document Title

WIRING DIAGRAM

Document Type

PRODUCT SCHEMATIC

Document No

20904123

Issue Index

15

Volume No

02(02)

Page No

24(76)

| Part Name | Description | Location | Part Type |
|-----------|------------------------------------|----------|------------------|
| BB2:7 | Horn(contacts steering wheelside) | {IS 3 C} | inline_connector |
| BB2:8 | Horn supply | {IS 3 B} | inline_connector |
| BB2:9 | Horn (contacts steer.wheel centre) | {IS 2 C} | inline_connector |
| BB2:10 | Alarm | {GB 2 B} | inline_connector |
| BB2:11 | Emergency switch | {AA 0 C} | inline_connector |
| BB2:12 | Signal 4 pulses/meter C6 | {NB 1 A} | inline_connector |
| BB3:1 | Head lamps off | {GB 2 B} | inline_connector |
| BB3:2 | Prevent ECS action | {BC 3 B} | inline_connector |
| BB3:3 | Kneeling position | {FA 1 D} | inline_connector |
| BB3:4 | Lowering Prodection | {FB 2 B} | inline_connector |
| BB3:5 | Hazard warning lamps | {GB 2 B} | inline_connector |
| BB3:6 | DRL Output | {GB 0 C} | inline_connector |
| BB3:7 | Next stop indicator | {NA 2 D} | inline_connector |
| BB3:8 | Pram indicator | {NA 2 D} | inline_connector |
| BB3:9 | + 15 Ignition | {AC 0 C} | inline_connector |
| BB3:10 | Speed signal C3 | {BA 1 D} | inline_connector |
| BB3:11 | + 30 main switch (fuse F12) | {BB 0 B} | inline_connector |
| BB3:12 | + 15 ignition(fuse F29) | {BB 0 B} | inline_connector |
| BB4:1 | Glass heating | {BC 3 B} | inline_connector |
| BB4:2 | Host call | {BC 3 B} | inline_connector |
| BB4:3 | Toilet fluid level | {BC 3 B} | inline_connector |
| BB4:4 | Toilet occupied | {BC 3 B} | inline_connector |
| BB4:5 | Door failure | {BC 3 B} | inline_connector |
| BB4:6 | Door brake, status | {BC 2 B} | inline_connector |
| BB4:7 | Door brake,request | {EP 2 B} | inline_connector |
| BB4:8 | Speed signal 5 km/h | {BA 0 D} | inline_connector |
| BB4:9 | Any door open | {NA 2 D} | inline_connector |
| BB4:10 | Speed signal X km/h | {BA 0 D} | inline_connector |
| BB4:11 | Dimmer,dashboard illumination | {GB 4 B} | inline_connector |
| BB4:12 | N/A | {CG 1 B} | inline_connector |
| BB5.A:1 | | {GB 1 C} | inline_connector |
| BB5.A:2 | | {GB 3 C} | inline_connector |
| BB5.A:3 | | {GB 0 C} | inline_connector |
| BB5.A:4 | | {GB 4 C} | inline_connector |
| BB5.A:5 | | {GB 2 C} | inline_connector |
| BB5.A:6 | | {GB 2 C} | inline_connector |
| BB5.A:7 | | {GB 1 C} | inline_connector |
| BB5.A:8 | | {GB 3 C} | inline_connector |
| BB5.A:9 | | {GB 2 C} | inline_connector |
| BB5.A:10 | | {GB 3 C} | inline_connector |
| BB5.A:11 | | {GB 1 C} | inline_connector |
| BB5.A:12 | | {GB 3 C} | inline_connector |
| BB5.B:1 | | {GB 1 D} | inline_connector |
| BB5.B:2 | | {GB 3 D} | inline_connector |
| BB5.B:3 | | {GB 0 D} | inline_connector |
| BB5.B:4 | | {GB 4 D} | inline_connector |
| BB5.B:5 | | {GB 2 D} | inline_connector |
| BB5.B:6 | | {GB 2 B} | inline_connector |
| BB5.B:7 | | {GB 1 D} | inline_connector |
| BB5.B:8 | | {GB 3 D} | inline_connector |
| BB5.B:9 | | {GB 2 D} | inline_connector |
| BB5.B:10 | | {GB 3 D} | inline_connector |
| BB5.B:11 | | {GB 1 D} | inline_connector |

VOLVO

Volvo Bus Corporation

Document Title

WIRING DIAGRAM

Document Type

PRODUCT SCHEMATIC

Document No

20904123

Issue Index

15

Volume No

02(02)

Page No

25(76)

| Part Name | Description | Location | Part Type |
|-----------|--|----------------------|------------------|
| BB5.B:12 | | {GB 3 D} | inline_connector |
| BB5:1 | dipped beam.Left | {GB 1 C} | inline_connector |
| BB5:2 | Dipped beam.Right | {GB 3 C} | inline_connector |
| BB5:3 | Direction indicator,front and side.Left | {GB 0 D} | inline_connector |
| BB5:4 | Direction indicator,Front and side. Right | {GB 4 D} | inline_connector |
| BB5:5 | Fog lamps,front | {GB 2 C} | inline_connector |
| BB5:6 | Additional main beam | {GB 3 B} {GB 2 B} | inline_connector |
| BB5:7 | End-outline maker,side marker,position lamps.Left | {GB 1 C} | inline_connector |
| BB5:8 | End-outline marker,side marker, position lamps.Right | {GB 3 C} | inline_connector |
| BB5:9 | Main beam 2. Left | {GB 2 C} | inline_connector |
| BB5:10 | Main beam 2.Right | {GB 2 C} | inline_connector |
| BB5:11 | Main beam 1.Left | {GB 1 C} | inline_connector |
| BB5:12 | Main beam 1.Right | {GB 3 C} | inline_connector |
| BB6.A1:1 | | {BC 2 C} | inline_connector |
| BB6.A1:2 | | {GA 1 A} | inline_connector |
| BB6.A1:4 | | {GA 2 A} | inline_connector |
| BB6.A1:5 | | {BB 2 D} | inline_connector |
| BB6.A1:6 | | {BB 2 B} | inline_connector |
| BB6.A1:7 | | {CG 3 B} | inline_connector |
| BB6.A1:8 | | {CG 3 B} | inline_connector |
| BB6.A1:9 | | {CG 3 B} | inline_connector |
| BB6.A1:10 | | {CG 4 B} | inline_connector |
| BB6.A1:11 | | {CG 4 B} | inline_connector |
| BB6.A1:12 | | {GA 2 C} | inline_connector |
| BB6.A2:1 | | {BC 2 D} | inline_connector |
| BB6.A2:2 | | {GA 1 B} | inline_connector |
| BB6.A2:4 | | {GA 2 A} | inline_connector |
| BB6.A2:5 | | {BB 2 D} | inline_connector |
| BB6.A2:6 | | {BB 2 B} | inline_connector |
| BB6.A2:7 | | {CG 3 B} | inline_connector |
| BB6.A2:8 | | {CG 3 B} | inline_connector |
| BB6.A2:9 | | {CG 3 B} | inline_connector |
| BB6.A2:10 | | {CG 4 B} | inline_connector |
| BB6.A2:11 | | {CG 4 B} | inline_connector |
| BB6.A2:12 | | {GA 2 D} | inline_connector |
| BB6.A3:1 | | {BC 2 D} | inline_connector |
| BB6.A3:2 | | {GA 1 B} | inline_connector |
| BB6.A3:4 | | {GA 2 A} | inline_connector |
| BB6.A3:5 | | {BB 2 C} | inline_connector |
| BB6.A3:6 | | {BB 2 A} | inline_connector |
| BB6.A3:7 | | {CG 3 B} | inline_connector |
| BB6.A3:8 | | {CG 3 B} | inline_connector |
| BB6.A3:9 | | {CG 3 B} | inline_connector |
| BB6.A3:10 | | {CG 4 B} | inline_connector |
| BB6.A3:11 | | {CG 4 B} | inline_connector |
| BB6.A3:12 | | {GA 2 D} | inline_connector |
| BB6:1 | Starter inhibitor, engine hatch | {BC 2 C} | inline_connector |
| BB6:2 | N/A | {GA 1 A} | inline_connector |
| BB6:3 | AC compressor 3 | {CL 3 C} | inline_connector |
| BB6:4 | + 30 main swith(fuse F54) | {GA 2 A} | inline_connector |

VOLVO

Volvo Bus Corporation

Document Title

WIRING DIAGRAM

Document Type

PRODUCT SCHEMATIC

Document No

20904123

Issue Index

15

Volume No

02(02)

Page No

26(76)

| Part Name | Description | Location | Part Type |
|-----------|---------------------------|----------|------------------|
| BB6:5 | Luggage hatch, open | {BB 2 D} | inline_connector |
| BB6:6 | Luggage compartment light | {BB 2 B} | inline_connector |
| BB6:7 | | {CG 3 B} | inline_connector |
| BB6:8 | | {CG 3 B} | inline_connector |
| BB6:9 | | {CG 3 B} | inline_connector |
| BB6:10 | | {CG 3 B} | inline_connector |
| BB6:11 | | {CG 4 B} | inline_connector |
| BB6:12 | Reverse warning signal | {GA 3 C} | inline_connector |
| BB6A:4 | | {GD 0 A} | inline_connector |
| BB6A:5 | | {GD 1 A} | inline_connector |
| BB6A:6 | | {GD 1 A} | inline_connector |
| BB6B:1 | | {BC 2 D} | inline_connector |
| BB6B:2 | | {GA 1 B} | inline_connector |
| BB6B:4 | | {GA 2 B} | inline_connector |
| BB6B:5 | | {BB 2 C} | inline_connector |
| BB6B:6 | | {BB 2 A} | inline_connector |
| BB6B:7 | | {CG 3 B} | inline_connector |
| BB6B:8 | | {CG 3 B} | inline_connector |
| BB6B:9 | | {CG 3 B} | inline_connector |
| BB6B:10 | | {CG 3 B} | inline_connector |
| BB6B:11 | | {CG 4 B} | inline_connector |
| BB6B:12 | | {GA 3 D} | inline_connector |
| BB7.A1:1 | | {GC 2 B} | inline_connector |
| BB7.A1:2 | | {GA 3 C} | inline_connector |
| BB7.A1:3 | | {GA 1 C} | inline_connector |
| BB7.A1:4 | | {GC 2 B} | inline_connector |
| BB7.A1:5 | | {GA 0 C} | inline_connector |
| BB7.A1:6 | | {GC 2 B} | inline_connector |
| BB7.A1:7 | | {GA 0 C} | inline_connector |
| BB7.A1:8 | | {GC 3 B} | inline_connector |
| BB7.A1:9 | | {GC 0 B} | inline_connector |
| BB7.A1:10 | | {GC 0 B} | inline_connector |
| BB7.A1:11 | | {GA 1 C} | inline_connector |
| BB7.A1:12 | | {GA 2 C} | inline_connector |
| BB7.A2:1 | | {GC 2 C} | inline_connector |
| BB7.A2:2 | | {GA 3 D} | inline_connector |
| BB7.A2:3 | | {GA 1 D} | inline_connector |
| BB7.A2:4 | | {GC 2 C} | inline_connector |
| BB7.A2:5 | | {GA 0 D} | inline_connector |
| BB7.A2:6 | | {GC 2 C} | inline_connector |
| BB7.A2:7 | | {GA 0 D} | inline_connector |
| BB7.A2:8 | | {GC 3 C} | inline_connector |
| BB7.A2:9 | | {GC 0 C} | inline_connector |
| BB7.A2:10 | | {GC 0 C} | inline_connector |
| BB7.A2:11 | | {GA 1 D} | inline_connector |
| BB7.A2:12 | | {GA 2 C} | inline_connector |
| BB7.A3:1 | | {GC 2 C} | inline_connector |
| BB7.A3:2 | | {GA 3 D} | inline_connector |
| BB7.A3:3 | | {GA 1 D} | inline_connector |
| BB7.A3:4 | | {GC 2 C} | inline_connector |
| BB7.A3:5 | | {GA 0 D} | inline_connector |
| BB7.A3:6 | | {GC 2 C} | inline_connector |
| BB7.A3:7 | | {GA 0 D} | inline_connector |

VOLVO

Volvo Bus Corporation

Document Title

WIRING DIAGRAM

Document Type

PRODUCT SCHEMATIC

Document No

20904123

Issue Index

15

Volume No

02(02)

Page No

27(76)

| Part Name | Description | Location | Part Type |
|-----------|---|----------|------------------|
| BB7.A3:8 | | {GC 3 C} | inline_connector |
| BB7.A3:9 | | {GC 0 C} | inline_connector |
| BB7.A3:10 | | {GC 0 C} | inline_connector |
| BB7.A3:11 | | {GA 1 D} | inline_connector |
| BB7.A3:12 | | {GA 2 D} | inline_connector |
| BB7:1 | Stop lamp.Right | {GC 1 B} | inline_connector |
| BB7:2 | Reversing lamps | {GA 3 C} | inline_connector |
| BB7:3 | Direction indicator.Rear left | {GA 1 C} | inline_connector |
| BB7:4 | Direction indicator.Rear right | {GC 2 B} | inline_connector |
| BB7:5 | Extra direction indicator.Left | {GA 1 C} | inline_connector |
| BB7:6 | Extra direction indicator.Right | {GC 2 B} | inline_connector |
| BB7:7 | Rear position lamps.Left | {GA 0 C} | inline_connector |
| BB7:8 | Rear position lamp.Right | {GC 3 B} | inline_connector |
| BB7:9 | End-outline marker,sidemarkers.Rear left | {GC 0 C} | inline_connector |
| BB7:10 | End-outline marker,side marker lamps.Rear right | {GC 1 C} | inline_connector |
| BB7:11 | Stop lamp,left and Category S3 stop lamps | {GA 1 C} | inline_connector |
| BB7:12 | Fog lamps,Rear | {GA 2 C} | inline_connector |
| BB7_T:1 | Rear position lamp.Right | {GA 3 A} | inline_connector |
| BB7_T:2 | Rear position lamp.Right | {GA 3 A} | inline_connector |
| BB7_T:3 | Rear position lamp.Right | {GA 4 A} | inline_connector |
| BB7_T:4 | Rear position lamp.Right | {GA 3 A} | inline_connector |
| BB7_T:7 | Rear position lamp.Right | {GA 4 A} | inline_connector |
| BB7_T:8 | Rear position lamp.Right | {GA 3 A} | inline_connector |
| BB7_T:11 | Rear position lamp.Right | {GA 3 A} | inline_connector |
| BB7A:1 | Reversing lamps | {GD 0 B} | inline_connector |
| BB7A:2 | Reversing lamps | {GD 1 B} | inline_connector |
| BB7A:3 | Direction indicator.Rear left | {GD 1 B} | inline_connector |
| BB7A:4 | Direction indicator.Rear right | {GD 1 B} | inline_connector |
| BB7A:5 | Xtra direction indicator.Left | {GD 1 B} | inline_connector |
| BB7A:6 | Extra direction indicator.Right | {GD 1 B} | inline_connector |
| BB7A:7 | Rear position lamps.Left | {GD 2 B} | inline_connector |
| BB7A:8 | Rear position lamps.Right | {GD 2 B} | inline_connector |
| BB7A:9 | End-outline marker,sidemarkers.Rear left | {GD 2 B} | inline_connector |
| BB7A:10 | End-outline marker,sidemarkers.Rear right | {GD 3 B} | inline_connector |
| BB7A:11 | Stop lamps,left and Category S3 stop lamps | {GD 3 B} | inline_connector |
| BB7A:12 | Fog lamps ,Rear | {GD 4 B} | inline_connector |
| BB7B:1 | Stop lamp.Right | {GC 1 C} | inline_connector |
| BB7B:2 | Reversing lamps | {GA 3 D} | inline_connector |
| BB7B:3 | Direction indicator.Rear left | {GA 1 D} | inline_connector |
| BB7B:4 | Stop lamp.Right | {GC 2 C} | inline_connector |
| BB7B:5 | Direction indicator.Rear left | {GA 1 D} | inline_connector |
| BB7B:6 | Direction indicator.Rear left | {GC 2 C} | inline_connector |
| BB7B:7 | Direction indicator.Rear left | {GA 0 D} | inline_connector |
| BB7B:8 | Stop lamp.Right | {GC 3 C} | inline_connector |
| BB7B:9 | Direction indicator.Rear left | {GC 0 C} | inline_connector |
| BB7B:10 | Direction indicator.Rear left | {GC 1 C} | inline_connector |
| BB7B:11 | Direction indicator.Rear left | {GA 2 D} | inline_connector |
| BB7B:12 | Direction indicator.Rear left | {GA 2 D} | inline_connector |

VOLVO

Volvo Bus Corporation

Document Title

WIRING DIAGRAM

Document Type

PRODUCT SCHEMATIC

Document No

20904123

Issue Index

15

Volume No

02(02)

Page No

28(76)

| Part Name | Description | Location | Part Type |
|-----------|---|-----------------------|------------------|
| BB8:1 | End-outline marker lamp.Front left | {GB 1 D} | inline_connector |
| BB8:2 | End-outline marker lamp.Front right | {GB 4 D} | inline_connector |
| BB8:3 | Extra main beam | {GB 2 B} | inline_connector |
| BB10A:1 | remote control of extra power amplifier(12V) | {IU 1 E} | inline_connector |
| BB10A:3 | +15(12V) | {IU 1 B} | inline_connector |
| BB10A:5 | +30(12V) | {IU 1 B} | inline_connector |
| BB10A:7 | Ground | {IU 0 B} | inline_connector |
| BB10A:9 | Mute | {IU 1 E} | inline_connector |
| BB10B:1 | remote control of extra power amplifier (12V) | {IU 1 E} | inline_connector |
| BB10B:3 | +15(12V) | {IU 1 B} | inline_connector |
| BB10B:5 | +30(12V) | {IU 1 B} | inline_connector |
| BB10B:7 | Ground | {IU 0 B} | inline_connector |
| BB10B:9 | Mute | {IU 1 E} | inline_connector |
| BB11:1 | Connected to RL:3 | {GB 0 D} | inline_connector |
| BB13:1 | AC 1 - 50% | {BC 0 B} | inline_connector |
| BB13:2 | AC compressor 2 | {CL 1 A} | inline_connector |
| BB13:3 | AC compressor 3 | {CL 1 A} | inline_connector |
| BB13:4 | Lowering Protection | {FB 2 B} | inline_connector |
| BB13:5 | TORQUE REDUCTION | {BC 0 B} | inline_connector |
| BB13:6 | AC compressor 2 | {CL 2 D} | inline_connector |
| BB13:7 | AC compressor 3 | {CL 2 D} | inline_connector |
| BB13:8 | | {CL 3 B} | inline_connector |
| BB13:9 | | {AC 1 D} | inline_connector |
| BB13:10 | | {AC 2 D} | inline_connector |
| BB13:11 | | {AC 3 D} | inline_connector |
| BBOX:1 | | {AA 1 D} | inline_connector |
| BBOX:2 | | {AB 1 B} | inline_connector |
| BBOX:3 | | {NB 0 A} {AB3 1 C} | inline_connector |
| BFEED:1 | | {CU 0 A} | inline_connector |
| BIO:1 | | {CG 2 B} | inline_connector |
| BIO:2 | | {XD 4 C} | inline_connector |
| BIO:3 | | {XD 4 C} | inline_connector |
| BIO:4 | | {BC 3 B} | inline_connector |
| BIO:5 | | {BC 3 B} | inline_connector |
| BIO:6 | | {BC 3 D} | inline_connector |
| BIO:7 | | {BC 3 D} | inline_connector |
| BIO:8 | | {CG 0 A} | inline_connector |
| BIO:9 | | {AA 3 A} | inline_connector |
| BIO:10 | | {ZC 4 D} | inline_connector |
| BIO:11 | | {CG 1 A} | inline_connector |
| BIO:12 | | {CL 3 C} | inline_connector |
| BIO_J:4 | | {BC 3 C} | inline_connector |
| BIO_J:5 | | {BC 3 C} | inline_connector |
| BIO_J:6 | | {BC 3 D} | inline_connector |
| BIO_J:7 | | {BC 3 D} | inline_connector |
| BMUX:1 | | {XD 1 A} | inline_connector |
| BMUX:2 | | {XD 1 A} | inline_connector |
| BMUX:3 | Externa main switch | {AA 0 B} | inline_connector |
| BMUX:4 | Externa main switch | {AA 0 C} | inline_connector |
| BMUX:5 | | {AA 0 B} | inline_connector |

VOLVO

Volvo Bus Corporation

Document Title

WIRING DIAGRAM

Document Type

PRODUCT SCHEMATIC

Document No

20904123

Issue Index

15

Volume No

02(02)

Page No

29(76)

| Part Name | Description | Location | Part Type |
|------------|-------------|----------------------|------------------|
| BOGIE.A1:1 | | {FB 1 D} | inline_connector |
| BOGIE.A1:2 | | {FB 0 D} | inline_connector |
| BOGIE.A1:3 | | {FA 0 D} | inline_connector |
| BOGIE.A1:4 | | {FA 0 D} | inline_connector |
| BOGIE.A1:5 | | {FA 0 D} | inline_connector |
| BOGIE.A1:6 | | {EP 0 B} | inline_connector |
| BOGIE.A1:7 | | {EP 1 B} | inline_connector |
| BOGIE.A1:8 | | {EP 1 B} | inline_connector |
| BOGIE.A1:9 | | {EP 1 B} | inline_connector |
| BOGIE:1 | | {FB 1 B} | inline_connector |
| BOGIE:2 | | {FB 1 B} | inline_connector |
| BOGIE:3 | | {FA 3 D} | inline_connector |
| BOGIE:4 | | {FA 3 D} | inline_connector |
| BOGIE:5 | | {FA 1 D} {FA 3 D} | inline_connector |
| BOGIE:6 | | {EP 1 B} | inline_connector |
| BOGIE:7 | | {EP 1 B} | inline_connector |
| BOGIE:8 | | {EP 1 B} | inline_connector |
| BOGIE:9 | | {EP 1 B} | inline_connector |
| BOGIE:10 | | {ZC 1 D} | inline_connector |
| BOGIE:11 | | {BB 4 C} | inline_connector |
| BOGIE:12 | | {BB 4 C} | inline_connector |
| BS1:2 | | {EO 2 B} | inline_connector |
| BS1:3 | | {EO 2 B} | inline_connector |
| BS1:4 | | {EO 2 B} | inline_connector |
| BS1:5 | | {EO 2 B} | inline_connector |
| BS1:8 | | {EP 0 A} | inline_connector |
| BS1:9 | | {EP 0 A} | inline_connector |
| BS1:10 | | {EP 0 B} | inline_connector |
| BS1:11 | | {EP 0 A} | inline_connector |
| BS1:12 | | {EP 0 A} | inline_connector |
| BS2:2 | | {EP 2 B} | inline_connector |
| BS2:3 | | {EP 2 B} | inline_connector |
| BS2:5 | | {EP 3 B} | inline_connector |
| BS2:6 | | {EP 3 C} | inline_connector |
| BS3.A1:1 | | {EO 2 D} | inline_connector |
| BS3.A1:2 | | {EO 2 D} | inline_connector |
| BS3.A1:3 | | {EO 3 D} | inline_connector |
| BS3.A1:4 | | {EO 3 D} | inline_connector |
| BS3.A1:5 | | {EP 3 B} | inline_connector |
| BS3.A1:6 | | {EP 3 A} | inline_connector |
| BS3.A1:7 | | {EP 3 D} | inline_connector |
| BS3.A1:8 | | {NA 3 B} | inline_connector |
| BS3.A1:9 | | {BB 3 D} | inline_connector |
| BS3.A1:10 | | {BA 4 C} | inline_connector |
| BS3.A1:11 | | {BA 4 C} | inline_connector |
| BS3.A1:12 | | {BA 4 C} | inline_connector |
| BS3.A2:1 | | {EO 2 D} | inline_connector |
| BS3.A2:2 | | {EO 2 D} | inline_connector |
| BS3.A2:3 | | {EO 3 C} | inline_connector |
| BS3.A2:4 | | {EO 3 C} | inline_connector |
| BS3.A2:5 | | {EP 3 B} | inline_connector |
| BS3.A2:6 | | {EP 3 B} | inline_connector |

VOLVO

Volvo Bus Corporation

Document Title

WIRING DIAGRAM

Document Type

PRODUCT SCHEMATIC

Document No

20904123

Issue Index

15

Volume No

02(02)

Page No

30(76)

| Part Name | Description | Location | Part Type |
|-----------|-------------|----------|------------------|
| BS3.A2:7 | | {EP 3 D} | inline_connector |
| BS3.A2:8 | | {NA 3 B} | inline_connector |
| BS3.A2:9 | | {BB 3 C} | inline_connector |
| BS3.A2:10 | | {BA 4 B} | inline_connector |
| BS3.A2:11 | | {BA 4 C} | inline_connector |
| BS3.A2:12 | | {BA 4 C} | inline_connector |
| BS3.A3:1 | | {EO 2 C} | inline_connector |
| BS3.A3:2 | | {EO 2 C} | inline_connector |
| BS3.A3:3 | | {EO 3 C} | inline_connector |
| BS3.A3:4 | | {EO 3 C} | inline_connector |
| BS3.A3:5 | | {EP 3 B} | inline_connector |
| BS3.A3:6 | | {EP 3 B} | inline_connector |
| BS3.A3:7 | | {EP 3 D} | inline_connector |
| BS3.A3:8 | | {NA 3 A} | inline_connector |
| BS3.A3:9 | | {BB 3 C} | inline_connector |
| BS3.A3:10 | | {BA 4 B} | inline_connector |
| BS3.A3:11 | | {BA 4 B} | inline_connector |
| BS3.A3:12 | | {BA 4 C} | inline_connector |
| BS3:1 | | {EO 3 D} | inline_connector |
| BS3:2 | | {EO 3 D} | inline_connector |
| BS3:3 | | {EO 3 D} | inline_connector |
| BS3:4 | | {EO 3 D} | inline_connector |
| BS3:5 | | {EP 3 B} | inline_connector |
| BS3:6 | | {EP 3 A} | inline_connector |
| BS3:7 | | {EP 3 D} | inline_connector |
| BS3:8 | | {NA 2 A} | inline_connector |
| BS3:9 | | {BB 3 D} | inline_connector |
| BS3:10 | | {BA 4 B} | inline_connector |
| BS3:11 | | {BA 4 B} | inline_connector |
| BS3:12 | | {BA 4 C} | inline_connector |
| BS3B:1 | | {EO 2 B} | inline_connector |
| BS3B:2 | | {EO 2 B} | inline_connector |
| BS3B:3 | | {EO 3 B} | inline_connector |
| BS3B:4 | | {EO 3 B} | inline_connector |
| BS3B:8 | | {NA 2 B} | inline_connector |
| BS3B:9 | | {BB 3 C} | inline_connector |
| BS3B:10 | | {BA 4 A} | inline_connector |
| BS3B:11 | | {BA 4 A} | inline_connector |
| BS3B:12 | | {BA 4 A} | inline_connector |
| CAN:1 | | {XC 0 D} | inline_connector |
| CAN:2 | | {XC 0 D} | inline_connector |
| CAN:3 | | {XD 1 D} | inline_connector |
| CAN:4 | | {XD 1 D} | inline_connector |
| CAN:5 | | {CV 3 D} | inline_connector |
| CAN:6 | | {CV 3 D} | inline_connector |
| CAN_EMS:1 | | {XD 0 D} | inline_connector |
| CAN_EMS:2 | | {XD 0 D} | inline_connector |
| CAN_EMS:3 | | {XC 2 D} | inline_connector |
| CAN_EMS:4 | | {XC 2 C} | inline_connector |
| CAN_RAS:1 | | {XD 0 C} | inline_connector |
| CAN_RAS:2 | | {XD 0 C} | inline_connector |
| CAN_RAS:3 | | {XC 3 C} | inline_connector |
| CAN_RAS:4 | | {XC 3 C} | inline_connector |

VOLVO

Volvo Bus Corporation

Document Title

WIRING DIAGRAM

Document Type

PRODUCT SCHEMATIC

Document No

20904123

Issue Index

15

Volume No

02(02)

Page No

31(76)

| Part Name | Description | Location | Part Type |
|------------------|-------------|----------|------------------|
| CNG:1 | | {CG 1 D} | inline_connector |
| CNG:2 | | {CG 2 D} | inline_connector |
| CNG:3 | | {CG 2 D} | inline_connector |
| CNG:4 | | {CG 2 D} | inline_connector |
| CNG:5 | | {CG 3 D} | inline_connector |
| CNG:6 | | {CG 3 D} | inline_connector |
| CNG:7 | | {CG 3 D} | inline_connector |
| CNG:8 | | {CG 0 D} | inline_connector |
| CNG:9 | | {CG 4 D} | inline_connector |
| CNG_CONVERTER:1 | | {CF 1 E} | inline_connector |
| CNG_CONVERTER:2 | | {CF 1 E} | inline_connector |
| CNG_CONVERTER:3 | | {CF 0 E} | inline_connector |
| CNG_CONVERTER:4 | | {CF 2 E} | inline_connector |
| CNG_CONVERTER:5 | | {CF 2 E} | inline_connector |
| CNG_CONVERTER:6 | | {CF 2 E} | inline_connector |
| CNG_CONVERTER:7 | | {CF 1 E} | inline_connector |
| CNG_CONVERTER:8 | | {CF 1 E} | inline_connector |
| CNG_CONVERTER:9 | | {CF 0 C} | inline_connector |
| CNG_CONVERTER:10 | | {CF 0 C} | inline_connector |
| CNG_CONVERTER:11 | | {CF 0 C} | inline_connector |
| CNG_CONVERTER:12 | | {CF 0 C} | inline_connector |
| CNG_CONVERTER:13 | | {CE 3 C} | inline_connector |
| CNPB1:1 | | {NA 3 B} | inline_connector |
| CNPB1:2 | | {NF 3 A} | inline_connector |
| CNPB1:3 | | {NF 3 A} | inline_connector |
| CNPB1:4 | | {NF 3 A} | inline_connector |
| CNPB1:5 | | {NF 3 A} | inline_connector |
| CNPB1:6 | | {NF 3 A} | inline_connector |
| CNPB1:7 | | {NF 2 A} | inline_connector |
| CNPB1:8 | | {NF 2 A} | inline_connector |
| CNPB1:9 | | {NF 2 A} | inline_connector |
| CNPB1:10 | | {NF 2 A} | inline_connector |
| CNPB1:11 | | {NF 2 A} | inline_connector |
| CNPB1:12 | | {NF 2 A} | inline_connector |
| CNPB1:13 | | {NF 2 A} | inline_connector |
| CNPB1:14 | | {NF 1 A} | inline_connector |
| CNPB1:15 | | {NF 1 A} | inline_connector |
| CNPB1:16 | | {NF 1 A} | inline_connector |
| CNPB1:17 | | {NF 2 A} | inline_connector |
| CNPB1:18 | | {NF 2 A} | inline_connector |
| CNPB1:19 | | {NG 3 D} | inline_connector |
| CNPB1:20 | | {NG 2 D} | inline_connector |
| CNPB1:21 | | {NG 2 D} | inline_connector |
| CNPB1:22 | | {NG 3 B} | inline_connector |
| CNPB1:23 | | {NG 3 B} | inline_connector |
| CNPB1:24 | | {NG 3 C} | inline_connector |
| CNPB1:25 | | {NG 3 B} | inline_connector |
| CNPB2:1 | | {NF 1 A} | inline_connector |
| CNPB2:2 | | {NF 1 A} | inline_connector |
| CNPB2:3 | | {NF 1 A} | inline_connector |
| CNPB2:4 | | {NF 1 A} | inline_connector |
| CNPB2:5 | | {NF 1 A} | inline_connector |
| CNPB2:6 | | {NF 1 C} | inline_connector |

VOLVO

Volvo Bus Corporation

Document Title

WIRING DIAGRAM

Document Type

PRODUCT SCHEMATIC

Document No

20904123

Issue Index

15

Volume No

02(02)

Page No

32(76)

| Part Name | Description | Location | Part Type |
|-----------|---------------------|----------|------------------|
| CNPB2:7 | | {NF 1 C} | inline_connector |
| CNPB2:8 | | {NF 1 C} | inline_connector |
| CNPB2:9 | | {NF 0 C} | inline_connector |
| CNPB2:10 | | {NG 2 D} | inline_connector |
| CNPB2:11 | | {NG 2 D} | inline_connector |
| CNPB2:12 | | {NG 2 D} | inline_connector |
| CNPB2:13 | | {NG 3 D} | inline_connector |
| CNPB2:14 | | {NG 0 D} | inline_connector |
| CNPB2:15 | | {NG 0 D} | inline_connector |
| CNPB2:16 | | {NG 0 C} | inline_connector |
| CNPB2:17 | | {NG 0 C} | inline_connector |
| CNPB2:19 | | {NG 1 C} | inline_connector |
| CNPB2:21 | | {NG 1 C} | inline_connector |
| CNPB2:22 | | {NG 1 D} | inline_connector |
| CNPB2:23 | | {NG 1 C} | inline_connector |
| CNPB2:24 | | {NG 1 D} | inline_connector |
| CNPB3:1 | | {AA 1 C} | inline_connector |
| CNPB3:2 | | {AA 0 B} | inline_connector |
| CNPB3:3 | Externa main switch | {AA 0 B} | inline_connector |
| CNPB3:4 | | {NF 1 D} | inline_connector |
| CNPB3:5 | | {NF 1 D} | inline_connector |
| CNPB3:6 | | {NF 1 D} | inline_connector |
| CNPB3:7 | | {NF 1 C} | inline_connector |
| CNPB3:8 | | {NF 0 D} | inline_connector |
| CNPB3:9 | | {NF 1 D} | inline_connector |
| CNPB3:10 | | {NF 1 D} | inline_connector |
| CNPB3:11 | | {NF 1 D} | inline_connector |
| CNPB3:12 | | {NF 1 D} | inline_connector |
| CNPB3:13 | | {NF 2 D} | inline_connector |
| CNPB3:14 | | {NF 2 D} | inline_connector |
| CNPB3:15 | | {NF 2 D} | inline_connector |
| CNPB3:16 | | {NF 2 D} | inline_connector |
| CNPB3:17 | | {NF 2 D} | inline_connector |
| CNPB3:18 | | {NF 2 D} | inline_connector |
| CNPB3:19 | | {NF 2 D} | inline_connector |
| CNPB3:20 | | {NF 2 D} | inline_connector |
| CNPB3:21 | | {NF 0 D} | inline_connector |
| CNPB3:22 | | {NF 0 D} | inline_connector |
| CNPB3:23 | | {NF 3 D} | inline_connector |
| CNPB3:24 | | {NF 3 D} | inline_connector |
| CNPB3:25 | | {ZC 0 D} | inline_connector |
| CNPB4:1 | | {NG 0 A} | inline_connector |
| CNPB4:2 | | {NG 0 B} | inline_connector |
| CNPB4:3 | | {NG 0 B} | inline_connector |
| CNPB4:4 | | {NG 0 A} | inline_connector |
| CNPB4:5 | | {NG 0 B} | inline_connector |
| CNPB4:6 | | {NG 0 B} | inline_connector |
| CNPB4:7 | | {NG 0 A} | inline_connector |
| CNPB4:8 | | {NG 0 B} | inline_connector |
| CNPB4:9 | | {NG 0 B} | inline_connector |
| CNPB4:10 | | {NG 0 A} | inline_connector |
| CNPB4:11 | | {NG 0 B} | inline_connector |
| CNPB4:12 | | {NG 0 B} | inline_connector |

VOLVO

Volvo Bus Corporation

Document Title

WIRING DIAGRAM

Document Type

PRODUCT SCHEMATIC

Document No

20904123

Issue Index

15

Volume No

02(02)

Page No

33(76)

| Part Name | Description | Location | Part Type |
|-----------------|-------------|----------|------------------|
| CNPB4:13 | | {NG 1 A} | inline_connector |
| CNPB4:14 | | {NG 1 B} | inline_connector |
| CNPB4:15 | | {NG 1 B} | inline_connector |
| CNPB4:16 | | {NG 1 A} | inline_connector |
| CNPB4:17 | | {NG 1 B} | inline_connector |
| CNPB4:18 | | {NG 1 B} | inline_connector |
| CNPB4:19 | | {NF 0 A} | inline_connector |
| CNPB4:20 | | {NF 0 A} | inline_connector |
| DBUS_EXT_plug:1 | | {CL 2 D} | inline_connector |
| DBUS_EXT_plug:2 | | {CL 2 D} | inline_connector |
| DBUS_INT:1 | | {CL 2 A} | inline_connector |
| DBUS_INT:2 | | {CL 1 A} | inline_connector |
| DF:1 | | {NC 2 B} | inline_connector |
| DF:2 | | {NC 0 B} | inline_connector |
| DF:3 | | {NC 0 C} | inline_connector |
| DF:4 | | {XD 1 A} | inline_connector |
| DF:5 | | {XD 1 A} | inline_connector |
| DF:6 | | {NC 1 B} | inline_connector |
| DF:11 | | {NC 1 D} | inline_connector |
| ECS1:1 | | {FA 1 D} | inline_connector |
| ECS1:2 | | {FA 1 D} | inline_connector |
| ECS1:3 | | {FA 0 D} | inline_connector |
| ECS1:4 | | {FB 0 B} | inline_connector |
| ECS1:5 | | {FB 0 B} | inline_connector |
| ECS1:6 | | {FB 2 B} | inline_connector |
| ECS1:7 | | {FB 4 B} | inline_connector |
| | | {FB 3 B} | |
| ECS1:8 | | {FB 0 C} | inline_connector |
| ECS1:9 | | {FB 0 B} | inline_connector |
| ECS1:10 | | {FB 3 B} | inline_connector |
| ECS1:11 | | {FB 3 B} | inline_connector |
| ECS1:12 | | {FA 1 C} | inline_connector |
| ECS2.A1:1 | | {FA 2 B} | inline_connector |
| ECS2.A1:2 | | {FA 2 B} | inline_connector |
| ECS2.A1:3 | | {FA 2 B} | inline_connector |
| ECS2.A1:4 | | {FB 0 D} | inline_connector |
| ECS2.A1:5 | | {FB 0 D} | inline_connector |
| ECS2.A1:6 | | {FB 1 D} | inline_connector |
| ECS2.A1:7 | | {FB 2 D} | inline_connector |
| ECS2.A1:8 | | {FB 0 D} | inline_connector |
| ECS2.A1:9 | | {FB 0 D} | inline_connector |
| ECS2.A1:10 | | {FB 3 B} | inline_connector |
| ECS2.A1:11 | | {FB 2 B} | inline_connector |
| ECS2.A1:12 | | {FA 0 A} | inline_connector |
| ECS2.A2:1 | | {FA 0 C} | inline_connector |
| ECS2.A2:2 | | {FA 0 C} | inline_connector |
| ECS2.A2:3 | | {FA 0 C} | inline_connector |
| ECS2.A2:4 | | {FB 0 D} | inline_connector |
| ECS2.A2:5 | | {FB 1 D} | inline_connector |
| ECS2.A2:6 | | {FB 3 B} | inline_connector |
| ECS2.A2:7 | | {FB 4 B} | inline_connector |
| ECS2.A2:8 | | {FB 0 D} | inline_connector |
| ECS2.A2:9 | | {FB 0 D} | inline_connector |

VOLVO

Volvo Bus Corporation

Document Title

WIRING DIAGRAM

Document Type

PRODUCT SCHEMATIC

Document No

20904123

Issue Index

15

Volume No

02(02)

Page No

34(76)

| Part Name | Description | Location | Part Type |
|------------|-------------|----------|------------------|
| ECS2.A2:10 | | {FB 3 B} | inline_connector |
| ECS2.A2:11 | | {FB 2 B} | inline_connector |
| ECS2.A2:12 | | {FA 1 A} | inline_connector |
| ECS2.A3:1 | | {FA 0 C} | inline_connector |
| ECS2.A3:2 | | {FA 0 C} | inline_connector |
| ECS2.A3:3 | | {FA 0 C} | inline_connector |
| ECS2.A3:4 | | {FB 0 E} | inline_connector |
| ECS2.A3:5 | | {FB 1 E} | inline_connector |
| ECS2.A3:6 | | {FB 3 C} | inline_connector |
| ECS2.A3:7 | | {FB 4 C} | inline_connector |
| ECS2.A3:8 | | {FB 0 E} | inline_connector |
| ECS2.A3:9 | | {FB 0 E} | inline_connector |
| ECS2.A3:10 | | {FB 3 C} | inline_connector |
| ECS2.A3:11 | | {FB 2 C} | inline_connector |
| ECS2.A3:12 | | {FA 0 A} | inline_connector |
| ECS2:1 | | {FA 0 D} | inline_connector |
| ECS2:2 | | {FA 0 D} | inline_connector |
| ECS2:3 | | {FA 0 D} | inline_connector |
| ECS2:4 | | {FB 0 B} | inline_connector |
| ECS2:5 | | {FB 1 B} | inline_connector |
| ECS2:6 | | {FB 1 D} | inline_connector |
| ECS2:7 | | {FB 2 B} | inline_connector |
| ECS2:8 | | {FB 1 D} | |
| ECS2:8 | | {FB 0 B} | inline_connector |
| ECS2:9 | | {FB 0 B} | inline_connector |
| ECS2:10 | | {FB 3 B} | inline_connector |
| ECS2:10 | | {FB 1 D} | |
| ECS2:11 | | {FB 2 B} | inline_connector |
| ECS2:11 | | {FB 1 D} | |
| ECS2:12 | | {FA 0 B} | inline_connector |
| ECS2B:1 | | {FA 0 C} | inline_connector |
| ECS2B:2 | | {FA 0 C} | inline_connector |
| ECS2B:3 | | {FA 0 C} | inline_connector |
| ECS2B:4 | | {FB 0 B} | inline_connector |
| ECS2B:5 | | {FB 1 B} | inline_connector |
| ECS2B:6 | | {FB 1 D} | inline_connector |
| ECS2B:7 | | {FB 1 D} | inline_connector |
| ECS2B:8 | | {FB 0 B} | inline_connector |
| ECS2B:9 | | {FB 0 B} | inline_connector |
| ECS2B:10 | | {FB 1 D} | inline_connector |
| ECS2B:11 | | {FB 1 D} | inline_connector |
| ECS2B:12 | | {FA 0 B} | inline_connector |
| EGS_C:1 | | {DA 3 D} | inline_connector |
| EMS.A1:1 | | {BA 0 D} | inline_connector |
| EMS.A1:2 | | {XC 3 D} | inline_connector |
| EMS.A1:3 | | {XC 3 D} | inline_connector |
| EMS.A1:6 | | {BA 2 B} | inline_connector |
| EMS.A1:7 | | {BA 2 B} | inline_connector |
| EMS.A1:8 | | {BA 1 E} | inline_connector |
| EMS.A1:9 | | {BA 1 C} | inline_connector |
| EMS.A1:10 | | {ZC 1 D} | inline_connector |
| EMS.A1:11 | | {BB 4 C} | inline_connector |

VOLVO

Volvo Bus Corporation

Document Title

WIRING DIAGRAM

Document Type

PRODUCT SCHEMATIC

Document No

20904123

Issue Index

15

Volume No

02(02)

Page No

35(76)

| Part Name | Description | Location | Part Type |
|-----------|-------------|----------------------------------|------------------|
| EMS.A1:12 | | {AC 1 B} | inline_connector |
| EMS.A2:1 | | {BA 0 D} | inline_connector |
| EMS.A2:2 | | {XC 3 D} | inline_connector |
| EMS.A2:3 | | {XC 3 D} | inline_connector |
| EMS.A2:6 | | {BA 3 B} | inline_connector |
| EMS.A2:7 | | {BA 2 B} | inline_connector |
| EMS.A2:8 | | {FC 2 C} | inline_connector |
| EMS.A2:9 | | {BA 1 C} | inline_connector |
| EMS.A2:10 | | {ZC 1 C} | inline_connector |
| EMS.A2:11 | | {BB 4 B} | inline_connector |
| EMS.A2:12 | | {AC 1 B} | inline_connector |
| EMS.A3:1 | | {BA 0 D} | inline_connector |
| EMS.A3:2 | | {XC 2 D} | inline_connector |
| EMS.A3:3 | | {XC 2 D} | inline_connector |
| EMS.A3:4 | | {XD 2 D} | inline_connector |
| EMS.A3:5 | | {XD 2 D} | inline_connector |
| EMS.A3:6 | | {BA 3 B} | inline_connector |
| EMS.A3:7 | | {BA 1 B} | inline_connector |
| EMS.A3:9 | | {BA 1 C} | inline_connector |
| EMS.A3:10 | | {ZC 1 C} | inline_connector |
| EMS.A3:11 | | {BB 4 A} | inline_connector |
| EMS.A3:12 | | {AC 1 C} | inline_connector |
| EMS:1 | | {BA 0 D} | inline_connector |
| EMS:2 | | {XC 3 D} {XC 3 C} {DQ 3 B} | inline_connector |
| EMS:3 | | {XC 3 D} {XC 3 C} {DQ 3 B} | inline_connector |
| EMS:4 | | {XD 0 B} | inline_connector |
| EMS:5 | | {XD 0 B} | inline_connector |
| EMS:6 | | {BA 2 A} | inline_connector |
| EMS:7 | | {BA 2 A} | inline_connector |
| EMS:8 | | {BA 1 E} | inline_connector |
| EMS:9 | | {BA 0 C} | inline_connector |
| EMS:10 | | {ZC 1 D} | inline_connector |
| EMS:11 | | {BB 3 C} | inline_connector |
| EMS:12 | | {AC 2 B} | inline_connector |
| EMSB:1 | | {CA 0 B} | inline_connector |
| EMSB:2 | | {XC 1 C} | inline_connector |
| EMSB:3 | | {XC 1 C} | inline_connector |
| EMSB:4 | | {XD 0 C} | inline_connector |
| EMSB:5 | | {XD 0 C} | inline_connector |
| EMSB:6 | | {CA 4 A} | inline_connector |
| EMSB:7 | | {CA 0 A} | inline_connector |
| EMSB:9 | | {CA 1 A} | inline_connector |
| EMSB:10 | | {CA 3 A} | inline_connector |
| EMSB:12 | | {CO 1 C} | inline_connector |
| ENG1.A1:1 | | {AA 3 D} | inline_connector |
| ENG1.A1:2 | | {AA 4 C} | inline_connector |
| ENG1.A1:3 | | {BD 2 D} | inline_connector |
| ENG1.A1:4 | | {AA 3 C} | inline_connector |
| ENG1.A1:5 | | {BD 2 A} | inline_connector |

VOLVO

Volvo Bus Corporation

Document Title

WIRING DIAGRAM

Document Type

PRODUCT SCHEMATIC

Document No

20904123

Issue Index

15

Volume No

02(02)

Page No

36(76)

| Part Name | Description | Location | Part Type |
|------------|-------------|----------|------------------|
| ENG1.A1:6 | | {AG 1 B} | inline_connector |
| ENG1.A1:7 | | {AC 1 D} | inline_connector |
| ENG1.A1:8 | | {AC 1 C} | inline_connector |
| ENG1.A1:9 | | {AC 4 C} | inline_connector |
| ENG1.A1:10 | | {NA 4 C} | inline_connector |
| ENG1.A1:11 | | {NA 0 B} | inline_connector |
| ENG1.A1:12 | | {ZC 2 D} | inline_connector |
| ENG1.A2:1 | | {AA 3 D} | inline_connector |
| ENG1.A2:2 | | {AG 1 B} | inline_connector |
| ENG1.A2:3 | | {BD 2 D} | inline_connector |
| ENG1.A2:4 | | {AG 1 C} | inline_connector |
| ENG1.A2:5 | | {BD 2 A} | inline_connector |
| ENG1.A2:6 | | {AG 1 B} | inline_connector |
| ENG1.A2:7 | | {AC 1 D} | inline_connector |
| ENG1.A2:8 | | {AG 1 C} | inline_connector |
| ENG1.A2:9 | | {AC 4 C} | inline_connector |
| ENG1.A2:10 | | {NA 4 C} | inline_connector |
| ENG1.A2:11 | | {NA 0 B} | inline_connector |
| ENG1.A2:12 | | {ZC 2 C} | inline_connector |
| ENG1.A3:1 | | {AA 4 D} | inline_connector |
| ENG1.A3:2 | | {AG 1 C} | inline_connector |
| ENG1.A3:3 | | {BD 3 D} | inline_connector |
| ENG1.A3:4 | | {AG 1 C} | inline_connector |
| ENG1.A3:5 | | {BD 3 A} | inline_connector |
| ENG1.A3:6 | | {AG 1 C} | inline_connector |
| ENG1.A3:7 | | {AC 1 E} | inline_connector |
| ENG1.A3:8 | | {AG 1 C} | inline_connector |
| ENG1.A3:9 | | {AC 4 D} | inline_connector |
| ENG1.A3:11 | | {NA 0 A} | inline_connector |
| ENG1:1 | | {AA 3 D} | inline_connector |
| ENG1:2 | | {AA 4 C} | inline_connector |
| ENG1:3 | | {BD 1 D} | inline_connector |
| ENG1:4 | | {AA 3 C} | inline_connector |
| ENG1:5 | | {BD 1 B} | inline_connector |
| ENG1:6 | | {AG 0 B} | inline_connector |
| ENG1:7 | | {AC 0 D} | inline_connector |
| ENG1:8 | | {AC 1 C} | inline_connector |
| ENG1:9 | | {AC 4 D} | inline_connector |
| ENG1:10 | | {NA 4 C} | inline_connector |
| ENG1:11 | | {NA 4 A} | inline_connector |
| | | {NA 0 B} | |
| ENG1:12 | | {ZC 2 D} | inline_connector |
| ENG1B:1 | | {AA 3 D} | inline_connector |
| ENG1B:2 | | {AG 1 D} | inline_connector |
| | | {AG 2 D} | |
| ENG1B:3 | | {BD 3 D} | inline_connector |
| | | {BD 0 D} | |
| ENG1B:4 | | {AG 1 D} | inline_connector |
| | | {AG 2 C} | |
| ENG1B:5 | | {BD 3 B} | inline_connector |
| | | {BD 0 B} | |
| ENG1B:6 | | {AG 1 D} | inline_connector |
| | | {AG 2 C} | |

VOLVO

Volvo Bus Corporation

Document Title

WIRING DIAGRAM

Document Type

PRODUCT SCHEMATIC

Document No

20904123

Issue Index

15

Volume No

02(02)

Page No

37(76)

| Part Name | Description | Location | Part Type |
|-----------|-------------|--|------------------|
| ENG1B:7 | | {AE 0 C} | inline_connector |
| ENG1B:8 | | {AG 1 D} {AG 2 C} | inline_connector |
| ENG1B:9 | | {AE 4 B} | inline_connector |
| ENG1B:11 | | {NA 1 A} | inline_connector |
| ESI1:1 | | {CH 1 C} | inline_connector |
| ESI1:2 | | {CH 1 D} | inline_connector |
| ESI2:1 | | {CH 2 D} | inline_connector |
| ESI2:2 | | {CH 2 D} | inline_connector |
| ESI2:3 | | {CH 2 D} | inline_connector |
| ESI2:4 | | {CH 2 D} | inline_connector |
| EU4.A1:1 | | {CO 0 B} | inline_connector |
| EU4.A1:2 | | {CO 1 B} | inline_connector |
| EU4.A1:3 | | {NA 1 D} | inline_connector |
| EU4.A1:8 | | {BA 0 B} | inline_connector |
| EU4.A1:9 | | {AC 2 B} | inline_connector |
| EU4.A1:10 | | {CU 0 A} | inline_connector |
| EU4.A1:11 | | {CV 4 B} | inline_connector |
| EU4.A1:12 | | {CV 4 B} | inline_connector |
| EU4.A2:1 | | {CO 0 B} | inline_connector |
| EU4.A2:2 | | {CO 1 B} | inline_connector |
| EU4.A2:3 | | {NA 1 D} | inline_connector |
| EU4.A2:8 | | {BA 1 B} | inline_connector |
| EU4.A2:9 | | {AC 2 B} | inline_connector |
| EU4.A2:10 | | {CU 0 A} | inline_connector |
| EU4.A2:11 | | {CV 3 B} | inline_connector |
| EU4.A2:12 | | {CV 3 B} | inline_connector |
| EU4.A3:1 | | {CO 0 C} | inline_connector |
| EU4.A3:2 | | {CO 1 C} | inline_connector |
| EU4.A3:3 | | {NA 1 E} | inline_connector |
| EU4.A3:8 | | {BA 1 B} | inline_connector |
| EU4.A3:9 | | {AC 2 C} | inline_connector |
| EU4.A3:10 | | {CU 0 B} | inline_connector |
| EU4.A3:11 | | {CV 3 B} | inline_connector |
| EU4.A3:12 | | {CV 3 B} | inline_connector |
| EU4:1 | | {CO 0 B} | inline_connector |
| EU4:2 | | {CO 1 B} | inline_connector |
| EU4:3 | | {NA 1 D} | inline_connector |
| EU4:4 | | {EO 3 D} | inline_connector |
| EU4:5 | | {EO 4 D} | inline_connector |
| EU4:6 | | {EO 4 D} | inline_connector |
| EU4:7 | | {EO 4 D} | inline_connector |
| EU4:8 | | {BA 1 B} | inline_connector |
| EU4:9 | | {AC 2 B} | inline_connector |
| EU4:10 | | {CU 0 A} | inline_connector |
| EU4:11 | | {CV 3 A} {CV 3 A} {CV 3 B} {CV 3 C} | inline_connector |
| EU4:12 | | {CV 3 B} {CV 3 A} {CV 3 B} {CV 3 C} | inline_connector |

VOLVO

Volvo Bus Corporation

Document Title

WIRING DIAGRAM

Document Type

PRODUCT SCHEMATIC

Document No

20904123

Issue Index

15

Volume No

02(02)

Page No

38(76)

| Part Name | Description | Location | Part Type |
|-----------|-------------|-----------|------------------|
| EU4B:1 | | {CO 0 C} | inline_connector |
| EU4B:2 | | {CO 1 C} | inline_connector |
| EU4B:3 | | {NA 2 C} | inline_connector |
| EU4B:8 | | {CA 1 B} | inline_connector |
| EU4B:9 | | {CA 2 A} | inline_connector |
| EU4B:11 | | {CV 2 C} | inline_connector |
| EU4B:12 | | {CV 2 C} | inline_connector |
| FAN:1 | | {CA2 4 C} | inline_connector |
| FAN:2 | | {CA2 4 C} | inline_connector |
| FEED:1 | | {BA 0 A} | inline_connector |
| FEEDX:1 | | {GN 1 A} | inline_connector |
| FH1A:1 | | {DN 1 B} | inline_connector |
| FH1A:2 | | {DN 1 B} | inline_connector |
| FH1A:3 | | {DN 1 A} | inline_connector |
| FH1A:4 | | {EX 1 B} | inline_connector |
| FH1A:6 | | {IS 3 A} | inline_connector |
| FH1A:7 | | {FA 4 A} | inline_connector |
| FH1A:8 | | {EO 0 B} | inline_connector |
| FH1A:10 | | {NA 3 A} | inline_connector |
| FH1A:11 | | {AC 0 A} | inline_connector |
| FH1A:12 | | {AC 0 A} | inline_connector |
| FH1B:1 | | {BA 0 A} | inline_connector |
| FH1B:2 | | {BA 0 A} | inline_connector |
| FH1B:3 | | {BA 0 A} | inline_connector |
| FH1B:4 | | {AG 0 A} | inline_connector |
| FH1B:6 | | {BB 0 A} | inline_connector |
| FH1B:7 | | {BB 0 A} | inline_connector |
| FH1B:8 | | {CO 0 A} | inline_connector |
| FH1B:10 | | {NC 0 B} | inline_connector |
| FH1B:11 | | {BB 0 A} | inline_connector |
| FH2A:1 | | {GM 2 A} | inline_connector |
| FH2A:2 | | {DC 1 A} | inline_connector |
| FH2A:3 | | {NE 1 A} | inline_connector |
| FH2A:4 | | {EO 0 B} | inline_connector |
| FH2A:5 | | {AA 3 A} | inline_connector |
| FH2A:6 | | {NA 3 A} | inline_connector |
| FH2A:7 | | {AC 2 A} | inline_connector |
| FH2A:8 | | {AC 4 A} | inline_connector |
| FH2A:9 | | {AC 3 A} | inline_connector |
| FH2B:1 | | {BB 0 A} | inline_connector |
| FH2B:2 | | {AC 2 A} | inline_connector |
| FH2B:3 | | {NA 0 A} | inline_connector |
| FH2B:4 | | {DM 1 A} | inline_connector |
| FH2B:5 | | {AA 3 A} | inline_connector |
| FH2B:6 | | {NB 0 A} | inline_connector |
| FH2B:7 | | {DA 0 A} | inline_connector |
| FH2B:8 | | {FA 4 A} | inline_connector |
| FH2B:9 | | {GM 1 A} | inline_connector |
| FH3A:1 | | {BA 2 A} | inline_connector |
| FH3A:2 | | {BA 2 A} | inline_connector |
| FH3A:3 | | {BA 0 A} | inline_connector |
| FH3A:4 | | {GA 2 A} | inline_connector |
| FH3A:5 | | {BB 4 A} | inline_connector |

VOLVO

Volvo Bus Corporation

Document Title

WIRING DIAGRAM

Document Type

PRODUCT SCHEMATIC

Document No

20904123

Issue Index

15

Volume No

02(02)

Page No

39(76)

| Part Name | Description | Location | Part Type |
|-----------|-------------|----------------------|------------------|
| FH3A:7 | | {NA 0 A} | inline_connector |
| FH3A:8 | | {BB 2 A} | inline_connector |
| FH3A:10 | | {DM 0 A} | inline_connector |
| FH3A:12 | | {IU 0 A} | inline_connector |
| FH3B:1 | | {CL 3 B} | inline_connector |
| FH3B:2 | | {CL 3 B} | inline_connector |
| FH3B:3 | | {CL 3 B} | inline_connector |
| FH3B:4 | | {AA 1 A} | inline_connector |
| FH3B:5 | | {GA 2 A} | inline_connector |
| FH3B:7 | | {CG 2 A} {CH 1 B} | inline_connector |
| FH3B:9 | | {GA 1 A} | inline_connector |
| FH3B:11 | | {DD 3 B} | inline_connector |
| FH3B:12 | | {DD 3 B} | inline_connector |
| FH4A:2 | | {CU 0 B} | inline_connector |
| FH4A:3 | | {CU 0 A} | inline_connector |
| FH4A:5 | | {GA 1 A} | inline_connector |
| FH4A:7 | | {NA 3 A} | inline_connector |
| FH4A:8 | | {GA 1 A} | inline_connector |
| FH4A:12 | | {GA 0 A} | inline_connector |
| FH4B:1 | | {GC 0 B} | inline_connector |
| FH4B:2 | | {GC 1 B} | inline_connector |
| FH4B:3 | | {GC 1 A} | inline_connector |
| FH4B:4 | | {IU 0 A} | inline_connector |
| FH4B:5 | | {GA 0 A} | inline_connector |
| FH4B:7 | | {AA 0 A} | inline_connector |
| FH4B:8 | | {GA 1 A} | inline_connector |
| FH4B:12 | | {GA 0 A} | inline_connector |
| FL2:1 | | {ZC 0 A} | inline_connector |
| FL2:2 | | {ZC 0 A} | inline_connector |
| FL2:3 | | {ZC 1 A} | inline_connector |
| FL2:4 | | {GB 2 D} | inline_connector |
| FL2:5 | | {GB 2 D} | inline_connector |
| FL2:6 | | {ZC 1 A} | inline_connector |
| FL2:7 | | {GB 0 E} | inline_connector |
| FL2:8 | | {GB 1 D} | inline_connector |
| FL2:9 | | {GB 1 D} | inline_connector |
| FL2:10 | | {GB 1 D} | inline_connector |
| FL2:11 | | {GB 0 B} | inline_connector |
| FL2:12 | | {ZC 1 A} | inline_connector |
| FL3:1 | | {ZC 0 A} | inline_connector |
| FL3:2 | | {ZC 0 A} | inline_connector |
| FL3:3 | | {ZC 0 A} | inline_connector |
| FL3:4 | | {GB 2 D} | inline_connector |
| FL3:5 | | {GB 2 D} | inline_connector |
| FL3:6 | | {ZC 0 A} | inline_connector |
| FL3:7 | | {GB 4 D} | inline_connector |
| FL3:8 | | {GB 3 D} | inline_connector |
| FL3:9 | | {GB 3 D} | inline_connector |
| FL3:10 | | {GB 3 D} | inline_connector |
| FL3:11 | | {GB 0 B} | inline_connector |
| FL3:12 | | {ZC 0 A} | inline_connector |
| FM:1 | | {ND 1 B} | inline_connector |

VOLVO

Volvo Bus Corporation

Document Title

WIRING DIAGRAM

Document Type

PRODUCT SCHEMATIC

Document No

20904123

Issue Index

15

Volume No

02(02)

Page No

40(76)

| Part Name | Description | Location | Part Type |
|-----------|-------------|----------------------|------------------|
| FM:2 | | {ND 1 B} | inline_connector |
| FM:3 | | {ND 1 B} | inline_connector |
| FM:4 | | {ND 1 B} | inline_connector |
| FS1:1 | | {BD 4 B} | inline_connector |
| FS1:2 | | {BD 4 C} | inline_connector |
| FTM:1 | | {CG 2 B} {CH 1 B} | inline_connector |
| FTM:2 | | {XD 4 D} | inline_connector |
| FTM:3 | | {XD 4 D} | inline_connector |
| FTM:4 | | {BC 2 B} {CH 0 C} | inline_connector |
| FTM:5 | | {BC 3 B} {CH 0 C} | inline_connector |
| FTM:6 | | {BC 2 D} {CH 0 C} | inline_connector |
| FTM:7 | | {BC 3 D} {CH 0 C} | inline_connector |
| FTM:8 | | {CG 0 A} | inline_connector |
| FTM:9 | | {AA 3 A} | inline_connector |
| FTM:10 | | {ZC 4 D} | inline_connector |
| FTM:11 | | {CG 1 A} | inline_connector |
| FTM:12 | | {CL 3 C} | inline_connector |
| FTM_J:4 | | {BC 2 C} | inline_connector |
| FTM_J:5 | | {BC 3 C} | inline_connector |
| FTM_J:6 | | {BC 2 D} | inline_connector |
| FTM_J:7 | | {BC 3 D} | inline_connector |
| FUEL.A1:1 | | {NA 4 C} | inline_connector |
| FUEL.A1:2 | | {NA 4 C} | inline_connector |
| FUEL.A1:3 | | {NA 4 B} | inline_connector |
| FUEL.A1:5 | | {NA 3 A} | inline_connector |
| FUEL.A1:6 | | {NA 3 B} | inline_connector |
| FUEL:1 | | {NA 1 E} | inline_connector |
| FUEL:2 | | {NA 0 E} | inline_connector |
| FUEL:3 | | {NA 0 D} | inline_connector |
| FUEL:5 | | {NA 0 B} | inline_connector |
| FUEL:6 | | {NA 0 D} | inline_connector |
| FUEL:7 | | {FA 1 D} | inline_connector |
| FUEL:8 | | {FA 2 D} | inline_connector |
| FUEL:9 | | {FA 2 D} | inline_connector |
| FUEL:10 | | {FB 4 B} | inline_connector |
| FUEL:11 | | {FB 1 B} | inline_connector |
| FUEL_B:1 | | {NA 4 B} {NA 0 E} | inline_connector |
| FUEL_B:2 | | {NA 4 B} | inline_connector |
| FUEL_B:3 | | {NA 4 A} {NA 0 D} | inline_connector |
| FUEL_B:5 | | {NA 0 B} {NA 0 B} | inline_connector |
| FUEL_B:6 | | {NA 0 D} {NA 0 D} | inline_connector |
| FUEL_B:7 | | {FA 2 D} {FA 1 D} | inline_connector |
| FUEL_B:8 | | {FA 2 D} | inline_connector |

VOLVO

Volvo Bus Corporation

Document Title

WIRING DIAGRAM

Document Type

PRODUCT SCHEMATIC

Document No

20904123

Issue Index

15

Volume No

02(02)

Page No

41(76)

| Part Name | Description | Location | Part Type |
|-----------|-------------|----------|------------------|
| FUEL_B:9 | | {FA 2 D} | inline_connector |
| FUEL_B:10 | | {FB 4 B} | inline_connector |
| FUEL_B:11 | | {FB 1 B} | inline_connector |
| GB1.A3:1 | | {DB 0 D} | inline_connector |
| GB1.A3:2 | | {DB 1 B} | inline_connector |
| GB1.A3:3 | | {DB 1 A} | inline_connector |
| GB1.A3:4 | | {DB 0 D} | inline_connector |
| GB1.A3:5 | | {DB 2 B} | inline_connector |
| GB1.A3:7 | | {XC 3 E} | inline_connector |
| GB1.A3:8 | | {XC 3 E} | inline_connector |
| GB1.A3:9 | | {XD 3 C} | inline_connector |
| GB1.A3:10 | | {XD 3 C} | inline_connector |
| GB1:1 | | {DB 0 D} | inline_connector |
| GB1:2 | | {DB 1 B} | inline_connector |
| GB1:3 | | {DB 1 A} | inline_connector |
| GB1:4 | | {DB 1 D} | inline_connector |
| GB1:5 | | {DB 2 B} | inline_connector |
| GB1:7 | | {XC 4 E} | inline_connector |
| GB1:8 | | {XC 4 E} | inline_connector |
| GB1:9 | | {XD 3 D} | inline_connector |
| GB1:10 | | {XD 3 D} | inline_connector |
| GBX.A1:1 | | {DM 4 E} | inline_connector |
| GBX.A1:2 | | {DN 1 B} | inline_connector |
| GBX.A1:3 | | {DC 2 B} | inline_connector |
| GBX.A1:4 | | {DD 2 B} | inline_connector |
| GBX.A1:5 | | {DM 0 B} | inline_connector |
| GBX.A1:6 | | {DM 0 B} | inline_connector |
| GBX.A1:9 | | {XD 3 C} | inline_connector |
| GBX.A1:10 | | {XD 2 C} | inline_connector |
| GBX.A1:11 | | {DD 4 B} | inline_connector |
| GBX.A1:12 | | {DD 4 B} | inline_connector |
| GBX.A1:13 | | {NA 1 B} | inline_connector |
| GBX.A1:15 | | {DD 2 C} | inline_connector |
| GBX.A1:16 | | {DD 3 B} | inline_connector |
| GBX.A2:1 | | {DM 4 C} | inline_connector |
| GBX.A2:2 | | {DN 2 B} | inline_connector |
| GBX.A2:3 | | {DC 2 B} | inline_connector |
| GBX.A2:4 | | {DB 2 A} | inline_connector |
| GBX.A2:5 | | {DM 0 C} | inline_connector |
| GBX.A2:6 | | {DM 1 B} | inline_connector |
| GBX.A2:9 | | {XD 3 C} | inline_connector |
| GBX.A2:10 | | {XD 2 C} | inline_connector |
| GBX.A2:11 | | {DD 4 B} | inline_connector |
| GBX.A2:12 | | {DD 4 B} | inline_connector |
| GBX.A2:13 | | {NA 1 A} | inline_connector |
| GBX.A2:15 | | {DD 2 C} | inline_connector |
| GBX.A2:16 | | {DD 3 B} | inline_connector |
| GBX.A3:1 | | {DM 3 C} | inline_connector |
| GBX.A3:2 | | {DN 2 B} | inline_connector |
| GBX.A3:3 | | {DC 1 B} | inline_connector |
| GBX.A3:4 | | {DD 3 C} | inline_connector |
| GBX.A3:5 | | {DM 0 C} | inline_connector |
| GBX.A3:6 | | {DM 1 C} | inline_connector |

VOLVO

Volvo Bus Corporation

Document Title

WIRING DIAGRAM

Document Type

PRODUCT SCHEMATIC

Document No

20904123

Issue Index

15

Volume No

02(02)

Page No

42(76)

| Part Name | Description | Location | Part Type |
|-----------|-------------|----------|------------------|
| GBX.A3:9 | | {XD 3 D} | inline_connector |
| GBX.A3:10 | | {XD 2 D} | inline_connector |
| GBX.A3:11 | | {DD 4 B} | inline_connector |
| GBX.A3:12 | | {DD 4 B} | inline_connector |
| GBX.A3:13 | | {NA 1 B} | inline_connector |
| GBX.A3:15 | | {DD 2 D} | inline_connector |
| GBX.A3:16 | | {DD 3 B} | inline_connector |
| GBX:1 | | {DM 3 E} | inline_connector |
| GBX:2 | | {DN 1 B} | inline_connector |
| GBX:3 | | {DC 1 B} | inline_connector |
| GBX:4 | | {DD 3 B} | inline_connector |
| GBX:5 | | {DM 0 B} | inline_connector |
| GBX:6 | | {DM 0 C} | inline_connector |
| GBX:7 | | {XC 4 C} | inline_connector |
| GBX:8 | | {XC 4 C} | inline_connector |
| GBX:9 | | {XD 3 D} | inline_connector |
| GBX:10 | | {XD 3 D} | inline_connector |
| GBX:11 | | {DD 4 B} | inline_connector |
| GBX:12 | | {DD 4 B} | inline_connector |
| GBX:13 | | {NA 1 B} | inline_connector |
| GBX:14 | | {CC 4 C} | inline_connector |
| GBX:15 | | {DD 3 B} | inline_connector |
| GBX:16 | | {DD 3 B} | inline_connector |
| GBX:17 | | {BA 2 D} | inline_connector |
| GBX:18 | | {BA 2 D} | inline_connector |
| GBX_R:1 | | {DM 3 D} | inline_connector |
| GBX_R:2 | | {DN 1 B} | inline_connector |
| GBX_R:3 | | {DD 3 C} | inline_connector |
| GBX_R:4 | | {DD 3 C} | inline_connector |
| GBX_R:5 | | {DM 0 B} | inline_connector |
| GBX_R:6 | | {DM 0 C} | inline_connector |
| GBX_R:9 | | {XD 4 D} | inline_connector |
| GBX_R:10 | | {XD 3 D} | inline_connector |
| GBX_R:11 | | {DD 4 C} | inline_connector |
| GBX_R:12 | | {DD 4 C} | inline_connector |
| GBX_R:13 | | {NA 1 B} | inline_connector |
| GBX_R:14 | | {CC 4 C} | inline_connector |
| GBX_R:15 | | {DD 3 C} | inline_connector |
| GBX_R:16 | | {DD 3 C} | inline_connector |
| GBX_V:3 | | {DQ 2 B} | inline_connector |
| GBX_V:4 | | {DQ 0 C} | inline_connector |
| GBX_V:9 | | {DQ 1 C} | inline_connector |
| GBX_V:10 | | {DQ 1 C} | inline_connector |
| GBX_V:15 | | {DQ 2 D} | inline_connector |
| GBX_Z:1 | | {DP 3 C} | inline_connector |
| GBX_Z:3 | | {DP 2 C} | inline_connector |
| GBX_Z:4 | | {DP 2 C} | inline_connector |
| GBX_Z:11 | | {DP 1 C} | inline_connector |
| GBX_Z:12 | | {DP 1 C} | inline_connector |
| GBX_Z:15 | | {DP 3 C} | inline_connector |
| GBX_Z:16 | | {DP 2 C} | inline_connector |
| GND1UA:1 | | {CU 3 E} | inline_connector |
| GND1UB:1 | | {CU 3 E} | inline_connector |

VOLVO

Volvo Bus Corporation

Document Title

WIRING DIAGRAM

Document Type

PRODUCT SCHEMATIC

Document No

20904123

Issue Index

15

Volume No

02(02)

Page No

43(76)

| Part Name | Description | Location | Part Type |
|-----------|-------------|----------|------------------|
| GS1.A1:3 | | {DB 2 A} | inline_connector |
| GS1.A1:4 | | {DB 2 A} | inline_connector |
| GS1.A1:5 | | {DB 3 B} | inline_connector |
| GS1.A2:3 | | {DB 2 B} | inline_connector |
| GS1.A2:4 | | {DB 2 B} | inline_connector |
| GS1.A2:5 | | {DB 3 B} | inline_connector |
| GS1.A3:3 | | {DB 2 B} | inline_connector |
| GS1.A3:4 | | {DB 2 B} | inline_connector |
| GS1.A3:5 | | {DB 3 B} | inline_connector |
| GS1:3 | | {DB 3 B} | inline_connector |
| GS1:4 | | {DB 3 B} | inline_connector |
| GS1:5 | | {DB 3 B} | inline_connector |
| IB1:1 | | {NA 3 B} | inline_connector |
| IB1:2 | | {NA 2 D} | inline_connector |
| IB1:3 | | {NA 2 D} | inline_connector |
| IB1:4 | | {NA 2 D} | inline_connector |
| IB1:5 | | {NA 2 D} | inline_connector |
| IB1:6 | | {NA 2 D} | inline_connector |
| IB1:7 | | {NA 3 B} | inline_connector |
| IB1:8 | | {NA 2 C} | inline_connector |
| IB1:9 | | {NA 2 D} | inline_connector |
| IB1:10 | | {NA 2 B} | inline_connector |
| IB1:11 | | {NA 2 B} | inline_connector |
| IB1:12 | | {NA 1 C} | inline_connector |
| IB1:13 | | {NA 1 C} | inline_connector |
| IB1:14 | | {XC 1 A} | inline_connector |
| IB1:15 | | {XC 1 B} | inline_connector |
| IB1:16 | | {XD 1 A} | inline_connector |
| IB1:17 | | {XD 1 A} | inline_connector |
| IB1:18 | | {NA 3 B} | inline_connector |
| IB2:1 | | {NA 2 D} | inline_connector |
| IB2:2 | | {NA 1 D} | inline_connector |
| IB2:3 | | {NA 2 D} | inline_connector |
| IB2:4 | | {NA 2 D} | inline_connector |
| IB2:5 | | {NA 1 B} | inline_connector |
| IB2:6 | | {NA 1 D} | inline_connector |
| IB2:7 | | {GC 1 A} | inline_connector |
| IB2:8 | | {ZC 0 D} | inline_connector |
| IB2:9 | | {GA 2 B} | inline_connector |
| IB2:10 | | {EX 1 C} | inline_connector |
| IB2:11 | | {IS 2 D} | inline_connector |
| IB2:12 | | {IS 3 D} | inline_connector |
| IB2:13 | | {EP 2 C} | inline_connector |
| IB2:14 | | {EP 2 C} | inline_connector |
| IB2:15 | | {EP 2 C} | inline_connector |
| IB2:16 | | {EP 2 C} | inline_connector |
| IB2:17 | | {AA 1 B} | inline_connector |
| IB2:18 | | {NC 0 B} | inline_connector |
| IB3:1 | | {BA 3 B} | inline_connector |
| IB3:2 | | {BA 3 B} | inline_connector |
| IB3:3 | | {BA 3 B} | inline_connector |
| IB3:4 | | {BA 3 C} | inline_connector |
| IB3:5 | | {BA 3 B} | inline_connector |

VOLVO

Volvo Bus Corporation

Document Title

WIRING DIAGRAM

Document Type

PRODUCT SCHEMATIC

Document No

20904123

Issue Index

15

Volume No

02(02)

Page No

44(76)

| Part Name | Description | Location | Part Type |
|-----------|-------------|----------------------|------------------|
| IB3:6 | | {BA 3 D} | inline_connector |
| IB3:7 | | {BA 2 C} | inline_connector |
| IB3:8 | | {BA 2 C} | inline_connector |
| IB3:9 | | {BA 1 C} | inline_connector |
| IB3:10 | | {BA 2 C} | inline_connector |
| IB3:11 | | {BA 1 C} | inline_connector |
| IB3:12 | | {BA 1 C} | inline_connector |
| IB3:13 | | {BA 3 C} | inline_connector |
| IB3:14 | | {IU 0 A} | inline_connector |
| IB3:15 | | {IU 0 A} | inline_connector |
| IB3:16 | | {IU 0 B} | inline_connector |
| IB3:17 | | {AC 3 B} | inline_connector |
| IB3:18 | | {ZC 0 D} | inline_connector |
| IB4:1 | | {GB 2 B} | inline_connector |
| IB4:2 | | {GB 1 B} | inline_connector |
| IB4:3 | | {GB 0 B} | inline_connector |
| IB4:4 | | {GB 1 B} | inline_connector |
| IB4:5 | | {GB 1 B} | inline_connector |
| IB4:6 | | {GA 2 C} | inline_connector |
| IB4:7 | | {GB 2 C} | inline_connector |
| IB4:8 | | {GB 1 B} | inline_connector |
| IB4:9 | | {GB 1 B} | inline_connector |
| IB4:10 | | {GB 2 B} | inline_connector |
| IB4:11 | | {GB 2 B} | inline_connector |
| IB4:12 | | {GB 3 B} | inline_connector |
| IB4:13 | | {GB 3 B} | inline_connector |
| IB4:14 | | {GB 2 B} {GB 3 B} | inline_connector |
| IB4:15 | | {EP 4 B} | inline_connector |
| IB4:16 | | {EP 4 B} | inline_connector |
| IB4:17 | | {EP 3 B} | inline_connector |
| IB4:18 | | {EP 3 B} | inline_connector |
| IB5:1 | | {EX 1 B} | inline_connector |
| IB5:2 | | {AA 2 B} | inline_connector |
| IB5:3 | | {BA 3 C} | inline_connector |
| IB5:4 | | {AA 1 C} | inline_connector |
| IB5:5 | | {AA 0 B} | inline_connector |
| IB5:6 | | {AA 1 D} | inline_connector |
| IB5:7 | | {AA 0 C} | inline_connector |
| IB5:8 | | {FA 1 B} | inline_connector |
| IB5:9 | | {FA 2 D} | inline_connector |
| IB5:10 | | {NA 4 D} | inline_connector |
| IB5:11 | | {FA 1 C} | inline_connector |
| IB5:12 | | {FA 1 C} | inline_connector |
| IB5:13 | | {AA 1 B} | inline_connector |
| IB5:14 | | {FA 3 D} | inline_connector |
| IB5:15 | | {FA 3 D} | inline_connector |
| IB5:16 | | {FA 2 D} | inline_connector |
| IB5:17 | | {EO 1 C} | inline_connector |
| IB5:18 | | {NA 1 C} | inline_connector |
| IB6:1 | | {NB 0 B} | inline_connector |
| IB6:2 | | {XC 2 C} | inline_connector |
| IB6:3 | | {XC 2 C} | inline_connector |

VOLVO

Volvo Bus Corporation

Document Title

WIRING DIAGRAM

Document Type

PRODUCT SCHEMATIC

Document No

20904123

Issue Index

15

Volume No

02(02)

Page No

45(76)

| Part Name | Description | Location | Part Type |
|-----------|-------------|----------|------------------|
| IB6:4 | | {NB 0 B} | inline_connector |
| IB6:5 | | {ZC 0 D} | inline_connector |
| IB6:6 | | {NB 1 B} | inline_connector |
| IB6:7 | | {NB 1 C} | inline_connector |
| IB6:8 | | {NB 1 C} | inline_connector |
| IB6:9 | | {NB 1 C} | inline_connector |
| IB6:10 | | {NB 1 C} | inline_connector |
| IB6:11 | | {CP 2 D} | inline_connector |
| IB6:12 | | {NB 2 C} | inline_connector |
| IB7:1 | | {GM 1 B} | inline_connector |
| IB7:2 | | {GB 4 B} | inline_connector |
| IB7:3 | | {GB 4 B} | inline_connector |
| IB7:4 | | {GM 3 B} | inline_connector |
| IB7:5 | | {CV 4 C} | inline_connector |
| IB7:6 | | {CV 4 C} | inline_connector |
| IB7:7 | | {NA 2 C} | inline_connector |
| IB7:8 | | {GM 3 C} | inline_connector |
| IB7:9 | | {CO 1 A} | inline_connector |
| IB7:10 | | {ZC 0 D} | inline_connector |
| IB7:11 | | {NA 2 D} | inline_connector |
| IB7:12 | | {GM 4 B} | inline_connector |
| IB8:1 | | {EO 0 B} | inline_connector |
| IB8:2 | | {EO 0 B} | inline_connector |
| IB8:3 | | {EO 1 B} | inline_connector |
| IB8:4 | | {EO 0 B} | inline_connector |
| IB8:5 | | {EO 0 B} | inline_connector |
| IB8:6 | | {DD 2 B} | inline_connector |
| IB8:7 | | {GB 4 B} | inline_connector |
| IB8:8 | | {CL 2 C} | inline_connector |
| IB8:9 | | {CL 2 D} | inline_connector |
| IB8:10 | | {CL 2 D} | inline_connector |
| IB8:11 | | {CL 1 B} | inline_connector |
| IB8:12 | | {CL 1 B} | inline_connector |
| IB9:1 | | {BA 1 D} | inline_connector |
| IB9:2 | | {BA 2 C} | inline_connector |
| IB9:3 | | {GE 1 A} | inline_connector |
| IB9:4 | | {ZC 0 D} | inline_connector |
| IB9:5 | | {GE 0 B} | inline_connector |
| IB9:6 | | {GA 4 D} | inline_connector |
| IB9:7 | | {BA 2 C} | inline_connector |
| IB9:8 | | {BA 2 C} | inline_connector |
| IB9:9 | | {BA 2 C} | inline_connector |
| IB9:10 | | {BA 2 C} | inline_connector |
| IB9:11 | | {BA 3 C} | inline_connector |
| IB9:12 | | {BA 2 C} | inline_connector |
| IB10:1 | | {DN 0 B} | inline_connector |
| IB10:2 | | {GA 3 B} | inline_connector |
| IB10:3 | | {BB 1 D} | inline_connector |
| IB10:4 | | {DA 1 B} | inline_connector |
| IB10:5 | | {DA 0 B} | inline_connector |
| IB10:6 | | {DA 0 B} | inline_connector |
| IB10:7 | | {DA 1 A} | inline_connector |
| IB10:8 | | {DN 1 B} | inline_connector |

VOLVO

Volvo Bus Corporation

Document Title

WIRING DIAGRAM

Document Type

PRODUCT SCHEMATIC

Document No

20904123

Issue Index

15

Volume No

02(02)

Page No

46(76)

| Part Name | Description | Location | Part Type |
|-------------|-------------|----------|------------------|
| IB10:9 | | {ZC 3 D} | inline_connector |
| IB10:10 | | {DM 4 B} | inline_connector |
| IB10:11 | | {DD 4 B} | inline_connector |
| IB10:12 | | {DD 4 B} | inline_connector |
| IB10_B:2 | | {GA 3 B} | inline_connector |
| IB10_B:3 | | {BB 0 D} | inline_connector |
| IB10_B:9 | | {ZC 4 C} | inline_connector |
| IB10_E:2 | | {DA 1 B} | inline_connector |
| IB10_E:3 | | {BB 1 D} | inline_connector |
| IB10_E:4 | | {DA 1 B} | inline_connector |
| IB10_E:5 | | {DA 0 C} | inline_connector |
| IB10_E:6 | | {DA 0 C} | inline_connector |
| IB10_E:7 | | {DA 1 A} | inline_connector |
| IB10_E:9 | | {ZC 4 C} | inline_connector |
| IB10_E:10 | | {DM 4 B} | inline_connector |
| IB10_I:1 | | {DN 0 B} | inline_connector |
| IB10_I:8 | | {DN 0 B} | inline_connector |
| IB10_I:9 | | {ZC 3 C} | inline_connector |
| IB10_I:10 | | {DM 4 B} | inline_connector |
| IB10_VO:9 | | {ZC 3 C} | inline_connector |
| IB10_VO:10 | | {DM 4 B} | inline_connector |
| IB10_VO:11 | | {DD 4 B} | inline_connector |
| IB10_VO:12 | | {DD 4 B} | inline_connector |
| IB10_ZF5:9 | | {ZC 3 C} | inline_connector |
| IB10_ZF5:10 | | {DM 4 B} | inline_connector |
| IB10_ZF5:11 | | {DD 4 B} | inline_connector |
| IB10_ZF5:12 | | {DD 4 B} | inline_connector |
| IB10_ZF:9 | | {ZC 3 C} | inline_connector |
| IB10_ZF:10 | | {DM 4 B} | inline_connector |
| IS:1 | | {XD 1 A} | inline_connector |
| IS:2 | | {XD 1 A} | inline_connector |
| IS:3 | | {XC 0 B} | inline_connector |
| IS:4 | | {XC 0 B} | inline_connector |
| KH1A:1 | | {FA 4 C} | inline_connector |
| KH1A:2 | | {FA 4 D} | inline_connector |
| KH1A:3 | | {FA 4 D} | inline_connector |
| KH1A:4 | | {CL 3 B} | inline_connector |
| KH1A:5 | | {FA 4 C} | inline_connector |
| KH1A:7 | | {CL 3 C} | inline_connector |
| KH1A:8 | | {AA 0 C} | inline_connector |
| KH1A:9 | | {AA 0 C} | inline_connector |
| KH1A:10 | | {CL 2 C} | inline_connector |
| KH1A:11 | | {CL 2 B} | inline_connector |
| KH1A:12 | | {AA 0 C} | inline_connector |
| KH1A:14 | | {AA 0 C} | inline_connector |
| KH1B:1 | | {DN 0 A} | inline_connector |
| KH1B:2 | | {DN 0 A} | inline_connector |
| KH1B:3 | | {DN 0 A} | inline_connector |
| KH1B:4 | | {DA 0 B} | inline_connector |
| KH1B:5 | | {DN 0 A} | inline_connector |
| KH1B:7 | | {DA 0 B} | inline_connector |
| KH1B:8 | | {DA 0 B} | inline_connector |
| KH1B:10 | | {DA 0 B} | inline_connector |

VOLVO

Volvo Bus Corporation

Document Title

WIRING DIAGRAM

Document Type

PRODUCT SCHEMATIC

Document No

20904123

Issue Index

15

Volume No

02(02)

Page No

47(76)

| Part Name | Description | Location | Part Type |
|-----------|-------------|----------|------------------|
| KH1B:11 | | {DA 0 B} | inline_connector |
| KH1B:12 | | {DA 0 B} | inline_connector |
| KH1B:14 | | {DA 0 B} | inline_connector |
| KH1B:15 | | {DA 0 B} | inline_connector |
| KH2A:1 | | {BA 2 D} | inline_connector |
| KH2A:3 | | {BA 0 C} | inline_connector |
| KH2A:4 | | {BA 2 D} | inline_connector |
| KH2A:5 | | {BA 0 B} | inline_connector |
| KH2A:6 | | {BA 0 C} | inline_connector |
| KH2A:7 | | {AC 0 C} | inline_connector |
| KH2A:8 | | {AC 0 C} | inline_connector |
| KH2A:9 | | {BA 0 B} | inline_connector |
| KH2A:10 | | {AC 0 C} | inline_connector |
| KH2A:11 | | {AC 0 C} | inline_connector |
| KH2A:12 | | {AC 0 C} | inline_connector |
| KH2B:1 | | {AA 2 D} | inline_connector |
| KH2B:2 | | {GM 2 B} | inline_connector |
| KH2B:3 | | {GM 2 B} | inline_connector |
| KH2B:4 | | {AA 2 D} | inline_connector |
| KH2B:5 | | {GM 2 B} | inline_connector |
| KH2B:6 | | {GM 2 C} | inline_connector |
| KH2B:7 | | {AC 0 B} | inline_connector |
| KH2B:8 | | {AC 0 B} | inline_connector |
| KH2B:9 | | {GM 2 C} | inline_connector |
| KH2B:11 | | {AC 0 B} | inline_connector |
| KH2B:12 | | {AC 0 B} | inline_connector |
| KH3A.1:1 | | {BF 2 B} | inline_connector |
| KH3A.1:2 | | {BF 2 B} | inline_connector |
| KH3A.1:3 | | {BF 2 B} | inline_connector |
| KH3A.1:4 | | {BF 2 B} | inline_connector |
| KH3A.1:5 | | {BF 0 A} | inline_connector |
| KH3A.1:6 | | {BF 2 B} | inline_connector |
| KH3A.1:7 | | {BF 2 B} | inline_connector |
| KH3A.1:8 | | {BF 1 A} | inline_connector |
| KH3A.1:9 | | {BF 3 B} | inline_connector |
| KH3A.1:10 | | {BF 3 B} | inline_connector |
| KH3A.1:11 | | {BF 3 B} | inline_connector |
| KH3A.1:12 | | {BF 3 B} | inline_connector |
| KH3A.1:13 | | {BF 3 B} | inline_connector |
| KH3A.1:14 | | {BF 3 B} | inline_connector |
| KH3A.1:15 | | {BF 3 B} | inline_connector |
| KH3A.2:1 | | {BF 2 C} | inline_connector |
| KH3A.2:2 | | {BF 2 C} | inline_connector |
| KH3A.2:3 | | {BF 2 C} | inline_connector |
| KH3A.2:4 | | {BF 2 C} | inline_connector |
| KH3A.2:5 | | {BF 0 D} | inline_connector |
| KH3A.2:6 | | {BF 2 C} | inline_connector |
| KH3A.2:7 | | {BF 2 C} | inline_connector |
| KH3A.2:8 | | {BF 1 B} | inline_connector |
| KH3A.2:9 | | {BF 3 C} | inline_connector |
| KH3A.2:10 | | {BF 3 C} | inline_connector |
| KH3A.2:11 | | {BF 3 C} | inline_connector |
| KH3A.2:12 | | {BF 3 C} | inline_connector |

VOLVO

Volvo Bus Corporation

Document Title

WIRING DIAGRAM

Document Type

PRODUCT SCHEMATIC

Document No

20904123

Issue Index

15

Volume No

02(02)

Page No

48(76)

| Part Name | Description | Location | Part Type |
|-----------|-------------|----------|------------------|
| KH3A.2:13 | | {BF 3 C} | inline_connector |
| KH3A.2:14 | | {BF 3 C} | inline_connector |
| KH3A.2:15 | | {BF 3 C} | inline_connector |
| KH3A:1 | | {AA 1 B} | inline_connector |
| KH3A:3 | | {AA 1 B} | inline_connector |
| KH3A:4 | | {BB 2 B} | inline_connector |
| KH3A:5 | | {AA 1 B} | inline_connector |
| KH3A:6 | | {AA 1 B} | inline_connector |
| KH3A:7 | | {BB 2 B} | inline_connector |
| KH3A:8 | | {AA 3 C} | inline_connector |
| KH3A:9 | | {AA 3 C} | inline_connector |
| KH3A:10 | | {BB 3 B} | inline_connector |
| KH3A:11 | | {BB 3 B} | inline_connector |
| KH3A:12 | | {AA 3 C} | inline_connector |
| KH3A:14 | | {AA 3 C} | inline_connector |
| KH3B:1 | | {BB 4 B} | inline_connector |
| KH3B:2 | | {BB 4 B} | inline_connector |
| KH3B:3 | | {BB 4 B} | inline_connector |
| KH3B:4 | | {DM 0 B} | inline_connector |
| KH3B:5 | | {BB 4 B} | inline_connector |
| KH3B:7 | | {DM 0 B} | inline_connector |
| KH3B:8 | | {DM 1 B} | inline_connector |
| KH3B:10 | | {DM 0 B} | inline_connector |
| KH3B:11 | | {DM 0 B} | inline_connector |
| KH3B:12 | | {DM 1 B} | inline_connector |
| KH3B:14 | | {DM 1 B} | inline_connector |
| KH3B:15 | | {DM 1 B} | inline_connector |
| KV:A | | {DA 0 D} | inline_connector |
| KV:B | | {DA 1 D} | inline_connector |
| KV:C | | {DA 1 D} | inline_connector |
| KV:D | | {DA 1 D} | inline_connector |
| KV:E | | {DA 0 D} | inline_connector |
| KV:F | | {DA 0 D} | inline_connector |
| KV:G | | {DA 2 D} | inline_connector |
| KV:H | | {DA 2 D} | inline_connector |
| KV:J | | {DA 2 D} | inline_connector |
| KV:K | | {DA 2 D} | inline_connector |
| KV:L | | {DA 1 D} | inline_connector |
| KV:M | | {DA 1 D} | inline_connector |
| KV:P | | {DA 0 D} | inline_connector |
| KV:Q | | {DA 3 D} | inline_connector |
| KV:R | | {DA 3 D} | inline_connector |
| KV:S | | {DA 3 D} | inline_connector |
| KV:T | | {DA 2 D} | inline_connector |
| LA:1 | | {AF 2 C} | inline_connector |
| LA:2 | | {AF 3 C} | inline_connector |
| LA:4 | | {AF 4 B} | inline_connector |
| LA:5 | | {AF 2 E} | inline_connector |
| LA:6 | | {AF 3 C} | inline_connector |
| LKS:1 | | {BE 1 B} | inline_connector |
| LKS:2 | | {BE 2 B} | inline_connector |
| LKS:3 | | {BE 2 B} | inline_connector |
| LKS:4 | | {BE 2 B} | inline_connector |

VOLVO

Volvo Bus Corporation

Document Title

WIRING DIAGRAM

Document Type

PRODUCT SCHEMATIC

Document No

20904123

Issue Index

15

Volume No

02(02)

Page No

49(76)

| Part Name | Description | Location | Part Type |
|-----------|-------------|----------|------------------|
| LKS:5 | | {BE 1 B} | inline_connector |
| LKS:6 | | {BE 0 B} | inline_connector |
| LKS:7 | | {BE 0 B} | inline_connector |
| LKS:8 | | {BE 2 D} | inline_connector |
| LT1:2 | | {LB 3 A} | inline_connector |
| LT1:3 | | {LB 1 B} | inline_connector |
| LT1:4 | | {NA 0 E} | inline_connector |
| LT1:5 | | {NA 0 D} | inline_connector |
| LT1:6 | | {NA 4 E} | inline_connector |
| LT1:7 | | {NA 4 E} | inline_connector |
| LT1:8 | | {LB 2 B} | inline_connector |
| LT1:9 | | {GD 0 B} | inline_connector |
| LT1:10 | | {FO 2 B} | inline_connector |
| LT1:11 | | {FO 3 D} | inline_connector |
| LT1:12 | | {FO 3 D} | inline_connector |
| LT2:1 | | {CL 0 B} | inline_connector |
| LT2:2 | | {CL 0 B} | inline_connector |
| LT:1 | | {EO 3 C} | inline_connector |
| LT:2 | | {EO 4 C} | inline_connector |
| LT:3 | | {EO 4 C} | inline_connector |
| LT:4 | | {EO 4 C} | inline_connector |
| LT:5 | | {CL 1 D} | inline_connector |
| LT:6 | | {CL 2 D} | inline_connector |
| LT:7 | | {CL 2 D} | inline_connector |
| LT:8 | | {FA 1 C} | inline_connector |
| LT:9 | | {FA 2 C} | inline_connector |
| LT:10 | | {FA 2 C} | inline_connector |
| LT:11 | | {FA 2 B} | inline_connector |
| LT:12 | | {FB 4 D} | inline_connector |
| LT:13 | | {FB 4 D} | inline_connector |
| LT:14 | | {FB 4 D} | inline_connector |
| LT:15 | | {FB 1 B} | inline_connector |
| LT:16 | | {FB 1 B} | inline_connector |
| LT:17 | | {FB 1 C} | inline_connector |
| LT:18 | | {FO 3 D} | inline_connector |
| LT:19 | | {ZC 2 C} | inline_connector |
| LT:20 | | {LB 1 C} | inline_connector |
| LT:21 | | {FO 3 D} | inline_connector |
| LT:22 | | {FO 3 D} | inline_connector |
| LT:23 | | {FO 3 D} | inline_connector |
| LT:25 | | {FO 2 C} | inline_connector |
| LT:26 | | {FO 0 C} | inline_connector |
| LT:27 | | {LB 1 C} | inline_connector |
| LT:28 | | {LB 2 C} | inline_connector |
| LT:29 | | {LB 2 B} | inline_connector |
| LT:30 | | {LB 1 B} | inline_connector |
| LT:31 | | {LB 2 B} | inline_connector |
| M01.A:1 | | {GM 4 E} | inline_connector |
| M01.A:2 | | {GM 3 C} | inline_connector |
| M01.A:3 | | {GM 3 C} | inline_connector |
| M01.A:5 | | {GM 3 C} | inline_connector |
| M01.A:6 | | {GM 4 C} | inline_connector |
| M01:1 | | {GM 4 C} | inline_connector |

VOLVO

Volvo Bus Corporation

Document Title

WIRING DIAGRAM

Document Type

PRODUCT SCHEMATIC

Document No

20904123

Issue Index

15

Volume No

02(02)

Page No

50(76)

| Part Name | Description | Location | Part Type |
|-----------|-------------|----------------------|------------------|
| M01:2 | | {GM 4 C} | inline_connector |
| M01:3 | | {GM 3 C} | inline_connector |
| M01:4 | | {GM 3 C} | inline_connector |
| M01:5 | | {GM 3 E} | inline_connector |
| M01:6 | | {GM 1 B} | inline_connector |
| M01:8 | | {GM 1 D} | inline_connector |
| M01:9 | | {GM 1 B} | inline_connector |
| M01:11 | | {GM 1 D} | inline_connector |
| M01:12 | | {GM 1 C} | inline_connector |
| M01:13 | | {GM 0 D} | inline_connector |
| M01:14 | | {GM 1 B} | inline_connector |
| M40A:1 | | {CA2 3 B} | inline_connector |
| M40A:3 | | {CA2 4 B} | inline_connector |
| M41A:1 | | {CA2 3 B} | inline_connector |
| M41A:3 | | {CA2 4 B} | inline_connector |
| M42A:1 | | {CA2 3 B} | inline_connector |
| M42A:3 | | {CA2 4 B} | inline_connector |
| ML1:1 | | {GB 0 E} | inline_connector |
| ML1:2 | | {ZC 2 A} {ZC 0 B} | inline_connector |
| ML1:3 | | {GB 1 D} {GE 0 C} | inline_connector |
| ML1:4 | | {ZC 2 A} {ZC 0 B} | inline_connector |
| ML1:5 | | {GB 1 D} {GE 0 C} | inline_connector |
| ML1:6 | | {ZC 2 A} {ZC 0 B} | inline_connector |
| ML1:7 | | {GE 0 C} | inline_connector |
| ML2:1 | | {GB 4 D} | inline_connector |
| ML2:2 | | {ZC 1 A} {ZC 0 B} | inline_connector |
| ML2:3 | | {GB 4 D} {GE 1 C} | inline_connector |
| ML2:4 | | {ZC 1 A} {ZC 1 B} | inline_connector |
| ML2:5 | | {GB 3 D} {GE 1 C} | inline_connector |
| ML2:6 | | {ZC 1 A} {ZC 1 B} | inline_connector |
| ML2:7 | | {GE 2 C} | inline_connector |
| ML3:1 | | {BB 2 C} | inline_connector |
| ML3:2 | | {BB 2 A} | inline_connector |
| ML3:3 | | {GC 1 D} | inline_connector |
| ML3:4 | | {GC 1 D} | inline_connector |
| ML3:5 | | {GC 1 D} | inline_connector |
| ML3:6 | | {GA 2 B} | inline_connector |
| ML3:7 | | {GC 1 D} | inline_connector |
| ML3A:1 | | {GD 1 C} | inline_connector |
| ML3A:3 | | {GD 3 D} | inline_connector |
| ML3A:4 | | {GD 3 D} | inline_connector |
| ML3A:5 | | {GD 3 D} | inline_connector |
| ML3A:7 | | {GD 3 D} | inline_connector |

VOLVO

Volvo Bus Corporation

Document Title

WIRING DIAGRAM

Document Type

PRODUCT SCHEMATIC

Document No

20904123

Issue Index

15

Volume No

02(02)

Page No

51(76)

| Part Name | Description | Location | Part Type |
|-----------|-------------|----------|------------------|
| ML3B:1 | | {GD 1 B} | inline_connector |
| ML3B:2 | | {GD 1 B} | inline_connector |
| ML3B:3 | | {GD 3 C} | inline_connector |
| ML3B:4 | | {GD 3 C} | inline_connector |
| ML3B:5 | | {GD 3 C} | inline_connector |
| ML3B:6 | | {GD 0 B} | inline_connector |
| ML3B:7 | | {GD 3 C} | inline_connector |
| ML4:1 | | {BB 2 C} | inline_connector |
| ML4:2 | | {BB 2 A} | inline_connector |
| ML4:3 | | {GC 0 D} | inline_connector |
| ML4:4 | | {GC 0 D} | inline_connector |
| ML4:5 | | {GC 0 D} | inline_connector |
| ML4:6 | | {GA 2 B} | inline_connector |
| ML4:7 | | {GC 0 D} | inline_connector |
| ML4A:1 | | {GD 1 C} | inline_connector |
| ML4A:3 | | {GD 2 D} | inline_connector |
| ML4A:4 | | {GD 2 D} | inline_connector |
| ML4A:5 | | {GD 2 D} | inline_connector |
| ML4A:7 | | {GD 2 D} | inline_connector |
| ML4B:1 | | {GD 1 B} | inline_connector |
| ML4B:2 | | {GD 1 B} | inline_connector |
| ML4B:3 | | {GD 2 C} | inline_connector |
| ML4B:4 | | {GD 2 C} | inline_connector |
| ML4B:5 | | {GD 2 C} | inline_connector |
| ML4B:6 | | {GD 0 B} | inline_connector |
| ML4B:7 | | {GD 2 C} | inline_connector |
| ML5:1 | | {GC 3 D} | inline_connector |
| ML5:2 | | {GC 3 D} | inline_connector |
| ML5:3 | | {GC 3 D} | inline_connector |
| ML5:4 | | {GC 3 D} | inline_connector |
| ML5:5 | | {GC 4 D} | inline_connector |
| ML5:6 | | {GC 4 D} | inline_connector |
| ML5:7 | | {GC 4 D} | inline_connector |
| ML6:1 | | {GC 3 D} | inline_connector |
| ML6:2 | | {GC 3 D} | inline_connector |
| ML6:3 | | {GC 3 D} | inline_connector |
| ML6:4 | | {GC 3 D} | inline_connector |
| ML6:5 | | {GC 4 D} | inline_connector |
| ML6:6 | | {GC 4 D} | inline_connector |
| ML6:7 | | {GC 4 D} | inline_connector |
| ML7:5 | | {GA 3 B} | inline_connector |
| ML7:6 | | {GA 3 B} | inline_connector |
| ML8:1 | | {GF 1 C} | inline_connector |
| ML8:3 | | {GF 3 C} | inline_connector |
| ML8:4 | | {GF 3 C} | inline_connector |
| ML8:5 | | {GF 3 C} | inline_connector |
| ML8:7 | | {GF 3 D} | inline_connector |
| ML9:1 | | {GF 1 C} | inline_connector |
| ML9:3 | | {GF 2 C} | inline_connector |
| ML9:4 | | {GF 2 C} | inline_connector |
| ML9:5 | | {GF 2 C} | inline_connector |
| ML9:7 | | {GF 2 D} | inline_connector |
| R905A:1 | | {CU 0 D} | inline_connector |

VOLVO

Volvo Bus Corporation

Document Title

WIRING DIAGRAM

Document Type

PRODUCT SCHEMATIC

Document No

20904123

Issue Index

15

Volume No

02(02)

Page No

52(76)

| Part Name | Description | Location | Part Type |
|-----------|-------------|----------|------------------|
| R905A:2 | | {CU 0 D} | inline_connector |
| R905B:1 | | {CU 0 D} | inline_connector |
| R905B:2 | | {CU 1 D} | inline_connector |
| R905C:1 | | {CU 1 C} | inline_connector |
| R905C:2 | | {CU 0 D} | inline_connector |
| R906A:1 | | {CU 1 D} | inline_connector |
| R906A:2 | | {CU 1 D} | inline_connector |
| R906B:1 | | {CU 1 D} | inline_connector |
| R906B:2 | | {CU 1 D} | inline_connector |
| R906C:1 | | {CU 1 C} | inline_connector |
| R906C:2 | | {CU 1 D} | inline_connector |
| R908A:1 | | {CU 2 D} | inline_connector |
| R908A:2 | | {CU 2 D} | inline_connector |
| R908B:1 | | {CU 2 D} | inline_connector |
| R908B:2 | | {CU 2 D} | inline_connector |
| R908C:1 | | {CU 2 C} | inline_connector |
| R908C:2 | | {CU 2 D} | inline_connector |
| R910A:1 | | {CU 1 D} | inline_connector |
| R910A:2 | | {CU 1 D} | inline_connector |
| R910B:1 | | {CU 2 D} | inline_connector |
| R910B:2 | | {CU 2 D} | inline_connector |
| R910C:1 | | {CU 2 C} | inline_connector |
| R910C:2 | | {CU 1 D} | inline_connector |
| RA1.A1:1 | | {NB 0 C} | inline_connector |
| RA1.A1:2 | | {NB 1 C} | inline_connector |
| RA1.A1:3 | | {NB 1 C} | inline_connector |
| RA1.A1:4 | | {NB 1 C} | inline_connector |
| RA1.A1:5 | | {NA 2 C} | inline_connector |
| RA1.A1:6 | | {AC 2 C} | inline_connector |
| RA1.A1:7 | | {AC 2 C} | inline_connector |
| RA1.A1:8 | | {AC 3 C} | inline_connector |
| RA1.A1:10 | | {NA 0 C} | inline_connector |
| RA1.A1:11 | | {AB 0 B} | inline_connector |
| RA1.A2:1 | | {NB 0 D} | inline_connector |
| RA1.A2:2 | | {NB 1 D} | inline_connector |
| RA1.A2:3 | | {NB 1 D} | inline_connector |
| RA1.A2:4 | | {NB 1 D} | inline_connector |
| RA1.A2:5 | | {NA 2 B} | inline_connector |
| RA1.A2:6 | | {AC 2 C} | inline_connector |
| RA1.A2:7 | | {AC 2 C} | inline_connector |
| RA1.A2:8 | | {AC 3 C} | inline_connector |
| RA1.A2:10 | | {NA 0 B} | inline_connector |
| RA1.A2:11 | | {AB 0 B} | inline_connector |
| RA1.A3:1 | | {NB 0 D} | inline_connector |
| RA1.A3:2 | | {NB 1 D} | inline_connector |
| RA1.A3:3 | | {NB 1 D} | inline_connector |
| RA1.A3:4 | | {NB 1 D} | inline_connector |
| RA1.A3:5 | | {NA 2 B} | inline_connector |
| RA1.A3:6 | | {AC 2 D} | inline_connector |
| RA1.A3:7 | | {AC 2 D} | inline_connector |
| RA1.A3:8 | | {AC 3 D} | inline_connector |
| RA1.A3:10 | | {NA 0 B} | inline_connector |
| RA1.A3:11 | | {AB 0 A} | inline_connector |

VOLVO

Volvo Bus Corporation

Document Title

WIRING DIAGRAM

Document Type

PRODUCT SCHEMATIC

Document No

20904123

Issue Index

15

Volume No

02(02)

Page No

53(76)

| Part Name | Description | Location | Part Type |
|-----------|-------------|----------------------|------------------|
| RA1:1 | | {NB 0 C} {NB 0 D} | inline_connector |
| RA1:2 | | {NB 0 C} {NB 1 D} | inline_connector |
| RA1:3 | | {NB 0 C} {NB 1 D} | inline_connector |
| RA1:4 | | {NB 0 C} {NB 1 D} | inline_connector |
| RA1:5 | | {NA 2 B} | inline_connector |
| RA1:6 | | {AC 1 D} | inline_connector |
| RA1:7 | | {AC 2 D} | inline_connector |
| RA1:8 | | {AC 3 D} | inline_connector |
| RA1:9 | | {ND 1 B} | inline_connector |
| RA1:10 | | {NA 4 B} {NA 1 C} | inline_connector |
| RA1:11 | | {AB 1 B} | inline_connector |
| RA1:12 | | {EX 1 C} | inline_connector |
| RA1B:1 | | {NB 0 D} | inline_connector |
| RA1B:2 | | {NB 0 D} | inline_connector |
| RA1B:3 | | {NB 0 D} | inline_connector |
| RA1B:4 | | {NB 0 D} | inline_connector |
| RA1B:5 | | {NA 1 B} | inline_connector |
| RA1B:6 | | {AE 2 B} | inline_connector |
| RA1B:7 | | {AE 2 B} | inline_connector |
| RA1B:8 | | {AE 3 B} | inline_connector |
| RA1B:10 | | {NA 0 B} | inline_connector |
| RA1B:11 | | {AE 1 D} | inline_connector |
| REG_HP:A | | {CG 1 D} | inline_connector |
| REG_HP:B | | {CG 1 D} | inline_connector |
| REG_HP:C | | {CG 1 D} | inline_connector |
| REG_LP:1 | | {CG 1 D} | inline_connector |
| REG_LP:2 | | {CG 1 E} | inline_connector |
| REV:1 | | {DC 3 B} {DD 0 B} | inline_connector |
| RL1:1 | | {GC 1 D} | inline_connector |
| RL1:2 | | {GC 1 D} | inline_connector |
| RL1:3 | | {GC 3 C} | inline_connector |
| RL1:4 | | {GC 3 D} | inline_connector |
| RL1:5 | | {GC 2 C} | inline_connector |
| RL1:6 | | {GC 2 D} | inline_connector |
| RL1:7 | | {GA 3 D} | inline_connector |
| RL1:8 | | {GA 3 E} | inline_connector |
| RL1:9 | | {GA 2 D} | inline_connector |
| RL1:10 | | {GA 2 E} | inline_connector |
| RL1:11 | | {GC 1 D} | inline_connector |
| RL1:12 | | {GC 1 D} | inline_connector |
| RL2:1 | | {GA 1 D} | inline_connector |
| RL2:2 | | {GA 1 E} | inline_connector |
| RL2:3 | | {GA 0 D} | inline_connector |
| RL2:4 | | {GA 0 E} | inline_connector |
| RL2:5 | | {GA 1 D} | inline_connector |
| RL2:6 | | {GA 1 E} | inline_connector |
| RL2:7 | | {GA 3 D} | inline_connector |

VOLVO

Volvo Bus Corporation

Document Title

WIRING DIAGRAM

Document Type

PRODUCT SCHEMATIC

Document No

20904123

Issue Index

15

Volume No

02(02)

Page No

54(76)

| Part Name | Description | Location | Part Type |
|-----------|-------------|----------|------------------|
| RL2:8 | | {GA 3 E} | inline_connector |
| RL2:9 | | {GA 2 D} | inline_connector |
| RL2:10 | | {GA 2 E} | inline_connector |
| RL2:11 | | {GA 1 D} | inline_connector |
| RL2:12 | | {GA 1 E} | inline_connector |
| RL3:1 | | {GC 0 D} | inline_connector |
| RL3:2 | | {GC 0 D} | inline_connector |
| RL3:3 | | {GA 1 D} | inline_connector |
| RL3:4 | | {GC 3 D} | inline_connector |
| RL3:5 | | {GA 1 B} | inline_connector |
| RL3:6 | | {GA 3 D} | inline_connector |
| | | {GE 4 C} | |
| RL3:7 | | {GC 2 D} | inline_connector |
| | | {GE 4 C} | |
| RL3:8 | | {BC 2 E} | inline_connector |
| RL3:9 | | {GC 4 D} | inline_connector |
| RL3:10 | | {GA 2 D} | inline_connector |
| | | {GE 3 C} | |
| RL3:11 | | {GA 2 B} | inline_connector |
| RL3:12 | | {ZC 2 B} | inline_connector |
| | | {ZC 3 A} | |
| RL4:1 | | {GA 0 D} | inline_connector |
| RL4:2 | | {GC 2 D} | inline_connector |
| RL4:3 | | {GC 0 D} | inline_connector |
| RL4:4 | | {GC 1 D} | inline_connector |
| RL4:5 | | {GA 2 D} | inline_connector |
| RL4:6 | | {GC 4 D} | inline_connector |
| RL4:7 | | {GA 3 D} | inline_connector |
| RL5:1 | | {GD 3 C} | inline_connector |
| | | {GF 3 B} | |
| RL5:2 | | {GD 3 D} | inline_connector |
| | | {GF 3 D} | |
| RL5:3 | | {GD 2 C} | inline_connector |
| | | {GF 1 B} | |
| RL5:4 | | {GD 2 D} | inline_connector |
| | | {GF 1 D} | |
| RL5:5 | | {GD 1 C} | inline_connector |
| | | {GF 1 B} | |
| RL5:6 | | {GD 1 D} | inline_connector |
| | | {GF 1 D} | |
| RL5:7 | | {GD 1 C} | inline_connector |
| | | {GF 0 B} | |
| RL5:8 | | {GD 1 D} | inline_connector |
| | | {GF 0 D} | |
| RL5:9 | | {GD 4 D} | inline_connector |
| | | {GF 4 B} | |
| RL5:10 | | {GD 4 D} | inline_connector |
| | | {GF 4 D} | |
| RL5:11 | | {GD 3 C} | inline_connector |
| | | {GF 3 B} | |
| RL5:12 | | {GD 3 D} | inline_connector |
| | | {GF 3 D} | |
| RL6:1 | | {GD 2 D} | inline_connector |

VOLVO

Volvo Bus Corporation

Document Title

WIRING DIAGRAM

Document Type

PRODUCT SCHEMATIC

Document No

20904123

Issue Index

15

Volume No

02(02)

Page No

55(76)

| Part Name | Description | Location | Part Type |
|-----------|-------------|----------------------|------------------|
| RL6:2 | | {GD 3 D} | inline_connector |
| RL6:3 | | {GD 1 C} {GF 1 B} | inline_connector |
| RL6:4 | | {GD 1 C} {GF 1 B} | inline_connector |
| RL6:5 | | {GF 2 B} | inline_connector |
| RL6:6 | | {GD 1 C} {GF 1 B} | inline_connector |
| RL6:7 | | {GD 0 C} {GF 0 B} | inline_connector |
| RL6:8 | | {GF 3 B} | inline_connector |
| RL6:9 | | {GF 2 D} | inline_connector |
| RL6:10 | | {GD 4 D} {GF 4 B} | inline_connector |
| RL6:11 | | {LA 3 B} | inline_connector |
| RL6:12 | | {GD 0 D} {GF 0 D} | inline_connector |
| RL7:1 | | {GD 0 C} {GF 0 B} | inline_connector |
| RL7:2 | | {GD 0 D} {GF 0 D} | inline_connector |
| RL7:3 | | {GD 2 C} {GF 2 B} | inline_connector |
| RL7:4 | | {GD 2 D} {GF 2 D} | inline_connector |
| RL7:5 | | {GD 1 C} {GF 1 B} | inline_connector |
| RL7:6 | | {GD 1 D} {GF 1 D} | inline_connector |
| RL7:7 | | {GD 0 C} {GF 0 B} | inline_connector |
| RL7:8 | | {GD 0 D} {GF 0 D} | inline_connector |
| RL7:9 | | {GD 4 D} {GF 4 B} | inline_connector |
| RL7:10 | | {GD 4 D} {GF 4 D} | inline_connector |
| RL7:11 | | {GD 0 C} {GF 0 B} | inline_connector |
| RL7:12 | | {GD 0 D} {GF 0 D} | inline_connector |
| RL8:1 | | {GF 3 C} | inline_connector |
| RL8:2 | | {GF 3 C} | inline_connector |
| RL8:3 | | {GF 1 C} | inline_connector |
| RL8:4 | | {GF 1 C} | inline_connector |
| RL8:5 | | {GF 1 C} | inline_connector |
| RL8:6 | | {GF 1 C} | inline_connector |
| RL8:7 | | {GF 0 C} | inline_connector |
| RL8:8 | | {GF 0 C} | inline_connector |
| RL8:9 | | {GF 4 C} | inline_connector |
| RL8:10 | | {GF 4 C} | inline_connector |
| RL8:11 | | {GF 3 C} | inline_connector |
| RL8:12 | | {GF 3 C} | inline_connector |

VOLVO

Volvo Bus Corporation

Document Title

WIRING DIAGRAM

Document Type

PRODUCT SCHEMATIC

Document No

20904123

Issue Index

15

Volume No

02(02)

Page No

56(76)

| Part Name | Description | Location | Part Type |
|-------------|-------------|----------|------------------|
| RL9:1 | | {GF 2 C} | inline_connector |
| RL9:2 | | {GF 3 C} | inline_connector |
| RL9:3 | | {GF 1 C} | inline_connector |
| RL9:4 | | {GF 1 C} | inline_connector |
| RL9:6 | | {GF 1 C} | inline_connector |
| RL9:7 | | {GF 0 C} | inline_connector |
| RL9:10 | | {GF 4 C} | inline_connector |
| RL9:12 | | {GF 0 C} | inline_connector |
| RL10:1 | | {GF 0 C} | inline_connector |
| RL10:2 | | {GF 0 C} | inline_connector |
| RL10:3 | | {GF 2 C} | inline_connector |
| RL10:4 | | {GF 2 C} | inline_connector |
| RL10:5 | | {GF 1 C} | inline_connector |
| RL10:6 | | {GF 1 C} | inline_connector |
| RL10:7 | | {GF 0 C} | inline_connector |
| RL10:8 | | {GF 0 C} | inline_connector |
| RL10:9 | | {GF 4 C} | inline_connector |
| RL10:10 | | {GF 4 C} | inline_connector |
| RL10:11 | | {GF 0 C} | inline_connector |
| RL10:12 | | {GF 0 C} | inline_connector |
| RL:1 | | {GB 0 C} | inline_connector |
| RL:3 | | {GB 0 C} | inline_connector |
| RL_DA:1 | | {GB 0 D} | inline_connector |
| RL_DB:1 | | {GB 0 B} | inline_connector |
| S901_U1:1 | | {AG 3 D} | inline_connector |
| S901_U1:2 | | {AG 3 D} | inline_connector |
| S904C.1:1 | | {BF 1 A} | inline_connector |
| S904C.2:1 | | {BF 1 D} | inline_connector |
| S908:1 | | {AG 4 D} | inline_connector |
| S908:3 | | {AG 4 D} | inline_connector |
| S_T_S:1 | | {NB 2 D} | inline_connector |
| S_T_S:2 | | {NB 2 D} | inline_connector |
| S_T_S:3 | | {NB 2 D} | inline_connector |
| S_T_T:3 | | {NB 2 D} | inline_connector |
| SP_F:1 | | {CL 4 B} | inline_connector |
| SP_F:2 | | {CL 4 B} | inline_connector |
| SP_F:3 | | {CL 4 B} | inline_connector |
| SP_F:4 | | {CL 4 B} | inline_connector |
| SP_RR:1 | | {CL 4 C} | inline_connector |
| SP_RR:2 | | {CL 4 C} | inline_connector |
| SP_RR:3 | | {CL 4 C} | inline_connector |
| SP_RR:4 | | {CL 4 C} | inline_connector |
| Throttle :1 | | {CD 3 B} | inline_connector |
| Throttle :2 | | {CD 3 B} | inline_connector |
| Throttle :3 | | {CD 3 B} | inline_connector |
| Throttle :4 | | {CD 3 B} | inline_connector |
| Throttle :5 | | {CD 3 B} | inline_connector |
| Throttle :6 | | {CD 3 B} | inline_connector |
| TOW:1 | | {GA 4 B} | inline_connector |
| TOW:2 | | {GA 4 B} | inline_connector |
| TOW:3 | | {GA 4 B} | inline_connector |
| TOW:4 | | {GA 3 B} | inline_connector |
| TOW:5 | | {GA 3 B} | inline_connector |

VOLVO

Volvo Bus Corporation

Document Title

WIRING DIAGRAM

Document Type

PRODUCT SCHEMATIC

Document No

20904123

Issue Index

15

Volume No

02(02)

Page No

57(76)

| Part Name | Description | Location | Part Type |
|-----------|-------------|----------|------------------|
| TOW:6 | | {GA 3 B} | inline_connector |
| TOW:7 | | {GA 3 B} | inline_connector |
| TRAIL1:1 | | {FO 1 B} | inline_connector |
| TRAIL1:2 | | {FO 1 B} | inline_connector |
| TRAIL1:3 | | {FO 1 C} | inline_connector |
| TRAIL1:4 | | {LB 1 B} | inline_connector |
| TRAIL1:5 | | {LB 1 B} | inline_connector |
| TRAIL1:6 | | {LB 2 B} | inline_connector |
| TRAIL1:7 | | {LB 2 B} | inline_connector |
| TRAIL1:8 | | {LB 2 B} | inline_connector |
| TRAIL1:9 | | {FO 1 C} | inline_connector |
| TRAIL1:10 | | {FO 1 C} | inline_connector |
| TRAIL1:11 | | {FO 2 B} | inline_connector |
| TRAIL1:12 | | {FO 3 B} | inline_connector |
| TRAIL1:13 | | {FO 3 B} | inline_connector |
| TRAIL1:14 | | {BC 1 D} | inline_connector |
| TRAIL1:15 | | {BC 1 D} | inline_connector |
| TRAIL1:16 | | {LA 1 B} | inline_connector |
| TRAIL1:17 | | {LA 2 A} | inline_connector |
| TRAIL1:18 | | {LA 2 A} | inline_connector |
| TRAIL1:20 | | {LA 1 A} | inline_connector |
| TRAIL1:21 | | {LA 2 B} | inline_connector |
| TRAIL1:22 | | {LB 1 B} | inline_connector |
| TRAIL1:23 | | {LA 3 B} | inline_connector |
| TRAIL1:25 | | {LA 2 B} | inline_connector |
| TRAIL1:28 | | {BC 1 C} | inline_connector |
| TRAIL1:29 | | {BC 1 C} | inline_connector |
| TRAIL2:1 | | {EO 3 C} | inline_connector |
| TRAIL2:2 | | {EO 4 C} | inline_connector |
| TRAIL2:3 | | {EO 4 C} | inline_connector |
| TRAIL2:4 | | {EO 4 C} | inline_connector |
| TRAIL2:5 | | {CL 1 D} | inline_connector |
| TRAIL2:6 | | {CL 2 D} | inline_connector |
| TRAIL2:7 | | {CL 2 D} | inline_connector |
| TRAIL2:8 | | {FA 1 C} | inline_connector |
| TRAIL2:9 | | {FA 2 C} | inline_connector |
| TRAIL2:10 | | {FA 2 C} | inline_connector |
| TRAIL2:11 | | {FB 4 B} | inline_connector |
| TRAIL2:12 | | {FB 1 B} | inline_connector |
| TRAIL3:1 | | {BC 0 D} | inline_connector |
| TRAIL3:2 | | {BC 0 E} | inline_connector |
| TRAIL3:3 | | {BC 1 D} | inline_connector |
| TRAIL3:4 | | {BC 1 E} | inline_connector |
| TRAIL:1 | | {EP 2 C} | inline_connector |
| TRAIL:2 | | {EP 2 C} | inline_connector |
| TRAIL:3 | | {EP 2 C} | inline_connector |
| TRAIL:4 | | {EP 2 C} | inline_connector |
| TRAIL:5 | | {FB 1 B} | inline_connector |
| TRAIL:6 | | {FB 1 B} | inline_connector |
| TRAIL:7 | | {FA 3 C} | inline_connector |
| TRAIL:8 | | {FA 3 C} | inline_connector |
| TRAIL:9 | | {FA 3 C} | inline_connector |
| TRAIL:10 | | {FB 3 D} | inline_connector |

VOLVO

Volvo Bus Corporation

Document Title

WIRING DIAGRAM

Document Type

PRODUCT SCHEMATIC

Document No

20904123

Issue Index

15

Volume No

02(02)

Page No

58(76)

| Part Name | Description | Location | Part Type |
|------------|-------------|----------------------|------------------|
| TRAIL:11 | | {FB 3 D} | inline_connector |
| TRAIL:12 | | {FB 3 C} | inline_connector |
| TRAIL:13 | | {FB 3 C} | inline_connector |
| TRAIL:14 | | {FB 1 C} | inline_connector |
| TRAIL:15 | | {FB 1 B} | inline_connector |
| TRAIL:16 | | {BC 0 B} | inline_connector |
| TRAIL:17 | | {BC 0 B} | inline_connector |
| TRAIL:18 | | {BC 0 B} | inline_connector |
| TRAIL:19 | | {GD 0 C} | inline_connector |
| TRAIL:20 | | {GD 1 C} | inline_connector |
| TRAIL:21 | | {GD 1 C} | inline_connector |
| TRAIL:22 | | {GD 1 C} | inline_connector |
| TRAIL:23 | | {GD 1 C} | inline_connector |
| TRAIL:24 | | {GD 1 C} | inline_connector |
| TRAIL:25 | | {GD 2 C} | inline_connector |
| TRAIL:26 | | {GD 2 C} | inline_connector |
| TRAIL:27 | | {GD 2 C} | inline_connector |
| TRAIL:28 | | {GD 3 C} | inline_connector |
| TRAIL:29 | | {GD 3 C} | inline_connector |
| TRAIL:30 | | {GD 4 C} | inline_connector |
| TRAIL:31 | | {FA 3 A} | inline_connector |
| UDS12:1 | | {CV 1 C} | inline_connector |
| UDS12:2 | | {CV 1 C} | inline_connector |
| UDS12:3 | | {CU 1 B} | inline_connector |
| UDS12:4 | | {CU 1 B} | inline_connector |
| UDS12:5 | | {XE 1 C} | inline_connector |
| UDS12:6 | | {XE 1 C} | inline_connector |
| UDS12:7 | | {CU 1 B} | inline_connector |
| UDS12:8 | | {CU 2 B} | inline_connector |
| UDS12:9 | | {CU 3 B} | inline_connector |
| UDS12:11 | | {CU 0 B} | inline_connector |
| UDS12:12 | | {CU 4 D} | inline_connector |
| UDS12_B:1 | | {CV 1 A} {CV 1 B} | inline_connector |
| UDS12_B:2 | | {CV 1 A} {CV 1 B} | inline_connector |
| UDS12_B:3 | | {CU 1 B} | inline_connector |
| UDS12_B:4 | | {CU 1 B} | inline_connector |
| UDS12_B:5 | | {XE 2 C} | inline_connector |
| UDS12_B:6 | | {XE 2 C} | inline_connector |
| UDS12_B:7 | | {CU 1 B} | inline_connector |
| UDS12_B:8 | | {CU 2 B} | inline_connector |
| UDS12_B:9 | | {CU 3 B} | inline_connector |
| UDS12_B:11 | | {CU 0 B} | inline_connector |
| UDS12_B:12 | | {CU 4 D} | inline_connector |
| UDS12_F:1 | | {CV 2 A} {CV 2 B} | inline_connector |
| UDS12_F:2 | | {CV 2 A} {CV 2 B} | inline_connector |
| UDS12_F:3 | | {CU 1 B} | inline_connector |
| UDS12_F:4 | | {CU 2 B} | inline_connector |
| UDS12_F:5 | | {XE 1 C} | inline_connector |
| UDS12_F:6 | | {XE 1 C} | inline_connector |

VOLVO

Volvo Bus Corporation

Document Title

WIRING DIAGRAM

Document Type

PRODUCT SCHEMATIC

Document No

20904123

Issue Index

15

Volume No

02(02)

Page No

59(76)

| Part Name | Description | Location | Part Type |
|------------|-------------|----------------------|------------------|
| UDS12_F:7 | | {CU 1 B} | inline_connector |
| UDS12_F:8 | | {CU 2 B} | inline_connector |
| UDS12_F:9 | | {CU 3 B} | inline_connector |
| UDS12_F:11 | | {CU 0 B} | inline_connector |
| UDS12_F:12 | | {CU 4 D} | inline_connector |
| UDS12_M:1 | | {CV 2 A} {CV 2 B} | inline_connector |
| UDS12_M:2 | | {CV 2 A} {CV 2 B} | inline_connector |
| UDS12_M:3 | | {CU 1 B} | inline_connector |
| UDS12_M:4 | | {CU 1 B} | inline_connector |
| UDS12_M:5 | | {XE 1 C} | inline_connector |
| UDS12_M:6 | | {XE 1 C} | inline_connector |
| UDS12_M:7 | | {CU 1 B} | inline_connector |
| UDS12_M:8 | | {CU 2 B} | inline_connector |
| UDS12_M:9 | | {CU 3 B} | inline_connector |
| UDS12_M:11 | | {CU 0 B} | inline_connector |
| UDS12_M:12 | | {CU 4 D} | inline_connector |
| UDS:1 | | {CV 1 C} | inline_connector |
| UDS:2 | | {CV 1 C} | inline_connector |
| UDS:5 | | {CU 3 B} | inline_connector |
| UDS:6 | | {CU 3 B} | inline_connector |
| UDS_B:1 | | {CV 1 B} | inline_connector |
| UDS_B:2 | | {CV 1 B} | inline_connector |
| UDS_B:3 | | {XE 0 C} | inline_connector |
| UDS_B:4 | | {XE 0 C} | inline_connector |
| UDS_F:1 | | {CV 2 B} | inline_connector |
| UDS_F:2 | | {CV 2 B} | inline_connector |
| UDS_F:3 | | {XE 0 C} | inline_connector |
| UDS_F:4 | | {XE 0 C} | inline_connector |
| UDS_M:1 | | {CV 1 B} | inline_connector |
| UDS_M:2 | | {CV 1 B} | inline_connector |
| UDS_M:3 | | {XE 0 C} | inline_connector |
| UDS_M:4 | | {XE 0 C} | inline_connector |
| UDS_TL:1 | | {CV 1 C} | inline_connector |
| UDS_TL:2 | | {CV 1 C} | inline_connector |
| UDS_TLA:1 | | {CV 1 C} | inline_connector |
| UDS_TLA:2 | | {CV 1 C} | inline_connector |
| VIC2:1 | | {CA 2 C} | inline_connector |
| VIC2:2 | | {CA 2 C} | inline_connector |
| VIC2:3 | | {CA 2 C} | inline_connector |
| VIC2:4 | | {CA 2 C} | inline_connector |
| VIC2:6 | | {CA 3 C} | inline_connector |
| VIC2:7 | | {CA 3 C} | inline_connector |
| VIC_MD7:1 | | {XC 4 A} {XC 0 D} | inline_connector |
| VIC_MD7:2 | | {XD 4 A} {XD 2 D} | inline_connector |
| VIC_MD7:3 | | {CN 0 B} | inline_connector |
| VIC_MD7:4 | | {XC 4 A} {XC 0 D} | inline_connector |
| VIC_MD7:5 | | {XD 4 A} {XD 2 D} | inline_connector |

VOLVO

Volvo Bus Corporation

Document Title

WIRING DIAGRAM

Document Type

PRODUCT SCHEMATIC

Document No

20904123

Issue Index

15

Volume No

02(02)

Page No

60(76)

| Part Name | Description | Location | Part Type |
|------------|-------------|----------------------|------------------|
| VIC_MD7:6 | | {CN 0 B} | inline_connector |
| VIC_MD7:7 | | {CN 2 B} | inline_connector |
| VIC_MD7:8 | | {CN 0 B} | inline_connector |
| VIC_MD7:9 | | {AD 2 B} {CF 4 C} | inline_connector |
| VIC_MD7:10 | | {AD 3 B} | inline_connector |
| VIC_MD7:12 | | {AD 0 D} | inline_connector |
| VIC_MD7:13 | | {CN 1 B} | inline_connector |
| VIC_MD7:14 | | {BD 0 B} | inline_connector |
| VIC_MD7:15 | | {CN 1 B} | inline_connector |
| VIC_MD7:16 | | {BD 0 C} | inline_connector |
| VIC_MD7:17 | | {AD 2 B} {CF 4 C} | inline_connector |
| VIC_MD7:18 | | {CN 1 B} | inline_connector |
| VIC_MD7:19 | | {CG 1 D} | inline_connector |
| VIC_MD7:20 | | {CN 1 B} | inline_connector |
| VIC_MD7:21 | | {CN 4 C} | inline_connector |
| VIC_MD7:22 | | {CN 4 C} {CG 1 D} | inline_connector |
| VIC_MD7:23 | | {CG 1 D} | inline_connector |
| VIC_MD7:24 | | {CN 3 B} {CF 3 B} | inline_connector |
| VIC_MD7:25 | | {CN 1 B} | inline_connector |
| VIC_MD7:26 | | {CN 1 C} {CN 4 C} | inline_connector |
| VIC_MD7:27 | | {CN 3 A} | inline_connector |
| VIC_MD7:28 | | {CN 1 B} | inline_connector |
| VIC_MD7:29 | | {CF 3 C} | inline_connector |
| VIC_MD7:30 | | {CN 1 B} | inline_connector |
| VIC_MD7:31 | | {CN 2 B} | inline_connector |
| VIC_MD7:32 | | {CN 2 B} | inline_connector |
| VIC_MD7:33 | | {CN 0 B} | inline_connector |
| VIC_MD7:34 | | {CN 3 B} | inline_connector |
| VIC_MD7:35 | | {AD 0 B} | inline_connector |
| VIC_MD7:36 | | {CN 3 B} | inline_connector |
| VIC_MD7:37 | | {CN 3 A} | inline_connector |
| VIC_MD7:38 | | {CF 2 D} | inline_connector |
| VIC_MD7:39 | | {CN 2 B} | inline_connector |
| VIC_MD9:1 | | {XC 1 D} | inline_connector |
| VIC_MD9:2 | | {XD 0 D} | inline_connector |
| VIC_MD9:3 | | {CA 0 B} | inline_connector |
| VIC_MD9:4 | | {XC 1 D} | inline_connector |
| VIC_MD9:5 | | {XD 0 D} | inline_connector |
| VIC_MD9:6 | | {CA 0 B} | inline_connector |
| VIC_MD9:7 | | {CA 3 B} | inline_connector |
| VIC_MD9:8 | | {CA 0 B} | inline_connector |
| VIC_MD9:9 | | {AE 2 C} {AH 1 C} | inline_connector |
| VIC_MD9:10 | | {AE 4 C} {AH 2 C} | inline_connector |
| VIC_MD9:11 | | {AE 2 C} | inline_connector |
| VIC_MD9:12 | | {AE 2 D} {AH 1 D} | inline_connector |

VOLVO

Volvo Bus Corporation

Document Title

WIRING DIAGRAM

Document Type

PRODUCT SCHEMATIC

Document No

20904123

Issue Index

15

Volume No

02(02)

Page No

61(76)

| Part Name | Description | Location | Part Type |
|------------|-------------|--|------------------|
| VIC_MD9:13 | | {CA 1 B} | inline_connector |
| VIC_MD9:14 | | {BD 3 B} {BD 1 B} {BD 2 B} {BD 0 B} | inline_connector |
| VIC_MD9:15 | | {CA 1 B} | inline_connector |
| VIC_MD9:16 | | {BD 3 C} {BD 1 C} {BD 2 C} {BD 0 C} | inline_connector |
| VIC_MD9:17 | | {AE 2 C} | inline_connector |
| VIC_MD9:18 | | {CA 1 B} | inline_connector |
| VIC_MD9:21 | | {CA 4 B} | inline_connector |
| VIC_MD9:22 | | {CG 3 A} {CA 4 C} | inline_connector |
| VIC_MD9:23 | | {CG 3 A} | inline_connector |
| VIC_MD9:24 | | {CG 3 A} {CA 2 B} | inline_connector |
| VIC_MD9:25 | | {CG 3 A} | inline_connector |
| VIC_MD9:26 | | {CG 4 A} {CA 2 D} | inline_connector |
| VIC_MD9:28 | | {CA 2 B} | inline_connector |
| VIC_MD9:30 | | {CA 3 B} | inline_connector |
| VIC_MD9:31 | | {CA 3 B} | inline_connector |
| VIC_MD9:33 | | {CA 0 B} | inline_connector |
| VIC_MD9:34 | | {CB 0 E} {CA 2 B} | inline_connector |
| VIC_MD9:35 | | {AE 0 C} {AH 0 C} | inline_connector |
| VIC_MD9:37 | | {CA 2 B} | inline_connector |
| VIC_MD9:38 | | {CB 1 D} | inline_connector |
| VIC_MD9:39 | | {CA 3 B} | inline_connector |
| X25:1 | | {DB 2 C} | inline_connector |
| X25:2 | | {XD 3 E} | inline_connector |
| X25:3 | | {DB 1 C} | inline_connector |
| X25:4 | | {XD 3 E} | inline_connector |
| X25:6 | | {DB 3 B} | inline_connector |
| X25:7 | | {DB 3 C} | inline_connector |
| X25:8 | | {DB 1 C} | inline_connector |
| X25:9 | | {DB 1 B} | inline_connector |
| XC102:1 | | {CE 3 B} | inline_connector |
| XC102:2 | | {CE 3 C} | inline_connector |
| XC105:1 | | {BF 1 A} | inline_connector |
| XC105:2 | | {BF 1 B} | inline_connector |
| XC906:1 | | {AB 0 B} | inline_connector |
| XC906:2 | | {AB 0 B} | inline_connector |
| XC906:3 | | {AB 0 B} | inline_connector |
| XC906:4 | | {AB 0 B} | inline_connector |
| XC906:5 | | {AB 1 B} | inline_connector |
| XC906:6 | | {AB 1 B} | inline_connector |
| XC906A:1 | | {AB3 1 A} | inline_connector |
| XC906A:2 | | {AB3 0 A} | inline_connector |
| XC906A:3 | | {AB3 0 A} | inline_connector |

VOLVO

Volvo Bus Corporation

Document Title

WIRING DIAGRAM

Document Type

PRODUCT SCHEMATIC

Document No

20904123

Issue Index

15

Volume No

02(02)

Page No

62(76)

| Part Name | Description | Location | Part Type |
|-----------|-------------|-----------|------------------|
| XC906A:4 | | {AB3 0 A} | inline_connector |
| XC906A:5 | | {AB3 0 A} | inline_connector |
| XC906A:6 | | {AB3 1 A} | inline_connector |
| XC906A:7 | | {AB3 1 A} | inline_connector |
| XC908:1 | | {BA 3 D} | inline_connector |
| XC908:2 | | {BA 3 D} | inline_connector |
| XC908:3 | | {BA 3 D} | inline_connector |
| XC908:4 | | {BA 1 D} | inline_connector |
| XC908:5 | | {BE 3 D} | inline_connector |
| XC908:6 | | {BE 3 D} | inline_connector |
| XC909:1 | | {BE 1 B} | inline_connector |
| XC909:2 | | {BE 0 B} | inline_connector |
| XC909:5 | | {BE 3 C} | inline_connector |
| XC909:6 | | {BE 3 D} | inline_connector |
| XC912:1 | | {BB2 4 D} | inline_connector |
| XC912:2 | | {BB2 3 D} | inline_connector |
| XC912:3 | | {BB2 3 D} | inline_connector |
| XC913:1 | | {BB2 3 D} | inline_connector |
| XC913:2 | | {BB2 2 D} | inline_connector |
| XC913:3 | | {BB2 3 D} | inline_connector |
| XC914A:1 | | {CA 2 A} | inline_connector |
| XC914A:2 | | {CA 2 B} | inline_connector |
| XC914A:3 | | {CA 3 D} | inline_connector |
| XC914A:4 | | {CA 3 D} | inline_connector |
| XC914A:5 | | {NA 4 B} | inline_connector |
| XC914A:7 | | {NA 4 A} | inline_connector |
| XC914A:8 | | {NA 4 B} | inline_connector |
| XC914A:9 | | {NA 4 A} | inline_connector |
| XC915:1 | | {NA 0 E} | inline_connector |
| XC915:2 | | {BB2 3 C} | inline_connector |
| XC915:3 | | {NA 0 D} | inline_connector |
| XC915:4 | | {BB2 2 C} | inline_connector |
| XC915:5 | | {NA 0 B} | inline_connector |
| XC915:6 | | {NA 0 D} | inline_connector |
| XC915:7 | | {BB2 3 C} | inline_connector |
| XC916:1 | | {AH 2 C} | inline_connector |
| XC916:2 | | {AH 2 C} | inline_connector |
| XC916:4 | | {AH 3 C} | inline_connector |
| XC916:5 | | {AH 1 D} | inline_connector |
| XC916:6 | | {AH 3 C} | inline_connector |
| XC917:1 | | {CL 1 D} | inline_connector |
| XC917:2 | | {CL 1 D} | inline_connector |
| XC917:3 | | {CL 0 D} | inline_connector |
| XC917:4 | | {CL 1 D} | inline_connector |
| XC920:1 | | {FC 2 B} | inline_connector |
| XC920:2 | | {FC 2 A} | inline_connector |
| XC921:1 | | {CL 1 C} | inline_connector |
| XC921:2 | | {CL 2 C} | inline_connector |
| XC921:3 | | {CL 2 C} | inline_connector |
| XC922:1 | | {GB 3 B} | inline_connector |
| XC922:3 | | {GB 3 B} | inline_connector |
| XC925:1 | | {NE 2 D} | inline_connector |
| XC925:2 | | {NE 1 D} | inline_connector |

VOLVO

Volvo Bus Corporation

Document Title

WIRING DIAGRAM

Document Type

PRODUCT SCHEMATIC

Document No

20904123

Issue Index

15

Volume No

02(02)

Page No

63(76)

| Part Name | Description | Location | Part Type |
|-------------|-------------|------------------------|------------------|
| XC926:1 | | {BB2 4 B} {BB2 1 B} | inline_connector |
| XC926:2 | | {BB2 3 B} {BB2 1 B} | inline_connector |
| XC926:3 | | {BB2 3 B} {BB2 0 B} | inline_connector |
| XC926:4 | | {BB2 2 B} {BB2 0 B} | inline_connector |
| XC926:5 | | {AC 0 B} | inline_connector |
| XC927_1/2:1 | | {GE 0 B} | inline_connector |
| XC927_1/2:2 | | {GE 1 B} | inline_connector |
| XC927_1:1 | | {GE 0 B} | inline_connector |
| XC927_1:2 | | {GE 1 B} | inline_connector |
| XC927_2:1 | | {GE 0 B} | inline_connector |
| XC927_2:2 | | {GE 1 B} | inline_connector |
| XC928:1 | | {NA 2 B} | inline_connector |
| XC928:2 | | {NA 2 B} | inline_connector |
| XC930:1 | | {CG 3 B} | inline_connector |
| XC930:2 | | {CG 3 B} | inline_connector |
| XC930:3 | | {CG 3 B} | inline_connector |
| XC930:4 | | {CG 3 B} | inline_connector |
| XC930:5 | | {CG 4 B} | inline_connector |
| XC931:1 | | {LB 1 B} | inline_connector |
| XC931:2 | | {LB 1 B} | inline_connector |
| XC931:3 | | {LB 2 A} | inline_connector |
| XC931:4 | | {LB 2 A} | inline_connector |
| XC931:5 | | {LB 2 B} | inline_connector |
| XC931:6 | | {LB 1 A} | inline_connector |
| XC932:1 | | {CG 1 C} | inline_connector |
| XC932:2 | | {CG 1 C} | inline_connector |
| XC932:3 | | {CG 1 C} | inline_connector |
| XC932A:1 | | {CL 0 B} | inline_connector |
| XC932A:2 | | {CL 0 B} | inline_connector |
| XC932B:1 | | {CL 0 B} | inline_connector |
| XC932B:2 | | {CL 0 B} | inline_connector |
| XC935:1 | | {NF 1 C} | inline_connector |
| XC935:2 | | {NF 1 C} | inline_connector |
| XC935:3 | | {NF 1 C} | inline_connector |
| XC935:4 | | {NF 3 A} | inline_connector |
| XC935:5 | | {NF 2 A} | inline_connector |
| XC935:7 | | {NF 0 C} | inline_connector |
| XC935:8 | | {NF 1 C} | inline_connector |
| XC935:10 | | {NF 0 A} | inline_connector |
| XC935:12 | | {NF 0 A} | inline_connector |
| XC936:1 | | {NG 0 A} | inline_connector |
| XC936:2 | | {NG 0 B} | inline_connector |
| XC936:3 | | {NG 0 B} | inline_connector |
| XC936:4 | | {NG 0 A} | inline_connector |
| XC936:5 | | {NG 0 B} | inline_connector |
| XC936:6 | | {NG 0 B} | inline_connector |
| XC936:7 | | {NG 0 A} | inline_connector |
| XC936:8 | | {NG 0 B} | inline_connector |
| XC936:9 | | {NG 0 B} | inline_connector |

VOLVO

Volvo Bus Corporation

Document Title

WIRING DIAGRAM

Document Type

PRODUCT SCHEMATIC

Document No

20904123

Issue Index

15

Volume No

02(02)

Page No

64(76)

| Part Name | Description | Location | Part Type |
|-----------|-------------|-----------|------------------|
| XC936:10 | | {NG 0 A} | inline_connector |
| XC936:11 | | {NG 0 B} | inline_connector |
| XC936:12 | | {NG 0 B} | inline_connector |
| XC936:13 | | {NG 1 A} | inline_connector |
| XC936:14 | | {NG 1 B} | inline_connector |
| XC936:15 | | {NG 1 B} | inline_connector |
| XC936:16 | | {NG 1 A} | inline_connector |
| XC936:17 | | {NG 1 B} | inline_connector |
| XC936:18 | | {NG 1 B} | inline_connector |
| XC941:1 | | {NC 4 A} | inline_connector |
| XC941:3 | | {NC 4 A} | inline_connector |
| XC942:1 | | {CV 3 E} | inline_connector |
| XC942:2 | | {CV 1 E} | inline_connector |
| XC942:3 | | {CV 1 D} | inline_connector |
| XC942:4 | | {CV 1 D} | inline_connector |
| XC942:5 | | {CU 2 B} | inline_connector |
| XC942:6 | | {CU 2 B} | inline_connector |
| XC942:7 | | {CU 3 B} | inline_connector |
| XC942:8 | | {CU 3 B} | inline_connector |
| XC943:1 | | {NC 4 C} | inline_connector |
| XC943:2 | | {NC 4 C} | inline_connector |
| XC944:1 | | {CA2 1 B} | inline_connector |
| XC944:2 | | {CA2 2 B} | inline_connector |
| XC944:3 | | {CA2 0 C} | inline_connector |
| XC944:5 | | {CA2 0 C} | inline_connector |
| XC944:7 | | {CA2 1 C} | inline_connector |
| XC944:9 | | {CA2 2 C} | inline_connector |
| XC944:11 | | {CA2 2 C} | inline_connector |
| XC945:1 | | {CA2 2 A} | inline_connector |
| XC945:2 | | {CA2 2 A} | inline_connector |
| XCAN1:1 | | {XC 4 C} | inline_connector |
| XCAN1:2 | | {XC 4 C} | inline_connector |
| XCAN1:3 | | {XC 4 C} | inline_connector |
| XCAN2:1 | | {XD 4 A} | inline_connector |
| XCAN2:2 | | {XD 4 A} | inline_connector |
| XCB604M:1 | | {BD 1 E} | inline_connector |
| XCU1:1 | | {CE 2 B} | inline_connector |
| XCU1:2 | | {CE 3 B} | inline_connector |
| XCU1:3 | | {CE 3 B} | inline_connector |
| XCU1:4 | | {CE 3 C} | inline_connector |
| XCU1:5 | | {CE 1 B} | inline_connector |
| XCU1:6 | | {CE 1 B} | inline_connector |
| XCU1:7 | | {CE 1 B} | inline_connector |
| XCU1:8 | | {CE 2 B} | inline_connector |
| XCU1:9 | | {CE 2 B} | inline_connector |
| XCU1:10 | | {CE 2 B} | inline_connector |
| XCU1:11 | | {CE 1 B} | inline_connector |
| XCU1:12 | | {CE 1 B} | inline_connector |
| XCU1:13 | | {CE 1 B} | inline_connector |
| XCU1:14 | | {CE 3 B} | inline_connector |
| XCU1:15 | | {CE 3 B} | inline_connector |
| XCU1:16 | | {CE 1 B} | inline_connector |
| XCU1:17 | | {CE 1 B} | inline_connector |

VOLVO

Volvo Bus Corporation

Document Title

WIRING DIAGRAM

Document Type

PRODUCT SCHEMATIC

Document No

20904123

Issue Index

15

Volume No

02(02)

Page No

65(76)

| Part Name | Description | Location | Part Type |
|-----------|-------------|-----------|------------------|
| XCU1:18 | | {CE 1 B} | inline_connector |
| XCU1:19 | | {CE 2 B} | inline_connector |
| XCU1:20 | | {CE 2 B} | inline_connector |
| XCU1:21 | | {CE 2 B} | inline_connector |
| XCU1:22 | | {CE 1 B} | inline_connector |
| XCU1:23 | | {CE 1 B} | inline_connector |
| XCU1:24 | | {CE 2 B} | inline_connector |
| XCU1:25 | | {CD 3 B} | inline_connector |
| XCU1:26 | | {CE 1 D} | inline_connector |
| XCU1:27 | | {CD 0 B} | inline_connector |
| XCU1:28 | | {XD 4 A} | inline_connector |
| XCU1:29 | | {XD 4 A} | inline_connector |
| XCU1:30 | | {CD 0 B} | inline_connector |
| XCU2:A | | {CD 0 B} | inline_connector |
| XCU2:B | | {CD 1 B} | inline_connector |
| XCU2:C | | {CD 2 B} | inline_connector |
| XCU2:D | | {CD 2 B} | inline_connector |
| XCU2:E | | {CD 2 B} | inline_connector |
| XCU2:F | | {CD 2 B} | inline_connector |
| XCU2:G | | {CE 2 D} | inline_connector |
| XCU2:H | | {CD 2 B} | inline_connector |
| XCU2:J | | {CE 2 D} | inline_connector |
| XCU2:K | | {CD 4 B} | inline_connector |
| XCU2:L | | {CD 4 B} | inline_connector |
| XCU2:M | | {CD 2 B} | inline_connector |
| XCU2:N | | {CD 3 B} | inline_connector |
| XCU2:O | | {CD 2 B} | inline_connector |
| XCU2:P | | {CD 2 B} | inline_connector |
| XCU2:Q | | {CD 3 B} | inline_connector |
| XCU2:R | | {CD 3 B} | inline_connector |
| XCU2:T | | {CE 3 D} | inline_connector |
| XCU2:U | | {CE 2 D} | inline_connector |
| XCU2:V | | {CD 3 B} | inline_connector |
| XCU2:W | | {CE 2 D} | inline_connector |
| XFSEN:1 | | {BD 0 B} | inline_connector |
| XFSEN:2 | | {BD 0 C} | inline_connector |
| XJB:1 | | {BC 1 D} | inline_connector |
| XJB:2 | | {BC 1 E} | inline_connector |
| XJB:3 | | {BC 1 D} | inline_connector |
| XJB:4 | | {BC 1 E} | inline_connector |
| XJK:1 | | {BC 1 B} | inline_connector |
| XJK:2 | | {BC 0 E} | inline_connector |
| XJK:3 | | {BC 1 C} | inline_connector |
| XJK:4 | | {BC 2 E} | inline_connector |
| XK2:5 | | {GA 3 B} | inline_connector |
| XK2:6 | | {GA 3 B} | inline_connector |
| XU25:1 | | {AA2 1 B} | inline_connector |
| XU25:2 | | {AA2 1 B} | inline_connector |
| XU25:3 | | {AA2 2 B} | inline_connector |
| XU25:4 | | {AA2 1 B} | inline_connector |
| XU25:5 | | {AA2 2 B} | inline_connector |
| Y17:1 | | {DM 1 D} | inline_connector |
| | | {DQ 3 D} | |

VOLVO

Volvo Bus Corporation

Document Title

WIRING DIAGRAM

Document Type

PRODUCT SCHEMATIC

Document No

20904123

Issue Index

15

Volume No

02(02)

Page No

66(76)

| Part Name | Description | Location | Part Type |
|-----------|-------------|----------------------|---------------------------|
| Y17:2 | | {DM 1 D} {DQ 3 D} | inline_connector |
| Y17:3 | | {DM 2 C} {DQ 3 D} | inline_connector |
| Y17:4 | | {DM 2 C} {DQ 3 D} | inline_connector |
| Y17:5 | | {DM 2 B} {DQ 2 D} | inline_connector |
| Y17:6 | | {DM 2 C} {DQ 4 D} | inline_connector |
| Y17:7 | | {DM 2 B} {DQ 4 D} | inline_connector |
| Y901_A:1 | | {NB 3 B} | inline_connector |
| Y901_A:2 | | {NB 3 B} | inline_connector |
| Y901_B:1 | | {NB 3 A} | inline_connector |
| Y901_B:2 | | {NB 3 A} | inline_connector |
| BATS_D_1 | | {AB 0 A} | physical_splice_connector |
| XE1 | | {CB 0 B} | physical_splice_connector |
| XE5 | | {CB 2 A} | physical_splice_connector |
| XE8 | | {CB 4 C} | physical_splice_connector |
| XE10 | | {CB 3 D} | physical_splice_connector |
| XS01 | | {CA2 4 C} | physical_splice_connector |
| XS02 | | {CA2 3 B} | physical_splice_connector |
| XS03 | | {CA2 4 B} | physical_splice_connector |
| XSA1 | | {CH 2 D} | physical_splice_connector |
| XSA01 | | {XC 1 A} | physical_splice_connector |
| XSA02 | | {XC 1 B} | physical_splice_connector |
| XSA03 | | {XC 2 A} | physical_splice_connector |
| XSA04 | | {XC 3 B} | physical_splice_connector |
| XSA05 | | {XC 3 A} | physical_splice_connector |
| XSA06 | | {XC 3 B} | physical_splice_connector |
| XSA07 | | {XC 3 A} | physical_splice_connector |
| XSA08 | | {XC 3 B} | physical_splice_connector |
| XSA09 | | {XC 4 A} | physical_splice_connector |
| XSA10 | | {XC 4 B} | physical_splice_connector |
| XSA11 | | {XC 4 C} | physical_splice_connector |
| XSA12 | | {XC 4 C} | physical_splice_connector |
| XSA13 | | {XD 2 A} | physical_splice_connector |
| XSA14 | | {XD 2 A} | physical_splice_connector |
| XSA15 | | {XD 2 A} | physical_splice_connector |
| XSA16 | | {XD 2 A} | physical_splice_connector |
| XSA17 | | {XD 3 A} | physical_splice_connector |
| XSA18 | | {XD 3 A} | physical_splice_connector |
| XSA19 | | {XD 3 A} | physical_splice_connector |
| XSA20 | | {XD 3 A} | physical_splice_connector |
| XSA21 | | {XD 3 A} | physical_splice_connector |
| XSA22 | | {XD 3 A} | physical_splice_connector |
| XSA23 | | {XD 4 B} | physical_splice_connector |
| XSA24 | | {XD 4 B} | physical_splice_connector |
| XSA25 | | {ZC 0 E} | physical_splice_connector |
| XSA26 | | {AA 0 D} | physical_splice_connector |
| XSA27 | | {FA 1 D} | physical_splice_connector |
| XSA28 | | {AA 2 C} | physical_splice_connector |

VOLVO

Volvo Bus Corporation

Document Title

WIRING DIAGRAM

Document Type

PRODUCT SCHEMATIC

Document No

20904123

Issue Index

15

Volume No

02(02)

Page No

67(76)

| Part Name | Description | Location | Part Type |
|-----------|-------------|-----------|---------------------------|
| XSA29 | | {BA 0 D} | physical_splice_connector |
| XSA31 | | {ZC 1 D} | physical_splice_connector |
| XSA32 | | {BA 1 D} | physical_splice_connector |
| XSA34 | | {AA 2 A} | physical_splice_connector |
| XSA35 | | {ZC 3 D} | physical_splice_connector |
| XSA37 | | {FB 3 B} | physical_splice_connector |
| XSA40 | | {FB 2 B} | physical_splice_connector |
| XSA43 | | {ZC 2 D} | physical_splice_connector |
| XSA44 | | {AC 0 D} | physical_splice_connector |
| XSA46 | | {BB 2 D} | physical_splice_connector |
| XSA50 | | {BA 0 B} | physical_splice_connector |
| XSA52 | | {ZC 2 D} | physical_splice_connector |
| XSA53 | | {GM 2 B} | physical_splice_connector |
| XSA54 | | {DM 1 B} | physical_splice_connector |
| XSA55 | | {BF 1 B} | physical_splice_connector |
| XSA57 | | {BF 1 C} | physical_splice_connector |
| XSA59 | | {BA 0 C} | physical_splice_connector |
| XSA60 | | {NA 1 D} | physical_splice_connector |
| XSA61 | | {BA 0 B} | physical_splice_connector |
| XSA62 | | {XD 2 A} | physical_splice_connector |
| XSA63 | | {XC 1 A} | physical_splice_connector |
| XSA64 | | {XC 1 B} | physical_splice_connector |
| XSA65 | | {XD 2 A} | physical_splice_connector |
| XSA68 | | {BC 3 C} | physical_splice_connector |
| XSA69 | | {BC 2 C} | physical_splice_connector |
| XSA70 | | {BC 3 C} | physical_splice_connector |
| XSA71 | | {BC 3 C} | physical_splice_connector |
| XSA72 | | {AB 0 B} | physical_splice_connector |
| XSA73 | | {AB 0 B} | physical_splice_connector |
| XSA74 | | {NB 0 A} | physical_splice_connector |
| XSA75 | | {BB2 3 B} | physical_splice_connector |
| XSA075 | | {AB3 0 A} | physical_splice_connector |
| XSA76 | | {BB2 2 C} | physical_splice_connector |
| XSA100 | | {NB 0 B} | physical_splice_connector |
| XSB01 | | {XC 0 A} | physical_splice_connector |
| XSB02 | | {XC 0 B} | physical_splice_connector |
| XSB03 | | {XD 1 A} | physical_splice_connector |
| XSB04 | | {XD 1 A} | physical_splice_connector |
| XSB05 | | {XD 0 A} | physical_splice_connector |
| XSB06 | | {XD 0 A} | physical_splice_connector |
| XSB07 | | {IS 1 C} | physical_splice_connector |
| XSB08 | | {IS 1 C} | physical_splice_connector |
| XSB09 | | {ZC 0 D} | physical_splice_connector |
| XSB10 | | {ZC 0 B} | physical_splice_connector |
| XSB11 | | {ZC 0 C} | physical_splice_connector |
| XSB12 | | {GM 2 C} | physical_splice_connector |
| XSB13 | | {GB 3 A} | physical_splice_connector |
| XSB14 | | {ZC 0 B} | physical_splice_connector |
| XSB15 | | {GB 3 B} | physical_splice_connector |
| XSB18 | | {IU 0 C} | physical_splice_connector |
| XSB19 | | {IU 0 C} | physical_splice_connector |
| XSB20 | | {AC 3 B} | physical_splice_connector |
| XSB21 | | {IU 1 C} | physical_splice_connector |

VOLVO

Volvo Bus Corporation

Document Title

WIRING DIAGRAM

Document Type

PRODUCT SCHEMATIC

Document No

20904123

Issue Index

15

Volume No

02(02)

Page No

68(76)

| Part Name | Description | Location | Part Type |
|-----------|-------------|-----------|---------------------------|
| XSB22 | | {NC 1 B} | physical_splice_connector |
| XSB23 | | {NC 1 C} | physical_splice_connector |
| XSB24 | | {NC 0 C} | physical_splice_connector |
| XSB25 | | {AA 1 D} | physical_splice_connector |
| XSB26 | | {NC 1 C} | physical_splice_connector |
| XSB28 | | {CV 4 C} | physical_splice_connector |
| XSB29 | | {CV 4 C} | physical_splice_connector |
| XSB30 | | {IU 0 C} | physical_splice_connector |
| XSB31 | | {IU 1 C} | physical_splice_connector |
| XSB32 | | {XC 0 A} | physical_splice_connector |
| XSB33 | | {XC 0 B} | physical_splice_connector |
| XSB34 | | {NA 3 C} | physical_splice_connector |
| XSB36 | | {NA 0 D} | physical_splice_connector |
| XSB37 | | {NC 3 A} | physical_splice_connector |
| XSB38 | | {NC 4 B} | physical_splice_connector |
| XSB39 | | {NC 4 B} | physical_splice_connector |
| XSB40 | | {NA 3 C} | physical_splice_connector |
| XSB41 | | {CP 2 B} | physical_splice_connector |
| XSB45 | | {XC 2 C} | physical_splice_connector |
| XSB46 | | {XC 2 C} | physical_splice_connector |
| XSB47 | | {NA 1 C} | physical_splice_connector |
| XSB48 | | {NA 1 C} | physical_splice_connector |
| XSB49 | | {XC 0 A} | physical_splice_connector |
| XSB50 | | {XC 0 A} | physical_splice_connector |
| XSBEN | | {NA 1 A} | physical_splice_connector |
| XSC01 | | {ZC 1 A} | physical_splice_connector |
| XSC02 | | {GE 1 C} | physical_splice_connector |
| XSC03 | | {GB 2 D} | physical_splice_connector |
| XSC04 | | {GE 0 C} | physical_splice_connector |
| XSC05 | | {GE 0 C} | physical_splice_connector |
| XSC06 | | {GE 2 C} | physical_splice_connector |
| XSC07 | | {ZC 1 B} | physical_splice_connector |
| XSC08 | | {GB 3 D} | physical_splice_connector |
| XSC09 | | {GB 1 D} | physical_splice_connector |
| XSC11 | | {DA 2 B} | physical_splice_connector |
| XSC12 | | {DA 3 B} | physical_splice_connector |
| XSC13 | | {ZC 4 C} | physical_splice_connector |
| XSC14 | | {ZC 1 B} | physical_splice_connector |
| XSC15 | | {ZC 1 A} | physical_splice_connector |
| XSC16 | | {GB 0 B} | physical_splice_connector |
| XSC17 | | {ZC 1 B} | physical_splice_connector |
| XSC18 | | {ZC 0 A} | physical_splice_connector |
| XSC19 | | {AE 2 A} | physical_splice_connector |
| XSC21 | | {DN 0 D} | physical_splice_connector |
| XSC23 | | {DD 1 B} | physical_splice_connector |
| XSC24 | | {DD 1 C} | physical_splice_connector |
| XSC25 | | {DD 1 C} | physical_splice_connector |
| XSC30 | | {CA2 2 C} | physical_splice_connector |
| XSC31 | | {CA2 1 B} | physical_splice_connector |
| XSC32 | | {CA2 1 A} | physical_splice_connector |
| XSC33 | | {CA2 1 B} | physical_splice_connector |
| XSC34 | | {CA2 1 D} | physical_splice_connector |
| XSC35 | | {CA2 2 A} | physical_splice_connector |

VOLVO

Volvo Bus Corporation

Document Title

WIRING DIAGRAM

Document Type

PRODUCT SCHEMATIC

Document No

20904123

Issue Index

15

Volume No

02(02)

Page No

69(76)

| Part Name | Description | Location | Part Type |
|-----------|-----------------------------|----------------------|---------------------------|
| XSC50 | | {DP 3 C} | physical_splice_connector |
| XSC51 | | {DP 2 C} | physical_splice_connector |
| XSC52 | | {DP 2 C} | physical_splice_connector |
| XSC53 | | {DP 1 C} | physical_splice_connector |
| XSC54 | | {DP 1 C} | physical_splice_connector |
| XSC97 | | {CL 2 B} | physical_splice_connector |
| XSC98 | | {CL 2 B} | physical_splice_connector |
| XSC99 | | {CL 1 B} | physical_splice_connector |
| XSD05 | | {DC 2 B} | physical_splice_connector |
| XSD06 | | {DC 2 C} | physical_splice_connector |
| XSD07 | | {DC 1 B} | physical_splice_connector |
| XSD08 | | {DC 3 B} | physical_splice_connector |
| XSE01 | | {CB 3 A} {CM 0 C} | physical_splice_connector |
| XSE01_ | Unit injector cylider 1 2 3 | {CC 2 D} | physical_splice_connector |
| XSE02 | | {AE 3 D} | physical_splice_connector |
| XSE02_ | Unit injector cylider 1 2 3 | {CC 2 D} | physical_splice_connector |
| XSE03 | | {CM 0 C} | physical_splice_connector |
| XSE03_ | Unit injector cylider 1 2 3 | {CC 3 D} | physical_splice_connector |
| XSE04 | | {CA 1 C} | physical_splice_connector |
| XSE04_ | Unit injector cylider 1 2 3 | {CC 3 D} | physical_splice_connector |
| XSE05 | | {CA 1 B} | physical_splice_connector |
| XSE05_ | Unit injector cylider 1 2 3 | {CC 3 D} | physical_splice_connector |
| XSE06 | | {CM 1 C} | physical_splice_connector |
| XSE06_ | Unit injector cylider 1 2 3 | {CC 3 D} | physical_splice_connector |
| XSE07 | | {CA 1 B} | physical_splice_connector |
| XSE07_ | Unit injector cylider 1 2 3 | {CC 3 D} | physical_splice_connector |
| XSE08 | | {CA 2 C} | physical_splice_connector |
| XSE08_ | Unit injector cylider 1 2 3 | {CC 3 D} | physical_splice_connector |
| XSE09 | | {CM 2 C} | physical_splice_connector |
| XSE09_ | Unit injector cylider 1 2 3 | {CC 3 D} | physical_splice_connector |
| XSE10 | | {CM 3 A} | physical_splice_connector |
| XSE10_ | Unit injector cylider 4 5 6 | {CC 3 D} | physical_splice_connector |
| XSE11 | | {CM 3 C} | physical_splice_connector |
| XSE12 | | {CA 0 D} | physical_splice_connector |
| XSE13 | | {CM 1 D} | physical_splice_connector |
| XSE13_ | | {CC 3 B} | physical_splice_connector |
| XSE14 | | {CM 1 D} | physical_splice_connector |
| XSE14_ | GND | {CC 3 C} | physical_splice_connector |
| XSE15 | | {CM 2 D} | physical_splice_connector |
| XSE15_ | +30 main switch (F15 15A) | {CC 1 B} | physical_splice_connector |
| XSE16 | | {CM 2 D} | physical_splice_connector |
| XSE16_ | | {CC 0 B} | physical_splice_connector |
| XSE17 | | {CM 2 D} | physical_splice_connector |
| XSE18 | | {CM 2 D} | physical_splice_connector |
| XSE18_ | Ground for sensors | {CC 1 E} | physical_splice_connector |
| XSE19 | | {CM 2 D} | physical_splice_connector |
| XSE19_ | Power supply 5V | {CC 1 D} | physical_splice_connector |
| XSE20 | | {CM 2 D} | physical_splice_connector |
| XSE20_ | | {CC 0 E} | physical_splice_connector |
| XSE21 | | {CM 2 D} | physical_splice_connector |
| XSE22 | | {CM 1 D} | physical_splice_connector |
| XSE23 | | {CM 2 D} | physical_splice_connector |

VOLVO

Volvo Bus Corporation

Document Title

WIRING DIAGRAM

Document Type

PRODUCT SCHEMATIC

Document No

20904123

Issue Index

15

Volume No

02(02)

Page No

70(76)

| Part Name | Description | Location | Part Type |
|-----------|-------------|----------|---------------------------|
| XSE24 | | {CA 0 D} | physical_splice_connector |
| XSE25 | | {CA 1 D} | physical_splice_connector |
| XSE26 | | {CM 3 D} | physical_splice_connector |
| XSE27 | | {CM 3 D} | physical_splice_connector |
| XSE28 | | {CM 3 D} | physical_splice_connector |
| XSE29 | | {CM 3 D} | physical_splice_connector |
| XSE30 | | {CM 3 D} | physical_splice_connector |
| XSE31 | | {CM 3 D} | physical_splice_connector |
| XSE32 | | {CM 4 D} | physical_splice_connector |
| XSE33 | | {CM 4 D} | physical_splice_connector |
| XSE34 | | {CM 3 D} | physical_splice_connector |
| XSE35 | | {CM 3 D} | physical_splice_connector |
| XSE36 | | {CA 1 D} | physical_splice_connector |
| XSE39 | | {CM 3 A} | physical_splice_connector |
| XSE40 | | {CM 3 B} | physical_splice_connector |
| XSE41 | | {CN 2 B} | physical_splice_connector |
| XSE42 | | {CN 2 C} | physical_splice_connector |
| XSE43 | | {CN 4 D} | physical_splice_connector |
| XSE44 | | {CN 2 C} | physical_splice_connector |
| XSE45 | | {CN 2 D} | physical_splice_connector |
| XSE46 | | {CN 0 D} | physical_splice_connector |
| XSE47 | | {CN 0 D} | physical_splice_connector |
| XSE48 | | {CN 1 D} | physical_splice_connector |
| XSE49 | | {CN 2 D} | physical_splice_connector |
| XSE50 | | {CM 4 C} | physical_splice_connector |
| XSE51 | | {CM 1 B} | physical_splice_connector |
| XSE52 | | {CM 2 C} | physical_splice_connector |
| XSE53 | | {CB 3 A} | physical_splice_connector |
| XSE54 | | {CB 3 B} | physical_splice_connector |
| XSE55 | | {CB 1 B} | physical_splice_connector |
| XSE56 | | {CB 1 A} | physical_splice_connector |
| XSE57 | | {CB 1 E} | physical_splice_connector |
| XSE58 | | {CB 2 D} | physical_splice_connector |
| XSE59 | | {CB 3 D} | physical_splice_connector |
| XSE60 | | {CM 0 D} | physical_splice_connector |
| XSE61 | | {CA 4 B} | physical_splice_connector |
| XSE63 | | {CA 3 B} | physical_splice_connector |
| XSE68 | | {CA 2 C} | physical_splice_connector |
| XSE70 | | {CA 2 D} | physical_splice_connector |
| XSE71 | | {CA 3 C} | physical_splice_connector |
| XSE72 | | {CA 4 D} | physical_splice_connector |
| XSE82 | | {XC 4 B} | physical_splice_connector |
| XSE83 | | {XC 4 B} | physical_splice_connector |
| XSE84 | | {CD 0 B} | physical_splice_connector |
| XSE93 | | {CV 2 A} | physical_splice_connector |
| | | {CV 2 B} | |
| XSE94 | | {CV 2 A} | physical_splice_connector |
| | | {CV 2 B} | |
| XSE98 | | {CF 1 A} | physical_splice_connector |
| XSE100 | | {CF 1 A} | physical_splice_connector |
| XSE102 | | {CF 0 B} | physical_splice_connector |
| XSE103 | | {CF 1 B} | physical_splice_connector |
| XSE104 | | {CF 1 B} | physical_splice_connector |

VOLVO

Volvo Bus Corporation

Document Title

WIRING DIAGRAM

Document Type

PRODUCT SCHEMATIC

Document No

20904123

Issue Index

15

Volume No

02(02)

Page No

71(76)

| Part Name | Description | Location | Part Type |
|-----------|-------------|--|---------------------------|
| XSE105 | | {CF 2 B} | physical_splice_connector |
| XSE107 | | {CF 1 C} | physical_splice_connector |
| XSE108 | | {CF 1 C} | physical_splice_connector |
| XSE109 | | {CF 2 C} | physical_splice_connector |
| XSE111 | | {CF 3 C} | physical_splice_connector |
| XSE112 | | {CG 1 D} | physical_splice_connector |
| XSE222 | | {CC 0 C} | physical_splice_connector |
| XSF01 | | {GE 4 B} | physical_splice_connector |
| XSF02 | | {GD 2 B} | physical_splice_connector |
| XSF03 | | {GA 2 D} | physical_splice_connector |
| XSF04 | | {GA 3 D} | physical_splice_connector |
| XSF05 | | {GC 1 C} | physical_splice_connector |
| XSF06 | | {GD 3 B} | physical_splice_connector |
| XSF07 | | {ZC 3 B} | physical_splice_connector |
| XSF08 | | {CA 3 B} | physical_splice_connector |
| XSF09 | | {GC 0 C} | physical_splice_connector |
| XSF10 | | {GC 1 C} | physical_splice_connector |
| XSF11 | | {GE 4 C} | physical_splice_connector |
| XSF12 | | {GA 2 B} | physical_splice_connector |
| XSF13 | | {GE 3 C} | physical_splice_connector |
| XSF14 | | {ZC 2 B} | physical_splice_connector |
| XSF19 | | {ZC 2 D} | physical_splice_connector |
| XSF20 | | {CU 1 B} | physical_splice_connector |
| XSF21 | | {ZC 4 C} | physical_splice_connector |
| XSF22 | | {CU 1 B} | physical_splice_connector |
| XSF23 | | {CU 1 B} | physical_splice_connector |
| XSF26 | | {DM 2 B} | physical_splice_connector |
| XSF29 | | {FB 0 B} | physical_splice_connector |
| XSF31 | | {GD 1 A} | physical_splice_connector |
| XSF32 | | {FB 0 C} | physical_splice_connector |
| XSF33 | | {GD 1 A} | physical_splice_connector |
| XSF34 | | {GD 0 A} | physical_splice_connector |
| XSF35 | | {BA 1 A} | physical_splice_connector |
| XSF36 | | {CV 2 C} | physical_splice_connector |
| XSF37 | | {GA 1 D} | physical_splice_connector |
| XSF38 | | {CN 0 A} | physical_splice_connector |
| XSF39 | | {CV 2 C} | physical_splice_connector |
| XSF40 | | {FA 0 B} | physical_splice_connector |
| XSF41 | | {XD 1 D} {XD 1 D} {XD 1 D} {XD 1 D} {XD 2 D} {XE 1 B} | physical_splice_connector |
| XSF42 | | {XD 1 C} {XD 1 C} {XD 1 C} {XD 1 C} {XD 2 C} {XE 1 B} | physical_splice_connector |
| XSF43 | | {CM 3 B} | physical_splice_connector |
| XSF44 | | {CM 0 B} | physical_splice_connector |
| XSF45 | | {CN 1 B} | physical_splice_connector |

VOLVO

Volvo Bus Corporation

Document Title

WIRING DIAGRAM

Document Type

PRODUCT SCHEMATIC

Document No

20904123

Issue Index

15

Volume No

02(02)

Page No

72(76)

| Part Name | Description | Location | Part Type |
|-----------|-------------|-----------|---------------------------|
| XSF46 | | {CA 2 B} | physical_splice_connector |
| XSF47 | | {CV 1 C} | physical_splice_connector |
| XSF48 | | {CV 1 C} | physical_splice_connector |
| XSF49 | | {CV 2 D} | physical_splice_connector |
| XSF50 | | {CV 2 D} | physical_splice_connector |
| XSF51 | | {CV 2 D} | physical_splice_connector |
| XSF52 | | {CV 2 D} | physical_splice_connector |
| XSF54 | | {XC 1 C} | physical_splice_connector |
| XSF55 | | {XC 0 C} | physical_splice_connector |
| XSF60 | | {CN 2 B} | physical_splice_connector |
| XSF61 | | {ZC 2 C} | physical_splice_connector |
| XSF62 | | {CA 1 A} | physical_splice_connector |
| XSF64 | | {CL 1 D} | physical_splice_connector |
| XSF70 | | {CU 0 B} | physical_splice_connector |
| XSF71 | | {CU 3 D} | physical_splice_connector |
| XSF72 | | {CU 0 E} | physical_splice_connector |
| XSF73 | | {CU 0 E} | physical_splice_connector |
| XSF74 | | {ZC 1 D} | physical_splice_connector |
| XSF75 | | {AG 2 C} | physical_splice_connector |
| XSF76 | | {CU 0 B} | physical_splice_connector |
| XSF77 | | {ZC 2 A} | physical_splice_connector |
| XSF78 | | {ZC 2 A} | physical_splice_connector |
| XSF79 | | {ZC 3 A} | physical_splice_connector |
| XSF80 | | {XC 1 C} | physical_splice_connector |
| XSF81 | | {XC 1 C} | physical_splice_connector |
| XSF82 | | {CV 2 A} | physical_splice_connector |
| | | {CV 2 B} | |
| XSF83 | | {CV 2 A} | physical_splice_connector |
| | | {CV 2 B} | |
| XSF84 | | {CV 1 B} | physical_splice_connector |
| | | {CV 1 A} | |
| XSF85 | | {CV 1 A} | physical_splice_connector |
| | | {CV 1 B} | |
| XSF86 | | {CV 1 C} | physical_splice_connector |
| XSF87 | | {CV 1 C} | physical_splice_connector |
| XSF88 | | {CV 0 B} | physical_splice_connector |
| XSF89 | | {CV 0 B} | physical_splice_connector |
| XSF90 | | {CV 2 A} | physical_splice_connector |
| XSF91 | | {CV 2 A} | physical_splice_connector |
| XSF93 | | {BB2 1 C} | physical_splice_connector |
| XSF94 | | {BB2 1 B} | physical_splice_connector |
| XSF96 | | {CN 3 B} | physical_splice_connector |
| XSF97 | | {XD 0 D} | physical_splice_connector |
| XSF98 | | {XD 0 D} | physical_splice_connector |
| XSF99 | | {AG 3 D} | physical_splice_connector |
| XSF100 | | {CV 3 C} | physical_splice_connector |
| XSF101 | | {CV 3 C} | physical_splice_connector |
| XSF102 | | {CU 2 A} | physical_splice_connector |
| XSF103 | | {CU 2 A} | physical_splice_connector |
| XSF104 | | {CU 2 A} | physical_splice_connector |
| XSF105 | | {CU 3 A} | physical_splice_connector |
| XSF106 | | {CU 1 A} | physical_splice_connector |
| XSF107 | | {CU 1 A} | physical_splice_connector |

VOLVO

Volvo Bus Corporation

Document Title

WIRING DIAGRAM

Document Type

PRODUCT SCHEMATIC

Document No

20904123

Issue Index

15

Volume No

02(02)

Page No

73(76)

| Part Name | Description | Location | Part Type |
|-----------|-------------|----------------------|---------------------------|
| XSF108 | | {CU 1 A} | physical_splice_connector |
| XSF109 | | {CU 1 A} | physical_splice_connector |
| XSF110 | | {CU 0 A} | physical_splice_connector |
| XSF111 | | {CU 0 A} | physical_splice_connector |
| XSF112 | | {CU 0 A} | physical_splice_connector |
| XSF113 | | {CU 4 E} | physical_splice_connector |
| XSF114 | | {CU 4 E} | physical_splice_connector |
| XSF119 | | {XC 2 D} | physical_splice_connector |
| XSF120 | | {XC 2 D} | physical_splice_connector |
| XSF121 | | {DQ 2 D} | physical_splice_connector |
| XSF122 | | {DQ 2 C} | physical_splice_connector |
| XSF123 | | {DQ 2 D} | physical_splice_connector |
| XSG01 | | {AD 3 C} | physical_splice_connector |
| XSG02 | | {AD 2 D} | physical_splice_connector |
| XSG03 | | {AH 1 D} | physical_splice_connector |
| XSG04 | | {AH 2 D} | physical_splice_connector |
| XSG05 | | {AE 2 D} | physical_splice_connector |
| XSG06 | | {AF 4 B} | physical_splice_connector |
| XSG07 | | {AF 3 D} | physical_splice_connector |
| XSG08 | | {CB 3 A} | physical_splice_connector |
| XSJ01 | | {GD 3 C} | physical_splice_connector |
| XSJ02 | | {GD 3 C} | physical_splice_connector |
| XSJ03 | | {GD 4 C} | physical_splice_connector |
| XSJ04 | | {GD 1 C} | physical_splice_connector |
| XSJ05 | | {GD 0 C} | physical_splice_connector |
| XSJ06 | | {GD 2 C} | physical_splice_connector |
| XSJ07 | | {ZC 4 B} | physical_splice_connector |
| XSJ08 | | {ZC 2 C} | physical_splice_connector |
| XSJ09 | | {FB 1 C} | physical_splice_connector |
| XSJ10 | | {FB 1 B} | physical_splice_connector |
| XSJ11 | | {FB 3 D} | physical_splice_connector |
| XSJ12 | | {FB 3 D} | physical_splice_connector |
| XSJ13 | | {DO 2 C} | physical_splice_connector |
| XSJ14 | | {DO 1 B} | physical_splice_connector |
| XSJ15 | | {DO 2 B} | physical_splice_connector |
| XSJ16 | | {GF 2 B} | physical_splice_connector |
| XSJ17 | | {BB 4 B} | physical_splice_connector |
| XSJ18 | | {FB 0 D} | physical_splice_connector |
| XSJ19 | | {FB 0 D} | physical_splice_connector |
| XSJ20 | | {FA 2 A} | physical_splice_connector |
| XSJ21 | | {DD 4 A} | physical_splice_connector |
| XSJ22 | | {DD 4 A} | physical_splice_connector |
| XSJ23 | | {FC 1 B} | physical_splice_connector |
| XSJ24 | | {FC 1 B} | physical_splice_connector |
| XSJ25 | | {FC 2 C} | physical_splice_connector |
| XSJ26 | | {FC 2 B} {FC 1 B} | physical_splice_connector |
| XSJ27 | | {ZC 3 B} | physical_splice_connector |
| XSJ28 | | {ZC 4 B} | physical_splice_connector |
| XSJ30 | | {FC 1 B} | physical_splice_connector |
| XSJ31 | | {FC 1 B} | physical_splice_connector |
| XSJ32 | | {FC 0 D} | physical_splice_connector |
| XSJ33 | | {GF 3 B} | physical_splice_connector |

VOLVO

Volvo Bus Corporation

Document Title

WIRING DIAGRAM

Document Type

PRODUCT SCHEMATIC

Document No

20904123

Issue Index

15

Volume No

02(02)

Page No

74(76)

| Part Name | Description | Location | Part Type |
|-----------|-------------------------|----------|---------------------------|
| XSJ34 | | {ZC 1 C} | physical_splice_connector |
| XSJ35 | | {XC 2 D} | physical_splice_connector |
| XSJ36 | | {XC 2 D} | physical_splice_connector |
| XSJ37 | | {FC 2 A} | physical_splice_connector |
| XSJ40 | | {NA 0 E} | physical_splice_connector |
| XSJ41 | | {NA 0 D} | physical_splice_connector |
| XSJ42 | | {NA 0 C} | physical_splice_connector |
| XSJ43 | | {NA 0 C} | physical_splice_connector |
| XSJ44 | | {LA 1 B} | physical_splice_connector |
| XSJ45 | | {GD 0 B} | physical_splice_connector |
| XSJ46 | | {GF 2 D} | physical_splice_connector |
| XSJ47 | | {LA 2 B} | physical_splice_connector |
| XSJ48 | | {LA 2 B} | physical_splice_connector |
| XSJ50 | | {CL 3 C} | physical_splice_connector |
| XSJ51 | | {GD 1 C} | physical_splice_connector |
| XSJ52 | | {GD 1 C} | physical_splice_connector |
| XSJ53 | | {DC 2 B} | physical_splice_connector |
| XSJ54 | | {DC 2 B} | physical_splice_connector |
| XSJ55 | | {DC 2 B} | physical_splice_connector |
| XSJ56 | | {DM 4 D} | physical_splice_connector |
| XSJ57 | | {DM 4 D} | physical_splice_connector |
| XSJ58 | | {DM 4 C} | physical_splice_connector |
| XSK1 | | {CG 0 B} | physical_splice_connector |
| XSK02 | | {FO 3 D} | physical_splice_connector |
| XSK4 | | {CG 2 B} | physical_splice_connector |
| XSK6 | | {CG 2 B} | physical_splice_connector |
| XSK06 | | {LA 1 B} | physical_splice_connector |
| XSK13 | | {LA 2 B} | physical_splice_connector |
| XSK15 | +15 ignition | {LB 1 B} | physical_splice_connector |
| XSK16 | | {LB 2 B} | physical_splice_connector |
| XSK17 | | {LB 1 C} | physical_splice_connector |
| XSK18 | | {ZC 2 C} | physical_splice_connector |
| XSK19 | | {LB 3 C} | physical_splice_connector |
| XSK20 | | {LA 1 C} | physical_splice_connector |
| XSK21 | | {LB 3 C} | physical_splice_connector |
| XSK22 | | {GF 1 B} | physical_splice_connector |
| XSK23 | | {GF 1 B} | physical_splice_connector |
| XSK24 | | {LB 2 B} | physical_splice_connector |
| XSK25 | | {LB 2 C} | physical_splice_connector |
| XSL1 | | {CG 1 E} | physical_splice_connector |
| XSL2 | | {CG 3 E} | physical_splice_connector |
| XSL10 | | {CU 2 D} | physical_splice_connector |
| XSL11 | | {CU 2 E} | physical_splice_connector |
| XSL12 | | {CU 2 E} | physical_splice_connector |
| XSL13 | | {CU 2 E} | physical_splice_connector |
| XSM01 | | {GN 1 B} | physical_splice_connector |
| XSM02 | | {ZC 1 C} | physical_splice_connector |
| XSM03 | Analogue ground sensors | {FO 2 C} | physical_splice_connector |
| XSM04 | +30 main switch | {FO 1 B} | physical_splice_connector |
| XSM05 | +15 ignition | {FO 2 B} | physical_splice_connector |
| XSP01 | | {BE 1 C} | physical_splice_connector |
| XSP02 | | {BE 0 C} | physical_splice_connector |

VOLVO

Volvo Bus Corporation

Document Title

WIRING DIAGRAM

Document Type

PRODUCT SCHEMATIC

Document No

20904123

Issue Index

15

Volume No

02(02)

Page No

75(76)

VOLVO

Volvo Bus Corporation

Document Title

WIRING DIAGRAM

Document Type

PRODUCT SCHEMATIC

Document No

20904123

Issue Index

15

Volume No

02(02)

Page No

76(76)

English Sweden.

VOLVO

Volvo Bus Corporation

Göteborg, Sweden