

Foreword

The descriptions and service procedures contained in this manual are based on designs and methods studies carried out up to December 2012.

The products are under continuous development. Vehicles and components produced after the above date may therefore have different specifications and repair methods. When this is judged to have a significant bearing on this manual, an updated version of this manual will be issued to cover the changes.

The following levels of observations, cautions and warnings are used in this Service Documentation:

Note: Indicates a procedure, practice, or condition that must be followed in order to have the vehicle or component function in the manner intended.

Caution: Indicates an unsafe practice where damage to the product could occur.

Warning: Indicates an unsafe practice where personal injury or severe damage to the product could occur.

Danger: Indicates an unsafe practice where serious personal injury or death could occur.

Volvo Truck Corporation
Göteborg, Sweden

Note: Check always the latest information at the “Wiring diagrams-site”.

Order number: 89141432

©2012 Volvo Truck Corporation, Göteborg, Sweden

All rights reserved. No part of this publication may be reproduced, stored in retrieval system, or transmitted in any forms by any means, electronic, mechanical, photocopying, recording or otherwise, without the prior written permission of Volvo Truck Corporation .

Contents

Component wiring diagram index	1
Component wiring diagrams	5
Illustrations index	129
Illustrations	130
Fuses	228
Relays	231
FRC (A01) connectors	233
Wiring harness layout	237
Ground connections	239
List of connectors	240
List of components	283
Abbreviations	296
Cable colour code	298
Feedback	299

Component wiring diagram index

AA	Power supply, starting system.....	“ ”, page 5
AB	Power distribution, CCIOM.....	“ ”, page 6
AC	Main switch, UADR.....	“ ”, page 7
AD	Main switch, ADR1/ADR2	“ ”, page 8
AE	Main switch, ADR3	“ ”, page 9
AF	Key switch.....	“ ”, page 10
BA	Instrument.....	“ ”, page 11
BC	Tachograph.....	“ ”, page 12
BE	VMCU, Vehicle Master Control Unit	“ ”, page 13
BG	CIOM, Cab IO Module	“ ”, page 14
BU	TIS Telematics service.....	“ ”, page 15
BX	TIS Toll collect, FMS connector.....	“ ”, page 16
CA	Engine interface	“ ”, page 17
CA1	Engine interface, networks	“ ”, page 18
CB	Engine D13, EM-EC01	“ ”, page 19
	Engine D13, EM-EC06/EM-EU5, page 1	“ ”, page 20
	Engine D13, EM-EC06/EM-EU5, page 2	“ ”, page 21
	Engine D13, EML4 EM-EU6, page 1.....	“ ”, page 22
	Engine D13, EML4 EM-EU6, page 2.....	“ ”, page 23
	Engine D13, EM-EU6, page 1	“ ”, page 24
	Engine D13, EM-EU6, page 2	“ ”, page 25
	Engine D13,, EM-JPN10, page 1	“ ”, page 26
	Engine D13,, EM-JPN10, page 2	“ ”, page 27
	Engine D16, page 1	“ ”, page 28
	Engine D16, page 2	“ ”, page 29
CE	After treatment system, EM-EU5.....	“ ”, page 30
CE1	After treatment system, EM-EU5 EM-JPN10.....	“ ”, page 31
CF	After treatment system, Adblue tank control, EM-EU5.....	“ ”, page 32
CF AUS	After treatment system, Adblue tank control, AUSTRALIA.....	“ ”, page 33
CK	After treatment system, EML4 EM-EU6	“ ”, page 34
CK1	After treatment system, EML4 EM-EU6	“ ”, page 35
CL	After treatment system, Adblue tank control, EML4 EM-EU6	“ ”, page 36
CN	After treatment system, japan, EM-JPN10.....	“ ”, page 37
CO	After treatment system, Adblue tank control, EM-JPN10	“ ”, page 38
DA	Transmission, manual (interface).....	“ ”, page 39
DA1	Transmission, manual (gearbox and retarder).....	“ ”, page 40
DC	Transmission , I-SHIFT (interface)	“ ”, page 41
DC1	Transmission, I-SHIFT (gearbox and retarder)	“ ”, page 42

DG	Differential lock and fuel level sensor	“ ”, page 43
DK	Retarder (interface).....	“ ”, page 44
DM	Retarder (interface) EML4 EM-EU6	“ ”, page 45
EA	ABS.....	“ ”, page 46
EE	EBS, control unit.....	“ ”, page 47
EF	EBS, front axle modulator.....	“ ”, page 48
EG	EBS, rear axle modulator	“ ”, page 49
EH	EBS, 6x2 and tridem.....	“ ”, page 50
EI	EBS, trailer modulator.....	“ ”, page 51
FA	Air-suspension, front.....	“ ”, page 52
FB	Air-suspension, rear, level sensor, WRG.....	“ ”, page 53
FC	Air-suspension, rear, 6x2, 6x4 and tridem, valves.....	“ ”, page 54
FD	Air-suspension, rear, 4x2.....	“ ”, page 55
FE	Air management, APM, Air Production Modulator with EPB.....	“ ”, page 56
FH	Front axle steering, hydraulic	“ ”, page 57
FI	Front axle steering, electronic, FAS	“ ”, page 58
FL	Rear axle steering, electronic, RAS	“ ”, page 59
FM	Rear axle steering, self steering, RAS.....	“ ”, page 60
FO	EAS, extra axle steering	“ ”, page 61
FQ	Bogie lift, A-ride with load sensor	“ ”, page 62
GA	Exterior light, front, left, road.....	“ ”, page 63
GB	Exterior light, front, right, bending light road.....	“ ”, page 64
GC	Exterior light, rear	“ ”, page 65
GE	Exterior light, side and load light.....	“ ”, page 66
GF	Exterior light, roof, identification light.....	“ ”, page 67
GK	Trailer connection, RIGID	“ ”, page 68
GL	Trailer connection, TRACTOR.....	“ ”, page 69
GM	Trailer connections, RIGID TREL-14.....	“ ”, page 70
GN	Trailer light converter, AUSTRALIA	“ ”, page 71
GP	Wiper, washer.....	“ ”, page 72
HA	Climate unit.....	“ ”, page 73
HB	Integrated parking cooler, IPC	“ ”, page 74
HC	Parking heater, water.....	“ ”, page 75
HD	Parking heater, air.....	“ ”, page 76
HE	Amb. temp, short stop heater, AC clutch	“ ”, page 77
HF	Fuel hose heater.....	“ ”, page 78
IA	Interior light	“ ”, page 79
IB	Interior light	“ ”, page 80
IC	Interior light, instep light.....	“ ”, page 81

IF	Comfort accessories.....	“ ”, page 82
IG	12V power supply 20A/20A/11A.....	“ ”, page 83
IK	Audio.....	“ ”, page 84
IL	Amplifier.....	“ ”, page 85
IN	DVD, bunk display	“ ”, page 86
IO	Video switch, camera, SID display	“ ”, page 87
IP	Horn	“ ”, page 88
IQ	Japan mirror folding	“ ”, page 89
IR	Door, left.....	“ ”, page 90
IS	Door, right	“ ”, page 91
IT	Seats.....	“ ”, page 92
IU	Sun roof, sun visor	“ ”, page 93
KA	Cab tilt.....	“ ”, page 94
LA	Lubrication system.....	“ ”, page 95
NA	Body builder, BBM	“ ”, page 96
NB	Body builder, VMCU	“ ”, page 97
NC	Body builder, CCIOM, PTO	“ ”, page 98
ND	Body builder electrical center	“ ”, page 99
ND1	Body builder electrical center AUXSW4	“ ”, page 100
ND2	Body builder, Tipper prep kit	“ ”, page 101
NE	Body builder electrical center, extra lighting	“ ”, page 102
NF	Body builder extra lighting	“ ”, page 103
NK	Body builder plough lamps	“ ”, page 104
PA	DACU, Driver Assistance Control Unit	“ ”, page 105
PB	Lane position	“ ”, page 106
PE	SRS, Supplementary Restrain System, airbag	“ ”, page 107
PH	Alcolock, start prevention system.....	“ ”, page 108
RA	Alarm.....	“ ”, page 109
SA	Backbone 1.....	“ ”, page 110
SB	Backbone 2.....	“ ”, page 111
SC	Cab subnet	“ ”, page 112
SD	Chassis subnet.....	“ ”, page 113
SE	Infotainment subnet	“ ”, page 114
SF	Security subnet.....	“ ”, page 115
SK	Switch module topology, CIOM	“ ”, page 116
SL	Switch module topology, HMIOM	“ ”, page 117
XA	OBD interface	“ ”, page 118
YA	Ground, chassis, ECU	“ ”, page 119
YB	Ground, chassis, front/rear load	“ ”, page 120

YD	Ground, chassis, lower front.....	“ ”, page 121
YF	Ground, cab, FRC, BBEC.....	“ ”, page 122
YG	Ground, cab, instrument panel	“ ”, page 123
YH	Ground, cab, instrument panel	“ ”, page 124
YK	Ground, cab, front shelf	“ ”, page 125
YK_RHD	Ground, cab, front shelf, headliner	“ ”, page 126
YM	Ground, cab, lower bunk/floor	“ ”, page 127
YN	Ground, cab, firewall, cockpit carrier plate	“ ”, page 128

Component wiring diagrams

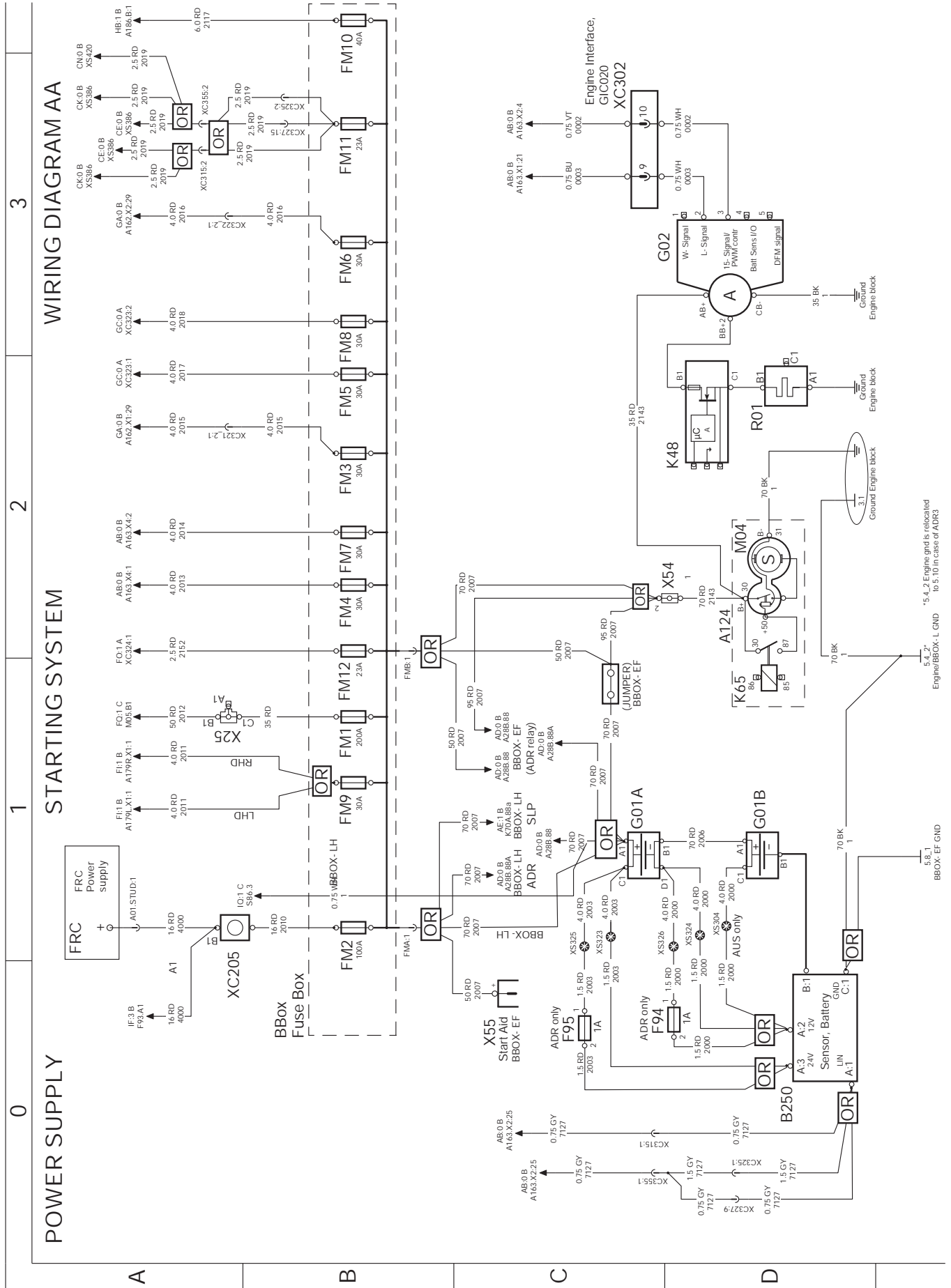

T3087469

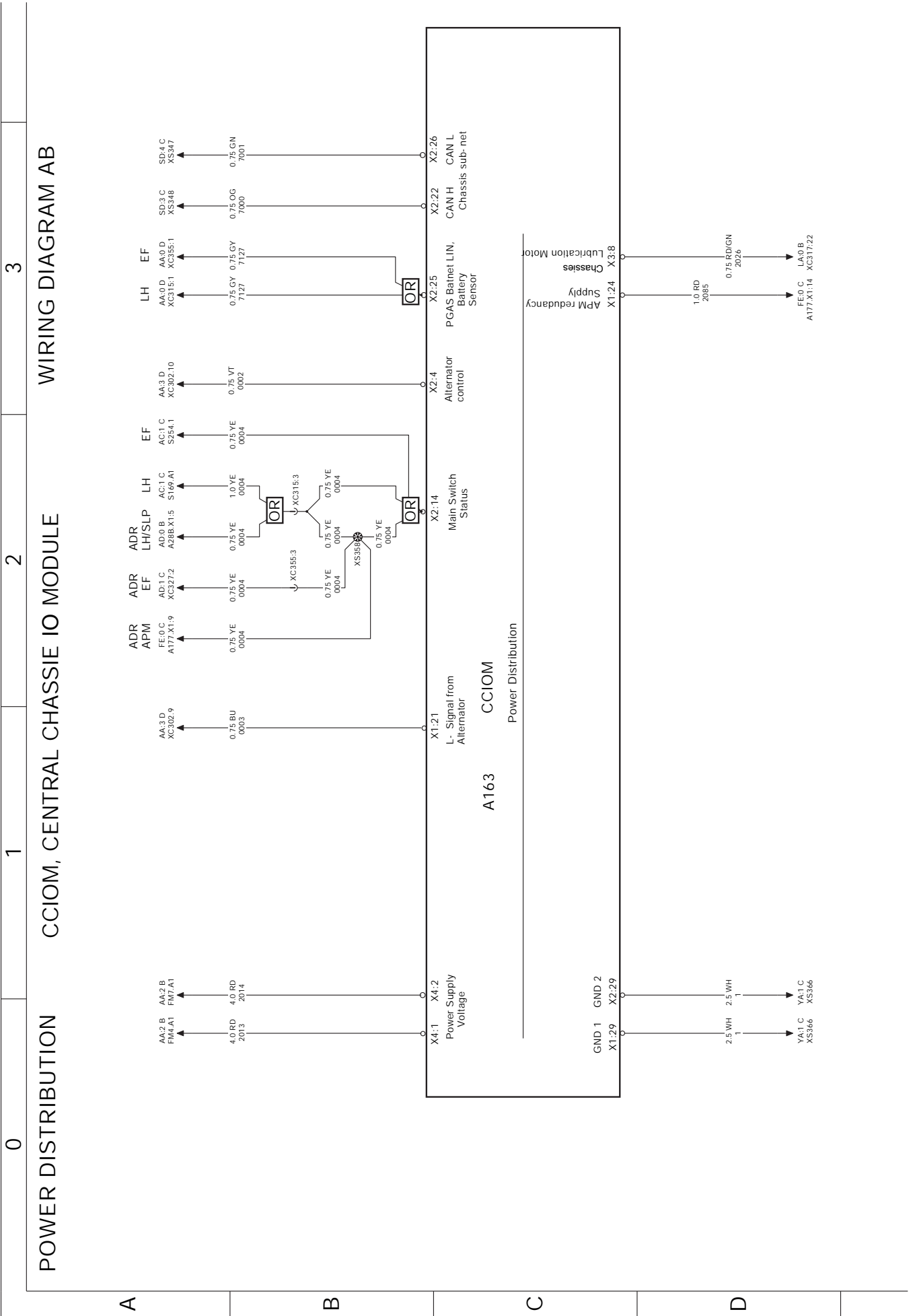

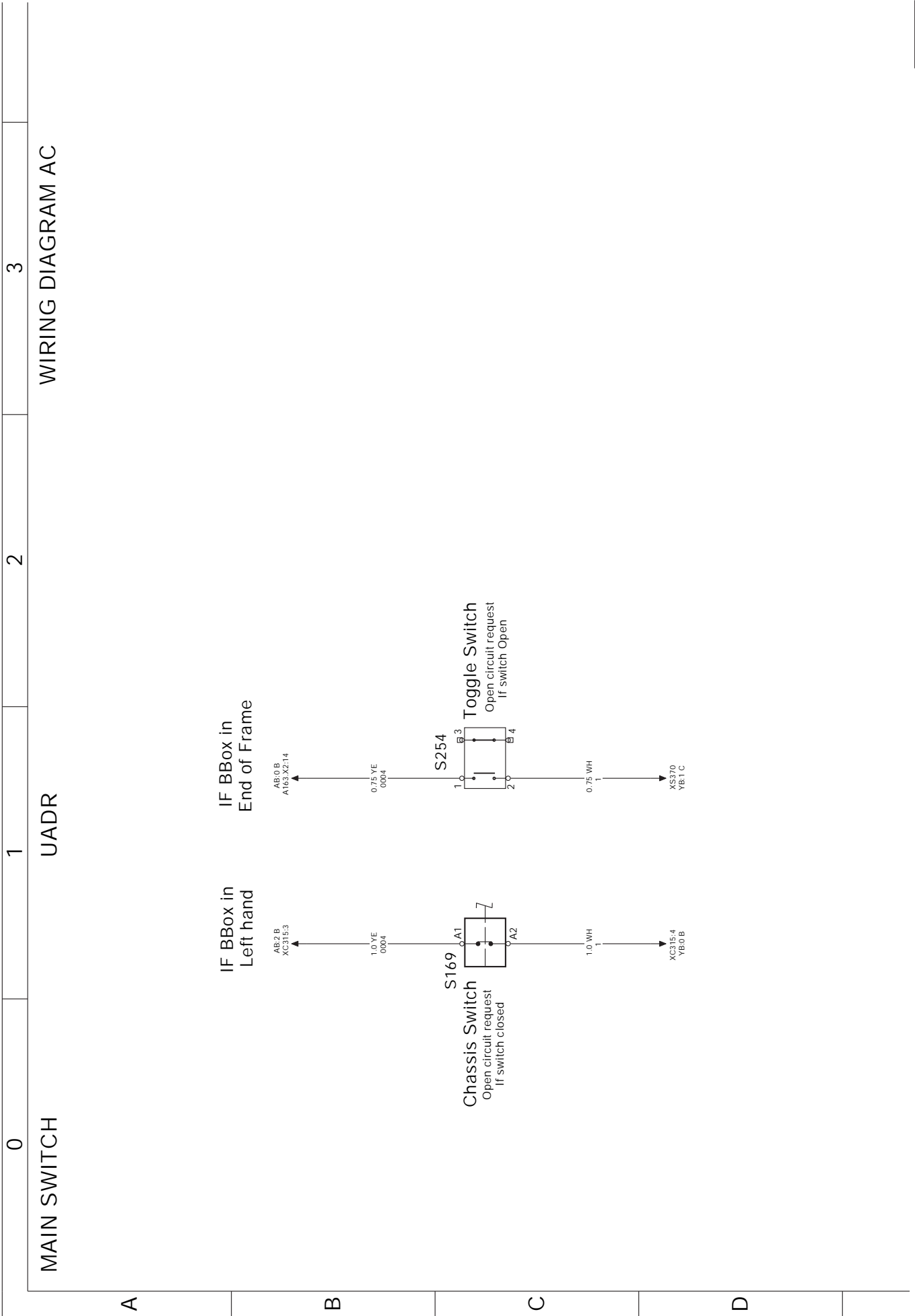

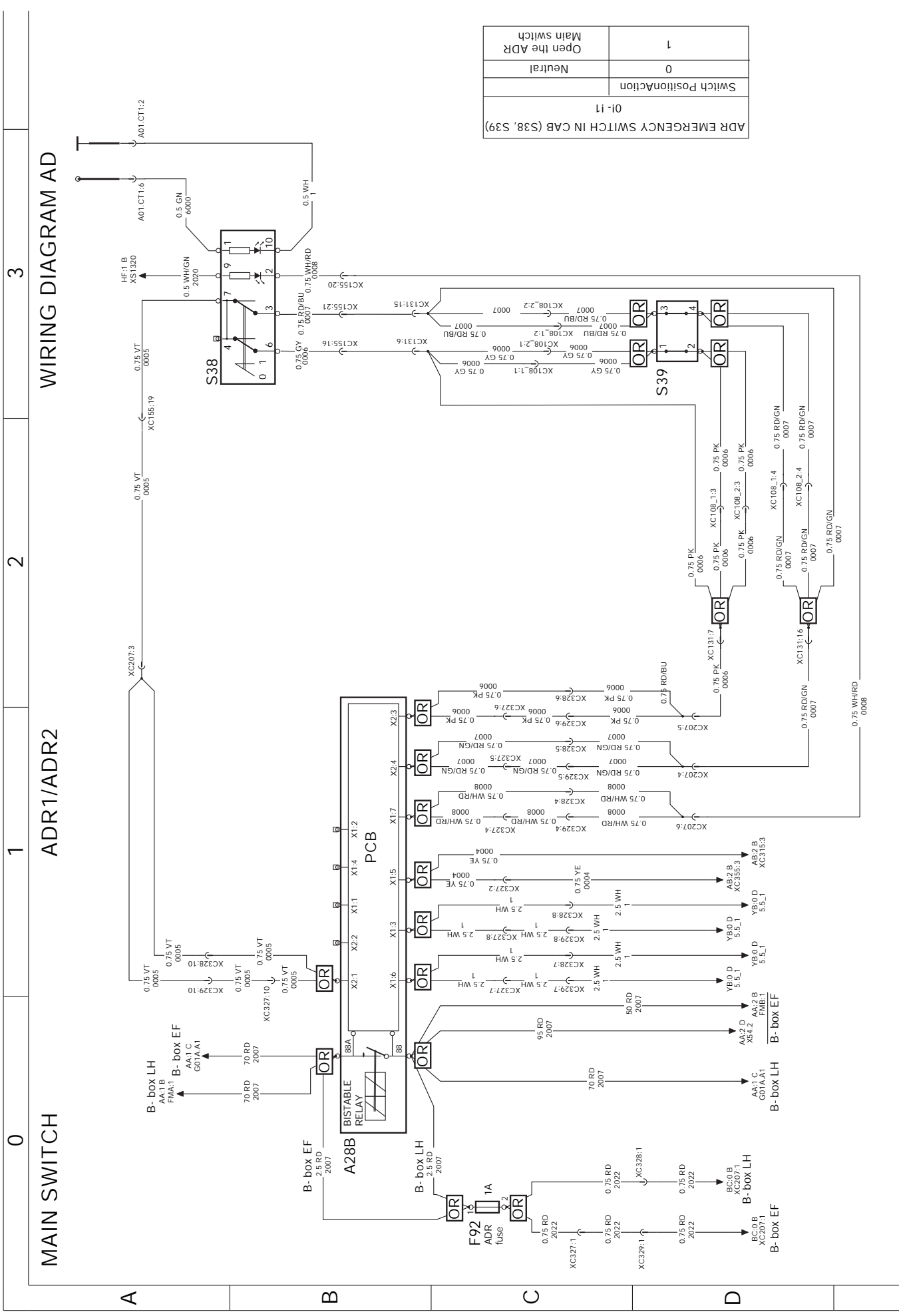

ADR EMERGENCY SWITCH IN CAB (S38, S39)	01-11	Switch Position>Action	0	1
		Neutral		
		Open the ADR		
		Main switch		

WIRING DIAGRAM AD

ADR1/ADR2

MAIN SWITCH

3

2

1

0

A

B

C

D

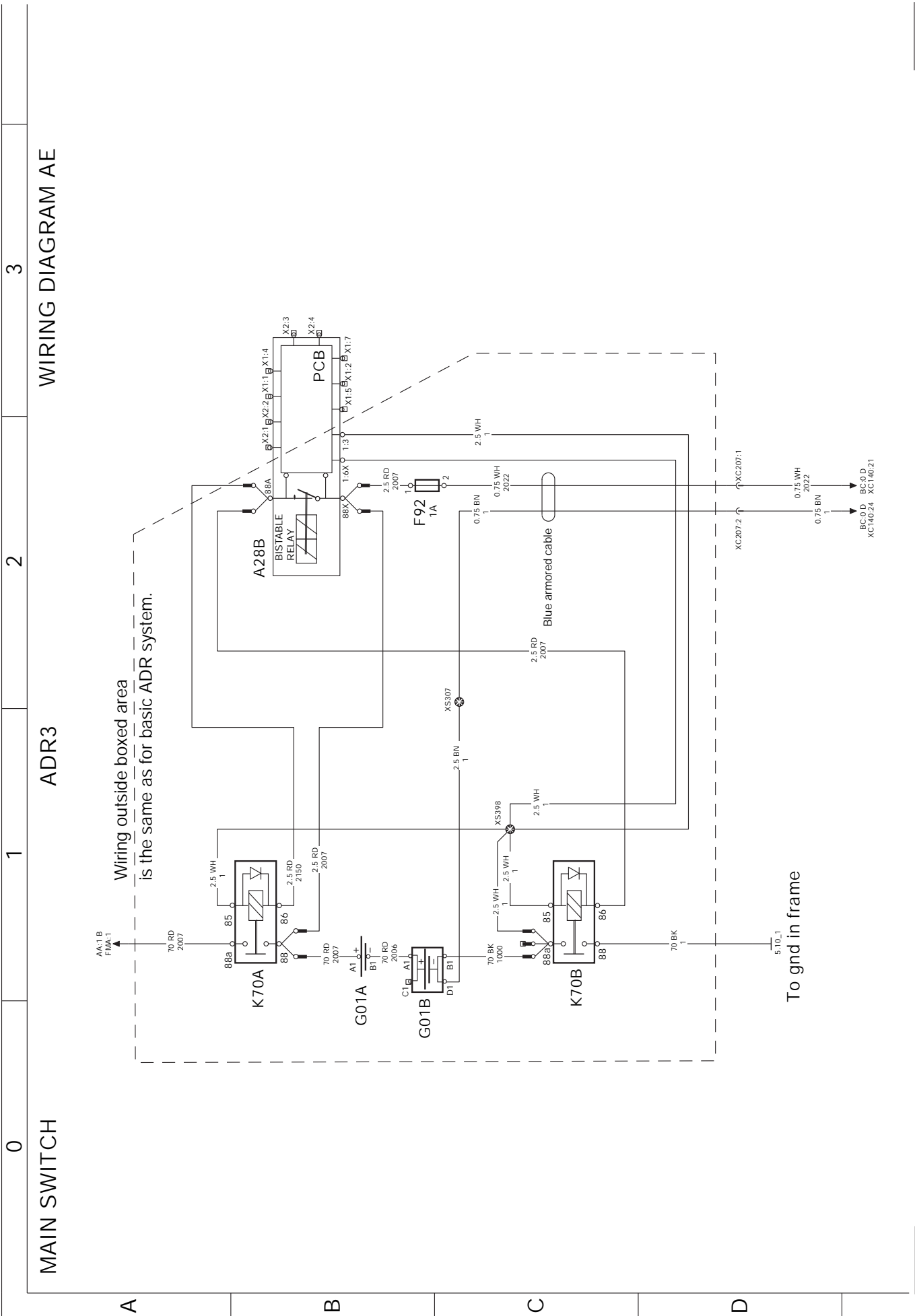

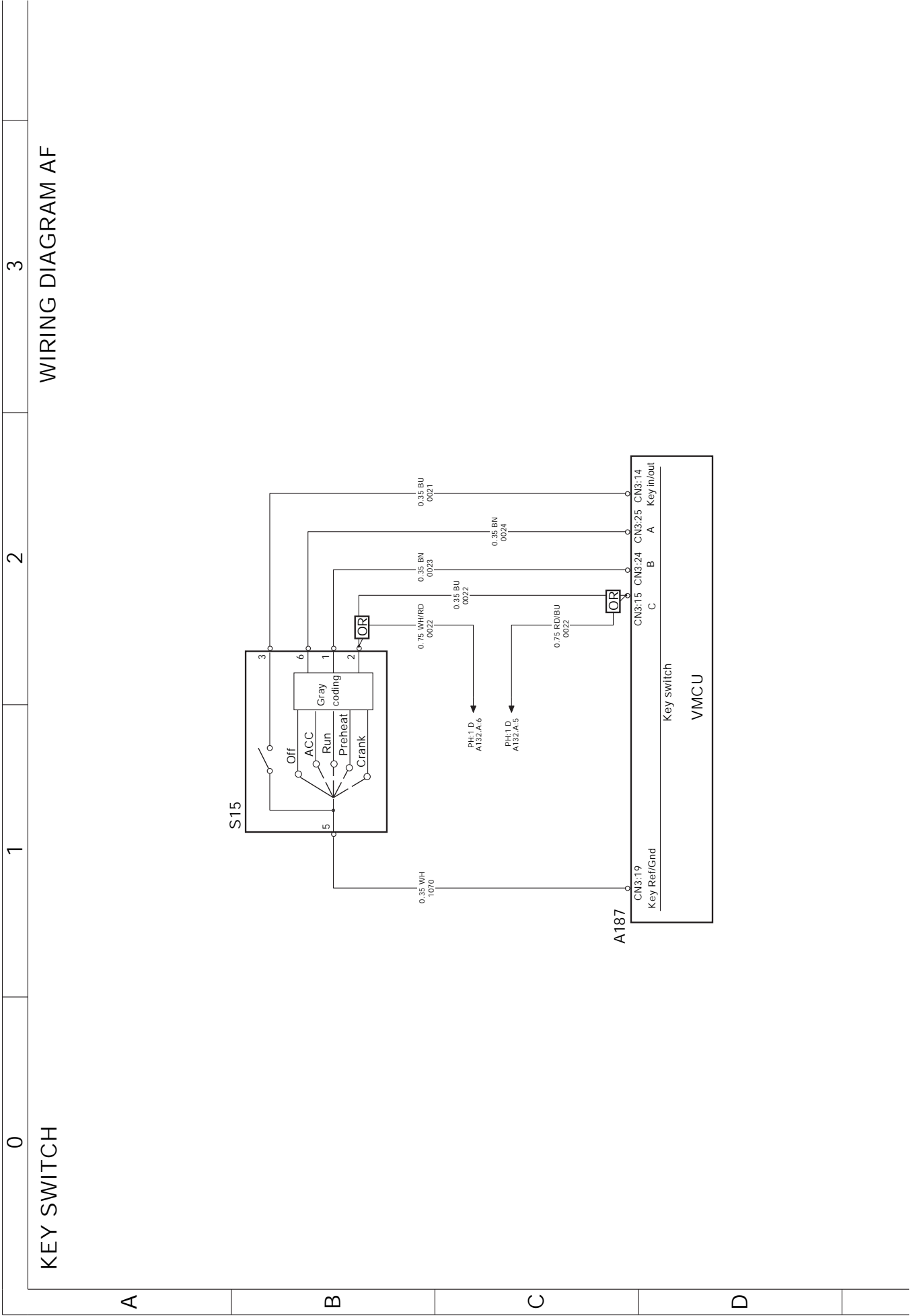

0 INSTRUMENT

1

2

3

WIRING DIAGRAM BA

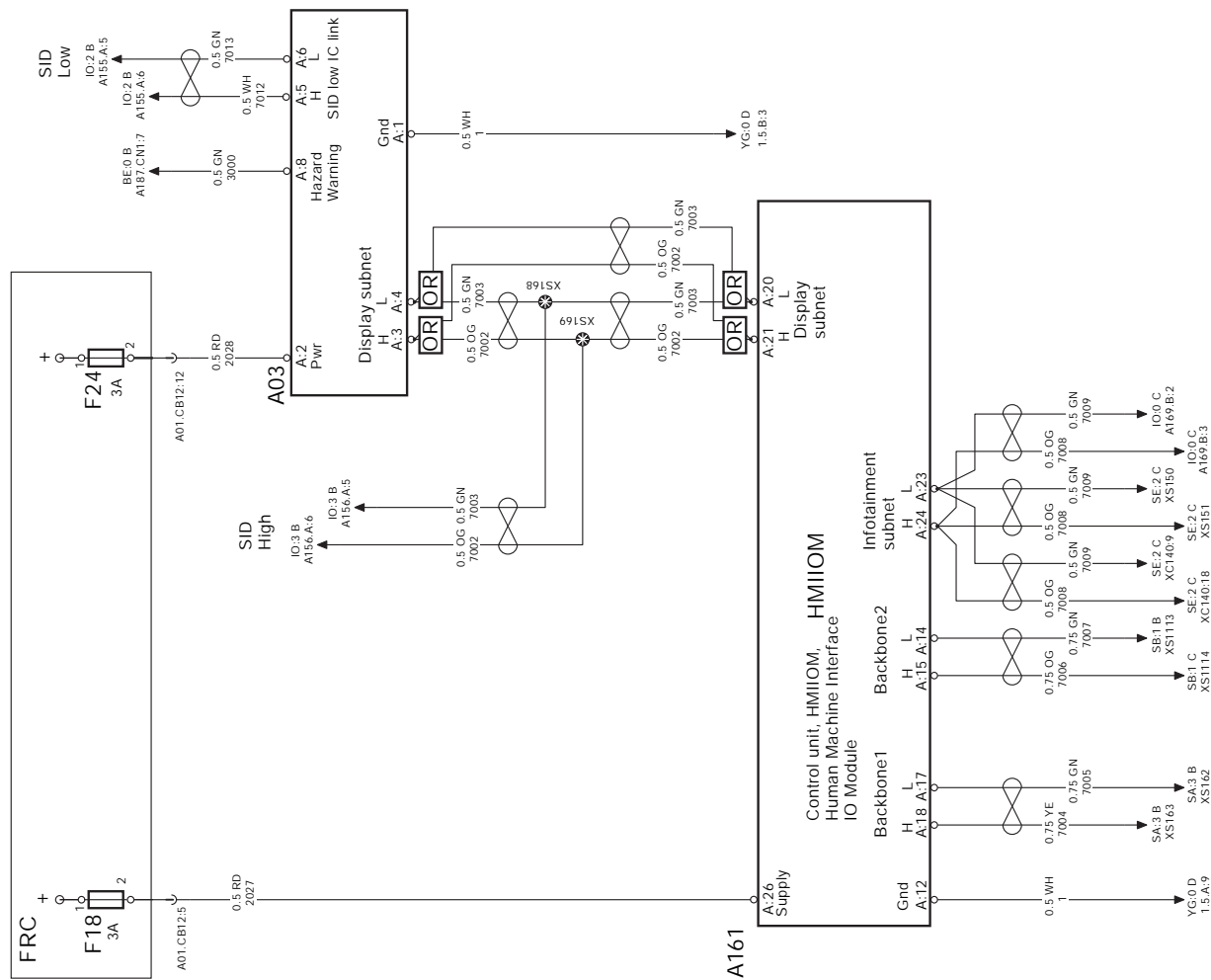

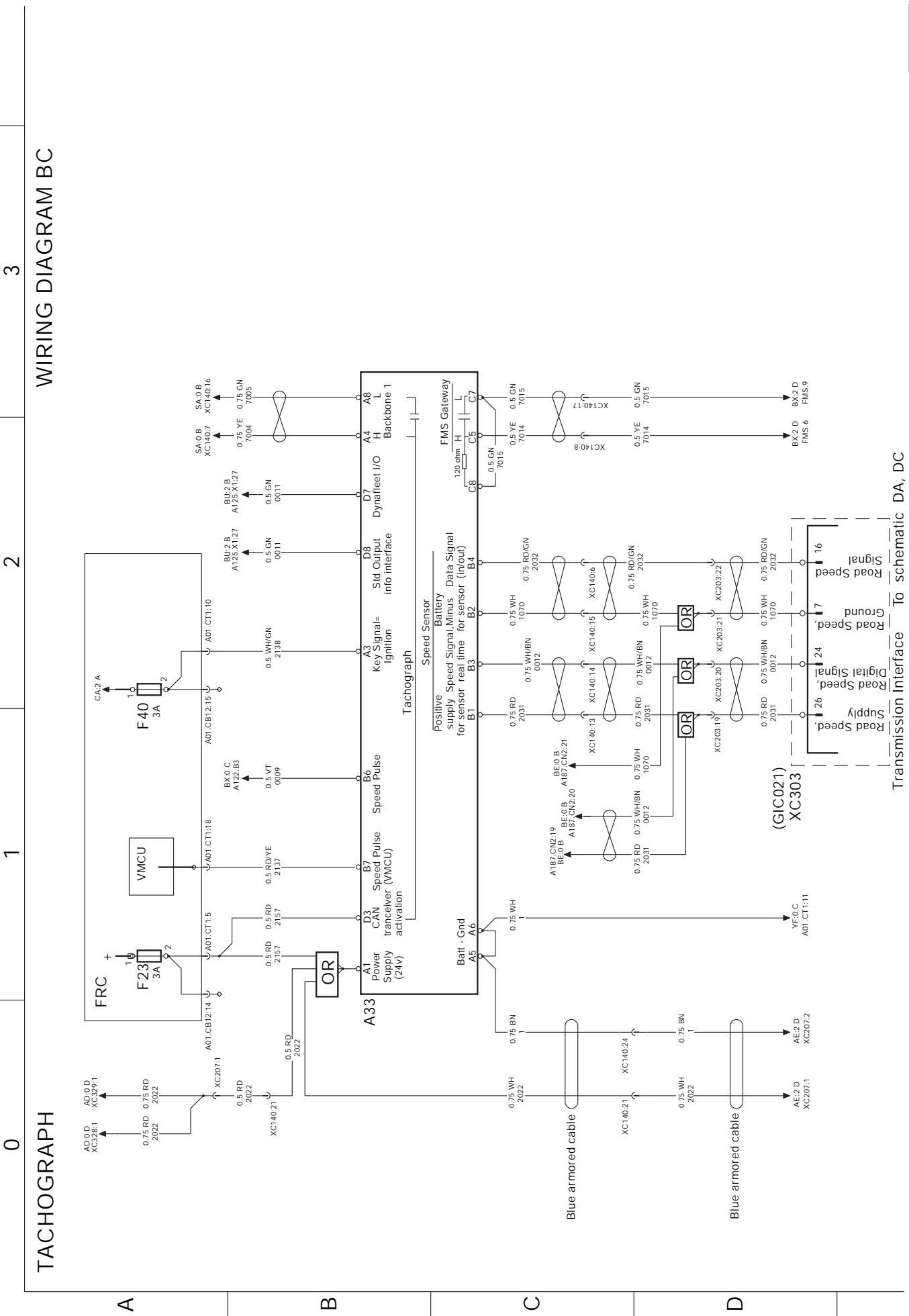

WIRING DIAGRAM BC

3

2

1

0

TACHOGRAPH

A

B

C

D

To schematic DA, DC

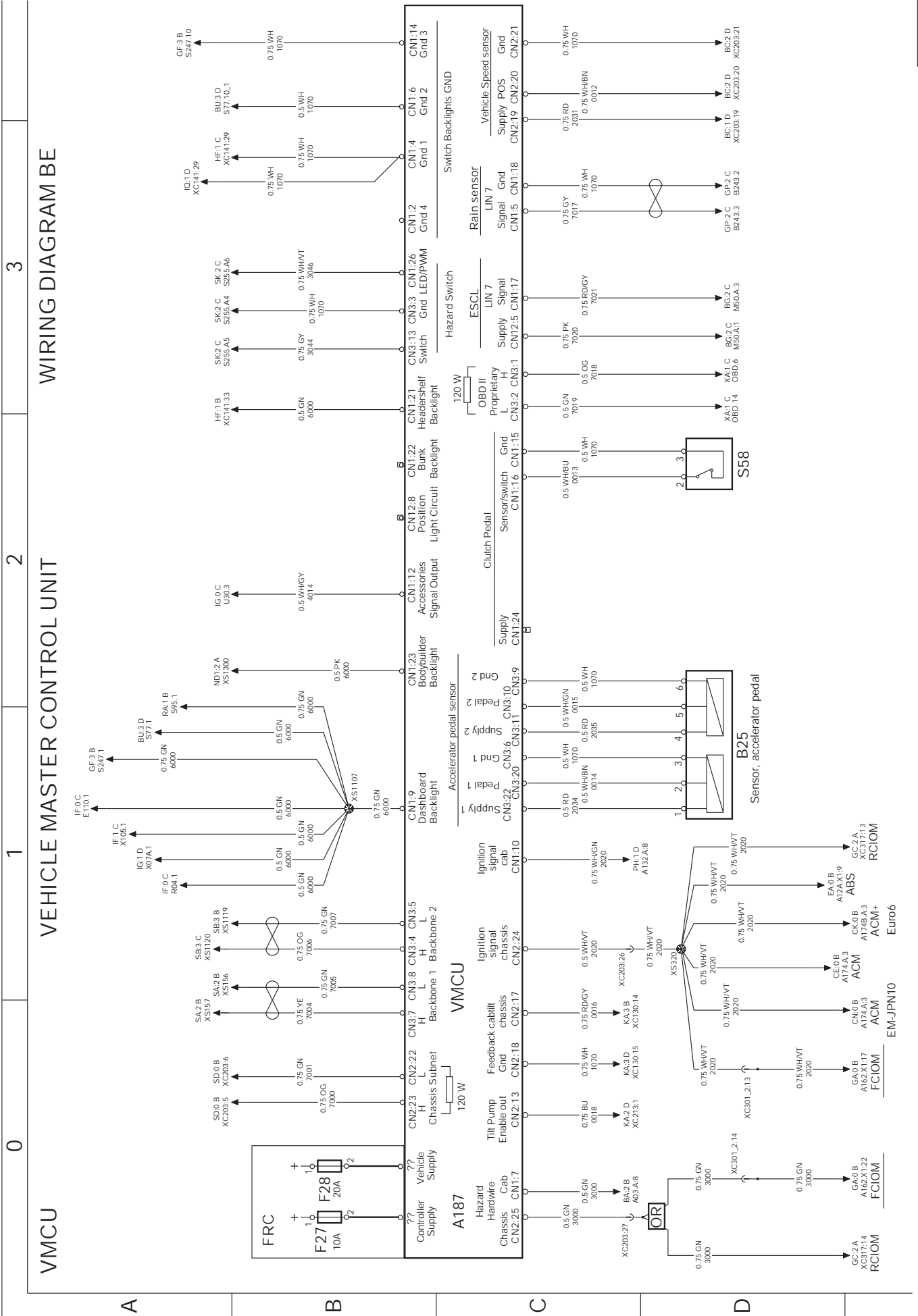

CIOM

CAB IO MODULE

WIRING DIAGRAM BG

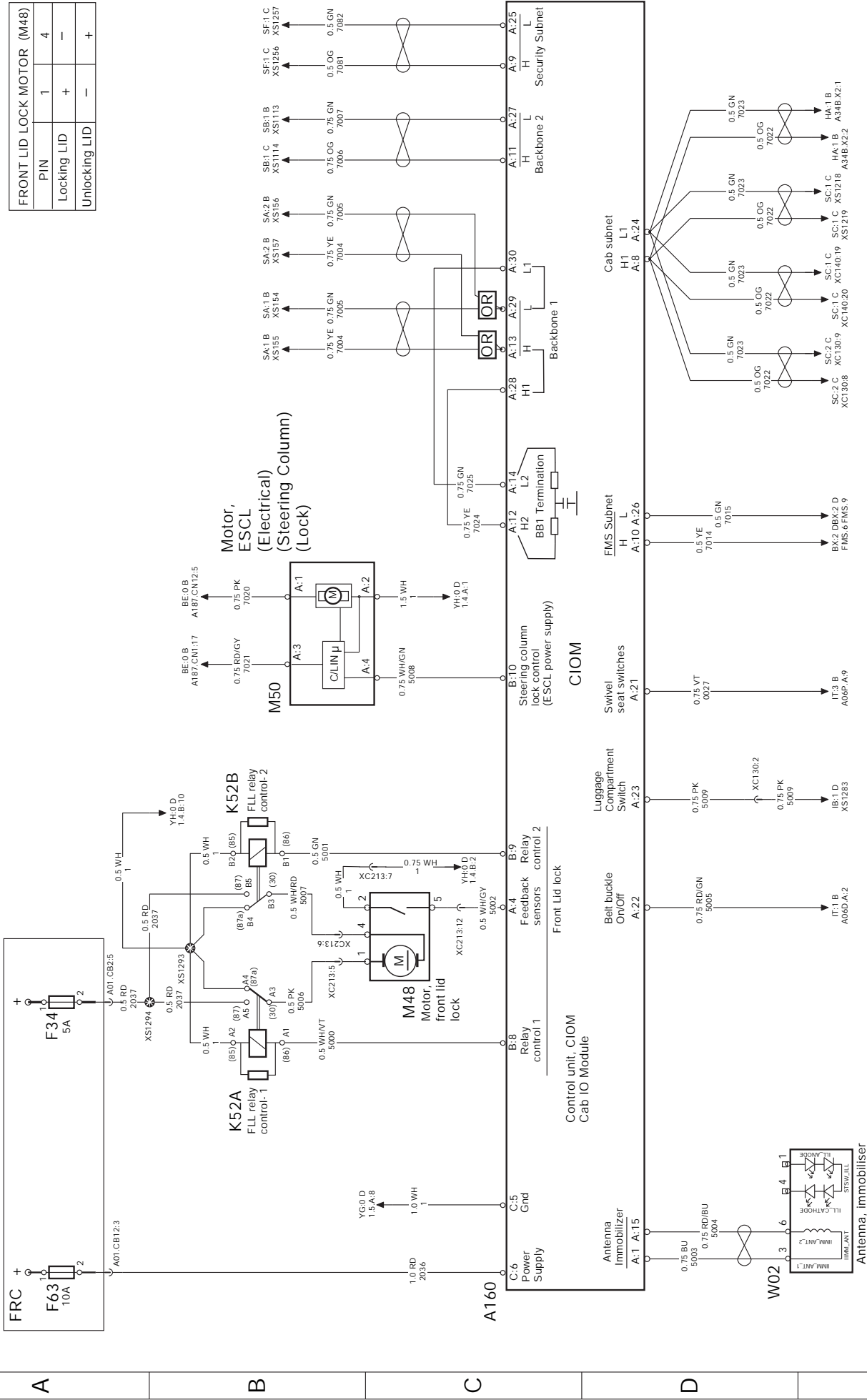

PIN	1	4
Locking LID	+	-
Unlocking LID	-	+

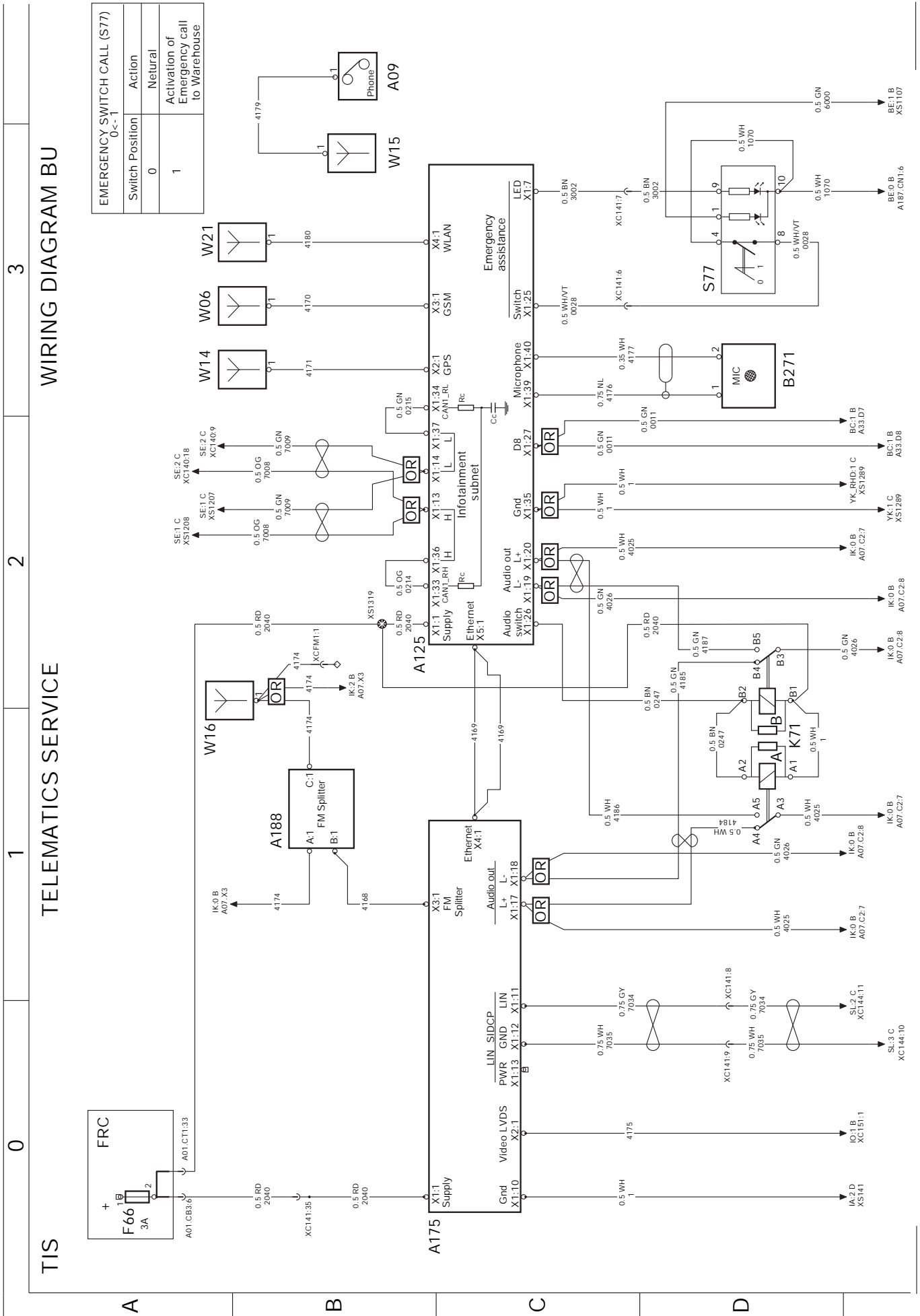

EMERGENCY SWITCH CALL (S77)	
Switch Position	Action
0	Neutral
1	Activation of Emergency call to Warehouse

TELEMATICS SERVICE

WIRING DIAGRAM BU

3

2

1

0

A

B

C

D

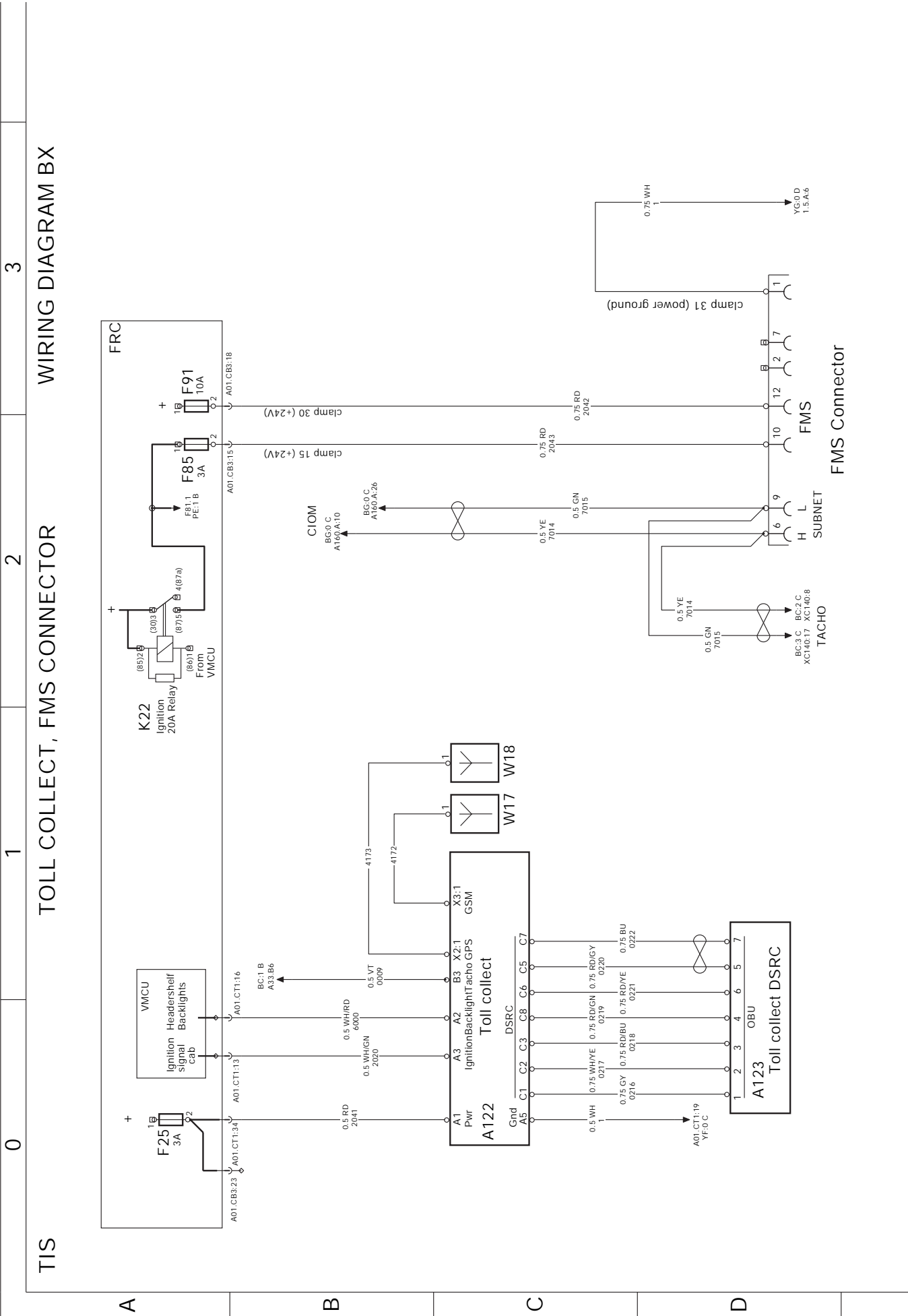

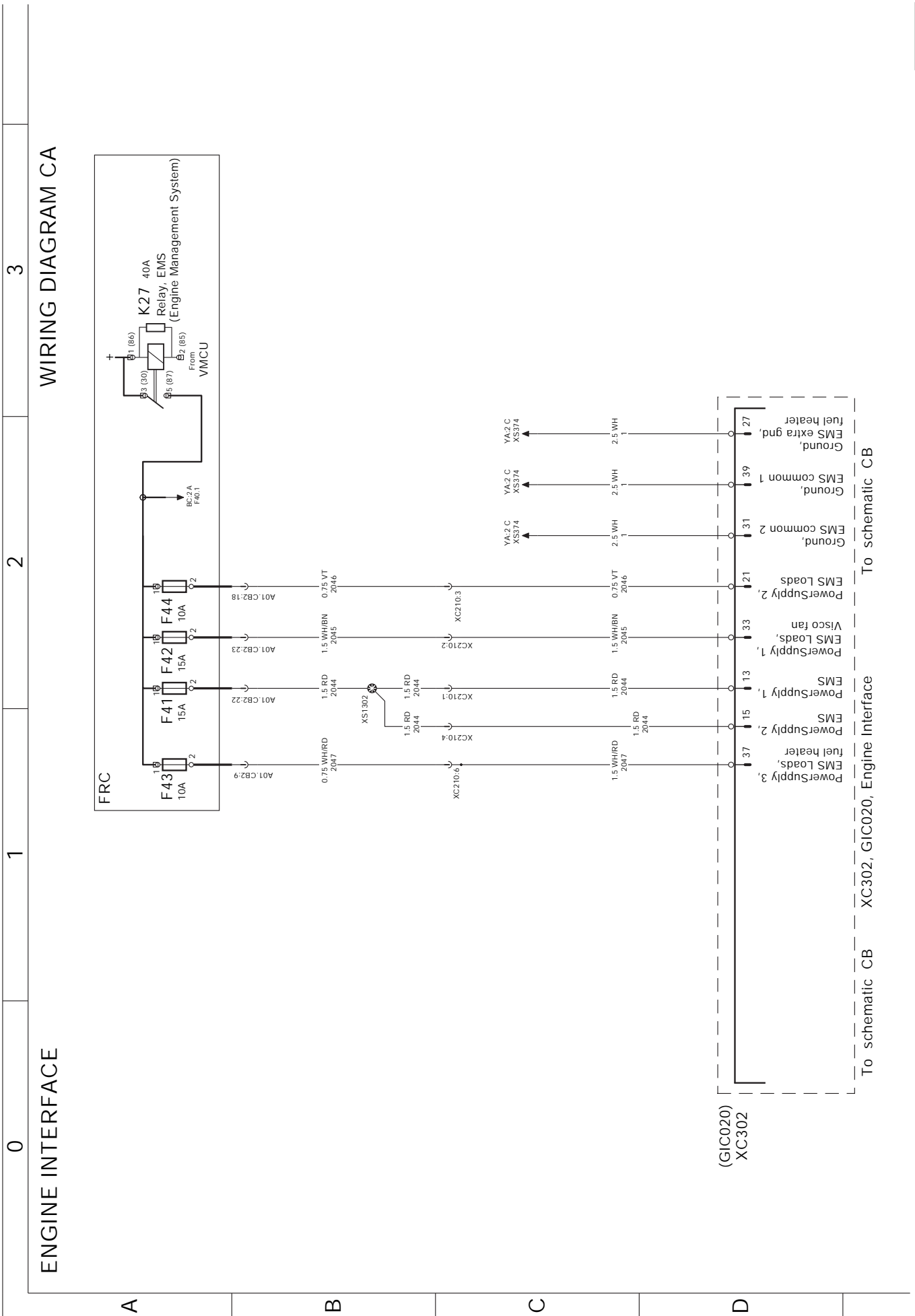

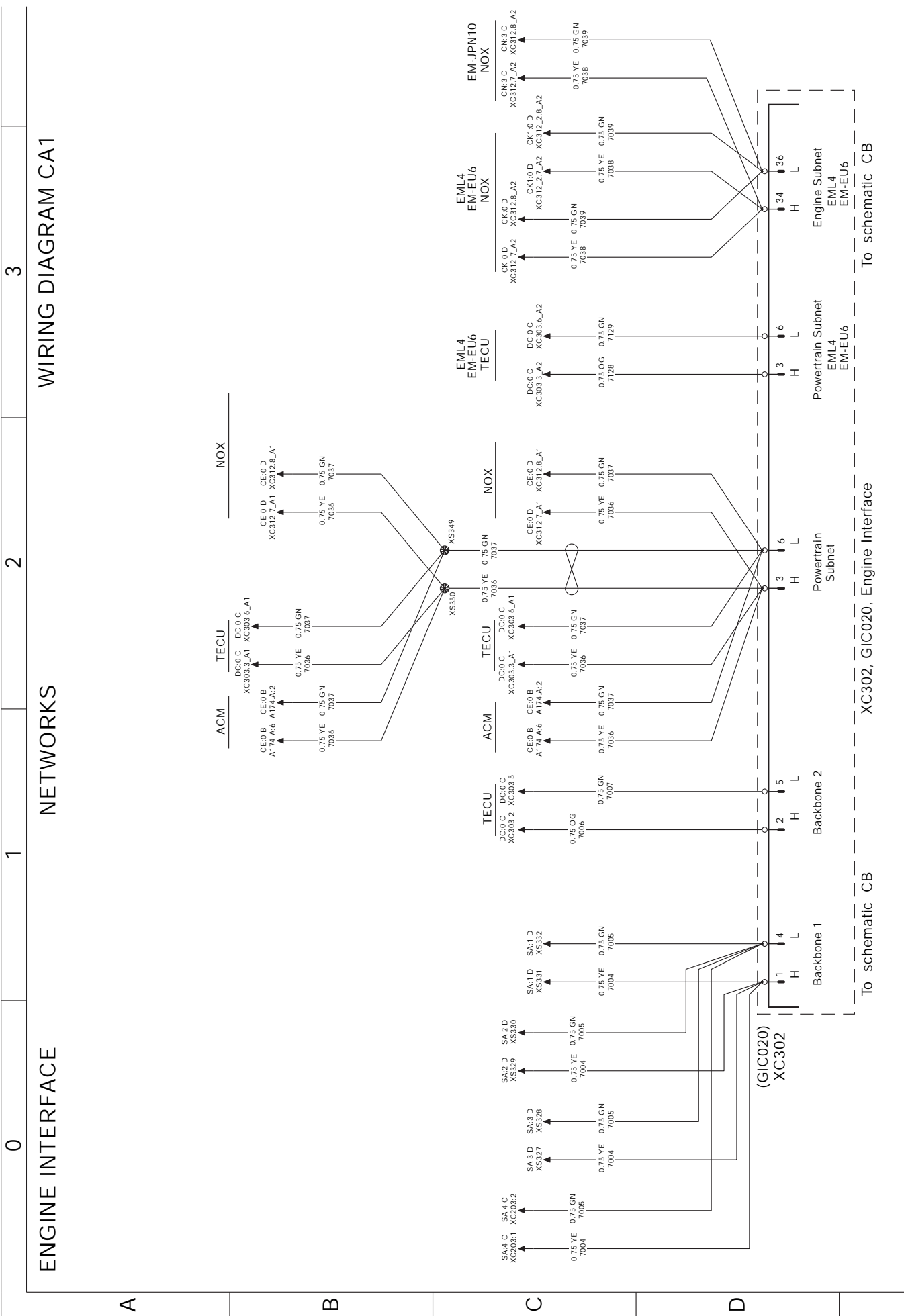

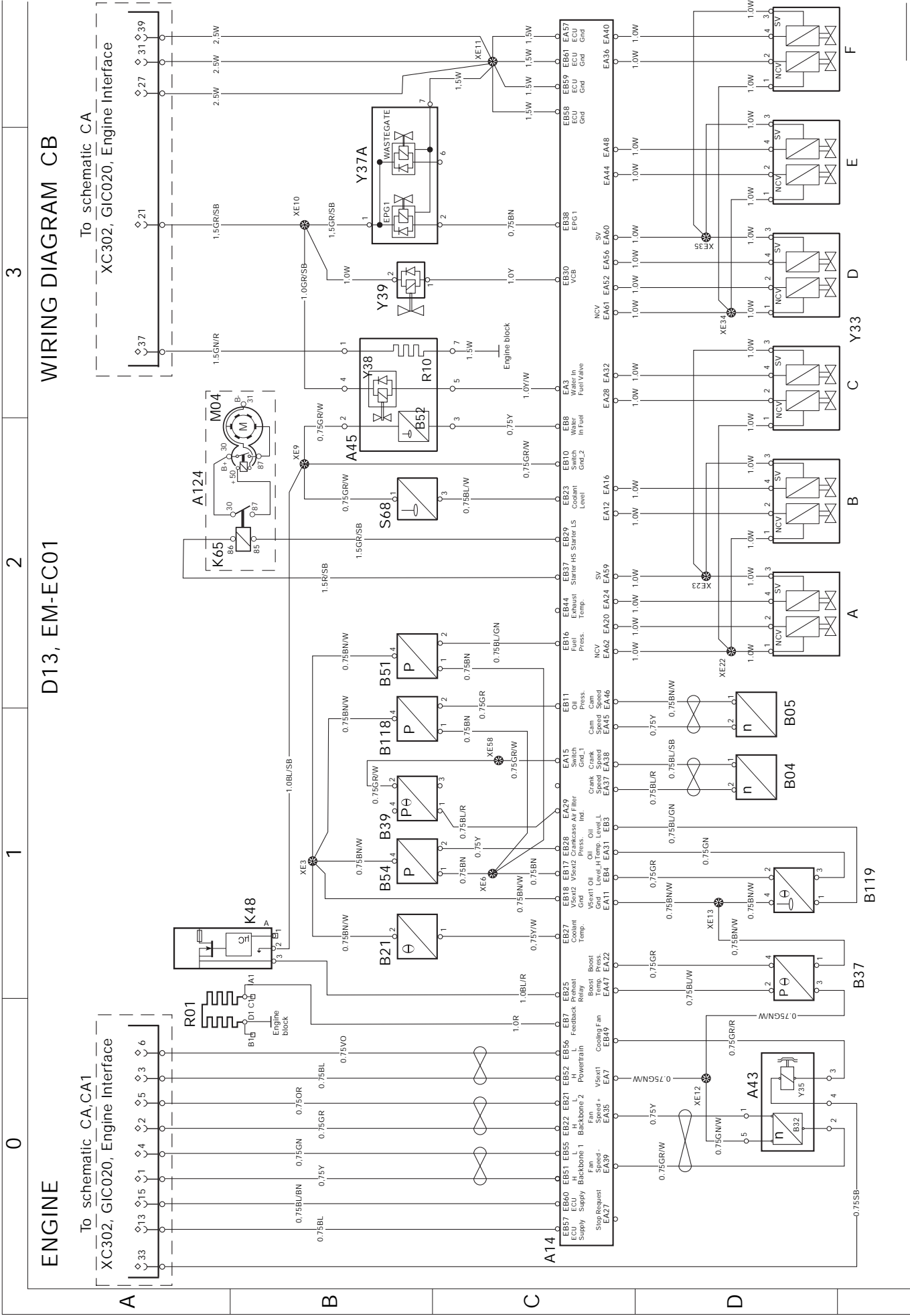

ENGINE

D13, EM-EC01

WIRING DIAGRAM CB

To schematic CA CA1

XC302, GIC020, Engine Interface

To schematic CA

XC302, GIC020, Engine Interface

ENGINE

D13, EM-EC06, EM-EU5

WIRING DIAGRAM CB

To schematic CA, CA1
XC302, GIC020, Engine Interface

To schematic CA
XC302, GIC020, Engine Interface

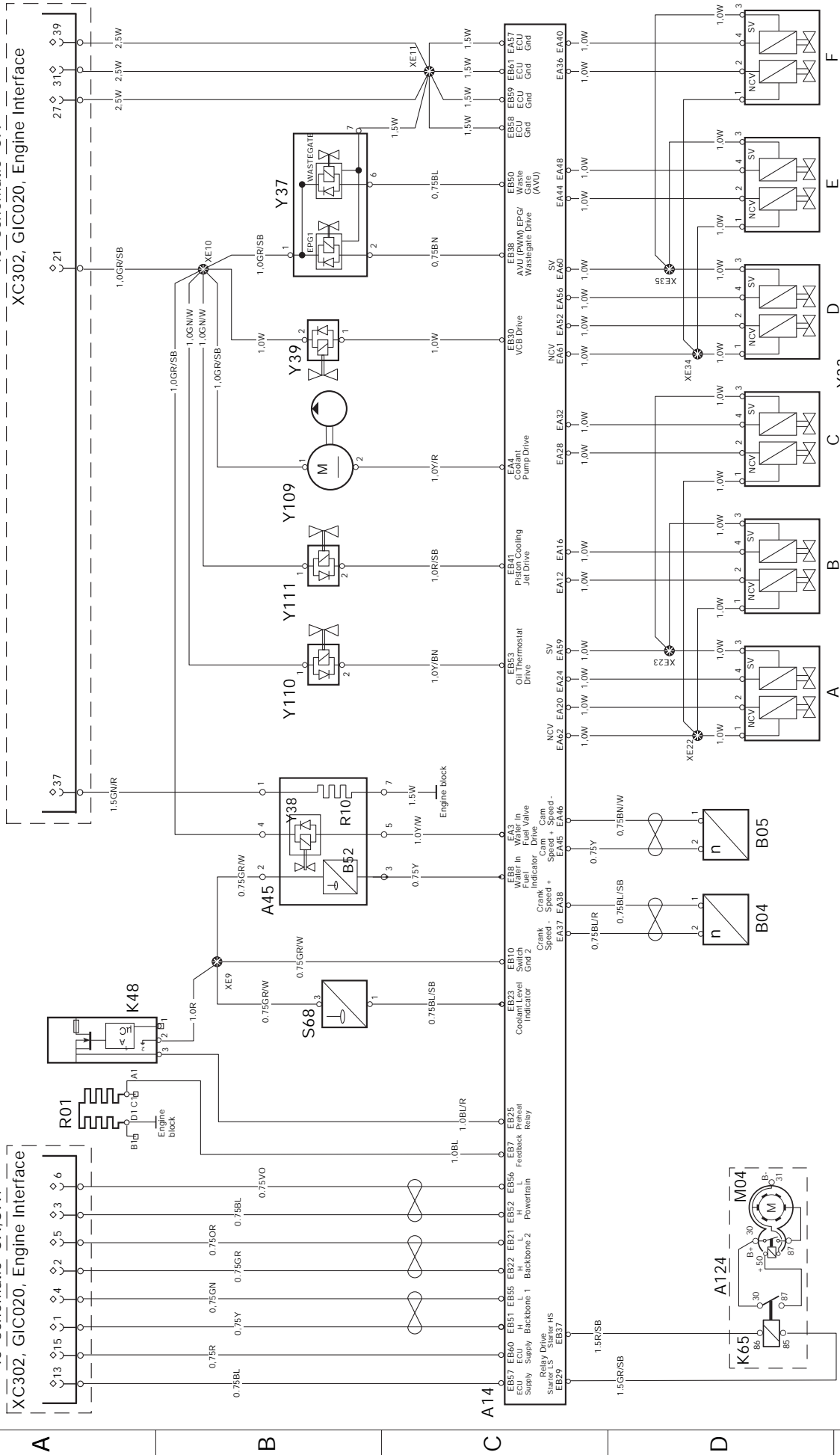

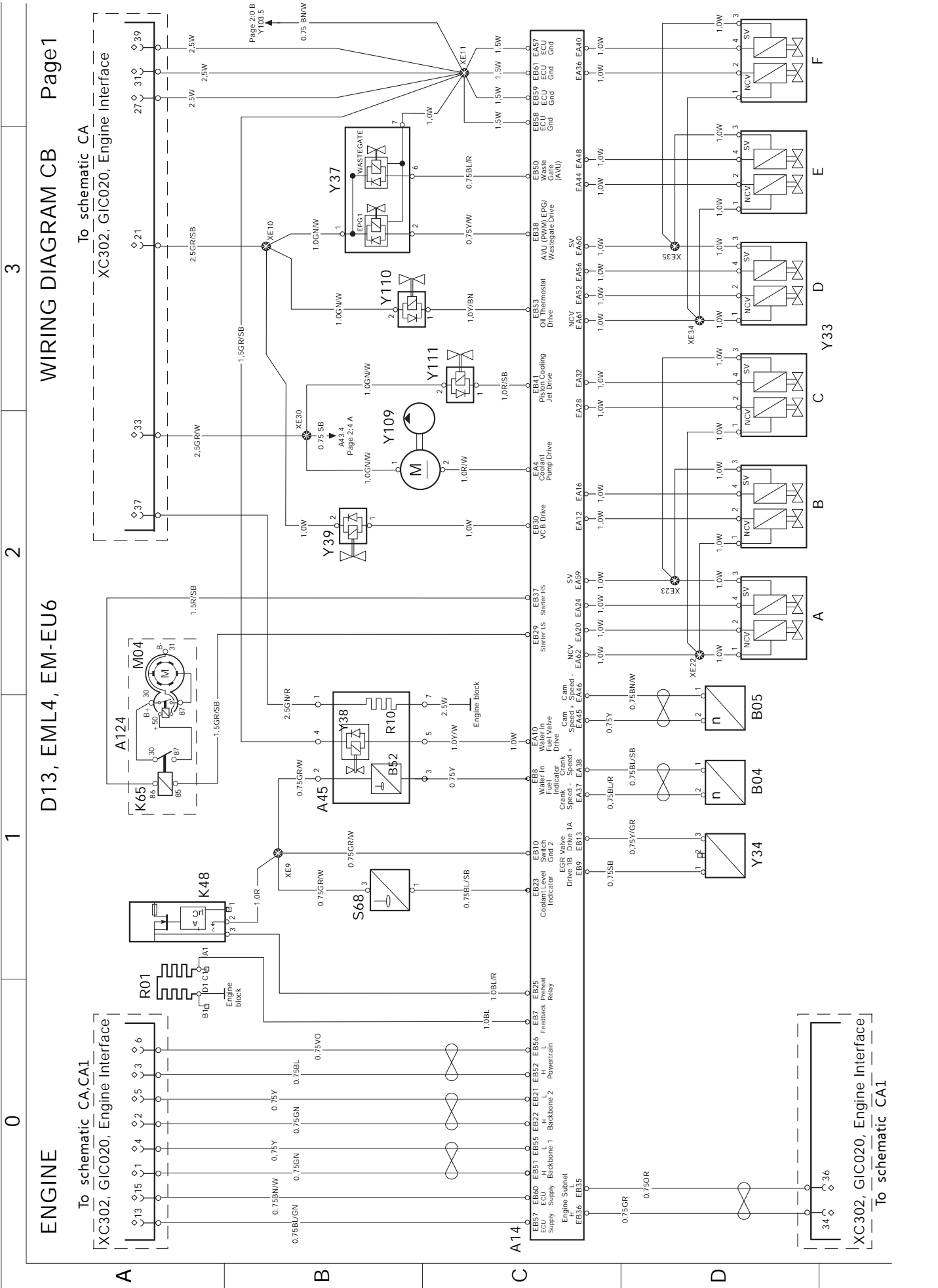

T3081109

0

1

2

3

Page 1:4 C
XE11

Page 1:2 B
XE30

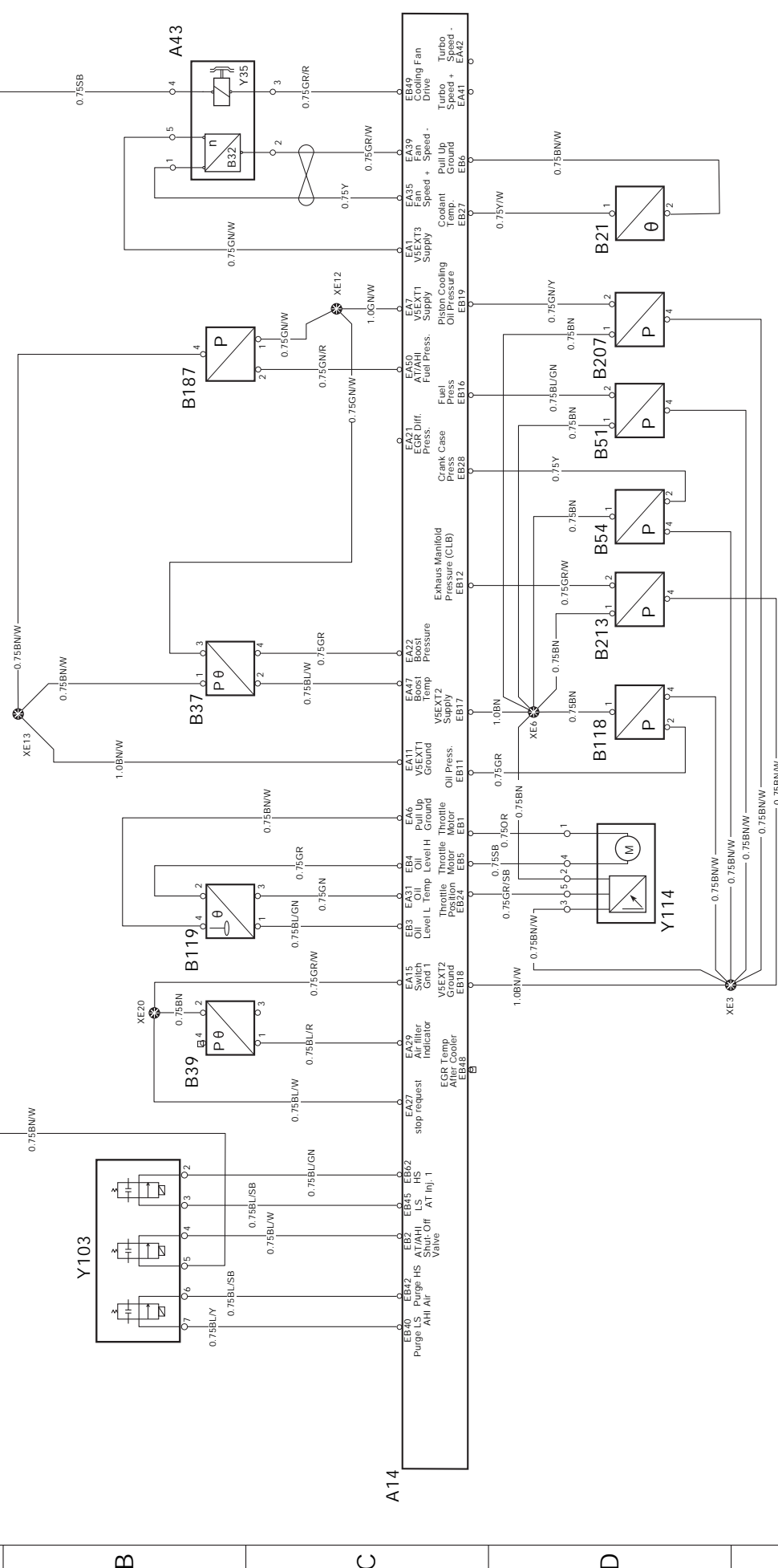

To schematic CA1
XC302, GIC020, Engine Interface

To schematic CA
XC302, GIC020, Engine Interface

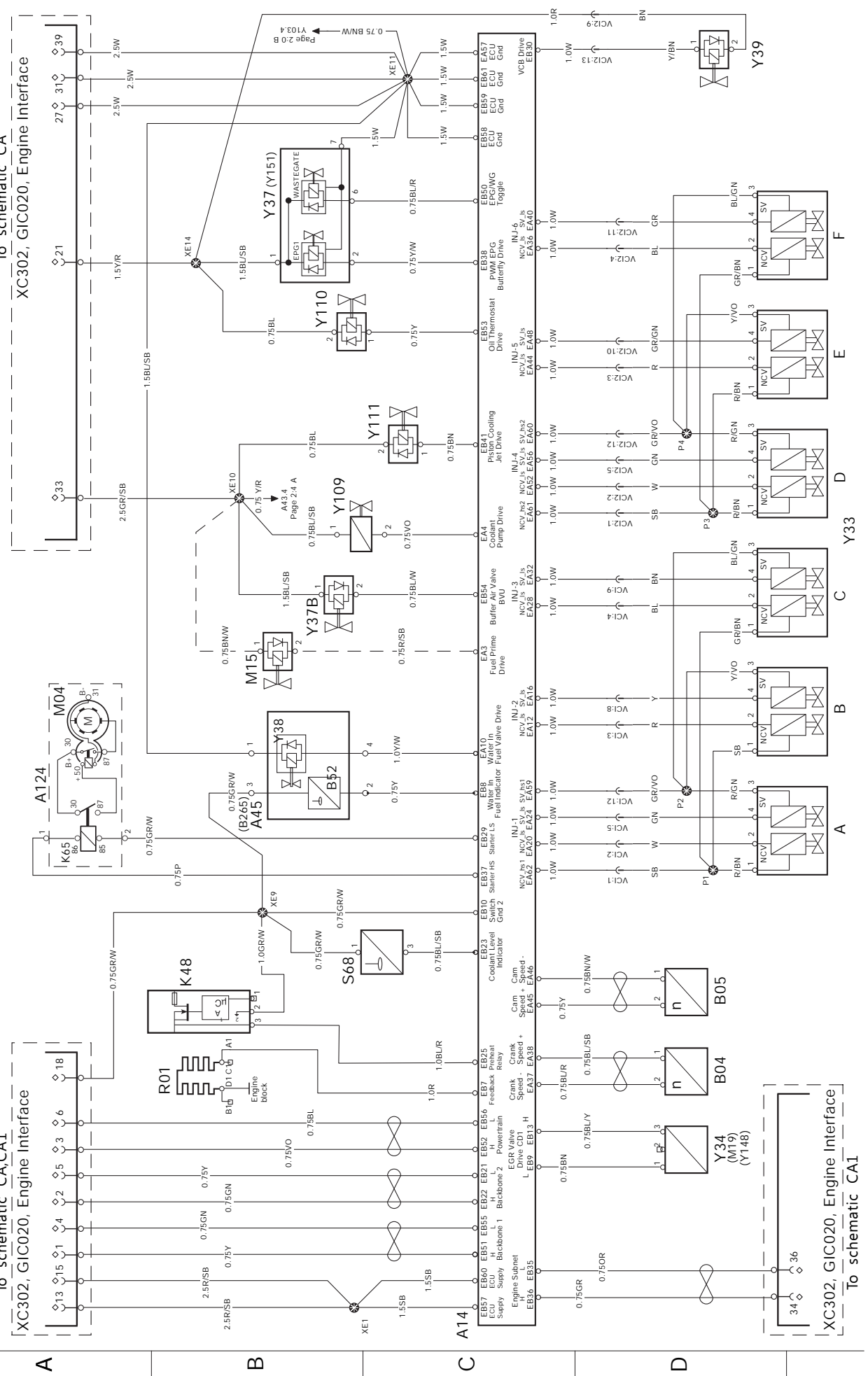

Page 1:4 C
XET11

Page 1:2 B
XET10

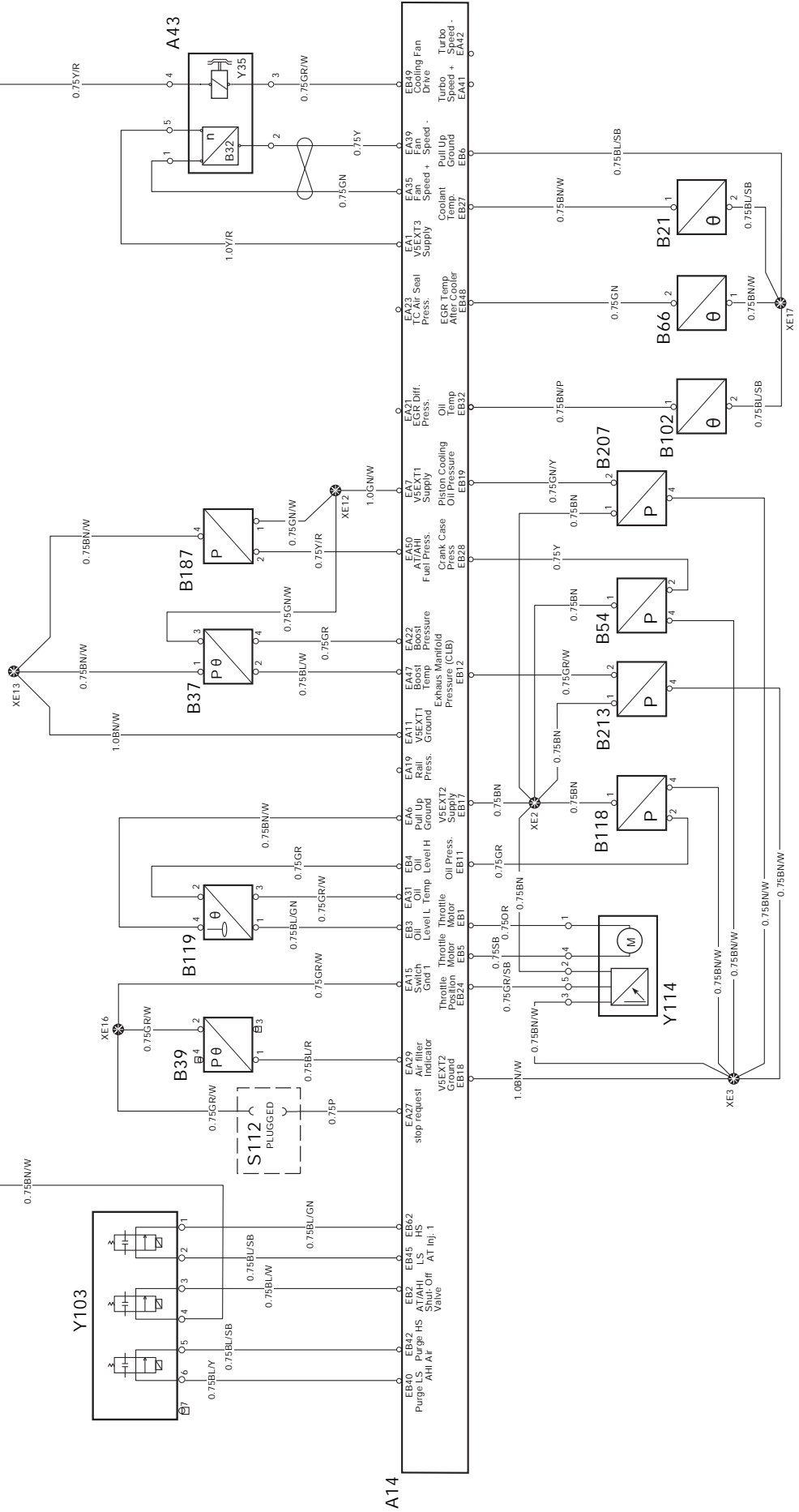

A14

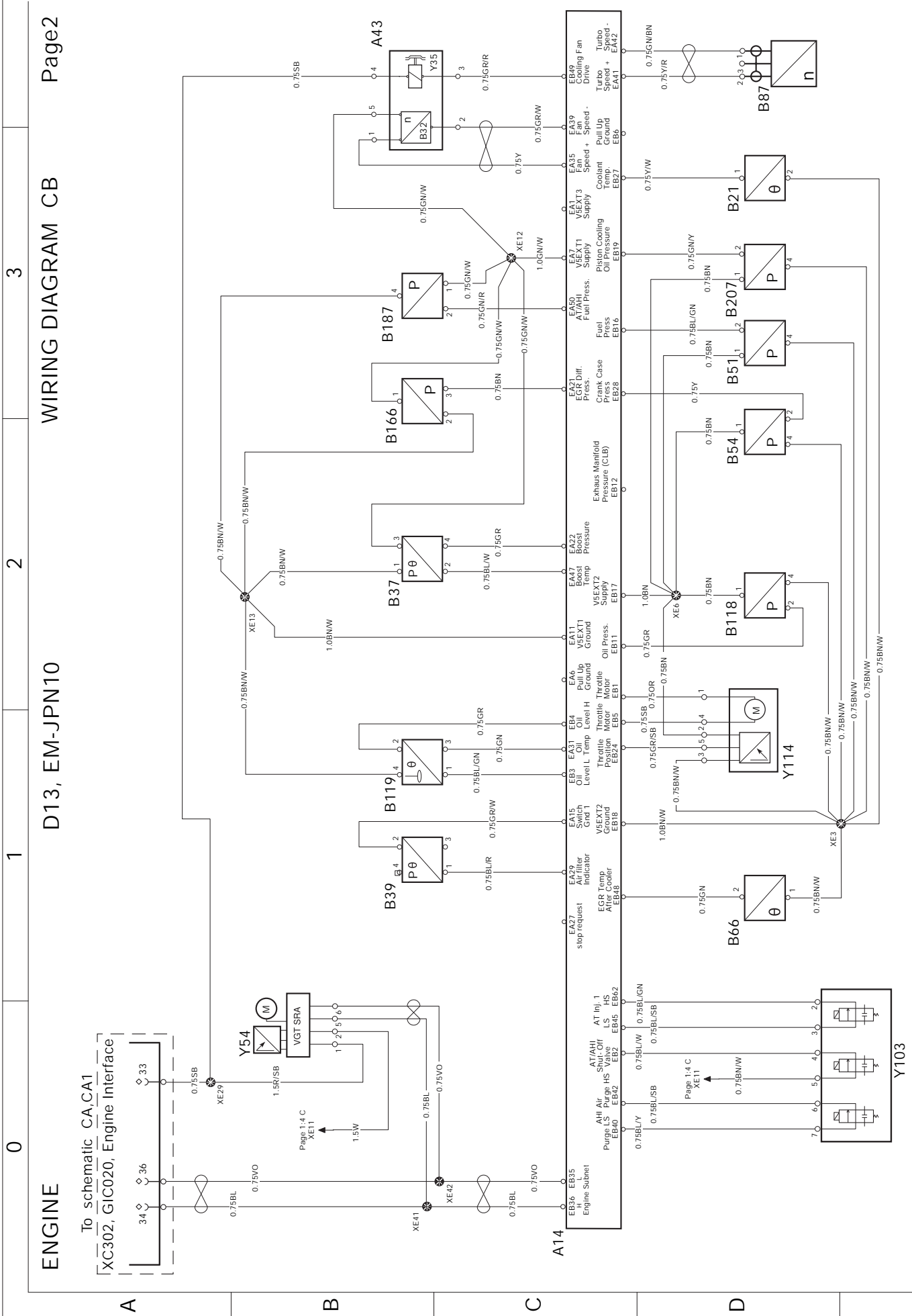

ENGINE

D13, EM-JPN10

WIRING DIAGRAM CB

Page2

To schematic CA,CA1
XC302, GIC020, Engine Interface

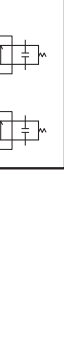
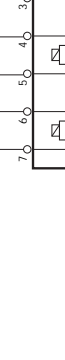
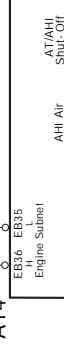
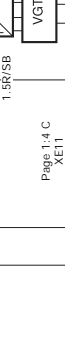
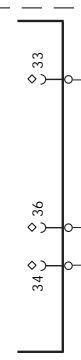

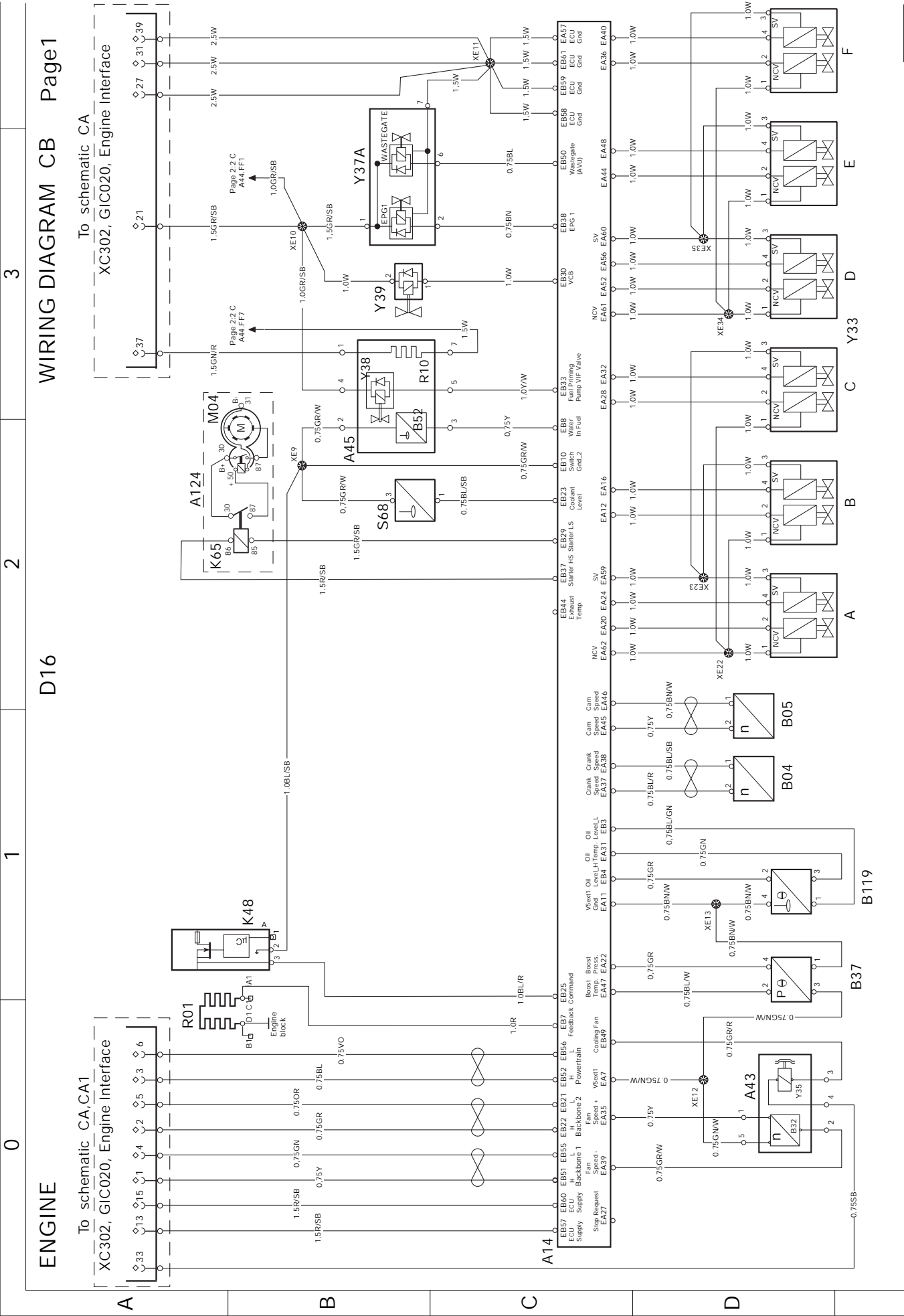

ENGINE

D16

WIRING DIAGRAM CB Page1

To schematic CA, CA1
XC302, GIC020, Engine Interface

To schematic CA
XC302, GIC020, Engine Interface

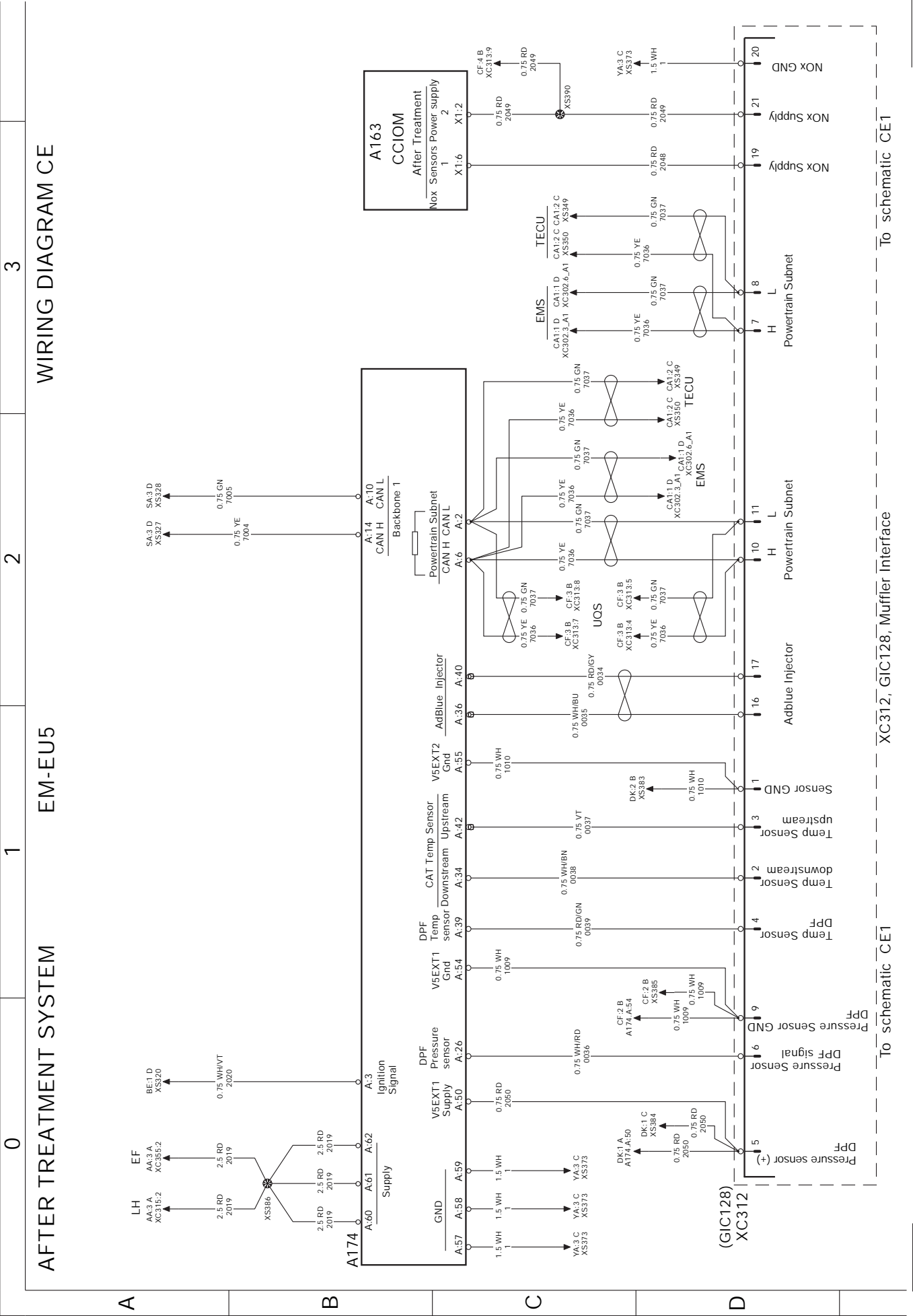

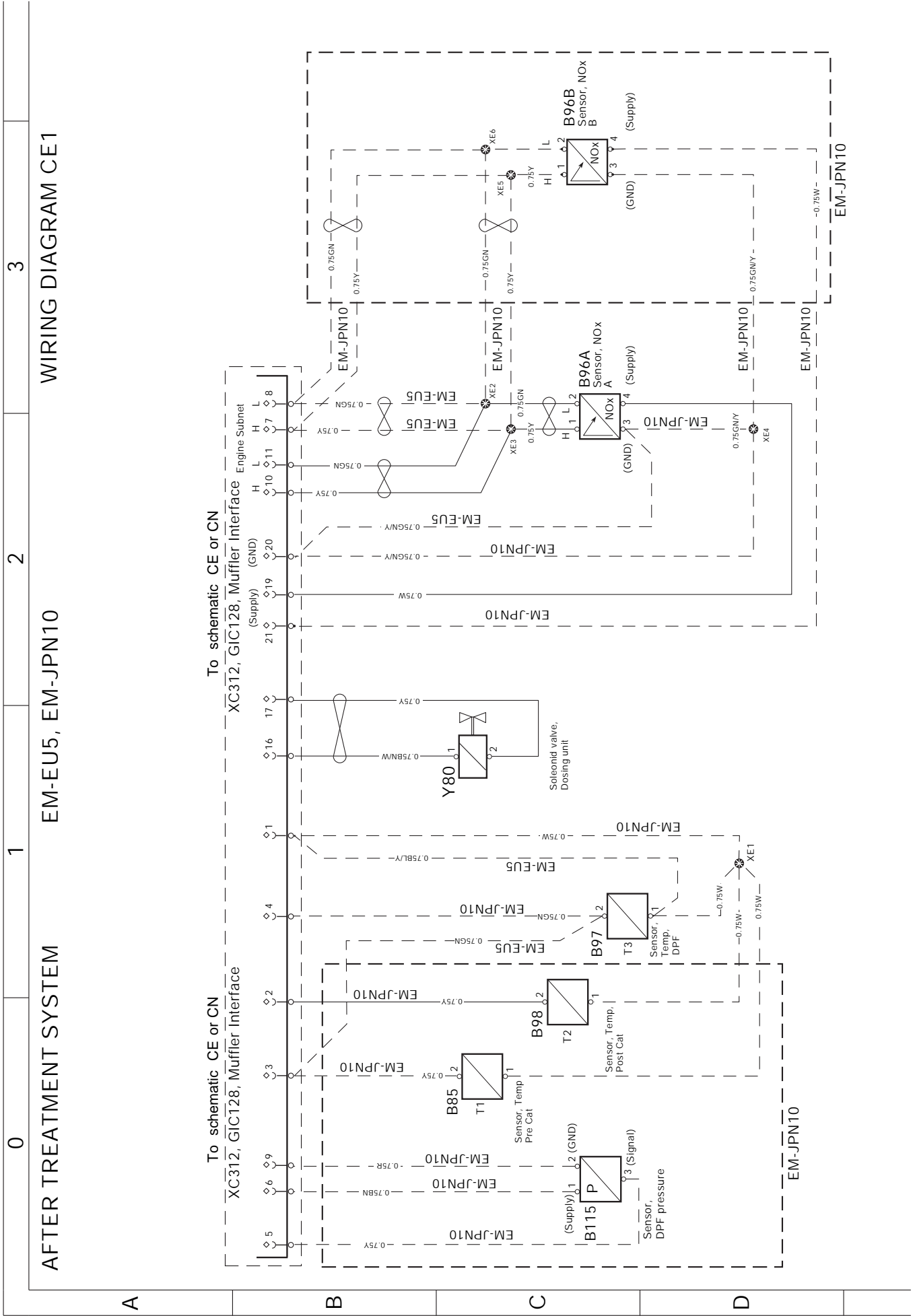

0

1

2

3

AFTER TREATMENT SYSTEM

ADBLUE TANK CONTROL, EM-EU5

WIRING DIAGRAM CF

A

B

C

D

The diagram illustrates the electrical control system for the AdBlue tank. It is organized into four vertical sections (A, B, C, D) and four horizontal sections (0, 1, 2, 3).

- Section A (ACM):** Contains the AdBlue Heater Hose (A174) with outputs 1, 2, and 3. It also includes the AdBlue Pump module control (V5FX12) and the Heat valve (A-4).
- Section B:** Shows the supply to actuators (A-52 to A-56) and the AdBlue level/temperature sensor (A-18, A-46). It details the wiring for various relays (XC313:18 to XC313:21) and solenoid valves (DK:1 D, DK:1 A, DK:2 B).
- Section C:** Details the AdBlue Pump module control (A-7 to A-12) and the supply to actuators (A-52 to A-56). It shows the wiring for relays (XC316:13 to XC316:16) and solenoid valves (DK:1 A, DK:1 B, DK:1 C).
- Section D:** Shows the final control elements, including the Pump, Reversing Valve, Pressure Sensor, and solenoid valves (Y81, B142, B247). It also shows the connection to the AdBlue level/temperature sensor (A-18, A-46) and the AdBlue level/temperature sensor (A-18, A-46).

The diagram uses standard electrical symbols for relays, solenoid valves, pumps, and sensors. Wire colors and gauges are indicated throughout the circuit.

T3087583

Page 32 (300)

Wiring diagram

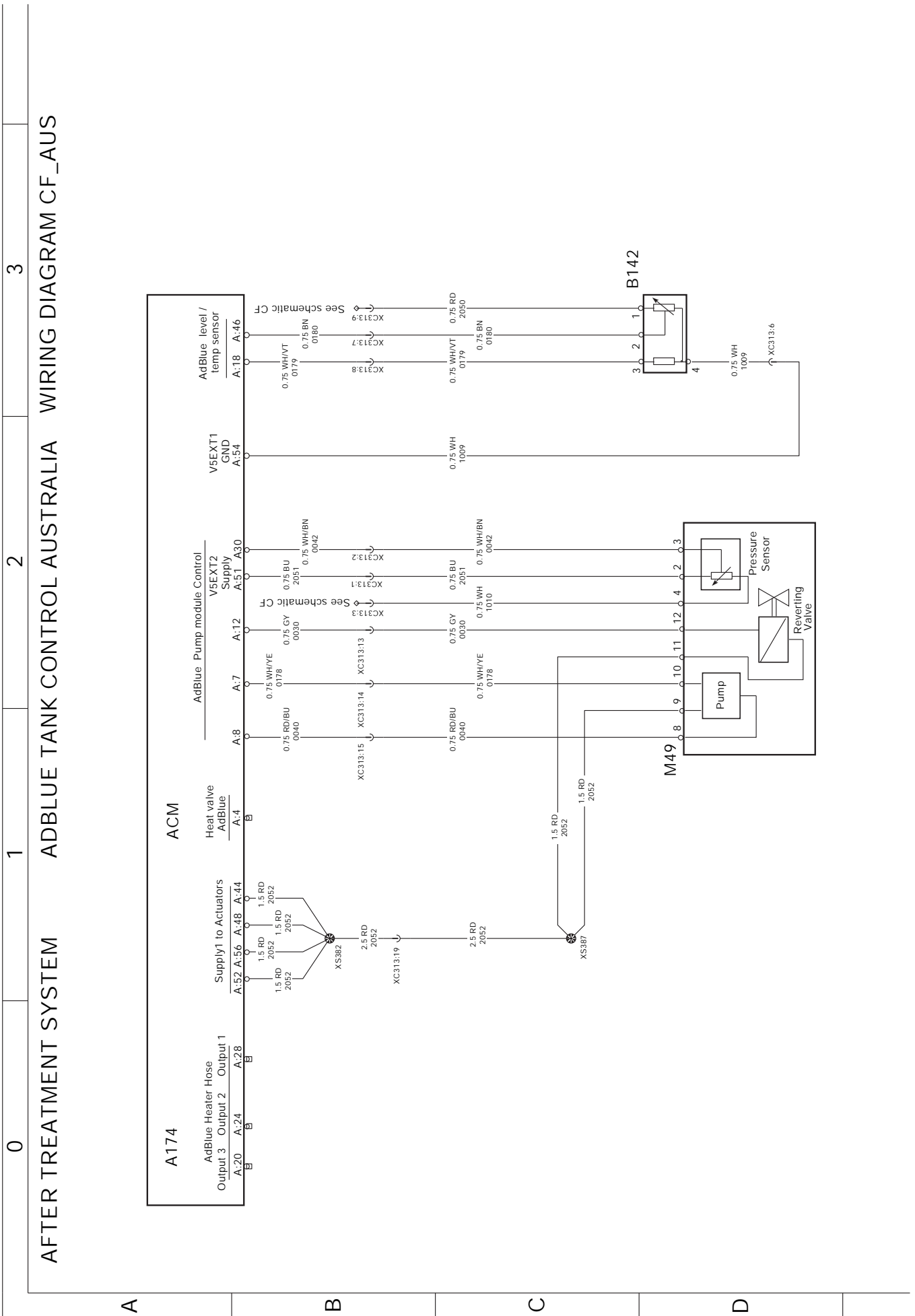

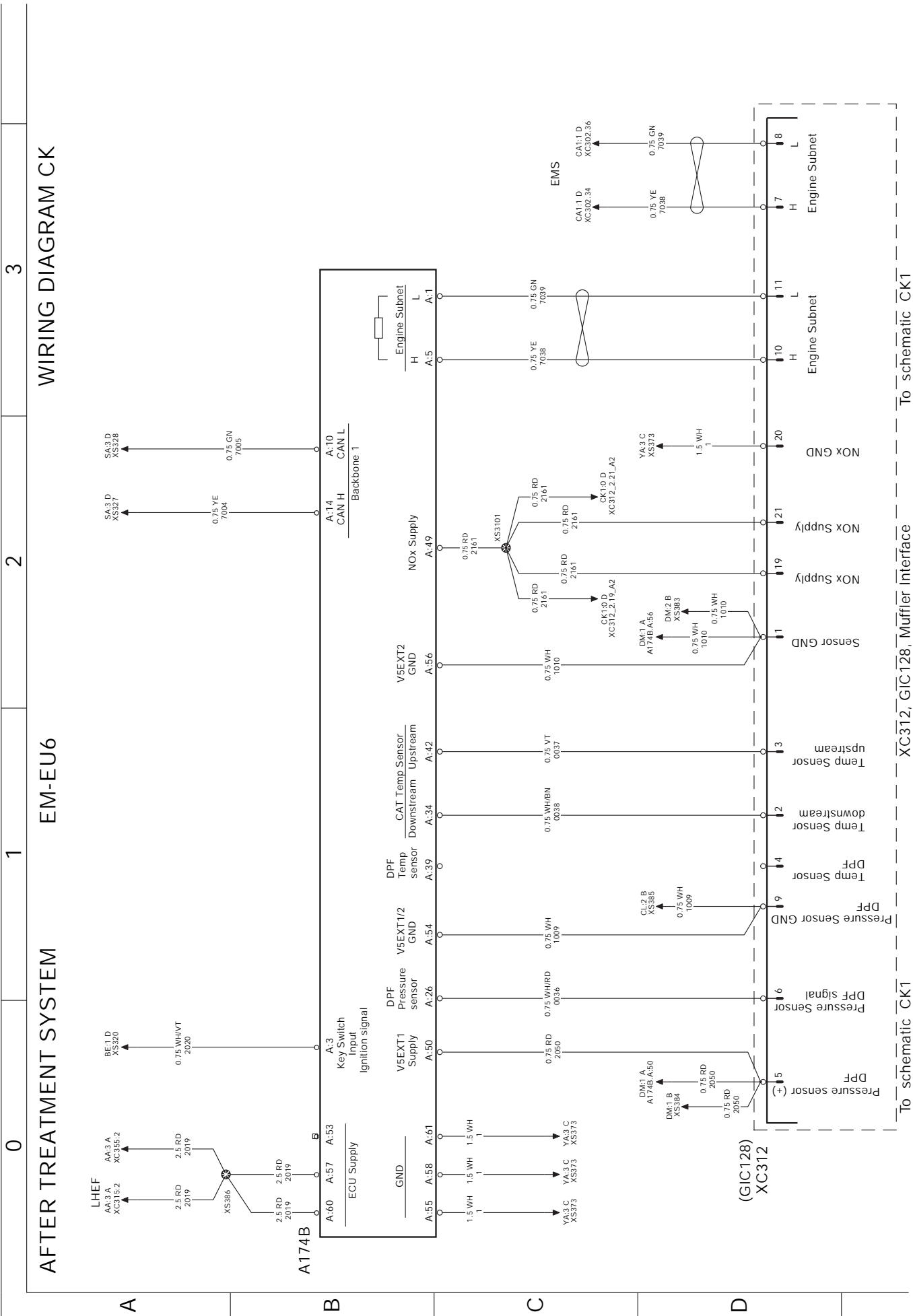

3 WIRING DIAGRAM CK

2 EM-EU6

1 AFTER TREATMENT SYSTEM

0

A

B

C

D

To schematic CK1

XC312, GIC128, Muffler Interface

To schematic CK1

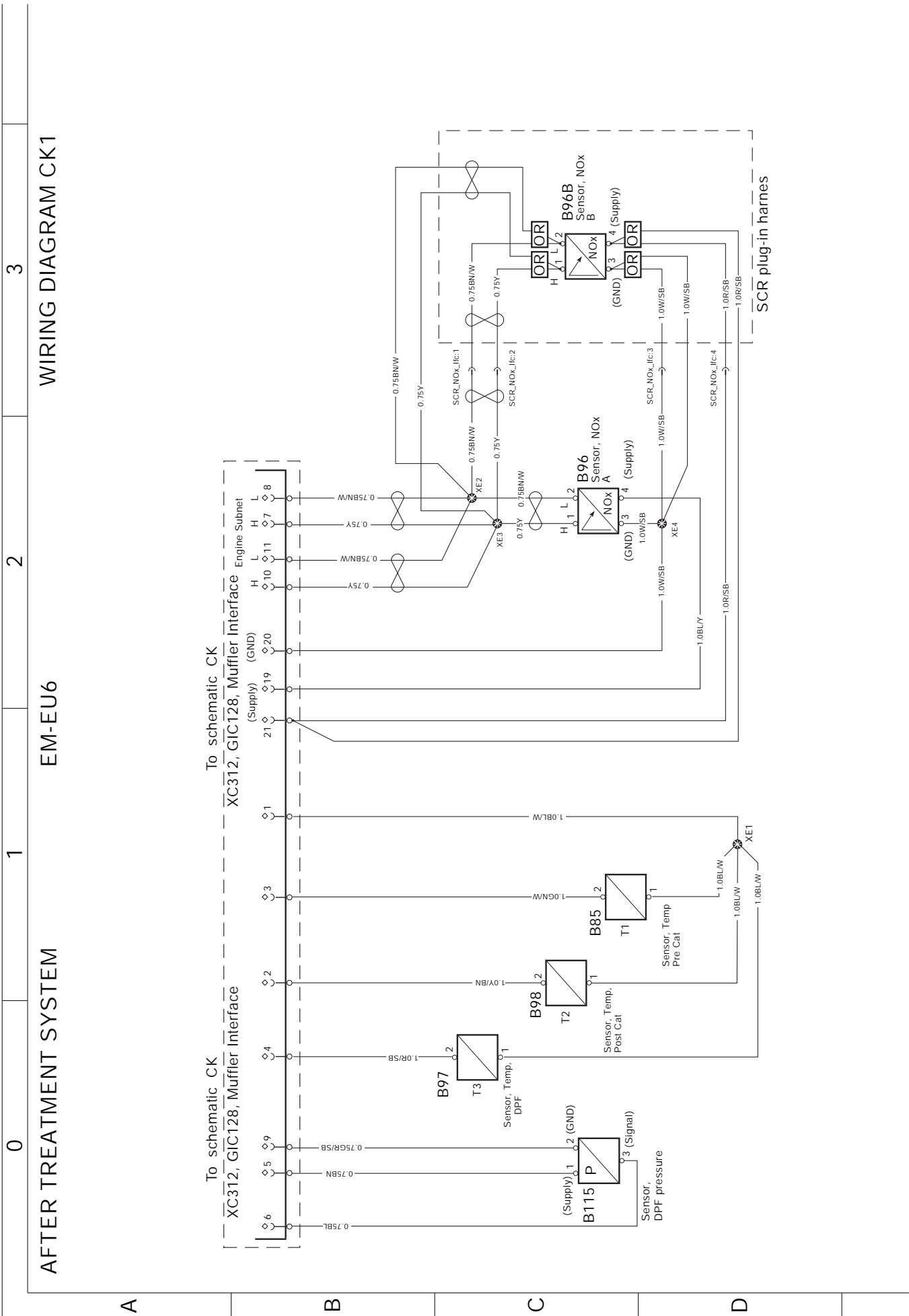

0

1

2

3

AFTER TREATMENT SYSTEM

ADBLUE TANK CONTROL, EM-EU6

WIRING DIAGRAM CL

A174B

The diagram illustrates the electrical control system for the Adblue tank. It features several input and output terminals on the left, connected to various components on the right:

- Terminals A:28 to A:32:** Adblue Heater Hose Output 2 (RD/GY), Adblue Heater Hose Output 1 (WH/BU), and Supply to Urea Hoses (RD, BU, YE).
- Terminals A:35 to A:47:** Air Control Valve Temp (BU), Urea Temp (WH), Urea pressure (GY), and Air Pressure (YE).
- Terminals A:46 to A:51:** Adblue level/temp sensor (WH/BN, WH/VT, GY).
- Terminals A:54 to A:62:** Supply to Urea Loads (RD, BU, YE).

Key components and their connections include:

- Heaters:** R56A (YELLOW Euro6) and R57A (BLACK) are controlled by terminals A:32 and A:33.
- Valves:** Air valve (A190) and Urea valve (Y81C) are controlled by terminals A:35 and A:36.
- Sensors:** Urea level sensor (B142B) and Air pressure sensor (B262, B263) are connected to terminals A:46 and A:47.
- Pumps:** Urea pump (B262) and Air pump (B263) are controlled by terminals A:51 and A:47.
- Motor:** Motor M73 is controlled by terminals A:28 and A:29.

The diagram uses standard electrical symbols for relays (XC), pumps (P), valves (V), sensors (S), and heaters (H). Wire colors and gauges are specified throughout the diagram.

T3086413

Page 36 (300)

Wiring diagram

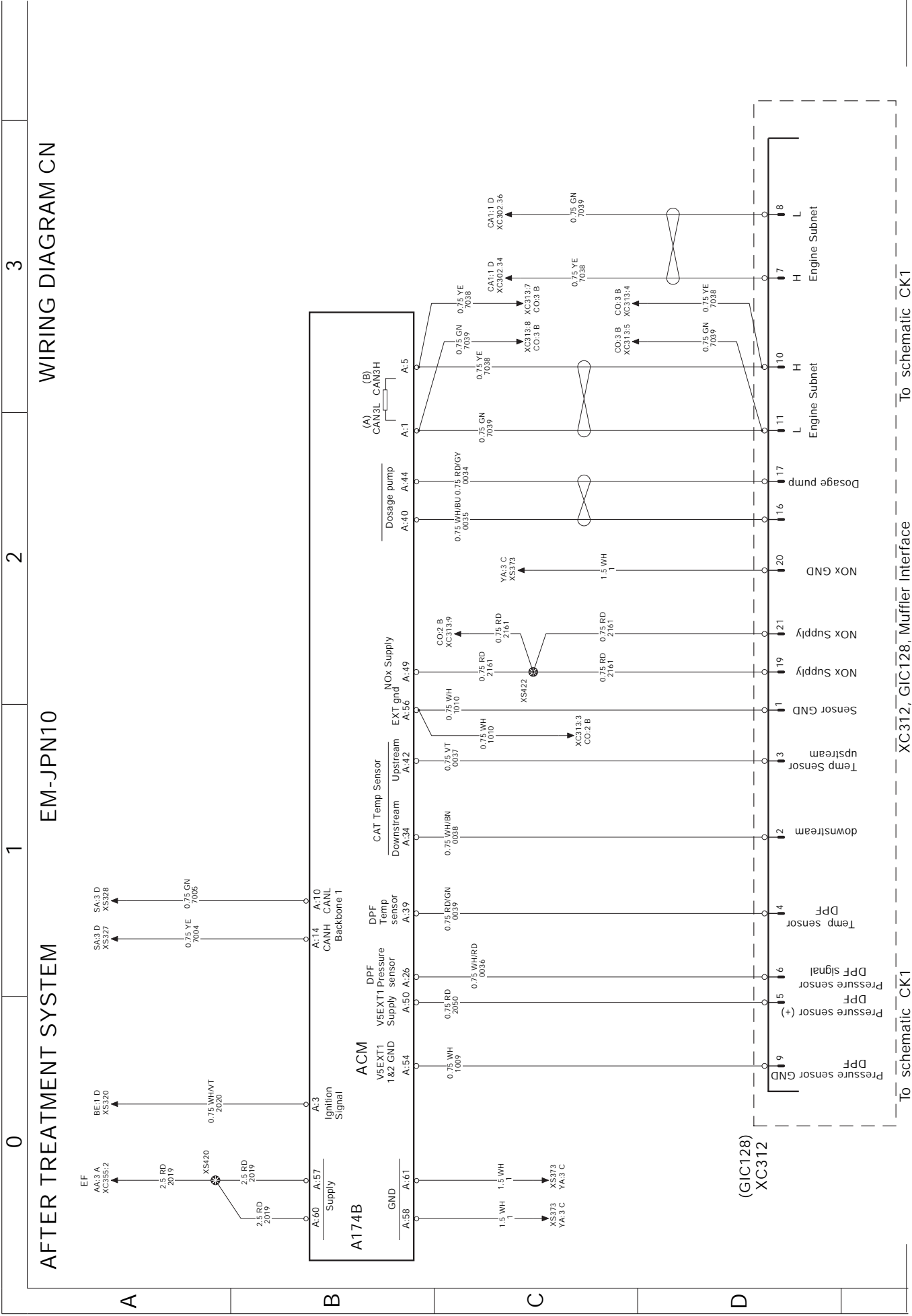

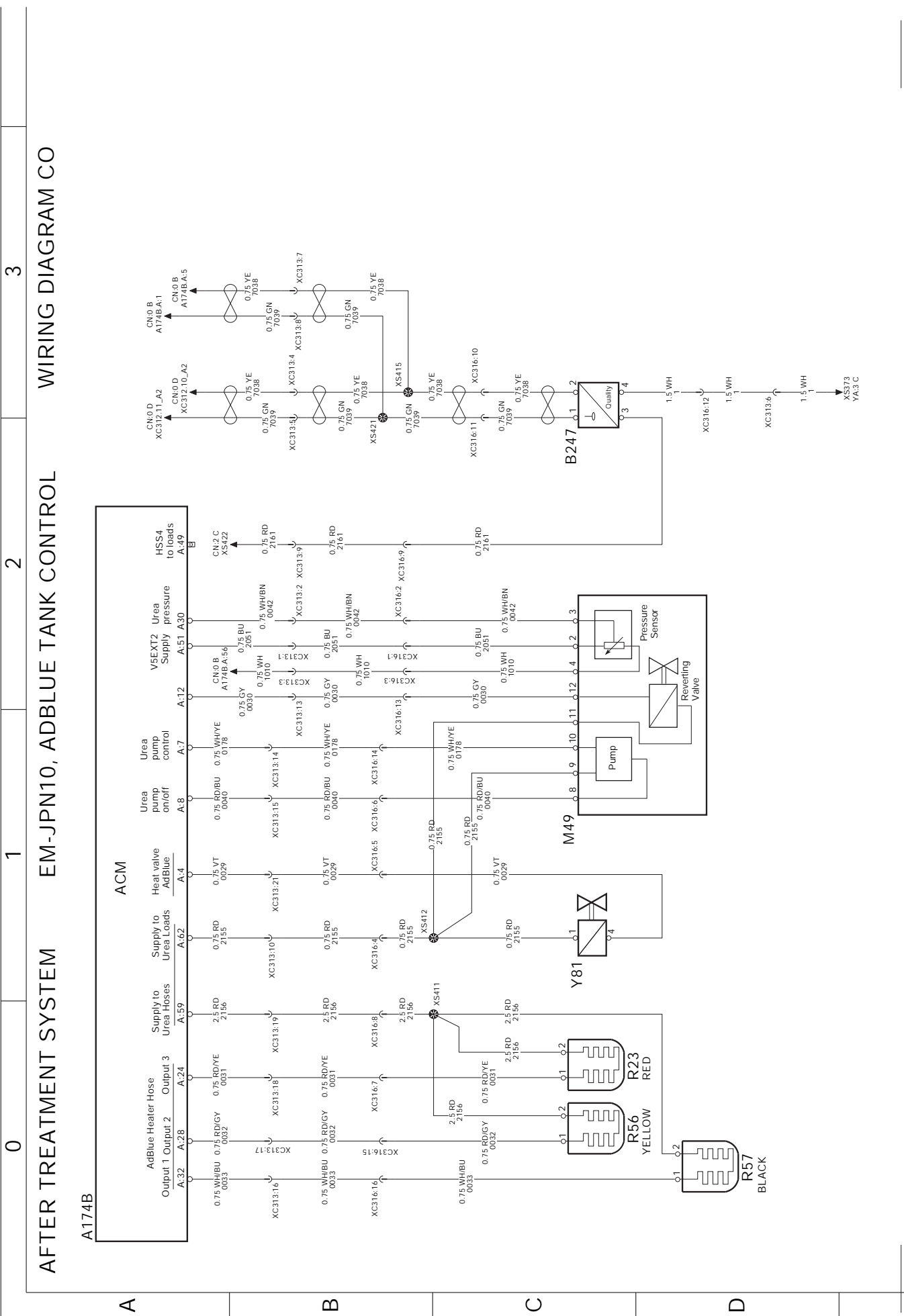

3 WIRING DIAGRAM CO

2 EM-JPN10, ADBLUE TANK CONTROL

1 AFTER TREATMENT SYSTEM

0

A174B

ACM

A174B.A

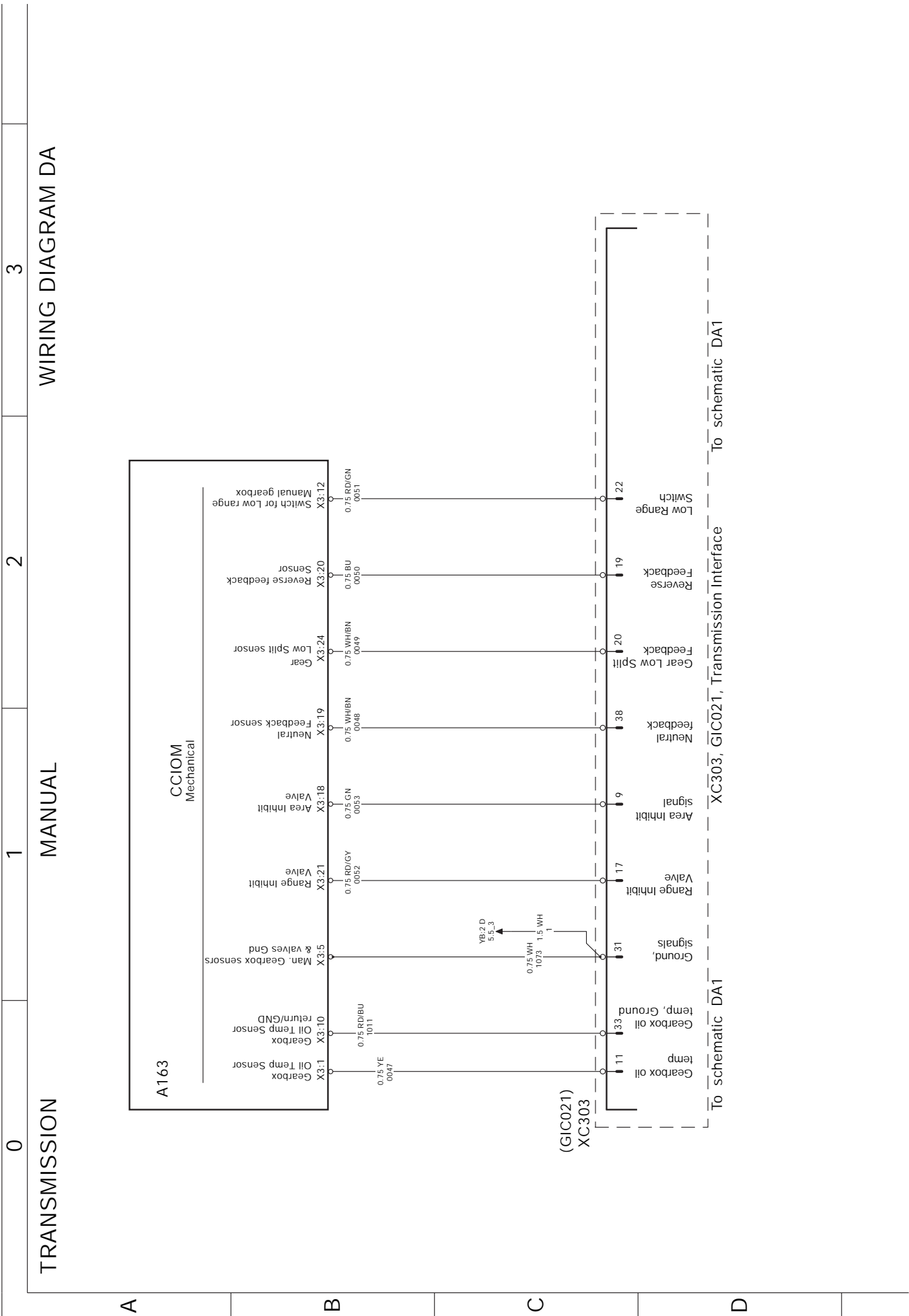

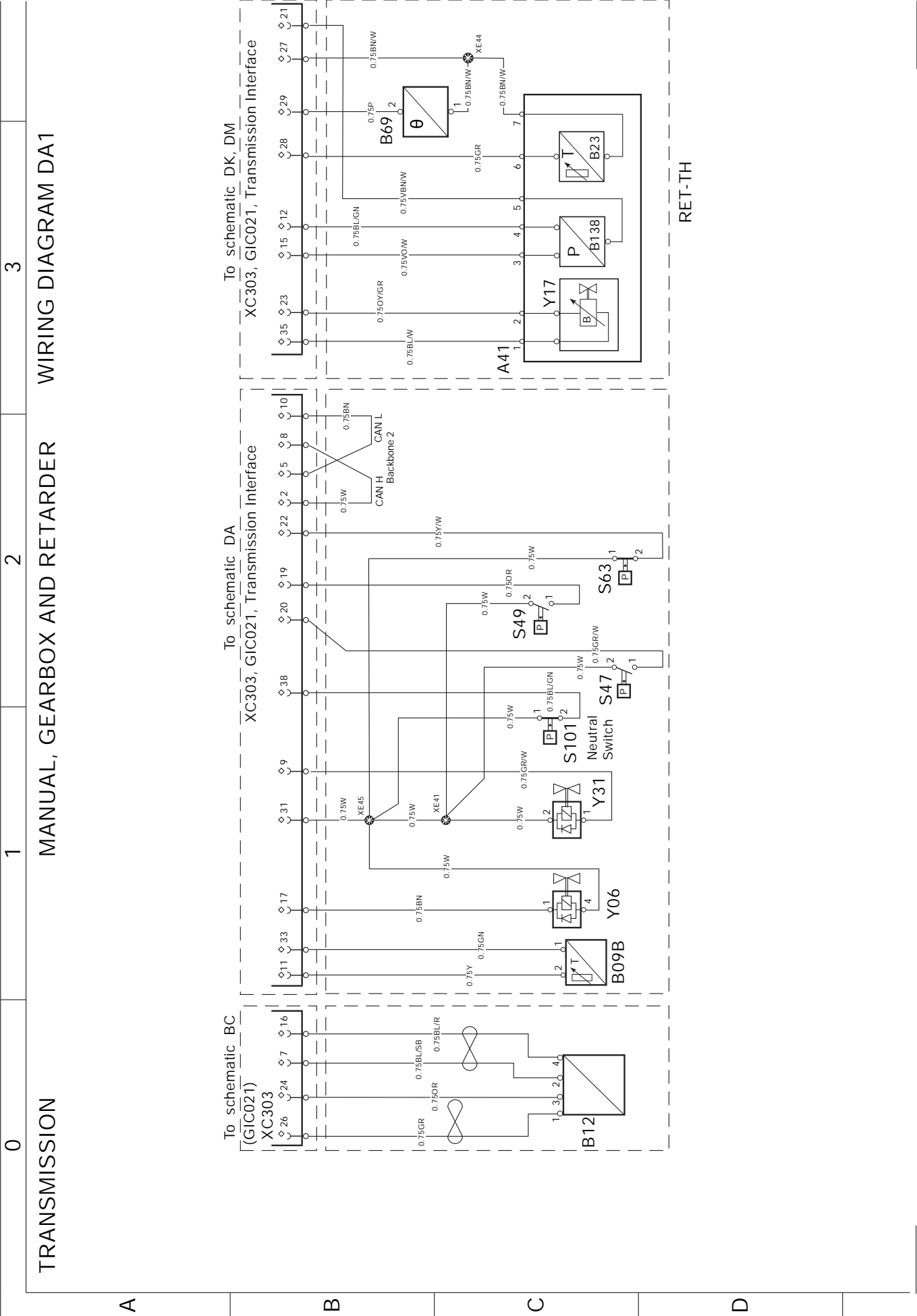

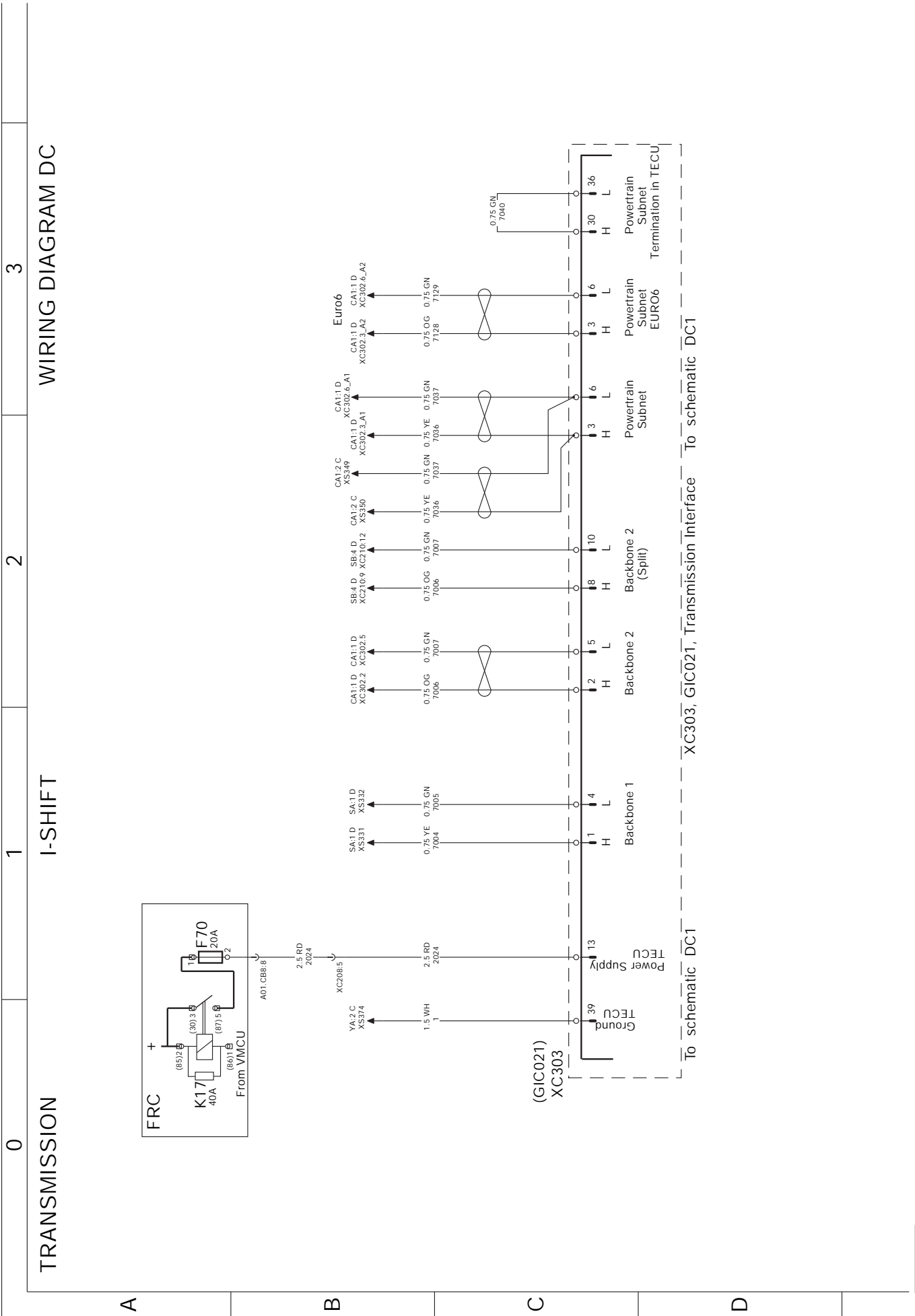

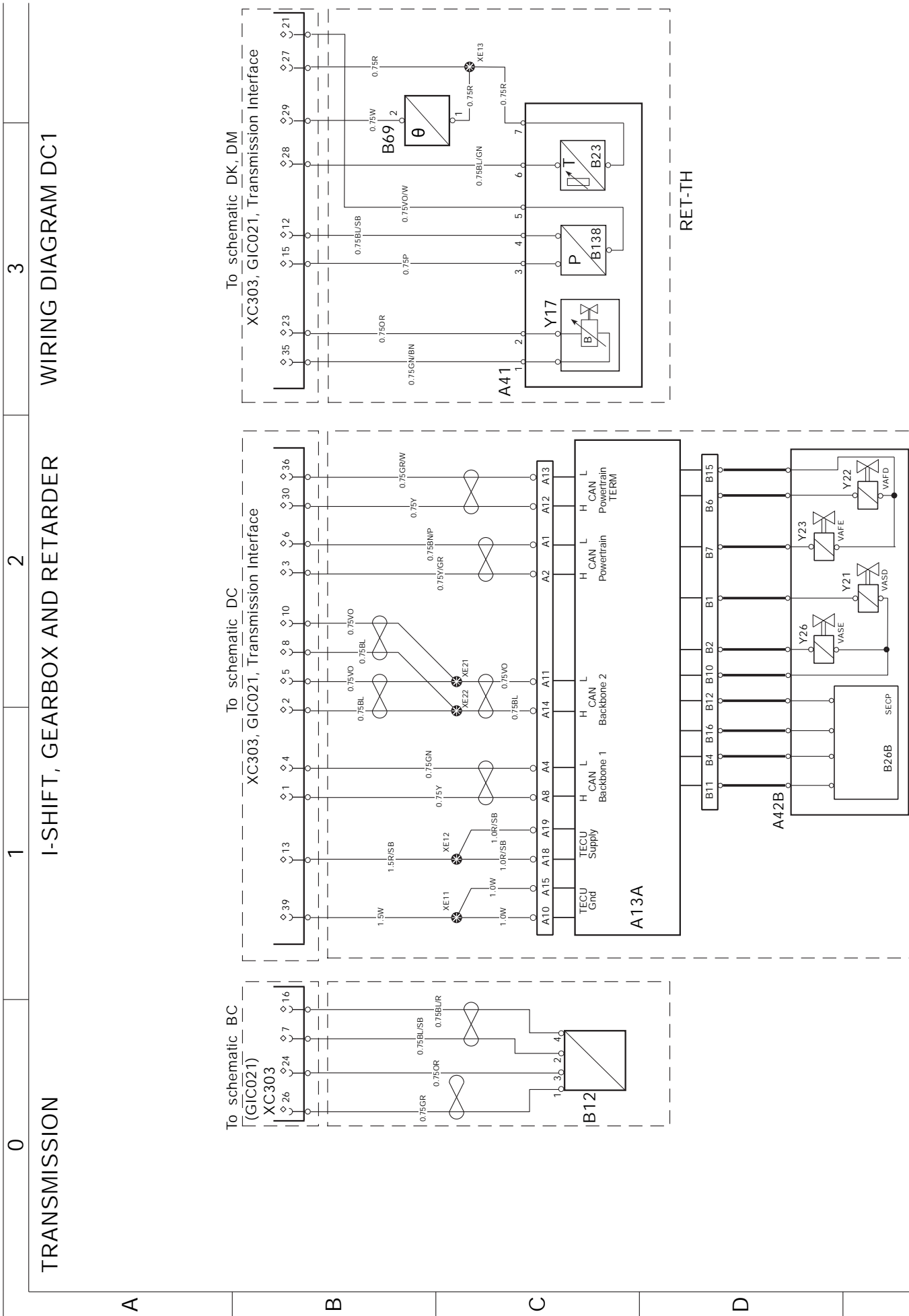

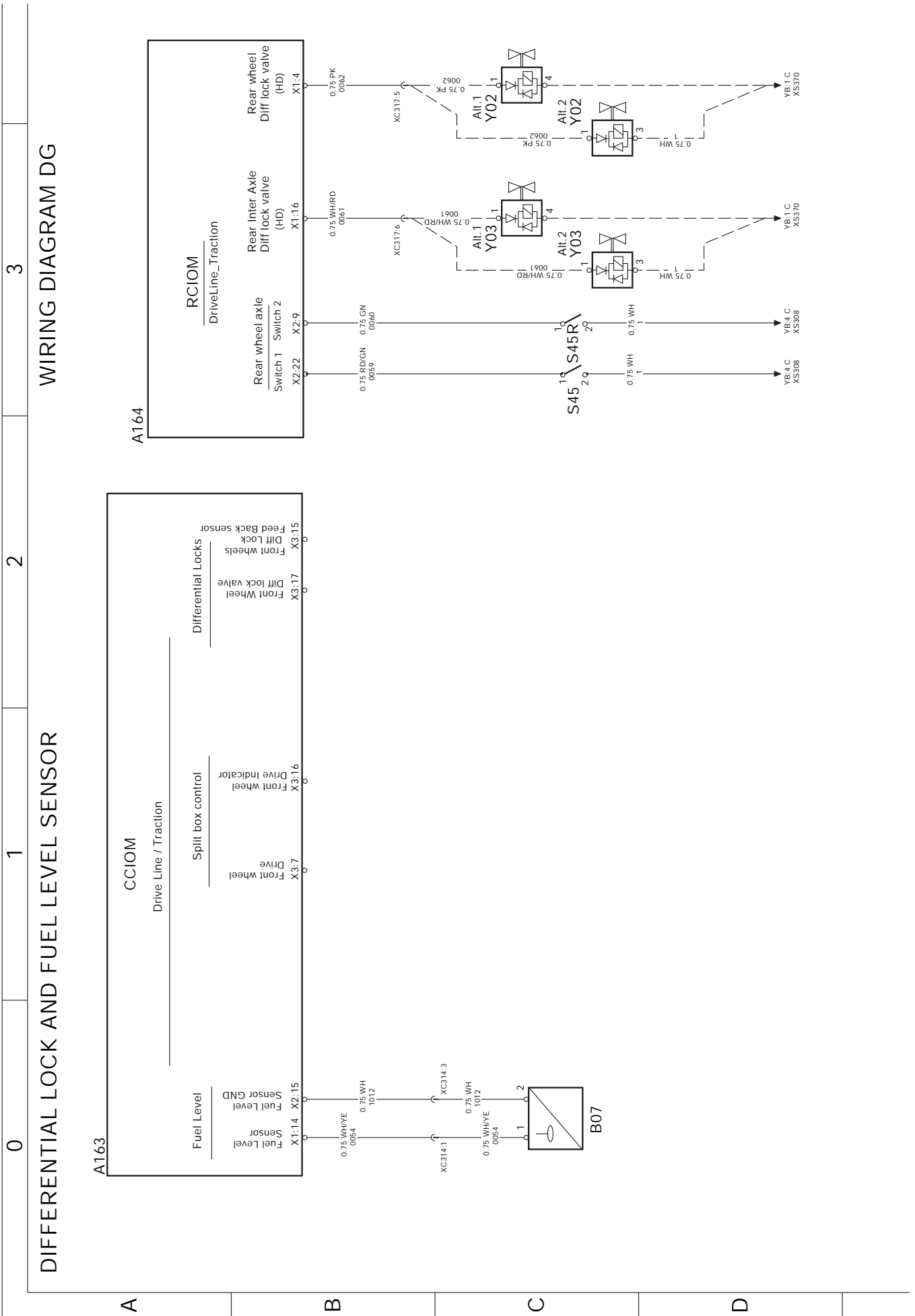

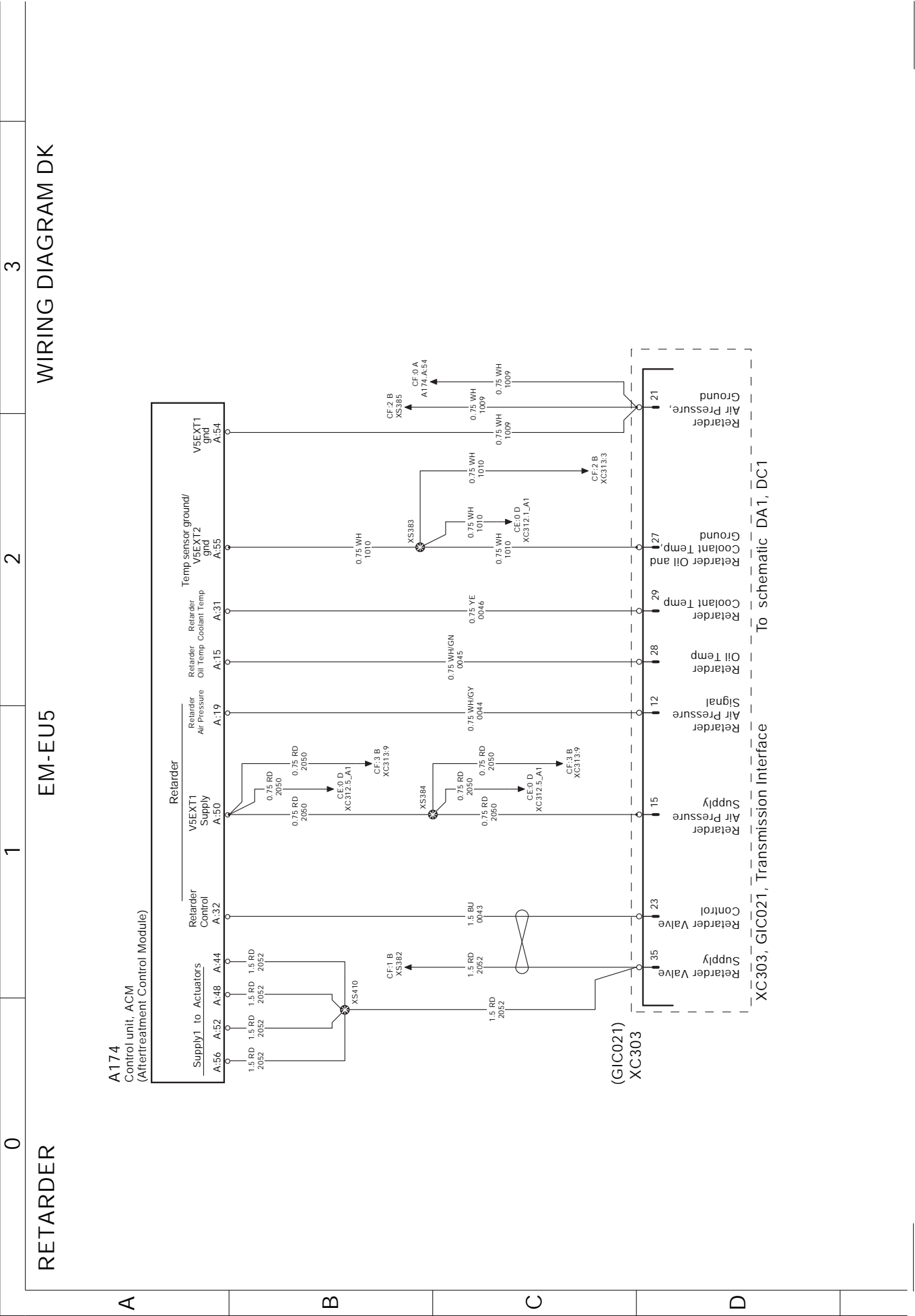

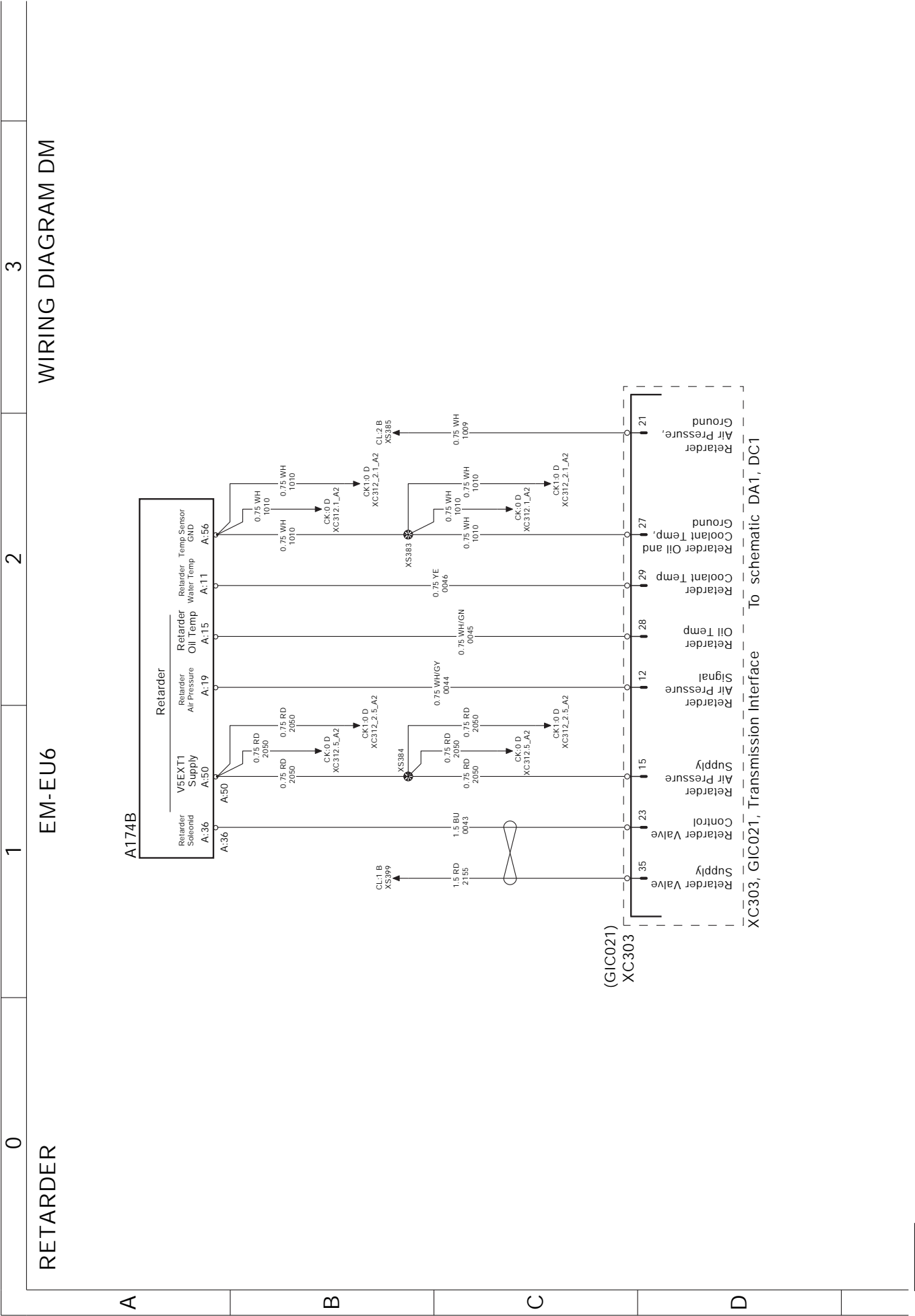

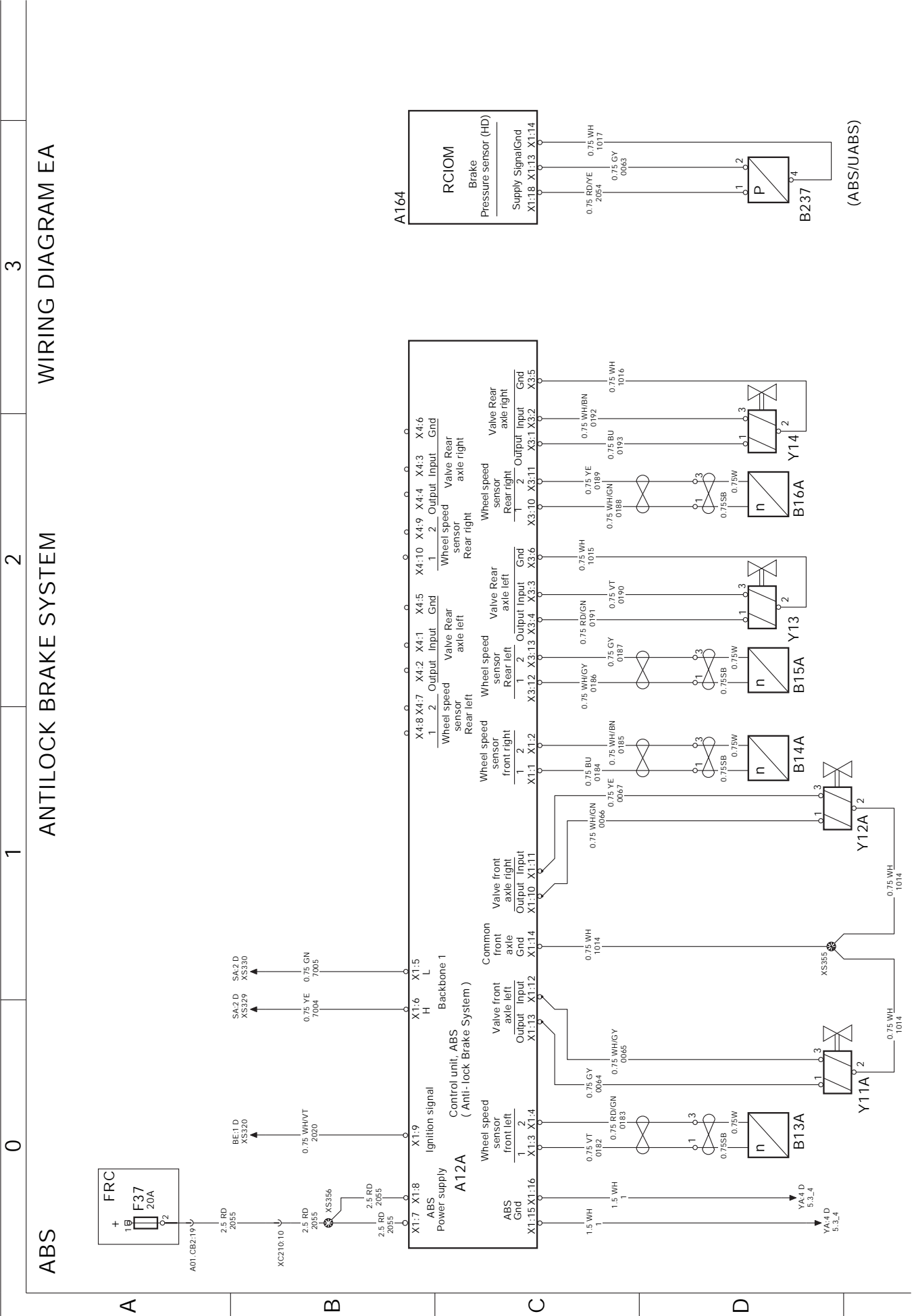

0 1 2 3 WIRING DIAGRAM EA

ANTILOCK BRAKE SYSTEM

ABS

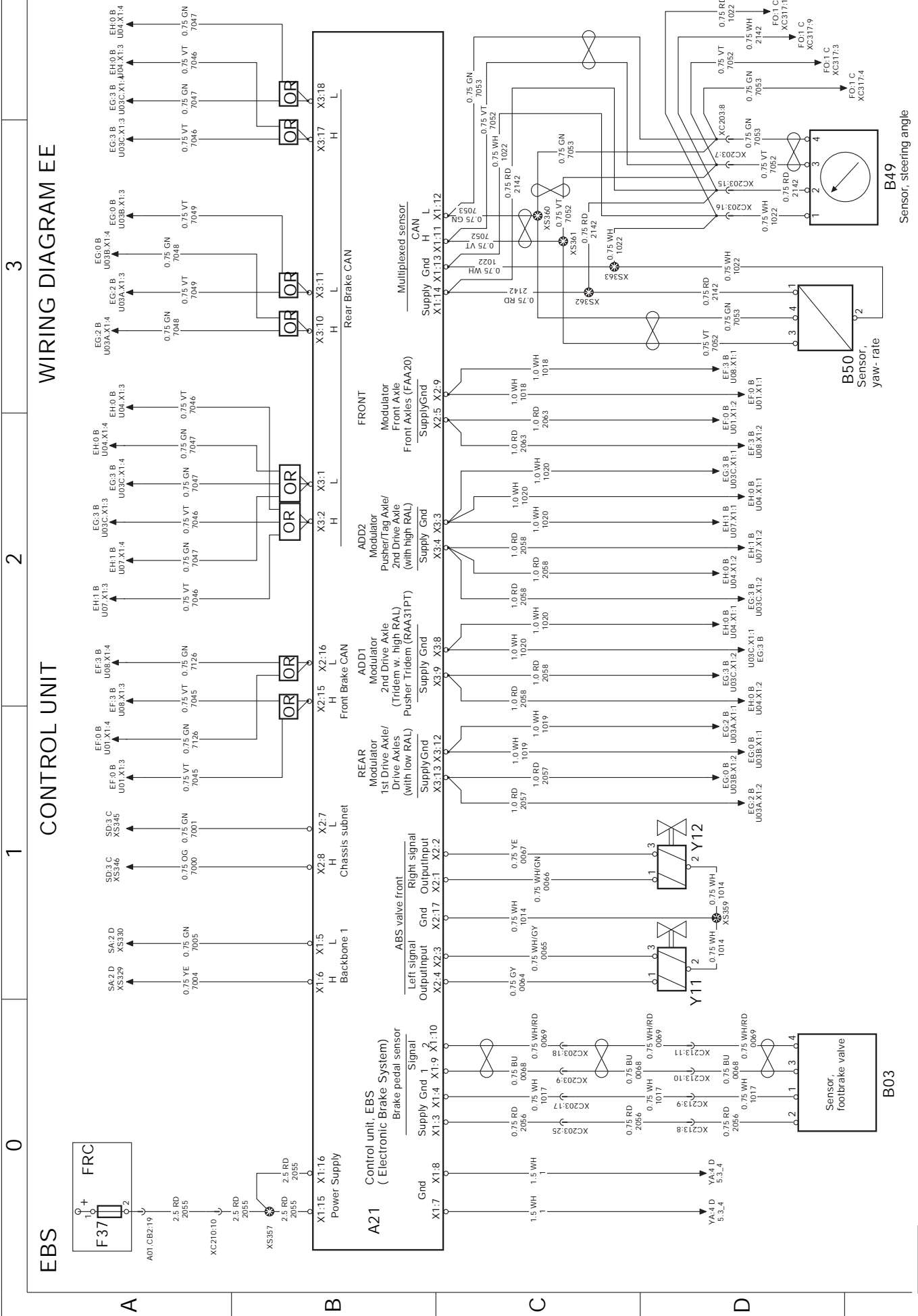

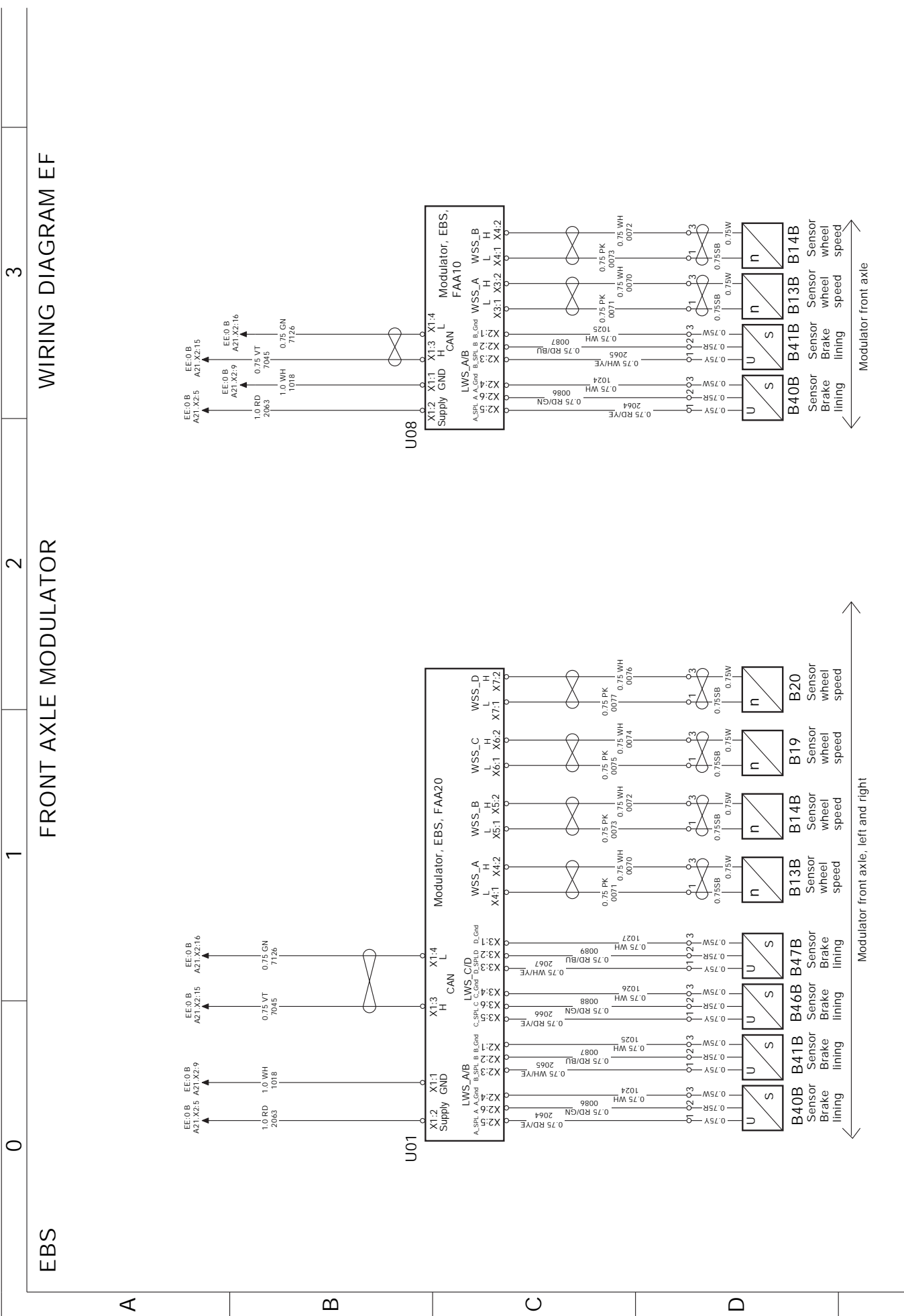

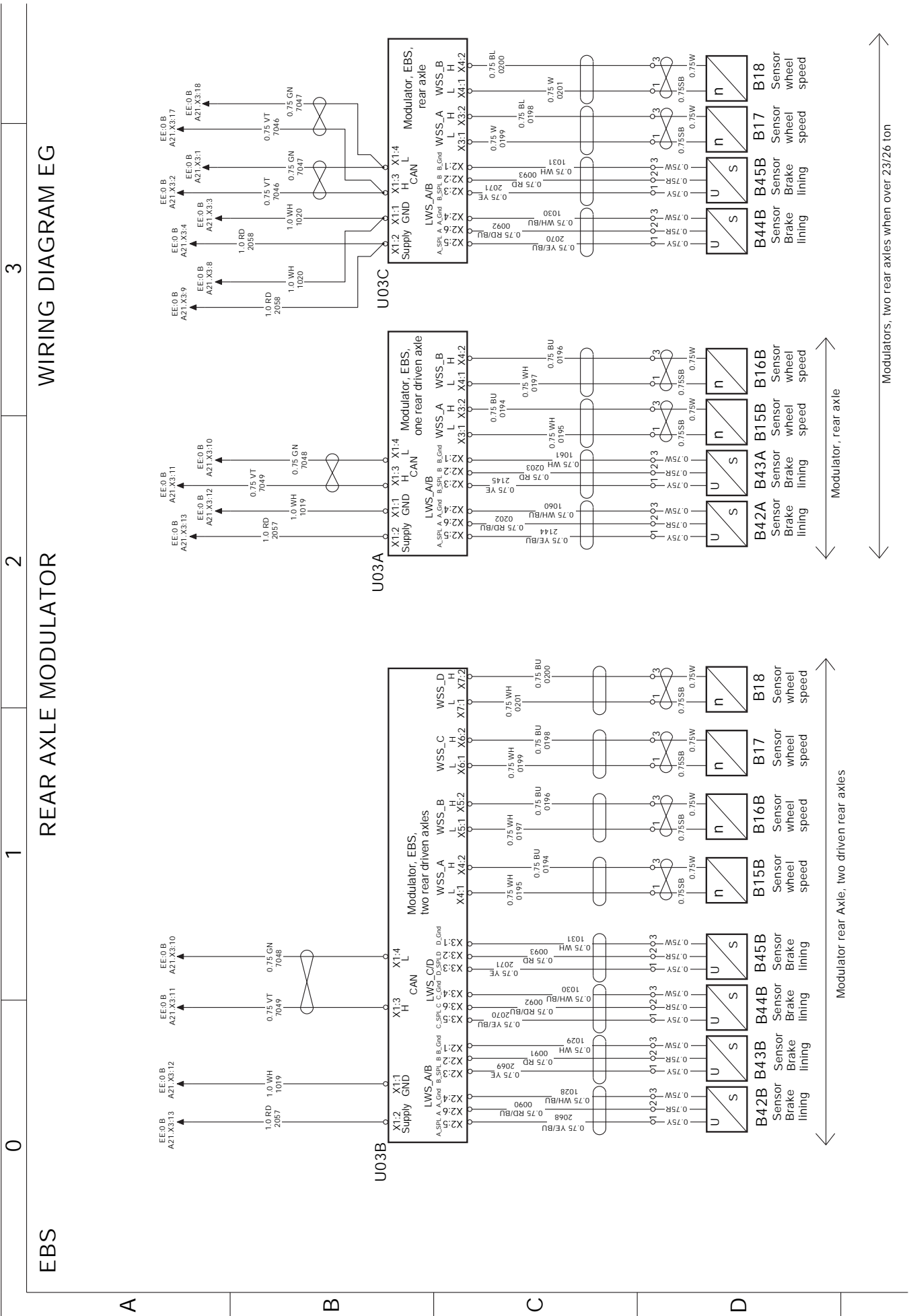

3

2

1

0

REAR AXLE MODULATOR

WIRING DIAGRAM EG

EBS

A

B

C

D

Modulator rear axle, two driven rear axles

Modulator, rear axle

Modulators, two rear axles when over 23/26 ton

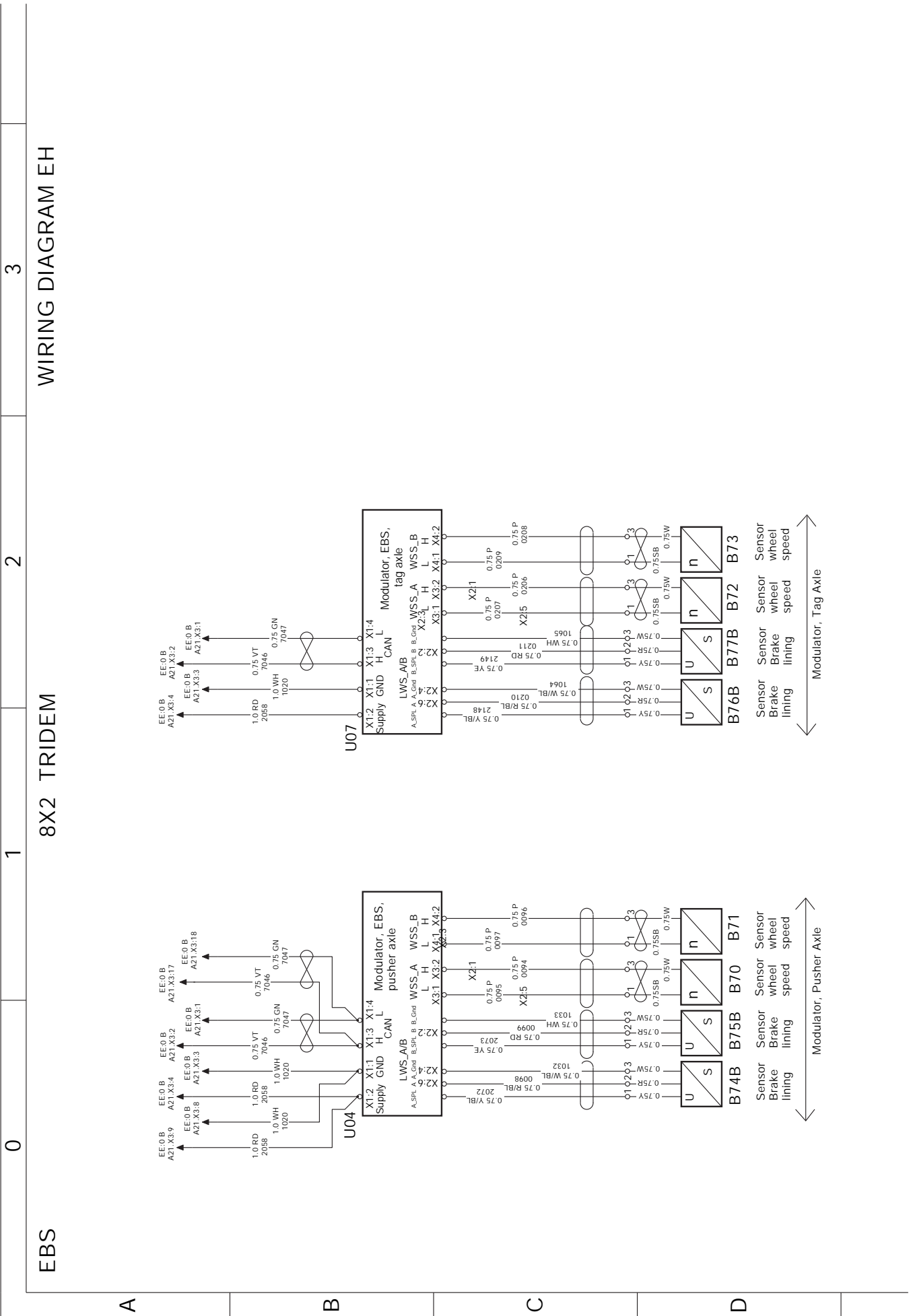

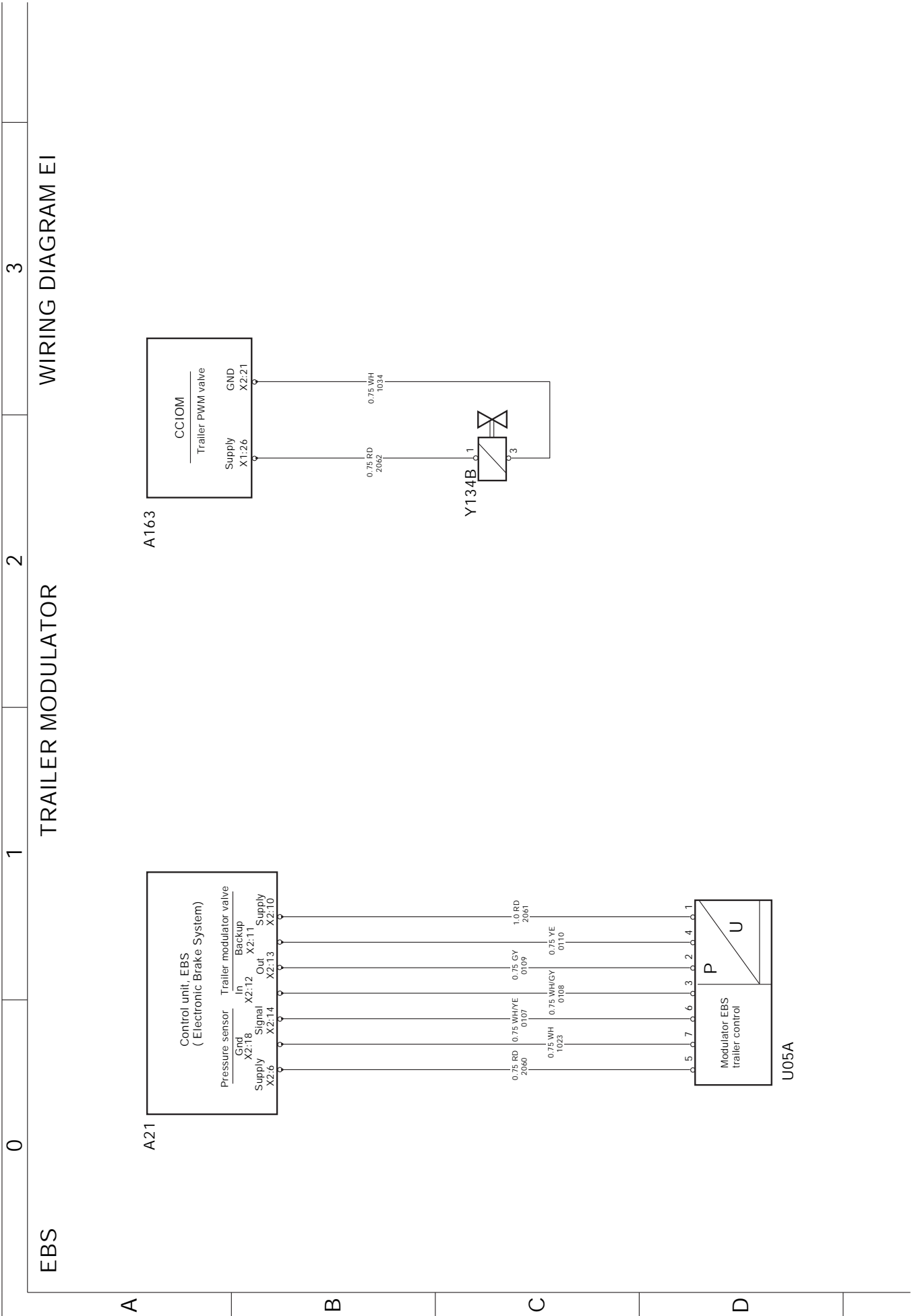

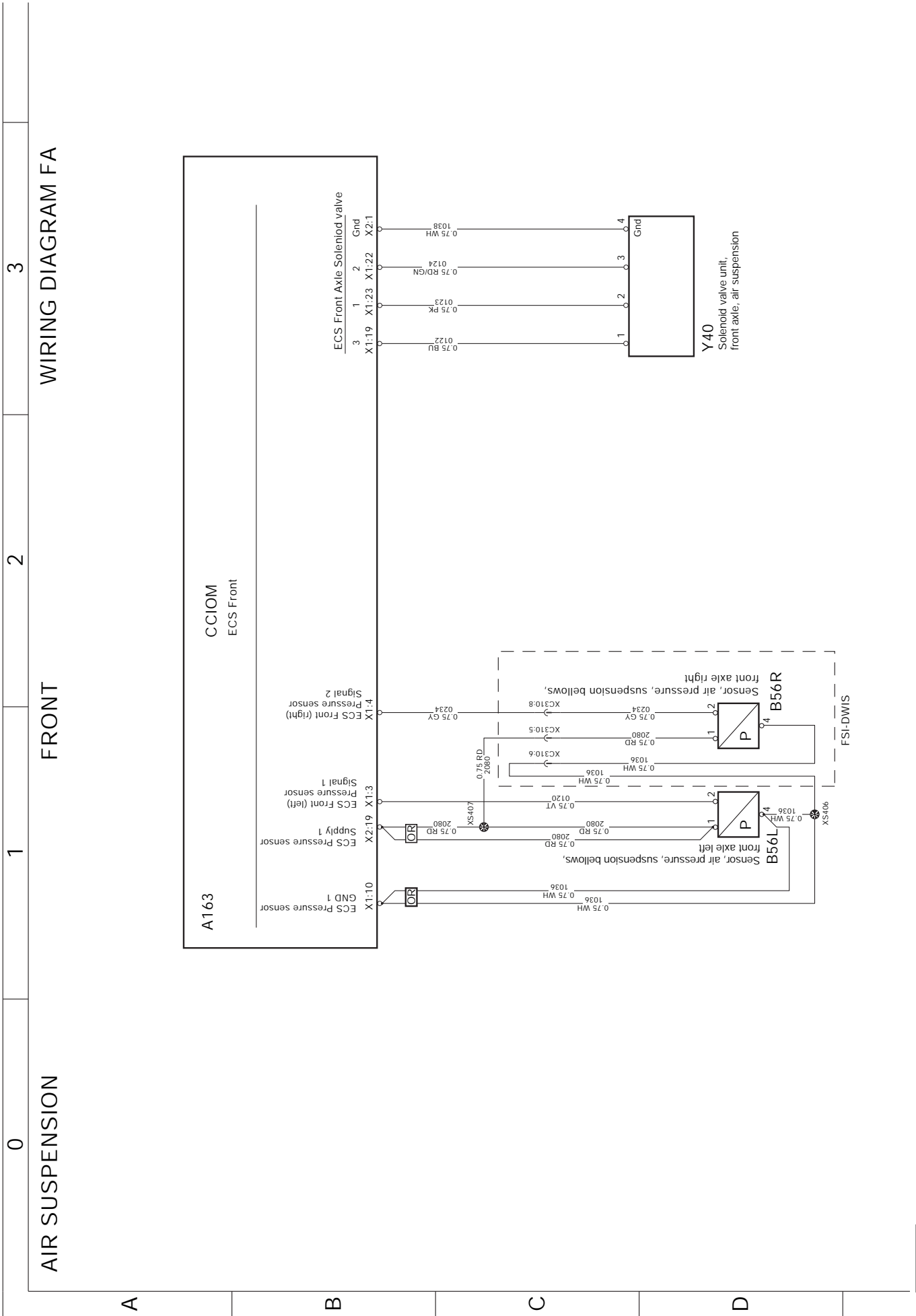

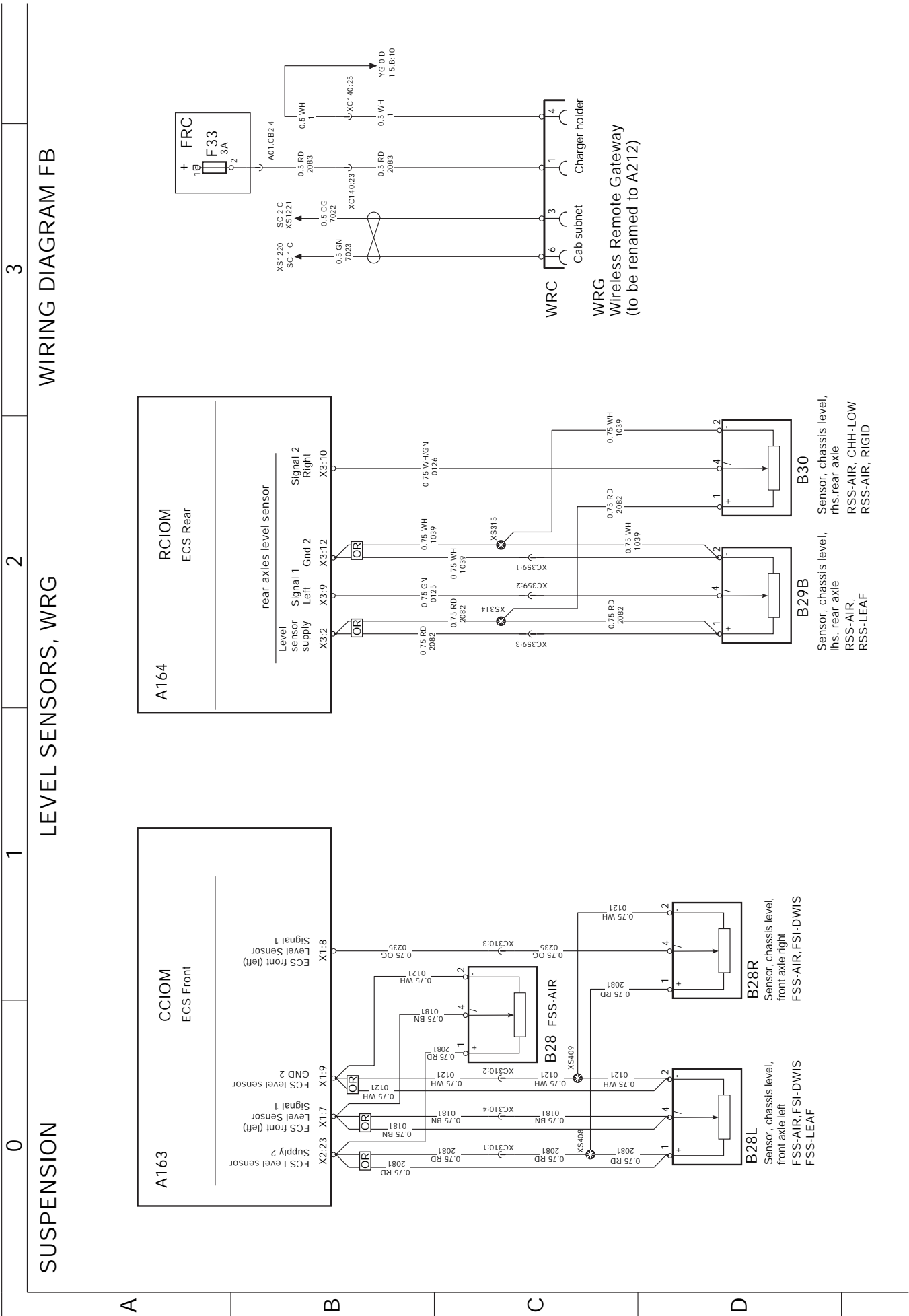

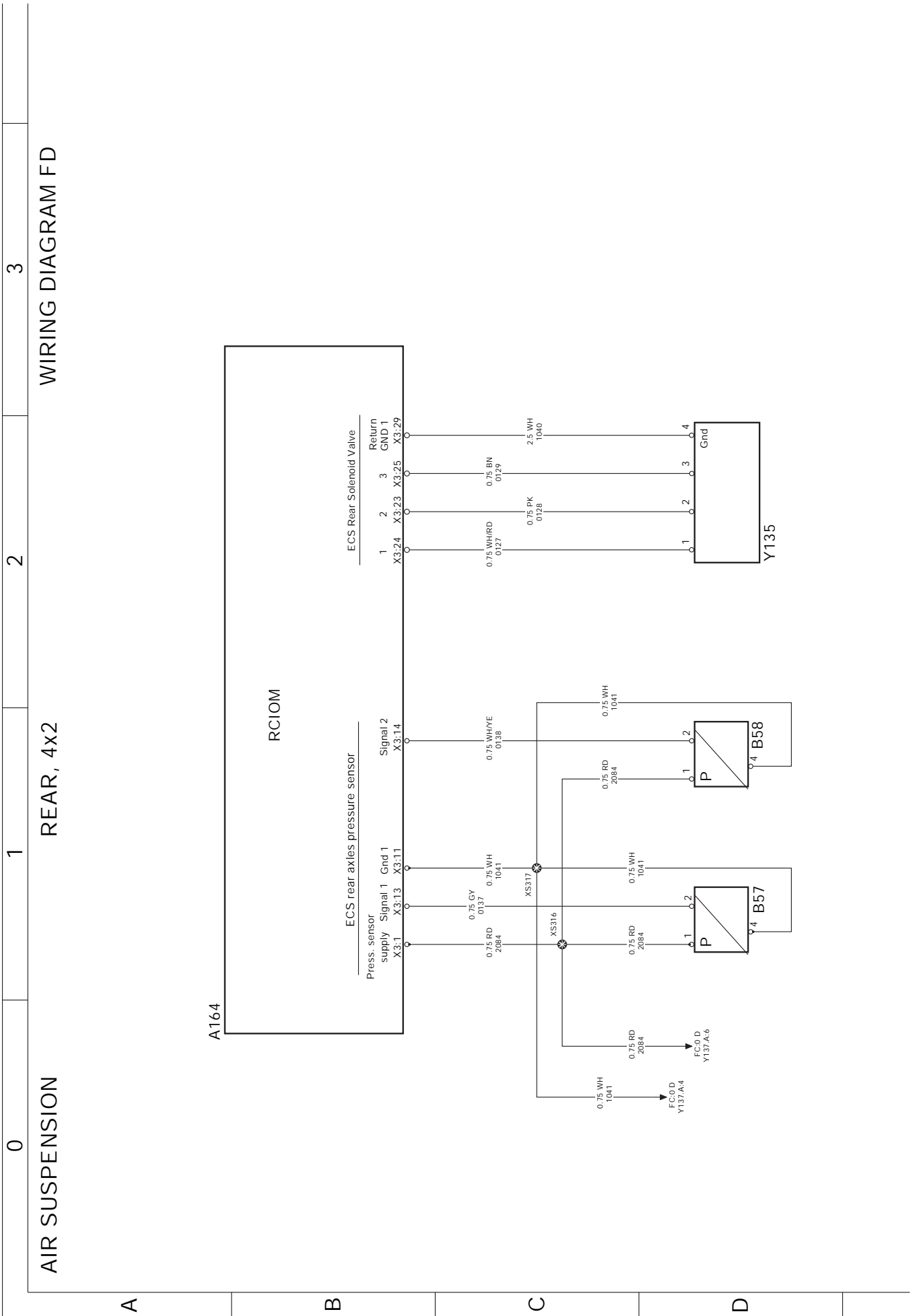

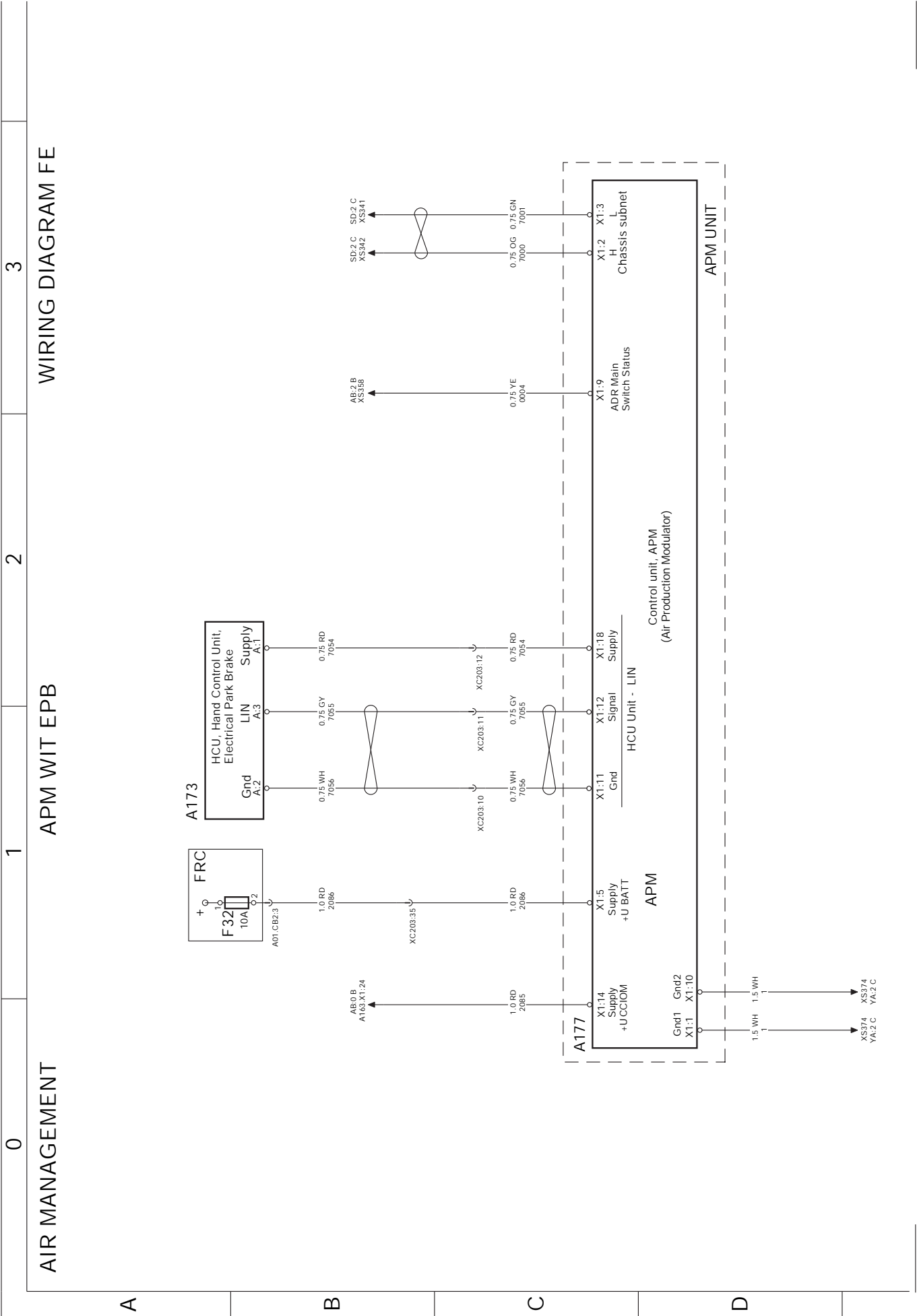

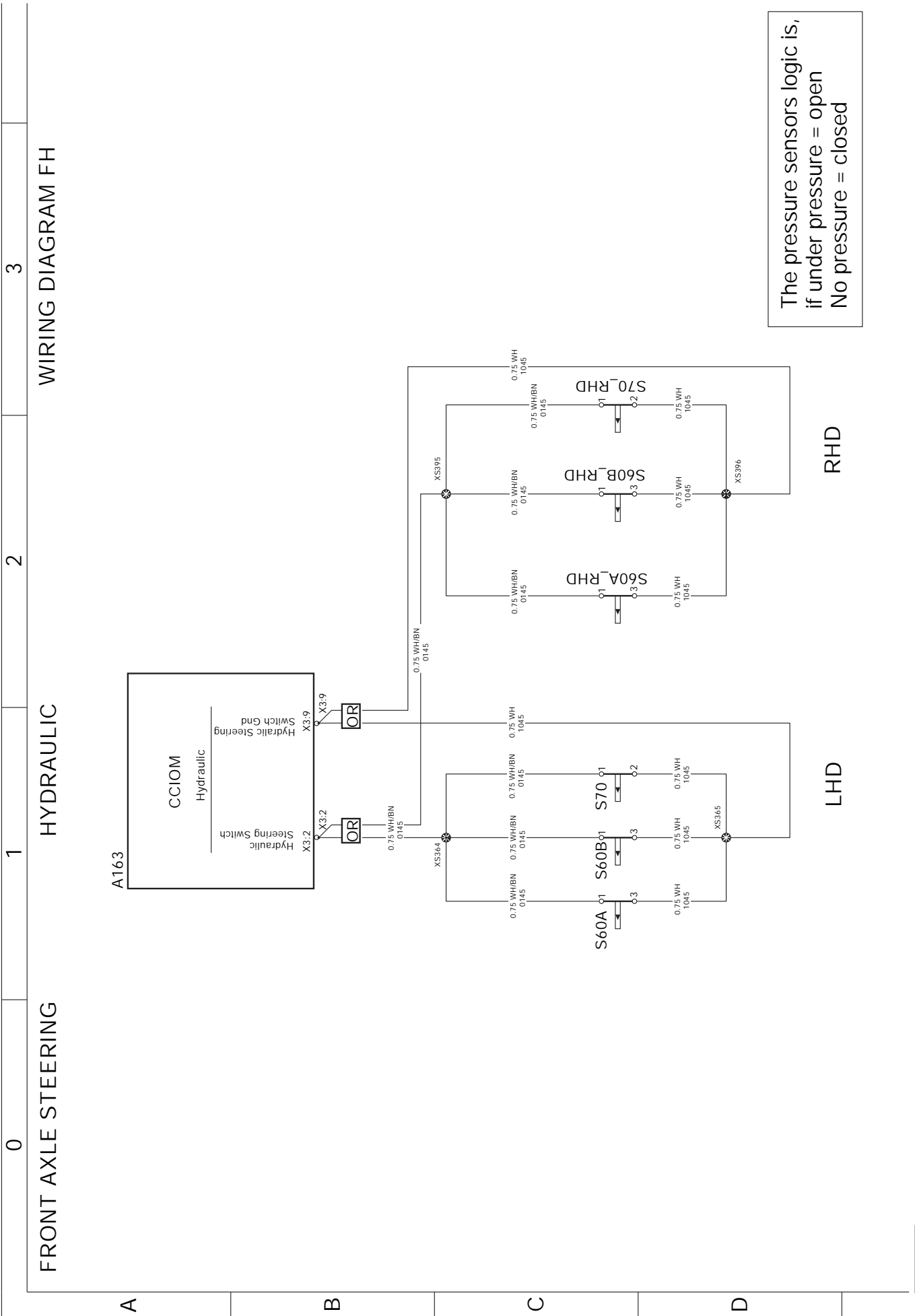

The pressure sensors logic is,
 if under pressure = open
 No pressure = closed

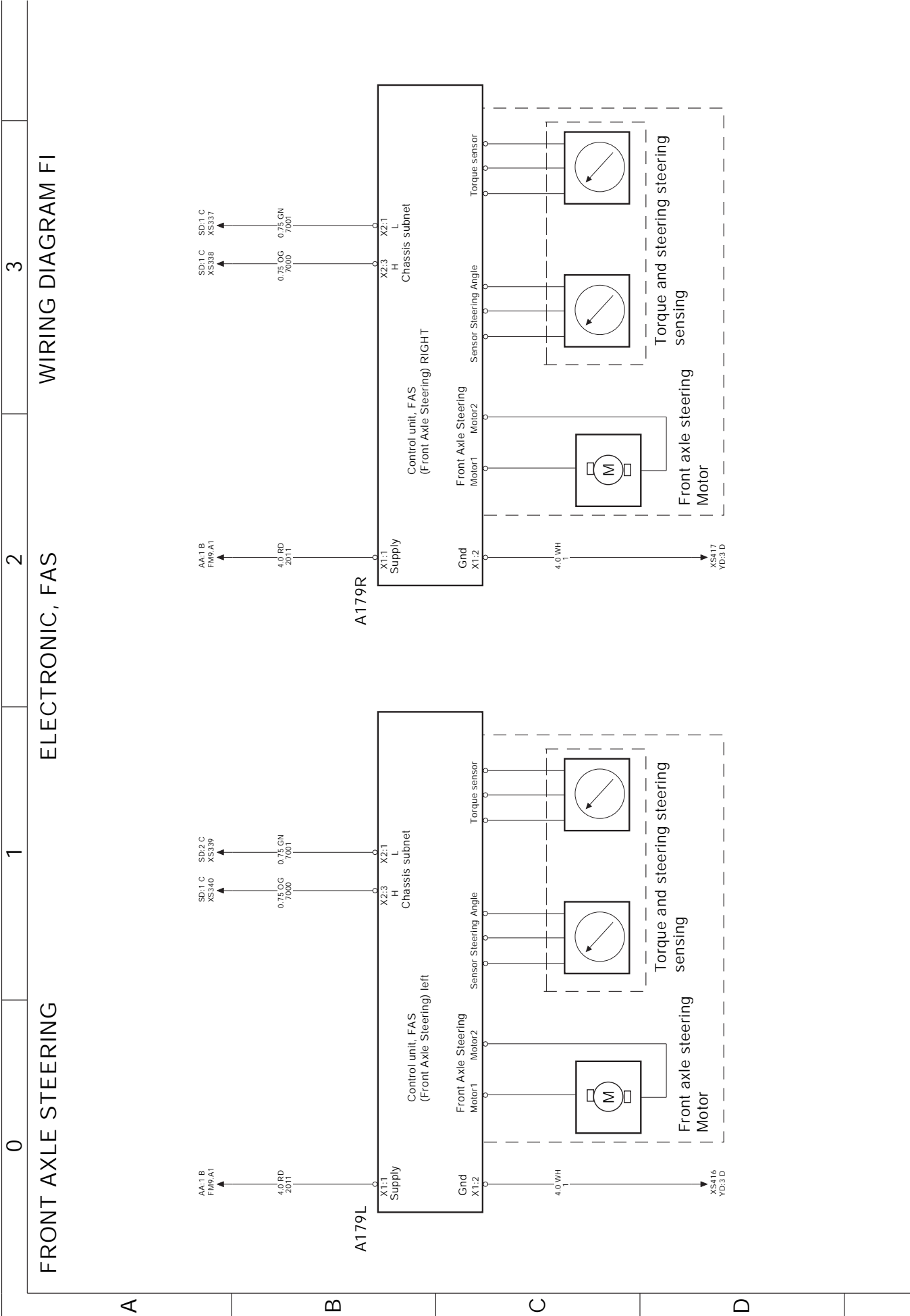

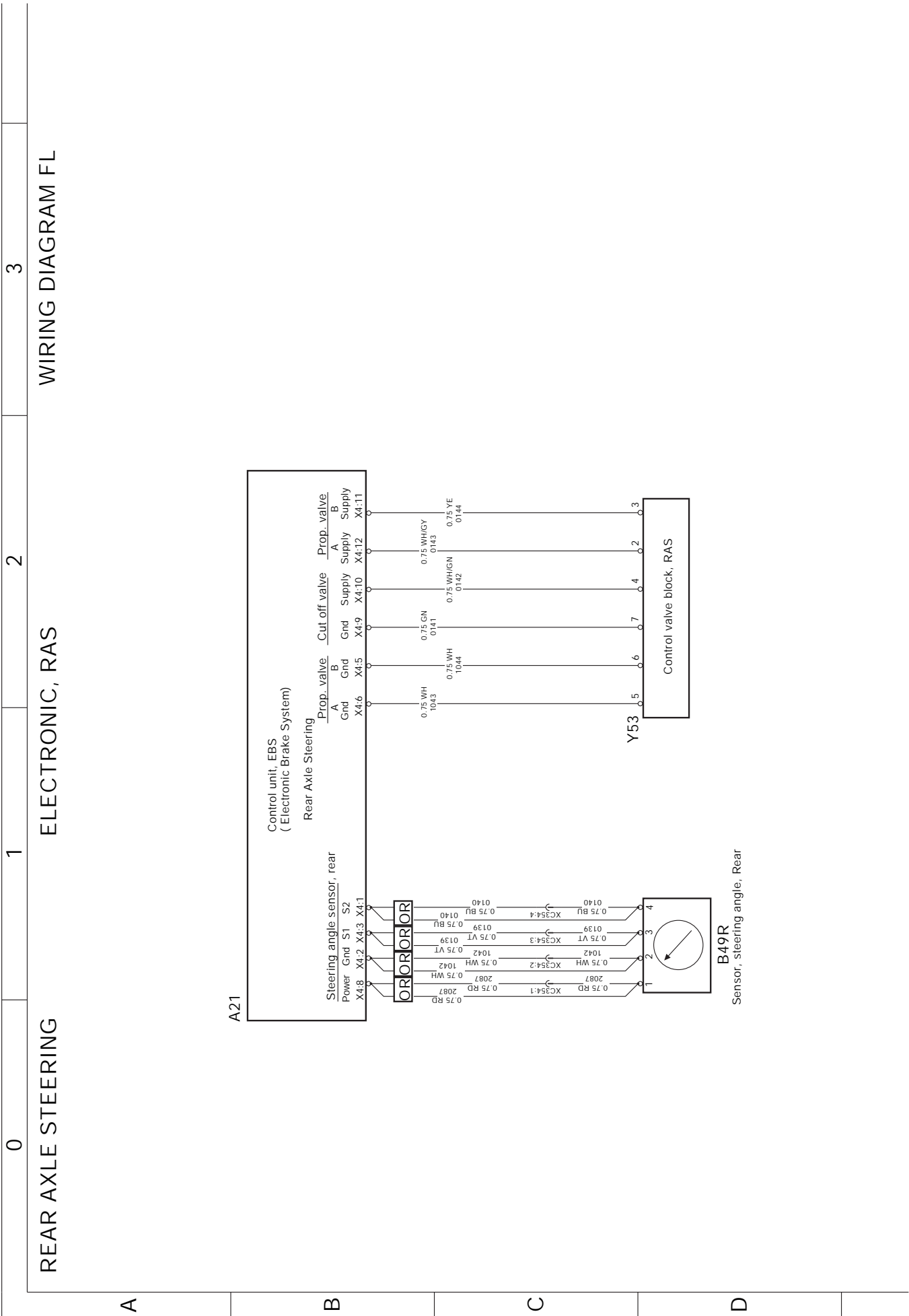

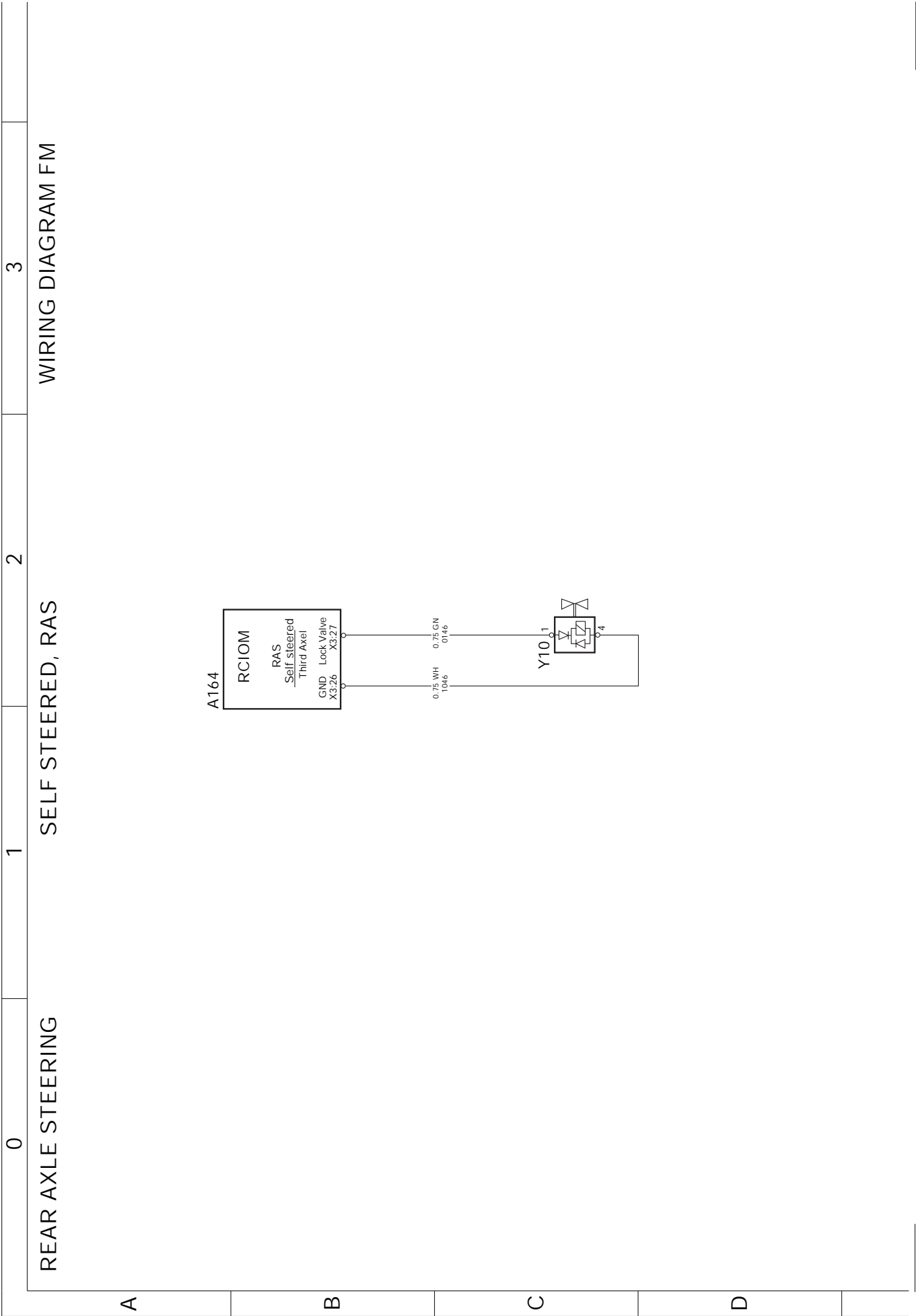

T3065456

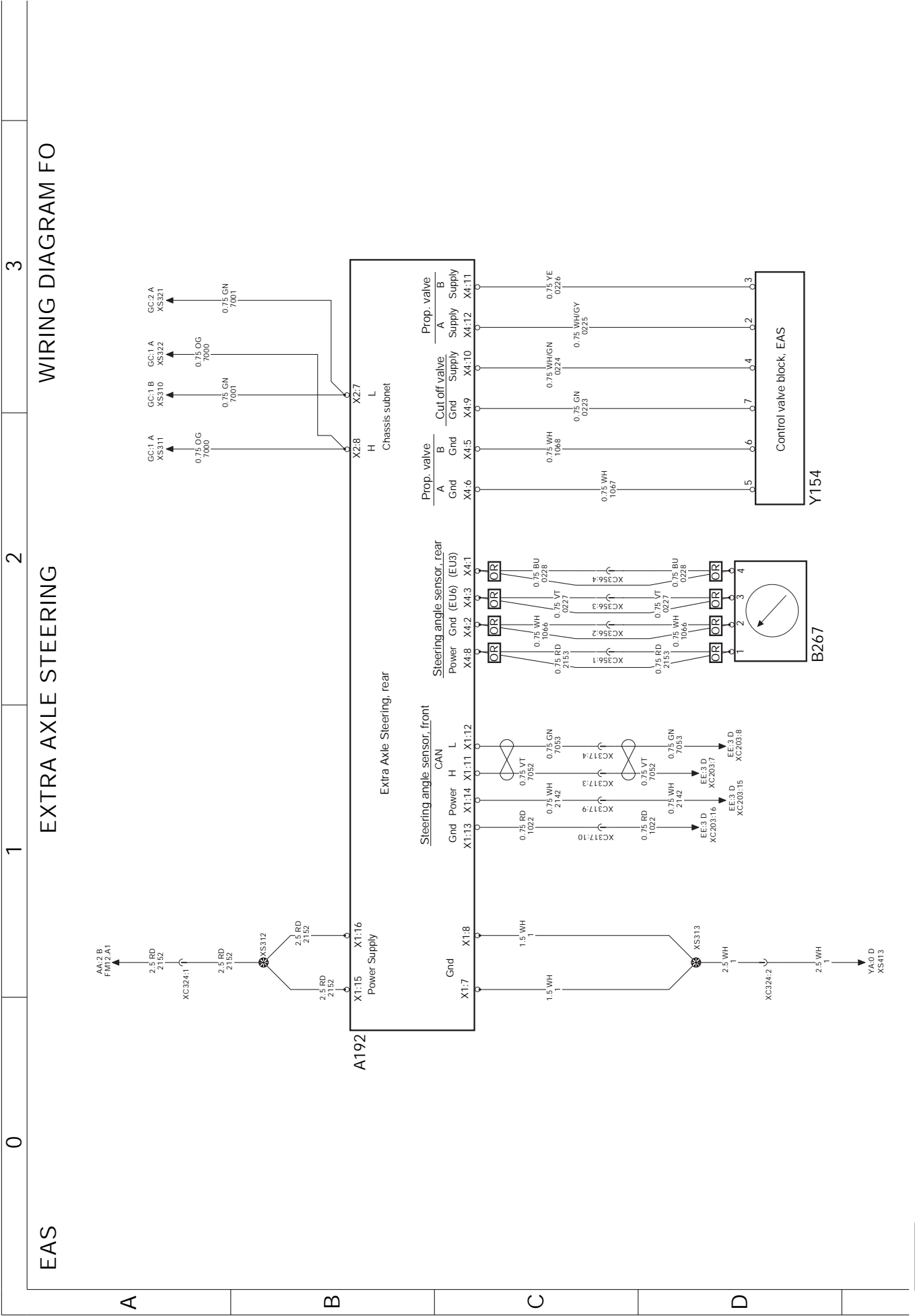

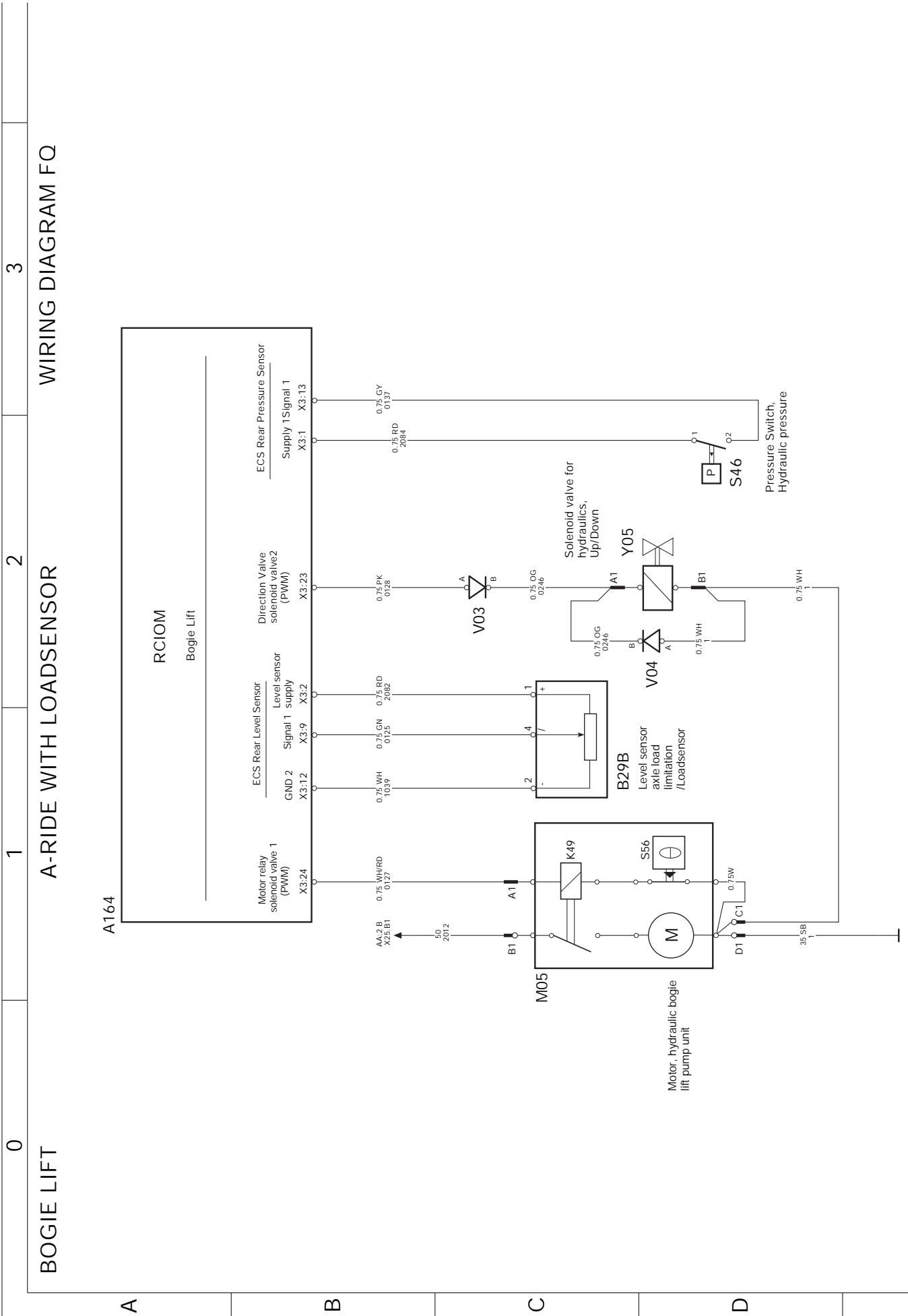

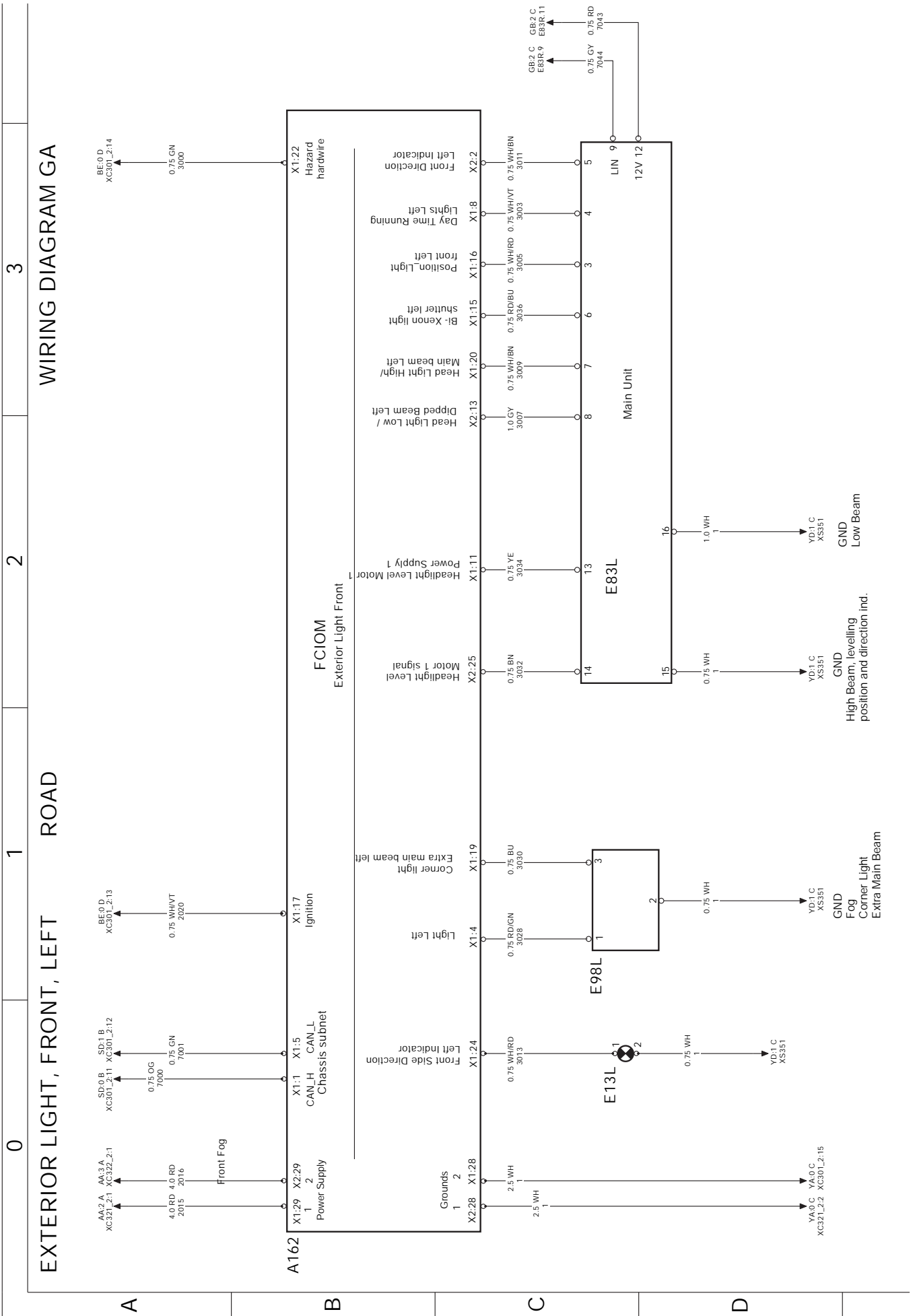

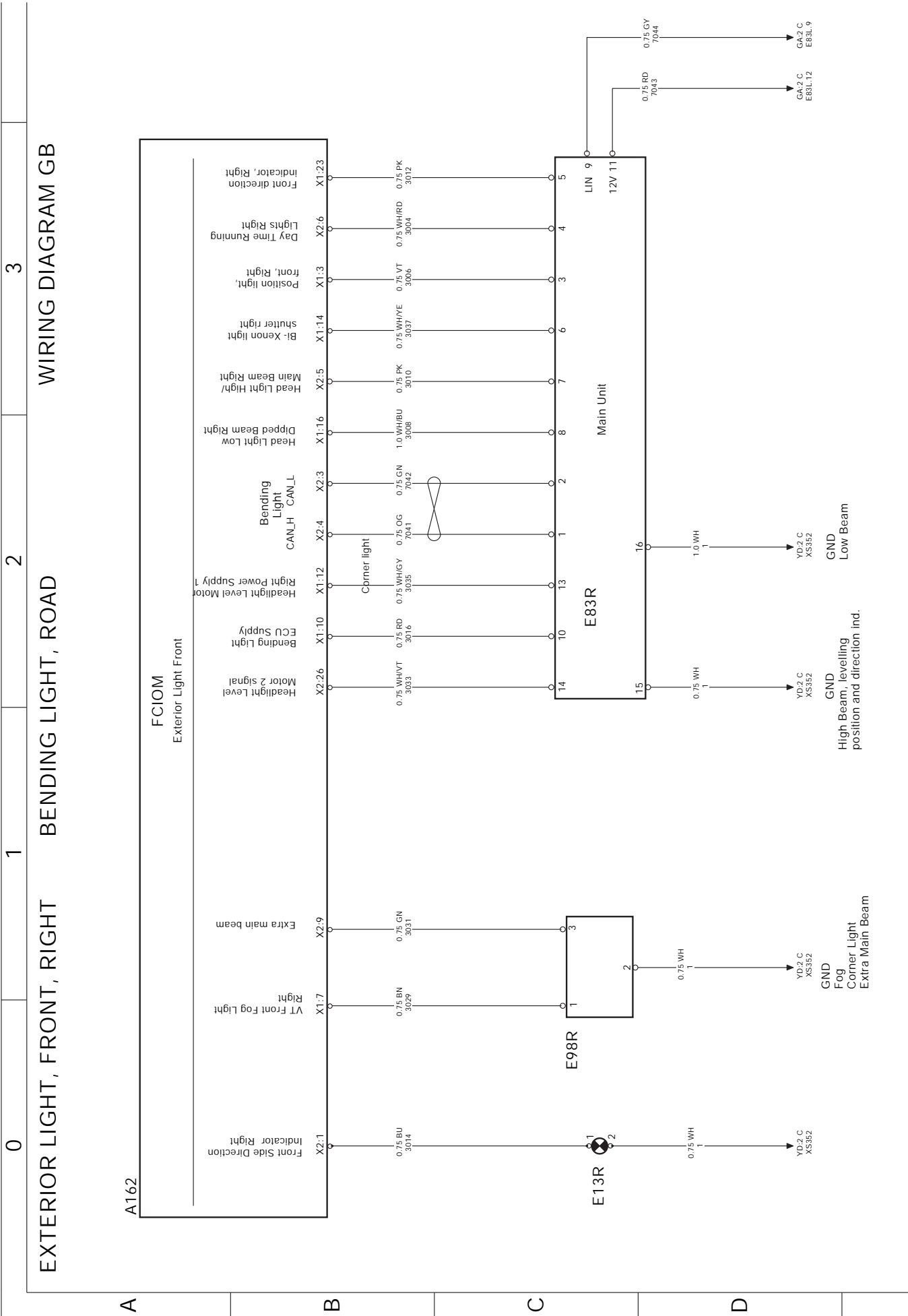

T3086421

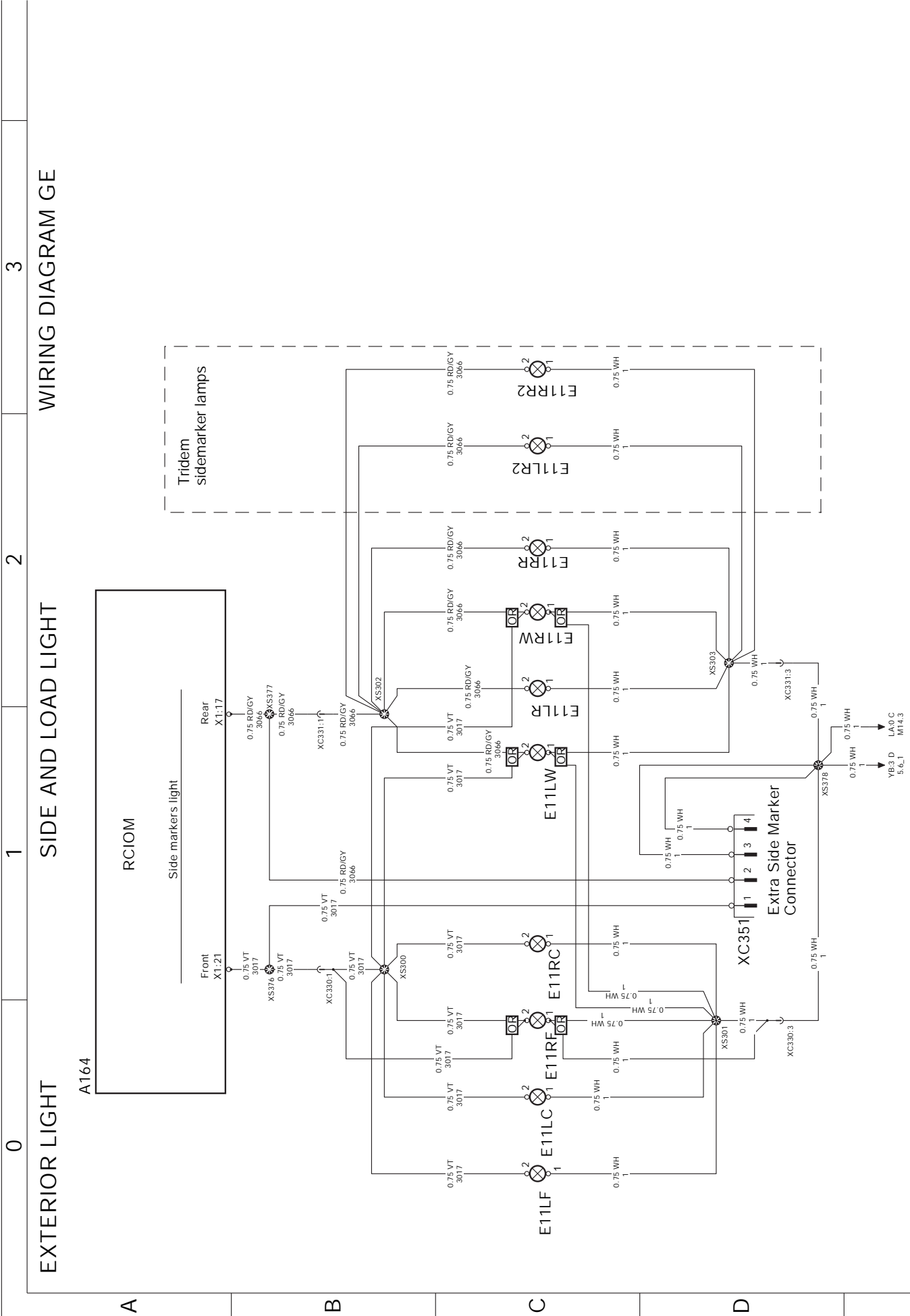

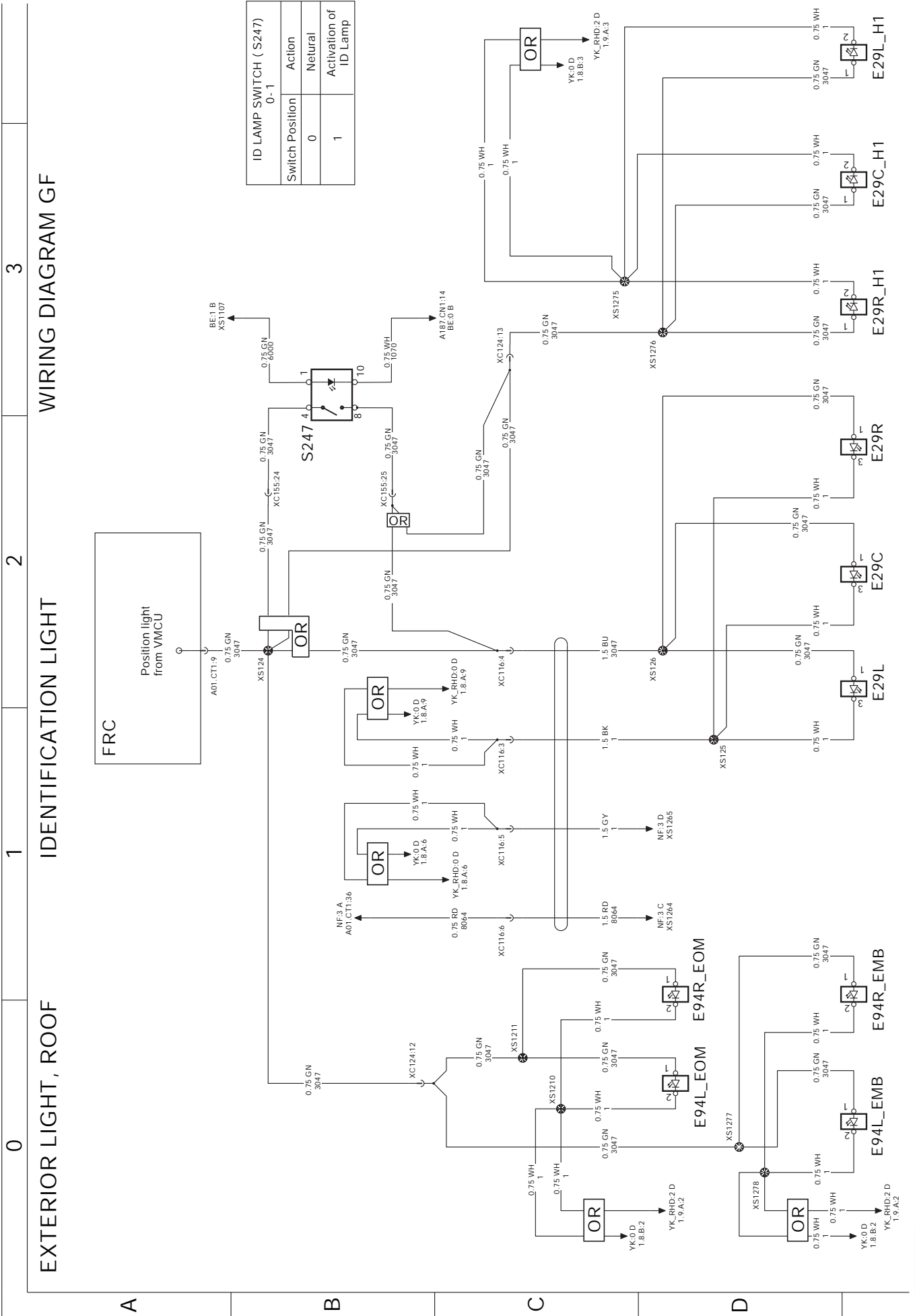

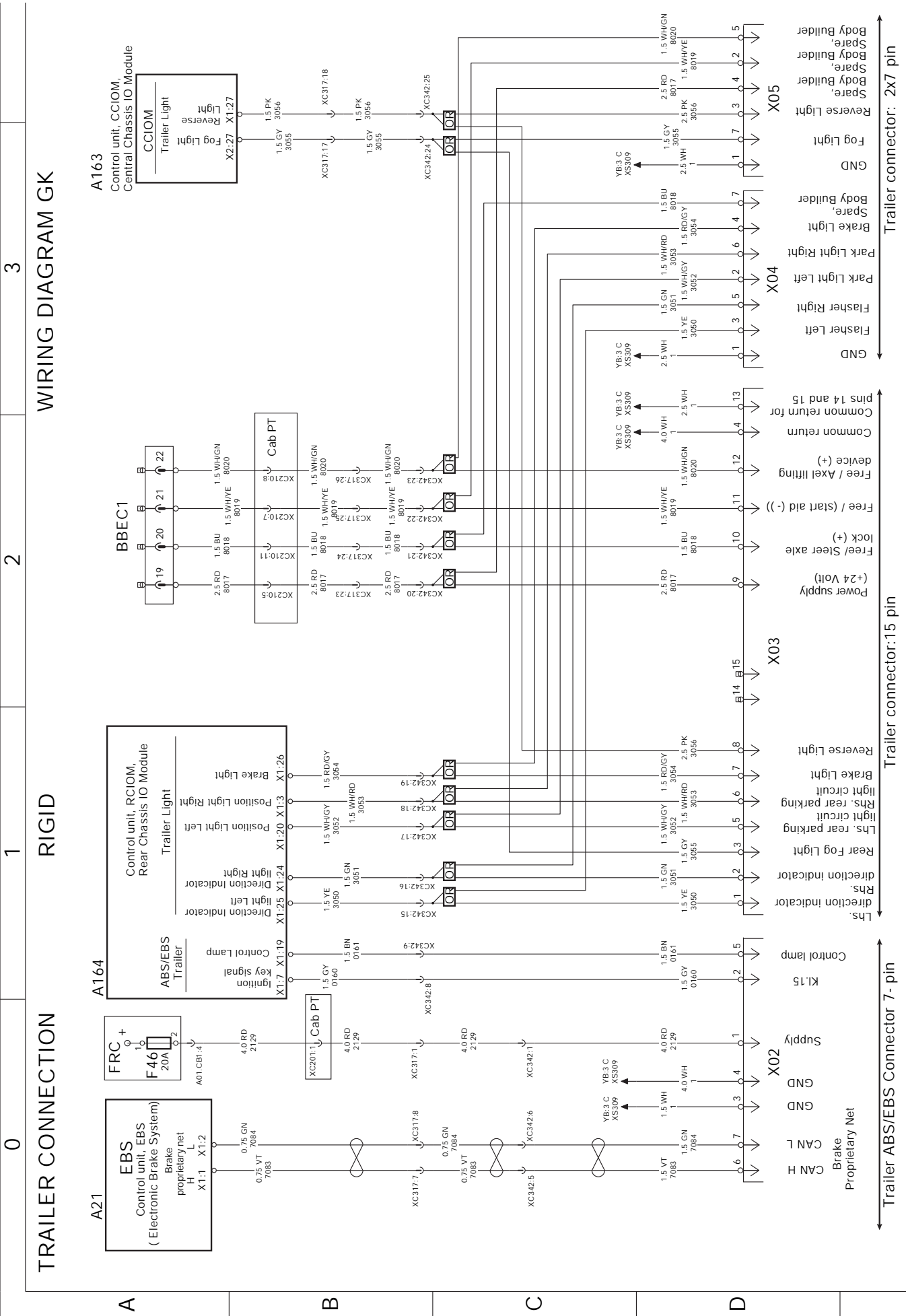

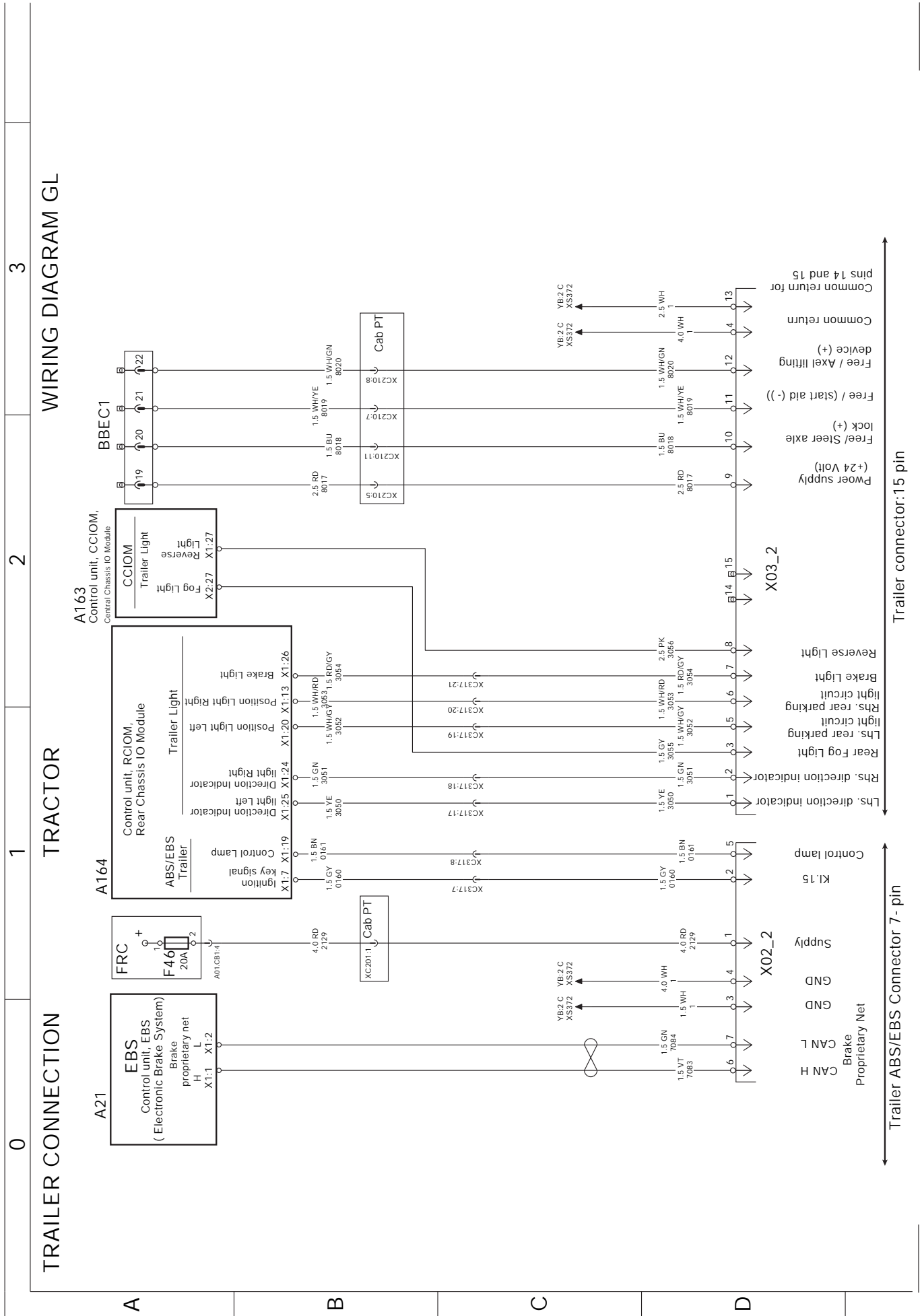

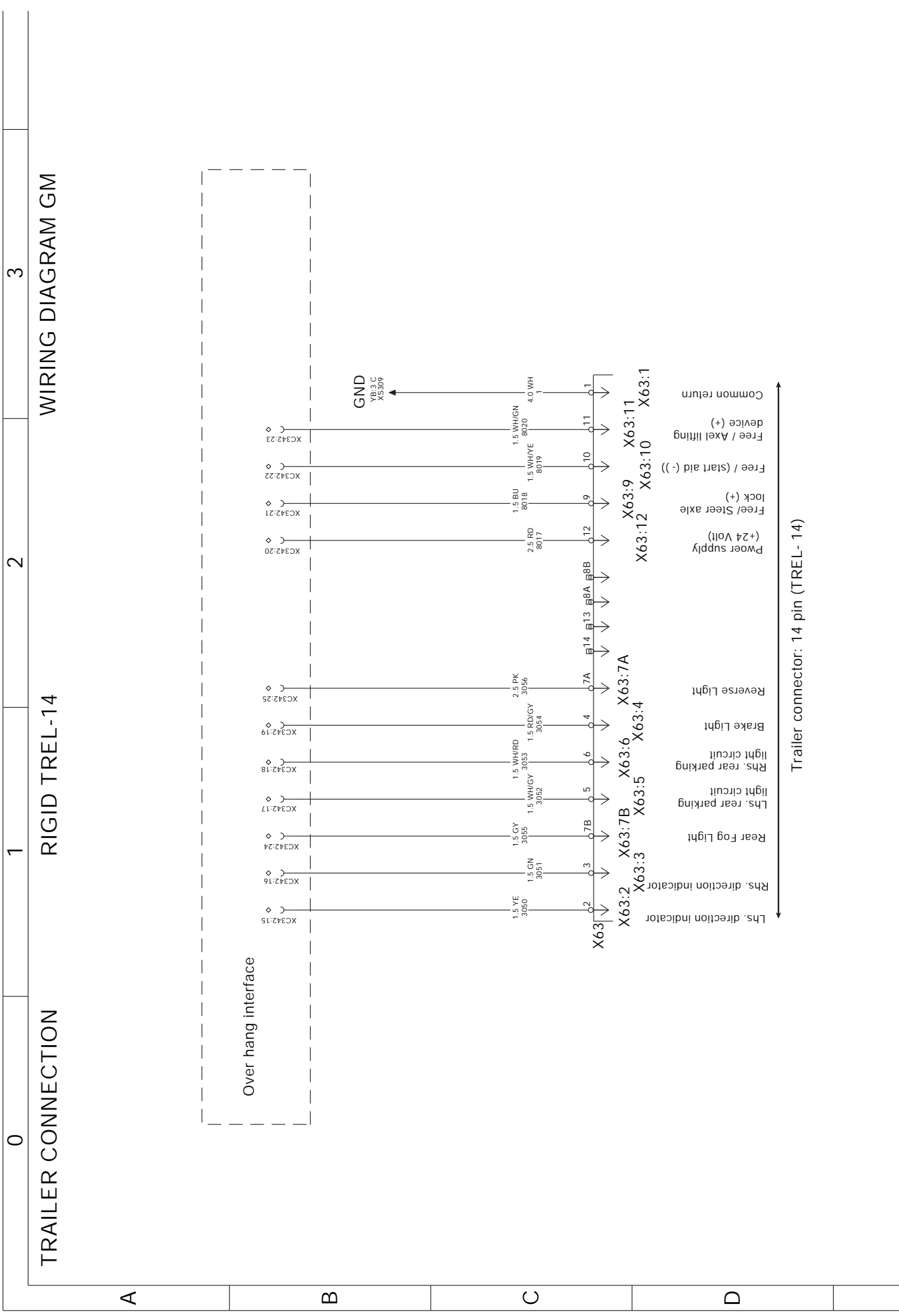

Trailer connector: 14 pin (TREL- 14)

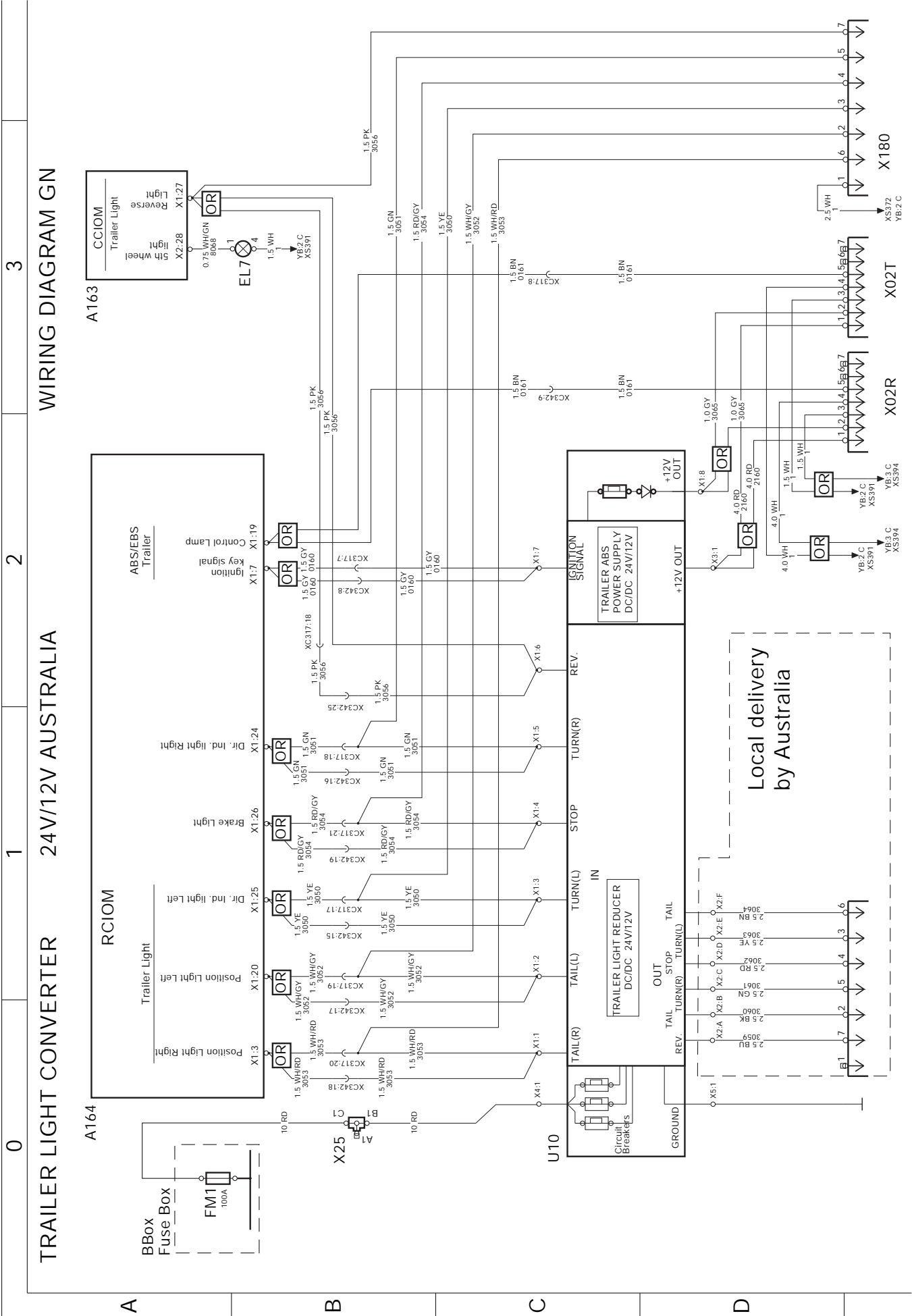

TRAILER LIGHT CONVERTER 24V/12V AUSTRALIA

WIRING DIAGRAM GN

0

1

2

3

A

B

C

D

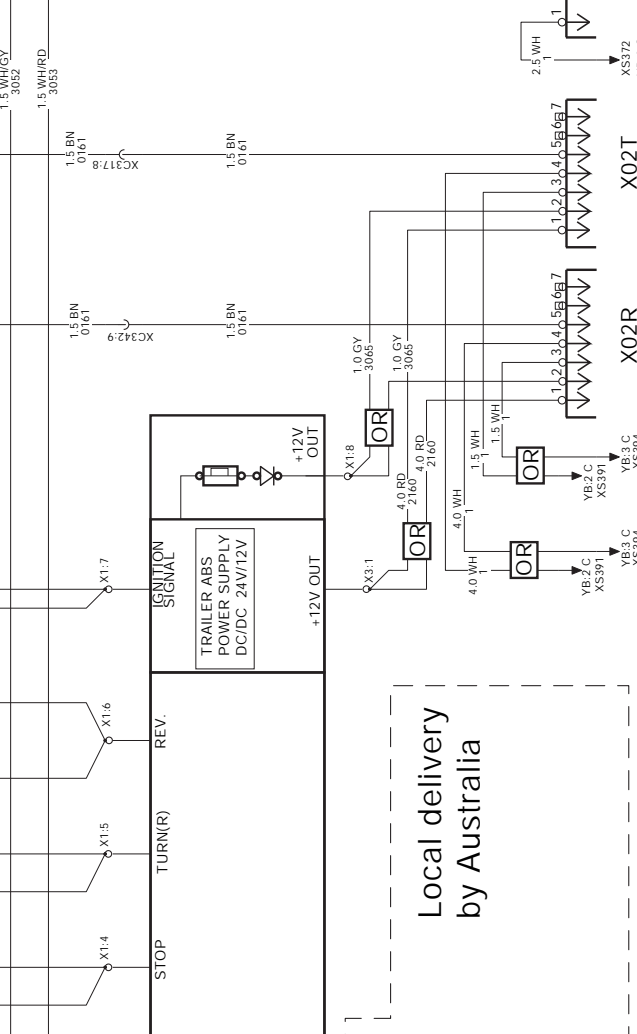
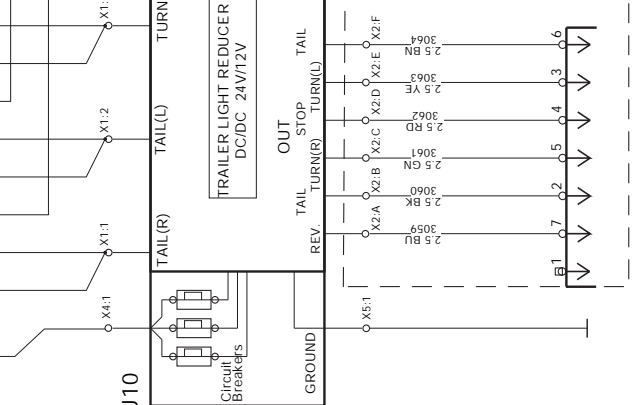
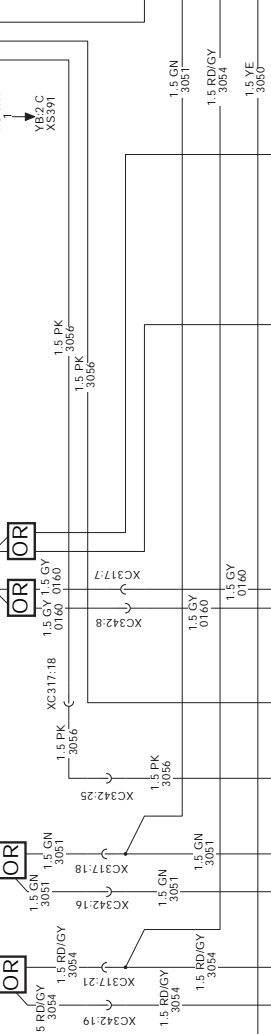
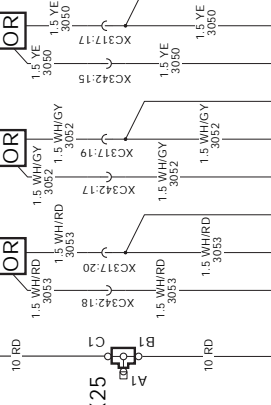
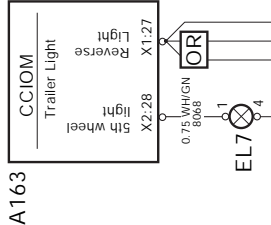
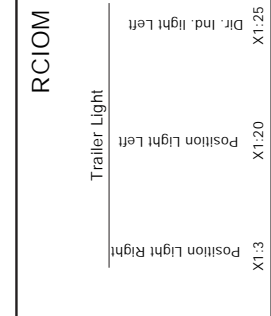
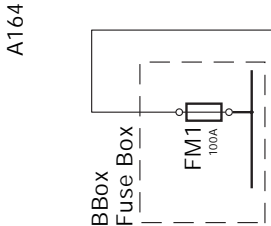

Local delivery by Australia

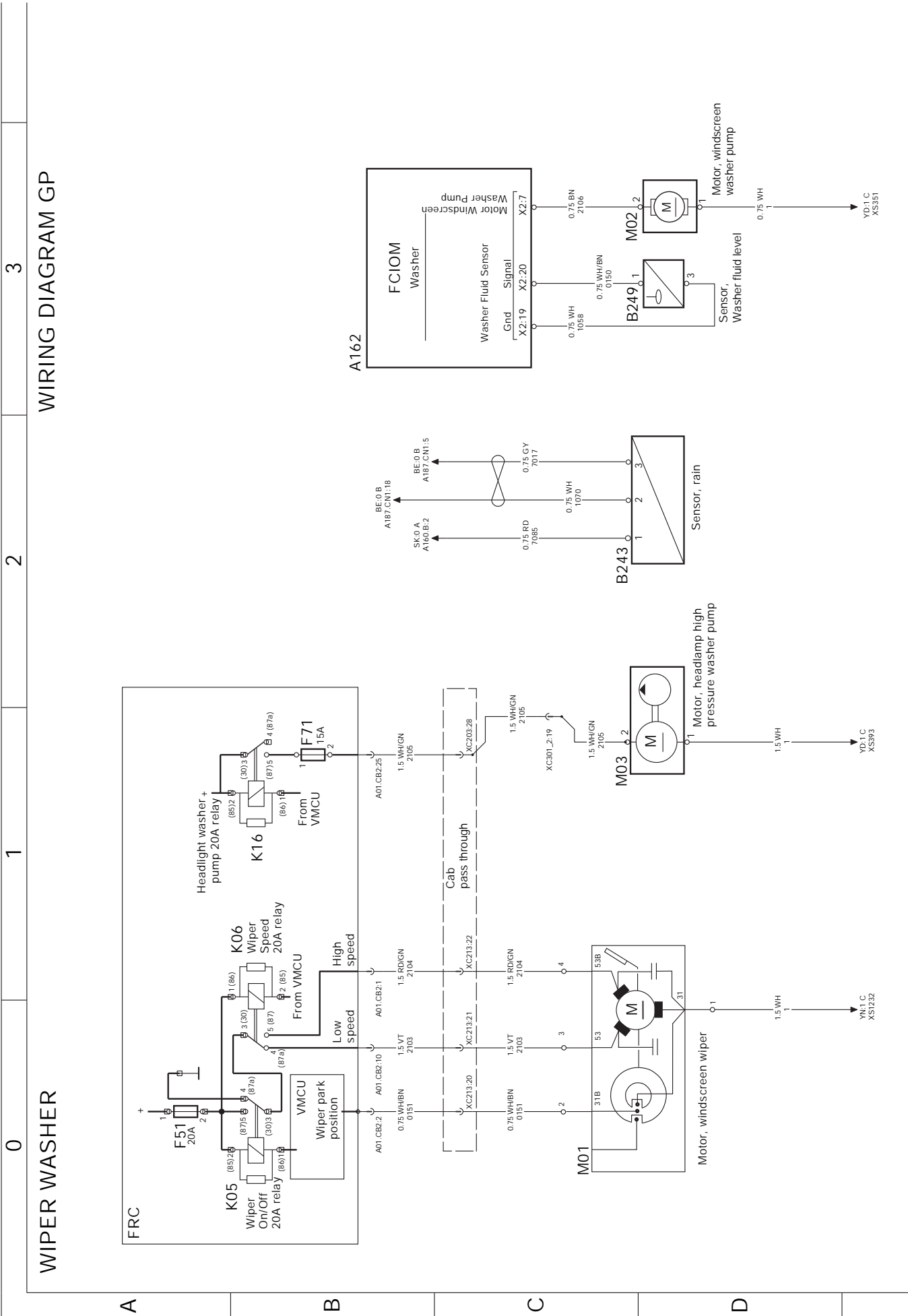

WIRING DIAGRAM HA

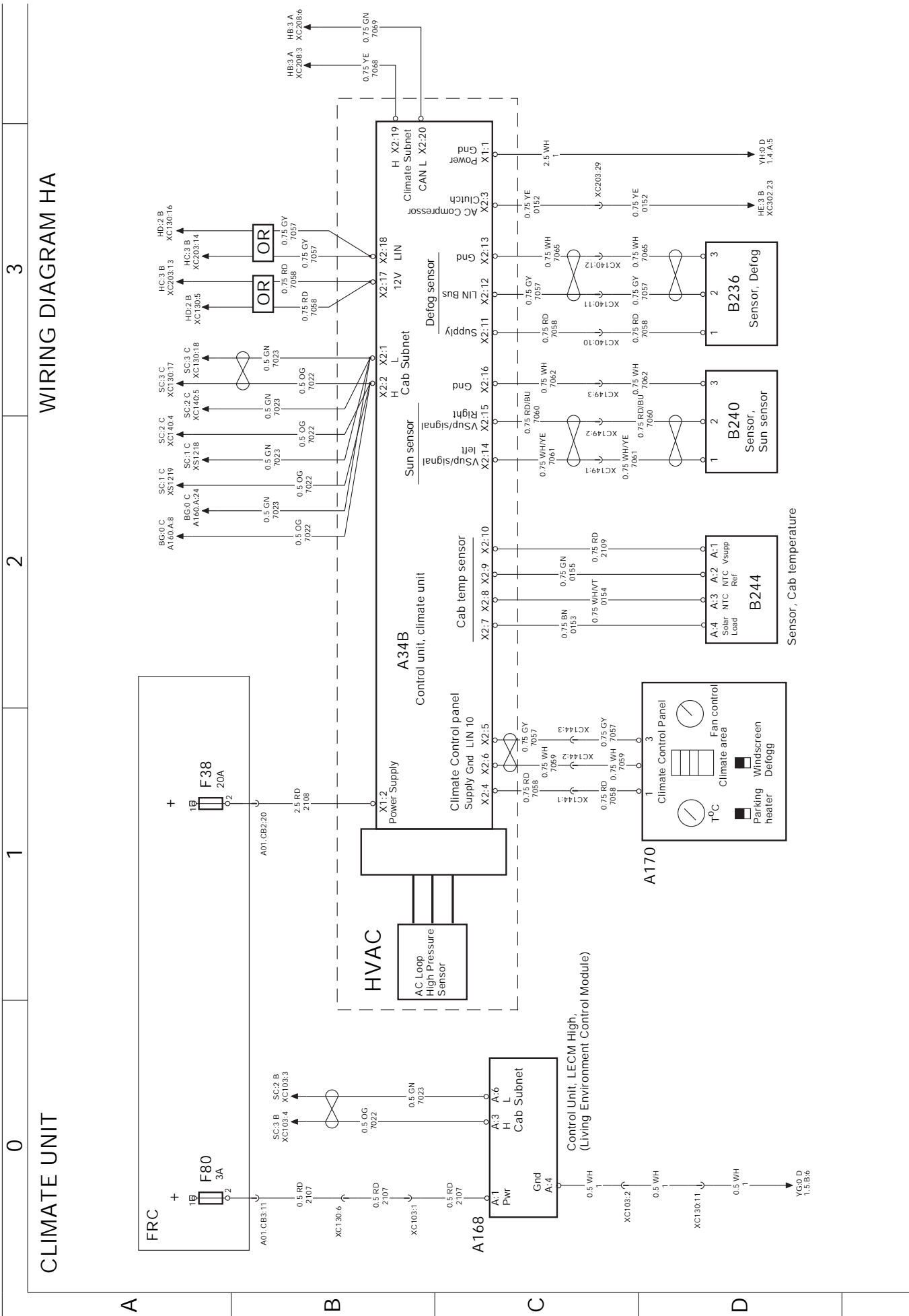

T3086424

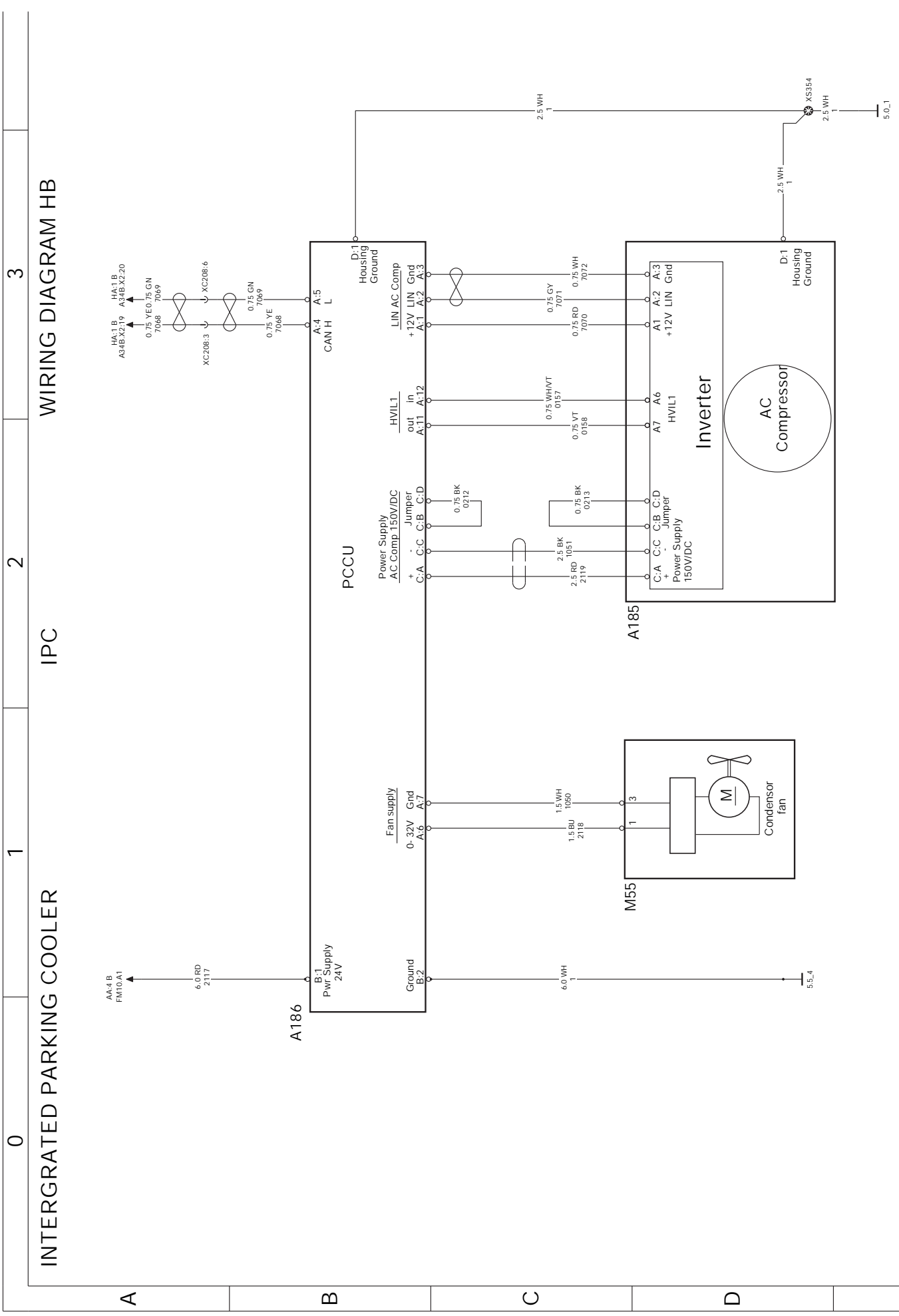

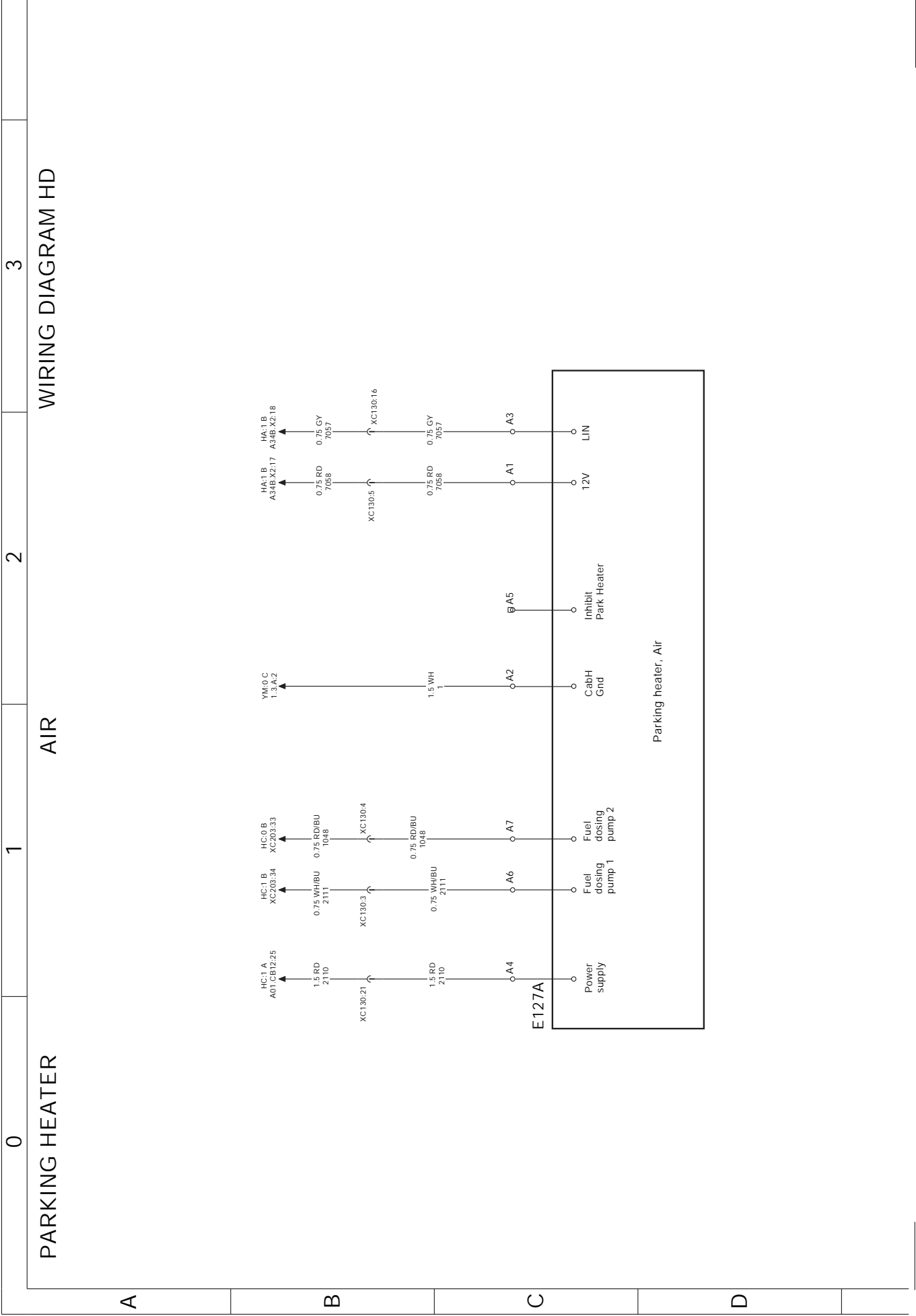

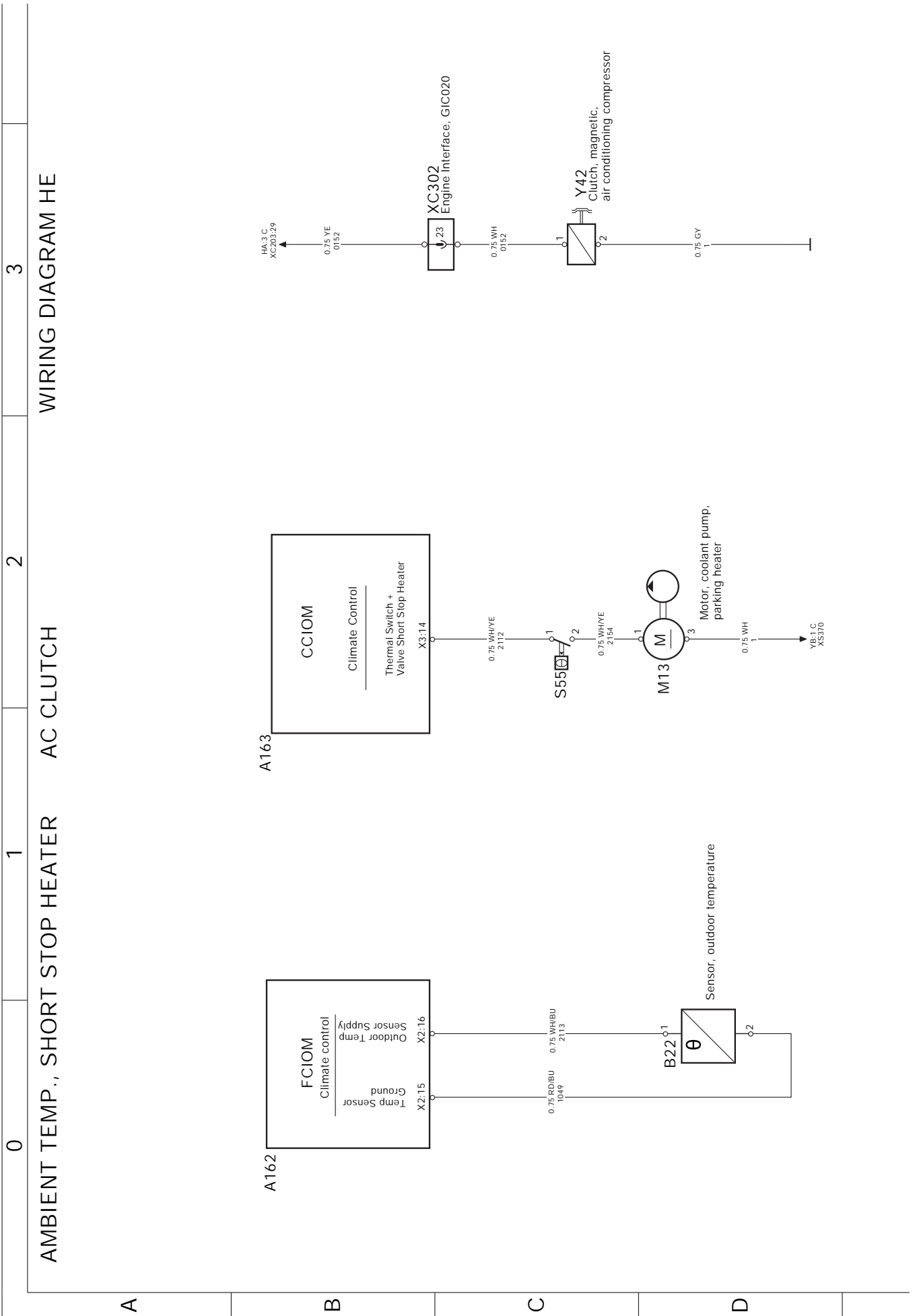

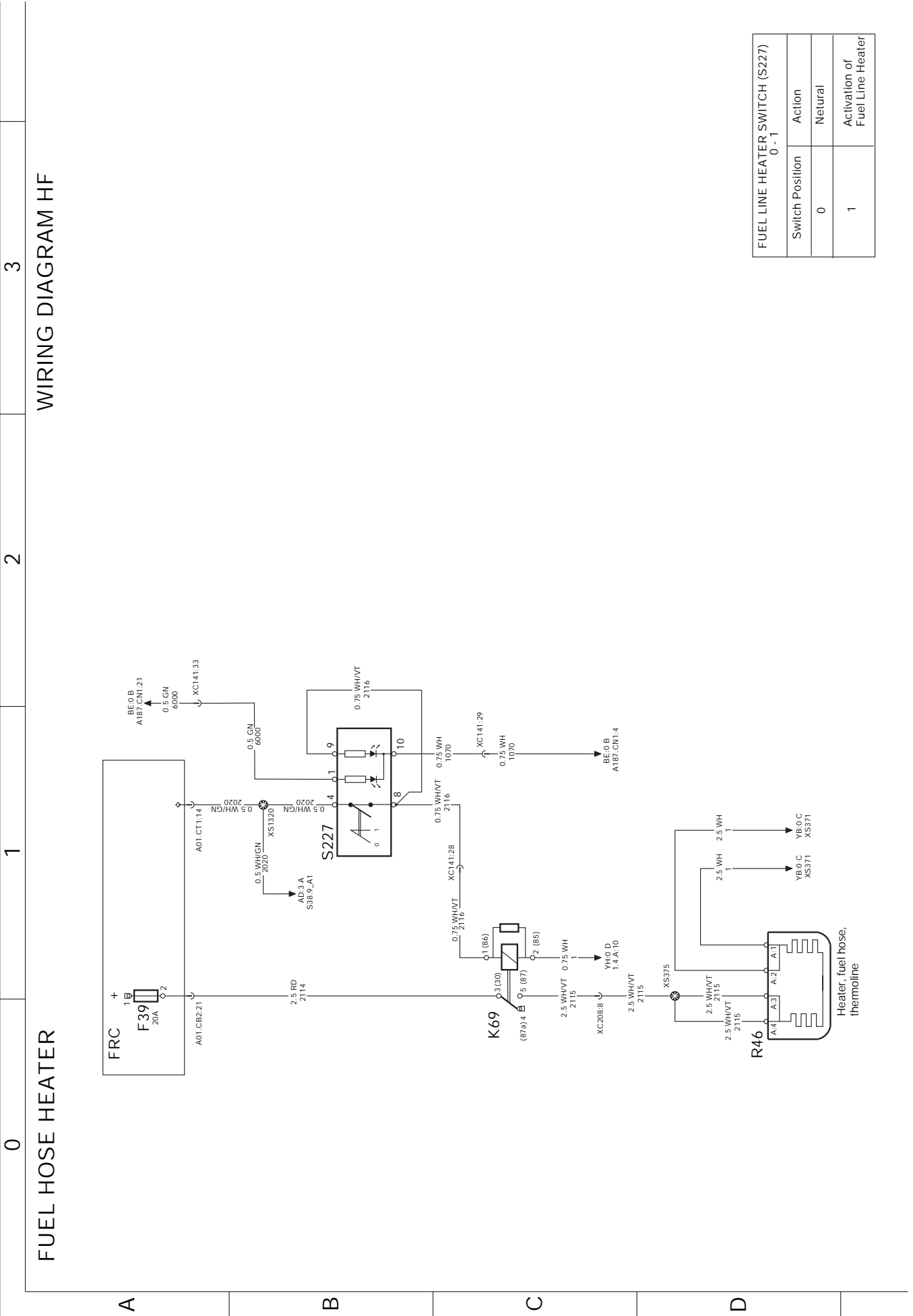

FUEL LINE HEATER SWITCH (S227)		
Switch Position	Action	
0	Neutral	
1	Activation of Fuel Line Heater	

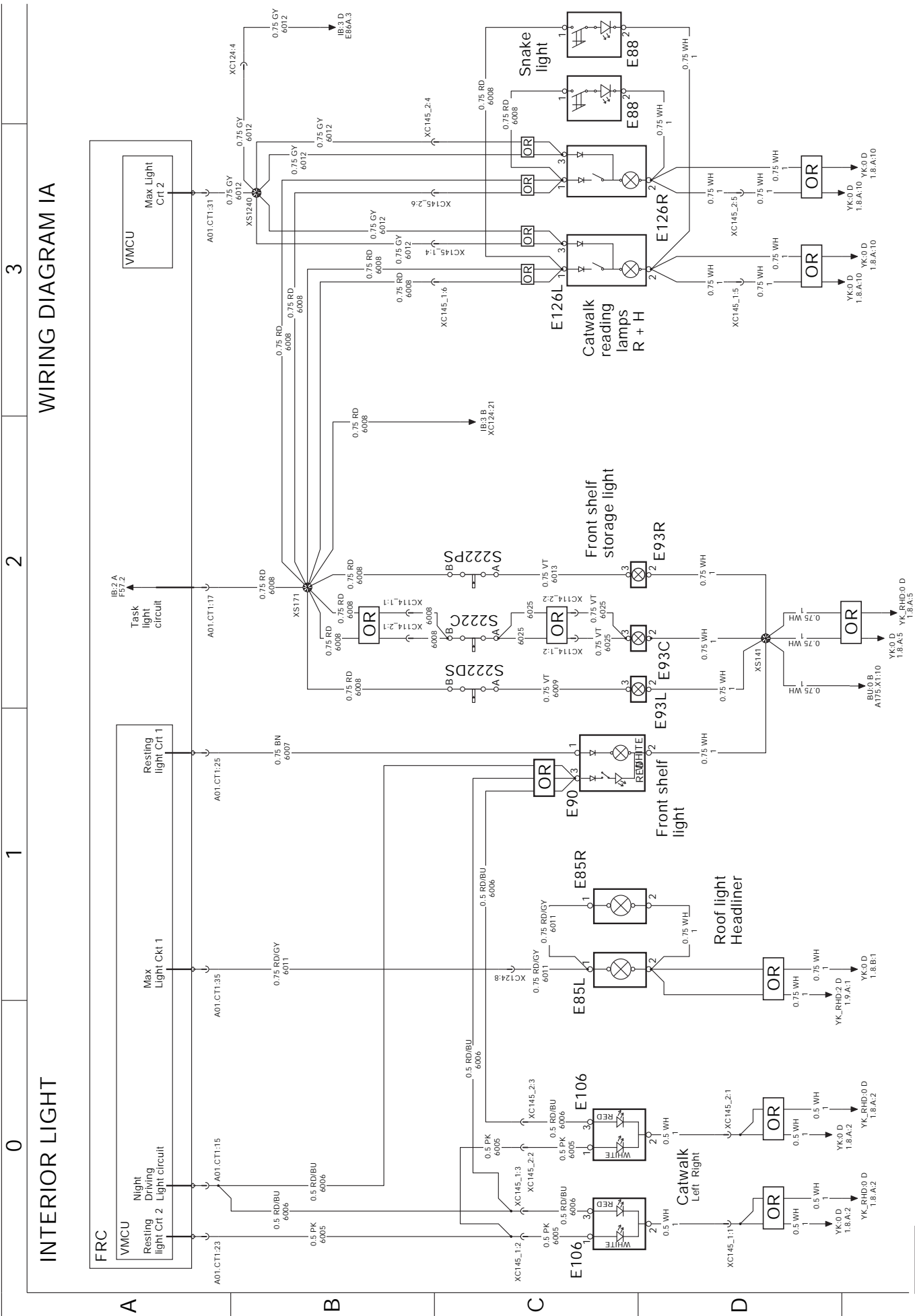

INTERIOR LIGHT

3

2

1

0

A

B

C

D

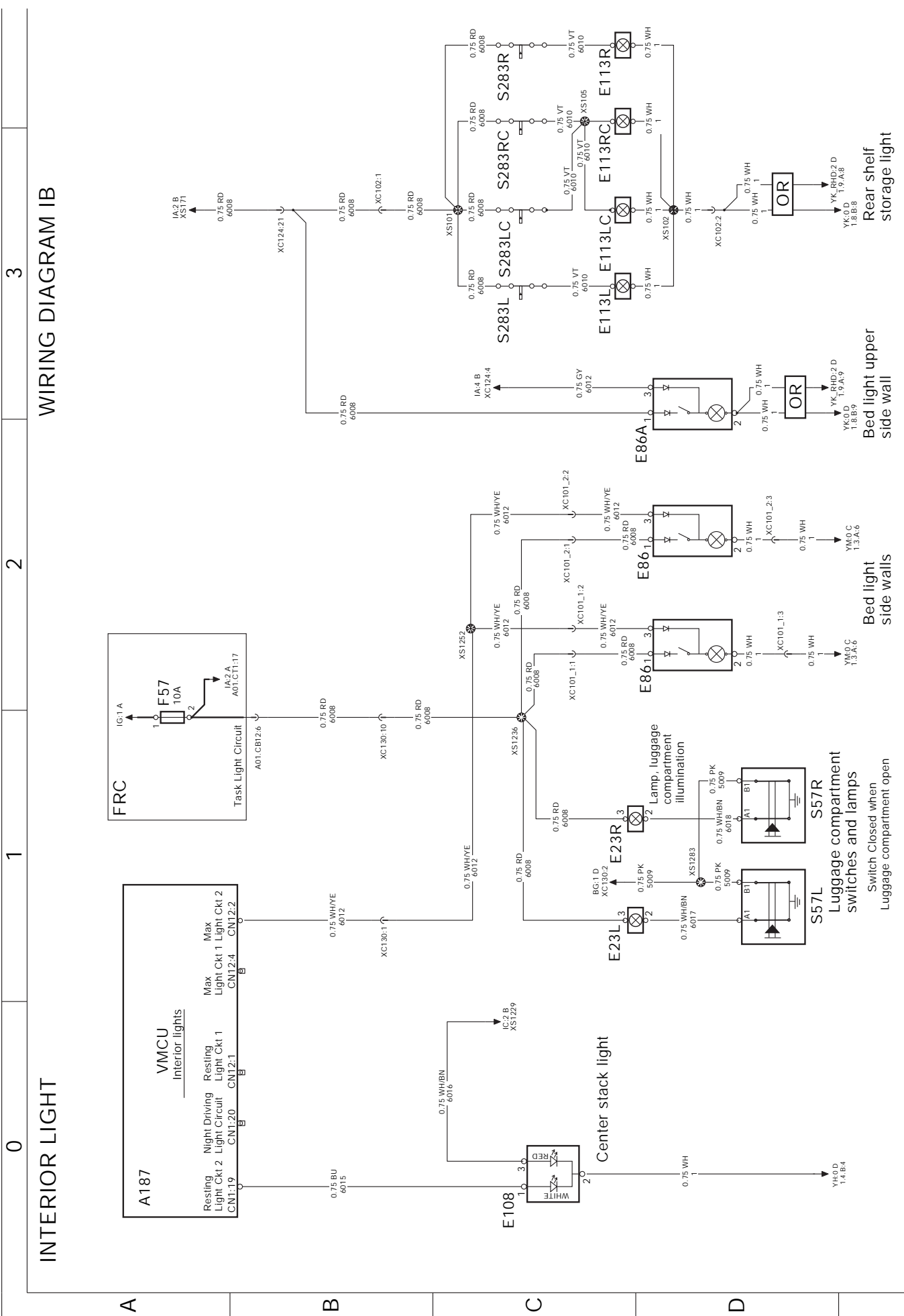

T3086427

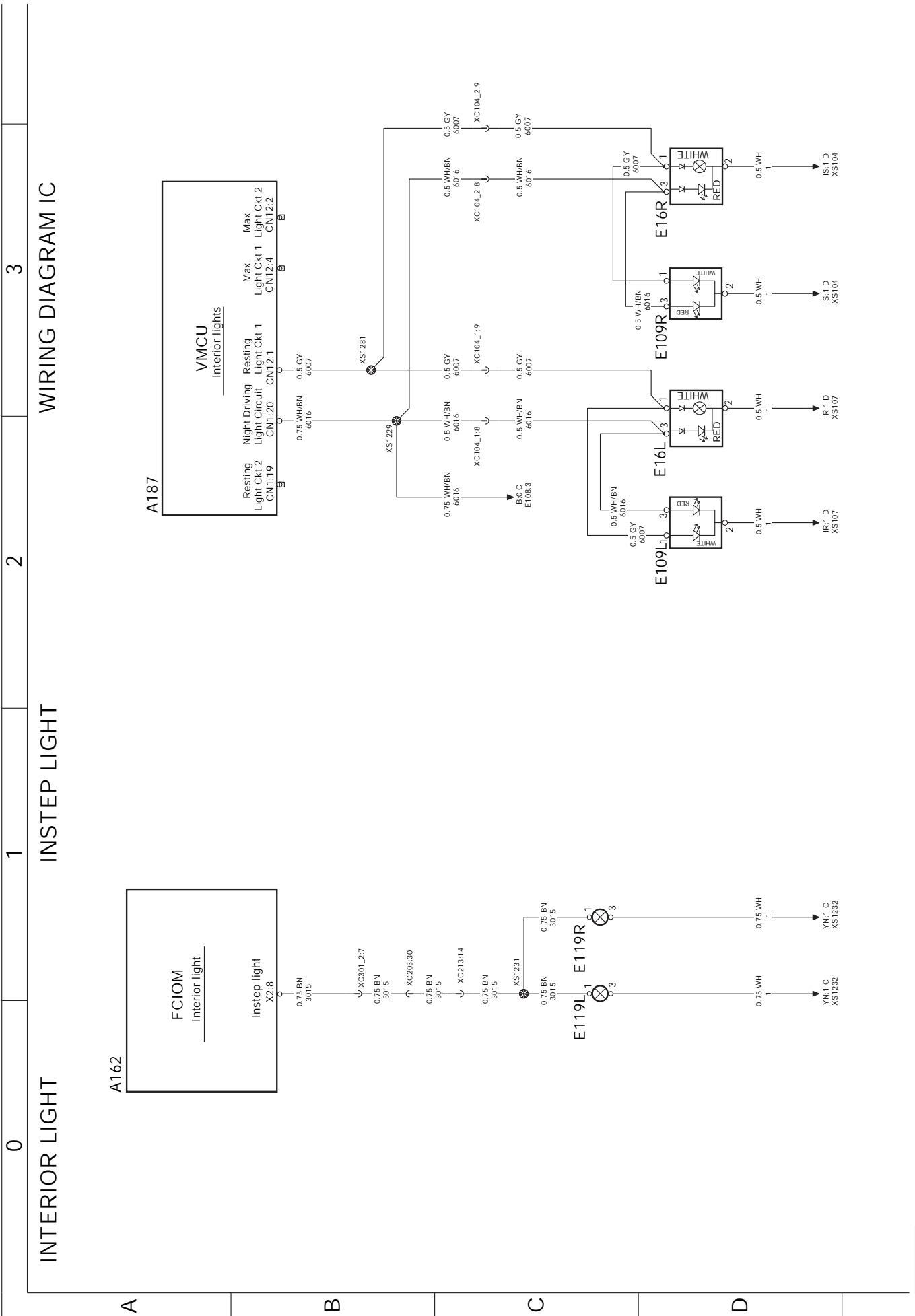

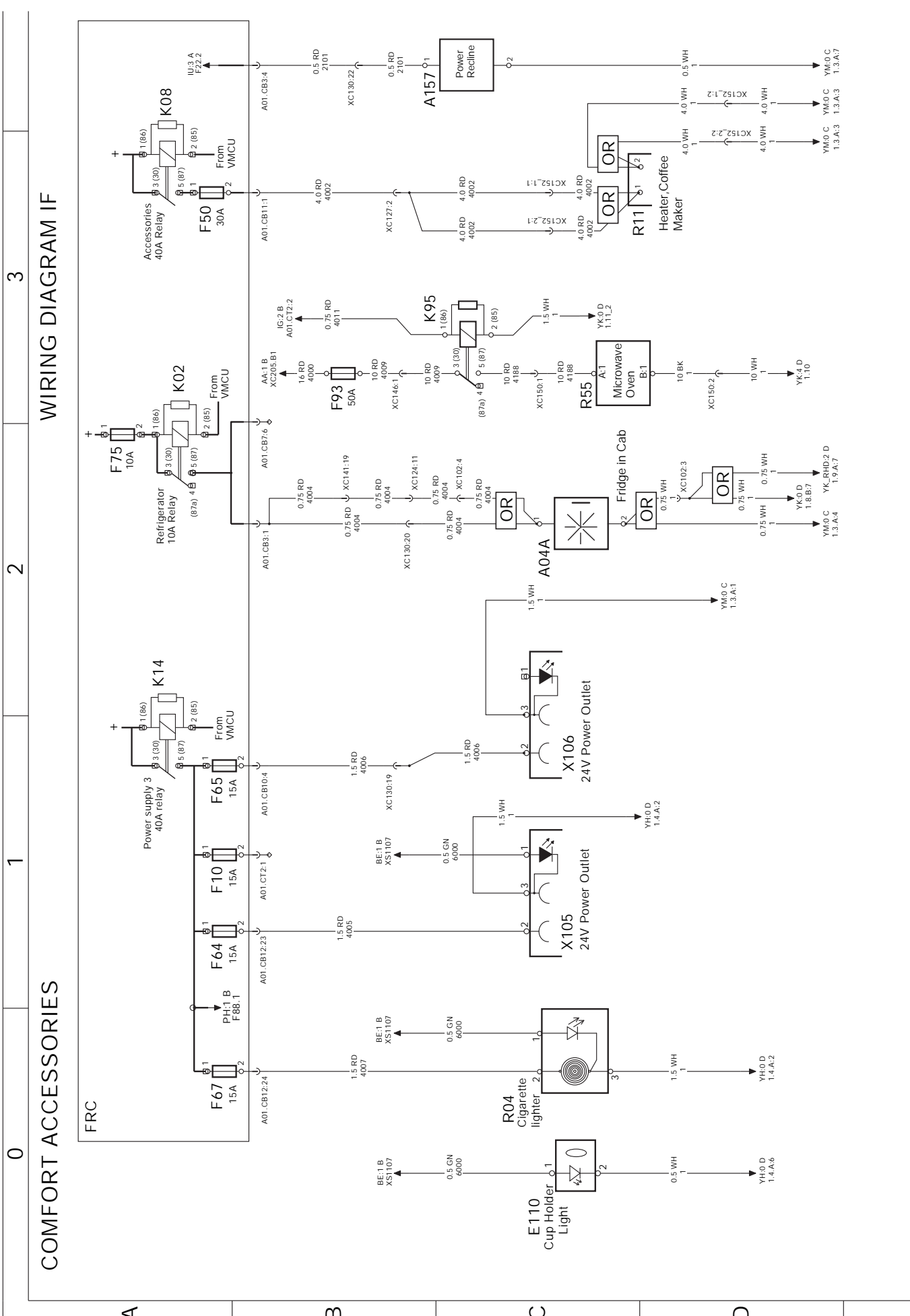

COMFORT ACCESSORIES

WIRING DIAGRAM IF

0 1 2 3

A

B

C

D

T3086428

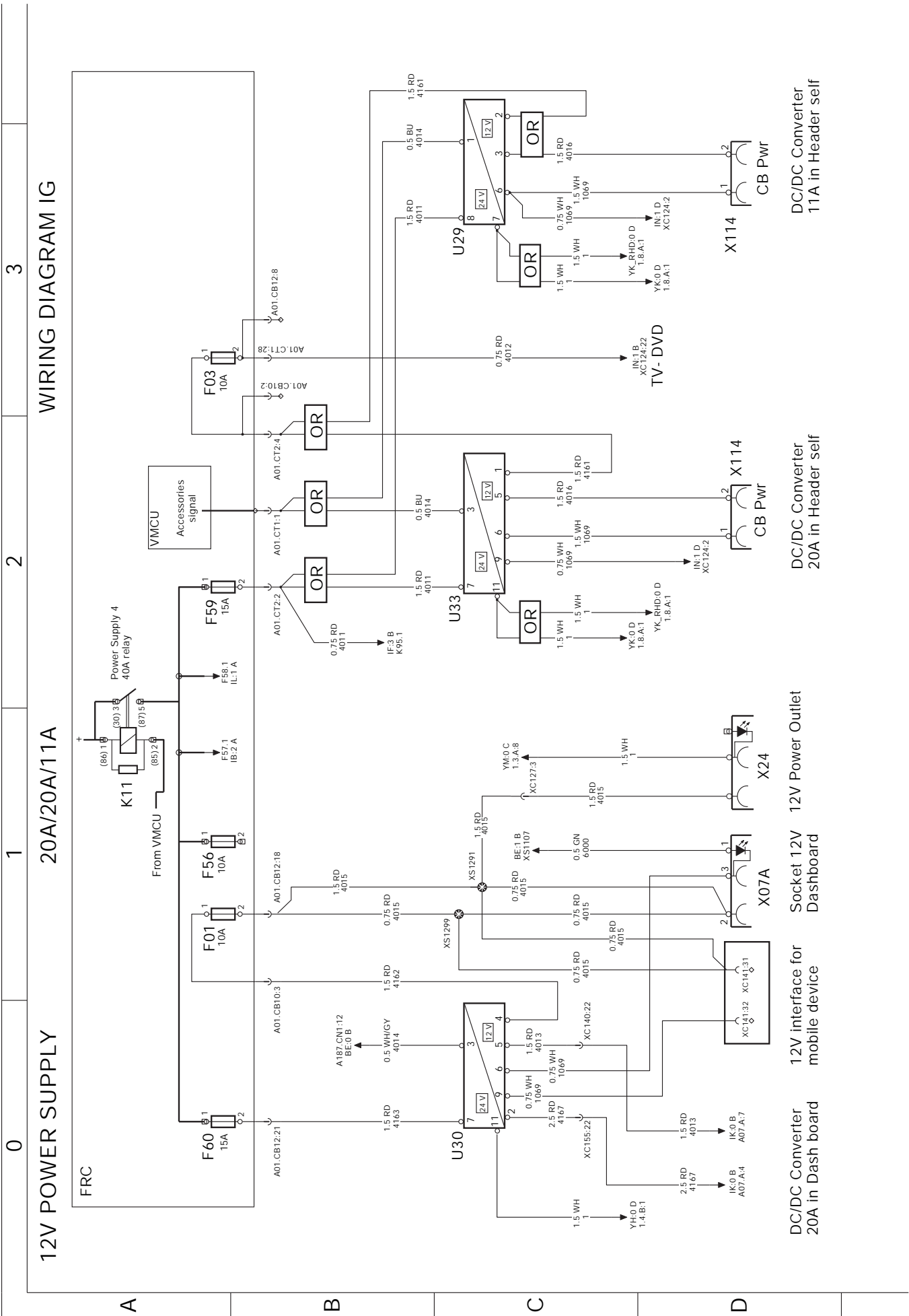

12V POWER SUPPLY

20A/20A/11A

WIRING DIAGRAM IG

DC/DC Converter
11A in Header self

DC/DC Converter
20A in Header self

Socket 12V
Dashboard

12V interface for
mobile device

DC/DC Converter
20A in Dash board

DC/DC Converter
11A in Header self

WIRING DIAGRAM IK

AUDIO

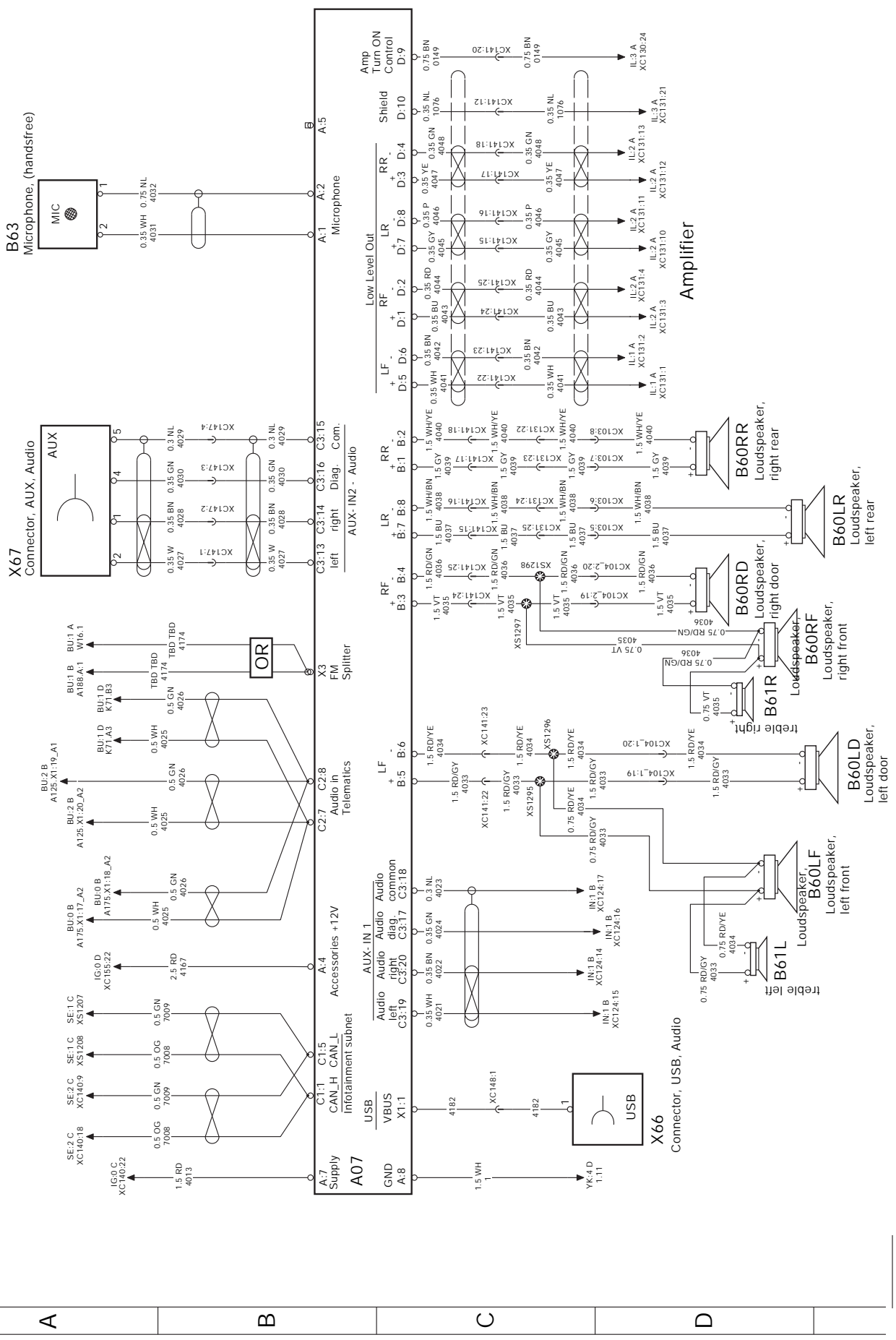

B63
Microphone, (handsfree)

X67
Connector, AUX, Audio

X66
Connector, USB, Audio

Amplifier

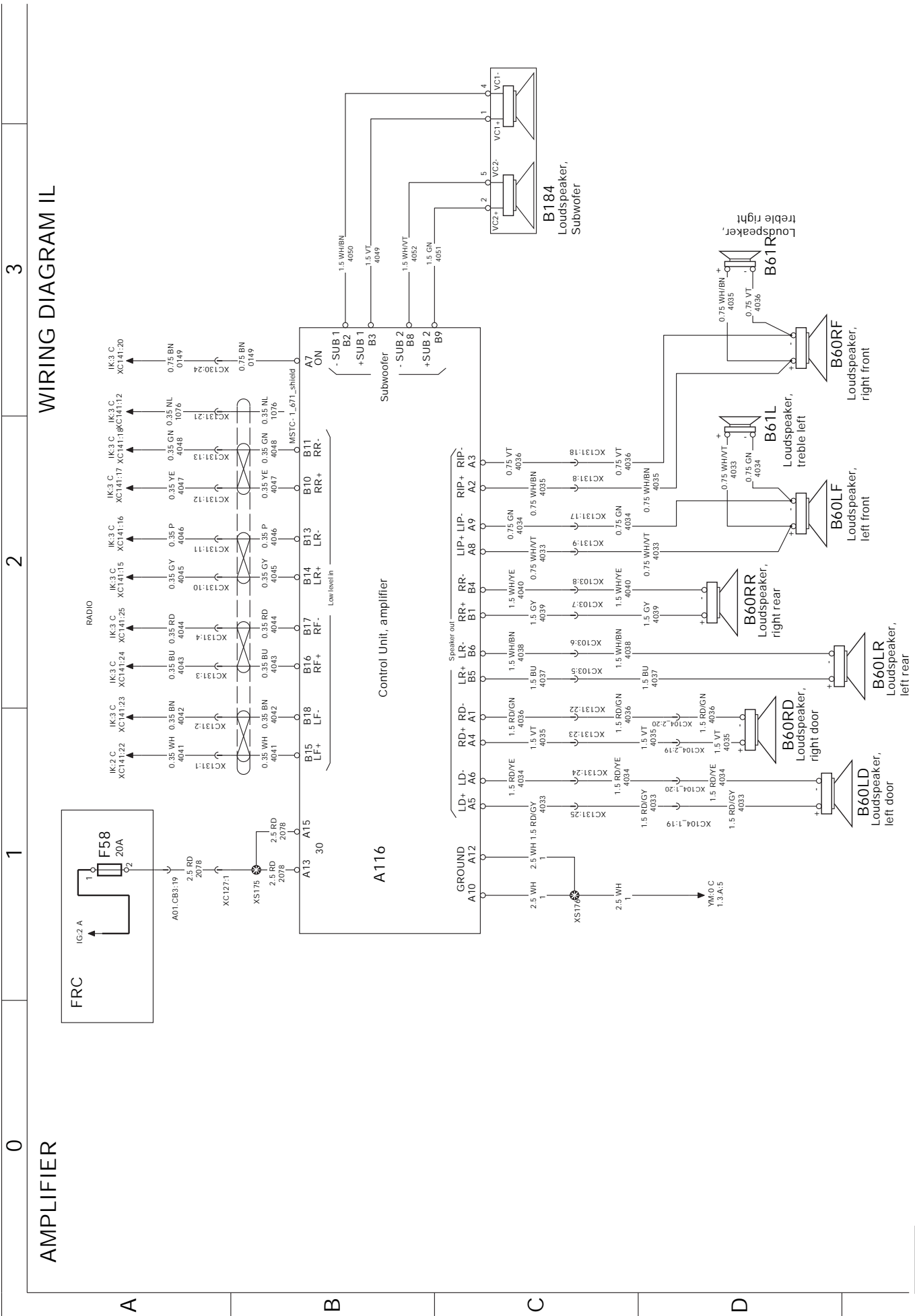

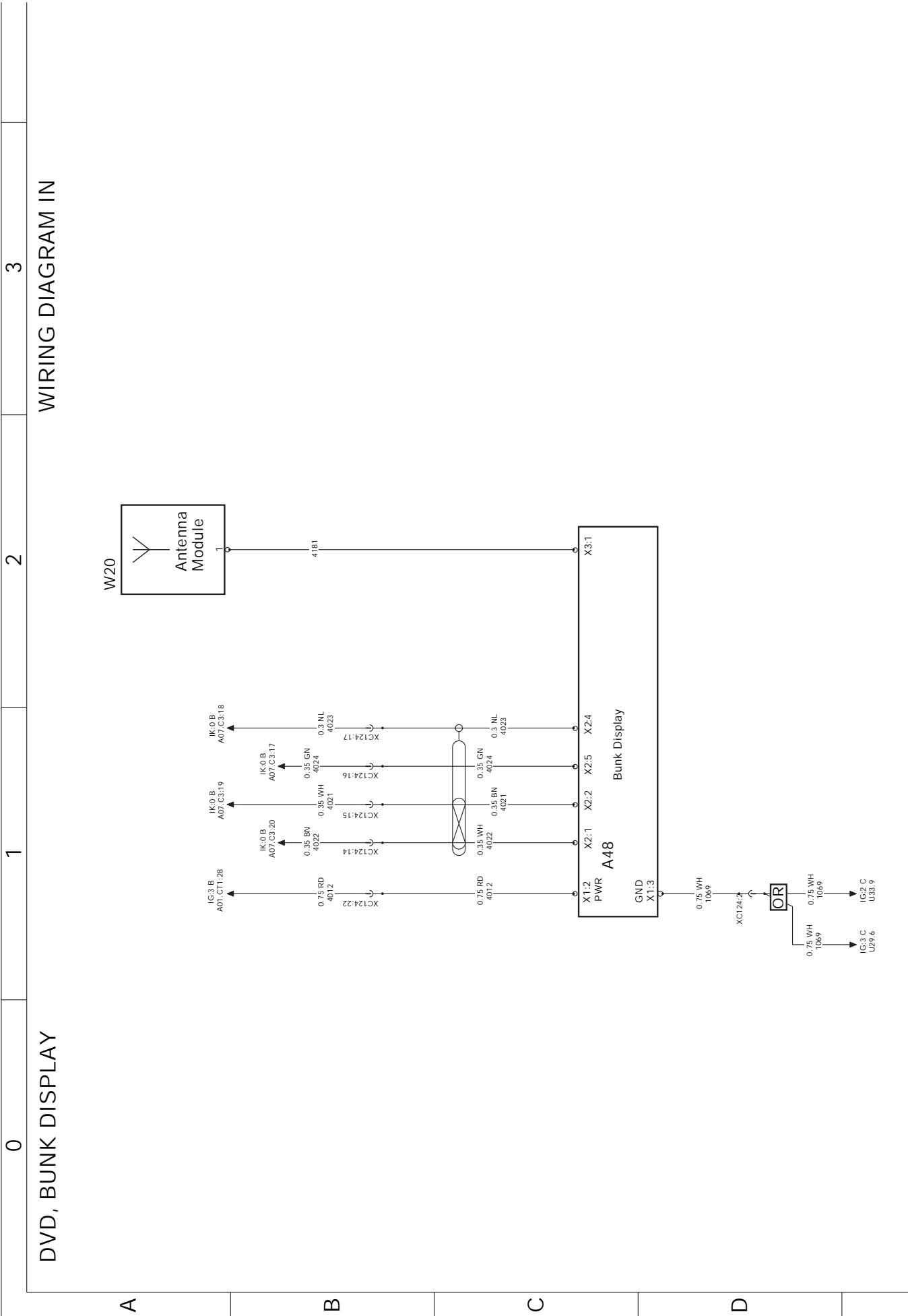

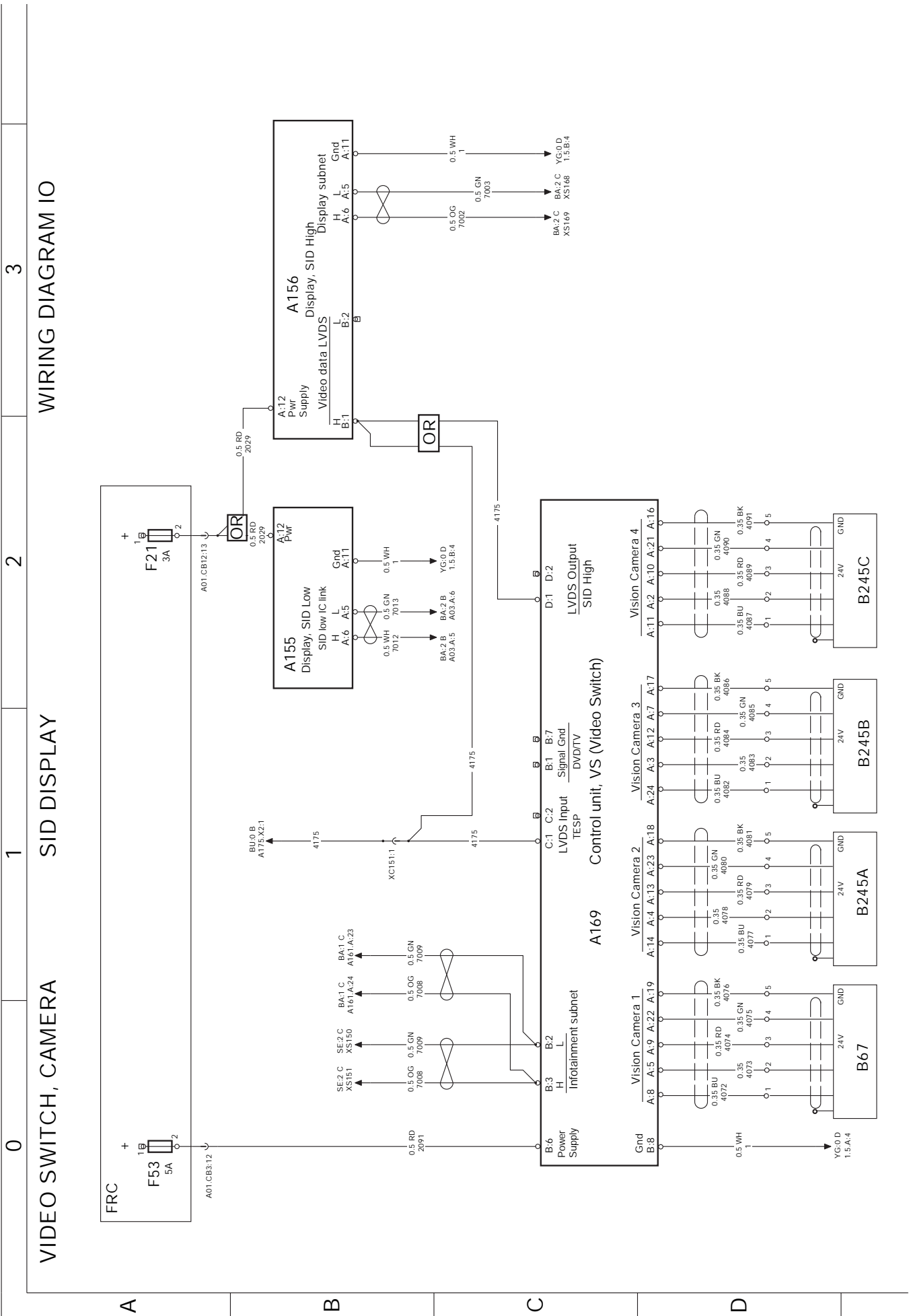

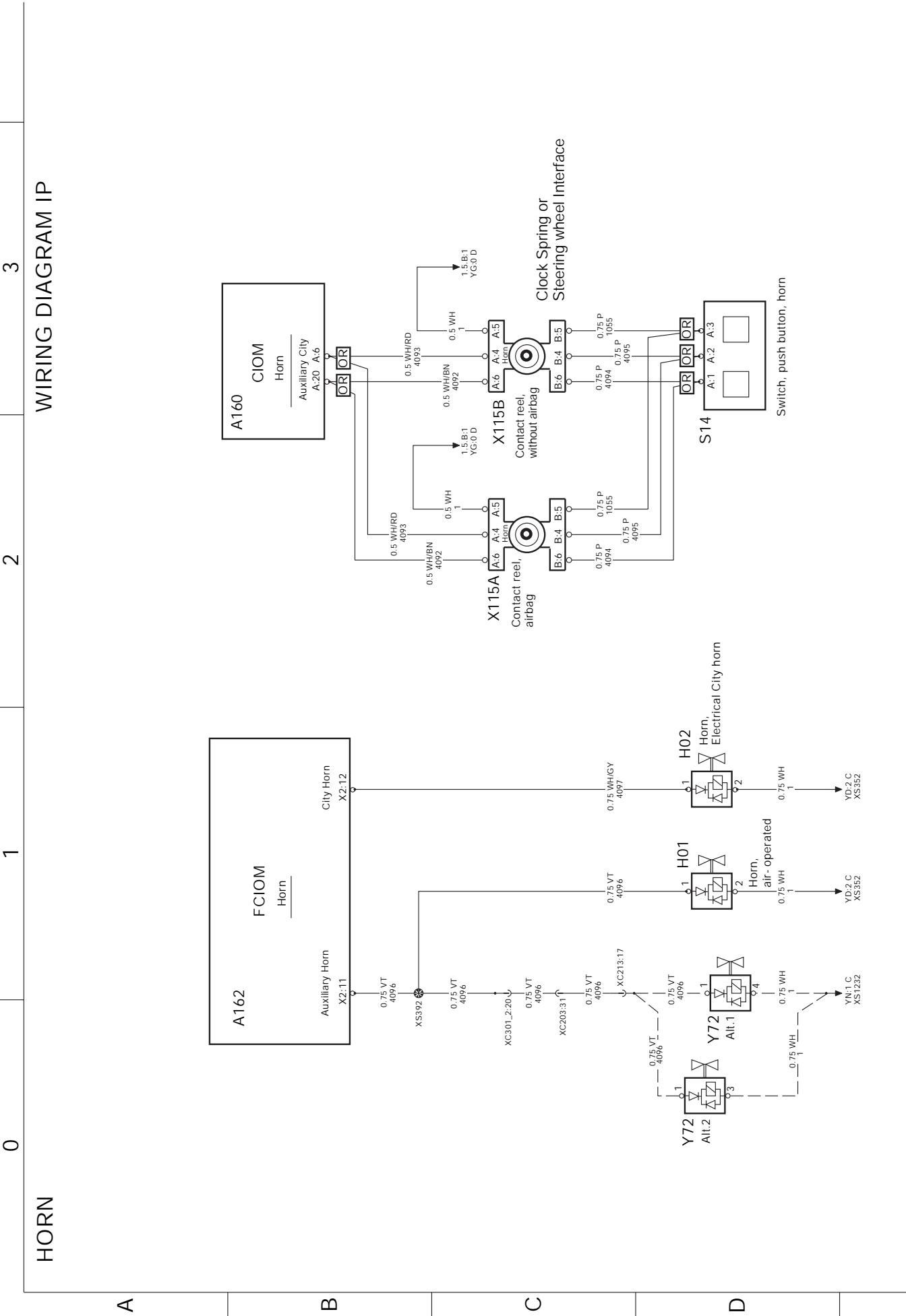

T3087597

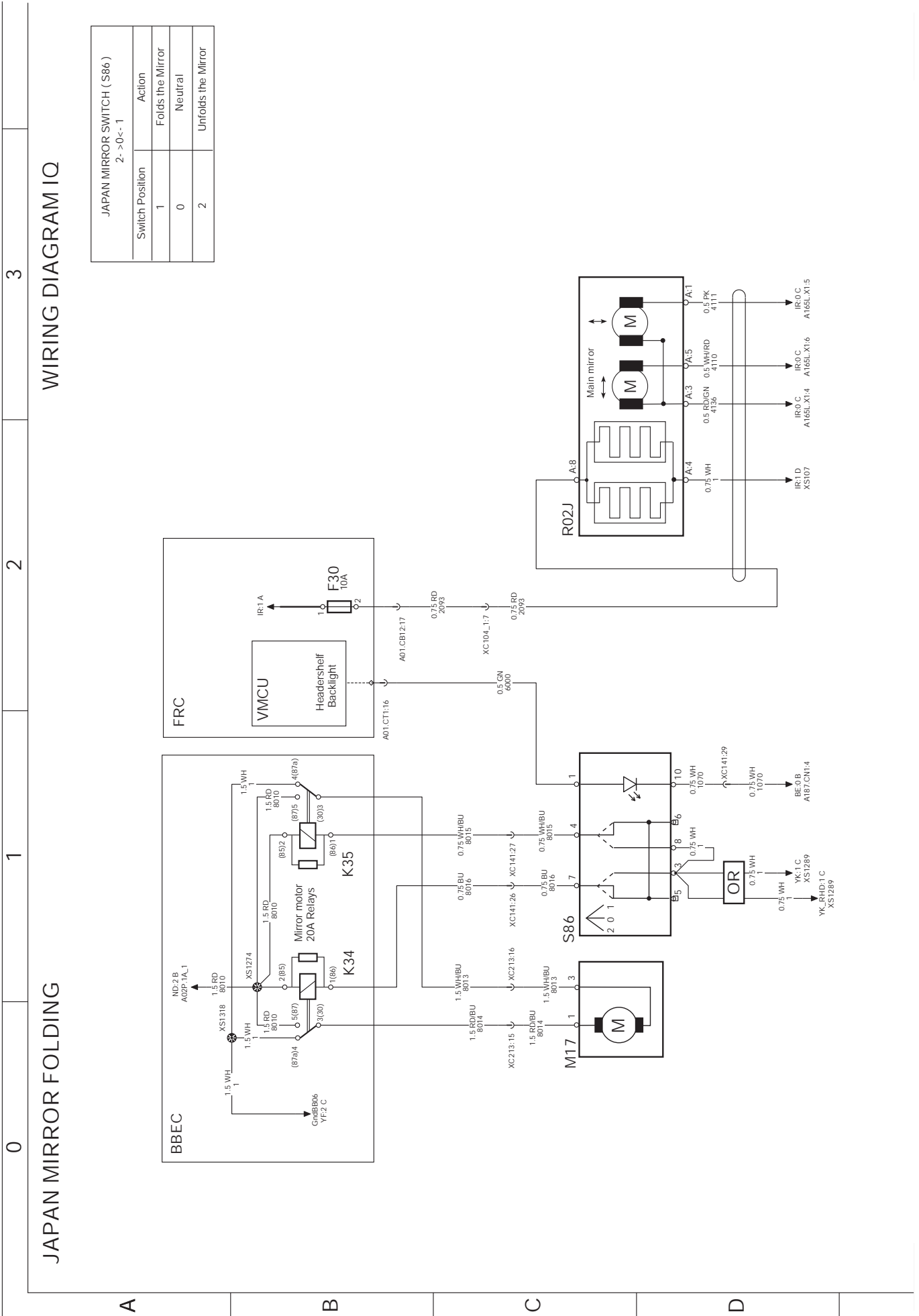

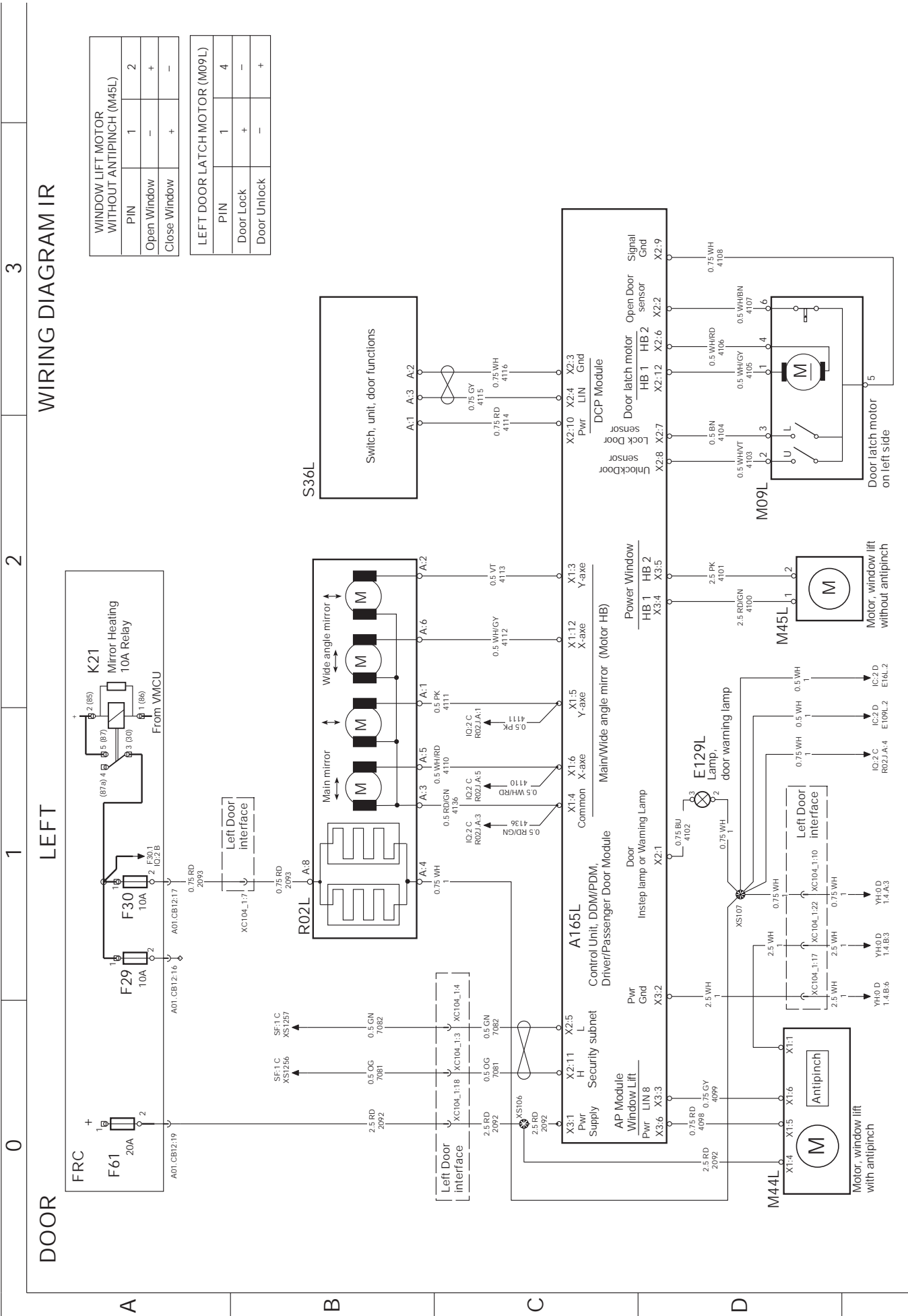

WINDOW LIFT MOTOR WITHOUT ANTIPINCH (M45L)		
PIN	1	2
Open Window	-	+
Close Window	+	-

LEFT DOOR LATCH MOTOR (M09L)		
PIN	1	4
Door Lock	+	-
Door Unlock	-	+

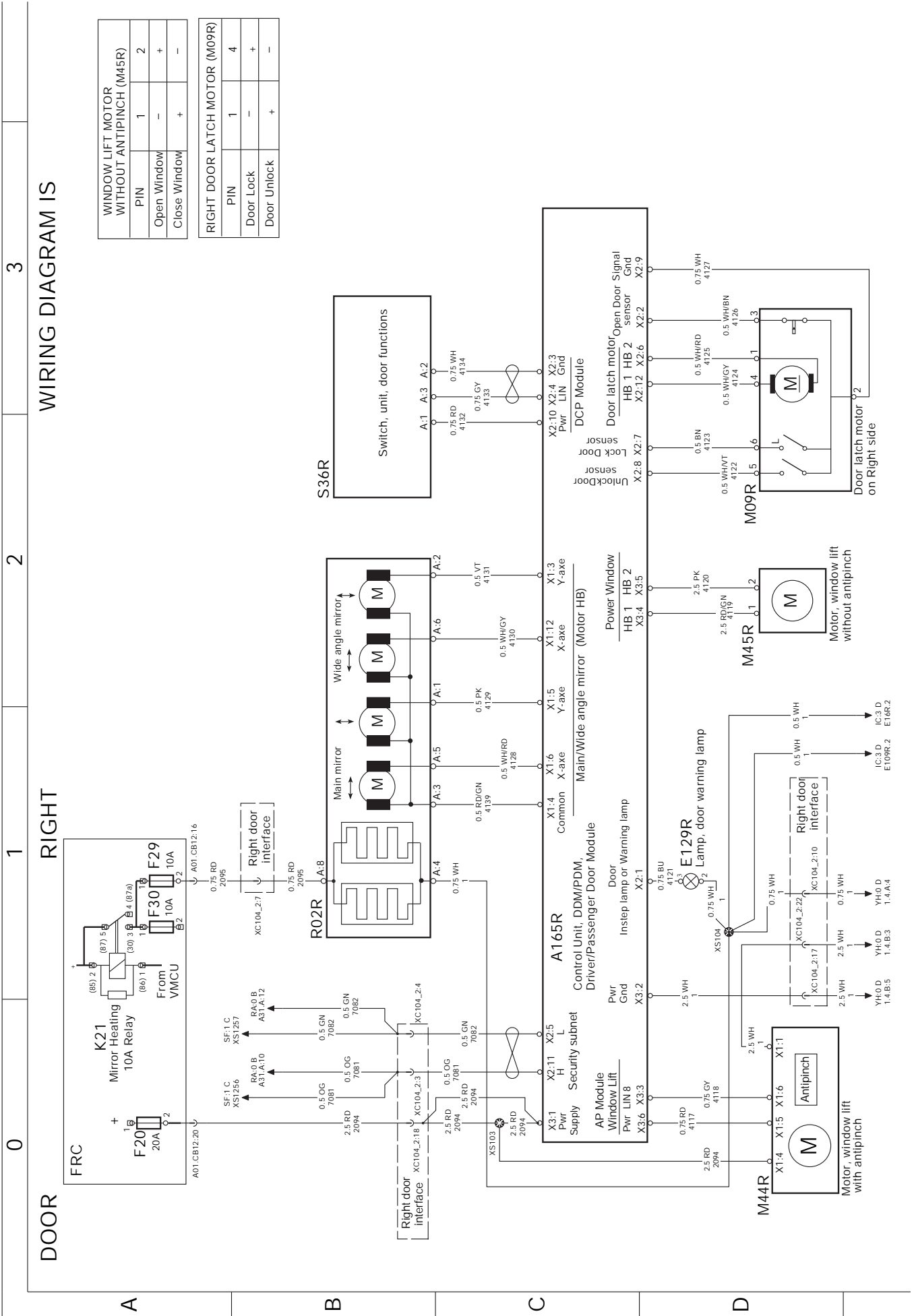

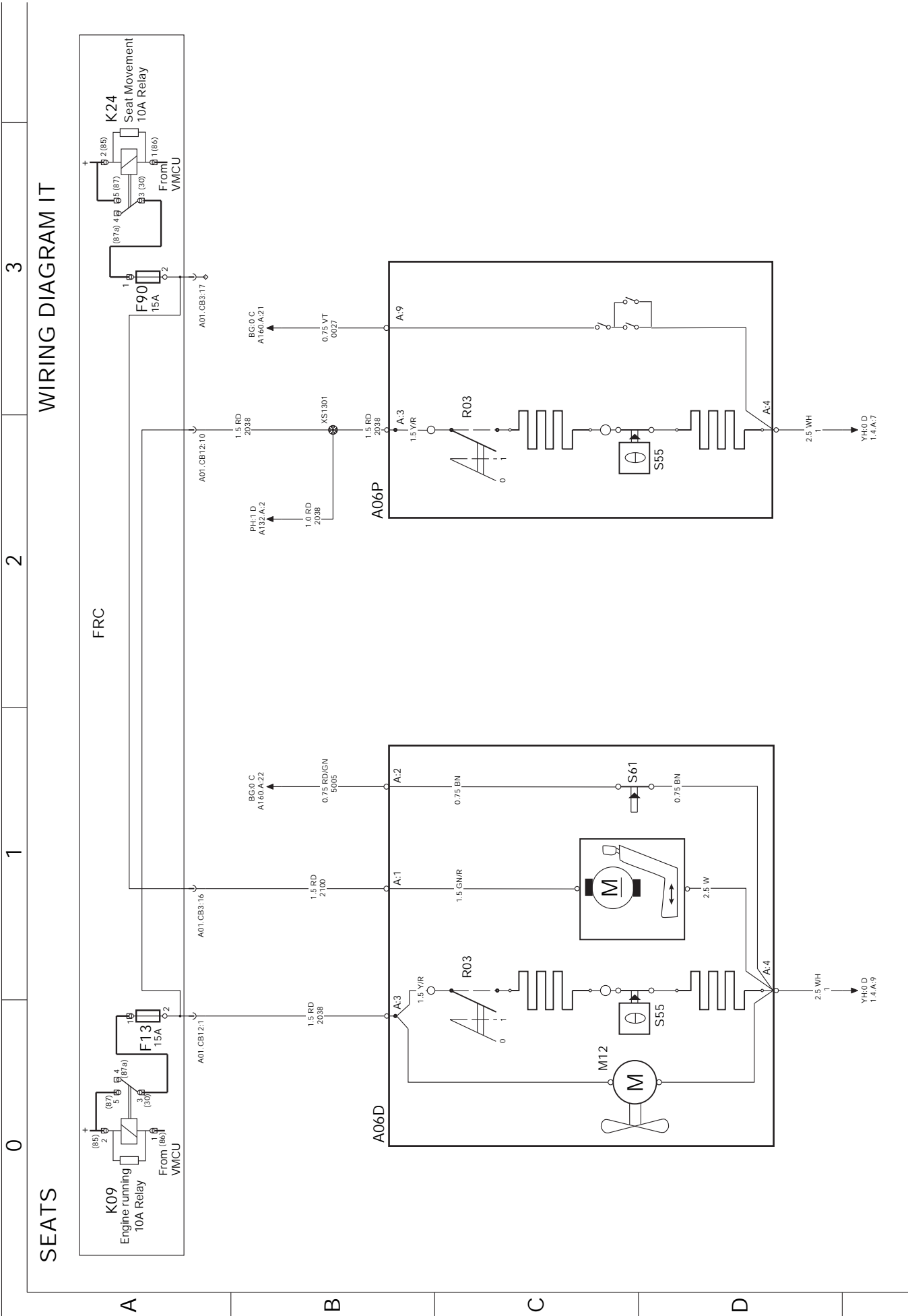

T3065595

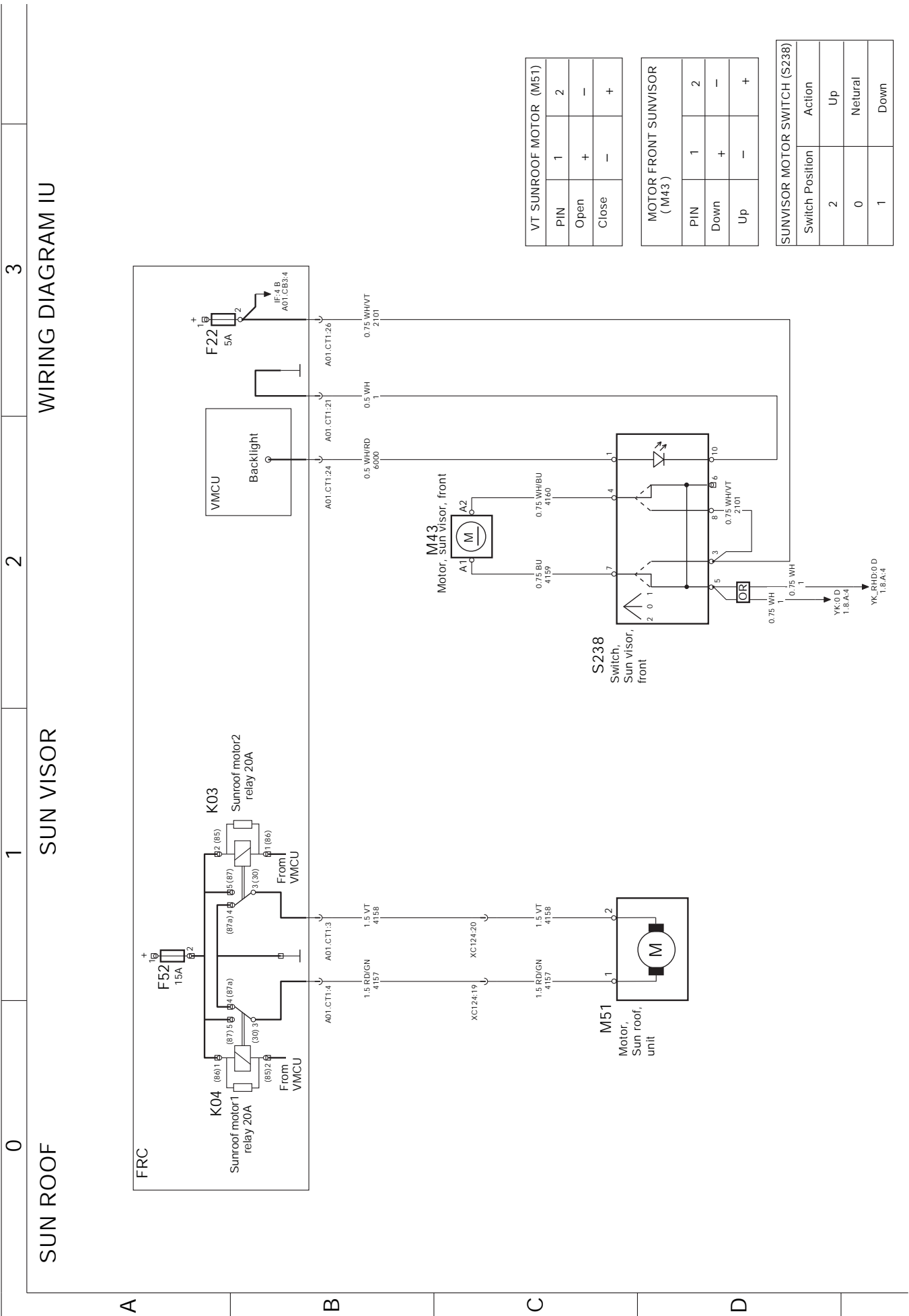

WIRING DIAGRAM IU

3

2

1

0

SUN VISOR

SUN ROOF

VT SUNROOF MOTOR (M51)	
PIN	1 2
Open	+ -
Close	- +

MOTOR FRONT SUNVISOR (M43)	
PIN	1 2
Down	+ -
Up	- +

SUNVISOR MOTOR SWITCH (S238)	
Switch Position	Action
2	Up
0	Neutral
1	Down

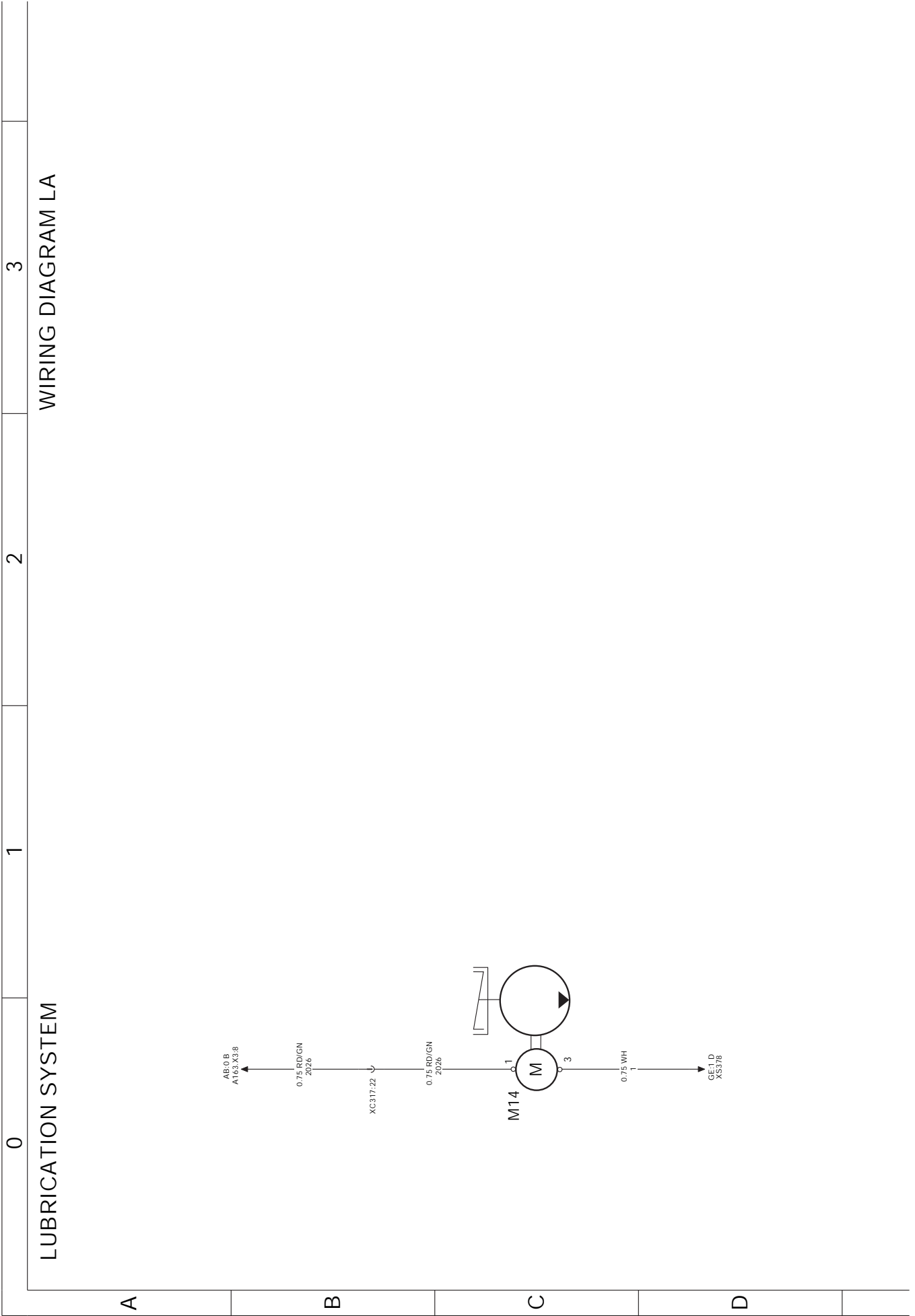

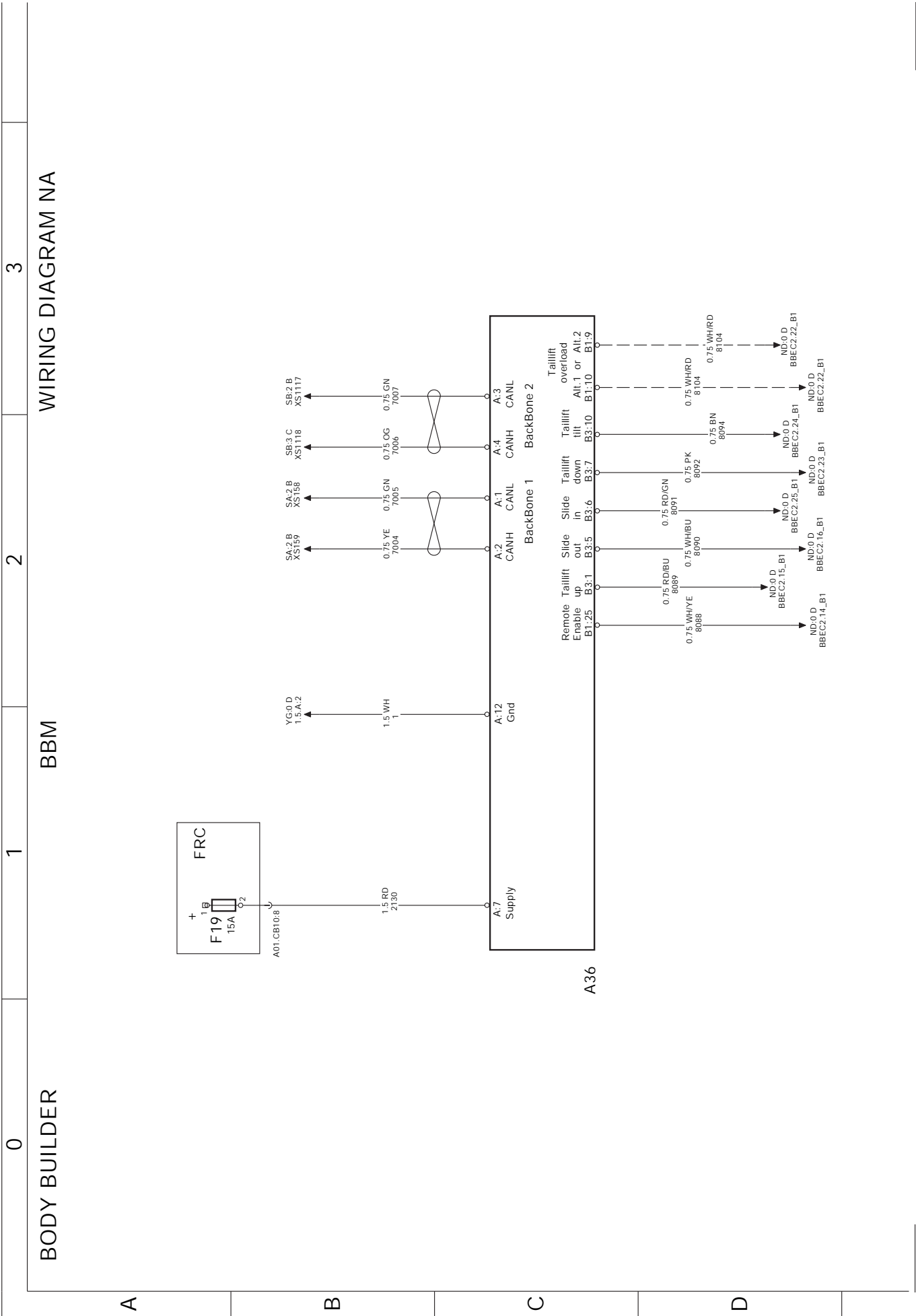

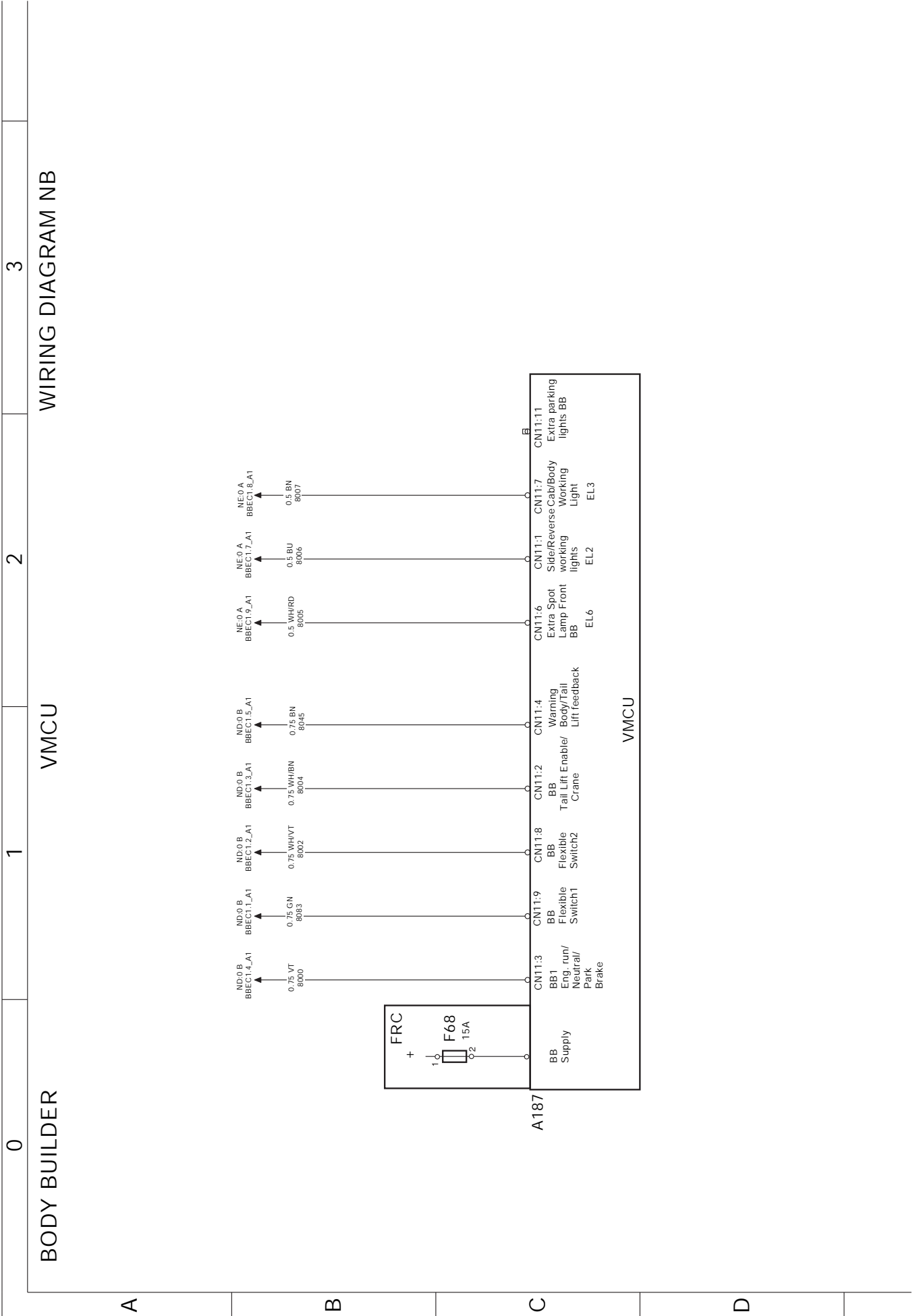

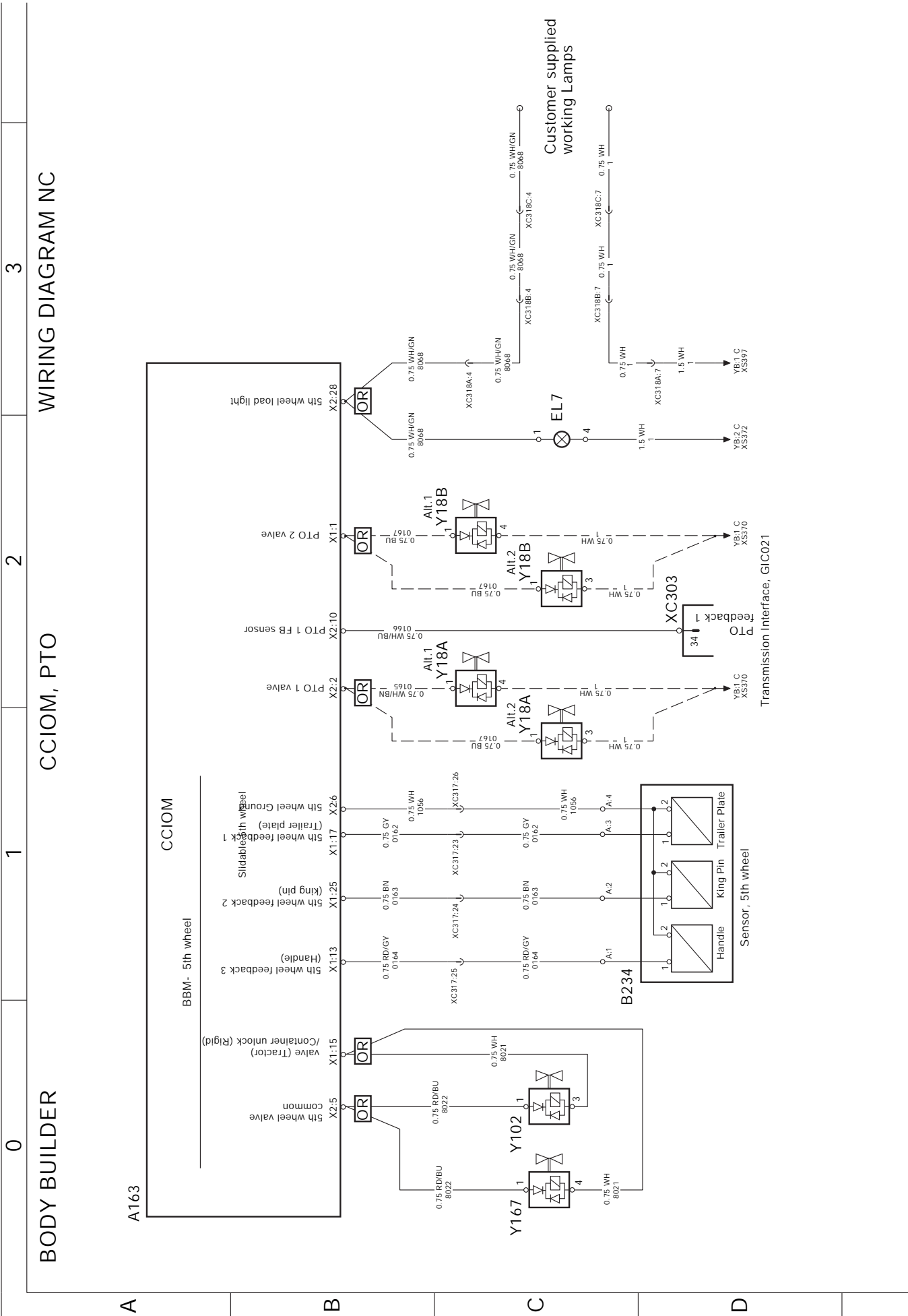

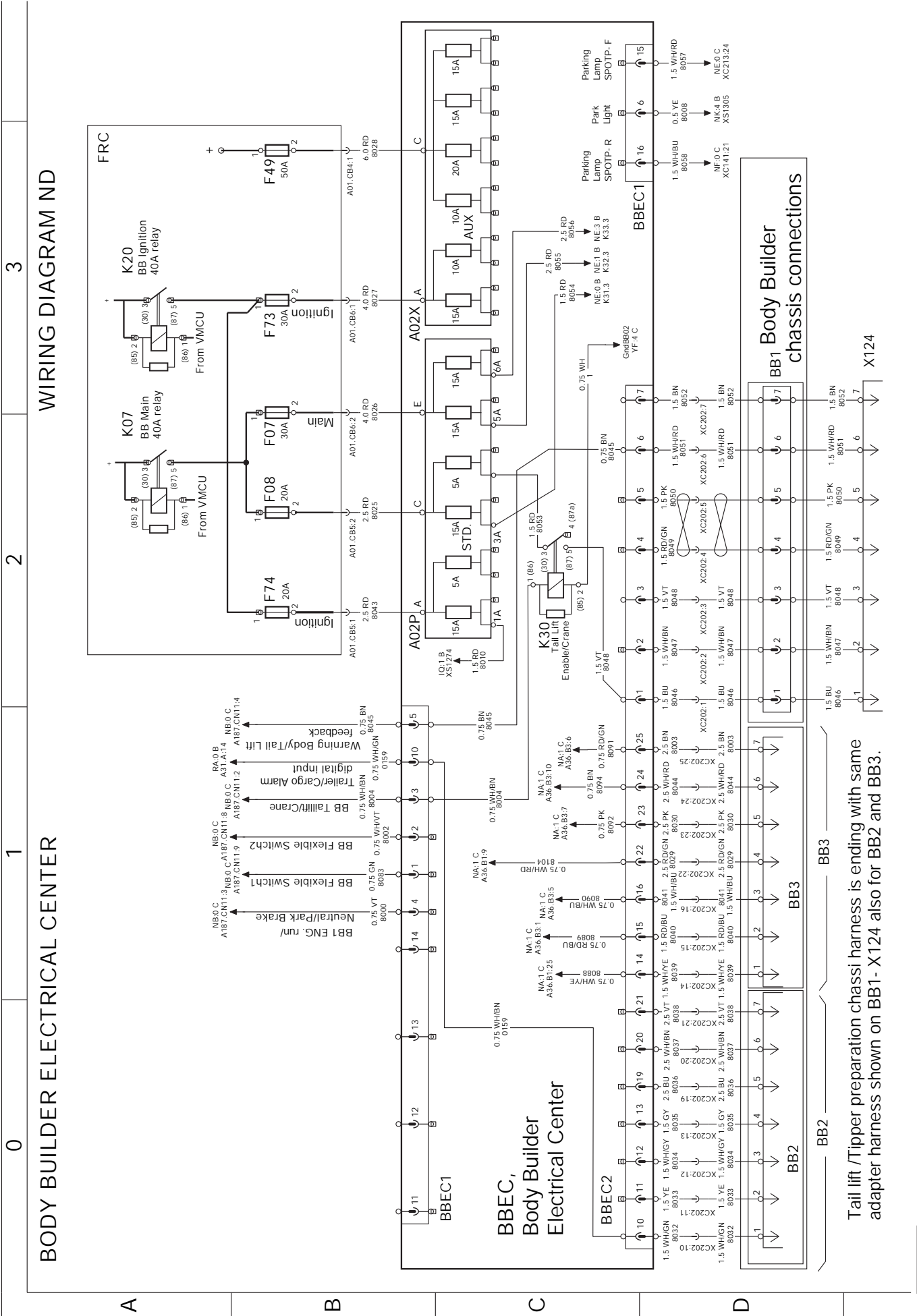

Tail lift /Tipper preparation chassi harness is ending with same adapter harness shown on BB1- X124 also for BB2 and BB3.

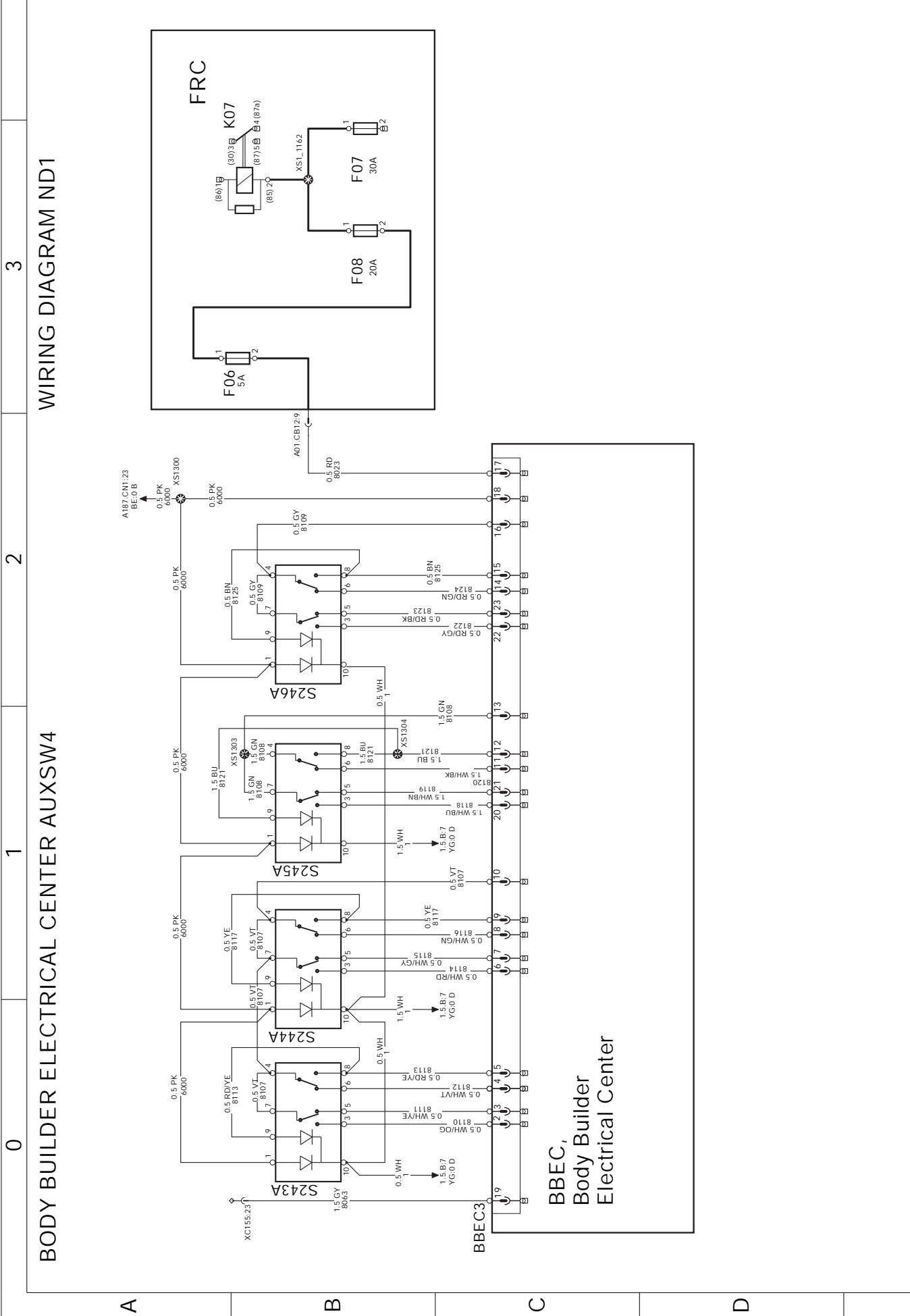

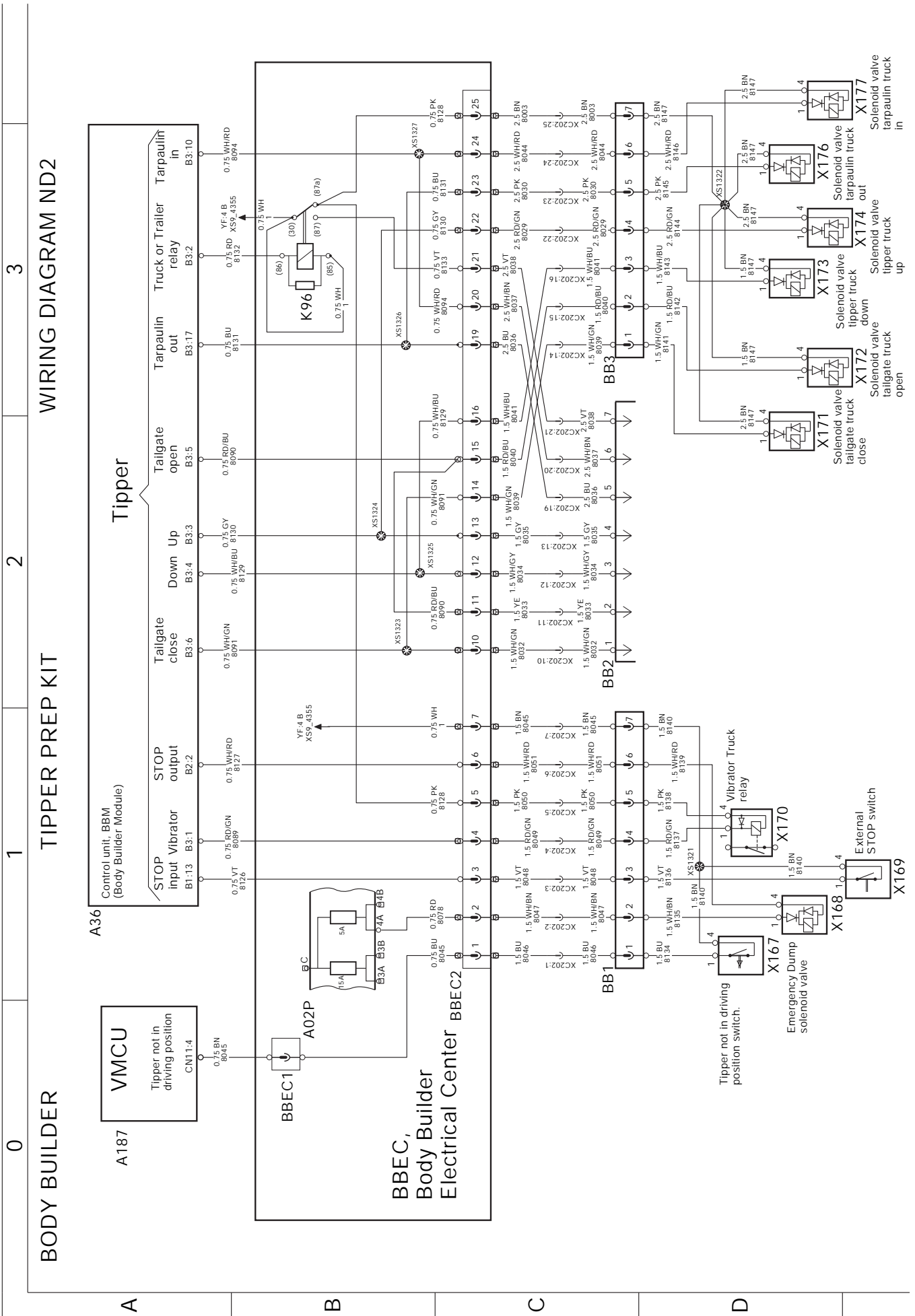

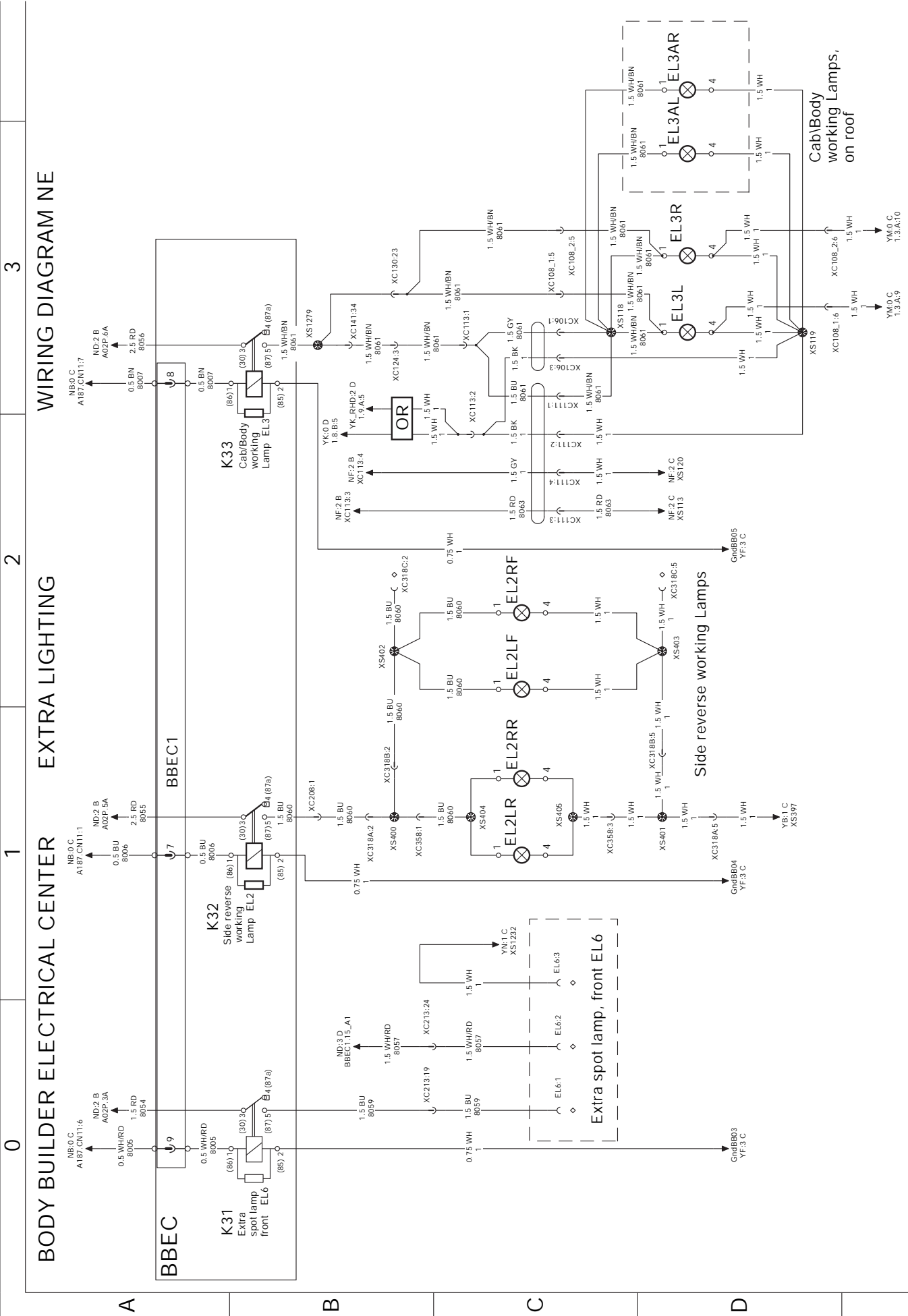

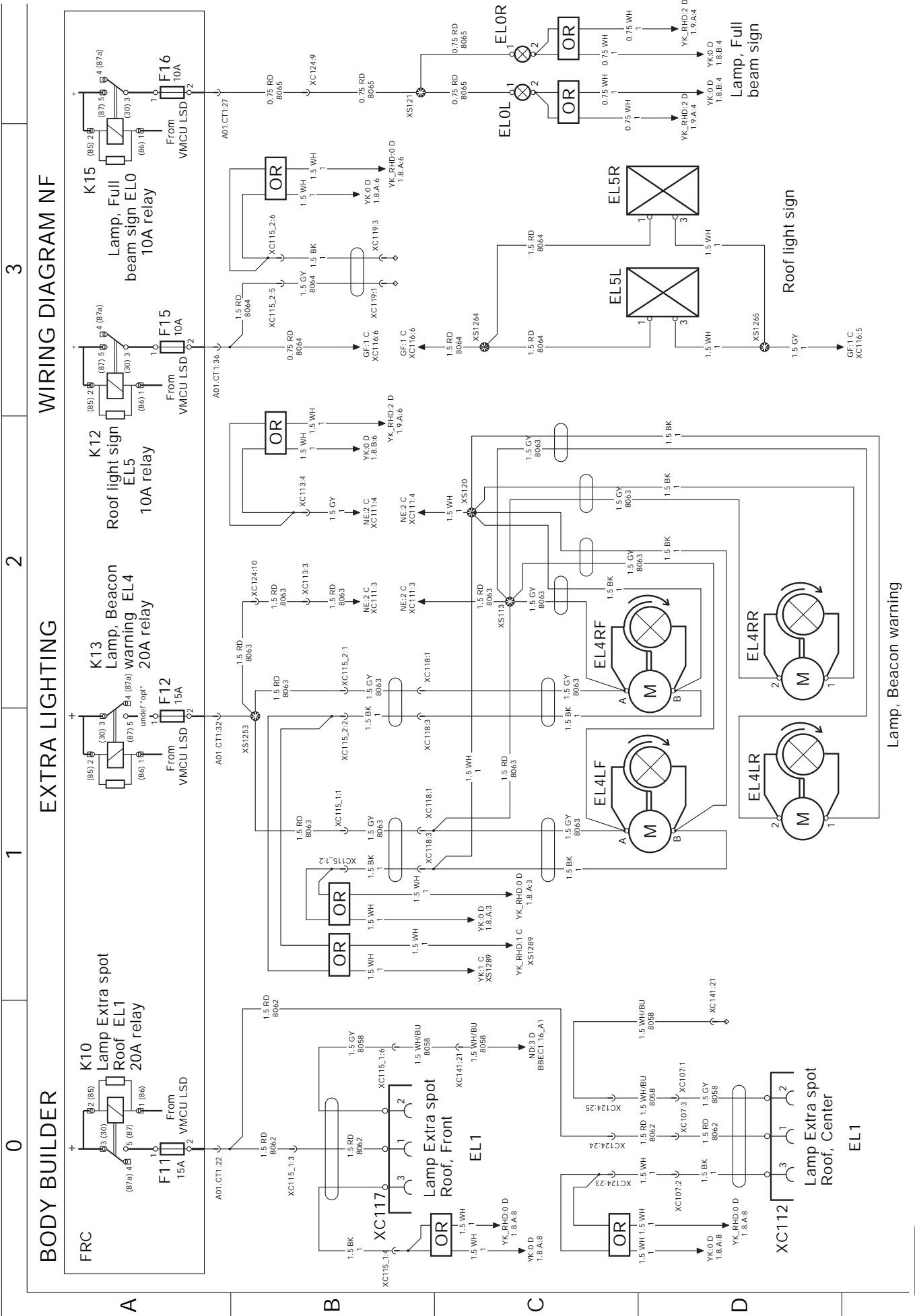

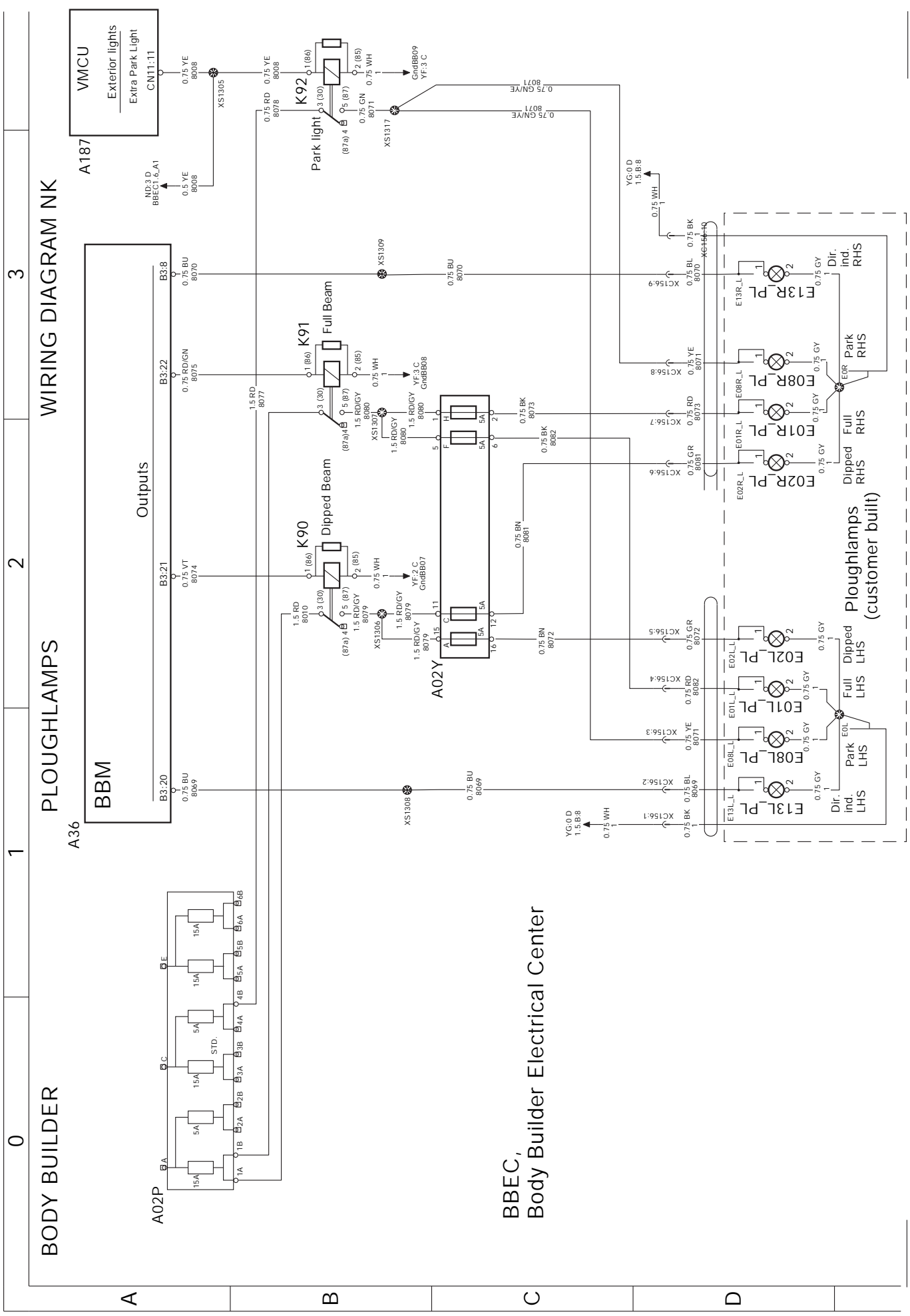

BBEC,
Body Builder Electrical Center

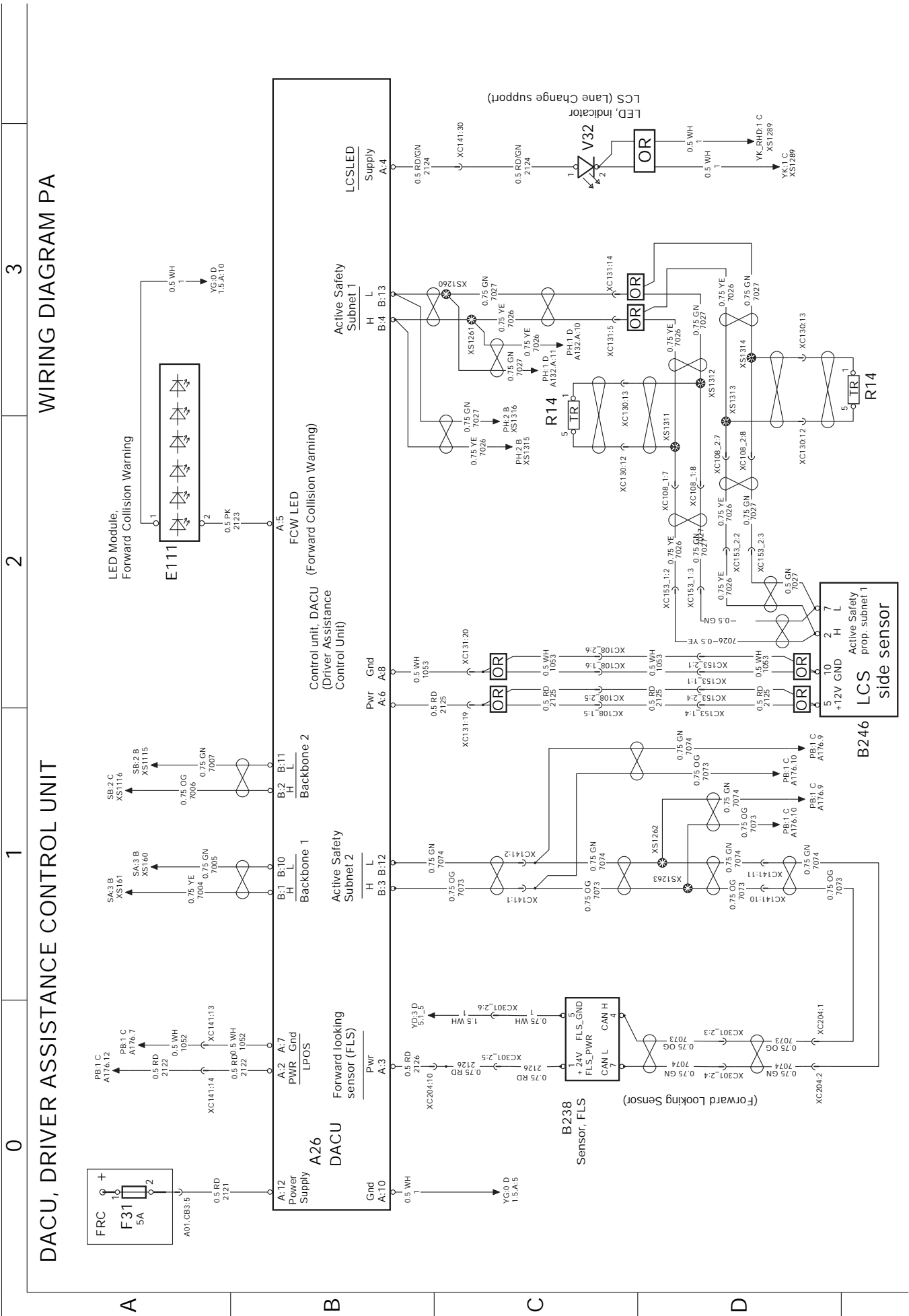

WIRING DIAGRAM PA

DACU, DRIVER ASSISTANCE CONTROL UNIT

3

2

1

0

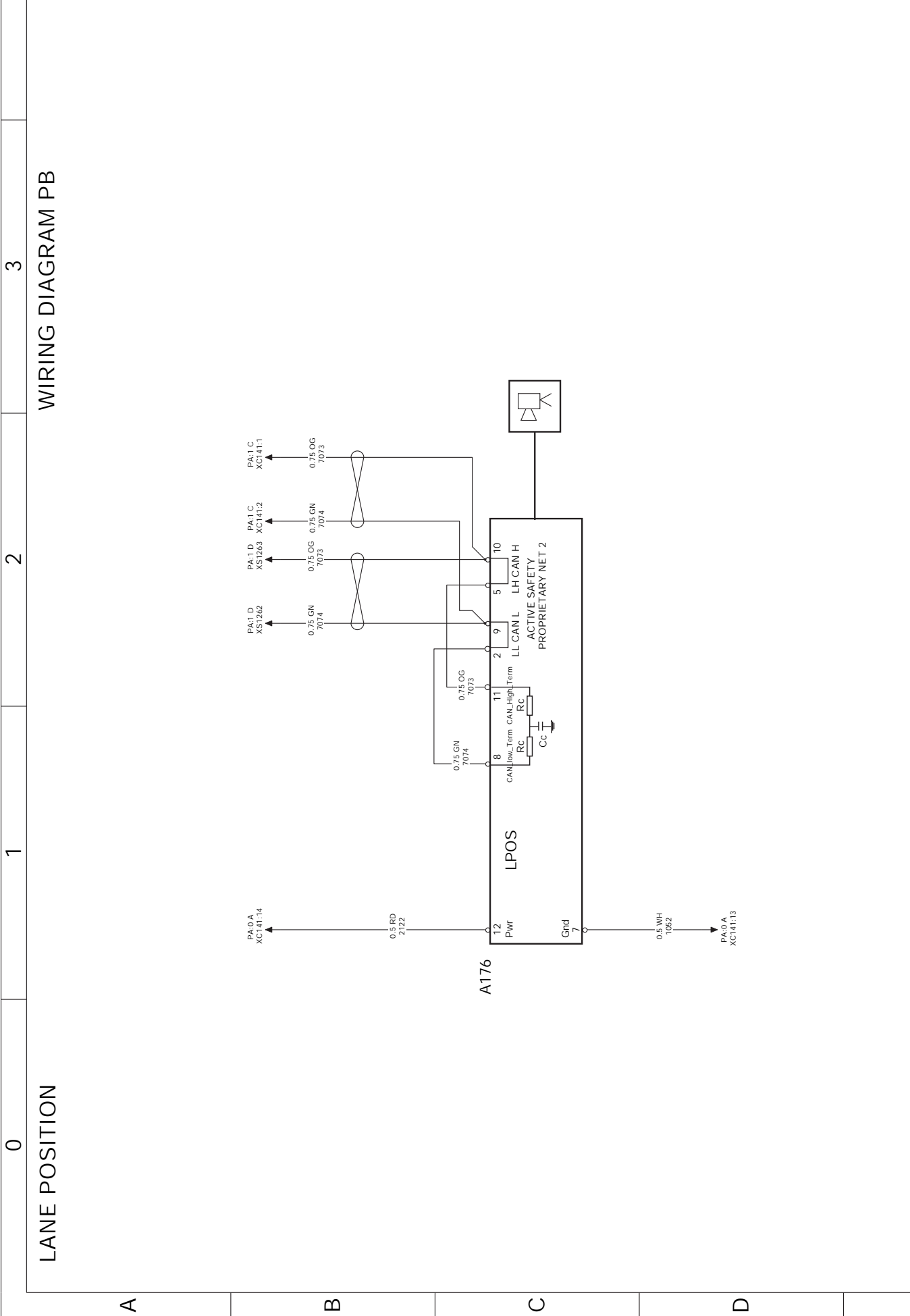

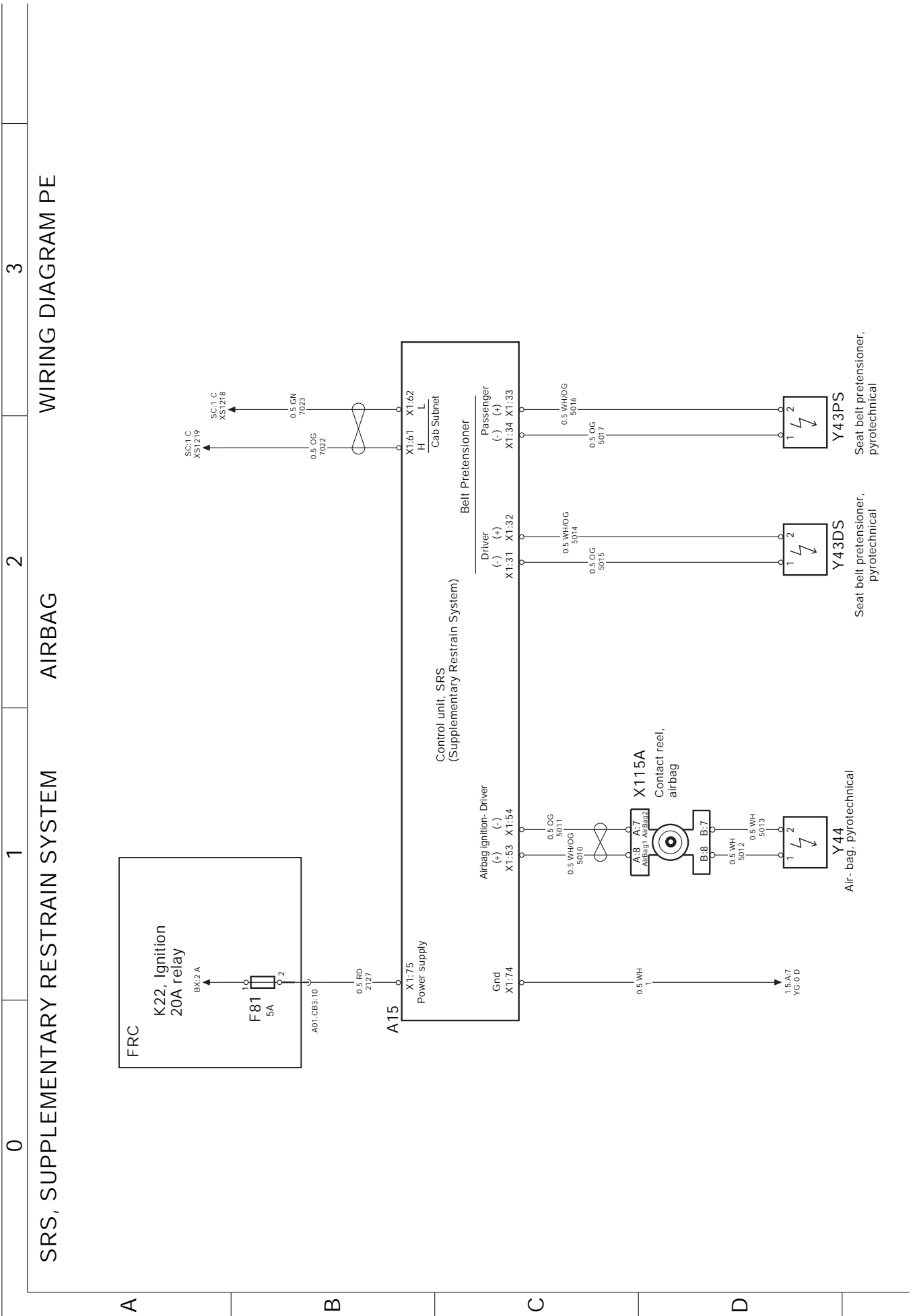

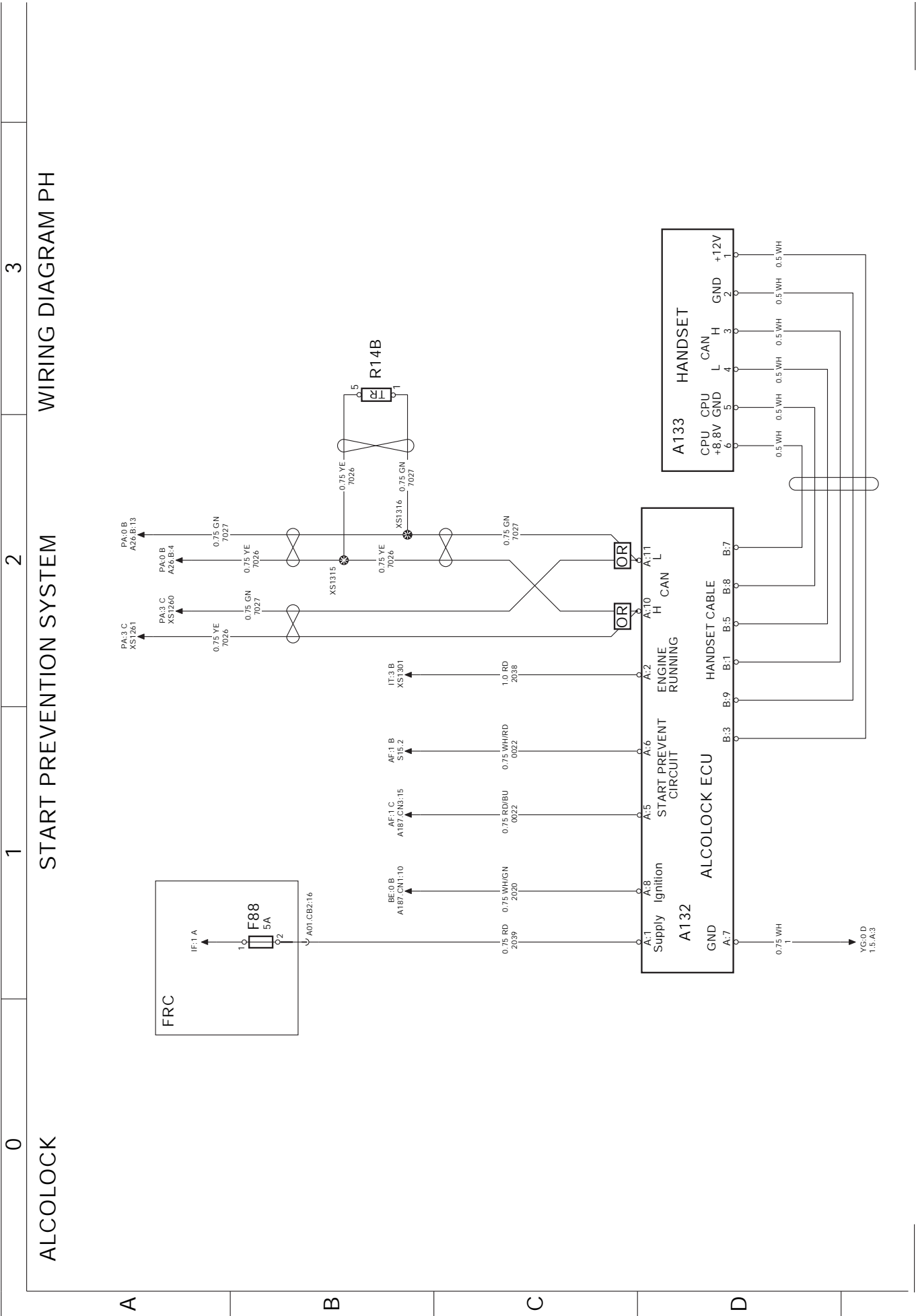

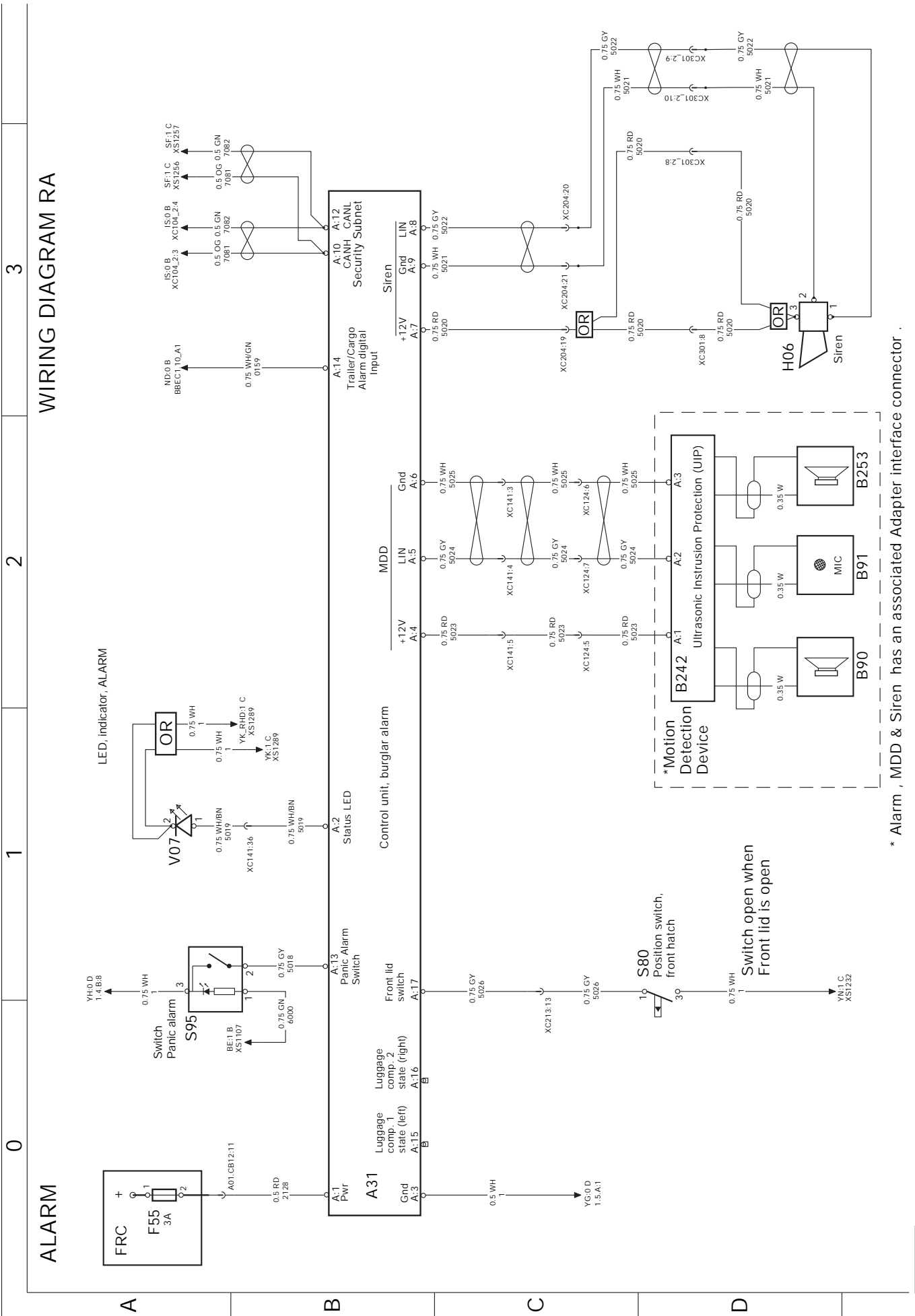

* Alarm , MDD & Siren has an associated Adapter interface connector .

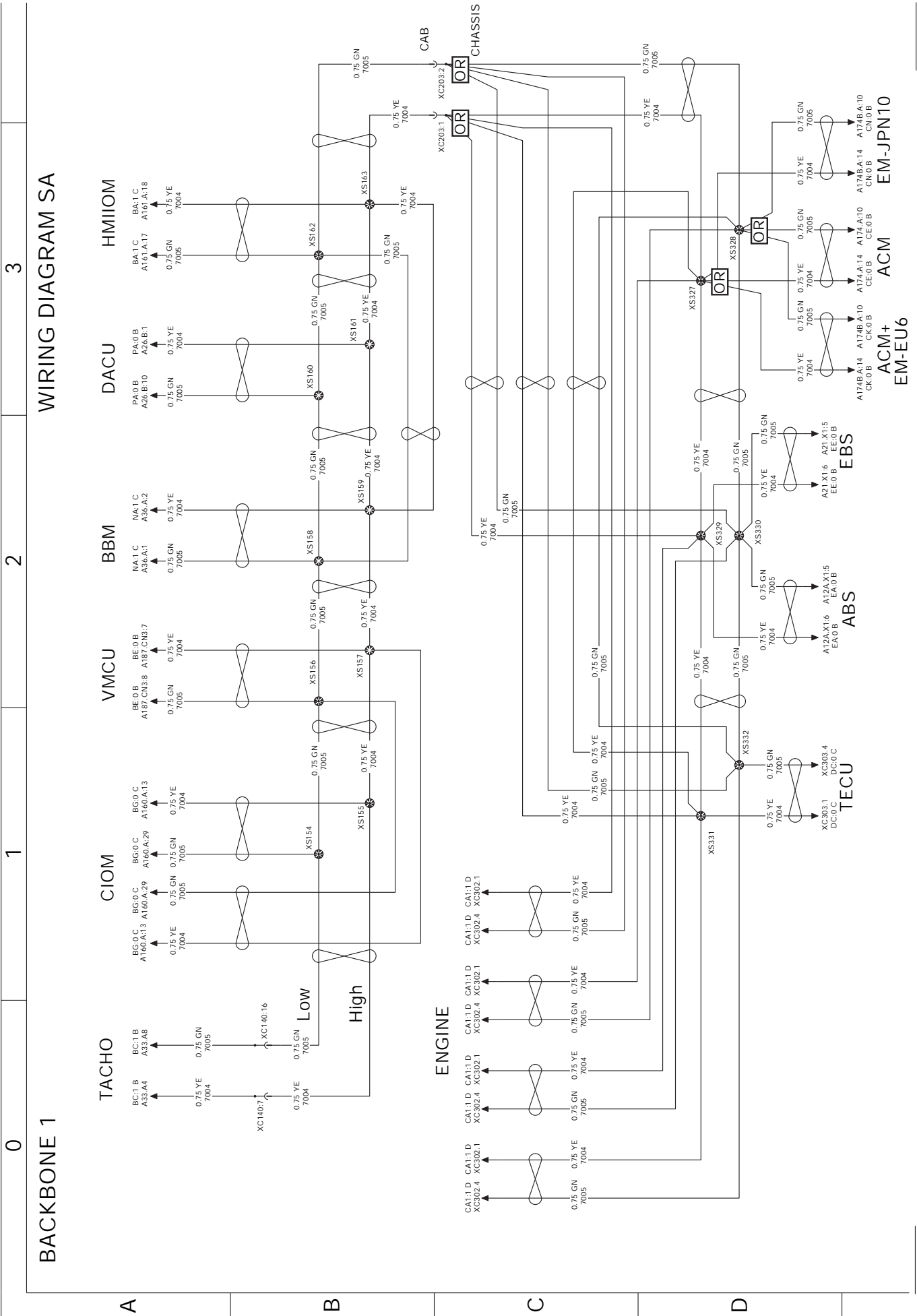

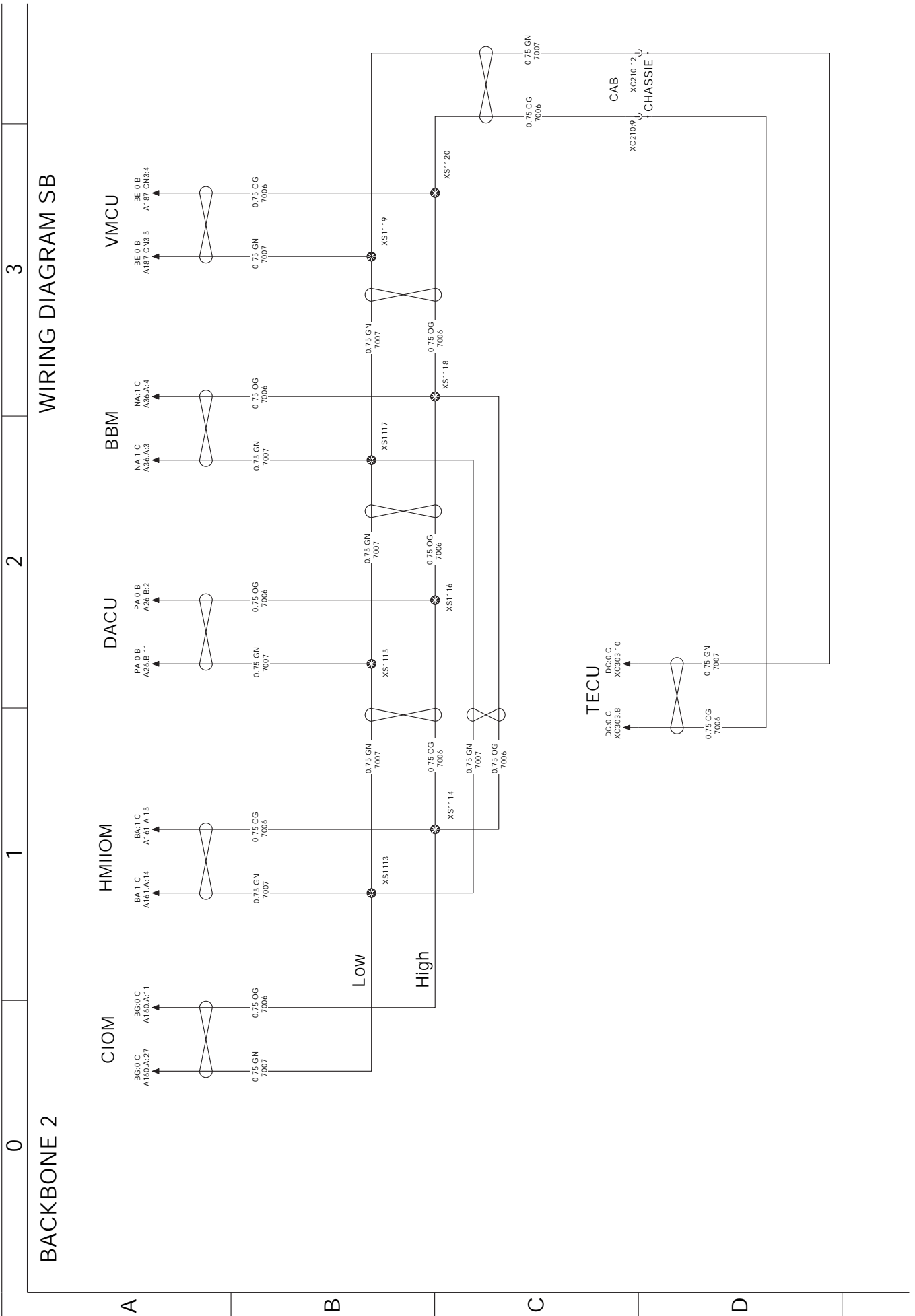

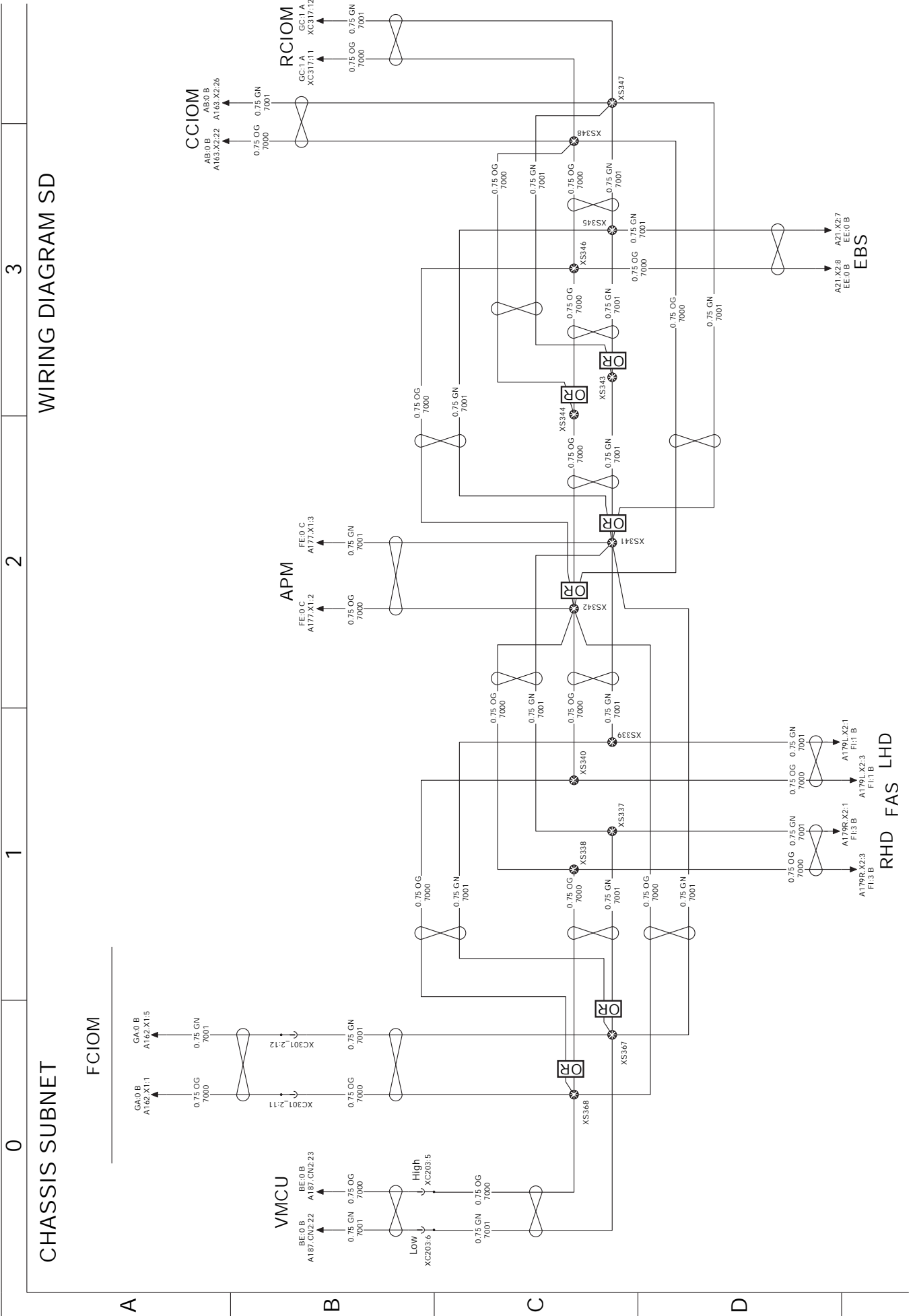

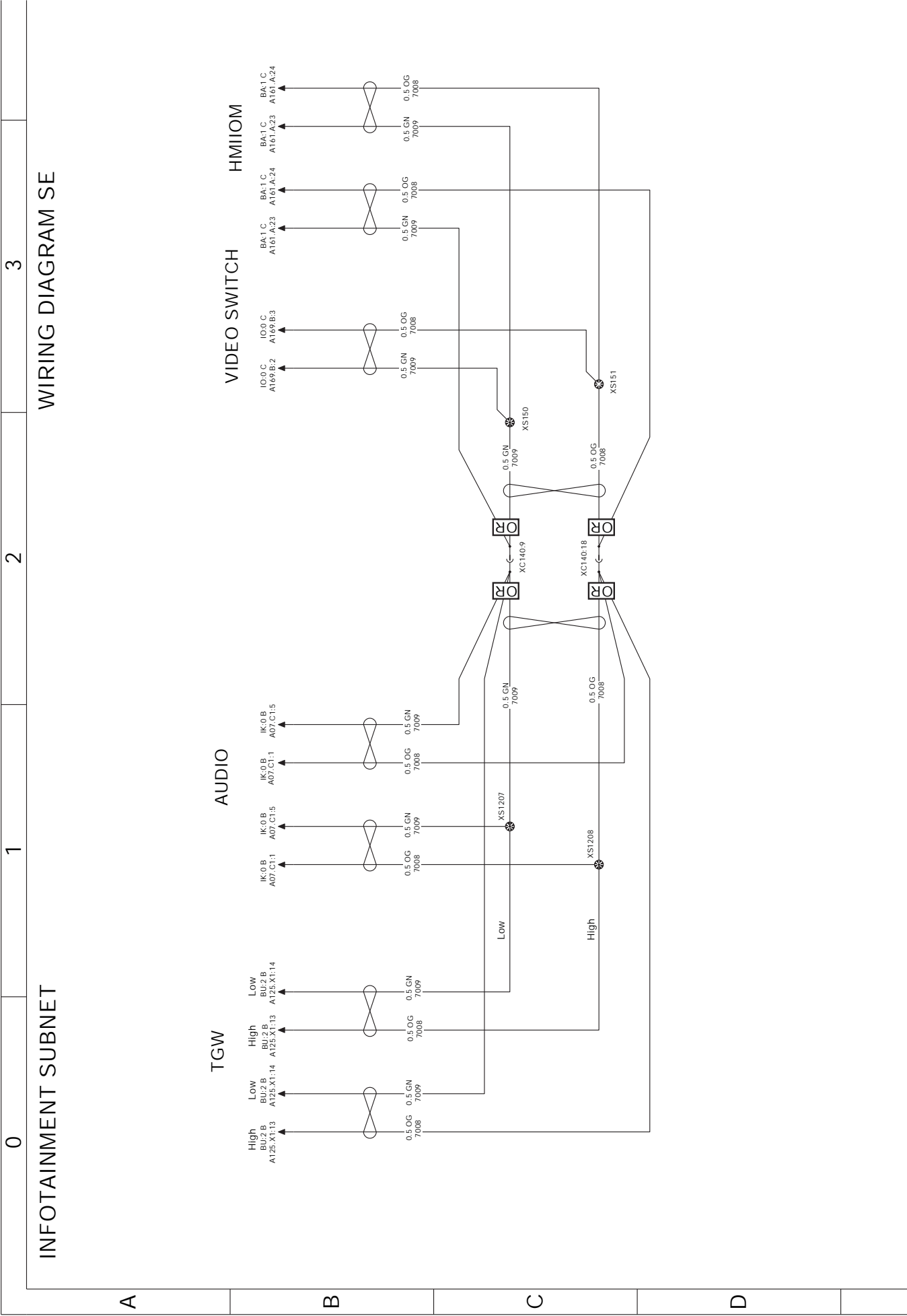

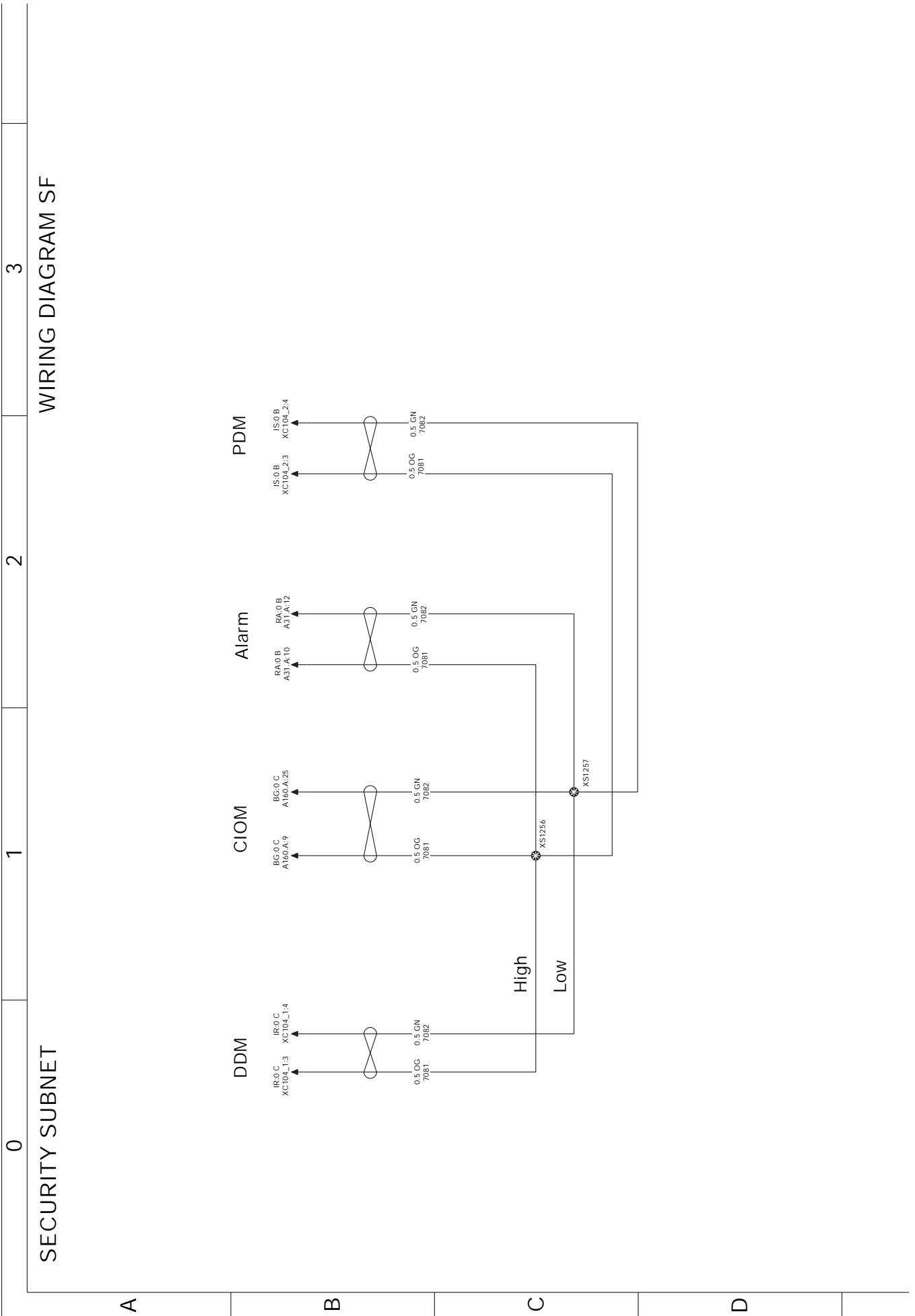

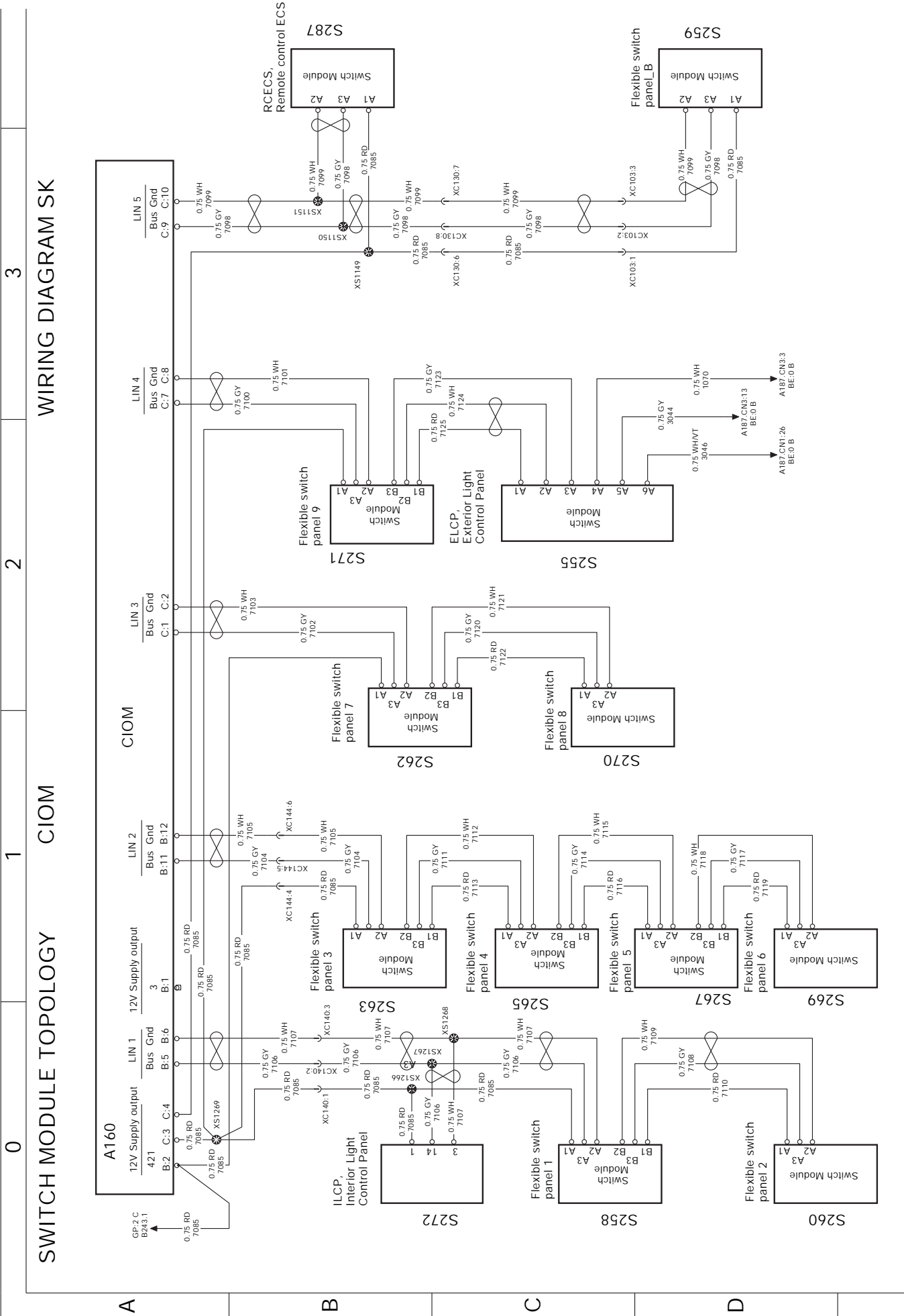

SWITCH MODULE TOPOLOGY

CIOM

WIRING DIAGRAM SK

3

2

1

0

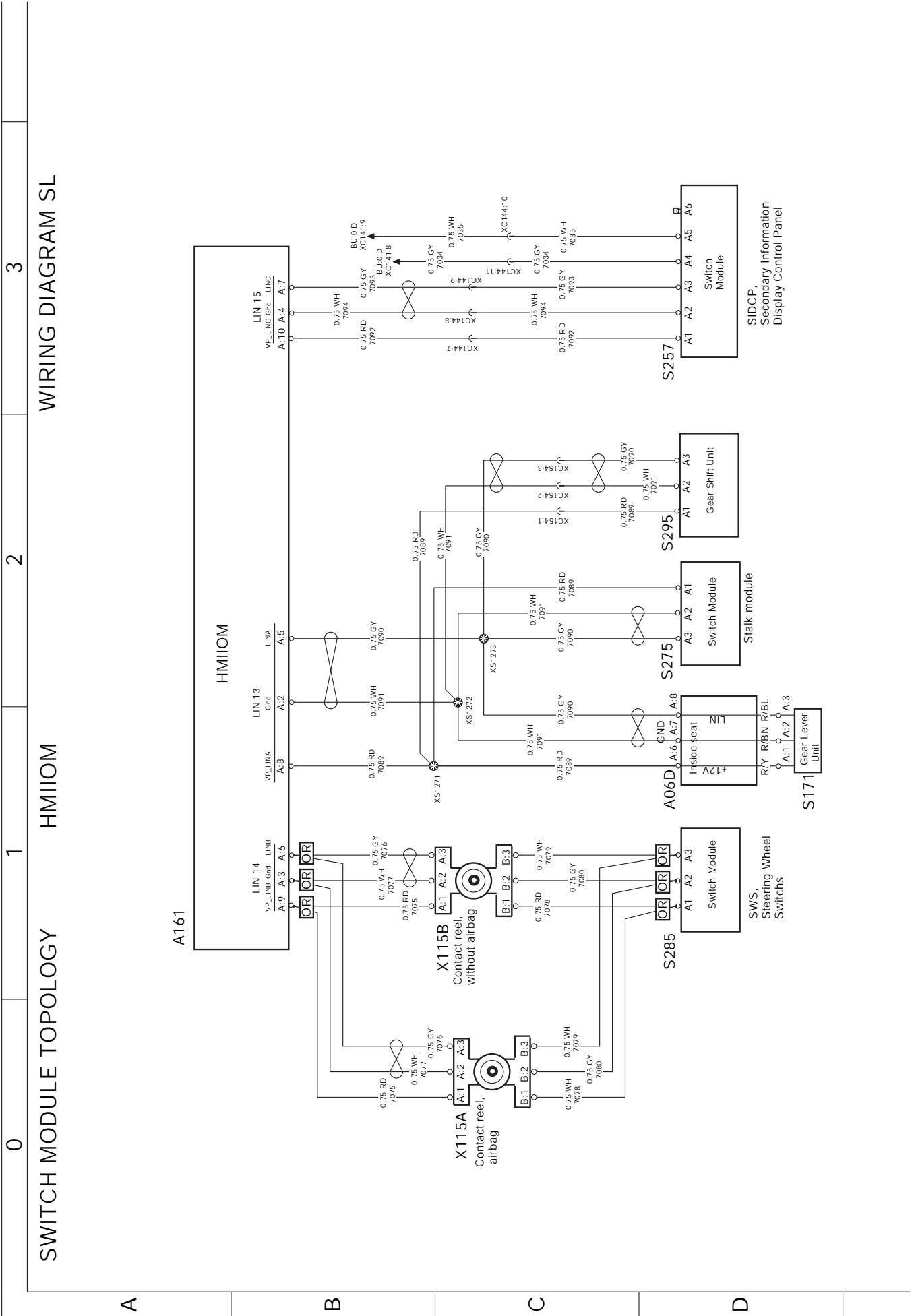

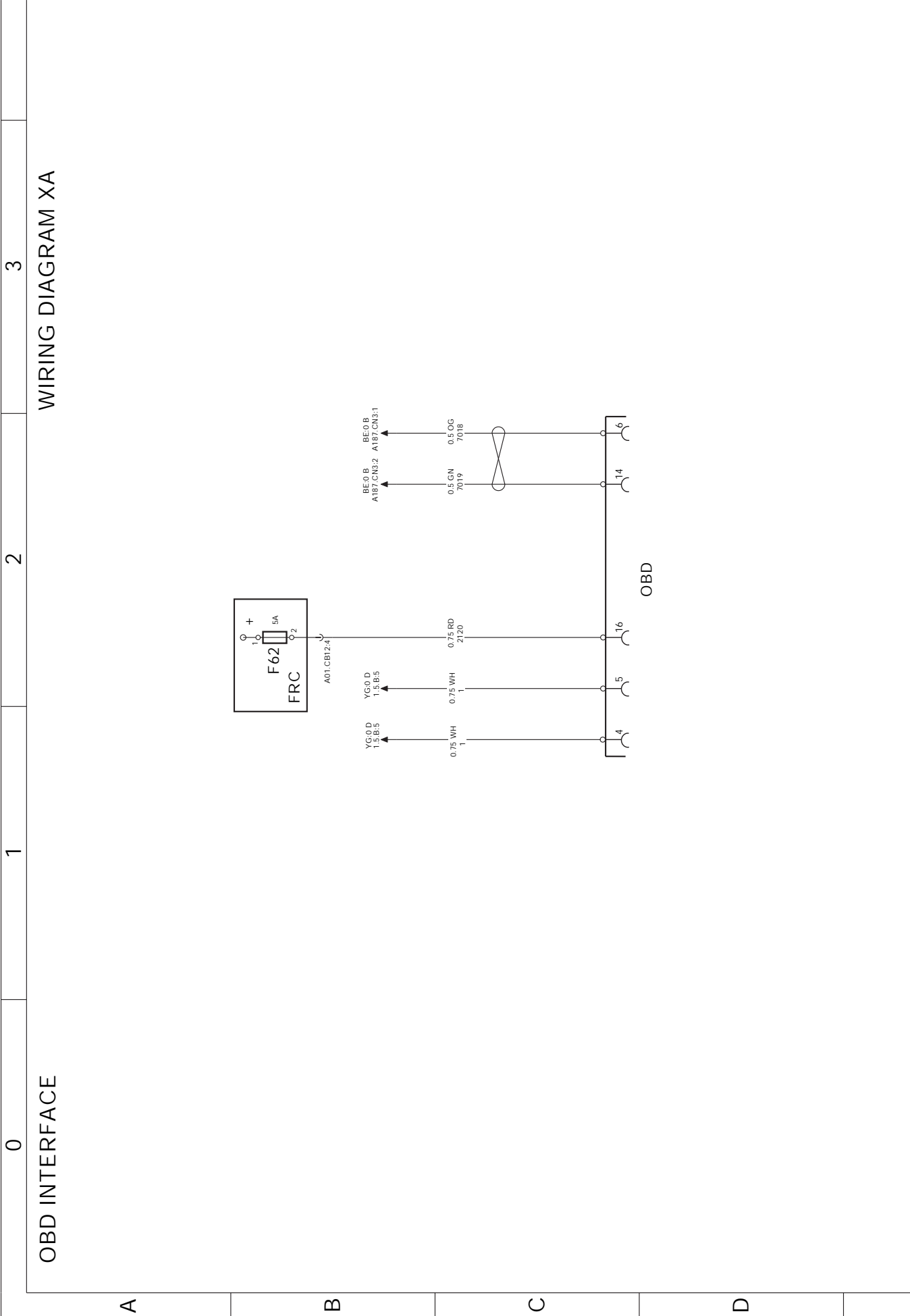

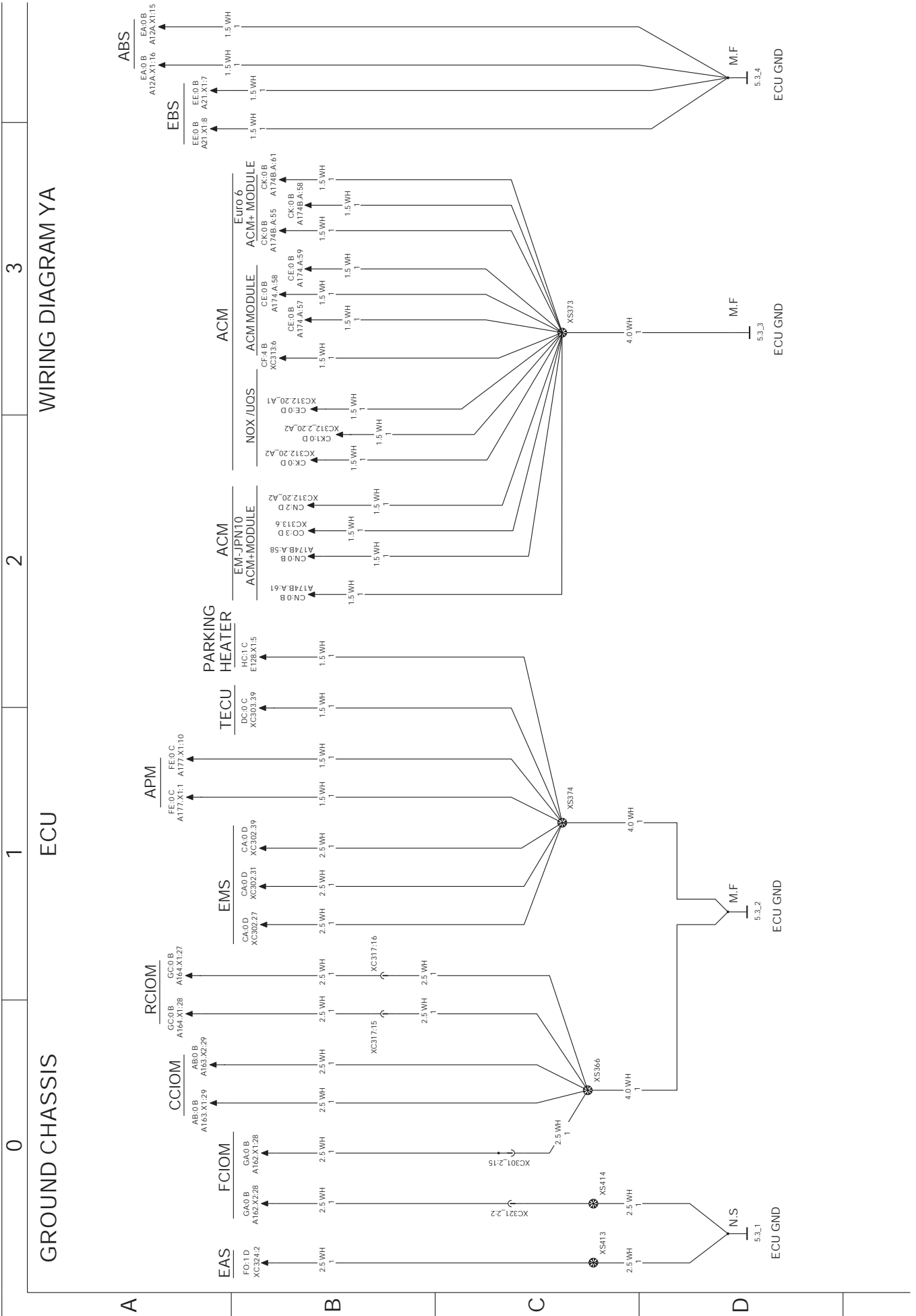

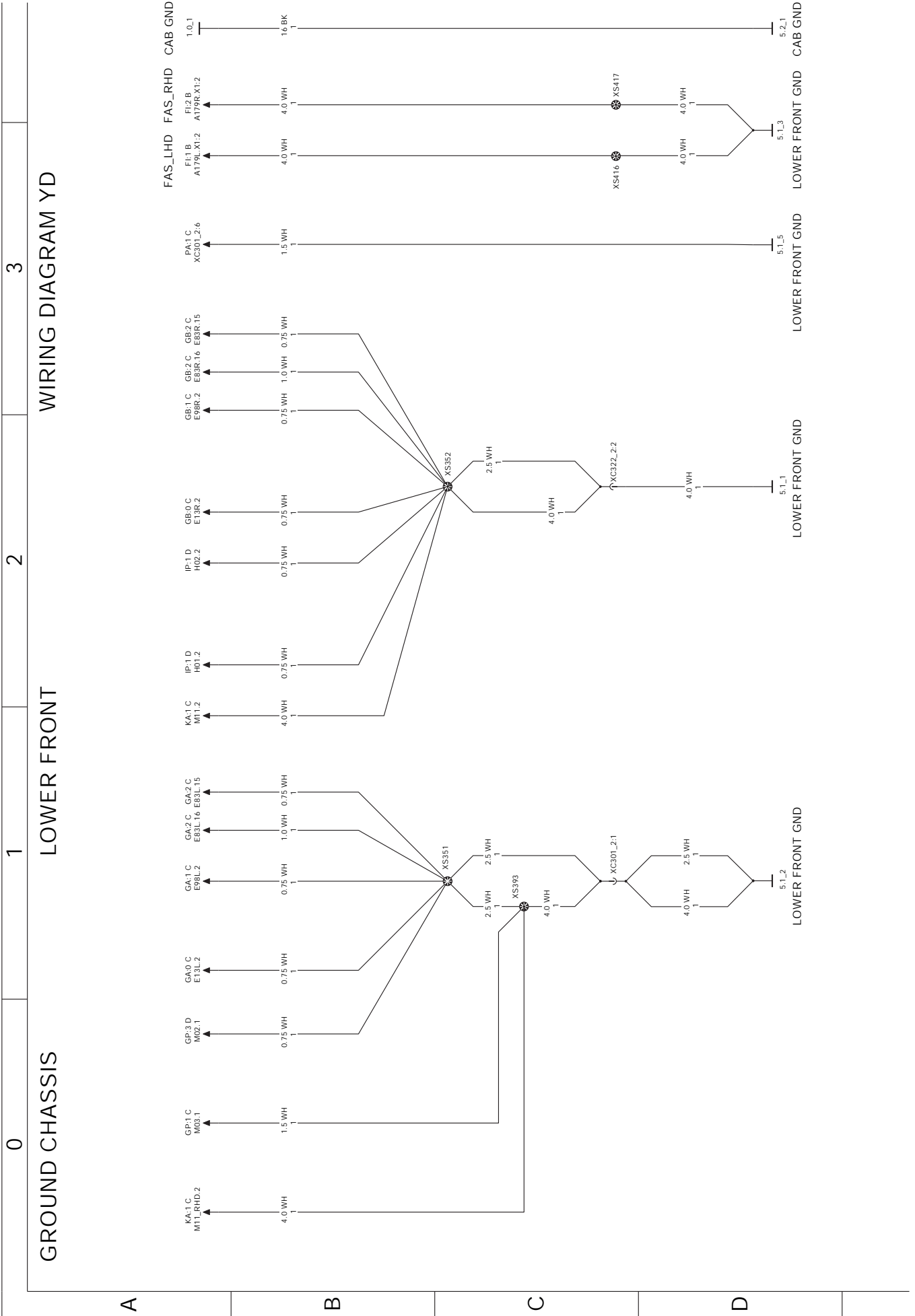

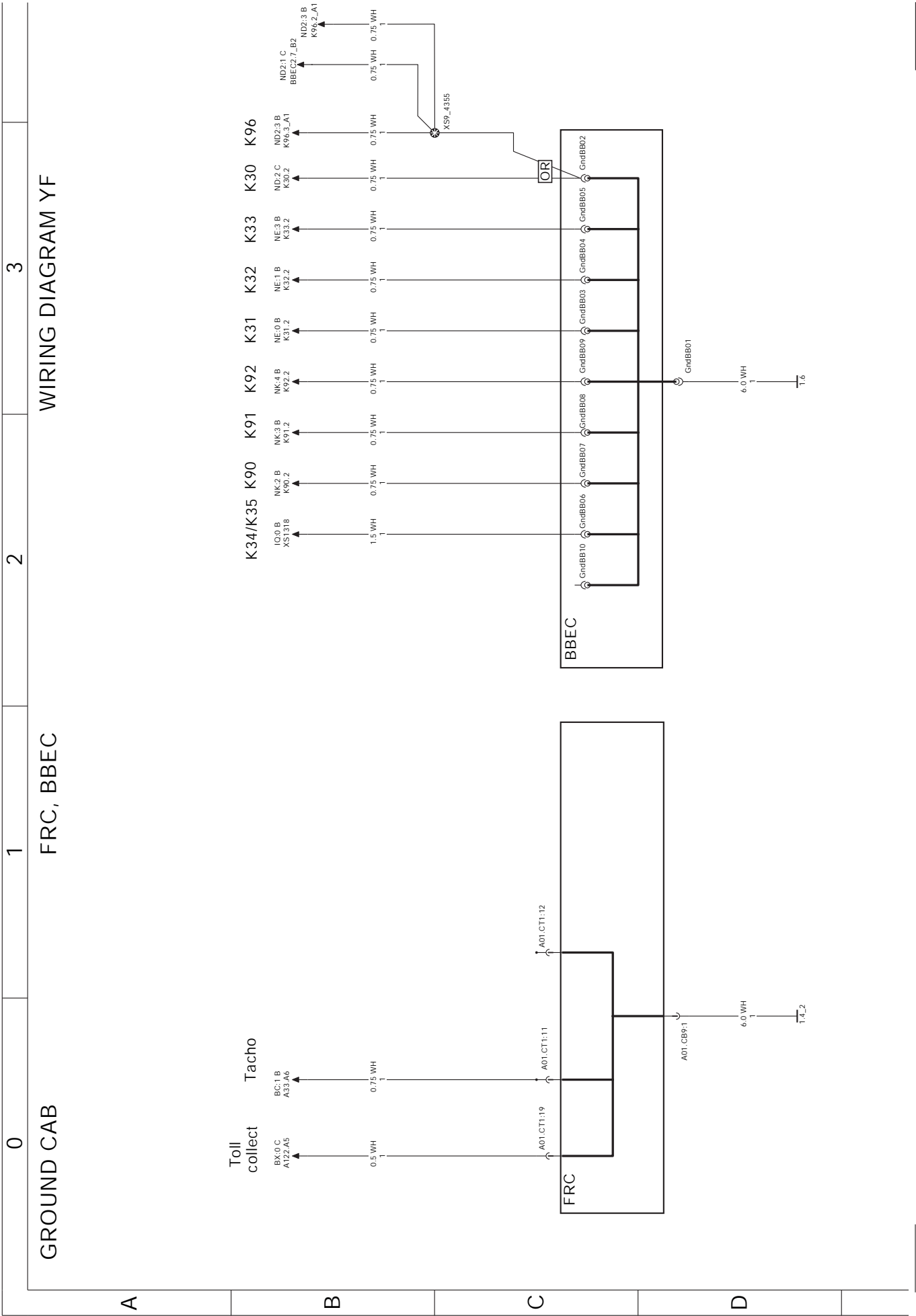

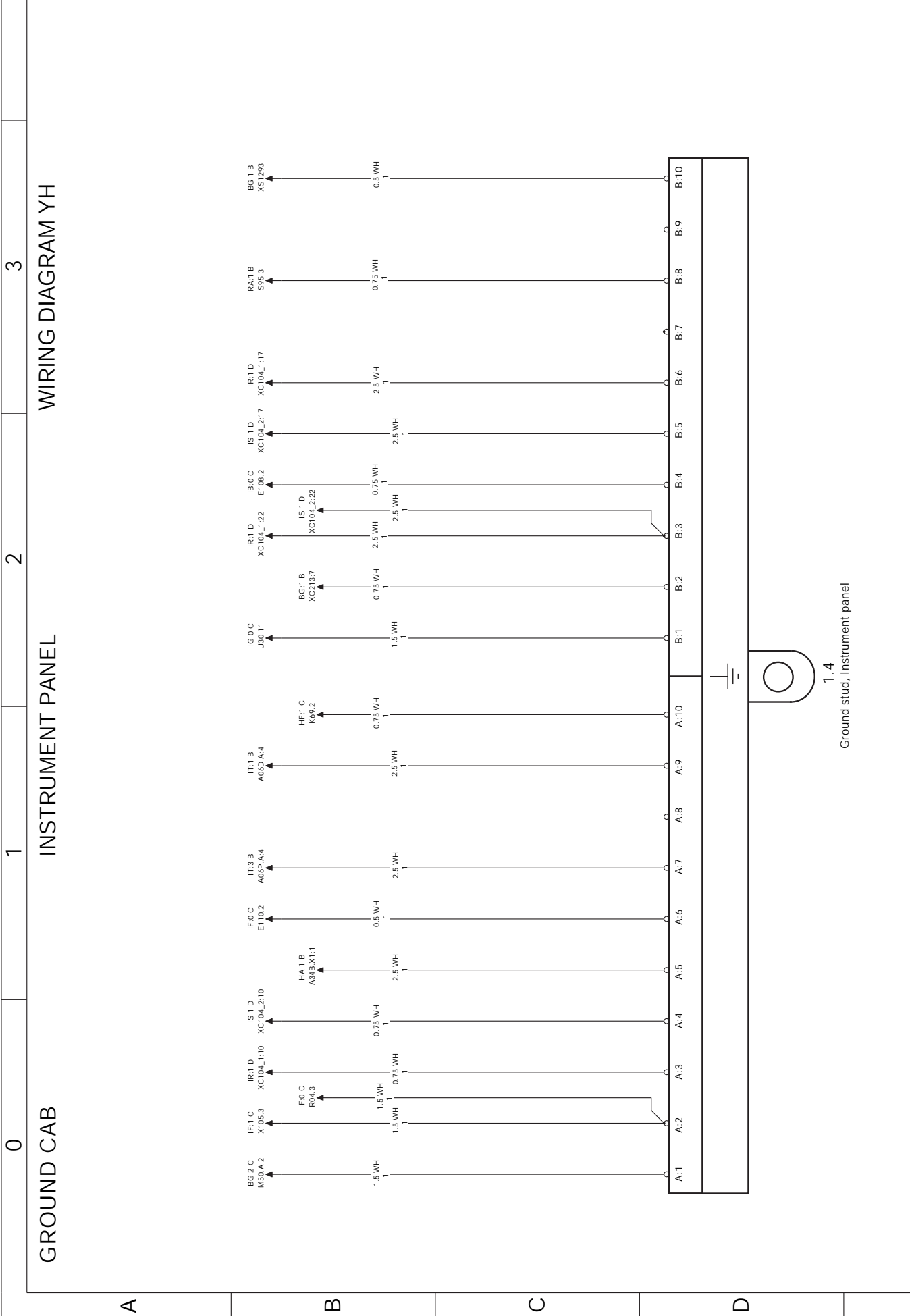

1.4
Ground stud, instrument panel

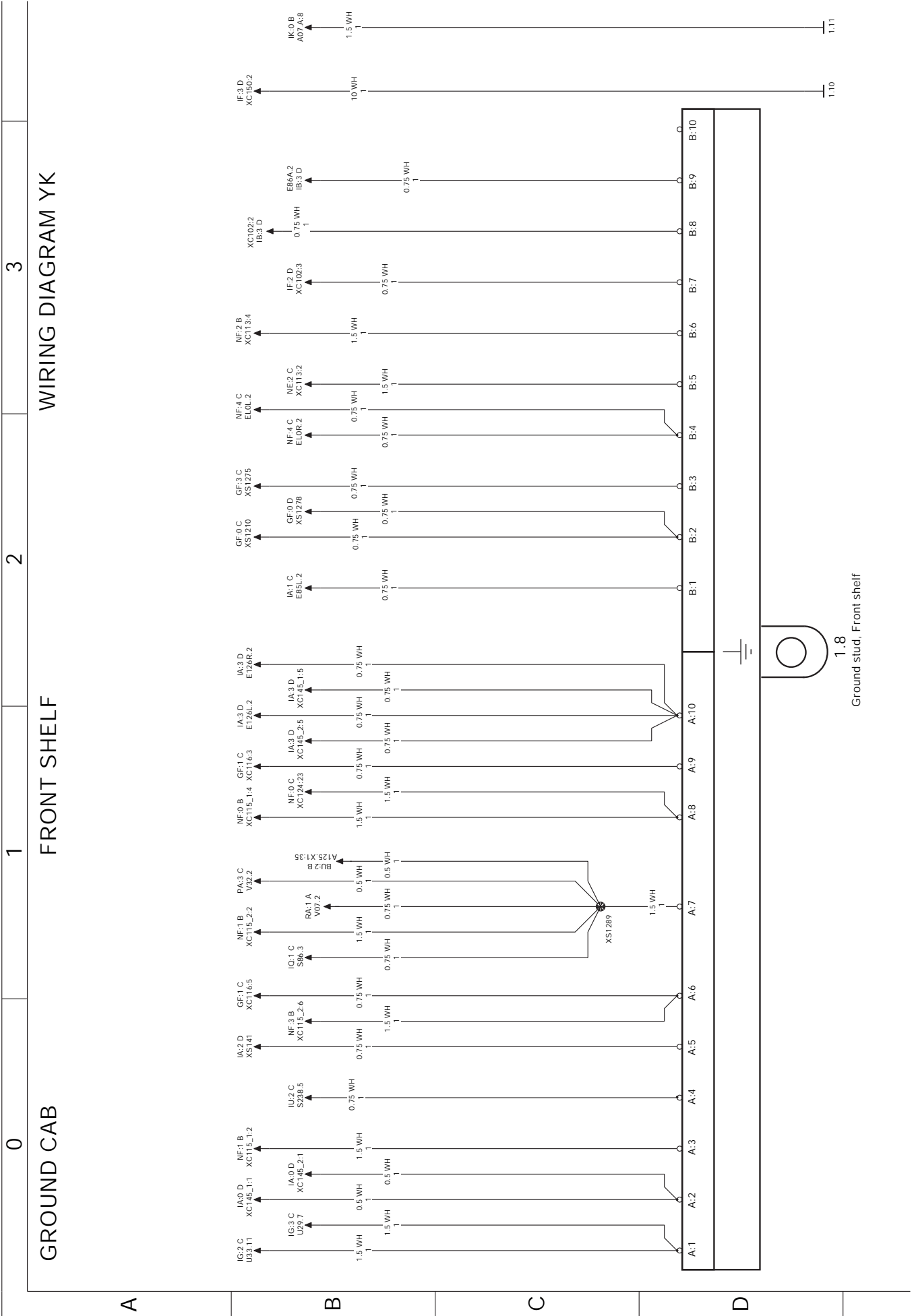

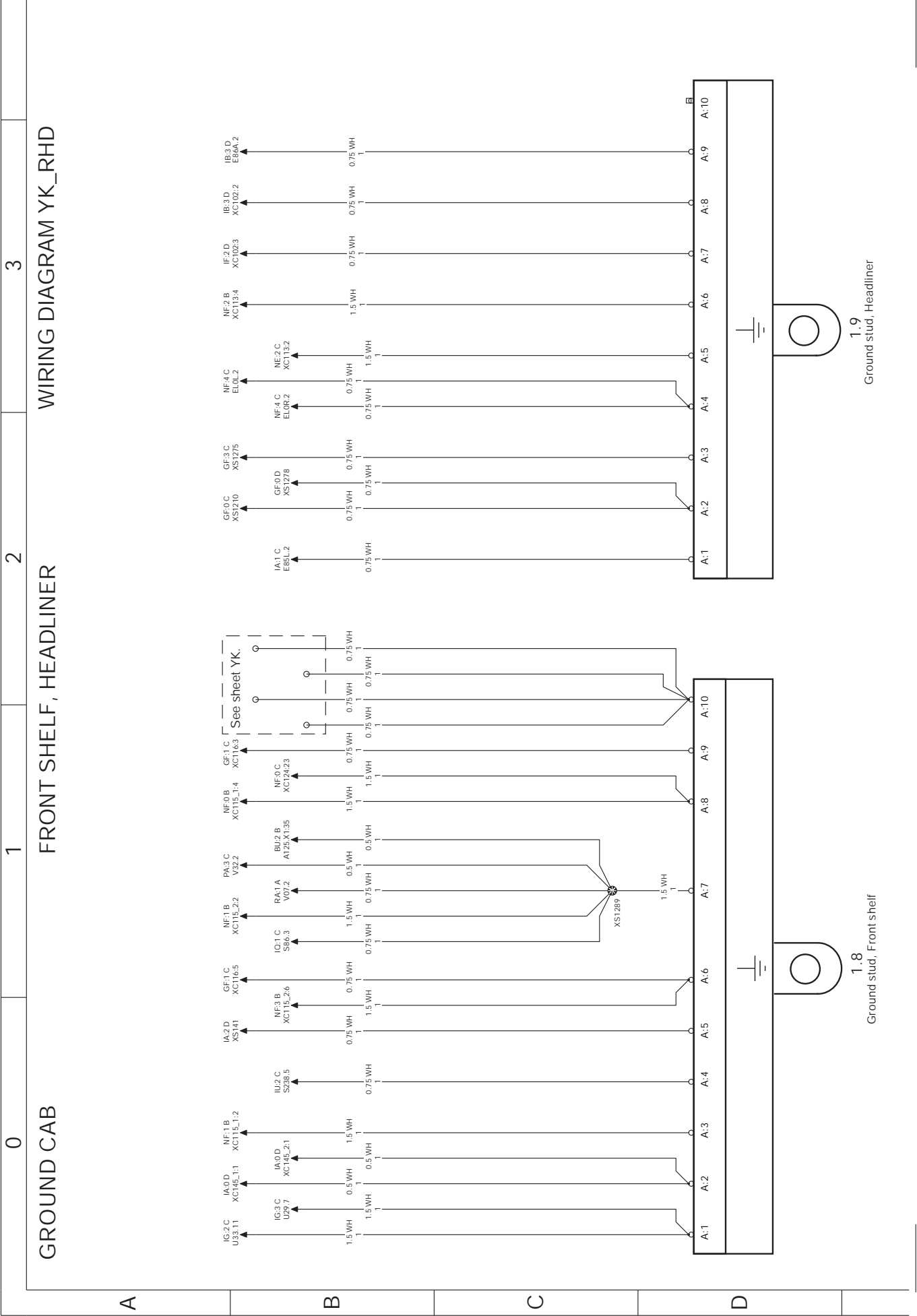

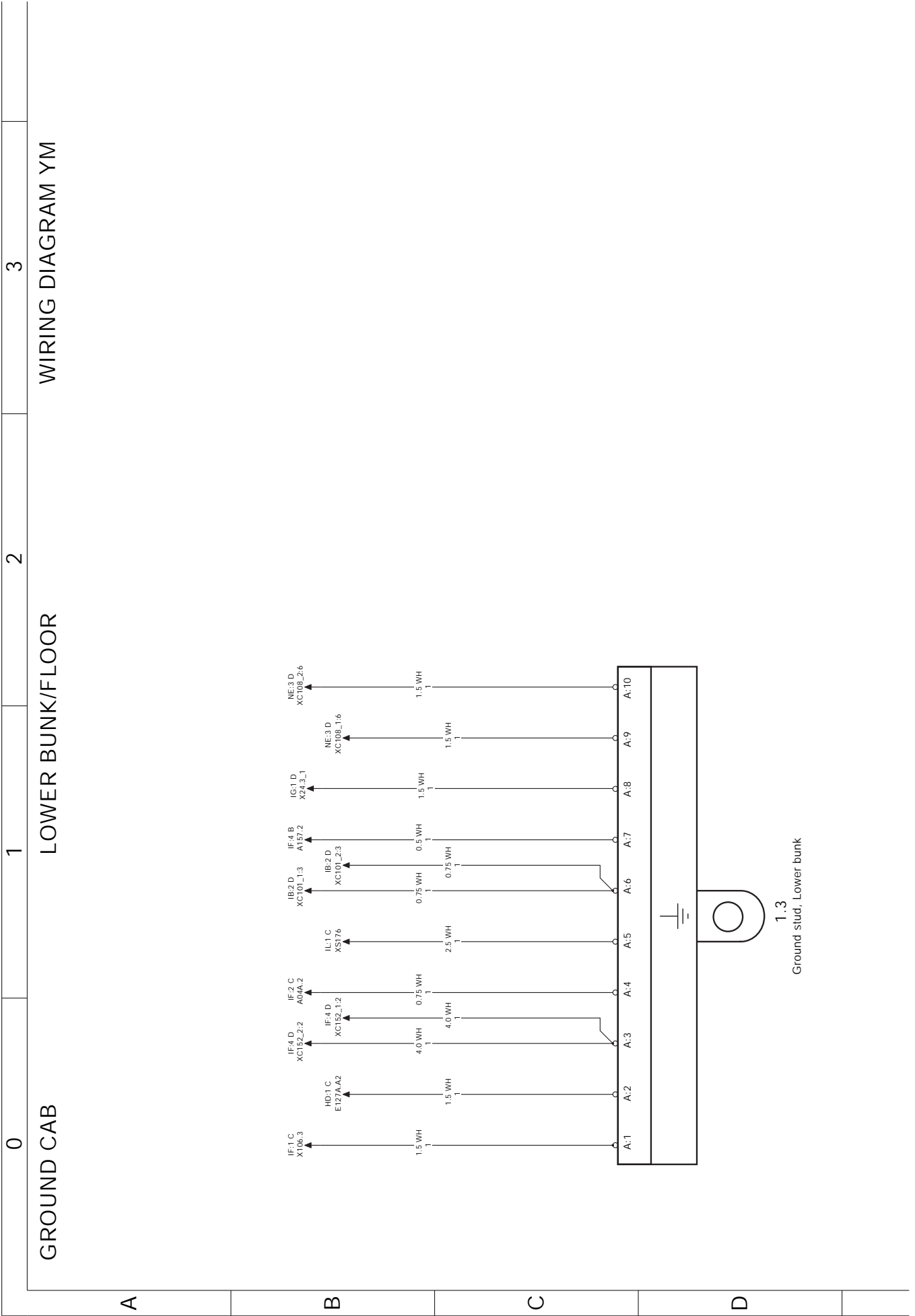

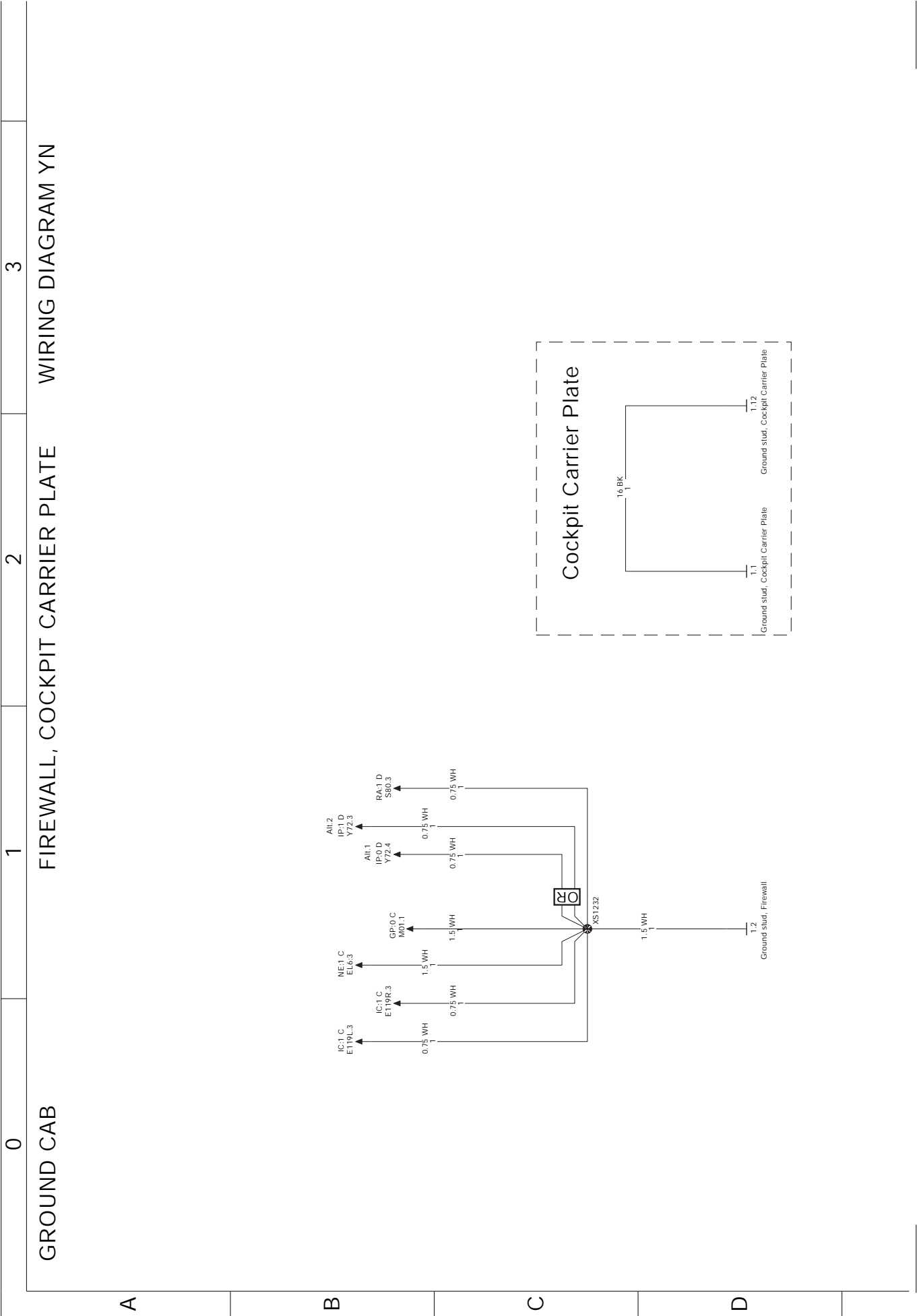

Illustrations index

-	Power supply	“ ”, page 130
-	Ground connections.....	“ ”, page 134
-	Fuse and relay centre	“ ”, page 135
-	ECU.....	“ ”, page 136
-	Antenna.....	“ ”, page 138
-	Switches.....	“ ”, page 140
-	Cab inlet.....	“ ”, page 144
1000	Wiring harness, instruments	“ ”, page 145
1100	Wiring harness, front shelf	“ ”, page 152
1110	Wiring harness, roof rear shelf.....	“ ”, page 156
1140	Wiring harness, rear wall	“ ”, page 160
1150	Wiring harness, door.....	“ ”, page 162
1160	Wiring harness, firewall.....	“ ”, page 164
2000	Wiring harness, lower front	“ ”, page 166
2010	Wiring harness, main front.....	“ ”, page 167
2020	Wiring harness, battery box	“ ”, page 178
2030	Wiring harness, SCR	“ ”, page 184
2040	Wiring harness, main rear.....	“ ”, page 191
2050	Wiring harness, side marking lights	“ ”, page 201
2060	Wiring harness, trailer connection	“ ”, page 192
2070	Wiring harness, rear lights, diff.	“ ”, page 191
2080	Wiring harness, ECS	“ ”, page 191
2090	Wiring harness, ABS/EBS	“ ”, page 202
2100	Wiring harness, RAS-EC	“ ”, page 203
2120	Wiring harness, body builder	“ ”, page 211
2125	Wiring harness, side/reverse working light.....	“ ”, page 201
2130	Wiring harness, plough light	“ ”, page 164
3000	Wiring harness, engine.....	“ ”, page 212
3010	Wiring harness, gearbox.....	“ ”, page 224
3020	Wiring harness, retarder	“ ”, page 226

Illustrations

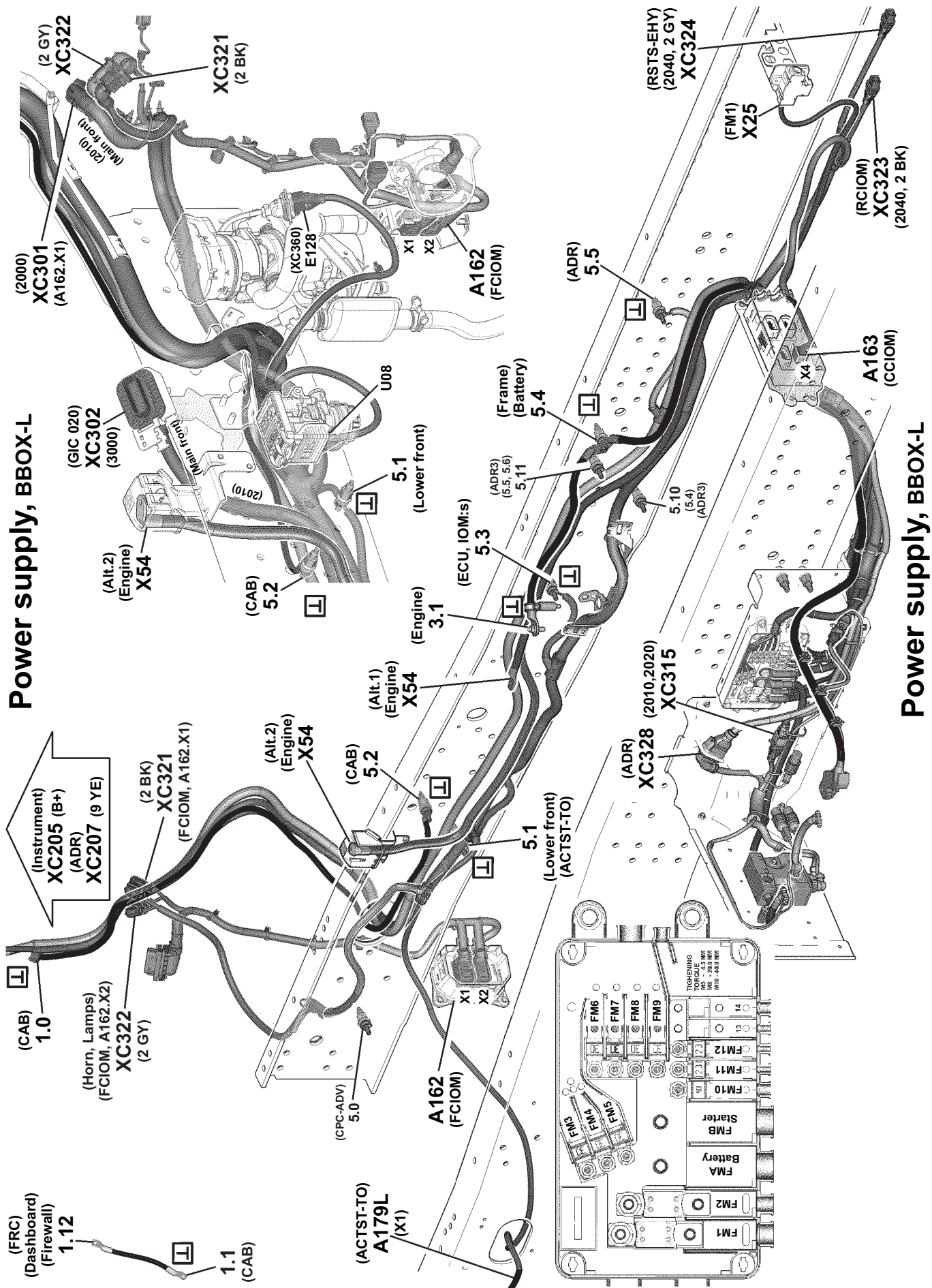

Power supply, FAA20

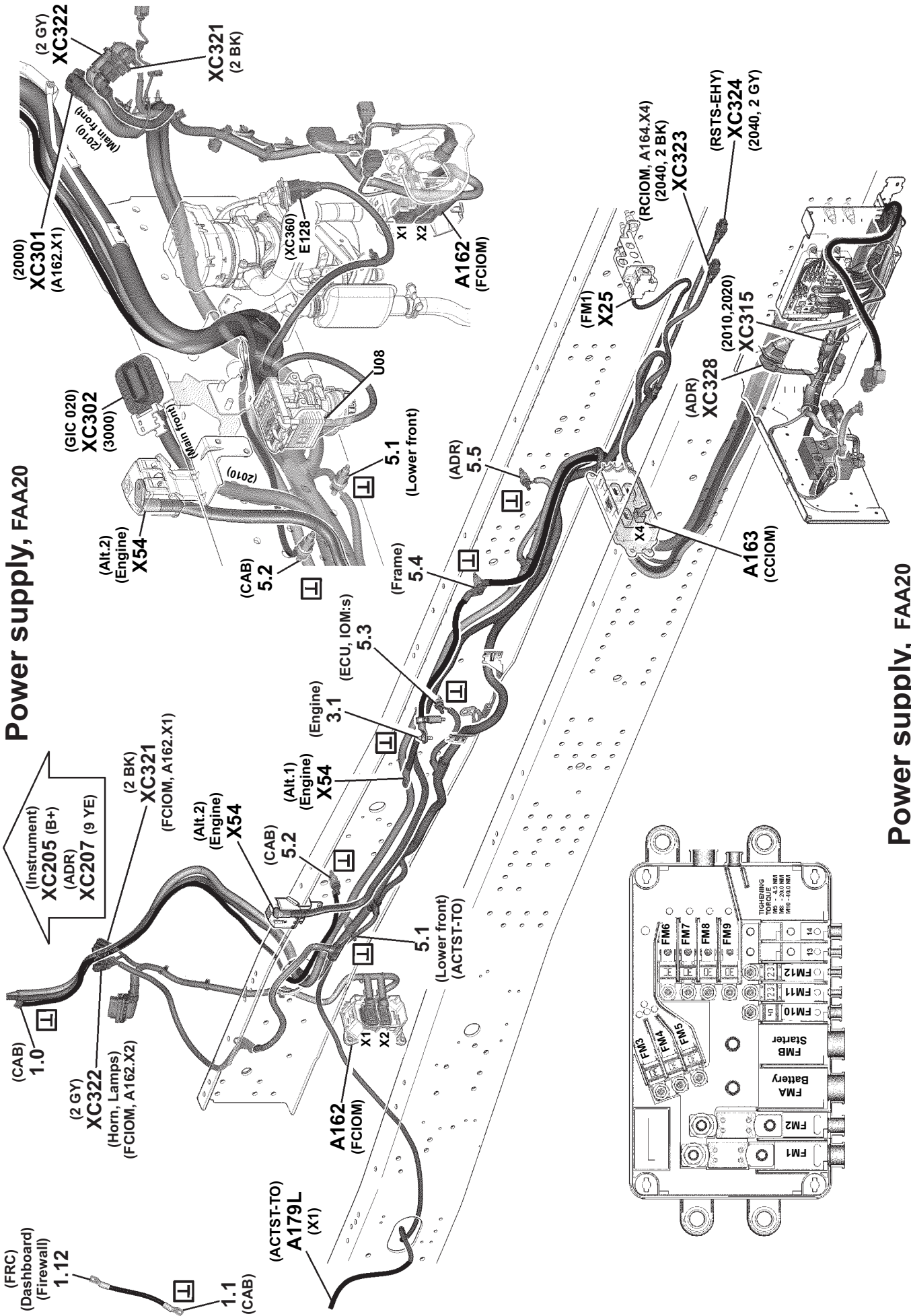

Power supply, FAA20

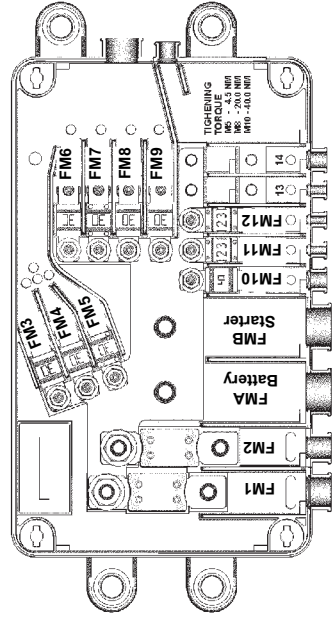

Ground

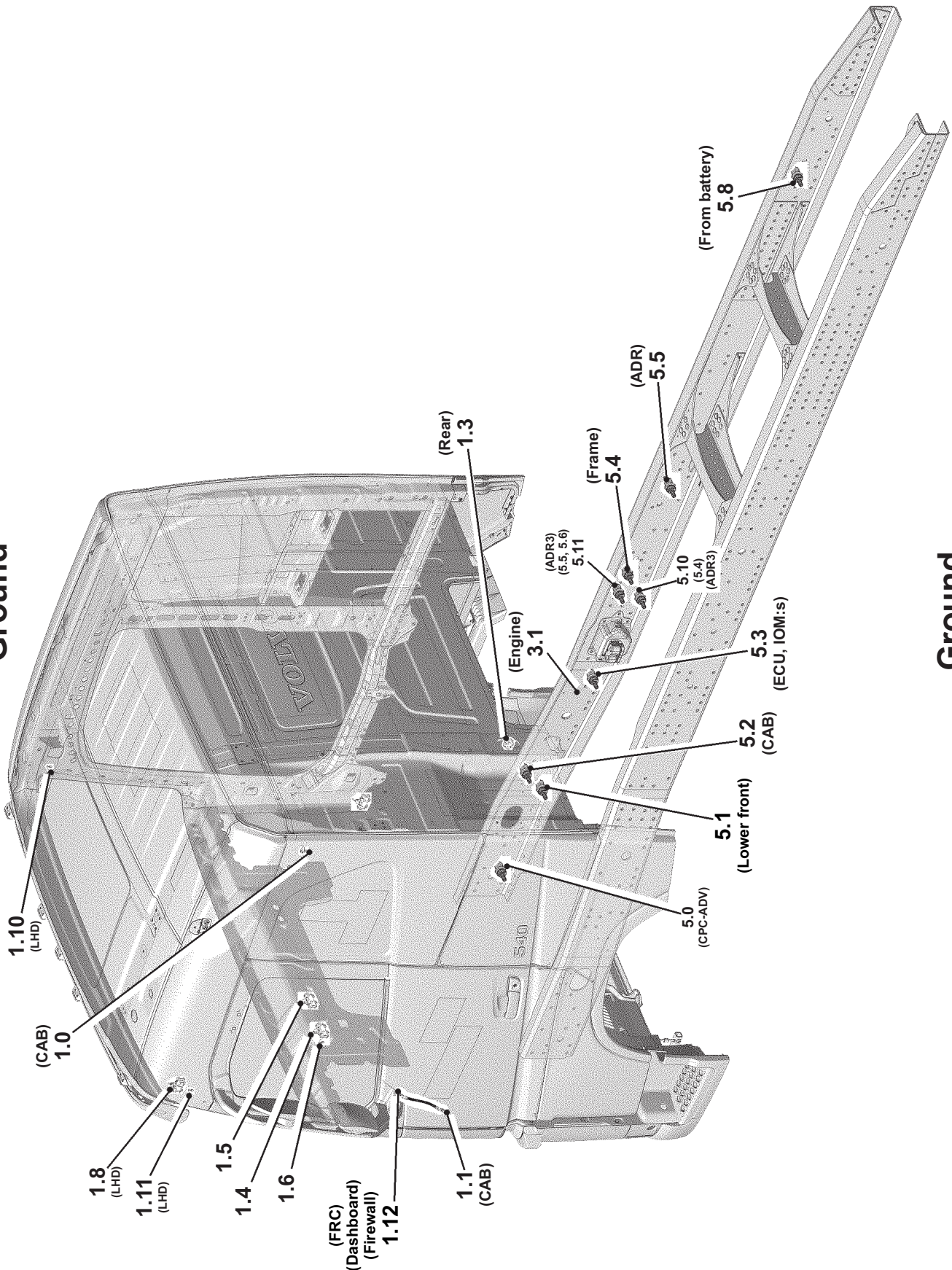

Ground

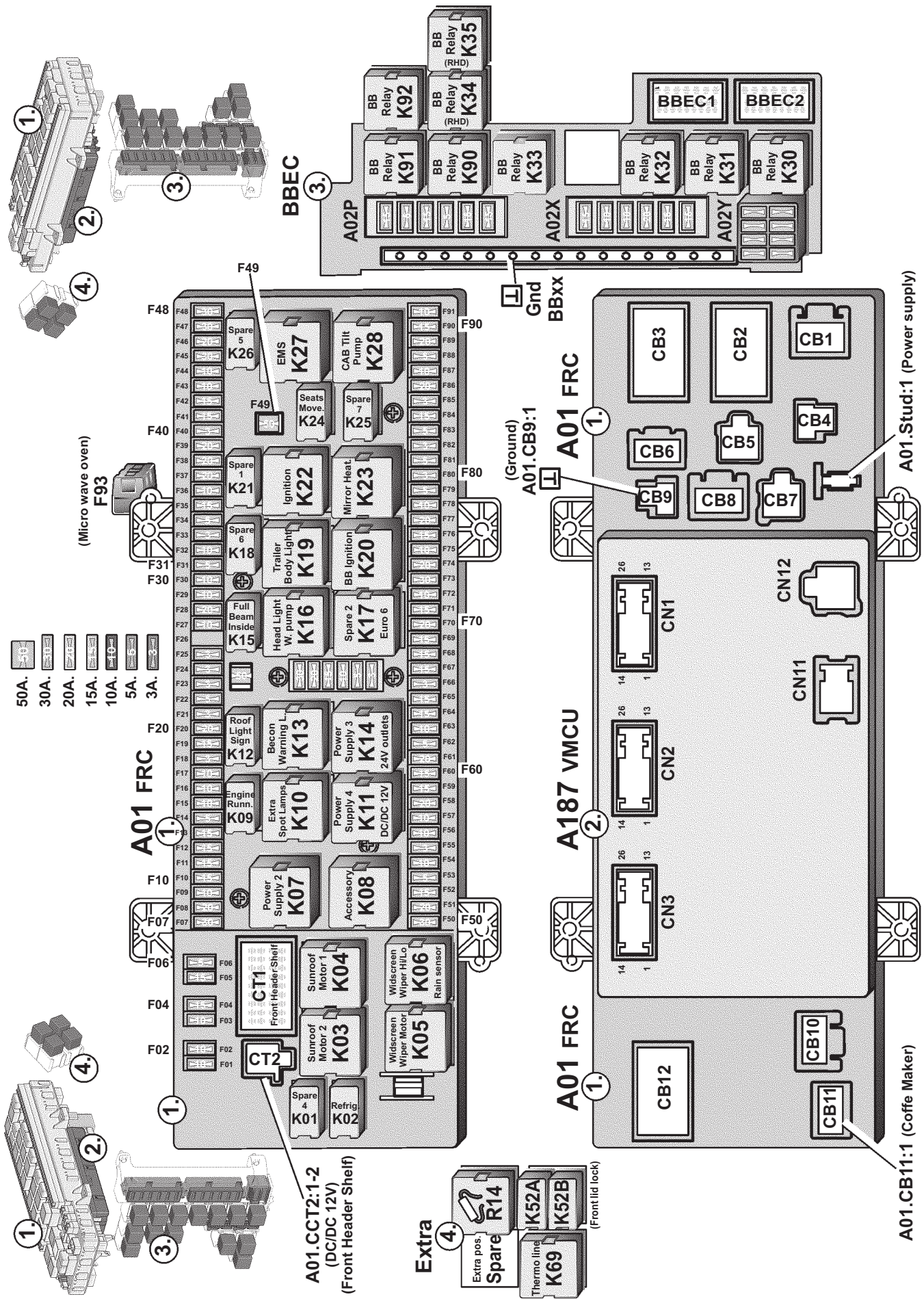

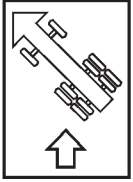

ECU, LHD

ECU, LHD

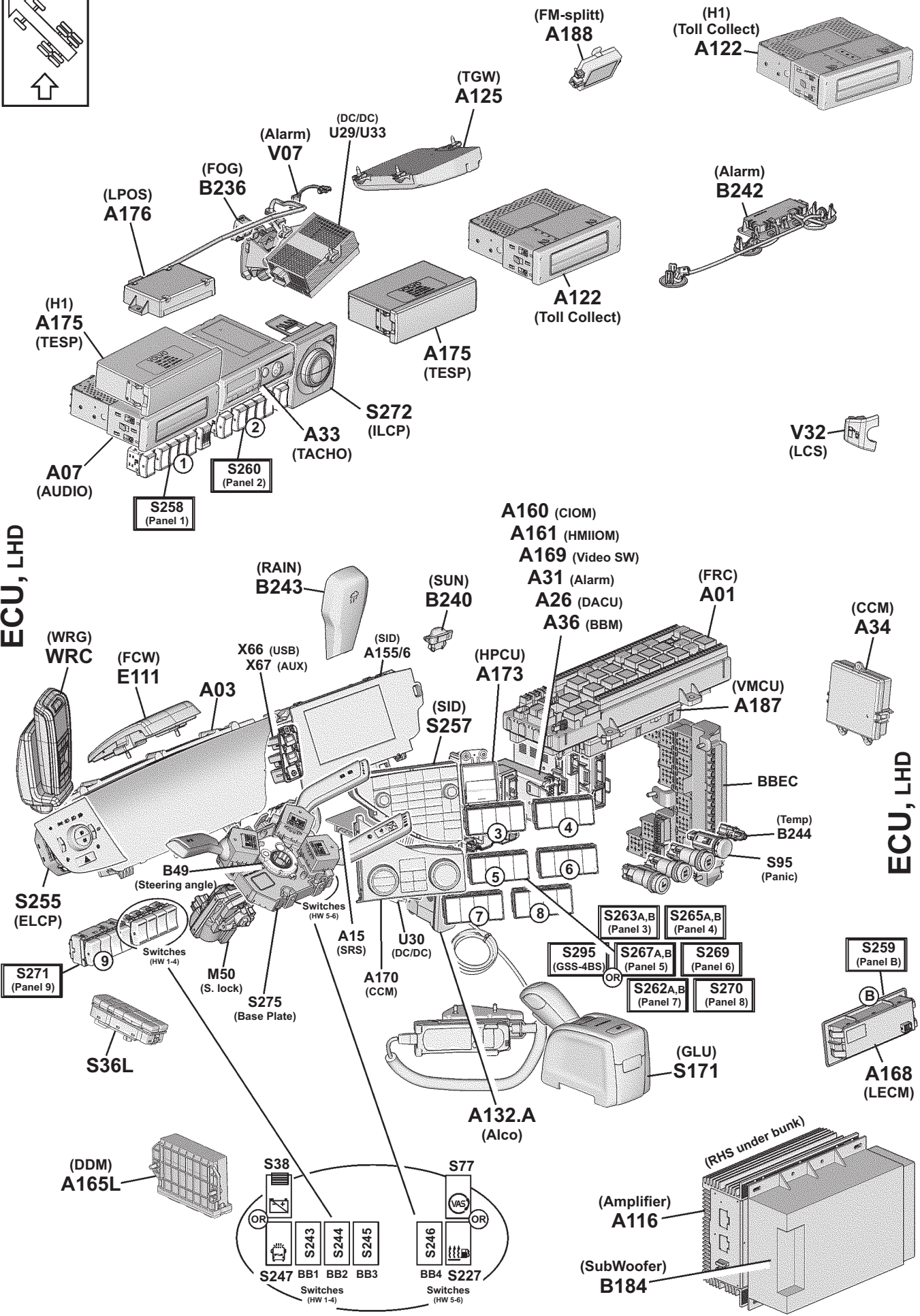

T3081032

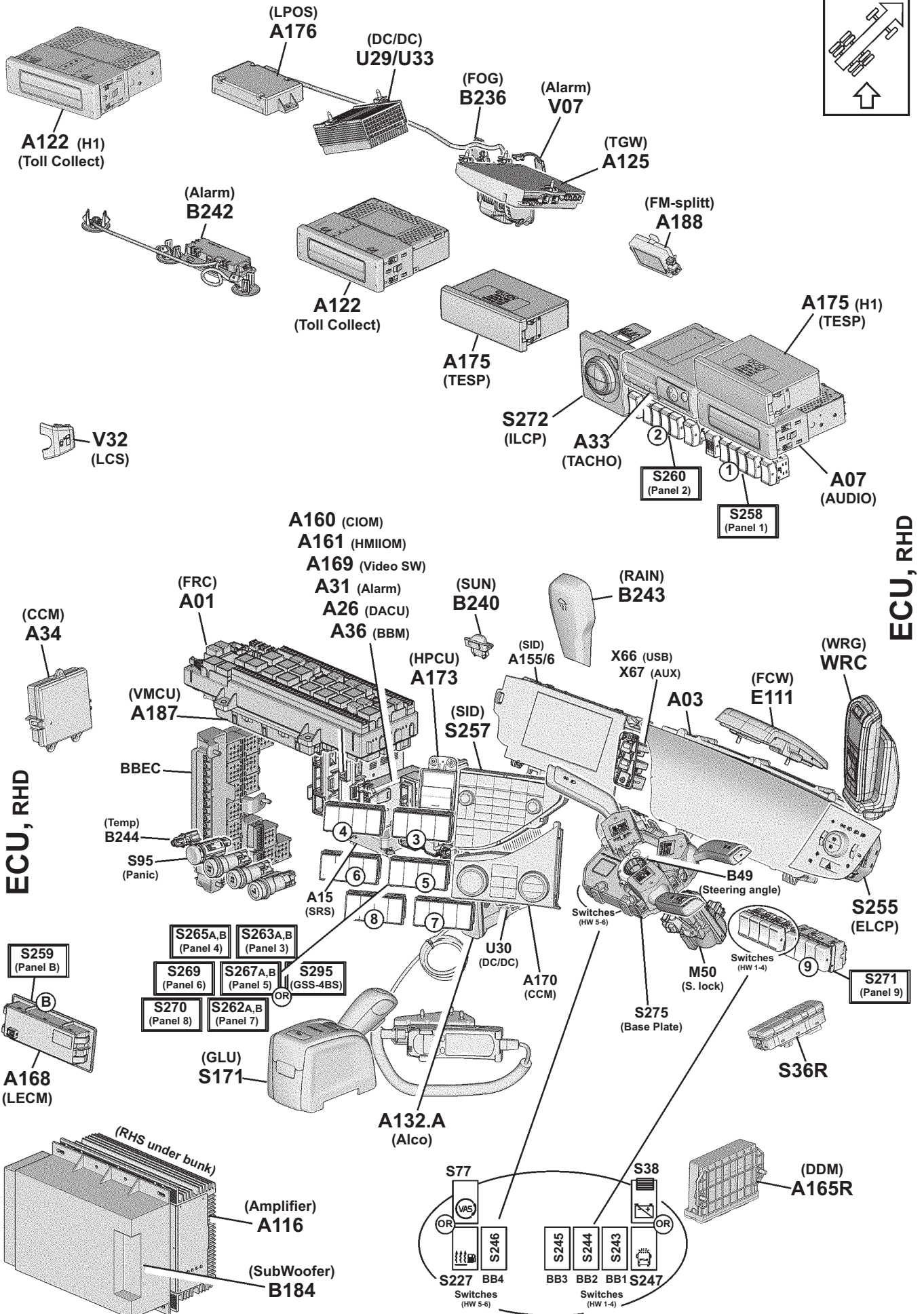
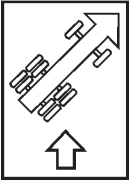

ECU, RHD

ECU, RHD

T3081033

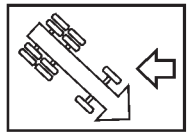

Antennas, H1

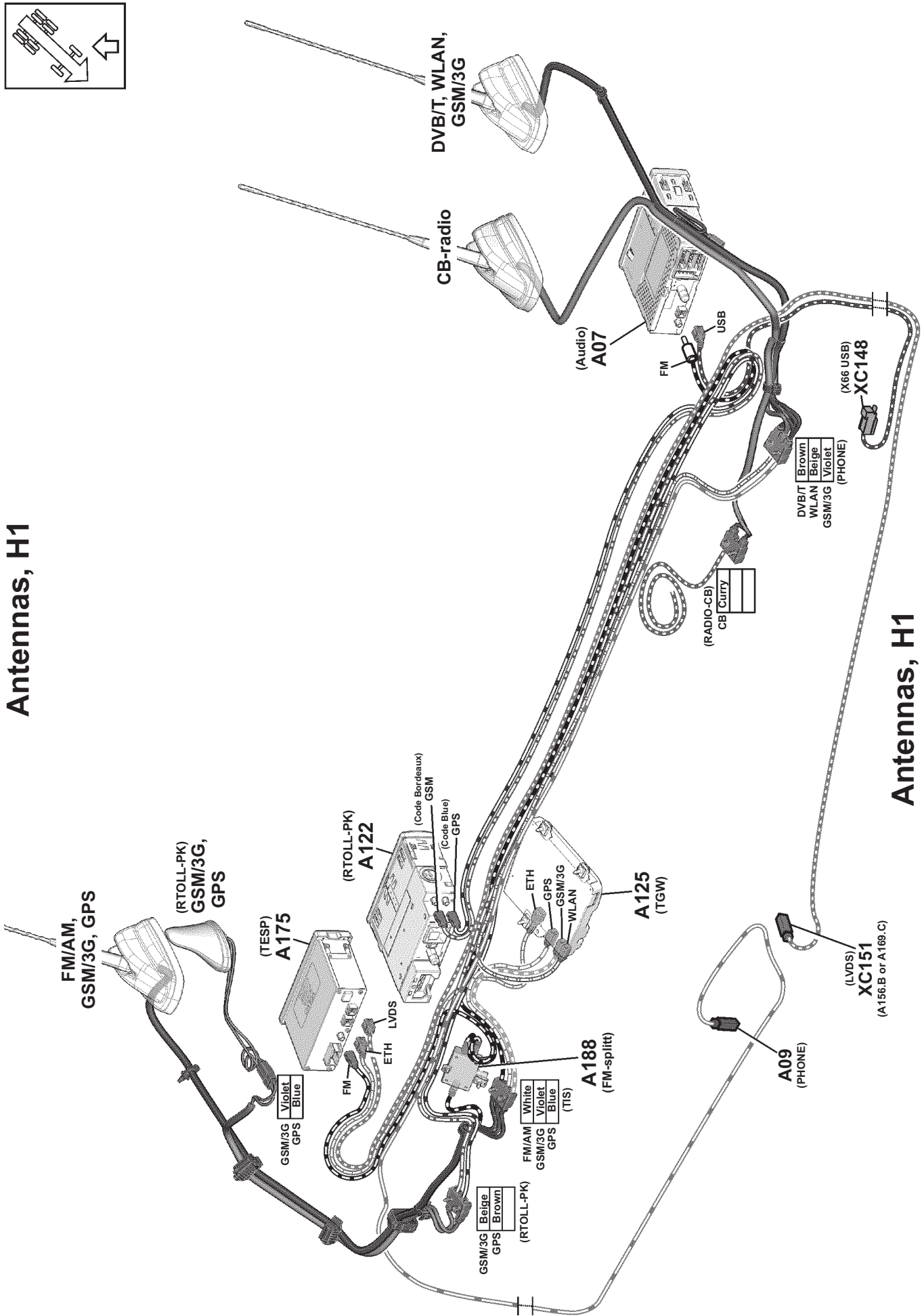

Antennas, H1

T3065123

Antennas, H2/H3

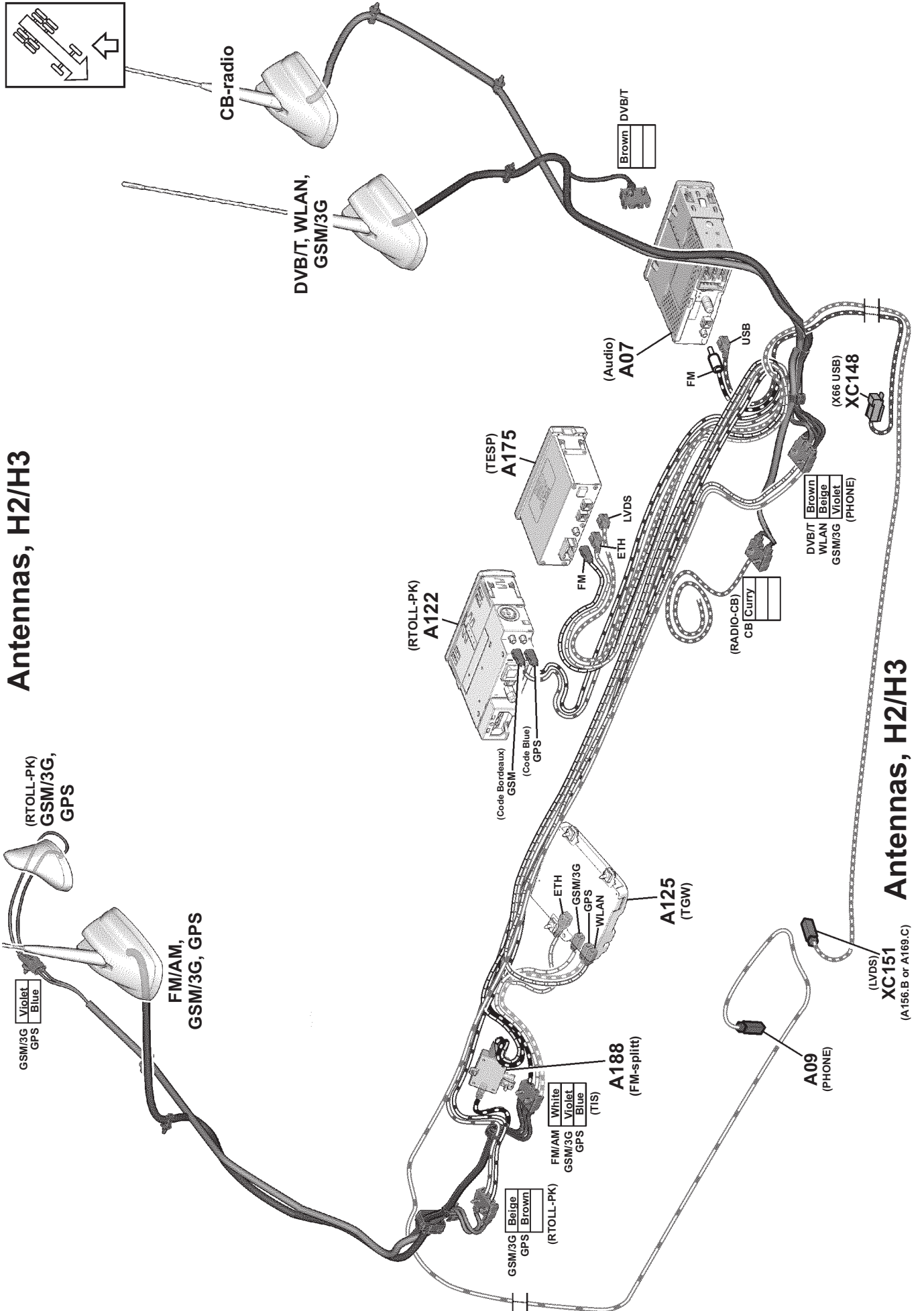

T3076467

Switches

B02B		S02		S03		S03A		S05A		S08	
Temperature adjustment		Interior lighting		Work lights, fifth wheel		Work lights, cab rear		Automatic interior lighting		Differential lock rear	
S09		S10		S11		S12		S20			
Differential lock between rear axles		Roof sign light		Bogie lift		Plough lights		Steering lock, rear axle			
S23		S26		S28A		S28B		S31		S32	
Roof hatch		Cab tilt		Power take off 1		Power take off 2		Traction control		Hill start aid	
		S73		S75		S76		S76A		S76B	
		Reverse warning		Warning lamp, roof		Auxiliary lamps, headlamps		Headlamps roof		Headlamps front	
		S79		S79A		S83		S86		S96	
		Side revers/working light		Side working light		Container lock		Folding mirrors		Alarm reduce set	
S113		S127		S188		S202		S210		S211	
Tridem axle lift		Crane		Interior lighting, night		Lane keeping support (LKS)		Identification light		Regeneration	

Switches

Flexible switches

Component number	Switch id	Description
B02B	3	Switch, parking heater adjustmt
S02	1	Switch, interior light
S03	23	Switch, fifth wheel light
S03A	24	Switch, working light cab back
S05A	5	Switch, interior light and door auto
S08	35	Switch, diff. lock rear wheels
S09	36	Switch, diff. lock inter axle and rear wheel
S10	15	Switch, roof sign light
S11	42	Switch, bogie lift
S12	20	Switch, plough light
S20	34	Switch, 3:rd axle lock
S23	4	Switch, roof hatch
S26	12	Switch, cab tilt
S28A	50	Switch, power take off 1
S28B	51	Switch, power take off 2
S31	38	Switch, traction control
S32	39	Switch, hill start aid
S73	29	Switch, back up alarm
S75	16	Switch, beacon warning light
S76	14	Switch, extra main beams
S76A	17	Switch, spot light roof
S76B	18	Switch, spot light front
S79	22	Switch, side reverse/working light
S79A	22	Switch, side working light
S83	10	Switch, fifth wheel slide lock/container lock
S96	13	Switch, alarm reduced set
S113	44, 45	Switch, tridem axle lift
S127	27	Switch, crane
S188	26	Switch, interior light, night light
S202	30	Switch, lane keeping support
S210	15	Switch, identification light
S211	66	Switch, regeneration inhibit

Flexible switches

<i>Component number</i>	<i>Switch id</i>	<i>Description</i>
S212	8	Switch, tail lift
S218	2	Switch, parking heater
S220	19	Switch, static corner light
S228	40, 41, 42, 43	Switch, tridem bogie control
S299	31	Switch, Lane Change Support, LCS
S300	32	Switch, Forward Collision Warning, FCW
S301	48	Switch, alt. ride height
S302	61	Switch, alt. loading height
S303	63	Switch, height mode, ferry transport
S304	62	Switch, kneeling
S305	9	Switch, reposition fifth wheel
S306	33	Switch, Driver Alert Support, DAS
S308	21	Switch, auto reversing light
S309	47	Switch, alt. power transfer/maximum traction
S310	41	Switch, maximum traction
S311	47	Switch, alt. load distribution/maximum traction
S312	48	Switch, traction bogie lift

CAB inlet

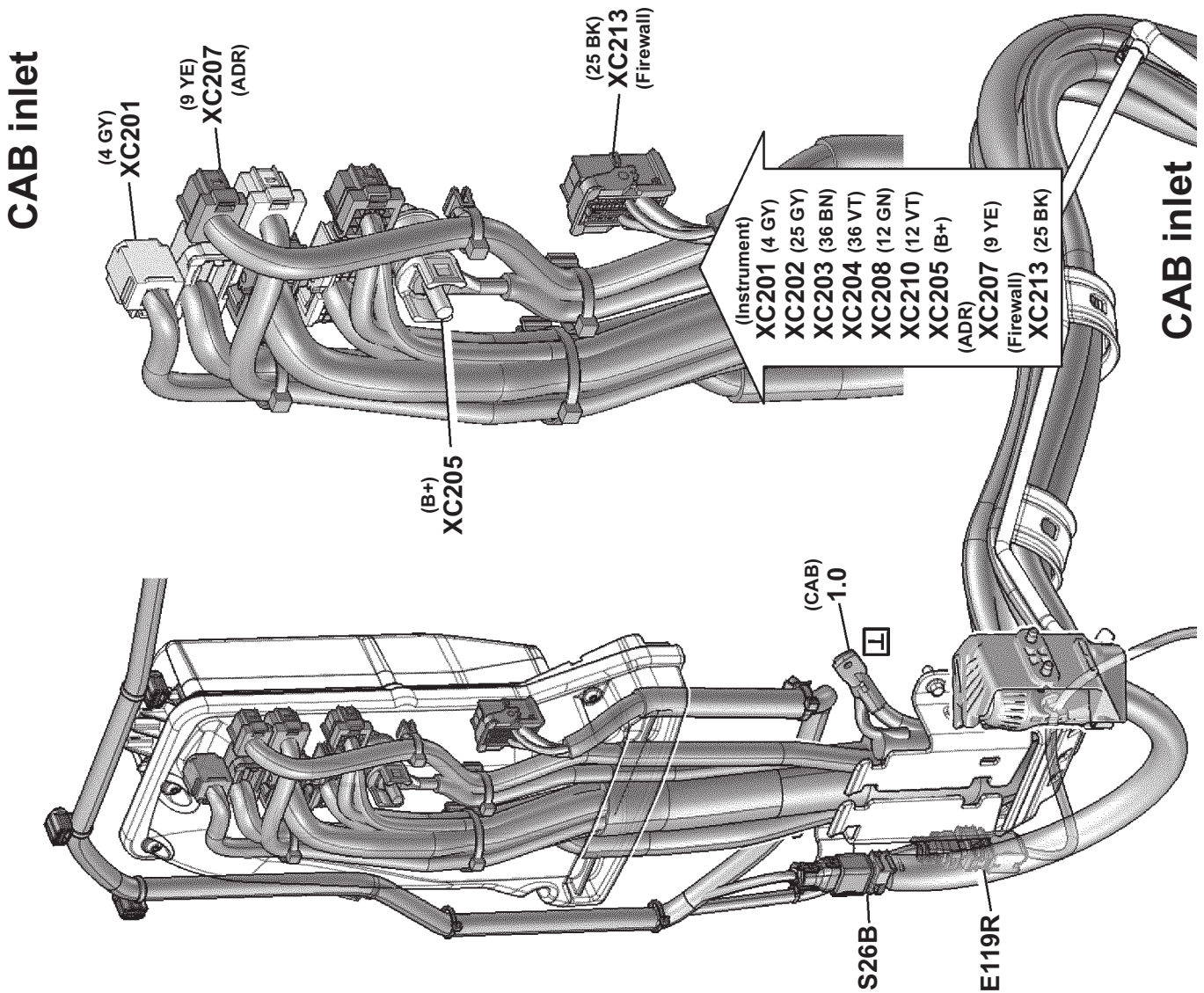
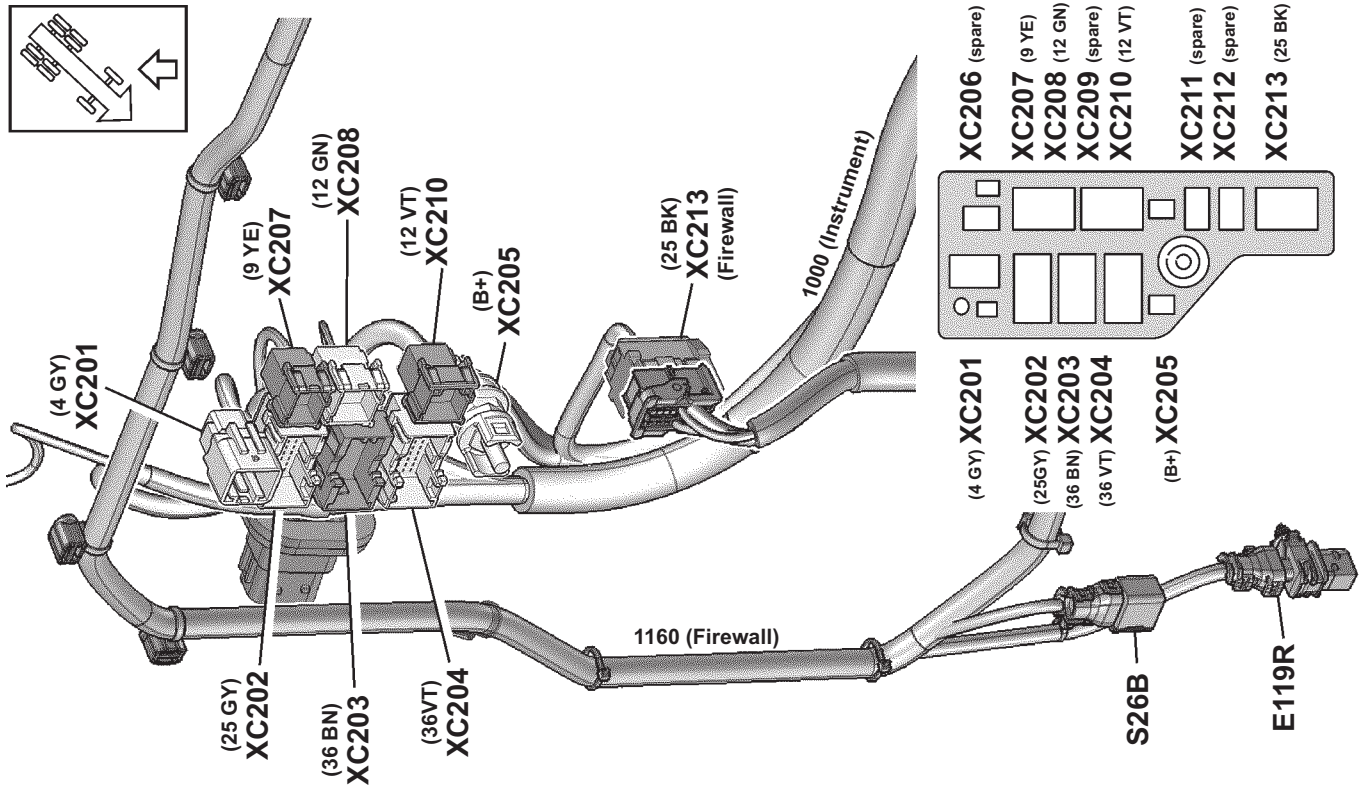

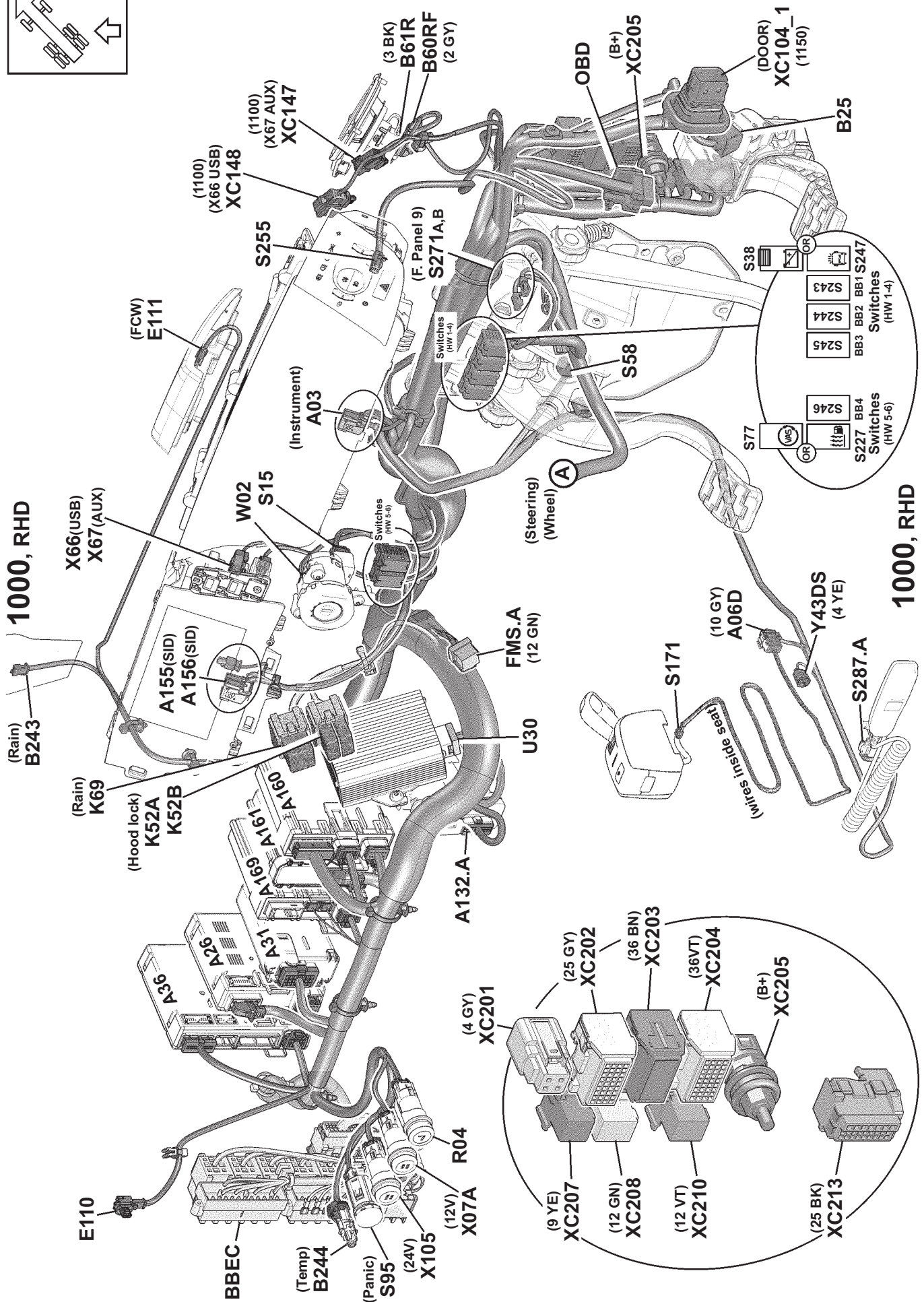
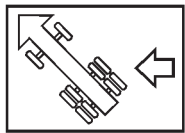

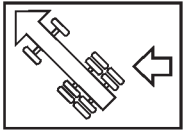

1000, Steering wheel

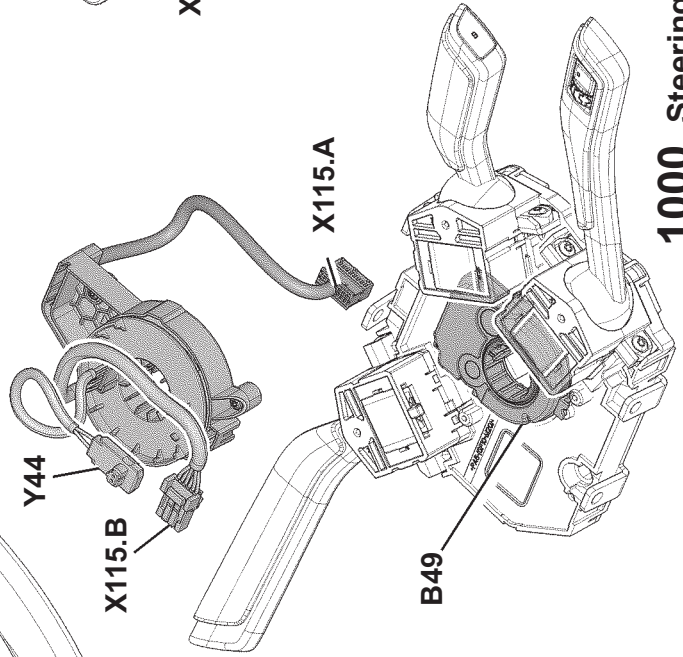
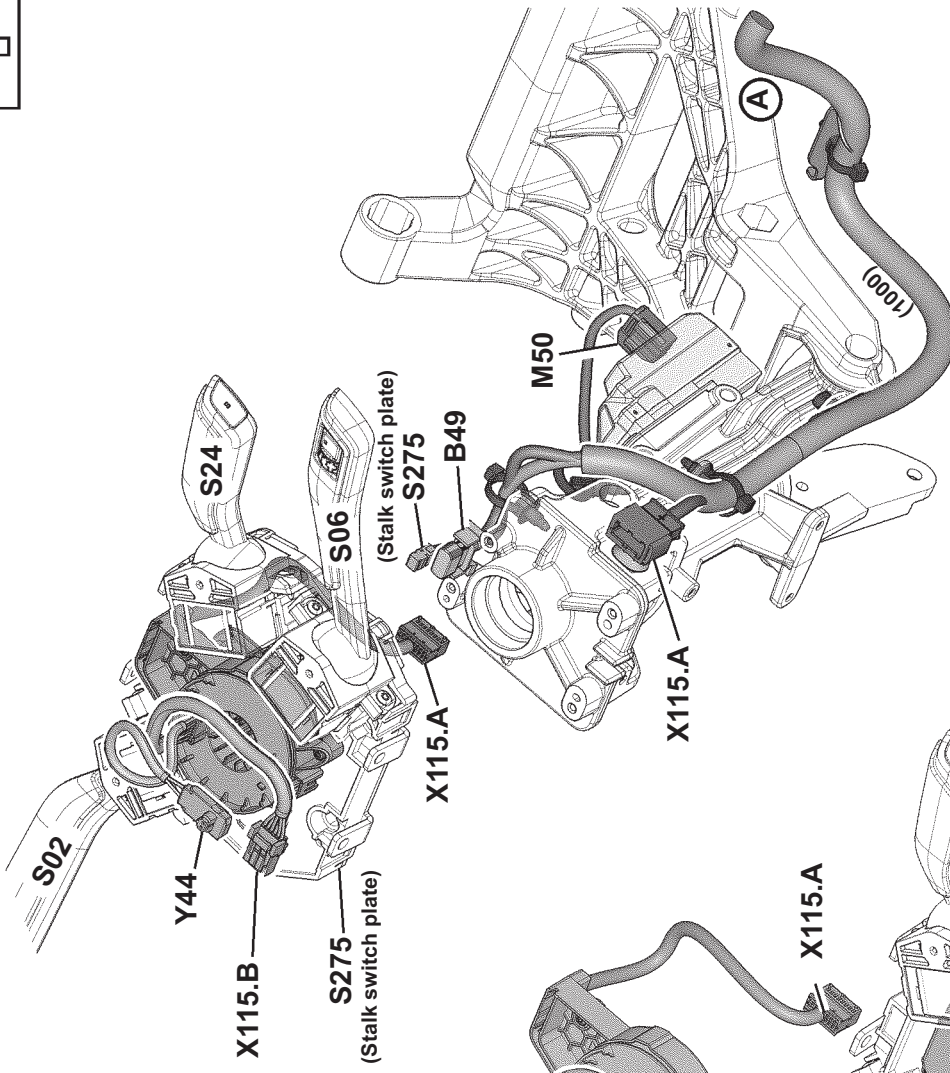
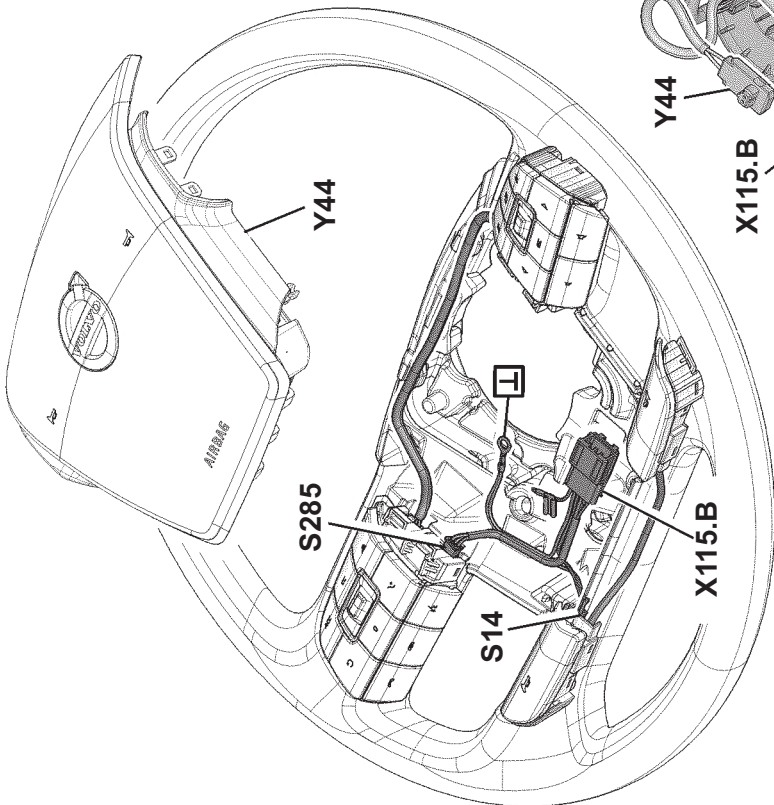

1000, Steering wheel

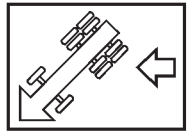

1000, LHD

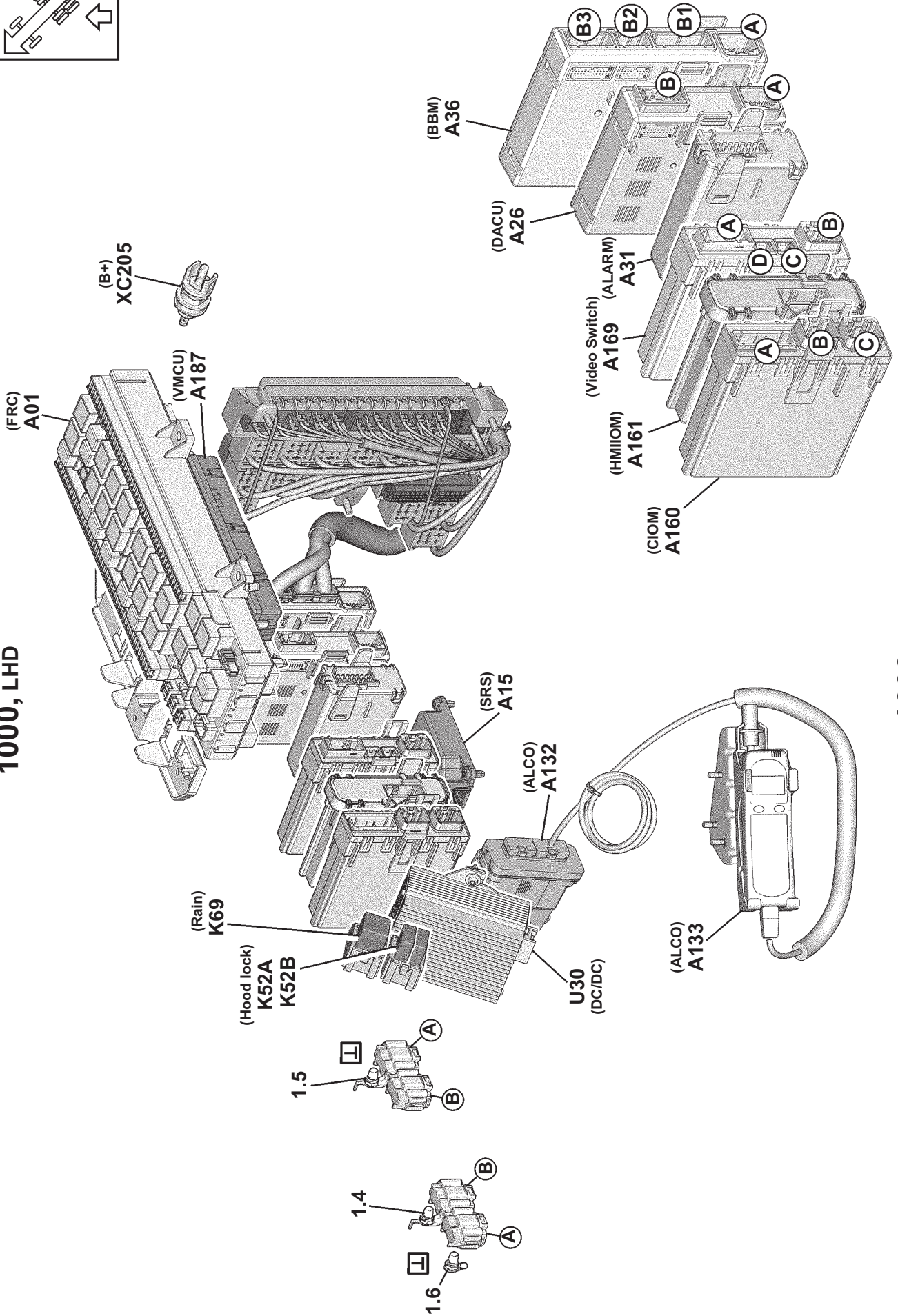

1000, LHD

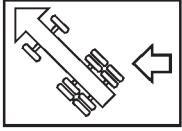

1000, RHD

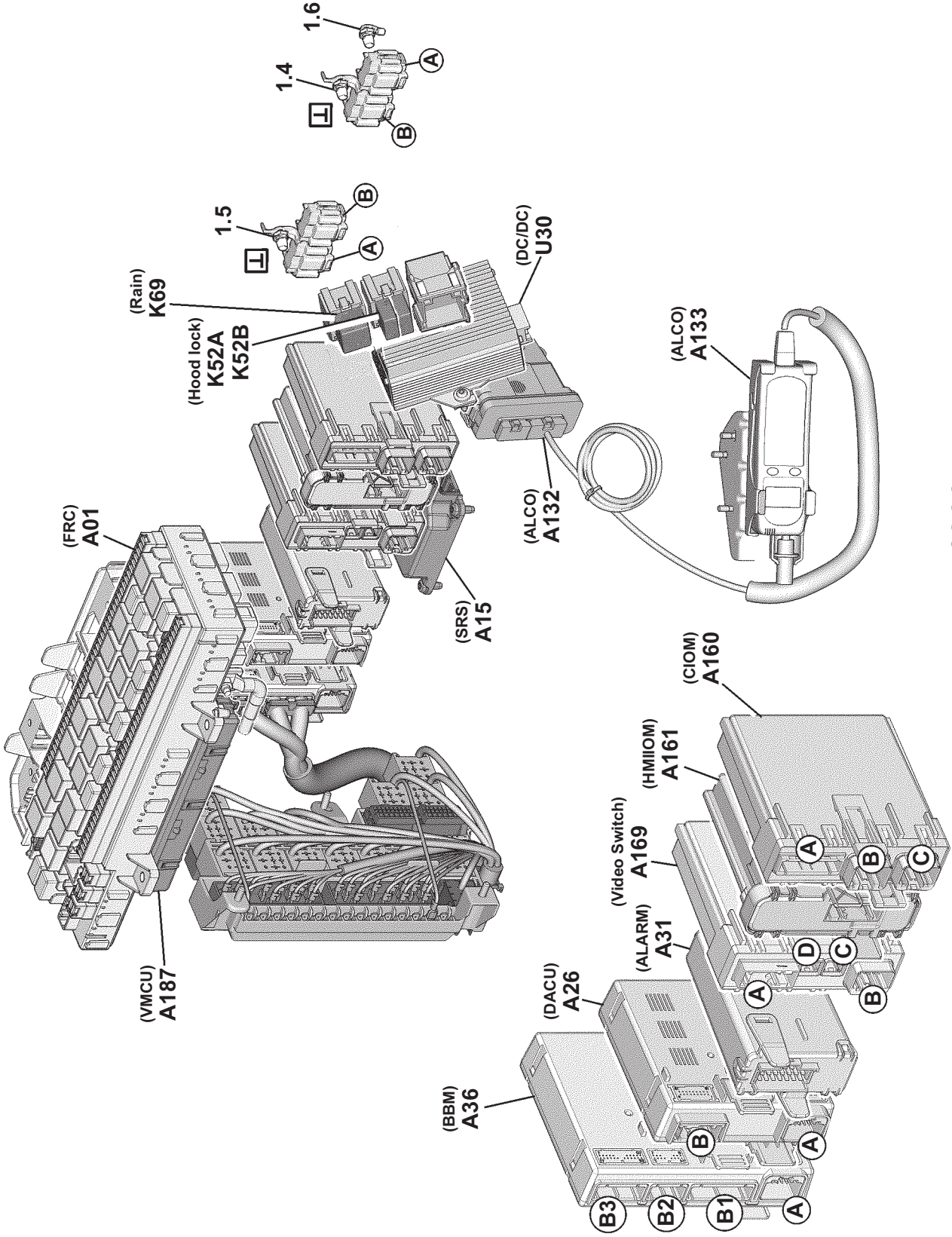

1000, RHD

1000, LHD

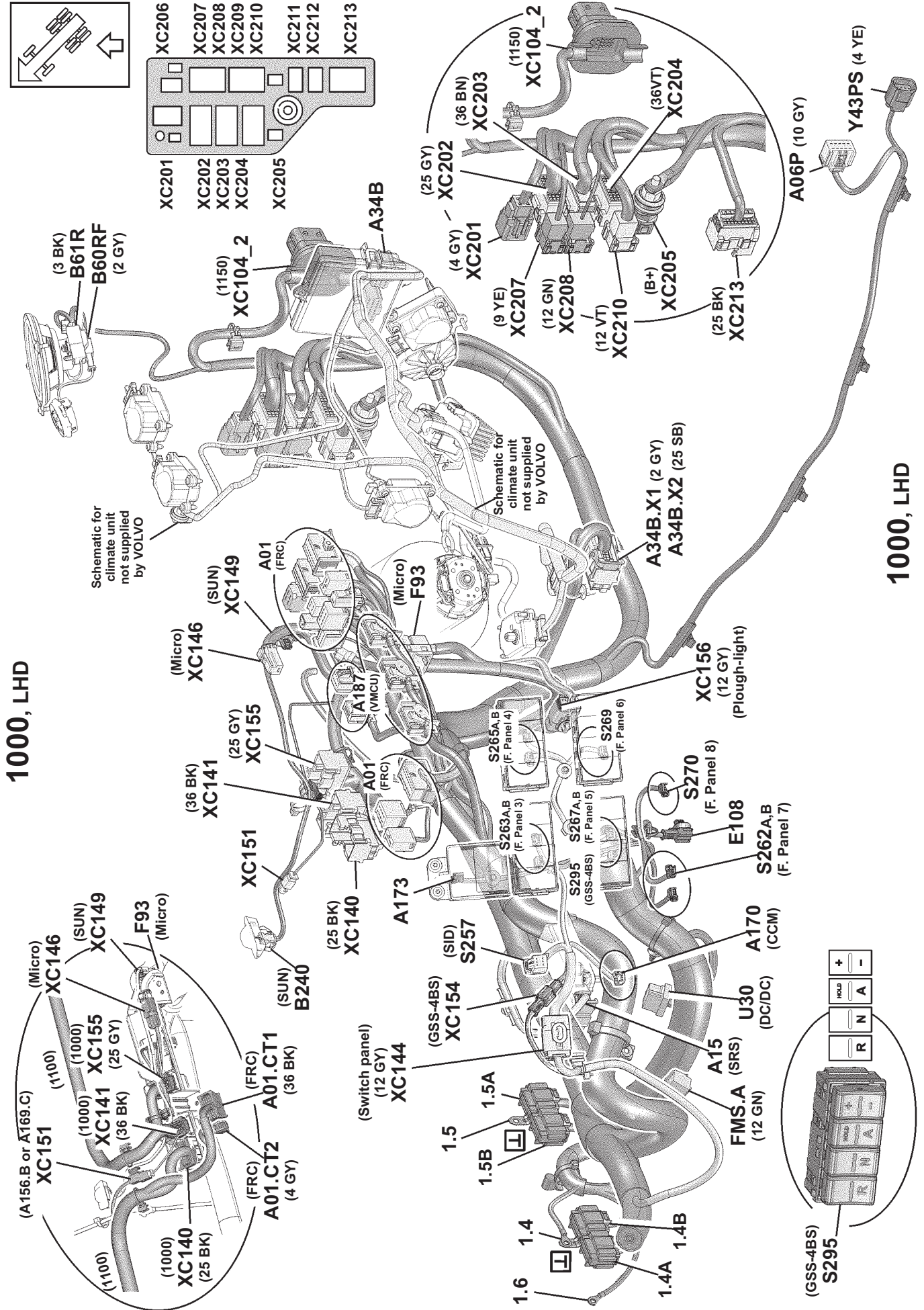

T3080989

1000, RHD

1000, RHD

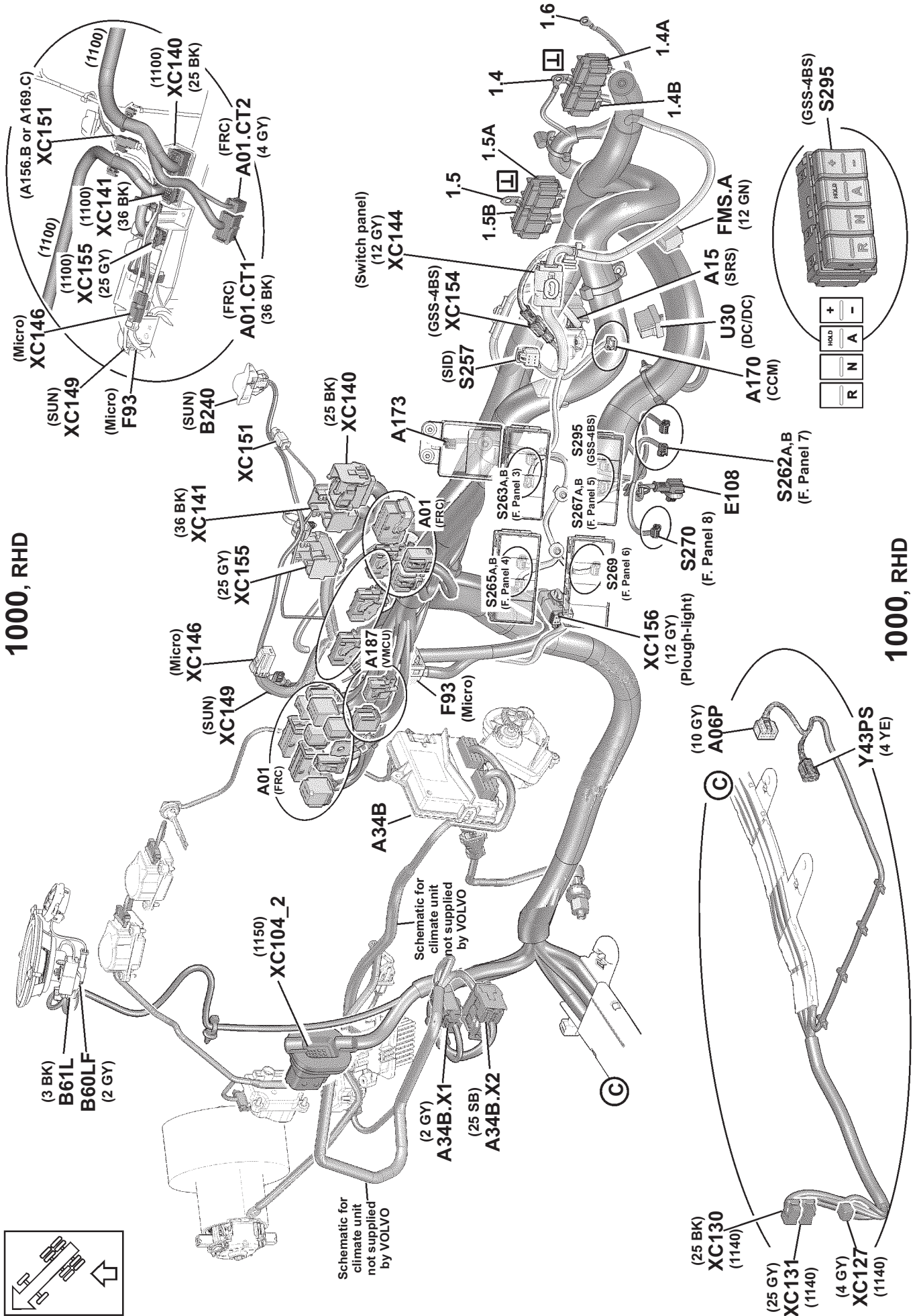

T3080990

1100, H1, LHD

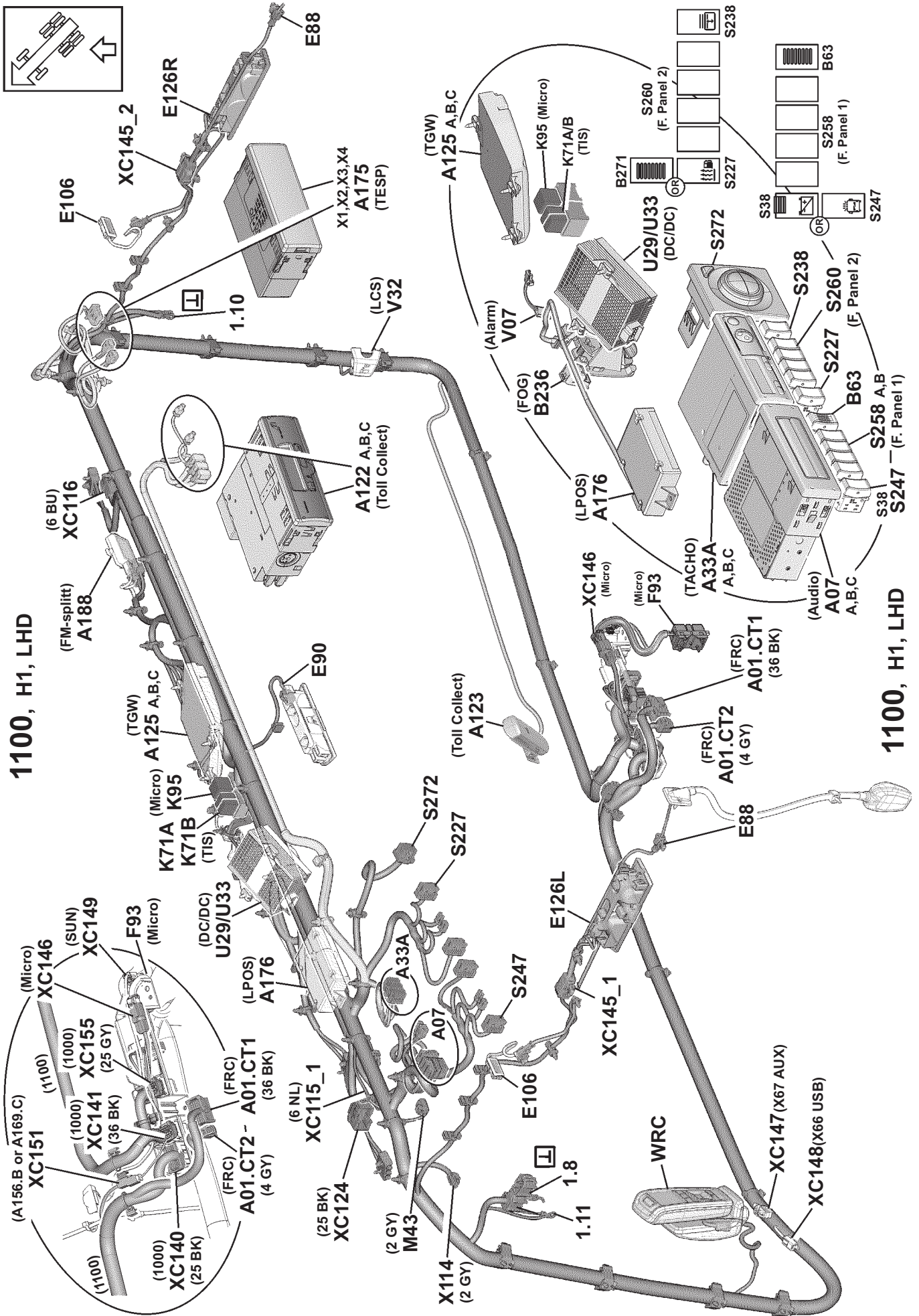

1100, H1, LHD

T3080991

1110, H1

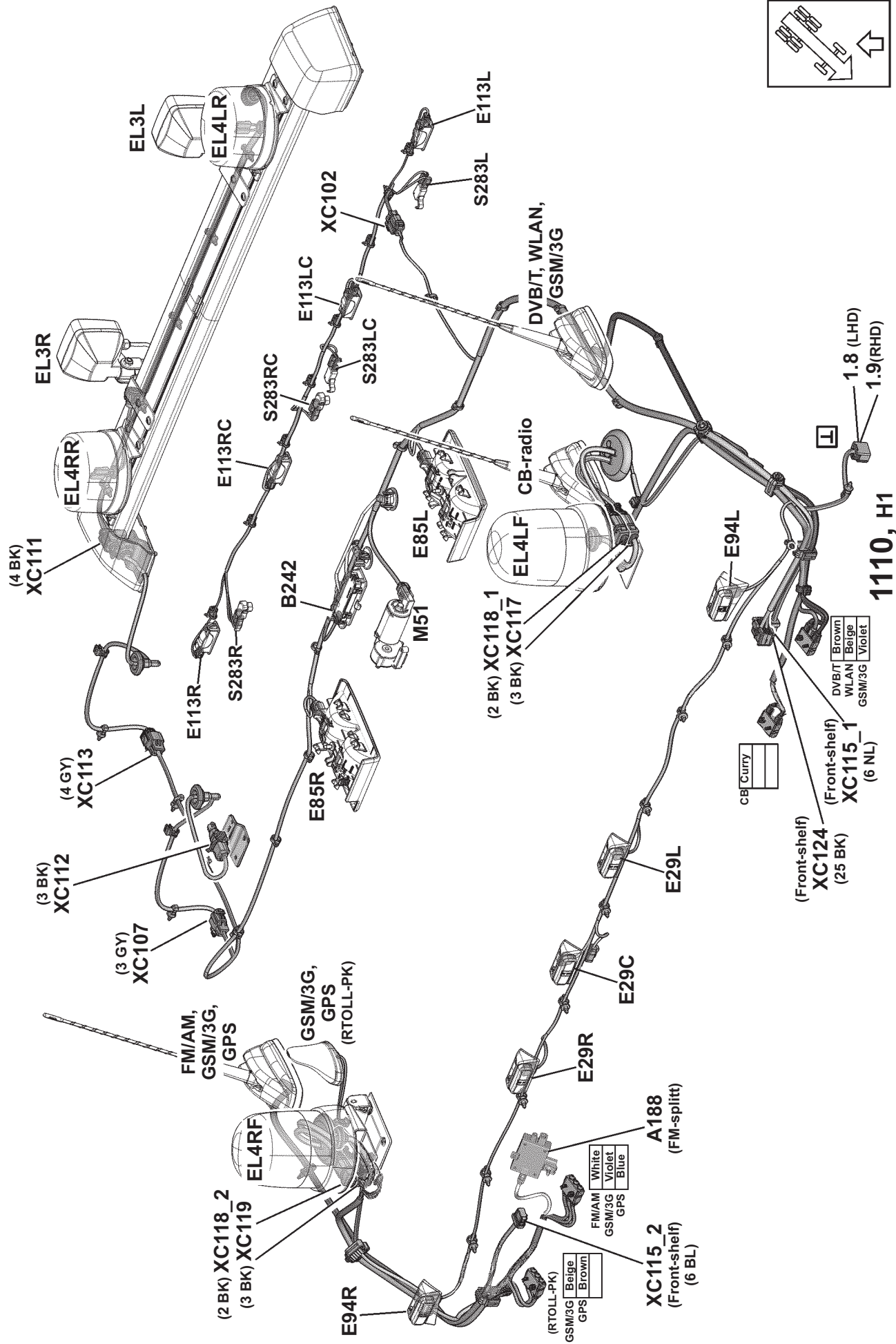

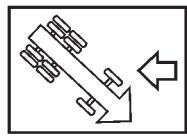

1110, H1

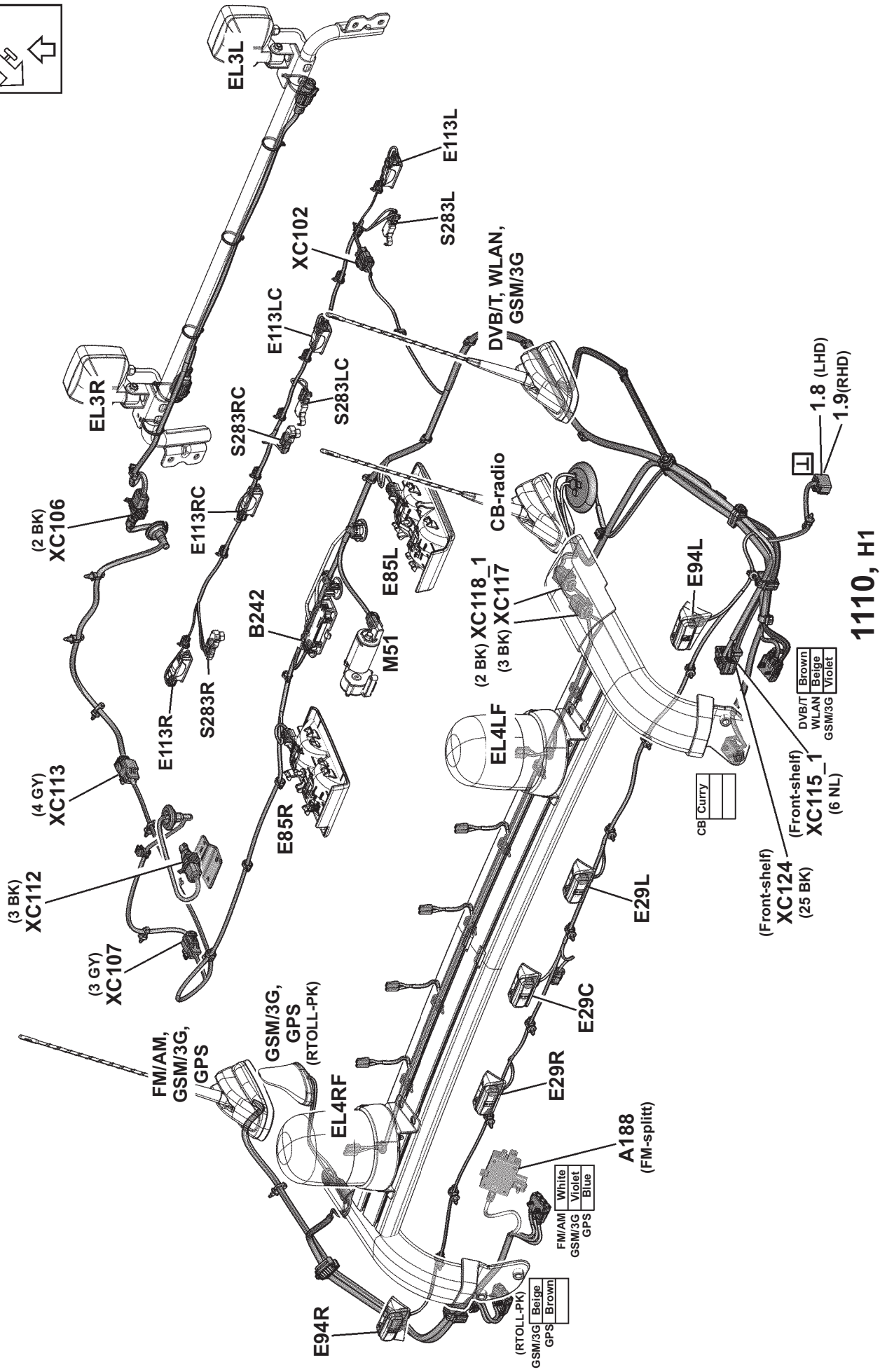

1110, H1

1140, LHD

1140, LHD

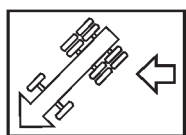
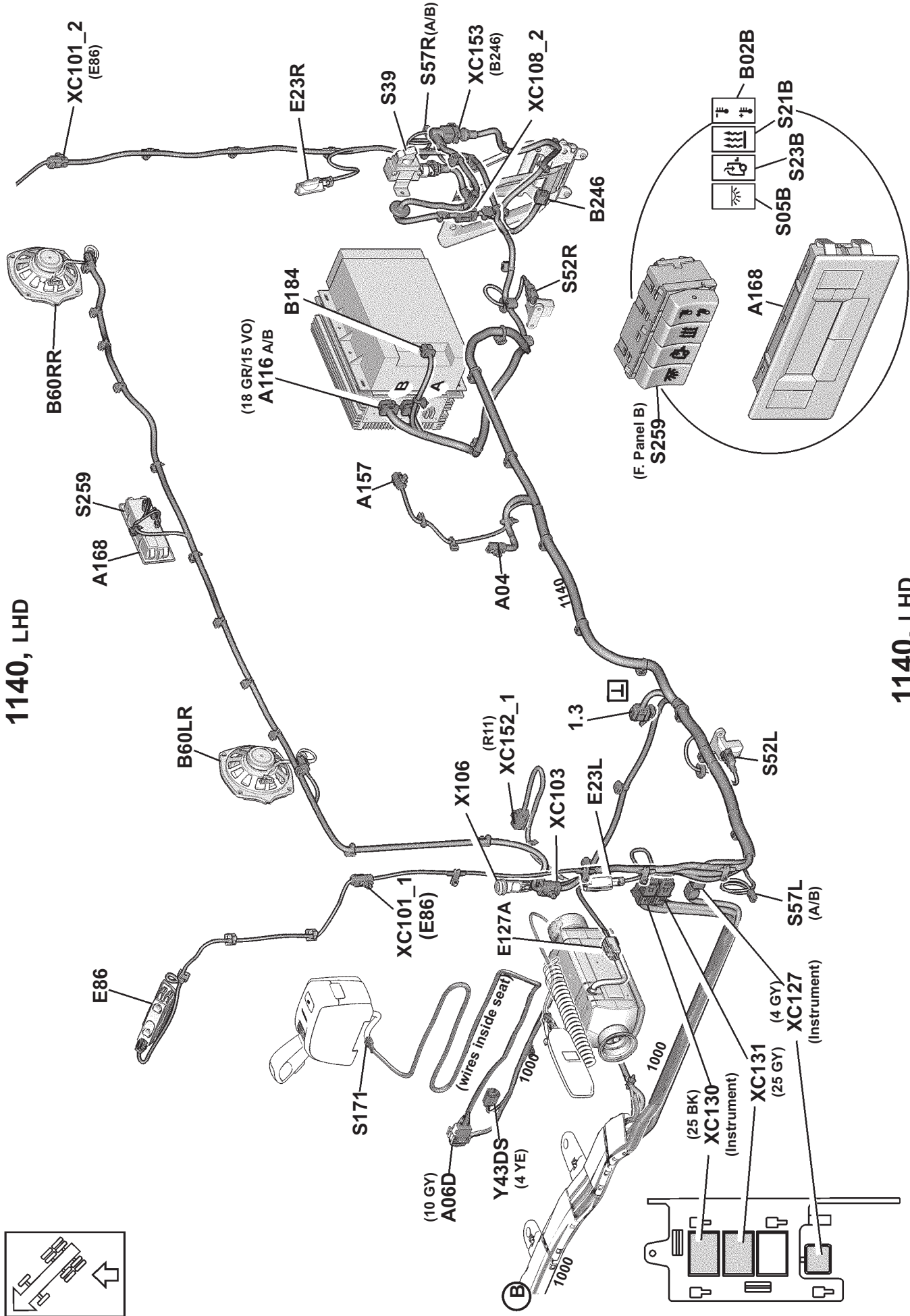

T3079516

1140, RHD

1140, RHD

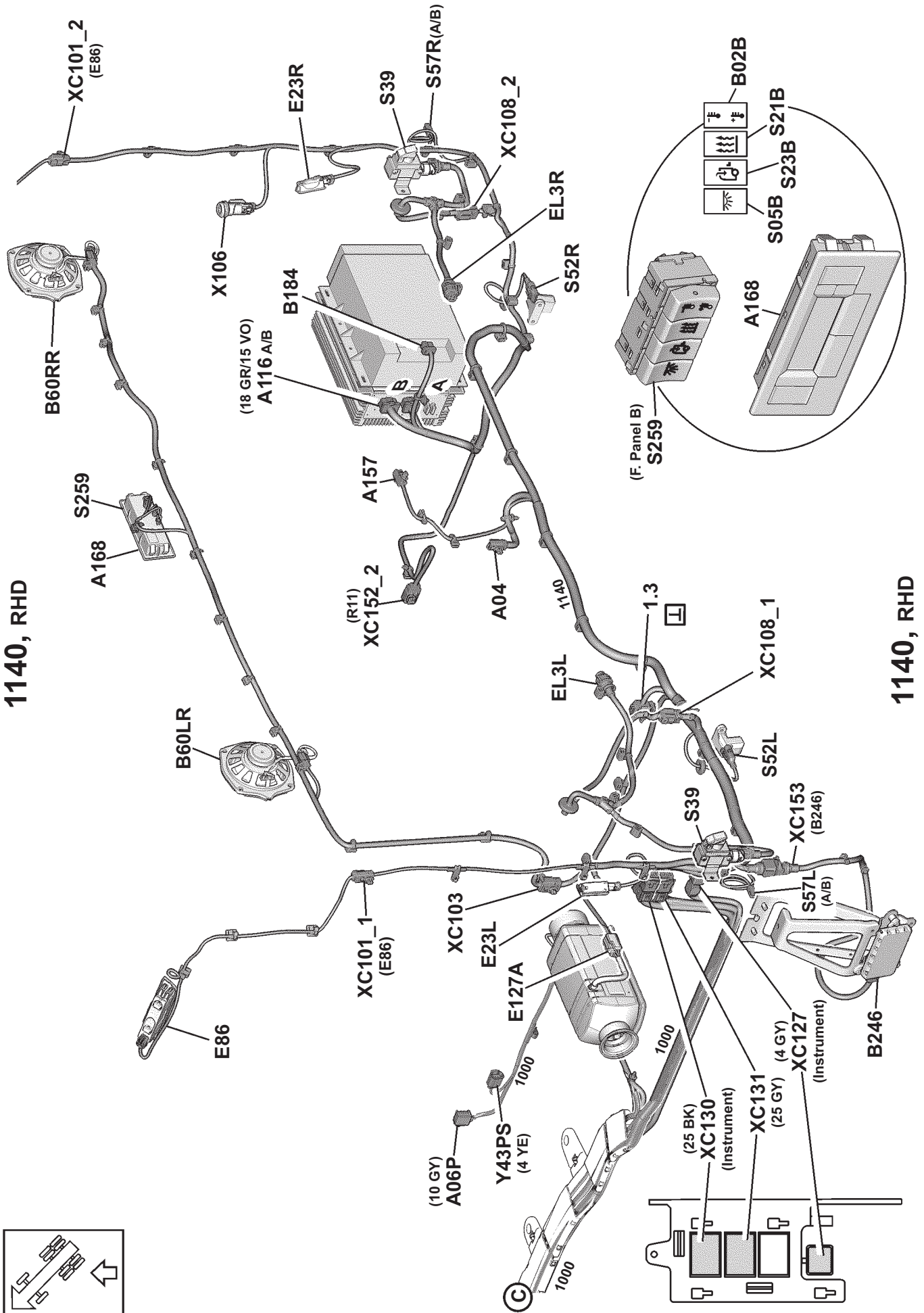

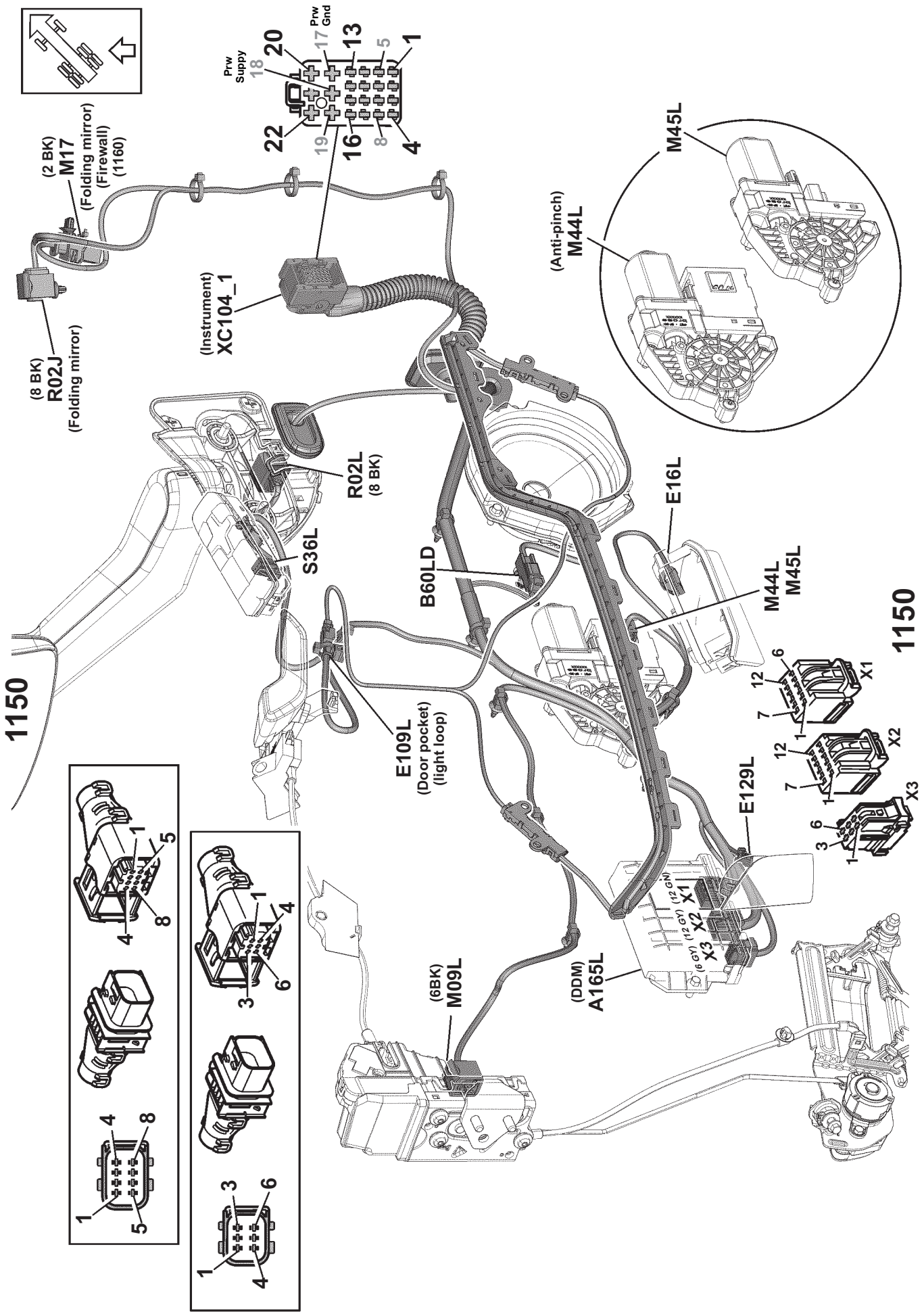

1150

1150

1150

1150

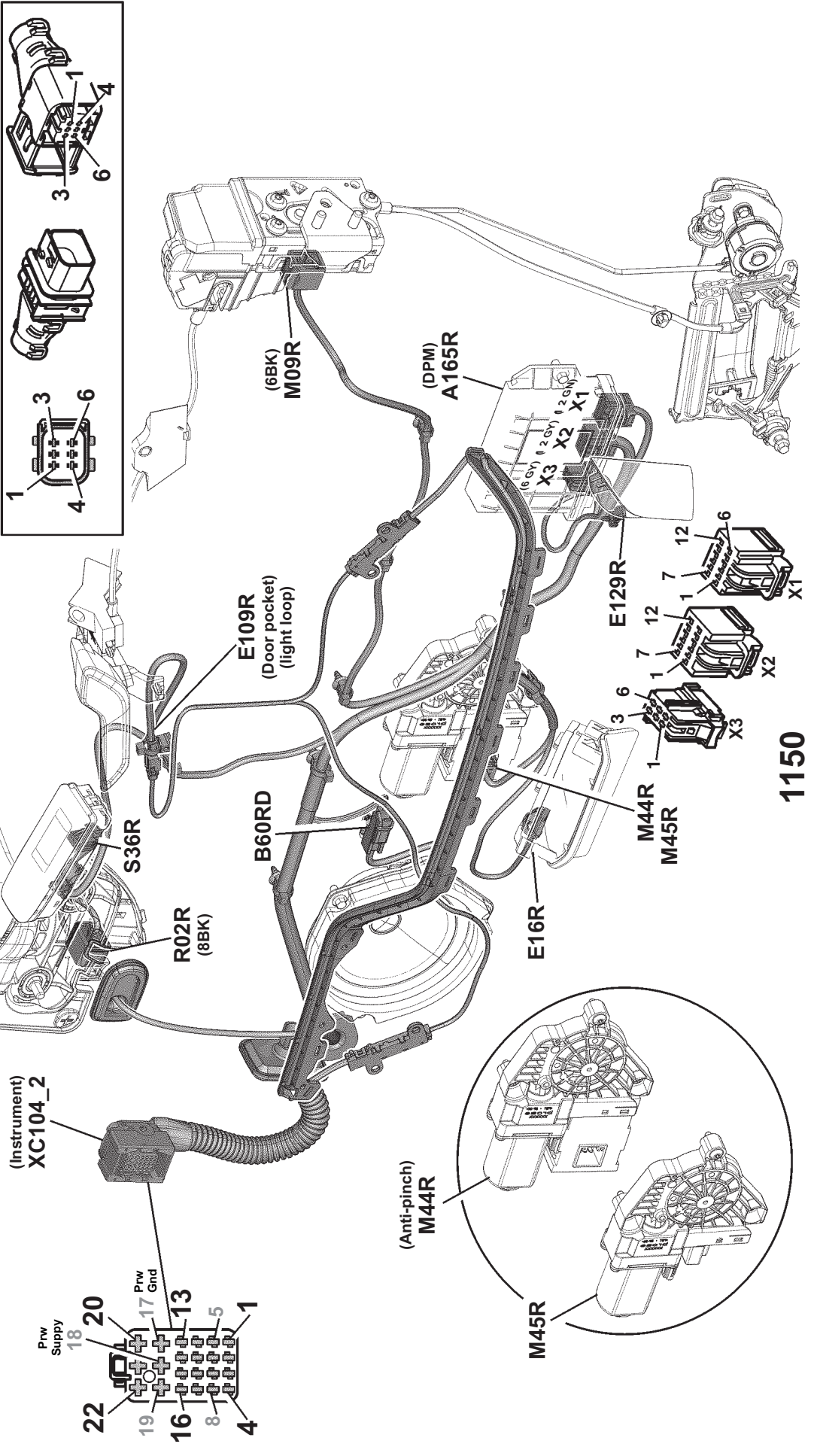
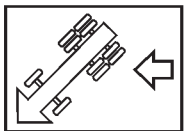

(Instrument)
XC104_2

(6BK)
M09R

(DPM)
A165R

E109R
(Door pocket)
(light loop)

S36R

R02R
(8BK)

B60RD

E16R

E129R

M44R
M45R

(Anti-pinch)
M44R

M45R

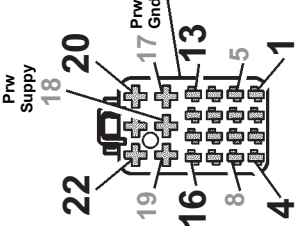

1160, 2130, LHD

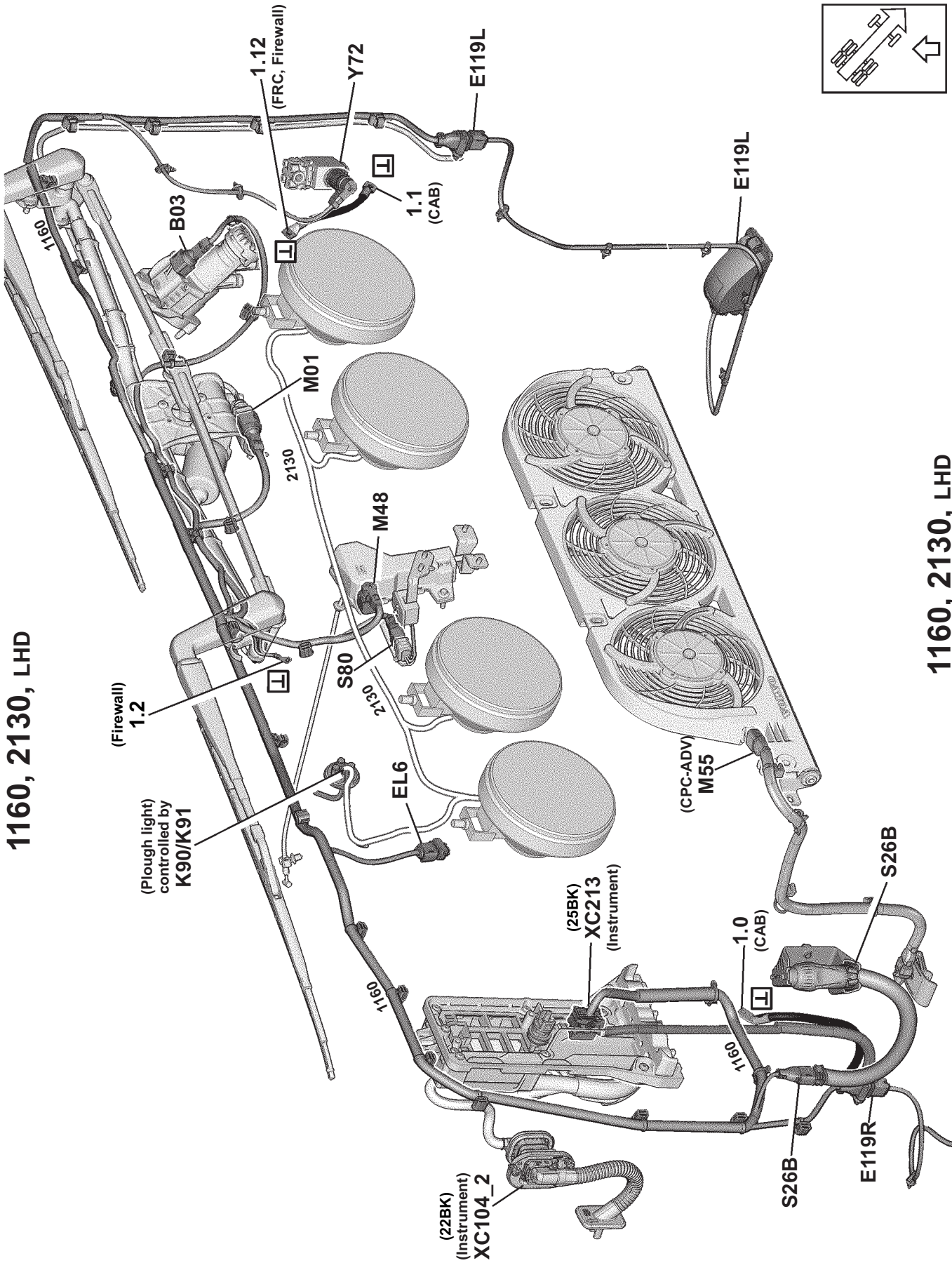

1160, 2130, LHD

1160, 2130, RHD

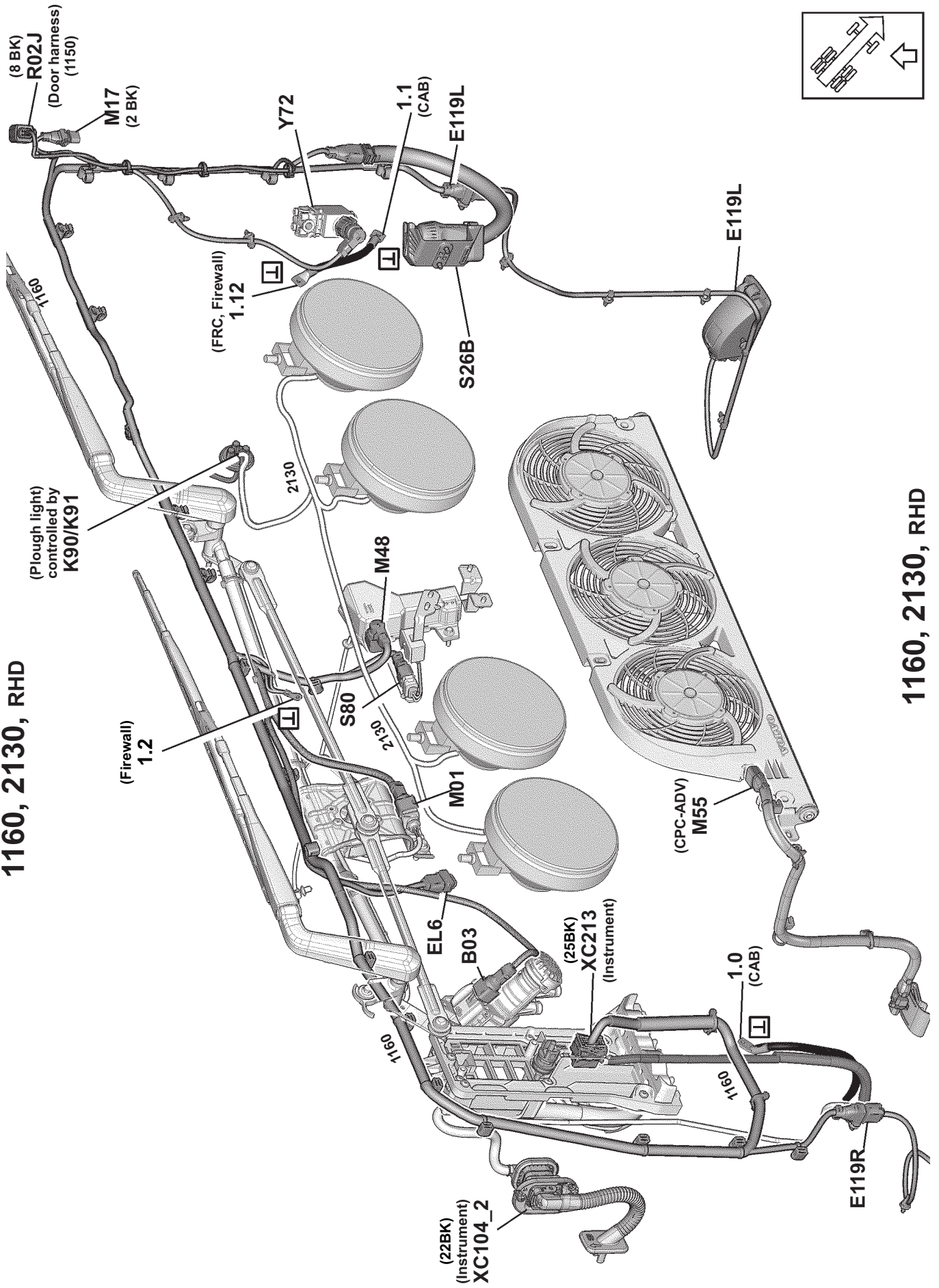

1160, 2130, RHD

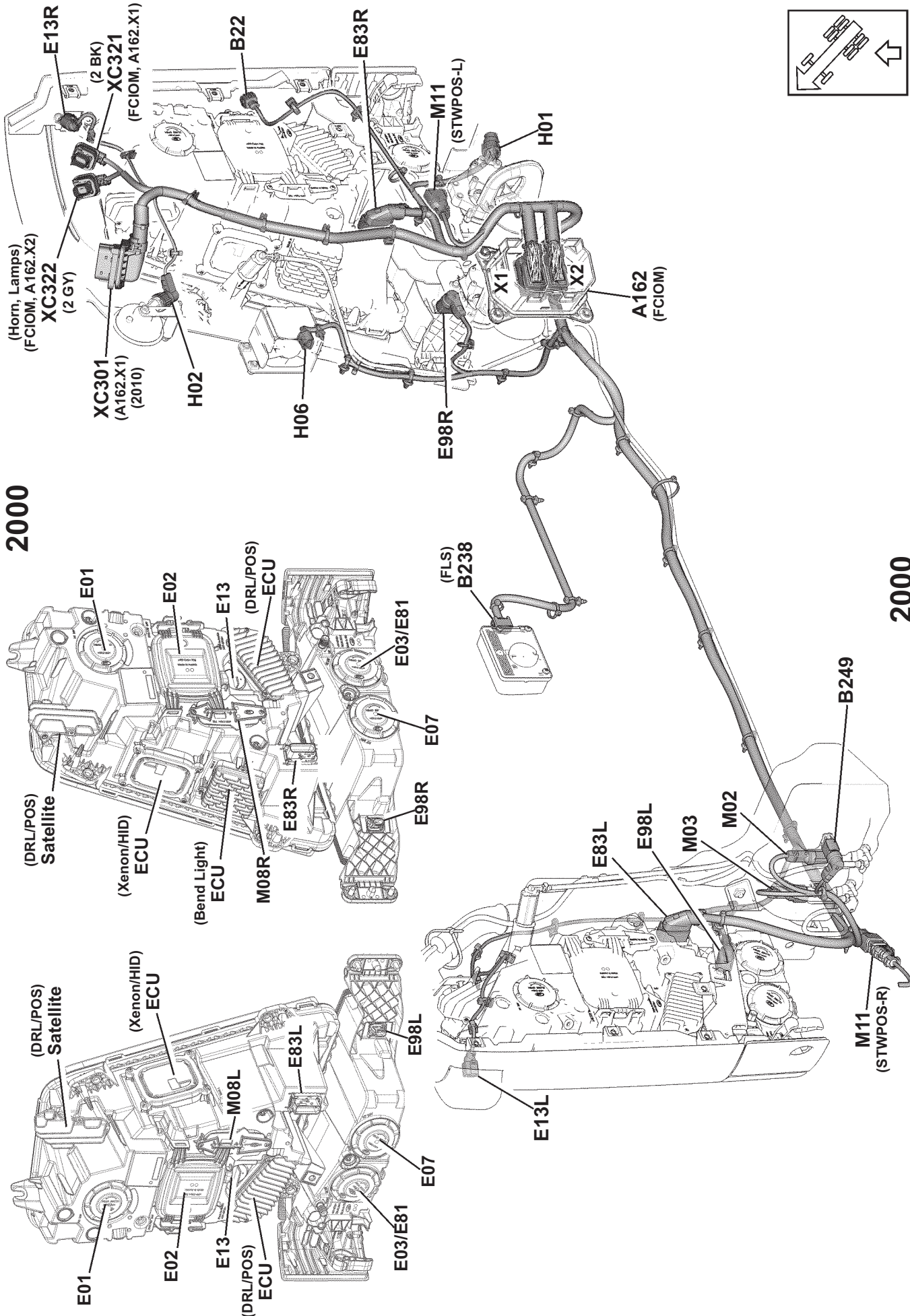

2000

2000

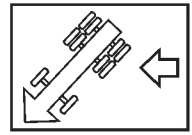

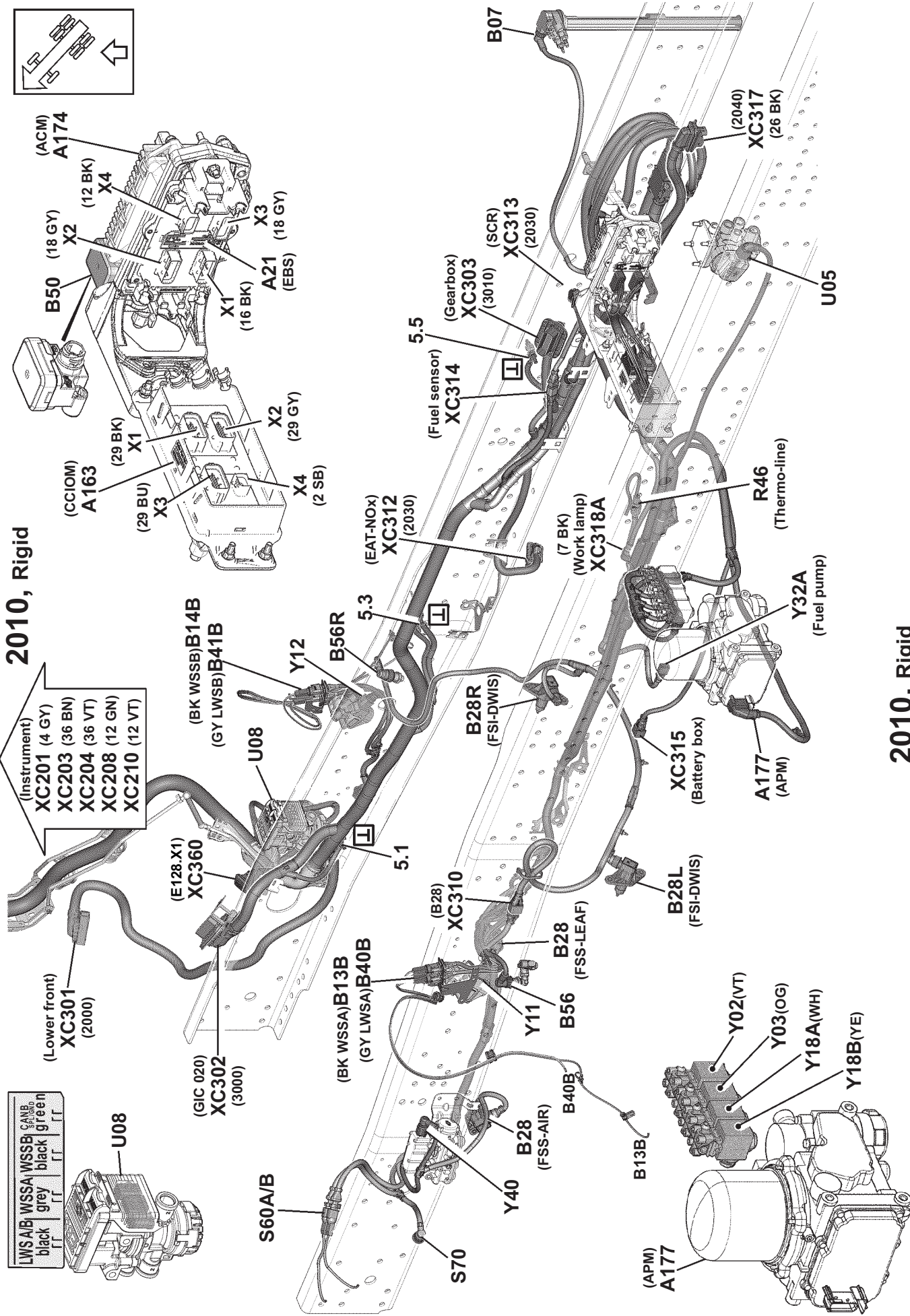

2010, Tractor BBOX-EF

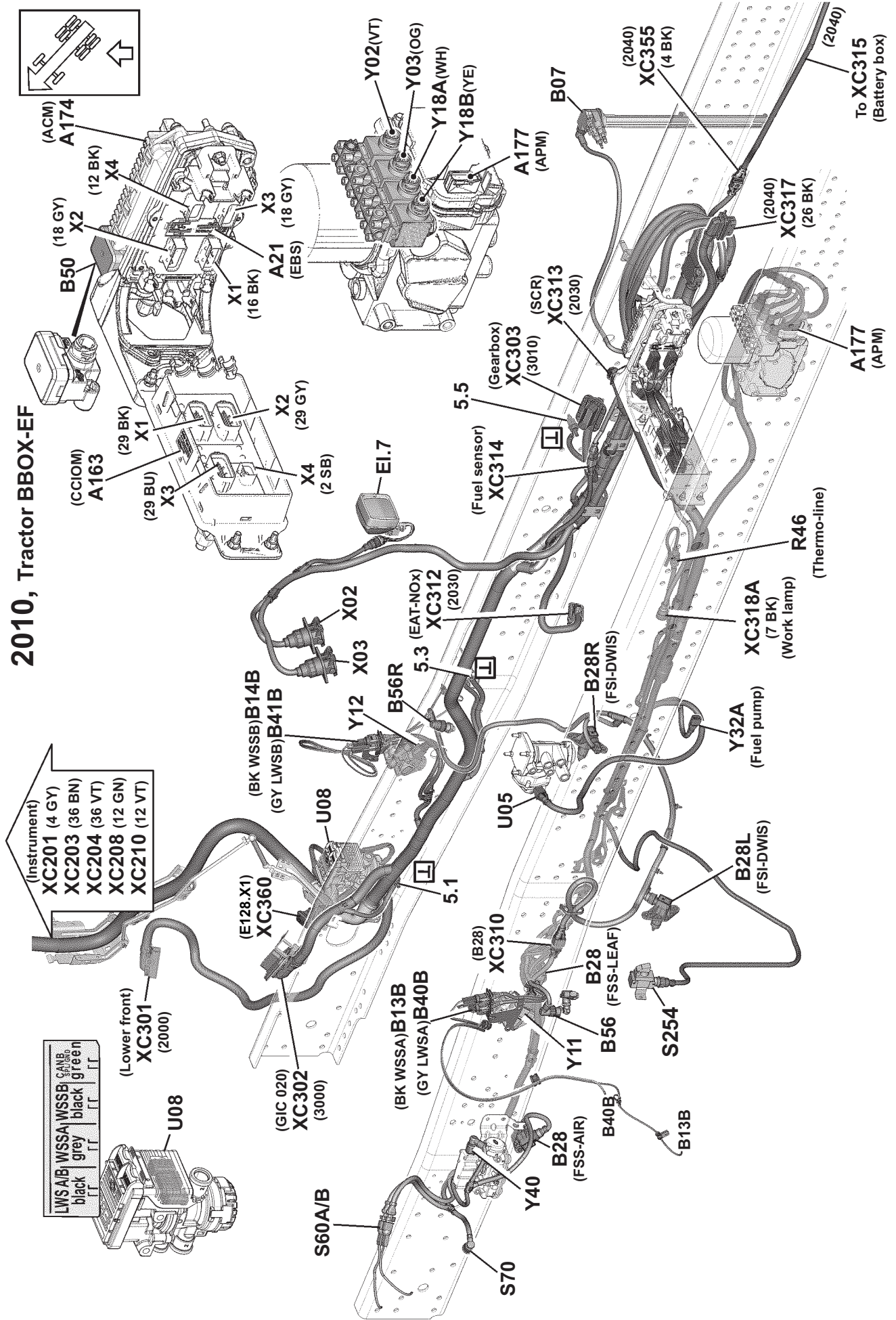

2010, Tractor BBOX-EF

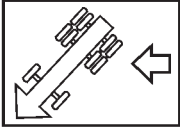

2000, 2010, LHS

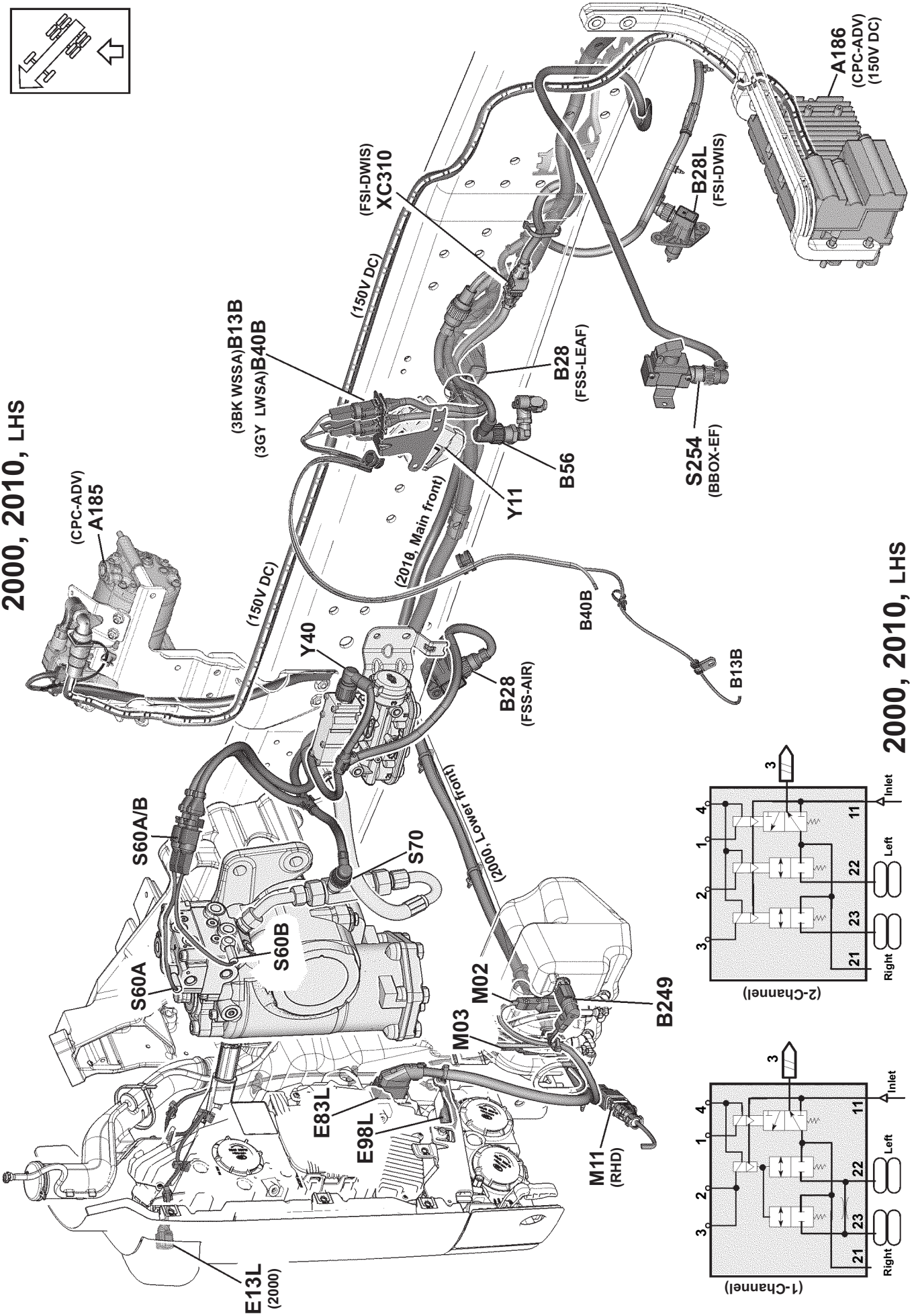

2000, 2010, LHS

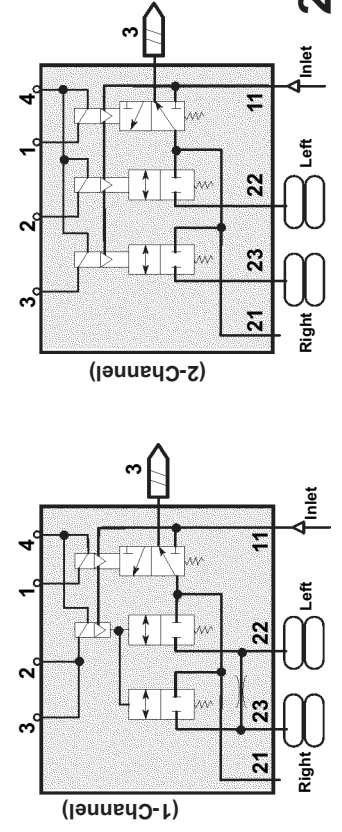

T3080722

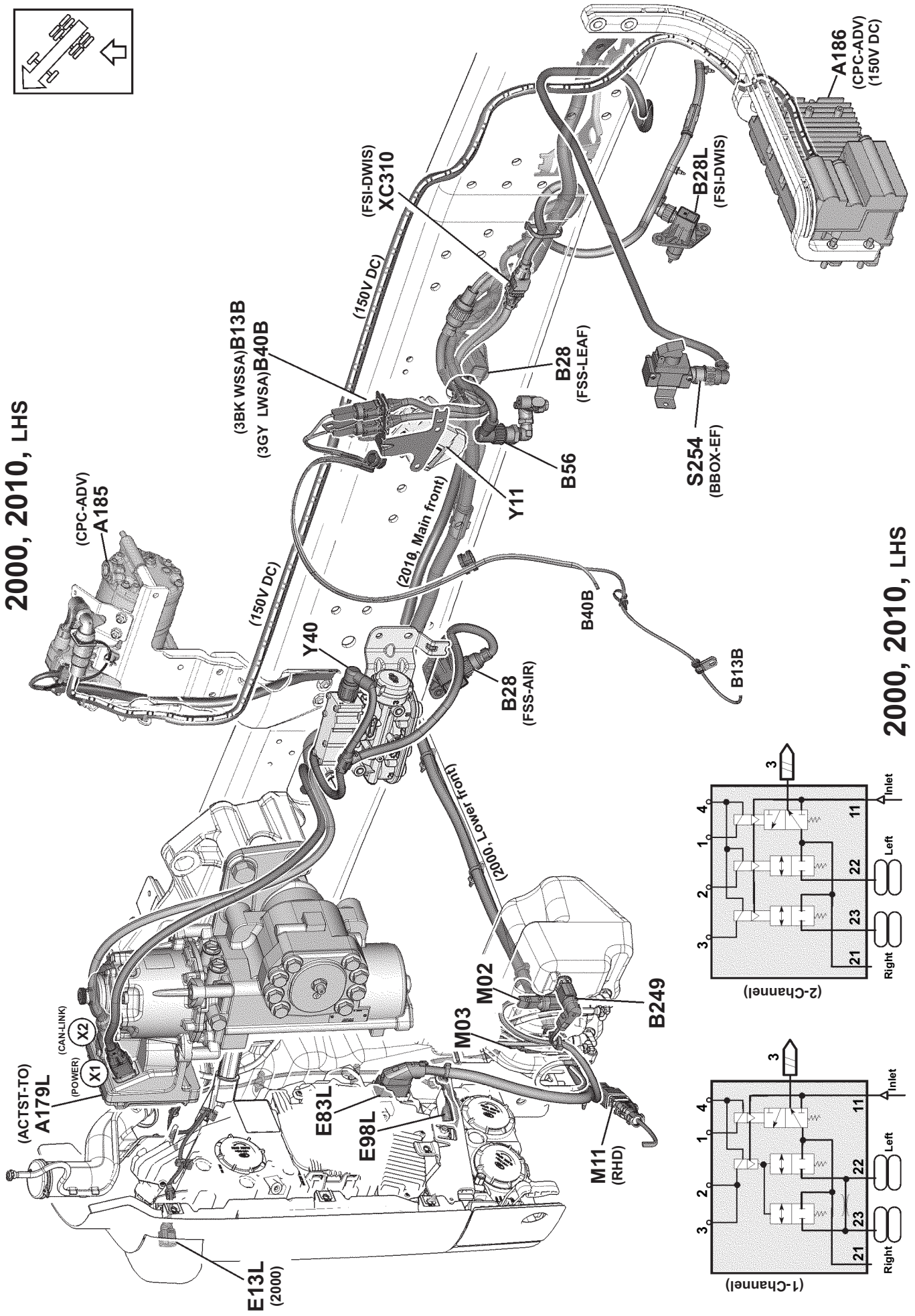

2000, 2010, LHS

2000, 2010, LHS

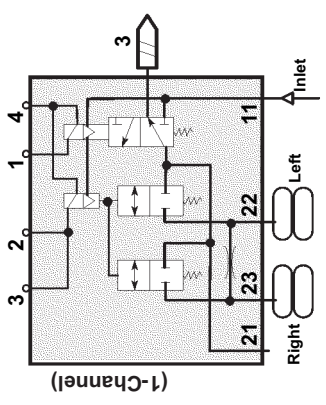
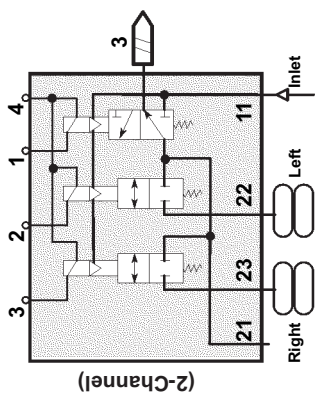

T3076468

2000, 2010, RHS

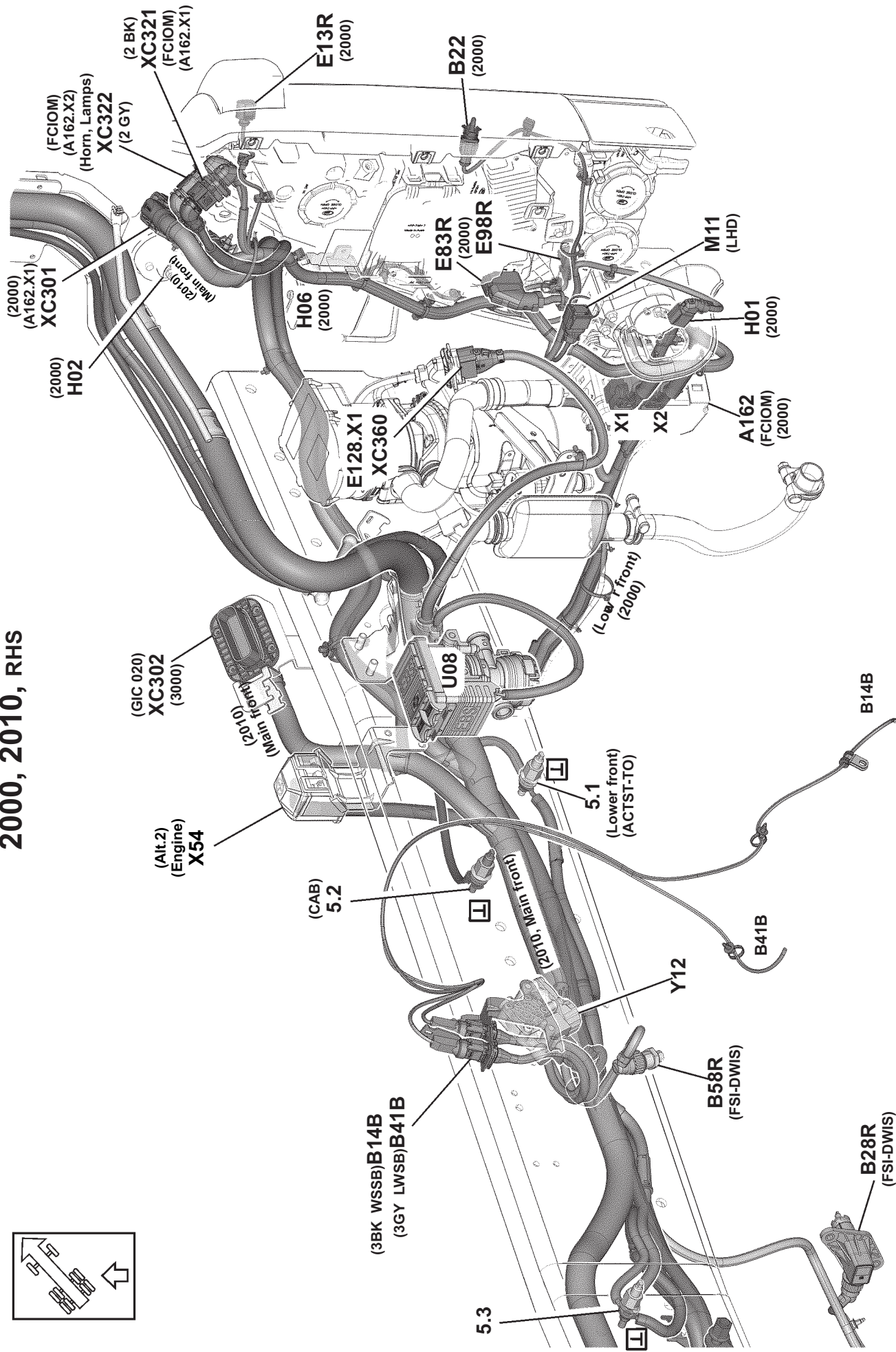
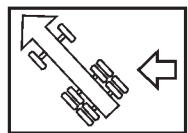

2000, 2010, RHS

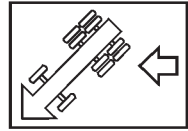

2010, IPC, CPC-ADV

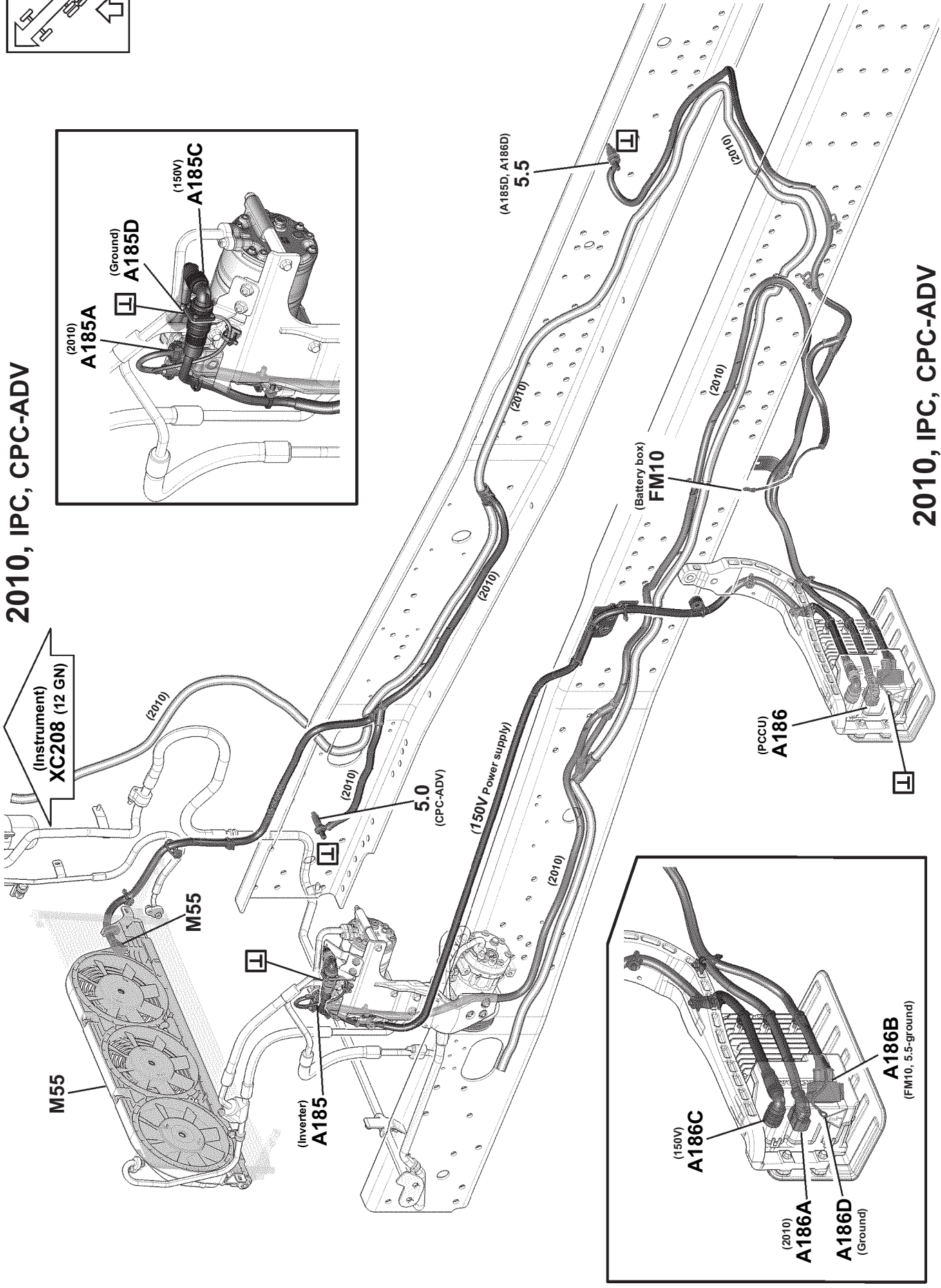

2010, IPC, CPC-ADV

T3071167

2010, FAA10, BSYS-CON

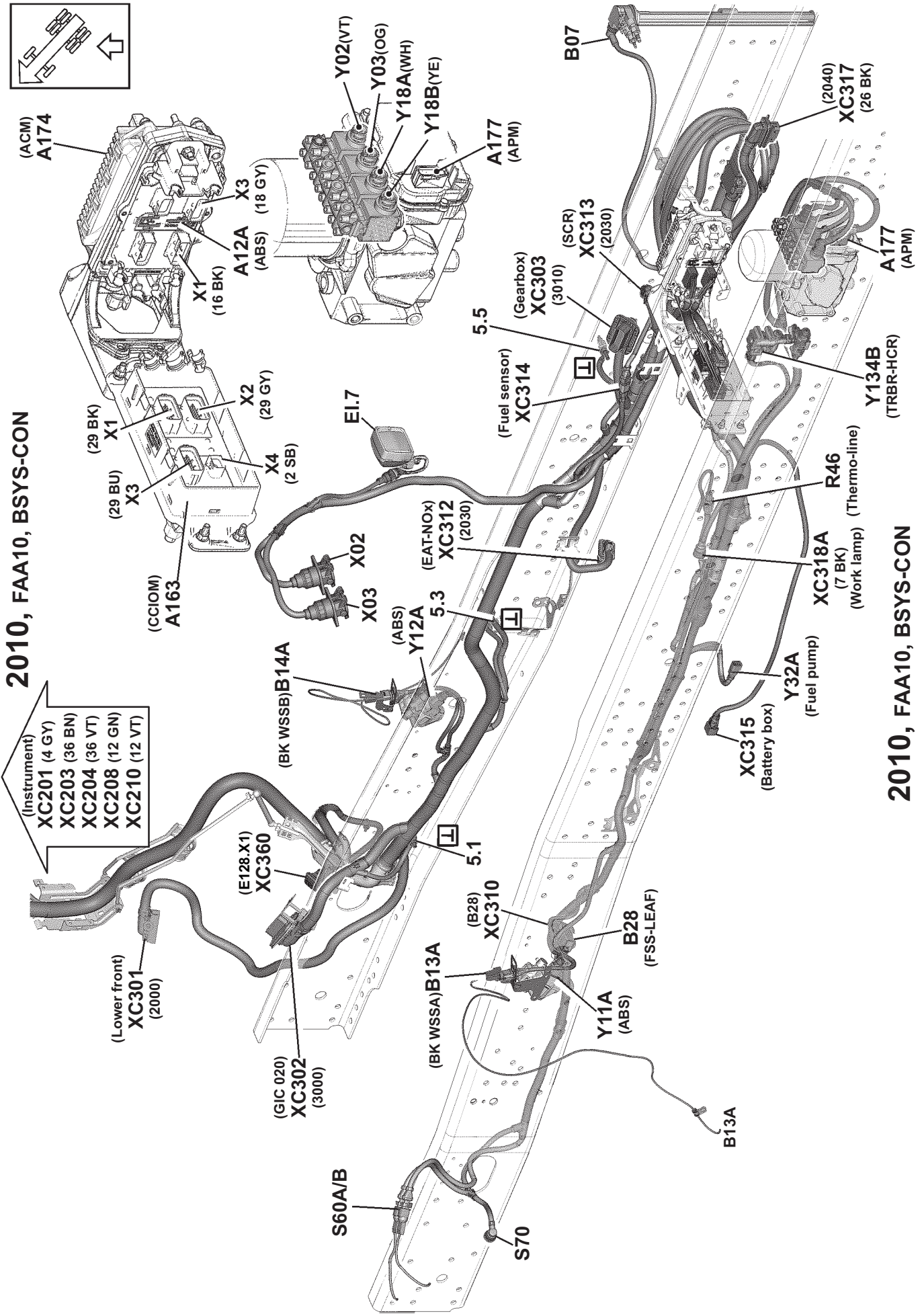

2010, FAA10, BSYS-CON

MSWI-B, MSWI-R, UADR

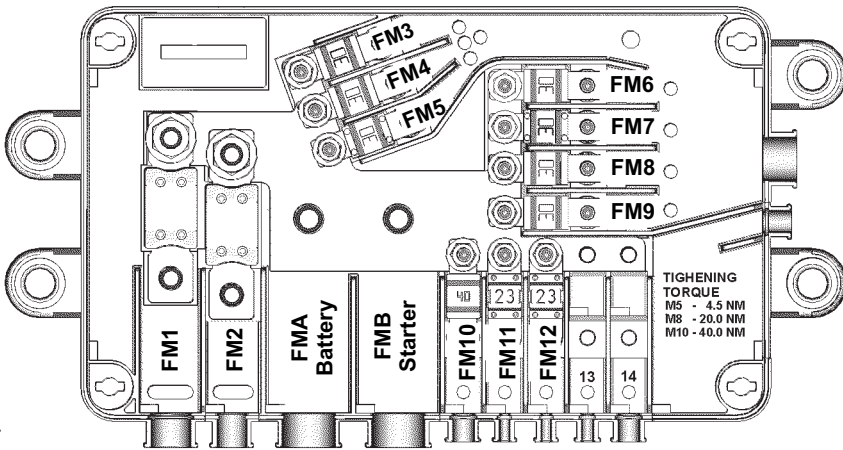
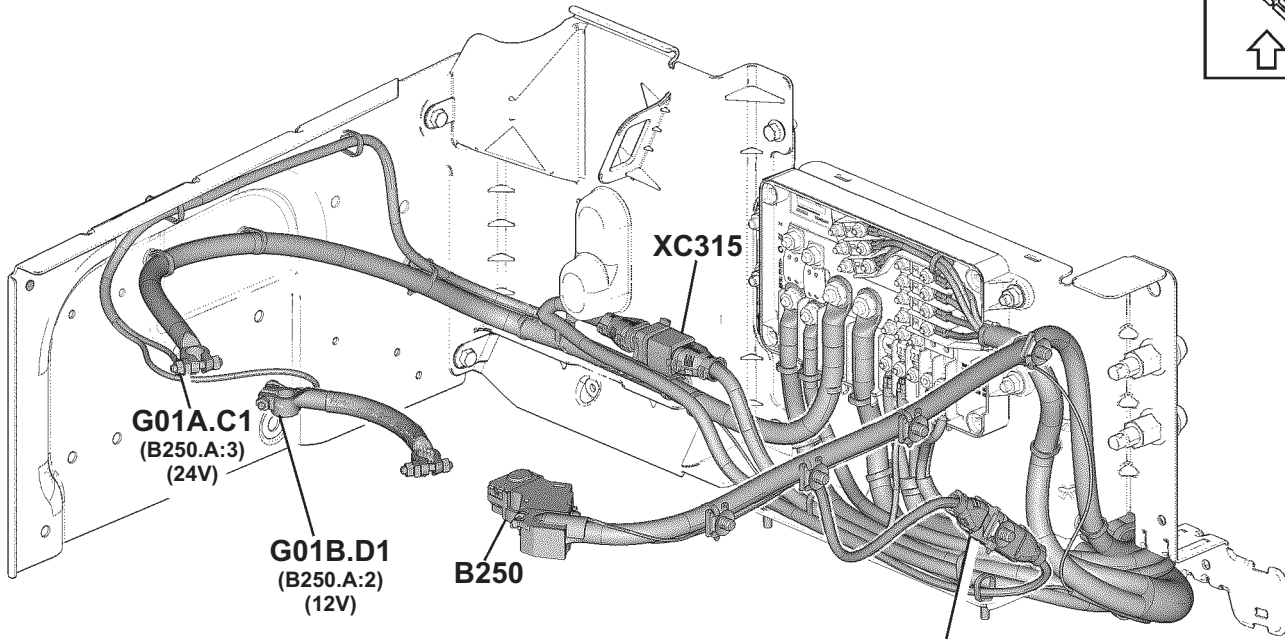
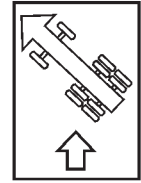

FM A	Batt	No Fuse	M10
FM B	Start	No Fuse	M10
FM 1	BB	200A	M8
FM 2	Cab	100A	M8
FM 3	FCIOM	30A	M5
FM 4	CCIOM	30A	M5
FM 5	RCIOM	30A	M5
FM 6	FCIOM	30A	M5
FM 7	CCIOM	30A	M5
FM 8	RCIOM	30A	M5
FM 9	FAS	30A	M5
FM 10	PCCU	40A	M5
FM 11	ACM	23A	M5
FM 12	RAS	23A	M5

TIGHTENING TORQUE
M5 - 4.5 NM
M8 - 20.0 NM
M10 - 40.0 NM

2020, BBOX-L

2020, BBOX-L

MSWI-C, UADR

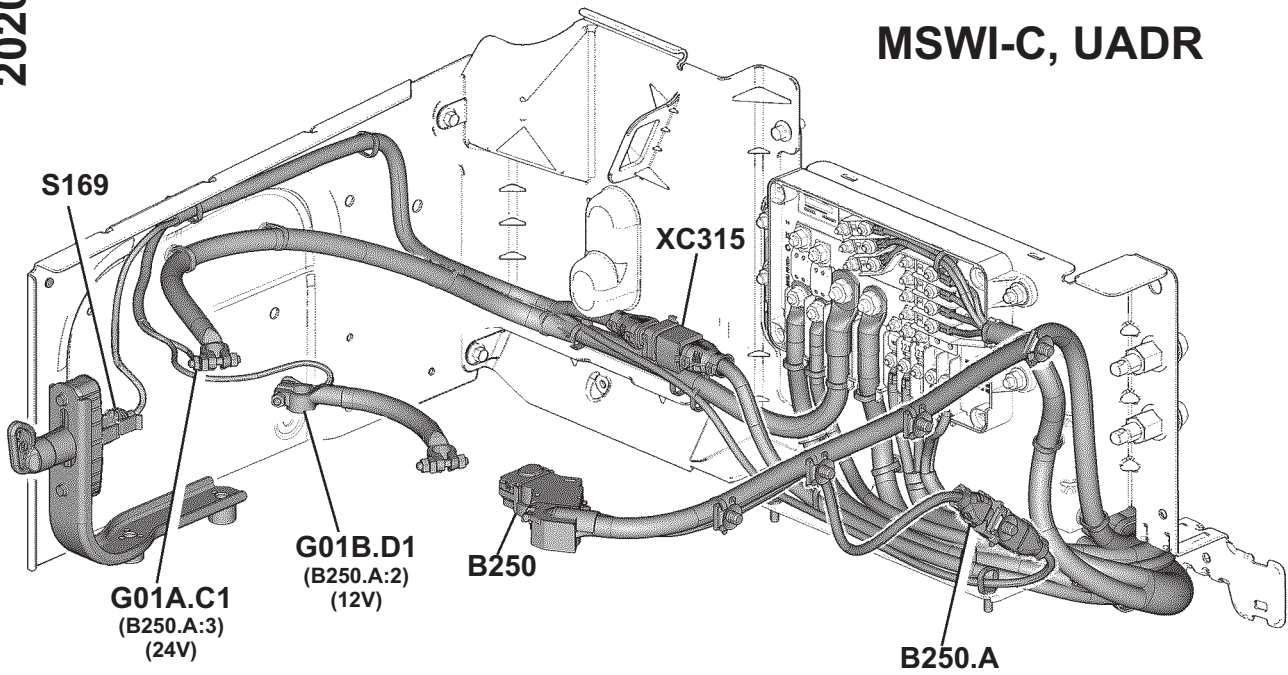

MSWI-A, ADR1, ADR2

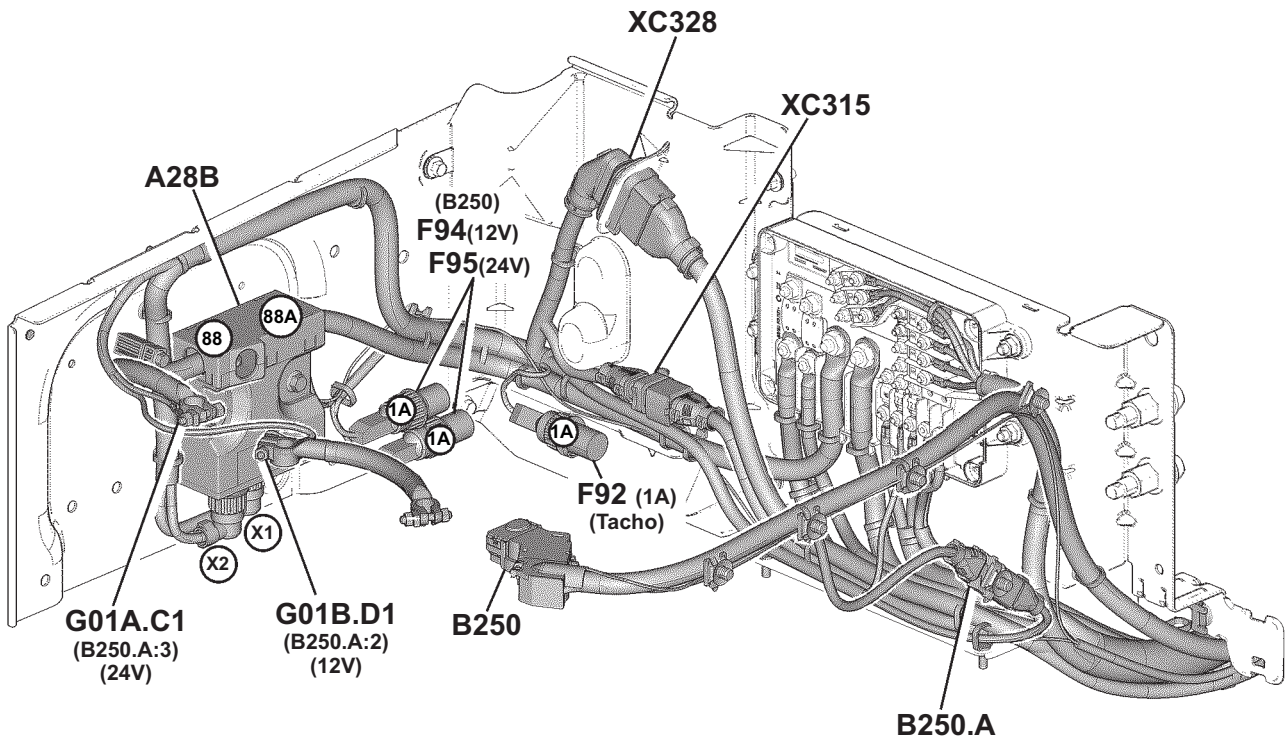
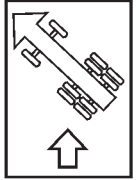

2020, BBOX-L

2020, BBOX-L

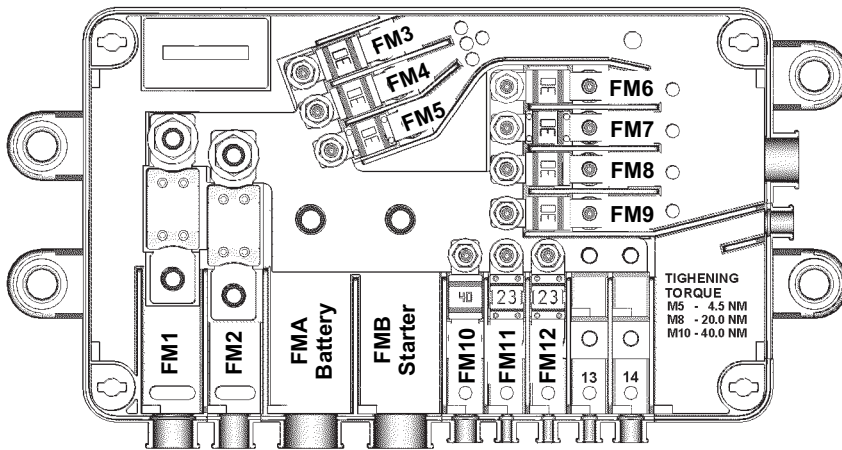

<i>FM</i>	<i>Batt</i>	<i>No Fuse</i>	<i>M10</i>
<i>FM B</i>	<i>Start</i>	<i>No Fuse</i>	<i>M10</i>
<i>FM 1</i>	<i>BB</i>	<i>200A</i>	<i>M8</i>
<i>FM 2</i>	<i>Cab</i>	<i>100A</i>	<i>M8</i>
<i>FM 3</i>	<i>FCIOM</i>	<i>30A</i>	<i>M5</i>
<i>FM 4</i>	<i>CCIOM</i>	<i>30A</i>	<i>M5</i>
<i>FM 5</i>	<i>RCIOM</i>	<i>30A</i>	<i>M5</i>
<i>FM 6</i>	<i>FCIOM</i>	<i>30A</i>	<i>M5</i>
<i>FM 7</i>	<i>CCIOM</i>	<i>30A</i>	<i>M5</i>
<i>FM 8</i>	<i>RCIOM</i>	<i>30A</i>	<i>M5</i>
<i>FM 9</i>	<i>FAS</i>	<i>30A</i>	<i>M5</i>
<i>FM 10</i>	<i>PCCU</i>	<i>40A</i>	<i>M5</i>
<i>FM 11</i>	<i>ACM</i>	<i>23A</i>	<i>M5</i>
<i>FM 12</i>	<i>RAS</i>	<i>23A</i>	<i>M5</i>

MSWI-A, ADR3

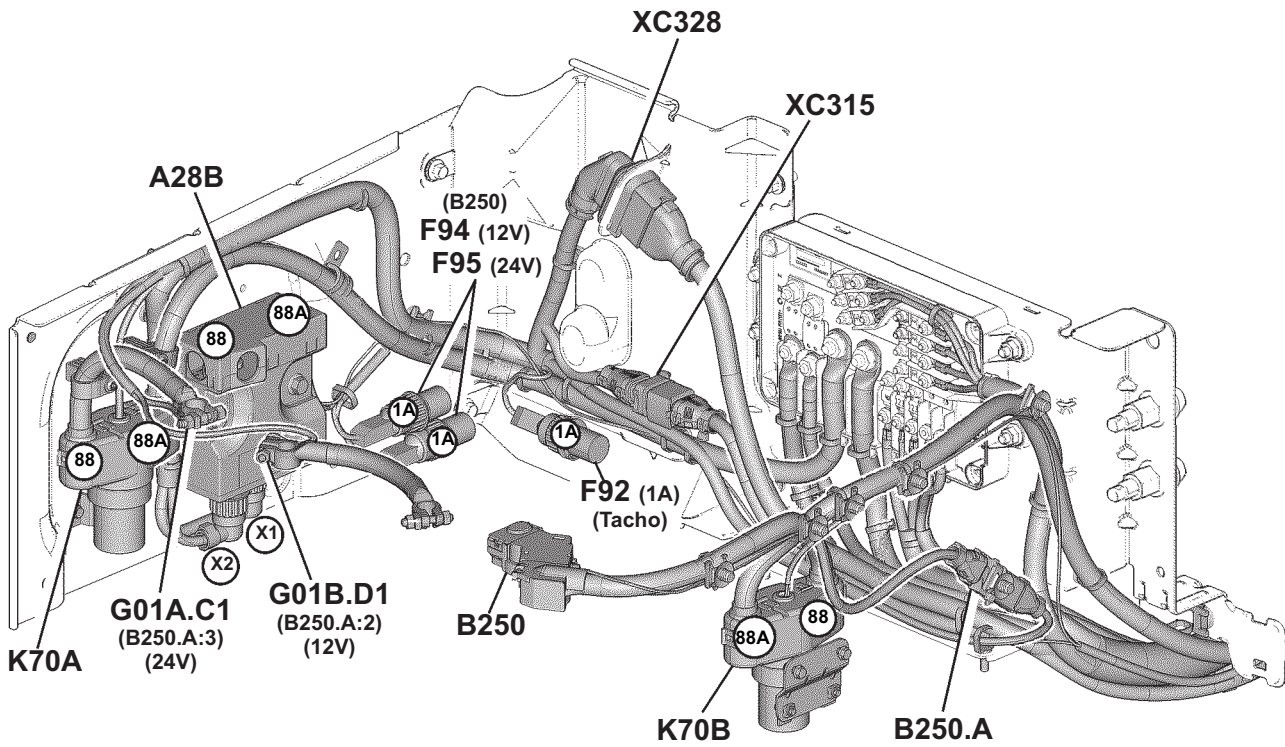
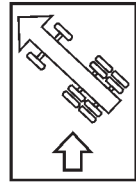

2020, BBOX-L

2020, BBOX-L

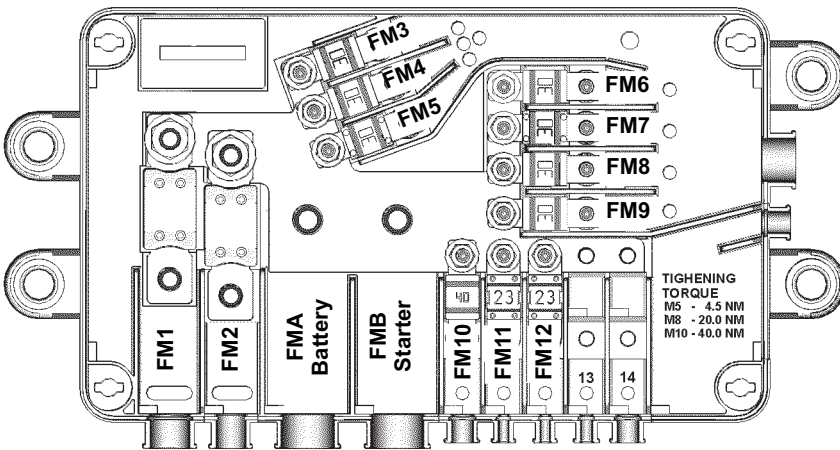

FM A	Batt	No Fuse	M10
FM B	Start	No Fuse	M10
FM 1	BB	200A	M8
FM 2	Cab	100A	M8
FM 3	FCIOM	30A	M5
FM 4	CCIOM	30A	M5
FM 5	RCIOM	30A	M5
FM 6	FCIOM	30A	M5
FM 7	CCIOM	30A	M5
FM 8	RCIOM	30A	M5
FM 9	FAS	30A	M5
FM 10	PCCU	40A	M5
FM 11	ACM	23A	M5
FM 12	RAS	23A	M5

MSWI-B, MSWI-C, MSWI-R

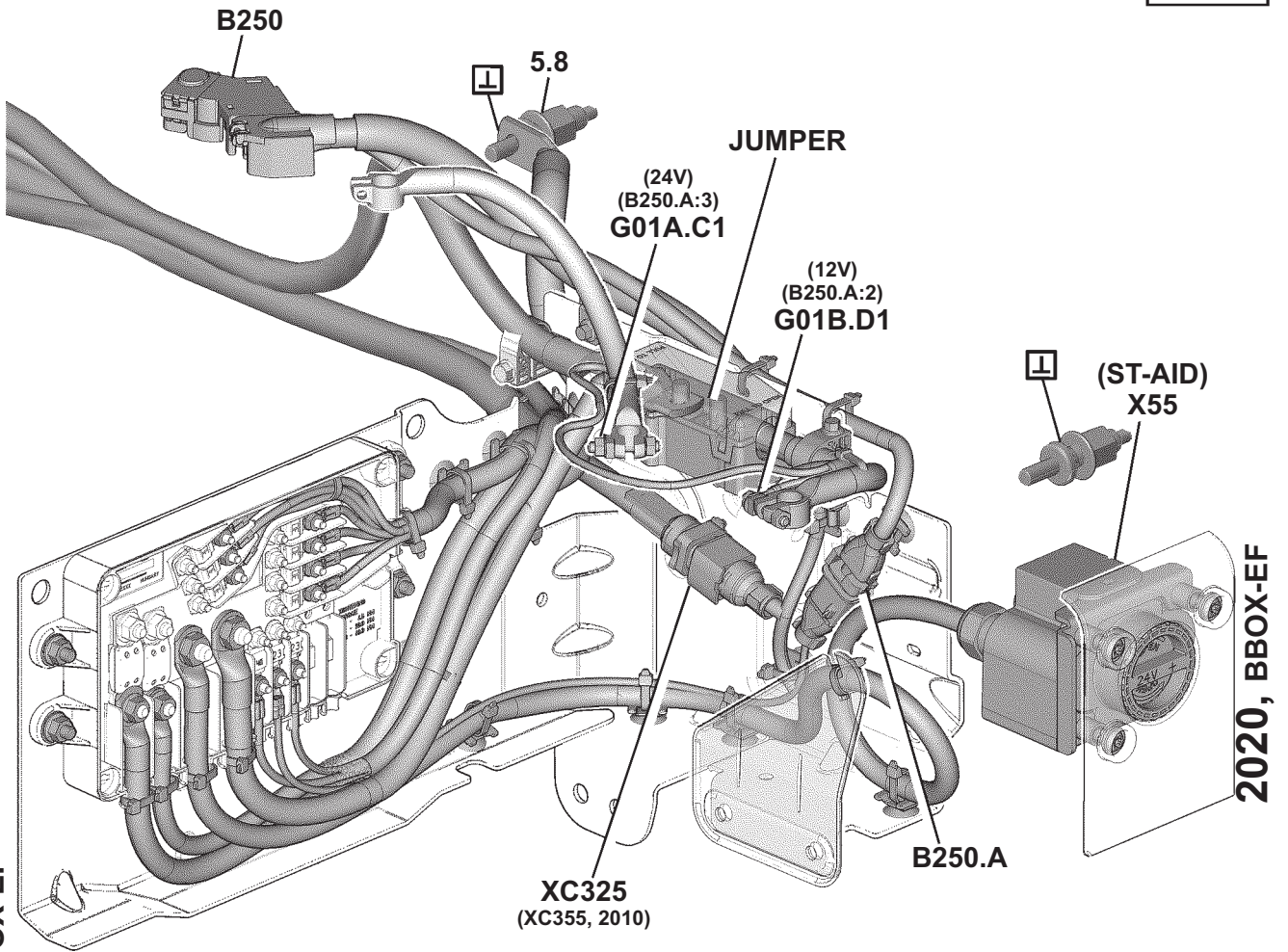
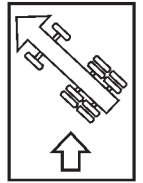

2020, BBOX-EF

2020, BBOX-EF

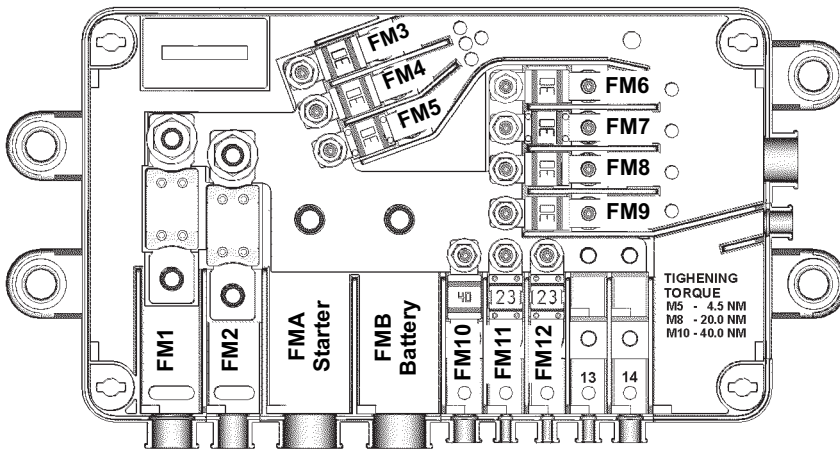

FM	Start	No Fuse	M10
FM B	Batt	No Fuse	M10
FM 1	BB	200A	M8
FM 2	Cab	100A	M8
FM 3	FCIOM	30A	M5
FM 4	CCIOM	30A	M5
FM 5	RCIOM	30A	M5
FM 6	FCIOM	30A	M5
FM 7	CCIOM	30A	M5
FM 8	RCIOM	30A	M5
FM 9	FAS	30A	M5
FM 10	PCCU	40A	M5
FM 11	ACM	23A	M5
FM 12	RAS	23A	M5

MSWI-A, ADR1, ADR2

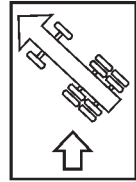

2020, BBOX-EF

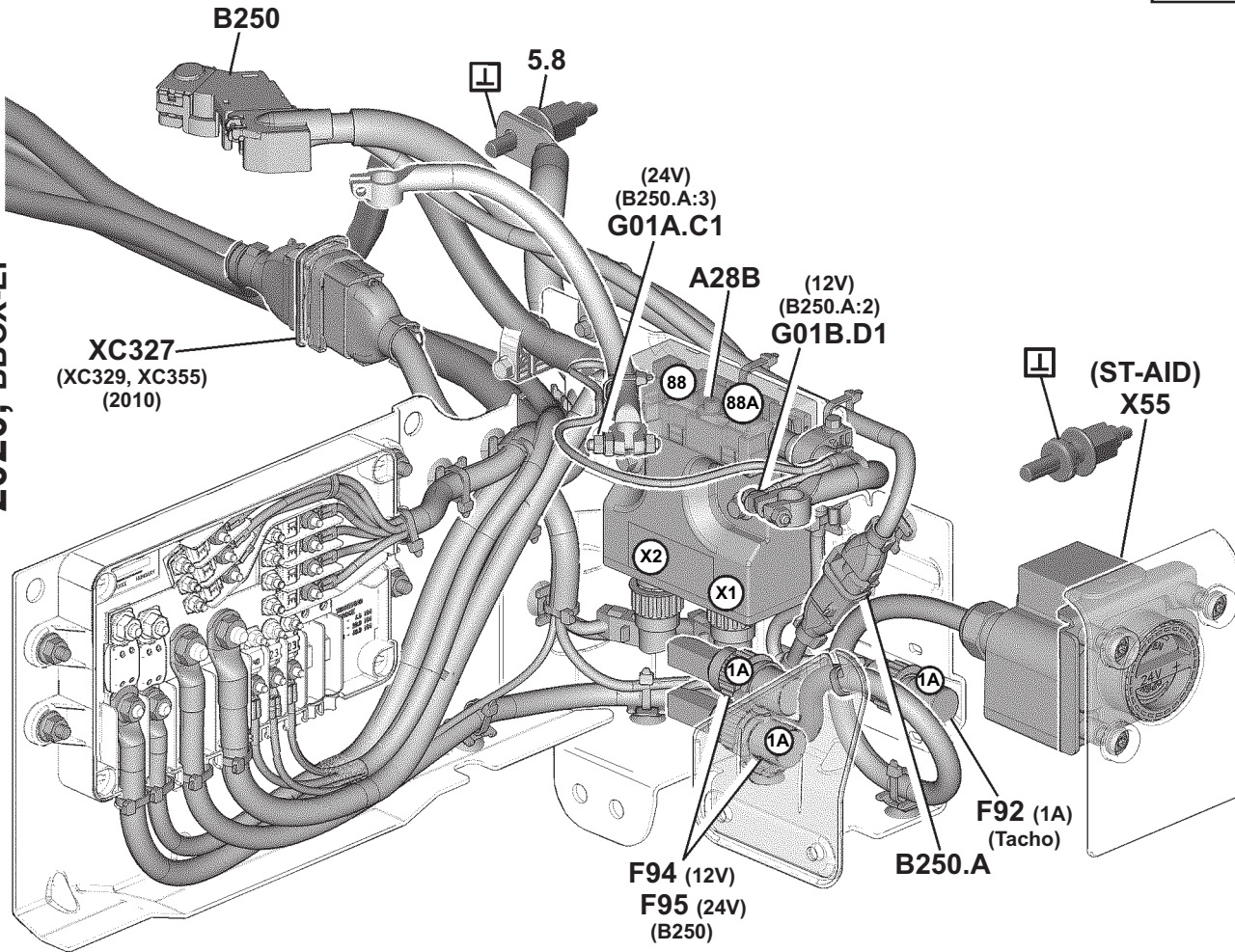

2020, BBOX-EF

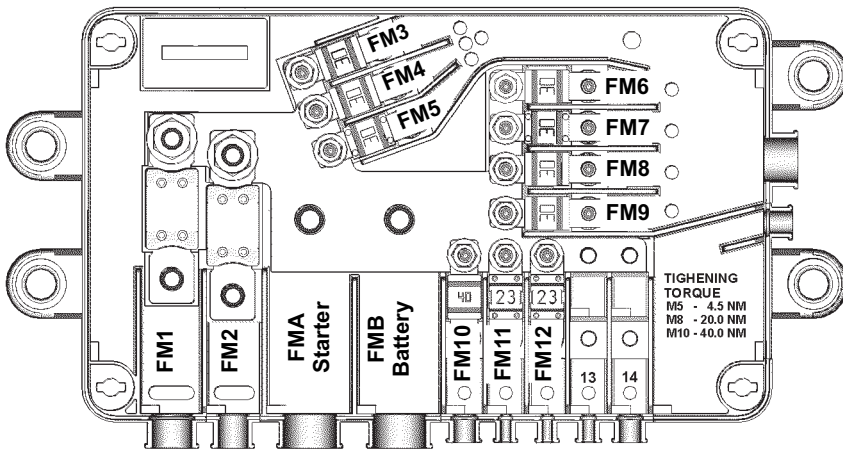

FM A	Start	No Fuse	M10
FM B	Batt	No Fuse	M10
FM 1	BB	200A	M8
FM 2	Cab	100A	M8
FM 3	FCIOM	30A	M5
FM 4	CCIOM	30A	M5
FM 5	RCIOM	30A	M5
FM 6	FCIOM	30A	M5
FM 7	CCIOM	30A	M5
FM 8	RCIOM	30A	M5
FM 9	FAS	30A	M5
FM 10	PCCU	40A	M5
FM 11	ACM	23A	M5
FM 12	RAS	23A	M5

MSWI-B, MSWI-R, UADR

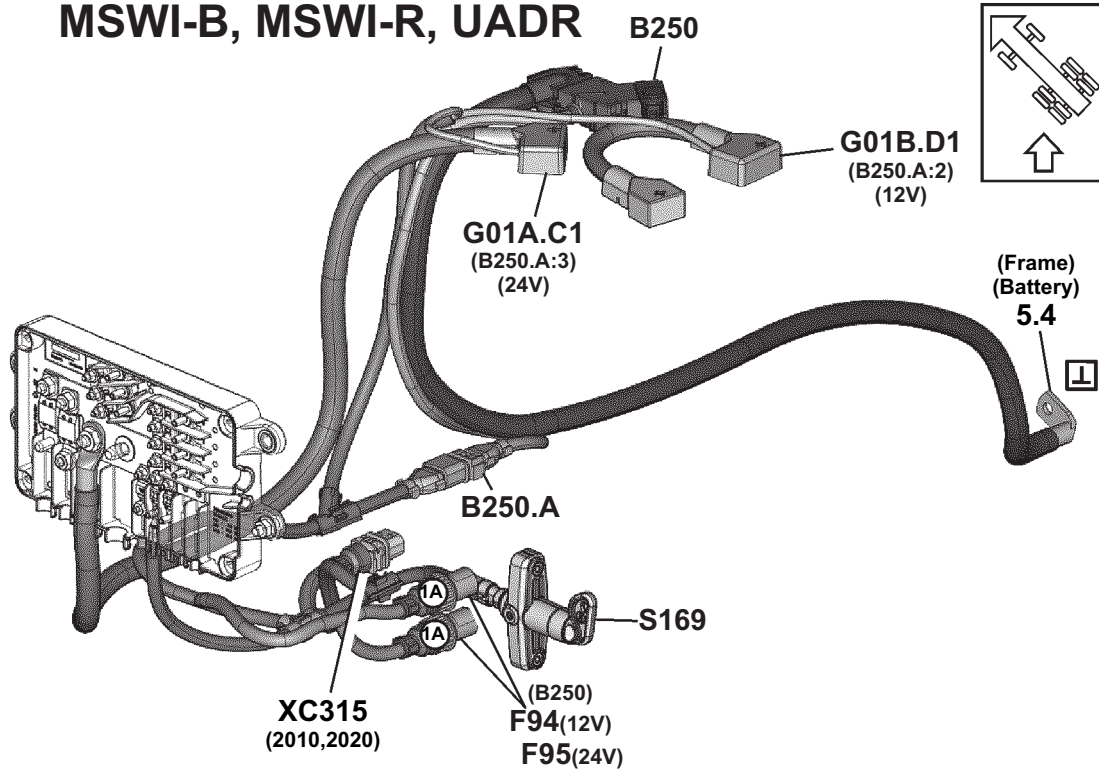

2020, BBOX-AC

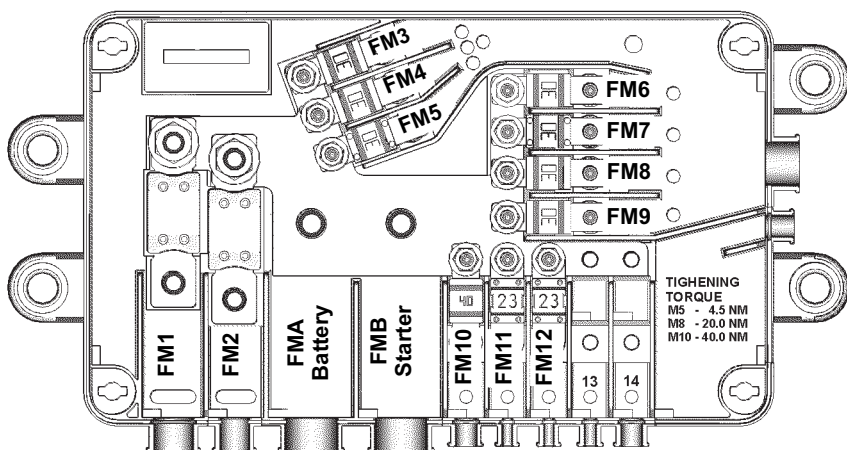

FM A	Batt	No Fuse	M10
FM B	Start	No Fuse	M10
FM 1	BB	100A	M8
FM 2	Cab	100A	M8
FM 3	FCIOM	30A	M5
FM 4	CCIOM	30A	M5
FM 5	RCIOM	30A	M5
FM 6	FCIOM	30A	M5
FM 7	CCIOM	30A	M5
FM 8	RCIOM	30A	M5
FM 9	FAS	30A	M5
FM 10	-----	-----	-----
FM 11	ACM	23A	M5
FM 12	RAS	23A	M5

2020, BBOX-AC

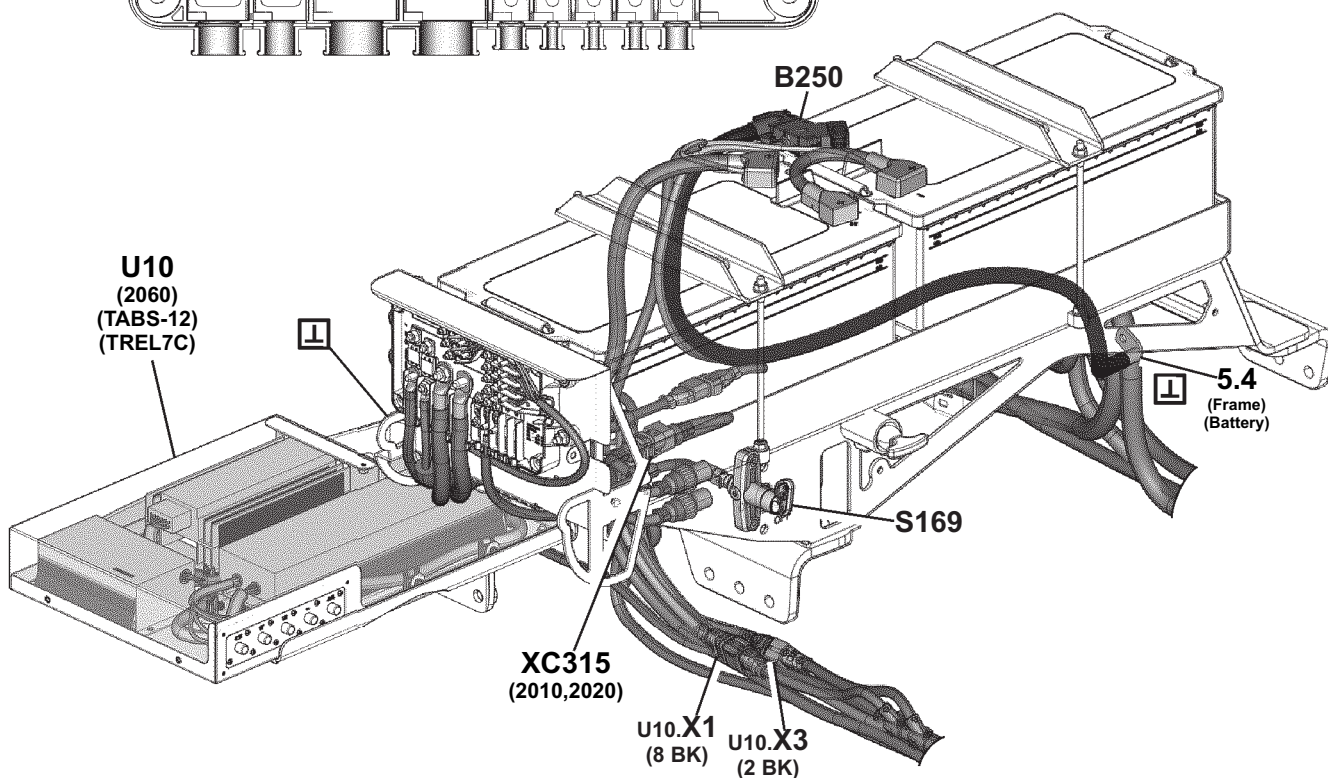

T3086699

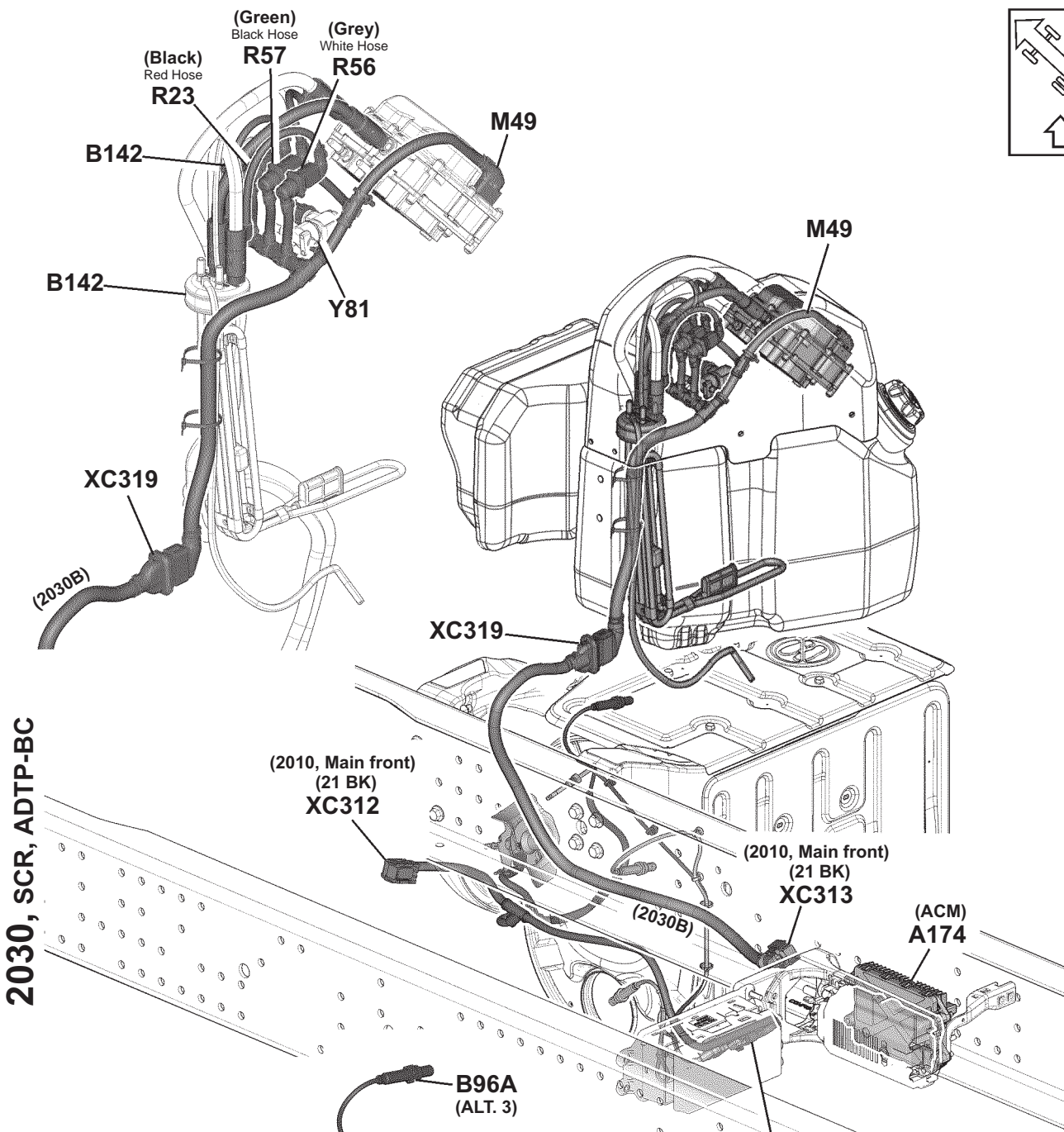
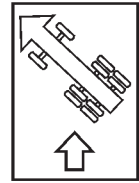

2030, SCR, ADTP-BC

2030, SCR, ADTP-BC

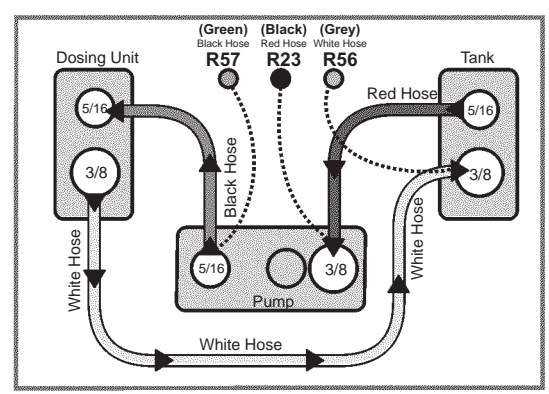
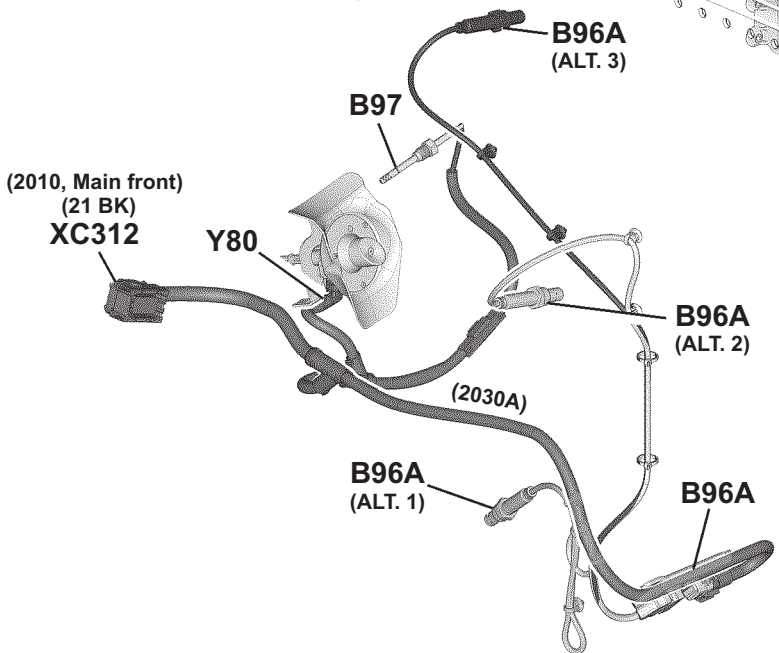

T3065163

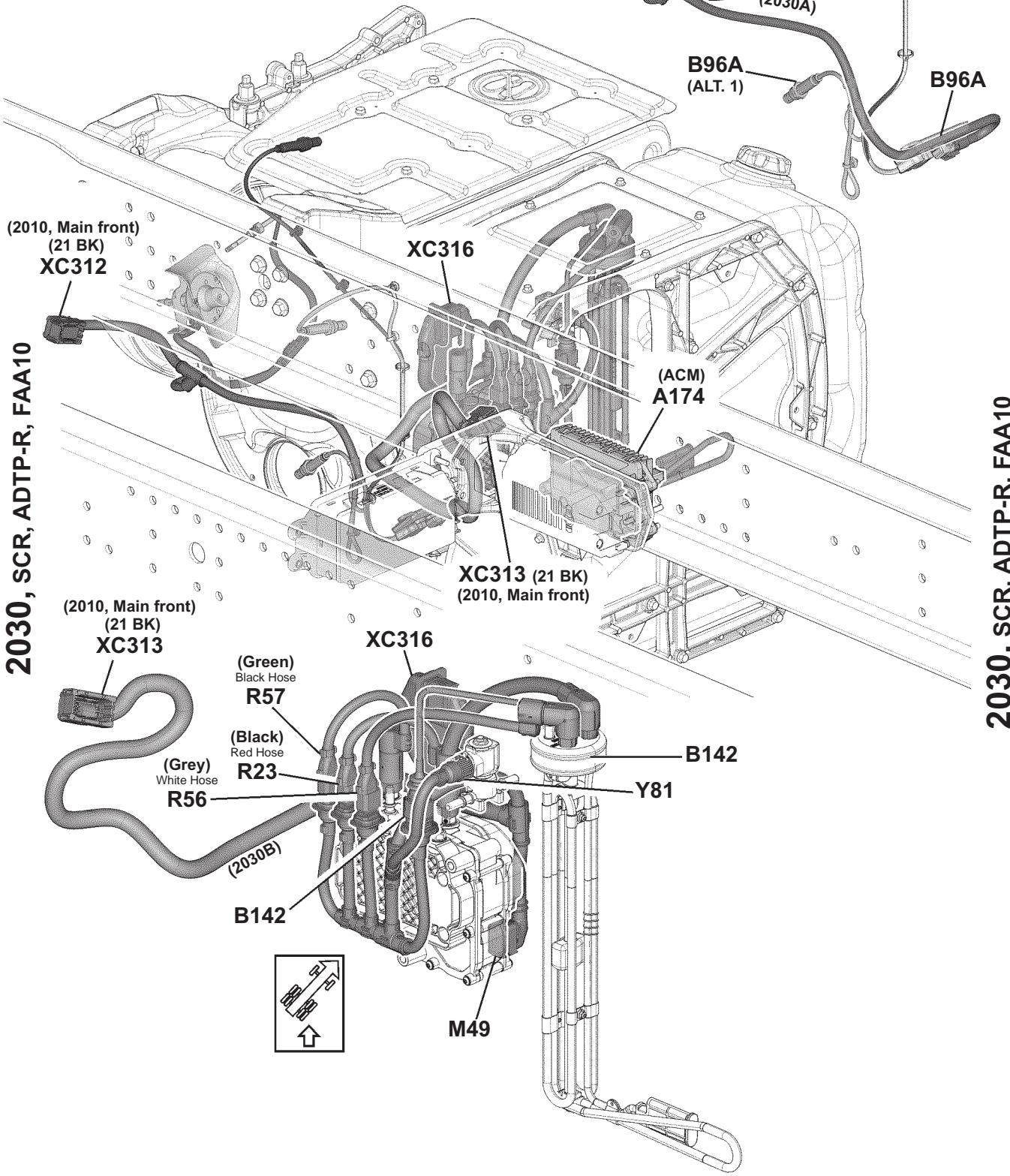
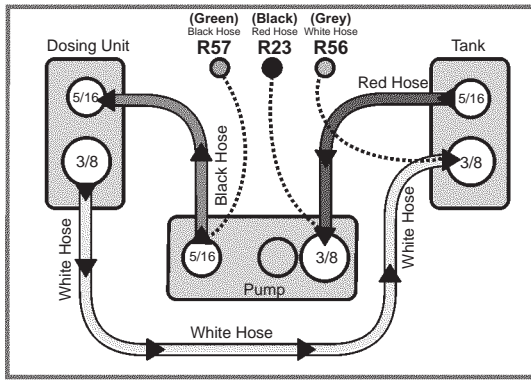

2030, SCR, ADTP-L, FAA20

2030, SCR, ADTP-L, FAA20

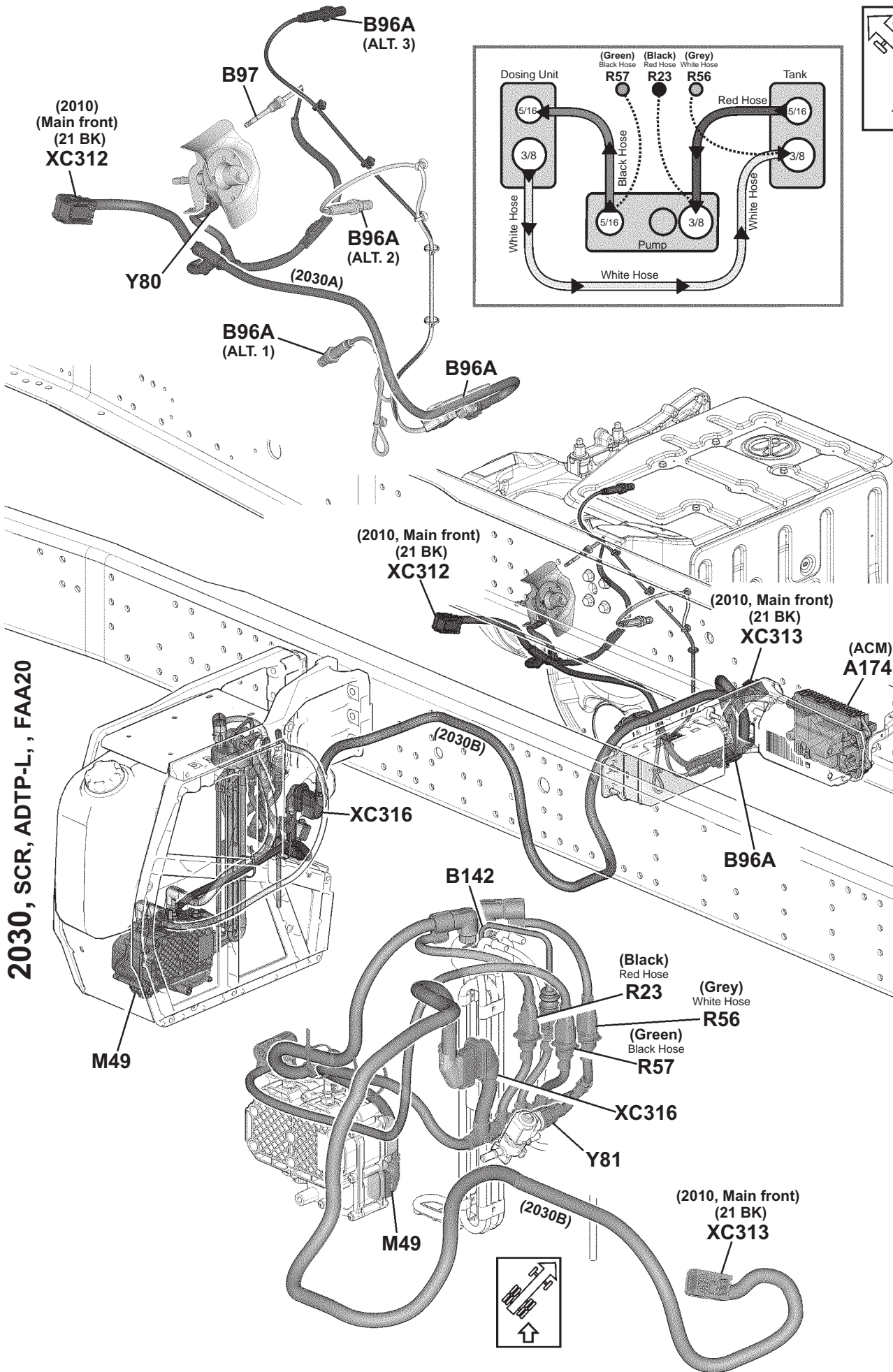

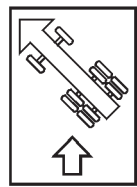

2030, EASP5, ADTP-BC, EM-EU6

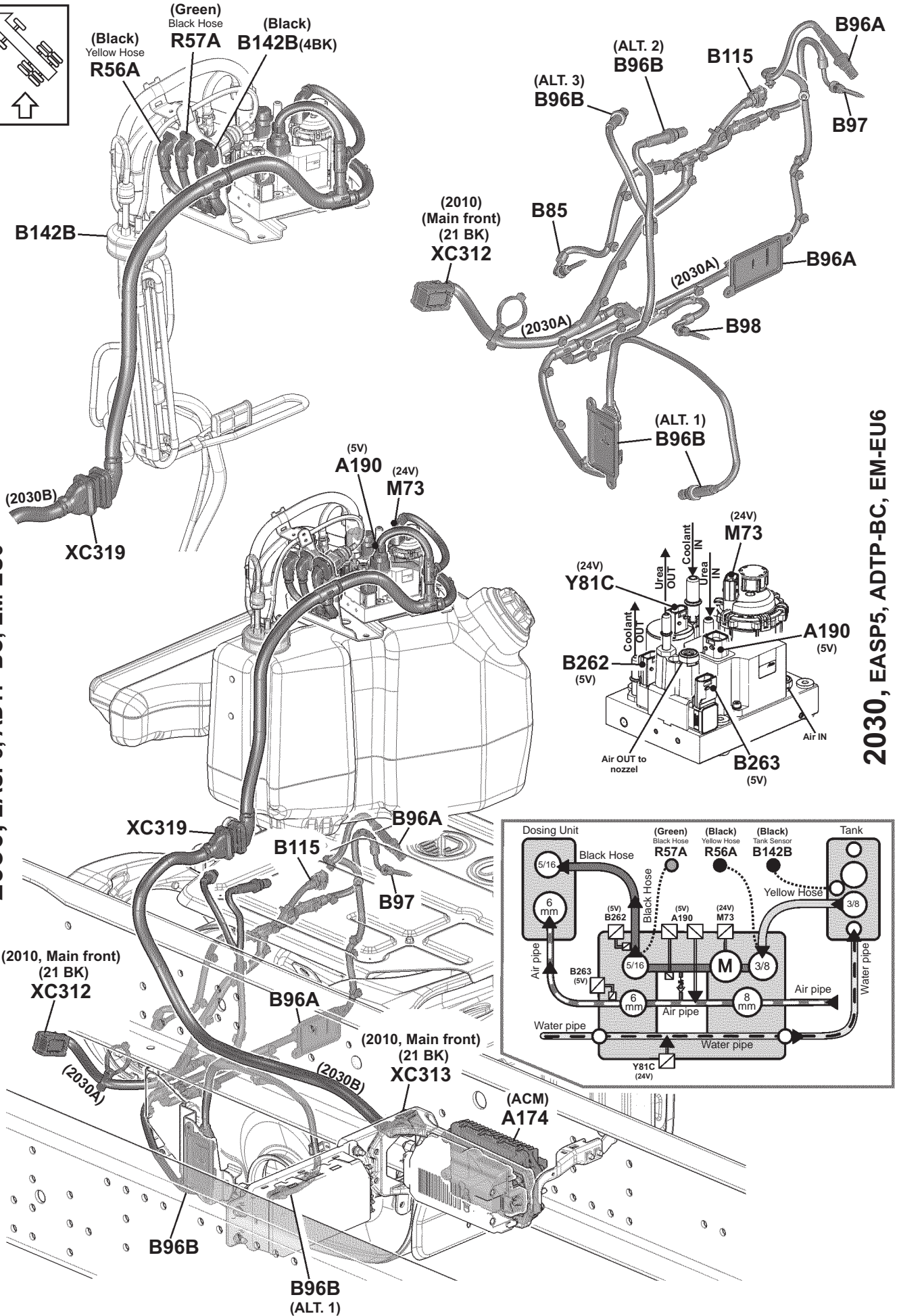

2030, EASP5, ADTP-BC, EM-EU6

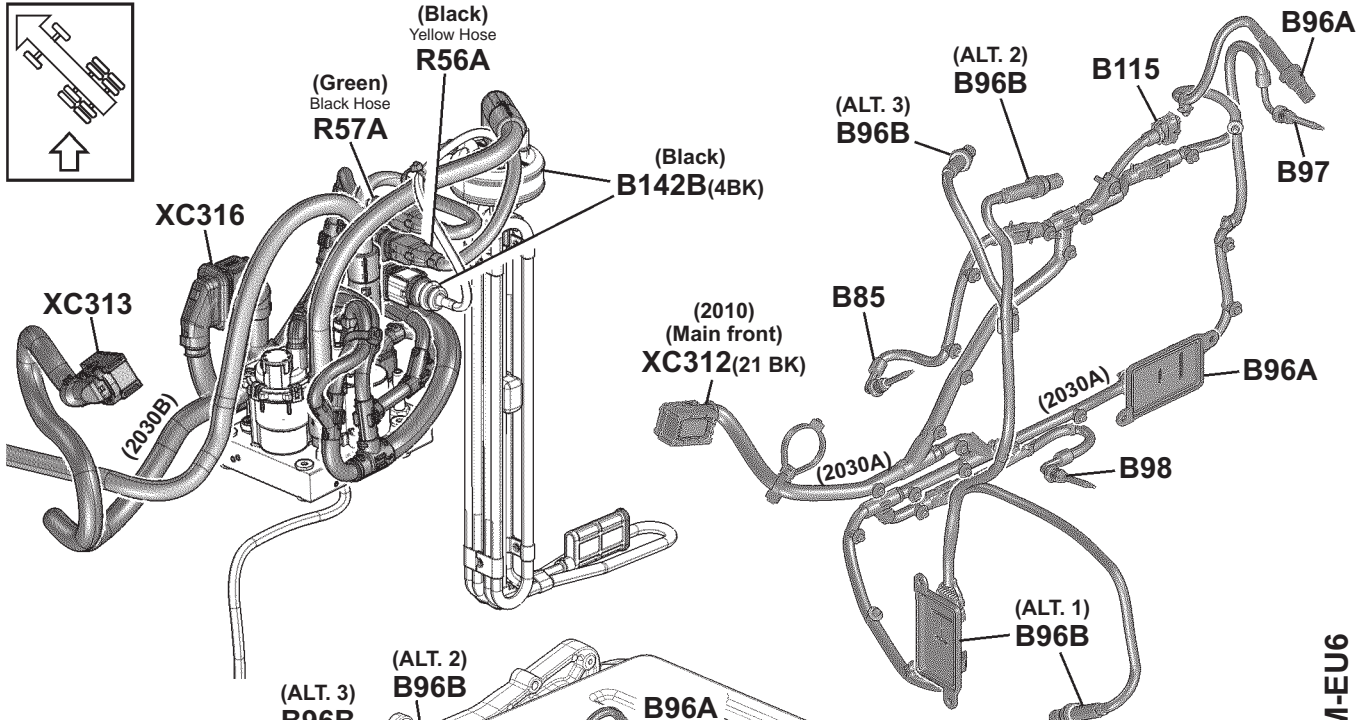
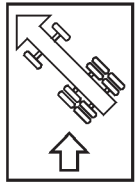

2030, EASP5, ADTP-R, EM-EU6

2030, EASP5, ADTP-R, EM-EU6

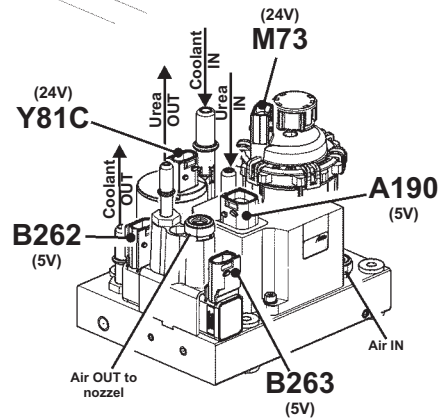
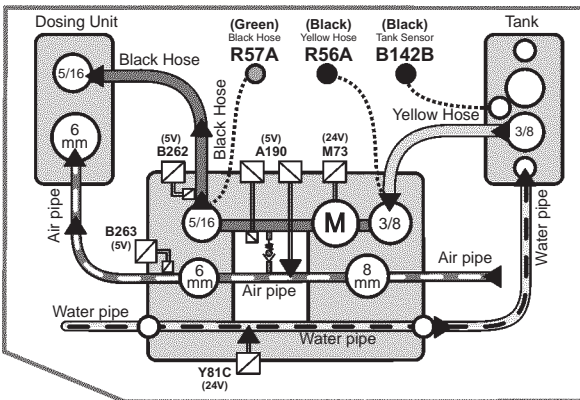
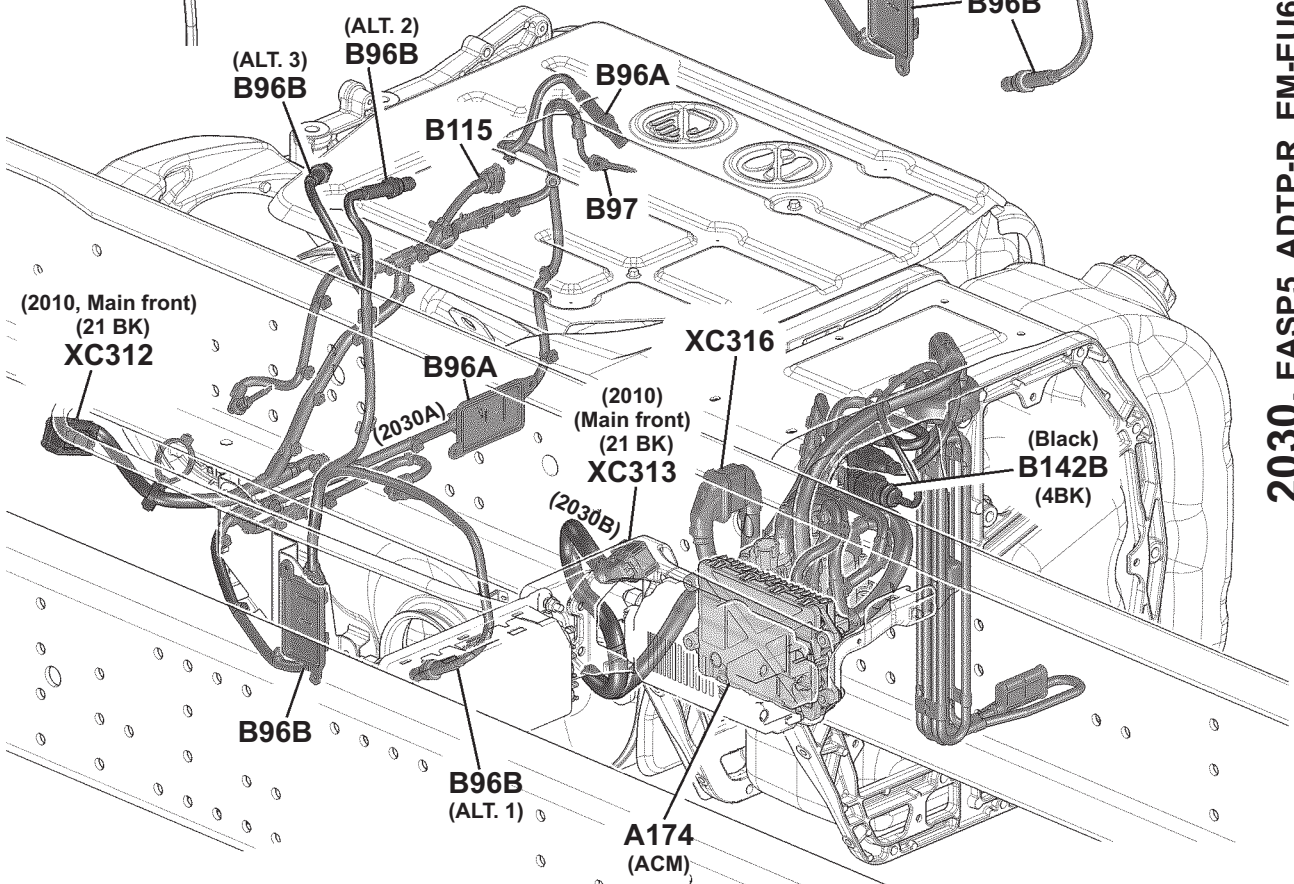

T3082375

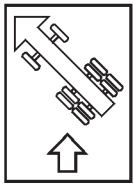

2030, EASP7, ADTP-L, EM-EU6

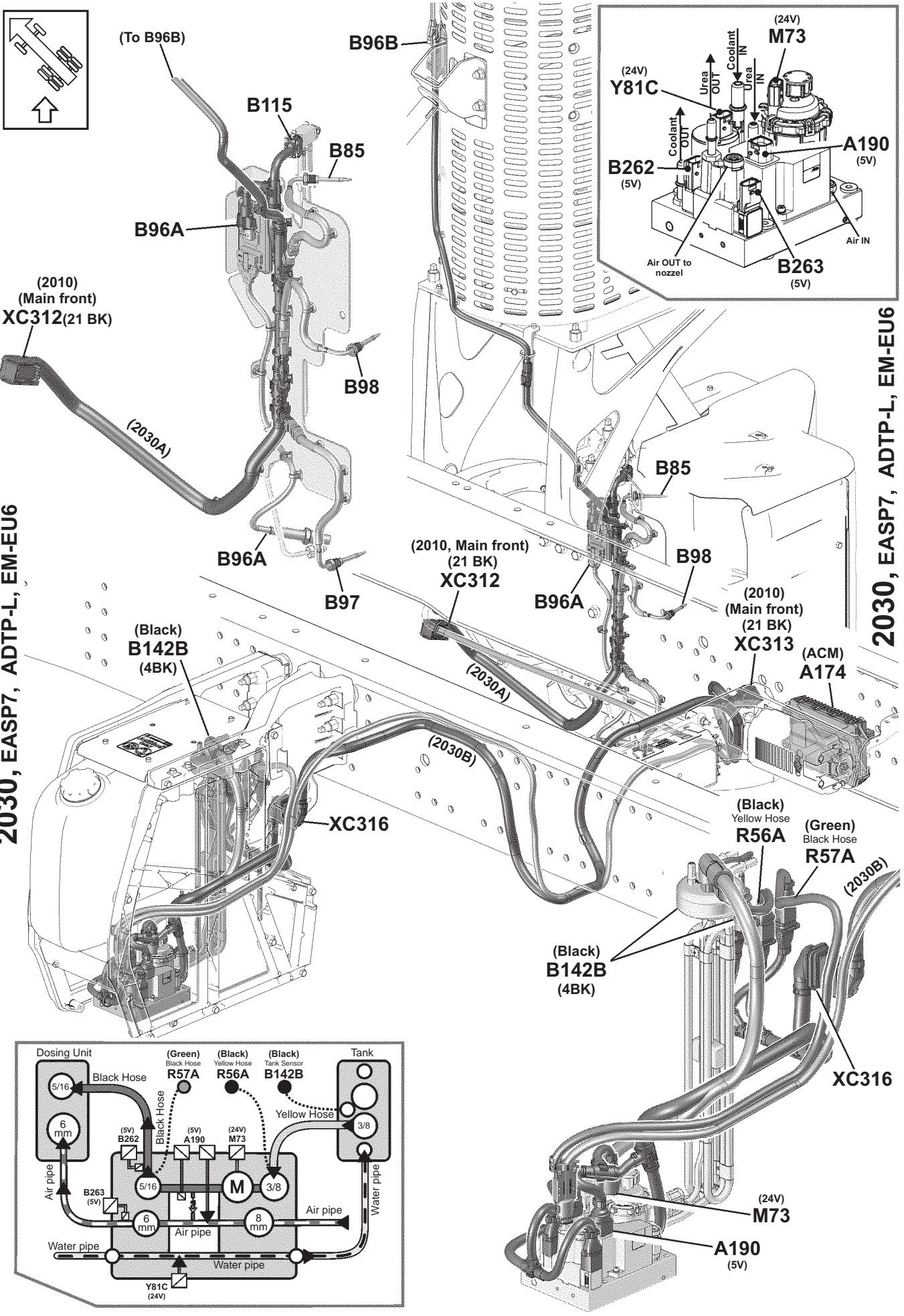

2030, EASP7, ADTP-L, EM-EU6

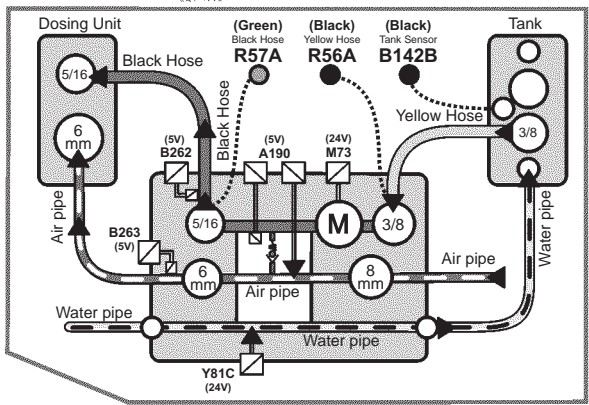

T3082376

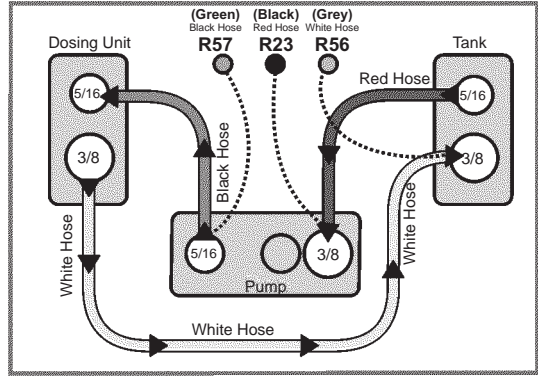
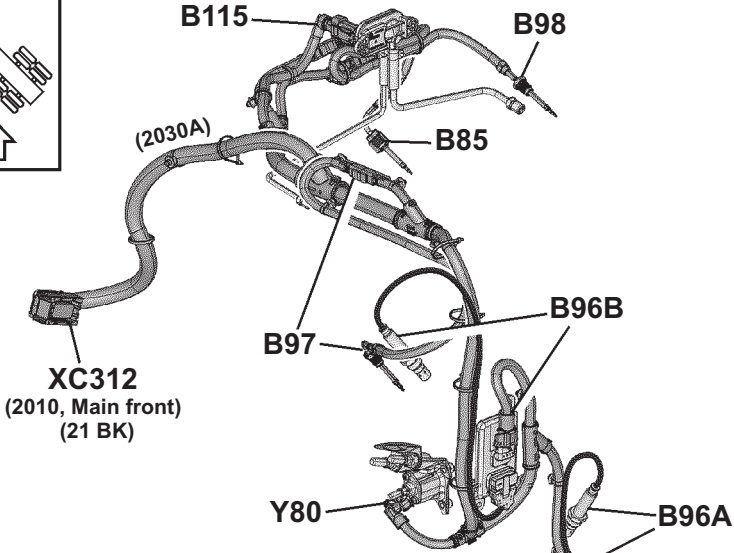
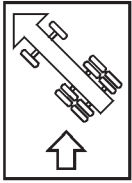

XC312
(2010, Main front)
(21 BK)

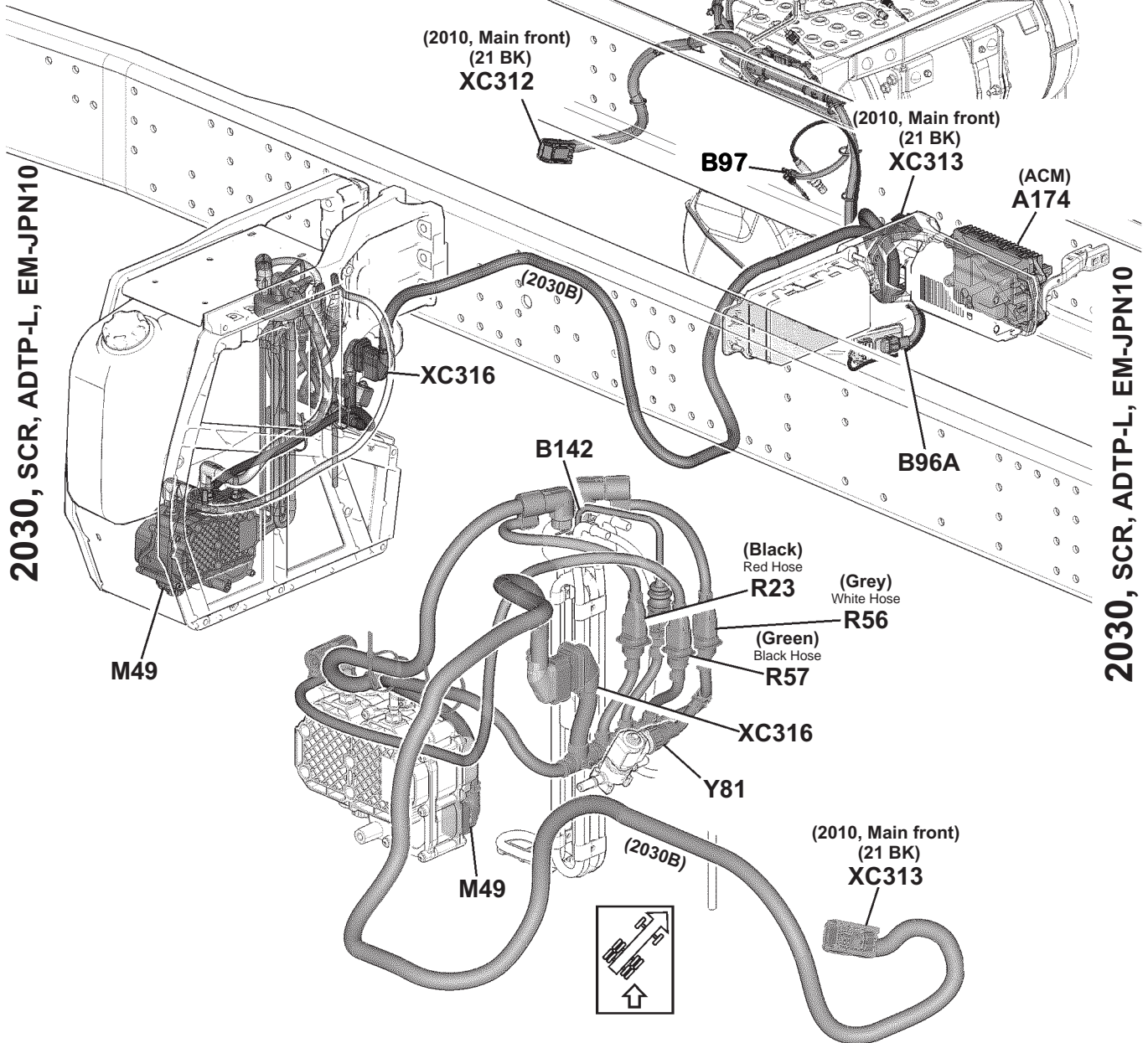

2030, SCR, ADTP-L, EM-JPN10

2030, SCR, ADTP-L, EM-JPN10

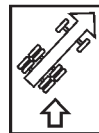

2040, 2060, 2070, 2080, RADT-GR

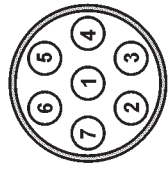
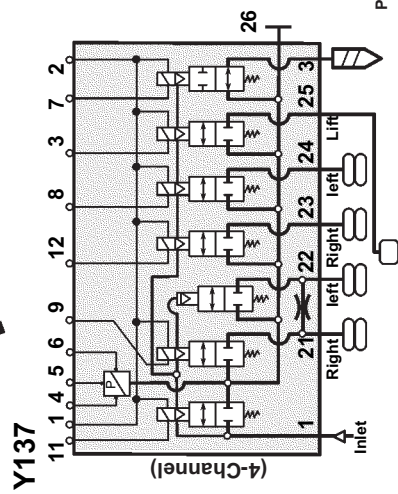
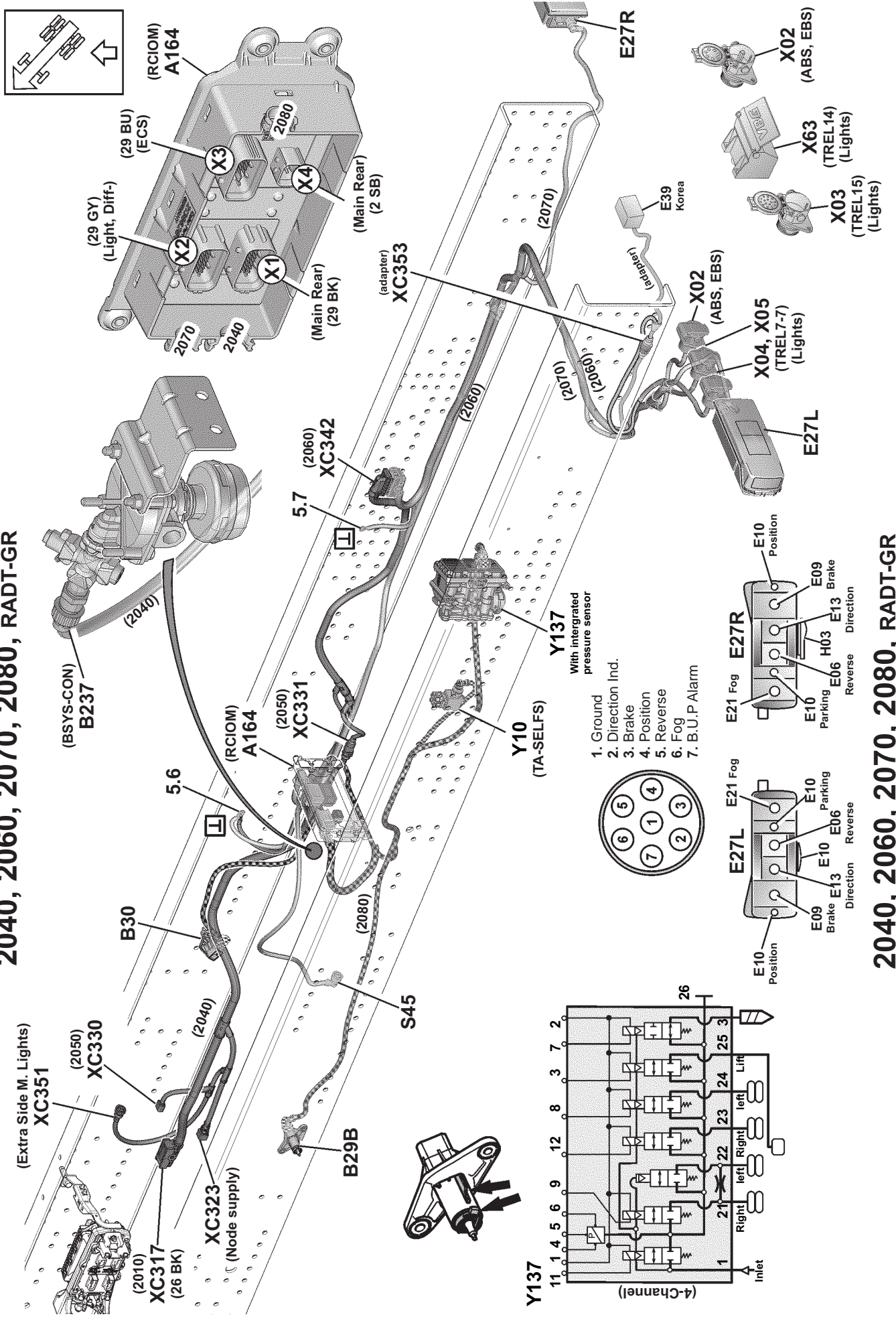

- 1. Ground
- 2. Direction Inc.
- 3. Brake
- 4. Position
- 5. Reverse
- 6. Fog
- 7. B.U.P Alarm

With integrated pressure sensor

2040, 2060, 2070, 2080, RADT-GR

2040, 2070, 2080, RAPD-GR, Tractor

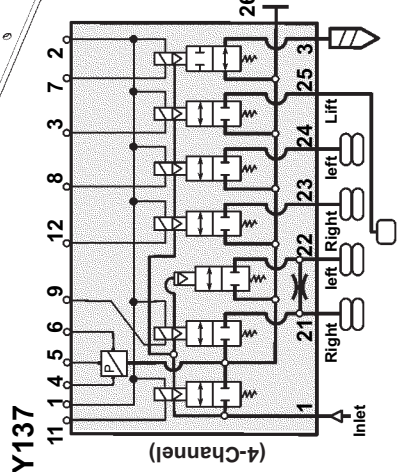
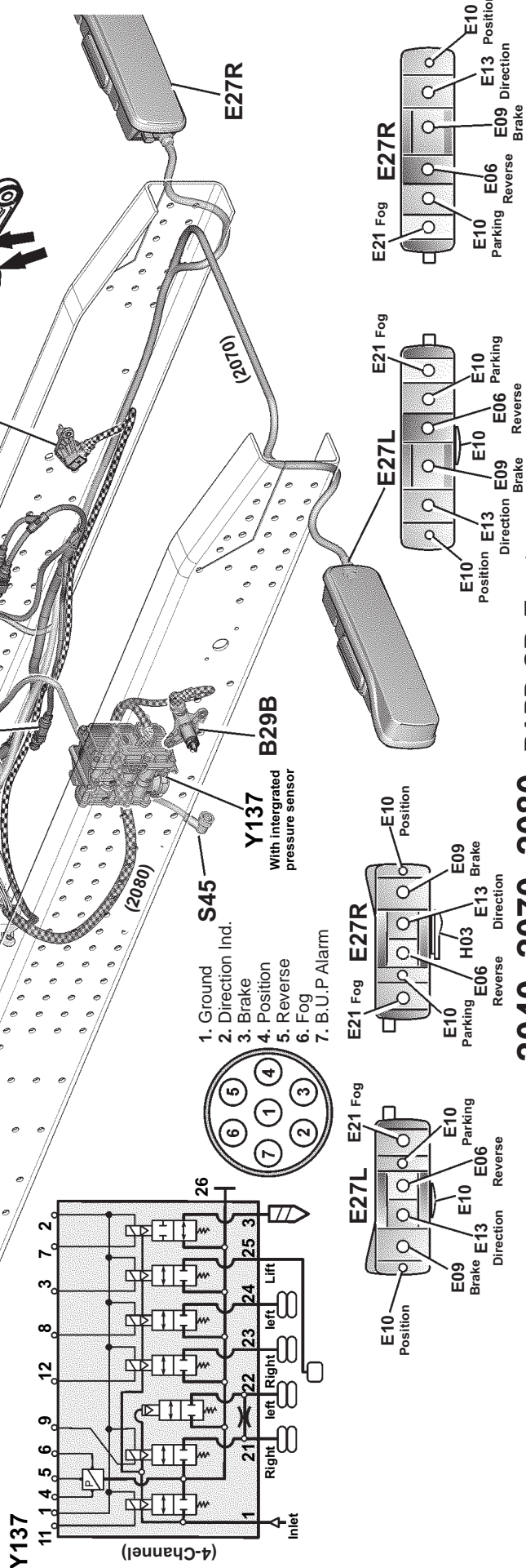
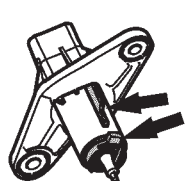
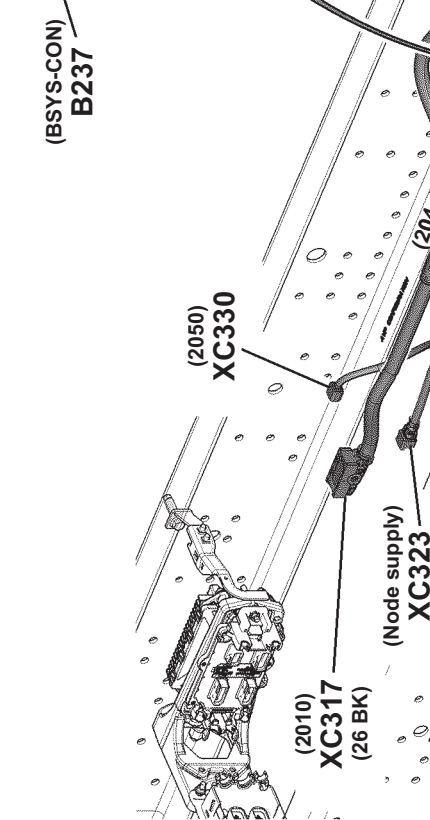
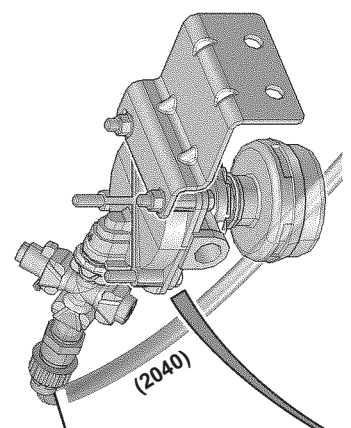
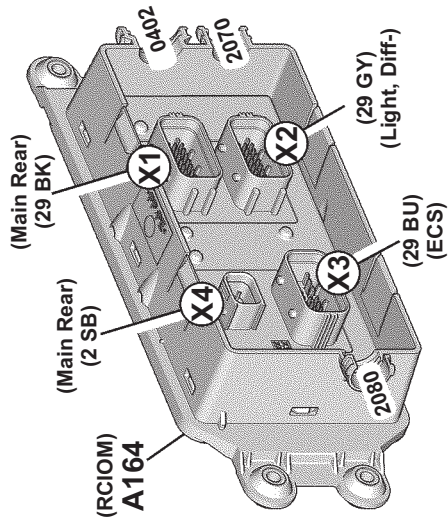
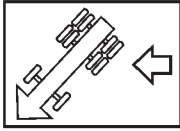

1. Ground
2. Direction Ind.
3. Brake
4. Position
5. Reverse
6. Fog
7. B.U.P Alarm

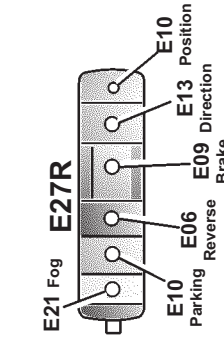
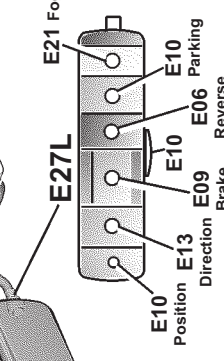
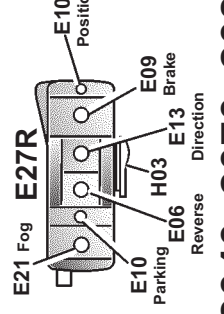
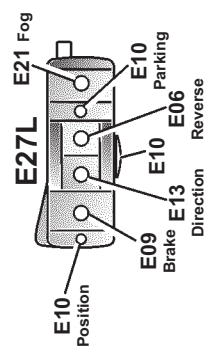
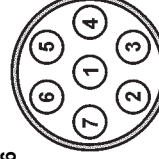

2040, 2070, 2080, RAPD-GR, Tractor

2040, 2070, 2080, RADD-GR, Tractor

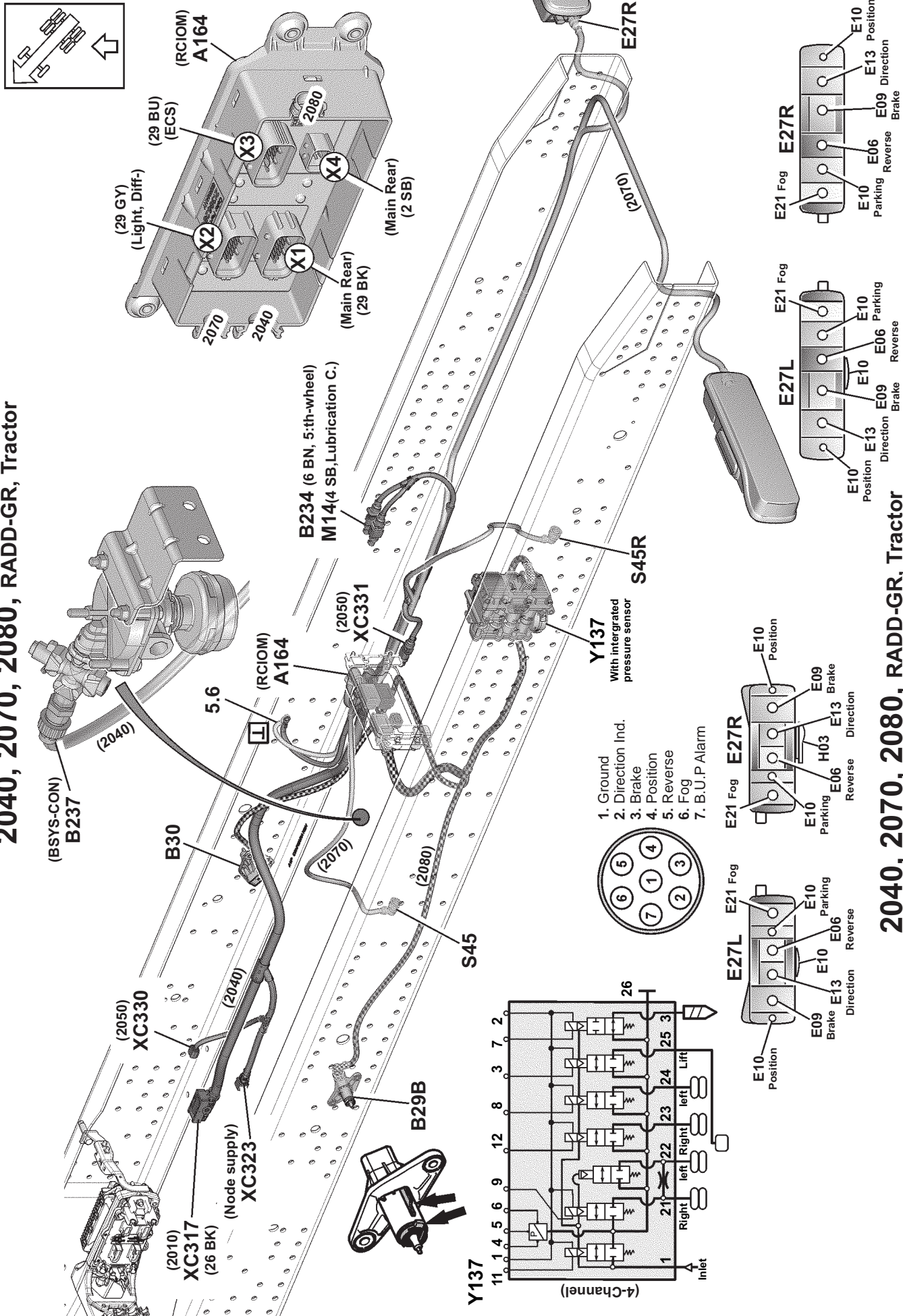

T3065171

2040, 2060, 2070, 2080, RAPDD-GR, RAPDT-GR

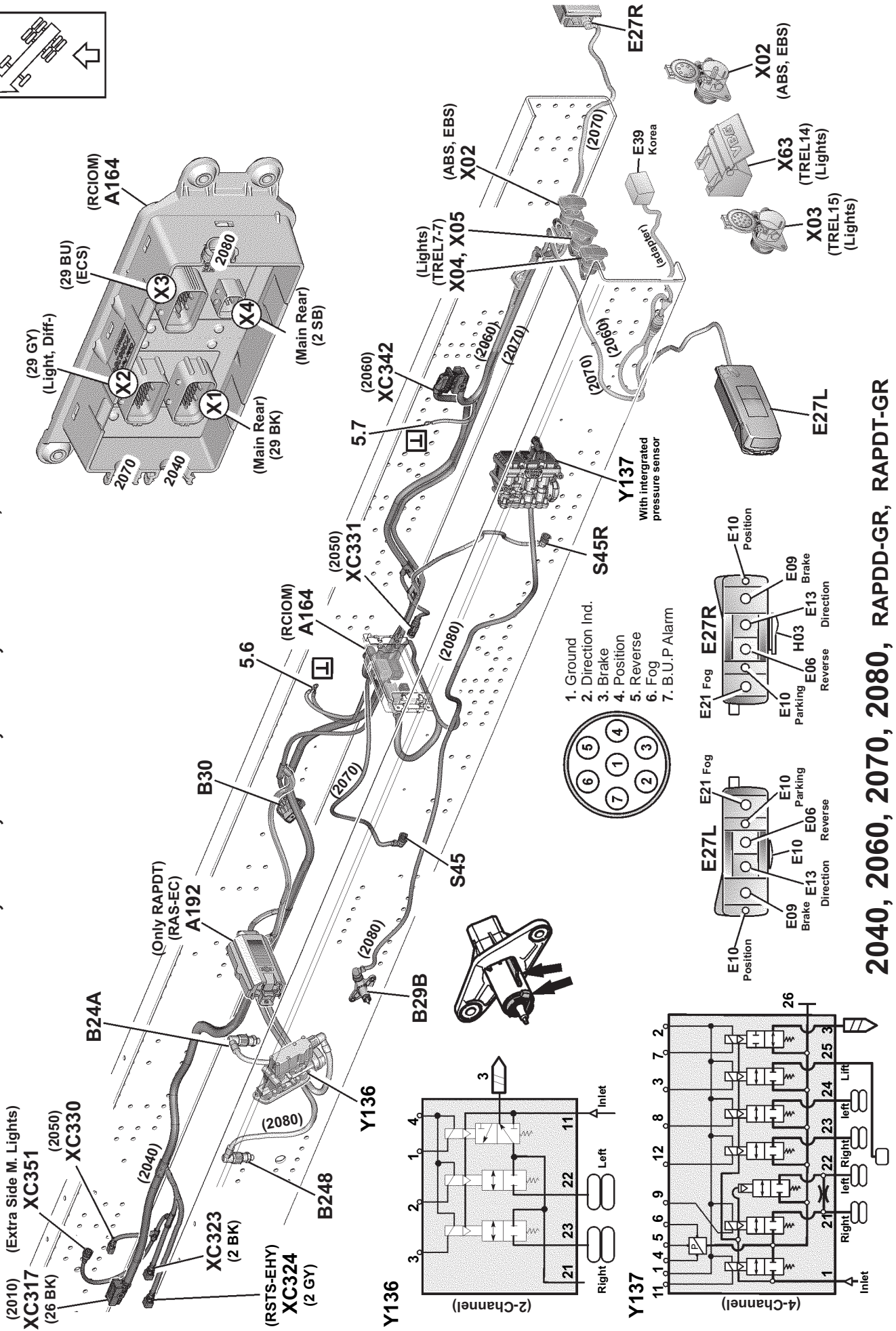
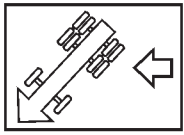

2040, 2060, 2070, 2080, RAPDD-GR, RAPDT-GR

T3076470

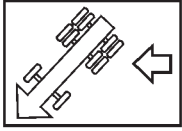

2125, 2050

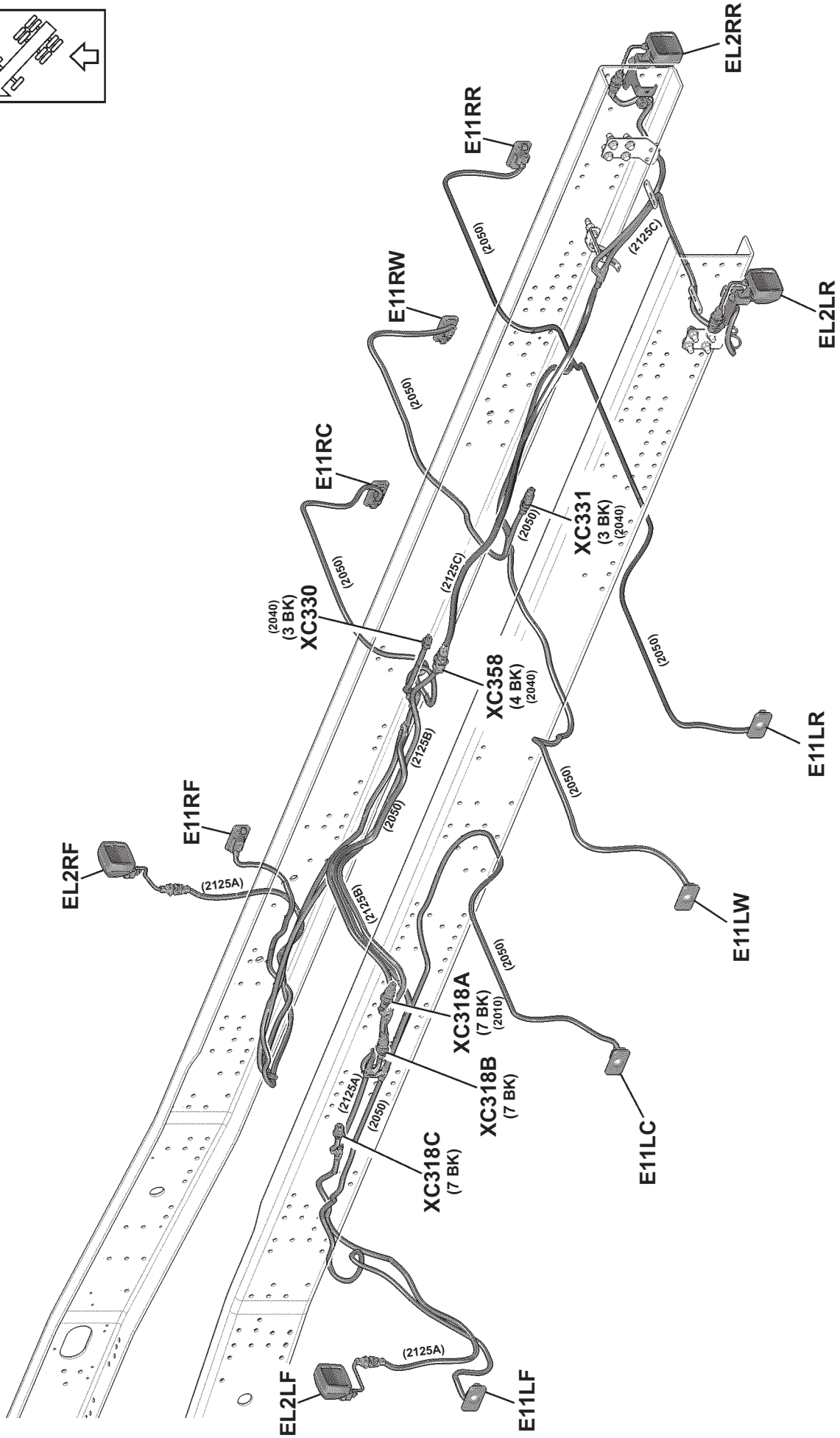

2125, 2050

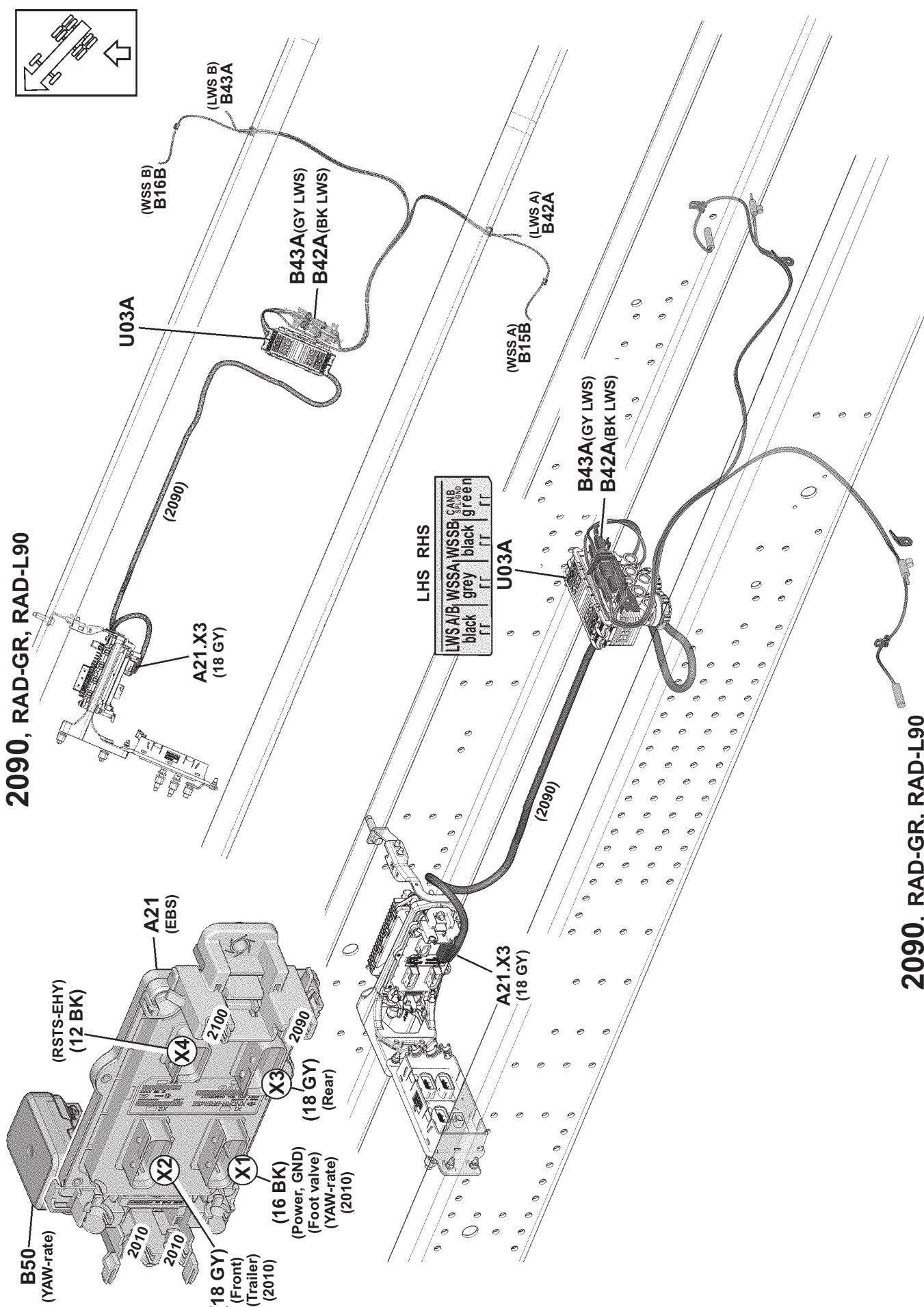

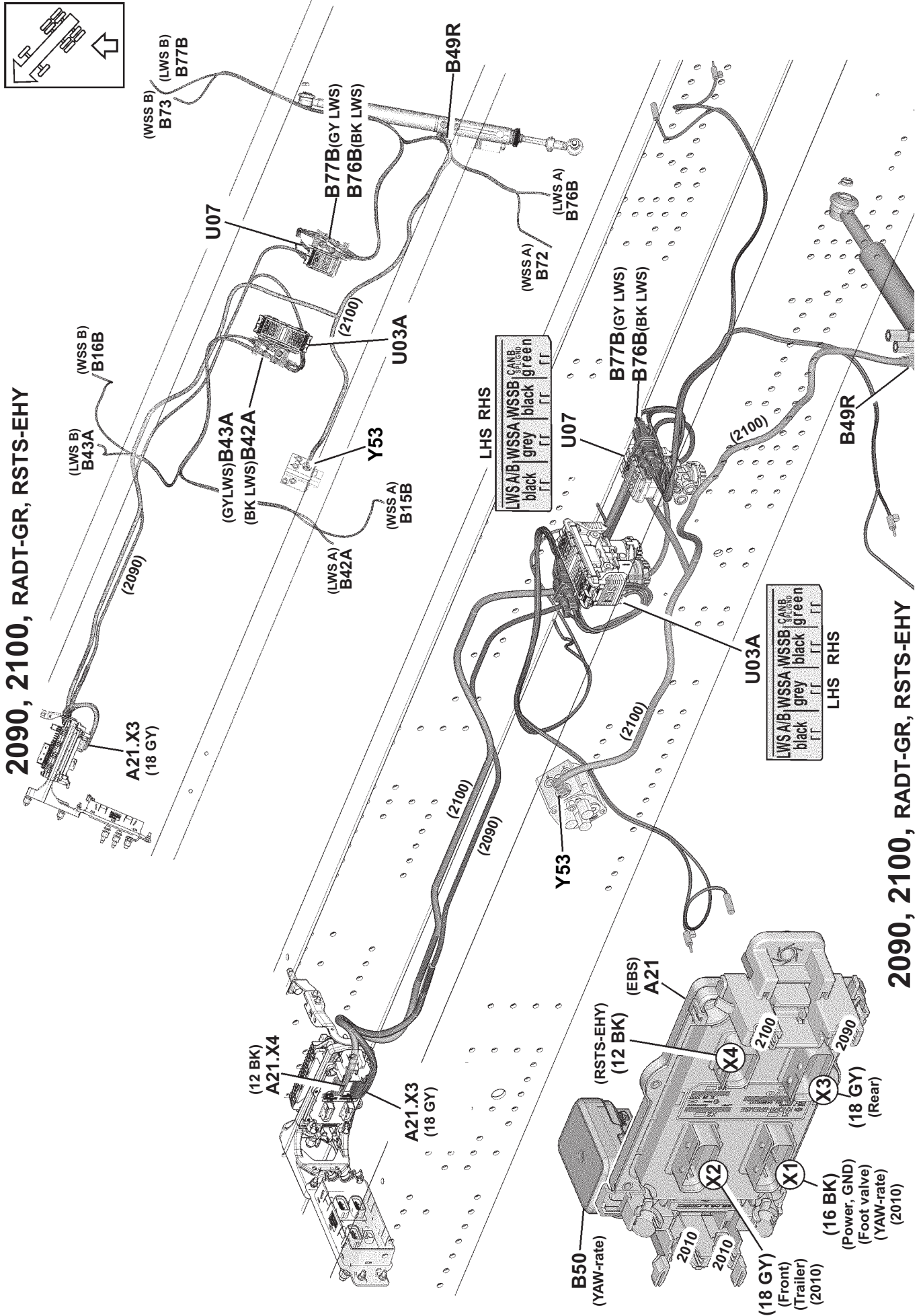

2090, 2100, RADT-GR, RSTS-EHY

2090, 2100, RADT-GR, RSTS-EHY

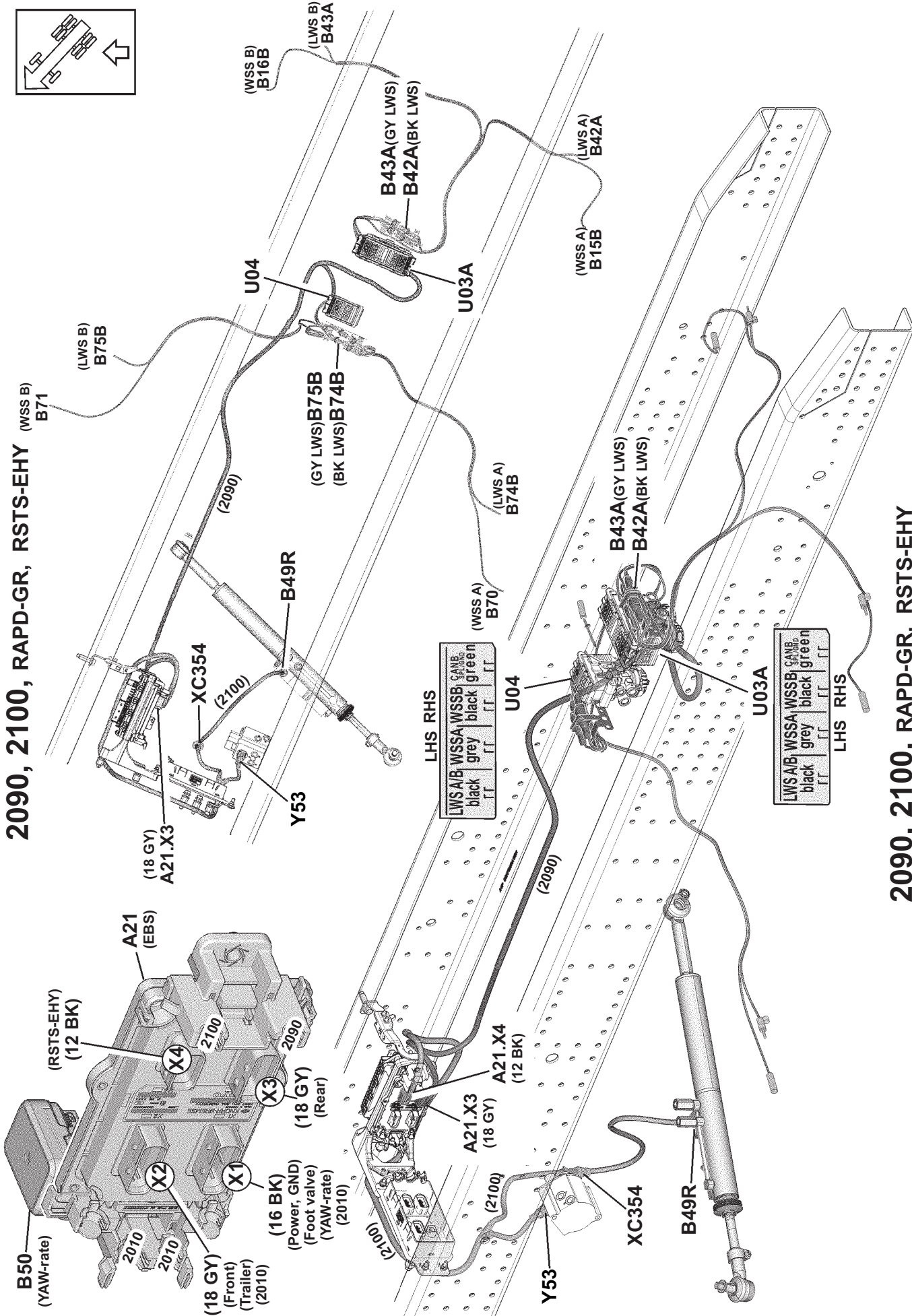

T3081806

2090, RADD-BR/-TR1/-TR2, RAL>23

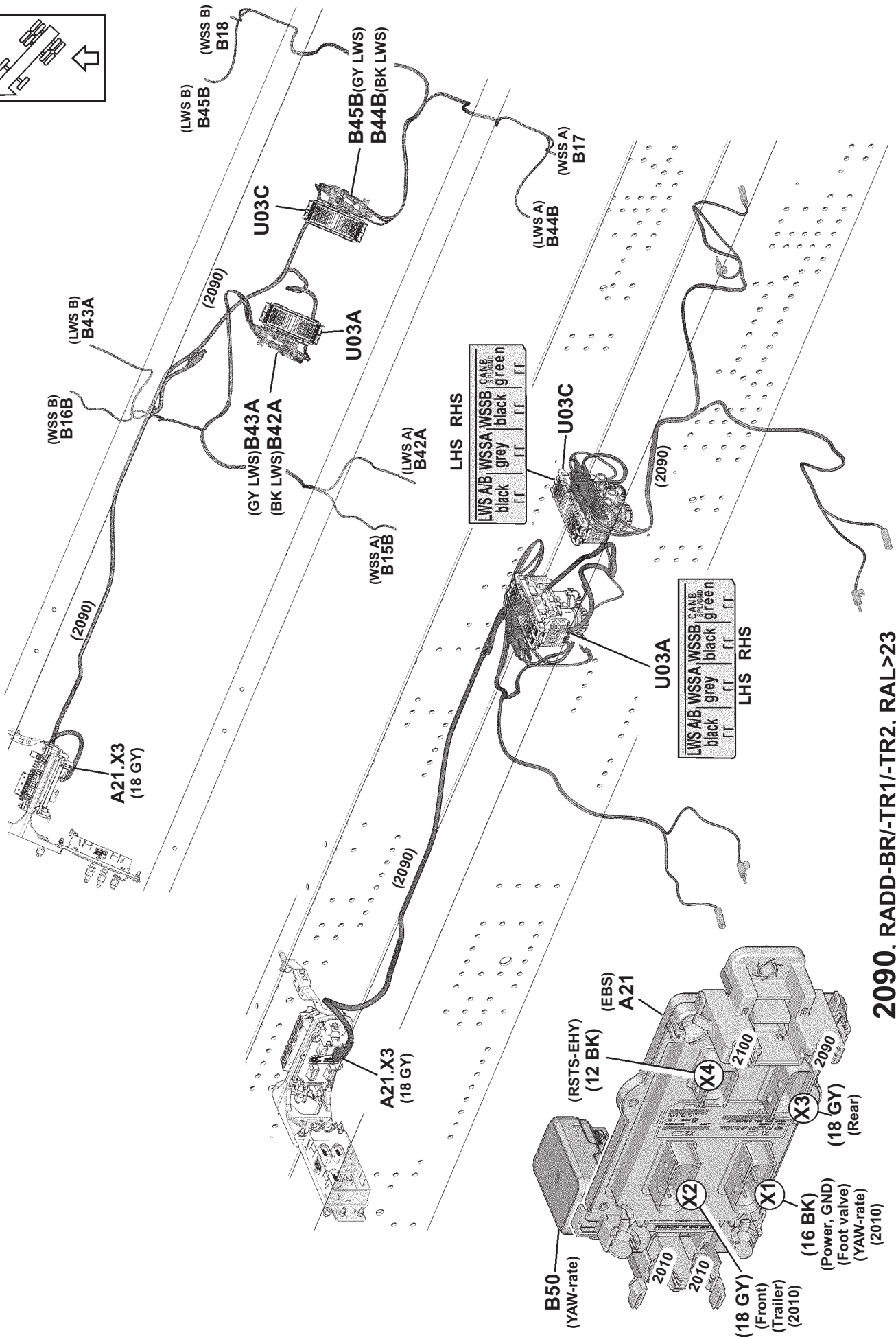
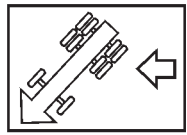

2090, RADD-BR/-TR1/-TR2, RAL>23

T3081808

2090, 2100, RADDT-GR, RSTS-EHY, RAL>33

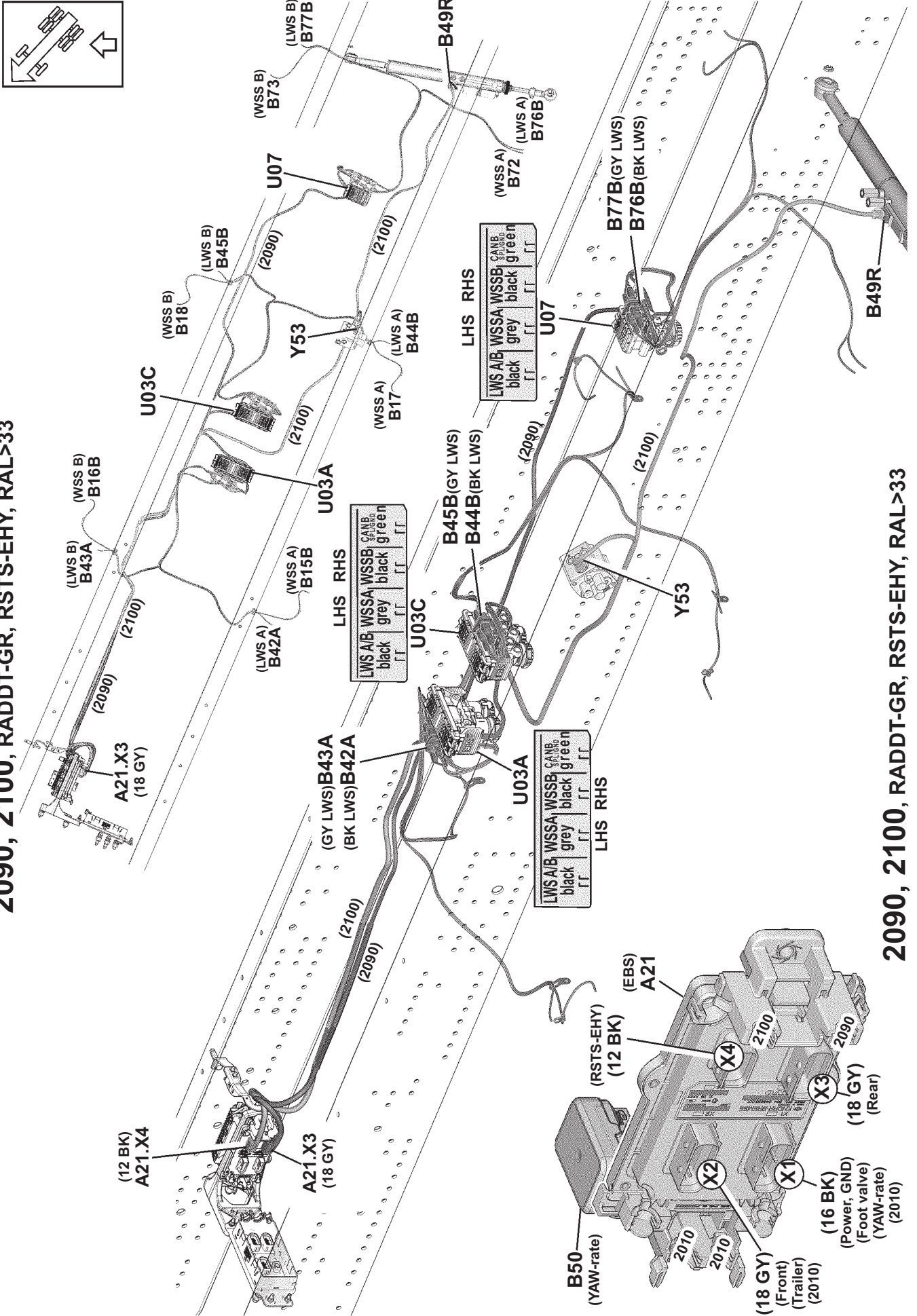

2090, 2100, RADDT-GR, RSTS-EHY, RAL>33

2090, ABS

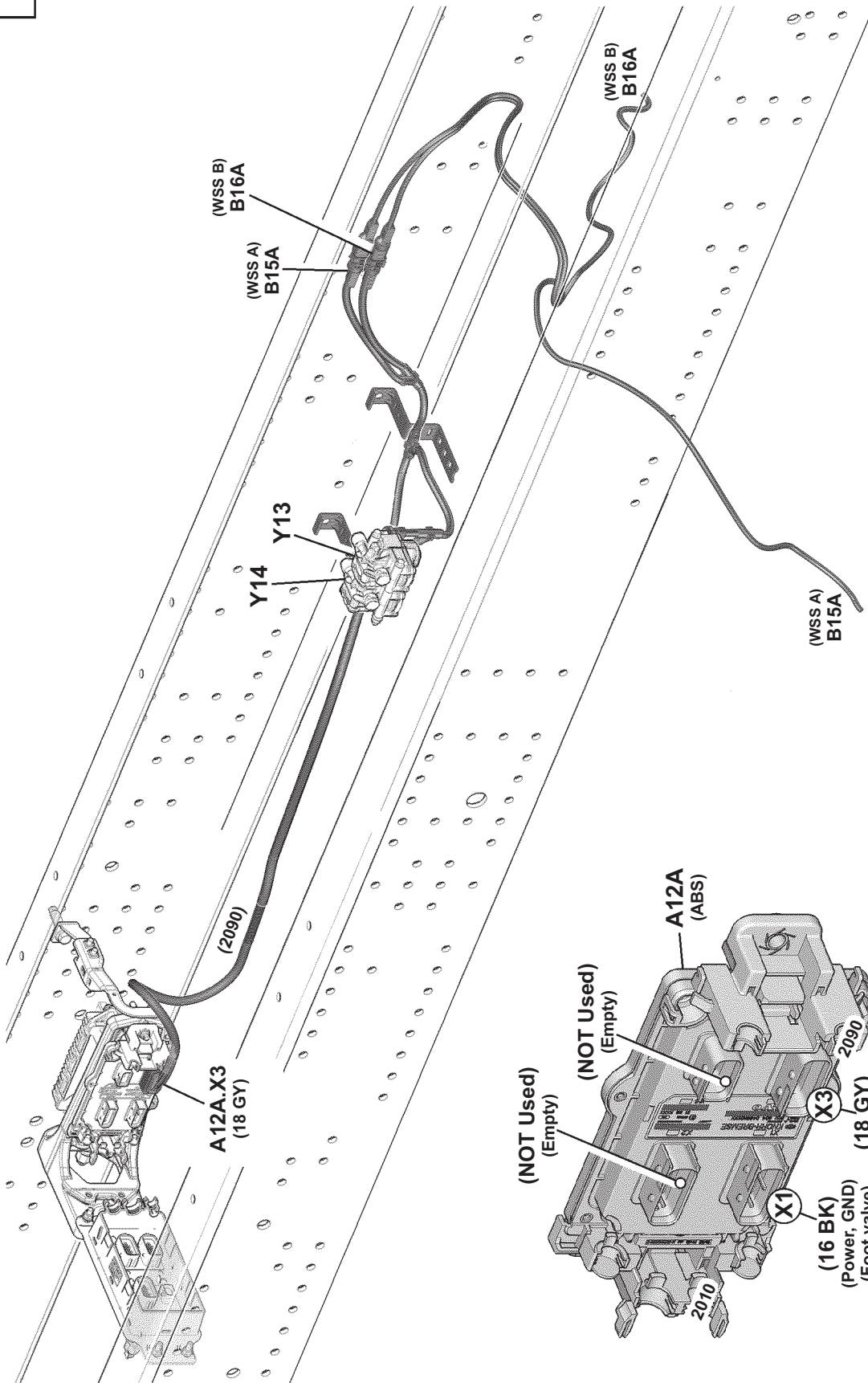
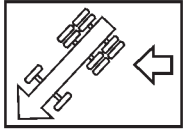

2090, ABS

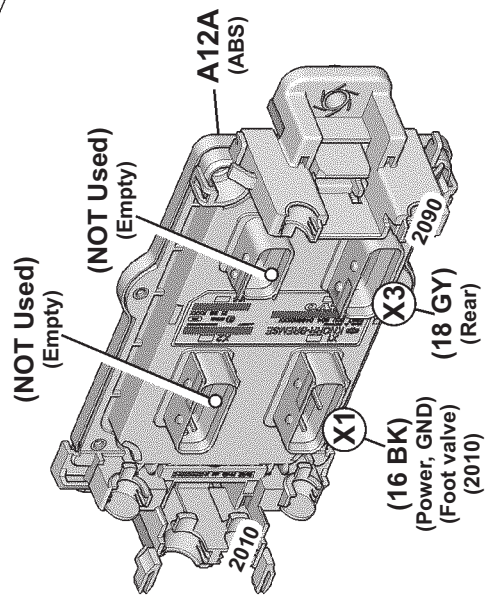

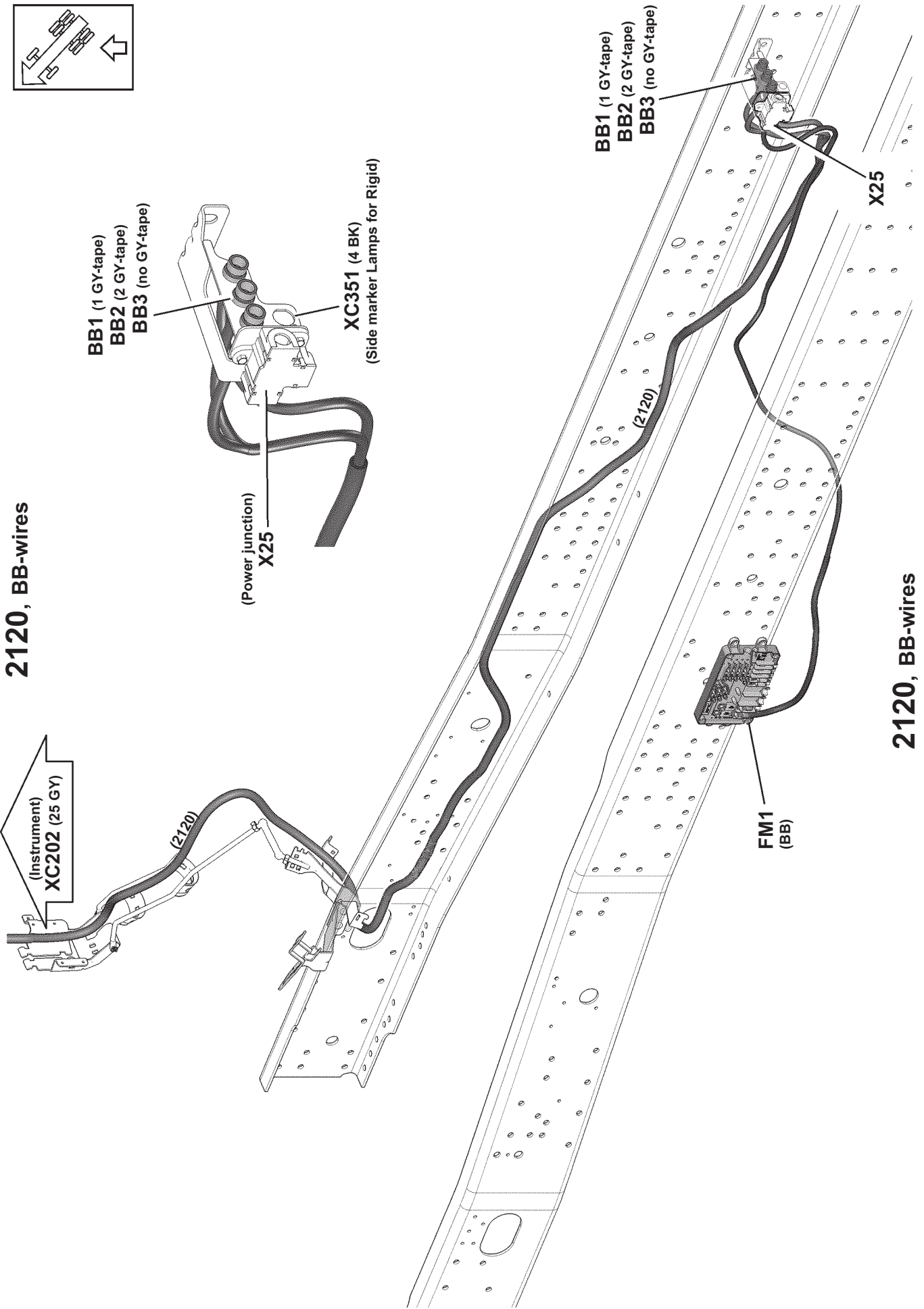

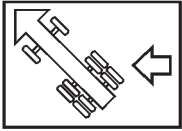

3000, MD13, EM-EU3

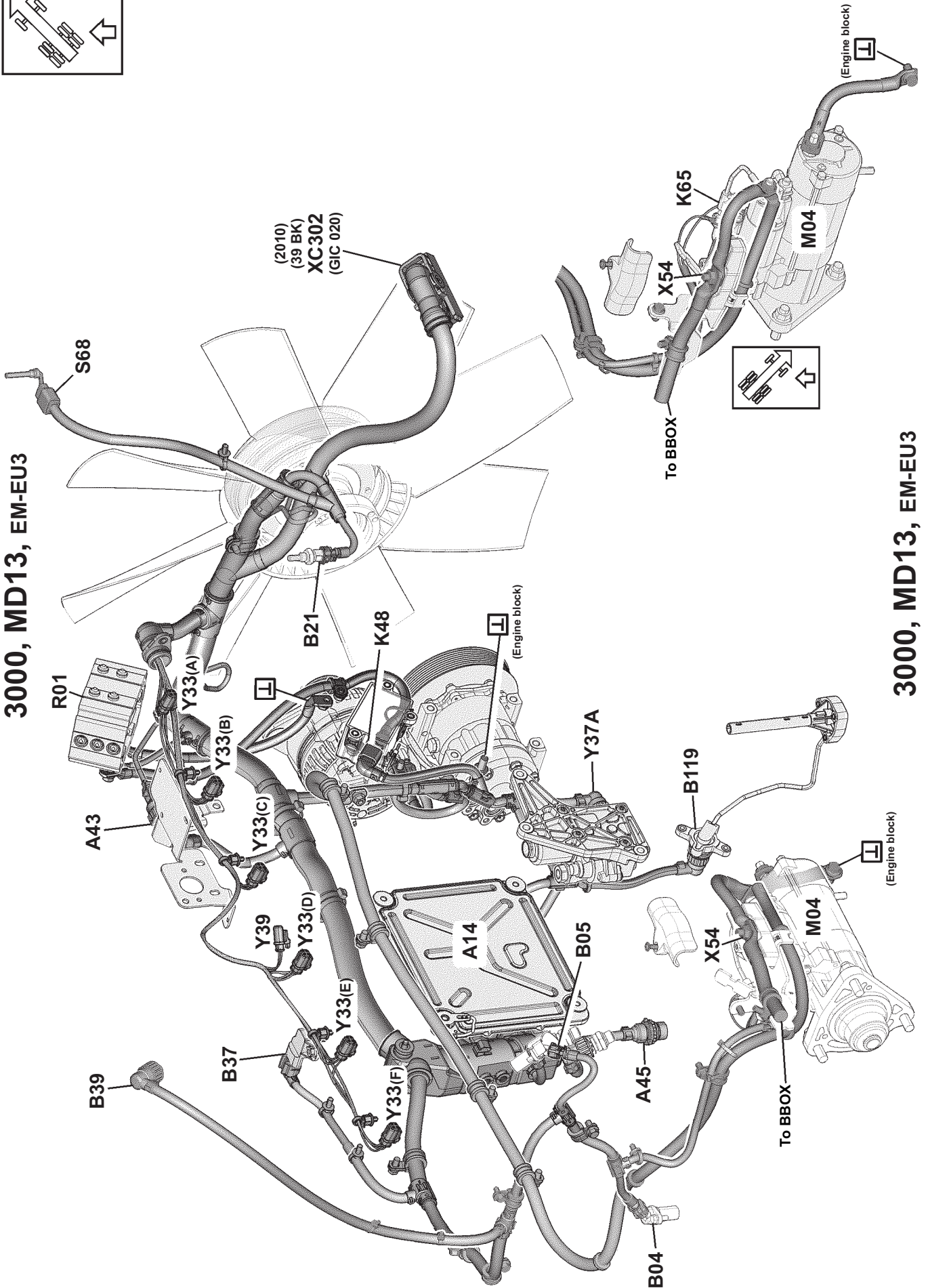

3000, MD13, EM-EU3

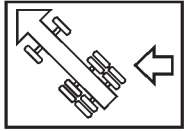

3000, MD13, EM-EU5

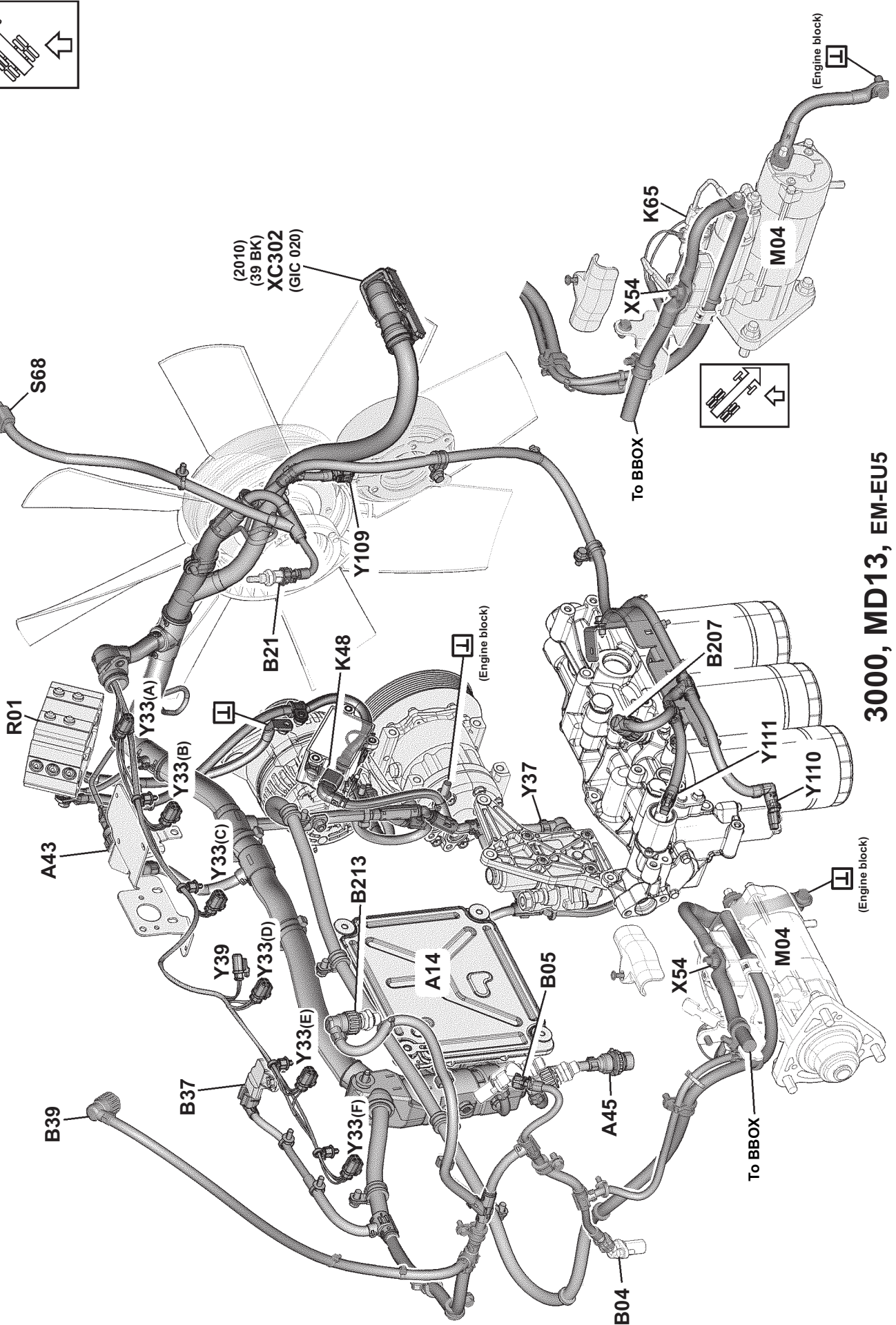

3000, MD13, EM-EU5

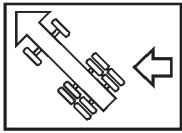

3000, MD13, EML4

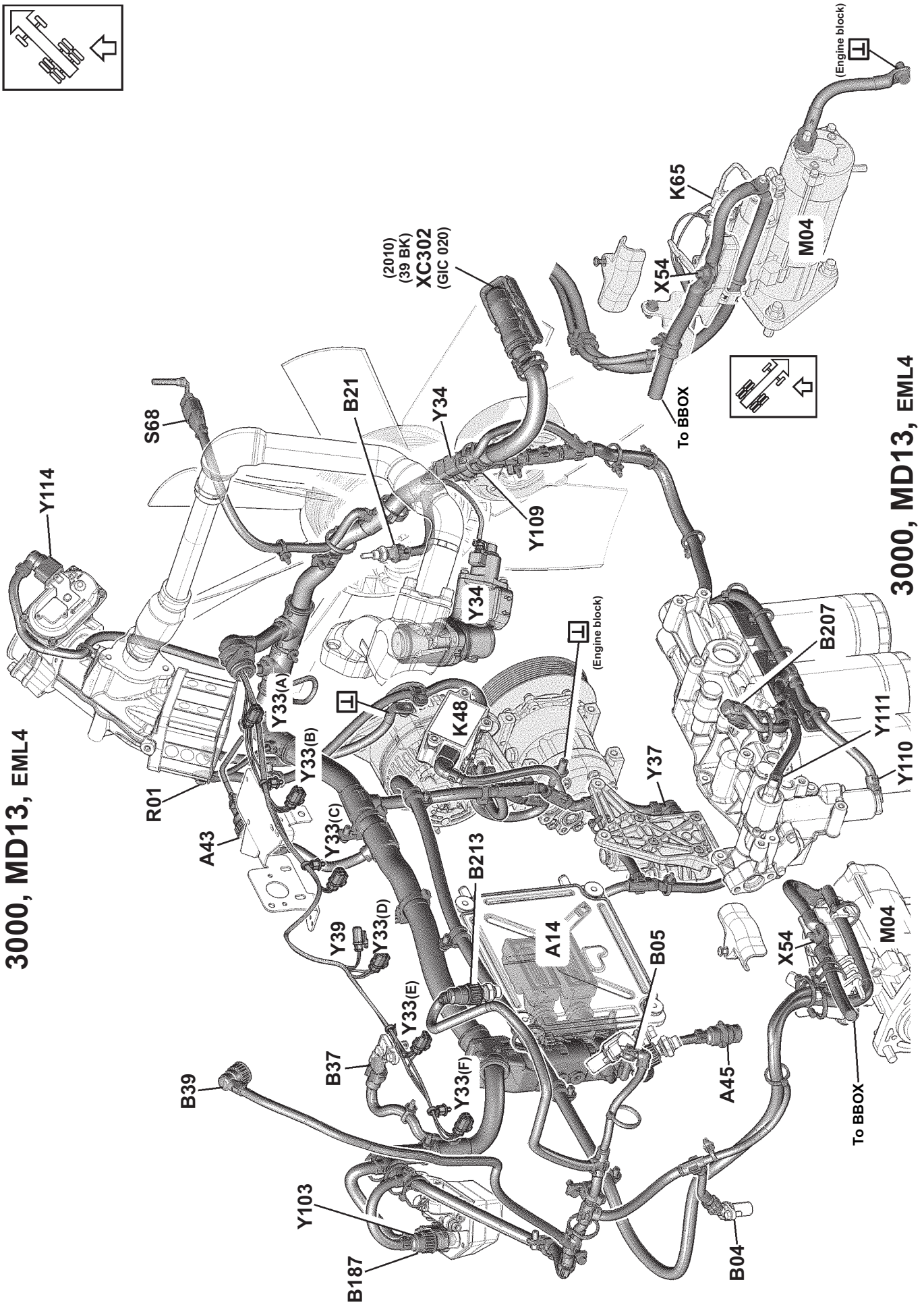

3000, MD13, EML4

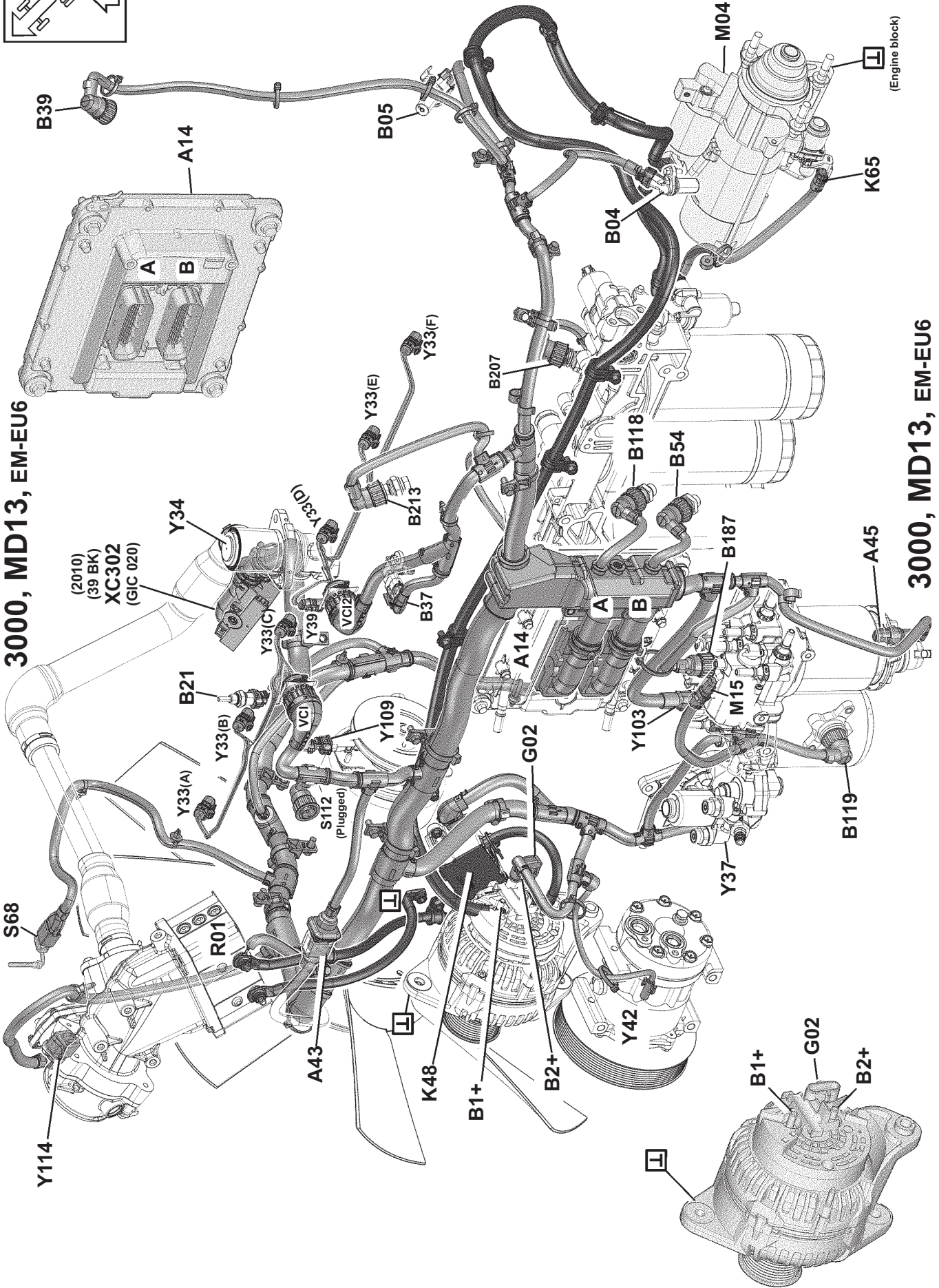
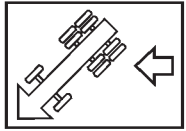

3000, MD13, EM-EU6

3000, MD13, EM-EU6

T3076472

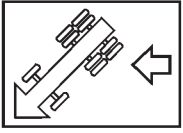

3000, MD16

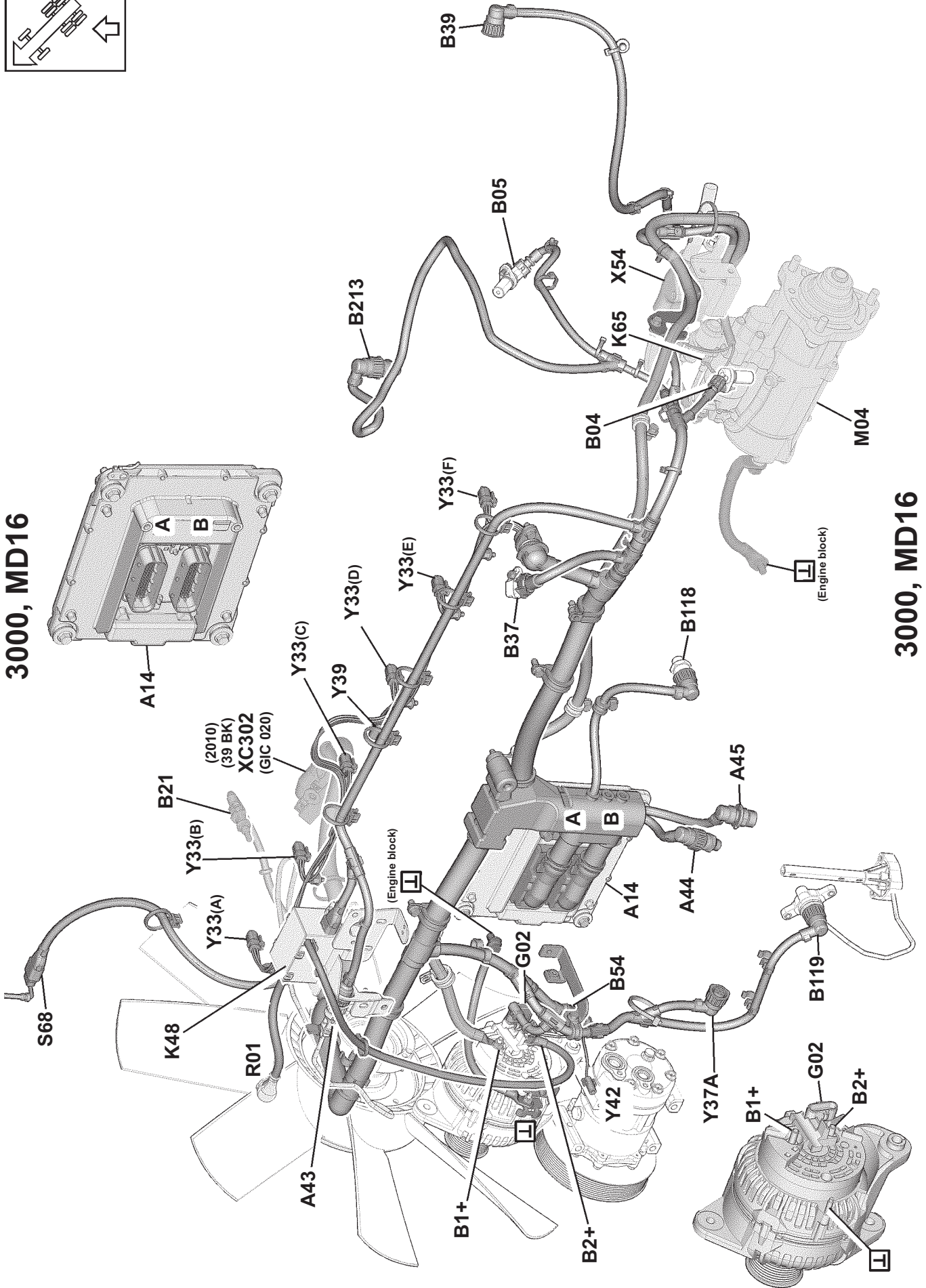

3000, MD16

T3065198

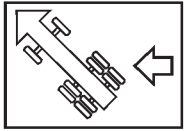

3000, MD16

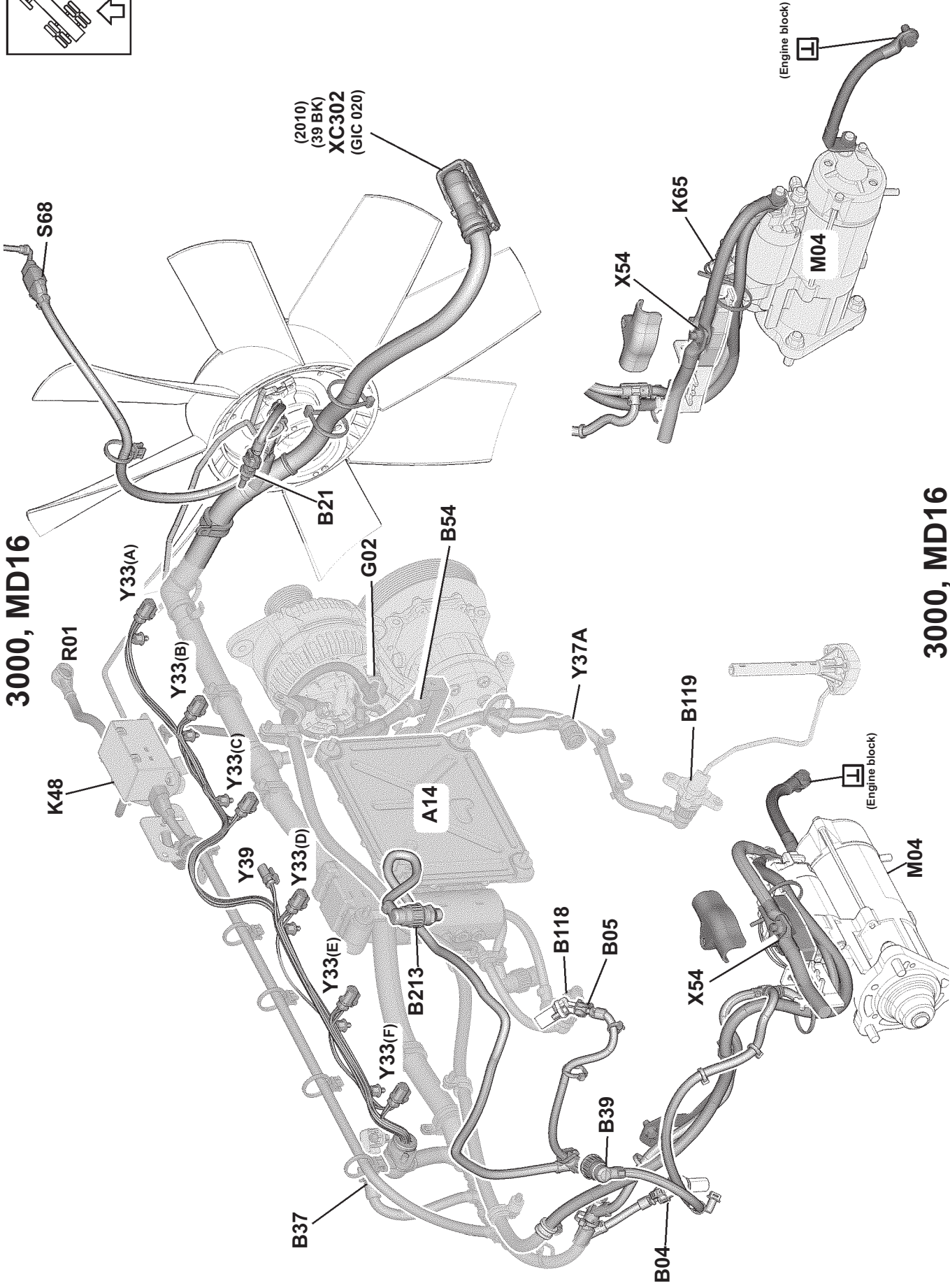

3000, MD16

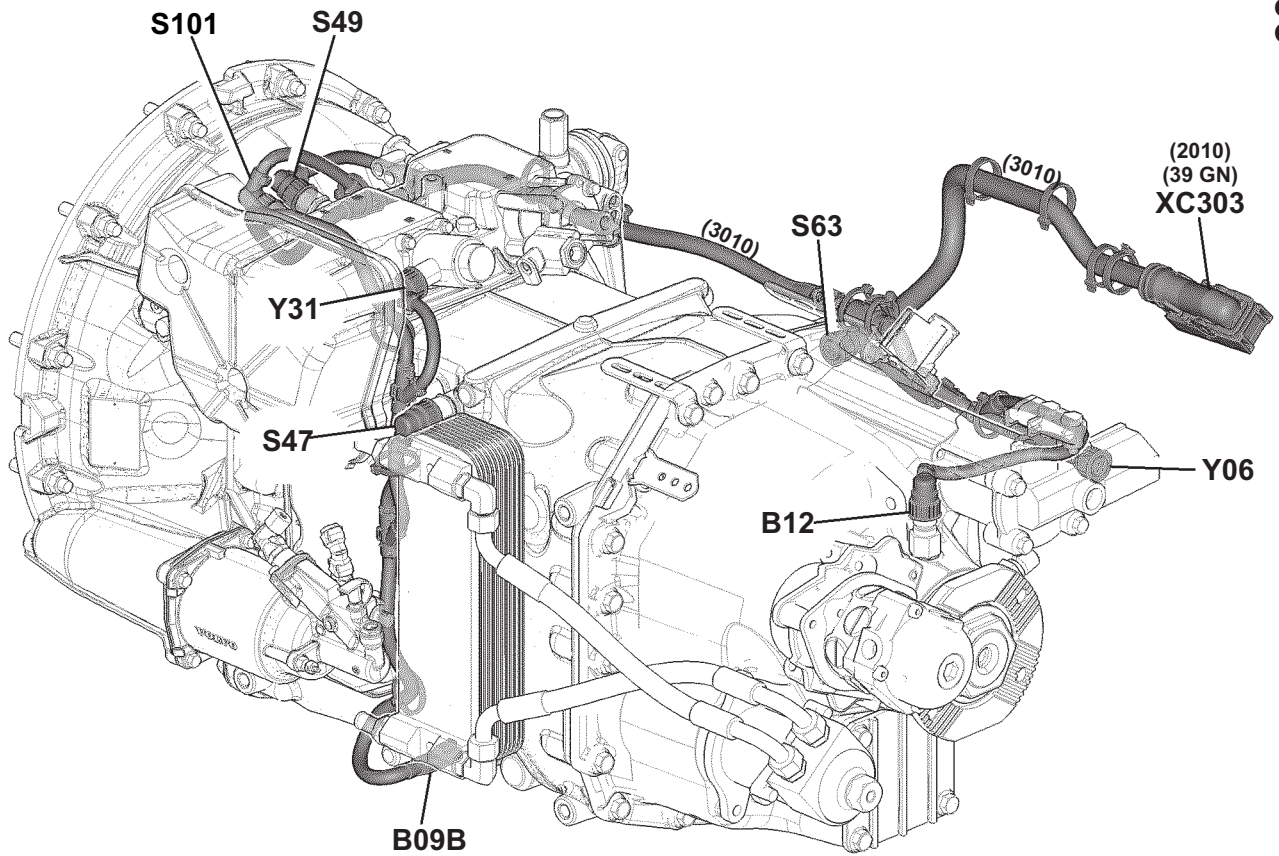
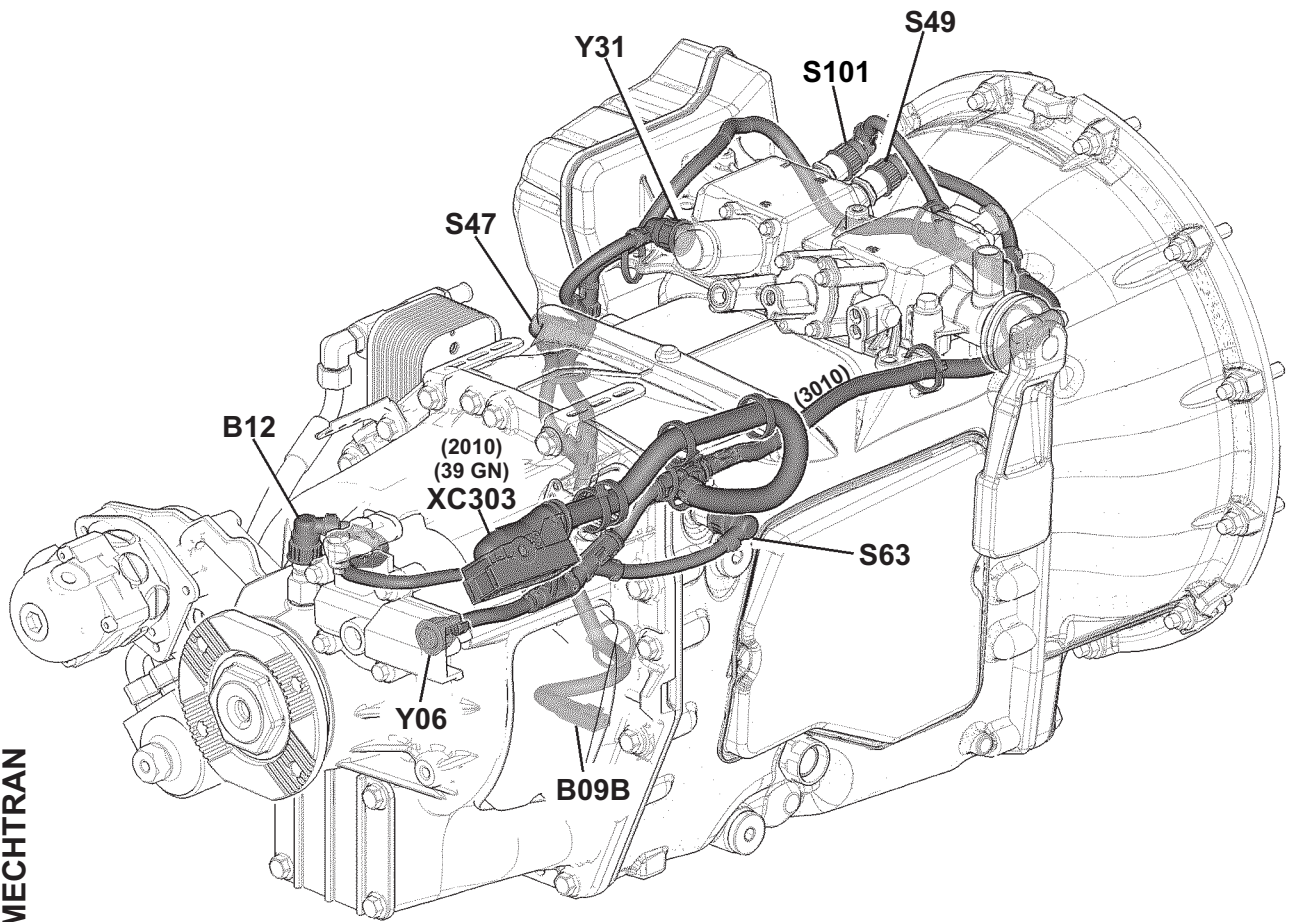

3010, I-SHIFT

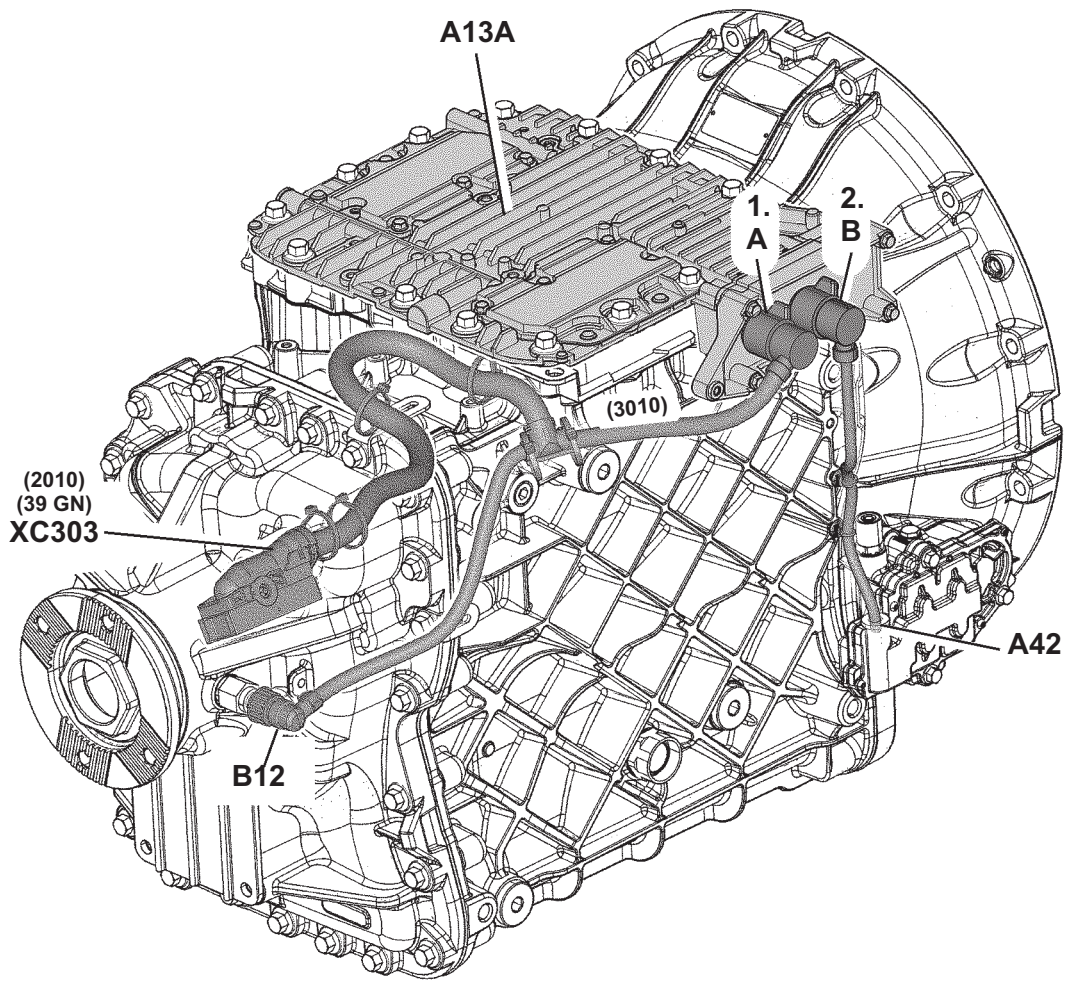

3010, I-SHIFT

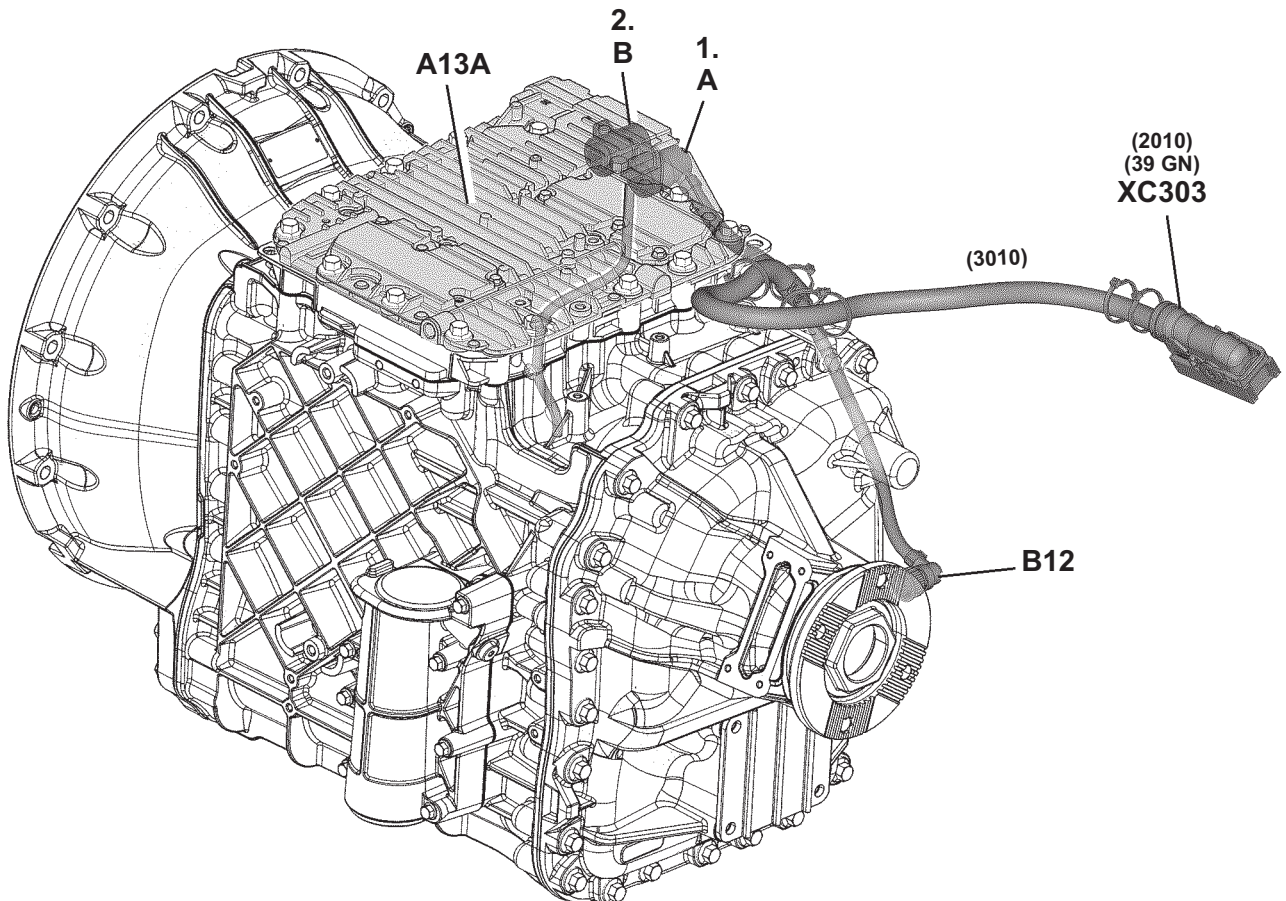

3010, 3020, MECHTRAN

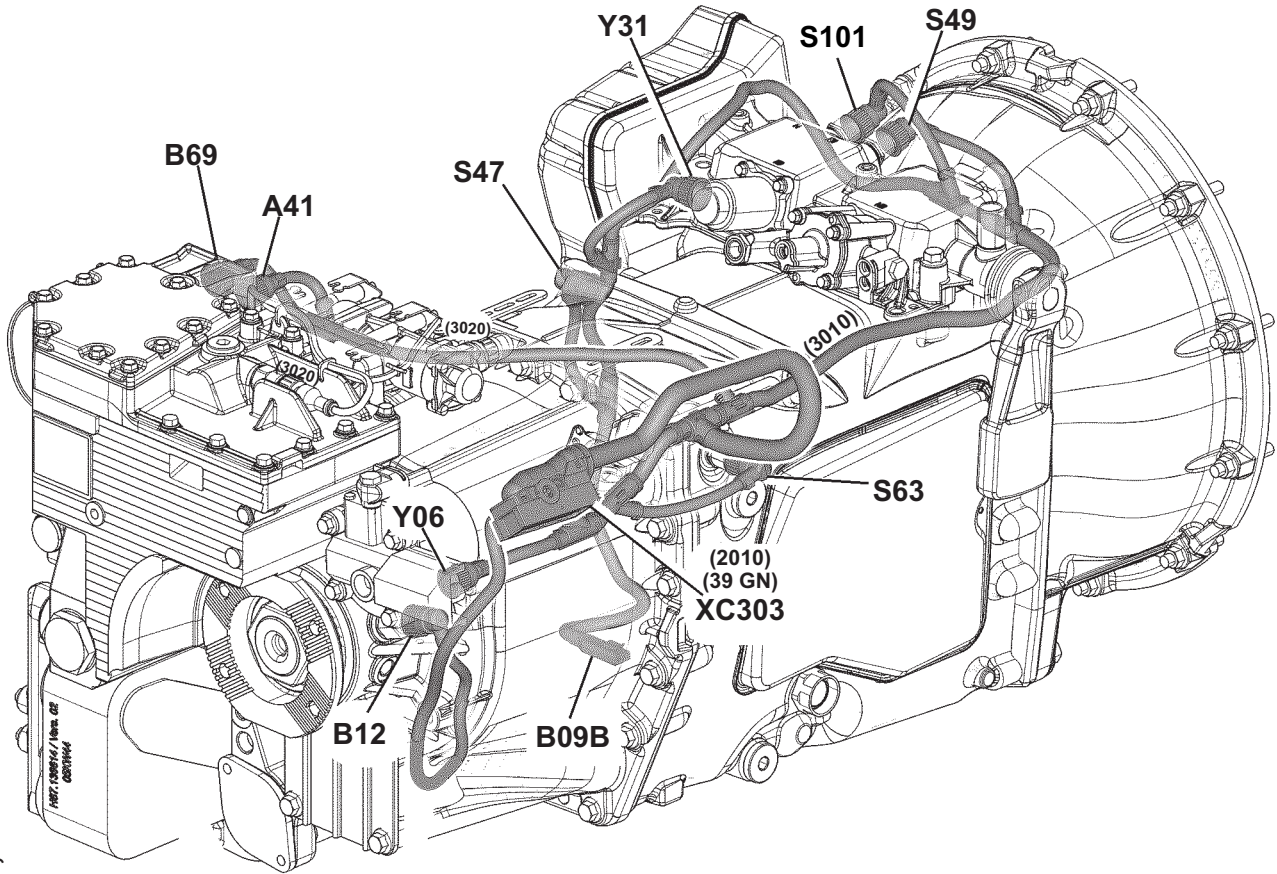

3010, 3020, MECHTRAN

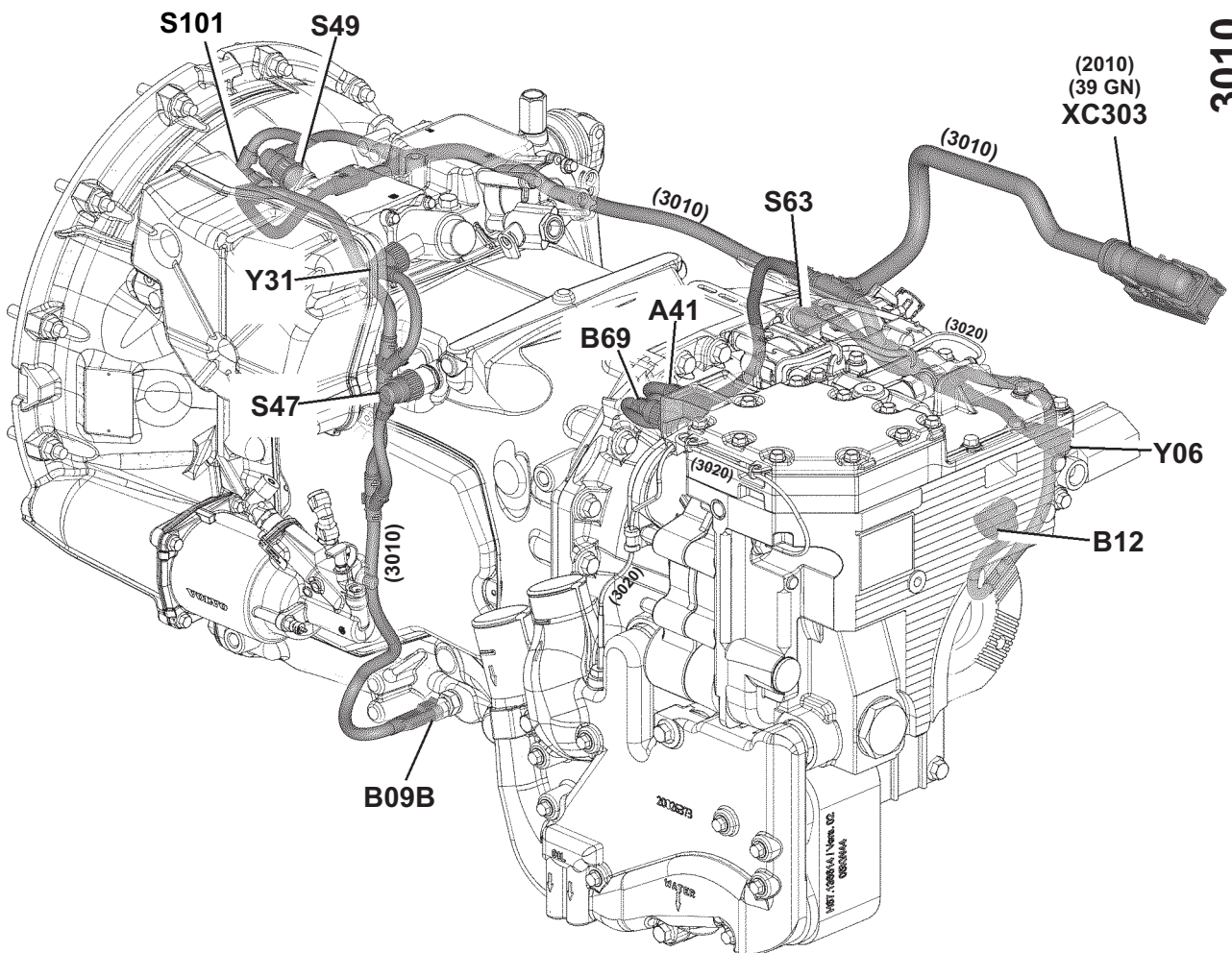

T3065202

3010, 3020, I-SHIFT

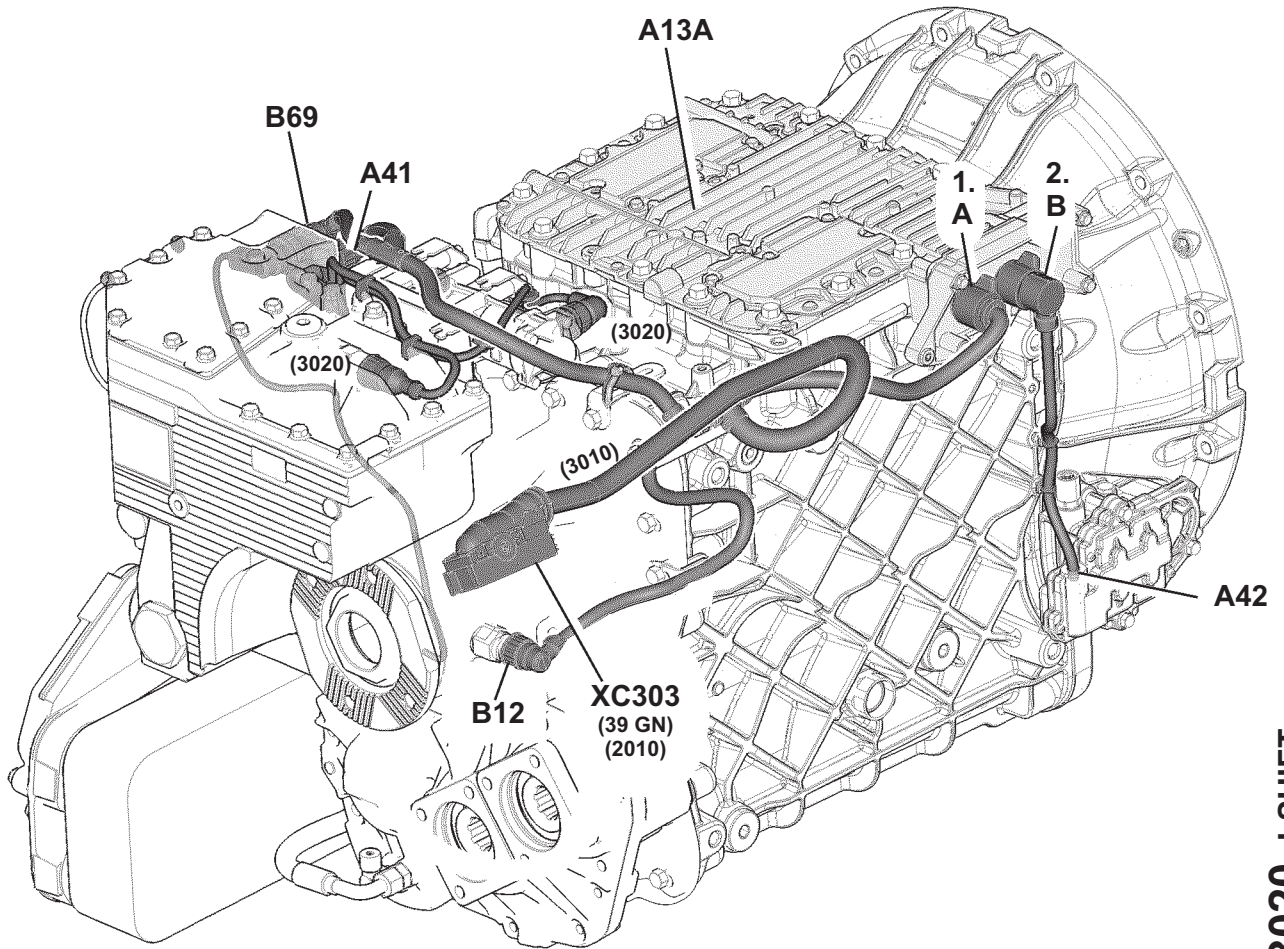

3010, 3020, I-SHIFT

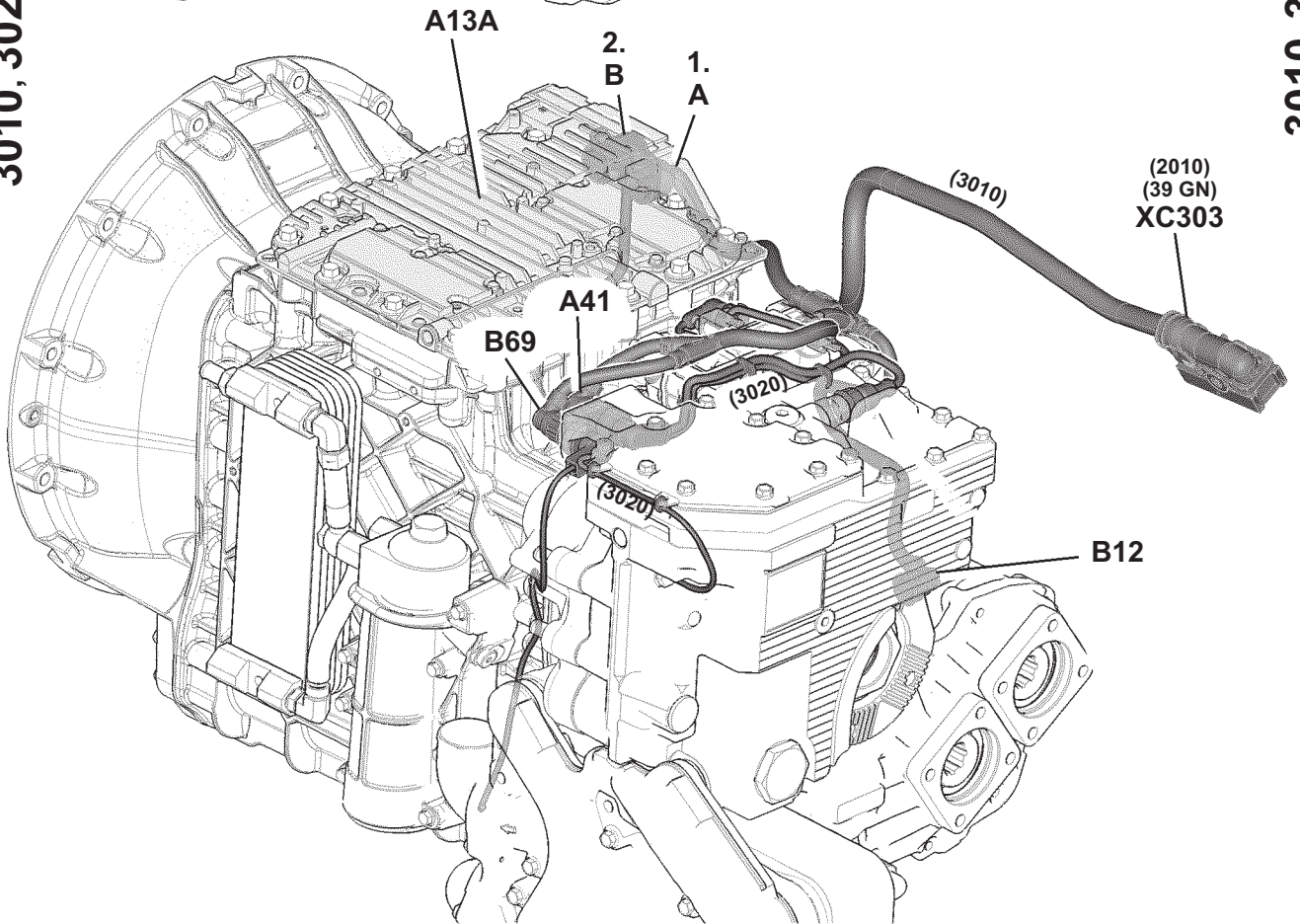

Fuses

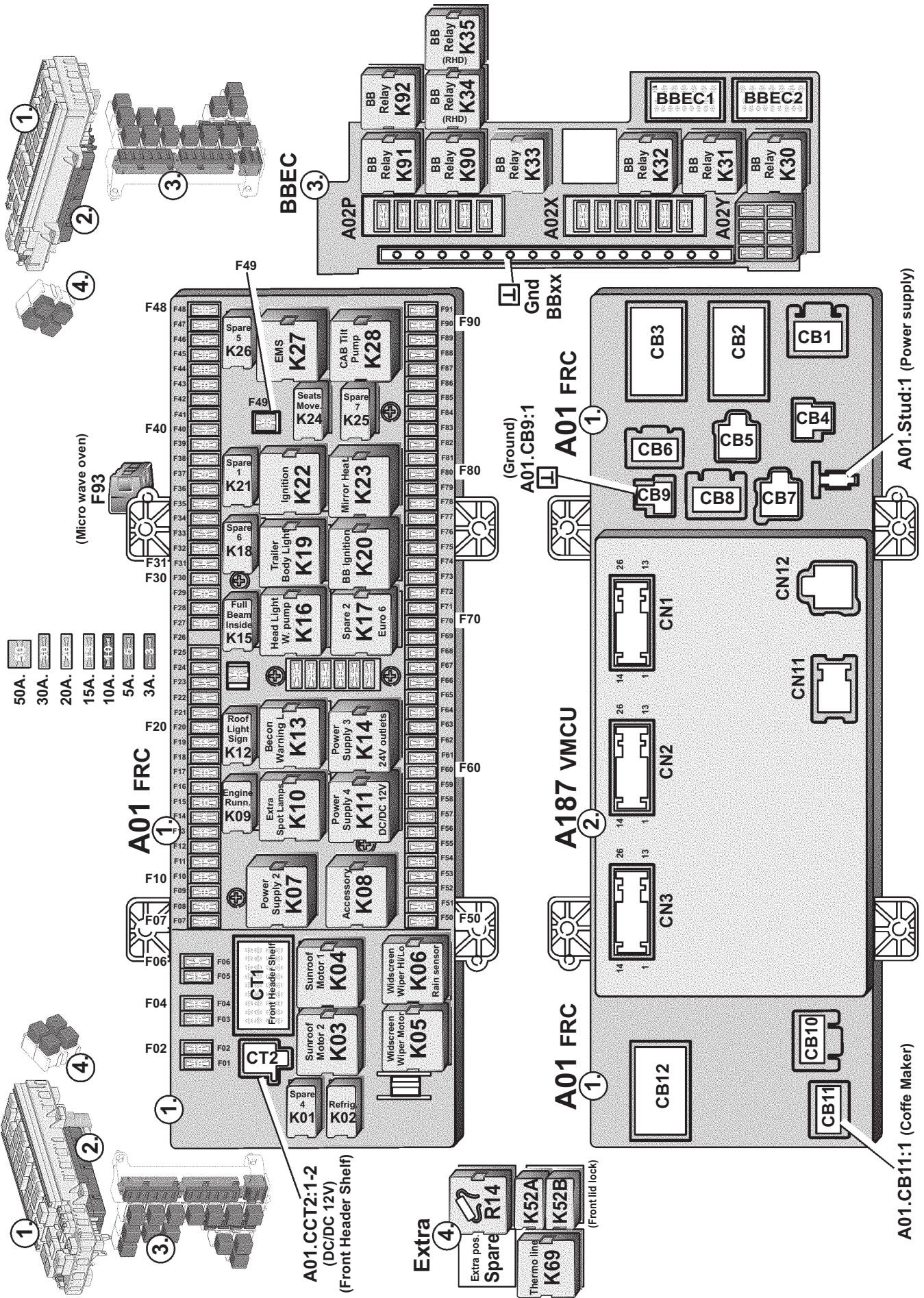

F01	12V power outlet supply	(IG:1 A)	F31	DACU (Driver Assistance Control Unit) power supply	(PA:0 A)
F02	-		F32	APM (Air Pressure Monitoring) power supply.....	(FE:1 A)
F03	TV prep kit, power supply	(IG:3 A)	F33	Wireless remote control	(FB:3 C)
F04	-		F34	Electrical front lid lock	(BG:1 A)
F05	-		F35	-	
F06	Body Builder switch, power supply.....	(ND:2 A/ ND1:3 A)	F36	-	
F07	Body Builder Electrical Centre, main power supply 1 (30A).....	(ND:3 B)	F37	ABS/EBS power supply	(EA:0 A/ EE:0 A)
F08	Body Builder Electrical Centre, main power supply 2 (20A).....	(ND:2 B/ ND1:3 B)	F38	CCM (Climate Control Module) supply.....	(HA:1 A)
F09	-		F39	Fuel line heater power supply.....	(HF:1 A)
F10	-	(IF:1 A)	F40	Tachograph ignition power supply	(BC:2 A)
F11	Extra spot lamps roof, EL1	(NF:0 A)	F41	EMS (Engine Management System) ECU power supply main.....	(CA:2 A)
F12	Beacon warning lamps roof EL4...	(NF:1 A)	F42	EMS controlled loads 1	(CA:2 A)
F13	Driver and passenger seats heater, Alcolock , engine running power supply.....	(IT:1 A)	F43	Fuel filter heater	(CA:1 A)
F14	-		F44	EMS controlled loads 2	(CA:2 A)
F15	Roof light sign or roof EL 5	(NF:3 A)	F45	Cab tilt pump motor supply	(KA:1 A)
F16	Full beam inside sign area EL 0 ...	(NF:4 A)	F46	Trailer ABS/EBS power supply	(GK:0 A/ GL:1 A)
F17	-		F47	-	
F18	HMI/OM (Human Machine interface input & output module) power supply.....	(BA:1 A)	F48	-	
F19	BBM (Body Builder Module) power supply.....	(NA:1 A)	F49	Body Builder chassis main power supply.....	(ND:3 B)
F20	DDM/PDM (Driver/Passenger Door Module) right, power supply.	(IS:0 A)	F50	Coffee maker accessory power supply.....	(IF:3 A)
F21	SID (Secondary instrument display) power supply.....	(IO:2 A)	F51	Windscreen wiper motor on & off low speed/high speed.....	(GP:0 A)
F22	Sun visor, bunk recline power supply.....	(IU:3 A)	F52	Sunroof motor supply.....	(IU:1 A)
F23	Tachograph power supply.....	(BC:1 A)	F53	Video Switch power supply.....	(IO:0 A)
F24	Instrument power supply.....	(BA:2 A)	F54	-	
F25	Toll collect power supply	(BX:0 A)	F55	Alarm power supply	(RA:0 A)
F26	-		F56	-	(IG:1 A)
F27	VMCU	(BE:0 B)	F57	Interior light	(IB:2 B)
F28	VMCU	(BE:0 B)	F58	Amplifier power supply.....	(IL:1 A)
F29	Right mirror heating	(IR:1 A/ IS:1 A)	F59	Converter power supply in header shelf	(IG:2 A)
F30	Left mirror heating.....	(IQ:1 A/ IR:1 A/ IS:1 A)	F60	Converter power supply in dashboard.....	(IG:0 A)
			F61	DDM/PDM (Driver/Passenger Door Module) left, power supply ...	(IR:0 A)
			F62	OBD diagnostic connector, power supply.....	(XA:2 B)

F63	CIOM (Cab Input/Output Module) power supply..... (BG:0 A)	F79	-
F64	24V power outlet supply 1 in dashboard..... (IF:1 A)	F80	LECM (Living Environment Control Module) power supply (HA:0 A)
F65	24V power outlet supply 2 in bunk panel (IF:1 A)	F81	SRS (Security Restrain System) airbag ignition power supply (PE:1 B)
F66	TIS (Transport Information System) & Telematics System power supply..... (BU:0 A)	F82	-
F67	Cigarette lighter..... (IF:0 A)	F83	-
F68	VMCU (NB:0 C)	F84	-
F69	Cab parking heater power supply . (HC:1 A)	F85	FMS (Fleet Management System) connector ignition power supply ... (BX:2 A)
F70	TECU (DC:1 A)	F86	-
F71	Headlight washer pump motor..... (GP:1 B)	F87	-
F72	-	F88	Alcolock power supply (PH:1 B)
F73	Body Builder Electrical Centre ignition supply (30A) (ND:3B)	F89	-
F74	Body Builder Electrical Centre ignition supply (20A) (ND:2 B)	F90	Seat motor (IT:3 A)
F75	Refrigerator power supply..... (IF:3 A)	F91	FMS connector power supply (BX:3 A)
F76	-	F92	Tachograph, ADR (2020)..... (AD:0 C/ AE:2 B)
F77	-	F93	Microwave oven (1000) (IF:3 B)
F78	-	F94	ADR (2020)..... (AA:0 D)
		F95	ADR (2020)..... (AA:0 D)

Main fuse in battery box

FM1	Body builder supply..... AA:2 B)
FM2	Cab, main power supply, (AA:1 B)
FM3	FCIOM power supply 1 (AA:2 B)
FM4	CCIOM power supply 1 (AA:2 B)
FM5	RCIOM power supply 1 (AA:3 B)
FM6	FCIOM power supply 2 (AA:3 B)
FM7	CCIOM power supply 2 (AA:2 B)
FM8	RCIOM power supply 2 (AA:3 B)
FM9	RASEC power supply (AA:1 B)
FM10	IPC power supply (AA:4 B)
FM11	ACM power supply (AA:3 B)
FM12	EAS power supply (AA:2 B)

Relays

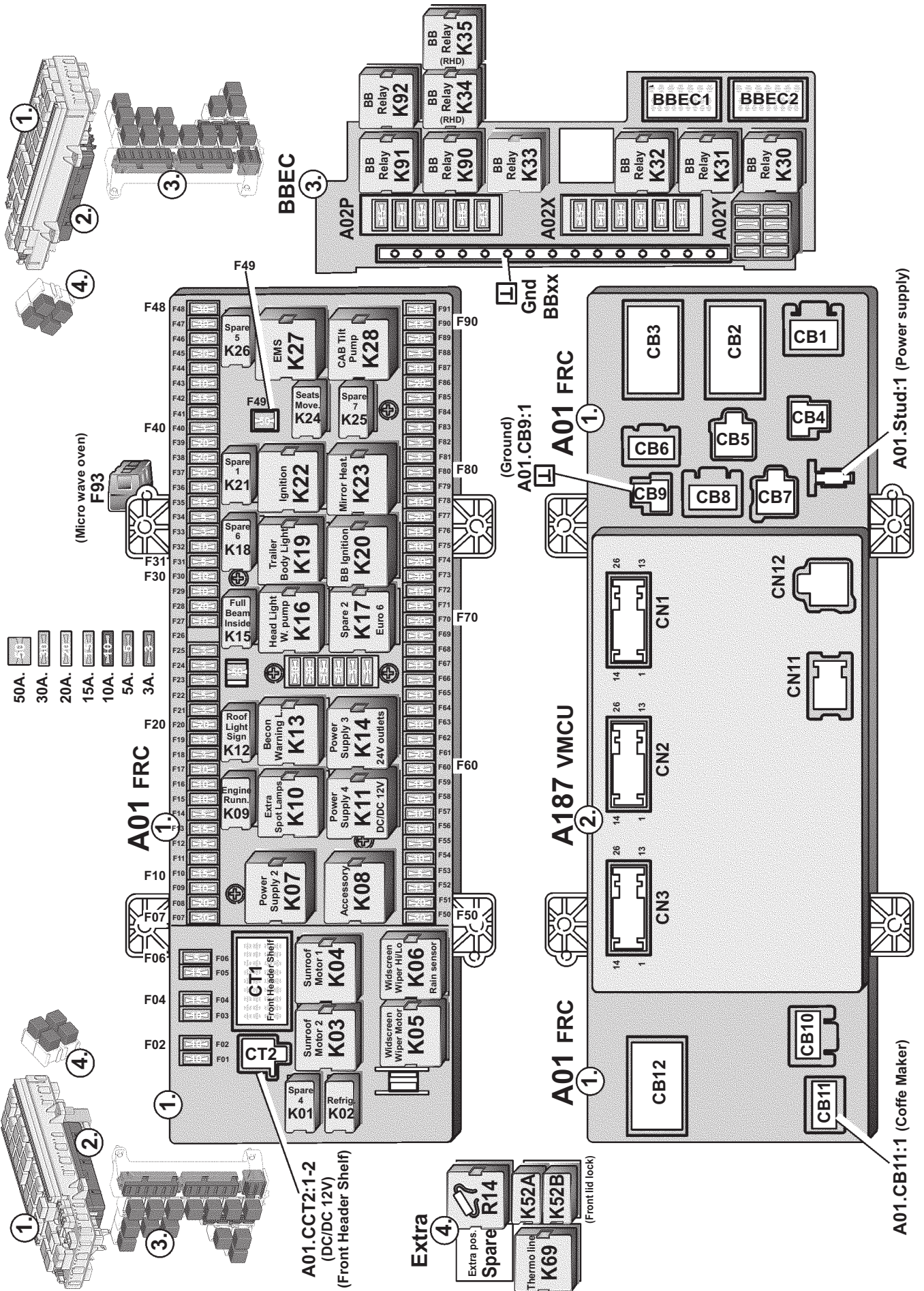

K01	-		K52B	Power relay, FLL motor 2	(BG:1 B)
K02	Relay, refrigerator	(IF:2 A)	K65	Relay, starter motor.....	(CB:2 B)
K03	Relay, sunroof motor 2.....	(IU:1 B)	K69	Relay, fuel heater	(HF:1 C)
K04	Relay, sunroof motor 1	(IU:0 B)	K70A	Relay, ADR3/SLP (2020).....	(AE:1 B)
K05	Relay, front wiper on/off	(GP:0 B)	K70B	Relay, ADR3/SLP (2020).....	(AE:1 C)
K06	Relay, front wiper low/high.....	(GP:0 B)	K71	Relay, audio switch telematics, L+ (1100).....	(BU:1 D)
K07	Relay, body builder electrical center, power supply 2.....	(ND:2 A/ ND1:3 B)	K90	Relay.....	(NK:2 B)
K08	Relay, accessories.....	(IF:3 A)	K91	Relay.....	(NK:3 B)
K09	Relay, seats heater	(IT:0 A)	K92	Relay.....	(NK:4 B)
K10	Relay, body builder electrical center, extra spot lamps.....	(NF:0 A)	K95	Relay, microwave oven (1100).....	(IF:3 C)
K11	Relay, power supply 4.....	(IG:2 A)	K96	Relay.....	(ND2:3 B)
K12	Relay, roof light sign.....	(NF:3 A)			
K13	Relay, beacon warning lamps.....	(NF:1 A)			
K14	Relay, power supply 3.....	(IF:1 A)			
K15	Relay, full beam inside sign area ..	(NF:4 A)			
K16	Relay, headlight washer pump	(GP:1 B)			
K17	TECU	(DC;0 A)			
K18	-				
K19	-				
K20	Relay, BB ignition.....	(ND:3 A)			
K21	Relay, mirror heating.....	(IR:1 A/ IS:1 A)			
K22	Relay, ignition.....	(BX:2 A)			
K23	-				
K24	Relay, adjustable seat.....	(IT:3 A)			
K25	-				
K26	-				
K27	Relay, engine management system.....	(CA:3 A)			
K28	Relay, cab tilt pump.....	(KA:1 A)			
K30	Relay, tail lift enable/crane.....	(ND:2 C)			
K31	Relay, extra spot lamp front EL6...	(NE:0 B)			
K32	Relay, side reverse working lamp EL2.....	(NE:1 B)			
K33	Relay, cab/body working lamp EL3.....	(NE:3 B)			
K34	Relay,Japan mirror Motor	(IQ:0 B)			
K35	Relay,Japan mirror Switch	(IQ:1 B)			
K48	Power relay, engine preheating (3000).....	(AA:2 D/ CB:1 A)			
K52A	Power relay, FLL motor 1	(BG:1 B)			

FRC (A01) connectors

A01.CB1

Pin no:	Circuit function	Wiring no:	Diagram
3	Cab tilt pump motor supply	2131	KA:1 B
4	Trailer ABS, EBS power supply	2129	GK:0 A/GL:1 A

A01.CB2

Pin no:	Circuit function	Wiring no:	Diagram
1	Windscreen wiper high speed	2104	GP:1 B
2	Windscreen wiper park position signal	0151	GP:0 B
3	APM power supply	2086	FE:1 B
4	WRG power supply	2083	FB:2 B
5	Direct battery	2037	BG:1 A
9	Fuel filter heater power supply	2047	CA:1 B
10	Windscreen wiper low speed	2103	GP:0 B
16	Power supply	2039	PH:1 B
18	EMS load power supply 2	2046	CA:2 B
19	Direct battery	2055	EA:0 A/EE:0 A
20	CCM power supply	2108	HA:1 B
21	Fuel heater relay supply	2114	HF:1 A
22	EMS power supply 1	2044	CA:2 B
23	EMS load power supply 1	2045	CA:2 B
25	Headlight washer pump supply	2105	GP:1 B

A01.CB3

Pin no:	Circuit function	Wiring no:	Diagram
1	Refrigerator supply	4004	IF:2 B
4	Sunvisor and power recline supply	2101	IF:4 B
5	DACU power supply	2121	PA:0 A
6	Direct battery	2040	BU:0 A
10	SRS power supply	2127	PE;1 B
11	LECM power supply	2107	HA:0 B
12	VS power supply	2091	IO:0 A
15	Ignition	2043	BX:2 B
16	Seats movement	2100	IT:1 A
18	Direct battery	2042	BX:3 B
19	Amplifier supply	2078	IL:1 A

A01.CB4

Pin no:	Circuit function	Wiring no:	Diagram
1	BBEC main C power supply	8028	ND:3 B

A01.CB5

Pin no:	Circuit function	Wiring no:	Diagram
1	BBEC ignition supply	8043	ND:2 B
2	BBEC main power supply 2	8025	ND:2 B

A01.CB6

Pin no:	Circuit function	Wiring no:	Diagram
1	BBEC ignition power supply	8027	ND:3 B
2	BBEC main power supply 1	8026	ND:3 B

A01.CB7

Pin no:	Circuit function	Wiring no:	Diagram
8	Cab tilt enable switch	2139	KA:2 B

A01.CB8

Pin no:	Circuit function	Wiring no:	Diagram
6	Parking air, water heater supply	2110	HC:1 A
8	TECU power supply	2024	DC:1 B

A01.CB9

Pin no:	Circuit function	Wiring no:	Diagram
1	Ground	1	YF:1 D

A01.CB10

Pin no:	Circuit function	Wiring no:	Diagram
3	12V dashboard output	4162	IG:1 B
4	24V power outlet supply 2	4006	IF:1 B
8	BBM power supply	2130	NA:1 B

A01.CB11

Pin no:	Circuit function	Wiring no:	Diagram
1	Coffe maker supply	4002	IF:3 B

A01.CB12

Pin no:	Circuit function	Wiring no:	Diagram
1	Engine running	2038	IT:1 A
3	CIOM power supply	2036	BG:0 A
4	OBD interface power supply	2120	XA:2 B
5	HMIOM power supply	2027	BA:1 A
6	Task light ckt	6008	IB:2 B
9	BBEC switch main power supply	8023	ND:2 A
10	Engine running	2038	IT:3 A
11	Alarm power supply	2128	RA:0 B
12	Instrument cluster power supply	2028	BA:2 A
13	SID power supply	2029	IO:2 A
16	Mirror power supply passenger	2095	IS:1 A
17	Mirror power supply driver	2093	IQ:2 B/IR:1 A
18	12V dashboard socket supply	4015	IG:1 B
19	DDM power supply/window lift with antipinch supply	2092	IR:0 A
20	PDM power supply/window lift with antipinch supply	2094	IS:0 A
21	DC/DC converter supply	4163	IG:0 B
23	24V power outlet supply 1	4005	IF:1 B
24	Cigarette lighter supply	4007	IF:0 B
25	Parking air, water heater supply	2110	HC:1 A

A01.CT1

Pin no:	Circuit function	Wiring no:	Diagram
1	Accessories signal	4014	IG:2 B
2	Ground	1	AD:3 B/GF:3 A
3	Sunroof motor signal 2	4158	IU:1 B
4	Sunroof motor signal 1	4157	IU:1 B
5	Main power supply 1	2157	BC:1 A
6	Backlight	6000	AD:3 A/GF:3 A
9	Position light circuit supply	3047	GF:2 A
10	Key ignition	2138	BC:2 A
11	Ground	1	YF:0 C
12	Ground	1	YF:1 C
13	Ignition signal	2020	BX:0 B
14	Ignition signal	2020	HF:1 A
15	Night driving light Ckt	6006	IA:0 A
16	Backlight	6000	BX:0 B/IQ:2 B
17	Task light ckt	6008	IA:2 A
18	Speed pulse	2137	BC:1 A
19	Ground	1	YF:0 C
21	Ground	1	IU:3 B
22	EL1 extra spot lamp power supply	8062	NF:0 A
23	Resting light ckt 2	6005	IA:0 A
24	Backlight	6000	IU:2 B
25	Resting light ckt 1	6007	IA:1 A
26	Sunvisor and power recline supply	2101	IU:3 B
27	Full beam lamp supply	8065	NF:4 A
28	Accessory supply	4012	IG:3 B
31	Max light Ckt 2	6012	IA:3 A
32	Beacon lamp power supply	8063	NF: 1 A
33	Direct battery	2040	BU:0 A
34	Direct battery	2041	BX: 0 B
35	Max light Ckt 1	6011	IA:1 A
36	Roof light sign EL5 power supply	8064	NF:3 A

A01.CT2

Pin no:	Circuit function	Wiring no:	Diagram
2	DC/DC converter power supply	4011	IG:2 B
4	DC/DC output supply	4161	IG:2 B

Wiring harness layout

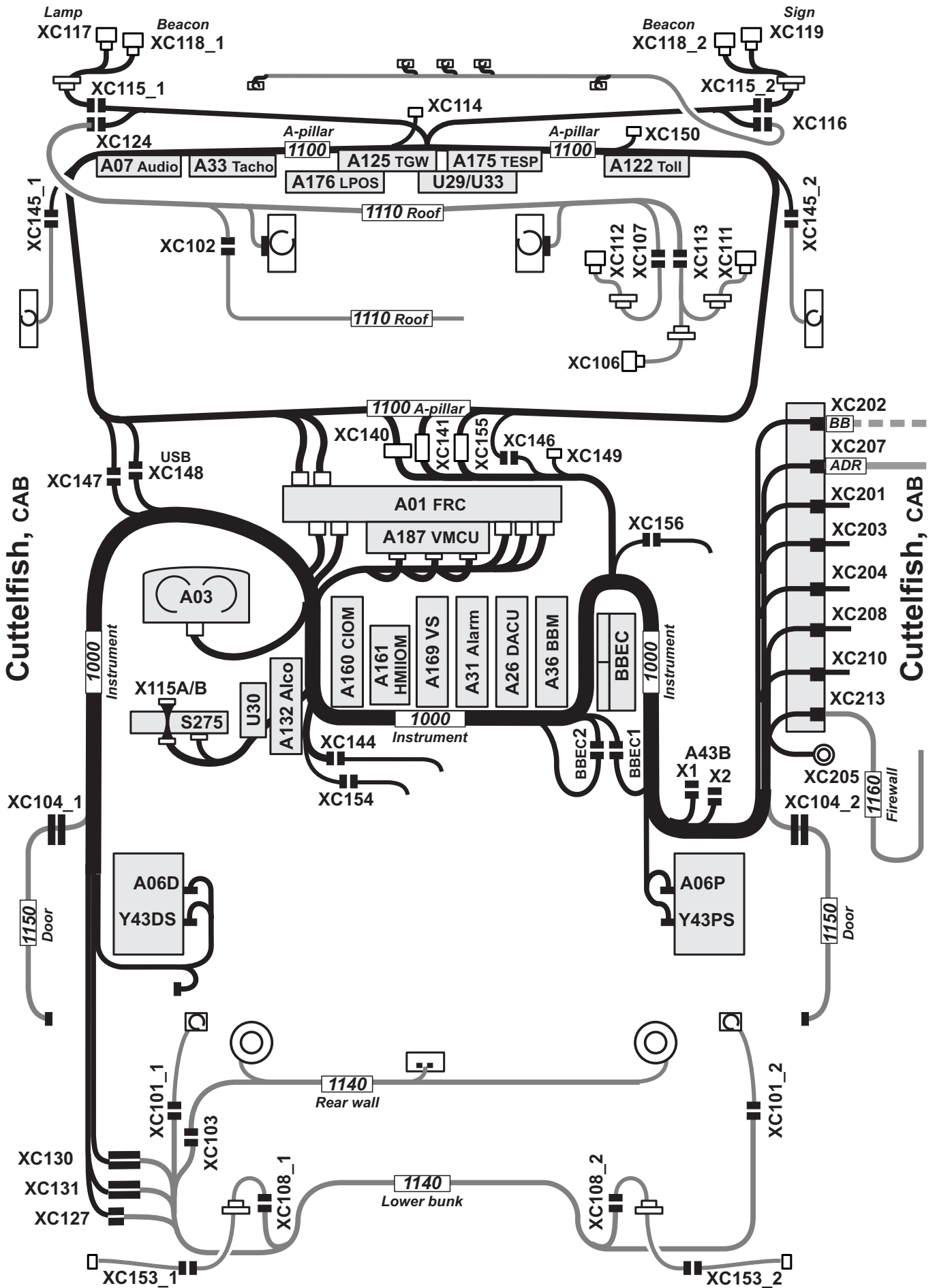

T3079532

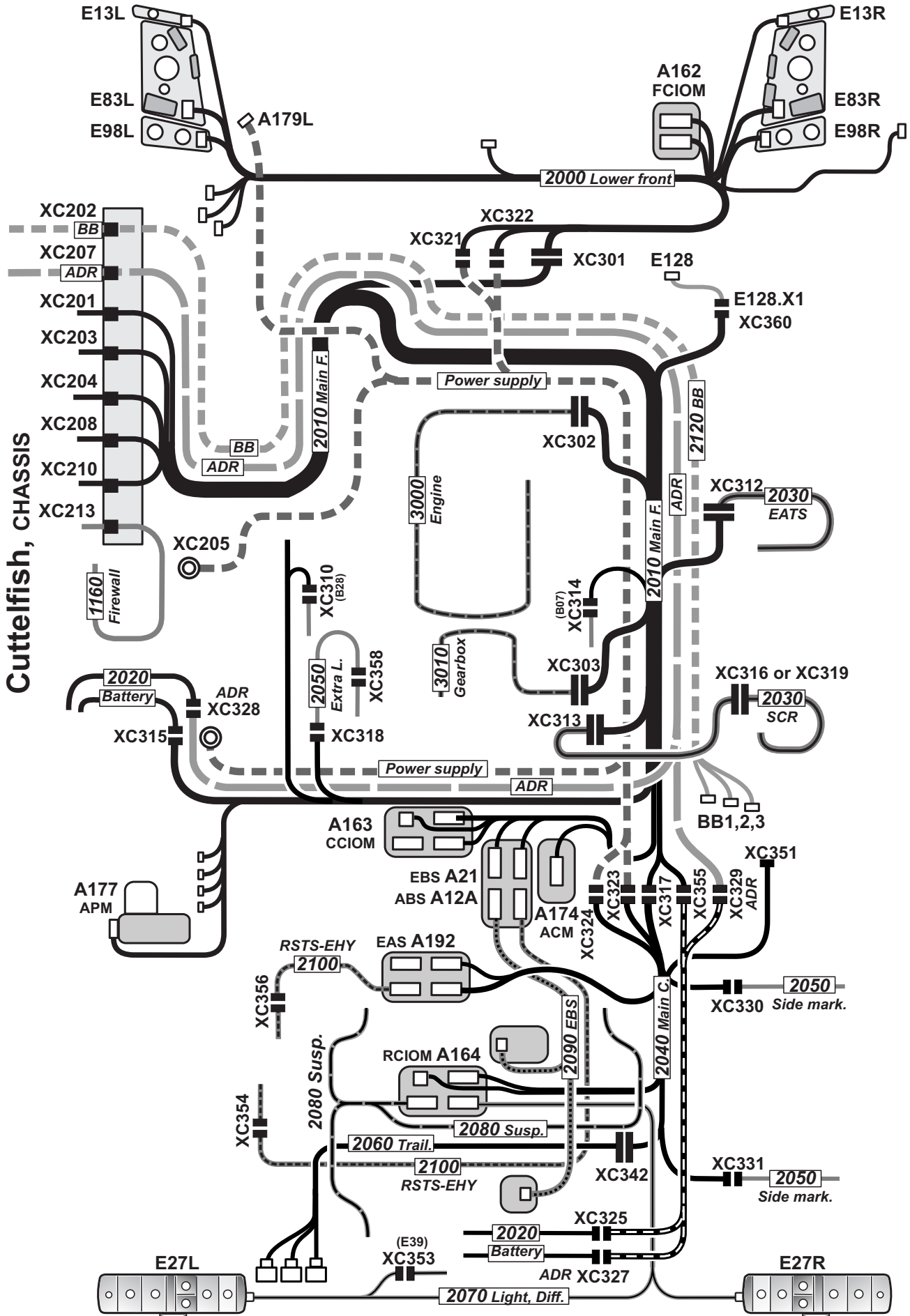

Ground connections

List of ground connections

1.0_1	(YD:4 A) “ ”, page 130	5.5_2	(YB:0 D) “ ”, page 130
1.1	(YN:2 D) “ ”, page 130	5.5_3	(YB:2 D) “ ”, page 130
1.10	(YK:4 D) “ ”, page 152	5.5_4	(HB:1 D) “ ”, page 130
1.11	(YK:4 D) “ ”, page 152	5.6_1	(YB:3 D) “ ”, page 191
1.12	(YN:3 D) “ ”, page 130	5.6_2	(YB:4 D) “ ”, page 191
1.2	(YN:1 D) “ ”, page 164	5.7_1	(YB:3 D) “ ”, page 192
1.3	(YM:1 D) “ ”, page 160	5.7_2	(YB:3 D) “ ”, page 192
1.4	(YH:2 D) “ ”, page 148	5.8_1	(AA:1 E) “ ”, page 131
1.4_2	(YF:1 D) “ ”, page 148	5.10_1	(AE:1 D) “ ”, page 130
1.5	(YG:2 D) “ ”, page 148		
1.6	(YF:3 D) “ ”, page 148		
1.8	(YK:2 D) “ ”, page 152		
1.8	(YK_RHD:1 E) “ ”, page 152		
1.9	(YK_RHD:3 E) “ ”, page 156		
3.1	(AA:2 D) “ ”, page 130		
5.0_1	(HB:4 E) “ ”, page 130		
5.1_1	(YD:2 D) “ ”, page 130		
5.1_2	(YD:1 D) “ ”, page 130		
5.1_5	(YD:3 D) “ ”, page 130		
5.2_1	(YD:4 D) “ ”, page 130		
5.3_1	(YA:0 D) “ ”, page 130		
5.3_2	(YA:1 D) “ ”, page 130		
5.3_3	(YA:3 D) “ ”, page 130		
5.3_4	(YA:4 D) “ ”, page 130		
5.4_2	(AA:2 E) “ ”, page 130		
5.5_1	(YB:0 D) “ ”, page 130		

List of connectors

XC101_1

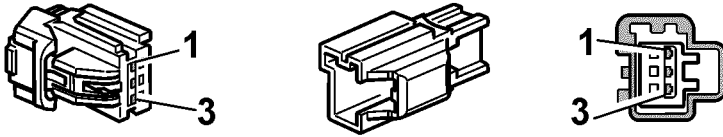

T3071137

Pin no:	Circuit function	Wiring no:	Diagram
1	Task light ckt	6008	IB:2 C
2	Max light Ckt 2	6012	IB:2 C
3	Ground	1	IB:2 D

XC101_2

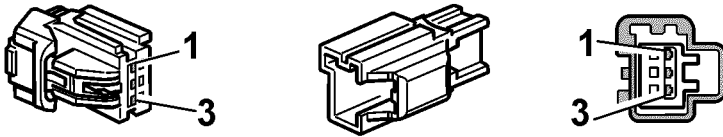

T3071137

Pin no:	Circuit function	Wiring no:	Diagram
1	Task light ckt	6008	IB:3 C
2	Max light Ckt 2	6012	IB:3 C
3	Ground	1	IB:3 D

XC102

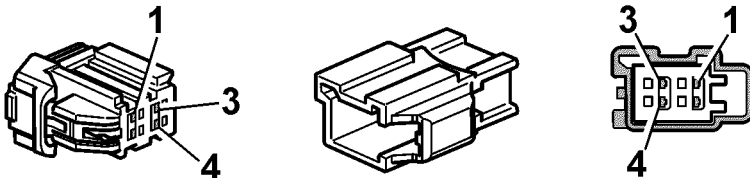

T3071138

Pin no:	Circuit function	Wiring no:	Diagram
1	Task light ckt	6008	IB:3 B
2	Ground	1	IB:3 D
3	Ground	1	IF:2 D
4	Refrigerator supply	4004	IF:2 C

XC103

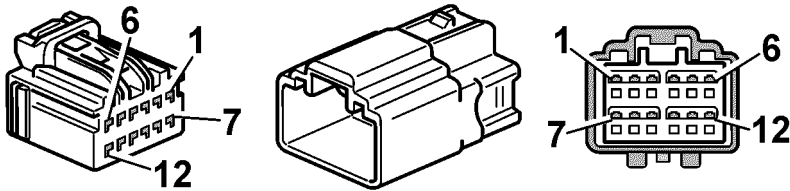

T3071127

Pin no:	Circuit function	Wiring no:	Diagram
1	LECM power supply	2107	HA:0 B
1	CIOM 12V output 1 power supply	7085	SK:3 C
2	Ground	1	HA:0 C
2	CIOM LIN5 bus	7098	SK:3 C
3	Cab subnet low	7023	SC:2 B
3	CIOM LIN5 ground	7099	SK:3 C
4	Cab subnet high	7022	SC:3 B
5	Radio audio Rear Left loudspeaker +	4037	IK:2 D/IL:2 C
6	Radio audio Rear Left loudspeaker –	4038	IK:2 D/IL:2 C
7	Radio audio Rear Right loudspeaker +	4039	IK:2 D/IL:2 C
8	Radio audio Rear Right loudspeaker –	4040	IK:2 D/IL:2 C

XC104_1

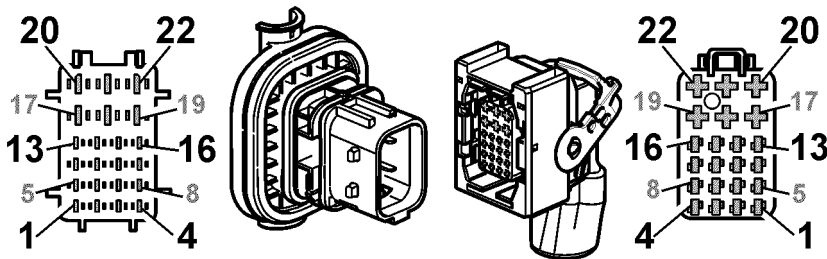

T3071142

Pin no:	Circuit function	Wiring no:	Diagram
3	Security subnet high	7081	IR:0 C
4	Security subnet low	7082	IR:0 C
7	Mirror power supply driver	2093	IQ:2 C/IR:1 B
8	Night driving light CKt	6016	IC:2 C
9	Resting light ckt 1	6007	IC:3 C
10	Ground	1	IR:1 D
17	Ground	1	IR:1 D
18	DDM power supply / window lift with antipinch supply	2092	IR:0 C
19	Radio audio front Left loudspeaker +	4033	IK:1 D/IL1 D
20	Radio audio front Left loudspeaker –	4034	IK:1 D/IL1 D
22	Ground	1	IR:1 D

XC104_2

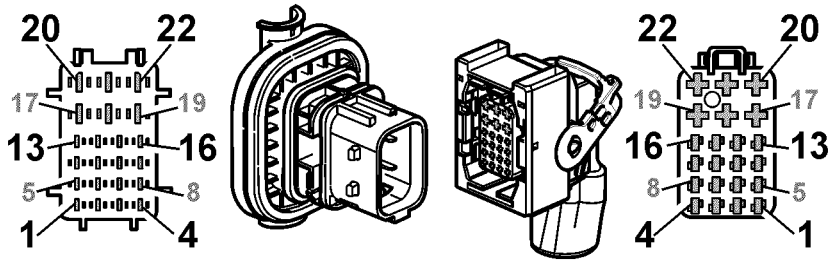

T3071142

Pin no:	Circuit function	Wiring no:	Diagram
3	Security subnet high	7081	IS:0 C
4	Security subnet low	7082	IS:0 C
7	Mirror power supply passenger	2095	IS:1 B
8	Night driving light CKt	6016	IC:3 C
9	Resting light ckt 1	6007	IC:3 C
10	Ground	1	IS:1 D
17	Ground	1	IS:1 D
18	PDM power supply / window lift with antipinch supply	2094	IS:0 B
19	Radio audio front Right loudspeaker +	4035	IK:2 D
19	Radio audio front Left loudspeaker +	4033	IL:1 D
20	Radio audio front Right loudspeaker –	4036	IK:2 D
20	Radio audio front Left loudspeaker –	4034	IL:1 D
22	Ground	1	IS:1 D

XC106

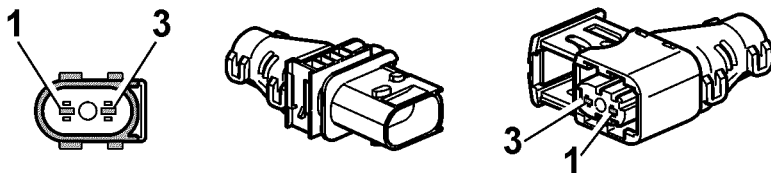

T3071119

Pin no:	Circuit function	Wiring no:	Diagram
1	Cab body working lamp power supply	8061	NE:3 C
3	Ground	1	NE:3 C

XC107

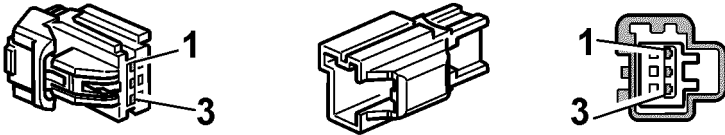

T3071137

Pin no:	Circuit function	Wiring no:	Diagram
1	BBEC parking lamp SPOTP-R signal	8058	NF:0 D
2	Ground	1	NF:0 D
3	EL1 extra spot lamp power supply	8062	NF:0 D

XC108_1

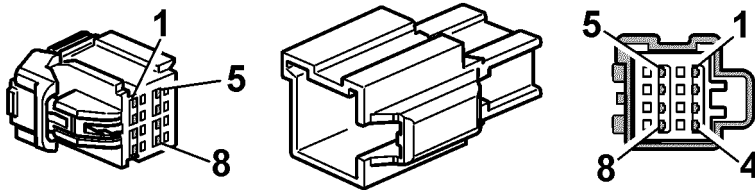

T3071139

Pin no:	Circuit function	Wiring no:	Diagram
1	ADR main switch closing request	0006	AD:3 B
2	ADR main switch closing request	0007	AD:3 B
3	ADR main switch closing request	0006	AD:2 D
4	ADR main switch closing request	0007	AD:2 D
5	Cab body working lamp power supply	8061	NE:3 C
5	Side sensor + 12V	2125	PA:2 C
6	Ground	1	NE:3 D
6	Side sensor ground	1053	PA:2 C
7	Active safety proprietary subnet 1 high	7026	PA:2 D
8	Active safety proprietary subnet 1 low	7027	PA:2 D

XC108_2

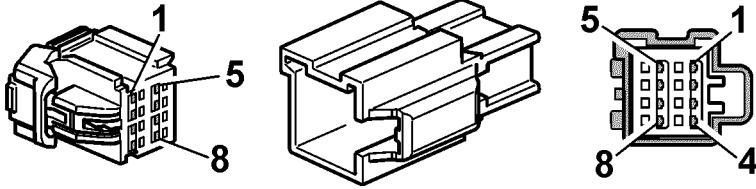

T3071139

Pin no:	Circuit function	Wiring no:	Diagram
1	ADR main switch closing request	0006	AD:3 C
2	ADR main switch closing request	0007	AD:3 C
3	ADR main switch closing request	0006	AD:2 D
4	ADR main switch closing request	0007	AD:2 D
5	Cab body working lamp power supply	8061	NE:3 C
5	Side sensor + 12V	2125	PA:2 C
6	Ground	1	NE:3 D
6	Side sensor ground	1053	PA:2 C
7	Active safety propriatery subnet 1 high	7026	PA:2 D
8	Active safety propriatery subnet 1 low	7027	PA:2 D

XC111

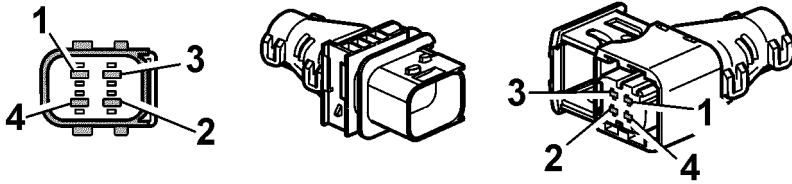

T3071144

Pin no:	Circuit function	Wiring no:	Diagram
1	Cab body working lamp power supply	8061	NE:3 C
2	Ground	1	NE:2 C
3	Beacon lamp power supply	8063	NE:2 C
4	Ground	1	NE:2 C

XC112

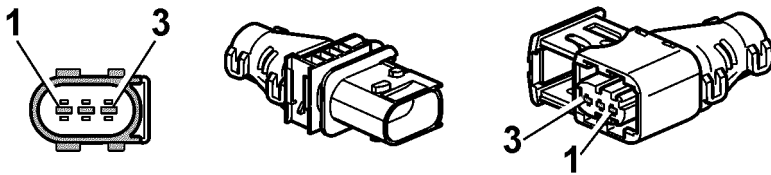

T3071121

Pin no:	Circuit function	Wiring no:	Diagram
1	EL1 extra spot lamp power supply	8062	NF:0 D
2	BBEC parking lamp SPOTP-R signal	8058	NF:0 D
3	Ground	1	NF:0 D

XC113

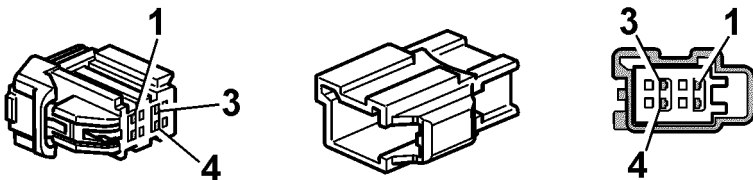

T3071138

Pin no:	Circuit function	Wiring no:	Diagram
1	Cab body working lamp power supply	8061	NE:3 C
2	Ground	1	NE:2 C
3	Beacon lamp power supply	8063	NF:2 B
4	Ground	1	NF:2 B

XC114_1

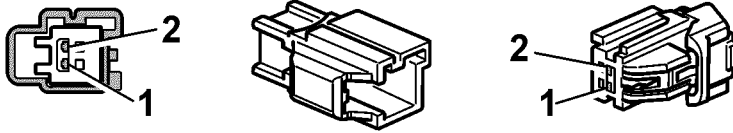

T3071136

Pin no:	Circuit function	Wiring no:	Diagram
1	Task light ckt	6008	IA:2 B
2	Frontshelf compartent switch 3 contact	6025	IA:2 C

XC114_2

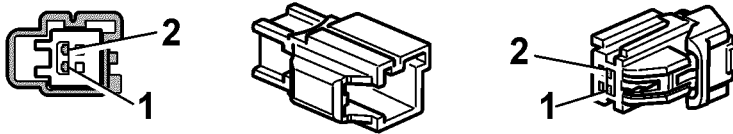

T3071136

Pin no:	Circuit function	Wiring no:	Diagram
1	Task light ckt	6008	IA:2 B
2	Frontshelf compartent switch 3 contact	6025	IA:2 C

XC115_1

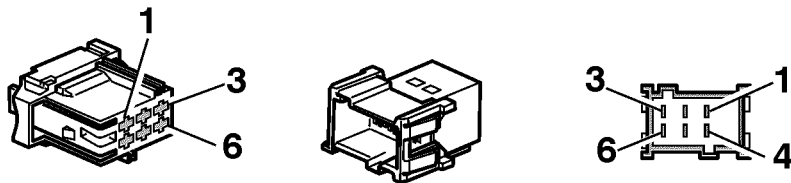

T3019918

Pin no:	Circuit function	Wiring no:	Diagram
1	Beacon lamp power supply	8063	NF:1 B
2	Ground	1	NF:1 B
3	EL1 extra spot lamp power supply	8062	NF:0 B
4	Ground	1	NF:0 B
6	BBEC parking lamp SPOTP-R signal	8058	NF:0 B

XC115_2

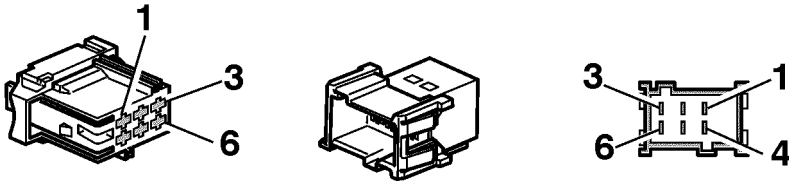

T3019918

Pin no:	Circuit function	Wiring no:	Diagram
1	Beacon lamp power supply	8063	NF:2 B
2	Ground	1	NF:1 B
5	Roof light sign EL5 power supply	8064	NF:3 B
6	Ground	1	NF:3 B

XC116

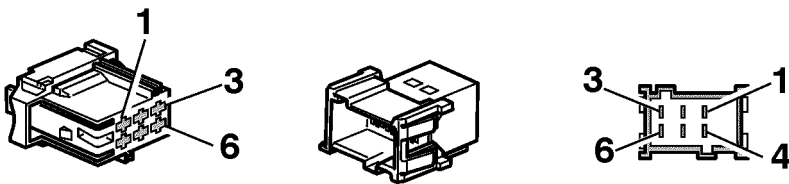

T3019918

Pin no:	Circuit function	Wiring no:	Diagram
3	Ground	1	GF:1 C
4	Position light circuit supply	3047	GF:2 C
5	Ground	1	GF:1 C
6	Roof light sign EL5 power supply	8064	GF:1 C

XC117

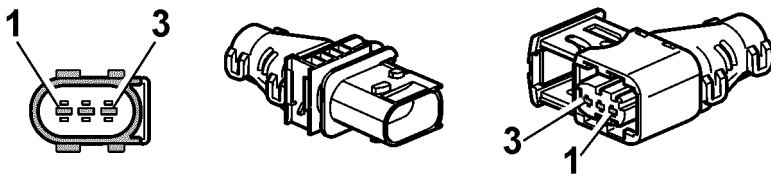

T3071121

Pin no:	Circuit function	Wiring no:	Diagram
1	EL1 extra spot lamp power supply	8062	NF:B D
2	BBEC parking lamp SPOTP-R signal	8058	NF:B D
3	Ground	1	NF:B D

XC118

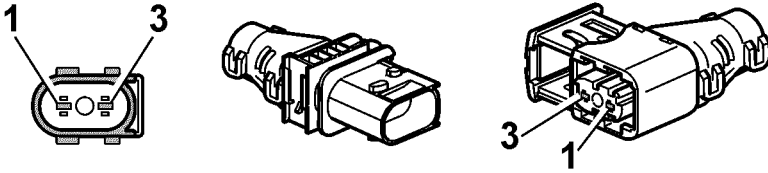

T3071119

Pin no:	Circuit function	Wiring no:	Diagram
1	Beacon lamp power supply	8063	NF:1 B/NF:2 B
3	Ground	1	NF:1 B/NF:1 B

XC119

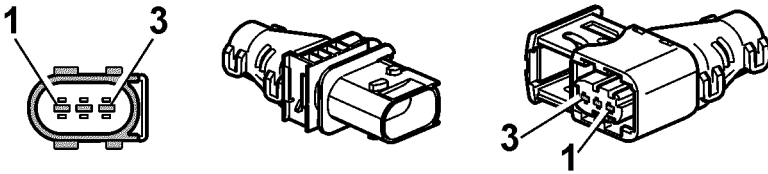

T3071121

Pin no:	Circuit function	Wiring no:	Diagram
1	Roof light sign EL5 power supply	8064	NF:3 B
3	Ground	1	NF:3 B

XC124

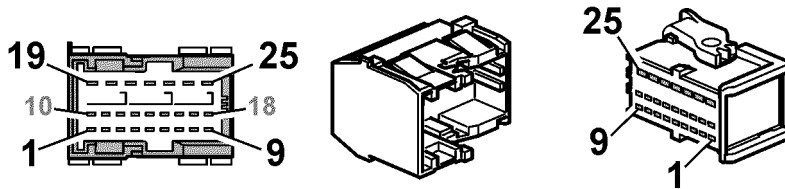

T3071131

Pin no:	Circuit function	Wiring no:	Diagram
2	Converter 12V ground	1069	IN:1 D
3	Cab body working lamp power supply	8061	NE:3 B
4	Max light Ckt 2	6012	IA:4 B
5	(UIP) MDD 12V supply	5023	RA:2 C
6	(UIP) MDD 12V ground	5025	RA:2 C
7	(UIP) MDD 12V LIN	5024	RA:2 C
8	Max light Ckt 1	6011	IA:1 C
9	Full beam lamp supply	8065	NF:4 B
10	Beacon lamp power supply	8063	NF:2 B
11	Refrigerator supply	4004	IF:2 B
12	Position light circuit supply	3047	GF:0 B
13	Position light circuit supply	3047	GF:2 B
14	Aux IN-1 audio right	4022	IN:1 B
15	Aux IN-1 audio left	4021	IN:1 B
16	Aux IN-1 audio diagnostic	4024	IN:1 B
17	Aux IN-1 audio common	4023	IN:1 B
19	Sunroof motor signal 1	4157	IU:1 C
20	Sunroof motor signal 2	4158	IU:1 C
21	Task light ckt	6008	IB:3 B
22	TV/DVD supply	4012	IN:1 B
23	Ground	1	NF:0 C
24	EL1 extra spot lamp power supply	8062	NF:0 C
25	BBEC parking lamp SPOTP-R signal	8058	NF:0 C

XC127

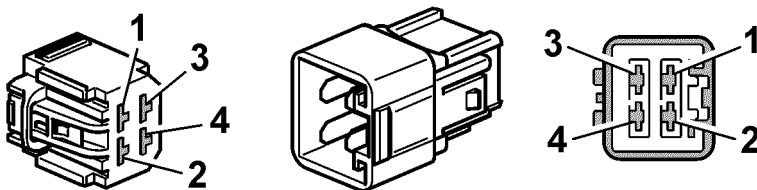

T3080327

Pin no:	Circuit function	Wiring no:	Diagram
1	Amplifier supply	2078	IL:1 A
2	Coffe maker supply	4002	IF:3 B

XC130

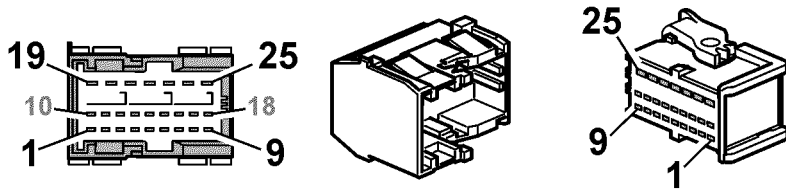

T3071131

Pin no:	Circuit function	Wiring no:	Diagram
1	Max light Ckt 2	6012	IB:1 B
2	Luggage compartment switch status	5009	BG:1 D
3	Fuel dosing pump 1 + supply	2111	HD:1 B
4	Fuel dosing pump 2 (-)	1048	HD:1 B
5	Climate control LIN 12V supply	7066	HD:2 B
6	LECM power supply	2107	HA:0 B
6	CIOM 12V output 1 power supply	7085	SK:3 C
7	CIOM LIN 5 ground	7099	SK:3 C
8	Cab subnet high	7022	SC:2 C
8	CIOM LIN 5 bus	7098	SK:3 C
9	Cab subnet low	7023	SC:2 C
10	Task light ckt	6008	IB:2 B
11	Ground	1	HA:0 D
12	Active safety propriatery subnet 1 high	7026	PA:2 C/PA:2 D
13	Active safety propriatery subnet 1 low	7027	PA:3 C/PA:3 D
14	Cab tilt feedback	0016	KA:3 B
15	Electronic ground	1070	KA:3 D
16	Climate control communication LIN	7067	HD:2 B
17	Cab subnet high	7022	SC:3 C
18	Cab subnet low	7023	SC:3 C
19	24V power outlet supply 2	4006	IF:1 B
20	Refrigerator supply	4004	IF:2 B
21	Parking air, water heater supply	2110	HD:1 B
22	Sunvisor and power recline supply	2101	IF:4 B
23	Cab body working lamp power supply	8061	NE:3 B
24	Amplifier wake up	0149	IL:3 A

XC131

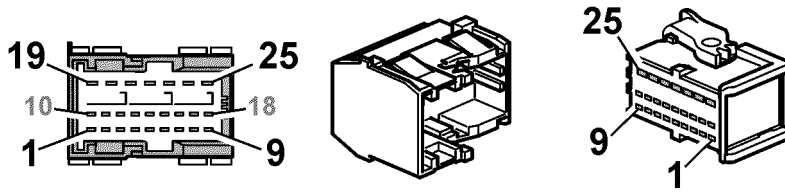

T3071131

Pin no:	Circuit function	Wiring no:	Diagram
1	Radio audio front left amplifier +	4041	IL:1 A
2	Radio audio front left amplifier –	4042	IL:1 A
3	Radio audio front right amplifier +	4043	IL:2 A
4	Radio audio front right amplifier –	4044	IL:2 A
5	Active safety propriatery subnet 1 high	7026	PA:3 D
6	ADR main switch closing request	0006	AD:3 B
7	ADR main switch closing request	0006	AD:2 D
8	Radio audio rear right loudspeaker –	4040	IL:2 C
9	Radio audio front right amplifier +	4043	IL:2 C
10	Radio audio rear left amplifier +	4045	IL:2 A
11	Radio audio rear left amplifier –	4046	IL:2 A
12	Radio audio rear right amplifier +	4047	IL:2 A
13	Radio audio rear right amplifier –	4048	IL:2 A
14	Active safety propriatery subnet 1 low	7027	PA:3 D
15	ADR main switch closing request	0007	AD:3 B
16	ADR main switch closing request	0007	AD:2 D
17	Radio audio front left loudspeaker –	4034	IL:2 C
18	Radio audio front right loudspeaker –	4036	IL:2 C
19	APM redundancy power supply	2125	PA:2 C
20	Side sensor ground	1053	PA:2 C
21	Shield Low Level Signals Audio unit Amplifier	1076	IL:3 A
22	Radio audio rear right loudspeaker –	4040	IK:2 C
22	Radio audio front right loudspeaker –	4036	IL:1 C
23	Radio audio rear right loudspeaker +	4039	IK:2 C
23	Radio audio front right loudspeaker +	4035	IL:1 C
24	Radio audio rear left loudspeaker –	4038	IK:2 C
24	Radio audio front left loudspeaker –	4034	IL:1 C
25	Radio audio rear left loudspeaker +	4037	IK:2 C
25	Radio audio front left loudspeaker +	4033	IL:1 C

XC140

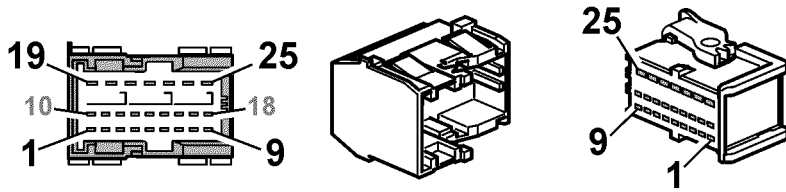

T3071131

Pin no:	Circuit function	Wiring no:	Diagram
1	CIOM 12V output 2 power supply	7086	SK:0 B
2	CIOM LIN1 bus	7106	SK:0 B
3	CIOM LIN1 ground	7107	SK:0 B
4	Cab subnet high	7022	SC:2 C
5	Cab subnet low	7023	SC:2 C
6	Digital signal IO	2032	BC:2 C
7	Backbone 1high	7004	SA:0 B
8	FMS subnet high	7014	BC:2 C
9	Infotainment subnet low	7009	SE:2 C
10	Defog sensor supply	7064	HA:3 C
11	Defog sensor LIN	7063	HA:3 C
12	Defog sensor ground	7065	HA:3 C
13	Tachograph speedometer supply	2031	BC:1 C
14	Speed signal real time	0012	BC:2 C
15	Electronic ground	1070	BC:2 C
16	Backbone 1 low	7005	SA:0 B
17	FMS subnet low	7015	BC:3 C
18	Infotainment subnet high	7008	SE:2 C
19	Cab subnet low	7023	SC:1 C
20	Cab subnet high	7022	SC:1 C
21	ADR tachometer power supply	2022	BC:0 B/BC:0 D
22	Audio supply	4013	IG:0 C
23	WRG power supply	2083	FB:2 B
24	Ground	1	BC:0 D
25	Ground	1	FB:2 B

XC141

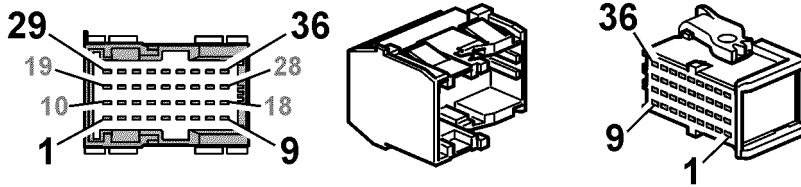

T3071134

Pin no:	Circuit function	Wiring no:	Diagram
1	Active safety proprietary subnet 2 high	7073	PA:1 C
2	Active safety proprietary subnet 2 low	7074	PA:1 C
3	(UIP) MDD ground	5025	RA:3 C
4	(UIP) MDD LIN	5024	RA:2 C
5	(UIP) MDD 12V supply	5023	RA:2 C
6	Emergency assistance switch status	0028	BU:3 C
7	Emergency assistance LED	3002	BU:3 C
8	LIN IR receiver	7034	BU:0 D
9	IR receiver ground	7035	BU:0 D
10	Active safety proprietary subnet 2 high	7073	PA:1 D
11	Active safety proprietary subnet 2 low	7074	PA:1 D
12	Shield Low Level Signals Audio unit Amplifier	1076	IK:3 C
13	LPOS ground	1052	PA:0 A
14	ADR tachometer power supply	2122	PA:0 A
15	Radio audio rear left loudspeaker +	4037	IK:2 C
15	Radio audio rear left amplifier +	4045	IK:3 C
16	Radio audio rear left loudspeaker -	4038	IK:2 C
16	Radio audio rear left amplifier -	4046	IK:3 C
17	Radio audio rear right loudspeaker +	4039	IK:2 C
17	Radio audio rear right amplifier +	4047	IK:3 C
18	Radio audio rear right loudspeaker -	4040	IK:2 C
18	Radio audio rear right amplifier -	4048	IK:3 C
19	Refrigerator supply	4004	IF:2 B
20	Amplifier wake up	0149	IK:3 C
21	BBEC parking lamp SPOTP-R signal	8058	NF;0 C/NF:0 D
22	Radio audio front left loudspeaker +	4033	IK:1 C
22	Radio audio front left amplifier +	4041	IK:2 C
23	Radio audio front left loudspeaker -	4034	IK:1 C
23	Radio audio front left amplifier -	4042	IK:3 C
24	Radio audio front right loudspeaker +	4035	IK:2 C
24	Radio audio front right amplifier +	4043	IK:3 C
25	Radio audio front right loudspeaker -	4036	IK:2 C
25	Radio audio front right amplifier -	4044	IK:3 C

28	Fuel heater switch signal	2116	HF:1 C
29	Electronic ground	1070	HF:1 C
30	LCS LED indicator supply	2124	PA:3 C
31	12V dashboard socket supply	4015	IG:1 D
32	Converter 12V ground	1069	IG:1 D
33	Backlight	6000	HF:1 B
34	Cab body working lamp power supply	8061	NE:3 B
35	Direct battery	2040	BU:0 B
36	Alarm indicator status LED	5019	RA:1 B

XC144

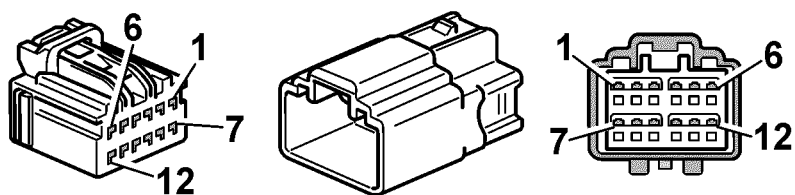

T3071127

Pin no:	Circuit function	Wiring no:	Diagram
1	Climate control LIN supply	7058	HA:1 C
2	Climate control panel ground	7059	HA:1 C
3	Climate control LIN	7057	HA:1 C
4	CIOM 12V output 2 power supply	7086	SK:1 B
5	CIOM LIN2 bus	7104	SK:1 B
6	CIOM LIN2 ground	7105	SK:1 B
7	HMIOM LIN15 comm supply	7092	SL:2 C
8	HMIOM LIN13 comm ground	7094	SL:2 C
9	HMIOM LIN13 comm LIN	7093	SL:2 C
10	IR receiver ground	7035	SL:3 C
11	LIN IR receiver	7034	SL:2 C

XC145_1

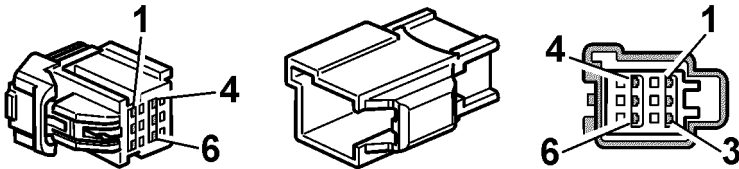

T3071123

Pin no:	Circuit function	Wiring no:	Diagram
1	Ground	1	IA: 0 D
2	Resting light ckt 2	6005	IA: 0 C
3	Night driving light Ckt	6006	IA: 0 C
4	Max light Ckt 2	6012	IA: 3 C
5	Ground	1	IA: 3 D
6	Task light ckt	6008	IA: 3 C

XC145_2

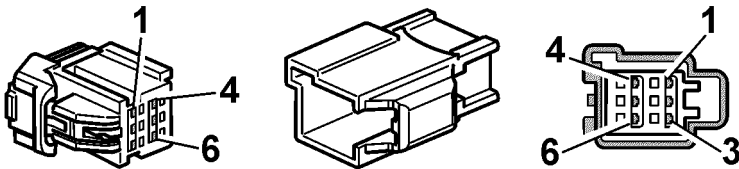

T3071123

Pin no:	Circuit function	Wiring no:	Diagram
1	Ground	1	IA:0 D
2	Resting light ckt 2	6005	IA:0 C
3	Night driving light Ckt	6006	IA:0 C
4	Max light Ckt 2	6012	IA:4 C
5	Ground	1	IA:3 D
6	Task light ckt	6008	IA:3 C

XC147

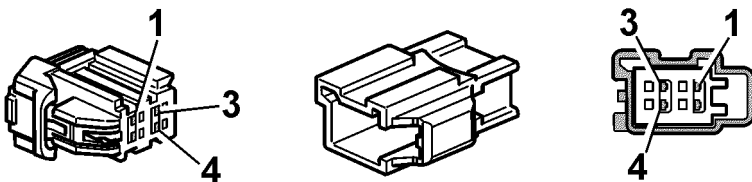

T3071138

Pin no:	Circuit function	Wiring no:	Diagram
1	Aux IN-2 audio left	4027	IK:2 B
2	Aux IN-2 audio right	4028	IK:2 B
3	Aux IN-2 audio diagnostic	4030	IK:2 B
4	Aux IN-2 audio common	4029	IK:2 B

XC149

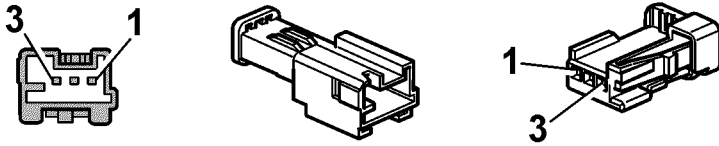

T3071135

Pin no:	Circuit function	Wiring no:	Diagram
1	Sunsensor supply	7061	HA:2 C
2	Sunsensor LIN	7060	HA:3 C
3	Sunsensor ground	7062	HA:3 C

XC153_1

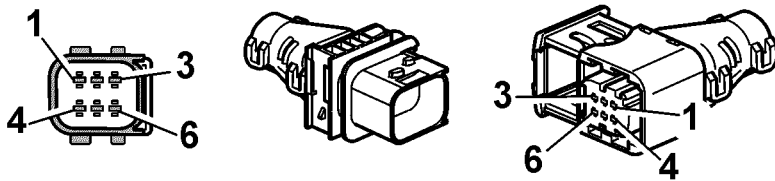

T3071146

Pin no:	Circuit function	Wiring no:	Diagram
1	Side sensor ground	1053	PA:2 D
2	Active safety proprietary subnet 1 high	7026	PA:2 D
3	Active safety proprietary subnet 1 low	7027	PA:2 D
4	Side sensor +12V	2125	PA:2 D

XC153_2

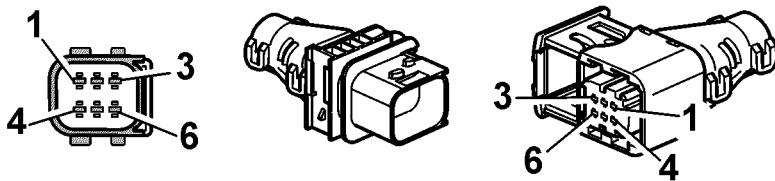

T3071146

Pin no:	Circuit function	Wiring no:	Diagram
1	Side sensor ground	1053	PA:2 D
2	Active safety proprietary subnet 1 high	7026	PA:2 D
3	Active safety proprietary subnet 1 low	7027	PA:2 D
4	Side sensor +12V	2125	PA:2 D

XC155

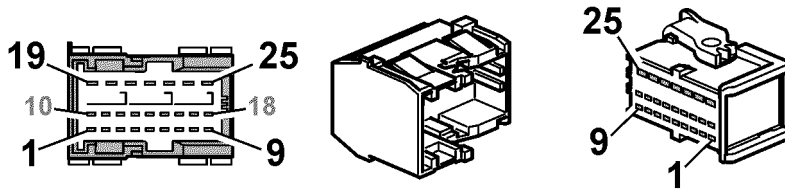

T3071131

Pin no:	Circuit function	Wiring no:	Diagram
16	ADR Main switch closing request	0006	AD:3 B
19	ADR Main switch closing request	0005	AD:3 A
20	ADR Main switch closing request	0008	AD:3 B
21	ADR Main switch closing request	0007	AD:3 B
22	Accessories +12V supply	4167	IG:0 D
23	Beacon lamp power supply	8063	ND1:0 B
24	Position light circuit supply	3047	GF:2 B
25	Position light circuit supply	3047	GF:3 B

XC156

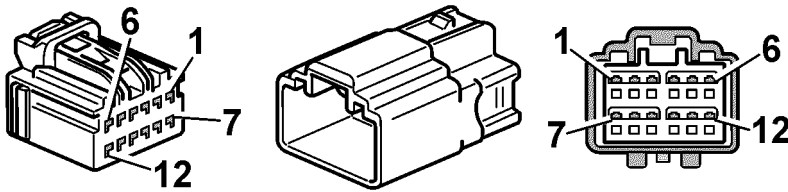

T3071127

Pin no:	Circuit function	Wiring no:	Diagram
1	Ground	1	NK:1 D
2	Direction indicator plough lamp LHS supply	8069	NK:1 D
3	Park lamps LHS plough lamp supply	8071	NK:1 D
4	Full beam plough lamp supply	8082	NK:2 D
5	Dipped beam plough lamp supply	8072	NK:2 D
6	Dipped beam plough lamp supply	8081	NK:2 D
7	Full beam plough lamp supply	8073	NK:3 D
8	Park lamps LHS plough lamp supply	8071	NK:3 D
9	Direction indicator plough lamp RHS supply	8070	NK:3 D
10	Ground	1	NK:3 D

XC201

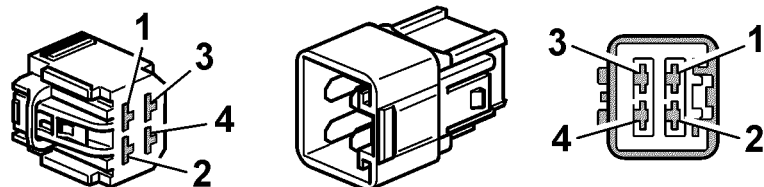

T3080327

Pin no:	Circuit function	Wiring no:	Diagram
1	Trailer ABS, EBS power supply	2129	GK:0 B/GL:1 B
2	Cab tilt pump motor supply	2131	KA:1 B

XC202

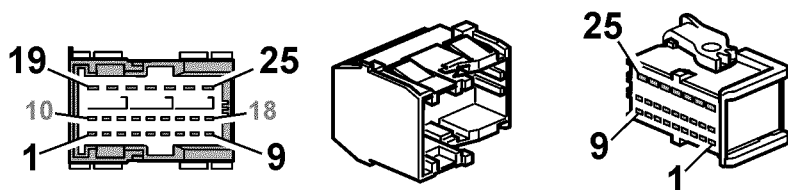

T3071131

Pin no:	Circuit function	Wiring no:	Diagram
1	BB1 connector interface pin 1	8046	ND:2 D/ND2:1 C
2	BB1 connector interface pin 2	8047	ND:2 D/ND2:1 C
3	BB1 connector interface pin 3	8048	ND:2 D/ND2:1 C
4	BB1 connector interface pin 4	8049	ND:2 D/ND2:1 C
5	BB1 connector interface pin 5	8050	ND:2 D/ND2:1 C
6	BB1 connector interface pin 6	8051	ND:2 D/ND2:1 C
7	BB1 connector interface pin 7	8052	ND:3 D
7	Warning Body/Tail lift feedback	8045	ND2:1 C
10	BB2 connector interface pin 1	8032	ND:0 D/ND2:2 C
11	BB2 connector interface pin 2	8033	ND:0 D/ND2:2 C
12	BB2 connector interface pin 3	8034	ND:0 D/ND2:2 C
13	BB2 connector interface pin 4	8035	ND:0 D/ND2:2 C
14	BB3 connector interface pin 1	8039	ND:1 D/ND2:3 C
15	BB3 connector interface pin 2	8040	ND:1 D/ND2:3 C
16	BB3 connector interface pin 3	8041	ND:1 D/ND2:3 C
19	BB2 connector interface pin 5	8036	ND:0 D/ND2:2 C
20	BB2 connector interface pin 6	8037	ND:0 D/ND2:2 C
21	BB2 connector interface pin 7	8038	ND:0 D/ND2:2 C
22	BB3 connector interface pin 4	8029	ND:1 D/ND2:3 C
23	BB3 connector interface pin 5	8030	ND:1 D/ND2:3 C
24	BB3 connector interface pin 6	8044	ND:1 D/ND2:3 C
25	BB3 connector interface pin 7	8003	ND:1 D/ND2:4 C

XC203

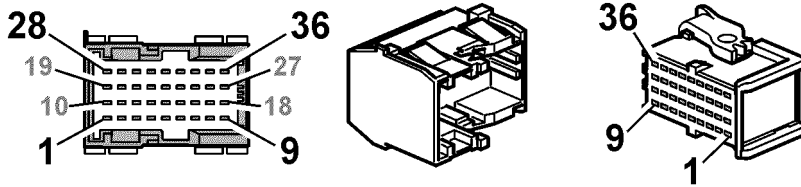

T3080545

Pin no:	Circuit function	Wiring no:	Diagram
1	Backbone 1 high	7004	SA:4 C
2	Backbone 1 low	7005	SA:4 C
5	Chassis subnet high	7000	SD:0 B
6	Chassis subnet low	7001	SD:0 B
7	EBS sensor CAN high	7052	EE:3 D
8	EBS sensor CAN low	7053	EE:3 D
9	Foot brake sensor signal 1	0068	EE:0 C
10	HCU ground	7056	FE:1 C
11	LIN HCU	7055	FE:1 C
12	12V power supply	7054	FE:2 C
13	Climate control LIN 12V supply	7066	HC:3 B
14	Climate control communication LIN	7067	HC:3 B
15	Direct battery	2142	EE:3 D
16	Multiplexed sensor ground	1022	EE:3 D
17	Brake pedal sensor ground	1017	EE:0 C
18	Foot brake sensor signal 2	0069	EE:0 C
19	Tachograph speedometer supply	2031	BC:1 D
20	Speed signal real time	0012	BC:2 D
21	Electronic ground	1070	BC:2 D
22	Digital signal IO	2032	BC:2 D
25	Brake pedal sensor supply	2056	EE:0 C
26	Ignition signal	2020	BE:1 C
27	Hazard hardwired	3000	BE:0 D
28	Headlight washer pump supply	2105	GP:1 C
29	AC compressor clutch signal	0152	HA:3 C
30	Side instep light	3015	IC:1 B
31	Auxillary horn signal	4096	IP:1 C
33	Fuel dosing pump 2 (-)	1048	HC:0 B
34	Fuel dosing pump 1 + supply	2111	HC:1 B
35	APM power supply	2086	FE:1 B
36	Parking air, water heater supply	2110	HC:1 B

XC204

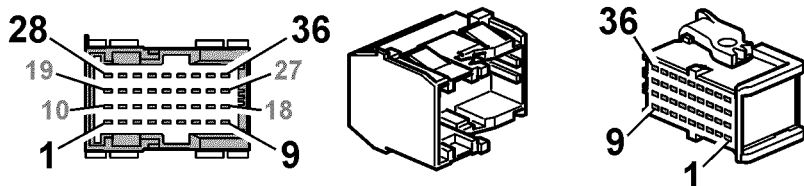

T3080545

Pin no:	Circuit function	Wiring no:	Diagram
1	EBS sensor CAN low	7053	PA:1 D
2	Active safety proprietary subnet 2 low	7074	PA:0 D
3	Cab tilt enable switch	2139	KA:2 C
4	Cab tilt pump enable	0018	KA:2 D
10	FLS sensor power supply	2126	PA:0 C
19	Burglar alarm siren 12V	5020	RA:3 C
20	Burglar alarm siren LIN	5022	RA:3 C
21	Burglar alarm siren ground	5021	RA:3 C

XC207

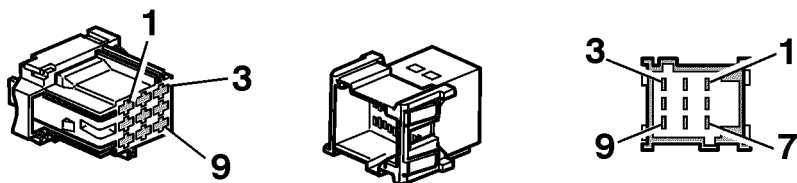

T3019929

Pin no:	Circuit function	Wiring no:	Diagram
1	ADR tachometer power supply	2022	AE:2 D/BC:0 B
2	Ground	1	AE:2 D
3	ADR main switch closing request	0005	AD:2 A
4	ADR main switch closing request	0007	AD:1 D
5	ADR main switch closing request	0006	AD:1 D
6	ADR main switch closing request	0008	AD:1 D

XC208

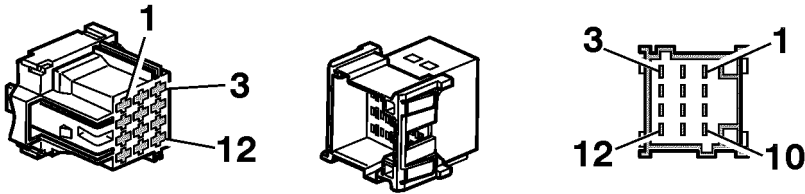

T3019801

Pin no:	Circuit function	Wiring no:	Diagram
1	Side revers working lamp power supply	8060	NE:1 B
2	Cab body working lamp power supply	8061	NE:3 A
3	Climate subnet high	7068	HB:3 A
5	TECU power supply	2024	DC:1 B
6	Climate subnet low	7069	HB:3 A
8	Fuel heater supply	2115	HF:1 C

XC210

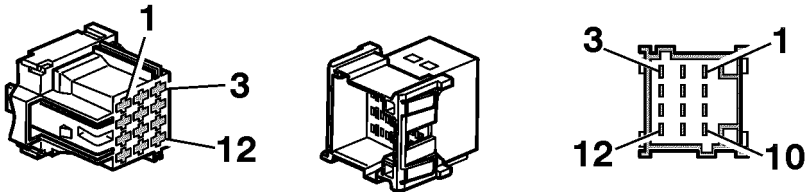

T3019801

Pin no:	Circuit function	Wiring no:	Diagram
1	EMS power supply 1	2044	CA:2 C
2	EMS load power supply 1	2045	CA:2 C
3	EMS load power supply 2	2046	CA:2 C
4	EMS power supply 1	2044	CA:1 C
5	Trailer power supply +24V	8017	GK:2 B/GL:2 B
6	Fuel filter heater power supply	2047	CA:1 C
7	Trailer strat aid/free	8019	GK:2 B/GL:3 B
8	Trailer body light EL8 relay supply	8020	GK:2 B/GL:3 B
9	Backbone 2 high	7006	SB:4 D
10	Direct battery	2055	EA:0 B/EE:0 A
11	Trailer steering lock/free	8018	GK:2 B/GL:2 B
12	Backbone 2 low	7007	SB:4 D

XC213

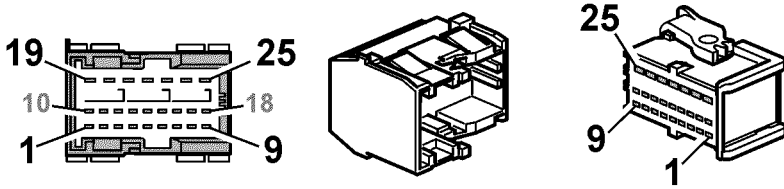

T3071131

Pin no:	Circuit function	Wiring no:	Diagram
1	Cab tilt pump enable	0018	KA:2 D
2	Cab tilt enable switch	2139	KA:2 C
5	Front lid lock motor supply 1	5006	BG:1 B
6	Front lid lock motor supply 2	5007	BG:1 B
7	Ground	1	BG:1 B
8	Brake pedal sensor supply	2056	EE:0 D
9	Brake pedal sensor ground	1017	EE:0 D
10	Foot brake sensor signal 1	0068	EE:0 D
11	Foot brake sensor signal 2	0069	EE:0 D
12	Front lid lock sensor feedback	5002	BG:1 C
13	Front lid switch signal	5026	RA:1 C
14	Side instep light	3015	IC:1 C
17	Auxillary horn signal	4096	IP:1 C
19	Extra spot lamp EL6 front power supply	8059	NE:0 C
20	Windscreen wiper park position signal	0151	GP:0 C
21	Windscreen wiper low speed	2103	GP:0 C
22	Windscreen wiper high speed	2104	GP:1 C
24	BBEC parking lamp SPOTP-F signal	8057	NE:0 C

XC301_2

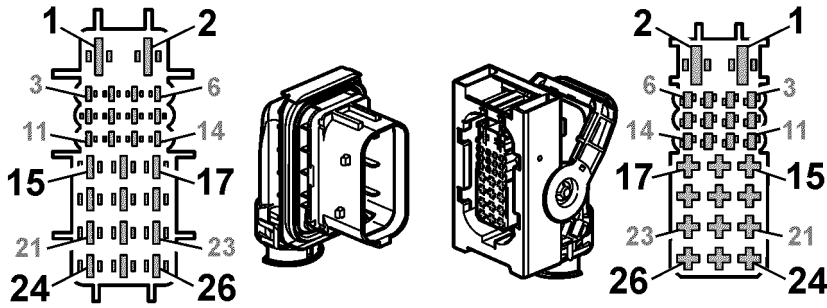

T3071132

Pin no:	Circuit function	Wiring no:	Diagram
1	Ground	1	YD:1 C
2	Cab tilt pump motor supply	2131	KA:1 B
3	Active safety proprietary subnet 2 high	7073	PA:1 D
4	Active safety proprietary subnet 2 low	7074	PA:0 D
5	FLS sensor power supply	2126	PA:0 C
6	Ground	1	PA:1 C
7	Side instep light	3015	IC:1 B
8	Burgler alarm siren 12V	5020	RA:3 D
9	Burgler alarm siren LIN	5022	RA:4 D
10	Burgler alarm siren ground	5021	RA:4 D
11	Chassis subnet high	7000	SD:0 B
12	Chassis subnet low	7001	SD:1 B
13	Ignition signal	2020	BE:0 D
14	Hazard hardwired	3000	BE:0 D
15	Ground	1	YA:0 C
19	Headlight washer pump supply	2105	GP:1 C
20	Auxiliary horn signal	4096	IP:1 C

XC302 (GIC020)

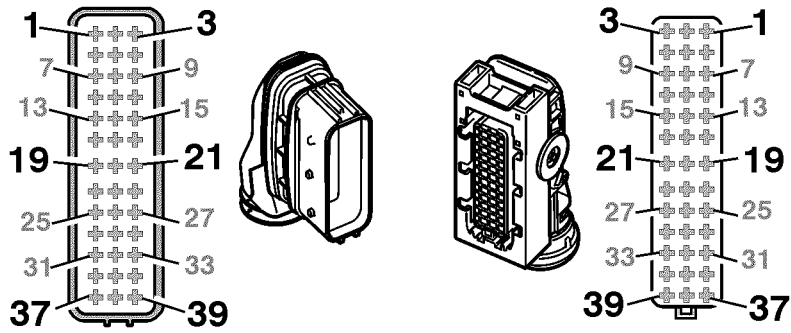

T3019924

Pin no:	Circuit function	Wiring no:	Diagram
1	Backbone 1 high	7004	CA:1:1 D
2	Backbone 2 high	7006	CA:1:1 D
3	PWT subnet high	7036	CA:1:2 D
3	PWT subnet high	7128	CA:1:3 D
4	Backbone 1 low	7005	CA:1:1 D
5	Backbone 2 low	7007	CA:1:1 D
6	PWT subnet low	7037	CA:1:2 D
6	PWT subnet low	7129	CA:1:3 D
9	Alternator L-signal	0003	AA:3 D
10	Alternator control	0002	AA:3 D
13	EMS power supply 1	2044	CA:2 D
15	EMS power supply 1	2044	CA:1 D
21	EMS load power supply 2	2046	CA:2 D
23	AC compressor clutch signal	0152	HE:3 C
27	Ground	1	CA:2 D
31	Ground	1	CA:2 D
33	EMS load power supply 1	2045	CA:2 D
34	Engine subnet high	7038	CA:1:3 D
36	Engine subnet low	7039	CA:1:4 D
37	Fuel filter heater power supply	2047	CA:1 D
39	Ground	1	CA:2 D

XC303 (GIC021)

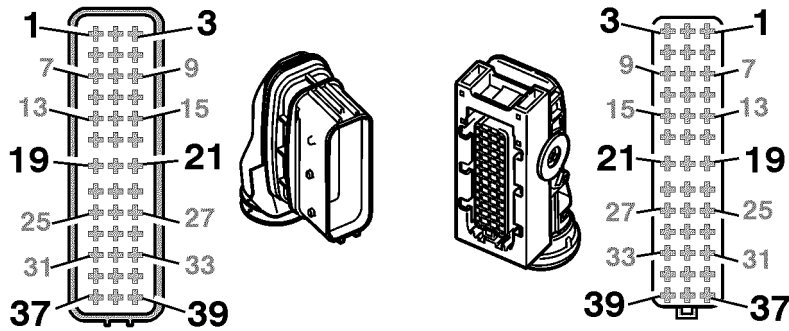

T3019924

Pin no:	Circuit function	Wiring no:	Diagram
1	Backbone 1 high	7004	DC:1 C
2	Backbone 2 high	7006	DC:2 C
3	PWT subnet high	7036	DC:2 C
4	Backbone 1 low	7005	DC:1 C
5	Backbone 2 low	7007	DC:2 C
6	PWT subnet low	7037	DC:3 C
7	Electronic ground	1070	BC:2 D
8	Backbone 2 high	7006	DC:2 C
9	Area inhibit valve on/off	0053	DA:1 C
10	Backbone 2 low	7007	DC:2 C
11	Gearbox oil temp sensor	0047	DA:0 C
12	Retarder air pressure	0044	DK:1 D/DM:2 D
13	TECU power supply	2024	DC:1 C
15	V5EXT 1 supply	2050	DK:1 D
15	V5EXT 2 supply	2051	DM:1 D
16	Digital signal IO	2032	BC:2 D
17	Range inhibit valve on/off	0052	DA:1 C
19	Revers feedback sensor	0050	DA:2 C
20	Gearbox low split sensor	0049	DA:2 C
21	V5EXT 1 ground	1009	DK:3 D/DM:2 D
22	Low range manual gearbox switch	0051	DA:2 C
23	Retarder PWM control	0043	DK:1 D/DM:1 D
24	Speed signal real time	0012	BC:2 D
26	Tachograph speedometer supply	2031	BC:1 D
27	V5EXT 2 ground	1010	DK:2 D/DM:2 D
28	Retarder oil temperature	0045	DK:2 D/DM:2 D
29	Retarder water temperature	0046	DK:2 D/DM:2 D
30	PWT subnet terminal resistor strap	7040	DC:2 C
31	Ground	1	DA:1 C
31	Manual Gearbox sensors & valves ground	1073	DA:1 C
33	Gearbox oil temperature sensor ground	1011	DA:0 C

35	Actuator supply-1	2052	DK:1 D
35	Supply to Adblue loads	2155	DM:1 D
36	PWT subnet terminal resistor strap	7040	DC:3 C
38	Neutral feedback sensor	0048	DC:1 C
39	Ground	1	DC:0 C

XC310

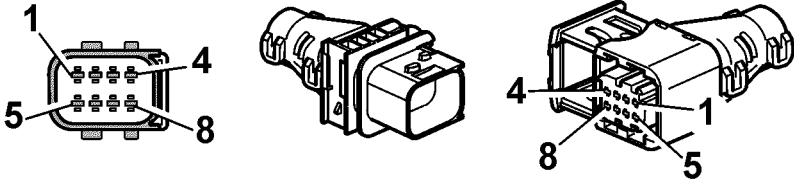

T3071145

Alternative connector

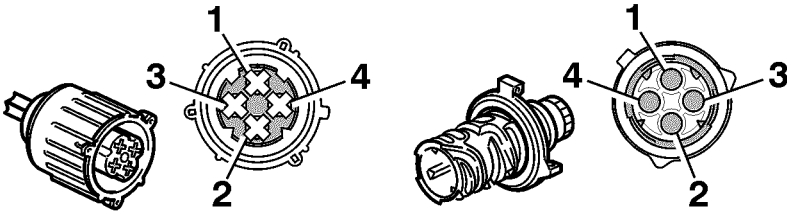

T3019922

Pin no:	Circuit function	Wiring no:	Diagram
1	ECS level sensor supply 2	2081	FA:2 C
2	ECS level sensor ground 2	0121	FA:2 C
3	ECS Front Level sensor signal 2	0235	FA:2 C
4	ECS level sensor signal 1	0181	FA:2 C
5	ECS pressure sensor supply 1	2080	FA:1 C
6	ECS pressure sensor ground 1	1036	FA:1 C
8	ECS Front Pressure sensor signal 2	0234	FA:1 C

XC312 (GIC128)

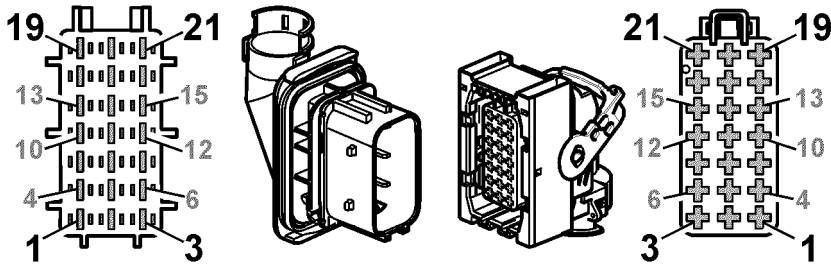

T3071130

Pin no:	Circuit function	Wiring no:	Diagram
1	V5EXT 2 ground	1010	CE:1 D/CK:2 D
2	CAT temp downstream	0038	CE:1 D/CK:1 D
3	CAT temp upstream	0037	CE:1 D/CK:1 D
4	Temp after DPF	0039	CE:1 D/CK:1 D
5	V5EXT 1 supply	2050	CE:0 D/CK:0 D
6	DPF pressure	0036	CE:0 D/CK:1 D
7	PWT subnet high	7036	CE:3 D
7	Engine subnet high	7038	CK:3 D
8	PWT subnet low	7037	CE:3 D
8	Engine subnet low	7039	CK:3 D
9	V5EXT 1 ground	1009	CE:0 D/CK:1 D
10	PWT subnet high	7036	CE:2 D
10	Engine subnet high	7038	CK:3 D
11	PWT subnet low	7037	CE:2 D
11	Engine subnet low	7039	CK:3 D
16	Adblue injector lsd	0035	CE:1 D
17	Adblue injector hsd	0034	CE:2 D
19	Nox-1 power supply	2048	CE:3 D
19	NOx supply	2161	CK:2 D
20	Ground	1	CE:4 D/CK:2 D
21	Nox-2 power supply	2049	CE:4 D
21	NOx supply	2161	CK:2 D

XC313

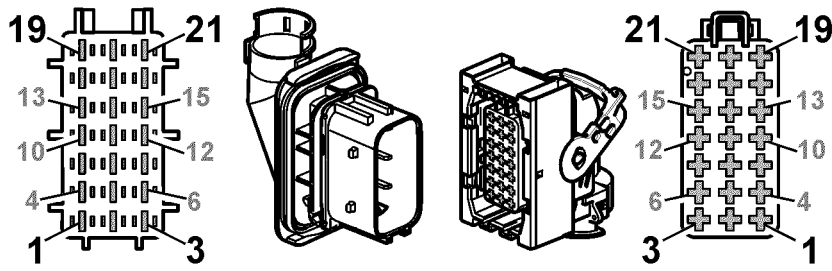

T3071130

Pin no:	Circuit function	Wiring no:	Diagram
1	V5EXT 2 supply	2051	CF:2 B/CF_AUS:2 B
1	Adblue temp control	0231	CL:1 B
2	Adblue pressure	0042	CF:2 B/CL:3 B/CF_AUS:2 B
3	V5EXT 2 ground	1010	CF:2 B/CF_AUS:2 B
3	Adblue air pressure	0030	CL:3 B
4	PWT subnet high	7036	CF:3 B
5	PWT subnet low	7037	CF:3 B
6	V5EXT 1 ground	1009	CF:2 B/CL:2 B/CF_AUS:3 D
6	Ground	1	CF:4 B
7	Adblue level control	0180	CF:3 B/CL:2 B/CF_AUS:3 B
7	PWT subnet high	7036	CF:3 B
8	Adblue temp control	0179	CF:2 B/CL:2 B/CF_AUS:2 B
8	PWT subnet low	7037	CF:3 B
9	V5EXT 1 supply	2050	CF:3 B/CF_AUS:3 B
9	Nox-2 power supply	2049	CF:4 B
13	Adblue air pressure	0030	CF:2 B/CF_AUS:2 B
13	V5EXT 2 supply	2051	CL:2 B
14	Adblue air temp control	0178	CF:1 B/CF_AUS:2 B
14	Adblue air valve on/off	0040	CL:1 B
15	Adblue air valve on/off	0040	CF:1 B/CF_AUS:2 B
15	Supply to Adblue loads	2155	CL:1 B
16	Adblue heater hose control 1	0033	CF:0 B/CL:0 B
17	Adblue heater hose control 2	0032	CF:0 B/CL:0 B
18	Adblue heater hose control 3	0031	CF:0 B
18	Adblue dosage pump L	0230	CL:4 B
19	Actuator supply-1	2052	CF:0 B/CF_AUS:2 B

19	Supply to Adblue hoses	2156	CL:0 B
20	Adblue dosage pump H	0229	CL:3 B
21	Adblue tank heating valve on/off	0029	CF:1 B/CL:0 B

XC314

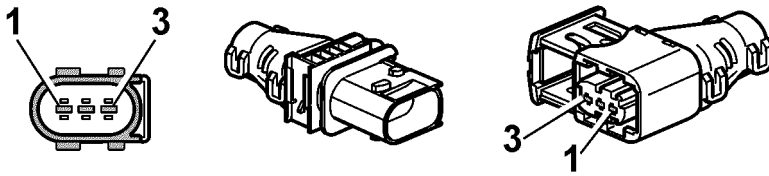

T3071121

Pin no:	Circuit function	Wiring no:	Diagram
1	Fuel level sensor	0054	DG:0 C
3	Fuel level sensor ground	1012	DG:0 C

XC315

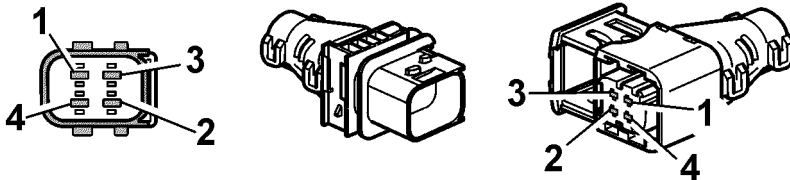

T3071144

Pin no:	Circuit function	Wiring no:	Diagram
1	LIN battery sensor	7127	AA:0 D
2	ACM power supply	2019	AA:3 A
3	Main switch status	0004	AB:2 B
4	Ground	1	YB:0 B

XC316

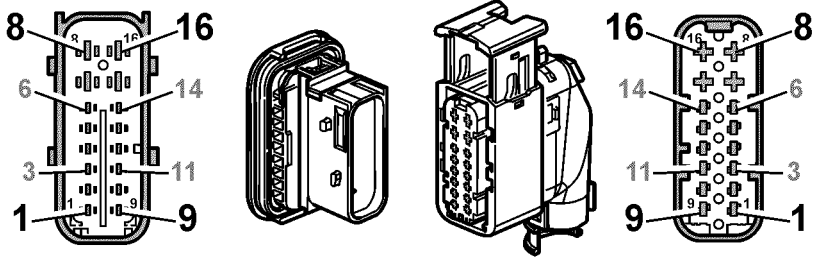

T3071129

Pin no:	Circuit function	Wiring no:	Diagram
1	V5EXT 2 supply	2051	CF:2 C
1	Adblue temp control	0231	CL:1 C
2	Adblue pressure	0042	CF:2 C/CL:3 C
3	V5EXT 2 ground	1010	CF:2 C
3	Adblue air pressure	0030	CL:3 C
4	Adblue dosage pump H	0229	CL:3 C
5	Adblue tank heating valve on/off	0029	CF:1 C/CL:0 C
6	Adblue air valve on/off	0040	CF:1 C
6	Supply to Adblue loads	2155	CL:1 C
7	Adblue heater hose control 3	0031	CF:0 C
7	Adblue dosage pump L	0230	CL:4 C
8	Actuator supply-1	2052	CF:0 C
8	Supply to Adblue hoses	2156	CL:0 C
9	V5EXT 2 supply	2051	CF:3 C
9	Nox-2 power supply	2049	CF:4 C
10	Adblue level control	0180	CF:3 C/CL:2 C
10	PWT subnet high	7036	CF:3 C
11	Adblue temp control	0179	CF:2 C/CL:2 C
11	PWT subnet low	7037	CF:3 C
12	V5EXT 1 ground	1009	CF:2 C/CL:1 C
12	Grund	1	CF:4 C
13	Adblue air pressure	0030	CF:2 C
13	V5EXT 2 supply	2051	CL:2 C
14	Adblue air temp control	0178	CF:1 C
14	Adblue air valve on/off	0040	CL:1 C
15	Adblue heater hose control 2	0032	CF:0 C/CL:0 C
16	Adblue heater hose control 1	0033	CF:0 C/CL:0 C

XC317

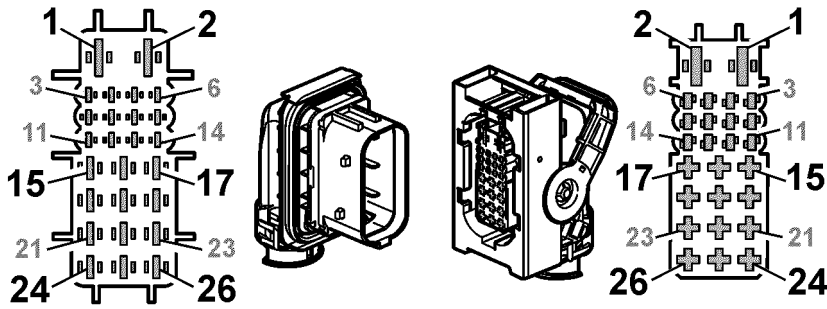

T3071132

Pin no:	Circuit function	Wiring no:	Diagram
1	Trailer ABS, EBS power supply	2129	GK:0 B
3	EBS sensor CAN high	7052	FO:1 C
4	EBS sensor CAN low	7053	FO:1 C
5	Rear diff lock valve on/off	0062	DG:4 C
6	Rear inter axle diff lock valve on/off	0061	DG:3 C
7	EBS proprietary net high	7083	GK:0 B
7	Trailer ignition key signal	0160	GL:1 C
8	EBS proprietary net low	7084	GK:0 B
8	Trailer control lamp	0161	GL:1 C
9	Direct battery	2142	FO:1 C
10	Multiplexed sensor ground	1022	FO:1 C
11	Chassis subnet high	7000	GC:1 A
12	Chassis subnet low	7001	GC:1 A
13	Ignition signal	2020	GC:2 A
14	Hazard hardwired	3000	GC:2 A
15	Ground	1	YA:1 B
16	Ground	1	YA:1 B
17	Trailer fog light	3055	GK:3 B
17	Trailer direction indicator left	3050	GL:1 C/GN:1 B
18	Trailer reverse light	3056	GK:4 B/GN:2 B
18	Trailer direction indicator right	3051	GL:1 C/GN:2 B
19	Trailer position light left	3052	GL:1 C/GN:1 B
20	Trailer position light right	3053	GL:2 C/GN:0 B
21	Trailer brake light	3054	GL:2 C/GN:1 B
22	Lubrication motor power supply	2026	LA:0 B
23	Trailer power supply +24V	8017	GK:2 B
23	5th wheel feedback 1	0162	NC:1 C
24	Trailer steering lock/free +	8018	GK:2 B
24	5th wheel feedback 2	0163	NC:1 C
25	Trailer strat aid/free -	8019	GK:2 B
25	5th wheel feedback 3	0164	NC:1 C

26	Trailer body light EL8 relay supply	8020	GK:2 B
26	5th wheel feedback common ground	1056	NC:1 C

XC318A

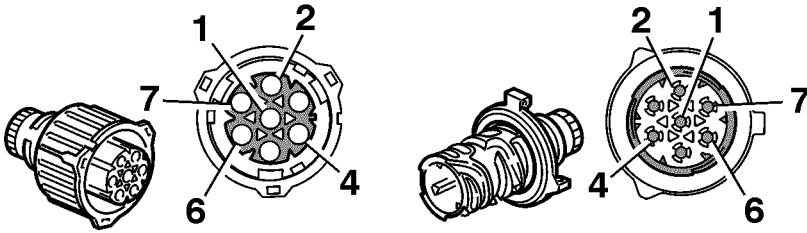

T3020295

Pin no:	Circuit function	Wiring no:	Diagram
2	Side reverse working lamp power supply	8060	NE:1 B
3	Cab body working lamp power supply	8061	NE:3 B
4	5th wheel load light	8068	NC:3 C
5	Ground	1	NE:1 D
6	Ground	1	NE:4 B
7	Ground	1	NC:3 D

XC318B

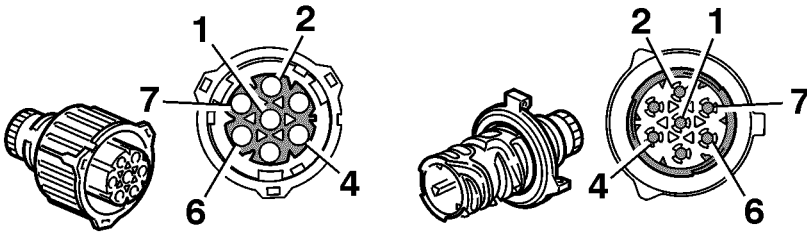

T3020295

Pin no:	Circuit function	Wiring no:	Diagram
2	Side reverse working lamp power supply	8060	NE:1 B
3	Cab body working lamp power supply	8061	NE:3 B
4	5th wheel load light	8068	NC:3 C
5	Ground	1	NE:1 D
6	Ground	1	NE:4 B
7	Ground	1	NC:3 C

XC318C

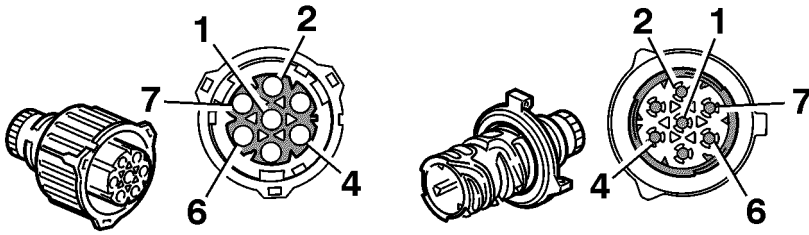

T3020295

Pin no:	Circuit function	Wiring no:	Diagram
2	Side reverse working lamp power supply	8060	NE:2 B
3	Cab body working lamp power supply	8061	NE:3 B
4	5th wheel load light	8068	NC:3 C
5	Ground	1	NE:2 D
6	Ground	1	NE:4 B
7	Ground	1	NC:3 C

XC319

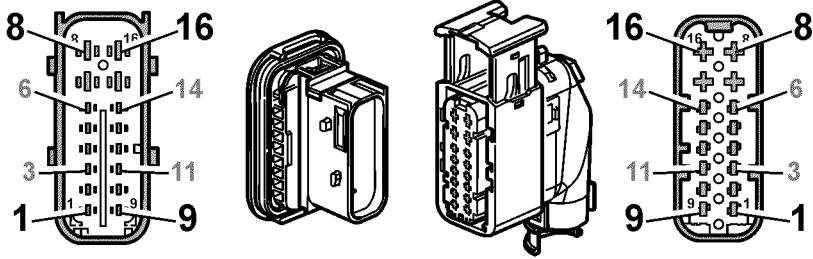

T3071129

Pin no:	Circuit function	Wiring no:	Diagram
1	V5EXT 2 supply	2051	CF:2 C
1	Adblue temp control	0231	CL:1 C
2	Adblue pressure	0042	CF:2 C/CL:3 C
3	V5EXT 2 ground	1010	CF:2 C
3	Adblue air pressure	0030	CL:3 C
4	Adblue dosage pump H	0229	CL:4 C
5	Adblue tank heating valve on/off	0029	CF:1 C/CL:0 C
6	Adblue air valve on/off	0040	CF:1 C
6	Supply to Adblue loads	2155	CL:1 C
7	Adblue heater hose control 3	0031	CF:0 C
7	Adblue dosage pump L	0230	CL:4 C
8	Actuator supply-1	2052	CF:0 C
8	Supply to Adblue hoses	2156	CL:0 C
9	V5EXT 2 supply	2051	CF:3 C
10	Adblue level control	0180	CF:3 C/CL:2 C
11	Adblue temp control	0179	CF:2 C/CL:2 C
12	V5EXT 1 ground	1009	CF:2 C/CL:2 C
13	Adblue air pressure	0030	CF:2 C
13	V5EXT 2 supply	2051	CL:2 C
14	Adblue air temp control	0178	CF:1 C
14	Adblue air valve on/off	0040	CL:1 C
15	Adblue heater hose control 2	0032	CF:0 C/CL:0 C
16	Adblue heater hose control 1	0033	CF:0 C/CL:0 C

XC321_2

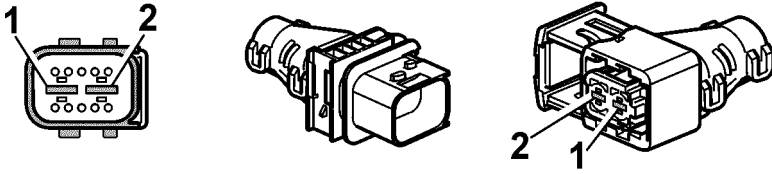

T3071143

Pin no:	Circuit function	Wiring no:	Diagram
1	FCIOM power supply	2015	AA:2 A
2	Ground	1	YA:0 C

XC322_2

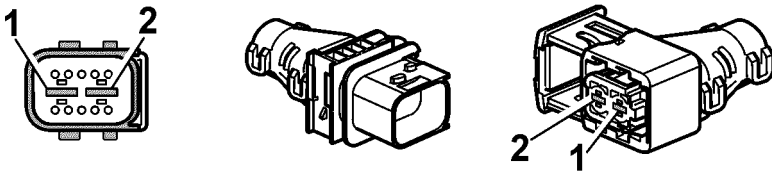

T3071143

Pin no:	Circuit function	Wiring no:	Diagram
1	FCIOM power supply	2016	AA:3 A
2	Ground	1	YD:2 C

XC323

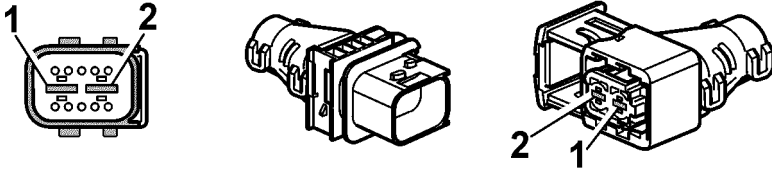

T3071143

Pin no:	Circuit function	Wiring no:	Diagram
1	RCIOM power supply	2017	GC:0 A
2	RCIOM power supply	2018	GC:0 A

XC324

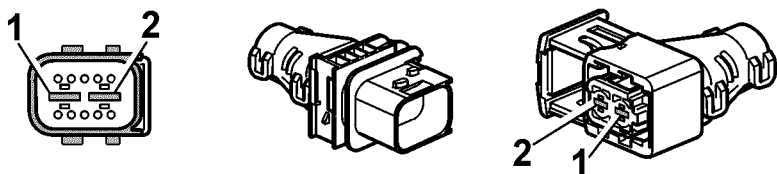

T3071143

Pin no:	Circuit function	Wiring no:	Diagram
1	EAS power supply	2152	FO:1 A
2	Ground	1	FO:1 D

XC325

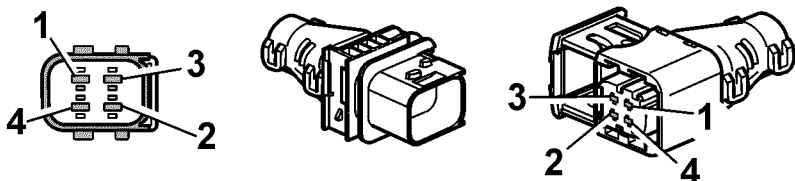

T3071144

Pin no:	Circuit function	Wiring no:	Diagram
1	LIN battery sensor	7127	AA:0 D
2	ACM power supply	2019	AA:4 B

XC327

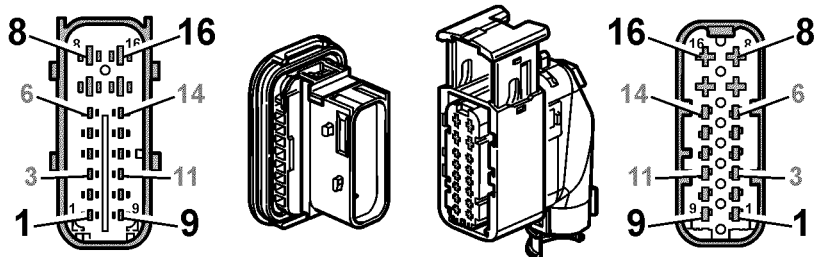

T3071129

Pin no:	Circuit function	Wiring no:	Diagram
1	ADR tachometer power supply	2022	AD:0 C
2	Main switch status	0004	AD:1 C
4	ADR main switch closing request	0008	AD:1 C
5	ADR main switch closing request	0007	AD:1 C
6	ADR main switch closing request	0006	AD:1 C
7	Ground	1	AD:1 C
8	Ground	1	AD:1 C
9	LIN battery sensor	7127	AA:0 D
10	ADR main switch closing request	0005	AD:1 B
15	ACM power supply	2019	AA:4 B

XC328

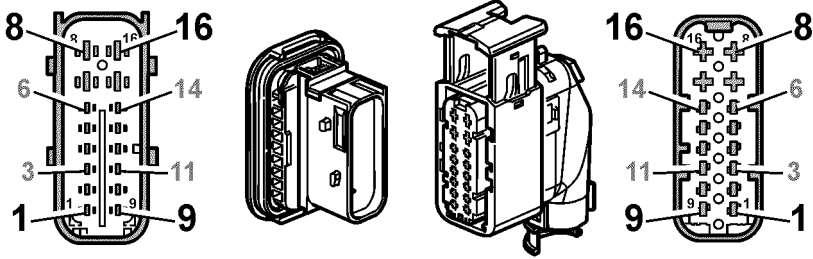

T3071129

Pin no:	Circuit function	Wiring no:	Diagram
1	ADR tacho power supply	2022	AD:0 D
4	ADR main switch closing request	0008	AD:1 C
5	ADR main switch closing request	0007	AD:1 C
6	ADR main switch closing request	0006	AD:2 C
7	Ground	1	AD:1 C
8	Ground	1	AD:1 C
10	ADR main switch closing request	0005	AD:1 A

XC329

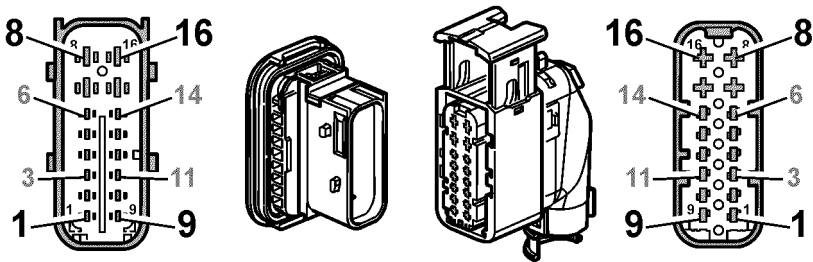

T3071129

Pin no:	Circuit function	Wiring no:	Diagram
1	ADR tacho power supply	2022	AD:0 D
4	ADR main switch closing request	0008	AD:1 C
5	ADR main switch closing request	0007	AD:1 C
6	ADR main switch closing request	0006	AD:1 C
7	Ground	1	AD:1 C
8	Ground	1	AD:1 C
10	ADR main switch closing request	0005	AD:1 A

XC330

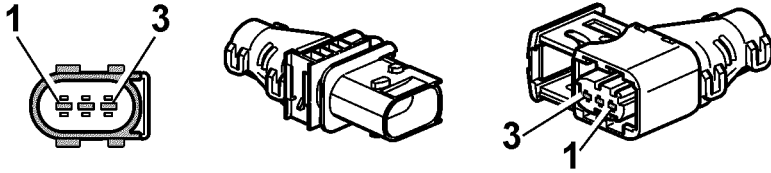

T3071121

Pin no:	Circuit function	Wiring no:	Diagram
1	Side markers light	3017	GE:1 B
3	Ground	1	GE:0 D

XC331

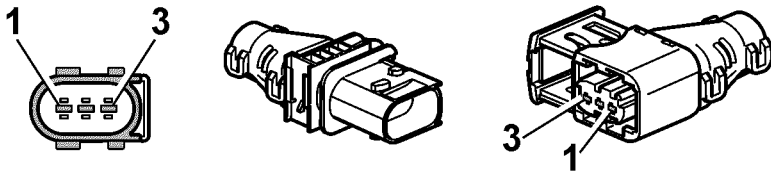

T3071121

Pin no:	Circuit function	Wiring no:	Diagram
1	Side markers light	3017	GE:1 B
3	Ground	1	GE:2 D

XC342

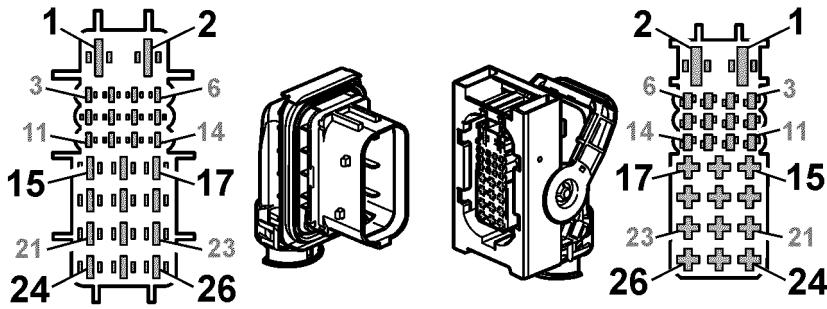

T3071132

Pin no:	Circuit function	Wiring no:	Diagram
1	Trailer ABS, EBS power supply	2129	GK:0 C
5	EBS proprietary net high	7083	GK:0 C
6	EBS proprietary net low	7084	GK:0 C
8	Trailer ignition key signal	0160	GK:1 B
9	Trailer control lamp	0161	GK:1 B
15	Trailer direction indicator left	3050	GK:1 B/GM:1 B/ GN:1 B
16	Trailer direction indicator right	3051	GK:1 B/GM:1 B/ GN:1 B
17	Trailer position light left	3052	GK:1 B/GM:1 B/ GN:1 B
18	Trailer position light right	3053	GK:1 B/GM:1 B/ GN:0 B
19	Trailer brake light	3054	GK:1 B/GM:1 B/ GN:1 B
20	Trailer power supply + 24V	8017	GK:2 BC/GM:2 B
21	Trailer steering lock/free +	8018	GK:2 B/GM:2 B
22	Trailer strat aid/free -	8019	GK:2 B/GM:2 B
23	Trailer body light EL8 relay supply	8020	GK:2 B/GM:3 B
24	Trailer fog light	3055	GK:3 B/GM:1 B
25	Trailer reverse light	3056	GK:4 B/GM:2 B/ GN:2 B

XC351

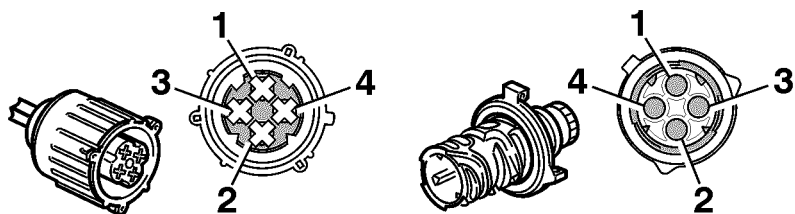

T3019922

Pin no:	Circuit function	Wiring no:	Diagram
1	Side markers light	3017	GE:1 D
2	Side Marker light Rear	3066	GE:1 D
3	Ground	1	GE:1 D
4	Ground	1	GE:1 D

XC353

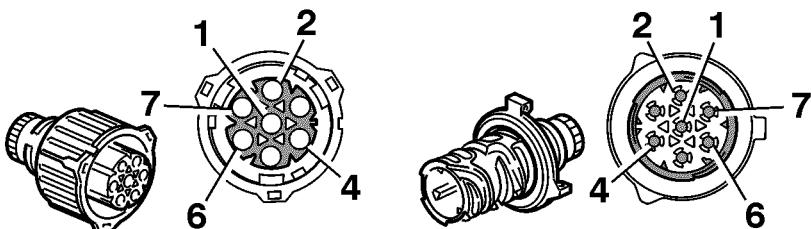

T3020295

Pin no:	Circuit function	Wiring no:	Diagram
1	Ground	1	GC:1 E
2	Rear direction indicator left	3025	GC:1 C
3	Brake light left	3021	GC:1 C
4	Position light rear left	3023	GC:1 C
5	Reverse light rear left	3019	GC:1 C
6	Rear fog light left	3042	GC:1 C
7	Reverse Warning	3067	GC:1 C

XC354

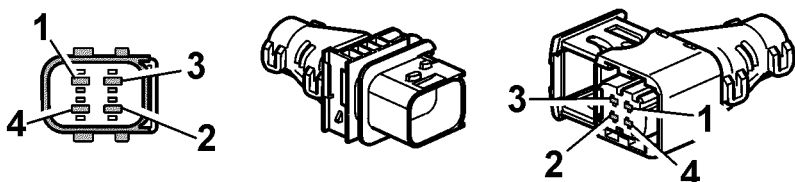

T3071144

Pin no:	Circuit function	Wiring no:	Diagram
1	Steering angle sensor supply	2087	FL:1 C
2	Steering angle sensor rear ground	1042	FL:1 C
3	Steering angle sensor rear signal 1	0139	FL:1 C
4	Steering angle sensor rear signal 2	0140	FL:1 C

XC355

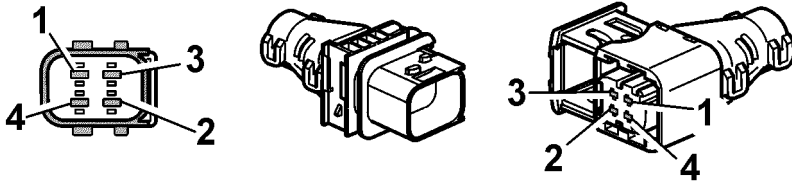

T3071144

Pin no:	Circuit function	Wiring no:	Diagram
1	LIN battery sensor	7127	AA:0 D
2	ACM power supply	2019	AA:3 A
3	Main switch status	0004	AB:2 B

XC356

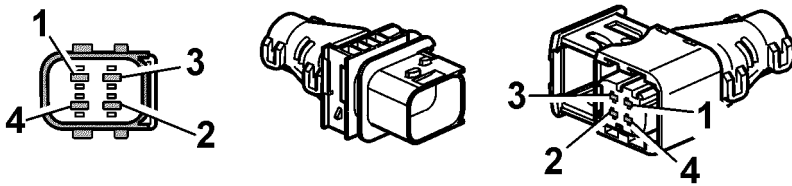

T3071144

Pin no:	Circuit function	Wiring no:	Diagram
1	EAS rear angle sensor supply	2153	FO:2 C
2	EAS rear angle sensor ground	1066	FO:2 C
3	Steering angle sensor rear signal 1	0227	FO:2 C
4	Steering angle sensor rear signal 2	0228	FO:2 C

XC358

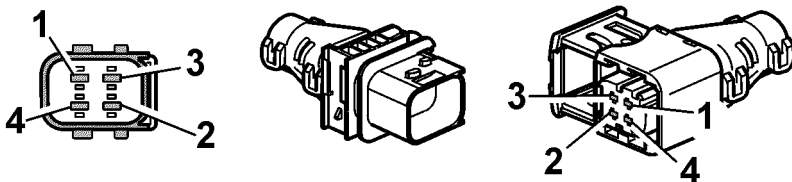

T3071144

Pin no:	Circuit function	Wiring no:	Diagram
1	Side reverse working lamp power supply	8060	NE:1 B
3	Ground	1	NE:1 C

XC359

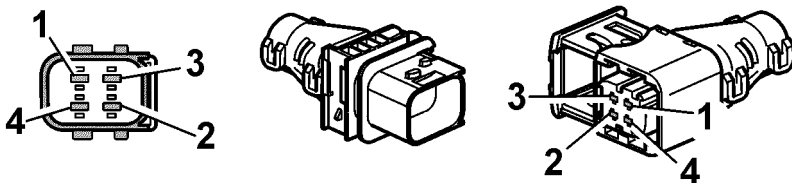

T3071144

Pin no:	Circuit function	Wiring no:	Diagram
1	ECS level sensor ground 2	1039	FB:0 C

2	ECS Rear Level Sensor signal 1	0125	FB:0 C
3	ECS rear level sensor supply 2	2082	FB:0 C

List of components

A01	FRC, (Fuse and Relay Centre) (1000/1100)	A36	Control unit, BBM (Body Builder Module) (NA:1 C/NK:1 A/ND2:1 A) (1000)
A02P	Fuse holder, 6–fuses, bodybuilder (ND:2 B/NK:0 B/ND2:0 B) (BBEC)	A41	Component group transmission. Contains B23, B138 and Y17 (DA1:3 C/DC1:3 C) (3020)
A02X	Fuse holder, 6–fuses, bodybuilder (ND:3 B) (BBEC)	A41B	Component group transmission. Contains B23, B138 and Y17 (DM:1 C)
A02Y	Fuse holder, 6–fuses, bodybuilder (NK:2 C) (BBEC)	A42B	Component group transmission. Contains B26, Y21, Y22, Y23 and Y26 (DC1:1 D) (3010)
A03	Instrument (BA:2 B) (1000)		
A04A	Refrigerator (IF:2 C) (1110/1140)	A43	Electric fan control (B32 fan speed sensor, Y35 visco clutch) (CB:0 D) (3000)
A06D	El. adjustable seat (optional fan and heat) (IT:1 B/SL:1 D) (1000)	A44	Fuel filter bracket (B51 fuel pressure sensor, M15 priming pump) (CB:2 B) (3000)
A06P	El. adjustable seat (optional fan and heat) (IT:3 B) (1000)	A45	Fuel conditioner (B52 water level sensor, R10 heater, Y38 water drain solenoid) (CB:1 B) (3000)
A07	Control unit, Audio (IK:0 B) (1100)		
A09	Telephone (BU:4 B)	A48	TV (IN:1 C) (1110)
A12A	Control unit, ABS (Anti-lock Brake System) (EA:0 B) (2090)	A116	Control unit, amplifier (IL:1 B) (1140)
A13A	Control unit, TECU (Transmission ECU) (DC1:1 C) (3010)	A122	Control unit , toll collect OBU (BX:0 C) (1100)
A14	Control unit, ECM (Engine Control Module) (CB:0 C) (3000)	A123	Control unit toll collect DSRC (BX:0 D) (1100)
A15	Control unit, SRS (Supplementary Restrain System) (PE:1 B) (1000)	A124	Component group engine (K65 power relay, starter motor pre-relay M04 starter motor) (CB:0 D)
A21	Control unit, EBS (Electronic Brake System) (EE:0 B/EI:0 A/FL:0 B/GK:0 A/GL:0 A/GN:3 A) (2010)	A125	Control unit, TGW (Telematics Gateway) (BU:2 B) (1100)
A26	Control unit, DACU (Driver Assistance Control Unit) (PA:0 B) (1000)	A132	Control unit, alcolock (PH:1 D) (1000)
A28B	Control unit, ADR main switch (AD:0 B/AE:2 B) (2020)	A133	Handset, alcolock (PH:2 D) (1000)
A31	Control unit, burglar alarm (RA:0 B) (1000)	A155	Display, SID Low (IO:2 B) (1000)
A33	Tachograph (BC:1 B) (1100)	A156	Display, SID High (IO:3 B) (1000)
A34B	Control unit, climate unit (HA:1 B) (1000)	A157	Power Recliner, Bunk (IF:4 B) (1140)
		A160	Control unit, CIOM Cab IO Module (BG:0 C/IP:3 B/SK:0 A) (1000)

A161	Control unit, HMIOM Human Machine Interface IO Module (BA:1 C/SL:1 A) (1000)	A186	Control unit, PCCU (Parking Cooler Control Unit) (HB:1 B) (2010)
A162	Control unit, FCIOM Front Chassis IO Module (GA:0 B/GB:0 A/GP:3 B/HE:0 B/IC:0 A/IP:1 B) (2000)	A187	Control unit, VMCU, Vehicle Master Control Unit (AF:2 C/BE:0 B/IB:0 A/IC:2 A/NB:0 C/NK:4 A/ND2:0 A) (1000)
A163	Control unit, CCIOM Central Chassis IO Module (AB:0 B/CE:3 B/DA:0 A/DG:0 A/EI:2 A/FA:0 A/FB:0 A/FH:1 A/GK:3 A/GL:2 A/GN:2 A/HE:2 B/NC:0 A) (2010)	A188	FM signal splitter (BU:1 B) (1100)
A164	Control unit, RCIOM Rear Chassis IO Module (DG:3 A/EA:4 B/FB:2 A/FC:0 A/FD:1 A/FM:0 A/FQ:1 A/GC:0 B/GE:0 A/GK:1 A/GL:1 A/GN:1 A) (2040)	A190	Component group Adblue (CL:1 D) (2030)
A165L	Control unit, DDM/PDM, Drive/Passenger Door Module (IR:0 C) (1150)	A192	Control unit, EAS, (Extra Axle Steering) (FO:0 B) (2040)
A165R	Control unit, DDM/PDM, Drive/Passenger Door Module (IS:0 C) (1150)	B02B	Thermostat, parking heater (1140)
A168	Control unit, LECM High, (Living Environment Control Module) (HA:0 C) (1140)	B03	Sensor, footbrake valve (EE:0 D) (1160)
A169	Control unit, VS (Video Switch) (IO:0 C) (1000)	B04	Sensor, engine speed, crankshaft (CB:1 D) (3000)
A170	Control panel, climate (HA:1 D) (1000)	B05	Sensor, engine speed, camshaft (CB:1 D) (3000)
A173	HCU, Hand Control Unit, Electrical Park Brake (FE:1 B) (1000)	B07	Sensor, fuel level (DG:0 C) (2010)
A174	Control unit, ACM (Aftertreatment Control Module) (CE:0 B/CF:0 A/CF_AUS:0 A/CN:0 B/CO:0 A/DK:1 A) (2010)	B09B	Sensor, oil temperature, gearbox (DA1:1 C) (3010)
A174B	Control unit, ACM (Aftertreatment Control Module) (CK:0 B/CL:0 A/CO:0A/DM:1 A)	B12	Sensor, tachograph/speedometer (DA1:0 C/DC1:0 C) (3010)
A175	Control unit, TESP, (Telematics Service Platform) (BU:0 B) (1100)	B13A	Sensor, wheel speed, lhs. 1:st front axle (EA:0 D) (2010)
A176	Control unit, LPOS, Lane Position Object Sensor (PB:1 B) (1100)	B13B	Sensor, wheel speed, lhs. 1:st front axle (EF:1 D/EF:3 D) (2010)
A177	Control unit, APM, (Air Production Modulator) (FE:0 C) (2010)	B14A	Sensor, wheel speed, rhs. 1:st front axle (EA:1 D) (2010)
A179L	Control unit, FAS, (Front Axle Steering) left (FI:1 B) (2010)	B14B	Sensor, wheel speed, rhs. 1:st front axle (EF:1 D/EF:3 D) (2010)
A179R	Control unit, FAS, (Front Axle Steering) right (FI:2 B)	B15A	Sensor, wheel speed, lhs. 1:st driven rear axle (EA:2 D) (2090)
A185	Electric AC Compressor, EACC, parking cooler (HB:2 D) (2010)	B15B	Sensor, wheel speed, lhs. 1:st driven rear axle (EG:2 D/EG:1 D) (2090)
		B16A	Sensor, wheel speed, rhs. 1:st driven rear axle (EA:2 D) (2090)
		B16B	Sensor, wheel speed, rhs. 1:st driven rear axle (EG:3 D/EG:1 D) (2090)

B17	Sensor, wheel speed, lhs. 2:nd driven rear axle (EG:3 D/EG:1 D) (2090)	B42A	Sensor, brake lining wear indicator, lhs. 1:st driven rear axle (EG:2 D) (2090)
B18	Sensor, wheel speed, rhs. 2:nd driven rear axle (EG:4 D/EG:2 D) (2090)	B42B	Sensor, brake lining wear indicator, lhs. 1:st driven rear axle (EG:0 D) (2090)
B19	Sensor, wheel speed, lhs. 2:nd front axle (EF:1 D) (2010)	B43A	Sensor, brake lining wear indicator, rhs. 1:st driven rear axle (EG:2 D) (2090)
B20	Sensor, wheel speed, rhs. 2:nd front axle (EF:2 D) (2010)	B43B	Sensor, brake lining wear indicator, rhs. 1:st driven rear axle (EG:0 D) (2090)
B21	Sensor, coolant temperature, engine (CB:1 B) (3000)	B44B	Sensor, brake lining wear indicator, lhs. 2:nd driven rear axle (EG:3 D/EG:0 D) (2090)
B22	Sensor, outdoor temperature (HE:0 D) (2000)	B45B	Sensor, brake lining wear indicator, rhs. 2:nd driven rear axle (EG:3 D/EG:1 D) (2090)
B23A	Sensor, oil temperature, retarder (DA1:3 C/DC1:3 C)	B46B	Sensor, brake lining wear indicator, lhs. 2:nd front axle (EF:0 D) (2010)
B24A	Sensor, air pressure, bogie lift bellow (FC:3 D) (2080)	B47B	Sensor, brake lining wear indicator, rhs. 2:nd front axle (EF:1 D) (2010)
B25	Sensor, accelerator pedal (BE:1 D) (1000)	B49	Sensor, steering angle (EE:3 D) (1000)
B28	Sensor, chassis level, front axle (FB:0 C) (2010)	B49R	Sensor, steering angle, rear (FL:1 D) (2100)
B28L	Sensor, chassis level, front axle left (FB:0 D) (2010)	B50	Sensor, yaw-rate (EE:3 D) (2010)
B28R	Sensor, chassis level, front axle right (FB:0 D) (2010)	B51	Sensor, fuel pressure (CB:2 B) (3000)
B29B	Sensor, chassis level, lhs. rear axle (FB:2 D/FQ:1 C) (2080)	B52	Sensor, water level (Included in A45) (CB:2 B)
B30	Sensor, chassis level, rhs. rear axle (FB:2 D) (2080)	B54	Sensor, crank case pressure (CB:1 B) (3000)
B32	Sensor, engine cooling fan speed (Included in A43) (CB:0 D)	B56L	Sensor, air pressure, suspension bellows, front axle left (FA:1 D) (2010)
B37	Sensor, boost pressure and boost temperature (CB:1 D) (3000)	B56R	Sensor, air pressure, suspension bellows, front axle right (FA:1 D) (2010)
B39	Sensor, air filter pressure and air filter temperature (CB:1 B) (3000)	B57	Sensor, air pressure, suspension bellows, lhs. rear (FD:1 D) (2080)
B40B	Sensor, brake lining wear indicator, lhs. 1:st front axle (EF:0 D/EF:3 D) (2010)	B58	Sensor, air pressure, suspension bellows, rhs. rear (FD:1 D) (2080)
B41B	Sensor, brake lining wear indicator, rhs. 1:st front axle (EF:0 D/EF:3 D) (2010)	B60LD	Loudspeaker, left door (IK:1 D/IL:1 E) (1150)
		B60LF	Loudspeaker, left front (IK:1 D/IL:2 D) (1000)

B60LR	Loudspeaker, left rear (IK:2 D/IL:2 E) (1140)	B91	Receiver, movement sensor (Included in B242) (RA:2 D)
B60RD	Loudspeaker, right door (IK:2 D/IL:1 D) (1150)	B96A	Sensor, NOx (CE1:2 C/CK1:2 C) (2030)
B60RF	Loudspeaker, left front (IK:2 D/IL:3 D) (1000)	B96B	Sensor, NOx (CE1:3 C/CK1:3 C) (2030)
B60RR	Loudspeaker, right rear (IK:2 D/IL:2 D) (1140)	B97	Sensor, exhaust temp, upstream catalyst (CE1:1 C/CK1:0 C) (2030)
B61L	Loudspeaker, treble left (IK:1 D/IL:2 D) (1000)	B98	Sensor, exhaust temp, downstream catalyst (CE1:1 C/CK1:0 C) (2030)
B61R	Loudspeaker, treble right (IK:1 D/IL:3 D) (1000)	B102	Sensor, oil temperature (CB:3 D) (3000)
B63	Microphone, (handsfree) (IK:3 A) (1100)	B115	Sensor, DPF pressure (CE1:0 C/CK1:0 C) (2030)
B66	Sensor, EGR temperature (CB:3 D) (3000)	B118	Sensor, oil pressure (CB:1 B) (3000)
B67	Rear view camera (IO:0 D)	B119	Sensor, oil level and oil temp (CB:1 D) (3000)
B69	Sensor, coolant temperature, retarder (DA1:3 B/DC1:3 B) (3020)	B138	Sensor, Control pressure retarder (Included in A41) (DA1:3 C/DC1:3 C)
B70	Sensor, wheel speed, lhs., pusher axle (EH:1 C) (2090)	B142	Sensor, AdBlue level and temperature (CF:3 C/CF_AUS:3 C) (2030)
B71	Sensor, wheel speed, rhs., pusher axle (EH:1 C) (2090)	B142B	Sensor, AdBlue level and temperature (CL:2 D) (2030)
B72	Sensor, wheel speed, lhs., tag axle (EH:2 C) (2090)	B184	Loudspeaker, subwofer (IL:3 C) (1140)
B73	Sensor, wheel speed, rhs., tag axle (EH:2 C) (2090)	B187	AT/AHI fuel pressure (CB:3 B) (3000)
B74B	Sensor, brake lining wear indicator, lhs., pusher axle (EH:0 C) (2090)	B207	Sensor, oil cooling jet pressure (CB:3 B) (3000)
B75B	Sensor, brake lining wear indicator, rhs., pusher axle (EH:0 C) (2090)	B213	Sensor, pressure, butterfly valve back-pressure (CB:4 B) (3000)
B76B	Sensor, brake lining wear indicator, lhs., tag axle (EH:1 C) (2090)	B234	Sensor, 5th wheel (NC:1 D) (2040)
B77B	Sensor, brake lining wear indicator, rhs., tag axle (EH:2 C) (2090)	B236	Sensor, Defog (HA:3 D) (1100)
B85	Sensor, exhaust temp, downstream DPF (CE1:0 C/CK1:1 C) (2030)	B237	Sensor, Brake pressure (EA:3 D) (2040)
B90	Transmitter, movement sensor (Included in B242) (RA:2 D)	B238	Sensor, FLS (Forward Looking Sensor) (PA:0 C) (2000)
		B240	Sensor, Sun sensor (HA:2 D) (1000)
		B242	Ultrasonic Intrusion Protection (UIP) (RA:2 D) (1110)
		B243	Sensor, rain (GP:2 C) (1000)

B244	Sensor, Cab temperature (HA:2 D) (1000)	E02R_PL	Lamp, dipped beams (NK:2 D)
B245A	Camera, accessory (IO:1 D)	E06	Lamp, reversing light (GC:1 D/GC:2 D) (2070)
B245B	Camera, accessory (IO:1 D)	E08L_PL	Lamp, parking light, front (NK:1 D)
B245C	Camera, accessory (IO:2 D)	E08R_PL	Lamp, parking light, front (NK:3 D)
B246	Sensor, Side sensor (PA:2 D) (1140)	E09	Lamp, brake light (GC:1 D/GC:2 D) (2070)
B247	Sensor, AdBlue quality sensor (CF:3 D/CO:3 C)	E10	Lamp, tail light (GC:1 D/GC:2 D) (2070)
B248	Sensor, pressure, pusher air suspension (FC:2 D) (2080)	E11LC	Lamp, side marker light, (GE:0 C) (2050)
B249	Sensor, Washer fluid level (GP:3 D) (2000)	E11LF	Lamp, side marker light (GE:0 C) (2050)
B250	Sensor, Battery (AA:0 D) (2020)	E11LR	Lamp, side marker light (GE:2 C) (2050)
B253	Transmitter, Burglar Alarm (Included in B242) (RA:3 D)	E11LR2	Lamp, side marker light (GE:2 C)
B262	Sensor, Adblue pressure (CL:2 D) (2030)	E11LW	Lamp, side marker light (GE:1 C) (2050)
B263	Sensor, Adblue air pressure (CL:3 D) (2030)	E11RC	Lamp, side marker light (GE:1 C) (2050)
B267	Sensor, steering angle, EAS (Extra Axle Steering) (FO:2 D) (2100)	E11RF	Lamp, side marker light (GE:0 C) (2050)
B271	Microphone, TGW2 (BU:3 D)	E11RR	Lamp, side marker light (GE:2 C) (2050)
BB1	Connector, Chassis Body Builder 1 (ND:2 D/ND2:1 C) (2120)	E11RR2	Lamp, side marker light (GE:3 C)
BB2	Connector, Chassis Body Builder 2 (ND:0 D/ND2:2 C) (2120)	E11RW	Lamp, side marker light (GE:2 C) (2050)
BB3	Connector, Chassis Body Builder 3 (ND:1 D/ND2:3 C) (2120)	E13	Lamp, direction indicator (GC:1 D) (2070)
BBEC1	Connector, Body Builder Electrical Center 1 (GK:2 A/GL:2 A/ND:0 B/ND:3 D/NE:0 A/ND2:0 B) (1000)	E13L	Lamp, direction indicator (GA:0 C) (2000)
BBEC2	Connector, Body Builder Electrical Center 2 (ND:0 D/ND2:1 C) (1000)	E13L_PL	Lamp, direction indicator (NK:1 D)
BBEC3	Connector, Body Builder Electrical Center 3 (ND1:0 C)	E13R	Lamp, direction indicator (GB:0 C) (2000)
E01L_PL	Lamp, full beams (NK:2 D)	E13R_PL	Lamp, direction indicator (NK:3 D)
E01R_PL	Lamp, full beams (NK:3 D)	E16L	Lamp, instep light (IC:2 D) (1150)
E02L_PL	Lamp, dipped beams (NK:2 D)	E16R	Lamp, instep light (IC:3 D) (1150)
		E21	Lamp, rear fog light (GC:1 D/GC:2 D) (2070)
		E23L	Lamp, luggage compartment illumination (IB:1 C) (1140)
		E23R	Lamp, luggage compartment illumination (IB:1 C) (1140)

E27L	Tail lamp module (GC:1 D) (2070)	E98R	Auxiliary unit, right (GB:1 C) (2000)
E27R	Tail lamp module (GC:2 C) (2070)	E106	Lamp, interior light, ambient light, catwalk (IA:0 C/IA:0 C) (1100)
E29C	Lamp, identification light (GF:2 E) (1100)	E108	Lamp, interior light, ambient light, center stack (IB:0 C) (1000)
E29C_H1	Lamp, identification light (GF:3 E) (1110)	E109L	Lamp, door trim list, light guides (IC:2 D) (1150)
E29L	Lamp, identification light (GF:2 E) (1100)	E109R	Lamp, door trim list, light guides (IC:3 D) (1150)
E29L_H1	Lamp, identification light (GF:4 E) (1110)	E110	Lamp, interior light, cup holder light (IF:0 C) (1000)
E29R	Lamp, identification light (GF:2 E) (1100)	E111	LED module, forward collision warning (PA:2 A) (1000)
E29R_H1	Lamp, identification light (GF:3 E) (1110)	E113L	Lamp, interior light, storage light, rear shelf (IB:3 C) (1110)
E39	Lamp, Licence Plate Illumination (GC:2 D) (2070)	E113LC	Lamp, interior light, storage light, rear shelf (IB:3 C) (1110)
E83L	Headlight module (GA:2 C) (2000)	E113R	Lamp, interior light, storage light, rear shelf (IB:4 C) (1110)
E83R	Headlight module (GB:2 C) (2000)	E113RC	Lamp, interior light, storage light, rear shelf (IB:4 C) (1110)
E85L	Lamp, interior light, roof (IA:1 C) (1110)	E119L	Lamp, instep light (IC:1 C) (1160)
E85R	Lamp, interior light, roof (IA:1 C) (1110)	E119R	Lamp, instep light (IC:1 C) (1160)
E86	Lamp, interior light, bed light, side walls (IB:2 D/IB:2 D) (1140)	E126L	Lamp, interior light, catwalk reading light (IA:3 D) (1100)
E86A	Lamp, interior light, bed light, side walls (IB:3 D) (1110)	E126R	Lamp, interior light, catwalk reading light (IA:3 D) (1100)
E88	Lamp, interior light, snake lamp (IA:4 C/IA:4 C) (1100)	E127A	Parking heater, air (HD:1 C) (1140)
E90	Lamp, interior light, map/reading light, midsection (IA:1 D) (1100)	E128	Parking heater, water (HC:1 C) (2010)
E93C	Lamp, interior light, storage light, front shelf (IA:2 D) (1100)	E129L	Lamp, door warning lamp (IR:1 D) (1150)
E93L	Lamp, interior light, storage light, front shelf (IA:2 D) (1100)	E129R	Lamp, door warning lamp (IS:1 D) (1150)
E93R	Lamp, interior light, storage light, front shelf (IA:2 D) (1100)	EL0L	Lamp, full beam, inside sign area, roof (NF:4 C) (1110)
E94L_EMB	Lamp, position light, EMB (GF:0 E) (1110)	EL0R	Lamp, full beam, inside sign area, roof (NF:4 C) (1110)
E94L_EOM	Lamp, position light, EOM (GF:0 D)	EL2LF	Lamp, side/reverse working light (NE:2 C) (2125)
E94R_EMB	Lamp, position light, EMB (GF:1 E) (1110)		
E94R_EOM	Lamp, position light, EOM (GF:1 D)		
E98L	Auxiliary unit, left (GA:1 C) (2000)		

EL2LR	Lamp, side/reverse working light (NE:1 C) (2125)	H06	Siren (RA:3 D) (2000)
EL2RF	Lamp, side/reverse working light (NE:2 C) (2125)	JUMPER	(AA:2 C) (2020)
EL2RR	Lamp, side/reverse working light (NE:1 C) (2125)	K02	Relay, refrigerator (IF:2 A)
EL3AL	Lamp, cab/body working light (NE:3 D)	K03	Relay, sunroof motor 2 (IU:1 B)
EL3AR	Lamp, cab/body working light (NE:4 D)	K04	Relay, sunroof motor 1(IU:0 B)
EL3L	Lamp, cab/body working light (NE:3 D) (1110/1140)	K05	Relay, front wiper on/off (GP:0 B)
EL3R	Lamp, cab/body working light (NE:3 D) (1110/1140)	K06	Relay, front wiper low/high (GP:0 B)
EL4LF	Lamp, beacon warning lamp, roof (NF:1 C) (1110)	K07	Relay, body builder electrical centre, power supply 2 (ND:2 A/ND1:3 B)
EL4LR	Lamp, beacon warning lamp, roof (NF:1 D) (1110)	K08	Relay, accessories (IF:3 A)
EL4RF	Lamp, beacon warning lamp, roof (NF:2 C) (1110)	K09	Relay, engine running (IT:0 A)
EL4RR	Lamp, beacon warning lamp, roof (NF:2 D) (1110)	K10	Relay, body builder electrical centre, extra spot lamps (NF:0 A)
EL5L	Lamp, roof light sign (NF:3 D) (1100)	K11	Relay, power supply 4 (IF:3 A/IG:2 A)
EL5R	Lamp, roof light sign (NF:3 D) (1100)	K12	Relay, roof light sign (NF:3 A)
EL6	Lamp, extra spot, front (NE:2 C) (1160)	K13	Relay, beacon warning lamps (NF:1 A)
EL7	Lamp, 5th wheel/load light (NC:3 C/GN:2 B) (2010)	K14	Relay, power supply 3 (IF:1 A)
FMS	Connector, FMS, Fleet Management Systems (BX:2 D) (1000)	K15	Relay, full beam inside sign area (NF:4 A)
G01A	Battery (AA:1 D/AE:1 B) (2020)	K16	Relay, headlight washer pump (GP:1 B)
G01B	Battery (AA:1 D/AE:1 B) (2020)	K17	Relay, TECU (DC:0 A)
G02	Alternator (AA:3 D) (3000)	K20	Relay, BB ignition (ND:3 A)
GIC020	Engine interface (CA:0 D/CB:0 A) (3000)	K21	Relay, mirror heating (IR:1 A/IS:1 A)
H01	Horn, air-operated (IP:1 D) (2000)	K22	Relay, ignition (BX:2 A)
H02	Horn (IP:1 D) (2000)	K24	Relay, seats movement (IT:3 A)
H03	Reverse warner, acoustic (GC:3 D) (2070)	K27	Relay, EMS (Engine Management System) (CA:3 A)
		K28	Relay, cab tilt pump (KA:1 A)
		K30	Relay, taillift enable/crane (ND:2 C)
		K31	Relay, extra spot lamp front EL6 (NE:0 B)
		K32	Relay, side reverse working lamp EL2 (NE:1 B)

K33	Relay, cab/body working lamp EL3 (NE:3 B)	M13	Motor, coolant pump, parking heater (HE:2 D)
K34	Relay, Japan mirror Motor (IQ:0 B)	M14	Motor, central lubrication pump (LA:0 C) (2040)
K35	Relay, Japan mirror Switch (IQ:1 B)	M15	Motor, electrical fuel pump (CB:2 B) (3000)
K48	Power relay, engine preheating (AA:2 D/ CB:1 B) (3000)	M17	Motor, foldable rearview mirror arm, Japan (IQ:0 C) (1150)
K52A	Power relay, FLL motor 1 (BG:1 B) (1000)	M43	Motor, sun visor, front (IU:2 C) (1100)
K52B	Power relay, FLL motor 2 (BG:1 B) (1000)	M44L	Motor, window lift with antipinch (IR:0 D) (1150)
K65	Relay, starter motor (CB:0 D) (3000)	M44R	Motor, window lift with antipinch (IS:0 D) (1150)
K69	Relay, fuel heater (HF:1 C) (1000)	M45L	Motor, window lift without antipinch (IR:2 D) (1150)
K70A	Relay, ADR/SLP (AE:1 B) (2020)	M45R	Motor, window lift without antipinch (IS:2 D) (1150)
K70B	Relay, ADR/SLP (AE:1 C) (2020)	M48	Motor, front lid lock (BG:1 B) (1160)
K71	Relay, audio switch telematics, L+ (BU:1 D) (1100)	M49	Adblue pump module (CF:1 D/CF_AUS:2 D/CO:1 C) (2030)
K90	Relay, (NK:2 B)	M50	Motor, ESCL (Electrical Steering Column Lock) (BG:2 C) (1000)
K91	Relay, (NK:3 B)	M51	Motor, sun roof, unit (IU:1 C) (1110)
K92	Relay, (NK:4 B)	M55	Condensor fan, parking cooler (HB:1 C) (1160)
K95	Relay, microwave oven (IF:3 C) (1100)	M73	Motor, AdBlue dosage pump (CL:4 D) (2030)
K96	Relay (ND2:3 B)	OBD	Connector, OBD, (On-Board Diagnostics) (XA:1 C) (1000)
M01	Motor, windscreen wiper (GP:0 C) (1160)	R01	Heater, engine preheat (AA:3 D/CB:0 A) (3000)
M02	Motor, windscreen washer pump (GP:3 D) (2000)	R02J	Mirror, Japan Foldable (IQ:2 C) (1150)
M03	Motor, headlamp high pressure washer pump (GP:1 C) (2000)	R02L	Heater, rear-view mirror (IR:1 B) (1150)
M04	Motor, starter motor (AA:2 D/CB:0 D) (3000)	R02R	Heater, rear-view mirror (IS:1 B) (1150)
M05	Motor, hydraulic bogie lift pump unit (FQ:1 C) (2080)	R04	Cigarette lighter (IF:0 C) (1000)
M09L	Motor, door lock (IR:2 D) (1150)	R10	Heater, fuel pre filter (Included in A45) (CB:3 B)
M09R	Motor, door lock (IS:2 D) (1150)		
M11	Motor, cab tilt pump (KA:1 C) (2000)		
M11_RHD	Motor, cab tilt pump (KA:1 C) (2000)		

R11	Heater, coffee maker (IF:3 D) (1140)	S46	Pressure switch, bogie lift indicator, NO. (FQ:2 D) (2080)
R14	Termination resistor (PA:3 C/PA:3 E)	S47	Position switch, low split indicator, NO. (DA1:2 C) (3010)
R14B	Termination resistor (PH:3 B)		
R23	Heater, AdBlue hose, red (CF:0 D/CO:0 C) (2030)	S49	Position switch, reverse lamps, NO. (DA1:2 C) (3010)
R46	Heater, fuel hose, thermoline (HF:1 D) (2010)	S52L	Proximity switch, cab lock, NO. (KA:3 C) (1140)
R55	Microwave oven (IF:3 C)	S52R	Proximity switch, cab lock, NO. (KA:3 D) (1140)
R56	Heater, AdBlue hose, white (CF:0 D/CO:0 C) (2030)	S55	Thermal switch (HE:2 C)
R56A	Heater, AdBlue hose, yellow (CL:0 D) (2030)	S57L	Position switch, luggage compartment lighting, NC. (IB:1 D) (1140)
R57	Heater, AdBlue hose, black (CF:0 D/CO:0 D) (2030)	S57R	Position switch, luggage compartment lighting, NC. (IB:1 D) (1140)
R57A	Heater, AdBlue hose, black (CL:0 D) (2030)	S58	Position switch, clutch pedal, NO. (BE:2 D) (1000)
S02	Stalk switch, full-/dipped beam, direction indicator (see S275) (1000)	S60A	Pressure switch, oil, power steering, NC. (FH:1 C) (2010)
S06	Stalk switch, windscreen wiper (see S275) (1000)	S60A_RHD	Pressure switch, oil, power steering, NC. (FH:2 C)
S14	Switch, push button, horn (IP:3 D) (1000)	S60B	Pressure switch, oil, power steering, NC. (FH:1 C) (2010)
S15	Switch, key switch (AF:1 B) (1000)	S60B_RHD	Pressure switch, oil, power steering, NC. (FH:2 C)
S24	Stalk switch, retarder (see S275) (1000)		
S26B	Switch, cab tilt pump, chassis (KA:2 C) (1160)	S63	Position switch, low range gear (DA1:2 C) (3010)
S36L	Switch unit, door functions (IR:2 B) (1150)	S68	Proximity switch, coolant level (CB:2 B) (3000)
S36R	Switch unit, door functions (IS:2 C) (1150)	S70	Position switch, flow sensor, power-steering, NC. (FH:1 C) (2010)
S38	Switch, ADR, emergency switch, cab (AD:3 A) (1000)	S70_RHD	Position switch, flow sensor, power-steering, NC. (FH:3 C)
S39	Switch, ADR, emergency switch, exterior (AD:3 C) (1140)	S77	Switch, emergency call (BU:3 D) (1000)
S45	Position switch, differential gear lock indicator, rear wheels (DG:3 C) (2070)	S80	Position switch, front hatch (RA:1 D) (1160)
S45R	Position switch, differential gear lock indicator, rear wheels (DG:3 C) (2070)	S86	Switch, foldable rearview mirror arm, Japan (IQ:1 C)

S95	Switch, Panic alarm (RA:1 B) (1000)	S258	Switch, flexible panel 1 (SK:0 C) (1100)
S101	Switch, position switch, gear box neutral position (DA1:1 C) (3010)	S259	Switch, flexible panel B(SK:4 D) (1140)
S169	Switch, battery main switch (AC:1 C) (2020)	S260	Switch, flexible panel 2 (SK:0 D) (1100)
S171	Switch, GLU (Gearlever unit (1000)	S262	Switch, flexible panel 7 (SK:2 B) (1000)
S222C	Switch, interior light, storage, front shelf (IA:2 C) (1100)	S263	Switch, flexible panel 3 (SK:1 B) (1000)
S222DS	Switch, interior light, storage, front shelf (IA:2 C) (1100)	S265	Switch, flexible panel 4 (SK:1 C) (1000)
S222PS	Switch, interior light, storage, front shelf (IA:2 C) (1100)	S267	Switch, flexible panel 5 (SK:1 D) (1000)
S227	Switch, fuel heater, thermoline (HF:1 B) (1000/1100)	S269	Switch, flexible panel 6 (SK:1 D) (1000)
S238	Switch, sun visor, front (IU:2 C) (1100)	S270	Switch, flexible panel 8 (SK:2 C) (1000)
S243	Switch 1, body builder electrical centre (ND1:0 B)	S271	Switch, flexible panel 9 (SK:2 B) (1000)
S243A	Switch 1, body builder electrical centre (ND:0 B)	S272	Switch, ILCP, Interior Light Control Panel (SK:0 B) (1100)
S244	Switch 2, body builder electrical centre (ND:0 B)	S275	Stalk module, on steering column (connected to S02, S06 and S24) (SL:2 D) (1000)
S244A	Switch 2, body builder electrical centre (ND1:0 B)	S283L	Switch, interior light, storage, rear shelf (IB:3 C) (1110)
S245	Switch 3, body builder electrical centre (ND:0 B)	S283LC	Switch, interior light, storage, rear shelf (IB:3 C) (1110)
S245A	Switch 3, body builder electrical centre (ND1:1 B)	S283R	Switch, interior light, storage, rear shelf (IB:4 C) (1110)
S246	Switch 4, body builder electrical centre (ND:1 B)	S283RC	Switch, interior light, storage, rear shelf (IB:4 C) (1110)
S246A	Switch 4, body builder electrical centre (ND1:2 B)	S285	Steering wheel switch module (SL:1 D) (1000)
S247	Switch, identification lights (GF:3 B) (1100)	S287	Switch unit, ECS, wired remote control (SK:4 B) (1000)
S254	Switch, battery main switch (AC:1 C) (2010)	S295	Switch unit, ECS, dash GSU (Gear Shift Unit) (SL:2 D) (1000)
S255	Exterior light control panel (SK:2 C) (1000)	U01	Modulator, EBS, front FAA20 (EF:0 B) (2010)
S257	SID control panel (SL:2 D) (1000)	U03A	Modulator, EBS, one rear driven axle (EG:2 B) (2090)
		U03B	Modulator, EBS, two rear driven axles (EG:0 B) (2090)

U03C	Modulator, EBS, rear axle (EG:3 B) (2090)	X02R	Trailer connection, ABS/EBS, Rigid (GN:3 E)
U04	Modulator, EBS, pusher axle (EH:0 B) (2090)	X02T	Trailer connection, ABS/EBS, Tractor (GN:3 E)
U05	Modulator, EBS, trailer (EI:0 D) (2010)	X02_2	Connector, trailer ABS/EBS 7-pin (GL:0 D) (2010)
U07	Modulator, EBS, tag axle (EH:1 B) (2090)	X03	Trailer connection, 15-pole unit (GK:1 D) (2060)
U08	Modulator, EBS, front FAA10 (EF:3 B) (2010)	X03_2	Connector, trailer 15-pin (GL:1 D) (2010)
U10	Voltage converter, 12V ABS Trailer (GN:0 C) (2010)	X04	Trailer connection, 7-pole unit, 24 N (GK:3 D) (2060)
U29	Voltage converter (IG:3 C) (1100)	X05	Trailer connection, 7-pole unit, 24 S (GK:3 D) (2060)
U30	Voltage converter (IG:0 C) (1000)		
U33	Voltage converter (IG:2 C) (1100)	X07A	Socket, 12V (IG:1 D) (1000)
V03	Diode (FQ:2 C) (2080)	X24	Socket, 12V Accessories power supply (IG:1 D)
V04	Diode (FQ:2 C) (2080)	X25	Connector, B+ frame (AA:2 B/GN:0 B)
V07	LED, indicator, Alarm (RA:1 B) (1100)	X51	Plug, 12V Trailer connector (GN:1 E)
V32	LED, indicator, LCS (Lane Change Support) (PA:3 C) (1100)	X54	Connector, Engine (B+) power (AA:2 D) (3000)
W02	Antenna, immobiliser (BG:0 D) (1000)	X55	Plug, start aid (AA:1 C) (2020)
W06	Antenna, GSM (BU:3 B)	X63	Trailer connection, VBG 14 (GM:1 C) (2060)
W14	Antenna, GSM/GPS (BU:3 A)		
W15	Antenna, module (BU:3 B)	X66	Connector, USB, Audio (IK:0 C) (1000)
W16	Antenna, FM (BU:1 A)	X67	Connector, USB, AUX (IK:2 A) (1000)
W17	Antenna, GSM, toll collect (BX:1 C)	X105	Socket, 24V outlet (IF:1 C) (1000)
W18	Antenna, GPS, toll collect (BX:1 C)	X106	Socket, 24V outlet (IF:1 C) (1140)
W20	Antenna, module (IN:2 B)	X114	Socket, connector, CB supply (IG:2 D/IG:3 D) (1100)
W21	Antenna, WLAN, Wireless Local Area Network (BU:3 A)	X115A	Contact reel, airbag (IP:2 C/PE:1 C/SL:0 B) (1000)
WRC	Connector, WRG, Wireless Remote Control (FB:3 C) (1100)	X115B	Contact reel, without airbag (IP:3 C/SL:2 B) (1000)
X02	Trailer connection, ABS/EBS (GK:0 D) (2060)	X167	Connector, Tipper prep kit 1 (ND2:1 D)
		X168	Connector, Tipper prep kit 2 (ND2:1 D)

X169	Connector, Tipper prep kit 3 (ND2:1 E)	Y13	Solenoid valve unit, ABS, lhs. rear (EA:2 D) (2090)
X170	Connector, Tipper prep kit 4 (ND2:1 D)	Y14	Solenoid valve unit, ABS, rhs. rear (EA:2 D) (2090)
X171	Connector, Tipper prep kit 5 (ND2:2 D)	Y17	Solenoid valve, retarder (Included in A41) (DA1:3 C/DC1:3 C)
X172	Connector, Tipper prep kit 6 (ND2:3 D)	Y18A	Solenoid valve, PTO (Power Take Off) (NC:2 C) (2010)
X173	Connector, Tipper prep kit 7 (ND2:3 D)	Y18B	Solenoid valve, PTO (Power Take Off) (NC:2 C) (2010)
X174	Connector, Tipper prep kit 8 (ND2:3 D)	Y31	Solenoid valve, area inhibitor (DA1:1 C) (3010)
X176	Connector, Tipper prep kit 9 (ND2:3 D)	Y32A	Fuel dosing pump, parking heater (HC:1 D) (2010)
X177	Connector, Tipper prep kit 10 (ND2:4 D)	Y33	Solenoid valve, UI (Unit Injectors) (CB:3 D) (3000)
X180	Trailer connection, 7-pole, Tractor (GN:4 E)	Y34	Actuator, EGR system (CB:0 D) (3000)
XC205	Cab passthrough, B+ (AA:1 B) (1000)	Y35	Actuator, EGR system (Included in A43) (CB:0 B)
XC302	Connector, GIC020, engine interface (AA:3 D/CA:0 D/CA1:1 D/HE:3 B) (2010/3000)	Y37	Solenoid valve unit, AVU (Air Valve Unit) (CB:2 B) (3000)
XC303	Connector, GIC021, transmission interface (BC:1 D/DA:0 C/DC:0 C/DK:1 D/DM:1 C/NC:2 D) (2010/3010)	Y37A	Solenoid valve unit, AVU (Air Valve Unit) (CB:3 B) (3000)
XC312	Connector, GIC128, muffler interface (CE:0 D/CK:0 D) (2010/2030)	Y37B	Solenoid valve unit, AVU2 (Air Valve Unit) (CB:2 B) (3000)
Y02	Solenoid valve, differential lock, rear wheels (DG:4 C) (2010)	Y38	Solenoid valve, WIF, fuel pre filter water draining (Included in A45) (CB:1 B)
Y03	Solenoid valve, differential lock, inter axles, rear (DG:3 C) (2010)	Y39	Solenoid valve, VCB (CB:3 B) (3000)
Y05	Solenoid valve, bogie lift (FQ:2 C) (2080)	Y40	Solenoid valve unit, front axle, air suspension (FA:2 D) (2010)
Y06	Solenoid valve, range inhibitor (DA1:1 C) (3010)	Y42	Clutch, magnetic, air conditioning compressor (HE:3 C) (3000)
Y10	Solenoid valve, 3:rd axle lock (FM:2 C) (2080)	Y43DS	Seat belt tensioner, pyrotechnical (PE:2 D) (1000)
Y11	Solenoid valve unit, ABS, lhs. front (EE:1 D) (2010)	Y43PS	Seat belt tensioner, pyrotechnical (PE:2 D) (1000)
Y11_A	Solenoid valve unit, ABS, lhs. front (EA:1 D) (2010)	Y44	Air-bag, pyrotechnical (PE:1 D) (1000)
Y12	Solenoid valve unit, ABS, rhs. front (EE:1 D) (2010)	Y53	Control valve block , RAS (FL:2 D) (2100)
Y12_A	Solenoid valve unit, ABS, rhs. front (EA:1 D) (2010)		

Y72	Solenoid valve, Airhorn (IP:1 D) (1160)
Y80	Solenoid valve, AdBlue dosing unit (CE1:1 C) (2030)
Y81	Solenoid valve, AdBlue tank heating (CF:1 D/CO:1 C) (2030)
Y81C	Solenoid valve, AdBlue tank heating (CL:1 D) (2030)
Y102	Solenoid valve, 5th wheel slide (NC:0 C)
Y103	AHI (CB:0 B) (3000)
Y109	Electro clutch, coolant pump (CB:2 B) (3000)
Y110	Solenoid valve, oil thermostat (CB:2 B) (3000)
Y111	Solenoid valve, oil piston cooling jet (CB:2 B) (3000)
Y114	Throttle (CB:1 D) (3000)
Y134B	Solenoid valve, ETB (Electrical Trailer Brake) (EI:3 C) (2010)
Y135	Solenoid valve unit (FD:2 D) (2080)
Y136	Solenoid valve unit (FC:2 D) (2080)
Y137	Mega valve unit (FC:0 D) (2080)
Y154	Control valve block, EAS (Extra Axle Steering) (FO:2 D) (Y154)

Abbreviations

ABS	Antilock brake system	FAA10	1 front axle, non driven
ACTST-TO	Active steering, torque overlay	FAA20	2 front axle, non driven
ADR1	ADR adaptation, 1 switch	FAS	Front axle steering
ADR2	ADR adaptation, 2 switches	FMS.....	Fleet management system
ADR3	ADR adaptation, for safe loading pass (SLP)	FRC.....	Fuse and relay center
ADTP-BC	Ad-blue tank position right, below cab	FSI-DWIS.....	Front suspension installation, double wish bone
ADTP-L	Ad-blue tank position left	FSS-LEAF.....	Leaf suspension, front
ADTP-LF	Ad-blue tank position left, front	GSS-AGS.....	Automatic gear shifting system (I-shift)
ADTP-M	Ad-blue tank position mid	GSS-RC	Range gear shifting, cable manoeuvred
ADTP-MR.....	Ad-blue tank position mid, right side	GSS-SRC.....	Split and range gear shifting, cable manoeuvred
ADTP-R.....	Ad-blue tank position right2	GSS-4BS	Four button gear selector
AUXSW4.....	Wiring for four AUX switches	IPC	Integrated parking cooler
BBEC	Body builder electrical center	L	Left
BBM	Body builder module	LF	Left front
BBOX-EF	Battery box, end of frame	LHD.....	Left hand drive
BBOX-L.....	Battery box, left hand side	LHS	Left hand side
BSYS-CON.....	Brake system, conventional	LR.....	Left rear
CHH-LOW.....	Chassis height low	MAINSWI	Electromechanical main switch
CPC-ADV.....	Cab parking cooler, advanced	MAINSW-M.....	Mechanical main switch
DACU.....	Driver assistance control unit	MSWI-A.....	Main switch, ADR
DS	Driver side	MSWI-B.....	Main switch, circuit shutdown (timer)
EAS	Extra axle steering	MSWI-C	Main switch, chassis controlled circuit shutdown
EASP5	Exhaust aftertreatment system RH chassis 70 cm X-DIR	MSWI-R	Main switch, remote controlled circuit shutdown
EASP7	Exhaust aftertreatment system RH chassis 50 cm X-DIR + back of cab	ODB	On Board Diagnostic
EBS	Electronic brake system	PH-CAB	Cab parking heater
EM-EC01	European community 2001 level EURO 3	PH-ENGCA.....	Engine and cab parking heater
EM-EC06	European community 2006 level EURO 4	PS	Passenger side
EM-EU5	Engine emission control, EURO 5	PSS-DUAL.....	Power steering system dual
EM-EU6	Engine emission control, EURO 6	PTO.....	Power take off
EML4.....	Emission level, early introduction stages	R.....	Right
ENG-VE13.....	Volvo engine 13 litre	RAD-L90	Rear axle installation, 1 axle, 1 driven, 2 leaf, 90 mm
ENG-VE16.....	Volvo engine 16 litre	RAD-GR.....	Rear axle installation, 1 axle, 1 driven, air (GRAS) suspension
EPB	Electrical park brake	RADD-BR.....	Rear axle installation, 2 axle, 2 driven, leaf, B-ride

RADD-GR.....	Rear axle installation, 2 axle, 2 driven, air (GRAS) suspension	TIS-BAS.....	Transport information system, Logger and Positioning
RADD-TR1.....	Rear axle installation, 2 axle, 2 driven, leaf narrow	TIS-HIGH.....	Transport information system, Logg. Pos. and Adv. message system
RADD-TR2.....	Rear axle installation, 2 axle, 2 driven, leaf wide	TIS-MED.....	Transport information system, Logg. Pos. and message
RADDT-GR.....	Rear axle installation, 3 axle, 2 driven, air (GRAS) suspension, tag	TRACTOR.....	Semi-trailer tractor
RAPDD-GR.....	Rear axle installation, 3 axle, 2 driven, air (GRAS) suspension, pusher	TREL7-7.....	Trailer connectors 2x7-pole unit
RAPDT-GR.....	Rear axle installation, 3 axle, 1 driven, air (GRAS) suspension, pusher, low end	TREL14.....	Trailer connectors 14-pole unit
RADT-AR.....	Rear axle installation, 2 axle, 1 driven, 2 leaf, A-ride, tag	UADR.....	Without ADR adaptation
RADT-GR.....	Rear axle installation, 2 axle, 1 driven, air (GRAS) suspension, tag	UMAINSWI.....	Without main switch
RAPD-GR.....	Rear axle installation, 2 axle, 1 driven, air (GRAS) suspension, pusher	URETARD.....	Without retarder
RAL17.....	Rear axle load 17 tonnes	UTRBRAKE.....	Without trailer brake valve
RAL21.....	Rear axle load 21 tonnes		
RAL23.....	Rear axle load 23 tonnes		
RAL26.....	Rear axle load 26 tonnes		
RAL33.....	Rear axle load 33 tonnes		
RF.....	Right front		
RHD.....	Right hand drive		
RHS.....	Right hand side		
RIGID.....	Platform or tipper truck		
RR.....	Right rear		
RSTS-EHY.....	Rear steering system, electrical controlled, hydraulic		
SCR.....	Selective Catalyst Reduction		
SI-GRAF.....	Tachograph		
SI-GRAFR.....	Tachograph		
SI-SPEED.....	Speedometer		
SPEED-DU.....	Dual speed limiter		
SRS.....	Supplementary restrain system		
STWPOS-L.....	Steering wheel position left hand side		
STWPOS-R.....	Steering wheel position right hand side		
TECU.....	Transmission electronic control unit		

Cable colour code

BK.....	Black
BN.....	Brown
BU.....	Blue
GN.....	Green
GY.....	Grey
OG.....	Orange
PK.....	Pink
RD.....	Red
VT.....	Violet
WH.....	White
YE.....	Yellow

Alternative cable colour code (engine and transmission)

BL.....	Blue
BN.....	Brown
GN.....	Green
GR.....	Grey
OR.....	Orange
P.....	Pink
R.....	Red
SB.....	Black
VO.....	Violet
W.....	White
Y.....	Yellow

Note: If a wire have two colours, this is written out like the following example: YE/RD = Yellow/Red.

Feedback

One of our objectives is that workshop personnel should have access to correct and appropriate service manuals where it concerns fault tracing, repairs and maintenance of Volvo vehicles.

In order to maintain the high standards of our service information, your opinions and experiences when using this information would be greatly appreciated.

If you have any comments or suggestions, use "Argus dealer" or send them to us using the email address below.

VPCS technical team
Smalleheerweg 29
BE-9041 Gent
Belgium
technical.team@volvo.com
Fax +32 9 2556767

VOLVO TRUCKS. DRIVING PROGRESS

VOLVO

Volvo Truck Corporation
www.volvotrucks.com