

CEAM019604

# Operation & Maintenance Manual

# 930E-4

**DUMP TRUCK**

SERIAL NUMBERS **A30601 - A30692**

**KOMATSU**<sup>®</sup>



This material is proprietary to Komatsu America Corp (KAC), and is not to be reproduced, used, or disclosed except in accordance with written authorization from KAC.

It is the policy of the Company to improve products whenever it is possible and practical to do so. The Company reserves the right to make changes or add improvements at any time without incurring any obligation to install such changes on products sold previously.

Because of continuous research and development, periodic revisions may be made to this publication. Customers should contact their local Komatsu distributor for information on the latest revision.

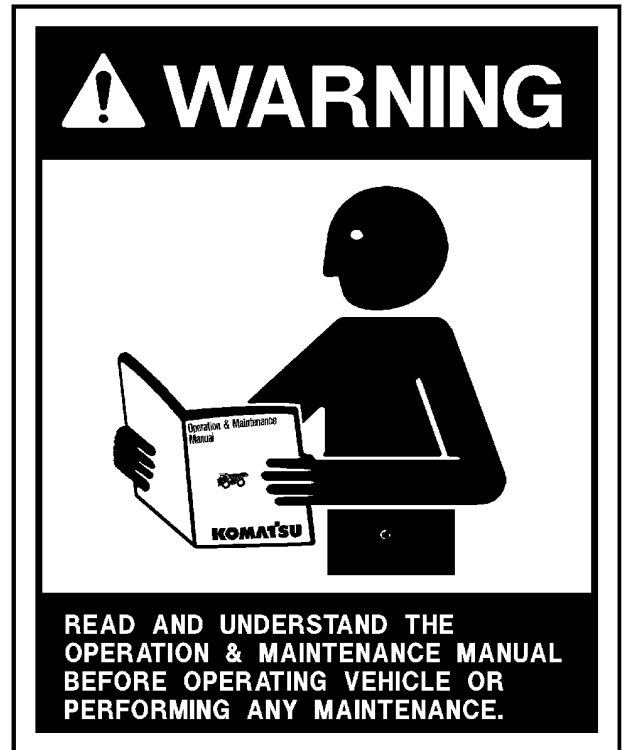

*Unsafe use of this machine may cause serious injury or death. Operators and maintenance personnel must read and understand this manual before operating or maintaining this machine.*

*This manual should be kept in or near the machine for reference, and periodically reviewed by all personnel who will come into contact with it.*

**CALIFORNIA  
Proposition 65 Warning**

*Diesel engine exhaust, some of its constituents, and certain vehicle components contain or emit chemicals known to the State of California to cause cancer, birth defects or other reproductive harm.*

**CALIFORNIA  
Proposition 65 Warning**

*Battery posts, terminals and related accessories contain lead and lead compounds, chemicals known to the State of California to cause cancer and birth defects or other reproductive harm. Wash hands after handling.*

**CALIFORNIA  
Proposition 65 Warning**

*Mercury and mercury compounds are known to the State of California to cause developmental problems. This machine may be equipped with optional HID lamps which contain mercury. There is no risk of exposure unless the lamps are broken. However, the lamps must be reused, recycled or properly disposed of in accordance with Local, State and Federal Laws at the end of their useful lives.*



### **NON-OEM PARTS IN CRITICAL SYSTEMS**

***For safety reasons, Komatsu America Corp. strongly recommends against the use of non-OEM replacement parts in critical systems of all Komatsu equipment. Critical systems include but are not limited to steering, braking and operator safety systems.***

***Replacement parts manufactured and supplied by unauthorized sources may not be designed, manufactured or assembled to Komatsu's design specifications; accordingly, use of such parts may compromise the safe operation of Komatsu products and place the operator and others in danger should the part fail.***

***Komatsu is also aware of repair companies that will rework or modify an OEM part for reuse in critical systems. Komatsu does not generally authorize such repairs or modifications for the same reasons as noted above.***

***Use of non-OEM parts places full responsibility for the safe performance of the Komatsu product on the supplier and user. Komatsu will not in any case accept responsibility for the failure or performance of non-OEM parts in its products, including any damages or personal injury resulting from such use.***

## INTRODUCTION

### FOREWORD

This manual is written for use by the operator and/or the service technician. It is designed to help these persons to become fully knowledgeable of the truck and all of its systems in order to keep it operating safely and efficiently. All operators and maintenance personnel should read and understand the information in this manual before operating the truck or performing maintenance and/or operational checks on the truck. All safety notices, warnings, and cautions should be understood and followed when operating the truck or performing repairs on the truck.

A product identification plate is located on the frame in front of the right side front wheel. It designates the Truck Model Number, Product Identification Number (vehicle serial number), and Maximum GVW (Gross Vehicle Weight) rating.

The KOMATSU truck model designation consists of three numbers and one letter (i.e. 930E).

The three numbers represent the basic truck model.

The letter "M", when present, designates a Mechanical drive system.

The letter "E", when present, designates an Electrical wheel motor drive system.

The Product Identification Number (vehicle serial number) contains information which identifies the original manufacturing bill of material for this unit. This complete number will be necessary for proper ordering of many service parts and/or warranty consideration.

The Gross Vehicle Weight (GVW) is what determines the load on the drive train, frame, tires, and other components. The vehicle design and application guidelines are sensitive to the maximum GVW.

GVW is *total weight*: **empty vehicle weight + fuel & lubricants + payload.**

To determine the *allowable payload*, fill all lubricants to the proper level and fill the fuel tank of an empty truck (which includes all accessories, body liners, tailgates, etc.), and then weigh the truck. Record this value and subtract it from the GVW. The result is the allowable payload.

*NOTE: Accumulations of mud, frozen material, etc, become part of the GVW and reduces the allowable payload. To maximize payload and to keep from exceeding the maximum GVW rating, these accumulations should be removed as often as practical.*

Exceeding the allowable payload will reduce the expected life of truck components.

### **▲WARNING**

**Unsafe use of this machine may cause serious injury or death. Operators and maintenance personnel must read this manual before operating or maintaining this machine. This manual should be kept in or near the machine for reference and periodically reviewed by all personnel who come in contact with it.**

## TRUCK MODEL ILLUSTRATION

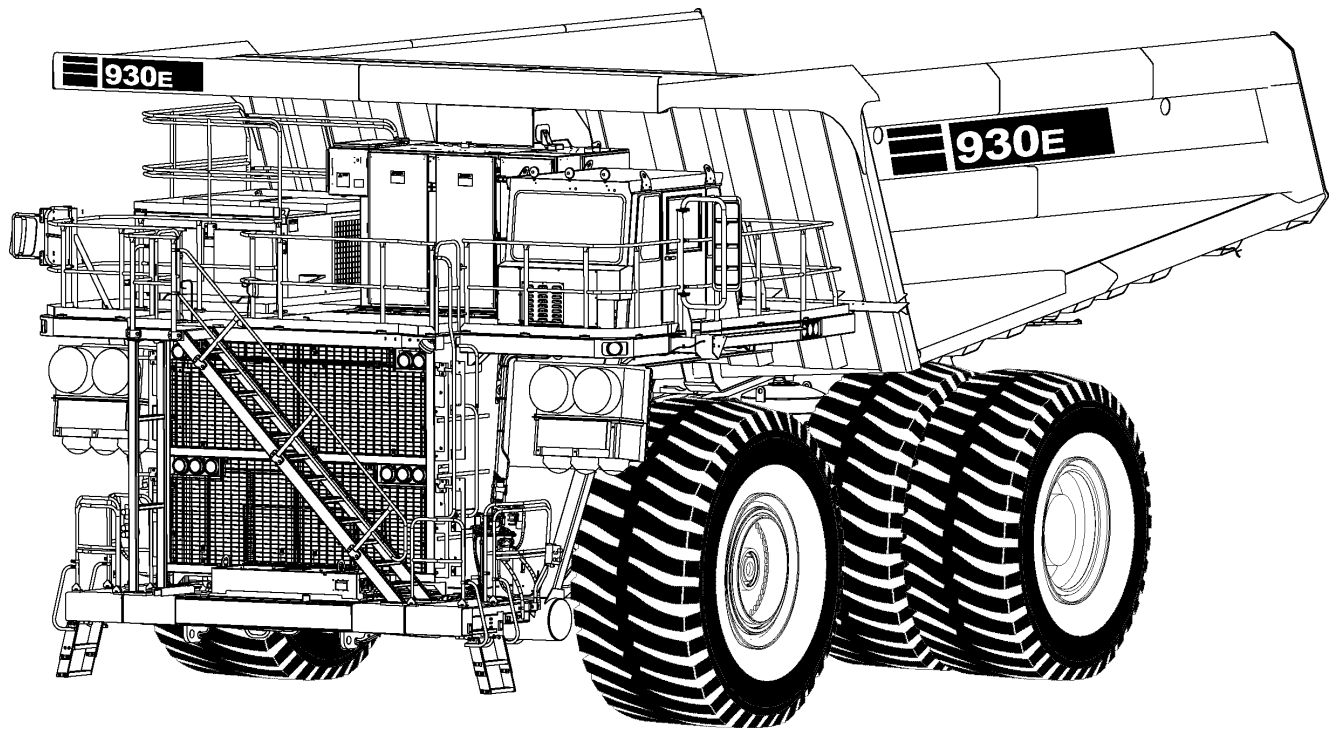

**KOMATSU MODEL 930E-4 DUMP TRUCK**

## ABOUT THIS MANUAL

The front cover of this manual includes a form number. This form number should be referenced when ordering additional copies of this manual or for any other correspondence regarding the coverage in this manual.

Direct all inquiries to:

Komatsu America Corp.  
Datakom, Peoria Technical Publications  
P.O. Box 240  
Peoria, IL 61650-0240  
(309)-672-7072 - FAX

This first section is an Introduction to the manual. It contains the Table of Contents for locating specific areas of interest. Other sections include:

- Torque Tables & Conversion Charts
- Safety
- Warnings and Cautions
- Operating Instructions
- Operator Cab and Controls
- Lubrication and Service
- Automatic Lubrication System
- Components & Specifications
- Payload Meter III
- AM/FM Radio / CD Player

When searching for a specific area of interest, go first to the Table of Contents to locate the section in which the subject might generally be included. Then, find a subject description that most closely describes the specific area of interest and go to that page. Section numbers and page numbers are located at the top, outside corner of the page.

At the top, inside corner of the page is a document (module) number. If there is ever a question regarding the information in a particular section, refer to the document (module) number, the manual form number, and use the address shown above to correspond. If there is a date (month/year) behind the document (module) number, that date indicates the latest revision date of that page.

The illustrations used in this manual are *TYPICAL* of the component shown and may not be an *exact* reproduction of what is found on the truck.

This manual shows dimensioning of U.S. standard and metric (SI) units throughout. All references to "right," "left," "front," or "rear" are made with respect to the operator's normal seated position unless specifically stated otherwise.

When assembly instructions are provided without references to specific torque values, standard torque values should be used. Standard torque values are shown in torque charts in the Standard Charts and Tables section in this manual and in the General Information section of the truck shop manual. Specific torques, when provided in the text, are in bold face type, such as **135 N•m (100 ft lb)**. All torque specifications have  $\pm 10\%$  tolerance unless otherwise specified.

## ALERTS PAGE



*This ALERT symbol is used in this manual, along with the signal words “CAUTION”, “DANGER” and “WARNING”, to alert the reader to hazards arising from improper operating and maintenance practices.*



*“DANGER” identifies a specific potential hazard  
WHICH WILL RESULT  
in either INJURY OR DEATH  
if proper precautions are not taken.*



*“WARNING” identifies a specific potential hazard  
WHICH MAY RESULT  
in either INJURY OR DEATH  
if proper precautions are not taken.*



*“CAUTION” is used for general reminders  
of proper safety practices  
OR  
to direct the reader’s attention to avoid unsafe  
or improper practices which may result  
in damage to the equipment.*



**TABLE OF CONTENTS**

<b>INTRODUCTION</b> .....	<b>10-1</b>
FOREWORD .....	10-1
TRUCK MODEL ILLUSTRATION .....	10-2
ABOUT THIS MANUAL .....	10-3
ALERTS PAGE .....	10-4
TABLE OF CONTENTS .....	10-5
<b>TORQUE TABLES AND CONVERSION CHARTS</b> .....	<b>12-1</b>
<b>SAFETY</b> .....	<b>20-1</b>
GENERAL .....	20-1
Safety Rules .....	20-1
Safety Features .....	20-1
Fire Extinguishers And First Aid Kits .....	20-1
Clothing And Personal Items .....	20-1
Leaving The Operator's Seat .....	20-2
Mounting And Dismounting .....	20-2
Fire Prevention For Fuel And Oil .....	20-2
Precautions With High Temperature Fluids .....	20-3
Asbestos Dust Hazard Prevention .....	20-3
Prevention Of Injury By Work Equipment .....	20-3
Unauthorized Modification .....	20-3
ROPS Precautions .....	20-3
Precautions For Attachments .....	20-4
Precautions For Starting The Truck .....	20-4
<b>PRECAUTIONS BEFORE OPERATION</b> .....	20-4
Safety At The Work Site .....	20-4
Fire Prevention .....	20-5
Ventilation In Enclosed Areas .....	20-5
Preparing For Operation .....	20-5
Mirrors, Windows, And Lights .....	20-5
In The Operator Cab (Before Starting The Engine) .....	20-5
Seat Belts .....	20-5
<b>OPERATING THE TRUCK</b> .....	20-6
When Starting The Engine .....	20-6
General Truck Operation .....	20-6
Ensuring Good Visibility .....	20-6
Traveling .....	20-7
Traveling In Reverse .....	20-7
Traveling On Slopes .....	20-7
Operating On Snow Or Ice .....	20-7
Avoid Damage To The Dump Body .....	20-7

## TABLE OF CONTENTS (cont.)

Driving Near High Voltage Cables .....	20-8
When Dumping .....	20-8
When Loading .....	20-8
Working On Loose Ground .....	20-8
Parking The Truck .....	20-8
Towing .....	20-8
WORKING NEAR BATTERIES .....	20-9
Battery Hazard Prevention .....	20-9
Starting With Booster Cables .....	20-9
BEFORE PERFORMING MAINTENANCE .....	20-10
Stopping The Engine .....	20-10
Warning Tag .....	20-10
Proper Tools .....	20-10
Securing The Dump Body .....	20-10
WHILE PERFORMING MAINTENANCE .....	20-11
Keep The Truck Clean .....	20-11
Attachments .....	20-11
Working Under The Truck .....	20-11
Rotating Fan And Belts .....	20-11
Waste Materials .....	20-11
Adding Fuel Or Oil .....	20-12
Radiator Coolant Level .....	20-12
Use Of Lighting .....	20-12
Precautions With The Battery .....	20-12
Handling High Pressure Hoses .....	20-12
Precautions With High Pressure Oil .....	20-12
Performing Maintenance Near High Temperature Or High Pressure .....	20-12
TIRES .....	20-13
Handling Tires .....	20-13
Storing Tires After Removal .....	20-13
WHEN REPAIRS ARE NECESSARY .....	20-14
SPECIAL PRECAUTIONS FOR WORKING ON AC DRIVE TRUCKS .....	20-15
PRELIMINARY PROCEDURES BEFORE WELDING OR PERFORMING MAINTENANCE ...	20-15
ENGINE SHUTDOWN PROCEDURE BEFORE WELDING OR PERFORMING MAINTENANCE .....	20-15
CAPACITOR DISCHARGE SYSTEM .....	20-17
Necessary Tools .....	20-17
Warnings And Cautions .....	20-18
Manual DC Link Capacitor Discharge Procedure .....	20-19
Failure of the Discharge System .....	20-21
Manual Discharge of Capacitors .....	20-22
Short Isolated Capacitor Terminals .....	20-24
ADDITIONAL JOB SITE RULES .....	20-26

**TABLE OF CONTENTS (cont.)**

<b>WARNINGS AND CAUTIONS</b> .....	<b>22-1</b>
<b>OPERATING INSTRUCTIONS</b> .....	<b>30-1</b>
PREPARING FOR OPERATION .....	30-1
WALK AROUND INSPECTION .....	30-1
ENGINE START-UP .....	30-5
AFTER ENGINE START-UP .....	30-6
PRE-SHIFT BRAKE CHECK (IF EQUIPPED) .....	30-6
Operation .....	30-7
Performing The Brake Tests .....	30-8
EMERGENCY STEERING SYSTEM .....	30-10
Operation .....	30-10
Pre-Operation Testing .....	30-10
MACHINE OPERATION SAFETY PRECAUTIONS .....	30-11
OPERATING ON THE HAUL ROAD .....	30-12
STARTING ON A GRADE WITH A LOADED TRUCK .....	30-13
PASSING .....	30-13
LOADING .....	30-13
Overload Speed Limit Function .....	30-13
DUMPING .....	30-14
Raising The Dump Body .....	30-14
Lowering The Dump Body (when dumping on flat ground) .....	30-15
Lowering The Dump Body (when dumping over a berm or into a crusher) .....	30-15
TOWING .....	30-16
Special Wiring Harness .....	30-16
SAFE PARKING PROCEDURES .....	30-19
NORMAL ENGINE SHUTDOWN PROCEDURE .....	30-19
SUDDEN LOSS OF ENGINE POWER .....	30-20
FUEL DEPLETION .....	30-20
DISABLED TRUCK DUMPING PROCEDURE .....	30-21
Hookup .....	30-21
Raising the Body .....	30-21
Lowering the Body .....	30-21
RESERVE ENGINE OIL SYSTEM .....	30-22
Operation .....	30-22
Changing Oil .....	30-22
<b>OPERATOR CAB AND CONTROLS</b> .....	<b>32-1</b>
STEERING WHEEL AND CONTROLS .....	32-2
Horn Button .....	32-2
Tilt/Telescope Lever .....	32-2

## TABLE OF CONTENTS (cont.)

Multi-Function Turn Signal Switch .....	32-2
Turn Signal Operation .....	32-2
High Beam Headlight Operation .....	32-2
Windshield Wiper Operation .....	32-2
DYNAMIC RETARDING .....	32-3
Retarder Lever .....	32-3
Brake/Retarder Pedal .....	32-3
Throttle/Accelerator Pedal .....	32-3
GRADE/SPEED CHART .....	32-4
OVERHEAD PANEL AND DISPLAYS .....	32-5
Speakers .....	32-5
Warning Alarm Buzzer .....	32-5
Radio/CD Player .....	32-5
Warning Indicator Light Dimmer Control .....	32-5
Status/Warning Indicator Light Panel .....	32-5
Air Cleaner Restriction Gauges .....	32-5
CENTER CONSOLE .....	32-6
Direction Control Lever .....	32-6
Override/Fault Reset Switch .....	32-7
Engine Shutdown Switch .....	32-7
Window Control Switches .....	32-7
Hoist Control Lever .....	32-7
Retard Speed Control (RSC) Adjustment Dial .....	32-8
Retard Speed Control (RSC) Switch .....	32-8
Data Store Button .....	32-9
KOMTRAX Plus Snapshot In Progress Light .....	32-9
Link Energized Light .....	32-9
Service Engine Light .....	32-9
12V Auxiliary Power Outlets .....	32-9
DIAGNOSTIC PORTS .....	32-9
KOMTRAX Plus Diagnostic Port .....	32-9
Interface Module (IM) Diagnostic Port .....	32-9
Payload Meter Diagnostic Port .....	32-9
Truck Control Interface (TCI) Diagnostic Port .....	32-9
Propulsion System Controller (PSC) Diagnostic Port .....	32-9
Engine Diagnostic Port (CENSE) .....	32-9
Engine Diagnostic Port (QUANTUM) .....	32-9
OPERATOR'S SEAT .....	32-10
Seat Belts .....	32-10
Adjustment .....	32-10

**TABLE OF CONTENTS (cont.)**

HEATER / AIR CONDITIONER CONTROLS .....	32-11
Fan Speed Control Knob .....	32-11
Temperature Control Knob .....	32-11
Air Flow Directional Knob .....	32-11
Heater/Air Conditioner Vents .....	32-11
INSTRUMENT PANEL .....	32-12
Control Symbols .....	32-12
Key Switch .....	32-14
Air Conditioner Compressor Switch .....	32-14
Rotating Beacon Switch (optional) .....	32-14
Heated Mirror Switch (optional) .....	32-14
AC Drive System Rest Switch .....	32-14
Wheel Brake Lock Switch .....	32-15
Hazard Warning Light Switch .....	32-15
Heater/Air Conditioner Vents .....	32-15
Engine Oil Pressure Gauge .....	32-15
Right Turn Signal Indicator .....	32-15
Digital Tachometer .....	32-15
High Beam Indicator .....	32-15
Speedometer/Payload Meter Display .....	32-15
Left Turn Signal Indicator .....	32-16
Coolant Temperature Gauge .....	32-16
Lamp Check Switch .....	32-16
Light Switch (3-Way) .....	32-16
Ladder Light Switch .....	32-16
Backup Light Switch .....	32-16
Fog Light Switch .....	32-17
Payload Meter Switch .....	32-17
Panel Illumination Light Dimmer Switch .....	32-17
Hydraulic Oil Temperature Gauge .....	32-17
Engine Hourmeter .....	32-17
Fuel Gauge .....	32-17
OVERHEAD STATUS/WARNING INDICATORS .....	32-18
A1. High Brake Oil Temperature .....	32-19
B1. Low Steering Pressure .....	32-19
C1. Low Accumulator Precharge Pressure .....	32-20
D1. Not used .....	32-20
E1. Low Brake Pressure .....	32-20
A2. Low Hydraulic Tank Level .....	32-20
B2. Low Automatic Lubrication System Pressure .....	32-20
C2. Circuit Breaker Tripped .....	32-20
D2. Hydraulic Oil Filter Monitor .....	32-21
E2. Low Fuel .....	32-21

## TABLE OF CONTENTS (cont.)

A3. Parking Brake	32-21
B3. Service Brake	32-21
C3. Body Up	32-21
D3. Dynamic Retarding	32-21
E3. Stop Engine	32-21
A4. Cranking Motor Failure	32-22
B4. Backup Lights	32-22
C4. Engine Shutdown Timer	32-22
D4. Retard Speed Control (RSC) Indicator	32-22
E4. Check Engine	32-22
A5. No Power	32-22
B5. Propulsion System Warning	32-22
C5. Propulsion System Temperature	32-22
D5. System/Component Failure	32-23
E5. Battery Charging System Failure	32-23
A6. No Propel	32-23
B6. Propulsion System At Rest	32-23
C6. Propulsion System Not Ready	32-23
D6. Reduced Propulsion	32-23
E6. Retard At Continuous Level	32-23
REAR AXLE LIGHT BAR	32-24
Backup Lights	32-24
Retard Lights	32-24
Brake Lights	32-24
Backup Alarm	32-24
KOMTRAX PLUS	32-25
Operation	32-25
Interface Module	32-26
Basic Precautions	32-26
KOMATSU WIRELESS BRIDGE (Optional)	32-28
General Information	32-28
Communication Setup	32-28
Switching to the KWB_SETUP Network	32-28
Setting the Computer Subnet Mask and IP Address	32-29
Properties	32-29
Setting Up the KWB	32-30
Adding Encryption	32-30
Final Computer Settings	32-30
Data Downloading	32-31
Resetting the KWB	32-31
KWB Lights	32-31
FUSES AND CIRCUIT BREAKERS	32-32

**TABLE OF CONTENTS (cont.)**

<b>LUBRICATION AND SERVICE</b> .....	<b>40-1</b>
GENERAL .....	40-1
SERVICE CAPACITIES .....	40-1
HYDRAULIC TANK SERVICE .....	40-1
Adding Oil .....	40-1
COOLING SYSTEM SERVICE .....	40-2
Radiator Filling Procedure .....	40-2
Coolant Specifications .....	40-2
Unacceptable Practices .....	40-2
WHEEL MOTOR SERVICE .....	40-2
RESERVE OIL TANK SERVICE .....	40-3
Reserve Oil Tank Filling Procedure (Remote Fill) .....	40-3
QUICK FILL SERVICE CENTER .....	40-4
LUBRICATION CHART .....	40-5
10 HOUR (DAILY) INSPECTION .....	40-6
50 HOUR LUBRICATION AND MAINTENANCE CHECKS .....	40-8
100 HOUR LUBRICATION AND MAINTENANCE CHECKS .....	40-8
250 HOUR LUBRICATION AND MAINTENANCE CHECKS .....	40-8
500 HOUR LUBRICATION AND MAINTENANCE CHECKS .....	40-11
1000 HOUR LUBRICATION AND MAINTENANCE CHECKS .....	40-13
5000 HOUR MAINTENANCE CHECKS .....	40-13
 <b>AUTOMATIC LUBRICATION SYSTEM</b> .....	 <b>42-1</b>
GENERAL DESCRIPTION .....	42-1
SYSTEM COMPONENTS .....	42-3
Filter .....	42-3
Hydraulic Motor and Pump .....	42-3
Grease Reservoir .....	42-3
Pressure Reducing Valve .....	42-3
Flow Control Valve .....	42-3
Solenoid Valve .....	42-3
Vent Valve .....	42-3
Lubrication Cycle Timer .....	42-3
Over Pressure Cutoff Switch .....	42-3
Grease Pressure Failure Switch .....	42-3
Injectors .....	42-3
Relief Valve (Unloader Valve) .....	42-3
SYSTEM OPERATION .....	42-4
GENERAL INSTRUCTIONS .....	42-5
Required Lubricant .....	42-5
System Priming .....	42-5
Filter Assembly .....	42-5

## TABLE OF CONTENTS (cont.)

LUBRICANT PUMP .....	42-6
Pump Housing Oil Level .....	42-6
Pump Pressure Control .....	42-6
INJECTORS (SL-1 Series H) .....	42-7
Injector Specifications .....	42-7
Injector Adjustment .....	42-7
Injector Operation .....	42-8
PREVENTIVE MAINTENANCE PROCEDURES .....	42-9
Daily Lubrication System Inspection .....	42-9
250 Hour Inspection .....	42-9
1,000 Hour Inspection .....	42-9
SYSTEM CHECKOUT .....	42-10
Lubrication Controller Check .....	42-10
Lubrication Controller Components .....	42-10
Lubrication Controller Adjustment .....	42-10
SYSTEM TROUBLESHOOTING CHART .....	42-12
<b>COMPONENTS &amp; SPECIFICATIONS .....</b>	<b>50-1</b>
MAJOR COMPONENT DESCRIPTIONS .....	50-1
Truck And Engine .....	50-1
Main Alternator .....	50-1
AC Induction Traction Motorized Wheels .....	50-1
Suspension .....	50-1
Operator's Cab .....	50-1
Power Steering .....	50-1
Dynamic Retarding .....	50-1
Brake System .....	50-1
SPECIFICATIONS .....	50-3
Engine .....	50-3
AC Electric Drive System .....	50-3
Dynamic Retarding .....	50-3
Battery Electric System .....	50-3
Service Capacities .....	50-3
Hydraulic Systems .....	50-4
Service Brakes .....	50-4
Steering .....	50-4
Tires .....	50-4
Standard Dump Body Capacities And Dimensions .....	50-4
Weight Distribution .....	50-5
<b>PAYLOAD METER III™ .....</b>	<b>60-1</b>



**TABLE OF CONTENTS (cont.)**

<b>AM/FM RADIO / CD PLAYER</b> .....	<b>70-1</b>
OPERATING INSTRUCTIONS .....	70-1
GENERAL RADIO RECEIVER FUNCTIONS .....	70-1
Turning On the Power .....	70-1
One-Hour Timer .....	70-1
Display .....	70-2
Setting a Default Display .....	70-2
Adjusting the Brightness of the Display .....	70-2
Auxiliary Mode .....	70-2
Adjusting the Receiver Settings .....	70-2
USING THE CLOCK .....	70-3
Setting the Clock .....	70-3
USING THE ALARM .....	70-3
Setting the Alarm .....	70-3
Turning the Alarm Off .....	70-3
Activating Snooze .....	70-3
Setting Alarm Volume .....	70-3
USING THE RADIO .....	70-4
Finding a Station .....	70-4
Setting the Presets .....	70-4
USING THE WEATHERBAND .....	70-5
USING THE COMPACT DISC PLAYER .....	70-5
PLAYING AN MP3 DISC .....	70-6
TROUBLESHOOTING .....	70-8

---

# NOTES

## TORQUE TABLES AND CONVERSION CHARTS



This manual provides dual dimensioning for many specifications. Metric units are specified first, with U.S. standard units in parentheses. When torque values are not specified in the assembly instructions contained in this manual, use the standard torque value for the hardware being used. Standard value torque tables are contained in this chapter for metric and SAE hardware.

***References throughout the manual to standard torques or other standard values will be to one of the following tables. Do not use standard values to replace specific torque values in assembly instructions.***

*NOTE: This truck is assembled with both metric and SAE (U.S.) hardware. Reference the correct table when determining the proper torque value.*

For values not shown in any of the charts or tables, standard conversion factors for most commonly used measurements are provided in the following tables.

### INDEX OF TABLES

TABLE .....	Page
TABLE 1      Standard Tightening Torque For Metric Cap screws and Nuts .....	12-2
TABLE 2      Standard Tightening Torque For SAE Grade 5 & 8 Cap Screws and Nuts .....	12-3
TABLE 3      Standard Tightening Torque 12-Pt, Grade 9, Cap Screws (SAE) .....	12-4
TABLE 4      Tightening Torque for T-Bolt Type Hose Clamps. ....	12-5
TABLE 5      Standard Tightening Torque For Split Flange Clamp Bolts .....	12-5
TABLE 6      Tightening Torque For Flared Tube And Hose Fittings .....	12-5
TABLE 7      JIC 37° Swivel Nuts Torque Chart (SAE) .....	12-6
TABLE 8      Pipe Thread Torque Chart (SAE) .....	12-6
TABLE 9      O-Ring Boss Torque Chart (SAE) .....	12-7
TABLE 10     O-Ring Face Seal Torque Chart (SAE) .....	12-7
TABLE 11     Common Conversions Multipliers - Metric -to- English .....	12-8
TABLE 12     Common Conversions Multipliers - English -to- Metric .....	12-9
TABLE 13     Temperature Conversions. ....	12-10

### EFFECT OF SPECIAL LUBRICANTS On Fasteners and Standard Torque Values

The Komatsu engineering department does not recommend the use of special friction-reducing lubricants, such as Copper Coat, Never-Seez®, and other similar products, on the threads of standard fasteners where standard torque values are applied. The use of special friction-reducing lubricants will significantly alter the clamping force being applied to fasteners during the tightening process.

If special friction-reducing lubricants are used with the standard torque values listed in this chapter, excessive stress and possible breakage of the fasteners may result.

Where the torque tables specify “Lubricated Threads” for the standard torque values listed, these standard torque values are to be used with simple lithium base chassis grease (multi-purpose EP NLGI) or a rust-preventive grease (see below) on the threads and seats unless specified otherwise.

*NOTE: Ensure the threads of fasteners and tapped holes are free of burrs and other imperfections before assembling.*

#### Suggested\* Sources for Rust Preventive Grease:

- American Anti-Rust Grease #3-X from Standard Oil Company (also American Oil Co.)
- Gulf NoRust #3 from Gulf Oil Company.
- Mobilarma 355, Product No. 66705 from Mobil Oil Corporation.
- Rust Ban 326 from Humble Oil Company.
- Rustolene B Grease from Sinclair Oil Co.
- Rust Preventive Grease - Code 312 from the Southwest Grease and Oil Company.

*NOTE: This list represents the current engineering approved sources for use in Komatsu manufacture. It is not exclusive. Other products may meet the same specifications of this list.*

### STANDARD TIGHTENING TORQUES For Class 10.9 Cap screws & Class 10 Nuts

The following specifications apply to required assembly torques for all metric class 10.9 finished hexagon head cap screws and class 10 nuts.

- Cap screw threads and seats shall not be lubricated when assembled. These specifications are based on all cap screws, nuts, and hardened washers being phosphate and oil coated.

If zinc-plated hardware is used, each piece must be lubricated with simple lithium base chassis grease (multi-purpose EP NLGI) or a rust preventive grease (see list, this page) to achieve the same clamping forces provided below.

- Torques are calculated to give a clamping force of approximately 75% of proof load.
- The maximum torque tolerance shall be within  $\pm 10\%$  of the torque value shown.
- In the following table under “Cap Screw Size”, the first number represents the shank diameter (mm). The second number represents threads per millimeter.

Example: M20 x 2.25

M20 = shank diameter (20 mm)

2.25 = thread pitch in millimeters



Cap Screw Size	Torque N•m	Torque ft lb	Torque kg•m
M6 x1	12	9	1.22
M8 x 1.25	30	22	3.06
M10 x 1.5	55	40	5.61
M12 x 1.75	95	70	9.69
M14 x 2	155	114	15.81
M16 x 2	240	177	24.48
M20 x 2.25	465	343	47.43
M24 x 3	800	590	81.6
M30 x 3.5	1600	1180	163.2
M36 x 4	2750	2028	280.5

### STANDARD TIGHTENING TORQUES For SAE Grade 5 and Grade 8 Cap screws

The following specifications apply to required assembly torques for all grade 5 and grade 8 cap screws.

- Cap screw threads and seats shall be lubricated when assembled.

Unless instructions specifically recommend otherwise, these standard torque values are to be used with simple lithium base chassis grease (multi-purpose EP NLGI) or a rust- preventive grease (see list, previous page) on the threads.

- Torques are calculated to give a clamping force of approximately 75% of proof load.

- The maximum torque tolerance shall be  $\pm 10\%$  of the torque value shown.
- In the following table under Cap Screw Size, the first number represents the shank diameter (in.). The second number represents threads per inch.

Example: 7/16 - 20

7/16 = shank diameter (7/16 inch (0.438 inch))

20 = threads per inch

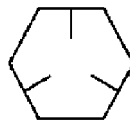

GRADE 5

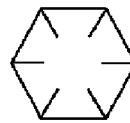

GRADE 8

TABLE 2.  
Standard Tightening Torque  
for SAE Hex Head Cap Screw And Nut Assembly

Cap Screw Size	Torque - Grade 5			Torque - Grade 8			Cap Screw Size	Torque - Grade 5			Torque - Grade 8		
	N-m	ft lb	kg-m	N-m	ft lb	kg-m		N-m	ft lb	kg-m	N-m	ft lb	kg-m
1/4-20	9.5	7	0.97	13.6	10	1.38	3/4-16	319	235	32.5	454	335	46.3
1/4-28	10.8	8	1.11	14.9	11	1.52	7/8-9	475	350	48.4	678	500	69.2
5/16-18	20.3	15	2.07	28	21	2.90	7/8-14	508	375	51.9	719	530	73.3
5/16-24	22	16	2.21	30	22	3.04	1.0-8	712	525	72.6	1017	750	103.7
3/8-16	34	25	3.46	47	35	4.84	1.0-12	759	560	77.4	1071	790	109.3
3/8-24	41	30	4.15	54	40	5.5	1.0-14	773	570	78.8	1085	800	110.6
7/16-14	54	40	5.5	79	58	8.0	1 1/8-7	881	650	89.9	1424	1050	145
7/16-20	61	45	6.2	84	62	8.57	1 1/8-12	949	700	96.8	1546	1140	158
1/2-13	88	65	9	122	90	12.4	1 1/4-7	1234	910	125.9	2007	1480	205
1/2-20	95	70	9.7	129	95	13.1	1 1/4-12	1322	975	134.8	2142	1580	219
9/16-12	122	90	12.4	169	125	17.3	1 3/8-6	1627	1200	166	2630	1940	268
9/16-18	129	95	13.1	183	135	18.7	1 3/8-12	1776	1310	181	2874	2120	293
5/8-11	169	125	17.3	237	175	24.2	1 1/2-6	2142	1580	219	3471	2560	354
5/8-18	183	135	18.7	258	190	26.2	1 1/2-12	2305	1700	235	3756	2770	383
3/4-10	298	220	30.4	420	310	42.8							

1 ft. lb. = 0.138 kg-m = 1.356 N.m

## STANDARD TIGHTENING TORQUES For SAE Grade 9 Cap screws

The following specifications apply to required assembly torques for all 12-point, grade 9 (170,000 psi minimum tensile), cap screws.

- Cap screw threads and seats shall be lubricated when assembled.

*Unless instructions specifically recommend otherwise, these standard torque values are to be used with simple lithium base chassis grease (multi-purpose EP NLGI) or a rust- preventive grease (see list, this page) on the threads.*

- Torques are calculated to give a clamping force of approximately 75% of proof load.
- The maximum torque tolerance shall be  $\pm 10\%$  of the torque value shown.

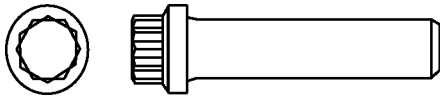

Cap Screw Size*	Torque N-m	Torque ft lb	Torque kg-m
0.250 - 20	16	12	1.7
0.312 - 18	33	24	3.3
0.375 - 16	57	42	5.8
0.438 -14	95	70	9.7
0.500 -13	142	105	14.5
0.562 - 12	203	150	20.7
0.625 - 11	278	205	28.3
0.750 - 10	488	360	49.7
0.875 - 9	780	575	79.4
1.000 - 8	1166	860	119
1.000 - 12	1240	915	126
1.125 - 7	1670	1230	170
1.125 - 12	1800	1330	184
1.250 - 7	2325	1715	237
1.250 - 12	2495	1840	254
1.375 - 6	3080	2270	313
1.375 - 12	3355	2475	342
1.500 - 6	4040	2980	411
1.500 - 12	4375	3225	445

\* Shank Diameter (in.) - Threads per inch

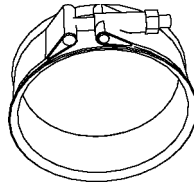

TABLE 4. Tightening Torque For T-Bolt Type Hose Clamp (SAE J1508 Type TB)			
Thread Size	Band Width	Newton meters (N·m)	Inch Pounds (in. lb)
0.25-28 UNF	19.05 mm (0.75 in.)	8.5 ± 0.6 N·m	75 ± 5 in lb

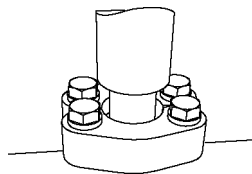

TABLE 5. Tightening Torque For Split Flange Clamp Bolts				
Cap Screw Thread Diameter (mm)	Width Across Flat (mm)	Newton meters (N·m) Tolerances ±10%	Foot Pounds (ft lb) Tolerances ±10%	Kilogram meters (kg·m) Tolerances ±10%
10	14	66	48	6.7
12	17	112	83	11.5
16	22	279	206	28.5

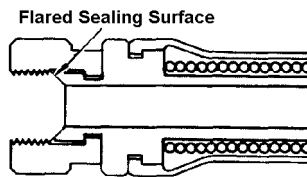
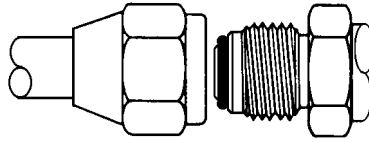
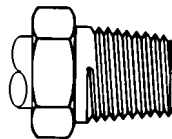

TABLE 6. Tightening Torque For Flared Tube And Hose Fittings				
Thread Diameter of Nut (mm)	Width Across Flat (mm)	Newton meters (N·m) Tolerances ±10%	Foot Pounds (ft lb) Tolerances ±10%	Kilogram meters (kg·m) Tolerances ±10%
14	19	25	18	2.5
18	24	50	36	5
22	27	80	58	8
24	32	140	101	14
30	36	175	130	18
33	41	195	145	20
36	46	245	180	25
42	55	295	215	30



**TABLE 7.**  
**Torque Chart For JIC 37° Swivel NutS**  
**With Or Without O-ring Seals**

Size Code	Tube Size (OD)	Threads UNF-2B	Newton meters (N·m)	Foot Pounds (ft lb)
- 2	0.125	0.312 - 24	5 ± 1	4 ± 1
- 3	0.188	0.375 - 24	11 ± 4	8 ± 3
- 4	0.250	0.438 - 20	16 ± 4	12 ± 3
- 5	0.312	0.500 - 20	20 ± 4	15 ± 3
- 6	0.375	0.562 - 18	24 ± 7	18 ± 5
- 8	0.500	0.750 - 16	40 ± 7	30 ± 5
- 10	0.625	0.875 - 14	54 ± 7	40 ± 5
- 12	0.750	1.062 - 12	75 ± 7	55 ± 5
- 14	0.875	1.188 - 12	88 ± 7	65 ± 5
- 16	1.000	1.312 - 12	108 ± 7	80 ± 5
- 20	1.250	1.625 - 12	136 ± 14	100 ± 10
- 24	1.500	1.875 - 12	163 ± 14	120 ± 10
- 32	2.000	2.500 - 12	312 ± 27	230 ± 20



**TABLE 8.**  
**Torque Chart For**  
**Pipe Thread Fittings**

Size Code	Pipe Thread Size	With Sealant N·m	With Sealant ft lb	Without Sealant N·m	Without Sealant ft lb
- 2	0.125 - 27	20 ± 4	15 ± 3	27 ± 7	20 ± 5
- 4	0.250 - 18	27 ± 7	20 ± 5	34 ± 7	25 ± 5
- 6	0.375 - 18	34 ± 7	25 ± 5	48 ± 7	35 ± 5
- 8	0.500 - 14	48 ± 7	35 ± 5	61 ± 7	45 ± 5
- 12	0.750 - 14	61 ± 7	45 ± 5	75 ± 7	55 ± 5
- 16	1.000 - 11.50	75 ± 7	55 ± 5	88 ± 7	65 ± 5
- 20	1.250 - 11.50	95 ± 7	70 ± 5	108 ± 7	80 ± 5
- 24	1.500 - 11.50	108 ± 7	80 ± 5	129 ± 14	95 ± 10
- 32	2.000 - 11.50	129 ± 14	95 ± 10	163 ± 14	120 ± 10



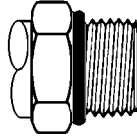

**TABLE 9.**  
Torque Chart For  
O-ring Boss Fittings

Size Code	Tube Size (OD)	Threads UNF-2B	Newton meters (N·m)	Foot Pounds (ft lb)
- 2	0.125	0.312 - 24	4 ± 3	4 ± 2
- 3	0.188	0.375 - 24	7 ± 3	5 ± 2
- 4	0.250	0.438 - 20	11 ± 4	8 ± 3
- 5	0.312	0.500 - 20	14 ± 4	10 ± 3
- 6	0.375	0.562 - 18	18 ± 4	13 ± 3
- 8	0.500	0.750 - 16	33 ± 7	24 ± 5
- 10	0.625	0.875 - 14	43 ± 7	32 ± 5
- 12	0.750	1.062 - 12	65 ± 7	48 ± 5
- 14	0.875	1.188 - 12	73 ± 7	54 ± 5
- 16	1.000	1.312 - 12	98 ± 7	72 ± 5
- 20	1.250	1.625 - 12	109 ± 7	80 ± 5
- 24	1.500	1.875 - 12	109 ± 7	80 ± 5
- 32	2.000	2.500 - 12	130 ± 14	96 ± 10

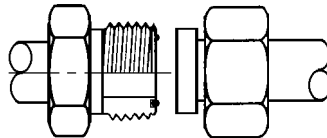

**TABLE 10.**  
Torque Chart For  
O-ring Face Seal Fittings

Size CodeE	Tube Size (O.D.)	Threads UNF-2B	Newton meters (N·m)	Foot Pounds (ft lb)
- 4	0.250	0.438 - 20	15 ± 1	11 ± 1
- 6	0.375	0.562 - 18	24 ± 3	18 ± 2
- 8	0.500	0.750 - 16	48 ± 5	35 ± 4
- 10	0.625	0.875 - 14	69 ± 7	51 ± 5
- 12	0.750	1.062 - 12	96 ± 10	71 ± 7
- 16	1.000	1.312 - 12	133 ± 8	98 ± 6
- 20	1.250	1.625 - 12	179 ± 10	132 ± 7
- 24	1.500	1.875 - 12	224 ± 20	165 ± 15

<b>TABLE11. Common Conversion Multipliers Metric To English</b>		
<b>To Convert From</b>	<b>To</b>	<b>Multiply By</b>
millimeter (mm)	inch (in.)	0.0394
centimeter (cm)	inch (in.)	0.3937
meter (m)	foot (ft)	3.2808
meter (m)	yard (yd)	1.0936
kilometer (km)	mile (mi)	0.6210
square centimeters (cm <sup>2</sup> )	square inch (in. <sup>2</sup> )	0.1550
square centimeters (cm <sup>2</sup> )	square feet (ft <sup>2</sup> )	0.001
cubic centimeters (cm <sup>3</sup> )	cubic inch (in. <sup>3</sup> )	0.061
liters (l)	cubic inch (in. <sup>3</sup> )	61.02
cubic meters (m <sup>3</sup> )	cubic feet (ft <sup>3</sup> )	35.314
liters (l)	cubic feet (ft <sup>3</sup> )	0.0353
grams (g)	ounce (oz)	0.0353
milliliter (ml)	fluid ounce (fl oz)	0.0338
kilogram (kg)	pound (mass)	2.2046
Newton (N)	pounds (lb)	0.2248
Newton meters (N·m)	kilogram meters (kg·m)	0.102
Newton meters (N·m)	foot pounds (ft lb)	0.7376
kilogram meters (kg·m)	foot pounds (ft lb)	7.2329
kilogram meters (kg·m)	Newton meters (N·m)	9.807
kilopascals (kPa)	pounds/square inch (psi)	0.1450
megapascals (MPa)	pounds/square inch (psi)	145.038
kilograms/cm <sup>2</sup> (kg/cm <sup>2</sup> )	pounds/square inch (psi)	14.2231
kilograms/cm <sup>2</sup> (kg/cm <sup>2</sup> )	kilopascals (kPa)	98.068
kilogram (kg)	short ton (tn)	0.0011
metric ton	short ton (tn)	1.1023
liters (l)	quart (qt)	1.0567
liters (l)	gallon (gal)	0.2642
Watts (W)	horsepower (hp)	0.00134
kilowatts (kW)	horsepower (hp)	1.3410

<b>TABLE 12. Common Conversion Multipliers English to Metric</b>		
<b>To Convert From</b>	<b>To</b>	<b>Multiply By</b>
inch (in.)	millimeter (mm)	25.40
inch (in.)	centimeter (cm)	2.54
foot (ft)	meter (m)	0.3048
yard (yd)	meter (m)	0.914
mile (mi)	kilometer (km)	1.61
square inch (in. <sup>2</sup> )	square centimeters (cm <sup>2</sup> )	6.45
square feet (ft <sup>2</sup> )	square centimeters (cm <sup>2</sup> )	929
cubic inches (in. <sup>3</sup> )	cubic centimeters (cm <sup>3</sup> )	16.39
cubic inches (in. <sup>3</sup> )	liters (l)	0.016
cubic feet (ft <sup>3</sup> )	cubic meters (m <sup>3</sup> )	0.028
cubic feet (ft. <sup>3</sup> )	liters (l)	28.3
ounce (oz)	kilogram (kg)	0.028
fluid ounce (fl oz)	milliliter (ml)	29.573
pound (lb)	kilogram (kg)	0.454
pound (lb)	Newton (N)	4.448
inch pounds (in. lb)	Newton meters (N·m)	0.113
foot pounds (ft lb)	Newton meters (N·m)	1.356
foot pounds (ft lb)	kilogram meters (kg·m)	0.138
kilogram meters (kg·m)	Newton meters (N·m)	9.807
pounds/square inch (psi)	kilopascals (kPa)	6.895
pounds/square inch (psi)	megapascals (MPa)	0.007
pounds/square inch (psi)	kilograms/square centimeter (kg/cm <sup>2</sup> )	0.0704
short ton (tn)	kilogram (kg)	907.2
short ton (tn)	metric ton (t)	0.0907
quart (qt)	liters (l)	0.946
gallon (gal)	liters (l)	3.785
horsepower (hp)	Watts (w)	745.7
horsepower (hp)	kilowatts (kw)	0.745

**TABLE 13.**

**Temperature Conversions**

**Formula:  $F^{\circ} - 32 \div 1.8 = C^{\circ}$  or  $C^{\circ} \times 1.8 + 32 = F^{\circ}$**

Celsius C°		Fahrenheit F°	Celsius C°		Fahrenheit F°	Celsius C°		Fahrenheit F°
121	250	482	63	145	293	4	40	104
118	245	473	60	140	284	2	35	95
116	240	464	57	135	275	- 1	30	86
113	235	455	54	130	266	- 4	25	77
110	230	446	52	125	257	- 7	20	68
107	225	437	49	120	248	- 9	15	59
104	220	428	46	115	239	- 12	10	50
102	215	419	43	110	230	- 15	5	41
99	210	410	41	105	221	- 18	0	32
96	205	401	38	100	212	- 21	- 5	23
93	200	392	35	95	203	- 23	- 10	14
91	195	383	32	90	194	- 26	- 15	5
88	190	374	29	85	185	- 29	- 20	- 4
85	185	365	27	80	176	- 32	- 25	- 13
82	180	356	24	75	167	- 34	- 30	- 22
79	175	347	21	70	158	- 37	- 35	- 31
77	170	338	18	65	149	- 40	- 40	- 40
74	165	329	15	60	140	- 43	- 45	- 49
71	160	320	13	55	131	- 46	- 50	- 58
68	155	311	10	50	122	- 48	- 55	- 67
66	150	302	7	45	113	- 51	- 60	- 76

*NOTE: The numbers in the unmarked columns refer to temperature in either degrees Celsius (C°) or Fahrenheit (F°). Select a number in this unmarked column and read to the left to convert to degrees Celsius (C°) or read to the right to convert to degrees Fahrenheit (F°). If starting with a known temperature (either C° or F°), find that temperature in the marked column and read the converted temperature in the center, unmarked column.*

## SAFETY

### GENERAL

Safety records from most organizations will show that the greatest percentage of accidents are caused by unsafe acts performed by people. The remainder are caused by unsafe mechanical or physical conditions. Report all unsafe conditions to the proper authority.

The following safety rules are provided as a guide for the operator. However, local conditions and regulations may add many more to this list.



**Read and follow all safety precautions. Failure to do so may result in serious injury or death.**

### Safety Rules

- Only trained and authorized personnel may operate and maintain the truck.
- Follow all safety rules, precautions and instructions when operating or performing maintenance on the truck.
- When working with another operator or a person on work site traffic duty, make sure that all personnel understand all hand signals that are to be used.

### Safety Features

- Make sure that all guards and covers are in their proper position. Have any damaged guards and covers repaired. (See Operating Instructions - Section 30, Preparing For Operation)
- Learn the proper use of safety features such as safety locks, safety pins, and seat belts. Use these safety features properly.
- Never remove any safety features. Always keep them in good operating condition.
- Improper use of safety features could result in serious bodily injury or death.
- Check the seat belt fabric, buckle and hardware for damage or wear. Replace any worn or damaged parts immediately.
- The seat belts must be replaced 5 years after seat belt manufacture, or after every 3 years of use, whichever comes first.

### Fire Extinguisher And First Aid Kit

- Make sure that fire extinguishers are accessible and proper usage techniques are known.
- Provide a first aid kit at the storage point.
- Know what to do in the event of a fire.
- Keep the phone numbers of persons you should contact in case of an emergency on hand.

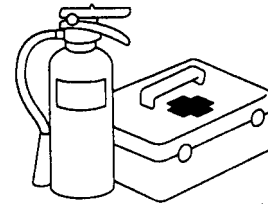

A0055070

### Clothing And Personal Items

- Avoid loose clothing, jewelry, and loose long hair. They can catch on controls or in moving parts and cause serious injury or death. Also, never wear oily clothes as they are flammable.
- Wear a hard hat, safety glasses, safety shoes, mask and gloves when operating or maintaining a truck. Always wear safety goggles, hard hat and heavy gloves if your job involves scattering metal chips or minute materials--particularly when driving pins with a hammer or when cleaning air cleaner elements with compressed air. Also, ensure that the work area is free from other personnel during such tasks.

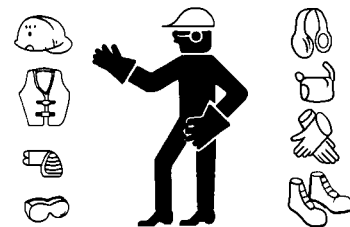

A0055010

### Leaving The Operator's Seat

When preparing to leave the operator's seat, do not touch any control lever that is not locked. To prevent accidental operations from occurring, always perform the following:

- Move the directional control lever to PARK. **Do not use the wheel brake lock when the engine will be turned off.**
- Lower the dump body to the frame.
- Stop the engine. When exiting the truck, always lock compartments and take the keys with you. If the truck should suddenly move or move in an unexpected way, this may result in serious bodily injury or death.

### Mounting And Dismounting

- Use the handrails and steps when getting on or off the truck.
- Never jump on or off the truck. Never climb on or off a truck while it is moving.
- When climbing on or off a truck, face the truck and use the hand-hold and steps.
- Never hold any control levers when getting on or off a truck.
- Always maintain three-point contact with the hand-holds and steps to ensure that you support yourself.
- When bringing tools into the operator's compartment, always pass them by hand or pull them up by rope.
- If there is any oil, grease, or mud on the hand-holds or steps, wipe them clean immediately. Always keep these components clean. Repair any damage and tighten any loose bolts.

### Fire Prevention For Fuel And Oil

- Fuel, oil, and antifreeze can be ignited by a flame. Fuel is extremely flammable and can be hazardous. Keep flames away from flammable fluids.
- Keep oil and fuel in a designated location and do not allow unauthorized persons to enter.
- When refueling, stop the engine and do not smoke.
- Refueling and oiling should be done in well ventilated areas.
- Tighten all fuel and oil tank caps securely.



A0055020



A0055030



A0055040

### Precautions With High Temperature Fluids

Immediately after truck operation, engine coolant, engine oil, and hydraulic oil are at high temperatures and are pressurized. If the cap is removed, the fluids are drained, the filters are replaced, etc., there is danger of serious burns. Allow heat and pressure to dissipate before performing such tasks and follow proper procedures as outlined in the service manual.

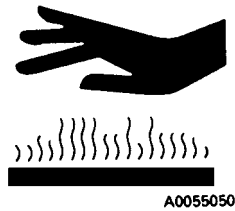

To prevent hot coolant from spraying:

1. Stop the engine.
2. Wait for the coolant temperature to decrease.
3. Depress the pressure release button on the cap to vent cooling system pressure.
4. Turn the radiator cap slowly to release the pressure before removing.

To prevent hot engine oil spray:

1. Stop the engine.
2. Wait for the oil temperature to cool down.
3. Turn the cap slowly to release the pressure before removing the cap.

### Asbestos Dust Hazard Prevention

Asbestos dust is hazardous to your health when inhaled. If you handle materials containing asbestos fibers, follow the guidelines below:

- Never use compressed air for cleaning.
- Use water for cleaning to control dust.
- Operate the truck or perform tasks with the wind to your back whenever possible.
- Use an approved respirator when necessary.

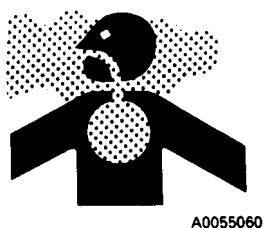

### Prevention Of Injury By Work Equipment

Never enter or put your hand, arm or any other part of your body between movable parts such as the dump body, chassis or cylinders. If the work equipment is operated, clearances will change and may lead to serious bodily injury or death.

### Unauthorized Modification

Any modification made to this vehicle without authorization from Komatsu America Corp. can possibly create hazards.

Before making any modification, consult the authorized regional Komatsu America Corp. distributor. Komatsu will not be responsible for any injury or damage caused by any unauthorized modification.

### ROPS Precautions

The ROPS is intended to protect the operator if the truck should roll over. It is designed not only to support the load of the truck, but also to absorb the energy of the impact.

- The Rollover Protection Structure (ROPS) must be properly installed before the truck is operated.
- ROPS installed on equipment manufactured and designed by Komatsu America Corp. fulfills all of the regulations and standards for all countries. If it is modified or repaired without authorization from Komatsu, or if it is damaged when the truck rolls over, the strength of the structure will be compromised and will not be able to fulfill its intended purpose. Optimum strength of the structure can only be achieved if it is repaired or modified as specified by Komatsu.
- When modifying or repairing the ROPS, always consult your nearest Komatsu distributor.
- Even with the ROPS installed, the operator must always use the seat belt when operating the truck.

### Precautions For Attachments

- When installing and using optional equipment, read the instruction manual for the attachment and the information related to attachments in this manual.
- Do not use attachments that are not authorized by Komatsu America Corp. or the authorized regional Komatsu distributor. Use of unauthorized attachments could create a safety problem and adversely affect the proper operation and useful life of the truck.
- Any injuries, accidents, and product failures resulting from the use of unauthorized attachments will not be the responsibility of Komatsu America Corp. or the authorized regional Komatsu distributor.

### Precautions For Starting The Truck

Start the engine from the operator's seat only. Never attempt to start the engine by shorting across cranking motor terminals. This may cause a fire, or serious injury or death to anyone in truck's path.



## PRECAUTIONS BEFORE OPERATION

Safety is thinking ahead. Prevention is the best safety program. Prevent a potential accident by knowing the employer's safety requirements and all necessary job site regulations. In addition, know the proper use and care of all the safety equipment on the truck. Only qualified operators or technicians should attempt to operate or maintain a Komatsu machine.

Safe practices start before the operator gets to the equipment.

### Safety At The Worksite

- When walking to and from a truck, maintain a safe distance from all machines even when the operator is visible.
- Before starting the engine, thoroughly check the area for any unusual conditions that could be dangerous.
- Examine the road surface at the job site and determine the best and safest method of operation.
- Choose an area where the ground is as horizontal and firm as possible before performing the operation.
- If you need to operate on or near a public road, protect pedestrians and cars by designating a person for work site traffic duty or by installing fences around the work site.
- The operator must personally check the work area, the roads to be used, and the existence of obstacles before starting operations.
- Always determine the travel roads at the work site and maintain them so that it is always safe for the machines to travel.
- If travel through wet areas is necessary, check the depth and flow of water before crossing the shallow parts. Never drive through water that exceeds the permissible water depth.



## Fire Prevention

- Remove wood chips, leaves, paper, and other flammable items that have accumulated in the engine compartment. Failure to do so could result in a fire.
- Check the fuel, lubrication, and hydraulic systems for leaks. Repair any leaks. Clean any excess oil, fuel or other flammable fluids, and dispose of them properly.
- Make sure that a fire extinguisher is present and in proper working condition.
- Do not operate the truck near open flames.



## Ventilation In Enclosed Areas

If it is necessary to start the engine within an enclosed area, provide adequate ventilation. Inhaling exhaust fumes from the engine can kill.

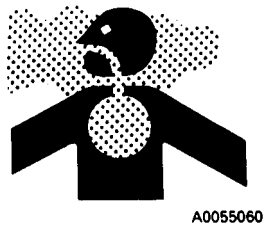

## Preparing For Operation

- Always mount and dismount while facing the truck. Never attempt to mount or dismount the truck while it is in motion. Always use handrails and ladders when mounting or dismounting the truck.
- Check the deck areas for debris, loose hardware and tools. Check for people and objects that might be in the area.
- Become familiar with and use all protective equipment devices on the truck and ensure that these items (anti-skid material, grab bars, seat belts, etc.) are securely in place.

## Mirrors, Windows And Lights

- Remove any dirt from the surface of the windshield, cab windows, mirrors and lights. Good visibility may prevent an accident.
- Adjust the rear view mirror to a position where the operator can see best from the operator's seat. If any glass or light is broken, replace it with a new part.
- Make sure that the headlights, work lights, and taillights are in proper working order. Make sure that the truck is equipped with the proper work lamps that are needed for the operating conditions.

## In The Operator Cab (Before Starting The Engine)

- Do not leave tools or spare parts lying around. Do not allow trash to accumulate in the cab of the truck. Keep all unauthorized reading material out of the truck cab.
- Keep the cab floor, controls, steps and handrails free of oil, grease, snow and excess dirt.
- Read and understand the contents of this manual. Pay special attention to Sections 30 and 32 pertaining to safety and operating instructions. Become thoroughly acquainted with all gauges, instruments and controls before attempting operation of the truck.
- Read and understand the **WARNING** and **CAUTION** decals in the operator's cab.
- Make sure that the steering wheel, horn, controls and pedals are free of any oil, grease or mud.
- Check the operation of the windshield wiper, condition of wiper blades, and the washer fluid reservoir level.
- Be familiar with all steering and brake system controls, warning devices, road speeds and loading capabilities before operating the truck.

## Seat Belts

- On both driver and passenger seats, check the seat belt fabric, buckle, all belt retractors and hardware for damage or wear. Replace any worn or damaged parts immediately.
- Even if there are no signs of damage, replace both driver and passenger seat belts 5 years after seat belt manufacture, or every 3 years after start of use, whichever comes first. The passenger seat belt date of manufacture label is sewn into the seat belt near the buckle. The driver seat belt date of manufacture label is sewn into the shoulder harness belt, near the retractor end.

## OPERATING THE TRUCK

### When Starting The Engine

- Never attempt to start the engine by shorting across cranking motor terminals. This may cause a fire, or serious injury or death to anyone in truck's path.
- Never start the engine if a warning tag has been attached to the controls.
- When starting the engine, sound the horn as an alert.
- Start and operate the truck only while seated in the operator's seat.
- Do not allow any unauthorized persons in the operator's compartment or any other place on the truck.

### General Truck Operation

- **Wear the seat belt at all times.**
- Only authorized persons are allowed to ride in the truck. Riders must be in the cab and belted in the passenger seat.
- Do not allow anyone to ride on the decks or steps of the truck.
- Do not allow anyone to get on or off the truck while it is in motion.
- Do not move the truck in or out of a building without a signal person present.
- Know and obey the hand signal communications between operator and spotter. When other machines and personnel are present, the operator should move in and out of buildings, loading areas, and through traffic under the direction of a signal person. Courtesy at all times is a safety precaution!
- Immediately report any adverse conditions at the haul road, pit or dump area that may cause an operating hazard.
- Check for flat tires periodically during a shift. If the truck has been operating on a "flat", do not park the truck inside a building until the tire cools. If the tire must be changed, do not stand in front of the rim and locking ring when inflating a tire mounted on the truck. Observers should not be permitted in the area and should be kept away from the side of such tires.



*The tire and rim assembly may explode if subjected to excessive heat. Personnel should move to a remote or protected location if sensing excessively hot brakes, smelling burning rubber or observing evidence of fire near the tire and wheel area.*

*If the truck must be approached to extinguish a fire, those personnel should do so only while facing the tread area of the tire (front or back) unless protected by using large heavy equipment as a shield. Stay at least 50 ft. (15 m) from the tread of the tire.*

*In the event of fire in the tire and wheel area (including brake fires), stay away from the truck for at least 8 hours or until the tire and wheel are cool.*

- Keep serviceable fire fighting equipment on hand. Report empty extinguishers for replacement or refilling.
- Always place the directional control lever in the PARK when the truck is parked and unattended. Do not leave the truck unattended while the engine is running.
- Park the truck a safe distance away from other vehicles as determined by the supervisor.
- Stay alert at all times! In the event of an emergency, be prepared to react quickly and avoid accidents. If an emergency arises, know where to get prompt assistance.

### Ensuring Good Visibility

- When working in dark places, install work lamps and head lamps. Set up extra lighting in the work area if necessary.
- Discontinue operations if visibility is poor, such as in mist, snow, or rain. Wait for the weather to improve to allow the operation to be performed safely.

**Traveling**

- When traveling on rough ground, travel at low speeds. When changing direction, avoid turning suddenly.
- Lower the dump body and set the dump lever to the FLOAT position before traveling.
- If the engine stops while the truck is in motion, secondary steering and braking enable the truck to be steered and stopped. A fixed amount of reserve oil provides temporary steering and braking to briefly allow the truck to travel to a safe area. Apply the brakes immediately and stop the truck as quickly and safely as possible off of the haul road, if possible.

**Traveling In Reverse**

Before operating the truck:

- Sound the horn to warn people in the area. Make sure that the back-up horn also works properly.
- Check for personnel near the truck. Be particularly careful to check behind the truck.
- When necessary, designate a person to watch the area near the truck and signal the operator. This is particularly necessary when traveling in reverse.
- When operating in areas that may be hazardous or have poor visibility, designate a person to direct work site traffic.
- Do not allow any one to enter the line of travel of the truck. This rule must be strictly observed even with machines equipped with a back-up horn or rear view mirror.

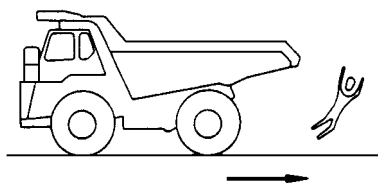
**Traveling On Slopes**

- Traveling on slopes could result in the truck tipping over or slipping.
- Do not change direction on slopes. To ensure safety, drive to level ground before turning.
- Do not travel up and down on grass, fallen leaves, or wet steel plates. These materials may make the truck slip on even the slightest slope. Avoid traveling sideways, and always keep travel speed low.
- When traveling downhill, use the retarder to reduce speed. Do not turn the steering wheel suddenly. Do not use the foot brake except in an emergency.
- If the engine should stop on a slope, apply the service brakes fully and stop the truck. Move the directional control lever to PARK after the truck has stopped.

**Operating On Snow Or Ice**

- When working on snowy or icy roads, there is danger that the truck may slip to the side on even the slightest slope. Always travel slowly and avoid sudden starting, turning, or stopping in these conditions.
- Be extremely careful when clearing snow. The road shoulder and other objects are buried in the snow and cannot be seen.

**Avoid Damage To The Dump Body**

Always be extremely cautious when working in tunnels, on bridges, under electric cables, or when entering a parking place or any other place where there are height limits. The dump body must be completely lowered before driving the truck.

### Driving Near High Voltage Cables

Driving near high-voltage cables can cause electric shock. Always maintain safe distances between the truck and the electric cable as listed below.

Voltage	Minimum Safety Distance	
6.6 kV	3 m	10 ft.
33.0 kV	4 m	14 ft.
66.0 kV	5 m	17 ft.
154.0 kV	8 m	27 ft.
275.0 kV	10 m	33 ft.

The following actions are effective in preventing accidents while working near high voltages:

- Wear shoes with rubber or leather soles.
- Use a signalman to give warning if the truck approaches an electric cable.
- If the work equipment touches an electric cable, the operator should not leave the cab.
- When performing operations near high voltage cables, do not allow anyone to approach the truck.
- Check with the electrical maintenance department about the voltage of the cables before starting operations.

### Working On Loose Ground

- Avoid operating the truck near cliffs, overhangs and deep ditches. If these areas collapse, the truck could fall or tip over and result in serious injury or death. Remember that ground surfaces in these areas may be weakened after heavy rain or blasting.
- Freshly laid soil and the soil near ditches is loose. It can collapse under the weight or vibration of the truck. Avoid these areas whenever possible.

### When Dumping

- Before starting the dumping operation, make sure that there are no persons or objects behind the truck.
- Stop the truck in the desired location. Check again for persons or objects behind the truck. Give the determined signal, then slowly operate the dump body. If necessary, use blocks for the wheels or position a flagman.
- When dumping on slopes, truck stability is poor and there is danger of tipping over. Always use extreme care when performing such operations.
- Never travel with the dump body raised.

### When Loading

- Make sure that the surrounding area is safe. Stop the truck in the correct loading position, then load the body uniformly.
- Do not leave the operator's seat during the loading operation.

### Parking The Truck

- Choose a flat, level surface to park the truck. If the truck has to be parked on a slope, put blocks behind all the wheels to prevent truck movement.
- When parking on public roads, provide fences and signs, such as flags or lights, on the truck to warn pedestrians and other vehicles. Make sure that the truck, flags or lights do not obstruct traffic.
- Before leaving the truck, lower the dump body fully, move the directional control lever to PARK, stop the engine and lock everything. Always take the key with you.



***Do not activate the wheel brake lock when the parking brake is activated. Bleed down of hydraulic pressure may occur, causing the truck to roll away.***

### Towing

- Improper towing methods may lead to serious personal injury and/or damage.
- Use a towing device with ample strength for the weight of this truck.
- Never tow a truck on a slope.
- Inspect towing components, such as tow bars and couplings, for any signs of damage. Never use damaged or worn components to tow a disabled vehicle.
- Keep a safe distance from the trucks and towing apparatus while towing a vehicle.
- When connecting a truck that is to be towed, do not allow anyone to go between the tow vehicle and the disabled vehicle.
- Set the coupling of the truck being towed in a straight line with the towing portion of the tow truck, and secure it in position.
- For towing methods, refer to Operating Instructions - Section 30, Towing.

## WORKING NEAR BATTERIES

### Battery Hazard Prevention

- Battery electrolyte contains sulfuric acid, which can quickly burn the skin and eat holes in clothing. If you spill acid on yourself, immediately flush the area with water.
- Battery acid can cause blindness if splashed into your eyes. If acid gets into your eyes, flush them immediately with large quantities of water and see a doctor at once.
- If you accidentally drink acid, drink a large quantity of water, milk, beaten eggs or vegetable oil. Call a doctor or poison prevention center immediately.
- Always wear safety glasses or goggles when working with batteries.

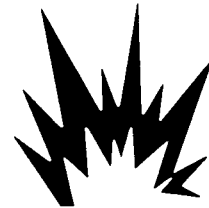
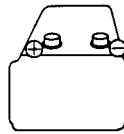
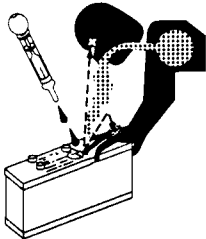

A030005

- Batteries generate hydrogen gas. Hydrogen gas is very explosive and can easily be ignited with a small spark or flame.
- Before working with batteries, stop the engine and turn the key switch to the OFF position.
- Avoid short-circuiting the battery terminals through accidental contact with metallic objects, such as tools, across the terminals.
- When removing or installing batteries, check which is the positive (+) terminal and the negative (-) terminal.
- Tighten battery caps securely.
- Tighten the battery terminals securely. Loose terminals can generate sparks and lead to an explosion.

### Starting With Booster Cables

- Always wear safety glasses or goggles when starting the truck with booster cables.
- When starting from another truck, do not allow the two trucks to touch.
- Connect the positive (+) cable first when installing booster cables. Disconnect the ground or negative (-) cable first during removal.

- If any tool touches between the positive (+) terminal and the chassis, it will cause sparks. Always be cautious when using tools near the battery.
- Connect the batteries in parallel: positive to positive and negative to negative.
- When connecting the ground cable to the frame of the truck to be started, connect it as far as possible from the battery.

### INCORRECT

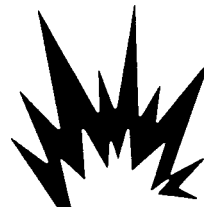
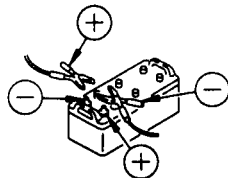

A030006

## BEFORE PERFORMING MAINTENANCE

### Stopping The Engine

- Before performing inspections or maintenance, stop the truck on firm flat ground, lower the dump body, move the directional control lever to PARK, and stop the engine.
- If the engine must be run during service, such as when cleaning the radiator, the directional control lever must be in PARK. Always perform this work with two people. One person must sit in the operator's seat to stop the engine if necessary. During these situations, never move any controls that are not related to the task at hand.
- When servicing the truck, do not touch any moving parts. Never wear loose clothing or jewelry.
- Put wheel blocks under the wheels to prevent truck movement.
- When performing service with the dump body raised, place the dump lever in the HOLD position and apply the lock (if equipped). Install the body-up safety pins or cable securely.

### Warning Tag

Starting the engine or operating the controls while other personnel are performing maintenance on the truck can lead to serious injury and/or death. Always attach the warning tag to the control lever in the operator's cab to alert others that you are working on the truck. Attach additional warning tags around the truck, if necessary.

These tags are available from your Komatsu distributor. **Warning tag part number:** 09963-03001

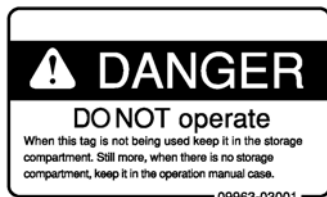

### Proper Tools

Only use tools that are suited to the task. Using damaged, low quality, faulty or makeshift tools could cause personal injury.



### Securing The Dump Body



**To avoid serious personal injury or death, the body retention sling must be installed whenever personnel are required to perform maintenance on the truck while the dump body in the raised position.**

**The Komatsu body-up safety sling can only be used with a Komatsu body. Non-OEM body may not accommodate the Komatsu body-up safety sling. The end user must ensure that a proper cable/sling is used.**

1. Raise the body to its maximum height.
2. Install two shackles (2, Figure 20-1) and body retention sling (3) between rear body ear (1) and the axle housing.
3. Secure the shackle pins with cotter pins.
4. Move the hoist lever to the FLOAT position to slowly lower the body until the sling is supporting the full weight of the body. Then move the hoist lever to the HOLD position.
5. After service work is completed, reverse the installation steps to remove the sling.

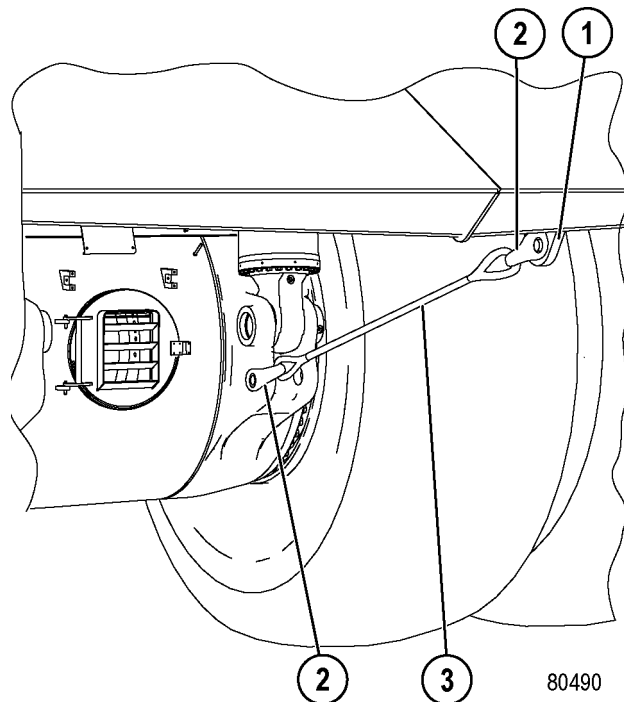

FIGURE 20-1. BODY RETENTION SLING INSTALLATION

1. Rear Body Ear
2. Shackle & Pin
3. Body Retention Sling

## WHILE PERFORMING MAINTENANCE

*NOTE: Only authorized personnel should service and repair the truck.*

### Keep The Truck Clean

- Spilled oil, grease, scattered tools, etc., can cause you to slip or trip. Always keep your truck clean and tidy.
- If water gets into the electrical system, there is danger that the truck may move unexpectedly and/or damage to components may occur. Do not use water or steam to clean any sensors, connectors or the inside of the operator's compartment.
- Use extreme care when washing the electrical control cabinet. Do not allow water to enter the control cabinet around the doors or vents. Do not allow any water to enter the cooling air inlet duct above the electrical control cabinet. If water enters the control cabinet through any opening or crevice, major damage to the electrical components is possible.
- Never spray water into the rear wheel electric motor covers. Damage to the wheel motor armatures may occur.
- Do not spray water into the retarding grids. Excess water in the retarding grids can cause a ground fault, which will prevent propulsion.

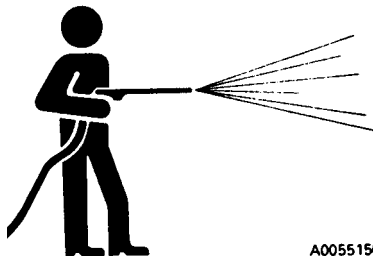

A0055150

### Attachments

Place attachments that have been removed from the truck in a safe place and manner to prevent them from falling.



A0055130

### Working Under The Truck

- Always lower all movable work equipment to the ground or to their lowest position before performing service or repairs under the truck.
- Always block the tires of the truck securely.
- Never work under the truck if the truck is poorly supported.



A0055140

### Rotating Fan And Belts

Stay away from all rotating parts such as the radiator fan and fan belts. Serious bodily injury may result from direct or indirect contact with rotating parts and flying objects.

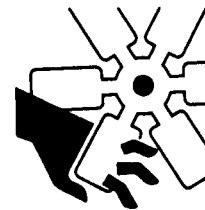

A0063830

### Waste Materials

- Never dump oil into a sewer system, river, etc.
- Always put oil drained from your truck in appropriate containers. Never drain oil directly onto the ground.
- Obey appropriate laws and regulations when disposing of harmful objects such as oil, fuel, coolant, solvent, filters and batteries.
- The machine may be equipped with optional High Intensity Discharge (HID) lighting lamps which contain mercury. These lamps must be reused, recycled or properly disposed of in accordance with applicable local, state and federal laws.

### INCORRECT

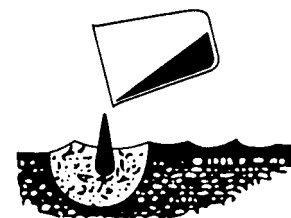

A0055220

### Adding Fuel Or Oil

- Spilled fuel and oil may cause slipping. Always clean up spills immediately.
- Always add fuel and oil in a well-ventilated area.
- When refueling, stop the engine and do not smoke.
- Tighten the cap of the fuel and oil fillers securely.
- Never use fuel to wash parts.

### Radiator Coolant Level

If it is necessary to add coolant to the radiator, stop the engine and allow the engine and radiator to cool down before adding the coolant. Depress the pressure release button on the cap to vent cooling system pressure. Slowly loosen the cap to relieve any remaining pressure.

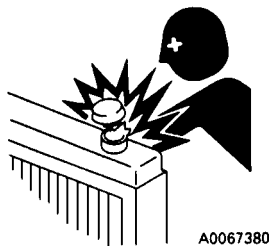

### Use Of Lighting

When checking fuel, oil, coolant or battery electrolyte, always use lighting with anti-explosion specifications. If such lighting equipment is not used, there is danger of an explosion.



### Precautions With The Battery

When repairing the electrical system or performing electrical welding, remove the negative (-) terminal of the battery to stop the flow of current.

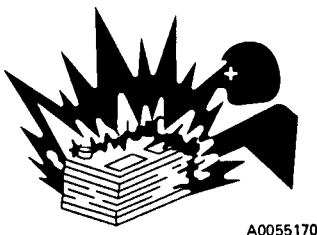

### Handling High Pressure Hoses

- Do not bend high pressure hoses or hit them with hard objects. Do not use any bent or cracked piping, tubes or hoses. They may burst during use.
- Always repair any loose or broken hoses. If fuel or oil leaks, it may result in a fire.

### Precautions With High Pressure Oil

- Work equipment circuits are always under pressure. Do not add oil, drain oil or perform maintenance or inspections before completely releasing the internal pressure.
- Small, high-pressure pin hole leaks are extremely dangerous. The jet of high-pressure oil can pierce the skin and eyes. Always wear safety glasses and thick gloves. Use a piece of cardboard or a sheet of wood to check for oil leakage.
- If you are hit by a jet of high-pressure oil, consult a doctor immediately for medical attention.



### Performing Maintenance Near High Temperature Or High Pressure

Immediately after stopping operation, engine coolant and operating oils are at high temperature and under high pressure. If the cap is removed, the oil or water is drained, or the filters are replaced under these conditions, it may result in burns or other injury. Wait for the temperature to cool and pressure to subside before performing the inspection and/or maintenance as outlined in the shop manual.

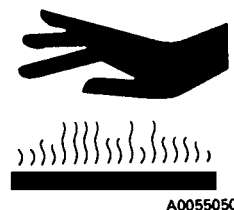



## TIRES

### Handling Tires

If tires are not used under the specified conditions, they may overheat and burst, or be cut and burst by sharp stones on rough road surfaces. This may lead to serious injury or damage.

To maintain tire safety, always use the specified tires. Inflate the tires to the specified pressure. An abnormal level of heat is generated when the inflation pressure is too low.

The tire inflation pressure and permissible speeds are general values. The actual values may differ depending on the type of tire and the condition under which they are used. For details, please consult the tire manufacturer.

When tires become hot, a flammable gas is produced and may ignite. It is particularly dangerous if the tires become overheated while the tires are pressurized. If the gas generated inside the tire ignites, the internal pressure will suddenly rise and the tire will explode, resulting in danger to personnel in the area. Explosions differ from punctures or tire bursts because the destructive force is extremely large. Therefore, the following operations are strictly prohibited when the tire is pressurized:

- Welding the rim
- Welding near the wheel or tire
- Smoking or creating open flames

If the proper procedure for performing maintenance or replacement of the wheel or tire is not used, the wheel or tire may burst and cause serious injury or damage. When performing such maintenance, consult your authorized regional Komatsu distributor or the tire manufacturer.

### Storing Tires After Removal

- As a basic rule, store the tires in a warehouse in which unauthorized persons cannot enter. If the tires are stored outside, always erect a fence around the tires and put up "No Entry" signs and other warning signs that even young children can understand.
- Stand the tire on level ground and block it securely so that it cannot roll or fall over.
- If the tire falls over, flee the area quickly. The tires for dump trucks are extremely heavy. Never attempt to hold or support the tire. Attempting to hold or support a tire may lead to serious injury.

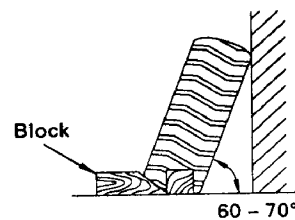

A030008

## WHEN REPAIRS ARE NECESSARY

*NOTE: Only qualified maintenance personnel who understand the systems being repaired should attempt repairs.*

- Many components on the Komatsu truck are large and heavy. Ensure that lifting equipment - hoists, slings, chains, and lifting eyes - are of adequate capacity to handle the lift.
- Do not work under a suspended load. Do not work under a raised body unless body safety cables, props or pins are in place to hold the body in up position.
- Do not repair or service the truck while the engine is running, except when adjustments can only be made under such conditions. Keep a safe distance from moving parts.
- When servicing any air conditioning system with refrigerant, wear a face shield and cold resistant gloves for protection against freezing. Follow all current regulations for handling and recycling refrigerants.
- Follow package directions carefully when using cleaning solvents.
- If an auxiliary battery assist is needed, first use one cable to connect the 24V positive (+) post of the disabled truck batteries to the 24V positive (+) post of the auxiliary assist. Use a second cable to connect the 24V negative (-) post of the auxiliary assist battery to a **frame ground (-)** on the disabled truck away from the battery.
- Always disconnect the positive and negative battery cables of the vehicle before doing any welding on the unit. Failure to do so may seriously damage the battery and electrical equipment. Disconnect the battery charging alternator lead wire and isolate the electronic control components before making welding repairs. (It is not necessary to disconnect or remove any control circuit cards on electric drive dump trucks or any of the AID circuit control cards.)

- Always fasten the welding machine ground (-) lead to the piece being welded. The grounding clamp must be attached as near as possible to the weld area. Never allow welding current to pass through ball bearings, roller bearings, suspensions or hydraulic cylinders. Always avoid laying welding cables over or near the vehicle electrical harnesses. Welding voltage could be induced into the electrical harness and possibly cause damage to components.
- If the truck must be towed, use a rigid tow bar. Check the truck frame for a decal recommending special towing precautions. Also refer to Operating Instructions - Section 30, Towing.
- Drain, clean, and ventilate fuel tanks and hydraulic tanks before making any welding repairs.

### **WARNING**

***Any operating fluid, such as hydraulic oil, escaping under pressure can have sufficient force to enter a person's body by penetrating the skin. Serious injury and possibly death may result if proper medical treatment by a physician familiar with this injury is not received immediately.***

- Relieve pressure in lines or hoses before making any disconnects.
- After adjustments or repairs, replace all shields, screens and clamps.
- Only a qualified operator or maintenance personnel who are also qualified in truck operation should move the truck under its own power in the repair facility or during road testing after repairs are complete.

## SPECIAL PRECAUTIONS FOR WORKING ON AC DRIVE TRUCKS

### PRELIMINARY PROCEDURES BEFORE WELDING OR PERFORMING MAINTENANCE

Before welding or repairing an AC drive truck, maintenance personnel should notify a Komatsu service representative. Only qualified personnel, specifically trained for servicing the AC drive system, should perform this service.

If it is necessary to perform welding or repair to the truck without the field engineer present, the following procedures must be followed to ensure that the truck is safe for maintenance personnel to work on and to reduce the chance for damage to equipment.



***Anytime the engine is running, do not open any of the cabinet doors or remove any covers. Do not use any of the power cables for hand holds or foot steps. Do not touch the retarding grid elements.***



***Before opening any cabinets or touching a retarding grid element or a power cable, the engine must be shutdown and the red drive system warning lights must not be illuminated.***

### ENGINE SHUTDOWN PROCEDURE BEFORE WELDING OR PERFORMING MAINTENANCE

Normal operation of the AC drive system at shutdown should leave the system safe to service. However, in the event of a system failure, performing the following procedure before any maintenance activities will ensure that no hazardous voltages are present in the AC drive system.

1. Before shutting down the engine, verify the status of all the drive system warning lights on the overhead display panel. Use the lamp test switch to verify that all lamps are functioning properly.  
If any of the red drive system warning lights remain on, do not attempt to open any cabinets, disconnect any cables, or reach inside the retarding grid cabinet without a trained drive system technician present, even if the engine is off. Only qualified personnel, specifically trained for servicing the AC drive system, should perform this service.
2. If all red drive system warning lights are off, follow the Normal Engine Shutdown Procedure in Section 30, Operating Instructions.
3. After the engine has been stopped for at least five minutes, inspect the link voltage lights on the exterior of the main control cabinet and back wall of the operator's cab (DID panel). If all lights are off, it is safe to work on the retarding grids, wheel motors, alternator and related power cables.
4. Locate the GF cut-out switch in the access panel on the left side of the main control cabinet. Place the switch in the "alternator cutout" position. This will prevent the alternator from re-energizing and creating system voltage until the switch is returned to its former position.

5. Before welding on the truck, disconnect all electrical harnesses from the Engine Control System (ECS) inside the electrical cabinet behind the operator's cab. Also, disconnect the ground strap from the ECS.
6. **Do not weld on the rear of the control cabinet!** The metal panels on the back of the cabinet are part of capacitors and cannot be heated.
7. **Do not weld on the retarding grid exhaust louvers!** They are made of stainless steel. Some power cable panels throughout the truck are also made of aluminum or stainless steel. They must be repaired with the same material or the power cables may be damaged.
8. Power cables must be cleated in wood or other non-ferrous materials. Do not repair cable cleats by encircling the power cables with metal clamps or hardware. Always inspect power cable insulation before servicing the cables and returning the truck to service. Discard cables with broken insulation.
10. Power cables and wiring harnesses should be protected from weld spatter and heat.  
Always fasten the welding machine ground (-) lead to the piece being welded. **The grounding clamp must be attached as near as possible to the weld area.**  
  
Always avoid laying welding cables over or near the vehicle electrical harnesses. Welding voltage could be induced into the electrical harness and cause damage to components.  
  
Before doing any welding on the truck, disconnect the battery charging alternator lead wire and isolate electronic control components.  
  
Also, always disconnect the negative and positive battery cables of the vehicle. Failure to do so may seriously damage the battery and electrical equipment.  
  
Never allow welding current to pass through ball bearings, roller bearings, suspensions or hydraulic cylinders.
11. If the red lights on the exterior of the control cabinet and/or the back wall of the operator's cab continue to be illuminated after following the above procedure, a fault has occurred.  
  
Leave all cabinet doors in place. Do not touch the retarding grid elements. Do not disconnect any power cables or use them as hand or foot holds.  
  
Notify your Komatsu service representative immediately. Only qualified personnel, specifically trained for servicing the AC drive system, should perform this service.
12. Replace all covers and doors. Place the GF cutout switch and battery disconnect switches in their original positions. Reconnect all harnesses prior to starting the truck.  
  
Leave the drive system in the rest mode until the truck is to be moved.

## CAPACITOR DISCHARGE SYSTEM

The control cabinets are equipped with two capacitor charge lights, one on the exterior of the cabinet and one in the interior. The capacitor charge lights, when off, indicate to service personnel that the drive system is safe to work on. Certain drive system failures, however, can result in a condition where one or more capacitors can remain in a charged state even though the capacitor charge lights are off.

Because a danger can still exist with the capacitor charge lights off, it is necessary to adhere to the following instructions before touching or servicing drive system components. Only authorized service personnel are allowed to service the drive system.

Refer to the shop manual for rules when servicing the drive system. Adhere to the proper procedures for disabling the drive system.

### Necessary Tools

- 2000 VDC meter (Figure 20-2)  
(Komatsu p/n PC3186)  
(Bierer RCDC 1000 or equivalent)



FIGURE 20-2. VOLT METER (PC3186)

- Personal Protective Equipment (PPE) for working with 2000 VDC meter  
(safety shoes, high voltage gloves, and safety glasses)
- Multimeter for ground resistance measurement
- Grounding stick pair (Figure 20-3)  
(Komatsu p/n PC3299)  
(HVR Advanced Power Components MAS-000039 Ground Stick Pair or equivalent)

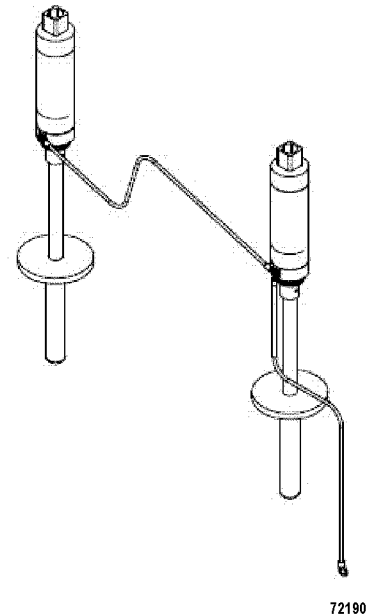

FIGURE 20-3. GROUNDING STICKS (PC3299)

## Warnings And Cautions

All applicable local mine, government, and industry rules for working with high voltage must be followed. Required personal protective equipment, including but not limited to safety shoes, high voltage gloves, and safety glasses must be worn.

Safety cautions and warnings appear throughout the instructions. WARNING indicates the potential for personal injury and CAUTION indicates the potential for equipment damage. Read the following warnings prior to working on this drive system.

### **WARNING**

***Hazardous voltages are present in this equipment. Ensure that the Control Power Switch (CPS) is in the OFF position and that the Generator Field Contactor (GFCO) switch is in the CUT-OUT position before attempting any work on the drive system components. Check that Capacitor Charge Lights (CCL's) are not illuminated.***

***Use measurement and protective equipment rated for 2000 VDC minimum to verify that no voltage is present before touching any terminal.***

***Verify functionality of the measurement equipment using site-approved procedures both before and after performing control group measurements.***

***Failure to observe these precautions may result in death or serious personal injury.***

### **WARNING**

***Verify that the Capacitor Charge Light (CCL) above the high voltage contactor area is not illuminated before opening the doors to the high voltage area or the high voltage contactor area.***

***Use measurement and protective equipment rated for 2000 VDC minimum to verify that no voltage is present before touching any terminal.***

***Verify functionality of the measurement equipment using site-approved procedures both before and after performing control group measurements.***

***Failure to observe these precautions may result in death or serious personal injury.***

### **WARNING**

***Hazardous voltages are present in this equipment. Avoid touching any energized equipment when the door to the low voltage area is open.***

***Failure to do so may result in personal injury and equipment damage.***

### **WARNING**

***Hazardous voltages may be present in this equipment even if the engine and capacitor charge lights are off.***

***Use measurement and protective equipment rated for 2000 VDC minimum to verify that no voltage is present before touching any terminal.***

***Verify functionality of the measurement equipment using site-approved procedures both before and after performing control group measurements.***

***Failure to observe these precautions may result in death or serious personal injury.***

### **WARNING**

***Voltages in excess of 1500 VDC may be present. Any measurement and/or protective equipment used must be rated at 2000 VDC minimum.***

***Verify functionality of the measurement equipment using site-approved procedures both before and after performing control group measurements.***

***Failure to observe these precautions may result in death or serious personal injury.***

### Manual DC Link Capacitor Discharge Procedure

Follow any and all local and site specific procedures and requirements for working on off-highway mining equipment.

Verify that:

- The engine is off and the parking brake is on.
- The generator field is cut out via GF cutout switch (2, Figure 20-4) in the low voltage area of the control cabinet.

1. Apply control power for a minimum of 30 seconds. Then, turn off control power using control power switch (1) on the switch panel.

With control power on, an RP contactor closes and discharges the DC link through the retarding grids in less than 10 seconds.

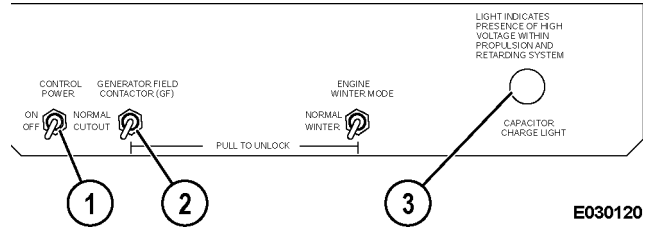

FIGURE 20-4. INFORMATION DISPLAY PANEL

1. Control Power Switch
2. GF Cutout Switch
3. Capacitor Charge Light

In most control cabinets, RP2 is the normal discharge path. In groups containing an RP3 contactor, RP2 and RP3 are alternated as the normal discharge path. Refer to Figure 20-5.

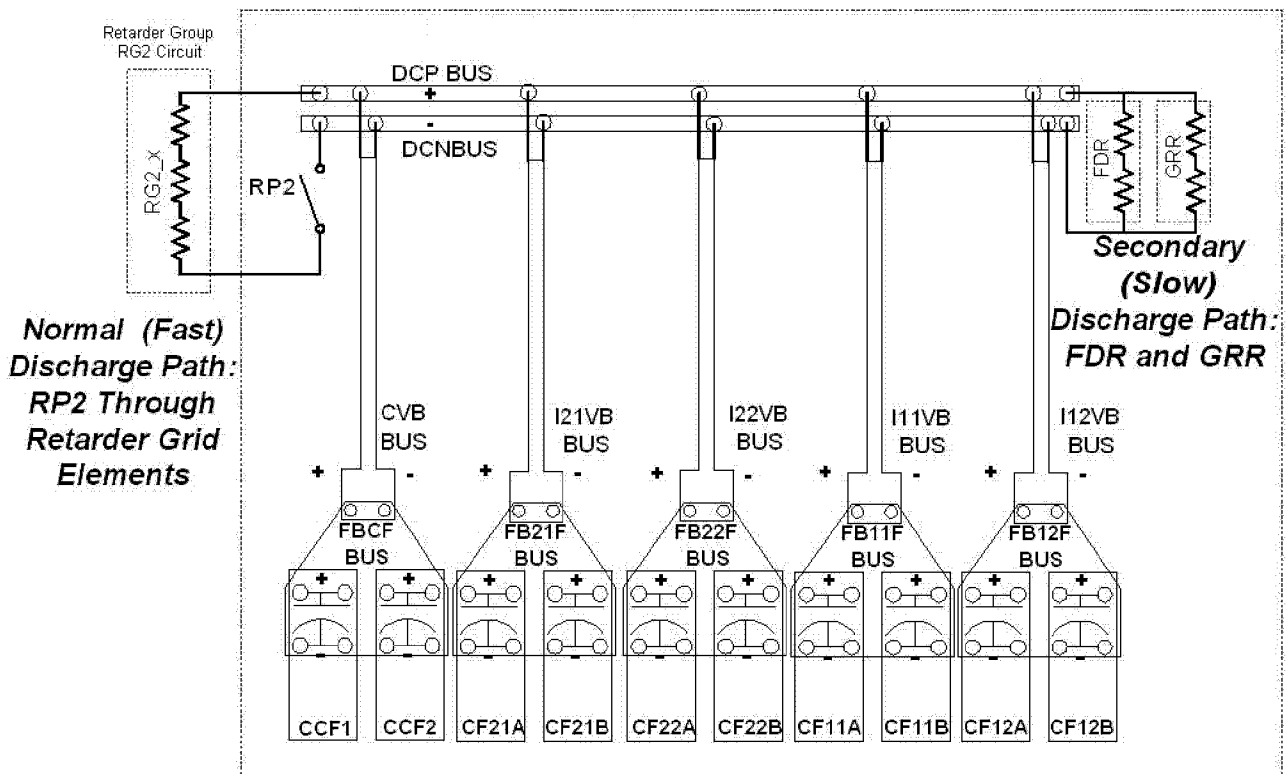

FIGURE 20-5. DISCHARGE PATHS

2. Observe both capacitor charge lights (CCL1, CCL2). CCL1 is on the outside of the contactor box. CCL2 is on the switch panel inside the low voltage area. The lights will stay illuminated as long as the voltage on the DC link is greater than 50 VDC. Refer to Figure 20-6.

## **⚠ WARNING**

*Hazardous voltages may be present in this equipment even if the engine and capacitor charge lights are off.*

*Use measurement and protective equipment rated for 2000 VDC minimum to verify that no voltage is present before touching any terminal.*

## **⚠ WARNING**

*Verify functionality of the measurement equipment using site-approved procedures both before and after performing control group measurements.*

*Failure to observe these precautions may result in death or serious personal injury.*

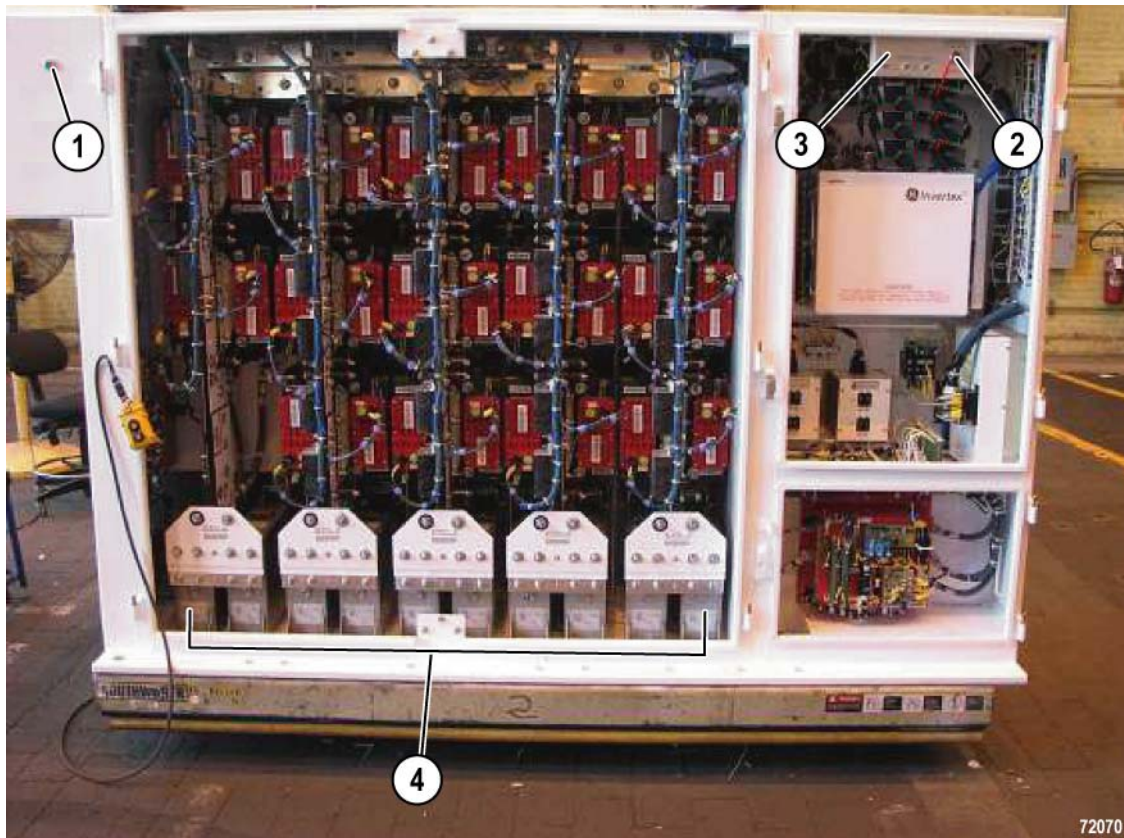

FIGURE 20-6. CAPACITOR CHARGE LIGHTS

- |   |                              |
|---|------------------------------|
| 1. Exterior Capacitor Charge Light (CCL2) | 3. Information Display Panel |
| 2. Interior Capacitor Charge Light (CCL1) | 4. DC Link Capacitors        |



### Failure of the Discharge System

If the capacitor charge lights remain illuminated, a failure of the normal (fast) capacitor discharge system (RP discharge path) has likely occurred. The slow discharge resistors that are hard wired across the DC link should then discharge the capacitors. The slow discharge resistors will discharge the DC link to less than 1 VDC in under 7.5 minutes. If after 7.5 minutes, the capacitor charge lights are still illuminated, it must be assumed that the automatic discharge system is not working and that high voltage is present in the high voltage area.

1. Open the high voltage area doors.
2. With a suitable high voltage meter rated for at least 2000 VDC, such as PC3186 or equivalent, plus suitable protective equipment, measure the voltage across each of the DC link capacitors. Place one meter lead on the positive (+) capacitor terminal, and the other meter lead on the negative (-) capacitor terminal, and observe the voltage. See Figure 20-7 and Figure 20-8. If the voltage is less than 1.0 V the capacitor is sufficiently discharged. Repeat on all DC Link capacitors. If the voltage of any capacitor is above 1.0 V, manually discharge the capacitor as described in Manual Discharge of Capacitors on page 30-22.



72184

FIGURE 20-7. DC METER ON CAPACITOR

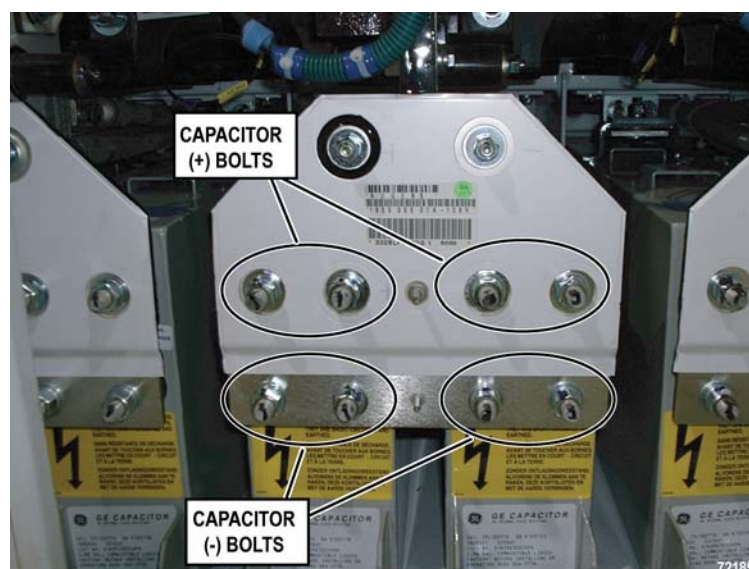

72185

FIGURE 20-8. CAPACITOR TERMINAL POLARITY

## Manual Discharge of Capacitors

If the voltage is greater than 1V on any of the capacitors, the capacitor must be manually discharged. With a suitable capacitor discharge device, such as ground stick pair (PC3299), discharge the capacitors where needed per the following instructions:

1. With the control cabinet high voltage compartment doors closed, connect the ground stick pair ground lead to ground. The most convenient location is the middle top bolt that attaches the door center post to the control cabinet frame.
2. Verify the ground connection and ground stick resistance levels. Measure the resistance between each individual ground stick tip to either the GND1 or GND2 ground block in the low voltage compartment of the control cabinet using a multimeter (Figure 20-9). Ensure that the resistance is within the manufacturer's specifications for the ground sticks.

For PC3299 grounding sticks, the valid range is 80 to 125 ohms per stick.

3. Discharge the relevant capacitors. Open the door(s) and place one grounding stick on one of the positive (+) capacitor terminals and the other on the diagonally located negative (-) terminal. Refer to Figure 20-8 and Figure 20-10. Attempt to minimize the time between application of the positive stick and the negative stick so that the current flow will be positive to negative rather than either to ground. Leave sticks in place until capacitors are discharged. Refer to Figure 20-10.

*NOTE: On the capacitors located behind the door post, it is difficult to access diagonal terminals on the same capacitor. If using adjacent terminals, use care to keep the tips separated while discharging or else use a positive terminal on one capacitor and negative terminal of the adjacent capacitor on the same bus bar.*

For PC3299 grounding sticks, the discharge times from 2000 volts are:

- 15 seconds (maximum) for 2 capacitors
- 75 seconds (maximum) for 10 capacitors

## **⚠ WARNING**

***Hazardous voltages are present in this equipment. Avoid touching any energized equipment when the door to the low voltage area is open. Failure to do so may result in personal injury and equipment damage.***

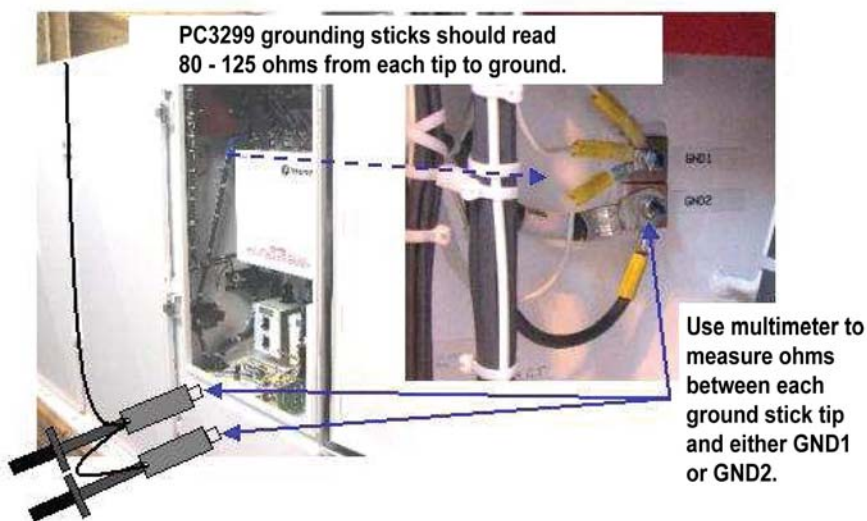

72185

FIGURE 20-9. GROUNDING STICK LEAD CONNECTION AND CHECK

**⚠ WARNING**

***Voltages in excess of 1500 VDC may be present. Any measurement and/or protective equipment used must be rated at 2000 VDC minimum.***

***Verify functionality of the measurement equipment using site-approved procedures both before and after performing control group measurements.***

***Failure to observe these precautions may result in death or serious personal injury.***

4. Measure voltage on all capacitors as described in Failure of the Discharge System on page 30-21. Discharge any capacitors that show voltage.
5. If all capacitors read discharged, verify that the meter is functioning correctly using site-approved procedures. If so, proceed to Short Isolated Capacitor Terminals on page 30-24.

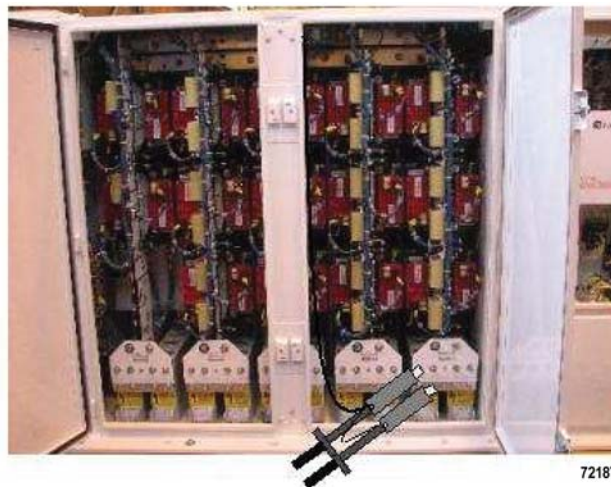

FIGURE 20-10. APPLICATION OF GROUNDING STICKS TO CAPACITOR TERMINALS

### Short Isolated Capacitor Terminals



*Hazardous voltages may be present in this equipment even if the engine and capacitor charge lights are off.*

*Use measurement and protective equipment rated for 2000 VDC minimum to verify that no voltage is present before touching any terminal.*

*Verify functionality of the measurement equipment using site-approved procedures both before and after performing control group measurements.*

*Failure to observe these precautions may result in death or serious personal injury.*

Any capacitor that is isolated from the DC link and confirmed discharged must have its terminals electrically shorted together to prevent static charge build up. Use bare wire to jumper all four terminals on the capacitor. See Figure 20-11. Proceed to troubleshoot and repair the control group to restore it to original functionality.

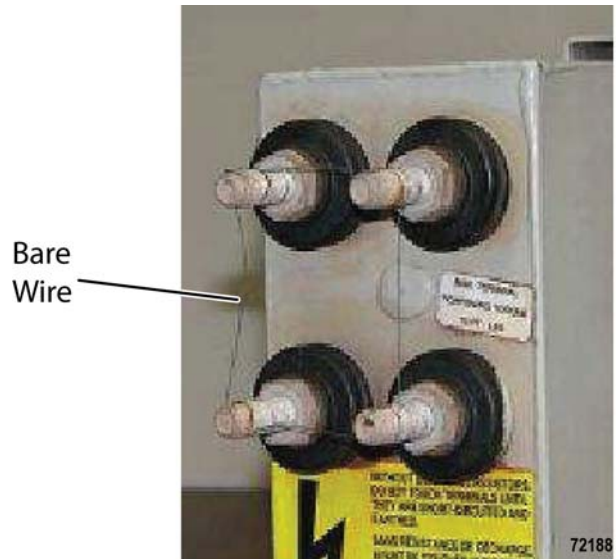
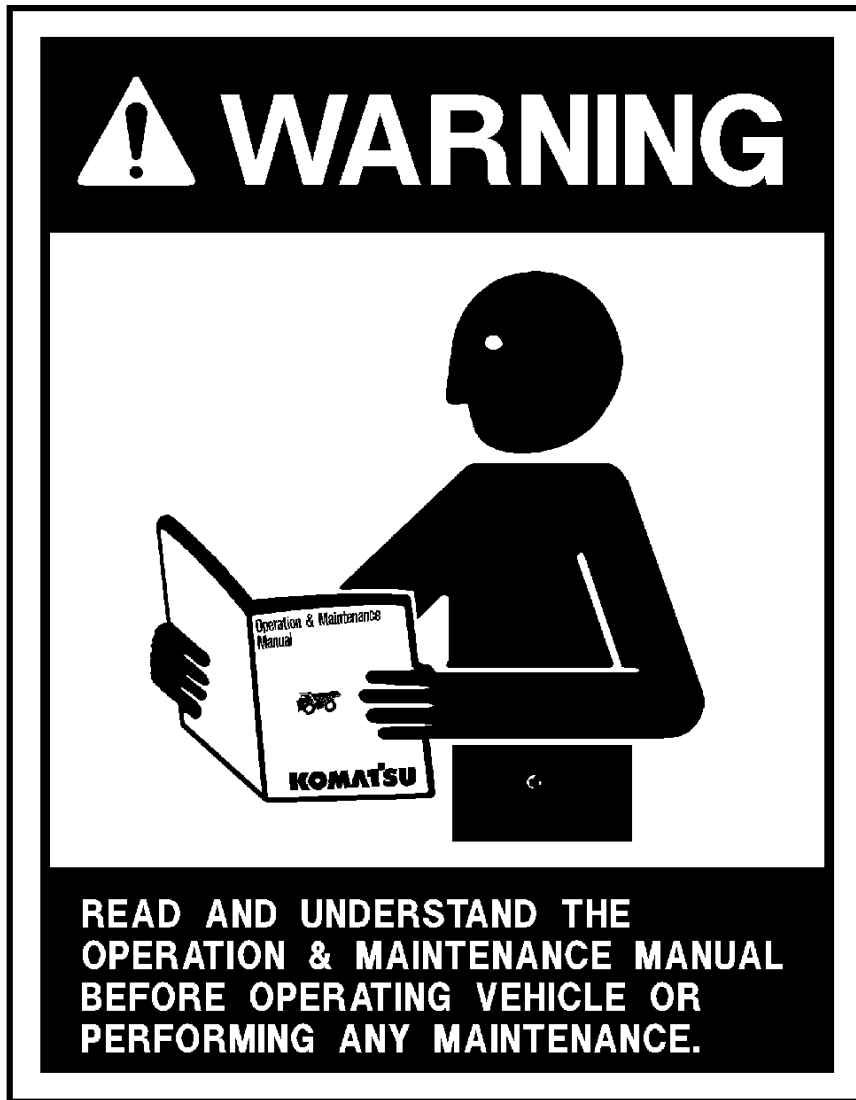

FIGURE 20-11. JUMPER ALL TERMINALS ON ISOLATED CAPACITOR





## WARNINGS AND CAUTIONS

The following pages give an explanation of the warning, caution, and service instruction plates and decals attached to the truck. The plates and decals listed here are typical of this Komatsu model, but because of customer options, individual trucks may have plates and decals that are different from those shown here.

The plates and decals must be kept clean and legible. If any decal or plate becomes damaged or illegible, replace it with a new one.

### GRADE/SPEED CHART

A grade/speed retard chart is located on the left front post of the operator's cab. It provides the recommended maximum speeds to be used when descending various grades with a loaded truck. Always refer to the decal in operator's cab. This decal may change with optional truck equipment such as wheel motor drive train ratios, retarding grids, tire sizes, etc.

**CAUTION**

**DO NOT DESCEND GRADES AT SPEEDS GREATER THAN LISTED WHEN VEHICLE IS LOADED AT MAX. G.V.W. 1,100,000 LB. (498,957 kg) & 53/80 R 63 TIRES.**

	EFFECTIVE GRADE	SPEED (CONTINUOUS)	SPEED (SHORT TERM)
	%	MPH(KM/H)	MPH(KM/H)
	12	15(24)	19(31)
	10	11(18)	23(37)
	8	14(23)	29(47)
	6	19(31)	36(58)
	4	29(47)	36(58)

THE ACTUAL GRADE CAPABILITY WILL VARY DEPENDING ON OUTSIDE TEMPERATURE, SYSTEM TEMPERATURE, ROLLING RESISTANCE, LOAD, AND TIRE SIZE. THE ABOVE IS BASED ON 32° C (90°F) OUTSIDE TEMPERATURE AND ASSUMES THAT ROAD AND VISIBILITY CONDITIONS PERMIT THE USE OF ALL AVAILABLE RETARDING TORQUE WITHOUT SKIDDING. FOR ADDITIONAL BRAKING AND RETARD INFORMATION, SEE OPERATION MANUAL.

ACTUAL GRADE, NOT INCLUDING ROLLING RESISTANCE.

WB2751

### KEY SWITCH

A warning decal is below the key switch located to the right of the steering column on the instrument panel. The warning stresses the importance of reading the operator's manual before operation.

**WARNING**

**KEY SWITCH**

**DO NOT OPERATE VEHICLE BEFORE READING AND UNDERSTANDING OPERATION MANUALS.**

WB2490

### ROPS/FOPS

A plate attached to the right rear corner of the cab states that the Rollover Protective Structure (ROPS) and Falling Object Protective Structure (FOPS) meet various SAE performance requirements.

The plate also contains a WARNING about making modifications or repairs to the structure. Unauthorized modifications or repairs will void the certification.

ROPS/FOPS NO. \_\_\_\_\_ MACHINE MODEL \_\_\_\_\_

AS INSTALLED BY THE MANUFACTURER ON THIS DUMPER HAVING WEIGHT WITHOUT BODY LESS THAN \_\_\_\_\_ KG. THIS ROLLOVER PROTECTIVE STRUCTURE AND FALLING OBJECT PROTECTIVE STRUCTURE MEETS THE PERFORMANCE REQUIREMENTS OF SAE-J1040 APR 89, SAE-J2281 JAN 81 AND SAE-J1184 MAY 89

**WARNING** THE PROTECTION OFFERED MAY BE IMPAIRED IF SUBJECTED TO ANY MODIFICATIONS OR DAMAGE TO MAINTAIN MANUFACTURERS CERTIFICATION ANY REPAIR OR ALTERATION ON THIS STRUCTURE, INCLUDING INSTALLATION OF A NON-STANDARD SEAT, OR RELOCATION OF SEAT MUST HAVE PRIOR WRITTEN APPROVAL.

Komatsu America Corporation  
2300 NE Adams St, Peoria, Illinois 61650-0240 U.S.A.

## BATTERIES

A danger decal is located on the front exterior of the battery box. It stresses the need to keep from making any sparks near the battery. When another battery or 24VDC power source is used for auxiliary power, all switches must be OFF before making any connections. When connecting auxiliary power cables, positively maintain correct polarity. Connect the positive (+) posts together and then connect the negative (-) lead of the auxiliary power cable to a good frame ground. **Do not connect to the negative posts of the truck battery or near the battery box.** This hookup completes the circuit but minimizes the danger of sparks near the batteries.

Sulfuric acid is corrosive and toxic. Use proper safety gear, goggles, rubber gloves and a rubber apron when handling and servicing batteries. If sulfuric acid is swallowed, gets into your eyes or contacts your skin, get proper medical help immediately.

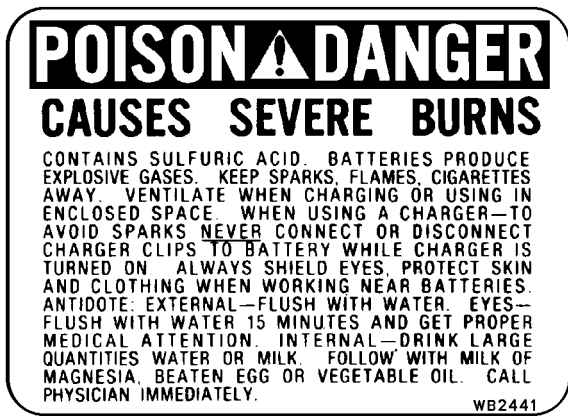

This decal is located on the front exterior of the battery box. It warns about the potential hazard of stored energy remaining in the hydraulic system if the battery disconnect switch is opened before the steering accumulators have bled down completely.

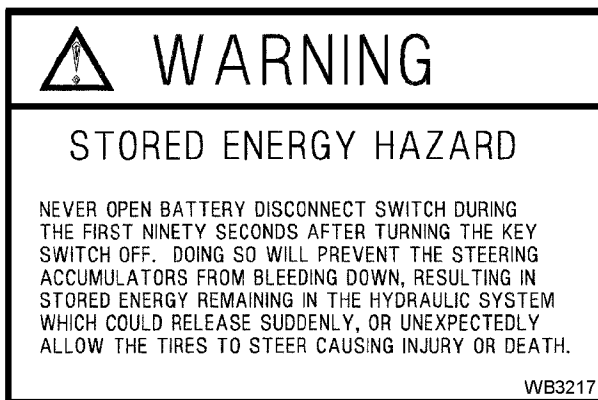

This decal is placed on the battery box near the battery disconnect switches to indicate that the battery system (24VDC) is a negative (-) ground system.



A decal that outlines the correct battery cable removal procedure is located on the front exterior of the battery box.

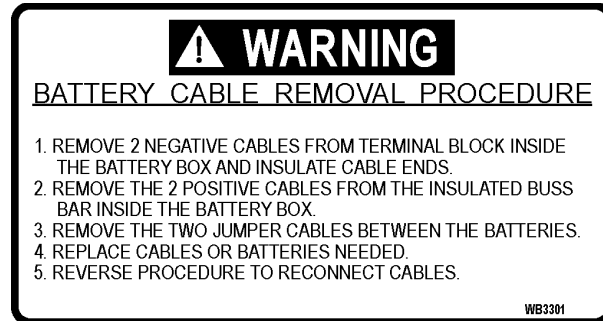

## CAPACITORS

This decal is located on the front of the contactor box and on the inside of the left control cabinet door.

When any of the indicator lights are on, high voltage is present throughout the propulsion and retarding system. Extreme care should be exercised.

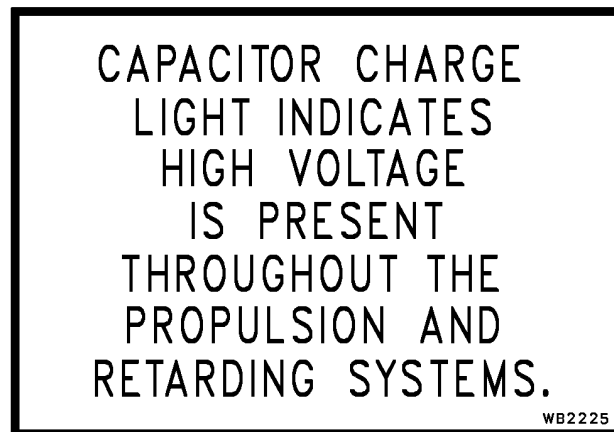



### CRUSHING HAZARD

Warning decals are mounted on the frame in front of both front tires and to the rear of both front tires. They warn that the clearances change when the truck is steered and could cause serious injury.



Warning decals are attached to both the hydraulic tank and fuel tank to alert technicians not to work on the truck with the body in the raised position unless the body-up retention device (pins or cable) is in position.



### CYLINDER PRESSURE

These danger decals are mounted on the outside of each frame rail to remind technicians to read the warning labels attached to the side of each of the accumulators (see below) before releasing internal nitrogen pressure or disconnecting any hydraulic lines or hardware. There are similar decals mounted on top of each of the accumulators (both steering and brake) with the same danger message.



These warning decals are mounted on the side of each of the accumulators (both steering and brake) to alert technicians to discharge all gas and hydraulic pressure, and to read the maintenance/service manual before performing any service.

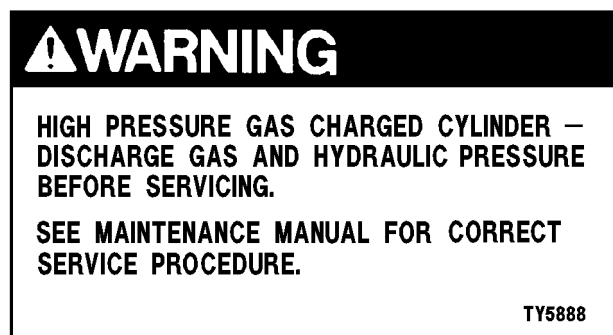

This danger decal is attached to all four suspensions. It contains instructions for releasing internal pressure before disconnecting any hardware. Serious injury can occur if these directions are not followed.

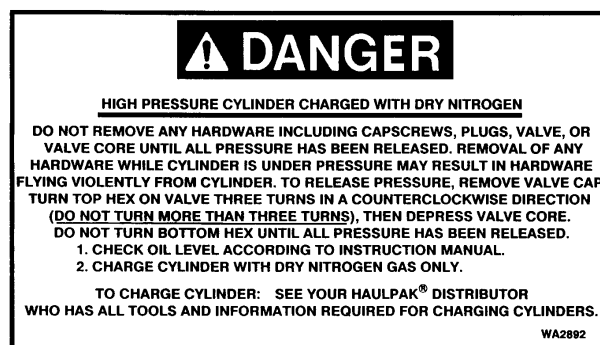

## FILLING THE HYDRAULIC TANK

A decal mounted on the side of the hydraulic tank provides instructions for filling the hydraulic tank.

To lessen the chances of system contamination, keep the system open to the atmosphere only as long as absolutely necessary. Service the tank with clean Type C-4 hydraulic oil. All oil that is being put into the hydraulic tank should be filtered through 3 micron filters.

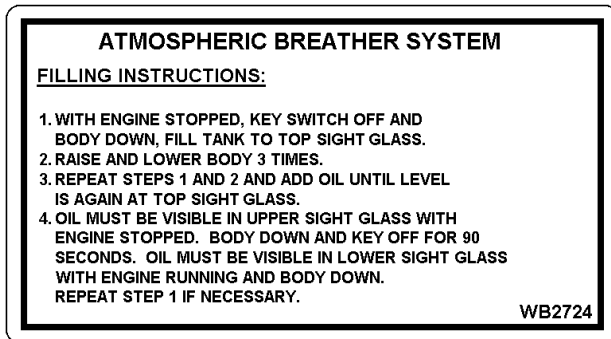

A caution decal is attached below the hydraulic tank oil level sight gauge. Check the oil level with the body down, engine stopped, and key switch OFF. Add oil per filling instructions if the oil level is below the top of the sight glass.



## HYDRAULIC OIL PRESSURE

A warning plate is attached to the hydraulic tank to warn technicians that high pressure hydraulic oil is present during operation. When it is necessary to open the hydraulic system, be sure the engine is stopped and the key switch is OFF to bleed down hydraulic pressure. There is always a chance of residual pressure being present. Open fittings slowly to allow all pressure to bleed off before removing any connections.



Two warning decals are located on the doors of the hydraulic brake cabinet to warn technicians not to disconnect any hydraulic brake lines until the machine has been properly shut down.

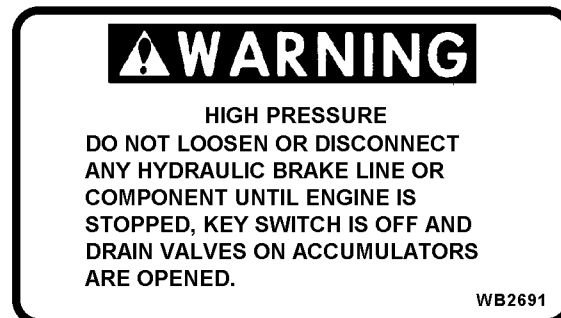

**HOT OIL SPRAY**

If equipped, this decal is placed on both front wheel hubs to warn about hot oil inside the wheel hubs. Remove the oil level plug carefully to avoid injury.

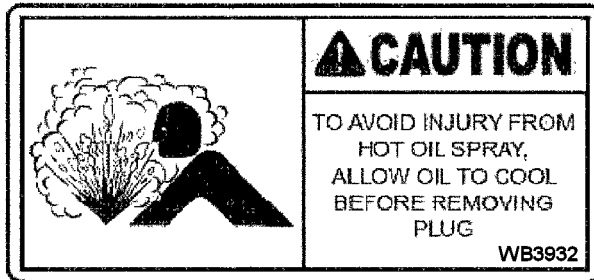
**WHEEL MOTOR OIL LEVEL**

A wheel motor oil level decal is attached to the gear cover on both electric wheel motors. This decal stresses that the truck must be parked for 20 minutes prior to checking the oil level in order to get an accurate reading.

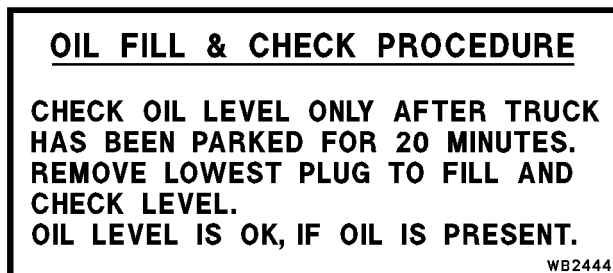
**HOT EXHAUST**

A caution decal is also attached to the door of the rear axle hatch and around the retarding grid cabinet to alert personnel that hot exhaust air is present and may cause injury.

**RADIATOR**

A warning decal is mounted on top of the radiator surge tank cover near the radiator cap. The engine cooling system is pressurized. **Always turn the key switch OFF and allow the engine to cool before removing the radiator cap.** Unless the pressure is first released, removing the radiator cap after the engine has been running for a time will result in hot coolant being expelled from the radiator. **Serious scalding and burning may result.**

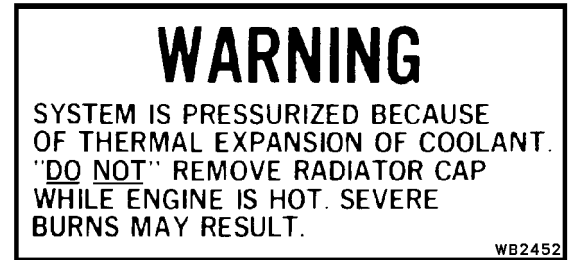
**EMERGENCY LADDER**

This decal is located by the emergency ladder on both sides of the truck.

**ACCUMULATOR DRAIN VALVES**

Warning decals are applied to both brake accumulators located inside the hydraulic brake cabinet behind the operator cab. These decals remind servicing technicians to close the accumulator drain valves after they have been opened to bleed the brake pressure. It further warns not to overtighten the drain valves in order to prevent damage to the valve seat(s).



## EMERGENCY DUMP PROCEDURE

A decal which provides the operator or technician with the emergency procedure for dumping a loaded, disabled truck by using a functional truck for hydraulic power is located on the frame near the left hoist cylinder.

Refer to Section L in the shop manual for additional information about using this procedure.

### EMERGENCY DUMP PROCEDURE

1. CONNECT A HYDRAULIC POWER SUPPLY CAPABLE OF 2500 PSI (17.2 MPa) WHICH HAS A RESERVE CAPACITY EXCEEDING 80 GAL. (303 l) TO THE QUICK DISCONNECTS ON L.H. HOIST CYLINDER.
2. PLACE HOIST VALVE IN HOLD POSITION.
3. DUMP LOAD AND LOWER BODY USING CONTROL VALVE ON HYDRAULIC POWER SUPPLY UNIT.

WB2246

## EMERGENCY TOWING PROCEDURE

A decal which provides the operator or technician with the emergency procedure for towing a disabled truck is located on the left frame rail near the steering accumulators.

### WARNING

#### EMERGENCY TOWING PROCEDURE

1. ENGINE MUST BE STOPPED AND ACCUMULATOR(S) DISCHARGED.
2. EXTERNAL SUPPLY MUST BE ABLE TO MAINTAIN 3000 PSI AND HAVE A MIN. CAPACITY OF 20 GAL.
3. CONNECT EXTERNAL SUPPLY TO THE 'QD' SUPPLY AND 'QD' RETURN PORTS ON THE BLEEDOWN MANIFOLD.
4. CHECK OPERATION OF STEERING AND BRAKES.
5. PROCEED WITH TOWING OPERATION.

WB2443

## WELDING

This caution decal is placed near the battery disconnect switches to alert service technicians to always disconnect the battery charging alternator lead wire before making welding repairs.

In addition, always isolate electronic control components and disconnect the positive and negative battery cables of the vehicle. Failure to do so may seriously damage the battery and electrical equipment.

### CAUTION

PRIOR TO WELDING ON TRUCK  
DISCONNECT LEAD WIRE ON  
BATTERY CHARGING ALTERNATOR

WB2442

Always fasten the welding machine ground (-) lead to the piece being welded. **The grounding clamp must be attached as near as possible to the weld area.** Never allow welding current to pass through ball bearings, roller bearings, suspensions, or hydraulic cylinders. Always avoid laying welding cables over or near the vehicle electrical harnesses. Welding voltage could be induced into the electrical harness and possibly cause damage to components.

## EMERGENCY SHUTDOWN

This decal is placed on the ground level engine shutdown switch, which is mounted on the right side of the front bumper structure. It specifies that this switch is for emergency shutdown only.

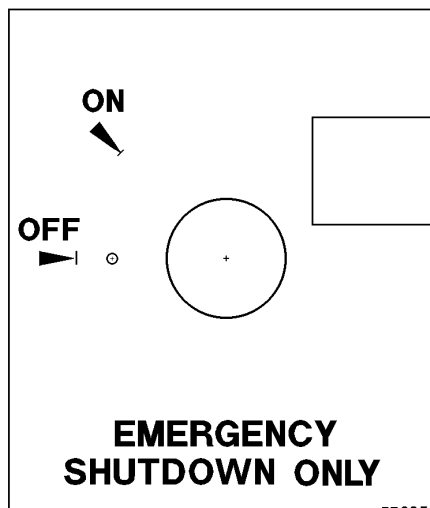

TZ6931

### INFORMATION DISPLAY

This information decal is placed on the left door of the control cabinet.

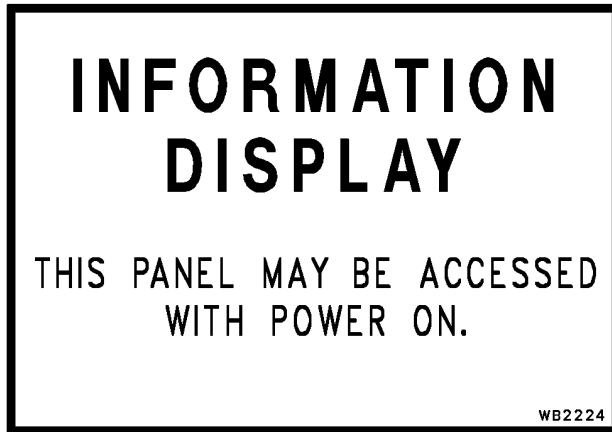

### WIRELESS SIGNALS

Wireless signals from the truck's KOMTRAX Plus system can interfere with other wireless signals in the area. This interference can cause a malfunction in a blast zone resulting in an unintended detonation. Know the locations of blast zones in the area and keep a safe distance to avoid unintentional blasts. Operating frequency of KOMTRAX Plus is 148 MHz to 150 MHz.

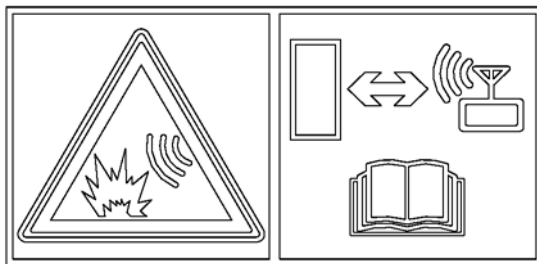

### HIGH VOLTAGE

A high voltage danger decal is attached to the door of the rear hatch cover. **High voltage may be present!** Only authorized personnel should access this rear housing.



These danger decals are mounted on all the AC drive control housings and cabinets. **High voltage may be present!** Only authorized personnel should access this component.

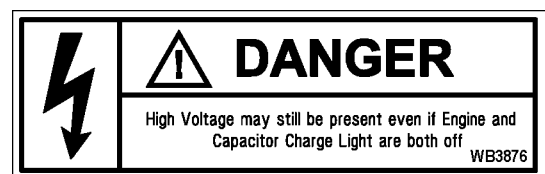
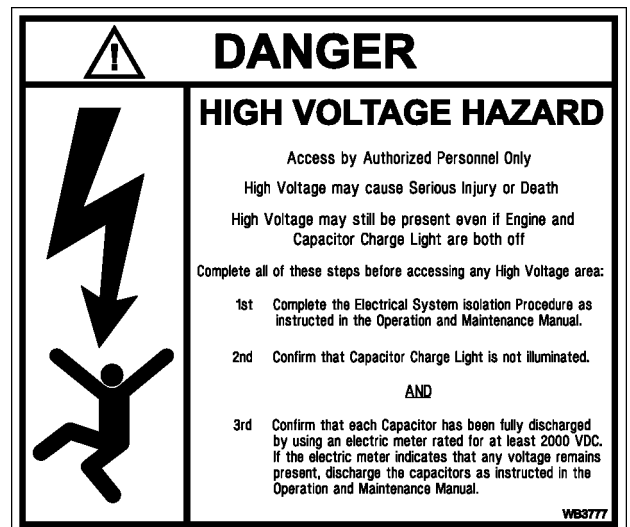

## LIFTING INSTRUCTIONS

This page illustrates a variety of decals which are placed on deck mounted cabinets, housings, and structures that must be lifted in a specific manner and from specific points in order to safely move them.

If any of these decals is damaged or defaced so it is no longer legible, it should be replaced immediately.

**Maintenance personnel must follow these lifting instructions.**

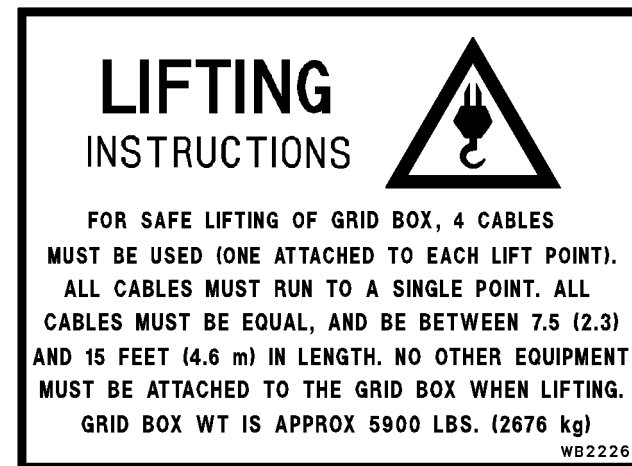
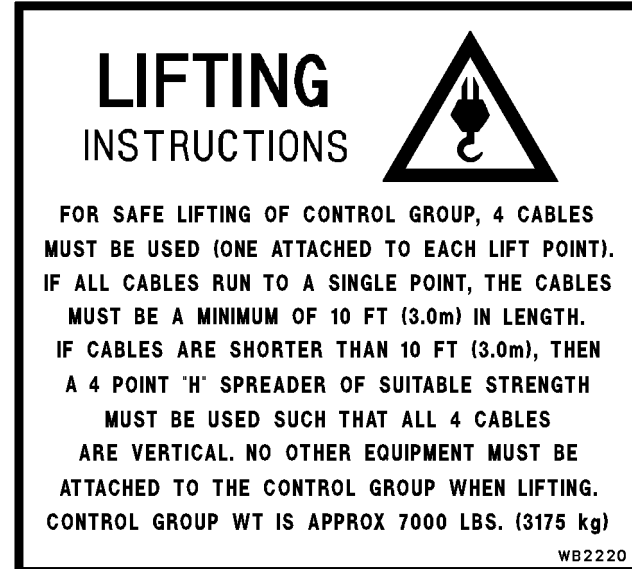
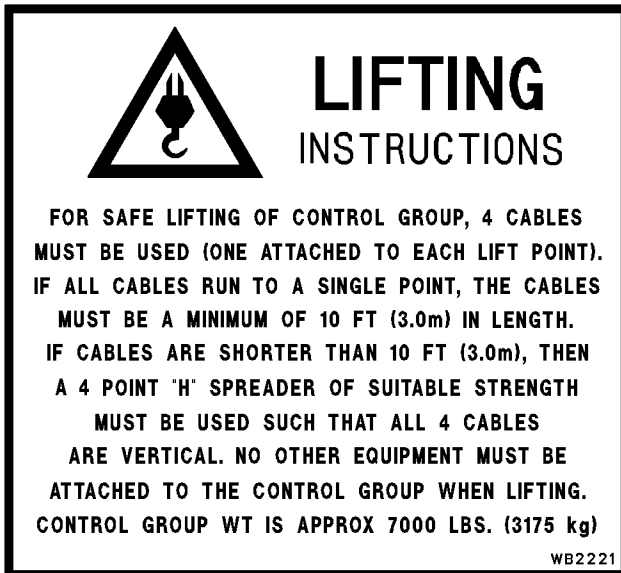
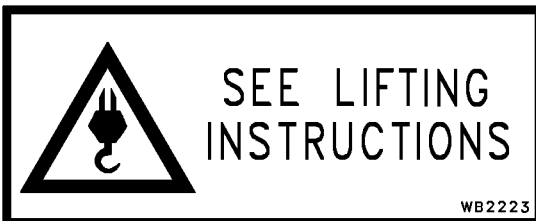
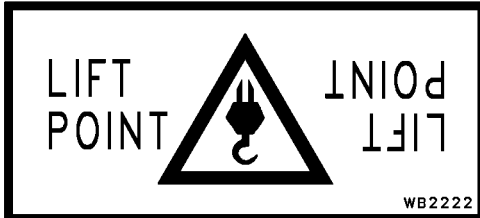

### PRODUCT IDENTIFICATION PLATE

A product identification plate is located on the frame in front of the right side front wheel. It shows the Truck Model Number, Maximum GVW, and Product Identification Number (PIN).

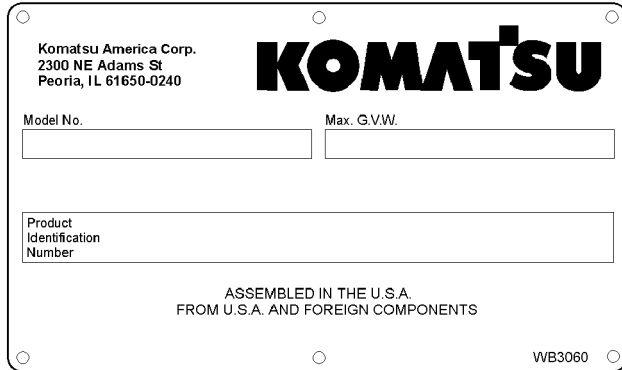

The Product Identification Number (PIN) consists of a total of 19 characters. The first and last characters are tamper preventive symbols (\*). The remaining 17 alpha/numeric characters are used to identify the following five characteristics of the machine:

**WMC** - Character positions 1, 2 and 3 identify the Worldwide Manufacturer Code (WMC). The WMC designates the manufacturer of the product. Komatsu brand products are identified with the letters KMT.

**MDS** - Character positions 4, 5, 6, 7 and 8 identify the Machine Descriptor Section (MDS). The MDS code identifies general information regarding machine specifications. The MDS is a code for the machine type and model.

**CL** - Character position 9 identifies the Check Letter (CL). The CL is used to verify the accuracy of the individual PIN.

**FC** - Character positions 10 and 11 identify the Factory Code (FC). The FC identifies the Komatsu factory in charge of claims for the product. The FC for electric drive trucks is 61.

**SN** - Character positions 12, 13, 14, 15, 16 and 17 identify the Serial Number (SN). The SN is a unique sequential number.

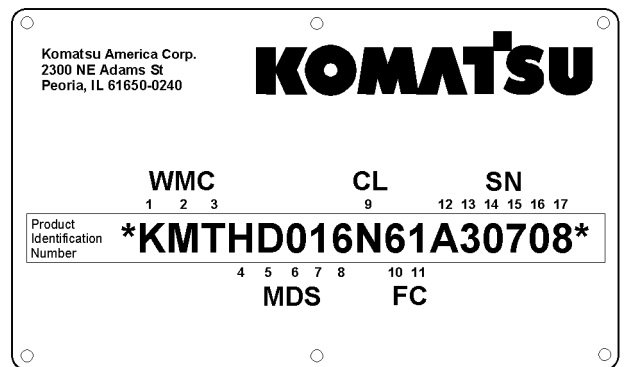

## LUBRICATION CHART

The lubrication chart is mounted on the right hand side of the radiator grille structure. Refer to Section 40, Lubrication and Service, for more complete lubrication instructions.

# LUBRICATION CHART

LUBRICATION SPECIFICATIONS											
LUBE KEY	TYPE LUBRICANT										
A	ENGINE OIL ----- SEE ENGINE MANUAL										
B	HYDRAULIC OIL ----- SAE 10W C-4 -----					AUXILIARY HEATERS REQUIRED BELOW -10°F(-23°C)					
C	HEAVY-DUTY SYNTHETIC GEAR OIL ----- SEE DRIVE SYSTEM MANUAL										
D	MULTI-PURPOSE EXTREME PRESSURE GREASE ----- NLGI NO.2 (5% MIN. MOLY-DISULFIDE)										
E	MULTI-PURPOSE GEAR OIL ----- SAE 80W-90										
SYM	DESCRIPTION	PTS	LUBE KEY	10 HR	50 HR	100 HR	250 HR	500 HR	1000 HR	2000 HR	2500 HR
1	CRANKCASE OIL LEVEL	1	A	CHECK							
2	ENGINE LUBE OIL FILTERS				SEE ENGINE MANUAL						
3	FUEL FILTER										
4	FUEL SEPERATOR (DAVCO)										
5	FUEL TANK	1					DRAIN H <sub>2</sub> O & SEDIMENT				
6	GE PREFILTER BLOWER	1	D				GREASE				
7	FUEL TANK BREATHER	1							CLEAN		
8	HYDRAULIC OIL LEVEL	1	B	CHECK					*CHANGE		
9	HYDRAULIC STRAINER	2							CLEAN		
10	HYDRAULIC TANK BREATHER	2							CHANGE		
11	HYDRAULIC FILTERS	3			**	**	**		CHANGE		
12	MOTORIZED WHEEL OIL LEVEL	2	C						SEE DRIVE SYSTEM MANUAL		
13	HYD. PUMP DRIVE SHAFT	2	D						GREASE		
14	CHASSIS LUBE LEVEL	1	D						GREASE		
15	SEAT SLIDES & STEER SHAFT	4	D						GREASE		
16	WHEEL MOTOR BLOWER	2	D						GREASE		
17	FRONT WHEEL BEARINGS ***	2	E						CHECK		CHANGE
18	FRONT TRUNION	1	D						GREASE		
19	MAGNETIC PLUG FRONT WHL COVER ****	2							CHECK		

\* 1000 HR INTERVAL CAN BE EXTENDED TO 2500 HR PROVIDED OIL SAMPLING AND ANALYSIS IS CONDUCTED EVERY 250 HR.  
 \*\* ONE-TIME CHANGE AT 50, 100 AND 250 HR.  
 \*\*\* NOT APPLICABLE FOR 930E  
 \*\*\*\* APPLICABLE FOR 930E ONLY

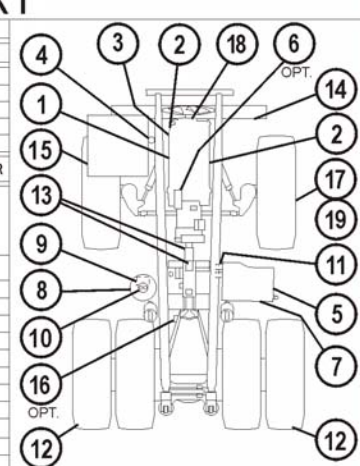

630E, 730E, 830E, & 930E

WB2790



## OPERATING INSTRUCTIONS

### PREPARING FOR OPERATION

The safest trucks are those which have been properly prepared for operation. At the beginning of each shift, a careful check of the truck should be made before attempting to start the engine.

Safety is thinking ahead. Prevention is the best safety program. Prevent a potential accident by knowing the employer's safety requirements, all necessary job site regulations, and use and care of the safety equipment on the truck. Only qualified operators or technicians should attempt to operate or maintain a Komatsu truck.

Safe practices start before the operator gets to the equipment.

- Wear the proper clothing. Loose fitting clothing, unbuttoned sleeves and jackets, jewelry, etc., can catch on a protrusion and cause a potential hazard.
- Always use the personal safety equipment provided for the operator such as hard hats, safety shoes, safety glasses or goggles. There are some conditions when protective hearing devices should also be worn for operator safety.
- When walking to and from the truck, maintain a safe distance from all machines, even if the operator is visible.

### WALK AROUND INSPECTION

At the beginning of each shift, a careful walk around inspection should be performed before attempting to start the engine. A walk around inspection is a systematic ground level inspection of the truck and its components to ensure that the truck is safe to operate before entering the operator's cab.

Start at the left front corner of the truck (see the illustration on the next page) and move in a counterclockwise direction. Move front-to-rear, across the rear, and continue forward up the opposite side of the truck to the original starting point.

If these steps are performed in sequence and are repeated from the same point and in the same direction before every shift, many potential problems may be avoided or scheduled for maintenance. Unscheduled downtime and loss of production can be reduced as a result.

Local work practices may prevent an operator from performing all tasks suggested here. To the extent permitted, the operator should follow this routine.



***High voltage may be present on this truck! DO NOT open any electrical cabinet doors on this truck while the engine is running. Never climb on any power cables or use power cables for handholds or footholds unless the engine has been shut down and the system has been verified to be at "rest".***

1. Start at left front of truck. Visually inspect all lights and safety equipment for damage. Make sure that the lenses are clean and unbroken.

Empty the dust collectors on the left side air cleaner assemblies. (A ladder may be necessary to reach the air cleaners.) Make sure that the battery box covers are in place and secure.

2. Move in front of the left front tire. Inspect the hub and brake assemblies for leaks and any abnormal conditions.
3. Make sure that all suspension mounting hardware is secure. Inspect the mounting key area for evidence of wear. Make sure that the suspension extension (exposed piston rod) is correct and that there are no leaks.
4. Make sure that the anchor end of the steering cylinder is secure and properly greased.
5. With the engine stopped, check the engine oil level. Use the service light, if necessary.
6. Inspect the air conditioner belts for correct tension, obvious wear, and tracking. Make sure that the fan guard is secure and in good condition. When leaving this point, turn off the service light if used.
7. Move outside of the front wheel. Make sure that all of the mounting nuts/studs are in place and tight. Check the tires for cuts, damage, or bubbles. Check for evidence of incorrect tire inflation.
8. Move in behind the front wheel. Make sure that the steering cylinder is properly greased and the mounting hardware is tight. Check the suspension mounting hardware and suspension extension. Make sure that the suspension protective boot is in good condition. Inspect the hub and brakes for any unusual conditions. Check the entire area for leaks.

# START HERE

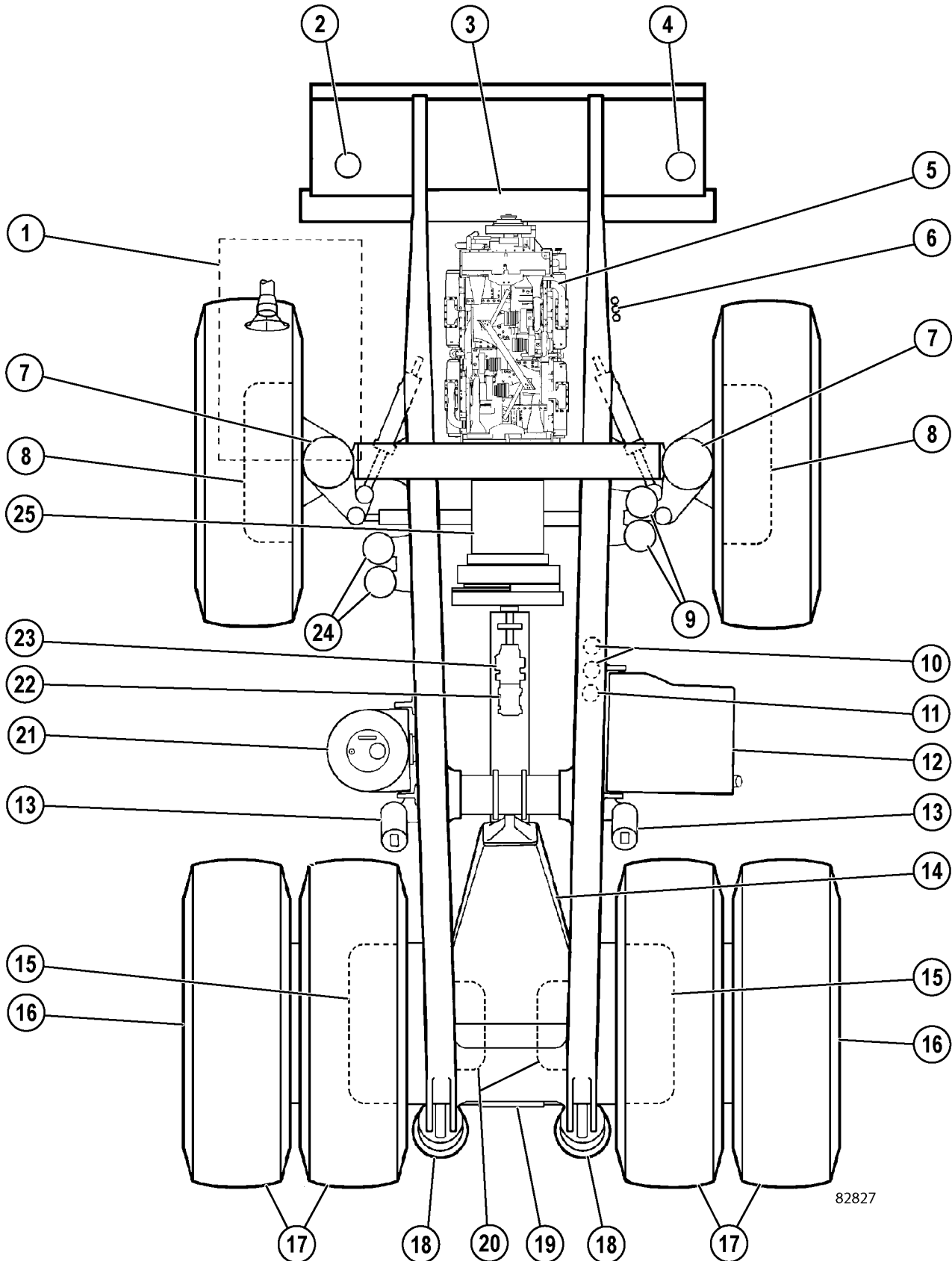

82827

FIGURE 30-1. TOP VIEW

1. Operator Cab
2. Auto Lubrication
3. Radiator
4. Reserve Oil System
5. Engine
6. Fuel Filters
7. Suspension
8. Wet Disc Brake
9. Brake Accumulators
10. Hoist Filters
11. Steering Filter
12. Fuel Tank
13. Hoist Cylinder
14. Rear Axle Housing
15. Wet Disc Brake
16. Wheel Motor Transmission
17. Rear Tires
18. Rear Suspension
19. Rear Axle Hatch
20. AC Electric Motor
21. Hydraulic Tank
22. Steering Pump
23. Hoist Pump
24. Steering Accumulators
25. Alternator

9. Inspect the sight glass on the hydraulic tank. With the engine stopped and the body down, the hydraulic oil level must be visible in the center of the upper sight glass.
10. Verify that all hydraulic tank shut-off valves are locked in their fully open positions.
11. Move around the hydraulic tank and in front of the rear dual tires. Inspect the hoist cylinder for any damage and leaks. Make sure that both upper and lower hoist cylinder pins are secure and properly greased.
12. Look under the lower edge of the chassis to make sure that the flexible duct that carries the air from the main blower to the final drive housing is in good condition. Also, look up at the main hydraulic pumps to see if there is any leakage or any other unusual condition with the pumps or pump drive shafts.

13. Move around the left side dual tires. Make sure that all wheel nuts/studs are in place and tight. Inspect the wheel for any oil that would indicate brake leakage or wheel motor leakage.

Check the dual tires for cuts, damage, and bubbles. Verify that tire inflation is correct. If the truck has been run on a "flat", the tire must be cooled before moving the truck inside. Check for any rocks that might be lodged between the dual tires.

14. Inspect the left rear suspension for damage, correct rod exposure, and leaks. Ensure that the covers over the chrome piston rod are in good condition.
15. Open the rear hatch cover. Inspect for leaks around the parking brakes. Make sure the cooling air exhaust ductwork is intact and there are no obstructions.
16. While standing at the rear hatch, look up to check that the rear lights and back-up horns are in good condition. Look up at panhard rod to check that it is properly greased. Also check both body hinge pins for proper greasing and any abnormal condition. Check the hoist limit switch and clear any mud or debris from the contacts.
17. Perform the same inspections on the right rear suspension.
18. Move around the right side dual tires. Inspect between the tires for rocks. Inspect the tires for cuts, damage and proper inflation.
19. Make sure that all wheel nuts/studs are in place and tight. Inspect the wheel for any oil that would indicate brake leakage or wheel motor leakage.
20. Move in front of right dual tires. Inspect the hoist cylinder in the same manner as the left side. Make sure the body-up limit switch is secure and in good condition. Remove any mud or dirt accumulation from the switch.
21. Move around the fuel tank. Make sure that the fuel gauge agrees with the fuel gauge in the cab. Inspect the mounting hardware for the fuel tank at the upper saddles and at the lower back side of the tank. Check the hoist filters for leaks.

22. Move in behind the right front wheel. Make sure that the steering cylinder is properly greased and the mounting hardware is secure. Check the suspension mounting hardware and suspension extension. Make sure that the suspension protective boot is in good condition. Inspect the hub and brakes for any unusual conditions. Check the entire area for leaks.
23. Move out and around the right front wheel. Make sure that all wheel nuts/studs are in place and tight.
24. Move behind the front of the right front wheel. Check the hub and brakes for leaks and any unusual conditions. Make sure that the steering cylinder is secure and properly greased. Inspect the engine compartment for any leaks and unusual conditions. Inspect the fan guard and belts. Check for any debris behind the radiator.
25. Inspect the auto lube system. See Section 42, Automatic Lubrication System, for more information about the auto lube system.
26. Move around to the right front of the truck. Empty the dust collectors on the right side air cleaner assemblies. (A ladder may be necessary to reach the air cleaners.)
27. As you move in front of the radiator, remove any debris that is stuck in front of the radiator. Check for any coolant leaks. Inspect the headlights and fog lights.
28. Before climbing the ladder to first level, make sure that the ground level engine shutdown switch is ON. Inspect the fire control actuator. Make sure that the safety pin and the plastic tie that prevents accidental actuation are in place and in good condition. Make sure that the battery disconnect switches are activated.
29. Always use handrails and ladders when mounting or dismounting the truck. Clean any foreign material such as ice, snow, oil or mud from the ladders and handrails.



***If the engine has been running, allow the coolant to cool before removing the fill cap or draining the radiator. Serious burns may result if skin comes in contact with hot coolant.***

30. Use the coolant level sight gauge to check the coolant level in the radiator. If it is necessary to remove the radiator cap, make sure that the engine is off, then relieve the coolant pressure by *slowly* removing the radiator cap.
31. Inspect the retarding grid covers. Make sure that the latches are in place and secure. Inspect the main air inlet to ensure that it is clear. Make sure that all cabinet door latches are secure.
32. Move around to the rear of the cab. Open the doors of the brake cabinet and check inside the cabinet for leaks.
33. Clean the cab windows and mirrors. Clean out the cab floor, if necessary. Make sure that the steering wheel, operator controls, and pedals are free of any grease or mud.
34. Stow any personal gear in the cab so that it does not interfere with any operation of the truck. Dirt or trash buildup, specifically in the operator's cab, should be cleared. Do not carry tools or supplies in the cab or on the deck.
35. Adjust the seat and the steering wheel for the most operator comfort.
36. Before operating the truck, read about and understand the locations and functions of all operator controls listed in Section 32, Operator Cab Controls.

**ENGINE START-UP**

**Never attempt to start the engine by shorting across the starter terminals. This may cause fire, or serious injury or death to anyone in the machine's path. Start the engine from the operator's seat only.**

**If the truck is equipped with an auxiliary cold weather heater system, do not attempt to start the engine while the heaters are in operation. Damage to the coolant heaters will result!**

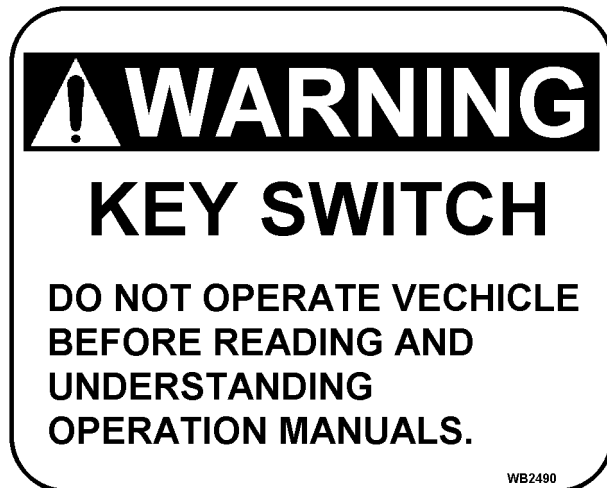

1. Make sure that all personnel are clear of the truck before starting the engine. Always sound the horn as a warning before moving any controls.
2. If the truck is in an enclosure, make sure that there is adequate ventilation before start-up. Exhaust fumes are dangerous!
3. Make sure that the directional control lever is in PARK before starting.
4. Place the rest switch in the ON position to put drive system in rest mode. For more information, refer to Section 32, Operator Cab And Controls.



**Do not crank an electric starter for more than 30 seconds. Allow two minutes for cooling before attempting to start the engine again. Severe damage to the starter motors can result from overheating.**

5. The key switch is a four-position switch (ACC, OFF, RUN, START). The ACC position is not currently used.
  - a. Turn the key switch one position clockwise to the RUN (not START) position. All electrical circuits except the start circuit are activated.
  - b. Turn the key switch fully clockwise to the START position and hold this position until the engine starts. The START position is spring-loaded and will return the switch to the RUN position when the key is released.

*NOTE: This truck is equipped with an engine prelube system. With this feature, a noticeable time delay may occur before engine cranking begins as the engine lube oil passages are being filled and pressurized.*

6. After the engine has started, place the rest switch in the OFF position to deactivate the rest mode. Refer to Section 32, Operator Cab And Controls for more information on the rest switch.

*NOTE: In cold ambient conditions and when the engine is cold, the engine rpm will not increase above low idle speed until the engine controller determines it is safe to do so. This time delay will vary from 30 seconds to 11 minutes which allows the coolant and engine oil to warm up.*

## AFTER ENGINE START-UP



**Do not leave the truck unattended while the engine is running. Move the directional control lever to *PARK* and turn off the engine before leaving the truck.**

Become thoroughly familiar with the steering, braking and emergency controls.

1. After the engine has been started and the low pressure warning systems are normal, test the steering by turning the steering wheel fully to the left and right.

If the steering system is not operating properly, turn the engine immediately. Determine the steering system problem and have it repaired before resuming operation.

2. Operate each of the truck's brake circuits at least twice before operating and moving the truck. These circuits include the service brake, parking brake, and brake lock. With the engine running and the hydraulic circuit fully charged, activate each circuit individually from the operator's cab.

If any application or release of any brake circuit appears sluggish or improper, or if warning alarms are activated, turn off the engine and notify maintenance personnel immediately. Do not operate the truck until the faulty brake circuit is fully operational.

3. Check the gauges, warning lights, and instruments before moving the truck to ensure proper system operation and proper instrument functioning. Pay special attention to the braking and steering hydraulic circuit warning lights. If warning lights come on, turn off the engine immediately and determine the cause.
4. Make sure that the headlights, worklights, and taillights are in proper working order. Check the operation of windshield wiper. Good visibility may help prevent an accident.

## PRE-SHIFT BRAKE CHECK (if equipped)

*NOTE: Komatsu recommends that operators perform static brake tests to verify that the braking systems are adequate at the beginning of each shift before operating the truck.*

The static brake test allows the operator to check the service brake, parking brake and the dynamic retarder. The purpose of these tests is to verify the functionality of the service brake, parking brake and retarder systems at the time they are tested.

After performing each test, it is the operator's responsibility to determine if the truck passed each test and if the truck is safe for operation.

The order of performing the brake tests, (service brake, parking brake or retard system) does not matter. Each brake test is a separate test, where one brake system or all three can be tested at any time.

If an operator has questions during brake testing, refer to the drive system Diagnostic Information Display (DID) panel, located on the back wall of the cab for guidance.



***If the truck fails any brake test, notify maintenance personnel immediately. Do not resume operation unless the truck passes all brake tests.***

### Events

The following events have been added to the drive system software to support the brake test feature.

- 645-1 Service Brake test Performed
- 645-2 Parking Brake Test Performed
- 645-3 Retard Test Performed
- 645-4 Brake Test Switch stuck closed

The Events Log will record when and which brake tests have been performed.

## OPERATION

The static brake test utilizes a momentary switch and a check light located in the overhead display panel.

### Brake Test Switch

The brake test switch is used to initiate a brake test. Press on the momentary switch to enter the brake test mode. If certain conditions are met, the operator can enter a brake test sequence.

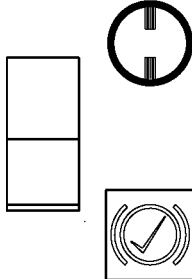

### Brake Check Light

The amber light is used to indicate when the truck is in the brake test mode. When illuminated, a brake test is ready. When flashing, the brake test is at the validation point, or the retard system test is finished.



### Description

The operator can choose which brake test to perform, and will set the truck controls based on the settings in Table 1. The drive system will detect the position of the directional control lever, and will prepare for the appropriate test. The operator will then press the brake test switch.

If the brake check light is illuminated solid after pressing the brake test switch, the system is in brake test mode and is ready for the chosen test to be initiated by the operator. After testing, the operator will then determine if the truck passed the brake tests, and if it is safe for operation.

If the brake check light does not illuminate immediately after pressing the brake test switch, there is most likely a problem with the setup. Refer to the setup conditions and take action to prepare the truck for a brake test.

If there is a problem with the truck setup, the DID panel will display the problem.

For example if the engine is off:

ERROR Entering Brake Test  
Engine not running

If the Truck is loaded:

ERROR Entering Brake Test  
Truck is NOT Empty

If all of the conditions are correct, except the brakes are not set correctly, an error message will be displayed. For example, if the service brake and parking brake are both applied together:

ERROR Entering Brake Test  
Set Brakes for Test

### Brake Test Exit Criteria

Numerous conditions can occur which may interrupt a brake test, including the following:

- Any of the setup conditions becoming false
- Drive system fault which restricts the LINK or Propel mode
- Truck Speed greater than 3.2 kph (2.0 mph)
- Drive system at torque level for more than 30 seconds
- Brake test requested, but not initiated by the operator within 60 seconds after pressing the brake test switch

Test Type	Wheel Brake Lock	Service Brake Pedal	Directional Control Lever
Service Brake	OFF	FULLY APPLIED	NEUTRAL
Parking Brake	OFF	RELEASED	PARK
Retard Test	OFF	RELEASED	PARK

## PERFORMING THE BRAKE TESTS

### Setup

Before performing any brake test, the following conditions must be met:

- Dump body empty

*NOTE: The drive system will not enter any brake test if the truck is loaded.*

- Truck located outside on a flat area, where truck movement is allowed.

- 



***Ensure the area around the truck is free of personnel and objects. Some truck movement could occur during brake testing.***

***The drive system is unable to determine if the truck is on a hill or in a parking ditch. Testing during these conditions will affect test results.***

Before performing any brake test, the truck must be in the following state:

- Engine on (low idle)
- Drive system ready (Ready Mode)
- Dump body down
- No drive system warning lights ON (Can not be in LIMP mode.)
- Zero ground speed

### Service Brake Test

1. Firmly depress the service brake pedal.
2. Place the directional control lever in the NEUTRAL position. Ensure the wheel brake lock switch is OFF.
3. Press the brake test switch and wait for the brake check light to be on solid.
4. Fully depress the service brake pedal. Ensure full brake application is reached. Failure to reach full brake application will affect the service brake test results.
5. The DID panel will display:

Service Brake Test READY  
Press Accel Pedal to Start

6. With the service brake pedal still fully applied, fully depress the accelerator pedal. The drive system controller will enter propel mode and generate torque up to the service brake limit. Maintain full service brake pressure during the test.

*NOTE: The drive system can only detect if the service brakes are applied. It can not detect the percentage of application. It is up to the operator to press hard enough on the service brake pedal to achieve a full brake application.*

7. The DID panel will display:

Service Brake Test ACTIVE  
Check Truck Movement when Light Flashes

8. Once torque has reached the limit for the service brake test, the brake check light will begin to flash. This is the indication for the operator to make a determination as to the status of the service brake system.

- **If the truck did not move:**

The service brake system passed the test.

- **If the truck moved during the test:**

The service brake system failed the test.



9. Release the accelerator pedal and the torque will be reduced, the test will stop and the brake check light will turn off.
10. Place the directional control lever in the PARK position. Release the service brake pedal.
11. If the truck failed the service brake test, notify maintenance personnel immediately.

## **WARNING**

***If the truck fails the service brake test, notify maintenance personnel immediately. Do not resume operation unless the truck passes all brake tests.***

*NOTE: If the operator partially or fully releases the accelerator pedal during the test, torque will be reduced and the brake check light will go back on solid when torque falls below the test set point. The operator can re-apply the accelerator pedal to increase torque and the brake check light will again flash when the torque is at the test limit.*

If the test exits abnormally, or if the operator simply does not press the accelerator pedal far enough to achieve the torque level for the service brake test, the DID panel will display:

Brake Test ERROR  
Test did NOT complete

### **Parking Brake Test**

1. Place the directional control lever in the PARK position.
2. Press the brake test switch and wait for the brake check light to be on solid.
3. The DID panel will display:

Parking Brake or Retard Test READY  
Press Accel or Retard Pedal to Start

4. Fully depress the accelerator pedal. The drive system controller will enter propel mode and generate torque up to the park brake limit.
5. The DID panel will display:

Park Brake Test ACTIVE  
Check Truck Movement when Light Flashes

6. Once the torque has reached the limit for the parking brake test, the brake check light will begin to flash. This is the indication for the operator to make a determination as to the status of the parking brake system.

- **If the truck did not move:**

The park brake system passed the test.

- **If the truck moved during the test:**

The park brake test has failed. Release the accelerator pedal. If the truck starts to roll, apply the service brakes to hold the truck stationary. Notify maintenance personnel immediately.

## **WARNING**

***If the truck fails the parking brake test, notify maintenance personnel immediately. Do not resume operation unless the truck passes all brake tests.***

7. When the operator releases the accelerator pedal, torque will be reduced, the test will stop and the brake check light will turn off.

## Retard System Test

1. Place the directional control lever in the PARK position.
2. Press the brake test switch and wait for the brake check light to be on solid.
3. The DID panel will display:

Parking Brake or Retard Test READY  
Press Accel or Retard Pedal to Start

4. Fully depress the retard pedal. The drive system controller will ramp up the engine speed, close RP1, close RP2, close RP3 (if present), turn on the choppers, and test the retarding system. The system will verify current flow through each grid leg and the grid blower motor.
5. The DID panel will display the current status of the test.

Retard System Test ACTIVE  
RP1 RP2 RP3 CHOP

(Elements are added as the test progresses.)

6. Upon successful completion of the test, the light will flash for 10 seconds indicating a successful test. The DID panel will display:

Retard System Test PASSED

or

Retard System Test FAILED or Incomplete

*NOTE: If the brake check light never flashes, but turns off, the test has failed.*



***If the truck fails the retard system test, notify maintenance personnel immediately. Do not resume operation unless the truck passes all brake tests.***

7. When the operator releases the retard pedal, the test will stop and the brake check light will turn off.
8. If the retard system failed the test, notify maintenance personnel immediately. Do not resume operation unless the truck passes all brake tests.

## EMERGENCY STEERING SYSTEM

### Operation

This truck is equipped with an emergency steering system. This system is a backup in the event of loss of oil supply to the main steering system. The emergency steering system was designed to meet or exceed SAE J1511 and ISO 5010 standards.

If the low steering system pressure indicator light and alarm are activated, a failure in the hydraulic oil supply to the steering and brake system exists. When the alarm is activated, typically there is enough hydraulic pressure stored in the brake and steering accumulators to allow brief operation of the steering and brake functions. However, this oil supply is limited. Therefore, it is important to stop the truck as quickly and safely as possible after the alarm is first activated.

If the oil supply pressure drops to a predetermined level, the low brake pressure warning light will also illuminate. If the oil pressure continues to decrease, the brake auto-apply feature will activate the service brakes to stop the truck.

### Pre-Operation Testing

*NOTE: Komatsu recommends that operators perform this test to verify that the steering accumulator precharge pressure is adequate at the beginning of each shift before operating the truck.*

1. Park the empty truck on flat, level ground. Lower the dump body onto the frame and stop the engine. Make sure that the key switch is in the OFF position.
2. Wait at least 90 seconds to verify that all hydraulic pressure has been relieved from the steering accumulators. Turn the steering wheel from stop to stop. If the front wheels do not move, there is no hydraulic pressure.
3. Check the hydraulic tank oil level. The oil level must be visible in the center of the upper sight glass and must not cover the entire upper sight glass. Add oil if necessary. **Do not overfill.**

4. Turn the key switch to the ON position, but do not start the engine.
  - a. *Steering system pressure:* Verify that the low steering pressure warning light is illuminated. If it is not illuminated, immediately notify maintenance personnel. Do not operate the truck until the problem is corrected.
  - b. *Steering accumulator precharge:* Verify that the low accumulator precharge warning light is not illuminated and the warning buzzer is not sounding. If the warning light is illuminated and the buzzer is sounding, immediately notify maintenance personnel. Do not operate the truck until the problem is corrected.
5. Start the engine and allow the steering accumulators to fully charge. Turn the steering wheel so that the front wheels are straight.
6. Check the hydraulic tank oil level while the engine is on.
  - a. If the oil level is visible in center of the lower sight glass and does not cover the entire lower sight glass, the steering accumulators are adequately charged. Proceed to Step 7.
  - b. If the oil level is below the lower sight glass, the steering accumulators are not adequately charged. Stop the engine and turn the key switch to the OFF position. Immediately notify maintenance personnel. Do not operate the truck until the problem is corrected.
7. If the steering accumulators are adequately charged, stop the engine by using the emergency shutdown switch. Leave the key switch in the ON position. This allows the steering accumulators to retain their hydraulic charge. The low steering pressure warning light and the low accumulator precharge warning light should not illuminate.
8. Turn the steering wheel from stop to stop. The front wheels should turn fully to the left and to the right. Also, the low steering pressure warning light should illuminate and the warning buzzer should sound.
 

If the front wheels cannot be turned fully to the left and right, or if the warning light and buzzer do not activate, immediately notify maintenance personnel. Do not operate the truck until the problem is corrected.

If the truck passes this test, the emergency steering system is functioning properly.

## MACHINE OPERATION SAFETY PRECAUTIONS

After the engine is started and all systems are functioning properly, the operator must follow all local safety rules to ensure safe machine operation.



***If any of the red warning lights come on or if any gauge reads in the red area during truck operation, a malfunction is indicated. Stop the truck as soon as possible and turn off the engine. Have the problem corrected before resuming truck operation.***



***The truck is equipped with "slip/slide" control. If this function becomes inoperative, operating the truck with stalled or free spinning wheel motors may cause serious damage to the wheel motors. If the truck does not begin to move within 10 seconds after depressing the throttle pedal with the directional control lever in a F or R position, release the throttle pedal and allow the wheels to regain traction before accelerating again.***

- Always look to the rear before backing the truck. Watch for and obey the ground spotter's hand signals before making any reverse movements. Sound the warning horn (three blasts). The spotter should have a clear view of the entire area at the rear of the truck.
- Operate the truck only while properly seated with seat belt fastened. Keep hands and feet inside the cab while the truck is in operation.
- Do not allow unauthorized personnel to ride in or on the truck. Do not allow anyone to ride on the ladder of the truck.
- Check the gauges and instruments frequently during operation for proper readings.
- Observe all regulations pertaining to the job site's traffic pattern. Be alert to any unusual traffic pattern. Obey the spotter's signals.

- Match the truck speed to haul road conditions. Slow down the truck in congested areas. Keep a firm grip on the steering wheel at all times.
- Do not allow the engine to run at idle for extended periods of time.
- When the truck body is in the dump position, do not allow anyone beneath it unless the body-up retaining pin or cable is in place.



***Do not use the brake lock or the emergency brake (if equipped) for parking. With the engine stopped, hydraulic pressure will bleed down, allowing the brakes to release.***

- Check the brake lock performance periodically for safe loading and dump operation.
  - Proceed slowly on rough terrain to avoid deep ruts or large obstacles. Avoid traveling close to soft edges or the edge of a fill area.
  - Do not drive over unprotected power cables.
  - Truck operation requires concentrated effort by the driver. Avoid distractions of any kind while operating the truck.
4. When backing up the truck, give a back-up signal of three blasts on the horn. When starting forward, give two blasts on the horn. These signals must be given each time the truck is moved forward or backward.
  5. Use extreme caution when approaching a haul road intersection. Maintain a safe distance from oncoming vehicles.
  6. Maintain a safe distance when following another vehicle. Never follow another vehicle in the same lane closer than 15 m (50 ft). When driving on a downgrade, this distance should be at least 30 m (100 ft).
  7. Do not stop or park on a haul road unless it is unavoidable. If you must stop, move the truck to a safe place, move the directional control lever to PARK and turn off the engine before leaving the cab. Chock the wheels securely and notify maintenance personnel for assistance.
  8. Before driving up or down a grade, maintain a speed that will ensure safe driving and provide effective retarding under all conditions. Refer to Dynamic Retarding in Section 32, Operator Cab And Controls. Refer to the grade/speed chart in the operator's cab to determine the maximum safe truck speeds for descending various grades with a loaded truck.
  9. When operating the truck in darkness, or when visibility is poor, do not move the truck unless all headlights, clearance lights, and tail lights are on. Do not back up the truck if the back-up horn or lights are inoperative. Always dim the headlights when meeting oncoming vehicles.
  10. If the emergency steering light and/or low brake pressure warning light illuminate during operation, steer the truck immediately to a safe area away from other traffic, if possible, and stop the truck. Refer to Step 7.
  11. Check the tires for proper inflation periodically during your shift. If the truck has been run on a "flat", or under-inflated tire, it must not be parked in a building until the tire cools.

## **OPERATING ON THE HAUL ROAD**

1. Always stay alert! If you are unfamiliar with the road, drive with extreme caution. The cab doors should remain closed at all times if the truck is in motion or unattended.
2. Obey all road signs. Operate the truck so it is under control at all times. Govern the truck speed by the road conditions, weather, and visibility. Report poor haul road conditions immediately. Muddy or icy roads, pot holes, or other obstructions can present hazards.
3. Initial propulsion with a loaded truck should begin from a level surface whenever possible. If there are circumstances where starting on a hill or grade cannot be avoided, refer to Starting On a Grade With a Loaded Truck.

## STARTING ON A GRADE WITH A LOADED TRUCK

Initial propulsion with a loaded truck should begin from a level surface whenever possible. If the truck must be started on a hill or grade, use the following procedure:

1. Fully depress the service brake pedal. Do not use the retarder lever to hold the truck on the grade. With the service brakes fully applied, move the directional control lever to a drive position (FORWARD or REVERSE) and increase the engine rpm with the throttle pedal.
2. As the engine rpm approaches the maximum, and the operator senses the propulsion effort working against the brakes, release the brakes and let truck movement start. Completely release the service brake pedal. As the truck speed increases above 5-8 kph (3-5 mph), the propulsion system controller (PSC) will drop the propulsion if the retarder is still applied.

*NOTE: Releasing and re-applying dynamic retarding during a hill start operation will result in loss of propulsion.*

## PASSING

1. Do not pass another truck on a hill or blind curve. Only use areas designated for passing.
2. Before passing, make sure that the road ahead is clear. If a disabled truck is blocking your lane, slow down and pass with extreme caution.

## LOADING

1. Pull into the loading area with caution. Remain at a safe distance while the truck ahead is being loaded.
2. When approaching or leaving a loading area, watch out for other vehicles and personnel working in the area.
3. When pulling in under a loader or shovel, follow the spotter or shovel operator's signals. The truck operator may speed up loading operations by observing the location and loading cycle of the truck being loaded ahead, then follow a similar pattern.
4. During loading, the operator must stay in the cab with the engine running. Place the directional control lever in NEUTRAL and apply the brake lock.
5. When loaded, pull away from shovel as quickly as possible but with extreme caution.

## Overload Speed Limit Function

*NOTE: This feature can be enabled or disabled at the discretion of site management. The setting for payload trigger and speed limits are also adjustable by local site preference.*

The overload speed limit function limits the speed of the truck if a payload limit setting has been exceeded. The overload signal becomes true (24 volts) when the PLMIII early estimate of payload exceeds the preset payload ton threshold.

The PLMIII early estimate of payload calculation occurs after 12 seconds of travel above 5 kph (3 mph) after being loaded. Once the overload signal becomes true, it stays true until the payload is dumped.

By default, the overload speed limit is disabled (option 0 in the configuration file). The configuration file can be set to:

Option 1 - Overload speed limit is imposed.

or

Option 2 - No propel restriction is imposed and logged. The truck cannot move under its own power when the overload signal becomes true.

The overload speed limit can be adjusted by modifying the configuration file. Use the Payload Service Software Lite Version (available for download at [www.KomatsuAmerica.net](http://www.KomatsuAmerica.net)) to set the overload threshold.

When option 1 is selected, and the overload signal is true, tractive effort is reduced to attempt to respect the speed limit setting. The retard effort will not be engaged to lower the speed of the truck. Once the truck speed matches that of the overload speed limit setting, limited propel efforts and retarding efforts will be used as necessary. This feature maintains the truck speed at the maximum of the overload speed limit setting.

## DUMPING

### Raising The Dump Body

1. Pull into the dump area with extreme caution. Make sure the area is clear of persons and obstructions, including overhead utility lines. Obey signals directed by the spotter, if present.
2. Avoid unstable areas. Stay a safe distance from the edge of the dump area.



***To prevent tipping or rolling, position the truck on a solid, level surface before dumping. As the body raises, the truck center of gravity will move.***

3. Carefully maneuver the truck into the dump position. When backing the truck into the dump position, use only the foot-operated brake pedal to stop and hold the truck. Do not rely on the wheel brake lock to stop the truck. This control is not modulated and applies the **rear service brakes only**.
4. When the truck is stopped and in the dump position, apply the brake lock and move the directional control lever to NEUTRAL.



***Dumping very large rocks (10% of payload or greater) or sticky material (loads that do not flow freely from the body) may allow the material to move too fast and cause the body to move rapidly and suddenly. This sudden movement may jolt the truck violently and cause possible injury to the operator and/or damage to the hoist cylinders, frame, and/or body hinge pins.***

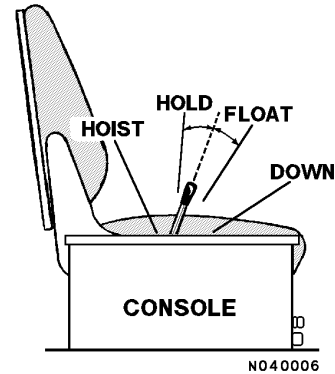

5. Pull the lever to the rear to actuate the hoist circuit. Releasing the lever anywhere during "hoist up" will hold the body at that position.
6. Raise the engine rpm to accelerate the hoist speed. If dumping very large rocks or sticky material as described in the WARNING above, slowly accelerate the engine to raise the body. When the material starts to move, release the hoist lever to the HOLD position. If the material does not continue moving and clear the body, repeat this procedure until the material has cleared the body.
7. Reduce the engine rpm as the last stage of the hoist cylinder begins to extend. Let the engine go to low idle as the last stage reaches half-extension.
8. Release the hoist lever as the last stage of the hoist cylinder reaches full extension.
9. After the material being dumped clears the body, lower the body to the frame.

***NOTE: If the directional control lever is in REVERSE when the dump body is raised, reverse propel is inhibited. To deactivate, lower the dump body and move the directional control lever out of REVERSE.***

### Lowering The Dump Body (When dumping on flat ground)

It is very likely when dumping on flat ground that the dumped material will build up enough to prevent the body from lowering. In this case, the truck will have to be driven forward a short distance (just enough to clear the material) before the body can be lowered.

1. Move the directional control lever to FORWARD, release the brake lock, depress the override button, and drive just far enough forward for the body to clear the material.
2. Stop, move the directional control lever to NEUTRAL, and apply the brake lock.
3. Move the hoist lever forward to the DOWN position. Release the lever to place the hoist control valve in the FLOAT position, which allows the body to return to the frame.

If dumped material builds up at the rear of the body and the body cannot be lowered, then perform the following steps:

- a. Move the hoist lever back to the RAISE position to fully raise the dump body. Then release the hoist lever so it returns to the HOLD position.
- b. Move the directional control lever to FORWARD, release the brake lock, depress the override button, and drive forward to clear the material.
- c. Stop, move the directional control lever to NEUTRAL, apply the brake lock, and lower the body.

*NOTE: Failure to hoist the body after making an unsuccessful attempt at lowering the body may result in the dump body suddenly lowering after the truck has pulled ahead of the material that was previously preventing the body from lowering.*



**Do not move the truck with the dump body raised except in an emergency. Failure to lower body before moving truck may cause damage to hoist cylinders, frame and/or body hinge pins.**

4. With the body returned to frame, move the directional control lever to FORWARD, release the brake lock, and leave the dump area carefully.

### Lowering The Dump Body (When dumping over a berm or into a crusher)

1. Move the hoist lever forward to the DOWN position. Release the lever to place the hoist control valve in the FLOAT position, which allows the body to return to the frame.

If dumped material builds up at the rear of the body and the body cannot be lowered, perform the following steps:

- a. Move hoist lever back to the HOIST position to fully raise the dump body. Release the hoist lever so it returns to the HOLD position.

*NOTE: Do not drive forward if the tail of body will not clear the crusher wall in the fully raised position.*

- b. Move the directional control lever to FORWARD, release the brake lock, depress the Override button, and drive forward to clear the material.

- c. Stop, move the directional control lever to NEUTRAL, apply the brake lock and lower the body.

*NOTE: Failure to hoist the body after making an unsuccessful attempt at lowering the body may result in the dump body **suddenly lowering** after the truck has pulled ahead of the material that was previously preventing the body from lowering.*



**Do not move the truck with the dump body raised except in an emergency. Failure to lower the body before moving the truck may cause damage to the hoist cylinders, frame and/or body hinge pins.**

2. With the body returned to the frame, move the directional control lever to FORWARD, release the brake lock, and leave the dump area carefully.

## TOWING



***Before towing a truck, many factors must be carefully considered. Serious personal injury and/or significant property damage may result if important safety practices, procedures and preparation for moving heavy equipment are not observed.***

A disabled machine may be towed after the following precautions have been taken.

- Do not tow the truck any faster than 8 kph (5 mph).
- Tow with a solid tow bar. DO NOT tow with a cable. Use a towing device with ample strength for the weight of this truck.
- Never tow a truck on a slope.
- Inspect towing components, such as tow bars and couplings, for any signs of damage. Never use damaged or worn components to tow a disabled vehicle.
- Keep a safe distance from the trucks and towing apparatus while towing a vehicle.
- When connecting a truck that is to be towed, do not allow anyone to go between the tow vehicle and the disabled vehicle.
- Set the coupling of the truck being towed in a straight line with the towing portion of the tow truck, and secure it in position.
- An operator is to remain in the cab of the towed vehicle at all times during the towing procedure.

## Special Wiring Harness

Before towing, a special wiring harness must be made in order to release the parking brake. The harness will require approximately 9 meters (30 ft) of #14 wire, and one ON/OFF switch (capable of carrying 2 amps of current) and two ring terminals. Using a ring terminal, one end of the wire must connect to a 24VDC bus bar (1, Figure 30-7) in the auxiliary control cabinet to supply 24V to the solenoid. Switch (2) must be positioned in the harness so the operator can operate the switch while seated in the operators seat. The harness must be fitted with a connector (4) to allow it to be plugged into parking brake solenoid (3) inside the brake cabinet. Wire (5) leading from this connector is to be connected to the ground block using a ring terminal. Refer to Figure 3-7 for an overview of the special wiring harness when installed on the truck.

The parts required to connect to the solenoid are:

- one housing (PB8538)
- two sockets (08191-05430)
- one wedge (PB8540)

1. Shut the engine off.
2. Block the wheels on the disabled truck to prevent movement while preparing the truck for towing and while attaching the tow bar.
3. Ensure the towing vehicle has adequate capacity to both move and stop the towed truck under all conditions.
4. Ensure that the tow bar has adequate strength (approximately 1.5 times the empty vehicle weight of truck being towed). Install tow bar between the two vehicles.
5. If necessary, install quick disconnect fittings to the bleeddown manifold to allow the hydraulic system to be operational. Install hydraulic connections for steering/braking between the tow vehicle the and disabled vehicle. An auxiliary power unit can also be used.
6. After the hydraulic connections are made, check the disabled vehicle braking and steering systems for normal operation.
7. If the truck is loaded, dump the entire load. Never pull or tow a loaded truck. Refer to "Disabled Truck Dumping Procedure".



8. The parking brakes must be released before towing. To release the parking brake, follow the steps below to install a special wiring harness to release the parking brakes.
  - a. Ensure switch (1) is in the OFF position.
  - b. Connect one lead of the special wiring harness to the 24VDC bus bar terminal on the side wall in the auxiliary control cabinet for the 24V supply.
  - c. Disconnect the truck wiring harness from parking brake solenoid (2, Figure 30-8). Connect special wiring harness (3, Figure 30-9) to the parking brake solenoid. Attach short lead (2) to ground.
  - d. With the window lowered, place the end of the special wiring harness inside the cab so the operator can control switch (1).
9. When ready to tow the disabled truck, remove blocking from the wheels.
10. The operator in the disabled truck should now move switch (1) to the ON position. This will release the parking brakes.
11. Tow the disabled truck. Sudden movement may cause tow bar failure. Smooth, gradual truck movement is preferred. Do not tow the truck any faster than 8 kph (5 mph).

12. Minimize the tow angle at all times. **Never exceed 30 degrees.** The towed truck must be steered in the direction of the tow bar.
13. When the desired location has been reached, the operator in the towed vehicle is to apply the service brakes, then turn switch (1) to the OFF position. This will apply the parking brakes.
14. Block the wheels to prevent roll-away.
15. Shut down the engine in the pulling vehicle. Disconnect the hydraulic hoses.
16. Disconnect special wiring harness (3) from the truck. Connect the truck wiring harness back to the parking brake solenoid.
17. Disconnect the tow bar.

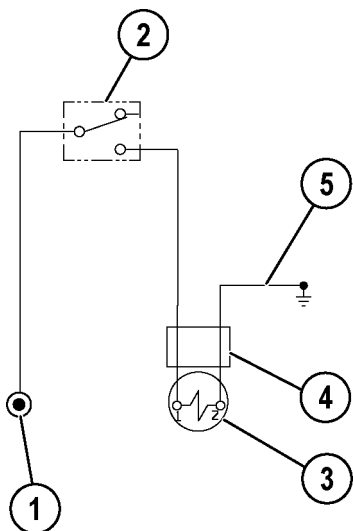

82834  
FIGURE 30-1. PARKING BRAKE HARNESS

- |                        |                |
|------------------------|----------------|
| 1. 24VDC Bus Bar       | 4. Connector   |
| 2. Switch (ON/OFF)     | 5. Ground Wire |
| 3. Park Brake Solenoid |                |

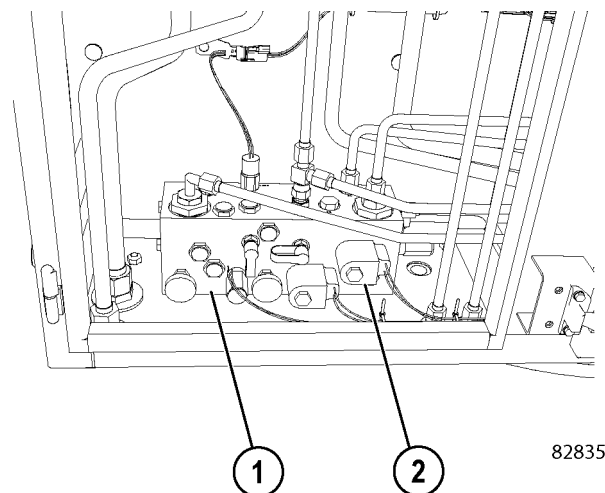

82835  
FIGURE 30-2. BRAKE CABINET

- |                   |                           |
|-------------------|---------------------------|
| 1. Brake Manifold | 2. Parking Brake Solenoid |
|-------------------|---------------------------|

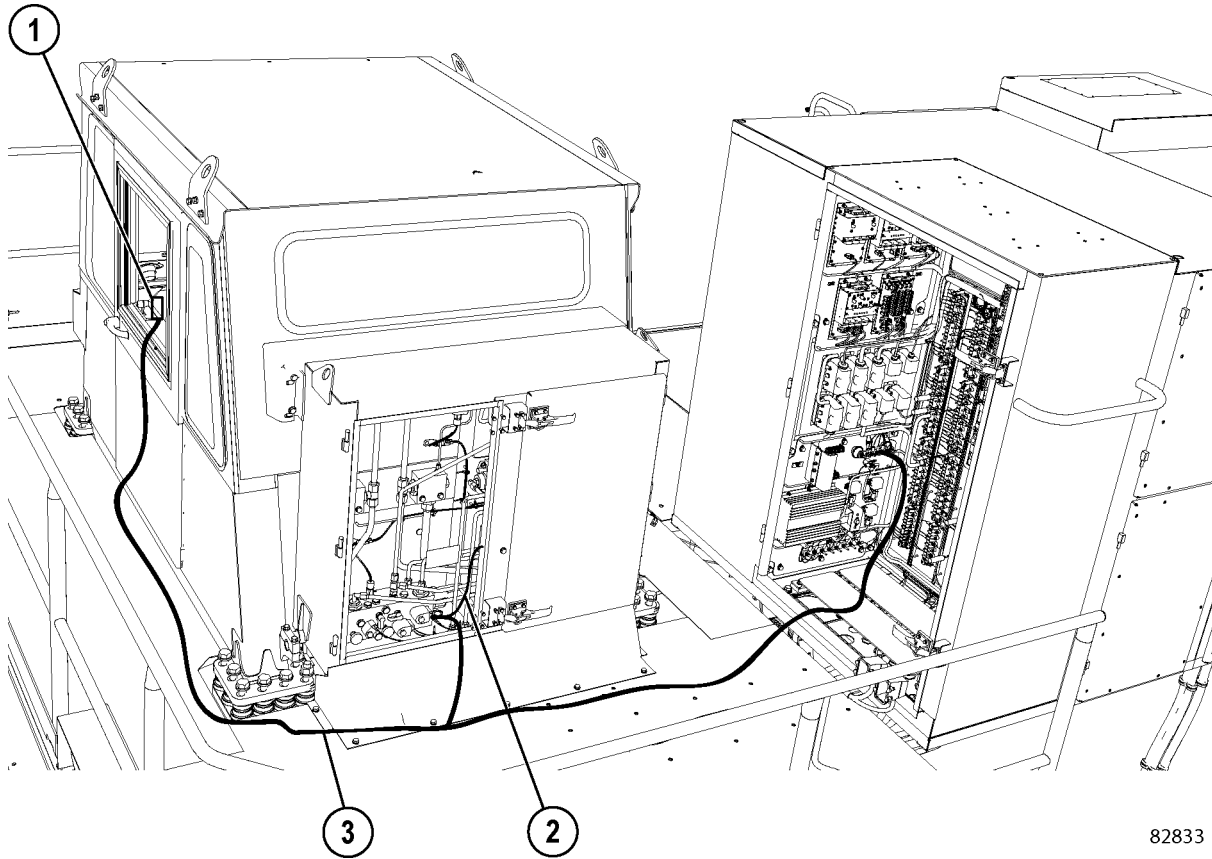

82833

FIGURE 30-3. PARKING BRAKE WIRING FOR TOWING

1. Switch

2. Ground Wire

3. Harness

## SAFE PARKING PROCEDURES

Continue to use safety precautions when preparing for parking and engine shutdown.

If the truck is being used in consecutive shifts, any questionable truck performance the operator may have noticed must be checked by maintenance personnel before the truck is released to another operator.

1. Park the truck on level ground, if possible. If the truck must be parked on a grade, position the truck at a right angle to the grade.
2. The directional control lever must be in PARK and chocks must be placed in front of and behind the wheels to help prevent the truck from rolling. Each truck should be parked at a reasonable distance from one another.



***Do not activate the wheel lock feature when the parking brake is activated. Bleed down of hydraulic pressure may occur, causing the truck to roll away.***

3. Haul roads are not safe parking areas. In an emergency, pick the safest spot that is most visible to other machines in the area. If the truck becomes disabled where traffic is heavy, mark the truck with warning flags in daylight or flares at night.

## NORMAL ENGINE SHUTDOWN PROCEDURE

Follow this procedure at each engine shutdown:

1. Stop the truck out of the way of other traffic on a level surface. Make sure that there are no overhead power lines or other obstructions in case the dump body must be raised.
2. Reduce the engine speed to idle.
3. Place the directional control lever in PARK. Make sure that the parking brake applied indicator light is illuminated.
4. Place the rest switch in the ON position to put the AC drive system in the rest mode. Make sure that the rest mode indicator light is illuminated.

5. Turn the key switch to the OFF position. A shutdown timing sequence will be activated automatically to allow the engine to cool down before it is turned off. The timing sequence may last up to three minutes.

If the engine does not shutdown with the key switch after the timing sequence is done, use the engine shutdown switch on the operator cab center console. Pull this switch up until the engine stops.

6. With the key switch OFF and engine stopped, wait at least 90 seconds. Make sure that the steering circuit is completely depressurized by turning the steering wheel back and forth several times. The front wheels should not turn when the hydraulic pressure is relieved. If the front wheels can still be turned, notify maintenance personnel.
7. Make sure that the link voltage light in the control cabinet is off. Notify maintenance personnel if a light remains illuminated for longer than five minutes after the engine is shut down.
8. Close and lock all windows. Remove the key from the key switch and lock the cab to prevent unauthorized truck operation. Dismount the truck properly. Put wheel chocks in place.

## SUDDEN LOSS OF ENGINE POWER

If the engine suddenly stops, there is enough hydraulic pressure stored in the brake and steering accumulators to allow the operation of the steering and brake functions. However, this oil supply is limited, so it is important to stop the truck as quickly and safely as possible after the loss of engine power.

If the brake supply pressure drops to a pre-determined level, the low brake oil pressure warning light will illuminate and sonalarm will sound. If the brake pressure continues to decrease, the auto-apply feature will activate and the service brakes will apply automatically to stop the truck.

1. Stop the truck as safely and quickly as possible by using the foot pedal to apply the service brakes. If possible, steer the truck to the side of the road while braking.



***Dynamic retarding will not be available. Do not use the service brakes for continuous retarding purposes.***

2. Move the directional control lever to PARK as soon as the truck has stopped moving.
3. Turn the key switch to the OFF position and notify maintenance personnel immediately.
4. If traffic is heavy near the disabled machine, mark the truck with warning flags during daylight hours or use flares at night. Adhere to local regulations.

## FUEL DEPLETION

The high pressure injection (HPI) fuel system uses fuel to adjust fuel delivery timing by creating a hydraulic link between the upper plunger and the timing plunger. Metered fuel is also used for lubricating the injector plunger and barrel. The maximum demand for metered fuel is required during high speed / low load conditions.



***Operating the truck to fuel depletion forces the injector train into a no-follow condition. No fuel flow between the plungers may cause damage to the injectors and the overhead due to adhesive wear, resulting in costly repairs and unnecessary downtime.***



***Allowing the Komatsu truck to operate until fuel depletion can lead to unsafe operating conditions possibly resulting in an uncontrollable vehicle and/or personal injury.***

## DISABLED TRUCK DUMPING PROCEDURE

Sometimes it is necessary to dump a load from the body of a truck if the hoist system is inoperable. The following instructions describe the use of a “good” truck to provide the hydraulic power required to raise the body of the “disabled” truck to dump the load.

In the following example, Figure 30-4 illustrates a typical hookup from the good truck. The disabled truck may be the same truck model or a different Komatsu truck model.

### Hookup

Make sure that there is an adequate, clear area to dump the loaded body. When the good truck is in position, turn off the engine and allow the hydraulic system to bleed down. Make sure that the pressure has bled off before connecting the hoses.

1. With the good truck parked as close as possible to the disabled truck, attach a hose from the **power up** quick disconnect (4, Figure 30-4) to the **power down** circuit of the disabled truck. The hose must be rated to withstand 17,000 kPa (2500 psi) or greater pressure.

*NOTE: The power down circuit will use a smaller diameter hose (tube) than the power up circuit.*

2. Connect another hose from the **power down** quick disconnect (3) to the **power up** circuit of the disabled truck.

*NOTE: If both trucks are the same model, the hoses will be installed at the quick disconnects shown in Figure 30-4 and **will be crossed** when connected.*

### Raising the Body

1. On the disabled truck, move the hoist control lever to power up and then release it to place the hoist pilot valve in the HOLD position (leave in this position during entire procedure).
2. Start the engine on the good truck, place the hoist control in the POWER DOWN position and increase the engine rpm to high idle to dump the disabled truck. If the body of the disabled truck fails to raise, increase the good truck power down relief pressure as follows:
  - a. Shut down engine and allow the hydraulic system to bleed down.
  - b. Remove the cap from the hoist pilot valve relief valve (2), located in the hydraulics components cabinet behind the cab. While counting the number of turns, slowly turn the relief valve adjustment screw clockwise until it bottoms. Repeat Step 2.

### Lowering the Body

1. Place the hoist lever of the good truck in FLOAT to lower the body. If necessary, momentarily place the hoist control in POWER UP until the body is able to descend in FLOAT. Do not accelerate the engine.
2. After the body is lowered, shut down the engine, bleed the hydraulic system, and disconnect the hoses.
3. Reduce the power down relief valve pressure on the good truck to normal by turning the adjustment counterclockwise the same number of turns as required in Step 2b of “Raising the Body.”
4. Check the power down relief pressure. Refer to Section L, Hydraulic Check-Out Procedure, in the shop manual.
5. Check the hydraulic tank oil level.

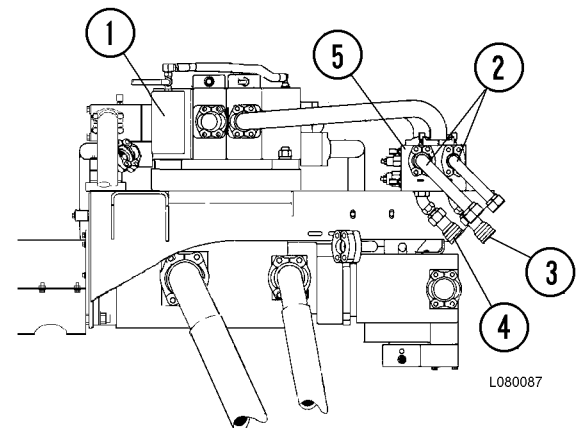

FIGURE 30-4. PUMP MODULE, HOSE HOOKUP

1. Hoist Valve
2. Tubes to LH Hoist Cylinder
3. Power Down Quick Disconnect (Connect to power up circuit of disabled truck.)
4. Power Up Quick Disconnect (Connect to power down circuit of disabled truck.)
5. Overcenter Manifold

## RESERVE ENGINE OIL SYSTEM

The reserve oil tank for the engine is designed to add more oil capacity to the engine and to allow less frequent servicing of the engine oil. The circulation of oil between the engine sump and reserve tank increases the total volume of working oil. This dilutes the effects of contamination and loss of additives and maintains the oil quality over longer periods. A filter in the supply circuit protects the pumping unit and prevents transfer of contaminants to the engine sump which might enter the tank during servicing. It also gives an added level of oil cleanup.

### Operation

Engine oil is circulated between the engine sump and the reserve tank by two electrically driven pumps within a single pumping unit (11, Figure 30-5). The pump unit is mounted on the side of the reserve tank, and is equipped with an LED monitor light on one side.

Pump 1 (in the pump unit) draws oil from the engine sump at a preset control point (determined by the height of the suction tube). Oil above this point is withdrawn and transferred to reserve tank (9). This lowers the level in the engine sump until air is drawn.

Air reaching the pumping unit activates pump 2 (in the pump unit) which returns oil from the reserve tank and raises the engine sump level until air is no longer drawn by pump 1. Pump 2 then turns off. The running level is continuously adjusted at the control point by alternation between withdrawal and return of oil at the sump.

### LED Monitor Light

- *On steadily* - Pump 1 is withdrawing oil from the engine sump and bringing down the oil level.
- *Regular pulsing* - Pump 2 is returning oil to the engine sump and raising the oil level.
- *Irregular pulsing* - Oil is on the correct running level.

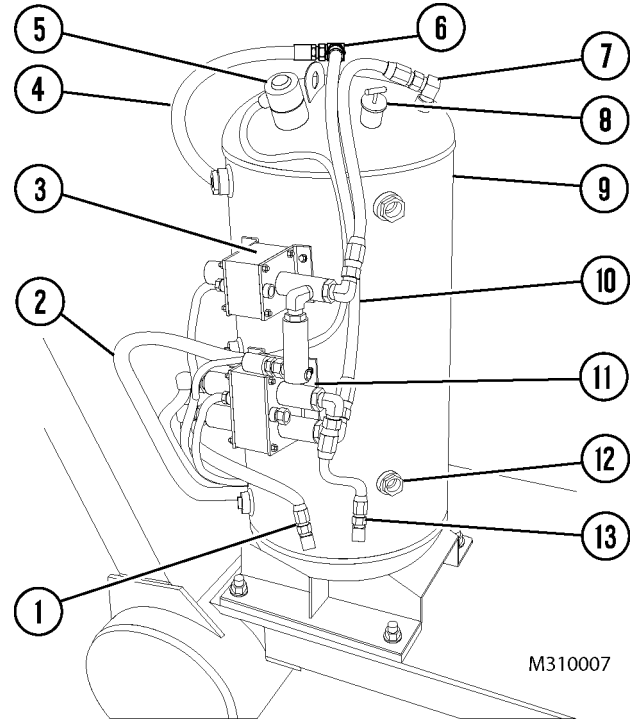

FIGURE 30-5. RESERVE ENGINE OIL SYSTEM

- |                     |                      |
|---------------------|----------------------|
| 1. Oil Suction      | 8. Fill Cap          |
| 2. Oil Tank Fill    | 9. Reserve Oil Tank  |
| 3. Fill Valve       | 10. Engine Fill Line |
| 4. Engine Fill Line | 11. Pump Unit        |
| 5. Oil Level Sensor | 12. Sight Gauge      |
| 6. Air Valve        | 13. Tank Return Line |
| 7. Tank Fill Line   |                      |

### Changing Oil

1. Drain both the engine sump and the reserve tank. Refill both engine and reserve tank with new oil to proper levels.
2. Change engine and reserve tank filters as required.
3. Start engine and check for proper operation.

**NOTE:** Do not use the oil in the reserve tank to fill the engine sump. Both must be at proper level before starting engine.

4. Check the engine oil level with the engine dipstick at every shift change. If the oil level in the engine is incorrect, check for proper operation of the reserve engine oil system.
5. The oil level in the reserve tank must also be checked at every shift change. Oil must be visible in middle sight gauge (12). If not, add oil to the reserve tank by using the quick fill system. For filling instructions, refer to Section 40, Lubrication and Service.

# OPERATOR CAB AND CONTROLS

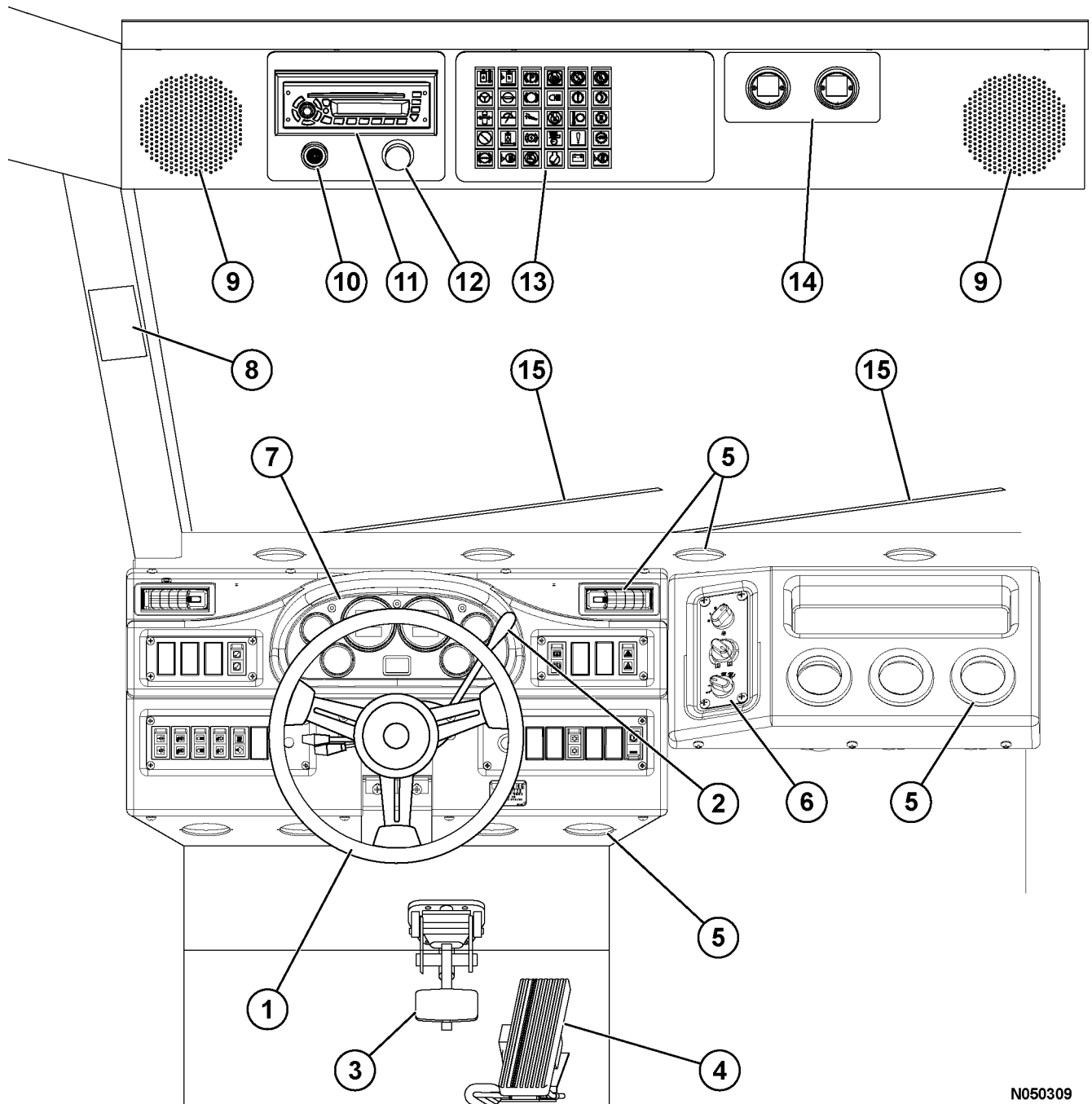

N050309

FIGURE 32-1. CAB INTERIOR - OPERATOR VIEW

- |                                 |                                    |                                     |
|---------------------------------|------------------------------------|-------------------------------------|
| 1. Steering Wheel               | 6. Heater/Air Conditioner Controls | 11. Radio/CD Player                 |
| 2. Retarder Lever               | 7. Instrument Panel                | 12. Warning Lights Dimmer Control   |
| 3. Brake/Retarder Pedal         | 8. Grade/Speed Chart               | 13. Warning/Status Indicator Lights |
| 4. Throttle/Accelerator Pedal   | 9. Radio Speakers                  | 14. Air Cleaner Restriction Gauges  |
| 5. Heater/Air Conditioner Vents | 10. Warning Alarm Buzzer           | 15. Windshield Wipers               |

## STEERING WHEEL AND CONTROLS

Steering wheel (1, Figure 32-2) can be telescoped “in” and “out” and the tilt angle can be adjusted to provide a comfortable steering wheel position for most operators.

### Horn Button

Actuate horn (2, Figure 32-2) by pushing the button in the center of the steering wheel. Ensure that the horn operates before moving the truck. Observe all local safety rules regarding the use of the horn as a warning signal device before starting the engine and moving the vehicle.

### Tilt / Telescope Lever

The steering column can be telescoped and the steering wheel can be tilted with lever (3, Figure 32-2) in front of the turn signal lever.

Adjust the tilt of the steering wheel by pulling the lever toward the steering wheel and moving the wheel to the desired angle. Releasing the lever will lock the wheel in the desired location.

Adjust the steering column by pushing the lever forward to unlock the telescoping function. After positioning as desired, release the lever to lock the steering column in position.

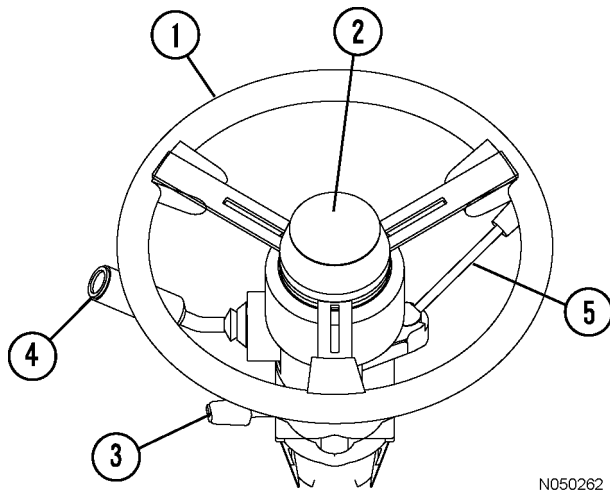

N050262

FIGURE 32-2. STEERING WHEEL & CONTROLS

- |                         |                                      |
|-------------------------|--------------------------------------|
| 1. Steering Wheel       | 4. Multi-Function Turn Signal Switch |
| 2. Horn Button          | 5. Retarder Lever                    |
| 3. Tilt/Telescope Lever |                                      |

## Multi-Function Turn Signal Switch



N050186

Multi-function turn signal switch (4, Figure 32-2) is used to activate the turn signal lights, the windshield wipers, and to select either high or low beam headlights.

### Turn Signal Operation

Move the lever upward to signal a right turn. 

An indicator in the top, center of the instrument panel will illuminate to indicate turn direction selected. Refer to Instrument Panel and Indicator Lights in this section.







Move the lever downward to signal a left turn. 

**NOTE:** The turn signal does not automatically cancel after the turn has been completed. The turn signal lever must be manually returned to the neutral position.

### High Beam Headlight Operation

Pulling the lever inward (toward the rear of the cab) changes the headlights to high beam. When the high beams are selected, the indicator in the top center of the instrument panel will illuminate. Moving the switch back to the original position will return the headlights to low beam. 

### Windshield Wiper Operation

- |   |  |
|---|--|
|  | Windshield Wipers OFF  |
|  | Intermittent - Long Delay  |
|  | Intermittent -Medium Delay   |
|  | Intermittent -Short Delay  |
|  | Low Speed  |
|  | High Speed   |
|  | Depressing the button at the end of the lever will activate the windshield washer. |

**NOTE:** The wipers will not come on automatically when activating the washer. This must be done manually.



## DYNAMIC RETARDING

Dynamic retarding is a braking torque (not a brake) produced through electrical generation by the wheelmotors when the truck motion (momentum) is the propelling force.

For normal truck operation, dynamic retarding should be used to slow and control truck speed.

Dynamic retarding is available in FORWARD/REVERSE at all truck speeds above 0 kph/mph. However, as the truck speed slows below 5 kph (3 mph), the available retarding force may not be effective. Use the service brakes to bring the truck to a complete stop.

Dynamic retarding will not hold a stationary truck on an incline. Use the parking brake or wheel brake lock for this purpose.

When in NEUTRAL, dynamic retarding is available only when truck speed is above 5 kph (3 mph).

When dynamic retarding is in operation, engine rpm will automatically go to an advance retard speed setting. This rpm will vary depending on temperature of several electrical system components.

Dynamic retarding will be applied automatically if the speed of the truck obtains the maximum speed setting programmed in the control system software.

When dynamic retarding is activated, an indicator light in the overhead display will illuminate. The grade/speed retard chart should always be used to determine safe downhill speeds. Refer to Grade/Speed Chart in this chapter.

### Retarder Lever

Retarder lever (5, Figure 32-2) mounted on the right side of the steering column can be used to modulate retarding effort. The lever will command the full range of retarding and will remain at a fixed position when released.

- When the lever is rotated to full “up” (counterclockwise) position, it is in the OFF/no retard position. An adjustable detent holds the lever in the OFF position. Refer to Section J in the service manual for adjustment procedures.
- When the lever is rotated to full “down” (clockwise) position, it is in the full ON/retard position.
- For long downhill hauls, the lever may be positioned to provide desired retarding effort, and it will remain where it is positioned.

*NOTE: The retarder lever must be rotated back to the OFF position before the truck will resume the propel mode of operation.*

The lever and foot-operated retarder/service brake pedal can be used simultaneously or independently. The Propulsion System Controller (PSC) will determine which device is requesting the most retarding effort and apply that amount.

### Brake/Retarder Pedal

Brake/retarder pedal (3, Figure 32-1) is a single, foot-operated pedal that controls both retarding and service brake functions. The first portion of pedal travel commands retarding effort through a rotary potentiometer. The second portion of pedal travel modulates service brake pressure directly through a hydraulic valve. Thus, the operator must first apply, and maintain, full dynamic retarding in order to apply the service brakes. Releasing the pedal returns brake and retarder to the OFF position.

When the pedal is partially depressed, the dynamic retarding is actuated. As the pedal is further depressed, to where dynamic retarding is fully applied; the service brakes (while maintaining full retarding) are actuated through a hydraulic valve which modulates pressure to the service brakes. **Completely depressing the pedal causes full application of both dynamic retarding and the service brakes.** Indicator light (B3, Figure 32-8) in the overhead panel will illuminate, and an increase in pedal resistance will be felt when the service brakes are applied.

For normal truck operation, **dynamic retarding** (lever or foot-operated pedal) should be used to slow and control the speed of the truck.

**Service brakes** should be applied only when dynamic retarding requires additional braking force to slow the truck speed quickly or when bringing the truck to a complete stop.

### Throttle/Accelerator Pedal

Throttle/accelerator pedal (4, Figure 32-1) is a foot-operated pedal which allows the operator to control engine rpm depending on pedal depression.

It is used by the operator to request torque from the motors when in forward or reverse. In this mode, the propulsion system controller commands the correct engine speed for the power required. In NEUTRAL, this pedal controls engine speed directly.

## GRADE/SPEED CHART

Grade/speed chart (8, Figure 32-1 and shown below) provides the recommended MAXIMUM retarding limits at various truck speeds and grades with a fully loaded truck.

This decal in the truck may differ from the decal below due to optional truck equipment such as: wheel motor drive train ratios, retarder grids, tire sizes, etc. Always refer to this decal in the operator's cab and follow these recommendations for truck operation.

The operator should refer to this chart before descending any grade with a loaded truck. Proper use of dynamic retarding will maintain a safe speed.

**CAUTION**

**DO NOT DESCEND GRADES AT SPEEDS GREATER THAN LISTED WHEN VEHICLE IS LOADED AT MAX. G.V.W. 1,100,000 LB. (498,957 kg) & 53/80 R 63 TIRES.**

EFFECTIVE GRADE	SPEED (CONTINUOUS)	SPEED (SHORT TERM)
%	MPH(KM/H)	MPH(KM/H)
12	11 (18)	15 (24)
10	14 (23)	19 (31)
8	19 (31)	23 (37)
6	29 (47)	29 (47)
4	29 (47)	36 (58)

THE ACTUAL GRADE CAPABILITY WILL VARY DEPENDING ON OUTSIDE TEMPERATURE, SYSTEM TEMPERATURE, ROLLING RESISTANCE, LOAD, AND TIRE SIZE. THE ABOVE IS BASED ON 32° C (90°F) OUTSIDE TEMPERATURE AND ASSUMES THAT ROAD AND VISIBILITY CONDITIONS PERMIT THE USE OF ALL AVAILABLE RETARDING TORQUE WITHOUT SKIDDING. FOR ADDITIONAL BRAKING AND RETARD INFORMATION, SEE OPERATION MANUAL.

ACTUAL GRADE, NOT INCLUDING ROLLING RESISTANCE.

WB2751

Two speed lists are provided, one for *continuous* retarding, and the second for *short term* retarding. Both lists are matched to the truck at maximum Gross Vehicle Weight (GVW). The two ratings are guidelines for proper usage of the retard function on downhill grades.

The “short term” numbers listed on the chart indicate the combination of speeds and grades which the vehicle can safely negotiate for a short duration before system components reach the maximum allowable temperature during retarding. These speeds are faster than the “continuous” values, reflecting the short term thermal capacity of various system components.

*NOTE: The “short term” rating will successfully accommodate most downhill loaded hauls.*

If the vehicle is operated at "short term" grade and speed limits for a period of time, it is possible to reach the thermal capacity of the drive system components. The Propulsion System Controller (PSC) will then gradually reduce the retarding effort from "short term" to "continuous". The "retard @ continuous" indicator light will flash for 15 seconds, then illuminate steadily alerting the operator of the reduction in retarding performance and the need for a reduction in speed. The operator must control the speed of the truck in accordance to the “continuous speeds” on the grade/speed chart. The operator must use the service brakes to **quickly** slow the truck to the maximum "continuous" retarding limits (or less) based on the grade the truck is currently on.



*Do not LIGHTLY apply the service brakes when attempting to slow the truck on a downhill grade. Overheating of the brakes will result. Apply the brakes (within safe limits for road conditions) in order to quickly slow the truck to maximum “continuous” retarding limits or less.*

The “continuous” numbers on the chart indicate the combination of speeds and grades which the vehicle can safely negotiate for unlimited time or distance during retarding.

DO NOT exceed these recommended MAXIMUM speeds when descending grades with a loaded truck.

## OVERHEAD PANEL AND DISPLAYS

The components described below are located on the overhead panel. Refer to Figure 32-1.

### Speakers

Speakers (9, Figure 32-1) for the radio/CD player are located at the far left and right of the overhead panel.

### Warning Alarm Buzzer

A warning alarm buzzer (10) will sound when activated by any one of several truck functions. Refer to Instrument Panel and Indicator Lights in this section for a detailed description of functions and indicators that will activate this alarm.

### Radio/CD Player

This panel will normally contain a radio/CD player (11). Refer to Section 70 for a complete description of the radio/CD player and its functions. Individual customers may use this area for other purposes, such as a two-way communications radio.

### Warning Indicator Light Dimmer Control

Dimmer control (12) below the radio/CD player permits the operator to adjust the brightness of the warning indicator lights.

## Status/Warning Indicator Light Panel

Status/ warning indicator panel (13) contains an array of indicator lights to provide the operator with important status messages concerning selected truck functions. Refer to Instrument Panel and Indicator Lights in this section for a detailed description of these indicators.

### Air Cleaner Restriction Gauges

Air cleaner restriction gauges (14) provide a continuous reading of the maximum air cleaner restriction reached during operation. The air cleaner(s) should be serviced when the gauge(s) shows the maximum recommended restriction of 25 inches of H<sub>2</sub>O vacuum.

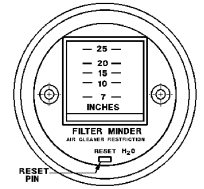

*NOTE: After service, push the reset button on the face of the gauge to return the gauge to zero.*

## CENTER CONSOLE

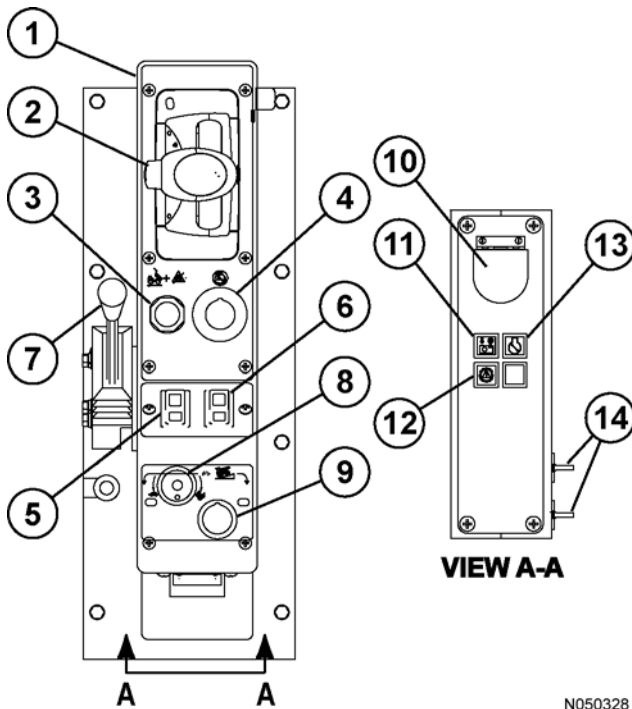

N050328

FIGURE 32-3. CENTER CONSOLE

1. Center Console
2. Directional Control Lever
3. Override/Fault Reset Switch
4. Engine Shutdown Switch
5. L.H. Window Control Switch
6. R.H. Window Control Switch
7. Hoist Control Lever
8. Retarder Speed Control Dial
9. Retarder Speed Control Switch
10. Data Store Button
11. KOMTRAX Plus Snapshot In Progress Light
12. Link Energized Light (red)
13. Service Engine Light (blue)
14. 12V Auxiliary Power Outlets

### Directional Control Lever

Directional lever (2, Figure 32-3) is mounted on the console to the right of the operator's seat. It is a four position lever that controls the park, reverse, neutral and forward movement of the truck.

Before moving the directional control lever, apply the service brakes to completely stop the truck. Depress the button on the side to release the detent lock, then move the control lever to the desired position. When the control lever is in the center N position, it is in NEUTRAL. When the control lever is in the P position, it is in PARK, and the parking brake will be applied. The parking brake is spring applied and hydraulically released. It is designed to hold the truck stationary when the engine is off and the key switch is turned OFF. The truck must be completely stopped before moving the control lever to PARK, or damage may occur to the parking brake.

When the key switch is ON, and the control lever is in PARK, parking brake indicator light (A3, Figure 32-8) in the overhead panel will be illuminated.

## ▲ IMPORTANT ▲

***The directional control lever must be in PARK to start the engine.***

***NOTE: Do not move the directional control lever to the PARK position at the shovel or dump site.***

The operator can select FORWARD drive by moving the lever to the F position.

The operator can select REVERSE drive by moving the lever to the R position. Do not allow the control lever to travel too far and go into the PARK position when REVERSE is desired.

***NOTE: The truck must be completely stopped before the control lever is moved to a drive position or into PARK. A fault will be recorded if the control lever is placed into the PARK position while the truck is still moving.***

### Override/Fault Reset Switch

This push-button switch (3, Figure 32-3) is spring-loaded to the OFF position. When pushed in and held, this switch may be used for several functions.

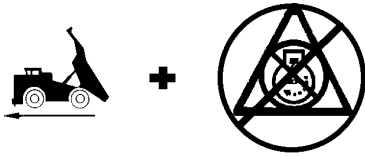

- The switch permits the operator to override the body-up limit switch and move the truck forward when the directional control lever is in FORWARD, the dump body is raised, and the brakes are released. **Use of the override switch for this purpose is intended for emergency situations only!**
- The push-button deactivates the retard pedal function when the truck speed is below 5 kph (3 mph).
- The switch is also used to reset an electric system fault that is indicated by a red warning light. Refer to Overhead Status/Warning Indicators later in this section.

### Engine Shutdown Switch

Engine shutdown switch (4, Figure 32-3) is used for engine shutdown. Pull the switch up to stop the engine. Push the switch back down to enable engine operation.



Use this switch to shutdown the engine if the key switch fails or to stop the engine without turning off the 24 VDC electrical circuits.

A ground level engine shutdown switch is also located at the left front corner of the truck.

### Window Control Switches

Control switches (5 and 6, Figure 32-3) are spring-loaded to the OFF position. Pushing the front of the switch raises the left hand or right hand cab window. Pushing the rear of the switch lowers the window.

### Hoist Control Lever

Hoist control (7, Figure 32-3) is a four position hand-operated lever located between the operator seat and the center console (see illustration below).

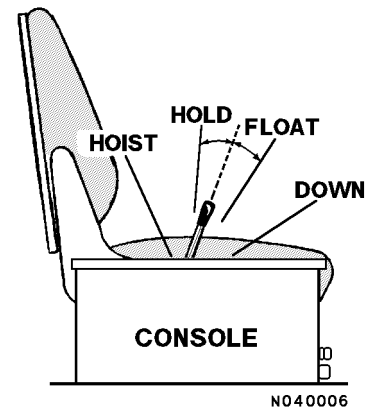

#### Raising The Dump Body

1. Pull the lever to the rear to actuate the hoist circuit. Releasing the lever anywhere during "hoist up" will place the body in HOLD at that position.
2. Raise engine rpm to increase hoist speed.
3. Reduce the engine speed as the last stage of the hoist cylinders begin to extend, then let the engine go to low idle as the last stage reaches half-extension.
4. Release the hoist lever as the last stage reaches full extension.
5. After the material being dumped clears the body, lower the body to the frame.

Refer to Section 30, Operating Instructions - Dumping, for more complete details about this control.

#### Lowering The Dump Body

Move the hoist lever forward to the DOWN position and release. Releasing the lever places hoist control valve in the FLOAT position, allowing the body to return to the frame.

### Retard Speed Control (RSC) Adjustment Dial

RSC adjustment dial (8, Figure 32-3) allows the operator to vary the downhill truck speed that the retard speed control system will maintain when descending a grade. This function can be overridden by the throttle pedal, retard lever, or brake/retard pedal.

When the dial is rotated counterclockwise toward this symbol, the truck will descend a grade at lower speeds.



When the dial is rotated clockwise toward this symbol, the truck speed will increase.



*NOTE: Always refer to the grade/speed chart in the operator's cab and follow the recommendations for truck operation. DO NOT exceed these recommended MAXIMUM speeds when descending grades with a loaded truck.*

Throttle pedal position will override the RSC setting. If the operator depresses the throttle pedal to increase truck speed, dynamic retarding will not come on unless the truck overspeed setting is reached or the brake/retarder pedal is used. When the throttle pedal is released and the RSC switch is ON, dynamic retarding will come on at, or above, the RSC dialed speed and will adjust the truck speed to, and maintain, the dialed speed.

To adjust the RSC control, pull up switch (9) and start with dial (8) rotated toward fastest speed while driving truck at the desired maximum speed. Release the throttle pedal to let the truck coast and turn the RSC adjusting dial slowly counterclockwise until dynamic retarding is activated. Dynamic retarding will now be activated automatically anytime the "set" speed is reached, the RSC switch is on, and the throttle pedal is released.

With the RSC switch on and dial adjusted, the system will function as follows:

As the truck speed increases to the "set" speed and the throttle pedal is released, dynamic retarding will apply. As the truck speed tries to increase, the amount of retarding effort will automatically adjust to keep the selected speed. When the truck speed decreases, the retarding effort is reduced to maintain the selected speed. If the truck speed continues to decrease to approximately 5 kph (3 mph) below the "set" speed, dynamic retarding will turn off automatically. If the truck speed must be reduced further, the operator can turn the dial to a new setting or depress the brake/retarder pedal.

If the operator depresses the foot operated retard pedal and the retard effort called for is greater than that from the automatic system, the foot pedal retard will override RSC.

### Retard Speed Control (RSC) Switch

Retard speed control switch (9, Figure 32-3) turns the system on and off. Push the knob in for OFF and pull the knob out to turn the system ON.

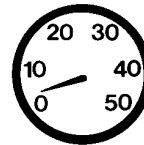

### Data Store Button

Button (10, Figure 32-3) is for use by qualified maintenance personnel to record in memory a “snapshot” of the AC drive system. It will also trigger the VHMS system to store a snapshot of the truck operating system. Light (11, Figure 32-3) will stay illuminated while the VHMS system is recording the snapshot.

### KOMTRAX Plus Snapshot In Progress Light

Light (11, Figure 32-3) is an indicator that will illuminate while KOMTRAX Plus is in the process of taking a snapshot of machine data.

### Link Energized Light

Light (12, Figure 32-3) is a red indicator that, when illuminated, indicates that the AC drive system is energized. No one is permitted to work on the AC drive system while this light is illuminated.

### Service Engine Light

Light (13, Figure 32-3) is a blue indicator that will illuminate if a problem is detected by the electronic engine monitoring system.

Electric propulsion and dynamic retarding will still be available.

If this light is ON, notify maintenance personnel so they can diagnose and repair the problem the next time the truck is in the shop for repairs or at the next PM (Preventive Maintenance) interval.

### 12V Auxiliary Power Outlets

Outlets (14, Figure 32-3) can be used to provide 12VDC power for tools and accessories.

## DIAGNOSTIC PORTS

### KOMTRAX Plus Diagnostic Port

Diagnostic port (1) is used to download truck operation data from the KOMTRAX Plus controller.

### Interface Module (IM) Diagnostic Port

Diagnostic port (2) is used to connect the interface module to a computer for installing software.

### Payload Meter Diagnostic Port

Diagnostic port (3) is used to download data from the payload meter system. Refer to Section 60, Payload Meter III, for a more complete description of the payload meter and its functions.

### Truck Control Interface (TCI) Diagnostic Port

Diagnostic port (4) is used to access diagnostic information for the Truck Control Interface (TCI).

### Propulsion System Controller (PSC) Diagnostic Port

Diagnostic port (5) is used to access diagnostic information for the Propulsion System Controller (PSC).

### Engine Diagnostic Port (CENSE)

3-pin diagnostic port (6) is used to access diagnostic information for the engine monitoring system.

### Engine Diagnostic Port (QUANTUM)

9-pin diagnostic port (7) is used to access diagnostic information for the engine monitoring system.

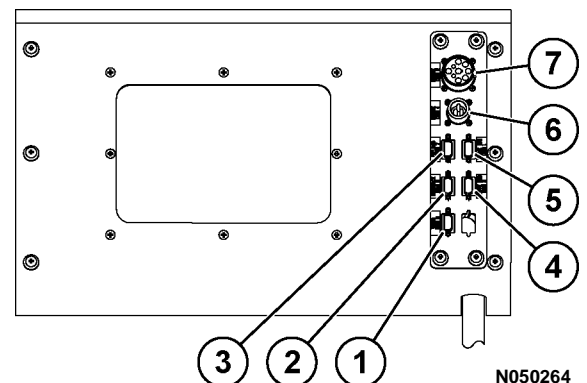

FIGURE 32-4. DIAGNOSTIC PORTS  
(D.I.D. PANEL AT REAR OF CAB)

- |                                  |                                     |
|----------------------------------|-------------------------------------|
| 1. KOMTRAX Plus Diagnostic Port  | 4. TCI Diagnostic Port              |
| 2. IM Diagnostic Port            | 5. PSC Diagnostic Port              |
| 3. Payload Meter Diagnostic Port | 6. Engine Diagnostic Port (CENSE)   |
|                                  | 7. Engine Diagnostic Port (QUANTUM) |

## OPERATOR'S SEAT

The operator's seat provides a fully adjustable cushioned ride for driver comfort and easy operation.

### Seat Belts

- On both driver and passenger seats, check the seat belt fabric, buckle, all belt retractors and hardware for damage or wear. Replace any worn or damaged parts immediately.
- Even if there are no signs of damage, replace both driver and passenger seat belts 5 years after seat belt manufacture, or every 3 years after start of use, whichever comes first. The passenger seat belt date of manufacture label is sewn into the seat belt near the buckle. The driver seat belt date of manufacture label is sewn into the shoulder harness belt, near the retractor end.

### Adjustment

The following adjustments must be made while sitting in the seat.

1. **Headrest:** (1, Figure 32-5) will move up, down, fore, or aft by moving headrest to desired position.
2. **Armrests:** rotate adjusting knob until armrest is in desired position.
3. **Backrest:** Lift handle (3) to release and select backrest angle: release control handle to set.
4. **Seat Belt:** Operator should always have seat belt (4) buckled in place and properly adjusted whenever vehicle is in motion.
5. **Seat Slope:** Lift lever (5) and hold to adjust the slope of the seat. Release lever to lock adjustment.
6. & 7. **Air Lumbar Support:** Each rocker switch (6 or 7) controls an air pillow. Switch (7) controls the lower air pillow and switch (6) controls the upper air pillow. To inflate, press on top of rocker switch and hold for desired support, then release. To deflate, press on bottom of rocker switch and hold for desired support, then release. Adjust each pillow for desired support.
8. **Seat Suspension:** Press rocker switch (8) on top to increase ride firmness. Press on lower part of rocker switch to decrease ride firmness.
9. **Fore/Aft Location of Seat:** Lift lever (9) and hold. Bend knees to move seat to a comfortable position: release control lever to lock adjustment.
12. **Seat Height:** Lift lever (12) and hold to adjust the height of the seat. Release lever to lock adjustment.

Optimum ride height is obtained when the suspension is at the middle of its stroke. To properly adjust, raise the seat to its highest level. Then, lower the seat approximately 51 mm (2 in.) to the middle of the suspension stroke.

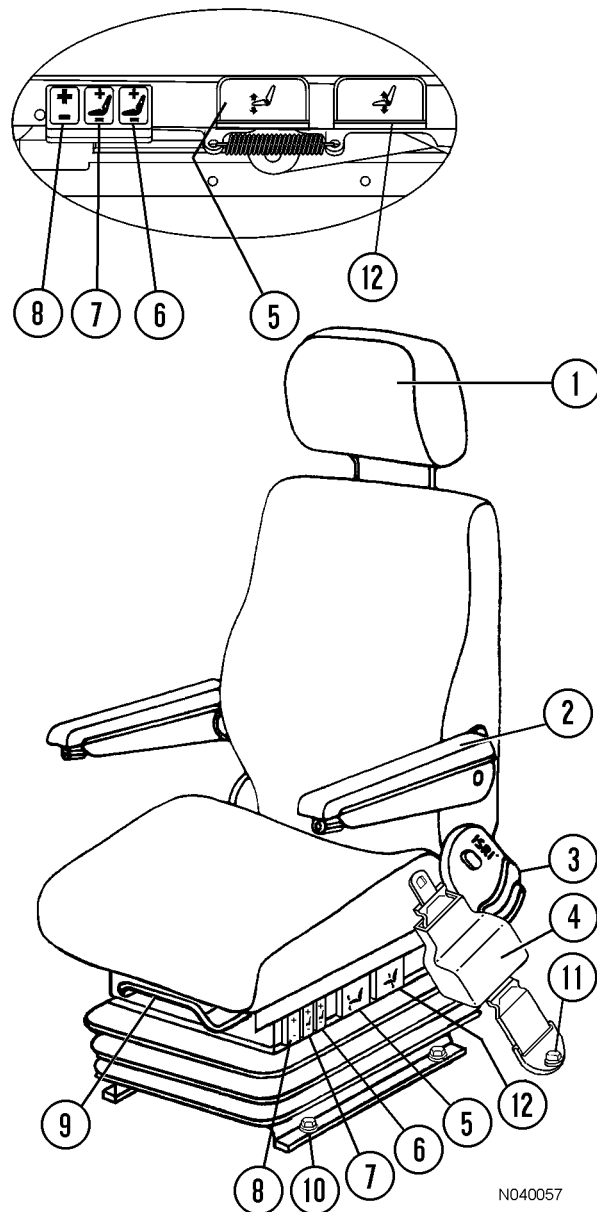

N040057

FIGURE 32-5. OPERATOR'S SEAT ADJUSTMENT CONTROLS

- |                                    |                                    |
|------------------------------------|------------------------------------|
| 1. Headrest                        | 7. Lower Air Pillow Lumbar Support |
| 2. Armrest Adjustment              | 8. Seat Suspension Adjustment      |
| 3. Backrest Adjustment             | 9. Fore/Aft Adjustment             |
| 4. Seat Belt                       | 10. Mounting Hardware              |
| 5. Seat Slope Adjustment           | 11. Tether Capscrew                |
| 6. Upper Air Pillow Lumbar Support | 12. Seat Height Adjustment         |



## HEATER/AIR CONDITIONER COMPARTMENT AND CONTROLS

The heater/air conditioner compartment contains the heater/air conditioner controls and some of the heater/air conditioner components, such as the blower motor assembly and heater coils. Optimum cab air climate can be selected by using the following controls in various combinations.

### Fan Speed Control Knob

Fan control knob (1, Figure 32-6) controls the cab air fan motor. The fan motor is a 3-speed motor: low (setting 1), medium (setting 2), and high (setting 3). Speeds are selected by rotating the control knob clockwise to the desired position. OFF is full counterclockwise position (setting 0).

### Temperature Control Knob

Temperature control knob (2, Figure 32-6) allows the operator to select a comfortable temperature.

- Rotating the knob counterclockwise (blue arrow) will select cooler temperatures. Full counterclockwise position is the coldest air setting.
- Rotating the knob clockwise (red arrow) will select warmer temperatures. Full clockwise position is the warmest heater setting.

### Air Flow Directional Knob

Directional control knob (3, Figure 32-6) directs heated air to different areas of the cab.

- The full counterclockwise position directs air to the floor vents only.
- Turning the knob one position clockwise directs air to both the floor and dash vents.
- Turning the knob one more position clockwise directs air to the dash vents only.
- Turning the knob one more position clockwise directs air to the windshield defrost vents only.
- The full clockwise position directs air to both the floor and windshield defrost vents.

### Heater/Air Conditioner Vents

Each heater/air conditioner vent (4, Figure 32-6) is a flapper type which may be opened or closed or rotated 360 degrees for optimum air flow. There are four (three not shown) across the top of the panel, one each in the right and left panel modules, and four below the panel.

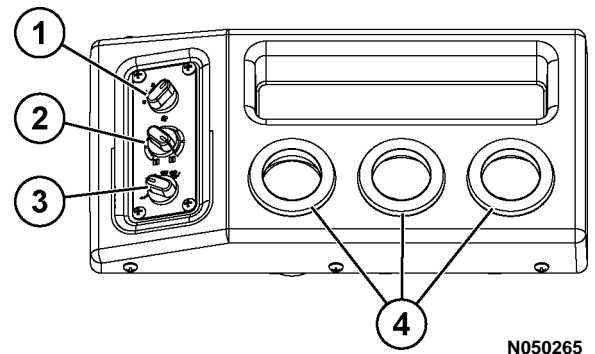

FIGURE 32-6. HEATER/AIR CONDITIONER CONTROLS

## INSTRUMENT PANEL

The operator must understand the function and operation of each instrument and control. Control functions are identified with international symbols that the operator should learn to recognize immediately. This knowledge is essential for proper and safe operation.

Items that are marked "optional" do not apply to every truck.

### Control Symbols

Many control functions are identified with international symbols that the operator should learn to recognize immediately. The operator must understand the function and operation of each instrument and control. This knowledge is essential for proper and safe operation of the machine.

The following symbols are general indicators and may appear in multiple locations and combinations on the instrument panel.

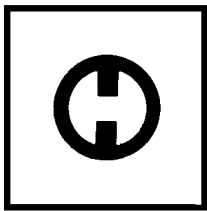

This symbol may be used alone or with another symbol. This symbol identifies the OFF position of a switch or control.

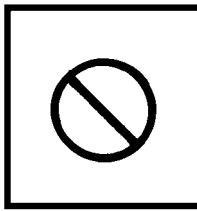

This symbol when it appears on an indicator or control identifies that this indicator or control is NOT used.

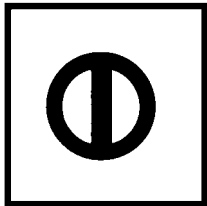

This symbol may be used alone or with another symbol. This symbol identifies the ON position of a switch or control.

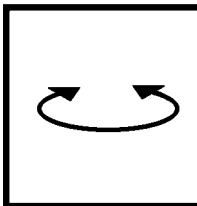

This symbol identifies a rotary control or switch. Rotate the knob clockwise or counterclockwise for functions.

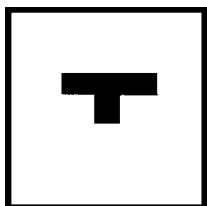

This symbol identifies the "Pushed-In" position of a push-pull switch or control.

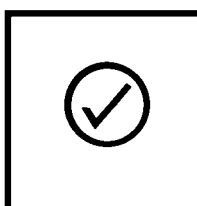

This symbol identifies a switch used to test or check a function. Press the switch on the side near the symbol to perform the test.

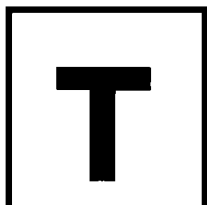

This symbol identifies the "Pulled-Out" position of a push-pull switch or control.

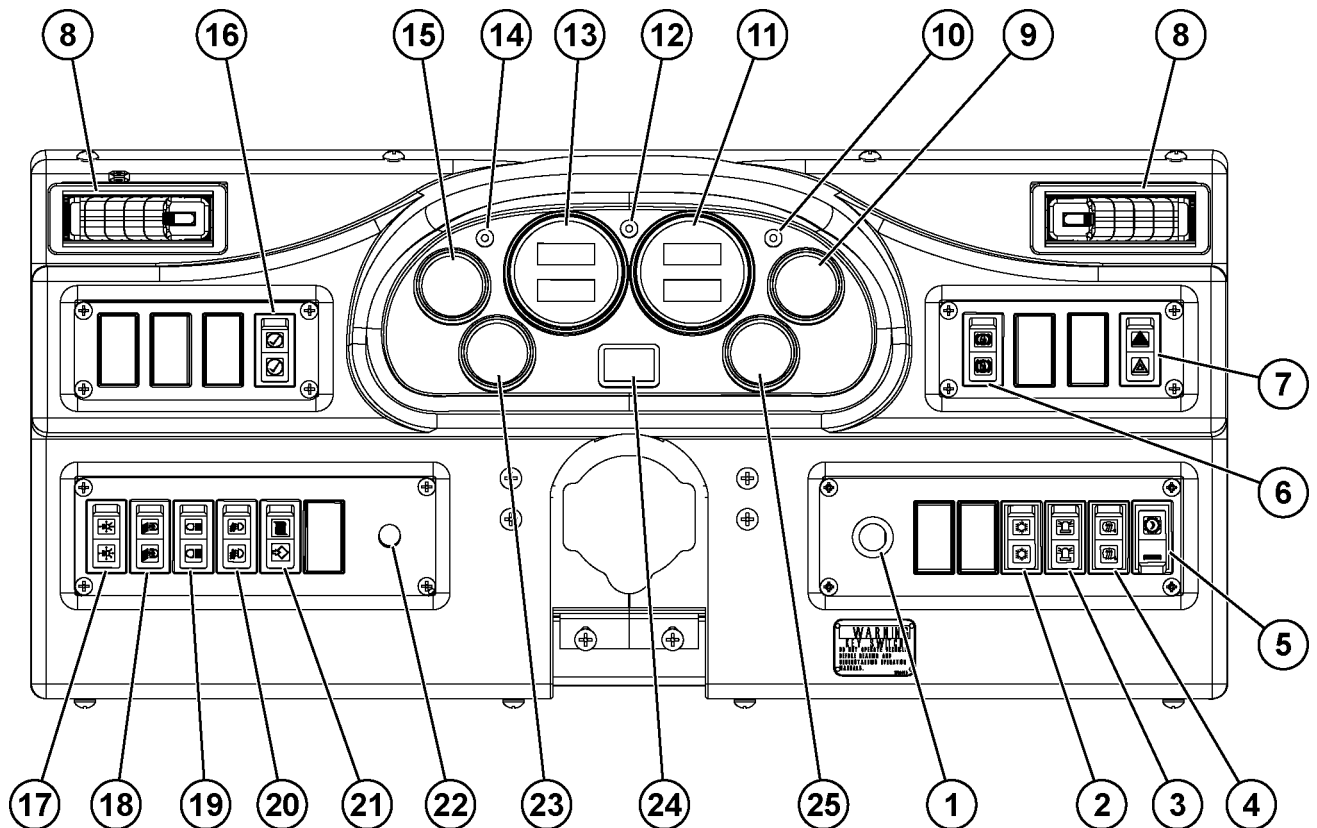
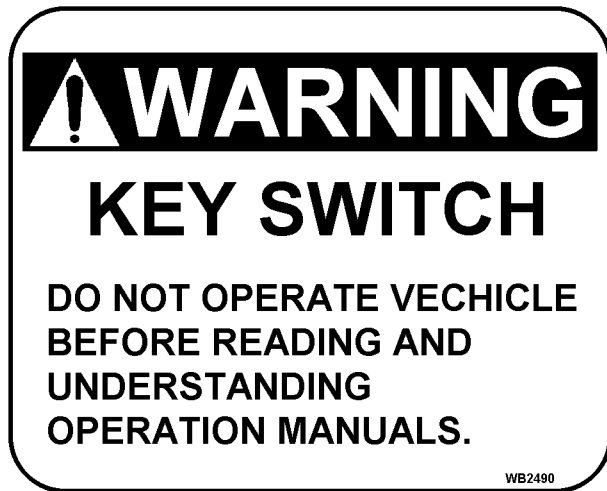

FIGURE 32-7. PANEL GAUGES, INDICATORS, AND CONTROLS

- |                                       |  |
|---------------------------------------|--|
| 1. Key Switch                         | 14. Left Turn Signal Indicator                 |
| 2. Air Conditioner Compressor Switch  | 15. Water Temperature Gauge                    |
| 3. Rotating Beacon Switch (optional)  | 16. Lamp Check Switch                          |
| 4. Heated Mirrors Switch (optional)   | 17. Headlight/Panel Illumination Lights Switch |
| 5. AC Drive System Rest Switch        | 18. Ladder Light Switch (3-Way)                |
| 6. Wheel Brake Lock Switch            | 19. Backup Light Switch                        |
| 7. Hazard Lights Switch               | 20. Fog Light Switch                           |
| 8. Heater/Air Conditioner Vents       | 21. Payload Meter Switch                       |
| 9. Engine Oil Pressure Gauge          | 22. Panel Illumination Lights Dimmer Switch    |
| 10. Right Turn Signal Indicator Light | 23. Hydraulic Oil Temperature Gauge            |
| 11. Digital Tachometer                | 24. Engine Hourmeter                           |
| 12. High Beam Headlight Indicator     | 25. Fuel Level Gauge                           |
| 13. Speedometer/Payload Meter Display |  |

## Key Switch



Key switch (1, Figure 32-7) is a four-position switch (ACC, OFF, RUN, START). The ACC position is not currently used.

When the switch is rotated one position clockwise, it is in the RUN position and all electrical circuits (except START are activated).

1. With the directional control lever in PARK, rotate key switch fully clockwise to START position, and hold this position until engine starts. START position is spring-loaded to return to RUN when key is released.
2. After the engine has started, place rest switch (5, Figure 32-7) in the OFF position to deactivate the rest mode of operation.

## Air Conditioner Compressor Switch

Air conditioner compressor switch (2, Figure 32-7) provides the operator the option to disable the A/C compressor when the cab heater is being used. The A/C compressor will operate whenever the blower fan is ON, regardless of whether heating or cooling is being used. This feature will help improve the service life of the A/C compressor.

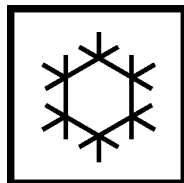

## Rotating Beacon Switch (optional)

Rotating beacon switch (3, Figure 32-7) is used to activate the rotating beacon (if equipped) on top of the operator cab.



## Heated Mirrors Switch (optional)

Heated mirrors switch (4, Figure 32-7) is used to activate the heated mirrors (if equipped) on both sides of the truck.

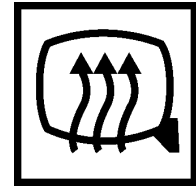

## AC Drive System Rest Switch

Rest switch (5, Figure 32-7) is a rocker switch with a locking device for the OFF position. A small tab must be pushed to unlock the switch before it can be depressed to the ON position. When in the ON position, an amber lamp in the switch will illuminate.

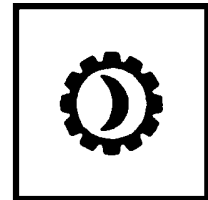

The switch should be in the ON position to de-energize the AC drive system whenever the engine is to be shutdown or the truck will be parked for a length of time with the engine running. The directional control lever must be in PARK or NEUTRAL and the vehicle not moving to enable this function. This will allow the engine to continue running while the AC drive system is de-energized.

Amber indicator light (B6, Figure 32-8) in the overhead panel will illuminate when the rest mode is activated.



**Activation of the rest switch alone DOES NOT completely ensure that the drive system is safe to work on. Refer to Section 20, Safety, for more information on servicing an AC drive truck. Check all "link-on" or "link energized" indicator lights to verify that the AC drive system is de-energized before performing any maintenance on the drive system. DO NOT activate the rest switch while the truck is moving! The truck may unintentionally enter the rest mode after stopping.**

### Wheel Brake Lock Switch

Wheel brake lock switch (6, Figure 32-7) should be used with engine running for dumping and loading operations only. The brake lock switch actuates the hydraulic brake system which locks the **rear wheel service brakes only**. When pulling into shovel or dump area, stop the truck using the foot-operated service brake pedal. When truck is completely stopped and in loading position, apply the brake lock by pressing the top of the rocker switch. To release the brake, press the bottom of the rocker switch.

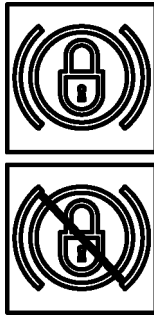

*NOTE: Use at the shovel and dump only to hold the truck in position.*

## ⚠ WARNING

**Do not use the wheel brake lock switch to stop the truck unless foot-operated treadle valve is inoperative. Use of this switch applies rear service brakes at a reduced, unmodulated pressure. Do not use brake lock for parking. With engine stopped, hydraulic pressure will bleed down, allowing brakes to release.**

### Hazard Warning Light Switch

Hazard warning light switch (7, Figure 32-7) flashes all the turn signal lights. Pressing the bottom of the rocker switch activates these lights. Pressing the top of the rocker switch turns these lights off.



### Heater/Air Conditioner Vents

Heater/air conditioner vents (8, Figure 32-7) may be directed by the operator to provide the most comfortable cabin air flow.

### Engine Oil Pressure Gauge

Engine oil pressure gauge (9, Figure 32-7) indicates pressure in the engine lubrication system.

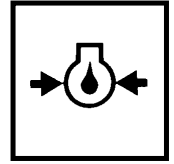

Normal operating pressure after engine warm-up should be:

Idle: 138 kPa (20 psi) minimum

Rated Speed: 310 - 483 kPa (45 - 70 psi)

### Right Turn Signal Indicator

Indicator (10, Figure 32-7) illuminates to indicate that the right turn signals are operating when the turn signal lever on the steering column is moved upward. Moving the lever to its center position will turn the indicator off.

### Digital Tachometer

Digital tachometer (11, Figure 32-7) registers engine crankshaft speed in hundreds of revolutions per minute (rpm).

Governed Speed	
Low Idle	750 rpm
High Idle	1910 rpm
Full Load	1900 rpm

### High Beam Indicator

When lit, high beam indicator (12, Figure 32-7) indicates that the headlights are on high beam. To switch the headlights to high beam, push the turn indicator lever away from the steering wheel. For low beam, pull the lever toward the steering wheel.

### Speedometer/Payload Meter Display

Speedometer/payload meter display (13, Figure 32-7) indicates the truck speed in kilometers per hour (kph) or in miles per hour (mph). The display also shows payload meter information. For more information, see Section 60, Payload Meter III.

### Left Turn Signal Indicator

Indicator (14, Figure 32-7) illuminates to indicate that the left turn signals are operating when the turn signal lever is moved downward. Moving the lever to its center position will turn the indicator off.

### Water Temperature Gauge

Water temperature gauge (15, Figure 32-7) indicates the temperature of the coolant in the engine cooling system. The temperature range after engine warm-up and with the truck operating under normal conditions should be 85° - 97°C (185° - 207°F).

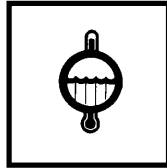

### Lamp Check Switch

Lamp check switch (16, Figure 32-7) is provided to allow the operator to test the indicator lamps prior to starting the engine. To test the lamps and the warning horn, turn the key switch to the RUN position and press the bottom side of the rocker switch for the CHECK position. All lamps should illuminate except those which are for optional equipment that may not be installed. The warning alarm should also sound. Any lamp bulbs which do not illuminate should be replaced before operating the truck. Releasing the spring-loaded switch will allow the switch to return to the OFF position.

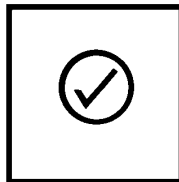

*NOTE: Do not use the lamp check switch while the engine is on. Pressing this switch while the engine is on will cause false electrical system faults. Warning light (D5, Figure 32-8) will illuminate and engine shutdown is required to turn it off.*

### Light Switch (3-Way)

The instrument panel lights, clearance lights, and the headlights are controlled by three-position rocker switch (17, Figure 32-7). OFF is selected by pressing the bottom of the switch. Press the top of the switch until it reaches the first detent to select the panel lights, clearance lights and tail lights only. Press the top of the switch again until it reaches the second detent to select headlights, panel lights, clearance lights and tail lights.

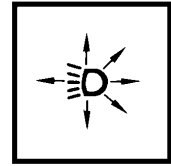

### Ladder Light Switch

Ladder light switch (18, Figure 32-7) turns the ladder lights on or off after or before using ladder. Pressing the top of the rocker switch turns the lights on. Pressing the bottom of the switch turns the lights off. Another switch is mounted at the front left of truck near the base of ladder.

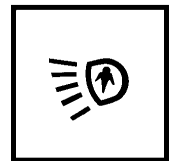

*NOTE: This switch can be used to activate the lights whenever the key switch is in the ON position.*

### Backup Light Switch

Backup light switch (19, Figure 32-7) allows the backup lights to be turned on for added visibility and safety when the directional control lever is not in the REVERSE position. When the switch is in the ON position, the backup light indicator (B4, Figure 32-8) in the overhead panel will be illuminated.

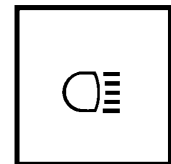

**Fog Light Switch**

Pressing the top of fog light switch (20, Figure 32-7) turns the lights on. Pressing the bottom of the switch turns the lights off.

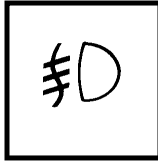
**Payload Meter Switch**

Payload Meter switch (21, Figure 32-7) is a two-way momentary rocker switch. The top position is the SELECT position. The SELECT position is used to step through the different displays. The lower position is the SET position. The SET position is used to set the operator ID, or clear the load and total ton counters. Refer to Section 60, Payload Meter III, for a more complete description of the payload meter system and its functions.

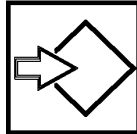
**Panel Illumination Light Dimmer Switch**

Panel illumination light dimmer switch (22, Figure 32-7) is a rheostat which allows the operator to vary the brightness of the instruments and panel illumination lights.



Rotating knob to the full counterclockwise position turns panel lights on to brightest condition. Rotating knob clockwise continually dims lights until the OFF position is reached at full clockwise rotation.

**Hydraulic Oil Temperature Gauge**

Hydraulic oil temperature gauge (23, Figure 32-7) indicates the hydraulic oil temperature. There are two colored bands: green and red.

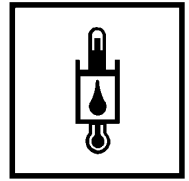

Green indicates normal operation.

As the needle approaches the red zone, minimum engine idle speed will increase to help cool the oil.

Red indicates high oil temperature. Continued operation could damage components in the hydraulic system. Warning lights (A1, Figure 32-8) and (E1) in the overhead panel will illuminate when the temperature exceeds a certain level (when the needle enters the red zone). If this occurs, the operator should safely stop the truck, move directional control lever to PARK and operate the engine at 1200 - 1500 rpm to reduce system temperature.

*NOTE: If the temperature gauge does not move into the green range after a few minutes, and the warning lights do not go out, shut down the truck and notify maintenance personnel immediately.*

**Engine Hourmeter**

Engine hourmeter (24, Figure 32-7) registers the total number of hours the engine has been in operation.

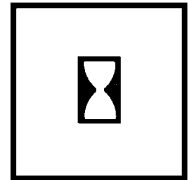
**Fuel Gauge**

Fuel gauge (25, Figure 32-7) indicates how much diesel fuel is in the fuel tank. The fuel tank capacity is 4542 liters (1200 gallons).

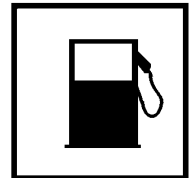

## OVERHEAD STATUS / WARNING INDICATORS

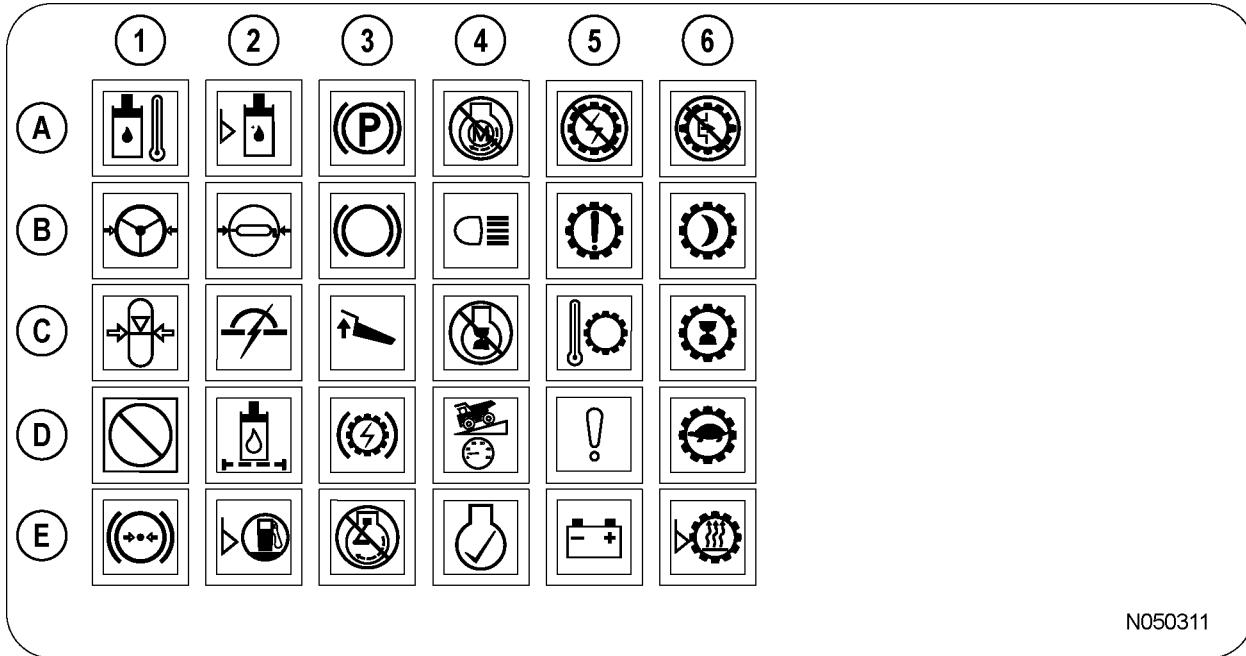

FIGURE 32-8. OVERHEAD STATUS / WARNING INDICATOR

Row / Column	Indicator Description	Indicator Color Wire Index
A1*	High Brake Oil Temp.	Red-24VIM/34TL
B1*	Low Steering Pressure	Red-12F/33A
C1	Low Accumulator Press.	Red-12F/33K
D1	Not Used	
E1	Low Brake Pressure	Red-12F/33L
A2*	Low Hydraulic Oil Level	Red-12F4/34LL
B2*	Low Automatic Lubrication Pressure	Amber-12MD8/68LLP
C2*	Circuit Breaker Tripped	Amber-12MD3/31CB
D2*	Hydraulic Oil Filter	Amber-12MD/39
E2*	Low Fuel	Amber-24VIM/38
A3*	Park Brake Applied	Amber-24VIM/52AL
B3*	Service Brake Applied	Amber-12MD/44L
C3*	Body Up	Amber-12MD6/63L
D3*	Dynamic Retarding	Amber-12MD/44DL
E3	Stop Engine	Red-12M/31MT
A4*	Starter Failure	Amber-21SL/24VIM
B4*	Manual Backup Lights	Amber-12MD/47L
C4*	Timed Engine Shutdown	Amber-12MD/23L1
D4*	Retard Speed Control	Amber-12MD/31R
E4*	Check Engine	Amber-12MD7/419

Row / Column	Indicator Description	Indicator Color Wire Index
A5	No Propel/ No Retard	Red-12M/75-6P1
B5	Propulsion System Warning	Amber-12F/79W1
C5	Propulsion System Temperature	Amber -12F/34TW1
D5	System/Component Failure	Red-24VIM/311MLI
E5	Battery Charge System Failure	Red-24VIM/11BCF1
A6	NO PROPEL	Red-12M/75NPI
B6	Propulsion System @ Rest	Amber-12M/72PR1
C6*	Propulsion System Not Ready	Amber-12MD/72NR1
D6*	Reduced Propulsion	Amber-12MD/72LP1
E6*	Retard @ Continuous Level	Amber-12MD/76LR1

\* Brightness for these indicator lamps can be adjusted by using dimmer control (12, Figure 32-1).



Indicator lights that are amber (yellow) in color alert the operator that the indicated truck function requires some precaution when lighted.

Indicator lights that are red in color alert the operator that the indicated truck function requires **immediate action** by the operator. Safely stop the truck and notify maintenance personnel.

### **DO NOT OPERATE THE TRUCK WITH A RED WARNING LIGHT ILLUMINATED!**

Refer to Figure 32-8 and the descriptions below for explanations of the symbols. Location of the symbols is described by rows (A - E) and columns (1 - 6).

#### **A1. High Brake Oil Temperature**

This red warning light indicates that the brake oil temperature is too high. The low brake pressure warning light will also illuminate.

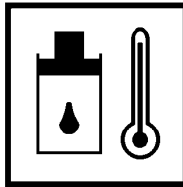

If these lights come on, the operator should safely stop the truck, move the directional control lever to PARK and operate the engine at 1200 - 1500 rpm to reduce system temperature.

If temperature gauge (22, Figure 32-7) does not move into the green range after a few minutes, and the warning lights do not go out, turn off the engine and notify maintenance personnel immediately.



***If temperature gauge does not move into the green range after a few minutes, and the red overhead indicator light does not go out, stop the engine and notify maintenance personnel immediately.***

#### **B1. Low Steering Pressure**

When the key switch is turned ON, this red warning light will illuminate and the warning buzzer will sound until the steering system hydraulic pressure reaches 15 860 kPa (2,300 psi). Both will remain on until the accumulator has been charged.

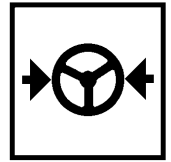

During truck operation, the low steering pressure warning light, low brake pressure warning light, and warning buzzer will turn on if steering system hydraulic pressure drops below 15 860 kPa (2,300 psi).

- If the light illuminates momentarily (flickers) while turning the steering wheel at low truck speed and low engine rpm, this may be considered normal and truck operation may continue.
- If the indicator lights illuminate at a higher truck speed and high engine rpm, **do not operate the truck.**



***If the low steering warning light continues to illuminate and the alarm continues to sound, low steering pressure is indicated. The remaining pressure in the accumulators allows the operator to control the truck to a stop. If the oil pressure continues to decrease, the brake auto-apply feature will activate and the service brakes will apply automatically to stop the truck. Do not attempt further operation until the malfunction is located and corrected.***

1. Stop the truck as quickly as possible by using the foot pedal to apply the service brakes. If possible, steer the truck to the side of the road while braking.
2. As soon as the truck has stopped moving, shift the directional control lever to PARK. This will apply the parking brake.
3. Slowly release the service brakes to check the capacity of the parking brake. If the parking brake can not hold the truck stationary, apply the service brakes and hold them ON. **DO NOT** turn the key switch OFF, and do not release the service brakes.
4. Notify maintenance personnel immediately.
5. If the truck is on level ground, or if the parking brake can hold the truck stationary and the truck is in a stable condition, it is then OK to turn the key switch OFF.

6. If safe to do so, have maintenance personnel place wheel chocks or other mechanisms in front or behind the wheels to reduce the risk of the truck rolling.
7. If traffic is excessive near the disabled machine, mark the truck with warning flags during day-light hours or use flares at night. Adhere to local regulations.

*NOTE: If the engine is stopped, and the key switch is OFF and the light is flashing, a malfunction has been detected in the accumulator bleed down system, indicating there is still hydraulic pressure in the system. The system/component system failure light will also be illuminated, and the warning horn will be on. Do not operate the truck, and notify maintenance personnel.*

### C1. Low Accumulator Precharge Pressure

This red warning light indicates low nitrogen precharge for the steering accumulator(s). To check for proper accumulator precharge, the engine must be stopped and the hydraulic system must be completely depressurized. Turn the key switch to RUN. The warning light will not come on if the system is properly charged. The warning light will flash if the nitrogen precharge in the accumulator(s) is below  $7\ 585 \pm 310$  kPa (1,100  $\pm$  45 psi).

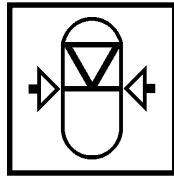

## **⚠ WARNING**

***If the low accumulator precharge warning light flashes, notify maintenance personnel. Do not attempt further operation until the accumulators have been properly charged with nitrogen. Sufficient pressure for emergency steering may not be available if the system is not properly charged.***

### D1. Not used

This light is reserved for future use by the AC drive system.

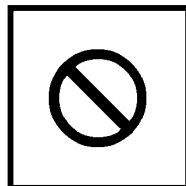

### E1. Low Brake Pressure

This red warning light indicates a malfunction within the hydraulic brake circuit. If this light comes on and the warning buzzer sounds, shut down the truck and notify maintenance personnel. Adequate hydraulic oil is stored to allow the operator to safely stop the truck.

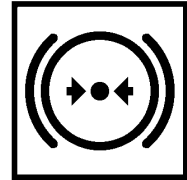

### A2. Low Hydraulic Tank Level

This red warning light indicates that the oil level in the hydraulic tank is below the recommended level. Damage to the hydraulic pumps may occur if operation continues. Shut down the truck and notify maintenance personnel immediately.

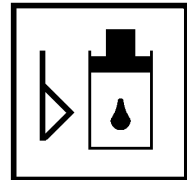

### B2. Low Automatic Lubrication System Pressure

This amber indicator light will illuminate if the automatic lubrication system fails to reach 13 790 kPa (2,000 psi) at the junction block located on the rear axle housing within one minute after the lube timer initiates a cycle of grease. To turn the light off, turn key switch OFF, then back to ON again. Notify maintenance personnel at shift change.

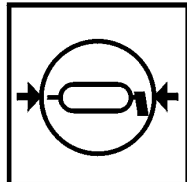

### C2. Circuit Breaker Tripped

This amber indicator light will illuminate if any of the circuit breakers in the relay circuit control boards are tripped. The relay circuit boards are located in the electrical control cabinet.

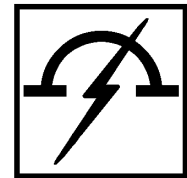

*NOTE: Additional circuit breakers are in the operator cab behind the center console. However, tripping of these circuit breakers should not activate this light.*

**D2. Hydraulic Oil Filter Monitor**

This amber indicator light indicates a restriction in the high pressure filter assembly for either the steering or hoist circuit. This light will come on before the filters start to bypass. Notify maintenance personnel as soon as possible after the light comes on.



*NOTE: The filter monitor warning light may also illuminate after the engine is initially started if the oil is cold. If the light turns off after the oil is warmed, filter maintenance is not required.*

**E2. Low Fuel**

When the usable fuel remaining in the tank is approximately 950 liters (250 gallons), this amber indicator light will flash twice and the warning buzzer will also sound twice. Then, the warning buzzer will sound once more and the indicator light will remain illuminated. This will repeat every 15 minutes while the fuel level is still low.

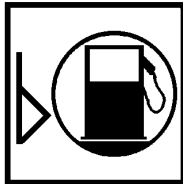
**A3. Parking Brake**

This amber indicator light will illuminate when the parking brake is applied. The parking brake is applied by placing the directional control lever in the PARK position.



If the parking brake light is flashing, that is an indication that the parking brake is requested, but has not applied. The operator must not leave the cab. Notify maintenance personnel immediately.

**B3. Service Brake**

This amber indicator light will illuminate when the service brake pedal is applied or when wheel brake lock or emergency brake is applied. Do not attempt to drive the truck from a stopped position with the service brakes applied, except as noted in Section 30, Operating Instructions - Starting On A Grade With A Loaded Truck.

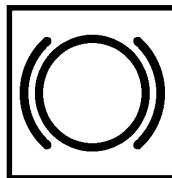
**C3. Body Up**

This amber indicator light will illuminate if the body is not completely down on the frame. The truck should not be driven until body is down and the light is off.

**D3. Dynamic Retarding**

This amber indicator light illuminates whenever the brake/retarder pedal (or retarder lever) is operated, retarder speed control (RSC) switch is activated, or the automatic overspeed retarding circuit is energized, indicating that the dynamic retarding function of the truck is operating.

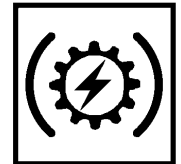
**E3. Stop Engine**

This red warning light will illuminate if a serious engine malfunction is detected in the electronic engine control system. Electric propulsion to the wheel motors will be discontinued. Dynamic retarding will still be available if needed to slow or stop the truck.



## CAUTION

***Stop the truck as quickly as possible in a safe area and move the directional control lever to PARK. TURN OFF THE ENGINE IMMEDIATELY. Additional engine damage is likely to occur if operation is continued.***

Listed below are a few conditions that could cause the stop engine light to illuminate:

- Low Oil Pressure - red warning light will illuminate, but engine does not shutdown.
- Low Coolant Level - red warning light will illuminate, but engine does not shutdown.
- Low Coolant Pressure - red warning light will illuminate, but engine does not shutdown.
- High Coolant Temperature - red warning light will illuminate, but engine does not shutdown.

#### A4. Cranking Motor Failure

This amber indicator will illuminate when either starter motor (of two) fails to crank the engine, leaving just one cranking motor to start the engine. With only one cranking motor doing the work of two, the motor life will be shortened. If this indicator illuminates, truck operation may continue, but maintenance personnel should be alerted as soon as possible.



This indicator light will also illuminate if the cranking motors have been operational for more than 30 seconds at a time, or if seven attempts at starting for the full 30 seconds is reached.

#### B4. Backup Lights

This amber indicator light will illuminate when backup light switch (18, Figure 32-7) is turned ON.

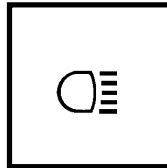

#### C4. Engine Shutdown Timer

When the key switch has been turned OFF, and certain conditions have been met, this amber indicator light will illuminate to indicate that the shutdown timing sequence has started. The engine could operate for up to three minutes.



- If the directional control lever is moved out of PARK, the engine will stop immediately.
- If the key switch is turned back ON, the engine stop sequence will be terminated, and the engine will remain running.

#### D4. Retard Speed Control (RSC) Indicator

This amber indicator light is illuminated when RSC switch (9, Figure 32-3) is pulled out to the ON position. The light indicates that the retarder is active. It is for feedback only and does not signal a problem.

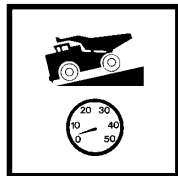

#### E4. Check Engine

This amber indicator light will illuminate if a malfunction is detected by the engine electronic control system.

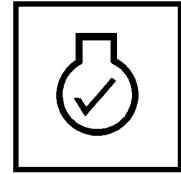

If this indicator light illuminates, truck operation may continue, but maintenance personnel should be alerted as soon as possible.

#### A5. No Power

This red “no retard/no propel” indicator light indicates that a fault has occurred which has eliminated the retarding and propulsion capability. A warning buzzer will also sound.

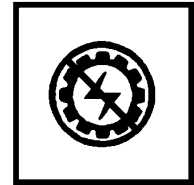

If this condition occurs, the operator should safely stop the truck, move the directional control lever to PARK, turn off the engine, and notify maintenance personnel immediately.

#### B5. Propulsion System Warning

This amber indicator light indicates a drive system fault has occurred. Many faults will result in a speed limit restriction, which could be as low as 16 kph (10 mph). The operator must notify maintenance personnel immediately.

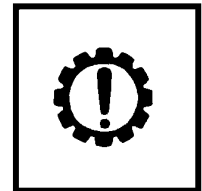

#### C5. Propulsion System Temperature

This amber indicator light indicates that the drive system temperature is above a certain level. When this condition occurs, the operator should consider modifying truck operation in order to reduce system temperature.

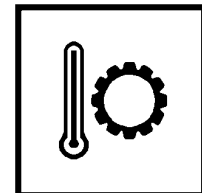

The operator is not required to stop the truck at this time.

**D5. System/Component Failure**

This red warning light indicates that the interface module system detected a failure somewhere on the truck. There are many conditions that could trigger the light to illuminate.

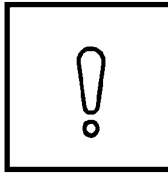

If this warning light illuminates, the operator should safely stop the truck, move selector switch to PARK, shut the engine off, and notify maintenance personnel immediately.

**E5. Battery Charging System Failure**

The red warning light indicates a problem has been detected in the charging system, and system voltage is outside the normal operating range.

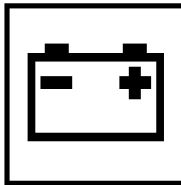

If this light illuminates, the safely stop the truck, move directional control lever to PARK, shut off the engine, and notify maintenance personnel immediately. If truck operation continues, and the battery voltage drops below 20 volts, the propulsion system will not operate, but retarding will still be available.

The following conditions will also illuminate this light:

- Battery voltage below 24.5V, engine rpm above 1450. Resets at 26V.
- Battery voltage below 23V with engine off. Resets at 25.5V.
- Battery voltage above 32V with engine operating. Resets at 27.5V.

**A6. No Propel**

This red warning light indicates that a fault has occurred which has eliminated the propulsion capability. If this condition occurs, the operator should safely stop the truck, move the directional control lever to PARK, turn off the engine, and notify maintenance personnel immediately.

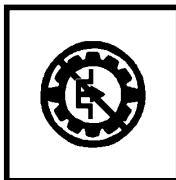
**B6. Propel System At Rest**

This amber indicator light illuminates if the AC drive system is de-energized and propulsion is not available. This light is activated when rest switch (5, Figure 32-7) is turned ON and the AC drive system is de-energized. Link energized light (12, Figure 32-3) on the rear of the center console should NOT be illuminated at this time.

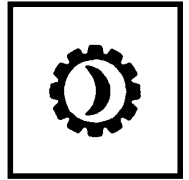
**C6. Propel System Not Ready**

This amber indicator light functions during start-up much like the hourglass icon on a computer screen. This light indicates the computer is in the process of performing the self-diagnostics and set-up functions at start-up. Propulsion will not be available at this time.

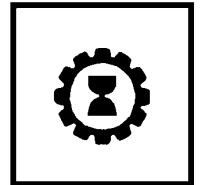
**D6. Reduced Propulsion**

This amber indicator light illuminates if the full AC drive system performance in propulsion is not available. At this time, the only event that should activate this light is the use of "limp home" mode. This mode of operation requires a technician to enable.

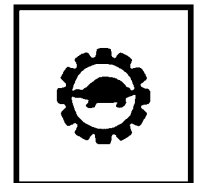
**E6. Retard At Continuous Level**

When the drive system detects that any of its components has reached maximum temperature, this amber indicator light will flash for 15 seconds, then illuminate steadily when the retarding performance is limited to the continuous level. The operator should control the speed of the truck in accordance to the "continuous speeds" on the grade/speed chart.

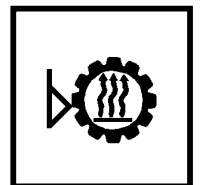

## REAR AXLE LIGHT BAR

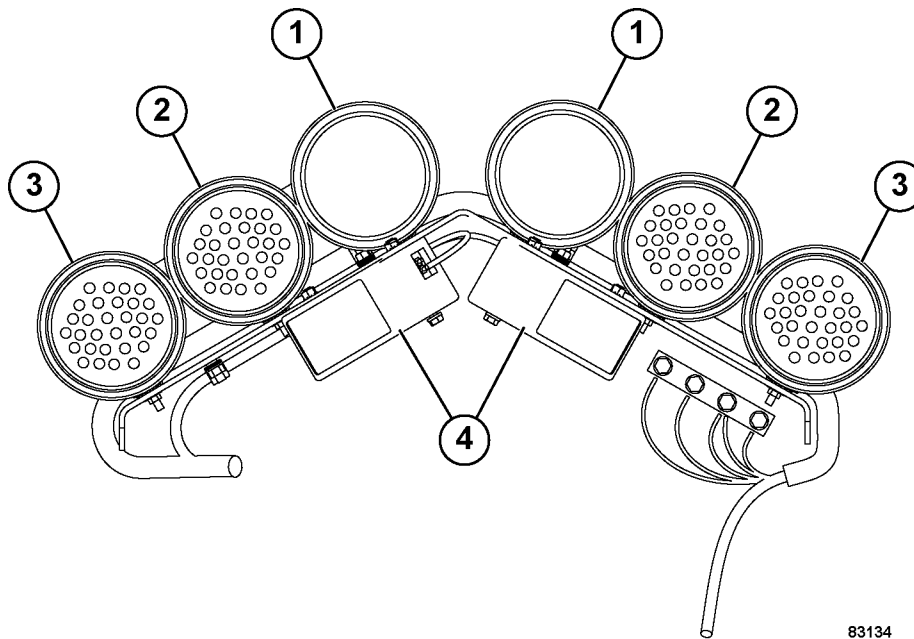

83134

FIGURE 32-9. REAR AXLE LIGHT BAR

- |                 |                 |
|-----------------|-----------------|
| 1. Backup Light | 3. Brake Light  |
| 2. Retard Light | 4. Backup Alarm |

*NOTE: The brake light is functional at all times regardless of key switch position. All other lights (and the backup alarm) are only functional with the key switch in the RUN position.*

### Backup Lights

Backup lights (1, Figure 32-9) illuminate when the operator moves the directional control lever to REVERSE. The lights can also be activated by using the backup light switch in the cab. Using the switch turns the lights on regardless of directional control lever position.

### Retard Lights

Retard lights (2) will illuminate when the operator uses the retard function to slow the truck. The amber light signals to traffic that the truck is slowing.

### Brake Lights

Brake lights (3) will illuminate when the operator depresses the brake pedal. The red light signals to traffic that the truck is slowing.

### Backup Alarm

Backup alarm (4) will sound when the operator moves the directional control lever to REVERSE. The alarm can also be turned on by using the backup light switch. Using the switch turns the alarm on regardless of directional control lever position.

## KOMTRAX PLUS

### Operation

This system uses KOMTRAX Plus controller (formerly known as VHMS) (6, Figure 32-11) to gather data about the operation of the truck from sensors and other controllers installed on the truck. The data stored in KOMTRAX Plus is collected by a laptop personal computer (PC) or transmitted directly by communications satellite (utilizing the ORBCOMM controller). This data is then compiled at the Komatsu computer server. Based on this information, the servicing Komatsu distributor will suggest improvements and provide information aimed at reducing machine repair costs and downtime.

*NOTE: A contract is necessary before KOMTRAX Plus can be used. Contact your Komatsu distributor for more information.*

### CAUTION

**DO NOT disassemble, repair, or modify the KOMTRAX Plus system without proper authorization. Changes to the system may cause machine failures and fire.**

**DO NOT touch the KOMTRAX Plus system components during machine operation.**

**DO NOT pull on KOMTRAX Plus system wiring harnesses, connectors, or sensors. This may cause short circuits or open circuits and lead to machine failure or fire.**

**DO NOT allow water, dirt, or oil onto system components.**

**The ORBCOMM satellite requires the installation of a pole and antenna, adding to the overall height of the machine. The height increase is 410 mm (16.2 in.). With the guard installed, the overall height increases another 260 mm (10.2 in.). Use caution when operating in areas with height restrictions.**

### DANGER

**Anyone with a pacemaker must remain a minimum of 22 cm (9 in.) from the communications antenna. Radio waves from the antenna can interfere with pacemaker operation.**

### IMPORTANT

**The KOMTRAX Plus system uses wireless components that transmit via radio waves. It is necessary to conform to local laws when using this system.**

**Proper operation of the system is dependent on good reception. Operating in tunnels, mountain ranges and covered areas may prevent communication of the system.**

**Contact your Komatsu distributor before selling or exporting a truck equipped with KOMTRAX Plus. It may be necessary to remove the system before transfer of ownership.**

**Contact your Komatsu distributor before installing equipment that may interfere with the KOMTRAX Plus system.**

**Komatsu is not responsible for any failures that result from neglecting KOMTRAX Plus system precautions and instructions.**

### DANGER

**ORBCOMM is a two-way radio communication device. Wireless signals from the system can interfere with other wireless signals in the area. This interference can cause a malfunction in a blast zone resulting in an unintended detonation. Know the locations of blast zones in the area and keep a safe distance to avoid unintentional blasts. If the machine is operating within a distance of 12m (40 ft) of a blast zone, disconnect the ORBCOMM harness. Failure to do so could result in serious injury or death.**

**This warning does not supersede requirements or regulations of the area or country where this machine is in operation. The following specifications are provided to ensure compliance with all of the applicable requirements or regulations:**

**Transmit power: 5-10 Watts**

**Operating Frequency Range: 148 - 150 MHz**

*NOTE: The ORBCOMM modem installed from the factory on all new trucks may not be approved for use in certain countries of the world. Local regulation may prohibit the use of the ORBCOMM modem/satellite communicator. Depending on local regulation, you may need to either remove the modem or disconnect it and remove the antenna.*

*Check with KAC service for assistance and preferred action in your area.*

*The following is a list of "at risk" countries: China, Russia, Serbia, Tanzania, Senegal, Zambia, Botswana and Namibia.*

When data store button (1, Figure 32-10) is pressed on the back side of the center console, it will store a "snapshot" of the electric drive system. It will also trigger the KOMTRAX Plus system to store a "snapshot" of the truck operating system. Indicator light (2, Figure 32-10) will stay illuminated while the KOMTRAX Plus system is recording the "snapshot", which lasts for 7.5 minutes.

The KOMTRAX Plus system is turned on by the truck key switch. Immediately after receiving 24V power from the key switch, the KOMTRAX Plus controller begins the power-up initialization sequence. This sequence takes about three seconds, during which time red LED digits (7, Figure 32-11) display a circular sequence of flashing LED segments.

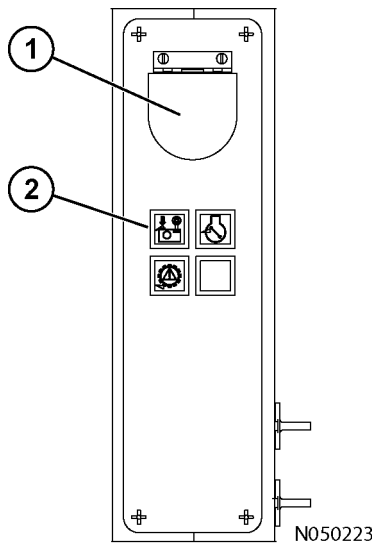

FIGURE 32-10. CENTER CONSOLE, REAR

- 1. Data Store Button
- 2. KOMTRAX Plus Snapshot In Progress Light

During normal truck operation, the red LED digits on the KOMTRAX Plus controller will count from 00-99 continuously.

When the key switch is turned OFF, the KOMTRAX Plus controller will remain on while it finishes processing internal data and saves the recent data into permanent memory. When the data has been safely stored, the two digit LED display will turn OFF. This process could take up to three minutes to complete.



***If 24V power is disconnected (using the battery disconnect switches) from the KOMTRAX Plus controller before it has completed its shut down procedure, the KOMTRAX Plus controller will lose all data gathered since the key switch was last turned ON. Do not disconnect battery power until the KOMTRAX Plus controller has completed the shut down procedure and has turned the LED digits off.***

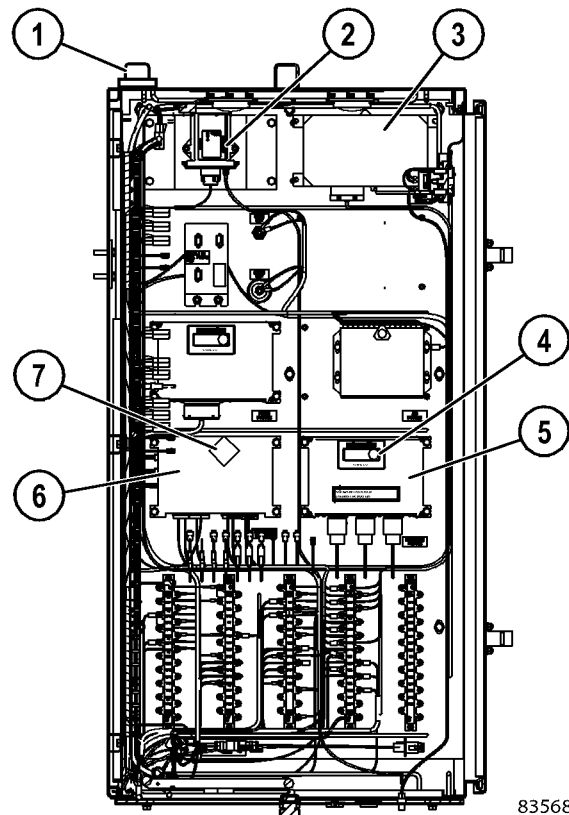

83568

FIGURE 32-11. KOMTRAX PLUS COMPONENT LOCATION

- 1. Antenna
- 2. Wireless Bridge
- 3. ORBCOMM Controller
- 4. Green LED Light
- 5. Interface Module
- 6. KOMTRAX Plus Controller
- 7. Red LED Lights



ORBCOMM controller (3, Figure 32-11) transmits data through antenna (1, Figure 32-12) mounted on top of the cab. The antenna coaxial cable is routed through the inside of the cab to protect it from damage. If the antenna or coaxial cable is damaged, replace the parts.

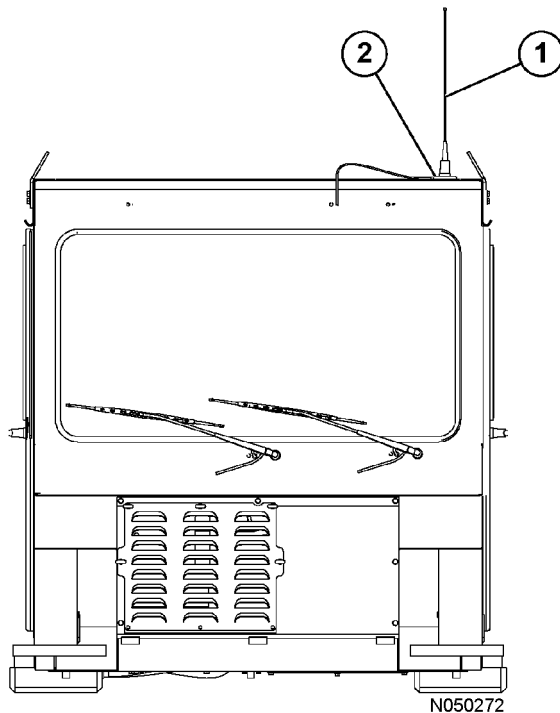

FIGURE 32-12. ORBCOMM ANTENNA

1. ORBCOMM Antenna                      2. Magnetic Base

### Interface Module

Interface module (5, Figure 32-11) receives data from the sensors installed on the truck and sends this information to the KOMTRAX Plus controller. There is a small green LED light on the face of the controller. With the key switch ON, the light must be blinking. If the light is continuously illuminated, there is a problem in the controller.

When a new interface module controller is installed on the truck, new software has to be installed inside the controller. IM-Diag connector (1, Figure 32-13) is used to connect the interface module to a laptop PC for installing software.

### Basic Precautions

- When using this truck, there is no particular need to operate the KOMTRAX Plus system.
- Never disassemble, repair, or modify the KOMTRAX Plus system. This may cause failure or fire on the machine or this system.
- Do not touch the system when operating the machine.
- Do not pull on the wiring harnesses, connectors, or sensors of this system. This may cause short circuits or disconnections that lead to failure or fire on the machine or this system.
- Do not get water, dirt or oil on the system controllers.
- If there is any abnormality with the KOMTRAX Plus system, please consult the servicing Komatsu distributor.

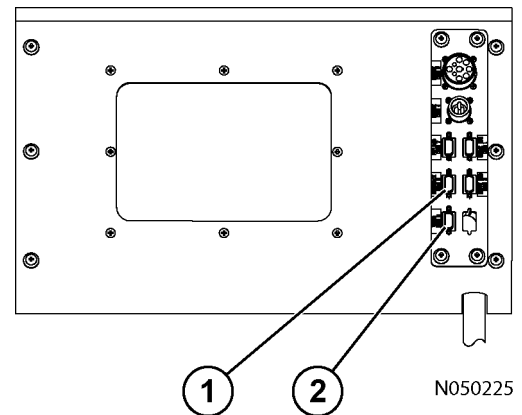

FIGURE 32-13. DIAGNOSTIC PORTS  
(D.I.D. PANEL AT REAR OF CAB)

1. IM Diagnostic Port  
2. KOMTRAX Plus Diagnostic Port

## KOMATSU WIRELESS BRIDGE (Optional)

### General Information

The Komatsu wireless bridge (2, Figure 32-11) allows for the transfer of information from the KOMTRAX Plus controller to a laptop computer with wireless network capabilities. The information that is downloaded through the KWB (Komatsu wireless bridge) is the same information that is gathered during a manual download from the KOMTRAX Plus system. Downloads can be performed with the laptop computer located on or near a stationary truck, or the computer can be located close to a path of moving trucks. Total download time is approximately 10 seconds. If only a portion of the data is downloaded while the truck is passing by a laptop computer, the remaining information will be downloaded the next time a data download occurs.

The wireless bridge transmits data using antenna (1).

### Communication Setup

A computer running a Microsoft® operating system (with a wireless network adaptor) is required to download data from the KWB. The individual steps required are different depending upon the computer operating system and each computer's specific wireless adaptor.

Please refer to the computer and/or adaptor manuals for further details.

1. Ensure that the KWB:

- shows power and function (LEDs illuminated)
- has not been previously setup
- is within range of the computer

2. Use the computer to scan for any available wireless networks. The computer should find a network with **KWB\_SETUP** as its SSID (SSID = Service Set Identifier). If this SSID is present the KWB is transmitting correctly. Switch to the KWB\_SETUP network.

If the KWB\_SETUP SSID is not detected, verify all connections to the KWB. If all connections are correct, the KWB will need to be reset. Reset the KWB by pushing the reset button (2, Figure 32-14) next to the connector plug.

*NOTE: A KWB\_SETUP SSID could be transmitted by another laptop computer and not by the desired KWB. Power down any other wireless sources with an SSID of KWB\_SETUP.*

### Switching to the KWB\_SETUP Network

The computer should be on the same network as the KWB. It will be necessary to "create a profile" for the new network. Check the wireless adaptor's manual for details.

3. Configure the new profile as follows:

- Set the profile name to KWB\_SETUP.
- Set the SSID to KWB\_SETUP.
- Select the wireless network type as "ad hoc."
- In the security settings, select "no encryption" or a similar setting.
- Select channel 11 (most adaptors will automatically select a channel).

Some wireless adaptor software allows the setting of a static IP address and subnet mask for each profile. If this option is available, complete the following steps:

- a. Set the IP address to 192.168.0.xxx, where xxx is any number between 1 and 255. 123 is recommended if only one computer will be used to interact with the KWB. If multiple computers are used, each must be set to a different IP address.

Set the subnet mask to 255.255.0.0. If asked for a default gate-way, this may be assigned the same IP address as the computer.

### Setting the Computer Subnet Mask and IP Address

If the adaptor software does not allow for setting an IP address, then this must be done manually.

The Windows TCP/IP settings must be modified for the correct subnet mask and an adequate IP address. The steps to reach the point where the TCP/IP settings can be modified vary according to the operating system and are described below. The actual steps for making the changes to the settings are described for the following operating systems.

Windows 2000:

1. Click on the start menu, select settings and then "Network and Dial-up Connections."
2. Right click on the wireless network adaptor and select "properties." Skip instructions for other Operating Systems and continue to the topic of "Properties".

Windows XP:

1. Click on the start menu, right click on "My Networks" and select "Properties." A window with all available networks will be shown.
2. Right click on the wireless network and select "Properties." Skip instructions for Windows Vista and continue to the topic of "Properties".

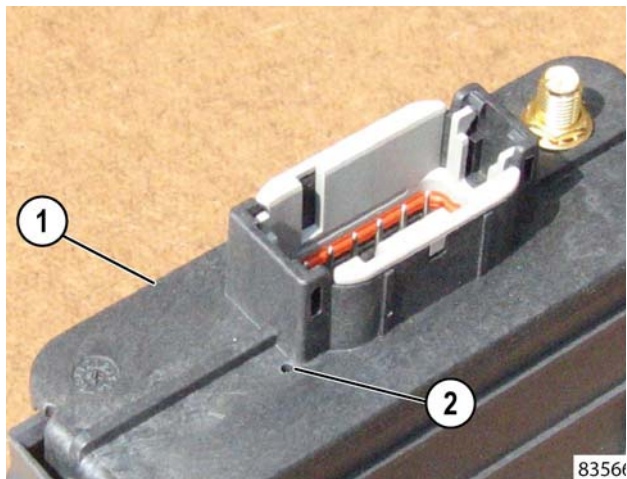

FIGURE 32-14. RESET LOCATION

1. Komatsu Wireless
2. Reset Button Hole Bridge

Windows Vista:

1. Click on the Windows menu, right click on "Network" then select "Properties." A window will open with the option "Manage network connections" as one of the options on the left side. Select that option.
2. A new window showing all available networks will open. Right click on the wireless network to be used to connect to the KWB and select "Properties." Vista will inquire if this was an intentional selection; select "Continue." Continue to the topic of "Properties".

### Properties

Once the window with the list of available protocols is shown, the TCP/IP should then be selected. Click on "Properties" and bring up a window for setting the IP address and the subnet mask (alternatively, double click on TCP/IP). Before making any changes, write down the current settings. These settings will be needed to restore the original computer settings if needed.

3. Select "Use the following IP address," then set the IP address to 192.168.0.xxx, where xxx represents any number between 1 and 255. 123 is generally used. However, no two computers should use the same IP address). The subnet mask should now be set to 255.255.0.0. If a gateway address is requested, this is set to the same as the IP address.

This prepares the computer to communicate with the KWB and to interact with the automatic download software.

*NOTE: The previous steps are not necessary if the software that comes with the computer/adaptor allows an IP address and mask to be assigned to each profile. This is done automatically by selecting the profile.*

*It may be necessary to repeat these steps to restore the computer settings when connecting to another network.*

## Setting Up the KWB

The KWB is preset from the factory. It is recommended that the SSID be changed at setup to establish a unique identity from other KWBs. No previously installed KWBs should show up as KWB\_SETUP.

Changing the network channel may be necessary. For example, if another network in the vicinity uses channel 11 for transmission, the KWB may interfere with this network.

If the information downloaded from the KOMTRAX Plus controller is considered sensitive and private, then the KWB data should be encrypted.

Once the computer has been setup correctly the KWB may be setup using a web browser as follows:

1. On the KWB, label locate the IP address.
2. Type the KWB IP address into the address bar of a web browser (just the numbers and the periods).
3. When prompted to enter a User Name and Password, enter "dpac" for both.
4. The initial screen that is displayed will show the current status of the KWB. Select "Network" from the top right corner.
5. Change the SSID to any name. (for example, "KOMTRAX controller"). The SSID is used to separate networks. If one computer will be used to download data from excavators, one from haul trucks, and one from dozers, then the KWB that will be installed on these machines could have their SSID set to "KOMTRAX\_dig," "KOMTRAX\_haul," and "KOMTRAX\_push" respectively. This would make excavators and haul trucks invisible to the computer setup to download data from dozers. All KWBs that are to be in the same network should be set to the same SSID.

If the default channel (11) is used by another network in the vicinity, change the channel. It is preferable to assign channels that are at least three channels apart.

## Adding Encryption

It is recommended that encryption be added.

1. On "Wireless Security Mode," select WEP128. In "WEP key 1", using only numbers and the letters from "A" to "F," input a 26 character long passkey, for example "0123456789ABCDEF0123456789" (a more complex combination should be used). All KWBs that are to be in the same network should have the same WEP key, SSID, and be on the same channel.
2. Keep a record of the key.

*NOTE: If a more secure encryption method is desired, consult a network professional to setup WPA encryption.*

3. If the "DHCP Client Name" is blank, input the KWB IP address in this field before pressing the "Save" button at the bottom of the page. No further network settings are required.
4. Once the KWB is reset, all the settings will be applied. Reset the KWB when prompted or, if you prefer to review the settings, click on "Networks" and, when reviewing is complete, click on "Reset." Both of these options are in the blue bar under "KWB-1".

## Final Computer Settings

Once the KWB SSID is changed, the KWB is no longer in the KWB\_SETUP network. In order to establish communications with the KWB, the computer must be setup to have the same settings as the KWB. Follow steps 1 through 3 beginning in "Communication Setup", but use the new settings to create a different network profile. Once all settings are complete, typing the KWB IP address in the browser's address bar should open the KWB settings page. This confirms that the KWB and the computer are on the same network.

Once the steps described above have been performed, the computer will have two network profiles in the program that manages the network adaptor. The KWB\_SETUP profile should remain in the list in order to setup other KWBs in the future. The other profile will be the one used to communicate with the existing KWB. For both networks, the computer IP address can remain the same. Therefore, Step 3 as described in "Switching to the KWB\_SETUP Network" is not required. If the computer is also used to connect to the internet, select "obtain IP address automatically" when connecting to the internet.

## Data Downloading

To obtain the software for data downloading from the KOMTRAX Plus controller, go to the Komatsu Extranet (<https://www.komatsuamerica.net>).

1. Select KOMTRAX / VHMS / PLM.
2. Select VHMS / PLM, then select SOFTWARE.
3. Select KWB - Komatsu Wireless Bridge (Wireless Download Software). Load and install the software. The icon "VHMS Controller Auto Download Tool" will be created during the download process.

Running the software for the first time will offer the opportunity to choose a login name and password; "user" should be used for "User Name" and "1" for "Password." This may change this the next time the software is run. Clicking "OK" will start the download tool. If any KWBs are within range and are connected to the VHMS controller, the tool will automatically download all the data from each VHMS controller.

The auto-download software will not download from KOMTRAX Plus controllers that have not had the vehicle data setup (this is a consideration only when replacing a KOMTRAX Plus Controller or installing a KOMTRAX Plus Controller for the first time nor will any KWB that is not connected to a KOMTRAX Plus controller show up in the list of available download sources. Once the data from one vehicle has been downloaded, the tool will not perform another download for that vehicle until 20 hours have passed.

It is possible to force a download by right clicking on a vehicle in "View." Vehicles in "View" are shown in the top list; vehicles that have been previously in "View" are shown in the lower list.

## Resetting the KWB

It may be necessary to reset the KWB. For example, if the WEP key was incorrectly typed when setting up the KWB, it will not be possible to connect to that KWB without the correct key.

1. Remove the power by turning OFF the key or by disconnecting the harness from the KWB.
2. Lightly insert, press and hold a paperclip into the hole on the connector face. To prevent damage to the internal switch do not use sharp objects.
3. Restore power to the KWB while keeping the reset switch depressed. The LEDs should begin to flash. The KWB is now reset.

*NOTE: After a reset, the KWB will revert to the KWB\_SETUP SSID.*

4. Switch to the KWB\_SETUP SSID network. The IP address after a reset will be 192.168.1.0.
5. When setting the KWB, the IP address must be changed from the reset IP address. Use the address on the KWB label.

## KWB Lights

**Table 1: KWB LIGHTS**

Name	Description
CONN	Reserved for future use.
LINK	When ON, the KWB is operational. When OFF, the KWB may not be set for Ad-Hoc, or it may be damaged. An ON condition is not an indication that the antenna or antenna cable is in good condition or that the antenna is connected.
CFG	When ON, the KWB has an IP address. When OFF, the KWB may be configured for DHCP (DHCP should not be selected for ad-hoc mode).
POST	When ON, the KWB is receiving power and is operational. When OFF, the KWB may not be powered or it may be defective.

## FUSES AND CIRCUIT BREAKERS

The fuses are located in four fuse blocks in the auxiliary control cabinet.

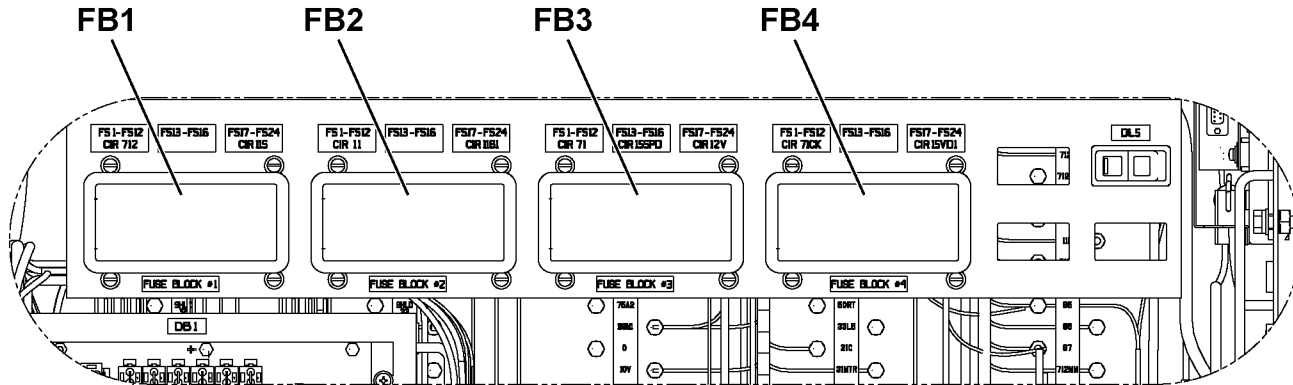

FIGURE 32-15. FUSE BLOCKS

N050271

### FUSE BLOCK #1

LOCATION	AMPS	DEVICE(S) PROTECTED	CIRCUIT
1	15	A/C, Heater Blower Motor	12H
2	10	Windshield Washer / Wiper	63
3	5	Instrument Panel Gauges	712G
4	10	Key Switch Power	712P
5	10	Hoist Limit Solenoid	712H
6	15	Turn Signal / Clearance Lights	712T
7	10	Engine Options	712E
8	10	AID and Indicator Lights	12M
9	5	Engine Start Failure	712SF
10	10	Engine Shutters	712R
11	10	Dome Light Switch	712A
17	15	Key Switch Supplemental Power	11KS
18	15	PLMIII Lights	39J
19	5	PLMIII Power	39G

**FUSE BLOCK #2**

LOCATION	AMPS	DEVICE(S) PROTECTED	CIRCUIT
1	15	Service Lights	11SL
2	15	Cab Dome, Fog, Ladder Lights	11L
3	15	Hazard Lights	46
4	10	Interface Module	11INT
5	10	VHMS & Orbcmm Controllers Power	85
6	20	Modular Mining System	11M
7	15	VHMS & Orbcmm Controllers Battery	11DISP
8	15	Headlights	11HDL
9	15	Reserve Oil System Pump	11ORS
10	15	Reserve Oil System Control	11RCNT
11	20	Hydraulic Bleed Down	11BD
12	10	Engine Load Signal Power	11EM
13	10	Key Switch Power	11KS
17	20	Engine ECM Power	11E1
18	20	Engine ECM Power	11E2
19	20	Engine ECM Power	11E3
20	20	Engine ECM Power	11E4

**FUSE BLOCK #3**

LOCATION	AMPS	DEVICE(S) PROTECTED	CIRCUIT
1	15	Cab Drive System	71P
2	10	Automatic Lube Pump	68ES
3	15	Interface Module (GE Power)	71IM
4	20	Operator Seat Power	71IOS
13	10	Right Front Wheel Speed Sensor	15RFWS
14	10	Left Front Wheel Speed Sensor	15LFWS
17	10	12V Auxiliary Outlets	67C
18	20	R.H. Cab Window	67R
19	20	L.H. Cab Window	67P

**FUSE BLOCK #4**

LOCATION	AMPS	DEVICE(S) PROTECTED	CIRCUIT
1	10	Brake Circuits	71BC
2	5	PLMIII	712PL
3	5	Interface Module	87
4	10	VHMS Controller	71VHM
5	5	Modular Mining Hub Power	712MM
6	5	Display Module	86
7	15	Hydraulic Bleed Down	71BD
8	10	Switch LED Power	71LS
9	1	Selector Switch Power	71SS
17	5	Gauge Voltage	15V
18	5	Pedal Voltage	15PV
19	5	Engine Interface	15VL

The following two fuses are located in the fusible link between the prelube timer solenoid and #2 cranking motor.

LOCATION	AMPS	DEVICE(S) PROTECTED	CIRCUIT
Fusible link	150 each	Cranking Motors	11ST

The circuit breakers are located on the relay boards on the left inside wall of the auxiliary control cabinet.

### CIRCUIT BREAKERS

LOCATION	AMPS	DEVICE(S) PROTECTED	CIRCUIT
RB1 - CB13	12.5	Turn Signals / Clearance Lights	11CL
RB1 - CB15	12.5	Tail Lights	41T
RB3 - CB16	12.5	Retard Lights	44D
RB3 - CB17	12.5	Manual Backup Lights	47B
RB3 - CB18	12.5	Stop Lights	44A
RB3 - CB19	12.5	Backup Lights and Horn	79A
RB4 - CB20	12.5	Engine Control Power	23D
RB4 - CB21	12.5	Service Lights, Horn, Solenoid	11A
RB4 - CB22	12.5	Engine Run Relay	439E
RB5 - CB23	12.5	Headlights, Left Low Beam	11DL
RB5 - CB24	12.5	Headlights, Right Low Beam	11DR
RB5 - CB25	12.5	Headlights, Left High Beam	11HL
RB5 - CB26	12.5	Headlights, Right High Beam	11HR
RB5 - CB27	12.5	Headlights and Dash Lights	11D

The following circuit breaker is located in the battery control box.

LOCATION	AMPS	DEVICE(S) PROTECTED	CIRCUIT
CB60	50	24V to 12V Converter	11BS



## LUBRICATION AND SERVICE

### GENERAL

Recommended preventive maintenance will contribute to the long life and dependability of the truck and its components. The use of proper lubricants and the performance of checks and adjustments at the recommended intervals is most important.

Lubrication requirements are referenced to the lube key found in the Lubrication Chart (page 2-5). For detailed service requirements for specific components, refer to the shop manual section for that component (for example, Section H for suspensions, Section L for hydraulic system, etc).

Refer to the manufacturer's service manual when servicing any components of the General Electric propulsion system.

Refer to engine manufacturer's service manual when servicing the engine or any of its components.

The service intervals presented here are in hours of operation. **These intervals are recommended in place of an oil analysis program which may determine different intervals.** However, if the truck is being operated under extreme conditions, some or all of the intervals may need to be shortened and the service should be performed more frequently.

The 930E truck is equipped with a Lincoln Automatic Lubrication System. The initial setup for this system provides for nominal amounts of lubricant to be delivered to each serviced point. The lubrication injectors can be adjusted to vary the amount of lubricant delivered. In addition, the timer for lubrication intervals is normally adjustable. For adjustments to these devices, refer to Section 42, Automatic Lubrication System.

### SERVICE CAPACITIES

Component/System	Liters	U.S. Gallons
<b>Crankcase</b> (including 4 oil filters) Komatsu SSDA16V160 Engine	280	74
<b>Cooling System</b> Komatsu SSDA16V160 Engine	594	157
<b>Hydraulic System</b> Refer to "Hydraulic Tank Service"	1325	350
<b>Wheel Motors</b> (each side)	95	25
<b>Fuel Tank</b> (Diesel fuel only)	4542	1200

### HYDRAULIC TANK SERVICE

There are two sight gauges (1, Figure 40-1) on the side of the hydraulic tank. With the engine stopped, key switch OFF, hydraulic system depressurized, and body down, the oil level should be visible in the center of the top sight gauge. If the oil level is not visible in the center of the top sight gauge, follow the instructions below for adding oil.

#### Adding Oil

*NOTE: Keep the system open to the atmosphere only as long as absolutely necessary to lessen chances of system contamination.*

Service the tank with clean Type C-4 hydraulic oil only. All oil being put into the hydraulic tank should be filtered through 3 micron filters.

1. Make sure that the engine is stopped, key switch is OFF, hydraulic system is depressurized, and body is down
2. Remove fill cap (2) and add hydraulic oil until the oil level is visible in the center of the top sight gauge.
3. Install the fill cap.
4. Start the engine. Raise and lower the dump body three times.
5. Check the hydraulic oil level again with the engine stopped, key switch OFF, hydraulic system depressurized, and body down.
6. Repeat Steps 1 - 5 until the oil level is maintained in the center of the top sight gauge.

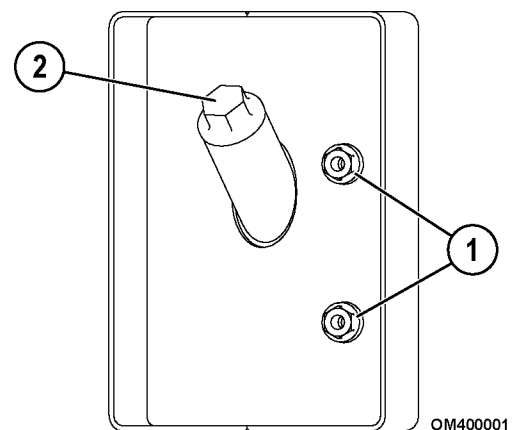

FIGURE 40-1. HYDRAULIC TANK SERVICE

1. Sight Gauges      2. Fill Cap

## COOLING SYSTEM SERVICE

Check coolant level sight gauge (1, Figure 40-2). If coolant cannot be seen in the sight gauge, add coolant to the system before truck operation. Refer to the procedure below for the proper filling procedure.

### Radiator Filling Procedure

#### **⚠ WARNING**

**The cooling system is pressurized due to thermal expansion of coolant. Do not remove the radiator cap while the engine and coolant are hot. Severe burns may result.**

*NOTE: If coolant is added using the Wiggins service center, the radiator cap must still be removed before adding coolant.*

Engine coolant must always be visible in the sight gauge before truck operation.

1. With the engine and coolant at ambient temperature, remove radiator cap (2).
2. Fill the radiator with the proper coolant mixture until coolant is visible in the sight gauge.
3. Install the radiator cap.
4. Run the engine for five minutes, then check the coolant level.
5. If coolant is not visible in the sight gauge, repeat Steps 1 - 4. Any excess coolant will be discharged through the vent hose after the engine reaches normal operating temperature.

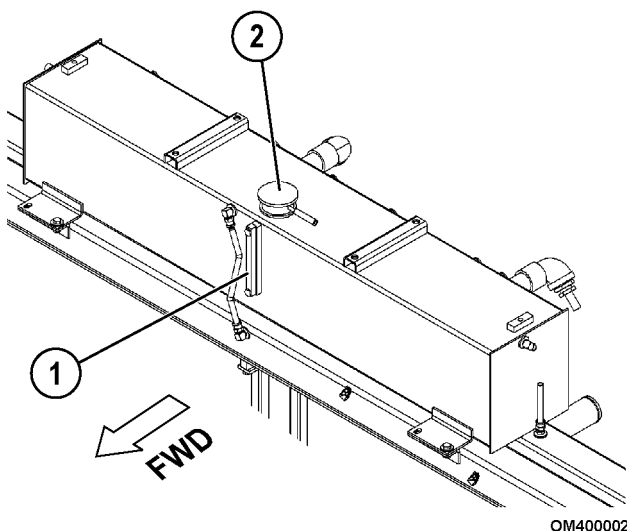

FIGURE 40-2. COOLING SYSTEM SERVICE

1. Sight Gauge

2. Radiator Cap

### Coolant Specifications

- For ambient temperatures of -25° F (-32° C) and above, use a standard 50/50 anti-freeze-to-water mixture.
- For arctic climates with ambient temperatures between -25° F (-32° C) and -65° F (-54° C), use a 60/40 anti-freeze-to-water mixture.

*NOTE: Do not use propylene glycol coolant in arctic climates. Only use ethylene glycol coolants.*

### Unacceptable Practices

- Use of high-silicate anti-freeze.
- Under concentration or over concentration of Extended Service Additive (SCA).
- Use of anti-freezes/coolants that are **not** fully formulated for extended service intervals.
- Use of sealing additives (stop-leak) in the cooling system.
- Use of soluble oils in the cooling system.
- Use of poor-quality water. See the engine manufacturer's specifications for water quality requirements.
- Use of anti-freeze, Extended Service Additive (SCA) or coolant filter(s) that do **not** meet the engine manufacturer's specifications.
- Use of Treated Water coolant.
- Use of coolants with less than 40 percent antifreeze.

## WHEEL MOTOR SERVICE

Due to differences in gear ratio and component evolution/design, wheel motor service intervals may be unit number and/or mine specific. Because of the wide variety of factors involved, it is necessary to consult your area Komatsu representative for all wheel motor service intervals and instructions. General intervals for oil service and sampling are listed in the interval charts.

## RESERVE OIL TANK SERVICE

The reserve engine oil system is designed to add more oil capacity to the engine to reduce the frequent servicing of the engine oil. The engine oil level must still be checked every shift by using the dipstick. If the engine oil level is not correct, check for proper operation of the reserve engine oil system. Never add oil to the engine unless it has been drained.

If the engine oil has been drained from the oil pan, new oil must be added to the engine oil pan before starting. Do not use the oil in the reserve tank to fill an empty engine with oil. After an oil change, both the engine and reserve tank must be full of oil before starting the engine.

With the engine running, check the operation of the red LED light on the pump.

- **Continuously on** - Pump 1 is withdrawing oil from the engine sump and bringing down the oil level.
- **Regular pulsing** - Pump 2 is returning oil to the engine sump and raising the oil level.
- **Irregular pulsing** - Oil is at the correct running level.

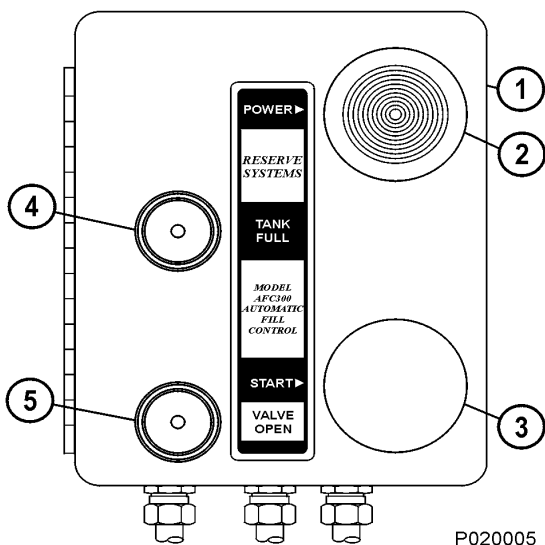

FIGURE 40-3. REMOTE FILL CONTROL BOX

- |                       |                     |
|-----------------------|---------------------|
| 1. Remote Control Box | 4. FULL Light       |
| 2. Power Switch       | 5. VALVE OPEN Light |
| 3. Start Switch       |                     |

Oil should always be visible in the bottom sight gauge. If not, add oil to the reserve oil tank until oil is visible in the top sight gauge.

- Never add oil to the engine unless it has been completely drained.
- If the engine oil has been drained from the oil pan, new oil must be added to the oil pan. **Do not use the oil in the reserve oil tank to fill an empty engine oil pan.**
- After an oil change, both the engine and reserve oil tank must be full of oil before starting the engine.

### Filling the Reserve Oil Tank (Remote Fill)

1. Connect the supply hose from the new oil supply to the quick disconnect coupling on the truck. Open the valve on the supply hose to apply pressure.
2. Pull power switch (2, Figure 40-3) to turn the system ON.
3. Push start switch (3). VALVE OPEN light (5) should illuminate and the filling process will begin.
4. When tank is full, VALVE OPEN light (5) will turn off and FULL light (4) will illuminate.
5. Close the valve in the supply hose.
6. Press and hold start switch (3) for a couple of seconds.
7. Disconnect the supply hose from the quick disconnect coupling on the truck.
8. Push power switch (2) to turn the system OFF.

### Inline Screen

There is an inline screen located at the inlet of the fill valve. This screen does not require periodic maintenance, but it can be cleaned by removing the screen and back flushing.

## QUICK FILL SERVICE CENTER

The service center (Figure 2-4) can be located on either side of the truck and is used to fill system fluids. Table 1 shows the maximum recommended fill pressures for the service center.

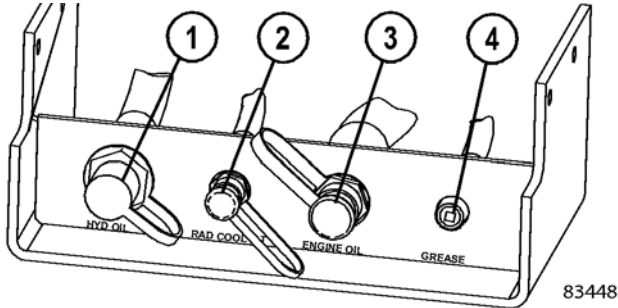

FIGURE 2-4. SERVICE CENTER

- 1. Hydraulic Oil
- 2. Radiator Coolant
- 3. Engine Oil
- 4. Grease

Fill System	kPa	psi
Engine Crankcase	345	50
Reserve Tank	862	125
Hydraulic Tank	345	50
Coolant	345	50
Grease	10 342	1,500

# LUBRICATION CHART

## LUBRICATION SPECIFICATIONS

LUBE KEY	TYPE LUBRICANT	PTS	LUBE KEY	10 HR	50 HR	100 HR	250 HR	500 HR	1000 HR	2000 HR	2500 HR
A	ENGINE OIL ----- SEE ENGINE MANUAL										
B	HYDRAULIC OIL ----- SAE 10W C-4 -----										
C	HEAVY-DUTY SYNTHETIC GEAR OIL ----- SEE DRIVE SYSTEM MANUAL										
D	MULTI-PURPOSE EXTREME PRESSURE GREASE ----- NLGI NO.2 (5% MIN. MOLY-DISULFIDE)										
E	MULTI-PURPOSE GEAR OIL ----- SAE 80W-90										
SYM	DESCRIPTION	PTS	LUBE KEY	10 HR	50 HR	100 HR	250 HR	500 HR	1000 HR	2000 HR	2500 HR
1	CRANKCASE OIL LEVEL	1	A	CHECK							
2	ENGINE LUBE OIL FILTERS										
3	FUEL FILTER										
4	FUEL SEPARATOR (DAVCO)										
5	FUEL TANK										
6	GE PREFILTER BLOWER	1	D								
7	FUEL TANK BREATHER	1							CLEAN		
8	HYDRAULIC OIL LEVEL	1	B	CHECK					*CHANGE		
9	HYDRAULIC STRAINER	2							CLEAN		
10	HYDRAULIC TANK BREATHER	2						CHANGE			
11	HYDRAULIC FILTERS	3			**	**	**	CHANGE			
12	MOTORIZED WHEEL OIL LEVEL	2	C					SEE DRIVE SYSTEM MANUAL			
13	HYD. PUMP DRIVE SHAFT	2	D					GREASE			
14	CHASSIS LUBE LEVEL	1	D					GREASE			
15	SEAT SLIDES & STEER SHAFT	4	D					GREASE			
16	WHEEL MOTOR BLOWER	2	D					GREASE			
17	FRONT WHEEL BEARINGS ***	2	E					CHECK			CHANGE
18	FRONT TRUNION	1	D					GREASE			
19	MAGNETIC PLUG							CHECK			
	FRONT WHL COVER ****	2						CHECK			

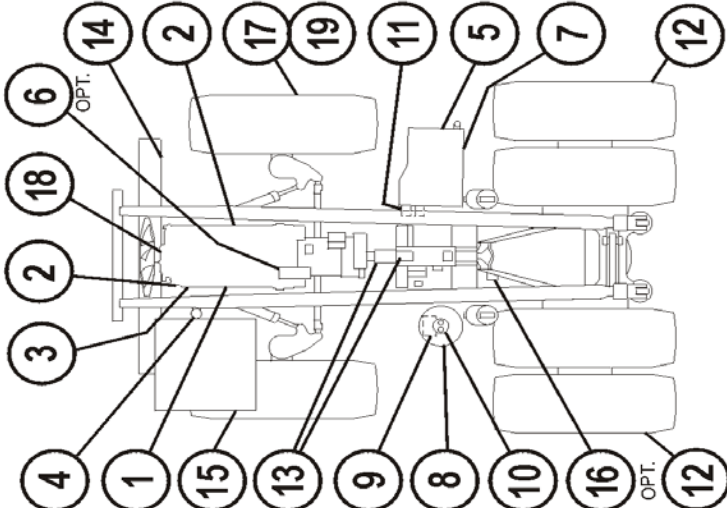

630E, 730E, 830E, & 930E

WB2790

SEE ENGINE MANUAL

\* 1000 HR INTERVAL CAN BE EXTENDED TO 2500 HR PROVIDED OIL SAMPLING AND ANALYSIS IS CONDUCTED EVERY 250 HR.  
 \*\* ONE-TIME CHANGE AT 50, 100 AND 250 HR.  
 \*\*\* NOT APPLICABLE FOR 930E  
 \*\*\*\* APPLICABLE FOR 930E ONLY

## LUBRICATION CHART

### 10 HOUR (DAILY) INSPECTIONS

NOTE: "Lube Key" references are to the **Lubrication Chart** on page 40-5.

Truck Serial Number _____ Site Unit Number _____ Date _____				
Hourmeter _____ Name of Service Technician _____				
	TASK	COMMENTS	CHECKED	INITIALS
1.	MACHINE - Inspect the entire machine for leaks, worn parts and damage. Repair as necessary.			
2.	FAN DRIVE AND TURBOCHARGERS - Check for leaks, vibration and unusual noise. Check the condition and alignment of the alternator and fan belt.			
3.	RADIATOR - Check the coolant level and fill the radiator with the proper coolant mixture according to Coolant Specifications on page 40-2. Refer to the engine service manual for additional coolant recommendations.			
4.	ENGINE - 1. Check the oil level. To obtain an accurate measurement, remove the dipstick and wipe it off. Then reinsert the dipstick and remove it again to check the oil level. Refer to the engine service manual for oil recommendations. (Lube Key "A") 2. Check the oil level in the reserve tank. The oil level should be visible in the center of the top sight gauge. If it is not, add oil to the reserve tank until the oil level is visible in the center of the top sight gauge. Also, with the engine running, check the operation of the LED monitor light. Refer to "Reserve Engine Oil System" in Section 30, Operating Instructions. 3. Make sure that the exhaust piping is secure. 4. Check for abnormal noises and fluid leaks. 5. Check the operating indicator of the eliminator filter.			
5.	HYDRAULIC TANK - Check the oil level in the tank. Add oil if necessary. Refer to Hydraulic Tank Service on page 40-1. (Lube Key "B")			
6.	WHEELS AND TIRES - 1. Inspect the tires for wear and proper inflation. 2. Check for embedded debris in the treads. 3. Check for damaged, loose or missing wheel mounting nuts and studs. Replace damaged or missing hardware and tighten to standard torque before truck operation.			

**10 HOUR (DAILY) INSPECTIONS (Cont.)**

	<b>TASK</b>	<b>COMMENTS</b>	<b>CHECKED</b>	<b>INITIALS</b>
7.	COOLING AIR DUCTWORK - Inspect the ductwork from the blower to the rear axle. Make sure that the ductwork is secure, undamaged and unrestricted.			
8.	AIR INTAKE PIPING - Check all mounting hardware, joints and connections. Make sure that there are no air leaks and all hardware is properly tightened.			
9.	AIR CLEANERS - Check the air cleaner restriction gauges in the operator cab. The air cleaners should be serviced if the gauges show a maximum restriction of 25 inches of H <sub>2</sub> O vacuum.  Refer to Section C5 in the shop manual for servicing instructions. Empty the air cleaner dust caps. After service, push the reset button on face of gauges to return the gauges to zero.			
10.	CAB AIR FILTER - In extremely dusty conditions, check this filter daily and service as frequently as required. See the 250 Hour Lubrication and Maintenance Checks for the cleaning procedure.			
11.	WASHER FLUID - Check the level of washer fluid in the bottle behind the cab. Fill as needed.			
12.	FUEL TANK -  1. Check the quick fill fuel receivers for excessive wear, leaks and mud buildup.  2. Check the vent on top of the fuel tank for mud buildup or any other obstructions. Clean if necessary. See the 1000 Hour Lubrication and Maintenance Checks for cleaning instructions.			
13.	FUEL FILTERS - Drain any water from the bottom drain valve on each fuel separator.			
14.	AUTO LUBE SYSTEM -  1. Check the reservoir grease level. Fill as required. (Lube Key "D")  2. When filling the grease reservoir, check the grease filter indicator. Clean or replace the grease filter if a problem is indicated.  3. Inspect the system for leaks and check for proper operation. Make sure that the following important areas are receiving adequate amounts of grease. (Lube Key "D")  • Steering Linkage  • Final Drive Pivot Pin  • Rear Suspension Pin Joints (Upper and Lower)  • Body Hinge Pins  • Hoist Cylinders Pins (Upper and Lower)  • Anti-Sway Bar (Both Ends)			

### 50 HOUR LUBRICATION AND MAINTENANCE CHECKS

Truck Serial Number _____ Site Unit Number _____ Date _____ Hourmeter _____ Name of Service Technician _____			
TASK	COMMENTS	CHECKED	INITIALS
*1. FUEL FILTERS - Replace the fuel filters. Refer to the engine operation and maintenance manual for filter replacement instructions.			
*2. HYDRAULIC SYSTEM FILTERS - Replace the filter elements. Check the oil level. Add oil as necessary. (Lube Key "B")			

\* These checks are required **only after the initial 50 hours of operation**, such as the commissioning of a new truck or after installing a new or rebuilt component.

### 100 HOUR LUBRICATION AND MAINTENANCE CHECKS

Truck Serial Number _____ Site Unit Number _____ Date _____ Hourmeter _____ Name of Service Technician _____			
TASK	COMMENTS	CHECKED	INITIALS
*1. HYDRAULIC SYSTEM FILTERS - Replace the filter elements. Check the oil level. Add oil as necessary. (Lube Key "B")			

\* This check is required **only after the initial 100 hours of operation**, such as the commissioning of a new truck or after installing a new or rebuilt component.

### 250 HOUR LUBRICATION AND MAINTENANCE CHECKS

Truck Serial Number _____ Site Unit Number _____ Date _____ Hourmeter _____ Name of Service Technician _____			
TASK	COMMENTS	CHECKED	INITIALS
*1. HYDRAULIC SYSTEM FILTERS - Replace the filter elements. Check the oil level. Add oil as necessary. (Lube Key "B")			

\* This check is required **only after the initial 250 hours of operation**, such as the commissioning of a new truck or after installing a new or rebuilt component.



### 250 HOUR LUBRICATION AND MAINTENANCE CHECKS (Cont.)

All 10 Hour (Daily) Inspections should also be performed at this time.

NOTE: "Lube Key" references are to the **Lubrication Chart** on page 40-5.

Truck Serial Number _____ Site Unit Number _____ Date _____				
Hourmeter _____ Name of Service Technician _____				
	TASK	COMMENTS	CHECKED	INITIALS
2.	<b>ENGINE -</b>  1. Change the engine oil. Refer to the engine operation and maintenance manual for engine oil specifications. (Lube Key "A")  <i>NOTE: If the engine is equipped with the Centinel™ oil system and/or the Eliminator™ filter system, engine oil and filter change intervals are extended beyond 250 hours. Take an engine oil sample for analysis. Refer to engine operation and maintenance manual for specific oil and filter change intervals.</i>  2. Replace the engine oil filters. Follow the instructions of the filter manufacturer, which are normally printed on the outside of the filter. <b>Do not use a wrench or strap to tighten filter elements.</b>  3. Change the reserve tank oil filter.  4. Check the tension and condition of each accessory drive belt. Refer to the engine operation and maintenance manual for specific adjustment instructions.  5. Check the torque on the cooling fan mounting capscrews. Tighten to <b>237 N•m (175 ft lb)</b> .			
3.	<b>COOLING SYSTEM -</b>  1. Check the coolant level and fill the radiator with the proper coolant mixture according to Coolant Specifications on page 40-2. Refer to the engine operation and maintenance manual for additional coolant recommendations.  2. Change the coolant filters. Refer to the engine operation and maintenance manual for coolant filter replacement instructions.  3. Check the cooling system hoses for damage and deterioration. Replace as necessary.			
4.	<b>FUEL FILTERS -</b> Change the fuel filters. Refer to the engine operation and maintenance manual for filter replacement instructions.			
5.	<b>FUEL TANK -</b> Drain water and sediment from the fuel tank. Refer to Section B4, Fuel Tank - Cleaning, in the shop manual.			

## 250 HOUR LUBRICATION AND MAINTENANCE CHECKS (Cont.)

	TASK	COMMENTS	CHECKED	INITIALS
6.	STEERING LINKAGE - Check the torque on the pin retaining nuts for the steering cylinders and tie rods. Tighten to <b>1017 N•m (750 ft lb)</b> .			
7.	HYDRAULIC PUMP DRIVESHAFT & U-JOINTS - Add one or two applications of grease to each grease fitting. Make sure that each bearing of the cross and bearing assembly is receiving grease. Replace bearings if any wear is detected. (Lube Key "D")			
8.	REAR WHEEL MOUNTING - Use a flashlight and a mirror on a long rod to inspect all inner and outer wheel mounting nuts and studs. Check for loose, damaged or missing hardware.  If wheel mounting nuts and studs must be tightened or replaced, the outer wheel must be removed for access. Refer to Section G in the shop manual for the procedures.			
9.	REAR AXLE HOUSING - Check the rear axle housing for oil leaks by removing the two drain plugs on the bottom of the axle housing. If oil is present, the cause of the leak must be found and corrected before operating the truck.			
10.	FRONT WHEEL HUB - Remove the magnetic plugs from the front wheel hub covers and check for debris. Clean the plugs and perform any necessary repairs.			
11.	MOTORIZED WHEELS -  1. Check for the correct oil level. Rotate the wheel so that the magnetic plug is at the 6 o'clock position and remove the plug. The oil level should be even with the bottom of the plug opening.  2. Inspect the magnetic plugs for ferrous materials. Service the wheel motor as necessary.			
12.	WHEEL MOTOR OIL SAMPLING - Refer to Section G5, Wheel Motor, in the shop manual for oil sampling information.			
13.	AUTOMATIC LUBRICATION SYSTEM - Perform the 250 hour checks as outlined in Automatic Lubrication System, Section 42, in this manual.			
14.	DUMP BODY PADS - Check the pads, shims and mounting hardware for wear and proper tightening.			
15.	BATTERIES - Check the electrolyte level and add water if necessary.			
16.	BODY-UP AND HOIST LIMIT SWITCHES - Check the operation of the switches. Clean any dirt from the sensing areas and inspect the wiring for damage.			

### 250 HOUR LUBRICATION AND MAINTENANCE CHECKS (Cont.)

	TASK	COMMENTS	CHECKED	INITIALS
17.	CAB RECIRCULATION AIR FILTER - Clean the filter element with mild soap and water. Rinse completely and allow to air dry before reinstalling the filter.			
18.	CAB AIR FILTER - Clean the filter element with mild soap and water. Rinse completely and dry with pressure air of 275 kPa (40 psi) maximum. Reinstall the filter.			

### 500 HOUR LUBRICATION AND MAINTENANCE CHECKS

All 10 Hour (Daily) Inspections and 250 Hour Lubrication and Maintenance Checks should also be performed at this time.

NOTE: "Lube Key" references are to the **Lubrication Chart** on page 40-5.

Truck Serial Number _____ Site Unit Number _____ Date _____ Hourmeter _____ Name of Service Technician _____				
	TASK	COMMENTS	CHECKED	INITIALS
1.	FINAL DRIVE CASE BREATHERS - Remove the breather elements for the motorized wheels. Clean or replace the elements.			
2.	HYDRAULIC SYSTEM FILTERS - Replace the hydraulic tank breathers and high pressure filter elements. Check the oil level. Add oil as necessary. (Lube Key "B")			
3.	HYDRAIR® SUSPENSION - Check for proper piston extension (front and rear).			
4.	THROTTLE AND BRAKE PEDAL - Lubricate the treadle roller and hinge pins with lubricating oil. Lift the boot from the mounting plate and apply a few drops of lubricating oil between the mounting plate and the plunger.			
5.	HOIST LEVER LINKAGE - Check the lever operation. Clean, lubricate and adjust the linkage as necessary.			
6.	PARKING BRAKE - Refer to Section J7, Parking Brake, in the shop manual for the recommended inspections.			

### 500 HOUR LUBRICATION AND MAINTENANCE CHECKS (Cont.)

	TASK	COMMENTS	CHECKED	INITIALS
7.	<b>RESERVE ENGINE OIL SYSTEM -</b>  1. Check the electrical system connections for tightness, corrosion and damage. Check the battery, oil pressure switch, junction boxes, remote control box and the circuit breakers.  2. Examine all electrical cables over their entire length for possible damage.  3. Inspect all reserve engine oil system hoses for leaks, cracks or other damage. Check all fittings for tightness, leakage or damage.			
8.	<b>BLADDER ACCUMULATORS -</b> Check the precharge pressure. Failure to maintain the correct precharge pressure may result in bladder failures.			
9.	<b>TIE ROD -</b> Check the torque on the locknuts for the tie rod threaded rod ends. Refer to Tie Rod Inspection and Torque Procedure in Section G3, Front Wheel Hub and Spindle, in the shop manual.			
9.	<b>WHEEL MOTOR OIL -</b> Change or filter the wheel motor oil. The oil must be filtered/changed earlier if oil analysis indicates contaminated oil.			
10.	<b>KOMTRAX PLUS DATA DOWNLOAD -</b> Perform a data download from the KOMTRAX Plus controller and send the data to WebCARE. Refer to Section D in the shop manual for more detailed instructions.			
11.	<b>FRAME AND AXLE BOX INSPECTION -</b> Wash the truck, clean all of the weld joints, and visually inspect the entire frame and axle box for cracking or damage.			

### 1000 HOUR LUBRICATION AND MAINTENANCE CHECKS

All 10 Hour (Daily) Inspections, 250 Hour Lubrication and Maintenance Checks, and 500 Hour Lubrication and Maintenance Checks should also be performed at this time.

NOTE: "Lube Key" references are to the **Lubrication Chart** on page 40-5.

Truck Serial Number _____ Site Unit Number _____ Date _____				
Hourmeter _____ Name of Service Technician _____				
	TASK	COMMENTS	CHECKED	INITIALS
1.	HYDRAULIC TANK - Drain the hydraulic tank and clean the inlet strainers. Refer to Section L3 in the shop manual. Refill the hydraulic tank. (Lube Key "B")			
2.	RADIATOR - Clean the cooling system with a good quality cleaning compound. Flush with water.  Fill the radiator with the proper coolant mixture according to Coolant Specifications on page 40-2. Refer to the engine service manual for additional coolant recommendations.			
3.	FUEL TANK - Remove the fuel tank breather and clean it in solvent. Dry the breather with pressurized air and install it on the tank.			
4.	OPERATOR'S SEAT - Apply grease to the slide rails. (Lube Key "D")			
5.	AUTOMATIC BRAKE APPLICATION - Make sure that the brakes are automatically applied when the brake pressure decreases below the specified limit. Refer to Section J, Brake Circuit Check-Out Procedure, in the shop manual.			

### 5000 HOUR MAINTENANCE CHECKS

All 10 Hour (Daily) Inspections, 250 Hour Lubrication and Maintenance Checks, 500 Hour Lubrication and Maintenance Checks, and 1000 Hour Lubrication and Maintenance Checks should also be performed at this time.

NOTE: "Lube Key" references are to the **Lubrication Chart** on page 40-5.

Truck Serial Number _____ Site Unit Number _____ Date _____				
Hourmeter _____ Name of Service Technician _____				
	TASK	COMMENTS	CHECKED	INITIALS
1.	AIR CLEANERS - Clean the Donacelone tubes in the precleaner section of the air filter. Use low pressure cold water or low pressure air to clean the tubes. Refer to Section C5 in the shop manual.			

---

# NOTES

## AUTOMATIC LUBRICATION SYSTEM

### GENERAL DESCRIPTION

The automatic lubrication system is a pressurized lubricant delivery system which delivers a controlled amount of lubricant to designated lube points. The system is controlled by an electronic timer which signals a solenoid valve to operate a hydraulic motor powered grease pump. Hydraulic oil for pump operation is supplied by the truck steering circuit.

Grease output is proportional to the hydraulic motor input flow. A pump control manifold, mounted on top of the hydraulic motor, controls input flow and pressure. A 24VDC solenoid mounted on the manifold turns the pump on and off.

The pump is driven by the rotary motion of the hydraulic motor, which is then converted to reciprocating motion through an eccentric crank mechanism.

The reciprocating action causes the pump cylinder to move up and down. The pump is a positive displacement, double-acting type as grease output occurs on both the up and the down stroke.

During the down stroke, the pump cylinder is extended into the grease. Through the combination of shovel action and vacuum generated in the pump cylinder chamber, the grease is forced into the pump cylinder. Simultaneously, grease is discharged through the outlet of the pump. The volume of grease during intake is twice the amount of grease output during one cycle. During the upstroke, the inlet check valve closes. One half of the grease taken in during the previous stroke is transferred through the outlet check and discharged to the outlet port.

### **WARNING**

**Over-pressurizing the system, modifying parts, using incompatible chemicals and fluids, or using worn or damaged parts may result in equipment damage and/or serious personal injury.**

- **DO NOT exceed the stated maximum working pressure of the pump or the lowest rated component in the system.**
- **Do not alter or modify any part of this system unless approved by the factory.**
- **Do not attempt to repair or disassemble the equipment while the system is pressurized.**
- **Make sure all fluid connections are securely tightened before using this equipment.**
- **Always read and follow the fluid manufacturer's recommendations regarding fluid compatibility, and the use of protective clothing and equipment.**
- **Check all equipment regularly. Repair or replace worn or damaged parts immediately.**

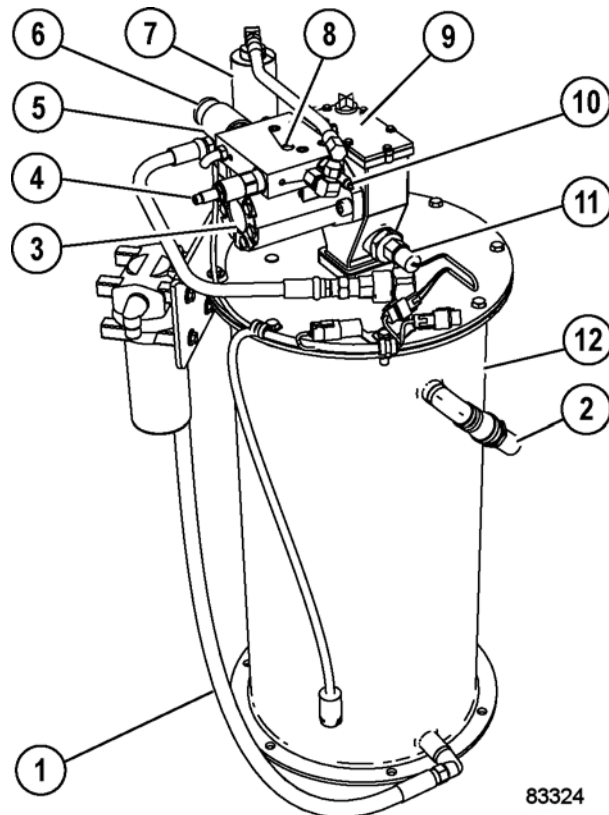

FIGURE 42-1. PUMP & RESERVOIR

- |                            |                        |
|----------------------------|------------------------|
| 1. Hose From Filter        | 7. Vent Valve          |
| 2. Vent Hose               | 8. Pipe Plug           |
| 3. Hydraulic Motor         | 9. Pump Assembly       |
| 4. Pressure Reducing Valve | 10. Flow Control Valve |
| 5. Solenoid Valve          | 11. Pressure Switch    |
| 6. Override Switch         | 12. Grease Reservoir   |

**This equipment generates very high grease pressure. Extreme caution must be used when operating this equipment as material leaks from loose or ruptured components can inject fluid through the skin and into the body causing serious bodily injury including possible need for amputation. Adequate protection is recommended to prevent splashing of material onto skin or into the eyes.**

**If any fluid appears to penetrate the skin, get emergency medical care immediately! Do not treat as a simple cut. Tell attending physician exactly what fluid was injected.**

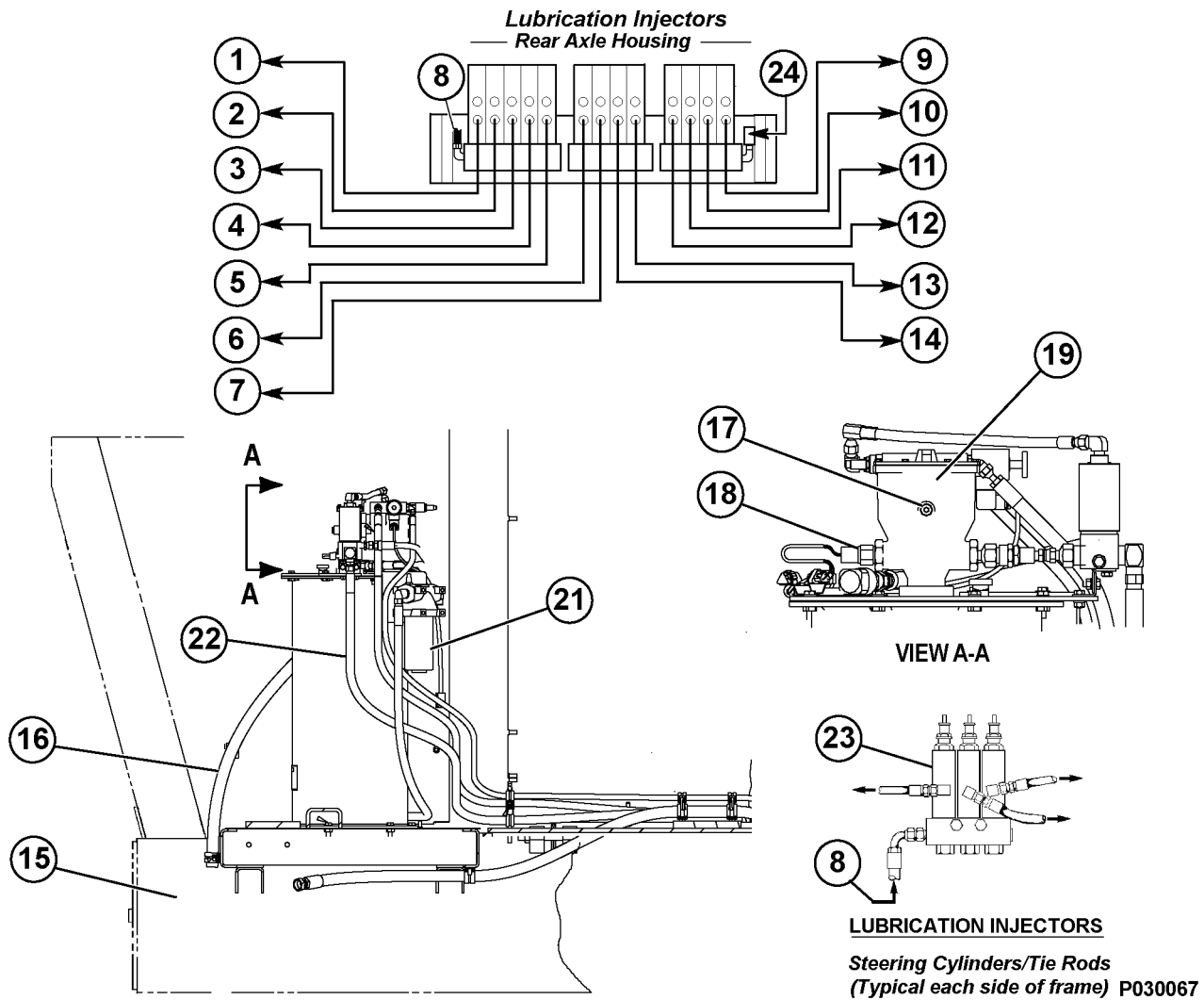

FIGURE 42-2. AUTOMATIC LUBRICATION SYSTEM INSTALLATION

*NOTE: The above illustration shows the standard location for the lube pump and reservoir (right platform). This assembly may be located on the left platform on some models.*

- |   |   |
|---|---|
| 1. L.H. Suspension, Bottom Bearing      | 13. R.H. Anti-Sway Bar Bearing                    |
| 2. L.H. Hoist Cylinder, Top Bearing     | 14. R.H. Suspension, Top Bearing                  |
| 3. L.H. Hoist Cylinder, Bottom Bearing  | 15. Truck Frame                                   |
| 4. L.H. Anti-Sway Bar Bearing           | 16. Vent Hose                                     |
| 5. L.H. Suspension, Top Bearing         | 17. Pipe Plug (Oil Level)                         |
| 6. L.H. Body Pivot Pin                  | 18. Pressure Switch, N.O., 20 684 kPa (3,000 psi) |
| 7. R.H. Body Pivot Pin                  | 19. Grease Pump                                   |
| 8. Grease Supply From Pump              | 20. Vent Valve                                    |
| 9. R.H. Suspension, Bottom Bearing      | 21. Filter  |
| 10. R.H. Hoist Cylinder, Top Bearing    | 22. Grease Supply to Injectors                    |
| 11. R.H. Hoist Cylinder, Bottom Bearing | 23. Injectors                                     |
| 12. Rear Axle Pivot Pin                 | 24. Pressure Switch, N.O., 13 790 kPa (2,000 psi) |



## SYSTEM COMPONENTS

### Filter

Filter assembly (21, Figure 42-2) mounted on the grease reservoir filters the grease prior to refilling the reservoir from the shop supply. A bypass indicator alerts service personnel when the filter requires replacement.

### Hydraulic Motor and Pump

Rotary hydraulic pump (3 & 9, Figure 42-1) is a fully hydraulically operated grease pump. An integrated pump control manifold is incorporated with the motor to control input flow and pressure.

*NOTE: The pump crankcase oil level must be maintained to the level of the pipe plug (17, Figure 42-2) or use the dip stick. If necessary, refill with 10W-30 motor oil.*



***Hydraulic oil supply inlet pressure must not exceed 24 132 kPa (3,500 psi). Exceeding the rated pressure may result in damage to the system components and personal injury.***

### Grease Reservoir

Reservoir (12, Figure 42-1) has an approximate capacity of 41 kg (90 lb) of grease. When the grease supply is replenished by filling the system at the service center, the grease is passed through the filter to remove contaminants before it flows into the reservoir.

### Pressure Reducing Valve

Pressure reducing valve (4, Figure 42-1), located on the manifold, reduces the hydraulic supply pressure (from the truck steering circuit) to a suitable operating pressure for the hydraulic motor used to drive the lubricant pump. **The pressure control valve has been factory adjusted and the setting should not be disturbed unless grease output pressure is outside the recommendations.**

A pressure gauge can be installed where pipe plug (8, Figure 42-1) is located. The pressure gauge will indicate hydraulic oil pressure to the inlet of the hydraulic motor. Normal pressure is 2241 - 2413 kPa (325 - 350 psi).

### Flow Control Valve

Flow control valve (10, Figure 42-1) mounted on the manifold, controls the amount of oil flow to the hydraulic motor. **The flow control valve has been factory adjusted and the setting should not be disturbed.**

### Solenoid Valve

Solenoid valve (5, Figure 42-1), when energized, allows oil to flow to the hydraulic motor.

### Vent Valve

With vent valve (7, Figure 42-1) closed, the pump continues to operate until maximum grease pressure is achieved. As this occurs, the vent valve opens and allows the grease pressure to drop to zero, so the injectors can recharge for their next output cycle.

### Lubrication Cycle Timer

The solid state lubrication cycle timer provides a 24 VDC timed-interval signal to energize solenoid valve (3, Figure 42-3) providing oil flow to operate the grease pump motor. This timer is mounted in the Electrical Interface Cabinet.

### Over Pressure Cut Off Switch

Pressure switch (18, Figure 42-2) is a normally open switch set at 20 684 kPa (3,000 psi). This switch de-energizes the pump solenoid relay if the grease line pressure reaches the switch pressure setting, turning off the motor and pump.

### Grease Pressure Failure Switch

Pressure switch (24, Figure 42-2) is a normally open switch set at 13 789 kPa (2,000 psi). If the appropriate grease pressure is not achieved during the normal pump cycle, the warning system will be activated, illuminating the warning lamp in the overhead display to notify the operator a problem exists in the lube system.

### Injectors

Each injector (23, Figure 42-2) delivers a controlled amount of pressurized lubricant to a designated lube point. Refer to Figure 42-2 for locations.

### Relief Valve (unloader valve)

Relief valve (14, Figure 42-3) protects the pump from high pressures. This relief valve is set at 27 580 kPa (4,000 psi).

## SYSTEM OPERATION

### Normal Operation

1. During truck operation, the lubrication cycle timer will energize the system at a preset time interval.
2. The timer provides 24 VDC to energize the pump solenoid valve (3, Figure 42-3), allowing hydraulic oil provided by the truck steering pump circuit to flow to the pump motor and initiate a pumping cycle.
3. The hydraulic oil from the steering circuit is directed through the pressure reducing valve (4) and flow control valve (6) before entering the motor. Pump pressure can be read on optional pressure gauge (5) mounted on the manifold.
4. With oil flowing into the hydraulic motor, the grease pump will operate, pumping grease from the reservoir to the injectors (13), through a check valve (10) and to the vent valve (11).
5. During this period, the injectors will meter the appropriate amount of grease to each lubrication point.
6. When grease pressure reaches pressure switch (18, Figure 42-2) setting, the switch contacts will close and energize the relay RB7-K5, removing power from the hydraulic motor/pump solenoid and the pump will stop. The relay will remain energized until grease pressure drops (pressure switch opens again) and the timer turns off.
7. After the pump solenoid valve is de-energized, hydraulic pressure in the manifold drops and vent valve (11, Figure 42-3) will open, releasing grease pressure in the lines to the injector banks. When this occurs, the injectors are then able to recharge for the next lubrication cycle.
8. The system will remain at rest until the lubrication cycle timer turns on and initiates a new grease cycle.
9. During the normal lubrication cycle, if grease pressure fails to reach 13 790 kPa (2,000 psi) within 120 seconds at the pressure switch located on the rear axle housing, an amber indicator light will illuminate on the overhead panel.

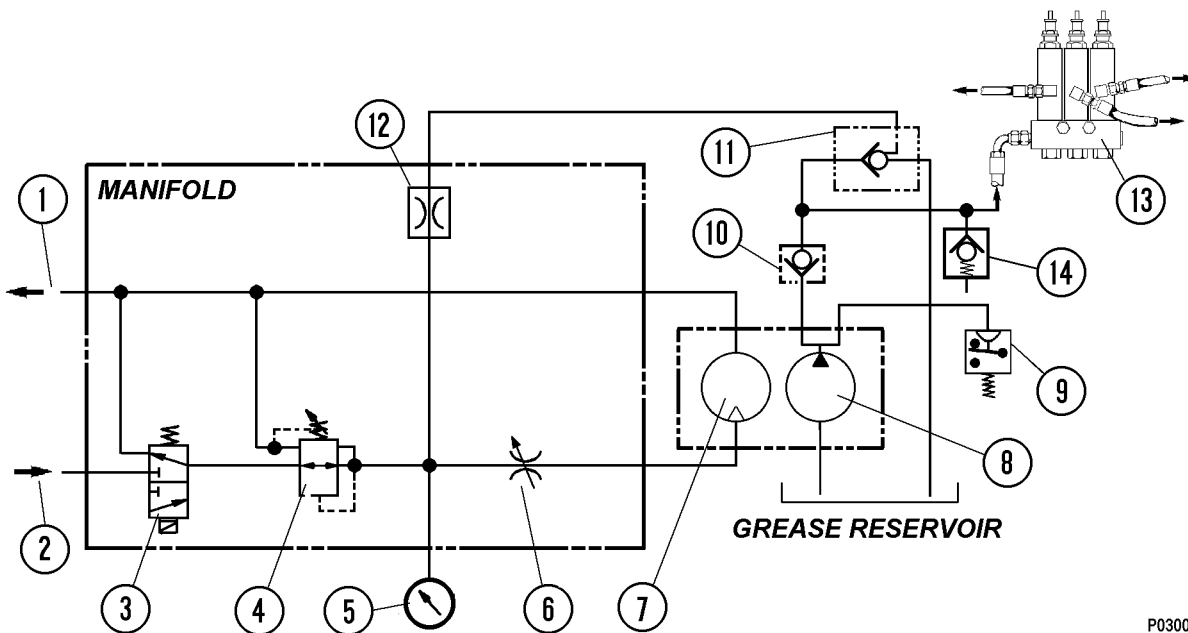

FIGURE 42-3. HYDRAULIC SCHEMATIC

- |                            |                           |                   |
|----------------------------|---------------------------|-------------------|
| 1. Hydraulic Oil Return    | 6. Flow Control Valve     | 11. Vent Valve    |
| 2. Hydraulic Oil Supply    | 7. Hydraulic Motor        | 12. Orifice       |
| 3. Solenoid Valve          | 8. Grease Pump            | 13. Injector Bank |
| 4. Pressure Reducing Valve | 9. Pressure Switch (N.O.) | 14. Relief Valve  |
| 5. Pressure Gauge          | 10. Check Valve           |                   |

P030072

## GENERAL INSTRUCTIONS

### Lubricant Required For System

Grease requirements will depend on ambient temperatures encountered during truck operation:

- Above 32°C (90°F) - Use NLGI No. 2 multipurpose grease (MPG).
- -32° to 32°C (-25° to 90°F) - Use NLGI No. 1 multipurpose grease (MPG).
- Below -32°C (-25°F) - Refer to local supplier for extreme cold weather lubricant requirements.

### System Priming

The system must be full of grease and free of air pockets to function properly. After maintenance, if the primary or secondary lubrication lines were replaced, it will be necessary to prime the system to eject all entrapped air.

1. Fill lube reservoir with lubricant, if necessary.
2. To purge air from the main supply line, remove the main supply line at the grease canister. Connect an external grease supply to the line.
3. Remove plugs from each injector group in sequence (right front, left front, and rear axle).
4. Using the external grease source, pump grease until grease appears at the group of injectors and re-install the pipe plug. Repeat for remaining injector groups.
5. Remove the caps from each injector and connect an external grease supply to the zerk on the injector and pump until grease appears at the far end of the individual grease hose or the joint being greased.

### Filter Assembly

Filter element (5, Figure 42-4) must be replaced if bypass indicator (2) shows excessive element restriction.

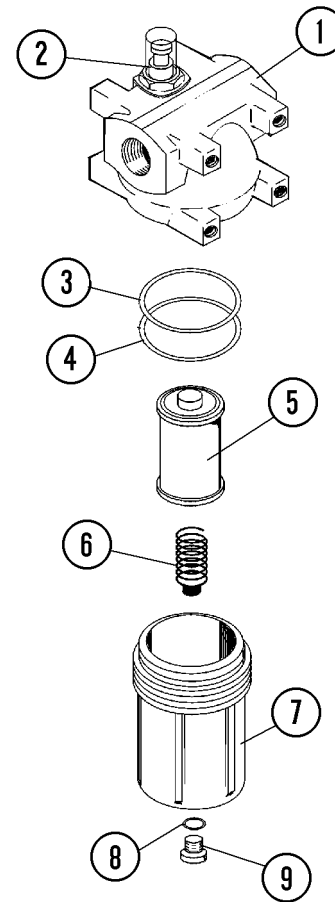

P030023

FIGURE 42-4. FILTER ASSEMBLY

- |                     |           |
|---------------------|-----------|
| 1. Housing          | 6. Spring |
| 2. Bypass Indicator | 7. Bowl   |
| 3. O-Ring           | 8. O-Ring |
| 4. Backup Ring      | 9. Plug   |
| 5. Element          |           |

## LUBRICANT PUMP

### Pump Housing Oil Level

The pump housing must be filled to the proper level with SAE 10W-30 motor oil. Oil level should be checked at 1,000 hour intervals. To add oil, remove dipstick (4, Figure 42-5) on top of the pump housing and fill the housing to the proper level marked on the dipstick.

*If the pump is not equipped with dipstick (4), remove oil level plug (5) and fill the housing to the bottom of the plug hole.*

### Pump Pressure Control

High pressure hydraulic fluid from the truck steering system is reduced by the pressure reducing valve located on the manifold on top of the pump motor. This pressure can be read if pipe plug (3) is removed, and a gauge is installed on the manifold.

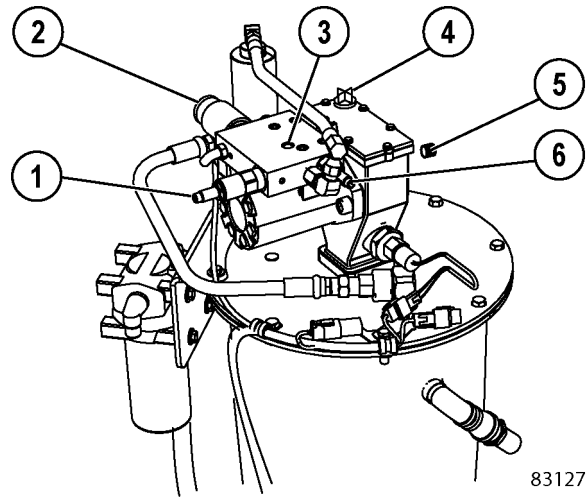

FIGURE 42-5. PUMP CONTROLS

- |                           |                       |
|---------------------------|-----------------------|
| 1. Pressure Control Valve | 4. Dipstick           |
| 2. Override Switch        | 5. Oil Level Plug     |
| 3. Pipe Plug              | 6. Flow Control Valve |

## INJECTORS (SL-1 Series "H")

### Injector Specifications

- Each lube injector services only one grease point. In case of pump malfunction, each injector is equipped with a covered grease fitting to allow the use of external lubricating equipment.
- Injector output volume:
  - Maximum output = . . . . . 1.31 cc (0.08 in<sup>3</sup>).
  - Minimum output = . . . . . 0.13 cc (0.008 in<sup>3</sup>).
- Operating Pressure:
  - Minimum - . . . . . 12 755 kPa (1,850 psi)
  - Maximum - . . . . . 24 133 kPa (3,500 psi)
  - Recommended - . . . . . 17 238 kPa (2,500 psi)
- Maximum Vent Pressure - (Recharge)
  - . . . . . 4 137 kPa (600 psi)

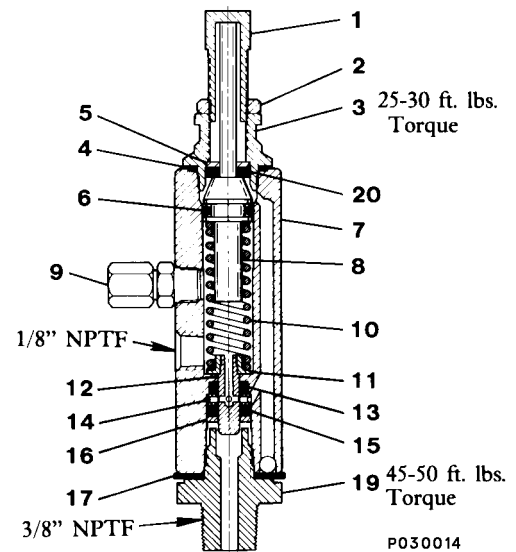

P030014

### Injector Adjustment

The injectors may be adjusted to supply from 0.13 - 1.31 cc (0.008 - 0.08 in<sup>3</sup>) of lubricant per injection cycle. The injector piston travel distance determines the amount of lubricant supplied. This travel is in turn controlled by an adjusting screw in the top of the injector housing.

Turn adjusting screw (1, Figure 42-6) counterclockwise to increase lubricant amount delivered and clockwise to decrease the lubricant amount.

When the injector is not pressurized, maximum injector delivery volume is attained by turning the adjusting screw (1) fully counterclockwise until the indicating pin just touches the adjusting screw. At the maximum delivery point, about 9.7 mm (0.38 in.) adjusting screw threads should be showing. Decrease the delivered lubricant amount by turning the adjusting screw clockwise to limit injector piston travel. If only half the lubricant is needed, turn the adjusting screw to the point where about 4.8 mm (0.19 in.) threads are showing. The injector will be set at minimum delivery point with about 0.22 mm (0.009 in.) thread showing.

*NOTE: The above information concerns adjustment of injector delivery volume. The timer adjustment should also be changed, if overall lubricant delivery is too little or too much. Injector output should NOT be adjusted to less than 1/4 capacity.*

FIGURE 42-6. TYPE SL-1 INJECTOR

- |                        |                   |
|------------------------|-------------------|
| 1. Adjusting Screw     | 11. Spring Seat   |
| 2. Locknut             | 12. Plunger       |
| 3. Piston Stop Plug    | 13. Viton Packing |
| 4. Gasket              | 14. Inlet Disc    |
| 5. Washer              | 15. Viton Packing |
| 6. Viton O-Ring        | 16. Washer        |
| 7. Injector Body Assy. | 17. Gasket        |
| 8. Piston Assembly     | 18. Adapter Bolt  |
| 9. Fitting Assembly    | 19. Adapter       |
| 10. Plunger Spring     | 20. Viton Packing |

*NOTE: The piston assembly (8) has a visible indicator pin at the top of the assembly to verify injector operation.*

**Injector Operation**

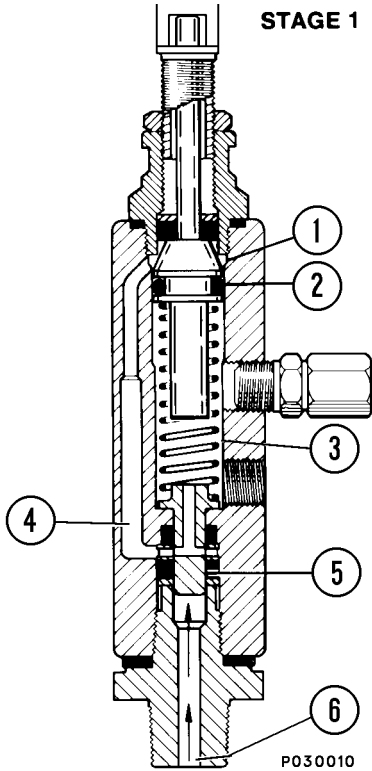

**STAGE 1.**

The injector piston (2) is in its normal or "rest" position. The discharge chamber (3) is filled with lubricant from the previous cycle. Under the pressure of incoming lubricant (6), the slide valve (5) is about to open the passage (4) leading to the measuring chamber (1) above the injector piston (2).

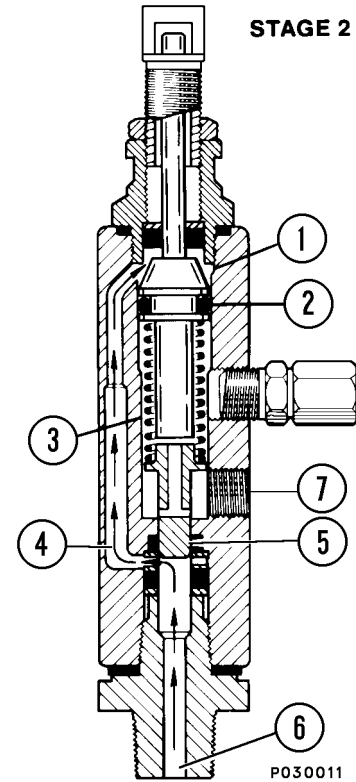

**STAGE 2.**

When the slide valve (5) uncovers the passage (4), lubricant (6) is admitted to the measuring chamber (1) above the injector piston (2) which forces lubricant from the discharge chamber (3) through the outlet port (7) to the bearing.

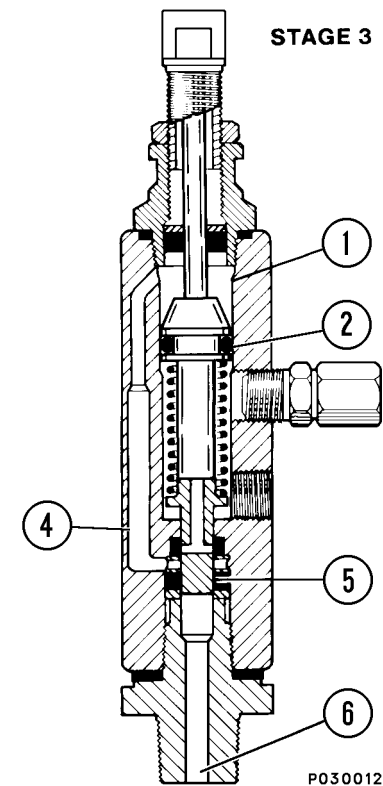

**STAGE 3.**

As the injector piston (2) completes its stroke, it pushes the slide valve (5) past the passage (4), cutting off further admission of lubricant (6) to the passage (4) and measuring chamber (1). The injector piston (2) and slide valve (5) remain in this position until lubricant pressure in the supply line (6) is vented.

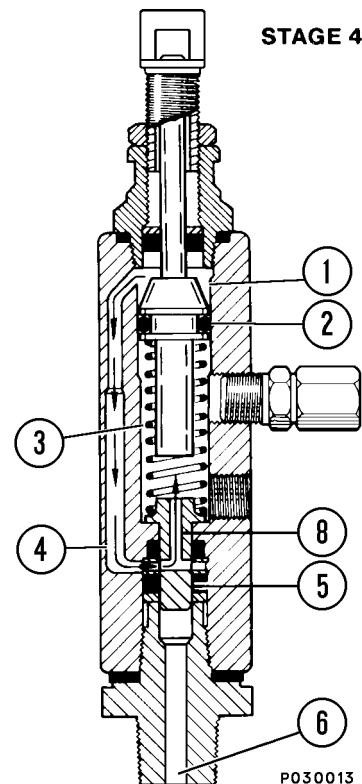

**STAGE 4.**

After venting, the injector spring expands, causing the slide valve (5) to move, so that the passage (4) and discharge chamber (3) are connected by a valve port (8). Further expansion of the spring causes the piston to move upward, forcing the lubricant in the measuring chamber (1) through the passage (4) and valve port (8) to refill the discharge chamber (3).

Injector is now ready for the next cycle.

## PREVENTIVE MAINTENANCE PROCEDURES

Use the following maintenance procedures to ensure proper system operation.

### Daily Lubrication System Inspection

1. Check the grease reservoir level after each shift of operation. Grease usage should be consistent from day-to-day operations. Lack of lubricant usage would indicate an inoperative system. Excessive usage would indicate a broken supply line.
2. Check filter bypass indicator when filling reservoir. Replace element if bypassing.
3. Check all grease hoses from the SL-1 Injectors to the lubrication points.
  - a. Repair or replace all damaged feed line hoses.
  - b. Ensure that all air is purged and all new feed line hoses are filled with grease before returning the truck to service.
4. Inspect the key lubrication points for a bead of lubricant around seal. If a lubrication point appears dry, troubleshoot and repair problem.

### 250 Hour Inspection

1. Check all grease hoses from the SL-1 Injectors to the lubrication points (see Figure 42-2).
  - a. Repair or replace all worn or broken hoses.
  - b. Ensure that all air is purged and all new feed line hoses are filled with grease before returning the truck to service.
2. Check all grease supply line hoses from the pump to the SL-1 injectors.
  - a. Repair or replace all worn / broken supply lines.
  - b. Ensure that all air is purged and all new supply line hoses are filled with grease before returning the truck to service.
3. Check the grease reservoir level.
  - a. Fill the reservoir if the grease level is low. Check the filter bypass indicator when filling the reservoir. Replace the element if bypassing.
  - b. Check the reservoir for contaminants. Clean the reservoir, if required.
  - c. Ensure that all filler plugs, covers and breather vents on the reservoir are intact and free of contaminants.

4. Inspect all bearing points for a bead of lubricant around the bearing seal.

It is good practice to manually lube each bearing point at the grease fitting provided on each injector. This will indicate if there are any frozen or plugged bearings, and it will help flush the bearings of contaminants.

### 5. System Checkout

- a. Remove all SL-1 injector cover caps to allow visual inspection of the injector cycle indicator pins during system operation.
- b. Start truck engine.
- c. Actuate lube system override switch (6, Figure 42-1). The hydraulic motor and grease pump should operate.
- d. With the grease under pressure, check each SL-1 injector assembly.  
The cycle indicator pin should be retracted inside the injector body.
- e. When the system is at 16 203 - 17 237 kPa (2,350 - 2,500 psi), the pump should shut off and the pressure in the system should drop to zero, venting back to the grease reservoir.
- f. After the system has vented, check the SL-1 injector indicator pins. All of the pins should be visible. Replace or repair any defective injectors.
- g. Install all injector cover caps.
- h. Check the lubrication timer operation.

*NOTE: With the engine on, the lube system should activate within five minutes. The system should build to 13 790 kPa (2,000 psi) at the rear axle during normal pump cycle.*

- i. If the system is working properly, the machine is ready for operation.
- j. If the system is malfunctioning, refer to the troubleshooting chart.

### 1000 Hour Inspection

1. Check the pump housing oil level using the dipstick on top of the pump unit. If necessary, add SAE 10W-30 motor oil.

## SYSTEM CHECKOUT

To check system operation (not including timer), proceed as follows:

1. Remove the dust covers from the injectors.
2. Start the engine.
3. Actuate the manual override button at the pump assembly and observe pin movement at each injector.
4. Check for pump, hose or injector damage or leakage with the system under pressure.
5. After checking system, stop the engine. Observing normal precautions regarding high voltage present in the propulsion system before attempting to repair lube system.
6. Re-install the injector dust covers.

### Lubrication Controller Check

Pressing the manual lube button on the enclosure cover will initiate a lube event (see Figure 42-7).

### Lubrication Controller Components

Mode switch (2, Figure 42-7) consists of four dip switches. The first, second and third dip switches are not functional. These settings have been pre-set and are not changeable.

The fourth dip switch is used to select "memory off" or "memory on". When the switch is set to "memory off", a lube cycle will occur each time power is turned on. The lube cycle will start at the beginning of the on time setting.

When the switch is set to "memory on", the controller will function as follows:

1. When power is turned off during 'off time' (between cycles), the lube cycle will resume at the point of interruption after power is restored. In other words, the controller will remember its position in the cycle.
2. When power is turned off during 'on time' (during a cycle), the controller will reset to the beginning of the lube cycle after power is restored.

The time between lube events is determined by the setting of the Off Time rotary switch (1, Figure 42-7). Off time switch is used to select units of time. Possible time intervals are: 0.5, 1, 2, 4, 8, 15, 24 or 30 minutes.

Cover (3) contains three LED windows and a manual lube switch. The LEDs indicate system operation and status. When power is on, a green LED will illuminate. When the pump is on, another green LED will illuminate. A red LED will illuminate when an alarm condition occurs.

### Lubrication Controller Adjustment

The lubrication controller is factory set to the following switch settings:

Dip Switch 1 - 120 SEC (not adjustable)

Dip Switch 2 - CONTROLLER (not adjustable)

Dip Switch 3 - MINUTES (not adjustable)

Dip Switch 4 - MEMORY OFF

Rotary Switch - 15 minutes

*NOTE: Only dip switch 4 and the rotary switch are adjustable.*



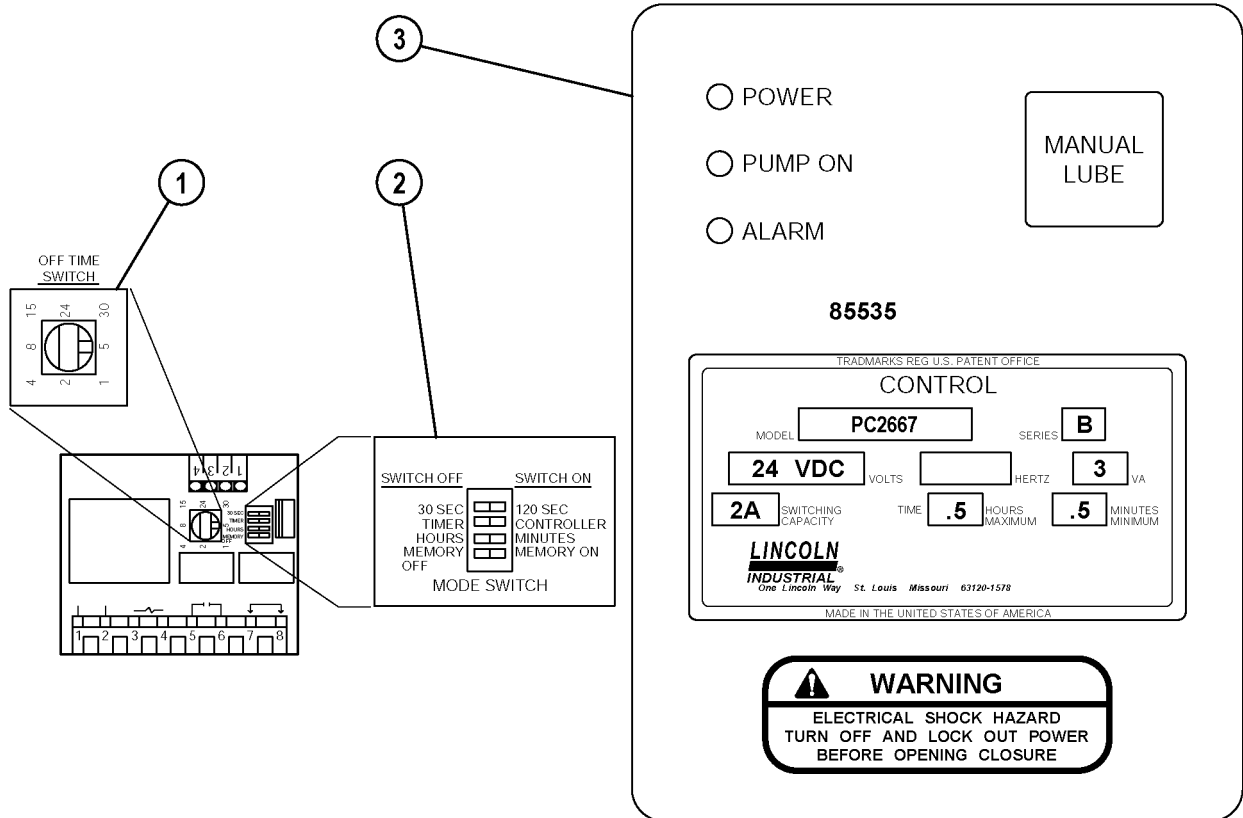

P030073

FIGURE 42-7. LUBRICATION CYCLE TIMER

- 1. Off Time Switch
- 2. Mode Switch

- 3. Cover

## SYSTEM TROUBLESHOOTING CHART

*NOTE: If the following procedures do not correct the problem, contact a factory authorized service center.*

TROUBLE	POSSIBLE CAUSES	SUGGESTED CORRECTIVE ACTION
<b>Pump Does Not Operate</b>	Lube system not grounded.  Electrical power loss.  Timer malfunction. Solenoid valve malfunctioning. Relay malfunctioning. Motor or pump malfunction.	Correct grounding connections to pump assembly and truck chassis.  Locate cause of power loss and repair. 24 VDC power required. Ensure key switch is ON.  Replace timer assembly.  Replace the solenoid valve assembly.  Replace relay.  Repair or replace motor and/or pump assembly. (Refer to shop manual for rebuild instructions.)
<p><i>NOTE: On initial startup of the lube system, the timing capacitor will not contain a charge, therefore the first timing cycle will be about double in length compared to the normal interval. Subsequent timer cycles should be as specified.</i></p>		
<b>Pump Will Not Prime</b>	Low lubricant supply.	Dirt in reservoir, pump inlet clogged, filter clogged.
<b>Pump Will Not Build Pressure</b>	Air trapped in lubricant supply line. Lubricant supply line leaking.  Vent valve leaking. Pump is worn or scored.	Prime system to remove trapped air.  Check lines and connections to repair leakage.  Clean or replace vent valve.  Repair or replace pump assembly. (Refer to shop manual for rebuild instructions.)
<p><i>NOTE: Normally, during operation, the injector indicator stem will move into the body of the injector when pressure builds properly. When the system vents (pressure release) the indicator stem will again move out into the adjusting yoke.</i></p>		
<b>Injector Indicator Stem Does Not Operate</b>	Malfunctioning injector - usually indicated by the pump building pressure and then venting.  All injectors inoperative - pump build up not sufficient to cycle injectors.	Replace individual injector assembly.  Service and/or replace pump assembly. (Refer to shop manual for rebuild instructions.)
<b>Pressure Gauge Does Not Register Pressure (pressure gauge not included with pump)</b>	No system pressure to the pump motor. No 24 VDC signal at pump solenoid. Pressure reducing valve set too low.  24V Relay (RB7K8 or RB7K5) may be defective.	Check hydraulic hose from steering system.  Determine problem in 24 VDC electric system.  Refer to "Pressure Control Valve Adjustment".  Replace relay.

TROUBLE	POSSIBLE CAUSES	SUGGESTED CORRECTIVE ACTION
<b>Pump Pressure Builds Very Slowly Or Not At All</b>	No signal at solenoid.	Check timer.
<b>Controller Does Not Operate</b>	No electric power to controller.	Turn on electric power to pump. "POWER" LED should light, "PUMP ON" LED should light when "MANUAL LUBE" is pressed.
<b>"PUMP ON" LED Lights, But Load Connected To Terminals 3 &amp; 4 Will Not Energize</b>	Printed circuit board failure.	Remove and replace.
<b>Load Connected To Terminals 3 &amp; 4 Energized, But "PUMP ON" LED Does Not Light</b>	Failure of the printed circuit board or keypad.	Remove and replace.
<b>Bearing Points Excessively Lubricated</b>	Controller memory mode is OFF.	Switch controller memory mode to ON.
	Injector output adjustment setting too high.	Readjust to lower setting.
<b>Bearing Points Are Not Sufficiently Lubricated</b>	Timer/controller cycle time setting too low.	Set to longer cycle time or reevaluate lube requirements.
	Injector output adjustment setting too low.	Readjust injector output setting.
	Timer/controller cycle time setting does not deliver lubricant often enough.	Set to shorter cycle time or reevaluate lube requirements.
	System too large for pump output.	Calculate system requirements per planning manual.

---

# NOTES

## COMPONENTS & SPECIFICATIONS

### MAJOR COMPONENT DESCRIPTIONS

#### Truck And Engine

The 930E-4 Dump Truck is an off-highway, rear dump truck with AC Electric Drive. The gross vehicle weight is 498 960 kg (1,100,000 lb). The engine is a Komatsu SSDA16V160 rated @ 2700 HP (2014 kW).

#### Main Alternator

The diesel engine drives an in-line alternator at engine speed. The alternator produces AC current which is rectified to DC within the main control cabinet. The rectified DC power is converted back to AC by groups of devices called "inverters", which are also within the main control cabinet. Each inverter consists of six phase modules under the control of a gate driver power converter (GDPC). The two GDPCs control the operation of each phase module.

Each phase module contains paired positive and negative semiconductor switches referred to as insulated gate bipolar transistors (IGBT). The IGBTs cycle on and off at varying frequencies to create an AC power signal from the DC supply.

The AC power signal produced by each inverter is a variable-voltage, variable-frequency (VVVF) signal. Frequency and voltage are changed to suit the operating conditions.

Cooling air for the control/power group and wheel motors, as well as the alternator itself, is provided by dual fans mounted on the alternator shaft.

#### AC Induction Traction Motorized Wheels

The alternator output supplies electrical energy to the two wheel motors attached to the rear axle housing. The motorized wheels use three-phase AC induction motors with full-wave AC power.

The two wheel motors convert electrical energy back to mechanical energy through built-in gear trains within the wheel motor assembly. The direction of the wheel motors is controlled by a directional control lever located on the center console.

#### Suspension

Hydrair II® suspension cylinders located at each wheel provide a smooth and comfortable ride for the operator and dampens shock loads to the chassis during loading and operation.

#### Operator's Cab

The operator cab has been engineered for operator comfort and to allow for efficient and safe operation of the truck. The cab provides wide visibility with an integral 4-post ROPS/FOPS structure and an advanced analog operator environment. It includes a tinted safety-glass windshield and power-operated side windows, a deluxe interior with a fully adjustable seat with lumbar support, a fully adjustable/tilt steering wheel, controls mounted within easy reach of the operator, and an analog instrument panel which provides the operator with all instruments and gauges which are necessary to control and/or monitor the truck's operating systems.

#### Power Steering

The truck is equipped with a full time power steering system which provides positive steering control with minimum operator effort. The system includes nitrogen-charged accumulators which automatically provide emergency power if the steering hydraulic pressure is reduced below an established minimum.

#### Dynamic Retarding

The dynamic retarding is used to slow the truck during normal operation or control speed coming down a grade. The dynamic retarding ability of the electric system is controlled by the operator through the activation of the retarder pedal (or by operating a lever on the steering wheel) in the operators cab and by setting the RSC (Retarder Speed Control). Dynamic retarding is automatically activated, if the truck speed goes to a preset overspeed setting.

#### Brake System

Service brakes at each wheel are oil-cooled multiple disc brakes applied by an all-hydraulic actuation system. Depressing the brake pedal actuates both front and rear brakes after first applying the retarder. All wheel brakes will be applied automatically if the brake system pressure decreases below a preset minimum.

The parking brake is a dry disc type, mounted inboard on each rear wheel motor, and is spring-applied and hydraulically-released with wheel speed application protection (will not apply with truck moving).

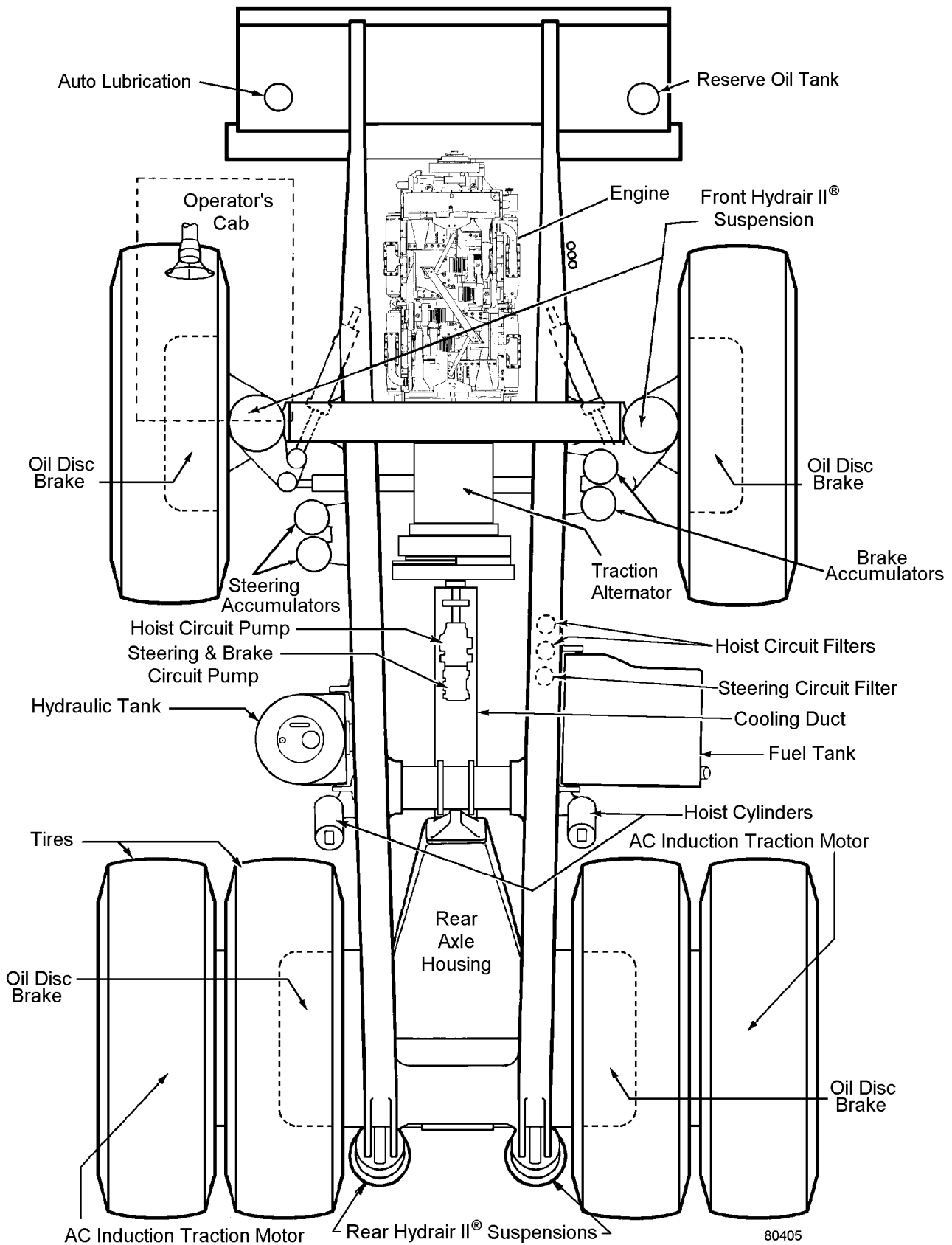

**930E-4 MAJOR COMPONENTS**

## SPECIFICATIONS

These specifications are for the standard Komatsu 930E-4 Truck. Customer options may change this listing.

### ENGINE

#### Komatsu SSDA16V160

No. of Cylinders . . . . .	16
Operating Cycle . . . . .	4-Stroke
Rated Brake HP . . . . .	2 014 kW (2,700 HP) @ 1900 RPM
Flywheel HP . . . . .	1 902 kW (2,550 HP) @ 1900 RPM
Weight (Wet)* . . . . .	9 608 kg (21,182 lb)

\* Weight does not include Radiator, Sub-frame, or Alternator.

### AC ELECTRIC DRIVE SYSTEM

(AC/DC Current)

Alternator . . . . .	General Electric GTA-41
Dual Impeller, In-Line Blower . . . . .	340 m <sup>3</sup> / min (12,000 cfm)
Motorized Wheels . . . . .	GDY106 AC Induction Traction Motors
Standard Gear Ratio* . . . . .	32.62:1
Maximum Speed . . . . .	64.5 km/h (40 mph)

\* Wheel motor application depends upon GVW, haul road grade and length, rolling resistance, and other parameters. Komatsu and GE must analyze each job condition to ensure proper application.

### DYNAMIC RETARDING

Electric Dynamic Retarding . . . . .	Standard
Maximum Rating . . . . .	4 026 kW (5,400 HP)
Continuous* . . . . .	2 460 kW (3,300 HP)

\* Continuously rated high-density blown grids with retard at engine idle and retard in reverse propulsion.

### BATTERY ELECTRIC SYSTEM

Batteries . . . . .	Four 8D, 12 volt wet batteries with disconnect switch
Cold Cranking Amps . . . . .	1450 CCA
Alternator . . . . .	24 Volt, 260 Amp Output
Lighting . . . . .	24 Volts
Starters (2) . . . . .	24 Volts

### SERVICE CAPACITIES

Crankcase (including lube oil filters) . . . . .	280 liters (74 gallons)
Cooling System . . . . .	594 liters (157 gallons)
Fuel . . . . .	4 542 liters (1,200 gallons)
Hydraulic System . . . . .	1 325 liters (350 gallons)
Wheel Motor Gear Box . . . . .	95 liters (25 gallons) per wheel

**HYDRAULIC SYSTEMS**

Hoist and Brake Cooling Pump .....	Tandem Gear
Rating .....	931 L/min (246 gpm) @ 1900 RPM and 17 237 kPa (2,500 psi)
Steering/Brake Pump .....	Pressure Compensated Piston
Rating .....	246 L/min (65 gpm) @ 1900 RPM and 18 961 kPa (2,750 psi)
Relief Pressure - Hoist .....	17 237 kPa (2,500 psi)
Relief Pressure - Steering/Brake .....	27 579 kPa (4,000 psi)
Hoist Cylinders (2) .....	3-Stage Hydraulic
Tank (Vertical/Cylindrical) .....	Non-Pressurized
Tank Capacity .....	947 liters (250 gallons)
Filtration .....	In-line replaceable elements
Suction .....	Single, Full Flow, 100 Mesh
Hoist and Steering Filters (Dual In-Line, High Pressure) .....	Beta <sub>12</sub> Rating =200

**SERVICE BRAKES**

All Hydraulic Actuation with Traction System Wheel Slip/Slide Control	
Front and Rear Oil-Cooled Multiple Discs on each wheel	
Total Friction Area / Brake .....	97 019 cm <sup>2</sup> (15,038 in <sup>2</sup> )
Maximum Apply Pressure .....	17 238 kPa (2,500 psi)

**STEERING**

Twin hydraulic cylinders with accumulator assist to provide constant rate steering	
Emergency power steering automatically provided by accumulators	
Turning Circle (SAE) .....	29.7 m (97 ft. 7 in.)

**TIRES**

Radial Tires (standard) .....	53/80 R63
Rock Service, Deep Tread .....	Tubeless
Rims .....	patented Phase I New Generation™ rims

**STANDARD DUMP BODY CAPACITIES AND DIMENSIONS**

**Capacity**

Heaped @ 2:1 (SAE) .....	.211 m <sup>3</sup> (276 yd <sup>3</sup> )
Struck .....	.171 m <sup>3</sup> (224 yd <sup>3</sup> )
Width (Inside) .....	8.15 m (26 ft. 9 in.)
Depth .....	3.2 m (10 ft. 7 in.)
Loading Height .....	7.06 m (23 ft. 2 in.)
Dumping Angle .....	45°

*NOTE: Optional capacity dump bodies are available.*



**WEIGHT DISTRIBUTION**

**Empty Vehicle**

Front Axle (49.3%) . . . . . 103 301 kg (227,738 lb)  
 Rear Axle (50.7 %) . . . . . 107 518 kg (237,034 lb)  
 Total (with 50% fuel) . . . . . 210 819 kg (464,772 lb)

Standard Komatsu body . . . . . 30 362 kg (66,936 lb)  
 Standard tire weight . . . . . 26 127 kg (57,600 lb)

**Loaded Vehicle**

Front Axle (33.0%) . . . . . 165 554 kg (364,980 lb)  
 Rear Axle (67.0%) . . . . . 336 124 kg (741,020 lb)  
 Total . . . . . 501 678 kg (1,106,000 lb)

Nominal Payload\* . . . . . 290 859 kg (641,228 lb)

\* *Nominal payload* is defined within Komatsu America Corporation's payload policy documentation. Nominal payload must be adjusted if the weight of any customized body or tires vary from that of the standard Komatsu body and tires. Nominal payload must also be adjusted to take into account the additional weight of any custom/optional extras fitted to the truck which are not stated within the Standard Features list of the applicable specification sheet.

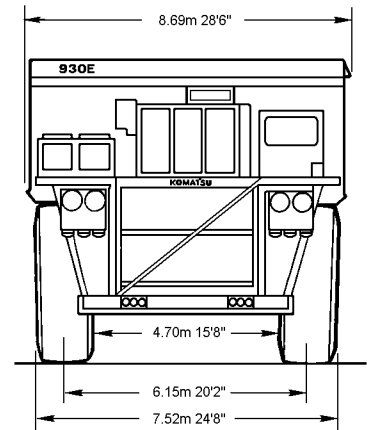
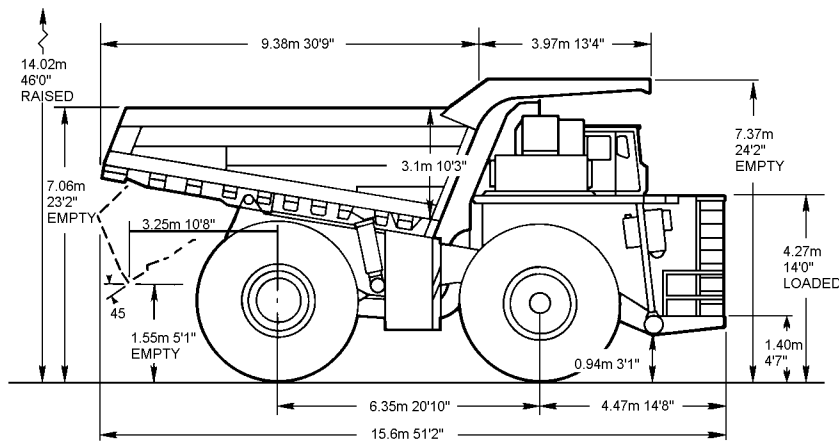

**All Dimensions with 171/211m<sup>3</sup> 224/276 yd<sup>3</sup> Body**

BODIES	Struck		2:1 Heap		Loading Height	
	M <sup>3</sup>	Yd <sup>3</sup>	M <sup>3</sup>	Yd <sup>3</sup>	M	Feet
Standard	171	224	211	276	7.06	23'2"

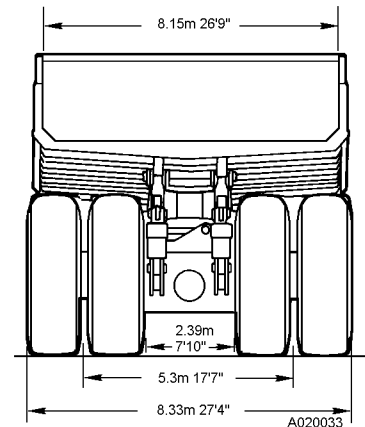

A020033

---

# NOTES

**PAYLOAD METER III™****INDEX**

INTRODUCTION .....	60-3
Data Summary .....	60-3
Data Gathering .....	60-3
COMPONENT DESCRIPTION .....	60-4
System Diagram .....	60-4
Suspension Pressure Sensors .....	60-4
Inclinometer .....	60-4
Operator Display .....	60-4
Operator Switch .....	60-5
Speed Input .....	60-5
Body-Up Switch .....	60-5
Brake Lock Switch .....	60-5
Payload Meter .....	60-5
Communications Ports .....	60-5
Key switch Input .....	60-6
Payload Meter Power .....	60-6
Load Lights .....	60-6
Wiring and Termination .....	60-7
TCI Outputs .....	60-7
OPERATOR'S DISPLAY AND SWITCH .....	60-8
Reading the Speedometer .....	60-8
Reading the Load Display .....	60-8
Using the Operator ID .....	60-8
Using the Load and Ton Counter .....	60-8
Total Ton Counter .....	60-8
Total Load Counter .....	60-9
Clearing the Counters .....	60-9
Viewing Live Sensor Data .....	60-9
Other Display Messages .....	60-9
PAYLOAD OPERATION & CALCULATION .....	60-10
Haul Cycle States .....	60-10
Haul Cycle Description .....	60-10
Load Calculation .....	60-11
Carry Back .....	60-11
Measurement Accuracy .....	60-11
SOURCES FOR PAYLOAD ERROR .....	60-11
Payload Error .....	60-11
Loading Conditions .....	60-12
Pressure Sensors .....	60-12
Swingloads .....	60-12
Speed and Distance .....	60-12

HAUL CYCLE DATA .....	60-12
Haul Cycle Data .....	60-13
Haul Cycle Warning Flags .....	60-14
Frame Torque Data .....	60-15
Sprung Weight Data .....	60-15
Maximum Speed Data .....	60-15
Alarm Records .....	60-15
Fault Code Data .....	60-16
PC SOFTWARE OVERVIEW .....	60-17
PC Overview .....	60-17
System Configuration .....	60-17
Installing the PLMIII Software .....	60-17
DOWNLOADING DATA .....	60-18
PLM III SYSTEM CONFIGURATION .....	60-19
Starting Communications .....	60-19
Displayed Payload Units .....	60-19
Time Units .....	60-19
Connection Menu .....	60-19
Connecting to the Payload Meter .....	60-20
Configure the Payload Meter .....	60-20
Setting the Date and Time .....	60-20
Setting the Truck Type .....	60-21
Setting the Gauge Display Units .....	60-21
Setting the Frame Serial Number .....	60-21
Setting the Truck Number .....	60-21
Setting the Komatsu Distributor .....	60-21
Setting the Komatsu Customer .....	60-21
Clean Truck Tare .....	60-22
Inclinometer Calibration .....	60-22
DATA ANALYSIS .....	60-23
Creating a Query .....	60-23
Sorting on Truck Unit Number .....	60-23
Sorting on Truck Type .....	60-23
Sorting on Date Range .....	60-24
Sorting on Time Range .....	60-24
Payload Detail Screen .....	60-25
Creating Reports .....	60-25
Summary - one page report .....	60-26
Detailed - multi-page report .....	60-26
Creating Graphs .....	60-27
Exporting Data .....	60-27
CSV Export .....	60-27
Compressed .....	60-28
Importing Data .....	60-29
Deleting Haul Cycle Records .....	60-29
Viewing Alarms .....	60-30
Deleting Alarm Records .....	60-30

## INTRODUCTION

Payload Meter III (PLMIII) measures, displays and records the weight of material being carried by an off-highway truck. The system generally consists of a payload meter, a gauge display, deck-mounted lights, and sensors. The primary sensors are four suspension pressures and an inclinometer. Other inputs include a body up signal, brake lock signal, and speed.

### Data Summary

5208 haul cycles can be stored in memory. The following information is recorded for each haul cycle:

- Payload
- Operator ID number (0000-9999)
- Distance traveled loaded and empty
- The amount of time spent empty run/stop, loading, loaded run/stop, and dumping
- Maximum speed loaded and empty with time of day
- Average speed loaded and empty
- Empty carry-back load
- Haul-cycle, loading, dumping start time of day.
- Peak positive and peak negative frame torque with time of day
- Peak sprung load with time of day
- Tire ton-mph for each front and average per rear tires

The payload meter stores lifetime data that cannot be erased. This data includes:

- Top 5 maximum payloads and time stamps.
- Top 5 positive and negative frame torque and time stamps
- Top 5 maximum speeds and time stamps

### Data Gathering

Windows 95/98/NT software is available to download, store and view payload and fault information. The PC software will download an entire truck fleet into one Paradox database file. Users can query the database by date, time, truck type and truck number to produce reports, graphs and export the data. The software can export the data in '.CSV' format that can be easily imported into most spreadsheet applications. The Windows software is not compatible with the Payload Meter II system.

It is important that each payload meter be configured for each truck using the PC software. The information for frame serial number and truck number is used by the database program to organize the payload data. In addition, the payload meter must be configured to make calculations for the proper truck model. Improper configuration can lead to data loss and inaccurate payload calculations.

## COMPONENT DESCRIPTION

### System Diagram

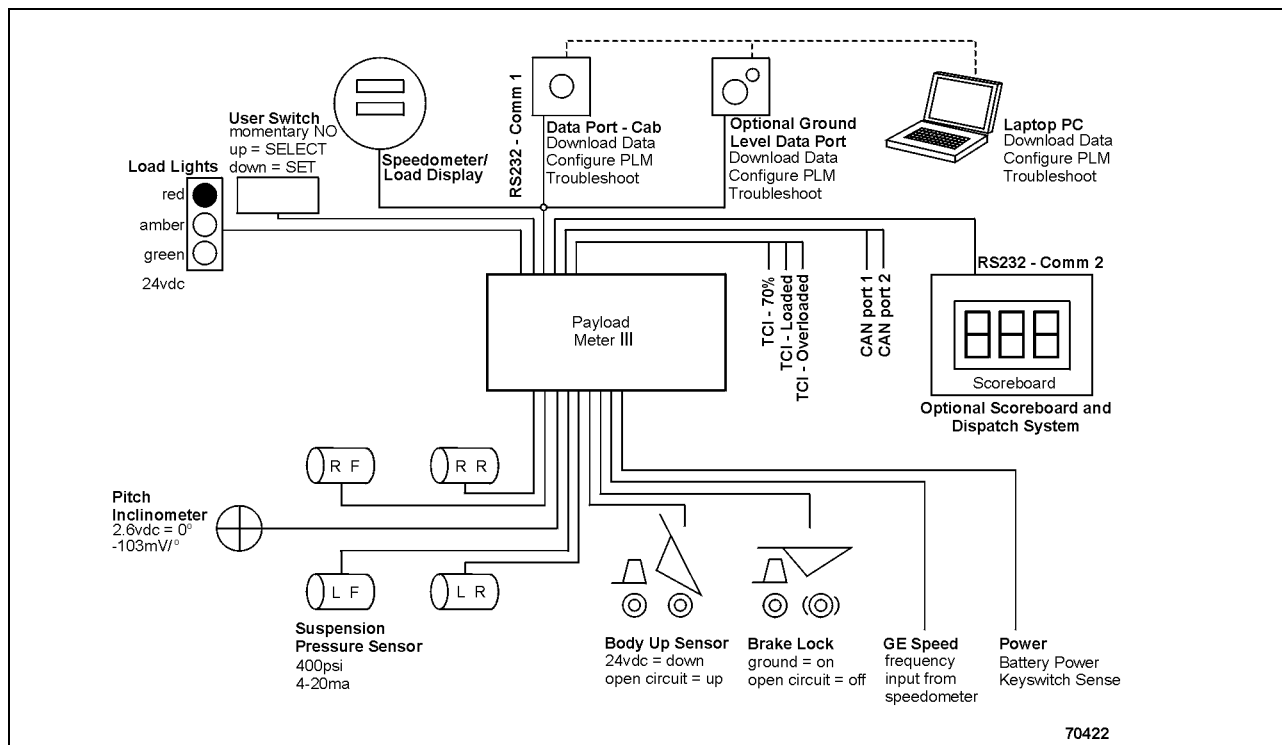

### Suspension Pressure Sensors

PLMIII uses a two-wire pressure sensor. The range for the pressure sensor is 4000 psi (281 kg/cm<sup>2</sup>) and the overload limit is 10,000 psi (700 kg/cm<sup>2</sup>). One wire to the sensor is the supply voltage and the other is the signal. The 0-4000 psi range is converted into an electrical current between 4-20 ma. The supply voltage for the sensor is nominally +18vdc. Each pressure sensor has an 118 in. (3000 mm) length of cable. The cable is specially shielded and reinforced to provide mechanical strength and electronic noise immunity.

### Inclinometer

The inclinometer is used to increase the accuracy of load calculations on an incline. The inclinometer uses three wires. For the sensor, red is the +18vdc supply voltage, black is ground and the white is the signal. The incline signal is a voltage between 1 and 4 volts. Zero degrees of incline is represented by 2.6vdc on the signal line. The voltage signal will be decreased by 0.103vdc for every degree of nose up incline.

### Operator Display

The speedometer/display gauge is used as a speedometer and payload display. The top display is used for speed and can display metric (km/h) or English (mph) units. Grounding terminal #4 on the back of the speedometer will switch the meter to display metric units. Leaving terminal #4 unconnected will cause the gauge to display English units. The speedometer can be adjusted using a calibration potentiometer in the back just like existing speedometers.

The payload meter uses the lower display for payload information. The normal display mode shows the current payload. The display can be changed to show the load and total tons counter or the Operator ID. Using the operator switch on the dash panel, the current suspension pressures and incline can be displayed. The units for display are set using the PC software. Payloads can be displayed in short tons, long tons or metric tons.

### Operator Switch

The payload operator switch is used to set, view and clear the total load counter and total ton counter. It is also used to enter the operator ID number (0-9999). This switch can also be used to view the suspension pressures and inclinometer. The payload meter operator switch is located on the dashboard. It is a two-way momentary switch. The top position is the SELECT position. The SELECT position is used step through the different displays. The lower position is the SET position. The SET position is used to set the operator ID or clear the load and total ton counters. Normally the inputs from the switch to the payload meter are open circuit. The switch momentarily connects the circuit to ground.

### Speed Input

PLMIII uses a speed signal to calculate speed, distance, and other performance data. This input is critical to the proper operation of the system. PLMIII receives this signal from the speedometer/operator display on the dashboard. The same signal displayed to the operator is used by the system. Distance calculations are made based on the rolling radius of the tires for a particular truck.

### Body-Up Switch

The body-up input signal is received from a magnetic switch located on the inside of the truck frame, forward the pivot pin of the truck body. This is the same switch typically used for input to the drive system. When the body is down, the switch closes and completes the circuit to 71-control power. 24vdc indicates the body is down. Open circuit indicates that the body is up.

### Brake Lock Switch

The brake lock is used to lock the rear brakes on the truck. It is necessary for the accurate calculation of swingloads during the loading process. Without the brake lock applied, the payload meter will not calculate swingloads during the loading process. Without the brake lock, the payload meter will assume that the truck was loaded using a continuous loader and flag the haul cycle record. All other functions will be normal regardless of brake lock usage. The brake lock input comes from the switch located on the dash panel. The brake lock switch connects the circuit to ground. Open circuit indicates brake lock off. Ground indicates brake lock on.

### Payload Meter

The payload meter is housed in a black aluminum housing. There is a small window on the face of the unit. Status and active alarm codes can be viewed through the window. During normal operation, a two-digit display flashes 0 back and forth. Active fault codes will be displayed for two seconds. These codes are typically viewed using the laptop computer connected to the serial communications port.

There is one 40-pin connector on the payload meter. A jack-screw is used to hold the payload meter and wire harness connector housings together. This screw requires a 4mm or 5/32 hex wrench. The correct tightening torque for this screw is 25 lb-in. Four bolts hold the payload meter housing to its mounting bracket in the cab.

The circuit board inside the payload meter housing is made from multi-layer, dual-sided surface-mount electronics. There are no field serviceable components inside. The electronics are designed to withstand the harsh operating environment of the mining industry. Opening the payload meter housing will result in voiding the warranty.

### Communications Ports

The payload meter has two RS232 serial communications ports and two CAN ports. Connections for the two serial ports are available inside the payload meter junction box. The two CAN ports are available for future electronics systems.

Serial port #1 is used to communicate with the dashboard display. It is also used to connect to the laptop computer. The display gauge will remain blank when the PC is using the serial port. This port initially operates with serial settings at 9600,8,N,1. These settings change automatically to increase the communications rate when the PC is using the port. This serial port uses a 3-wire hardware connection.

Serial port #2 is used to communicate to other on-board electronics like Modular Mining's Dispatch® system or the scoreboard from Komatsu. This port uses a 3-wire hardware connection. Connections to this serial port need to be approved by Komatsu. Several protocol options are available and detailed technical information is available depending on licensing.

### **Key Switch Input**

PLMIII monitors the status of the key switch. 24vdc indicates that the key switch is on, open indicates the key switch is off. The payload meter does not receive its electrical power from the key switch circuit. The payload meter will remain on for several seconds after key switch is removed. When the key switch power is removed, payload meter performs a series of internal memory operations before turning itself off. To allow for these operations, the key switch should be turned off for at least 15 seconds before turning the key switch back on. The payload meter will automatically reset itself without error if not enough time is given for these operations. The display may blink briefly.

### **Payload Meter Power**

The payload meter receives its power from the battery circuit on the truck. Removing battery power from the payload meter before removing key switch and waiting 15 seconds may result in lost haul cycle data. The payload meter turns itself off approximately 15 seconds after the key switch power is removed. Some haul cycle data will be lost if battery power is removed before waiting 15 seconds. The payload meter system operates at a nominal voltage of 24vdc at 1 to 2 amps depending on options. The payload meter is designed to turn itself off if the supply voltage rises above 36vdc. The payload meter is also protected by a 5 amp circuit breaker located in the junction box.

Power to the load lights comes from the same battery circuit. The load lights are powered through a relay. The key switch circuit controls the relay. The load lights are also protected by a 15 amp circuit breaker in the junction box.

### **Load Lights**

PLMIII uses load lights to indicate to the shovel operator the approximate weight of the material in the truck. The load lights are illuminated only when the brake lock is applied. The lights are controlled by the payload meter through a series of relays in the junction box. The payload meter controls the relays with 24vdc outputs. A 24vdc signal from the payload meter powers the relay coil and connects battery power to the load light. When the relay is not powered by the payload meter, a pre-warm resistor connects the load light to a reduced voltage. This circuit pre-warms the load light filaments and reduces the inrush current when the light is fully illuminated. This lengthens the operating life of the load lights.

The load lights progressively indicate to the shovel operator the approximate weight of the material in the truck.

A flashing green light indicates the next swingload will make the measured load greater than 50% of rated load. A solid green light indicates that the current load is greater than 50% of rated capacity.

A flashing amber light indicates the next swingload will make the measured load greater than 90% of rated load. A solid amber light indicates that the current load is greater than 90% of rated capacity.

A flashing red light indicates the next swingload will make the measured load greater than 105% of rated load. A solid red light indicates that the current load is greater than 105% of rated capacity.

The optimal loading target is a solid green and amber lights with a flashing red light. This indicates that the load is between 90% and 105% of rated load for the truck and the next swingload will load the truck over 105%.



**Wiring and Termination**

Most of the PLMIII truck connections use a heavy-duty cable. This yellow multi-conductor cable uses a 16awg, finely stranded wire designed for continuous motion operations. The conductors are protected by a foil and braided shield for electronic noise immunity and physical strength. This wire is typically terminated with a #10 ring terminal. Most connections for the PLMIII system are made in the payload meter junction box.

**TCI Outputs**

The GE drive system on the 930E/960E requires information from the payload meter regarding the loaded condition of the truck. There are three outputs from the payload meter to GE to indicate the relative load in the truck. 24 vdc on the 73MSL circuit indicates that the load is 70% of rated load. 24 vdc on the 73FSL circuit indicates the truck is 100% loaded. The 73OSL circuit is not currently used.

## OPERATOR'S DISPLAY AND SWITCH

### Reading the Speedometer

The top window of the speedometer/display gauge is the speedometer section. The display shows the speed indicated by the frequency being received by the gauge. This can be adjusted using the potentiometer on the back of the gauge. In addition, the units for the display can be changed. Terminal #4 controls the displayed units. If #4 is grounded, the display will be metric. If terminal #4 is left open, the display will be in English units.

### Reading the Load Display

The lower display on the speedometer/display gauge is used for payload information. The SELECT position on the operator switch allows the user to scroll through a number of useful displays. The order for the displays is as follows:

- $PL$  = Payload
- $Id$  = Operator ID
- $LL$  = Total Shift Tons
- $LC$  = Shift Load Counter
- $LF$  = Left Front Suspension Pressure
- $rF$  = Right Front Suspension Pressure
- $Lr$  = Left Rear Suspension Pressure
- $rr$  = Right Rear Suspension Pressure
- $In$  = Inclinator

The display holds the displayed information until the SELECT switch is pressed again. The suspension pressures, inclinometer, and payload displays are based on current sensor inputs.

Communications to the display use the same serial link as the download connection. Whenever another computer is connected to serial port #1 to download or configure the system, the lower display will blank. This is not the same connection used by mine dispatch systems.

### Using the Operator ID

The current operator ID number is recorded with each haul cycle. The number can be between 0 and 9999.

To set the Operator ID:

1. Press the "SELECT" switch until  $Id$  is displayed.
2. Hold the "SET" button until  $0000$  is displayed. The first digit should be flashing.
3. Press the "SET" button again to change the digit.
4. Press the "SELECT" button once to adjust the second digit.
5. Use the "SET" button again to change the digit.
6. Press the "SELECT" button once to adjust the third digit.
7. Use the "SET" button again to change the digit.
8. Press the "SELECT" button once to adjust the fourth digit.
9. Use the "SET" button again to change the digit.
10. Press the "SELECT" button one more time to enter the ID.

If no buttons are pressed for 30 seconds, the display will return to normal operation. The number being entered will be lost and the ID number returns to the previous ID number.

### Using the Load and Ton Counter

PLMIII allows the truck operator to monitor and track the total tons hauled and the number of haul cycles during the shift. This display can be cleared at the beginning of each shift to allow the operator to record how many loads and tons have been hauled during the shift.

### Total Ton Counter

The total ton counter records the number of tons hauled since the last time it was cleared. This display is in 100's of tons. For example, if the display shows  $432$  the total tons is 43,200. This display can be cleared at the beginning of each shift to allow the operator to record how many tons have been hauled during the shift. The units are selected using the PC software.

- To view the total ton counter press and release the "SELECT" switch until  $LL$  is displayed on the gauge.

### Total Load Counter

The total load counter records the number of loads hauled since the last time it was cleared. This display can be cleared at the beginning of each shift to allow the operator to record how many loads have been hauled during the shift.

- To view the total load counter press and release the "SELECT" switch until  $L\bar{C}=$  is displayed on the gauge.

### Clearing the Counters

Clearing the total ton counter or total load counter clears both records.

To clear the total ton and total load counter:

1. Press the "SELECT" switch until  $L\bar{L}=$  or  $L\bar{C}=$  is displayed.
2. Hold the "SET" button until the display clears.

### Viewing Live Sensor Data

The display can also be used to quickly show the current readings from the four suspension pressure sensors and the inclinometer. This can be used during regularly scheduled service periods to check the state of the suspensions. These displays are live and will update as the values change.

The live displays cannot be cleared and the SET button will have no effect.

The units for the display are controlled by the configuration of the payload meter. If the payload meter is set to display metric units, the pressures will be displayed in tenths of  $\text{kg}/\text{cm}^2$ . For example, if the display shows  $20\bar{2}$  the actual value is  $20.2 \text{ kg}/\text{cm}^2$ . If the payload meter is set to display short tons, the pressures will be displayed in psi ( $\text{lbs}/\text{in}^2$ ). Multiply by 14.2 to convert  $\text{kg}/\text{cm}^2$  to psi. (example --  $1 \text{ kg}/\text{cm}^2 \times 14.2 = 14.2 \text{ psi}$ ). There is no way to detect the units setting for the gauge without the PC software.

The inclinometer displays whole degrees of incline. Positive incline is truck nose up. The gauge will quickly display the type of information shown every 10 seconds. For example, if the left-front pressure is being displayed,  $L\bar{F}=$  will flash on the display every minute. Only the payload display,  $P\bar{L}=$  does not display this information.

- Left Front Pressure - To display the pressure in the left-front suspension, press and release the "SELECT" switch until  $L\bar{F}=$  is displayed.
- Right Front Pressure - To display the pressure in the right-front suspension, press and release the "SELECT" switch until  $r\bar{F}=$  is displayed.
- Left Rear Pressure - To display the pressure in the left-rear suspension, press and release the "SELECT" switch until  $L\bar{r}=$  is displayed.
- Right Rear Pressure - To display the pressure in the right-rear suspension, press and release the "SELECT" switch until  $r\bar{r}=$  is displayed.
- Inclinometer - To display the truck incline, press and release the "SELECT" switch until  $I\bar{n}=$  is displayed.

### Other Display Messages

On startup of the payload meter system, the gauge display will scroll the truck type that the PLMIII is configured for. For example, on a 930E, the gauge will scroll,  $---930E---$ .

If the PLMIII encounters memory problems, it will display  $ER\bar{88}$ , where 88 is the specific memory error. In this very rare circumstance, the system should be turned off for 30 seconds and restarted.

## PAYLOAD OPERATION & CALCULATION

### Haul Cycle States

The typical haul cycle can be broken down into eight distinct stages or states. Each state requires the payload meter to make different calculations and store different data.

1. Tare Zone
2. Empty
3. Loading
4. Maneuvering
5. Final Zone
6. Hauling
7. Dumping
8. After Dump

### Haul Cycle Description

A new haul cycle is started after the load has been dumped from the previous cycle. The payload meter will stay in the after\_dump state for 10 seconds to confirm that the load has actually been dumped. If the current payload is less than 20% of rated load, the payload meter will switch to the tare\_zone and begin calculating a new empty tare. If, after dumping, the payload has not dropped below 20% of rated load the meter will return to the maneuvering or hauling states. In this case, the false\_body\_up flag will be recorded in the haul cycle record.

While in the tare\_zone state, and moving faster than 5 km/h (3 mph), the payload meter calculates the empty sprung weight of the truck. This tare value will be subtracted from the loaded sprung weight to calculate the final payload. The payload meter will switch from the tare\_zone or empty to the loading state if swingloads are detected. By raising the dump body while in the empty state the payload meter can be manually switched back to the tare\_zone to calculate a new tare.

From the empty state, the payload meter will switch to the loading state through one of two means. If the brake lock is applied, the payload meter will be analyzing the suspension pressures to detect a swingload. If a swingload is detected, the meter will switch to the loading state. The minimum size for swingload detection is 10% of rated load. Swingload detection usually takes 4-6 seconds. The second method to switch from empty to loading is through continuous loading. This can happen if the brake lock is not used during loading. If the load increases above 50% of rated load for 10 seconds without the brake lock applied, the meter will switch to loading and record the continuous\_loading flag in the haul cycle.

The payload meter switches from loading to maneuvering as soon as the truck begins moving. The maneuvering zone is 160m and is designed to allow the operator to reposition the truck under the shovel. More payload can be added anytime within the maneuvering zone. Once the truck travels 160m (0.1 miles) the payload meter switches to the final\_zone and begins calculating payload. If the body is raised while the payload meter is in the maneuvering state, the no\_final\_load flag will be recorded in the haul cycle record, no payload will be calculated, and the meter will switch to the dumping state.

While in the final\_zone moving faster than 5 km/h (3 mph), the payload meter calculates the loaded sprung weight of the truck. The same advanced algorithm is used to calculate the empty and loaded sprung weights. The payload meter will switch from the final\_zone to the dumping state if the Body-Up signal is received. If the truck has moved for less than 1 minute in the final\_zone, the payload meter will calculate the final payload using an averaging technique which may be less accurate. If this happens, the average\_load flag will be recorded in the haul cycle.

The payload meter switches to the dumping state when the dump body rises. The payload meter will switch from dumping to after\_dump when the dump body comes back down.

From the after\_dump, the payload meter will switch to one of three states:

1. If the average payload is greater than 20% of rated load and no final payload has been calculated, the payload meter will return to the maneuvering state. After the truck travels 160m (0.1 mile) the meter will switch to the final\_zone and attempt to calculate the payload again. The false\_body\_up flag will be recorded in the haul cycle record.
2. If the average payload is greater than 20% of rated load and the final payload has been calculated, the payload meter will switch back to the hauling state. The false\_body\_up flag will be recorded in the haul cycle record.
3. If the average payload is less than 20% of rated load, the payload meter will switch to the tare\_zone and begin to calculate a new empty tare.

### **Load Calculation**

The final load calculation is different from the last swingload calculation. The accuracy of the swing load calculation depends on loading conditions and the position of the truck during loading. The last swingload calculation is not the value recorded in memory as the final load. The final load is determined by a series of calculations made while the truck is traveling to the dump site.

### **Carry Back**

Carry back is calculated as the difference between the current truck tare and the clean truck tare. The clean truck tare is calculated using the PC software. When the suspensions are serviced or changes are made that may affect the sprung weight of the truck, a new clean truck tare should be calculated.

### **Measurement Accuracy**

Payload measurements are typically repeatable within 1%. Accuracy for a particular scale test depends on specific combinations of pressure sensors and payload meters as well as the specifics of each scale test. Comparisons from different scale tests are often made without considering the differences introduced by the specific installation and operation of the scales for each test. In addition, each pressure sensor and payload meter introduces its own non-linearity. Each truck becomes an individual combination of sensors and payload meter. Errors from these sources can introduce up to a  $\pm 7\%$  bias in the payload meter calculations for a specific scale test, for an individual truck.

Because the PLMIII calculates a new empty tare for each payload, a detailed scale test must weigh the trucks empty and loaded for each haul cycle. Using a simple average of 2 or 3 empty truck weights as an empty tare for the entire scale test will introduce significant error when comparing scale weights to PLMIII weights.

## **SOURCES FOR PAYLOAD ERROR**

### **Payload Error**

The number one source of error in payload calculation is improperly serviced suspensions. The payload meter calculates payload by measuring differences in the sprung weight of the truck when it is empty and when it is loaded. The sprung weight is the weight of the truck supported by the suspensions. The only method for determining sprung weight is by measuring the pressure of the nitrogen gas in the suspensions. If the suspensions are not properly maintained, the payload meter cannot determine an accurate value for payload. The two critical factors are proper oil height and proper nitrogen charge.

If the suspensions are overcharged, the payload meter will not be able to determine the empty sprung weight of the truck. The suspension cylinder must be able to travel up and down as the truck drives empty. The pressure in an overcharged suspension can push the suspension rod to full extension. In this case, the pressure inside the cylinder does not accurately represent the force necessary to support that portion of the truck.

If the suspensions are undercharged, the payload meter will not be able to determine the loaded sprung weight of the truck. The suspension cylinder must be able to travel up and down as the truck drives loaded. If the pressure in an undercharged suspension cannot support the load, the suspension will collapse and make metal-to-metal contact. In this case, the pressure inside the cylinder does not accurately represent the force necessary to support that portion of the truck.

Low oil height can also introduce errors by not correctly supporting a loaded truck. This is why the correct oil height and nitrogen charge are the most critical factors in the measurement of payload. If the suspensions are not properly maintained, accurate payload measurement is not possible. In addition, suspension maintenance is very important to the life of the truck.

## Loading Conditions

The final load calculation of the PLMIII system is not sensitive to loading conditions. The final load is calculated as the truck travels away from the shovel. Variations in road conditions and slope are compensated for in the complex calculations performed by the payload meter.

## Pressure Sensors

Small variations in sensors can also contribute to payload calculation error. Every pressure sensor is slightly different. The accuracy differences of individual sensors along the range from 0 to 4000 psi can add or subtract from payload measurements. This is also true of the sensor input circuitry within individual payload meters. These differences can stack up 7% in extreme cases. These errors will be consistent and repeatable for specific combinations of payload meters and sensors on a particular truck.

## Swingloads

Swingload calculations can be affected by conditions at the loading site. Parking the truck against the berm or large debris can cause the payload meter to inaccurately calculate individual swingloads. While the PLMIII system uses an advanced calculation algorithms to determine swingloads, loading site conditions can affect the accuracy.

## Speed and Distance

The payload meter receives the same speed signal as the speedometer. This signal is a frequency that represents the speed of the truck. The payload meter uses this frequency to calculate speeds and distances. The meter assumes a single value for the rolling radius of the tire. The rolling radius may change at difference speeds by growing larger at higher speeds. The actual rolling radius of the tire will also change between a loaded and empty truck. The payload meter does not compensate for these changes.

*NOTE: Earlier 730E and 830E models are subject to incorrect speed data due to electrical interference. The incorrect speeds are generated while the truck is stopped. An attenuator was added to newer production models to prevent this error from occurring. A kit was released to update older PLMIII systems with the attenuator. Consult your area service representative for details.*

## HAUL CYCLE DATA

PLMIII records and stores data in its on-board flash memory. This memory does not require a separate battery. The data is available through the download software.

PLMIII can store 5208 payload records. When the memory is full, the payload meter will erase the oldest 745 payload records and continue recording.

PLMIII can store 512 alarm records in memory. When the memory is full, the payload meter will erase the oldest 312 alarm records and continue recording.

All data is calculated and stored in metric units within the payload meter. The data is downloaded and stored in metric units within the Paradox database on the PC. The analysis program converts units for displays, graphs and reports.

The units noted in the Table 1 are the actual units stored in the data file. The value for the haul cycle start time is the number of seconds since January 1, 1970 to the start of the haul cycle. All other event times are referenced in seconds since the haul cycle start time. The PC download and analysis program converts these numbers into dates and times for graphs and reports.

**Haul Cycle Data**

The following information is recorded for each haul cycle:

<b>Table 1: HAUL CYCLE DATA</b>		
<b>Data</b>	<b>Unit</b>	<b>Remark</b>
Truck #	alpha-numeric	Up to 22 characters can be stored in this field to identify the truck. Typically this field will be just the truck number.
Haul Cycle Start Date/Time	seconds	Number of seconds from 1/1/70 to the start of the haul cycle, haul cycle starts when the meter transitions from dumping to empty state after the previous haul cycle, download program converts seconds into date and time for display
Payload	tons	Stored as metric, download program allows for conversion to short or long tons.
Number of Swingloads	number	The number of swingloads detected by the payload meter
Operator ID	number	This is a 4 digit number that can be entered by the operator at the start of the shift.
Warning Flags	alpha	Each letter represents a particular warning message about the haul cycle, details are located on page 19.
Carry-back load	tons	The difference between the latest empty tare and the clean truck tare
Empty haul time	seconds	Number of seconds in the tare_zone and empty states with the truck moving
Empty stop time	seconds	Number of seconds in the tare_zone and empty states with the truck stopped
Loading time	seconds	Number of seconds in the loading state
Loaded haul time	seconds	Number of seconds in the maneuvering, final_zone and loaded states with the truck moving
Loaded stop time	seconds	Number of seconds in the maneuvering, final_zone and loaded states with the truck stopped
Dumping time	seconds	Number of seconds in the dumping state
Loading start time	seconds	Number of seconds from the start of the haul cycle to when the meter transitions from empty to loading state
Dump start time	seconds	Number of seconds from the start of the haul cycle to the time when the meter switches from loaded to dumping state
Loaded haul distance	m	Distance traveled while loaded
Empty haul distance	m	Distance traveled while empty
Loaded max speed	km/h	Maximum speed recorded while the truck is loaded
Loaded max speed time	seconds	Number of seconds from the start of the haul cycle to the time when the max speed occurred
Empty max speed	km/h	Maximum speed recorded while the truck is empty
Empty max speed time	seconds	Number of seconds from the start of the haul cycle to the time when the max speed occurred
Peak positive frame torque	ton-meter	Positive frame torque is measured as the frame twists in the clockwise direction as viewed from the operator's seat.
Peak frame torque time	seconds	Number of seconds from the start of the haul cycle to the peak torque, download program converts to time for display
Peak negative frame torque	ton-meter	Negative frame torque is measured as the frame twists in the counter-clockwise direction as viewed from the operator's seat.
Peak frame torque time	seconds	Number of seconds from the start of the haul cycle to the peak torque, download program converts to time for display
Peak sprung load	tons	Peak dynamic load calculation
Peak sprung load time	seconds	Number of seconds from the start of the haul cycle to the peak instantaneous load calculation
Front-left tire-ton-km/h	t-km/h	Tire ton-km/h for haul cycle
Front-right tire-ton-km/h	t-km/h	Tire ton-km/h for haul cycle
Average rear tire-ton-km/h	t-km/h	Tire ton-km/h for haul cycle
Truck Frame Serial Number	alpha	The truck serial number from the nameplate on the truck frame
Reserved 1-10	number	These values are internal calculations used in the continued development of the PLMIII system and should be ignored

## **Haul Cycle Warning Flags**

The payload meter expects haul cycles to progress in a particular way. When something unexpected takes place, the system records a warning flag. Several events within the haul cycle can cause a warning flag to be generated. Each one indicates an unusual occurrence during the haul cycle. They do not necessarily indicate a problem with the payload meter or payload calculation.

### **A: Continuous Loading**

This message is generated when the truck is loaded over 50% full without the payload meter sensing swingloads. This indicates that a continuous loading operation was used to load the truck. It may also indicate that the payload meter did not receive the brake lock input while the truck was being loaded. There may be a problem with the wiring or the brake lock was not used. The payload meter will not measure swingloads unless the brake lock is used during the loading process.

### **B: Loading to Dumping Transition**

This message is generated when the payload meter senses a body up input during the loading process. This message is usually accompanied by a `no_final_load` flag.

### **C: No Final Load**

This message is generated when the payload meter is unable to determine the final payload in the truck. Typically, this means that the payload meter switched from a loaded state to the dumping state before the load could be accurately measured.

### **D: Maneuvering to Dumping Transition**

This message is generated when the payload meter senses a body-up input during the maneuvering or repositioning process indicating that the operator has dumped the load. It may also be generated if the body-up signal is not properly reaching the payload meter and the weight in the truck falls dramatically while the truck is maneuvering or repositioning.

### **E: Average Load or Tare Used**

This message indicates that the recorded payload may not be as accurate as a typical final load calculation. Typically, this is recorded when loading begins before an accurate tare is calculated or the load is dumped before the load can be accurately measured.

### **F: Final Zone to Dumping Transition**

This message is generated when the payload meter senses a body-up while it is calculating the final payload indicating that the operator has dumped the load. It may also be generated if the body-up signal is not properly reaching the payload meter and the weight in the truck falls dramatically while the truck is calculating the final payload.

### **H: False Body Up**

This message indicates that the body was raised during the haul cycle without the load being dumped. The body-up signal indicated that the truck was dumping, but the weight of the truck did not fall below 20% of the rated load.

### **I: Body Up Signal Failed**

This message indicates that the load was dumped without a body-up signal being received by the payload meter. The weight of the truck fell below 20%, but the payload meter did not receive a body-up signal from the sensor.

### **J: Speed Sensor Failed**

This message indicates that the payload meter sensed the truck loading and dumping without receiving a speed signal.

### **K: New Tare Not Calculated**

The payload meter was not able to accurately calculate a new empty sprung weight for the truck to use as the tare value for the haul cycle. The tare value from the last haul cycle was used to calculate payload.

### **L: Incomplete Haul Cycle**

The payload meter did not have proper data to start the haul cycle with after powering up. When the PLMIII powers off, it records the data from the haul cycle in progress into memory. This flag indicates that this data was not recorded the last time the payload meter was shut down. This can happen when the main battery disconnect is used to shut the truck down instead of the key switch. A haul cycle with this warning flag should not be considered accurate. Haul cycles with this warning are displayed in red on the Payload Summary window and are not included in the summary statistics for reports or display.



**M: Haul Cycle Too Long**

The haul\_cycle\_too\_long flag indicates that the haul cycle took longer than 18.2 hours to complete. The times stored for particular events may not be accurate. This does not affect the payload calculation.

**N: Sensor Input Error**

An alarm was set for one of the 5 critical sensor inputs during the haul cycle. The five critical sensors are the four pressure sensors and the inclinometer. Without these inputs, the payload meter cannot calculate payload. A haul cycle with this warning flag should not be considered accurate. Haul cycles with this warning are displayed in red on the Payload Summary window and are not included in the summary statistics for reports or display.

**Frame Torque Data**

Payload meter records the top 5 peak positive and negative frame torque values and the time they occurred. The frame torque is a measure of the twisting action along the centerline of the truck. Positive frame torque is measured when the suspension forces on the front of the truck act to twist the frame in the clockwise direction as viewed from the operator's seat. Negative frame torque is measured when the forces from the suspensions act in the opposite direction.

For example, if the left front and right rear pressure rises as the right front and left rear pressure drops, the truck frame experiences a twisting motion along the longitudinal centerline. In this case, the payload meter will record a positive frame torque.

The 5 highest values in the positive and negative direction are stored in permanent memory within the payload meter.

**Sprung Weight Data**

The payload meter is constantly monitoring the live payload calculation. This value naturally rises and falls for a loaded truck depending on road and driving conditions. The payload meter records the top 5 highest payload calculations and the time they occurred. This information is stored in permanent memory inside the meter.

**Maximum Speed Data**

The payload meter records the top 5 highest speeds and the time they occurred. This information is stored in permanent memory inside the meter.

**Alarm Records**

The payload meter stores alarm records to give service personnel a working history of the system. All codes are viewed using the PC connected to the payload meter. Active codes are also displayed on the two-digit display on the meter itself. Each code has a specific cause and should lead to an investigation for correction. Some failures can be overcome by the payload meter. Haul cycle data will indicate if an alarm condition was present during the cycle. Failures with the suspension or inclinometer sensors cannot be overcome.

**Fault Code Data**

<b>Table 2:</b>		
<b>Fault Code</b>	<b>Name</b>	<b>Description</b>
1	Left front pressure high	Input current > 22 ma
2	Left front pressure low	Input current < 2 ma
3	Right front pressure high	Input current > 22 ma
4	Right front pressure low	Input current < 2 ma
5	Left rear pressure high	Input current > 22 ma
6	Left rear pressure low	Input current < 2 ma
7	Right rear pressure high	Input current > 22 ma
8	Right rear pressure low	Input current < 2 ma
9	Inclinometer high	Input voltage < 0.565 vdc
10	Inclinometer low	Input voltage > 5.08 vdc
11	Speed input failure	Not Used
12	Brake lock input failure	Not Used
13	Body-up input failure	Payload meter detected dumping activity without receiving a body up signal
16	Memory write failure	Indicates possible memory problem at power start up. Cycle power and recheck.
17	Memory read failure	Indicates possible memory problem at power start up. Cycle power and recheck.
18	Rear right suspension flat	Payload meter detected an undercharged suspension condition on the rear right suspension.
19	Rear left suspension flat	Payload meter detected an undercharged suspension condition on the rear left suspension.
20	Time change	Payload meter time was changed by more than 10 minutes. The Alarm Set time indicates original time. The Alarm Clear time indicates the new time.
21	Tare value reset	The user manually forced the payload meter to reset the haul cycle empty (tare) sprung weight. This forced the meter into the tare_zone state and lost all data for the previous haul cycle.
22	Excessive carryback	The payload meter detected an empty carryback load in excess of the user-defined carryback threshold on two consecutive haul cycles.
26	User switch fault - SELECT	Select switch on for more than 2 minutes, may indicate short to ground
27	User switch fault - SET	Set switch on for more than 2 minutes, may indicate short to ground

## PC SOFTWARE OVERVIEW

### PC Overview

The PC software has several basic functions:

- Configure the PLMIII system on the truck.
- Troubleshoot and check the PLMIII system.
- Download data from the PLMIII system.
- Analyze data from the payload systems.

Configuration, troubleshooting and downloading require a serial connection to the payload meter on the truck. Analysis can be done at any time without a connection to the payload meter.

Payload data is downloaded from several trucks into one database on the PC. The database can be queried to look at the entire fleet, one truck or truck model. The data can be graphed, reported, imported or exported. The export feature can take payload data and save it in a format that spreadsheet programs like Excel or word processing programs can easily import.

### System Configuration

PLMIII needs to be configured for operation when it is first installed on the truck. This process requires several steps and uses the laptop computer to make the necessary settings. The setup procedure can be broken down into several steps:

- Connecting the laptop to the PLMIII system.
- Starting communications
- Setting the time & date
- Setting the truck type
- Setting the truck ID
- Setting the speedometer/display gauge units

### Installing the PLMIII Software

The CD-ROM containing the Payload Data Management (PDM) software will automatically begin installation when it is inserted into the drive on the PC. If this does not happen, the software can be installed by running the Setup.exe program on the CD-ROM.

The minimum PC requirements for running the software is a Pentium 133Mhz with 64 MB of ram and at least 300 MB of free hard drive space available. For improved performance, the recommended PC would have a Celeron, AMD K6-2 or better processor with 128 MB of ram running at 400 Mhz. The PDM software uses a powerful database to manipulate the large amounts of data gathered from the PLMIII system. Using a more powerful computer and added memory to run the software can result in a significant improvement in performance. The software is written to use a minimum 800x600 screen resolution.

## DOWNLOADING DATA

PLMIII records many types of data. The PLMIII PC software is designed to download the data from a whole truck fleet. Instead of creating one data file for each truck, the PC software combines all the data from many trucks into one database on the hard drive of the computer. The software then allows users to query the database to create custom reports and graphs. Data for individual trucks or groups of trucks can be easily analyzed. This same data can be exported for use in other software applications like word processors and spreadsheet applications.

As the database grows, performance of the PC software for analysis will slow down. It may be helpful to periodically export data. For example, query the database to show the oldest quarter, month, or half year and print out a summary report. Then export the data to a compressed format and save the file in a secure location. Once the data is exported, delete the entire query results from the database. If necessary, the data can easily be imported back into the main database for analysis at a future date. Removing this older data will improve performance.



To download the payload meter:

1. Connect to the payload meter and start the PC software.
2. From the main menu, select "Connect to Payload Meter". The PC will request the latest status information from the payload meter. The number of haul cycles and alarms will be displayed.
3. Select the "Begin Download" button. The PC will request the payload and alarm data from the payload meter and save it into the database. This may take several minutes. A progress bar at the bottom will show the approximate time left.

The PC software downloads the data from the payload meter into a single Paradox database. The data from all the trucks is added to the same database. Downloading the payload meter can take several minutes. The data is added to the database on the laptop used to download.

To move the data to another computer, a query must be run to isolate the particular data for export. Do not press the operator switch on the dashboard while downloading

## PLM III SYSTEM CONFIGURATION

### Starting Communications

The PDM software allows users to download and configure the system.

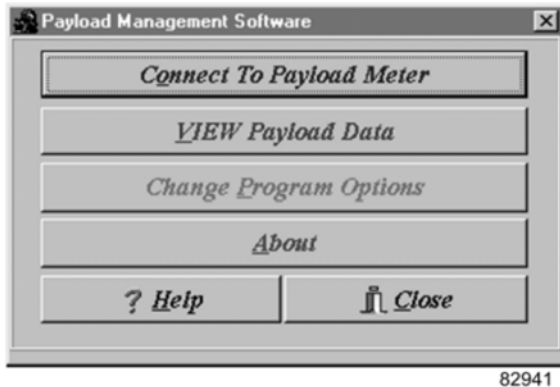

82941

Before connecting to the payload meter, select "Change Program Options" and confirm that the program has selected the correct laptop serial port. Most laptops use Comm 1 for serial communications. The units displayed for reports and graphs by the PC software can be set on this form. Click "Done" to return to the main menu.

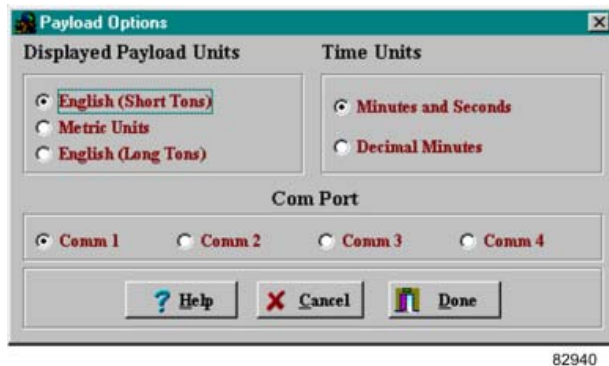

82940

From the main menu, click the "Connect to Payload Meter" button. The PC will try to connect to the payload meter and request basic information from the system. In the event of communications trouble, the PC will try 3 times to connect before "timing-out". This may take several seconds.

### Displayed Payload Units

Three options are available for the display of units in the PC software, reports, and graphs:

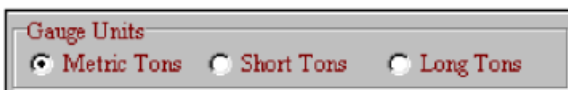

82949

*Short Tons:* Payload is displayed in short tons, distances and speeds will be displayed in Miles

*Metric Tons:* Payload is displayed in metric tons, distances and speeds are displayed in Kilometers

*Long Tons:* Payload is displayed in long tons, distances and speeds are displayed in Miles

### Time Units

Minutes and Seconds Example:

Five minutes and thirty-two seconds = 5:32

Decimal Minutes Example:

Five minutes and thirty-two seconds = 5.53

### Connection Menu

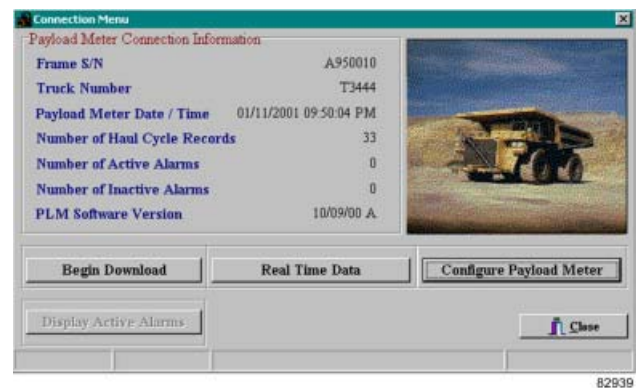

82939

The connection screen displays basic system information to the user.

- Frame S/N should agree with the truck serial number from the serial plate located on the truck frame.
- Truck Number is an ID number assigned to the truck by the mine.
- The Payload Meter Date / Time values come from the payload meter at the moment of connection.
- Number of Haul Cycle Records is the number of haul cycles records stored in memory and available for download.
- Number of Active Alarms shows how many alarms are currently active in the system at the time of connection. If there are active alarms, the "Display Active Alarms" button is available.
- Number of Inactive Alarms shows how many alarms have been recorded in memory and are available for download.
- PLM Software Version displays the current version of software in the payload meter.

The information on the connection menu comes from the configuration of the payload system on the truck.

There are also many configuration and download options available from this screen. The Connection Menu is updated only when the connection is first made. It does not update automatically. To view changes made while connected, the user must close the window and reconnect to the payload meter.

The connection menu is displayed after a serial connection has been established and the PC software has connected to the payload meter.

### Connecting to the Payload Meter

Communications to the PLMIII requires a laptop computer running the PDM software. The software connects to the payload meter through the meter's serial port #1. This is the same port used by the speedometer/display gauge. When the laptop is using the serial port, the lower display on the operator gauge on the dashboard will be blank. This does not affect the operation of the speedometer.

- Connect the laptop to the system using the EF9160 or PC2525 communications harness. The download connector is typically located on the housing mounted in the cab to the back wall. The PLMIII system uses the same connection as the Payload Meter II system.

### Configure the Payload Meter

Configuration of the payload meter requires a serial connection to the PLMIII system. Clicking the "Configure Payload Meter" button will bring up the Truck Configuration screen and menu. This screen displays the latest configuration information stored on the payload meter.

When changes are made to the configuration, the "Save Changes" button must be pressed to save the changes into the payload meter. To confirm the changes, exit to the main menu and re-connect to the payload meter.

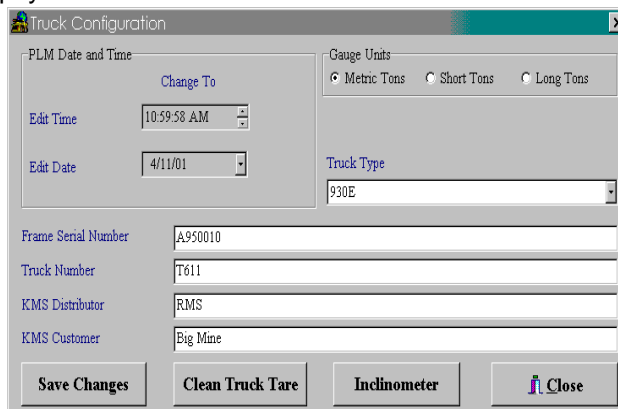

### Setting the Date and Time



The time shown on the form is the time transmitted from the payload when the connection was first established.



The date and time are maintained by a special chip on the PLMIII circuit board. The memory for this chip is maintained by a very large capacitor when the power is removed from the payload meter. This will maintain the date and time settings for approximately 30 days. After this time, it is possible for the payload meter to lose the date and time setting. It is recommended that the system be powered every 20 days to maintain the date and time. If the date and time is lost, simply reset the information using this procedure. It takes approximately 90 minutes to recharge the capacitor.

Changing the date and time will affect the haul cycle in progress and may produce unexpected results in the statistical information for that one haul cycle.

*NOTE: If the truck is equipped with VHMS, do not set the time or date in the PLM III controller. The PLM III clock is synchronized by the VHMS clock.*

To change the time:

1. Click on the digit that needs to be changed.
2. Use the up/down arrows to change or type in the correct value.
3. Press the "Save Changes" button to save the new time in the payload meter.

To change the date:

1. Click on the digit that needs to be changed.
2. Type in the correct value or use the pull-down calendar to select a date.
3. Press the "Save Changes" button to save the new time in the payload meter.

### Setting the Truck Type

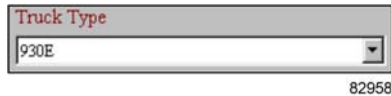

1. From the Truck Configuration screen, use the pull-down menu to select the truck type that the payload meter is installed on.
2. Press the "Save Changes" button to program the change into the meter.

### Setting the Gauge Display Units

The payload meter speedometer / display gauge displays the speed on the upper display. The units for the speed display are selected using a jumper on the rear of the case.

The payload units on the lower display can be changed from metric to short tons or long tons using the Truck Configuration screen. This selection also switches between metric (kg/cm<sup>2</sup>) and psi (lbs/in<sup>2</sup>) for the live display of pressure on the gauge.

1. From the Truck Configuration screen, select the payload units to be used on the lower display of the speedometer/display gauge.
2. Press the "Save Changes" button to program the change into the payload meter.

### Setting the Frame Serial Number

Frame Serial Number	A950010
Truck Number	T3444
KMS Distributor	RMS
KMS Customer	Pit Mine

The frame serial number is located on the plate mounted to the truck frame. The plate is outboard on the lower right rail facing the right front tire. It is very important to enter the correct frame serial number. This number is one of the key fields used within the haul cycle database. The field will hold 20 alpha-numeric characters.

1. On the Truck Configuration screen, enter the truck frame serial number in the appropriate field.
2. Press the "Save Changes" button to program the change into the payload meter.

### Setting the Truck Number

Most mining operations assign a number to each piece of equipment for quick identification. This number or name can be entered in the Truck Number field. It is very important to enter a unique truck number for each truck using the PLMIII system. This number is one of the key fields used within the haul cycle database. The field will hold 20 alpha-numeric characters.

1. On the Truck Configuration screen, enter the truck number in the appropriate field.
2. Press the "Save Changes" button to program the change into the payload meter.

### Setting the Komatsu Distributor

This field in the haul cycle record can hold the name of the Komatsu distributor that helped install the system. Komatsu also assigns a distributor number to each distributor. This number is used on all warranty claims. This Komatsu distributor number can also be put into this field. The field will hold 20 alpha-numeric characters.

1. On the Truck Configuration screen, enter the distributor name or number in the appropriate field.
2. Press the "Save Changes" button to program the change into the payload meter.

### Setting the Komatsu Customer

This field in the haul cycle record can hold the name of the mine or operation where the truck is in service. Komatsu also assigns a customer number to each customer. This number is used on all warranty claims. This Komatsu customer number can also be put into this field. The field will hold 20 alpha-numeric characters.

1. On the Truck Configuration screen, enter the customer name or number in the appropriate field.
2. Press the "Save Changes" button to program the change into the payload meter.

## Clean Truck Tare

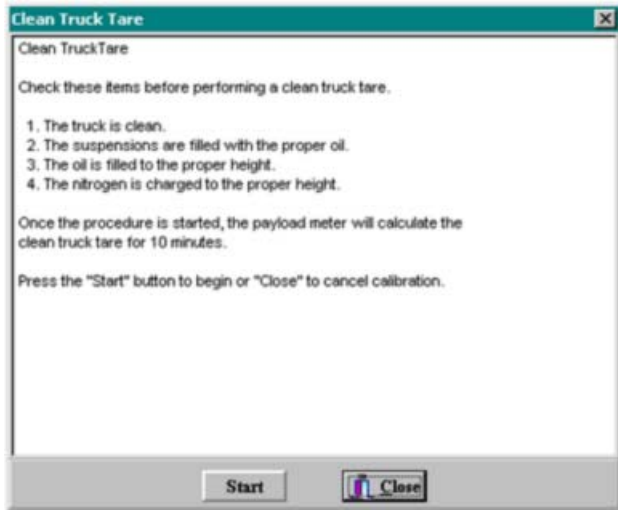

82944

The payload meter uses the clean truck tare value to calculate carry-back load for each haul cycle. The carry-back stored in the haul cycle record is the new empty tare minus the clean truck tare.

This procedure should be performed after service to the suspensions or when significant changes are made to the sprung weight of the truck. Before performing this procedure, be sure the suspensions are properly filled with oil and charged. It is critical to payload measurement that the proper oil height and gas pressure be used.

Once the clean tare process is started, the payload meter will begin to calculate the clean empty sprung weight of the truck. This calculation continues while the truck drives to the next loading site. Once the procedure is started, there is no reason to continue to monitor the process with the PC. The truck does not need to be moving to start this procedure.

1. After cleaning debris from the truck and checking to see that the suspensions are properly serviced, use the PLMIII software to connect to the payload meter.
2. From the "Truck Configuration" screen, select "Clean Truck Tare".
3. Be sure to follow the screen instructions.

## Inclinometer Calibration

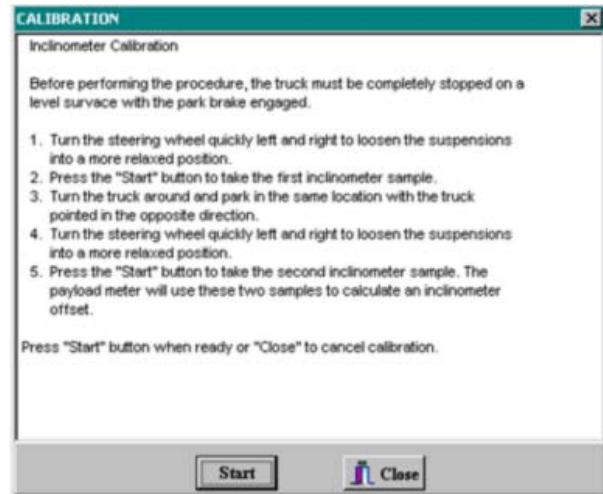

82945

The inclinometer calibration procedure is designed to compensate for variations in the mounting attitude of the inclinometer. The inclinometer input is critical to the payload calculation.

This procedure should be performed on relatively flat ground. Often the maintenance area is an ideal location for this procedure.

1. After cleaning debris from the truck and checking to see that the suspensions are properly serviced, use the PLMIII software to connect to the payload meter.
2. From the "Truck Configuration" screen, select "Inclinometer".
3. With the truck stopped and the park brake on, press the "Start" button. This instructs the payload meter to sample the inclinometer once.
4. Turn the truck around. Drive the truck around and park in the exact same spot as before, facing the other direction.
5. With the truck stopped and the brake lock on, press the "Start" button. This instructs the payload meter to sample the inclinometer again. The payload meter will average the two samples to determine the average offset.
6. Be sure to follow the screen instructions.



## DATA ANALYSIS

### PAYLOAD SUMMARY FORM

**Date:** Sorts the data within a date range. eg. "Dec 1, 2000 through Dec 31, 2000"

**Truck Number:** Sorts the data by the truck unit number, eg. "374"

**Time:** Sorts the data within a time for each day within the data range. "8:00 AM to 5:00PM"

**Truck Type:** Sorts the data by the truck type, eg. "930E" or "830E"

**Query Database & Display:** Sorts the data by the selected query options (unit, type, date, time) and displays the results.

**Output Options:** Use to create reports, graphs and expert data from the selected query.

**Cycle Summary:** Cycle time summary from the selected query.

**Summary Statistics:**

Payload Data Summary		Cycle Time Summary	
Units - (Metric Tons)		Units - (min:ss)	
Total Tons	28,360,482	Avg. Load Time	0:32
Final Payload	17,011,874	Avg. Haul Time	0:40
Max. Payload	360	Avg. Haul Stop Time	0:23
Min. Payload	252	Avg. Return Time	1:01
Avg. Payload	318	Avg. Return Stop Time	0:59
Std. Deviation	25	Avg. Operating Time	4:08
		Avg. Dump Time	0:22

**Haul Cycle Records:**

Truck Number	Date	Time	Payload	# Swings	Total Time
351	07/10/2000	8:22:40 AM	323.8	5	7:09
351	07/10/2000	8:36:12 AM	323.8	5	5:23
351	07/10/2000	8:41:35 AM	323.8	5	5:24
351	07/10/2000	8:46:58 AM	321.5	1	30:11
351	07/10/2000	9:17:06 AM	321.9	0	0:32
351	07/10/2000	9:17:37 AM	318.0	0	0:32

**Haul Cycle Records:**  
Summary view of the haul cycle records from the selected query. Double Click to view the details for individual haul cycle records.  
Haul cycles in red area are not included in the summary statistics..

The data analysis tools allow the user to monitor the performance of the payload systems across the fleet. Analysis begins when the "View Payload Data" button is pressed. This starts an "all trucks, all dates, all times" query of the database and displays the results in the Payload Summary Form.

The user can change the query by changing the dates, times, or trucks to include in the query for display.

Haul cycles in the data grid box at the bottom can be double-clicked to display the detailed results of that haul.

#### Creating a Query

The program defaults to show all trucks, all types, all dates and all times for the initial query. The display can be narrowed by selecting which trucks or types to view and for what dates and times.

The query items are added in the "AND" condition. If the user selects a truck # and date range, the query will sort the data for that truck number AND the date range.

#### Sorting on Truck Unit Number

The truck unit number is the truck unit number entered into the payload meter when it was configured at installation. The query can be set to look for all trucks or one particular truck number. When the program begins, it searches through the database for all the unique truck numbers and creates a list to select from.

Choosing one particular truck number will limit the data in the displays, summaries and reports to the one selected truck. To create reports for truck number 374, select 374 from the pull-down menu and hit the "Query Database and Display" button.

#### Sorting on Truck Type

The truck type is the size of the truck from the family of Komatsu trucks. This allows the user to quickly view results from different types of trucks on the property. For example, a separate report can be generated for 830E and 930E trucks.

### Sorting on Date Range

The default query starts in 1995 and runs through the current date on the PC. To narrow the range to a specific date, change the "From" and "To" dates. For example, to view the haul cycle reports from truck 374 for the month of July, 2000:

1. Select truck 374 from the Truck Unit pull-down menu.



82946

2. Change the "From" date to July 1, 2000.

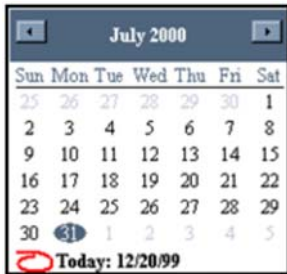

82947

3. Change the "To" date to July 31, 2000.
4. Press the "Query Database and Display" to view the results.

### Sorting on Time Range

The time range sorts the times of the day for valid dates. Changing the time range to 6:00AM to 6:00PM will limit the payloads displayed to the loads that occurred between those times for each day of the date range. Times are entered in 24:00 format. To view the haul cycle reports from the first shift for truck 374 from January 5, 2000 to January 8, 2000:

1. Select truck 374 from the Truck Unit pull-down menu.



2. Change the "From" date to January 5, 2000.

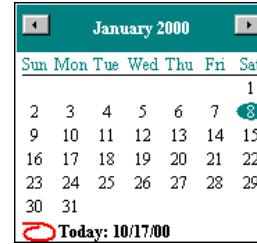

3. Change the "To" date to January 8, 2000.
4. Change the "From" time to 06:00.
5. Change the "To" time to 18:00.



6. Press the "Query Database and Display" to view the results.

This query will display haul cycles from January 5 to January 8, from 6:00 AM to 6:00 PM.

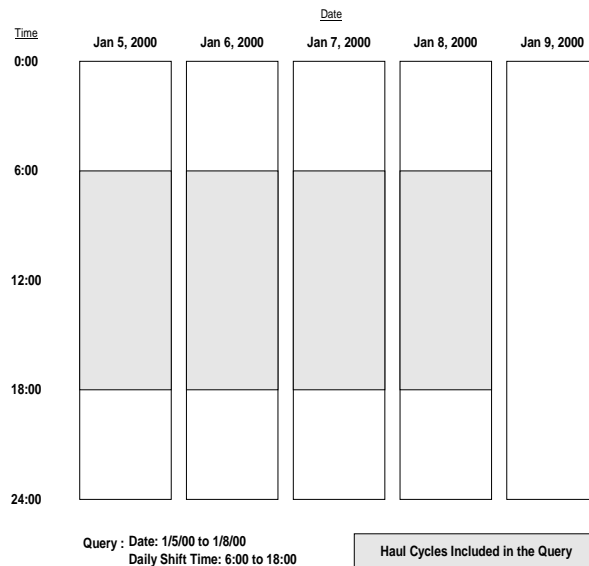

The shift times selected can extend the query past the original date. If the dates set for the query are January 5 to January 8 and the times were changed to query the 6:00 PM (18:00) to 6:00 AM (06:00) shift, the results would extend into the morning of the 9th. This can be seen in the following example:

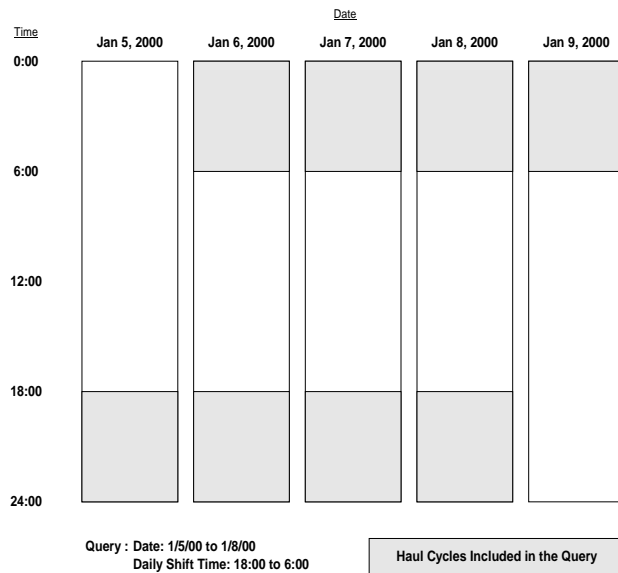

### Payload Detail Screen

The Payload Detail screen gives the details for any individual haul cycle. From the "Payload Summary" screen, double-click on any haul cycle to display the detail.



### Creating Reports

Reports can be generated and viewed on the screen or printed. These reports are generated from the query displayed on the Payload Summary Screen. From the example in "Sorting on Time Range", the report printed would only contain data from truck 374 during the month of July 2000, from 8:00 AM to 5:00 PM.

It is important to carefully select the query data and press the "Query Database & Display" button before printing a report.

*NOTE: Some haul cycles may contain the Sensor Input warning flag. This indicates that one of the four pressure sensors or inclinometer was not functioning properly during the haul cycle. Haul cycles with this warning are displayed in red on the Payload Summary window and are not included in the summary statistics for reports or display.*

**Summary - one page report**

A summary of the queried data can be printed onto 1 page. The cycle data is summarized onto one sheet. Displayed is the speeds, cycle times, load statistics, frame and tire data.

**Detailed - multi-page report**

The detail report starts with the summary report and follows with pages of data for each haul cycle. The detailed report prints date, time, payload, cycle times, and cycle distances, speeds and the number of swing loads.

Payload Summary Report			
<b>Report Date: October 17, 2000</b>			
<b>Query used for summary:</b>			
Truck Number: ALL			
Truck Type: ALL			
Dates: 8/28/00 to 10/3/00			
Daily Shift Time: 00:00 to 24:00			
			<b>Cycle Distance Averages (miles)</b>
<b>Time Period</b>	<b>Date</b>	<b>Time</b>	Loaded 2.2
First Load	08/28/2000	03:54:13 PM	Empty 2.4
Last Load	10/03/2000	12:08:36 PM	Avg Total Distance 4.6
<b>Payload Data</b>		<b>Short Tons</b>	<b>Date</b> <b>Time</b>
Average		326	
Standard Deviation		27.1	
Maximum		417	09/08/2000 01:27:37 PM
Minimum		10	09/15/2000 09:13:53 AM
Total Tons		373,959	
Number of Payloads		1,148	
Avg Carry Back		2.3	
<b>Frame Data</b>		<b>Torque</b>	<b>Date</b> <b>Time</b>
Max Peak Pos		12,958	09/15/2000 10:12:12 PM
Max Peak Neg		13,352	08/31/2000 3:37:26 PM
Avg Peak Pos		5,767	
Avg Peak Neg		6,588	
<b>Cycle Time Averages (Min:Sec)</b>		<b>Avg Tire (Ton-MPH)</b>	
Load	3:00	Left Front	528
Haul Run	11:36	Right Front	527
Haul Stop	2:48	Rear	377
Empty Run	7:20		
Empty Stop	4:05		
Dump	1:17		
Avg Total Cycle Time	30:09		
		<b>SPEED DATA (mph)</b>	
		Loaded Max	47.24
		Loaded Avg	9.30
		Empty Max	47.24
		Empty Avg	12.52

82949

Page 1

**Payload Detail Report**  
**Report Date: October 17, 2000**  
**Query used for summary:**  
 Truck Number: ALL  
 Truck Type: ALL  
 Dates: 8/28/00 to 10/3/00  
 Daily Shift Time: 00:00 to 24:00

No.	Date	Time	Payload S.Tons	#Swings	CYCLE Times(min:sec)					CYCLE DISTANCE(mi.)			SPEEDS(mph)					
					Load	Haul	Haul Stop	Dump	Return	Return Stop	Total	Haul	Return	Total	Max	Haul Avg	Max	Return Avg
1	8/28/00	3:54P	347	7	4:40	11:11	0:06	0:52	7:54	14:28	39:11	1.9	2.0	4.0	21.99	10.14	31.03	5.48
2	8/28/00	5:18P	301	6	3:39	11:10	0:25	0:43	8:12	3:43	27:52	1.9	1.9	3.8	23.02	9.91	26.05	9.42
3	8/28/00	5:46P	300	6	3:32	11:32	2:32	0:56	7:07	0:09	25:48	1.9	1.9	3.8	23.02	8.30	25.02	15.49
4	8/28/00	6:11P	330	4	1:58	17:51	2:49	1:58	11:34	1:41	37:51	3.9	2.6	6.5	36.21	11.37	24.07	11.73
5	8/28/00	6:49P	344	4	1:54	18:26	13:04	1:50	11:20	0:24	46:58	4.0	3.9	7.9	34.97	7.56	37.06	20.15
6	8/28/00	7:36P	380	5	2:12	19:52	1:07	1:39	11:32	0:48	37:10	4.0	4.0	8.0	30.00	11.28	34.03	19.59
7	8/28/00	8:13P	352	4	2:26	18:17	0:23	1:54	11:54	1:56	36:50	3.9	4.0	8.0	31.97	12.62	34.07	17.49
8	8/28/00	8:50P	356	4	1:56	18:52	0:21	1:55	11:59	0:38	35:41	4.0	4.0	8.0	36.17	12.34	36.21	19.09
9	8/28/00	9:25P	370	5	2:18	16:17	2:18	0:53	12:25	0:25	34:36	2.7	4.1	6.7	34.97	8.55	36.17	19.14
10	8/28/00	10:00P	363	5	3:07	16:56	5:48	0:52	9:02	0:33	36:18	2.7	2.7	5.3	32.97	6.99	32.97	16.61
11	8/28/00	10:36P	341	7	3:58	12:23	0:23	0:53	7:26	0:57	26:00	2.0	2.0	3.9	21.03	9.20	32.00	14.10
12	8/28/00	11:02P	321	4	2:24	16:19	5:06	0:50	10:17	1:05	36:01	2.7	2.6	5.3	34.03	7.49	31.97	13.71
13	8/28/00	11:38P	316	5	2:49	15:21	7:06	0:58	13:01	13:11	52:26	3.9	4.0	7.9	40.12	10.30	40.12	9.16
14	8/29/00	12:56A	320	5	2:23	15:18	0:07	0:55	13:16	11:43	43:42	3.9	3.8	7.7	36.21	14.99	41.10	9.18
15	8/29/00	1:40A	302	4	1:55	14:12	0:08	0:54	10:34	0:11	27:54	3.9	3.9	7.7	40.12	16.15	41.10	21.64
16	8/29/00	2:08A	310	5	2:21	15:14	4:55	1:01	9:46	4:59	38:16	3.9	3.9	7.7	40.12	11.51	41.16	15.67
17	8/29/00	2:46A	318	5	2:25	14:44	0:15	0:54	10:36	0:19	29:13	3.9	3.9	7.7	41.10	15.50	41.10	21.28
18	8/29/00	3:15A	278	4	2:01	15:53	1:12	0:46	10:38	2:08	32:38	4.3	3.8	8.1	38.13	15.06	41.10	18.05
19	8/29/00	3:48A	328	5	2:25	17:38	3:08	0:57	10:07	0:20	34:35	4.3	3.9	8.2	34.03	12.41	41.10	22.19
20	8/29/00	4:22A	287	4	2:49	17:00	15:44	1:02	11:59	4:49	53:23	4.3	4.0	8.2	40.12	7.87	41.10	14.09
21	8/29/00	1:41P	285	4	2:15	16:08	6:14	5:21	9:02	14:43	53:43	4.0	3.0	6.9	34.97	10.58	34.03	7.55
22	8/29/00	2:50P	340	7	3:38	10:14	0:06	0:54	8:41	7:10	30:43	1.8	3.3	5.2	27.07	10.54	39.07	12.65
23	8/29/00	3:20P	326	5	3:32	9:47	0:08	1:09	5:21	0:16	20:13	1.8	1.8	3.6	27.05	10.98	30.02	18.98
24	8/29/00	3:41P	342	6	3:59	11:24	0:08	0:47	19:49	15:18	51:25	1.9	6.2	8.1	23.02	10.02	32.00	10.56
25	8/29/00	4:43P	349	7	4:46	11:12	0:18	0:57	7:52	3:12	27:57	1.8	1.9	3.8	23.02	9.50	27.07	10.87
26	8/29/00	5:11P	322	4	2:11	5:29	19:58	1:29	15:38	59:19	104:04	1.1	5.1	6.1	42.20	2.52	42.20	4.05
27	8/30/00	4:27A	330	7	4:27	10:33	0:09	1:02	21:08	159:27	196:46	1.7	4.3	6.0	23.02	9.69	28.01	1.42
28	8/30/00	4:55P	320	6	3:52	10:42	0:14	1:00	5:43	1:42	23:13	1.7	1.7	3.4	24.07	9.55	29.06	13.47
29	8/30/00	5:18P	338	6	3:16	10:45	0:51	0:58	6:00	2:34	24:24	1.7	1.6	3.3	23.02	8.71	29.04	11.36
30	8/30/00	5:42P	343	6	3:52	10:28	0:08	1:01	6:06	0:25	22:00	1.7	1.6	3.3	24.08	9.57	28.03	14.70

### Creating Graphs

The PLMIII software can generate graphs that quickly summarize payload data. These graphs can be customized for printing. Just like the reports, the graphs are generated from the query displayed on the "Payload Summary" screen. From the "Sorting on Time Range" example, the graph that is printed would only contain data from truck 374 during the month of July 2000, from 8:00 AM to 5:00 PM.

It is important to carefully select the query data and press the "Query Database & Display" button before creating a graph.

1. From the Payload Summary Screen select the "Graph" button at the bottom. The Histogram Setup screen will display

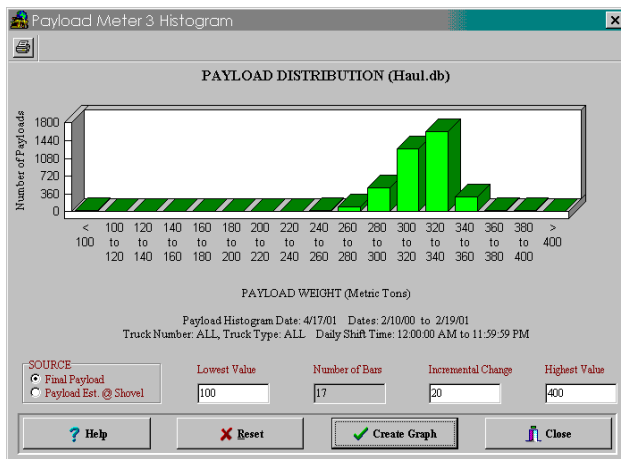

2. Enter the "Lowest Value". This will be the lowest payload on the graph. Any payloads less than this value will be summed in the first bar.
3. Enter the "Highest Value". This will be the highest value on the graph. Payloads over this value will be summed in the last bar.
4. Enter the "Incremental Change". This will determine the number of bars and the distance between them. The program limits the number of bars to 20. This allows graphs to fit on the screen and print onto 1 page.
5. Press the "Create Graph" button.

The graph will be displayed based on the query settings from the Payload Summary screen. The graph can be customized and printed.

### Exporting Data

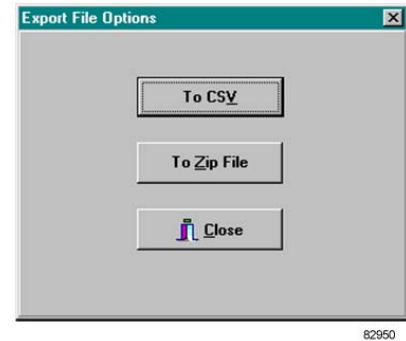

The data from the database can be exported for use with other software applications. The data is selected from the currently displayed query. The exported data can be put into a ".CSV" file or a compressed ".zip" file.

- The ".CSV" format allows data to be easily imported into spreadsheet applications and word processing applications.
- The ".zip" format allows data to be transferred from one computer to the PDM Software database on another computer. This offers a compact way to transfer data from one computer to another.

### CSV Export

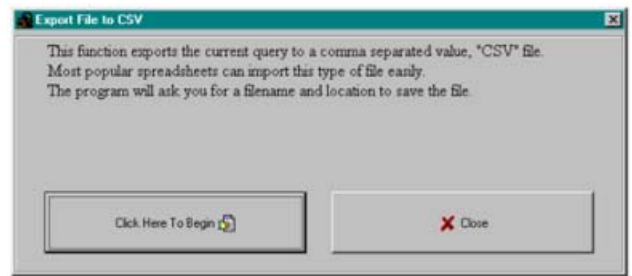

CSV stands for Comma Separated Value. This is an ASCII text file format that allows spreadsheet applications like Excel and Lotus 123 to import data easily. To export the data into a ".csv" file, press the "Export" button at the bottom of the payload summary screen and select "To CSV". The program will request a filename and location for the file.

Truck #	Date	Time	Payload	Swingloads	Operator ID	Status	Flg	Carry Back	Total Cyl	E-Run	Tot E-Stop	Tot Loading	Tot
374	12/5/99	4:06:40 PM	294.4	2	0	E		-12	27	1	0.2	0.2	0.2
374	12/5/99	4:10:09 PM	298.6	2	0	1		-14	7.2	0.6	0.6	0.6	0.6
374	12/5/99	4:41:01 PM	365.5	3	0			15.6	20.1	4.6	3.9	2.2	2.2
374	12/5/99	5:24:54 PM	277.5	0	0	AK		0	27	4.6	6.4	1.1	1.1
374	12/5/99	6:21:27 PM	231	3	0			15.5	27.7	4.5	5	1.1	1.1
374	12/5/99	7:09:08 PM	365.5	3	0	H		17.1	23.9	4.2	3.2	1.1	1.1
374	12/5/99	7:39:53 PM	362.4	4	0			14.1	29.7	4.3	3.7	2.2	2.2
374	12/5/99	8:29:32 PM	221.1	3	0			15.6	27.7	4.5	5	1.1	1.1
374	12/5/99	8:57:11 PM	365.5	3	0			15.6	20.1	4.6	3.9	2.2	2.2
374	12/5/99	9:17:13 PM	365.4	3	0	H		17	23.9	4.2	3.1	1.1	1.1
374	12/5/99	9:40:05 PM	277.4	0	0	AK		0	27	4.6	6.4	1.1	1.1

82952

Two sets of data are exported. At the top of the file will be the haul cycle data. The columns, left to right are:

- Truck number
- Haul cycle start date
- Haul cycle start time
- Payload
- Swingloads
- Operator ID
- Warning Flags
- Carry Back
- Total Haul Cycle time
- Empty Running Time
- Empty stop time
- Loading time
- Loaded running time
- Loaded stopped time
- Dumping time
- Loading start time
- Dumping start time
- Loaded haul distance
- Empty haul distance
- Loaded maximum speed
- Time when loaded maximum speed occurred
- Empty maximum speed
- Time when loaded maximum speed occurred
- Maximum + frame torque
- Time when the maximum + frame torque occurred
- Maximum - frame torque
- Time when the maximum - frame torque occurred
- Maximum sprung weight calculation
- Time when the maximum sprung weight calculation occurred
- Left Front Tire-kilometer-hour
- Right Front Tire-kilometer-hour
- Average Rear Tire-kilometer-hour
- Frame serial number

- Reserved 1-5, 7-10: These values are internal calculations used in the continued development of PLMIII and should be ignored.
- Reserved 6: This value is the payload estimate at the shovel just before the truck begins to move.

Alarm Type	Date Set	Time Set	Description	Date Cleared	Time Cleared
10	12/5/99	8:51:25 AM	INCL SENSOR LO	12/5/99	8:51:29 AM
10	12/5/99	8:56:07 AM	INCL SENSOR LO	12/5/99	8:56:12 AM
10	12/5/99	9:00:49 AM	INCL SENSOR LO	12/5/99	9:00:54 AM
10	12/5/99	9:05:31 AM	INCL SENSOR LO	12/5/99	9:05:36 AM
10	12/5/99	9:10:13 AM	INCL SENSOR LO	12/5/99	9:10:17 AM
10	12/5/99	9:14:54 AM	INCL SENSOR LO	12/5/99	9:14:59 AM
10	12/5/99	9:19:37 AM	INCL SENSOR LO	12/5/99	9:19:41 AM
10	12/5/99	9:24:19 AM	INCL SENSOR LO	12/5/99	9:24:24 AM
10	12/5/99	9:29:01 AM	INCL SENSOR LO	12/5/99	9:29:06 AM
10	12/5/99	9:33:44 AM	INCL SENSOR LO	12/5/99	9:33:48 AM
10	12/5/99	9:38:26 AM	INCL SENSOR LO	12/5/99	9:38:30 AM
10	12/5/99	9:43:08 AM	INCL SENSOR LO	12/5/99	9:43:13 AM
10	12/5/99	9:47:50 AM	INCL SENSOR LO	12/5/99	9:47:55 AM
10	12/5/99	9:52:32 AM	INCL SENSOR LO	12/5/99	9:52:37 AM
10	12/5/99	9:57:13 AM	INCL SENSOR LO	12/5/99	9:57:17 AM
10	12/5/99	10:01:55 AM	INCL SENSOR LO	12/5/99	10:01:59 AM

82953

The second series of data below the haul cycle data is the alarms. The alarm columns, left to right are:

- The alarm type
- The date the alarm was set
- The time the alarm was set
- Alarm description
- The date the alarm was cleared
- The time the alarm was cleared

### Compressed

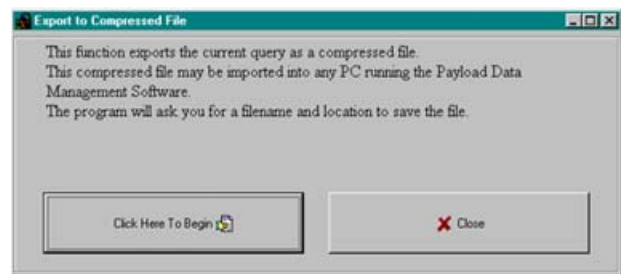

82954

This export function allows the data from one laptop to be transferred to another computer. This can be useful when a service laptop is used to download multiple machines and transfer the data to a central computer for analysis. This can also be used to copy haul data from a particular truck onto a diskette for analysis.

The file format is a compressed binary form of the displayed query. The file can only be imported by another computer running the PDM software.

To export data in ZIP format:

1. Confirm that the data displayed is the query data that needs to be exported.
2. From the payload summary screen, press the "EXPORT" button and select "To ZIP".
3. The program will ask for a filename and location.

### Importing Data

This import function allows the data from one laptop to be transferred to another computer. This can be useful when a service laptop is used to download multiple machines and transfer the data to a central computer for analysis. This can also be used to copy haul data from a particular truck from a diskette into a database for analysis.

To import data, press the "IMPORT" button at the bottom of the "Payload Summary" screen. The program will ask for a ".zip" file to import, locate the file and press "Open". The program will only import ".zip" files created by another computer running the PDM Software.

### Deleting Haul Cycle Records

To delete haul cycle records from the main database, press the "Delete" button at the bottom of the "Payload Summary" screen. The program will display a summary of the records from the displayed query. To delete a record, select one at a time and press the "Delete" button. It is recommended that records be exported to a ".zip" file for archival purposes before deletion. Multiple records may be selected by holding down the Shift key. Pressing the "Delete All" button will select all the records from the current query and delete them.

*NOTE: There is no recovery for records that have been deleted from the main database. It is highly recommended that all records be exported and archived in a compressed file format for future reference before being deleted.*

Truck Number	Date	Time	Payload	# Swings	Total Time
374	08/08/2000	3:54:13 PM	346.7	7	39:11
374	08/08/2000	5:18:14 PM	301.5	6	27:52
374	08/08/2000	5:46:04 PM	300.0	6	23:48
374	08/08/2000	6:11:50 PM	300.5	4	37:51
374	08/08/2000	6:49:37 PM	343.7	4	46:58
374	08/08/2000	7:36:31 PM	379.9	5	37:10
374	08/08/2000	8:13:37 PM	351.6	4	36:50
374	08/08/2000	8:50:22 PM	356.3	4	33:41
374	08/08/2000	9:25:59 PM	369.6	5	34:56
374	08/08/2000	10:00:31 PM	362.6	5	36:58
374	08/08/2000	10:36:44 PM	340.5	7	26:00
374	08/08/2000	11:02:42 PM	330.9	4	36:01
374	08/08/2000	11:38:40 PM	316.5	5	52:26
374	08/09/2000	12:56:37 AM	319.7	5	43:42
374	08/09/2000	1:40:16 AM	301.6	4	27:54

### Viewing Alarms

From the Payload Summary screen, click the "Alarms" button to display the alarm screen. The alarms are sorted by the query settings from the Payload Summary screen. Alarms can be displayed as Active or Inactive.

Truck Number	Type	Set Date	Set Time	Description	Cleared Date	Cleared Time
374	13	8/31/00	2:34:48 AM	ALARM BODY UP SWITCH	8/31/00	2:34:52 AM
374	13	8/31/00	2:36:57 PM	ALARM BODY UP SWITCH	8/31/00	2:37:01 PM
374	13	8/31/00	2:45:22 PM	ALARM BODY UP SWITCH	8/31/00	2:45:26 PM
374	13	8/31/00	9:19:43 PM	ALARM BODY UP SWITCH	8/31/00	9:19:48 PM
374	13	8/30/00	2:42:05 AM	ALARM BODY UP SWITCH	8/30/00	2:42:10 AM

82946

### Deleting Alarm Records

To delete alarm records from the main database, press the "Delete" button at the bottom of the "Alarm Display" screen. The program will display a summary of the alarms from the query. To delete an alarm, select one at a time and press the "Delete" button. It is recommended that the query data be exported to a ".zip" file for archival purposes before deletion. Multiple records may be selected by holding down the Shift key. Pressing the "Delete All" button will select all the alarms from the current query and delete them.

*NOTE: There is no recovery for alarms that have been deleted from the main database. It is highly recommended that all records be exported and archived in a compressed file format for future reference before being deleted.*

Truck Number	Alarm Type	Set Date	Set Time	Description	Cleared Date	Cleared Time
374	13	8/31/00	2:34:48 AM	ALARM BODY UP SWITCH	8/31/00	2:34:52 AM
374	13	8/31/00	2:36:57 PM	ALARM BODY UP SWITCH	8/31/00	2:37:01 PM
374	13	8/31/00	2:45:22 PM	ALARM BODY UP SWITCH	8/31/00	2:45:26 PM
374	13	8/31/00	9:19:43 PM	ALARM BODY UP SWITCH	8/31/00	9:19:48 PM
374	13	8/30/00	2:42:05 AM	ALARM BODY UP SWITCH	8/30/00	2:42:10 AM

82957

PORTIONS OF THIS PRODUCT RELATING TO PAYLOAD MEASURING SYSTEMS ARE MANUFACTURED UNDER LICENSE FROM  
L.G. HAGENBUCH, holder of U.S. Patent Numbers  
5,416,706; 5,528,499; 5,631,832; 5,631,835; 5,644,489; 5,650,928; 5,650,930; 5,742,914

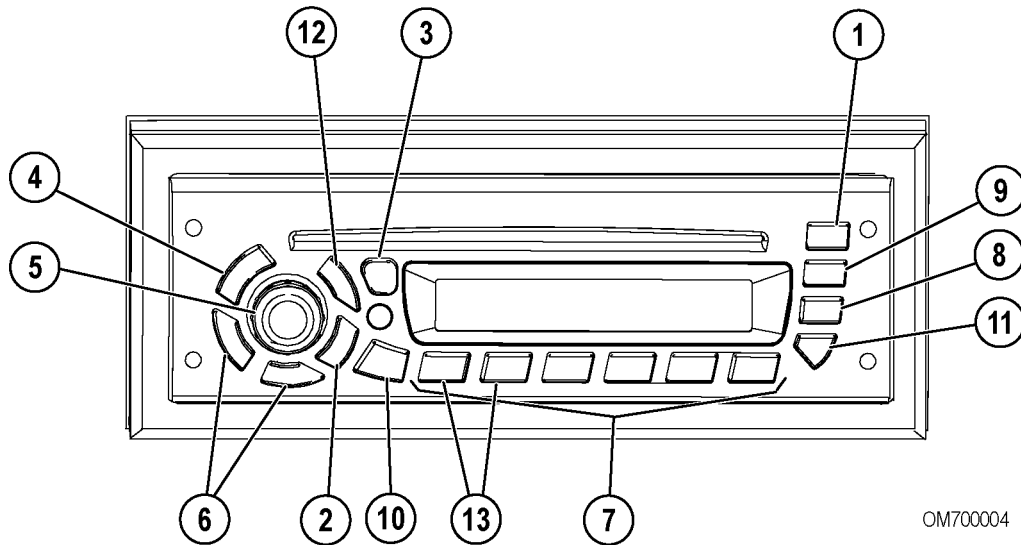

**AM/FM RADIO / CD PLAYER**

OM700004

FIGURE 70-1. AM/FM RADIO / CD PLAYER

- |  |  |
|--|--|
| <ol style="list-style-type: none"> <li>1. Ejects CD</li> <li>2. BAND Switches between AM, FM1, FM2, FM3, WX (Weatherband) and Auxiliary Mode</li> <li>3. TMSET/DSPL Switches to time set mode/Changes display</li> <li>4. PWR Power</li> <li>5. ON/AUDIO Power/volume/receiver settings</li> <li>6. +TUNE/SEEK- Changes radio station or CD/MP3 track</li> </ol> | <ol style="list-style-type: none"> <li>7. Push Buttons 1-6 Pre-set stations/CD/MP3 functions</li> <li>8. PSCN/AUTO Scans presets on current band/stores strongest stations to preset</li> <li>9. SCAN/DIM Scans all stations in current band or on CD/MP3</li> <li>10. ALARM Switches to alarm set mode</li> <li>11. RDM Plays CD/MP3 tracks randomly</li> <li>12. Switches to CD/MP3 mode</li> <li>13. FLDR+/- Changers folders on an MP3 disc</li> </ol> |
|--|--|

**OPERATING INSTRUCTIONS**

To learn how to get the most from the receiver, read all of the instructions that follow.

**GENERAL RADIO RECEIVER FUNCTIONS**

The receiver is equipped with:

- An AM band with 6 AM presets
- Three FM bands for a total 18 FM presets
- One Weatherband with 6 WX presets

**Turning On the Power**

With the key switch ON, the receiver can be turned on and off by pressing the PWR (4, Figure 70-1) button. Pressing the ON/AUDIO (5) knob also activates the receiver.

**One-Hour Timer**

With the key switch OFF, pressing the PWR (4) button or the ON/AUDIO (5) knob will turn on the receiver and activate the receiver's one-hour timer. The receiver will turn off after one hour. Pressing the PWR (4) button or the ON/AUDIO (5) knob again reactivates the one-hour timer.

## Display

The receiver will display the time of day when it is off. Momentarily pressing the TMSET/DSPL (3) button when the receiver is on allows to toggle between displays.

When the receiver is set to AM, FM1, FM2, FM3 or WX, the display will toggle between the frequency and time of day.

When in the CD mode, the display will toggle between track number and elapsed time, and time of day.

When playing an MP3 disc, the display will toggle between the ID3 tag (song title, artist and album title) and time of day.

### Setting a Default Display

1. Press the BAND (2) button to enter the mode to set a default display.
2. Press and hold the TMSET/DSPL button for 2 seconds until the hours digits flash.
3. Press push button (6) until the desired display appears.

After 5 seconds of inactivity, the selected default will be displayed.

### Adjusting the Brightness of the Display

If the dash dimmer does not control the brightness of the receiver display or the receiver is operating in One-Hour Timer mode, press and hold the SCAN/DIM (9) button until DIM and the brightness level appear on the display. Rotate the AUDIO knob clockwise to increase the brightness of the receiver display and counter-clockwise to decrease it.

## Auxiliary Mode

When in Auxiliary mode, the radio can play an audio source from an iPOD or an MP3 player that is connected via the auxiliary radio lines.

To enable the Auxiliary mode:

- Press and hold the BAND (2) button for at least 2 seconds until the display shows EXTERNAL AUDIO.

To disable Auxiliary mode:

- Press and hold the BAND (2) button for at least 2 seconds until the radio reverts to the previous mode.

### Adjusting the Receiver Settings

To adjust the Volume, Bass, Treble, Fade, Balance, Seek Sensitivity and Speakers, press and release the ON/AUDIO (5) knob repeatedly until the desired feature appears on the display.

**VOLUME:** Rotate the AUDIO knob clockwise to increase the volume and counter-clockwise to decrease it. The display will show VOL and the volume level.

**BASS:** Press the AUDIO knob until BASS and the current setting appears on the display. Rotate the knob clockwise to increase the bass sound and counter-clockwise to decrease it.

**TREBLE:** Press the AUDIO knob until TREBLE and the current setting appears. Rotate the knob clockwise to increase the treble sounds and counter-clockwise to decrease it.

**FADE:** Press the AUDIO knob until FADE and the current setting appears on the display. Rotate the knob clockwise to move the sound to the front speakers and counter-clockwise to move the sound to the rear.

**BALANCE:** Press the AUDIO knob until BALANCE and the level appear. Rotate the knob clockwise to move the sound to the right speakers and counter-clockwise to move the sound to the left.

**SEEK SENSITIVITY:** To adjust seek sensitivity, press the AUDIO knob until SEEK and the sensitivity level appear. Rotate the AUDIO knob to the desired setting. Increasing the sensitivity will help find more stations, including slightly weaker ones, while decreasing it will cause fewer, but stronger stations to be found.

**SPEAKERS:** Press the AUDIO knob until SPKR 4 appears on the display; rotate the knob to switch to 2-speaker functionality. SPKR 2 will appear on the display.

After 5 seconds of inactivity, the receiver will return to the default display.

## USING THE CLOCK

The clock can function in a 12 or 24-hour mode. The 12-hour mode distinguishes between AM and PM. The 24-hour mode operates as military time. To toggle between the two modes:

1. Turn the key switch ON.
2. Press and hold the TMSET/ DSPL button for 2 seconds until the digits flash. This indicates you are in the time set mode.
3. Press and release push-button 5 to toggle between 12-hour and 24-hour modes.

After 5 seconds of inactivity, the display will return to the default display, and the current mode will be set.

### Setting the Clock

1. Turn the key switch ON.
2. Press and hold the TMSET/DSPL button until the hours digits flash.
3. Press the +TUNE/SEEK- (6) to set the correct hour.
4. Press the TMSET/DSPL button again, and the minutes digits will flash.
5. Press the +TUNE/SEEK- (6) button to set the correct minute. Seconds are reset to zero when the minutes setting is changed.

After 5 seconds of inactivity, the display will return to the default display and the clock will be set.

## USING THE ALARM

Momentarily pressing the ALARM (10) button will display the alarm set time.

When the ALARM icon is on the display, the alarm has been set. If the radio is on when the alarm sounds, there will be a beeping noise. If the receiver is off, the alarm will turn on and play the radio at the alarm volume. The alarm will continue to sound until the snooze is activated or the alarm is turned off.

### Setting the Alarm

1. Press and hold the ALARM (10) button for 2 seconds until the ALARM icon and the display show AL TIME plus the current alarm time. This indicates the alarm-setting mode.
2. Press and release the +TUNE/SEEK- (6) until the desired alarm hour appears on the display.
3. Press the ALARM (10) button again to select the minutes display.
4. Press the +TUNE/SEEK- (6) until the desired alarm minutes appear on the display.

After 5 seconds of inactivity, the receiver will return to the default display, and the ALARM icon will remain illuminated indicating the alarm is set.

### Turning the Alarm Off

Press and hold the ALARM (10) button until the display shows ALARM DISABLED and the ALARM icon on the display disappears.

### Activating Snooze

Press any button on the radio faceplate when the alarm is sounding. The alarm will sound again in 9 minutes.

### Setting Alarm Volume

1. Turn the receiver on.
2. Press and hold the ALARM button for 2 seconds until the ALARM icon and the display shows AL TIME plus the current alarm time. Rotate the AUDIO knob to increase or decrease the alarm volume as desired.

After 5 seconds of inactivity, the receiver will return to the default display and the volume level at which the receiver was previously playing.

*NOTE: The alarm will be activated unless the ALARM button is held for 2 seconds again.*

## USING THE RADIO

### Finding a Station

**BAND (2):** Press this button to switch between AM, FM1, FM2, FM3, and Weather (WX). The receiver display will show your selection.

**+TUNE/SEEK- (6):** Press and hold both +TUNE and BAND (2) for 2 seconds to switch between manual tune and seek modes. The display will show either MANUAL or SEEK to indicate the mode.

**MANUAL TUNE:** Press the +TUNE/SEEK- (6) button once to tune to the next higher or lower station, one frequency at a time. Holding +TUNE/SEEK- for more than half a second begins fast tuning.

**SEEK:** Press the +TUNE/SEEK- (6) button once to tune to the next higher or lower station. Holding +TUNE/SEEK- for more than half a second activates the Seek function, and SEEK will appear on the display. When a station with a strong enough signal is found, Seek will stop and the station will play. If a station is not found with a strong enough signal after searching the band twice, the Seek function will end and NO STATION FOUND will appear for 5 seconds. Then, the default display will appear and the radio will continue to play. Seek can be cancelled by pressing +TUNE/SEEK- again.

**AUDIO STORE (AUTO):** AUTO automatically stores the 6 strongest stations onto pushbuttons 1-6. Press and hold PSCN/AUTO (8) until AUTO and the AS icon appear on the display. AUTO STORE only saves presets in the band to which you are listening. If you press AUTO while listening to FM1, the presets on AM, FM2, FM3 and WX will not change. Pressing and holding AUTO again for more than 2 seconds will cancel Auto Store, and the original presets will be restored.

**SCAN:** Press SCAN/DIM (9) to scan all stations on the current band. When a frequency of sufficient strength is found, the radio will play for 5 seconds and then continue scanning until you press SCAN again. The display will show SCAN and the frequency being scanned.

**PSCN:** Press PSCN/AUTO (8) to scan the presets on the band the radio is currently playing (FM will scan FM1, FM2 and FM3). When a preset frequency of sufficient strength is found, the radio will play for 5 seconds and then continue scanning. The display will show PSCN, the frequency, preset number and the band icon. Preset Scan will continue until the PSCN is pressed again.

### Setting the Presets

The six numbered pushbuttons allow to preset 6 favorite stations per band and easily return to them with the touch of a button. To set the presets:

1. Turn the key switch and the receiver ON.
2. Select the band.
3. Tune to the desired station.
4. Press and hold one of the six numbered buttons for more than 2 seconds to store the selected station. During the 2-second set time, the radio will be muted and the number icon will not be visible. Both the audio and selected preset icon will return, indicating the station has been set.
5. Repeat steps 1-4 for each push-button.

Pressing a preset button in the future will tune the radio to the station you set on the band to which you are listening.

## USING THE WEATHERBAND

NOAA Weather Radio is a service of the National Weather Service. It provides continuous broadcasts of the latest weather information directly from the National Weather Service offices. Taped weather messages are repeated every four to six minutes and are revised every one to three hours or more frequently if needed. Most of the stations operate 24 hours a day.

The weather for the local area can be found on one of 7 stations. When in the Weatherband mode, the display will show the WX icon and CH plus the channel number. The channel can be changed using the +TUNE/SEEK- (6) button and can also be preset to the pushbuttons.

The frequencies associated with each channel are as follows:

1. 162.550 MHz
2. 162.400 MHz
3. 162.475 MHz
4. 162.425 MHz
5. 162.450 MHz
6. 162.500 MHz
7. 162.525 MHz

The National Weather Service operates approximately 372 stations. Close to 90 percent of the nation's population is within listening range of an NOAA Weather Radio broadcast.

## USING THE COMPACT DISC PLAYER

The integral CD player plays full size CDs and MP3 discs. Press the to switch to CD/MP3 mode.

### Playing a Compact Disc

1. Turn the key switch and the receiver on.
2. Insert a disc partway into the slot, label-side up. The player will automatically pull the disc in once it has been partially inserted. The CD icon and the words READING DISC will appear, and the disc will begin to play.
3. If the radio is currently tuned to AM/FM/WX press the CD button to play a CD that has been loaded into the player. If no CD has been loaded, the display will show NO CD for 5 seconds and return to the default display. If a CD has been loaded, the display will show the track number and the elapsed time on the display

If a CD is ejected and not removed within 25 seconds, the CD will be reloaded, but will not start playing until the CD button is pressed.

A CD can be inserted while the key switch is OFF. To do so, press and insert a CD within 25 seconds.

### Button Functions

**+TUNE:** Press + TUNE once to forward to the next track. The track number and elapsed time will appear. Press and hold + TUNE to advance tracks quickly.

**SEEK-:** Press SEEK- once to return to the beginning of the track being played. Pressing this button during the first 8 seconds of the track will play the previous track. The track number and elapsed time will appear. Press and hold SEEK- to fast reverse.

**3/PAUSE:** Press PAUSE to pause a CD. PAUSE will be displayed, and the audio will be muted. Press PAUSE again to resume playing the CD.

**4/REV:** Press and hold REV to fast reverse. Upon release, the CD will play at normal speed. The display will show the track number and elapsed time. After 5 seconds, the default display will reappear.

**5/FF:** Press and hold FF to fast-forward. Upon release, the CD will play at normal speed. The display will show the track number and elapsed time. After 5 seconds the default display will reappear.

**6/RPT:** Press RPT to repeat the current track. RPT on the display indicates that this feature is on. The track will be repeated until RPT is pressed again.

**EJECT:** Press to eject a CD.

**RDM (11):** Press RDM (11) to activate random track selection. RDM will appear on the display, and tracks on loaded CDs will play in random order. Press the RDM (11) button again to turn off "random play" beginning with the next track.

**SCAN/DIM (9):** Press SCAN to scan all tracks on the CD. The player will immediately advance to the next track on the CD being played. SCAN and the track number will appear on the display and 10 seconds of the track will play. Then, the CD will advance to the next track, play 10 seconds and continue. To deactivate, press SCAN again.

## PLAYING AN MP3 DISC

### MP3 Format Compatibility

This MP3 Player will play MP3 files recorded on a CD-R up to 700 MB. Files can be recorded at a variable bit rate or the following fixed-bit rates: 32 kpbs, 40 kpbs, 56 kpbs, 64 kpbs, 80 kpbs, 96 kpbs, 112 kpbs, 128 kpbs, 160 kpbs, 192 kpbs, 224 kpbs, 256 kpbs and 320 kpbs. Both single and multi-session discs will play. Song title, artist name and album are available when discs are recorded using ID3 tags versions 1 and 2.

The MP3 player will be able to read and play a maximum of 95 folders, 50 play lists or 20 sessions and 949 files. Long file, folder or playlists names or a combination of a large number of them can reduce the number files, folders, playlists, or sessions that can be played. To play large numbers of files, folders, playlists or sessions, minimize the length of the file, folder or play list name. It can also play an MP3 recorded without file folders. The system can support up to 11 levels of folder nesting. If a disc contains more than the maximum of 95 folders, 50 playlists, 20 sessions and 949 files, the player will only access and navigate the maximum and ignore additional items.

### Root Directory

The root directory is treated as a folder. If the root directory has compressed audio files, the directory is displayed as F1 ROOT. All files contained directly under the root directory are accessed prior to any root directory folders. However, playlists (Px) are always accessed before root folders or files.

### Empty Directory or Folder

If there is a root directory or a folder in the file structure that contains empty folders/subfolders, play advances to the next folder in the file structure that contains compressed audio files. The empty folder will not be displayed or numbered.

### No Folder

When a disc contains only compressed files, the files are located under the root folder. The next and previous folder functions have no function on a CD recorded without folders or play lists. When displaying the name of the folder, the radio displays ROOT.

When the CD contains only playlist and compressed audio files, but no folders, all files are located under the root folder. The "folder down" and "folder up" buttons search play lists (Px) first and then the root folder. When the radio displays the name of the folder, the radio displays ROOT.

### File Name Display

A song name is displayed when contained in the ID3 tag. If the song name is not in the ID3 tag, the radio displays the file name without the extension (such as.mp3) as the track name.

Track names longer than 16 characters scroll at a rate of one page every 1.5 seconds until the entire name is shown. To speed up page changes, press the TMSET/DSPL button. When all pages have been shown once, the first page of the ID3 tag appears and remains on the display. To restart automatic paging, press TMSET/DSPL.

### Pre-Programmed Playlists

Pre-programmed play list function like folders containing compressed audio song files. This radio plays pls, m3u, and rmp playlist formats. The pre-programmed play lists can not be edited.

### Playing MP3 Files

Insert a disc partway into the slot, label side up. The player will pull it in, and READING DISC will appear on the display. The CD will begin playing, and the CD icon will appear on the display.

Play begins from the first track in the first playlist and continues sequentially through all tracks in each playlist. When the last track of the last playlist has been played, play continues from the first track of the first folder's playlist until FLDR +/- (13) is pressed. When play enters a new folder, the display will show the new folder name for 5 seconds then revert to the default display.

If the CD does not contain any playlists, play begins from the first track under the root directory. When all tracks from the root directory have been played, play continues by the numerical file listing. After playing the last track from the last folder, play begins again at the first track of the first playlist, folder or root directory.

If the songs on a playlist cannot be accessed, the radio ignores it and treats the disc as if it only has folders and tracks. If the disc contains multiple sessions and the table of contents cannot be accessed for all sessions, the radio plays the sessions with an available table of contents.

### Button Functions

**1/FLD (NEXT FOLDER):** Press this button to go to the first track in the next folder or playlist. Pressing this button while in folder random mode will move to the first track in the next folder and play the tracks in that folder randomly.

**2/FLD (PREVIOUS FOLDER):** Press this button to go to the first track in the previous folder or playlist. Pressing this button while in folder random mode will move to the first track in the previous folder and play the tracks in that folder randomly.

**3/PAUSE:** Press this button to pause playback. PAUSE will be displayed. Press PAUSE again to resume playing the disc.

**4/REV (REVERSE):** Press and hold REV to fast-reverse. Upon release, the CD will play at normal speed. The display will show the track number and elapsed time. After 5 seconds, the default display will appear.

**5/FF (FAST FORWARD):** Press and hold FF to fast-forward. Upon release, the CD will play at normal speed. The display will show the track number and elapsed time. After 5 seconds, the default display will appear.

**6/RPT:** Press RPT to repeat the current track. The RPT icon on the display indicates the feature is on. The track will be repeated until RPT is pressed again.

**RDM (RANDOM):** Press and release this button to play the tracks in the current folder or playlist in random order. RDM will appear on the display. Once all tracks in the current folder or playlist have been played, the system will move to the next folder or playlist and play the tracks in random order. When random is activated, pressing TUNE + or SEEK - will move to the next or previous random track. Pressing RDM (11) again cancels random play.

**+ TUNE:** Press + TUNE once to forward to the next track. The track number and elapsed time will appear. Press and hold + TUNE to advance tracks quickly.

**SEEK -:** Press SEEK- once to return to the beginning of the track being played. Pressing this button during the first 8 seconds of the track will play the previous track. The track number and elapsed time will appear. Press and hold SEEK- to fast reverse.

**DSPL/TM SET:** Pressing this button toggles between the ID3 tag (song title, artist and album title) and time of day. There are 3 display types that can be set as default: track, folder/playlist, and time of day. The default display is track.

To display the folder/playlist or time of day, follow the instructions in the Setting a Default Display section.

- Track mode displays the current track number and ID3 tag song title.
- Folder/playlist mode displays the current folder or playlist number and name plus the ID3 tag song title.
- Time-of-day mode displays the time of day and the ID3 tag song title.

## TROUBLESHOOTING

The following error messages may appear while playing a CD or MP3 disc:

- NO CD:** No CD has been loaded in the player.
- FOCUS:** Lens could not focus on CD. Possible reasons include: Disc is inserted upside down - eject and reinsert CD. Disc is dirty, scratched, or wet - try cleaning CD. Lens is dirty - clean CD lens with a lens cleaner. It is very humid - wait an hour and try again.
- TRACKING:** Loss of tracking control. Possible reasons include: Disc is dirty or scratched - try cleaning CD. Lens is dirty - clean CD lens with a lens cleaner.
- LOAD:** Load/unload motor problem - contact dealer.

*NOTE: The sound quality, an increase in skipping, difficulty in finding tracks, and/or difficulty in loading/ejecting a CD-R may be affected by a CD-R's quality, the method of recording, the quality of the music that has been recorded, or the way the CD-R has been handled. If these problems occur, try a known good CD. If any error occurs repeatedly or if an error cannot be corrected, contact the local dealer. If the radio displays an error message, write it down and provide it to your dealer when reporting the problem.*





**KOMATSU**®

[www.komatsuamerica.com](http://www.komatsuamerica.com)

Copyright 2011 Komatsu  
Printed in U.S.A.  
Komatsu America Corp.