

CEAM021602

Operation & Maintenance Manual

860E-1KT

DUMP TRUCK

SERIAL NUMBERS **A30004 - A30014**

KOMATSU®

This material is proprietary to Komatsu America Corp (KAC), and is not to be reproduced, used, or disclosed except in accordance with written authorization from KAC.

It is the policy of the Company to improve products whenever it is possible and practical to do so. The Company reserves the right to make changes or add improvements at any time without incurring any obligation to install such changes on products sold previously.

Because of continuous research and development, periodic revisions may be made to this publication. Customers should contact their local Komatsu distributor for information on the latest revision.

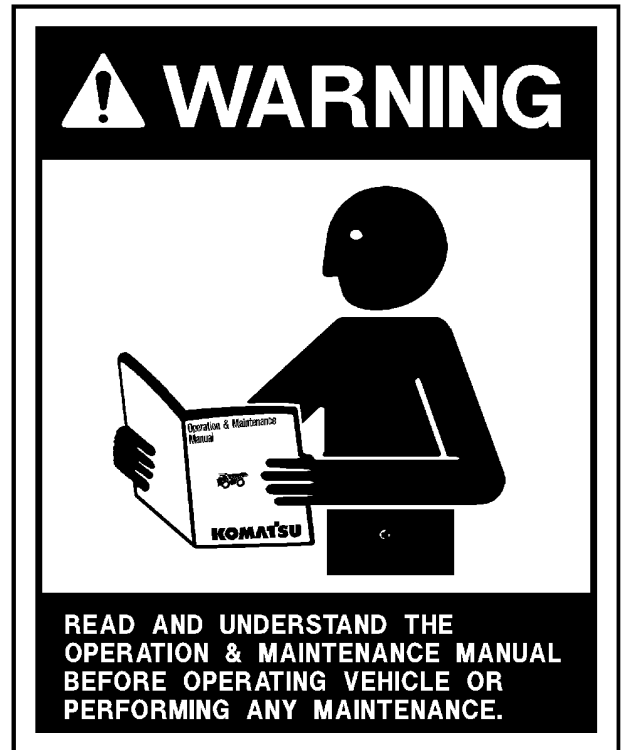

Unsafe use of this machine may cause serious injury or death. Operators and maintenance personnel must read and understand this manual before operating or maintaining this machine.

This manual should be kept in or near the machine for reference, and periodically reviewed by all personnel who will come into contact with it.

CALIFORNIA Proposition 65 Warning

Diesel engine exhaust, some of its constituents, and certain vehicle components contain or emit chemicals known to the State of California to cause cancer, birth defects or other reproductive harm.

CALIFORNIA Proposition 65 Warning

Battery posts, terminals and related accessories contain lead and lead compounds, chemicals known to the State of California to cause cancer and birth defects or other reproductive harm. Wash hands after handling.

CALIFORNIA Proposition 65 Warning

Mercury and mercury compounds are known to the State of California to cause developmental problems. This machine may be equipped with optional HID lamps which contain mercury. There is no risk of exposure unless the lamps are broken. However, the lamps must be reused, recycled or properly disposed of in accordance with Local, State and Federal Laws at the end of their useful lives.



NON-OEM PARTS IN CRITICAL SYSTEMS

For safety reasons, Komatsu America Corp. strongly recommends against the use of non-OEM replacement parts in critical systems of all Komatsu equipment. Critical systems include but are not limited to steering, braking and operator safety systems.

Replacement parts manufactured and supplied by unauthorized sources may not be designed, manufactured or assembled to Komatsu's design specifications; accordingly, use of such parts may compromise the safe operation of Komatsu products and place the operator and others in danger should the part fail.

Komatsu is also aware of repair companies that will rework or modify an OEM part for reuse in critical systems. Komatsu does not generally authorize such repairs or modifications for the same reasons as noted above.

Use of non-OEM parts places full responsibility for the safe performance of the Komatsu product on the supplier and user. Komatsu will not in any case accept responsibility for the failure or performance of non-OEM parts in its products, including any damages or personal injury resulting from such use.

INTRODUCTION

FOREWORD

This manual is written for use by the operator and/or the service technician. It is designed to help these persons to become fully knowledgeable of the truck and all of its systems in order to keep it operating safely and efficiently. All operators and maintenance personnel should read and understand the information in this manual before operating the truck or performing maintenance and/or operational checks on the truck. All safety notices, warnings, and cautions should be understood and followed when operating the truck or performing repairs on the truck.

A product identification plate is located on the frame in front of the right side front wheel. It designates the Truck Model Number, Product Identification Number (vehicle serial number), and Maximum GVW (Gross Vehicle Weight) rating.

The KOMATSU truck model designation consists of three numbers and one letter (i.e. 860E).

The three numbers represent the basic truck model.

The letter "M", when present, designates a Mechanical drive system.

The letter "E", when present, designates an Electrical wheel motor drive system.

The Product Identification Number (vehicle serial number) contains information which identifies the original manufacturing bill of material for this unit. This complete number will be necessary for proper ordering of many service parts and/or warranty consideration.

The Gross Vehicle Weight (GVW) is what determines the load on the drive train, frame, tires, and other components. The vehicle design and application guidelines are sensitive to the maximum GVW.

GVW is *total weight*: **empty vehicle weight + fuel & lubricants + payload.**

To determine the *allowable payload*, fill all lubricants to the proper level and fill the fuel tank of an empty truck (which includes all accessories, body liners, tailgates, etc.), and then weigh the truck. Record this value and subtract it from the GVW. The result is the allowable payload.

NOTE: Accumulations of mud, frozen material, etc, become part of the GVW and reduces the allowable payload. To maximize payload and to keep from exceeding the maximum GVW rating, these accumulations should be removed as often as practical.

Exceeding the allowable payload will reduce the expected life of truck components.

▲WARNING

Unsafe use of this machine may cause serious injury or death. Operators and maintenance personnel must read this manual before operating or maintaining this machine. This manual should be kept in or near the machine for reference and periodically reviewed by all personnel who come in contact with it.

TRUCK MODEL ILLUSTRATION

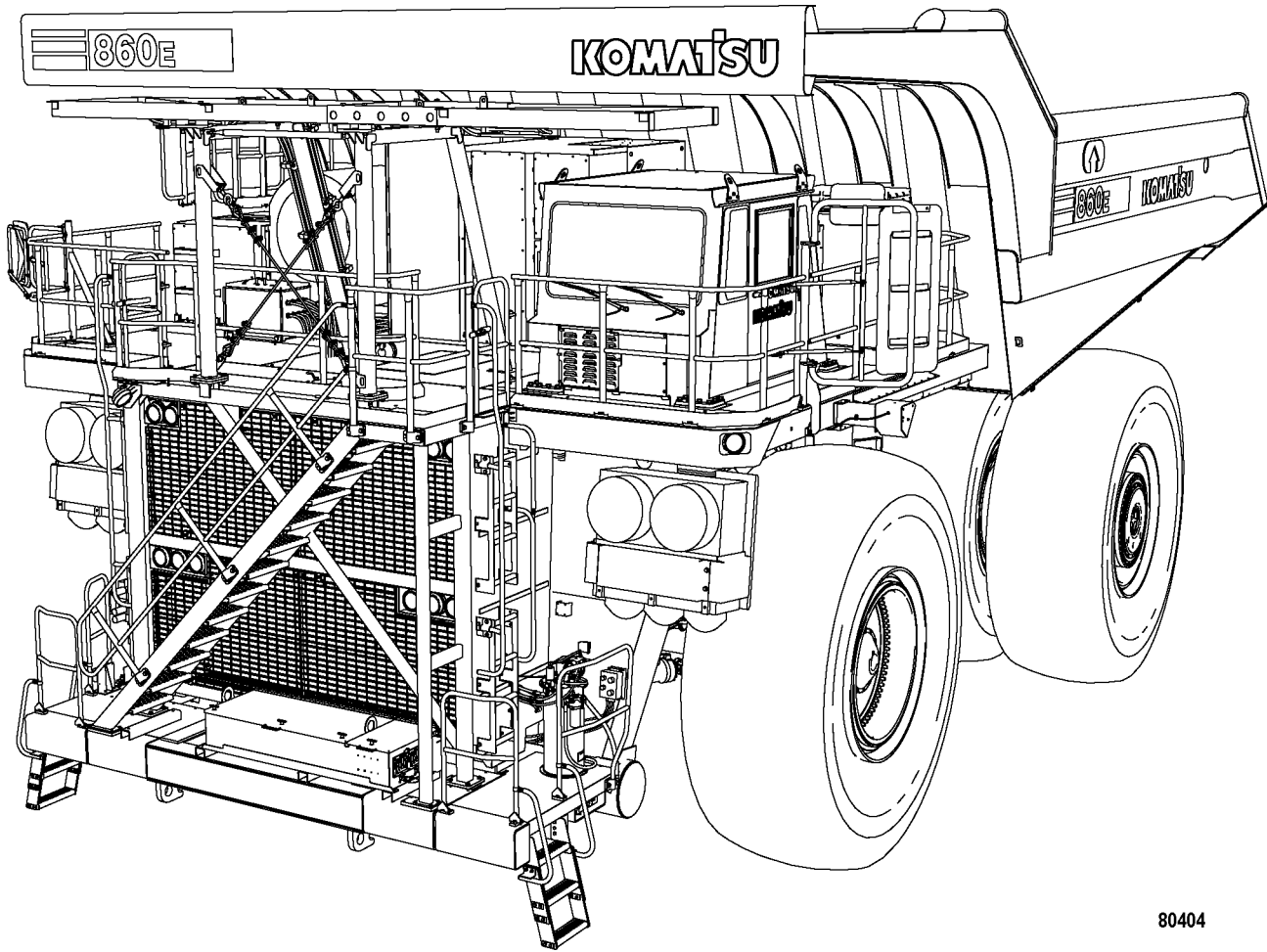

80404

KOMATSU MODEL 860E Dump Truck

ABOUT THIS MANUAL

The front cover of this manual includes a form number. This form number should be referenced when ordering additional copies of this manual or for any other correspondence regarding the coverage in this manual.

Direct all inquiries to:

Komatsu America Corp.
Technical Publications - Mining Equipment
P.O. Box 240
Peoria, IL 61650-0240
(309)-672-7072 - FAX

This first section is an Introduction to the manual. It contains the Table of Contents for locating specific areas of interest. Other sections include:

- Standard Charts and Tables
- Safety
- Warnings and Cautions
- Operating Instructions
- Operator Cab and Controls
- Lubrication and Service
- Automatic Lubrication System
- Major Component Descriptions/Specifications
- Payload Meter III
- Radio, AM/FM Stereo Cassette

When searching for a specific area of interest, go first to the Table of Contents to locate the section in which the subject might generally be included. Then, find a subject description that most closely describes the specific area of interest and go to that page. Section numbers and page numbers are located at the top, outside corner of the page.

At the top, inside corner of the page is a document (module) number. If there is ever a question regarding the information in a particular section, refer to the document (module) number, the manual form number, and use the address shown above to correspond. If there is a date (month/year) behind the document (module) number, that date indicates the latest revision date of that page.

The illustrations used in this manual are *TYPICAL* of the component shown and may not be an *exact* reproduction of what is found on the truck.

This manual shows dimensioning of U.S. standard and metric (SI) units throughout. All references to "right," "left," "front," or "rear" are made with respect to the operator's normal seated position unless specifically stated otherwise.

When assembly instructions are provided without references to specific torque values, standard torque values should be used. Standard torque values are shown in torque charts in the Standard Charts and Tables section in this manual and in the General Information section of the truck shop manual. Specific torques, when provided in the text, are in bold face type, such as **135 N•m (100 ft lbs)**. All torque specifications have $\pm 10\%$ tolerance unless otherwise specified.

ALERTS PAGE



This ALERT symbol is used in this manual, along with the signal words “CAUTION”, “DANGER” and “WARNING”, to alert the reader to hazards arising from improper operating and maintenance practices.

▲ DANGER

*“DANGER” identifies a specific potential hazard
WHICH WILL RESULT
in either INJURY OR DEATH
if proper precautions are not taken.*

▲ WARNING

*“WARNING” identifies a specific potential hazard
WHICH MAY RESULT
in either INJURY OR DEATH
if proper precautions are not taken.*

▲ CAUTION

*“CAUTION” is used for general reminders
of proper safety practices
OR
to direct the reader’s attention to avoid unsafe
or improper practices which may result
in damage to the equipment.*

TABLE OF CONTENTS

INTRODUCTION	10-1
FOREWARD	10-1
TRUCK MODEL ILLUSTRATION	10-2
ABOUT THIS MANUAL	10-3
ALERTS PAGE	10-4
TABLE OF CONTENTS	10-5
STANDARD CHARTS AND TABLES	12-1
SAFETY	20-1
GENERAL	20-1
Safety Rules	20-1
Safety Features	20-1
Fire Extinguisher And First Aid Kit	20-1
Clothing And Personal Items	20-1
Leaving The Operator's Seat	20-2
Mounting And Dismounting	20-2
Fire Prevention For Fuel And Oil	20-2
Precautions With High Temperature Fluids	20-3
Asbestos Dust Hazard Prevention	20-3
Prevention Of Injury By Work Equipment	20-3
Unauthorized Modification	20-3
ROPS Precautions	20-3
Precautions For Attachments	20-4
Precautions For Starting The Truck	20-4
PRECAUTIONS BEFORE OPERATION	20-4
Safety At The Worksite	20-4
Fire Prevention	20-5
Preparing For Operation	20-5
Ventilation In Enclosed Areas	20-5
In Operator's Cab - Before Starting The Engine	20-5
Mirrors, Windows And Lights	20-5
OPERATING THE TRUCK	20-6
When Starting The Engine	20-6
General Truck Operation	20-6
Traveling In Reverse	20-7
Traveling	20-7
Traveling On Slopes	20-7
Ensuring Good Visibility	20-7
Operating On Snow Or Ice	20-7
Avoiding Damage To Dump Body	20-7
Driving Near High Voltage Cables	20-8

TABLE OF CONTENTS (cont.)

When Dumping	20-8
Working On Loose Ground	20-8
When Loading	20-8
Parking The Truck	20-8
TOWING	20-8
WORKING NEAR BATTERIES	20-9
Battery Hazard Prevention	20-9
Jump Starting With Booster Cables	20-10
Jump Starting With Receptacles	20-10
BEFORE PERFORMING MAINTENANCE	20-11
Warning Tag	20-11
Stopping The Engine Before Service	20-11
Proper Tools	20-11
Securing The Dump Body	20-11
WHILE PERFORMING MAINTENANCE	20-12
Keep The Truck Clean	20-12
Attachments	20-12
Working Under The Truck	20-12
Rotating Fan And Belts	20-12
Adding Fuel Or Oil	20-12
Radiator Coolant Level	20-13
Use Of Lighting	20-13
Precautions With The Battery	20-13
Handling High Pressure Hoses	20-13
Precautions When Performing Maintenance Near High Temperature Or High Pressure	20-13
Precautions With High Pressure Oil	20-13
Waste Materials	20-13
TIRES	20-14
Handling Tires	20-14
Tire Maintenance	20-14
Storing Tires After Removal	20-14
WHEN REPAIRS ARE NECESSARY	20-15
SPECIAL PRECAUTIONS FOR WORKING ON AC DRIVE TRUCKS	20-16
Engine Shutdown Procedure Before Welding or Performing Maintenance	20-16
Precautions Before Welding or Performing Maintenance	20-17
ADDITIONAL JOB SITE RULES	20-19
WARNINGS AND CAUTIONS	22-1

TABLE OF CONTENTS (cont.)

OPERATING INSTRUCTIONS	30-1
PREPARING FOR OPERATION	30-1
WALK AROUND INSPECTION	30-1
ENGINE START-UP	30-6
AFTER ENGINE HAS STARTED	30-7
MACHINE OPERATION SAFETY PRECAUTIONS	30-8
OPERATING ON THE HAUL ROAD	30-9
STARTING ON A GRADE WITH A LOADED TRUCK	30-9
PASSING	30-10
LOADING	30-10
DUMPING	30-10
Raising The Dump Body	30-10
Lowering The Dump Body (When dumping on flat ground):	30-10
Lowering The Dump Body (When dumping over a berm or into a crusher):	30-11
TROLLEY OPERATING INSTRUCTIONS	30-12
Operating in trolley line mode	30-12
Getting on line	30-12
Operating on trolley	30-13
Getting off line	30-13
Line status signals	30-14
Trolley disconnect	30-14
Traffic consideration for trolley line operation	30-15
Approaching slow moving vehicles in a trolley assisted truck	30-15
Operating slow moving vehicles on trolley assist ramps	30-16
Truck failure while on trolley	30-16
USING THE SPEED CONTROL FEATURE	30-17
SAFE PARKING PROCEDURES	30-17
NORMAL ENGINE SHUTDOWN PROCEDURE	30-18
SUDDEN LOSS OF ENGINE POWER	30-19
FUEL DEPLETION	30-19
TOWING	30-20
Special Wiring Harness	30-20
Towing Procedure	30-20
DISABLED TRUCK OPERATION	30-23
GENERAL	30-23
STEERING AND BRAKE SYSTEM	30-23
Components Required	30-23
Hookup	30-24
DISABLED TRUCK DUMPING PROCEDURE	30-25
Hookup	30-25
Raising the Body	30-25
Lowering the Body	30-26
RESERVE ENGINE OIL SYSTEM	30-27

TABLE OF CONTENTS (cont.)

OPERATOR CAB AND CONTROLS	32-1
STEERING WHEEL AND CONTROLS	32-2
Horn Button	32-2
Tilt / Telescope Lever	32-2
Speed Control Lever	32-2
Multi-Function Turn Signal Switch	32-2
DYNAMIC RETARDING	32-3
Dynamic Retarder/Service Brake Pedal	32-3
Throttle/Accelerator Pedal	32-3
GRADE/SPEED RETARD CHART	32-4
OVERHEAD PANEL COMPONENTS	32-4
CENTER CONSOLE	32-5
Directional Control Lever	32-5
Override/Fault Reset Switch	32-6
Engine Shutdown Switch	32-6
L.H. Window Control Switch R.H. Window Control Switch	32-6
Hoist Control Lever	32-6
Ashtray	32-7
Lighter	32-7
Data Store Button	32-7
Service Engine Light	32-7
12V Auxiliary Power Outlets	32-7
DIAGNOSTIC PORTS	32-7
Drive System #1	32-7
Engine (QUANTUM)	32-7
Drive System #3	32-7
Engine (CENSE)	32-7
Interface Module	32-7
VHMS	32-7
Payload Meter	32-7
OPERATOR'S SEAT	32-8
Adjustment	32-8
PASSENGER SEAT	32-9
Adjustment	32-9
HEATER/AIR CONDITIONER COMPARTMENT AND CONTROLS	32-10
Fan Speed Control Knob	32-10
Temperature Control Knob	32-10
Air Flow Directional Knob	32-10
Heater/Air Conditioner Vents	32-10
INSTRUMENT PANEL	32-11
Control Symbols	32-11
Key Switch	32-13
Speed Control Switch	32-13
Traction Control Switch	32-13

TABLE OF CONTENTS (cont.)

Retarding Grid Drier Switch	32-13
AC Drive System Rest Switch	32-13
Wheel Brake Lock Switch	32-14
Pantograph Switch	32-14
Hazard Warning Lights	32-14
Heater/Air Conditioner Vents	32-14
Fuel Level Gauge	32-14
Hydraulic Oil Temperature Gauge	32-14
Speedometer/Digital Display	32-15
Coolant Temperature Gauge	32-15
Drive System Temperature Gauge	32-15
Headlight/Panel Illumination Light Switch	32-15
Ladder Light Switch (3-Way)	32-15
Backup Light Switch	32-15
Fog Light Switch	32-15
Mode Switches	32-16
Panel Illumination Light Dimmer Switch	32-16
Right/Left Turn Signal Indicators	32-16
Digital Display Contrast Buttons	32-16
Warning Light	32-16
STATUS INDICATOR LIGHTS	32-17
Body Up	32-17
Parking Brake Applied	32-17
Propulsion System Not Ready	32-17
No Propel	32-18
Engine Warming Up	32-18
Engine Delay	32-18
Grid Drier	32-18
Wheel Brake Lock Applied	32-18
Traction Control	32-18
Repair Monitor	32-18
Snapshot	32-18
Pantograph Energized	32-19
Pantograph Up	32-19
Service Brake Applied	32-19
Dynamic Retarding	32-19
No DC Link Voltage	32-19
DIGITAL DISPLAY OPERATION	32-20
Toggling Through Main Level Screens	32-20
Toggling Through Warning Screens	32-21
Entering Payload Meter Data	32-22
REAR AXLE LIGHT BAR	32-23
KOMTRAX Plus	32-24
Operation	32-25
Basic Precautions	32-26

TABLE OF CONTENTS (cont.)

LUBRICATION AND SERVICE	40-1
GENERAL	40-1
860E-1K SERVICE CAPACITIES	40-1
HYDRAULIC TANK SERVICE	40-1
Adding Oil	40-1
COOLING SYSTEM SERVICE	40-2
Radiator Filling Procedure	40-2
Coolant Specifications	40-2
Unacceptable Practices	40-2
RESERVE ENGINE OIL SYSTEM	40-3
Reserve Oil Tank Filling Procedure (Remote fill)	40-3
Inline Screen	40-3
QUICK FILL SERVICE CENTER	40-4
LUBRICATION CHART	40-5
10 HOUR (DAILY) INSPECTIONS	40-6
INITIAL 50 HOUR LUBRICATION AND MAINTENANCE CHECKS	40-9
INITIAL 100 HOUR LUBRICATION AND MAINTENANCE CHECKS	40-9
250 HOUR LUBRICATION AND MAINTENANCE CHECKS	40-10
500 HOUR LUBRICATION AND MAINTENANCE CHECKS	40-13
1,000 HOURS LUBRICATION AND MAINTENANCE CHECKS	40-15
2,000 HOUR MAINTENANCE CHECKS	40-17
3,000 HOUR MAINTENANCE CHECKS	40-17
5,000 HOUR MAINTENANCE CHECKS	40-18
6,000 HOUR MAINTENANCE CHECKS	40-18
AUTOMATIC LUBRICATION SYSTEM	42-1
GENERAL DESCRIPTION	42-1
SYSTEM COMPONENTS	42-3
Filter Assembly	42-3
Hydraulic Motor and Pump	42-3
Grease Reservoir	42-3
Pressure Reducing Valve	42-3
Flow Control Valve	42-3
Solenoid Valve	42-3
Vent Valve	42-3
Interface Module	42-3
Grease System Failure Switch	42-3
Injectors	42-3
Unloader Valve	42-3
SYSTEM OPERATION	42-4
GENERAL INSTRUCTIONS	42-5
Required Lubricant	42-5
System Priming	42-5
Filter Assembly	42-5

TABLE OF CONTENTS (cont.)

LUBRICANT PUMP	42-6
Pump Housing Oil Level	42-6
Pump Pressure Control	42-6
INJECTORS (SL-1 Series "H")	42-7
Injector Specifications	42-7
Injector Adjustment	42-7
INJECTOR OPERATION	42-8
PREVENTIVE MAINTENANCE PROCEDURES	42-9
Daily Lubrication System Inspection	42-9
250 Hour Inspection	42-9
1000 Hour Inspection	42-9
SYSTEM CHECKOUT	42-10
Lubrication Cycle Operation	42-10
SYSTEM TROUBLESHOOTING CHART	42-11
COMPONENTS & SPECIFICATIONS	50-1
MAJOR COMPONENTS DESCRIPTIONS	50-1
SPECIFICATIONS	50-3
PAYLOAD METER III	60-1
AM/FM RADIO / CD PLAYER	70-1
OPERATING INSTRUCTIONS	70-1
GENERAL RADIO RECEIVER FUNCTIONS	70-1
Turning On the Power	70-1
One-Hour Timer	70-1
Display	70-2
Setting a Default Display	70-2
Adjusting the Brightness of the Display	70-2
Auxiliary Mode	70-2
Adjusting the Receiver Settings	70-2
USING THE CLOCK	70-3
Setting the Clock	70-3
USING THE ALARM	70-3
Setting the Alarm	70-3
Turning the Alarm Off	70-3
Activating Snooze	70-3
Setting Alarm Volume	70-3
USING THE RADIO	70-4
Finding a Station	70-4
Setting the Presets	70-5

TABLE OF CONTENTS (cont.)

USING THE WEATHERBAND	70-5
USING THE COMPACT DISC PLAYER	70-5
Playing a Compact Disc	70-5
Button Functions	70-5
PLAYING AN MP3 DISC	70-6
MP3 Format Compatibility	70-6
Root Directory	70-6
Empty Directory or Folder	70-6
No Folder	70-6
File Name Display	70-6
Pre-Programmed Playlists	70-7
Playing MP3 Files	70-7
Button Functions	70-7
TROUBLESHOOTING	70-8

TORQUE TABLES AND CONVERSION CHARTS



This manual provides dual dimensioning for many specifications. Metric units are specified first, with U.S. standard units in parentheses. When torque values are not specified in the assembly instructions contained in this manual, use the standard torque value for the hardware being used. Standard value torque tables are contained in this chapter for metric and SAE hardware.

References throughout the manual to standard torques or other standard values will be to one of the following tables. Do not use standard values to replace specific torque values in assembly instructions.

NOTE: This truck is assembled with both metric and SAE (U.S.) hardware. Reference the correct table when determining the proper torque value.

For values not shown in any of the charts or tables, standard conversion factors for most commonly used measurements are provided in the following tables.

INDEX OF TABLES

TABLE	Page
TABLE 1 Standard Tightening Torque For Metric Cap screws and Nuts	12-2
TABLE 2 Standard Tightening Torque For SAE Grade 5 & 8 Cap Screws and Nuts	12-3
TABLE 3 Standard Tightening Torque 12-Pt, Grade 9, Cap Screws (SAE)	12-4
TABLE 4 Tightening Torque for T-Bolt Type Hose Clamps.	12-5
TABLE 5 Standard Tightening Torque For Split Flange Clamp Bolts	12-5
TABLE 6 Tightening Torque For Flared Tube And Hose Fittings	12-5
TABLE 7 JIC 37° Swivel Nuts Torque Chart (SAE)	12-6
TABLE 8 Pipe Thread Torque Chart (SAE)	12-6
TABLE 9 O-Ring Boss Torque Chart (SAE)	12-7
TABLE 10 O-Ring Face Seal Torque Chart (SAE)	12-7
TABLE 11 Common Conversions Multipliers - Metric -to- English	12-8
TABLE 12 Common Conversions Multipliers - English -to- Metric	12-9
TABLE 13 Temperature Conversions.	12-10

EFFECT OF SPECIAL LUBRICANTS On Fasteners and Standard Torque Values

The Komatsu engineering department does not recommend the use of special friction-reducing lubricants, such as Copper Coat, Never-Seez®, and other similar products, on the threads of standard fasteners where standard torque values are applied. The use of special friction-reducing lubricants will significantly alter the clamping force being applied to fasteners during the tightening process.

If special friction-reducing lubricants are used with the standard torque values listed in this chapter, excessive stress and possible breakage of the fasteners may result.

Where the torque tables specify “Lubricated Threads” for the standard torque values listed, these standard torque values are to be used with simple lithium base chassis grease (multi-purpose EP NLGI) or a rust-preventive grease (see below) on the threads and seats unless specified otherwise.

NOTE: Ensure the threads of fasteners and tapped holes are free of burrs and other imperfections before assembling.

Suggested* Sources for Rust Preventive Grease:

- American Anti-Rust Grease #3-X from Standard Oil Company (also American Oil Co.)
- Gulf NoRust #3 from Gulf Oil Company.
- Mobilarma 355, Product No. 66705 from Mobil Oil Corporation.
- Rust Ban 326 from Humble Oil Company.
- Rustolene B Grease from Sinclair Oil Co.
- Rust Preventive Grease - Code 312 from the Southwest Grease and Oil Company.

NOTE: This list represents the current engineering approved sources for use in Komatsu manufacture. It is not exclusive. Other products may meet the same specifications of this list.

STANDARD TIGHTENING TORQUES For Class 10.9 Cap screws & Class 10 Nuts

The following specifications apply to required assembly torques for all metric class 10.9 finished hexagon head cap screws and class 10 nuts.

- Cap screw threads and seats shall not be lubricated when assembled. These specifications are based on all cap screws, nuts, and hardened washers being phosphate and oil coated.

If zinc-plated hardware is used, each piece must be lubricated with simple lithium base chassis grease (multi-purpose EP NLGI) or a rust preventive grease (see list, this page) to achieve the same clamping forces provided below.

- Torques are calculated to give a clamping force of approximately 75% of proof load.
- The maximum torque tolerance shall be within $\pm 10\%$ of the torque value shown.
- In the following table under “Cap Screw Size”, the first number represents the shank diameter (mm). The second number represents threads per millimeter.

Example: M20 x 2.25

M20 = shank diameter (20 mm)

2.25 = thread pitch in millimeters



Cap Screw Size	Torque N•m	Torque ft lb	Torque kg•m
M6 x1	12	9	1.22
M8 x 1.25	30	22	3.06
M10 x 1.5	55	40	5.61
M12 x 1.75	95	70	9.69
M14 x 2	155	114	15.81
M16 x 2	240	177	24.48
M20 x 2.25	465	343	47.43
M24 x 3	800	590	81.6
M30 x 3.5	1600	1180	163.2
M36 x 4	2750	2028	280.5

STANDARD TIGHTENING TORQUES For SAE Grade 5 and Grade 8 Cap screws

The following specifications apply to required assembly torques for all grade 5 and grade 8 cap screws.

- Cap screw threads and seats shall be lubricated when assembled.

Unless instructions specifically recommend otherwise, these standard torque values are to be used with simple lithium base chassis grease (multi-purpose EP NLGI) or a rust- preventive grease (see list, previous page) on the threads.

- Torques are calculated to give a clamping force of approximately 75% of proof load.

- The maximum torque tolerance shall be $\pm 10\%$ of the torque value shown.
- In the following table under Cap Screw Size, the first number represents the shank diameter (in.). The second number represents threads per inch.

Example: 7/16 - 20

7/16 = shank diameter (7/16 inch (0.438 inch))

20 = threads per inch

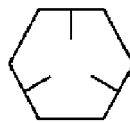

GRADE 5

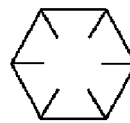

GRADE 8

TABLE 2.
Standard Tightening Torque
for SAE Hex Head Cap Screw And Nut Assembly

Cap Screw Size	Torque - Grade 5			Torque - Grade 8			Cap Screw Size	Torque - Grade 5			Torque - Grade 8		
	N-m	ft lb	kg-m	N-m	ft lb	kg-m		N-m	ft lb	kg-m	N-m	ft lb	kg-m
1/4-20	9.5	7	0.97	13.6	10	1.38	3/4-16	319	235	32.5	454	335	46.3
1/4-28	10.8	8	1.11	14.9	11	1.52	7/8-9	475	350	48.4	678	500	69.2
5/16-18	20.3	15	2.07	28	21	2.90	7/8-14	508	375	51.9	719	530	73.3
5/16-24	22	16	2.21	30	22	3.04	1.0-8	712	525	72.6	1017	750	103.7
3/8-16	34	25	3.46	47	35	4.84	1.0-12	759	560	77.4	1071	790	109.3
3/8-24	41	30	4.15	54	40	5.5	1.0-14	773	570	78.8	1085	800	110.6
7/16-14	54	40	5.5	79	58	8.0	1 1/8-7	881	650	89.9	1424	1050	145
7/16-20	61	45	6.2	84	62	8.57	1 1/8-12	949	700	96.8	1546	1140	158
1/2-13	88	65	9	122	90	12.4	1 1/4-7	1234	910	125.9	2007	1480	205
1/2-20	95	70	9.7	129	95	13.1	1 1/4-12	1322	975	134.8	2142	1580	219
9/16-12	122	90	12.4	169	125	17.3	1 3/8-6	1627	1200	166	2630	1940	268
9/16-18	129	95	13.1	183	135	18.7	1 3/8-12	1776	1310	181	2874	2120	293
5/8-11	169	125	17.3	237	175	24.2	1 1/2-6	2142	1580	219	3471	2560	354
5/8-18	183	135	18.7	258	190	26.2	1 1/2-12	2305	1700	235	3756	2770	383
3/4-10	298	220	30.4	420	310	42.8							

1 ft. lb. = 0.138 kg-m = 1.356 N.m

STANDARD TIGHTENING TORQUES For SAE Grade 9 Cap screws

The following specifications apply to required assembly torques for all 12-point, grade 9 (170,000 psi minimum tensile), cap screws.

- Cap screw threads and seats shall be lubricated when assembled.

Unless instructions specifically recommend otherwise, these standard torque values are to be used with simple lithium base chassis grease (multi-purpose EP NLGI) or a rust- preventive grease (see list, this page) on the threads.

- Torques are calculated to give a clamping force of approximately 75% of proof load.
- The maximum torque tolerance shall be $\pm 10\%$ of the torque value shown.

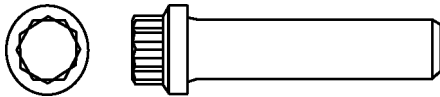

Cap Screw Size*	Torque N-m	Torque ft lb	Torque kg-m
0.250 - 20	16	12	1.7
0.312 - 18	33	24	3.3
0.375 - 16	57	42	5.8
0.438 -14	95	70	9.7
0.500 -13	142	105	14.5
0.562 - 12	203	150	20.7
0.625 - 11	278	205	28.3
0.750 - 10	488	360	49.7
0.875 - 9	780	575	79.4
1.000 - 8	1166	860	119
1.000 - 12	1240	915	126
1.125 - 7	1670	1230	170
1.125 - 12	1800	1330	184
1.250 - 7	2325	1715	237
1.250 - 12	2495	1840	254
1.375 - 6	3080	2270	313
1.375 - 12	3355	2475	342
1.500 - 6	4040	2980	411
1.500 - 12	4375	3225	445
* Shank Diameter (in.) - Threads per inch			

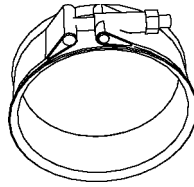

TABLE 4. Tightening Torque For T-Bolt Type Hose Clamp (SAE J1508 Type TB)			
Thread Size	Band Width	Newton meters (N·m)	Inch Pounds (in. lb)
0.25-28 UNF	19.05 mm (0.75 in.)	8.5 ± 0.6 N·m	75 ± 5 in lb

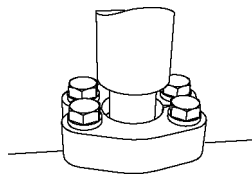

TABLE 5. Tightening Torque For Split Flange Clamp Bolts				
Cap Screw Thread Diameter (mm)	Width Across Flat (mm)	Newton meters (N·m) Tolerances ±10%	Foot Pounds (ft lb) Tolerances ±10%	Kilogram meters (kg·m) Tolerances ±10%
10	14	66	48	6.7
12	17	112	83	11.5
16	22	279	206	28.5

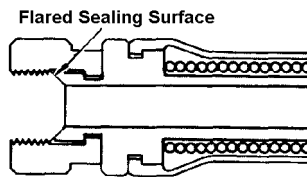

TABLE 6. Tightening Torque For Flared Tube And Hose Fittings				
Thread Diameter of Nut (mm)	Width Across Flat (mm)	Newton meters (N·m) Tolerances ±10%	Foot Pounds (ft lb) Tolerances ±10%	Kilogram meters (kg·m) Tolerances ±10%
14	19	25	18	2.5
18	24	50	36	5
22	27	80	58	8
24	32	140	101	14
30	36	175	130	18
33	41	195	145	20
36	46	245	180	25
42	55	295	215	30

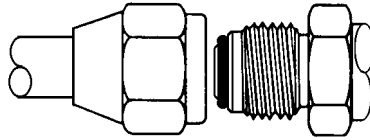

TABLE 7.
Torque Chart For JIC 37° Swivel Nuts
With Or Without O-ring Seals

Size Code	Tube Size (OD)	Threads UNF-2B	Newton meters (N·m)	Foot Pounds (ft lb)
- 2	0.125	0.312 - 24	5 ± 1	4 ± 1
- 3	0.188	0.375 - 24	11 ± 4	8 ± 3
- 4	0.250	0.438 - 20	16 ± 4	12 ± 3
- 5	0.312	0.500 - 20	20 ± 4	15 ± 3
- 6	0.375	0.562 - 18	24 ± 7	18 ± 5
- 8	0.500	0.750 - 16	40 ± 7	30 ± 5
- 10	0.625	0.875 - 14	54 ± 7	40 ± 5
- 12	0.750	1.062 - 12	75 ± 7	55 ± 5
- 14	0.875	1.188 - 12	88 ± 7	65 ± 5
- 16	1.000	1.312 - 12	108 ± 7	80 ± 5
- 20	1.250	1.625 - 12	136 ± 14	100 ± 10
- 24	1.500	1.875 - 12	163 ± 14	120 ± 10
- 32	2.000	2.500 - 12	312 ± 27	230 ± 20

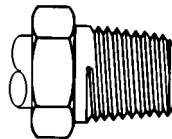

TABLE 8.
Torque Chart For
Pipe Thread Fittings

Size Code	Pipe Thread Size	With Sealant N·m	With Sealant ft lb	Without Sealant N·m	Without Sealant ft lb
- 2	0.125 - 27	20 ± 4	15 ± 3	27 ± 7	20 ± 5
- 4	0.250 - 18	27 ± 7	20 ± 5	34 ± 7	25 ± 5
- 6	0.375 - 18	34 ± 7	25 ± 5	48 ± 7	35 ± 5
- 8	0.500 - 14	48 ± 7	35 ± 5	61 ± 7	45 ± 5
- 12	0.750 - 14	61 ± 7	45 ± 5	75 ± 7	55 ± 5
- 16	1.000 - 11.50	75 ± 7	55 ± 5	88 ± 7	65 ± 5
- 20	1.250 - 11.50	95 ± 7	70 ± 5	108 ± 7	80 ± 5
- 24	1.500 - 11.50	108 ± 7	80 ± 5	129 ± 14	95 ± 10
- 32	2.000 - 11.50	129 ± 14	95 ± 10	163 ± 14	120 ± 10

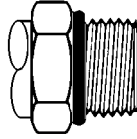

TABLE 9.
Torque Chart For
O-ring Boss Fittings

Size Code	Tube Size (OD)	Threads UNF-2B	Newton meters (N·m)	Foot Pounds (ft lb)
- 2	0.125	0.312 - 24	4 ± 3	4 ± 2
- 3	0.188	0.375 - 24	7 ± 3	5 ± 2
- 4	0.250	0.438 - 20	11 ± 4	8 ± 3
- 5	0.312	0.500 - 20	14 ± 4	10 ± 3
- 6	0.375	0.562 - 18	18 ± 4	13 ± 3
- 8	0.500	0.750 - 16	33 ± 7	24 ± 5
- 10	0.625	0.875 - 14	43 ± 7	32 ± 5
- 12	0.750	1.062 - 12	65 ± 7	48 ± 5
- 14	0.875	1.188 - 12	73 ± 7	54 ± 5
- 16	1.000	1.312 - 12	98 ± 7	72 ± 5
- 20	1.250	1.625 - 12	109 ± 7	80 ± 5
- 24	1.500	1.875 - 12	109 ± 7	80 ± 5
- 32	2.000	2.500 - 12	130 ± 14	96 ± 10

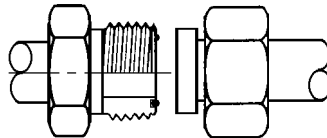

TABLE 10.
Torque Chart For
O-ring Face Seal Fittings

Size CodeE	Tube Size (O.D.)	Threads UNF-2B	Newton meters (N·m)	Foot Pounds (ft lb)
- 4	0.250	0.438 - 20	15 ± 1	11 ± 1
- 6	0.375	0.562 - 18	24 ± 3	18 ± 2
- 8	0.500	0.750 - 16	48 ± 5	35 ± 4
- 10	0.625	0.875 - 14	69 ± 7	51 ± 5
- 12	0.750	1.062 - 12	96 ± 10	71 ± 7
- 16	1.000	1.312 - 12	133 ± 8	98 ± 6
- 20	1.250	1.625 - 12	179 ± 10	132 ± 7
- 24	1.500	1.875 - 12	224 ± 20	165 ± 15

TABLE11. Common Conversion Multipliers Metric To English		
To Convert From	To	Multiply By
millimeter (mm)	inch (in.)	0.0394
centimeter (cm)	inch (in.)	0.3937
meter (m)	foot (ft)	3.2808
meter (m)	yard (yd)	1.0936
kilometer (km)	mile (mi)	0.6210
square centimeters (cm ²)	square inch (in. ²)	0.1550
square centimeters (cm ²)	square feet (ft ²)	0.001
cubic centimeters (cm ³)	cubic inch (in. ³)	0.061
liters (l)	cubic inch (in. ³)	61.02
cubic meters (m ³)	cubic feet (ft ³)	35.314
liters (l)	cubic feet (ft ³)	0.0353
grams (g)	ounce (oz)	0.0353
milliliter (ml)	fluid ounce (fl oz)	0.0338
kilogram (kg)	pound (mass)	2.2046
Newton (N)	pounds (lb)	0.2248
Newton meters (N·m)	kilogram meters (kg·m)	0.102
Newton meters (N·m)	foot pounds (ft lb)	0.7376
kilogram meters (kg·m)	foot pounds (ft lb)	7.2329
kilogram meters (kg·m)	Newton meters (N·m)	9.807
kilopascals (kPa)	pounds/square inch (psi)	0.1450
megapascals (MPa)	pounds/square inch (psi)	145.038
kilograms/cm ² (kg/cm ²)	pounds/square inch (psi)	14.2231
kilograms/cm ² (kg/cm ²)	kilopascals (kPa)	98.068
kilogram (kg)	short ton (tn)	0.0011
metric ton	short ton (tn)	1.1023
liters (l)	quart (qt)	1.0567
liters (l)	gallon (gal)	0.2642
Watts (W)	horsepower (hp)	0.00134
kilowatts (kW)	horsepower (hp)	1.3410

TABLE 12. Common Conversion Multipliers English to Metric		
To Convert From	To	Multiply By
inch (in.)	millimeter (mm)	25.40
inch (in.)	centimeter (cm)	2.54
foot (ft)	meter (m)	0.3048
yard (yd)	meter (m)	0.914
mile (mi)	kilometer (km)	1.61
square inch (in. ²)	square centimeters (cm ²)	6.45
square feet (ft ²)	square centimeters (cm ²)	929
cubic inches (in. ³)	cubic centimeters (cm ³)	16.39
cubic inches (in. ³)	liters (l)	0.016
cubic feet (ft ³)	cubic meters (m ³)	0.028
cubic feet (ft. ³)	liters (l)	28.3
ounce (oz)	kilogram (kg)	0.028
fluid ounce (fl oz)	milliliter (ml)	29.573
pound (lb)	kilogram (kg)	0.454
pound (lb)	Newton (N)	4.448
inch pounds (in. lb)	Newton meters (N·m)	0.113
foot pounds (ft lb)	Newton meters (N·m)	1.356
foot pounds (ft lb)	kilogram meters (kg·m)	0.138
kilogram meters (kg·m)	Newton meters (N·m)	9.807
pounds/square inch (psi)	kilopascals (kPa)	6.895
pounds/square inch (psi)	megapascals (MPa)	0.007
pounds/square inch (psi)	kilograms/square centimeter (kg/cm ²)	0.0704
short ton (tn)	kilogram (kg)	907.2
short ton (tn)	metric ton (t)	0.0907
quart (qt)	liters (l)	0.946
gallon (gal)	liters (l)	3.785
horsepower (hp)	Watts (w)	745.7
horsepower (hp)	kilowatts (kw)	0.745

TABLE 13.
Temperature Conversions
 Formula: $F^{\circ} - 32 \div 1.8 = C^{\circ}$ or $C^{\circ} \times 1.8 + 32 = F^{\circ}$

Celsius C°		Fahrenheit F°	Celsius C°		Fahrenheit F°	Celsius C°		Fahrenheit F°
121	250	482	63	145	293	4	40	104
118	245	473	60	140	284	2	35	95
116	240	464	57	135	275	- 1	30	86
113	235	455	54	130	266	- 4	25	77
110	230	446	52	125	257	- 7	20	68
107	225	437	49	120	248	- 9	15	59
104	220	428	46	115	239	- 12	10	50
102	215	419	43	110	230	- 15	5	41
99	210	410	41	105	221	- 18	0	32
96	205	401	38	100	212	- 21	- 5	23
93	200	392	35	95	203	- 23	- 10	14
91	195	383	32	90	194	- 26	- 15	5
88	190	374	29	85	185	- 29	- 20	- 4
85	185	365	27	80	176	- 32	- 25	- 13
82	180	356	24	75	167	- 34	- 30	- 22
79	175	347	21	70	158	- 37	- 35	- 31
77	170	338	18	65	149	- 40	- 40	- 40
74	165	329	15	60	140	- 43	- 45	- 49
71	160	320	13	55	131	- 46	- 50	- 58
68	155	311	10	50	122	- 48	- 55	- 67
66	150	302	7	45	113	- 51	- 60	- 76

NOTE: The numbers in the unmarked columns refer to temperature in either degrees Celsius (C°) or Fahrenheit (F°). Select a number in this unmarked column and read to the left to convert to degrees Celsius (C°) or read to the right to convert to degrees Fahrenheit (F°). If starting with a known temperature (either C° or F°), find that temperature in the marked column and read the converted temperature in the center, unmarked column.

SAFETY

GENERAL

Safety records from most organizations will show that the greatest percentage of accidents are caused by unsafe acts performed by people. The remainder are caused by unsafe mechanical or physical conditions. Report all unsafe conditions to the proper authority.

The following safety rules are provided as a guide for the operator. However, local conditions and regulations may add many more to this list.



Read and follow all safety precautions. Failure to do so may result in serious injury or death.

Safety Rules

- Only trained and authorized personnel may operate and maintain the truck.
- Follow all safety rules, precautions and instructions when operating or performing maintenance on the truck.
- When working with another operator or a person on work site traffic duty, make sure that all personnel understand all hand signals that are to be used.

Safety Features

- Make sure that all guards and covers are in their proper position. Have any damaged guards and covers repaired. (See Operating Instructions - Section 30, Preparing For Operation.)
- Learn the proper use of safety features such as safety locks, safety pins, and seat belts. Use these safety features properly.
- Never remove any safety features. Always keep them in good operating condition.
- Improper use of safety features could result in serious bodily injury or death.
- Check the seat belt fabric, buckle and hardware for damage or wear. Replace any worn or damaged parts immediately.
- The seat belts must be replaced 5 years after seat belt manufacture, or after every 3 years of use, whichever comes first.

Fire Extinguisher And First Aid Kit

- Make sure that fire extinguishers are accessible and proper usage techniques are known.
- Provide a first aid kit at the storage point.
- Know what to do in the event of a fire.
- Keep the phone numbers of persons you should contact in case of an emergency on hand.

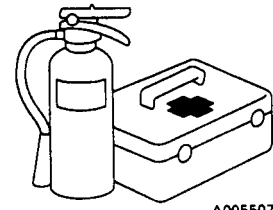

A0055070

Clothing And Personal Items

- Avoid loose clothing, jewelry, and loose long hair. They can catch on controls or in moving parts and cause serious injury or death. Also, never wear oily clothes as they are flammable.
- Wear a hard hat, safety glasses, safety shoes, mask and gloves when operating or maintaining a truck. Always wear safety goggles, hard hat and heavy gloves if your job involves scattering metal chips or minute materials--particularly when driving pins with a hammer or when cleaning air cleaner elements with compressed air. Also, ensure that the work area is free from other personnel during such tasks.

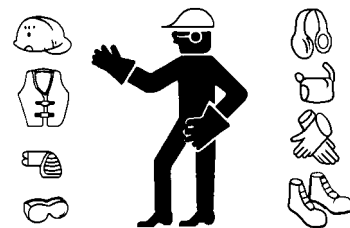

A0055010

Leaving The Operator's Seat

When preparing to leave the operator's seat, do not touch any control lever that is not locked. To prevent accidental operations from occurring, always perform the following:

- Move the directional control lever to PARK. **Do not use the wheel brake lock when the engine will be turned off.**
- Lower the dump body to the frame.
- Stop the engine. When exiting the truck, always lock compartments and take the keys with you. If the truck should suddenly move or move in an unexpected way, this may result in serious bodily injury or death.

Mounting And Dismounting

- Use the handrails and steps when getting on or off the truck.
- Never jump on or off the truck. Never climb on or off a truck while it is moving.
- When climbing on or off a truck, face the truck and use the hand-hold and steps.
- Never hold any control levers when getting on or off a truck.
- Always maintain three-point contact with the hand-holds and steps to ensure that you support yourself.
- When bringing tools into the operator's compartment, always pass them by hand or pull them up by rope.
- If there is any oil, grease, or mud on the hand-holds or steps, wipe them clean immediately. Always keep these components clean. Repair any damage and tighten any loose bolts.

Fire Prevention For Fuel And Oil

- Fuel, oil, and antifreeze can be ignited by a flame. Fuel is extremely flammable and can be hazardous. Keep flames away from flammable fluids.
- Keep oil and fuel in a designated location and do not allow unauthorized persons to enter.
- When refueling, stop the engine and do not smoke.
- Refueling and oiling should be done in well ventilated areas.
- Tighten all fuel and oil tank caps securely.



A0055020

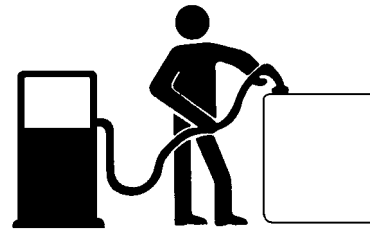

A0055030



A0055040

Precautions With High Temperature Fluids

Immediately after truck operation, engine coolant, engine oil, and hydraulic oil are at high temperatures and are pressurized. If the cap is removed, the fluids are drained, the filters are replaced, etc., there is danger of serious burns. Allow heat and pressure to dissipate before performing such tasks and follow proper procedures as outlined in the service manual.

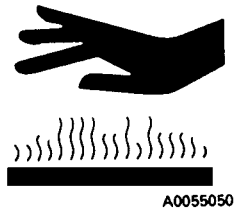

To prevent hot coolant from spraying:

1. Stop the engine.
2. Wait for the coolant temperature to decrease.
3. Depress the pressure release button on the cap to vent cooling system pressure.
4. Turn the radiator cap slowly to release the pressure before removing.

To prevent hot engine oil spray:

1. Stop the engine.
2. Wait for the oil temperature to cool down.
3. Turn the cap slowly to release the pressure before removing the cap.

Asbestos Dust Hazard Prevention

Asbestos dust is hazardous to your health when inhaled. If you handle materials containing asbestos fibers, follow the guidelines below:

- Never use compressed air for cleaning.
- Use water for cleaning to control dust.
- Operate the truck or perform tasks with the wind to your back whenever possible.
- Use an approved respirator when necessary.

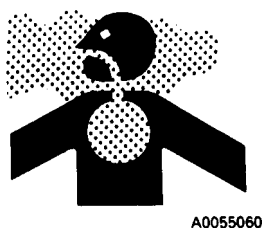

Prevention Of Injury By Work Equipment

Never enter or put your hand, arm or any other part of your body between movable parts such as the dump body, chassis or cylinders. If the work equipment is operated, clearances will change and may lead to serious bodily injury or death.

Unauthorized Modification

Any modification made to this vehicle without authorization from Komatsu America Corp. can possibly create hazards.

Before making any modification, consult the authorized regional Komatsu America Corp. distributor. Komatsu will not be responsible for any injury or damage caused by any unauthorized modification.

ROPS Precautions

The ROPS is intended to protect the operator if the truck should roll over. It is designed not only to support the load of the truck, but also to absorb the energy of the impact.

- The Rollover Protection Structure (ROPS) must be properly installed before the truck is operated.
- ROPS installed on equipment manufactured and designed by Komatsu America Corp. fulfills all of the regulations and standards for all countries. If it is modified or repaired without authorization from Komatsu, or if it is damaged when the truck rolls over, the strength of the structure will be compromised and will not be able to fulfill its intended purpose. Optimum strength of the structure can only be achieved if it is repaired or modified as specified by Komatsu.
- When modifying or repairing the ROPS, always consult your nearest Komatsu distributor.
- Even with the ROPS installed, the operator must always use the seat belt when operating the truck.

Precautions For Attachments

- When installing and using optional equipment, read the instruction manual for the attachment and the information related to attachments in this manual.
- Do not use attachments that are not authorized by Komatsu America Corp. or the authorized regional Komatsu distributor. Use of unauthorized attachments could create a safety problem and adversely affect the proper operation and useful life of the truck.
- Any injuries, accidents, and product failures resulting from the use of unauthorized attachments will not be the responsibility of Komatsu America Corp. or the authorized regional Komatsu distributor.

Precautions For Starting The Truck

Start the engine from the operator's seat only. Never attempt to start the engine by shorting across cranking motor terminals. This may cause a fire, or serious injury or death to anyone in truck's path.



PRECAUTIONS BEFORE OPERATION

Safety is thinking ahead. Prevention is the best safety program. Prevent a potential accident by knowing the employer's safety requirements and all necessary job site regulations. In addition, know the proper use and care of all the safety equipment on the truck. Only qualified operators or technicians should attempt to operate or maintain a Komatsu machine.

Safe practices start before the operator gets to the equipment.

Safety At The Worksite

- When walking to and from a truck, maintain a safe distance from all machines even when the operator is visible.
- Before starting the engine, thoroughly check the area for any unusual conditions that could be dangerous.
- Examine the road surface at the job site and determine the best and safest method of operation.
- Choose an area where the ground is as horizontal and firm as possible before performing the operation.
- If you need to operate on or near a public road, protect pedestrians and cars by designating a person for work site traffic duty or by installing fences around the work site.
- The operator must personally check the work area, the roads to be used, and the existence of obstacles before starting operations.
- Always determine the travel roads at the work site and maintain them so that it is always safe for the machines to travel.
- If travel through wet areas is necessary, check the depth and flow of water before crossing the shallow parts. Never drive through water that exceeds the permissible water depth.

Fire Prevention

- Remove wood chips, leaves, paper, and other flammable items that have accumulated in the engine compartment. Failure to do so could result in a fire.
- Check the fuel, lubrication, and hydraulic systems for leaks. Repair any leaks. Clean any excess oil, fuel or other flammable fluids, and dispose of them properly.
- Make sure that a fire extinguisher is present and in proper working condition.
- Do not operate the truck near open flames.



A0055020

Ventilation In Enclosed Areas

If it is necessary to start the engine within an enclosed area, provide adequate ventilation. Inhaling exhaust fumes from the engine can kill.

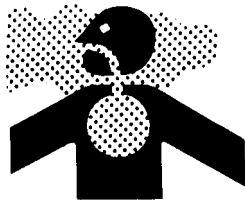

A0055060

Preparing For Operation

- Always mount and dismount while facing the truck. Never attempt to mount or dismount the truck while it is in motion. Always use handrails and ladders when mounting or dismounting the truck.
- Check the deck areas for debris, loose hardware and tools. Check for people and objects that might be in the area.
- Become familiar with and use all protective equipment devices on the truck and ensure that these items (anti-skid material, grab bars, seat belts, etc.) are securely in place.

Mirrors, Windows And Lights

- Remove any dirt from the surface of the windshield, cab windows, mirrors and lights. Good visibility may prevent an accident.
- Adjust the rear view mirror to a position where the operator can see best from the operator's seat. If any glass or light is broken, replace it with a new part.
- Make sure that the headlights, work lights, and taillights are in proper working order. Make sure that the truck is equipped with the proper work lamps that are needed for the operating conditions.

In Operator Cab (Before Starting The Engine)

- Do not leave tools or spare parts lying around. Do not allow trash to accumulate in the cab of the truck. Keep all unauthorized reading material out of the truck cab.
- Keep the cab floor, controls, steps and handrails free of oil, grease, snow and excess dirt.
- Read and understand the contents of this manual. Pay special attention to Sections 30 and 32 pertaining to safety and operating instructions. Become thoroughly acquainted with all gauges, instruments and controls before attempting operation of the truck.
- Read and understand the **WARNING** and **CAUTION** decals in the operator's cab.
- Make sure that the steering wheel, horn, controls and pedals are free of any oil, grease or mud.
- Check the operation of the windshield wiper, condition of wiper blades, and the washer fluid reservoir level.
- Be familiar with all steering and brake system controls, warning devices, road speeds and loading capabilities before operating the truck.

Seat Belts

- On both driver and passenger seats, check the seat belt fabric, buckle, all belt retractors and hardware for damage or wear. Replace any worn or damaged parts immediately.
- Even if there are no signs of damage, replace both driver and passenger seat belts 5 years after seat belt manufacture, or every 3 years after start of use, whichever comes first. The passenger seat belt date of manufacture label is sewn into the seat belt near the buckle. The driver seat belt date of manufacture label is sewn into the shoulder harness belt, near the retractor end.

OPERATING THE TRUCK

When Starting The Engine

- Never attempt to start the engine by shorting across cranking motor terminals. This may cause a fire, or serious injury or death to anyone in truck's path.
- Never start the engine if a warning tag has been attached to the controls.
- When starting the engine, sound the horn as an alert.
- Start and operate the truck only while seated in the operator's seat.
- Do not allow any unauthorized persons in the operator's compartment or any other place on the truck.

General Truck Operation

- **Wear the seat belt at all times.**
- Only authorized persons are allowed to ride in the truck. Riders must be in the cab and belted in the passenger seat.
- Do not allow anyone to ride on the decks or steps of the truck.
- Do not allow anyone to get on or off the truck while it is in motion.
- Do not move the truck in or out of a building without a signal person present.
- Know and obey the hand signal communications between operator and spotter. When other machines and personnel are present, the operator should move in and out of buildings, loading areas, and through traffic under the direction of a signal person. Courtesy at all times is a safety precaution!
- Immediately report any adverse conditions at the haul road, pit or dump area that may cause an operating hazard.
- Check for flat tires periodically during a shift. If the truck has been operating on a "flat", do not park the truck inside a building until the tire cools. If the tire must be changed, do not stand in front of the rim and locking ring when inflating a tire mounted on the truck. Observers should not be permitted in the area and should be kept away from the side of such tires.



The tire and rim assembly may explode if subjected to excessive heat. Personnel should move to a remote or protected location if sensing excessively hot brakes, smelling burning rubber or observing evidence of fire near the tire and wheel area.

If the truck must be approached to extinguish a fire, those personnel should do so only while facing the tread area of the tire (front or back) unless protected by using large heavy equipment as a shield. Stay at least 50 ft. (15 m) from the tread of the tire.

In the event of fire in the tire and wheel area (including brake fires), stay away from the truck for at least 8 hours or until the tire and wheel are cool.

- Keep serviceable fire fighting equipment on hand. Report empty extinguishers for replacement or refilling.
- Always place the directional control lever in the PARK when the truck is parked and unattended. Do not leave the truck unattended while the engine is running.

NOTE: DO NOT use wheel brake lock when parking the truck.

- Park the truck a safe distance away from other vehicles as determined by the supervisor.
- Stay alert at all times! In the event of an emergency, be prepared to react quickly and avoid accidents. If an emergency arises, know where to get prompt assistance.

Ensuring Good Visibility

- When working in dark places, install work lamps and head lamps. Set up extra lighting in the work area if necessary.
- Discontinue operations if visibility is poor, such as in mist, snow, or rain. Wait for the weather to improve to allow the operation to be performed safely.

Traveling

- When traveling on rough ground, travel at low speeds. When changing direction, avoid turning suddenly.
- Lower the dump body and set the dump lever to the FLOAT position before traveling.
- If the engine stops while the truck is in motion, secondary steering and braking enable the truck to be steered and stopped. A fixed amount of reserve oil provides temporary steering and braking to briefly allow the truck to travel to a safe area. Apply the brakes immediately and stop the truck as quickly and safely as possible off of the haul road, if possible.

Traveling In Reverse

Before operating the truck:

- Sound the horn to warn people in the area. Make sure that the back-up horn also works properly.
- Check for personnel near the truck. Be particularly careful to check behind the truck.
- When necessary, designate a person to watch the area near the truck and signal the operator. This is particularly necessary when traveling in reverse.
- When operating in areas that may be hazardous or have poor visibility, designate a person to direct work site traffic.
- Do not allow any one to enter the line of travel of the truck. This rule must be strictly observed even with machines equipped with a back-up horn or rear view mirror.

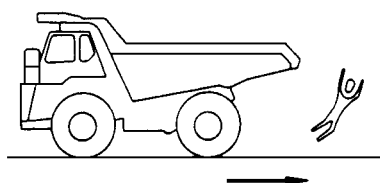

Traveling On Slopes

- Traveling on slopes could result in the truck tipping over or slipping.
- Do not change direction on slopes. To ensure safety, drive to level ground before turning.
- Do not travel up and down on grass, fallen leaves, or wet steel plates. These materials may make the truck slip on even the slightest slope. Avoid traveling sideways, and always keep travel speed low.
- When traveling downhill, use the retarder to reduce speed. Do not turn the steering wheel suddenly. Do not use the foot brake except in an emergency.
- If the engine should stop on a slope, apply the service brakes fully and stop the truck. Move the directional control lever to PARK after the truck has stopped.

Operating On Snow Or Ice

- When working on snowy or icy roads, there is danger that the truck may slip to the side on even the slightest slope. Always travel slowly and avoid sudden starting, turning, or stopping in these conditions.
- Be extremely careful when clearing snow. The road shoulder and other objects are buried in the snow and cannot be seen.

Avoiding Damage To Dump Body

- Always be extremely cautious when working in tunnels, on bridges, under electric cables, or when entering a parking place or any other place where there are height limits. The dump body must be completely lowered before driving the truck.



Driving with a raised dump body or raising the dump body in an enclosed area may result in serious damage and bodily injury or death. Always drive with the dump body resting on the frame.

Driving Near High Voltage Cables

Driving near high-voltage cables can cause electric shock. Always maintain safe distances between the truck and the electric cable as listed below.

Voltage	Minimum Safety Distance	
6.6 kV	3 m	10 ft.
33.0 kV	4 m	14 ft.
66.0 kV	5 m	17 ft.
154.0 kV	8 m	27 ft.
275.0 kV	10 m	33 ft.

The following actions are effective in preventing accidents while working near high voltages:

- Wear shoes with rubber or leather soles.
- Use a signalman to give warning if the truck approaches an electric cable.
- If the work equipment touches an electric cable, the operator should not leave the cab.
- When performing operations near high voltage cables, do not allow anyone to approach the truck.
- Check with the electrical maintenance department about the voltage of the cables before starting operations.

Working On Loose Ground

- Avoid operating the truck near cliffs, overhangs and deep ditches. If these areas collapse, the truck could fall or tip over and result in serious injury or death. Remember that ground surfaces in these areas may be weakened after heavy rain or blasting.
- Freshly laid soil and the soil near ditches is loose. It can collapse under the weight or vibration of the truck. Avoid these areas whenever possible.

When Dumping

- Before starting the dumping operation, make sure that there are no persons or objects behind the truck.
- Stop the truck in the desired location. Check again for persons or objects behind the truck. Give the determined signal, then slowly operate the dump body. If necessary, use blocks for the wheels or position a flagman.
- When dumping on slopes, truck stability is poor and there is danger of tipping over. Always use extreme care when performing such operations.
- Never travel with the dump body raised.

When Loading

- Make sure that the surrounding area is safe. Stop the truck in the correct loading position, then load the body uniformly.
- Do not leave the operator's seat during the loading operation.

Parking The Truck

- Choose a flat, level surface to park the truck. If the truck has to be parked on a slope, put blocks behind all the wheels to prevent truck movement.
- When parking on public roads, provide fences and signs, such as flags or lights, on the truck to warn pedestrians and other vehicles. Make sure that the truck, flags or lights do not obstruct traffic.
- Before leaving the truck, lower the dump body fully, move the directional control lever to PARK, stop the engine and lock everything. Always take the key with you.



Do not activate the wheel brake lock when parking the truck. Bleed down of hydraulic pressure may occur, causing the truck to roll away. Always shift to PARK to apply the parking brake.

Towing

- Improper towing methods may lead to serious personal injury and/or damage.
- Tow with a solid tow bar. DO NOT tow with a cable. Use a towing device with ample strength for the weight of this truck.
- Never tow a truck on a slope.
- Inspect towing components, such as tow bars and couplings, for any signs of damage. Never use damaged or worn components to tow a disabled vehicle.
- Keep a safe distance from the trucks and towing apparatus while towing a vehicle.
- When connecting a truck that is to be towed, do not allow anyone to go between the tow vehicle and the disabled vehicle.
- Set the coupling of the truck being towed in a straight line with the towing portion of the tow truck, and secure it in position.
- For towing methods, refer to Operating Instructions - Section 30, Towing.

WORKING NEAR BATTERIES

Battery Hazard Prevention

- Battery electrolyte contains sulfuric acid, which can quickly burn the skin and eat holes in clothing. If you spill acid on yourself, immediately flush the area with water.
- Battery acid can cause blindness if splashed into your eyes. If acid gets into your eyes, flush them immediately with large quantities of water and see a doctor at once.
- If you accidentally drink acid, drink a large quantity of water, milk, beaten eggs or vegetable oil. Call a doctor or poison prevention center immediately.
- Always wear safety glasses or goggles when working with batteries.
- Batteries generate hydrogen gas. Hydrogen gas is very explosive and can easily be ignited with a small spark or flame.
- Before working with batteries, stop the engine and turn the key switch to the OFF position.
- Avoid short-circuiting the battery terminals through accidental contact with metallic objects, such as tools, across the terminals.
- When removing or installing batteries, check which is the positive (+) terminal and the negative (-) terminal.
- Tighten the battery terminals securely. Loose terminals can generate sparks and lead to an explosion.
- Tighten battery caps securely.

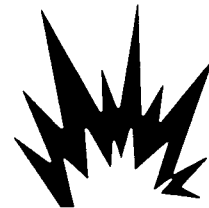
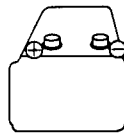
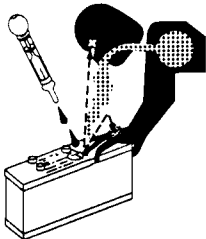

A030005

Jump Starting With Booster Cables

- Always wear safety glasses or goggles when starting the truck with booster cables.
- When starting from another truck, do not allow the two trucks to touch.
- Perform the operation with two people: one person in the cab of the disabled machine, the other person working with the jumper cables.
- Ensure the parking brake is applied on both machines.
- Ensure the size of the booster cables and clips are suitable for the battery size. Inspect the cables and connectors for any damage or corrosion.
- Ensure the key switch and both battery disconnect switches on the disabled machine are in the OFF position.
- Connect the batteries in parallel: positive to positive and negative to negative.
- Connect the positive (+) cable from the good machine to the (+) on the disabled machine first. Then connect the ground cable from the negative (-) battery terminal on the good machine to the frame of the disabled machine, as far away as possible from the batteries. This will prevent a spark from possibly starting a battery fire.
- If the batteries are low, DO NOT attempt starting the machine with only one set of jumper cables installed. Install the second set of jumper cables in the same way as already described.
- For booster cable removal, disconnect the ground or negative (-) cable first, then the (24VDC +) cable last.
- If any tool touches between the positive (+) terminal and the chassis, it will cause sparks. Always be cautious when using tools near the battery.

Jump Starting With Receptacles

- Always wear safety glasses or goggles when starting the machine with booster cables.
- While jump starting with another machine, DO NOT allow the two machines to touch.
- Perform the operation with two people: one person in the cab of the disabled machine, the other person working with the jumper cables.
- Ensure the parking brake is applied on both machines.
- Inspect the cables and connectors for any damage or corrosion.
- Ensure the key switch and both battery disconnect switches on the disabled machine are in the OFF position.
- Connect the jumper cable to the receptacle on the good machine to the receptacle on the disabled machine.
- Allow time for the batteries to charge.

NOTE: The batteries will charge even with the battery disconnect switches are in the OFF position.

- If the batteries are low, DO NOT attempt starting the machine with only one set of jumper cables installed. Install the second set of jumper cables in the same way as already described.
- Turn the battery disconnect switches to the ON position and attempt starting.
- For booster cable removal, disconnect the cables from each machine.
- If any tool touches between the positive (+) terminal and the chassis, it will cause sparks. Always use caution when using tools near the battery.

BEFORE PERFORMING MAINTENANCE

Stopping The Engine Before Service

- Before performing inspections or maintenance, stop the truck on firm flat ground, lower the dump body, move the directional control lever to PARK, and stop the engine.
- Wait two minutes after the engine has stopped. If no warning lights illuminate, then turn the battery disconnect switches to the OFF position. Verify that the disconnects are functioning.
- If the engine must be run during service, such as when cleaning the radiator, the directional control lever must be in PARK. Always perform this work with two people. One person must sit in the operator's seat to stop the engine if necessary. During these situations, never move any controls that are not related to the task at hand.
- When servicing the truck, do not touch any moving parts. Never wear loose clothing or jewelry.
- Put wheel blocks under the wheels to prevent truck movement.
- When performing service with the dump body raised, always place the dump lever in the HOLD position, and apply the lock (if equipped). Install the body-up safety sling securely.

Warning Tag

Starting the engine or operating the controls while other personnel are performing maintenance on the truck can lead to serious injury and/or death. Always attach the warning tag to the control lever in the operator's cab to alert others that you are working on the truck. Attach additional warning tags around the truck, if necessary.

These tags are available from your Komatsu distributor. **Warning tag part number:** 09963-03001

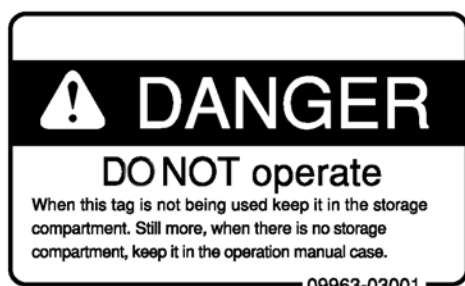

Proper Tools

Only use tools that are suited to the task. Using damaged, low quality, faulty or makeshift tools could cause personal injury.

Securing The Dump Body

WARNING

To avoid serious personal injury or death, the body retention sling must be installed whenever personnel are required to perform maintenance on the truck while the dump body is in the raised position.

The Komatsu body-up safety sling can only be used with a Komatsu body. Non-OEM body may not accommodate the Komatsu body-up safety sling. The end user must ensure that a proper cable/sling is used.

1. Raise the body to its maximum height.
2. Install two shackles (2, Figure 20-1) and body retention sling (3) between rear body ear (1) and axle housing.
3. Secure the shackle pins with cotter pins.
4. Move the hoist lever to the FLOAT position to slowly lower the body until the cable is supporting the full weight of the body. Then move the hoist lever to the HOLD position.
5. After service work is completed, reverse the installation steps to remove the sling.

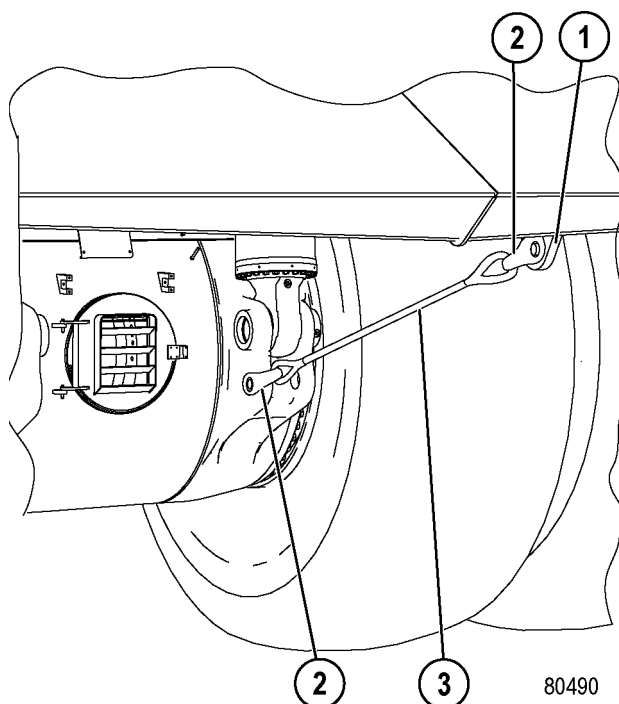

FIGURE 20-1. BODY RETENTION SLING INSTALLATION

- | | |
|------------------|-------------------------|
| 1. Rear Body Ear | 3. Body Retention Sling |
| 2. Shackle & Pin | |

80490

WHILE PERFORMING MAINTENANCE

NOTE: Only authorized personnel should service and repair the truck.

Keep The Truck Clean

- Spilled oil, grease, scattered tools, etc., can cause you to slip or trip. Always keep your truck clean and tidy.
- If water gets into the electrical system, there is danger that the truck may move unexpectedly and/or damage to components may occur. Do not use water or steam to clean any sensors, connectors or the inside of the operator's compartment.
- Use extreme care when washing the electrical control cabinet. Do not allow water to enter the control cabinet around the doors or vents. Do not allow any water to enter the cooling air inlet duct above the electrical control cabinet. If water enters the control cabinet through any opening or crevice, major damage to the electrical components is possible.
- Never spray water into the rear wheel electric motor covers. Damage to the wheel motor armatures may occur.
- Do not spray water into the retarding grids. Excess water in the retarding grids can cause a ground fault, which will prevent propulsion.

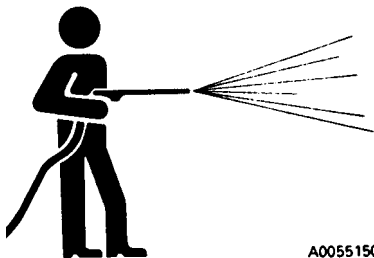

A0055150

Attachments

Place attachments that have been removed from the truck in a safe place and manner to prevent them from falling.



A0055130

Working Under The Truck

- Always lower all movable work equipment to the ground or to their lowest position before performing service or repairs under the truck.
- Always block the tires of the truck securely.
- Never work under the truck if the truck is poorly supported.

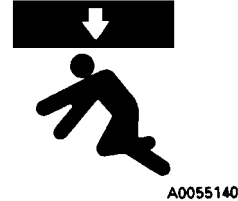

A0055140

Rotating Fan And Belts

Stay away from all rotating parts such as the radiator fan and fan belts. Serious bodily injury may result from direct or indirect contact with rotating parts and flying objects.

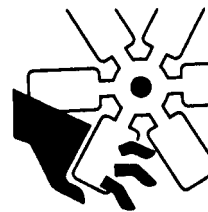

A0063830

Waste Materials

- Never dump oil into a sewer system, river, etc.
- Always put oil drained from your truck in appropriate containers. Never drain oil directly onto the ground.
- Obey appropriate laws and regulations when disposing of harmful objects such as oil, fuel, coolant, solvent, filters and batteries.
- The machine may be equipped with optional High Intensity Discharge (HID) lighting lamps which contain mercury. These lamps must be reused, recycled or properly disposed of in accordance with applicable local, state and federal laws.

INCORRECT

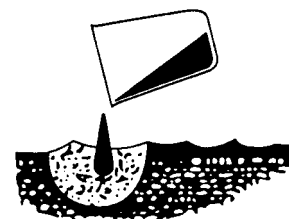

A0055220

Adding Fuel Or Oil

- Spilled fuel and oil may cause slipping. Always clean up spills immediately.
- Always add fuel and oil in a well-ventilated area.
- When refueling, stop the engine and do not smoke.
- Tighten the cap of the fuel and oil fillers securely.
- Never use fuel to wash parts.

Radiator Coolant Level

If it is necessary to add coolant to the radiator, stop the engine and allow the engine and radiator to cool down before adding the coolant. Depress the pressure release button on the cap to vent cooling system pressure. Slowly loosen the cap to relieve any remaining pressure.

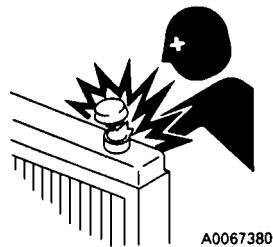

A0067380

Use Of Lighting

When checking fuel, oil, coolant or battery electrolyte, always use lighting with anti-explosion specifications. If such lighting equipment is not used, there is danger of an explosion.



A0055160

Precautions With The Battery

When repairing the electrical system or performing electrical welding, remove the negative (-) terminal of the battery to stop the flow of current.



A0055170

Handling High Pressure Hoses

- Do not bend high pressure hoses or hit them with hard objects. Do not use any bent or cracked piping, tubes or hoses. They may burst during use.
- Always repair any loose or broken hoses. If fuel or oil leaks, it may result in a fire.

Precautions With High Pressure Oil

- Work equipment circuits are always under pressure. Do not add oil, drain oil or perform maintenance or inspections before completely releasing the internal pressure.
- Small, high-pressure pin hole leaks are extremely dangerous. The jet of high-pressure oil can pierce the skin and eyes. Always wear safety glasses and thick gloves. Use a piece of cardboard or a sheet of wood to check for oil leakage.
- If you are hit by a jet of high-pressure oil, consult a doctor immediately for medical attention.



A030007

Precautions When Performing Maintenance Near High Temperature Or High Pressure

Immediately after stopping operation, engine coolant and operating oils are at high temperature and under high pressure. If the cap is removed, the oil or water is drained, or the filters are replaced under these conditions, it may result in burns or other injury. Wait for the temperature to cool and pressure to subside before performing the inspection and/or maintenance as outlined in the shop manual.



TIRES

Handling Tires

Rim and tire maintenance can be hazardous unless the correct procedures are followed by trained personnel.

Improperly maintained or inflated tires can overheat and burst due to excessive pressure. Improper inflation can also result in cuts in the tire caused by sharp stones. Both of these conditions can lead to tire damage, serious personal injury, or even death.

To safely maintain a tire, adhere to the following conditions:

- Before a tire is removed from a vehicle for tire repair, the valve core must be partially removed to allow deflation, and then the tire/rim assembly can be removed. During deflation, persons must stand outside of the potential trajectory of the locking ring of a multi-piece wheel rim.
- After the tire/rim assembly is installed on the vehicle, inflate the tires to their specified pressure. Abnormal heat is generated, particularly when the inflation pressure is too low.

NOTE: To prevent injury from the wheel rims during tire inflation, use one of the following:

- A wheel cage or other restraining device that will constrain all wheel rim components during an explosive separation of a multi-piece wheel rim, or during the sudden release of air.
- A stand-off inflation device which permits a person to stand outside of the potential trajectory of the wheel components.
- Use the specified tires.

The tire inflation pressure and permissible speeds, given in this manual, are general values. The actual values may differ, depending on the type of tire and the specific operating conditions. For details, please consult the tire manufacturer.

When the tires become overheated, a flammable gas is produced inside the tire which can ignite. It is particularly dangerous if the tires become overheated while the tires are pressurized. If the gas generated inside the tire ignites, the internal pressure will suddenly rise, and the tire will explode, resulting in danger and/or death to personnel in the area. Explosions differ from punctures or tire bursts because the destructive force of the explosion is extremely large. Therefore, the following operations are strictly prohibited when the tire is pressurized:

- Welding the rim
- Welding near the wheel or tire.
- Smoking or creating open flames



Tire Maintenance

If the proper procedure for performing maintenance or replacement of the wheel or tire is not used, the wheel or tire may burst, causing damage, serious injury, or even death. When performing such maintenance, consult your authorized regional Komatsu distributor, or the tire manufacturer.

Refer to the Society of Automotive Engineers (SAE), SAE J1337, Off-Road Rim Maintenance Procedures and Service Precautions, Section 4.2 for additional information on demounting the tires and rim assemblies. Also, refer to Section 4.4 of SAE J1337 for assembly and inflation recommendations.

The U.S. Department of Labor Mine Safety and Health Administration (MSHA) addresses tire repairs in its Title 30 Code of Federal Regulations, 30 CFR 57.14104.



DO NOT stand in front of a rim and locking ring when inflating a tire mounted on the machine. Observers must not be permitted in the area.

DO NOT weld or heat the rim assembly with the tire mounted on the rim. Resulting gases inside the tire may ignite, causing explosion of the tire and rim.

Storing Tires After Removal

- As a basic rule, store the tires in a warehouse in which unauthorized persons cannot enter. If the tires are stored outside, always erect a fence around the tires and put up "No Entry" signs and other warning signs that even young children can understand.
- Stand the tire on level ground and block it securely so that it cannot roll or fall over.
- If the tire falls over, flee the area quickly. The tires for dump trucks are extremely heavy. Never attempt to hold or support the tire. Attempting to hold or support a tire may lead to serious injury.

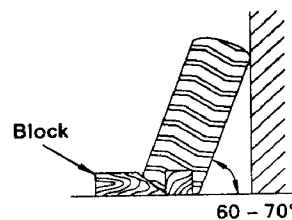

A030008

- Mounted tires stored as spares must be inflated to the minimum inflation pressure necessary to keep the tire beads properly seated. Maximum inflation pressure of the stored tire must not exceed 15% of the tire's cold inflation pressure.

WHEN REPAIRS ARE NECESSARY

NOTE: Only qualified maintenance personnel who understand the systems being repaired should attempt repairs.

- Many components on the Komatsu truck are large and heavy. Ensure that lifting equipment - hoists, slings, chains, and lifting eyes - are of adequate capacity to handle the lift.
 - Do not work under a suspended load. Do not work under a raised body unless body safety cables, props or pins are in place to hold the body in up position.
 - Do not repair or service the truck while the engine is running, except when adjustments can only be made under such conditions. Keep a safe distance from moving parts.
 - When servicing any air conditioning system with refrigerant, wear a face shield and cold resistant gloves for protection against freezing. Follow all current regulations for handling and recycling refrigerants.
 - Follow package directions carefully when using cleaning solvents.
 - If an auxiliary battery assist is needed, refer to Jump Starting With Booster Cables or Jump Starting With Receptacles earlier in this section.
 - Always disconnect the positive and negative battery cables of the vehicle before doing any welding on the unit. Failure to do so may seriously damage the battery and electrical equipment. Disconnect the battery charging alternator lead wire and isolate the electronic control components before making welding repairs. (It is not necessary to disconnect or remove any control circuit cards on electric drive dump trucks or any of the AID circuit control cards.)
- Always fasten the welding machine ground (-) lead to the piece being welded. The grounding clamp must be attached as near as possible to the weld area. Never allow welding current to pass through ball bearings, roller bearings, suspensions or hydraulic cylinders. Always avoid laying welding cables over or near the vehicle electrical harnesses. Welding voltage could be induced into the electrical harness and possibly cause damage to components.
 - If the truck must be towed, use a rigid tow bar. Check the truck frame for a decal recommending special towing precautions. Also refer to Operating Instructions - Section 30, Towing.
 - Drain, clean and ventilate fuel tanks and/or hydraulic tanks before making any welding repairs.

WARNING

Any operating fluid, such as hydraulic oil, escaping under pressure can have sufficient force to enter a person's body by penetrating the skin. Serious injury and possibly death may result if proper medical treatment by a physician familiar with this injury is not received immediately.

- Relieve pressure in lines or hoses before making any disconnects.
- After adjustments or repairs, replace all shields, screens and clamps.
- Only a qualified operator or maintenance personnel who are also qualified in truck operation should move the truck under its own power in the repair facility or during road testing after repairs are complete.

SPECIAL PRECAUTIONS FOR WORKING ON AC DRIVE TRUCKS

Before welding or repairing an AC drive truck, maintenance personnel should notify a Komatsu service representative. Only qualified personnel, specifically trained for servicing the AC drive system, should perform this service.

If it is necessary to perform welding or repair to the truck without the field engineer present, the following procedures must be followed to ensure that the truck is safe for maintenance personnel to work on and to reduce the chance for damage to equipment.



Anytime the engine is running, do not open any of the cabinet doors or remove any covers. Do not use any of the power cables for hand holds or foot steps. Do not touch the retarding grid elements.



Before opening any cabinets, removing any covers, or touching a retarding grid element or power cable, the engine must be shut down and the green link voltage light must be illuminated.

Engine Shutdown Procedure Before Welding or Performing Maintenance

Normal operation of the drive system at shutdown will leave the system safe to maintain. However, in the event of a system failure, performing the following procedure prior to any maintenance activities will ensure that no hazardous voltages are present in the AC drive system.

1. Before shutting down the engine, verify the status of all the drive system status lights on the status indicator panel.

If any drive system warning messages are displayed, DO NOT attempt to open any cabinets, disconnect any cables, or reach inside the retarder grid cabinet without a trained drive system technician present - even if engine is off.

Only qualified personnel, specifically trained for servicing the A-C drive system, must perform this service.

2. If there are no drive system warning messages, follow all of the instructions for "Safe Parking Procedures."
3. After the engine has stopped, open the access panel at the left front side of the control cabinet. Verify that the green link voltage light is illuminated and the DC bus voltage gauge reads 0.0 V. Notify qualified drive system maintenance personnel if the green link voltage light remains off longer than five minutes after engine shutdown.
4. Locate the alternator cutoff switch in the front access panel on the left side of the main control cabinet. Place the CUTOFF switch in the ON position. This will prevent the alternator from re-energizing and creating system voltage until the switch is returned to the previous position.
5. Ensure both battery disconnect switches are in the OFF position. Verify that the battery disconnects are functioning.
6. Leave the drive system in the rest mode until the truck is to be moved.

Precautions Before Welding or Performing Maintenance

1. Open the access panel at the right front side of the control cabinet. Verify that the green link voltage light is illuminated and the DC bus voltage gauge reads 0.0 V. Notify qualified drive system maintenance personnel if the green link voltage light remains off longer than five minutes after engine shutdown.
2. Locate the alternator cutoff switch access panel at the right front side of the control cabinet. Place the CUTOFF switch in the ON position. This will prevent the alternator from re-energizing and creating system voltage until the switch is returned to its former position.
3. Before doing any welding on the truck, always disconnect the battery charging alternator lead wire.
4. **Do not weld on any drive system components!** Consult your Komatsu service representative before attempting any welding procedures.
5. Power cables must be cleated in wood or other non-ferrous materials. DO NOT repair cable cleats by encircling the power cables with metal clamps or hardware. Always inspect power cable insulation before servicing the cables and returning the truck to service. Discard cables with broken insulation.

6. Power cables and wiring harnesses must be protected from weld spatter and heat.

Always fasten the welding machine ground (-) lead to the piece being welded. **The grounding clamp must be attached as near as possible to the weld area.**

Avoid laying welding cables over or near the truck electrical harnesses. Welding voltage could be induced into the electrical harness and cause damage to components.

Before welding on the truck, disconnect the battery charging alternator lead wire and isolate the electronic control components. Also, disconnect the negative and positive battery cables of the truck. Failure to do so may seriously damage the battery and electrical equipment.

Never allow welding current to pass through ball bearings, roller bearings, suspensions or hydraulic cylinders.

7. If the green link voltage light is off and the DC bus voltage gauge reads more than 0.0 V after following the precautions, a fault has occurred.

Leave all cabinet doors in place. Do not touch the retarding grid elements. Do not disconnect any power cables or use them as hand or foot holds.

Notify your Komatsu service representative immediately. Only qualified personnel who are specifically trained for servicing the AC drive system should perform this service.

8. After welding or maintenance is complete, install all covers and close all access doors. Place the alternator cutout switch and battery disconnect switches in their original positions. Reconnect all harnesses before starting the truck.

NOTE: Leave the drive system in the "rest" mode until the truck is to be moved.

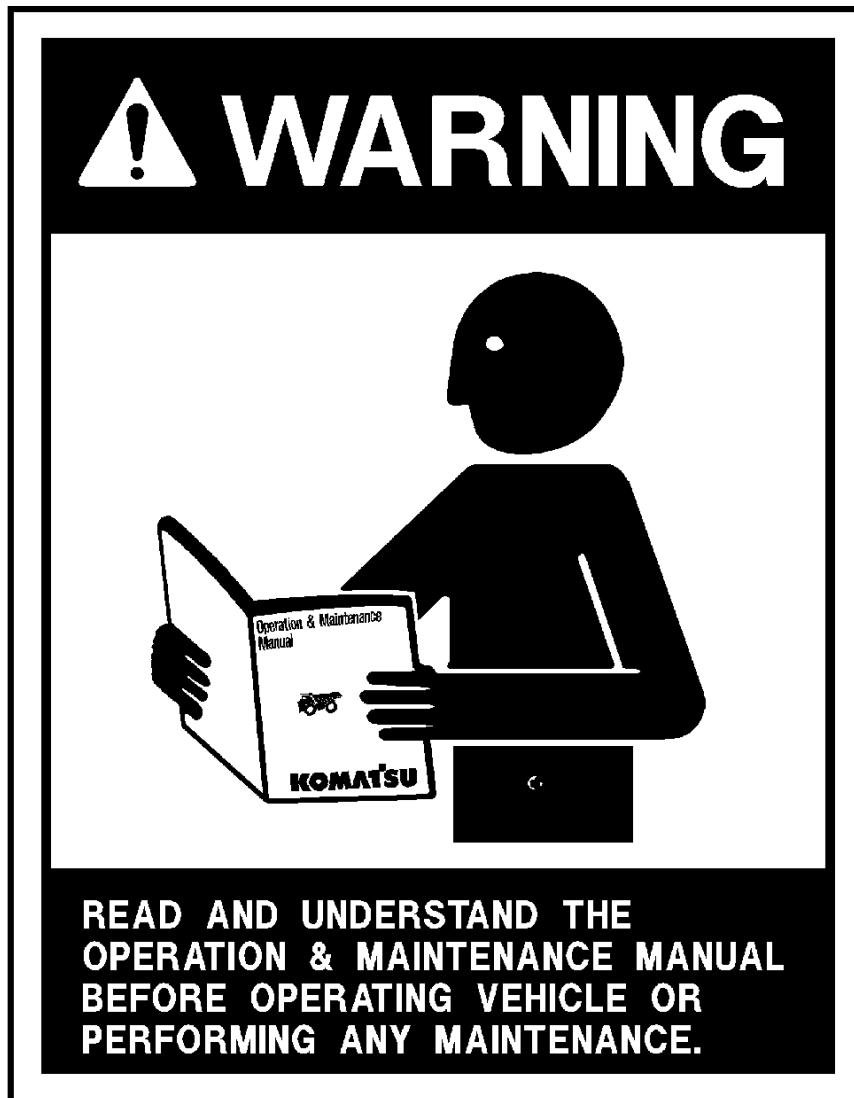

NOTES

WARNINGS AND CAUTIONS

The following pages give an explanation of the warning, caution, and service instruction plates and decals attached to the truck. The plates and decals listed here are typical of this Komatsu model, but because of customer options, individual trucks may have plates and decals that are different from those shown here.

The plates and decals must be kept clean and legible. If any decal or plate becomes damaged or illegible, replace it with a new one.

GRADE/SPEED CHART

A grade/speed retard chart is located on the left front post of the operator's cab. It provides the recommended maximum speeds to be used when descending various grades with a loaded truck. Always refer to the decal in operator's cab. This decal may change with optional truck equipment such as wheel motor drive train ratios, retarding grids, tire sizes, etc.

CAUTION

DO NOT DESCEND GRADES AT SPEEDS GREATER THAN LISTED WHEN VEHICLE IS LOADED AT MAX. G.V.W. 1,001,700 LB. (454,492 kg) & 50/80 R 57 TIRES.

ACTUAL GRADE %	SPEED KM/H(MPH)
12 _____	25(16)
10 _____	31(19)
8 _____	40(25)
6 _____	48(30)
4 _____	62(39)

THE ACTUAL GRADE CAPABILITY WILL VARY DEPENDING ON OUTSIDE TEMPERATURE, SYSTEM TEMPERATURE, ROLLING RESISTANCE, LOAD, AND TIRE SIZE. THE ABOVE IS BASED ON 32°C (90°F) OUTSIDE TEMPERATURE AND ASSUMES THAT ROAD AND VISIBILITY CONDITIONS PERMIT THE USE OF ALL AVAILABLE RETARDING TORQUE WITHOUT SKIDDING. FOR ADDITIONAL BRAKING AND RETARD INFORMATION, SEE OPERATION MANUAL.

○ SPEED VALUES BASED ON 1% ROLLING RESISTANCE ○

WB3564

INSTRUMENT PANEL

A warning decal is below the key switch located to the right of the steering column on the instrument panel. The warning stresses the importance of reading the operator's manual before operation.

WARNING

KEY SWITCH

DO NOT OPERATE VEHICLE BEFORE READING AND UNDERSTANDING OPERATION MANUALS.

WB2490

Another warning decal is located to the right of the steering column on the instrument panel. The warning stresses the importance of placing the selector lever in PARK before exiting the cab.

WARNING

SHIFT SELECTOR MUST BE PLACED IN PARK POSITION BEFORE EXITING OPERATOR CAB. FAILURE TO DO SO MAY RESULT IN UNEXPECTED MOVEMENT OF VEHICLE.

WB3295

BATTERIES

Attached to the exterior of the battery box is a danger decal which stresses the need to keep from making any sparks near the battery. When another battery or 24VDC power source is used for auxiliary power, all switches must be OFF before making any connections. When connecting auxiliary power cables, positively maintain correct polarity. Connect the positive (+) posts together and then connect the negative (-) lead of the auxiliary power cable to a good frame ground. **Do not connect to the negative posts of the truck battery or near the battery box.** This hookup completes the circuit but minimizes the danger of sparks near the batteries.

Sulfuric acid is corrosive and toxic. Use proper safety gear, goggles, rubber gloves and a rubber apron when handling and servicing batteries. If sulfuric acid is swallowed, gets into your eyes or contacts your skin, get proper medical help immediately.

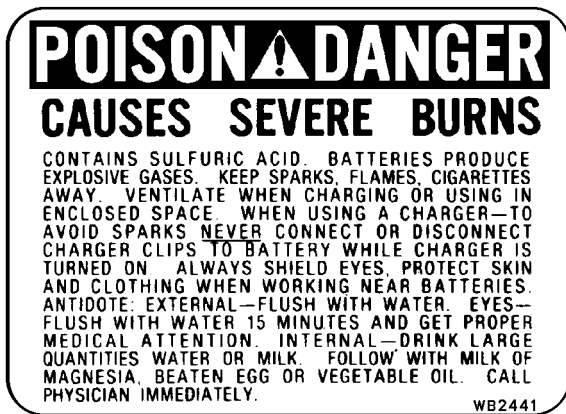

This decal is also attached to the exterior of the battery box. It details the correct procedure for disconnecting the battery cables from the batteries.

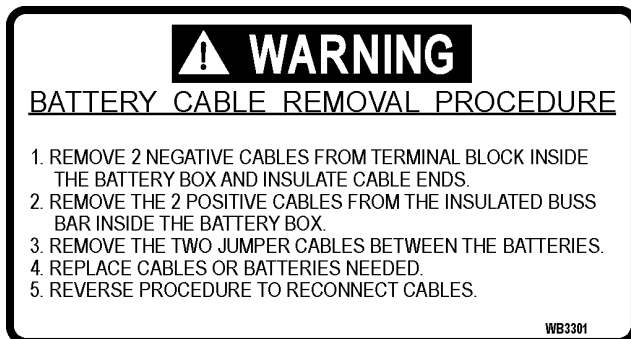

This decal is placed on the exterior of the battery box and near the battery disconnect switches to indicate that the battery system (24VDC) is a negative (-) ground system.



These decals are placed above the battery disconnect switches on the side of the battery box to indicate OFF and ON positions of the switches.

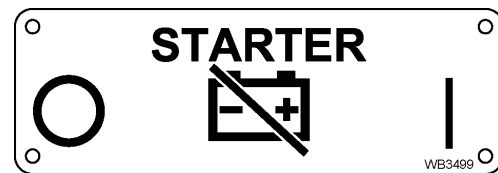
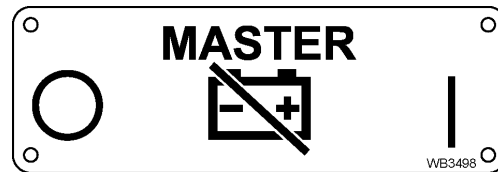

HIGH VOLTAGE

A high voltage danger plate is attached to the access door of the rear axle housing.

High voltage may be present! Only authorized personnel should access this rear housing.



RADIATOR

A warning plate is mounted on top of the radiator surge tank cover near the radiator cap. The engine cooling system is pressurized. **Always turn the key switch OFF and allow the engine to cool before removing the radiator cap.** Unless the pressure is first released, removing the radiator cap after the engine has been running for a time will result in hot coolant being expelled from the radiator. **Serious scalding and burning may result.**

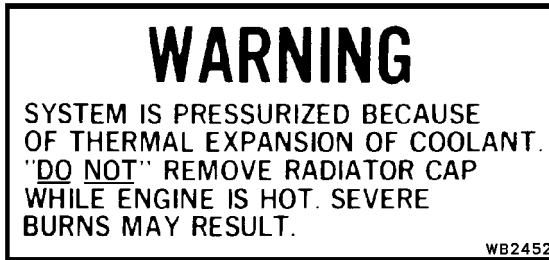
**CRUSHING HAZARD**

Warning plates are mounted on the frame in front of both front tires and to the rear of both front tires. They warn that the clearances change when the truck is steered and could cause serious injury.



Warning plates are attached to both the hydraulic tank and fuel tank to alert technicians not to work on the truck with the body in the raised position unless the body-up sling is in position.

**CYLINDER PRESSURE**

These danger plates are mounted on the outside of each frame rail to remind technicians to read the warning labels attached to the side of each of the accumulators (see below) before releasing internal nitrogen pressure or disconnecting any hydraulic lines or hardware. There are similar decals mounted on top of each of the accumulators (both steering and brake) with the same danger message.



This danger plate is attached to all four suspensions. It contains instructions for releasing internal pressure before disconnecting any hardware. Serious injury can occur if these directions are not followed.

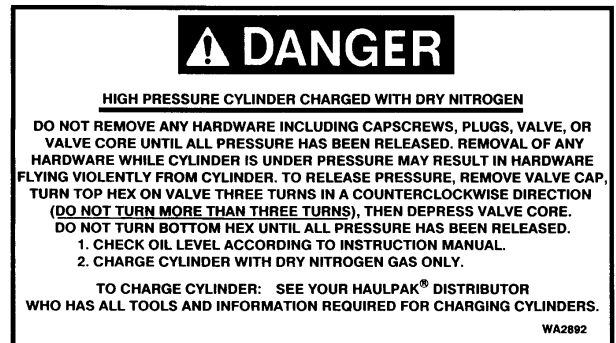

FILLING THE HYDRAULIC TANK

A plate mounted on the side of the hydraulic tank provides instructions for filling the hydraulic tank.

To lessen the chances of system contamination, keep the system open to the atmosphere only as long as absolutely necessary. Service the tank with clean Type C-4 hydraulic oil. All oil that is being put into the hydraulic tank should be filtered through 3 micron filters.

ATMOSPHERIC BREATHER SYSTEM

FILLING INSTRUCTIONS:

1. WITH ENGINE STOPPED, KEY SWITCH OFF AND BODY DOWN, FILL TANK TO TOP SIGHT GLASS.
2. RAISE AND LOWER BODY 3 TIMES.
3. REPEAT STEPS 1 AND 2 AND ADD OIL UNTIL LEVEL IS AGAIN AT TOP SIGHT GLASS.
4. OIL MUST BE VISIBLE IN UPPER SIGHT GLASS WITH ENGINE STOPPED. BODY DOWN AND KEY OFF FOR 90 SECONDS. OIL MUST BE VISIBLE IN LOWER SIGHT GLASS WITH ENGINE RUNNING AND BODY DOWN. REPEAT STEP 1 IF NECESSARY.

WB2724

A caution decal is attached below the hydraulic tank oil level sight gauge. Check the oil level with the body down, engine stopped, and key switch OFF. Add oil per filling instructions if the oil level is below the top of the sight glass.

 **CAUTION**

**DO NOT ADD OIL
UNLESS ENGINE IS
STOPPED, KEY IS
OFF, AND BODY
IS DOWN**

WA6628

HYDRAULIC OIL PRESSURE

A warning plate is attached to the hydraulic tank to warn technicians that high pressure hydraulic oil is present during operation. When it is necessary to open the hydraulic system, be sure the engine is stopped and the key switch is OFF to bleed down hydraulic pressure. There is always a chance of residual pressure being present. Open fittings slowly to allow all pressure to bleed off before removing any connections.

WARNING

HIGH PRESSURE

**DO NOT LOOSEN OR DISCONNECT
ANY HYDRAULIC LINE OR
COMPONENT UNTIL ENGINE IS
STOPPED AND KEY SWITCH IS
OFF.**

WB2439

This warning decal is located near the battery disconnect switches to warn personnel not to disconnect the batteries during the first two minutes after the engine has stopped.

Turn the key switch to the OFF position and wait for the engine to stop. After the engine has stopped, wait two minutes, and if no warning lights illuminate, then turn the battery disconnect switches to the OFF position.

The first two minutes after the engine has stopped is the bleeddown process. Turning the battery disconnect switches off within two minutes could interrupt the bleeddown process and leave stored energy in the accumulator. Wait two minutes after the engine has stopped, then observe for bleeddown malfunction warning message in dash panel. If a warning is being displayed, notify maintenance immediately. Turning the battery disconnect switches to the OFF position sooner than two minutes could mask a problem that was detected during the bleeddown process.

 **WARNING**

STORED ENERGY HAZARD

NEVER OPEN BATTERY DISCONNECT SWITCH DURING THE FIRST TWO MINUTES AFTER THE ENGINE HAS SHUT DOWN. DOING SO WILL PREVENT THE STEERING ACCUMULATORS FROM BLEEDING DOWN, RESULTING IN STORED ENERGY REMAINING IN THE HYDRAULIC SYSTEM WHICH COULD RELEASE SUDDENLY, OR UNEXPECTEDLY ALLOW THE TIRES TO STEER CAUSING INJURY OR DEATH.

WB3565

EMERGENCY TOWING PROCEDURE

A decal which provides the operator or technician with the emergency procedure for towing a disabled truck is located on the left frame rail near the steering accumulators.

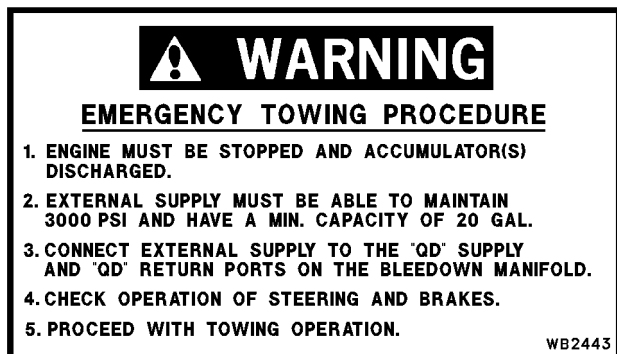

EMERGENCY DUMP PROCEDURE

A decal which provides the operator or technician with the emergency procedure for dumping a loaded, disabled truck by using a functional truck for hydraulic power is located on the frame near the left hoist cylinder.

Refer to Section L in the shop manual for additional information about using this procedure.

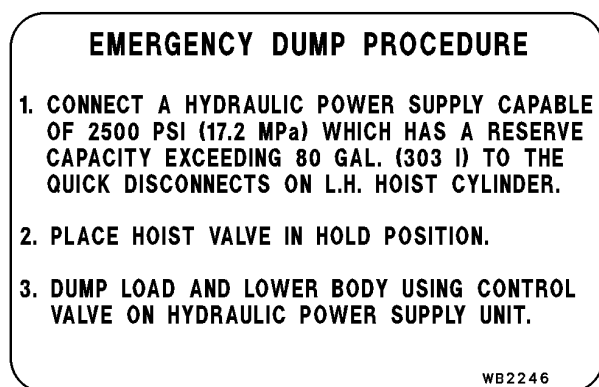

ACCUMULATOR DRAIN VALVES

Warning decals are applied inside the brake system cabinet behind the operator cab. These decals remind servicing technicians to close the accumulator drain valves after they have been opened to bleed the brake pressure. It further warns not to overtighten the drain valves in order to prevent damage to the valve seat(s).

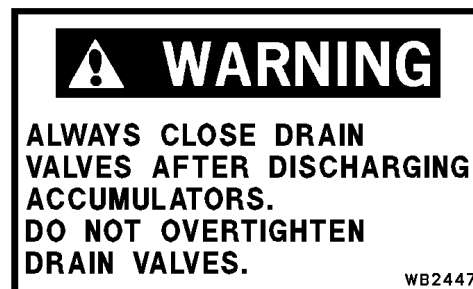

GREASE POINT

This decal is located on the rear of the alternator. It cautions maintenance personnel not to over grease the rear bearing on the alternator. Refer to the Lubrication section of this manual for proper lubrication instructions.



WELDING

This caution decal is placed near the battery disconnect switches on the side of the battery box to alert service technicians to always disconnect the battery charging alternator lead wire before making welding repairs.

In addition, always isolate electronic control components and disconnect the positive and negative battery cables of the vehicle. Failure to do so may seriously damage the battery and electrical equipment.



Always fasten the welding machine ground (-) lead to the piece being welded. **The grounding clamp must be attached as near as possible to the weld area.** Never allow welding current to pass through ball bearings, roller bearings, suspensions, or hydraulic cylinders. Always avoid laying welding cables over or near the vehicle electrical harnesses. Welding voltage could be induced into the electrical harness and possibly cause damage to components.

EMERGENCY SHUTDOWN

This decal is placed on the ground level engine shutdown switch, which is mounted on the right side of the front bumper structure. It specifies that this switch is for emergency shutdown only.

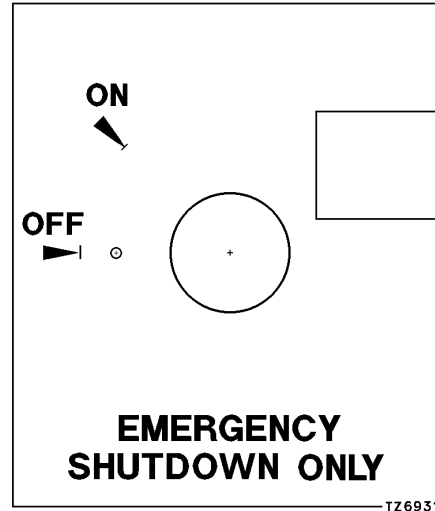

LIFTING POINT

This page illustrates a decal which is placed on deck mounted cabinets, housings, and structures that must be lifted from specific points in order to safely move them.

If any of these decals is damaged or defaced so it is no longer legible, it should be replaced immediately.

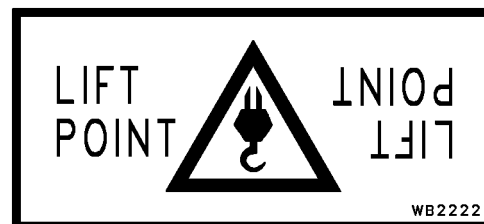

SPRING PRESSURE

This danger plate is mounted on each brake assembly. It warns the service technician that there are springs inside the brake assembly under pressure. Refer to the shop manual for proper procedure to safely disassemble the brake assembly.



EMERGENCY EGRESS

This caution decal is placed near both vertical ladders on either side of the radiator. It informs personnel that these ladders are intended for emergency use only. The diagonal ladder in front of the radiator is the preferred ladder to use.



ROPS/FOPS

A plate attached to the right rear corner of the cab states that the Rollover Protective Structure (ROPS) and Falling Object Protective Structure (FOPS) meet various ISO performance requirements.

The plate also contains a WARNING about making modifications or repairs to the structure. Unauthorized modifications or repairs will void the certification.



Wireless Signal

Wireless signals from the trucks KOMTRAX Plus system (if equipped with ORBCOMM) can interfere with other wireless signals in the area. This interference can cause a malfunction in a blast zone resulting in an unintended detonation. Know the location of blast zones in the area and keep a safe distance to avoid unintentional blasts. The KOMTRAX Plus system uses frequencies 148Hz to 150Hz

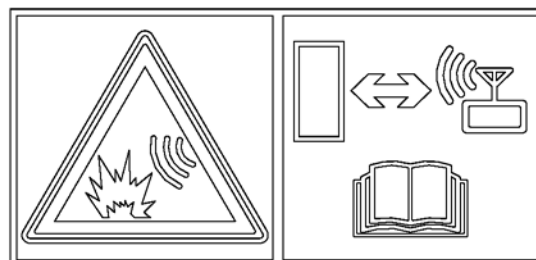

09845 - 00480

OIL FILL AND CHECK

A wheel motor oil level decal is attached to the gear cover on both electric wheel motors. This decal stresses the fact that the truck must be on a level surface and parked for 20 minutes prior to checking the oil level. This is necessary in order to get an accurate reading.

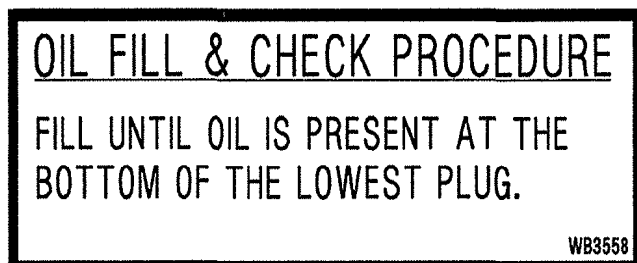

PRODUCT IDENTIFICATION PLATE

A product identification plate is located on the frame in front of the right side front wheel. It shows the Truck Model Number, Maximum GVW, and Product Identification Number (PIN).

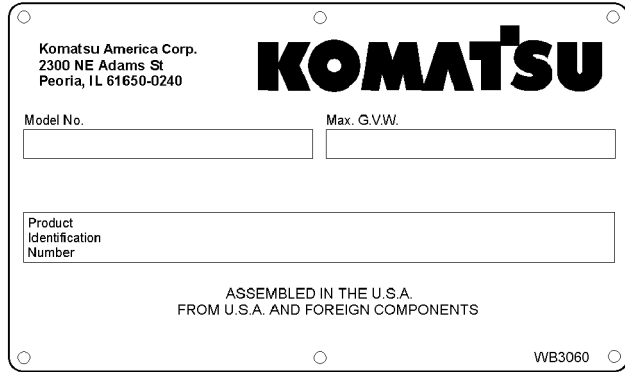

The Product Identification Number (PIN) consists of a total of 19 characters. The first and last characters are tamper preventive symbols (*). The remaining 17 alpha/numeric characters are used to identify the following five characteristics of the machine:

WMC - Character positions 1, 2 and 3 identify the Worldwide Manufacturer Code (WMC). The WMC designates the manufacturer of the product. Komatsu brand products are identified with the letters KMT.

MDS - Character positions 4, 5, 6, 7 and 8 identify the Machine Descriptor Section (MDS). The MDS code identifies general information regarding machine specifications. The MDS is a code for the machine type and model.

CL - Character position 9 identifies the Check Letter (CL). The CL is used to verify the accuracy of the individual PIN.

FC - Character positions 10 and 11 identify the Factory Code (FC). The FC identifies the Komatsu factory in charge of claims for the product. The FC for electric drive trucks is 61.

SN - Character positions 12, 13, 14, 15, 16 and 17 identify the Serial Number (SN). The SN is a unique sequential number.

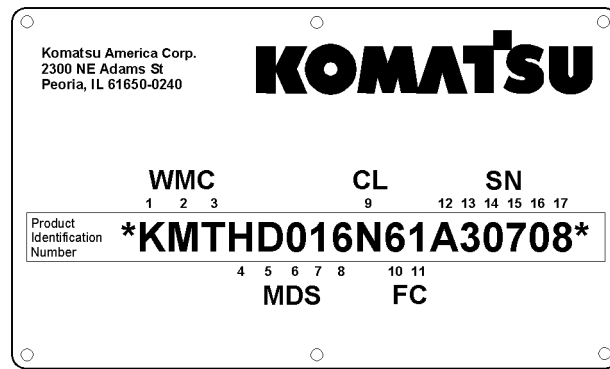

LUBRICATION CHART

The lubrication chart is mounted on the right side of the radiator grille structure. Refer to Section 40, Lubrication and Service, for more complete lubrication instructions.

LUBRICATION CHART		LUBRICATION SPECIFICATIONS												
LINE NO.	TYPE/LUBRICANT	LINE NO.	TYPE/LUBRICANT											
1	ENGINE OIL	1	SEE ENGINE MANUAL											
2	HYDRAULIC OIL	2	ISO-VG 46 ***											
3	TRANSMISSION OIL	3	ISO-VG 46 ***											
4	DIFFERENTIAL OIL	4	ISO-VG 46 ***											
5	WHEEL END OIL	5	ISO-VG 46 ***											
6	STEERING OIL	6	ISO-VG 46 ***											
7	WHEEL END OIL	7	ISO-VG 46 ***											
8	WHEEL END OIL	8	ISO-VG 46 ***											
9	WHEEL END OIL	9	ISO-VG 46 ***											
10	WHEEL END OIL	10	ISO-VG 46 ***											
11	WHEEL END OIL	11	ISO-VG 46 ***											
12	WHEEL END OIL	12	ISO-VG 46 ***											
13	WHEEL END OIL	13	ISO-VG 46 ***											
14	WHEEL END OIL	14	ISO-VG 46 ***											
15	TRACTION MOTOR BEARING	15	SEE SERVICE MANUAL											
16	TRACTION MOTOR BEARING	16	SEE SERVICE MANUAL											
17	TRACTION MOTOR BEARING	17	SEE SERVICE MANUAL											
18	TRACTION MOTOR BEARING	18	SEE SERVICE MANUAL											
19	TRACTION MOTOR BEARING	19	SEE SERVICE MANUAL											
20	TRACTION MOTOR BEARING	20	SEE SERVICE MANUAL											
21	TRACTION MOTOR BEARING	21	SEE SERVICE MANUAL											

OPERATING INSTRUCTIONS

PREPARING FOR OPERATION

The safest trucks are those which have been properly prepared for operation. At the beginning of each shift, a careful check of the truck should be made before attempting to start the engine.

Safety is thinking ahead. Prevention is the best safety program. Prevent a potential accident by knowing the employer's safety requirements, all necessary job site regulations, and use and care of the safety equipment on the truck. Only qualified operators or technicians should attempt to operate or maintain a Komatsu truck.

Safe practices start before the operator gets to the equipment.

- Wear the proper clothing. Loose fitting clothing, unbuttoned sleeves and jackets, jewelry, etc., can catch on a protrusion and cause a potential hazard.
- Always use the personal safety equipment provided for the operator such as hard hats, safety shoes, safety glasses or goggles. There are some conditions when protective hearing devices should also be worn for operator safety.
- When walking to and from the truck, maintain a safe distance from all machines, even if the operator is visible.

WALK AROUND INSPECTION

At the beginning of each shift, a careful walk around inspection should be performed before attempting to start the engine. A walk around inspection is a systematic ground level inspection of the truck and its components to ensure that the truck is safe to operate before entering the operator's cab.

Start at the left front corner of the truck (see the illustration on the next page) and move in a counterclockwise direction. Move front-to-rear, across the rear, and continue forward up the opposite side of the truck to the original starting point.

If these steps are performed in sequence and are repeated from the same point and in the same direction before every shift, many potential problems may be avoided or scheduled for maintenance. Unscheduled downtime and loss of production can be reduced as a result.

Local work practices may prevent an operator from performing all tasks suggested here. To the extent permitted, the operator should follow this routine.



High voltage may be present on this truck! DO NOT open any electrical cabinet doors on this truck while the engine is running. Never climb on any power cables or use power cables for handholds or footholds unless the engine has been shut down and the system has been verified to be at "rest".

START HERE

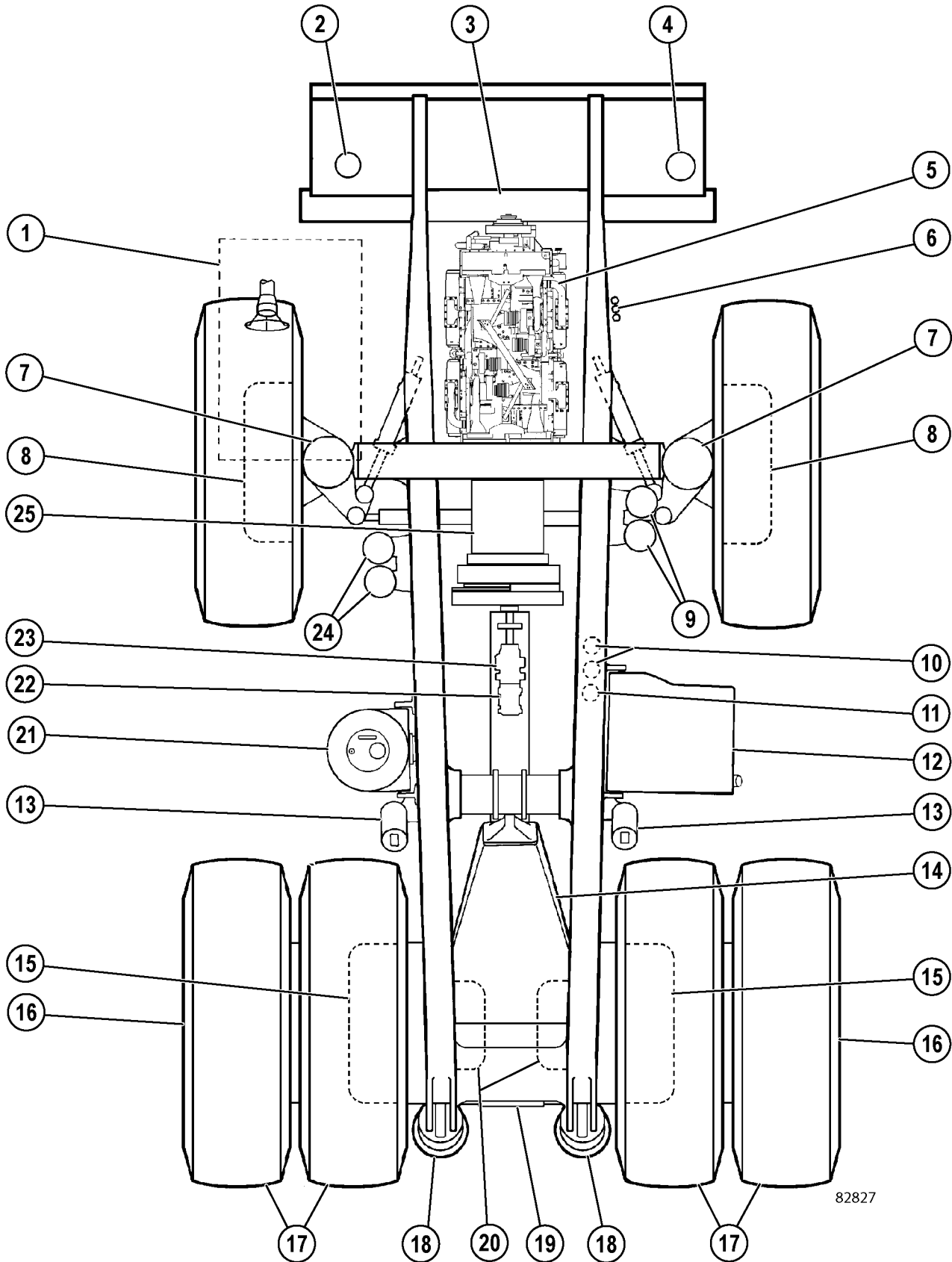

82827

FIGURE 30-1. TOP VIEW

FIGURE 30-1. TOP VIEW

1. Operator Cab
2. Auto Lubrication
3. Radiator
4. Reserve Oil System
5. Engine
6. Fuel Filters
7. Suspension
8. Wet Disc Brake
9. Brake Accumulators
10. Hoist Filters
11. Steering Filter
12. Fuel Tank
13. Hoist Cylinder
14. Rear Axle Housing
15. Wet Disc Brake
16. Wheel Motor Transmission
17. Rear Tires
18. Rear Suspension
19. Rear Axle Hatch
20. AC Electric Motor
21. Hydraulic Tank
22. Steering Pump
23. Hoist Pump
24. Steering Accumulators
25. Alternator

1. Start at left front of truck. Visually inspect all lights and safety equipment for damage. Ensure that the lenses are clean and unbroken.
2. Empty the dust collectors on the left side air cleaner assemblies. (A ladder may be necessary to reach the air cleaners.) Ensure that the battery box covers are in place and secure.
3. Inspect the auto lube system (2, Figure 30-1). See Section 42, Automatic Lubrication System, for more information about the auto lube system.
4. Move in front of the left front tire. Inspect the hub and brake assemblies for leaks and any abnormal conditions.

5. Check that all suspension attaching hardware is secure. Inspect the mounting key area for evidence of wear. Check that the suspension extension (exposed piston rod) is correct and that there are no leaks.
6. With the engine stopped, check the engine oil level. First pull the dipstick out and wipe it clean. Then insert and pull the dipstick again and then check the oil level. Use the service light, if necessary.
7. Inspect the air conditioner belts for correct tension, obvious wear, and tracking. Check that the fan guard is secure and in good condition. When leaving this point, turn off the service light if used.
8. Ensure that the anchor end of the steering cylinder is secure and properly greased.
9. Move outside of the front wheel. Ensure that all of the wheel attaching nuts/studs are in place and tight. Check the tires for cuts, damage, or bubbles. Check for evidence of incorrect tire inflation.
10. Move in behind the front wheel. Check that the steering cylinder is properly greased and the attaching hardware is tight. Check the suspension attaching hardware and suspension extension. Ensure that the suspension protective boot is in good condition. Inspect the hub and brakes for any unusual conditions. Check the entire area for leaks.
11. Inspect the sight glass on hydraulic tank (21). With the engine stopped and the body down, hydraulic fluid must be visible in the upper sight glass.
12. If equipped, verify that all hydraulic tank shut off valves are locked in their fully open positions.
13. Move around the hydraulic tank and in front of the rear dual tires. Inspect the hoist cylinder for any damage and leaks. Ensure that both upper and lower hoist cylinder pins are secure and properly greased.

14. Look under the lower edge of the chassis to ensure that the flexible duct that carries the air from the main blower to the final drive housing is in good condition. Also look up at the main hydraulic pumps to see if there is any leakage or any other unusual condition with the pumps or pump drive shafts.
15. Move around the left side dual tires. Check that all wheel nuts/studs are in place and tight. Inspect the wheel for any oil that would indicate brake leakage or wheel motor leakage.
16. Check the dual tires for cuts, damage, and bubbles. Verify that tire inflation is correct. If the truck has been run on a "flat," the tire must be cooled before moving the truck inside. Check for any rocks that might be lodged between the dual tires.
17. Inspect the left rear suspension for damage, correct rod exposure, and leaks. Ensure that the covers over the chrome piston rod are in good condition.
18. While standing at the rear hatch, look up to check that the rear lights and back-up horns are in good condition. Look up at panhard rod to check that it is properly greased. Also check both body hinge pins for proper greasing and any abnormal condition. Check the hoist limit switch and clear any mud or debris from the contacts.
19. Perform the same inspections on the right rear suspension.
20. Move around the right side dual tires. Inspect between the tires for rocks. Inspect the tires for cuts, damage and proper inflation.
21. Check that all wheel nuts/studs are in place and tight. Inspect the wheel for any oil that would indicate brake leakage or wheel motor leakage.
22. Move in front of right dual tires. Inspect the hoist cylinder in the same manner as the left side. Ensure the body-up limit switch is secure and in good condition. Remove any mud or dirt accumulation from the switch.
23. Move around fuel tank (12). Inspect the fuel gauge. This should agree with the fuel gauge in the cab. Inspect the attaching hardware for the fuel tank at the upper saddles and at the lower back side of the tank. Check the hoist filters for leaks.
24. Move in behind the right front wheel. Check that the steering cylinder is properly greased and the attaching hardware is secure. Check the suspension attaching hardware and suspension extension. Ensure that the suspension protective boot is in good condition. Inspect the hub and brakes for any unusual conditions. Check the entire area for leaks.
25. Move out and around the right front wheel. Check that all wheel nuts/studs are in place and tight.
26. Move behind the front of the right front wheel. Check the hub and brakes for leaks and any unusual conditions. Check that the steering cylinder is secure and properly greased. Inspect the engine compartment for any leaks and unusual conditions. Inspect the fan guard and belts. Check the fuel filters for leaks. Check for any debris behind the radiator.
27. Move around to the right front of the truck. Empty the dust collectors on the right side air cleaner assemblies. (A ladder may be necessary to reach the air cleaners.) If equipped, check the oil level in the reserve tank.
28. As you move in front of radiator (3), remove any debris that is stuck in front of the radiator. Check for any coolant leaks. Inspect the headlights and fog lights.

29. Before climbing the ladder to first level, ensure that the ground level engine shutdown switch is activated. If equipped, inspect the fire control actuator. Ensure that the safety pin is in place and the plastic tie that prevents accidental actuation is in place and in good condition. Ensure that the battery disconnect switches are activated.

⚠ WARNING

Always mount and dismount ladders facing the truck. Never attempt to mount or dismount while the truck is in motion.

30. Always use handrails and ladders when mounting or dismounting the truck. Clean any foreign material such as ice, snow, oil or mud from the ladders and handrails.

⚠ WARNING

If the engine has been running, allow the coolant to cool before removing the fill cap or draining the radiator. Serious burns may result if skin comes in contact with hot coolant.

31. Use the coolant level sight gauge to check the coolant level in the radiator. If it is necessary to remove the radiator cap, ensure the engine is shut down and relieve coolant pressure by *slowly* removing the radiator cap.
32. Inspect the retarding grid and covers. Ensure that the latches are in place and secure. Inspect the main air inlet to be sure it is clear. Ensure that all cabinet door latches are secure.

33. Check the coolant level in the inverter cabinet radiator. The coolant level must be visible at the halfway mark in the upper sight gauge.
34. Move around to the rear of the cab. Open the doors of the brake cabinet and check inside the cabinet for leaks.
35. Clean the cab windows and mirrors. Clean out the cab floor, if necessary. Ensure that the steering wheel, operator controls, and pedals are free of any grease or mud.
36. Stow any personal gear in the cab so that it does not interfere with any operation of the truck. Dirt or trash buildup, specifically in the operator's cab, should be cleared. Do not carry tools or supplies in the cab or on the deck.
37. Adjust the seat and the steering wheel for the operator's comfort.
38. Before operating the truck, read about and understand the locations and functions of all operator controls listed in Section 32, Operator Cab And Controls.

ENGINE START-UP



Never attempt to start the engine by shorting across the starter terminals. This may cause fire, or serious injury or death to anyone in the machine's path. Start the engine from the operator's seat only.

If the truck is equipped with an auxiliary cold weather heater system, do not attempt to start the engine while the heaters are in operation. Damage to the coolant heaters will result!

1. Ensure that all personnel are clear of the truck before starting the engine. Always sound the horn as a warning before moving any controls.
2. If the truck is in an enclosure, ensure that there is adequate ventilation before start-up. Exhaust fumes are dangerous!
3. Ensure that the directional control lever is in PARK before starting.

NOTE: The park brake will always be applied whenever the directional control lever is in the park position and the truck is moving slower than 0.5 mph.

4. Press on the small red tab (to unlock the switch), then press on the top of the rest switch to put the drive system in the rest mode of operation. For more information, refer to Section 32, Operator Cab And Controls.
5. The key switch is a three position (OFF, RUN, START) switch. When the switch is rotated one position clockwise, it is in the RUN position and all electrical circuits (except START) are activated.
 - a. Turn key switch to the RUN (not START) position. Verify that all indicator lights and gauges are functioning.
 - b. After the message "System Initializing" is displayed, rotate the key switch fully clockwise to the START position, and hold this position until the engine starts (see NOTE below). The START position is spring-loaded and will return to RUN when the key is released.

NOTE: This truck is equipped with an engine prelube system. With this feature, a noticeable time delay may occur (while engine lube oil passages are being filled and pressurized) before engine cranking will begin.

- c. After the engine has started, place the rest switch in the OFF position to enable the drive system. Refer to the discussion on the rest switch in Section 32, Operator Cab Controls.

NOTE: In cold ambient conditions and when the engine is cold, the engine rpm will not increase above low idle speed until the engine controller determines it is safe to do so. This time delay will vary from 30 seconds to 11 minutes which allows the coolant and engine oil to warm up. A warning light will also be illuminated indicating that the engine is too cold for truck operation.



Starting fluid is extremely volatile and flammable! Use with extreme care.

If truck is equipped with optional engine starting aid and ambient temperature is below 10°C (50°F), turn the key switch to the START position, and while cranking the engine, move the engine starting aid switch to the ON position for three seconds **MAXIMUM**, then release engine starting aid. If the engine does not start, wait 15 seconds before repeating the procedure.

NOTE: The electric cranking motors have a 30 second time limit. If the 30 second limit is reached, cranking will be prohibited for two minutes. After two minutes, cranking will be allowed. If the 30 second limit is reached seven consecutive times, the key switch must be turned to the OFF position. This will allow the interface module to power down and reset, which requires seven minutes to complete. A warning will be displayed in the monitor panel if the 30 second time limit or seven attempts is reached.



AFTER ENGINE HAS STARTED

Do not leave the truck unattended while the engine is running. Move the directional control lever to PARK and turn off the engine before leaving the truck.

1. Become thoroughly familiar with steering and emergency controls. After the engine has been started, DO NOT accelerate engine speed or drive truck until low pressure and warning systems are normal, and the coolant temperature is at least 71°C (160°F).
2. With the service brakes applied, move the directional control to the NEUTRAL position, then apply the wheel brake lock. Release the service brakes. Test the truck steering in extreme right and left directions. If the steering system is not operating properly, shut the engine off immediately. Determine the steering system problem and have it repaired before resuming operation.
3. Operate each of the truck's brake circuits at least twice prior to operating and moving the truck. These circuits include individual activation from the operator's cab of the service brake, parking brake, and wheel brake lock. With the engine running and with the hydraulic circuit fully charged, activate each circuit individually.
 - a. Park the truck on level ground.
 - b. To operate the park brake, place the directional control lever in the PARK position.
 - c. To operate the wheel brake lock, apply the service brake and move directional control lever to NEUTRAL. Release service brakes, and apply wheel brake lock. Turn the wheel brake lock OFF, then back ON again.
 - d. Release wheel brake lock and apply service brakes several times.
 - e. With service brakes applied, move directional control lever to PARK.
4. If any application or release of any brake circuit appears sluggish or improper, or if warning alarms are activated on application or release, shut the engine off and notify maintenance personnel. DO NOT operate the truck until the brake circuit in question is fully operational.
5. Check the gauges, warning lights and instruments before moving the truck to ensure proper system operation and proper instrument functioning. Pay special attention to braking and steering circuit hydraulic warning lights. If warning lights come on, shut off the engine immediately and determine the cause.
6. Ensure the headlights, work lights and taillights are in proper working order. Good visibility may prevent an accident. Check operation of the windshield wipers.
7. Any time the directional control lever is placed in the FORWARD or the REVERSE position, the engine speed will go to 1,600 rpm for 15 seconds in preparation for truck movement. If the throttle pedal is not touched within 15 seconds, engine speed will return to 750 rpm.
8. Any time the truck is moving and engine rpm is above 1,600 rpm and the throttle pedal is released, engine rpm will hold at 1,600 rpm. If the throttle pedal is not touched within 15 seconds, then engine rpm will return to 750 rpm.

MACHINE OPERATION SAFETY PRECAUTIONS

After the engine is started and all systems are functioning properly, the operator must follow all local safety rules to ensure safe machine operation.

WARNING

If the red warning light comes on or if any gauge reads in the red area during truck operation, a malfunction is indicated. Stop the truck as soon as possible and shut down the engine. Have the problem corrected before resuming truck operation.

CAUTION

The truck is equipped with "slip/slide" control. If this function becomes inoperative, operating the truck with stalled or free spinning wheel motors may cause serious damage to the wheel motors. If the truck does not begin to move within 10 seconds after depressing the throttle pedal with the directional control lever in a drive position, release the throttle pedal and allow the wheels to regain traction before accelerating again.

1. Always look to the rear before backing the truck. Watch for and obey the ground spotter's hand signals before making any reverse movements. Sound the warning horn (three blasts). The spotter should have a clear view of the entire area at the rear of the truck.
2. Operate the truck only while properly seated with seat belt fastened. Keep hands and feet inside the cab while the truck is in operation.
3. Check the gauges and instruments frequently during operation for proper readings.

4. Observe all regulations pertaining to the job site's traffic pattern. Be alert to any unusual traffic pattern. Obey the spotter's signals.
5. Match the truck speed to haul road conditions. Slow down the truck in congested areas. Keep a firm grip on the steering wheel at all times.
6. Do not allow the engine to run at idle for extended periods of time.
7. Check the parking brake periodically during your shift. Move the directional control lever to PARK only when parking the truck. Do not move the directional control lever to PARK for loading/dumping or while the truck is moving.

WARNING

Do not use the brake lock or the emergency brake (if equipped) for parking. With the engine stopped, hydraulic pressure will bleed down, allowing the brakes to release.

8. Check the brake lock performance periodically for safe loading and dump operation.
9. Proceed slowly on rough terrain to avoid deep ruts or large obstacles. Avoid traveling close to soft edges or the edge of a fill area.
10. Truck operation requires concentrated effort by the driver. Avoid distractions of any kind while operating the truck.

OPERATING ON THE HAUL ROAD

1. Always stay alert! If you are unfamiliar with the road, drive with extreme caution. The cab doors should remain closed at all times if the truck is in motion or unattended.
2. Obey all road signs. Operate the truck so it is under control at all times. Govern the truck speed by the road conditions, weather, and visibility. Report poor haul road conditions immediately. Muddy or icy roads, pot holes, or other obstructions can present hazards.
3. Initial propulsion with a loaded truck should begin from a level surface whenever possible. If there are circumstances where starting on a hill or grade cannot be avoided, refer to Starting On a Grade With a Loaded Truck.
4. When backing up the truck, give a back-up signal of three blasts on the horn. When starting forward, give two blasts on the horn. These signals must be given each time the truck is moved forward or backward.
5. Use extreme caution when approaching a haul road intersection. Maintain a safe distance from oncoming vehicles.
6. Maintain a safe distance when following another vehicle. Never follow another vehicle in the same lane closer than 15 m (50 ft). When driving on a downgrade, this distance should be at least 30 m (100 ft).
7. Do not stop or park on a haul road unless it is unavoidable. If you must stop, move the truck to a safe place, move the directional control lever to PARK and turn off the engine before leaving cab. Block the wheels securely and notify maintenance personnel for assistance.
8. Before starting up or down a grade, maintain a speed that will ensure safe driving and provide effective retarding under all conditions. Refer to Dynamic Retarding in Section 32, Operator Cab And Controls. The grade/speed retard chart in the operator's cab should always be referenced to determine the maximum safe truck speeds for descending various grades with a loaded truck.

9. When operating the truck in darkness, or when visibility is poor, do not move the truck unless all headlights, clearance lights, and tail lights are on. Do not back up the truck if the back-up horn or lights are inoperative. Always dim the headlights when meeting oncoming vehicles.
10. If the emergency steering and/or low brake pressure warning are activated during operation, steer the truck **immediately** to a safe area away from other traffic, if possible, and stop the truck. Refer to Step 7.
11. Check the tires for proper inflation periodically during your shift. If the truck has been run on a "flat", or under-inflated tire, it must not be parked in a building until the tire cools.

STARTING ON A GRADE WITH A LOADED TRUCK

Initial propulsion with a loaded truck should begin from a level surface whenever possible. If there are circumstances when starting on a hill or grade cannot be avoided, use one of the following procedures:

- The truck is equipped with an anti-roll feature to assist on hill starts without any truck rollback. This feature automatically activates the brake lock solenoid if the truck is on an incline, engine running, and the directional control lever in forward or reverse position, and the truck is stationary.

The brake lock solenoid will deactivate once the throttle pedal is depressed at least 50% and enough torque is built up to move the truck.

PASSING

1. Do not pass another truck on a hill or blind curve. Only use areas designated for passing.
2. Before passing, ensure the road ahead is clear. If a disabled truck is blocking your lane, slow down and pass with extreme caution.

LOADING

1. Pull into the loading area with caution. Remain at a safe distance while the truck ahead is being loaded.
2. Do not drive over unprotected power cables.
3. When approaching or leaving a loading area, watch out for other vehicles and personnel working in the area.
4. When pulling in under a loader or shovel, follow the spotter or shovel operator's signals. The truck operator may speed up loading operations by observing the location and loading cycle of the truck being loaded ahead, then follow a similar pattern.
5. During loading, the operator must stay in the cab with the engine running. Place the directional control lever in NEUTRAL and apply the brake lock.
6. When loaded, pull away from shovel as quickly as possible but with extreme caution.

DUMPING

Raising The Dump Body

1. Pull into the dump area with extreme caution. Ensure the area is clear of persons and obstructions, including overhead utility lines. Obey signals directed by the spotter, if present.
2. Avoid unstable areas. Stay a safe distance from the edge of the dump area.

⚠ WARNING

To prevent tipping or rolling, position the truck on a solid, level surface before dumping. As the body raises, the truck center of gravity will move.

3. Carefully maneuver the truck into the dump position. When backing the truck into the dump position, use only the foot-operated brake pedal to stop and hold the truck. Do not rely on the wheel brake lock to stop the truck. This control is not modulated and applies the **rear service brakes only**.

4. When the truck is stopped and in the dump position, apply the wheel brake lock and move the directional control lever to NEUTRAL.

⚠ WARNING

Dumping very large rocks (10% of payload or greater) or sticky material (loads that do not flow freely from the body) may allow the material to move too fast and cause the body to move rapidly and suddenly. This sudden movement may jolt the truck violently and cause possible injury to the operator and/or damage to the hoist cylinders, frame, and/or body hinge pins.

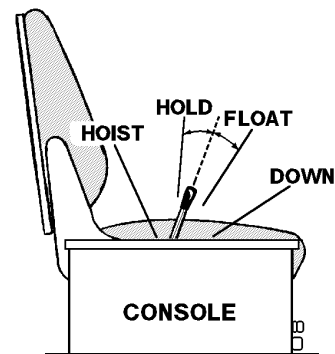

5. Pull the lever to the rear to actuate the hoist circuit. Releasing the lever anywhere during "hoist up" will hold the body at that position.
6. Raise the engine rpm to accelerate the hoist speed.
If dumping very large rocks or sticky material as described in the WARNING above, slowly accelerate the engine to raise the body. When the material starts to move, release the hoist lever to the HOLD position. If the material does not continue moving and clear the body, repeat this procedure until the material has cleared the body.
7. Reduce the engine rpm as the last stage of the hoist cylinder begins to extend. Let the engine go to low idle as the last stage reaches half-extension.
8. Release the hoist lever as the last stage of the hoist cylinder reaches full extension.
9. After the material being dumped clears the body, lower the body to the frame.

**Lowering The Dump Body
(When dumping on flat ground):**

It is very likely when dumping on flat ground that the dumped material will build up enough to prevent the body from lowering. In this case, the truck will have to be driven forward a short distance (just enough to clear the material) before the body can be lowered.

1. Move the directional control lever to FORWARD, release the brake lock, depress the override button, and drive just far enough forward for the body to clear the material.
2. Stop, move the directional control lever to NEUTRAL, and apply the brake lock.
3. Move the hoist lever forward to the DOWN position. Release the lever to place the hoist control valve in the FLOAT position, which allows the body to return to the frame.

If dumped material builds up at the rear of the body and the body cannot be lowered, then perform the following steps:

- a. Move the hoist lever back to the RAISE position to fully raise the dump body. Then release the hoist lever so it returns to the HOLD position.
- b. Move the directional control lever to FORWARD, release the brake lock, depress the override button, and drive forward to clear the material.
- c. Stop, move the directional control lever to NEUTRAL, apply the brake lock, and lower the body.

NOTE: Failure to "hoist" the body after making an unsuccessful attempt at lowering the body may result in the dump body suddenly lowering after the truck has pulled ahead of the material that was previously preventing the body from lowering.



The truck should not be moved with the dump body raised except in an emergency. Failure to lower body before moving truck may cause damage to hoist cylinders, frame and/or body hinge pins.

4. With the body returned to frame, move the directional control lever to FORWARD, release the brake lock, and leave the dump area carefully.

**Lowering The Dump Body
(When dumping over a berm or into a crusher):**

1. Move the hoist lever forward to the DOWN position. Release the lever to place the hoist control valve in the FLOAT position, which allows the body to return to the frame.

If dumped material builds up at the rear of the body and the body cannot be lowered, perform the following steps:

- a. Move hoist lever back to the HOIST position to fully raise the dump body. Release the hoist lever so it returns to the HOLD position.

NOTE: Do not drive forward if the tail of body will not clear the crusher wall in the fully raised position.

- b. Move the directional control lever to FORWARD, release the brake lock, depress the Override button, and drive forward to clear the material.
- c. Stop, move the directional control lever to NEUTRAL, apply the brake lock and lower the body.

NOTE: Failure to "hoist" the body after making an unsuccessful attempt at lowering the body may result in the dump body suddenly lowering after the truck has pulled ahead of the material that was previously preventing the body from lowering.



The truck should not be moved with the dump body raised except in an emergency. Failure to lower the body before moving the truck may cause damage to the hoist cylinders, frame and/or body hinge pins.

2. With the body returned to the frame, move the directional control lever to FORWARD, release the wheel brake lock, and leave the dump area carefully.

TROLLEY OPERATING INSTRUCTIONS

The instructions provided here are specifically for trolley use. General operating instructions outlined earlier in this chapter apply.

If a haul truck is unable to get on trolley, the operator will continue up the ramp in the diesel mode, and contact the supervisor immediately describing the problem encountered.

Operating in trolley line mode

Only trucks that are loaded will travel on the trolley line. Trucks operating on trolley will have a faster speed than when operating on diesel. Because of the faster speed, all safety and warning recommendations must be followed very closely.

All recommendations for diesel operation apply for trolley operation with the addition of the following recommendations:

1. Loaded trucks operating on diesel will not be as fast as loaded trucks that are on trolley.
2. If there is something in the path of a truck while on trolley, and it is necessary to go around it, the truck will have to drop off the trolley and use diesel power. After driving around the object, the truck can return to trolley.



Always keep the pantographs stowed in the lowered position when not in use on trolley. Never drive near or under the trolley lines with raised pantographs unless the truck is properly aligned with the trolley line. If this procedure is not followed, pantograph and line damage will occur.

3. Trolley-assist is to be used for loaded uphill haul only. Trucks must have the dump body at least half loaded, or more, before going uphill on trolley. Empty trucks are not to go uphill on trolley.

Getting on line

When operating a trolley truck, follow the procedure listed below to get on the trolley line.

1. Move the directional control lever to the T position to prepare for trolley operation.
2. Approach the trolley line equipped portion of the haul road at 8 - 16 kph (5 - 10 mph) to allow for smooth transition into trolley assist propulsion. If speed of the truck (in diesel mode) is below 8 kph (5 mph), the trolley system will not start the trolley sequence. Increase speed to 8 - 16 kph (5 - 10 mph). Sufficient distance must be allowed between trucks to prevent overloading of the trolley line electrical supply system and/or conductors and trucks being rejected from the trolley line.
3. Align the truck with the entrance area of the trolley line system when entering the overhead cables for trolley. The operator should center the truck pantographs with the cables as he enters the trolley pick up area.

NOTE: The center of operation is approximately the center of the truck cab with the left overhead power cable.

4. With accelerator pedal still fully depressed, press the pantograph raise switch and hold for 0.5 seconds or longer. The pantograph will then raise to contact the overhead cables. The "Pantograph Up" light on the Status Monitor Panel will illuminate.
5. After the pantograph is in contact with the cables for two seconds, and the voltage is within limits, the trolley sequence will complete and the wheel motor power will switch to the overhead power cables. The Status Monitor Panel indicator light for "Pantograph Energized" should illuminate. The engine speed will decrease to the low idle setting.

NOTE: If the drive system detects low voltage on the overhead power lines, the pantograph will lower and a fault message will be issued.

Operating on trolley

1. The directional control lever must remain in the T position while on trolley.
2. Truck speed is regulated by throttle pedal position.
3. If stopping or rapid slowing is required while on trolley, release the throttle pedal and depress the retarder/brake pedal as necessary. This action will lower the pantograph and the truck will switch back to diesel mode.
4. If the current leakage circuit detects a short between the overhead trolley system and the truck chassis, the pantographs will lower and the truck electrical controller will switch back to diesel mode.
5. While on trolley:
 - If something happens to cause the trolley to reject, the pantograph will lower and the truck will return to diesel power.
 - If the pantograph becomes disconnected from the trolley line for any reason, the pantograph will lower and the truck will return to diesel power.
 - If the brake/retarder pedal is used while on trolley, the pantograph will lower and the truck will return to diesel power.
 - If the truck speed drops below 8 kph (5 mph) while on trolley, the pantograph will lower and the truck will return to diesel power.
 - To obtain trolley operation again, ensure the truck is properly aligned under the power cables. With the directional control lever still in the T position, the operator can press the pantograph switch to raise it and try to connect again. The truck speed must be over 8 kph (5 mph) before this sequence will be completed.



DO NOT operate the truck on the trolley line if the truck trolley system is not working correctly.

Getting off line

As the truck approaches the end of the trolley line, it must exit the line properly. There will be signs or signals near the end of the line indicating to the operator to exit the trolley lines.

NOTE: The overhead cables taper upward as the truck approaches the end of the line. If the proper drop out sequence is not started at the right location, the truck will drive out from under the cables with the pantograph still up. This will cause damage to the pantograph because of the arcing that will occur.

1. At the designated location, the operator must press the pantograph switch to lower it, or move the directional control lever from T to F. This will start the change over process from trolley mode to diesel propulsion mode.
2. Truck speed will decrease, and the engine speed will increase to high idle.
3. The drive system will cut over to diesel propulsion mode as smoothly as possible. The Status Monitor Panel indicator light for "Pantograph Energized" and "Pantograph Up" will turn off.
4. After the pantograph is fully retracted, the operator can steer the truck out from under the trolley cables.

In the event an operator is required to get off of a trolley line to drive around an obstruction, such as rocks or disabled equipment, the operator will follow the procedure for getting off line, drive around the obstacle and follow the procedure for getting on line.



DO NOT touch the trolley assist lines unless the system has been de-energized and grounded by qualified electricians.

Only persons who have been properly trained and are qualified to perform the lock-out and grounding will be authorized to isolate the line or lines. Such authorization will be made in writing by the electrical engineering or electrical maintenance departments.

Line status signals

Line status signals are lights that advise operators whether segments of trolley lines are energized and ready to accept haulage traffic. A different status signal light is used for each section of the trolley line that is energized.

The lights are mounted to allow the driver to check the status of the line that the truck is approaching, so the pantograph can be lowered before that section of line is reached if the line is not able to accept haulage trucks. Each ramp that is trolley equipped may have several different sections of energized trolley lines that make up the trolley line for the entire ramp. Each section of line that is energized will have a separate line status signal.

Since it is important that a driver lower the pantograph before the truck reaches a de-energized section of ramp, the drivers must constantly monitor the line status signals and lower the pantograph if the line status signals indicate that an approaching section of line is not ready to accept haulage trucks.

If an operator approaches a line status signal that is indicating the line is not ready to accept haulage traffic, the driver will lower the pantograph before reaching that section of line. After proceeding past the section of line and the next line status signal indicates the next section of line is ready to accept haulage traffic, the operator will re-engage the trolley line as previously instructed and continue on trolley assist.

Trolley disconnect

Trucks operating on trolley assist may be rejected from a trolley assist line for several reasons. They include:

1. System current overload - The trolley system is capable of power output to a certain rating. If too many trucks are using a section of line at one time, this rated power output may be exceeded and the section of line will automatically de-energize, rejecting the haulage units operating on that section of line.
2. No throttle signal - If, at any time while on trolley assist, the operator releases the throttle pedal, the truck speed will slow down. When truck speed is below 8 kph (5 mph), the drive system will stop trolley operation, the pantographs will lower, and the truck will come to a stop. Then the anti-roll feature will hold the truck stationary. Move the directional control lever to the Park position immediately to hold the truck stationary.
3. Electrical system malfunction - The truck is equipped with systems that monitor the status of the trucks trolley control system. If any abnormal condition is detected in the electrical system, the electric control system will lower the pantograph, and switch the truck back to the diesel mode.

If a truck is rejected while the operator has the throttle pedal fully depressed, the transition back to a diesel mode will be smooth and the operator will notice the truck speed decrease from trolley speed to diesel speed. The truck will not stop and the operator can proceed up the ramp. If the operator releases the throttle pedal, the truck will stop in either mode.

Traffic consideration for trolley line operation

Trucks operating on trolley assist will travel faster than trucks unable to operate on trolley, most support equipment and some maintenance equipment. Because of this speed difference, trucks operating on trolley assist will actually be able to overtake some slower moving vehicles if allowed. To maintain the highest level of effectiveness and efficiency of the trolley system, it is important that all personnel operating equipment in the pit area react properly to trolley assisted haulage equipment and be aware of the proper procedures to allow faster moving haulage trucks to overtake the slower moving vehicles when possible.

Approaching slow moving vehicles in a trolley assisted truck

As trucks operating on trolley assist approach slower moving vehicles, the truck operator must begin to reduce the trolley truck speed. Operators must be looking well enough ahead to begin speed reduction before the truck gets too close behind the slow moving vehicle less than 30 meters (100 ft).

NOTE: Haul trucks must continue to maintain minimum following distances between equipment or vehicles of 30 meters (100 ft) uphill or on the level, and 60 meters (200 ft) downhill.

If a slower moving vehicle, traveling in front of a trolley assisted haulage truck, does not take the required action allowing the faster truck to overtake, the truck will reduce speed adequately to maintain proper following distances. If proper following distances cannot be maintained while operating on trolley assist, and the slow moving vehicle does not, or cannot, take the required action to allow overtaking, the trolley assisted truck will switch back to diesel mode, if necessary.

If the slower moving vehicle takes the necessary action to allow the trolley assisted truck to overtake them, the trolley assisted truck will obtain maximum speed and overtake the slower moving vehicle as quickly as possible.

Operating slow moving vehicles on trolley assist ramps

Personnel operating any vehicle on a trolley assist ramp that is moving slower than trolley assisted trucks should be aware of the following general safety considerations:

1. Trucks traveling on trolley assist will travel approximately 15 mph. Whenever a trolley assisted truck is capable of overtaking slower moving vehicles, the slower moving vehicle (if possible) should take the required action to allow the faster moving truck to travel up the trolley ramps without interruption.
2. It may not always be possible to take the action required to allow a trolley assisted haulage trucks to overtake a slower moving vehicle. Personnel will not jeopardize the safety of themselves or others if conditions do not permit overtaking.
3. Permitting a trolley assisted truck to overtake a slower moving vehicle helps the trolley system become more efficient and cost effective. It is not absolutely necessary for a trolley assisted truck to be able to overtake all slower moving vehicles. The trolley assisted truck can travel slower up the ramp under diesel generated power, if necessary, to maintain safe traffic patterns or traffic flows.

Truck failure while on trolley

If the truck fails while on trolley, perform the following:

1. Stop the truck using the service brakes and move the directional control lever to the P position to apply the parking brake.
2. Lower the pantograph.
3. Contact a supervisor.

In the event that the pantograph remains attached:

1. Remain in the cab and warn personnel not to approach or touch the truck.



If the pantograph is attached to the trolley line, DO NOT touch the truck while standing on the ground.

2. Contact a supervisor on the radio. Inform the supervisor of the situation. DO NOT allow anyone to approach the truck until the trolley line has been de-energized and grounded.

USING THE SPEED CONTROL FEATURE

The speed control feature functions much like cruise control in a car. The truck must be travelling faster than 5 kph (3 mph) before speed control will engage, and the set speed must be above 8 kph (5 mph).

1. Press the speed control switch on the dash panel to turn on the speed control feature.
 2. Accelerate to the desired truck speed.
 3. Press the button on the end of the speed control lever to set the cruising speed at the current truck speed.
- The set speed can be increased incrementally by 1 kph (1 mph) by tapping up on the lever or continuously by holding the lever up.
 - The set speed can be decreased incrementally by 1 kph (1 mph) by tapping down on the lever or continuously by holding the lever down.
 - If the accelerator pedal is used to accelerate the truck above the set speed, the truck will return to the set speed when the pedal is released.
 - If the service brake pedal is used to decelerate the truck below the set speed, tapping up on the lever will return the truck to the set speed when the pedal is released.

SAFE PARKING PROCEDURES

The operator must continue to use safety precautions when preparing for parking and stopping the engine.

In the event that the equipment is being used in consecutive shifts, any questionable truck performance the operator may have noticed must be checked by maintenance personnel before the truck is released to another operator.

1. Park the truck on level ground, if possible. If it is necessary to park on a grade, the truck must be positioned at right angles to the grade.
2. Stop the truck using the service brakes. Place the directional control lever in the PARK position. This will apply the parking brake. Slowly release the service brakes. If the truck starts to roll, apply the service brakes and notify maintenance personnel immediately.
3. If the truck is stationary with only the parking brake applied, place chocks fore/aft of the wheels to reduce the risk of the truck rolling. Each truck must be parked at a reasonable distance from other trucks/equipment.
4. Haul roads are not safe parking areas. In an emergency, pick the safest spot most visible to other machines in the area. If the truck becomes disabled where traffic is heavy, mark the truck with warning flags in daylight, or flares at night.
5. If desired, proceed to Normal Engine Shutdown Procedure.

NORMAL ENGINE SHUTDOWN PROCEDURE

The following procedure must be followed to shut the engine off.

1. Stop the truck out of the way of other traffic. Park on a level surface, free of overhead power lines or other objects that could prevent raising the dump body.
 - a. Reduce engine speed to idle.
 - b. Place the directional control lever in PARK. This will apply the parking brake. DO NOT apply the wheel brake lock.

NOTE: If the truck starts to roll, apply the service brakes and notify maintenance personnel immediately.

- c. Ensure the parking brake applied indicator light in the dash display panel is illuminated.
2. Place the rest switch in the ON position to put the AC drive system in rest mode. The NO DC LINK VOLTAGE status light and the NO PROPEL status light should be illuminated.
3. Turn the key switch counterclockwise to the OFF position to stop the engine.

The engine may continue to run for up to three minutes after the key switch is turned OFF, if the park brake has been set. The engine may also stop before three minutes has elapsed if the engine coolant is not too hot, and the engine rpm's and fuel delivery has been low for a period of time before the key switch was placed in the OFF position. The Timed Engine shutdown status light in the monitor panel will be illuminated during the shutdown sequence.

NOTE: If the engine must be shut down immediately, stop the truck, shift the directional control lever to PARK, turn the key switch OFF, then pull up on the engine stop switch located in the operator cab center console. Push the switch back down to enable engine operation.

NOTE: There is also an engine stop switch located at ground level at the left front corner of the truck. When this switch is activated, the engine will stop immediately, with no cooling off time.

4. With the key switch OFF and engine stopped, wait at least two minutes. If any warning messages are displayed, notify maintenance personnel immediately.
5. Ensure the steering circuit is completely bled down by turning the steering wheel back and forth several times. No front wheel movement will occur when hydraulic pressure is relieved. If the front tires continue to steer after the engine is stopped, notify maintenance personnel.
6. Open the access panel at the left front side of the control cabinet. Verify that the green link voltage light is illuminated and the DC bus voltage gauge reads 0.0 V. Notify qualified drive system maintenance personnel if the green link voltage light fails to illuminate within five minutes after engine shutdown.
7. Close and lock all windows. Remove the key from the key switch and lock the cab doors to prevent possible unauthorized truck operation. Properly dismount the truck. Put wheel chocks in place.

SUDDEN LOSS OF ENGINE POWER

If the engine suddenly stops, there is enough hydraulic pressure stored in the brake and steering accumulators to allow the operation of the steering and brake functions. However, this oil supply is limited so it is important to stop the truck as quickly and safely as possible after the loss of engine power.

If the brake supply pressure drops to a pre-determined level, the low brake pressure warning message will illuminate and a buzzer will sound. If the brake pressure continues to decrease, the auto-apply feature will activate and the service brakes will apply automatically to stop the truck.

1. Bring the truck to a safe stop as quickly as possible by using the foot pedal to apply the service brakes. If possible, safely steer the truck to the side of the road while braking.

WARNING

***Dynamic retarding will not be available!
DO NOT use the service brakes for continuous retarding purposes.***

2. As soon as the truck has stopped moving, shift the directional control lever to PARK. This will apply the parking brake.
3. Slowly release the service brakes to check the capacity of the parking brake. If the parking brake can not hold the truck stationary, apply the service brakes and hold them ON. DO NOT turn the key switch OFF, and DO NOT release the service brakes.
4. Notify maintenance personnel immediately.
5. If the truck is on level ground, or if the parking brake can hold the truck stationary and the truck is in a stable condition, it is then OK to turn the key switch OFF.
6. If safe to do so, have maintenance personnel place wheel chocks or other mechanisms in front or behind the wheels to reduce the risk of the truck rolling.
7. If traffic is heavy near the disabled machine, mark the truck with warning flags during daylight hours or use flares at night. Adhere to local regulations.

FUEL DEPLETION

The high pressure injection (HPI) fuel system uses fuel to adjust fuel delivery timing by creating a hydraulic link between the upper plunger and the timing plunger. Metered fuel is also used for lubricating the injector plunger and barrel. The maximum demand for metered fuel is required during high speed / low load conditions.

CAUTION

Operating the truck to fuel depletion forces the injector train into a no-follow condition. No fuel flow between the plungers may cause damage to the injectors and the overhead due to adhesive wear, resulting in costly repairs and unnecessary downtime.

WARNING

Allowing the Komatsu truck to operate until fuel depletion can lead to unsafe operating conditions possibly resulting in an uncontrollable vehicle and/or personal injury.

TOWING

WARNING

Before towing a truck, many factors must be carefully considered. Serious personal injury and/or significant property damage may result if important safety practices, procedures and preparation for moving heavy equipment are not observed.

A disabled machine may be towed after the following precautions have been taken.

- Do not tow the truck any faster than 8 kph (5 mph).
- Tow with a solid tow bar. DO NOT tow with a cable. Use a towing device with ample strength for the weight of this truck.
- Never tow a truck on a slope.
- Inspect towing components, such as tow bars and couplings, for any signs of damage. Never use damaged or worn components to tow a disabled vehicle.
- Keep a safe distance from the trucks and towing apparatus while towing a vehicle.
- After connecting a truck that is to be towed, do not allow anyone to go between the tow vehicle and the disabled vehicle.
- Set the coupling of the truck being towed in a straight line with the towing portion of the tow truck, and secure it in position.
- An operator is to remain in the cab of the towed vehicle at all times during the towing procedure.

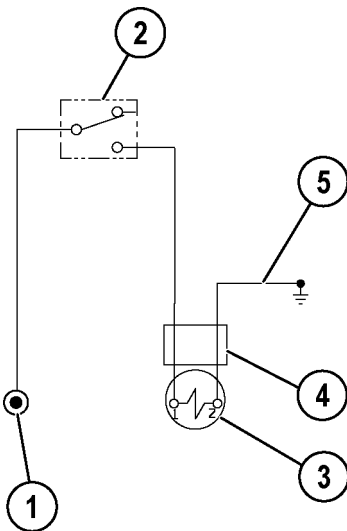

82834

FIGURE 30-2. PARKING BRAKE HARNESS

- | | |
|------------------------|----------------|
| 1. 24VDC Connection | 4. Connector |
| 2. Switch (ON/OFF) | 5. Ground Wire |
| 3. Park Brake Solenoid | |

Special Wiring Harness

Before towing, a special wiring harness must be made in order to release the parking brake. The harness will require approximately 9 meters (30 ft) of #14 wire, and one ON/OFF switch (capable of carrying 2 amps of current) and two ring terminals. Using a ring terminal, one end of the wire must connect to a 24VDC bus bar (1, Figure 30-2) in the auxiliary control cabinet to supply 24V to the solenoid. Switch (2) must be positioned in the harness so the operator can operate the switch while seated in the operators seat. The harness must be fitted with a connector (4) to allow it to be plugged into parking brake solenoid (3) inside the brake cabinet. Wire (5) leading from this connector is to be connected to the ground block using a ring terminal. Refer to Figure 30-3 for an overview of the special wiring harness when installed on the truck.

The parts required to connect to the solenoid are: 1 housing (PB8538), 2 sockets (0819105430) and 1 wedge (PB8540).

Towing Procedure

1. Shut the engine off.
2. Block the wheels on the disabled truck to prevent movement while preparing the truck for towing and while attaching the tow bar.
3. Ensure the towing vehicle has adequate capacity to both move and stop the towed truck under all conditions.
4. Ensure that the tow bar has adequate strength (approximately 1.5 times the empty vehicle weight of truck being towed). Install tow bar between the two vehicles.
5. Block the wheels on the tow vehicle to prevent movement while preparing the disabled truck for towing.
6. If necessary, install quick disconnect fittings to the bleeddown manifold to allow the hydraulic system to be operational. Install hydraulic connections for steering/braking between the tow vehicle the and disabled vehicle. An auxiliary power unit can also be used. For additional information on hydraulic connections, refer to Disabled Truck Operation, this section.
7. After the hydraulic connections are made, check the disabled vehicle braking and steering systems for normal operation. Install 24 100 kPa (3,500 psi) pressure gauges on both the BF test port and the BR test port on the brake manifold in the brake cabinet. Ensure proper pressure is displayed on the gauge when depressing the brake pedal.

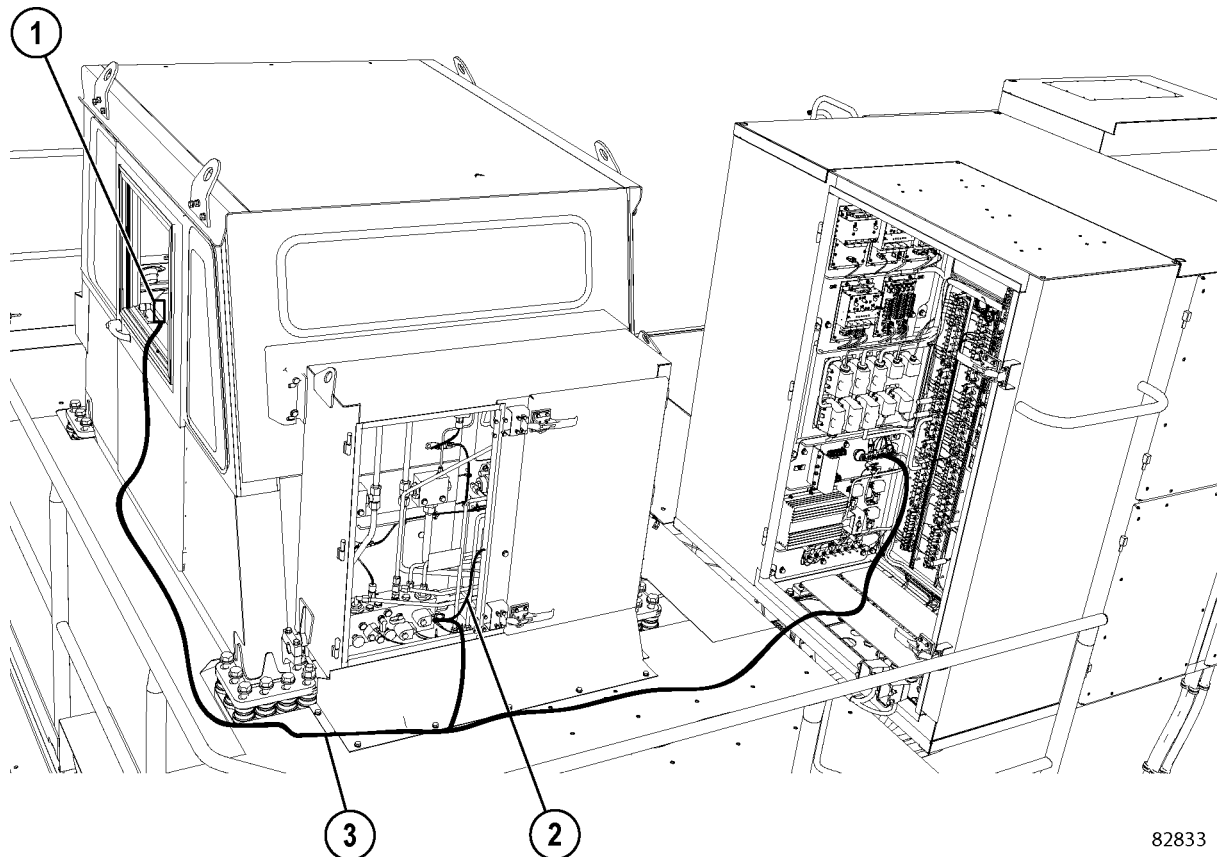

82833

FIGURE 30-3. PARKING BRAKE WIRING FOR TOWING

- 1. Switch
- 2. Ground Wire

- 3. Harness

8. If the truck is loaded, dump the entire load. Never pull or tow a loaded truck. Refer to "Disabled Truck Dumping Procedure".

9. The parking brakes must be released before towing. To release the parking brake, follow the steps below to install a special wiring harness to release the parking brakes.

- a. Ensure switch (1, Figure 30-3) is in the OFF position.
- b. Connect one lead of the special wiring harness to the 24VDC bus bar terminal on the side wall in the auxiliary control cabinet for the 24V supply.
- c. Disconnect the truck wiring harness from parking brake solenoid (2, Figure 30-4). Connect special wiring harness (3, Figure 30-3) to the parking brake solenoid. Attach the short lead (2) to ground.

d. With the window lowered, place the end of the special wiring harness inside the cab so the operator can control the parking brake with switch (1).

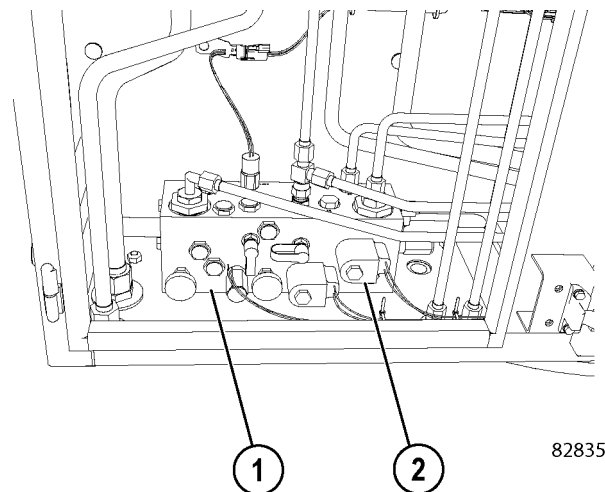

82835

FIGURE 30-4. BRAKE CABINET

- 1. Brake Manifold
- 2. Park Brake Solenoid

10. Ensure the operator in the towing vehicle has 2-way radio communications with the driver in the disabled truck.
11. When ready to tow the disabled truck, remove blocking from the wheels.
12. The operator in the disabled truck should now move switch (1, Figure 30-3) to the ON position. This will release the parking brakes.
13. Tow the disabled truck. Sudden movement may cause tow bar failure. Smooth, gradual truck movement is preferred. Do not tow the truck any faster than 8 kph (5 mph).
14. Minimize the tow angle at all times. **Never exceed 30 degrees.** The towed truck must be steered in the direction of the tow bar.
15. When the desired location has been reached, the operator in the towed vehicle is to apply the service brakes, then turn switch (1) to the OFF position. This will apply the parking brakes.
16. Block the wheels on the towing vehicle and the disabled truck to prevent roll-away.
17. Shut down the engine in the towing vehicle. Disconnect the hydraulic hoses.
18. Disconnect special wiring harness (3) from the truck. Connect the truck wiring harness back to the parking brake solenoid.
19. Disconnect the tow bar.

DISABLED TRUCK OPERATION

GENERAL

Refer to the shop manual for repair and troubleshooting procedures for the hoist system components and steering system components. Refer to the shop manual for repair and troubleshooting procedures for the hydraulic brake system components.

STEERING AND BRAKE SYSTEM

Quick disconnect fittings (1 and 2, Figure 30-5) can be installed to allow operation of the steering and brake circuits for temporary truck operation if the steering/brake pump is not operational. Once these fittings are installed, two hoses (supply and return) must be connected to a hydraulic source (such as an operational truck or an auxiliary power unit) to use this feature.

Components Required

The following parts will be needed to install quick disconnect fittings that will allow the use of alternate hydraulic power source.

1. Stop the truck engine and wait two minutes to allow the hydraulic system pressure to bleeddown.
2. Remove the plug and install the necessary QD supply fittings listed in Table 1 into the QD Supply port on the bleeddown manifold.

Qty	Part Number	Description
1	PB4686	Dust Cover
1	PB4683	Disconnect Fitting
1	VN3308	Swivel Adapter
1	WB0593	Fitting

3. Remove the plug and install the necessary QD return fittings listed in Table 2 into the QD Return port on the bleeddown manifold.

Qty	Part Number	Description
1	TA2968	Dust Cover
1	PB4685	Disconnect Fitting
1	WA3568	Swivel Adapter
1	WB0599	Fitting

4. The supply jumper hose must be equipped with quick disconnect fitting PB4682. This will connect to quick disconnect fitting (1).
5. The return jumper hose must be equipped with fitting PB4684 to connect with return quick disconnect fitting (2).

Hookup

1. When the good truck is in position, stop the engine and wait two minutes to allow the hydraulic system to bleed down. Ensure hydraulic pressure has bled off before connecting any fittings or hoses.

NOTE: Maximum hydraulic pressure is not to exceed 24 304 kPa (3,525 psi).

2. Connect the hydraulic supply hose to the supply disconnect coupling (1, Figure 30-5).

NOTE: Failure to attach the return hose from the disabled truck to the hydraulic pressure source could cause the disabled truck hydraulic tank to overflow, or potentially damage the hydraulic power source due to lack of oil.

3. Connect the return hose to the return disconnect coupling (2).
4. Start the engine on the good truck. Check the operation of the steering and brake system of the good truck before moving the disabled truck.

5. To disconnect the hoses, stop the engine(s) on both trucks. Wait two minutes for the hydraulic systems on both trucks to bleed down. Ensure all hydraulic pressure has been relieved before disconnecting the hoses.

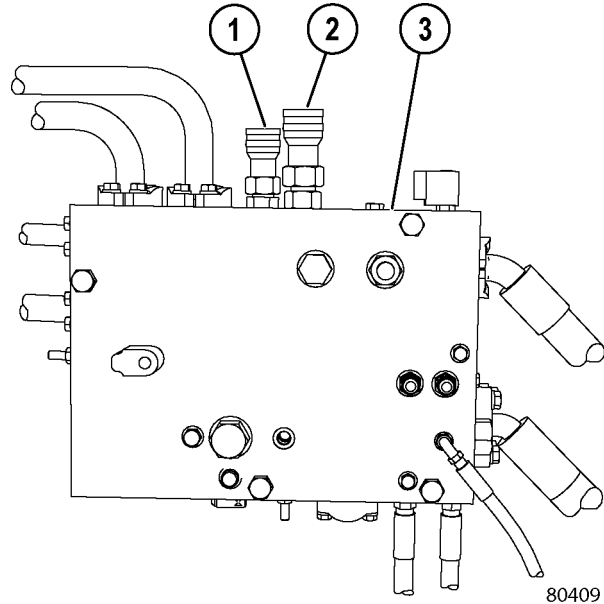

FIGURE 30-5. BLEEDDOWN MANIFOLD

1. Supply Quick Disconnect
2. Return Quick Disconnect
3. Bleeddown Manifold

DISABLED TRUCK DUMPING PROCEDURE

Sometimes it is necessary to dump a load from the body of a truck when the hoist system is inoperable. To use this feature, two hoses (supply and return) must be connected to a hydraulic source (such as an operational truck or an auxiliary power unit).

Quick disconnect fittings (3 & 4, Figure 30-6) are provided on the overcenter valve to allow operation of the hoist circuit for temporary truck operation if the hoist pump, hoist valve or other hoist system component is not operational. This will allow maintenance personnel to raise the truck body to dump the load before moving the disabled truck.

In the example, Figure 30-6 illustrates a typical hookup from the good truck. The disabled truck may be another Model 860E, or a different Komatsu electric drive truck model.

Hookup

Ensure that there is an adequate, clear area to dump the loaded body. When the good truck is in position, shut down the engine and allow the hydraulic system to bleed down. Ensure that the pressure has bled off before connecting the hoses.

1. With the good truck parked as close as possible to the disabled truck, attach a hose from the **power up** quick disconnect (4, Figure 30-6) to the **power down** circuit of the disabled truck. The hose must be rated to withstand 17 000 kPa (2,500 psi) or greater pressure.

NOTE: The power down circuit will use a smaller diameter hose (tube) than the power up circuit.

2. Connect another hose from the **power down** quick disconnect (3) to the **power up** circuit of the disabled truck.

*NOTE: If both trucks are the same model, the hoses will be installed at the quick disconnects shown in Figure 30-6 and **will be crossed** when connected.*

Raising the Body

1. On the disabled truck, move the hoist control lever to power up and then release it to place the hoist pilot valve in the HOLD position (leave in this position during entire procedure).
2. Start the engine on the good truck, place the hoist control in the POWER DOWN position and increase the engine rpm to high idle to dump the disabled truck. If the body of the disabled truck fails to raise, increase the good truck power down relief pressure as follows:
 - a. Stop the engine and wait two minutes to allow the hydraulic system pressure to bleed down.
 - b. Remove the cap from the hoist pilot valve relief valve located in the hydraulics components cabinet behind the cab. While counting the number of turns, slowly turn the relief valve adjustment screw clockwise until it bottoms. Repeat Step 2.

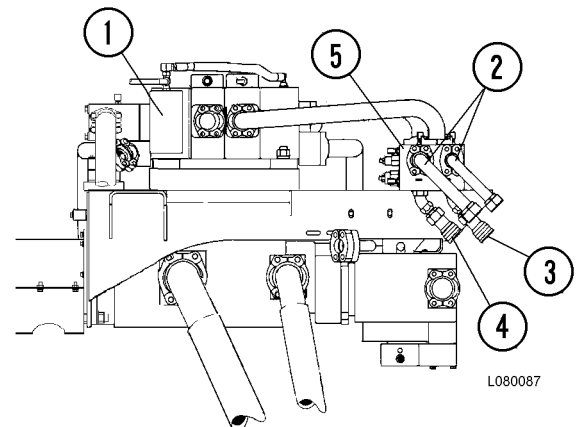

FIGURE 30-6. PUMP MODULE, HOSE HOOKUP

1. Hoist Valve
2. Tubes to LH Hoist Cylinder
3. Power Down Quick Disconnect (Connect to power up circuit of disabled truck.)
4. Power Up Quick Disconnect (Connect to power down circuit of disabled truck.)
5. Overcenter Manifold

Lowering the Body

1. Place the hoist lever of the good truck in FLOAT to lower the body. If necessary, momentarily place the hoist control in POWER UP until the body is able to descend in FLOAT. Do not accelerate the engine.
2. After body is lowered, stop the engine and wait two minutes to allow the hydraulic system to bleeddown. Then disconnect the hoses.
3. Reduce the power down relief valve pressure on the good truck to normal by turning the adjustment counterclockwise the same number of turns as required in Step 2b of "Raising the Body."
4. Check the power down relief pressure. Refer to Section L, Hydraulic Check-Out Procedure in the shop manual.
5. Check the hydraulic tank oil level.

RESERVE ENGINE OIL SYSTEM

The reserve oil tank for the engine is designed to add more oil capacity to the engine and to make less frequent servicing of the engine oil. The circulation of oil between the engine sump and reserve tank increases the total volume of working oil. This dilutes the effects of contamination and loss of additives and maintains the oil quality over longer periods.

Operation

Engine oil is circulated between the engine sump and the reserve tank by two electrically driven pumps within a single pumping unit (11, Figure 30-7). The pump unit is mounted on the side of the reserve tank, and is equipped with an LED monitor light on one side.

Pump 1 (in the pump unit) draws oil from the engine sump at a preset control point (determined by the height of the suction tube). Oil above this point is withdrawn and transferred to reserve tank (9). This lowers the level in the engine sump until air is drawn.

Air reaching the pumping unit activates pump 2 (in the pump unit) which returns oil from the reserve tank and raises the engine sump level until air is no longer drawn by pump 1. Pump 2 then turns off. The running level is continuously adjusted at the control point by alternation between withdrawal and return of oil at the sump.

LED Monitor Light

- Steady - Pump 1 is withdrawing oil from the engine sump and bringing down the oil level.
- Regular Pulsing - Pump 2 is returning oil to the engine sump and raising the oil level.
- Irregular Pulsing - Oil is on the correct running level.

Changing Oil

1. Drain both the engine sump and the reserve tank. Refill both engine and reserve tank with new oil to proper levels.
2. Change engine filters as required.
3. Start engine and check for proper operation.

NOTE: Do not use the oil in the reserve tank to fill the engine sump. Both must be at proper level before starting engine.

4. The engine oil level should be checked with the engine dipstick at every shift change. If the oil level in the engine is incorrect, check for proper operation of the reserve engine oil system.

5. The oil level in the reserve tank must also be checked at every shift change. Oil must be visible in lower sight gauge (12). If not, add oil to the reserve tank by using the quick fill system utilizing tank fill valve (3). For filling instructions, refer to Section 40, Lubrication and Service.

NOTE: Oil must always be visible in the lower sight gauge (12). If the tank is equipped with three sight gauges, oil must always be visible in the middle sight gauge.

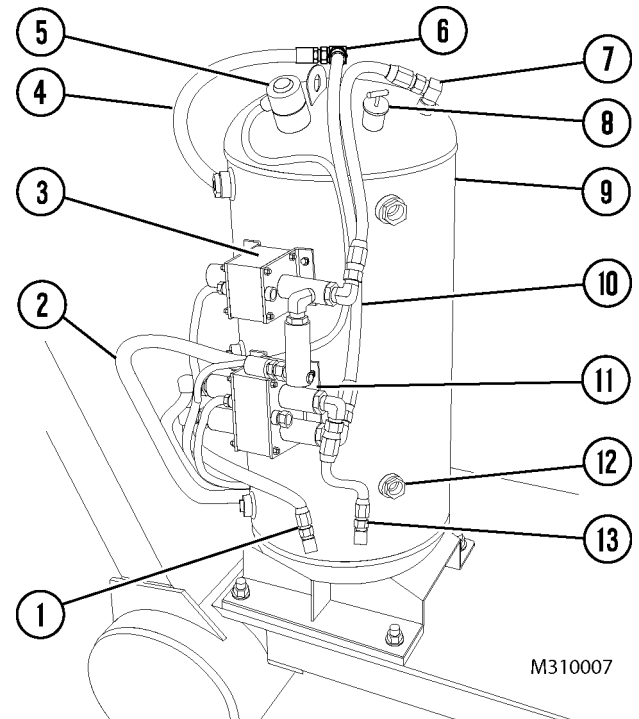
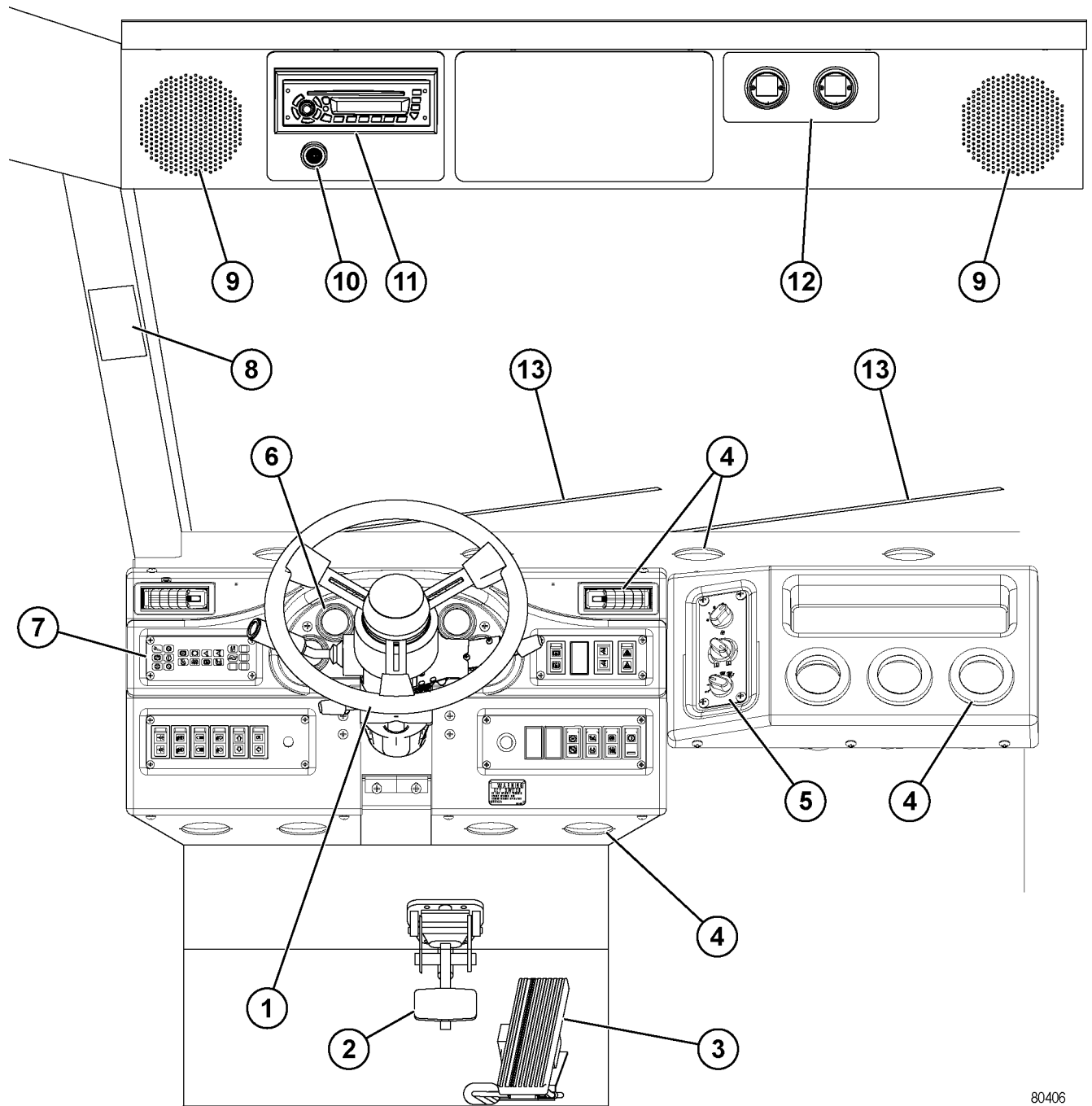

FIGURE 30-7. RESERVE ENGINE OIL SYSTEM

- | | |
|---------------------|----------------------|
| 1. Oil Suction | 8. Fill Cap |
| 2. Oil Tank Fill | 9. Reserve Oil Tank |
| 3. Fill Valve | 10. Engine Fill Line |
| 4. Engine Fill Line | 11. Pump Unit |
| 5. Oil Level Sensor | 12. Sight Gauge |
| 6. Air Valve | 13. Tank Return Line |
| 7. Tank Fill Line | |

NOTES:

OPERATOR CAB AND CONTROLS



80406

FIGURE 32-1. CAB INTERIOR - OPERATOR VIEW

- | | | |
|------------------------------------|------------------------------|------------------------------------|
| 1. Steering Wheel | 6. Instrument Panel | 11. Radio/CD Player |
| 2. Retarder/Service Brake Pedal | 7. Status Indicator Lights | 12. Air Cleaner Restriction Gauges |
| 3. Throttle/Accelerator Pedal | 8. Grade/Speed Retard Chart | 13. Windshield Wipers |
| 4. Heater/Air Conditioner Vents | 9. Radio Speakers | |
| 5. Heater/Air Conditioner Controls | 10. Warning Alarm (Sonalarm) | |

STEERING WHEEL AND CONTROLS

Horn Button

Activate the horn by pushing button (2, Figure 32-2) in the center of steering wheel (1). Ensure that the horn operates before moving the truck. Observe all local safety rules regarding the use of the horn as a warning signal device.

Tilt / Telescope Lever

Adjust the tilt of the steering wheel by pulling lever (3) toward the steering wheel and moving the wheel to the desired angle. Releasing the lever will lock the wheel in the desired location.

Push the lever forward to unlock the telescoping function. After positioning as desired, release the lever to lock the steering column in position.

Speed Control Lever

Lever (4) is used to set, cancel and make fine adjustments to the speed control set speed.

- (a) Press to set speed.
- (b) Tap up to resume or increase speed.
- (c) Tap down to decrease speed.
- (d) Pull to cancel set speed.

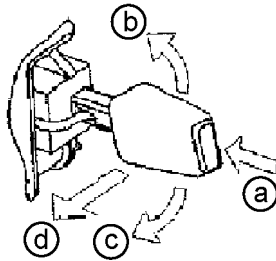

Refer to “Using the Speed Control Feature” in Section 30, Operating Instructions, for more information.

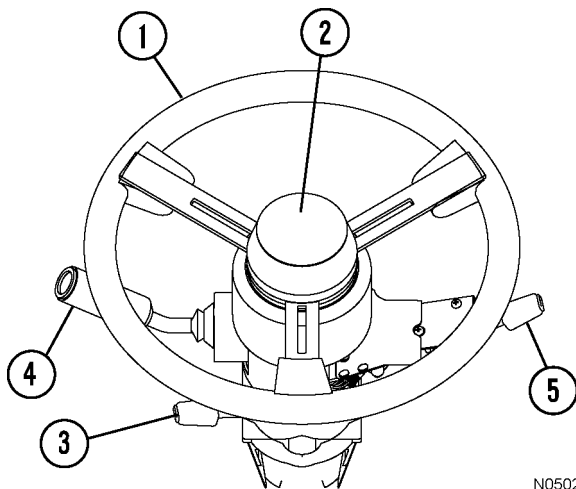

N050278

FIGURE 32-2. STEERING WHEEL & CONTROLS

- 1. Steering Wheel
- 2. Horn Button
- 3. Tilt/Telescope Lever
- 4. Multi-Function Turn Signal Switch
- 5. Speed Control Lever

Multi-Function Turn Signal Switch



N050186

Multi-function turn signal switch (5) is used to activate the turn signal lights and windshield wipers (13, Figure 32-1), and to select either high or low beam headlights.

Turn Signal Operation

Move the lever upward to signal a right turn.

An indicator in the top, center of the instrument panel will illuminate to indicate turn direction selected. Refer to Instrument Panel and Indicator Lights in this section.

Move the lever downward to signal a left turn.

NOTE: The turn signal does not automatically cancel after the turn has been completed. The turn signal lever must be manually returned to the neutral position.

High Beam Headlight Operation

Pulling the lever inward (toward the rear of the cab) changes the headlights to high beam. When the high beams are selected, the indicator in the top center of the instrument panel will illuminate. Moving the switch back to the original position will return the headlights to low beam.

Windshield Wiper Operation

- Windshield Wipers OFF
- Intermittent - Long Delay
- Intermittent -Medium Delay
- Intermittent -Short Delay
- Low Speed
- High Speed

Depressing the button at the end of the lever will activate the windshield washer.

NOTE: The windshield wipers will not come on automatically when activating the washer. This must be done manually.

DYNAMIC RETARDING

Dynamic retarding is a braking torque (not a brake) produced through electrical generation by the wheelmotors when the truck motion (momentum) is the propelling force.

For normal truck operation, **dynamic retarding should be used to slow and control truck speed.**

Dynamic retarding is available in FORWARD/REVERSE at all truck speeds above 0.5 kph (0.3 mph). However, as the truck speed slows below 5 kph (3 mph), the available retarding force may not be effective. **Use the service brakes to bring the truck to a complete stop.**

Dynamic retarding will not hold a stationary truck on an incline. Move the directional control lever to PARK or use the wheel brake lock for this purpose.

When in NEUTRAL, dynamic retarding is available only when truck speed is above 5 kph (3 mph).

When dynamic retarding is in operation, engine rpm will automatically go to an advance retard speed setting. This rpm will vary depending on temperature of several electrical system components.

Dynamic retarding will be applied automatically if the speed of the truck obtains the maximum speed setting programmed in the control system software.

The grade/speed retard chart should always be used to determine safe downhill speeds. Refer to Grade/Speed Retard Chart on the following page.

Dynamic Retarder/Service Brake Pedal

Retarder/service brake pedal (2, Figure 32-1) is a single foot-operated pedal that controls both retarding and service brake functions. The first portion of pedal travel commands retarding effort through a rotary potentiometer. The second portion of pedal travel modulates service brake pressure directly through a hydraulic valve. Thus, the operator must first apply and maintain full dynamic retarding in order to apply the service brakes. Releasing the pedal returns the brake and retarder to the OFF position.

When the pedal is partially depressed, the dynamic retarding is actuated. As the pedal is further depressed to where dynamic retarding is fully applied, the service brakes (while maintaining full retarding) are actuated through a hydraulic valve which modulates pressure to the service brakes. **Completely depressing the pedal causes full application of both dynamic retarding and the service brakes.** Indicator light (8, Figure 32-9) on the instrument panel will illuminate, and an increase in pedal resistance will be felt when the service brakes are applied.

For normal truck operation, **dynamic retarding** should be used to slow and control the speed of the truck. **Service brakes** should be applied only when dynamic retarding requires additional braking force to slow the truck speed quickly or when bringing the truck to a complete stop.

Throttle/Accelerator Pedal

Throttle/accelerator pedal (3, Figure 32-1) is a foot-operated pedal which allows the operator to control engine rpm. It is used by the operator to request torque from the motors when in FORWARD or REVERSE. In this mode, the propulsion system controller commands the correct engine speed for the power required. In NEUTRAL, this pedal controls engine speed directly.

GRADE/SPEED RETARD CHART

Grade/speed retard chart (8, Figure 32-1 and shown below) provides the recommended MAXIMUM retarding limits at various truck speeds and grades with a fully loaded truck. The operator should reference this chart before descending any grade with a loaded truck. Proper use of dynamic retarding will maintain a safe speed.



Do not LIGHTLY apply the service brakes when attempting to slow the truck on a downhill grade. Overheating of the brakes will result. FULLY apply the brakes (within safe limits for road conditions) in order to quickly slow the truck to maximum retarding limits or less.

The numbers on the chart indicate the combination of speeds and grades which the vehicle can safely negotiate for unlimited time or distance during retarding. DO NOT exceed these recommended MAXIMUM speeds when descending grades with a loaded truck.

NOTE: The decal in the truck may differ from the decal below due to optional truck equipment such as: wheel motor drive train ratios, retarder grids, tire sizes, etc. Always refer to the decal in the operator's cab and follow these recommendations for truck operation.

CAUTION

DO NOT DESCEND GRADES AT SPEEDS GREATER THAN LISTED WHEN VEHICLE IS LOADED AT MAX. G.V.W. 1,001,700 LB. (454,492 kg) & 50/80 R 57 TIRES.

ACTUAL GRADE	SPEED
%	KM/H(MPH)
12 _____	25(16)
10 _____	31(19)
8 _____	40(25)
6 _____	48(30)
4 _____	62(39)

THE ACTUAL GRADE CAPABILITY WILL VARY DEPENDING ON OUTSIDE TEMPERATURE, SYSTEM TEMPERATURE, ROLLING RESISTANCE, LOAD, AND TIRE SIZE. THE ABOVE IS BASED ON 32°C (90°F) OUTSIDE TEMPERATURE AND ASSUMES THAT ROAD AND VISIBILITY CONDITIONS PERMIT THE USE OF ALL AVAILABLE RETARDING TORQUE WITHOUT SKIDDING. FOR ADDITIONAL BRAKING AND RETARD INFORMATION, SEE OPERATION MANUAL.

○ SPEED VALUES BASED ON 1% ROLLING RESISTANCE ○

WB3564

OVERHEAD PANEL COMPONENTS

The components described below are located on the overhead panel. Refer to Figure 32-1.

Speakers

Two speakers (9) for the radio/cassette player are located at the far left and right of the overhead panel. Two additional speakers are located in the rear of the cab.

Warning Alarm (Sonalarm)

Warning alarm (10) will sound when activated by any one of several truck functions. Refer to Instrument Panel and Indicator Lights in this section for a detailed description of functions and indicators that will activate this alarm.

Radio/CD Player

This panel will normally contain radio/CD player (11). Refer to Section 70 for a complete description of the radio/CD player and its functions. Individual customers may use this area for other purposes, such as a two-way communications radio.

Air Cleaner Restriction Gauges

Air cleaner restriction gauges (12) provide a continuous reading of the maximum air cleaner restriction reached during operation. The air cleaner(s) should be serviced when the gauge(s) shows the maximum recommended restriction of 25 inches of H₂O vacuum.

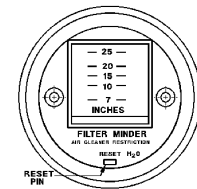

NOTE: After service, push the reset button on face of gauge to allow the gauge to return to zero.

CENTER CONSOLE

FIGURE 32-3. CENTER CONSOLE

1. Center Console
2. Directional Control Lever
3. Override/Fault Reset Switch
4. Engine Shutdown Switch
5. L.H. Window Control Switch
6. R.H. Window Control Switch
7. Hoist Control Lever
8. Ashtray
9. Lighter
10. Data Store Button
11. Service Engine Light (blue)
12. 12V Auxiliary Power Outlets

Directional Control Lever

Directional control lever (2, Figure 32-3) is mounted on the console to the right of the operator's seat. It is a five position lever that controls the park, reverse, neutral and forward movement, and trolley operation of the truck.

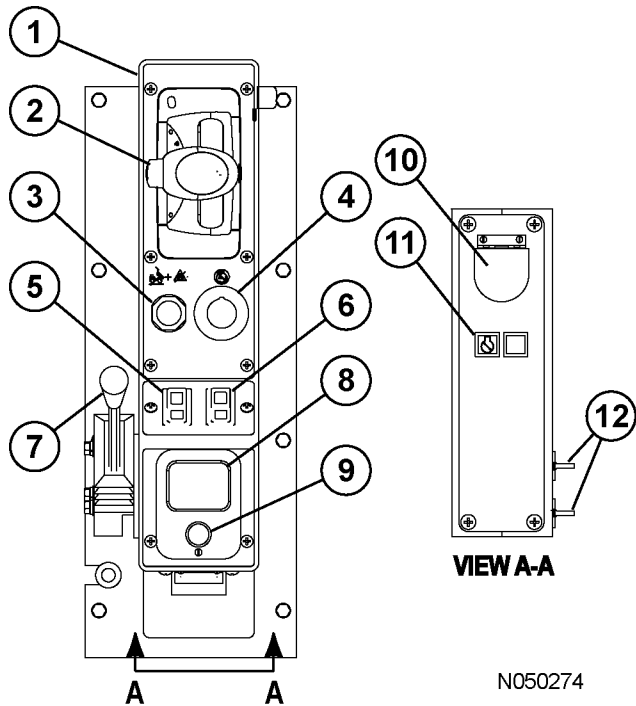
Before moving the directional control lever, apply the service brakes to completely stop the truck. Depress the button on the side to release the detent lock, then move the control lever to the desired position. When the control lever is in the center N position, it is in NEUTRAL. When the control lever is in the P position, it is in PARK, and the parking brake will be applied. The parking brake is spring applied and hydraulically released. It is designed to hold the truck stationary when the engine is off and the key switch is turned OFF.

When the key switch is ON, and the control lever is in PARK, parking brake indicator light (2, Figure 32-9) on the instrument panel will be illuminated.

! IMPORTANT !

The directional control lever must be in PARK to start the engine.

NOTE: Do not move the directional control lever to the PARK position at the shovel or dump site.

The operator can select FORWARD drive by moving the lever to the F position.

The operator can select REVERSE drive by moving the lever to the R position. Do not allow the control lever to travel too far and go into the PARK position when REVERSE is desired.

Any time the directional control lever is placed in the FORWARD or the REVERSE position, the engine speed will go to 1,600 rpm for 15 seconds in preparation for truck movement. If the throttle pedal is not touched within 15 seconds, engine speed will return to 750 rpm.

Any time the truck is moving and engine rpm is above 1,600 rpm and the throttle pedal is released, engine rpm will hold at 1,600 rpm. If the throttle pedal is not touched within 15 seconds, then engine rpm will return to 750 rpm.

The operator can select TROLLEY by moving the lever to the T position. This position will prepare the truck for trolley operation. The pantograph switch on the dash panel is now active. When desired, the operator can raise the pantograph to receive electricity from the overhead wires.

NOTE: The truck must be completely stopped before the control lever is moved to a drive position or into PARK. A fault will be recorded if the control lever is placed into the PARK position while the truck is still moving.

Override/Fault Reset Switch

This push-button switch (3, Figure 32-3) is spring-loaded to the OFF position. When pushed in and held, this switch may be used for several functions.

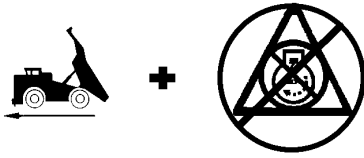

- The switch permits the operator to override the body-up limit switch and move the truck forward when the directional control lever is in FORWARD, the dump body is raised, and the brakes are released. **Use of the override switch for this purpose is intended for emergency situations only!**
- The switch deactivates the retard pedal function when the truck speed is below 5 kph (3 mph) for facilitating starting the truck on a hill.
- The switch is used to reset an electrical system fault while the truck is stopped.
- The switch is used to allow full torque in REVERSE. Standard torque in REVERSE is limited to 50%.
- If a ground fault occurs, holding down the switch allows the operator to drive the truck for less than two minutes to a safe stop.

Engine Shutdown Switch

Engine shutdown switch (4, Figure 32-3) is used for engine shutdown. Pull the switch up to stop the engine. Push the switch back down to enable engine operation.



SWITCH UP
ENGINE OFF



SWITCH DOWN
ENGINE ON

Use this switch **ONLY** in an emergency situation to shutdown the engine, or if the key switch should fail to operate.

However, it can also be used for Emergency Steering Check, or during diagnostic testing to stop the engine without turning off the 24 VDC electrical circuits and without bleeding down the accumulators.

A ground level engine shutdown switch is also located at the right front corner of the truck near the reserve oil tank or at the left front corner of the truck near the automatic lubrication pump, depending on the diagonal ladder configuration.

L.H. Window Control Switch

R.H. Window Control Switch

Control switches (5) and (6, Figure 32-3) are spring-loaded to the OFF position. Pushing the top of the switch raises the left hand or right hand cab window. Pushing the bottom of the switch lowers the window.

Hoist Control Lever

Hoist control (7, Figure 32-3) is a four position hand-operated lever located between the operator seat and the center console (see illustration below).

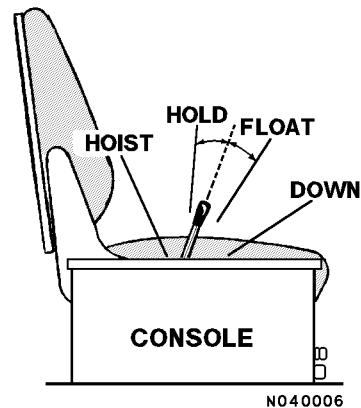

Raising The Dump Body

1. Pull the lever to the rear to actuate hoist circuit. Releasing the lever anywhere during "hoist up" will place the body in HOLD at that position.
2. Raise engine rpm to increase hoist speed.
3. Reduce engine rpm as the last stage of the hoist cylinders begin to extend and then let the engine go to low idle as the last stage reaches half-extension.
4. Release hoist lever as the last stage reaches full extension.
5. After material being dumped clears the body, lower the body to frame.

Refer to Section 30, Operating Instructions - Dumping, for more complete details concerning this control.

Lowering The Dump Body

Move the hoist lever forward to the DOWN position and release. Releasing the lever places hoist control valve in the FLOAT position, allowing the body to return to the frame.

Ashtray

Ashtray (8, Figure 32-3) is to be used for extinguishing and depositing smoking materials only. Ensure that all ashes are extinguished. Do not deposit flammable materials such as gum wrappers and tissues.

Lighter

Lighter (9, Figure 32-3) may be used for lighting cigarettes and cigars. It may also be used as a 12VDC power supply.

Data Store Button

This button (10, Figure 32-3) is for use by qualified maintenance personnel to record in memory a "snapshot" of the AC drive system. Operators can also use this feature during times when the truck is not operating correctly to record potential problems.

Service Engine Light

Service engine light (11, Figure 32-3) is a blue indicator that will illuminate if a problem is detected by the electronic engine monitoring system.

Electric propulsion and dynamic retarding will still be available.

If this light is ON, notify maintenance personnel so they can diagnose and repair the problem the next time the truck is in the shop for repairs or at the next maintenance interval.

12V Auxiliary Power Outlets

Outlets (12, Figure 32-3) can be used to provide 12VDC power for tools and accessories.

DIAGNOSTIC PORTS**Drive System #1**

Diagnostic port (1, Figure 32-4) is used to access diagnostic information for the AC drive system.

Engine (QUANTUM)

Diagnostic port (2) is used to access diagnostic information for the engine monitoring system.

Drive System #3

Diagnostic port (3) is used to access diagnostic information for the AC drive system.

Engine (CENSE)

Diagnostic port (4) is used to access diagnostic information for the engine monitoring system.

Interface Module

Diagnostic port (5) is used to connect the interface module to a computer for installing software.

VHMS

Diagnostic port (6) is used to download truck operation data from the VHMS controller.

Payload Meter

Diagnostic port (7) is used to download data from the payload meter system. Refer to Section 60, Payload Meter III, for a more complete description of the payload meter and its functions.

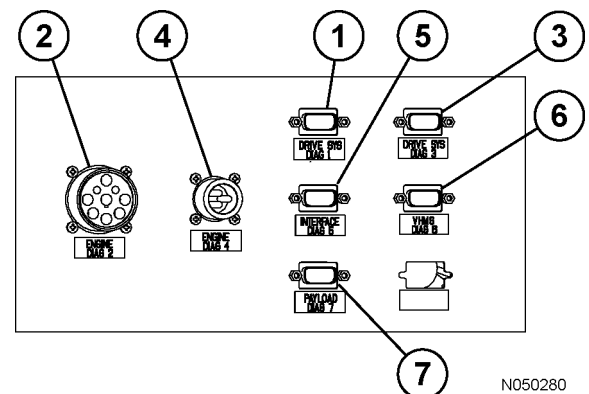

N050280

FIGURE 32-4. DIAGNOSTIC PORTS
(BOX BEHIND OPERATOR'S SEAT)

- | | |
|---------------------|---------------------|
| 1. Drive System #1 | 5. Interface Module |
| 2. Engine (QUANTUM) | 6. KOMTRAX Plus |
| 3. Drive System #3 | 7. Payload Meter |
| 4. Engine (CENSE) | |

OPERATOR'S SEAT

The operator's seat provides a fully adjustable cushioned ride for driver comfort and easy operation.

Seat Belts

- On both driver and passenger seats, check the seat belt fabric, buckle, all belt retractors and hardware for damage or wear. Replace any worn or damaged parts immediately.
- Even if there are no signs of damage, replace both driver and passenger seat belts 5 years after seat belt manufacture, or every 3 years after start of use, whichever comes first. The passenger seat belt date of manufacture label is sewn into the seat belt near the buckle. The driver seat belt date of manufacture label is sewn into the shoulder harness belt, near the retractor end.

Adjustment

The following adjustments must be made while sitting in the seat. Refer to Figure 32-5.

1. **Headrest** - Move headrest (1) up or down to the desired position. It can also be tilted forward by pulling on the top of the headrest. There are four positions. Pulling the headrest completely forward will release the ratchet mechanism and return the headrest to the furthest back position.
2. **Seat Height** - Push and hold switch (2) to adjust the height of the seat. Release the switch when the desired height is reached.
Optimum ride height is obtained when the suspension is at the middle of its stroke. To properly adjust, raise the seat to its highest level. Then, lower the seat approximately 51 mm (2 in.) to the middle of the suspension stroke.
3. **Lumbar Support** - Move dial (3) to adjust the lumbar support to the desired position.
4. **Armrest Tilt** - Rotate adjusting knob (4) until the armrest is in desired position.
5. **Seat Belt** - The operator must always have seat belt (5) buckled and properly adjusted whenever the truck is being operated.
6. **Backrest Recline** - Lift handle (6) to select the desired backrest recline. Release the handle to set the position.
7. **Fore/Aft Location of Seat Cushion (if equipped)** - Lift and hold lever (7) and move the seat cushion to a comfortable position. Release the lever to lock the position adjustment.

8. **Suspension Dampener** - Adjust suspension dampener (8) to obtain the desired stiffness of the adjustable shock absorber. Move the lever upward to stiffen the absorbency of the shock. Move the lever downward to soften the ride. Five detented settings are available.

NOTE: This seat contains a fixed rate shock absorber in addition to the adjustable shock absorber that is controlled by the suspension dampener.

9. **Seat Cushion Tilt (if equipped)** - Lift and hold lever (9) and tilt the seat cushion to a comfortable position. Release the lever to lock the position adjustment.
10. **Fore/Aft Location of Seat** - Lift and hold lever (10) and move the seat to a comfortable height. Release the lever to lock the height adjustment.

NOTE: The seat compressor must be allowed to cool down for ten minutes for every one minute of continuous operation. The compressor must not be operated continuously for more than three minutes.

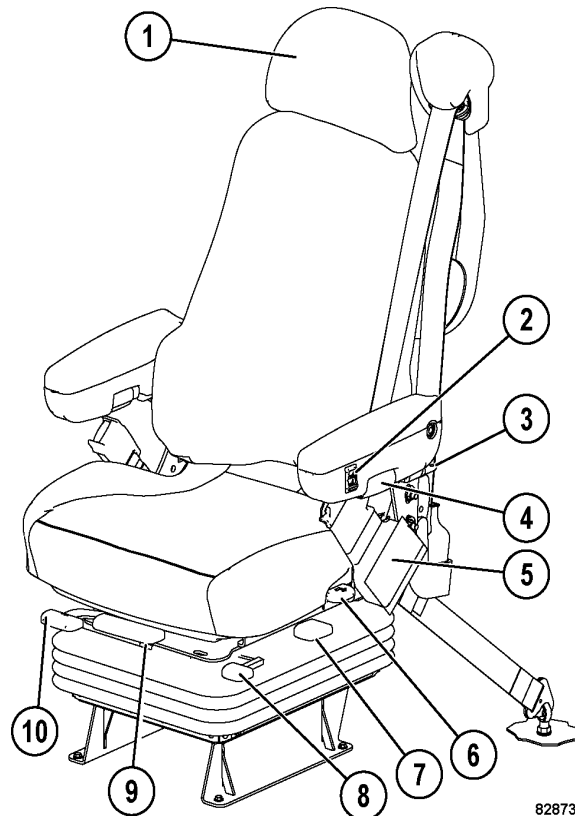

82873

FIGURE 32-5. OPERATOR'S SEAT CONTROLS

- | | |
|---------------------|------------------------------|
| 1. Headrest | 7. Seat Cushion Fore and Aft |
| 2. Seat Height | 8. Suspension Dampener |
| 3. Lumbar Support | 9. Seat Tilt |
| 4. Armrest Tilt | 10. Fore and Aft |
| 5. Seat Belt | |
| 6. Backrest Recline | |

PASSENGER SEAT (STANDARD SEAT)

The passenger seat provides a fully adjustable cushioned ride for driver comfort and easy operation.

Seat Belts

- On both driver and passenger seats, check the seat belt fabric, buckle, all belt retractors and hardware for damage or wear. Replace any worn or damaged parts immediately.
- Even if there are no signs of damage, replace both driver and passenger seat belts 5 years after seat belt manufacture, or every 3 years after start of use, whichever comes first. The passenger seat belt date of manufacture label is sewn into the seat belt near the buckle. The driver seat belt date of manufacture label is sewn into the shoulder harness belt, near the retractor end.

Adjustment

The following adjustments must be made while sitting in the seat. Refer to Figure 32-6.

1. **Fore/Aft Location of Seat Cushion (if equipped)** - Lift and hold lever (1) and move the seat cushion to a comfortable position. Release the lever to lock the position adjustment.
2. **Seat Height** - Pull up on handle (2), then adjust the height of the seat. When the desired height is reached, release the handle.
3. **Weight Adjustment** - Rotate knob (3) until the weight indicator next to the knob is pointing to the weight of the person that will be riding in the seat. This will provide the most comfortable ride setting.
4. **Fore/Aft Location of Seat** - Lift and hold lever (4) and move the seat to a comfortable location. Release the lever to lock the fore/aft location.

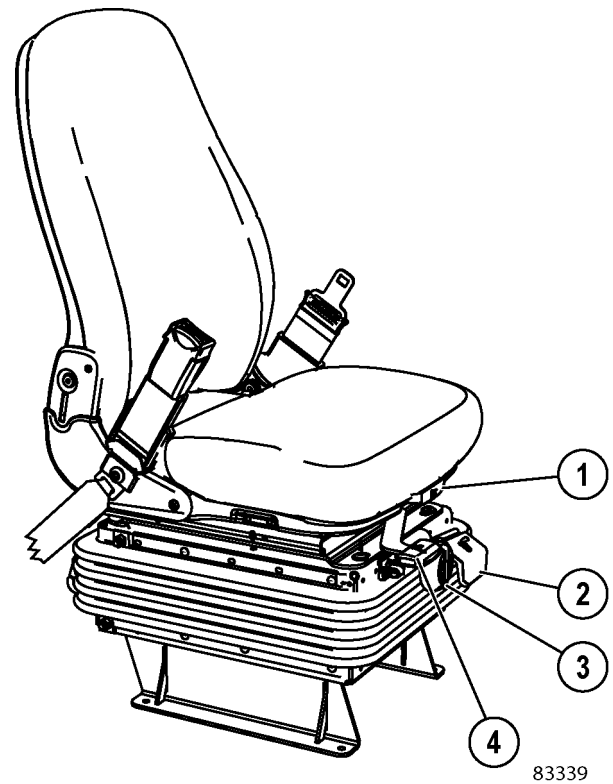

FIGURE 32-6. PASSENGER SEAT CONTROLS

- | | |
|------------------------------|----------------------|
| 1. Seat Cushion Fore and Aft | 3. Weight Adjustment |
| 2. Seat Height | 4. Fore and Aft |

HEATER/AIR CONDITIONER COMPARTMENT AND CONTROLS

The heater/air conditioner compartment contains heater/air conditioner controls and some of the heater/air conditioner components, such as the blower motor assembly and the heater coil. Optimum cab air climate can be selected by using the following controls in various combinations.

Fan Speed Control Knob

Fan speed control knob (1, Figure 32-7) is provided to control the cab air fan motor. The fan motor is a 3-speed motor (low, medium and high). Speeds are selected by rotating the control knob clockwise to the desired position. OFF is in the full counter-clockwise position. The control knob must be switched ON for the air conditioner to function.

Temperature Control Knob

Temperature control knob (2, Figure 32-7) allows the operator to select a comfortable air temperature.





The control knob determines the operation of the air conditioning and heater modes.

Rotating the control knob counter-clockwise (blue zone (3)) will cause the A/C compressor to operate and result in cooler air temperatures. Full counter-clockwise position is the coldest air setting.

Rotating the control knob clockwise (red zone (4)) will affect coolant flow through the heater core and result in warmer air temperatures. The full clockwise position is the warmest heater setting.

Air Flow Directional Knob

- Air flow directional knob (5, Figure 32-7) controls the direction of airflow as follows:

	Provides airflow to floor vents only.
	Provides airflow to upper vents and floor vents.
	(Blue Icon) Provides dehumidified air to the upper vents and the floor vents.
	Defrost - Provides dehumidified air to the upper vents only.
	Defrost - Provides dehumidified air to the upper vents and the floor vents.

Heater/Air Conditioner Vents

Heater/air conditioner vents (6, Figure 32-7) may be rotated 360°. There are three vents in the heater/air conditioner compartment, four vents across the top of the instrument panel, and one vent each in the RH and LH instrument panels. There are also an additional four vents under the instrument panel. Air flow through the vents is controlled by manually opening, closing or turning the louvers.

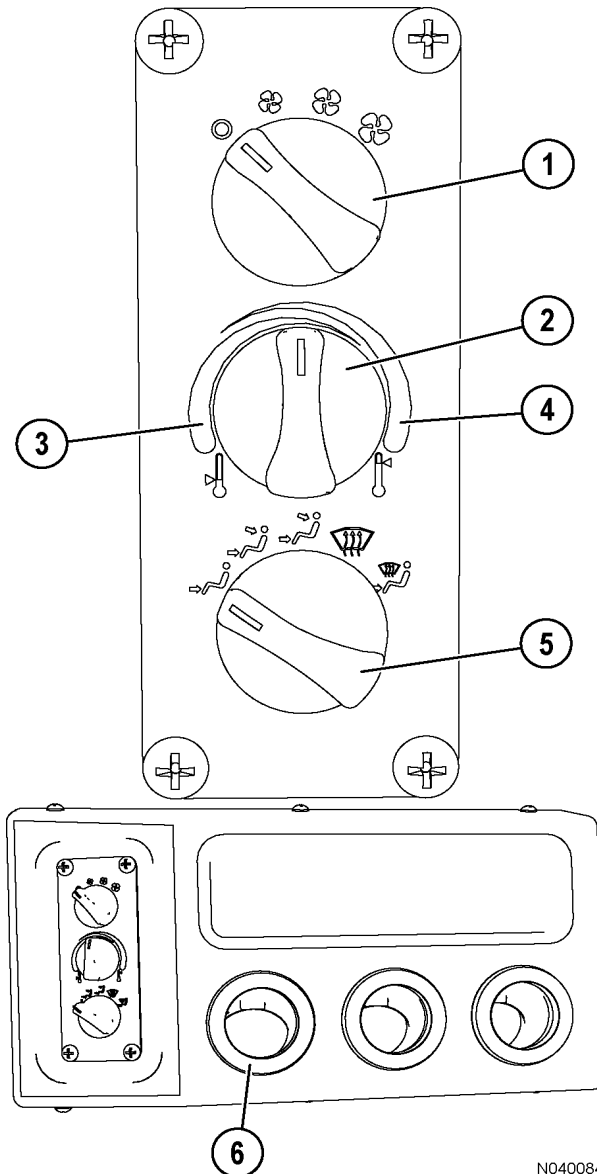

N040084

FIGURE 32-7. A/C & HEATER CONTROLS

- | | |
|-----------------------------|------------------------------|
| 1. Fan Speed Control Knob | 4. Red Zone |
| 2. Temperature Control Knob | 5. Air Flow Directional Knob |
| 3. Blue Zone | 6. Vents |

INSTRUMENT PANEL

The operator must understand the function and operation of each instrument and control. Control functions are identified with "international" symbols that the operator should learn to recognize immediately. This knowledge is essential for proper and safe operation.

Items that are marked "optional" do not apply to every truck.

Control Symbols

Many control functions are identified with international symbols that the operator should learn to recognize immediately. The operator must understand the function and operation of each instrument and control. This knowledge is essential for proper and safe operation of the machine.

The following symbols are general indicators and may appear in multiple locations and combinations on the instrument panel.

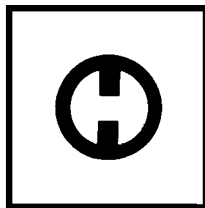

This symbol may be used alone or with another symbol. This symbol identifies the OFF position of a switch or control.

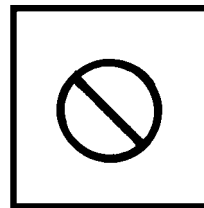

This symbol when it appears on an indicator or control identifies that this indicator or control is NOT used.

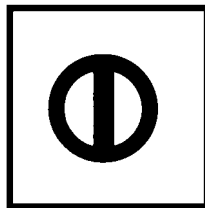

This symbol may be used alone or with another symbol. This symbol identifies the ON position of a switch or control.

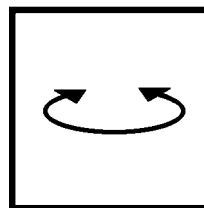

This symbol identifies a rotary control or switch. Rotate the knob clockwise or counterclockwise for functions.

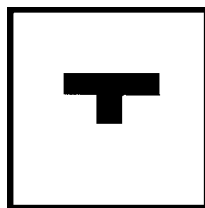

This symbol identifies the "Pushed-In" position of a push-pull switch or control.

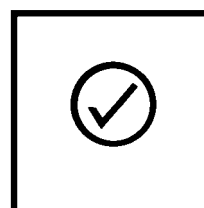

This symbol identifies a switch used to test or check a function. Press the switch on the side near the symbol to perform the test.



This symbol identifies the "Pulled-Out" position of a push-pull switch or control.

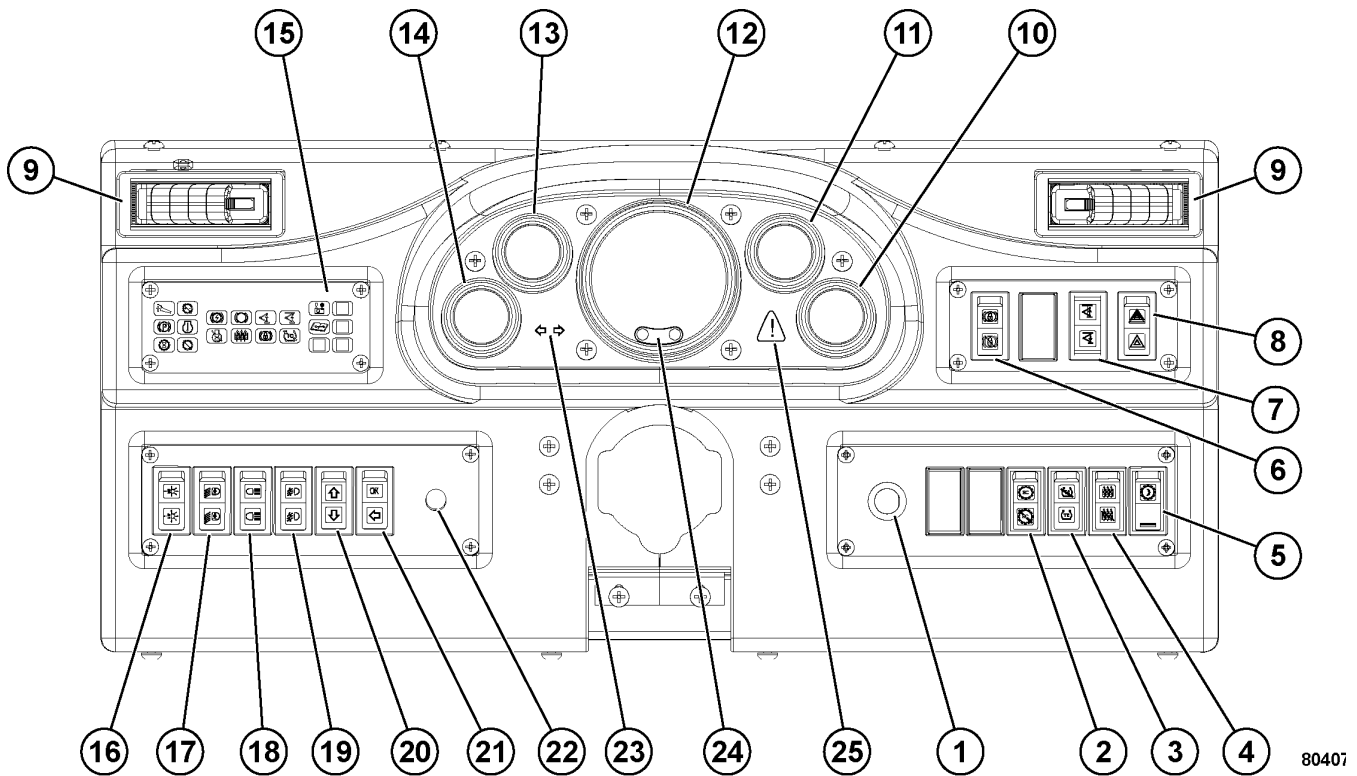

FIGURE 32-8. INSTRUMENT PANEL GAUGES, INDICATORS AND CONTROLS

- | | |
|------------------------------------|---|
| 1. Key Switch | 14. Hydraulic Oil Temperature Gauge |
| 2. Speed Control Switch | 15. Status Indicator Lights (amber) |
| 3. Traction Control Switch | 16. Headlight/Panel Illumination Light Switch |
| 4. Retarding Grid Drier Switch | 17. Ladder Light Switch (3-Way) |
| 5. AC Drive System Rest Switch | 18. Backup Light Switch |
| 6. Wheel Brake Lock Switch | 19. Fog Light Switch |
| 7. Pantograph Raise/Lower Switch | 20. Mode Switch #2 |
| 8. Hazard Lights Switch | 21. Mode Switch #1 |
| 9. Heater/Air Conditioner Vents | 22. Panel Illumination Lights Dimmer Switch |
| 10. Drive System Temperature Gauge | 23. Turn Signal Indicators |
| 11. Fuel Level Gauge | 24. Digital Display Contrast Buttons |
| 12. Speedometer/Digital Display | 25. Warning Light (red) |
| 13. Coolant Temperature Gauge | |

Key Switch

Key switch (1, Figure 32-8) is a four-position (ACC, OFF, RUN, START) switch. The ACC position is not currently used.

When the switch is rotated one position clockwise, it is in the RUN position and all electrical circuits (except START are activated).

1. With the directional control lever in PARK, turn the key switch fully clockwise to START and hold this position until the engine starts. The START position is spring-loaded to return to the RUN position when the key is released.
2. After the engine has started, place rest switch (5, Figure 32-8) in the OFF position. For more information, refer to "Rest Switch" on the next page.

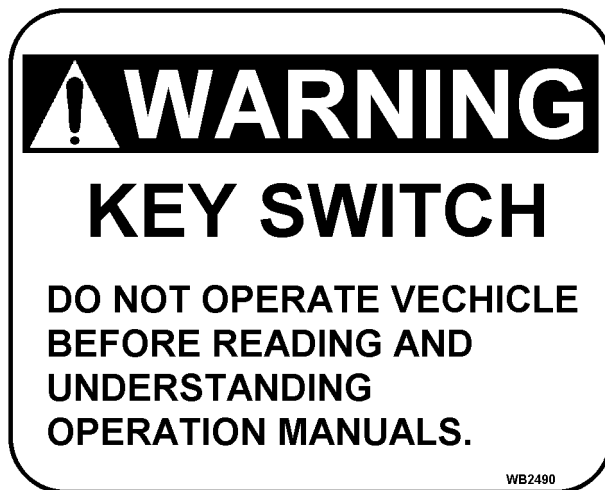

Speed Control Switch

Speed control switch (2, Figure 32-8) is a rocker switch. When in the ON position, the speed control lever on the steering column can be used as a "cruise control" function.

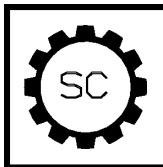

Traction Control Switch

Traction control switch (3, Figure 32-8) is a rocker switch. When in the OFF position, the traction control feature is turned off. This can be used in dry operating conditions when the chance of slipping or sliding is minimal so that the drive system will always put maximum power to the ground.



Retarding Grid Drier Switch

Retarding grid drier switch (4, Figure 32-8) is a rocker switch. When in the ON position, this feature is used to dry the retarding grids when starting the truck after it has been washed or parked in rainy conditions. This will minimize the possibility of activating a ground fault due to water in the grids. It can also be used to keep the engine warm in cold conditions because it puts a small amount of load against the engine.

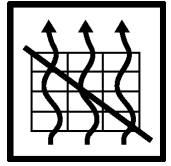

AC Drive System Rest Switch

Rest switch (5, Figure 32-8) is a rocker switch with a locking device. A safety tab on the switch must be pushed to unlock the switch before the top of the switch can be depressed to activate the rest mode.

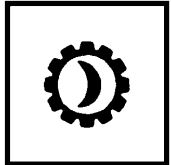

When activated, an internal amber lamp will illuminate. The switch should be activated to de-energize the AC drive system whenever the engine is to be shutdown or parked for a length of time with the engine running.

The directional control lever must be in PARK or NEUTRAL and the vehicle not moving to enable this function. This will allow the engine to continue running while the AC drive system is de-energized.



Activation of the rest switch alone DOES NOT completely ensure that the drive system is safe to work on. Refer to Section 20, Safety, for more information on servicing an AC drive truck. Check all "link-on" or "link energized" indicator lights to verify the AC drive system is de-energized before performing any maintenance on the drive system. DO NOT activate the rest switch while the truck is moving! The truck may unintentionally enter the "rest" mode after stopping.

Wheel Brake Lock Switch

Wheel brake lock switch (6, Figure 32-8) should be used with engine running for dumping and loading operations only. The brake lock switch actuates the hydraulic brake system which locks the **rear wheel service brakes only**. When pulling into shovel or dump area, stop the truck using the foot-operated service brake pedal. When truck is completely stopped and in loading position, move the directional control lever to NETURAL, then apply the brake lock by pressing the top of the rocker switch. To release the brake, press the bottom of the rocker switch.

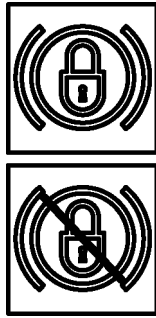

NOTE: The wheel brake lock will not function if the directional control lever is in the PARK position.



Do not use the wheel brake lock switch to stop the truck unless foot-operated treadle valve is inoperative. Use of this switch applies rear service brakes at a reduced, unmodulated pressure. Do not use brake lock for parking. With engine stopped, wheel brake will release.

Pantograph Switch

Pantograph switch (7, Figure 32-8) controls the position of the pantograph. The switch will only operate when the directional control lever is in the "T" (trolley) position. Pressing the top side of the rocker switch will raise the pantograph. Pressing the lower side of the switch will lower the pantograph. Ensure truck is in position under the wires before raising the pantograph.



Hazard Warning Lights

Hazard warning light switch (8, Figure 32-8) flashes all the turn signal lights. Pressing the bottom side of the rocker switch activates these lights. Pressing the top side of the rocker switch turns these lights off.

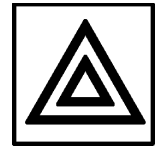

Heater/Air Conditioner Vents

Heater/air conditioner vents (9, Figure 32-8) are may be directed by the operator to provide the most comfortable cabin air flow.

Fuel Level Gauge

Fuel level gauge (10, Figure 32-8) indicates how much diesel fuel is in the fuel tank. When there is only 10% of total fuel tank capacity remaining, the amber low fuel level indicator on the gauge will illuminate.

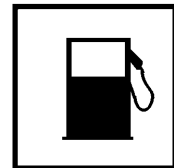

Hydraulic Oil Temperature Gauge

Hydraulic oil temperature gauge (11, Figure 32-8) indicates the oil temperature in the hydraulic tank. There are two colored bands: green and red.

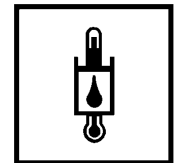

Green indicates normal operation.

As the needle approaches the red zone, minimum engine idle speed will increase to help cool the oil.

Red indicates high oil temperature in the hydraulic tank. Continued operation could damage components in the hydraulic system. If this occurs, the operator should safely stop the truck, move directional control lever to PARK and operate the engine at 1200 - 1500 rpm to reduce system temperature.

NOTE: If the temperature gauge does not move into the green range after a few minutes, shut down the truck and notify maintenance personnel immediately.

Speedometer/Digital Display

Speedometer/digital display (12, Figure 32-8) has several functions:

- The analog speedometer indicates the truck speed in miles per hour (mph) or in kilometers per hour (kph).
- The digital display shows payload meter information. For more information, see Section 60, Payload Meter III.
- The digital display also shows warning messages and fault codes indicating abnormal operating conditions and critical problems. See Digital Display Operation for more information.

Coolant Temperature Gauge

Coolant temperature gauge (13, Figure 32-8) indicates the temperature of the coolant in the engine cooling system. The temperature range after engine warm-up and a truck operating under normal conditions should be 85° to 97°C (185° to 207°F).

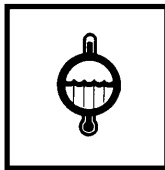
**Drive System Temperature Gauge**

Drive system temperature gauge (14, Figure 32-8) indicates the status of the highest measured temperature range in the drive system.

Status Indicator Light Panel

Status indicator light panel (15, Figure 32-8) contains an array of indicator lights to provide the operator with important status messages concerning selected truck functions. Refer to Status Indicator Lights later in this section for a detailed description of these indicators.

Headlight/Panel Illumination Light Switch

The instrument panel lights, clearance lights, and the headlights are controlled by this three-position rocker type switch (16, Figure 32-8). OFF is selected by pressing the bottom of the switch. Press the top of the switch until it reaches the first detent to select the panel lights, clearance lights and tail lights only. Press the top of the switch again until it reaches the second detent to select headlights, panel lights, clearance lights and tail lights.

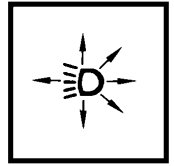
**Ladder Light Switch (3-Way)**

Ladder light switch (17, Figure 32-8) turns the ladder lights on or off after or before using ladder. Pressing the top of the rocker switch turns the lights on. Pressing the bottom of the switch turns the lights off. Another switch is mounted at the front left of truck near the base of ladder.

**Backup Light Switch**

Backup light switch (18, Figure 32-8) allows the backup lights to be turned on for added visibility and safety when the directional control lever is not in the REVERSE position. When the switch is in the ON position, the backup light indicator on the instrument panel will be illuminated.

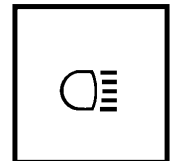
**Fog Light Switch**

Pressing the top of fog light switch (19, Figure 32-8) turns the lights on. Pressing the bottom of the switch turns the lights off.

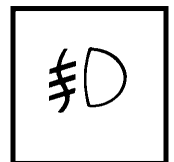

Mode Switches

Mode switches (20) and (21, Figure 32-8) are two-way momentary rocker switches. The arrows are used to toggle through the different options and messages on the digital display. The OK position is used to acknowledge and clear warnings and faults and set certain Payload Meter III settings.

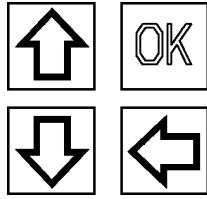

Refer to Digital Display Operation later in this section for more information about using the digital display. Refer to Section 60, Payload Meter III, for a more complete description of the payload meter system and its functions.

Panel Illumination Light Dimmer Switch

Panel illumination light dimmer switch (22, Figure 32-8) is a rheostat which allows the operator to vary the brightness of the instruments and panel illumination lights.



Rotating knob to the full counterclockwise position turns panel lights on to brightest condition. Rotating knob clockwise continually dims lights until the OFF position is reached at full clockwise rotation.

Right/Left Turn Signal Indicators

Indicators (23, Figure 32-8) illuminate to indicate that the right or left turn signals are operating when the turn signal lever on the steering column is moved upward or downward. Moving the lever to its center position will turn the indicator off.

Digital Display Contrast Buttons

Cold ambient operating temperatures may affect the contrast of the digital display. If necessary, use buttons (24, Figure 32-8) to increase or decrease the contrast of the digital display to make it easier to read.

Warning Light

Red warning light (25, Figure 32-8) will come on to indicate that a truck function requires **immediate action** by the operator. Safely stop the truck and notify maintenance personnel. A warning message will appear on the digital display.



STATUS INDICATOR LIGHTS

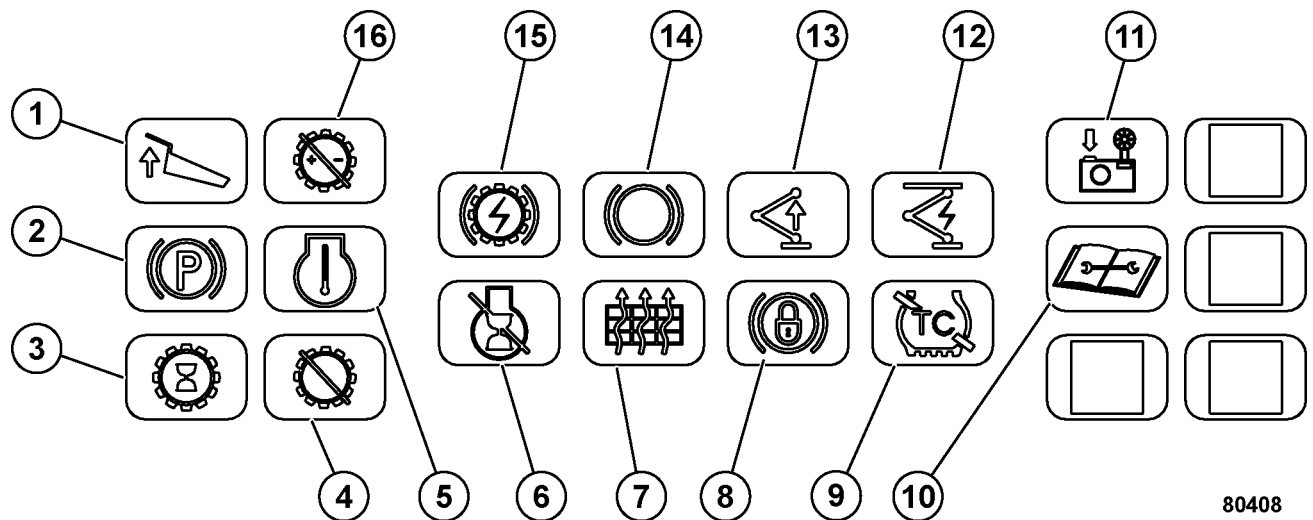

80408

FIGURE 32-9. STATUS INDICATOR LIGHTS

- | | |
|--------------------------------|---------------------------|
| 1. Body Up | 9. Traction Control |
| 2. Parking Brake Applied | 10. Repair Monitor |
| 3. Propulsion System Not Ready | 11. Snapshot In Progress |
| 4. No Propel | 12. Pantograph Energized |
| 5. Not Used | 13. Pantograph Up |
| 6. Engine Shut Down Timer | 14. Service Brake Applied |
| 7. Grid Drier | 15. Dynamic Retarding |
| 8. Wheel Brake Lock Applied | 16. No DC Link Voltage |

When lighted, these amber (yellow) status lights alert the operator that the indicated truck function requires some precaution. Refer to Figure 32-9 and the following descriptions for explanations of the symbols.

Body Up

Indicator light (1, Figure 32-9) will illuminate when the body is not completely down on the frame. The truck should not be driven until body is down and the light is off.

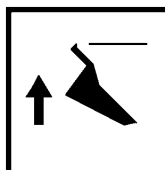

Parking Brake Applied

Indicator light (2, Figure 32-9) will illuminate when the parking brake is applied (directional control lever is in PARK). Do not attempt to drive the truck with the parking brake applied.



Propulsion System Not Ready

Indicator light (3, Figure 32-9) functions during start-up much like the hourglass icon on a computer screen. This light indicates that the computer is in the process of performing the self-diagnostics and set-up functions at start-up. Propulsion will not be available at this time.



No Propel

Indicator light (4, Figure 32-9) will illuminate to indicate that a fault has occurred which has eliminated the propulsion capability. If this condition occurs, the operator should safely stop the truck, move the directional control lever to PARK, shut down the engine, and notify maintenance personnel immediately.

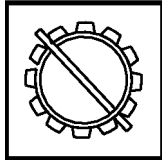

Wheel Brake Lock Applied

Indicator light (8, Figure 32-8) will illuminate when the wheel brake lock is on. The wheel brake lock should only be used when the truck is completely stopped and in loading position.



Engine Warming Up

Indicator light (5, Figure 32-9) not used this application.



Traction Control

Indicator light (9, Figure 32-8) will illuminate when the traction control switch is in the OFF position. This feature should always be used when conditions are wet or slippery.



Engine Delay

When the key switch has been turned OFF, and certain conditions have been met, this indicator light (6, Figure 32-9) will illuminate to indicate that the shutdown timing sequence has started. The engine could operate for up to three minutes.



Repair Monitor

Indicator light (10, Figure 32-8) will illuminate if a "repair" fault is detected, which must be corrected after the operator's shift is done.

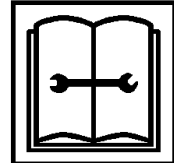

- If the directional control lever is moved out of PARK, the engine will stop immediately.
- If the key switch is turned back ON, the engine stop sequence will be terminated, and the engine will remain running.

Snapshot

Indicator light (11, Figure 32-8) indicates that the KOMTRAX Plus system is in the process of recording a "snapshot" of certain vehicle conditions.



Grid Drier

Indicator light (7, Figure 32-9) indicates that the grid drier feature is in operation. This feature is used to dry the retarding grids when starting the truck after it has been washed or parked in rainy conditions.

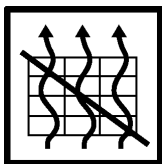

Pantograph Energized

Indicator light (12, Figure 32-9) will illuminate when the pantograph is fully extended and is receiving power from the electrical lines.

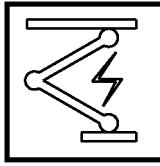
**Pantograph Up**

Indicator light (13, Figure 32-9) will illuminate when the pantograph is not fully retracted.

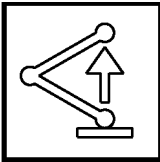
**Service Brake Applied**

Indicator light (14, Figure 32-9) will illuminate when the service brake pedal is applied. Do not attempt to drive the truck from a stopped position with the service brakes applied, except as noted in Section 30, Operating Instructions - Starting On A Grade With A Loaded Truck.

**Dynamic Retarding**

Indicator light (15, Figure 32-9) illuminates whenever the retarder pedal is operated or the automatic overspeed retarding circuit is energized, indicating that the dynamic retarding function is operating.

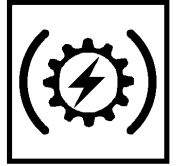
**No DC Link Voltage**

Indicator light (16, Figure 32-9) indicates that the DC link in the control cabinet is not providing voltage to the propulsion system.

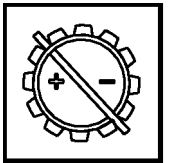

DIGITAL DISPLAY OPERATION

Toggleing Through Main Level Screens

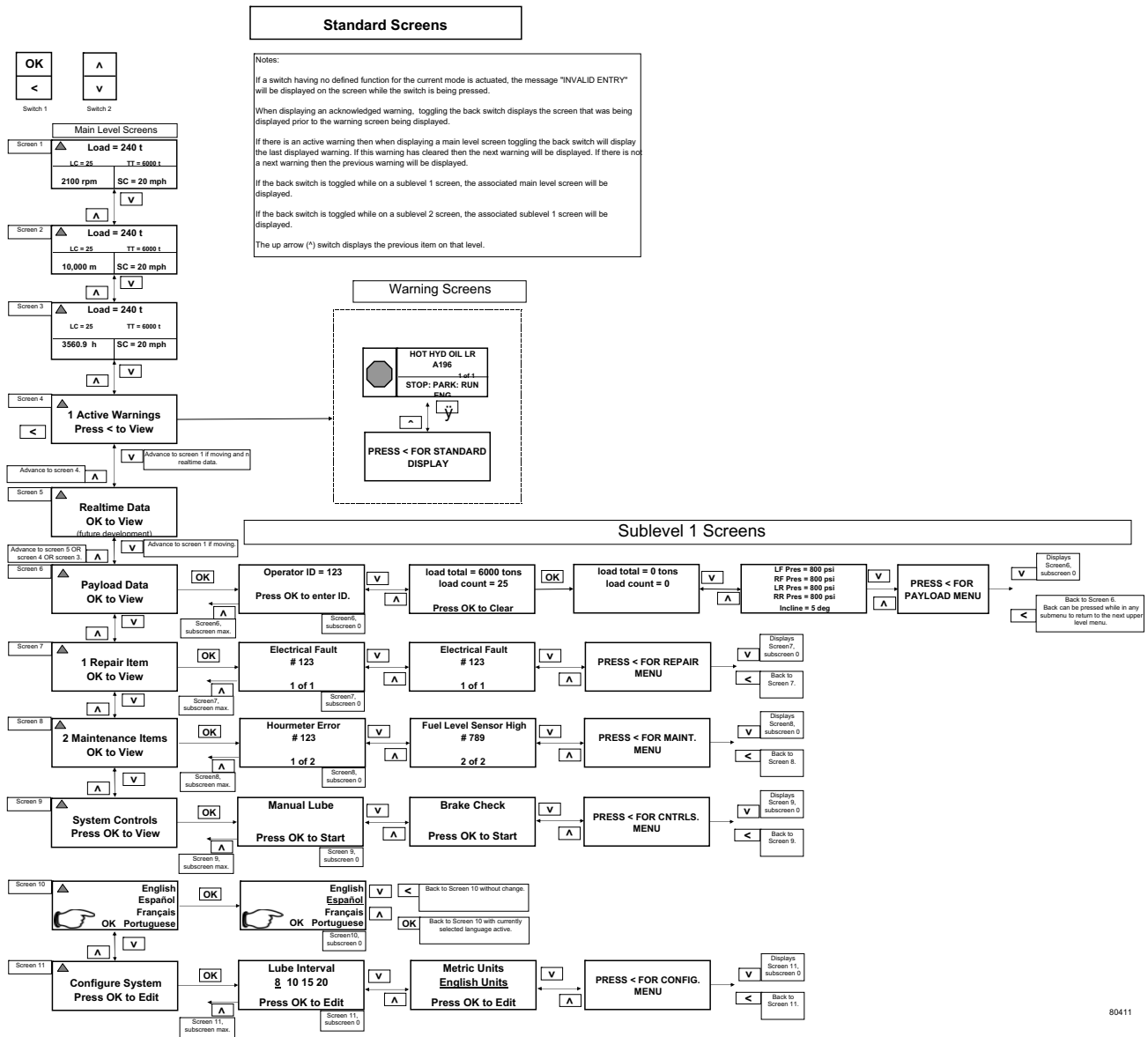

Toggleing Through Warning Screens

Warning Screens



Note: If a switch having no defined function for the current mode is actuated, the message "INVALID ENTRY" will be displayed on the screen while the switch is being pressed.

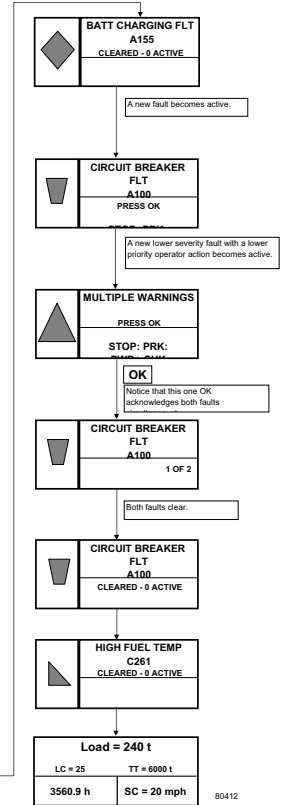
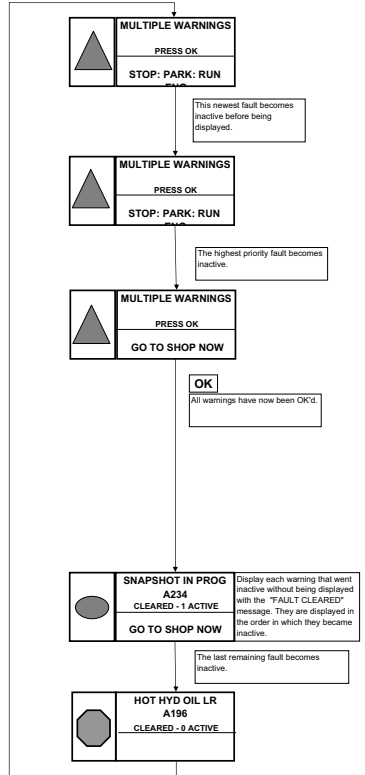
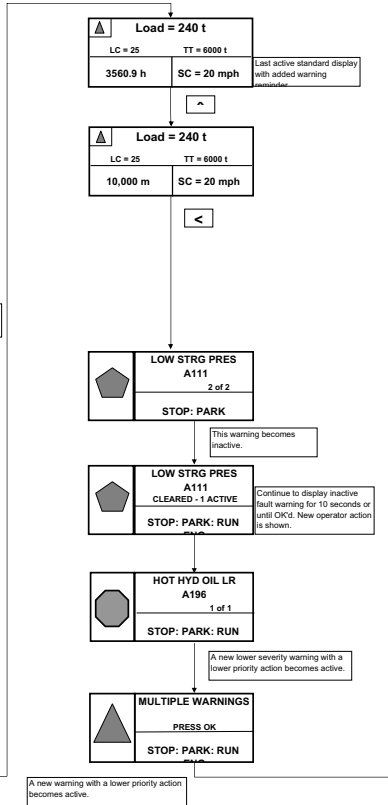
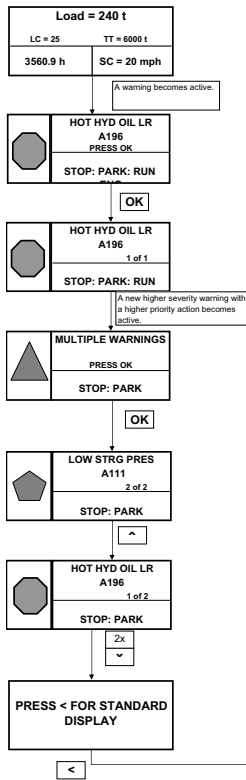

Entering Payload Meter Data

Data Entry Detail (Sublevel 2)

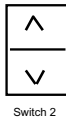
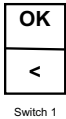

Note: If a switch having no defined function for the current mode is actuated, the message "INVALID ENTRY" will be displayed on the screen while the switch is being pressed.
If the back switch is actuated before accepting a new driver ID, the old ID will remain in effect.

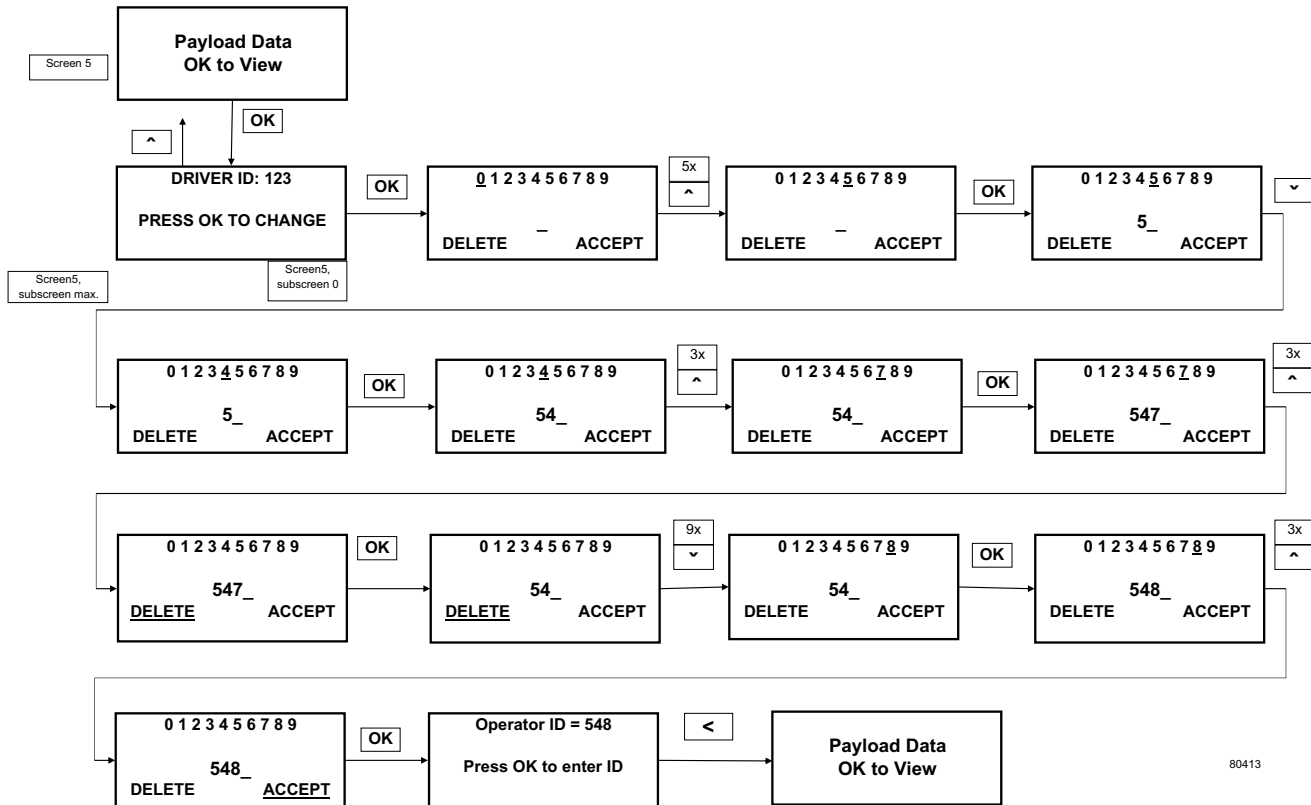

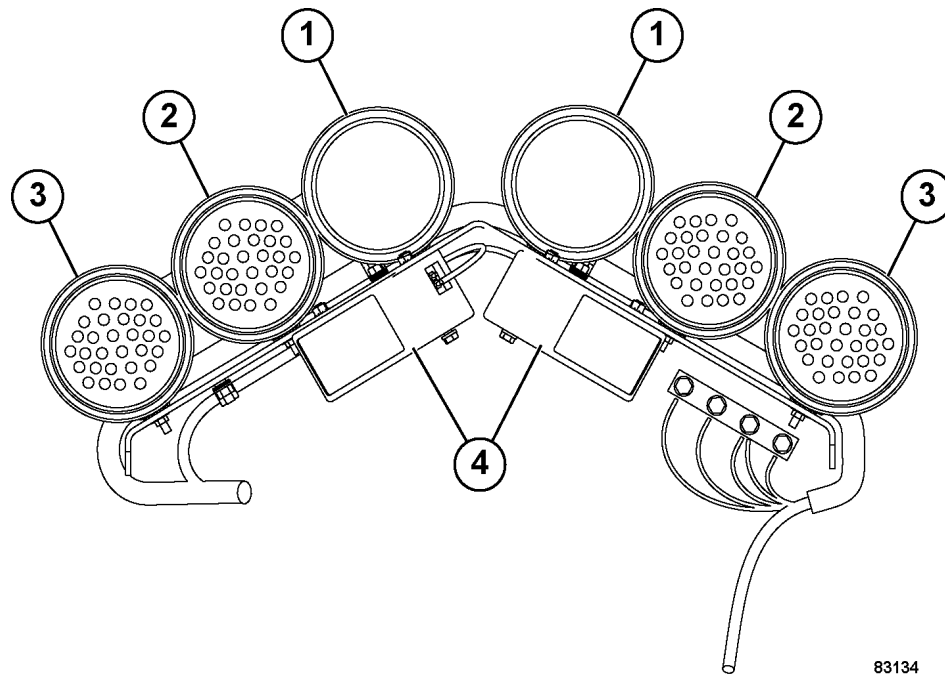
REAR AXLE LIGHT BAR

83134

FIGURE 32-10. REAR AXLE LIGHT BAR

- | | |
|------------------|-----------------|
| 1. Backup Lights | 3. Brake Lights |
| 2. Retard Lights | 4. Backup Alarm |

NOTE: The brake light is functional at all times regardless of key switch position. All other lights (and the backup alarm) are only functional with the key switch in the RUN position.

Backup Lights

Backup lights (1, Figure 32-10) illuminate when the operator moves the directional control lever to REVERSE. The lights can also be activated by using the backup light switch in the cab. Using the switch turns the lights on regardless of directional control lever position.

Retard Lights

Retard lights (2) will illuminate when the operator uses the retard function to slow the truck. The amber light signals to traffic that the truck is slowing.

Brake Light

Brake light (3) will illuminate when the operator depresses the brake pedal. The red light signals to traffic that the truck is slowing.

Backup Alarm

Backup alarm (4) will sound when the operator moves the directional control lever to REVERSE. The alarm can also be turned on by using the backup light switch. Using the switch turns the alarm on regardless of directional control lever position.

KOMTRAX PLUS

Operation

This system uses the KOMTRAX Plus controller (2, Figure 32-12) to gather data about the operation of the truck from sensors and other controllers installed on the truck. The data stored in the KOMTRAX Plus controller is downloaded by computer using KOMTRAX diagnostic port (6, Figure 32-4) or transmitted directly by communications satellite utilizing Orbcmm controller (1, Figure 32-12), if equipped. This data is then compiled at the Komatsu computer server. Based on this information, the servicing Komatsu distributor will suggest improvements and provide information aimed at reducing machine repair costs and downtime.

NOTE: A contract is necessary before KOMTRAX Plus can be used. Contact your Komatsu distributor for more information.

CAUTION

DO NOT disassemble, repair, or modify the KOMTRAX Plus system without proper authorization. Changes to the system may cause machine failures and fire.

DO NOT touch the KOMTRAX Plus system components during machine operation.

DO NOT pull on KOMTRAX Plus system wiring harnesses, connectors, or sensors. This may cause short circuits or open circuits and lead to machine failure or fire.

DO NOT allow water, dirt, or oil onto system components.

The ORBCOMM satellite requires the installation of a pole and antenna, adding to the overall height of the machine. The height increase is 410 mm (16.2 in.). With the guard installed, the overall height increases another 260 mm (10.2 in.). Use caution when operating in areas with height restrictions.

DANGER

Anyone with a pacemaker must remain a minimum of 22 cm (9 in.) from the communications antenna. Radio waves from the antenna can interfere with pacemaker operation.

IMPORTANT

The KOMTRAX Plus system uses wireless components that transmit via radio waves. It is necessary to conform to local laws when using this system.

Proper operation of the system is dependent on good reception. Operating in tunnels, mountain ranges and covered areas may prevent communication of the system.

Contact your Komatsu distributor before selling or exporting a truck equipped with KOMTRAX Plus. It may be necessary to remove the system before transfer of ownership.

Contact your Komatsu distributor before installing equipment that may interfere with the KOMTRAX Plus system.

Komatsu is not responsible for any failures that result from neglecting KOMTRAX Plus system precautions and instructions.

DANGER

ORBCOMM is a two-way radio communication device. Wireless signals from the system can interfere with other wireless signals in the area. This interference can cause a malfunction in a blast zone resulting in an unintended detonation. Know the locations of blast zones in the area and keep a safe distance to avoid unintentional blasts. If the machine is operating within a distance of 12m (40 ft) of a blast zone, disconnect the ORBCOMM harness. Failure to do so could result in serious injury or death.

This warning does not supersede requirements or regulations of the area or country where this machine is in operation. The following specifications are provided to ensure compliance with all of the applicable requirements or regulations:

Transmit power: 5-10 Watts

Operating Frequency Range: 148 - 150 MHz

NOTE: The ORBCOMM modem installed from the factory on all new trucks may not be approved for use in certain countries of the world. Local regulation may prohibit the use of the ORBCOMM modem/satellite communicator. Depending on local regulation, you may need to either remove the modem or disconnect it and remove the antenna.

Check with KAC service for assistance and preferred action in your area.

The following is a list of "at risk" countries: China, Russia, Serbia, Tanzania, Senegal, Zambia, Botswana and Namibia.

When data store button (1, Figure 32-11) on the rear of the center console is pressed, it will store a "snapshot" of the SIBAS drive system. It will also trigger KOMTRAX Plus to store a snapshot of the truck operating system. A "snapshot in progress" message will be displayed on the speedometer/digital display while KOMTRAX Plus system is recording the snapshot.

KOMTRAX is turned on by the truck key switch. Immediately after receiving 24V power from the key switch, the KOMTRAX Plus controller begins the power-up initialization sequence. This sequence takes about three seconds, during which time red LED digits (3, Figure 32-12) near the top of the controller will display a circular sequence of flashing LED segments.

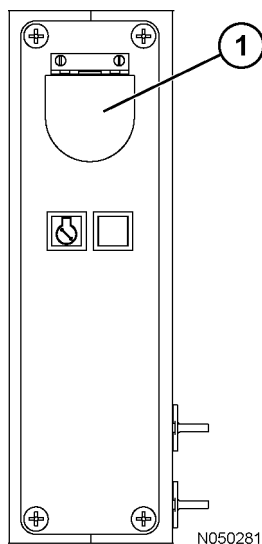

FIGURE 32-11. REAR OF CENTER CONSOLE

1. Data Store Button

During normal truck operation, the red LED digits on the KOMTRAX Plus controller will count from 1-99 continuously.

When the key switch is turned to OFF, the controller will remain on while it finishes processing internal data and saves the recent data into permanent memory. When the data has been safely stored, the two digit LED display will turn off. This process could take up to three minutes to complete.



If 24V power is disconnected (using the battery disconnect switches) from the KOMTRAX Plus controller before it has completed its shutdown procedure, the controller will lose all data gathered since the key switch was last turned to ON. Do not disconnect battery power until the controller has completed the shutdown procedure and has turned the LED digits off.

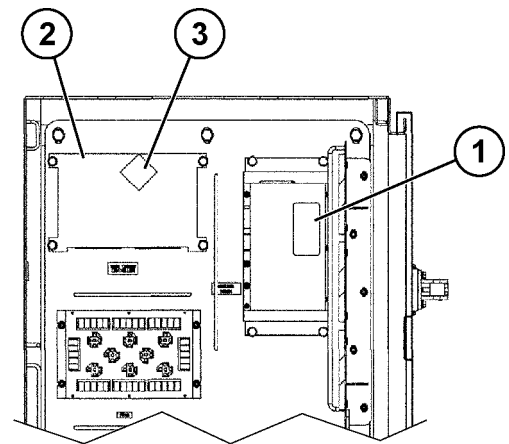

FIGURE 32-12. KOMTRAX PLUS
COMPONENT LOCATION
(R.H. WALL OF AUXILIARY CONTROL CABINET)

1. Orbcmm Controller
2. KOMTRAX Plus Controller
3. Red LED Digits

The Orbcomm controller transmits data through antenna (1, Figure 32-13) mounted on top of the cab with magnetic mount (2). The antenna coaxial cable is routed through the cab to protect it from damage. If the antenna or coaxial cable is damaged, replace the part.

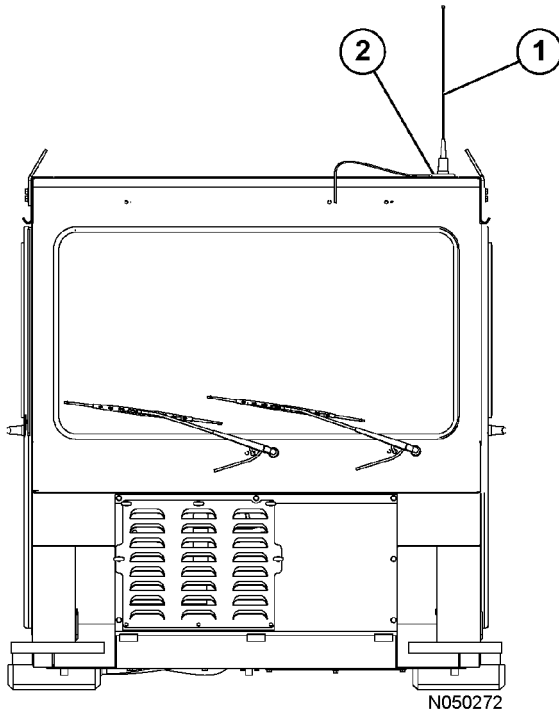

FIGURE 32-13. ORBCOMM ANTENNA

1. Orbcomm Antenna
2. Magnetic Mount

Interface module (1, Figure 32-14) receives data from the sensors installed on the truck and sends this information to the KOMTRAX Plus controller. There is a small green LED light (2) on the face of the controller. When the key switch is ON, the light should be blinking. If the light is continuously illuminated, there is a problem in the controller.

When a new interface module is installed on the truck, new software has to be installed inside the controller. IM diagnostic port (5, Figure 32-4) on the box behind the operator's seat is used to connect the interface module to a computer for installing software.

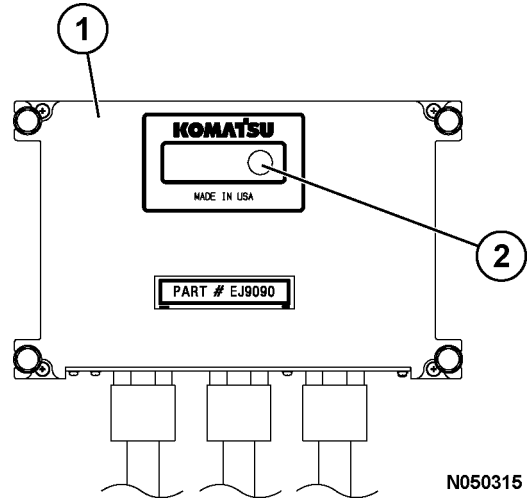

FIGURE 32-14. INTERFACE MODULE
(REAR WALL OF AUXILIARY CONTROL CABINET)

1. Interface Module
2. Green LED Light

Basic Precautions

Never disassemble, repair, or modify the KOMTRAX Plus system. This may cause failure or fire on the machine or this system.

Do not touch the system when operating the machine.

Do not pull on the wiring harnesses, connectors, or sensors of this system. This may cause short circuits or disconnections that lead to failure or fire on the machine or this system.

Do not get water, dirt, or oil on the system controllers.

If there is any abnormality with the KOMTRAX Plus system, consult the servicing Komatsu distributor.

FUSES AND CIRCUIT BREAKERS

The fuses are located in three fuse blocks in the auxiliary control cabinet.

The circuit breakers are located on the relay boards on the left inside wall of the auxiliary control cabinet.

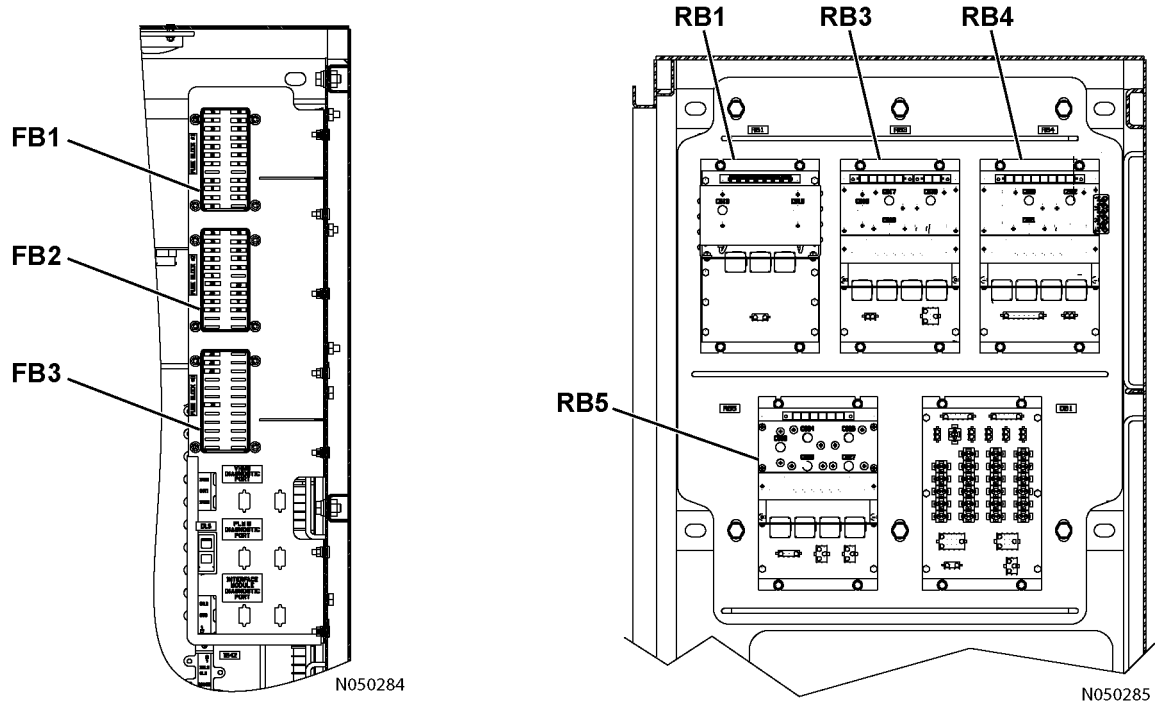

FIGURE 32-15. FUSE BLOCKS AND RELAY BOARDS

FUSE BLOCK #1

LOCATION	AMPS	DEVICES(S) PROTECTED	CIRCUIT
1	15	A/C, Heater Blower Motor	12H
2	10	Windshield Washer / Wiper	63
3	5	Instrument Panel Gauges	712G
4	10	Key Switch Power	712P
5	10	Hoist Limit Switch	712H
6	15	Turn Signal / Clearance Lights	712T
7	10	Engine Options	712E
8	10	Indicator Lights	12M
9	10	Engine Start Failure	712SF
10	10	Engine Shutters	712R
11	10	Auxiliary Control Cabinet Dome Lights	712A
12	10	Operator Seat	712DS
13	15	Drive System Power	71P
14	10	Auto Lube	68ES
17	10	Brake Circuits	71bc
18	5	Payload Meter Module	712PL
19	5	Interface Module Power	87
20	5	VHMS Power	71VHM
21	5	Dispatch System Power	712MM
22	5	Dash Switch Power	49B
23	1	Selector Switch	71SS

FUSE BLOCK #2

LOCATION	AMPS	DEVICES(S) PROTECTED	CIRCUIT
1	15	Engine Service Lights	11SL
2	15	Cab Dome, Fog, Ladder Lights, Rotating Beacon	11L
3	15	Hazard Lights	46
4	10	Interface Module	11INT
5	10	Display Module	11DISP
6	20	Modular Mining Hub	11M
7	10	VHMS & Orbcomm Controllers Power	85
8	15	Oil Reserve System Pump	11ORS
9	15	Oil Reserve Control Module	11RCNT
10	15	HID Headlights	11HDL
11	5	Interface Module Power	11IM2
13	20	Engine ECM Power	11E1
14	20	Engine ECM Power	11E2
15	20	Engine ECM Power	11E3
16	20	Engine ECM Power	11E4
17	15	Key Switch Power	11KS
18	5	Payload Meter	39J
19	5	Payload Meter	39G

FUSE BLOCK #3

LOCATION	AMPS	DEVICES(S) PROTECTED	CIRCUIT
1	20	Cab 12V Power Receptacle	67C
3	20	R.H Cab Window	67R
5	20	L.H Cab Window	67P
13	10	Radio	65

The following circuit breakers are located on the relay boards on the left inside wall of the auxiliary control cabinet.

Location	Amps	Devices protected	Circuit
RB1 - CB13	12.5	Turn Signals / Clearance Lights	11CL
RB1 - CB14	12.5	Turn Signal Flasher	11Z
RB1 - CB15	12.5	Tail Lights	41T
RB3 - CB11	12.5	Backup Lights and Horn	79A
RB3 - CB16	12.5	Retard Lights	44D
RB3 - CB17	12.5	Manual Backup Lights	47B
RB3 - CB18	12.5	Stop Lights	44A
RB4 - CB20	5	Engine Control Power	23D
RB4 - CB21	12.5	Service Lights, Forward Horn	11A
RB4 - CB22	5	Engine Run Relay	439E
RB5 - CB23	12.5	Headlights, Left Low Beam	11DL
RB5 - CB24	12.5	Headlights, Right Low Beam	11DR
RB5 - CB25	12.5	Headlights, Left High Beam	11HL
RB5 - CB26	12.5	Headlights, Right High Beam	11HR
RB5 - CB27	12.5	Headlights and Dash Lights	11D

The following two fuses are located in the fusible link between the prelube timer solenoid and #2 cranking motor.

Location	Amps	Devices protected	Circuit
Fusible link	300 each	Engine Prelube Motor	11ST

The following circuit breaker is located in the auxiliary control cabinet.

Location	Amps	Devices protected	Circuit
Auxillary Control Cabinet - CB60	50	24V to 12V Converter	11B5

LUBRICATION AND SERVICE

GENERAL

Recommended preventive maintenance will contribute to the long life and dependability of the truck and its components. The use of proper lubricants and the performance of checks and adjustments at the recommended intervals is most important.

Lubrication requirements are referenced to the lube key found in the Lubrication Chart (page 2-5). For detailed service requirements for specific components, refer to the shop manual section for that component.

Refer to the manufacturer's service manual when servicing any components of the propulsion system.

Refer to engine manufacturer's service manual when servicing the engine or any of its components.

The service intervals presented here are in hours of operation. **These intervals are recommended in place of an oil analysis program which may determine different intervals.** However, if the truck is being operated under extreme conditions, some or all of the intervals may need to be shortened and the service should be performed more frequently.

The truck is equipped with an automatic lubrication system. The initial setup for this system provides for nominal amounts of lubricant to be delivered to each serviced point. The lubrication injectors can be adjusted to vary the amount of lubricant delivered. In addition, the timer for lubrication intervals is normally adjustable. For adjustments to these devices, refer to Section 42, Automatic Lubrication System.

860E-1K SERVICE CAPACITIES

Component/System	Liters	U.S. Gallons
Crankcase Komatsu SSDA16V160 Engine	280	74
Cooling System Komatsu SSDA16V160 Engine	473	125
Hydraulic System Refer to "Hydraulic Tank Service"	1325	350
Wheel Motors (each side)	121	32
Fuel Tank (Diesel fuel only)	4542	1200
Inverter Cabinet Cooling System	25	6.5

HYDRAULIC TANK SERVICE

There are two sight gauges on the side of the hydraulic tank. With the engine stopped, key switch OFF, hydraulic system bled down and body down, oil should be visible in the top sight gauge. If hydraulic oil is not visible in the top sight gauge, follow Adding Oil instructions below.

Adding Oil

Keep the system open to the atmosphere only as long as absolutely necessary to lessen the chances of system contamination.

Service the tank with clean Type C-4 hydraulic oil only. All oil being put into the hydraulic tank must be filtered through filters rated at three microns.

1. Ensure that the engine is stopped, key switch is OFF, hydraulic accumulators depressurized, and body is down.
2. Remove fill cap (2, Figure 40-1) and add hydraulic oil until the oil level is visible in the center of the top sight gauge.
3. Install the fill cap.
4. Start the engine. Raise and lower the dump body three times.
5. Check the hydraulic oil level again with the engine stopped, key switch OFF, hydraulic accumulators depressurized, and body down.
6. Repeat Steps 1 - 5 until the oil level is maintained in the center of the top sight gauge.

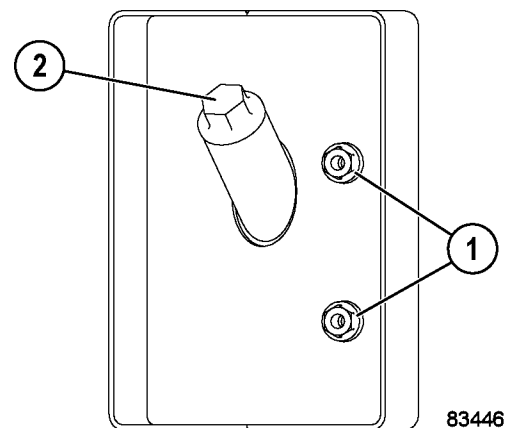

FIGURE 40-1. HYDRAULIC TANK SERVICE

1. Sight Gauges

2. Fill Cap

COOLING SYSTEM SERVICE

Check the coolant level sight gauge. If coolant cannot be seen in the sight gauge, add coolant to the system before truck operation. Refer to the procedure below for the proper filling procedure.

Radiator Filling Procedure

⚠ WARNING

The cooling system is pressurized due to thermal expansion of coolant. Do not remove the radiator cap while the engine and coolant are hot. Severe burns may result.

NOTE: If coolant is added using the Wiggins quick fill system, the radiator cap must be removed before adding coolant.

NOTE: Engine coolant must always be visible in the sight gauge before truck operation.

1. With the engine and coolant at ambient temperature, remove the radiator cap (2, Figure 40-2).
2. Fill the radiator with the proper coolant mixture until coolant is visible in the sight gauge.
3. Install the radiator cap.
4. Run the engine for five minutes, then check the coolant level.
5. If coolant is not visible in the sight gauge, repeat Steps 1 - 4. Any excess coolant will be discharged through the vent hose after the engine reaches normal operating temperature..

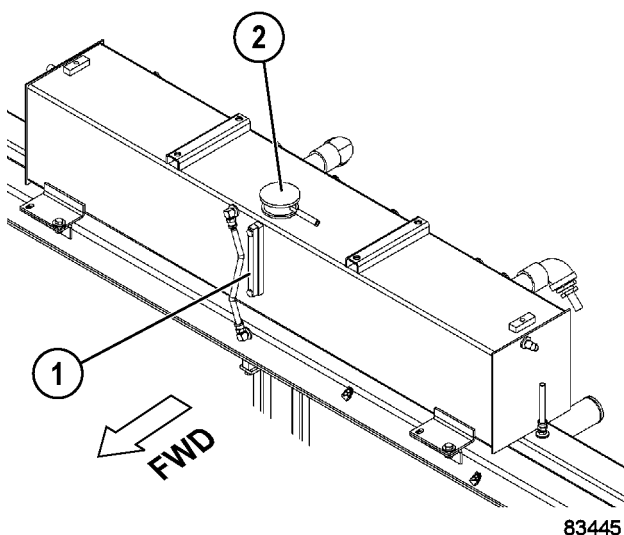

FIGURE 40-2. COOLING SYSTEM SERVICE

1. Sight Gauge

2. Radiator Cap

Coolant Specifications

- For ambient temperatures of -32° C (-25° F) and above, use a standard 50/50 anti-freeze-to-water mixture.
- For arctic climates with ambient temperatures between -32° C (-25° F) and -54° C (-65° F), use a 60/40 anti-freeze-to-water mixture.

NOTE: Do not use propylene glycol coolant in arctic climates. Only use ethylene glycol coolants.

Unacceptable Practices

- Use of high-silicate anti-freeze.
- Under concentration or over concentration of Extended Service Additive (SCA).
- Use of anti-freezes/coolants that are **not** fully formulated for extended service intervals.
- Use of sealing additives (stop-leak) in the cooling system.
- Use of soluble oils in the cooling system.
- Use of poor-quality water. See the engine manufacturer's specifications for water quality requirements.
- Use of anti-freeze, Extended Service Additive (SCA) or coolant filter(s) that do **not** meet the engine manufacturer's specifications.
- Use of Treated Water coolant.
- Use of coolants with less than 40 percent antifreeze.

RESERVE ENGINE OIL SYSTEM

The reserve oil tank for the engine is designed to add more oil capacity to the engine to reduce the frequent servicing of the engine oil. The engine oil level must still be checked every shift using the dipstick. If engine oil level is not correct, check for proper operation of the reserve oil system. Never add oil to the engine unless it has been drained.

If the engine oil has been drained from the oil pan, the new oil must be added to the engine oil pan before starting. DO NOT use the oil in the reserve tank to fill an empty engine with oil. After an oil change, both the engine and reserve tank must be full of oil before starting the engine.

With the engine running, check the operation of the red LED light on the pump.

- **Continuously on** - Pump 1 is withdrawing oil from the engine sump and bringing down the oil level.
- **Regular pulsing** - Pump 2 is returning oil to the engine sump and raising the oil level.
- **Irregular pulsing** - Oil is at the correct running level.

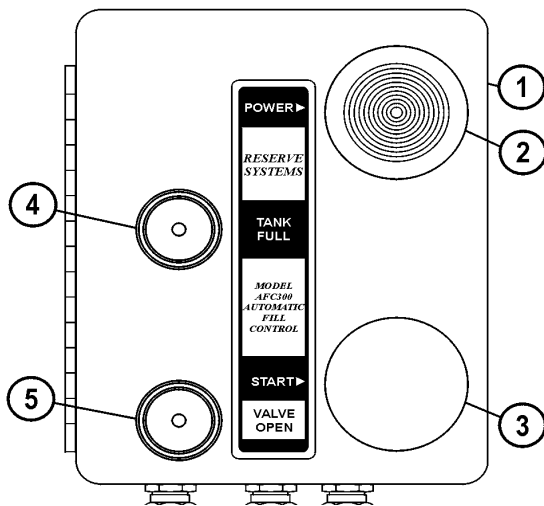

FIGURE 40-3. CONTROL PANEL

- | | |
|-----------------------|---------------------|
| 1. Remote Control Box | 4. FULL Light |
| 2. Power Switch | 5. VALVE OPEN Light |
| 3. Start Switch | |

Oil should always be visible in the bottom sight gauge. If not, add oil to the reserve oil tank until oil is visible in the top sight gauge.

- Never add oil to the engine unless it has been completely drained.
- If the engine oil has been drained from the oil pan, new oil must be added to the oil pan. **Do not use the oil in the reserve oil tank to fill an empty engine oil pan.**

After an oil change, both the engine and reserve oil tank must be full of oil before starting the engine.

Reserve Oil Tank Filling Procedure (Remote fill)

1. Connect the pressure supply hose from the new oil supply to the quick coupler on the truck. Open valve on supply hose to apply pressure.
2. Pull out on switch (2, Figure 40-3) to turn the system on.
3. Push start switch (3). The VALVE OPEN light (5) should illuminate and the filling process will begin.
4. When tank is full, the VALVE OPEN light will turn off and FULL light (4) will illuminate.
5. Close the oil supply valve in the fill hose.
6. Press and hold start switch (3) for a couple of seconds.
7. Disconnect the new oil supply hose.
8. Push switch (2) in to turn system power OFF.

NOTE: Maximum recommended fill pressure for the reserve oil system is 862 kPa (125 psi)

Inline Screen

There is an inline screen located at the inlet of the fill valve. This screen does not require periodic maintenance, but it can be cleaned by removing the screen and back flushing.

QUICK FILL SERVICE CENTER

The service center can be located on either side of the machine (Figure 40-4) and is used to fill system fluids. Table 1 on page 4 shows the maximum recommended fill pressures for the service center.

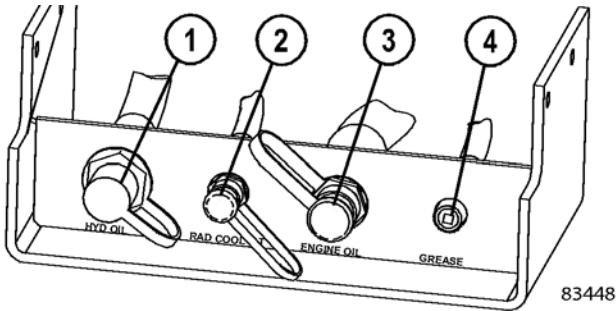

FIGURE 40-4. SERVICE CENTER

- 1. Hydraulic Oil
- 2. Radiator Coolant
- 3. Engine Oil
- 4. Grease

Fill System	kPa	psi
Engine Crankcase	345	50
Reserve Tank	862	125
Hydraulic Tank	345	50
Coolant	345	50
Grease	10 342	1,500
Fuel	103	15

LUBRICATION CHART

LUBRICATION SPECIFICATIONS												
LUBE KEY	TYPE LUBRICANT	LUBE KEY	TYPE LUBRICANT									
A	ENGINE OIL ----- SEE ENGINE MANUAL											
B	HYDRAULIC OIL ----- SAE 10W C-4 ***	6	MOBILITH AWW 2									
C	TO50/(SAE 50W)											
D	MULTI-PURPOSE EXTREME PRESSURE GREASE ----- NLGI NO. 2 (5% MIN. MOLY-DISULFIDE)											
E	MOBILITH SHC 100											
SEE ENGINE MANUFACTURER'S SERVICE MANUAL												
SYM	DESCRIPTION	PTS	LUBE KEY	10 HR	50 HR	100 HR	250 HR	500 HR	1000 HR	2000 HR	3000 HR	6000 HR
1	CRANKCASE OIL LEVEL	1	A									
2	ENGINE LUBE OIL FILTERS	4										
3	FUEL FILTERS	5										
4	COOLANT FILTERS	2										
5	FUEL TANK	1					DRAIN H ₂ O & SEDIMENT					
6	FUEL TANK BREATHER	1							CLEAN			
7	HYDRAULIC OIL LEVEL	1	B	CHECK					*CHANGE			
8	HYDRAULIC STRAINER	2							CLEAN			
9	HYDRAULIC TANK BREATHER	2							CHANGE			
10	HYDRAULIC FILTERS	3			**	**	**		CHANGE			
11	MOTORIZED WHEEL OIL LEVEL	2	C				CHECK			CHANGE		
12	HYD. PUMP DRIVE SHAFT	2	D				BREASE					
13	CHASSIS LUBE LEVEL	1	D	CHECK								
14												
15	TRACTION MOTOR BEARINGS	4	E									ADD 360g GREASE PER BEARING
16	MAIN BLOWER MOTOR BEARINGS	2	E						BREASE			
17	GRID BLOWER MOTOR BEARINGS	2	E						BREASE			
18	GRID BLOWER SHAFT COUPLING	1	S							BREASE		
19	GRID BLOWER SHAFT BEARINGS	2	S						BREASE			
20	TRACTION ALTERNATOR BEARING	1	E									ADD 80g GREASE PER BEARING
21	INVERTER CABINET RADIATOR COOLING PUMP	2	E						BREASE			

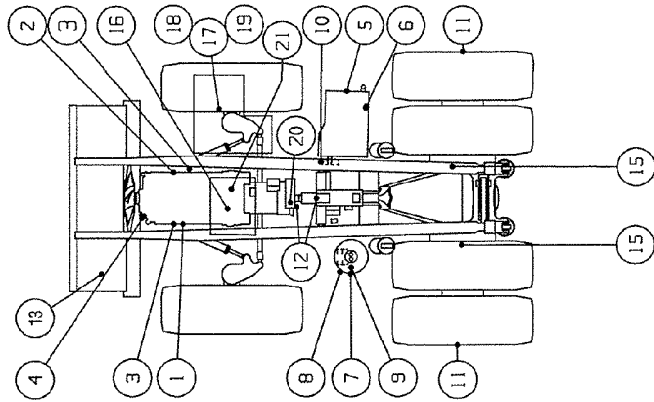

XB9917

* 1000 HR INTERVAL CAN BE EXTENDED TO 2500 HR PROVIDED OIL SAMPLING AND ANALYSIS IS CONDUCTED EVERY 250 HR.
 ** ONE-TIME CHANGE AT 50, 100 AND 250 HR.
 *** AUXILIARY HEATERS REQUIRED BELOW -10°F (-23°C).

LUBRICATION CHART

10 HOUR (DAILY) INSPECTIONS

Truck Serial Number _____ Site Unit Number _____ Date _____				
Hourmeter _____ Name of Service Technician _____				
	TASK	COMMENTS	CHECKED	INITIALS
1.	MACHINE - Inspect the entire machine for leaks, worn parts and damage. Repair as necessary.			
2.	TURBOCHARGERS - Check for leaks, vibration and unusual noise.			
3.	RADIATOR - Check the coolant level, it must always be visible in the sight gauge. Refer to Cooling System Service for coolant specifications and filling procedure. Refer to the engine service manual for the proper coolant additives.			
4.	ENGINE a. Check the oil level. To obtain an accurate measurement, remove the dipstick and wipe it off. Then reinsert the dipstick and remove it again to check the oil level. Refer to the engine manual for oil recommendations. (Lube Key "A"). b. Check the oil level in the reserve tank. The oil level must be visible in the lower sight gauge. If it is not, add oil to the reserve tank using the reserve oil tank filling procedure. Also, with the engine running, check the operation of the LED monitor light. Refer to "Reserve Engine Oil System" in Section 30, Operating Instructions. c. Inspect exhaust piping for integrity. d. Check for abnormal noises and fluid leaks. e. Eliminator Filter - Check operating indicator.			
5.	HYDRAULIC TANK - Check the oil level in the tank. Oil should be visible in the top sight glass. Add oil if necessary. DO NOT overfill. Refer to Hydraulic Tank Service - Adding Oil - Lube Key "B".			
6.	WHEELS AND TIRES a. Inspect the tires for wear and proper inflation. b. Check for embedded debris in tread and remove. c. Check for damaged, loose or missing wheel mounting nuts and studs. Replace damaged or missing hardware and tighten to standard torque before truck operation.			

10 HOUR (DAILY) INSPECTIONS (Cont.)

Truck Serial Number _____ Site Unit Number _____ Date _____				
Hourmeter _____ Name of Service Technician _____				
	TASK	COMMENTS	CHECKED	INITIALS
7.	COOLING AIR DUCTWORK - Inspect the ductwork from the blower to the rear axle. Ensure that the ductwork is secure, undamaged and unrestricted.			
8.	AIR CLEANERS - Check the air cleaner vacuum gauges in the operator cab, Figure 40-5. The air cleaner(s) must be serviced if the gauge(s) shows the following maximum restriction: Komatsu SDA16V160 or SSDA16V160 Engines: 625 mm (25 in.) of water vacuum. Refer to the shop manual for servicing instructions for the air cleaner elements. <i>NOTE: After air filter service, push the reset button on face of gauge to allow the gauge to return to zero.</i>			
9.	DRIVE SYSTEM COOLANT - Check the sight gauges inside the drive system control cabinet. The upper sight gauge should be 1/2 full. If necessary, add coolant. Use Antifrogen only.			
10.	WIPER & WASHER - Inspect the wiper blades for wear or damage. Replace if necessary. Check the windshield washer fluid level. If below 1/2 full, add windshield washer fluid.			

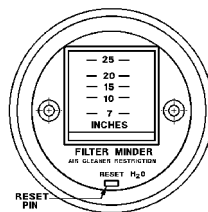

FIGURE 40-5.

10 HOUR (DAILY) INSPECTIONS (Cont.)

11.	<p>FUEL FILTERS (Water Separators) - Drain water from the bottom drain valve on each Stage 1 fuel separator. See Figure 40-6.</p>			
12.	<p>AUTO LUBE SYSTEM</p> <ol style="list-style-type: none"> a. Check the reservoir grease level. Fill as required. (Lube Key D) b. When filling the grease reservoir, check the grease filter indicator. Clean or replace the grease filter if a problem is indicated. c. Inspect the system for leaks and check for proper operation. Ensure that the following important areas are receiving adequate amounts of grease. (Lube Key D) <ul style="list-style-type: none"> • Steering Linkage • Final Drive Pivot Pin • Rear Suspension Pin Joints (Upper and Lower) • Body Hinge Pins • Hoist Cylinders Pins (Upper and Lower) • Anti-Sway Bar (Both Ends) 			

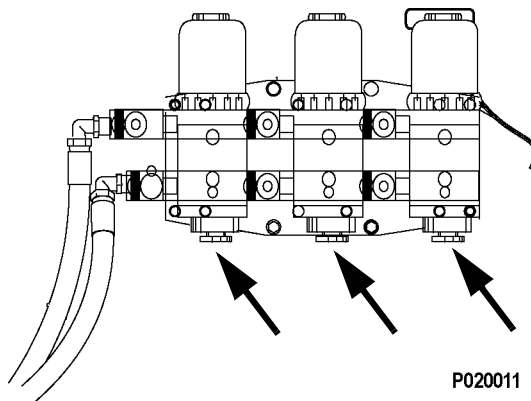

FIGURE 40-6. STAGE 1 FUEL FILTERS & WATER SEPERATORS

INITIAL 50 HOUR LUBRICATION AND MAINTENANCE CHECKS

Truck Serial Number _____ Site Unit Number _____ Date _____				
Hourmeter _____ Name of Service Technician _____				
	TASK	COMMENTS	CHECKED	INITIALS
*1.	FUEL FILTERS - Change the Stage 1 and Stage 2 fuel filters. Refer to engine Operation & Maintenance manual for specific filter replacement instructions.			
*2.	HYDRAULIC SYSTEM FILTERS - Replace the filter elements. Check the oil level. Add oil as necessary. (Lube Key B)			
*3.	FAN DRIVE ASSEMBLY - Check torque for the six fan mounting cap screws: 237 N·m (175 ft lb) .			

* These checks are required **only after the initial 50 hours of operation**, such as the commissioning of a new truck or after installing a new or rebuilt component.

INITIAL 100 HOUR LUBRICATION AND MAINTENANCE CHECKS

Truck Serial Number _____ Site Unit Number _____ Date _____				
Hourmeter _____ Name of Service Technician _____				
	TASK	COMMENTS	CHECKED	INITIALS
*1.	HYDRAULIC SYSTEM FILTERS - Replace the filter elements. Check the oil level. Add oil as necessary. (Lube Key B)			

* This check is required **only after the initial 100 hours of operation**, such as the commissioning of a new truck or after installing a new or rebuilt component.

250 HOUR LUBRICATION AND MAINTENANCE CHECKS

All 10 Hour (Daily) Inspections should also be performed at this time.

NOTE: "Lube Key" references are to the **Lubrication Chart** on page 40-5.

Truck Serial Number _____ Site Unit Number _____ Date _____			
Hourmeter _____ Name of Service Technician _____			
TASK	COMMENTS	CHECKED	INITIALS
*1. HYDRAULIC SYSTEM FILTERS - Replace the filter elements. Check the oil level. Add oil as necessary. (Lube Key "B")			
2. ENGINE - Refer to the engine manufacturer's Operation & Maintenance manual for complete specifications regarding engine lube oil specifications. <i>NOTE: If the engine is equipped with the *Centinel™ oil system and/or the Eliminator™ filter system, engine oil and filter change intervals are extended beyond 250 hours. Take an engine oil sample for analysis. Refer to engine Operation & Maintenance manual for specific oil and filter change intervals.</i> * The Centinel™ system is a duty-cycle-dependent lubrication management system whereby oil is blended with the fuel and burned and an extension of oil change intervals can occur. <ol style="list-style-type: none"> a. Change engine oil. (Lube Key A) b. If equipped, replace the engine oil filters. Follow the instructions of the filter manufacturer, which are normally printed on the outside of the filter. Do not use a wrench or strap to tighten filter elements. c. Check the torque on the cooling fan (1, Figure 40-7) mounting cap screws. Tighten cap screws (2) to 237 N·m (175 ft lb). d. Check the tension and condition of each accessory drive belt. Refer to the engine operation and maintenance manual for specific adjustment instructions. 			
3. FUEL FILTERS - Change the Stage 1 and Stage 2 fuel filters. Refer to engine Operation & Maintenance manual for specific filter replacement instructions.			
4. FUEL TANK - Drain water and sediment from the fuel tank. Refer to the shop manual for cleaning instructions.			
5. AIR INTAKE PIPING - Check all mounting hardware, joints and connections. Ensure that there are no air leaks and all hardware is properly tightened.			

* This is required **only after the initial 250 hours of operation**, such as the commissioning of a new truck or after installing a new or rebuilt component.

250 HOUR LUBRICATION AND MAINTENANCE (Cont.)

	TASK	COMMENTS	CHECKED	INITIALS
6.	<p>COOLING SYSTEM</p> <p>a. COOLANT MIXTURE - Check for proper coolant mixture. Add coolant as required.</p> <p>b. COOLANT FILTERS - Change coolant filters.</p> <p>c. COOLING SYSTEM HOSES - Check cooling system hoses for damage and signs of deterioration.</p> <p>Refer to the engine maintenance manual for coolant filter replacement instructions and proper coolant mixture instructions.</p>			
7.	<p>STEERING LINKAGE</p> <p>a. Check the torque on the steering pin retaining nuts (1, Figure 40-8). Tighten to 712 N•m (525 ft lbs).</p> <p>b. Check the torque on the tie rod retaining nuts (2). Tighten to 420 N•m (310 ft lbs).</p>			
8.	<p>HYDRAULIC PUMP DRIVESHAFT & U-JOINTS - Add one or two applications of grease to each grease fitting. Ensure that each bearing of the cross and bearing assembly is receiving grease. Replace bearings if any wear is detected. (Lube Key D)</p>			
9.	<p>REAR WHEEL MOUNTING - Use a flashlight and a mirror on a long rod to inspect all inner and outer wheel mounting nuts and studs. Check for loose, damaged or missing hardware.</p>			

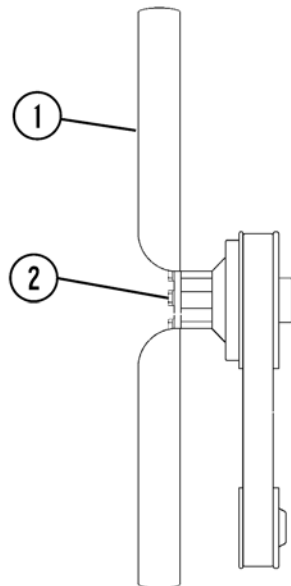

FIGURE 40-7.

P020008

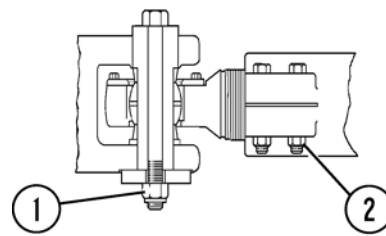

FIGURE 40-8.

G030035

250 HOUR LUBRICATION AND MAINTENANCE (Cont.)

10.	REAR AXLE HOUSING - Check the rear axle housing for oil leaks by removing the two drain plugs on the bottom of the axle housing. If oil is present, the cause of the leak must be found and corrected before operating the truck.			
11.	FRONT WHEEL HUB - Remove the magnetic plugs from the front wheel hub covers and check for debris. Clean the plugs and perform any necessary repairs.			
12.	MOTORIZED WHEELS a. Check for the correct oil level. There are eight oil level plugs. Rotate the wheel so one plug is at the 6 o'clock position. The oil level should be even with the bottom of the plug opening. (Lube Key C) b. Inspect the magnetic plugs for ferrous materials. Service the wheel motor as necessary.			
13.	WHEEL MOTOR OIL SAMPLING - Take an oil sample of the wheel motor oil. Refer to the shop manual for oil sampling instructions.			
14.	BATTERIES - Check the electrolyte level and add water if necessary.			
15.	DUMP BODY PADS - Check the pads, shims and mounting hardware for wear and proper tightening.			
16.	BODY-UP AND HOIST LIMIT SWITCHES - Check the operation of the switches. Clean any dirt from the sensing areas and inspect the wiring for damage.			
17.	CAB RECIRCULATION AIR FILTER - Under normal operating conditions, clean every 250 hours. In extremely dusty conditions, service as frequently as required. Clean the filter element with mild soap and water. Rinse completely clean and allow to air dry before use.			
18.	CAB AIR FILTER - Under normal operating conditions, clean every 250 hours. In extremely dusty conditions, service as frequently as required. Clean the filter element with mild soap and water. Rinse completely clean and air dry with a maximum of 275 kPa (40 psi). Reinstall the filter. Refer to Figure 40-9.			

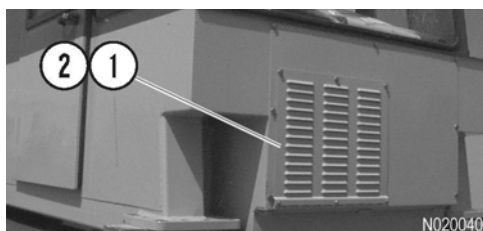

FIGURE 40-9.

1. Filter Cover 2. Cab Filter

500 HOUR LUBRICATION AND MAINTENANCE CHECKS

All 10 Hour (Daily) Inspections and 250 Hour Lubrication and Maintenance Checks should also be performed at this time.

NOTE: "Lube Key" references are to the **Lubrication Chart** on page 40-5.

Truck Serial Number _____ Site Unit Number _____ Date _____				
Hourmeter _____ Name of Service Technician _____				
	TASK	COMMENTS	CHECKED	INITIALS
1.	HYDRAULIC SYSTEM FILTERS - Replace the hydraulic tank breathers and high pressure filter elements. Check the oil level. Add oil as necessary. (Lube Key B)			
2.	HYDRAIR® SUSPENSION - Check for the proper piston extension (front and rear). Refer to Section H4 in the shop manual for more information on proper suspension extension and maintenance procedures.			
3.	THROTTLE AND BRAKE PEDAL - Lubricate the treadle roller and hinge pins with lubricating oil. Lift the boot from the mounting plate and apply a few drops of lubricating oil between the mounting plate and the plunger.			
4.	HOIST LEVER LINKAGE - Check the lever operation. Clean, lubricate and adjust the linkage as necessary.			
5.	PARKING BRAKE - Refer to the shop manual for the recommended inspections.			
6.	RESERVE ENGINE OIL SYSTEM <ul style="list-style-type: none"> a. Check the electrical system connections for tightness, corrosion and damage. Check the battery, oil pressure switch, junction boxes, remote control box and the circuit breakers. b. Examine all electrical cables over their entire length for possible damage. c. Inspect all reserve engine oil system hoses for leaks, cracks or other damage. Check all fittings for tightness, leakage or damage. 			
7.	IGBT CONTROL BOX <ul style="list-style-type: none"> a. Check the clean air sections of the cabinet for moisture, dust, and dirt. b. Download event statistics, parameter settings, motor temps. c. Visually inspect coolant level with the radiator sight glasses. Add coolant as necessary with correct ratio antifrogen/water. 			

500 HOUR LUBRICATION AND MAINTENANCE (Cont.)

8.	BLADDER ACCUMULATORS - Check the precharge pressure. Failure to maintain the correct precharge pressure may result in bladder failures.			
9.	HVAC a. Ensure the air conditioner cab drains are clear of any obstructions. b. Also wash the air conditioner condensor with a low pressure hose. Check for any obstructions to airflow, clean as required.			
10.	KOMTRAX Plus DATA DOWNLOAD - Perform a data download from the KOMTRAX Plus controller and send the data to WebCARE. Refer to the shop manual for more detailed instructions.			
11.	GRID BLOWER SHAFT BEARINGS - Add one or two applications of grease to each grease fitting. Ensure that each bearing is receiving grease. Replace bearings if any wear is detected. (Lube Key G)			
12.	CONTROL CABINET COOLANT - Check the coolant level of the drive system controller inside the control cabinet. Coolant must be visible in the middle of the upper sight gauge.			
13.	FRAME AND AXLE BOX INSPECTION - Wash the truck, clean all of the weld joints, and visually inspect the entire frame and axle box for cracking or damage.			
14.	RETARDING GRID - Visually inspect grid resistors for damage by looking in the grid box outlet, replace resistors if necessary.			
15.	MAIN BLOWER a. Check that the motor is clean and that the interior is free of any dirt or oil. b. Verify the terminal box is sealed, reseal and add sealent as necessary.			

1,000 HOURS LUBRICATION AND MAINTENANCE CHECKS

All 10 Hour (Daily) Inspections, 250 Hour Lubrication and Maintenance Checks, and 500 Hour Lubrication and Maintenance Checks should also be performed at this time.

NOTE: "Lube Key" references are to the **Lubrication Chart** on page 40-5.

Truck Serial Number _____ Site Unit Number _____ Date _____				
Hourmeter _____ Name of Service Technician _____				
6.				
	TASK	COMMENTS	CHECKED	INITIALS
1.	HYDRAULIC TANK - Drain the hydraulic tank and clean the inlet strainers. Refer to "Hydraulic Tank Strainers" in the shop manual. Refill the hydraulic tank. (Lube Key B) <i>NOTE: Oil change interval can be extended to 2,500 hours if oil is sampled at every 250 hour intervals and no abnormalities are detected.</i>			
2.	FUEL TANK - Remove the fuel tank breather and clean it in solvent. Dry the breather with pressurized air and install it on the tank.			
3.	OPERATOR'S SEAT - Apply grease to the slide rails. (Lube Key D)			
4.	AUTOMATIC BRAKE APPLICATION - Ensure that the brakes are automatically applied when the brake pressure decreases below the specified limit. Refer to Brake Circuit Check-Out Procedure, in the shop manual.			
5.	MAIN BLOWER BEARINGS - On the main blower below the control cabinet, add grease until small amount comes out of drain. Ensure that each bearing is receiving grease. Replace bearings if any wear is detected. (Lube Key E) Check that the motor is clean and that the interior is free of any dirt or oil.			
6.	GRID BLOWER MOTOR SHAFT BEARINGS - On each end of the electric motor, add grease until a small amount comes out of the drains. Ensure that each bearing is receiving grease. Replace bearings if any wear is detected. (Lube Key E)			

1,000 HOURS LUBRICATION AND MAINTENANCE CHECKS (cont.)

	TASK	COMMENTS	CHECKED	INITIALS
7.	INVERTER CABINET RADIATOR COOLING PUMP - Add one or two applications of grease to each bearing grease fitting. Ensure that each bearing is receiving grease. (Lube Key E)			
8.	IGBT CONTROL BOX - Clean out the cabinet radiator. - Remove any dirt or debris from the transformer with a small brush and a vacuum.			
9.	ELIMINATOR FILTER - Clean and check centrifuge. Refer to engine manufacturer's Operation & Maintenance Manual. (Service interval is dependent on duty cycle, oil quality, etc.).			
10.	AUTOMATIC LUBE SYSTEM PUMP - Check pump housing oil level using dipstick on top of the pump unit (or oil level plug on side). If necessary, add SAE 10W-30 motor oil.			

2,000 HOUR MAINTENANCE CHECKS

All 10 Hour (Daily) Inspections, 250 Hour Lubrication and Maintenance Checks, 500 Hour Lubrication and Maintenance Checks, and 1000 Hour Lubrication and Maintenance Checks should also be performed at this time.

NOTE: "Lube Key" references are to the **Lubrication Chart** on page 40-5.

Truck Serial Number _____ Site Unit Number _____ Date _____				
Hourmeter _____ Name of Service Technician _____				
	TASK	COMMENTS	CHECKED	INITIALS
1.	MOTORIZED WHEELS - Drain and refill the wheel motor final drive with new oil. (Lube key C).			
2.	IGBT CONTROL BOX - Inspect contactor K103, K105, and K109 for excessive wear, replace as necessary.			
3.	GRID BLOWER SHAFT COUPLING - On the coupling, add one or two applications of grease. (Lube Key G)			

3,000 HOUR MAINTENANCE CHECKS

All 10 Hour (Daily) Inspections, 250 Hour Lubrication and Maintenance Checks, 500 Hour Lubrication and Maintenance Checks, and 1000 Hour Lubrication and Maintenance Checks should also be performed at this time.

NOTE: "Lube Key" references are to the **Lubrication Chart** on page 40-5.

Truck Serial Number _____ Site Unit Number _____ Date _____				
Hourmeter _____ Name of Service Technician _____				
	TASK	COMMENTS	CHECKED	INITIALS
1.	MAIN ALTERNATOR a. Add 80 g (2 oz) of grease per bearing. Do not over grease. (Lube Key E) b. Clean condensation water drain holes at the underside of the alternator.			

5,000 HOUR MAINTENANCE CHECKS

All 10 Hour (Daily) Inspections, 250 Hour Lubrication and Maintenance Checks, 500 Hour Lubrication and Maintenance Checks, and 1000 Hour Lubrication and Maintenance Checks should also be performed at this time.

NOTE: "Lube Key" references are to the **Lubrication Chart** on page 40-5.

Truck Serial Number _____ Site Unit Number _____ Date _____			
Hourmeter _____ Name of Service Technician _____			
TASK	COMMENTS	CHECKED	INITIALS
1. AIR CLEANERS - Clean the Donacelone tubes in the precleaner section of the air filter. Use low pressure cold water or low pressure air to clean the tubes. Refer to the shop manual for more specific cleaning instructions.			

6,000 HOUR MAINTENANCE CHECKS

All 10 Hour (Daily) Inspections, 250 Hour Lubrication and Maintenance Checks, 500 Hour Lubrication and Maintenance Checks, 1000 Hour Lubrication and Maintenance Checks and 2000 Hour Lubrication and Maintenance Checks should also be performed at this time.

NOTE: "Lube Key" references are to the **Lubrication Chart** on page 40-5.

Truck Serial Number _____ Site Unit Number _____ Date _____			
Hourmeter _____ Name of Service Technician _____			
TASK	COMMENTS	CHECKED	INITIALS
1. MOTORIZED WHEELS a. Inside the rear axle housing, use the four grease fittings to grease the four wheel bearings. Each bearing requires 360 g (12.7 oz) of grease. (Lube Key E) b. Inspect each motor's connections and check for external damage. c. Clean the drainage holes.			

AUTOMATIC LUBRICATION SYSTEM

GENERAL DESCRIPTION

The automatic lubrication system is a pressurized lubricant delivery system which delivers a controlled amount of lubricant to designated lube points. The system is controlled by an electronic timer which signals a solenoid valve to operate a hydraulic motor powered grease pump. Hydraulic oil for pump operation is supplied by the truck steering circuit.

Grease output is proportional to the hydraulic motor input flow. A pump control manifold, mounted on top of the hydraulic motor, controls input flow and pressure. A 24VDC solenoid mounted on the manifold turns the pump on and off.

The pump is driven by the rotary motion of the hydraulic motor, which is then converted to reciprocating motion through an eccentric crank mechanism.

The reciprocating action causes the pump cylinder to move up and down. The pump is a positive displacement, double-acting type as grease output occurs on both the up and the down stroke.

During the down stroke, the pump cylinder is extended into the grease. Through the combination of shovel action and vacuum generated in the pump cylinder chamber, the grease is forced into the pump cylinder. Simultaneously, grease is discharged through the outlet of the pump. The volume of grease during intake is twice the amount of grease output during one cycle. During the upstroke, the inlet check valve closes. Half of the grease taken in during the previous stroke is transferred through the outlet check and discharged to the outlet port.

⚠ WARNING

Over-pressurizing the system, modifying parts, using incompatible chemicals and fluids, or using worn or damaged parts may result in equipment damage and/or serious personal injury.

- **DO NOT** exceed the stated maximum working pressure of the pump or the lowest rated component in the system.
- Do not alter or modify any part of this system unless approved by the factory.
- Do not attempt to repair or disassemble the equipment while the system is pressurized.
- Ensure that all fluid connections are securely tightened before using this equipment.
- Always read and follow the fluid manufacturer's recommendations regarding fluid compatibility and the use of protective clothing and equipment.
- Check all equipment regularly. Repair or replace worn or damaged parts immediately.

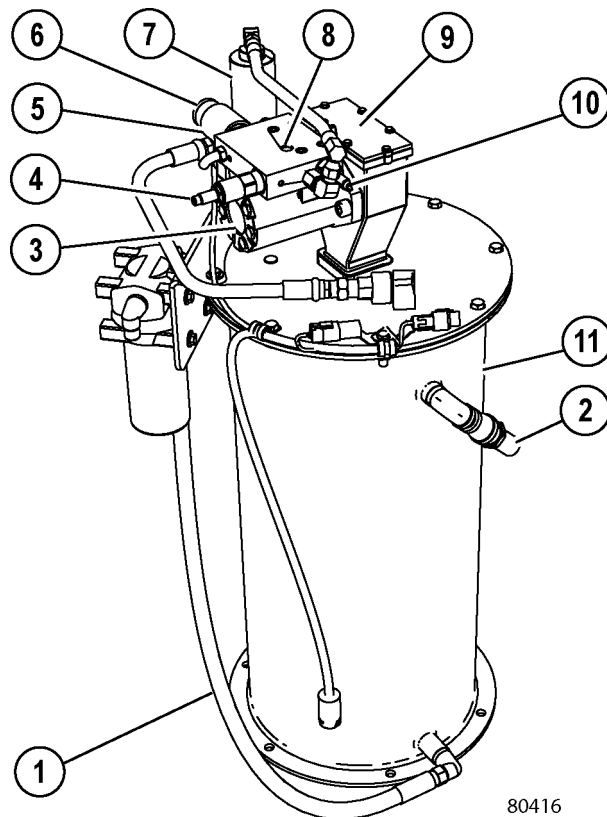
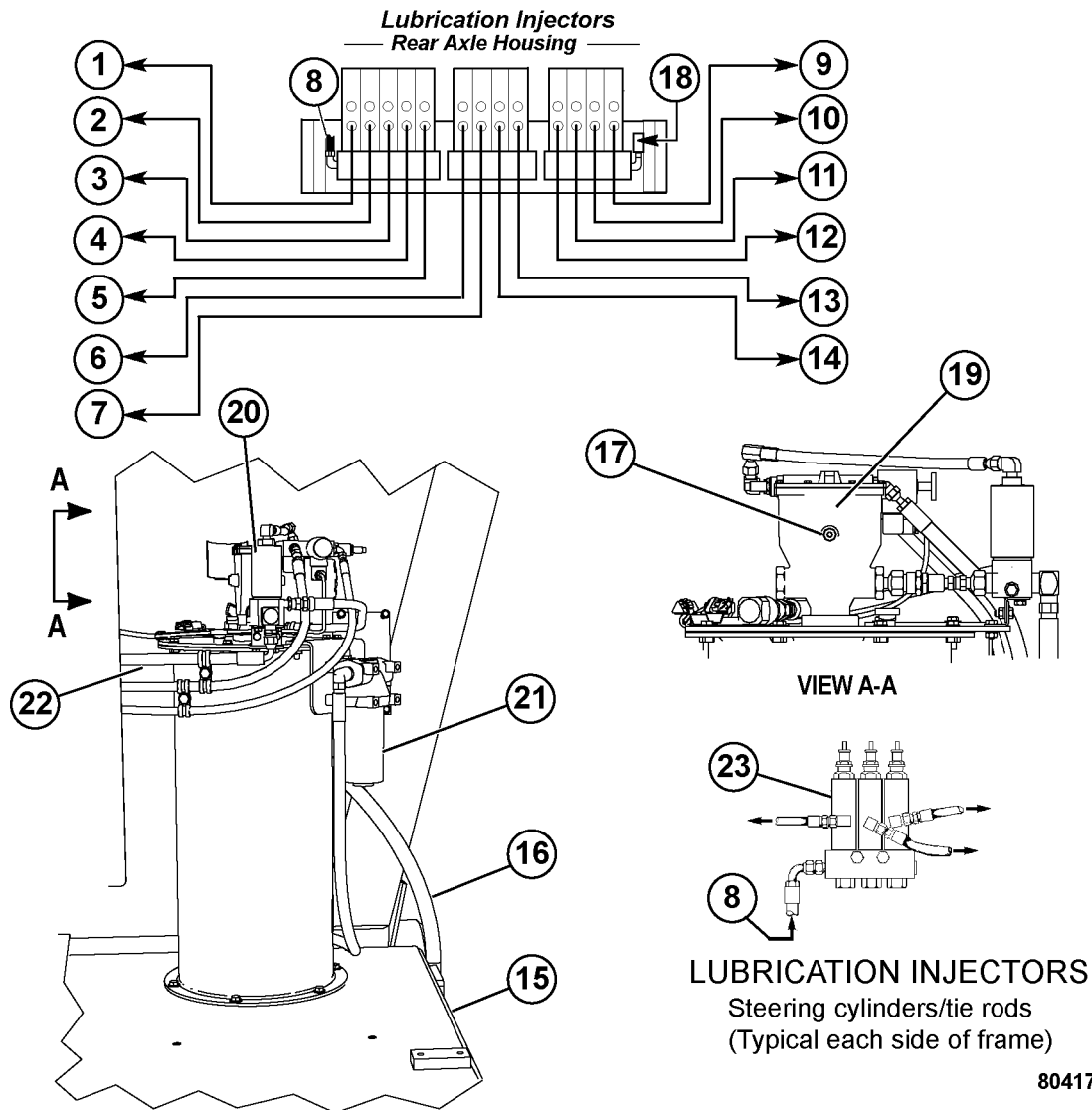

FIGURE 42-1. PUMP & RESERVOIR

- | | |
|----------------------------|------------------------------|
| 1. Hose From Filter | 8. Pressure Gauge (optional) |
| 2. Outlet to Injectors | 9. Pump Assembly |
| 3. Hydraulic Motor | 10. Flow Control Valve |
| 4. Pressure Reducing Valve | 11. Grease Reservoir |
| 5. Solenoid Valve | |
| 6. Override Switch | |
| 7. Vent Valve | |

This equipment generates very high grease pressure. Extreme caution must be used when operating this equipment as material leaks from loose or ruptured components can inject fluid through the skin and into the body, causing serious bodily injury including possible need for amputation. Adequate protection is recommended to prevent splashing of material onto skin or into the eyes.

If any fluid appears to penetrate the skin, get emergency medical care immediately! Do not treat as a simple cut. Tell attending physician exactly what fluid was injected.



80417

FIGURE 42-2. AUTOMATIC LUBRICATION SYSTEM INSTALLATION

- | | |
|---|----------------------------------|
| 1. L.H. Suspension, Bottom Bearing | 13. R.H. Suspension, Top Bearing |
| 2. L.H. Hoist Cylinder, Bottom Bearing | 14. R.H. Body Pivot Pin |
| 3. L.H. Anti-Sway Bar Bearing | 15. Truck Frame |
| 4. L.H. Suspension, Top Bearing | 16. Vent Hose |
| 5. L.H. Body Pivot Pin | 17. Pipe Plug (Oil Level) |
| 6. L.H. Hoist Cylinder, Top Bearing | 18. Pressure Switch, N.O. |
| 7. R.H. Hoist Cylinder, Top Bearing | 19. Grease Pump |
| 8. Grease Supply From Pump | 20. Vent Valve |
| 9. R.H. Suspension, Bottom Bearing | 21. Filter |
| 10. R.H. Hoist Cylinder, Bottom Bearing | 22. Grease Supply to Injectors |
| 11. Rear Axle Pivot Pin | 23. Injectors |
| 12. R.H. Anti-Sway Bar Bearing | |

SYSTEM COMPONENTS

Filter Assembly

Filter assembly (21, Figure 42-2), mounted on the grease reservoir, filters the grease prior to refilling the reservoir from the shop supply. A bypass indicator alerts service personnel when the filter requires replacement.

Hydraulic Motor and Pump

Rotary hydraulic pump (3 and 9, Figure 42-1) is a fully hydraulically-operated grease pump. An integrated pump control manifold is incorporated with the motor to control input flow and pressure.

NOTE: The pump crankcase oil level must be maintained to the level of pipe plug (17, Figure 42-2). If equipped, use the dipstick on top of the pump housing to check the oil level. Add 10W-30 motor oil, if necessary.



Hydraulic oil supply inlet pressure must not exceed 24 132 kPa (3,500 psi). Exceeding the rated pressure may result in damage to the system components and personal injury.

Grease Reservoir

Reservoir (11, Figure 42-1) has an approximate capacity of 41 kg (90 lb) of grease. When the grease supply is replenished by filling the system at the service center, the grease is passed through the filter to remove contaminants before it flows into the reservoir.

Pressure Reducing Valve

Pressure reducing valve (4, Figure 42-1), located on the manifold, reduces the hydraulic supply pressure (from the truck steering circuit) to a suitable operating pressure for the hydraulic motor used to drive the lubricant pump. **The pressure control valve has been factory adjusted and the setting should not be disturbed unless grease output pressure is outside the recommendations.**

A pressure gauge can be installed where pipe plug (8, Figure 42-1) is located. The pressure gauge will indicate hydraulic oil pressure to the inlet of the hydraulic motor. Normal pressure is 2241 - 2413 kPa (325 - 350 psi).

Flow Control Valve

Flow control valve (10, Figure 42-1), mounted on the manifold, controls the amount of oil flow to the hydraulic motor. **The flow control valve has been factory adjusted and the setting should not be disturbed.**

Solenoid Valve

Solenoid valve (5, Figure 42-1), when energized, allows oil to flow to the hydraulic motor.

Vent Valve

With vent valve (7, Figure 42-1) closed, the pump continues to operate until maximum grease pressure is achieved. As this occurs, the vent valve opens and allows the grease pressure to drop to zero, so the injectors can recharge for their next output cycle.

Interface Module

The interface module provides a 24 VDC timed-interval signal to energize solenoid valve (3, Figure 42-3), providing oil flow to operate the grease pump motor. This interface module is mounted in the auxiliary control cabinet.

Grease System Failure Switch

Pressure switch (18, Figure 42-2) is a normally open switch set at 13 789 kPa (2,000 psi). This switch monitors grease pressure in the injector bank on the rear axle housing. If the appropriate grease pressure is not achieved during the normal pump cycle, the warning system will be activated. The repair light will illuminate and a message will be displayed on the dash panel to notify the operator that a problem exists in the lubrication system.

Injectors

Each injector (23, Figure 42-2) delivers a controlled amount of pressurized lubricant to a designated lube point. Refer to Figure 42-2 for locations.

Unloader Valve

Unloader valve (9, Figure 42-3) protects the pump from high pressures. This relief valve is set at 27 580 kPa (4,000 psi).

SYSTEM OPERATION

1. During truck operation, the lubrication cycle logic (in the interface module) will energize the system at a preset time interval.
2. The interface module provides a path to ground to energize pump solenoid valve (3, Figure 42-3), allowing hydraulic oil provided by the steering pump circuit to flow to the pump motor and initiate a pumping cycle.
3. The hydraulic oil from the steering circuit is directed through the pressure reducing valve (4) and flow control valve (6) before entering the motor. Pump pressure can be read on optional pressure gauge (5) mounted on the manifold.
4. With oil flowing into the hydraulic motor, the grease pump will operate, pumping grease from the reservoir to injectors (13), through check valve (10) and to vent valve (11).
5. During this period, the injectors will meter the appropriate amount of grease to each lubrication point.
6. When grease pressure reaches the setting of pressure switch (18, Figure 42-2), the switch contacts will close and energize relay RB7-K8, disconnecting the ground path from the hydraulic motor/pump solenoid so the pump will stop. The relay will remain energized until the interface module completes its 120 second ON cycle.
7. After the pump solenoid valve is de-energized, hydraulic pressure in the manifold drops and vent valve (11, Figure 42-3) will open, releasing grease pressure in the lines to the injector banks. When this occurs, the injectors are then able to recharge for the next lubrication cycle.
8. The system will remain at rest until the next lubrication cycle turns on and initiates a new grease cycle.
9. During the normal lubrication cycle, if grease pressure fails to reach 13 790 kPa (2,000 psi) at the pressure switch located on the rear axle housing, an repair indicator light will illuminate on the monitor display panel. In addition, fault A190 "Auto Lube Fault" will be shown in the repair fault menu.

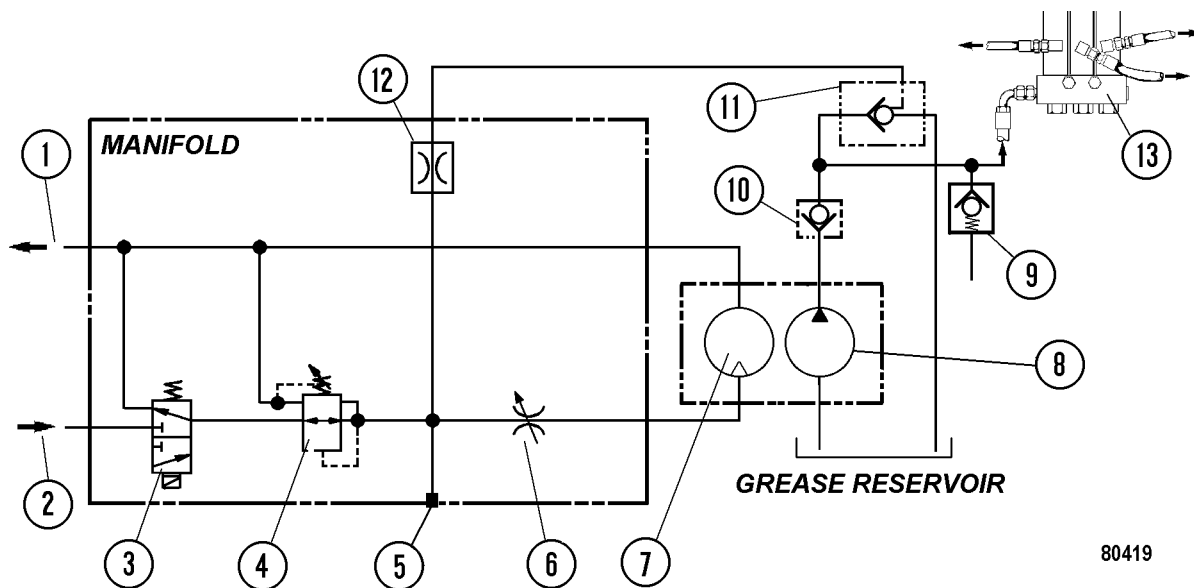

80419

FIGURE 42-3. HYDRAULIC SCHEMATIC

- | | | |
|----------------------------|-----------------------|-------------------|
| 1. Hydraulic Oil Return | 6. Flow Control Valve | 11. Vent Valve |
| 2. Hydraulic Oil Supply | 7. Hydraulic Motor | 12. Orifice |
| 3. Pump Solenoid Valve | 8. Grease Pump | 13. Injector Bank |
| 4. Pressure Reducing Valve | 9. Unloader Valve | |
| 5. Pipe Plug (Test Port) | 10. Check Valve | |

GENERAL INSTRUCTIONS

Required Lubricant

Grease requirements will depend on ambient temperatures encountered during truck operation:

- **Above 32°C (90°F)** - Use NLGI No. 2 multipurpose grease (MPG).
- **-32° to 32°C (-25° to 90°F)** - Use NLGI No. 1 multipurpose grease (MPG).
- **Below -32°C (-25°F)** - Refer to local supplier for extreme cold weather lubricant requirements.

System Priming

The system must be full of grease and free of air pockets to function properly. After maintenance, if the primary or secondary lubrication lines were replaced, it will be necessary to prime the system to eject all entrapped air.

1. Fill the lube reservoir with lubricant, if necessary.
2. To purge air from the main supply line, remove the main supply line at the grease canister. Connect an external grease supply to the line.
3. Remove the plugs from each injector group in sequence (right front, left front, and rear axle).
4. Using the external grease source, pump until grease appears at the group of injectors, then install the pipe plug. Repeat for the remaining injector groups.
5. Remove the caps from each injector and connect an external grease supply to the fitting on the injector. Pump until grease appears at the far end of the individual grease hose or the joint that is being greased.

Filter Assembly

Filter element (5, Figure 42-4) must be replaced if bypass indicator (2) shows excessive element restriction.

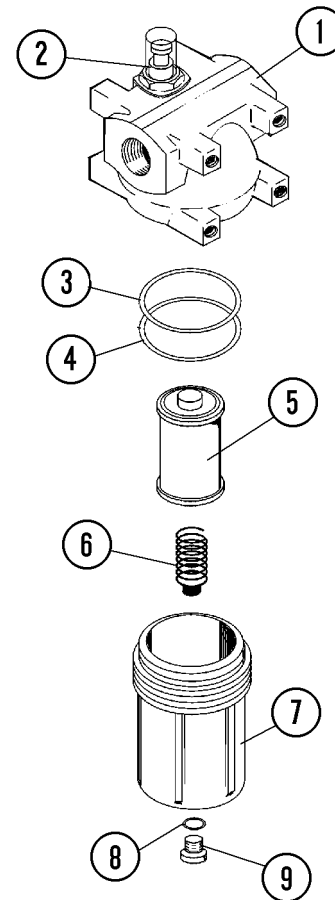

P030023

FIGURE 42-4. FILTER ASSEMBLY

- | | |
|---------------------|-----------|
| 1. Housing | 6. Spring |
| 2. Bypass Indicator | 7. Bowl |
| 3. O-Ring | 8. O-Ring |
| 4. Backup Ring | 9. Plug |
| 5. Element | |

LUBRICANT PUMP

Pump Housing Oil Level

The pump housing must be filled to the proper level with SAE 10W-30 motor oil. Check the oil level at the 1,000 hour maintenance interval. To add oil, remove dipstick (4, Figure 42-5) on top of the pump housing and fill the housing to the proper level marked on the dipstick.

Pump Pressure Control

High pressure hydraulic fluid from the truck steering system is reduced by the pressure reducing valve located on the manifold on top of the pump motor. This pressure can be read if pipe plug (3) is removed and a gauge is installed on the manifold.

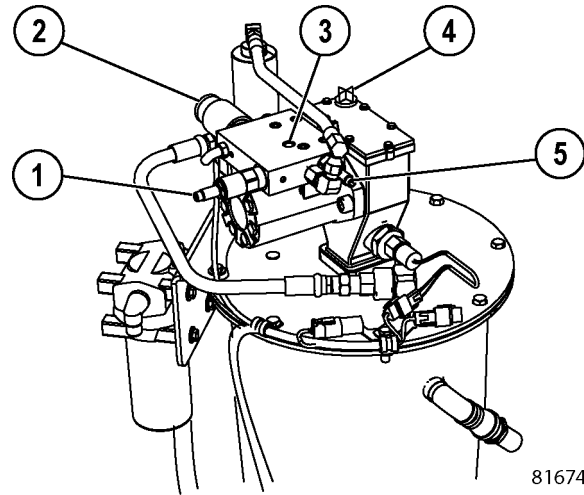

81674

FIGURE 42-5. AUTO LUBE PUMP CONTROLS

- | | |
|--------------------------|-----------------------|
| 1. Pump Pressure Control | 4. Dipstick |
| 2. Override Switch | 5. Flow Control Valve |
| 3. Pipe Plug | |

INJECTORS (SL-1 Series "H")

Injector Specifications

Each lube injector services only one grease point. In case of pump malfunction, each injector is equipped with a covered grease fitting to allow the use of external lubricating equipment.

- Injector output volume:
 - Maximum output = 1.31 cc (0.08 in³).
 - Minimum output = 0.13 cc (0.008 in³).
- Operating Pressure:
 - Minimum - 12,755 kPa (1850 psi)
 - Maximum - 24,133 kPa (3500 psi)
 - Recommended - 17,238 kPa (2500 psi)
- Maximum Vent Pressure - (Recharge)
 - 4137 kPa (600 psi)

Injector Adjustment

The injectors may be adjusted to supply from 0.13 - 1.31 cc (0.008 - 0.08 in³) of lubricant per injection cycle. The injector piston travel distance determines the amount of lubricant supplied. This travel is in turn controlled by an adjusting screw in the top of the injector housing.

Turn adjusting screw (1, Figure 42-6) counterclockwise to increase lubricant amount delivered and clockwise to decrease the lubricant amount.

When the injector is not pressurized, maximum injector delivery volume is attained by turning the adjusting screw (1) fully counterclockwise until the indicating pin just touches the adjusting screw. At the maximum delivery point, about 9.7 mm (0.38 in.) adjusting screw threads should be showing. Decrease the delivered lubricant amount by turning the adjusting screw clockwise to limit injector piston travel. If only half the lubricant is needed, turn the adjusting screw to the point where about 4.8 mm (0.19 inch) threads are showing. The injector will be set at minimum delivery point with about 0.22 mm (0.009 in.) thread showing.

NOTE: The above information concerns adjustment of injector delivery volume. The lube cycle interval adjustment should also be changed if overall lubricant delivery is too little or too much. Injector output should not be adjusted to less than 1/4 capacity.

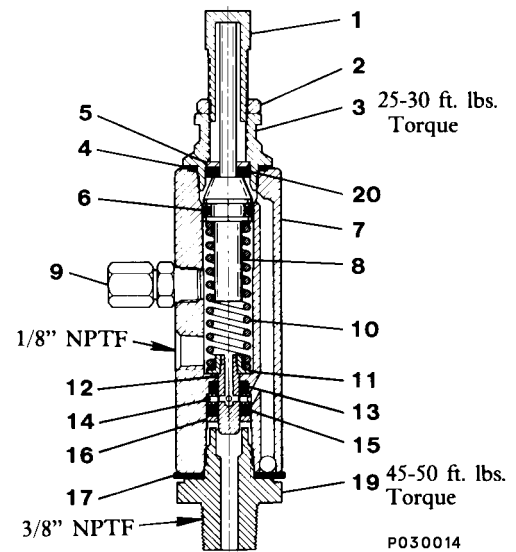
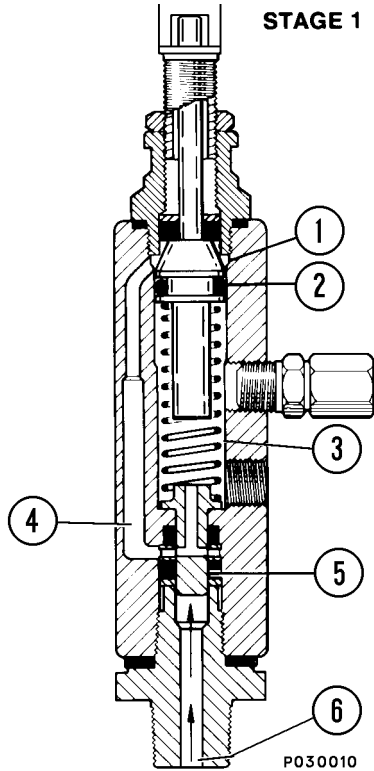

FIGURE 42-6. TYPE SL-1 INJECTOR

- | | |
|------------------------|-------------------|
| 1. Adjusting Screw | 11. Spring Seat |
| 2. Locknut | 12. Plunger |
| 3. Piston Stop Plug | 13. Viton Packing |
| 4. Gasket | 14. Inlet Disc |
| 5. Washer | 15. Viton Packing |
| 6. Viton O-Ring | 16. Washer |
| 7. Injector Body Assy. | 17. Gasket |
| 8. Piston Assembly | 18. Adapter Bolt |
| 9. Fitting Assembly | 19. Adapter |
| 10. Plunger Spring | 20. Viton Packing |

NOTE: Piston assembly (8) has a visible indicator pin at the top of the assembly to verify injector operation.

INJECTOR OPERATION



STAGE 1.
 The injector piston (2) is in its normal or "rest" position. The discharge chamber (3) is filled with lubricant from the previous cycle. Under the pressure of incoming lubricant (6), the slide valve (5) is about to open the passage (4) leading to the measuring chamber (1) above the injector piston (2).

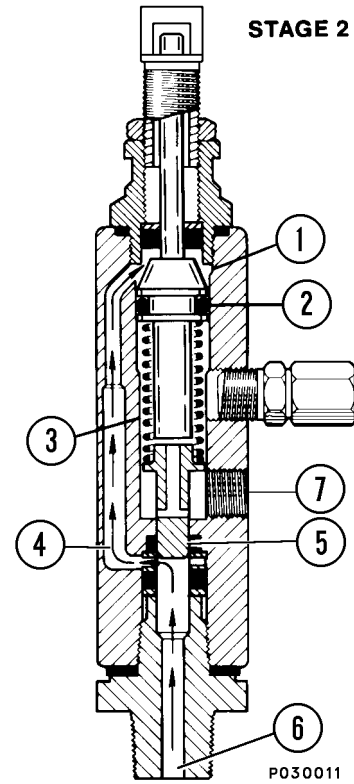

STAGE 2.
 When the slide valve (5) uncovers the passage (4), lubricant (6) is admitted to the measuring chamber (1) above the injector piston (2) which forces lubricant from the discharge chamber (3) through the outlet port (7) to the bearing.

STAGE 3.

As the injector piston (2) completes its stroke, it pushes the slide valve (5) past the passage (4), cutting off further admission of lubricant (6) to the passage (4) and measuring chamber (1). The injector piston (2) and slide valve (5) remain in this position until lubricant pressure in the supply line (6) is vented.

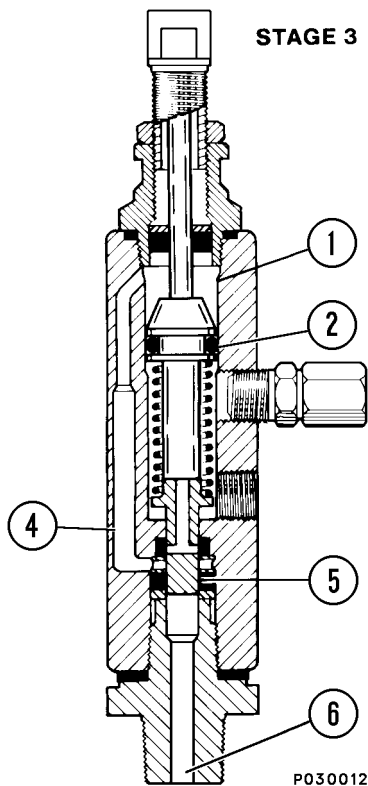

STAGE 4.

After venting, the injector spring expands, causing the slide valve (5) to move, so that the passage (4) and discharge chamber (3) are connected by a valve port (8). Further expansion of the spring causes the piston to move upward, forcing the lubricant in the measuring chamber (1) through the passage (4) and valve port (8) to refill the discharge chamber (3).

Injector is now ready for the next cycle.

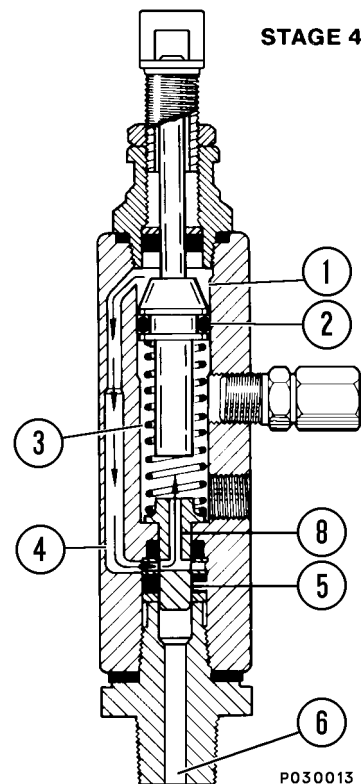

PREVENTIVE MAINTENANCE PROCEDURES

Use the following maintenance procedures to ensure proper system operation.

Daily Lubrication System Inspection

1. Check the grease reservoir level after each shift of operation. Grease usage should be consistent from day-to-day operations. Lack of lubricant usage would indicate an inoperative system. Excessive usage would indicate a broken supply line.
2. Check the filter bypass indicator when filling the reservoir. Replace the element if bypassing.
3. Check all grease hoses from the SL-1 Injectors to the lubrication points.
 - a. Repair or replace all damaged feed line hoses.
 - b. Ensure that all air is purged and all new feed line hoses are filled with grease before returning the truck to service.
4. Inspect the key lubrication points for a bead of lubricant around the seal. If a lubrication point appears dry, troubleshoot and repair the problem.

250 Hour Inspection

1. Check all grease hoses from the SL-1 Injectors to the lubrication points (see Figure 42-2).
 - a. Repair or replace all worn or broken hoses.
 - b. Ensure that all air is purged and all new feed line hoses are filled with grease before returning the truck to service.
2. Check all grease supply line hoses from the pump to the SL-1 injectors.
 - a. Repair or replace all worn or broken supply lines.
 - b. Ensure that all air is purged and all new supply line hoses are filled with grease before returning the truck to service.
3. Check the grease reservoir level.
 - a. Fill the reservoir if the grease level is low. Check the filter bypass indicator when filling the reservoir. Replace the element if bypassing.
 - b. Check the reservoir for contaminants. Clean the reservoir, if required.
 - c. Ensure that all filler plugs, covers and breather vents on the reservoir are intact and free of contaminants.

4. Inspect all bearing points for a bead of lubricant around the bearing seal.

NOTE: It is good practice to manually lube each bearing point at the grease fitting provided on each Injector. This will indicate whether there are any frozen or plugged bearings, and it will help flush the bearings of contaminants.

5. System Checkout

- a. Remove all SL-1 injector cover caps to allow visual inspection of the injector cycle indicator pins during system operation.
- b. Start the engine.
- c. Actuate override switch (6, Figure 42-1). The hydraulic motor and grease pump should operate.
- d. With the grease under pressure, check each SL-1 injector assembly. The cycle indicator pin should be retracted inside the injector body.
- e. When the system is at 16 203 - 17 237 kPa (2,350 - 2,500 psi), the pump should shut off and the pressure in the system should drop to zero, venting back to the grease reservoir.
- f. After the system has vented, check the SL-1 injector indicator pins. All of the pins should be visible. Replace or repair any defective injectors.
- g. Install all injector cover caps.
- h. Initiate one or more lubrication cycles to check the system operation.

NOTE: Turning the key switch to the ON position will not initiate a lube cycle. To initiate a lube cycle while the truck is stationary, select manual lube using the dash display panel, or use the switch on the lubrication pump. The system should build 13 790 kPa (2,000 psi) at the rear axle during normal pump cycle.

- If the system is working properly, the machine is ready for operation.
- If the system is malfunctioning, refer to the troubleshooting chart.

1000 Hour Inspection

Use the dipstick to check the pump housing oil level. If necessary, fill with SAE 10W-30 motor oil to the proper oil level marked on the dipstick.

SYSTEM CHECKOUT

To check system operation, proceed as follows:

1. Remove the dust covers from the injectors.
2. Start the engine.
3. Actuate the manual override button at the pump assembly and observe pin movement at each injector.
4. Check for pump, hose or injector damage or leakage with the system under pressure.
5. After checking system, stop the engine. Observing normal precautions regarding high voltage present in the propulsion system before attempting to repair lube system.
6. Re-install the injector dust covers.

Lubrication Cycle Operation

The time between lube events is determined by the setting selected in the dash panel. Refer to Figure 42-7 for lubrication menu screens. With the key switch ON, scroll through the display menu screens and select either 8, 15, 24 or 30 minutes between lube cycles. The default setting is 15 minutes.

NOTE: Turning the key switch to the ON position will not initiate a lube cycle. To initiate a lube cycle while the truck is stationary, select manual lube using the dash display panel, or use the switch on the lubrication pump.

The truck must be moving before the lube system will initiate lube cycles based on the time interval selected.

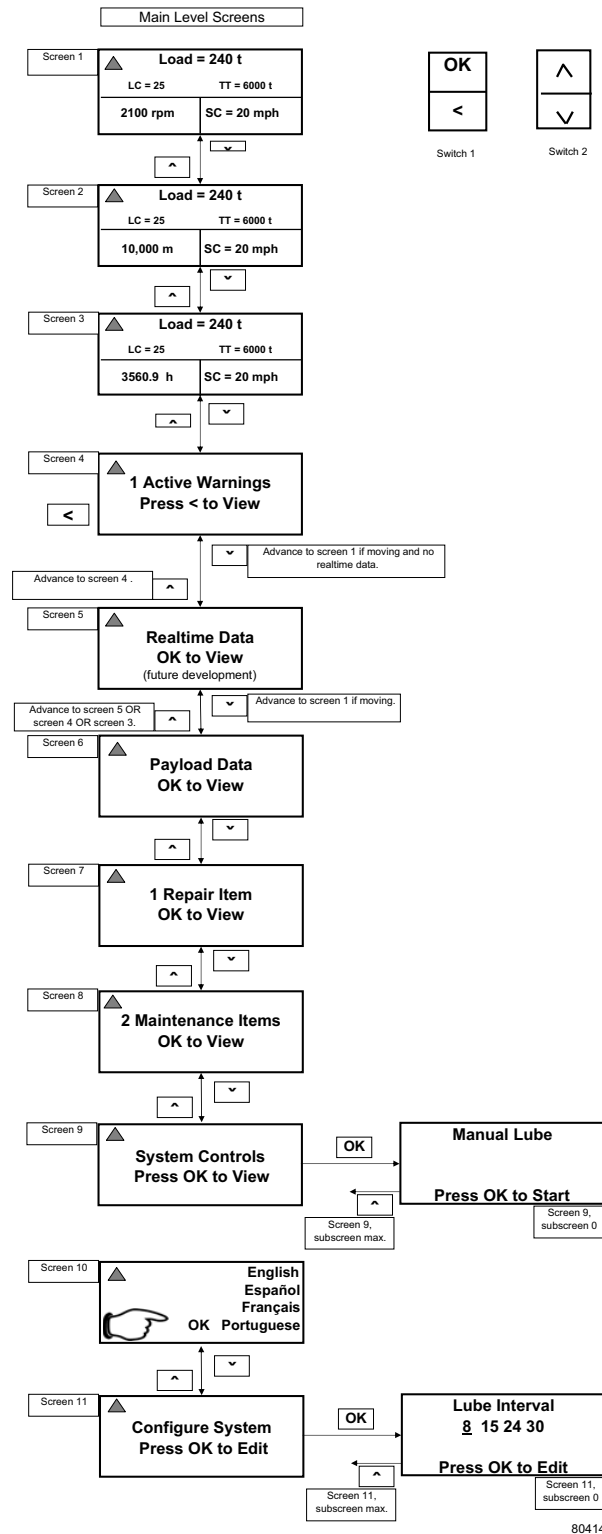

80414

FIGURE 42-7. LUBRICATION MENU

SYSTEM TROUBLESHOOTING CHART

NOTE: If the following procedures do not correct the problem, contact a factory authorized service center.

TROUBLE	POSSIBLE CAUSES	SUGGESTED CORRECTIVE ACTION
Pump Does Not Operate	Lube system not grounded. Electrical power loss. Lube cycle malfunction. Solenoid valve malfunctioning. Relay malfunctioning Motor or pump malfunction.	Correct grounding connections to pump assembly and truck chassis. Locate cause of power loss and repair. 24 VDC power required. Ensure key switch is ON. KOMTRAX Plus - Check fault logs Replace the solenoid valve assembly Replace relay Repair or replace motor and/or pump assembly. (Refer to shop manual for rebuild instructions.)
Pump Will Not Prime	Low lubricant supply.	Dirt in reservoir, pump inlet clogged, filter clogged.
Pump Will Not Build Pressure	Air trapped in lubricant supply line. Lubricant supply line leaking. Vent valve leaking. Pump worn or scored.	Prime system to remove trapped air. Check lines and connections to repair leakage. Clean or replace vent valve. Repair or replace pump assembly. (Refer to shop manual for rebuild instructions.)
Injector Indicator Stem Does Not Operate	<i>NOTE: Normally, during operation, the injector indicator stem will move into the body of the injector when pressure builds properly. When the system vents (pressure release) the indicator stem will again move out into the adjusting yoke.</i>	
	Malfunctioning injector - usually indicated by the pump building pressure and then venting. All injectors inoperative - pump build up not sufficient to cycle injectors.	Replace individual injector assembly. Service and/or replace pump assembly. (Refer to shop manual for rebuild instructions.)
Pressure Gauge Does Not Register Pressure	No system pressure to the pump motor. No 24 VDC signal at pump solenoid. Pressure reducing valve set too low. 24V Relay (RB7K8) may be defective.	Check hydraulic hose from steering system. Determine problem in 24 VDC electric system. Refer to "Pressure Control Valve Adjustment". Replace relay.

TROUBLE	POSSIBLE CAUSES	SUGGESTED CORRECTIVE ACTION
Pump Pressure Builds Very Slowly Or Not At All	No signal at solenoid.	Check wiring for open circuit. Also check for fault codes on dash panel display.
Controller Does Not Operate	No electric power to controller.	Turn on electric power to pump. "POWER" LED should light, "PUMP ON" LED should light when "MANUAL LUBE" is pressed.
Bearing Points Excessively Lubricated	Lube cycle interval set to low.	Select larger lube cycle interval.
	Injector output adjustment setting too high.	Readjust to lower setting.
Bearing Points Are Not Sufficiently Lubricated	Lube cycle interval set to high.	Select smaller lube cycle interval.
	Injector output adjustment setting too low.	Readjust injector output setting.
	System too large for pump output.	Calculate system requirements per planning manual.

COMPONENTS & SPECIFICATIONS

MAJOR COMPONENT DESCRIPTIONS

Truck And Engine

The 860E Dump Truck is an off-highway, rear dump truck with AC Electric Drive. The gross vehicle weight is 454 363 kg (1,001,700 lbs). The engine is a Komatsu SSDA16V160 rated @ 2700 HP (2014 kW).

Main Alternator

The diesel engine drives an in-line alternator at engine speed. The alternator produces AC current which is rectified to DC within the main control cabinet. The rectified DC power is converted back to AC by groups of devices called "inverters", which are also within the main control cabinet. Each inverter consists of six phase modules under the control of a gate driver power converter (GDPC). The two GDPCs control the operation of each phase module.

Each phase module contains paired positive and negative semiconductor switches referred to as insulated gate bipolar transistors (IGBT). The IGBTs cycle on and off at varying frequencies to create an AC power signal from the DC supply.

The AC power signal produced by each inverter is a variable-voltage, variable-frequency (VVVF) signal. Frequency and voltage are changed to suit the operating conditions.

Cooling air for the control/power group and wheel motors, as well as the alternator itself, is provided by a main blower mounted below the control cabinet.

AC Induction Traction Motorized Wheels

The alternator output supplies electrical energy to the two wheel motors attached to the rear axle housing. The motorized wheels use three-phase AC induction motors with full-wave AC power.

The two wheel motors convert electrical energy back to mechanical energy through built-in gear trains within the wheel motor assembly. The direction of the wheel motors is controlled by a directional control lever located on the center console.

Suspension

Hydrair II® suspension cylinders located at each wheel provide a smooth and comfortable ride for the operator and dampens shock loads to the chassis during loading and operation.

Operator's Cab

The operator cab has been engineered for operator comfort and to allow for efficient and safe operation of the truck. The cab is rubber-mounted to reduce noise and vibration, provides wide visibility with an integral 4-post ROPS/FOPS structure, and has an advanced analog operator environment. It includes a tinted safety-glass windshield and power-operated side windows, a deluxe interior with a fully adjustable seat with lumbar support, a fully adjustable/tilt steering wheel, controls mounted within easy reach of the operator, and an digital/analog instrument panel which provides the operator with all instruments and gauges which are necessary to control and/or monitor the truck's operating systems.

Power Steering

The truck is equipped with a full time power steering system which provides positive steering control with minimum operator effort. The system includes nitrogen-charged accumulators which automatically provide emergency power if the steering hydraulic pressure is reduced below an established minimum.

Dynamic Retarding

The dynamic retarding is used to slow the truck during normal operation or control speed coming down a grade. The dynamic retarding ability of the electric system is controlled by the operator through the activation of the retarder pedal in the operators cab and by setting the RSC (Retarder Speed Control). Dynamic retarding is automatically activated, if the truck speed goes to a preset overspeed setting.

Brake System

Service brakes at each wheel are oil-cooled multiple disc brakes applied by an all-hydraulic actuation system. Depressing the brake pedal actuates both front and rear brakes after first applying the retarder. All wheel brakes will be applied automatically if the brake system pressure decreases below a preset minimum.

The parking brake is a wet disc type, integral to the service brakes, and is spring-applied and hydraulically-released with wheel speed application protection (will not apply with truck moving).

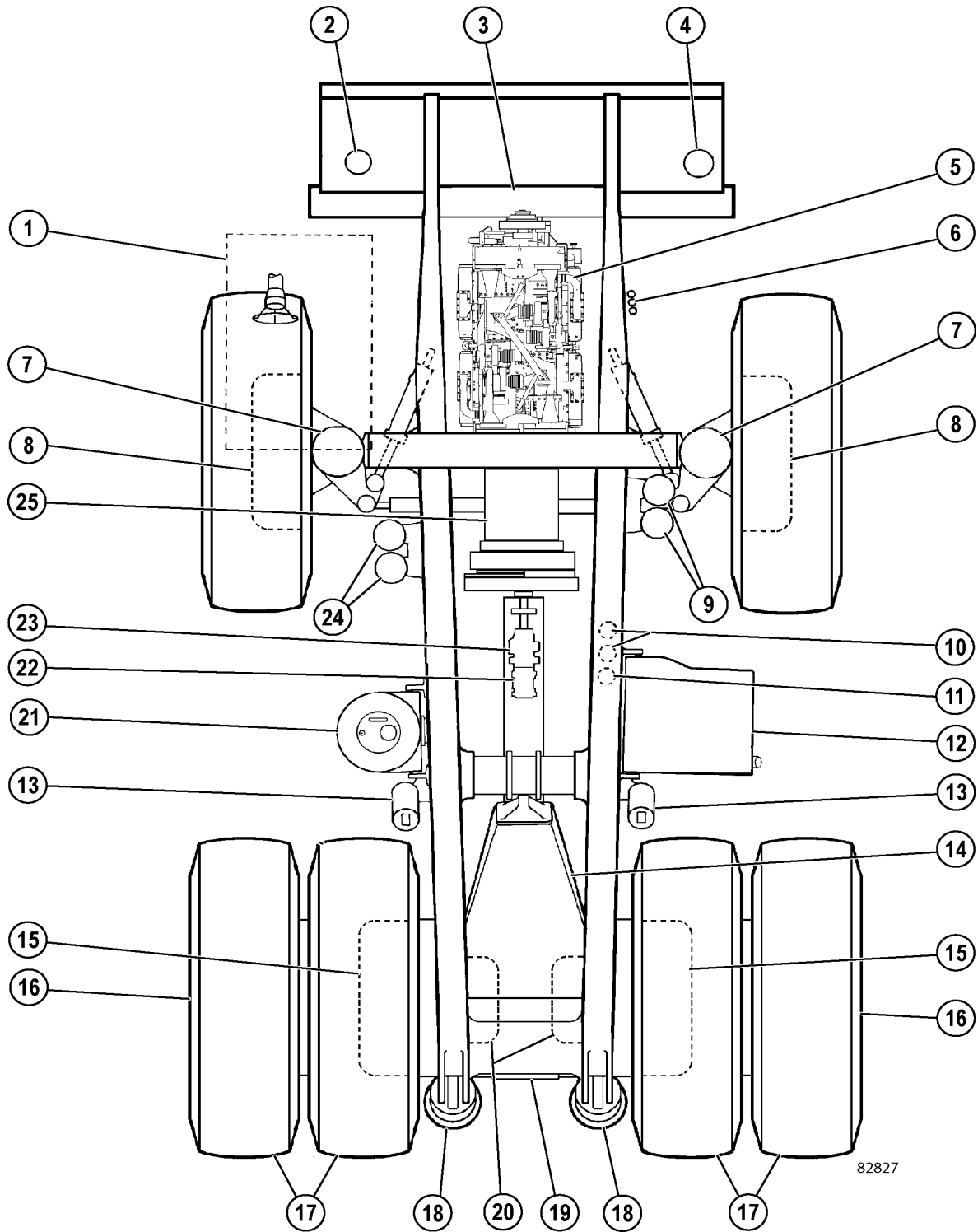

FIGURE 30-1. TOP VIEW

- | | | | |
|-----------------------|-----------------------|------------------------------|---------------------------|
| 1. Operator Cab | 8. Wet Disc Brake | 15. Wet Disc Brake | 21. Hydraulic Tank |
| 2. Auto Lubrication | 9. Brake Accumulators | 16. Wheel Motor Transmission | 22. Steering Pump |
| 3. Radiator | 10. Hoist Filters | 17. Rear Tires | 23. Hoist Pump |
| 4. Reserve Oil System | 11. Steering Filter | 18. Rear Suspension | 24. Steering Accumulators |
| 5. Engine | 12. Fuel Tank | 19. Rear Axle Hatch | 25. Alternator |
| 6. Fuel Filters | 13. Hoist Cylinder | 20. AC Electric Motor | |
| 7. Suspension | 14. Rear Axle Housing | | |

SPECIFICATIONS

These specifications are for the standard Komatsu 860E Dump Truck. Customer options may change this listing.

ENGINE

Komatsu SSSA16V160

No. of Cylinders	16
Operating Cycle	4-Stroke
Rated Brake HP	.2700 HP (2014 kW) @ 1900 RPM
Flywheel HP	.2550 HP (1902 kW) @ 1900 RPM
Weight (Wet)*	9608 kg (21,182 lbs)

* Weight does not include Radiator, Sub-frame, or Alternator.

AC ELECTRIC DRIVE SYSTEM

(AC/DC Current)

Alternator	DRLDZ5010-AL
Motorized Wheels	AC Induction Traction Motors
Standard Gear Ratio*	35.526:1
Maximum Speed	64.5 km/h (40 mph)

* Wheel motor application depends upon GVW, haul road grade and length, rolling resistance, and other parameters. Komatsu must analyze each job condition to ensure proper application.

DYNAMIC RETARDING

Electric Dynamic Retarding	Standard
Continuous*	3469 kW (4650 HP)

* Continuously rated high-density blown grids with retard at engine idle and retard in reverse propulsion.

BATTERY ELECTRIC SYSTEM

Batteries	Four 8D, 12 volt wet batteries with disconnect switch
Cold Cranking Amps	1450 CCA
Alternator	24 Volt, 140 Amp Output
Lighting	24 Volts
Cranking Motors (2)	24 Volts

SERVICE CAPACITIES

Crankcase	280 liters (74 gallons)
Cooling System	473 liters (125 gallons)
Fuel	4542 liters (1200 gallons)
Hydraulic System	1 325 liters (350 gallons)
Wheel Motor Gear Box	121 liters (32 gallons) per wheel
Inverter Cabinet Cooling System	25 liters (6.5 gallons)

HYDRAULIC SYSTEMS

Hoist and Brake Cooling Pump	Tandem Gear
Rating	931 L/min (246 gpm) @ 1900 RPM and 17 237 kPa (2,500 psi)
Steering/Brake Pump	Pressure Compensated Piston
Rating	246 L/min (65 gpm) @ 1900 RPM and 18 961 kPa (2,750 psi)
Relief Pressure - Hoist	17 237 kPa (2,500 psi)
Relief Pressure - Steering/Brake	18 961 kPa (2,750 psi)
Hoist Cylinders (2)	3-Stage Hydraulic
Tank (Vertical/Cylindrical)	Non-Pressurized
Tank Capacity	947 liters (250 gallons)
Filtration	In-line replaceable elements
Suction	Single, Full Flow, 100 Mesh
Hoist and Steering Filters (Dual In-Line, High Pressure)	Beta ₁₂ Rating =200

SERVICE BRAKES

All Hydraulic Actuation with Traction System Wheel Slip/Slide Control	
Front and Rear Oil-Cooled Multiple Discs on each wheel	
Total Friction Area / Brake	97 019 cm ² (15,038 in ²)
Maximum Apply Pressure	16 545 kPa (2,400 psi)

STEERING

Twin hydraulic cylinders with accumulator assist to provide constant rate steering	
Emergency power steering automatically provided by accumulators	
Turning Circle (SAE)	31.1 m (102 ft. 0 in.)

TIRES

Radial Tires (standard)	50/80 R57
Rock Service, Deep Tread	Tubeless
Rims	flange mount rims

STANDARD DUMP BODY CAPACITIES AND DIMENSIONS

Capacity

Heaped @ 2:1 (SAE)	169 m ³ (221yd ³)
Struck	122 m ³ (160 yd ³)
Width (Front Inside)	7.64 m (25 ft. 1 in.)
Depth	7.87 m (25 ft. 10 in.)
Loading Height	6.38 m (20 ft 11 in.)
Dumping Angle	45°

NOTE: Optional capacity dump bodies are available.

WEIGHT DISTRIBUTION**Vehicle Weights**

Standard Trolley Chassis	140 046 kg	(308,749 lbs)
Standard Komatsu body	. 33 643 kg	(74,171 lbs)
Standard tire weight	23 033 kg	(50,780 lbs)
Option Allowance	3 629 kg	(8,000 lbs)

Empty Vehicle Weight . 200 351 kg (441,700 lbs)

Front Axle (49%)	98 361 kg	(216,850 lbs)
Rear Axle (51%)	101 990 kg	(224,850 lbs)

Gross Vehicle Weight . . . 454 363 kg (1,001,700 lbs)

Front Axle (33.5%)	152 392 kg	(335,871 lbs)
Rear Axle (66.5%)	301 971 kg	(665,829 lbs)

Max. Nominal Payload* . . 254 012 kg (560,000 lbs)

NOTE: All weights shown with 100% fuel load.

* *Nominal payload* is defined within Komatsu America Corporation's payload policy documentation. In general, the nominal payload must be adjusted for the specific vehicle configuration and site application. The figures listed are provided for basic product description purposes. Please contact your Komatsu distributor for specific application requirements.

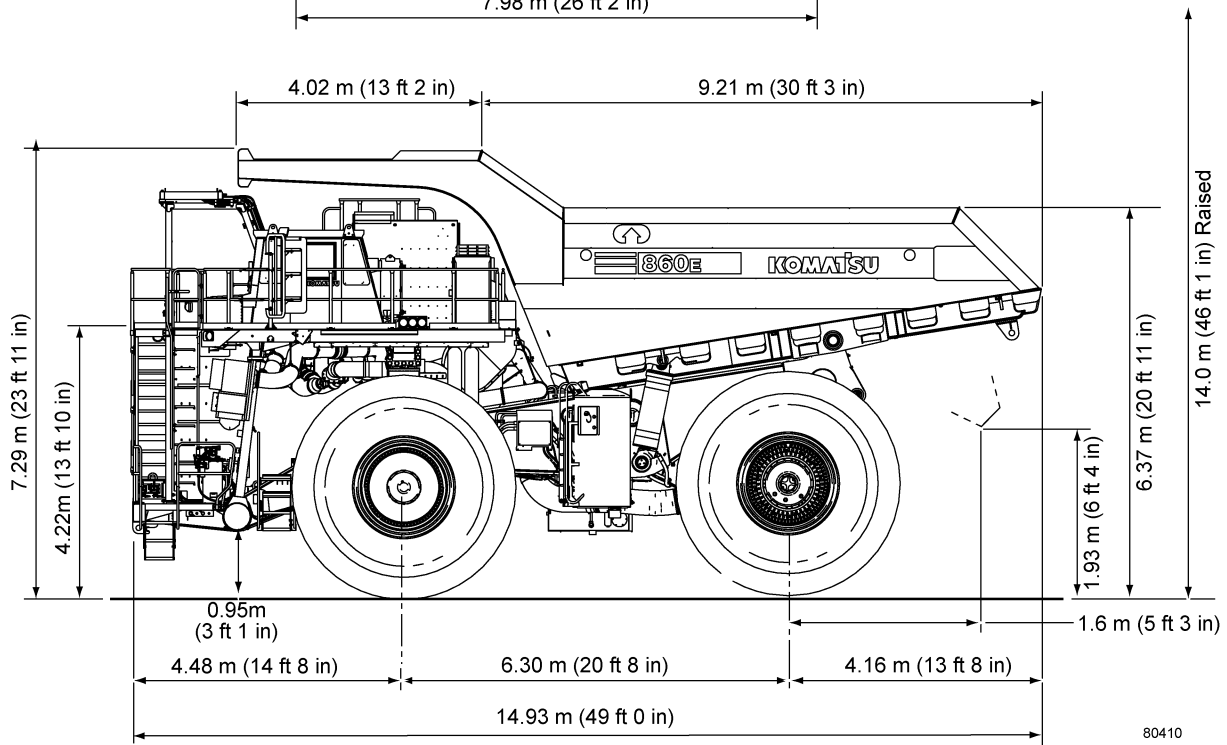
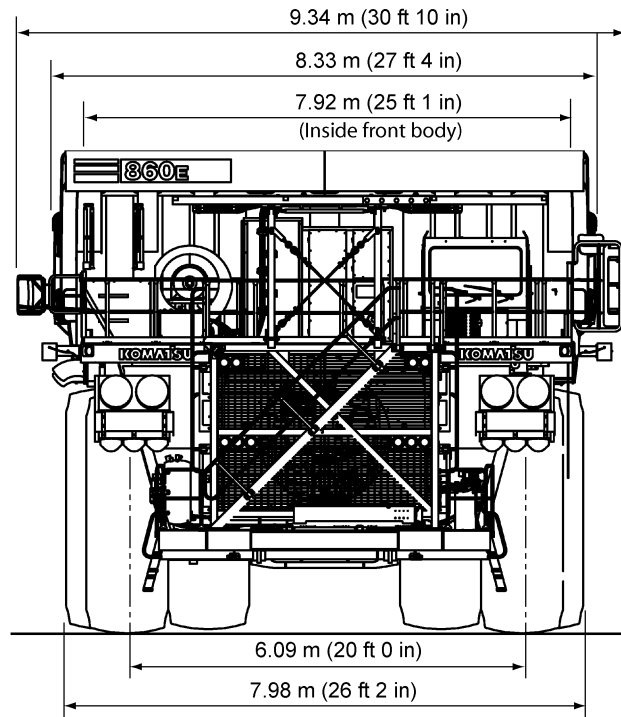

80410

PAYLOAD METER III™

INTRODUCTION

Payload Meter III (PLMIII) measures, displays and records the weight of material being carried by an off-highway truck. The system generally consists of a payload meter, a gauge display, deck-mounted lights, and sensors. The primary sensors are four suspension pressures and an inclinometer. Other inputs include a body up signal, brake lock signal, and speed.

Data Summary

5208 haul cycles can be stored in memory. The following information is recorded for each haul cycle:

- Payload
- Operator ID number (0000-9999)
- Distance traveled loaded and empty
- The amount of time spent empty run/stop, loading, loaded run/stop, and dumping
- Maximum speed loaded and empty with time of day
- Average speed loaded and empty
- Empty carry-back load
- Haul-cycle, loading, dumping start time of day
- Peak positive and peak negative frame torque with time of day
- Peak sprung load with time of day
- Tire ton-mph for each front and average per rear tires

The payload meter stores lifetime data that cannot be erased. This data includes:

- Top 5 maximum payloads and time stamps.
- Top 5 positive and negative frame torque and time stamps
- Top 5 maximum speeds and time stamps

Data Gathering

Windows software is available to download, store and view payload and fault information. The software will download an entire truck fleet into one Paradox database file. Users can query the database by date, time, truck type and truck number to produce reports and graphs, and to export the data. The software can export the data in a .CSV format that can be easily imported into most spreadsheet applications. The Windows software is not compatible with the Payload Meter II system.

It is important that each payload meter be configured for each truck using the software. The information for frame serial number and truck number is used by the database program to organize the payload data. In addition, the payload meter must be configured to make calculations for the proper truck model. Improper configuration can lead to data loss and inaccurate payload calculations.

COMPONENT DESCRIPTION

System Diagram

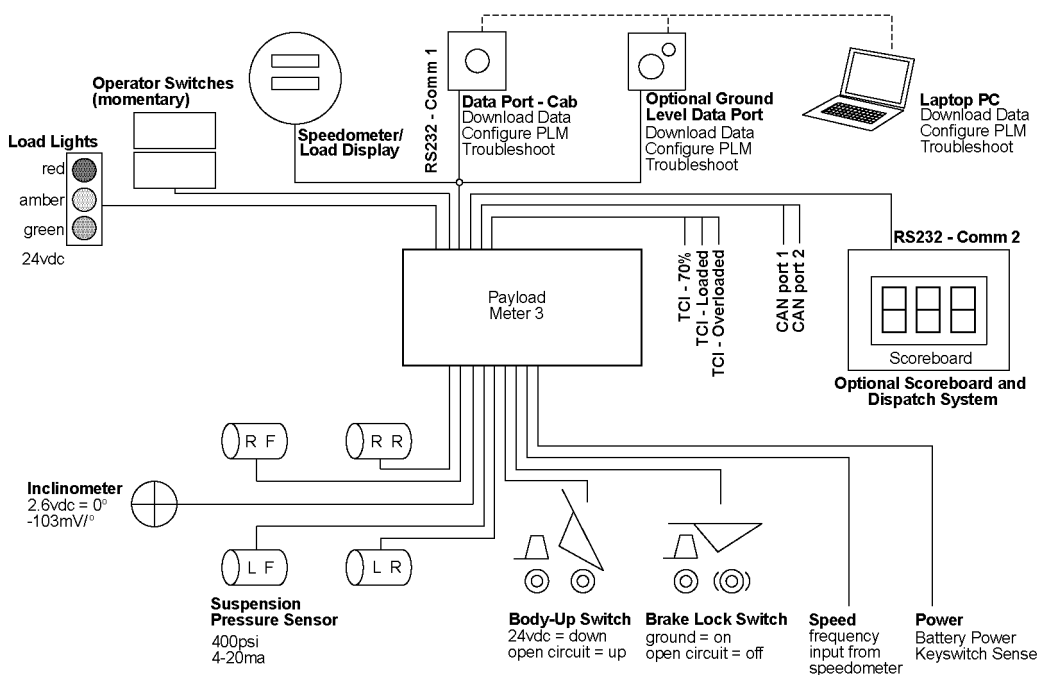

Suspension Pressure Sensors

PLMIII uses a two-wire pressure sensor. The range for the pressure sensor is 281 kg/cm² (4000 psi) and the overload limit is 700 kg/cm² (10,000 psi). One wire to the sensor is the supply voltage and the other is the signal. The 0 - 281 kg/cm² (0 - 4000 psi) range is converted into an electrical current between 4 and 20 ma. The supply voltage for the sensor is nominally +18VDC. Each pressure sensor has an 3000 mm (118 in.) length of cable. The cable is specially shielded and reinforced to provide mechanical strength and electronic noise immunity.

Inclinometer

The inclinometer is used to increase the accuracy of load calculations on an incline. The inclinometer uses three wires. For the sensor, red is the +18VDC supply voltage, black is ground and the white is the signal. The incline signal is a voltage between 1 and 4 volts. Zero degrees of incline is represented by 2.6VDC on the signal line. The voltage signal will be decreased by 0.103VDC for every degree of nose up incline.

Speedometer/Load Display

The speedometer/load display is used as a speedometer and as a payload information display. The top display is used for speed and can display metric (km/h) or English (mph) units. See "Digital Display Operation" in Section 32 for instructions on setting the displayed units. The speedometer can be adjusted using a calibration potentiometer in the back just like existing speedometers.

The payload meter uses the lower display for payload information. The normal display mode shows the current payload. The display can be changed to show the load and total tons counter or the Operator ID. Using the operator switches on the dash panel, the current suspension pressures and incline can be displayed. The units for display are set using the PC software. Payloads can be displayed in short tons, long tons or metric tons.

Operator Switches

In addition to toggling through warning screens and various truck information, the operator switches can be used to set, view and clear the total load counter and total ton counter of the payload meter. It is also used to enter the operator ID number (0-9999) and view the suspension pressures and inclinometer.

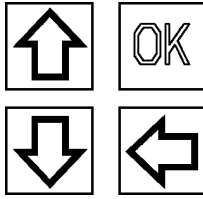

The operator switches are two-way momentary switches located on the lower left hand dash panel. The arrow positions are used to step through the different displays. The OK position is used to set the operator ID or clear the load and total ton counters. Normally, the inputs from the switches to the payload meter are open circuit. For more information of these switches refer to Operator and Cab Controls, Section 32, of this manual.

Speed Input

PLMIII uses a speed signal to calculate speed, distance, and other performance data. This input is critical to the proper operation of the system. PLMIII receives this signal from the speedometer/load display on the instrument panel. The same signal displayed to the operator is used by the system. Distance calculations are made based on the rolling radius of the tires for a particular truck.

Body-Up Switch

The body-up input signal is received from a magnetic switch located on the inside of the truck frame, forward the pivot pin of the truck body. This is the same switch typically used for input to the drive system. When the body is down, the switch closes and completes the circuit to 71-control power. 24VDC indicates that the body is down. Open circuit indicates that the body is up.

Brake Lock Switch

The brake lock is used to lock the rear brakes on the truck. It is necessary for the accurate calculation of swingloads during the loading process. Without the brake lock applied, the payload meter will not calculate swingloads during the loading process. Without the brake lock, the payload meter will assume that the truck was loaded using a continuous loader and flag the haul cycle record. All other functions will be normal regardless of brake lock usage. The brake lock input comes from the switch located on the dash panel. The brake lock switch connects the circuit to ground. Open circuit indicates that the brake lock is off. Ground indicates that the brake lock is on.

Payload Meter

The payload meter is housed in a black aluminum housing. There is a small window on the face of the unit. Status and active alarm codes can be viewed through the window. During normal operation, a two-digit display flashes 0 back and forth. Active fault codes will be displayed for two seconds. These codes are typically viewed using the laptop computer connected to the serial communications port.

There is one 40-pin connector on the payload meter. A jack-screw is used to hold the payload meter and wire harness connector housings together. This screw requires a 4mm or 5/32 in. hex wrench. The tightening torque for this screw is **3 N•m (25 in lbs)**. Four bolts hold the payload meter housing to its mounting bracket in the cab.

The circuit board inside the payload meter housing is made from multi-layer, dual-sided surface-mount electronics. There are no field serviceable components inside. The electronics are designed to withstand the harsh operating environment of the mining industry. Opening the payload meter housing will result in voiding the warranty.

Communications Ports

The payload meter has two RS232 serial communications ports and two CAN ports. Connections for the two serial ports are available inside the payload meter junction box. The two CAN ports are available for future electronics systems.

Serial port #1 is used to communicate with the dashboard display. It is also used to connect to the laptop computer. The display gauge will remain blank when the PC is using the serial port. This port initially operates with serial settings at 9600,8,N,1. These settings change automatically to increase the communications rate when the PC is using the port. This serial port uses a 3-wire hardware connection.

Serial port #2 is used to communicate to other on-board electronics like Modular Mining's Dispatch® system or the scoreboard from Komatsu. This port uses a 3-wire hardware connection. Connections to this serial port need to be approved by Komatsu. Several protocol options are available and detailed technical information is available depending on licensing.

Key Switch Input

PLMIII monitors the status of the key switch. 24VDC indicates that the key switch is on. Open indicates the key switch is off. The payload meter does not receive its electrical power from the key switch circuit. The payload meter will remain on for several seconds after key switch is removed. When the key switch power is removed, payload meter performs a series of internal memory operations before turning itself off. To allow for these operations, the key switch should be turned off for at least 15 seconds before turning the key switch back on. The payload meter will automatically reset itself without error if not enough time is given for these operations. The display may blink briefly.

Payload Meter Power

The payload meter receives its power from the battery circuit on the truck. Removing battery power from the payload meter before removing key switch and waiting 15 seconds may result in lost haul cycle data. The payload meter turns itself off approximately 15 seconds after the key switch power is removed. Some haul cycle data will be lost if battery power is removed before waiting 15 seconds. The payload meter system operates at a nominal voltage of 24VDC at 1 - 2 amps depending on options. The payload meter is designed to turn itself off if the supply voltage rises above 36VDC. The payload meter is also protected by a 5 amp circuit breaker located in the junction box.

Power to the load lights comes from the same battery circuit. The load lights are powered through a relay. The key switch circuit controls the relay. The load lights are also protected by a 15 amp circuit breaker in the junction box.

Load Lights

PLMIII uses load lights to indicate to the shovel operator the approximate weight of the material in the truck. The load lights are illuminated only when the brake lock is applied. The lights are controlled by the payload meter through a series of relays in the junction box. The payload meter controls the relays with 24VDC outputs. A 24VDC signal from the payload meter powers the relay coil and connects battery power to the load light. When the relay is not powered by the payload meter, a pre-warm resistor connects the load light to a reduced voltage. This circuit pre-warms the load light filaments and reduces the inrush current when the light is fully illuminated. This lengthens the operating life of the load lights.

The load lights progressively indicate to the shovel operator the approximate weight of the material in the truck.

A flashing green light indicates the next swingload will make the measured load greater than 50% of rated load. A solid green light indicates that the current load is greater than 50% of rated capacity.

A flashing amber light indicates the next swingload will make the measured load greater than 90% of rated load. A solid amber light indicates that the current load is greater than 90% of rated capacity.

A flashing red light indicates the next swingload will make the measured load greater than 105% of rated load. A solid red light indicates that the current load is greater than 105% of rated capacity.

The optimal loading target is a solid green and amber lights with a flashing red light. This indicates that the load is between 90% and 105% of rated load for the truck and the next swingload will load the truck over 105%.

Wiring and Termination

Most of the PLMIII truck connections use a heavy-duty cable. This yellow multi-conductor cable uses a 16AWG, finely stranded wire designed for continuous motion operations. The conductors are protected by a foil and braided shield for electronic noise immunity and physical strength. This wire is typically terminated with a #10 ring terminal. Most connections for the PLMIII system are made in the payload meter junction box.

LOAD DISPLAY AND OPERATOR SWITCHES

The top display on the speedometer/load display is the speedometer and can display metric (km/h) or English (mph) units. See “Digital Display Operation” in Section 32 for instructions on setting the displayed units. The speedometer can be adjusted using a calibration potentiometer in the back just like existing speedometers.

The lower display on the speedometer/load display is used for payload information. Use the operator switches to scroll to the “PAYLOAD DATA” main level screen, then through the following payload meter information displays:

- Operator ID
- Total Shift Tons
- Shift Load Counter
- Suspension Pressures and Inclinometer

The display holds the operator ID and total shift tons information until the OK position of the operator switch is pressed. The suspension pressures, inclinometer, and payload displays are based on current sensor inputs.

Communications to the display use the same serial link as the download connection. Whenever another computer is connected to serial port #1 to download or configure the system, the lower display will blank. This is not the same connection used by mine dispatch systems.

Setting the Operator ID

The current operator ID number is recorded with each haul cycle. The number can be between 0 and 9999.

To set the operator ID, use the arrow positions of the operator switches to scroll to the “PAYLOAD DATA” main level screen. Then refer to Digital Display Operation - Entering Payload Meter Data in Section 32, Operator Cab and Controls. Follow the flow chart, substituting your operator ID for the one in the example.

If no buttons are pressed for 30 seconds, the display will return to normal operation. The number being entered will be lost and the operator ID returns to the previous number.

Total Ton and Total Load Counters

PLMIII allows the truck operator to monitor and track the total tons hauled and the number of haul cycles during the shift. This display can be cleared at the beginning of each shift to allow the operator to record how many loads and tons have been hauled during the shift.

To view the total ton and total load counters, refer to Digital Display Operation - Toggling Through Main Level Screens in Section 32, Operator Cab and Controls. Follow the flow chart to the desired payload meter information screen.

The total ton counter records the number of tons hauled since the last time it was cleared. This display is in 100's of tons. For example, if the display shows 432 , the total tons is 43,200. This display can be cleared at the beginning of each shift to allow the operator to record how many tons have been hauled during the shift. The units are selected using the PC software.

The total load counter records the number of loads hauled since the last time it was cleared. This display can be cleared at the beginning of each shift to allow the operator to record how many loads have been hauled during the shift.

Clearing the total ton counter or total load counter clears both records.

To clear the total ton and total load counter, press the OK position of the operator switch while viewing this screen.

Viewing Live Sensor Data

The display can also be used to quickly show the current readings from the four suspension pressure sensors and the inclinometer. This can be used during regularly scheduled service periods to check the state of the suspensions. These displays are live and will update as the values change.

The live displays cannot be cleared and the OK position of the operator switch will have no effect.

The units for the display are controlled by the configuration of the payload meter. If the payload meter is set to display metric units, the pressures will be displayed in tenths of kg/cm^2 . For example, if the display shows 20.2 , the actual value is 20.2 kg/cm^2 . If the payload meter is set to display short tons, the pressures will be displayed in psi (lbs/in^2). Multiply by 14.2 to convert kg/cm^2 to psi. (example -- $1\text{kg}/\text{cm}^2 \times 14.2 = 14.2$ psi). There is no way to detect the units setting for the gauge without the PC software.

The inclinometer displays whole degrees of incline. Positive incline is truck nose up. The gauge will quickly display the type of information shown every 10 seconds. For example, if the left front pressure is being displayed, *LF Press* will flash on the display every minute.

- Left Front Pressure - To display the pressure in the left front suspension, press and release the OK position of the operator switch until *LF Press* is displayed.
- Right Front Pressure - To display the pressure in the right front suspension, press and release the OK position of the operator switch until *RF Press* is displayed.
- Left Rear Pressure - To display the pressure in the left rear suspension, press and release the OK position of the operator switch until *LR Press* is displayed.
- Right Rear Pressure - To display the pressure in the right rear suspension, press and release the OK position of the operator switch until *RR Press* is displayed.
- Inclinometer - To display the truck incline, press and release the OK position of the operator switch until *Incline* is displayed.

Other Display Messages

On startup of the payload meter system, the operator display will scroll the truck type that the PLMIII is configured for. For example, on a 960E, the display will scroll ---*960E*---

If the PLMIII encounters memory problems, it will display *ERR88*, where 88 is the specific memory error. In this very rare circumstance, the system should be turned off for 30 seconds and restarted.

PAYLOAD OPERATION & CALCULATION

Description of Haul Cycles

The typical haul cycle can be broken down into eight distinct “stages” or “states”. Each state requires the payload meter to make different calculations and store different data.

1. Tare Zone
2. Empty
3. Loading
4. Maneuvering
5. Final Zone
6. Hauling
7. Dumping
8. After Dump

A new haul cycle is started after the load has been dumped from the previous cycle. The payload meter will stay in the after dump state for 10 seconds to confirm that the load has actually been dumped. If the current payload is less than 20% of rated load, the payload meter will switch to the tare zone and begin calculating a new empty tare. If, after dumping, the payload has not dropped below 20% of rated load the meter will return to the maneuvering or hauling states. In this case, the *false_body_up* flag will be recorded in the haul cycle record.

While in the tare zone state, and moving faster than 5 km/h (3 mph), the payload meter calculates the empty sprung weight of the truck. This tare value will be subtracted from the loaded sprung weight to calculate the final payload. The payload meter will switch from the tare zone or empty to the loading state if swingloads are detected. By raising the dump body while in the empty state the payload meter can be manually switched back to the tare zone to calculate a new tare.

From the empty state, the payload meter will switch to the loading state through one of two means. If the brake lock is applied, the payload meter will be analyzing the suspension pressures to detect a swingload. If a swingload is detected, the meter will switch to the loading state. The minimum size for swingload detection is 10% of rated load. Swingload detection usually takes 4-6 seconds. The second method to switch from empty to loading is through continuous loading. This can happen if the brake lock is not used during loading. If the load increases above 50% of rated load for 10 seconds without the brake lock applied, the meter will switch to loading and record the *continuous_loading* flag in the haul cycle.

The payload meter switches from loading state to maneuvering state as soon as the truck begins moving. The maneuvering zone is 160m (0.1 mile) and is designed to allow the operator to reposition the truck under the shovel. More payload can be added anytime within the maneuvering zone. Once the truck travels 160m (0.1 mile) the payload meter switches to the final zone and begins calculating payload. If the body is raised while the payload meter is in the maneuvering state, the `no_final_load` flag will be recorded in the haul cycle record, no payload will be calculated, and the meter will switch to the dumping state.

While in the final zone, and moving faster than 5 km/h (3 mph), the payload meter calculates the loaded sprung weight of the truck. The same advanced algorithm is used to calculate the empty and loaded sprung weights. The payload meter will switch from the final zone to the dumping state if the body-up signal is received. If the truck has moved for less than one minute in the final zone, the payload meter will calculate the final payload using an averaging technique which may be less accurate. If this happens, the `average_load` flag will be recorded in the haul cycle.

The payload meter switches to the dumping state when the dump body rises. The payload meter will switch from dumping state to after dump state when the dump body comes back down.

From the after dump state, the payload meter will switch to one of three states:

1. If the average payload is greater than 20% of rated load and no final payload has been calculated, the payload meter will return to the maneuvering state. After the truck travels 160m (0.1 mile) the meter will switch to the final zone and attempt to calculate the payload again. The `false_body_up` flag will be recorded in the haul cycle record.
2. If the average payload is greater than 20% of rated load and the final payload has been calculated, the payload meter will switch back to the hauling state. The `false_body_up` flag will be recorded in the haul cycle record.
3. If the average payload is less than 20% of rated load, the payload meter will switch to the tare zone and begin to calculate a new empty tare.

Load Calculation

The final load calculation is different from the last swingload calculation. The accuracy of the swingload calculation depends on loading conditions and the position of the truck during loading. The last swingload calculation is not the value recorded in memory as the final load. The final load is determined by a series of calculations made while the truck is traveling to the dump site.

Carry Back

Carry back is calculated as the difference between the current truck tare and the clean truck tare. The clean truck tare is calculated using the PC software. When the suspensions are serviced or changes are made that may affect the sprung weight of the truck, a new clean truck tare should be calculated.

Measurement Accuracy

Payload measurements are typically repeatable within 1%. Accuracy for a particular scale test depends on specific combinations of pressure sensors and payload meters as well as the specifics of each scale test. Comparisons from different scale tests are often made without considering the differences introduced by the specific installation and operation of the scales for each test. In addition, each pressure sensor and payload meter introduces its own non-linearity. Each truck becomes an individual combination of sensors and payload meter. Errors from these sources can introduce up to a $\pm 7\%$ bias in the payload meter calculations for a specific scale test, for an individual truck.

Because the PLMIII calculates a new empty tare for each payload, a detailed scale test must weigh the trucks empty and loaded for each haul cycle. Using a simple average of two or three empty truck weights as an empty tare for the entire scale test will introduce significant error when comparing scale weights to PLMIII weights.

SOURCES FOR PAYLOAD ERROR

Suspensions

The number one source of error in payload calculation is improperly serviced suspensions. The payload meter calculates payload by measuring differences in the sprung weight of the truck when it is empty and when it is loaded. The sprung weight is the weight of the truck supported by the suspensions. The only method for determining sprung weight is by measuring the pressure of the nitrogen gas in the suspensions. If the suspensions are not properly maintained, the payload meter cannot determine an accurate value for payload. The two critical factors are proper oil height and proper nitrogen charge.

If the suspensions are overcharged, the payload meter will not be able to determine the empty sprung weight of the truck. The suspension cylinder must be able to travel up and down as the truck drives empty. The pressure in an overcharged suspension can push the suspension rod to full extension. In this case, the pressure inside the cylinder does not accurately represent the force necessary to support that portion of the truck.

If the suspensions are undercharged, the payload meter will not be able to determine the loaded sprung weight of the truck. The suspension cylinder must be able to travel up and down as the truck drives loaded. If the pressure in an undercharged suspension cannot support the load, the suspension will collapse and make metal-to-metal contact. In this case, the pressure inside the cylinder does not accurately represent the force necessary to support that portion of the truck.

Low oil height can also introduce errors by not correctly supporting a loaded truck. This is why the correct oil height and nitrogen charge are the most critical factors in the measurement of payload. If the suspensions are not properly maintained, accurate payload measurement is not possible. In addition, suspension maintenance is very important to the life of the truck.

Loading Conditions

The final load calculation of the PLMIII system is not sensitive to loading conditions. The final load is calculated as the truck travels away from the shovel. Variations in road conditions and slope are compensated for in the complex calculations performed by the payload meter.

Pressure Sensors

Small variations in pressure sensors can also contribute to payload calculation error. Every pressure sensor is slightly different. The accuracy differences of individual sensors along the range from 0 - 281 kg/cm² (0 to 4000 psi) can add or subtract from payload measurements. This is also true of the sensor input circuitry within individual payload meters. These differences can stack up 7% in extreme cases. These errors will be consistent and repeatable for specific combinations of payload meters and sensors on a particular truck.

Swingloads

Swingload calculations can be affected by conditions at the loading site. Parking the truck against the berm or large debris can cause the payload meter to inaccurately calculate individual swingloads. While the PLMIII system uses an advanced calculation algorithms to determine swingloads, loading site conditions can affect the accuracy.

Speed and Distance

The payload meter receives the same speed signal as the speedometer. This signal is a frequency that represents the speed of the truck. The payload meter uses this frequency to calculate speeds and distances. The meter assumes a single value for the rolling radius of the tire. The rolling radius may change at difference speeds by growing larger at higher speeds. The actual rolling radius of the tire will also change between a loaded and empty truck. The payload meter does not compensate for these changes.

HAUL CYCLE DATA

PLMIII records and stores data in its on-board flash memory. This memory does not require a separate battery. The data is available through the download software.

PLMIII can store 5208 payload records. When the memory is full, the payload meter will erase the oldest 745 payload records and continue recording.

PLMIII can store 512 alarm records. When the memory is full, the payload meter will erase the oldest 312 alarm records and continue recording.

All data is calculated and stored in metric units within the payload meter. The data is downloaded and stored in metric units within the Paradox database on the PC. The analysis program converts units for displays, graphs and reports.

The units noted in the Table 1 are the actual units stored in the data file. The value for the haul cycle start time is the number of seconds since January 1, 1970 to the start of the haul cycle. All other event times are referenced in seconds since the haul cycle start time. The PC download and analysis program converts these numbers into dates and times for graphs and reports.

Haul Cycle Warning Flags

The payload meter expects haul cycles to progress in a particular way. When something unexpected takes place, the system records a warning flag. Several events within the haul cycle can cause a warning flag to be generated. Each one indicates an unusual occurrence during the haul cycle. They do not necessarily indicate a problem with the payload meter or payload calculation.

A: Continuous Loading

This message is generated when the truck is loaded over 50% full without the payload meter sensing swingloads. This indicates that a continuous loading operation was used to load the truck. It may also indicate that the payload meter did not receive the brake lock input while the truck was being loaded. There may be a problem with the wiring or the brake lock was not used. The payload meter will not measure swingloads unless the brake lock is used during the loading process.

B: Loading to Dumping Transition

This message is generated when the payload meter senses a body up input during the loading process. This message is usually accompanied by a no_final_load flag.

C: No Final Load

This message is generated when the payload meter is unable to determine the final payload in the truck. Typically, this means that the payload meter switched from a loaded state to the dumping state before the load could be accurately measured.

D: Maneuvering to Dumping Transition

This message is generated when the payload meter senses a body-up input during the maneuvering or repositioning process indicating that the operator has dumped the load. It may also be generated if the body-up signal is not properly reaching the payload meter and the weight in the truck falls dramatically while the truck is maneuvering or repositioning.

E: Average Load or Tare Used

This message indicates that the recorded payload may not be as accurate as a typical final load calculation. Typically, this is recorded when loading begins before an accurate tare is calculated or the load is dumped before the load can be accurately measured.

F: Final Zone to Dumping Transition

This message is generated when the payload meter senses a body-up while it is calculating the final payload indicating that the operator has dumped the load. It may also be generated if the body-up signal is not properly reaching the payload meter and the weight in the truck falls dramatically while the truck is calculating the final payload.

H: False Body Up

This message indicates that the body was raised during the haul cycle without the load being dumped. The body-up signal indicated that the truck was dumping, but the weight of the truck did not fall below 20% of the rated load.

I: Body Up Signal Failed

This message indicates that the load was dumped without a body-up signal being received by the payload meter. The weight of the truck fell below 20%, but the payload meter did not receive a body-up signal from the sensor.

J: Speed Sensor Failed

This message indicates that the payload meter sensed the truck loading and dumping without receiving a speed signal.

K: New Tare Not Calculated

The payload meter was not able to accurately calculate a new empty sprung weight for the truck to use as the tare value for the haul cycle. The tare value from the last haul cycle was used to calculate payload.

L: Incomplete Haul Cycle

The payload meter did not have proper data to start the haul cycle with after powering up. When the PLMIII powers off, it records the data from the haul cycle in progress into memory. This flag indicates that this data was not recorded the last time the payload meter was shut down. This can happen when the main battery disconnect is used to shut the truck down instead of the key switch. A haul cycle with this warning flag should not be considered accurate. Haul cycles with this warning are displayed in red on the Payload Summary window and are not included in the summary statistics for reports or display.

M: Haul Cycle Too Long

The `haul_cycle_too_long` flag indicates that the haul cycle took longer than 18.2 hours to complete. The times stored for particular events may not be accurate. This does not affect the payload calculation.

N: Sensor Input Error

An alarm was set for one of the five critical sensor inputs during the haul cycle. The five critical sensors are the four pressure sensors and the inclinometer. Without these inputs, the payload meter cannot calculate payload. A haul cycle with this warning flag should not be considered accurate. Haul cycles with this warning are displayed in red on the Payload Summary window and are not included in the summary statistics for reports or display.

Frame Torque Data

Payload meter records the top five peak positive and negative frame torque values and the time they occurred. The frame torque is a measure of the twisting action along the centerline of the truck. Positive frame torque is measured when the suspension forces on the front of the truck act to twist the frame in the clockwise direction as viewed from the operator's seat. Negative frame torque is measured when the forces from the suspensions act in the opposite direction.

For example, if the left front and right rear pressure rises as the right front and left rear pressure drops, the truck frame experiences a twisting motion along the longitudinal centerline. In this case, the payload meter will record a positive frame torque.

The five highest values in the positive and negative direction are stored in permanent memory within the payload meter.

Sprung Weight Data

The payload meter is constantly monitoring the live payload calculation. This value naturally rises and falls for a loaded truck depending on road and driving conditions. The payload meter records the top five highest payload calculations and the time they occurred. This information is stored in permanent memory inside the meter.

Maximum Speed Data

The payload meter records the top five highest speeds and the time they occurred. This information is stored in permanent memory inside the meter.

Table 1: HAUL CYCLE DATA		
Data	Unit	Remark
Truck #	alpha-numeric	Up to 22 characters can be stored in this field to identify the truck. Typically this field will be just the truck number.
Haul Cycle Start Date/Time	seconds	Number of seconds from 1/1/70 to the start of the haul cycle, haul cycle starts when the meter transitions from dumping to empty state after the previous haul cycle, download program converts seconds into date and time for display
Payload	tons	Stored as metric, download program allows for conversion to short or long tons.
Number of Swingloads	number	The number of swingloads detected by the payload meter
Operator ID	number	This is a 4 digit number that can be entered by the operator at the start of the shift.
Warning Flags	alpha	Each letter represents a particular warning message about the haul cycle, details are located on page 19.
Carry-back load	tons	The difference between the latest empty tare and the clean truck tare
Empty haul time	seconds	Number of seconds in the tare_zone and empty states with the truck moving
Empty stop time	seconds	Number of seconds in the tare_zone and empty states with the truck stopped
Loading time	seconds	Number of seconds in the loading state
Loaded haul time	seconds	Number of seconds in the maneuvering, final_zone and loaded states with the truck moving
Loaded stop time	seconds	Number of seconds in the maneuvering, final_zone and loaded states with the truck stopped
Dumping time	seconds	Number of seconds in the dumping state
Loading start time	seconds	Number of seconds from the start of the haul cycle to when the meter transitions from empty to loading state
Dump start time	seconds	Number of seconds from the start of the haul cycle to the time when the meter switches from loaded to dumping state
Loaded haul distance	m	Distance traveled while loaded
Empty haul distance	m	Distance traveled while empty
Loaded max speed	km/h	Maximum speed recorded while the truck is loaded
Loaded max speed time	seconds	Number of seconds from the start of the haul cycle to the time when the max speed occurred
Empty max speed	km/h	Maximum speed recorded while the truck is empty
Empty max speed time	seconds	Number of seconds from the start of the haul cycle to the time when the max speed occurred
Peak positive frame torque	ton-meter	Positive frame torque is measured as the frame twists in the clockwise direction as viewed from the operator's seat.
Peak frame torque time	seconds	Number of seconds from the start of the haul cycle to the peak torque, download program converts to time for display
Peak negative frame torque	ton-meter	Negative frame torque is measured as the frame twists in the counter-clockwise direction as viewed from the operator's seat.
Peak frame torque time	seconds	Number of seconds from the start of the haul cycle to the peak torque, download program converts to time for display
Peak sprung load	tons	Peak dynamic load calculation
Peak sprung load time	seconds	Number of seconds from the start of the haul cycle to the peak instantaneous load calculation
Front-left tire-ton-km/h	t-km/h	Tire ton-km/h for haul cycle
Front-right tire-ton-km/h	t-km/h	Tire ton-km/h for haul cycle
Average rear tire-ton-km/h	t-km/h	Tire ton-km/h for haul cycle
Truck Frame Serial Number	alpha	The truck serial number from the nameplate on the truck frame
Reserved 1-10	number	These values are internal calculations used in the continued development of the PLMIII system and should be ignored

Alarm Records

The payload meter stores alarm records to give service personnel a working history of the system. All fault codes are viewed using the PC connected to the payload meter. Active fault codes are also displayed on the two-digit display on the meter itself. Each fault

code has a specific cause and should lead to an investigation for correction. Some failures can be overcome by the payload meter. Haul cycle data will indicate if an alarm condition was present during the cycle. Failures with the suspension or inclinometer sensors cannot be overcome. Refer to Table 2.

Table 2: FAULT CODES

Fault Code	Name	Description
1	Left front pressure high	Input current > 22 ma
2	Left front pressure low	Input current < 2 ma
3	Right front pressure high	Input current > 22 ma
4	Right front pressure low	Input current < 2 ma
5	Left rear pressure high	Input current > 22 ma
6	Left rear pressure low	Input current < 2 ma
7	Right rear pressure high	Input current > 22 ma
8	Right rear pressure low	Input current < 2 ma
9	Inclinometer high	Input voltage < 0.565 vdc
10	Inclinometer low	Input voltage > 5.08 vdc
11	Speed input failure	Not Used
12	Brake lock input failure	Not Used
13	Body-up input failure	Payload meter detected dumping activity without receiving a body up signal
16	Memory write failure	Indicates possible memory problem at power start up. Cycle power and recheck.
17	Memory read failure	Indicates possible memory problem at power start up. Cycle power and recheck.
18	Rear right suspension flat	Payload meter detected an undercharged suspension condition on the rear right suspension.
19	Rear left suspension flat	Payload meter detected an undercharged suspension condition on the rear left suspension.
20	Time change	Payload meter time was changed by more than 10 minutes. The Alarm Set time indicates original time. The Alarm Clear time indicates the new time.
21	Tare value reset	The user manually forced the payload meter to reset the haul cycle empty (tare) sprung weight. This forced the meter into the tare_zone state and lost all data for the previous haul cycle.
22	Excessive carryback	The payload meter detected an empty carryback load in excess of the user-defined carryback threshold on two consecutive haul cycles.
26	User switch fault - SELECT	Select switch on for more than 2 minutes, may indicate short to ground
27	User switch fault - SET	Set switch on for more than 2 minutes, may indicate short to ground

PDM SOFTWARE OVERVIEW

The Payload Data Management (PDM) software has several basic functions:

- Configure the PLMIII system on the truck.
- Troubleshoot and check the PLMIII system.
- Download data from the PLMIII system.
- Analyze data from the payload systems.

Configuration, troubleshooting and downloading require a serial connection to the payload meter on the truck. Analysis can be done at any time without a connection to the payload meter.

Payload data is downloaded from several trucks into one database on the computer. The database can be queried to look at the entire fleet, one truck or one truck model. The data can be graphed, reported, imported or exported. The export feature can save payload data in a format that spreadsheet programs (like Excel) or word processing programs can easily import.

System Configuration

PLMIII needs to be configured for operation when it is first installed on the truck. This process requires a laptop computer and can be broken down into several steps:

- Connecting the laptop to the PLMIII system
- Starting communications
- Setting the time and date
- Setting the truck type
- Setting the truck ID
- Setting the speedometer/load display units

Installing the PDM Software

The CD-ROM containing the PDM software should automatically begin installation when it is inserted into the drive on the PC. If this does not happen, the software can be installed by running the **Setup.exe** program on the CD-ROM.

The minimum PC requirements for running the software are a Pentium 133Mhz with 64 MB of RAM and at least 300 MB of free hard drive space. For improved performance, the recommended PC would be a Celeron, AMD K6-2 or better processor with 128 MB of RAM running at 400 Mhz. The PDM software uses a powerful database to manipulate the large amounts of data gathered from the PLMIII system. Using a more powerful computer and more memory can result in a significant improvement in performance. The software is written to use a minimum 800x600 screen resolution.

DOWNLOADING DATA

PLMIII records many types of data. The PDM software is designed to download the data from a whole truck fleet. Instead of creating one data file for each truck, the software combines all the data from many trucks into a single Paradox database on the computer's hard drive. Users can then query the database to create custom reports and graphs. Data for individual trucks or groups of trucks can be easily analyzed. This same data can be exported for use in other software applications such as spreadsheet applications and word processors.

As the database grows, performance of the software for analysis will slow down. It may be helpful to periodically export data. For example, query the database to show the oldest quarter, month, or half year and print out a summary report. Then export the data to a compressed format and save the file in a secure location. Once the data is exported, delete the query results from the database. If necessary, the data can easily be imported back into the main database for analysis at a future date. Removing this older data will improve performance.

To move the data to another computer, a query must be run to isolate the particular data for export. Do not press the operator switches on the dash panel while downloading.



To download the payload meter data:

1. Connect the computer to the payload meter and start the PM software.
2. From the main menu, select "Connect to Payload Meter". The software will request the latest status information from the payload meter. The number of haul cycles and alarms will be displayed.
3. Select the "Begin Download" button. The software will request the payload and alarm data from the payload meter and save it into the database. This may take several minutes. A progress bar at the bottom of the screen will show the approximate time left.

PLM III SYSTEM CONFIGURATION

Starting Communications

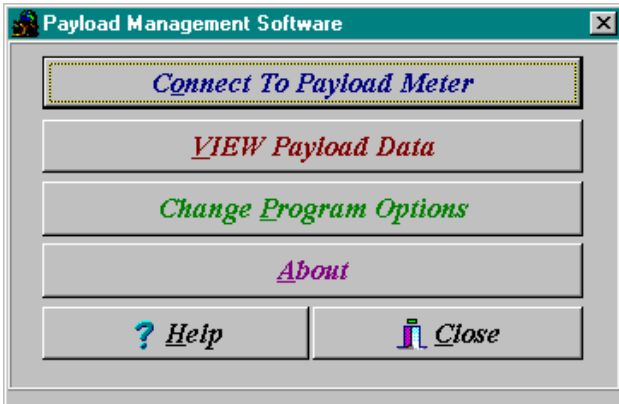

Before connecting to the payload meter, select "Change Program Options".

- Confirm that the program has selected the correct Com Port. Most laptop computers use Comm 1 for serial communications.
- Three options are available for the displaying payload units in the software, reports, and graphs:

Short Tons: Payload is displayed in short tons, distances and speeds will be displayed in miles.

Metric Tons: Payload is displayed in metric tons, distances and speeds are displayed in kilometers.

Long Tons: Payload is displayed in long tons, distances and speeds are displayed in miles.

- Two options are available for displaying time units in the software, reports, and graphs:

Minutes and Seconds:

Five minutes and thirty-two seconds = **5:32**

Decimal Minutes:

Five minutes and thirty-two seconds = **5.53**

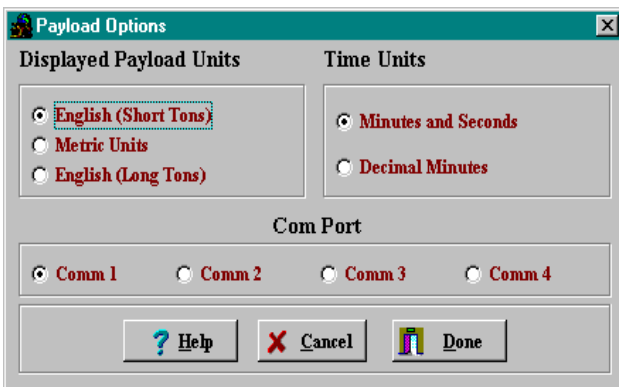

Click "Done" to return to the main menu. From the main menu, select "Connect to Payload Meter". The computer will try to connect to the payload meter and request basic information from the system. In the event of communications trouble, the computer will try three times to connect before "timing out". This may take several seconds.

Connection Menu

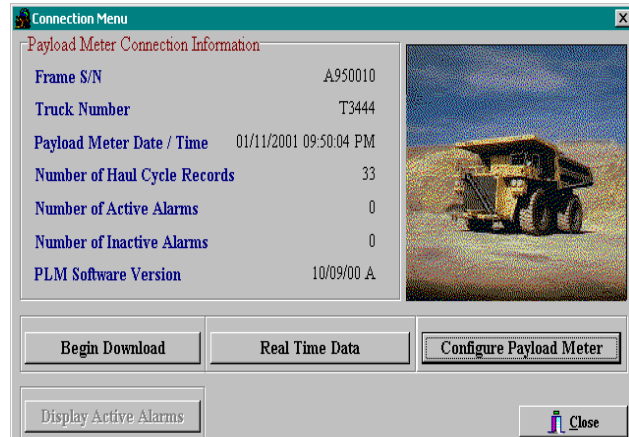

The connection screen displays basic system information to the user.

- **Frame S/N** should be the same as the truck serial number from the serial plate located on the truck frame.
- **Truck Number** is an ID number assigned to the truck by the mine.
- **Payload Meter Date / Time** values come from the payload meter at the moment of connection.
- **Number of Haul Cycle Records** is the number of haul cycles records stored in memory and available for download.
- **Number of Active Alarms** shows how many alarms are currently active in the system at the time of connection. If there are active alarms, the "Display Active Alarms" button is available.
- **Number of Inactive Alarms** shows how many alarms have been recorded in memory and are available for download.
- **PLM Software Version** displays the current version of software in the payload meter.

The information on the connection menu comes from the configuration of the payload system on the truck.

There are also many configuration and download options available from this screen. The Connection Menu is updated only when the connection is first made. It does not update automatically. To view changes made while connected, the user must close the window and reconnect to the payload meter.

The connection menu is displayed after a serial connection has been established and the PDM software has connected to the payload meter.

Connecting to the Payload Meter

Communications to the PLMIII requires a laptop computer running the PDM software. The software connects to the payload meter through the meter's serial port #1. This is the same port used by the speedometer/load display. When the laptop is using the serial port, the lower display on the speedometer/load display will be blank. This does not affect the operation of the speedometer.

Connect the laptop to the system by using the EF9160 communications harness. The download connector is located in the back wall of the operator cab.

Configuring the Payload Meter

Configuration of the payload meter requires a serial connection to the PLMIII system. Clicking the "Configure Payload Meter" button will bring up the Truck Configuration screen and menu. This screen displays the latest configuration information stored on the payload meter.

When changes are made to the configuration, the "Save Changes" button must be pressed to save the changes into the payload meter. To confirm the changes, exit to the main menu and re-connect to the payload meter.

Setting the Date and Time

The time shown on the form is the time transmitted from the payload when the connection was first established.

The date and time are maintained by a special chip on the PLMIII circuit board. The memory for this chip is maintained by a very large capacitor when the power is removed from the payload meter. This will maintain the date and time settings for approximately 30 days. After this time, it is possible for the payload meter to lose the date and time setting. It is recommended that the system be powered every 20 days to maintain the date and time. If the date and time is lost, simply reset the information by using this procedure. It takes approximately 90 minutes to recharge the capacitor.

Changing the date and time will affect the haul cycle in progress and may produce unexpected results in the statistical information for that one haul cycle.

To change the time:

1. Click on the digit that needs to be changed.
2. Use the up/down arrows to change or type in the correct value.
3. Press the "Save Changes" button to save the new time in the payload meter.

To change the date:

1. Click on the digit that needs to be changed.
2. Type in the correct value or use the pull-down calendar to select a date.
3. Press the "Save Changes" button to save the new time in the payload meter.

Setting the Truck Type



1. From the Truck Configuration screen, use the pull-down menu to select the truck type that the payload meter is installed on.
2. Press the "Save Changes" button to program the change into the meter.

Setting the Display Units

The speedometer/load display shows the truck speed on the upper display. The units for the speed display are selected by using a jumper on the rear of the case.

The payload units on the lower display can be changed from metric to short tons or long tons using the Truck Configuration screen. This selection also switches between metric (kg/cm²) and psi (lbs/in²) for the live display of pressures.

1. From the Truck Configuration screen, select the payload units to be used on the lower display of the speedometer/load display.
2. Press the "Save Changes" button to program the change into the payload meter.

Setting the Frame Serial Number

Frame Serial Number	A950010
Truck Number	T3444
KMS Distributor	RMS
KMS Customer	Pit Mine

The frame serial number is located on the plate mounted to the truck frame. The plate is outboard on the lower right rail facing the right front tire. It is very important to enter the correct frame serial number. This number is one of the key fields used within the haul cycle database. The field will hold 20 alpha-numeric characters.

1. On the Truck Configuration screen, enter the truck frame serial number in the appropriate field.
2. Press the "Save Changes" button to program the change into the payload meter.

Setting the Truck Number

Most mining operations assign a number to each piece of equipment for quick identification. This number or name can be entered in the Truck Number field. It is very important to enter a unique truck number for each truck using the PLMIII system. This number is one of the key fields used within the haul cycle database. The field will hold 20 alpha-numeric characters.

1. On the Truck Configuration screen, enter the truck number in the appropriate field.
2. Press the "Save Changes" button to program the change into the payload meter.

Setting the Komatsu Distributor

This field in the haul cycle record can hold the name of the Komatsu distributor that helped install the system. Komatsu also assigns a distributor number to each distributor. This number is used on all warranty claims. This Komatsu distributor number can also be put into this field. The field will hold 20 alpha-numeric characters.

1. On the Truck Configuration screen, enter the distributor name or number in the appropriate field.
2. Press the "Save Changes" button to program the change into the payload meter.

Setting the Komatsu Customer

This field in the haul cycle record can hold the name of the mine or operation where the truck is in service. Komatsu also assigns a customer number to each customer. This number is used on all warranty claims. This Komatsu customer number can also be put into this field. The field will hold 20 alpha-numeric characters.

1. On the Truck Configuration screen, enter the customer name or number in the appropriate field.
2. Press the "Save Changes" button to program the change into the payload meter.

Clean Truck Tare

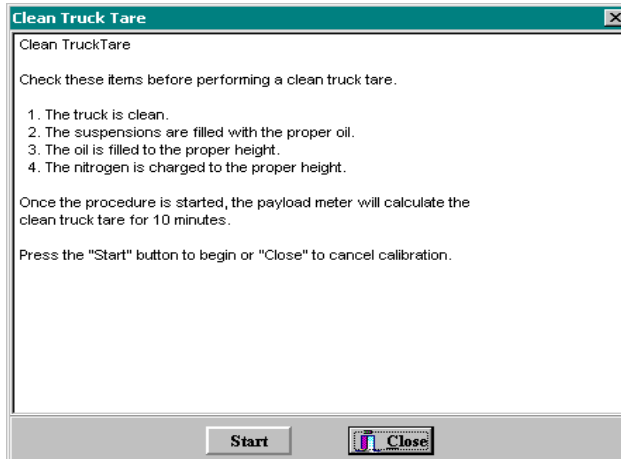

The payload meter uses the clean truck tare value to calculate carry-back load for each haul cycle. The carry-back stored in the haul cycle record is the new empty tare minus the clean truck tare.

This procedure should be performed after service to the suspensions or when significant changes are made to the sprung weight of the truck. Before performing this procedure, make sure that the suspensions are properly filled with oil and charged. It is critical to payload measurement that the proper oil height and gas pressure be used.

Once the clean tare process is started, the payload meter will begin to calculate the clean empty sprung weight of the truck. This calculation continues while the truck drives to the next loading site. Once the procedure is started, there is no reason to continue to monitor the process with the PC. The truck does not need to be moving to start this procedure.

1. After cleaning debris from the truck and checking to see that the suspensions are properly serviced, use the PDM software to connect to the payload meter.
2. From the Truck Configuration screen, select "Clean Truck Tare".
3. Follow the on-screen instructions.

Inclinometer Calibration

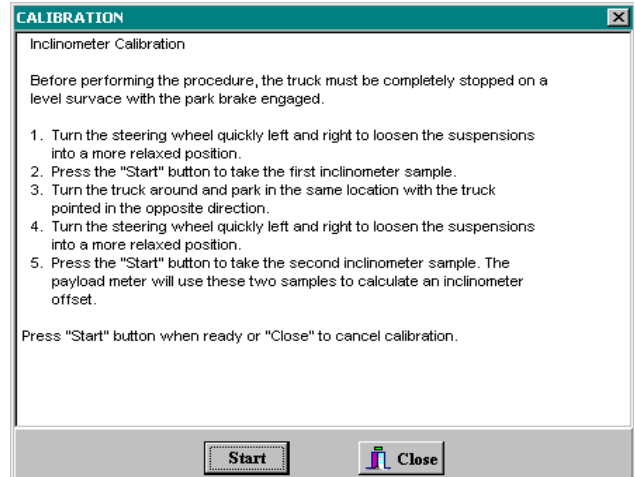

The inclinometer calibration procedure is designed to compensate for variations in the mounting attitude of the inclinometer. The inclinometer input is critical to the payload calculation.

This procedure should be performed on relatively flat ground. The maintenance area is often an ideal location for this procedure.

1. After cleaning debris from the truck and checking to see that the suspensions are properly serviced, use the PDM software to connect to the payload meter.
2. From the Truck Configuration screen, select "Inclinometer".
3. With the truck stopped and the brake lock on, click on "Start". This instructs the payload meter to sample the inclinometer once.
4. Turn the truck around. Drive the truck around and park in the exact same spot as before, facing the other direction.
5. With the truck stopped and the brake lock on, click on "Start". This instructs the payload meter to sample the inclinometer again. The payload meter will average the two samples to determine the average offset.
6. Follow the on-screen instructions.

DATA ANALYSIS

PAYLOAD SUMMARY FORM

Date: Sorts the data within a date range. eg. "Dec 1, 2000 through Dec 31, 2000"

Truck Number: Sorts the data by the truck unit number, eg. "374"

Payload Data Summary: Summary statistical analysis of the payloads from the selected query.

Output Options: Use to create reports, graphs and expert data from the selected query.

Time: Sorts the data within a time for each day within the data range. "8:00 AM to 5:00PM"

Truck Type: Sorts the data by the truck type, eg. "930E" or "830E"

Query Database & Display: Sorts the data by the selected query options (unit, type, date, time) and displays the results.

Cycle Summary: Cycle time summary from the selected query.

Haul Cycle Records: Summary view of the haul cycle records from the selected query. Double Click to view the details for individual haul cycle records. Haul cycles in red area are not included in the summary statistics..

Truck Number	Date	Time	Payload	# Swings	Total Time
351	07/10/2000	8:22:40 AM	323.8	5	7:09
351	07/10/2000	8:36:12 AM	323.8	5	5:23
351	07/10/2000	8:41:35 AM	323.8	5	5:24
351	07/10/2000	8:46:58 AM	321.5	1	30:11
351	07/10/2000	9:17:06 AM	321.9	0	0:32
351	07/10/2000	9:17:37 AM	318.0	0	0:32

The data analysis tools allow the user to monitor the performance of the payload systems across the fleet. Analysis begins when the "View Payload Data" button is selected. This starts an "all trucks, all dates, all times" query of the database and displays the results in the Payload Summary Form.

The user can change the query by changing the dates, times, or trucks to include in the query for display.

Haul cycles in the data grid box at the bottom can be double-clicked to display the detailed results of that haul.

Creating a Query

The program defaults to show all trucks, all types, all dates and all times for the initial query. The display can be narrowed by selecting which trucks or types to view and for what dates and times.

The query items are added in the "AND" condition. If the user selects a truck # and date range, the query will sort the data for that truck number AND the date range.

Sorting on Truck Unit Number

The truck unit number is the truck unit number entered into the payload meter when it was configured at installation. The query can be set to look for all trucks or one particular truck number. When the program begins, it searches through the database for all the unique truck numbers and creates a list to select from.

Choosing one particular truck number will limit the data in the displays, summaries and reports to the one selected truck. To create reports for truck number 374, select "374" from the pull-down menu and click on "Query Database and Display".

Sorting on Truck Type

The truck type is the size of the truck from the family of Komatsu trucks. This allows the user to quickly view results from different models of trucks on the property. For example, separate reports can be generated for 860E and 960E trucks.

Sorting on Date Range

The default query starts in 1995 and runs through the current date on the computer. To narrow the range to a specific date, change the "From" and "To" dates. For example, to view the haul cycle reports from truck 374 for the month of July, 2000:

1. Select "374" from the Truck Unit pull-down menu.

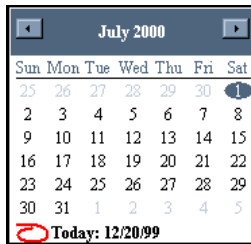

2. Change the "From" date to July 1, 2000.

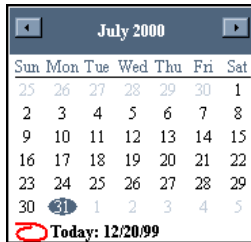

3. Change the "To" date to July 31, 2000.
4. Click on "Query Database and Display" to view the results.

Sorting on Time Range

The time range sorts the times of the day for valid dates. Changing the time range to 6:00AM to 6:00PM will limit the payloads displayed to the loads that occurred between those times for each day of the date range. Times are entered in 24:00 format. To view the haul cycle reports from the first shift for truck 374 from January 5, 2000 to January 8, 2000:

1. Select "374" from the Truck Unit pull-down menu.

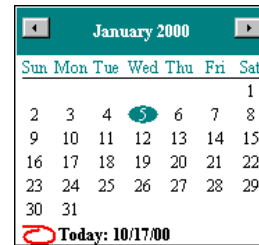

2. Change the "From" date to January 5, 2000.



3. Change the "To" date to January 8, 2000.
4. Change the "From" time to 06:00.
5. Change the "To" time to 18:00.

Daily Shift Time To

6. Click on "Query Database and Display" to view the results.

This query will display haul cycles from January 5 to January 8, from 6:00 AM to 6:00 PM.

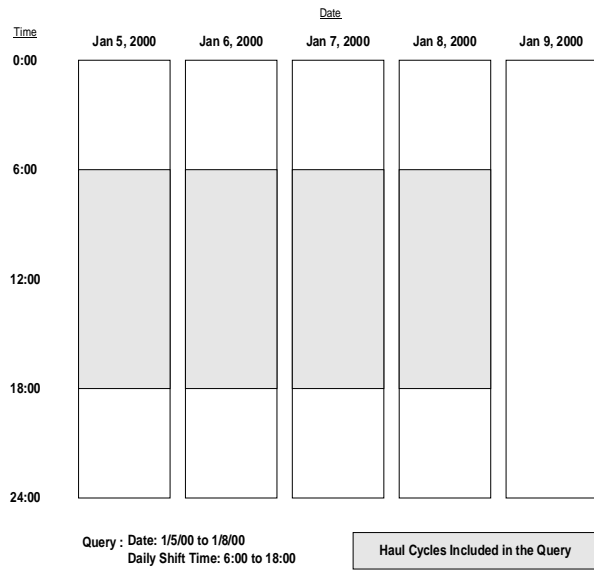

Payload Detail Screen

The Payload Detail screen gives the details for any individual haul cycle. From the Payload Summary screen, double-click on any haul cycle to display the detail.



The selected shift times can extend the query past the original date. If the dates set for the query are January 5 to January 8 and the times were changed to query the 6:00 PM (18:00) to 6:00 AM (06:00) shift, the results would extend into the morning of the 9th. This can be seen in the following example:

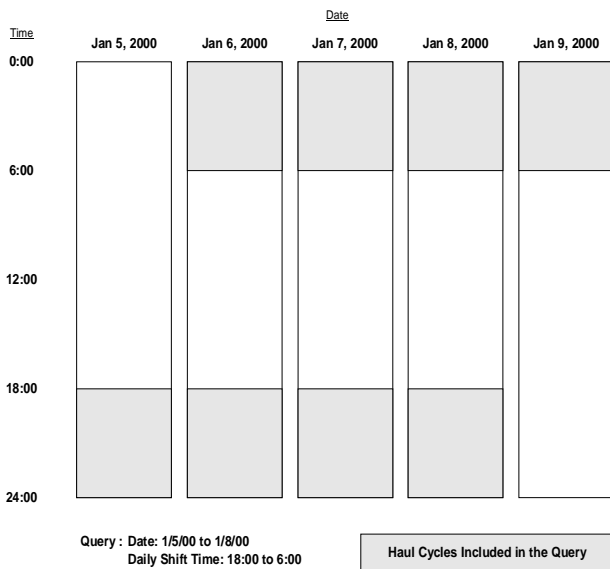

Creating Reports

Reports can be generated and viewed on-screen or printed. These reports are generated from the query displayed on the Payload Summary screen. From the example in **Sorting on Time Range**, the report printed would only contain data from truck 374 during the month of July 2000, from 8:00 AM to 5:00 PM.

It is important to carefully select the query data and click on "Query Database & Display" before printing a report.

NOTE: Some haul cycles may contain the Sensor Input warning flag. This indicates that one of the four pressure sensors or inclinometer was not functioning properly during the haul cycle. Haul cycles with this warning are displayed in red on the Payload Summary window and are not included in the summary statistics for reports or display.

Summary (one-page report): A summary of the queried data can be printed onto one page. The cycle data is summarized onto one sheet. Displayed is the speeds, cycle times, load statistics, frame and tire data.

Detailed (multi-page report): The detailed report starts with the summary report and follows with pages of data for each haul cycle. The detailed report prints date, time, payload, cycle times, and cycle distances, speeds and the number of swing loads.

Payload Summary Report			
Report Date: April 11, 2001			
Query used for summary:			
Truck Number: ALL		Dates: 2/10/00 to 2/19/01	
Truck Type: ALL		Daily Shift Time: 00:00 to 24:00	
			Cycle Distance Averages (miles)
Time Period			Loaded 1.9
Date			Empty 2.0
Time			Avg Total Distance 3.9
First Load	02/10/2000	03:25:30 PM	
Last Load	02/19/2001	07:20:30 AM	
Payload Data			
		Short Tons	Date
Final Payload			Time
Total, All Loads		1,495,086	
Maximum		421	01/24/2001 09:05:22 AM
Minimum		0	01/27/2001 04:11:24 AM
Average		321	
Standard Deviation		28.6	
Payload Estimate @ Shovel			
Total, All Loads		1,532,025	
Maximum		425	01/11/2001 06:45:50 PM
Minimum		250	02/11/2000 06:27:34 AM
Average		320	
Standard Deviation		36.3	
Number of Loads		4,654	
Avg Carry Back		2.2	
Cycle Time Averages (Min:Sec)		Avg Tire (Ton-MPH)	
Load		Left Front 583	
Haul Run		Right Front 576	
Haul Stop		Rear 415	
Empty Run			
Empty Stop			
Dump			
Avg Total Cycle Time			
		Speed Data (mph)	
		Loaded Max 37.32	
		Loaded Avg 10.57	
		Empty Max 37.97	
		Empty Avg 11.43	

Payload Detail Report										Page 1									
Report Date: October 17, 2000																			
Query used for summary:																			
Truck Number: ALL																			
Truck Type: ALL																			
Dates: 8/28/00 to 10/3/00																			
Daily Shift Time: 00:00 to 24:00																			
		CYCLE Times(min:sec)					CYCLE DISTANCE(mi)					SPEEDS(mph)							
No.	Date	Time	Payload S.Tons	#Swings	Load	Haul	Stop	Dump	Return	Return Stop	Total	Haul	Return	Total	Max	Avg	Max	Return	Avg
1	8/28/00	3:54P	347	7	4.40	11:11	0:06	0:52	7:54	14:28	39:11	1.9	2.0	4.0	21.99	10.14	31.03	5.48	
2	8/28/00	5:18P	301	6	3.39	11:10	0:25	0:43	8:12	3:43	27:52	1.9	1.9	3.8	23.02	9.91	26.05	9.42	
3	8/28/00	5:46P	300	6	3.32	11:32	2:32	0:56	7:07	0:09	25:48	1.9	1.9	3.8	23.02	8.30	25.02	15.49	
4	8/28/00	6:11P	330	4	1:58	17:51	2:49	1:58	11:34	1:41	37:51	3.9	2.6	6.5	36.21	11.37	24.07	11.73	
5	8/28/00	6:49P	344	4	1:54	18:26	13:04	1:50	11:20	0:24	46:58	4.0	3.9	7.9	34.97	7.56	37.06	20.15	
6	8/28/00	7:36P	380	5	2:12	19:52	1:07	1:39	11:32	0:48	37:10	4.0	4.0	8.0	30.00	11.28	34.03	19.59	
7	8/28/00	8:13P	352	4	2:26	18:17	0:23	1:54	11:54	1:56	36:50	3.9	4.0	8.0	31.97	12.62	34.07	17.49	
8	8/28/00	8:50P	356	4	1:56	18:52	0:21	1:55	11:59	0:38	35:41	4.0	4.0	8.0	36.17	12.34	36.21	19.09	
9	8/28/00	9:25P	370	5	2:18	16:17	2:18	0:53	12:25	0:25	34:36	2.7	4.1	6.7	34.97	8.55	36.17	19.14	
10	8/28/00	10:00P	363	5	3:07	16:56	5:48	0:52	9:02	0:33	36:18	2.7	2.7	5.3	32.97	6.99	32.97	16.61	
11	8/28/00	10:36P	341	7	3:58	12:23	0:23	0:53	7:26	0:57	26:00	2.0	2.0	3.9	21.03	9.20	32.00	14.10	
12	8/28/00	11:02P	321	4	2:24	16:19	5:06	0:50	10:17	1:05	36:01	2.7	2.6	5.3	34.03	7.49	31.97	13.71	
13	8/28/00	11:38P	316	5	2:49	15:21	7:06	0:58	13:01	13:11	52:26	3.9	4.0	7.9	40.12	10.30	40.12	9.16	
14	8/29/00	12:56A	320	5	2:23	15:18	0:07	0:55	13:16	11:43	43:42	3.9	3.8	7.7	36.21	14.99	41.10	9.18	
15	8/29/00	1:40A	302	4	1:55	14:12	0:08	0:54	10:34	0:11	27:54	3.9	3.9	7.7	40.12	16.15	41.10	21.64	
16	8/29/00	2:08A	310	5	2:21	15:14	4:55	1:01	9:46	4:59	38:16	3.9	3.9	7.7	40.12	11.51	41.16	15.67	
17	8/29/00	2:46A	318	5	2:25	14:44	0:15	0:54	10:36	0:19	29:13	3.9	3.9	7.7	41.10	15.50	41.10	21.28	
18	8/29/00	3:15A	278	4	2:01	15:53	1:12	0:46	10:38	2:08	32:38	4.3	3.8	8.1	38.13	15.06	41.10	18.05	
19	8/29/00	3:48A	328	5	2:25	17:38	3:08	0:57	10:07	0:20	34:35	4.3	3.9	8.2	34.03	12.41	41.10	22.19	
20	8/29/00	4:22A	287	4	2:49	17:00	15:44	1:02	11:59	4:49	53:23	4.3	4.0	8.2	40.12	12.87	41.10	14.09	
21	8/29/00	1:41P	285	4	2:15	16:08	6:14	5:21	9:02	14:43	53:43	4.0	3.0	6.9	34.97	10.58	34.03	7.55	
22	8/29/00	2:50P	340	7	3:38	10:14	0:06	0:54	8:41	7:10	30:43	1.8	3.3	5.2	27.07	10.54	39.07	12.65	
23	8/29/00	3:20P	326	5	3:32	9:47	0:08	1:09	5:21	0:16	20:13	1.8	1.8	3.6	27.05	10.98	30.02	18.98	
24	8/29/00	3:41P	342	6	3:59	11:24	0:08	0:47	19:49	15:18	51:25	1.9	6.2	8.1	23.02	10.02	30.02	10.56	
25	8/29/00	4:43P	349	7	4:46	11:12	0:18	0:57	7:32	3:12	27:57	1.8	1.9	3.8	23.02	9.50	27.07	10.87	
26	8/29/00	5:11P	322	4	2:11	5:29	19:58	1:29	15:38	59:19	104:04	1.1	5.1	6.1	42.20	2.52	42.20	4.05	
27	8/30/00	4:27A	330	7	4:27	10:33	0:09	1:02	21:08	159:27	196:46	1.7	4.3	6.0	23.02	9.69	28.01	1.42	
28	8/30/00	4:55P	320	6	3:52	10:42	0:14	1:00	5:43	1:42	23:13	1.7	1.7	3.4	24.07	9.55	29.06	13.47	
29	8/30/00	5:18P	338	6	3:16	10:45	0:51	0:58	6:00	2:34	24:24	1.7	1.6	3.3	23.02	8.71	29.04	11.36	
30	8/30/00	5:42P	343	6	3:52	10:28	0:08	1:01	6:06	0:25	22:00	1.7	1.6	3.3	24.08	9.57	28.03	14.70	

Creating Graphs

The PDM software can generate graphs that quickly summarize payload data. These graphs can be customized for printing. Just like the reports, the graphs are generated from the query displayed on the "Payload Summary" screen. From the example in **Sorting on Time Range**, the graph that is printed would only contain data from truck 374 during the month of July 2000, from 8:00 AM to 5:00 PM.

It is important to carefully select the query data and click on "Query Database & Display" before printing a graph.

1. Click on the "Graph" button at the bottom of the Payload Summary Screen. The Histogram Setup screen will appear.

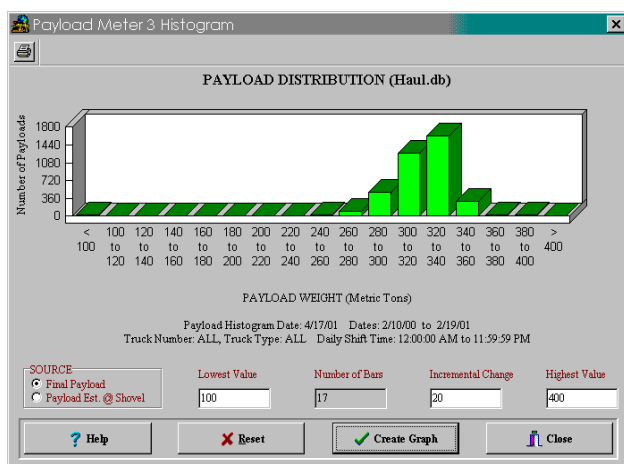

2. Enter the "Lowest Value". This will be the lowest payload on the graph. Any payloads less than this value will be summed in the first bar.
3. Enter the "Highest Value". This will be the highest value on the graph. Payloads over this value will be summed in the last bar.
4. Enter the "Incremental Change". This will determine the number of bars and the distance between them. The program limits the number of bars to 20. This allows graphs to fit on the screen and print onto one page.
5. Click on the "Create Graph" button.

The graph will be displayed based on the query settings from the Payload Summary screen. The graph can be customized and printed.

Exporting Data

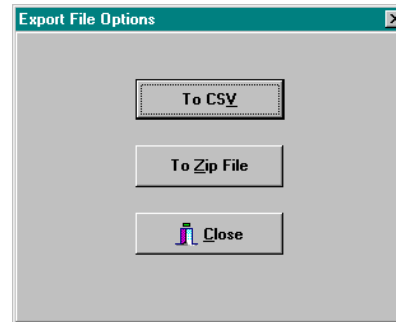

The data from the database can be exported for use with other software applications. The data is selected from the currently displayed query. The exported data can be put into a .CSV file or compressed into a .zip file.

- The .CSV format allows data to be easily imported into spreadsheet applications and word processing applications.
- The .zip format allows data to be transferred from one computer to the PDM software database on another computer. This offers a compact way to transfer data from one computer to another.

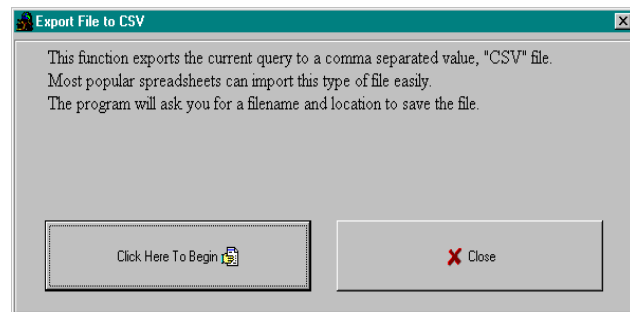

CSV format: CSV stands for *Comma Separated Value*. This is an ASCII text file format that allows spreadsheet applications such as Excel and Lotus 123 to import data easily. To export the data into a .CSV file, click on the "Export" button at the bottom of the Payload Summary screen and select "To CSV". The program will request a filename and location for the file.

Truck#	Date	Time	Payload	Swingloads	Operator ID	Status	Fla	Carry Back	Total Cyc	E-Run	Tim	E-Stop	Tu	Loading
374	2/11/00	4:06:48 PM	294.4	2	0 E			-1.2	2.7	1	0.2	0		
374	2/11/00	4:10:09 PM	298.6	2	0 I			-1.4	7.2	0.6	0.6	0		
374	2/11/00	4:41:01 PM	265.5	3	0			15.6	20.1	4.6	3.9	2		
374	2/11/00	5:24:54 PM	277.5	0	0 AK			0	27	4.6	6.4	1		
374	2/11/00	6:21:27 PM	231	3	0			15.5	27.7	4.5	5	1		
374	2/11/00	7:09:08 PM	265.5	3	0 H			17.1	23.9	4.2	3.2	1		
374	2/11/00	7:59:53 PM	262.4	4	0			14.1	29.7	4.3	3.7	2		
374	2/11/00	8:29:32 PM	225.1	3	0			15.6	27.7	4.5	5	1		
374	2/11/00	8:57:11 PM	265.5	3	0			15.6	20.1	4.6	3.9	2		
374	2/11/00	9:17:13 PM	265.4	3	0 H			17	23.9	4.2	3.1			
374	2/11/00	9:41:05 PM	277.4	0	0 AK			0	27	4.6	6.4	1		

Two sets of data are exported. At the top of the file will be the haul cycle data. The columns, from left to right, are:

- Truck number
- Haul cycle start date
- Haul cycle start time
- Payload
- Swingloads
- Operator ID
- Warning Flags
- Carry Back
- Total Haul Cycle time
- Empty Running Time
- Empty stop time
- Loading time
- Loaded running time
- Loaded stopped time
- Dumping time
- Loading start time
- Dumping start time
- Loaded haul distance
- Empty haul distance
- Loaded maximum speed
- Time when loaded maximum speed occurred
- Empty maximum speed
- Time when loaded maximum speed occurred
- Maximum + frame torque
- Time when the maximum + frame torque occurred
- Maximum - frame torque
- Time when the maximum - frame torque occurred
- Maximum sprung weight calculation
- Time when the maximum sprung weight calculation occurred
- Left Front Tire-kilometer-hour
- Right Front Tire-kilometer-hour
- Average Rear Tire-kilometer-hour
- Frame serial number
- Reserved 1-5, 7-10: These values are internal calculations used in the continued development of PLMIII and should be ignored.
- Reserved 6: This value is the payload estimate at the shovel just before the truck begins to move.

Alarm Type	Date Set	Time Set	Description	Date Cleared	Time Cleared
10	12/5/99	8:51:25 AM	INCL SENSOR LO	12/5/99	8:51:29 AM
10	12/5/99	8:56:07 AM	INCL SENSOR LO	12/5/99	8:56:12 AM
10	12/5/99	9:00:49 AM	INCL SENSOR LO	12/5/99	9:00:54 AM
10	12/5/99	9:05:31 AM	INCL SENSOR LO	12/5/99	9:05:36 AM
10	12/5/99	9:10:13 AM	INCL SENSOR LO	12/5/99	9:10:17 AM
10	12/5/99	9:14:54 AM	INCL SENSOR LO	12/5/99	9:14:59 AM
10	12/5/99	9:19:37 AM	INCL SENSOR LO	12/5/99	9:19:41 AM
10	12/5/99	9:24:19 AM	INCL SENSOR LO	12/5/99	9:24:24 AM
10	12/5/99	9:29:01 AM	INCL SENSOR LO	12/5/99	9:29:06 AM
10	12/5/99	9:33:44 AM	INCL SENSOR LO	12/5/99	9:33:48 AM
10	12/5/99	9:38:26 AM	INCL SENSOR LO	12/5/99	9:38:30 AM
10	12/5/99	9:43:08 AM	INCL SENSOR LO	12/5/99	9:43:13 AM
10	12/5/99	9:47:50 AM	INCL SENSOR LO	12/5/99	9:47:55 AM
10	12/5/99	9:52:32 AM	INCL SENSOR LO	12/5/99	9:52:37 AM
10	12/5/99	9:57:13 AM	INCL SENSOR LO	12/5/99	9:57:17 AM
10	12/5/99	10:01:55 AM	INCL SENSOR LO	12/5/99	10:01:59 AM

The second set of data below the haul cycle data is the alarms. The alarm columns, left to right are:

- The alarm type
- The date the alarm was set
- The time the alarm was set
- Alarm description
- The date the alarm was cleared
- The time the alarm was cleared

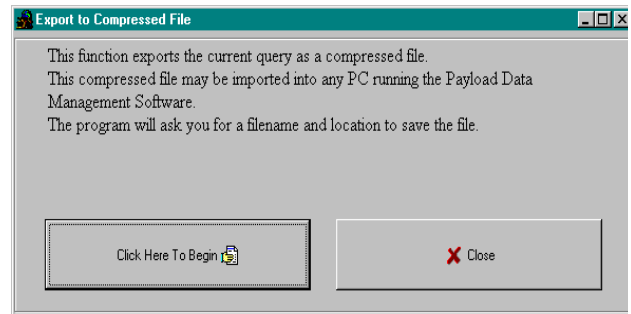

ZIP format: This export function allows the data from one laptop to be transferred to another computer. This can be useful when a service laptop is used to download multiple machines and transfer the data to a central computer for analysis. This can also be used to copy haul data from a particular truck onto a disk for analysis.

The file format is a compressed binary form of the displayed query. The file can only be imported by another computer running the PDM software.

To export data in ZIP format:

1. Confirm that the data displayed is the query data that needs to be exported.
2. From the payload summary screen, press the "EXPORT" button and select "To ZIP".
3. The program will ask for a filename and location.

Importing Data

This import function allows the data from one computer to be transferred to another computer. This can be useful when a service laptop is used to download multiple machines and transfer the data to a central computer for analysis. This can also be used to copy haul data from a particular truck from a disk into a database for analysis.

To import data, click on the "Import" button at the bottom of the Payload Summary screen. The program will ask for a .zip file to import. Locate the file and click on "Open". The program will only import .zip files created by another computer that is running the PDM software.

Deleting Haul Cycle Records

To delete haul cycle records from the main database, click on the "Delete" button at the bottom of the Payload Summary screen. The program will display a summary of the records from the displayed query. To delete a record, select one at a time and click on the "Delete" button. It is recommended that records be exported to a .zip file for archival purposes before deletion. Multiple records may be selected by holding down the Shift key. Clicking on the "Delete All" button will select all the records from the current query and delete them.

NOTE: There is no recovery for records that have been deleted from the main database. It is highly recommended that all records be exported and archived in a compressed file format for future reference before being deleted.

Truck Number	Date	Time	Payload	# Swings	Total Time
374	08/28/2000	3:54:13 PM	346.7	7	39:11
374	08/28/2000	5:18:14 PM	301.5	6	27:52
374	08/28/2000	5:46:04 PM	300.0	6	25:48
374	08/28/2000	6:11:30 PM	330.5	4	37:51
374	08/28/2000	6:49:37 PM	343.7	4	46:58
374	08/28/2000	7:36:31 PM	379.9	5	37:10
374	08/28/2000	8:13:37 PM	351.6	4	36:50
374	08/28/2000	8:50:22 PM	356.3	4	35:41
374	08/28/2000	9:25:59 PM	369.6	5	34:36
374	08/28/2000	10:00:31 PM	362.6	5	36:18
374	08/28/2000	10:36:44 PM	340.5	7	26:00
374	08/28/2000	11:02:42 PM	320.9	4	36:01
374	08/28/2000	11:38:40 PM	316.5	5	52:26
374	08/29/2000	12:56:37 AM	319.7	5	43:42
374	08/29/2000	1:40:16 AM	301.6	4	27:54

Viewing Alarms

From the Payload Summary screen, click on the "Alarms" button to display the alarm screen. The alarms are sorted by the query settings from the Payload Summary screen. Alarms can be displayed as Active or Inactive.

Truck Number	Type	Set Date	Set Time	Description	Cleared Date	Cleared Time
374	13	8/31/00	2:34:48 AM	ALARM BODY UP SWTCH	8/31/00	2:34:52 AM
374	13	9/11/00	2:36:57 PM	ALARM BODY UP SWTCH	9/11/00	2:37:01 PM
374	13	9/11/00	2:45:22 PM	ALARM BODY UP SWTCH	9/11/00	2:45:26 PM
374	13	9/13/00	9:19:43 PM	ALARM BODY UP SWTCH	9/13/00	9:19:48 PM
374	13	9/30/00	2:42:05 AM	ALARM BODY UP SWTCH	9/30/00	2:42:10 AM

Deleting Alarm Records

To delete alarm records from the main database, click on the "Delete" button at the bottom of the Alarm Display screen. The program will display a summary of the alarms from the query. To delete an alarm, select one at a time and click on the "Delete" button. It is recommended that the query data be exported to a .zip file for archival purposes before deletion. Multiple records may be selected by holding down the Shift key. Clicking on the "Delete All" button will select all the alarms from the current query and delete them.

NOTE: There is no recovery for alarms that have been deleted from the main database. It is highly recommended that all records be exported and archived in a compressed file format for future reference before being deleted.

Truck Number	Alarm Type	Set Date	Set Time	Description	Cleared Date	Cleared Time
374	13	8/31/00	2:34:48 AM	ALARM BODY UP SWTCH	8/31/00	2:34:52 AM
374	13	9/11/00	2:36:57 PM	ALARM BODY UP SWTCH	9/11/00	2:37:01 PM
374	13	9/11/00	2:45:22 PM	ALARM BODY UP SWTCH	9/11/00	2:45:26 PM
374	13	9/13/00	9:19:43 PM	ALARM BODY UP SWTCH	9/13/00	9:19:48 PM
374	13	9/30/00	2:42:05 AM	ALARM BODY UP SWTCH	9/30/00	2:42:10 AM

NOTES

NOTES

PORTIONS OF THIS PRODUCT RELATING TO PAYLOAD MEASURING SYSTEMS ARE
MANUFACTURED UNDER LICENSE FROM

L.G. HAGENBUCH holder of
U.S. Patent Numbers 4,831,539 and 4,839,835

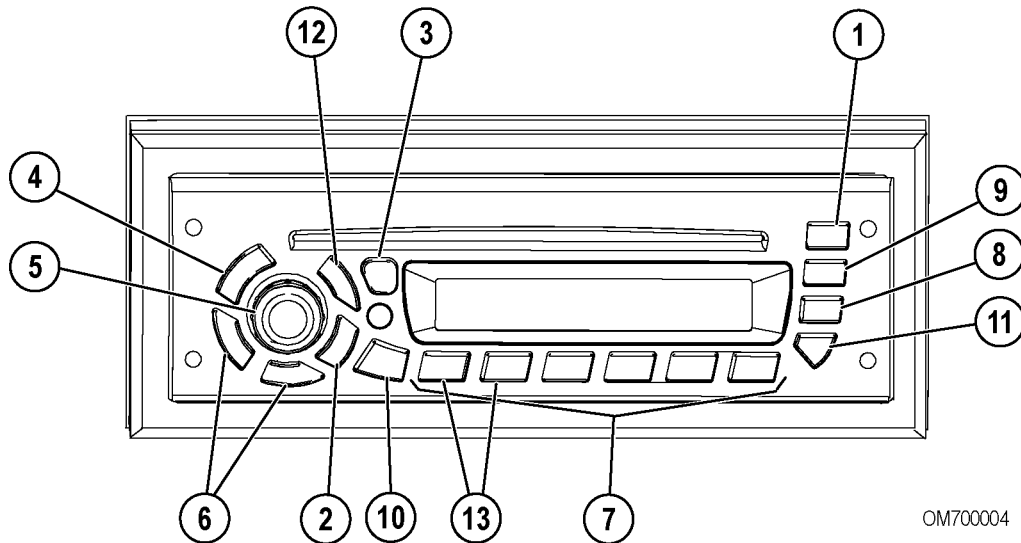
AM/FM RADIO / CD PLAYER

OM700004

FIGURE 70-1. AM/FM RADIO / CD PLAYER

- | | |
|--|--|
| <ol style="list-style-type: none"> 1. Ejects CD 2. BAND Switches between AM, FM1, FM2, FM3, WX (Weatherband) and Auxiliary Mode 3. TMSET/DSPL Switches to time set mode/Changes display 4. PWR Power 5. ON/AUDIO Power/volume/receiver settings 6. +TUNE/SEEK- Changes radio station or CD/MP3 track | <ol style="list-style-type: none"> 7. Push Buttons 1-6 Pre-set stations/CD/MP3 functions 8. PSCN/AUTO Scans presets on current band/stores strongest stations to preset 9. SCAN/DIM Scans all stations in current band or on CD/MP3 10. ALARM Switches to alarm set mode 11. RDM Plays CD/MP3 tracks randomly 12. Switches to CD/MP3 mode 13. FLDR+/- Changers folders on an MP3 disc |
|--|--|

OPERATING INSTRUCTIONS

To learn how to get the most from the receiver, read all of the instructions that follow.

GENERAL RADIO RECEIVER FUNCTIONS

The receiver is equipped with:

- An AM band with 6 AM presets
- Three FM bands for a total 18 FM presets
- One Weatherband with 6 WX presets

Turning On the Power

With the key switch ON, the receiver can be turned on and off by pressing the PWR (4, Figure 70-1) button. Pressing the ON/AUDIO (5) knob also activates the receiver.

One-Hour Timer

With the key switch OFF, pressing the PWR (4) button or the ON/AUDIO (5) knob will turn on the receiver and activate the receiver's one-hour timer. The receiver will turn off after one hour. Pressing the PWR (4) button or the ON/AUDIO (5) knob again reactivates the one-hour timer.

Display

The receiver will display the time of day when it is off. Momentarily pressing the TMSET/DSPL (3) button when the receiver is on allows to toggle between displays.

When the receiver is set to AM, FM1, FM2, FM3 or WX, the display will toggle between the frequency and time of day.

When in the CD mode, the display will toggle between track number and elapsed time, and time of day.

When playing an MP3 disc, the display will toggle between the ID3 tag (song title, artist and album title) and time of day.

Setting a Default Display

1. Press the BAND (2) button to enter the mode to set a default display.
2. Press and hold the TMSET/DSPL button for 2 seconds until the hours digits flash.
3. Press push button (6) until the desired display appears.

After 5 seconds of inactivity, the selected default will be displayed.

Adjusting the Brightness of the Display

If the dash dimmer does not control the brightness of the receiver display or the receiver is operating in One-Hour Timer mode, press and hold the SCAN/DIM (9) button until DIM and the brightness level appear on the display. Rotate the AUDIO knob clockwise to increase the brightness of the receiver display and counter-clockwise to decrease it.

Auxiliary Mode

When in Auxiliary mode, the radio can play an audio source from an iPOD or an MP3 player that is connected via the auxiliary radio lines.

To enable the Auxiliary mode:

- Press and hold the BAND (2) button for at least 2 seconds until the display shows EXTERNAL AUDIO.

To disable Auxiliary mode:

- Press and hold the BAND (2) button for at least 2 seconds until the radio reverts to the previous mode.

Adjusting the Receiver Settings

To adjust the Volume, Bass, Treble, Fade, Balance, Seek Sensitivity and Speakers, press and release the ON/AUDIO (5) knob repeatedly until the desired feature appears on the display.

VOLUME: Rotate the AUDIO knob clockwise to increase the volume and counter-clockwise to decrease it. The display will show VOL and the volume level.

BASS: Press the AUDIO knob until BASS and the current setting appears on the display. Rotate the knob clockwise to increase the bass sound and counter-clockwise to decrease it.

TREBLE: Press the AUDIO knob until TREBLE and the current setting appears. Rotate the knob clockwise to increase the treble sounds and counter-clockwise to decrease it.

FADE: Press the AUDIO knob until FADE and the current setting appears on the display. Rotate the knob clockwise to move the sound to the front speakers and counter-clockwise to move the sound to the rear.

BALANCE: Press the AUDIO knob until BALANCE and the level appear. Rotate the knob clockwise to move the sound to the right speakers and counter-clockwise to move the sound to the left.

SEEK SENSITIVITY: To adjust seek sensitivity, press the AUDIO knob until SEEK and the sensitivity level appear. Rotate the AUDIO knob to the desired setting. Increasing the sensitivity will help find more stations, including slightly weaker ones, while decreasing it will cause fewer, but stronger stations to be found.

SPEAKERS: Press the AUDIO knob until SPKR 4 appears on the display; rotate the knob to switch to 2-speaker functionality. SPKR 2 will appear on the display.

After 5 seconds of inactivity, the receiver will return to the default display.

USING THE CLOCK

The clock can function in a 12 or 24-hour mode. The 12-hour mode distinguishes between AM and PM. The 24-hour mode operates as military time. To toggle between the two modes:

1. Turn the key switch ON.
2. Press and hold the TMSET/ DSPL button for 2 seconds until the digits flash. This indicates you are in the time set mode.
3. Press and release push-button 5 to toggle between 12-hour and 24-hour modes.

After 5 seconds of inactivity, the display will return to the default display, and the current mode will be set.

Setting the Clock

1. Turn the key switch ON.
2. Press and hold the TMSET/DSPL button until the hours digits flash.
3. Press the +TUNE/SEEK- (6) to set the correct hour.
4. Press the TMSET/DSPL button again, and the minutes digits will flash.
5. Press the +TUNE/SEEK- (6) button to set the correct minute. Seconds are reset to zero when the minutes setting is changed.

After 5 seconds of inactivity, the display will return to the default display and the clock will be set.

USING THE ALARM

Momentarily pressing the ALARM (10) button will display the alarm set time.

When the ALARM icon is on the display, the alarm has been set. If the radio is on when the alarm sounds, there will be a beeping noise. If the receiver is off, the alarm will turn on and play the radio at the alarm volume. The alarm will continue to sound until the snooze is activated or the alarm is turned off.

Setting the Alarm

1. Press and hold the ALARM (10) button for 2 seconds until the ALARM icon and the display show AL TIME plus the current alarm time. This indicates the alarm-setting mode.
2. Press and release the +TUNE/SEEK- (6) until the desired alarm hour appears on the display.
3. Press the ALARM (10) button again to select the minutes display.
4. Press the +TUNE/SEEK- (6) until the desired alarm minutes appear on the display.

After 5 seconds of inactivity, the receiver will return to the default display, and the ALARM icon will remain illuminated indicating the alarm is set.

Turning the Alarm Off

Press and hold the ALARM (10) button until the display shows ALARM DISABLED and the ALARM icon on the display disappears.

Activating Snooze

Press any button on the radio faceplate when the alarm is sounding. The alarm will sound again in 9 minutes.

Setting Alarm Volume

1. Turn the receiver on.
2. Press and hold the ALARM button for 2 seconds until the ALARM icon and the display shows AL TIME plus the current alarm time. Rotate the AUDIO knob to increase or decrease the alarm volume as desired.

After 5 seconds of inactivity, the receiver will return to the default display and the volume level at which the receiver was previously playing.

NOTE: The alarm will be activated unless the ALARM button is held for 2 seconds again.

USING THE RADIO

Finding a Station

BAND (2): Press this button to switch between AM, FM1, FM2, FM3, and Weather (WX). The receiver display will show your selection.

+TUNE/SEEK- (6): Press and hold both +TUNE and BAND (2) for 2 seconds to switch between manual tune and seek modes. The display will show either MANUAL or SEEK to indicate the mode.

MANUAL TUNE: Press the +TUNE/SEEK- (6) button once to tune to the next higher or lower station, one frequency at a time. Holding +TUNE/SEEK- for more than half a second begins fast tuning.

SEEK: Press the +TUNE/SEEK- (6) button once to tune to the next higher or lower station. Holding +TUNE/SEEK- for more than half a second activates the Seek function, and SEEK will appear on the display. When a station with a strong enough signal is found, Seek will stop and the station will play. If a station is not found with a strong enough signal after searching the band twice, the Seek function will end and NO STATION FOUND will appear for 5 seconds. Then, the default display will appear and the radio will continue to play. Seek can be cancelled by pressing +TUNE/SEEK- again.

AUDIO STORE (AUTO): AUTO automatically stores the 6 strongest stations onto pushbuttons 1-6. Press and hold PSCN/AUTO (8) until AUTO and the AS icon appear on the display. AUTO STORE only saves presets in the band to which you are listening. If you press AUTO while listening to FM1, the presets on AM, FM2, FM3 and WX will not change. Pressing and holding AUTO again for more than 2 seconds will cancel Auto Store, and the original presets will be restored.

SCAN: Press SCAN/DIM (9) to scan all stations on the current band. When a frequency of sufficient strength is found, the radio will play for 5 seconds and then continue scanning until you press SCAN again. The display will show SCAN and the frequency being scanned.

PSCN: Press PSCN/AUTO (8) to scan the presets on the band the radio is currently playing (FM will scan FM1, FM2 and FM3). When a preset frequency of sufficient strength is found, the radio will play for 5 seconds and then continue scanning. The display will show PSCN, the frequency, preset number and the band icon. Preset Scan will continue until the PSCN is pressed again.

Setting the Presets

The six numbered pushbuttons allow to preset 6 favorite stations per band and easily return to them with the touch of a button. To set the presets:

1. Turn the key switch and the receiver ON.
2. Select the band.
3. Tune to the desired station.
4. Press and hold one of the six numbered buttons for more than 2 seconds to store the selected station. During the 2-second set time, the radio will be muted and the number icon will not be visible. Both the audio and selected preset icon will return, indicating the station has been set.
5. Repeat steps 1-4 for each push-button.

Pressing a preset button in the future will tune the radio to the station you set on the band to which you are listening.

USING THE WEATHERBAND

NOAA Weather Radio is a service of the National Weather Service. It provides continuous broadcasts of the latest weather information directly from the National Weather Service offices. Taped weather messages are repeated every four to six minutes and are revised every one to three hours or more frequently if needed. Most of the stations operate 24 hours a day.

The weather for the local area can be found on one of 7 stations. When in the Weatherband mode, the display will show the WX icon and CH plus the channel number. The channel can be changed using the +TUNE/SEEK- (6) button and can also be preset to the pushbuttons.

The frequencies associated with each channel are as follows:

1. 162.550 MHz
2. 162.400 MHz
3. 162.475 MHz
4. 162.425 MHz
5. 162.450 MHz
6. 162.500 MHz
7. 162.525 MHz

The National Weather Service operates approximately 372 stations. Close to 90 percent of the nation's population is within listening range of an NOAA Weather Radio broadcast.

USING THE COMPACT DISC PLAYER

The integral CD player plays full size CDs and MP3 discs. Press the to switch to CD/MP3 mode.

Playing a Compact Disc

1. Turn the key switch and the receiver on.
2. Insert a disc partway into the slot, label-side up. The player will automatically pull the disc in once it has been partially inserted. The CD icon and the words READING DISC will appear, and the disc will begin to play.
3. If the radio is currently tuned to AM/FM/WX press the CD button to play a CD that has been loaded into the player. If no CD has been loaded, the display will show NO CD for 5 seconds and return to the default display. If a CD has been loaded, the display will show the track number and the elapsed time on the display

If a CD is ejected and not removed within 25 seconds, the CD will be reloaded, but will not start playing until the CD button is pressed.

A CD can be inserted while the key switch is OFF. To do so, press and insert a CD within 25 seconds.

Button Functions

+TUNE: Press + TUNE once to forward to the next track. The track number and elapsed time will appear. Press and hold + TUNE to advance tracks quickly.

SEEK-: Press SEEK- once to return to the beginning of the track being played. Pressing this button during the first 8 seconds of the track will play the previous track. The track number and elapsed time will appear. Press and hold SEEK- to fast reverse.

3/PAUSE: Press PAUSE to pause a CD. PAUSE will be displayed, and the audio will be muted. Press PAUSE again to resume playing the CD.

4/REV: Press and hold REV to fast reverse. Upon release, the CD will play at normal speed. The display will show the track number and elapsed time. After 5 seconds, the default display will reappear.

5/FF: Press and hold FF to fast-forward. Upon release, the CD will play at normal speed. The display will show the track number and elapsed time. After 5 seconds the default display will reappear.

6/RPT: Press RPT to repeat the current track. RPT on the display indicates that this feature is on. The track will be repeated until RPT is pressed again.

EJECT: Press to eject a CD.

RDM (11): Press RDM (11) to activate random track selection. RDM will appear on the display, and tracks on loaded CDs will play in random order. Press the RDM (11) button again to turn off "random play" beginning with the next track.

SCAN/DIM (9): Press SCAN to scan all tracks on the CD. The player will immediately advance to the next track on the CD being played. SCAN and the track number will appear on the display and 10 seconds of the track will play. Then, the CD will advance to the next track, play 10 seconds and continue. To deactivate, press SCAN again.

PLAYING AN MP3 DISC

MP3 Format Compatibility

This MP3 player will play MP3 files recorded on a CD-R up to 700 MB. Files can be recorded at a variable bit rate or the following fixed-bit rates: 32 kpbs, 40 kpbs, 56 kpbs, 64 kpbs, 80 kpbs, 96 kpbs, 112 kpbs, 128 kpbs, 160 kpbs, 192 kpbs, 224 kpbs, 256 kpbs and 320 kpbs. Both single and multi-session discs will play. Song title, artist name and album are available when discs are recorded using ID3 tags versions 1 and 2.

The MP3 player will be able to read and play a maximum of 95 folders, 50 play lists or 20 sessions and 949 files. Long file, folder or playlists names or a combination of a large number of them can reduce the number files, folders, playlists, or sessions that can be played. To play large numbers of files, folders, playlists or sessions, minimize the length of the file, folder or play list name. It can also play an MP3 recorded without file folders. The system can support up to 11 levels of folder nesting. If a disc contains more than the maximum of 95 folders, 50 playlists, 20 sessions and 949 files, the player will only access and navigate the maximum and ignore additional items.

Root Directory

The root directory is treated as a folder. If the root directory has compressed audio files, the directory is displayed as F1 ROOT. All files contained directly under the root directory are accessed prior to any root directory folders. However, playlists (Px) are always accessed before root folders or files.

Empty Directory or Folder

If there is a root directory or a folder in the file structure that contains empty folders/subfolders, play advances to the next folder in the file structure that contains compressed audio files. The empty folder will not be displayed or numbered.

No Folder

When a disc contains only compressed files, the files are located under the root folder. The next and previous folder functions have no function on a CD recorded without folders or play lists. When displaying the name of the folder, the radio displays ROOT.

When the CD contains only playlist and compressed audio files, but no folders, all files are located under the root folder. The "folder down" and "folder up" buttons search play lists (Px) first and then the root folder. When the radio displays the name of the folder, the radio displays ROOT.

File Name Display

A song name is displayed when contained in the ID3 tag. If the song name is not in the ID3 tag, the radio displays the file name without the extension (such as.mp3) as the track name.

Track names longer than 16 characters scroll at a rate of one page every 1.5 seconds until the entire name is shown. To speed up page changes, press the TMSET/DSPL button. When all pages have been shown once, the first page of the ID3 tag appears and remains on the display. To restart automatic paging, press TMSET/DSPL.

Pre-Programmed Playlists

Pre-programmed playlist function like folders containing compressed audio song files. This radio plays pls, m3u, and rmp playlist formats. The pre-programmed play lists can not be edited.

Playing MP3 Files

Insert a disc partway into the slot, label side up. The player will pull it in, and READING DISC will appear on the display. The CD will begin playing, and the CD icon will appear on the display.

Play begins from the first track in the first playlist and continues sequentially through all tracks in each playlist. When the last track of the last playlist has been played, play continues from the first track of the first folder's playlist until FLDR +/- (13) is pressed. When play enters a new folder, the display will show the new folder name for 5 seconds then revert to the default display.

If the CD does not contain any playlists, play begins from the first track under the root directory. When all tracks from the root directory have been played, play continues by the numerical file listing. After playing the last track from the last folder, play begins again at the first track of the first playlist, folder or root directory.

If the songs on a playlist cannot be accessed, the radio ignores it and treats the disc as if it only has folders and tracks. If the disc contains multiple sessions and the table of contents cannot be accessed for all sessions, the radio plays the sessions with an available table of contents.

Button Functions

1/FLD (NEXT FOLDER): Press this button to go to the first track in the next folder or playlist. Pressing this button while in folder random mode will move to the first track in the next folder and play the tracks in that folder randomly.

2/FLD (PREVIOUS FOLDER): Press this button to go to the first track in the previous folder or playlist. Pressing this button while in folder random mode will move to the first track in the previous folder and play the tracks in that folder randomly.

3/PAUSE: Press this button to pause playback. PAUSE will be displayed. Press PAUSE again to resume playing the disc.

4/REV (REVERSE): Press and hold REV to fast-reverse. Upon release, the CD will play at normal speed. The display will show the track number and elapsed time. After 5 seconds, the default display will appear.

5/FF (FAST FORWARD): Press and hold FF to fast-forward. Upon release, the CD will play at normal speed. The display will show the track number and elapsed time. After 5 seconds, the default display will appear.

6/RPT: Press RPT to repeat the current track. The RPT icon on the display indicates the feature is on. The track will be repeated until RPT is pressed again.

RDM (RANDOM): Press and release this button to play the tracks in the current folder or playlist in random order. RDM will appear on the display. Once all tracks in the current folder or playlist have been played, the system will move to the next folder or playlist and play the tracks in random order. When random is activated, pressing TUNE + or SEEK - will move to the next or previous random track. Pressing RDM (11) again cancels random play.

+ TUNE: Press + TUNE once to forward to the next track. The track number and elapsed time will appear. Press and hold + TUNE to advance tracks quickly.

SEEK -: Press SEEK- once to return to the beginning of the track being played. Pressing this button during the first 8 seconds of the track will play the previous track. The track number and elapsed time will appear. Press and hold SEEK- to fast reverse.

DSPL/TM SET: Pressing this button toggles between the ID3 tag (song title, artist and album title) and time of day. There are 3 display types that can be set as default: track, folder/playlist, and time of day. The default display is track.

To display the folder/playlist or time of day, follow the instructions in the Setting a Default Display section.

- Track mode displays the current track number and ID3 tag song title.
- Folder/playlist mode displays the current folder or playlist number and name plus the ID3 tag song title.
- Time-of-day mode displays the time of day and the ID3 tag song title.

TROUBLESHOOTING

The following error messages may appear while playing a CD or MP3 disc:

- NO CD:** No CD has been loaded in the player.
- FOCUS:** Lens could not focus on CD. Possible reasons include: Disc is inserted upside down - eject and reinsert CD. Disc is dirty, scratched, or wet - try cleaning CD. Lens is dirty - clean CD lens with a lens cleaner. It is very humid - wait an hour and try again.
- TRACKING:** Loss of tracking control. Possible reasons include: Disc is dirty or scratched - try cleaning CD. Lens is dirty - clean CD lens with a lens cleaner.
- LOAD:** Load/unload motor problem - contact dealer.

NOTE: The sound quality, an increase in skipping, difficulty in finding tracks, and/or difficulty in loading/ejecting a CD-R may be affected by a CD-R's quality, the method of recording, the quality of the music that has been recorded, or the way the CD-R has been handled. If these problems occur, try a known good CD. If any error occurs repeatedly or if an error cannot be corrected, contact the local dealer. If the radio displays an error message, write it down and provide it to your dealer when reporting the problem.

KOMATSU®

www.komatsuamerica.com