

Field Assembly Manual

WA800-3LC

WHEEL LOADER

SERIAL NUMBERS **WA800-3LC** - **A50001** and UP

This material is proprietary to Komatsu Mining Systems and is not to be reproduced, used, or disclosed except in accordance with written authorization from Komatsu Mining Systems.

It is our policy to improve our products whenever it is possible and practical to do so. We reserve the right to make changes or add improvements at any time without incurring any obligation to install such changes on products sold previously.

Due to this continuous program of research and development, periodic revisions may be made to this publication. It is recommended that customers contact their distributor for information on the latest revision.

TABLE OF CONTENTS

TABLE OF CONTENTS	2
CHART OF SEPERATED UNITS	4
DIMENSIONS AND WEIGHTS OF SEPARATED UNITS	5
TRANSPORTATION BY LAND	6
SPECIFICATIONS.....	6
WHEN TRAVELING UNDER OWN POWER	6
TRANSPORTATION BY TRAILER	6
TRAILERS REQUIRED TO MOVE MACHINE	7
SERVICE REFILL CAPACITIES	7
ORDER, FACILITIES AND SCHEDULE FOR ASSEMBLY.....	8
WORK SPACE LAYOUT DIAGRAM	10
TOOLS AND EQUIPMENT REQUIRED.....	11
TOOLS REQUIRED	11
EQUIPMENT REQUIRED	12
LIFTING TOOLS REQUIRED	13
OIL, GREASE, FUEL, PAINT, ETC.....	15
PROTECTIVE WEAR.....	16
LOCAL MANUFACTURING DIAGRAM FOR TOOLS	16
PROCEDURE FOR FIELD ASSEMBLY	20
A-1 SETTING BARE MACHINE ON SUPPORTS	20
A-2 ASSEMBLY OF REAR AXLE	23
A-3 ASSEMBLY OF FRONT AND REAR DRIVE SHAFTS.....	28
A-4 INSTALLATION OF FRONT AXLE	30
A-5 ASSEMBLY OF FUEL TANK.....	35
A-6 ASSEMBLY OF LADDER (LEFT/RIGHT)	43
A-7 ASSEMBLY OF CAB.....	44
A-8 ASSEMBLY OF HAND RAIL.....	47
A-9 ASSEMBLY OF REAR TIRE AND WHEEL ASSEMBLIES	48
A-10 ASSEMBLY OF BATTERY BOXES	50
A-11 ASSEMBLY OF COUNTERWEIGHT	55
A-12 ASSEMBLY OF EXHAUST PIPE.....	57
A-13 ASSEMBLY OF HANDRAILS AND REAR ACCESS STEPS	59

A-14 ASSEMBLY OF BOOM..... 67

A-15 ASSEMBLY OF FRONT FENDERS..... 73

A-16 ASSEMBLY OF FRONT LAMP ASSEMBLIES 75

A-17 ASSEMBLY OF ROPS CANOPY 76

A-18 ASSEMBLY OF BUCKET..... 81

A-19 ASSEMBLY OF FLOOR MAT 86

PROCEDURE FOR TESTING ASSEMBLY 87

M-1 BLEEDING AIR FROM WHEEL BRAKE CIRCUIT 87

M-2 GREASING WORK EQUIPMENT AND CHASSIS 90

M-3 ADJUSTING BUCKET POSITIONER..... 90

M-4 ADJUSTING BOOM KICK-OUT..... 92

M-5 PROCEDURE FOR STARTING ENGINE 93

M-6 INSPECTION OF ALL PARTS..... 93

M-7 PROCEDURE FOR BLEEDING AIR FROM PISTON PUMP 94

M-8 BLEEDING AIR FROM WORK EQUIPMENT CIRCUIT 95

INSPECTION REPORT..... 96

CHART OF SEPERATED UNITS

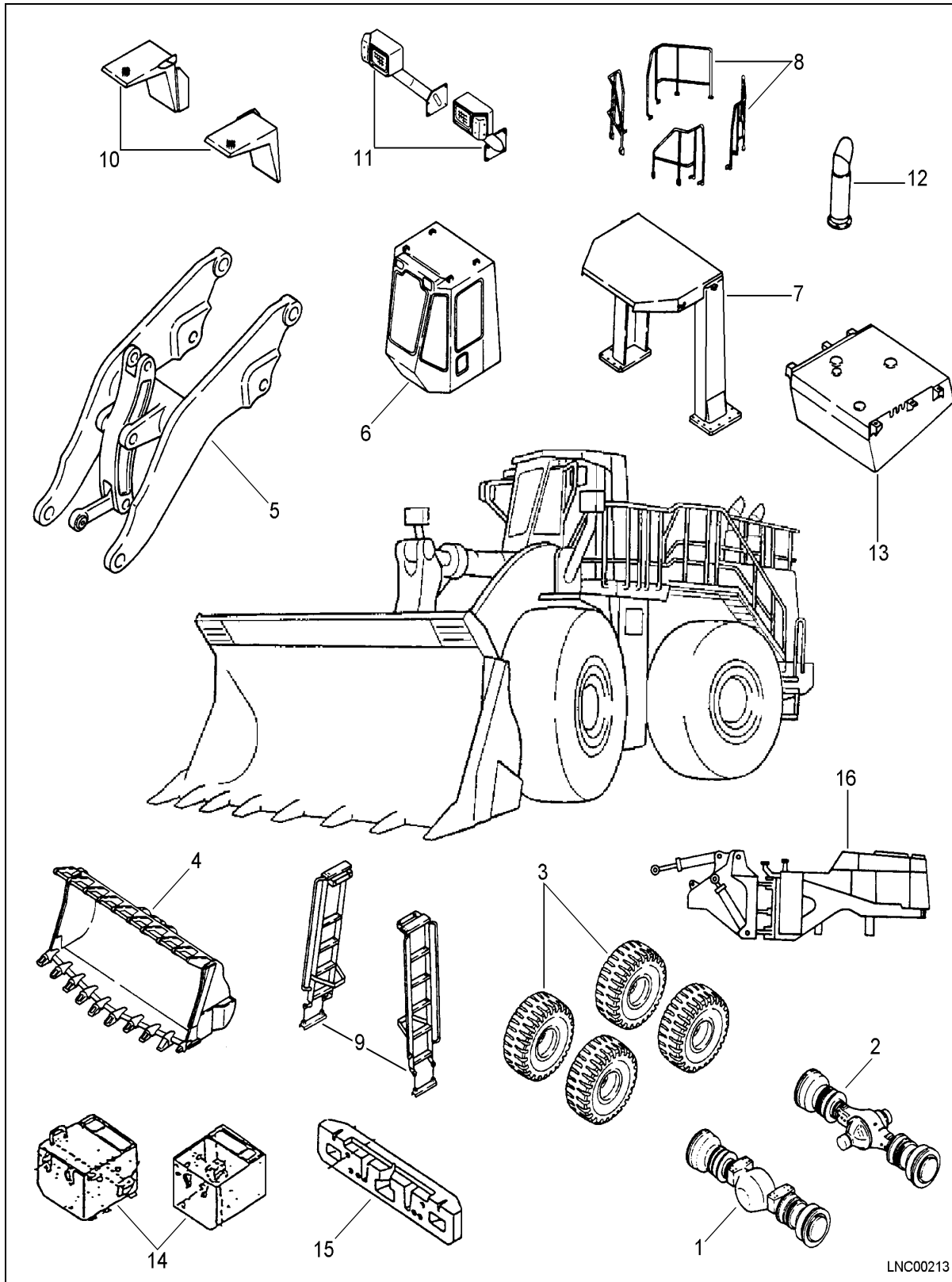

DIMENSIONS AND WEIGHTS OF SEPARATED UNITS

No.	Unit	Dimensions			
		Weight kg / (lbs)	Length mm / (Inch)	Width mm / (Inch)	Height mm / (Inch)
1	Front Axle Assembly	8200 (18,078)			
2	Rear Axle Assembly (axle support)	7990 (17,615) 300 (662)			
3	Wheel and Tire Assembly (each)	13920 (30,688) 3480 (7,672)			
4	Bucket Assembly	10,970 (24,184)			
5	Boom Assembly	9470 (20,878)			
6	Floor and Cab Assembly	760 (1,676)			
7	ROPS Canopy Assembly	1350 (2,976)			
8	Floor Hand Rail Assembly and rear access step	650 (1,433)			
9	Ladder Assembly	60 (132)			
10	Front Fender (each)	170 (375)			
11	Front Lamp Assembly (each)	65 (143)			
12	Muffler Stack	50 (110)			
13	Fuel Tank Assembly	790 (1,742)			
14	Battery Box Assembly	580 (1,279)			
15	Counterweight	2900 (6,394)			
16	Bare Machine	38435 (84,735)	10435 (411)	3260 (128)	3180 (125)
Total		99480 (219,316)			

TRANSPORTATION BY LAND

SPECIFICATIONS

Specifications	Related values			
	Weight	Overall length	Overall width	Overall height
When traveling under own power	101,130 kg (222,955 lbs) (Operating weight)	14,325 mm (47' 0")	4,815 mm (15' 10") (Bucket width)	5,275 mm (17' 4") (Top of ROPS)
Transportation by trailer (see note 1 and 2)	(Bare machine)	9,900 mm (32' 5")	3,200 mm (10' 5")	3,300 mm (10' 9")
Traveling under own power	Less than 20 tons	More than 12 m (39' 4")	Less than 2.5 m (8' 2")	Less than 3.8 m (12' 5")
Traveling by trailer	Maximum payload	Machine length x 1.1	Trailer width	Less than 3.8 m (12' 5")

WHEN TRAVELING UNDER OWN POWER

- JIS posture for traveling under own power (with teeth).

A	Overall length	14,085 mm (46' 3")
B	Overall height (with ROPS)	5,275 mm (17' 4")

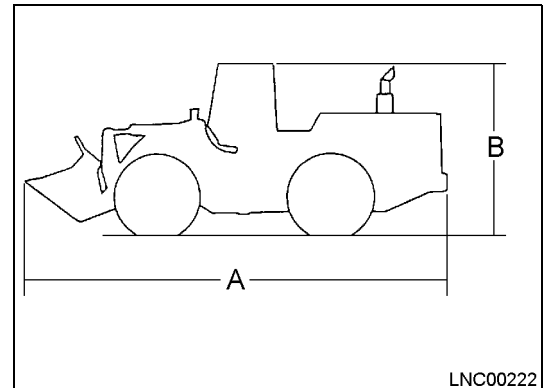

TRANSPORTATION BY TRAILER

- Posture of load when transporting by trailer.

C	Length of bare machine.	10,450 mm (34' 3")
D	Height from ground to top of machine.	4,000 mm (13' 2")
E	Height from ground to top of platform.	500 mm (1' 7")
F	Height from bottom of front frame to top of front frame.	3,180 mm (10' 4")

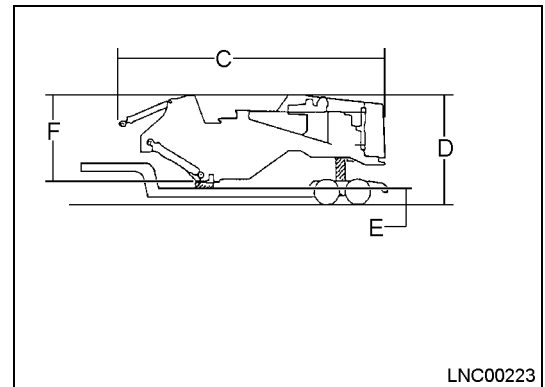

2. Trailer dimensions (36 ton, low platform type).

G	Overall length	11,900 mm (39' 1")
H	Length of platform	6,300 mm (20' 7")
J	Length of gooseneck	2,500 mm (8' 2")
K	Height from ground to top of gooseneck	1,500 mm (4' 9")
L	Height from ground to top of platform.	500 mm (1' 7")
-	Width of platform.	3,200 mm (10' 5")
-	Maximum payload.	36 ton

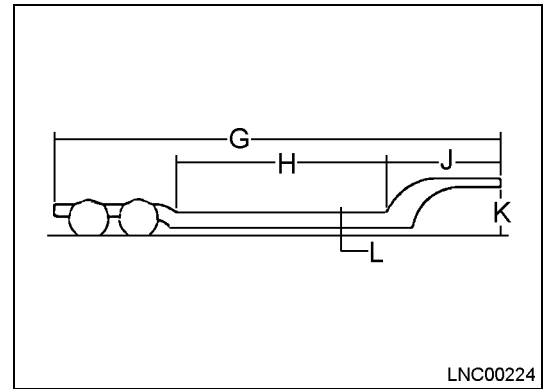





TRAILERS REQUIRED TO MOVE MACHINE

Trailer Size	Qty.	Remarks
36 ton	1	For machine body excluding removed parts.
15 ton	4	For bucket, loader link, front axle, rear axle (including swivel support), tire and wheel assemblies, cab and operator's compartment, bodywork (hood, grille, fender, ladder, platforms, handrails, light supports), counterweight, fuel tank (including fuel), exhaust pipe.

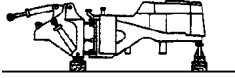
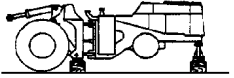
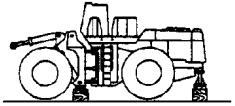
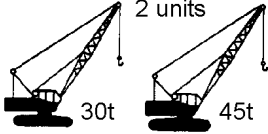

SERVICE REFILL CAPACITIES

Cooling system	319 liters (79.5 U.S. gal)
Fuel Tank	1,425 liters (376.5 U.S. gal)
Engine Oil	132 liters (34.9 U.S. gal)
Hydraulic system	725 liters (191.5 U.S. gal)
Axle (each front and rear)	360 liters (95.1 U.S. gal)
Torque Converter and Transmission	140 liters (37.0 U.S. gal)
Brake Oil	31 liters (8.2 U.S. gal)

ORDER, FACILITIES AND SCHEDULE FOR ASSEMBLY

Day Time (hrs)	1st day								
	1	2	3	4	5	6	7	8	9
Assembly unit	 1. Set chassis on supports			 1. Rear axle assembly 2. Front axle assembly 3. Front wheel and tire assembly 4. Front and rear drive shafts			 1. Fuel tank assembly 2. Ladder assembly 3. Floor and cab assembly 4. Floor handle assembly 5. Rear wheel and tire assembly		
Assembly number and maintenance number (adjustment)	A-1			A-2 thru A-4			A-5 thru A-9		
Crane (hydraulic type with operator)	 2 units 30t 45t								
Air compressor Komatsu EC35ZS or equivalent	37 m ³ /min. (1307 ft ³ /min.) 								
Number of workers	 5 persons								
Forklift truck (operator included in number of workers above)	 2t			(Previous experience has shown that using a forklift is more efficient, Komatsu strongly recommends use of forklift)					
Remarks	Meeting before starting operation, unloading parts, start of assembly.								

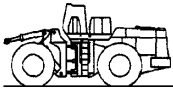
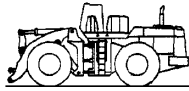
LNC00214

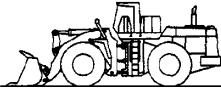
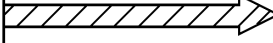
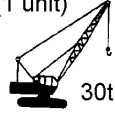
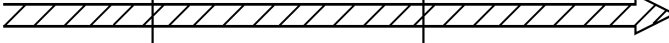
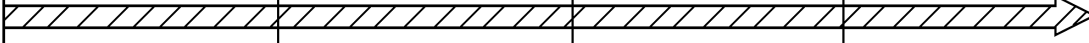
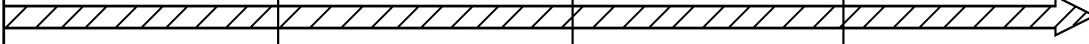
2nd day					3rd day												
10	11	12	13	14	15	16	17	18	19	20	21	22	23				
 <p>1. Battery and countweight assemblies</p> <ul style="list-style-type: none"> ★ Bleed air from brake lines ★ Tighten wheel mounting nuts to specified torque 					 <p>1. Muffler stack 2. Lift arm assembly</p> <ul style="list-style-type: none"> ★ Check oil and coolant levels, add if necessary ★ Start engine ★ Grease chassis and work equipment ★ Charge A/C with R134-a freon 					 <p>1. Front fenders 2. Front lamp assemblies 3. ROPS canopy assembly</p>				 <p>1. Bucket assembly</p> <ul style="list-style-type: none"> ★ Adjust bucket positioner and boom kick-out ★ Check for oil leakage 			
A-10, A-11, M-1 (A-9)					A-12 thru A-14 M-2, M-6 thru M-9					A-15 thru A-17				A-18 M-3 thru M-5			
					 <p>(1 unit) 30t (20t crane OK)</p>												
																	
																	
Remove supports					Start engine					Completion of assembly							
LNC00215																	

WORK SPACE LAYOUT DIAGRAM

Use as large a work space as possible, it is easier to assembly the machine. The area shown in diagram below (25 m/82 ft x 30 m/98.5 ft) is the minimum size required.

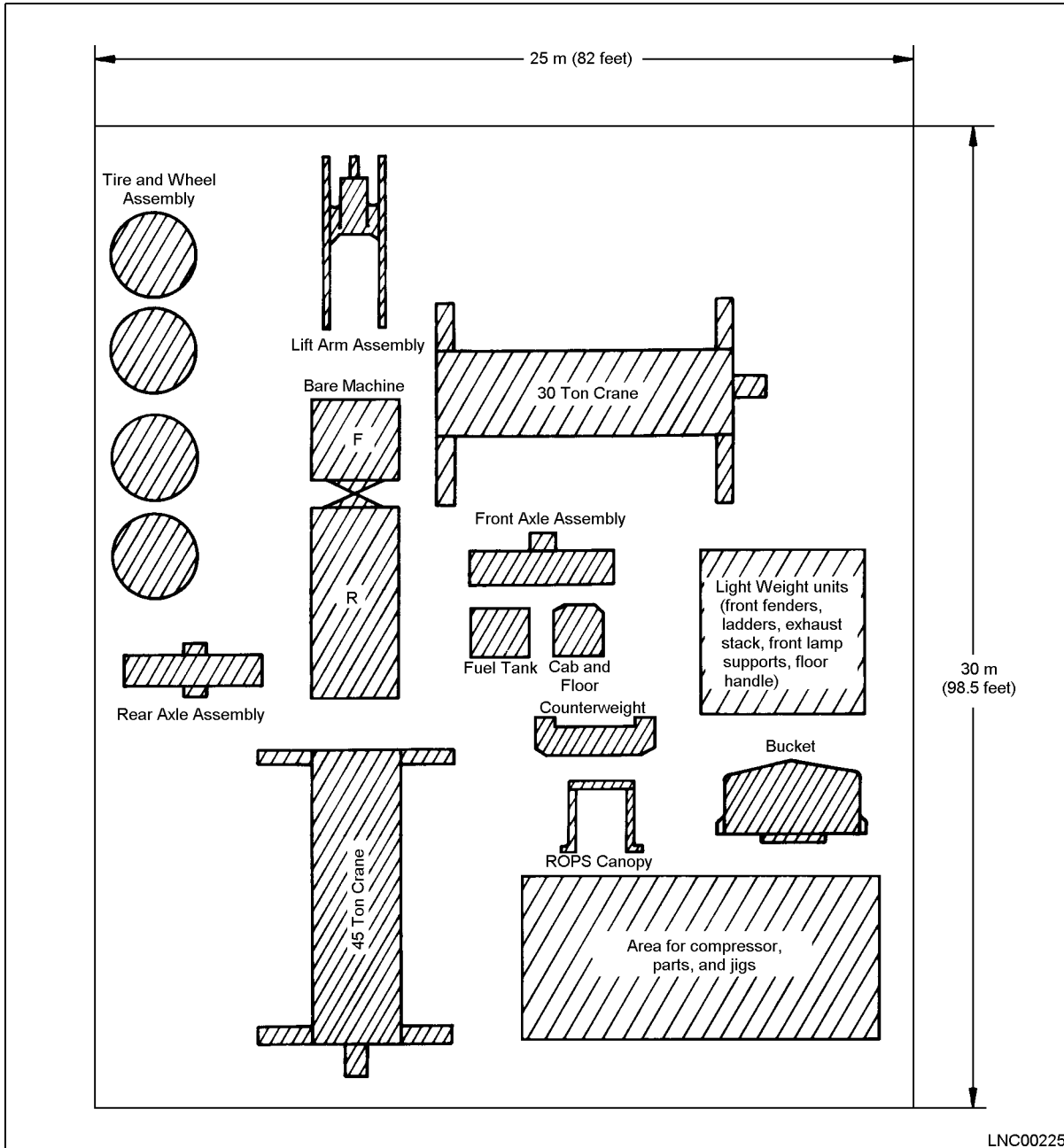

TOOLS AND EQUIPMENT REQUIRED

TOOLS REQUIRED

No.	Name	Specification	Qty.	Remarks
1	Set of common standard tools	Spanners, two-ended ring wrench, box wrench, cold chisel, screwdrivers, hammer, adjustable wrench, hexagon wrench, etc.	2	
2	Power wrench	16 times	1	Front, rear axle mounts, ROPS canopy mount
3	Power wrench	4 times	1	Fuel tank
4	Socket	60 (insertion angle; 38.1) x L: 84	1	Front and rear axle mount
5	Socket	36 (insertion angle; 25.4) x L: 68	1	Rear axle support cover, tires, counterweight (lower)
6	Socket	46 (insertion angle; 25.4) x L: 72	1	Fuel tank, counterweight
7	Socket	55 (insertion angle; 38.1) x L: 82	1	ROPS mount
8	Socket	55 (insertion angle; 25.4) x L: 82	1	ROPS mount
9	Extension bar	Intersection angle: 12.7 x L: 150	1	Fuel tank
10	Adapter	Intersection angle: 19 x 12.7 x L: 55	1	Fuel tank
11	Extension bar	Intersection angle: 25.4 x L: 160	1	Tires, counterweight, ROPS canopy
12	Preset torque wrench (box type)	4 - 28 kgf m (29 - 203 lbf ft) {39 - 275 N m}	1	Power wrench
13	Interchangeable head type preset torque wrench	6 - 14 kgf m (43 - 101 lbf ft) {20 - 44 N m}	1	Connecting hoses and tubes
14	Interchangeable head type preset torque wrench	2 - 4.5 kgf m (14 - 33 lbf ft) {20 - 40 N m}	1	Connecting hoses and tubes
15	Interchangeable head type preset torque wrench	3 - 7 kgf m (21 - 51 lbf ft) {29 - 69 N m}	1	Connecting hoses and tubes
16	Heads (spanner type) for interchangeable head type preset	Width across flats: 27 (intersection hole: 15) Width across flats: 19 (intersection hole: 12) Width across flats: 22 (intersection hole: 12) Width across flats: 24 (intersection hole: 12)	One each	Connecting hoses and tubes
17	Preset torque wrench (box type)	20- 140 kgf m (144 - 1013 lbf ft) {196 - 1373 N m}	1	Rear axle support cover, counterweight
18	Preset torque wrench (box type)	50 - 210 kgf m (362 - 1519 lbf ft) {490 - 2060 N m}	1	Counterweight
19	Preset torque wrench (box type)	6 - 42 kgf m (43 - 304 lbf ft) {59 - 412 N m}	1	Rear axle support cover

No.	Name	Specification	Qty.	Remarks
20	Impact wrench	Capacity: 1.5 - 7.5 kgf m (11 - 55 lbf ft) {15 - 74 N m}	1	
21	Impact wrench	Capacity: 5.5 - 31.5 kgf m (40 - 228 lbf ft) {54 - 309 N m}	1	
22	Impact wrench	Capacity: 20.5 - 84.5 kgf m (148 - 611 lbf ft) {201 - 829 N m}	1	Tires, ROPS canopy
23	Adapter	Intersection angle: 19 x 25.4 x L: 71	1	Power wrench, torque wrench
24	Adapter	Intersection angle: 12.7 x 9.5 x L: 41	1	Power wrench, torque wrench
25	Large hammer	10 pounds	1	
26	Air grinder		1	
27	Bars	Large, medium, small	Two each	Hole adjustment, moving heavy things
28	Bar		2	Hole adjustment
29	Grease gun (hand pump type)	Capacity: 300 cc (10 fl oz.)	1	Oiling to pin
30	Oil container	Capacity: 1000 - 2000 cc (34 - 68 fl oz.)	1	Bleeding air from brake line
31	Vinyl hose	I.D. 6.5 - 7.0 x L: 1000 - 1500 (I.D. 1/4" x 1/4" x 39 - 60")	1	Bleeding air from brake line
32	Interchangeable head type preset torque wrench	15 - 25 kgf m (108 - 181 lbf ft) {147 - 245 N m}	1	Connecting hoses and tubes
33	Interchangeable head type preset torque wrench	13 - 23 kgf m (94 - 167 lbf ft) {128 - 226 N m}	1	Connecting hoses and tubes

EQUIPMENT REQUIRED

No.	Name	Specification	Qty.	Remarks
1	Truck crane	45 ton	1	
2	Truck crane	30 ton	1	
3	Forklift truck	2 ton	1	Unloading comparatively light components and parts, assembling fuel tank
4	Compressor	Capacity: 8.5 gal (32 liter)	1	Impact wrench, bleeding air from brake
5	Roller (for moving rear axle to side)		1	
6	Lever block	1 ton	3	Supporting cylinders, drive shafts
7	Stand (for worker)	4 steps (approx. 1.5 m)	3	Use during operation
8	Steel sheet	(t) 9 x 1219 x 2438 (3/8" x 48" x 96")	4	Positioning bare machine

No.	Name	Specification	Qty.	Remarks
9	Steel sheet	(t)25 x 250 600 (1" x 10" x 24")	4	Positioning bare machine
10	Wooden blocks	400 x 400 x 900 (16" x 16" x 36") 200 x 400 x 800 (8" x 16" x 32")	14 4	Positioning bare machine
11	Air type grease gun	Capacity: 18 liter (5 gal)	1	
12	Air compressor gas charger	Charge manifold, leak detector	1	If another gas charger is used, follow instructions supplied with it
13	Tester		1	

LIFTING TOOLS REQUIRED

No.	Name	Specification	Qty.	Remarks
1	Front frame lifting tool	2-point suspension (L=2250 chain diameter = 20, sling hook = (SL))	1	See diagram
2	Rear frame lifting tool	Balanced 2-point suspension (L=2250 chain diameter = 20, sling hook = (SL))	1	See diagram
3	Rear axle lifting tool	2-point suspension (L=5500 chain diameter = 16, grab hook = (G))	1	See diagram
4	Nylon sling	50 x 2000 mm (2" x 7')	2	Axle support, cylinder sling
5	Front, rear axle lifting tool	Balanced 2-point suspension (chain diameter = 16, sling hook = (SL)) (diameter = 12.5, grab hook = (G))	1	See diagram
6	Nylon sling for drive shaft	50 x 5000 mm (2" x 16.5')	1	
7	Fuel tank lifting tool	2-point suspension (L=5000 chain diameter = 6.3, sling hook = (SL))	2	See diagram
8	Floor and cab lifting tool	2-point suspension (L=2000 chain diameter = 6.3, sling hook = (SL))	2	See diagram
9	Nylon sling	150 x 10000 mm (6" x 33')	1	Lifting tool for tires
10	Wire sling	Capacity: 15 ton L=8' (2500 mm) Capacity: 11 ton L=7' (2000 mm)	2 1	Lifting tool for boom (lifting front) when removing blocks under chassis
11	Shackle	2, 5, 10, and 15 ton	Two each	

1. Front Frame Lifting Tool

Dimension A	2250 mm (7' 3/8")
Chain diameter	20 mm (7/8")
Hook type	SL (sling type)

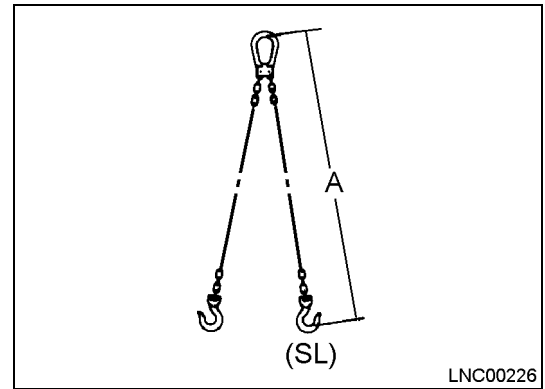

2. Rear Frame Lifting Tool

Dimension B	3900 mm (13')
Dimension C	2850 mm (9.5')
Dimension D	2500 mm (8')
Chain diameter	1) 20 mm (7/8") 2) 20 mm (7/8")
Hook type	SL (sling hook)

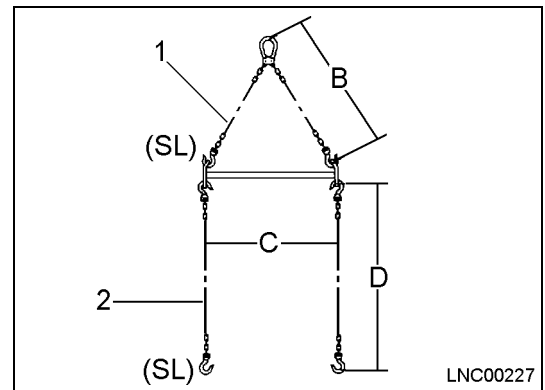

3. Rear Axle Lifting Tool

Dimension E	5500 mm (18')
Chain diameter	16 mm (5/8")
Hook type	G (grab hook)

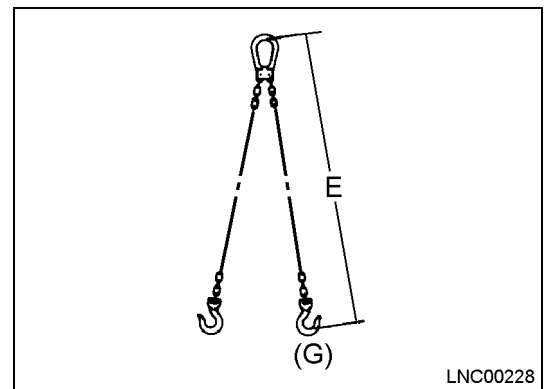

4. Front, Rear Axle Lifting Tool

Dimension F	2000 mm (7')
Dimension G	2000 mm (7')
Dimension H	5500 mm (18')
Chain diameter	3) 16 mm (5/8") 4) 12.5 mm (1/2")
Hook type	SL (sling hook) G (grab hook)

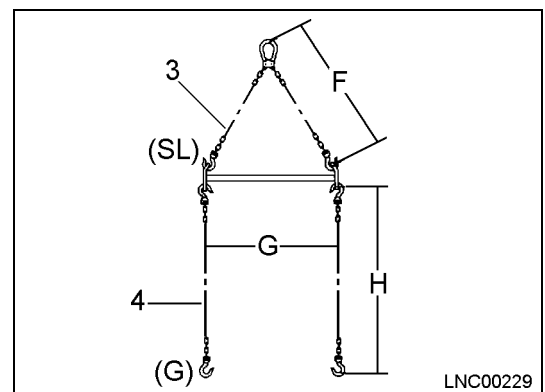

5. Fuel Tank Lifting Tool

Dimension J	5000 mm (16.5')
Chain diameter	6.3 mm (1/4")
Hook type	SL (sling type)

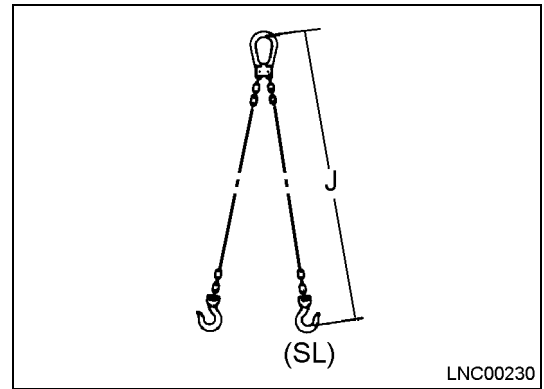

6. Floor and Cab Lifting Tool

Dimension K	2000 mm (7')
Chain diameter	6.3 mm (1/4")
Hook type	SL (sling type)

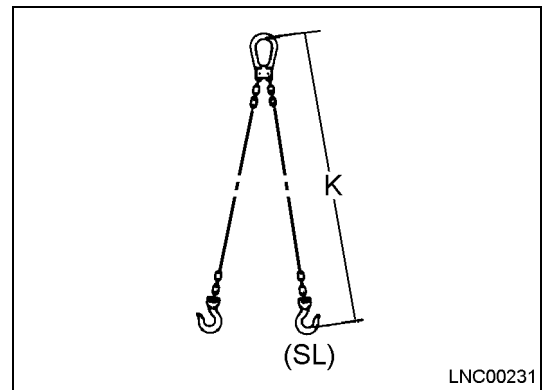

OIL, GREASE, FUEL, PAINT, ETC

- Molybdenum disulfide grease with high pressure additive:
KES LM-P, SAE J310a NLGI: No. 1 or equivalent) 500 mL (17 fl oz.)
- Molybdenum disulfide grease with high pressure additive:
KES LM-G, SAE J310a NLGI: No. 2 (No. 1) or equivalent) 10 liters (3 gal).
- Fuel:
Diesel fuel as required - fuel tank: 1425 liters (376.5 U.S. gal)
- Paint for touch up: natural yellow and cloud gray.
- Air conditioner gas:
R134-a Freon - One 400 g (14 oz.) can.
- Window washer:
2 liters (2 quarts)
- Others:
Roller for moving rear axle to side.

Item	Description	Dimension
A	Four angle iron	50 x 50 x 850 mm (2" x 2" x 33.5")
B	Height	90 mm (3.5")
C	Width	770 mm (30")
D	Length	1000 mm (39")

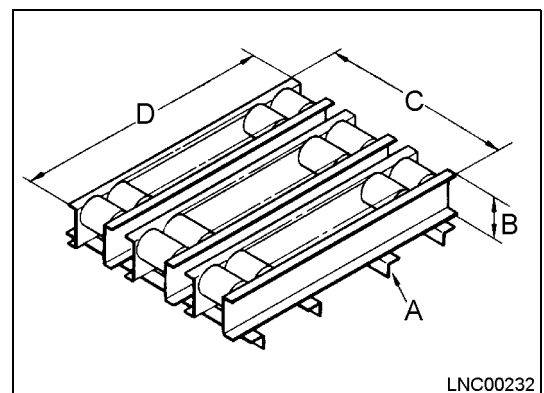

PROTECTIVE WEAR

1. Work cloths, safety boots, helmet, thick gloves, safety goggles, rain coat

LOCAL MANUFACTURING DIAGRAM FOR TOOLS

1. Axle Lifting Tool

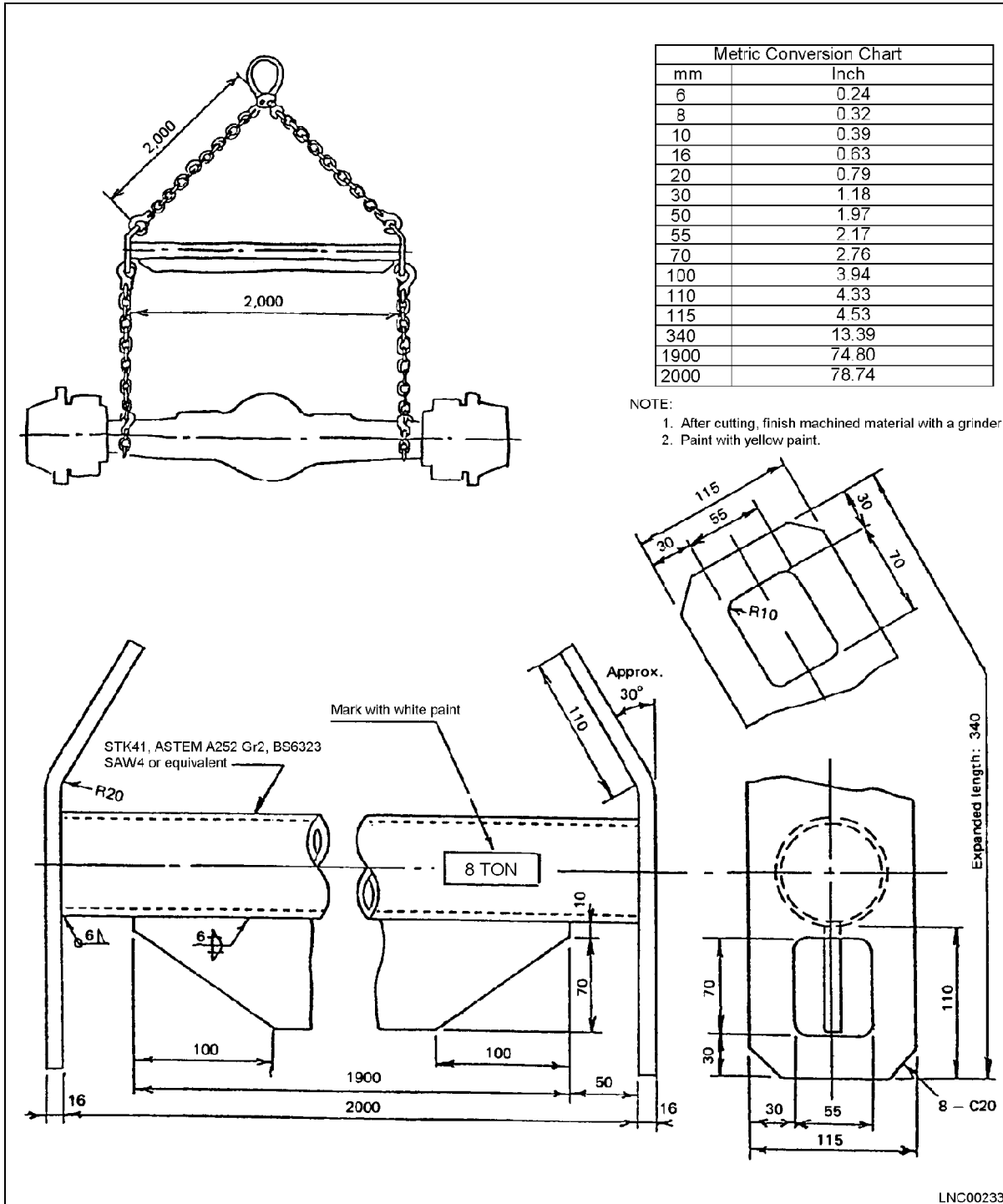

LNC00233

2. Frame Lifting Tool

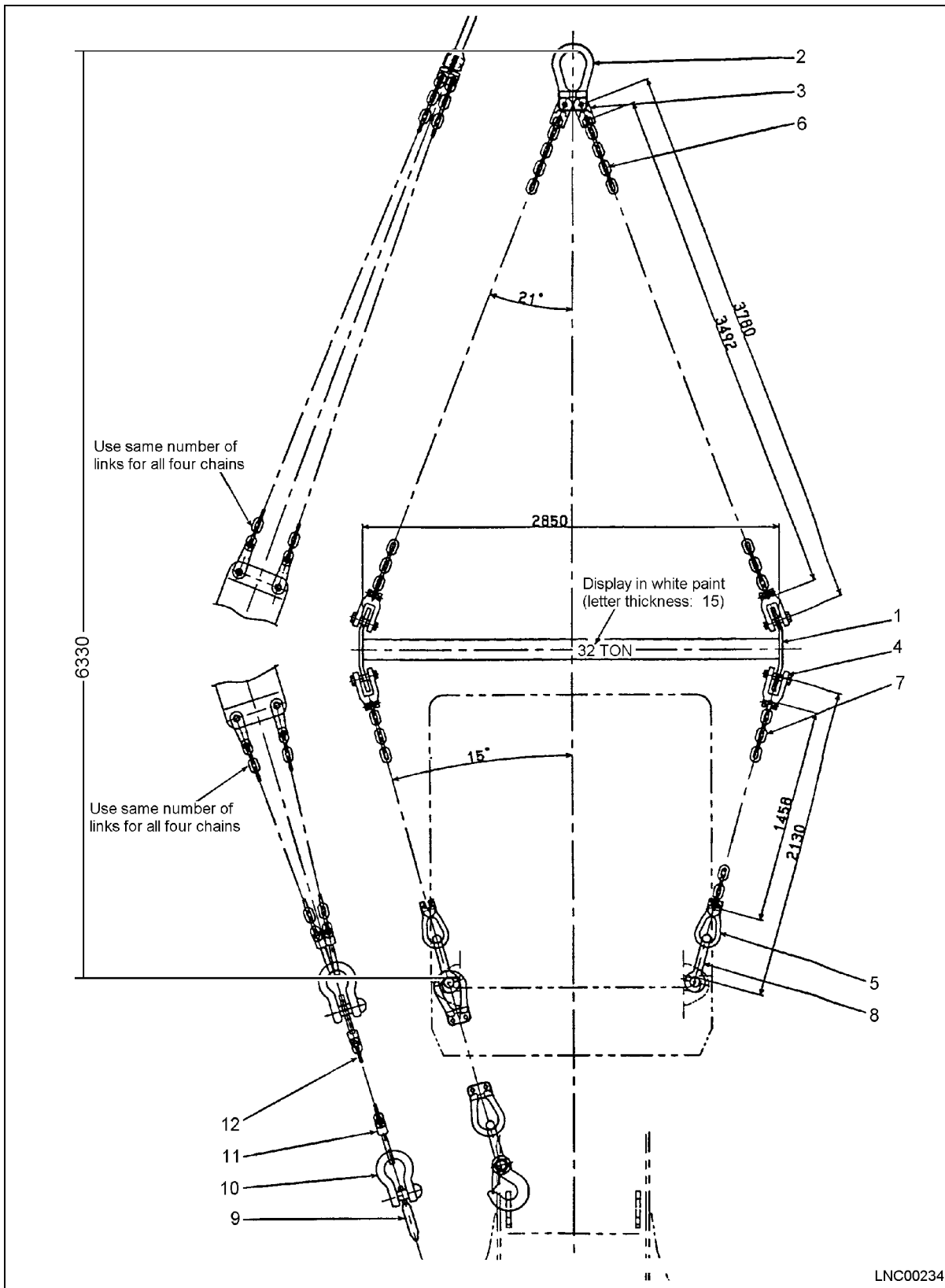

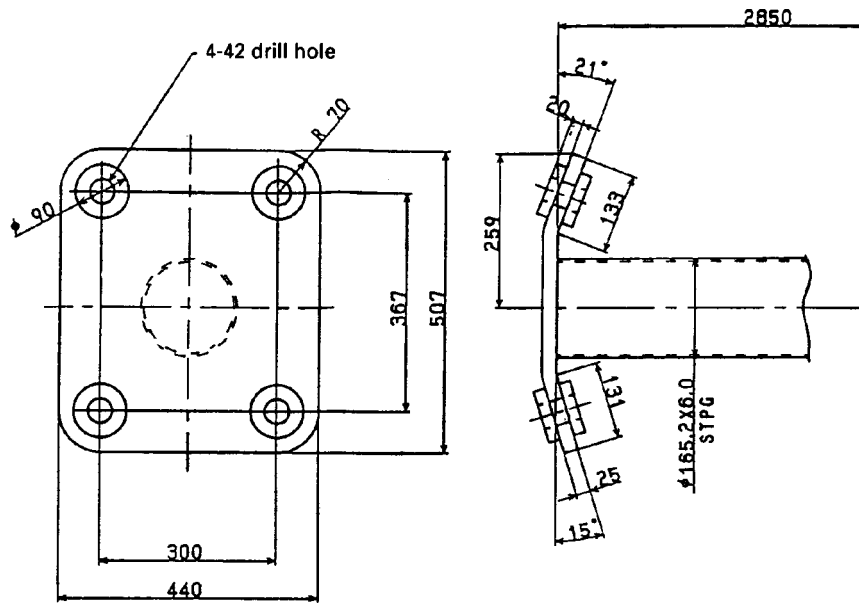

For welds with no specific instructions, weld to $\overline{6V} \text{ TT}$

Assembly Parts List		
Item	Description	Qty.
1	Balance	1
2	Lifting Tool	1
3	Connecting Tool	2
4	Shackle	8
5	Lifting Tool	4
6	Link Chain	4
7	Link Chain	4
8	Shackle	2
9	Sling Hook	2
10	Shackle	4
11	Lifting Tool	4
12	Link Chain	4

Metric Conversion Chart	
mm	Inch
20	0.79
25	0.98
42	1.65
70	2.76
90	3.54
131	5.16
133	5.24
259	10.20
300	11.81
367	14.45
440	17.32
507	19.96
1458	57.40
3120	83.86
2850	112.21
3492	137.48
3780	148.82
6330	249.21
165.2 x 6.0	6.6 x 0.24

LNC00235

3. Roller for Moving Axle to Side

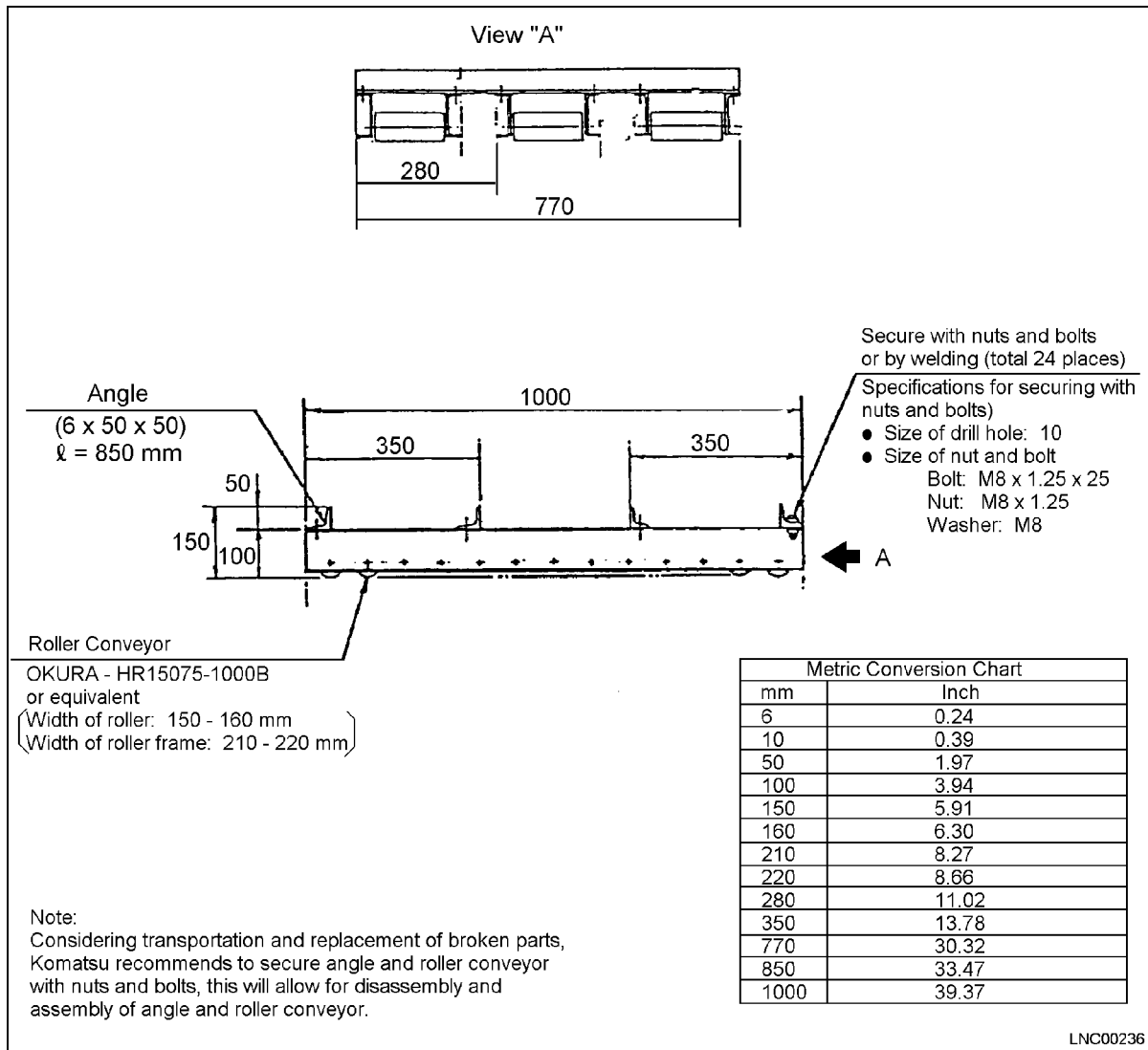

PROCEDURE FOR FIELD ASSEMBLY

A-1 SETTING BARE MACHINE ON SUPPORTS

Tools and Materials Required

No.	Description	Qty.
1	Bar	2
2	30 ton crane	1
3	45 ton crane	1
4	Steel plate (t) 9 x 1219 x 2438 mm (0.35" x 48" x 96")	3
5	Steel plate (t) 25 x 250 x 600 mm (1" x 10" x 24")	-
6	Wooden block 400 x 400 x 900 mm (16" x 16" x 36")	14
7	Wooden block 200 x 400 x 800 mm (8" x 16" x 32")	4

- Using a 30 ton and 45 ton crane, fix hooks in lifting eyes of front and rear frames and raise the machine.

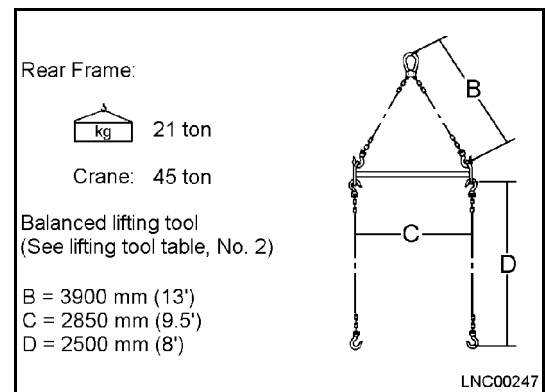
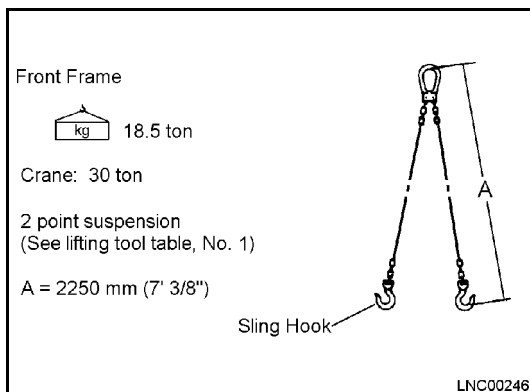

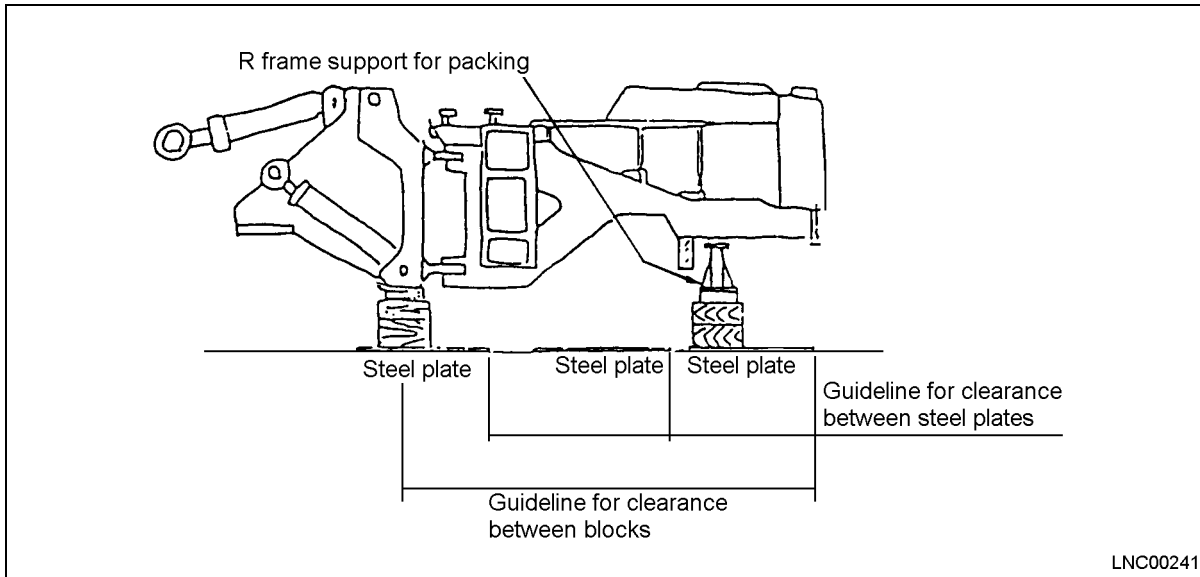

2. Set bare machine on blocks as shown above. Measure height of tires to determine the proper amount of cribbing to be used to raise the machine far enough from ground level, so tire and wheel assemblies can be installed. When machine is setting on an earth surface, put steel plates under the wooden blocks to prevent machine from sinking or tilting to one side. Use three steel sheets, one sheet is used for sliding rear axle to side.
 - Be sure to set the machine on flat level ground, and take every precaution to prevent the chassis from tilting to the right or left side. If the chassis does tilt, it is difficult to adjust the pin hole position when installing the boom assembly.
 - If wooden blocks are difficult to obtain, Komatsu recommends you make a steel stand as shown on the following page.

STEEL STAND DRAWING

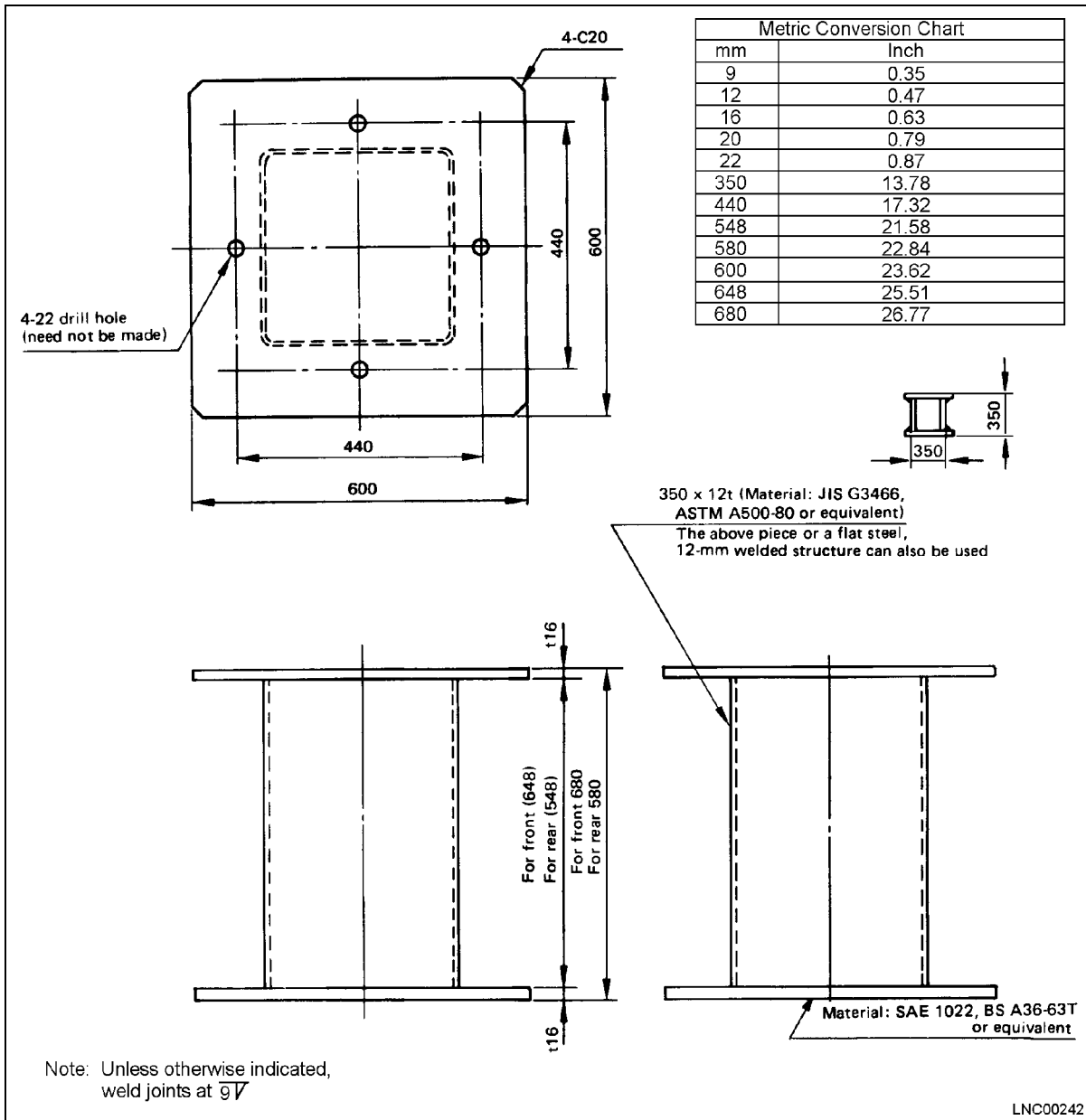

Quantity: 2 for front
2 for rear

A-2 ASSEMBLY OF REAR AXLE

OUTLINE

Tools Required

No.	Description	Qty.
1	Power wrench (x16) Torque wrench: 22 kgf m (159 lbf ft) {216 N m}	1
2	Socket: 60	1
3	Socket: 36	1
4	Crane: 30 ton	1
5	Roller for moving axle to side	1
6	Torque wrench: 6 - 10 kgf m (43 - 72 lbf ft) {59 - 98 N m} spanner type	1

Assembly Parts for Rear Axle

Mark	No.	Part	Part Number	Qty
*	1	Bolt	427-46-12130	4
*	2	Washer	01643-33990	8
*	3	Nut	01580-03931	4
o	4	Bolt	01011-52420	16
o#	5	Washer	01643-32460	32
#	6	Bolt	01011-52400	16
o	7	Washer	427-46-12160	2
o	8	Plate	427-46-12170	1
o	9	Cover	427-46-12180	1
#	10	Nipple	566-35-14340	2
#	11	Hose	07102-20315	1
#	12	Breather	07030-00252	1

*: Sent as individual parts.

o: Temporarily installed to axle.

#: Temporarily installed to frame.

- Assemble front axle support assembly to rear axle.
 - After installing front axle support to rear axle, tie support to the axle with wire. This will prevent the support from coming out.
- Axle assembly is shipped with a plug installed in breather location, remove shipping plug and replace with nipple from breather line attached to frame.
- Assemble rear axle and support assembly to rear frame.

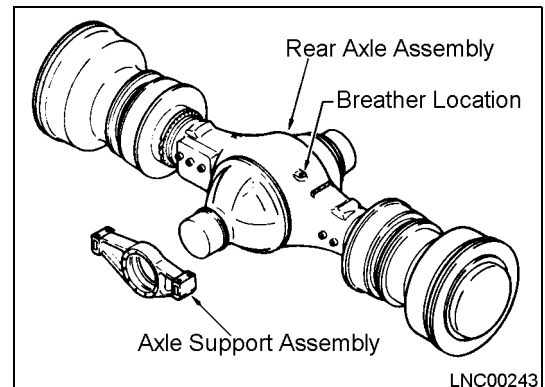

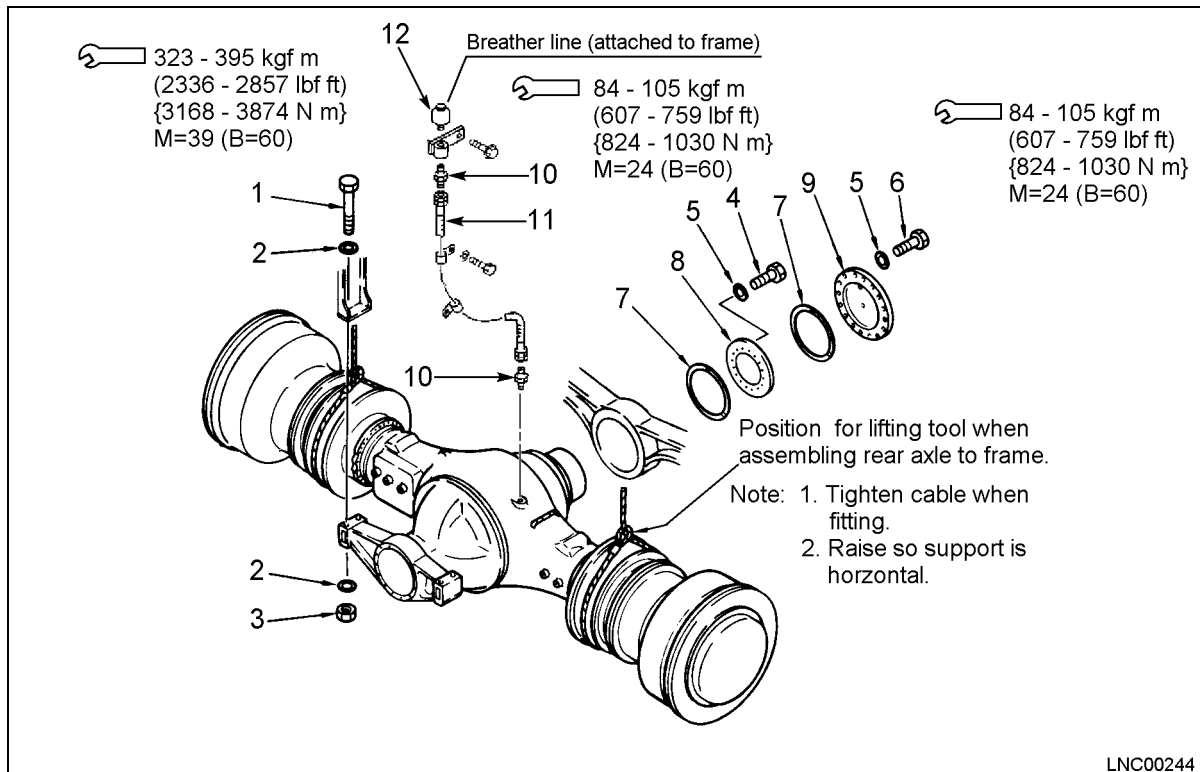

- Attach breather line hose (already attached to frame) to nipple that replaced shipping plug in step 2.
- Connect brake line hoses to rear axle side (2 pieces).

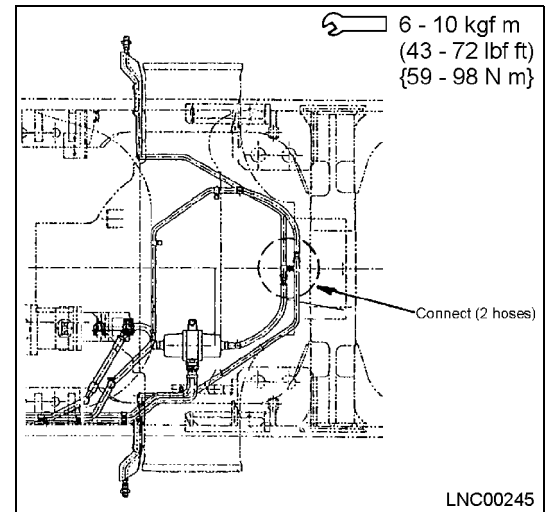

ASSEMBLY PROCEDURE

- Wipe inside of rear axle support clean with a cloth, then coat inside face of bushing with grease.

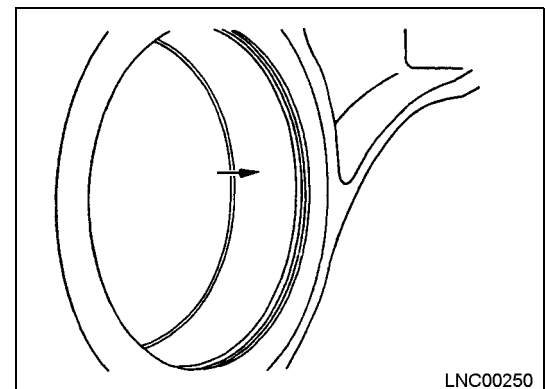

- Set one end of rear axle on top of roller used to slide axle to under rear frame.

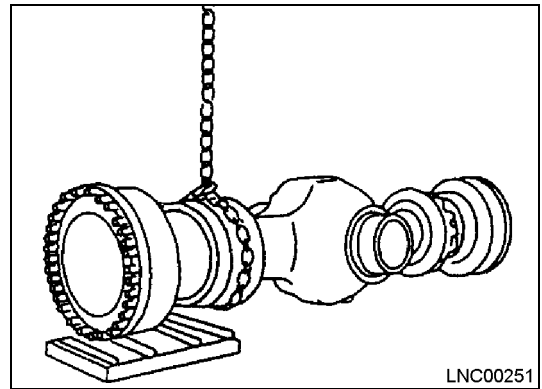
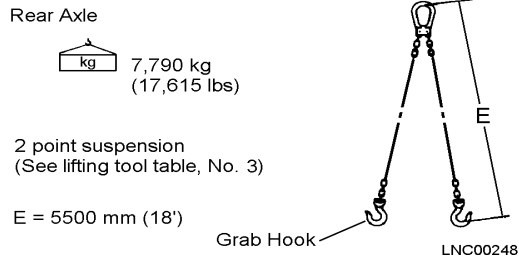

- Clean mounting surface of rear axle and inside surface of front axle support, coat with grease, then assemble front support to axle.
 - After installing front axle support to axle, fix it to axle with wire to prevent support from coming out

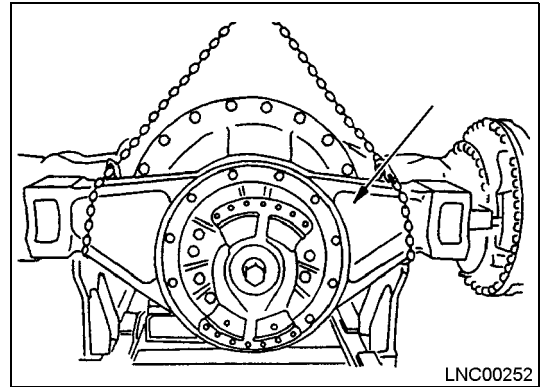
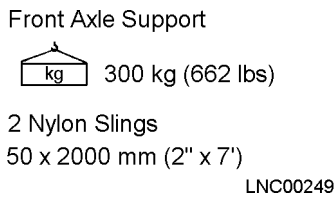

- Raise axle end off ground with crane (with other end on roller) push axle and center under rear frame.

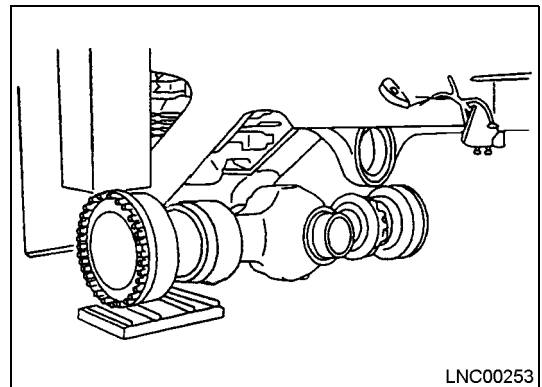

- Clean the contact surfaces of front support and frame, and mating surfaces of rear support and frame. Change lifting tool, raise rear axle and insert rear axle mount into rear support. Insert mounting bolts of front axle support, and tighten temporarily.

Rear Axle with Front Support

 8,290 kg
(18,276 lbs)

Balanced lifting tool
(See lifting tool table, No. 5)

F = 2000 mm (7')
G = 2000 mm (7')
H = 5500 mm (18')

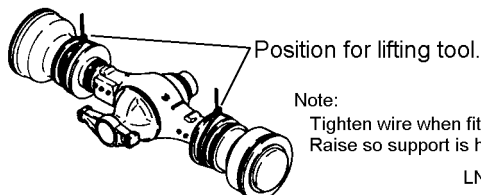
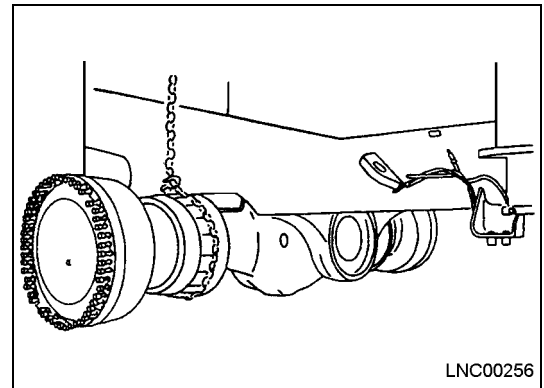
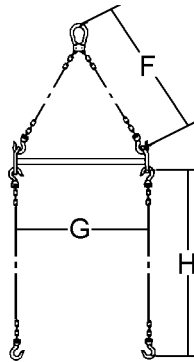

- Assembly thrust washers (7), and plate (8), to rear of the rear axle support. Coat front and rear faces of thrust washers with grease.

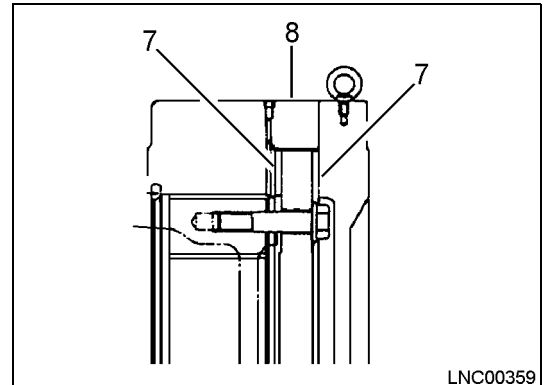

7. Assembly cover (9) to rear of the rear axle support.

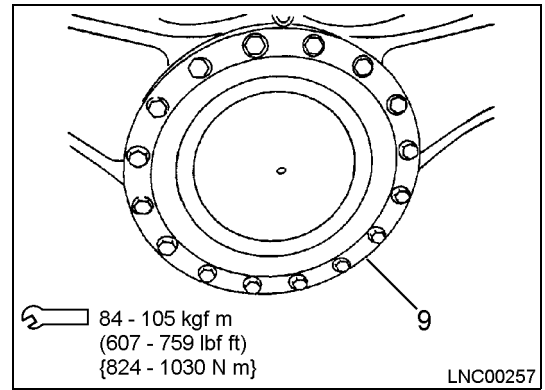

- Use four workers to install cover, with one bolt. Using this bolt as a fulcrum, turn cover to set it into position, then install the other bolts.

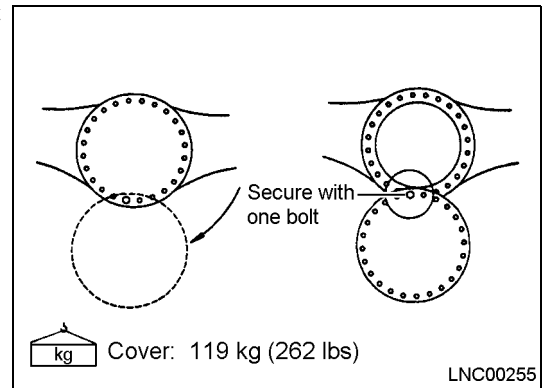

8. Using power wrench (x16), tighten mounting bolts of front axle support to specified torque. Then connect brake lines to slack adjuster.

N·m 3521 ± 353 Nm (2596.5 ± 260.5 lbf-ft)

9. Connect brake lines to slack adjuster.

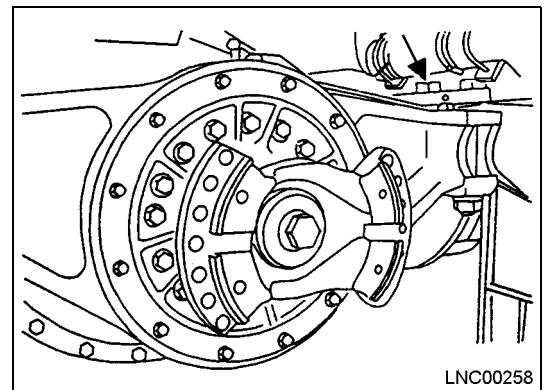

A-3 ASSEMBLY OF FRONT AND REAR DRIVE SHAFTS

OUTLINE

Tools Required

No.	Description	Qty.
1	Torque wrench: 40 kgf m (290 lbf ft) {392 N m}	1
2	Crane: 30 ton	1
3	Lever block (1 ton)	1

Assembly Parts for Drive Shafts

Mark	No.	Part	Part Number	Qty
*	1	Rear drive shaft	427-20-12112	1
*	2	Front drive shaft	427-20-13112	8
o	3	Bolt	01050-61895	4

- *: Sent as individual parts.
- o: Temporarily installed to axle or frame.

1. Assembly of rear drive shaft

- Clean mounting surfaces before assembling drive shafts.
- Assemble so that grease fittings of the front and rear drive shafts face same direction as the grease fitting of the center shaft.

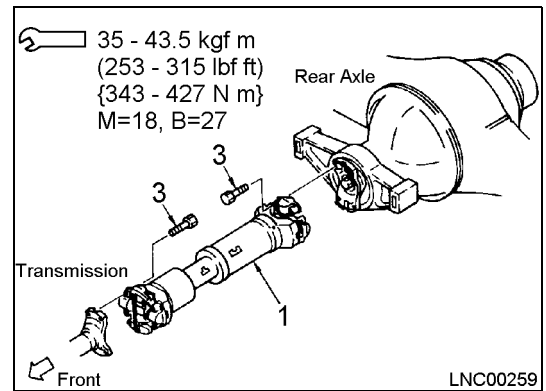

2. Assembly of front drive shaft

- Clean mounting surfaces before assembling drive shafts.
- Assemble so that grease fittings of the front and rear drive shafts face same direction as the grease fitting of the center shaft.

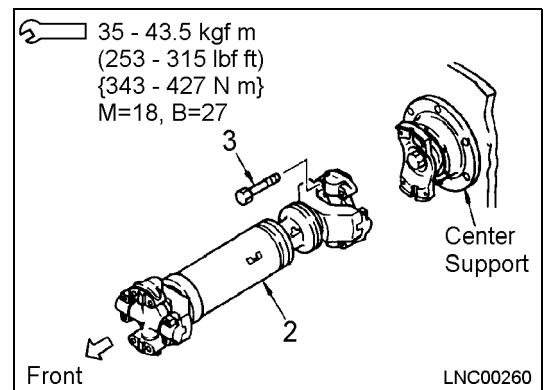

ASSEMBLY PROCEDURE

NOTE: Be sure to give clear signals to the crane operator.

1. Adjust position of rear drive shaft by passing a long nylon sling (50 x 5000 mm {2" x 16'}) through center of frame, raise with a crane from top of rear platform, adjust position and install.



Rear drive shaft: 186 kg (410 lbs)

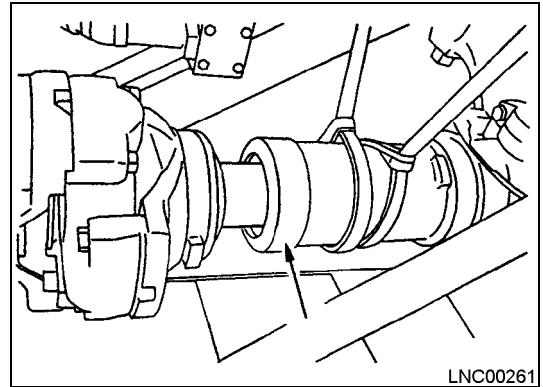

2. Support front drive shaft by using a crane, raise from top of front frame. Adjust position and assemble to center support end. After assembling, use a lever block to support front drive shaft so it faces slightly up (approximately 10°) from a level position.



Front drive shaft: 173 kg (382 lbs)

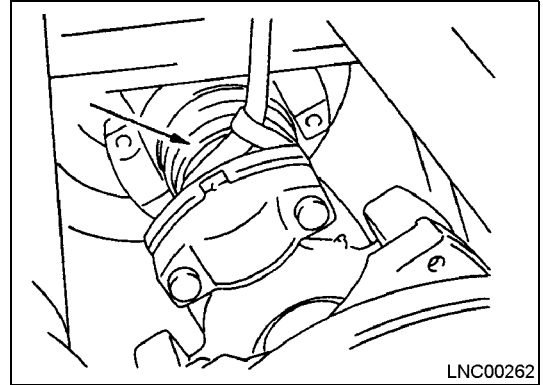

A-4 INSTALLATION OF FRONT AXLE

OUTLINE (INSTALLING FRONT AXLE)

Tools Required

No.	Description	Qty.
1	Power wrench (x16) Torque wrench: 22 kgf m (159 lbf ft) {216 N m}	1
2	Socket: 60	1
3	Socket: 36	1
4	Crane: 30 ton	1
5	Roller for moving axle to side	1
6	Torque wrench: 6 - 10 kgf m (43 - 72 lbf ft) {59 - 98 N m} spanner type	1

Assembly Parts for Front Axle

Mark	No.	Part	Part Number	Qty
o	1	Bolt	427-46-11451	16
o	2	Washer	01643-33990	32
o	3	Nut	01580-03931	16
o	4	Bolt	01050-61895	4

o: Already installed to front axle.

1. Assembly of front axle.

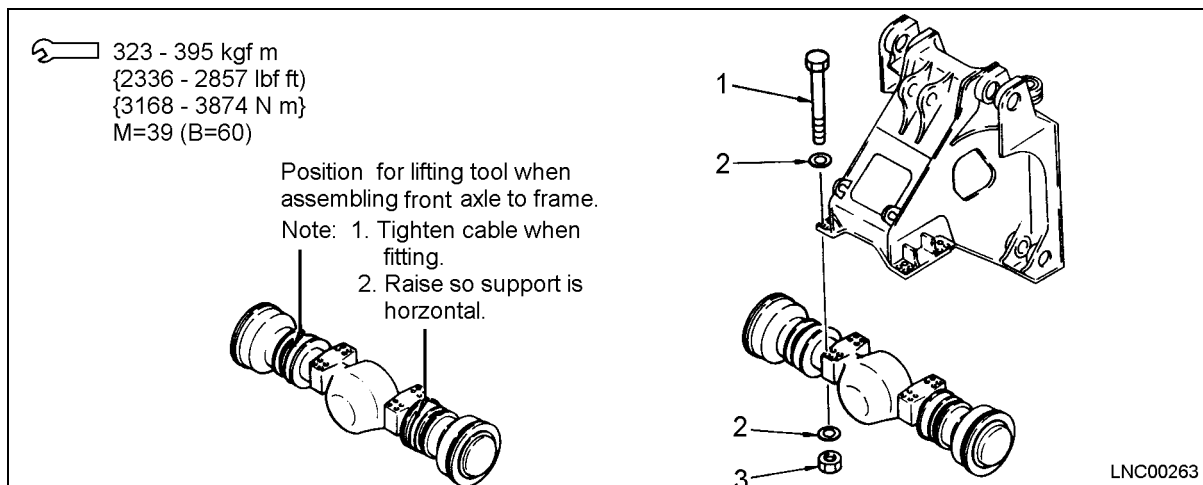

2. Connecting brake line and parking brake hoses.

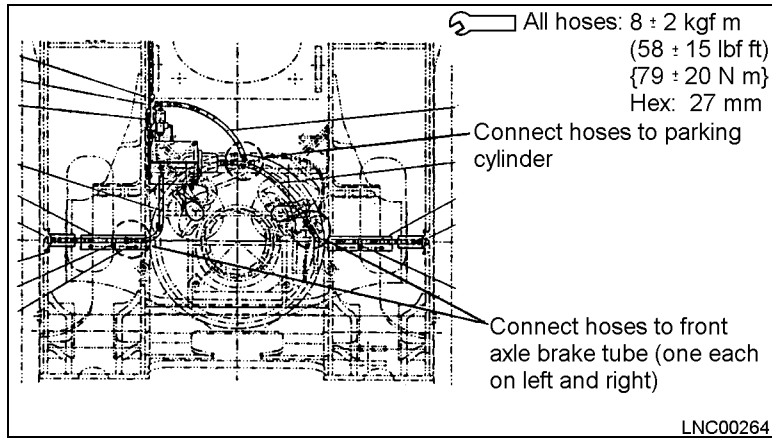

3. Connecting drive shaft

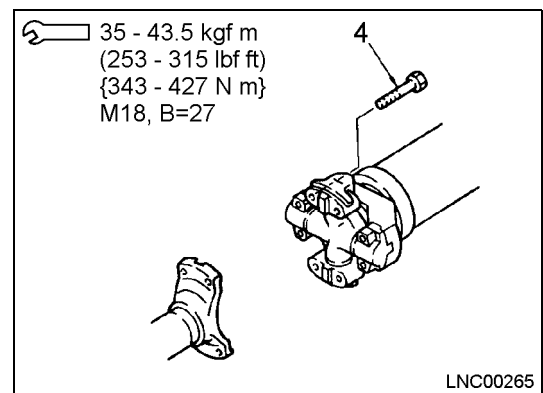

ASSEMBLY PROCEDURE

1. Clean mating surfaces of front axle and front frame. Raise front axle and install it to frame and tighten mounting bolts to specified torque.

Front Axle

 8,200 kg (18,078 lbs)

Balanced lifting tool
(See lifting tool table, No. 5)

F = 2000 mm (7')
G = 2000 mm (7')
H = 5500 mm (18')

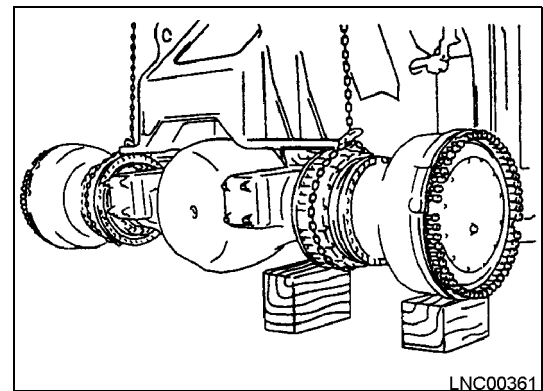
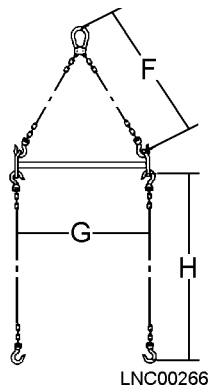

- 2. Connect front drive shaft to front axle yoke. Adjust position using a lever block.

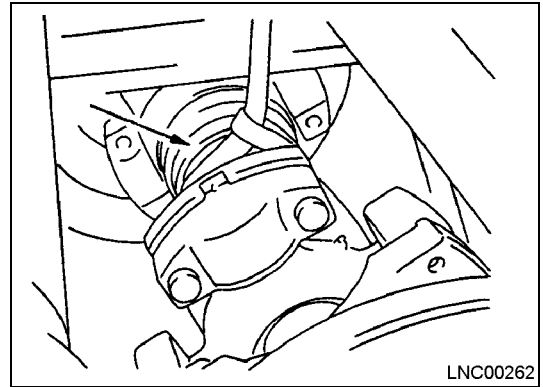

- 3. Connect brake lines to slack adjuster.

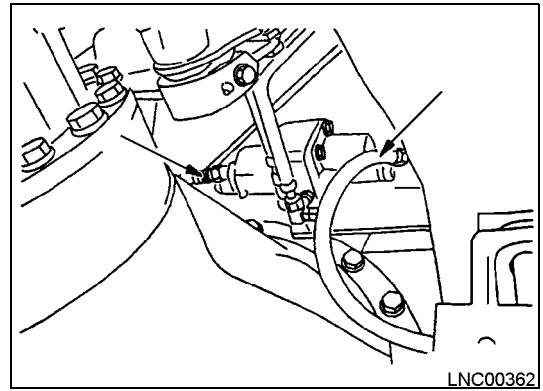

- 4. Connect air hoses to the left and right parking brake cylinders

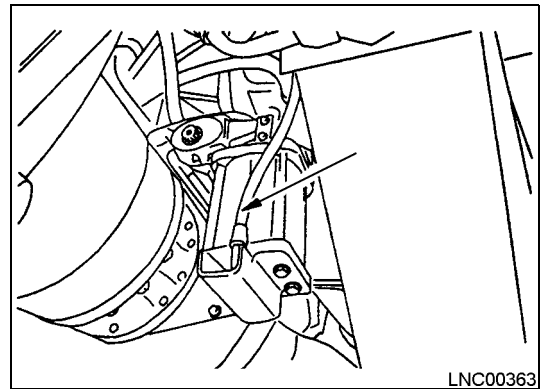

OUTLINE (INSTALLING FRONT TIRE AND WHEEL ASSEMBLIES)

Tools Required

No.	Description	Qty.
1	Torque wrench: 84 kgf m (608 lbf ft) {824 N m}	1
2	Socket: 36 mm	1
3	Extension bar	1
4	Crane: 30 ton	1
5	Nylon sling, 150 x 10,000 mm (6" x 33')	1

Assembly Parts for Front Tire and wheel assemblies

Mark	No.	Part	Part Number	Qty
o	1	Nut	426-22-12930	106
o	2	Washer	01643-32460	106

o: Already temporarily installed to front axle.

1. Method for lifting tire and wheel assembly

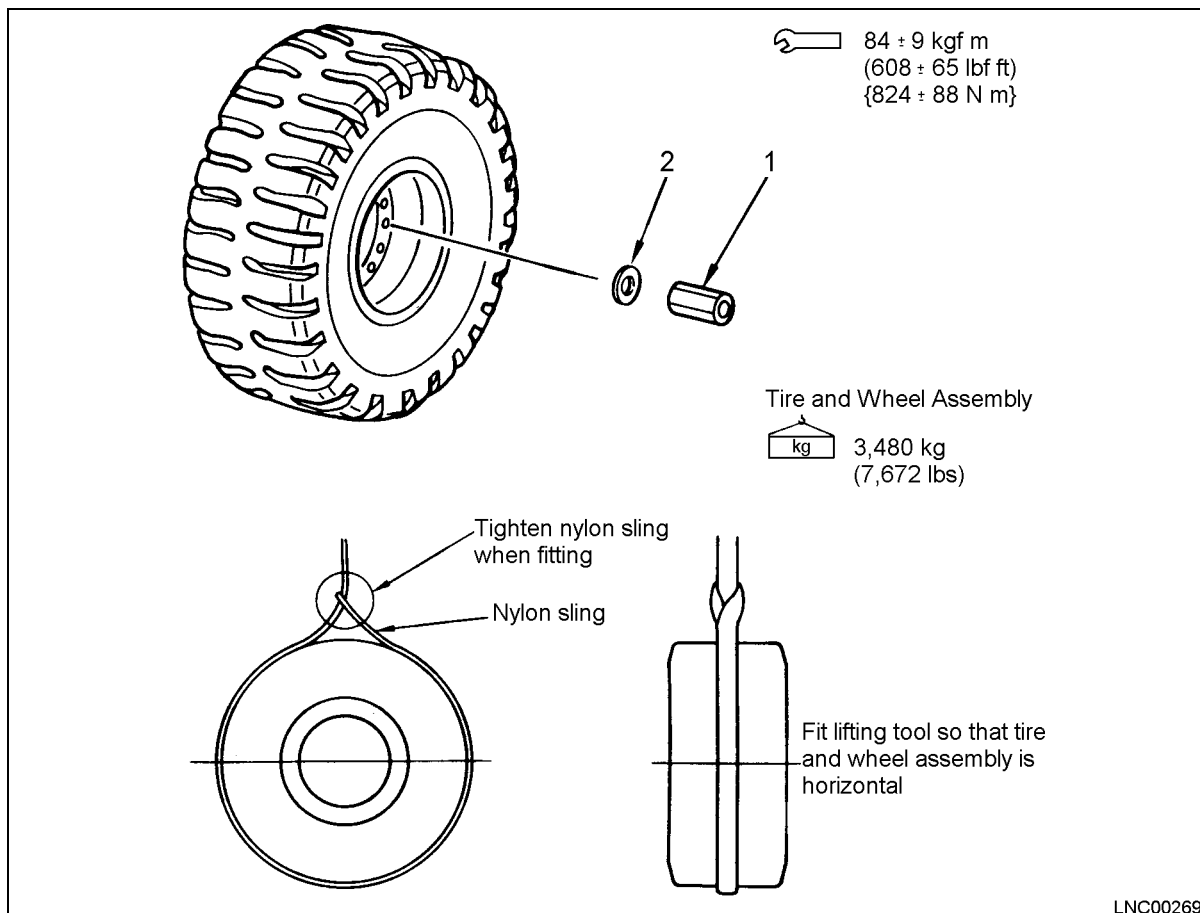

ASSEMBLY PROCEDURE (FRONT TIRE AND WHEEL ASSEMBLY)

1. Raise tire and wheel with a crane and nylon sling and set on front axle, then install lug nuts.
 - When positioning tire and wheel assembly, be careful not damage the tire inflation tube.

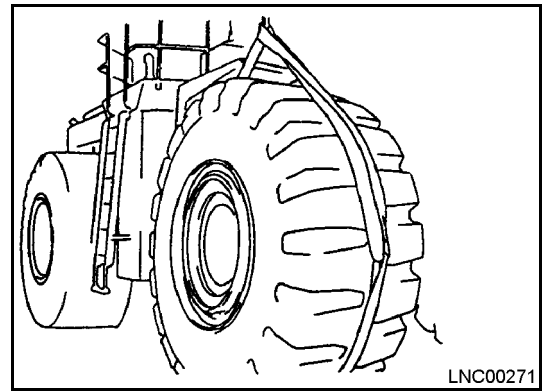

Tire and wheel assembly: 3,480 kg (7,672 lbs)

2. Temporarily tighten lug nuts with an impact wrench.
 - This operation is carried out in a high position, and there are 106 lug nuts to tighten, so Komatsu suggests the use of a balancer to support the impact wrench.
3. Raise front of machine with a 45 ton crane using a No. 6 type wire sling (45 x 3000 mm [1 3/4" x 13"]) and remove the supports.

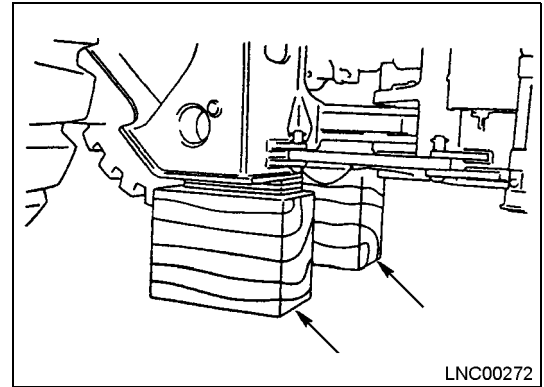

Front of machine: 26,308 kg (58,000 lbs)

4. Using a torque wrench, tighten lug nuts to specified torque.

A-5 ASSEMBLY OF FUEL TANK**OUTLINE****Tools Required**

No.	Description	Qty.
1	Impact wrench	1
2	Power wrench (x4)	1
3	Torque wrench set: (174 lbf ft) 24 kgf m {235 N m}	1
4	Extension	1
5	Socket, 46 mm	1
6	Socket, 14 mm	1
7	Crane (30 ton)	1

Assembly Parts for Fuel Tank

Mark	No.	Part	Part Number	Qty
o	1	Mounting Bolt	01011-63000	6
o	2	Washer	01643-33080	6
x	3	Shim	416-855-1190	10
o	4	Clamp	08036-13014	2
o	5	Bolt	01010-51020	2
o	6	Washer	01643-51032	2
o	7	Bolt	01435-01030	2
o	8	Bolt	01435-01030	4

o: Already temporarily installed to fuel tank.

x: Sent as individual parts.

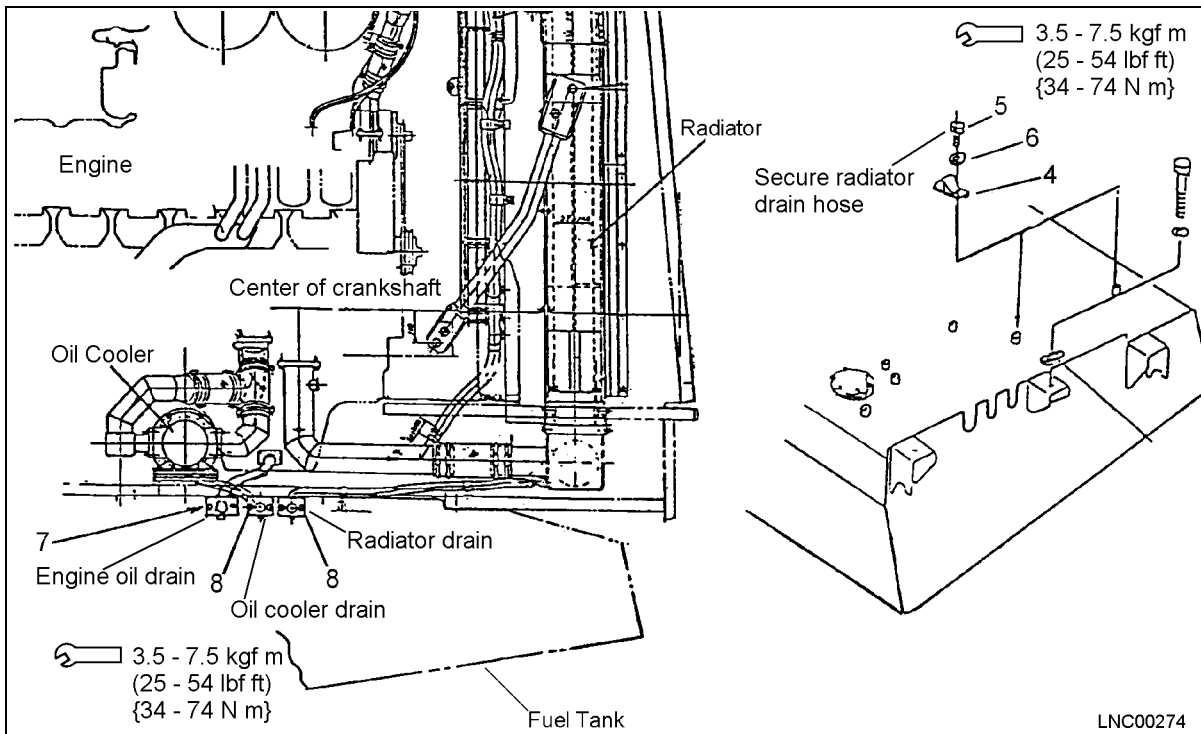
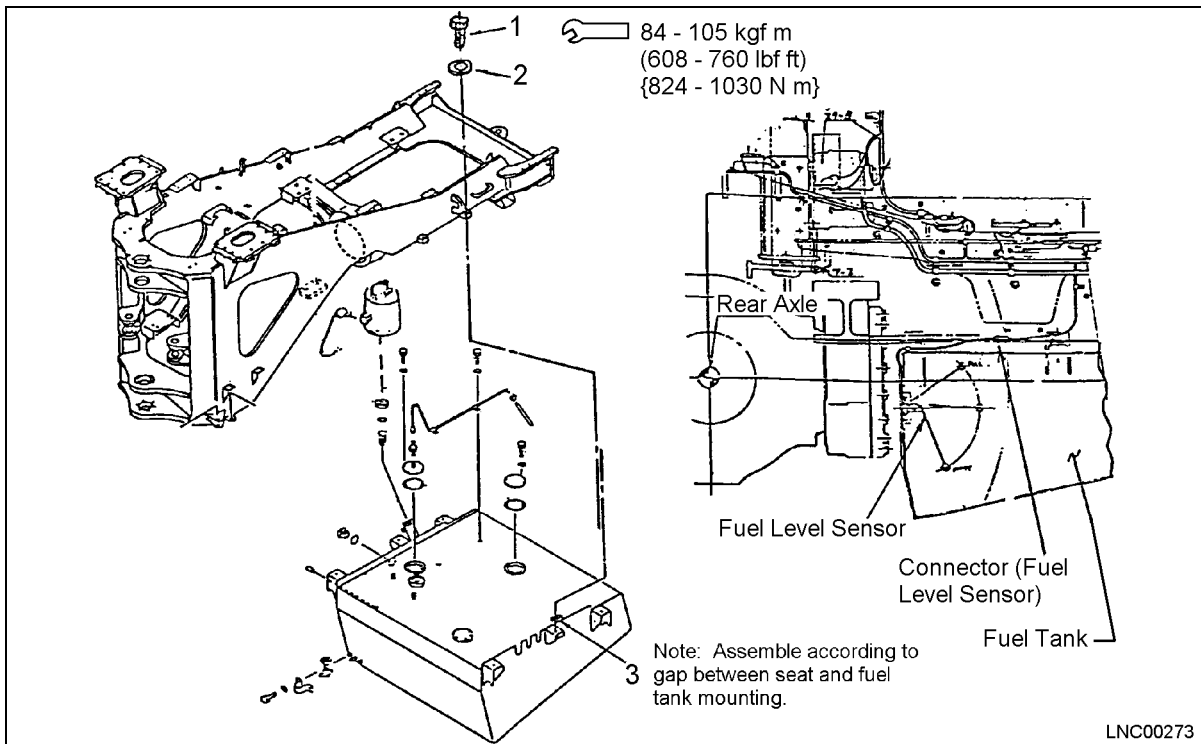

OPERATION FOR CONNECTING FUEL SUCTION AND RETURN HOSES**Tools Required**

No.	Description	Qty.
1	Impact wrench	1
2	Socket, 14 mm	1
3	SP type torque wrench (24 x 500 kgcm)	1
4	SP type torque wrench (27 x 800 kgcm)	1

Assembly Parts for Securing Fuel Hoses

Mark	No.	Part	Part Number	Qty
o	1	Clip	04434-5160	2
o	2	Clip	04434-5140	2
o	3	Clip	424-06-12790	1
o	4	Bolt	01435-01020	2

o: Already temporarily installed to fuel tank.

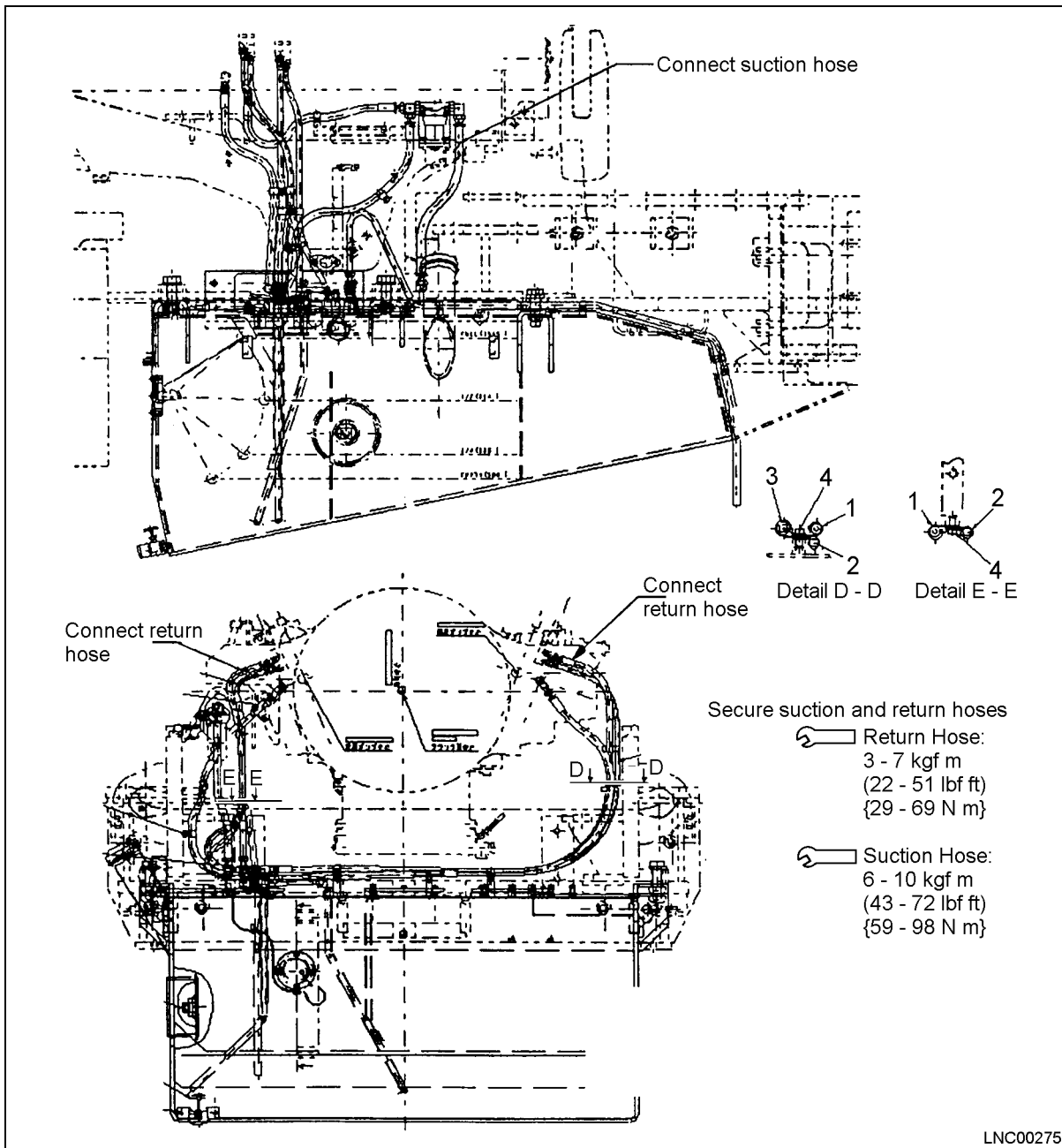

OPERATION FOR SECURING ENGINE DRAIN LINES

Tools Required

No.	Description	Qty.
1	Impact wrench	1
2	Socket, 14 mm, 17 mm	1

Assembly Parts for Securing Fuel Hoses

Mark	No.	Part	Part Number	Qty
o	1	Clip	08036-02514	5
o	2	Clip	08036-02514	8
o	3	Clip	01435-01016	5
o	4	Bolt	01435-01016	3
o	5	Washer	01643-31032	3
o	6	Clip	424-06-12790	1

o: Already temporarily installed to fuel tank.

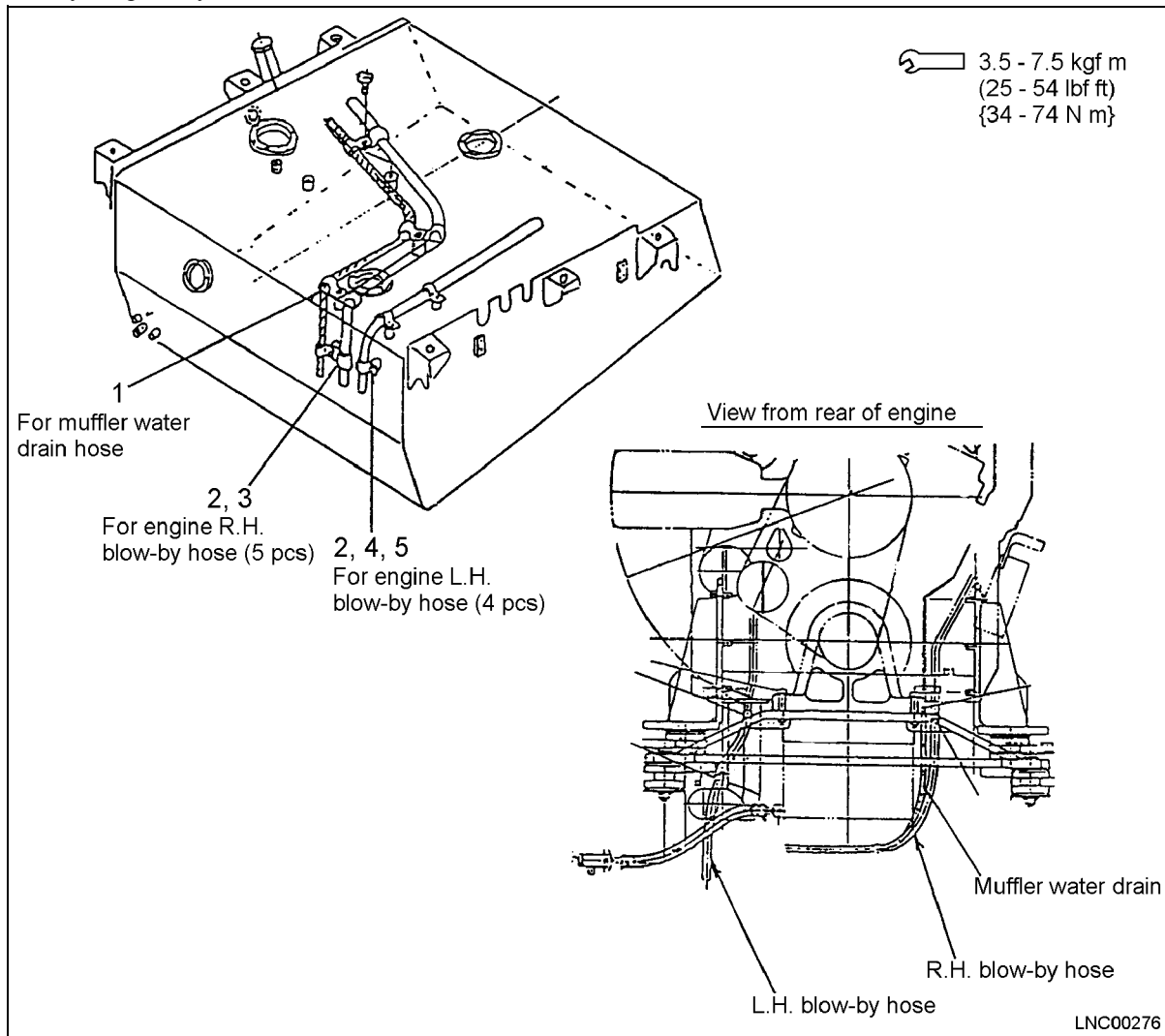

OPERATION FOR SECURING FUEL TANK VENT LINE

Tools Required

No.	Description	Qty.
1	Impact wrench	1
2	Socket, 14 mm	1

Assembly Parts for Securing Fuel Vent Line

Mark	No.	Part	Part Number	Qty
o	1	Tube	427-04-21231	1
o	2	Clip	04434-51810	3
o	3	Bolt	01435-01020	3
o	4	Tube	07286-01945	1
o	5	Clip	07280-02023	1

o: Already temporarily installed to fuel tank.

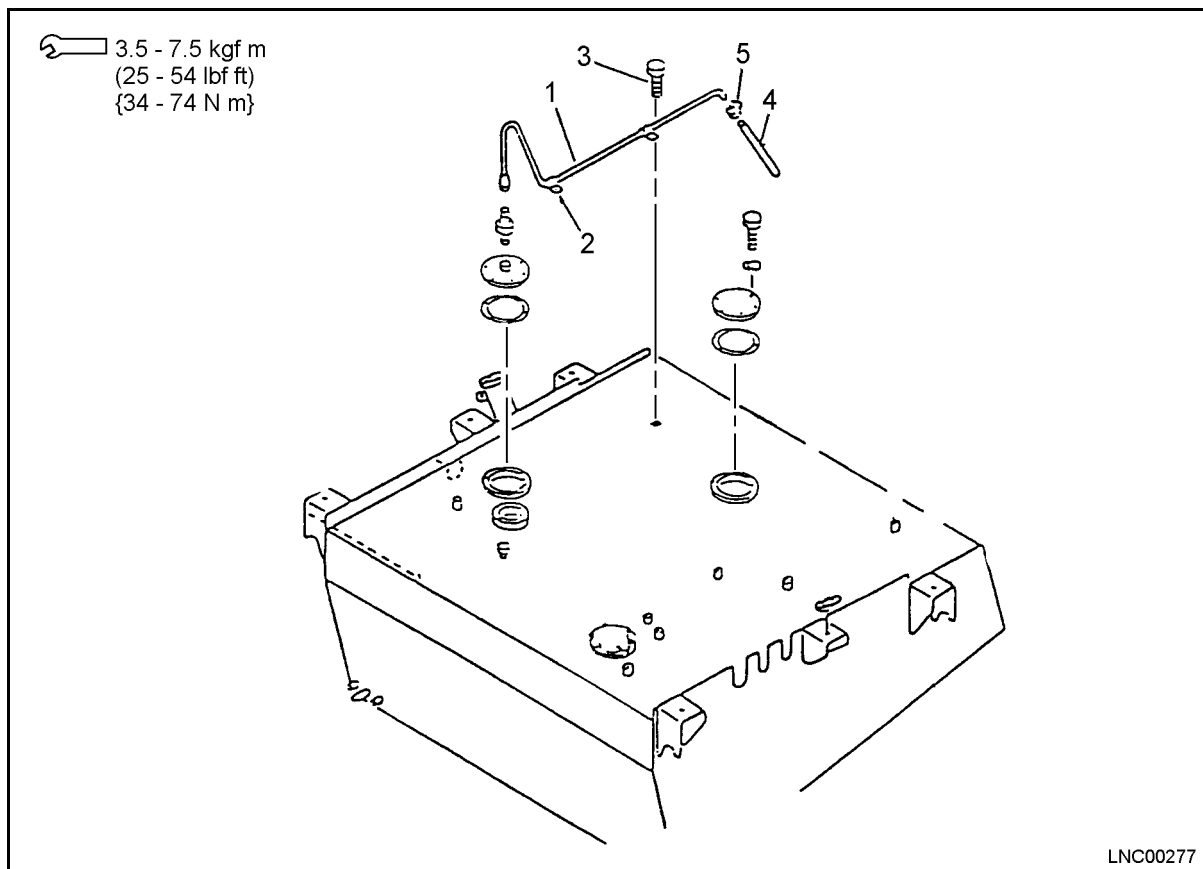

ASSEMBLY PROCEDURE

- Using a forklift, set fuel tank under rear frame. Then with the proper lifting tools, raise fuel tank and tighten mounting bolts to specified torque.

 Fuel tank: 765 kg (1,687 lbs)

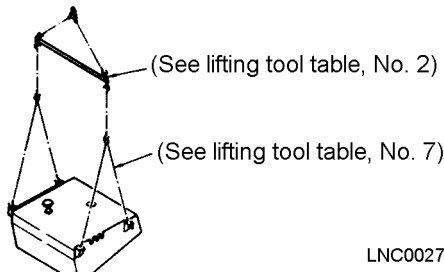

LNC00278

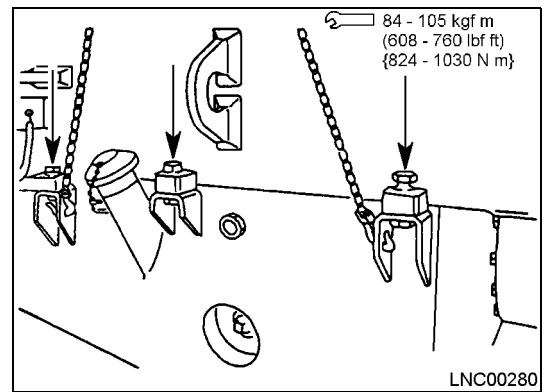

LNC00280

- The fuel tank can be raised using the main winch and auxiliary winch of the crane. (When doing this, set crane boom at right angles to machine body.

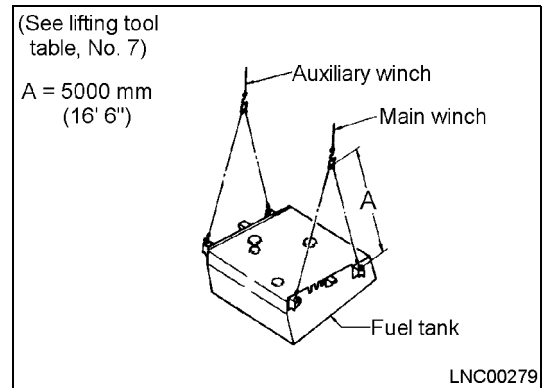

LNC00279

- Install drain tubes of engine, torque converter, and radiator to left side of fuel tank.

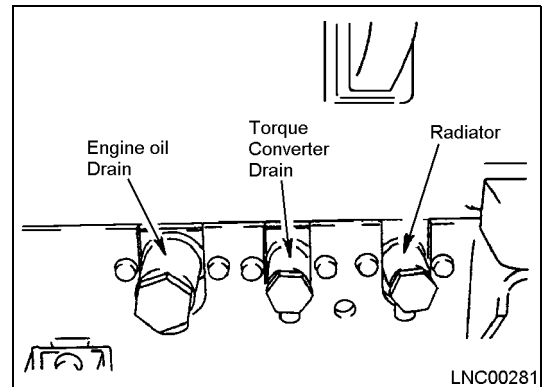

LNC00281

- Connect fuel level sensor wiring harness.

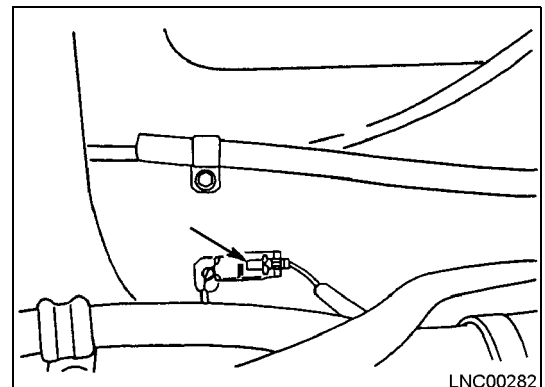

LNC00282

4. Connect fuel suction and return hoses.

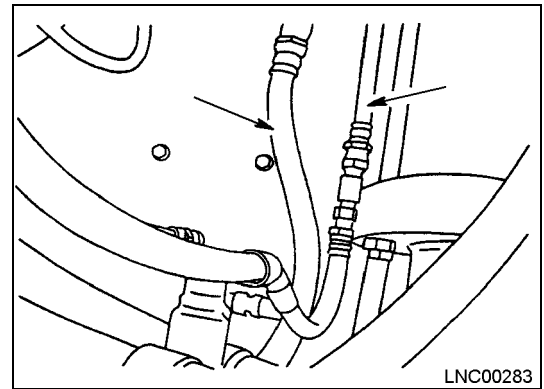

5. Connect blow-by, muffler, and cylinder block drain hoses.

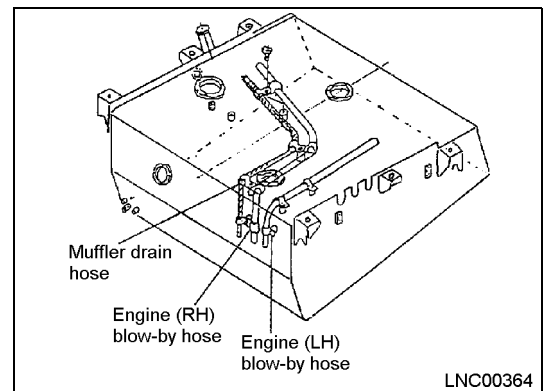

6. Install fuel tank breather tube.

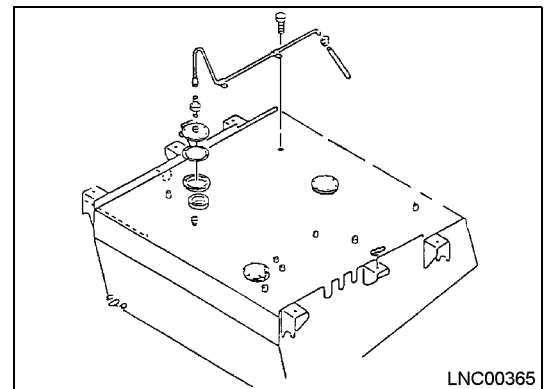

A-6 ASSEMBLY OF LADDER (LEFT/RIGHT)

Tools Required

No.	Description	Qty.
1	Crane, 30 ton	1
2	Impact wrench	1
3	Socket, 17 mm, 24 mm	1

Assembly Parts for Ladder

Mark	No.	Part	Part Number	Qty
o	1	Bolt	01010-51635	2
o	2	Washer	01643-31645	2
o	3	Bolt	01010-51230	2

o: Already temporarily installed to air tank and air component box.

7. Assemble left side ladder to air component box, and right side ladder to hydraulic tank.

NOTE: Ladder assemblies are different. On the right side ladder, the top mounting hole is near top step.

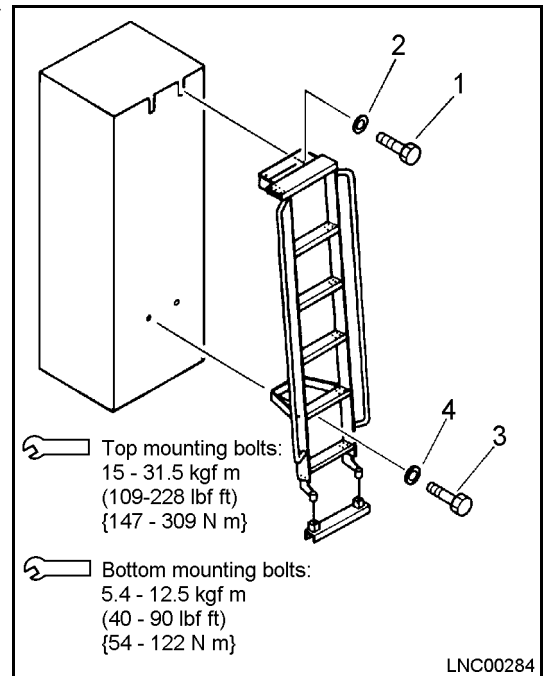

A-7 ASSEMBLY OF CAB

Tools Required

No.	Description	Qty.
1	Lifting tool, 1 ton - 4 point	1
2	Impact wrench	1
3	Socket, 24 mm	1
4	Spanner	1
5	Crane, 30 ton	1

ASSEMBLY PROCEDURE

1. Raise cab assembly slowly, and keep horizontal when lifting.



Cab assembly: 400 kg (882 lbs)

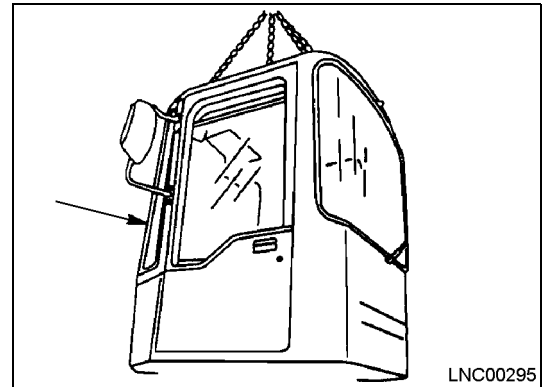

2. When installing cab assembly, do not forget to install seal. Coat seal uniformly with adhesive



Cab Seal: Adhesive (Cemedyne 366E)

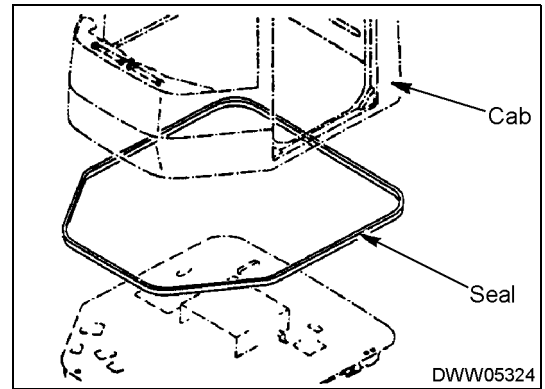

3. Install four mounting bolts at intermediate position, and two mounting bolts at rear of cab.

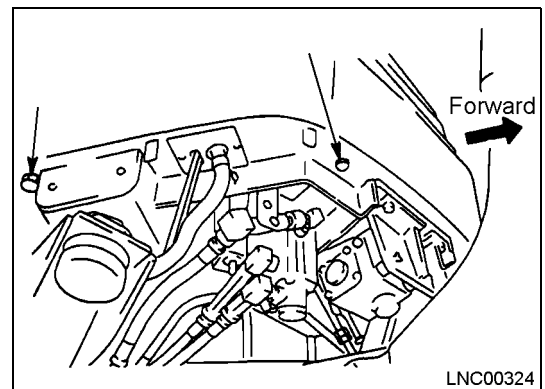

- 4. Set column tilt lever to the unlock position and push steering column fully forward away from operator's seat, then install four bolts at bottom of column.

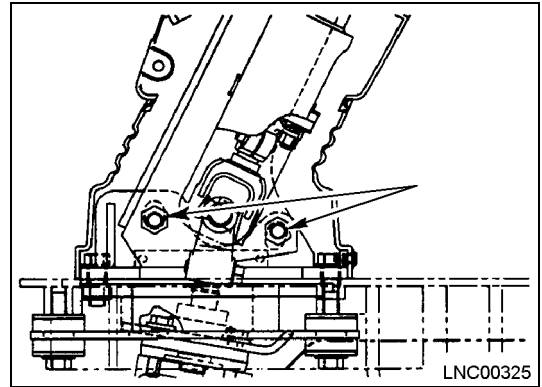

- 5. Pull rubber boot into place and install plastic mounting bolts.

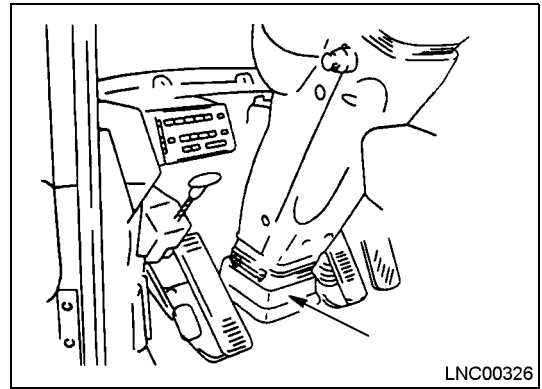

- 6. Install two steering post lock bolts.

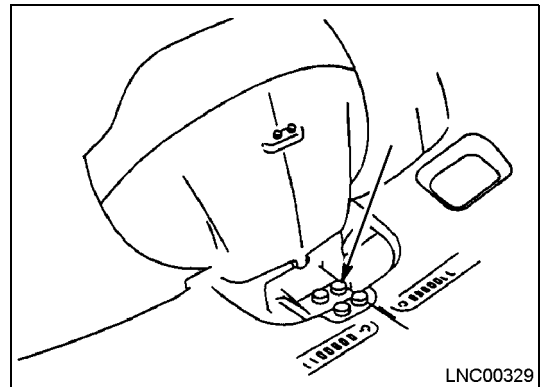

- 7. Connect electrical wiring connectors CN-CL1, CL2, and CL3.
- 8. Connect window washer hose, then fill washer tank with washer fluid.

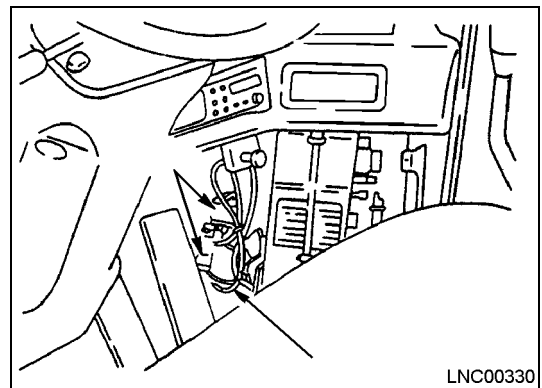

Two washer tanks: 1 L (1 qt.) each

- 9. Install right cover inside cab.

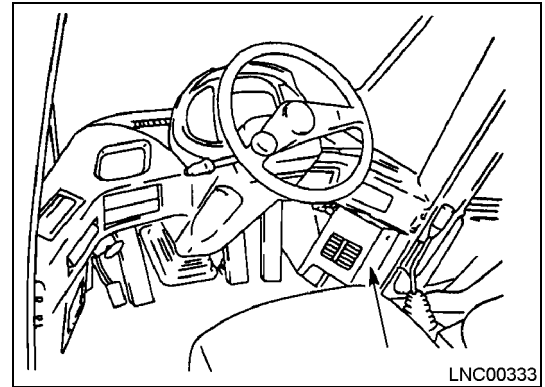

- 10. Install covers at bottom of floor frame.

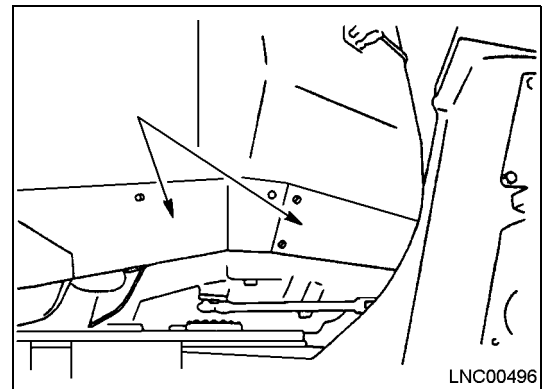

A-8 ASSEMBLY OF HAND RAIL

Tools Required

No.	Description	Qty.
1	Impact wrench	1
2	Socket, 17 mm	1
3	Crane, 30 ton	1
4	Nylon lifting equipment	1

Assembly Parts for Hand Rails

Mark	No.	Part	Part Number	Qty
x	1	Handrail	427-54-25121	1
o	2	Bolt	01435-01230	9
x	3	Handrail	427-54-25141	1
o	4	Bolt	01435-01230	9

- x: Sent as individual part.
- o: Already temporarily installed to floor.

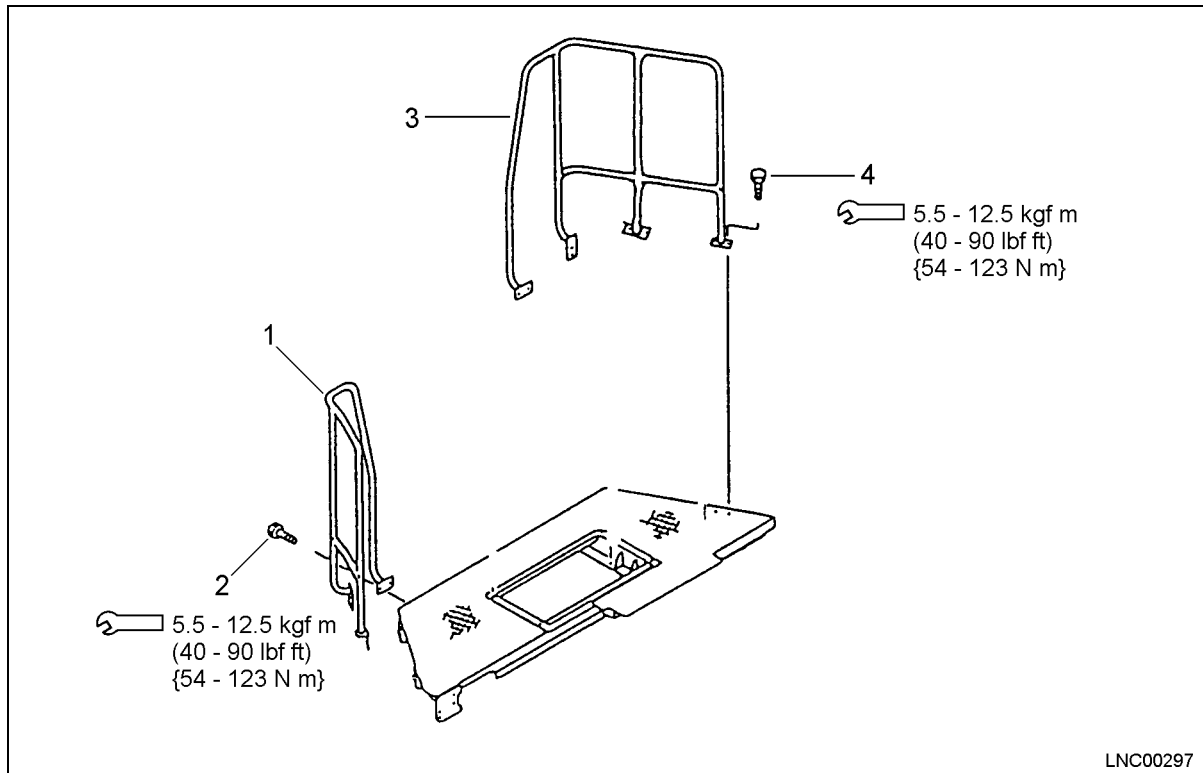

A-9 ASSEMBLY OF REAR TIRE AND WHEEL ASSEMBLIES

Tools Required

No.	Description	Qty.
1	Torque wrench: 84 kgf m (608 lbf ft) {824 N m}	1
2	Socket: 36 mm	1
3	Extension bar	1
4	Crane: 30 ton	1
5	Nylon sling, 150 x 10,000 mm (6" x 33')	1

Assembly Parts for Rear Tire and wheel assemblies

Mark	No.	Part	Part Number	Qty
o	1	Nut	426-22-12930	106
o	2	Washer	01643-32460	106

o: Already temporarily installed to rear axle.

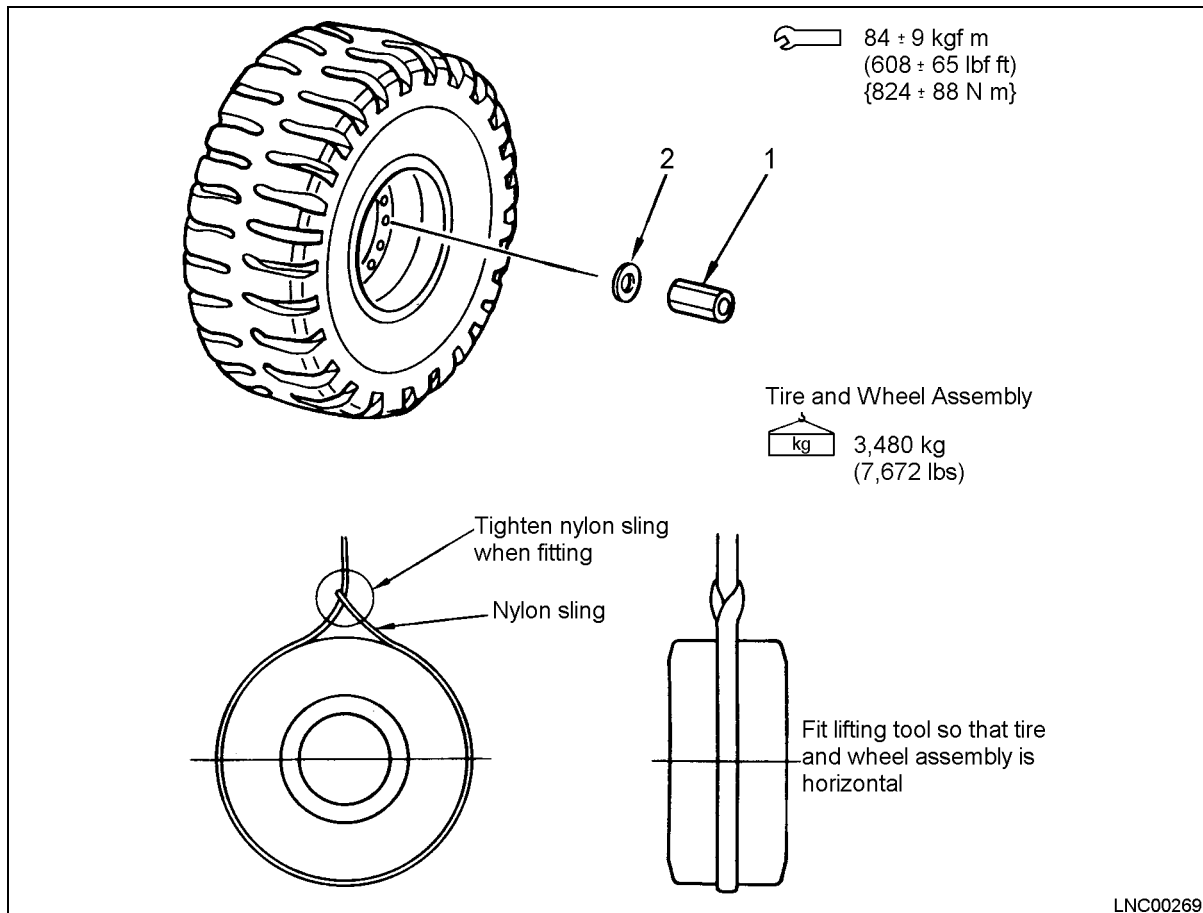

ASSEMBLY PROCEDURE (REAR TIRE AND WHEEL ASSEMBLY)

1. Raise tire and wheel with a crane and set on rear axle, then install lug nuts.
 - When positioning tire and wheel assembly, be careful not damage the tire inflation tube.



Tire and wheel assembly: 3,480 kg (7,672 lbs)

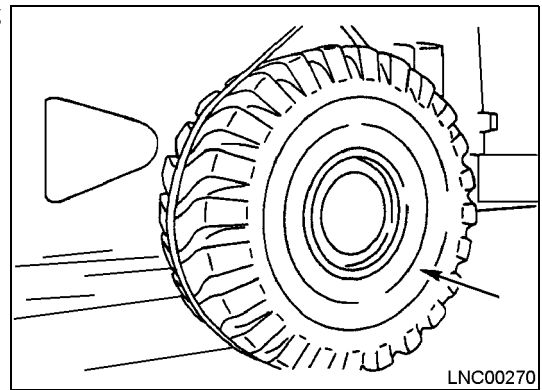

2. Temporarily tighten lug nuts with an impact wrench.
 - This operation is carried out in a high position, and there are [106 lug nuts to tighten, so Komatsu suggests the use of a balancer to support the impact wrench.

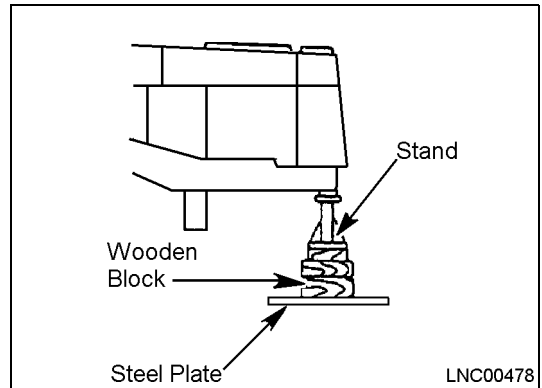

3. Raise rear of machine with a 30 ton crane and remove the supports.

Rear of Machine:



17,960 kg (39,000 lbs)

Crane: 30 ton

Balanced lifting tool
(See lifting tool table, No. 2)

- B = 3900 mm (13')
- C = 2850 mm (9.5')
- D = 2500 mm (8')

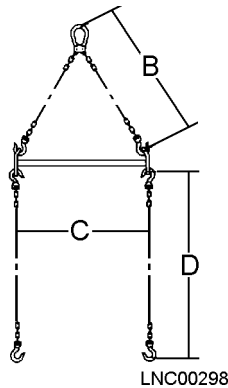

4. Using a torque wrench, tighten lug nuts to specified torque.

A-10 ASSEMBLY OF BATTERY BOXES

Tools Required

No.	Description	Qty.
1	Torque wrench: 10000 QLE	1
2	Socket: 36 mm	1
3	Impact wrench	1
4	Crane (30 ton) or Forklift truck (1 ton)	1
5	Nylon lifting equipment	1

Assembly Parts for Battery Box Components

Mark	No.	Part	Part Number	Qty
o	1	Bolt	01011-32450	4
o	2	Bolt	01011-32470	4
o	3	Washer	01643-32460	8

o: Already temporarily installed to rear frame.

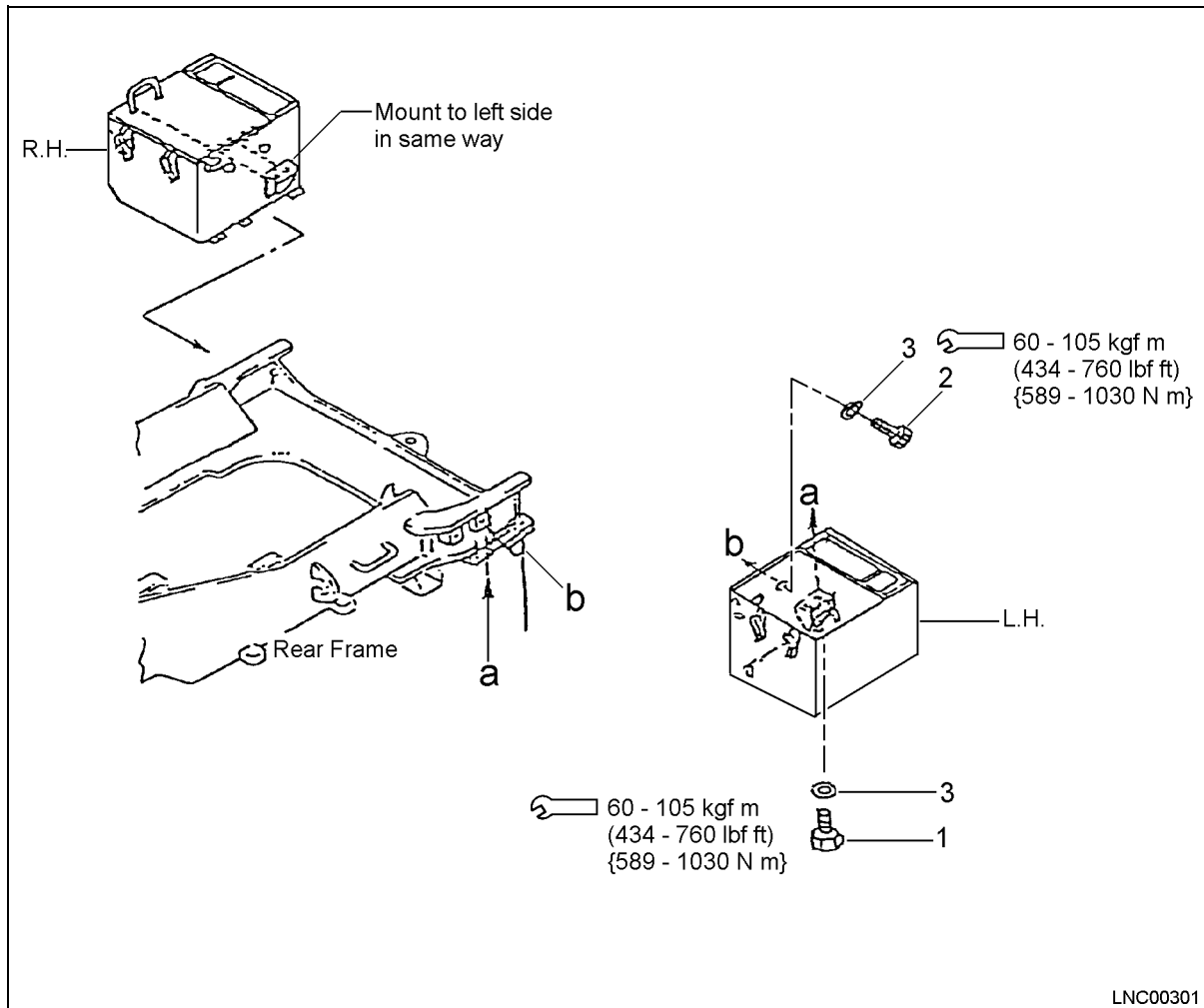

PROCEDURE FOR CONNECTING AND SECURING WIRING INSIDE BATTERY BOX

Tools Required

No.	Description	Qty.
1	Impact wrench	1
2	Socket: 14 mm	1

Assembly Parts for Wiring Harnesses and Wires

Mark	No.	Part	Part Number	Qty
o	1	Cap	08038-00035	2
o	2	Cap	424-09-12540	1
o	3	Clip	04434-51910	3
o	4	Bolt	01435-01016	2

o: Sent as individual parts.

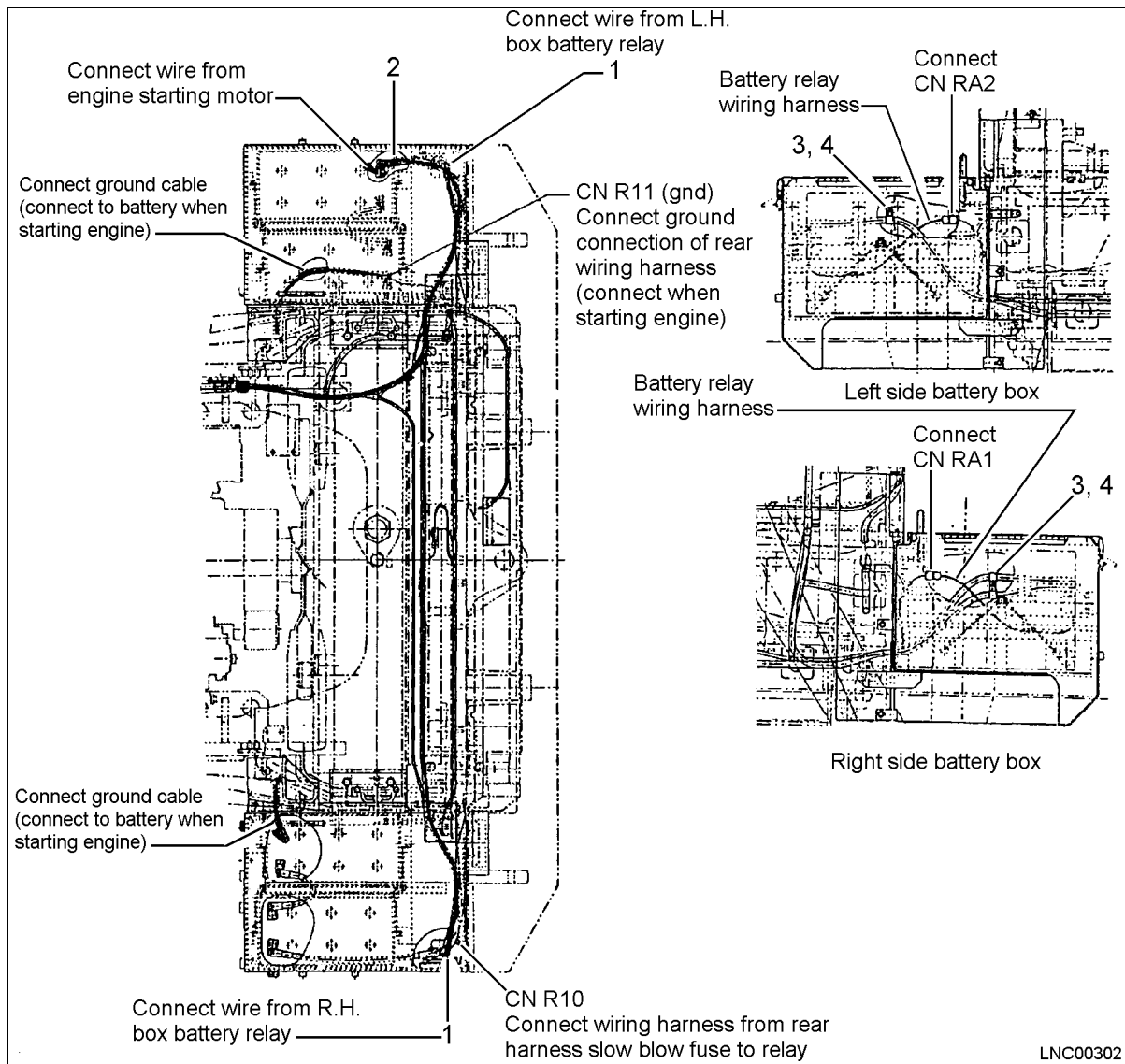

CIRCUIT DIAGRAM

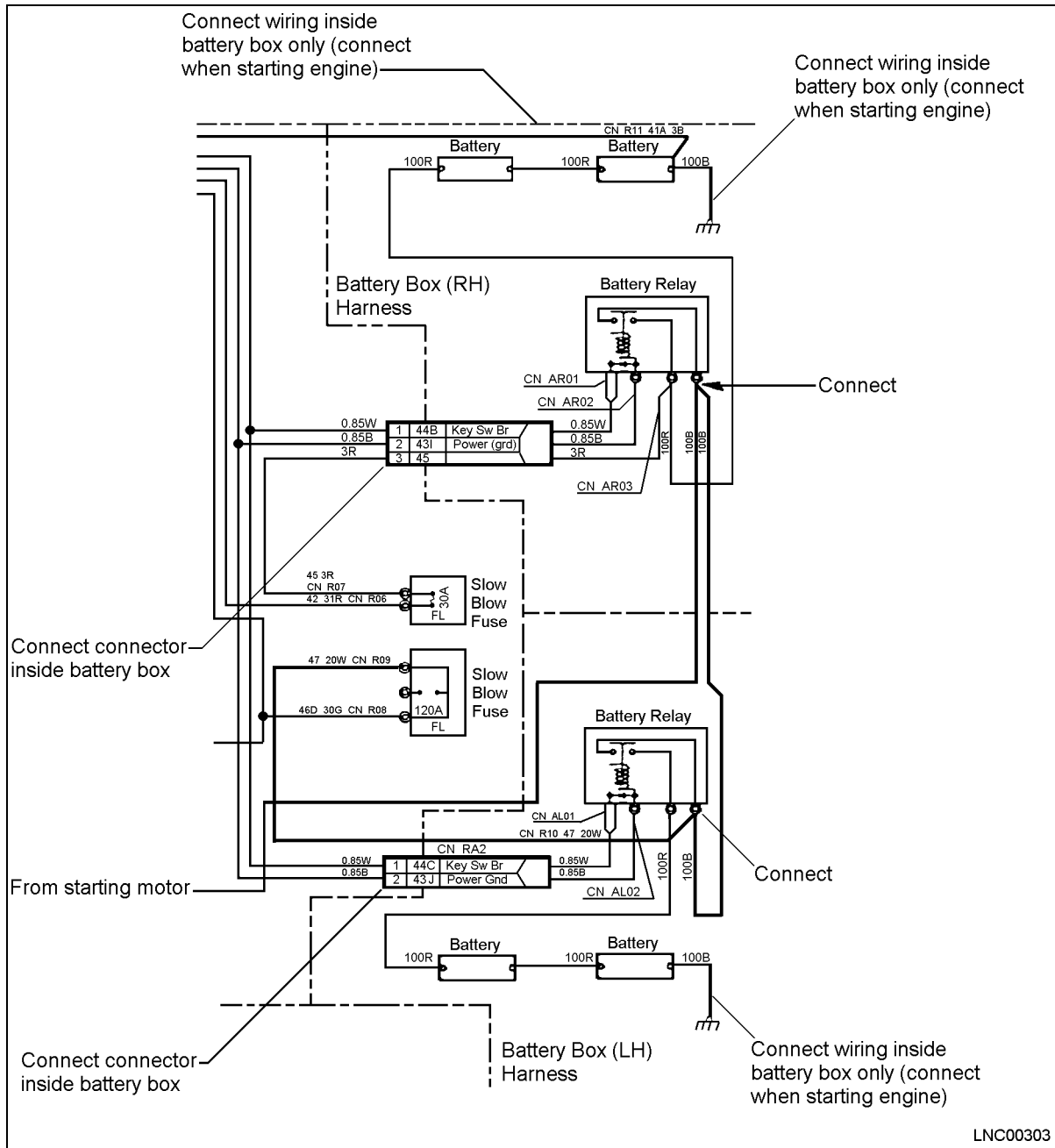

OPERATION FOR INSTALLING BATTERY BOX COVERS

Tools Required

No.	Description	Qty.
1	Impact wrench	1
2	Socket: 17 mm, 30mm	1
3	Forklift truck (1 ton)	1

Assembly Parts for Cover Components

Mark	No.	Part	Part Number	Qty
o	1	Cover, LH	427-06-24130	1
o	2	Cover, RH	427-06-24140	1
o	3	Bolt	01435-01220	6
	4	Cover	427-46-25130	1
x	5	Bolt	01010-82045	4
x	6	Washer	01643-32060	4

No mark: Sent as individual parts.

o: Already temporarily installed to battery boxes.

x: Already temporarily installed to cover.

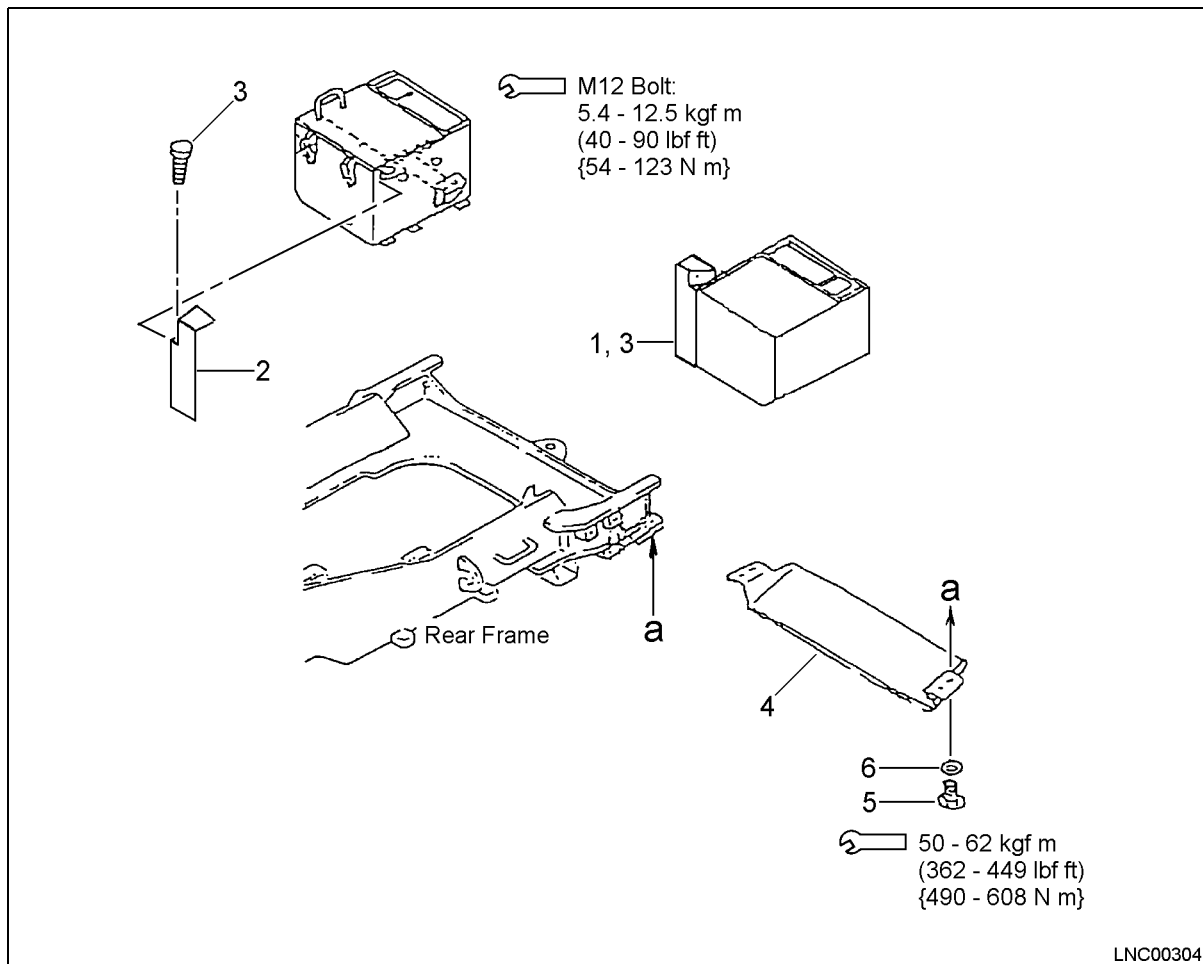

ASSEMBLY OF STEP ASSEMBLIES

Tools Required

No.	Description	Qty.
1	Impact wrench	1
2	Socket: 17 mm	1

Assembly Parts for Steps

Mark	No.	Part	Part Number	Qty
o	1	Step, LH	427-54-22130	1
o	2	Step, RH	427-54-24180	1
x	3	Bolt	01435-01225	12
x	4	Washer	01643-31232	12
x	5	Bolt	01435-01230	8

- o: Sent as individual parts.
- x: Already temporarily installed to battery boxes.

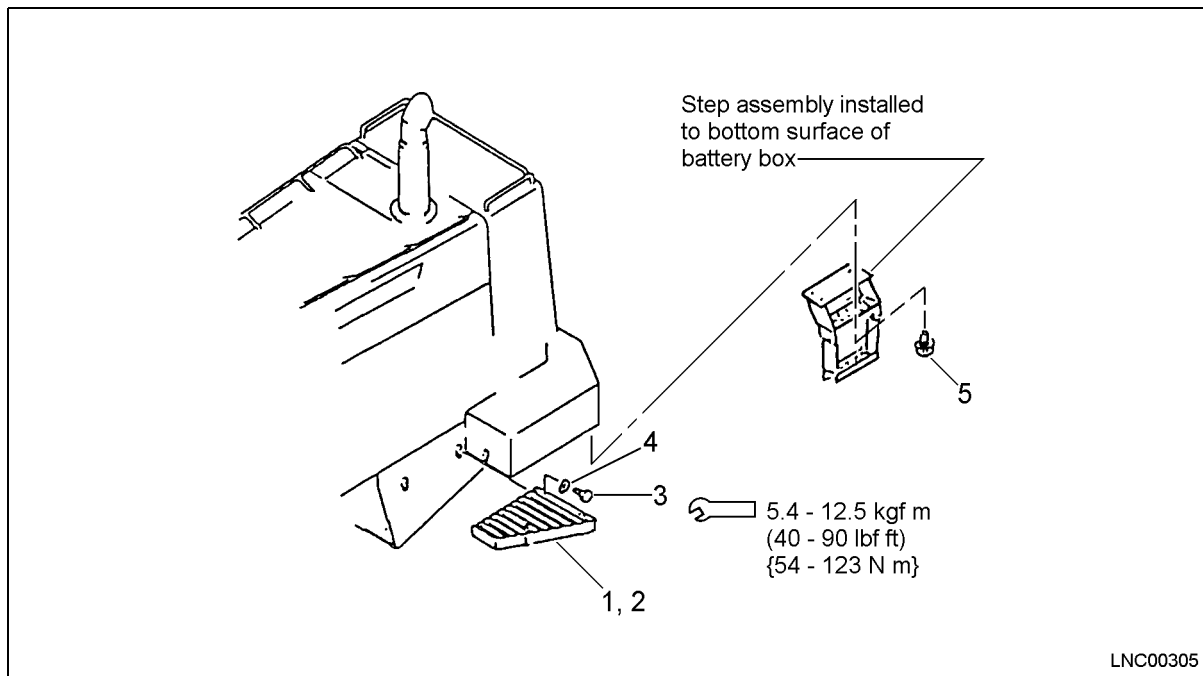

A-11 ASSEMBLY OF COUNTERWEIGHT**OUTLINE****Tools Required**

No.	Description	Qty.
1	Torque wrench: 21000 QLE	1
2	Socket: 46 mm	1
3	Extension	1
4	Impact wrench (for M30)	1
5	Crane, 30 ton	1

Assembly Parts for counterweight

Mark	No.	Part	Part Number	Qty
	1	Counterweight	427-46-25121	1
x	2	Bolt	425-974-1160	6
x	3	Washer	01643-33080	6
	4	Spacer	427-975-1120	4
	5	Counterweight	427-975-2110	1
	6	Bolt	419-09-11180	4
	7	Washer	426-09-11510	4
	8	Cover	427-46-25210	1
	9	Bolt	01010-82045	4
	10	Washer	01643-32060	4
o	11	Pin, towing	427-46-13120	1

No mark: Sent as individual parts.

x: Already temporarily installed to rear of rear frame.

o: Already temporarily installed to counterweight.

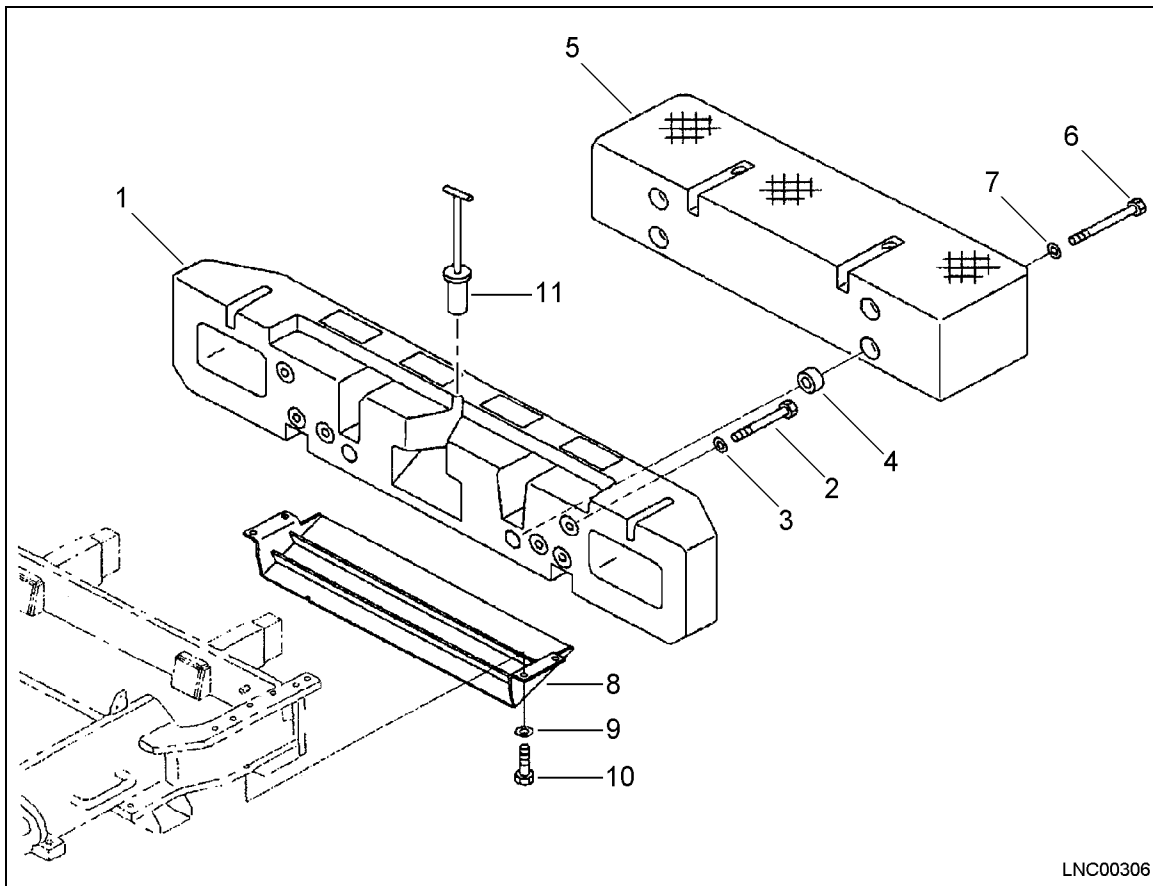

LNC00306

NOTE: When lifting counterweights, be careful to maintain balance.

- Using a forklift and crane, sling counterweight (1) and lift into place. Secure with bolts (2) and washers (3).



Counterweight (1): 2,900 kg (6,394 lbs)
 Counterweight (5): 1,600 kg (3,528 lbs)



Bolt (2): 1530 - 1920 Nm (1129 - 1416 lbf ft)

- Using a forklift and crane, sling counterweight (5) and lift into place. Secure with spacers (4), bolts (6), and washers (7).



Bolts (6): 825 - 1030 Nm (609 - 760 lbf ft)

- Install cover (8) between counterweight and fuel tank with bolts (10) and washers (9).

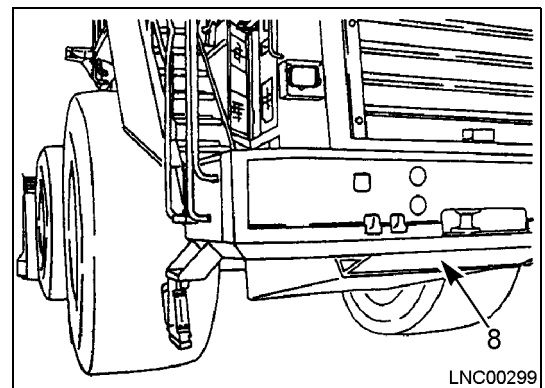

LNC00299

A-12 ASSEMBLY OF EXHAUST PIPE**Tools Required**

No.	Description	Qty.
1	Impact wrench	1
2	Socket: 17 mm	1

Assembly Parts for Exhaust pipe

Mark	No.	Part	Part Number	Qty
o	1	Counterweight	427-02-11121	2
x	2	Plate	427-02-11130	1
x	3	Bolt	01435-01230	6
x	4	Bolt	01435-01250	6

o: Sent as individual parts.

x: Already temporarily installed to top of center hood.

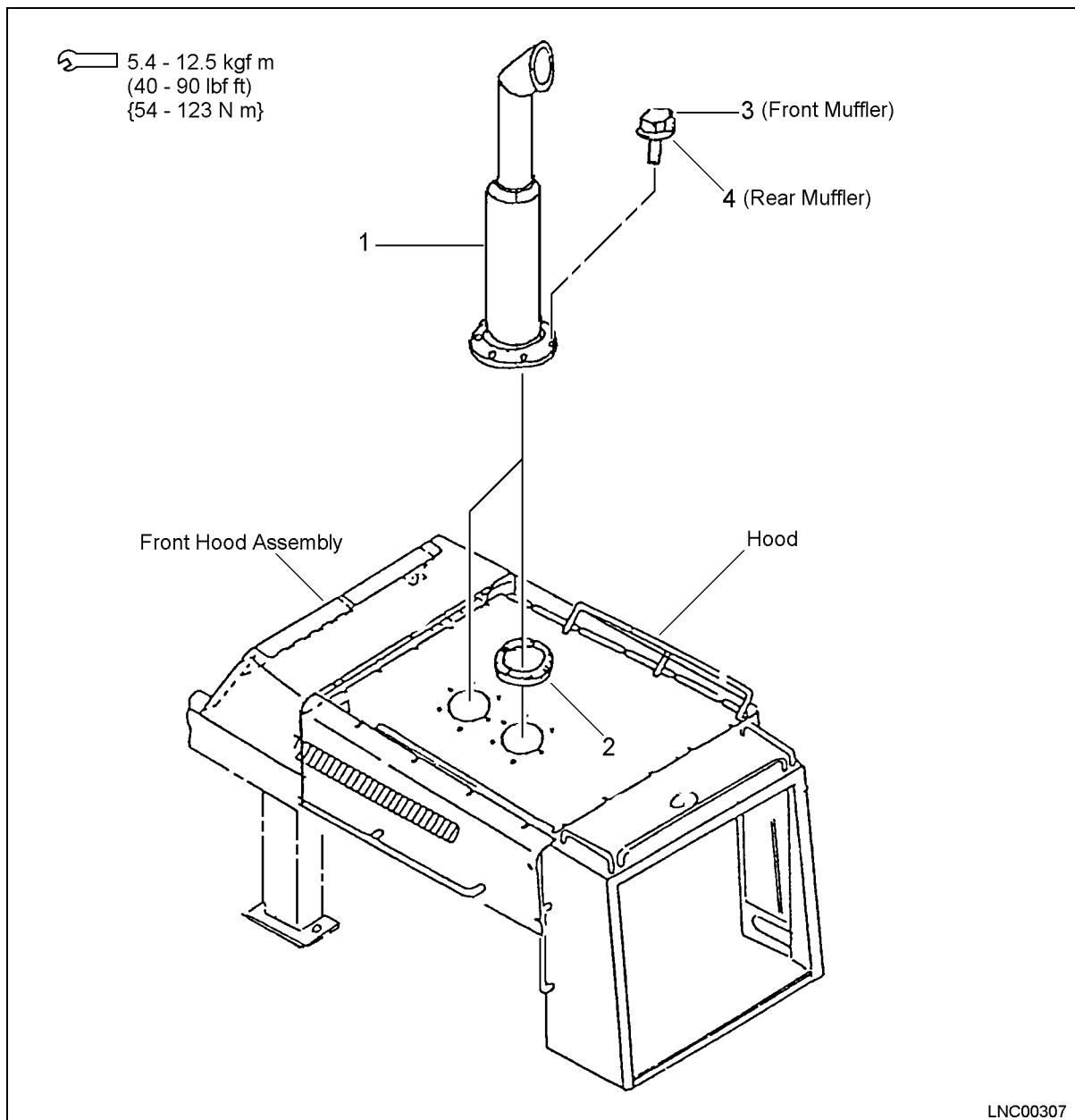

Exhaust Pipe: 22 kg (48.5 lbs) x 2 pieces

A-13 ASSEMBLY OF HANDRAILS AND REAR ACCESS STEPS**ASSEMBLY OF HANDRAILS (RIGHT SIDE AND TOP OF HOOD)****Tools Required**

No.	Description	Qty.
1	Impact wrench	1
2	Socket: 17 mm	1

Assembly Parts for Handrails

Mark	No.	Part	Part Number	Qty
o	1	Handrail	427-54-25191	1
o	2	Bolt	01435-01230	6
o	3	Handrail	427-54-25210	2
x	4	Bolt	01435-01230	16
o	5	Handrail	427-54-25220	1
x	6	Bolt	01435-01230	8
o	7	Handrail	427-54-25230	1
x	8	Bolt	01435-01230	6
o	9	Handrail	427-54-25180	1
x	10	Bolt	01435-01230	4

o: Sent as individual parts.

x: Already temporarily installed to chassis.

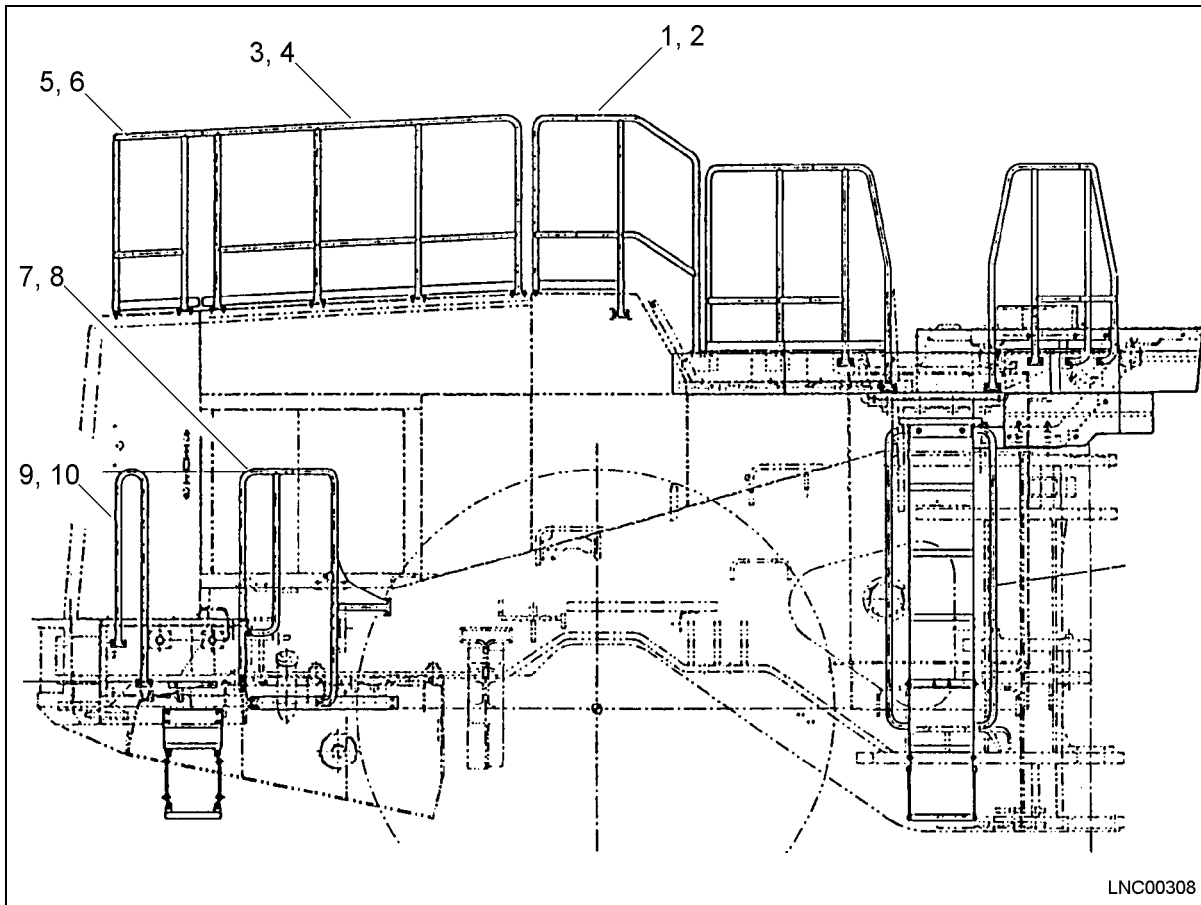

ASSEMBLY OF REAR ACCESS STEP**Tools Required**

No.	Description	Qty.
1	Impact wrench	1
2	Socket: 17, 19, 22, 24 mm	1

Assembly Parts for Rear Access Step

Mark	No.	Part	Part Number	Qty
0	1	Floor	427-54-24142	1
x	2	Bolt	01010-81435	8
x	3	Washer	01643-31445	8
o	4	Step	427-54-24251	1
x	5	Bolt	01010-81435	10
x	6	Washer	01643-31445	10
x	7	Bolt	01010-81635	6
x	8	Washer	01643-31645	6
0	9	Cover	427-54-42191	1
x	10	Bolt	01435-01220	6
x	11	Washer	124-54-26540	6
o	12	Cover	427-54-42260	1
x	13	Bolt	01435-01220	7
x	14	Washer	124-54-26540	7
o	15	Fender	427-54-21580	1
x	16	Bolt	01010-81225	4
x	17	Washer	01643-31232	4

o: Sent as individual parts.

x: Already temporarily installed to chassis.

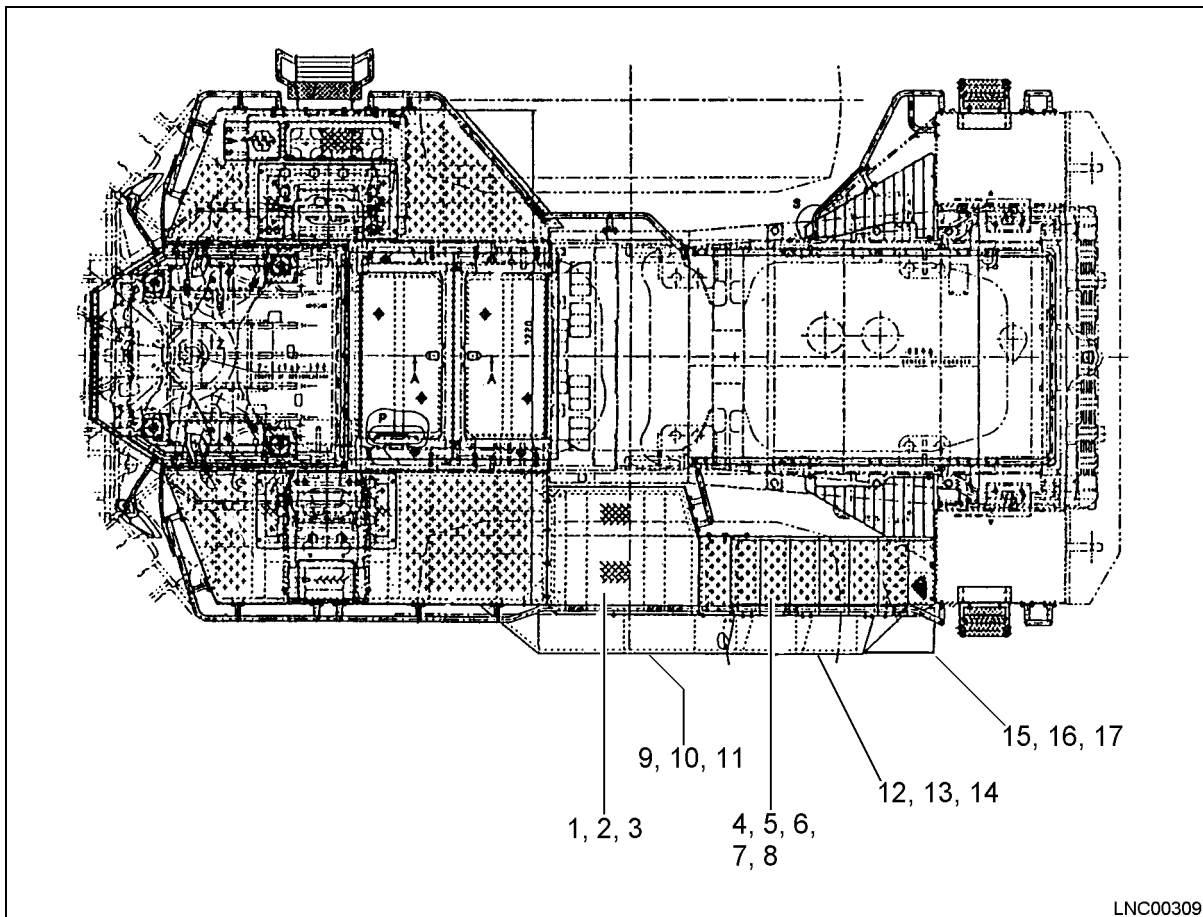

LNC00309

ASSEMBLY OF HANDRAIL (LEFT SIDE) AND MUDGUARD COVER**Tools Required**

No.	Description	Qty.
1	Impact wrench	1
2	Socket: 14, 17, 19 mm	1

Assembly Parts for Hand rail and Cover

Mark	No.	Part	Part Number	Qty
x	1	Handrail (LH)	427-54-25122	1
o	2	Bolt	01435-01230	9
x	3	Handrail	427-54-25132	1
o	4	Bolt	01435-01230	10
x	5	Handrail	427-54-25161	1
o	6	Bolt	01435-01225	4
o	7	Bolt	01435-01230	4
x	8	Handrail	427-54-25170	1
o	9	Bolt	01435-01230	4
x	10	Plate	427-54-21560	1
x	11	Rubber	427-54-21571	1
x	12	Bolt	01435-01020	3
x	13	Bracket	427-54-25260	1
o	14	Bolt	01435-01020	2
x	15	Handrail	427-54-25151	1
0	16	Bolt	01435-01230	6

o: Sent as individual parts.

x: Already temporarily installed to chassis.

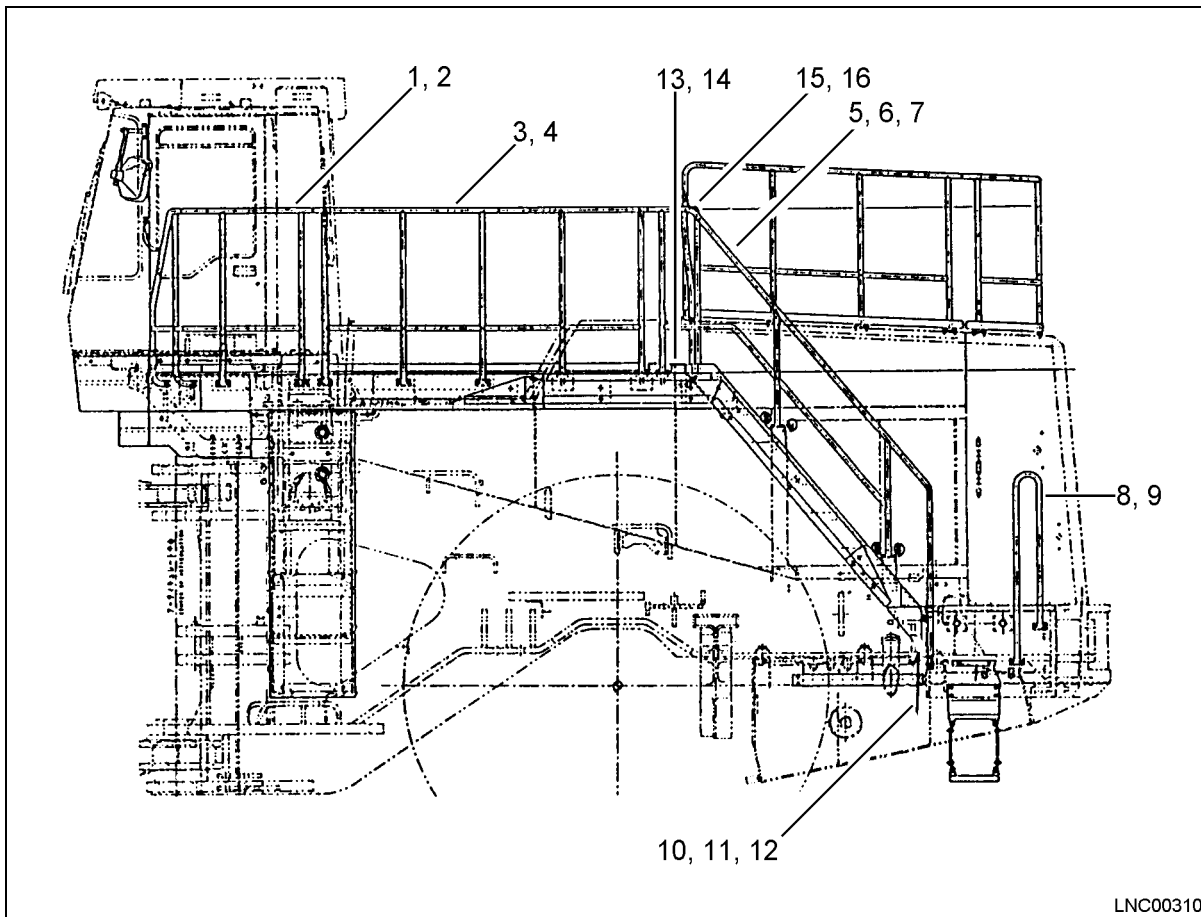

LNC00310

ASSEMBLY OF SAFETY CABLE AND MIRRORS**Tools Required**

No.	Description	Qty.
1	Impact wrench	1
2	Socket: 14 mm	1

Assembly Parts for Safety Cable and Mirrors

Mark	No.	Part	Part Number	Qty
#	1	Cable (safety)	427-54-25250	3
#	2	Hose	09483-00508	3
#	3	Pin	04052-11038	3
#	4	Washer	01643-31032	3
#	5	Hose	427-54-25240	3
x#	6	Bolt	01435-01020	3
o	7	Stay (LH)	426-54-25710	1
o	8	Stay (RH)	426-54-25720	1
x	9	Bolt	01435-01025	8
x	10	Cap	353-54-31450	8
o	11	Mirror (outside)	421-54-25610	2
o	12	Spring pin	04025-00632	2

o: Sent as individual parts.

x: Already temporarily installed to cab.

#: Already temporarily installed to handrail.

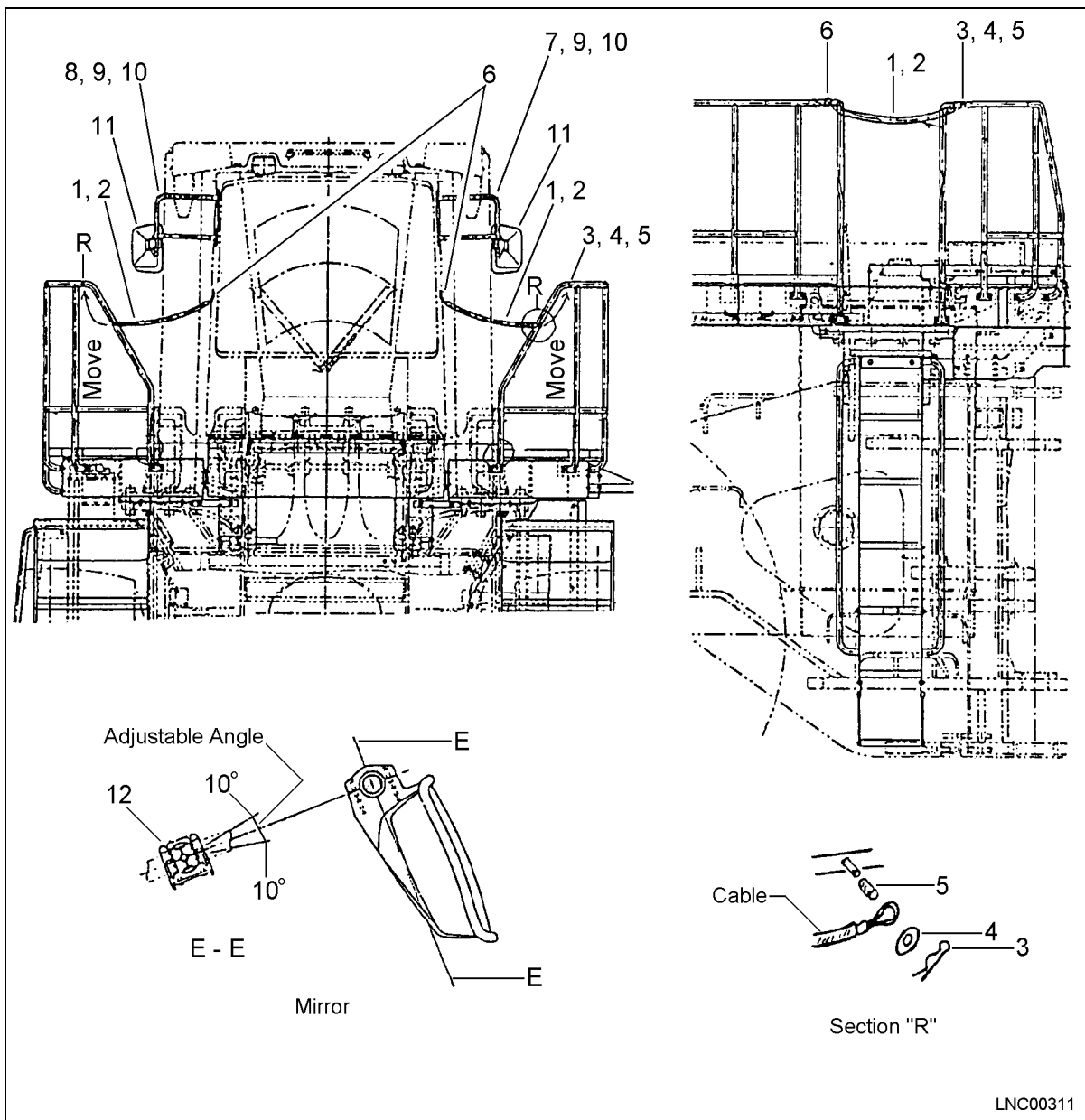

LNC00311

A-14 ASSEMBLY OF BOOM**BOOM ASSEMBLY****Tools Required**

No.	Description	Qty.
1	Impact wrench	1
2	Socket: 14, 17, 19 mm	1

Assembly Parts for Boom

Mark	No.	Part	Part Number	Qty
o	1	Pin (for pivot at front frame end)	427-70-11993	2
	2	Shim (for pivot at front frame end)	427-70-11460	4
o	3	Bolt (for pivot at front frame end)	01010-52450	2
o	4	Washer (for pivot at front frame end)	427-70-11480	2
	5	Shim (for pivot at front frame end)	427-70-11470	2
x	6	Pin (for connecting boom cylinder and rod)	427-70-11971	2
x	7	Bolt (for connecting boom cylinder and rod)	01010-52035	2
x	8	Washer (for connecting boom cylinder and rod)	427-70-11290	2
%	9	Pin	427-70-11941	1
@	10	Plug	07049-01620	15
#	11	Bolt	01010-52035	1
#	12	Washer	427-70-11290	1

No mark: Sent as individual parts.

o: Already temporarily installed to front frame pivot.

x: Already temporarily installed to boom pivot.

@: Already temporarily installed to pin.

#: Already temporarily installed to bellcrank pivot.

?: Already temporarily installed to bellcrank.



WARNING! Before assembling boom, start engine. For details, see M-6 procedure for starting engine.



WARNING! When aligning pin holes, always use a pry bar, never insert your fingers in the pin holes, personal injury may occur.

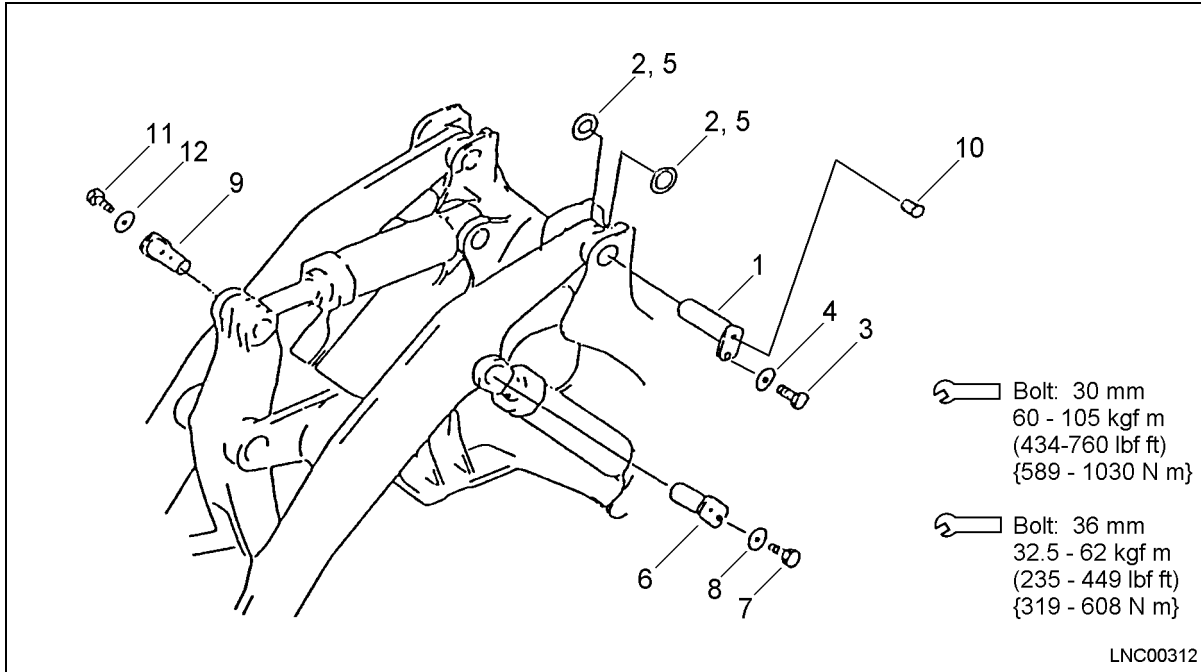

CONNECTION OF REMOTE GREASE TUBE

Tools Required

No.	Description	Qty.
1	Impact wrench	1
2	Socket: 14, 17, 19 mm	1

Assembly Parts for Remote Tube Line

Mark	No.	Part	Part Number	Qty
o	13	Elbow	426-70-13270	1
x	14	Elbow	07217-50712	4

- o: Already installed to pin temporarily installing bellcrank.
- x: Already installed to pin temporarily installing front frame boom pivot

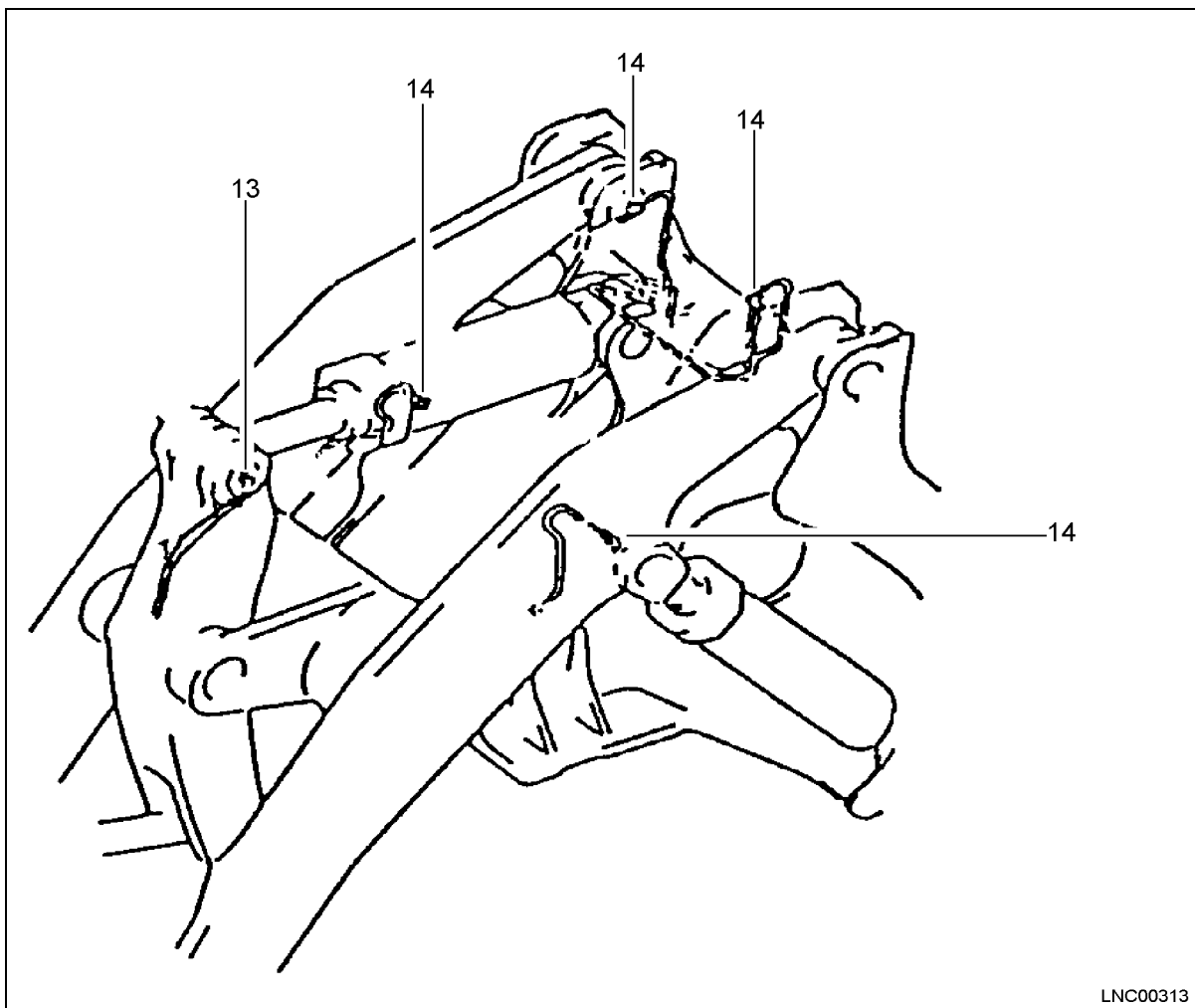

LNC00313

ASSEMBLY PROCEDURE

1. Level loader with crib blocks before installing lift arm assembly.
 - Loader should be level when installing boom assembly to eliminate binding, and insure proper shimming during assembly.

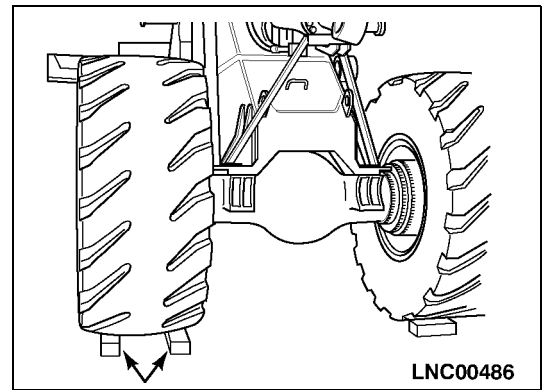

2. Hold bucket cylinder in place with a second crane.

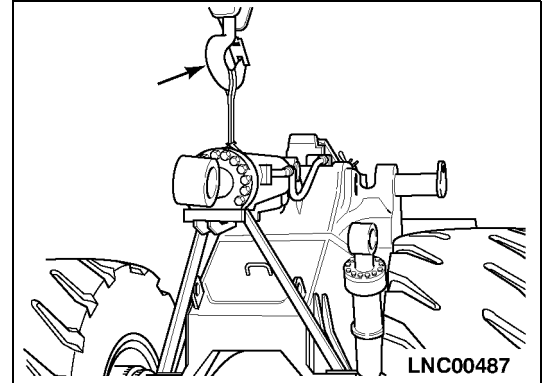

3. Remove front A-frame brace for holding bucket cylinder in place during shipping.

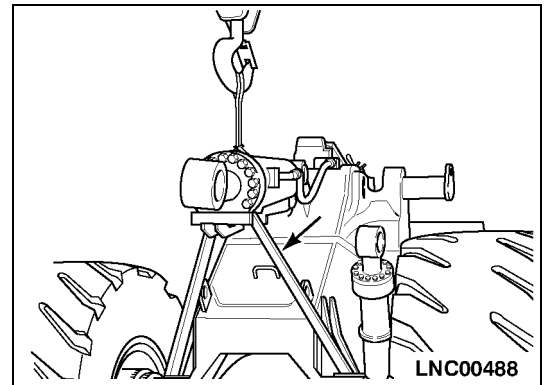

4. Holding dump and lift cylinders using a lever block.

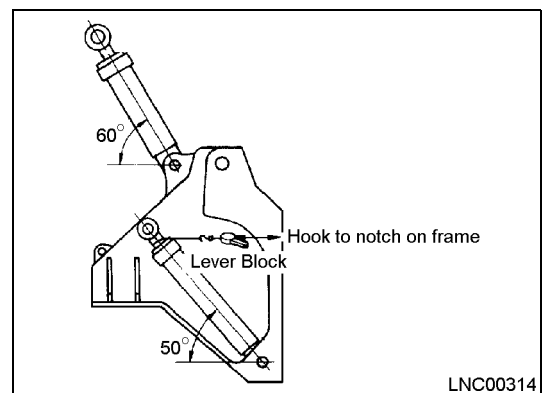

5. Raise boom assembly with a crane and a No 6A wire sling (40 x 1500 mm [1.5" x 5']), move above front frame, set in position, and then insert hinge pins.

- Use caution to balance boom assembly, and be careful not to damage cab
- When aligning position of pin hole, use a bar. Never put your fingers in the pin hole.
- Before inserting pins, wipe inside surface of front frame and boom holes with a cloth, then coat inside of bushings in boom hole with molybdenum disulfide paste LM-P.

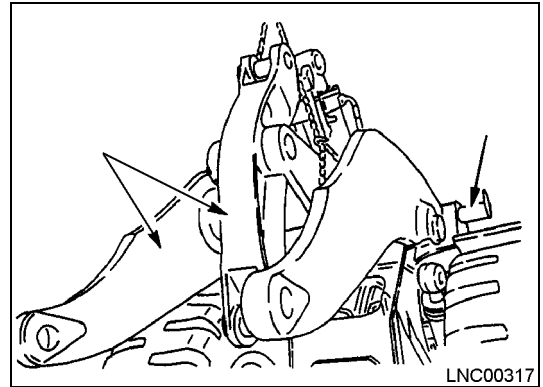

- Before inserting pin, adjust with shims so the clearance is less than specified to the right. Adjust so that clearance is equal on both left and right sides.
- When inserting pins, coat seals with grease, and be careful not to damage seals.
- When raising boom assembly, be careful not to hit and damage the pin at lifting point.

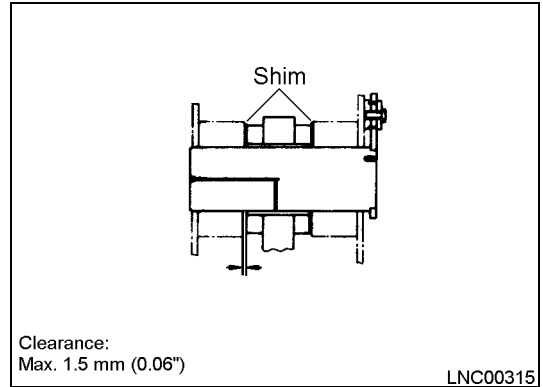

6. Connect grease tubes to left and right boom hinge pins.

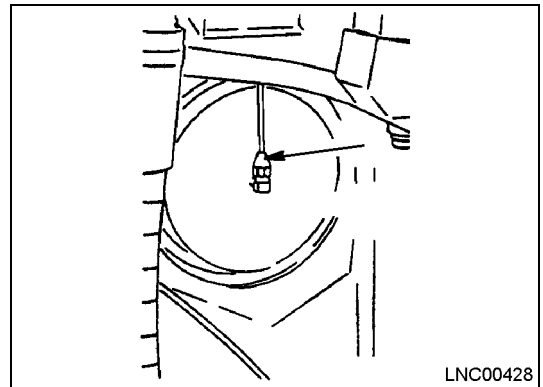

7. Insert lift cylinder head pin after adjusting position at boom end and lift cylinder end.

- When aligning position of pin hole, use a bar. Never put your fingers in the pin hole.
- Before inserting pins, wipe inside surfaces of boom and lift cylinder holes with a cloth, then coat inside of bushings in lift cylinders with molybdenum disulphide paste LM-P.
- When inserting pins, coat seals with grease, and be careful not to damage seals.

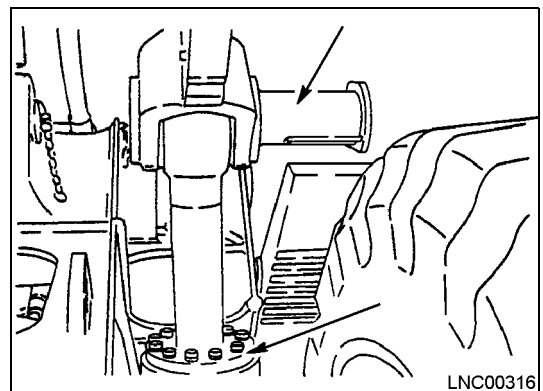

8. Connect grease tube to lift cylinder mounting pin.

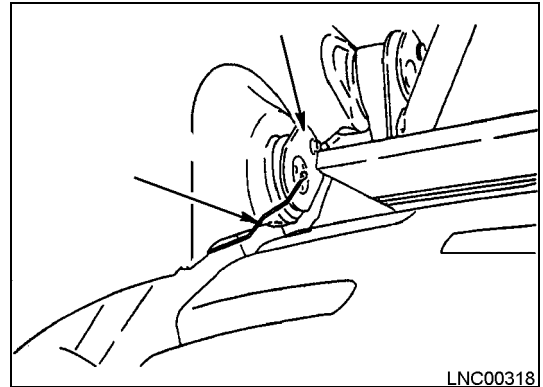

9. Using a crane, raise dump cylinder head and adjust into position, then insert dump cylinder head pin and connect grease line to pin.
- When aligning position of pin hole, use a bar. Never put your fingers in the pin hole.
 - Start engine, then raise boom and adjust position of the hole.
 - Before inserting pin, wipe inside surfaces of bellcrank and dump cylinder holes with a cloth, then coat inside of bushing in bellcrank with molybdenum disulfide paste LM-P.
 - When inserting pins, coat seals with grease, and be careful not to damage seals.
 - After assembling, fill with molybdenum disulfide lithium grease, until grease comes out from joints.

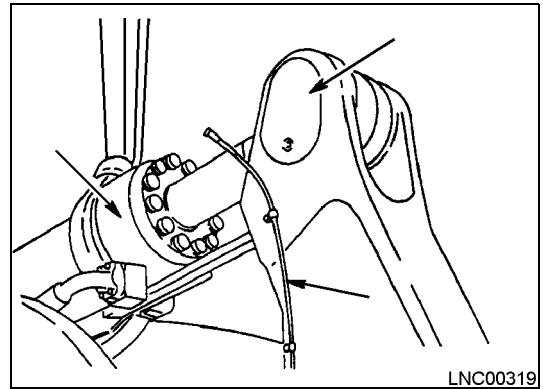

A-15 ASSEMBLY OF FRONT FENDERS**Tools Required**

No.	Description	Qty.
1	Impact wrench	1
2	Socket: 19, 24 mm	1
3	Torque wrench	1
4	Crane, 30 ton	1
5	Lifting wire	1

Assembly Parts for Fenders

Mark	No.	Part	Part Number	Qty
x	1	Bolt	01010-81635	6
x	2	Washer	01643-31645	6
x	3	Bracket, LH	427-54-13380	1
x	4	Bracket, RH	427-54-13410	1
x	5	Bolt	01010-81230	4
x	6	Bolt	01010-81245	4
x	7	Washer	01643-31232	8
x	8	Cap	09415-05016	6
o	9	Fender, LH	427-54-24152	1
o	10	Fender, RH	427-54-24162	1
#	11	Bolt	01010-81230	16
#	12	Washer	124-54-26540	16

- o: Sent as individual parts.
x: Already temporarily installed to left and right of front frame.
#: Already temporarily installed to fender.

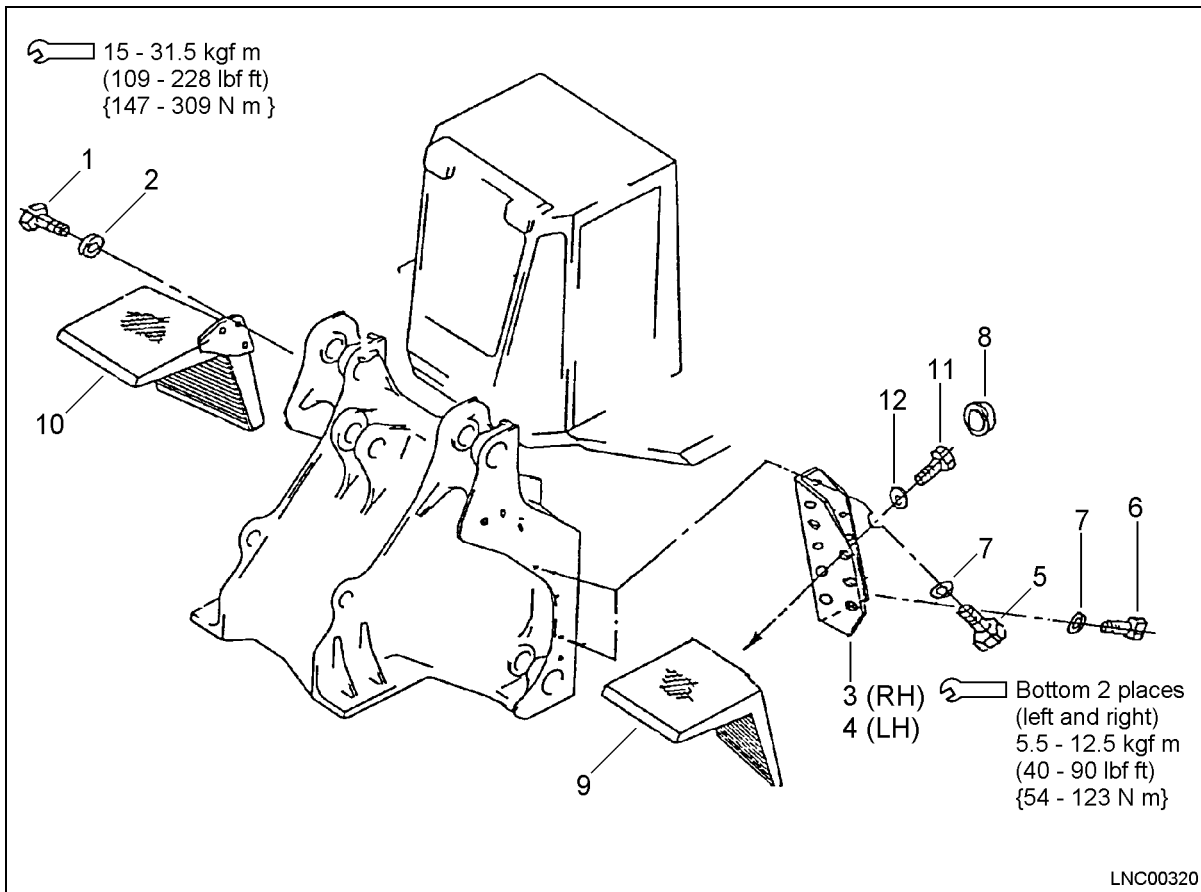

A-16 ASSEMBLY OF FRONT LAMP ASSEMBLIES

Tools Required

No.	Description	Qty.
1	Nylon lifting equipment	1
2	Impact wrench	1
3	Socket: 17 mm	1
4	Crane, 30 ton	1

Assembly Parts for Front Lamp Assemblies

Mark	No.	Part	Part Number	Qty
x	1	Bolt	01435-01245	8
	2	Clip		1
	3	Bolt		1
	4	Washer		1

x: Already temporarily installed to left and right of front frame.

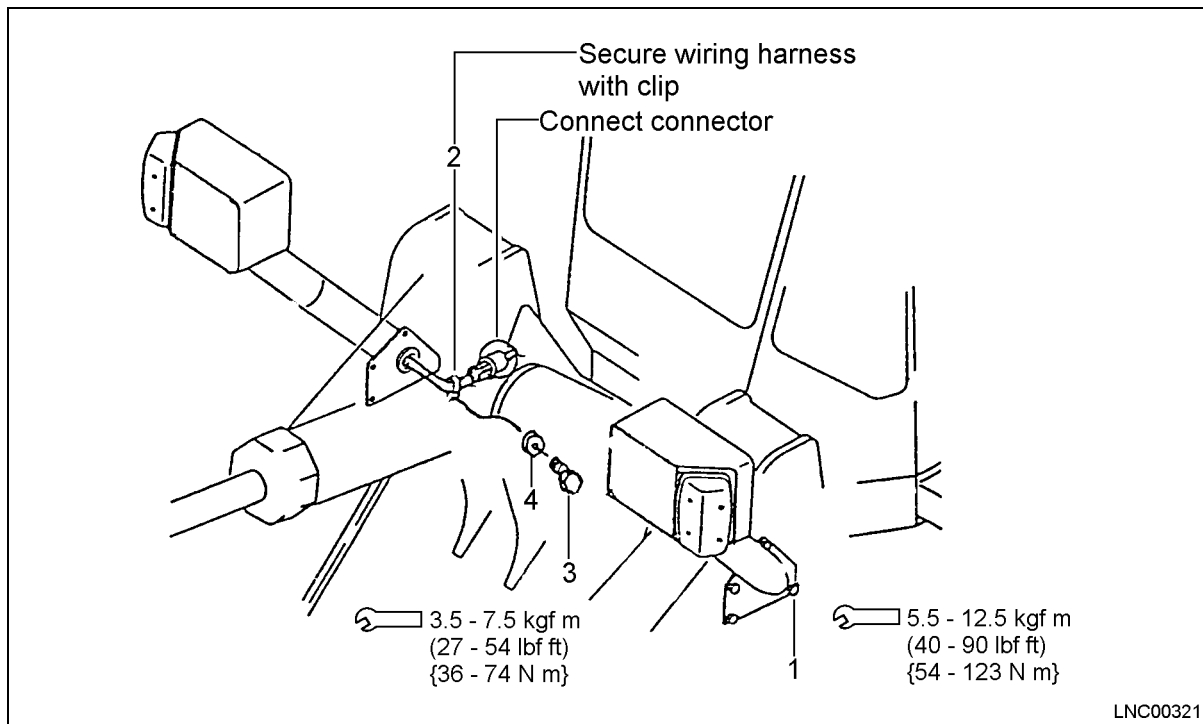

A-17 ASSEMBLY OF ROPS CANOPY

Operation for removal and installation of ROPS canopy support cover

Tools Required

No.	Description	Qty.
1	Impact wrench	1
2	Socket: 17 mm	1

Assembly Parts for ROPS canopy components

Mark	No.	Part	Part Number	Qty
x	1	Cover	427-54-24210	2
x	2	Bolt	01435-01220	8

x: Already temporarily installed to chassis.

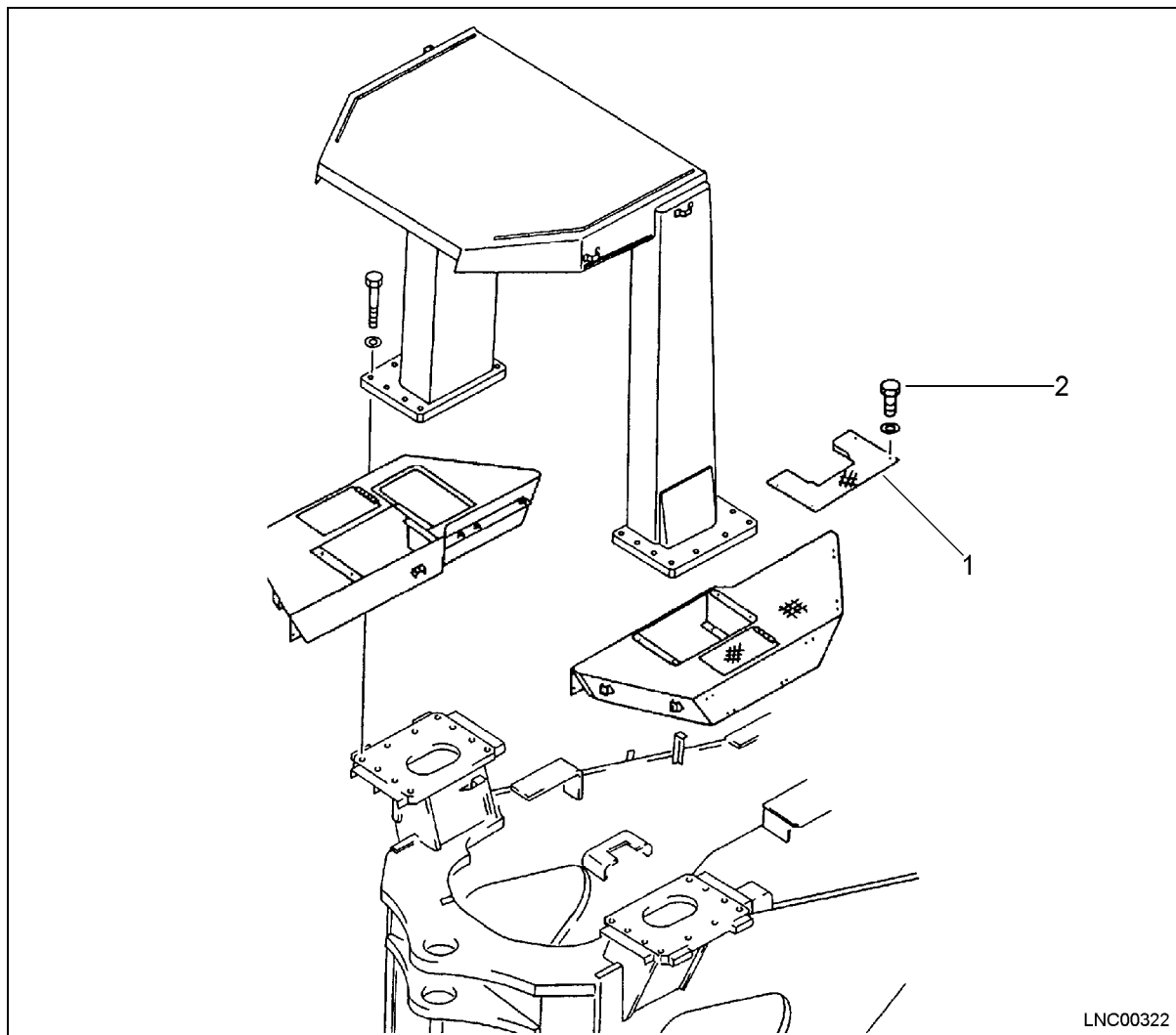

Operation for installing ROPS canopy and wiring.**Tools Required**

No.	Description	Qty.
1	Impact wrench	1
2	Socket: (HEX: 55 mm)	1
3	Torque wrench	1
4	Crane, 30 ton	1
5	Lifting wire	1
6	Spanner	1
7	Power wrench (x 16)	1
8	Extension	1

Assembly Parts for ROPS Canopy

Mark	No.	Part	Part Number	Qty
x	1	Bolt	01010-63650	30
x	2	Washer	01643-33690	30
o	3	Screw	01220-70412	2
o	4	Grommet	421-921-2410	1
o	5	Lamp	421-06-23310	2
o	6	Plate	427-06-13180	2
o	7	Work lamp	421-06-23350	1
o	8	Plate	427-06-22320	1
#	9	Bolt	01435-01220	2

o: Sent as individual parts.

x: Already temporarily installed to chassis.

#: Already temporarily installed to ROPS canopy.

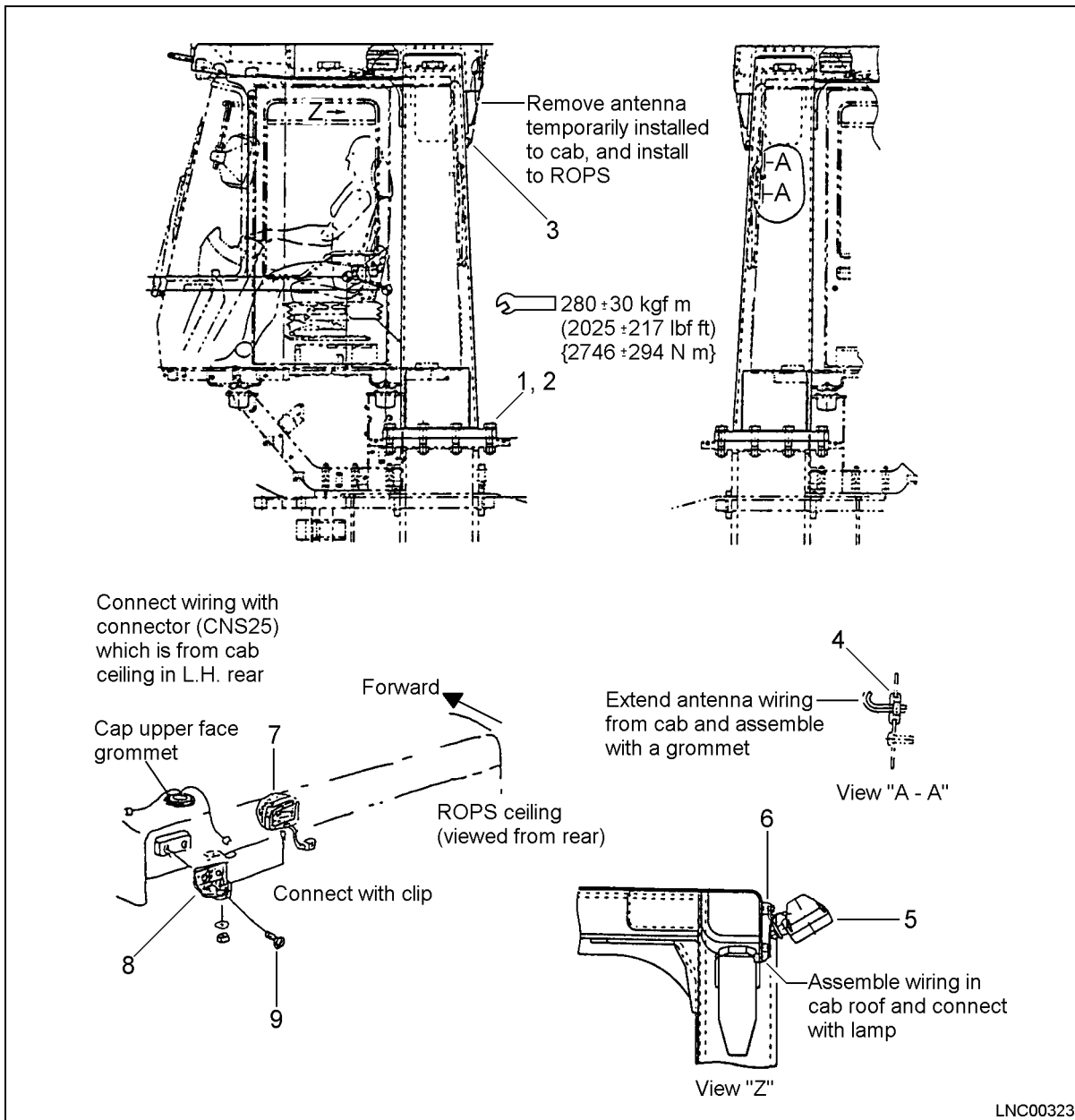

ASSEMBLY PROCEDURE

Tools Required

No.	Description	Qty.
1	Impact wrench	1
2	Socket: (HEX: 55 mm)	1
3	Torque wrench	1
4	Crane, 30 ton	1
5	Extension bar	1
6	Power wrench (x 16)	1
7	Torque wrench: 54 lbf ft (7.5 kgf m) {74 N m}	1

1. Remove canopy cover temporarily installed to top of floor frame.
2. Remove antenna installed to cab, then assemble wiring harness for side working lamp.

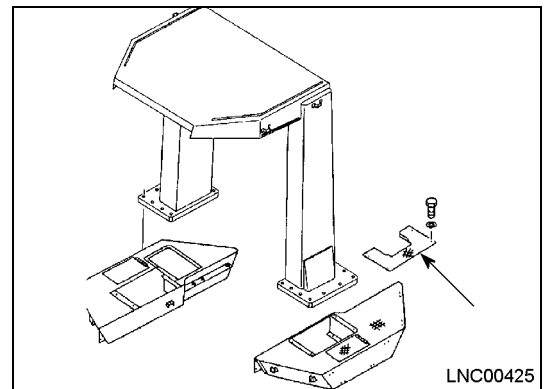

3. Using a 30 or 45 ton crane, raise ROPS canopy assembly and set into position on mounts, then tighten ROPS mounting bolts to specified torque with a power wrench and torque wrench.

ROPS Canopy



Crane: 30 ton

2 point suspension
(See lifting tool table, No. 8)

A = 2000 mm (7')

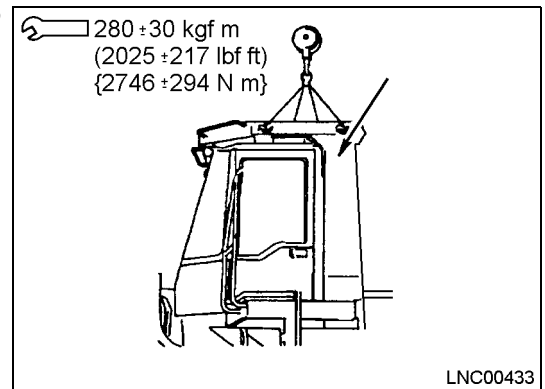
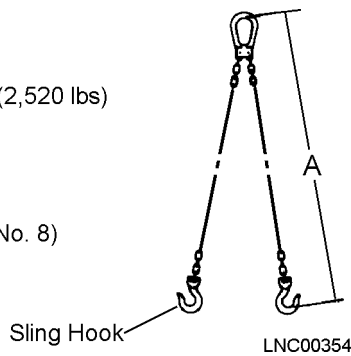

- 4. Assemble antenna to ROPS canopy, then assemble side working lamp, and connect wiring harness with connector CNS25 from cab ceiling in left rear.

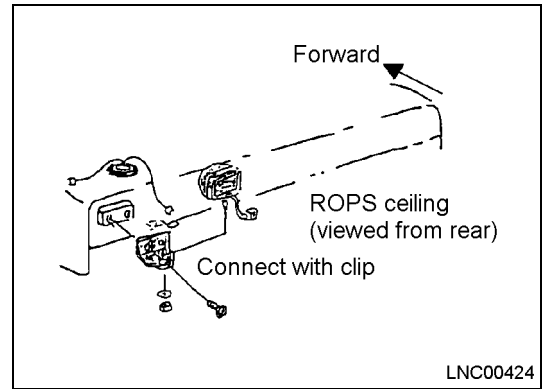

- 5. Install canopy cover (removed in step 1), with bolt to top of floor frame.

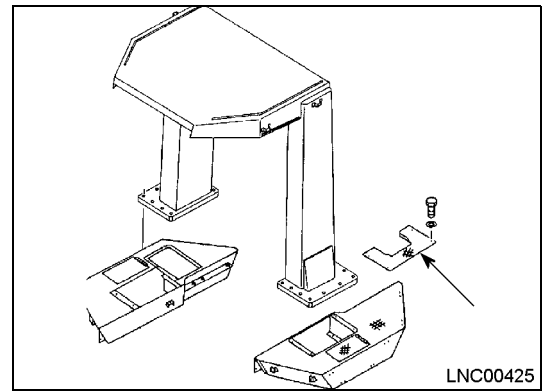

A-18 ASSEMBLY OF BUCKET

Tools Required

No.	Description	Qty.
1	Nylon lifting equipment	1
2	Socket: (HEX: 30 mm)	1
3	Impact wrench	1
4	Crane, 30 ton	1
5	Hammer	1

Assembly Parts for Bucket Link

Mark	No.	Part	Part Number	Qty
x	1	Pin	427-N42-1121	30
x	2	Bolt	01010-82035	30
x	3	Washer	427-70-11290	2
o	4	O-ring	427-N42-1210	1

- o: Sent as individual parts.
- x: Already temporarily installed to boom assembly.

Operation for Installation of Bucket Link

1. Wipe off all grease, dirt, and foreign material stuck to bucket link bushing and inside surface of the seal and pin.
2. Coat bucket link bushings and inside surface of seal with KES LM-P molybdenum disulphide paste.
3. Temporarily install O-ring (4) to bucket link, and align bellcrank to position of the hole. Install bucket link so that grease fittings faces down.
4. Insert pin (1) and tighten bolt (2).

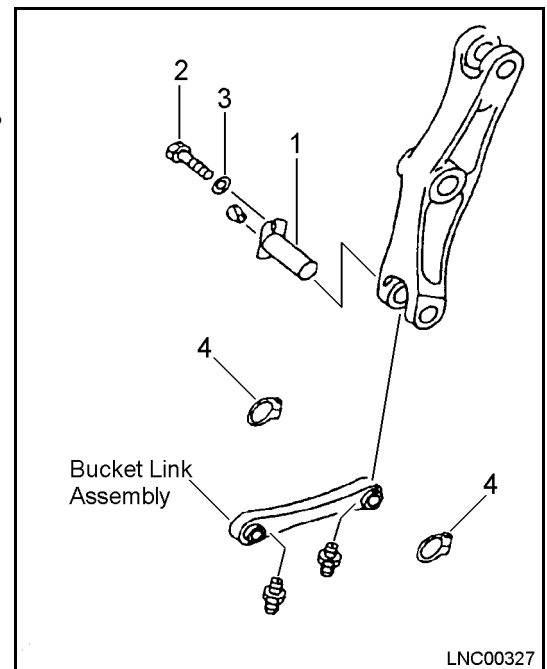

Assembly Parts for Bucket

Mark	No.	Part	Part Number	Qty
	1	Pin	427-N42-1150	1
	2	Pin	427-N42-1160	2
	3	Bolt	01010-82035	3
	4	Washer	427-70-11290	3
	5	O-ring	427-N42-1210	6
	6	Shim, T = 1.5 mm (0.06")	427-70-11440	6
	7	Shim, T = 3.0 mm (0.12")	427-70-11450	6

No mark: Sent as individual parts.

Apply grease (molybdenum disulphide grease) to grease fittings for lubricating bucket pins.

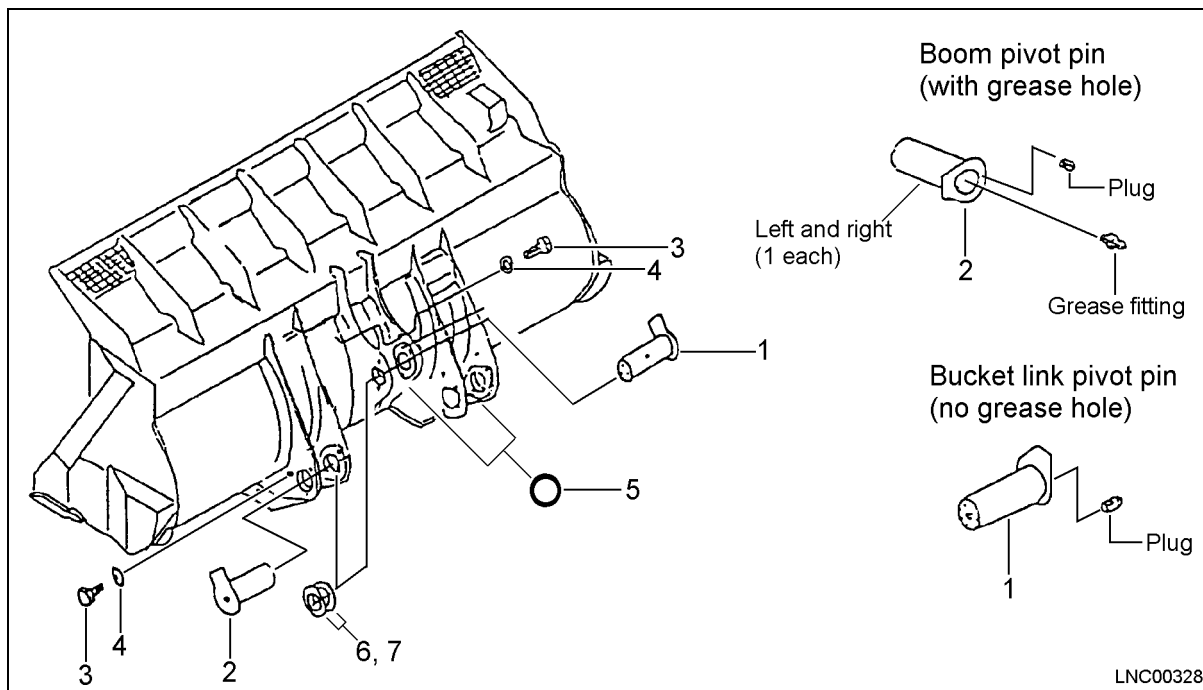

ASSEMBLY PROCEDURE

Tools Required

No.	Description	Qty.
1	Torque wrench	1
2	Crane, 30 ton	1
3	Grease gun	1

1. Raise bucket with crane and set at front of the machine. Use top part of balance of the balance lifting tool for rear axle.



Bucket: 8600 kg (18,960 lbs)

2. Wipe off all grease, dirt, paint, and foreign matter from around pin hole of the bucket.
3. Wipe off all grease, dirt, paint, and foreign matter from around pin holes of the boom pivot and bucket link pivot.

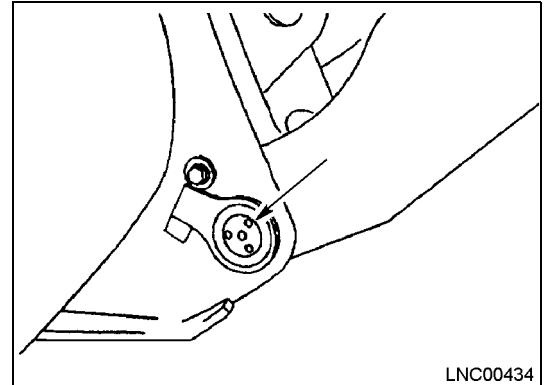

- Check that dust seal has been assembled correctly, the seal lip facing in correct direction.
- Check that dust seal does not extend from end face of the pivots of the boom and bucket link.

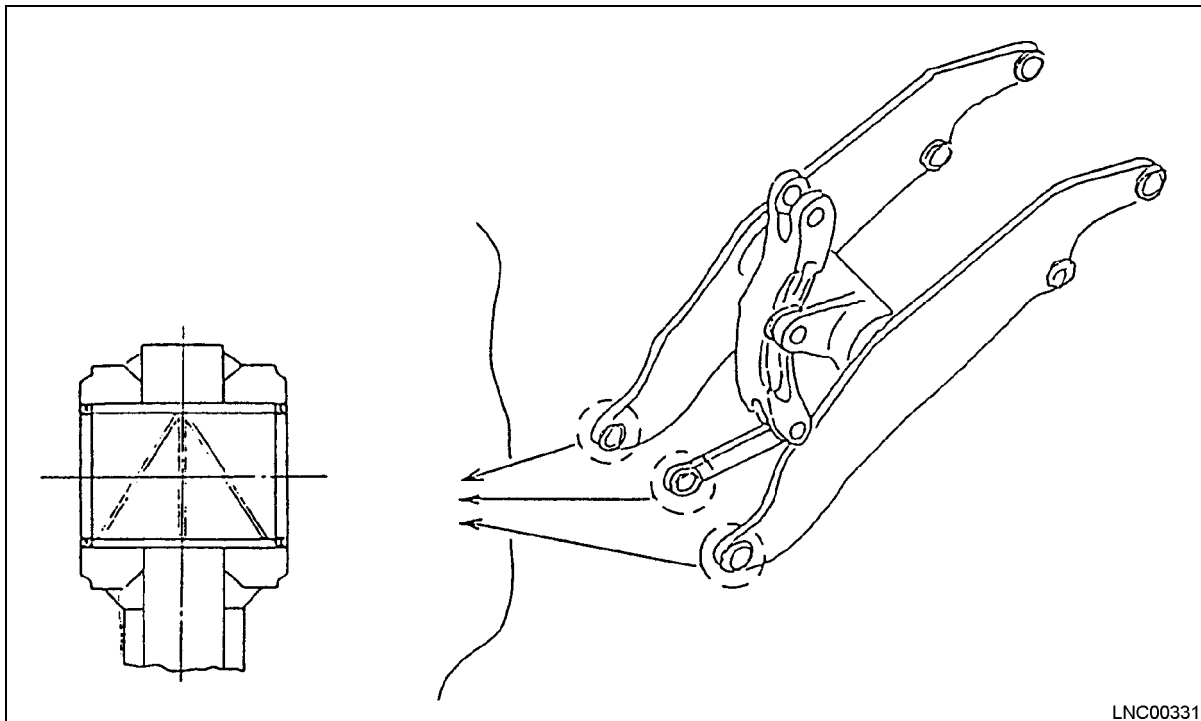

4. Assembling bucket to the boom, raise the bucket with a 30 ton crane and adjust position of the hole.

- a) Bring bucket close to boom and align the bucket mounting pin hole.
- b) Select shims so clearance T between boom pivot and bucket pivot is less than 1.5 mm (0.06").
- Select shims so the clearance is equal on both left and right sides.
- c) Remove bucket from the boom, then temporarily assemble cord ring to boom pivot.
- d) Assembly the shim pack selected in step 2) above to the clearance between the boom pivot and bucket pivot, then align the hole and insert pin.
- To prevent damage to the dust seal lip when assembling, coat inside surface of bushing and lip portion of dust seal, and pin with grease before starting. Coat with KES LM-P molybdenum disulphide paste.
- e) Assemble the cord ring to pivot portion.
- f) Tighten the vibration stopper bolt to pin.

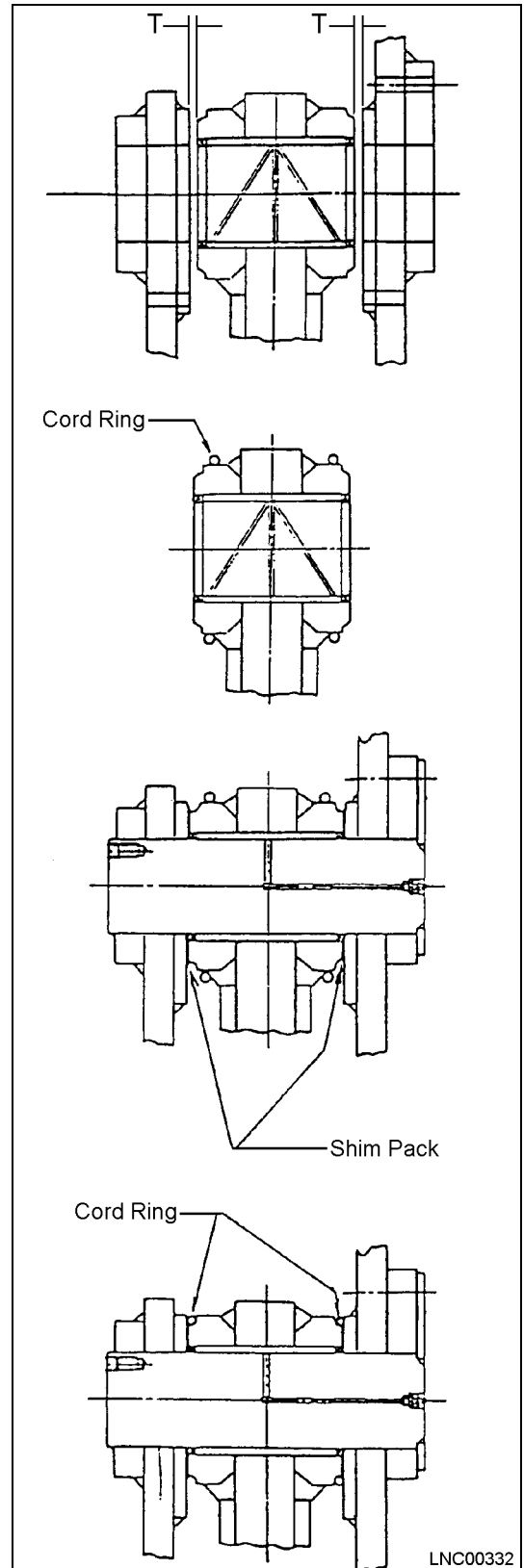

5. Connect bucket link to bucket pivot
 - For remaining procedure, assemble pin using the same procedure as for connecting boom pivot.

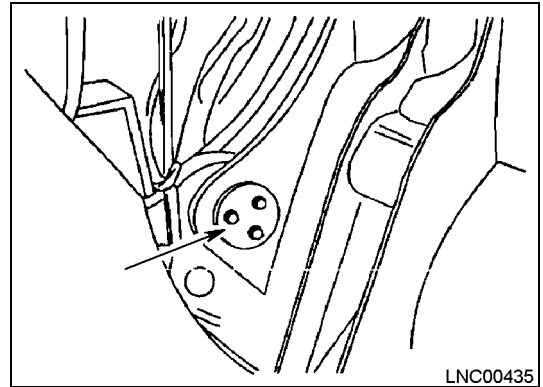

A-19 ASSEMBLY OF FLOOR MAT

Assembly Parts for Floor Mat

Mark	No.	Part	Part Number	Qty
	1	Floor mat	426-54-22831	1

No mark: Sent as individual parts.

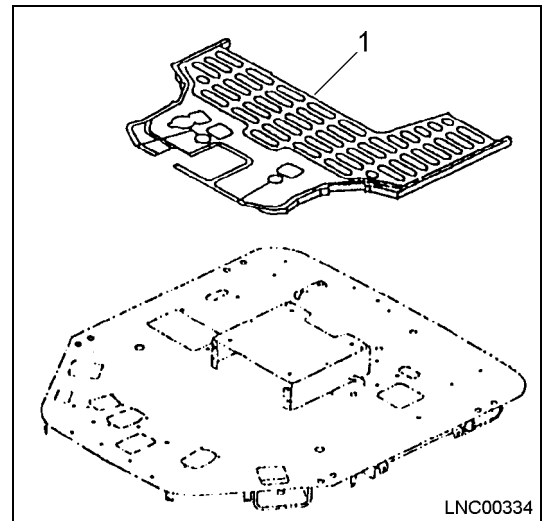

PROCEDURE FOR TESTING ASSEMBLY

M-1 BLEEDING AIR FROM WHEEL BRAKE CIRCUIT

BRAKE CIRCUIT DIAGRAM

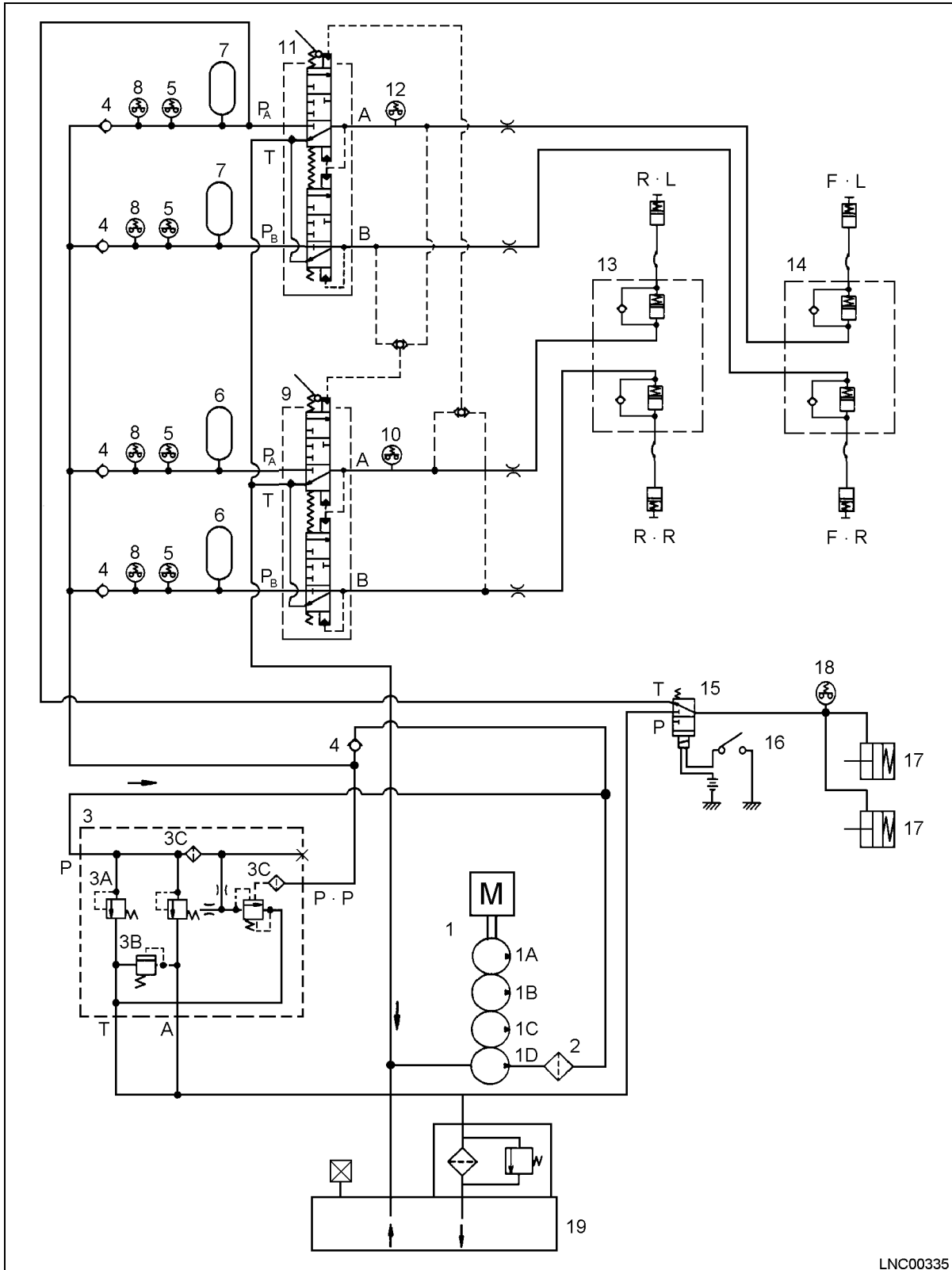

LNC00335

1. Torque converter charging, PPC, and brake pump
 - a) Torque converter charging pump
 - b) Torque converter charging pump
2. Strainer
3. Accumulator charge valve
 - a) Safety relief valve
 - b) Relief valve
 - c) Filter
4. Check valve
5. Low pressure switch
6. Rear brake accumulator
7. Front brake accumulator
8. Emergency brake switch
9. Brake valve (left)
10. Transmission cut-off switch
11. Brake valve (right)
12. Stop lamp switch
13. Rear slack adjuster
14. Front slack adjuster
15. Parking brake solenoid valve
16. Parking brake switch
17. Parking brake spring cylinder
18. Parking brake pilot lamp switch
19. Brake oil tank

Procedure for filling with oil.

1. Add oil up to center of top of the sight gauge.
2. Bleed air from brake lines (see procedure for bleeding air).
3. Charge accumulator fully. (Charge for approximately 2 minutes with engine at low idle).
4. In condition in step 3, check and make sure that the oil is at center of lower sight gauge.

Bleeding Air From Brake Circuit



WARNING! Apply parking brake and place blocks securely under tires.



WARNING! When engine is running, never bleed air from slack adjusters because drive shaft is rotating.

1. Start engine and accumulate pressure in accumulator (about 30 seconds at high idling speed).

2. Stop engine and insert either end of vinyl hose (1) in bleeders (2) of slack adjuster (3), then insert other end of hose in a container.

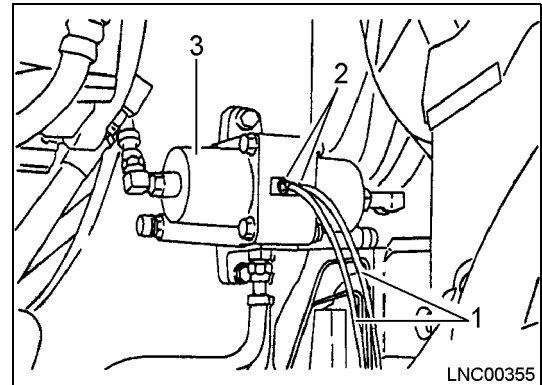

3. Depress left brake pedal, loosen bleeder screw and bleed air. Tighten screw, then release brake pedal slowly.

- Use two workers for this operation, one worker depresses the brake pedal while the other worker bleeds air from the system.
- Check brake oil level, and add oil if necessary.

4. Repeat steps 1, 2, and 3 until no more air bubbles come out with fluid, then depress brake pedal fully and tighten bleeder screw while oil is flowing out.

5. Bleed air from slack adjuster on opposite side and from bleeder (4) of each wheel.

- If pressure in accumulator drops, start engine and recharge the accumulator.
- After completion of bleeding air from wheel brake system, run engine at low idle, check hydraulic oil level, and add oil if necessary.

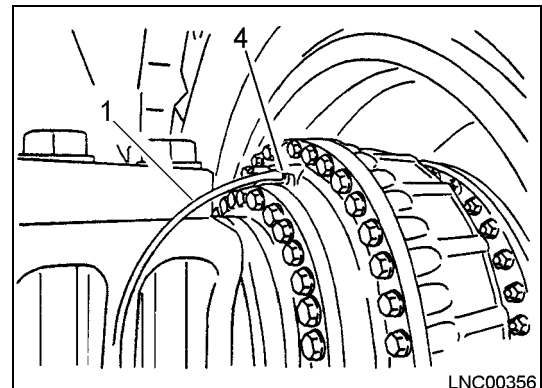

M-2 GREASING WORK EQUIPMENT AND CHASSIS

OUTLINE

Tools Required

No.	Description	Qty.
1	Grease gun (air type)	1
2	Compressor	1

1. Coat boom hinges, bucket cylinder head, and boom cylinder heads with grease.
2. Grease front and rear drive shafts
3. Grease rear axle support.

M-3 ADJUSTING BUCKET POSITIONER

OUTLINE

Tools Required

No.	Description	Qty.
1	Impact wrench	1
2	Socket, 19 mm	1
3	Torque wrench: 1.8 kgf m (13 lbf ft) {18 N m}, HEX: 36 mm	1
4	Spanner	1

Assembly Parts for Bucket Positioner

Mark	No.	Part	Part Number	Qty
x	1	Bracket	427-43-11112	1
o	2	Bolt	01010-81225	4
0	3	Washer	01643-31232	4

o: Sent as individual parts.

x: Already temporarily installed to bucket cylinder.

1. Lower bucket to ground and set it horizontal (it is assumed that the ground surface is horizontal).
2. Adjust the proximity switch (1) and secure it in position so that switch sensing surface is pulled in 0.5 - 1.0 mm (0.02" - 0.039") from tip of protector.
3. The trip bar is moving sideways from sensing surface of switch, so adjust so there is clearance of 3 - 5 mm (0.12" - 0.20") at all of trip surfaces.
4. Run engine at a mid-range speed (1500 rpm), actuate positioner, then adjust proximity switch mounting bracket so the bucket angle is facing 0 - 1° down when bucket is lowered to ground.
 - The relationship between bucket angle and cylinder length close to horizontal position above the ground is 8.7 mm/1° (0.34" /1°).
5. When positioner is actuated, the variation according to engine speed shall be within 4 ° when bucket is close to ground surface.

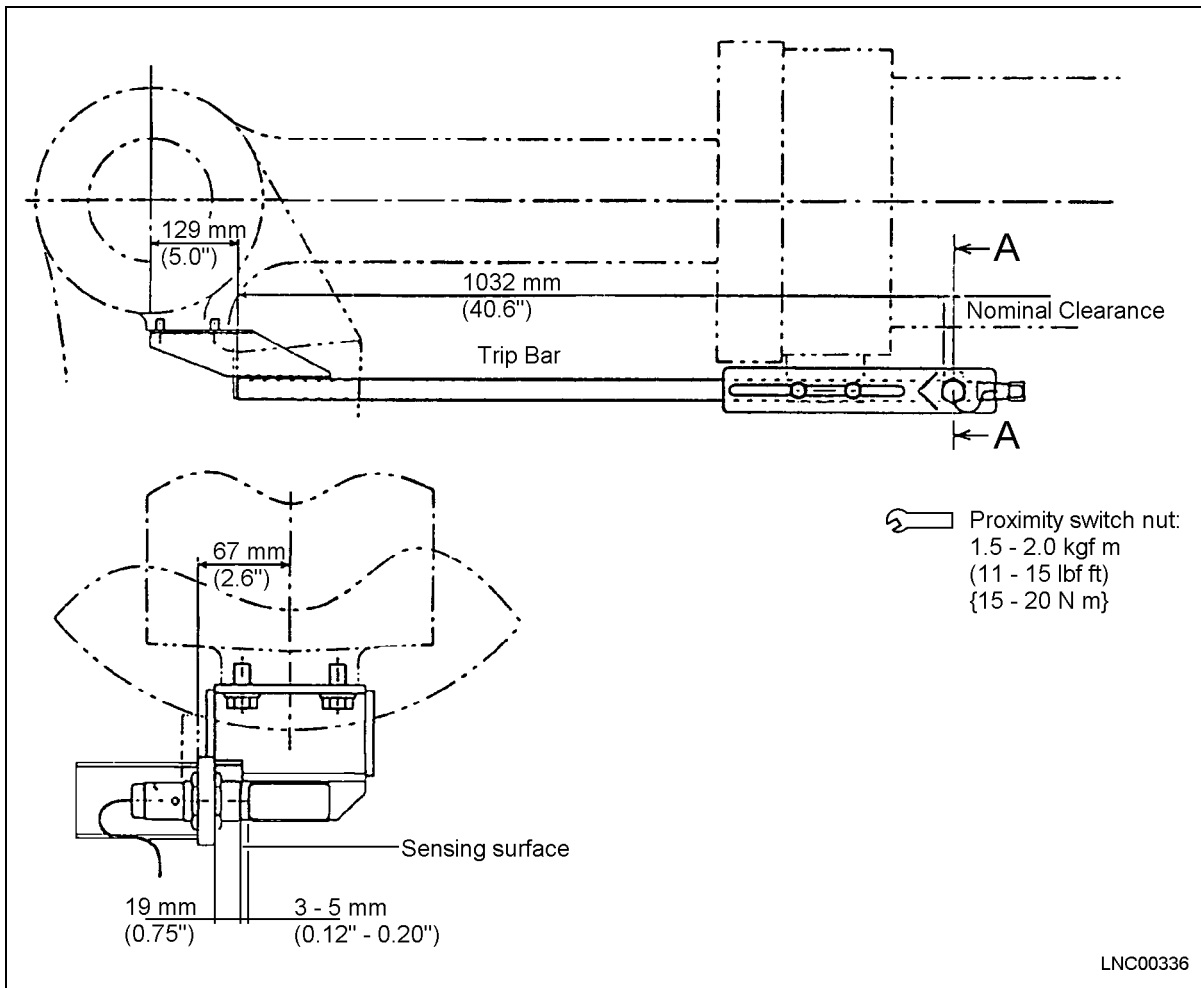

M-4 ADJUSTING BOOM KICK-OUT

OUTLINE

Tools Required

No.	Description	Qty.
1	Impact wrench	1
2	Socket, 14 mm	1
3	Torque wrench: 1.8 kgf m (13 lbf ft) {18 N m}, HEX: 36 mm	1
4	Spanner (HEX: 36mm)	1

Assembly Parts for Bucket Positioner

Mark	No.	Part	Part Number	Qty
x	1	Plate	427-43-29110	1
o	2	Bolt	01435-01020	2

o: Sent as individual parts.

x: Already temporarily installed to boom.

1. Raise boom to maximum height above ground, then secure the plate so the distance between center of switch and top of plate is 0 - 5 mm (0" - 0.12").
2. Secure the switch in position so the clearance between switch sensing surface and horizontal direction of the plate is 3 - 5 mm (0.12" - 0.20").

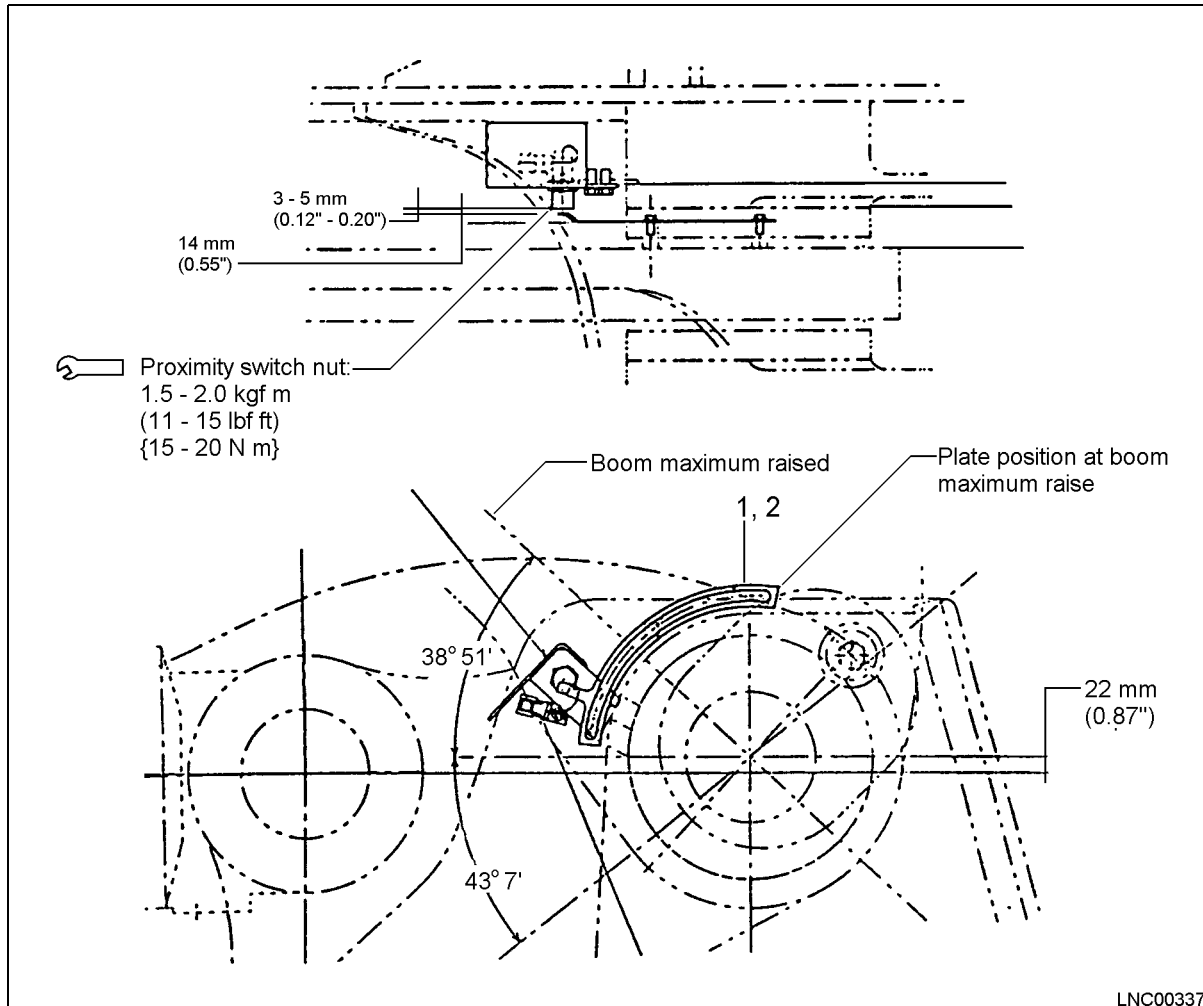

M-5 PROCEDURE FOR STARTING ENGINE

OUTLINE

1. Check all oil and coolant levels, and add if necessary.
 - Radiator coolant level.
 - Engine oil pan level.
 - Hydraulic tank oil level.
 - Fuel tank level.
 - For details of gauge positions and coolant, oil, and fuel levels, see Operation and Maintenance Manual.
2. Bleed air from piston pump, see M-7 procedure for details.
3. For details of starting and stopping the engine, see details in Operation and Maintenance Manual.
 - Run engine for 10 minutes at low idle.
 - Do not move any control levers.
 - Check to see if there any abnormalities, such as oil leakage or abnormal noise, stop the engine immediately.
4. Check for any oil leakage after stopping engine.
5. Bleed air from work equipment hydraulic circuit, see M-8 procedure for details.

LONG TERM STORAGE

When starting the engine of a machine (completed or semi-completed) that have been kept in long term storage for six months or more, carry out the following procedure.

1. Check that there are no persons or obstacles in the surrounding area, then sound horn and start engine.
2. **Do not** keep starting motor rotating continuously for more than 20 seconds. If the engine will not start, wait for at least 2 minutes before trying to start engine again.
3. Turn the key of the ignition switch to the **START** position to start the engine.

NOTE: This machine is equipped with an engine prelube system. With this feature, a noticeable time delay and pumping noise will occur, while the engine lube passages are being filled and pressurized, before engine cranking will begin. When an adequate engine oil lube pressure is attained, the pump will stop and engine cranking will begin.

4. When engine is started, release the key of ignition switch (1) and the key will return automatically to ON.

M-6 INSPECTION OF ALL PARTS

1. Inspect assembled parts for interference, oil leakage, and air leakage.
2. Check radiator coolant level, engine oil level, transmission oil level, hydraulic oil level, brake oil level, and window washer fluid level.

M-7 PROCEDURE FOR BLEEDING AIR FROM PISTON PUMP

Tools Required

No.	Description	Qty.
1	Spanner (HEX: 27mm)	1

NOTE: If the hydraulic oil has been completely drained from hydraulic tank, carry out the following procedure as necessary to prevent seizure of piston pump inner parts. As the machine is shipped with hydraulic tank full of oil, there is no particular need to perform this operation.

Procedure for bleeding air from piston pump.

1. Check to be sure hydraulic tank is full of hydraulic oil.
2. Loosen plugs (1), (2), and (3) installed to piston pump suction tube.

3. Loosen adapter on block end of case drain hose (4) of piston pump.
4. Remove oil filler cap from hydraulic tank, and charge tank with compressed air.
 - Approximately: 0.1 kg/cm² (1.4 psi) {9.8 kPa}
5. When oil flows from plugs (1), (2), (3), and adapter (4) in turn, then tighten plugs and hose adapter when air is bled completely.
 - Since oil level in hydraulic tank is higher than plugs (1), (2), (3), and adapter (4), air is bled easily.

6. Remove compressed air from hydraulic tank, check oil level, and add oil if necessary.
7. Wipe off all oil from around the plugs.

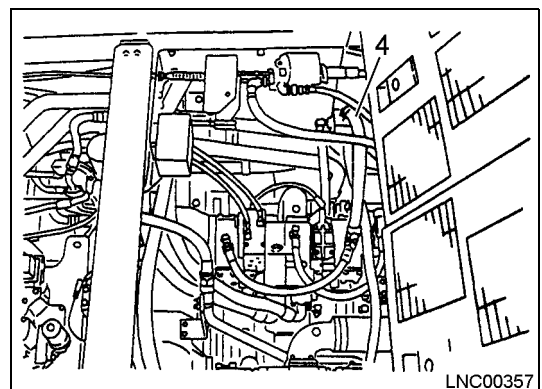
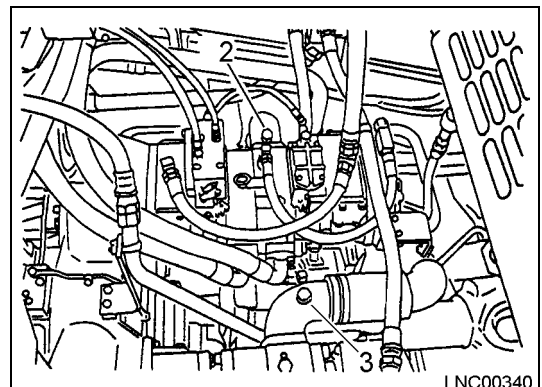
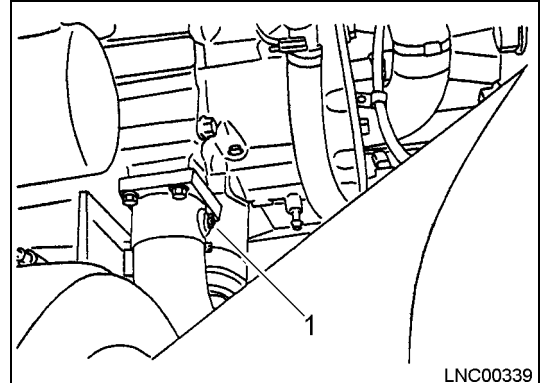

M-8 BLEEDING AIR FROM WORK EQUIPMENT CIRCUIT

Bleeding air from bucket and boom cylinders.

1. Start engine and run at idle for about 5 minutes.
2. Run engine at low idle and operate boom and bucket cylinders 3 - 4 times.
 - Operate the piston rod to approximately 100 mm (4 in.) before end of stroke. Be careful not to relieve the circuit.
3. Run engine at midrange idle and operate boom and bucket cylinders 3 - 4 times.
 - Operate the piston rod to approximately 100 mm (4 in.) before end of stroke. Be careful not to relieve the circuit.
4. Run engine at high idle and operate boom and bucket cylinders 3 - 4 times.
 - Operate the piston rod to approximately 100 mm (4 in.) before end of stroke. Be careful not to relieve the circuit.

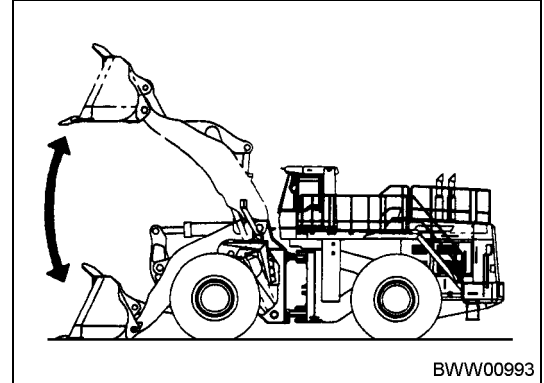

5. Run engine at low idle and operate boom and bucket cylinders to relief at the end of their stroke 3 - 4 times.
6. Run engine at midrange idle and operate boom and bucket cylinders to relief at the end of their stroke 3 - 4 times.
7. Run engine at high idle and operate boom and bucket cylinders to relief at the end of their stroke 3 - 4 times.

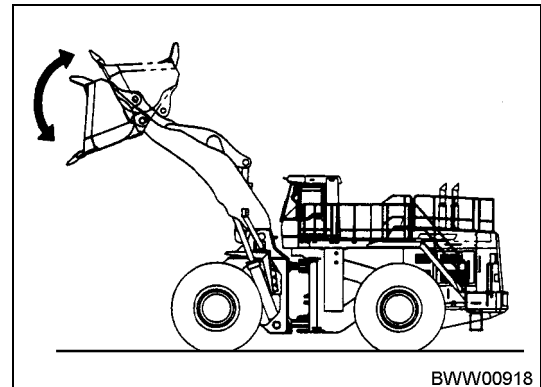

Bleeding air from PPC circuit.

1. Operate bucket control lever to TILT and boom control lever to FLOAT, and hold for 1 minute after cylinder reaches the end of its stroke.
2. Operate bucket control lever to DUMP and boom control lever to RAISE, and hold for 1 minute after cylinder reaches the end of its stroke.

INSPECTION REPORT

Report Number: _____

FIELD ASSEMBLY INSPECTION REPORT

After completion of assembling a machine, make inspections according to these check sheets for assuring machine performance and quality.

Model - Type WA800-3LC	Machine Serial No.	User Unit No.	Engine Model SAA12V140ZE-2	Engine Serial No.
Service Meter Reading	Date of Inspection	Attachment	1	2
			Manufacture	
Location of Machine at Inspection		Model		
		Serial No.		
Distributor's Name				

Customer's Name:	Address:	Signature:	Delivery report No. attached
		Date:	

Inspector's Comments:

Inspector's Name:	KOMATSU USE ONLY: C. Sheet Receiving Date: _____ By: _____ Remarks:
Title:	
Signature: _____	

Check sheets filling instructions:

1. Use following indexes for entry judgement.

...Normal
 Correction made on abnormal point
 ...Abnormal
 ...Not applied

2. Enter actually measured values in parentheses, ().

Notes:

(1) Criteria are based on the standards when machine is shipped out of factory.

Submittance of this report (and check sheets) to KOMATSU is one of the conditions of WARRANTY VALIDATION, copy for KOMATSU shall be forwarded to the regional office together with the copy of delivery service report.

LCN00507

Category	No.	Item	Judgement procedure and standard	Measured value	Judgement	Confirmation of repair	Nature of repair
A Specifications	1	Record serial number stamped on machine	Stamped on right side face of front frame				
	2	Record engine serial number	Stamped on right side face of cylinder block (as seen from fan)				
	3	Confirmation of specifications	Tires [23 - 45 - 34 PR, W/T, T/L, R, G] (Manufacture:)				
			Bucket [m ³ , w/teeth, w/o teeth, straight edge, spade nose]				
			Others (options) []				
			[]				
	4	Paint color	Standard, specified color	[]			
5	Engine oil capacity	15W-30	[]				
6	Antifreeze	Used/not used, density	[°C]				
B Lubricant, coolant capacity, tire inflation pressure	1	Engine coolant capacity	Above bottom edge of filler port	[Upper surface of core mm]			
	2	Engine oil capacity	H - L + 5, at least 15 minutes after stopping engine	[H± mm]			
	3	Brake oil capacity	At least 12 H after stopping engine →  Engine at low idling →				
	4	Hydraulic oil capacity	Between top and center of side gauge	[]			
	5	Transmission oil capacity	H - L + 5	[]			
	6	Axle oil capacity	Bottom edge of drain plug + 10 mm	[]			
	7	Washer fluid	At least 1/3 full	[]			
	8	Battery electrode level		[]			
	9	Greasing all parts	All specified parts must be greased	[]			
	10	Tire inflation pressure	5.05 - 5.65 kg/cm ²	[kg/cm ²]			
C Starting	1	Actuation, return of main switch	There must be no catching of key. Does it turn ON/OFF properly?				
	2	Actuation of monitor panel self check	All modules must light up				
			All dashboard lamps must light up				
			Central warning lamp must light up				
			Alarm buzzer must sound				
	3	Actuation of monitor for checks before starting	Brake oil level abnormality lamp must not light up				
			Engine oil level abnormality lamp must not light up				
			Engine coolant level abnormality lamp must not light up				
4	Sounding of horn	Volume must be correct. There must not be abnormal sound or vibration					
5	Actuation of directional lever neutral switch	Must be possible to start engine only when lever is at neutral position					
6	Actuation of starting motor	There must not be abnormal noise or idle running					
7	Ease of starting engine	Must start within 10 seconds					
8	Actuation, indication of hour meter	Pilot lamp must flash when engine is running	Counter display [H]				

LNC00509

Category	No.	Item	Judgement procedure and standard	Measured value	Judgement	Confirmation of repair	Nature of repair
C Starting	9	Abnormal lighting of caution pilot lamp	When engine is stopped or when engine is running				
	10	Confirmation of parking brake release	Lamp must light when switch is turned ON				
			Machine must not move when switch is ON and shift lever is at F or R				
		Buzzer must sound and warning lamp must light when switch is ON and shift lever is at F or R					
D Operating machine	Ⓞ Driving machine Operating time: F1 - 5 minutes, F2 - 5 minutes, F3 - 5 minutes, R1 - 5 minutes R2 - 5 minutes, R3 - 5 minutes Total: 30 minutes						
	1	Actuation of speedometer					
	2	Actuation of fuel gauge					
	3	Actuation of torque converter oil temperature gauge	Must be within green range				
	4	Actuation of water temperature gauge	Must be within green range				
	5	Abnormality with emergency caution lamp (If any gauge is in red range, pilot lamp and warning lamp must light, and warning buzzer must sound)	Failure in brake line				
			Engine oil pressure				
			Radiator coolant level				
			Engine coolant temperature				
			Torque converter oil temperature				
		Operation of emergency steering					
6	Abnormal noise, vibration from engine, transmission, axle						
7	Drive machine and check for abnormal heating of axle, parking brake						
8	Actuation of dust indicator	Red piston must not be shown					
E Performance, functions	Ⓞ Pressurization test: Operate lift cylinder to RAISE/LOWER, bucket cylinder to TILT/DUMP, and steering cylinder to left/right to full stroke 30 times each to pressurize. Depress left and right brake pedals 30 times (transmission cut-off switch ON position). Carry out V-shape loading 5 times (engine at full throttle, cylinder operated to full stroke).						
	1	Abnormal lighting up of monitor panel					
	2	Operating effort of accelerator pedal	Max. 9.0 kg	[kg]			
	3	Return of accelerator pedal	Must return slowly without catching				
	4	Actuation of parking brake					
	5	Actuation of brake pedal					
	6	Play, return of brake pedal	There must be no dragging				
	7	Braking effect	Stopping distance within 7.5 . when traveling at 20 km/h	[m]			
	8	Actuation of transmission cut-off switch	Pilot lamp must be off and transmission must not be cut when switch is OFF				
	9	Actuation of transmission cut-off					
	10	Time lag, shock, or other abnormalities in return after transmission cut-off					
11	Operation of directional lever	Max. 1.1 kg	[kg]				

LNC00510

Category	No.	Item	Judgement procedure and standard	Measured Value	Judgement	Confirmation or repair	Nature of repair
E Performance	12	Operation of speed lever	Max. 1.1 kg	[kg]			
	13	Actuation of speed lever 2nd speed stopper					
	14	Defective operation of directional lever	F → N, R → N, switching between F and R				
	15	Defective operation of speed lever	Shifting to 1, 2, 3				
	16	Time lag, shock, or other abnormality when shifting gear or starting off					
	17	Operation of lift lever	HOLD → RAISE, HOLD → LOWER: Max. 2.5 kg LOWER → FLOAT: Max. 5.5 kg	[kg]			
	18	Correct fitting of lever in notch	FLOAT, LOWER, RAISE				
	19	Operating effort of bucket lever	Max. 2.4 kg	[kg]			
	20	Correct fitting of bucket lever in notch	TILT				
	21	Actuation, adjustment of work equipment lever safety lock	Lock must not come off when lever is operated. Boom must not go down				
	22	Actuation of accumulator	Boom, bucket must go down when engine is stopped and lever is operated				
	23	Adjustment of boom kick-out					
	24	Adjustment of bucket leveler					
	25	Scratches or damage to lift cylinder rod					
	26	Scratches or damage to bucket cylinder rod					
	27	Operation of steering wheel	0.9 - 1.5 kg	[kg]			
	28	Play of steering wheel	20 - 70 mm	[Left: mm, right: mm]			
	29	Abnormal noise, vibration, hunting of engine, exhaust color					
	30	Engine stall	Engine must not stop during any stall operation				
	31	Engine pick-up	Engine must accelerate from each stall operation, low idling				
	32	Actuation of engine stop	Engine must stop properly when main switch is turned OFF				
	33	Chassis holding force	Is machine held off ground when boom is lowered and front tires are raised off ground				
	34	Parking brake effect	Must hold machine on 1/5 grade				
	35	Actuation of emergency steering	Must be possible to operate steering when engine stops while going downhill				
	36	Abnormal noise, vibration from engine, transmission, axle, work equipment during compression					
	F Other	1	Tension on hoses, wiring harnesses when boom is raised				
		2	Interference with hoses, wiring harnesses when boom is raised				
		3	Interference when there is rear wheel oscillation (check both left and right)				
4		Interference when turning steering (check on both left and right)					

LNC00511

Category	No.	Item	Judgement procedure and standard	Measured value	Judgement	Confirmation of repair	Nature of repair
G Measurement of basic performance	⊙	Engine speed Measurement conditions: When engine governor lever is operated to full throttle, it must contact governor stopper. Engine coolant temperature, torque converter oil temperature within operating range, hydraulic oil temperature: 45 - 55 °C.					
	1	Low idling	620 - 700 rpm	[rpm]			
	2	High idling	2170 - 2270 rpm	[rpm]			
	3	Torque converter stall	1940 - 2140 rpm	[rpm]			
	4	Work equipment stall	----- (Record only)	[rpm]			
	5	Full stall	----- (Record only)	[rpm]			
	6	Boom RAISE speed	9.9 - 10.0 sec.	[sec]			
	7	Boom LOWER speed	4.3 - 5.3 sec.	[sec]			
	8	Bucket tilt back speed (tilt w/boom raised max. height)	1.7 - 2.3 sec.	[sec]			
	9	Bucket tilt forward speed (tilt w/boom raised max. height)	3.3 - 4.3 sec.	[sec]			
	⊙	Hydraulic drift of work equipment Measurement conditions: Hydraulic oil temperature: 75 - 85 °C. Set with bucket and boom horizontal when starting measurement. Leave for 5 minutes before starting measurement.					
	10	Hydraulic drift of boom	Cylinder retraction Max. 40 mm/15 min.	[min.]			
	11	Hydraulic drift of bucket	Cylinder retraction Max. 20 mm/15min.	[min.]			
12	Rotating speed of steering wheel	Max. 5 sec. w/engine at full throttle	[Left sec], [Right				
H Lights	1	Actuation of light switches sec]	There must be no stiffness or looseness of knobs (front, working, hazard lamps)				
	2	Lighting parking lamp	(Front, rear, left, right)				
	3	Lighting clearance lamp	(Left, right)				
	4	Lighting tail lamp	(Left, right)				
	5	Lighting monitor lamp					
	6	Lighting front lamp (left, right)	Switching between low, high, lighting pilot				
	7	Lighting working lamp	(Front, rear, left, right) Lighting pilot				
	8	Lighting brake lamp	(Left, right)				
	9	Lighting back-up lamp	Back-up buzzer must sound				
	10	Actuation of turn signal indicator (front left, right, top, bottom; rear left, right), flashing pilot					
	11	Actuation of hazard (front left, right, top, bottom; rear left, right) lighting of pilot					
	12	Actuation of radio	Do switches work properly? Is there interference?				
	13	Actuation of stereo	Do switches work properly? Is there interference?				
	14	Lighting dome lamp	When switch is on, when door is open				
	15	Actuation of cigar lighter	Does it become red hot? Does it automatically return?				
	16	Actuation of wipers (left, right)	Is wiping range correct?				
	17	Actuation of window washer	Is direction of nozzle correct?				

LCN00512

Category	No.	Item	Judgement procedure and standard	Measured value	Judgement	Confirmation of repair	Nature of repair
H Lights	18	Actuation of air conditioner	Actuation of switches (lighting of lamps), actuation of air flow switch				
	19	Check freon charge	There must be no bubbles in receiver sight gauge				
	20	Actuation of air conditioner selector switches	Does cooling and heating work properly?				
	21	Does air conditioner FRESH/RECIRC selector switch work properly?					
	22	Operation of air conditioner condenser fan					
H Overall inspection	1	Check to be sure there are no coolant leaks from engine cooling system (left, right), radiator inlet/outlet hoses, radiator drain hose, radiator drain valve, radiator core, aeration hose, thermostat housing, water pump shaft seal, joint of cylinder block water jacket cover, water manifold, torque converter inlet/outlet hoses.					
	2	Check to be sure there no interference between water piping, hoses and sharp edge or movable parts					
	3	Check to be sure there no leaks from engine fuel line (left, right), oil filter joint, dipstick tube mount, oil filter mount, timing gear case joint, breather mount, head cover joint, crankshaft seal, turbocharger lubricant tube, turbocharger seal, air compressor lubricant tube, oil pan joint, engine oil drain hose, engine oil drain valve, engine oil cooler tube mount.					
	4	Check to be sure there is no interference between lubrication hoses and sharp edges or movable parts					
	5	Check to be sure there is no leakage from engine exhaust system (left, right), [Exhaust manifold mount, turbocharger mount, mufflet, head cover joint].					
	6	Check to be sure there is no leakage from fuel tank (tank assembly, tank inspection cover joint, tank unit mounting surface, fuel tank drain valve)					
	7	Check to be sure there is no loose or missing fuel tank mounting bolts					
	8	Check to be sure there is no leakage from torque converter piping (Torque converter pump suction tube and hose joints, torque converter filter inlet/outlet hose and tube joints, filter joint, torque converter cooler hose joint)					
	9	Check to be sure there is no interference between torque converter piping, hoses and sharp edges or movable parts					
	10	Check to be sure there is no leakage of oil from torque converter and transmission (Torque converter input shaft seal, joint of torque converter and transmission, transmission transfer case, transfer case front cover, transmission oil drain valve, transmission breather, transmission control valve mount and blind plug, transmission dipstick tube mount, transmission output shaft seal (front, rear)					
	11	Check to be sure there is no oil leakage from axles (front, rear)					
	12	Check to be sure there are no loose or missing axle mounting bolts (front, rear)					
	13	Check to be sure there are no loose or missing axle support mounting bolts (front, rear)					
	14	Check to be sure there are no loose or missing wheel lug nuts (front, rear)					
	15	Check to be sure there is no damage to side walls of tires (front, rear)					
	16	Check to be sure there are no loose or missing mounting bolts of drive shafts (front, rear) [Front drive shaft, rear drive shaft]					
	17	Check to be sure there is no oil leakage from hydraulic tank assembly (tank weldment, inspection cover {top, bottom, front}, drain plug, sight gauge)					
	18	Check to be sure there no oil leakage from hydraulic filter case (case weldment, inspection cover, filter cover)					
	19	Check to be sure there is no oil leakage from hydraulic pump (switch/loader/steering/torque converter/ emergency steering) [Pump mount, case, and cover]					
	20	Check to be sure there is no oil leakage from main control valve (left, right) [Relief valve, suction valve, unload valve, safety valve]					
	21	Check to be sure there is no oil leakage from steering valve (Relief valve, safety valve, lever shaft seal)					
	22	Check to be sure there is no oil leakage from PPC valve					
	23	Check to be sure there is no oil leakage from accumulator					
	24	Check to be sure there is no oil leakage from PPC relief valve					
	25	Check to be sure there is no oil leakage from boom cylinder (left, right) [shaft seal, head flange portion, tube weldment]					

LN000513

Category	No.	Item	Judgement procedure and standard	Measured value	Judgement	Confirmation of repair	Nature of repair
H Overall inspection	26	Check to be sure there is no oil leakage from bucket cylinder (Shaft seal, head flange portion tube weldment)					
	27	Check to be sure there is no oil leakage from steering cylinder (Shaft seal, head flange portion, tube weldment)					
	28	Check to be sure there no leakage from hydraulic piping (piping joints, welds, plugs)					
	29	Check to be sure there is no interference between hydraulic piping and sharp edges or movable parts					
	30	Check to be sure there is no oil leakage from brake system (Brake oil reservoir, brake valves, slack adjusters (front, rear), piping joints)					
	31	Check to be sure there is no interference between brake pining and sharp edges or movable parts					
	32	Check to be sure there are no loose or missing work equipment linkage lock pin bolts					
	33	Check to be sure there are no loose or missing fender weight mounting bolts					
	34	Check to be sure there is no stepped difference between counterweight and fuel tank	Stepped difference: Max. 5 mm				
	35	Check to be sure there are no loose or missing front fender (left, right) mounting bolts					
	36	Check to be sure there are no loose or missing front right support mounting bolts					
	37	Check to be sure there are no loose or missing cab step mounting bolts					
	38	Check that there is no oil leakage from engine throttle booster					
	39	Check to be sure there is no oil leakage from engine throttle booster inlet/outlet hose joints					
	40	Check to be sure there is no interference between engine throttle booster inlet/outlet hoses and sharp edges or movable parts					
	41	Check to be sure there is no interference between engine throttle cable and sharp edges or movable parts					
	42	Check to be sure there is no interference between electrical wiring and sharp edges or movable parts					
	43	Check to be sure there is no excessive tension of electrical wiring					
	44	Check to be sure there are no loose or missing connectors or electrical terminals (alternator, cranking motor, sensors, batteries, lamps, wipers)					
	45	Check to be sure there are no loose or missing cab mounting bolts					
	46	Check to be sure operator's seat adjustments (slide, tilt, up/down, weight, seat back) work properly					
	47	Check to be sure steering wheel tilt, lock works properly					
	48	Check to be sure cab door outer lock (key lock), inner lock work properly					
	49	Check to be sure there is no interference between air conditioner hoses and sharp edges or movable parts					
	50	Check to be sure there is no interference between heater hoses and sharp edges or movable parts					
	51	Check to be sure there is no peeling or dents to machine chassis					
	52	Check to be sure there are no peeling or missing name plates on machine					

LNCO0514