

Operation & Maintenance Manual

HD1500-7

DUMP TRUCK

SERIAL NUMBERS

**A30049-A30055, A30058-A30064,
A30067-A30070, A30073-A30075,
A30078-A30080, A30085-A30090,
A30095-A30108**

With SDA12V160 Engine

KOMATSU®

This material is proprietary to Komatsu America Corp (KAC), and is not to be reproduced, used, or disclosed except in accordance with written authorization from KAC.

It is the policy of the Company to improve products whenever it is possible and practical to do so. The Company reserves the right to make changes or add improvements at any time without incurring any obligation to install such changes on products sold previously.

Because of continuous research and development, periodic revisions may be made to this publication. Customers should contact their local Komatsu distributor for information on the latest revision.

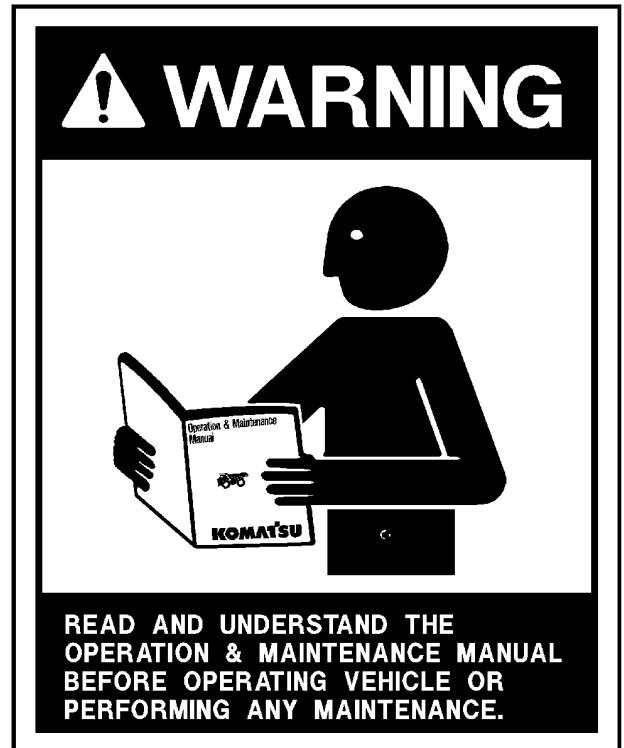

Unsafe use of this machine may cause serious injury or death. Operators and maintenance personnel must read and understand this manual before operating or maintaining this machine.

This manual should be kept in or near the machine for reference, and periodically reviewed by all personnel who will come into contact with it.

CALIFORNIA Proposition 65 Warning

Diesel engine exhaust, some of its constituents, and certain vehicle components contain or emit chemicals known to the State of California to cause cancer, birth defects or other reproductive harm.

CALIFORNIA Proposition 65 Warning

Battery posts, terminals and related accessories contain lead and lead compounds, chemicals known to the State of California to cause cancer and birth defects or other reproductive harm. Wash hands after handling.

CALIFORNIA Proposition 65 Warning

Mercury and mercury compounds are known to the State of California to cause developmental problems. This machine may be equipped with optional HID lamps which contain mercury. There is no risk of exposure unless the lamps are broken. However, the lamps must be reused, recycled or properly disposed of in accordance with Local, State and Federal Laws at the end of their useful lives.



NON-OEM PARTS IN CRITICAL SYSTEMS

For safety reasons, Komatsu America Corp. strongly recommends against the use of non-OEM replacement parts in critical systems of all Komatsu equipment. Critical systems include but are not limited to steering, braking and operator safety systems.

Replacement parts manufactured and supplied by unauthorized sources may not be designed, manufactured or assembled to Komatsu's design specifications; accordingly, use of such parts may compromise the safe operation of Komatsu products and place the operator and others in danger should the part fail.

Komatsu is also aware of repair companies that will rework or modify an OEM part for reuse in critical systems. Komatsu does not generally authorize such repairs or modifications for the same reasons as noted above.

Use of non-OEM parts places full responsibility for the safe performance of the Komatsu product on the supplier and user. Komatsu will not in any case accept responsibility for the failure or performance of non-OEM parts in its products, including any damages or personal injury resulting from such use.

FOREWORD

This manual is written for use by the operator and/or the service technician and is designed to help these persons to become fully knowledgeable of the truck and all its systems in order to keep it operating safely and efficiently.

All operators and maintenance personnel must understand the content in this manual before operating, maintaining or performing operational checks on the truck. All safety notices, warnings and cautions must be understood before operating or repairing the truck.

The first section is an introduction to the manual and contains a table of contents to locate specific areas of interest. Other sections include Safety, Operation, Maintenance, Specifications, and Optional Equipment.

This manual shows dimensioning of metric and (U.S. standard) units throughout. All references to right, left, front, or rear are made with respect to the operator's normal seated position, unless specifically stated otherwise.

Standard torque requirements are shown in torque charts in the Introduction section and individual torques are provided in the text in bold face type, such as **135 N·m (100 ft lb)**. All torque specifications have $\pm 10\%$ tolerance unless otherwise specified.

The illustrations used in this manual are typical of the component shown and may not be an exact reproduction of what is found on the truck.

A product identification plate is located on the frame in front of the right side front wheel and designates the truck model number, product identification number (vehicle serial number), and maximum Gross Vehicle Weight (GVW) rating.

The product identification number (vehicle serial number) contains information which will identify the original manufacturing bill of material for this unit. This complete number will be necessary for proper ordering of many service parts and/or warranty consideration.

The GVW is what determines the load on the drive train, frame, tires, and other components. The vehicle design and application guidelines are sensitive to the total maximum GVW. GVW is the total truck weight. This is equal to the empty vehicle weight + the fuel & lubricants + the payload.

To determine allowable payload: Service all lubricants to the proper level including the fuel tank. Weigh the empty truck. This includes all accessories, body liners, tailgates, etc. Record this value and subtract from the GVW rating. The result is the allowable payload.

NOTE: NOTE: Accumulations of mud, frozen material, etc. become a part of the GVW and reduces allowable payload. To maximize payload and to keep from exceeding the GVW rating, these accumulations must be removed as often as practical.



Exceeding the allowable payload will reduce expected life of truck components.

▲WARNING

Unsafe use of this machine may cause serious injury or death. Operators and maintenance personnel must read this manual before operating or maintaining this machine. This manual should be kept in or near the machine for reference and periodically reviewed by all personnel who come in contact with it.

ALERTS PAGE



The ALERT symbol is used with the signal words, CAUTION, DANGER, and WARNING in this manual to alert the reader to hazards arising from improper operating and maintenance practices.

DANGER

DANGER identifies a specific potential hazard WHICH WILL RESULT in either INJURY OR DEATH if proper precautions are not taken.

WARNING

WARNING identifies a specific potential hazard WHICH COULD RESULT in either INJURY OR DEATH if proper precautions are not taken.

CAUTION

*CAUTION is used for general reminders of proper safety practices
OR
to direct the reader's attention to avoid unsafe or improper practices which may result in damage to the machine.*

TABLE OF CONTENTS

| SUBJECT | SECTION / PAGE |
|--|-----------------------|
| FOREWARD | 10-1 |
| Alerts Page | 10-2 |
| TABLE OF CONTENTS | 10-3 |
| Truck Model Illustration | 10-8 |
| ABOUT THIS MANUAL | 10-9 |
| | |
| TORQUE TABLES AND CONVERSION CHARTS | 12-1 |
| | |
| SAFETY | 20-1 |
| HAUL ROADS | 20-4 |
| PRECAUTIONS DURING OPERATION | 20-4 |
| BEFORE STARTING THE ENGINE | 20-4 |
| OPERATING THE MACHINE | 20-6 |
| TOWING | 20-9 |
| WORKING NEAR BATTERIES | 20-9 |
| PRECAUTIONS FOR MAINTENANCE | 20-10 |
| BEFORE PERFORMING MAINTENANCE | 20-10 |
| DURING MAINTENANCE | 20-12 |
| TIRES | 20-14 |
| WHEN REPAIRS ARE NECESSARY | 20-15 |
| ADDITIONAL JOB SITE RULES | 20-16 |
| | |
| WARNINGS AND CAUTIONS | 22-1 |
| | |
| OPERATING INSTRUCTIONS | 30-1 |
| PREPARING FOR OPERATION | 30-1 |
| Walk Around Inspection | 30-1 |
| Cold Weather Heating System | 30-4 |
| ENGINE START-UP | 30-5 |
| Cold Weather Starting | 30-5 |
| Jump Starting | 30-6 |
| EMERGENCY STEERING SYSTEM | 30-6 |
| Operation | 30-6 |
| Pre-Operation Testing | 30-6 |
| AFTER THE ENGINE HAS STARTED | 30-7 |
| MACHINE OPERATION SAFETY PRECAUTIONS | 30-10 |
| LOADING | 30-11 |

TABLE OF CONTENTS

| SUBJECT | SECTION / PAGE |
|---|-----------------------|
| HAULING | 30-12 |
| RETARDER OPERATION | 30-12 |
| PASSING | 30-13 |
| DUMPING | 30-13 |
| Raising the Dump Body | 30-14 |
| Lowering The Dump Body | 30-14 |
| SAFE PARKING PROCEDURES | 30-15 |
| TURNING OFF THE ENGINE | 30-15 |
| SUDDEN LOSS OF ENGINE POWER | 30-16 |
| Emergency Steering And Braking | 30-16 |
| DISABLED TRUCK DUMPING PROCEDURE | 30-17 |
| Hookup | 30-17 |
| Raising the Body | 30-18 |
| Lowering the Body | 30-18 |
| DISABLED TRUCK STEERING AND BRAKING | 30-19 |
| TOWING | 30-21 |
| | |
| OPERATOR CAB AND CONTROLS | 32-1 |
| STEERING WHEEL AND CONTROLS | 32-2 |
| Horn Button | 32-2 |
| ARSC Set Lever | 32-2 |
| Telescoping/Tilt Wheel Lever | 32-2 |
| Multi-Function Turn Signal Lever | 32-2 |
| RETARDER CONTROL LEVER | 32-3 |
| SERVICE BRAKE PEDAL | 32-4 |
| ACCELERATOR PEDAL | 32-4 |
| INSTRUMENT PANEL | 32-4 |
| HEATER / AIR CONDITIONER CONTROLS | 32-5 |
| RETARDING CAPACITY CHART | 32-6 |
| RADIO SPEAKERS | 32-6 |
| AIR CLEANER VACUUM GAUGES | 32-6 |
| WARNING ALARM BUZZER | 32-6 |
| AM/FM RADIO / CD PLAYER | 32-6 |
| CENTER CONSOLE | 32-7 |
| Hoist Control Lever | 32-8 |
| Transmission Shift Lever | 32-8 |
| Parking Brake Switch | 32-9 |
| LH Window Control Switch | 32-9 |
| RH Window Control Switch | 32-9 |
| Auxiliary Power Outlets | 32-9 |
| OPERATOR'S SEAT | 32-10 |

TABLE OF CONTENTS**SUBJECT ----- SECTION / PAGE**

| | |
|--|-------|
| Seat Belts | 32-10 |
| Seat Adjustment | 32-10 |
| INSTRUMENT PANEL AND INDICATORS | 32-11 |
| UPPER RH SWITCH PANEL | 32-12 |
| Brake Lock Switch | 32-12 |
| F1 Start Switch | 32-12 |
| Hazard Warning Lights Switch | 32-12 |
| LOWER RH SWITCH PANEL | 32-13 |
| Key Switch | 32-13 |
| Ether Starting Aid Switch | 32-14 |
| ASR Cut Switch | 32-14 |
| ARSC Switch | 32-14 |
| Automatic Idle Selector Switch (AISS) | 32-14 |
| Auxiliary Brake Switch | 32-15 |
| UPPER LH SWITCH PANEL | 32-16 |
| Automatic Lubrication System Indicator | 32-16 |
| LOWER LH SWITCH PANEL | 32-17 |
| Head Light Switch | 32-17 |
| Ladder Light Switch | 32-17 |
| BackUp/Deck Light Switch | 32-17 |
| Fog Light Switch | 32-18 |
| Mode Select Switches 1 & 2 | 32-18 |
| Panel Light Dimmer Switch | 32-18 |
| ELECTRONIC DISPLAY PANEL | 32-19 |
| PILOT DISPLAY ITEMS | 32-20 |
| METER DISPLAYS | 32-22 |
| CAUTION ITEMS | 32-24 |
| EMERGENCY STOP ITEMS | 32-26 |
| CHARACTER DISPLAY | 32-29 |
| ACTION CODE DISPLAYS | 32-34 |
| CHECKING FAILURE CODES | 32-35 |
| CHARACTER DISPLAY FLOW CHART | 32-36 |
| REAR ELECTRICAL COMPARTMENT | 32-37 |
| AUTOMATIC RETARD SPEED CONTROL (ARSC) | 32-40 |
| AUTOMATIC SPIN REGULATOR (ASR) | 32-43 |
| | |
| EXTERIOR LIGHTING AND SWITCHES | 34-1 |
| DECK LIGHTING | 34-1 |
| High Beam Headlights | 34-1 |
| Forward Warning Horns | 34-1 |
| Clearance/Turn Signal Lights | 34-2 |

TABLE OF CONTENTS

SUBJECT ----- SECTION / PAGE

| | |
|--|-------|
| Deck Mounted Backup Lights | 34-2 |
| Payload Indicator Lights | 34-2 |
| UPRIGHTS | 34-3 |
| Ladder Lights | 34-3 |
| Low Beam Headlights | 34-3 |
| Ground Level Download Box | 34-3 |
| Ground Level Engine Shutdown Switch | 34-3 |
| Remote Grease Fill Port | 34-3 |
| Engine Service Lights | 34-4 |
| REAR AXLE LIGHT BAR | 34-4 |
| Backup Lights | 34-4 |
| Backup Alarm | 34-4 |
| Turn Signal Lights | 34-4 |
| Retard/Clearance Lights | 34-5 |
| Brake Light | 34-5 |
| | |
| LUBRICATION AND SERVICE | 40-1 |
| RADIATOR FILL PROCEDURE | 40-1 |
| HYDRAULIC TANK SERVICE | 40-2 |
| Filling Instructions | 40-2 |
| TRANSMISSION OIL LEVEL CHECK | 40-2 |
| PERIODIC REPLACEMENT OF CRITICAL PARTS | 40-4 |
| 10 HOUR (DAILY) INSPECTION | 40-5 |
| 250 HOUR INSPECTION | 40-7 |
| 500 HOUR INSPECTION | 40-9 |
| 1000 HOUR INSPECTION | 40-10 |
| 2000 HOUR INSPECTION | 40-11 |
| 5000 HOUR INSPECTION | 40-12 |
| | |
| AUTOMATIC LUBRICATION SYSTEM | 42-1 |
| GENERAL DESCRIPTION | 42-1 |
| SYSTEM COMPONENTS | 42-4 |
| SYSTEM OPERATION | 42-6 |
| INJECTOR OPERATION | 42-7 |
| LUBRICANT PUMP | 42-8 |
| Pump Housing Oil Level | 42-8 |
| Pump Pressure Control | 42-8 |
| INJECTORS (SL-1 Series "H") | 42-9 |
| Injector Specifications | 42-9 |
| Injector Adjustment | 42-9 |

TABLE OF CONTENTS

| SUBJECT ----- | SECTION / PAGE |
|---|-----------------------|
| SYSTEM PRIMING | .42-10 |
| Filter Assembly | .42-10 |
| SYSTEM CHECK | .42-11 |
| SYSTEM TROUBLESHOOTING CHART | .42-13 |
| PREVENTATIVE MAINTENANCE | .42-15 |
| | |
| MAJOR COMPONENT DESCRIPTION | .50-1 |
| | |
| VEHICLE HEALTH MONITORING SYSTEM (VHMS) | .60-1 |
| VHMS DOWNLOADING | .60-2 |
| PAYLOAD METER | .60-3 |
| NORMAL OPERATION DISPLAY | .60-4 |
| EXTERNAL DISPLAY LAMPS | .60-5 |
| PREDICTED LOAD DISPLAY | .60-5 |
| CALIBRATING PLM | .60-6 |
| DATA STORED IN PAYLOAD METER | .60-7 |
| PLM DOWNLOADING | .60-8 |
| SETTING THE MACHINE ID AND OPEN ID | .60-9 |
| PAYLOAD - CYCLE DATA ITEM | .60-10 |
| ADDITIONAL FUNCTIONS | .60-10 |
| | |
| AM/FM RADIO/CD PLAYER | .70-1 |
| OPERATING INSTRUCTIONS | .70-1 |
| GENERAL RADIO RECEIVER FUNCTIONS | .70-1 |
| USING THE CLOCK | .70-3 |
| USING THE ALARM | .70-3 |
| USING THE RADIO | .70-4 |
| USING THE WEATHERBAND | .70-5 |
| USING THE COMPACT DISC PLAYER | .70-5 |
| PLAYING AN MP3 DISC | .70-6 |
| TROUBLESHOOTING | .70-8 |

TRUCK MODEL ILLUSTRATION



A000029

KOMATSU HD1500 DUMP TRUCK

ABOUT THIS MANUAL

This manual is written for use by the operator and/or the service technician. It is designed to help these persons learn how to operate the truck and its systems in order to keep it operating safely and efficiently. All operators and maintenance personnel should read and understand the materials in this manual before operating the truck or performing maintenance and/or operational checks on the truck. All safety notices, warnings, and cautions should be understood and followed when operating or performing repairs on the truck.

The front cover of this manual includes a form number. This form number should be referenced when ordering additional copies of this manual, or for any other correspondence regarding the coverage in this manual.

Direct all inquiries to:

Komatsu America Corp.
Peoria Technical Publications
P.O. Box 240
Peoria, IL 61650-0240
(309)-672-7072 - FAX

This first section is an introduction to the manual and contains the table of contents to locate specific areas of interest. Other sections include Safety, Operating Instructions, Lubrication and Service, etc.

When searching for a specific area of interest, go first to the table of contents to locate the section in which the subject might generally be included. Then, go to that section of the table of contents to find a subject description that most closely describes the specific area of interest to find a page number and go to that page. Section numbers and page numbers are located at the top, outside corner of the page.

At the top, inside corner of the page is a document (module) number. If there is ever a question regarding the information in a particular section, refer to the document (module) number, the manual form number, and use the address shown above to correspond. If there is a date (month/year) behind the document (module) number, that indicates the latest revision date of that page.

The illustrations used in this manual are typical of the component shown and may not be an *exact* reproduction of what is found on the truck.

This manual shows dimensioning of U.S. standard and metric (SI) units throughout. All references to right, left, front, or rear are made with respect to the operator's normal seated position, unless specifically stated otherwise.

When assembly instructions are provided without references to torque values, standard torque values are to be assumed. Standard torque requirements are shown in torque charts on the following pages of this section, and in the General Information section of the truck service manual. Individual torques when provided in the text are in bold face type, such as **135 N·m (100 ft lb)**. All torque specifications have $\pm 10\%$ tolerance unless otherwise specified.

NOTES

TORQUE TABLES AND CONVERSION CHARTS



This manual provides dual dimensioning for many specifications. Metric units are specified first, with U.S. standard units in parentheses. When torque values are not specified in the assembly instructions contained in this manual, use the standard torque value for the hardware being used. Standard value torque tables are contained in this chapter for metric and SAE hardware.

References throughout the manual to standard torques or other standard values will be to one of the following tables. Do not use standard values to replace specific torque values in assembly instructions.

NOTE: This truck is assembled with both metric and SAE (U.S.) hardware. Reference the correct table when determining the proper torque value.

For values not shown in any of the charts or tables, standard conversion factors for most commonly used measurements are provided in the following tables.

INDEX OF TABLES

| TABLE | Page |
|---|-------|
| TABLE 1 Standard Tightening Torque For Metric Cap screws and Nuts | 12-2 |
| TABLE 2 Standard Tightening Torque For SAE Grade 5 & 8 Cap Screws and Nuts | 12-3 |
| TABLE 3 Standard Tightening Torque 12-Pt, Grade 9, Cap Screws (SAE) | 12-4 |
| TABLE 4 Tightening Torque for T-Bolt Type Hose Clamps. | 12-5 |
| TABLE 5 Standard Tightening Torque For Split Flange Clamp Bolts | 12-5 |
| TABLE 6 Tightening Torque For Flared Tube And Hose Fittings | 12-5 |
| TABLE 7 JIC 37° Swivel Nuts Torque Chart (SAE) | 12-6 |
| TABLE 8 Pipe Thread Torque Chart (SAE) | 12-6 |
| TABLE 9 O-Ring Boss Torque Chart (SAE) | 12-7 |
| TABLE 10 O-Ring Face Seal Torque Chart (SAE) | 12-7 |
| TABLE 11 Common Conversions Multipliers - Metric -to- English | 12-8 |
| TABLE 12 Common Conversions Multipliers - English -to- Metric | 12-9 |
| TABLE 13 Temperature Conversions. | 12-10 |
| TABLE 14 Sealants And Adhesives | 12-11 |

EFFECT OF SPECIAL LUBRICANTS On Fasteners and Standard Torque Values

The Komatsu engineering department does not recommend the use of special friction-reducing lubricants, such as Copper Coat, Never-Seez®, and other similar products, on the threads of standard fasteners where standard torque values are applied. The use of special friction-reducing lubricants will significantly alter the clamping force being applied to fasteners during the tightening process.

If special friction-reducing lubricants are used with the standard torque values listed in this chapter, excessive stress and possible breakage of the fasteners may result.

Where the torque tables specify “Lubricated Threads” for the standard torque values listed, these standard torque values are to be used with simple lithium base chassis grease (multi-purpose EP NLGI) or a rust-preventive grease (see below) on the threads and seats unless specified otherwise.

NOTE: Ensure the threads of fasteners and tapped holes are free of burrs and other imperfections before assembling.

Suggested* Sources for Rust Preventive Grease:

- American Anti-Rust Grease #3-X from Standard Oil Company (also American Oil Co.)
- Gulf NoRust #3 from Gulf Oil Company.
- Mobilarma 355, Product No. 66705 from Mobil Oil Corporation.
- Rust Ban 326 from Humble Oil Company.
- Rustolene B Grease from Sinclair Oil Co.
- Rust Preventive Grease - Code 312 from the Southwest Grease and Oil Company.

NOTE: This list represents the current engineering approved sources for use in Komatsu manufacture. It is not exclusive. Other products may meet the same specifications of this list.

STANDARD TIGHTENING TORQUES For Class 10.9 Cap screws & Class 10 Nuts

The following specifications apply to required assembly torques for all metric class 10.9 finished hexagon head cap screws and class 10 nuts.

- Cap screw threads and seats shall not be lubricated when assembled. These specifications are based on all cap screws, nuts, and hardened washers being phosphate and oil coated.

If zinc-plated hardware is used, each piece must be lubricated with simple lithium base chassis grease (multi-purpose EP NLGI) or a rust preventive grease (see list, this page) to achieve the same clamping forces provided below.

- Torques are calculated to give a clamping force of approximately 75% of proof load.
- The maximum torque tolerance shall be within $\pm 10\%$ of the torque value shown.
- In the following table under “Cap Screw Size”, the first number represents the shank diameter (mm). The second number represents threads per millimeter.

Example: M20 x 2.25

M20 = shank diameter (20 mm)

2.25 = threads pitch in millimeters



| Cap Screw Size | Torque N•m | Torque ft lb | Torque kg•m |
|----------------|------------|--------------|-------------|
| M6 | 13 | 10 | 1.35 |
| M8 | 31 | 23 | 3.2 |
| M10 | 66 | 48 | 6.7 |
| M12 | 112 | 83 | 11.5 |
| M14 | 177 | 130 | 18.0 |
| M16 | 279 | 206 | 28.5 |
| M18 | 383 | 282 | 39.0 |
| M20 | 549 | 405 | 56.0 |
| M22 | 745 | 550 | 76.0 |
| M24 | 927 | 684 | 94.5 |
| M27 | 1320 | 975 | 135 |
| M30 | 1720 | 1266 | 175 |
| M33 | 2210 | 1630 | 225 |
| M36 | 2750 | 2025 | 280 |
| M39 | 3280 | 2420 | 335 |

STANDARD TIGHTENING TORQUES For SAE Grade 5 and Grade 8 Cap screws

The following specifications apply to required assembly torques for all grade 5 and grade 8 cap screws.

- Cap screw threads and seats shall be lubricated when assembled.

Unless instructions specifically recommend otherwise, these standard torque values are to be used with simple lithium base chassis grease (multi-purpose EP NLGI) or a rust- preventive grease (see list, previous page) on the threads.

- Torques are calculated to give a clamping force of approximately 75% of proof load.

- The maximum torque tolerance shall be $\pm 10\%$ of the torque value shown.
- In the following table under Cap Screw Size, the first number represents the shank diameter (in.). The second number represents threads per inch.

Example: 7/16 - 20

7/16 = shank diameter (7/16 inch (0.438 inch))

20 = threads per inch

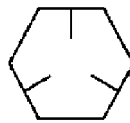

GRADE 5

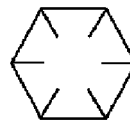

GRADE 8

TABLE 2.
Standard Tightening Torque
for SAE Hex Head Cap Screw And Nut Assembly

| Cap Screw Size | Torque - Grade 5 | | | Torque - Grade 8 | | | Cap Screw Size | Torque - Grade 5 | | | Torque - Grade 8 | | |
|----------------|------------------|-------|------|------------------|-------|------|----------------|------------------|-------|-------|------------------|-------|-------|
| | N-m | ft lb | kg-m | N-m | ft lb | kg-m | | N-m | ft lb | kg-m | N-m | ft lb | kg-m |
| 1/4-20 | 9.5 | 7 | 0.97 | 13.6 | 10 | 1.38 | 3/4-16 | 319 | 235 | 32.5 | 454 | 335 | 46.3 |
| 1/4-28 | 10.8 | 8 | 1.11 | 14.9 | 11 | 1.52 | 7/8-9 | 475 | 350 | 48.4 | 678 | 500 | 69.2 |
| 5/16-18 | 20.3 | 15 | 2.07 | 28 | 21 | 2.90 | 7/8-14 | 508 | 375 | 51.9 | 719 | 530 | 73.3 |
| 5/16-24 | 22 | 16 | 2.21 | 30 | 22 | 3.04 | 1.0-8 | 712 | 525 | 72.6 | 1017 | 750 | 103.7 |
| 3/8-16 | 34 | 25 | 3.46 | 47 | 35 | 4.84 | 1.0-12 | 759 | 560 | 77.4 | 1071 | 790 | 109.3 |
| 3/8-24 | 41 | 30 | 4.15 | 54 | 40 | 5.5 | 1.0-14 | 773 | 570 | 78.8 | 1085 | 800 | 110.6 |
| 7/16-14 | 54 | 40 | 5.5 | 79 | 58 | 8.0 | 1 1/8-7 | 881 | 650 | 89.9 | 1424 | 1050 | 145 |
| 7/16-20 | 61 | 45 | 6.2 | 84 | 62 | 8.57 | 1 1/8-12 | 949 | 700 | 96.8 | 1546 | 1140 | 158 |
| 1/2-13 | 88 | 65 | 9 | 122 | 90 | 12.4 | 1 1/4-7 | 1234 | 910 | 125.9 | 2007 | 1480 | 205 |
| 1/2-20 | 95 | 70 | 9.7 | 129 | 95 | 13.1 | 1 1/4-12 | 1322 | 975 | 134.8 | 2142 | 1580 | 219 |
| 9/16-12 | 122 | 90 | 12.4 | 169 | 125 | 17.3 | 1 3/8-6 | 1627 | 1200 | 166 | 2630 | 1940 | 268 |
| 9/16-18 | 129 | 95 | 13.1 | 183 | 135 | 18.7 | 1 3/8-12 | 1776 | 1310 | 181 | 2874 | 2120 | 293 |
| 5/8-11 | 169 | 125 | 17.3 | 237 | 175 | 24.2 | 1 1/2-6 | 2142 | 1580 | 219 | 3471 | 2560 | 354 |
| 5/8-18 | 183 | 135 | 18.7 | 258 | 190 | 26.2 | 1 1/2-12 | 2305 | 1700 | 235 | 3756 | 2770 | 383 |
| 3/4-10 | 298 | 220 | 30.4 | 420 | 310 | 42.8 | | | | | | | |

1 ft lb = 0.138 kg-m = 1.356 N.m

STANDARD TIGHTENING TORQUES For SAE Grade 9 Cap screws

The following specifications apply to required assembly torques for all 12-point, grade 9 (170,000 psi minimum tensile), cap screws.

- Cap screw threads and seats shall be lubricated when assembled.

Unless instructions specifically recommend otherwise, these standard torque values are to be used with simple lithium base chassis grease (multi-purpose EP NLGI) or a rust- preventive grease (see list, this page) on the threads.

- Torques are calculated to give a clamping force of approximately 75% of proof load.
- The maximum torque tolerance shall be $\pm 10\%$ of the torque value shown.

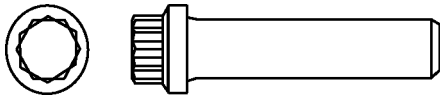

| Cap Screw Size* | Torque N-m | Torque ft lb | Torque kg-m |
|-----------------|---------------|-----------------|----------------|
| 0.250 - 20 | 16 | 12 | 1.7 |
| 0.312 - 18 | 33 | 24 | 3.3 |
| 0.375 - 16 | 57 | 42 | 5.8 |
| 0.438 -14 | 95 | 70 | 9.7 |
| 0.500 -13 | 142 | 105 | 14.5 |
| 0.562 - 12 | 203 | 150 | 20.7 |
| 0.625 - 11 | 278 | 205 | 28.3 |
| 0.750 - 10 | 488 | 360 | 49.7 |
| 0.875 - 9 | 780 | 575 | 79.4 |
| 1.000 - 8 | 1166 | 860 | 119 |
| 1.000 - 12 | 1240 | 915 | 126 |
| 1.125 - 7 | 1670 | 1230 | 170 |
| 1.125 - 12 | 1800 | 1330 | 184 |
| 1.250 - 7 | 2325 | 1715 | 237 |
| 1.250 - 12 | 2495 | 1840 | 254 |
| 1.375 - 6 | 3080 | 2270 | 313 |
| 1.375 - 12 | 3355 | 2475 | 342 |
| 1.500 - 6 | 4040 | 2980 | 411 |
| 1.500 - 12 | 4375 | 3225 | 445 |

* Shank Diameter (in.) - Threads per inch

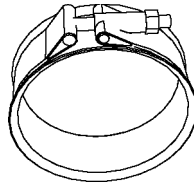

| TABLE 4. Tightening Torque For T-Bolt Type Hose Clamp (SAE J1508 Type TB) | | | |
|---|---------------------|------------------------|-------------------------|
| Thread Size | Band Width | Newton meters (N·m) | Inch Pounds (in. lb) |
| 0.25-28 UNF | 19.05 mm (0.75 in.) | 8.5 ± 0.6 N·m | 75 ± 5 in lb |

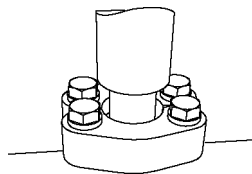

| TABLE 5. Tightening Torque For Split Flange Clamp Bolts | | | | |
|---|------------------------------|---|---|--|
| Cap Screw Thread Diameter (mm) | Width Across Flat (mm) | Newton meters (N·m) Tolerances ±10% | Foot Pounds (ft lb) Tolerances ±10% | Kilogram meters (kg·m) Tolerances ±10% |
| 10 | 14 | 66 | 48 | 6.7 |
| 12 | 17 | 112 | 83 | 11.5 |
| 16 | 22 | 279 | 206 | 28.5 |

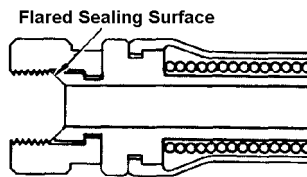

| TABLE 6. Tightening Torque For Flared Tube And Hose Fittings | | | | |
|--|------------------------------|---|---|--|
| Thread Diameter of Nut (mm) | Width Across Flat (mm) | Newton meters (N·m) Tolerances ±10% | Foot Pounds (ft lb) Tolerances ±10% | Kilogram meters (kg·m) Tolerances ±10% |
| 14 | 19 | 25 | 18 | 2.5 |
| 18 | 24 | 50 | 36 | 5 |
| 22 | 27 | 80 | 58 | 8 |
| 24 | 32 | 140 | 101 | 14 |
| 30 | 36 | 175 | 130 | 18 |
| 33 | 41 | 195 | 145 | 20 |
| 36 | 46 | 245 | 180 | 25 |
| 42 | 55 | 295 | 215 | 30 |

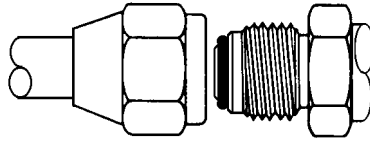

TABLE 7.
Torque Chart For JIC 37° Swivel NutS
With Or Without O-ring Seals

| Size Code | Tube Size (OD) | Threads UNF-2B | Newton meters (N·m) | Foot Pounds (ft lb) |
|-----------|----------------|----------------|---------------------|---------------------|
| - 2 | 0.125 | 0.312 - 24 | 5 ± 1 | 4 ± 1 |
| - 3 | 0.188 | 0.375 - 24 | 11 ± 4 | 8 ± 3 |
| - 4 | 0.250 | 0.438 - 20 | 16 ± 4 | 12 ± 3 |
| - 5 | 0.312 | 0.500 - 20 | 20 ± 4 | 15 ± 3 |
| - 6 | 0.375 | 0.562 - 18 | 24 ± 7 | 18 ± 5 |
| - 8 | 0.500 | 0.750 - 16 | 40 ± 7 | 30 ± 5 |
| - 10 | 0.625 | 0.875 - 14 | 54 ± 7 | 40 ± 5 |
| - 12 | 0.750 | 1.062 - 12 | 75 ± 7 | 55 ± 5 |
| - 14 | 0.875 | 1.188 - 12 | 88 ± 7 | 65 ± 5 |
| - 16 | 1.000 | 1.312 - 12 | 108 ± 7 | 80 ± 5 |
| - 20 | 1.250 | 1.625 - 12 | 136 ± 14 | 100 ± 10 |
| - 24 | 1.500 | 1.875 - 12 | 163 ± 14 | 120 ± 10 |
| - 32 | 2.000 | 2.500 - 12 | 312 ± 27 | 230 ± 20 |

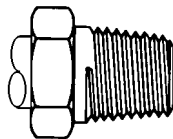

TABLE 8.
Torque Chart For
Pipe Thread Fittings

| Size Code | Pipe Thread Size | With Sealant N·m | With Sealant ft lb | Without Sealant N·m | Without Sealant ft lb |
|-----------|------------------|------------------|--------------------|---------------------|-----------------------|
| - 2 | 0.125 - 27 | 20 ± 4 | 15 ± 3 | 27 ± 7 | 20 ± 5 |
| - 4 | 0.250 - 18 | 27 ± 7 | 20 ± 5 | 34 ± 7 | 25 ± 5 |
| - 6 | 0.375 - 18 | 34 ± 7 | 25 ± 5 | 48 ± 7 | 35 ± 5 |
| - 8 | 0.500 - 14 | 48 ± 7 | 35 ± 5 | 61 ± 7 | 45 ± 5 |
| - 12 | 0.750 - 14 | 61 ± 7 | 45 ± 5 | 75 ± 7 | 55 ± 5 |
| - 16 | 1.000 - 11.50 | 75 ± 7 | 55 ± 5 | 88 ± 7 | 65 ± 5 |
| - 20 | 1.250 - 11.50 | 95 ± 7 | 70 ± 5 | 108 ± 7 | 80 ± 5 |
| - 24 | 1.500 - 11.50 | 108 ± 7 | 80 ± 5 | 129 ± 14 | 95 ± 10 |
| - 32 | 2.000 - 11.50 | 129 ± 14 | 95 ± 10 | 163 ± 14 | 120 ± 10 |

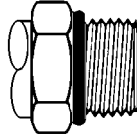

TABLE 9.
Torque Chart For
O-ring Boss Fittings

| Size Code | Tube Size (OD) | Threads UNF-2B | Newton meters (N·m) | Foot Pounds (ft lb) |
|-----------|----------------|----------------|---------------------|---------------------|
| - 2 | 0.125 | 0.312 - 24 | 4 ± 3 | 4 ± 2 |
| - 3 | 0.188 | 0.375 - 24 | 7 ± 3 | 5 ± 2 |
| - 4 | 0.250 | 0.438 - 20 | 11 ± 4 | 8 ± 3 |
| - 5 | 0.312 | 0.500 - 20 | 14 ± 4 | 10 ± 3 |
| - 6 | 0.375 | 0.562 - 18 | 18 ± 4 | 13 ± 3 |
| - 8 | 0.500 | 0.750 - 16 | 33 ± 7 | 24 ± 5 |
| - 10 | 0.625 | 0.875 - 14 | 43 ± 7 | 32 ± 5 |
| - 12 | 0.750 | 1.062 - 12 | 65 ± 7 | 48 ± 5 |
| - 14 | 0.875 | 1.188 - 12 | 73 ± 7 | 54 ± 5 |
| - 16 | 1.000 | 1.312 - 12 | 98 ± 7 | 72 ± 5 |
| - 20 | 1.250 | 1.625 - 12 | 109 ± 7 | 80 ± 5 |
| - 24 | 1.500 | 1.875 - 12 | 109 ± 7 | 80 ± 5 |
| - 32 | 2.000 | 2.500 - 12 | 130 ± 14 | 96 ± 10 |

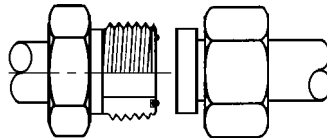

TABLE 10.
Torque Chart For
O-ring Face Seal Fittings

| Size Code E | Tube Size (O.D.) | Threads UNF-2B | Newton meters (N·m) | Foot Pounds (ft lb) |
|-------------|------------------|----------------|---------------------|---------------------|
| - 4 | 0.250 | 0.438 - 20 | 15 ± 1 | 11 ± 1 |
| - 6 | 0.375 | 0.562 - 18 | 24 ± 3 | 18 ± 2 |
| - 8 | 0.500 | 0.750 - 16 | 48 ± 5 | 35 ± 4 |
| - 10 | 0.625 | 0.875 - 14 | 69 ± 7 | 51 ± 5 |
| - 12 | 0.750 | 1.062 - 12 | 96 ± 10 | 71 ± 7 |
| - 16 | 1.000 | 1.312 - 12 | 133 ± 8 | 98 ± 6 |
| - 20 | 1.250 | 1.625 - 12 | 179 ± 10 | 132 ± 7 |
| - 24 | 1.500 | 1.875 - 12 | 224 ± 20 | 165 ± 15 |

| TABLE11. Common Conversion Multipliers Metric To English | | |
|---|---------------------------------|------------------------|
| To Convert From | To | Multiply By |
| millimeter (mm) | inch (in.) | 0.0394 |
| centimeter (cm) | inch (in.) | 0.3937 |
| meter (m) | foot (ft) | 3.2808 |
| meter (m) | yard (yd) | 1.0936 |
| kilometer (km) | mile (mi) | 0.6210 |
| square centimeters (cm ²) | square inch (in. ²) | 0.1550 |
| square centimeters (cm ²) | square feet (ft ²) | 0.001 |
| cubic centimeters (cm ³) | cubic inch (in. ³) | 0.061 |
| liters (l) | cubic inch (in. ³) | 61.02 |
| cubic meters (m ³) | cubic feet (ft ³) | 35.314 |
| liters (l) | cubic feet (ft ³) | 0.0353 |
| grams (g) | ounce (oz) | 0.0353 |
| milliliter (ml) | fluid ounce (fl oz) | 0.0338 |
| kilogram (kg) | pound (mass) | 2.2046 |
| Newton (N) | pounds (lb) | 0.2248 |
| Newton meters (N·m) | kilogram meters (kg·m) | 0.102 |
| Newton meters (N·m) | foot pounds (ft lb) | 0.7376 |
| kilogram meters (kg·m) | foot pounds (ft lb) | 7.2329 |
| kilogram meters (kg·m) | Newton meters (N·m) | 9.807 |
| kilopascals (kPa) | pounds/square inch (psi) | 0.1450 |
| megapascals (MPa) | pounds/square inch (psi) | 145.038 |
| kilograms/cm ² (kg/cm ²) | pounds/square inch (psi) | 14.2231 |
| kilograms/cm ² (kg/cm ²) | kilopascals (kPa) | 98.068 |
| kilogram (kg) | short ton (tn) | 0.0011 |
| metric ton | short ton (tn) | 1.1023 |
| liters (l) | quart (qt) | 1.0567 |
| liters (l) | gallon (gal) | 0.2642 |
| Watts (W) | horsepower (hp) | 0.00134 |
| kilowatts (kW) | horsepower (hp) | 1.3410 |

| TABLE 12. Common Conversion Multipliers English to Metric | | |
|--|---|--------------------|
| To Convert From | To | Multiply By |
| inch (in.) | millimeter (mm) | 25.40 |
| inch (in.) | centimeter (cm) | 2.54 |
| foot (ft) | meter (m) | 0.3048 |
| yard (yd) | meter (m) | 0.914 |
| mile (mi) | kilometer (km) | 1.61 |
| square inch (in. ²) | square centimeters (cm ²) | 6.45 |
| square feet (ft ²) | square centimeters (cm ²) | 929 |
| cubic inches (in. ³) | cubic centimeters (cm ³) | 16.39 |
| cubic inches (in. ³) | liters (l) | 0.016 |
| cubic feet (ft ³) | cubic meters (m ³) | 0.028 |
| cubic feet (ft ³) | liters (l) | 28.3 |
| ounce (oz) | kilogram (kg) | 0.028 |
| fluid ounce (fl oz) | milliliter (ml) | 29.573 |
| pound (lb) | kilogram (kg) | 0.454 |
| pound (lb) | Newton (N) | 4.448 |
| inch pounds (in. lb) | Newton meters (N·m) | 0.113 |
| foot pounds (ft lb) | Newton meters (N·m) | 1.356 |
| foot pounds (ft lb) | kilogram meters (kg·m) | 0.138 |
| kilogram meters (kg·m) | Newton meters (N·m) | 9.807 |
| pounds/square inch (psi) | kilopascals (kPa) | 6.895 |
| pounds/square inch (psi) | megapascals (MPa) | 0.007 |
| pounds/square inch (psi) | kilograms/square centimeter (kg/cm ²) | 0.0704 |
| short ton (tn) | kilogram (kg) | 907.2 |
| short ton (tn) | metric ton (t) | 0.0907 |
| quart (qt) | liters (l) | 0.946 |
| gallon (gal) | liters (l) | 3.785 |
| horsepower (hp) | Watts (w) | 745.7 |
| horsepower (hp) | kilowatts (kw) | 0.745 |

TABLE 13.
Temperature Conversions
Formula: $F^{\circ} - 32 \div 1.8 = C^{\circ}$ or $C^{\circ} \times 1.8 + 32 = F^{\circ}$

| Celsius C° | | Fahrenheit F° | Celsius C° | | Fahrenheit F° | Celsius C° | | Fahrenheit F° |
|---------------|-----|------------------|---------------|-----|------------------|---------------|------|------------------|
| 121 | 250 | 482 | 63 | 145 | 293 | 4 | 40 | 104 |
| 118 | 245 | 473 | 60 | 140 | 284 | 2 | 35 | 95 |
| 116 | 240 | 464 | 57 | 135 | 275 | - 1 | 30 | 86 |
| 113 | 235 | 455 | 54 | 130 | 266 | - 4 | 25 | 77 |
| 110 | 230 | 446 | 52 | 125 | 257 | - 7 | 20 | 68 |
| 107 | 225 | 437 | 49 | 120 | 248 | - 9 | 15 | 59 |
| 104 | 220 | 428 | 46 | 115 | 239 | - 12 | 10 | 50 |
| 102 | 215 | 419 | 43 | 110 | 230 | - 15 | 5 | 41 |
| 99 | 210 | 410 | 41 | 105 | 221 | - 18 | 0 | 32 |
| 96 | 205 | 401 | 38 | 100 | 212 | - 21 | - 5 | 23 |
| 93 | 200 | 392 | 35 | 95 | 203 | - 23 | - 10 | 14 |
| 91 | 195 | 383 | 32 | 90 | 194 | - 26 | - 15 | 5 |
| 88 | 190 | 374 | 29 | 85 | 185 | - 29 | - 20 | - 4 |
| 85 | 185 | 365 | 27 | 80 | 176 | - 32 | - 25 | - 13 |
| 82 | 180 | 356 | 24 | 75 | 167 | - 34 | - 30 | - 22 |
| 79 | 175 | 347 | 21 | 70 | 158 | - 37 | - 35 | - 31 |
| 77 | 170 | 338 | 18 | 65 | 149 | - 40 | - 40 | - 40 |
| 74 | 165 | 329 | 15 | 60 | 140 | - 43 | - 45 | - 49 |
| 71 | 160 | 320 | 13 | 55 | 131 | - 46 | - 50 | - 58 |
| 68 | 155 | 311 | 10 | 50 | 122 | - 48 | - 55 | - 67 |
| 66 | 150 | 302 | 7 | 45 | 113 | - 51 | - 60 | - 76 |

NOTE: The numbers in the unmarked columns refer to temperature in either degrees Celsius (C°) or Fahrenheit (F°). Select a number in this unmarked column and read to the left to convert to degrees Celsius (C°) or read to the right to convert to degrees Fahrenheit (F°). If starting with a known temperature (either C° or F°), find that temperature in the marked column and read the converted temperature in the center, unmarked column.

| TABLE 14. Sealants And Adhesives | | | |
|-------------------------------------|-----------------------------------|------------------|--|
| Nomenclature | Code | Three Bond * | Applications |
| Adhesives | LT-1A | TB1521 | Used to apply rubber pads, rubber gaskets and cork plugs. |
| | LT-1B | 1000B - 1000W | Used to apply resin, rubber, metallic and non-metallic parts when a fast, strong seal is needed. |
| | LT-2 | TB1374 | Preventing bolts, nuts and plugs from loosening and leaking oil. |
| | LT-2A | TB2411 | Preventing bolts, nuts and plugs from loosening and leaking oil. (1) |
| | LT-2B | TB2403 | Preventing bolts, nuts and plugs from loosening and leaking oil. (2) |
| | LT-2C | TB2430 or TB2440 | Preventing bolts, nuts and plugs from loosening and leaking oil. (2) |
| | LT-3 Main bond Hardening agent | TB2001 TB2105 | Provides an airtight, electrically insulating seal. Used for aluminum surfaces. |
| Liquid Gasket | LG-1 | TB1108B | Used with gaskets and packings to increase sealing effect. |
| | LG-3 | TB1107 | Heat-resistant gasket for precombustion chambers and exhaust piping. |
| | LG-4 | TB1104 | Used by itself on mounting surfaces on the final drive and transmission cases. Thickness after tightening: 0.07-0.08 mm (0.0027-0.0032 in) |
| | LG-5 | TB1110B | Used by itself to seal grease fittings, tapered screw fittings and tapered screw fittings in hydraulic circuits of less than 50 mm (2 in) in diameter. |
| Anti-friction compound | LM-P | - | Applied to bearings and taper shafts to facilitate press-fitting and to prevent sticking, burning or rusting. |
| Grease | G2-LI | - | Applied to bearings, sliding parts and oil seals for lubrication, rust prevention and facilitation of assembling work. |
| Vaseline | - | - | Used for protecting battery electrode terminals from corrosion. |

* NOTE: The part numbers in this column are not Komatsu numbers. These are vendor designations.

- (1) Used for threaded areas (for example, plug, nipple, elbow etc.) which are removable, and a pressure of 1965 kPa (285 psi) or less.
- (2) Used for threaded areas (for example, stud, etc.) which are not removable, and a pressure of 1965 kPa (285 psi) or less.

The sealants and adhesives listed below are manufactured and sold by Three Bond U.S.A., Inc. For information concerning Three Bond products, call or write to:

Three Bond U.S.A., Inc.
6184 Schumacher Park Drive
West Chester, OH 45069

Telephone: (513) 779-7300
Fax: (513) 779-7375

| Part Numbers | |
|--------------|--------------|
| Three Bond | Komatsu |
| TB1374 | 09940-00030 |
| TB1521 | 790-129-9030 |
| TB1104 | 790-129-9020 |
| TB1108B | 790-129-9010 |
| TB1110B | 790-129-9080 |

Hardware Tightening Method



Mark cap screws and nuts with paint or ink before tightening to the specified torque. This method provides verification that the hardware has been properly tightened.

1. Snug all of the hardware with an impact wrench or appropriate ratchet.
2. Apply a paint mark down the side of the hardware and onto the component surface. Verify that all of the hardware that is being tightened is marked.
3. Tighten the marked hardware to the proper torque. All of the paint marks should now be offset, showing that the hardware has been properly tightened.

SAFETY

Safety records from most organizations will show that the greatest percentage of accidents are caused by unsafe acts performed by people. The remainder are caused by unsafe mechanical or physical conditions. Report all unsafe conditions to the proper authority.

The following safety rules are provided as a guide for the operator. However, local conditions and regulations may add many more to this list.



Read and follow all safety precautions. Failure to do so may result in serious injury or death.

Safety Rules

- Only trained and authorized personnel can operate and maintain the machine.
- Follow all safety rules, precautions and instructions when operating or performing maintenance on the machine.
- Ensure all personnel understand all hand signals that are to be used during machine travel and maintenance.

Safety Features

- Ensure all guards and covers are in their proper position. Repair damaged guards and covers. Refer to Section 30, Operating Instructions - Walk-Around Inspection.
- Learn the proper use of safety features such as safety locks, safety pins, and seat belts. Use these safety features properly.
- Never remove any safety features. Always keep safety features in good operating condition.
- Improper use, or failure to maintain safety features could result in serious bodily injury or death.

Clothing And Personal Items

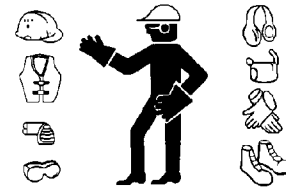

- Avoid loose clothing, jewelry, and loose long hair. Loose items can catch on controls or in moving parts and cause serious injury or death.
- Never wear oily clothes as they are flammable.
- Wear a hard hat, safety glasses, safety shoes, mask and gloves when operating or maintaining a machine. Always wear safety goggles, hard hat and heavy gloves if your job involves scattering metal chips or minute materials--particularly when driving pins with a hammer or when cleaning air cleaner elements with compressed air. Also, ensure that the work area is free from other personnel during such tasks.

Unauthorized Modification

- Any modification made to this vehicle without authorization from Komatsu America Corp. can possibly create hazards.
- Before making any modification, consult the authorized regional Komatsu America Corp. distributor. Komatsu will not be responsible for any injury or damage caused by any unauthorized modification.

Leaving The Operator's Seat

- When preparing to leave the operator's seat, DO NOT touch any control lever that is not locked. Unexpected machine movement may result in serious bodily injury or death. To prevent accidental machine movement from occurring, always perform the following:

Move the shift control lever to NEUTRAL and apply the parking brake.

Lower the dump body, set the dump lever to the FLOAT position.

Stop the engine. When exiting the machine, always lock compartments, and take the keys with you.

Mounting And Dismounting

- Never jump on or off the machine. Never climb on or off a machine while it is moving.
- When climbing on or off a machine, face the machine and use the hand-hold and steps.
- Never hold any control levers when getting on or off a machine.
- Always maintain three-point contact with the hand-holds and steps to ensure proper support and balance.
- When bringing tools into the operator's compartment, always pass them by hand or pull them up by rope.
- If there is any oil, grease, or mud on the hand-holds or steps, wipe them clean immediately. Always keep these areas clean. Repair any damage and tighten any loose bolts.
- Properly use the handrails and steps when getting on or off the machine.

Fire Prevention For Fuel And Oil

- Fuel, oil, and antifreeze can be ignited by a flame. Fuel is extremely flammable and can be hazardous.
- Keep flames away from flammable fluids.
- Stop the engine. Never smoke when refueling.
- Tighten all fuel and oil tank caps securely.
- Refueling and oiling must be done in well ventilated areas.
- Keep oil and fuel in a designated location and DO NOT allow unauthorized persons to enter.



Precautions With High Temperature Fluids

- Immediately after machine operation, fluids are at high temperatures and are pressurized. If a machine system is opened, there is danger of serious burns. Allow heat and pressure to dissipate before performing such tasks and follow proper procedures as outlined in the service manual.

To prevent hot coolant from spraying:

1. Stop the engine.
2. Wait for the coolant temperature to decrease.
3. Depress the pressure release button on the cap to vent cooling system pressure.
4. Turn the radiator cap slowly to release the pressure before removing.



To prevent hot engine oil spray:

1. Stop the engine.
2. Wait for the oil temperature to cool down.
3. Turn the cap slowly to release the pressure before removing the cap.

Asbestos Dust Hazard Prevention

Asbestos dust is hazardous to your health when inhaled. If you handle materials containing asbestos fibers, follow the guidelines below:



- Never use compressed air for cleaning.
- Use water for cleaning to control dust.
- Operate the machine or perform tasks with the wind to your back, whenever possible.
- Use an approved respirator when necessary.

Prevention Of Injury By Work Equipment

- Never enter or put your hand, arm or any other part of your body between movable parts such as the dump body, chassis or cylinders. If the work equipment is operated, clearances will change and may lead to serious bodily injury or death.

Fire Extinguisher And First Aid Kit

- Ensure fire extinguishers are accessible and proper usage techniques are known.
- Periodically check fire extinguishers. Verify that they are in working condition.
- Know what to do in the event of a fire.
- Provide a first aid kit at the storage point. Keep the kit fully stocked.
- Keep the phone numbers of persons you should contact in case of an emergency on hand.

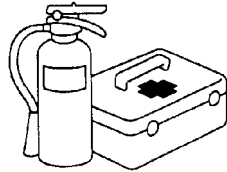

Precautions For Attachments

- When installing and using optional equipment, read the instruction manual for the attachment and the information related to attachments in this manual.
- DO NOT use attachments that are not authorized by Komatsu America Corp., or the authorized regional Komatsu distributor. Use of unauthorized attachments could create a safety problem and adversely affect the proper operation and useful life of the machine.
- Any injuries, accidents, and product failures resulting from the use of unauthorized attachments will not be the responsibility of Komatsu America Corp., or the authorized regional Komatsu distributor.

Precautions For ROPS

- The Rollover Protection Structure (ROPS) must be properly installed for machine operation.
- The ROPS is intended to protect the operator if the machine should roll over. It is designed not only to support the load of the machine, but also to absorb the energy of the impact.
- ROPS structures installed on equipment manufactured and designed by Komatsu America Corp. fulfill all of the regulations and standards for all countries. If it is modified or repaired without authorization from Komatsu, or is damaged when the machine rolls over, the strength of the structure will be compromised and will not be able to fulfill its intended purpose. Optimum strength of the structure can only be achieved if it is repaired or modified as specified by Komatsu.
- When modifying or repairing the ROPS, always consult your nearest Komatsu distributor.
- Even with the ROPS installed, the operator must always use the seat belt when operating the machine.

HAUL ROADS

- Determining the travel road at the work site is an important for safety, maintenance and speed.
- When possible restrict travel to one direction. If it is necessary to provide for traffic in both directions, ensure the road is wide enough.
- When creating haul roads, orient the road so the loaded truck passes on the side closest to the hill face. Keep the road as straight as possible. If curves are necessary, make the curve radius and road width as large as possible. Ramp the outside of curves so they are higher than the inside.
- Limit intersections if possible. Design any necessary intersections to provide safe crossings.
- Install mirrors at curves with poor visibility.
- Install signs to warn of any dangers along the road.
- Install adequate lighting and reflectors for safe travel.
- Road grades should not exceed 10% and emergency ramps installed for brake failures.
- Properly maintain haul roads for safe travel. Use a grader or a dozer to smooth rough roads and strengthen where necessary. Spray the roads with water to prevent excessive dust and poor visibility.

PRECAUTIONS DURING OPERATION

Prevention is the best safety program. Prevent a potential accident by knowing the employer's safety requirements and all necessary job site regulations. In addition, know the proper use and care of all the safety equipment on the truck. Only qualified operators or technicians should attempt to operate or maintain a Komatsu machine.

Safe practices start before the operator gets to the equipment!

BEFORE STARTING THE ENGINE

- When walking to and from a truck, maintain a safe distance from all machines even when the operator is visible.
- Before starting the engine, thoroughly check the area for any unusual conditions that could be dangerous.
- Examine the road surface at the job site and determine the best and safest method of operation.
- Choose an area where the ground is as horizontal and firm as possible before performing the operation.
- If it is necessary to operate the machine on or near a public road, protect pedestrians and cars by designating a person for work site traffic duty or by installing fences around the work site.
- The operator must personally check the work area, the roads to be used, and existence of obstacles before starting operations.
- Always determine the travel roads at the work site. Maintain roads to ensure machine and operator safety.
- If travel through wet areas is necessary, check the depth and flow of water before crossing the shallow parts. Never drive through water which exceeds the permissible water depth.

Fire Prevention

- Thoroughly remove wood chips, leaves, paper and other flammable items accumulated in the engine compartment. Failure to do so could result in a fire.
- Check fuel, lubrication, and hydraulic systems for leaks. Repair any leaks. Clean any excess oil, fuel or other flammable fluids, and dispose of properly.
- Ensure a fire extinguisher is present and in proper working condition.
- DO NOT operate the machine near open flames.

**Preparing For Operation**

- Always mount and dismount while facing the truck. Never attempt to mount or dismount the truck while it is in motion. Always use handrails and ladders when mounting or dismounting the truck.
- Check the deck areas for debris, loose hardware, and tools.
- Check for people and objects that might be in the area. Remove any obstructions and wait for any personnel in the area to disperse.
- Become familiar with and use all protective equipment devices on the truck and ensure that these items (anti-skid material, grab bars, seat belts, etc.) are securely in place.

Ventilation In Enclosed Areas

- If it is necessary to start the engine within an enclosed area, provide adequate ventilation. Exhaust fumes from the engine can kill.

**In Operator's Cab - Before Starting The Engine**

- DO NOT leave tools or spare parts lying around or allow trash to accumulate in the cab of the truck. Keep all unauthorized reading material out of the truck cab.
- Keep the cab floor, controls, steps, and handrails free of oil, grease, snow, and excess dirt.
- Check the seat belt, buckle and hardware for damage or wear. Replace any worn or damaged parts. Always use the seat belts when operating a machine.
- Read and understand the contents of this manual pertaining to safety and operating instructions with special attention. Become thoroughly acquainted with all gauges, instruments and controls before attempting operation of the truck.
- Read and understand the warning and caution decals in the operator's cab.
- Ensure the steering wheel, horn, controls and pedals are free of any oil, grease or mud.
- Check operation of the windshield wiper, condition of wiper blades, and check the washer fluid reservoir level.
- Be familiar with all steering and brake system controls, warning devices, road speeds and loading capabilities, before operating the truck.

Mirrors, Windows, And Lights

- Remove any dirt from the surface of the windshield, cab windows, mirrors and lights. Good visibility may prevent an accident.
- Adjust rear view mirrors to a position where the operator can see best from the operator's seat.
- If any glass or light should break, replace it with a new part.
- Ensure headlights, work lights and taillights are in proper working order. Ensure that the machine is equipped with the proper work lamps needed for the operating conditions.

OPERATING THE MACHINE

When Starting The Engine

- Never start the engine if a warning tag is attached to the controls.
- When starting the engine, sound the horn as an alert.
- Start and operate the machine only while seated in the operator's seat.
- DO NOT allow unauthorized persons in the operator's compartment or any other place on the machine.

Precautions For Starting Machine

- Start the engine from the operator's seat, only.
- Never attempt to start the engine by shorting across the starter terminals. This may cause fire, or serious injury or death to anyone in machine's path.



Truck Operation - General

- Wear seat belt at all times.
- Only authorized persons are allowed to ride in the truck. Riders must be in the cab and belted in the passenger seat.
- DO NOT allow anyone to ride on the decks or steps of the truck.
- DO NOT allow anyone to get on or off the truck while it is in motion.
- DO NOT move the truck in or out of a building without a signal person present.
- Know and obey the hand signal communications between operator and spotter. Use the direction of a signal person to travel near buildings, obstacles, people, etc. Courtesy at all times is a safety precaution!
- Immediately report any hazardous conditions at the haul road, pit or dump area.

- Check for flat tires periodically during a shift. If the truck has been operating on a flat tire, DO NOT park the machine inside of a building until the tire cools. DO NOT stand in front of the rim and locking ring when inflating a tire mounted on the machine. DO NOT allow observers in the area during tiring inflation and service.



The tire and rim assembly may explode if subjected to excessive heat. Move personnel to a remote or protected location if there is evidence of excessive heat in the wheel, brake and tire area.

If the truck must be approached to extinguish a fire, those personnel should do so only while facing the tread area of the tire (front or back), unless protected by use of large heavy equipment as a shield. Stay at least 15 m (50 ft) from the tread of the tire.

In the event of fire in the tire and wheel area (including brake fires), stay away from the truck for at least eight hours or until the tire and wheel are cool.

- Keep serviceable fire fighting equipment on hand. Report empty extinguishers for replacement or refilling.
- Always have the parking brake applied when the truck is parked and unattended. DO NOT leave the truck unattended while the engine is running.
- Park the truck a safe distance away from other vehicles as determined by the supervisor.
- Stay alert at all times! In the event of an emergency, be prepared to react quickly and avoid accidents. If an emergency arises, know where to get prompt assistance.

Traveling

- Lower the dump body and set the dump lever to the FLOAT position before traveling.
- When traveling on rough ground, travel at low speeds. Do not exceed 27 kph (17 mph). When changing direction, avoid turning suddenly.
- If the engine should stop while the machine is in motion, emergency steering as defined by ISO 5010 and braking enable the truck to be steered and stopped. A fixed amount of reserve oil provides temporary steering and braking to briefly allow machine travel to a safe area. Apply the brakes immediately and stop the machine as quickly and safely as possible (off of the haul road, if possible).



DO NOT move the shift lever to the N position while the truck is in motion. If the selector is shifted to N while in motion or while descending a hill the following may occur:

- ***Steering may be more difficult.***
- ***A lack of cooling oil may cause the braking system to overheat and fail.***
- ***Damage to the transmission may occur.***
- ***The engine cannot provide braking when the transmission is not in gear.***

Traveling In Reverse

Before operating the machine or work equipment, observe the following:

- Sound the horn to warn people in the area. For machines equipped with a back-up alarm, ensure the alarm works properly.
- Check for personnel near the machine. Be particularly careful to check behind the machine.
- When necessary, designate a person to watch the area near the truck and signal the operator. This is particularly necessary when traveling in reverse.

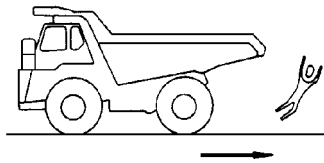

- When operating in areas that may be hazardous or have poor visibility, designate a person to direct work site traffic.
- DO NOT allow anyone to enter the line of travel of the machine. This rule must be strictly observed even with machines equipped with a back-up alarm or rear view mirror.

Traveling On Slopes

- Traveling on slopes could result in the machine tipping over or slipping.
- DO NOT turn the truck around on a slope. To ensure safety, drive to level ground before turning around.
- DO NOT travel up and down on grass, fallen leaves, or wet steel plates. These materials may make the machine slip on even the slightest slope. Avoid traveling sideways, and always keep travel speed low.
- When traveling downhill, use the retarder or service brake pedal to reduce truck speed. Bring the truck to a stop using the brake pedal and then apply the parking brake. Use caution when using the brake pedal. Excessive force when applying the service brakes may cause a loss of control of the truck.
- When turning, rotate the steering wheel gradually to avoid losing control of the truck.
- If the engine should fail while on a slope, apply the service brakes and bring the truck to a stop. Move the transmission range selector to NEUTRAL and apply the parking brake.

Ensure Good Visibility

- When working in dark places, install work lamps and head lamps. Set up extra lighting in the work area if necessary.
- Discontinue operations if visibility is poor, such as in mist, snow, or rain. Wait for the weather to improve to allow the operation to be performed safely.

Operate Carefully On Snow

- When working on snowy or icy roads, there is danger that the machine may slip to the side on even the slightest slope. Always travel slowly and avoid sudden starting, turning, or stopping in these conditions.
- Use extreme caution when clearing snow. The road shoulder and other objects are buried in the snow and cannot be seen.

Avoid Damage To Dump Body

- Always use extreme caution when working in tunnels, on bridges, under electric cables, or any other place where there are height limits. The dump body must be completely lowered before driving the machine.

Driving Near High Voltage Cables

- Driving near high-voltage cables can cause electric shock. Always maintain safe distances between the machine and electric cables, as listed below.

| Voltage | Minimum Safety Distance | |
|----------|-------------------------|-------|
| 6.6 kv | 3 m | 10 ft |
| 33.0 kv | 4 m | 14 ft |
| 66.0 kv | 5 m | 17 ft |
| 154.0 kv | 8 m | 27 ft |
| 275.0 kv | 10 m | 33 ft |

The following actions are effective in preventing accidents while working near high voltages:

- Wear shoes with rubber or leather soles.
- Use a signal person to give a warning if the machine approaches an electric cable.
- If the work equipment should touch an electric cable, the operator must remain in the cab.
- When driving near high voltage cables, DO NOT allow anyone to approach the machine.
- Check with the electrical maintenance department about the voltage of nearby cables before operating.

When Dumping

- Before dumping, check that there is no person or objects behind the machine.
- Stop the machine in the desired location. Check again for persons or objects behind the machine. Give the determined signal, then slowly operate the dump body. If necessary, use blocks for the wheels or position a flagman.
- When dumping on slopes, machine stability is poor and there is danger of tip over. Always perform such operations using extreme care.
- Never travel with the dump body raised.

Working On Loose Ground

- Avoid operating the machine near cliffs, overhangs, and deep ditches. If these areas collapse, the machine could fall or tip over, resulting in serious injury or death. Remember that ground surfaces in these areas may be weakened after heavy rain or blasting.
- Freshly laid soil and soil near ditches is loose. It can collapse under the weight or vibration of the machine. Avoid these areas whenever possible.

Loading The Body

- Check that the surrounding area is safe, stop the machine in the correct loading position, then evenly load the body.
- DO NOT leave the operator's seat during loading.

Parking The Machine

- Choose a horizontal road surface to park the machine. If the machine must be parked on a slope, always put blocks under all the wheels to prevent the machine from moving.
- When parking on public roads, provide signals, such as flags or lights, to warn pedestrians and other vehicles. Ensure the machine, flags, or lights do not obstruct the traffic.
- Before leaving the machine, fully lower the dump body, activate the parking brake, stop the engine, and lock everything. Always take the key with you.

TOWING

- Improper towing methods may lead to serious personal injury and/or damage.
- Use a towing device with ample strength for the weight of this machine.
- Never tow a machine on a slope.
- Inspect all towing apparatus for damage. DO NOT use tow rope that has kinks or is twisted.
- DO NOT stand near the towing cable during towing.
- When connecting a machine that is to be towed, DO NOT allow anyone to go between the tow machine and the machine that is being towed.
- Set the coupling of the machine being towed in a straight line with the towing portion of the tow machine, and secure it in position.

For towing methods, refer to Section 30, Operating Instructions - Towing.

- If acid is accidentally ingested, drink a large quantity of water, milk, beaten eggs or vegetable oil. Call a doctor or poison prevention center immediately.
- When working with batteries always wear safety glasses or goggles.
- Batteries generate hydrogen gas. Hydrogen gas is very explosive and is easily ignited with a small spark of flame.
- Before working with batteries, stop the engine and turn the key switch to the OFF position.
- Avoid short-circuiting the battery terminals through accidental contact with metallic objects, such as tools across the terminals.
- When removing or installing, check which is the positive (+) terminal and negative (-) terminal.
- Tighten battery caps securely.
- Tighten the battery terminals securely. Loose terminals can generate sparks and lead to an explosion.

WORKING NEAR BATTERIES

Battery Hazard Prevention

- Battery electrolyte contains sulfuric acid and can quickly burn the skin and eat holes in clothing. If acid comes in contact with any part of the body, immediately flush the area with water.
- Battery acid can cause blindness if splashed into the eyes. If acid gets into the eyes, flush them immediately with large quantities of water and see a doctor at once.

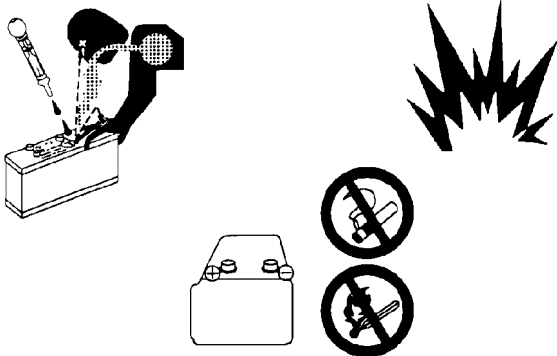

Starting With Booster Cables

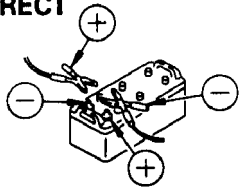
- Always wear safety glasses or goggles when starting the machine with booster cables. **INCORRECT** 
- When using booster cables, DO NOT allow the two machines to touch.
- Connect the positive (+) cable first when installing booster cables. Disconnect the ground or negative (-) cable first during removal.
- If any tool touches between the positive (+) terminal and the chassis, it will cause sparks. Always use caution when using tools near the battery.
- Connect the batteries in parallel: positive to positive and negative to negative.
- When connecting the ground cable to the frame of the machine to be started, connect it away from the battery to minimize the risk of explosion.

PRECAUTIONS FOR MAINTENANCE

BEFORE PERFORMING MAINTENANCE

Warning Tag

- Starting the engine or operating the controls while others are performing maintenance on the truck can lead to serious injury and/or death.

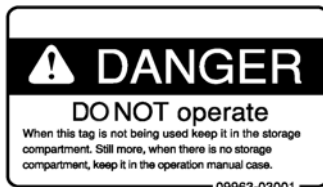

- Always attach the warning tag to the steering wheel in the operator's cab to alert others that you are working on the machine. Attach additional warning tags around the machine, if necessary.
- Tags are available from your Komatsu distributor.
- Warning tag part number (09963-03001)

Proper Tools

- Use only tools suited to the task. Using damaged, low quality, faulty, or makeshift tools can cause personal injury.



Stopping The Engine Before Service

- Before performing inspections or maintenance, stop the machine on firm, flat ground. Lower the dump body, stop the engine and apply the parking brake.
- If the engine must be operated during service, such as when cleaning the radiator, always move the transmission control lever to the NEUTRAL position and apply the parking brake. Always perform this work with two people. One person must sit in the operator's seat to stop the engine, if necessary. Never move any controls, not related to the task at hand, during these situations.
- When servicing the machine, DO NOT touch any moving parts. Never wear loose clothing or jewelry.
- Put wheel blocks under the wheels to prevent machine movement.
- When performing service with the dump body raised, always place the dump lever in the HOLD position. Install the body-up retention cable, securely.

Securing The Dump Body



Any time personnel are required to perform maintenance on the vehicle with the dump body in the raised position, the body-up retention cable must be installed.

The Komatsu body-up retention cable can only be used with a Komatsu body. Non-OEM dump bodies may not accommodate the Komatsu body-up retention cable. The end user must ensure that a proper cable/sling is used.

- To hold the dump body in the raised position, raise the body to its maximum height. Refer to Figure 20-1.

2. Remove cable (2) from its stored position on the body and install between dump body (1) and the axle housing ear.
3. Secure the cable clevis pins with cotter pins.
4. Move the hoist lever to the FLOAT position to slowly lower the body until the cable is supporting the full weight of the body. Then move the hoist lever to the HOLD position.
5. After maintenance is complete, return the cable to the stored position.

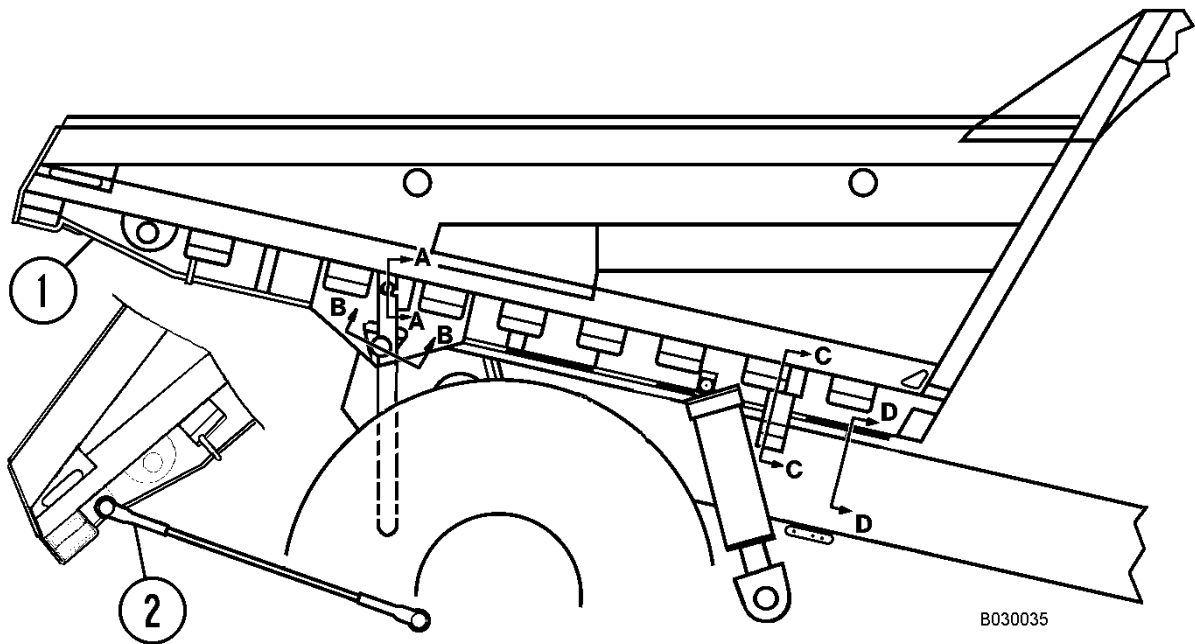

FIGURE 20-1. SECURING THE DUMP BODY

1. Dump Body

2. Body Retention Cable

DURING MAINTENANCE

Personnel

- Only authorized personnel may service and repair the machine.

Attachments

- Place attachments that have been removed from the machine in a safe place and manner to prevent them from falling.



Working Under The Machine

- Always lower all movable work equipment to the ground or to their lowest position before performing service or repairs under the machine.
- Always block the tires of the machine securely.
- Never work under the machine if the machine is poorly supported.



Keep The Machine Clean

- Spilled oil or grease, scattered tools, etc. can cause you to slip or trip. Always keep the machine clean and tidy.
- If water gets into the electrical system, there is danger that the machine may move unexpectedly and/or damage to components may occur. DO NOT use water or steam to clean any sensors, connectors, or the inside of the operator's compartment.



Rules To Follow When Adding Fuel Or Oil

- Spilled fuel and oil may cause slipping. Always clean up spills, immediately. Failure to clean up fuel or oil spills may lead to fires.
- Always tighten the cap of the fuel and oil fillers securely.
- Never use fuel to wash parts.
- Always add fuel and oil in a well-ventilated area.



Radiator Water Level

- If it is necessary to add coolant to the radiator, stop the engine, and allow the engine and radiator to cool.
- Depress the pressure release button on the cap to vent cooling system pressure.
- Slowly loosen the cap to relieve any remaining pressure during removal.

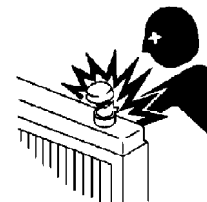

Use Of Lighting

- When checking fuel, oil, coolant, etc., always use lighting with anti-explosion specifications. If such lighting equipment is not used, there is danger of explosion.



Precautions With The Battery

- When repairing the electrical system or when performing electrical welding, remove the negative (-) terminal of the battery to stop the flow of current.

**Handling High Pressure Hoses**

- DO NOT bend high-pressure hoses or hit with hard objects. DO NOT use any bent or cracked piping, tubes or hoses. They may burst during use.
- Always repair any loose or broken hoses. Fuel or oil leaks may result in a fire.

Precautions With High Pressure Oil

- Work equipment circuits are always under pressure.
- DO NOT add oil, drain oil, or perform maintenance or inspections before completely releasing the internal pressure.
- Small, high pressure pin-hole leaks are extremely dangerous. The jet of high-pressure oil can pierce the skin and eyes. Always wear safety glasses and thick gloves. Use a piece of cardboard or a sheet of wood to check for oil leakage.
- If you are hit by a jet of high-pressure oil, consult a doctor immediately for medical attention.

**Precautions When Performing Maintenance Near High Temperature Or High Pressure**

- Immediately after stopping operation, engine coolant and operating oils are at high temperature and under high pressure. In these conditions, if the cap is removed, the oil or water drained, or the filters are replaced, it may result in burns or other injury. Wait for the temperature to cool and pressure to subside, before performing the inspection and/or maintenance as outlined in the service manual.

**Rotating Fan And Belts**

- Stay away from rotating parts such as the radiator fan and fan belts. Serious bodily injury may result from direct or indirect contact with rotating parts and flying objects.

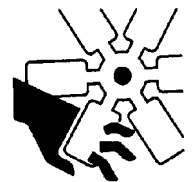
**Waste Materials**

- Never dump waste oil into a sewer system, river, etc.
- Always put used oil in appropriate containers. Never drain oil directly onto the ground.
- Obey appropriate laws and regulations when disposing of harmful objects such as oil, fuel, coolant, solvent, filters, batteries, etc.

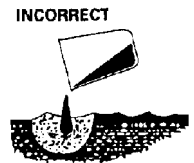

TIRES

Tire Maintenance

If the proper tires are not used for the mine conditions, the tires may overheat and burst. Improper tire usage can also lead to cuts from sharp stones resulting in bursting tires. This may lead to serious injury or damage.

To maintain tire safety, always adhere to the following conditions:

- Inflate the tires to the specified pressure. Abnormal heat is generated particularly when the inflation pressure is too low.
- Use the specified tires.

The tire inflation pressure and permissible speeds are general values. The actual values may differ depending on the type of tire and operating conditions. For details, please consult the tire manufacturer.

When tires become hot, a flammable gas is produced inside the tire, and may ignite. It is particularly dangerous if the tires become overheated while the tires are pressurized. If the gas generated inside the tire ignites, the internal pressure will suddenly rise, and the tire will explode, resulting in danger to personnel in the area. Explosions differ from punctures or tire bursts because the destructive force is extremely high. Therefore, the following actions are strictly prohibited when the tire is pressurized:

- Welding the rim
- Welding near the wheel or tire.
- Smoking or creating open flames



If the proper maintenance procedures are not used, the tire may burst and cause serious injury or damage. When performing tire/wheel maintenance, consult your authorized regional Komatsu distributor, or the tire manufacturer for questions regarding tire safety.

Refer to the Society of Automotive Engineers (SAE), SAE J1337, Off-Road Rim Maintenance Procedures and Service Precautions, Section 4.2 for additional information on demounting the tires and rim assemblies. Also, refer to Section 4.4 of SAE J1337 for assembly and inflation recommendations.

The U.S. Department of Labor Mine Safety and Health Administration (MSHA) addresses tire repairs in its Title 30 Code of Federal Regulations, 30 CFR 57.14104.



DO NOT stand in front of a rim and locking ring when inflating a tire mounted on the machine. Observers must not be permitted in the area.

DO NOT weld or heat the rim assembly with the tire mounted on the rim. Resulting gases inside the tire may ignite, causing explosion of the tire and rim.

Storing Tires After Removal

- As a basic rule, store the tires in a warehouse that unauthorized persons cannot enter. If the tires are stored outside, erect a barrier around the tires. Install a warning sign that young children can understand.
- Stand the tire on level ground. Block the tire securely so that it cannot roll or fall over.
- If the tire should fall over, flee the area quickly. Tires for mining equipment are extremely heavy. Never attempt to hold or support a tire may lead to serious injury.

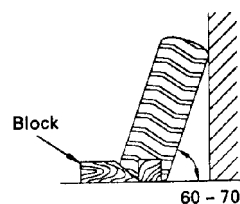

Mounted tires stored as spares must be inflated to the minimum inflation pressure necessary to keep the tire beads properly seated. Maximum inflation pressure of the stored tire must, in no instance, exceed 15% of the tire's cold inflation pressure.

WHEN REPAIRS ARE NECESSARY

1. Only qualified maintenance personnel, who understand the systems being repaired, may attempt repairs.
2. Many components on the truck are large and heavy. Ensure that lifting equipment is of adequate capacity to handle the lift.
3. DO NOT stand under a suspended load. DO NOT work under a raised body unless the body retention cable is in place to hold the body in the raised position.
4. DO NOT repair or service the truck while the engine is running, except when absolutely necessary. Keep a safe distance from moving parts.
5. When servicing an air conditioning system charged with refrigerant, wear a face shield and cold resistant gloves for protection against freezing. Follow all current regulations for handling and recycling refrigerants.
6. Follow package directions carefully when using cleaning solvents.
7. If an auxiliary battery assist is needed, first use one cable to connect the 24V positive (+) post of the disabled truck batteries to the 24V positive (+) post of the auxiliary assist. Use the second cable to connect the 24V negative (-) post of the auxiliary assist battery to a frame ground (-) on the disabled truck, away from the battery.
8. Always disconnect the positive and negative battery cables of the vehicle before doing any welding on the unit. Failure to do so may seriously damage the battery and electrical equipment. Disconnect the battery charging alternator lead wire and isolate electronic control components before making weld repairs.

Always fasten the welding machine ground (-) lead to the piece being welded. The grounding clamp must be attached, as near as possible, to the weld area. Never allow welding current to pass through ball bearings, roller bearings, suspensions, or hydraulic cylinders. Avoid laying welding cables over or near the vehicle electrical harnesses. Welding voltage could be induced into the electrical harness and cause damage to components.

9. If the truck is to be towed for any reason, always consider any special precautions. Refer to Section 30, Operating Instructions - Towing, for instructions on how to properly tow the truck.
10. Drain, clean and ventilate fuel tanks and/or hydraulic tanks before making any welding repairs.
11. Relieve pressure in lines or hoses before making any disconnects.

 **WARNING**

Any operating fluid, such as hydraulic oil escaping under pressure, can have sufficient force to enter a person's body by penetrating the skin. Serious injury and possibly death may result if proper medical treatment by a physician familiar with this injury is not received immediately.

12. After adjustments or repairs, replace all shields, screens and clamps.
13. Use extreme caution when working near tires and rims.:

 **WARNING**

DO NOT stand in front of a rim and locking ring when inflating a tire mounted on the machine. Observers must not be permitted in the area and must be kept away from the sides of such tires.

DO NOT weld or heat the rim assembly with the tire mounted on the rim. Gases inside the tire may ignite, causing explosion of the tire and rim.

14. Only a qualified operator may operate the truck in the repair facility or during road testing after repairs are complete.

WARNINGS AND CAUTIONS

The following pages provide a brief explanation of the warning, caution, and service instruction plates and decals attached to the truck. The plates and decals listed here are typical of this model. Because of customer options, individual trucks may have plates and decals that are different from those shown here.

The plates and decals must be kept clean and legible. If any decal or plate is illegible or damaged, it must be replaced with a new one.

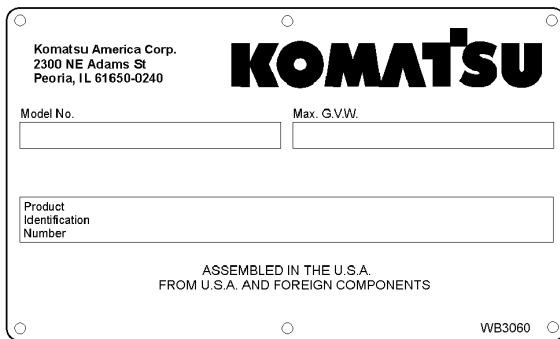

A product identification plate is located on the frame in front of the right side front wheel. It shows the truck model number, maximum Gross Vehicle Weight (GVW) and Product Identification Number (PIN)

MDS - Character positions 4, 5, 6, 7 and 8 identify the Machine Descriptor Section (MDS). The MDS code identifies general information regarding machine specifications. The MDS is a code for the machine type and model.

CL - Character position 9 identifies the Check Letter (CL). The CL is used to verify the accuracy of the individual PIN.

FC - Character positions 10 and 11 identify the Factory Code (FC). The FC identifies the Komatsu factory in charge of claims for the product. The FC for electric drive trucks is 61.

SN - Character positions 12, 13, 14, 15, 16, and 17 identify the Serial Number (SN). The SN is a unique sequential number.

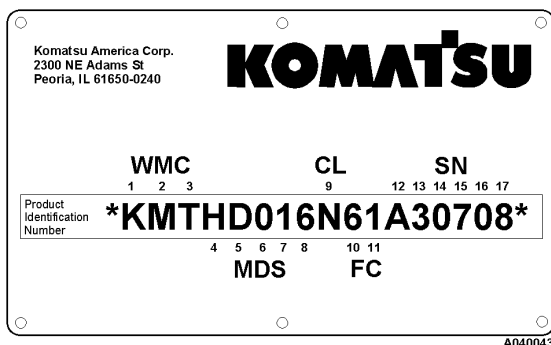

The PIN consists of 19 total characters. The first and last characters are tamper preventative symbols (*). The remaining 17 alpha/numeric characters are used to identify five characteristics of the machine. The five characteristics are detailed below.

WMC - Character positions 1, 2 and 3 identify the Worldwide Manufacturer Code (WMC). The WMC designates the manufacturer of the product. Komatsu brand products are identified with the letters KMT.

⚠ WARNING

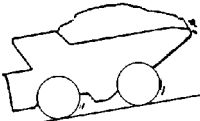

RETARDING CAPACITY
GVW: 550,000 LBS.
(249,478 kg)
TIRES: 33 X 51

MAX. BRAKE OIL TEMPERATURE: 248°F (120°C)
MAX. ENGINE SPEED: 2100 RPM

MAINTAIN HIGHEST ENGINE SPEED BELOW MAX.
SLOW TO NEXT LOWEST GEAR, IF COOLING OIL
TEMPERATURE NEEDS TO BE LOWERED.

| GEAR | SPEED MPH (KM/H) | CONTINUOUS GRADE % | SHORT LENGTH |
|------|---------------------|-----------------------|-----------------------------|
| | | | 1,970 FT. (600m) GRADE % |
| 1 | 6.4 (10.3) | 22.5 % | 26.5 % |
| 2 | 8.6 (13.8) | 16.5 % | 20.5 % |
| 3 | 11.4 (18.4) | 11.5 % | 16.0 % |
| 4 | 14.4 (23.2) | 9.0 % | 13.0 % |
| 5 | 19.2 (31.0) | 6.0 % | 10.0 % |
| 6 | 26.1 (42.1) | 4.0 % | 8.0 % |
| 7 | 34.8 (56.1) | 2.5 % | 6.5 % |

EC4433

AUXILIARY BRAKE

⚠ WARNING

PUSH TO APPLY ALL BRAKES

WB2488

When the auxiliary brake switch is activated, full, unmodulated brake pressure is applied to all wheels. The parking brake will also be applied.

Never actuate the auxiliary brake when the truck is moving, except in the event of an emergency.

A grade/speed plate is located on the left front post of the operator's cab. The decal provides the recommended maximum speeds to be used when descending various grades with a loaded truck.

Always refer to the decal in the operator's cab. This decal may change with optional truck equipment.

ROPS/FOPS NO. **FL2745** MACHINE MODEL **HD1500-7**

AS INSTALLED BY THE MANUFACTURER ON THIS DUMPER HAVING WEIGHT WITHOUT BODY LESS THAN **22450** KG. THIS ROLLOVER PROTECTIVE STRUCTURE AND FALLING OBJECT PROTECTIVE STRUCTURE MEETS THE PERFORMANCE REQUIREMENTS OF SAE-J1040 APR 88, SAE-J231 JAN 81 AND SAE-J1184 MAY 83

⚠ WARNING THE PROTECTION OFFERED MAY BE IMPAIRED IF SUBJECTED TO ANY MODIFICATIONS OR DAMAGE TO MAINTAIN MANUFACTURERS CERTIFICATION ANY REPAIR OR ALTERATION ON THIS STRUCTURE, INCLUDING INSTALLATION OF A NON-STANDARD SEAT, OR RELOCATION OF SEAT MUST HAVE PRIOR WRITTEN APPROVAL.

Komatsu America Corporation
2300 NE Adams St, Peoria, Illinois 61650-0240 U.S.A. EM3402

A plate attached to the right rear corner of the cab states the Roll-Over Protective Structure (ROPS) and Falling Object Protective Structure (FOPS) meet various SAE performance requirements.

⚠ WARNING

KEY SWITCH

DO NOT OPERATE VEHICLE
BEFORE READING AND
UNDERSTANDING
OPERATION MANUALS.

WB2490

A warning decal is located below the key switch on the instrument panel. The warning stresses the importance of reading the operator's manual before operation.

⚠ WARNING

DO NOT modify these components. DO NOT attempt to repair damage without written approval from the manufacturer. Unauthorized repairs will void certification.



Warning plates are attached to the hydraulic tank and the fuel tank. The decals alert technicians not to work on the truck with the body raised unless the body-up retention cable is in position.

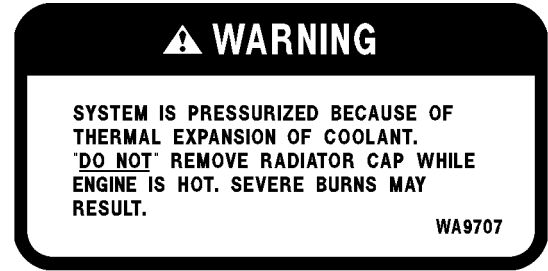

A warning plate is mounted on top of the radiator surge tank cover near the radiator cap. The engine cooling system is pressurized when the engine is on and/or when the system is hot. Turn the engine off and allow the engine to cool before removing the radiator cap. Release internal pressure by depressing the pressure relief. Unless the pressure is first released, removing the radiator cap will result in the hot coolant being expelled from the radiator. Serious scalding and burning can result.

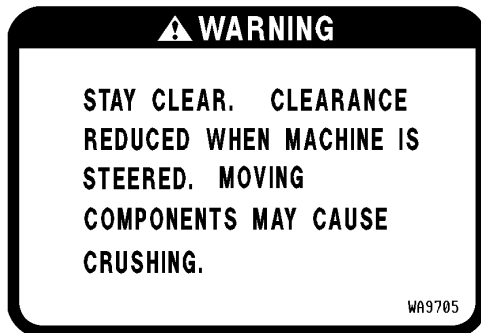

Warning plates are mounted on the truck frame in front of and to the rear of both front tires. The decal alerts all persons to remain at a distance when the truck is being started.

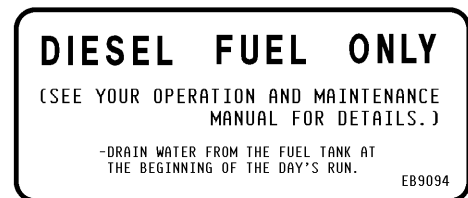

A plate is located next to the fill cap on the fuel tank specifying diesel fuel only. Refer to the engine operation and maintenance manual for more information on fuel requirements.

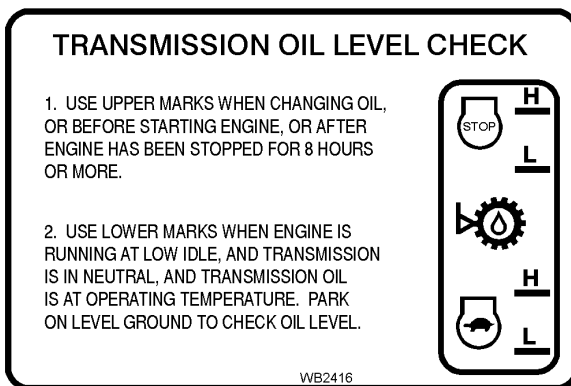

A plate is mounted on the left hand side of the transmission oil pan. The decal provides instructions for properly checking the transmission oil level. Refer to Section 40, Lubrication And Service, for more information on filling the transmission.



A caution decal is attached below the hydraulic tank oil level sight gauge. Check the oil level with the body down, engine stopped, and the key switch OFF. Refer to the filling instructions outlined in Section 40, Lubrication And Service. Instructions are also outlined on the following decal.



A plate on the side of the hydraulic tank provides instructions for filling the hydraulic tank.

Keep the system open to the atmosphere only as long as necessary to lessen the chances of system contamination. Service the tank with clean type C-4 hydraulic oil. All oil being put into the hydraulic tank must be filtered to 3 microns.

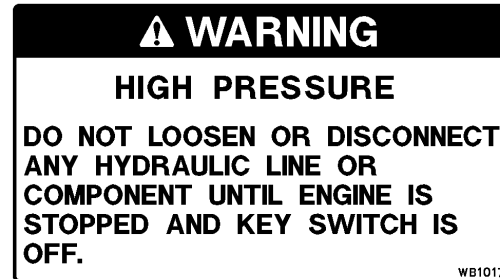

A warning plate is attached to the frame above the hydraulic system Auxiliary Power Unit (APU) quick disconnect fittings. The plate alerts technicians that high pressure hydraulic oil is present during operation. Use caution when opening the hydraulic system. There is always a chance of residual pressure being present. Loosen fittings slowly to allow pressure to dissipate before removing any connections.



Pressurized operating fluids, such as hydraulic oil, can have sufficient force to penetrate skin. Serious injury and death may result if proper medical treatment from a physician familiar with this injury is not received immediately.

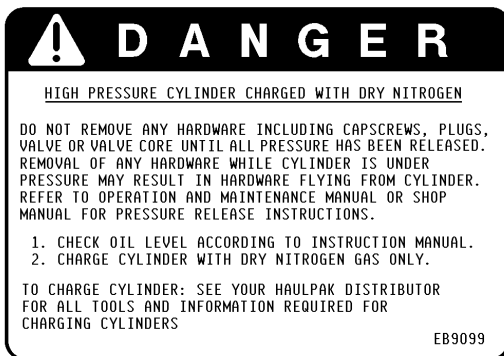

This danger plate is attached to each suspension and steering accumulator. These plates warn that the suspension and accumulators are charged with high pressure nitrogen. Read the service manual and follow safety procedures when performing service on these components.



This plate is located on the battery box and near the battery disconnect switches to indicate that the battery system is a negative ground system.

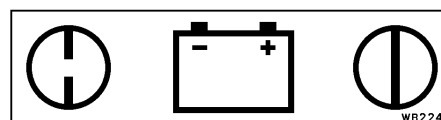

These decals are placed above the battery disconnect switches on the right side of the front bumper to indicate OFF and ON positions of the switches.

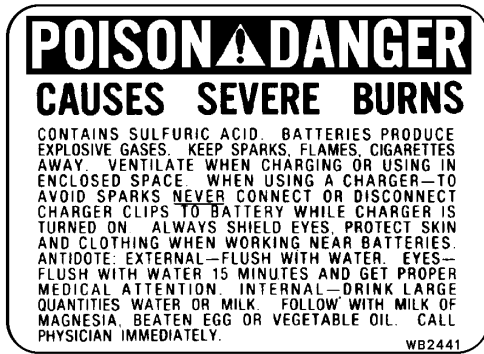

Attached to the exterior of the battery compartment is a danger plate. This plate stresses the prevention of sparks near the battery. When another battery or 24VDC power source is used for auxiliary power, all switches must be OFF prior to connecting. Maintain correct polarity: connect the positive (+) posts together and then connect the negative (-) lead of the auxiliary power cable to a good frame ground. Do not connect to the negative posts of the truck batteries. Do not connect near the battery box. These precautions minimize the danger of sparks near the batteries.

Sulfuric acid is corrosive, toxic and explosive. Use safety goggles, rubber gloves and a rubber apron when working near batteries.

If battery electrolyte is splashed into the eyes or is ingested, get the proper medical attention, immediately.

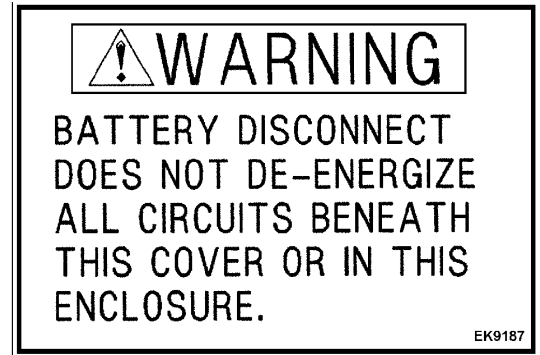

A warning decal is located on the rear compartment in the operator cab. Use caution when working around or in this compartment. Electrical potential may be present even when the battery disconnect has been switched to OFF.

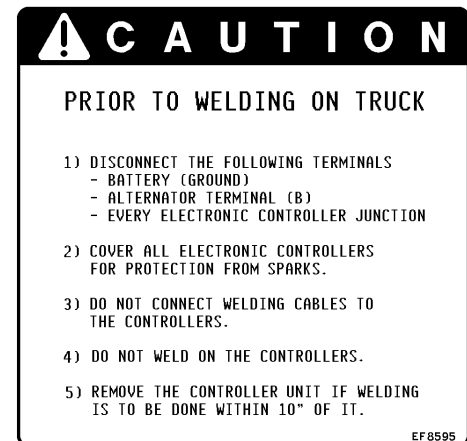

A caution plate is located on the side of the battery box. These instructions must be followed to avoid damage to electronic components when welding on the truck.

LUBRICATION CHART

| LUBRICATION SPECIFICATION | | -55°C TO -32°C | -32°C TO 0°C | 0°C TO 32°C | ABOVE 32°C | ABOVE 40°C | | | |
|---------------------------------|---------------------|----------------|----------------|----------------|------------------------------|----------------|---------|---------|---------|
| LUBE KEY | TYPE LUBRICANT | -65°F TO -25°F | -25°F TO +32°F | +32°F TO +90°F | ABOVE 90°F | ABOVE 105°F | | | |
| A | ENGINE OIL | SEE ENG MAN* | SEE ENG MAN* | SEE ENG MAN | SEE ENG MAN | SEE ENG MAN | | | |
| B | HYDRAULIC OIL | T030/SAE 30W | T030/SAE 30W | T030/SAE 30W | T030/SAE 30W OR T050/SAE 50W | T050/SAE 50W | | | |
| C | HYDRAULIC OIL | T010/SAE 10W* | T010/SAE 10W* | T030/SAE 30W | T030/SAE 30W | T030/SAE 30W | | | |
| D | MOLYDISULPHIDE LUBE | #0 | #1 | #2 | #2 | #2 | | | |
| E | HYDRAULIC OIL | SEE SER. MAN | SEE SER. MAN | SEE SER. MAN | SEE SER. MAN | SEE SER. MAN | | | |
| F | DRIVESHAFT GREASE | 56B-20-19910 | | | | | | | |
| DESCRIPTION | SYMPTS | L KEY | 10 HR | 50 HR | 250 HR | 500 HR | 1000 HR | 2000 HR | 5000 HR |
| ENGINE CRANKCASE OIL | 1 | 1 | A | CHECK | | SEE ENG MANUAL | | | |
| ENGINE LUBE FILTERS | 2 | 3 | | | | SEE ENG MANUAL | | | |
| ENGINE CRANKCASE BRTHR | 3 | 2 | | | | | CLEAN | | |
| TRANSMISSION OIL | 4 | 1 | C | CHECK | | | CHANGE | | |
| TRANS CASE BREATHER | 5 | 1 | | | CLEAN | | | | |
| TRANS OIL FILTERS | 6 | 2 | | | | CHANGE | | | |
| TRANS STRAINERS | 7 | 3 | | | | | CLEAN | | |
| HYD TANK (HST/STRG/BK/FRT AXLE) | 8 | 3 | C | CHECK | | | | CHANGE | |
| HYD TANK BREATHER | 9 | 1 | | | CHANGE | | | | |
| HYDRAULIC FILTERS | 10 | 4 | | | | CHANGE | | | |
| HYD TANK STRAINERS | 11 | 4 | | | | | CLEAN | | |
| DIFF CASE BREATHER | 12 | 1 | | | CLEAN | | | | |
| DIFFERENTIAL CASE | 13 | 1 | B | | CHECK | | CHANGE | | |
| FINAL DRIVE CASE | 14 | 2 | B | | CHECK | | CHANGE | | |
| FUEL FILTERS | 15 | 3 | | | SEE ENG MANUAL | | | | |
| CORROSION RESISTORS | 16 | 2 | | | SEE ENG MANUAL | | | | |
| PARKING BRAKE | 17 | 6 | D | | CHECK | | GREASE | | |
| LUBRICANT RSVR | 18 | 1 | D | | CHECK | | | | |
| DRIVESHAFT U-JOINTS | 19 | 2 | F | | | | | | GREASE |

EM4499-0

* AUXILIARY HEATERS REQUIRED BELOW -23°C (-10°F)

The lubrication chart is located on the LH side of the radiator. The chart specifies some of the critical maintenance items to be checked. Component location and service intervals are specified on the chart. The lube key lists the proper lubricants to be used. Refer to Section 40, Lubrication and Service, for more information on maintenance items.

OPERATING INSTRUCTIONS

PREPARING FOR OPERATION

The safest trucks are those which have been properly prepared for operation. At the beginning of each shift, the operator must perform a careful check of the truck before starting the engine.

Safety Is Thinking Ahead

Prevention is the best safety program. Prevent a potential accident by knowing the employer's safety requirements and all necessary job site regulations. Be familiar with use and care of the safety equipment on the truck. Only qualified operators or technicians may operate or maintain the truck.

A safe work environment begins before the operator boards the truck.

- Wear the proper clothing. Loose fitting clothing, unbuttoned sleeves and jackets, jewelry, etc., are a potential hazard.
- Use personal safety equipment provided for the operator such as a hard hat, safety shoes, and safety glass. There are some conditions when protective hearing devices must also be worn for operator safety.
- When walking to and from the truck, maintain a safe distance from all machines even if the operator is visible.

Walk Around Inspection

At the beginning of each shift, perform a careful walk around inspection on the truck before engine start-up. A walk around inspection is a systematic inspection of the truck and its components. The purpose is to ensure that the truck is safe to operate.

Start at the left front corner of the truck. Move in a counterclockwise direction, from front to rear. Move across the rear, and continue forward up the opposite side of the truck to the original starting point. If these steps are performed in sequence, and are repeated every shift, many potential problems can be avoided.

If problems or potential problems are found during the inspection, notify maintenance. Vehicle breakdowns, unscheduled downtime and loss of production can be reduced.

Local work practices may prevent an operator from performing all tasks suggested here. To the extent permitted, the operator must follow this or a similar routine.

1. Start at the left front of the truck. Visually inspect all lights and safety equipment for external damage from rocks or misuse. Ensure lenses are clean and are not cracked or broken.
2. Move behind the front of the left front tire. Inspect the hub and the oil disc brake assemblies for leaks and abnormalities.

Check that all suspension hardware is secure and inspect for evidence of wear. Verify suspension extension is within the proper range. Check for any leaks in the area.

3. Check the engine oil level. Verify engine oil filters or oil lines to filters are not leaking.

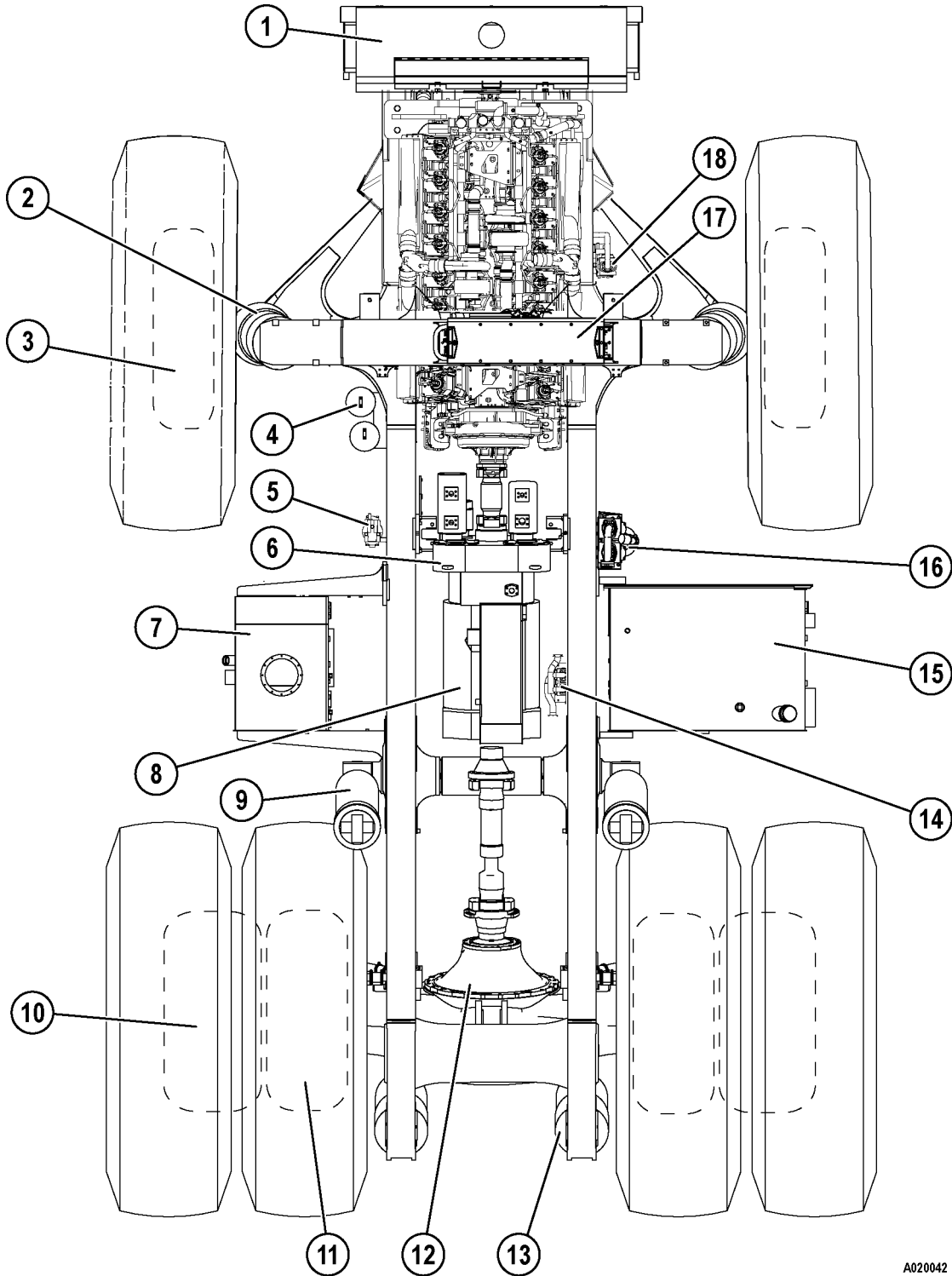

A020042

FIGURE 30-1. MAJOR COMPONENT LOCATION

- | | | |
|------------------------------|--------------------------|---------------------------|
| 1. Radiator | 7. Hydraulic Tank | 13. Rear Suspension |
| 2. Front Suspension | 8. Transmission | 14. Brake Cooling Filters |
| 3. Front Wet Disc Brakes | 9. Hoist Cylinders | 15. Fuel Tank |
| 4. Steering Accumulators | 10. Final Drive | 16. Transmission Filters |
| 5. Steering And Brake Filter | 11. Rear Wet Disc Brakes | 17. Hydraulics Cabinet |
| 6. Pump Drive | 12. Differential | 18. Brake Cooling Filter |

4. Inspect the fan and air conditioner belts for correct tension, wear, and tracking. Inspect the fan guard condition and secureness.
5. Move outboard of the front wheel. Inspect attaching lugs and clamps to ensure all are tight and intact. Check the tire for damage. Ensure the tire is properly inflated.
6. Move behind the rear of the front wheel. Check for leaks or any unusual conditions at the hub and brakes. Inspect the suspension hardware. Ensure the tie rod and steering cylinder pivots are properly greased. Check the secureness of all parts. Check for hydraulic leaks.
7. Check the transmission oil level. Check the pumps at the front of the transmission. Check for proper component mounting and ensure no leaks exist.
8. Move to the side of the hydraulic tank. Check the hydraulic fluid level for both the hydraulic tank and brake cooling oil. Oil must be visible in the sight glass with the engine stopped and the body down.
9. Move around the hydraulic tank and in front of the rear dual tires. Inspect the hoist cylinder for damage or leaks. Inspect the upper and lower hoist cylinder pins for secureness. Ensure the pins are properly greased.
10. Before leaving this position, verify there is no leakage or any other unusual condition with the transmission or rear drive shaft.
11. Move around the dual tires. Verify all lugs clamps are intact and tight. Check the wheel for leakage from inside of the wheel housing. Fluid may indicate planetary leakage. Check the dual tires damage and proper inflation. Check for rocks that might be lodged between the dual tires. Verify the rock ejector is in good condition and straight.
12. Check the left rear suspension for damage, proper extension, and leaks. Ensure the suspension pins are properly greased. Ensure the covers over the chrome piston rod are in good condition.
13. Check the axle housing breather. Replace the breather if obstructed. Check for leakage around the final drive, brake, and connecting hoses.
14. While standing at the rear of the truck, verify the rear lights and back up horns are in good condition. Inspect the linkage rods to verify all locations are properly greased. Check both body pivot pins. Ensure the pins are properly greased.
15. Perform the same inspection on the right rear suspension, as done on the left.
16. Move to the right dual tires. Check between the tires for rocks. Check rock ejector condition. Inspect the tires for damage, and proper inflation.
17. Check the wheel lugs and wedges, as done on the left dual wheels. Check for leaks.
18. Move in front of the right dual tires. Inspect the hoist cylinder, as done on the left side.
19. Move around the fuel tank, and inspect the fuel gauge. Inspect the mounting hardware at the upper and lower mounts. Ensure the mounts are secure and in good condition.
20. Move behind the right front wheel. Ensure the tie-rod and steering cylinder pivots are properly greased. Inspect the attaching hardware for the steering cylinder. Verify all parts are secure. Ensure the suspension protective cover is in good condition. Check suspension hardware and suspension extension. Ensure the mounting pins are properly greased.
21. Move around the right front wheel. Verify all lugs and clamps are intact and tight.
22. Move behind the right front wheel. Check the hub and brake for leaks or any unusual condition. Inspect the engine compartment for leaks or any unusual condition. Inspect the fan guard and belts. Check for debris from behind the radiator. Remove any debris that is found.
23. Move to the right front of the truck. Check for debris that might be trapped in front of the radiator. Remove any debris. Check for coolant leaks. Inspect all head lamps and fog lights.

24. Ensure the ground level engine shut off switch is ON.
25. Climb the ladder to the main deck. Always use the hand rails and ladder when mounting or dismounting the truck. Clean the ladder and hand rails of any foreign material, such as ice, snow, oil or mud.

⚠ WARNING

Face the truck when using the ladders. Never mount or dismount the truck while the truck is in motion.

26. Check the coolant in the radiator using the coolant level sight gauge.

⚠ WARNING

If the engine is hot, allow the coolant to cool before removing the radiator fill cap. Serious burns may be acquired from contact with hot coolant. Depress the pressure relief before removing the cap.

27. Inspect the battery box cover for damage. Ensure the cover is secured, tightly.
28. Check the air cleaner indicators. If the indicator is in the red area, the air filter must be cleaned or replaced before operating the truck.
29. Clean the cab windows and mirrors. Clean the cab floor, as necessary. Ensure the steering wheel, controls and pedals are free of foreign substances such as oil.
30. Stow personal gear in the cab so that it does not interfere with operation of the truck. Clean dirt or trash buildup, specifically in the operator's cab. DO NOT store tools or supplies in the cab or on the deck.
31. Adjust the seat and steering wheel so that it is comfortable for use.
32. Read and understand the information detailed in Operator Controls and Instrument Panel. Become familiar with all control locations and functions before operating the truck.

Cold Weather Heating System

Some trucks operating in cold weather climates may be fitted with an optional cold weather heating system. The system includes heaters in the transmission, hydraulic tank, engine oil pan, battery box, cooling system, and fuel system. Trucks fitted with -40°C (-40°F) equipment (or colder) may also contain heaters in the rear axle.

The power receptacle (2, Figure 30-2) is mounted inside the RH upright near the bottom of the radiator.

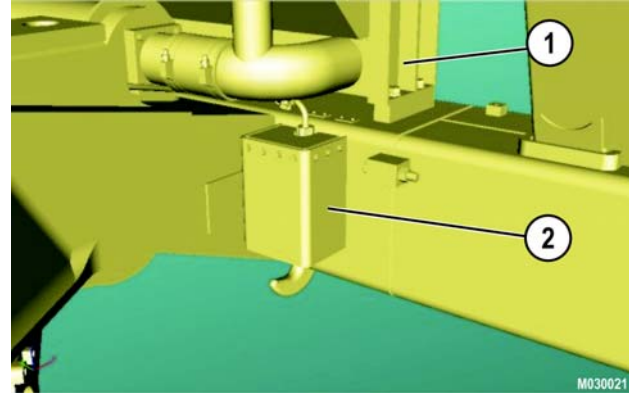

FIGURE 30-2. HEATING SYSTEM POWER RECEPTACLE

1. Radiator
2. Power Receptacle

The system operates on 220V and is controlled by various thermostats in the system. The thermostats operate the heaters within a certain temperature range.

⚠ CAUTION

Do not operate the engine while the heater system is operating. Lack of coolant circulation in the heaters will burn out the heating elements.

ENGINE START-UP

Safety rules must be observed upon engine start-up.

⚠ WARNING

Ensure there is adequate ventilation before start-up if the truck is in an enclosure. Exhaust fumes are dangerous!

1. Ensure all personnel are clear of the truck before starting the engine. Sound the horn as a warning before starting.
2. Ensure the transmission shift lever is in NEUTRAL and the parking brake is applied.

⚠ CAUTION

DO NOT attempt to start the engine while the cold weather starting heater (if equipped) is operating. Damage to coolant heaters will result due to lack of circulation.

3. The key switch is a four position (ACC, OFF, RUN, START) switch.

When the key slot is in the vertical position, the electrical system is off and no electrical devices are energized.

Use this key position to stop the engine when it is on.

ACC- When the key is rotated counterclockwise from the OFF position, it is in the accessory (ACC) position. This position is used to power certain accessories such as the radio when there is no intention of starting the engine.

4. When the switch is rotated one position clockwise, it is in RUN and all electrical circuits except START are energized.

With the selector lever in NEUTRAL and the parking brake applied, rotate the key switch fully clockwise to the START position. Hold this position until the engine starts (see the following note). The START position is spring loaded to return to RUN when the key is released.



NOTE: The engine is equipped with an oil prelube system. A noticeable time delay will occur, while engine oil passages are being filled, before cranking motor engagement and engine cranking will begin. The colder the engine oil temperature, the longer the time delay will be. In addition, if the truck is also equipped with an engine starting aid for cold weather starting, allow the engine prelube system to operate, first for 5-10 seconds, or until the cranking motor is engaged. Then activate the engine starting aid.

⚠ IMPORTANT ⚠

In cold ambient conditions and when the engine is cold, the engine rpm will not increase above low idle speed until the engine controller determines it is safe to do so. This time delay will vary from 30 seconds to 11 minutes which allows the coolant and engine oil to warm up. Acceleration and travel will not be available until the engine completes this warm-up cycle.

Cold Weather Starting

⚠ WARNING

Starting fluid is extremely volatile and flammable! Use extreme care when handling and using starting fluid.

If the truck is equipped with cold weather starting aid and the ambient temperature is below -5°C (23°F), push the engine starting aid switch in for three seconds. Release the starting aid switch and turn the key switch to START. If the engine does not start, wait at least 15 seconds before repeating the procedure.

⚠ WARNING

DO NOT crank the electric cranking motors for more than 30 seconds. Allow two minutes for the motor to cool before attempting to start the engine again. Severe damage to the cranking motors may result from overheating.

Jump Starting

The truck cannot be push started. Transmission lube and control systems are inoperative when the engine is not on.

When jumping battery power from one truck to another, all switches must be OFF prior to making any connections. Check connections for correct polarity.

Connect one lead of the booster cable to the 24V positive (+) post of battery needing assist, and the other lead of the booster cable to the 24V positive (+) post of the auxiliary battery. Connect one lead of the second booster cable to the 24V negative (-) post of the auxiliary battery and then connect the other lead of the booster cable to a good frame ground on the disabled truck, away from the battery needing assist. This procedure will avoid the possibility of causing sparks near the battery where explosive gases may be present.

NOTE: HD1500 trucks are equipped with four 12 volt batteries connected in series and parallel to provide 24 volt output. Maintain correct voltage and polarity when connecting booster cables. Damage to electrical components may result if voltage and polarity are not correct.

EMERGENCY STEERING SYSTEM

Operation

This truck is equipped with an emergency steering system. This system is a backup in the event of loss of oil supply to the main steering system. The emergency steering system was designed to meet or exceed SAE J1511 and ISO 5010 standards.

If the low steering system pressure indicator light and alarm are activated, a failure in the hydraulic oil supply to the steering and brake system exists. When the alarm is activated, typically there is enough hydraulic pressure stored in the brake and steering accumulators to allow brief operation of the steering and brakes. However, this oil supply is limited. Therefore, it is important to stop the truck as quickly and safely as possible after the alarm is first activated.

If the oil supply pressure drops to a predetermined level, the low brake pressure warning light will also illuminate. If the oil pressure continues to decrease, the brake auto-apply feature will activate the service brakes to stop the truck.

Pre-Operation Testing

Komatsu recommends that operators perform this test to verify that the steering accumulator precharge pressure is adequate at the beginning of each shift before operating the truck.

1. Park the empty truck on flat, level ground. Lower the dump body onto the frame and stop the engine. Verify that the key switch is in the OFF position.
2. Wait at least 90 seconds to verify that all hydraulic pressure has been relieved from the steering accumulators. Turn the steering wheel from stop to stop. If the front wheels do not move, there is no hydraulic pressure.
3. Check the hydraulic tank oil level. The oil level must be visible in the center of the upper sight glass and must not cover the entire upper sight glass. Add oil if necessary. Do not overfill.

4. Turn the key switch to the ON position, but do not start the engine.
 - a. Steering system pressure: Verify that the low steering pressure warning light is illuminated. If it is not illuminated, immediately notify maintenance personnel. Do not operate the truck until the problem is corrected.
 - b. Steering accumulator pressure: Verify that the low accumulator charge warning light is not illuminated and the warning buzzer is not sounding. If the warning light is illuminated and the buzzer is sounding, immediately notify maintenance personnel. Do not operate the truck until the problem is corrected.
5. Start the engine and allow the steering accumulators to fully charge. Turn the steering wheel so that the front wheels are straight.
6. Check the hydraulic tank oil level while the engine is on.
 - a. If the oil level is visible in center of the lower sight glass and does not cover the entire lower sight glass, the steering accumulators are adequately charged. Proceed to Step 7.
 - b. If the oil level is below the lower sight glass, the steering accumulators are not adequately charged. Stop the engine and turn the key switch to the OFF position. Immediately notify maintenance personnel. Do not operate the truck until the problem is corrected.
7. If the truck passes this test, the emergency steering system is functioning properly.

AFTER THE ENGINE HAS STARTED

If coolant temperature is below 50° C (122° F), the engine will operate at 1000 rpm in order to reach normal operating temperature. When coolant temperature rises above 50° C (122° F), the engine will return to normal low idle speed, 650 rpm. Refer to Automatic Idle Selector Switch in Section 32 for related information.

In cold ambient conditions and when the engine is cold, the engine rpm will not increase above low idle speed until the engine controller determines it is safe to do so. This time delay will vary from 30 seconds to 11 minutes which allows the coolant and engine oil to warm up.

Become thoroughly familiar with the steering, braking, and emergency controls. Perform the following checks to ensure safe truck operation before each shift.



During the following safety checks, if actuation or release of any steering, brake or emergency control circuit does not appear normal, shut the engine off, immediately. Notify maintenance personnel. DO NOT operate the truck until the system in question is fully operational. Ensure the area around the truck is clear before testing.

Steering

1. Test the truck steering in extreme right and left directions. If the steering system is not operating properly, shut the engine off, immediately. Determine the problem, and repair before resuming operation.

NOTE: The steering and brake systems each have two accumulators that store energy and provide capability to steer and stop the truck in the event of an unexpected engine or pump failure.

As part of the routine maintenance of the vehicle, one requirement to ensure proper operation of each system is to maintain proper accumulator nitrogen pre-charge. Refer to the shop manual for proper procedures when charging the accumulators.

Service Brake

2. With the truck on flat ground, check for normal operation of the service brake:
 - a. Depress brake pedal (5, Figure 30-3).
 - b. Move transmission shift lever (2, Figure 30-3) to the D position and gradually increase engine speed to 1700 rpm. The truck must remain stationary. Placing the shift lever in D ensures that the transmission will start in F2.
 - c. Reduce engine speed to low idle and release the service brake. Place the shift lever in N.

Retarder

3. With the truck on flat ground, check retarder operation:
 - a. Move retarder lever (2, Figure 30-3) to the maximum retard position -lever down. Verify the retarder pilot lamp in the electronic display panel illuminates.
 - b. Move the transmission shift lever to the D position and gradually increase engine speed to 1700 rpm. The truck must remain stationary. Placing the shift lever in D ensures the transmission will start in F2.
 - c. Reduce engine speed to low idle. Move the retarder lever to OFF -lever up. The retarder pilot lamp should turn off. Place the shift lever in NEUTRAL.

Parking Brake

4. Check operation of the parking brake:
 - a. Apply parking brake switch (3, Figure 30-4). Verify the red parking brake lamp in the electronic display panel illuminates.
 - b. Move transmission shift lever (2, Figure 30-4) to any position other than N. Verify the central warning lamp on the electronic display panel flashes.
 - c. Move the transmission shift lever to the D position. Gradually increase engine speed to 1550 rpm. Placing the shift lever in D ensures that the transmission will start in F2. The truck must remain stationary. If the truck moves, notify maintenance personnel to adjust the parking brake. DO NOT operate the truck until the parking brake is fully operational.
 - d. Reduce engine speed to low idle. Place the selector lever in NEUTRAL.

Auxiliary Brake

5. Check operation of the auxiliary brake:
 - a. Depress auxiliary brake switch (4, Figure 30-3). Verify the internal red lamp illuminates.
 - b. Move the transmission shift lever to 5 and gradually increase engine speed to full throttle. Placing the shift lever in 5 ensures the transmission will start in F1. The truck must remain stationary.



If the truck moves, notify maintenance personnel to immediately repair the brakes. DO NOT operate the truck until the auxiliary brake is fully operational.

- c. Reduce engine speed to low idle. Place the shift lever in NEUTRAL. Switch the auxiliary brake OFF. Verify the red indicator lamp turns off.

Brake Lock

6. Check the operation of the brake lock:
 - a. Depress brake lock switch (6, Figure 30-3). Verify the brake lock indicator lamp illuminates.
 - b. With the F1 start switch OFF, move the transmission shift lever to D to enable the transmission to start in second gear. Gradually increase engine speed to 1410 rpm. The truck must remain stationary.



If the truck moves, notify maintenance personnel to immediately repair the rear brakes. DO NOT operate the truck until the brake lock is fully operational.

- c. Reduce engine speed to low idle. Place the shift lever in NEUTRAL. Switch the brake lock to OFF. Verify the brake lock indicator lamp is off.
7. Check the gauges, warning lights and instruments before truck use to ensure proper system operation. If any warning lights are illuminated, shut off the engine immediately and determine the cause.
8. Ensure headlights, work lights and taillights are working properly. Good visibility may prevent an accident. Check the operation of the windshield wiper and washer.

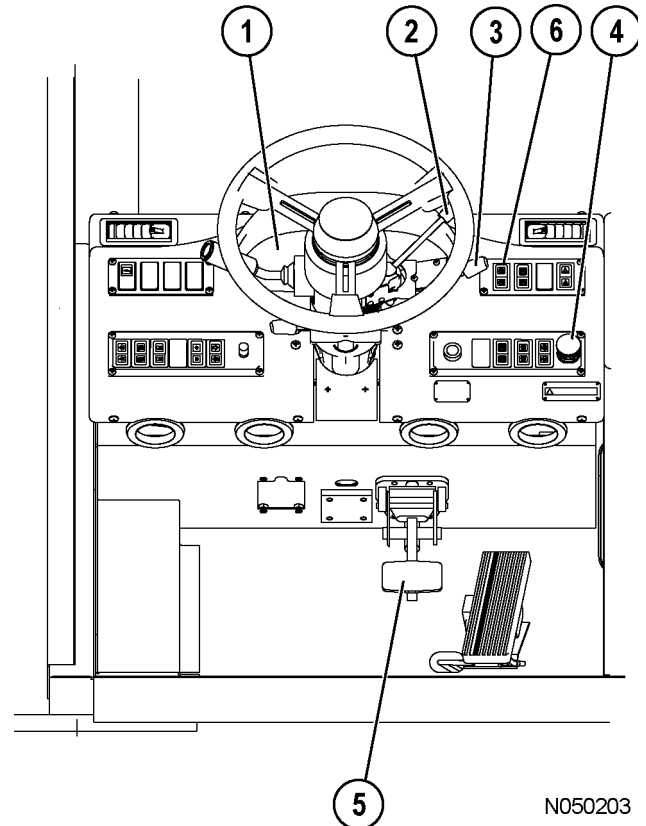

N050203

FIGURE 30-3. BRAKE SYSTEM CONTROLS

- | | |
|----------------------|---------------------------|
| 1. Center Dash Panel | 4. Auxiliary Brake Switch |
| 2. Retarder Lever | 5. Brake Pedal |
| 3. ARSC Lever | 6. Brake Lock Switch |

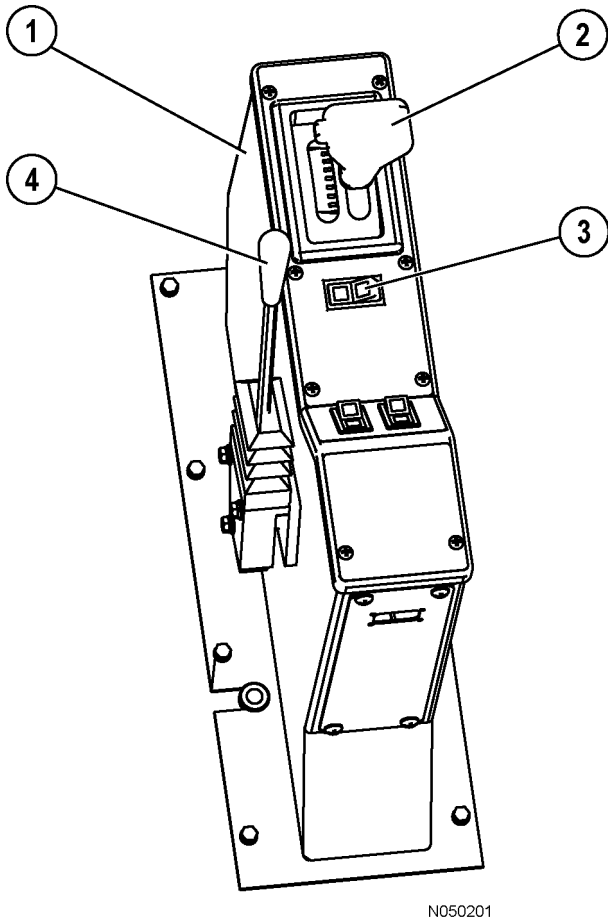

FIGURE 30-4. CONSOLE CONTROLS

- | | |
|-----------------------------|-------------------------|
| 1. Center Console | 3. Parking Brake Switch |
| 2. Transmission Shift Lever | 4. Hoist Control Lever |

9. When the body is raised, DO NOT allow anyone beneath unless the body-up retaining device is in place.
10. DO NOT use the fire extinguisher for any purpose other than putting out a fire! If the extinguisher is discharged, refill or replace the extinguisher.
11. DO NOT allow unauthorized personnel to ride in the truck. DO NOT allow anyone to ride on the ladder or on the deck of the truck.
12. DO NOT leave the truck unattended while the engine is on. Shut off the engine before leaving the cab.

MACHINE OPERATION SAFETY PRECAUTIONS

Follow all local safety rules to ensure safe machine operation.

⚠ WARNING

A malfunction exists if any of the red warning lights illuminate or if a gauge reads in the red area during truck operation. Safely stop the truck, and turn off the engine. Have the problem repaired before resuming truck operation.

1. Sound the warning horn before moving the truck. When moving in reverse, honk the horn three times as a back up signal. When starting forward, signal with two horn honks. Use these signals each time the truck is moved forward or backward. Look to the rear before backing the truck. Watch and obey the ground spotter's hand signals before reversing. The spotter must have a clear view of the total area at the rear of the truck.
2. Operate the truck while properly seated with the seat belt fastened. Keep hands and feet inside the cab compartment while driving. Keep a firm grip on the steering wheel at all times.
3. Frequently check the gauges and instrument panel for proper readings during operation.
4. Observe all regulations pertaining to the job site's traffic pattern. Be cautious of unusual traffic patterns. Match the truck speed to haul road conditions and slow the truck in congested areas. Obey the spotter's signals at the shovel and dump.
5. DO NOT allow the engine to idle for extended periods of time.
6. Check the parking brake periodically during the work shift. Use the parking brake for parking only. DO NOT attempt to apply the parking brake while the truck is moving!

7. Apply the brake lock switch at the shovel and dump areas.
8. Proceed slowly on rough terrain to avoid deep ruts or large obstacles. Do not travel along soft edges or the edge of the fill area.
9. Truck operation requires concentrated effort by the driver. Avoid distractions of any kind while operating the truck.
10. When driving at night or when visibility is poor, the headlights must be on. DO NOT travel in these conditions if the headlights are inoperative.
11. DO NOT travel in reverse if the back-up horn or lights are inoperative.
12. When driving in reverse, signal with three honks on the horn. When starting forward, signal with two honks on the horn. Signal each time the truck is moved forward or backward.
13. DO NOT stop or park on a haul road unless unavoidable. If you must stop, move the truck to a safe place. Apply the parking brake and turn off the engine. Block the wheels securely and notify maintenance personnel for assistance.
14. If the low steering pressure warning illuminates during operation, immediately steer the truck to a safe stopping area away from other traffic. Refer to the previous item above.
15. Report adverse haul road conditions, immediately. Muddy or icy roads, pot holes or other obstructions can present hazards.
16. Keep cab doors closed at all times while the truck is in motion or unattended.
17. Check for flat tires periodically during the shift. If the truck has been operating on a flat tire, allow the tire to cool before parking indoors.

LOADING

1. Approach the loading area with caution. Remain at a safe distance while the truck ahead is being loaded.
2. DO NOT drive over unprotected power cables.
3. When near loading areas, watch for other vehicles and for personnel working in the area.
4. When approaching a loader or shovel, follow the spotter or shovel operator signals. The loading process may be shortened by following similar patterns of the trucks that have already been loaded.
5. The operator must remain in the truck cab with the engine on during loading. Place the transmission shift lever in NEUTRAL and apply the brake lock switch.



If the operator must leave the truck cab during loading, the engine must be shut off and the parking brake applied. DO NOT use the secondary brake for parking. Remain far enough away from the truck to avoid being struck by flying material.

6. When the truck is loaded, drive away from the shovel as quickly as possible, but with extreme caution.

HAULING

1. Stay alert and drive with extreme caution.
2. Govern truck speed based on road conditions, weather and visibility.
3. Operate the truck with control at all times.
4. Use extreme caution when approaching an intersection. Maintain a safe distance between oncoming vehicles.
5. Obey all road signs.
6. Always dim high beam headlights before approaching other vehicles in motion.
7. Maintain a safe distance of 15 m (50 ft) when following another vehicle. When on a downhill grade, maintain a distance of 30 m (100 ft).
8. When driving down a grade, maintain a safe speed ensuring effective retarding.

When descending a known grade with a loaded truck, adjust the speed of the truck to select the proper transmission gear range. The truck must be maintained within the speeds listed on the retarding capacity decal. A version of the decal shown below is located inside the cab on the left front cab post. Use either the retarder control lever or the foot-operated brake pedal to control the speed of the truck.

⚠ WARNING

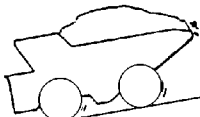

RETARDING CAPACITY
GVW: 550,000 LBS.
(249,478 kg)
TIRES: 33 X 51

MAX. BRAKE OIL TEMPERATURE: 248°F (120°C)
MAX. ENGINE SPEED: 2100 RPM

MAINTAIN HIGHEST ENGINE SPEED BELOW MAX.
SLOW TO NEXT LOWEST GEAR, IF COOLING OIL
TEMPERATURE NEEDS TO BE LOWERED.

| GEAR | SPEED | | CONTINUOUS | SHORT LENGTH |
|------|-------|--------|------------|-----------------------------|
| | MPH | (KM/H) | GRADE % | 1,970 FT. (600m) GRADE % |
| 1 | 6.4 | (10.3) | 22.5 % | 26.5 % |
| 2 | 8.6 | (13.8) | 16.5 % | 20.5 % |
| 3 | 11.4 | (18.4) | 11.5 % | 16.0 % |
| 4 | 14.4 | (23.2) | 9.0 % | 13.0 % |
| 5 | 19.2 | (31.0) | 6.0 % | 10.0 % |
| 6 | 26.1 | (42.1) | 4.0 % | 8.0 % |
| 7 | 34.8 | (56.1) | 2.5 % | 6.5 % |

EG 4433

RETARDER OPERATION

Two lists are provided on the retarding capacity decal. One list is for a continuous rating. The second list is for a short-length rating. Both lists are matched to the truck at maximum Gross Vehicle Weight (GVW).

The continuous numbers on the chart indicate the combination of speeds and grades the vehicle can safely negotiate for an unlimited time or distance.

The short-length numbers listed on the chart indicate the combination of speeds and grades the vehicle can safely negotiate for three minutes. These speeds are faster than the continuous values, reflecting the thermal capacity of various system components. System components can accept heating at a higher-than-continuous rate for a short period of time. Beyond this period, the system would become overheated.

The short-length rating, sometimes called the "three-minute" limit, will successfully accommodate most downhill hauls. It is necessary to divide the haul road grade segment length by allowable speed to determine actual time on the grade. If actual time on the grade exceeds the allowable amount, travel speed must be at continuous speed. Ambient temperature, as well as the temperature of the brake cooling oil can affect this number. (The brake cooling oil could already be above the normal range from recent operating conditions).



DO NOT exceed the recommended maximum speeds when descending grades with a loaded truck.

For efficient retarder operation, adhere to the following guidelines:

- Maintain engine speed between 2000 - 2100 rpm
- When descending a grade, apply the retarder and observe both the tachometer and the brake oil temperature gauge. Engine speed must be maintained at 2000 - 2100 rpm. Brake oil temperature must be maintained below 120°C (248°F).

If the maximum engine speed of 2100 rpm or the brake oil temperature of 120°C (248°F) is about to be exceeded, move the transmission shift lever to the next lower range. Adjust the retarder control to reduce speed and allow the transmission to down-shift into the selected gear range.

Continue this procedure to maintain engine speed at 2000 - 2100 rpm and brake oil temperature below 120°C (248°F). When the proper gear range is attained, continue to use the retarder as needed to maintain a safe speed.

If brake oil temperature exceeds 120°C (248°F), the brake oil temperature warning will turn on. As quickly as safety will permit, stop the truck away from traffic. Move the transmission shift lever to NEUTRAL and apply the parking brake. Operate the engine at high idle.

Keep the engine at high idle until the brake oil temperature warning light turns off and brake oil temperature cools to below 120°C (248°F). If the temperature does not return to this range within a few minutes, immediately report the condition to maintenance personnel. Wait for further instructions before moving the truck.

PASSING

1. DO NOT pass another truck on a hill or at a blind curve!
2. Before passing, ensure the road ahead is clear. If a disabled truck is blocking your lane, slow down and pass with extreme caution.
3. Use only the areas designated for passing.

DUMPING

1. Approach the dump area with extreme caution. Ensure the area is clear of personnel and obstructions such as overhead power lines. Obey spotter signals, if present.

Avoid unstable areas. Travel at a safe distance from the edge of a dump area. Position the truck on a solid, level surface before dumping.



As the body raises, the truck center of gravity will move. The truck must be on a level surface to prevent tipping!

2. Carefully maneuver the truck into dump position. When backing the truck into dump position, use the foot-operated brake pedal to stop and hold the truck.
3. When in the dump position, place the transmission shift lever in NEUTRAL, and apply the brake lock switch.

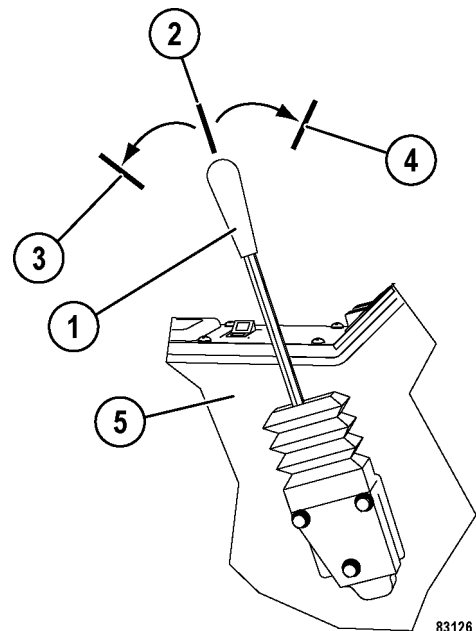

FIGURE 30-5. HOIST CONTROL

- | | |
|------------------------|------------------------|
| 1. Hoist Control Lever | 3. POWER DOWN Position |
| 2. FLOAT/HOLD Position | 4. POWER UP Position |
| | 5. Center Console |

Raising the Dump Body

⚠ WARNING

When dumping very large rocks or sticky material, the material may exit the body too fast. This may cause a violent jolt to the dump body and cause possible injury to the operator. Damage to the hoist cylinders, frame, and the dump body hinge pins may also result. If it is necessary to dump this kind of material, refer to the caution in the following procedure.

4. Move hoist control lever (1, Figure 30-5) to POWER UP position (4) and release the lever.

Releasing the hoist lever anywhere in the lever stroke when raising will place the dump body in HOLD at that position.

5. Raise engine rpm to accelerate the hoist speed.

Refer to the following caution note.

When the body is near the maximum angle, reduce engine rpm in order to reduce the shock load to the hydraulic system and hoist cylinders.

⚠ CAUTION

If dumping very large rocks or sticky material as described in the warning above, slowly accelerate engine rpm and raise the dump body. When the material starts to move, release the hoist lever to the HOLD position. If the material does not continue out of the dump body, repeat this procedure until the material has been dumped.

6. When the dump body rises to the desired position, release the hoist control lever. The lever will return to the HOLD position.

If necessary to raise the body further, move the dump lever to POWER UP. The dump body will rise until the hoist cylinders are fully extended.

Lowering The Dump Body

7. After the load clears the body, lower the body to the frame by moving the hoist control lever forward to the DOWN position. The dump body will start to move downward.
8. Releasing the lever during the downstroke will return the lever to the FLOAT position. The body will then float down under its own weight. If dumped material builds up at the body tailgate and the body cannot be lowered, shift the transmission shift lever to DRIVE. Release the brake lock switch, and drive forward to clear the material. Stop, and shift the transmission shift lever to NEUTRAL. Apply the brake lock switch and lower the dump body. See the note below.

⚠ CAUTION



DO NOT move the truck with the dump body raised except in the event of an emergency. Failure to lower the dump body before moving the truck may cause damage to the hoist cylinders, frame and body hinge pins.

NOTE: When traveling, always place the hoist control lever in the FLOAT position, regardless of whether or not the truck is loaded.

If the transmission shift lever is moved to any position other than NEUTRAL when the hoist control is not in FLOAT, the central warning lamp will flash and the alarm buzzer will sound intermittently.

9. With the body on the frame, move the transmission shift lever to DRIVE. Release the brake lock switch, and carefully exit the dump area.

SAFE PARKING PROCEDURES

The operator must continue to use safety precautions when parking and turning the engine off.

Any questionable truck performance must be checked by maintenance before the truck is used for another shift.

1. Park the truck on level ground when possible, and away from other vehicles. If parking on a grade, position the truck perpendicular to the grade.

Haul roads are not safe parking areas. In an emergency, choose the safest spot most visible to other machines in the area.

2. Apply the parking brake. Verify that the parking brake is operating properly and is capable of holding the truck stationary.



Use the parking brake when parking the truck. Verify the parking brake is capable of holding the truck stationary before stopping the engine.

DO NOT use the brake lock to secure the truck when parking. The brake lock will release when hydraulic pressure dissipates after the engine is turned off. This may result in truck movement, damage to surrounding objects, and serious injury to personnel in the area.

3. Install wheel chocks.
4. If the truck is disabled and near operating trucks, mark the truck with warning flags in daylight, or with flares at night.

TURNING OFF THE ENGINE

Follow the sequence below at the end of machine use.

1. Stop the truck, and reduce engine rpm to low idle. Place the transmission shift lever in NEUTRAL, and apply the parking brake. Refer to the guidelines in Safe Parking Procedures for proper instructions when parking the truck.
2. Allow the engine to cool gradually by operating at low idle for three to five minutes.
3. Turn the key switch to the OFF position to stop the engine.
4. Close and lock all windows. Remove the key from the key switch and lock the cab to prevent possible unauthorized truck operation.
5. Dismount the truck properly.

SUDDEN LOSS OF ENGINE POWER

If the engine suddenly stops, stored hydraulic pressure in the brake and steering accumulators enables temporary usage of steering and brake functions. Because accumulator oil supply is limited, it is important to stop the truck as quickly and safely as possible after the loss of engine power. When pressures drop to a pre-determined level, the low brake pressure and low steering pressure indicators will illuminate and a buzzer will sound. If the brake pressure continues to decrease, the auto-apply feature will activate and the service brakes will automatically apply to stop the truck.

Bring the truck to a safe stop as quickly as possible by using the foot pedal to apply the service brakes. If possible, steer the truck to the side of the road during braking. Apply the parking brake as soon as the truck comes to a complete stop. Turn the key switch OFF and notify maintenance personnel, immediately.

If the truck is disabled in a high-traffic area, mark the truck with warning flags during daylight hours, and flares at night.

Emergency Steering And Braking

The steering and brake systems each have accumulators that store energy. The accumulators provide hydraulic power in the event of an unexpected engine failure or pump failure.

Checking the accumulator nitrogen charge is a required routine maintenance item. Refer to the shop manual for proper procedures when charging the accumulators.

Audible and visual warnings will alert the operator if accumulator pressures drop below the preset values during operation.

DISABLED TRUCK DUMPING PROCEDURE

Sometimes it is necessary to dump a load from the body of a disabled truck with an inoperable hoist system. The following instructions describe the use of a "good" truck to provide the hydraulic power required to raise the body of a disabled truck to dump the load.

Figure 30-6 shows the quick disconnect fittings on a hoist manifold for connecting the hoist circuits between trucks.

Hookup

Ensure there is an adequate and safe area to dump the loaded dump body.

1. Safely park the good truck as close as possible to the disabled truck. When the good truck is in position next to the disabled truck, turn off the engine.
2. Purge the pressure from the brake accumulators, steering accumulators, and hydraulic tanks on each truck.
3. Attach a hose from the power up quick disconnect on the good truck to the power down circuit on the disabled truck. Hoses must be rated to withstand 19 305 kPa (2800 psi) or greater pressure.

NOTE: The power down circuit uses a smaller diameter hose (tube) than the power up circuit.

4. Connect another hose from the power down quick disconnect on the good truck to the power up circuit on the disabled truck.

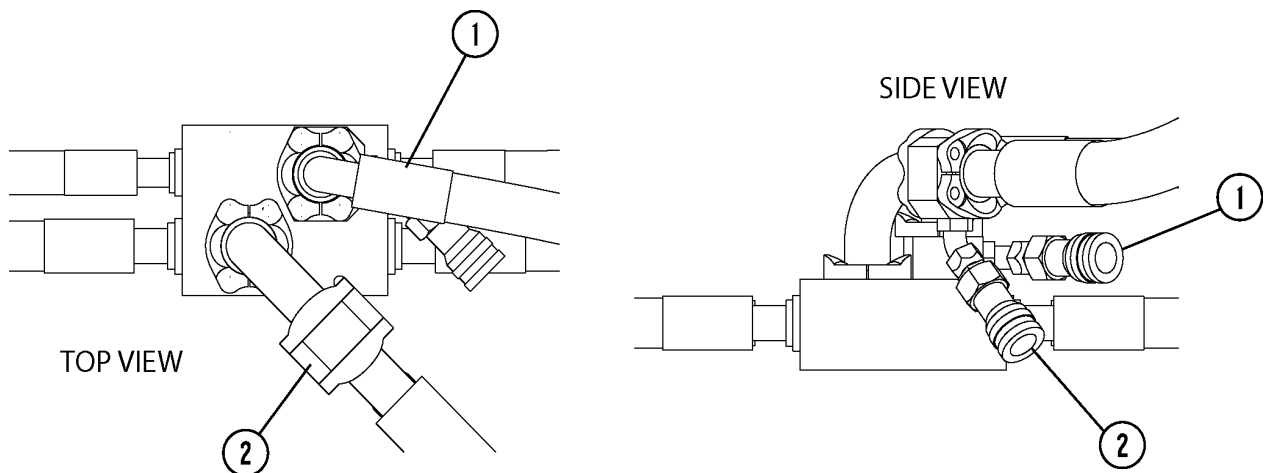

FIGURE 30-6. HOIST CIRCUIT QUICK DISCONNECT FITTINGS

1. Power Down Circuit

2. Power Up Circuit

L080094

Raising the Body

5. Move the hoist control lever on the disabled truck to the HOLD position. Leave the lever in this position during the entire procedure.
6. Adjust the power down relief setting on the good truck to the maximum setting. The power down relief valve (1, Figure 30-7) is located on pilot valve (2) inside of the brake cabinet. Gently, turn the adjustment screw clockwise until it bottoms out. Count the exact number of turns that the adjustment screw is turned, and note for later adjustment.
7. Start the engine on the good truck, and adjust the engine speed to 1000 rpm.
8. Place the hoist control in the POWER DOWN position. Continue to hold in this position until the hoist cylinders reach full extension. Increase engine speed as necessary.



DO NOT move the hoist control from the POWER DOWN position until full extension is reached. DO NOT attempt to move the lever to the HOLD position during this procedure.

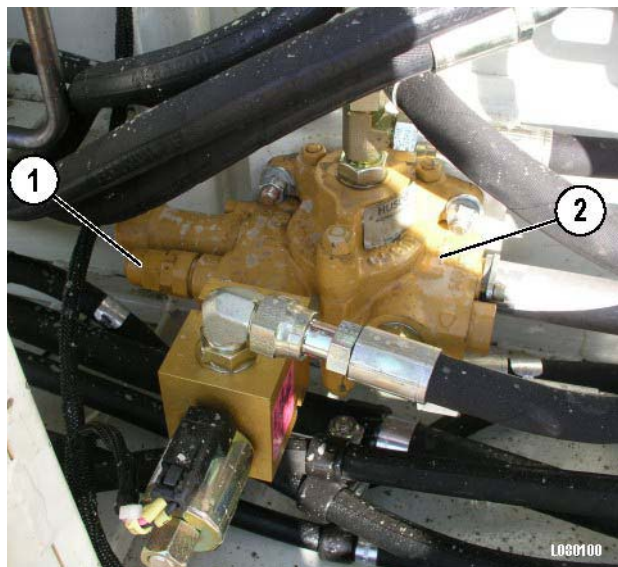

FIGURE 30-7. POWER DOWN RELIEF VALVE

1. Power Down Relief 2. Hoist Pilot Valve

Lowering the Body

9. After the load has been emptied from the body, release the hoist control lever. The body of the disabled truck should immediately begin floating downward.

If any residual material left in the body prevents lowering, perform the following:

- a. Place the good truck hoist lever in the POWER UP position, and monitor the body of the disabled truck for downward movement. The body of the good truck may rise a small amount during this step.
 - b. Once the body of the disabled truck begins downward, move the hoist control all the way forward. Then, release the lever to the FLOAT position.
10. Turn off the engine. Depressurize the brake accumulators, steering accumulators, and the hydraulic tanks on each truck.
 11. Disconnect the hoses from each truck.
 12. Readjust the relief valve setting on the good truck. Turn the screw counter-clockwise the same number of turns as was noted earlier in this procedure. The power down relief valve setting is 10 342 kPa (1500 psi).

DISABLED TRUCK STEERING AND BRAKING

During towing, it may be necessary to steer and stop a disabled truck using hydraulic power from the tow truck. The following instructions describe the use of a "good" truck to provide the hydraulic power required to steer and stop a disabled truck.

Figure 30-9 illustrates a typical hookup with another HD1500. Figure 30-8 shows the location of the quick disconnects on the bleed-down manifold.

▲ IMPORTANT ▲

Only install quick disconnects in the instance of a truck failure. During normal truck operation, the fittings must be absent from the manifold, and plugs installed.

1. When the good truck is in position in front of the disabled truck, turn off the engine, and apply the parking brake.
2. Purge any pressure from the steering accumulators on each truck. Verify no pressure exists by attempting to steer each machine.
3. Connect the supply and return hoses to the quick disconnects on each bleed-down manifold. Route and secure the hoses in a safe manner that will prevent hose damage during machine movement.
4. Install pressure gauges in the brake supply circuit on both trucks for verification of proper brake system pressures after machine start up.
5. Position the retarder lever on the bad truck in the OFF position. DO NOT use the retarder lever during machine towing.
6. Turn the disabled truck key switch to the ON position. This prevents oil transfer between trucks from the retarder command circuit.
7. Start the good truck, and allow the engine to idle for a minimum of three minutes.
8. Verify proper brake system pressures on both trucks. HD1500: 18 960 kPa (2750 psi).
9. Slowly operate the steering wheel on each truck to check steering function. Slow movement will allow any trapped air to bleed out of the system.
10. Check all hydraulic connections for leakage before machine travel.

11. If no problems are evident, begin moving the machines.

Maintain a travel speed equal to normal human walking speed. Steer the machine slowly while keeping turns at 1/4 revolution/second or less.

NOTE: Use the brakes sparingly when possible. Each braking application and release on the disabled truck transfers oil from the good truck to the disabled truck. It may be necessary to drain oil from the disabled truck if the hydraulic tank inherits too much oil.

12. When the trucks have reached their destination, apply the parking brake on each truck and shut the engine off.
13. Depressurize the steering accumulators before removing the hoses. Attempt to steer each truck to verify no pressure remains in the system.

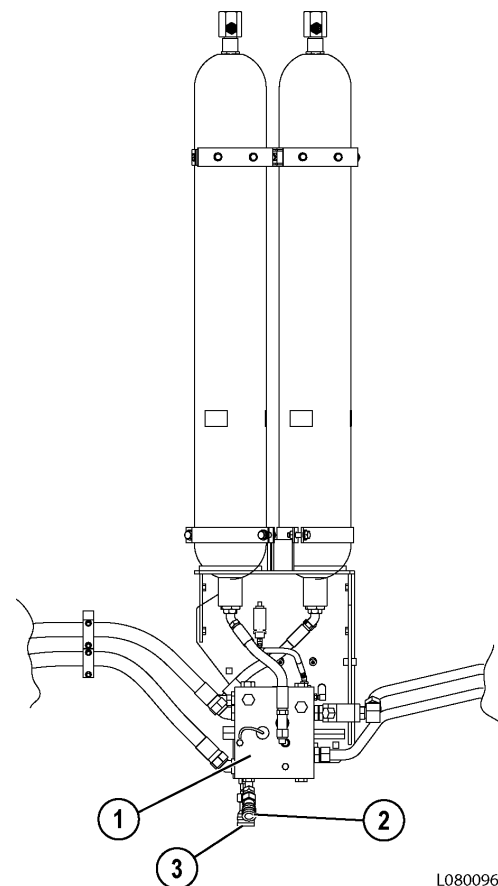

L080096

FIGURE 30-8. STEERING QUICK DISCONNECTS

- | | |
|---------------------------|----------------|
| 1. Bleed-down Manifold | 2. Supply Port |
| | 3. Return Port |

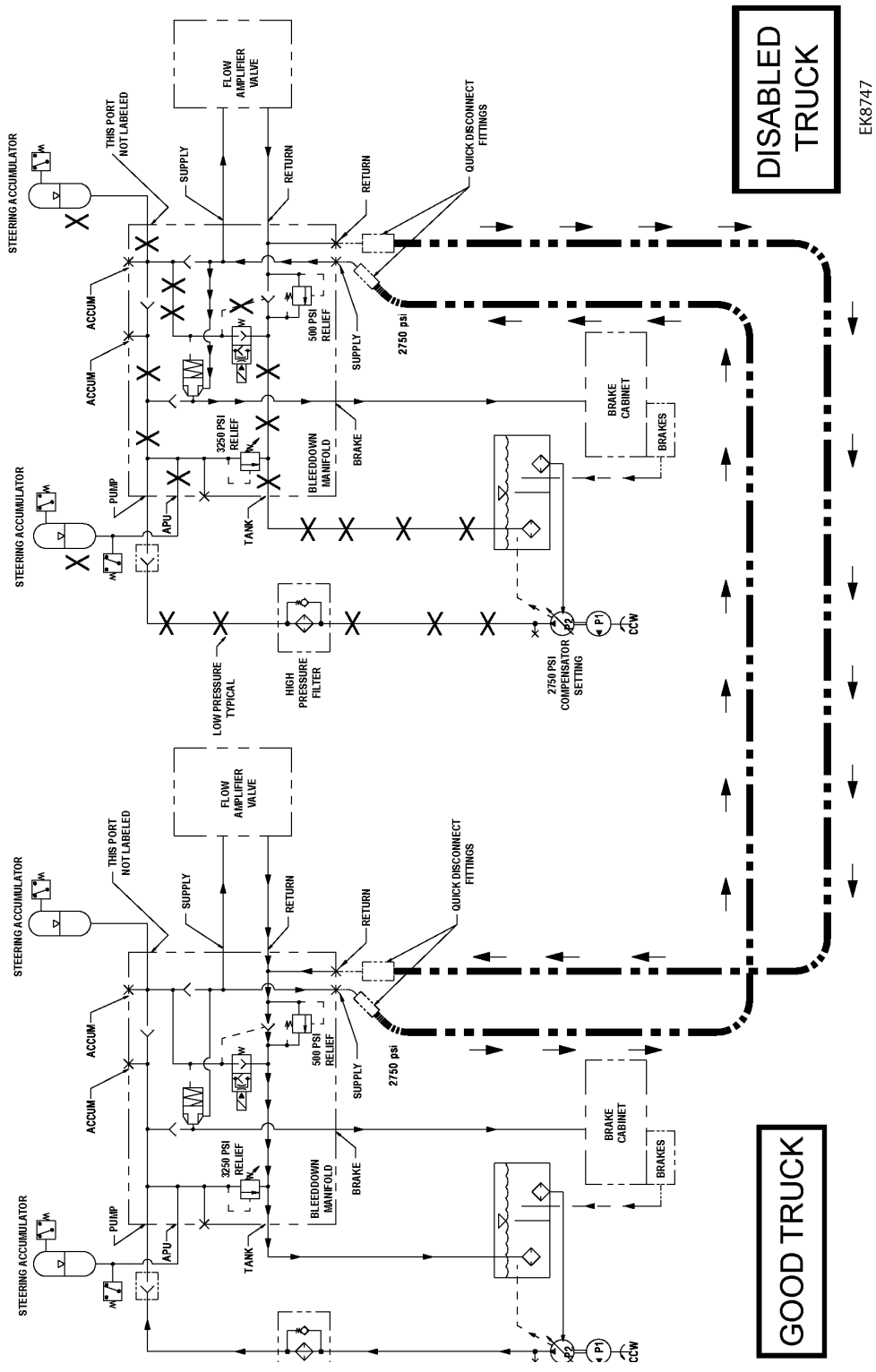

FIGURE 30-9. GOOD TRUCK / DISABLED TRUCK STEERING AND BRAKING HOOKUP

TOWING

Prior to towing a truck, many factors must be carefully considered. Serious personal injury and/or significant property damage may result if important safety practices and procedures are not observed. Use extreme care when towing a disabled truck.

- ***Towing a machine is only advised for short distances. For longer distances, the machine must be hauled.***
- ***All precautions must be observed to protect the operators in the event of wire rope breakage.***
- ***Wire rope capable of towing 77,110 kg (170,000 lb) is required for the HD1500.***
- ***An observer must be positioned in a safe location during towing for signalling the operators.***
- ***Towing speed must not exceed 2 kph (1 mph).***
- ***Tow rope angles must not exceed 10°.***

Observe all precautions outlined in this manual, as well as local regulations. Refer to the following steps when towing is necessary:

1. Block the disabled truck to prevent movement while preparing the truck for towing and attaching the wire rope and other connections.
2. Verify the towing capacity of the wire rope (it must be capable of towing 77,110 kg (170,000 lb)). Verify the rope is in good condition showing no indications of damage or wear.

3. Determine the primary reason that the truck is disabled.
 - a. If the truck is being towed because of engine failure, certain precautions must be observed. The loss of hydraulic power due to engine failure requires the use of hydraulic power from another source. The tow machine or an auxiliary power unit must be used to supply hydraulic power. Hydraulic power is necessary for dumping, steering and braking. Hydraulic power is also necessary to release the spring applied parking brake. Refer to Disabled Truck Dumping and Disabled Truck Steering and Braking in this chapter for more information on hookup.
 - b. If the truck is disabled because of a suspected final drive problem, both right and left drive axles must be removed before towing. Refer to Section G, Final Drive, in the shop manual for more information.



Extensive secondary damage may occur to final drive components and/or the transmission, if the truck is towed without first removing the drive axles.

Remove damaged components and any debris before moving the truck. Failure to remove debris or damaged components may result in further damage.

- c. If the truck is disabled because of a suspected transmission problem, remove the drive shaft between the transmission and the differential case. If the drive axles were removed, it is not necessary to remove the drive shaft.
4. Use the tow eyes installed under the front bumper for towing from the front of the disabled truck. Both tow hooks must be used. Use the tow pin on the rear axle when pulling the disabled truck from the rear.

5. If the engine on the disabled truck is operational, start the engine before towing to release the parking brake, and to enable steering and braking.
6. If the engine is inoperable, hydraulic power for steering, braking and transmission lubrication will not be available.

Install the necessary hydraulic connections between the tow vehicle and the disabled truck to provide hydraulic power. Refer to Disabled Truck Steering and Braking.

7. If the body of the disabled truck contains a load, dump the load before towing. If the engine is not operational, refer to Disabled Truck Dumping.
8. Remove all blocking, and release the disabled truck brakes. Begin towing the disabled truck. A spotter must signal the operators to stop the tow if any signs of danger or damage are evident.



- ***DO NOT exceed 2 kph (1 mph) when towing another truck.***
- ***Smooth and gradual truck movement is essential during towing. Sudden movement may cause wire rope failure leading to injury and/or truck damage.***
- ***Minimize the tow angle at all times - Never exceed 10° in any direction, vertically or horizontally. The towed truck must be steered in the direction of the wire rope.***

Consult your customer support manager for any questions or concerns about towing a disabled truck.

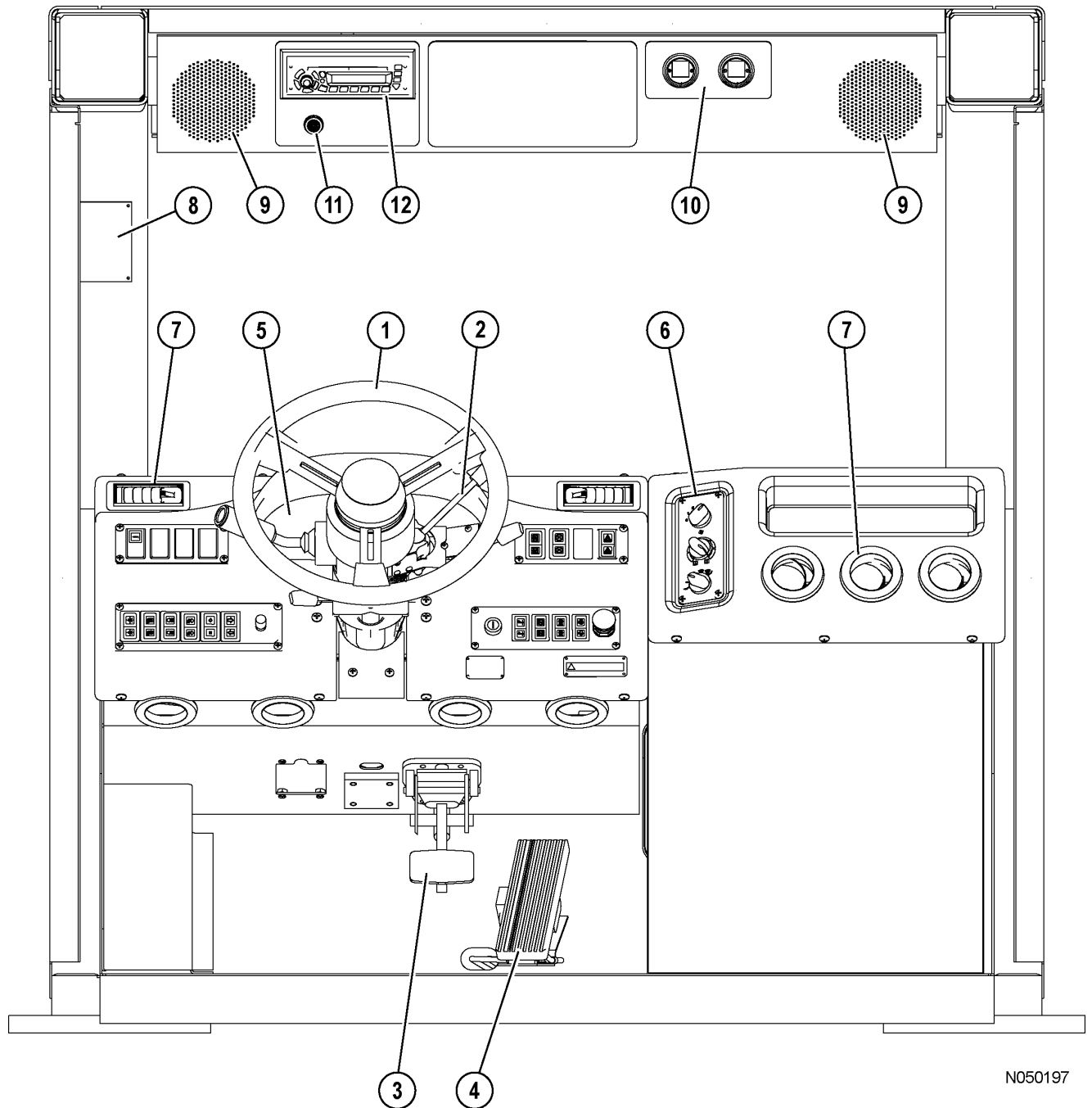
OPERATOR CAB AND CONTROLS

N050197

FIGURE 32-1. CAB INTERIOR - OPERATOR VIEW

- | | |
|------------------------------------|---------------------------------|
| 1. Steering Wheel | 7. Heater/Air Conditioner Vents |
| 2. Retarder Control Lever | 8. Retarding Capacity Chart |
| 3. Service Brake Pedal | 9. Radio Speakers |
| 4. Accelerator Pedal | 10. Air Cleaner Vacuum Gauges |
| 5. Instrument Panel | 11. Warning Alarm Buzzer |
| 6. Heater/Air Conditioner Controls | 12. Radio |

STEERING WHEEL AND CONTROLS

Steering wheel (1, Figure 32-2) will telescope "in" and "out" and adjust at a tilt angle to provide a comfortable wheel position for most operators.

Horn Button

Horn (2, Figure 32-2) is actuated by pushing the button in the center of the steering wheel. Verify the operation of the horn before moving the truck. Observe all local safety rules regarding the use of the horn as a warning signal device before starting the engine and moving the vehicle.

ARSC Set Lever

Automatic Retard Speed Control (ARSC) set lever (3) is used to set, cancel, or make fine adjustments to the ARSC set speed.

- (a) press this button to set
- (b) increase speed (tap up)
- (c) decrease speed (tap down)
- (d) cancel

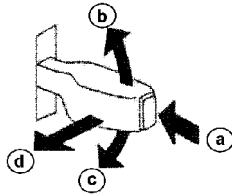

Refer to ARSC later in this section for more information.

Telescoping/Tilt Wheel Lever

Adjust the tilt angle of the steering wheel by pulling tilt adjustment lever (4, Figure 32-2) toward the steering wheel and moving the wheel to the desired angle. Releasing the lever will lock the wheel in the desired location. Push the lever towards the front of the truck to telescope the column in and out. Release the lever to lock the column adjustment.

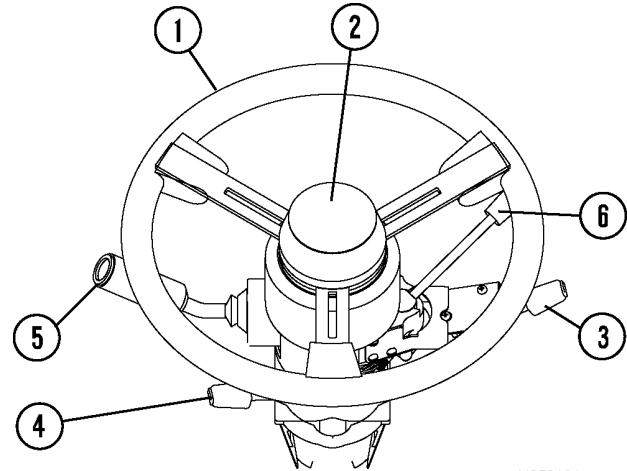

N050191

FIGURE 32-2. STEERING WHEEL AND CONTROLS

- | | |
|-------------------------------|-------------------------------------|
| 1. Steering Wheel | 5. Multi-Function Turn Signal Lever |
| 2. Horn | 6. Retarder Control Lever |
| 3. ARSC Lever | |
| 4. Telescope/Tilt Wheel Lever | |

Multi-Function Turn Signal Lever



N050186

Multi-function turn signal switch (5, Figure 32-2) is used to activate the turn signal lights, the windshield wipers, and to select either high or low beam headlights.

Turn Signal Operation

Move the lever upward to signal a right turn.

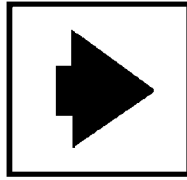

An indicator in the top, center of the instrument panel will illuminate to indicate turn direction selected. Refer to Instrument Panel and Indicator Lights in this section.

Move the lever downward to signal a left turn.

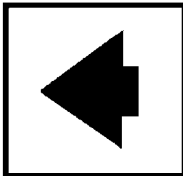





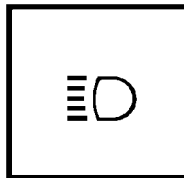

NOTE: The turn signal does not automatically cancel after the turn has been completed. The turn signal lever must be manually returned to the neutral position.

High Beam Headlight Operation

Pulling the lever inward (toward the rear of the cab) changes the headlights to high beam. When the high beams are selected, the indicator in the top center of the instrument panel will illuminate. Moving the switch back to the original position will return the headlights to low beam.



Windshield Wiper Operation

-  Windshield Wipers OFF
-  Intermittent - Long Delay
-  Intermittent -Medium Delay
-  Intermittent -Short Delay
-  Low Speed
-  High Speed
-  Depressing the button at the end of the lever will activate the windshield washer.

NOTE: The wipers will not come on automatically when activating the washer. This must be done manually.

RETARDER CONTROL LEVER

Retarder control lever (6, Figure 32-2) is mounted on the right side of the steering column. It can be used to modulate the full range of retarding/braking effort being applied to both the front and rear oil disc brakes. Any application of the retarder lever will cause an indicator light to illuminate in the center instrument panel Refer to Instrument Panel And Indicators later in this chapter.

- a. When the lever is rotated to the full "up" (counterclockwise) position, it is in the OFF/NO RETARD position.
- b. When the lever is rotated "downward" (clockwise), it is in the ON/RETARD position. The ON position encompasses a full range of motion that allows a variable retarding effort depending on the position of the lever. As the lever is rotated further clockwise, more retarding effort will be applied.
- c. For long downhill hauls, the lever may be positioned anywhere to provide the desired retarding effort. The lever will remain where it is positioned until moved. Refer to Retarder Operation in the previous section for cautions when using the retarder on a downhill grade.



When retarding is completed, and acceleration is resumed, return the lever to the full "up" (OFF/NO RETARD) position, to prevent rapid wear to brake discs and/or overheating of the brake cooling system.

The retarder lever and foot-operated service brake pedal can be used simultaneously or independently. The Retard Control Module (RCM) will determine which device is requesting the most retarding/braking effort and apply that amount.

SERVICE BRAKE PEDAL

Service brake pedal (3, Figure 32-3) is a single function, foot-operated pedal which controls and modulates service brake pressure directly through a hydraulic valve.

When the pedal is depressed, the service brakes are actuated through a hydraulic valve, which modulates pressure to the service brakes. Completely depressing the pedal causes full application of both the front and rear oil disc service brakes.

Refer to retarding capacity chart (8, Figure 32-1) to determine maximum safe truck speeds for descending various grades with a loaded truck.

ACCELERATOR PEDAL

Accelerator pedal (4, Figure 32-3) is a foot-operated pedal which allows the operator to control engine rpm, depending on pedal depression.

The foot-operated treadle pedal contains an electronic sensor which sends signals to the Quantum™ fuel control system. The movement of the fuel governor control arm corresponds directly to the travel of the treadle pedal as it is applied by the operator. When the pedal is released, springs return the control arm and the pedal to their rest positions and the engine speed returns to low idle.

INSTRUMENT PANEL

Instrument panel (5, Figure 32-1) includes a center electronic display panel, and LH & RH switch panels that contain a variety of switches.

Refer to Instrument Panel And Indicators later in this section for a detailed description of the function and location of each of these components.

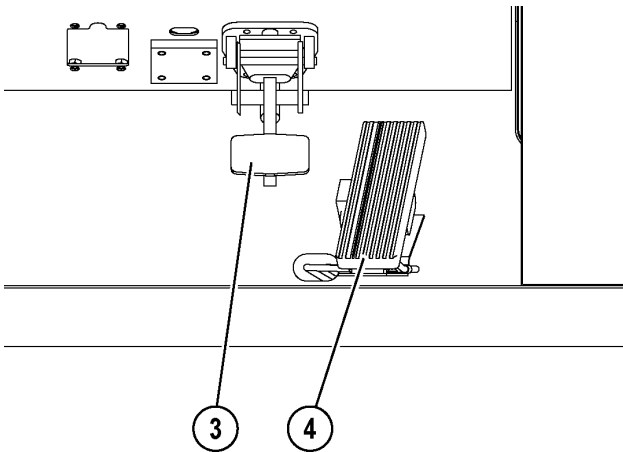

FIGURE 32-3. PEDALS

3. Brake Pedal

4. Accelerator Pedal

HEATER / AIR CONDITIONER CONTROLS

The heater/air conditioner compartment contains heater/air conditioner controls and some of the heater/air conditioner components, such as the blower motor, evaporator and heater coil. Optimum cab air climate can be obtained by using the following controls in various combinations.

Fan Speed Control Knob

Fan speed control knob (1, Figure 32-4) controls the blower motor. The fan (blower) motor is a 3-speed motor (low, medium and high). Speeds are selected by rotating the control knob clockwise to the desired position. OFF is in the full counterclockwise position. The fan speed control knob must be switched ON for the air conditioner to function.

Temperature Control Knob

Temperature control knob (2, Figure 32-4) allows the operator to select a comfortable air temperature.





The control knob determines the operation of the air conditioning and heater modes.

Rotating the control knob counterclockwise into blue zone (3) will cause the A/C compressor to operate and result in cooler air temperatures. The full counterclockwise position is the coldest air setting.

Rotating the control knob clockwise into red zone (4) will allow coolant to flow through the heater core resulting in warmer air temperatures. The full clockwise position is the warmest heater setting.

Air Flow Directional Knob

Air flow directional knob (5, Figure 32-4) controls the direction of airflow as follows:

| | |
|---|--|
|  | Provides airflow to floor vents, only. |
|  | Provides airflow to upper vents and floor vents. |
|  | (Blue Icon) Provides dehumidified air to the upper vents and the floor vents. |
|  | Defrost - Provides dehumidified air to the windshield. |
|  | Defrost - Provides dehumidified air to the windshield as well as to floor vents. |

Heater/Air Conditioner Vents

Heater/air conditioner vents (6, Figure 32-4) may be rotated 360°. There are three vents in the heater/air conditioner compartment, four vents across the top of the instrument panel, and one vent each in the RH and LH instrument panels. There are also an additional four vents under the instrument panel. Air flow through the vents is controlled by manually opening, closing or turning the louvers.

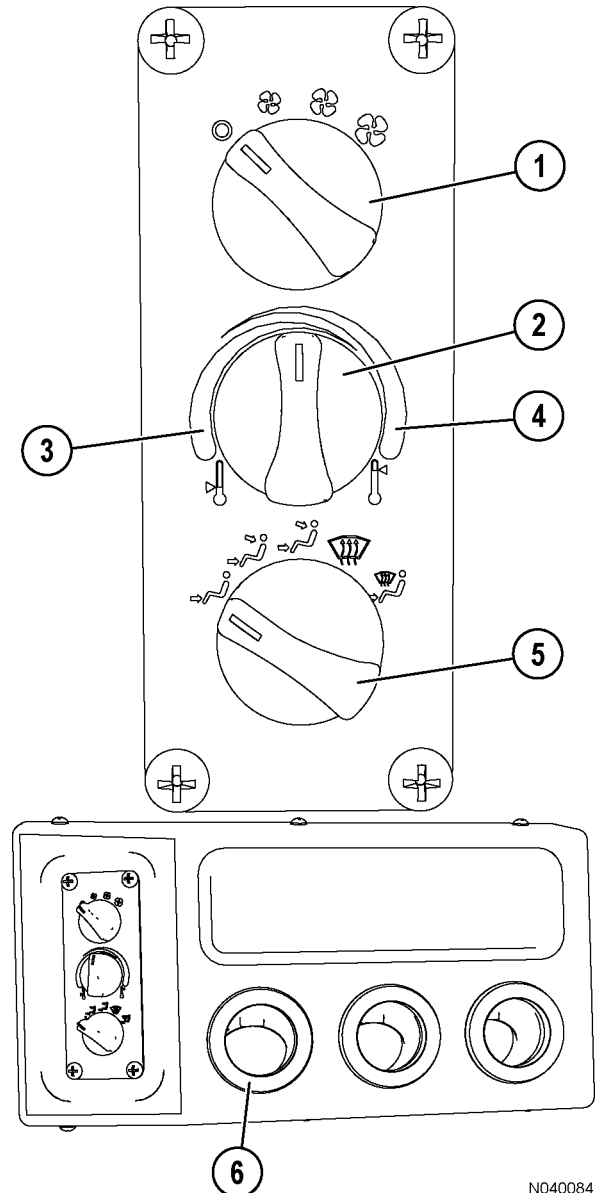

N040084

FIGURE 32-4. A/C & HEATER CONTROLS

- | | |
|-----------------------------|------------------------------|
| 1. Fan Speed Control Knob | 4. Red Zone |
| 2. Temperature Control Knob | 5. Air Flow Directional Knob |
| 3. Blue Zone | 6. Vents |

RETARDING CAPACITY CHART

Retarding capacity chart (8, Figure 32-1 & shown below) provides the recommended *maximum* truck speeds for descending various grades with a fully loaded truck.

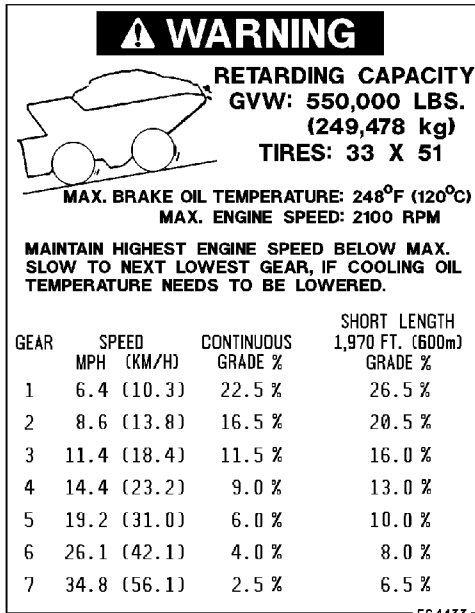

Reference the retarding capacity chart before descending any grade with a loaded truck. Proper selection of road grade, truck speed, transmission gear range, and use of the retarder lever and/or brake pedal are required to maintain a safe speed.

Customer specified options may cause this decal to change. Refer to the retarding capacity chart in the operator's cab, and follow the recommendations there for safe truck operation.



DO NOT exceed these recommended maximum speeds when descending grades with a loaded truck.

Refer to Operating Instructions, Retarder Operation, for more information on using the retarder function.

An automatic retard function is available on this truck. For more information refer to Automatic Retard Speed Control later in this chapter.

RADIO SPEAKERS

Radio speakers (9, Figure 32-1) for the AM/FM stereo radio are located at the far left and right of the overhead panel.

AIR CLEANER VACUUM GAUGES

Air cleaner vacuum gauges (10, Figure 32-1) provide a continuous reading of maximum air cleaner restriction reached during operation. The air cleaner(s) should be serviced when the gauge(s) reaches 25 inches of H₂O vacuum.

NOTE: After service, push the reset pin on the face of the gauge to allow the gauge to return to zero.

WARNING ALARM BUZZER

Warning alarm buzzer (11, Figure 32-1) will sound when activated by any one of several truck functions. Refer to Instrument Panel And Indicators for a detailed description of functions and indicators that will activate this alarm.

AM/FM RADIO / CD PLAYER

Radio (12, Figure 32-1) is an AM/FM radio with compact disc and MP3 capabilities.

Refer to Section 70, Cab Radio, for a more complete description of the radio and its functions. Individual customers may use this area for other purposes, such as a two-way communications radio.

CENTER CONSOLE

Center console (1, Figure 32-5) located to the right of the operator seat, is a housing which provides a mounting surface for certain operator controls. The passenger seat is located directly to the right of the console.

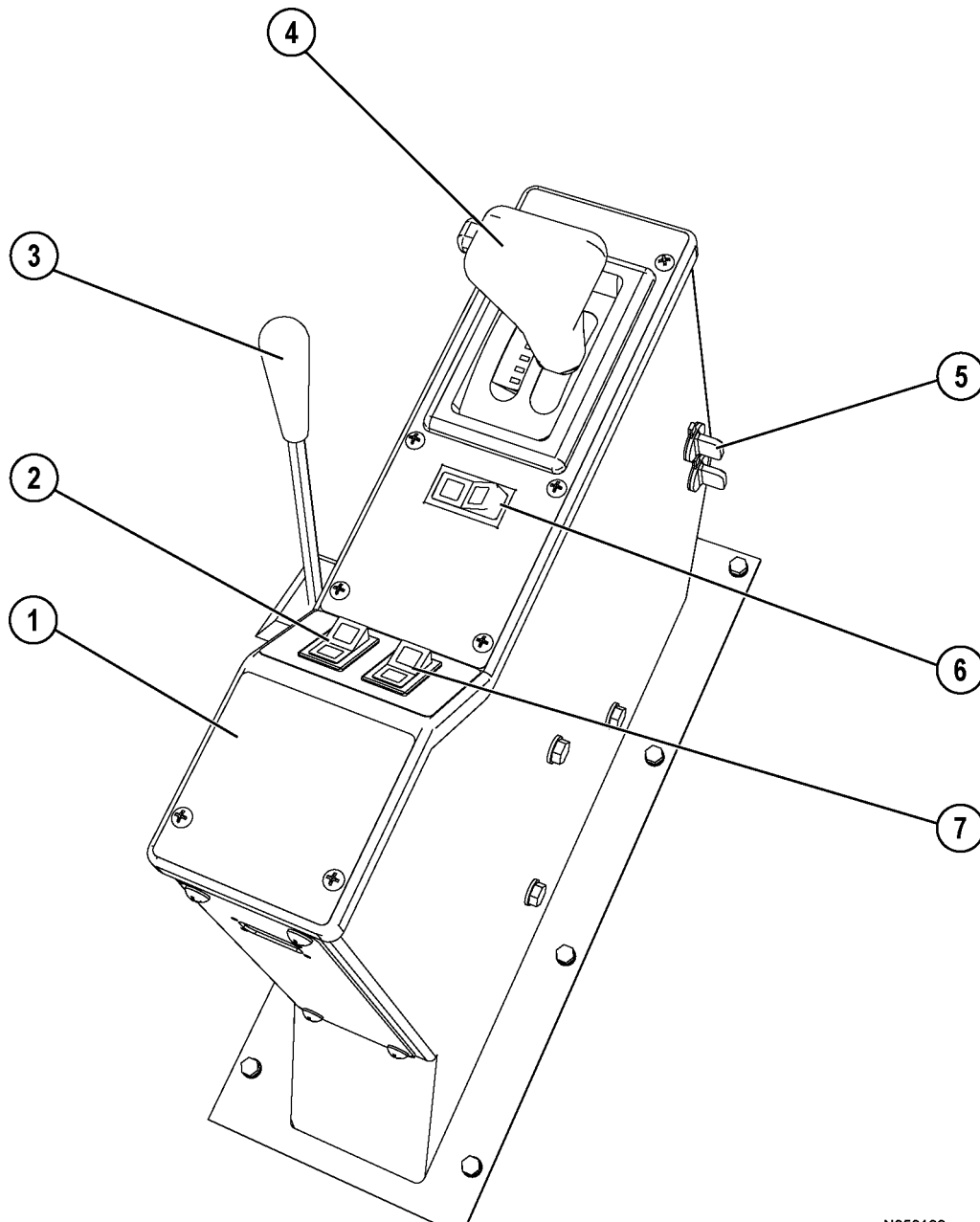

N050199

FIGURE 32-5. CENTER CONSOLE

- | | |
|-----------------------------|-----------------------------|
| 1. Center Console | 5. Auxiliary Power Outlets |
| 2. LH Window Control Switch | 6. Parking Brake Switch |
| 3. Hoist Control Lever | 7. RH Window Control Switch |
| 4. Transmission Shift Lever | |

Hoist Control Lever

Hoist control lever (3, Figure 32-5) is a four-function, three-position, hand-operated lever located between the operator seat and the center console.

Refer to Operating Instructions - Dumping, for more complete details concerning this control.

Transmission Shift Lever

Transmission shift lever (4, Figure 32-5) is mounted to the right of the operator's seat.

The transmission shift lever has nine positions (R, N, D, 6, 5, 4, 3, 2 and L). When moving the shift lever from N to R, or from D to 6, press the lock button on the end of the handle to release the lever and allow a gear change.

R - REVERSE position - is used to move the truck backwards. Bring the truck to a complete stop before shifting from DRIVE to REVERSE or vice-versa. The Reverse warning horn is activated when the REVERSE position is selected.

N - NEUTRAL position - is used when starting the engine, during loading and parking the truck with the engine on. The truck cannot be started unless the shift lever is in the N - NEUTRAL position.

D - DRIVE position (F1-F7) - When starting from a stationary position, the transmission will shift automatically into second gear. As the truck ground speed increases, the transmission will automatically upshift through each gear to seventh gear operation. As the truck ground speed slows down, the transmission will automatically downshift to the correct gear (including F1) for grade/load/engine conditions. When conditions permit, select position D for normal operation.

6, 5, 4, 3, 2 positions - Road and load conditions sometimes make it desirable to limit the automatic up-shifting to a lower range. These positions provide more effective retarding on grades. When the shift lever is placed in any one of these positions, the transmission starts in F1, and will not shift above the highest gear range selected. As the truck ground speed slows down, the transmission will automatically downshift to the correct gear (including F1) for grade/load/engine conditions. When conditions permit, select position D for normal operation.

L - LOW position - Use this range position when maneuvering in tight spaces and when pulling through mud or deep snow. Use this range position also when driving up and down steep grades where maximum driving power or maximum retarding is required. When the shift lever is placed in L, the transmission starts in F1, and will only upshift to F2. When conditions permit, select position D for normal operation.



DO NOT move the shift lever to the N position while the truck is in motion. If the selector is shifted to N while in motion or while descending a hill the following may occur:

- ***Steering may be more difficult.***
- ***A lack of cooling oil may cause the braking system to overheat and fail.***
- ***Damage to the transmission may occur.***
- ***The engine cannot provide braking when the transmission is not in gear.***

Parking Brake Switch



When parking brake switch (6, Figure 32-5) is in the ON position, the parking brake is applied.

When this switch is in the OFF position, the parking brake is released.

The parking brake is spring applied and hydraulically released. It will hold a stationary truck when the engine is stopped and the key switch is in the OFF position.



DO NOT apply the parking brake while the truck is in motion. Damage to parking brake components will occur.

When the key switch is ON and the parking brake is applied, an indicator light in the center dash panel will illuminate. Refer to Instrument Panel And Indicators later in this chapter.

LH Window Control Switch

LH window control switch (2, Figure 32-5) is spring-loaded to the center, OFF, position. Pushing the front of the switch lowers the left side cab window. Pushing the rear of the switch raises the window.



RH Window Control Switch

RH window control switch (7, Figure 32-5) is spring-loaded to the center, OFF position. Pushing the front of the switch lowers the right side cab window. Pushing the rear of the switch raises the window.

Auxiliary Power Outlets

Auxiliary power outlets (5, Figure 32-5) can be used to power accessory items. The outlets supply 12VDC.

OPERATOR SEAT

The operator's seat provides a fully adjustable cushioned ride for driver comfort and easy operation.

Seat Belts

- On both driver and passenger seats, check the seat belt fabric, buckle, all belt retractors and hardware for damage or wear. Replace any worn or damaged parts immediately.
- Even if there are no signs of damage, replace both driver and passenger seat belts 5 years after seat belt manufacture, or every 3 years after start of use, whichever comes first. The passenger seat belt date of manufacture label is sewn into the seat belt near the buckle. The driver seat belt date of manufacture label is sewn into the shoulder harness belt, near the retractor end.

Seat Adjustment

The following adjustments must be made while sitting in the seat.

1. **Headrest:** (1, Figure 32-6) will move up, down, fore, or aft by moving headrest to desired position.
2. **Armrests:** rotate adjusting knob until armrest is in desired position.
3. **Backrest:** Lift handle (3) to release and select backrest angle: release control handle to set.
4. **Seat Belt:** Operator should always have seat belt (4) buckled in place and properly adjusted whenever vehicle is in motion.
5. **Seat Slope:** Lift lever (5) and hold to adjust the slope of the seat. Release lever to lock adjustment.
6. & 7 **Air Lumbar Support:** Each rocker switch (6 or 7) controls an air pillow. Switch (7) controls the lower air pillow and switch (6) controls the upper air pillow. To inflate, press on top of rocker switch and hold for desired support, then release. To deflate, press on bottom of rocker switch and hold for desired support, then release. Adjust each pillow for desired support.
8. **Seat Suspension:** Adjust switch (8) to obtain the desired stiffness of the adjustable suspension. Press the switch upward to stiffen the absorbency of the suspension. Press the switch downward to soften the ride.
9. **Fore/Aft Location of Seat:** Lift lever (9) and hold. Bend knees to move seat to a comfortable position: release control lever to lock adjustment.
12. **Seat Height:** Lift and hold lever (12) to adjust the height of the seat. Release the lever to lock the position. Optimum ride height is obtained when the suspension is at the middle of its stroke. To properly adjust, raise the seat to its highest level. Then, lower the seat approximately 51 mm (2 in.) to the middle of the suspension stroke.

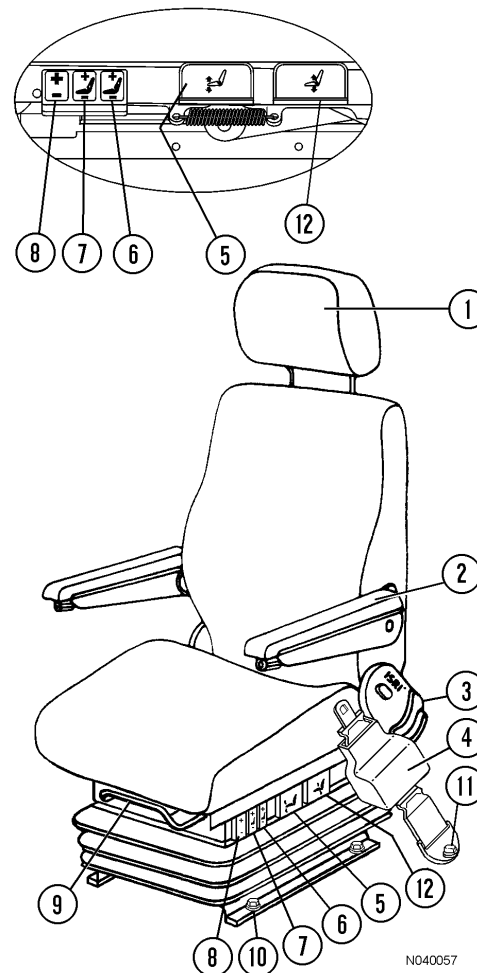

FIGURE 32-6. ADJUSTMENT CONTROLS

- | | |
|------------------------------------|----------------------------|
| 1. Headrest | 8. Height Adjustment |
| 2. Armrest Adjustment | 9. Fore and Aft Adjustment |
| 3. Backrest Adjustment | 10. Mounting Hardware |
| 4. Seat Belt | 11. Seat Tether Cap Screw |
| 5. Seat Slope Adjustment | 12. Seat Height Adjustment |
| 6. Upper Air Pillow Lumbar Support | |
| 7. Lower Air Pillow Lumbar Support | |

INSTRUMENT PANEL AND INDICATORS

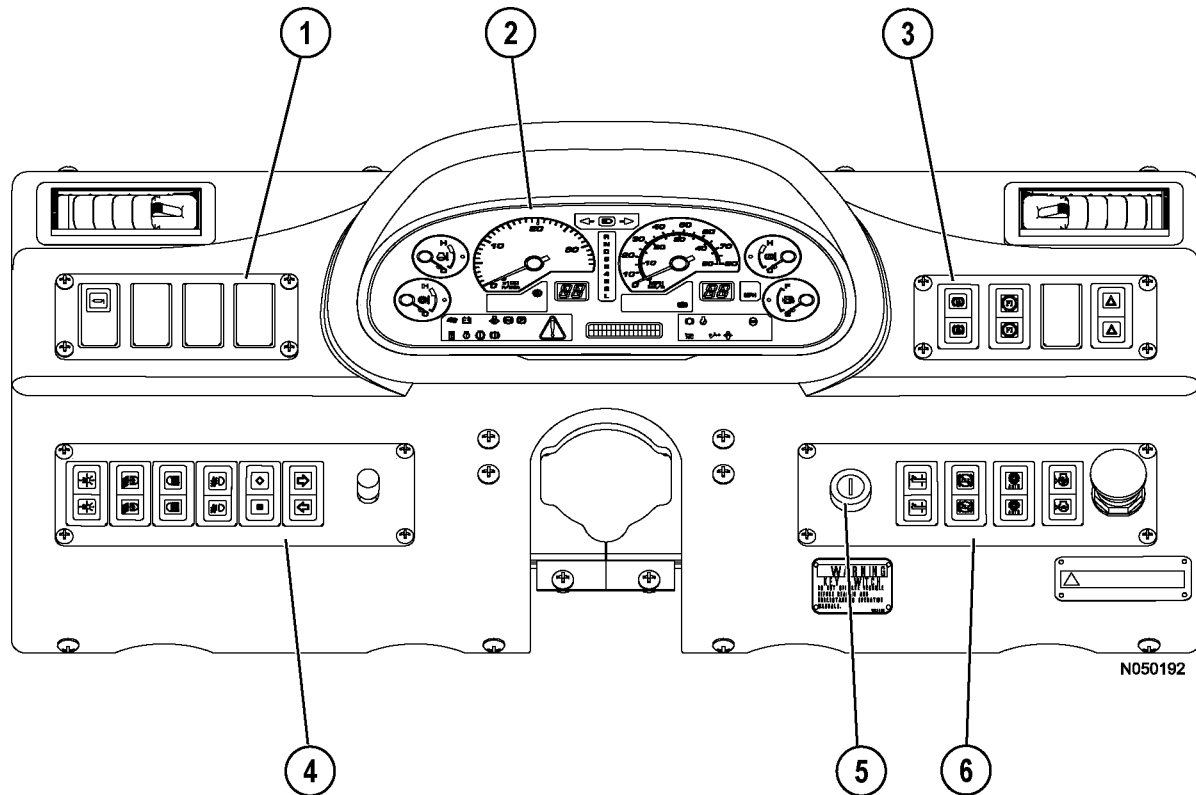

FIGURE 32-7. INSTRUMENT PANEL

- | | |
|--|--------------------------|
| 1. Upper LH Switch Panel | 4. Lower LH Switch Panel |
| 2. Center Electronic Display Panel (EDP) | 5. Key Switch |
| 3. Upper RH Switch Panel | 6. Lower RH Switch Panel |

The instrument panel consists of upper and lower RH & LH switch panels, and a center display panel with digital character display.

The center Electronic Display Panel (EDP) is equipped with a microcomputer to process and display the signals from the sensors. The display is a liquid crystal display.

The following pages will identify each element of the instrument panel and detail its function and purpose.

UPPER RH SWITCH PANEL

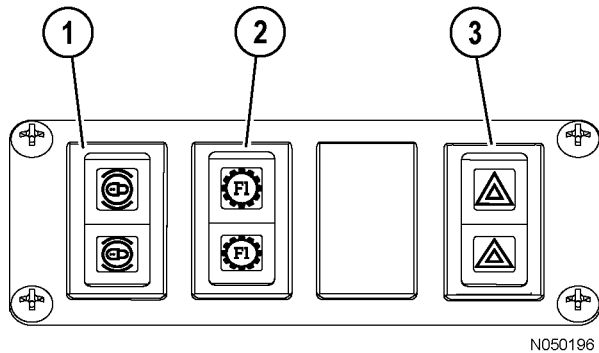

FIGURE 32-8. UPPER RH SWITCH PANEL

- 1. Brake Lock
- 2. F1 Start Switch
- 3. Hazard Flasher Switch

NOTE: If the truck is not equipped with the brake lock option, slot (1) will contain a plug.

The upper RH switch panel, located to the right of the steering wheel, contains the following:

Brake Lock Switch



Moving brake lock switch (1, Figure 32-8) to the ON position, applies the brake lock.

When this switch is in the OFF position, the brake lock is released.

The brake lock can only be used with the engine on. It is used for dumping and loading, only. The brake lock switch actuates the hydraulic brake system which locks the rear wheel service brakes.

When approaching a shovel or dump area, select an area with a level surface. When the truck is completely stopped and in loading position, apply the brake lock by moving the rocker switch to ON (up). To release, press the rocker switch to OFF (down).

WARNING

Use the brake lock function only while at the shovel or dump. The brake lock is to be used to hold the truck stationary.

Do not use this switch to stop the truck. Use of this switch applies the rear brakes at full, unmodulated pressure!

Do not use the brake lock in place of the parking brake. With the engine off, hydraulic pressure will depressurize, allowing the brakes to release!

F1 Start Switch

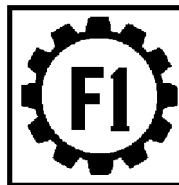

F1 start switch (2, Figure 32-8) is used to ensure that the transmission starts in F1 when the transmission shift lever is in D. When this switch is ON and the transmission shift lever is in the D position, the transmission will shift to F1 to start. When this switch is OFF and the shift lever is in D, the transmission will start in second gear. Refer to Transmission Shift Lever, D - DRIVE. All other forward gear ranges (L, F2, F3, F4, F5, F6) start out in F1 regardless of the F1 start switch position.

Depressing the bottom of the switch moves the switch to the ON position. Depressing the top moves the switch to the OFF position.

Hazard Warning Lights Switch



Hazard warning light switch (3, Figure 32-8) causes all turn signal lights to flash, simultaneously.

The rocker switch is an ON/OFF type. Depressing the bottom moves the switch to the ON position. Depressing the top of the switch moves the switch to the OFF position.

Use the hazard lights as a warning to alert other truck operators that a problem exists.

LOWER RH SWITCH PANEL

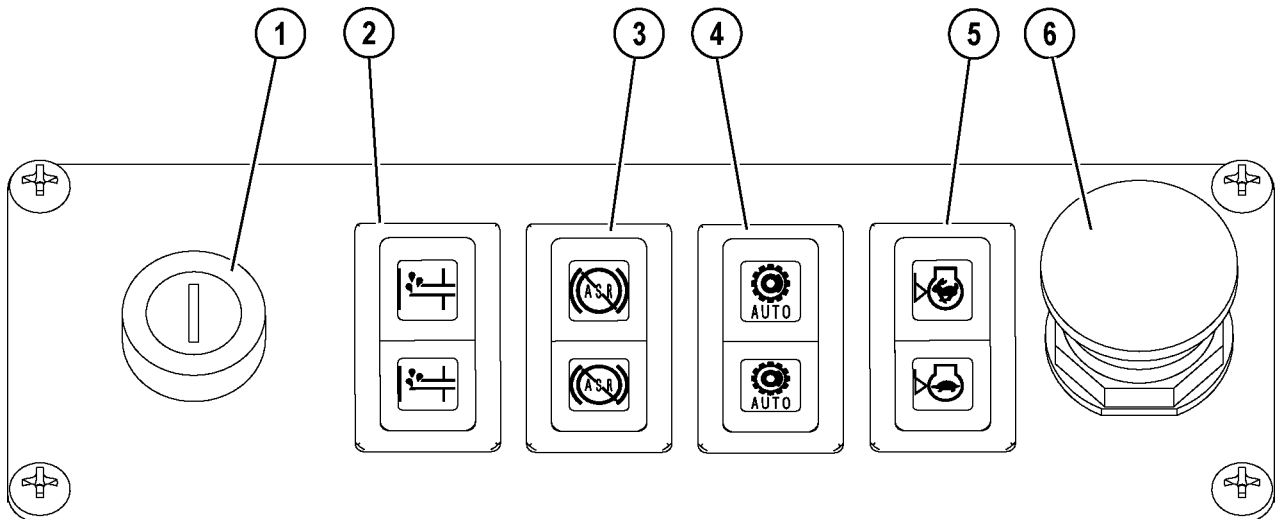

N050195

FIGURE 32-9. LOWER RH SWITCH PANEL

- | | |
|---|---------------------------|
| 1. Key Switch | 4. ARSC Switch |
| 2. Ether Starting Aid Switch (Optional) | 5. AISS Switch |
| 3. ASR Cut Switch | 6. Auxiliary Brake Switch |

The lower RH switch panel, located to the right of the steering wheel, contains the following:

Key Switch

Key switch (1, Figure 32-9) is a four position (ACC, OFF, RUN, START) switch.

OFF - Key insertion/withdrawal position

When the key slot is in the vertical position, the electrical system is off and no electrical devices are energized.

Use this key position to stop the engine when it is operating.

ACC- When the key is rotated counterclockwise from the OFF position, it is in the accessory (ACC) position. This position is used to power certain accessories such as the radio when there is no intention of starting the engine.

RUN - When the switch is rotated one position clockwise, it is in the RUN position and all electrical circuits (except START) are energized.



START - With the transmission selector lever in the NEUTRAL position, rotate the key switch fully clockwise to the START position, and hold this position until the engine starts (see NOTE below). The START position is spring loaded to return to RUN when the key is released.

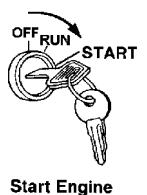

NOTE: The engine start circuit is equipped with a engine prelube system. A noticeable time delay will occur (while engine lube oil passages are being filled) before starter engagement and engine cranking will begin. The colder the engine oil temperature, the longer the time delay will be. In addition, if the truck is also equipped with an engine starting aid for cold weather starting, the engine prelube system should be engaged first for 5-10 seconds, or until the starter is engaged, before activating the engine starting aid.

⚠ WARNING

***Starting fluid is extremely volatile and flammable!
Use with extreme care.***

If the truck is equipped with an engine starting aid for cold weather starting, and ambient temperature is below -5°C (23°F), push the engine starting aid switch in for three seconds, then release. Turn the key switch to the START position. If the engine does not start, wait at least 15 seconds before repeating.

⚠ CAUTION

Do not crank an electric cranking motor for more than 30 seconds. Allow two minutes for the cranking motor to cool before attempting to start the engine again. Severe damage to the cranking motor may result from overheating.

Ether Starting Aid Switch



Ether starting aid switch (2, Figure 32-9) is an ON/OFF type rocker switch that is spring-loaded to the OFF position. This switch is optional equipment.

When the outside temperature is below -5°C (23°F), depress the top of this switch and hold for 2-3 seconds before starting the engine. The cold starting aid atomizes ether into the engine intake manifold.

Refer to Key Switch - START for further details regarding the use of this switch.

⚠ WARNING

DO NOT push the ether injection switch after the engine has started. Serious damage to the engine may occur.

ASR Cut Switch



ASR (Automatic Spin Regulator) cut switch (3, Figure 32-9) is used to activate or de-activate the traction control system.

The rocker switch is an ON/OFF type switch. Depressing the bottom turns the ASR system on. A green light will illuminate the switch to notify the operator that ASR is active. Depressing the top of the switch turns the ASR system off. An amber light will illuminate the switch notifying the operator that traction control is inactive.

When ASR is active, the system monitors individual wheel speeds. If it determines one of the rear wheels is slipping during acceleration, the brake is applied to the rear wheel with the higher speed. Refer to Automatic Spin Regulator later in this chapter for more information on using this function.

ARSC Switch



ARSC (Automatic Retard Speed Control) switch (4, Figure 32-9) is used to enable and disable the automatic retard speed control system. Press the top of the switch to enable automatic retard.

Press the bottom of the switch to disable the automatic retard system. Refer to Automatic Retard Speed Control later in this section for more information on this system.

Automatic Idle Selector Switch (AISS)

AISS switch (5, Figure 32-9) controls the idle speed of the engine. With the accelerator pedal released, the ATC sends a signal to the ECM for a low idle rpm.

This signal may be for either:

- 650 rpm - normal-low idle, or
- 1000 rpm - high-low idle, depending on the following conditions:

1. Depressing the top of the switch selects the OFF/AUTO position which is used for enhanced truck operation. When the AISS switch is in this position, the idle speed will be determined by two conditions: engine coolant temperature, and brake application.



- a. Engine Coolant Temperature - If the engine coolant temperature is below 30°C (86°F), the engine controller will signal for 1000 rpm, regardless of other conditions. If the engine coolant temperature is above 30°C (86°F), the engine controller will signal for 650 rpm, except as follows:
- b. Brake Application - If both the parking brake and service brake are released (acceleration anticipated), the engine controller will signal for 1000 rpm, regardless of other conditions.

NOTE: An amber light will illuminate the switch when the OFF/AUTO position is selected.

2. Depressing the bottom of the switch selects the ON/LOW position. When the AISS switch is in this position, the engine controller will signal for 650 rpm, regardless of other conditions. ON/LOW position is used when fine control movements are needed, such as parking in confined spaces.



NOTE: A green light will illuminate the switch when the ON/LOW position is selected.

Auxiliary Brake Switch

Auxiliary brake switch (6, Figure 32-9) is used to apply the auxiliary braking system.

Depress the button to apply the auxiliary brake system. When the switch is ON, the red lamp will illuminate.

Pull the switch out to disable the auxiliary brake system. The light will turn off.



When the auxiliary brake switch is activated, full, unmodulated hydraulic brake pressure (or whatever pressure remains, if the system is failing) is applied to all wheels. In addition, the parking brake is also applied.

Do not apply the auxiliary brake switch when the truck is moving, except in an emergency.

NOTE: This switch is for the manual activation of the auxiliary brake circuit by the operator. The auxiliary brake circuit will apply automatically if the hydraulic brake pressure decreases below a pre-set value.

IMPORTANT

In cold ambient conditions and when the engine is cold, the engine rpm will not increase above low idle speed until the engine controller determines it is safe to do so. This time delay will vary from 30 seconds to 11 minutes, allowing the coolant and engine oil to warm. AISS control will not be available until the engine completes this warm-up cycle.

UPPER LH SWITCH PANEL

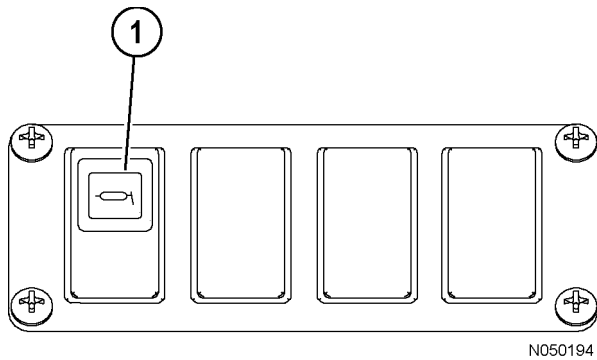

FIGURE 32-10. UPPER LH SWITCH PANEL

1. Automatic Lubrication System Indicator

Upper LH switch panel (1, Figure 32-7), located to the left of the steering wheel, currently does not contain any switches (standard or optional). The panel contains the following:

Automatic Lubrication System Indicator

Automatic lubrication system indicator (1, Figure 3-10) illuminates when lubrication system pressure fails to reach 15 168 kPa (2,000 psi) within one minute after the lube timer initiates a cycle of grease. Notify maintenance personnel at the earliest opportunity after the light comes on.

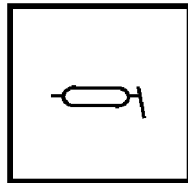

LOWER LH SWITCH PANEL

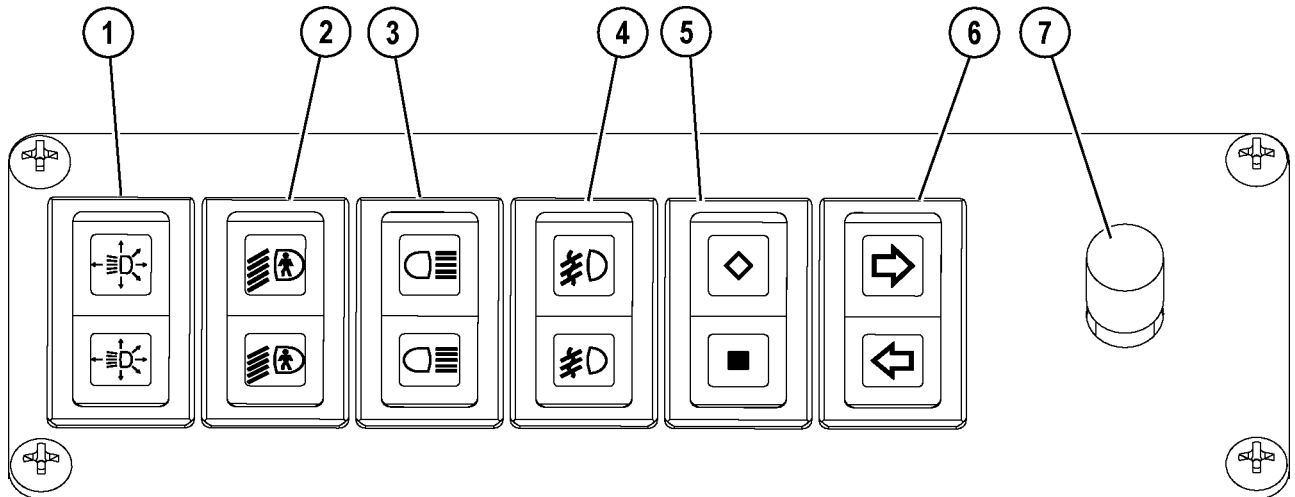

N050193

FIGURE 32-11. LH CONTROL/INDICATOR PANEL

- | | |
|--------------------------------|------------------------------|
| 1. Head Light Switch | 5. Mode Select Switch # 1 |
| 2. Ladder Light Switch | 6. Mode Select Switch # 2 |
| 3. Backup Light Switch | 7. Panel Light Dimmer Switch |
| 4. Fog Light Switch (Optional) | |

The lower LH switch panel, located to the left of the steering wheel, contains the following:

Head Light Switch

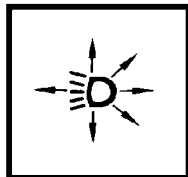

Head light switch (1, Figure 32-11) is a three position rocker switch that controls the instrument panel lights, clearance lights, and the head lights. Press the top of the switch until it reaches the first detent (middle) to select the panel, clearance, and tail lights, only.

Press the top of the switch again, until it reaches the second detent to select the headlights, as well as panel, clearance, and tail lights. Press the bottom of the switch to turn all of the lights off.

Ladder Light Switch

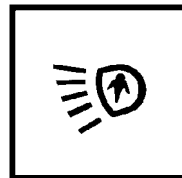

Ladder light switch (2, Figure 32-11) turns the ladder lights on or off. A similar switch is available at the ground level to turn the ladder lights on or off. Depress the bottom of the switch to turn the ladder lights on. Depress the top of the switch to turn the ladder lights off.

BackUp/Deck Light Switch

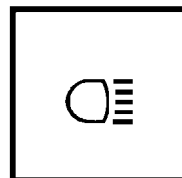

Backup/deck light switch (3, Figure 32-11) allows the backup lights to be turned on regardless of the transmission shift lever position. Depress the top of the switch to turn the backup/deck lights on. Depress the bottom of the switch to turn the backup/deck lights off.

Fog Light Switch

Fog light switch (4, Figure 32-11) controls the fog lights. The fog lights are optional and for use in foggy conditions and heavy rain. Pressing the bottom of the rocker switch turns the lights on. Pressing the top of the switch turns the lights off.

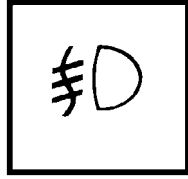

Mode Select Switches 1 & 2

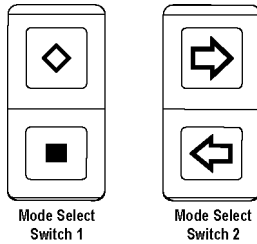

Mode switch 1 & 2 (5, 6, Figure 32-11) are used to scroll through the machine monitor character display. The button commands are as follows:

| | | |
|---|---|---------------------------------------|
| 1 | ◇ | Select, Run |
| 2 | ■ | Cancel, Release, Select (Yes/No Only) |
| 3 | ➡ | Right, Next, Continue |
| 4 | ⬅ | Left, Previous, Return |

Panel Light Dimmer Switch

Panel light dimmer switch (7, Figure 32-11) is used to adjust the brightness of the machine monitor. Turn the knob clockwise to make the display brighter. Turn the knob counter-clockwise to dim the display.

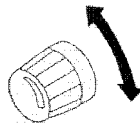

ELECTRONIC DISPLAY PANEL

When the engine starting switch is turned to the ON position before starting the engine, a system check is performed for 30 seconds. The following system checks occur:

- The central warning lamp illuminates for two seconds, and then turns off.
 - The alarm buzzer sounds for two seconds, and then stops.
 - The monitor lamp alternately illuminates for two seconds and then turns off for one second.
 - The shift indicator alternately displays 88 for two seconds and then turns off for one second.
 - After a three second system check, the meters start to function.
- The character display shows KOMATSU SYSTEM CHECK for three seconds.
 - If the lamps do not work, a failure in the circuit has occurred. Contact your Komatsu distributor for inspection.
 - When the starting switch is turned ON, if the shift lever is not in the NEUTRAL position, after completion of the system check, the shift lever position pilot lamp and the central warning lamp will illuminate, and the alarm buzzer will continue to sound intermittently. When this happens, if the shift lever is in NEUTRAL, N is displayed, the central warning lamp turns off, and the buzzer stops.

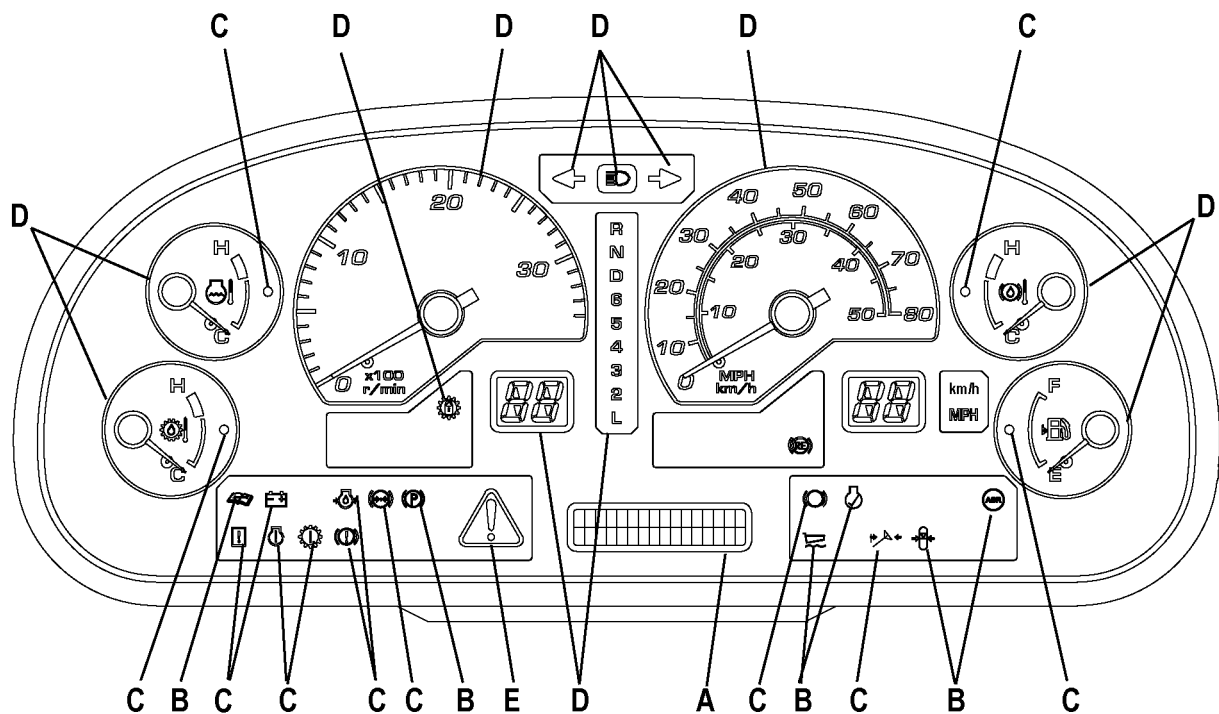

N050228

FIGURE 32-12. CENTER ELECTRONIC DISPLAY PANEL

- | | |
|-------------------------|--------------------------|
| A. Character Display | D. Meter Display Portion |
| B. Caution Items | E. Central Warning Lamp |
| C. Emergency Stop Items | |

PILOT DISPLAY ITEMS

When the key switch is in the ON position, controls that have been activated will illuminate the corresponding pilot display lamps.

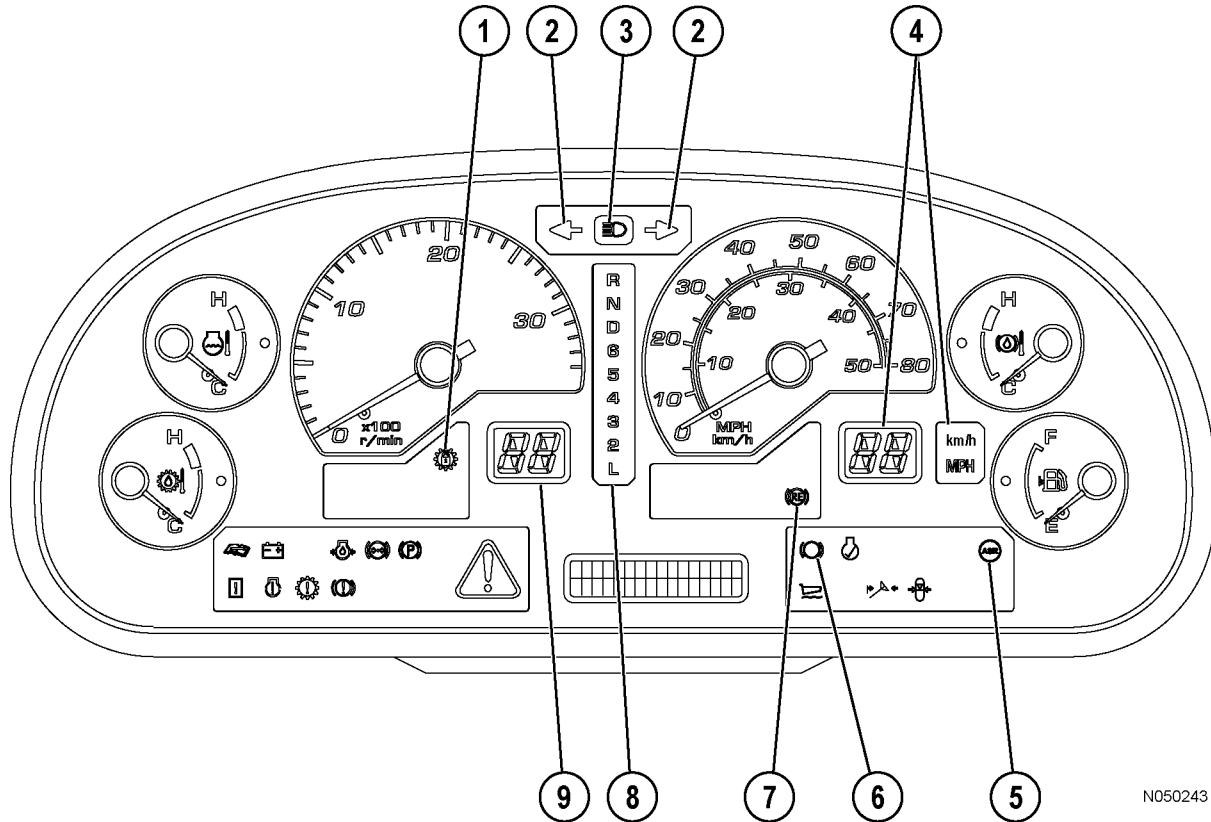

N050243

FIGURE 32-13. EDP - PILOT DISPLAY ITEMS

- | | |
|---------------------------------|-------------------------|
| 1. Lock-up Pilot Lamp | 6. Retarder Pilot Lamp |
| 2. Turn Signal Directional Lamp | 7. ARSC Pilot Lamp |
| 3. High Beam Pilot Lamp | 8. Shift Lever Position |
| 4. ARSC Set Speed Indicator | 9. Shift Indicator |
| 5. ASR Actuation Lamp | |

Lockup Pilot Lamp

The lockup pilot lamp will illuminate when the torque converter lockup is engaged and the transmission is shifted to direct drive.



Turn Signal Pilot Lamp



The turn signal pilot lamp arrow will flash simultaneously as the exterior turn signal lamps flash. If a right turn is selected using the turn signal lever, the right arrow will flash. If a left turn is selected using the turn signal lever, the left arrow will flash.

Head Lamp High Beam Pilot Lamp

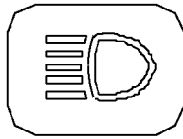

The high beam pilot lamp will illuminate when the head lamps are set to high beam using the multi-function turn signal lever.

Shift Lever Pilot Lamp

The shift lever pilot lamp displays the position of the shift lever.

The letter or number for the selected speed range will be illuminated.

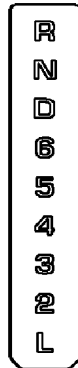

Shift Indicator

The shift indicator displays the transmission shift range (speed range).

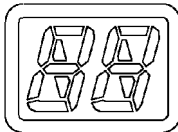

ARSC Set Speed Indicator

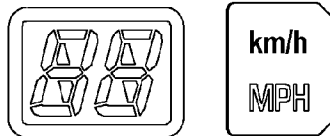

The ARSC set speed indicator displays the set travel speed for the auto retarder speed control.

When the ARSC switch is off, the monitor turns off. If the set travel speed has been canceled, 0 is displayed.

ASR Actuation Lamp

When the ASR system is active, this lamp will illuminate when slipping from the rear wheels is detected. The lamp indicates that the ASR system has actuated the brakes to prevent the slippage.



Retarder Pilot Lamp



The retarder pilot lamp will illuminate when the retarder control lever is actuated and the retarding system is active.

ARSC Pilot Lamp

The ARSC pilot lamp indicates that the automatic retard system is active. The system will maintain the truck at the set speed.



The lamp will turn off when the ARSC system is turned off.

METER DISPLAYS

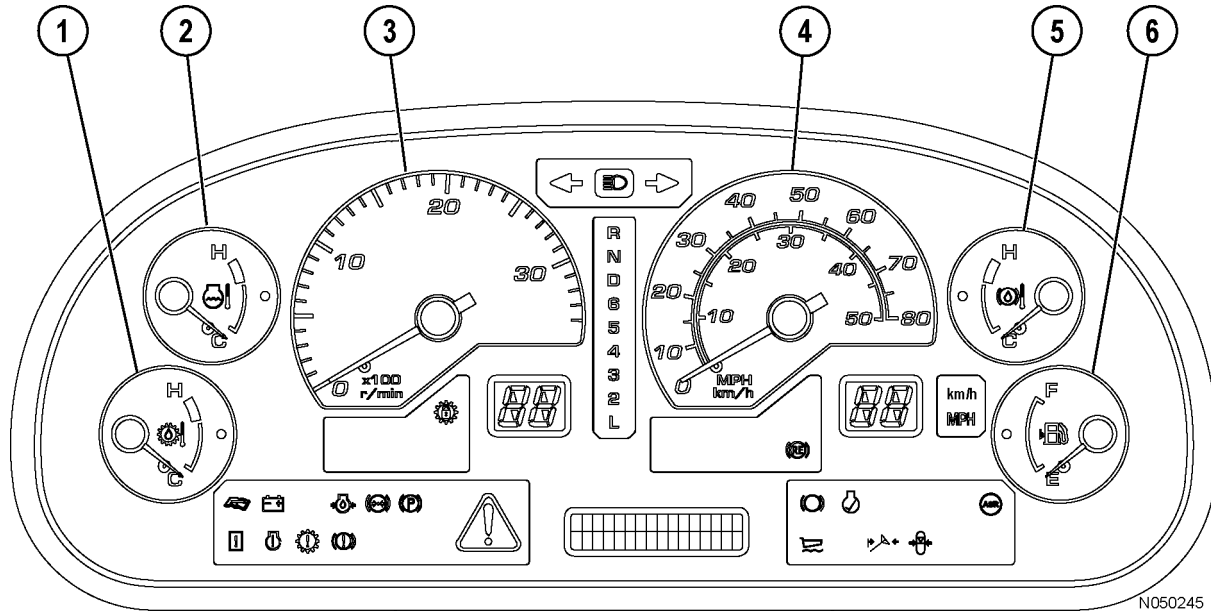

N050245

FIGURE 32-14. EDP - METERS

- | | |
|---|-----------------------------------|
| 1. Torque Converter Oil Temperature Gauge | 4. Speedometer |
| 2. Engine Water Temperature Gauge | 5. Retarder Oil Temperature Gauge |
| 3. Engine tachometer | 6. Fuel Gauge |

Speedometer

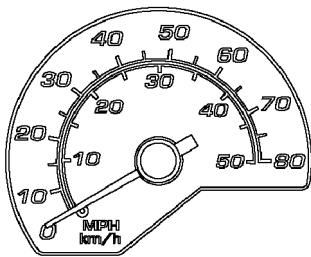

The speedometer indicates the travel speed of the truck.

Engine Tachometer

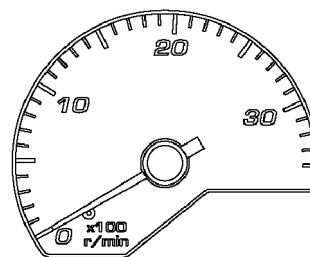

The engine tachometer displays the engine speed.

When engine speed exceeds 2250 rpm and moves into the red range on the meter, the alarm buzzer will sound and the central warning lamp will illuminate. Reduce engine speed to prevent damage to the engine.

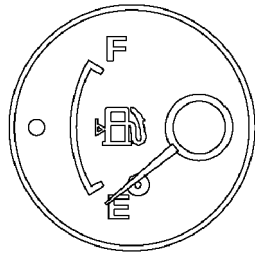
Fuel Gauge

The fuel gauge displays the amount of fuel remaining in the fuel tank. The fuel level caution lamp will illuminate when the fuel level drops to 140 liters (37.0 US gal).

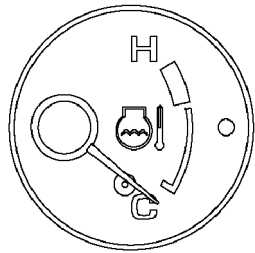
Coolant Temperature Gauge

The coolant temperature gauge displays the engine coolant temperature.

The white range indicates normal operating temperature. If the temperature rises to the red range during operation, the alarm buzzer will sound and the central warning lamp will illuminate. E02 ENGINE OVERHEAT will simultaneously be displayed on the character display. Engine output will automatically be limited. Stop the truck and operate the engine under no load at a mid-range speed until the meter enters the white range.

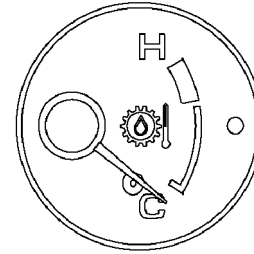
Torque Converter Oil Temperature Gauge

The torque converter oil temperature gauge displays the torque converter oil temperature.

The white range indicates normal operating temperature. If the temperature rises to the red range during operation, the alarm buzzer will sound and the central warning lamp will illuminate. E02 TC OVERHEAT will simultaneously be displayed on the character display. Stop the truck and operate the engine under no load at a mid-range speed until the meter enters the white range.

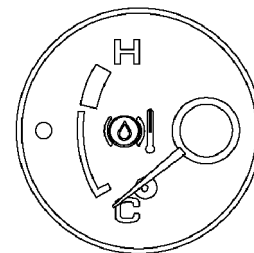
Retarder Oil Temperature Gauge

The retarder oil temperature gauge displays the retarder oil temperature.

The white range indicates normal operating temperature. If the temperature rises to the red range during operation, the alarm buzzer will sound and the central warning lamp will illuminate. E02 BRAKE OVERHEAT will simultaneously be displayed on the character display. Stop the truck and operate the engine under no load at a mid-range speed until the meter enters the white range.

CAUTION ITEMS



If a caution indicator icon illuminates during machine operation, quickly assess the problem to determine the necessary reaction.

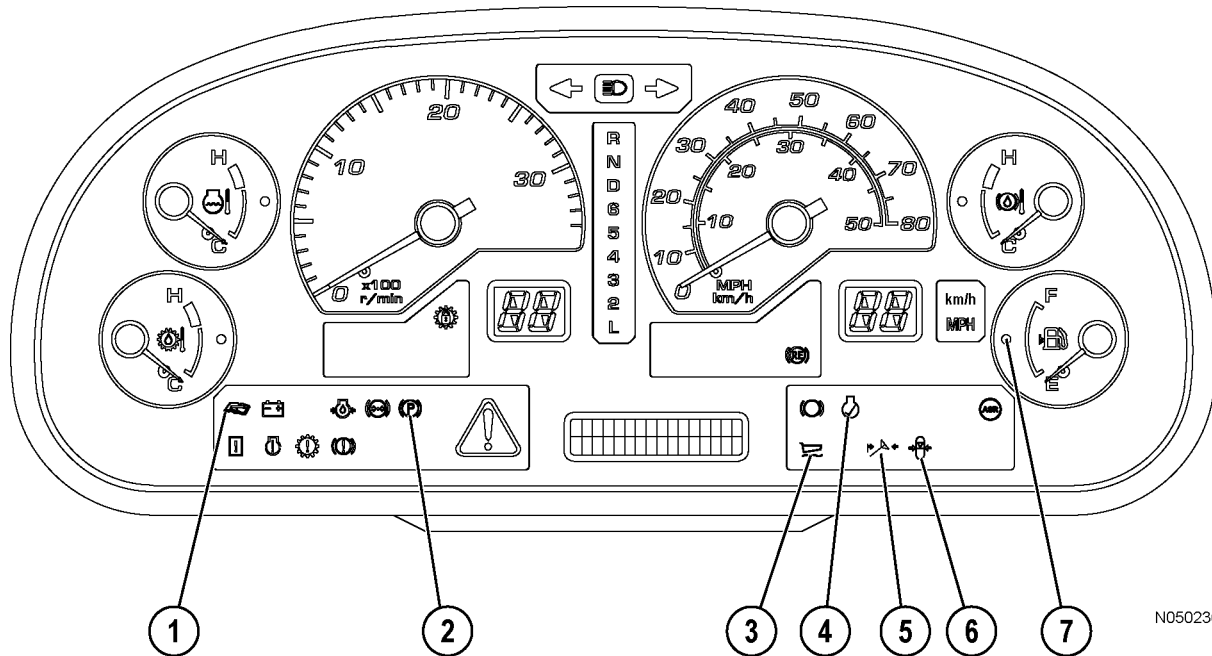

N050236

FIGURE 32-15. EDP CAUTION LAMPS

1. Maintenance Caution Lamp
2. Parking Brake Pilot Lamp
3. Dump Body Pilot Lamp
4. Check Engine Lamp

5. Emergency Steering Lamp
6. Accumulator Charge Pressure Lamp
7. Fuel Level Caution Lamp

Maintenance Caution Lamp

The maintenance caution lamp illuminates if any of the following occur:



- Low engine oil level
- Clogged engine oil filter
- Low hydraulic oil level
- Clogged air cleaner
- Clogged steering, hoist oil filter
- Clogged transmission oil filter
- Low coolant level
- Clogged brake cooling oil filter
- Worn rear brake discs
- Low battery electrolyte level
- Low transmission oil level

When the maintenance caution lamp illuminates, action code E01 is simultaneously displayed on the character display. Service the truck at the next available opportunity.

If a filter or oil replacement interval is displayed on the character display, the maintenance caution lamp will flash or illuminate. If the interval is approaching, the lamp will flash. If the interval has been exceeded, the lamp will remain on. Refer to Character Display later in this chapter for more information on maintenance indicators.

Parking Brake Pilot Lamp



The parking brake lamp illuminates when the parking brake is applied.

Dump Body Pilot Lamp

The dump body lamp illuminates when the dump body is raised or the dump body lever is in any position other than FLOAT.



Check Engine Lamp

The amber check engine lamp will illuminate if a problem occurs in the engine control system. The engine must be serviced within 24 hours of the illumination of the lamp.



Accumulator Charge Pressure Lamp

The accumulator charge pressure lamp will illuminate if steering accumulator nitrogen pressure is below 5861 kPa (850 psi).

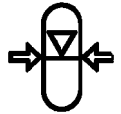

Fuel Level Caution Lamp

The fuel level caution lamp illuminates when the level of the fuel in the fuel tank falls below 140 liters (37 gal).

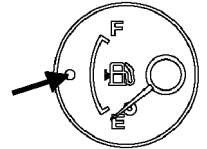

If the lamp is on, it will be necessary to add fuel shortly.



Operating the truck until the fuel is depleted forces the injector train into a no-follow condition. No fuel flow between the plungers may cause damage to the injectors and the overhead due to adhesive wear, resulting in costly repairs and unnecessary downtime. When the fuel level caution lamp illuminates, immediately add fuel to avoid damage to engine components.

EMERGENCY STOP ITEMS



If one of the emergency stop lamps illuminate, stop the truck immediately. Response instructions are documented on the following pages.

If a fault occurs with an emergency stop item, the alarm buzzer will sound intermittently and the lamp for that item will illuminate. The central warning lamp will illuminate simultaneously.

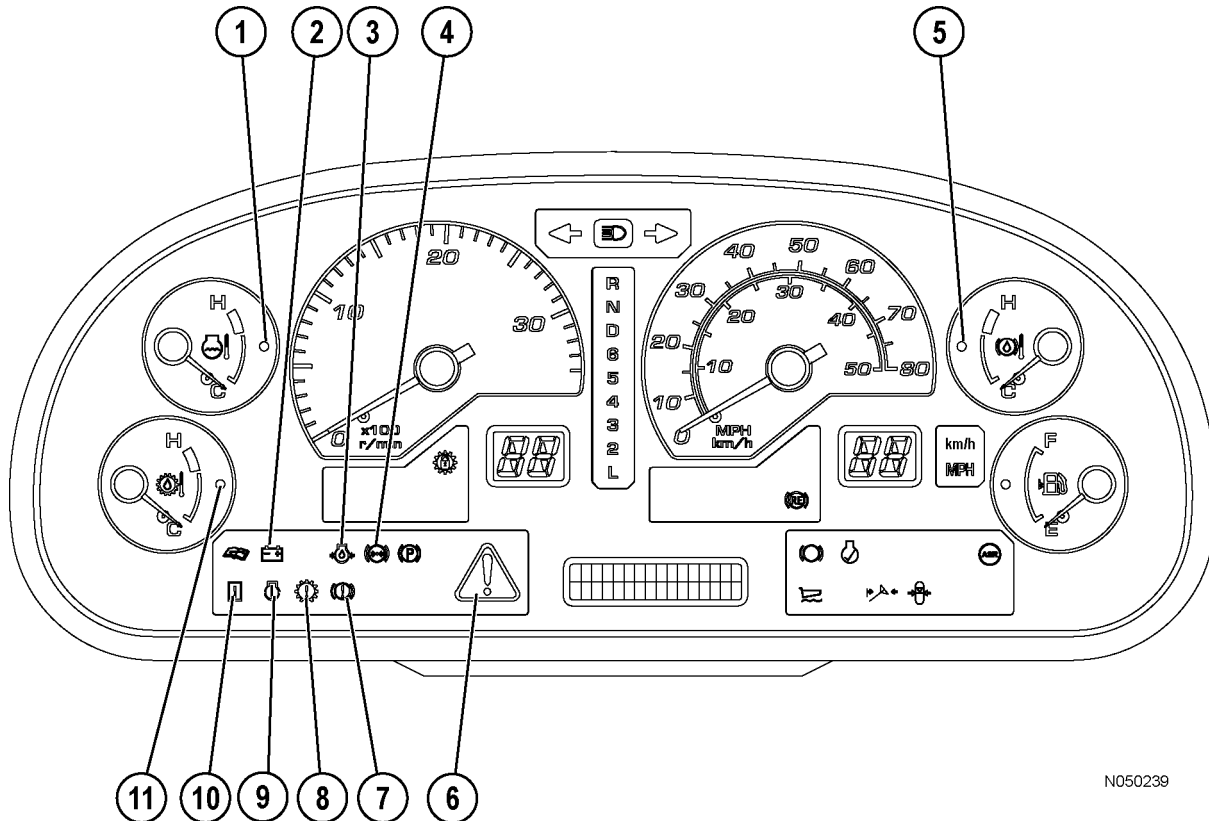

N050239

FIGURE 32-16. EDP - EMERGENCY STOP ITEMS

- | | |
|--|---|
| 1. Coolant Temperature Caution Lamp | 6. Central Warning Lamp |
| 2. Charging System Caution Lamp | 7. Retarder System Caution Lamp |
| 3. Engine Oil pressure Caution Lamp | 8. Transmission Caution Lamp |
| 4. Brake Oil pressure Caution Lamp (Accumulator Oil Pressure) | 9. Engine System Caution Lamp |
| 5. Retarder Oil temperature Caution Lamp | 10. Machine Monitor Caution Lamp |
| | 11. Torque Converter Oil Temperature Caution Lamp |

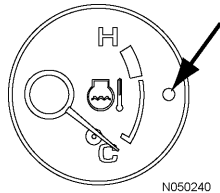
Coolant Temperature Caution Lamp

N050240

The coolant temperature caution lamp will illuminate when the coolant temperature has risen to a critical level.

When the lamp is lit, E02 ENGINE OVERHEAT will be displayed on the character display simultaneously. Engine output will be automatically limited. Stop the truck and operate the engine under no load at a mid-range speed until the lamp turns off.

Charging System Caution Lamp

The charging system caution lamp illuminates when an abnormality in the charging system has occurred with the engine on.

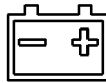

When the lamp is lit, E03 CHECK RIGHT NOW will simultaneously be displayed on the character display. Stop the machine immediately in a safe place, and turn the engine off. Notify maintenance.

Engine Oil Pressure Caution Lamp

The engine oil pressure caution lamp will illuminate when the engine oil pressure has dropped to a critical level. Oil pressure is monitored only when the engine is on.



When the lamp is lit, E03 CHECK RIGHT NOW will simultaneously be displayed on the character display and engine output automatically limited. Stop the machine immediately in a safe place, and turn off the engine. Notify maintenance.

Emergency Steering Lamp

The emergency steering lamp illuminates when steering pressure drops below 12 800 kPa (1850 psi).

**Brake Oil Pressure Caution Lamp**

The brake oil pressure caution lamp will illuminate if accumulator oil pressure fails to reach the specified value 30 seconds after engine startup. If the brake accumulator oil pressure has dropped below the specified value during truck operation the lamp will also illuminate.

When the lamp is lit, E03 CHECK RIGHT NOW will simultaneously be displayed on the character display. Stop the truck immediately in a safe place, and turn the engine off. Notify maintenance.

The central warning lamp and alarm buzzer are not actuated when the engine is off.

Retarder Oil Temperature Caution Lamp

The retarder oil temperature caution lamp will illuminate when the brake oil temperature has risen to a critical level.

When the lamp is lit, E02 BRAKE OVERHEAT will simultaneously be displayed on the character display. Stop the truck in a safe place. Move the shift lever to the N position, and operate the engine under no load at a mid-range speed until the lamp turns off.

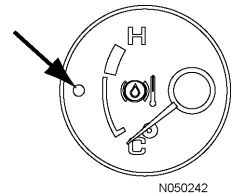

N050242

Central Warning Lamp

The central warning lamp and the alarm buzzer will sound intermittently to indicate that a failure is present. Any of the following will cause the central warning lamp to light:

- When an abnormality has occurred in any of emergency stop items. Refer to Emergency Stop Items earlier in this chapter.
- When action code E02 or E03 is displayed on the character display.
- When the parking brake is applied, but the shift lever is not in the N position.
- When the hoist control lever is not in the FLOAT position or the dump body is raised and the shift lever is not in the N position.
- When the engine tachometer rises to the red range.

Retarder System Caution Lamp



The retarder system caution lamp will illuminate when an abnormality has been detected by the RCM.

When the lamp is lit, E03 CHECK RIGHT NOW will simultaneously be displayed on the character display. Stop the truck immediately in a safe place, and turn off the engine. Notify maintenance.

Torque Converter Oil Temperature Caution Lamp

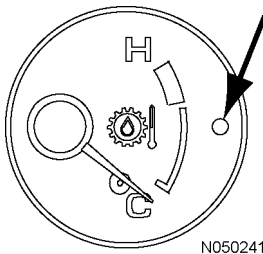

The torque converter oil temperature caution lamp will illuminate when the torque converter oil temperature has risen to a critical level.

When the lamp is lit, E02 TC OVERHEAT will simultaneously be displayed on the character display. Stop the truck in a safe place, and move the shift lever to the N. Operate the engine under no load at a mid-range speed until the lamp turns off.

Transmission Caution Lamp

The transmission caution lamp will illuminate when an abnormality has been detected by the transmission controller.



When the lamp is lit, E03 CHECK RIGHT NOW will simultaneously be displayed on the character display. Stop the truck and turn off the engine.

Engine System Caution Lamp



The red engine system caution lamp will illuminate when an abnormality has been detected by the engine controller.

When the lamp is lit, E03 CHECK RIGHT NOW will simultaneously be displayed on the character display. Stop the truck and turn off the engine.

Machine Monitor Caution Lamp

The machine monitor caution lamp will illuminate when an abnormality has been detected in the machine monitor. The lamp will also monitor certain optional equipment, if installed. If one of these monitored systems fail, the lamp will illuminate.

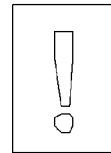

When the lamp is lit, E03 CHECK RIGHT NOW will simultaneously be displayed on the character display. Stop the truck and turn off the engine.

CHARACTER DISPLAY

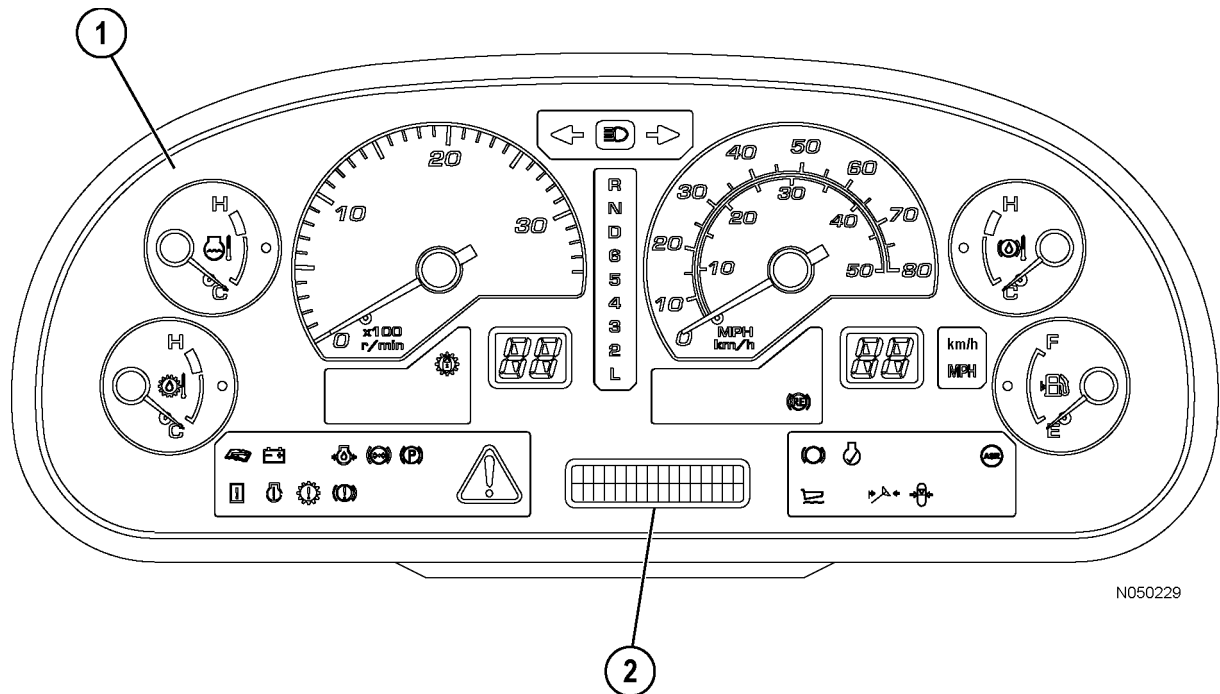

FIGURE 32-17. Electronic Display Panel

1. Electronic Display Panel

2. Character Display

Normally, the service meter/odometer is displayed on the character display.

If the machine experiences a failure or if it is necessary to perform maintenance, an action code is displayed to recommend a suitable response.

When filter replacement or an oil change is necessary, the maintenance monitor caution lamp will flash, and the filter or oil to be replaced is displayed. This will occur after completion of the system check with the key switch in the ON position. Refer to Filter And Oil Change Display later in this chapter.

Check the display to verify that there are no faults before driving the truck.

The following table lists the various displays of the character display while in Operator Mode. Service related information can be obtained in the service modes. Refer to the service manual for more information.

| Operator mode | |
|---------------|--|
| 1 | Service meter, odometer display (default) * |
| 2 | Operation Information |
| 3 | Reverse travel distance display function |
| 4 | Filter replacement, oil change interval display function |
| 5 | Telephone number input function |
| 6 | Language selection function |
| 7 | PLM setup function |
| 8 | Action code display function |
| 9 | Failure code display function |

* PLM information will override the default display when input is sent from VHMS. An active action code will also override the default display.

For details on the payload meter display, refer to Section 60, VHMS - Payload Meter.

Service Meter

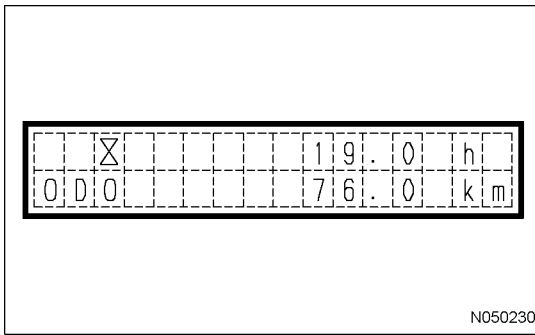

This meter displays the total time that the machine has been operating. While the engine is on, the service meter/odometer is the default display. The service meter/odometer advances by one for each hour of engine operation, regardless of engine speed. The service meter advances even if the machine is not moving.

NOTE: PLM information will override the default display when input is sent from VHMS. An active action code will also override the default display.

If the key switch is in the OFF position, the (◇) portion of mode select switch 1 can be pressed to display the service meter.

NOTE: If the service meter/odometer stays on while the key switch in the OFF position, a failure has occurred. Contact your Komatsu distributor for inspection.

Odometer

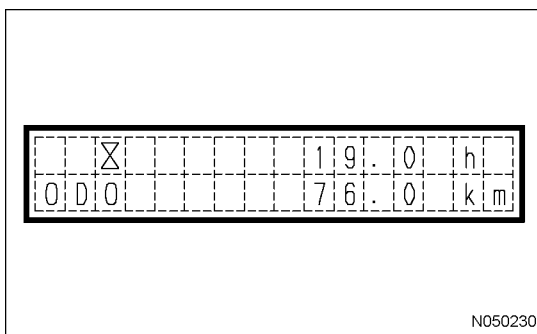

This meter indicates the total distance traveled in kilometers. The service meter/odometer is the default display.

If the key switch is in the OFF position, the (◇) portion of mode select switch 1 can be pressed to display the odometer.

Operation Information

Operation information allows the operator to view the total payload and dump counter.

To display operation information, the character display must be at the service meter/odometer display (or an action code, if present). If another display is showing, turn the key switch to OFF, then back to ON. After the initial check and the service meter/odometer is displayed, press the (◇) portion of mode select switch 1. The display should switch to operator information.

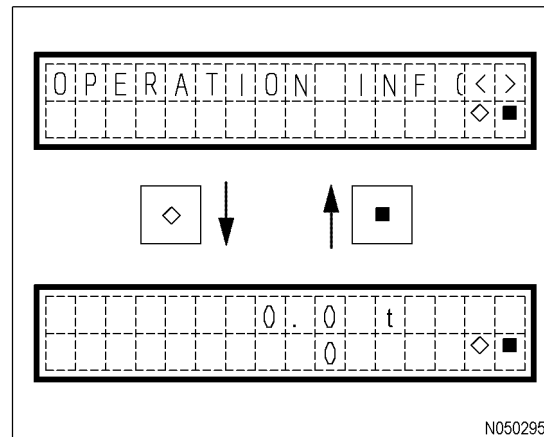

Reverse Travel Odometer

This meter indicates the total distance traveled in reverse.

- To display the reverse travel odometer, the character display must be at the service meter/odometer display (or an action code, if present). If another display is showing, turn the key switch to OFF, then back to ON. After the initial check and the service meter/odometer is displayed, press the (◇) portion of mode select switch 1. The display should switch to the operation information display.

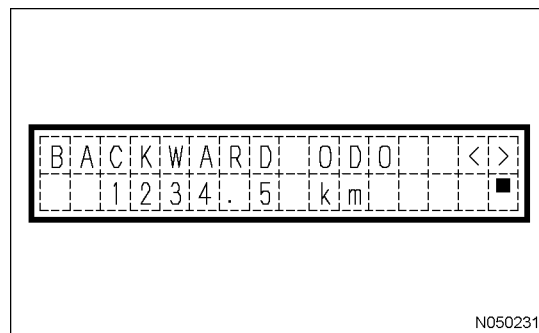

2. Press (>) or (<) on mode select switch 2 to scroll to the reverse odometer display.
3. To close the display, press the (■) portion of mode select switch 1 or turn the key switch to OFF.

Filter And Oil Change Display

After completion of the system check after turning the key switch to ON, the character display will indicate the filters and oil which are near the replacement interval. When a maintenance interval reaches 30 hours before replacement, it will be displayed. The maintenance caution lamp will flash or illuminate at the same time. This will occur for 30 seconds.

As replacement intervals approach, the maintenance caution lamp flashes. If a replacement interval has been exceeded, the lamp illuminates steady.

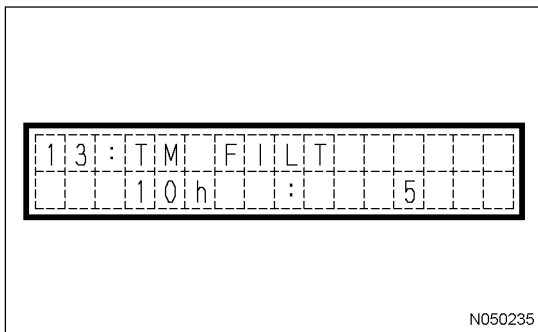

N050235

The top line of the character display lists the name and ID number of the item needing replacement. The bottom line displays the remaining time until replacement and the total number of times the item has been replaced. If there two or more items to be displayed, they alternate at three second intervals. If there are more than 10 items to be displayed, all the items are displayed once time.

The display will be active for 30 seconds, and will switch back to the default display. The filter and oil change display will return again only when the key switch is turned to the ON position again.

If an action code is present however, the filter and oil change display will not be displayed until the action code has been removed.

After replacing the filter or changing the oil, reset the replacement interval. Refer to Resetting The Filter/Oil Replacement Meter.

Display Items

| Item | Interval In Hours | Character Display | ID Number |
|--|-------------------|-------------------|-----------|
| Fuel filter | 250 | FUEL FILT | 03 |
| Engine oil filter | 250 | ENG FILT | 02 |
| Engine oil | 250 | ENG OIL | 01 |
| Transmission oil filter | 500 | TM FILT | 13 |
| Corrosion resistor | 250 | CORR RES | 06 |
| Torque converter, transmission and brake cooling oil | 1000 | TC/TM/BKOIL | 24 |
| Brake cooling oil filter | 1000 | BK C FILT | 16 |
| Hydraulic oil filter | 1000 | HYD FILT | 04 |
| Differential case oil | 2000 | DIFF OIL | 11 |
| Final drive oil | 2000 | FNL OIL | 08 |
| Hydraulic oil | 4000 | HYD OIL | 10 |

Refer to Section 40, Lubrication and Service, for more information on maintenance items.

Refer to the service manual for details on servicing the machine.

Resetting The Filter/Oil Replacement Meter

The filter and oil replacement time is displayed on the character display for items needing maintenance. If a filter and/or oil have been replaced, reset the filter and oil change time.

1. Beginning at the service meter, press the (◇) portion of mode select switch 1 to display the operation information. Press (>) or (<) on mode select switch 2 until MAINTENANCE MONITOR is displayed.

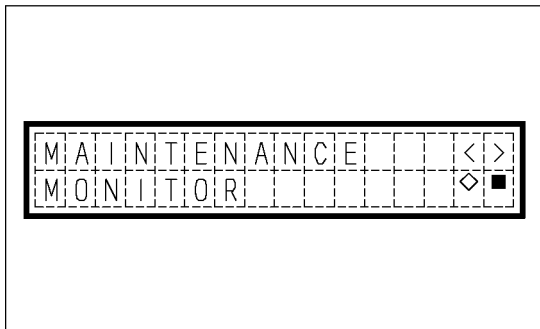

2. Press the (◇) portion of mode select switch 1. The display will show a component, the replacement time and the number of times it has been changed. For the following display the fuel filter replacement time is 500 hr. The filter has been replaced 9 times.

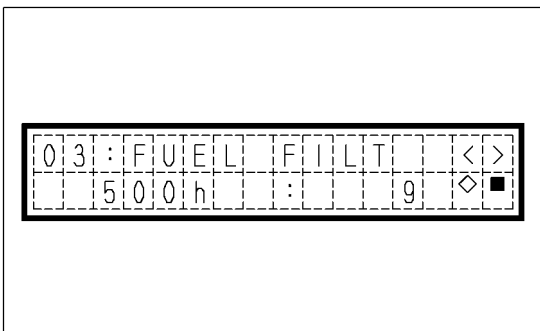

3. Press (>) or (<) on mode select switch 2 to display the item to be reset.
4. When the correct item is displayed, press the (◇) portion of mode select switch 1. The display will change to the reset display. The top line displays Reset and Item to be reset alternately.

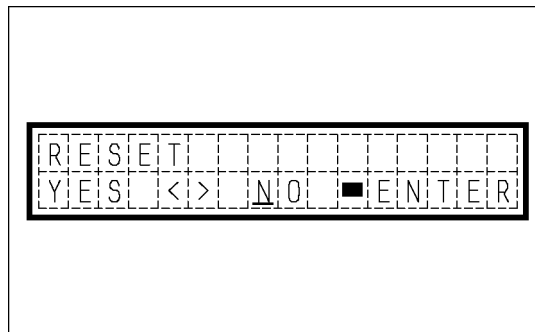

5. When resetting the replacement time, press (>) or (<) on mode select switch 2 to align the cursor with YES, then press (■) on mode select switch 1. It will reset and return to the previous screen.

To abandon, align the cursor with NO, then press (■) on mode select switch 1.

To reset the replacement time for another item, repeat this process. After all items are reset, press (■) on mode select switch 1 twice or turn the key switch to OFF to exit.

Inputting Telephone Numbers

1. Beginning at the service meter display, press the (◇) on mode select switch 1 to display the operation information.
2. Press (>) or (<) on mode select switch 2 to scroll to TEL.

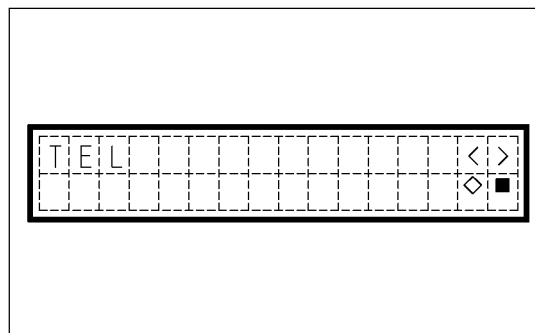

3. Press (◇) on mode select switch 1. This will change to the telephone input display. Up to 12 digits can be displayed for the telephone number. Input from the first digits.

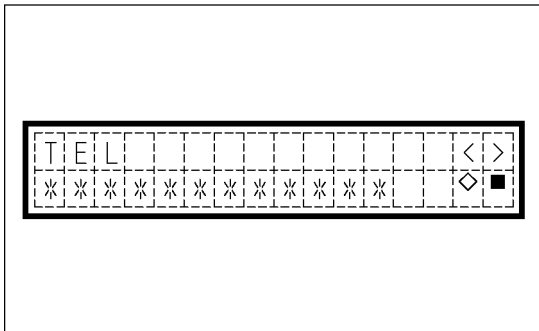

4. The cursor is displayed at the input position. Press (>) or (<) on mode select switch 2 to scroll through numbers 0-9. To leave a blank, select *. When the correct digit is displayed, press (◇) on mode select switch 1. The cursor will advance to the next position.

Repeat the input process until all digits have been entered. At the last digit, press (◇) on mode select switch 1 to input another telephone number. If there is a mistake in the input or the input is to be stopped, press (■) on mode select switch 1 to return to the previous screen.

When complete, press (■) on mode select switch 2 twice to exit or turn the key switch to OFF. All input telephone numbers will be displayed next time this display is accessed.

Selecting A Language

This function can be used to change the default language for the character display.

1. Beginning at the service meter display, press the (◇) on mode select switch 1 to display the operation information.
2. Press (>) or (<) on mode select switch 2 to scroll to the LANGUAGE display.

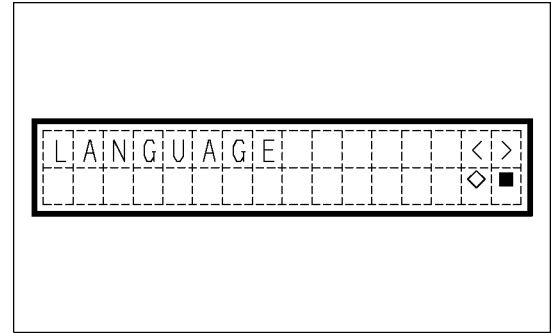

3. Press the (◇) on mode select switch 1. The current default language is displayed.

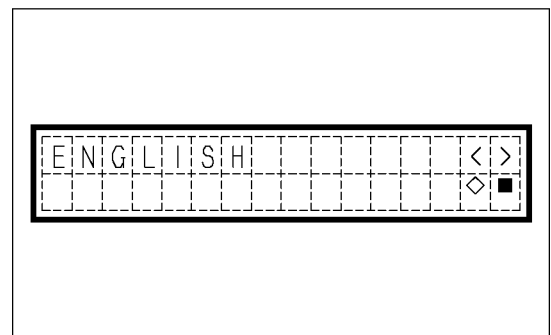

4. Press (>) or (<) on mode select switch 2 to select a different language. The available languages are: English, Japanese, German, French, Italian, Spanish, and Swedish.

| Language | Display |
|----------|----------|
| English | ENGLISH |
| Japanese | 日本語* |
| German | DEUTSCH |
| French | FRANCAIS |
| Italian | ITALIANO |
| Spanish | Español |
| Swedish | SVENSKA |

5. Press the (◇) on mode select switch 1 to activate the new language change. The display will then return to the previous screen.

If the desired language has been set, press (■) on mode selector switch 2 twice or turn the key switch to OFF to exit.

ACTION CODE DISPLAYS



Stop the machine immediately when E03 codes are displayed. Contact your Komatsu distributor for repairs.

If there is a machine failure or if maintenance is necessary, an action code is displayed on the character display to recommend a suitable response.

If more than one failure is present, the most important action code is displayed. The order of importance, starting from the highest, is E03, E02, and E01. If failures of equal importance occur at the same time, the latest one is displayed.

When action codes E02 or E03 occur, the alarm buzzer sounds intermittently and the central warning lamp illuminates.

E03 Codes

When E03 is displayed, stop the machine immediately. Check the failure code, and contact your Komatsu distributor for repairs. Refer to Checking Failure Codes later in this chapter.

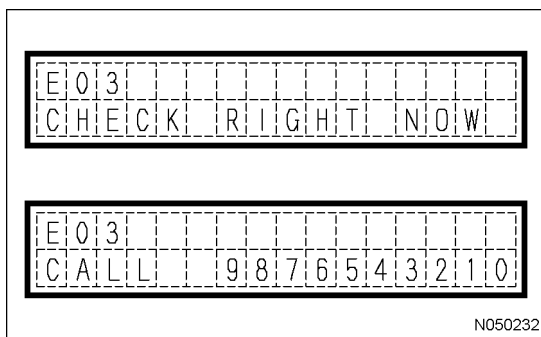

When an E03 code is present, the top line displays E03. The bottom line alternates between CHECK RIGHT NOW and CALL. The display will alternate in 3 second intervals. The telephone number is displayed to the right of CALL. If the telephone number has not been set, the spaces will be blank. Refer to Character Display - Inputting Telephone Numbers.

E02 Codes

When an E02 code is present, the top line of the character display will indicate E02. The bottom line indicates whether the condition of the machine is related to overspeed or overheat.

When an E02 code is displayed, it is important to act accordingly.

- If an overspeed related fault is displayed, reduce the engine speed and the speed of the machine.
- If an overheat related fault is displayed, safely stop the machine and operate the engine under no load at a mid-range speed.

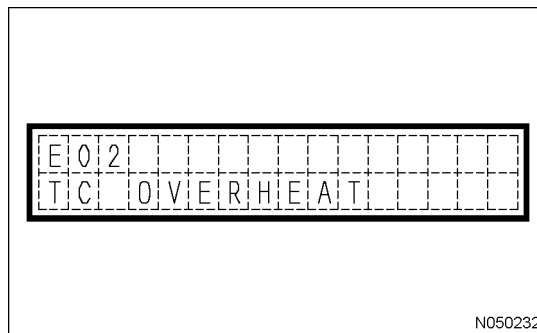

If an action code is still displayed after altering the operating conditions, check the failure code and contact your Komatsu distributor for repairs.

E01 Codes

When an E01 code is present, the top line of the character display will display E01. The bottom line will either display MAINTENANCE or another description that indicates the affected system. E01 codes do not require immediate attention. If desired, the truck can operate until the end of the shift before returning for service.

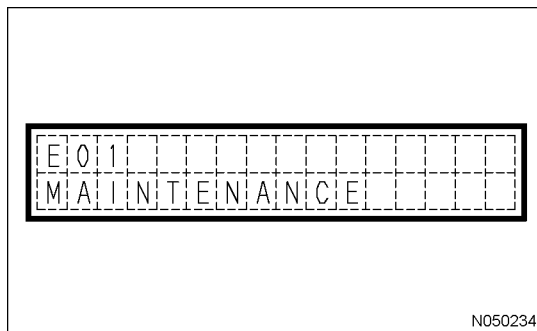

If MAINTENANCE is displayed, check the failure code and contact your Komatsu distributor for repairs.

CHECKING FAILURE CODES

If an action code is present on the character display, check the failure codes as follows:

1. Press (>) on mode select switch 2 to display the failure code. The failure code for that action code will be displayed on the character display.
2. Press (>) on mode select switch 2 again to see if any other codes are present. Check the failure code for each action code present and note. If no other codes are present, the character display will return to the service meter/odometer.

The six digit code displayed on the top line of the character display is the failure code. The code displayed to the right of the failure code is the controller that detected the fault.

- MON: Machine Monitor
- TM: Automatic Transmission Controller
- BK: Retard Control Module

The bottom line on the character display lists the system where the failure was generated.

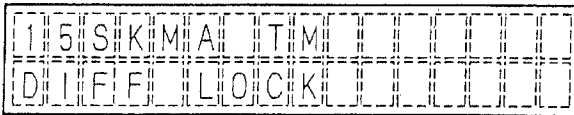

D310105

CHARACTER DISPLAY FLOW CHART

(*1) PLM display function when VMS data is received (see illustration on next page)

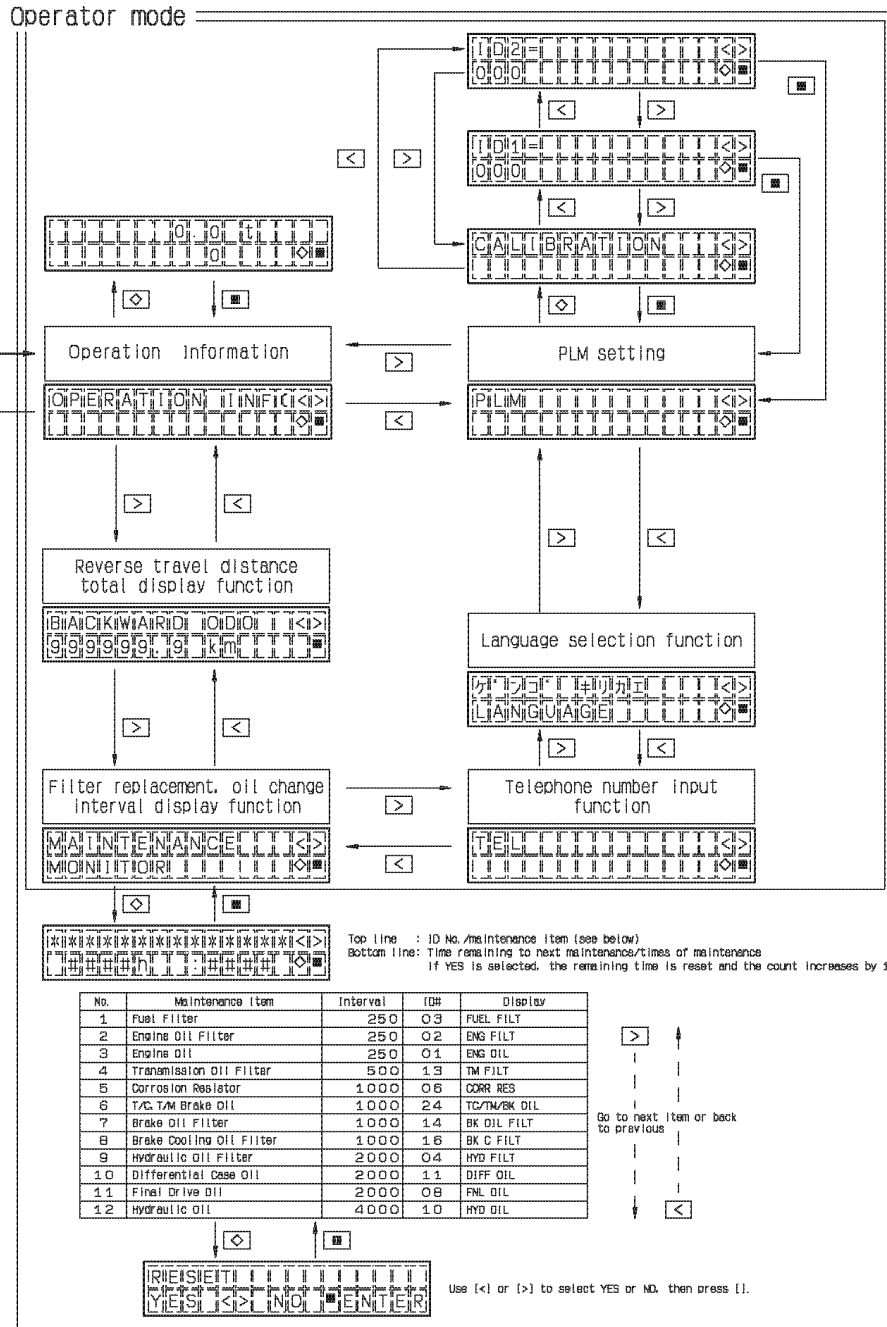
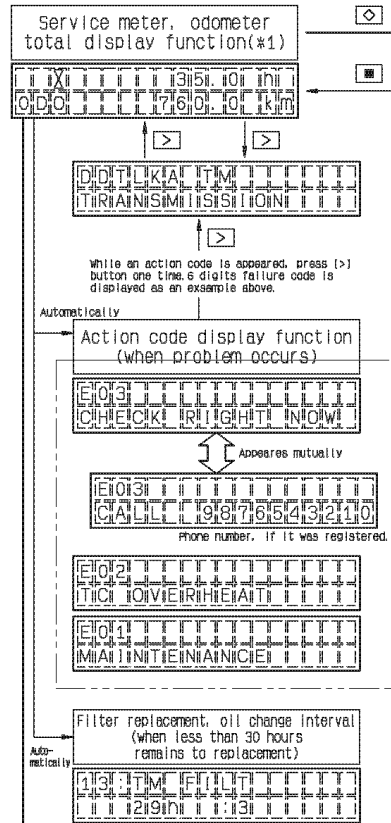

REAR ELECTRICAL COMPARTMENT

The following components are located behind the operator and passenger seats across the back wall of the operator cab (Refer to Figure 32-19):

1. ATC - Automatic Transmission Controller

The ATC controls and monitors the automatic transmission. It controls the shift patterns and lock-up clutch modulation and monitors numerous other sensor inputs. Refer to the service manual for specific information regarding this device.

2. Fuse Panel

The fuse panel contains all of the electrical fuses on the truck.

3. RCM - Retard Control Module

This panel controls and monitors the retarder system. Refer to the service manual for specific information regarding this device.

4. Vehicle Health Monitoring System (VHMS)

The VHMS controller gathers data related to the operational health of the machine from each of the controllers and sensors. Refer to Section 60, VHMS, for more information.

5. VHMS Download Connector

6. Payload Meter (PLM) Download Connector

7. CENSE Engine Download Connector - (SDA12V160 only)

8. Engine Maintenance Light -

The engine maintenance light will illuminate when engine maintenance is necessary. It is not necessary to service the truck until the next scheduled preventive maintenance.

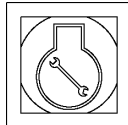

| | | | | | | | |
|---|---------------------|---------------------------------|-----|---------------------|--------------------------------|---------------|---------------|
| 1 = BATTERY DIRECT POWER 11 = BATTERY DISCONNECT POWER | 1 | VHMS KEY SW SIG | 5A | 10A | PLM LIGHTS | 2 | FUSE BLOCK #1 |
| | 3 | SBDT | 5A | 10A | LINCOLN LUBE | 4 | |
| | 5 | HOIST LIMIT SW | 5A | 10A | BRAKE LIGHT | 6 | |
| | 7 | BRAKE CONTROLS | 10A | 10A | REAR RETARD LT | 8 | |
| | 9 | KOMATSU PROG. PORT (KEY SWITCH) | 10A | --- | --- | 10 | |
| | 11 | --- | --- | --- | --- | 12 | |
| | 13 | TIER 1 ENGINE POWER (BATTERY) | 10A | 5A | VHMS/ORBCOMM | 14 | |
| | 15 | KOMATSU PROG. PORT (BATTERY) | 10A | 5A | LUBE FILL LIGHT | 16 | |
| | 17 | LO BEAM HD LT OUTSIDE POSITION | 15A | 15A | HI BEAM HD LT OUTSIDE POSITION | 18 | |
| | 19 | HI BEAM HD LT INSIDE POSITION | 15A | 10A | SERVICE LTS | 20 | |
| 21 | FOG LIGHTS | 10A | 5A | SBDT | 22 | FUSE BLOCK #2 | |
| 23 | --- | --- | --- | --- | 24 | | |
| 12 = KEY SWITCH 24V POWER 21 = KEY SWITCH START SIGNAL | 1 | LT AUX TURN SIG | 15A | 15A | RT AUX TURN SIG | | 2 |
| | 3 | HEAD LT CONTROLS | 5A | 15A | LO BM HD LT INSIDE POSITION | | 4 |
| | 5 | CLEARANCE LIGHTS | 15A | 10A | ATC | | 6 |
| | 7 | EDP | 5A | 15A | FRT HORN & D-LTS | | 8 |
| | 9 | HAZARD LIGHTS | 10A | 10A | RCM | | 10 |
| | 11 | --- | --- | --- | --- | | 12 |
| | 13 | START SIGNAL | 5A | --- | --- | | 14 |
| | 15 | --- | --- | --- | --- | | 16 |
| | 17 | --- | --- | --- | --- | 18 | |
| | 19 | --- | --- | --- | --- | 20 | |
| 21 | TIER 2 ENGINE POWER | 10A | 10A | TIER 2 ENGINE POWER | 22 | FUSE BLOCK #3 | |
| 23 | TIER 2 ENGINE POWER | 10A | 10A | TIER 2 ENGINE POWER | 24 | | |
| 13 = KEY SWITCH A/C POWER 12V = KEY SWITCH 12V POWER | 1 | A/C AND HEATER | 20A | 10A | ATC | | 2 |
| | 3 | SHIFTER | 5A | 5A | EDP SIGNALS | | 4 |
| | 5 | --- | --- | 5A | TURN SIGNALS | | 6 |
| | 7 | REAR BU LT & HRN | 15A | 10A | DECK BACKUP LTS | | 8 |
| | 9 | WINDSHIELD WIPER | 15A | 5A | DRIVERS SEAT | | 10 |
| | 11 | ETHER START | 5A | --- | --- | | 12 |
| | 13 | KEY SW SIGNAL | 5A | 5A | GSK KEY SIGNAL | | 14 |
| | 15 | EDP | 5A | 5A | SWITCH LIGHTS | | 16 |
| | 17 | AM/FM RADIO | --- | --- | --- | 18 | |
| | 19 | 12V AUX POWER #1 | 10A | 10A | 12V AUX POWER #2 | 20 | |
| 21 | LFT WINDOW MOTOR | 20A | 20A | RT WINDOW MOTOR | 22 | WB3246 | |
| 23 | --- | --- | --- | --- | 24 | | |

FIGURE 32-18. FUSE PANEL DESCRIPTIONS

9. Engine Communications Connector

| TABLE I. CIRCUIT BREAKER CHART | | | | | |
|--------------------------------|------|-------|----------------|-----|--|
| CIRCUIT BREAKER IDENTIFICATION | | | CIRCUIT NUMBER | | CONTROL DESCRIPTION |
| No. | AMPS | VOLTS | IN | OUT | |
| LOCATION: BATTERY BOX | | | | | |
| CB24V | 50 | +24 | 3 | 12 | 24 Volt Control Power (To Power Bus #3 on Cab Rear Wall) |
| CB12V | 50 | +12 | 4 | 12V | 12 Volt Control Power (To Power Bus #4 on Cab Rear Wall) |
| LOCATION: AC/HEATER UNIT | | | | | |
| A/C-CB | 20 | +24 | 12AC | - | Internal Automatic Reset Circuit Breaker |

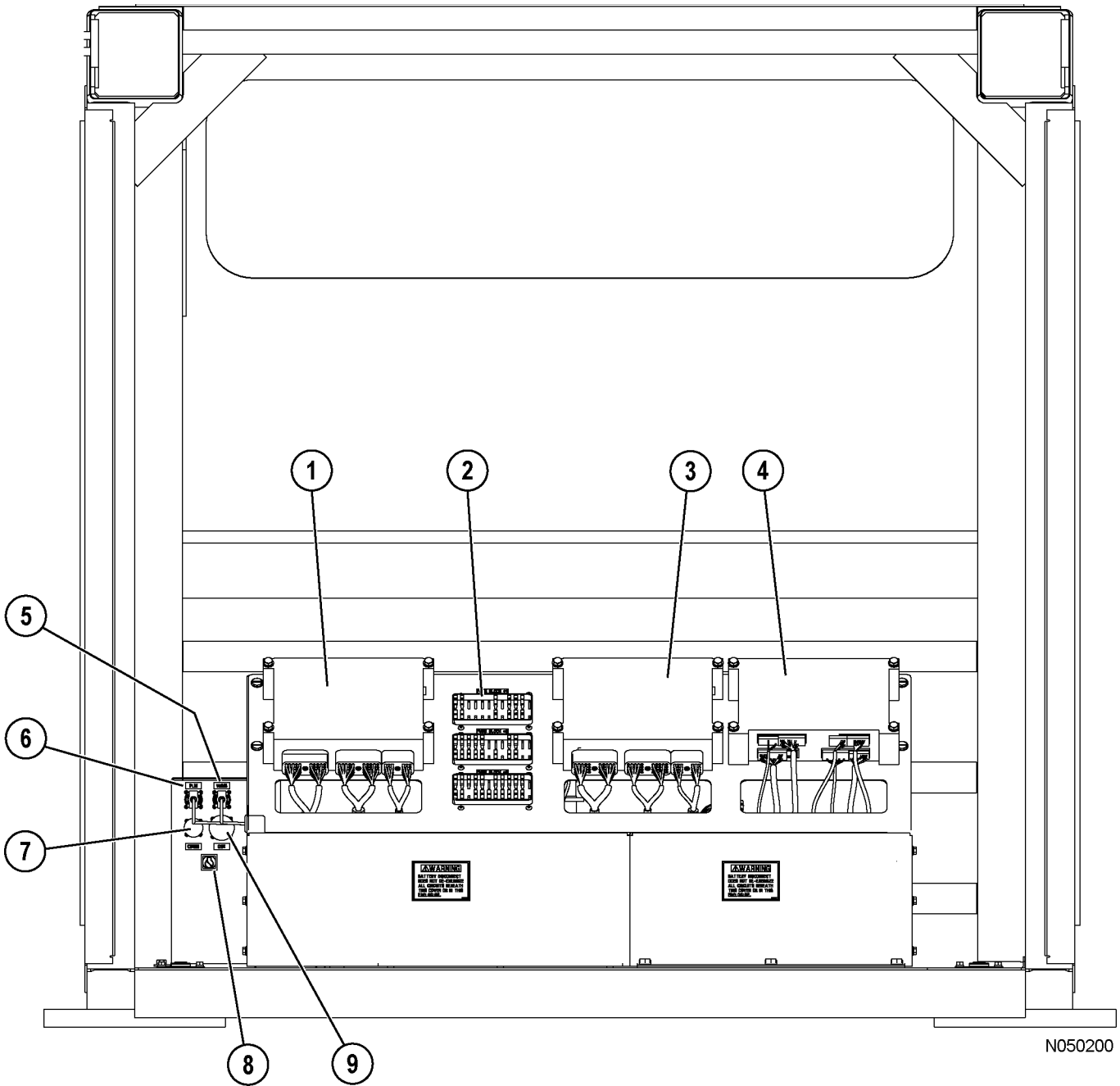
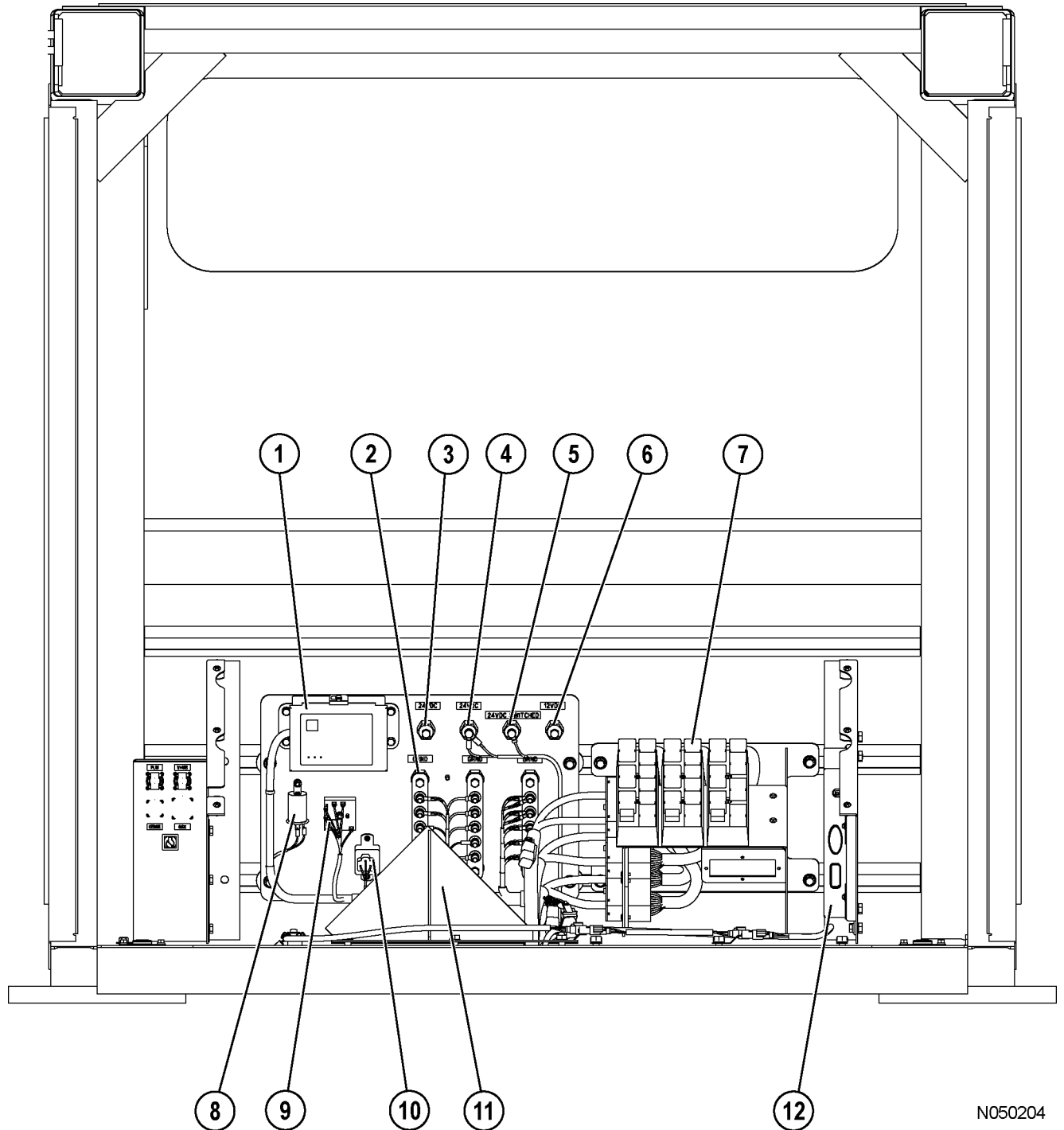

FIGURE 32-19. REAR ELECTRICAL COMPARTMENT

- | | |
|--|--|
| 1. Automatic Transmission Controller (ATC) | 6. Payload Meter Download Connector |
| 2. Fuse Panel | 7. CENSE Engine Download Connector - (SDA12V160 Only) |
| 3. Retard Control Module (RCM) | 8. Engine Maintenance Light |
| 4. Vehicle Health Monitoring System (VHMS) | 9. QSK Engine Communications Connector |
| 5. VHMS Download Connector | |



N050204

FIGURE 32-20. REAR ELECTRICAL COMPARTMENT

(Enclosure Removed)

- | | |
|--|---|
| 1. Automatic Lubrication System Timer | 8. Turn Signal Flasher |
| 2. Ground Bus Bars | 9. Steering Bleeddown Timer |
| 3. Power Bus # 1, 24V Battery Direct Power | 10. Windshield Wiper Delay Timer |
| 4. Power Bus # 2, 24V Battery Disconnect Power | 11. External Harness Interface Connection Panel |
| 5. Power Bus # 3, 24V Key Controlled Power | 12. ORBCOMM Modem |
| 6. Power Bus # 4, 12V Key Controlled Power | |
| 7. Relay Centers | |

AUTOMATIC RETARD SPEED CONTROL (ARSC)

Automatic Retard Speed Control (ARSC) automatically actuates the retard system to maintain the travel speed at a set speed controlled by the operator. This system is designed to make retarding easier and more constant.

For instance, if the ARSC is on, and the set speed is set to 20 km/h (12 mph), the ARSC system will automatically apply retarding effort to slow the truck. As the truck descends a grade and attempts to exceed 20 km/h (12 mph), the ARSC maintains the set speed without the operator having to use the brake pedal or manual retard lever.



Refer to the retarding capacity chart in the cab before setting the travel speed. If the set speed exceeds the maximum permissible speed on the chart, overheating and damage to the retarding system may occur.



When the ARSC is actuated on slippery road surfaces, the wheels may lock. If this occurs, turn the ARSC system off and use the manual retard lever or brakes to safely control the truck.

The ARSC system will only apply retarding effort when the ARSC switch is on. If the switch is turned off during retarding, the set speed indicator and ARSC pilot lamp will turn off and the brakes will release.

The ARSC will only apply retarding effort when the accelerator pedal is not being depressed. If the accelerator is pressed while the ARSC system is on, the RCM will cancel the ARSC. The service brakes and the retarder lever will both continue to function while the ARSC system is on.

The retard lever is more responsive when the ARSC system is on. Use small increments when moving the lever to avoid locking the brakes.

If any failure in the system occurs during operation, the alarm sounds and the central warning lamp will illuminate. The RCM will turn the ARSC system off. Use the retarder control lever and/or the brake pedal to stop the machine in a safe place. Turn the ARSC switch off and notify maintenance.

Set Speed Functionality

When setting the ARSC, vehicle speed cannot be set to less than 10 km/h (6 mph). If the set speed is set while the truck is moving slower than 10 km/h (6 mph) the ARSC will default to 10 km/h (6 mph).

Likewise, the set speed cannot be set higher than 60 km/h (37 mph). If the set speed is set while the truck is moving faster than 60 km/h (37 mph), the set speed will default back to 60 km/h (37 mph). In all other instances, the speed will be set to the actual travel speed.

The time taken for the machine travel speed to match the set speed may differ according to the grade of the slope.

If the set travel speed is near a transmission shifting point or there is a change in the grade of the slope, the transmission may shift (up or down) even during retarding.

The ARSC system can be set in any gear range except N or R.

The set speed will remain in memory when the ARSC switch and/or the key switch is turned to OFF. The only method for removing the set speed from the memory is to cancel it using the ARSC lever. Refer to (d, Figure 32-21).

Cancelling And Changing The Set Speed

Moving the lever to the cancel position (d, Figure 32-21) for more than 1 second cancels the set speed. The set speed indicator will display a 0 when cancelled.

If it is desired to increase the set speed, depress the accelerator pedal to increase speed, and when the desired set travel speed is reached, press the set switch on the auto retarder (ARSC) set lever. The set travel speed will be changed to the new speed.

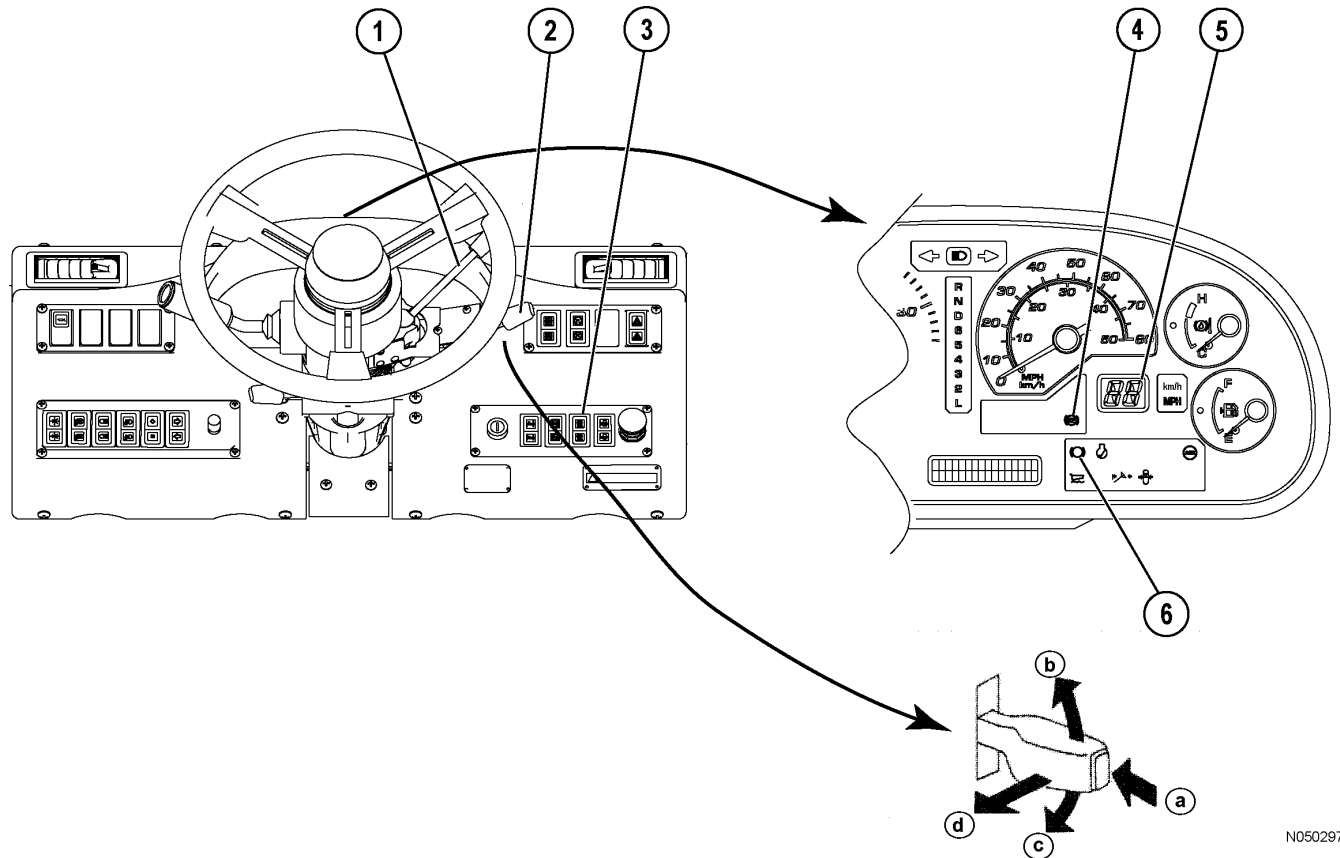

FIGURE 32-21. ARSC CONTROLS

- | | |
|-----------------------------|-------------------|
| 1. Retard Lever | a. Set |
| 2. ARSC Lever | b. Increase Speed |
| 3. ARSC Switch | c. Decrease Speed |
| 4. ARSC Pilot Lamp | d. Cancel |
| 5. ARSC Set Speed Indicator | |
| 6. Retarder Pilot Lamp | |

If it is desired to decrease the set speed, operate the retarder control lever to reduce speed, and when the desired set travel speed is reached, press the set switch on the auto retarder (ARSC) set lever. The set travel speed will be changed to the new speed.

To change the speed without using the accelerator or braking system, tap up (b, Figure 32-21) on the lever to increase the speed. The speed will increase by 1 km/h (0.6 mph). To decrease the speed, tap down (c, Figure 32-21) on the lever. The speed will decrease by 1 km/h (0.6 mph). The maximum speed change that can occur using the tap up - tap down functions is ± 5 km/h (3.1 mph).

If the set switch and cancel are operated at the same time, cancel is given priority.

If the set switch and tap up are operated at the same time, tap up is given priority.

If the set switch and tap down are operated at the same time, tap down is given priority.

Recommended Set Speeds

Refer to the retarding capacity chart in the cab for the maximum safe speeds for descending a grade.

Set the travel speed so that the engine speed is above 1800 rpm. The retarder oil temperature gauge must remain at normal operating temperature (in the white range on the gauge). If the retarder oil is close to overheating, the set speed is automatically reduced 1 km/h (0.6 mph) every 3 seconds. The set speed will not drop below 10 km/h (6 mph).

To set the ARSC:

1. Turn on ARSC switch (3, Figure 32-21) to turn the system on. ARSC pilot lamp (4) will illuminate to alert the operator that the system has been activated. The ARSC set speed indicator (5) will turn on and the previous set speed will be displayed. If the previous speed was cancelled, a 0 will be displayed.
2. When the truck speed reaches the desired set speed, press button (a) on the ARSC lever to set the travel speed. The set speed will be displayed on the ARSC set speed indicator (5). The set speed indicator may differ slightly from the speedometer display.

Refer to the retarding capacity chart in the cab for the proper speed for descending a grade.

3. To adjust the set speed, tap up (b) on the lever to increase the speed. The speed will increase by 1 km/h (0.6 mph). To decrease the speed, tap down (c) on the lever. The speed will decrease by 1 km/h (0.6 mph). To cancel the set speed, pull the lever towards the rear of the cab. The set speed indicator will display a 0.
4. To turn the system off, turn ARSC switch (3) off.

AUTOMATIC SPIN REGULATOR (ASR)

Automatic Spin Regulator (ASR) is a traction control system that helps prevent slipping of the drive wheels caused by excessive torque. ASR also provides traction on slippery road surfaces.

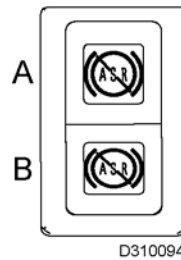

The ASR cut switch controls the status of the system.

A: ASR system OFF - amber lamp

B: ASR system ON - green lamp

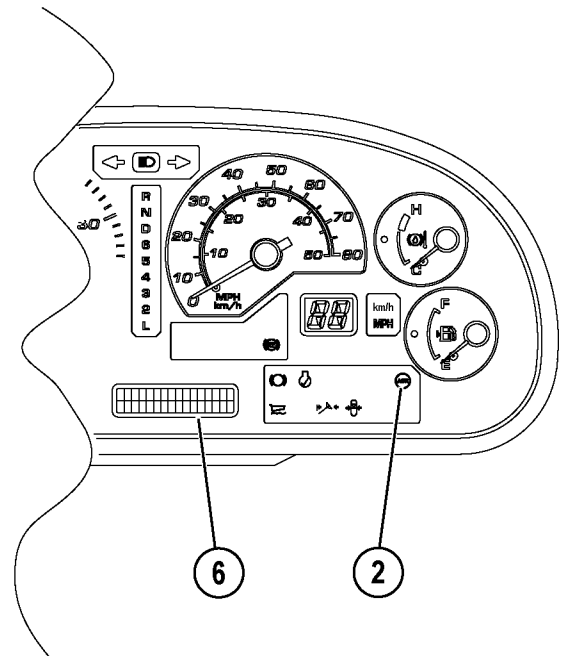
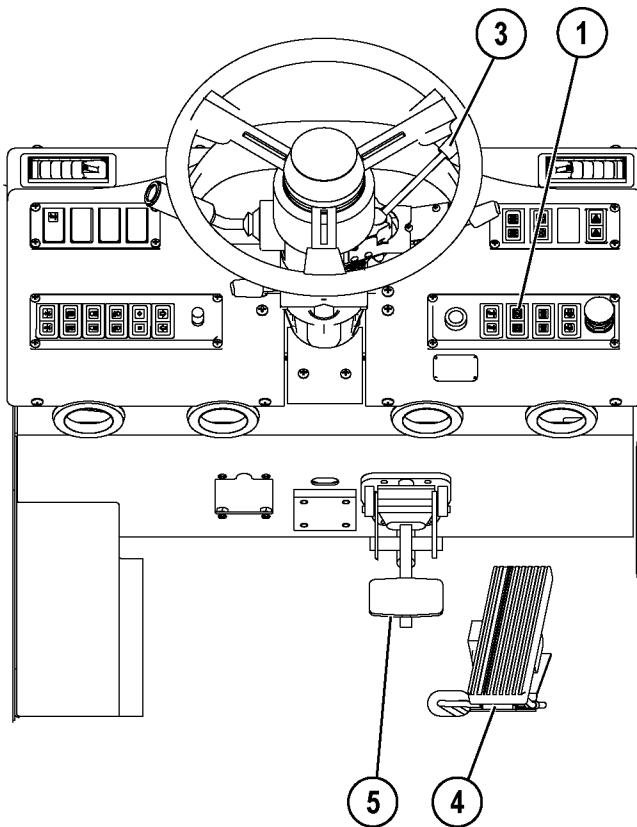

D310093

FIGURE 32-22. ASR OPERATION

- 1. ASR Cut Switch
- 2. ASR Actuation Lamp
- 3. Retarder Control Lever

- 4. Accelerator Pedal
- 5. Brake Pedal
- 6. Character Display

When the ASR switch is on, the system is active. ASR monitors the individual rear wheel speeds. If it determines one of the rear wheels is slipping during acceleration, the brake is applied to the rear wheel with the higher speed. ASR actuation lamp (2, Figure 32-22) will illuminate when the system detects slipping from the rear wheels and actuates the ASR.

If the brake pedal or retard lever are actuated during ASR actuation, ASR actuation will be cancelled.

The ASR system is actuated only when the accelerator pedal is being depressed and travel speed is 0 to 30 km/h (0 to 19 mph). If the pedal is released while the ASR is being actuated, the actuation of the ASR system is canceled.

If any abnormality occurs in the ASR system, an action code is shown on character display (6).

Depressing the top of the switch turns the ASR system off. An amber light will illuminate the switch notifying the operator that traction control is inactive.



If a malfunction occurs in the system, an action code is shown on the character display, and the ASR function is canceled. Immediately drive the truck to a safe area and turn the ASR cut switch off.

On slick road surfaces or on steep slopes, it may be impossible to drive safely even when the ASR is actuated.

If both rear wheels slip at the same speed, ASR will not function. If this occurs, reduce the engine output with the accelerator pedal.

EXTERIOR LIGHTING AND SWITCHES

Refer to Section 32, Operator Cab and Controls, for more specific information on controls and switches that are located in the cab.

DECK LIGHTING

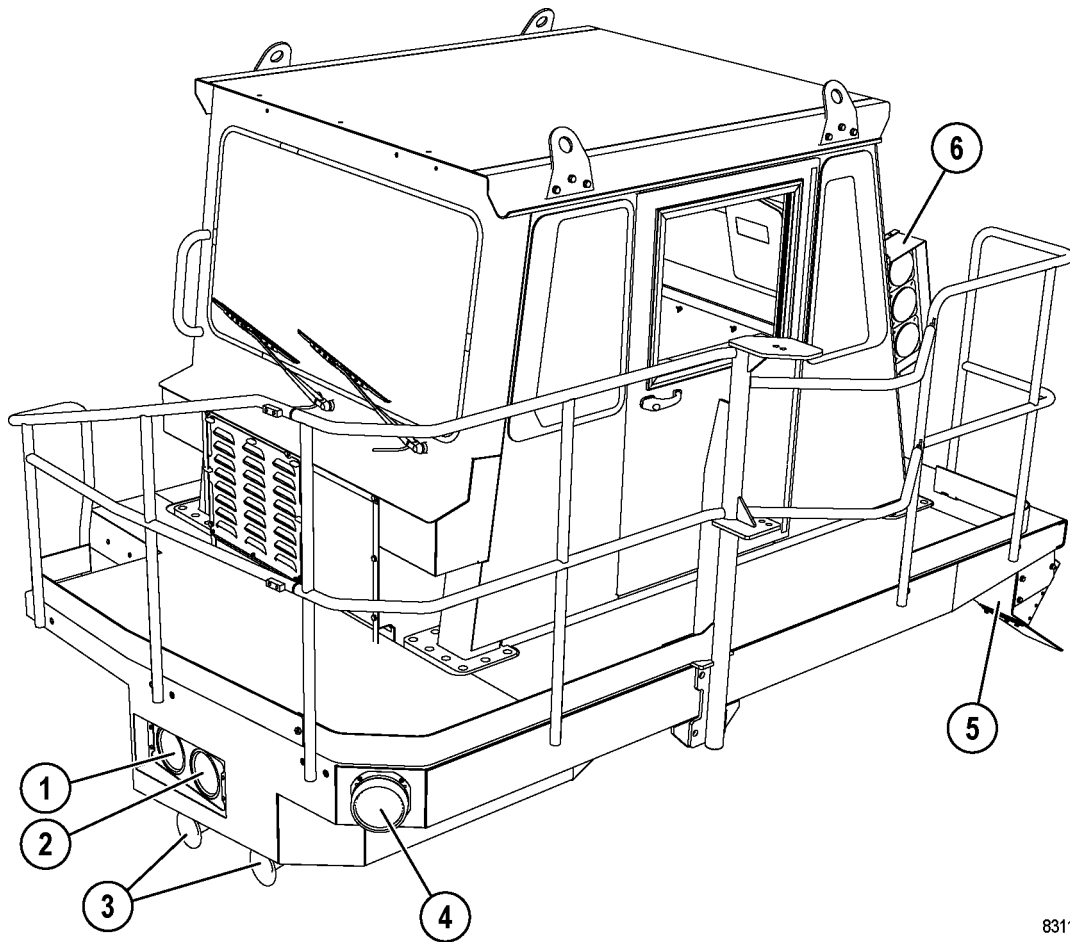

83116

FIGURE 34-1. LH DECK LIGHTS

- | | |
|--------------------------------|--------------------------------|
| 1. High Beam Headlight (Outer) | 4. Clearance/Turn Signal Light |
| 2. High Beam Headlight (Inner) | 5. Deck Mounted Backup Light |
| 3. Forward Warning Horns | 6. Payload Indicator Lights |

High Beam Headlights

High beam headlights (1 & 2, Figure 34-1) and (4 & 5, Figure 34-2) illuminate when the operator actuates the high beam function on the multi-function lever. The headlight switch must be on for the high beam headlights to work. These lights are functional regardless of key switch position.

Forward Warning Horns

Forward Warning horns (3, Figure 34-1) will sound when the operator presses the horn button on the steering wheel. The front horns are functional at all times regardless of key switch position.

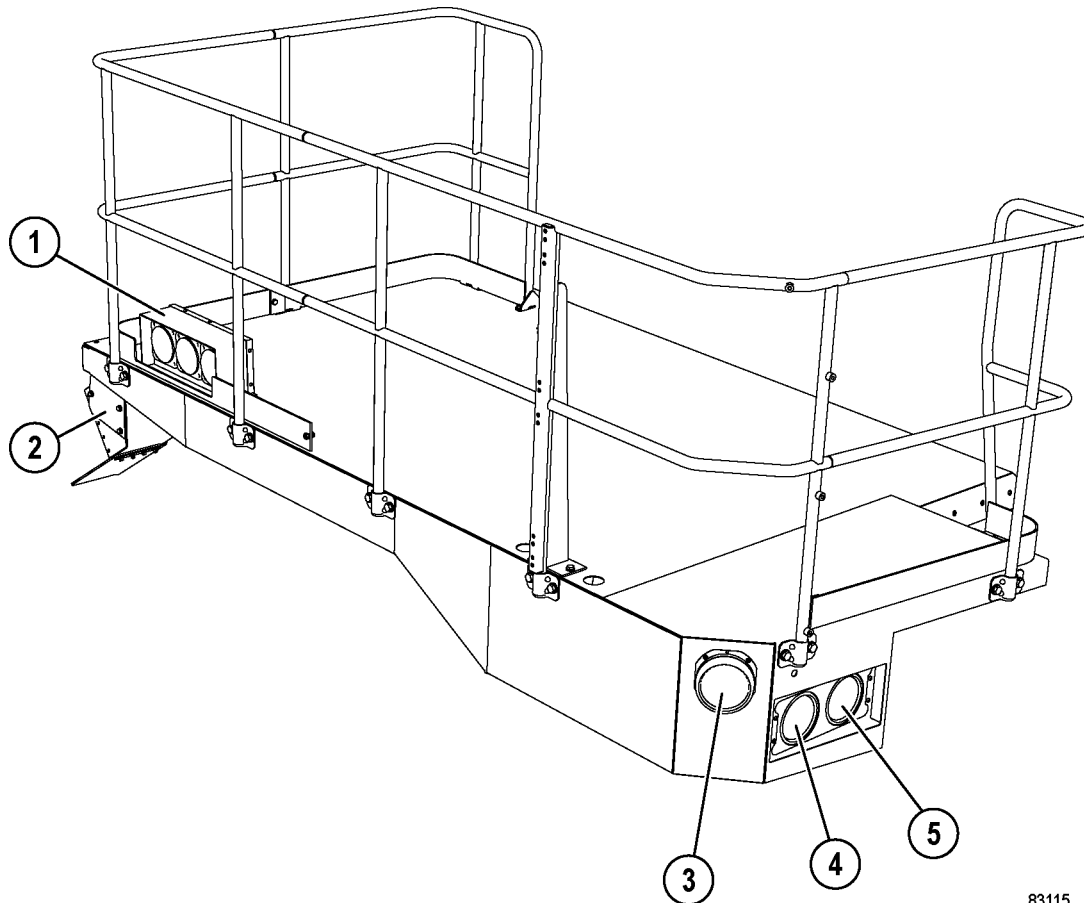

83115

FIGURE 34-2. RH DECK LIGHTS

- | | |
|---------------------------------|--------------------------------|
| 1. Payload Indicator Lights | 4. High Beam Headlight (Outer) |
| 2. Deck Mounted Backup Light | 5. High Beam Headlight (Inner) |
| 3. Clearance/Turn Signal Lights | |

Clearance/Turn Signal Lights

Clearance/turn signal lights (4, Figure 34-1) and (3, Figure 34-2) are dual function amber lights. When the headlights are on, a low beam clearance light will illuminate. When the operator signals a left turn using the multi-function lever, the left light will flash. When the operator signals a right turn using the multi-function lever, the right light will flash. These lights are functional regardless of key switch position.

Deck Mounted Backup Lights

Deck mounted backup lights (5, Figure 34-1) and (2, Figure 34-2) illuminate when the operator moves the transmission shift lever to REVERSE. The lights can also be activated by using the backup light switch in the cab. Using the switch turns the lights on regardless of shift lever position. These lights are only functional with the key switch in accessory mode or in run.

Payload Indicator Lights

Payload indicator lights (6, Figure 34-1) and (1, Figure 34-2) are used to signal to the shovel operator whether another shovel pass can be loaded onto the truck. The different colors signify different payload ranges. Refer to Section 60, Vehicle Health Monitoring System, for more specific information on the payload metering system.

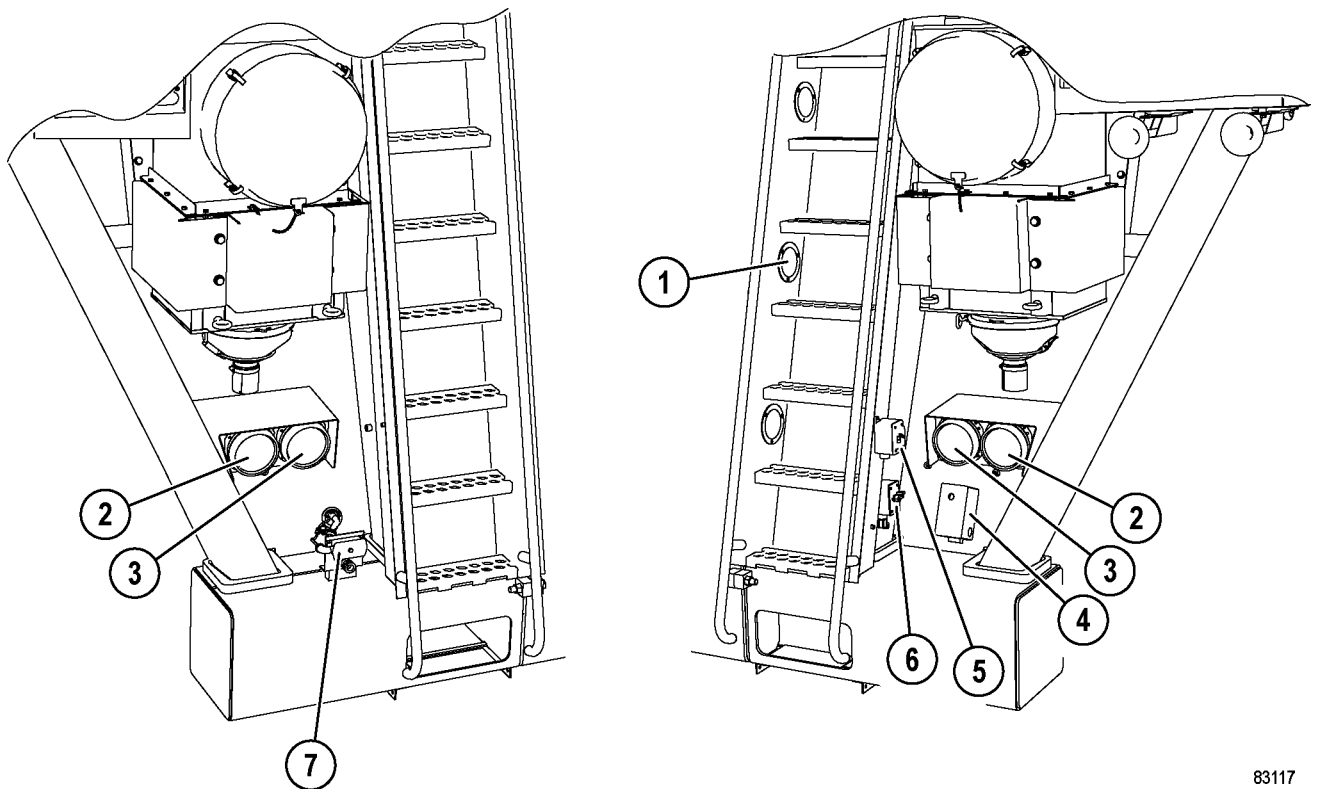
UPRIGHTS

83117

FIGURE 34-3. UPRIGHTS

1. Ladder Lights
2. Low Beam Headlight (Outer)
3. Low Beam Headlight (Inner)
4. Ground Level Download Box

5. Ladder Light Switch
6. Ground Level Engine Shutdown Switch
7. Remote Grease Fill Port

Ladder Lights

Ladder lights (1, Figure 34-3) illuminate when ladder light switch (5) is actuated. The ladder lights are functional at all times regardless of key switch position.

Low Beam Headlights

Low beam headlights (2 & 3, Figure 34-3) illuminate when the operator actuates the headlight switch. The multi-function lever must be in the low beam position for the low beam headlights to work. These lights are functional regardless of key switch position.

Ground Level Download Box

Ground level download box (4, Figure 34-3) provides a method to obtain payload meter and VHMS data without climbing up to the cab. Refer to Section 60, Vehicle Health Monitoring System, for more specific information on the payload metering system.

Ground Level Engine Shutdown Switch

Ground level engine shutdown switch (6, Figure 34-3) provides a method to turn off the engine without climbing up to the cab. The switch must be in the ON position in order to start the engine. This switch has lock-out capability.

Remote Grease Fill Port

Remote grease fill port (7, Figure 34-3) provides a method to fill the grease reservoir without climbing up to the decks. Refer to Section 42, Automatic Lubrication System, for more specific information.

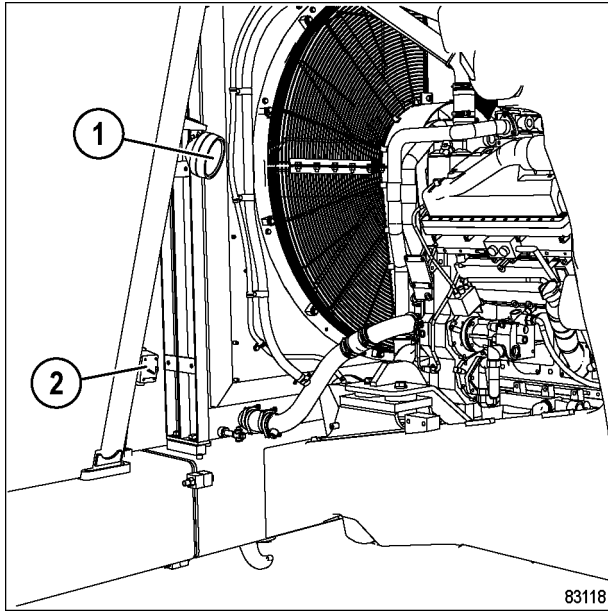

FIGURE 34-4. LH ENGINE SERVICE LIGHT

1. Service Light 2. Light Switch

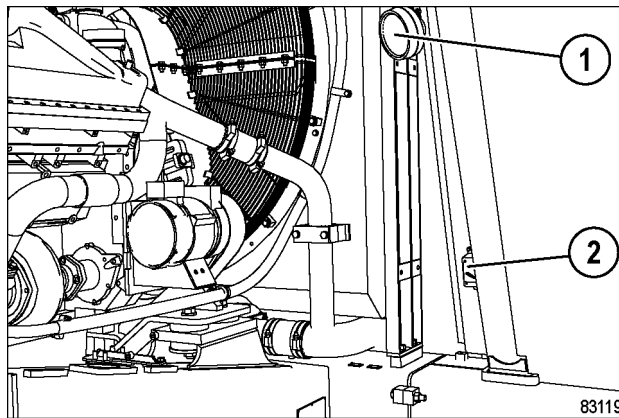

FIGURE 34-5. RH ENGINE SERVICE LIGHT

1. Service Light 2. Light Switch

Engine Service Lights

Engine service lights (1, Figure 34-4) illuminate when light switch (2) is actuated. There are service lights on both sides of the engines. The service lights are functional at all times regardless of key switch position.

REAR AXLE LIGHT BAR

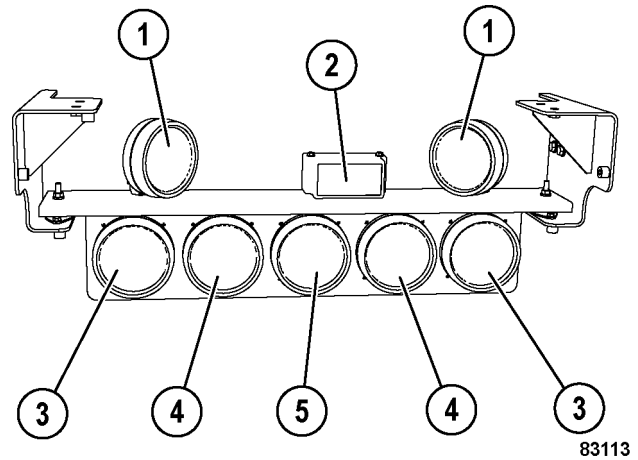

FIGURE 34-6. REAR AXLE LIGHT BAR

- | | |
|----------------------|---------------------------|
| 1. Backup Light | 4. Retard/Clearance Light |
| 2. Backup Alarm | 5. Brake Light |
| 3. Turn Signal Light | |

NOTE: The brake light is functional at all times regardless of key switch position. All other lights (and the backup alarm) are only functional with the key switch in the accessory mode or in run.

Backup Lights

Backup lights (1, Figure 34-6) illuminate when the operator moves the transmission shift lever to REVERSE. The lights can also be activated by using the backup light switch in the cab. Using the switch turns the lights on regardless of shift lever position.

Backup Alarm

Backup alarm (2) will sound when the operator moves the transmission shift lever to REVERSE. The alarm can also be turned on by using the backup light switch. Using the switch turns the alarm on regardless of shift lever position.

Turn Signal Lights

Turn signal lights (3) will flash when the operator signals a turn using the multi-function lever. The light on the left side of the bar will flash when a left turn is being signaled. The light on the right side of the bar will flash when a right turn is being signaled.

Retard/Clearance Lights

Retard/clearance lights (4) are dual function red lights. When the headlights are on, a low beam clearance light will illuminate. When the operator uses the retard function to slow the truck, a more brilliant light will illuminate to signal to traffic that the truck is slowing.

Brake Light

Brake light (5) will illuminate when the operator depresses the brake pedal. The red light signals to traffic that the truck is slowing.

NOTES

LUBRICATION AND SERVICE

Preventive maintenance contributes to the long life and dependability of the truck and its components. The use of proper lubricants and the performance of checks and adjustments at recommended intervals are crucial.

Lubrication requirements reference the lube key found in the lubrication chart. For detailed service requirements for specific components, refer to the shop manual.

The service intervals presented here are in hours of operation. Oil change intervals are recommended in the absence of an oil analysis program which may determine different intervals. However, if the truck is being operated in extreme conditions, some or all of the intervals may need to be performed more frequently.

Refer to the engine service manual when servicing the engine or any of its components.

| SERVICE CAPACITIES | | |
|--|--------|------------|
| | Liters | US Gallons |
| Engine Crankcase (including lube oil filters) | 193 | 51 |
| Cooling System | 532 | 141 |
| Hydraulic System Refer to Hydraulic Tank Service in this chapter | 900 | 238 |
| Differential Case | 297 | 78 |
| Final Drive Case (each planetary) | 120 | 32 |
| Fuel Tank (diesel fuel only) | 2120 | 560 |
| Transmission Case including torque converter | 153 | 41 |

COOLANT SPECIFICATIONS

- For ambient temperatures of -25° F (-32° C) and above, use a standard 50/50 anti-freeze-to-water mixture.
- For arctic climates with ambient temperatures between -25° F (-32° C) and -65° F (-54° C), use a 60/40 anti-freeze-to-water mixture.

NOTE: Do not use propylene glycol coolant in arctic climates. Only use ethylene glycol coolants.

Unacceptable Practices

- Use of high-silicate anti-freeze.
- Under concentration or over concentration of Extended Service Additive (SCA).
- Use of anti-freezes/coolants that are not fully formulated for extended service intervals.
- Use of sealing additives (stop-leak) in the cooling system.
- Use of soluble oils in the cooling system.
- Use of poor-quality water. See the engine manufacturer's specifications for water quality requirements.
- Use of anti-freeze, Extended Service Additive (SCA) or coolant filter(s) that do not meet the engine manufacturer's specifications.
- Use of Treated Water coolant.
- Use of coolants with less than 40 percent antifreeze.

RADIATOR FILL PROCEDURE



The cooling system is pressurized due to thermal expansion of coolant. DO NOT remove the radiator cap while the engine is hot. Severe burns may result.

1. With the engine and coolant at ambient temperature, depress the pressure relief to remove cooling system pressure. Slowly, remove the radiator cap.

NOTE: If coolant is added using the quick fill system, the radiator cap must be removed prior to adding coolant.

2. Fill the radiator with the proper coolant mixture as specified by the engine manufacturer. Fill until coolant reaches the radiator cap area.
3. Install the radiator cap.
4. Allow the engine to idle for 5 minutes. Shut the engine off and wait for the engine to cool.
5. Check the coolant level. If the radiator is not full, repeat the previous steps. Any excess coolant will be discharged through the vent hose after the engine reaches normal operating temperature.

HYDRAULIC TANK SERVICE

Filling Instructions

1. Lower the dump body and turn the key switch OFF.



The hydraulic tank may be pressurized! Depress the relief valve on the tank before removing the filler cap.

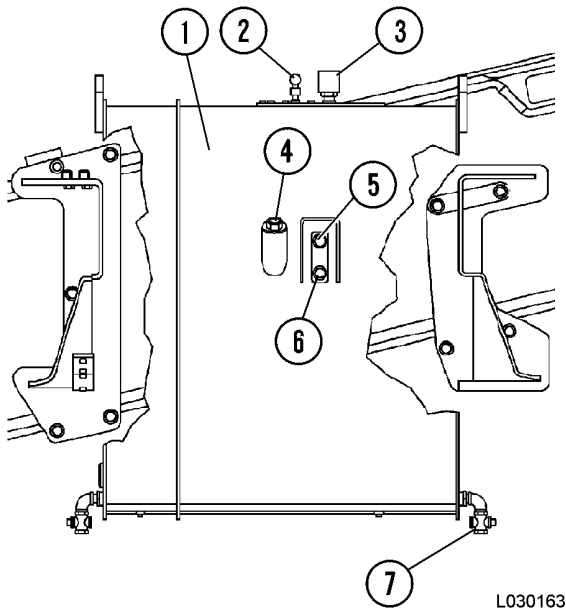

L030163

FIGURE 40-1. HYDRAULIC TANK

- | | |
|--------------------------|--|
| 1. Hydraulic Tank | 5. Hydraulic Oil Level Upper Sight Glass |
| 2. Pressure Relief Valve | 6. Hydraulic Oil Level Lower Sight Glass |
| 3. Breather | 7. Hydraulic Oil Drain |
| 4. Fill Cap | |

2. Depress relief valve (2, Figure 40-1) for 30 - 45 seconds to release any internal tank pressure. Remove fill cap (4). Turn the cap slowly to release any residual tank pressure.
3. Refer to lube key C on the lubrication chart. Fill the tank with the recommended oil until oil is visible in upper sight glass (5). Hydraulic tank capacity is: 576 l (152 gal).

4. Install the fill cap.
5. Start the engine. Raise and lower the dump body three times to circulate oil and fill hoses and components.
6. Repeat the previous steps until oil level is again in upper sight glass (5).
7. If oil level falls below lower sight glass (6) with the engine on, repeat this procedure.

TRANSMISSION OIL LEVEL CHECK

1. With the engine off:

The oil level must be visible in the upper part of the sight gauge between H and L. This sight gauge is to be used when changing oil, before engine start-up (engine off for eight hours or more).

Add clean oil as required through the transmission oil filler tube at the left rear of the transmission.

When the engine is turned on and transmission oil reaches normal operating temperature, check the oil level again, as described below.

2. With the engine on:

The oil level must be visible in the lower sight gauge between H and L.

Use this sight gauge with the following guidelines:

- truck parked on level surface
- engine at low idle
- shift lever in NEUTRAL
- transmission oil at normal operating temperature

Add clean oil as required through the transmission oil filler tube at the left rear of the transmission.

QUICK FILL SERVICE CENTER

The service center (Figure 40-2) is located on the left side of the truck below the hydraulic tank. The service center can be used to fill system fluids at a higher rate of speed than manually adding fluids and grease.

Connect a filling device to the appropriate fitting on the service center to add fluids/grease. Use caution when adding fluids to avoid overfilling.

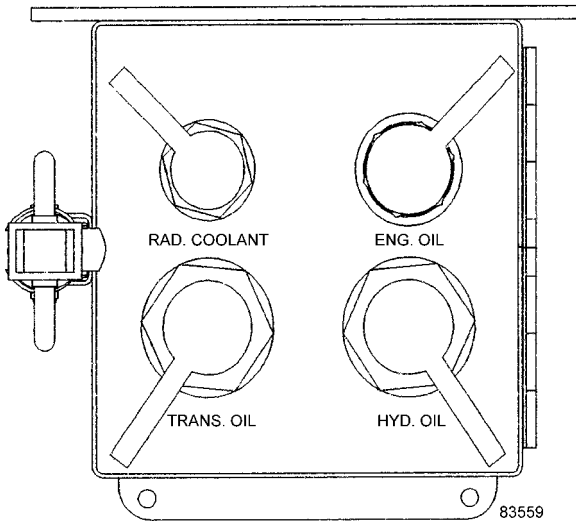

FIGURE 40-2. SERVICE CENTER

Refer to the following table for the maximum recommended fill pressures for the service center.

| MAXIMUM FILL PRESSURES | | |
|------------------------|--------|-------|
| Fill System | kPa | psi |
| Engine Crankcase | 345 | 50 |
| Hydraulic Tank | 345 | 50 |
| Coolant | 345 | 50 |
| Grease | 10 342 | 1,500 |

PERIODIC REPLACEMENT OF CRITICAL PARTS

To ensure safe operation of the truck, it is necessary to perform periodic maintenance for critical parts.

Fabrication of safety devices and other component parts have been designed to high standards. However, all parts are subject to wear and gradual fatigue during continuous use. Since it is difficult to determine accurately the process of change in quality, wear, or fatigue, judgments must be made whether or not some parts should be replaced even if they do not show any faulty symptom at the time. Of course, any part found to have an abnormality must be repaired or replaced, regardless of the time it has been used.

Replace the following parts every 4000 hours or every two years, whichever comes first:

1. Fuel system hoses
2. Rubber hoses for brake piping
3. High pressure hoses in steering circuit
4. High pressure hoses in hoist circuit
5. Hoses at brake cooling inlet and outlet (wheel)
6. Hose at discharge side of brake cooling pump
7. Hose at discharge side of transmission pump
8. Accumulators

Replace the following parts every three years:

1. Seat belt

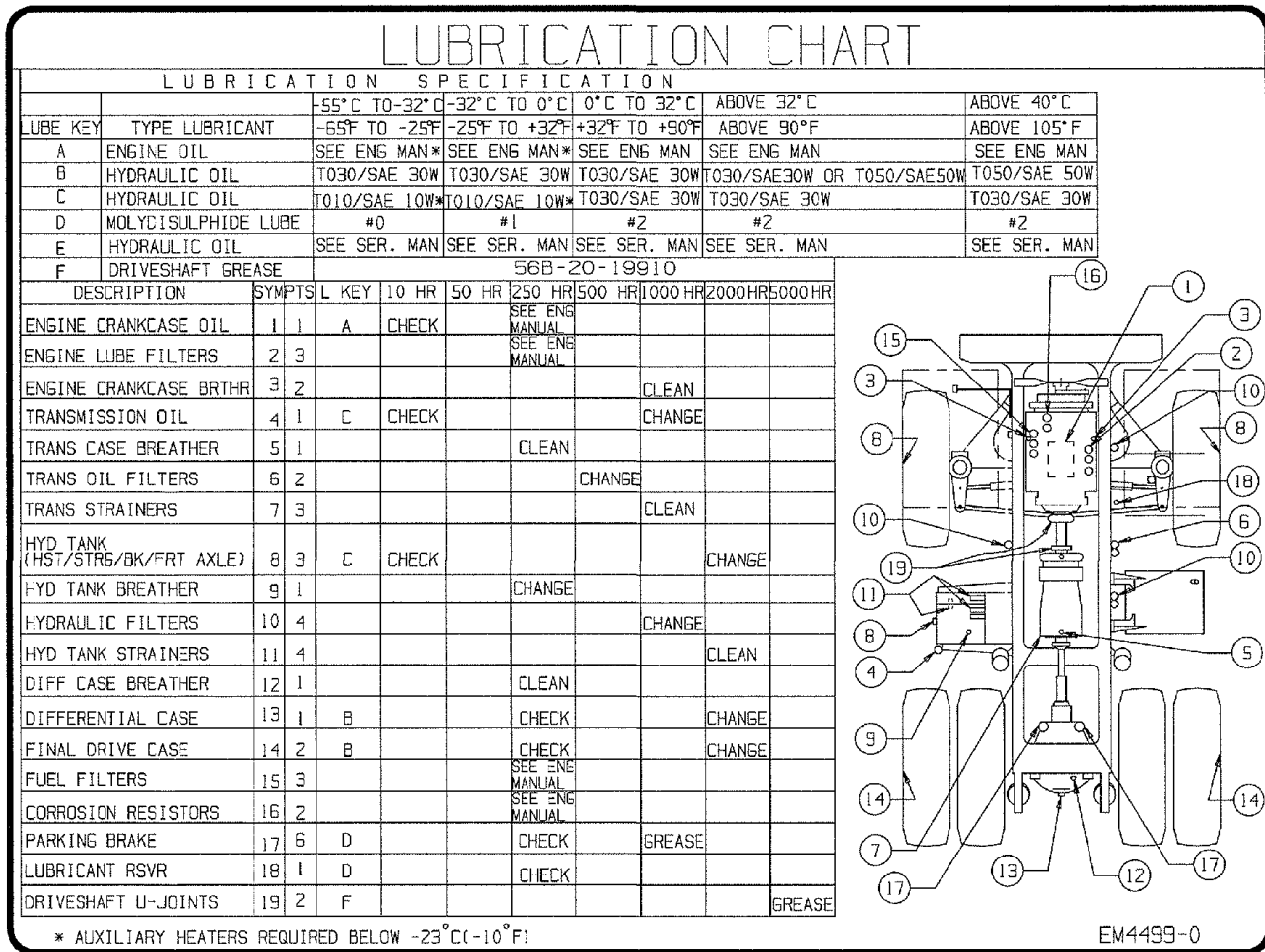

* AUXILIARY HEATERS REQUIRED BELOW -23°C (-10°F)

FIGURE 40-3. LUBRICATION CHART

10 HOUR (DAILY) INSPECTION

Perform a "walk around" inspection prior to each work shift. Check the general condition of the truck. Look for evidence of hydraulic leaks. Check all lights and mirrors for dirt and damage. Check the operator's cab for dirty or damaged accessories or controls. Inspect the frame, sheet metal and body for cracks. Notify the proper maintenance authority if any discrepancies are found.

| Truck Serial Number _____ | | Site Unit Number _____ | | Date _____ | |
|---------------------------|---|----------------------------------|---------|------------|--|
| Hourmeter _____ | | Name of Service Technician _____ | | | |
| TASK | | COMMENTS | CHECKED | INITIALS | |
| 1. | Check all fluid levels a. Engine Oil- <i>NOTE: Refer to the engine manufacturer service manual for oil recommendations.</i> | | | | |
| | b. Radiator - Check coolant level and fill with proper mixture as shown in Coolant Specifications at the beginning of this chapter. | | | | |
| | c. Batteries - Check electrolyte level and add water if necessary. | | | | |
| | d. Hydraulic Tank - Check oil level in tank, add if necessary. Lube key C. Refer to Hydraulic Tank Service, in this chapter. <i>NOTE: Check the oil level with the truck on a level surface, engine stopped, body down, and oil warm. Oil must be visible in sight glass. Do not overfill.</i> | | | | |
| | e. Transmission - Check oil level. Add oil if necessary. Lube key C. Refer to Transmission Oil Level Check in this chapter. | | | | |
| | f. Fuel Tank - Fill as required. | | | | |
| | g. Differential - On a level surface, the oil level must be even with the plug hole. Refill with oil, as necessary. Lube key B. | | | | |

10 HOUR (DAILY) INSPECTION (continued)

| Truck Serial Number _____ | | Site Unit Number _____ | | Date _____ | |
|---------------------------|--|----------------------------------|---------|------------|--|
| Hourmeter _____ | | Name of Service Technician _____ | | | |
| TASK | | COMMENTS | CHECKED | INITIALS | |
| 2. | <p>Air Cleaners Check air cleaner vacuum gauges. Clean or replace filter elements if restriction vacuum reaches 6 kPa (25 in. H₂O). Push the reset button on the face of the gauge to return to zero.</p> | | | | |
| 3. | <p>Drive Belts</p> <p>a. Check the condition of the alternator and fan belts. Check for proper tension.</p> <p>b. Inspect belt alignment.</p> | | | | |
| 4. | <p>Engine And Turbochargers Inspect for leaks, vibrations or odd noises.</p> | | | | |
| 5. | <p>Tires</p> <p>a. Check for proper inflation and wear.</p> <p>b. Inspect for embedded debris, cuts or other damage.</p> | | | | |
| 6 | <p>Windshield Wipers & Washer - Inspect the wiper blades for wear or damage. Replace if necessary. Check the windshield washer fluid level. If below 1/2 full, add fluid.</p> | | | | |

250 HOUR INSPECTION

| Truck Serial Number _____ Site Unit Number _____ Date _____ | | | |
|---|--|---------|----------|
| Hourmeter _____ Name of Service Technician _____ | | | |
| TASK | COMMENTS | CHECKED | INITIALS |
| INITIAL 250 HOUR SERVICE | | | |
| 1. | Perform the following maintenance after operating the machine for the first 250 hours. Thereafter, these services are to be performed at the normal interval schedules, as specified. <ul style="list-style-type: none"> a. Transmission - change oil and filter elements. b. Hydraulic System- change oil and filter elements. c. Differential Case - change oil. d. Final Drive Case - change oil. | | |
| 2 | Torque Converter and Transmission Oil Pressure Checks - Check torque converter and transmission operating pressures. Refer to Section F2 in the service manual. | | |
| EVERY 250 HOURS SERVICE | | | |
| 1. | Lubrication - <ul style="list-style-type: none"> a. Check the automatic lubrication system to ensure an ample grease supply is reaching pins and bearings. <ul style="list-style-type: none"> - Dump body hinge pin - 2 points. - Rear suspension - 4 points. - Axle support pins - 8 points. - Hoist cylinder pin - 4 points. - Front suspension assembly - 8 points. - Steering cylinder pin - 4 points. - Steering linkage - 5 points. - Front transmission mount - 1 point. b. Refill grease reservoir - Lube key D. Reservoir capacity is approximately 41 kg (90 lb) of grease. | | |
| 2 | Engine - Refer to the engine service manual for oil recommendations. <ul style="list-style-type: none"> - change engine oil. - change engine lube oil filter. | | |

250 HOUR INSPECTION (continued)

| Truck Serial Number _____ Site Unit Number _____ Date _____ | | Hourmeter _____ Name of Service Technician _____ | | |
|---|---|--|---------|----------|
| TASK | | COMMENTS | CHECKED | INITIALS |
| 3 | Alternator Belt - Check the alternator belt for cracks, cuts or glazing. Check for proper tension. Repair or adjust as necessary. | | | |
| 4 | Air Conditioner Compressor Belt- Check the compressor belt for cracks, cuts or glazing. Check for proper tension. Repair or adjust as necessary. | | | |
| 5 | Fan Belt - Check the fan belt for cracks, cuts or glazing. Check for proper tension. Repair or adjust as necessary. | | | |
| 6 | Transmission Case Breathers - Remove breathers, and disassemble. Remove the filter element, and clean in solvent. Dry with pressurized air. Reassemble and reinstall. | | | |
| 7 | Hydraulic Tank Breather - Remove breather, and disassemble. Remove the filter element and replace. Reassemble and reinstall. | | | |
| 8 | Differential Case - Check the oil level. Lube key B. | | | |
| 9 | Differential Case Breather - Remove breather. Clean the breather and reinstall. | | | |
| 10 | Final Drive Case - Check the oil level in RH and LH case. Lube key B. | | | |
| 11 | Parking Brake - Measure brake pads for proper wear and thickness. Refer to the service manual for limits and specifications. Lube key D. | | | |
| 12 | Fuel Filters Remove and replace fuel filter elements. | | | |
| 13 | Corrosion Resistors - Remove and replace corrosion resistor elements. | | | |
| 14 | Dump Body Pads - Check the pads, shims and mounting hardware for wear and proper tightening. | | | |

250 HOUR INSPECTION (continued)

| Truck Serial Number _____ Site Unit Number _____ Date _____ | | Hourmeter _____ Name of Service Technician _____ | | |
|---|--|--|---------|----------|
| TASK | | COMMENTS | CHECKED | INITIALS |
| 15 | HVAC Air Filter - Clean the filter element with mild soap and water. Rinse completely clean and air dry with a maximum of 275 kPa (40 psi). Reinstall the filter. | | | |
| 16 | Cab Air Filter - Under normal operating conditions, clean every 250 hours. In extremely dusty conditions, service as frequently as required. Clean the filter element with mild soap and water. Rinse completely clean and air dry with a maximum of 275 kPa (40 psi). Reinstall the filter. Refer to Figure 40-4. | | | |

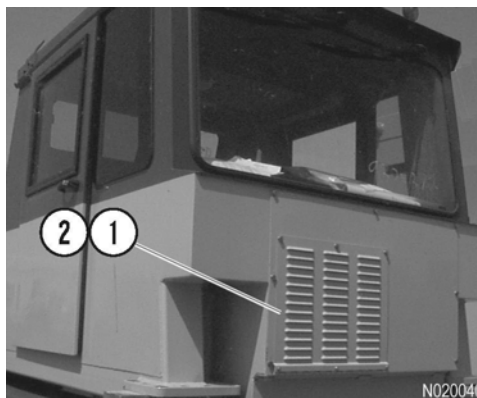

FIGURE 40-4.
1. Filter Cover 2. Cab Filter

500 HOUR INSPECTION

Perform the maintenance items for the 250 hour interval at this time, also.

| Truck Serial Number _____ Site Unit Number _____ Date _____ | | Hourmeter _____ Name of Service Technician _____ | | |
|---|--|--|---------|----------|
| TASK | | COMMENTS | CHECKED | INITIALS |
| 1 | Radiator - Check for clogged or damaged fins. Refer to Section C in the service manual for more information on radiator maintenance. | | | |
| 2 | Transmission Oil Filter - a. Remove and replace the two filter elements. b. Remove and replace control valve filter. Refer to the service manual for service information. | | | |
| 3 | Check Toe-In Adjustment - Check the steering toe-in adjustment and inspect the tires for abnormal wear. Adjust as necessary. Refer to the service manual for the adjustment procedure. | | | |
| 4 | Bladder Accumulators - Pre-charge pressure must be checked every 500 hours. Failure to maintain correct pressure may result in bladder failures. Refer to the information in the service manual detailing bladder accumulator repair. Comprehensive instructions are outlined for properly maintaining bladder accumulators. | | | |
| 5 | Front Wheel Bearings - Obtain an oil sample from each front wheel bearing oil cavity for analysis. Refer to Section G3 in the service manual for instructions. | | | |
| 6 | Engine Damper - Check the grease level in the engine damper. Fill as necessary with Komatsu grease (427-12-11871). The grease level must be maintained level with the fill plug opening. | | | |
| 7 | Frame And Rear Axle Housing - Wash the truck, clean all of the weld joints, and visually inspect the entire frame and axle housing for cracking or damage. | | | |
| 8 | Torque Converter and Transmission Oil Pressure Checks - Check torque converter and transmission operating pressures. Refer to Section F2 in the service manual. | | | |

1000 HOUR INSPECTION

Perform the maintenance items for the 250 and 500 hour intervals at this time, also.

| Truck Serial Number _____ | | Site Unit Number _____ | | Date _____ | |
|---------------------------|--|----------------------------------|---------|------------|--|
| Hourmeter _____ | | Name of Service Technician _____ | | | |
| TASK | | COMMENTS | CHECKED | INITIALS | |
| 1 | Parking brake -Manually lubricate the parking brake linkage at 6 points - Lube key D. | | | | |
| 2 | Transmission Oil - a. Drain oil, remove and replace element. Remove clean, and reinstall strainer. Refill sump with oil - Capacity, approximately 153 l (41 gal). Lube key C. b. Remove and clean the three transmission magnetic strainers. Refer to the service manual for service information. | | | | |
| 3 | Steering, Brake, Hoist, & Rear Brake Cooling Oil Filters - Replace the filters. Refer to the service manual for further instructions. | | | | |
| 4 | Front & Rear Brake Wear - Refer to the service manual for proper inspection procedures. | | | | |
| 5 | Engine Breather - Remove and clean the engine breather. Refer to the engine service manual. | | | | |
| 6 | Automatic Lubrication System Pump - Check pump housing oil level. Refill to bottom of level plug with SAE 10W-30 motor oil. Later models may equipped with a dipstick. If equipped with a dipstick, fill to the proper level on the dipstick. | | | | |

2000 HOUR INSPECTION

Perform the maintenance items for the 250, 500 and 1000 hour intervals at this time, also.

| Truck Serial Number _____ Site Unit Number _____ Date _____ | | | | |
|---|---|----------|---------|----------|
| Hourmeter _____ Name of Service Technician _____ | | | | |
| TASK | | COMMENTS | CHECKED | INITIALS |
| 1 | Hydraulic Tank Oil - a. Drain the oil from the tank and refill. Capacity of the hydraulic tank is 576 l (152 gal). Refer to the lubrication chart for type of oil to use. Lube key C. b. Remove and clean hydraulic tank strainers. Refer to Hydraulic Tank Service in this chapter for proper filling instructions. | | | |
| 2 | Front Wheel Hubs - Drain the hydraulic oil from each front wheel drain plug. Ensure the plugs are in the six o'clock position when draining. <div style="border: 2px solid black; padding: 5px; text-align: center;">  WARNING </div> <i>Drain the hydraulic tank prior to removing the drain plugs from the wheel hubs.</i> | | | |
| 3 | Final Drive - Position the machine so that the case casting line is horizontal and the drain plug is at the bottom. Drain the oil and reinstall the plug. Remove the fill plug at casting line and fill until oil reaches the plug hole. Service both final drives. Capacity is 120 l (32 gal) on each side. Lube key B. | | | |
| 4 | Differential Case - Drain the oil from the differential. Refill until oil reaches the fill plug hole. Oil capacity is 300 l (79 gal). Lube key B. | | | |

5000 HOUR INSPECTION

Perform the maintenance items for the 250, 500, and 1000 hour intervals at this time, also.

| Truck Serial Number _____ | | Site Unit Number _____ | | Date _____ | |
|---------------------------|---|----------------------------------|---------|------------|--|
| Hourmeter _____ | | Name of Service Technician _____ | | | |
| TASK | | COMMENTS | CHECKED | INITIALS | |
| 1 | Engine Driveline Adapter - Inspect driveline adapter rubber dampers. If any defects are found, repair as required. | | | | |
| 2 | Front And Rear Drive Shafts - a. Grease the U-joints on each drive shaft. Refer to lube key F on the lubrication chart. b. Inspect both front and rear drive shafts for binding, wear, vibration, etc. If U-joint damage or roughness is noted, both U-joints on a given shaft must be replaced. Refer to the service manual for replacement procedures. | | | | |
| 3 | Front Suspensions - Drain the front suspension oil. Disassemble and inspect the upper flange internal bearing. Replace any worn parts. Refill the suspension with clean oil and recharge with nitrogen. Refer to the service manual for service information on the suspensions. | | | | |
| 4 | Prelub™ System - Inspect system components for damage, leakage, etc. | | | | |
| 5 | Body Guide - Inspect the body guide wear points for excessive wear and damage. Replace as necessary. | | | | |

NOTES

AUTOMATIC LUBRICATION SYSTEM

GENERAL DESCRIPTION

The automatic lubrication system is a pressurized lubricant delivery system which delivers a controlled amount of lubricant to designated lube points. The system is controlled by an electronic controller which signals a solenoid valve to operate a hydraulic motor powered grease pump. Hydraulic oil for pump operation is supplied by the truck steering circuit.

Grease output is proportional to the hydraulic motor input flow. A pump control manifold, mounted on top of the hydraulic motor, controls input flow and pressure. A 24VDC Solenoid mounted on the manifold turns the pump on and off.

The pump is driven by the rotary motion of the hydraulic motor, which is then converted to reciprocating motion through an eccentric crank mechanism. The reciprocating action causes the pump cylinder to move up and down. The pump is a positive displacement, double-acting type pump. Grease output occurs on both the up and the down stroke.

During the down stroke, the pump cylinder is extended into the grease. Through the combination of shovel action and vacuum generated in the pump cylinder, the grease is forced into the pump cylinder. Simultaneously, grease is discharged through the outlet of the pump. The volume of grease during intake is twice the amount of grease output during one cycle. During the upstroke, the inlet check valve closes, and one half the grease taken in during the previous stroke is transferred through the outlet check and discharged to the outlet port.

WARNING

Over-pressurizing of the system, modifying parts, using incompatible chemicals and fluids, or using worn or damaged parts, may result in equipment damage and/or serious personal injury.

- **DO NOT exceed maximum working pressure for any component in the system.**
- **DO NOT alter or modify any part of this system unless factory authorization.**
- **DO NOT attempt to repair or disassemble the equipment while the system is pressurized.**
- **Ensure all fluid connections are securely tightened before using this equipment.**
- **Always read and follow the fluid manufacturer's recommendations regarding fluid compatibility.**
- **Check all equipment regularly and repair. Replace worn or damaged parts immediately.**

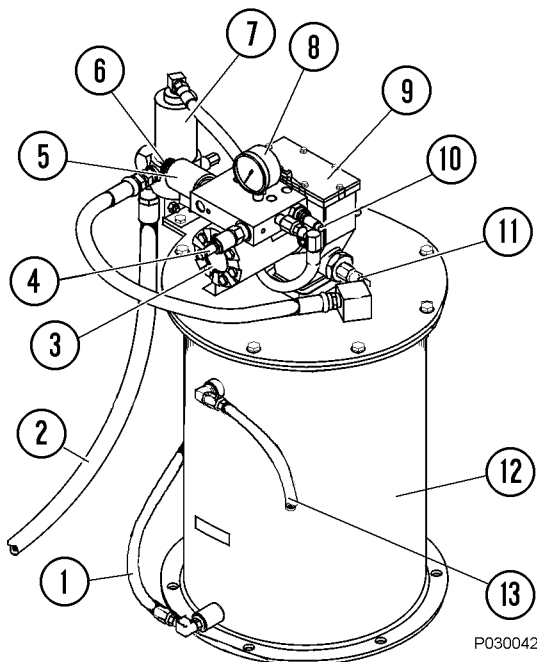
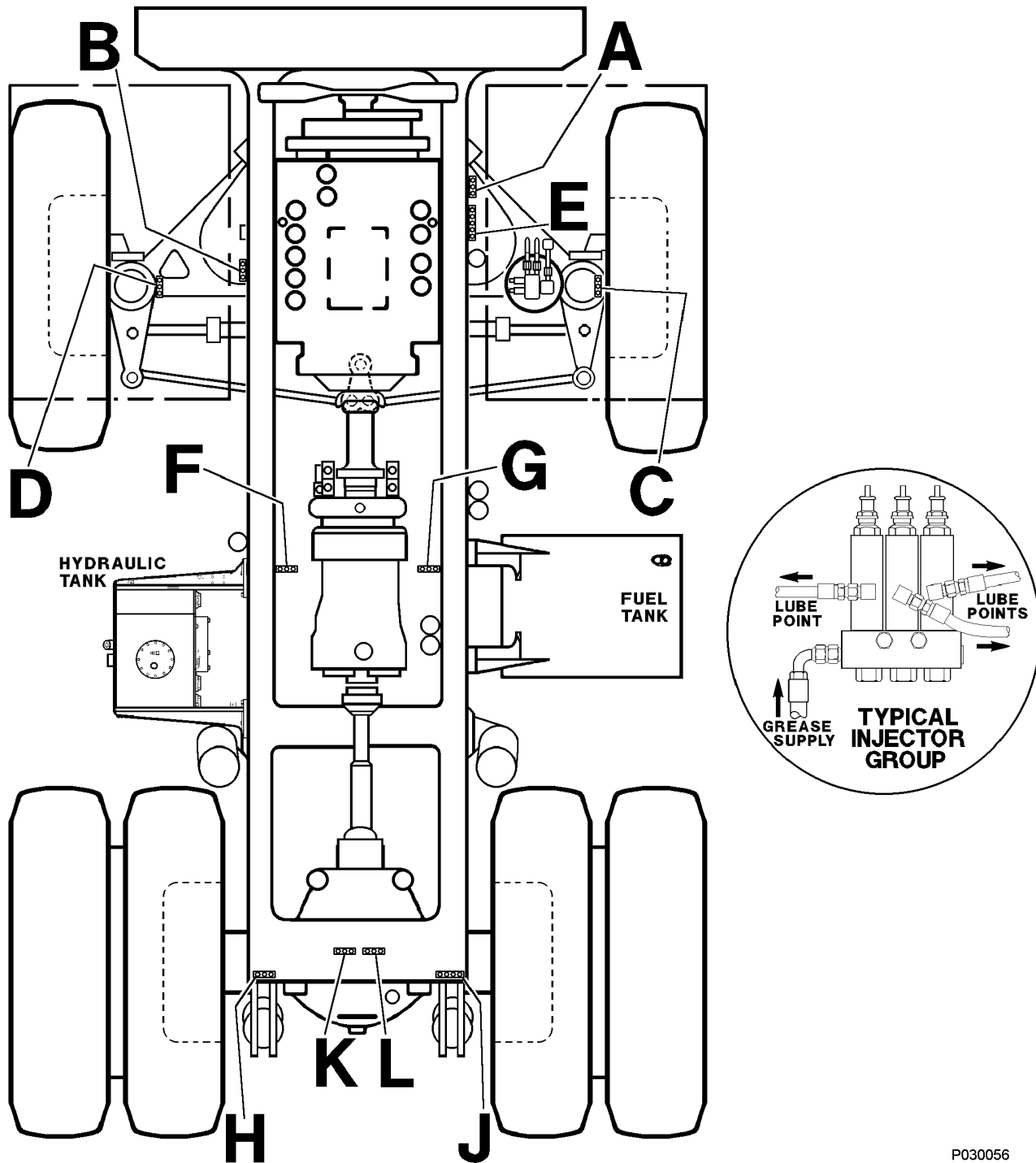

FIGURE 42-1. PUMP & RESERVOIR COMPONENTS

- | | |
|----------------------------|--------------------------------|
| 1. Hose From Filter | 8. Pressure Gauge |
| 2. Outlet to Injectors | 9. Pump Assembly |
| 3. Hydraulic Motor | 10. Flow Control Valve |
| 4. Pressure Reducing Valve | 11. Pressure Switch (Optional) |
| 5. Solenoid Valve | 12. Grease Reservoir |
| 6. Test Switch | 13. Vent Hose |
| 7. Vent Valve | |

This equipment generates very high grease pressure. Use extreme caution when operating this equipment. Pressurized grease can pierce the skin causing serious bodily injury. Adequate protection such as safety goggles and protective clothing is recommended.

If fluid penetrates the skin, get medical care immediately! Do not treat as a simple cut. Tell the attending physician exactly what fluid was injected.



P030056

FIGURE 42-2. AUTOMATIC LUBRICATION SYSTEM ARRANGEMENT

| | | | |
|-----------------------|-------------|-----------------------|-------------|
| Group Lube Location A | 3 Injectors | Group Lube Location G | 3 Injectors |
| Group Lube Location B | 3 Injectors | Group Lube Location H | 3 Injectors |
| Group Lube Location C | 3 Injectors | Group Lube Location J | 4 Injectors |
| Group Lube Location D | 3 Injectors | Group Lube Location K | 3 Injectors |
| Group Lube Location E | 5 Injectors | Group Lube Location L | 3 Injectors |
| Group Lube Location F | 3 Injectors | | |

| Figure 42-2. LUBE INJECTOR GROUPS | | |
|--|----------------------------|--|
| Lube Group | Number of Injectors | Injector Point of Lubrication |
| A | 3 | RH front suspension, top RH front suspension, rear A-arm RH front suspension, front A-arm |
| B | 3 | LH front suspension, top LH front suspension, rear A-arm LH front suspension, front A-arm |
| C | 3 | RH steering cylinder, spindle RH tie rod, spindle RH front suspension, bottom A-arm |
| D | 3 | LH steering cylinder, spindle LH tie rod, spindle LH front suspension, bottom A-arm |
| E | 5 | RH steering cylinder, frame LH steering cylinder, frame LH tie rod, pivot RH tie rod, pivot Center steering pivot, frame |
| F | 3 | Rear axle, bottom LH bar frame LH hoist cylinder, frame Transmission, front mount |
| G | 3 | Rear axle, top front bar frame Rear axle, bottom RH bar frame RH hoist cylinder, frame |
| H | 3 | LH rear suspension, frame LH hoist cylinder, body LH body pivot |
| J | 4 | Rear axle, top sway bar, frame RH rear suspension, frame RH hoist cylinder, body RH body pivot |
| K | 3 | LH rear suspension, axle Rear axle, top front bar, axle Rear axle, top sway bar, axle |
| L | 3 | Rear axle, bottom RH bar, axle LH rear suspension, frame RH rear suspension, axle |

SYSTEM COMPONENTS

Filter

A filter assembly mounted on the grease reservoir filters the grease from the shop supply. A bypass indicator alerts service personnel when the filter requires replacement.

Hydraulic Motor and Pump

Hydraulic motor (3, Figure 42-1) and pump (9) together are a fully hydraulic grease pump. An integrated pump control manifold is incorporated with the motor to control input flow and pressure.

NOTE: The pump crankcase oil level must be maintained to the level of the pipe plug port. Later models are equipped with a dipstick (3, 42-6). Refill with 10W-30 motor oil.



Hydraulic oil supply inlet pressure must not exceed 20 685 kPa (3000 psi). Exceeding the rated pressure may result in damage to system components and personal injury.

Grease Reservoir

Grease reservoir (12) has an approximate capacity of 41 kg (90 lb) of grease. When the grease supply is replenished, grease entering the system passes through the filter to remove contaminants before settling into the reservoir.

Pressure Reducing Valve

Pressure reducing valve (4), located on the manifold, reduces the hydraulic supply pressure from the truck steering circuit. Hydraulic pressure is reduced to an operating pressure of 2240 to 2415 kPa (325 to 350 psi). The hydraulic motor operates at this pressure to drive the grease pump. The pressure reducing valve has been factory adjusted. DO NOT attempt to adjust the setting.

Solenoid Valve

Solenoid valve (5), when energized, allows oil to flow to the hydraulic motor.

Flow Control Valve

Flow control valve (10) mounted on the manifold, controls the amount of oil flow to the hydraulic motor. The flow control valve has been factory adjusted. DO NOT attempt to adjust the setting.

Vent Valve

Vent valve (7, Figure 42-1) opens and closes to control the pressure in the system. With the valve closed, the pump continues to operate until maximum grease pressure is achieved. As this occurs, the vent valve opens and allows the grease pressure to drop to 0, so the injectors can recharge for their next output cycle.

Injectors

Each injector (Figure 42-2) delivers a controlled amount of pressurized lubricant to a designated lube point.

Lubrication Timer

Lubrication timer (1, Figure 42-3) is a solid state controller providing a 24 VDC timed-interval signal to energize solenoid valve (5, Figure 42-1). Operation of the solenoid valve controls the oil flow to operate the hydraulic motor. This controller is mounted in the electrical compartment in the rear of the cab.

Pressure Gauge

Pressure gauge (8, Figure 42-1) monitors hydraulic oil pressure to the inlet of the hydraulic motor.

NOTE: Newer models do not come equipped with a pressure gauge. However, a gauge may be installed in the port if desired.

Pump Cutoff Pressure Switch (Optional)

Pump cutoff pressure switch (11, Figure 42-1) de-energizes the pump solenoid relay when the grease pressure reaches the set pressure. This switch is used when the lubrication controller dip switch is set to “controller”.

Remote Fill Port

A remote fill port (1, Figure 42-4) is located on the RH bumper. Indicator light (2) will illuminate when the system grease level is full.

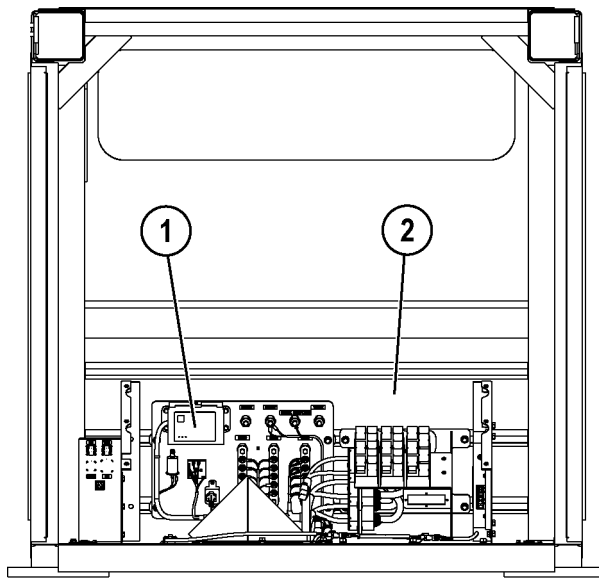

P030055

FIGURE 42-3. LUBRICATION CONTROLLER LOCATION

(Covers and controller panel, not shown.)

- 1. Lubrication Timer
- 2. Cab Rear Electrical Compartment

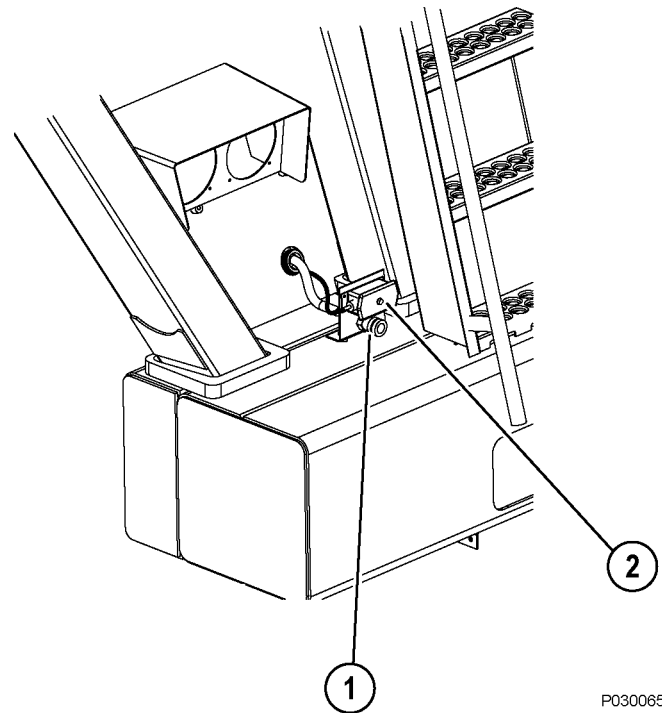

P03006E

FIGURE 42-4. REMOTE FILL PORT

- 1. Fill Port
- 2. Indicator Light

SYSTEM OPERATION

1. During truck operation, the lubrication controller will energize the system at a preset time interval.
2. The controller provides 24 VDC to energize the pump solenoid valve. The solenoid controls the hydraulic oil provided by the steering circuit. The hydraulic oil drives the motor and pump.
3. Hydraulic oil pressure from the steering circuit is reduced to 2240 to 2413 kPa (325 to 350 psi) by pressure reducing valve (4, Figure 42-5) before entering the motor. The amount of oil supplied to the pump is limited by flow control valve (6). Pump pressure can be read using gauge (5) mounted on the manifold.
4. With oil flowing into the hydraulic motor, the grease pump suctions grease from the reservoir. Grease output from the pump flows through check valve (10) to injectors (13) and to vent valve (11).
5. During this period, the injectors will meter the appropriate amount of grease to each lubrication point.
6. When the timing period is complete, the controller will remove the power from the pump solenoid valve.
7. After the pump solenoid is de-energized, hydraulic pressure in the manifold drops and vent valve (11) will open. When the vent valve opens, grease pressure in the lines is released to the injector banks. When this occurs, the injectors are then able to recharge for the next lubrication cycle.
8. The system will remain at rest until the lubrication controller turns on and initiates a new grease cycle.

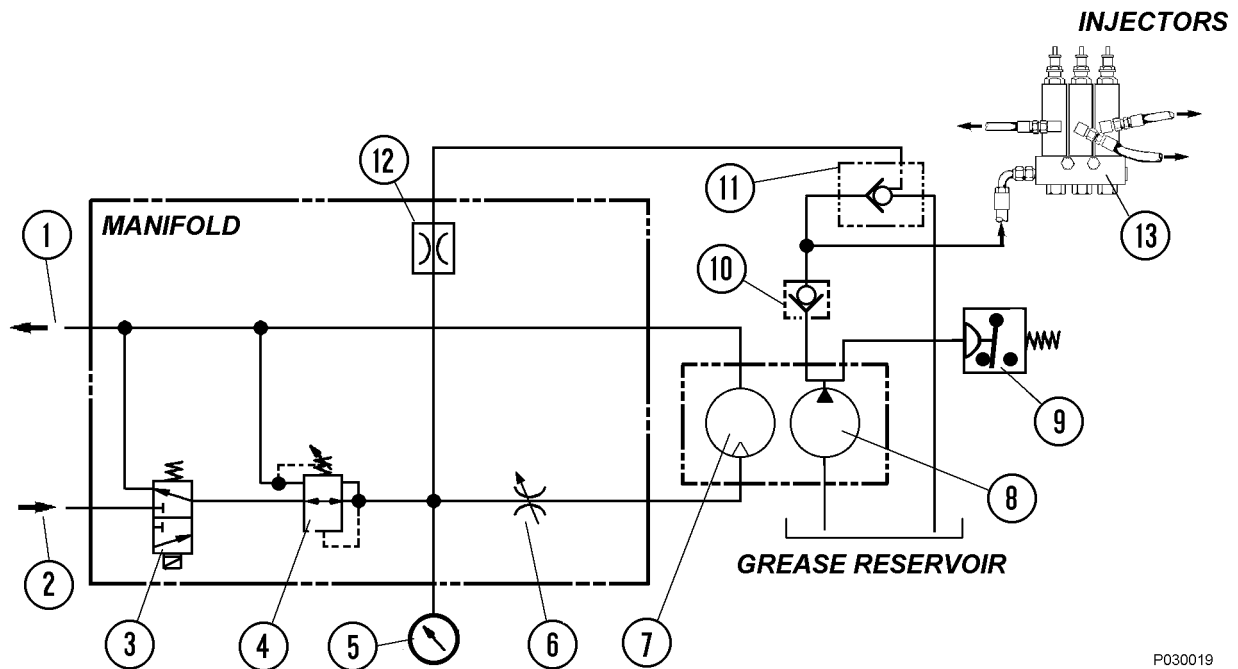

P030019

FIGURE 42-5. HYDRAULIC SCHEMATIC

- | | | |
|----------------------------|-------------------------------|-------------------|
| 1. Hydraulic Oil Return | 6. Flow Control Valve | 11. Vent Valve |
| 2. Hydraulic Oil Supply | 7. Hydraulic Motor | 12. Orifice |
| 3. Pump Solenoid Valve | 8. Grease Pump | 13. Injector Bank |
| 4. Pressure Reducing Valve | 9. Pressure Switch (Optional) | |
| 5. Motor Pressure Gauge | 10. Check Valve | |

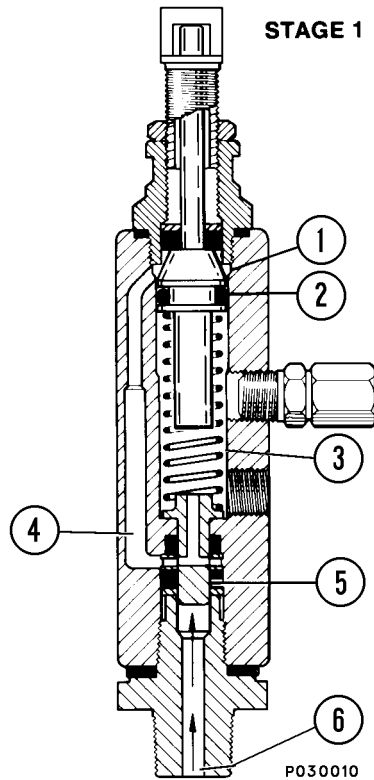

INJECTOR OPERATION

STAGE 1.

Injector piston (2) is in its normal or “rest” position. Discharge chamber (3) is filled with lubricant from the previous cycle. With pressure applied from incoming lubricant (6), slide valve (5) is about to open passage (4) leading to measuring chamber (1).

STAGE 2.

When slide valve (5) opens to passage (4), lubricant (6) is admitted to measuring chamber (1). This forces lubricant from discharge chamber (3) through outlet port (7) to the lubrication destination.

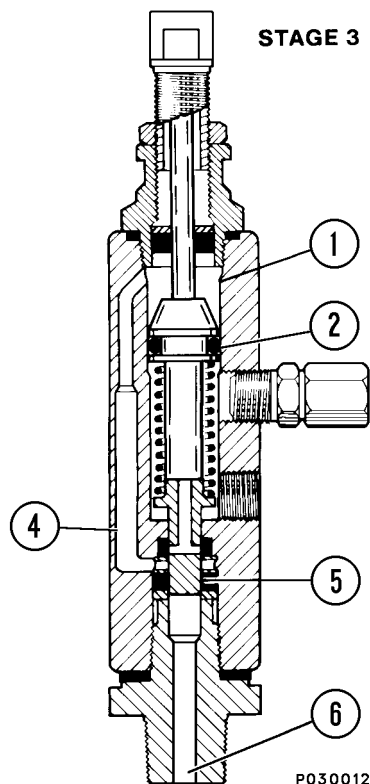
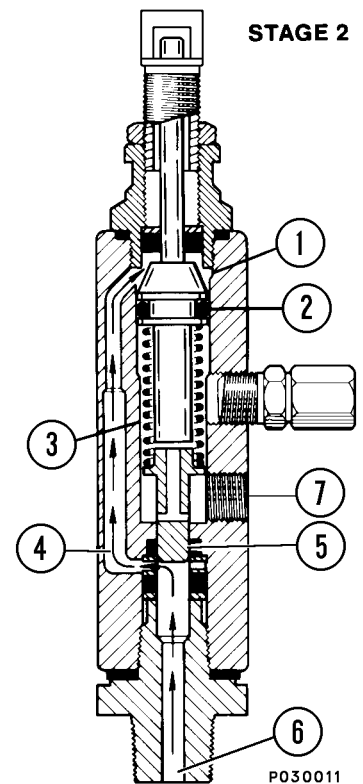

STAGE 3.

As injector piston (2) completes its stroke, it pushes slide valve (5) past passage (4). This stops further admission of lubricant (6) to passage (4) and measuring chamber (1). Injector piston (2) and slide valve (5) remain in this position until lubricant pressure in supply line (6) is vented.

STAGE 4.

After venting, the injector spring expands, causing slide valve (5) to move. As the valve moves, passage (4) and discharge chamber (3) connect through valve port (8). Further expansion of the spring causes the piston to move upward. This forces the grease into measuring chamber (1) through passage (4) and valve port (8). Discharge chamber (3) refills.

The injector is now ready for the next cycle.

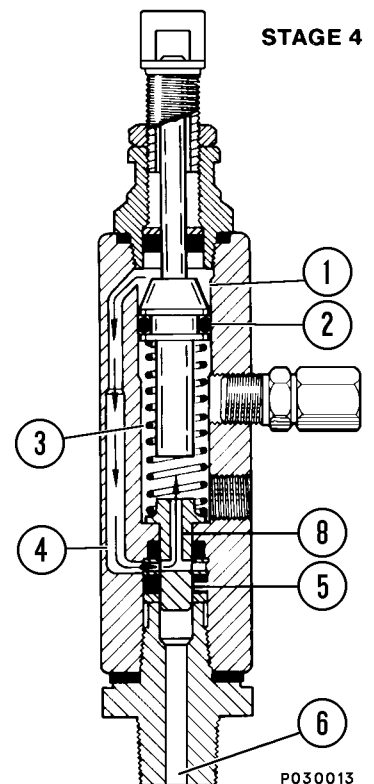

LUBRICANT PUMP

Pump Housing Oil Level

The pump housing must be filled to the proper level with SAE 10W-30 motor oil. Check the oil level at 1000 hour intervals. To add oil, remove plug (4, Figure 42-6) and fill the housing to the bottom of the plug hole. Newer models are equipped with a dipstick (3). Remove the dipstick and add oil to the proper level.

Pump Pressure Control

High pressure hydraulic fluid from the truck steering system is reduced to 2240 to 2413 kPa (325 to 350 psi) by pressure reducing valve (1). The reducing valve is located on the manifold on top of the pump motor. Operating pressure can be read on the gauge installed on the manifold. Occasionally check the gauge to verify pressure is within the specified range. The pressure reducing valve is not adjustable. If operating pressure is not within limits, the pressure reducing valve must be replaced.

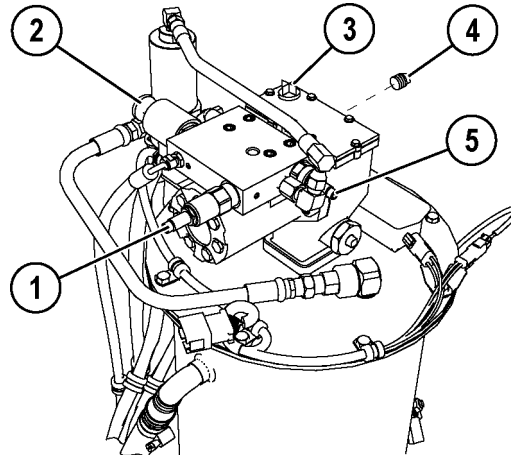

83114

FIGURE 42-6. PUMP CONTROLS

- | | |
|----------------------------|-----------------------|
| 1. Pressure Reducing Valve | 4. Oil Level Plug |
| 2. Test Switch | 5. Flow Control Valve |
| 3. Dipstick | |

INJECTORS (SL-1 Series “H”)

Injector Specifications

- Each lube injector services only one grease point. In case of pump malfunction, each injector is equipped with a covered grease fitting to allow the use of manual lubrication equipment.
- Injector output volume:
 - Maximum output = 1.31 cc (0.08 in³)
 - Minimum output = 0.13 cc (0.008 in³)
- Operating Pressure:
 - Minimum - 12 755 kPa (1850 psi)
 - Maximum - 24 133 kPa (3500 psi)
 - Recommended - 17 238 kPa (2500 psi)
- Maximum Vent Pressure - (Recharge)
 - 4137 kPa (600 psi)

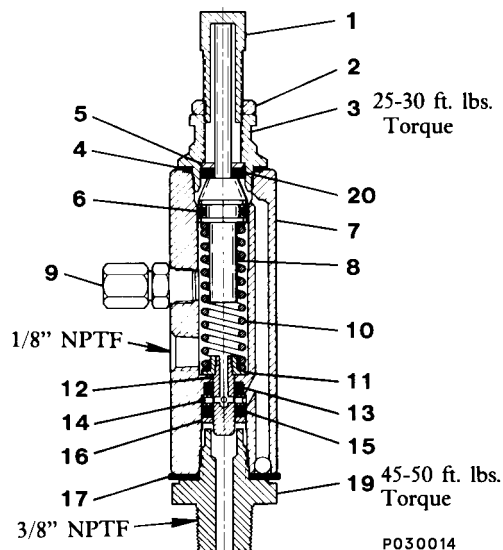

FIGURE 42-7. TYPE SL-1 INJECTOR

- | | |
|------------------------|-------------------|
| 1. Adjusting Screw | 11. Spring Seat |
| 2. Locknut | 12. Plunger |
| 3. Piston Stop Plug | 13. Viton Packing |
| 4. Gasket | 14. Inlet Disc |
| 5. Washer | 15. Viton Packing |
| 6. Viton O-Ring | 16. Washer |
| 7. Injector Body Assy. | 17. Gasket |
| 8. Piston Assembly | 18. Adapter Bolt |
| 9. Fitting Assembly | 19. Adapter |
| 10. Plunger Spring | 20. Viton Packing |

NOTE: Piston assembly (8) has a visible indicator pin at the top of the assembly to verify injector operation.

Injector Adjustment

The injectors may be adjusted to supply from 0.13 cc to 1.31 cc (0.008 in³ to 0.08 in³) of lubricant per injection cycle. The injector piston travel distance determines the amount of lubricant supplied. Piston travel is controlled by an adjusting screw in the top of the injector housing.

Turn adjusting screw (1, Figure 42-7) counterclockwise to increase injector output and clockwise to decrease injector output.

When the injector is not pressurized, maximum injector delivery volume is attained by turning the adjusting screw (1) fully counterclockwise. Turn until the indicating pin (8) just touches the adjusting screw. At the maximum delivery point, about 9.7 mm (0.38 in.) of adjusting screw threads will be exposed. Decrease the delivered lubricant amount by turning the adjusting screw clockwise to limit injector piston travel. If only half the lubricant is needed, turn the adjusting screw to the point where about 4.8 mm (0.19 in.) threads are exposed. The injector will be set at the minimum delivery point with about 0.22 mm (0.009 in.) thread exposed.

NOTE: The information above relates only to the adjustment of injector delivery volume. The timer adjustment must also be changed if overall lubricant delivery is inadequate or excessive. Do not adjust Injector output to less than one-fourth capacity.

SYSTEM PRIMING

The system must be full of grease and free of air pockets to function properly. After maintenance, if the primary or secondary lubrication lines were replaced, it will be necessary to prime the system to purge entrapped air.

1. Fill the reservoir with lubricant, if necessary.
2. To purge air from the main supply line, remove the main supply line at the reservoir and connect an external grease supply to the line.
3. Remove plugs from each injector group in sequence (right front, left front, and rear axle).
4. Using the external grease source, pump grease until it reaches the injector group. Install the pipe plug and repeat for the remaining injector groups.
5. Remove the caps from each injector. Connect an external grease supply to the zerk on the injector. Pump until grease reaches the far end of the individual grease hose or the joint being greased.

Filter Assembly

Replace element (5, Figure 42-8) if bypass indicator (2) indicates excessive element restriction.

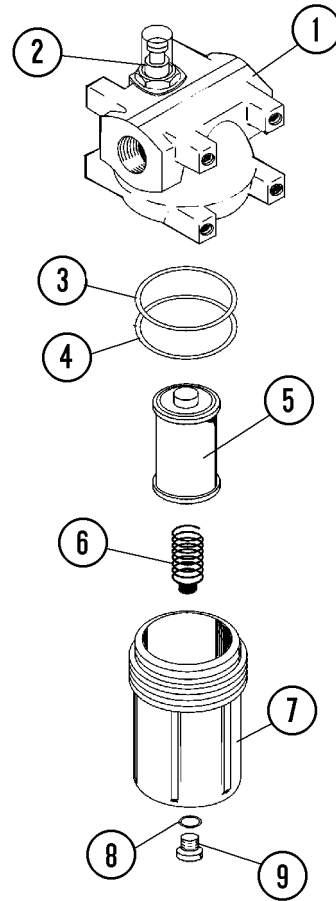

P030023

FIGURE 42-8. FILTER ASSEMBLY

- | | |
|---------------------|-----------|
| 1. Housing | 6. Spring |
| 2. Bypass Indicator | 7. Bowl |
| 3. O-Ring | 8. O-Ring |
| 4. Backup Ring | 9. Plug |
| 5. Element | |

SYSTEM CHECK

To check system operation (not including timer), proceed as follows:

1. Start the engine.
2. Actuate the lube system test switch at the reservoir/pump assembly.
3. The motor and pump should operate until the system attains 17 237 kPa (2500 psi).
4. Once the required pressure is achieved, turn the pump motor off. The system should vent.
5. Check for pump, hose or injector damage. Check for leakage with the system pressurized.
6. After checking the system, shut the engine off.

Lubrication Controller Check

Pressing the manual lube button on the enclosure cover will initiate a lube event. (See Figure 42-9).

Lubrication Controller Operation

The time between lube events is determined by the setting of the rotary switch and the dip switch. The rotary switch selects the numeral setting, and the dip switch selects the units in either minutes or hours.

Lubrication Controller Components

Mode switch (2, Figure 42-9) consists of four dip switches. The first dip switch controls the maximum amount of "on time", either 30 seconds or 120 seconds.

The second dip switch controls the mode, either timer mode or controller mode. When the switch is set to the timer mode, the amount of time that the pump is on will be determined by the setting of the dip switch - 30 seconds or 120 seconds. When the switch is set to the controller mode, a pressure switch must be installed in the lube supply line. The pressure switch will detect supply line pressure, and will reset the timer at a set pressure. If the pump fails to reach the set pressure within the dip switch set time, the controller will initiate an alarm.

The third dip switch is for selecting the units for the "off time". This setting is to be used in conjunction with off time switch (1). Hours or minutes may be selected.

The fourth dip switch is used to select "memory off" or "memory on". When the switch is set to "memory off", a lube cycle will occur each time power is turned on. The lube cycle will start at the beginning of the on time setting.

When the switch is set to "memory on", the controller will function as follows:

- When power is turned off between lube cycles, the lube cycle will resume at the point of interruption after power is restored. In other words, the controller will remember its position in the cycle.
- When power is turned off during a cycle, the controller will reset to the beginning of the lube cycle after power is restored.

Off time switch (1) is used to select units of time. Possible time intervals are: 0.5, 1, 2, 4, 8, 15, 24 or 30. The mode switch determines whether the off time units will be minutes or hours.

Cover (3) contains three Light Emitting Diode (LED) windows and a manual lube switch. The LED's indicate system operation and status. When power is on, a green LED will illuminate. When the pump is on, another green LED will illuminate. A red LED will illuminate when an alarm condition occurs.

The manual lube switch, when depressed, will initiate a lube cycle.

Lubrication Controller Adjustment

The lubrication controller is factory adjusted to the following switch settings:

| | |
|------------------------|-------------|
| Dip switch 1 | 120 seconds |
| Dip switch 2 | timer |
| Dip switch 3 | minutes |
| Dip switch 4 | memory off |
| Rotary Switch. | 15 minutes |

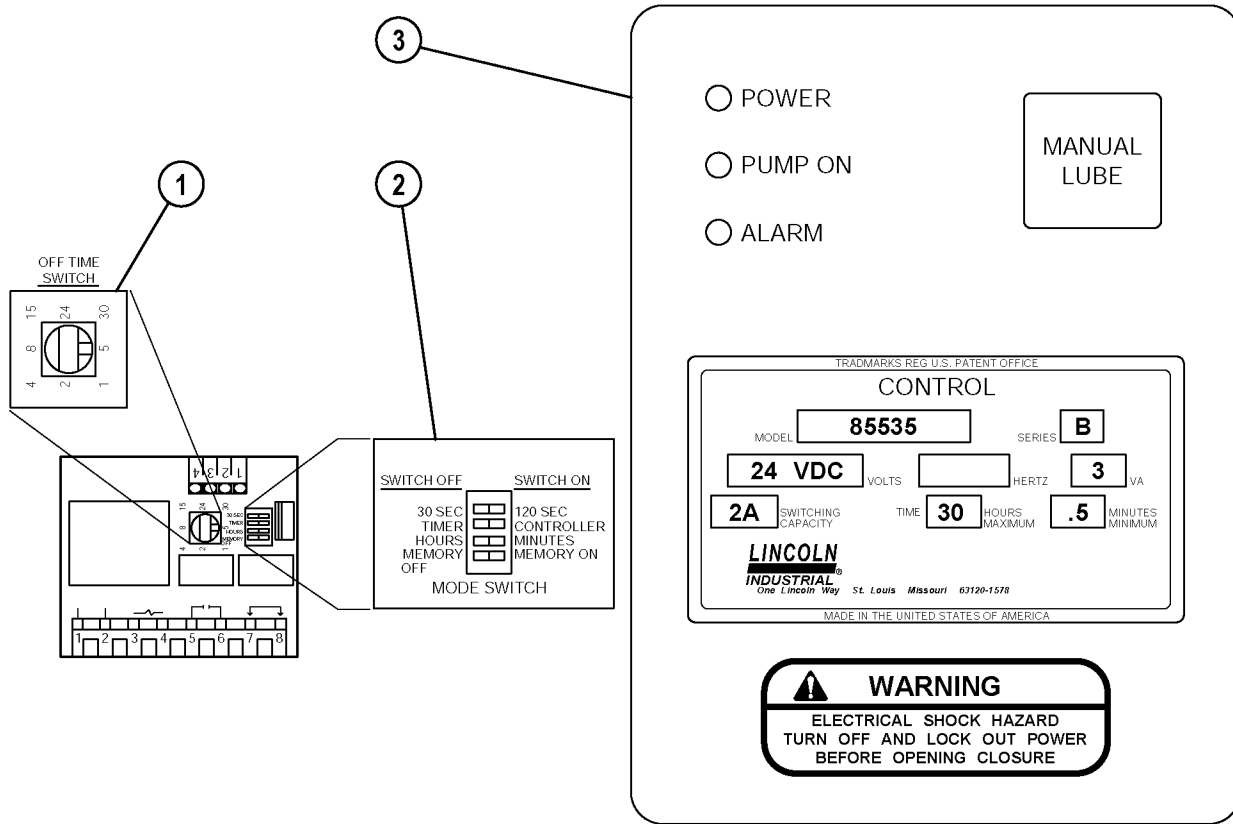

P030054

FIGURE 42-9. LUBRICATION TIMER

- 1. Off Time Switch
- 2. Mode Switch
- 3. Cover

SYSTEM TROUBLESHOOTING CHART

NOTE: If the following procedures do not correct the problem, contact a factory authorized service center.

| Symptom | Possible Causes | Corrective Action |
|--|--|--|
| Pump Does Not Operate | Lube system not grounded. Electrical power loss. Controller malfunction. Solenoid valve malfunctioning. Motor or pump malfunction. | Correct grounding connections to pump assembly and truck chassis. Locate cause of power loss and repair. 24 VDC power required. Ensure key switch is ON. Replace the controller assembly Replace the solenoid valve assembly Repair or replace motor and/or pump assembly. Refer to the service manual for rebuild instructions. |
| Pump Will Not Prime | Low lubricant supply. | Dirt in reservoir, pump inlet clogged, filter clogged. |
| Pump Will Not Build Pressure | Air trapped in lubricant supply line. Lubricant supply line leaking. Vent valve leaking. Pump worn or scored. | Prime system to remove trapped air. Check lines and connections to repair leakage. Clean or replace vent valve. Repair or replace pump assembly. Refer to the service manual for rebuild instructions. |
| Injector Indicator Stem Does Not Operate | <i>NOTE: Normally during operation, the injector indicator stem will move into the body of the injector when pressure builds. When the system vents and releases pressure, the indicator stem will again move out into the adjusting yoke.</i> | |
| | Malfunctioning injector - usually indicated by the pump building pressure and then venting. All injectors inoperative - pump build up not sufficient to cycle injectors. | Replace individual injector assembly. Service and/or replace pump assembly. Refer to the service manual for rebuild instructions. |
| Pressure Gauge Does Not Register Pressure | No system pressure to the pump motor. No 24 VDC signal at pump solenoid. Pressure reducing valve not functioning properly. | Check hydraulic hose from steering system. Determine problem in 24 VDC electric system. Refer to Pump Pressure Control. |

| Symptom | Possible Causes | Corrective Action |
|--|--|---|
| Pump Pressure Builds Very Slowly Or Not At All | No signal at solenoid. | Check timer. |
| Controller Does Not Operate | No electric power to controller. | Turn on electric power to pump. "POWER" LED should light, "PUMP ON" LED should light when "MANUAL LUBE" is pressed. |
| "PUMP ON" LED is lit, But Load Connected To Terminals 3 & 4 Will Not Energize | Printed circuit board failure. | Remove and replace. |
| Load Connected To Terminals 3 & 4 Energized, But "PUMP ON" LED Does Not Light | Printed circuit board failure or keypad failure. | Remove and replace. |
| Bearing Points Excessively Lubricated | Controller memory mode is off. | Switch controller memory mode to ON. |
| | Injector output adjustment setting too high. | Readjust to lower setting. |
| Bearing Points Are Not Sufficiently Lubricated | Timer/controller cycle time setting too low. | Set to longer cycle time or reevaluate lube requirements. |
| | Injector output adjustment setting too low. | Readjust injector output setting. |
| | Timer/controller cycle time setting does not deliver lubricant often enough. | Set to shorter cycle time or reevaluate lube requirements. |
| | System too large for pump output. | Calculate system requirements per planning manual. |

PREVENTATIVE MAINTENANCE

Use the following maintenance procedures to ensure proper system operation.

Daily Lubrication System Inspection

1. Check grease reservoir level.
Inspect grease level height after each shift of operation. Grease usage should be consistent from day-to-day operations.
 - Lack of lubricant usage would indicate an inoperative system. Excessive usage would indicate a broken supply line.
2. Check filter bypass indicator when filling reservoir. Replace element if bypassing.
3. Check all grease feed line hoses from the SL-1 injectors to the lubrication points.
 - a. Repair or replace all damaged hoses.
 - b. Ensure all air is purged and all new hoses are filled with grease before truck operation.
4. Inspect key lubrication points for a bead of lubricant around the seals. If a lubrication point appears dry, troubleshoot and repair the problem.

NOTE: It is good practice to manually lube each bearing point at the grease fitting provided on each Injector. This will indicate if there are any frozen or plugged bearings, and will help flush the bearings of contaminants.

250 Hour Inspection

1. Check all grease hoses from the SL-1 injectors to the lubrication points. See Figure 42-2.
 - a. Repair or replace all worn or broken hoses.
 - b. Ensure all air is purged and all new hoses are filled with grease before truck operation.
2. Check all grease hoses from the pump to the SL-1 injectors.
 - a. Repair or replace all worn or broken hoses.
 - b. Ensure all air is purged and all new hoses are filled with grease before truck operation.

3. Check the grease reservoir level.
 - a. Fill the reservoir as needed. Check the filter bypass indicator when filling the reservoir. Replace the element if grease is bypassing.
 - b. Check the reservoir for contaminants. Clean, if necessary.
 - c. Ensure all filler plugs, covers and breather vents on the reservoir are intact and free of contaminants.
4. Inspect all bearing points for a bead of lubricant around the bearing seal.
5. System Checkout
 - a. Remove all SL-1 injector cover caps to allow visual inspection of the injector cycle indicator pins during system operation.
 - b. Start the engine.
 - c. Actuate manual test switch (17, Figure 42-2). The hydraulic motor and grease pump should operate.
 - d. With the grease pressurized, check each SL-1 injector assembly.
The cycle indicator pin should be retracted inside the injector body.
 - e. When the system reaches 17 237 kPa (2500 psi), the pump should shut off. The pressure in the system should drop to zero, venting back to the grease reservoir.
 - f. With the system vented, check all of the SL-1 injector indicator pins; all of the pins should be visible. Replace or repair injectors, if defective.
 - g. Reinstall all injector cover caps.
 - h. Check controller operation.

NOTE: With the engine on, the lube system should activate within 5 minutes. The system should build 13 790 to 17 237 kPa (2000 to 2500 psi) within 25-40 seconds.

- i. If the system is working properly, the machine is ready for operation.
- j. If the system is malfunctioning, refer to the troubleshooting chart.

1000 Hour Inspection

1. Check the pump housing oil level. Fill to the bottom of the plug hole with SAE 10W-30 motor oil. Newer models are equipped with a dipstick (3). Remove the dipstick and add oil to the proper level.

MAJOR COMPONENTS AND SPECIFICATIONS

Engine

The Komatsu HD1500-7 dump truck is powered by a Komatsu SDA12V160 diesel engine. This engine is Tier 1 compliant.

Transmission

The torqflow transmission is a planetary gear, multiple disc clutch transmission. The transmission is hydraulically actuated and force-lubricated for optimum heat dissipation. A three-element, single-stage, two-phase torque converter is mounted to the front of the transmission.

The torqflow transmission is capable of seven forward speeds and one reverse speed. Automatic shifting is controlled by an electronic shift control system with automatic clutch modulation in all gears. A lockup system consisting of a wet, double-disc clutch, is activated in F1-F7 gears for increased fuel savings.

Final Drive

The final drive consists of a plug-in differential with planetary wheel drive.

Operator's Cab

The HD1500-7 operator's cab has been engineered for maximum operator comfort and to allow for efficient and safe operation of the truck.

The cab provides for wide visibility, with an integral four-post ROPS/FOPS. It includes the following: tinted safety-glass windshield, power-operated side windows, deluxe interior with a fully adjustable seat with lumbar support, fully adjustable tilt steering wheel, controls mounted within easy reach of the operator, and an electronic display/monitoring panel to keep the operator informed of the truck's operating circuits. Audible alarms and indicator lights warn the operator of system malfunctions.

Power Steering

The HD1500-7 truck is equipped with a full time power steering system. The system provides positive steering control with minimum effort by the operator. Nitrogen-charged accumulators automatically provide emergency power if steering pressure is reduced below an established minimum.

Brake System

Depressing the brake pedal, or operating the retarder, actuates the hydraulic front and rear service brakes. Both front and rear service brakes are oil-cooled, multiple-disc brakes. The brakes are automatically applied when engine speed exceeds the rated revolutions for the shift range. The system includes two nitrogen-charged accumulators for quick response. The accumulators provide secondary braking if a problem occurs in the primary braking circuit.

Retarder

The operator can manually apply both the front and rear oil-cooled, multiple-disc brakes by actuating the retarding system. The retarder control lever is mounted on the steering column.

The retarding system is also equipped with an Automatic Retard Speed Control (ARSC) system. The system automatically applies the retarder to maintain the set speed as initiated by the operator. Refer to Section 32, Operator Cab and Controls, for more information on the ARSC system.

Suspension

Hydro-pneumatic suspension cylinders are mounted at each wheel to reduce shock. The suspensions provide riding comfort for the operator and machine stability for safe travel.

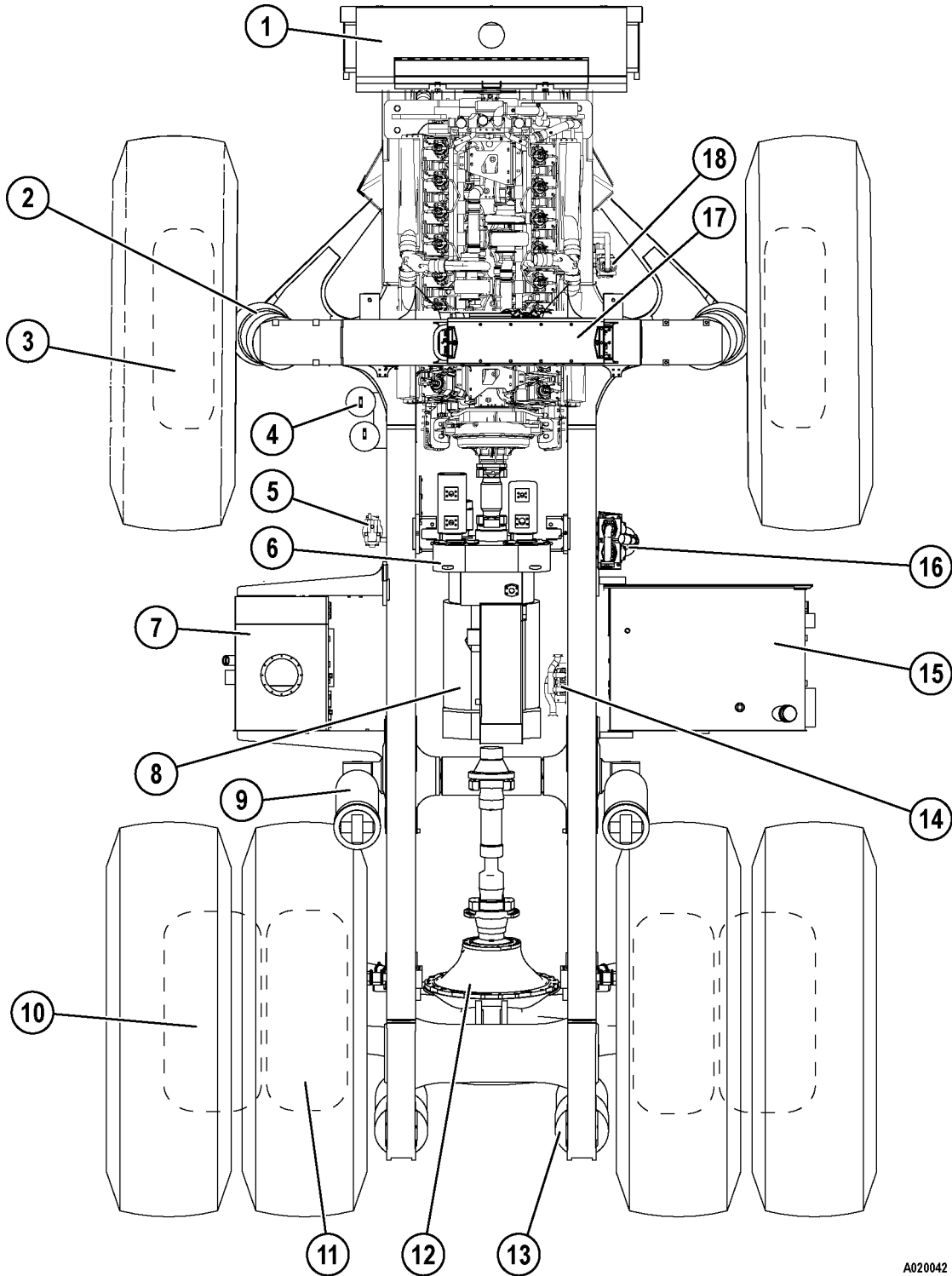

A020042

FIGURE 50-1. MAJOR COMPONENT LOCATION

- | | | |
|------------------------------|--------------------------|---------------------------|
| 1. Radiator | 7. Pump Drive | 13. Rear Suspension |
| 2. Front Suspension | 8. Transmission | 14. Brake Cooling Filters |
| 3. Front Wet Disc Brakes | 9. Hoist Cylinders | 15. Fuel Tank |
| 4. Steering Accumulators | 10. Final Drive | 16. Transmission Filters |
| 5. Steering And Brake Filter | 11. Rear Wet Disc Brakes | 17. Hydraulics Cabinet |
| 6. Hydraulic Tank | 12. Differential | 18. Brake Cooling Filter |

SPECIFICATIONS

Engine

Komatsu SDA12V160*
 Number of Cylinders 12
 Operating Cycle (diesel) 4-Stroke
 Rated . . . 1109 kW (1487 SAE Brake HP) at 1900 rpm
 Flywheel 1048 kW (1406 SAE HP) at 1900 rpm
 Weight (dry) 5813 kg (12,815 lb)
 * Tier 1 Compliant

Transmission

Automatic Electronic Shift Control with Automatic Clutch Modulation In All Gears.
 Torque Converter. 3-Element, Single-stage, Two-phase
 Lockup Clutch Wet, Double-disc, Activated in F1-F7 gears.
 Transmission 7 Forward Speeds, 1 Reverse Planetary Gear, Multiple Disc Clutch, Hydraulically Actuated, Force-lubricated

| Gear | kph | mph |
|-------------|------------|------------|
| 1 | 11.0 | 6.8 |
| 2 | 14.6 | 9.1 |
| 3 | 19.5 | 12.1 |
| 4 | 24.5 | 15.2 |
| 5 | 32.6 | 20.3 |
| 6 | 44.2 | 27.5 |
| 7 | 58.0 | 36.0 |
| Reverse | 10.6 | 6.6 |

Final Drive

Final Drive Plug-in Differential with Planetary Wheel Drive
 Reduction Ratios:
 Bevel Set 2.647:1
 Planetary Final Drive 7.235:1
 Total Reduction 19.151:1

Electrical System

Batteries (series-parallel) . . . 4 x 12V / 140 Amp-Hour
 Alternator 24 Volt, 140 Amp Output
 Lighting 24 Volt
 Cranking Motors Two - 24 Volt Electric

Service Capacities

| | Liters | U.S Gallons |
|--|---------------|--------------------|
| Engine (Includes Lube Oil Filters) | 193 | (51) |
| Cooling System | 532 | (141) |
| Fuel Tank | 2120 | (560) |
| Transmission And Torque Converter | 153 | (41) |
| Hydraulic System (Includes Retarder Cooling) | 900 | (238) |
| Differential | 297 | (78) |
| Final Drive (each planetary) | 120 | (32) |

Hydraulic System

Hydraulic Pumps (3)
 Hoist (Tandem Gear) 805 l/min. (213 gpm) @ 18 960 kPa (2,750 psi)
 Steering (Piston) 221 l/min. (58.5 gpm) @ 18 960 kPa (2,750 psi)
 Brake (Tandem Gear) 1512 l/min. (400 gpm)
 Hoist Control Valve Spool Type
 Positions Raise, Hold, Float, and Lower
 Hydraulic Cylinders
 Hoist 3-Stage Telescoping Piston
 Steering Twin - Double Acting Piston
 Relief Valve Setting 18 960 kPa (2,750 psi)
 Filtration In-line Replaceable Elements
 Suction Single, Full Flow, 100 Mesh
 Hoist & Steering Dual, Full Flow, In-line High Pressure. Beta 12 Rating = 200
 Transmission Dual, High Pressure

Service Brakes

Actuation: All-Hydraulic
 Front Oil-Cooled, Multiple-Disc
 Rear Oil-Cooled, Multiple-Disc
 Both act as service and retarder brakes
 Retarder Brakes:
 Normally Applied Manually By Operator. (w/ ARSC control)
 Automatically Actuated when engine speed exceeds the rated revolutions of the shift position for the transmission.
 Parking Brake: Spring-Applied, Oil Released Dry Caliper Disc Actuates On Rear Drive Shaft
 Secondary Brakes: Manual or automatic operation.

Steering

Turning Circle Diameter (SAE) 24.4 m (80 ft)
Automatic Emergency Steering 2 Accumulators

Tires

Rock Service (E-3) Tubeless
Standard 33.00 R51
Separable Tire Rims:
Rim Size 61x 12.95 x 12.7 cm (24 x 51 x 5 in.)

Dump Body Capacity (Standard)

Struck 54 m³ (71 yds³)
Heaped @ 2:1 (SAE) 78 m³ (102 yds³)

Overall Truck Dimensions

Loading Height 4.965 m (16' 3")
Minimum Clearance Height 5.85 m (19' 2")
Overall Length 11.37 m (37' 4")
Maximum Width 6.62 m (21' 9")

Weight Distribution

Empty Kilograms Pounds
Front Axle 51 714 114,008
Rear Axle 54 041 119,140
Total 105 755 233,148

Loaded (150 Ton Payload)

. Kilograms Pounds
Front Axle 83 824 184,800
Rear Axle 165 651 365,199
Total * 249 475 550,000

*Not to Exceed 249 475 kg (550,000 lb).

Including Options, Fuel & Payload

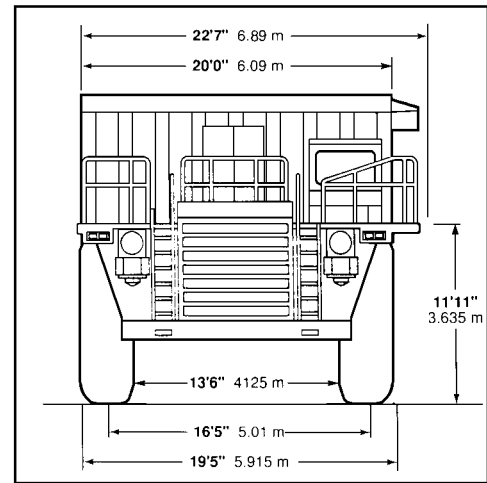
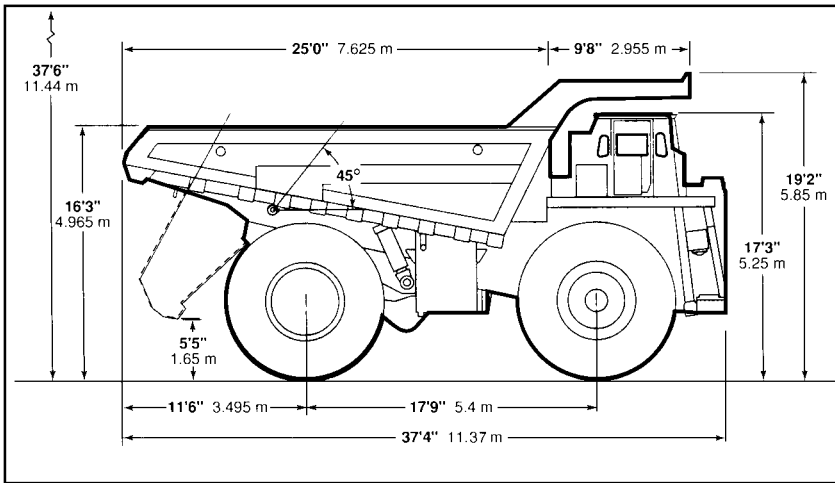

All dimensions are with 71/102 yd.³ 54/78 m³ body.
Vertical dimensions are for standard empty vehicle — subtract 4"/100 mm for vehicle loaded to max. GVW.
Minimum ground clearance (at max. GVW)..... 2'9" 838 mm

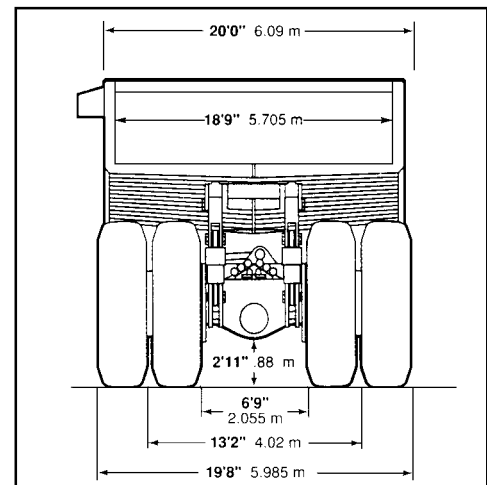

VEHICLE HEALTH MONITORING SYSTEM (VHMS)

The VHMS system is a machine management system. The VHMS controller gathers machine data sent from the other controllers and sensors installed on the machine. The data stored in the VHMS controller is sent via personal computer or sent automatically through a communications satellite (optional) to Komatsu. The data is compiled in the Komatsu computer server and analyzed.

Based on the machine data, your Komatsu distributor will provide information aimed at reducing machine repair costs and downtime.

NOTE: A contract is necessary before the VHMS system can be used. Contact your Komatsu distributor for more information.

CAUTION

DO NOT disassemble, repair, or modify the VHMS system without proper authorization. Changes to the system may cause machine failures and fire.

DO NOT touch VHMS system components during machine operation.

DO NOT pull on VHMS system wiring harnesses, connectors, or sensors. This may cause short circuits or open circuits and lead to machine failure or fire.

DO NOT allow water, dirt, or oil onto system components.

The Orbcomm satellite requires the installation of a pole and antenna, adding to the overall height of the machine. The height increase is 410 mm (16.2 in.). With the guard installed, the overall height increases another 260 mm (10.2 in.). Use caution when operating in areas with height restrictions.

DANGER

Anyone with a pacemaker must remain a minimum of 22 cm (9 in.) from the communications antenna. Radio waves from the antenna can interfere with pacemaker operation.

IMPORTANT

The VHMS system uses wireless components that transmit via radio waves. It is necessary to conform to local laws when using this system.

Proper operation of the system is dependent on good reception. Operating in tunnels, mountain ranges and covered areas may prevent communication of the system.

Contact your Komatsu distributor before selling or exporting a truck equipped with VHMS. It may be necessary to remove the system before transfer of ownership.

Contact your Komatsu distributor before installing equipment that may interfere with the VHMS system.

Komatsu is not responsible for any failures that result from neglecting VHMS system precautions and instructions.

DANGER

Orbcomm is a two-way radio communication device. Wireless signals from the system can interfere with other wireless signals in the area. This interference can cause a malfunction in a blast zone resulting in an unintended detonation. Know the locations of blast zones in the area and keep a safe distance to avoid unintentional blasts. If the machine is operating within a distance of 12m (40 ft) of a blast zone, disconnect the Orbcomm harness. Failure to do so could result in serious injury or death.

This warning does not supersede requirements or regulations of the area or country where this machine is in operation. The following specifications are provided to ensure compliance with all of the applicable requirements or regulations:

Transmit power: 5-10 Watts

Operating Frequency Range: 148 - 150 MHz

NOTE: The Orbcmm modem installed from the factory on all new trucks may not be approved for use in certain countries of the world. Local regulation may prohibit the use of the Orbcmm modem/satellite communicator. Depending on local regulation, you may need to either remove the modem or disconnect it and remove the antenna.

Check with KAC service for assistance and preferred action in your area.

The following is a list of "at risk" countries: China, Russia, Serbia, Tanzania, Senegal, Zambia, Botswana and Namibia.

VHMS DOWNLOADING

Downloading from inside the cab:

1. Turn the key switch to the ON position.
2. Connect the PLM download cable to PLM connector (1). Connect the other end of the cable to the RS232C port of the personal computer. If necessary, use a USB adapter to connect. Refer to Other Settings later in this chapter.
3. Download the data.

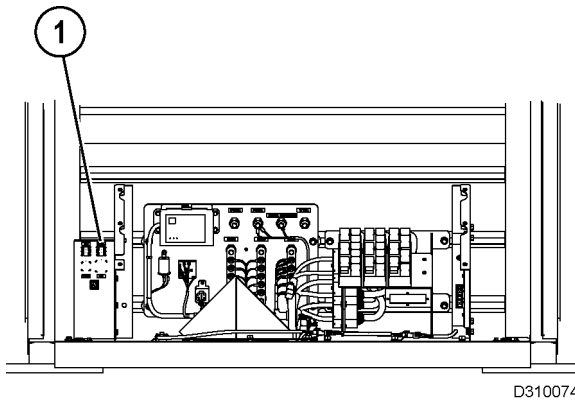

D310074

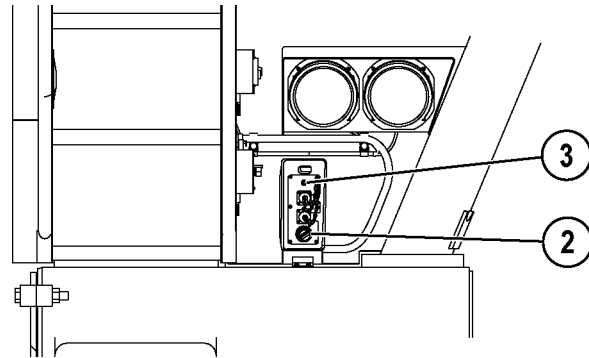

D310075

Downloading from the ground level download box:

1. Turn the key switch to the OFF position.
2. Open the download box on the LH bumper.
3. Move switch (2) inside the box to the ON position. When display lamp (3) illuminates, the system is ready to download.
4. After completion of downloading, return switch (2) to the OFF position.

PAYLOAD METER

The payload meter interprets machine data to calculate payload. The system uses the following inputs: suspension pressure sensors, inclinometer, body up switch, transmission shift lever, and speed sensors. The microcomputer built into the controller uses the inputs to calculate the payload. The calculated payload is displayed on the character display on the Electronic Display Panel (EDP). The external display lamps also display the payload conditions.

Data stored in the payload meter can be downloaded to a laptop computer using special software.

To ensure payload accuracy, set the shift lever to N, apply the brake lock, and release the retarder before dumping. Allow the machine to stabilize before dumping. If the machine is abruptly stopped at the dumping point, it will take a few moments for the payload display to stabilize. Dump on flat ground.

Payload display

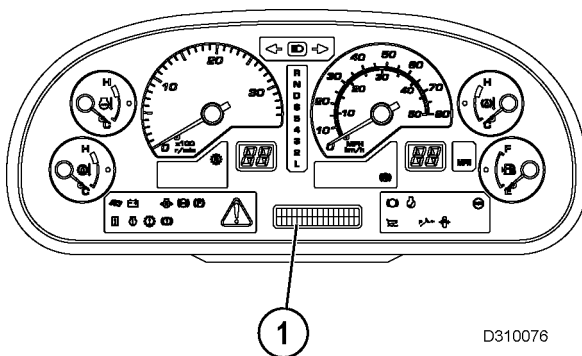

External display lamps

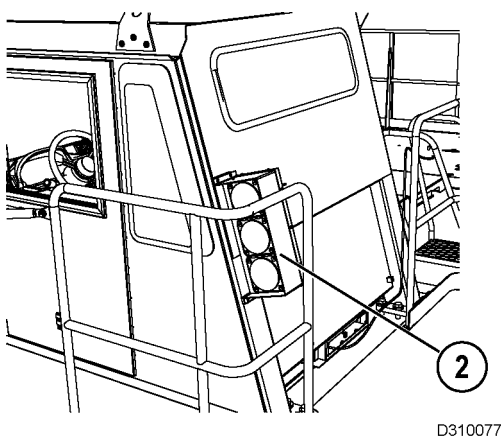

Download connector inside cab

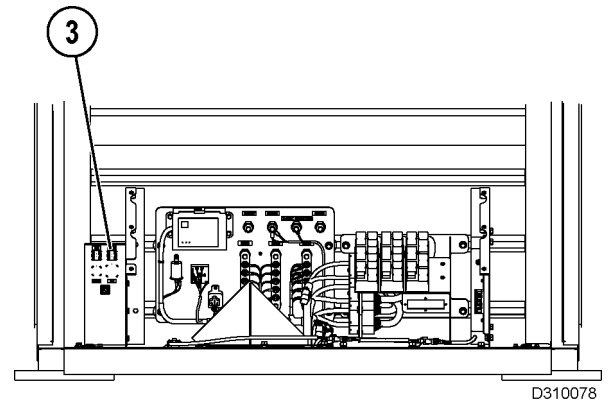

When downloading, remove the connected cable. After the download is complete, restore the cable to its original position. If the cable is not put back into place, download from the ground level box cannot be done.

Download connector outside cab

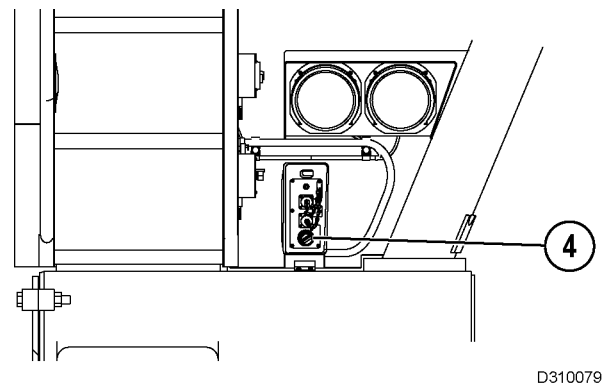

NORMAL OPERATION DISPLAY

| Machine condition | | Machine monitor display | External display lamps |
|----------------------------|--------------|------------------------------------|----------------------------|
| When starting switch is ON | | --- | Illuminates for 30 seconds |
| When empty | Stopped (*1) | Standard display (*2) | OFF |
| | Traveling | Standard display | OFF |
| During loading | Stopped | Payload display (*3) | Payload display |
| | Traveling | Standard display | OFF |
| When loaded | Stopped | Payload display | Payload display |
| | Traveling | Standard display | OFF |
| When dumping | Stopped | Payload display → standard display | Payload display → OFF |
| | Traveling | Standard display | OFF |

(*1) Stopped = shift lever is in the N position and the travel speed signal is 0.

(*2) For details of the standard display on the machine monitor, refer to Machine Monitor in Section 32.

(*3) The machine starts off empty and is being loaded. It is necessary to wait for the load to go above approximately 15% of the rated payload and for the change in the load to stabilize when the machine is stopped.

Example of payload display

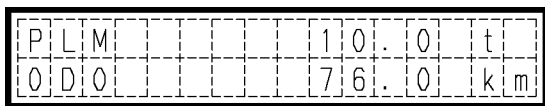

D310085

When the machine is stopped during loading, the service meter will not be displayed on the character display.

If it is desired to display the service meter, keep the machine monitor inspection switch pressed. The software version and service meter will be displayed in turn on the bottom line of the character display.

The payload at the loading point may differ slightly from the display at the dumping point. This is caused by the effect of the friction in the suspension, and is normal. Slight differences in payload from point to point do not indicate any failure in the payload meter.

Example of payload display when error occurs

If an error occurs in the suspension pressure sensors or in the inclinometer sensor, it becomes impossible to calculate the payload. The display will show [----].

EXTERNAL DISPLAY LAMPS

The external lamps display the payload as follows.

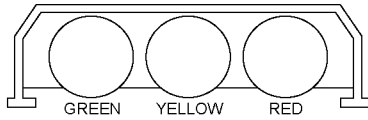

| Lamp Color | Payload - Metric Tons |
|------------|-----------------------|
| Green | 68 & up |
| Yellow | 122 & up |
| Red | 143 & up |

The green light signifies that additional loading is acceptable. The yellow light warns the operators that the load limit is approaching. The red light indicates an overload.



If the red lamp illuminates, the machine is overloaded. DO NOT haul a load with the red lamp on. Use the predicted load display to prevent overloading. Refer to Predicted Load Display.

PREDICTED LOAD DISPLAY

When the load changes as each bucket is loaded, the system estimates the total payload and flashes the appropriate lamp to prevent overloading.

The predicted load display and actual payload display are shown at the same time.

Example:

- Expected number of bucket loads 4
- 1st bucket 37 tons
- 2nd bucket 37 tons (total: 74 tons)
- 3rd bucket 37 tons (total: 111 tons)
- 4th bucket 37 tons (total: 148 tons)

When the machine is loaded in this manner, the external display lamps illuminate as shown in the table below.

| Number Of Loads | Indicator Lights | Explanation |
|-----------------|------------------|---|
| 1st Bucket | | The actual load is 37 tons, so none of the lamps illuminate. The predicted load is 74 tons, so none of the lamps flash. |
| 2nd Bucket | | The actual load is 74 tons, so none of the lamps illuminate. The predicted load is 111 tons, so the green lamp flashes. |
| 3rd Bucket | | The actual load is 111 tons, so the green lamp illuminates. The predicted load is 148 tons, so the yellow lamp flashes. |
| 4th Bucket | | The actual load is 148 tons, so the green and yellow lamps illuminate. The predicted load is 185 tons, so the red lamp flashes. |

CALIBRATING PLM

Perform calibrations when:

- the machine is received
- once every month
- when the suspension cylinder oil or nitrogen charge has been adjusted
- when a suspension pressure sensor has been replaced
- when the machine has been modified and the Empty Vehicle Weight (EVW) has changed more than 100 kg (221 lb)



Empty the body before calibration. Lower the body completely onto the frame. Place the hoist control in the FLOAT position.

Ensure no existing fault codes are present before calibration.

During calibration, operate the truck on a flat road surface. Travel in a straight line and maintain a speed of 10 km/h (6 mph).

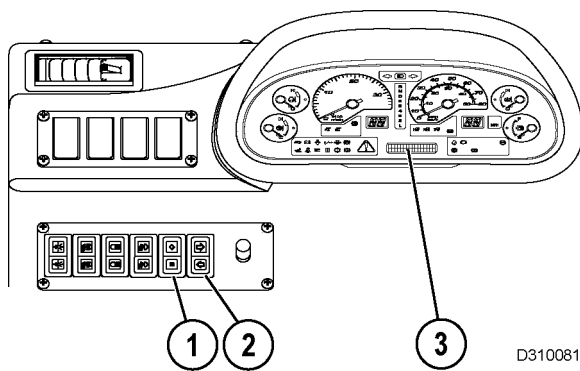

1. Operate the machine.
2. With the engine on, move the shift lever to the N position and stop the engine.

3. With the service meter/odometer value displayed on character display (3), press the (◇) portion of mode select switch (1) to switch to the operation information display.
4. Press the (>) portion of mode select switch (2) until the PLM display is reached.

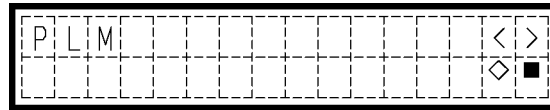

5. Press the (◇) portion of mode select switch (1) to display CALIBRATION. Then, press the (◇) again. The CALIBRATION display will flash.



6. Drive the machine at a speed of 10 km/h (6 mph). When the travel speed becomes stable, press the (◇) portion of mode select switch (1) to display CALIBRATION. The CALIBRATION display will flash two or three times, and then the display will change to the following.



NOTE: To cancel, press the (■) portion of mode select switch (1). The display will return to the service meter/odometer.

- Continue traveling at a speed of 10 km/h (6 mph). After approximately 30 seconds, the calibration should be completed and the display will change back to "PLM".

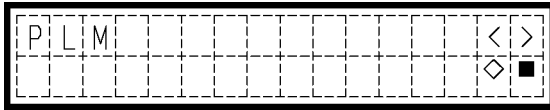

D310087

DATA STORED IN PAYLOAD METER

The payload meter interprets the period from one dump to the next dump as one cycle and records that data.

| Cycle Data Items | | | |
|------------------|--------------------------------------|--|---------------------------------------|
| Date (month/day) | Time of travel - empty | Time remaining stationary when loading | Time remaining stationary when loaded |
| Time of dump | Distance traveled - empty | Time of travel - loaded | Time taken to dump |
| Machine ID | Travel speed - empty (maximum) | Distance traveled - loaded | Speed limit |
| Open ID | Travel speed - empty (average) | Travel speed - loaded (maximum) | Warning items for each cycle |
| Payload | Time remaining stationary when empty | Travel speed - loaded (average) | |

The maximum limit for stored cycle data is 2900 cycles. When 2900 cycles is exceeded, the old data is overwritten.

Download the recorded data using the RS232C port on a personal computer with PLM software installed.

The downloaded data is saved in the specified location on the personal computer as a text file (CSV file). For details, see the instruction manual for the software.

It is possible to check the downloaded data with a commercially available spreadsheet software that can read text files.

PLM DOWNLOADING

Download the recorded data to a laptop computer that has the download software installed.

Downloading From Inside Of The Cab

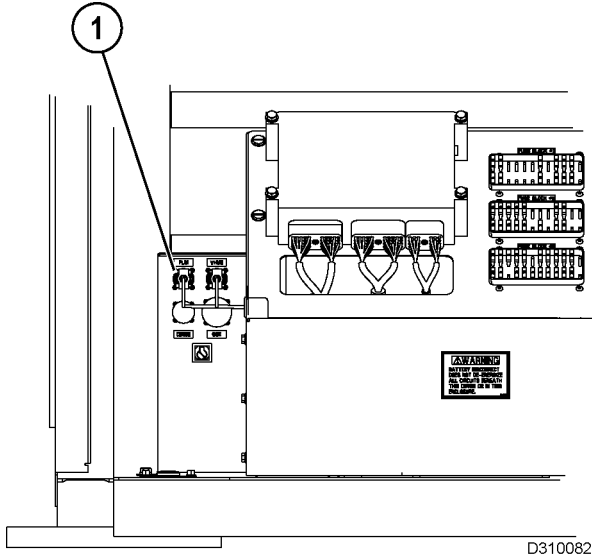

1. Connect the PLM download cable to PLM connector (1). Connect the other end of the cable to the RS232C port of the personal computer. If necessary, use a USB adapter to connect. Refer to Other Settings later in this chapter.
2. Turn the key switch to the ON position.
3. Turn on the computer and use the software to download the data.
4. After completing the download, remove the download cable.

Downloading From Ground Level Box



Before downloading from the ground level box, turn the key switch to the OFF position. Check the surrounding area and ensure it is safe.

1. Turn the key switch to the OFF position.
2. Open the ground level download box. Use the starting switch key to open and close the box.

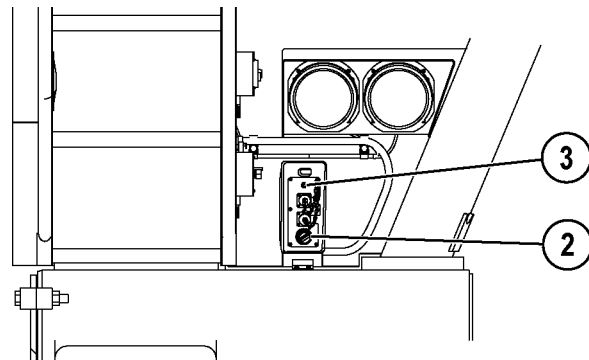

3. Turn switch (2) to the ON position. Display lamp (3) will illuminate.
4. Connect the PLM download cable to the PLM connector. Connect the other end of the cable to the RS232C port on the computer. If necessary, use a USB adapter to connect. Refer to Other Settings later in this chapter.
5. Turn on the computer and use the download software to download the data.
6. After completing the download, return the switch inside the box to the OFF position. Close the box.

SETTING THE MACHINE ID AND OPEN ID

It is possible to change the machine ID (identification) and open ID. These pieces of data are cycle data items. When changing the machine serial number for the machine ID or the operator or type of load for the open ID, set the value specified by the customer beforehand. This will make it possible to check the operator and type of load for the applicable cycle afterwards.

1. Start at the service meter/odometer display, and press the (◇) portion of mode select switch 1 to switch to the operation information display.

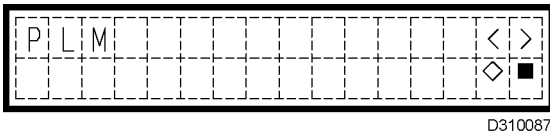

2. Press the (>) portion of mode select switch 2 until the PLM display is reached.

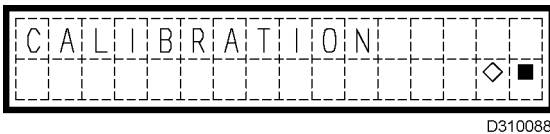

3. Press the (◇) portion of mode select switch 1 to display CALIBRATION.
4. Press the (>) portion of mode select switch 2. ID1 corresponds to the machine ID. The present setting is displayed on the bottom line.

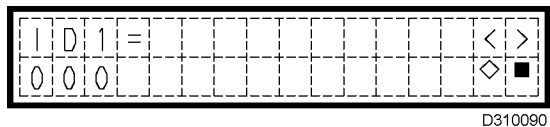

5. Press the (◇) portion of mode select switch 1.

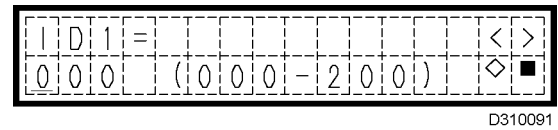

The available settings range from 0 to 200; input in order from the first digit. The place for insertion is marked by the cursor. Press the (<) or (>) to select 0 to 9. After inputting the value, press the (◇) portion of mode select switch 1. The cursor will move to the next position.

Repeat this procedure to input the values for all the digits. Confirm the settings and return to the previous screen.

If the (■) portion of mode select switch 1 is pressed while inputting any value, the value will stay as it is and the cursor will move to the first digit. If any mistake is made in the input, input again from the first digit.

To abandon the input step, press the (■) portion of mode select switch 1 to return to the previous screen.

6. When setting the open ID, press the (>) portion of mode select switch 2 (at Step 4).

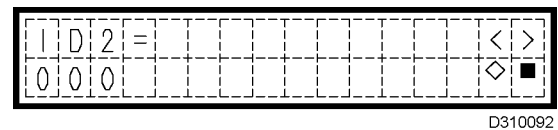

The procedure for setting ID2 is the same as for ID1 (machine ID).

Press the (■) portion of mode select switch 1 several times until the service meter/odometer id displayed.

PAYLOAD - CYCLE DATA ITEM

The payload measurements, which are recorded as data, apply to the haul payload in the applicable cycle.

The following two methods can be used for confirming the haul payload.

1. At the dumping point, record the payload when the dump lever is moved from FLOAT to any position other than FLOAT.
2. Process the data sampled when traveling from the loading point to the dumping point. Then confirm and record the haul payload when dumping.

When the machine is shipped from the factory, method (1) is used.

The method for processing and confirming the payload in method (2) is useful if the dumping point is at an angle.

If it is necessary to change the method for confirming the haul payload, consult your Komatsu distributor for instructions.

ADDITIONAL FUNCTIONS

Additional functions are available, but for normal use, there is no need to make any changes. If it is necessary to change these settings, please consult your Komatsu distributor.

Travel distance:

Travel distance is used to recognize completion of loading. The payload meter determines that the cycle is complete when the machine has traveled 160 m (525 ft) continuously from the loading point. If the dumping point is within 160 m (525 ft) from the loading point, the system will not recognize that a dump has occurred. Therefore, the cycle data will be incomplete. In instances where the loading point and the dumping point are extremely close, use this function to change the setting needed to recognize the completion of a cycle.

Confirming recorded payload:

Use this function to change how a haul payload is confirmed.

1. At the dumping point, record the payload when the dump lever is moved from FLOAT to any position other than FLOAT.
2. Process the data sampled when traveling from the loading point to the dumping point, then confirm and record the payload when dumping.

Other Settings

- If it is necessary to correct the data or time during the download, please consult your Komatsu distributor.
- If the payload and external display lamp display is different, or there is some error in the directory where the data is downloaded by the software, there may be an error in the machine setting. Please consult your Komatsu distributor.
- For computers that don't have a RS232C port, it may be possible to use a third party USB-RS232C conversion adapter. However, this does not guarantee the operation. In addition, the download software supports COM1 and COM2, so check which port it can be connected to.
- The payload meter has the function of communicating with the external equipment prepared by the customer. For details, please check with your Komatsu distributor. However, communications are carried out using the RS232C port for downloading, so in this case, it is impossible to download the data from the inside or outside of the cab.

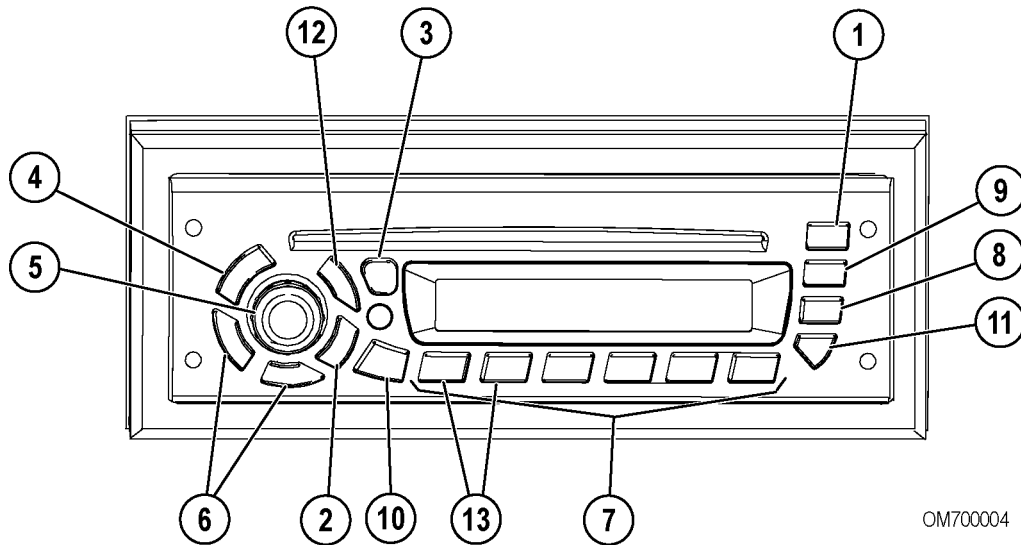
AM/FM RADIO / CD PLAYER

OM700004

FIGURE 70-1. AM/FM RADIO / CD PLAYER

- | | |
|--|--|
| <ol style="list-style-type: none"> 1. Ejects CD 2. BAND Switches between AM, FM1, FM2, FM3, WX (Weatherband) and Auxiliary Mode 3. TMSET/DSPL Switches to time set mode/Changes display 4. PWR Power 5. ON/AUDIO Power/volume/receiver settings 6. +TUNE/SEEK- Changes radio station or CD/MP3 track | <ol style="list-style-type: none"> 7. Push Buttons 1-6 Pre-set stations/CD/MP3 functions 8. PSCN/AUTO Scans presets on current band/stores strongest stations to preset 9. SCAN/DIM Scans all stations in current band or on CD/MP3 10. ALARM Switches to alarm set mode 11. RDM Plays CD/MP3 tracks randomly 12. Switches to CD/MP3 mode 13. FLDR+/- Changers folders on an MP3 disc |
|--|--|

OPERATING INSTRUCTIONS

To learn how to get the most from the receiver, read all of the instructions that follow.

GENERAL RADIO RECEIVER FUNCTIONS

The receiver is equipped with:

- An AM band with 6 AM presets
- Three FM bands for a total 18 FM presets
- One Weatherband with 6 WX presets

Turning On the Power

With the key switch ON, the receiver can be turned on and off by pressing the PWR (4, Figure 70-1) button. Pressing the ON/AUDIO (5) knob also activates the receiver.

One-Hour Timer

With the key switch OFF, pressing the PWR (4) button or the ON/AUDIO (5) knob will turn on the receiver and activate the receiver's one-hour timer. The receiver will turn off after one hour. Pressing the PWR (4) button or the ON/AUDIO (5) knob again reactivates the one-hour timer.

Display

The receiver will display the time of day when it is off. Momentarily pressing the TMSET/DSPL (3) button when the receiver is on allows to toggle between displays.

When the receiver is set to AM, FM1, FM2, FM3 or WX, the display will toggle between the frequency and time of day.

When in the CD mode, the display will toggle between track number and elapsed time, and time of day.

When playing an MP3 disc, the display will toggle between the ID3 tag (song title, artist and album title) and time of day.

Setting a Default Display

1. Press the BAND (2) button to enter the mode to set a default display.
2. Press and hold the TMSET/DSPL button for 2 seconds until the hours digits flash.
3. Press push button (6) until the desired display appears.

After 5 seconds of inactivity, the selected default will be displayed.

Adjusting the Brightness of the Display

If the dash dimmer does not control the brightness of the receiver display or the receiver is operating in One-Hour Timer mode, press and hold the SCAN/DIM (9) button until DIM and the brightness level appear on the display. Rotate the AUDIO knob clockwise to increase the brightness of the receiver display and counter-clockwise to decrease it.

Auxiliary Mode

When in Auxiliary mode, the radio can play an audio source from an iPOD or an MP3 player that is connected via the auxiliary radio lines.

To enable the Auxiliary mode:

- Press and hold the BAND (2) button for at least 2 seconds until the display shows EXTERNAL AUDIO.

To disable Auxiliary mode:

- Press and hold the BAND (2) button for at least 2 seconds until the radio reverts to the previous mode.

Adjusting the Receiver Settings

To adjust the Volume, Bass, Treble, Fade, Balance, Seek Sensitivity and Speakers, press and release the ON/AUDIO (5) knob repeatedly until the desired feature appears on the display.

VOLUME: Rotate the AUDIO knob clockwise to increase the volume and counter-clockwise to decrease it. The display will show VOL and the volume level.

BASS: Press the AUDIO knob until BASS and the current setting appears on the display. Rotate the knob clockwise to increase the bass sound and counter-clockwise to decrease it.

TREBLE: Press the AUDIO knob until TREBLE and the current setting appears. Rotate the knob clockwise to increase the treble sounds and counter-clockwise to decrease it.

FADE: Press the AUDIO knob until FADE and the current setting appears on the display. Rotate the knob clockwise to move the sound to the front speakers and counter-clockwise to move the sound to the rear.

BALANCE: Press the AUDIO knob until BALANCE and the level appear. Rotate the knob clockwise to move the sound to the right speakers and counter-clockwise to move the sound to the left.

SEEK SENSITIVITY: To adjust seek sensitivity, press the AUDIO knob until SEEK and the sensitivity level appear. Rotate the AUDIO knob to the desired setting. Increasing the sensitivity will help find more stations, including slightly weaker ones, while decreasing it will cause fewer, but stronger stations to be found.

SPEAKERS: Press the AUDIO knob until SPKR 4 appears on the display; rotate the knob to switch to 2-speaker functionality. SPKR 2 will appear on the display.

After 5 seconds of inactivity, the receiver will return to the default display.

USING THE CLOCK

The clock can function in a 12 or 24-hour mode. The 12-hour mode distinguishes between AM and PM. The 24-hour mode operates as military time. To toggle between the two modes:

1. Turn the key switch ON.
2. Press and hold the TMSET/ DSPL button for 2 seconds until the digits flash. This indicates you are in the time set mode.
3. Press and release push-button 5 to toggle between 12-hour and 24-hour modes.

After 5 seconds of inactivity, the display will return to the default display, and the current mode will be set.

Setting the Clock

1. Turn the key switch ON.
2. Press and hold the TMSET/DSPL button until the hours digits flash.
3. Press the +TUNE/SEEK- (6) to set the correct hour.
4. Press the TMSET/DSPL button again, and the minutes digits will flash.
5. Press the +TUNE/SEEK- (6) button to set the correct minute. Seconds are reset to zero when the minutes setting is changed.

After 5 seconds of inactivity, the display will return to the default display and the clock will be set.

USING THE ALARM

Momentarily pressing the ALARM (10) button will display the alarm set time.

When the ALARM icon is on the display, the alarm has been set. If the radio is on when the alarm sounds, there will be a beeping noise. If the receiver is off, the alarm will turn on and play the radio at the alarm volume. The alarm will continue to sound until the snooze is activated or the alarm is turned off.

Setting the Alarm

1. Press and hold the ALARM (10) button for 2 seconds until the ALARM icon and the display show AL TIME plus the current alarm time. This indicates the alarm-setting mode.
2. Press and release the +TUNE/SEEK- (6) until the desired alarm hour appears on the display.
3. Press the ALARM (10) button again to select the minutes display.
4. Press the +TUNE/SEEK- (6) until the desired alarm minutes appear on the display.

After 5 seconds of inactivity, the receiver will return to the default display, and the ALARM icon will remain illuminated indicating the alarm is set.

Turning the Alarm Off

Press and hold the ALARM (10) button until the display shows ALARM DISABLED and the ALARM icon on the display disappears.

Activating Snooze

Press any button on the radio faceplate when the alarm is sounding. The alarm will sound again in 9 minutes.

Setting Alarm Volume

1. Turn the receiver on.
2. Press and hold the ALARM button for 2 seconds until the ALARM icon and the display shows AL TIME plus the current alarm time. Rotate the AUDIO knob to increase or decrease the alarm volume as desired.

After 5 seconds of inactivity, the receiver will return to the default display and the volume level at which the receiver was previously playing.

NOTE: The alarm will be activated unless the ALARM button is held for 2 seconds again.

USING THE RADIO

Finding a Station

BAND (2): Press this button to switch between AM, FM1, FM2, FM3, and Weather (WX). The receiver display will show your selection.

+TUNE/SEEK- (6): Press and hold both +TUNE and BAND (2) for 2 seconds to switch between manual tune and seek modes. The display will show either MANUAL or SEEK to indicate the mode.

MANUAL TUNE: Press the +TUNE/SEEK- (6) button once to tune to the next higher or lower station, one frequency at a time. Holding +TUNE/SEEK- for more than half a second begins fast tuning.

SEEK: Press the +TUNE/SEEK- (6) button once to tune to the next higher or lower station. Holding +TUNE/SEEK- for more than half a second activates the Seek function, and SEEK will appear on the display. When a station with a strong enough signal is found, Seek will stop and the station will play. If a station is not found with a strong enough signal after searching the band twice, the Seek function will end and NO STATION FOUND will appear for 5 seconds. Then, the default display will appear and the radio will continue to play. Seek can be cancelled by pressing +TUNE/SEEK- again.

AUDIO STORE (AUTO): AUTO automatically stores the 6 strongest stations onto pushbuttons 1-6. Press and hold PSCN/AUTO (8) until AUTO and the AS icon appear on the display. AUTO STORE only saves presets in the band to which you are listening. If you press AUTO while listening to FM1, the presets on AM, FM2, FM3 and WX will not change. Pressing and holding AUTO again for more than 2 seconds will cancel Auto Store, and the original presets will be restored.

SCAN: Press SCAN/DIM (9) to scan all stations on the current band. When a frequency of sufficient strength is found, the radio will play for 5 seconds and then continue scanning until you press SCAN again. The display will show SCAN and the frequency being scanned.

PSCN: Press PSCN/AUTO (8) to scan the presets on the band the radio is currently playing (FM will scan FM1, FM2 and FM3). When a preset frequency of sufficient strength is found, the radio will play for 5 seconds and then continue scanning. The display will show PSCN, the frequency, preset number and the band icon. Preset Scan will continue until the PSCN is pressed again.

Setting the Presets

The six numbered pushbuttons allow to preset 6 favorite stations per band and easily return to them with the touch of a button. To set the presets:

1. Turn the key switch and the receiver ON.
2. Select the band.
3. Tune to the desired station.
4. Press and hold one of the six numbered buttons for more than 2 seconds to store the selected station. During the 2-second set time, the radio will be muted and the number icon will not be visible. Both the audio and selected preset icon will return, indicating the station has been set.
5. Repeat steps 1-4 for each push-button.

Pressing a preset button in the future will tune the radio to the station you set on the band to which you are listening.

USING THE WEATHERBAND

NOAA Weather Radio is a service of the National Weather Service. It provides continuous broadcasts of the latest weather information directly from the National Weather Service offices. Taped weather messages are repeated every four to six minutes and are revised every one to three hours or more frequently if needed. Most of the stations operate 24 hours a day.

The weather for the local area can be found on one of 7 stations. When in the Weatherband mode, the display will show the WX icon and CH plus the channel number. The channel can be changed using the +TUNE/SEEK- (6) button and can also be preset to the pushbuttons.

The frequencies associated with each channel are as follows:

1. 162.550 MHz
2. 162.400 MHz
3. 162.475 MHz
4. 162.425 MHz
5. 162.450 MHz
6. 162.500 MHz
7. 162.525 MHz

The National Weather Service operates approximately 372 stations. Close to 90 percent of the nation's population is within listening range of an NOAA Weather Radio broadcast.

USING THE COMPACT DISC PLAYER

The integral CD player plays full size CDs and MP3 discs. Press the to switch to CD/MP3 mode.

Playing a Compact Disc

1. Turn the key switch and the receiver on.
2. Insert a disc partway into the slot, label-side up. The player will automatically pull the disc in once it has been partially inserted. The CD icon and the words READING DISC will appear, and the disc will begin to play.
3. If the radio is currently tuned to AM/FM/WX press the CD button to play a CD that has been loaded into the player. If no CD has been loaded, the display will show NO CD for 5 seconds and return to the default display. If a CD has been loaded, the display will show the track number and the elapsed time on the display

If a CD is ejected and not removed within 25 seconds, the CD will be reloaded, but will not start playing until the CD button is pressed.

A CD can be inserted while the key switch is OFF. To do so, press and insert a CD within 25 seconds.

Button Functions

+TUNE: Press + TUNE once to forward to the next track. The track number and elapsed time will appear. Press and hold + TUNE to advance tracks quickly.

SEEK-: Press SEEK- once to return to the beginning of the track being played. Pressing this button during the first 8 seconds of the track will play the previous track. The track number and elapsed time will appear. Press and hold SEEK- to fast reverse.

3/PAUSE: Press PAUSE to pause a CD. PAUSE will be displayed, and the audio will be muted. Press PAUSE again to resume playing the CD.

4/REV: Press and hold REV to fast reverse. Upon release, the CD will play at normal speed. The display will show the track number and elapsed time. After 5 seconds, the default display will reappear.

5/FF: Press and hold FF to fast-forward. Upon release, the CD will play at normal speed. The display will show the track number and elapsed time. After 5 seconds the default display will reappear.

6/RPT: Press RPT to repeat the current track. RPT on the display indicates that this feature is on. The track will be repeated until RPT is pressed again.

EJECT: Press to eject a CD.

RDM (11): Press RDM (11) to activate random track selection. RDM will appear on the display, and tracks on loaded CDs will play in random order. Press the RDM (11) button again to turn off "random play" beginning with the next track.

SCAN/DIM (9): Press SCAN to scan all tracks on the CD. The player will immediately advance to the next track on the CD being played. SCAN and the track number will appear on the display and 10 seconds of the track will play. Then, the CD will advance to the next track, play 10 seconds and continue. To deactivate, press SCAN again.

PLAYING AN MP3 DISC

MP3 Format Compatibility

This MP3 player will play MP3 files recorded on a CD-R up to 700 MB. Files can be recorded at a variable bit rate or the following fixed-bit rates: 32 kpbs, 40 kpbs, 56 kpbs, 64 kpbs, 80 kpbs, 96 kpbs, 112 kpbs, 128 kpbs, 160 kpbs, 192 kpbs, 224 kpbs, 256 kpbs and 320 kpbs. Both single and multi-session discs will play. Song title, artist name and album are available when discs are recorded using ID3 tags versions 1 and 2.

The MP3 player will be able to read and play a maximum of 95 folders, 50 play lists or 20 sessions and 949 files. Long file, folder or playlists names or a combination of a large number of them can reduce the number files, folders, playlists, or sessions that can be played. To play large numbers of files, folders, playlists or sessions, minimize the length of the file, folder or play list name. It can also play an MP3 recorded without file folders. The system can support up to 11 levels of folder nesting. If a disc contains more than the maximum of 95 folders, 50 playlists, 20 sessions and 949 files, the player will only access and navigate the maximum and ignore additional items.

Root Directory

The root directory is treated as a folder. If the root directory has compressed audio files, the directory is displayed as F1 ROOT. All files contained directly under the root directory are accessed prior to any root directory folders. However, playlists (Px) are always accessed before root folders or files.

Empty Directory or Folder

If there is a root directory or a folder in the file structure that contains empty folders/subfolders, play advances to the next folder in the file structure that contains compressed audio files. The empty folder will not be displayed or numbered.

No Folder

When a disc contains only compressed files, the files are located under the root folder. The next and previous folder functions have no function on a CD recorded without folders or play lists. When displaying the name of the folder, the radio displays ROOT.

When the CD contains only playlist and compressed audio files, but no folders, all files are located under the root folder. The "folder down" and "folder up" buttons search play lists (Px) first and then the root folder. When the radio displays the name of the folder, the radio displays ROOT.

File Name Display

A song name is displayed when contained in the ID3 tag. If the song name is not in the ID3 tag, the radio displays the file name without the extension (such as.mp3) as the track name.

Track names longer than 16 characters scroll at a rate of one page every 1.5 seconds until the entire name is shown. To speed up page changes, press the TMSET/DSPL button. When all pages have been shown once, the first page of the ID3 tag appears and remains on the display. To restart automatic paging, press TMSET/DSPL.

Pre-Programmed Playlists

Pre-programmed playlist function like folders containing compressed audio song files. This radio plays pls, m3u, and rmp playlist formats. The pre-programmed play lists can not be edited.

Playing MP3 Files

Insert a disc partway into the slot, label side up. The player will pull it in, and READING DISC will appear on the display. The CD will begin playing, and the CD icon will appear on the display.

Play begins from the first track in the first playlist and continues sequentially through all tracks in each playlist. When the last track of the last playlist has been played, play continues from the first track of the first folder's playlist until FLDR +/- (13) is pressed. When play enters a new folder, the display will show the new folder name for 5 seconds then revert to the default display.

If the CD does not contain any playlists, play begins from the first track under the root directory. When all tracks from the root directory have been played, play continues by the numerical file listing. After playing the last track from the last folder, play begins again at the first track of the first playlist, folder or root directory.

If the songs on a playlist cannot be accessed, the radio ignores it and treats the disc as if it only has folders and tracks. If the disc contains multiple sessions and the table of contents cannot be accessed for all sessions, the radio plays the sessions with an available table of contents.

Button Functions

1/FLD (NEXT FOLDER): Press this button to go to the first track in the next folder or playlist. Pressing this button while in folder random mode will move to the first track in the next folder and play the tracks in that folder randomly.

2/FLD (PREVIOUS FOLDER): Press this button to go to the first track in the previous folder or playlist. Pressing this button while in folder random mode will move to the first track in the previous folder and play the tracks in that folder randomly.

3/PAUSE: Press this button to pause playback. PAUSE will be displayed. Press PAUSE again to resume playing the disc.

4/REV (REVERSE): Press and hold REV to fast-reverse. Upon release, the CD will play at normal speed. The display will show the track number and elapsed time. After 5 seconds, the default display will appear.

5/FF (FAST FORWARD): Press and hold FF to fast-forward. Upon release, the CD will play at normal speed. The display will show the track number and elapsed time. After 5 seconds, the default display will appear.

6/RPT: Press RPT to repeat the current track. The RPT icon on the display indicates the feature is on. The track will be repeated until RPT is pressed again.

RDM (RANDOM): Press and release this button to play the tracks in the current folder or playlist in random order. RDM will appear on the display. Once all tracks in the current folder or playlist have been played, the system will move to the next folder or playlist and play the tracks in random order. When random is activated, pressing TUNE + or SEEK - will move to the next or previous random track. Pressing RDM (11) again cancels random play.

+ TUNE: Press + TUNE once to forward to the next track. The track number and elapsed time will appear. Press and hold + TUNE to advance tracks quickly.

SEEK -: Press SEEK- once to return to the beginning of the track being played. Pressing this button during the first 8 seconds of the track will play the previous track. The track number and elapsed time will appear. Press and hold SEEK- to fast reverse.

DSPL/TM SET: Pressing this button toggles between the ID3 tag (song title, artist and album title) and time of day. There are 3 display types that can be set as default: track, folder/playlist, and time of day. The default display is track.

To display the folder/playlist or time of day, follow the instructions in the Setting a Default Display section.

- Track mode displays the current track number and ID3 tag song title.
- Folder/playlist mode displays the current folder or playlist number and name plus the ID3 tag song title.
- Time-of-day mode displays the time of day and the ID3 tag song title.

TROUBLESHOOTING

The following error messages may appear while playing a CD or MP3 disc:

- NO CD:** No CD has been loaded in the player.
- FOCUS:** Lens could not focus on CD. Possible reasons include: Disc is inserted upside down - eject and reinsert CD. Disc is dirty, scratched, or wet - try cleaning CD. Lens is dirty - clean CD lens with a lens cleaner. It is very humid - wait an hour and try again.
- TRACKING:** Loss of tracking control. Possible reasons include: Disc is dirty or scratched - try cleaning CD. Lens is dirty - clean CD lens with a lens cleaner.
- LOAD:** Load/unload motor problem - contact dealer.

NOTE: The sound quality, an increase in skipping, difficulty in finding tracks, and/or difficulty in loading/ejecting a CD-R may be affected by a CD-R's quality, the method of recording, the quality of the music that has been recorded, or the way the CD-R has been handled. If these problems occur, try a known good CD. If any error occurs repeatedly or if an error cannot be corrected, contact the local dealer. If the radio displays an error message, write it down and provide it to your dealer when reporting the problem.