

# **Operation & Maintenance Manual**

# **WA120-3**

# **WA120L-3**

## **WHEEL LOADER**

SERIAL NUMBERS WA120-3L -A30001 and up  
WA120L-3 -54001 - 54103

This material is proprietary to Komatsu America International Company and is not to be reproduced, used, or disclosed except in accordance with written authorization from Komatsu America International Company.

It is our policy to improve our products whenever it is possible and practical to do so. We reserve the right to make changes or improvements at any time without incurring any obligation to install such changes on products sold previously.

Due to this continuous program of research and development, revisions may be made to this publication. It is recommended that customers contact their distributor for information on the latest revision.

Copyright 2002 Komatsu  
DataKom Publishing Division

# PRODUCT PUBLICATIONS INFORMATION

VARIOUS PRODUCT PARTS & SERVICE PUBLICATIONS ARE AVAILABLE TO ALL **KOMATSU** CONSTRUCTION EQUIPMENT OWNERS, INCLUDING OPERATION & MAINTENANCE MANUALS, PARTS BOOKS AND SHOP MANUALS.

SPECIAL PUBLICATIONS SUCH AS SERVICE TOOL, AIR CONDITIONING, AND TURBOCHARGER SHOP MANUALS ARE ALSO AVAILABLE AS WELL AS SELECTED OPERATION & MAINTENANCE AND SHOP MANUALS IN FOREIGN LANGUAGES.

THE PUBLICATIONS LISTED BELOW ARE AVAILABLE FOR THIS PARTICULAR MACHINE(S).

DESCRIPTION	FORM NUMBER
<b>PARTS BOOK - PAPER:</b>	
Engine and Chassis .....	BEPB003900
<b>PARTS BOOK - MICROFICHE:</b>	
Engine and Chassis .....	BEPM003900
<b>OPERATION &amp; MAINTENANCE MANUAL:</b>	
Chassis .....	CEAM002300
<b>SHOP MANUAL:</b>	
Chassis .....	CEBM002000
Engine .....	SEBM010002
<b>SAFETY MANUAL .....</b>	<b>WLT70-1</b>

**PARTS AND SERVICE PUBLICATIONS CAN ONLY BE ACQUIRED BY AUTHORIZED KOMATSU DISTRIBUTORS, USING THE KOMATSU AMERICA INTERNATIONAL COMPANY PARTS INVENTORY PROCESSING SYSTEM (PIPS).**

**IF THE PIPS SYSTEM IS NOT AVAILABLE AT THE DISTRIBUTOR LOCATION, THEN THE FOLLOWING REQUISITION FOR TECHNICAL SERVICE PUBLICATIONS AND SERVICE FORMS CAN BE USED. FORM KDC91D IS SHOWN ON THE REVERSE SIDE OF THIS PAGE.**

**REQUISITION FOR TECHNICAL SERVICE PUBLICATIONS AND SERVICE FORMS**

**COMPLETE FORM**

**AND RETURN TO** →

**Komatsu America International Company**

440 North Fairway Drive  
 Vernon Hills, IL 60061-8112 U.S.A.  
 Attn: Technical Publications  
 Fax No. (847) 970-4186  
 Tel No. (847) 970-5887

**SHIP TO** →

COMPANY NAME	
ATTN.	
STREET ADDRESS	
CITY, STATE, ZIP CODE	
COUNTRY	

PURCHASE ORDER NO.
--------------------

**TYPE or PRINT ONLY** →

ORDER DATE
------------

PHONE NO.	FAX NO.	SHIPPING METHOD	DISTR/BRANCH CODE
-----------	---------	-----------------	-------------------

**IMPORTANT - TO ASSURE SHIPMENT OF THE CORRECT PUBLICATION(S), THE MODEL NUMBER AND MACHINE SERIAL NUMBER MUST BE SHOWN.**

QTY.	PUBLICATION FORM NO.	PARTS BOOK P-Paper M-Microfiche	PUBLICATION DESCRIPTION	MODEL NUMBER	SERIAL NUMBER

# **INTRODUCTION**

### 1. FORWARD

This manual describes procedures for operation, handling, lubrication, maintenance, checking, and adjustment. It will help the operator and maintenance personnel realize peak performance through effective, economical and safe machine operation and maintenance.

Keep this manual handy and have all personnel read it periodically. If this manual is lost or becomes dirty and can not be read, request a replacement manual from your local distributor.

If you sell the machine, be sure to give this manual to the new owner.

Continuing improvements in the design of this machine can lead to changes in detail, which may not be reflected in this manual. Consult your local distributor or Komatsu America International Company for the latest available information on your machine or for questions regarding information in this manual.



#### WARNING

- **Improper operation and maintenance of this machine can be hazardous and could result in serious injury or death.**
- **Operators and maintenance personnel must read this manual thoroughly before operating or maintaining this machine.**
- **This manual should be kept near the machine for reference and periodically reviewed by all personnel who come across it.**
- **Some actions involved in operation and maintenance can cause a serious accident, if they are not performed in the manner described in this manual.**
- **The procedures and precautions given in this manual apply only to intended uses of the machine. If you use your machine for any unintended uses that are not specifically prohibited, you must be sure that it is safe for you and others. In no event should you or others engage in prohibited uses or actions as described in this manual.**
- **Komatsu America International Company delivers machines that comply with all applicable regulations and standards of the country to which it has been shipped. If this machine has been purchased in another country or purchased from someone in another country, it may lack certain safety features and specifications that are necessary for use in your country. If there is any question about whether your product complies with the applicable standards and regulations of your country, consult your local distributor or Komatsu America International Company before operating the machine.**
- **The description of safety is given in SAFETY INFORMATION on page 0-3 and in SAFETY from page 1-2.**

## 2. SAFETY INFORMATION

Most accidents are caused by the failure to follow fundamental safety rules for the operation and maintenance of machines. To avoid accidents, read, understand and follow all precautions and warnings in this manual and on the machine before performing maintenance and machine operations.

To identify safety messages in this manual and on machine product graphics, the following signal words are used.



**DANGER!** - This word is used on safety messages and product graphics where there is a high probability of serious injury or death if the hazard is not avoided. These safety messages and product graphics usually describe precautions that must be taken to avoid the hazard. Failure to avoid this hazard may also result in serious damage to the machine.



**WARNING!** - This word is used on safety messages and product graphics where there is a potentially dangerous situation, which could result in serious injury or death if the hazard is not avoided. These safety messages and product graphics usually describe precautions that must be taken to avoid the hazard. Failure to avoid this hazard may also result in serious damage to the machine.



**CAUTION!** - This word is used on safety messages and product graphics for hazards, which could result in minor or moderate injury if the hazard is not avoided. These safety messages and product graphics might also use this word for hazards where the only result could be damage to the machine.

**NOTICE** - This word is used for precautions that must be taken to avoid actions, which could shorten the life of the machine.

Safety precautions are described in **SAFETY** beginning on page 1-2.

Komatsu America International Company cannot predict every circumstance that might involve a potential hazard in operation and maintenance. Therefore the safety message in this manual and on the machine may not include all possible safety precautions. If any procedures or actions not specifically recommended or allowed in this manual are used, you must be sure that you and others can do such procedures and actions safely and without damaging the machine. If you are unsure about the safety of some procedures, contact your local distributor or Komatsu America International Company.

### 3. INTRODUCTION

#### 3.1 INTENDED USE

This WHEEL LOADER is designed to be used mainly for the following work:

- Digging
- Leveling
- Pushing
- Loading

For details of the operating procedures, see "**12.13 WORK POSSIBLE USING WHEEL LOADER**" on page 2-46

#### 3.2 FEATURES

- Curved glass and improved sealing for reduced noise.
- Console and steering post with unencumbered foot area providing the same comfortable feeling as in an automobile
- Maintenance-free, wet-type disc parking brake (acts also as emergency brake).
- One-touch panel control and air conditioner with new refrigerant installed.
- Full fender system installed to help prevent mud or water from splashing on or around the machine.
- Light touch lever operations through use of electrical transmission control lever
- Pleasant operators compartment with low vibration and noise levels
- Large gull-wing side panels and a rear grill that opens fully for ease of maintenance
- Large safety lock lever for work equipment to ensure that operator does not forget to apply safety lock
- New engine that meets exhaust gas emission of 96 EPA & carb.

#### 3.3 BREAKING IN A NEW MACHINE

Your machine has been thoroughly adjusted and tested before shipment. However, operating the machine under severe conditions at the beginning can adversely affect the performance and shorten the machine life.

Be sure to break in the machine for the initial 100 hours (as indicated by the service meter).

During breaking in:

- After starting, let the engine idle for 5 minutes to allow proper engine warm-up prior to actual operation.
- Avoid operation with heavy loads or at high speeds.
- Avoid sudden starts or acceleration, unnecessarily abrupt stops and sharp steering except in cases of emergency.

The precautions given in this manual for operating, maintenance, and safety procedures are only those that apply when this product is used for the specified purpose. If the machine is used for a purpose that is not listed in this manual, Komatsu America International Company cannot bear any responsibility for safety. All consideration of safety in such operations is the responsibility of the user.

Operations that are prohibited in this manual must never be carried out under any circumstance.

## 4. LOCATION OF PLATES, TABLE TO ENTER SERIAL NO. AND DISTRIBUTOR

### 4.1 MACHINE SERIAL NO. PLATE POSITION

**(A) Position of plate**

On the center right of the front frame.

**(B) Position of stamp**

This is stamped on the center of the front frame on the right hand side of the machine.

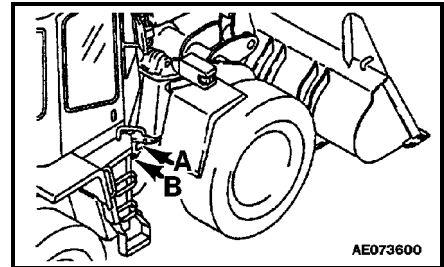

### 4.2 ENGINE SERIAL NO. PLATE POSITION

**Position of plate**

As viewed from the right hand side of the machine.

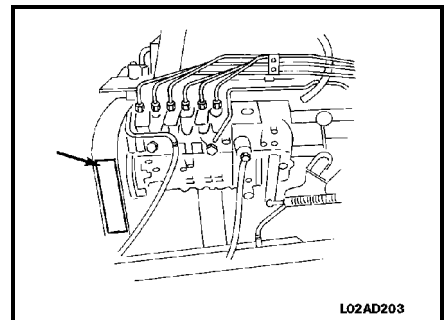

### 4.3 TABLE TO ENTER SERIAL NO. AND DISTRIBUTOR

Machine serial No.:	
Engine serial No.:	
Distributor name:	
Address:	Phone:
Service personnel for your machine:	

**REMARKS**



# INTRODUCTION

---

## 5. CONTENTS

### INTRODUCTION

1. FORWARD .....	0-2
2. SAFETY INFORMATION .....	0-3
3. INTRODUCTION .....	0-4
3.1 INTENDED USE .....	0-4
3.2 FEATURES .....	0-4
3.3 BREAKING IN A NEW MACHINE .....	0-4
4. LOCATION OF PLATES, TABLE TO ENTER SERIAL NO. AND DISTRIBUTOR .....	0-5
4.1 MACHINE SERIAL NO. PLATE POSITION .....	0-5
4.2 ENGINE SERIAL NO. PLATE POSITION .....	0-5
4.3 TABLE TO ENTER SERIAL NO. AND DISTRIBUTOR .....	0-5
5. CONTENTS .....	0-6

### SAFETY

6. GENERAL PRECAUTIONS .....	1-2
7. PRECAUTIONS DURING OPERATION .....	1-8
7.1 BEFORE STARTING ENGINE .....	1-8
7.2 AFTER STARTING ENGINE .....	1-11
7.3 TRANSPORTATION .....	1-20
7.4 BATTERY .....	1-21
7.5 TOWING .....	1-24
8. PRECAUTIONS FOR MAINTENANCE .....	1-25
8.1 BEFORE CARRYING OUT MAINTENANCE .....	1-25
8.2 DURING MAINTENANCE .....	1-30
8.3 TIRES .....	1-36
9. POSITION FOR ATTACHING SAFETY LABELS .....	1-38
9.1 POSITION FOR ATTACHING SAFETY LABELS .....	1-37

### OPERATION

10. GENERAL VIEW .....	2-2
10.1 GENERAL VIEW OF MACHINE .....	2-2
10.2 GENERAL VIEW OF CONTROLS AND GAUGES .....	2-3
11. EXPLANATION OF COMPONENTS .....	2-5
11.1 METER, LAMPS .....	2-5
11.2 SWITCHES .....	2-9
11.3 CONTROL LEVERS, PEDAL .....	2-15
11.4 CAP WITH LOCK .....	2-19
11.4.1 METHOD OF OPENING AND CLOSING CAP WITH LOCK .....	2-19
11.5 SAFETY BAR .....	2-19
11.6 TOWING PIN .....	2-20
11.7 GREASE PUMP CLAMP AND RUBBER RING .....	2-20
11.8 BACKUP ALARM .....	2-20
11.9 FUSE .....	2-21
11.9.1 FUSE CAPACITY AND NAME OF CIRCUIT .....	2-21

11.10	SLOW BLOW FUSE .....	2-22
11.11	STORAGE PLACE FOR THIS MANUAL .....	2-23
11.12	AUXILIARY POWER SOURCE .....	2-23
11.12.1	FOR MACHINES EQUIPPED WITH ROPS CAB .....	2-23
12.	CHECK BEFORE STARTING ENGINE .....	2-24
12.1	WALK AROUND CHECK .....	2-24
12.2	CHECK BEFORE STARTING .....	2-27
12.2.1	CHECK COOLANT LEVEL, ADD COOLANT .....	2-27
12.2.2	CHECK FUEL LEVEL, ADD FUEL .....	2-27
12.2.3	CHECK OIL LEVEL IN ENGINE OIL PAN, ADD OIL .....	2-28
12.2.4	CHECK AND REFILL OF OIL IN BRAKE OIL TANK .....	2-28
12.2.5	CHECK DUST INDICATOR .....	2-29
12.2.6	CHECK ELECTRICAL WIRING .....	2-29
12.2.7	DRAIN THE WATER FROM THE FUEL-WATER SEPARATOR .....	2-30
12.2.8	CHECK EFFECT OF PARKING BRAKE .....	2-30
12.2.9	CHECK EFFECT OF WHEEL BRAKES .....	2-31
12.2.10	CHECK SOUND OF HORN AND BACKUP ALARM .....	2-31
12.2.11	CHECK FLASHING OF LAMPS, CHECK FOR DIRT AND DAMAGE .....	2-31
12.2.12	CHECK ENGINE EXHAUST COLOR AND SOUND .....	2-31
12.2.13	CHECK OPERATIONS OF GAUGES .....	2-31
12.2.14	CHECK PLAY OF STEERING WHEEL, CHECK OPERATION OF STEERING .....	2-31
12.2.15	CHECK DIRECTION OF REAR VIEW MIRROR, CHECK FOR DIRT OR DAMAGE .....	2-31
12.2.16	CHECK LOCK OF CAB DOOR FOR MACHINES EQUIPPED WITH CAB .....	2-31
12.3	ADJUSTMENT BEFORE OPERATION .....	2-32
12.3.1	OPERATOR'S SEAT .....	2-32
12.3.2	ADJUST SEAT BELT .....	2-34
12.3.3	ADJUST REAR VIEW MIRRORS .....	2-35
12.4	OPERATIONS AND CHECKS BEFORE STARTING ENGINE .....	2-36
12.5	STARTING ENGINE .....	2-37
12.5.1	NORMAL STARTING PROCEDURES IN COLD AND WARM CONDITIONS .....	2-37
12.5.2	STARTING PROCEDURES AFTER EXTENDED SHUTDOWN OR OIL CHANGE .....	2-38
12.5.3	STARTING PROCEDURES AFTER CHANGING FUEL FILTERS .....	2-38
12.5.4	STARTING PROCEDURES AFTER RUNNING OUT OF FUEL .....	2-38
12.6	OPERATIONS AND CHECKS AFTER STARTING ENGINE .....	2-39
12.7	MOVING MACHINE OFF .....	2-40
12.8	CHANGING GEAR SPEED .....	2-42
12.9	CHANGING DIRECTION .....	2-42
12.10	TURNING .....	2-43
12.11	STOPPING MACHINE .....	2-44
12.12	OPERATION OF WORK EQUIPMENT .....	2-45
12.12.1	BOOM OPERATION (LEVER) .....	2-45
12.12.2	BUCKET OPERATION (LEVER) .....	2-45
12.13	WORK POSSIBLE USING WHEEL LOADER .....	2-46
12.13.1	DIGGING OPERATIONS WITH ROCK PILES .....	2-46
12.13.2	DIGGING OPERATIONS ON LEVEL GROUND .....	2-47
12.13.3	LEVELING OPERATION .....	2-48
12.13.4	PUSHING OPERATIONS .....	2-48
12.13.5	LOAD AND CARRY OPERATIONS .....	2-48
12.13.6	LOADING OPERATIONS .....	2-49
12.14	PRECAUTIONS FOR OPERATION .....	2-50
12.14.1	PERMISSIBLE WATER DEPTH .....	2-50
12.14.2	IF WHEEL BRAKE DOES NOT WORK .....	2-50
12.14.3	PRECAUTIONS WHEN DRIVING UP OR DOWN SLOPES .....	2-50
12.14.4	PRECAUTIONS WHEN DRIVING MACHINE .....	2-51
12.15	ADJUSTING WORK EQUIPMENT POSTURE .....	2-52
12.15.1	ADJUSTING BOOM KICKOUT .....	2-52
12.15.2	ADJUSTING BUCKET POSITIONER .....	2-53
12.15.3	BUCKET LEVEL INDICATOR .....	2-53

## INTRODUCTION

---

12.16	PARKING MACHINE .....	2-54
12.17	CHECKS AFTER COMPLETION OF ENGINE OPERATION .....	2-55
12.18	STOPPING ENGINE .....	2-55
12.19	CHECKS AFTER STOPPING ENGINE .....	2-56
12.20	LOCKING .....	2-56
12.21	HANDLING THE TIRES .....	2-57
12.21.1	PRECAUTIONS WHEN HANDLING THE TIRES .....	2-57
12.21.2	TIRE PRESSURE .....	2-57
13.	TRANSPORTATION .....	2-59
13.1	LOADING, UNLOADING WORK .....	2-59
13.2	PRECAUTION FOR LOADING .....	2-60
13.3	PRECAUTION FOR LIFTING UP THE VEHICLE .....	2-60
13.3.1	THE LOCATION OF DECALS REFERRING TO LIFTING POSITIONS .....	2-61
13.3.2	WEIGHT LIST .....	2-61
13.3.3	LIFTING PROCEDURE .....	2-62
14.	COLD WEATHER OPERATIONS .....	2-63
14.1	PRECAUTIONS FOR LOW TEMPERATURE .....	2-63
14.1.1	FUEL AND LUBRICANTS .....	2-63
14.1.2	COOLANT .....	2-63
14.1.3	BATTERY .....	2-64
14.2	PRECAUTIONS AFTER COMPLETION OF WORK .....	2-65
14.3	AFTER COLD WEATHER .....	2-65
15.	LONG TERM STORAGE .....	2-66
15.1	BEFORE STORAGE .....	2-66
15.2	DURING STORAGE .....	2-66
15.3	AFTER STORAGE .....	2-66
16.	TROUBLESHOOTING .....	2-67
16.1	WHEN MACHINE RUNS OUT OF FUEL .....	2-67
16.2	TOWING THE MACHINE .....	2-68
16.2.1	WHEN ENGINE CAN BE USED .....	2-70
16.2.2	WHEN ENGINE CANNOT BE USED .....	2-70
16.3	IF BATTERY IS DISCHARGED .....	2-71
16.3.1	REMOVAL AND INSTALLATION OF BATTERY .....	2-71
16.3.2	PRECAUTIONS FOR CHARGING BATTERY .....	2-72
16.3.3	STARTING ENGINE WITH BOOSTER CABLE .....	2-73
16.4	OTHER TROUBLE .....	2-75
16.4.1	ELECTRICAL SYSTEM .....	2-75
16.4.2	CHASSIS .....	2-76
16.4.3	ENGINE .....	2-79

## MAINTENANCE

17.	GUIDES TO MAINTENANCE .....	3-2
18.	OUTLINES OF SERVICE .....	3-5
18.1	OUTLINE OF OIL, FUEL, COOLANT .....	3-5
18.1.1	OIL .....	3-5
18.1.2	FUEL .....	3-6
18.1.3	COOLANT .....	3-6
18.1.4	GREASE .....	3-7
18.1.5	STORING OIL AND FUEL .....	3-7
18.1.6	FILTERS .....	3-7
18.2	OUTLINE OF ELECTRIC SYSTEM .....	3-8
19.	WEAR PARTS LIST .....	3-9

20. USE OF FUEL, COOLANT AND LUBRICANTS ACCORDING TO AMBIENT TEMPERATURE .....	3-10
20.1 ENGINE OIL SPECIFICATIONS .....	3-11
20.2 DIESEL FUEL SPECIFICATIONS .....	3-12
20.3 COOLANT SPECIFICATIONS .....	3-13
21. STANDARD TIGHTENING TORQUE FOR BOLTS AND NUTS .....	3-19
21.1 INTRODUCTION OF NECESSARY TOOLS .....	3-19
21.2 TORQUE LIST .....	3-20
22. PERIODIC REPLACEMENT OF SAFETY CRITICAL PARTS .....	3-22
23. MAINTENANCE SCHEDULE CHART .....	3-26
23.1 MAINTENANCE SCHEDULE CHART .....	3-26
24. SERVICE PROCEDURES .....	3-30
24.1 INITIAL 250 HOURS SERVICE .....	3-30
24.1.1 REPLACE FUEL FILTERS .....	3-30
24.1.2 REPLACE TRANSMISSION OIL FILTER ELEMENT .....	3-30
24.1.3 REPLACE HYDRAULIC TANK FILTER ELEMENT .....	3-30
24.2 WHEN REQUIRED .....	3-31
24.2.1 CHECK, CLEAN OR REPLACE AIR CLEANER ELEMENT .....	3-31
24.2.2 CHECK TRANSMISSION OIL LEVEL, ADD OIL .....	3-33
24.2.3 CHECK AXLE OIL LEVEL , ADD OIL .....	3-34
24.2.4 CLEAN THE AXLE CASE BREATHER .....	3-35
24.2.5 CLEAN RADIATOR FINS .....	3-35
24.2.6 REPLACE THE BOLT-ON CUTTING EDGES .....	3-36
24.2.7 REPLACE BUCKET TEETH (IF EQUIPPED) .....	3-37
24.2.8 CHECK AIR CONDITIONER (IF EQUIPPED) .....	3-38
24.2.9 CHECK THE AIR CONDITIONER CONDENSER (IF EQUIPPED) .....	3-39
24.2.10 CHECK WINDOW WASHING FLUID .....	3-39
24.2.11 ADJUST PARKING BRAKE .....	3-40
24.2.12 REPLACE SLOW BLOW FUSE .....	3-41
24.2.13 CHECK AIR INTAKE HEATER .....	3-41
24.3 CHECK BEFORE STARTING .....	3-42
24.4 EVERY 50 HOURS SERVICE .....	3-43
24.4.1 CHECK THE TIRE INFLATION PRESSURE .....	3-43
24.4.2 DRAIN WATER, SEDIMENT FROM FUEL TANK .....	3-43
24.4.3 CHECK ENGINE AIR INTAKE SYSTEM .....	3-43
24.5 EVERY 100 HOURS SERVICE .....	3-44
24.5.1 CHECK OIL LEVEL IN HYDRAULIC TANK, ADD OIL .....	3-44
24.5.2 CLEAN ELEMENT IN AIR CONDITIONER FRESH AIR FILTER .....	3-45
24.5.3 LUBRICATING .....	3-46
24.6 EVERY 250 HOURS SERVICE .....	3-47
24.6.1 CHANGE OIL IN ENGINE OIL PAN AND REPLACE ENGINE OIL FILTER .....	3-47
24.6.2 CHECK FOR LOOSE WHEEL HUB NUTS. TIGHTEN .....	3-48
24.6.3 CLEAN ELEMENT IN AIR CONDITIONER RECIRCULATION FILTER .....	3-48
24.6.4 CHECK AIR CONDITIONER COMPRESSOR BELT TENSION, ADJUST .....	3-49
24.6.5 CHECK BATTERY ELECTROLYTE LEVEL .....	3-50
24.6.6 CHECK AIR INTAKE SYSTEM .....	3-50
24.6.7 LUBRICATING .....	3-51
24.7 EVERY 500 HOURS SERVICE .....	3-52
24.7.1 REPLACE FUEL FILTERS .....	3-52
24.7.2 REPLACE TRANSMISSION OIL FILTER ELEMENT .....	3-54
24.7.3 LUBRICATE .....	3-55
24.8 EVERY 1000 HOURS SERVICE .....	3-56
24.8.1 CHANGE OIL IN TRANSMISSION CASE, CLEAN STRAINER .....	3-56
24.8.2 CLEAN TRANSMISSION CASE BREATHER .....	3-57
24.8.3 LUBRICATE .....	3-58

## **INTRODUCTION**

---

24.8.4	CHANGE OIL IN HYDRAULIC OIL TANK, REPLACE HYDRAULIC FILTER ELEMENT .....	3-59
24.8.5	ADJUST ENGINE VALVE LASH CLEARANCE .....	3-60
24.8.6	CHECK FAN BELT TENSION .....	3-61
24.8.7	CHECK FAN BELT TENSIONER BEARING & FAN HUB BEARING & INSPECT FAN BELT .....	3-61
24.8.8	CHECK TIGHTENING PARTS OF TURBOCHARGER .....	3-62
24.8.9	CHECK PLAY OF TURBOCHARGER ROTOR .....	3-62
24.9	EVERY 2000 HOURS SERVICE .....	3-62
24.9.1	COOLING SYSTEM, REPLACE COOLANT AND FLUSH THE SYSTEM .....	3-62
24.9.2	REPLACE HYDRAULIC TANK BREATHER ELEMENT .....	3-65
24.9.3	CHANGE AXLE OIL .....	3-65
24.9.4	CHECK BRAKE DISC WEAR .....	3-66
24.9.5	CHECK ALTERNATOR .....	3-66
24.9.6	CHECK STARTER MOTOR .....	3-66
24.9.7	CHECK VIBRATION DAMPER .....	3-66
24.9.8	REPLACE ELEMENT IN AIR COND. RECIRCULATION AIR FILTER & FRESH AIR FILTER .....	3-66
24.9.9	ADJUST ENGINE VALVE LASH CLEARANCE .....	3-67
24.9.10	CLEAN AND CHECK TURBOCHARGER .....	3-69
24.10	EVERY 4000 HOURS SERVICE .....	3-69
24.10.1	CHECK WATER PUMP .....	3-69

## **SPECIFICATONS**

25.	SPECIFICATIONS .....	4-2
-----	----------------------	-----

## **OPTIONS, ATTACHMENTS**

26.	AVAILABLE ATTACHMENTS .....	5-2
27.	HEATER AND AIR CONDITIONING (IF EQUIPPED) .....	5-4
27.1	GENERAL LOCATION AND FUNCTION OF CONTROL PANEL .....	5-4
27.2	COOL BOX COMPARTMENT .....	5-5
28.	HANDLING E.C.S.S. (ELECTRONIC CONTROLLED SUSPENSION SYSTEM) .....	5-6
28.1	STRUCTURE AND FUNCTION OF E.C.S.S. .....	5-6
28.2	METHOD OF OPERATING E.C.S.S. .....	5-7
28.3	PRECAUTIONS WHEN OPERATING E.C.S.S. .....	5-7
28.4	PRECAUTIONS WHEN HANDLING ACCUMULATOR .....	5-8

# SAFETY



## WARNING

**Read and follow all safety precautions. Failure to do so may result in serious injury or death.**

This safety section also contains precautions for optional equipment and attachments.



## 6. GENERAL PRECAUTIONS

### SAFETY RULES

- ONLY trained and authorized personnel should be allowed to operate and service this machine.
- Follow all safety rules, precautions and instructions when operating or performing maintenance on the machine.
- The owner and/or operator must replace any and all safety and warning product graphics if they are defaced or removed from the machine.
- Think before you act. Careful operators and service personnel are the best insurance against accidents.
- Do not rush. Hurrying can lead to accidents. Haste, carelessness and lack of training are the primary causes of equipment-related injuries.
- The operator must be alert, physically fit and free from the influences of alcohol, drugs and medications that might affect his eyesight, hearing or reactions.
- Safety must always be the operator's most important concern. He must refuse to operate when he knows it is unsafe and consult his supervisor when safety is in doubt.
- When working with another operator or a person on worksite traffic duty, be sure all personnel understand all hand signals that are to be used.

### SAFETY FEATURES

- Be sure all guards and covers are in their proper position. Be sure to replace them after servicing the machine. Have guards and covers repaired immediately if damaged.  
**Proper position → "See 12.1 WALK-AROUND CHECK".**
- Use safety features such as safety lock lever and seat belt properly.
- A seat belt is required by OSHA in almost all applications. DO NOT operate this machine without a seat belt.
- NEVER remove any safety features. ALWAYS keep them in good operating condition.  
**Safety lock lever → See "12.20 PARKING MACHINE".**  
**Seat belts → See "12.3.2 ADJUSTMENT BEFORE OPERATION".**
- Improper use of safety features could result in serious bodily injury or death.
- Be sure the machine has the correct equipment required by local rules and regulations.

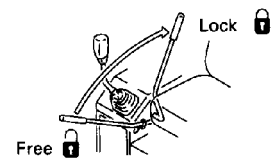

AE070130

### UNAUTHORIZED MODIFICATION

- Any modification made without authorization from Komatsu America International Company can create problems with safety.
- Before making a modification, consult your local distributor. Komatsu America International Company will not be responsible for any injury or damage caused by any unauthorized modification.



WARNING: Failure to follow these safety precautions may lead to a serious accident.

**CLOTHING AND PERSONAL PROTECTIVE ITEMS**

- Avoid loose clothing, jewelry, and loose long hair. They can catch on controls or in moving parts and cause serious injury or death. Also, do not wear oily clothes because they are flammable.
- Also do not wear oily clothes, because they are flammable.
- Wear a hard hat, safety glasses, safety shoes, mask or gloves when operating or maintaining the machine. Always wear safety goggles, hard hat and heavy gloves if your job involves scattering metal chips or minute materials - this is particularly important when driving pins with a hammer and when cleaning the air cleaner element with compressed air. Also check that there are no other personnel near the machine.
- Check that all protective equipment functions properly before using.

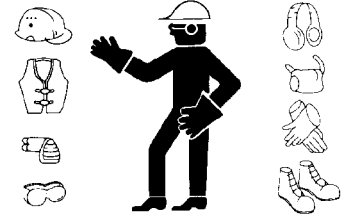

A0055010

**ALWAYS APPLY LOCK WHEN LEAVING OPERATOR'S SEAT**

- When standing up from the operator's seat, always place the safety lock lever securely in the LOCK position. If you accidentally touch the equipment levers when they are not locked, the machine or work equipment may move and cause serious injury or damage.
- When leaving the machine, lower the work equipment completely to the ground, set the safety lock lever to the LOCK position and the parking brake pedal to the LOCK position then stop the engine and use the key to lock all the equipment locks. Always take the key with you.

**Work equipment posture → See "12.20 PARKING MACHINE".**

**Locks → See "12.24 LOCKING".**

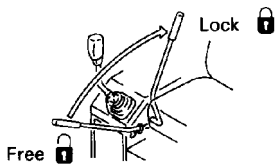

AE070130

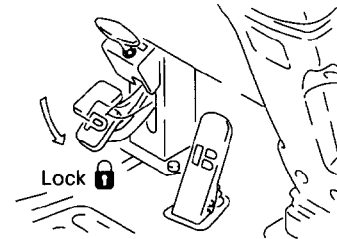

AE072800



**MOUNTING AND DISMOUNTING**

- NEVER jump on or off the machine. NEVER get on or off a moving machine.
- When mounting or dismounting, always face the machine and use the handrails and steps.
- Do not use the machine's controls or hoses as handrails when climbing on or off the machine. Controls and hoses can move and do not provide solid support. Movement of the controls may cause unexpected machine movement and injury.
- Ensure safety by always maintaining at least three-point contact of hands and feet with the handrails and steps.
- Always remove any oil or mud from the handrails and steps. If they are damaged, repair them and tighten any loose hardware.

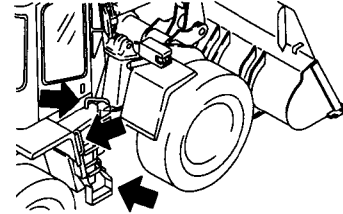
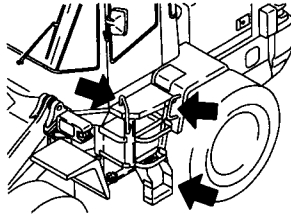

AE092800A

**FIRE PREVENTION FOR FUEL AND OIL**

Fuel, oil, and antifreeze can be ignited by a flame. Fuel is particularly **FLAMMABLE** and can be **HAZARDOUS**.

- Keep any flame away from flammable fluids.
- Stop the engine and do not smoke when refueling.
- Tighten all fuel and oil caps securely.
- Refueling and oiling should be made in well ventilated areas.
- Keep oil and fuel in the determined place and do not allow unauthorized persons to enter.





WARNING: Failure to follow these safety precautions may lead to a serious accident.

**PRECAUTIONS WHEN HANDLING AT HIGH TEMPERATURES**

- Immediately after operations are stopped, the engine coolant, engine oil, and hydraulic oil are at high temperatures, and are still under pressure. Attempting to remove the cap, drain the oil or water, or replace the filters may lead to serious burns. Always wait for the temperature to go down, and follow the specified procedures when carrying out these operations.
- To prevent hot water from spurting out:
  - 1) Turn engine off.
  - 2) Allow water to cool.
  - 3) Slowly loosen cap to relieve pressure before removing.  
(When checking if the water temperature has gone down, put your hand near the front face of the radiator and check the air temperature. Be careful not to touch the radiator.)
- To prevent hot oil from spurting out:
  - 1) Turn engine off.
  - 2) Allow oil to cool.
  - 3) Slowly loosen cap to relieve pressure before removing.  
(When checking if the oil temperature has gone down, put your hand near the front face of the hydraulic tank and check the air temperature. Be careful not to touch the hydraulic tank.)

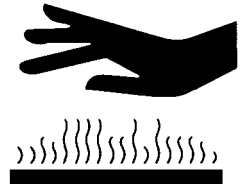

**ASBESTOS DUST HAZARD PREVENTION**

Asbestos dust can be HAZARDOUS to your health if it is inhaled. If you handle materials containing asbestos fibers, follow these guidelines as given below:

- NEVER use compressed air for cleaning.
- Use water for cleaning to keep down the dust.
- Operate the machine with the wind to your back, whenever possible.
- Use an approved respirator if necessary.



**CRUSHING OR CUTTING PREVENTION**

- Do not enter, or put your hand or arm or any other part of your body between movable parts such as between the work equipment and cylinders, or between the machine and work equipment. If the work equipment is operated, the clearance will change and this may lead to serious damage or personal injury.



A0055140

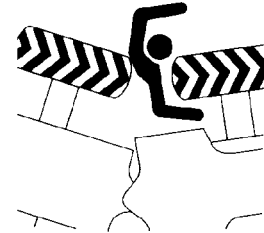

A0060760



### FIRE EXTINGUISHER AND FIRST AID KIT

- Be sure fire extinguishers have been provided and know how to use them.
- Provide a first aid kit at the storage point.
- Know what to do in the event of a fire.
- Be sure you know the phone numbers of persons you should contact in case of an emergency.

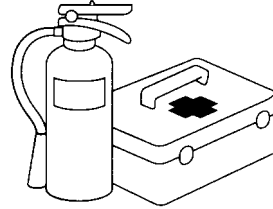

### PRECAUTIONS WHEN USING ROPS

The ROPS (ROLL OVER PROTECTIVE STRUCTURE) must never be removed when operating the machine.

The ROPS is installed to protect the operator if the machine should roll over. It is designed not only to support the load if the machine should roll over, but also to absorb the impact energy.

The ROPS fulfills all the regulations and standards for all countries, but if it is rebuilt without authorization or is damaged when the machine rolls over, the strength may drop and not be able to fulfill its function properly. It can only display its performance if it is repaired or modified in the specified way.

When modifying or repairing the ROPS, always contact your Komatsu America International Company distributor.

Even if the ROPS is installed, it cannot show its full effect if the operator does not fasten the seat belt properly. Always fasten the seat belt when operating.

**For seat belt adjustment see “12.3.2 ADJUSTMENT BEFORE OPERATION”.**

### PRECAUTIONS FOR ATTACHMENTS

- When installing and using an optional attachment, read the instruction manual for the attachment and the information related to attachments in this manual.
- Do not use attachments that are not authorized by your distributor or Komatsu America International Company. Use of unauthorized attachments could create a safety problem and adversely affect the proper operation and useful life of the machine.
- Any injuries, accidents, product failures resulting from the use of unauthorized attachments will not be the responsibility of Komatsu America International Company.



WARNING: Failure to follow these safety precautions may lead to a serious accident.

**SAFETY**

#### **PRECAUTION WHEN HANDLING ACCUMULATOR**

- If the travel damper switch is turned ON when the machine is traveling or when the work equipment is raised, the hydraulic accumulator in the travel damper will instantaneously be connected with the lift cylinder bottom circuit. Be careful when doing this, because the oil will then flow in or out in the direction to balance the oil pressure at the accumulator and lift cylinder bottom, so the work equipment will move.
- When releasing the pressure or charging with gas for the work equipment circuit of machines equipped with an accumulator, be careful to follow the instructions given for handling the accumulator.
- The accumulator is charged with high-pressure nitrogen gas, which is extremely dangerous, so read the follow items and be careful to handle the accumulator properly.
- Do not make any holes or bring any flame or heat close to the accumulator.
- Do not weld any boss to the accumulator.
- The gas must be released before disposing of the accumulator, ask your Komatsu distributor to do this.



## 7. PRECAUTIONS DURING OPERATION

### 7.1 BEFORE STARTING ENGINE (Also see "12.1 WALK AROUND CHECK")

#### SAFETY AT WORKSITE

- Before entering the operator's compartment, walk completely around the machine and clear the area of personnel and obstructions.
- Before starting the engine, thoroughly check the area for any unusual conditions that could be dangerous.
- Before starting the engine, examine the terrain and soil conditions of the worksite. Determine the best and safest method of operation.
- If you need to operate on a street, protect pedestrians and cars by designating a person for worksite traffic duty or by installing barriers around the worksite.
- If water lines, gas lines, telephone lines, and high-voltage electrical lines may be buried under the worksite, contact each utility and identify their locations. Be careful not to sever or cut any of these lines.
- Check the depth and flow of water before operating in water or crossing a river. NEVER be in water which is in excess of the permissible water depth.

**Permissible water depth → See "12.18 PRECAUTIONS FOR OPERATION".**

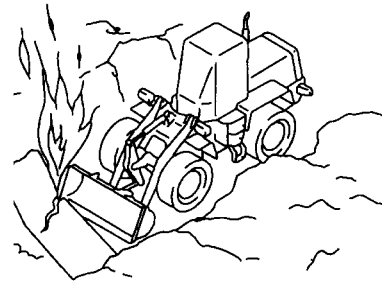

AE060770

#### FIRE PREVENTION

- Carry out the following checks before starting the engine at the beginning of the day's work.  
Failure to carry out these checks may lead to serious injury or damage.
- Completely remove all wood chips, leaves, grass, paper and other flammable materials accumulated in the engine compartment and around the battery. Check fuel, lubrication, and hydraulic system for leaks, and have any leaks repaired. Wipe up any excess oil, fuel or other flammable fluids. Return all containers to their proper place.
- Check for damage to the electrical wiring.
- Be sure a fire extinguisher is present and check the method of using it.
- Do not operate the machine near any fire or flame.



#### WALK AROUND CHECK

- Check that the coolant level, fuel level and oil level in the engine oil pan.
- Check for clogging of the air cleaner

**Check points → See "12.1 WALK AROUND CHECK".**



WARNING: Failure to follow these safety precautions may lead to a serious accident.

### IN OPERATOR'S CAB

- Do not leave tools, spare parts or personal items lying around in the operator's compartment. They may damage, break or jam the control levers or switches. Always put them in their proper place.
- Keep the cab floor, controls, steps and handrails free of oil, grease, snow, and excess dirt.
- Check the seat belt, buckle and hardware for damage or wear. Replace any worn or damaged parts. NEVER use bleach, dye or solvents on the seat belt because this may weaken the webbing and result in personal injury. Clean the seat belt with warm water and a mild detergent. ALWAYS use seat belts when operating your machine. Adjust the operator's seat to a position where it is easy to carry out operations.  
**Seat belts → See "12.3.2 ADJUSTMENT BEFORE OPERATION".**
- Check that the safety lock is at the LOCK position and the control levers are at the PARKING position.
- Check that the gauges work properly,  
**For method of checking operation of gauges → see "12.2 OPERATION AND CHECKS BEFORE STARTING".**
- Know the alternate exit routes from the operator's compartment for use in an emergency.

### VENTILATION FOR ENCLOSED AREAS

- If it is necessary to start the engine within an enclosed area, then provide adequate ventilation. Exhaust fumes from the engine can be **FATAL**.
- If you handle fuel or flushing of oil or paint within an enclosed area, then provide adequate ventilation to prevent gas poisoning.



### PRECAUTIONS FOR MIRRORS, WINDOWS, AND LIGHTS

- Remove all dirt from the surface of the windows and lights to ensure good visibility.
- Adjust all mirrors to give the best view from the operator's seat and clean the surface of the mirrors. If the mirror glass is damaged, replace it.
- Check that the head lamps and working lamps are installed to match the operating conditions. Check also that they light up properly. Correct and repair any abnormalities.

**WHEN STARTING ENGINE**

- Perform a visual check of the machine before starting the engine. Look for such things as missing protective devices, leaks, improper fluid levels, trash buildup and loose, damaged or missing parts. **DO NOT** start the engine until any unsafe conditions are corrected.
- Walk around your machine again just before mounting it, checking for people and objects that might be in the way.
- **NEVER** start the engine if a warning tag has been attached to the control (1).
  
- Understand all control functions before starting the engine.
- When starting the engine, sound the horn as an alert
- Start and operate the machine only while seated.
- Do not allow anyone other than the operator to ride in the cab or on the machine body.
- For machines equipped with a back-up alarm buzzer, check that the warning device operates correctly
- Keep hands and footwear free of grease, water and mud to insure positive control movement.
- Before driving the machine, adjust the seat and fasten the seat belt. Adjust the seat for maximum comfort and control of the machine. Adjust the seat belt to fit snugly and low around the hips to lessen the chance and severity of injury in the event of an accident. Never wear the seat belt across the abdomen.
- Before moving the machine, check the brakes, steering, attachment controls and safety devices such as the travel alarm for proper operation. **DO NOT** operate the machine until any unsafe conditions have been corrected.

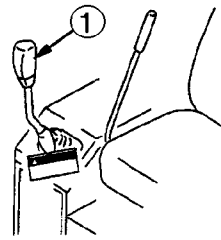
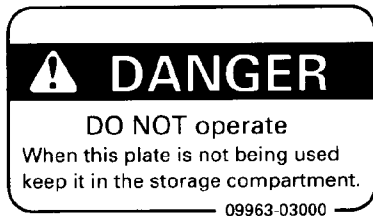

AE414620



WARNING: Failure to follow these safety precautions may lead to a serious accident.

## 7.2 AFTER STARTING ENGINE

### CHECKS AFTER STARTING ENGINE

Failure to carry out checks properly after starting the engine will lead to delays in discovery of abnormalities, and this may lead to serious injury or damage to the machine.

When carrying out the checks, use a wide area where there are no obstructions. Do not allow anyone near the machine.

- Check the operation of the gauges and equipment, and check the operation of the bucket, lift arm, brakes, travel system and steering system.
- Check for any abnormality in the sound of the machine, vibration, heat, smell, or gauges; check also for any leakage of air, oil or fuel.
- If any abnormalities are found, then carry out repairs immediately.
- If the machine is used when it is not in proper condition, it may lead to serious injury or damage to the machine.
- Before traveling or starting operations, check that the safety bar (1) is securely locked in the FREE position.

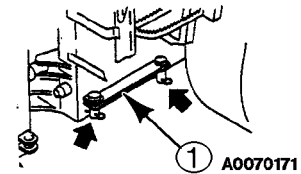

### PRECAUTIONS WHEN STARTING OFF

- Before starting off, check again that there is no one in the surrounding area and that there are no obstacles.
- When starting off, sound the horn as an alert.
- Always operate the machine when seated in the operator's seat.
- Always fasten the seat belt.
- Do not allow anyone to ride on the machine body.
- Check that the backup alarm works properly.



AE305800



## SAFETY



WARNING: For reasons of safety, always follow these safety precautions.

### CHECK WHEN CHANGING DIRECTION

To prevent serious injury or death, always do the following before moving the machine or the work equipment.

- Sound the horn to warn people in the area.
  - Check that there is no one near the machine. Be particularly careful to check behind the machine. This area cannot be seen from the operator's seat.
  - When operating in the areas that may be hazardous or have poor visibility, designate a person to direct worksite traffic.
  - Ensure that no unauthorized persons come within the direction of travel.
- Always be sure to carry out the above precautions even when the machine is equipped with a backup alarm.

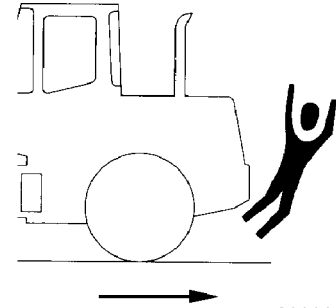

A0060780



WARNING: Failure to follow these safety precautions may lead to a serious accident.

### PRECAUTIONS WHEN TRAVELING

- Never turn the key in the starting switch to the OFF position when traveling. It is dangerous if the engine stops when the machine is traveling, because the steering becomes heavy. If the engine stops, apply the brake immediately to stop the machine.
- It is dangerous to look around you when operating. Always concentrate on your work.
- It is dangerous to drive too fast, or to start suddenly, stop suddenly, turn sharply, or zigzag.
- If you find any abnormality in the machine during operation (noise, vibration, smell, incorrect gauges, air leakage, oil leakage, etc.), move the machine immediately to a safe place and look for the cause.
- Set the work equipment to a height of 40 - 50 cm (16 - 20 in) from the ground level and travel on level ground.
- When traveling, do not operate the work equipment control levers. If the work equipment control levers have to be operated, stop the machine first, then operate the levers.
- Do not operate the steering wheel suddenly. The work equipment may hit the ground surface and cause the machine to lose its balance, or may damage the machine or structures in the area.
- When traveling on rough ground, travel at low speed, and avoid sudden changes in direction.
- Avoid traveling over obstacles as far as possible. If the machine has to travel over an obstacle, keep the work equipment as close to the ground as possible and travel at low speed.
- When traveling or carrying out operations, always keep your distance from other machines or structures to avoid coming into contact with them.
- NEVER be in water which is in excess of the permissible water depth.  
**Permissible water depth → See “12.18.1 PRECAUTIONS FOR OPERATION”.**
- When passing over bridges or structures on private land, check first that the structure is strong enough to support the mass of the machine. When traveling on public roads, check first with the relevant authorities and follow their instructions.
- Always obey the traffic regulations when traveling on public roads. This machine travels at a lower speed than normal automobiles, so keep to the side of the road and be careful to leave the center of the road free for other vehicles.
- If you drive the machine at high speed continuously for a long time, the tires will overheat and the internal pressure will become abnormally high. This may cause the tires to burst. If a tire bursts, it produces an extremely large destructive force, and this may cause serious injury or accident.
- If you are going to travel continuously, please consult your Komatsu distributor.

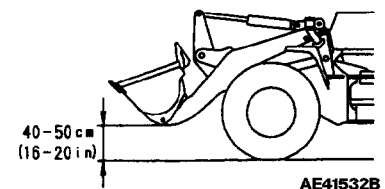

**TRAVELING ON SLOPES**

- Traveling on hills, banks or slopes that are steep could result in the machine tipping over or slipping.
- On hills, banks or slopes, carry the bucket closer to the ground. Approximately 20 to 30 cm (8 to 12 in) above the ground. In case of emergency, quickly lower the bucket to the ground to help the machine stop and prevent it from tipping over.
- Do not turn on slopes or travel across slopes. Always go down to a flat place to perform these operations.
- Do not travel up and down on grass, fallen leaves, or wet steel plates. Even slight slopes may cause the machine to slip to the side, so travel at low speed and make sure that the machine is always traveling directly up or down the slope.
- When traveling downhill, never shift gear or place the transmission at neutral. It is dangerous not to use the braking force of the engine. Always place the transmission in a low gear before starting to travel downhill.
- When traveling down a slope, use the braking force of the engine and travel slowly. If necessary, use the braking force of the engine together with the brake pedal to control the travel speed.
- If the engine stops when the machine is on a slope, immediately depress the brake, lower the bucket to the ground, then apply the parking brake to stop the machine.
- When carrying a load, travel forward when going uphill and in reverse when going downhill.
- When traveling on a slope with a loaded bucket, if the machine travels with the bucket facing downhill, there is danger that the machine may tip over.

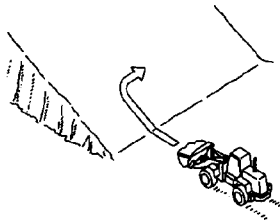
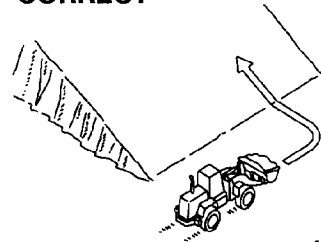
**INCORRECT****CORRECT**

AE060810

**PROHIBITED OPERATIONS**

To prevent the machine from turning over or the work equipment from being damaged because of overload, always keep within the maximum load specified for the machine. Never use the machine in excess of its capacity.



WARNING: Failure to follow these safety precautions may lead to a serious accident.

### PRECAUTIONS WHEN TRAVELING

- Be careful not to approach too close to the edge of cliffs. When making embankments or landfills, or when dropping soil over a cliff, dump one pile, then use the next pile to push the first pile.
- The vehicle may suddenly get lighter when a load is pushed over a cliff or when the machine reaches the top of a slope. When this happens there is danger in that the travel speed may suddenly increase, so be sure to reduce the travel speed prior to the danger.
- When the bucket is fully loaded, be particularly careful to avoid sudden starting, turning or stopping.
- When handling unstable loads, such as round or cylindrical objects, or piled sheets, if the work equipment is raised high, there is danger that the load may fall on top of the operator's compartment and cause serious injury or damage.

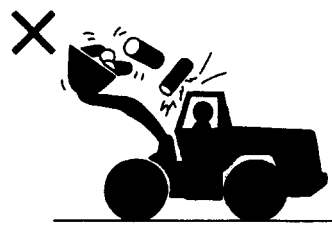
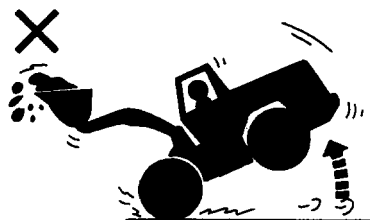

AE418210A

- When handling unstable loads, be careful not to raise the work equipment too high or tip the bucket back too much.
  - If the work equipment is suddenly lowered or suddenly stopped, the reaction may cause the machine to tip over. Particularly when carrying a load, be sure to operate the work equipment carefully.
  - Do not use the bucket or lift arm for crane work.
  - Carry out only work that is specified as the purpose of the machine. Carrying out other operations will cause breakdowns.
- Specified operations → See “12.13 WORK POSSIBLE USING PARALLEL TOOL CARRIER”.**
- Do the following to ensure good visibility.
  - When operating in dark places, turn on the working lamps and front lamps, and install lighting at the jobsite if necessary.
  - Do not carry out operations in fog, mist, snow, or heavy rain, or other conditions where the visibility is poor. Wait for the weather to clear so that visibility is sufficient to carry out work.
  - Always do the following to prevent the work equipment from hitting other objects.
  - When operating in tunnels, under bridges, under electric wires, or other places where the height is limited, be extremely careful not to let the bucket hit anything.
  - When loading dump trucks, check that there is no one in the area. Also, be careful that the load does not drop when it is being loaded.
  - To prevent accidents caused by hitting other objects, always operate the machine at a speed which is safe for operation, particularly in confined spaces, indoors, and in places where there are other machines.

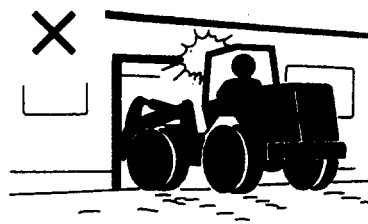
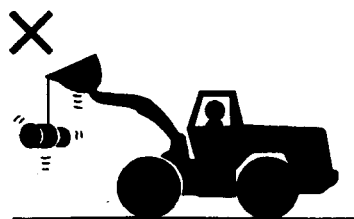

AE418230A

# SAFETY



WARNING: For reasons of safety, always follow these safety precautions.

## DO NOT GO CLOSE TO HIGH-VOLTAGE CABLES

- Do not let the machine touch any electrical cables. Even going close to high-voltage cables can cause an electric shock. Always maintain the safe distance given below between the machine and any electric cable.
- To prevent accidents, always do as follows.
  - On jobsites where there is danger that the machine may touch the electric cables, consult the electricity company before starting operations to check that the actions determined by the relevant laws and regulations have been taken.
  - Wear rubber shoes and gloves. Lay a rubber sheet on top of the operator's seat, and be careful not to touch the chassis with any exposed part of your body.
  - Use a signalman to give warning if the machine approaches too close to the electric cables.
  - If the work equipment should touch the electric cable, the operator should not leave the operator's compartment.
  - When carrying out operations near high voltage cables, do not let anyone come close to the machine.
  - Check with the electric utility company about the voltage of the cables before starting operations.

	Voltage	Min. Safety distance	
Low voltage	100-200 V	2 m	7 ft
	6,600 V	2 m	7 ft
Very high voltage	22,000 V	3 m	10 ft
	66,000 V	4 m	14 ft
	154,000 V	5 m	17 ft
	187000 V	6 m	20 ft
	275,000 V	7 m	23 ft
	500,000 V	11 m	36 ft

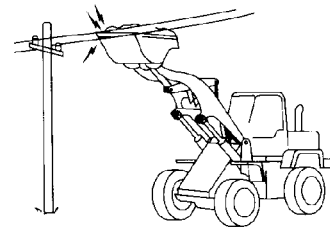

A0060820



WARNING: Failure to follow these safety precautions may lead to a serious accident.

### **ENSURE GOOD VISIBILITY**

- When working in dark places, install working lamps and head lamps, and set up lighting in the work area if necessary.
- Stop operations if the visibility is poor, such as in mist, snow, or rain, and wait for the weather to improve to a condition that allows the operation to be carried out safely.

### **OPERATE CAREFULLY ON SNOW**

- When working on snow or icy roads, even a slight slope may cause the machine to slip to the side, so always travel at low speed and avoid sudden starting, stopping, or turning.
- When there has been heavy snow, the road shoulder and objects placed beside the road are buried in the snow and cannot be seen, so always carry out snow-clearing operations carefully. There is danger of slipping particular on uphill or downhill slopes.
- With frozen road surfaces, the ground becomes soft when the temperature rises, so the travel conditions become unstable. In such cases be extremely careful when traveling.
- When there has been heavy snow, the road shoulder and objects placed beside the road are buried in the snow and cannot be seen, so always carry out snow-clearing operations carefully.
- When traveling on snow-covered roads, always install tire chains.
- When traveling on snow-covered slopes, never apply the brakes suddenly. Reduce the speed and use the engine as a brake while applying the foot brake intermittently (depress the brake intermittently several times). If necessary, lower the bucket to the ground to stop the machine.
- The load may change greatly, according to the type of the snow, so reduce the load according and be careful not to let the machine slip.

### **DO NOT HIT WORK EQUIPMENT**

- When working in places where there are height limits, such as in tunnels, under bridges, under electric cables, or in garages, be extremely careful not to hit the work equipment.

### **METHOD OF USING BRAKES**

- Do not put your foot on the brake pedal unless necessary.
- Do not depress the brake pedal repeatedly unless necessary
- When traveling downhill, use the engine as a brake, and always use the right brake pedal.
- Note that when the engine of a machine with booster stops, the brake pedal becomes 3.5 times heavier.



**WORKING ON LOOSE GROUND**

- Do not operate the machine on soft ground. It is difficult to get the machine out again.
- Avoid operating your machine too close to the edge of cliffs, overhangs, and deep ditches. If these areas collapse your machine could fall or tip over and result in serious injury or death. Remember that the soil after heavy rain, blasting, or earthquakes is weakened in these areas.
- Earth laid on the ground and the soil near ditches are loose. It can collapse under the weight or vibration of your machine and cause your machine to tip over.
- Install the head guard (FOPS) if working in areas where there is danger of falling rocks and dirt.
- Install the ROPS and wear the seat belt when working in areas where there is danger of falling rocks or of the machine turning over.

**PARKING THE MACHINE**

- Park on level ground where there is no danger of failing rocks or landslides, or of flooding if the land is low, and lower the work equipment to the ground.
  - If the machine must be parked on a slope, block the wheels to prevent the machine from moving, then dig the work equipment into the ground.
  - When parking on public roads, provide fences, signs, such as flags, or lights, on the machine to warn passerby to be careful. Be sure that the flags, and fences do not obstruct traffic.
- Parking procedure → See “12.18 PARKING MACHINE”.**
- When leaving the machine, lower the work equipment completely to the ground, set the safety lock to the LOCK position and parking brake pedal to the LOCK position, stop the engine, and use the key to lock all the equipment. Always take the key with you.
- Work equipment posture → See “12.18 PARKING MACHINE”.**
- Places to lock → See “12.24 LOCKING”.**

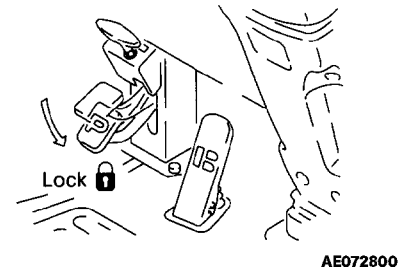
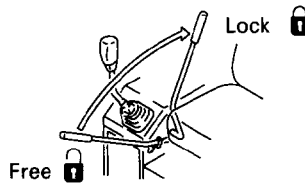
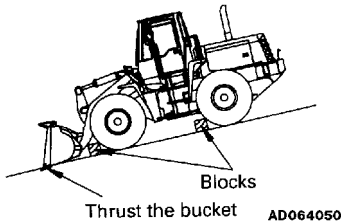



WARNING: Failure to follow these safety precautions may lead to a serious accident.

**PRECAUTIONS IN COLD AREAS**

- After completing operations, remove all water, snow, or mud stuck to the wiring harness, connector (1), switches, or sensors, and cover these parts.  
If the water freezes, it will cause malfunctions of the machine when it is next used, and this may lead to unexpected accidents.
- Carry out the warming-up operation thoroughly. If the machine is not thoroughly warmed up before the control levers are operated, the reaction of the machine will be slow, and this may lead to unexpected accidents.
- Operate the control levers to relieve the hydraulic pressure (raise to above the set pressure for the hydraulic circuit and release the oil to the hydraulic tank) to warm up the oil in the hydraulic circuit. This ensures good response from the machine and prevents malfunctions.
- If the battery electrolyte is frozen, do not charge the battery or start the engine with a different power source. There is danger that this will ignite the battery.  
When charging or starting the engine with a different power source, melt the battery electrolyte and check for leakage of battery electrolyte before starting.  
**Battery charge rate → See “14. COLD WEATHER OPERATION”.**

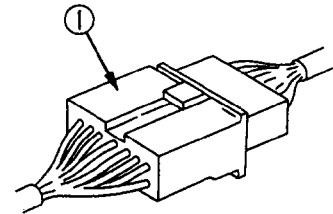

**AE305820**





## 7.3 TRANSPORTATION

### LOADING AND UNLOADING

- Loading and unloading the machine always involves potential hazards. **EXTREME CAUTION SHOULD BE USED.**  
When loading or unloading the machine, run the engine at low idle and travel at low speed.
- Perform loading and unloading on firm, level ground only. Maintain a safe distance from the edge of a road.
- **ALWAYS** block the wheels of the hauling vehicle and place blocks under both ramps before loading and unloading.
- **ALWAYS** use ramps of adequate strength. Be sure the ramps are wide and long enough to provide a safe loading slope.
- Be sure that the ramps are securely positioned and fastened, and that the two sides are at the same level as one another.
- Be sure the ramp surface is clean and free of grease, oil, ice and loose materials. Remove dirt from the machine tracks.
- **NEVER** correct your steering on the ramps. If necessary, drive away from the ramps and climb again.
- After loading, block the machine tires and secure the machine with tie-downs.

**Loading and unloading → See "13. TRANSPORTATION"**

**Tie downs → See "13. TRANSPORTATION"**

**CORRECT**

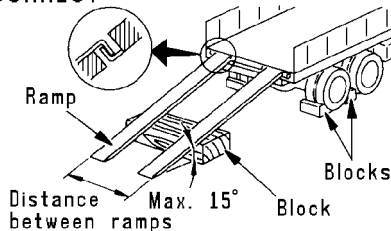

AE50648B

### SHIPPING

- When shipping the machine on a hauling vehicle, obey all state and local laws governing the weight, width, and length of a load. Also obey all applicable traffic regulations.
- Take into account the width, height, and weight of the load when determining the shipping route. **Height, width, load of machine → See "13.3 PRECAUTIONS FOR TRANSPORTATION"**.
- When passing over bridges or structures on private land, check first that the structure is strong enough to support the mass of the machine. When traveling on public roads, check first with the relevant authorities and follow their instructions.
- The machine can be divided into parts for transportation, so when transporting the machine, please contact your Komatsu distributor to have the work carried out.



WARNING: Failure to follow these safety precautions may lead to a serious accident.

## 7.4 BATTERY

### BATTERY HAZARD PREVENTION

Battery electrolyte contains sulphuric acid, and batteries generate hydrogen gas, so mistaken handling can lead to serious injury or fire. For this reason, always observe the following precautions.

- Never bring any lighted cigarette or flame near the battery.
- When working with batteries, ALWAYS wear safety glasses and rubber gloves.
- If you spill acid on your clothes or skin, immediately flush the area with large amounts of water.
- Battery acid could cause blindness if splashed into the eyes. If acid gets into your eyes, flush them immediately with large quantities of water and see a doctor at once.
- If you accidentally swallow battery acid, drink a large quantity of water or milk, beaten egg or vegetable oil. Call a doctor or poison prevention center immediately.
- Before working with batteries, stop the engine and turn the starting switch to the OFF position.
- Batteries generate hydrogen gas that is very explosive and easily ignited with a spark or flame.
- Avoid short-circuiting the battery terminals (between the positive ( + ) terminal and negative ( - ) terminal) through accidental contact with metal objects, such as tools, across the terminals.
- When installing the battery, connect the positive ( + ) terminal first, and when removing the battery, disconnect the negative ( - ) terminal (ground side) first.
- If the battery electrolyte is near the LOWER LEVEL, add distilled water. Do not add distilled water above the UPPER LEVEL.
- When cleaning the top surface of the battery, wipe it with a cloth. Never use gasoline, thinner, or any other organic solvent or cleaning agent.
- Loose terminals can cause sparks which cause explosions. Therefore securely tighten the terminals and the battery caps .
- If the battery electrolyte is frozen, do not charge the battery or start the engine with a different power source. There is danger that this will ignite the battery. When charging or starting the engine with a different power source, melt the battery electrolyte and check for leakage of battery electrolyte before starting.
- Always remove the battery from the chassis before charging it.

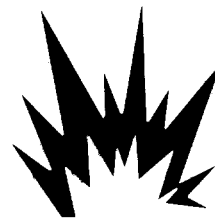
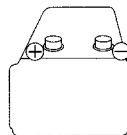
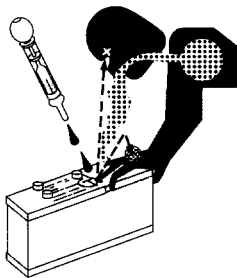

**STARTING WITH BOOSTER CABLES**

If any mistake is made in the method of connecting the booster cables, it may cause a fire, so always do as follows.

- Carry out the starting operation with two workers (with one worker sitting in the operator's seat)
- Always wear safety glasses when handling tools or booster cables near the batteries.
- When starting from another machine, do not allow the two machines to touch.
- When connecting the booster cables, turn the starting switch OFF for both the normal machine and problem machine.
- Be sure to connect the positive ( + ) cable first when installing the booster cables. Disconnect the ground or negative ( - ) cable first when removing them.
- If any tool touches between the positive ( + ) terminal and the chassis, it will cause sparks. This is dangerous, so be sure to work carefully.
- The final ground connection is the connection of the ground to the engine block of the problem machine. However, this will cause sparks, so be sure to connect it as far away as possible from the battery.  
**Starting with booster cables → See "16.3 IF BATTERY IS DISCHARGED".**
- When removing the booster cables, be careful not to let the booster cable clips touch each other or to let the clips touch the machine.
- Connect the batteries in parallel: positive ( + ) to positive ( + ) and negative ( - ) to negative ( - ).

INCORRECT

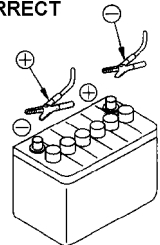



WARNING: Failure to follow these safety precautions may lead to a serious accident.

## SAFETY

### CHARGING BATTERY

- If the battery is handled incorrectly when it is being charged, there is danger that the battery may explode, so follow the instructions in HANDLING BATTERY and in the instruction manual for the charger, and always observe the following precautions.
- Carry out the charging in a well-ventilated place, and remove the battery caps. This disperses the hydrogen gas and prevents explosion.
- Set the voltage on the charger to match the voltage on the battery to be charged. If the voltage setting is wrong, it will cause the charger to overheat and catch fire, and this may lead to an explosion. Connect the positive ( + ) charging clip of the charger to the positive ( + ) terminal of the battery, then connect the negative ( - ) charging clip to the negative ( - ) terminal of the battery. Be sure to tighten both terminals securely.
- If the battery charge is less than 1/10 of the rated charge, and high speed charging is carried out, set to a value below the rated capacity of the battery.
- If there is an excessive flow of charging current, it may cause leakage or evaporation of the electrolyte, which may catch fire and explode.

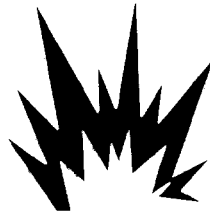

A0055110

INCORRECT

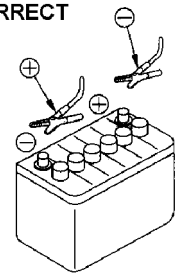



## 7.5 TOWING

### WHEN TOWING

- Towing in the wrong way may lead to serious personal injury or damage, so always do as follows.
- Do not tow in a different way from the method given in the section **Towing method** →See “16.2 TOWING THE MACHINE”.
- Always wear leather gloves when handling wire rope.
- When carrying out the preparation for towing with another worker, agree on signals before starting the operation.
- If the engine on the problem machine will not start or there is a failure in the brake system, please contact your Komatsu distributor for repairs.
- It is dangerous to tow a machine on a slope, so choose a place where there is a gradual slope. If there is no place with a gradual slope, carry out work to make the slope as small as possible.
- When using another machine to tow this machine, ALWAYS use a wire rope with ample strength for the weight of the this machine.
- Do not use a wire rope which has cut strands (A), kink (B), or reduced diameter (C).
- Do not straddle the towing cable or wire rope.
- When connecting up a towing machine do not let anyone enter the area between the towing machine and the machine equipment being towed.
- Set the towing machine and towing connection of equipment being towed in a straight line when connecting it. **Towing method** →See “16.2 TOWING THE MACHINE”.
- Place pieces of wood between the wire ropes and body to protect them from wear or damage.

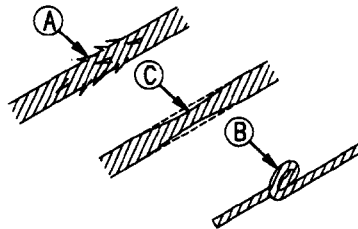

AE305B40

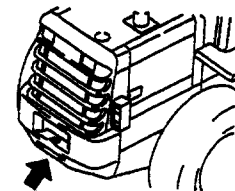

AE092830



WARNING: Failure to follow these safety precautions may lead to a serious accident.

## 8. PRECAUTIONS FOR MAINTENANCE

### 8.1 BEFORE CARRYING OUT MAINTENANCE

#### NOTIFICATION OF FAILURE

Carrying out maintenance not described in the Komatsu operation and maintenance manual may lead to unexpected failures.  
Please contact your Komatsu distributor for repairs.

#### WARNING TAGS

- If others start the engine or operate the controls while you are performing service or lubrication, you could suffer serious injury or death.
- ALWAYS attach the WARNING TAG to control lever (1) in the operator's cab to alert others that you are working on the machine. Attach additional warning tags around the machine, if necessary.
- These tags are available from your Komatsu distributor. (Part No. 09963-03000)

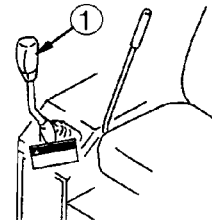
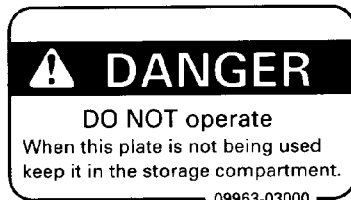

AE414620

#### CLEAN BEFORE INSPECTION AND MAINTENANCE

- Clean the machine before carrying out inspection and maintenance. This will ensure that dirt does not get into the machine and will also ensure that maintenance can be carried out safely.
- If inspection and maintenance are carried out with the machine still dirty, it will be difficult to find the location of problems, and there is also the danger that you will get dirty or mud in your eyes, and that you will slip and injure yourself.
- When washing the machine, always do as follows.
  - Wear non-slip shoes to prevent yourself from slipping on the wet surface.
  - When using high-pressure steam to wash the machine, always wear protective clothing. This will protect you from being hit by high-pressure water, and cutting your skin or getting mud or dust into your eyes.
  - Do not spray water directly on to the electrical system (sensors, connectors) (1). If water gets into the electrical system, there is danger that it will cause defective operation and malfunction.

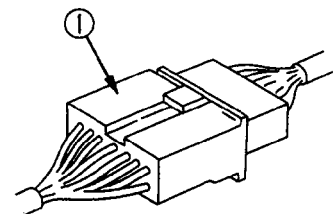
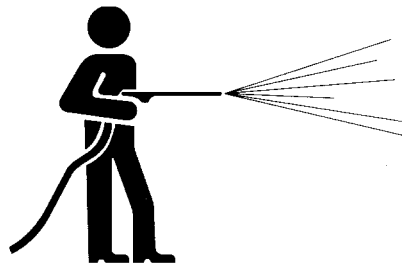

AE305820

## SAFETY



WARNING: For reasons of safety, always follow these safety precautions.

### STOP ENGINE BEFORE CARRYING OUT INSPECTION AND MAINTENANCE

- When carrying out inspection and maintenance, park the machine on level ground where there is no danger of falling rocks or landslides, or of flooding if the land is low, then lower the work equipment to the ground and stop the engine.
- After stopping the engine, operate bucket control lever (1) several times to the RAISE and LOWER positions to release the remaining pressure in the hydraulic circuit, then set safety lock (2) to the LOCK position.
- Apply the parking brake to the lock position, then block the wheels to prevent the machine from moving.
- Lock the front and rear frames with safety bar (4).
- The worker carrying out the maintenance should be extremely careful not to touch or get caught in any moving parts.
- If it is necessary to run the engine when carrying out maintenance, such as when cleaning the inside of the radiator, place the safety lock lever in the LOCK position and carry out the operation with two workers.
- One worker should sit in the operator's seat so that he can stop the engine immediately if necessary. He should also be extremely careful not to touch any levers by mistake. Touch the levers only when they have to be operated.

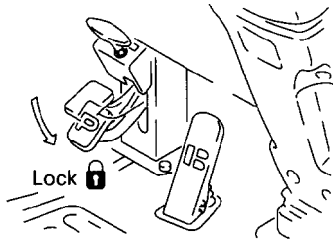

AE072800

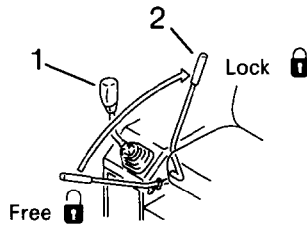

AE41825A

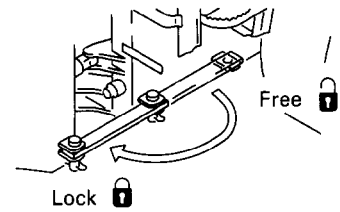

AE070170

### WORK EQUIPMENT SUPPORT

When carrying out inspection and maintenance with the bucket raised, fit stand (1) securely under the lift arm to prevent the work equipment from coming down.

Set the work equipment control lever (2) to the HOLD position, and set safety lock lever (3) to the LOCK position.

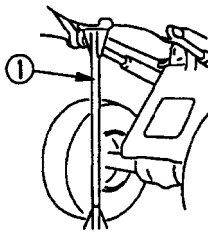

AE418280

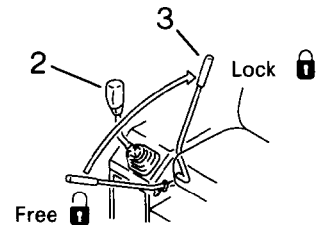

AE41829A



WARNING: Failure to follow these safety precautions may lead to a serious accident.

### PROPER TOOLS

- Use only tools suited to the task. Using damaged, low quality, faulty, or makeshift tools could cause personal injury.  
**Tools → See “21.1 INTRODUCTION OF NECESSARY TOOLS”.**



### PERIODIC REPLACEMENT OF SAFETY CRITICAL PARTS

Hoses and other parts of the fuel, hydraulic, and brake system are critical parts for ensuring safety, so they must be replaced periodically.

Replacement of safety critical parts requires skill, so please ask your Komatsu distributor to carry out replacement.

- Replace these components periodically with new ones, regardless of whether or not they appear to be defective. These components deteriorate over time.
- Replace or repair any such components if any defect is found, even though they have not reached the time specified.

**Replacement of safety critical components → See “22. PERIODIC REPLACEMENT OF SAFETY CRITICAL PARTS”.**

### USE OF LIGHTING

- When checking fuel, oil, coolant, battery electrolyte, or window washer fluid, always use lighting with anti-explosion specifications. If such lighting equipment is not used, there is danger of explosion.
- If work is carried out in dark places without installing lighting, there is danger of injury, so always install proper lighting.
- Even if it is dark, do not use a lighter or flame instead of lighting. There is danger of starting a fire, and if the battery gas ignites, it may cause an explosion.
- When using the machine as the power supply for the lighting, follow the instructions in this Operation and Maintenance Manual.

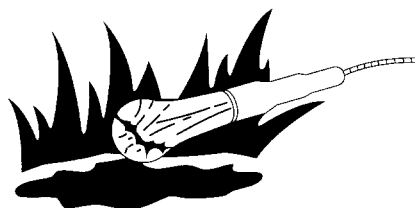



## SAFETY



WARNING: For reasons of safety, always follow these safety precautions.

### KEEP WORK PLACE CLEAN AND TIDY

Do not leave hammers or other tools lying around in the work place. Wipe up all grease, oil, or other substances that will cause you to slip. Always keep the work place clean and tidy to enable you to carry out operations safely. If the work place is not kept clean and tidy, there is danger that you will trip, slip, or fall over and injure yourself.

### APPOINT A LEADER WHEN WORKING WITH OTHERS

When repairing the machine or when removing and installing the work equipment, appoint a leader and follow his instructions during the operation.

When working with others, misunderstandings between workers can lead to serious accidents.

### RADIATOR WATER LEVEL

- When checking the radiator coolant level, stop the engine, and wait for the engine and radiator to cool down. Check the coolant level in the sub-tank. Under normal conditions, do not open the radiator cap.
- If there is no sub-tank, the radiator cap must be removed, always do as follows.
- Wait for the radiator coolant temperature to go down before checking the coolant level. (When checking if the coolant temperature has gone down, put your hand near the engine or radiator and check the air temperature. Be careful not to actually touch the radiator or engine.)
- Slowly loosen the radiator cap to release the internal pressure before removing the cap, and remove the radiator cap slowly.
- When adding coolant, add coolant through the sub-tank.

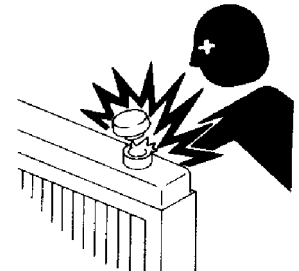
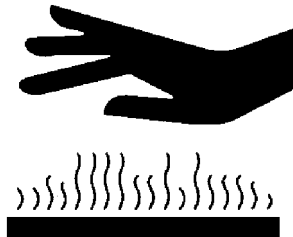



WARNING: Failure to follow these safety precautions may lead to a serious accident.

### **PREVENTION OF FIRE**

There is danger of the fuel and battery gas catching fire during maintenance, so always follow the precautions below when carrying out maintenance.

- Store fuel, oil, grease, and other flammable materials away from flame.
- Use non-flammable materials as the flushing oil for cleaning parts. Do not use diesel oil or gasoline. There is danger that they will catch fire.
- Never smoke when carrying out inspection or maintenance. Always smoke in the prescribed place.
- When checking fuel, oil, or battery electrolyte, always use lighting with anti-explosion specifications. Never use lighters or matches as lighting.
- When carrying out grinding or welding operations on the chassis, remove any flammable materials to a safe place.
- Be sure that a fire extinguisher is present at the inspection and maintenance point.



### **TURN E.C.S.S. SWITCH OFF**

- For machines equipped with a E.C.S.S., lower the bucket to the ground and turn the E.C.S.S. switch OFF before starting inspection or maintenance. NEVER turn the switch ON during inspection or maintenance. If the E.C.S.S. switch is turned ON, the hydraulic accumulator of the E.C.S.S. is connected to the bottom circuit of the lift cylinder. This is dangerous because hydraulic oil from the accumulator will flow in or out to balance the pressure, and the lift arms will move. If the starting switch is at the OFF position, the E.C.S.S. is not actuated even if the E.C.S.S. switch is ON, but if the starting switch is ON, the E.C.S.S. can be actuated, and it will be switched to the actuation condition when the E.C.S.S., switch is turned ON.



## 8.2 DURING MAINTENANCE

### PERSONNEL

Only authorized personnel can service and repair the machine. Do not allow unauthorized personnel into the area. If necessary, employ an observer.

Extra precaution should be used when grinding, welding, and using a sledge-hammer.

### ATTACHMENTS

- Appoint a leader before starting removal or installation operations for attachments.
- Do not allow anyone other than the workers close to the machine or attachment.
- Place attachments that have been removed from the machine in a safe place so that they do not fall. Put a fence around the attachments, and set up No Entry signs to prevent unauthorized persons from coming close. If they fall on you or others, serious injury could result.



### WORK UNDER THE MACHINE

- Stop the machine on firm, level ground, and lower all work equipment to the ground before performing service or repairs under the machine.
- Always block (1) the tires securely.
- It is extremely dangerous to work under the machine if the tires are off the ground and the machine is supported only by the work equipment. Never work under the machine if the machine is poorly supported.

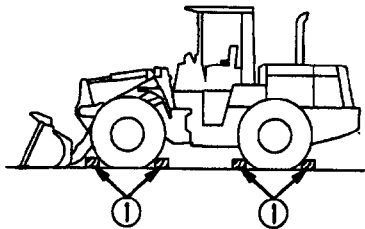

AE416300





WARNING: Failure to follow these safety precautions may lead to a serious accident.

**KEEP THE MACHINE CLEAN**

- Spilled oil or grease, or scattered tools or broken pieces are dangerous because they may cause you to slip or trip.  
Always keep your machine clean and tidy.
- If water gets into the electrical system, there is danger that the machine may not move or may move unexpectedly.  
Do not use water or steam to clean the sensors, connectors, or the inside of the operator's compartment.

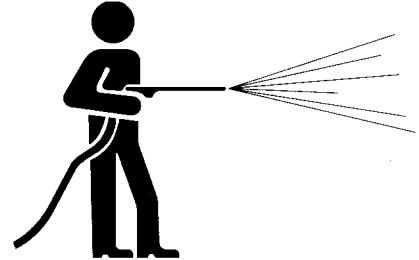

## SAFETY



WARNING: For reasons of safety, always follow these safety precautions.

### DO NOT DROP TOOLS OR PARTS INSIDE MACHINE

- When opening the inspection window or tank oil filler to carry out inspection, be careful not to drop any nuts, bolts, or tools inside the machine.  
If such parts are dropped into the machine, it will cause breakage of the machine, mistaken operation, and other failures. If you drop any part into the machine, always be sure to remove it from the machine.
- When carrying out inspection, do not carry any unnecessary tools or parts in your pocket.

### PRECAUTIONS WHEN USING HAMMER

- When using a hammer, always wear safety glasses, safety helmet, and other protective clothing, and put a brass bar between the hammer and the part being hammered.
- If hard metal parts such as pins, or bearings are hit with a hammer, there is danger that broken pieces might fly into your eyes and cause injury.

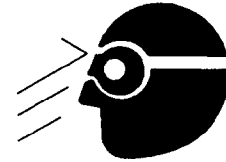

AE305880

### REPAIR WELDING

Welding operations must always be carried out by a qualified welder and in a place equipped with a proper equipment. Gas is generated, and there is danger of fire or electrocution when carrying out welding, so never allow any unqualified personnel to carry out welding.

The qualified welder must follow the precautions given below.

- Disconnect the battery terminals to prevent explosion of the battery.
- Remove the paint from the place being welded to prevent gas from being generated.
- If hydraulic equipment or piping, or pieces close to these are heated, flammable vapor or spray will be generated, and there is danger of this catching fire, so avoid applying heat to such places.
- If heat is applied directly to rubber hoses or piping under pressure, they may suddenly burst, so cover them with fireproof sheeting.
- Always wear protective clothing.
- Ensure that there is good ventilation.
- Clear up any flammable materials, and make sure that there is a fire extinguisher at the workplace.

### PRECAUTIONS WITH BATTERY

- When repairing the electrical system or when carrying out electrical welding, remove the negative (-) terminal of the battery to stop the flow of current.





WARNING: Failure to follow these safety precautions may lead to a serious accident.

## SAFETY

### WHEN ABNORMALITY IS LOCATED

- if any abnormality is found during inspection, always carry out repairs. In particular, if the machine is used when there is any abnormality in the brakes or work equipment systems, it may lead to serious accident.
- Depending on the type of failure, please contact your Komatsu distributor for repairs.

### RULES TO FOLLOW WHEN ADDING FUEL OR OIL

Fuel, oil, antifreeze, and window washer fluid can be ignited by a flame.

Always observe the following:

- Do not smoke.
- Spilled fuel, oil, antifreeze, or window washer fluid may cause you to slip, so always wipe the spill immediately.
- Always tighten all fuel, oil, antifreeze, and window washer fluid caps securely.
- Never use fuel for washing parts, or any part the machine.
- Use well-ventilated areas for adding or storing fuel, oil, antifreeze, and window washer fluid.



### HANDLING HIGH-PRESSURE HOSES

- Do not bend high-pressure hoses or hit them with hard objects. Do not use any bent or cracked piping, tubes or hoses. They may burst during use.
- Always repair any loose or broken fuel hoses or oil hoses. If fuel or oil leaks, it may cause a fire.

### ROTATING FAN AND BELT

- Keep away from rotating parts and be careful not to let anything get caught in them.
- If your body or tools come in contact with the rotating fan blades or fan belt It could cause you bodily injuries, therefore avoid contact with any rotating parts.

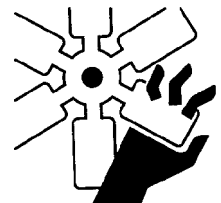



**WARNING:** For reasons of safety, always follow these safety precautions.

**PRECAUTION HIGH PRESSURE OIL**

- Do not forget that the work equipment circuits are always under pressure.
- Do not add oil, drain oil, or carry out maintenance or inspection before completely releasing the internal pressure.
- If oil is leaking under high pressure from small holes, it is dangerous if the jet of high-pressure oil hits your skin or enters your eyes. Always wear safety glasses and thick gloves, and use a piece of cardboard or a sheet of wood to check for oil leakage.
- If you are hit by a jet of high-pressure oil, consult a doctor immediately for medical attention.

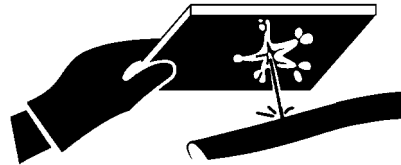
**PRECAUTIONS WHEN CARRYING OUT MAINTENANCE AT HIGH TEMPERATURE OR HIGH PRESSURE**

- Immediately after stopping machine operations, the engine cooling water and oil at all parts are at high temperatures and under high pressure. In this condition, if the radiator cap is removed, or the oil or water are drained, or the filters are replaced, this may result in burns or other injury. Wait for the temperature to go down, then carry out the inspection and maintenance in accordance with the procedures given in this manual.

**Clean inside of cooling system check lubricating oil level, add oil → see "24.2 WHEN REQUIRED".**

**Checking engine coolant level, engine oil pan level, brake oil level, add oil or coolant → see "24.3 CHECK BEFORE STARTING".**

**Checking hydraulic oil level, adding oil → see "24.5 EVERY 100 HOURS SERVICE".**

**Changing oil, replacing filters → see "24.6 EVERY 250 HOURS SERVICE".**





WARNING: Failure to follow these safety precautions may lead to a serious accident.

### **TIRE MAINTENANCE**

- Disassembly, repair, and assembly of tires requires specialist equipment and skill, please ask your specialist tire repair shop to carry out repairs.

### **CHECKS AFTER INSPECTION AND MAINTENANCE**

Failure to carry out inspection and maintenance fully, or failure to check the function of various maintenance locations may cause unexpected problems and may even lead to personal injury or damage, so always do as follows.

- Checks when engine is stopped
  - Have all the inspection and maintenance locations been checked?
  - Have all the inspection and maintenance items been carried out correctly?
  - Have any tools or parts dropped inside the machine? It is particularly dangerous if they get caught in the lever linkage.
  - Have coolant and oil leakage been repaired? Have bolts been tightened.

For details of checks when the engine is running, see “**8.2 DURING MAINTENANCE, MAINTENANCE WITH ENGINE RUNNING**”, AND BE EXTREMELY CAREFUL TO ENSURE SAFETY.

- Checks when engine is running
  - Do the inspection and maintenance locations work normally?
  - Is there any oil leakage when the engine speed is raised and load is applied to the hydraulic system?

### **WASTE MATERIALS**

- Never dump waste oil in a sewer system, rivers, etc.
- Always put oil drained from your machine in containers. Never drain oil directly on the ground.
- Obey appropriate laws and regulations when disposing of harmful objects such as oil, fuel, coolant, solvent, filters, batteries, and others.

INCORRECT

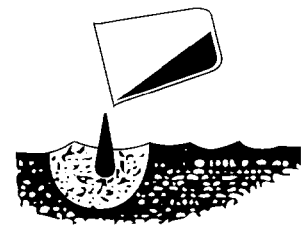

### **WHEN PERFORMING MAINTENANCE WITH THE CHASSIS RAISED**

- When carrying out maintenance with the work equipment or chassis raised, lock the front and rear frames with the safety lock, always place the levers in the HOLD position then lock the control levers with the safety lock, and block the work equipment and chassis.
- Always fit blocks under the wheels when jacking up the machine. After jacking up the machine, set blocks under it to hold position.





## 8.3 TIRES

### HANDLING TIRES

If tires are not used under the specified conditions, they may overheat and burst or be cut and burst from sharp stones on rough road surfaces. This may lead to serious injury or damage.

To maintain safety, always keep the following conditions.

- Inflate the tires to the specified pressure . Abnormal heat is generated particularly when the inflation pressure is too low.  
**Suitable inflation pressure → see "12.18 HANDLING THE TIRES".**
- Avoid overloading.  
**Suitable load → Normal load for bucket: 2240 kg (4940 lb)**  
**(When 1.4 m<sup>3</sup> (1.8 cu. yd) standard bucket is installed.)**
- Use of the specified tires.  
The values given in this manual for tire inflation pressures and permissible speed are general values. The actual value may differ depending on the type of tire and the condition under which they are used. For details, please contact your distributor or tire maker.
- When pumping up the tires, use an air chuck with a clip. When pumping up tires, parts of the wheel may fly off, so do not stand in front of the tire.
- Do not adjust the tire inflation pressure immediately after traveling at high speed or after carrying out work under high load.

If the tire is heated when installed to the wheel, flammable gas is produced. If this catches fire, the tire may explode and cause serious injury or damage. Unlike when a tire is punctured and burst, if a tire explodes, it produces a highly destructive force, so the following operations are strictly prohibited when the tire is installed to the wheel.

- Welding of the rim.
- Lighting fires or carrying out welding operations near the wheel or tire.

If you do not understand the proper procedure for carrying out maintenance or replacement of the wheel or tire, and you use the wrong method, the wheel or tire may burst and cause serious injury or damage. When carrying out such maintenance, please consult your distributor or tire maker.



A0055110



WARNING: Failure to follow these safety precautions may lead to a serious accident.

**STORING TIRES AFTER REMOVAL**

- As a basic rule, store the tire in a warehouse which unauthorized persons cannot enter. If the tires are stored outside, always erect a fence around the tires and put up a "No Entry" and other warning signs that even children can understand.
- Stand the tire on level ground, and block it securely so that it cannot roll or fall over.
- If the tire should fall over, get out of the way quickly. The tires for construction equipment are extremely heavy, so trying to hold the tire may lead to serious injury.

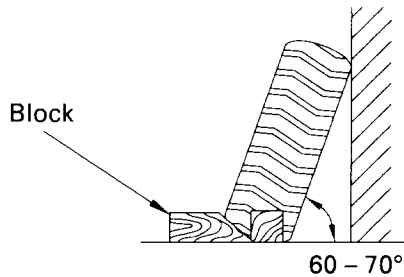

A0055130



**WARNING:** For reasons of safety, always follow these safety precautions.

## 9. POSITION FOR ATTACHING SAFETY LABELS

Always keep these labels clean. If they are lost or damaged, attach them again or replace them with a new label. There are other labels in addition to the safety labels listed as follows, so handle them in the same way. Safety labels may be available in languages other than English. To find out what labels are available, contact your local distributor.

### 9.1 POSITION FOR ATTACHING SAFETY LABELS

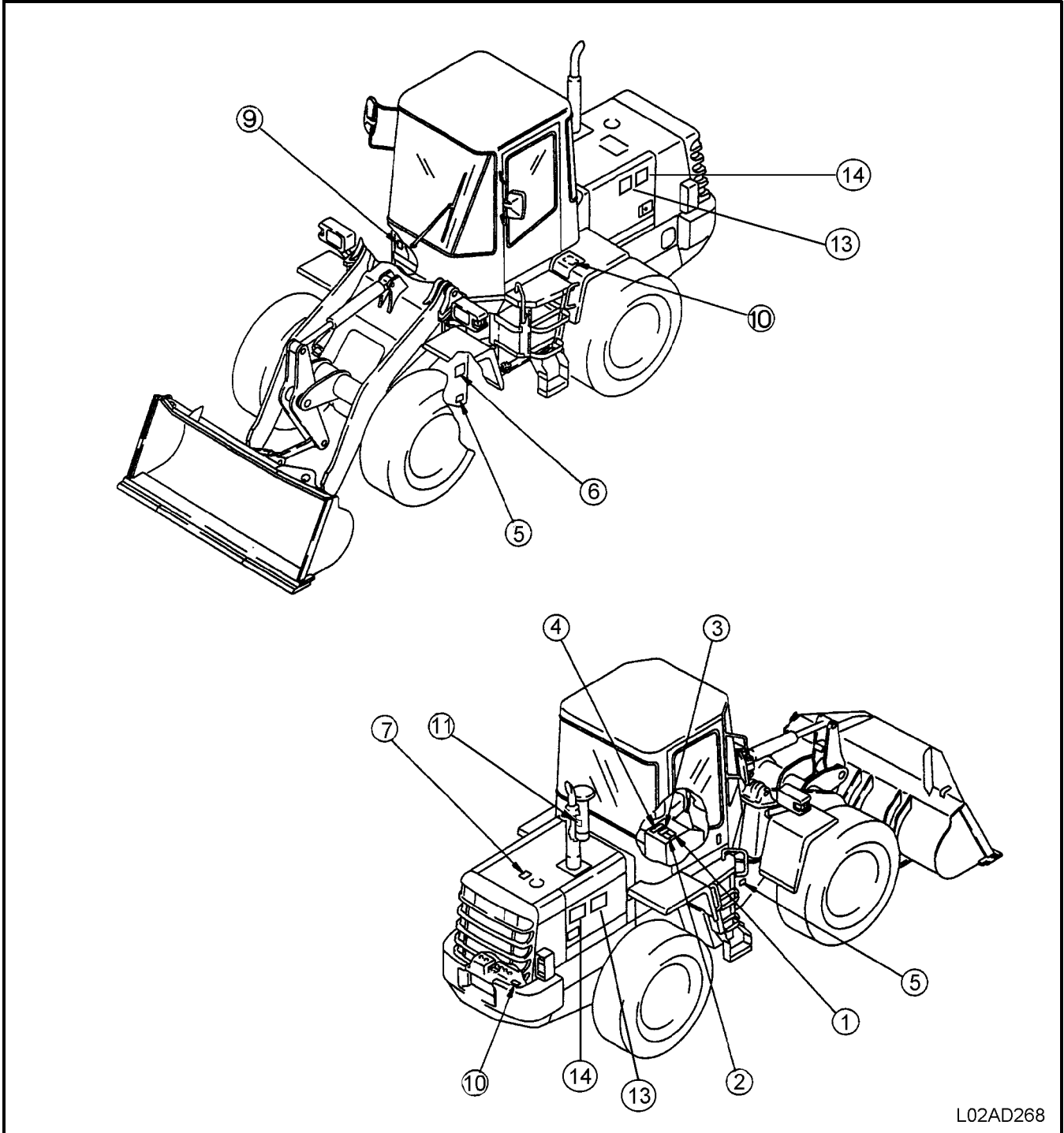

L02AD268



WARNING: Failure to follow these safety precautions may lead to a serious accident.

1. Precautions before starting.

**! WARNING**

Improper operation and maintenance can cause serious injury or death. Read manual and labels before operation and maintenance. Follow instructions and warnings in manual and in labels on machine. Keep manual in machine cab near operator. Contact Komatsu distributor for a replacement manual.

L02AD250

2. Precautions for safety lock lever.

**! WARNING**

To avoid hitting unlocked operation levers, lower equipment to ground and move SAFETY LOCK LEVER (located near seat) to LOCK position before standing up from operator's seat.

Sudden and unwanted machine movement can cause serious injury or death.

L02AD205

3. Precaution when traveling in reverse.

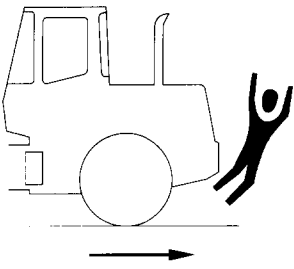

**! WARNING**

To prevent SEVERE INJURY or DEATH, do the following before moving machine or its attachments:

- Honk horn to alert people nearby.
- Be sure no one is on or near machine.
- Use spotter if view is obstructed.

Follow above even if machine equipped with back-up alarm and mirrors.

L02AD252

4. Precautions for parking brake.

**! WARNING**

Hydraulically-boosted brake system is used for this machine. If the engine is stopped, the required braking effort increases considerably. This in turn causes the braking distance to be extended and may lead to an accident. Never stop the engine while traveling.

L02AD253

## SAFETY



WARNING: For reasons of safety, always follow these safety precautions.

5. Do not enter.



L02AD208

7. Precautions when coolant is at high temperature.



L02AD210

6. Precautions for safety bar.

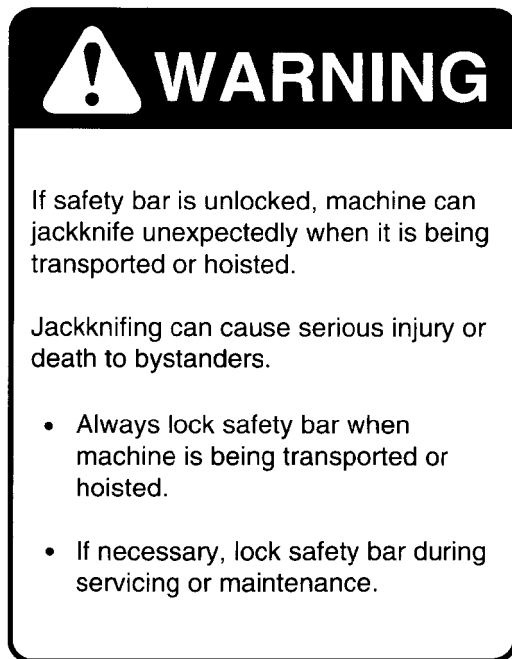

L02AD209

8. Precautions when oil is at high temperature.



L02AD211

9. Precautions for brake oil.

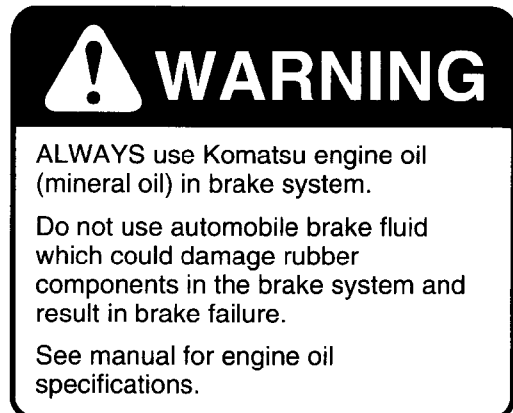

L02AD254



WARNING: Failure to follow these safety precautions may lead to a serious accident.

10. Precautions when handling battery cable.

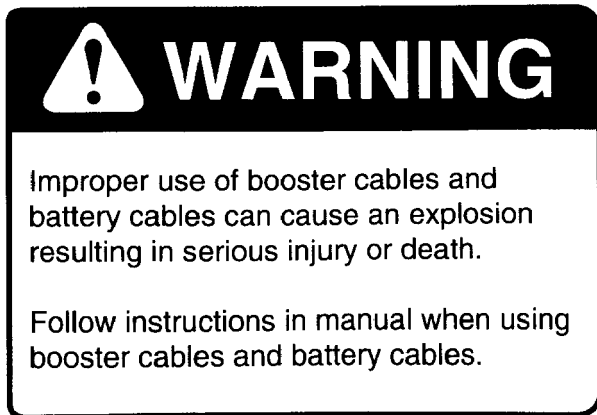

L02AD212

11. Do not use ether.



12. Do not go under work equipment warning (09807-C0880)



09807-C1680

This decal is to warn people around the machine. If anyone approaches the lift arm when it is raised, or goes under the bucket, give a warning to stop the person from approaching.

L02AD245

13. Do not open when engine is running warning (09667-A0880)

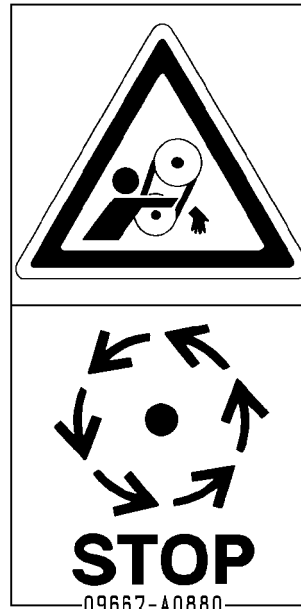

09667-A0880

Do not open the engine side doors while the engine is running

L02AD246

14. Do not come near machine warning (09806-C0880)

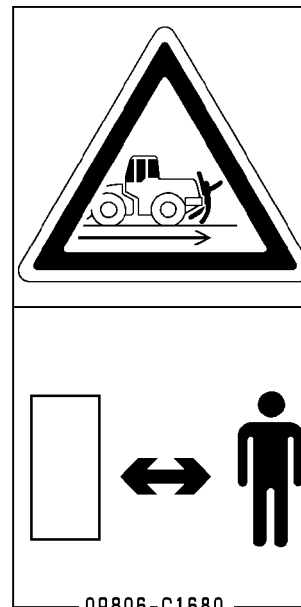

09806-C1680

This decal is to warn people around the machine. If anyone approaches the machine, warn them not to come close.

L02AD247

**SAFETY**

---



WARNING: For reasons of safety, always follow these safety precautions.

**-Memoranda-**

# **OPERATION**



## **10. GENERAL VIEW**

### **10.1 GENERAL VIEW OF MACHINE**

If directions are indicated in this manual, they refer to the directions shown by the arrows in the diagram below.

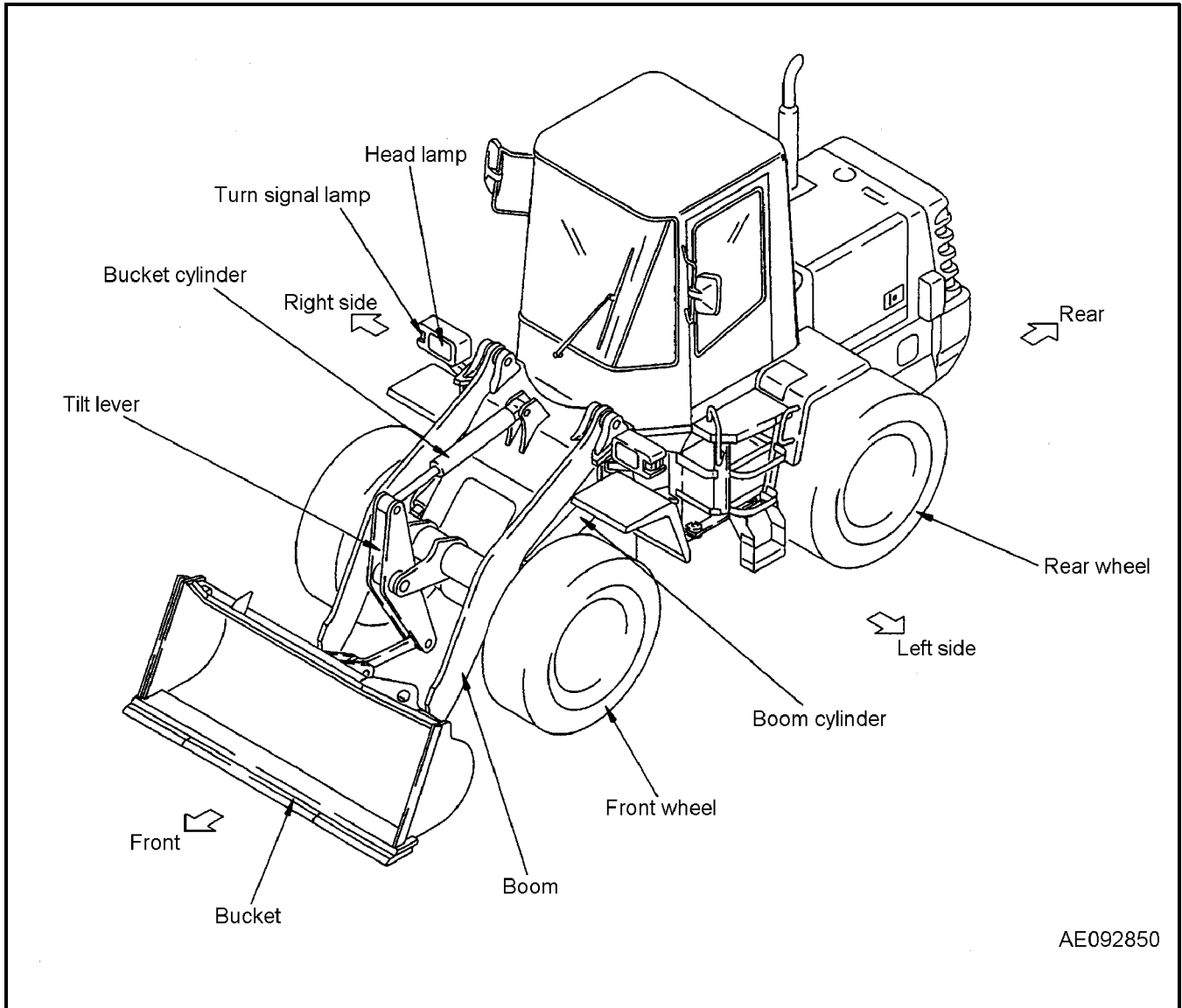

10.2 GENERAL VIEW OF CONTROLS AND GAUGES

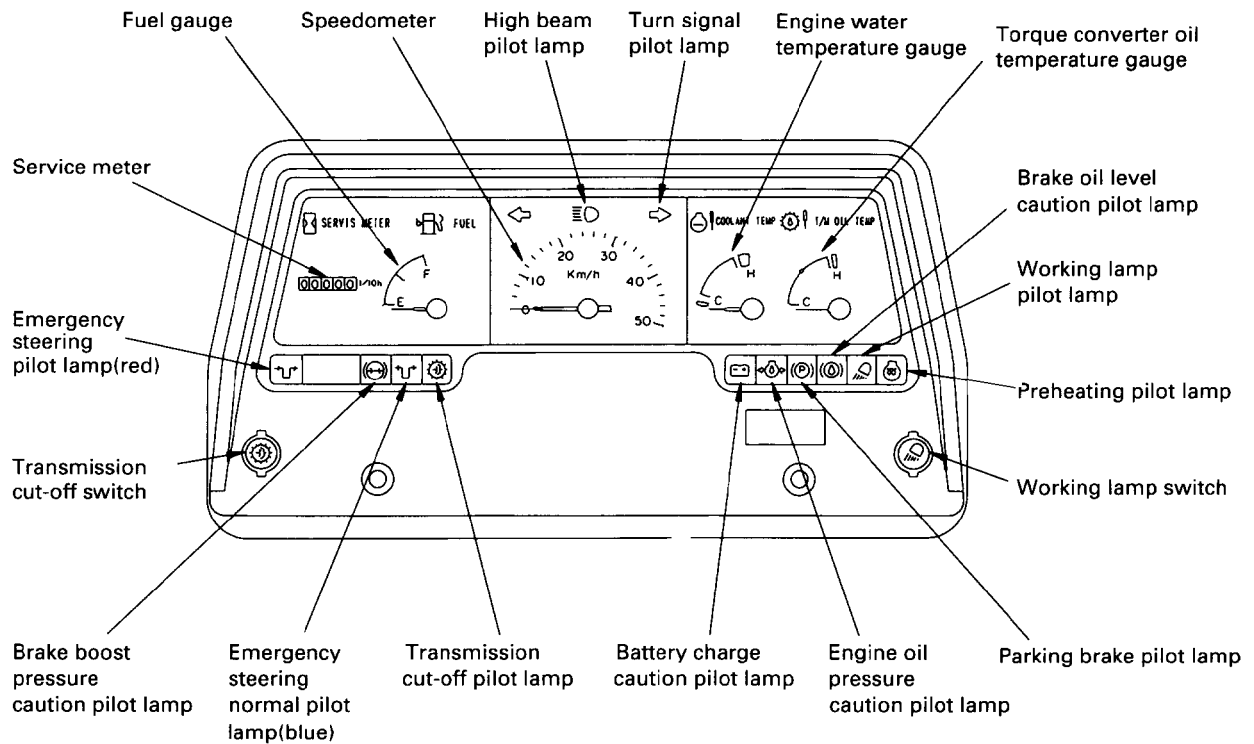
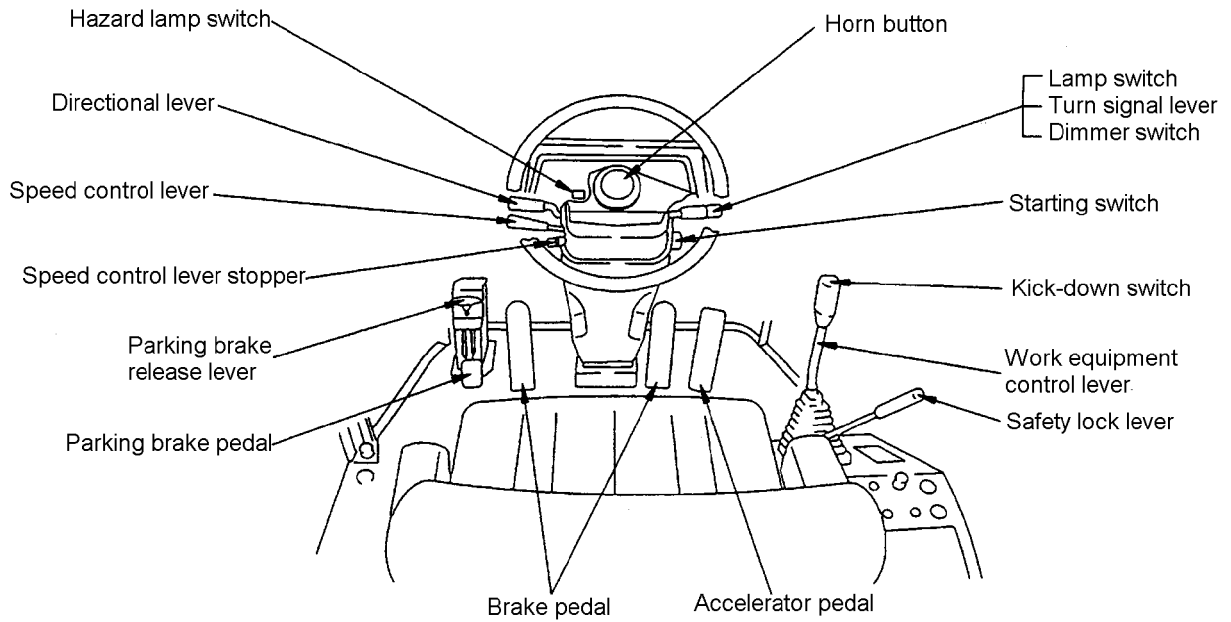

L11ZZ028

**MACHINE EQUIPPED WITH CAB**

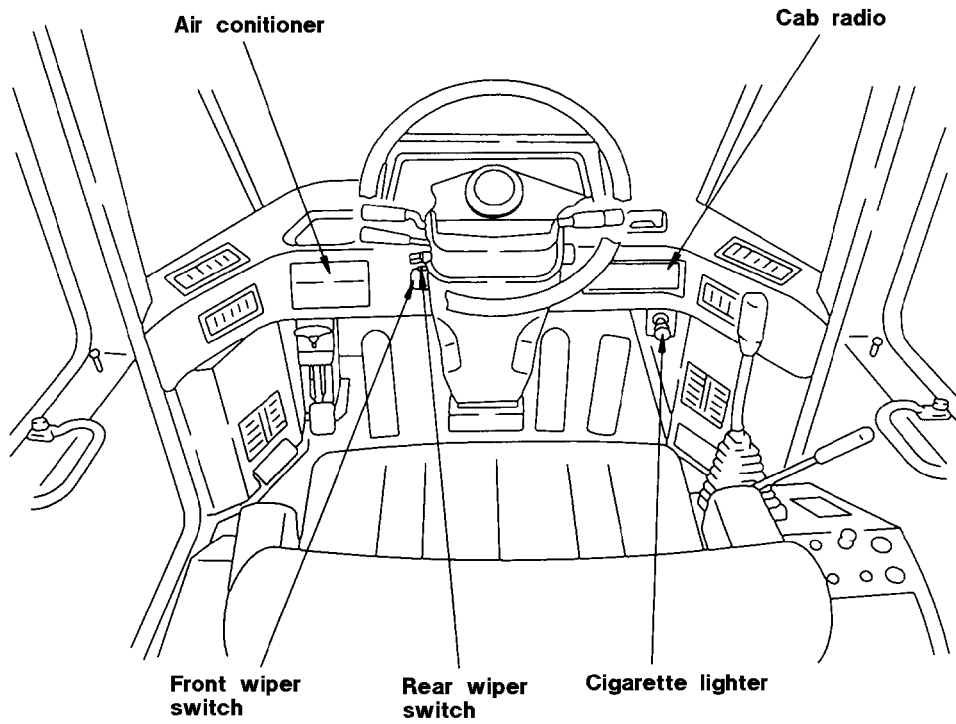

AE070251

## 11. EXPLANATION OF COMPONENTS

The following is an explanation of the devices needed for operating the machine.

To carry out suitable operations correctly and safely, it is important to understand fully the methods of operating the equipment and the meanings of the displays.

### 11.1 METER, LAMPS

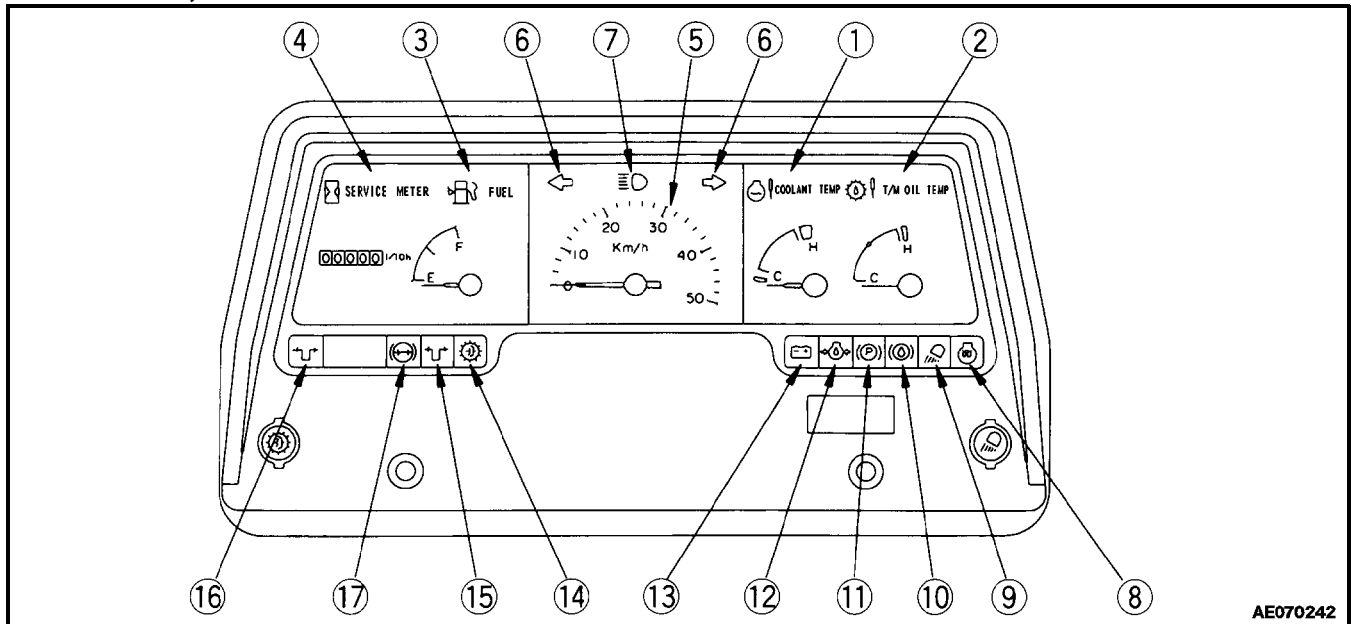

AE070242

#### 1. ENGINE COOLANT TEMPERATURE GAUGE

This gauge indicates the engine coolant temperature.

When the pointer of the temperature gauge shows in the white range, the temperature is normal.

When the pointer enters the red range, stop the machine immediately, and run the engine with no load at midrange speed until the coolant temperature drops to normal value.

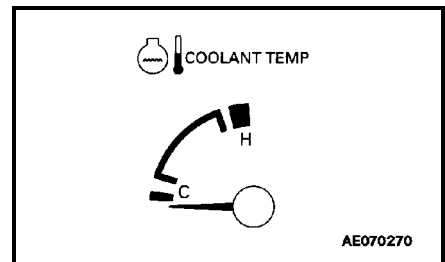

AE070270

#### NOTICE

If the engine coolant temperature gauge enters the red range frequently, check and clean the radiator fins.

#### 2. TORQUE CONVERTER OIL TEMPERATURE GAUGE

This gauge indicates the torque converter oil temperature.

When the pointer of the temperature gauge shows in the white range, the oil temperature is normal.

When the pointer enters the red range, stop the machine immediately, and run the engine with no load at midrange speed until the oil temperature drops to normal value.

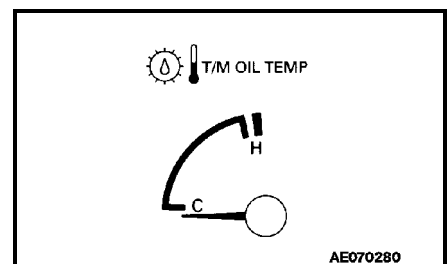

AE070280

## OPERATION

### 3. FUEL GAUGE

This gauge indicates the amount of fuel in the fuel tank.

E: Tank is EMPTY

F: Tank is FUEL

If the fuel gauge indicates E during operation, check and supply fuel.

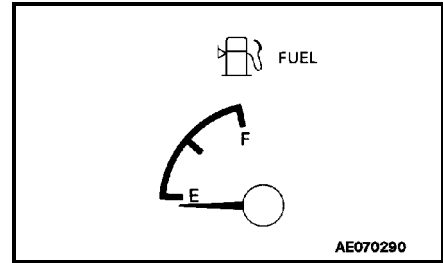

### 4. SERVICE METER

This meter shows the total operation hours of the machine.

The service meter advances while the engine is running - even if the machine is not traveling.

While the engine is running a green pilot lamp on the service meter flashes to show the service meter advances.

The service meter advances by 1 when the engine is operated for one hour, regardless of the engine speed.

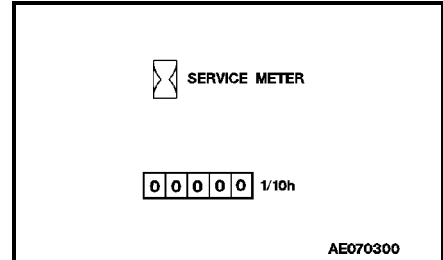

### 5. SPEEDOMETER

This meter indicates the travel speed of the machine.

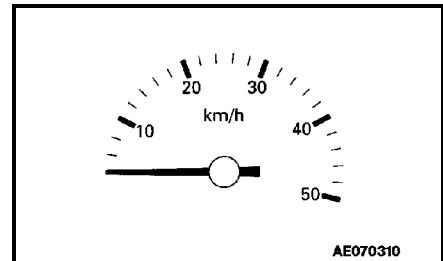

### 6. TURN SIGNAL PILOT LAMP

When the turn signal lamp flashes, the pilot lamp also flashes.

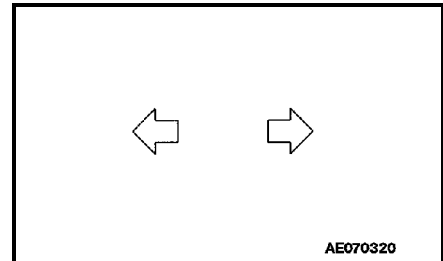

### 7. HIGH BEAM PILOT LAMP

This lamp lights up when head lamp is at high beam.

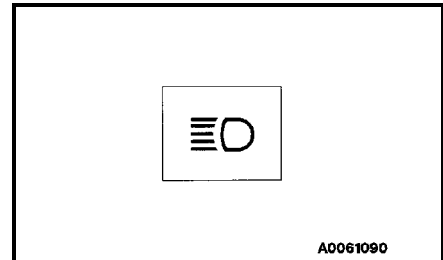

### 8. PREHEATING PILOT LAMP

This informs the operator that the air intake heater is heated.

This lamp lights up when the starting switch is turned to the ON position, on condition that ambient temperature is below 0°C (-18°F), and goes out when the preheating is completed.

The time that it remains lit up differs according to the coolant temperature when the engine is started.

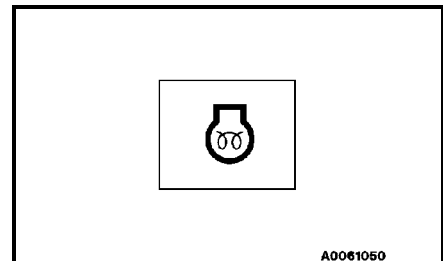

**9. WORKING LAMP PILOT LAMP**

This lamp lights up when the working lamp is switch ON.



A0061060

**10. BRAKE OIL LEVEL CAUTION PILOT LAMP**

This lamp indicates a low brake oil level.

It is kept turned OFF if the brake level is normal.

If the lamp lights, check the oil level and add brake oil as required.

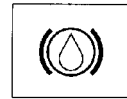

A0061000

**11. PARKING BRAKE PILOT LAMP**

This lamp lights up when the parking brake is applied.

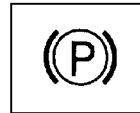

A0061040

**12. ENGINE OIL PRESSURE CAUTION PILOT LAMP**

This lamp warns the operator that the engine lubricating oil pressure has dropped. If it lights up, stop the engine and check the oil level.

When the engine is started, the lubrication pressure is formed and the lamp goes off. If the engine lubrication pressure drops, the warning lamp will light up.



A0061010

**13. BATTERY CHARGE CAUTION PILOT LAMP**

When the engine is started, the alternator generates electricity and the lamp goes out. If any abnormality occurs in the charging system, the caution pilot lamp will light up. If it lights up, check the charging circuit.

If this lamp does not light up when the starting switch is turned on, the bulb is broken. Replace the bulb in this case.



A0061020

## OPERATION

---

### 14 TRANSMISSION CUT-OFF PILOT LAMP

This lamp lights up when the transmission cut-off switch is turned to **ON**

If the lamp is ON and the brake pedal is depressed, the transmission will be returned to neutral.

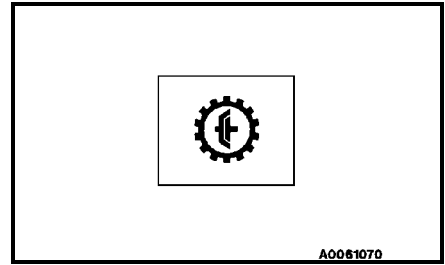

### 15. EMERGENCY STEERING NORMAL PILOT LAMP (BLUE)

When the machine is traveling, this lamp is ON to show that emergency steering pump is operating normally.

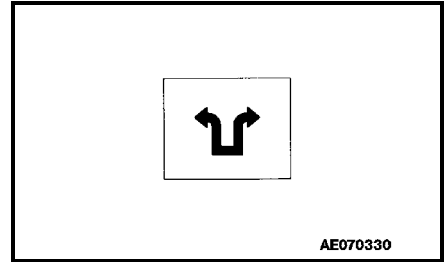

### 16 BRAKE BOOST PRESSURE WARNING PILOT LAMP

This lamp indicates a drop in the boost pressure of the brake booster.

If the lamp lights up, stop the machine immediately and check the brake booster system.

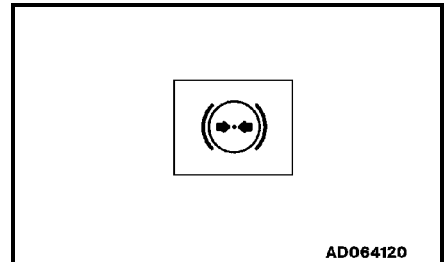

## 11.2 SWITCHES

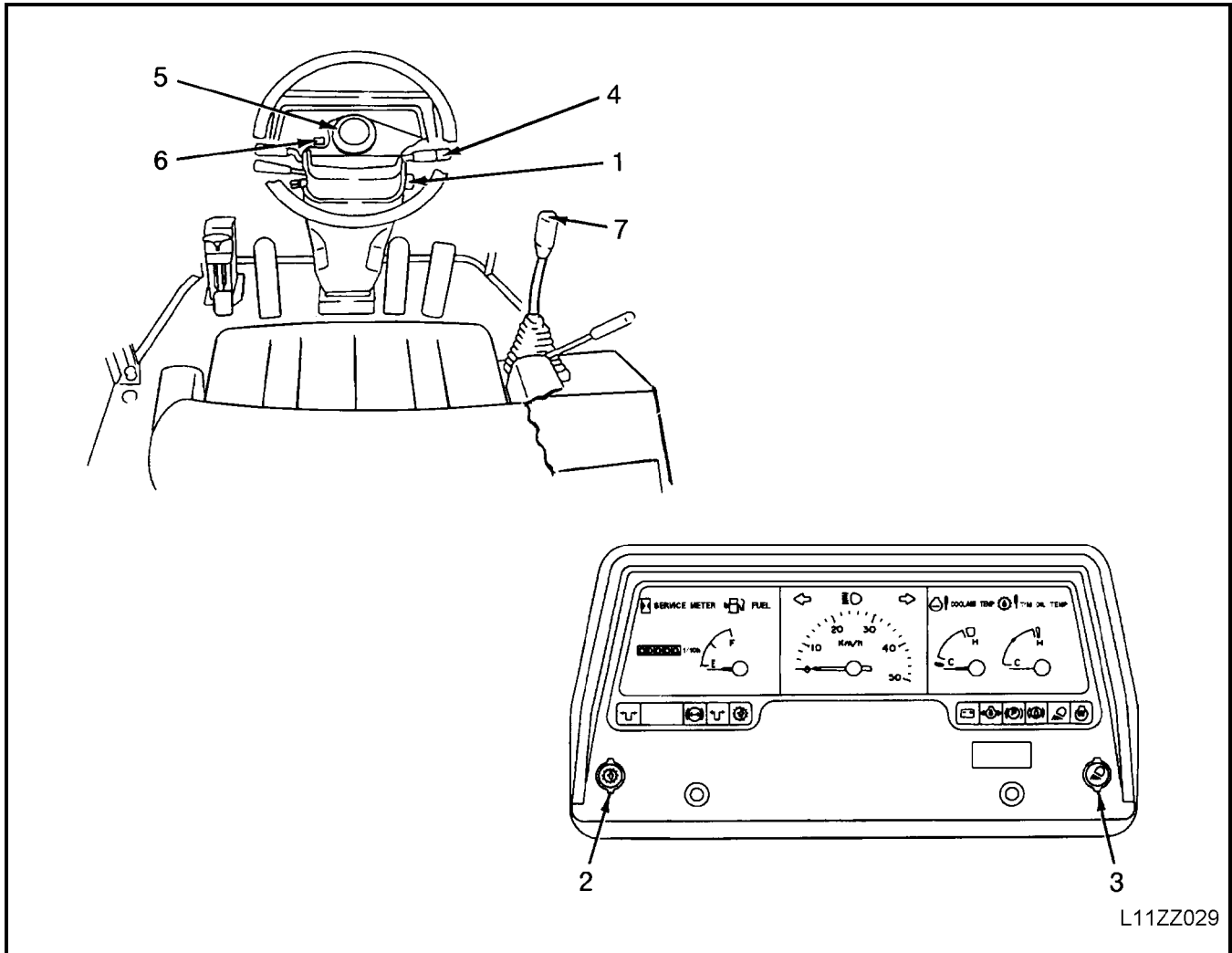
**1. STARTING SWITCH**

This switch is used to start or stop the engine.

**OFF position**

The key can be inserted and moved at this position. When the key is turned to this position, the electric circuit is turned off and the engine stops.

**ON position**

Electric current flows in the charging, lamp and accessory circuits.  
Keep the starting switch key at the ON position while the engine is running.

**START position**

This is the engine-start position. Keep the key at this position during cranking. Immediately after starting the engine, release the key which will automatically return to the ON position.

If your attempt to start the engine has failed then return the key to the OFF position before trying again.

The starting system has a feature that prevents the starting motor from cranking while the engine is running and must be reset by returning to the OFF position.

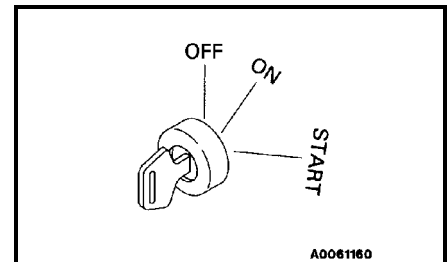



# OPERATION

## 2. TRANSMISSION CUT-OFF SWITCH



**WARNING**

If the machine has to be started on a slope, always turn the transmission cut-off switch to OFF and depress the left brake pedal. Then depress the accelerator pedal while releasing the left brake pedal to start the machine off slowly.

Normally, put this switch in ON position.

Position (1) (OFF) Acts as a normal brake (like right brake pedal).

Position (2) (ON): Acts as normal brake, but also switches transmission to NEUTRAL.

If the switch is ON, the transmission cut-off pilot lamp will light up.

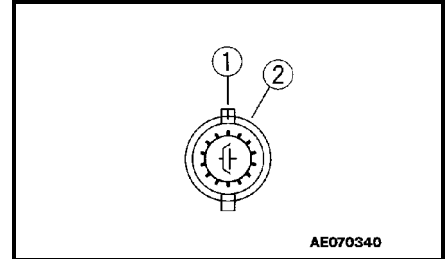

## 3. WORKING LAMP SWITCH



**WARNING**

Always turn the working lamp off before traveling on public roads.

When the working lamps are turned ON, the pilot lamp lights up.

Position (1): OFF

Position (2): Lights up

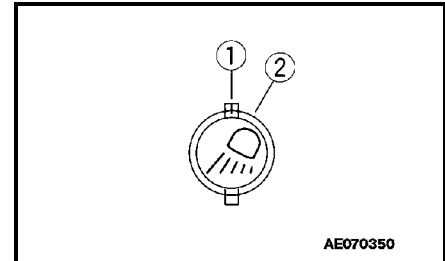

## 4. LAMP SWITCH

This is used to light up the head lamps, side clearance lamps, tail lamps, and instrument panel lighting.

(1) OFF

(2) position: Side clearance lamp, tail lamps, and gauge lighting light up

(3) position: Head lamps light up in addition to lamps at ② position

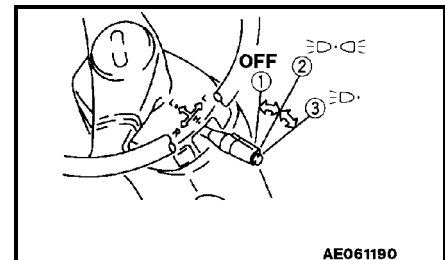

## REMARKS

The lamp switch can be operated regardless of the position of the lever.

**4. TURN SIGNAL LEVER**

This lever operates the turn signal lamps.

- (1) LEFT TURN: Push lever FORWARD.
- (2) RIGHT TURN: Pull lever BACK.

**REMARKS:**

When the lever is operated, the turn signal pilot lamp will also light up.

When the steering wheel is turned to the neutral position, the turn signal lever will return automatically to OFF. If not, return the lever to OFF manually.

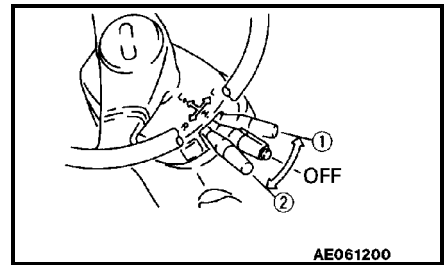

**4. DIMMER SWITCH**

This switches the head lamp between high beam and low beam.

- (A) Low beam
- (B) High beam

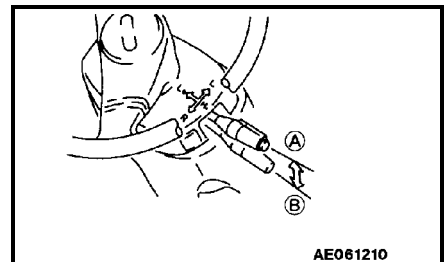

**5. HORN BUTTON**

When the button in the center of the steering wheel is pressed, the horn will sound.

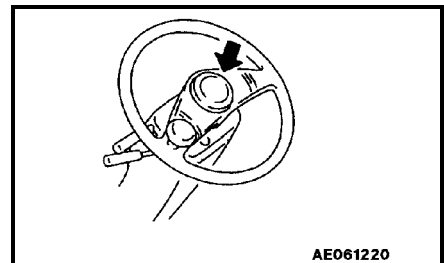

**6. HAZZARD LAMP SWITCH**



**Use the hazard lamps only in emergencies. Using the hazard lamps when traveling will cause problems for other machines.**

This switch is used in emergencies, such as when the machine breaks down.

ON: All turn signal lamps flash.

**REMARKS**

When this switch is turned to the ON position, the turn direction indicator lamps and turn indicator pilot lamp flashes, and the display lamp (1) lights up at the same time.

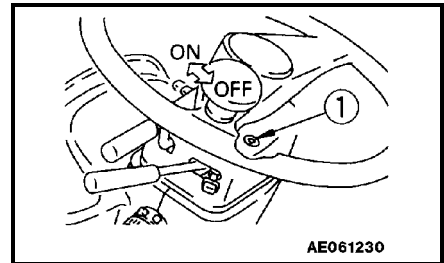

## OPERATION

---

### 7. KICK-DOWN SWITCH

When the speed control lever is in 2nd, and the switch at the top of the knob of the work equipment control lever is pressed, the transmission will shift down to 1st gear.

This switch is used to increase the drawbar pull in digging operations.

### REMARKS

To cancel the KICK-DOWN switch, move the directional lever to REVERSE or NEUTRAL, or move the speed control lever to any position except 2nd. It is also possible to cancel the KICK-DOWN switch by operating the parking brake switch or by turning the starting switch OFF.

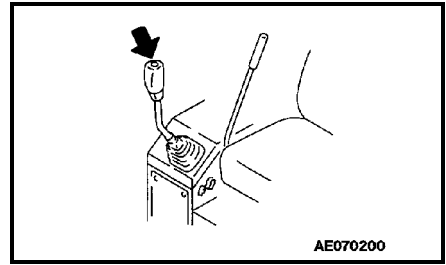

**MACHINE EQUIPPED WITH CAB**

(The following items 8 - 11 are added when the cab is installed as standard.)

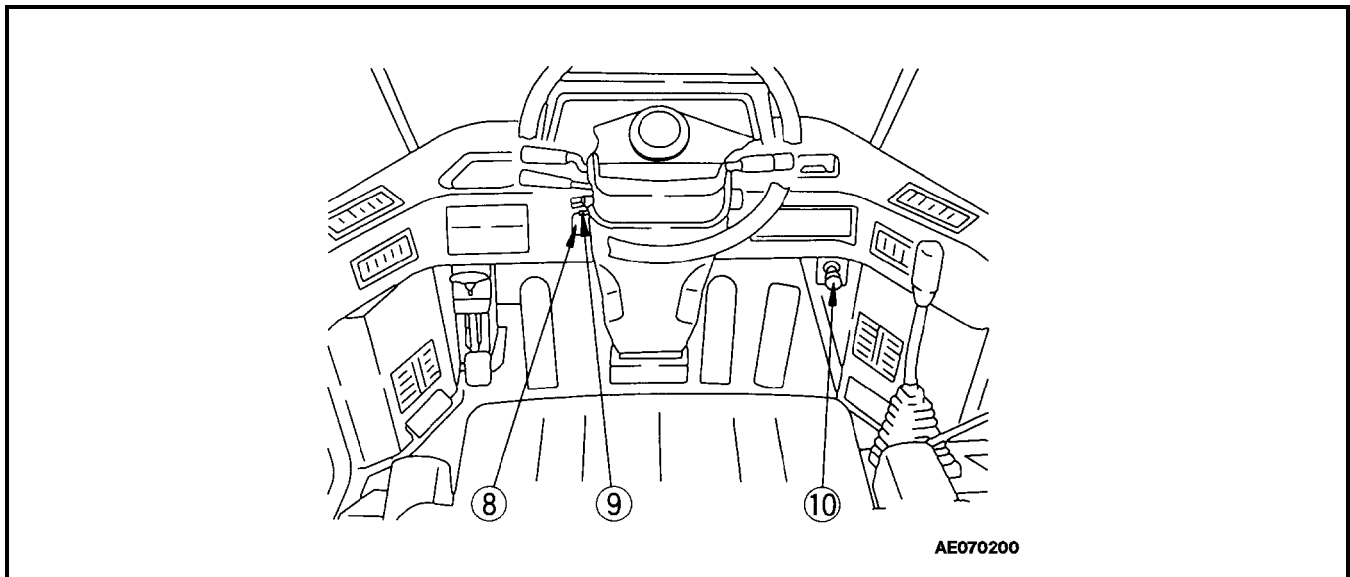

**8. FRONT WIPER SWITCH**

Turn switch (A) to operate the front wiper.

Switch position	Window display	Operation
1	OFF	OFF
2	INT	Intermittent wiper
3	1	Low-speed wiper
4	2	High-speed wiper

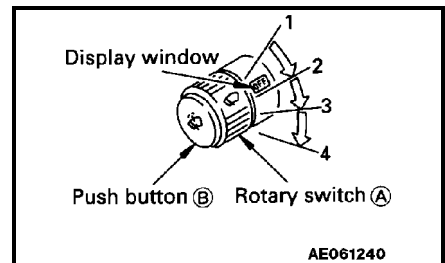

If button (B) is pressed, washer fluid will spray out on to the front glass.

**9. REAR WIPER SWITCH**

Turn lever © to operate the rear wiper.

Position of switch	Display	Operation
1		Washer fluid sprayed
2	OFF	OFF
3		Wiper actuated
4		Washer fluid sprayed, wiper actuated

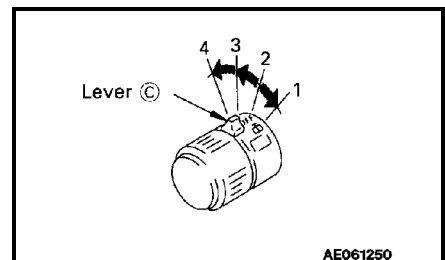

## OPERATION

### 10. CIGARETTE LIGHTER

This is used to light cigarettes.

To use, push the lighter in. After a few seconds it will spring back. At that time remove the lighter and light your cigarette.

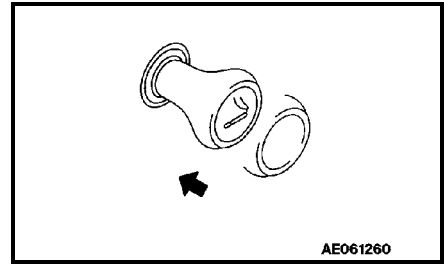

### 11. ROOM LAMP SWITCH

This lights up the room lamp.

ON position: lights up

Position 1: OFF

Position 2 Lights up when cab door is opened

Position 3: Lights up

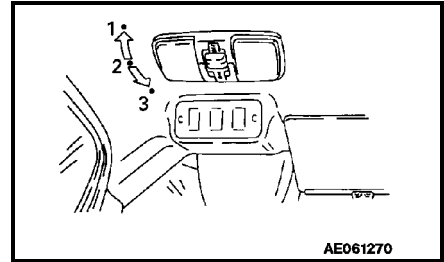

### REMARKS

- The room lamp lights up even when the main switch is OFF, therefore when leaving the operator's compartment, turn the switch to position 1 or 2.
- When operating with the cab door fully open, set the switch to position 1 (OFF).

11.3 CONTROL LEVERS, PEDAL

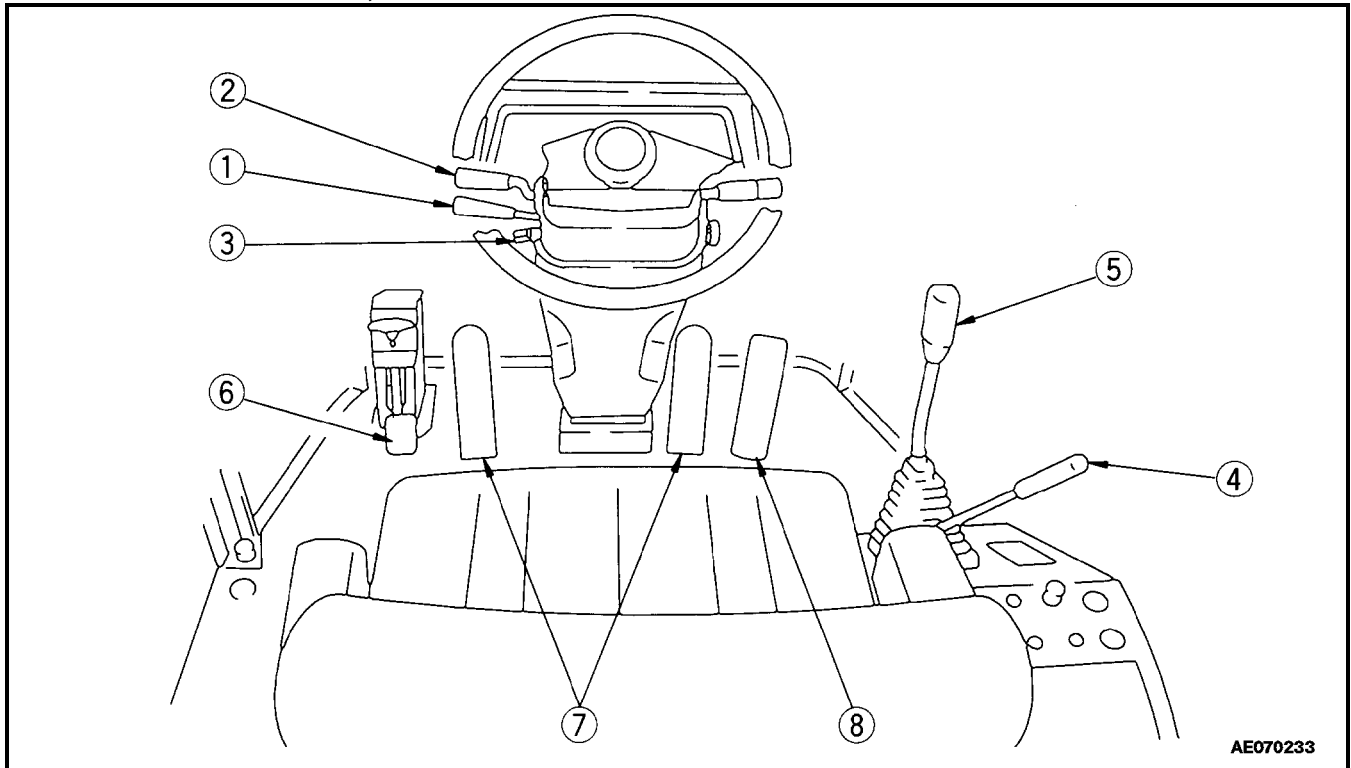

AE070233

1. SPEED CONTROL LEVER

This lever controls the travel speed of the machine.  
 This machine has a 4-FORWARD, 4-REVERSE speed transmission.

Place the speed control lever into the desired speed range.  
 1st and 2nd speeds are used for working.  
 3rd and 4th speeds are used for traveling.

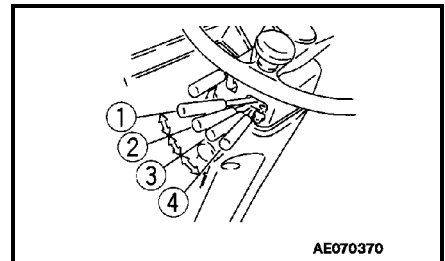

AE070370

- Position (1): 1st
- Position (2): 2nd
- Position (3): 3rd
- Position (4): 4th

REMARKS

The length of the lever can be adjusted to 3 stages (positions **A**, **B**, **C**). To adjust the length, remove the screw at the bottom of the lever knob, slide the knob to the desired position, then tighten the screw again.  
 (The lever is installed to position **B** when it is shipped from the factory.)

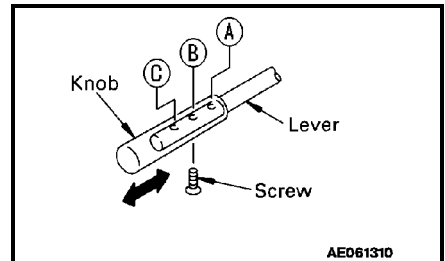

AE061310

## OPERATION

### 2. DIRECTIONAL LEVER

This lever is used to change the direction of travel of the machine.  
The engine can not be started if the directional lever is not at **N** (neutral).

- Position (1): Forward
- Position **N**: Neutral
- Position (2): Reverse

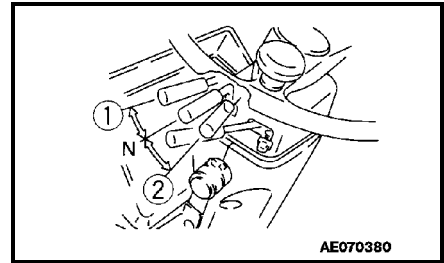

### REMARKS

The length of the lever can be adjusted to 3 stages (positions **A**, **B**, **C**). To adjust the length, remove the screw at the bottom of the lever knob, slide the knob to the desired position, then tighten the screw again.  
(The lever is installed to position **B** when it is shipped from the factory.)

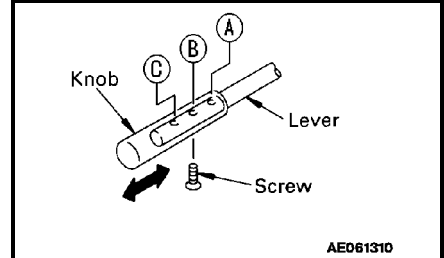

### 3. SPEED CONTROL LEVER STOPPER

This stopper prevents the speed control lever from entering the 3rd position when working.

- Position (1): Stopper actuated
- Position (2): Stopper released

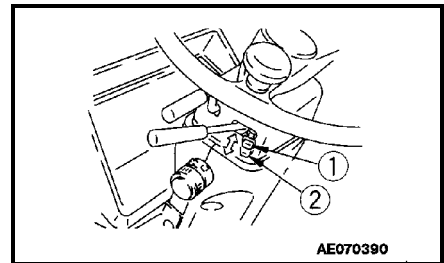

### 4. SAFETY LOCK LEVER

#### WARNING





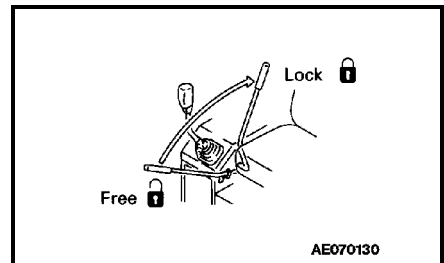

- When leaving the operators compartment, set the safety lock lever securely to the **LOCK** position. If the control levers are not locked, and they are touched by mistake, this could lead to a serious accident.
- If the safety lock lever is not placed securely in the **LOCK** position, the control levers may not be properly locked. Check that the situation is as shown in the diagram.
- When parking the machine or carrying out maintenance, always lower the bucket to the ground and apply the lock.

This is used to lock the work equipment levers.  
Pull the levers up to apply the lock.



**5. WORK EQUIPMENT CONTROL**

This lever operates the lift arm and the bucket.

- (1) RAISE (  )
- (2) HOLD (  ) The lift arm is kept in the same position.
- (3) LOWER (  )
- (4) FLOAT (  ) The lift arm moves freely under external force.
- (A) TILT (  )
- (B) DUMP (  )

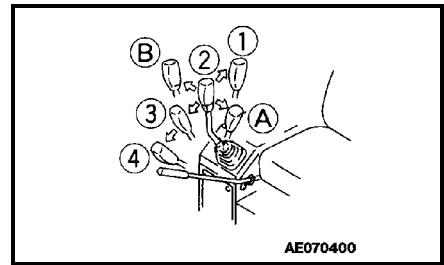

When the work equipment control lever is pulled further from the RAISE position, the lever is stop in this position until the lift arm reaches the preset position of the kick-out, and the lever is return to the HOLD position

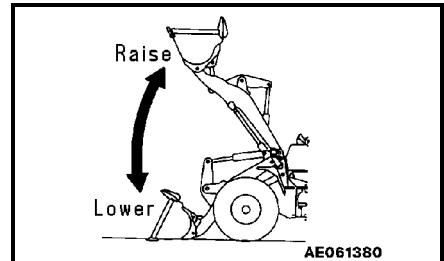

When the work equipment control lever is pulled further from the TILT position, the lever is stop in this position until the bucket reaches the preset position of the positioner, and the lever is return to the HOLD position

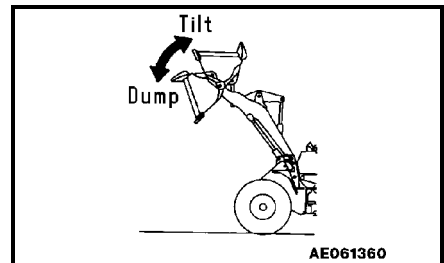

**NOTICE**

Do not use the FLOAT position when lowering the bucket.

**6. PARKING BRAKE PEDAL AND RELEASE LEVER**



Always apply the parking brake when leaving the machine or parking it.  
 Even if the parking brake lever is depressed to the lock position, for safety precaution keep the brake pedal depressed until the parking brake pilot lamp lights up.

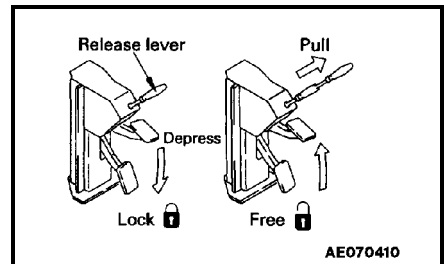

This lever operates the parking brake.

The brake is applied by depressing the pedal, and the parking brake pilot lamp lights up.

Pull the release lever to release the parking brake.

Before starting the engine be sure the parking brake is depressed to the lock position and the parking brake pilot lamp is lit up.

The machine does not start when the directional lever is operated with parking brake applied.

**NOTICE**

- Never use the parking brake switch to apply the brakes when traveling, except in an emergency. Apply the parking brake only after the machine has stopped.
- If the parking brake has been used as an emergency brake when traveling at high speed (near the maximum speed), contact your distributor to have the parking brake checked for any abnormality.



## OPERATION

### 7. BRAKE PEDALS

 **WARNING**

- When traveling downhill, use the engine as a brake, and always use the right brake pedal.
- Do not use the brake pedals repeatedly unless necessary.
- Do not put your foot on this pedal unless necessary.
- Note that when the engine of a machine with booster stops, the brake pedal becomes 3.5 times heavier.

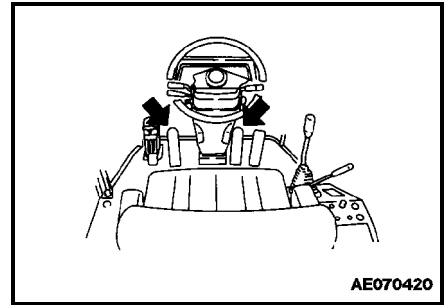

#### Right brake pedal

The right brake pedal operates the wheel brakes, and is used for normal braking.

#### Left brake pedal.

The left brake pedal operates the wheel brakes, and if the transmission cut-off switch is at ON, it also returns the transmission to neutral.

If the transmission cut-off switch is at OFF, the left brake pedal acts in the same way as the right brake pedal.

#### REMARKS

When the accelerator is being used for operating the work equipment, always use the left brake pedal to slow or stop the machine after putting the transmission cut-off switch to the ON position.

### 8. ACCELERATOR PEDAL

This pedal controls the engine speed and output.

The engine speed can be freely controlled between low idle and full speed.

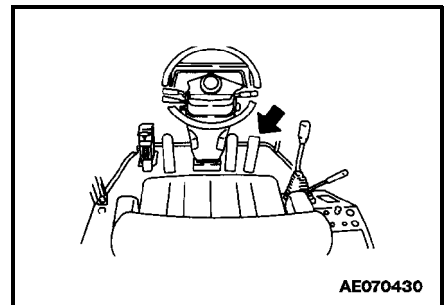

## 11.4 CAP WITH LOCK

The fuel tank filler port and the hydraulic tank filler port are equipped with locks.

Use the starter key to open and close the cap as follows.

### 11.4.1 METHOD OF OPENING AND CLOSING CAP WITH LOCK

#### TO OPEN THE CAP (For the fuel tank filler port)

1. Insert the key into the cap.  
insert the key as far as it will go. If the key is turned before it is inserted all the way in, it could break.
2. Turn the key clockwise, align the match mark on the cap with the rotor groove, then remove the cap.

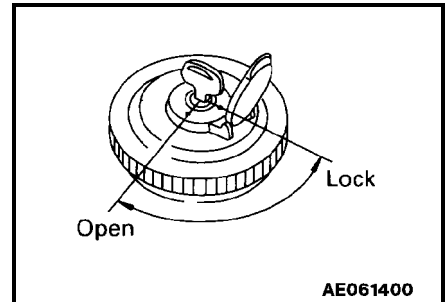

#### TO LOCK THE CAP

1. Turn the cap into place.
2. Turn the key clockwise and take the key out.

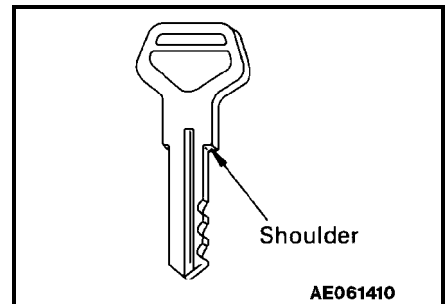

## 11.5 SAFETY BAR

**⚠ WARNING**

- Always use the safety bar for maintenance or when transporting the machine.
- Always remove the safety bar during normal travel operations

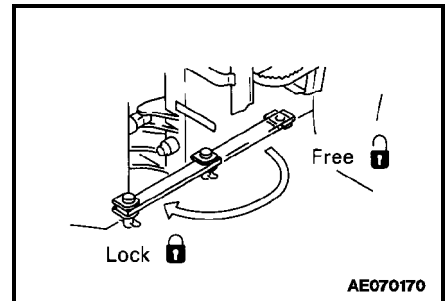

The safety bar is used during maintenance or when transporting the machine. It locks the front and rear frames, and prevents the front and rear frames from pivoting.

## OPERATION

### 11.6 TOWING PIN

1. Align protrusion (1) on the towing pin with groove (2) in the counterweight, then insert and turn the pin 180°

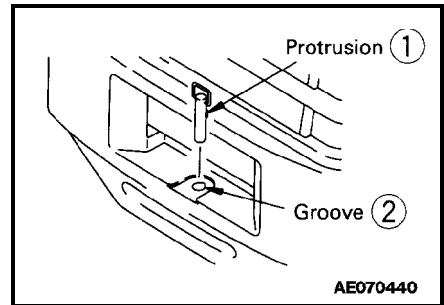

2. To prevent the pin from turning, bend the towing pin handle down and set it in position.  
When removing the towing pin carry out the above procedure in reverse.

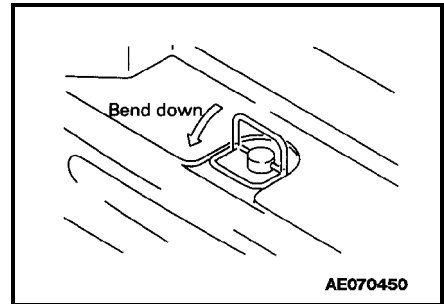

### 11.7 GREASE PUMP CLAMP AND RUBBER RING

Set the grease pump in the clamp which can be seen when the engine panel is opened, and fit the chain to the clamp to prevent any play

In addition, fit the rubber ring in a figure of 8 as shown in the diagram in the right to hold the grease pump in position.

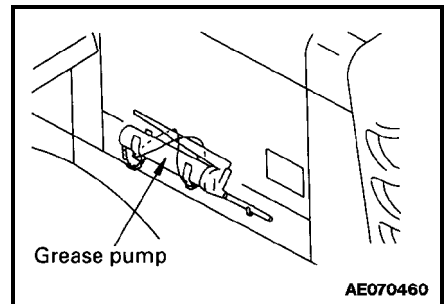

### 11.8 BACK-UP ALARM

This sounds an alarm when the directional lever is set to R position. It is used to warn people behind the machine that the machine will be traveling in reverse.

### 11.9 FUSE

**NOTICE**

Before replacing a fuse, be sure to turn OFF the starting switch.

The fuse protects the electrical equipment and wiring from burning out.

If a fuse becomes corroded, or white powder can be seen, or a fuse is loose in the fuse holder, replace the fuse.

Replace a fuse only with another of the same capacity.

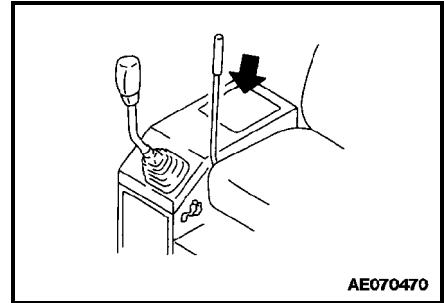

#### 11.9.1 FUSE CAPACITY AND NAME OF CIRCUIT

No.	Fuse capacity	Name of circuit
1	10A	Spare
2	10A	Spare
3	10A	Clearance lamp
4	10A	Head lamp
5	10A	Heater relay
6	20A	Working lamp
7	10A	Tail lamp, Back-up alarm, and Horn
8	10A	Turn signal lamp
9	20A	Main lamp circuit, Brake lamp
10	10A	Instrument panel
11	10A	Work equipment positioner
12	10A	Transmission control
13	10A	Hazard warning flashing lamp
14	10A	Starting switch

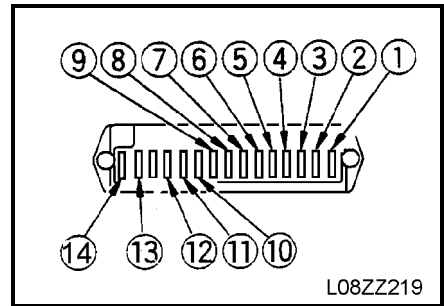

## OPERATION

Machine equipped with CAB  
The following fuses are added

No.	Fuse capacity	Name of circuit
1	10A	Spare
2	10A	Spare
3	10A	Spare
4	10A	Room lamp, Air conditioner
5	10A	Rotating lamp
6	20A	Cigarette lighter, radio
7	20A	Air conditioner
8	20A	Air conditioner
9	20A	Wiper motor

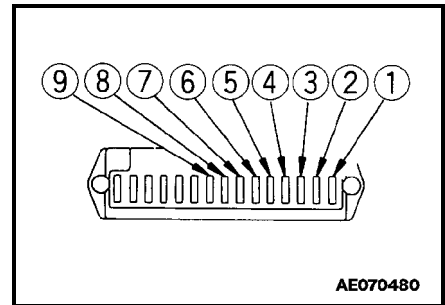

### 11.10 SLOW BLOW FUSE

If the power does not come on when the starting switch is turned ON, the slow-blow fuse could be blown, so check and replace it.

Open the right hand engine panel and look besides the rear frame

#### SLOW-BLOW FUSE

- (1) 80A: Main power
- (2) 120A: Power source for engine preheater relay, indicator lamp.

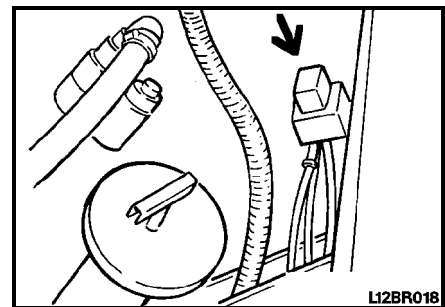

### 11.11 STORAGE PLACE FOR THIS MANUAL

Store this manual in the pocket provided on the back of the operator's seat.  
So it is immediately accessible when needed.

### 11.12 AUXILIARY POWER SOURCE

The fuse terminal (1) in the right console box provides optional power.  
The maximum electric supply is 10 A (240 W)

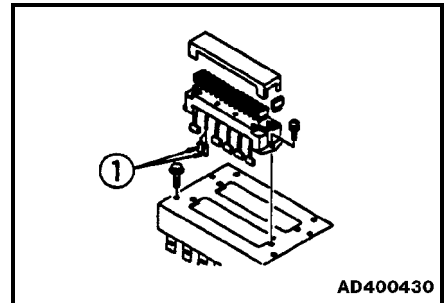

#### 11.12.1 FOR MACHINES EQUIPPED WITH ROPS CAB

The cigarette lighter (1) can also be used as an option power source.  
The maximum electric supply is 7 A (168 W)

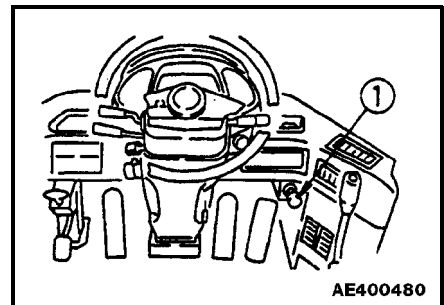

## 12. CHECK BEFORE STARTING ENGINE

### 12.1 WALK AROUND CHECK



Leakage of oil or fuel, or accumulation of flammable material around high temperature parts, such as the engine muffler or turbocharger, may cause fire. Check carefully, and if any abnormality is found, repair it or contact your distributor for assistance.

Before starting the engine, look around the machine and under the machine to check for loose nuts or bolts, or leakage of oil, fuel, or coolant, and check the condition of the work equipment and hydraulic system. Check also for loose wiring, play, and collection of dust at places which reach high temperatures.

Always carry out the items in this section before starting the engine each day.

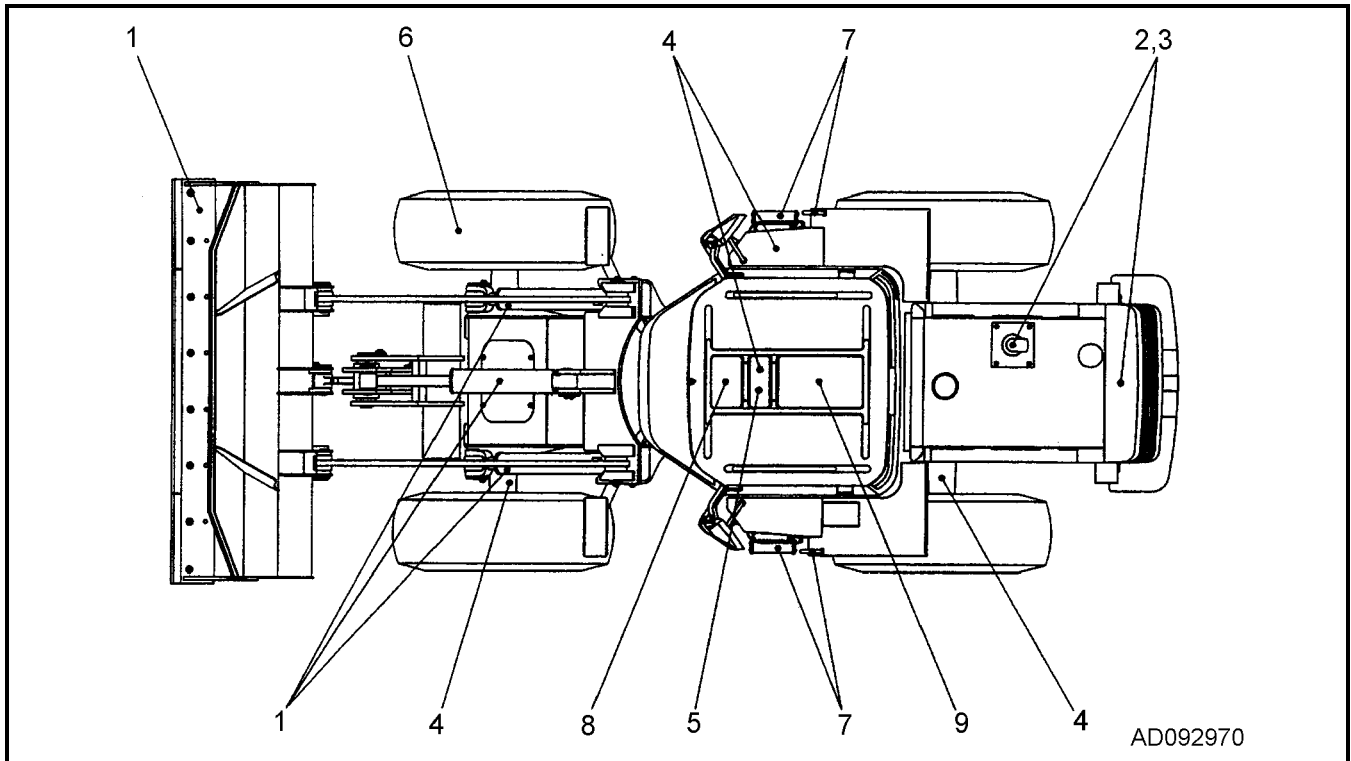

AD092970

**1. Check for damage, wear, or play in the work equipment, cylinders, linkage and hoses**

Check that there are no cracks, excessive wear, or play in the work equipment, cylinders, linkage, or hoses. If any abnormality is found, repair it.

**2. Remove dirt and dust from around engine, battery, radiator**

Check if there is any dirt or dust accumulated around the engine or radiator. Check also if there is any flammable material (dead leaves, twigs, grass, etc.) accumulated around the battery or high temperature engine parts, such as the muffler or turbocharger. Remove all such dirt or flammable material.

**3. Check for leakage of coolant or oil around engine**

Check that there is no leakage of oil from the engine or leakage of coolant from the cooling system. If any abnormality is found, repair it.

**4. Check for oil leakage from transmission case, axle, hydraulic equipment, hydraulic tank, hoses, joints**

Check that there is no oil leakage. If any abnormality is found, repair the place where the oil is leaking.

**5. Check for oil leakage from brake lines**

Check that there is no oil leakage. If any abnormality is found, repair the place where the oil is leaking.

**6. Check for damage or wear to tires, loose mounting bolts**

Check for cracks or peeling of tires and for cracks or wear to the wheels (side rim, rim base, lock ring). Tighten any loose wheel nuts. If any abnormality is found repair or replace the part. If any valve caps are missing, install new caps.

**7. Check for damage handrail and steps, loose bolts**

Repair any damage and tighten any loose bolts.

**8. Check for damage to gauges, monitor, loose bolts**

Check that there is no damage to the gauges and monitor in the operator's cab. If any abnormality is found, replace the parts. Clean off any dirt on the surface.



## OPERATION

### 9. Check seat belt and equipment



**WARNING**

Even if there appears to be no abnormality with the seat belt, always replace it once every three years.

### REMARKS

The date of manufacture of the seat belt is marked on the belt at the place indicated by the arrow in the diagram on the right.

Check that there are no loose bolts on the equipment mounting the seat belt to the machine, and tighten if necessary.

Tightening torque:  $24.5 \pm 4.9$  N•m ( $2.5 \pm$  kgm,  $18.1 \pm 3.6$  lbf ft)

If the belt is damaged or fluff is starting to form, or if there is any damage or deformation of the seat belt holders, replace the seat belt with a new part.

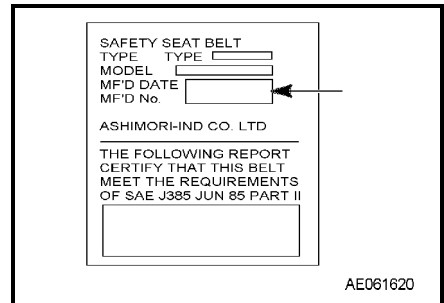
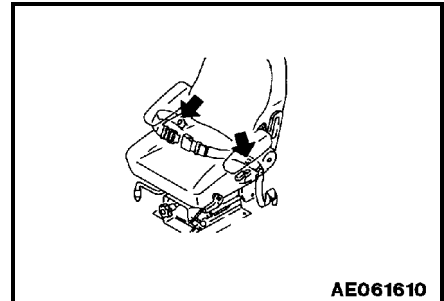

### 10. Check for loose bolts on ROPS

Check for any loose or damaged bolts. If any loose bolts are found tighten them to  $549 \pm 59$  N•m ( $56 \pm 6$  kgm,  $405 \pm 43$  lbf ft)

If any bolts are damaged, replace them with genuine Komatsu bolts.

### 11. Clean cab window

Clean the cab window to ensure good visibility when operating the machine.

### 12. Check for loose air cleaner mounting bolts

Check for any loose mounting bolts and tighten if necessary.

### 13. Check for loose battery terminals

Tighten any loose terminals.

### 14. Inspect engine cooling fan



**WARNING**

Personal injury can result from fan blade failure. Never pull or pry the fan. This can damage the fan blade and cause failure.

See the Maintenance Schedule for inspection instructions.

### 15. Check drive belt condition and tension

See the Maintenance Schedule for inspection instructions.

## 12.2 CHECK BEFORE STARTING

Always carry out the items in this section before starting the engine each day

### 12.2.1 CHECK COOLANT LEVEL, ADD COOLANT



**WARNING**

**Always wait for the engine to cool down before checking the water level, and check using the radiator overflow sub-tank**

1. Open the engine left hand side cover and check that the coolant level is between the FULL and LOW marks on the sub-tank (1). If the coolant level is low, add coolant to the FULL mark through the filler in the sub-tank. **For complete coolant specifications →see 20.3 COOLANT SPECIFICATIONS.**
2. After adding coolant then tighten cap securely.
3. If sub-tank (1) is empty, check for coolant leakage, then add coolant to the radiator and sub-tank.

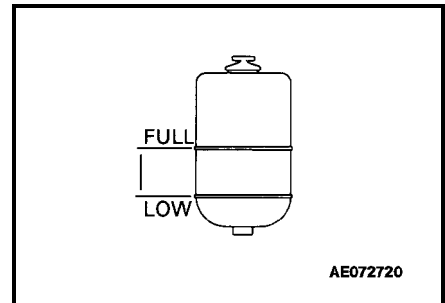
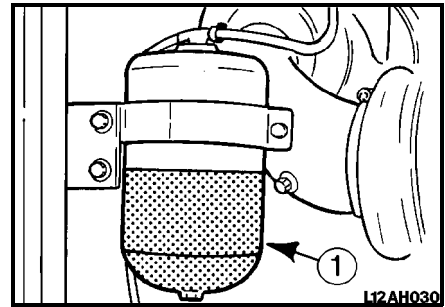

### 12.2.2 CHECK FUEL LEVEL, ADD FUEL



**WARNING**

**When adding fuel, never let the fuel overflow. This could cause a fire, thoroughly clean up any spillage.**

1. Turn the engine starting switch to the ON position, then check the fuel level on the fuel gauge (G). After checking, return the starting switch to the OFF position.
2. Add fuel through filler (F).

For details of the method for opening and closing the cap, see "11.4 CAP WITH LOCK".

For details of the fuel to use, see "20. USE OF FUEL, COOLANT AND LUBRICANTS ACCORDING TO AMBIENT TEMPERATURE".

3. After adding fuel, tighten cap securely.

FUEL CAPACITY: 133 ℓ (35.1 US gal, 29.3 UK gal)

**NOTE:** To eliminate moisture or corrosion in the fuel tank, it is recommended that fuel tank always be filled before storing the machine until the next work operation.

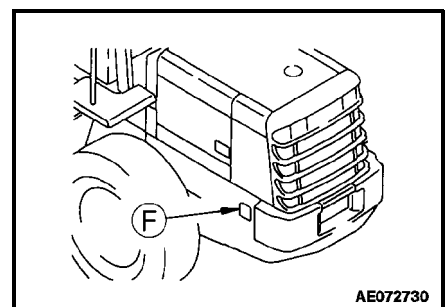
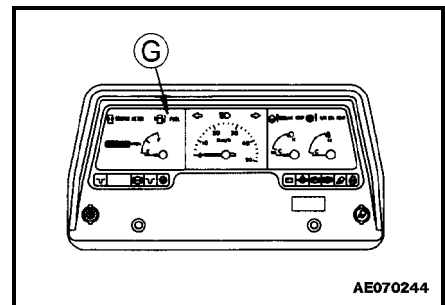

## OPERATION

### 12.2.3 CHECK OIL LEVEL IN ENGINE OIL PAN, ADD OIL

1. Open the engine side cover at the right rear side of the machine.
2. Remove dipstick (G) and wipe the oil off with a clean cloth.
3. Insert dipstick (G) fully in the guide tube, then take it out again.

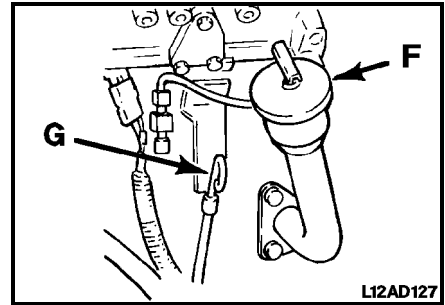

4. The oil level should be between the ADD and FULL marks on the dipstick.  
If the oil is below the ADD mark, add engine oil through oil filler (F).

**Oil specifications → SEE "20. USE OF FUEL, COOLANT AND LUBRICANTS ACCORDING TO AMBIENT TEMPERATURE".**

5. If the oil is above the FULL mark, drain the excess engine oil from the drain plug (P), and check the oil level again.
6. If the oil level is correct, tighten the oil filler cap securely and close the engine cover.

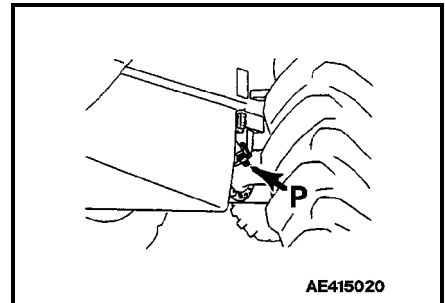
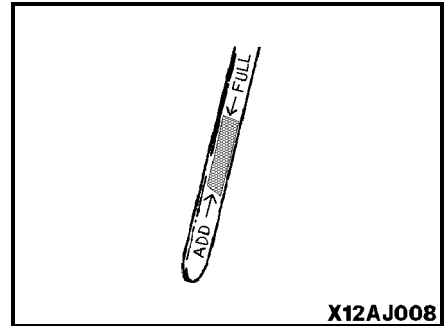

### REMARKS

When checking the oil level after the engine has been operated, wait for at least 15 minutes after stopping the engine before checking.  
If the machine is at an angle, make it horizontal before checking.

### 12.2.4 CHECK AND REFILL OF OIL IN BRAKE OIL TANK

 **WARNING**

**Always use engine oil to refill the brake oil tank.**

Open the inspection cover on the step on the left side of the machine, and check that the brake oil in the brake tank (1) is between the MAX and MIN marks, on the gauge at the side of the tank.  
If the oil is below the MIN mark, remove cap (2) and add engine oil.

For details of the oil to use, see “ 20. USE OF FUEL, COOLANT AND LUBRICANTS ACCORDING TO AMBIENT TEMPERATURE”.

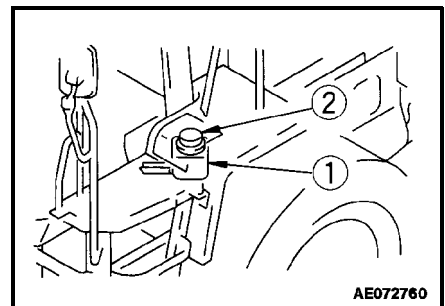

### 12.2.5 CHECK DUST INDICATOR

1. Check that the red piston of dust indicator (1) has not reached the service level.
2. If the red piston is showing, clean or replace the element immediately. For details of cleaning the element, **see “24.2 WHEN REQUIRED, CHECK, CLEAN, OR REPLACE AIR CLEANER ELEMENT.”**
3. After cleaning, push indicator (1) button to return red piston to original position.

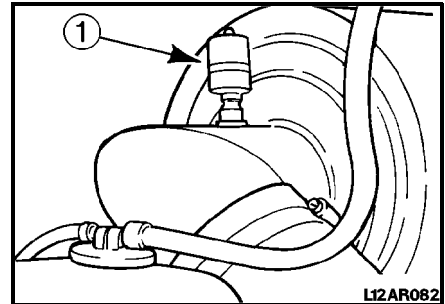

### 12.2.6 CHECK ELECTRICAL WIRING



#### WARNING

**If fuses are frequently blown or if there are traces of a short circuit in the wiring, locate the cause and carry out repair. Accumulation of all flammable material (dead leaves, twigs, grass, etc.) around the battery may cause fire, so always remove such material.**

Check for damaged fuses and any sign of disconnection or short circuit in the wiring. Check also for loose parts.

Check the following points carefully.

- Battery
- Starting motor
- Alternator

When carrying out walk-around checks or checks before starting, always check if there is any accumulation of flammable material around the battery, and remove such flammable material.

Please contact your distributor for investigation and correction of the cause.

## OPERATION

### 12.2.7 DRAIN THE WATER FROM THE FUEL-WATER SEPARATOR

With the engine shut-off, open the drain valve (1).

Turn the valve counterclockwise approximately 1-1/2 to 2 turns until draining occurs. Drain the filter sump of water until clear fuel is visible.

Do not over tighten the valve. Over tightening can damage the threads. Turn the valve clockwise approximately 1-1/2 to 2 turns to close the drain valve.

Even if a filter/water separator is installed be sure to check the fuel tank to remove water and sediment in the fuel.

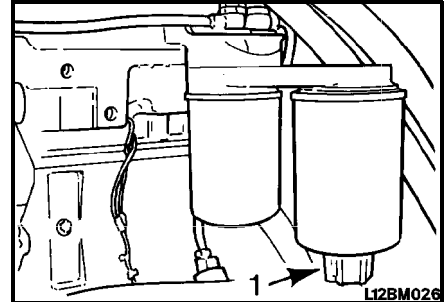

L12BM026

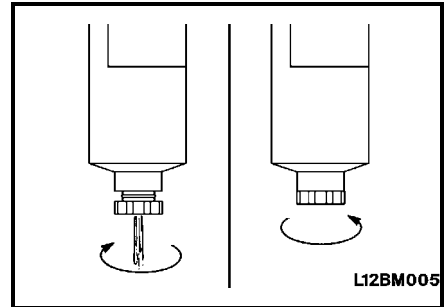

L12BM005

### 12.2.8 CHECK EFFECT OF PARKING BRAKE



**WARNING**

Even if the parking brake pedal is pressed **LOCK**, for safety precaution keep the brake pedal depressed until the parking brake pilot lamp lights up

#### Measurement conditions

- Tire inflation pressure: Specified pressure
- Road surface: Dry paved surface with 1/5 (11° 20')
- Machine: Operating condition

#### Method of measurement

1. Start the engine, set the machine facing straight to the front, then drive the machine up 1/5 grade with the bucket empty.
2. Depress the brake, stop the machine, return the directional lever to the neutral position, then stop the engine.
3. Press the parking brake pedal to the **LOCK** position, release the brake pedal slowly, and check that the machine is held in position.

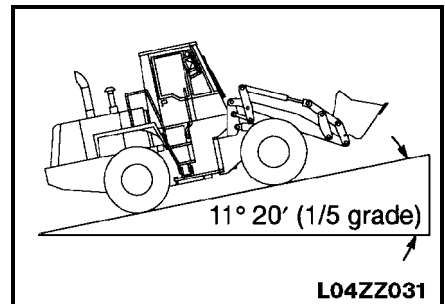

L04ZZ031

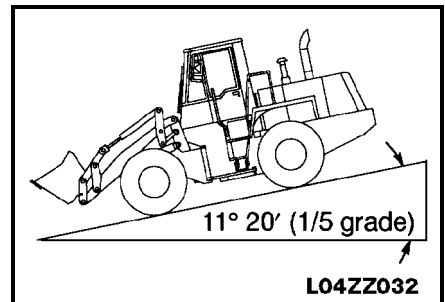

L04ZZ032

**12.2.9 CHECK EFFECT OF WHEEL BRAKES**

Drive the machine at a speed of 20 km/h (12.4 mph) on a dry flat concrete road surface, and check that the stopping distance is less than 5 m (16.4 ft).

**12.2.10 CHECK SOUND OF HORN AND BACKUP ALARM****12.2.11 CHECK FLASHING OF LAMPS, CHECK FOR DIRT AND DAMAGE****12.2.12 CHECK ENGINE EXHAUST COLOR AND SOUND****12.2.13 CHECK OPERATIONS OF GAUGES****12.2.14 CHECK PLAY OF STEERING WHEEL, CHECK OPERATION OF STEERING****12.2.15 CHECK DIRECTION OF REAR VIEW MIRROR, CHECK FOR DIRT OR DAMAGE****12.2.16 CHECK LOCK OF CAB DOOR FOR MACHINES EQUIPPED WITH CAB**

## OPERATION

### 12.3 ADJUSTMENT BEFORE OPERATION

#### 12.3.1 OPERATOR'S SEAT

 **WARNING**

Park the machine in a safe place and stop the engine when carrying out adjustment of the operator's seat.  
Adjust the seat before starting operations or when changing operators.  
Check that you can depress the brake pedal fully with your back against the seat backrest.

#### A: Forward-backward adjustment

Pull lever (1) up, and move the seat to the desired position, then release the lever to lock in place.

For-and-aft adjustment: 160 mm (6.3 in)  
(16 mm (0.63 in) x 10 stages)

#### B: Adjusting seat angle

Pull lever (2) up and push down on the rear of the seat to tilt it backwards.  
Push lever (2) down and push down on the front of the seat to tilt it forward.

Range of adjustment: 13° (front tilt, rear tilt: 4 stages each)

#### C: Adjusting seat weight

Turn grip (3) to adjust the strength of the suspension.

Adjustment range: (Target) 50 kg - 120 kg (110.3 - 264.6 lb)

#### D: Adjusting backrest angle

Move lever (4) and move the backrest to the front or rear.

Adjustment range: Front 66° (3° x 22 stages)  
Rear 72° (3° x 24 stages)

#### NOTICE

If the seat back is reclined too far, the seat could back hit the rear glass, so use it in a position where it does not contact the glass.

When reclining the seat fully to take a rest, set the seat in the following position.

Fore-and-aft adjustment: Max. front position

Up-down adjustment: Max. height

Seat angle adjustment: Horizontal or fully tilted

Reclining adjustment: Fully tilted backward 36° (12 stages)

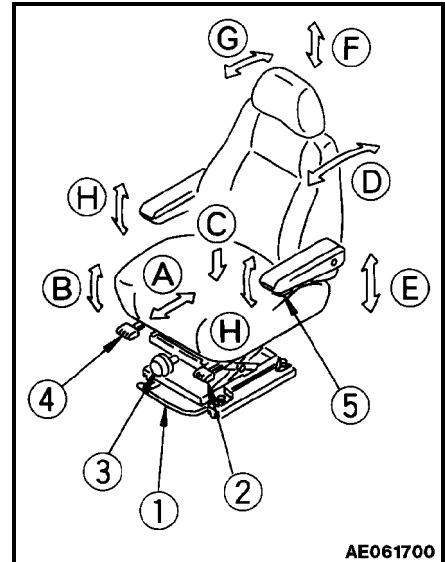

**E: Seat height adjustment**

Move lever (2) up/down, then move seat up or down as desired. Since lever (2) is also used for adjusting seat angle, set the seat to the desired height while adjusting the angle.

Adjustment range: 60 mm (2.36 in)

**F: Adjusting height of headrest**

Move the headrest up and down to the desired height.

Adjustment range: 25 mm (0.99 in)

**G: Adjusting headrest angle**

Rotate the headrest toward the front or rear.

**H: Angle of armrest**

Adjust angle of armrest by rotating knob (5) (left side only).

Adjustment range: 30° (forward tilt: 25°, backward tilt: 5°)

Also when armrest is turned, it will spring up.



## OPERATION

### 12.3.2 ADJUST SEAT BELT

Always install a seat belt on machines equipped with ROPS.

 **WARNING**

**Before fitting the seat belt, check that there is no abnormality in the mounting bracket and mounting of the belt. If the belt is worn or damaged, replace it.**

**Always fasten the seat belt before starting operations.**

**Do not twist the left or right side of the seat belt when fastening it.**

#### Fastening and removing belt

Fasten the belt so that it is tight without being too tight.

1. Sit on the seat, depress the brake pedal fully, and adjust the seat so that your back is pressed against the backrest.
2. After adjusting the seat position, adjust teaser belt (1). Tense the teaser belt and install it when there is no one sitting in the seat.
3. Sit on the seat, take buckle (2) and tongue (3) in your left and right hands, insert tongue (3) into buckle (2), and pull the belt to check that it is securely locked.
4. When removing belt, raise the lever of buckle (2) to free the belt.

Adjust the length of the buckle and tongue so that the belt follows your body without twisting, and adjust so that the buckle is in the middle at the front of your body.

#### Adjust belt length

To make belt shorter: Pull the free end of the belt at the buckle end or tongue end.

To make belt longer: Set the belt holding the buckle or tongue end at right angles to the buckle or tongue, and pull.

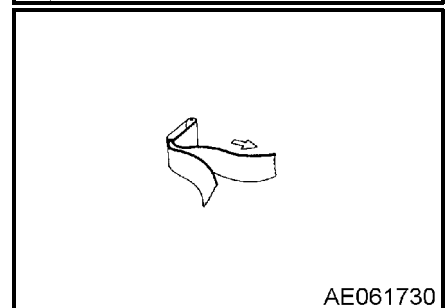
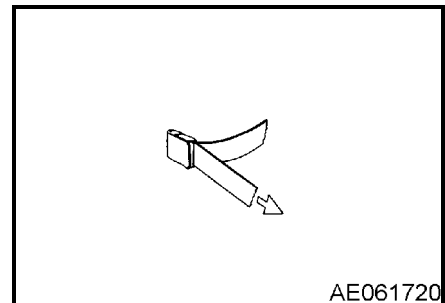
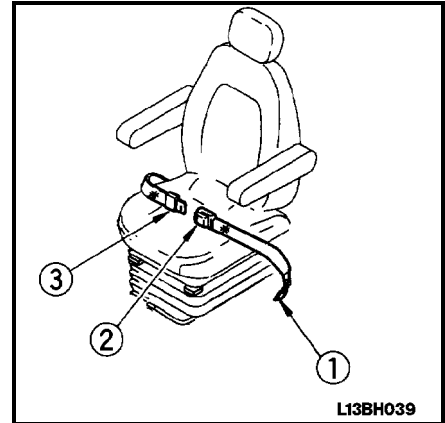

**12.3.3 ADJUST REAR VIEW MIRRORS**

Sit in the operator's seat and adjust the rear view mirror so that you can see properly to the rear.

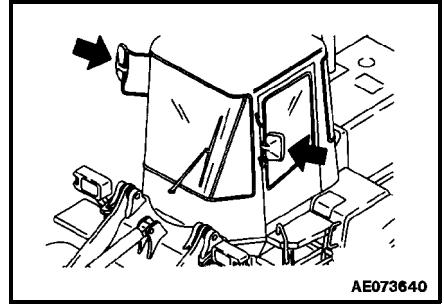

# OPERATION

## 12.4 OPERATIONS AND CHECKS BEFORE STARTING ENGINE

### WARNING

If the control levers are touched by accident, the work equipment could move suddenly. When leaving the operators compartment, always set the safety lever securely to the **LOCK** position. Before starting the engine, use a damp cloth to wipe off the dust accumulated on the top surface of the battery or on the starting motor and alternator.

1. Check that parking brake pedal (1) is at the **LOCK** position.
2. Check that directional lever (2) is at **N** position.  
When starting the engine, if directional lever (2) is not at the **N** position, the engine will not start.
3. Lower the bucket to the ground, then check that work equipment control lever (3) is locked by safety lock (4).
4. Insert the key in starting switch (5), turn the key to the **ON** position, and check that the pilot lamp lights up.

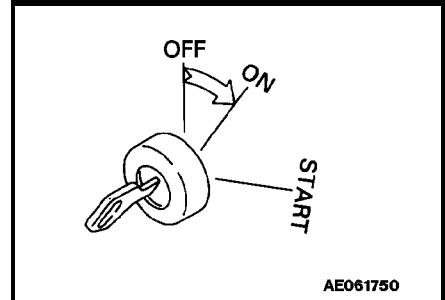
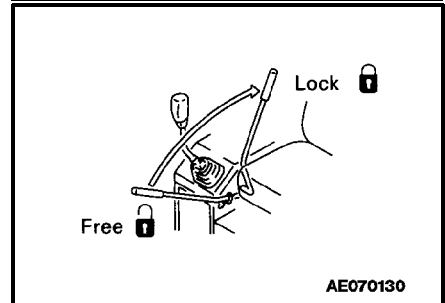
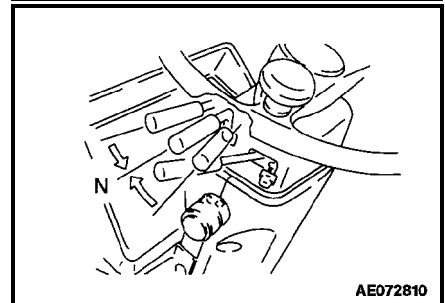
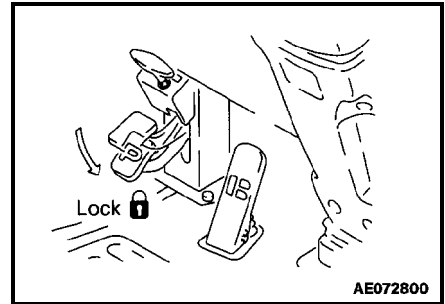
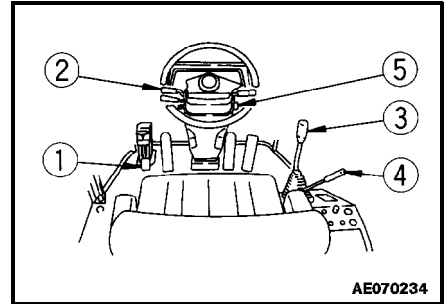

## 12.5 STARTING ENGINE

### 12.5.1 NORMAL STARTING PROCEDURES IN COLD AND WARM CONDITIONS

**WARNING**

Check that there are no persons or obstacles in the surrounding area, then sound the horn and start the engine.

**WARNING**

NEVER use starting fluid (such as ether) to help start the engine. This engine has a preheater in the intake manifold and this combination can cause an explosion.

**NOTICE:** Do not keep the starting motor rotating continuously for more than 20 seconds. If the engine will not start, wait at least 2 minutes before trying to start the engine again.

1. Turn the key in the starting switch (1) to the **ON** position. Preheating will automatically start and preheating pilot lamp (2) will light up.

The table shown below gives a guide to preheating time.

Temperature	Preheating time
Below -18°C (-2°F)	About 30 seconds
From -18° to -8°C (-2° to 17°F)	About 20 seconds
From -8° to 8°C (17° to 46°F)	About 10 seconds
Above 8°C (46°F)	0 seconds

The preheating time in cold areas changes according to the coolant temperature when starting the engine.

2. Depress accelerator pedal (3) lightly.
3. Check that preheat pilot (2) lamp is out, then turn the key of starting switch (1) to the **START** position to start the engine.
4. When engine is started, release the key of starting switch (1) and the key will return automatically to **ON**.

**CAUTION:**

- Do not idle the engine for long periods. Long periods of idling (more than 10 minutes) can damage an engine because combustion chamber temperatures drop so low the fuel will not burn completely. This will cause carbon to clog the injector spray holes and piston rings, and can cause the valves to stick. If the engine coolant temperature becomes too low (60°C {140°F}), raw fuel will wash the lubricating oil off the cylinder walls and dilute the crankcase oil; Therefore, all moving parts of the engine will not receive the correct amount of lubrication
- Idle the engine 3 to 5 minutes before operating with a load.

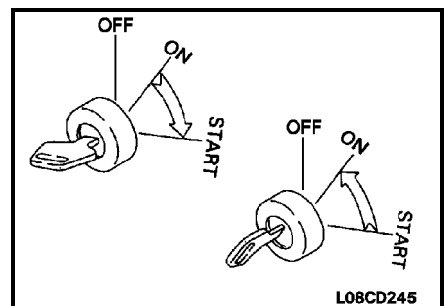
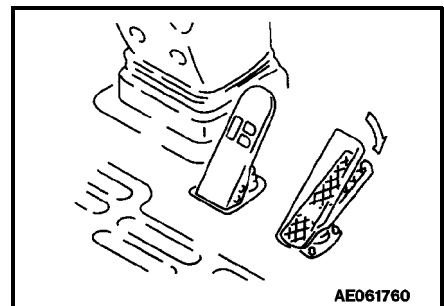
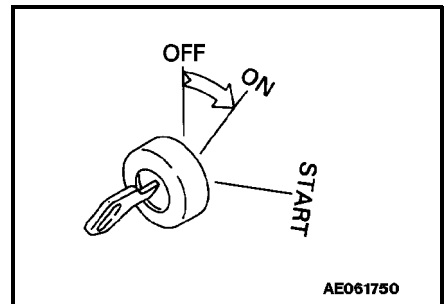
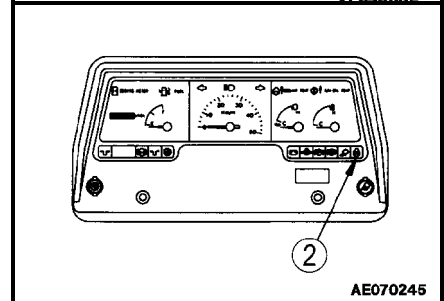
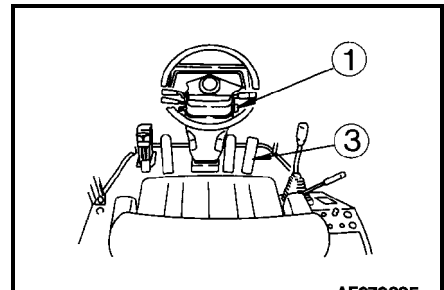

## OPERATION

---

### 12.5.2 STARTING PROCEDURES AFTER EXTENDED SHUTDOWN OR OIL CHANGE

Complete the following steps after each oil change, or after the engine has been shut off for more than 30 days to make sure the engine receives the correct oil flow through the lubricating oil system:

- Disconnect the electrical wire from the fuel pump solenoid valve.
- Rotate crankshaft, using the starting motor, until oil pressure appears on the gauge, or the warning light goes out.
- Connect the electrical wire to the fuel pump solenoid valve.
- Start the engine.

### 12.5.3 STARTING PROCEDURES AFTER CHANGING FUEL FILTERS

Controlled venting is provided at the injection pump through the fuel drain manifold. Small amounts of air introduced by changing the filters or injection pump supply line will be vented automatically, if the fuel filter is changed in accordance with the instructions. No manual bleeding of fuel lines is required.

**However, manual bleeding will be required if:**

- The fuel filter is not filled prior to installation.
- The injection pump has been replaced.
- High pressure fuel lines have been replaced.
- Machine has run out of fuel. (Fuel tank has run empty)

For **bleeding procedures** Refer to section on replacing fuel filter.

 **WARNING**

**Failure to properly bleed fuel lines after replacing the injection pump, high pressure fuel lines or not filling the fuel filter prior to installing it could result in damaging the injectors and the fuel pump.**

### 12.5.4 STARTING PROCEDURES AFTER RUNNING OUT OF FUEL

 **WARNING**

**If at all possible avoid running out of fuel. Running out of fuel can cause major damage to the injectors and the fuel pump.**

Manual bleeding is required after running out of fuel.

For **bleeding procedures** Refer to section on replacing fuel filter.

## 12.6 OPERATIONS AND CHECKS AFTER STARTING ENGINE

After starting the engine do not immediately start operations.  
First carry out the following operations and checks.

### NOTICE

**Do not suddenly accelerate the engine before the warming-up operation is completed.**

**Do not run the engine at low idle or high idle continuously for more than 10 minutes.**

**If it is necessary to run the engine at idle, apply a load from time to time or run the engine at mid-range speed.**

1. Depress accelerator pedal (1) lightly and run the engine with no load at mid-range speed for about 5 minutes.
  
2. To warm up the hydraulic oil only in cold areas, do as follows.  
During warm up operation, check that the engine rotation is smooth, then set the safety lock of the work equipment control lever to the FREE position and move the bucket control lever in and out of the TILT position to warm up the hydraulic oil.  
The relief time at the tilt position should be a maximum of 10 seconds.  
With this operation, the oil will reach the relief pressure and this will warm up the hydraulic oil quicker.
  
3. After carrying out the warming up operation, check that the gauges and caution lamps are normal.  
If there is any abnormality, carry out maintenance or repair.  
Run the engine under a light load until engine coolant temperature gauge (2) and torque and torque converter oil gauge (3) are in the green range.
  
4. Check that there know abnormality in the exhaust color, sound, or vibration.  
If there is any abnormality, carry out repairs.

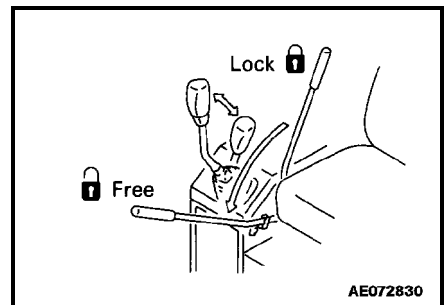
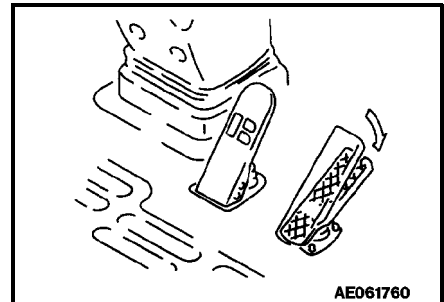
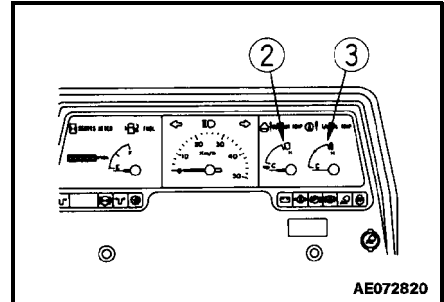
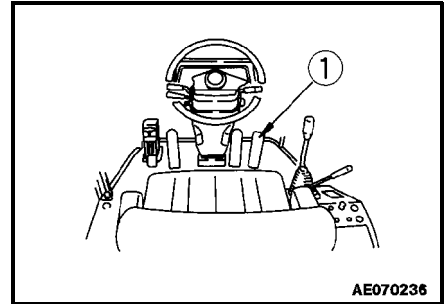

## OPERATION

### 12.7 MOVING MACHINE OFF

 **WARNING**

- When moving the machine off, check that the area around the machine is safe, then sound the horn before starting. Do not allow people near the machine.
- There is a blind spot behind the machine, so be particularly careful when traveling in reverse.

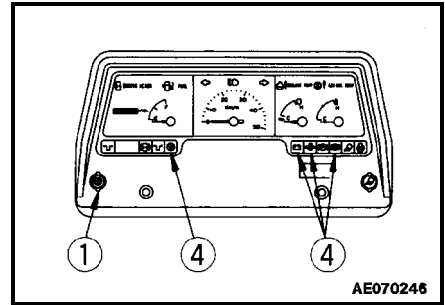

 **WARNING**

When starting the machine on slopes, set transmission cutoff switch (1) to the OFF position, depress left brake pedal (2) while depressing accelerator pedal (3), then gradually release left brake pedal (2) to allow the machine to start.

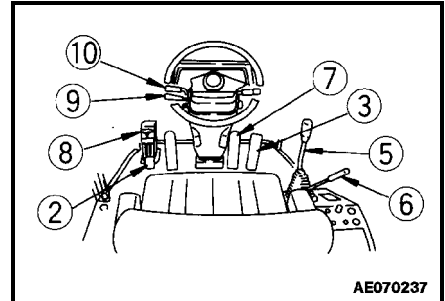

1. Check that caution pilot lamp (4) is not lit up.

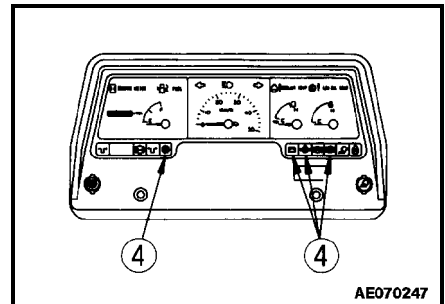

2. Set safety lock (6) of work equipment control lever (5) to the FREE position.

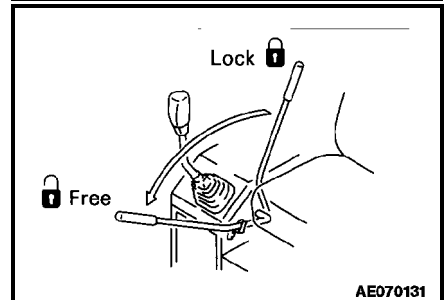

3. Operate work equipment control lever (5) to set the work equipment to the travel posture shown in diagram on right.

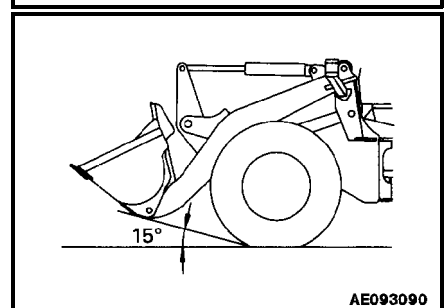

4. Depress right brake pedal (7) and pull parking brake release lever (8) to the FREE position to release the parking brake. Keep right brake pedal (7) depressed.

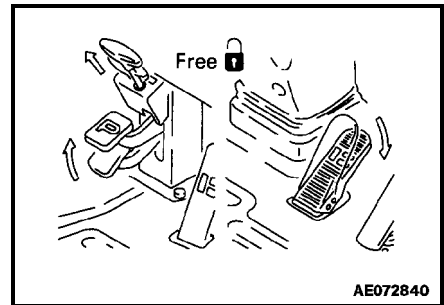

5. Set speed control lever (9) to the desired position.

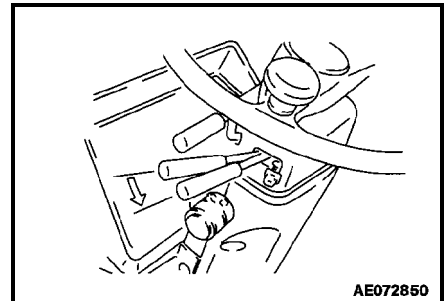

6. Set directional control lever (10) to the desired position.

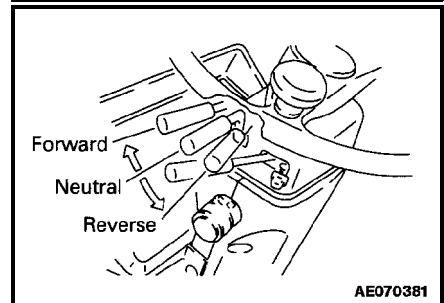

7. Release right brake pedal (7), then depress accelerator pedal (3) to move the machine off.

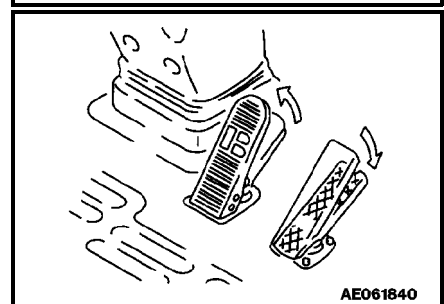



## OPERATION

### 12.8 CHANGING GEAR SPEED



**WARNING**

When traveling at high speed, do not change the gear speed suddenly. When shifting gears, use the brake to reduce the travel speed, then shift gears

Shift gear as follows.

Move speed control lever (1) to the desired position.

Only 1st or 2nd speeds are used for digging and loading operations, so actuate speed control lever stopper.

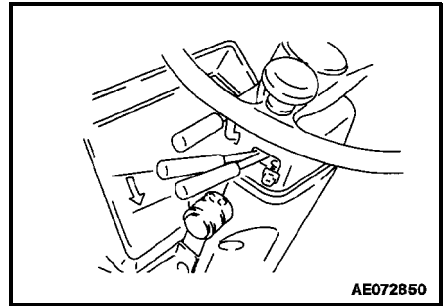
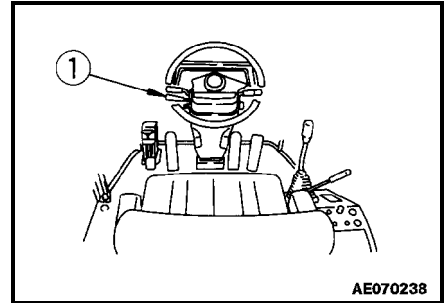

### 12.9 CHANGING DIRECTION



**WARNING**

- When changing direction between FORWARD and REVERSE, check that the new direction of travel is safe. There is a blind spot behind the machine, so be particularly careful when changing direction to travel in reverse.
- Do not switch FORWARD and REVERSE, when traveling at high speed.

There is no need to stop the machine even when switching between FORWARD and REVERSE.

Place directional lever (1) in the desired position.

When switching between FORWARD and REVERSE, depress the brake to reduce the travel speed sufficiently, then change the direction of travel.  
(Max. Speed for changing direction: 12 km/h (7.5 mph))

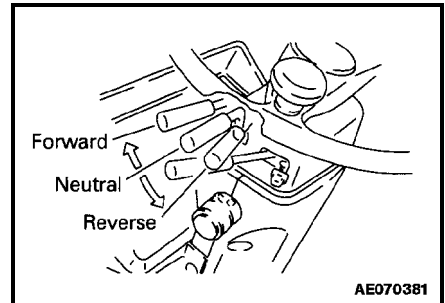
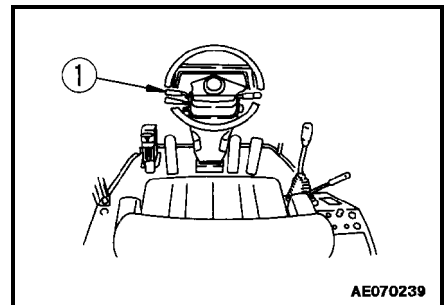

## 12.10 TURNING

 **WARNING**

- It is dangerous to turn the machine suddenly at high speed, or to turn on steep hills.
- If the engine quits while the machine is traveling, the steering wheel becomes heavy and hard to turn, so avoid killing the engine.

**This is particularly dangerous on hills, so never stop the engine while the machine is traveling.**

**If the engine quits, stop the machine immediately at a safe place.**

When traveling, use steering wheel (1) to turn the machine.

With this machine, the front frame is joined to the rear frame at the center of the machine by the center pin. The front and rear frames pivot at this point, and the rear wheels follow in the same track as the front wheels when turning.

Turn the steering wheel lightly to follow the machine as it turns. When turning the steering wheel fully, do not turn it beyond the end of the stroke.

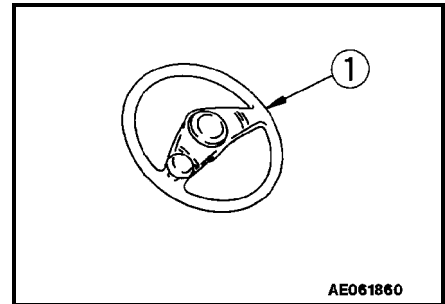

AE061860

## OPERATION

### 12.11 STOPPING MACHINE

 **WARNING**

- Avoid stopping suddenly. Allow ample room when stopping.
- Do not park the machine on slopes. If the machine has to be parked on a slope, set it facing directly down the slope, then dig the bucket into the ground and put blocks under the tires to prevent the machine from moving.
- If the control lever is touched by accident, the work equipment or the machine could move suddenly, and cause a serious accident. Before leaving the operator's seat always set the safety lock lever securely to the LOCK position.
- Even if the parking brake pedal is depressed LOCK, for safety precaution keep the brake pedal depressed until the pilot lamps lights up.

#### NOTICE

Never use the parking brake switch to brake the machine when traveling except in an emergency. Apply the parking only after the machine has stopped.

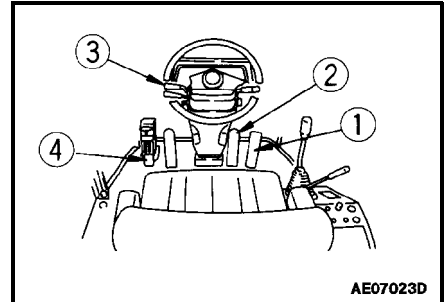
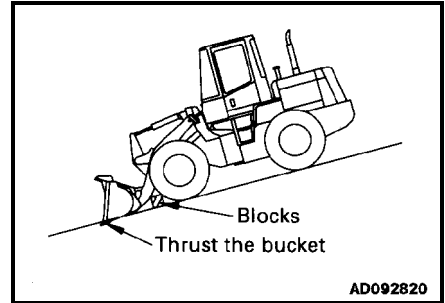

1. Release accelerator pedal (1), and depress brake pedal (2) to stop the machine.

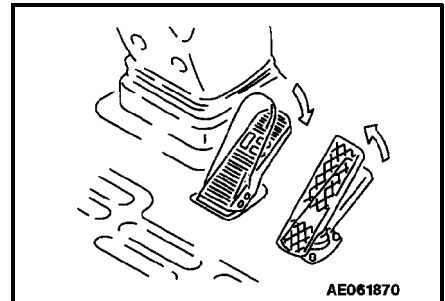

2. Place directional lever(3) in N (neutral).

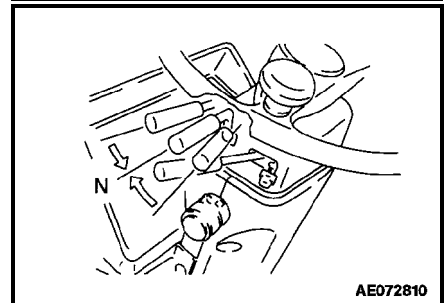

3. Depress parking brake pedal (4) to LOCK to apply the parking brake.

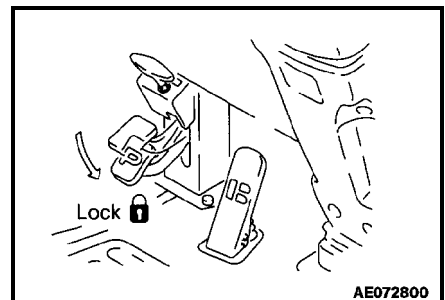



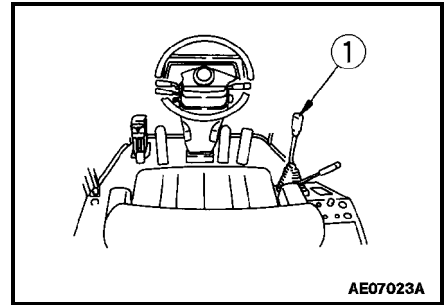

## 12.12 OPERATION OF WORK EQUIPMENT

Work equipment control lever (1) can be used to operate the boom and bucket as follows.



### 12.12.1 BOOM OPERATION (LEVER)

- (1) RAISE (  )
- (2) HOLD (  ): The boom is kept in the same position.
- (3) LOWER (  )
- (4) FLOAT (  ): The boom moves freely under external force.

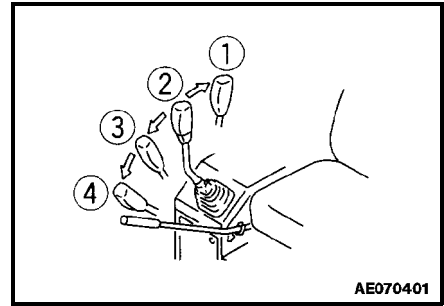



When the boom control lever is pulled further from the raise position, the lever is stopped in this position until the boom reaches the preset kick-out position, and the lever is return to hold position

**NOTICE:**

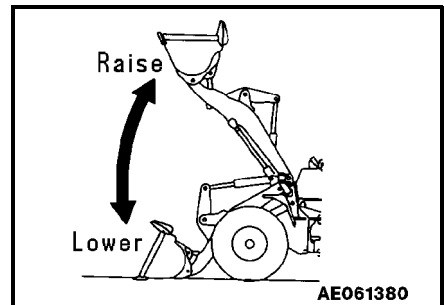
**Do not use the FLOAT position when lowering the bucket.**



### 12.12.2 BUCKET OPERATION (LEVER)

- (1) TILT (  ):
- (2) HOLD (  ): The boom is kept in the same position.
- (3) DUMP (  )

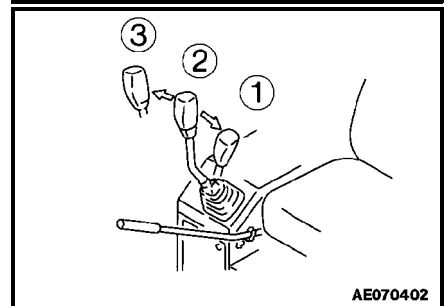

When the bucket control lever is pulled further from the tilt position, the lever is stopped in this position until the bucket reaches the preset position of the positioner, and the lever is returned to the hold position.

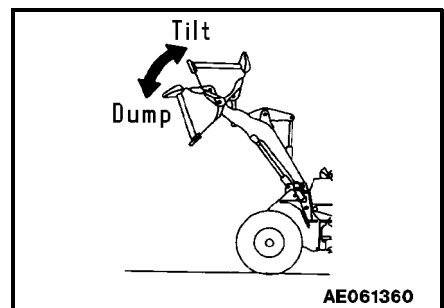

## OPERATION

### 12.13 WORK POSSIBLE USING WHEEL LOADER

In addition to the following, it is possible to further increase the range of applications by using various attachments.

#### 12.13.1 DIGGING OPERATIONS WITH ROCK PILES



**WARNING**

**Always set the machine facing directly to the front when carrying out digging or scooping operations. Never carry out these operations with the machine articulated.**

**NOTICE: If the tires slip, the life of the tire will be reduced, so avoid slipping or spinning the tires when operating the machine.**

When loading piled soil or blasted rock, drive the machine forward as follows to load. To prevent cutting of the tires caused by tires slipping, be careful of the following points.

- Always keep the job site flat, and remove any fallen rocks.
  - When working with stockpiles, operate the machine in 1st or 2nd; when loading blasted rock operate in 1st.
1. When driving forward and lowering the bucket, stop the bucket about 30 cm (12 in) from the ground, then lower it slowly.

#### REMARKS:

If the bucket hits the ground, the front wheels will raise up, and the tires will slip.

2. Shift down immediately in front of the material to be loaded. When completing the shift down, depress the accelerator pedal at the same time and thrust the bucket into the load.

3. When the material is in a stockpile, keep the cutting edge of the bucket horizontal; when loading blasted rock have the bucket tilted slightly down.

Be careful not to get blasted rock under the bucket. This will make the front tires come off the ground and slip.

Try to keep the load in the center of the bucket, the load will be unbalanced.

4. At the same time as thrusting the bucket into the material, raise the boom to prevent the bucket from going in too far. By raising the boom, ample traction will be produced by the front tires.

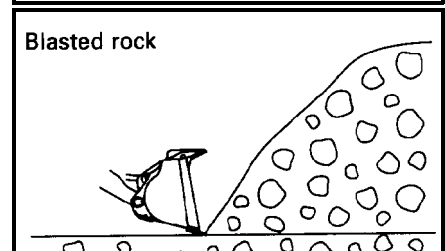
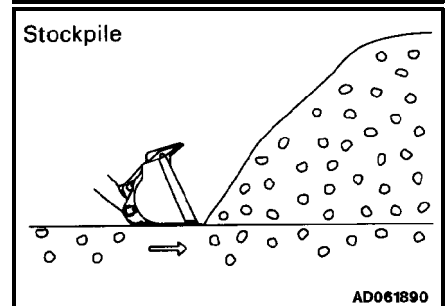
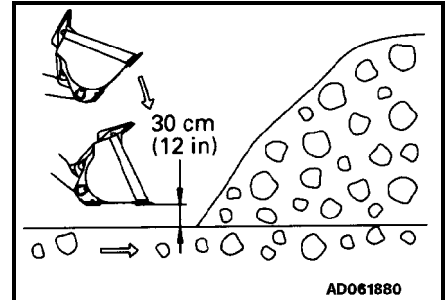

5. Check that there is enough material loaded into the bucket, then operate the bucket control lever to tilt the bucket and load the bucket fully.

**REMARKS:**

If the bucket edge is moved up and down while pushing in the bucket and digging, the front wheels could raise up and cause the tires to slip.

6. If there is too much material loaded in the bucket, tilt and dump the bucket quickly to remove excessive load. This prevents spillage of the load during hauling.

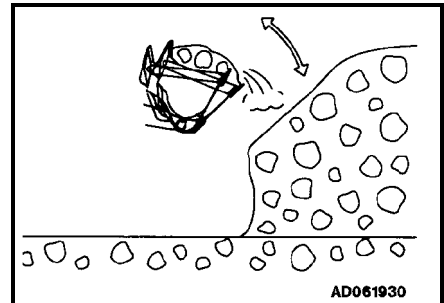
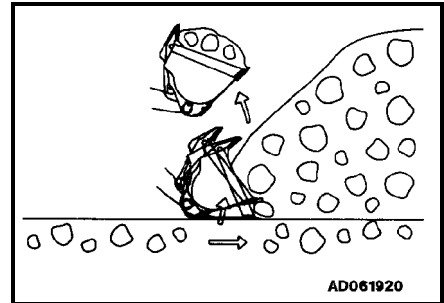

**12.13.2 DIGGING OPERATIONS ON LEVEL GROUND**

When digging and loading on level ground, set the bucket edge facing down slightly as follows and drive the machine forward. Always be careful not to load the bucket on one side and cause an unbalance load. This operation should be carried out in first gear.

1. Set the edge of the bucket facing slightly down.
2. Drive the machine forward and operate the boom control lever forward to cut a thin layer of the surface each time when excavating the soil.

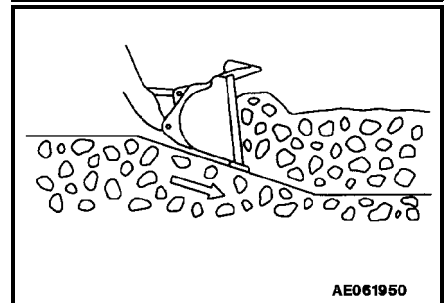
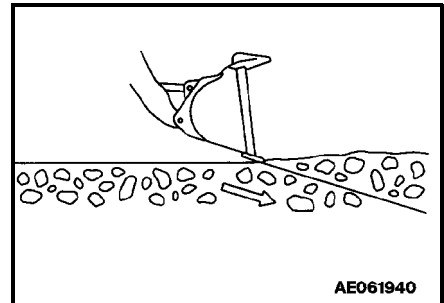

3. Operate the boom control lever slightly up and down to reduce the resistance when driving the machine forward.

When digging with the bucket, avoid imposing the digging force onto only one side of the bucket.

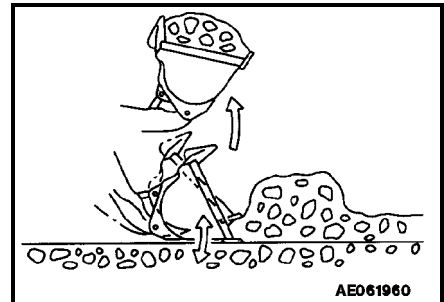

## OPERATION

### 12.13.3 LEVELING OPERATION

#### NOTICE:

Always operate the machine in reverse when carrying out leveling operations.

If it is necessary to carry out leveling operations when traveling forward, do not set the bucket dumping angle to more than 20°.

1. Scoop soil into bucket. Move the machine backward while spreading soil from the bucket little by little.
2. Go over the spread soil with the bucket teeth touching the ground and level the ground by back-dragging.
3. Scoop some more soil into the bucket, put the boom in float, level the bucket at ground level, and smooth the ground by moving backwards.

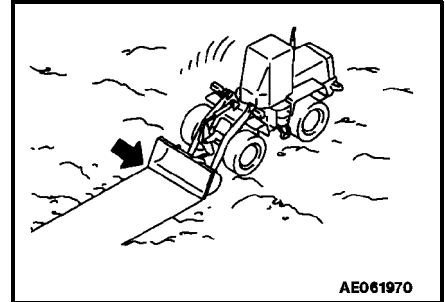

### 12.13.4 PUSHING OPERATIONS

#### NOTICE:

Never set the bucket to the DUMP position when carrying out pushing operation.

When carrying out pushing operations, set the bottom of the bucket parallel to the ground surface.

### 12.13.5 LOAD AND CARRY OPERATIONS



**WARNING**

**When carrying a load, lower the bucket to lower the center of gravity when traveling.**

The load and carry method for wheel loaders consist of a cycle of scooping - hauling - loading (into a hopper, pit etc.)

Always keep the travel path maintained.

When using the load and carry method, **SEE "12.25 HANDLING TIRES"**.

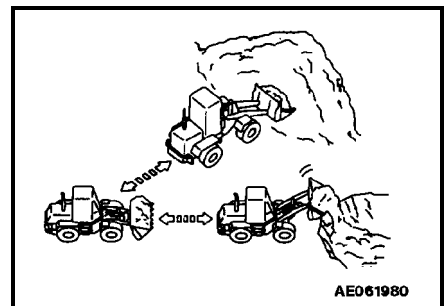

**12.13.6 LOADING OPERATIONS**

Select the method of operation which will give the minimum amount of turning and travel and provide the most efficient method for the job site.

**⚠ WARNING**

**Always keep the working area flat. Do not turn suddenly or apply the brake suddenly when traveling with a raised load. These actions are dangerous. It is also dangerous to drive the bucket at high speed into a stockpile or pile of rocks.**

**NOTICE:**

**If the tires slip, the tire life will be reduced, so avoid slipping or spinning of the tires during operation.**

**Avoid excessive shaking of the bucket.**

**CROSS DRIVE LOADING**

Always set the wheel loader facing at a right angle to the stock pile. After digging in and scooping up the load, drive the machine straight back in reverse, then bring the dump truck in between the stock pile and the wheel loader.

This method requires the least time for loading, and is extremely effective in reducing the cycle time.

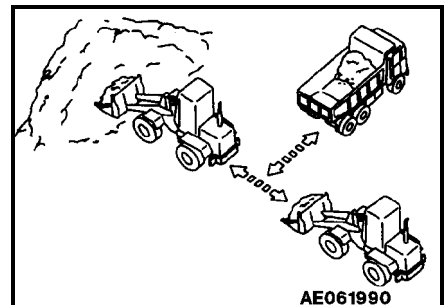

**V-SHAPE LOADING**

Position the dump truck so that the direction of approach of the wheel loader is approximately 60° from the direction of approach to the stockpile. After loading the bucket, drive the wheel loader in reverse, then turn it to face the dump truck and travel forward to load the dump truck.

The smaller the turning angle of the wheel loader is, the more efficient the operation becomes.

When loading a full bucket and raising it to maximum height, first shake the bucket to stabilize the load before raising the bucket. This will prevent the load from spilling to the rear.

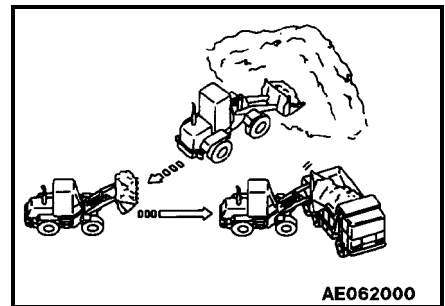

**Precautions when piling up loads**

When forming products into a pile, be careful not to let the rear counterweight come into contact with the ground.

Do not set the bucket to the DUMP position when carrying out piling-up operations.

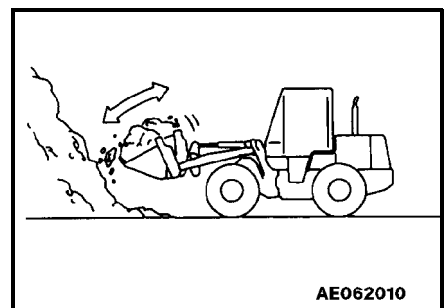



## OPERATION

---

### 12.14 PRECAUTIONS FOR OPERATION

#### 12.14.1 PERMISSIBLE WATER DEPTH

When working in water or on swampy ground, do not let the water come above the bottom of the axle housing.

After finishing the operation, wash and check the lubricating points.

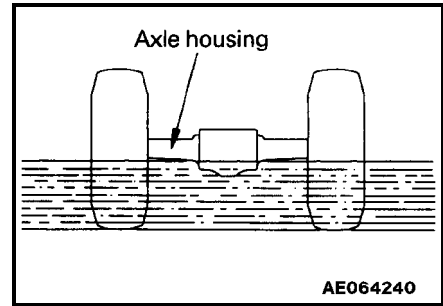

#### 12.14.2 IF WHEEL BRAKE DOES NOT WORK

If the machine is not stopped by depressing the brake pedal, use the parking brake to stop the machine.

#### NOTICE:

**If the parking brake has been used as an emergency brake, contact your distributor to have the parking brake checked for any abnormality.**

#### 12.14.3 PRECAUTIONS WHEN DRIVING UP OR DOWN SLOPES

##### LOWER THE CENTER OF GRAVITY BEFORE TURNING

When turning on slopes, lower the work equipment to lower the center of gravity before turning. It is dangerous to turn the machine with the work equipment raised.

##### BRAKING ON DOWNHILL SLOPES

If the service brake is used too frequently when traveling downhill, the brake may overheat and be damaged. To avoid this problem, shift down to a lower range and make full use of the braking force of the engine.

When braking use the right brake pedal.

If the speed control lever is not placed in a proper speed position, the torque converter oil may overheat. If it overheats place the speed control lever in the next lower gear speed to lower the oil temperature.

If the temperature gauge does not indicate the green range of the scale even with the lever in the 1st speed position, stop the machine, place the lever in neutral, and run the engine at medium speed until the gauge indicates the green range.

##### IF ENGINE STOPS

If the engine stops on a slope, depress the right brake pedal fully. Next, lower the work equipment to the ground and apply the parking brake. Then put the directional and speed control levers in neutral, and start the engine again. (If the directional lever is not in neutral, the engine will not start.)

**12.14.4 PRECAUTIONS WHEN DRIVING MACHINE**

When the machine travels at high speed for a long distance, the tires become extremely hot. This causes early wear of the tires, so it should be avoided as far as possible. If the machine must be driven for a long distance, take the following precautions.

- Follow the regulations related to this machine, and drive carefully.
- Before driving the machine, carry out the checks before starting.
- The most suitable tire pressure, travel speed, or tire type differ according to the condition of the travel surface. Contact your distributor or tire dealer for information.
- The following is a guide to suitable tire pressures and speeds when traveling on a paved surface with standard tires.  
Tire pressure (front and rear ): 294 kPa (3.0 kg/cm<sup>2</sup>, 42.6 psi)  
Speed: 25 km/h (16-18 mph)
- Check the tire pressure before starting, when the tires are cool.
- After traveling for 1 hour, stop for 30 minutes. Check the tires and other parts for damage; also check the oil and coolant levels.
- Always travel with bucket empty.
- Never put dry ballast in tires when traveling.

## OPERATION

### 12.15 ADJUSTING WORK EQUIPMENT POSTURE

 **WARNING**

- Stop the machine on flat ground and put blocks in front and behind the wheels.
- Apply the parking brake.
- Secure the front and rear frames with safety bar.
- Never go under the work equipment when the arm is raised.

The boom kickout makes it possible to set the bucket so that it automatically stops at the desired lifting height (work equipment higher than horizontal) and the bucket positioner makes it possible to set the bucket so that it automatically stops at the desired digging angle.

The setting can be adjusted to match the working conditions.

#### 12.15.1 ADJUSTING BOOM KICKOUT

1. Raise the bucket to the desired height, Set the work equipment control lever at Hold and lock the lever in position. Then stop the engine and adjust as follows.

2. Loosen two bolts (1), and adjust plate (2) so that the bottom edge is in line with the center of the sensing surface of proximity switch (3). Then tighten the bolts to the plate in position.

3. Loosen two nuts (4) to make clearance of 3 to 5 mm (0.12 to 0.20 in) between plate (2) and the sensing surface of proximity switch (3). Then tighten the nuts to hold in position.

Tightening torque:  $(17.2 \pm 2.5 \text{ N}\cdot\text{m})$  ( $1.75 \pm 0.25 \text{ kgm}$ ,  $12.7 \pm 1.8 \text{ lbf ft}$ )

4. After adjusting, start the engine and operate the work equipment control lever. Check that the lever is automatically returned to HOLD when the bucket reaches the desired height.

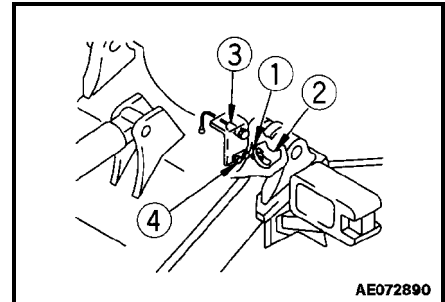

**12.15.2 ADJUSTING BUCKET POSITIONER**

1. Lower the bucket to the ground and adjust the bucket to the desired digging angle. Set the work equipment control lever at HOLD, stop the engine and adjust as follows.
2. Loosen two bolts (1) and adjust mounting bracket (4) of the proximity switch so that the rear tip of angle (2) is in line with the center of the sensing surface of the proximity switch (3). Then tighten the bolts to hold the bracket in position.
3. Loosen two nuts (5) and adjust to make a clearance of 0.5 to 2 mm (0.02 to 0.08 in) between bar (2) and support (6).. Then tighten the nuts to hold in position.

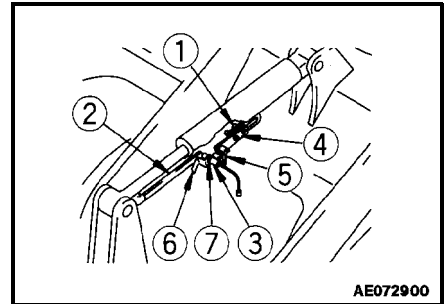

Tightening torque: (17.2 ± 2.5 N•m (1.75 ± 0.25 kgm, 12.7 ± 1.8 lbf ft)

4. Loosen two nuts (7) in order to make a clearance of 3 to 5 mm (0.12 to 0.20 in) between bar (2) and the sensing surface of proximity switch (3). Then tighten the nuts to hold in position.
5. After adjusting, start the engine and raise the lift arm. Operate the work equipment control lever to the DUMP position, then operate it to the TILT position and check that the work equipment control lever is automatically returned to HOLD when the bucket reaches the desired angle.

**12.15.3 BUCKET LEVEL INDICATOR**

(A) and (B) at the top rear of the bucket are the level indicators, so the bucket angle can be checked during operations.

- (A): Parallel with cutting edge
- (B): 90° to cutting edge

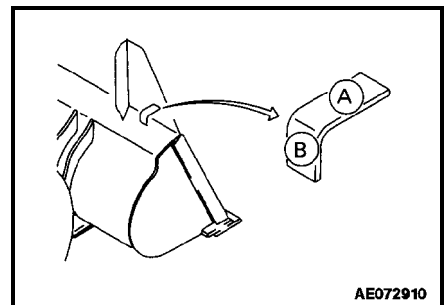

## OPERATION

### 12.16 PARKING MACHINE

 **WARNING**

- Avoid stopping suddenly. Allow ample room when stopping.
- Do not park the machine on slopes. If the machine has to be parked on a slope, set it facing directly down the slope, then dig the bucket into the ground and put blocks under the tires to prevent the machine from moving.
- If the control lever is touched by accident, the work equipment or the machine could move suddenly, and cause a serious accident. Before leaving the operator's seat always set the safety lock lever securely to the LOCK position.
- Even if the parking brake pedal is DEPRESSED to the LOCK position, for safety precaution keep the brake pedal depressed until the pilot lamps light up.

**NOTICE:**

- Never use the parking brake switch to brake the machine when traveling except in an emergency. Apply the parking only after the machine has stopped.

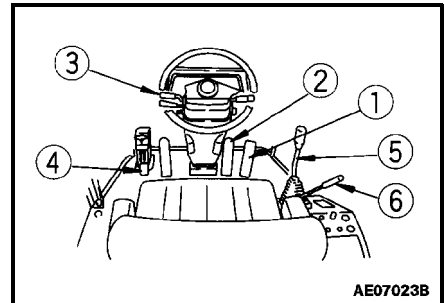
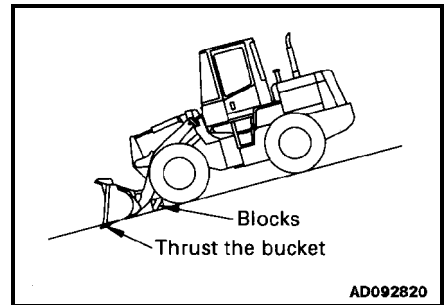

1. Release accelerator pedal (1), and depress brake pedal (2) to stop the machine.

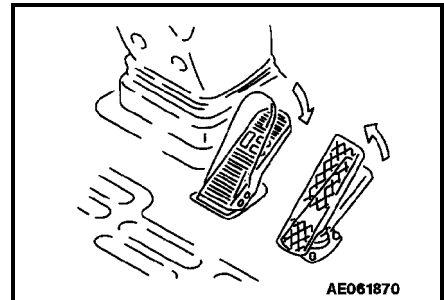

2. Place directional lever (3) in N (neutral).

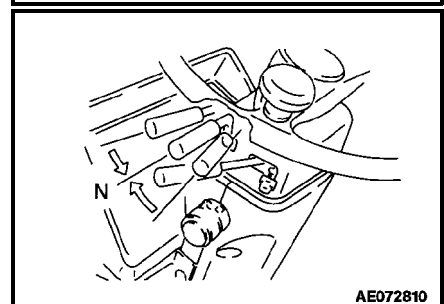

3. Depress parking brake pedal (4) to LOCK to apply the parking brake.

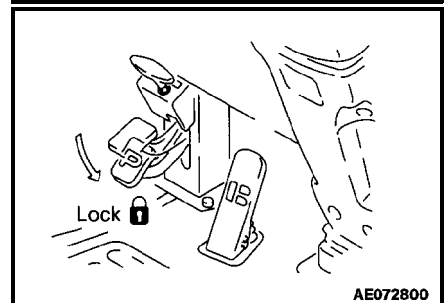

- Operate work equipment control lever (5) to lower the bucket to the ground.

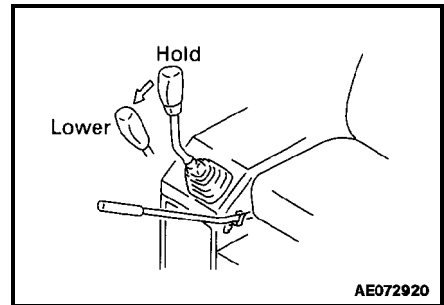

- Lock work equipment control lever (5) with safety lock (6).

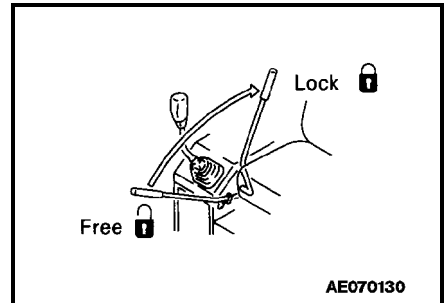

## 12.17 CHECKS AFTER COMPLETION OF OPERATION

Check the engine water temperature, engine oil pressure, torque converter oil temperature, and fuel level with the meter and lamps. If the engine has overheated, do not stop suddenly. Run the engine at a midrange speed to allow the engine to cool down before stopping it.

## 12.18 STOPPING ENGINE

### NOTICE:

If the engine is abruptly stopped before it has cooled down, engine life may be greatly shortened. Consequently, do not abruptly stop the engine apart from an emergency.

In particular, if the engine has overheated, do not abruptly stop it but run it at medium speed to allow it to cool gradually, then stop it.

- Run the engine at low idle for about 5 minutes to allow it to gradually cool down.
- Turn key in starting switch (1) to the OFF position and stop the engine.
- Remove the key from starting switch (1).

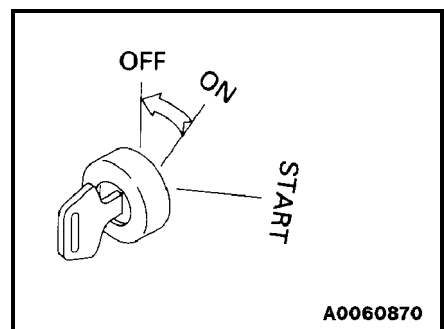
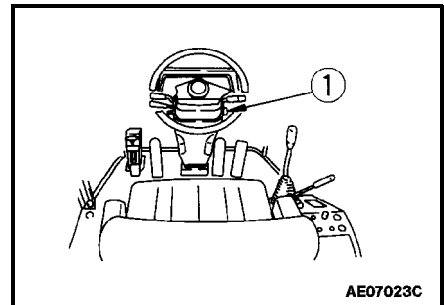

## OPERATION

### 12.19 CHECKS AFTER STOPPING ENGINE

1. Walk around the machine and check the work equipment, body work, and undercarriage, and check for oil and coolant leaks. If there are any leaks or abnormalities found, carry out repairs.
2. Fill the fuel tank.
3. Remove any waste paper or leaves from inside the engine compartment. They could cause a fire.
4. Remove any mud stuck to the undercarriage.

### 12.20 LOCKING

Always lock the following places.

- (1) Fuel tank filler cap
- (2) Engine side panel (left, right)
- (3) Rear grill
- (4) Cab door (left, right)

### REMARKS

The starting switch key is used also for locks (1),(2),(3) and (4).

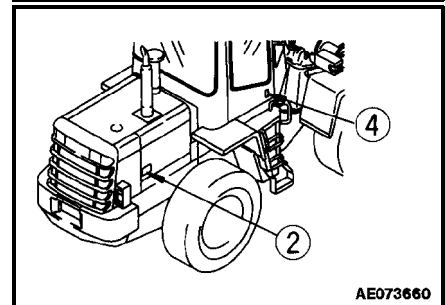
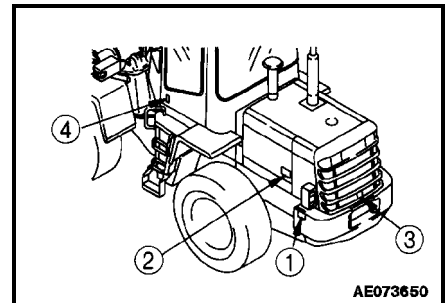

## 12.21 HANDLING THE TIRES

### 12.21.1 PRECAUTIONS WHEN HANDLING THE TIRES

If the following defects are found in a tire, for safety reason the tire should be replaced with a new one.

- Bead wire is broken or bent, or the tire is greatly deformed.
- Wear is excessive and the carcass ply (excluding breaker) is exposed for more than 1/4 of the circumference.
- Damage to the carcass exceeds 1/3 of the tire width.
- Tire layers are separated.
- Radial cracks reach the carcass.
- Deformation or damage which makes the tire unsuitable for use.

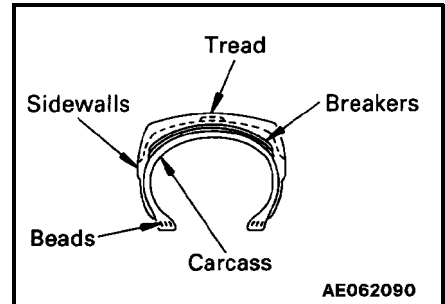

### 12.21.2 TIRE PRESSURE

Measure the tire pressure before starting operations, when the tires are cold. If the tire inflation pressure is too low, the tire will be overloaded; if it is too high, it will cause tire cuts and shock burst. To prevent these problems, adjust the tire inflation pressure according to the table on the next page.

$$\text{Deflection ratio} = \frac{H - h}{H} \times 100$$

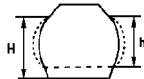

As a guideline that can be check visibly, the deflection ratio of the front tire (deflection/free height) is as follows.

- When carrying normal load (boom horizontal): Approximately 15 - 25 %
- When digging (rear wheels off ground): Approximately 25 - 35 %

When checking the tire inflation pressure, check also for small scratches or peeling of the tire, for nails or pieces of metal which may cause punctures, and for any abnormal wear.

Clearing fallen stones and rocks from the operating area and maintaining the surface will extend the life of the tires.

- For operations on normal road surfaces, rock digging operations:.....High end of range in air pressure chart
- Stockpile operations on soft ground:.....Average pressure in air pressure chart
- Operations on sand (operation not using much digging force)..... Low end of range in air pressure chart



## OPERATION

---

If the deflection of the tire is excessive, raise the inflation pressure within the limits given in this table to give a suitable deflection (see deflection ratio).

Tire size (pattern)	Ply rating	Inflation pressure (kg/cm <sup>2</sup> )			
		Soft ground (sandy ground)	Normal road		When shipped from factory
			Stockpile	Digging	
17.5 - 25 (L2 Traction)	12	1.8 - 3.5	1.8 - 3.5	1.8 - 3.5	Front tire: 3.0 Rear tire: 3.0
15.5 - 25 (L2 Traction)	8	2.0 - 3.5	2.0 - 3.5	2.0 - 3.5	Front tire: 3.0 Rear tire: 3.0
14.00 - 24 (L2 Traction)	12	1.8 - 3.0	1.8 - 3.5	1.8 - 3.5	Front tire: 3.0 Rear tire: 3.0
16.9 - 24 (L2 Traction)	10	2.0 - 2.2	2.0 - 2.4	2.0 - 2.4	Front tire: 2.4 Rear tire: 2.4

Stockpile operations means the loading of sand and other loose materials.

### PRECAUTION WITH LOAD AND CARRY METHOD

When traveling continuously with load and carry operations, choose the correct tires to match the operating conditions, or choose the operating conditions to match the tires. If this is not done, the tires could be damaged, so contact your distributor or tire dealer when selecting tires.

## 13. TRANSPORTATION

When transporting the machine, observe all the related laws and regulations, and always assure safety.

### 13.1 LOADING, UNLOADING WORK

**⚠ WARNING**

- **Make sure the ramp has sufficient width, length and thickness to enable the machine to be safely loaded and unloaded.**
- **When loading and unloading the machine, park the trailer on a flat firm roadbed. Keep a fairly long distance between the road shoulder and the machine.**
- **Remove the mud from the undercarriage to prevent the machine from slipping to the side on slopes.**
- **Be sure the ramp surface is clean and free of grease, oil, ice and loose materials.**
- **Never change the direction of travel when on the ramps. If it is necessary to change direction, drive off the ramp and correct the direction, then drive onto the ramp again**

When loading or unloading, always use ramps or a platform and carry out the operation as follows.

1. Properly apply the brakes on the trailer and insert the blocks beneath the tires to ensure that it does not move. Then fix the ramps in line with the centers of the trailer and the machine. Be sure that the two sides are at the same level as one another.  
If the ramp sags appreciably, reinforce it with blocks etc.
2. Determine the direction of ramp, then slowly load or unload the machine.

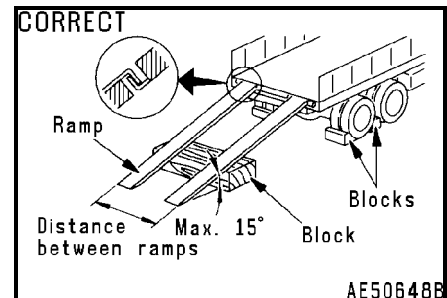

### REMARKS

When transmission cut-off switch is set to off, the left brake pedal and accelerator pedal are operated at the same time.

3. Correctly load the machine onto the specified part of the trailer.

## OPERATION

---

### 13.2 PRECAUTION FOR LOADING

After loading the machine in the specified position, secure it in place as follows.

1. Lower the work equipment slowly.
2. Apply the safety lock to lock all the control levers securely.
3. Turn the starting switch to the OFF position and stop the engine.  
Remove the key from the starting switch.
4. Lock front frame and rear frame with safety bar.
5. Put blocks in front and behind the wheels, and secure the machine with chains or rope to prevent the machine from moving during transportation.
6. Always retract the cab radio antenna fully.

### 13.3 PRECAUTION FOR LIFTING UP THE VEHICLE

 **DANGER**

- **Before lifting up the vehicle**
  - be sure the engine is stopped and not running.
  - be sure the parking brake lock is on.
  - be sure the safety lock bar is in LOCK position, to prevent vehicle from articulating and causing the load to shift and be unstable.
- Take caution when lifting up the vehicle with wire ropes, to prevent accidents or possible dropping of the vehicle. If wire cables are not strapped properly, severe injury or death could result.
- After raising the vehicle 100 to 200 mm above the ground, check the posture to be sure it is horizontal and check the wire ropes to be sure there is no slack.

 **WARNING**

- All lifting operations by crane or any other device must be performed by qualified persons only.
- The vehicle must be unmanned. Be sure no-one is in the vehicle prior to lifting.
- Be sure all wire ropes being used are of adequate strength for the vehicle weight.
- Do not attach ropes in any other positions or places other than what is specified or use any other lifting posture other than specified in the this procedure.

13.3.1 THE LOCATION OF DECALS REFERRING TO LIFTING POSITIONS

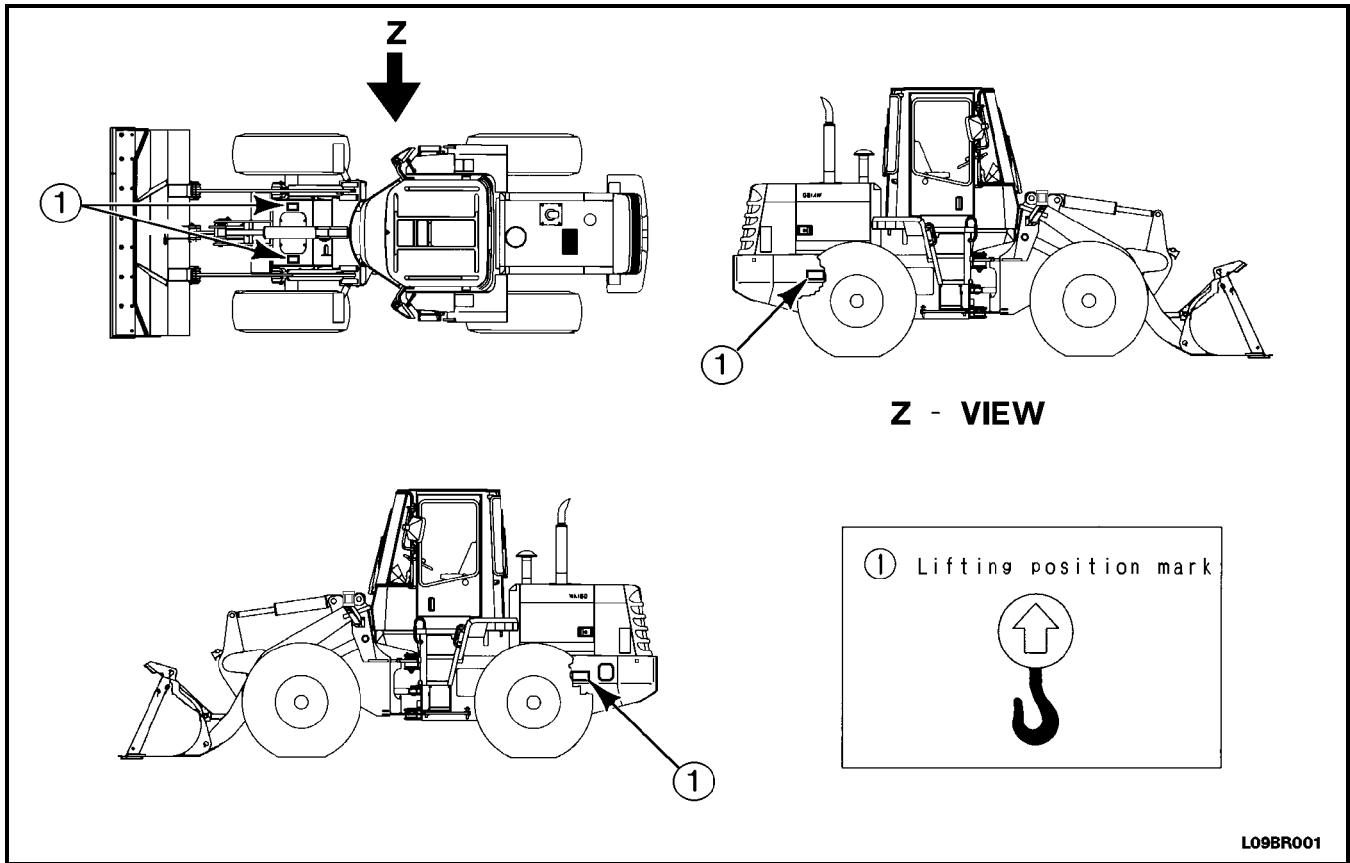

13.3.2 WEIGHT LIST

	VEHICLE WEIGHT	FRONT AXLE WEIGHT	REAR AXLE WEIGHT	POSITION OF THE CENTER OF GRAVITY (FROM FRONT AXLE)
WA120-3	7810 kg	3225 kg	4585 kg	1525 mm

## OPERATION

### 13.3.3 LIFTING PROCEDURE

Lifting is only for vehicles which have decals indicating lifting positions. First stop the vehicle on level ground to ensure the vehicle will be lifted horizontally.

Then proceed with the following instructions:

1. Start the engine, be sure the vehicle is on level ground, then set the work equipment to the travel position. For details, see “12.7 MOVING MACHINE OFF”.

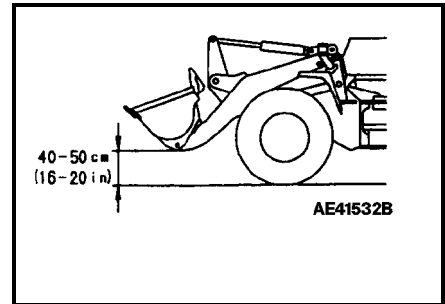

2. Move the work equipment safety lock lever to the LOCK position.

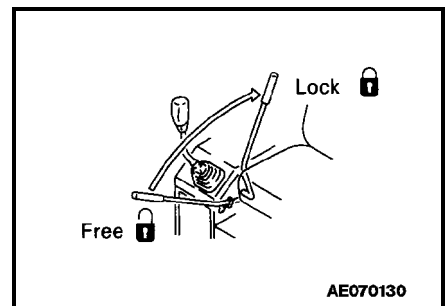

3. Stop the engine, check that the area around the operator's compartment is safe, then LOCK the safety bar so that the front frame and rear frame do not articulate upsetting the balance and causing the lifting to be unstable.

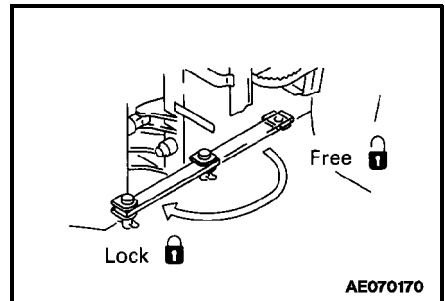

4. Hook up the lifting equipment to the lifting positions (marked by the lifting decals) at the front portion of the front frame, and the rear portion of the rear frame.
5. After raising the vehicle 100 to 200 mm (6 to 8 inches) above the ground, check the posture to be sure it is horizontal and check the wire ropes to be sure there is no slack.

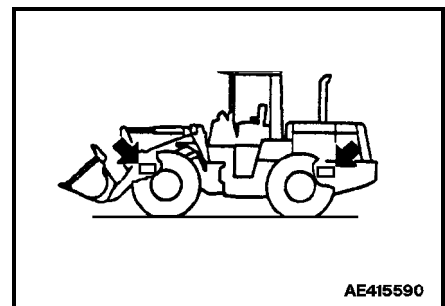

### WARNING

When lifting the machine, check for any oil leaks from the hydraulic circuit or any other part.

## 14. COLD WEATHER OPERATIONS

### 14.1 PRECAUTIONS FOR LOW TEMPERATURE

If the temperature drops real low, it may becomes difficult to start the engine, and the coolant may freeze, so do as follows.

#### 14.1.1 FUEL AND LUBRICANTS

Change to fuel and oil with low viscosity for all components. For details of the specified viscosity, **see "20. USE OF FUEL, COOLANT AND LUBRICANTS ACCORDING TO AMBIENT TEMPERATURE."**

#### 14.1.2 COOLANT



#### WARNING

Keep antifreeze fluid away from an open flame. Never smoke when using antifreeze.

#### NOTICE:

- Never use methanol, ethanol or propanol based antifreeze.
- Absolutely avoid using any water leak preventing agent irrespective of whether it is used independently or mixed with an antifreeze
- Do not mix one antifreeze with a different brand.

For details of the antifreeze mixture requirements, **see "20.3 COOLANT SPECIFICATIONS"**.

## OPERATION

---

### 14.1.3 BATTERY



#### WARNING

- To avoid gas explosions, do not bring fire or sparks near the battery.
- Battery electrolyte is dangerous. If it gets in your eyes or on your skin, wash it off with large amounts of water, and consult your doctor.

When the ambient temperature drops, the capacity of the battery will also drop. If the battery charge ratio is low the battery electrolyte may freeze. Maintain the battery charge as close as possible to 100%, and insulate it against cold temperature so that the machine will start easy the next morning.

#### REMARKS

Measure the specific gravity and calculate the rate of charge from the following conversion table

Rate of charge	Temperature of fluid				
	20°C (68°F)	0°C (32°F)	-10°C (14°F)	-20°C (-4°F)	-30°C (-22°F)
100%	1.28	1.29	1.30	1.31	1.32
90%	1.26	1.27	1.28	1.29	1.30
80%	1.24	1.25	1.26	1.27	1.28
75%	1.23	1.24	1.25	1.26	1.27

## 14.2 PRECAUTIONS AFTER COMPLETION OF WORK

To prevent mud and water in and on the machine from freezing and making it impossible for the machine to move on the following morning, observe the following precautions.

- Mud and water in and on the machine should be completely removed.
- Park the machine on hard, dry ground. If this is not possible, park the machine on wooden boards. The boards will help protect the machine from freezing to the soil.
- Drain any water collected in the fuel system, to prevent it from freezing.
- The battery capacity will drop in low freezing temperatures, therefore cover the battery or remove it from the machine, keep it in a warm place, and install it again the next morning.

## 14.3 AFTER COLD WEATHER

When the season changes and weather is warmer, proceed as follows.

- Replace the fuel and oil, use oil of the viscosity specified. For details, see **"20. USE OF FUEL, COOLANT AND LUBRICANTS ACCORDING TO AMBIENT TEMPERATURE"**.
- If for any reason permanent antifreeze cannot be used, and ethyl glycol base antifreeze (winter, one season type) is used instead, or if no antifreeze is used, drain the cooling system completely, then clean out the inside of the cooling system thoroughly, and fill with fresh water.



### 15. LONG TERM STORAGE

#### 15.1 BEFORE STORAGE

When putting the machine in storage for a long time, proceed as follows.

- After every part is washed and dried, house the machine in a dry building.  
If the machine must be left outdoors, park it on well drained concrete and cover it with canvas, etc.
- Completely fill the fuel tank, lubricate, and change the oil before storage.
- Apply a thin coat of grease to the metal surface of the hydraulic piston rods.
- Disconnect the negative terminal of the batteries and cover it, or remove it from the machine and store it separately.
- If the ambient temperature is expected to drop below 0°C (32°F) then always add antifreeze to the cooling water.
- Apply the safety locks to the bucket control lever, boom control lever, and directional lever, then apply the parking brake.

#### 15.2 DURING STORAGE



#### WARNING

**Provide necessary ventilation if the machine is operated indoors to prevent gas poisoning.**

- Operate the engine and move the machine for a short distance once a month so that a new film of oil will be coated over movable parts and component surfaces. At the same time, also charge the batteries.
- Before operating the work equipment, wipe off the grease on the hydraulic piston rod.
- For vehicles equipped with air conditioning, operate air conditioning once a month for 3-5 minutes at low idle to prevent the air compressor from seizing up from lack of lubricating oil and check the a/c gas volume twice a year.

#### 15.3 AFTER STORAGE

##### NOTICE:

**If the machine is stored without the monthly rust prevention operation, consult your distributor for service.**

Carry out the following procedures when taking the machine out of storage.

- Wipe off the grease from the hydraulic cylinder rods
- Add oil and grease to all places.

## 16. TROUBLESHOOTING

### 16.1 WHEN MACHINE RUNS OUT OF FUEL



#### WARNING

The engine could start, so check carefully that the area around the engine is safe before cranking the engine

If the machine has run out of fuel, add fuel to the fuel tank and to the fuel filters to minimis any air in the system.

**NOTE:** Controlled venting is provided at the injection pump through the fuel drain manifold. Small amounts of air introduced by refilling the fuel filters will be vented automatically.

For instructions on how to properly handle the fuel filters Refer to 24.7.1 REPLACE FUEL FILTERS.

## OPERATION

---

### 16.2 TOWING THE MACHINE



#### WARNING

- If the wheel loader is towed in the wrong way, it could lead to serious injury or damage.
- If there is a failure in the brake lines and the brakes can not be used, be extremely careful when towing.

#### NOTICE:

- Towing is for moving the machine to a place where inspection and maintenance can be carried out, and not for moving it long distances.

The machine must not be towed for long distances.

- For details of the procedures for towing a machine when it is broken down, contact your distributor.

This machine must not be towed except in emergencies. When towing the machine, take the following precautions.

- When releasing the brakes, put blocks under the wheels to prevent the machine from moving. If the wheels are not blocked, the machine could suddenly move.
- When towing a machine, tow it at low speed of less than 2 km/h (1.24 mph), and for a distance of a few meters to a place where repairs can be carried out. The machine should be towed only in emergencies. If the machine must be moved for a long distance, use a transporter.
- Fit a guard plate to the machine being towed to protect the operator if the tow rope or bar should break.
- Never let anyone sit on the machine, if the steering and brakes of the machine being towed cannot be operated.
- Check that the tow rope or bar is of ample strength for the weight of the machine being towed. If the machine being towed must travel through mud or up hills, use a tow rope or bar of a strength of at least 1.5 times the weight of the machine being towed.
- Keep the angle of the tow rope as small as possible. Keep the angle between the center lines of the two machines to within 30°.
- If the machine is moved suddenly, an excessive load will be applied to the tow rope or bar, and it could break. Always move the machine slowly at a fixed speed.

- The towing machine should normally be of the same class as the machine being towed. Check that the towing machine has ample braking power, weight, and rim pull to allow it to control both machines while on a slope.
- When towing the machine downhill, use a larger machine for towing to provide ample rim pull and braking power, or connect another machine to the rear of the machine being towed, in order to prevent either machine from losing control and turning over.
- Towing may be carried out under many different conditions, therefore it is impossible to determine beforehand all the requirements for towing. Towing on flat horizontal roads will require minimum rim pull, while towing on slopes or uneven road surfaces will require maximum rimpull.

## OPERATION

---

### 16.2.1 WHEN ENGINE CAN BE USED

- If the transmission and steering wheel can be operated, and the engine is running, it is possible to tow the machine out of the mud or move it for a short distance to the edge of the road.
- The operator should sit on the machine being towed and operate the steering in the direction that the machine is being towed.

### 16.2.2 WHEN ENGINE CANNOT BE USED



#### WARNING

**To prevent any serious injury or fatality, Understand that the parking brake is attached to the transmission and when the drive shafts are removed the parking brake is no longer functional. Therefore the tires must be blocked to prevent the machine from moving before any attempt is made to remove drive shafts.**

When towing a machine with the engine stopped, use the following procedure.

1. The transmission oil does not lubricate the system, therefore block the tires to prevent the machine from moving. and then remove the front and rear drive shafts.
2. The steering cannot be operated, therefore remove the steering cylinder. Even if the brakes are in good condition, there is no change in operating force to the brake pedal, but the braking force is reduced each time the pedal is depressed.
3. Connect the towing equipment securely. When carrying out towing operations, use two machines of the same class as the machine being towed. Connect one machine to the front and one to the rear of the machine being towed, then remove the blocks from the tires and tow the machine.

## 16.3 IF BATTERY IS DISCHARGED

### WARNING

- When checking or handling the battery, stop the engine and turn the starting switch key to the OFF position before starting.
- Before starting the engine, use a damp cloth to wipe off the dust accumulated on the top surface of the battery.
- The battery generates hydrogen gas, so there is danger of explosion. Do not bring lighted cigarettes near the battery, or do anything that will cause sparks.
- Battery electrolyte is dilute sulfuric acid, and it will attack your clothes and skin. If it gets on your clothes or on your skin, wash it immediately off with lots of water. If it gets in your eyes, wash it out with fresh water, and consult a doctor.
- When handling battery, always wear protective goggles.
- When removing the battery, first disconnect the cable from the ground terminal (normally, from the negative (-) terminal). When installing, install the positive (+) terminal first. If a tool touches the cable connecting the positive terminal and the chassis, there is danger that it will cause sparks.
- If the terminals are loose, there is danger that the defective contact may generate sparks that will cause an explosion. When installing the terminals, install them tightly.
- When removing or installing, check which is the positive (+) terminal and negative (-) terminal.

### 16.3.1 REMOVAL AND INSTALLATION OF BATTERY

When starting the engine with a booster cable, do as follows:

- When removing the battery, first disconnect the cable from the ground terminal (normally, from the negative (-) terminal). If a tool touches a cable connecting the positive terminal and the chassis, there is danger of sparks being emitted.
- When installing battery, the ground cable should be connected to the ground terminal as the last step.

#### REMARKS:

The batteries are on both sides of the rear of the machine. The battery used for the ground is on the left side on the machine.

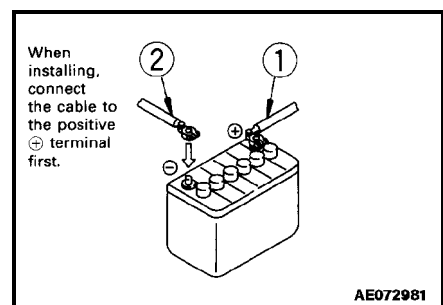
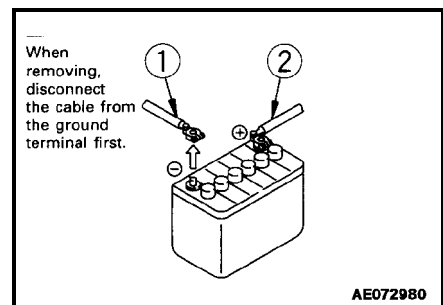

## **OPERATION**

---

### **16.3.2 PRECAUTIONS FOR CHARGING BATTERY**

#### **CHARGING BATTERY WHEN MOUNTED ON MACHINE**

- Before charging, disconnect the cable from the negative (-) terminal of the battery. Otherwise, an unusually high voltage could damage the alternator.
- While charging the battery, remove all battery plugs for satisfactory ventilation.  
To avoid gas explosions, do not bring fire or sparks near the battery.
- If the electrolyte temperature exceeds 45°C, stop charging for a while.
- Turn off the charger as soon as the battery is charged.  
Over charging the battery may cause the following:
  - 1) Overheating the battery
  - 2) decreasing the quantity of electrolyte
  - 3) Damaging the electrode plate
- Do not mix the cables ( positive (+) to negative (-) or negative (-) to positive (+) ), as this could damage the alternator.
- When performing any service to the battery besides checking the electrolyte level or measuring the specific gravity, disconnect cables from the battery.

#### **REMARKS:**

The batteries are on both sides at the rear of the machine. The battery used for the ground is on the left side of the machine.

### 16.3.3 STARTING ENGINE WITH BOOSTER CABLE

When starting the engine with a booster cable, do as follows:

#### Precautions when connecting and disconnecting booster cable

 **WARNING**

- When connecting the cables, never contact the positive (+) and negative (-) terminals together.
- When starting the engine with a booster cable, always wear safety glasses.
- Be careful not to let the normal machine and problem machine contact each other. This prevents sparks from generating near the battery which could ignite the hydrogen gas given off by the battery. If hydrogen gas explodes, it could cause serious injury.
- Make sure there is no mistake in the booster cable connections. The final connection is to the engine block of the problem machine, sparks could be generated when this is done, so connect to a place as far as possible from the battery. (However, avoid connecting the cable to the work equipment, as conduction is poor.)
- Use care when removing the cables from the machine that has been started. Do not allow the cable ends to contact each other or the machine, to avoid hydrogen explosion.

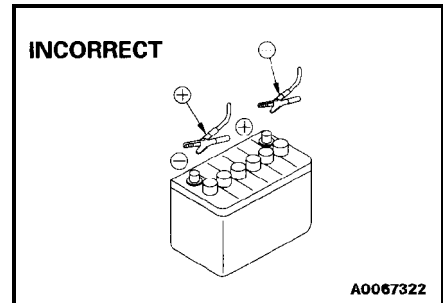

#### NOTICE

- The size of the booster cable and clip should be suitable for the battery size.
- The battery of the normal machine must be the same capacity as that of the engine to be started.
- Check the cables and clips for damage or corrosion.
- Make sure that the cables and clips are firmly connected.

#### REMARKS:

The batteries are on both sides at the rear of the machine. The battery used for the ground is on the left side of the machine.



## OPERATION

### Connecting the booster cables

Keep the starting switch at the OFF position.

Connect the booster cable as follows, in the order of the numbers marked in the diagram.

1. Make sure that the starting switches of the normal machine and problem machine are both at the OFF position.
2. Connect one clip of booster cable (A) to the positive (+) terminal of the problem machine.
3. Connect the other clip of booster cable (A) to the positive (+) terminal of the normal machine.
4. Connect one clip of booster cable (B) to the negative (-) terminal of the normal machine.
5. Connect the other clip of booster cable (B) to the engine block of the problem machine.

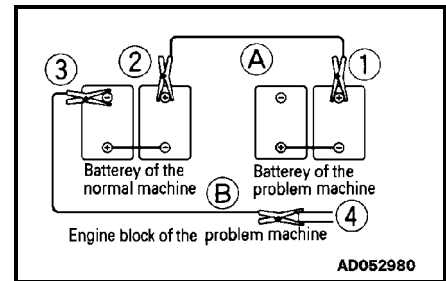

### Starting the engine

1. Make sure the clips are firmly connected to the battery terminals.
2. Start the engine of the normal machine and run it at high idle speed.
3. Turn the starting switch of the problem machine to the START position and start the engine. If the engine doesn't start at first, try again after 2 minutes or so.

### Disconnecting the booster cable

After the engine has started, disconnect the booster cables in the reverse order in which they were connected.

1. Remove one clip of booster cable (B) from the engine block of the problem machine.
2. Remove the other clip of booster cable (B) from the negative (-) terminal of the normal machine.
3. Remove one clip of booster cable (A) from the positive (+) terminal of the normal machine.
4. Remove the other clip of booster cable (A) from the positive (+) terminal of the problem machine.

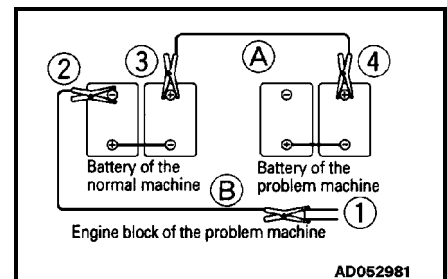

**16.4 OTHER TROUBLE**

**16.4.1 ELECTRICAL SYSTEM**

- ( ): Always contact your distributor when dealing with these items.
- In cases of abnormalities or causes which are not listed below, please contact your distributor for repairs.

Problem	Main cause	Remedy
Lamp does not glow brightly even when the engine runs at high speed	<ul style="list-style-type: none"> <li>● Defective wiring</li> <li>● Defective adjustment of fan belt tension</li> </ul>	<ul style="list-style-type: none"> <li>(● Check, repair loose terminals, disconnections)</li> <li>● Adjust fan belt tension</li> </ul> For details, see <b>"WHEN REQUIRED"</b> .
Lamp flickers while engine is running		
Even when the engine is running, the charging pilot lamp does not go out	<ul style="list-style-type: none"> <li>● Defective alternator</li> <li>● Defective wiring</li> <li>● Defective adjustment of fan belt tension</li> </ul>	<ul style="list-style-type: none"> <li>(● Replace)</li> <li>(● Check, repair)</li> <li>● Adjust fan belt tension.</li> </ul> See <b>"WHEN REQUIRED"</b> .
Abnormal noise is generated from alternator	<ul style="list-style-type: none"> <li>● Defective alternator</li> </ul>	<ul style="list-style-type: none"> <li>(● Replace)</li> </ul>
Starting motor does not turn when starting switch is turned to ON	<ul style="list-style-type: none"> <li>● Defective wiring</li> <li>● Insufficient battery charge</li> <li>● Defective starting motor</li> </ul>	<ul style="list-style-type: none"> <li>(● Check, repair)</li> <li>● Charge</li> <li>(● Replace)</li> </ul>
Pinion of starting motor keeps going in and out	<ul style="list-style-type: none"> <li>● Insufficient battery charge</li> </ul>	<ul style="list-style-type: none"> <li>● Charge</li> </ul>
Starting motor turns engine sluggishly	<ul style="list-style-type: none"> <li>● Insufficient battery charge</li> <li>● Defective starting motor</li> </ul>	<ul style="list-style-type: none"> <li>● Charge</li> <li>(● Replace)</li> </ul>
Starting motor disengages before engine starts	<ul style="list-style-type: none"> <li>● Defective wiring</li> <li>● Insufficient battery charge</li> </ul>	<ul style="list-style-type: none"> <li>(● Check, repair)</li> <li>● Charge</li> </ul>
Preheating pilot lamp does not light up when ambient temperature is below 0°C (-18°F)	<ul style="list-style-type: none"> <li>● Defected wiring</li> <li>● Defected relay, QHS controller, water temperature sensor</li> <li>● Defected preheating pilot lamp</li> </ul>	<ul style="list-style-type: none"> <li>(● Check repair)</li> <li>(● Replace)</li> </ul> <ul style="list-style-type: none"> <li>(● Replace)</li> </ul>
Even when engine is stopped, charge caution pilot lamp does not light up (starting switch at ON position)	<ul style="list-style-type: none"> <li>● Defective wiring</li> <li>● Defective caution pilot lamp</li> </ul>	<ul style="list-style-type: none"> <li>(● Check, repair)</li> <li>(● Replace)</li> </ul>
Even when engine is stopped, engine oil pressure caution pilot lamp does not light up (starting switch at ON position)	<ul style="list-style-type: none"> <li>● Defective caution pilot lamp</li> <li>● Defective caution pilot lamp</li> </ul>	<ul style="list-style-type: none"> <li>(● Replace)</li> <li>(● Replace)</li> </ul>

## OPERATION

### 16.4.2 CHASSIS

- ( ): Always contact your distributor when dealing with these items.
- In cases of abnormalities or causes which are not listed below, please contact your distributor for repairs.

Problem	Main causes	Remedy
<b>TRANSMISSION</b>		
Engine is running but machine does not move	<ul style="list-style-type: none"> <li>• Parking brake is applied</li> <li>• Directional lever is not shifted properly</li> <li>• Lack of oil in transmission</li> </ul>	<ul style="list-style-type: none"> <li>• Release parking brake</li> <li>• Shift lever properly</li> <li>• Add oil to specified level. <b>See "WHEN REQUIRED"</b>.</li> </ul>
Even when the engine is running at full power, the machine only moves slowly and lacks power.	<ul style="list-style-type: none"> <li>• Lack of oil in the transmission case</li> <li>• Screen is clogged</li> </ul>	<ul style="list-style-type: none"> <li>• Add oil to specified level. <b>See "WHEN REQUIRED"</b>.</li> <li>(• Disassemble and clean)</li> </ul>
Oil overheats	<ul style="list-style-type: none"> <li>• Too much oil or not enough oil</li> <li>• Machine is not traveling in the correct speed range</li> <li>• Torque converter is stalled for long periods</li> <li>• Engine is overheating</li> </ul>	<ul style="list-style-type: none"> <li>• Add or drain oil to specified level. <b>See "WHEN REQUIRED"</b>.</li> <li>• Place in correct speed range</li> <li>• Reduce stall time</li> <li>(• Check engine)</li> </ul>
Noise generated	<ul style="list-style-type: none"> <li>• Lack of oil</li> </ul>	<ul style="list-style-type: none"> <li>• Add oil to specified level. <b>See "WHEN REQUIRED"</b>.</li> </ul>
<b>AXLE</b>		
Noise generated	<ul style="list-style-type: none"> <li>• Lack of oil</li> </ul>	<ul style="list-style-type: none"> <li>• Add oil to specified level. <b>See "WHEN REQUIRED"</b>.</li> </ul>

## CHASSIS continued (16.4.2)

Problem	Main causes	Remedy
<b>BRAKE</b>		
Brake is not applied when pedal is depressed	<ul style="list-style-type: none"> <li>● Disc has reach wear limit</li> <li>● Lack of brake oil</li>   <li>● Air in brake line</li> </ul>	<ul style="list-style-type: none"> <li>● (Replace disc)</li> <li>● Add oil to specified level.</li> <li>● See "<b>CHECK BEFORE STARTING</b>".</li> <li>● Bleed air</li> </ul>
Brake drags or remains applied	<ul style="list-style-type: none"> <li>● Vent hole of brake valve is clogged</li> </ul>	<ul style="list-style-type: none"> <li>● Clean</li> </ul>
Brakes squeal	<ul style="list-style-type: none"> <li>● Disc is worn</li> <li>● Large amount of water in axle oil</li> <li>● Deteriorated axle oil due to overuse of brake</li> </ul>	<ul style="list-style-type: none"> <li>● (Replace disc)</li> <li>● Change axle oil</li>   <li>● Change axle oil</li> </ul>
<b>PARKING BRAKE</b>		
Braking effect is poor	<ul style="list-style-type: none"> <li>● Linkage is loose</li> <li>● Disc is worn</li> </ul>	<ul style="list-style-type: none"> <li>● Adjust</li> <li>(● Replace disc)</li> </ul>
<b>STEERING</b>		
Steering wheel is heavy	<ul style="list-style-type: none"> <li>● Defective hydraulic system</li> <li>Lack of oil</li> </ul>	<p>Add oil to specified level. See "<b>24.5 EVERY 100 HOURS SERVICE</b>".</p>
Steering wheel is loose	<ul style="list-style-type: none"> <li>● Play in steering cylinder pin</li> <li>● Defective hydraulic system</li> <li>Lack of oil</li> </ul>	<ul style="list-style-type: none"> <li>● Grease bearing or replace pin and bushing where there is play</li> </ul> <p>Add oil to specified level. See "<b>24.5 EVERY 100 HOURS SERVICE</b>".</p>

## OPERATION

### CHASSIS continued (16.4.2)

Problem	Main causes	Remedy
<b>HYDRAULIC SYSTEM</b>		
Lack of lifting power for bucket  Bucket takes time to raise	<ul style="list-style-type: none"> <li>● Lack of oil</li> <li>● Clogged hydraulic tank filter</li> </ul>	<ul style="list-style-type: none"> <li>● Add oil to specified level. <b>See "24.5 EVERY 100 HOURS SERVICE".</b></li> <li>● Replace filter. <b>See "24.8.4 CHANGE OIL IN HYD TANK, REPLACE FILTER ELEMENT".</b></li> </ul>
Excessive bubbles in oil	<ul style="list-style-type: none"> <li>● Low quality oil being used</li> <li>● Oil level is low</li> <li>● Air in oil line</li> </ul>	<ul style="list-style-type: none"> <li>● Replace with good quality oil</li> <li>● Add oil to specified level. <b>See "24.5 EVERY 100 HOURS SERVICE".</b></li> <li>● Bleed air.</li> </ul>
Hydraulic pressure is low	<ul style="list-style-type: none"> <li>● Oil level is low and pump is sucking in air</li> </ul>	<ul style="list-style-type: none"> <li>● Add oil to specified level. <b>See "24.5 EVERY 100 HOURS SERVICE".</b> Then bleed air.</li> </ul>
Movement of cylinder is irregular	<ul style="list-style-type: none"> <li>● Oil level is low</li> </ul>	<ul style="list-style-type: none"> <li>● Add oil to specified level. <b>See "24.5 EVERY 100 HOURS SERVICE".</b></li> </ul>

**16.4.3 ENGINE**

- ( ): Always contact your distributor when dealing with these items.
- In cases of abnormalities or causes which are not listed below, please contact your distributor for repairs.

Problem	Main causes	Remedy
Engine oil pressure caution pilot lamp lights up	<ul style="list-style-type: none"> <li>● Engine oil pan oil level is low (sucking in air)</li> <li>● Clogged oil filter cartridge</li> <li>● Defective tightening of oil pipe joint, oil leaks from damage parts</li> <li>● Defective eng oil presure sensor</li> </ul>	<ul style="list-style-type: none"> <li>● Add oil, <b>see 12.2.3 CHECK OIL LEVEL, ADD OIL.</b></li> <li>● Replace cartridge, <b>see 24.6.1 CHANGE OIL, REPLACE OIL FILTER.</b></li> <li>(● Check, repair)</li> <li>(● Replace sensor)</li> </ul>
<p>Steam is emitted from top part of radiator (pressure valve)</p> <p>Water temperature gauge is in red range coolant temperature monitor lights up</p>	<ul style="list-style-type: none"> <li>● Cooling water level low, water leakage</li> <li>● Loosen fan belt</li> <li>● Dirt or scale accumulated in cooling system</li> <li>● Clogged radiator fin or damaged fin</li> <li>● Defective thermostat</li> <li>● Loose radiator filler cap (high altitude operation)</li> <li>● Defective water level sensor</li> </ul>	<ul style="list-style-type: none"> <li>● Add coolant, repair, <b>see 12.2.1 CHECK BEFORE STARTING.</b></li> <li>● Adjust fan belt tension, <b>see 24.8.6 CHECK FAN BELT TENSION.</b></li> <li>● Change cooling water, clean inside of cooling system, <b>see 24.9.1 COOLING SYSTEM, REPLACE COOLANT AND FLUSH SYSTEM.</b></li> <li>● Clean or repair, <b>see 24.2.5 CLEAN THE RADIATOR CORE.</b></li> <li>● Replace thermostat</li> <li>● Tighten cap or replace packing</li> <li>● Replace sensor</li> </ul>
Water temperature gauge is in the white range on left	<ul style="list-style-type: none"> <li>● Defective thermostat</li> <li>● Defective monitor</li> </ul>	<ul style="list-style-type: none"> <li>(● Replace thermostat)</li> <li>(● Replace)</li> </ul>
Engine does not start when starting motor is turned	<ul style="list-style-type: none"> <li>● Lack of fuel</li> <li>● Air in fuel system</li> <li>● Defective fuel injection pump or nozzle</li> <li>● Starting motor cranks sluggishly</li> <li>● Preheating pilot lamp does not light up</li> <li>● Defective compression</li> <li>● Defective valve clearance</li> </ul>	<ul style="list-style-type: none"> <li>● Add fuel, <b>see 12.2.2 CHECK FUEL LEVEL ,ADD FUE.</b></li> <li>● Repair place where air is sucked in, <b>see 24.7.1 REPLACE FUEL FILTER.</b></li> <li>● Replace pump or nozzle</li> </ul> <p><b>See ELECTRICAL SYSTEM</b> <b>See ELECTRICAL SYSTEM</b></p> <p>Adjust valve clearance</p>
Exhaust is white or blue	<ul style="list-style-type: none"> <li>● Too much oil in oil pan</li> <li>● Improper fuel</li> </ul>	<ul style="list-style-type: none"> <li>● Add oil to specified level. <b>See 12.2.3 CHECK OIL LEVEL, ADD OIL.</b></li> <li>● Change to specified fuel</li> </ul>

## OPERATION

---

### ENGINE continued (16.4.3)

Problem	Main causes	Remedy
Exhaust gas occasionally turns black	<ul style="list-style-type: none"><li>● Clogged air cleaner element</li> <li>● Defective nozzle</li><li>● Defective compression</li> <li>● Defective turbocharger</li></ul>	<ul style="list-style-type: none"><li>● Clean or replace, <b>see 24.2.1 CLEAN / REPLACE AIR CLEANER ELEMENT.</b></li><li>(● Replace nozzle)</li><li>(● See defective compression above)</li><li>(● Clean or replace turbocharger)</li></ul>
Combustion noise occasionally makes breathing sound	<ul style="list-style-type: none"><li>● Defective nozzle</li></ul>	<ul style="list-style-type: none"><li>(● Replace nozzle)</li></ul>
Abnormal noise generated (combustion or mechanical)	<ul style="list-style-type: none"><li>● Low grade fuel being used</li><li>● Overheating</li> <li>● Damage inside muffler</li><li>● Excessive valve clearance</li></ul>	<ul style="list-style-type: none"><li>● Change to specified fuel</li><li>● Refer to "Water temperature gauge is in red range" as above</li><li>(● Replace muffler)</li><li>(● Adjust valve clearance)</li></ul>

# **MAINTENANCE**



## MAINTENANCE

---

### 17. GUIDES TO MAINTENANCE

Do not carry out any inspection and maintenance operation that is not given in this manual.

Perform maintenance work on hard, flat ground.

Set to the inspection and maintenance posture.

Always carry out inspection with the machine in the following posture unless otherwise specified.

- Lower the work equipment to the ground and set in the posture shown in the diagram on the right.
- Set all control levers to the neutral or HOLD position.
- Set the safety levers to the LOCK position.
- Press the parking brake switch to apply the parking brake.
- Put blocks in front and behind the tires.
- Lock the front and rear frames with the safety bar.

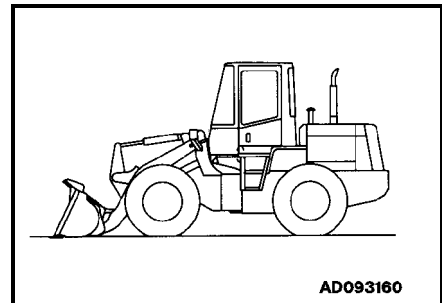

#### **Check service meter:**

Check the service meter reading every day to see if it is time for any necessary maintenance to be carried out.

#### **Komatsu genuine replacement parts:**

Use genuine Komatsu parts specified in the Parts Book as replacement parts.

#### **Komatsu genuine oils:**

Use genuine Komatsu oils and grease. Choose oils and grease with proper viscosities specified for ambient temperature.

#### **Always use clean washer fluid:**

Use automobile window washer fluid and be careful not to let any dirt get into it.

#### **Always use clean oil and grease:**

Use clean oil and grease. Also, keep containers of the oil and grease clean. Keep foreign materials away from oil and grease.

#### **Keeping the machine clean:**

Always keep the machine clean. This makes it easier to find parts causing problems. In particular keep grease fittings, breathers and oil level gauges clean and avoid foreign matters from getting in them.

#### **Be careful of hot water and oil:**

Draining hot oils and coolants and removing their filters immediately after the engine stops are hazardous. Allow the engine to cool.

If the oil has to be drained when it is cold, warm up the oil to a suitable temperature (approx. 20 - 40°C (68 - 104°F)) before draining it.

**Check for foreign materials in drained oil and on filter:**

After oil is changed or filters are replaced, check the oil and filters for metallic particles and foreign materials. If large quantities of metallic particles or foreign materials are found, consult your distributor.

**Fuel strainer:**

If your machine is equipped with a fuel strainer, do not remove it while fueling.

**Oil change:**

Check or change oils in the places where dust is scarce to keep foreign materials away from oils.

**Warning tag:**

Attach the warning tag to the starting switch or other appropriate control lever to avoid someone who is not aware of the circumstances from starting the engine.

The warning tag is supplied together with the tools.

**Obey precautions:**

During machine operation, always obey the precautions on the safety label attached to the machine.

**Welding instructions:**

- Turn off the engine starting switch.
- Do not apply more than 200 V continuously.
- Connect the grounding cable within 1 m from the area to be welded.
- Avoid seals or bearings from being between the area to be welded and the position of grounding point.
- Do not use the area around the work equipment pins or the hydraulic cylinders as the grounding point.
- Never weld any pipe or tube containing fuel or oil.

**Fire prevention:**

Use nonflammable cleaner or light oil for cleaning parts. Keep flame or lighted cigarette away from light oil.

**Clamp faces:**

When O-rings or gaskets are removed, clean the clamp faces and replace the O-rings and gaskets with new ones. Be sure to carefully install O-rings and gaskets when assembling.

**Objects in your pockets:**

Keep your pockets free of loose objects which can fall out and drop into the machinery; especially when you work on the machinery while bending over it.

## MAINTENANCE

---

### **Checking underneath machine:**

When working in rocky areas, check for damage underneath the machine, wear and damaged bolts and nuts.

### **Precautions when washing machine:**

- Never spray steam or water directly at the radiator.
- Do not allow water to get on any electrical component

### **Pre-and post-work checks:**

Before starting work in mud, rain, snow or at seashore, check plugs and valves for tightness.

Wash the machine immediately after working to protect components from rusting.

Lubricate components more frequently than usual. Be sure to lubricate work equipment pins daily if they are submerged in water.

On jobsites where heavy-duty operations are common, reduce the maintenance intervals and grease the machine more frequently.

### **Dusty worksites:**

When working at dusty worksites, do as follows:

- Inspect the air cleaner clogging pilot lamp to see whether the air cleaner is plugged up. Clean the air cleaner at shorter intervals than specified.
- Clean the radiator core frequently to avoid clogging.
- Clean and replace the fuel filter frequently.
- Clean electrical components, especially the starting motor and alternator, to avoid accumulation of dust.

### **Avoid mixing oils:**

Never mix oils of different brands. If the only oil you have is a different brand from the one that is used in the machine, do not add it in but replace all the oil.

## 18. OUTLINES OF SERVICE

- Use genuine Komatsu parts for replacement.
- When changing or adding oil, do not use a different type of oil.
- Unless otherwise specified, the oil and coolant used at the time of shipment from the factory are as shown in the table below.

Item	Kind of fluid
Engine oil pan	SAE 15W-40 API classification CF-4 or CF-4/SG
Transmission case	SAE 10W API classification CD
Axle (Front and rear)	AX075 ( For machines with standard differentials)
Brake oil tank	SAE 5W-10 API classification CD
Hydraulic tank	SAE 10W API classification CD
Linkage Pins	Multi purpose lithium grease with 3% molybdenum disulfide
Fuel	ASTM D975 No. 2 (However, ASTM D975 No. 1 is used for the winter season (October to March))
Radiator	50/50 Mixture of ethylene glycol antifreeze and water

### 18.1 OUTLINE OF OIL, FUEL, COOLANT

#### 18.1.1 OIL

- Oil is used in the engine and work equipment under extremely severe conditions (high temperature, high pressure), and it deteriorates with use.  
Always use oil that matches the grade and temperature for use given in the Operation and Maintenance Manual. Even if the oil is not dirty, always replace the oil after the specified interval.
- Oil corresponds to blood in the human body, so always be careful when handling it to prevent any impurities (water, metal particles, dirt, etc.) from entering the system.  
The majority of problems with machines are caused by the entry of such impurities.  
Take particular care not to let any impurities get in when storing or adding oil.
- Never mix oils of different grades or brands.
- Always maintain oil at specified levels.  
Having too much oil or too little oil are both causes of problems.
- If the oil in the work equipment is not clear, there is probably water or air entering the circuit.  
In such cases, please contact your distributor.
- When changing the oil, always replace the related filters at the same time.
- It is recommended that an analysis be made of the oil periodically to check the condition of the machine. For those who wish to use this service, please contact your distributor.

## MAINTENANCE

---

### 18.1.2 FUEL

- The fuel pump is a precision instrument, and if fuel containing water or dirt is used, it cannot work properly.
- Be extremely careful not to let impurities get in when storing or adding fuel.
- Always use the fuel specified in the Operation and Maintenance Manual. Fuel may congeal depending on the temperature when it is used (particularly in low temperatures below -15°C (5°F)), so it is necessary to change to a fuel that matches the temperature.
- To prevent the moisture in the air from condensing and forming water inside the fuel tank, always fill the fuel tank after completing the day's work.
- Before starting the engine, or when 10 minutes have passed after adding fuel, drain the sediment and water from the fuel tank.
- If the engine runs out of fuel, or if the filters have been replaced, it is necessary to bleed the air from the circuit.

### 18.1.3 COOLANT

- River water contains large amounts of calcium and other impurities, so if it is used, scale will stick to the engine and radiator. This will prevent proper heat exchange and cause overheating.  
**For specific requirements of the water, See "20.3 COOLANT SPECIFICATIONS."**
- When using anti-freeze, always observe the precautions given in the Operation and Maintenance Manual.
- An anti-freeze concentration greater than 68% will adversely affect freeze protection and heat transfer rates. Anti-freeze concentrations between 68% and 100% actually have a higher freezing point than a 68% anti-freeze concentration and should not be used due to reduced heat transfer rates.
- All cooling system inhibitors, including those in anti-freeze solutions, become depleted through normal operation. If the inhibitors in anti-freeze are allowed to become depleted, the anti-freeze becomes corrosive and attacks and coats the metallic surfaces of the cooling system which reduces heat transfer. Cooling system conditioners which contain these inhibitors must be added to maintain corrosion protection.
- Anti-freeze is inflammable, so be extremely careful not to expose it to flame or fire.
- The proportion of anti-freeze to water differs according to the ambient temperature.  
**For details of the mixing proportions, see "20.3 COOLANT SPECIFICATIONS."**
- If the engine overheats, wait for the engine to cool before adding coolant.
- If the coolant level is low, it will cause overheating and will also cause problems with corrosion from the air in the coolant.

**18.1.4 GREASE**

- Grease is used to reduce friction and help prevent wear, twisting and noise at the joints.
- Grease fittings that were not referred to in the maintenance schedule do not require any scheduled greasing. Add grease to these areas only if something becomes stiff or squeaky.
- Always wipe off all of the old grease that is pushed out when greasing. Be particularly careful to wipe off the old grease in places where sand or dirt sticking in the grease would cause wear of the rotating parts.

**18.1.5 STORING OIL AND FUEL**

- Keep indoors to prevent any water, dirt, or other impurities from getting into storage containers.
- When keeping drums for a long period, put the drum on its side so that the filler port of the drum is at the side. (To prevent moisture from being sucked in) Periodically inspect drums for leakage. If drums have to be stored outside, cover them with a waterproof sheet or take other measures to protect them.
- To prevent any change in quality during long-term storage, be sure to use in the order of first in - first out (use the oldest oil or fuel first).

**18.1.6 FILTERS**

- Filters are extremely important safety parts. They prevent impurities in the fluid and air circuits from entering important equipment and causing problems. Replace all filters periodically. For details, **see "23. MAINTENANCE SCHEDULE CHART"**. However, when working in severe conditions, it is necessary to consider replacing the filters at shorter intervals according to the oil and fuel (sulfur content) being used.
- Never try to clean the filters (cartridge type) and use them again. Always replace with new filters.
- When replacing oil filters, check if any metal particles are stuck to the old filter. If any metal particles are found, please contact your distributor.
- Do not open packs of spare filters until just before they are to be used.
- Always use genuine Komatsu filters.

**FUEL INJECTION PUMP****DO NOT ATTEMPT TO ADJUST THE FUEL INJECTION PUMP**

Unsatisfactory operation of the engine may not be due to the fuel injection pump. If unsatisfactory operation persists after servicing the filters, consult your distributor to service the fuel injection pump. Special equipment and knowledge are required for proper injection pump service. These are available at your distributor.

### 18.2 OUTLINE OF ELECTRIC SYSTEM

- If the wiring gets wet or the insulation is damaged, the electric system leaks and this could result in hazardous malfunction of the machine.
- Services relating to the electric system are (1) check of fan belt tension, (2) check of damage or wear in the fan belt and (3) check of battery fluid level.
- Never remove or disassemble any electric components installed in the machine.
- Never install any electric components other than those specified by Komatsu.
- Be careful to keep the electric system free of water when washing the machine or when it rains.
- When working on the seashore or any corrosive environment, carefully clean the electric system to prevent corrosion.
- When installing a cab cooler or any other electrical equipment, connect it to an independent power source connector. The optional power source must never be connected to the fuse, starting switch, or battery relay.

## 19. WEAR PARTS LIST

Wear parts such as filter elements, bucket teeth, bolt-on edge, etc. are to be replaced at the time of periodic maintenance or before their abrasion limits.

The wear parts should be changed correctly in order to use the machine economically.

For part replacement, genuine Komatsu parts of excellent quality should be used.

**Use the parts book to write in the current part number.**

**The parts in parentheses are to be replaced at the same time.**

Item	Part Number	Part Name	Qty	Replacement frequency
Engine oil filter		Lube oil filter	1	Every 250 Hours Service
Fuel filter		Fuel filter	2	Every 500 Hours Service
Transmission oil filter		Element (O-ring) (O-ring) (O-ring) (Gasket)	1 (1) (1) (1) (1)	Every 500 Hours Service
Transmission oil strainer		O-ring	1	Every 1000 Hours Service
Hydraulic oil filter		Element (O-ring)	1 (1)	Every 1000 Hours Service
Hydraulic tank breather		Element	1	Every 2000 Hours Service
Air cleaner		Outer and inner elements	1 1	When required
Air conditioner recirculation & fresh air filters - If equipped		Element	1	Every 2000 Hours Service
Bucket cutting edges and mounting bolts		Center edge End edge (Bolt) (Nut) (Washer)	1 2 (8) (8) (8)	When required
Electrical heater		Gasket	2	When required



# MAINTENANCE

## 20. USE OF FUEL, COOLANT AND LUBRICANTS ACCORDING TO AMBIENT TEMPERATURE

PROPER SELECTION OF FUEL, COOLANT AND LUBRICANTS

Reservoir	Kind of fluid	Ambient Temperature									Capacity	
		-22 -30	-4 -20	14 -10	32 0	50 10	68 20	86 30	104 40	122°F 50°C	Specified	Refill
Engine oil pan	Engine oil	<b>SAE 30</b>									13.5 ℓ 3.57 US gal 2.97 UK gal	12.0 ℓ 3.17 US gal 2.64 UK gal
		<b>SAE 10W</b>										
		<b>SAE 10W-30</b>										
		<b>SAE 15W-40</b>										
Brake	Engine oil	<b>SAE 5W</b>									1 ℓ 0.26 US gal 0.22 UK gal	1 ℓ 0.26 US gal 0.22 UK gal
		<b>SAE 10W</b>										
Transmission case	Engine oil	<b>SAE 10W</b>									28 ℓ 7.4 US gal 6.6 UK gal	23.5 ℓ 6.2 US gal 5.2 UK gal
		<b>SAE 10W</b>										
Hydraulic system	Engine oil	<b>SAE 10W</b>									80 ℓ 21.1 US gal 17.6 UK gal	41 ℓ 10.8 US gal 9.0 UK gal
		<b>SAE 10W</b>										
Axle (front & rear) (each)	Axle oil	<b>See Note 1</b>									14 ℓ 3.7 US gal 3.1 UK gal	14 ℓ 3.7 US gal 3.1 UK gal
		<b>See Note 1</b>										
Pins	Grease	<b>NLGI No. 2</b>									-	-
		<b>NLGI No. 2</b>										
Fuel tank	Diesel fuel	<b>ASTM D975 No. 2</b>									133 ℓ 35.1 US gal 29.3 UK gal	-
		<b>*</b>										
Cooling system	Coolant	<b>See 20.3 Coolant specification</b>									19.5 ℓ 5.1 US gal 4.3 UK gal	-
		<b>See 20.3 Coolant specification</b>										

**\* ASTM D975 No. 1**

Other equipment will be necessary, when operating the machine at temperatures below -20°C (-4°F), herefore consult your Komatsu distributor for your needs.

**Note 1:** For axle oil, use only the recommended oil as follows.

- SHELL: DONAX TT or TD
- CALTEX: RPM TRACTOR HYDRAULIC FLUID
- CHEVRON: TRACTOR HYDRAULIC FLUID
- TEXACO: TDH OIL
- MOBIL: MOBIL 424

It is possible to substitute engine oil SAE 30 API classification CD for axle oil. Although increased brake noise may result, durability is not affected.

ASTM: American Society of Testing and Materials  
SAE: Society of Automotive Engineers  
API: American Petroleum Institute

## **20.1 ENGINE OIL SPECIFICATIONS**

### **Normal operation**

Oil performance recommendations are as follows:

The use of a quality engine lubricating oil combined with appropriate oil and filter change intervals are critical factors in maintaining engine performance and durability.

SAE 15W-40 multi-viscosity oil meeting the American Petroleum Institute (API) performance classification of CF-4 or CF-4/SG is recommended.

**NOTE:** CE or CE/SF oils may be used in areas where CF-4 or CF-4/SG oil is not yet available.

A sulfated ash limit of 1.0 mass percent is suggested for optimum valve and piston deposit and oil consumption control. The sulfated ash **must not** exceed 1.85 mass percent. The sulfated ash limit of 1.85 mass percent has been placed on all engine lubricating oils recommended for use in the engine. Higher ash oils can cause valve and/or piston damage and lead to excessive oil consumption.

The API service symbol displays the following information. The upper half of the symbol displays the appropriate oil categories; the lower half may contain words to describe oil energy conserving features. The center section identifies the SAE oil viscosity grade.

Oil viscosity recommendations are as follows:

The use of a multi-graded lubricating oil has been found to improve oil consumption control and improve engine cranking in cold temperatures while maintaining lubrication at high operating temperatures.

While SAE 15W-40 multi-viscosity oil is recommended for most operating climates, refer to the previous chart for oil viscosity recommendations for extreme climates.

Single graded oils may be used if multi-graded oil is not available. But be sure to use oil that matches the temperature shown in the table.

Special "break-in" lubricating oils are **not** recommended for a new or rebuilt engine. Use the same type of oil during the "break-in" as specified for normal operation.

Additional information regarding lubricating oil availability throughout the world is available in the "E.M.A. Lubricating Oils Data Book for Automotive and Industrial Engines". The data book may be ordered from the Engine Manufacturers Association, 401 North Michigan Ave., Chicago, IL U.S.A. 60611. The telephone number is (312) 644-6610.

### **Arctic Operation**

If an engine is operated in ambient temperatures consistently below -23°C (-10°F) and there are no provisions to keep the engine warm when it is **not** in operation, use a synthetic API performance classification CE or CF-4 engine oil with adequate low temperature properties such as SAE 5W-20 or 5W-30.

The oil supplier **must** be responsible for meeting the performance service specifications.

### **NOTICE:**

**The use of a synthetic base oil does not justify extended oil change intervals. Extended oil change intervals can decrease engine life due to factors such as; corrosion, deposits and wear.**

## MAINTENANCE

---

### 20.2 DIESEL FUEL SPECIFICATIONS



#### WARNING

Do not mix gasoline or alcohol with diesel fuel. This mixture can cause an explosion.

#### NOTICE:

Due to the precise tolerances of diesel injection systems, it is extremely important that the fuel be kept clean and free of dirt or water. Dirt or water in the system can cause severe damage to both the injection pump and nozzles.

For normal service above  $-12^{\circ}\text{C}$  ( $+10^{\circ}\text{F}$ ), the use of ASTM Grade No. 2-D diesel fuel with a minimum Cetane number of 40 is recommended. The use of No. 2-D diesel fuel will result in optimum engine performance under most operating conditions. Fuels with Cetane numbers higher than 40 may be needed in high altitudes or extremely low ambient temperatures to prevent misfires and excessive smoke.

At operating temperatures below  $-12^{\circ}\text{C}$  ( $+10^{\circ}\text{F}$ ), use ASTM Grade No. 1-D diesel fuel. The use of lighter fuels can reduce fuel economy.

Where a winterized blend of Grade No. 2-D and No. 1-D fuels is available, it may be substituted for Grade No. 1-D fuel. However, it is the supplier's responsibility to provide the fuel for the anticipated ambient temperature.

Use a low sulfur content fuel having a cloud point that is at least 10 degrees below the lowest expected fuel temperature. Cloud point is the temperature at which crystals begin to form in the fuel.

The viscosity of the fuel **must** be kept above 1.3 cSt to provide adequate fuel system lubrication.

## **20.3 COOLANT SPECIFICATIONS**

### **General**

Selection and maintenance of the engine coolant is important to long engine life. The following information provides recommendations for selecting the engine coolant and maintaining the coolant inhibitors.

Heavy duty diesel engines require a balanced coolant mixture of water, antifreeze, and supplemental coolant additives. Supplemental coolant additive recommendations are included in the section entitled "Inhibitors/Conditioners". The coolant mixture **must** be drained and replaced at the specified service interval shown in "**23. MAINTENANCE SCHEDULED CHART**", or **every two years of operation, whichever comes first.**

### **Water**

Use water which has a low mineral content. Water used in conjunction with antifreeze, coolant filters and inhibited water must meet the following standards:

- Total Hardness -** Not to exceed 170 parts per million (10 grains/gallon maximum) to prevent scale deposits. Water containing dissolved magnesium and calcium (the usual reason for water hardness) above the specified amount will cause scale deposits to develop in the engine.
- Chlorides -** Not to exceed 40 parts per million (2.5 grains/gallon maximum) to prevent corrosion.
- Sulfites -** Not to exceed 100 parts per million (5.8 grains/gallon maximum) to prevent corrosion.
- Dissolved Solids -** Not to exceed 340 parts per million (20 grains/gallon maximum) to minimize sludge deposits, scale deposits, corrosion or a combination of these.

If any of the above requirements cannot be met, use distilled, de-ionized, or de-mineralized water. To determine if local water supplies meet these standards, water samples can be tested by water treatment laboratories. "Softened" water that is prepared using common salt (sodium chloride) contains excessive amounts of chlorides and should not be used.

**NOTICE: Never use water alone in the cooling system because corrosion will occur.**

### **Antifreeze**

In climates where the temperature is above -37°C (-34°F), use a coolant mixture that contains 50 percent antifreeze. **Antifreeze is essential in any climate.** It broadens the operating temperature range by lowering the coolant freezing point and by raising its boiling point. Do **not** use more than 50 percent antifreeze in the mixture unless additional freeze protection is required. **Never** use more than 68 percent antifreeze under any condition.

An antifreeze concentration greater than 68% will adversely affect freeze protection and heat transfer rates. Antifreeze concentrations between 68 and 100% actually have a higher freezing point than a 68% antifreeze concentration and should not be used due to reduced heat transfer rates.

Low silicate ethylene glycol antifreeze is recommended. The antifreeze should contain no more than 0.1% anhydrous alkali metasilicate. Low silicate antifreeze is recommended to avoid the formation of silica-gel (hydro-gel). This gel formation can occur when the cooling system contains an over concentration of high silicate antifreeze and/or supplemental coolant additive. **DO NOT** use methanol or alcohol as an antifreeze because of its low boiling point.

Antifreeze may retain its freeze protection for more than one season but coolant conditioners must be added to maintain corrosion protection.

Antifreeze formulated with methoxy propanol, or propylene glycol, is not recommended for this system.

### **NOTICE:**

**Do not mix types of antifreeze solutions. Mixed solutions make it impossible to determine the protection against freezing. Antifreeze containing sealer or anti-leak additives should NOT be used in this system. Sealer or anti-leak additives will cause plugging problems in the cooling system.**

Check the solution periodically and at normal operating temperature, to be sure the cooling system has sufficient protection against freezing.

## MAINTENANCE

The following table shows the approximate percentage of antifreeze solution required for various temperatures.

Approximate Freezing Point	Percentage of Antifreeze Concentration by Volume	Specific Gravity at 16°C (60°F)
0°C (+32°F)	0	1.000
-7°C (+20°F)	15	1.025
-12°C (+10°F)	25	1.040
-18°C (0°F)	33	1.053
-23°C (-10°F)	40	1.062
-29°C (-20°F)	45	1.070
-34°C (-30°F)	48	1.074
-40°C (-40°F)	53	1.080
-46°C (-50°F)	56	1.083
-51°C (-60°F)	59	1.088
-57°C (-70°F)	62	1.092
-62°C (-80°F)	65	1.095
-68°C (-90°F)	67	1.097
-69°C (-92°F)	68	1.098

In tropical climates where antifreeze availability may be limited, use a corrosion inhibitor DCA4, to protect the engine cooling system.

### Inhibitors/Conditioners

1. All cooling system inhibitors, including those in antifreeze solutions, become depleted through normal operation. If the inhibitors in antifreeze are allowed to become depleted, the antifreeze becomes corrosive and attacks and coats the metallic surfaces of the cooling system which reduces heat transfer. Cooling system conditioners which contain these inhibitors must be added to maintain corrosion protection.
2. SOLUBLE OIL IS NOT RECOMMENDED for use in this engine as its use will reduce heat transfer.
3. There are no miracle additives that will increase heat transfer or prevent overheating. Conditioned water is still the best coolant.
4. DCA4 is recommended to inhibit corrosion in the cooling system for the following reasons:
  - Improved compatibility with high silicate antifreezes to minimize hydro-gel formation if over concentration occurs.
  - Provides engine protection in the following areas:
    - Solder corrosion/bloom
    - Oil fouling
    - Aluminum cavitation corrosion
    - Copper corrosion/erosion/stress cracking
    - Cylinder liner cavitation corrosion
    - Seal and gasket degradation

### MAINTENANCE OF COOLING SYSTEM INHIBITORS

Keeping the engine coolant properly inhibited will keep the engine and radiator free of rust, scale deposits and corrosion.

New machines are delivered with antifreeze protection. Service at regular scheduled intervals specified in "**23. MAINTENANCE SCHEDULE CHART**" with a "service" DCA4 filter.

Each time the coolant is drained and replaced, the coolant must be recharged with DCA4. New coolant can be correctly charged with supplemental coolant additives by using DCA4 filters or DCA4 concentrate listed in the table entitled, "DCA4 Unit Guide".

If coolant is added between drain intervals, additional DCA4 will be required.

## COOLANT TESTING FOR CONDITIONER CONCENTRATION

When the cooling system is maintained as recommended, the conditioner concentration should be satisfactory. The DCA4 concentration must not fall below 1.0 unit per 3.8ℓ (1 US gal) or exceed 2 units per 3.8ℓ (1 US gal) of coolant. The only accurate method for testing chemical concentrations in coolant with mixed chemical compounds is a laboratory analysis. For this reason, the coolant inhibitor should be maintained as shown in "**23. MAINTENANCE SCHEDULE CHART**".

### NOTICE:

**Inadequate concentration of the coolant additive can result in major corrosive damage to cooling system components. Over concentration can cause formation of "gel" that can cause restriction, plugging of passages and overheating.**

## REPLENISHING COOLANT CONDITIONER

Install a "precharge" DCA4 filter when the coolant is changed or a significant (more than 50%) coolant loss occurs. Install a "service" DCA4 filter as specified in "**23. MAINTENANCE SCHEDULE CHART**". When antifreeze is added, add coolant conditioner equal to 1.0 unit per 3.8ℓ (1 US gal) of antifreeze.

### NOTICE:

**Mixing of DCA4 and other supplemental coolant additives is not recommended because there is currently no test kit available to measure concentration levels with mixed chemical solutions.**

## DCA4 UNIT MAINTENANCE GUIDE

Use supplemental coolant additives (corrosion inhibitors) to protect the engine cooling system from corrosion. Antifreeze alone does **not** provide enough corrosion protection for a heavy duty diesel engine. Supplemental corrosion protection **must** be supplied through periodic additions of supplemental coolant additives to the coolant.

To protect against corrosion, a new coolant charge **must** be brought up to 0.26 DCA4 unit per liter (one unit per U.S. gal) of coolant (initial charge). Maintain the correct DCA4 concentration by changing the service coolant filter at each engine oil and filter change interval.

Each time the coolant is drained and replaced, the coolant **must** be recharged with supplemental coolant additives. Use the appropriate DCA4 spin-on filter listed in following table. The coolant mixture **must** be drained and replaced as defined under "General".

The amount of replacement inhibitor is determined by the length of the service interval and the cooling system capacity. Refer to the DCA4 Unit Guide for the selection of the correct filter to replenish the DCA4.

If coolant is added between drain intervals, additional DCA4 will be required. Check the coolant DCA4 concentration level anytime make-up coolant is added to the system. The DCA4 concentration **must not** fall below 0.13 units per liter or exceed 0.5 units per liter (0.5 units per U.S. gallon or exceed 2 units per U.S. gallon).

# MAINTENANCE

## DCA4 Unit Guide

Fleetguard Part No.	DCA4 Units
<b>DCA4 Coolant Filter</b>	
WF-2070	2
WF-2071	4
WF-2072	6
WF-2073	8
WF-2074	12
WF-2075	15
WF-2076	23
WF-2077	0
<b>DCA4 Liquid</b>	
DCA60L	4 (1 Pint)
DCA80L	1760 (55 US gal)
<b>DCA4 Powder</b>	
DCA95	20

## DCA4 Precharge and Service Filters

System Capacity		Precharge Filter (See NOTE 1)	Service Filter (See NOTE 3)
Liters	Gallons		
19-29	5-7	WF-2072	WF-2070
30-41	8-10	WF-2073	WF-2071
42-60	11-15	WF-2074	WF-2071
61-79	16-20	WF-2075	WF-2071
80-117	21-30	WF-2076	WF-2072
118-190	31-50	(See NOTE 2)	WF-2073

NOTE 1 - After draining and replacing coolant, always precharge the cooling system to maintain the DCA4 concentration between 1.0 and 2.0 units per 3.8ℓ (1 US gal).

**NOTICE:** When performing service which requires draining the cooling system, discard the coolant. Reusing coolant can introduce contaminants or over concentrated chemicals, resulting in premature failure of cooling system components.

NOTE 2 - To precharge cooling systems larger than 114ℓ (30 gal) do the following:

- Install appropriate service filter listed in the above table based on cooling system capacity.

Example: 95 gal (360ℓ) cooling system capacity  
-15 Units (1) WF-2075 Filter  
 80 Units

- The answer represents the additional units required to precharge the cooling system. Four bottles of powder, part number DCA95, will provide a sufficient amount of DCA4 units (80) to precharge the example cooling system.
- Install the appropriate service filter at the next and subsequent maintenance intervals.

NOTE 3 - Change the coolant filter at every engine oil and filter change interval to protect the cooling system.

Maintain a nominal concentration of 1.0 DCA4 unit per 3.8ℓ (1 US gal) of coolant in the system. Less than 0.5 unit per 3.8ℓ (1 US gal) indicates an under-concentrated coolant solution. More than 2.0 units per 3.8ℓ (1 US gal) indicates an over-concentrated coolant solution.

To check the DCA4 concentration level, use the Fleetguard coolant test kit, CC2626. Instructions are included with the test kit.

**DCA4 Unit Concentration Guide**

<b>Number of Solution A Drops to Cause Color Change</b>	<b>Coolant Condition</b>	<b>Action Required</b>
0 - 10 Drops	Extremely under-concentrated - less than 0.4 DCA4 units per 3.8ℓ (1 US gal)	Initially charge the system to a minimum of 1.0 DCA4 unit per 3.8ℓ (1 US gal)
11 - 16 Drops	Marginally under-concentrated - 0.45 to 0.8 DCA4 units per 3.8ℓ (1 US gal)	Add DCA4 liquid units to maintain 1.0 DCA4 unit per 3.8ℓ (1 US gal) minimum or change the DCA4 coolant filter
17 - 25 Drops	Acceptable - 0.85 to 1.3 DCA4 units per 3.8ℓ (1 US gal)	NONE
26 - 35 Drops	Highly acceptable - 1.35 to 2.0 DCA4 units per 3.8ℓ (1 US gal)	NONE
36 - 55 Drops	Marginally over-concentrated - 2.1 to 3.3 DCA4 units per 3.8ℓ (1 US gal)	Review maintenance practice
Over 55 Drops	Extremely over-concentrated	Drain 50% of the coolant and replace with water antifreeze mixture. Retest the system for correct DCA4 unit concentration.



# MAINTENANCE

## TOOLS

The following tools may be purchased from your Komatsu America International Company distributor.

### Cooling system test kit

The Fleetguard® Coolant Test Kit is used to check the concentration of coolant additives in the cooling system.

Part Number: CC-2626

1. Test strip bottles
2. Solution #1 bottle
3. Small plastic container
4. Large plastic cup
5. syringe

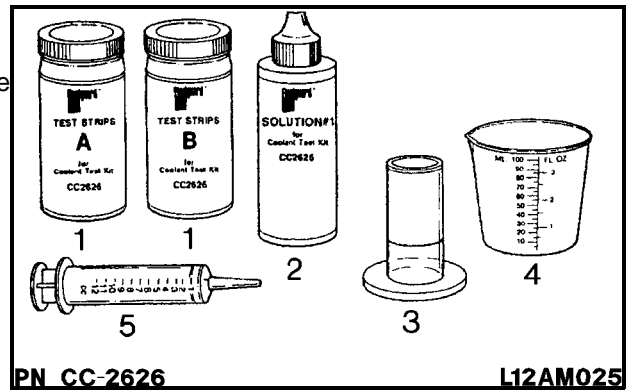

## 21. STANDARD TIGHTENING TORQUE FOR BOLTS AND NUTS

### 21.1 INTRODUCTION OF NECESSARY TOOLS

The following tools are needed when carrying out maintenance.

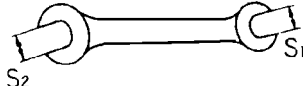
No.	Name of tool	Part No.	Remarks
1	Wrench set	09000-30006	Applicable width across flats ( $S_1 - S_2$ ) 8 mm - 10 mm 12 mm - 14 mm 13 mm - 17 mm 19 mm - 22 mm 24 mm - 27 mm 30 mm - 32 mm 
2	Screwdriver	09033-00190	Crosshead/flat head interchangeable type
3	Wrench	09014-10200	
4	Pliers	09036-00150	
5	Wrench	09001-03600	36jaw
6	Tire Wrench	417-98-11121	
7	Filter wrench	09019-08035	For filter cartridge
8	Bar	417-98-11110	
9	Tire gauge	09289-00000	
10	Grease pump	07952-70003	For greasing work
11	Nozzle	07951-31400	Hose nozzle for grease pump
12	Grease cartridge	07950-90403	(Lithium base grease: 400 g)
13	Thickness gauge	09054-00009	
14	Hammer	09039-00150	
15	Plate	09963-03000	Warning tag

If any of the above tools are broken, please order them from your distributor.

In addition to above items 1-15, rubber ring 07000-15090 is also provided. This is the rubber band used to secure the grease pump to the machine. For details of the method of using it, see "11. EXPLANATION OF COMPONENT".

# MAINTENANCE

## 21.2 TORQUE LIST

Unless otherwise specified, tighten the metric bolts and nuts to the torque shown in the table.

The torque value is determined by the width across the flats (b) of the nut and bolt.

If it is necessary to replace any nut or bolt, always use a genuine Komatsu part of the same size as the part that was replaced.

N•m (newton meter): 1 N•m  
 ≙ 0.1 kgm  
 ≙ 0.74 lbf ft

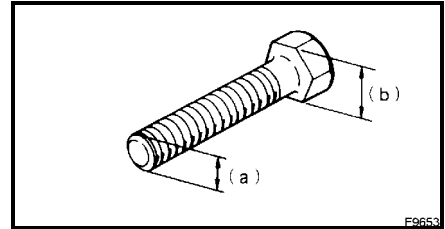

Thread diameter of bolt (mm) (a)	Width across flat (mm) (b)	T		H
		N•m	kgm	lbf ft
6	10	13.2 ± 1.4	1.35 ± 0.15	97.3 ± 1.03
8	13	31.4 ± 2.9	3.2 ± 0.3	23.2 ± 2.1
10	17	65.7 ± 6.8	6.7 ± 0.7	48.5 ± 5.0
12	19	112 ± 9.8	11.5 ± 1.0	82.6 ± 7.2
14	22	177 ± 19	18.0 ± 2.0	131 ± 14
16	24	279 ± 29	28.5 ± 3	206 ± 21
18	27	383 ± 39	39 ± 3	282 ± 29
20	30	549 ± 58	56 ± 6	405 ± 43
22	32	745 ± 78	76 ± 8	549 ± 58
24	36	927 ± 98	94.5 ± 10	684 ± 72
27	41	1320 ± 140	135 ± 15	973 ± 100
30	46	1720 ± 190	175 ± 20	1270 ± 140
33	50	2210 ± 240	225 ± 25	1630 ± 180
36	55	2750 ± 290	280 ± 30	2030 ± 210
39	60	3280 ± 340	335 ± 35	2420 ± 250

### NOTICE

When tightening panels or other parts having tightening fixtures made of plastic, be careful not to use excessive tightening torque: doing so will damage the plastic parts.

**Memoranda**

### 22. PERIODIC REPLACEMENT OF SAFETY CRITICAL PARTS

To ensure safety at all times when operating or driving the machine, the user of the machine must always carry out periodic maintenance. In addition, to further improve safety, the user should also carry out periodic replacement of the parts given in the table. These parts are particularly closely connected to safety and fire prevention.

With these parts, the material changes as time passes, or they easily wear or deteriorate. However, it is difficult to judge the condition of the parts simply by periodic maintenance, so they should always be replaced after a fixed time has passed, regardless of their condition. This is necessary to ensure that they always maintain their function completely.

However, if these parts show any abnormality before the replacement interval has passed, they should be repaired or replaced immediately.

If the hose clamps show any deterioration, such as deformation or cracking, replace the clamps at the same time as the hoses.

When replacing the hoses, always replace the O-rings, gaskets, and other such parts at the same time.

Ask your distributor to replace the safety critical parts.

**SAFETY CRITICAL PARTS**

No.	Safety critical parts for periodic replacement	Q'ty	Replacement interval
1	Fuel hose (fuel tank - injection pump)	1	Every 2 years or 4000 hours, whichever comes first
2	Fuel hose (fuel tank - strainer)	1	
3	Fuel hose (strainer - feed pump)	1	
4	Fuel spill hose (fuel return)	1	
5	Turbo hose (lubrication)	1	
6	Steering hose (pump - priority valve)	1	
7	Steering hose (Priority valve - orbitrol valve)	1	
8	Steering hose (orbitrol valve - steering cylinder)	2	
9	Steering hose (orbitrol valve - steering cylinder)	4	
10	Packing, seals, O-rings of steering cylinder	2	
11	Brake hose (oil tank - master cylinder))	2	
12	Brake hose (master cylinder - front brake)	1	
13	Brake hose (master cylinder - front brake)	1	
14	Brake hose (master cylinder - rear brake)	1	
15	Brake hose (master cylinder - rear brake)	1	
16	Piston and packing of master cylinder	1	
17	Seat belt	1	Every 3 years

# MAINTENANCE

## Fuel lines

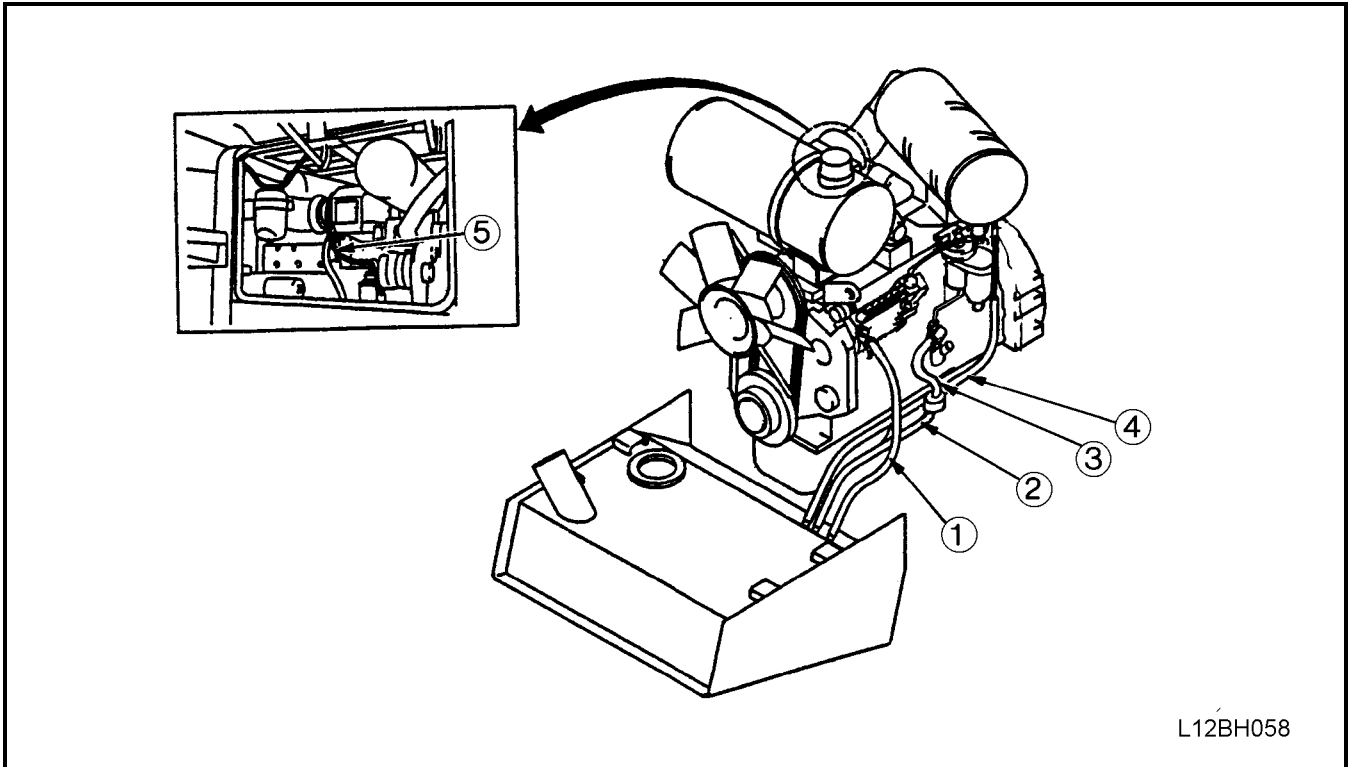

## Steering lines

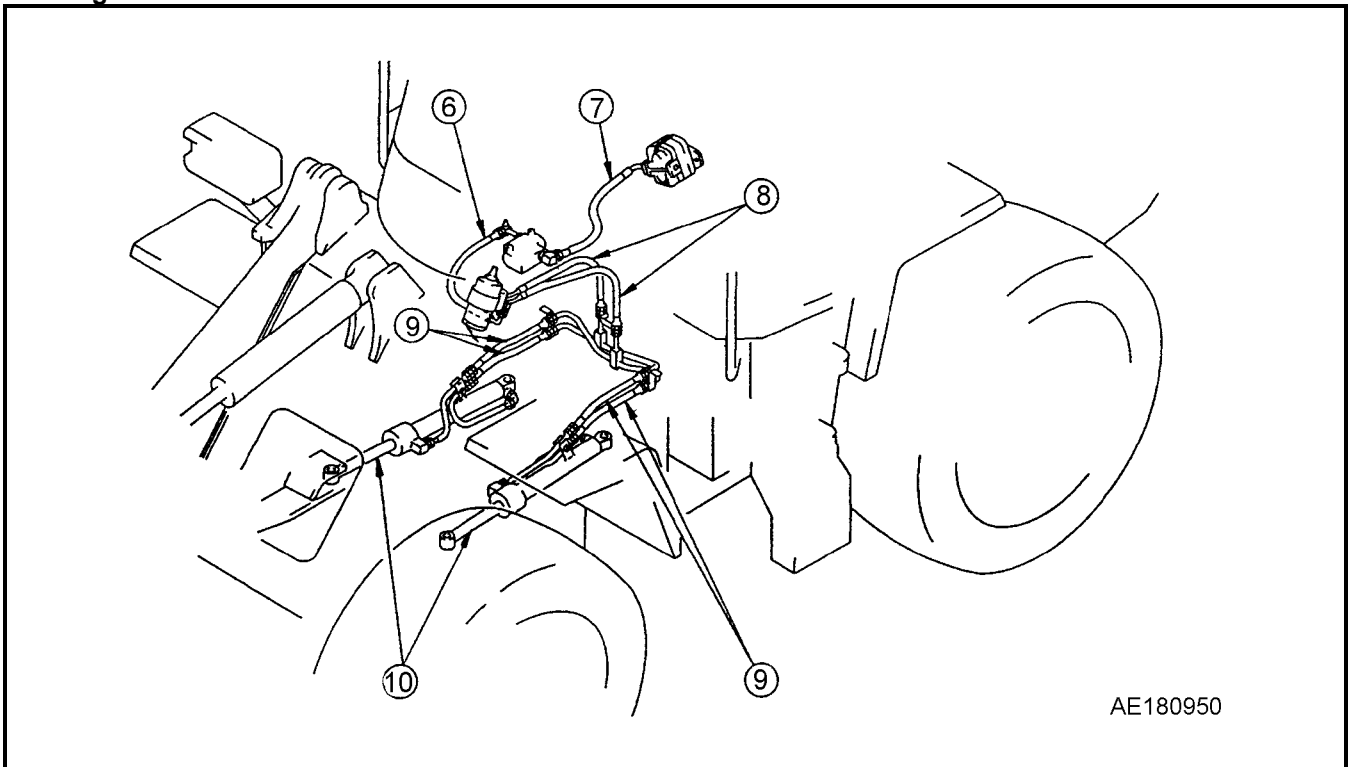

Brake lines

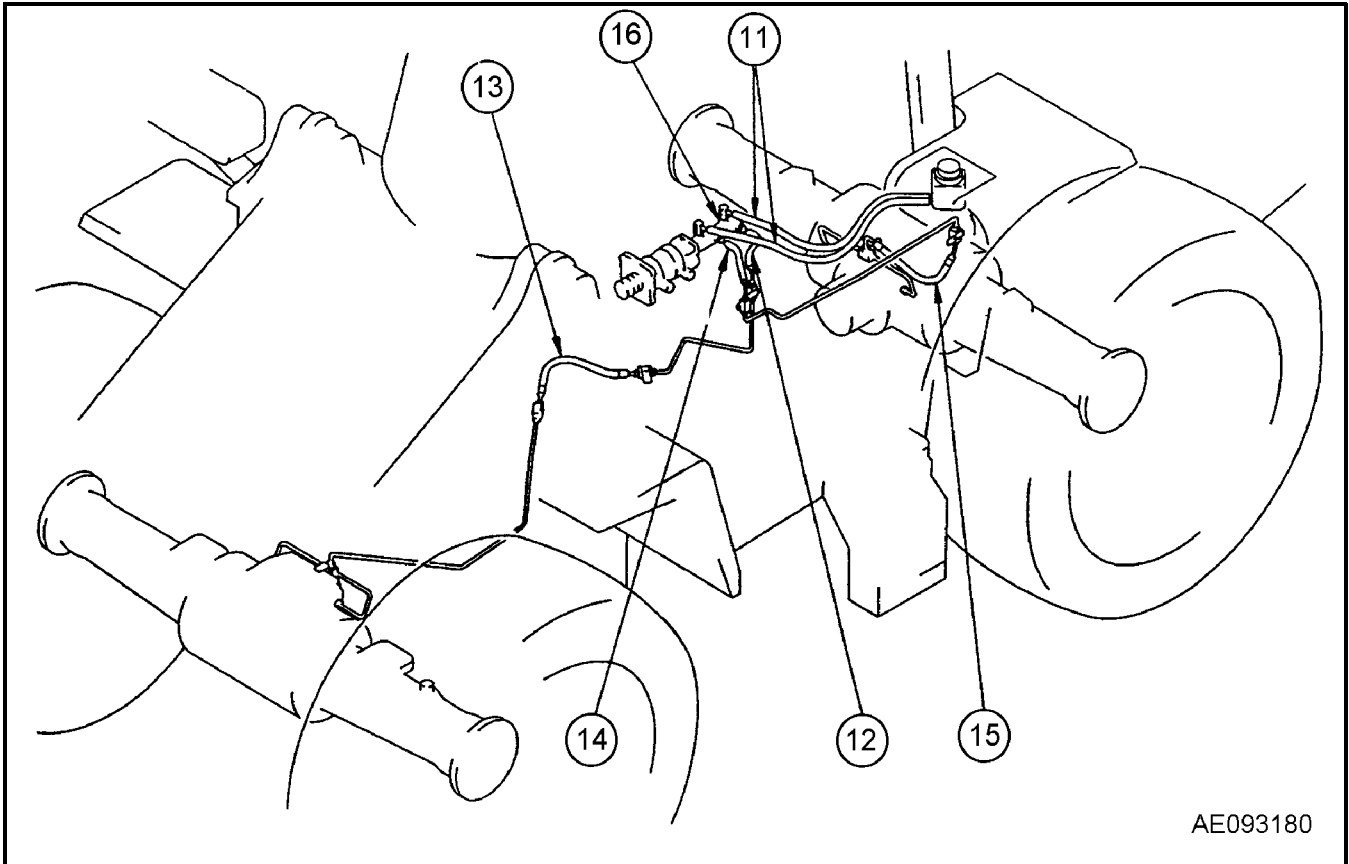

AE093180



## MAINTENANCE

### 23. MAINTENANCE SCHEDULE CHART

#### 23.1 MAINTENANCE SCHEDULE CHART

SERVICE ITEM	PAGE
<b>INITIAL 250 HOURS SERVICE (only after the first 250 hours)</b>	
Replace fuel filters	3-30
Replace transmission oil filter element	3-30
Replace hydraulic tank filter element	3-30
<b>WHEN REQUIRED</b>	
Check, clean or replace air cleaner element	3-31
Check transmission oil level, add oil	3-33
Check axle oil level, add oil	3-34
Clean axle case breather	3-35
Clean radiator fins	3-35
Replace bolt-on cutting edge	3-36
Replace bucket teeth	3-37
Check air conditioner	3-38
Clean the air conditioner condenser (if equipped)	3-39
Check window washer fluid level, add fluid	3-39
Adjust parking brake	3-40
Replace slow blow fuse	3-41
Check air intake heater	3-41
<b>CHECK BEFORE STARTING</b>	
Check coolant level, add coolant	2-27
Check fuel level, add fuel	2-27
Check oil level in engine oil pan, add oil	2-28
Check and refill oil in brake oil tank	2-28
Check dust indicator	2-29
Check electric wiring	2-29
Drain water from the fuel water separator	2-30
Drain the water from the fuel-water separator	2-30

<b>SERVICE ITEM</b>	<b>PAGE</b>
<b>CHECKS BEFORE STARTING (continued)</b>	
Check effect of parking brake	2-30
Check effect of wheel brakes	2-31
Check sound of horn and backup alarm	2-31
Check flashing of lamps, check for dirt or damage	2-31
Check engine exhaust color and sound	2-31
Check operation of gauges	2-31
Check play of steering wheel, check operation of steering	2-31
Check direction of rear view mirror, check for dirt or damage	2-31
Check lock of cab door (machine equipped with cab)	2-31
<b>EVERY 50 HOURS SERVICE</b>	
Check tire inflation pressure	3-43
Drain water, sediment from fuel tank	3-43
Check engine air intake system	3-43
<b>EVERY 100 HOURS SERVICE</b>	
Check oil level in hydraulic tank, add oil	3-44
Clean element in air conditioner fresh air filter	3-45
<b>Lubricate the following:</b>	3-46
● Bucket pin (2 places)	3-46
● Bucket link pin (2 places)	3-46
● Rear axle pivot pin (2 places)	3-46
<b>EVERY 250 HOURS SERVICE</b>	
Change oil in engine oil pan, replace engine oil filter	3-47
Check for loose wheel bolts, tighten	3-48
Clean element in air conditioner recirculation filter	3-48
Check air conditioner compressor belt tension, adjust	3-49
Check battery electrolyte level	3-50
Check air intake system	3-50
<b>Lubricate the following:</b>	3-51
● Bucket cylinder pin (2-places)	3-51

## MAINTENANCE

---

SERVICE ITEM	PAGE
<b>EVERY 250 HOURS SERVICE (continued)</b>	
● Boom cylinder pin (4 places)	3-51
● Boom pivot pin (2 places)	3-51
● Tilt lever pin (1 place)	3-51
● Steering cylinder pin (4 places)	3-51
<b>EVERY 500 HOURS SERVICE</b>	
Replace fuel filters	3-52
Replace transmission oil filter element	3-54
<b>Lubricate the following:</b>	3-55
● Center hinge pin (2 places)	3-55
<b>EVERY 1000 HOURS SERVICE</b>	
Change oil in transmission case, clean strainer	3-56
Clean transmission case breather	3-57
<b>Lubricate the following:</b>	3-58
● Front drive shaft (1 place)	3-58
● Drive shaft center support (1 place)	3-58
● Center drive shaft (2 places)	3-58
● Rear drive shaft (2 places)	3-58
Change oil in hydraulic tank, replace hydraulic filter element	3-59
Adjust engine valve lash clearance (After first 1000 hours only thereafter every 2000 hour intervals)	3-60
Check fan belt tension	3-61
Check fan belt tensioner bearing and fan hub bearing, and inspect fan belt	3-61
Check tightening parts of turbocharger	3-62
Check play of turbocharger rotor	3-62

<b>SERVICE ITEM</b>	<b>PAGE</b>
<b>EVERY 2000 HOURS SERVICE</b>	
Cooling system, replace coolant and flush the system	3-62
Replace hydraulic tank breather element	3-65
Change axle oil ★	3-65
Check brake disc wear	3-66
Check alternator	3-66
Check starter motor	3-66
Check vibration damper	3-66
Replace element in air conditioner recirculation air filter and fresh air filter	3-66
Adjust engine valve lash clearance	3-67
Clean and check turbocharger	3-69
<b>EVERY 4000 HOURS SERVICE</b>	
Check water pump	3-69

- ★ The interval of 2000 hours for changing the axle oil is for standard operations. If the brakes are used frequently or if the brakes make a noise then change the oil in shorter intervals.

## **24. SERVICE PROCEDURES**

### **24.1 INITIAL 250 HOURS SERVICE**

Carry out the following maintenance only after the first 250 hours.

#### **24.1.1 REPLACE FUEL FILTERS**

For Information of replacing or maintaining, see the sections on “**EVERY 500 HOURS SERVICE**”

#### **24.1.2 REPLACE TRANSMISSION OIL FILTER ELEMENT**

For Information of replacing or maintaining, see the sections on “**EVERY 500 HOURS SERVICE**”

#### **24.1.3 REPLACE HYDRAULIC TANK FILTER ELEMENT**

For Information of replacing or maintaining, see the sections on “**EVERY 2000 HOURS SERVICE**”

## 24.2 WHEN REQUIRED

### 24.2.1 CHECK, CLEAN OR REPLACE AIR CLEANER ELEMENT

**⚠ WARNING**

- Never clean or replace the air cleaner element with the engine running.
- When using pressurized air to clean the element wear safety glasses or goggles to protect the eyes.

#### CHECKING

Whenever the red piston in the dust indicator (1) appears, clean the air cleaner element.

#### Cleaning or replacing outer element

1. Remove wing nut (2), and cover (3), take out outer element.
2. Clean the inside of the air cleaner body.
3. Direct dry compressed air (less than 700 kPa (7 kg/cm<sup>2</sup>, 100 psi)) to element from inside along its folds, then direct it from outside along its folds and again from inside.
  - 1) Remove one seal from the outer element whenever the outer element has been cleaned.
  - 2) Replace the outer element which has been cleaned 6 times repeatedly or used throughout a year. Replace the inner element at the same time.
  - 3) If the dust indicator display red immediately after the outer element has been cleaned, replace both inner and outer elements, even if the outer element has not been cleaned 6 times.
  - 4) Check inner element mounting nuts (4) for looseness and, if necessary, re-tighten. (Torque to 5.4 ± 0.5 Nm (0.55 ± 0.05 kgm))
  - 5) Replace seal washer or wing nut with new parts if they are broken. (Torque to 5.4 ± 0.5 Nm (0.55 ± 0.05 kgm))
  - 6) Remove evacuator valve (6) and clean with compressed air. After cleaning, install it back to it's proper position.

#### NOTE:

After cleaning and drying the element, then check it by shining a light through it, if any small holes or thin cracks are found, then replace the element.

When cleaning the element, do not hit it or beat it against anything. Do not use an element that has any damaged folds, gaskets or seals.

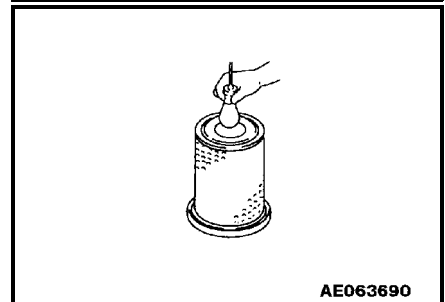
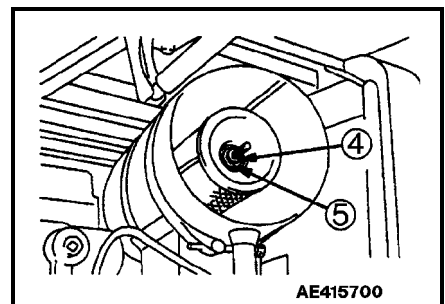
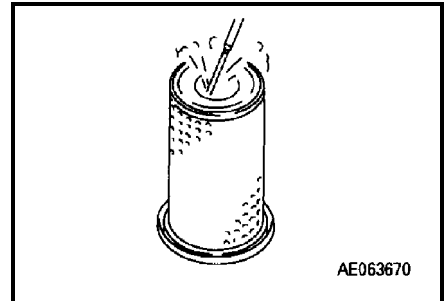
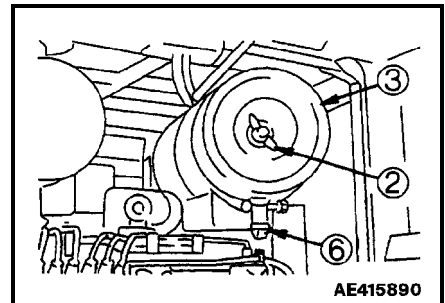
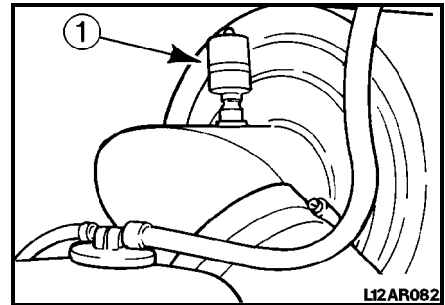

## MAINTENANCE

---

- 7) After cleaning, reinstall. (Torque to  $5.4 \pm 0.5$  Nm ( $0.55 \pm 0.05$  kgm))
- 8) Press the button of the indicator (1) to return the red piston to its original position.

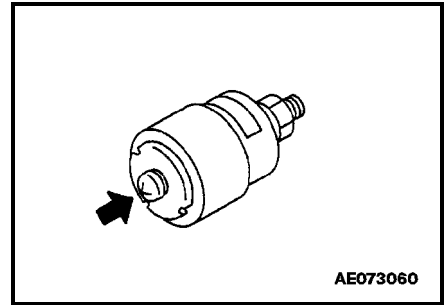

### REPLACING INNER ELEMENT

1. First remove the cover and the outer element, and then remove the inner element.
2. To prevent dust from getting in, use a clean cloth or tape to cover the air connector (outlet side).
3. Clean the air cleaner body interior, then remove the cover installed in Step 2.
4. Fit a new inner element to the connector and tighten it with nuts. Do not clean and reinstall an inner element.
5. Install the outer element.

### USING WATER

Wash the element with water at less than  $3 \text{ kg/cm}^2$  ( $43 \text{ psi} / 296 \text{ kPa}$ ) of pressure, from the inside along the folds, then from the outside and again from the inside. then let the element dry.

### USING WATER WITH A CLEANING AGENT

To remove oil, grease and carbon etc. clean the element in a lukewarm solution of mild detergent, then rinse in clean water and let it dry.

### REMARKS

Using warm water about  $40^\circ\text{C}$  ( $104^\circ\text{F}$ ) instead of soapy water may also be effective in cleaning the element.

To speed up the drying process, blow air with less than  $7 \text{ kg/cm}^2$  ( $100 \text{ psi} / 689 \text{ kPa}$ ), of force to the inside of the element.

**NOTE:** Do not attempt to heat the element.

**24.2.2 CHECK TRANSMISSION OIL LEVEL, ADD OIL**

**⚠ WARNING**

- **When checking the oil level, apply the parking brake and lock the front and rear frames with the safety bar and pin.**
- **The oil is at a high temperature after the machine has been operated. Always wait for the temperature to go down before carrying out this procedure**

Carry out this procedure if there is any sign of oil on the transmission case, or if there is oil mixed with the cooling water.

1. Start the engine and run it for at least 5 minutes.
2. Open the cap of oil filler port (F), remove dipstick (G), and wipe the oil off with a cloth.
3. Insert dipstick (G) fully into the oil filler pipe, then remove it.
4. The oil level should be between the **H** and **L** marks on the dipstick.

If the oil level is below the **L** mark, then add oil through the oil filler.

For details of the oil to use see **"20. USE OF FUEL, COOLANT AND LUBRICANTS ACCORDING TO AMBIENT TEMPERATURE.**

5. If the oil is above the **H** mark, then drain the excessive oil from the drain plug (P), then check the oil level again.
6. If the oil level is correct, then insert the dipstick back into the filler and tighten the cap.

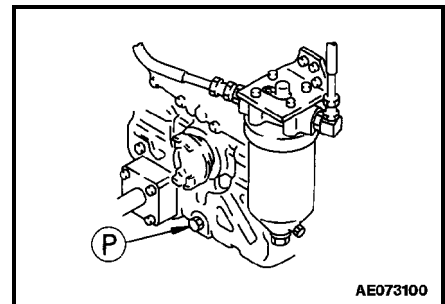
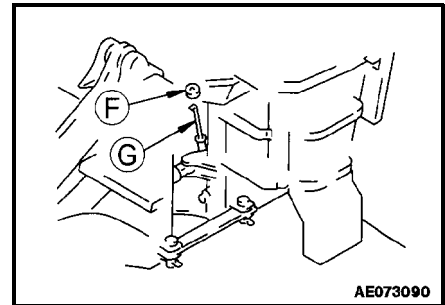



## MAINTENANCE

### 24.2.3 CHECK AXLE OIL LEVEL , ADD OIL

 **WARNING**

- When checking the oil level, apply the parking brake and lock the front and rear frames with the safety bar and pin.
- The oil is at a high temperature after the machine has been operated. Always wait for the temperature to go down before carrying out this procedure

Carry out this procedure if there is any sign of oil on the axle.

Carry out this inspection with the machine on a horizontal road surface. (If the road is at an angle, the oil level check will not be accurate.)

1. Turn OFF the engine and remove oil level plug (1).
2. Wipe off any oil adhering to the oil level gauge attached to the plug (1) with a cloth.
3. Set the oil level gauge (G) as shown in the right diagram.
4. The oil level is correct when it is between the two lines provided on the oil level gauge. If the oil level does not reach the lower line, add axle oil through the filler port (F).

For details of the oil to use, see "20. USE OF FUEL, COOLANT AND LUBRICANTS ACCORDING TO AMBIENT TEMPERATURE".

5. If the oil level is above the upper line, drain off the excess oil through drain plug (P) and check the oil level again.
6. If the oil level is correct then install plug (1).

Torque to  $132 \pm 39$  Nm ( $13.5 \pm 4$  kgm,  $98 \pm 29$  lbft)

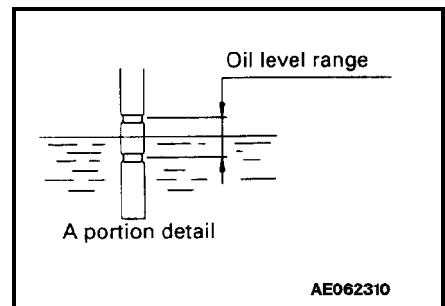
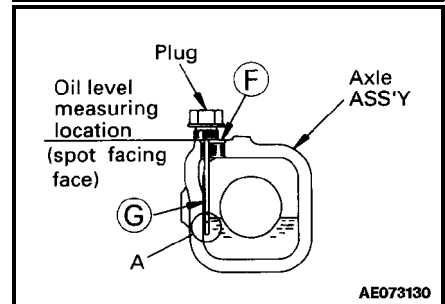
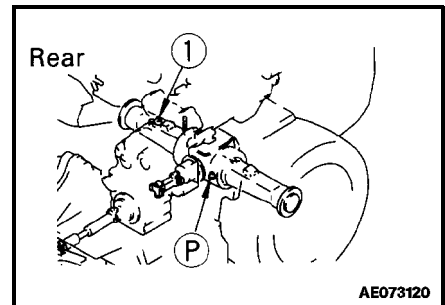
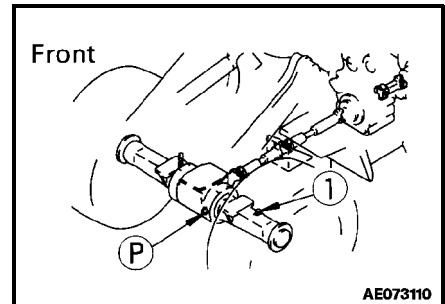

**24.2.4 CLEAN THE AXLE CASE BREATHER**

**⚠ WARNING**

- **When cleaning the axle case breathers, apply the parking brake and lock the front and rear frames with the safety bar and pin.**

There are two breathers to clean, one on the front axle and one on the rear

Remove all mud and dirt from around the breather with a brush.

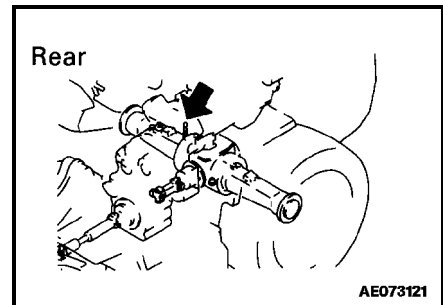
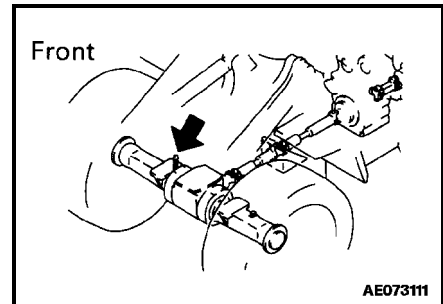

**24.2.5 CLEAN RADIATOR FINS**

Carry out this procedure if there is any dirt, mud, leaves etc. stuck to the radiator.

1. Open the rear grill at the rear of the machine.
2. Use compressed air to clean and remove the dirt and leaves from the radiator fins. Steam or water may be used instead if compressed air.

When using steam, the radiator fins could get damaged if the steam nozzle gets too close to the fins, so keep the nozzle well away from the fins.

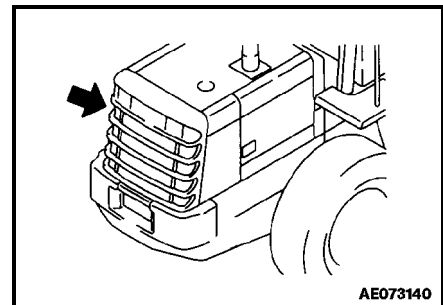

**NOTE:** Also! This is a good time to check the hoses.

See if any hoses show cracks or hardness due to ageing and if any of the clamps are loose.

## MAINTENANCE

### 24.2.6 REPLACE THE BOLT-ON CUTTING EDGES

 **WARNING**

**It is extremely dangerous if the work equipment moves when performing this procedure.**

**Set the work equipment in a stable position, turn off the engine, then set the safety lock for the work equipment control lever securely to the LOCK position.**

Turn or replace the cutting edges before the wear reaches the edge of the bucket.

1. Raise the bucket to a suitable height, then Position the bucket so that the bottom surface of the bucket is horizontal and put blocks under it to prevent it from coming down.
2. Remove nuts and bolts (1), then remove cutting edge (2).
3. Clean the mounting surface of the cutting edges.
4. Flip the cutting edges (2) over and re-assemble the end edges by placing them to the opposite side (left edge to the right side, right edge to the left side ).

If both sides of the cutting edge are worn then replace it with a new one.

**NOTE:** If the wear extended to the mounting surface then repair the surface before installing the cutting edge.

5. Tighten nuts and bolts (1) uniformly to prevent any gap from occurring between the bucket and the cutting edge.

Torque for mounting bolts:  $461 \pm 69 \text{ N}\cdot\text{m}$   
( $47 \pm 7 \text{ kgm}$ ,  $36 \pm 50 \text{ lbf ft}$ )

6. Re-torque the mounting bolts again after operating the equipment for several hours.

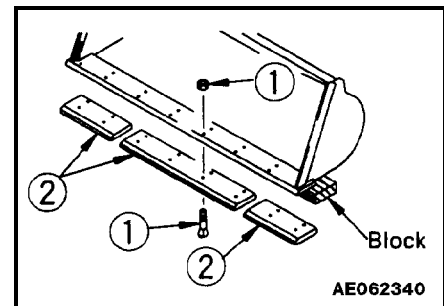

24.2.7 REPLACE BUCKET TEETH (IF EQUIPPED)

**⚠ WARNING**

It is extremely dangerous if the work equipment moves when performing this procedure.  
Set the work equipment in a stable position, turn off the engine, then set the safety lock for the work equipment control lever securely to the LOCK position.

When the bucket teeth are worn then replace them as follows.

1. Raise the bucket to a suitable height, then Position the bucket so that the bottom surface of the bucket is horizontal and put blocks under it to prevent it from coming down.

2. Remove nuts and bolts (1) and (2) then remove the teeth (3).

3. Clean the mounting surface of the bucket teeth.

If the mounting surface is worn then repair and correct it before installing new teeth.

4. Install new teeth and use shims to eliminate any clearance between the teeth and the top surface of the bucket.  
Minimum clearance should be less than one shim thickness 0.5 mm (0.02 in)

5. To prevent any gap from occurring between the tooth and the tip of the bucket, slightly tighten the hardware (temporarily) then hit the tip of the tooth with a hammer.

Torque for mounting bolts:  $461 \pm 69 \text{ N}\cdot\text{m}$  ( $47 \pm 7 \text{ kgm}$ ,  $340 \pm 51 \text{ lbf ft}$ )

6. Re-torque the mounting bolts again after operating the equipment for several hours.

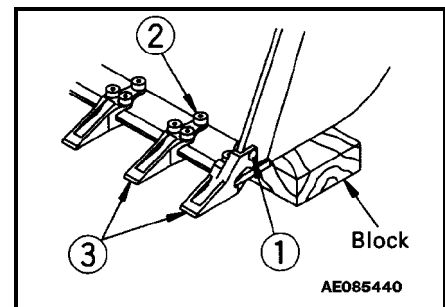

## MAINTENANCE

### 24.2.8 CHECK AIR CONDITIONER (IF EQUIPPED)

Check twice a year, spring time and autumn.

#### CHECK LEVELS OF REFRIGERANT (GAS)



**WARNING**

If the refrigerant used in the system gets into your eyes or on your hands, it could cause loss of sight or frostbite, so **NEVER** loosen any part of the refrigerant circuit.

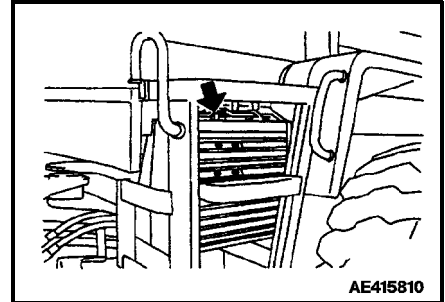

Operate the air conditioner system for 5 - 10 minutes, then touch the high pressure portion and low pressure portion of the compressor (or high pressure hose and low pressure hose joint) by hand. At the same time, inspect the flow of refrigerant gas (R134a) through the sight glass to check the level.

Contact your distributor concerning this inspection.

The sight glass is located on the air conditioner dryer receiver, which is located on the left side of the machine next to the condenser.

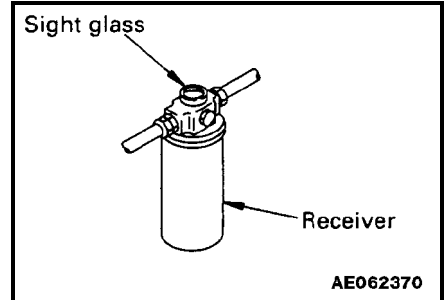

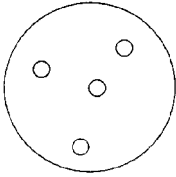
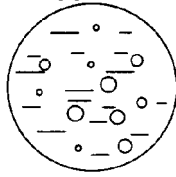
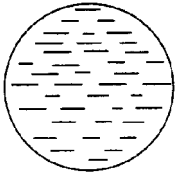
COOLER CONDITION	NORMAL	ABNORMAL	
Temperature of high and low pressure pipes	High pressure pipe is hot. Low pressure pipe is cold. Clear difference in temperature	High pressure pipe is warm. Low pressure pipe is cold. Little difference in temperature.	Almost no difference in temperature between high and low pressure pipes.
Sight glass	Almost transparent. Any bubbles disappear if the engine speed is raised or lowered. 	Bubbles are always flowing. Sometimes becomes transparent or white bubbles appear. 	Misty substance is flowing. 
System line Connections	Properly connected	Some parts dirty with oil	Some parts very dirty with oil.
General condition of air conditioner	refrigerant level correct, no abnormalities. Ready for use.	Could have a refrigerant leak. Contact your distributor for inspection and repair.	Almost all refrigerant has leaked out. Contact your distributor for inspection and repair

**24.2.9 CHECK THE AIR CONDITIONER CONDENSER (IF EQUIPPED)**

**⚠ WARNING**

Do not wash the condenser with a steam cleaner. Otherwise, the condenser will get hot and could break down

If there is mud or dust on the air conditioner condenser, clean it with water.  
 When washing with a high pressure machine, apply the water from a reasonable distance if the water pressure is too high it could deform the fins.

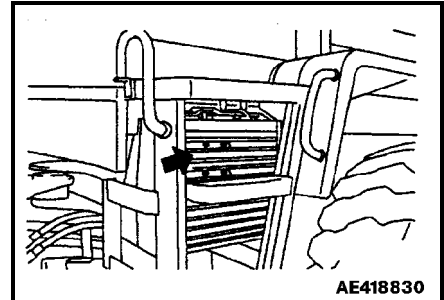

**24.2.10 CHECK WINDOW WASHING FLUID**

Check the washing fluid level in washer tank (1). When the fluid is low, add automotive window washing fluid.  
 To prevent the nozzle from clogging, be careful not to let dust get into the fluid.

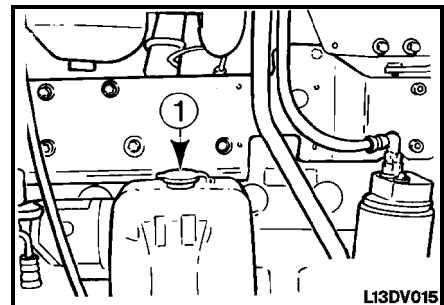

## MAINTENANCE

### 24.2.11 ADJUST PARKING BRAKE

the parking brake is a sealed wet type disc brake, so the brake itself does not need adjusting. However, if the travel of the brake pedal increases because of looseness of the control cable mount or elongation of the control cable, adjust as follows.

#### CHECKING

Depress the parking brake pedal with a force of approximately 30 kg (66 lb). If the travel of the brake pedal is more than 13 clicks, check for looseness of control cable mount (pedal and brake end). If any looseness is found, tighten and adjust as follows.

#### ADJUSTING



#### WARNING

Prior to adjusting, always block the tires to prevent the machine from moving and LOCK the front and rear frame with the safety bar.

1. Pull release lever (1) and release the parking brake.
2. Loosen lockout (2) and remove clevis pin (4).
3. Pull lever (5) at the parking brake end fully to release the brake and set it in the release position.
4. Screw in clevis (3), align the pin with the pin hole in lever (5) at the parking brake end, then assemble the clevis pin (4) and tighten lockout (2).

After adjusting, depress parking brake pedal (6) with a force of approximately 30 kg (66 lb), and check that the travel of the pedal is 7 - 11 clicks.

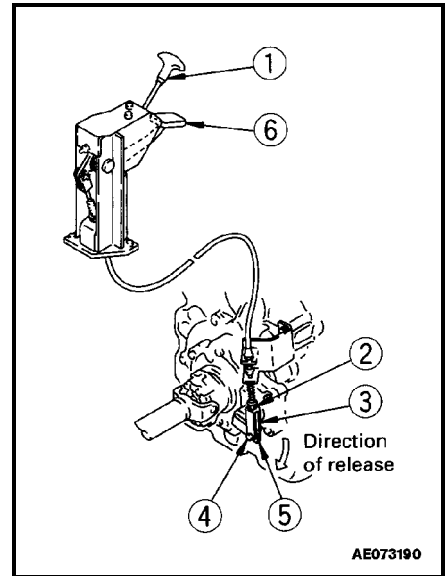

**24.2.12 REPLACE SLOW BLOW FUSE**

**⚠ WARNING**

**Whenever replacing slow blow fuse, be sure to turn OFF the power source by turning OFF the main starting switch.  
The slow blow fuse must be replaced with one that has the same capacity.**

- 1 Turn the main starting switch to **OFF**.
- 2 Remove the slow blow fuse box from the vehicle.
- 3 Open the cover (1), (2) & (3) of slow blow fuse box.  
Covers (2) & (3) can easily be removed by unlatching the hook of the cover from prying at it (A) with a screw driver.
- 4 Unfasten wires (7) & (8) from screws (4) & (5) and remove slow blow fuse (6).
- 5 Install the new slow blow fuse and fasten wires (7) & (8.)
- 6 Close the covers (1) (2) & (3) and install the fuse box back into the vehicle body.

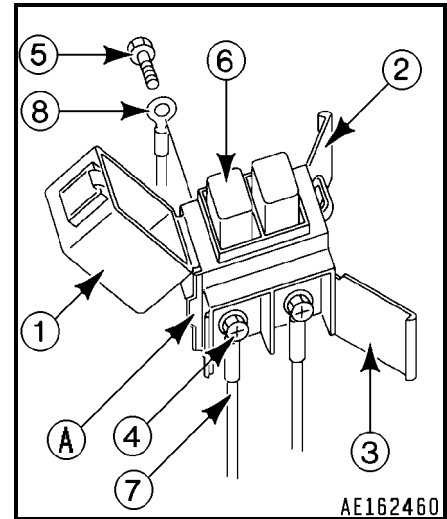

**24.2.13 CHECK AIR INTAKE HEATER**

Once a year have your distributor check and if necessary repair your air intake heater



**24.3 CHECK BEFORE STARTING**

See section on CHECK BEFORE STARTING ENGINE aforementioned in SECTION 2.

## **24.4 EVERY 50 HOURS SERVICE**

### **24.4.1 CHECK THE TIRE INFLATION PRESSURE**

Measure the inflation pressure before operation when the tires are cool.

Standard tire inflation pressure: 17.5-25 12pr

FRONT tire: 294 kPa (3.0 kg/cm<sup>2</sup>, 42.6 psi)

REAR tire: 294 kPa (3.0 kg/cm<sup>2</sup>, 42.6 psi)

**NOTE: The appropriate tire inflation pressure differs according to the type of work, see "12.21 HANDLING THE TIRES".**

### **24.4.2 DRAIN WATER, SEDIMENT FROM FUEL TANK**

Loosen valve (1) on the right side of the tank so that the sediment and water will be drained together with fuel.

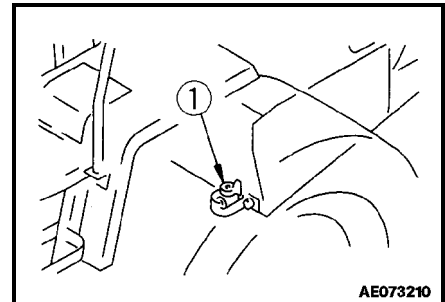

### **24.4.3 CHECK ENGINE AIR INTAKE SYSTEM**

Refer to "CUMMINS ENGINE OPERATION and MAINTENANCE MANUAL", see the Maintenance Schedule.

## MAINTENANCE

### 24.5 EVERY 100 HOURS SERVICE

Maintenance for every 50 hours should be carried out at the same time.

#### 24.5.1 CHECK OIL LEVEL IN HYDRAULIC TANK, ADD OIL

 **WARNING**

- When the oil filler cap is removed, oil may spurt out, so turn OFF the engine and wait for the oil temperature to cool down, then turn the cap slowly to release the internal pressure before removing the cap.
- If oil has been added to above the H mark, turn OFF the engine and wait for the hydraulic oil to cool down, then drain the excess oil from the drain plug.

1. Lower the bucket horizontally to the ground and turn OFF the engine. Wait for 5 minutes, then check sight gauge (G). The oil level should be between the H and L marks.

**NOTE: Do not add oil if the oil is above the H line. This will damage the hydraulic equipment and cause oil to spurt out.**

2. If the oil is below the L level, open the inspection cover above the step and add oil through oil filler port (F).

**For specification of the oil to use, see "20. USE OF FUEL, COOLANT AND LUBRICANTS ACCORDING TO AMBIENT TEMPERATURE".**

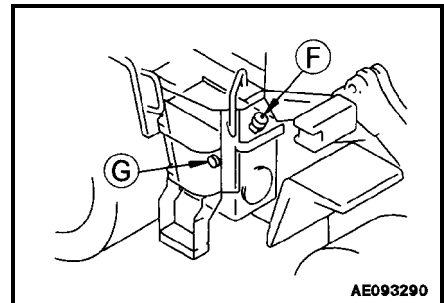
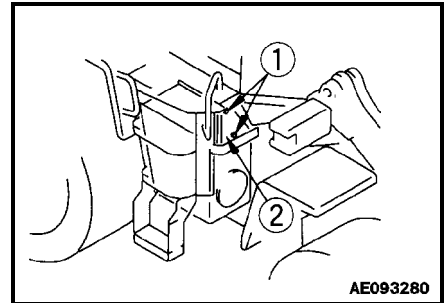

**24.5.2 CLEAN ELEMENT IN AIR CONDITIONER FRESH AIR FILTER**

**⚠ WARNING**

**When using compressed air, wear safety glasses and other things required to maintain safety.**

If the air conditioner has been used, then its air filter element could need cleaning.

Before cleaning the elements, turn the air conditioner OFF.

1. Loosen the thumb screws (1) and remove cover (2).

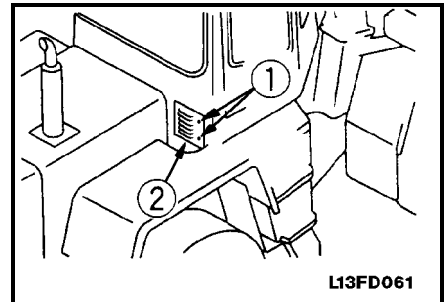

2. Unsnap the two clips (3) holding the element, and remove element (4) to clean it.
3. Direct compressed air (less than 7 kg/cm<sup>2</sup> [100 psi / 689 kPa]) to the element from the inside along its folds, then direct it from the outside along its folds and again from the inside. Check the element for damage and/or deterioration.

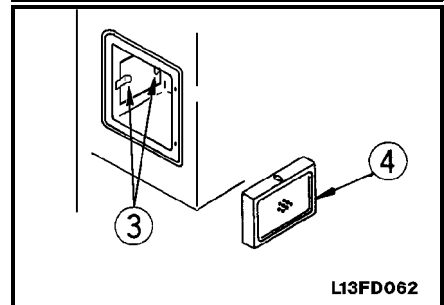

**REMARKS:**

When re-assembling the element, install it so that the arrow on top of the filter is facing the inside of the cab.

## MAINTENANCE

---

### 24.5.3 LUBRICATING

 **WARNING**

- Apply the parking brake, and lock the front and rear frames with the safety bar and pin.
- set the work equipment in a stable condition, then turn OFF the engine and apply the locks for the work equipment control levers.

- 1 Use a grease pump to pump in grease through the grease fittings marked by the arrows in the following diagrams.
- 2 After greasing, wipe off any old grease that was pushed out.

1 Bucket pin (2 places)

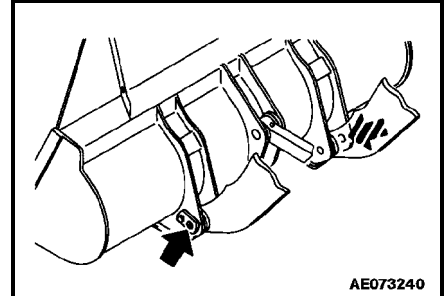

2 Bucket link pin (2 places)

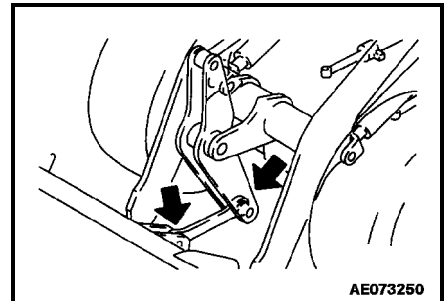

3 Rear axle pivot pin (2 places)

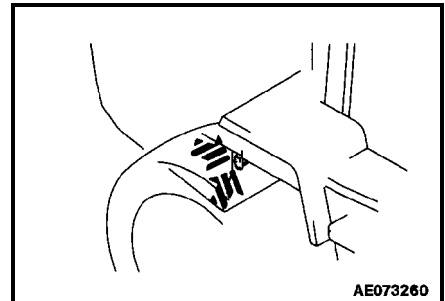

## 24.6 EVERY 250 HOURS SERVICE

Maintenance for every 50 and 100 hours should be carried out at the same time.

### 24.6.1 CHANGE OIL IN ENGINE OIL PAN AND REPLACE ENGINE OIL FILTER

**⚠ WARNING**

Before changing the oil, wait, at least 10 minutes for the engine to cool down after running it.  
If the filter is removed before the oil settles the oil might continue to spill.

For details of the oil to use and refill capacity see "20. USE OF FUEL, COOLANT AND LUBRICANTS ACCORDING TO AMBIENT TEMPERATURE.

1. Warm up the engine to operating temperature and then turn the engine OFF.
2. Open the engine hoods and lock in position.
3. Open oil filler (F) and remove drain plug (P) to drain oil. After draining, tighten the drain plug.
4. Clean the area around the oil filter.
5. Using a filter wrench, remove oil filter cartridge (C) by turning it counterclockwise.
6. Clean the filter gasket surface of the filter header.
7. Fill a new oil filter with engine oil. Then, apply engine oil or a thin coat of grease to the seal.
8. To install filter, bring its seal surface into contact with sealing surface of filter base and then tighten the filter ½ to ¾ turn by hand.

Be careful not to tighten it up excessively.

Be sure to use a genuine filter.

9. After replacing the filter, pour in the specified quantity of engine oil at oil filler (F) until the oil level is between the add and full mark on dipstick (G).
10. After refilling with oil, start the engine and idle it for a while. Inspect for oil leaks at the filter and drain plug. Then stop the engine and check the oil level. Wait for 5 minutes before checking.

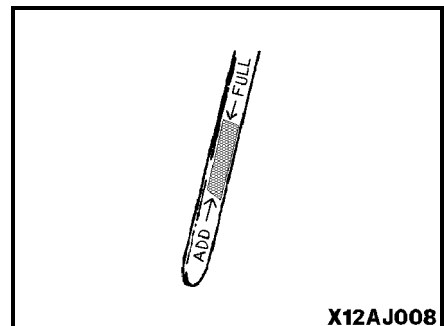
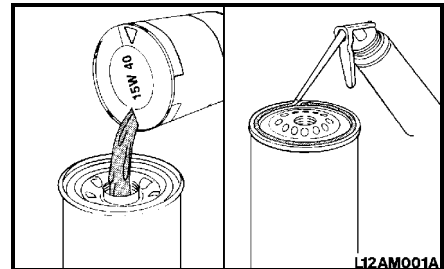
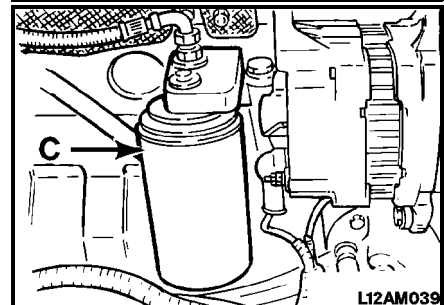
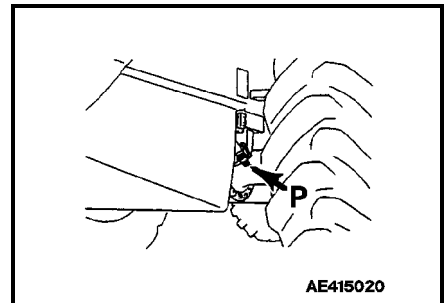
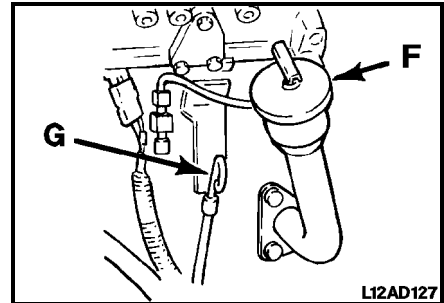

## MAINTENANCE

### 11. Close the engine hoods.

Diluted oil can cause severe damage to the engine. Check the condition of the used oil.

- Thin, black oil indicates fuel dilution.
- Milky discoloration indicates coolant dilution.

If you notice any excessive metal particles or foreign material then consult your distributor.

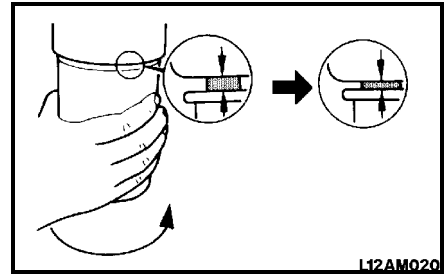

### 24.6.2 CHECK FOR LOOSE WHEEL BOLTS. TIGHTEN

If wheel bolts (1) are loose, tire wear will be increased and accidents could happen. If any nuts are loose, tighten them to the specified torque.

Torque:  $927 \pm 103$  Nm ( $94.5 \pm 10.5$  kgm,  $684 \pm 76$  lbf ft)

If any stud is broken, replace all studs for that wheel.

Always rotate in the direction of tightening when checking for loose bolts.

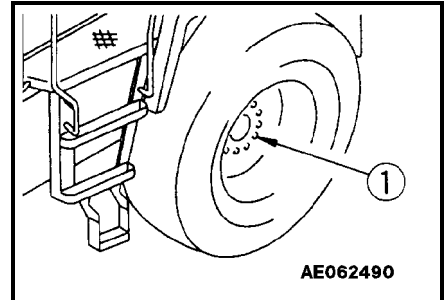

### 24.6.3 CLEAN ELEMENT IN AIR CONDITIONER RECIRCULATION FILTER

1. Open the filter inspection cover, remove the filter cover, then remove the filter in the direction of the arrow.  
When removing the filter to the side, put your weight on the seat, and push down.
2. Direct compressed air (less than  $7 \text{ kg/cm}^2$  [100 psi / 689 kPa]) to the filter from the inside along its folds, then direct it from the outside along its folds and again from the inside. Check the filter for damage and/or deterioration.  
If the filter is extremely dirty, rinse it in water. After rinsing the filter, dry it completely before installing it again.

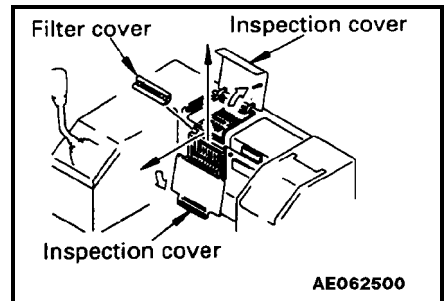

**24.6.4 CHECK AIR CONDITIONER COMPRESSOR BELT TENSION, ADJUST**

1. Open the engine hood and lock in place.
2. Visually inspect the drive belt. Replace belts that are cracked or frayed. Adjust belts that have a glazed or shiny surface, indicating belt slippage. Correctly installed tension show even pulley and belt wear.
3. Check each belt pulley for damage and pulley groove wear. Particularly, check whether the drive belt is contacting the bottom of the pulley groove through wear. Also, check for pulley alignment.
4. Check belt tension at the midway point of the longest pulley span using the deflection method.

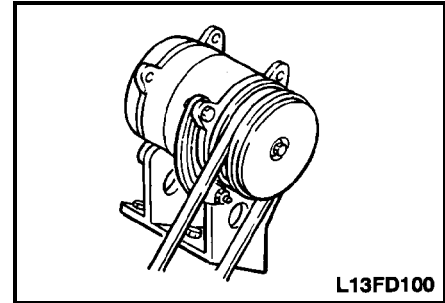

Proper belt deflection is 10 mm (25/64 in) when applying approximately 6 kg (13 lbs / 58 N) of force on the belt between the compressor drive pulley and the magnetic clutch. If the deflection is more than the specified range, the belt tension must be adjusted.

5. If necessary, adjust drive belt tension as follows:
  - 1) Loosen the arm adjusting bolts (2) and the mounting bracket pivot bolt (1).

When adjusting drive belt tension, do not attempt to move the compressor directly with a bar or similar tool, but use a wood block to prevent damage.

- 2) Move the compressor (3) to adjust belt tension.

3) When proper belt tension is obtained, tighten the arm adjusting bolts (2) and the mounting bracket pivot bolt (1) securely to hold the compressor in place.

6. Close the engine hood.

**NOTE: If proper belt tension can NOT be obtained, the drive belt may be stretched, leaving no allowance for adjustment, and should be replaced.**

**NOTE: When the belt is replaced, readjust its tension after running for one hour.**



## MAINTENANCE

### 24.6.5 CHECK BATTERY ELECTROLYTE LEVEL

 **WARNING**

- To avoid gas explosions, do not bring fire or spark near the battery.
- Battery electrolyte is dangerous. If it gets in your eyes or on your skin, wash it off with water, and consult your doctor.

1. Open the rear grill.
2. Remove caps (1), and check each cell, the electrolyte should be at a specified level (10 to 12 mm (0.40 to 0.47 in) above the plate). If the electrolyte level is low, add distilled water to the specified level.
3. If distill water has been added to any cell of the battery, add distill water also to the other cells.

**Note:** When adding distilled water in cold weather, add it just before operating the machine, to prevent the electrolyte from freezing.

4. Clean the air hole in the battery cap, then tighten the cap securely.

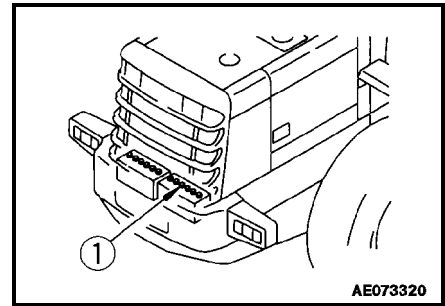

### 24.6.6 CHECK AIR INTAKE SYSTEM

Inspect the air intake system, the intake piping for cracked hoses, loose clamps, or punctures which can allow dirt and debris to enter the engine. Tighten or replace parts as necessary to make sure the air intake system does not leak.

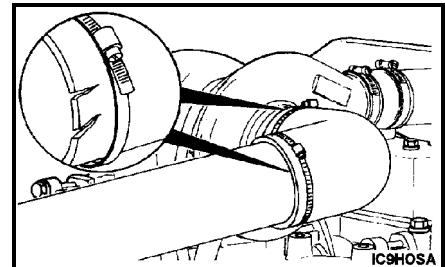

24.6.7 LUBRICATING

**⚠ WARNING**

- Set the work equipment in a stable condition, then turn OFF the machine and apply the lock for the work equipment control levers.
- Apply the parking brake, and lock the front and rear frames with the safety bar and pin.

1. Use a grease pump to pump in grease through the grease fittings marked by the arrows.

2. After greasing wipe off any old grease that was pushed out.

1. Bucket cylinder pin (2 places)
2. Boom cylinder pin (4 places)
3. Boom pivot pin (2 places)
4. Tilt lever pin (1 place)
5. Steering cylinder pin (4 Places)

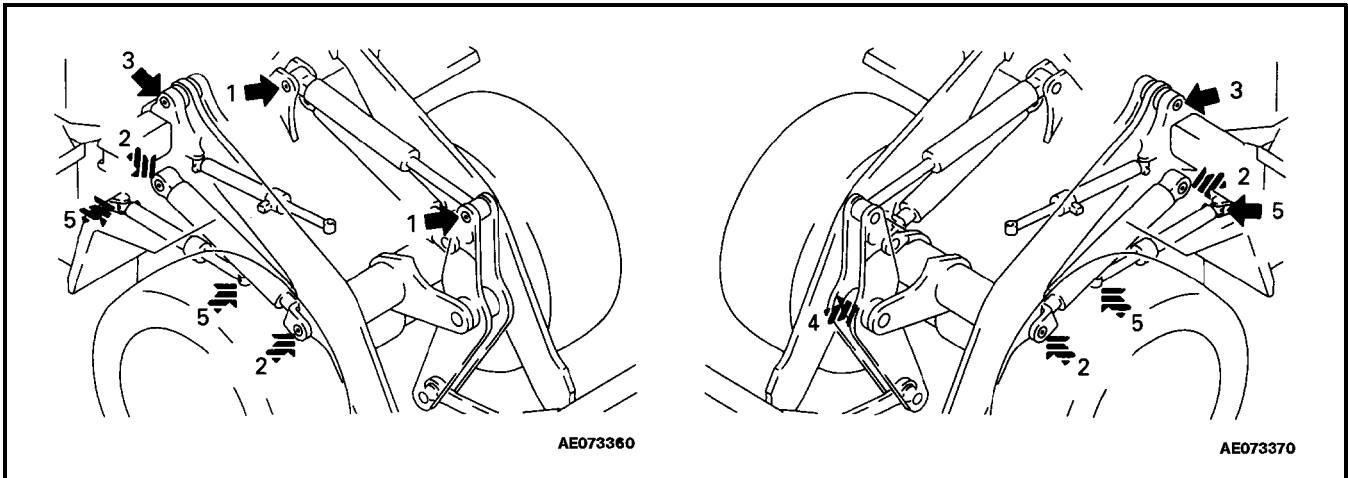

## MAINTENANCE

---

### 24.7 EVERY 500 HOURS SERVICE

Maintenance for every 50, 100 and 250 hours should be carried out at the same time.

#### 24.7.1 REPLACE FUEL FILTERS

 **WARNING**

- Engine is at a high temperature immediately after the machine has been operated. Wait for the machine to cool down before replacing the filter.
- Do not bring fire or sparks near the filters.

#### GENERAL

The fuel filters are spin-on type filters. These filters cannot be cleaned and should not be disturbed except when it becomes necessary to replace them.

Change the fuel filters as listed on the SCHEDULED MAINTENANCE GUIDE or sooner if a power loss is evident. If a power loss persists, consult your distributor.

**NOTE: Fuel with more than the average impurities may require changing filters at shorter intervals.**

There are two fuel filters (1) located on the right side of the machine.

Be careful not to allow dirt, water or other foreign material to get in the new filters. Keep new filters in the original package until ready for installation.

#### REPLACEMENT

1. Open the engine hood and lock into position.
2. Clean the area around the fuel filters.
3. Using a filter wrench, remove the fuel filters by turning them counterclockwise. Discard the filters in a suitable manner.
4. Clean the filter gasket surfaces of the filter header for each filter. Replace the filter O-rings.

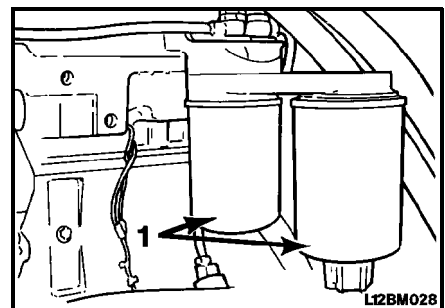

5. Fill the new filters with clean diesel fuel. Then, apply a thin coat of clean engine oil to the seal of the filter.

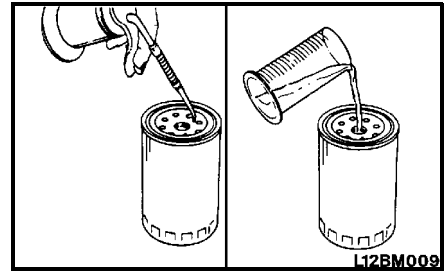

6. Install the filters on the filter header until the filter seal contacts the seal surface of the filter header and then, turn the filter an additional 1/2 to 3/4 turn by hand.

Do not over tighten the filter or damage may result to the filter seal or threads.

Use genuine filters.

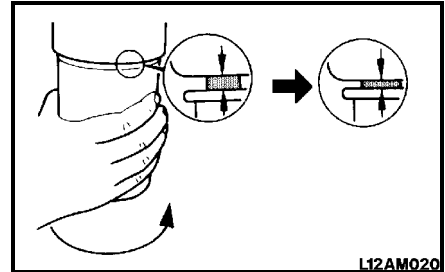

7. After replacing the filters, start the engine and idle it for a few minutes. Check the filters for possible fuel leakage.
8. Close the engine hood.

**NOTE: Controlled venting is provided at the injection pump through the fuel drain manifold. Small amounts of air introduced by changing the filters or injection pump supply line will be vented automatically, if the fuel filter is changed in accordance with the instructions.**

**However, manual bleeding will be required if:**

- The fuel filter is not filled prior to installation.
- The injection pump is replaced.
- High pressure fuel lines are replaced.

## MAINTENANCE

### 24.7.2 REPLACE TRANSMISSION OIL FILTER ELEMENT

1. Set a container under the filter case to catch the oil then remove drain plug (1) at the bottom of the filter case, and drain the oil. After draining the oil, tighten the plug.

Torque to:  $107.9 \pm 14.7 \text{ N}\cdot\text{m}$  ( $11 \pm 1.5 \text{ kgm}$ ,  $79.6 \pm 10.8 \text{ lbf ft}$ )

2. Hold case (2) and loosen center bolt (3), then remove case (2).

Be sure to use a genuine filter element.

Replace the filter gasket and O-rings with new parts. Coat the gasket and O-rings with clean engine oil before installing.

3. Remove the element, and clean the inside of the case. Assemble a new element, then install the case.

Before tightening center bolt (3), install bolt washer (4) so that its chamfered surfaces faces the hexagonal head of the center bolt.

Be careful not to apply excessive torque to center bolt (3).

Torque to: (3) to  $76.5 \pm 11.8 \text{ N}\cdot\text{m}$  ( $7.8 \pm 1.2 \text{ kgm}$ ,  $56.4 \pm 8.7 \text{ lbf ft}$ )

4. Run the engine for a short period of time at idle, then turn the engine off and check that the oil is at the specified level.

For details, see "24.2.2 CHECK TRANSMISSION OIL LEVEL, ADD OIL".

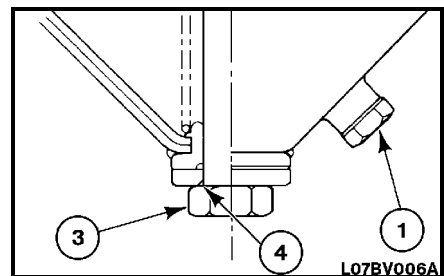
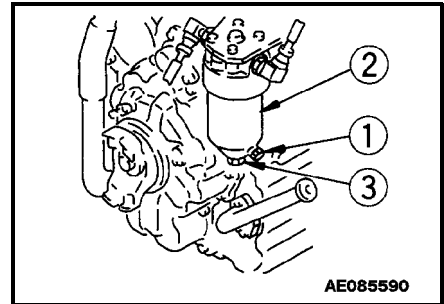

24.7.3 LUBRICATE

 **WARNING**

- **Set the work equipment in a stable condition, then turn OFF the machine and apply the lock for the work equipment control levers.**
- **Apply the parking brake, and lock the front and rear frames with the safety bar and pin.**

- Use a grease pump to pump in grease through the grease fittings marked by the arrows.
- After greasing wipe off any old grease that was pushed out.

Center hinge pin (2 places)

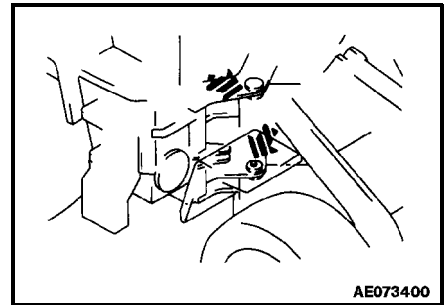

## MAINTENANCE

### 24.8 EVERY 1000 HOURS SERVICE

Maintenance for every 50, 100, 250 and 500 hours should be carried out at the same time.

#### 24.8.1 CHANGE OIL IN TRANSMISSION CASE, CLEAN STRAINER

 **WARNING**

- **The oil is hot if the machine has just been operated. Wait for the oil to cool down before changing**

1. Loosen drain plug (P), pull out the plug slowly to prevent the oil spouting out. After draining out the oil, then tighten up drain plug.

Torque to:  $17.2 \pm 2.5 \text{ N}\cdot\text{m}$  ( $1.75 \pm 0.25 \text{ kgm}$ ,  $12.7 \pm 1.8 \text{ lbf ft}$ )

2. Loosen drain plug (1) of transmission oil filter to drain oil. After draining out the oil, tighten up drain plug.

Torque to:  $107.9 \pm 14.7 \text{ N}\cdot\text{m}$  ( $11 \pm 1.5 \text{ kgm}$ ,  $79.6 \pm 10.8 \text{ lbf ft}$ )

3. Remove bolts (2) and cover (3), then remove strainer (4).

4. Remove all dirt from the surface of strainer (4), then wash in clean light oil (such as diesel oil or flushing oil). If strainer (4) is damaged, replace with a new part.

5. Install strainer (4) to cover (3).

Strainer torque:  $299 \pm 93.2 \text{ N}\cdot\text{m}$  ( $30.5 \pm 9.5 \text{ kgm}$ ,  $221 \pm 68.7 \text{ lbf ft}$ )

Replace the O-ring of the cover with a new part, then install the cover.

6. Pour in the specified amount of oil at oil filler (F).

For details of the oil to use and refill capacity see **"20. USE OF FUEL, COOLANT AND LUBRICANTS ACCORDING TO AMBIENT TEMPERATURE."**

7. After refilling, check that the oil is at the specified level.

For details, see **"24.2.2 CHECK TRANSMISSION OIL LEVEL, ADD OIL"**.

8. Check for oil leak at transmission case and filter.

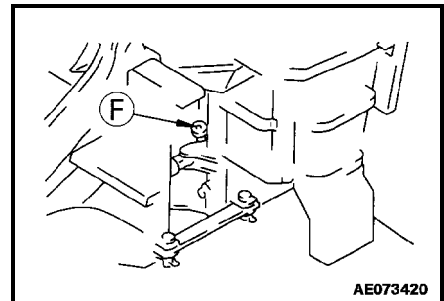
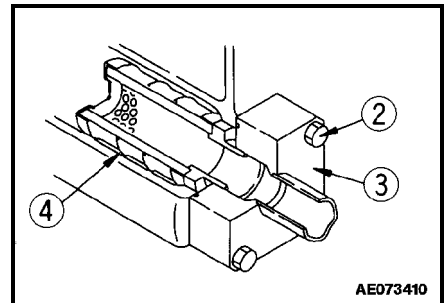
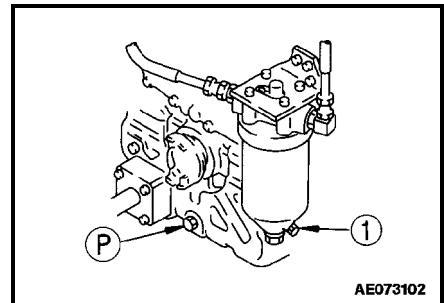

**24.8.2 CLEAN TRANSMISSION CASE BREATHER**

Remove all mud and dirt from around the breather, then remove the breather and put it into a cleaning fluid to clean.

Take care, so as not to let any dust or dirt get inside the transmission case through the port while the breather is removed.

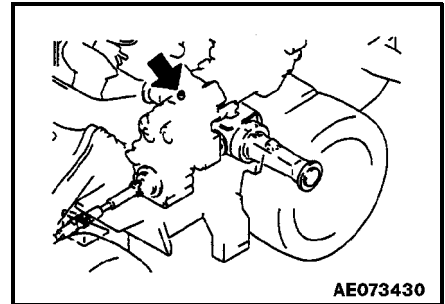



## MAINTENANCE

### 24.8.3 LUBRICATE

 **WARNING**

- Set the work equipment in a stable condition, then turn OFF the machine and apply the lock for the work equipment control levers.
- Apply the parking brake, and lock the front and rear frames with the safety bar and pin.

- Use a grease pump to pump in grease through the grease fittings marked by the arrows.
- After greasing wipe off any old grease that was pushed out.

1 Front drive shaft (1 Place)

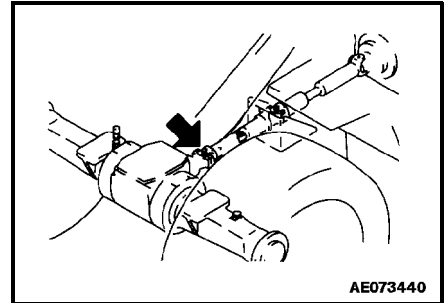

2 Drive shaft center support (1 place)

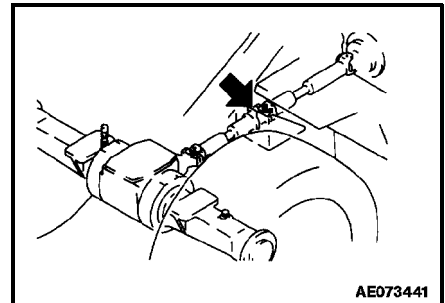

3 Center drive shaft (2 places)

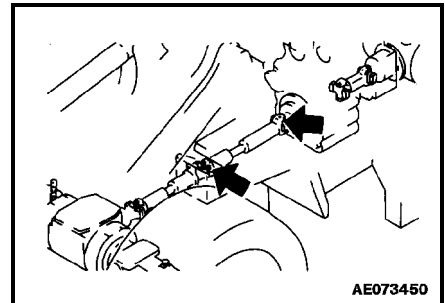

4 Rear drive shaft (2 places)

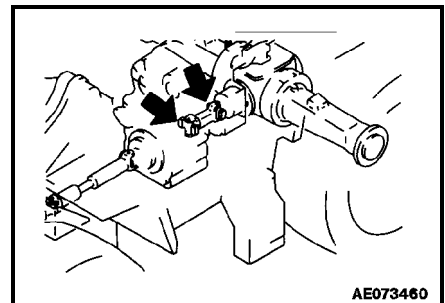

**24.8.4 CHANGE OIL IN HYDRAULIC OIL TANK, REPLACE HYDRAULIC FILTER ELEMENT**

**⚠ WARNING**

- The oil is hot if the machine has just been operated. Wait for the oil to cool down before changing it.
- When removing the oil filler cap turn it slowly to release the internal pressure, then remove it carefully.

1 Lower the bucket to the ground and apply the parking brake, then turn OFF the engine.

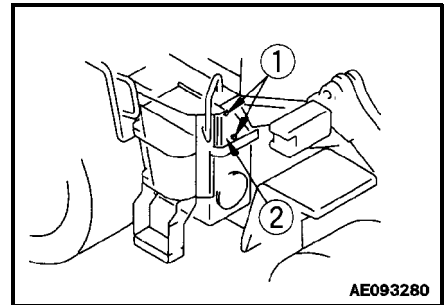

2 Remove bolts, (1) then remove cover. (2)

3 Keep knob (A) of oil filler port (F) pulled, then turn the cap counterclockwise and remove it.

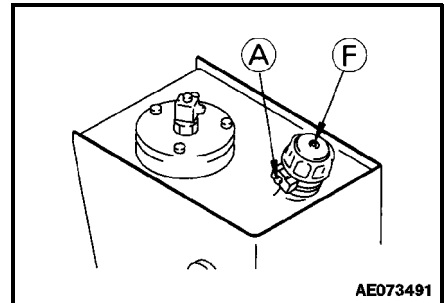

4 Set a container to catch the oil under drain plug (3).

5 Remove drain plug (3).

6 After draining the oil, tighten drain plug (3).

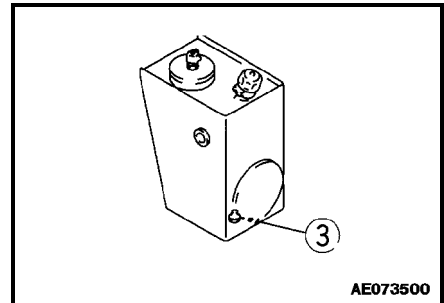

7 Remove the mounting bolt of filter cover (4), then remove the covers. While doing this the cover could fly off from the force of spring (5), so hold the cover down while removing the bolts.

8 Remove spring (5) and bypass valve (6), then remove element (7).

9 Before cleaning the inside of the tank, examine it for foreign matter

10 Install a new element, then install by pass valve (6), spring (5) & cover (4). If the O-ring of the cover is damaged or deteriorated, replace it with a new part.

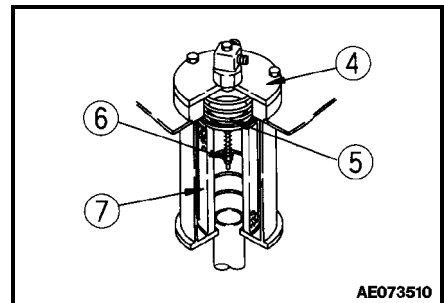

11 While installing the cover bolts, hold down the cover and tighten the bolts evenly.

## MAINTENANCE

---

- 12 Add hydraulic oil through oil filler port (F) to the specified level, then install cap.

For details of the oil to use and refill capacity see **"20. USE OF FUEL, COOLANT AND LUBRICANTS ACCORDING TO AMBIENT TEMPERATURE"**.

- 13 Check that the hydraulic oil is at the standard level.  
**See "EVERY 100 HOUR SERVICE"**.
- 14 Run the engine at low idle and extend and retract the steering, bucket and lift arm cylinders 4 - 5 times. Be careful not to operate the cylinder to the end of its stroke (stop approximately 100 mm (3.94 in) before the end of the stroke)

 **WARNING**

**If the engine is run immediately at high speed or the cylinder is operated to the end of its stroke, the air inside the cylinder could cause damage to the piston packing.**

15. Next, operate the steering, bucket, and lift arm cylinders to end their stroke 3-4 times, then turn OFF the engine and loosen bleed plug (8). Then run the engine at low idle to bleed the air from the hydraulic tank. After bleeding the air, turn OFF the engine and tighten plug (8) again.
- 16 Check the hydraulic oil level and add oil to the specified level. For details, see **"24.5 EVERY 100 HOURS SERVICE"**.
- 17 Next, increase the engine speed and repeat the procedure in Step 15 to bleed air. Continue this procedure until no more air comes out from plug (8).
- 18 tighten plug (8) and Torque to:  $11.3 \pm 1.5 \text{ N}\cdot\text{m}$  ( $1.15 \pm \text{kgm}$ ,  $8.3 \pm 1.1 \text{ lbf ft}$ )
- 19 Check that the hydraulic oil is at the standard level. For details, see **"24.5 EVERY 100 HOURS SERVICE"**.
- 20 Check to be sure, there are no oil leaks at the filter cover mount.

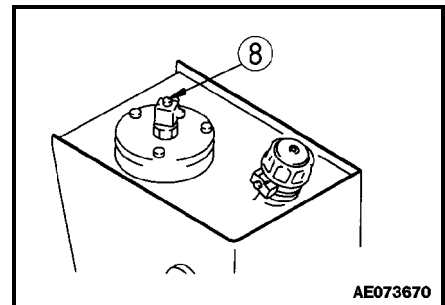

### 24.8.5 ADJUST ENGINE VALVE LASH CLEARANCE

After the first 1000 hours only thereafter every 2000 hour intervals.

For detail procedures to adjust valve lash clearance refer to the **"EVERY 2000 HOURS SERVICE"**.

**24.8.6 CHECK FAN BELT TENSION**

- 1 Measure the belt deflection at the longest span of the belt when pressed with the finger.

Maximum deflection: 9.5 - 12.7 mm  
(3/8 to 1/2 in)

NOTE: Cummins belt tension gauge ST-1293 may be used. The required gauge value is 267 to 578 N (60 to 130 lbf).

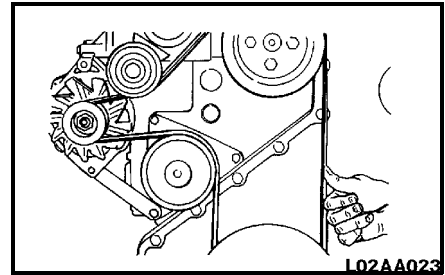

**24.8.7 CHECK FAN BELT TENSIONER BEARING & FAN HUB BEARING & INSPECT FAN BELT**

- 1 Remove drive belt and complete the following steps:
- 2 Inspect the belt for damage.
- 3 Check the tensioner bearing.

NOTE: The tensioner pulley should spin freely with no rough spots detected under hand pressure.

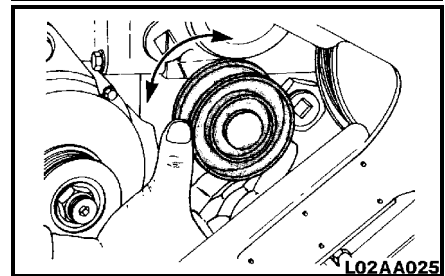
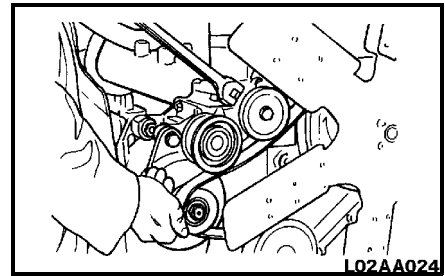

- 4 Check the fan hub bearing.

The fan hub should spin freely without excessive end play.

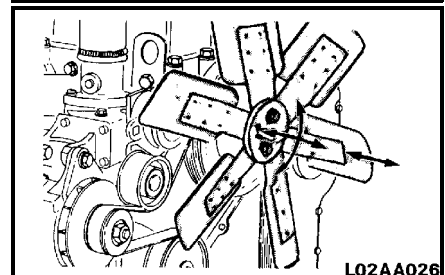

- 5 Inspect the belt for damage

Transverse (across the belt width) cracks are acceptable.

Longitudinal (direction of belt length) cracks that intersect with Transverse cracks are **not** acceptable.

Replace the belt if it has unacceptable cracks, is frayed or has pieces of material missing.

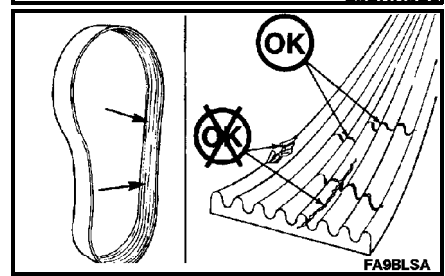

- 6 Install the fan belt

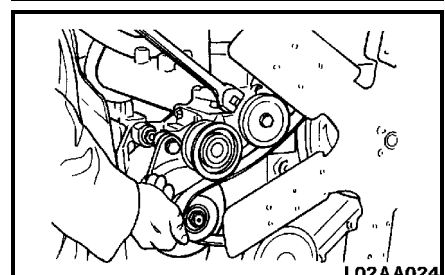

## MAINTENANCE

---

### 24.8.8 CHECK TIGHTENING PARTS OF TURBOCHARGER

Contact your Komatsu distributor to have tightening portions checked.

### 24.8.9 CHECK PLAY OF TURBOCHARGER ROTOR

Contact your Komatsu distributor to check the play of the turbocharger rotor.

## 24.9 EVERY 2000 HOURS SERVICE

Maintenance for every 50, 100, 250, 500 and 1000 hours should be carried out at the same time.

### 24.9.1 COOLING SYSTEM, REPLACE COOLANT AND FLUSH THE SYSTEM



#### WARNING

- If the engine was just running, then the coolant could be hot and cause personal injury. Allow the engine to cool before draining water.
- Never remove the radiator cap when the engine is at operating temperature. At operating temperature, the coolant is under pressure. Steam blowing up from the radiator could cause personal injury. Allow the engine to cool until the radiator filler cap is cool enough to touch with your hand. Remove the filler cap slowly to allow pressure to be relieved.
- Never go under the vehicle while the engine is running, since cleaning is performed while the engine is running, it is very dangerous to go under the machine in case the vehicle starts moving.

## GENERAL

The cooling system operates under pressure which is controlled by the pressure relief valve in the radiator cap.

The belt-driven water pump circulates the coolant through the engine block, cylinder heads, radiator and engine oil cooler. Circulation is controlled by the thermostat which by-passes coolant flow around the radiator until the engine reaches operating temperature.

Proper cooling is possible only when the system is sealed, the radiator cap gasket is in good condition, the pressure relief valve and thermostats are operating properly. The system is free of coolant and air flow restrictions and the system is filled to the proper level.

Selection and maintenance of the engine coolant is important to long engine life. The following information provides recommendations for selecting the engine coolant, maintaining the coolant inhibitors and servicing the cooling system.

The system operates successfully with a water/antifreeze mixture or inhibited/conditioned water as the coolant. Water alone allows rust, scale deposits, and corrosion to occur within the system.

After 2,000 hours or 1 year of operation, whichever comes first, the cooling system should be drained, flushed, and refilled.

**For complete coolant specifications see "20.3 COOLANT SPECIFICATIONS".**

## RADIATOR CAP GENERAL INFORMATION

The radiator cap seals the coolant filler opening of the radiator. Positive sealing requires a cap gasket and its contacting surfaces to be in good condition and a properly tightened cap.

The radiator cap incorporates a pressure relief valve. The pressure relief valve keeps the pressure of the coolant at approximately 34 to 64 kPa or 0.35 to 0.65 kg/cm<sup>2</sup> (5 to 9 psi).

**NOTICE:** Operating the machine without a radiator cap, or with a cap without a relief valve set to operate at the correct pressure, can cause damage.

## RADIATOR CAP REMOVAL



### WARNING

- Hot, scalding coolant can spray out if the radiator cap is removed suddenly. Relieve system pressure by slowly turning the cap to the first notch or lifting the safety lever (if equipped).
- Use extreme caution when adding coolant to a hot radiator to avoid being burned. Wear gloves and goggles and keep face away from the filler neck.

To remove the cap, turn the cap to the left, or counterclockwise up to the safety stop until all pressure is released. Press down on the cap and continue to turn until the cap is free to be removed.

## RADIATOR CAP INSTALLATION

When installing the cap, the gasket and contacting surfaces must be clean. Turn the cap to the right, or clockwise until snug.

## CHANGING THE COOLANT AND FLUSHING SYSTEM

**NOTE:** Park the machine on level ground

1. Run the engine until it reaches operating temperature; then turn the engine OFF.

**NOTE:** Check for damaged hoses and loose or damaged hose clamps. Replace and fix where needed. Check the radiator for leaks, damage and accumulation of dirt. Clean and repair

2. Remove the radiator cap (1) as outlined in this section.
3. Open the drain valve (2) located on the inside bottom of the radiator.
4. Allow the system to completely drain into a suitable container. (MAKE SURE the drain outlets do not plug up during draining.)
5. Close the drain valve.

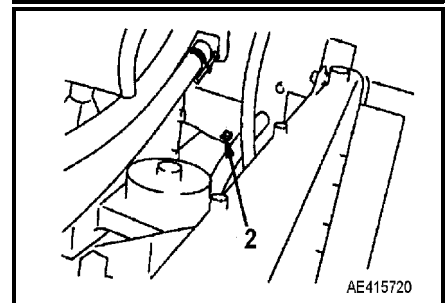
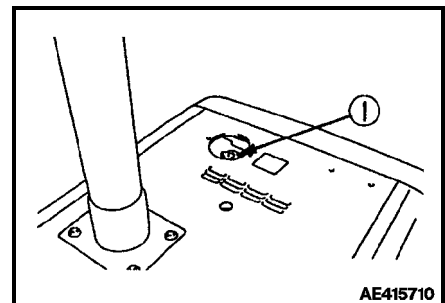

## MAINTENANCE

---

6. Refill the system with water only.
7. Then run the engine at low idle and open the drain valve (described in step 3.).
8. While the engine is running continue adding water in the top of the radiator, so that you are passing water through the cooling system for about 10 minutes.
9. After flushing the system with water then close the drain valve.
10. Now clean the system with a flushing agent. For details of cleaning see instructions given with the cleaning agent.

**NOTE: If the system shows mineral build-up, scale rust or oil, use a heavy duty radiator cleaner.**

**NOTE: Do not use a caustic cleaners in the cooling system. Aluminum components will be damaged.**

11. After cleaning with the flushing agent, refill the system with fresh water and repeat step 7. and 8.  
and run until clean water comes out the drain valve.
12. Now turn the engine OFF, drain all the water out, then close the drain valve.

 **WARNING**

**Antifreeze is flammable, so keep it away from any flame.**

13. Prepare the proper coolant for your environment as specified see "20.3 COOLANT SPECIFICATIONS".
14. Fill the system with the new coolant, leave the radiator cap off and run the engine for 5 minutes at low idle and then for 5 minutes at high idle to eliminate any trapped air in the system
15. Turn the engine OFF and wait 3 minutes then add more coolant until the radiator is full.
16. Repeat step 14 and 15 until your sure all trapped air has been eliminated.
17. Drain and clean the inside of the radiator overflow tank (1) Then add coolant up to the FULL mark.
18. Install the radiator cap as outlined in this section.

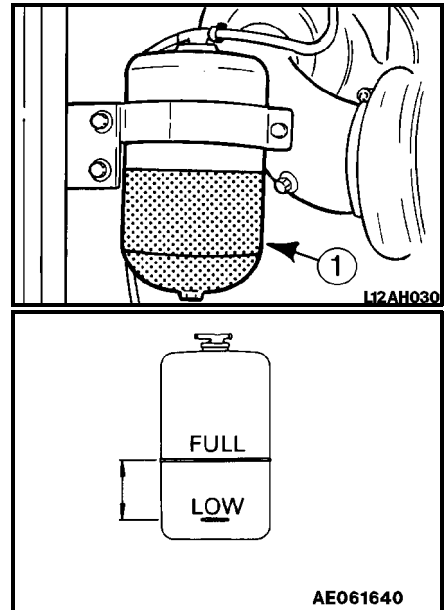

24.9.2 REPLACE HYDRAULIC TANK BREATHER ELEMENT

 **WARNING**

- The oil is hot if the machine has just been operated. Wait for the oil to cool down before changing it.
- When removing the oil filler cap turn it slowly to release the internal pressure, then remove it carefully.

- 1 Loosen bolt (1) at the top of the cap.
- 2 Remove the cap, then take out the element.
- 3 Coat the O-ring of the new element with grease, then install the element.
- 4 Align the cap with the body and tighten the bolts.

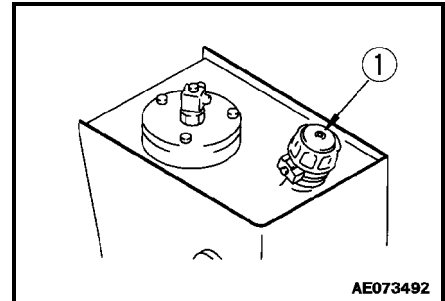

24.9.3 CHANGE AXLE OIL

 **WARNING**

The oil is hot if the machine has just been operated. Wait for the oil to cool down before changing it.

1. Set a container to catch the oil under drain plug (P).
2. Remove front and rear oil filler plugs (1), then remove drain plug (P) to drain the oil.
3. After draining the oil, clean drain plug (P), then install it.
4. Add axle oil through plug hole (1) to the specified level

For details of the oil to use and refill capacity see "20. USE OF FUEL, COOLANT AND LUBRICANTS ACCORDING TO AMBIENT TEMPERATURE".

To be sure that the oil is at the specified level, see "24.2.3 WHEN REQUIRED".

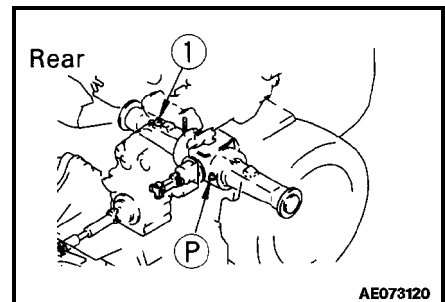
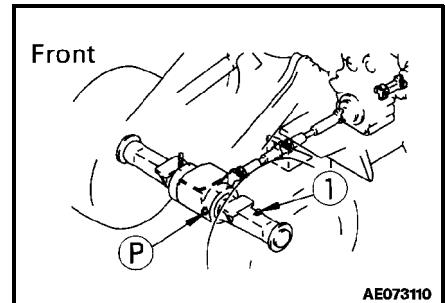

**REMARKS:**

For operations where the brake is used frequently, change the axle oil at shorter intervals.



## MAINTENANCE

---

### 24.9.4 CHECK BRAKE DISC WEAR

Have your distributor check and repair brake discs.

### 24.9.5 CHECK ALTERNATOR

The brushes and bearings may be worn. Have your distributor inspect and repair.

### 24.9.6 CHECK STARTER MOTOR

The brushes and bearings may be worn. Have your distributor inspect and repair.

### 24.9.7 CHECK VIBRATION DAMPER

The rubber element vibration damper is located at the fan end of the engine

1. Check the index lines (A) on the vibration damper hub (B) and the inertia member (C). If the lines are more than 1.59 mm (1/16 in) out of alignment, replace the vibration damper. Inspect the vibration damper hub (B) for cracks. Replace the vibration damper if the hub is cracked.
2. Inspect the rubber member for deterioration. If pieces of rubber are missing or if the elastic member is more than 3.18 mm (1/8 in) below the metal surface, replace the vibration damper.
3. Look for forward movement of the vibration damper ring on the hub. Replace the vibration damper if any movement is detected.

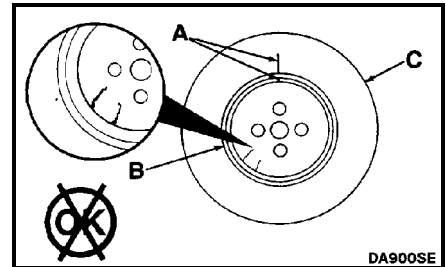

### 24.9.8 REPLACE ELEMENT IN AIR COND. RECIRCULATION AIR FILTER AND FRESH AIR FILTER

Remove both the recirculation filter and the fresh air filter in the same way as when cleaning, and replace them with new parts.

For details of cleaning the recirculation air filter, see "24.6.3 CLEAN ELEMENT IN AIR CONDITIONER RECIRCULATION FILTER".

For details of cleaning the fresh air filter, see "24.5.2 CLEAN ELEMENT IN AIR CONDITIONER FRESH AIR FILTER".

24.9.9 ADJUST ENGINE VALVE LASH CLEARANCE

- 1 15 mm wrench  
Remove the valve cover

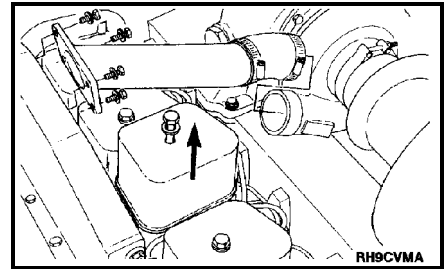

- 2 ½ inch drive, engine barring cover  
Locate Top Dead Center (TDC) for Cylinder Number 1 by barring engine slowly while pressing on the engine timing pin.  
The barring gear inserts into the flywheel housing and engages the flywheel ring gear. The engine can then be rotated by hand using a ½ inch ratchet or breaker bar.

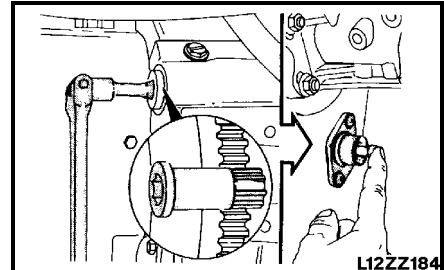

- 3 When the pin engages the hole in the camshaft gear, Cylinder Number 1 is at TDC on the compression stroke.

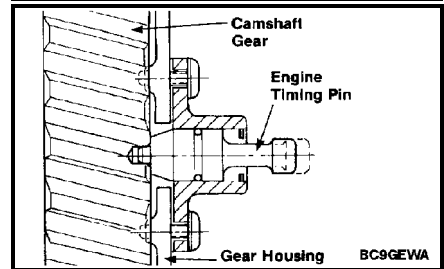

**WARNING**

To prevent damage to the engine or pin, be sure to disengage the pin after locating TDC.

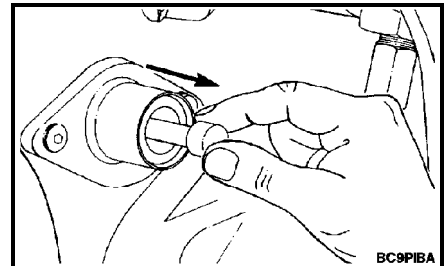

- 4 **Feeler Gauge**  
Intake Clearance: **0.254 mm (0.010 IN)**  
Exhaust Clearance: **0.508 mm (0.020 IN)**

Check and set valves with engine cold - **below 60°C (1400°F)**.

**NOTE:** The clearance is correct when some resistance is "felt" when the feeler gauge is slipped between the valve stem and the rocker lever.

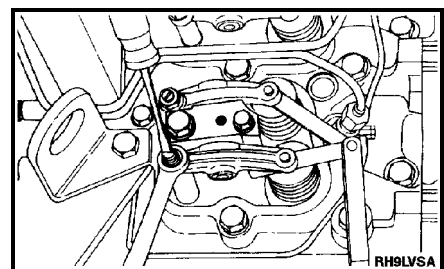

## MAINTENANCE

- 5 14 mm, Flatblade Screwdriver  
Locate Top Dead Center (TDC) for Cylinder Number 1  
Check and adjust the valves as indicated in the illustration  
(I = intake, E = Exhaust).  
Tighten the lock nut and measure the valve lash again.

**Torque Value:** 24 Nm [18 ft-lb]

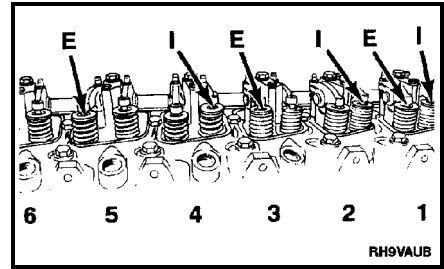

- 6 Mark the pulley/vibration damper and rotate the crankshaft 360 degrees.

**WARNING**

To prevent engine or pin damage, be sure timing pin is disengaged.

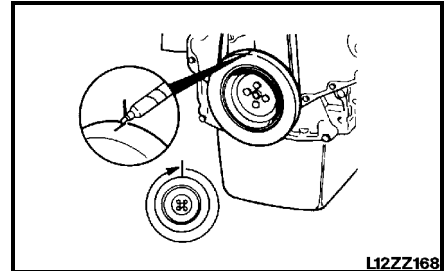

Adjust the valves as indicated in the illustration.

Tighten the lock nut and measure the valve lash again.

**Torque Value:** 24 Nm (18 ft-lb)

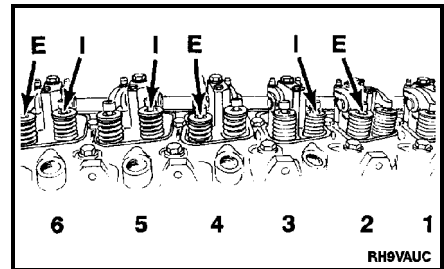

- 7 15 mm wrench  
Install the valve covers and tighten capscrews.

**Torque Value:** 24 Nm (18 ft-lb)

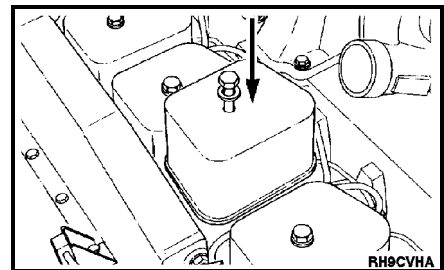

**24.9.10 CLEAN AND CHECK TURBOCHARGER**

If there is carbon or oil sludge stuck to the blower impeller, it will lower the performance of the turbocharger or cause it to break, so ask your Komatsu distributor to carry out the cleaning.

**24.10 EVERY 4000 HOURS SERVICE**

Maintenance for every 50, 100, 250, 500, 1000, and 2000 hours should be carried out at the same time.

**24.10.1 CHECK WATER PUMP**

Check that there is no play in the pulley, grease leakage, coolant leakage, or clogging of the drain hole. If any abnormality is found, please contact your Komatsu distributor for disassembly and repair or replacement.

**- Memoranda -**

# **SPECIFICATIONS**

## SPECIFICATIONS

### 25. SPECIFICATIONS

#### WA120-3

<b>PERFORMANCE</b>			
● Bucket capacity		1.4 m <sup>3</sup> (1.75 cu.yd)	
● Normal load		2240 kg (4940 lb)	
● Travel speed	FORWARD	1st	7.2 km/h (4.5 mph)
		2nd	12.0 km/h (7.5 mph)
		3rd	22.0 km/h (13.7 mph)
		4th	34.9 km/h (21.7 mph)
	REVERSE	1st	7.7 km/h (4.8 mph)
		2nd	12.6 km/h (7.8 mph)
		3rd	22.9 km/h (14.2 mph)
		4th	36.7 km/h (22.8 mph)
● Max. rimpull		7300 kg (71590N)	
● Min. turning radius	Outside of chassis		5180 mm (17 ft)
	Center of outside tire		4470 mm (14 ft 8 in)
● <b>WEIGHT</b>			
● Operating weight (includes 1 operator: 80 kg (176 lb) with bolt on cutting edge)		7810 kg (17220 lb)	
● <b>ENGINE</b>			
● Model		Komatsu S4D102E-1 Diesel Engine	
● Gross horsepower @ 2400 RPM		70kW (105 hp)	
● Net horsepower @ 2400 RPM		63 kW (100 hp)	
● Max. torque (gross) @ 1600 RPM		385 N•m (39.3 kgm)	
● Starter motor		24V 4.5 kW	
● Alternator		24V 50A	
● Battery (quantity 2)		12V 150 Ah	

# SPECIFICATIONS

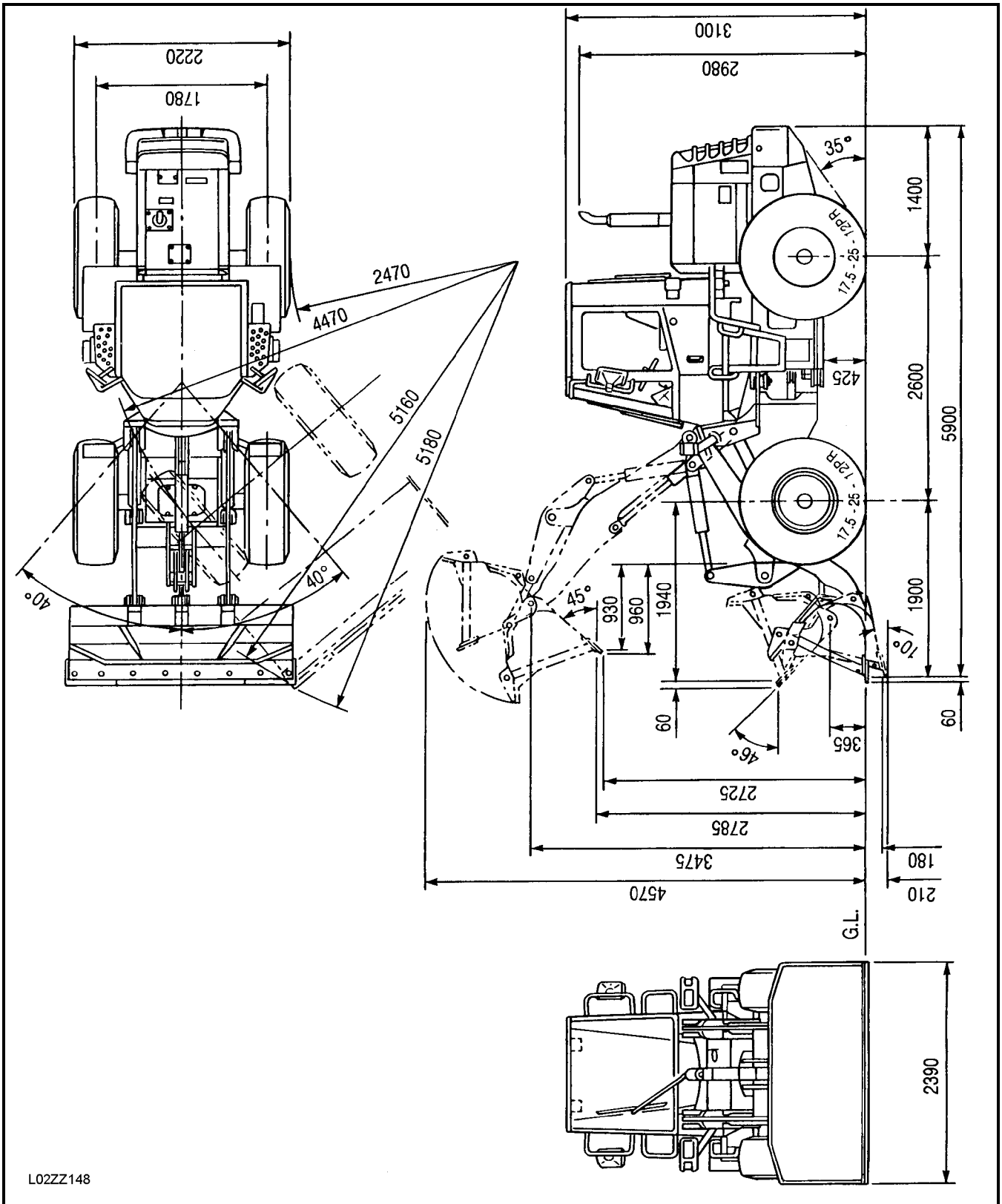

L02ZZ148



**MEMORANDA**

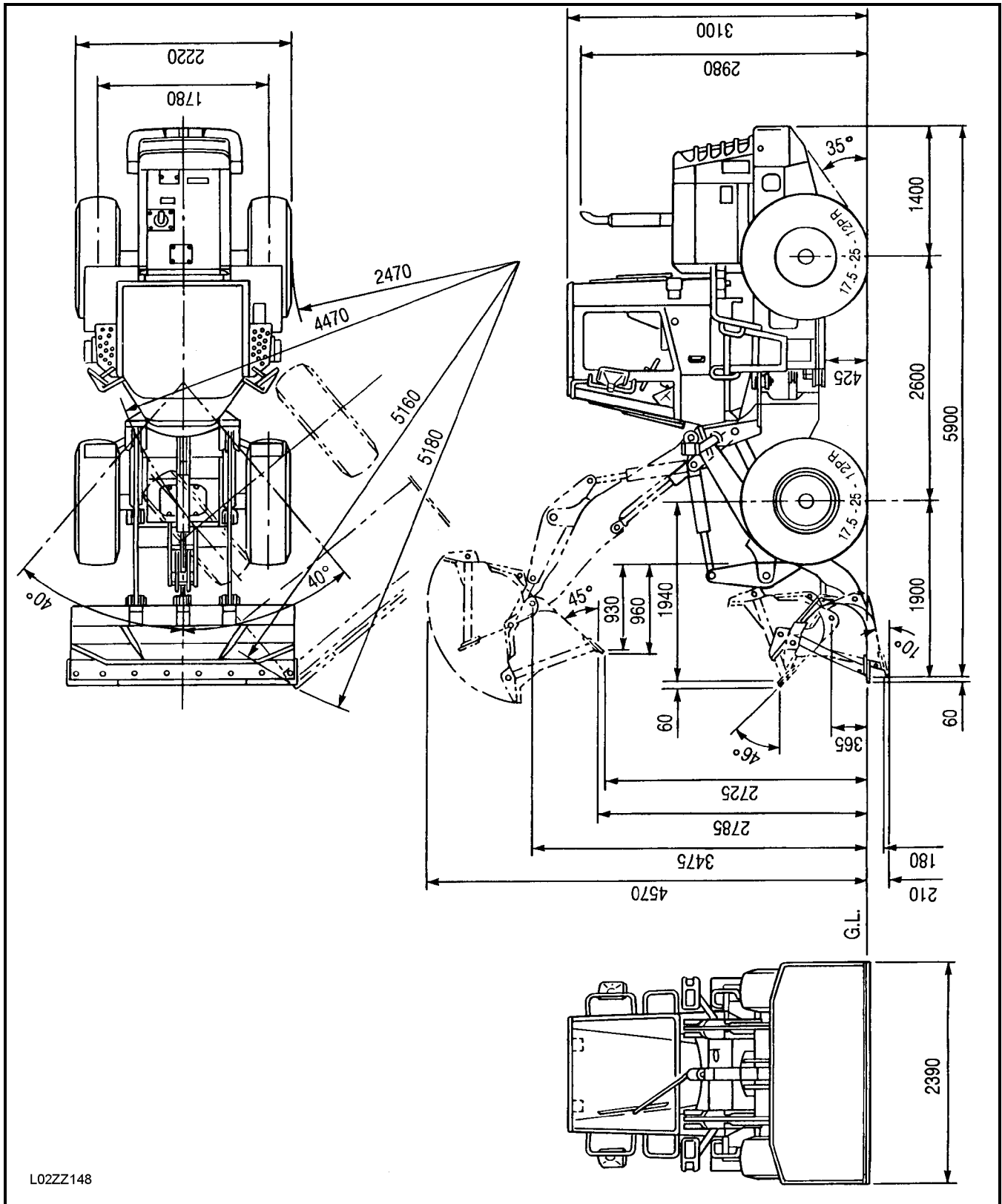

L02ZZ148

**OPTIONS, ATTACHMENTS**

## OPTIONS, ATTACHMENTS

---

### 26. AVAILABLE ATTACHMENTS

NAME	SPECIFICATION, USE
Excavating bucket	Capacity (flat edge for rock) 1.2 m <sup>3</sup> (1.6 cu yd)
Light material bucket	Capacity (for light duty work, snow bucket) 1.7 m <sup>3</sup> (2.2 cu yd)
Bucket tooth	<ul style="list-style-type: none"><li>● Bolt-on tooth</li><li>● Tip tooth</li></ul>
Lumber grapple	Loading and transporting large logs or lumber
Lumber fork	Loading and carrying comparatively small diameter lumber
Dumping fork	Loading and carrying comparatively small diameter lumber

The following attachments are also available.

- ROPS canopy
- Ground driven steering
- Air conditioner
- Heater and defroster
- E.C.S.S. (Electronic controlled suspension system)

Select the most suitable bucket and tires for the type of work and jobsite conditions.

TYPE OF WORK	BUCKET	GROUND CONDITIONS	TIRE
<ul style="list-style-type: none"> <li>● Loading products</li> <li>● Loading and carrying products</li> </ul>	<ul style="list-style-type: none"> <li>● Stockpile bucket 1.4 m<sup>3</sup> (1.8 yd<sup>3</sup>)</li> <li>● Light material bucket 1.7 m<sup>3</sup> (2.2 yd<sup>3</sup>)</li> </ul>	General ground condition	17.5-24-12pr (Traction) 14.00-24-12pr (Traction) 14.00-24-12pr (Traction)
		Level ground	17.5-24-12pr (Traction) 14.00-24-12pr (Traction) 14.00-24-12pr (Traction)
		On soft level ground	17.5-24-12pr (Traction) 14.00-24-12pr (Traction) 14.00-24-12pr (Traction)
		Hard ground	17.5-24-12pr (Rock) 15.5-24-12pr (Rock) 14.00-24-12pr (Rock)
<ul style="list-style-type: none"> <li>● Loading products and crushed rock</li> </ul>	Excavating bucket 1.2 m <sup>3</sup> (1.6 yd <sup>3</sup> )	General ground condition	17.5-24-12pr (Rock) 15.5-24-12pr (Rock) 14.00-24-12pr (Rock)
		Soft ground	17.5-24-12pr (Rock) 15.5-24-12pr (Rock) 14.00-24-12pr (Rock)
		Ground with a lot of rocks	17.5-24-12pr (Rock) 15.5-24-12pr (Rock) 14.00-24-12pr (Rock)
<ul style="list-style-type: none"> <li>● Loading, hauling lumber</li> </ul>	Dumping fork Lumber fork Lumber grapple	General ground condition	17.5-24-12pr (Traction) 14.00-24-12pr (Traction) 14.00-24-12pr (Traction)
		Soft ground	17.5-24-12pr (Traction) 14.00-24-12pr (Traction) 14.00-24-12pr (Traction)

The speed display differs according to tire size, so when using optional tires, please contact your distributor.

## 27. HEATER AND AIR CONDITIONING (IF EQUIPPED)

### 27.1 GENERAL LOCATION AND FUNCTION OF CONTROL PANEL

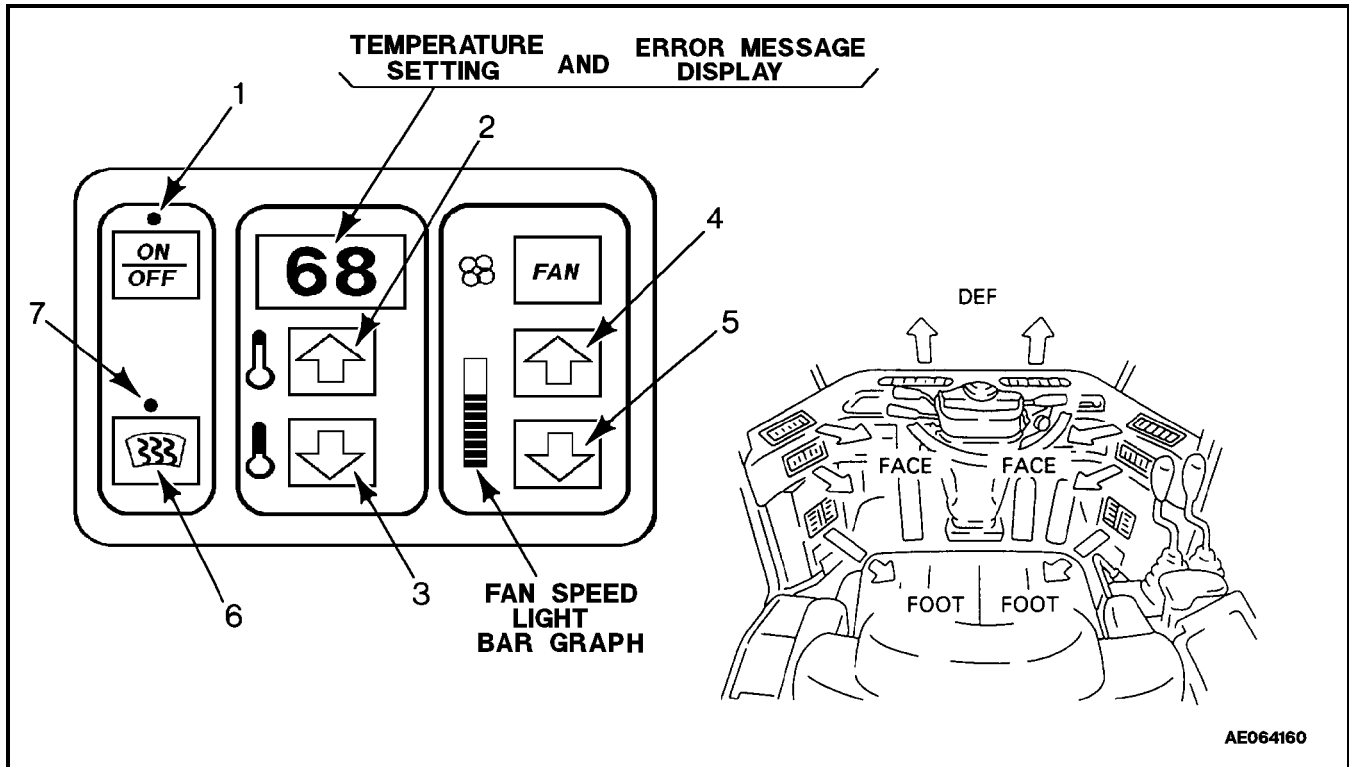

1. Press the "ON/OFF" square and light (1) and the "TEMPERATURE SETTING" will light up to indicate ON mode, press it again and the light will go out to indicate OFF mode.
2. Press "ARROW UP" (2) to increase the temperature setting, press "ARROW DOWN" (3) to decrease the temperature setting
3. Press the "FAN" square to turn the fan ON and the fan speed light bar graph will light up to indicate fan speed, press it again and the light will go out to indicate OFF mode.
3. Press "ARROW UP" (4) to increase fan speed and the light on the bar graph will go up, press "ARROW DOWN" (5) to decrease the fan speed and the light on the bar graph will go down.
4. Press square (6) for defroster mode and light (7) will light up and the fan speed will automatically jump to maximum high, press it again and the light will go out to indicate OFF mode.  
This feature causes the controller to cycle every 3 minutes, with the heat valve open, to remove humidity from the cab. The heat valve is cycled normally, during 3 minutes intervals, to maintain temperature set point. When activated the fan automatically increases to highest position. The fans can then be adjusted down and up. After deactivating defrost. the fans will return to the position set before activation.
5. Defroster (6), up arrow (2), and down arrow (3) when pressed simultaneously it will toggle the temperature units between FAHRENHEIT and CELSIUS.

- 6 Defroster (6) and down Arrow (3) when pressed simultaneously it will show whether the evaporator thermostat is open (OP) or closed (CL).  
OP Displayed - Clutch not engaged / coil to cold  
CL Displayed - Clutch is engaged / coil is at temperature set point, (opening temperature).
7. Arrow up (2) and arrow down (3) when pressed simultaneously, shows ambient inside cab temperature reading from thermistor probe.
- 8 **ERROR MESSAGES**  
(Will display in the temperature setting window)  
  
**EO** - Indicates a loss of power to the electric condenser fan.  
**E1** - Indicates an excessively low or high refrigerant pressure.

### 27.2 COOL BOX COMPARTMENT

When the air conditioner cooling is being used, this compartment can be used for keeping drinks and other things cool.

When the heater is being used, this compartment could help keep things warm.

When using the compartment open the vent grill. When not using the compartment close the vent grill.

It is not recommended to use the cool box compartment for things that smell, leak water or break easily, or for tools and small objects.

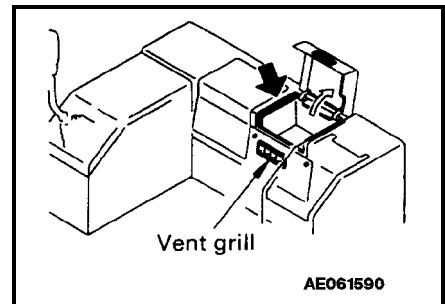

## 28. HANDLING E.C.S.S. (ELECTRONIC CONTROLLED SUSPENSION SYSTEM)

Always read this section before using the E.C.S.S. in order to enable you to use it safely and effectively.

### 28.1 STRUCTURE AND FUNCTION OF E.C.S.S.

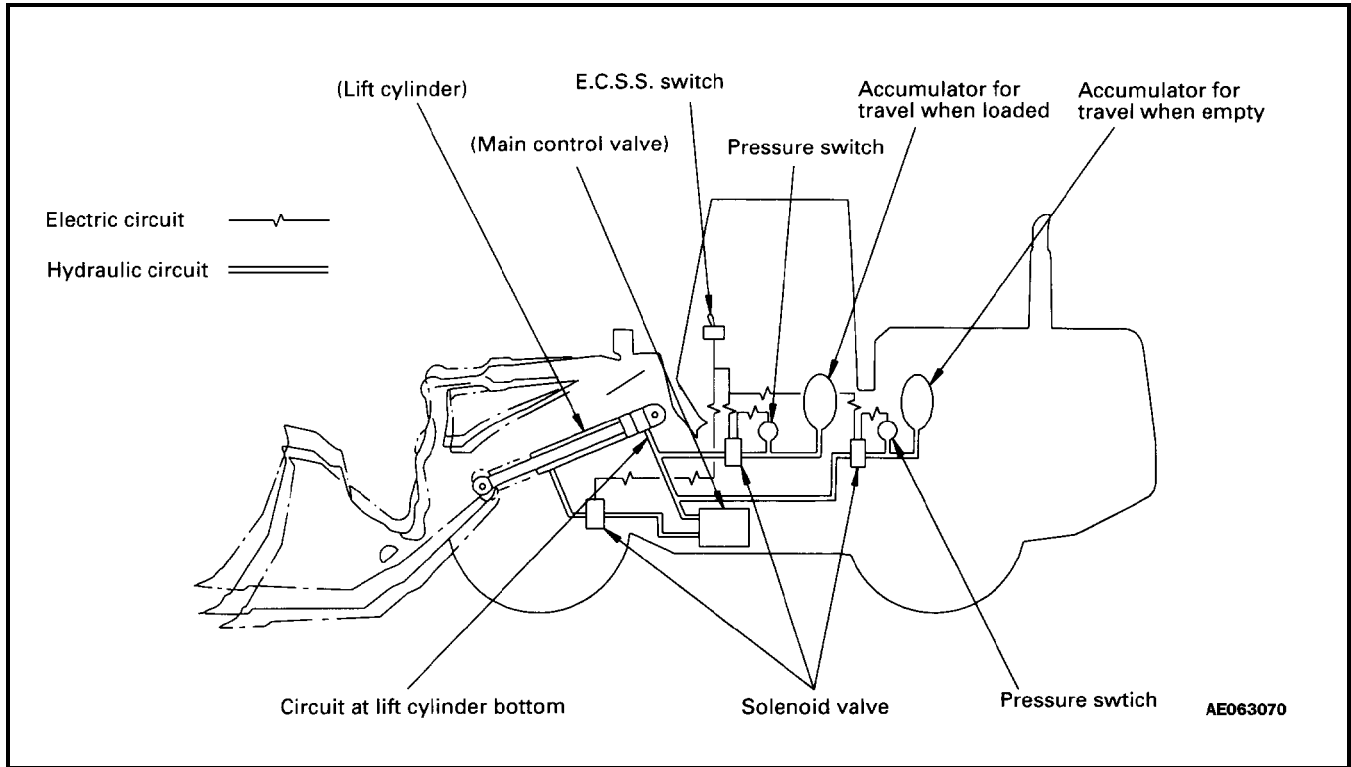

- The E.C.S.S. uses the hydraulic spring effect of the hydraulic accumulator installed to the circuit at the lift cylinder bottom to absorb the vibration of the chassis when the machine is traveling. This enables the machine to travel smoothly at high speed.
- The E.C.S.S. consist of the E.C.S.S. switch, hydraulic accumulator, solenoid valves, and pressure switches. When the E.C.S.S. switch is turned ON, the solenoid valves open, the circuit at the lift cylinder bottom is connected with the hydraulic accumulator, and the E.C.S.S. is actuated. When the E.C.S.S. switch is turned OFF, the solenoid valves close, the circuit at the lift cylinder bottom is shut off from the hydraulic accumulator, and the E.C.S.S. is not actuated.
- When the E.C.S.S. is actuated, the pressure switches automatically open and the close the solenoid valves in accordance with the bucket load to switch the accumulators. If the bucket is empty, the hydraulic accumulator for travel when empty is actuated; and if the machine is loaded, the hydraulic accumulator for travel when loaded is actuated. This enables the damper to provide the most effective absorption of the travel vibration both when traveling empty and when traveling loaded.



## 28.2 METHOD OF OPERATING E.C.S.S.

The E.C.S.S. switch is at the top of the console box on the right side of the operator's compartment.

- (1) OFF: E.C.S.S. cannot be actuated
- (2) ON: E.C.S.S. is in actuation condition
- It is possible to carry out operation with the E.C.S.S. switch kept ON. If the damper is kept ON during operations, and the hydraulic pressure in the circuit at the bottom end of the lift cylinder exceeds 14710 kpa (150 kg/cm<sup>2</sup>, 2130 psi) during operations, the solenoid valves are automatically closed, and the E.C.S.S. is canceled to protect the hydraulic accumulator from high pressure.

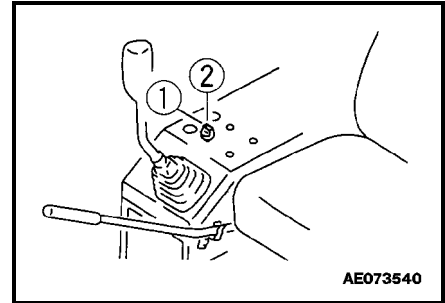

## 28.3 PRECAUTIONS WHEN OPERATING E.C.S.S.

**⚠ WARNING**

- If the E.C.S.S. switch is turned ON when the machine is traveling or when the work equipment is raised, the hydraulic accumulator for the E.C.S.S. is immediately connected to the circuit at the bottom of the lift cylinder, and the oil enters or leaves the hydraulic accumulator in the direction to maintain the balance. This means that the work equipment will move, so be extremely careful when operating the switch.
- If operations are carried out with E.C.S.S. switch kept ON, and the hydraulic accumulator is automatically switched by the action of the pressure switches during operation, the work equipment could immediately move.
- Never carry out inspection and maintenance with the E.C.S.S. switch kept ON. This is extremely dangerous, as the work equipment could move.

- Always stop the machine and lower the equipment to the ground before operating the E.C.S.S. switch.
- When carrying out inspection and maintenance, also lower the work equipment to the ground then turn the E.C.S.S. switch OFF before starting the maintenance operation.

### REMARKS:

- If the starting switch is at the OFF position the E.C.S.S. will not work even if the E.C.S.S. switch is at the ON position. However, if the starting switch is at the ON position it is possible for the E.C.S.S. to be actuated, so it will switch to the actuation condition if the E.C.S.S. switch is turned ON.

### 28.4 PRECAUTIONS WHEN HANDLING ACCUMULATOR

 **WARNING**

The accumulator is charged with high-pressure nitrogen gas, which is extremely dangerous, so read the following items and be careful to handle the accumulator properly.

- If any problem or failure occurs with the accumulator, contact your distributor immediately.
- The gas must be charged into the accumulator only by a qualified serviceman from your distributor or by a person licensed to handle high-pressure gas.
- Do not bring any flame or heat close to the accumulator when it is charged with gas.
- Do not make any hole in; or weld anything to, the accumulator.
- Always release the gas before disposing of the accumulator or disassembling it for maintenance.
- Use the air bleed valve to release the gas
- Every 2000 hours or once a year, have your distributor check the gas pressure.

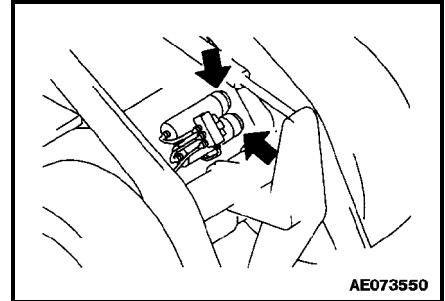

**PROPOSAL FOR MANUAL REVISION**

FOR INTERNAL USE ONLY -- No. PMR

<b>P R O P O S E R</b>	NAME OF COMPANY:	LOCATION:			
		PHONE NO:			
	DEPARTMENT:	DATE:			
	NAME:				
	MANUAL NAME:				
MANUAL NO:					
MACHINE MODEL: S/N IF APPLICABLE:					
PAGE NO:					
PROBLEM:					
Attach photo or sketch. If more space is needed, use another sheet.					
FOR INTERNAL USE ONLY					
CORRECTIVE ACTION:					
