

# Operation & Maintenance Manual

# 330M

**DUMP TRUCK**

SERIAL NUMBERS **A10212 - A10223**

**KOMATSU®**



## FOREWORD

This Manual is written for use by the operator and/or the service technician and is designed to help these persons to become fully knowledgeable of the truck and all its systems in order to keep it operating safely and efficiently.

All operators and maintenance personnel should read and understand the materials in this manual before operating the truck or performing maintenance and/or operational checks on the truck. All safety notices, warnings and cautions should be understood and followed when operating or accomplishing repairs on the truck.

The first section is an Introduction to the manual and contains a Table of Contents to locate specific areas of interest. Other sections include Safety, Operation, Maintenance, Specifications, and Optional Equipment.

The illustrations used in this manual are *TYPICAL* of the component shown and may not be an exact reproduction of what is found on the truck.

This manual shows dimensioning of metric and (U.S. standard) units throughout. All references to "Right", "Left", "Front", or "Rear" are made with respect to the operator's normal seated position, unless specifically stated otherwise.

Standard torque requirements are shown in torque charts in the Introduction section and individual torques are provided in the text in bold face type, such as **723 kg.m (100 ft.lbs.)** torque. All torque specifications have  $\pm 10\%$  tolerance unless otherwise specified.

A Product Identification plate is normally located on the truck frame upright in front of the left side front wheel and designates the Truck Model Number, Product Identification Number (vehicle serial number), and Maximum G.V.W. (Gross Vehicle Weight) rating.

The KOMATSU Haulpak Truck Model designation consists of three numbers and one letter (i.e. 330M).

The three numbers represent the basic truck model. The letter "M" designates a Mechanical drive and the letter "E" designates an Electrical wheelmotor drive system.

The Product Identification Number (vehicle serial number) contains information which will identify the original manufacturing bill of material for this unit. This complete number will be necessary for proper ordering of many service parts and/or warranty consideration.

The Gross Vehicle Weight (GVW) is what determines the load on the drive train, frame, tires, and other components. The vehicle design and application guidelines are sensitive to the total maximum **Gross Vehicle Weight (GVW)** and this means the **TOTAL WEIGHT: the Empty Vehicle Weight + the fuel & lubricants + the payload**.

To determine allowable payload:

Service all lubricants for proper level and fill fuel tank of empty truck (which includes all accessories, body liners, tailgates, etc.) and then weigh truck.

Record this value and subtract from the GVW rating. The result is the allowable payload.

*NOTE: Accumulations of mud, frozen material, etc. become a part of the GVW and reduces allowable payload. To maximize payload and to keep from exceeding the GVW rating, these accumulations should be removed as often as practical.*

**Exceeding the allowable payload will reduce expected life of truck components.**

### **⚠ WARNING**

**Unsafe use of this machine may cause serious injury or death. Operators and maintenance personnel must read this manual before operating or maintaining this machine. This manual should be kept in or near the machine for reference and periodically reviewed by all personnel who come in contact with it.**



*This “ALERT” symbol is used with the signal words, “CAUTION”, “DANGER”, and “WARNING” in this manual to alert the reader to hazards arising from improper operating and maintenance practices.*



*“DANGER” identifies a specific potential hazard  
WHICH WILL RESULT  
in either INJURY OR DEATH  
if proper precautions are not taken.*



*“WARNING” identifies a specific potential hazard  
WHICH MAY RESULT  
in either INJURY OR DEATH  
if proper precautions are not taken.*



*“CAUTION” is used for general reminders  
of proper safety practices  
OR  
to direct the reader’s attention to avoid unsafe  
or improper practices which may result  
in damage to the equipment.*

# TABLE OF CONTENTS

**SUBJECT . . . . . SECTION / PAGE**

**INTRODUCTION . . . . . SECTION 1**

Foreword . . . . . 1-1

ALERTS Page - a description of the DANGER, WARNING, and CAUTION symbols used in this manual. 1-2

TABLE OF CONTENTS . . . . . 1-3

Truck Model Illustration . . . . . 1-6

About This Manual . . . . . 1-7

STANDARD CHARTS and TABLES . . . . . 1-9

**SAFETY . . . . . SECTION 2**

Safety records of most organizations will show that the greatest percentage of accidents are caused by unsafe acts of persons. The remainder are caused by unsafe mechanical or physical conditions. Report all unsafe conditions to the proper authority. These safety rules are provided as a guide for the Haulpak Truck operator. However, local conditions and regulations may add many more to this list.

GENERAL SAFETY . . . . . 2-1

PRECAUTIONS DURING OPERATION . . . . . 2-5

    Operating Machine . . . . . 2-7

    Battery . . . . . 2-10

    Towing . . . . . 2-11

PRECAUTIONS FOR MAINTENANCE . . . . . 2-12

    Before Carrying Out Maintenance . . . . . 2-12

    During Maintenance . . . . . 2-13

    Tires . . . . . 2-16

WARNING, CAUTION, and Instruction Plates / Decals . . . . . 2-17

**OPERATION . . . . . SECTION 3**

This portion of the manual covers Identification, location, and operation of the controls, switches, and indicators in the Operator's Cab and use / function of these controls, switches, and indicators.

OPERATING INSTRUCTIONS

    Preparing For Operation . . . . . 3-1

    Safety Is Thinking Ahead . . . . . 3-1

    At The Truck - Ground Level Walk-Around Inspection . . . . . 3-1

ENGINE START-UP SAFETY PRACTICES . . . . . 3-5

AFTER ENGINE HAS STARTED . . . . . 3-7

MACHINE OPERATION SAFETY PRECAUTIONS . . . . . 3-8

LOADING . . . . . 3-8

HAULING . . . . . 3-9

PASSING . . . . . 3-10

DUMPING . . . . . 3-10

SAFE PARKING PROCEDURES . . . . . 3-11

SHUTDOWN PROCEDURE . . . . . 3-11

TOWING . . . . . 3-12

BRAKE RELEASE . . . . . 3-12

RELEASE OF PARKING BRAKE . . . . . 3-13

RELEASE OF EMERGENCY BRAKE . . . . . 3-13

## TABLE OF CONTENTS (Continued)

**SUBJECT . . . . . SECTION / PAGE**

**OPERATION (Continued) . . . . . SECTION 3**

- OPERATOR CAB and CONTROLS . . . . . 3-15
  - STEERING WHEEL AND CONTROLS (Figure 3-1) . . . . . 3-15
  - RETARDER CONTROL LEVER . . . . . 3-16
  - SERVICE BRAKE PEDAL . . . . . 3-16
  - THROTTLE PEDAL . . . . . 3-16
  - CENTER CONSOLE AND CONTROLS (Figure 3-2) . . . . . 3-16
  - ENGINE ELECTRICAL CONTROL SYSTEM . . . . . 3-20
    - Determining "FAULT" Codes . . . . . 3-21
    - Exiting The Diagnostics Mode . . . . . 3-21
  - DIFFERENTIAL LOCK PEDAL . . . . . 3-21
  - HOIST CONTROL VALVE . . . . . 3-22
    - Safety Lock . . . . . 3-22
  - OPERATOR SEAT (Figure 3-3) . . . . . 3-23
- INSTRUMENT PANEL AND INDICATOR LIGHTS . . . . . 3-25
- GAUGE AND MONITOR PANEL (Figure 3-4) . . . . . 3-26
- INDICATORS AND CONTROLS PANEL (Figures 3-5) . . . . . 3-27
- INDICATORS AND CONTROLS PANEL (Figures 3-6, -7) . . . . . 3-30
- INSTRUMENT PANEL, RIGHT SIDE (Figure 3-8) . . . . . 3-35

**MAINTENANCE . . . . . SECTION 4**

This portion of the manual pertains mainly to the periodic Lubrication and Service required to keep the truck operating at its design potential. Routine lubrication and maintenance procedures are provided in this section. For major repairs, refer to the appropriate section in the Truck Shop Manual.  
Refer to the engine shop manual when servicing the engine.

- LUBRICATION AND SERVICE . . . . . 4-1
  - Lubrication Chart . . . . . 4-2
  - 10 HOUR (SHIFT) Lubrication And Maintenance Checks . . . . . 4-3
  - 250 HOUR Lubrication And Maintenance Checks . . . . . 4-9
  - 500 HOUR Lubrication And Maintenance Checks . . . . . 4-11
  - 1000 HOUR Lubrication And Maintenance Checks . . . . . 4-12
  - 2000 HOUR Lubrication And Maintenance Checks . . . . . 4-13
  - 5000 HOUR Lubrication And Maintenance Checks . . . . . 4-14
- HYDRAULIC TANK SERVICE . . . . . 4-15
- HIGH PRESSURE HYDRAULIC FILTER SERVICE . . . . . 4-17
- TRANSMISSION FILTER SERVICE . . . . . 4-19
- PERODIC REPLACEMENT OF COMPONENT PARTS FOR SAFETY DEVICES . . . . . 4-20
  
- BRAKE CIRCUIT CHECKOUT AND ADJUSTMENT . . . . . 4-21
  - CHECKING FRONT BRAKE PAD WEAR . . . . . 4-21
  - CHECKING REAR BRAKE DISC WEAR . . . . . 4-22
  - BRAKE SYSTEM BLEEDING . . . . . 4-23
  - PARKING BRAKE INSPECTION AND ADJUSTMENT . . . . . 4-24

**TABLE OF CONTENTS (Continued)**

**SUBJECT . . . . . SECTION / PAGE**

**SPECIFICATIONS . . . . . SECTION 5**

This portion of the manual covers major component descriptions and truck specifications.

Major Component Descriptions . . . . .	5-1
Specifications . . . . .	5-3

**OPTIONAL EQUIPMENT . . . . . SECTION 6**

This portion of the manual covers operation/maintenance of OPTIONAL EQUIPMENT.

PAYLOAD METER II INDEX . . . . .	6-1
PAYLOAD METER II . . . . .	6-3 -- 6-34

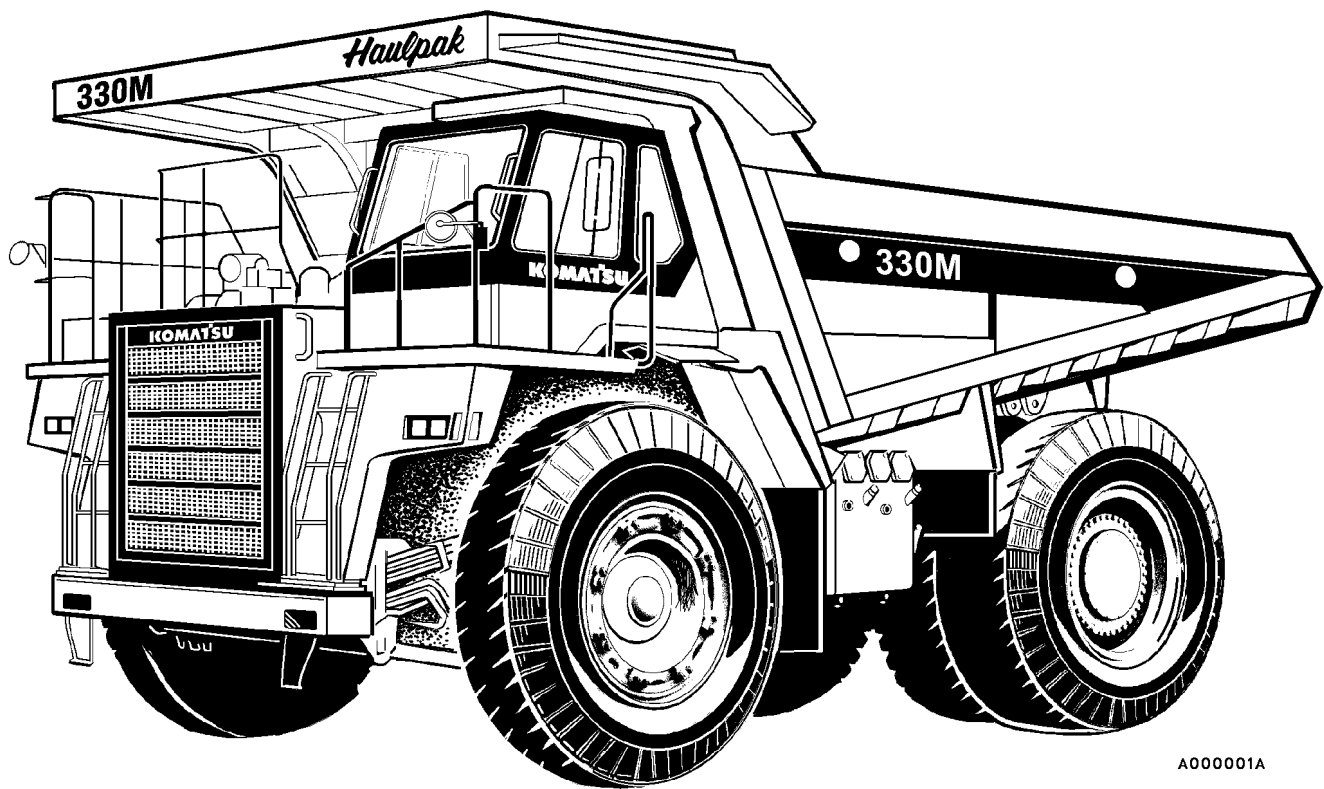

A000001A

## KOMATSU 330M HAULPAK TRUCK



## About This Manual

This Manual is written for use by the operator and/or the service technician and is designed to help these persons to become fully knowledgeable of the truck and all its systems in order to keep it operating safely and efficiently. All operators and maintenance personnel should read and understand the materials in this manual before operating the truck or performing maintenance and/or operational checks on the truck. All safety notices, warnings, and cautions should be understood and followed when operating or accomplishing repairs on the truck.

The front cover of this manual includes a Form Number. This Form No. should be referenced when ordering additional copies of this manual, or for any other correspondence regarding the coverage in this manual.

Direct all inquiries to:

Komatsu Mining Systems, Inc.  
Peoria Operations, Service Publications  
P.O. Box 240  
Peoria, IL 61650-0240  
(309)-672-7072 – FAX

This first section is an Introduction to the manual and contains a Table of Contents to locate specific areas of interest. Other sections include Safety, Operation, Maintenance, Specifications, and Optional Equipment.

When searching for a specific area of interest, go first to the Table of Contents to locate the Section in which the subject might generally be included. Then, go to that Section of the Table of Contents to find a Subject description that most closely describes the specific area of interest to find a page number and go to that page. Section Numbers and Page Numbers are located at the top, outside corner of the page. 

 At the top, inside corner of the page is a document (module) number. If there is ever a question regarding the information in a particular Section, refer to the document (module) number, the manual Form No., and use the address shown above to correspond. If there is a date (month/year) behind the document (module) number, that indicates the latest revision date of that page.

The illustrations used in this manual are *TYPICAL* of the component shown and *may not be an exact* reproduction of what is found on the truck.

This manual shows dimensioning of metric and (U.S. standard) units throughout. All references to “Right”, “Left”, “Front”, or “Rear” are made with respect to the operator’s normal seated position, unless specifically stated otherwise.

When assembly instructions are provided without references to torque values, standard torque values should be assumed. Standard torque requirements are shown in torque charts on the following pages of this section, and in the General Information section of the truck service manual. Individual torques when provided in the text are in bold face type, such as **723 kg.m (100 ft.lbs.)** torque. All torque specifications have  $\pm 10\%$  tolerance unless otherwise specified.

---

# NOTES

## STANDARD TABLES

This manual provides dual dimensioning for many specifications. Metric units are specified first, with U.S. standard units in parentheses. References throughout the manual to standard torques or other standard values will be to one of the following Tables.

For values not shown in any of the charts or tables, standard conversion factors for most commonly used measurements are provided in the conversion table below.

### INDEX OF TABLES

	Page
TABLE I STANDARD TIGHTENING TORQUE ..... For Capscrews and Nuts	1-10
TABLE II STANDARD TIGHTENING TORQUE ..... For Split Flange Bolts	1-10
TABLE III ..... TIGHTENING TORQUE FOR ... Flared Tube And Hose Fittings	1-10
TABLE IV TEMPERATURE CONVERSIONS	1-11
TABLE V ..... TORQUE CONVERSIONS .. kilogram.meters To foot pounds	1-11
TABLE VI ..... TORQUE CONVERSIONS kilogram.meters To Newton.meters	1-11
TABLE VII .... PRESSURE CONVERSIONS ..... kg/cm <sup>2</sup> To (psi)	1-12
TABLE VIII .... PRESSURE CONVERSIONS ..... kg/cm <sup>2</sup> To kPa	1-12
TABLE IX ... PRESSURE CONVERSIONS ..... psi To kPa	1-12

COMMON CONVERSIONS		
TO CONVERT FROM	TO	MULTIPLY BY
millimeter (mm)	inch - in.	0.0394
centimeter (cm)	inch - in.	0.3937
meter (m)	foot - ft.	3.2808
meter (m)	yard - yd.	1.0936
kilometer (km)	mile - mi.	0.6210
sq. centimeters (cm <sup>2</sup> )	sq. in. - in. <sup>2</sup>	0.1550
sq. centimeters (cm <sup>2</sup> )	sq. ft. - ft. <sup>2</sup>	0.001
cu. centimeters (cm <sup>3</sup> )	cu. in. - in. <sup>3</sup>	0.061
liters (l)	cu. in. - in. <sup>3</sup>	61.02
cu. meters (m <sup>3</sup> )	cu. ft. - ft. <sup>3</sup>	35.314
liters (l)	cu. ft. - ft. <sup>3</sup>	0.0353
grams (g)	ounce - oz.	0.0353
milliliter (ml)	fluid ounce - fl. oz.	0.0338
kilogram (kg)	pound (mass)	2.2046
Newton (N)	pound (force) - lbs.	0.2248
Newton.meters (N.m)	kilogram.meters (kg.m)	0.102
Newton.meters (N.m)	ft. lbs. (force)	0.7376
kilogram.meters (kg.m)	ft. lbs. (force)	7.2329
kilogram.meters (kg.m)	Newton.meters (N.m)	9.807
kilopascals (kPa)	psi (pressure)	0.1450
megapascals (MPa)	psi (pressure)	145.038
kilograms/cm <sup>2</sup> (kg/cm <sup>2</sup> )	psi (pressure)	14.2231
kilograms/cm <sup>2</sup> (kg/cm <sup>2</sup> )	kilopascals (kPa)	98.068
kilogram (kg)	ton (short)	0.0011
metric ton	ton (short)	1.1023
liters (l)	quart - qt.	1.0567
liters (l)	gallon - gal.	0.2642
Watts	HP (horsepower)	0.00134
kilowatts (kW)	HP (horsepower)	1.3410



**TABLE I**  
**STANDARD TIGHTENING TORQUE FOR**  
**METRIC HEX HEAD CAPSCREW AND NUT ASSEMBLY**



Capscrew Thread Diameter (mm)	Width Across Flat (mm)	Kilogram.meters (kg.m) Tolerances $\pm 10\%$	Newton.meters (N.m) Tolerances $\pm 10\%$	Foot Pounds (ft.lbs.) Tolerances $\pm 10\%$
6	10	1.35	13.2	10
8	13	3.2	31.4	23
10	17	6.7	65.7	48
12	19	11.5	112	83
14	22	18.0	177	130
16	24	28.5	279	206
18	27	39.0	383	282
20	30	56.0	549	405
22	32	76.0	745	550
24	36	94.5	927	684
27	41	135	1320	975
30	46	175	1720	1266
33	50	225	2210	1630
36	55	280	2750	2025
39	60	335	3280	2420

This Table represents standard values only.  
Do not use these values to replace torque values which are specified in the Service Manual instructions.

**TABLE II**  
**TIGHTENING TORQUE FOR SPLIT FLANGE BOLTS**

Capscrew Thread Diameter (mm)	Width Across Flat (mm)	Kilogram.meters (kg.m) Tolerances $\pm 10\%$	Newton.meters (N.m) Tolerances $\pm 10\%$	Foot Pounds (ft.lbs.) Tolerances $\pm 10\%$
10	14	6.7	65.7	48
12	17	11.5	112	83
16	22	28.5	279	206

This Table represents standard values only.  
Do not use these values to replace torque values which are specified in the Service Manual instructions.

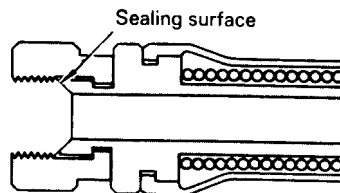

**TABLE III**  
**TIGHTENING TORQUE FOR FLARED TUBE AND HOSE FITTINGS**

Thread Diameter of Nut (mm)	Width Across Flat (mm)	Kilogram.meters (kg.m) Tolerances $\pm 10\%$	Newton.meters (N.m) Tolerances $\pm 10\%$	Foot Pounds (ft.lbs.) Tolerances $\pm 10\%$
14	19	2.5	25	18
18	24	5	50	36
22	27	8	80	58
24	32	14	140	101
30	36	18	175	130
33	41	20	195	145
36	46	25	245	180
42	55	30	295	215

TABLE IV TEMPERATURE CONVERSIONS								
FORMULA: $F^{\circ} - 32 \div 1.8 = C^{\circ}$ $C^{\circ} \times 1.8 + 32 = F^{\circ}$								
CELSIUS C°		FAHRENHEIT F°	CELSIUS C°		FAHRENHEIT F°	CELSIUS C°		FAHRENHEIT F°
121	250	482	63	145	293	4	40	104
118	245	473	60	140	284	2	35	95
116	240	464	57	135	275	-1	30	86
113	235	455	54	130	266	-4	25	77
110	230	446	52	125	257	-7	20	68
107	225	437	49	120	248	-9	15	59
104	220	428	46	115	239	-12	10	50
102	215	419	43	110	230	-15	5	41
99	210	410	41	105	221	-18	0	32
96	205	401	38	100	212	-21	-5	23
93	200	392	35	95	203	-23	-10	14
91	195	383	32	90	194	-26	-15	5
88	190	374	29	85	185	-29	-20	-4
85	185	365	27	80	176	-32	-25	-13
82	180	356	24	75	167	-34	-30	-22
79	175	347	21	70	158	-37	-35	-31
77	170	338	18	65	149	-40	-40	-40
74	165	329	15	60	140	-43	-45	-49
71	160	320	13	55	131	-46	-50	-58
68	155	311	10	50	122	-48	-55	-67
66	150	302	7	45	113	-51	-60	-76

NOTE: The numbers in the unmarked columns refer to temperature in either degrees Celsius (C°) or Fahrenheit, F°. Select a number in this unmarked column and read to the left to convert to degrees Celsius (C°) or read to the right to convert to degrees Fahrenheit, F°. If starting with a known temperature (either C° or F°), find that temperature in the **marked** column and read the converted temperature in the center, **unmarked** column.

TABLE V TORQUE CONVERSIONS										
kilogram.meter - kg.m To Foot Pounds - (ft.lbs.)										
1 kg.m = 7.2339 ft.lbs.										
kg.m	0	1	2	3	4	5	6	7	8	9
0	(ft. lbs.)	7.23	14.5	21.7	28.9	36.2	43.4	50.6	57.9	65.1
10	72.3	79.6	86.8	94.0	101.3	108.5	115.7	123.0	130.2	137.4
20	144.7	151.9	159.1	166.4	173.6	180.8	188.1	195.3	202.5	209.8
30	217.0	224.2	231.5	238.7	245.9	253.2	260.4	267.6	274.9	282.1
40	289.3	296.5	303.8	311.0	318.2	325.5	332.7	339.9	347.2	354.4
50	361.6	368.9	376.1	383.3	390.6	397.8	405.0	412.3	419.5	426.7
60	434.0	441.2	448.4	455.7	462.9	470.1	477.4	484.6	491.8	499.1
70	506.3	513.5	520.8	528.0	535.2	542.5	549.7	556.9	564.2	571.4
80	578.6	585.9	593.1	600.3	607.6	614.8	622.0	629.3	636.5	643.7
90	651.0	658.2	665.4	672.7	679.9	687.1	694.4	701.6	708.8	716.1

TABLE VI TORQUE CONVERSIONS										
kilogram.meter - kg.m To Newton.meters (N.m)										
1 kg.m = 9.807 N.m										
kg.m	0	1	2	3	4	5	6	7	8	9
0	(N.m)	9.8	19.6	29.4	39.2	49.0	58.8	68.6	78.5	88.3
10	98.1	107.9	117.7	127.5	137.3	147.1	156.9	166.7	176.5	186.3
20	196.1	205.9	215.8	225.6	235.4	245.2	255.0	264.8	274.6	284.4
30	294.2	304.0	313.8	323.6	333.4	343.2	353.1	362.9	372.7	382.5
40	392.3	402.1	411.9	421.7	431.5	441.3	451.1	460.9	470.7	480.5
50	490.4	500.2	510.0	519.8	529.6	539.4	549.2	559.0	568.8	578.6
60	588.4	598.2	608.0	617.8	627.6	637.5	647.3	657.1	666.9	676.7
70	686.5	696.3	706.1	716.0	725.7	735.5	745.3	755.1	764.9	774.8
80	784.6	794.4	804.2	814.0	823.8	833.6	843.4	853.2	863.0	872.8
90	882.6	892.4	902.2	912.1	921.9	931.7	941.5	951.3	961.1	970.9

TABLE VII PRESSURE CONVERSIONS										
kilograms/cm <sup>2</sup> (kg/cm <sup>2</sup> ) To pounds per sq. in. (psi)										
1 kg/cm <sup>2</sup> = 14.2231 psi										
kg/cm <sup>2</sup>	0	1	2	3	4	5	6	7	8	9
0	(psi)	14.2	28.4	42.7	56.9	71.1	85.3	99.6	113.8	128.0
10		142.2	156.5	170.7	185.0	199.1	213.3	227.6	241.8	256.0
20		284.5	298.7	312.9	327.1	341.4	355.6	369.8	384.0	398.2
30		426.7	440.9	455.1	469.4	483.6	497.8	512.0	526.3	540.5
40		568.9	583.1	597.4	611.6	625.8	640.0	654.3	668.5	682.7
50		711.2	725.4	739.6	753.8	768.0	782.3	796.5	810.7	824.9
60		853.4	867.6	881.8	896.1	910.3	924.5	938.7	952.9	967.2
70		995.6	1009.8	1024.1	1038.3	1052.5	1066.7	1081.0	1095.2	1109.4
80		1137.8	1152.1	1166.3	1180.5	1194.7	1209.0	1223.2	1237.4	1251.6
90		1280.1	1294.3	1308.5	1322.7	1337.0	1351.2	1365.4	1379.6	1393.9

TABLE XIII PRESSURE CONVERSIONS										
kilograms/cm <sup>2</sup> (kg/cm <sup>2</sup> ) To kilopascals (kPa)										
1 kg/cm <sup>2</sup> = 98.068 kPa										
kg/cm <sup>2</sup>	0	1	2	3	4	5	6	7	8	9
0	(kPa)	98	196	294	392	490	588	686	785	883
10		981	1079	1177	1275	1373	1471	1569	1667	1765
20		1961	2059	2157	2256	2354	2452	2550	2648	2746
30		2942	3040	3138	3236	3334	3432	3530	3629	3727
40		3923	4021	4119	4217	4315	4413	4511	4609	4707
50		4903	5001	5100	5198	5296	5394	5492	5590	5688
60		5884	5982	6080	6178	6276	6374	6472	6571	6669
70		6865	6963	7061	7159	7257	7355	7453	7551	7649
80		7845	7944	8042	8140	8238	8336	8434	8532	8630
90		8826	8924	9022	9120	9218	9316	9415	9513	9611

TABLE IX PRESSURE CONVERSIONS										
Pounds/sq. in. [psi] To kilopascals (kPa)										
Formula: psi x 6.895 = kPa										
PSI	0	1	2	3	4	5	6	7	8	9
0	(kPa)	6.895	13.79	20.68	27.58	34.47	41.37	48.26	55.16	62.05
10		68.95	75.84	82.74	89.63	96.53	103.42	110.32	117.21	124.1
20		137.9	144.8	151.7	158.6	165.5	172.4	179.3	186.2	193.1
30		206.8	213.7	220.6	227.5	234.4	241.3	248.2	255.1	262.0
40		275.8	282.7	289.6	296.5	303.4	310.3	317.2	324.1	331.0
50		344.7	351.6	358.5	365.4	372.3	379.2	386.1	393.0	399.9
60		413.7	420.6	427.5	434.4	441.3	448.2	455.1	462.0	468.9
70		482.6	489.5	496.4	503.3	510.2	517.1	524.0	530.9	537.8
80		551.6	558.5	565.4	572.3	579.2	586.1	593.0	599.9	606.8
90		620.5	627.4	634.3	641.2	648.1	655.0	661.9	668.8	675.7

NOTE: Tables such as Table V, VI, VII, VIII, and IX may be used as in the following example:

**Example:** Convert 955 kg.m to foot pounds (ft.lbs.).

1. Select Table V.
2. Go to **kg.m** row **90**, column **5**; read 687.1  
95 kg.m = 687.1 ft.lbs.
3. Multiply by 10:  
950 kg.m = 6871 ft.lbs.
4. Go to **kg.m** row **0**, column **5**; read 36.2  
5 kg.m = 36.2 ft.lbs. Add to step 3.
5. 950 + 5 kg.m = 6871 + 36.2 = 6907.2 ft.lbs.  
955 kg.m = 6907.2 ft.lbs.

<b>SEALANTS AND ADHESIVES</b>			
Nomenclature	Code	Three Bond *	Applications
Adhesives	LT-1A	TB1521	Used to apply rubber pads, rubber gaskets and cork plugs.
	LT-1B	1000B - 1000W	Used to apply resin, rubber, metallic and non-metallic parts when a fast, strong seal is needed.
	LT-2	TB1374	Preventing bolts, nuts and plugs from loosening and leaking oil.
	LT-2A	TB2411	Preventing bolts, nuts and plugs from loosening and leaking oil. (1)
	LT-2B	TB2403	Preventing bolts, nuts and plugs from loosening and leaking oil. (2)
	LT-2C	TB2430 or TB2440	Preventing bolts, nuts and plugs from loosening and leaking oil. (2)
	LT-3 Main bond Hardening agent	TB2001 TB2105	Provides an airtight, electrically insulating seal. Used for aluminum surfaces.
Liquid Gasket	LG-1	TB1108B	Used with gaskets and packings to increase sealing effect.
	LG-3	TB1107	Heat-resistant gasket for precombustion chambers and exhaust piping.
	LG-4	TB1104	Used by itself on mounting surfaces on the final drive and transmission cases. Thickness after tightening: 0.07-0.08 mm (0.0027-0.0032 in)
	LG-5	TB1110	Used by itself to seal grease fittings, tapered screw fittings and tapered screw fittings in hydraulic circuits of less than 50 mm (2 in ) in diameter.
Antifriction compound	LM-P	—	Applied to bearings and taper shafts to facilitate press-fitting and to prevent sticking, burning or rusting.
Grease	G2-LI	—	Applied to bearings, sliding parts and oil seals for lubrication, rust prevention and facilitation of assembling work.
Vaseline	—	—	Used for protecting battery electrode terminals from corrosion.
* NOTE: The Part Numbers in this column are <b>NOT</b> KOMATSU numbers. These are vendor designations.			

(1) Used for threaded areas (for example, plug, nipple, elbow etc.) which are removable and a pressure of 20 kg/cm<sup>2</sup> (285 psi) or less.

(2) Used for threaded areas (for example, stud, etc.) which are not removable and a pressure of 20 kg/cm<sup>2</sup> (285 psi) or less.

The sealants and adhesives listed below are manufactured and sold by Three Bond U.S.A., Inc.  
For information concerning Three Bond products, call or write to:

Three Bond U.S.A., Inc.  
6184 Schumacher Park Drive  
West Chester, OH 45069  
  
Telephone: (513) 779-7300  
Fax: (513) 779-7375

<b>PART NUMBERS</b>	
Three Bond	Komatsu
TB1374	09940-00030
TB1521	790-129-9030
TB1104	790-129-9020
TB1108B	790-129-9010

# NOTES



## GENERAL SAFETY

Safety records of most organizations will show that the greatest percentage of accidents are caused by unsafe acts of persons. The remainder are caused by unsafe mechanical or physical conditions. Report all unsafe conditions to the proper authority.

The following safety rules are provided as a guide for the operator. However, local conditions and regulations may add many more to this list.



***Read and follow all safety precautions. Failure to do so may result in serious injury or death.***

### SAFETY RULES

- ONLY trained and authorized personnel can operate and maintain the machine.
- Follow all safety rules, precautions and instructions when operating or performing maintenance on the machine.
- When working with another operator or a person on work site traffic duty, be sure all personnel understand all hand signals that are to be used.

### SAFETY FEATURES

- Be sure all guards and covers are in their proper position. Have guards and covers repaired if damaged. (See Walk-Around Inspection, Operating Instructions - Section 3)
- Learn the proper use of safety features such as safety locks, safety pins, and seat belts, and use these safety features properly.
- NEVER remove any safety features. ALWAYS keep them in good operating condition.
- Improper use of safety features could result in serious bodily injury or death.

### CLOTHING AND PERSONAL PROTECTIVE ITEMS

- Avoid loose clothing, jewelry, and loose long hair. They can catch on controls or in moving parts and cause serious injury or death. Also, do not wear oily clothes because they are flammable.
- Wear a hard hat, safety glasses, safety shoes, mask or gloves when operating or maintaining the machine. Always wear safety goggles, hard hat and heavy gloves if your job involves scattering metal chips or minute materials--this is so particularly when driving pins with a hammer and when cleaning the air cleaner element with compressed air. Check also that there is no one near the machine.

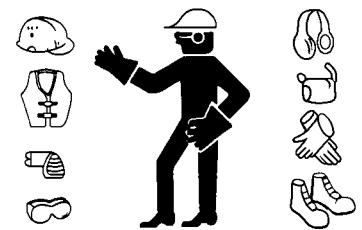

A0055010

### UNAUTHORIZED MODIFICATION

- Any modification made to this vehicle without authorization from Komatsu Mining Systems, Inc. can possibly create hazards.
- Before making any modification, consult the authorized regional Komatsu Mining Systems, Inc. distributor. Komatsu will not be responsible for any injury or damage caused by any unauthorized modification.

## LEAVING THE OPERATOR'S SEAT

- When preparing to leave the operator's seat, do not touch any control lever that is not locked. To prevent accidental operations from occurring, always carry out the following:
- Move the shift control lever to Neutral (N) and set the parking lever/switch to the PARKING position.
- Lower the dump body, set the dump lever to the FLOAT position.
- Stop the engine. When leaving the machine, always lock everything. Always remember to take the key with you. If the machine should suddenly move or move in an unexpected way, this may result in serious bodily injury or death.

## MOUNTING AND DISMOUNTING

- NEVER jump on or off the machine. NEVER get on or off a moving machine.
- When getting on or off the machine, face the machine and use the hand-hold and steps.
- Never hold any control levers when getting on or off the machine.
- Always maintain three-point contact with the hand-holds and steps to ensure that you support yourself.
- When bringing tools to the operator's compartment, always pass them by hand or pull them up by rope.
- If there is any oil, grease, or mud on the hand-holds or steps, wipe it off immediately. Always keep these parts clean. Repair any damage and tighten any loose bolts.
- Use the handrails and steps marked by arrows in the diagram below when getting on or off the machine.
  - A: For use when getting on or off the machine from the left door.
  - B: For use when getting on or off the machine from the engine hood or right door.

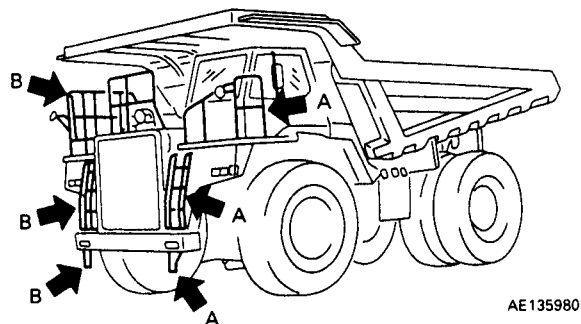

## FIRE PREVENTION FOR FUEL AND OIL

- Fuel, oil, and antifreeze can be ignited by a flame. Fuel is particularly FLAMMABLE and can be HAZARDOUS.
- Keep flame away from flammable fluids.
- Stop the engine and do not smoke when refueling.
- Tighten all fuel and oil tank caps securely.
- Refueling and oiling should be made in well ventilated areas.
- Keep oil and fuel in the determined place and do not allow unauthorized persons to enter.



A0055020



A0055030



A0055040

### PRECAUTIONS WHEN HANDLING AT HIGH TEMPERATURES

- Immediately after operations, the engine cooling water, engine oil, and hydraulic oil are at high temperature and are under pressure. If the cap is removed, or the oil or water is drained, or the filters are replaced, there is danger of serious burns. Always wait for the temperature to cool down, and carry out the operation according to the specified procedure.
- To prevent hot water from spurting out:
  - 1) Stop the engine.
  - 2) Wait for the water temperature to cool down.
  - 3) Turn the cap slowly to release the pressure before removing the cap.
- To prevent hot engine oil from spurting out:
  - 1) Stop the engine.
  - 2) Wait for the oil temperature to cool down.
  - 3) Turn the cap slowly to release the pressure before removing the cap.

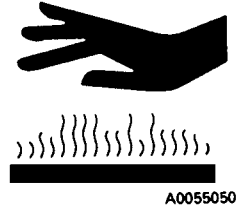

### ASBESTOS DUST HAZARD PREVENTION

Asbestos dust can be HAZARDOUS to your health if it is inhaled. If you handle materials containing asbestos fibers, follow these guidelines as given below:

- NEVER use compressed air for cleaning.
- Use water for cleaning to keep down the dust.
- Operate the machine with the wind to your back, whenever possible.
- Use an approved respirator if necessary.

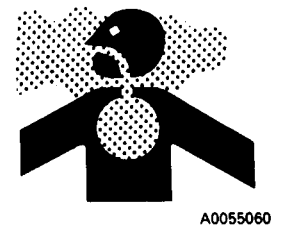

### PREVENTION OF INJURY BY WORK EQUIPMENT

- Never enter or put your hand or arm or any other part of your body between movable parts such as the dump body and chassis or cylinders. If the work equipment is operated, the clearance will change and this may lead to serious bodily injury or death.
- Never work or perform maintenance on machine with the body raised off the frame unless body is fully raised, the Safety Pins are installed, and the hoist lever is locked in the HOLD position.

### FIRE EXTINGUISHER AND FIRST AID KIT

- Be sure fire extinguishers have been provided and know how to use them.
- Provide a first aid kit at the storage point.
- Know what to do in the event of a fire.
- Be sure you know the phone numbers of persons you should contact in case of an emergency.

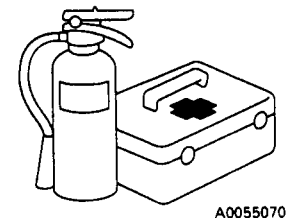

### **PRECAUTIONS WHEN USING ROPS**

- If ROPS is installed, the ROPS must never be removed when operating the machine.
- The ROPS is installed to protect the operator if the machine should roll over. It is designed not only to support the load if the machine should roll over, but also to absorb the impact energy.
- The ROPS installed on equipment manufactured and designed by Komatsu Mining Systems, Inc. fulfills all of the regulations and standards for all countries, but if it is modified or repaired without authorization from Komatsu Mining Systems, Inc., or is damaged when the machine rolls over, the strength will drop and it will not be able to fulfill its function properly. It can only display its performance if it is repaired or modified in the specified way.
- When modifying or repairing the ROPS, always consult the authorized regional Komatsu Mining Systems, Inc. distributor.
- Even if the ROPS is installed, it cannot show its full effect if the operator does not fasten the seat belt properly. Always fasten the seat belt when operating.

### **PRECAUTIONS FOR ATTACHMENTS**

- When installing and using optional equipment, read the instruction manual for the attachment and the information related to attachments in this manual.
- Do not use attachments that are not authorized by Komatsu Mining Systems, Inc., or the authorized regional Komatsu Mining Systems, Inc. distributor. Use of unauthorized attachments could create a safety problem and adversely affect the proper operation and useful life of the machine.
- Any injuries, accidents, and product failures resulting from the use of unauthorized attachments will not be the responsibility of Komatsu Mining Systems, Inc., or the authorized regional Komatsu Mining Systems, Inc. distributor.

## PRECAUTIONS DURING OPERATION

### BEFORE STARTING ENGINE

**Prevention** is the best safety program. Prevent a potential accident by knowing the employer's safety requirements and all necessary job site regulations. In addition, know the proper use and care of all the safety equipment on the truck. Only qualified operators or technicians should attempt to operate or maintain the Komatsu Truck.

Safe practices start before the operator gets to the equipment!

### SAFETY AT WORKSITE

- When walking to and from the truck, maintain a safe distance from all machines even if the operator is visible.
- Before starting the engine, thoroughly check the area for any unusual conditions that could be dangerous.
- Examine the road surface in the job site and determine the best and safest method of operation.
- Choose an area where the ground is as horizontal and firm as possible before carrying out the operation.
- If you need to operate on a road, protect pedestrians and cars by designating a person for work site traffic duty or by installing fences around the work site.
- The operator must check personally the work position, roads to be used, and existence of obstacles before starting operations.
- Always determine the travel roads in the work site and maintain them so that it is always safe for the machines to travel.
- If travel through wet areas is necessary, check the depth and flow of water before crossing the shallow parts. NEVER be in water which is in excess of the permissible water depth.

### FIRE PREVENTION

- Thoroughly remove wood chips, leaves, paper and other flammable things accumulated in the engine compartment. These could cause a fire.
- Check fuel, lubrication, and hydraulic systems for leaks. Have any leaks repaired. Wipe up any excess oil, fuel or other flammable fluids.
- Be sure a fire extinguisher is present and working.
- Do not operate the machine near any flame.



A0055020

### IN OPERATOR'S CAB

- Do not leave tools or spare parts lying around in the operator's compartment. They may damage or break the control levers or switches. Always put them in the tool box on the right side of the machine.
- Keep the cab floor, controls, steps and handrails free of oil, grease, snow, and excess dirt.
- Check the seat belt, buckle and hardware for damage or wear. Replace any worn or damaged parts. Always use seat belts when operating your machine.

### VENTILATION FOR ENCLOSED AREAS

- If it is necessary to start the engine within an enclosed area, provide adequate ventilation. Exhaust fumes from the engine can KILL.



A0055060

## **IN OPERATOR'S CAB - BEFORE STARTING ENGINE**

- Do not leave tools or spare parts lying around in the operator's compartment or allow trash to accumulate in cab of truck. Keep all unauthorized reading material out of truck cab.
- Keep the cab floor, controls, steps, and handrails free of oil, grease, snow, and excess dirt.
- Check the seat belt, buckle and hardware for damage or wear. Replace any worn or damaged parts. Always use seat belts when operating your machine.
- Read and understand the contents of this manual. Read the Section 3 pertaining to safety and operating instructions with special attention. Become thoroughly acquainted with all gauges, instruments and controls before attempting operation of the truck.
- Read and understand the **WARNING** and **CAUTION** decals in the operator's cab.
- Insure steering wheel, horn, controls and pedals are free of any oil, grease or mud.
- Check operation of windshield wiper, condition of wiper blades, and check washer reservoir for fluid level.
- Be familiar with all steering and brake system controls and warning devices, road speeds and loading capabilities, before operating the truck.

## **KEEP MIRRORS, WINDOWS, AND LIGHTS CLEAN**

- Remove any dirt from the windshield, cab windows and lights. Good visibility may prevent an accident.
- Adjust the rear view mirror to a position where the operator can see best from the operator's seat, and keep the surface of the mirror clean. If any glass or light should break, replace it with a new part.
- Insure headlights, work lights and taillights are in proper working order. Check that the machine is equipped with the head lamps and working lamps needed for the operating conditions.

## **OPERATING THE MACHINE**

### **WHEN STARTING ENGINE**

- Walk around your machine just before mounting it. Check for people and objects that might be in the way.
- NEVER start the engine if a warning tag has been attached to the control.
- When starting the engine, sound the horn as an alert.
- Start and operate the machine only while seated.
- Do not allow any person other than the operator in the operator's compartment or any other place on the machine.
- For machines equipped with a back-up alarm buzzer, check that the alarm buzzer works properly.

### **Truck Operation - General**

- **WEAR SEAT BELTS AT ALL TIMES.**
- Only authorized persons are allowed to ride in truck. Riders should be in cab only and belted in passenger seat.
- Do not allow anyone to ride on decks or steps of truck.
- Do not allow anyone to get on or off truck while it is in motion.
- Do not move truck into or out of a building without a signal person present.
- Know and obey the hand signal communications between operator and spotter. When other machines and personnel are present, the operator should move in and out of buildings, loading areas and through traffic, under the direction of a signal person. **Courtesy at all times is a safety precaution!**
- Report immediately to supervisor any conditions on haul road, pit or dump area that may cause an operating hazard.

- Check for flat tires periodically during shift. If truck has been run on a “flat”, **it must not be parked in a building until the tire cools**. If tire must be changed, do not stand in front of rim and locking ring when inflating tire mounted on the machine. Observers should not be permitted in the area and should be kept away from the side of such tires.



***Tire and rim assembly may explode if subjected to excessive heat. Personnel should move to a remote or protected location if sensing excessively hot brakes, smell of burning rubber or evidence of fire near tire and wheel area.***

***If the truck must be approached, such as to fight a fire, those personnel should do so only while facing the tread area of the tire (front or back), unless protected by use of large heavy equipment as a shield. Stay at least 50 ft. (15 m) from the tread of the tire.***

***In the event of fire in the tire and wheel area (including brake fires), stay away from the truck at least 8 hours or until the tire and wheel are cool.***

- Keep serviceable fire fighting equipment at hand. Report used extinguishers for replacement or refilling.
- Always have parking brake applied when the truck is parked and unattended. **DO NOT** leave truck unattended while engine is running.
- When parking, park a safe distance from other vehicles as determined by supervisor.
- Stay alert at all times! In the event of an emergency, be prepared to react quickly and avoid accidents. If an emergency arises, know where to get prompt assistance.

## **CHECK WHEN TRAVELING IN REVERSE**

Before operating the machine or work equipment, do as follows:

- Sound the horn to warn people in the area. For machines equipped with a back-up alarm, check that the alarm works properly.
- Check that there is no one near the machine. Be particularly careful to check behind the machine.
- If necessary, designate a person to check the safety. This is particularly necessary when traveling in reverse.
- When operating in areas that may be hazardous or have poor visibility, designate a person to direct work site traffic.
- Do not allow any one to enter the line of travel of the machine. This rule must be strictly observed even on machines equipped with a back-up alarm or rear view mirror.

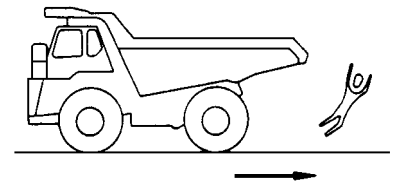

## **TRAVELING**

- When traveling on rough ground, travel at low speed. When changing direction, avoid turning suddenly.
- Lower the dump body and set the dump lever to the FLOAT position when traveling.
- If the engine should stop when the machine is traveling, the emergency steering system will be activated. Apply the brakes immediately and stop the machine as quickly and safely as possible, and off the haul road, if possible.

## TRAVELING ON SLOPES

- Traveling on slopes could result in the machine tipping over or slipping.
- Do not change direction on slopes. To ensure safety, go down to level ground before turning.
- Do not travel up and down on grass, fallen leaves, or wet steel plates. These materials may make the machine slip on even the slightest slope. Avoid traveling sideways, and always keep the travel speed low.
- When traveling downhill, use the retarder to reduce speed. Do not turn the steering wheel suddenly. Do not use the foot brake except in an emergency.
- If the engine should stop on a slope, apply the service brakes fully stop the machine and apply the parking brake after the machine has stopped.

## ENSURE GOOD VISIBILITY

- When working in dark places, install work lamps and head lamps, and set up lighting in the work area if necessary.
- **Stop operations if the visibility is poor, such as in mist, snow, or rain, and wait for the weather to improve to a condition that allows the operation to be carried out safely.**

## OPERATE CAREFULLY ON SNOW

- When working on snowy or icy roads, there is danger that the machine may slip to the side on even the slightest slope, so always travel slowly and avoid sudden starting, turning, or stopping.
- Be extremely careful when carrying out snow-clearing operations. The road shoulder and other objects are buried in the snow and cannot be seen. When traveling on snow-covered roads, always install tire chains.

## AVOID DAMAGE TO DUMP BODY

- When working in tunnels, on bridges, under electric cables, or when entering a parking place or any other place where there are height limits, always drive extremely carefully and lower the dump body completely before driving the machine.

## DO NOT GO CLOSE TO HIGH-VOLTAGE CABLES

- Going close to high-voltage cables can cause electric shock. Always maintain the safe distance given below between the machine and the electric cable.

Voltage	Minimum Safety Distance	
6.6 kV	3 m	10 ft.
33.0 kV	4 m	14 ft.
66.0 kV	5 m	17 ft.
154.0 kV	8 m	27 ft.
275.0 kV	10 m	33 ft.

- The following actions are effective in preventing accidents:
  - 1) Wear shoes with rubber or leather soles.
  - 2) Use a signalman to give warning if the machine approaches too close to the electric cable.
- If the work equipment should touch the electric cable, the operator should not leave the operator's compartment.
- When carrying out operations near high voltage cables, do not let anyone come close to the machine.
- Check with the electrical maintenance department about the voltage of the cables before starting operations.



### **WHEN DUMPING**

- Before starting the dumping operation, check that there is no person or object behind the machine.
- Stop the machine in the correct position, and check again that there is no person or object behind the machine. Give the determined signal, then slowly operate the dump body. If necessary, use blocks for the wheels or position a flagman.
- When carrying out dumping operations on slopes, the machine stability will become poor and there is danger that it may tip over. Always carry out such operations extremely carefully.
- Do not travel with the dump body raised.

### **WORKING ON LOOSE GROUND**

- Avoid operating the machine too close to the edge of cliffs, overhangs, and deep ditches. If these areas collapse, the machine could fall or tip over and result in serious injury or death. Remember that the soil after heavy rain or blasting is weakened in these areas.
- Earth laid on the ground and the soil near ditches is loose. It can collapse under the weight or vibration of the machine. Avoid these areas, if possible.

### **WHEN LOADING**

- Check that the surrounding area is safe, stop the machine in the correct loading position, then load the body uniformly.
- Do not leave the operator's seat during the loading operation.

### **PARKING THE MACHINE**

- Choose a horizontal road surface to park the machine. If the machine has to be parked on a slope, always put blocks under all the wheels to prevent the machine from moving.
- When parking on public roads, provide fences and signs, such as flags or lights, on the machine to warn pedestrians and other vehicles. Be sure that the machine, flags, or lights do not obstruct the traffic.
- Before leaving the machine, lower the dump body fully, set the parking lever to the PARKING position, stop the engine, then lock everything. Always take the key with you.

## **TOWING**

### **WHEN TOWING, FIX WIRE TO HOOK**

- Towing in the wrong way may lead to serious personal injury or damage.
- When using another machine to tow this machine, use a towing device with ample strength for the weight of this machine.
- Never tow a machine on a slope.
- Do not use any towing rope that has kinks or is twisted.
- Do not stand astride the towing cable or wire rope.
- When connecting a machine that is to be towed, do not let any one come between the towing machine and the machine that is being towed.
- Set the coupling of the machine being towed in a straight line with the towing portion of the machine, and secure it in position.

(For towing method, see Section 3, "Operating Instructions, TOWING".)

## BATTERY

### BATTERY HAZARD PREVENTION

- Battery electrolyte contains sulfuric acid and can quickly burn the skin and eat holes in clothing. If you spill acid on yourself, immediately flush the area with water.
- Battery acid could cause blindness if splashed into the eyes. If acid gets into the eyes, flush them immediately with large quantities of water and see a doctor at once.
- If you accidentally drink acid, drink a large quantity of water or milk, beaten egg or vegetable oil. Call a doctor or poison prevention center immediately.
- When working with batteries ALWAYS wear safety glasses or goggles.
- Batteries generate hydrogen gas. Hydrogen gas is very EXPLOSIVE, and is easily ignited with a small spark of flame.
- Before working with batteries, stop the engine and turn the starting switch to the OFF position.
- Avoid short-circuiting the battery terminals through accidental contact with metallic objects, such as tools, across the terminals.
- When removing or installing, check which is the positive (+) terminal and negative (-) terminal.
- Tighten the battery cap securely.
- Tighten the battery terminals securely. Loosened terminals can generate sparks and lead to an explosion.

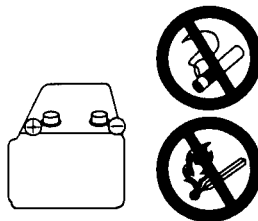
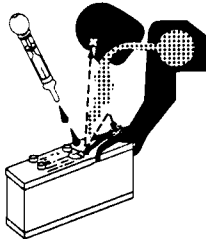

### STARTING WITH BOOSTER CABLES

- ALWAYS wear safety glasses or goggles when starting the machine with booster cables.
- When starting from another machine, do not allow the two machines to touch.
- Be sure to connect the positive (+) cable first when installing the booster cables. Disconnect the ground or negative (-) cable first when removing them.
- If any tool touches between the positive (+) terminal and the chassis, it will cause sparks. This is dangerous, so be sure to work carefully.
- Connect the batteries in parallel: positive to positive and negative to negative.
- When connecting the ground cable to the frame of the machine to be started, be sure to connect it as far as possible from the battery.

### INCORRECT

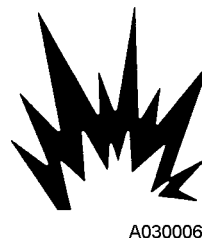
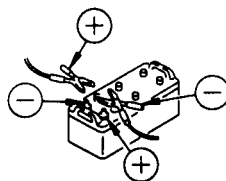

## PRECAUTIONS FOR MAINTENANCE

### BEFORE CARRYING OUT MAINTENANCE

#### WARNING TAG

- If others start the engine or operate the controls while you are performing service or lubrication, you could suffer serious injury or death.
- ALWAYS attach the WARNING TAG to the control lever in the operator's cab to alert others that you are working on the machine. Attach additional warning tags around the machine, if necessary.
- These tags are available from your Komatsu distributor. (Part No. 09963-03000)

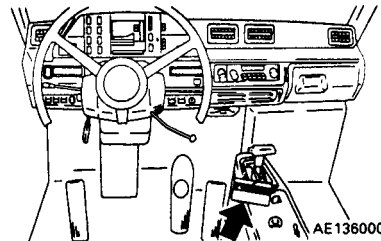

#### PROPER TOOLS

- Use only tools suited to the task. Using damaged, low quality, faulty, or makeshift tools could cause personal injury.



#### PERIODIC REPLACEMENT OF CRITICAL PARTS

- Periodically replace parts used to insure safety or prevent accident. (See "PERIODIC REPLACEMENT OF COMPONENT PARTS FOR SAFETY DEVICES", Section 4.)
- Replace these components periodically with new ones, regardless of whether or not they appear to be defective. These components deteriorate over time.
- Replace or repair any such components if any defect is found, even though they have not reached the time specified.

#### STOPPING THE ENGINE BEFORE SERVICE

- When carrying out inspection or maintenance, always stop the machine on firm flat ground, lower the dump body, then stop the engine.
- If the engine must be run during service, such as when cleaning the radiator, always move the shift control lever to the Neutral (N) position and set the parking brake lever to the PARKING position. Always carry out the work with two people. One person should sit on the operator's seat to stop the engine if necessary. NEVER move any controls not needed to operate.
- When servicing the machine, be careful not to touch any moving part or get clothing caught.
- Put blocks under the wheels.
- When carrying out service with the dump body raised, always place the dump lever at the HOLD position, and apply the lock (if equipped). Install the body-up safety pins (or cable) securely.

## SECURING THE DUMP BODY

The body pin is located under the dump body at the rear of the truck. This pin is intended to be used as a safety to hold the body in the up position while the technicians work under it.



***Always store pin in body storage hole. Placement of the pin in mainframe or matching body-up holes located on the body can cause damage to frame or body during dumping cycle.***

***Never work under a raised body unless body safety pin is in the proper position to hold body up.***

## DURING MAINTENANCE

### PERSONNEL

- Only authorized personnel can service and repair the machine. Extra precaution should be used when grinding, welding, and using a sledge-hammer.

### ATTACHMENTS

- Place attachments that have been removed from the machine in a safe place so that they do not fall. If they fall on you or others, serious injury could result.



### WORK UNDER THE MACHINE

- Always lower all movable work equipment to the ground or to their lowest position before performing service or repairs under the machine.
- Always block the tires of the machine securely.
- Never work under the machine if the machine is poorly supported.



### KEEP THE MACHINE CLEAN

- Spilled oil or grease, or scattered tools or broken pieces are dangerous because they may cause you to slip or trip. Always keep your machine clean and tidy.
- If water gets into the electrical system, there is danger that the machine may not move or may move unexpectedly. Do not use water or steam to clean the sensors, connectors, or the inside of the operator's compartment.

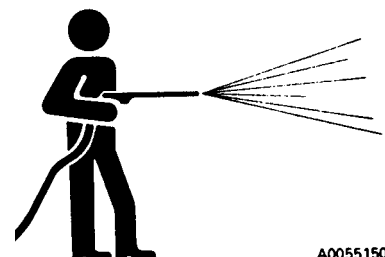

### RULES TO FOLLOW WHEN ADDING FUEL OR OIL

- Spilled fuel and oil may cause slipping. Always clean up spills immediately.
- Always tighten the cap of the fuel and oil fillers securely.
- Never use fuel for washing any parts.
- Always add fuel and oil in a well-ventilated place.



A0055020

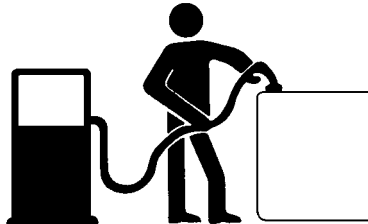

A0055030



A0055040

### RADIATOR WATER LEVEL

- If it is necessary to add water to the radiator, stop the engine and allow the engine and radiator to cool down before adding the water.
- Slowly loosen the cap to relieve pressure before removing the cap.

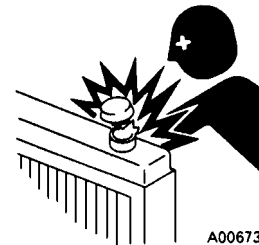

A0067380

### USE OF LIGHTING

When checking fuel, oil, coolant, or battery electrolyte, always use lighting with anti-explosion specifications. If such lighting equipment is not used, there is danger of explosion.



A0055160

### PRECAUTIONS WITH BATTERY

- When repairing the electrical system or when carrying out electrical welding, remove the negative (-) terminal of the battery to stop the flow of current.



A0055170

### HANDLING HIGH-PRESSURE HOSES

- Do not bend high-pressure hoses or hit them with hard objects. Do not use any bent or cracked piping, tubes or hoses. They may burst during use.
- Always repair any loose or broken fuel hoses or oil hoses. If fuel or oil leaks, it may cause a fire.

### PRECAUTIONS WITH HIGH PRESSURE OIL

- Do not forget that the work equipment circuits are always under pressure.
- Do not add oil, drain oil, or carry out maintenance or inspection before completely releasing the internal pressure.
- If oil is leaking under high pressure from small holes, it is dangerous if the jet of high-pressure oil hits the skin or enters the eyes. Always wear safety glasses and thick gloves, and use a piece of cardboard or a sheet of wood to check for oil leakage.
- If you are hit by a jet of high-pressure oil, consult a doctor immediately for medical attention.

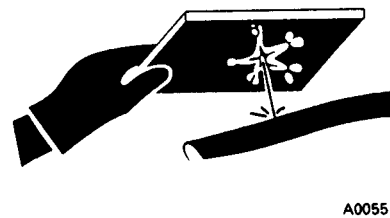

### PRECAUTIONS WHEN CARRYING OUT MAINTENANCE AT HIGH TEMPERATURE OR HIGH PRESSURE

- Immediately after stopping operations, the engine cooling water and oil at all parts are at high temperature and under high pressure. In this condition, if the cap is removed, or the oil or water are drained, or the filters are replaced, it may result in burns or other injury. Wait for the temperature to go down, then carry out the inspection and maintenance in accordance with the procedures given in this manual.

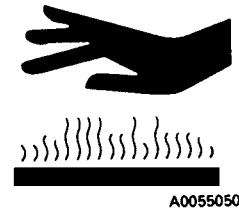

### ROTATING FAN AND BELT

- Keep away from rotating parts and be careful not to let anything get caught in them.
- If your body or tools touch the fan blades or fan belt, they may be cut off or sent flying, so never touch any rotating parts.

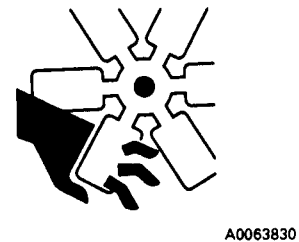

### WASTE MATERIALS

- Never dump waste oil in a sewer system, rivers, etc.
- Always put oil drained from your machine in containers. Never drain oil directly on the ground.
- Obey appropriate laws and regulations when disposing of harmful objects such as oil, fuel, coolant, solvent, filters, batteries, and others.

**INCORRECT**

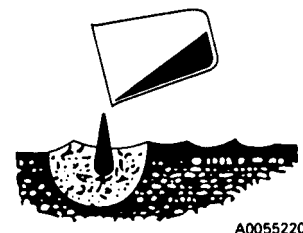

## TIRES

### HANDLING TIRES

If tires are not used under the specified conditions, they may overheat and burst or be cut and burst by sharp stones on rough road surfaces. This may lead to serious injury or damage.

To maintain safety, always keep to the following conditions:

- Inflate the tires to the specified pressure. Abnormal heat is generated particularly when the inflation pressure is too low.
- Use the specified tires.

The tire inflation pressure and permissible speeds are general values. The actual values may differ depending on the type of tire and the condition under which they are used. For details, please consult the tire manufacturer.

If the tires become hot, a flammable gas is produced, and this may ignite. It is particularly dangerous if the tires become overheated when the tires are under pressure. If the gas generated inside the tire ignites, the internal pressure will suddenly rise, and the tire will explode, and this may lead to serious personal injury. Explosions differ from punctures or tire bursts, because the destructive force is extremely large. Therefore, the following operations are strictly prohibited when the tire is under high internal pressure:

- Welding the rim
- Building fires or carrying out welding near the wheel or tire.



If the proper procedure for carrying out maintenance or replacement of the wheel or tire is not used, the wheel or tire may burst and cause serious injury or damage. When carrying out such maintenance, please consult the authorized regional Komatsu Mining Systems, Inc. distributor, or the tire manufacturer.

### STORING TIRES AFTER REMOVAL

- As a basic rule, store the tires in a warehouse which unauthorized persons cannot enter. If the tires are stored outside, always erect a fence around the tires and put up "No Entry" and other warning signs that even young children can understand.
- Stand the tire on level ground, and block it securely so that it cannot roll or fall over.
- If the tire should fall over, get out of the way quickly. The tires for construction equipment are extremely heavy, so trying to hold the tire may lead to serious injury.

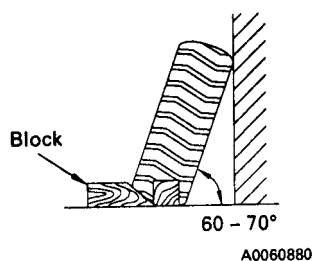

## WARNINGS AND CAUTIONS

The following paragraphs give an explanation of the WARNING, CAUTION, Service Instruction plates, and decals attached to the truck. The plates and decals listed here are typical of this model, but because of customer options, individual trucks may have plates and decals that are different from those shown here.

The plates and decals must be kept clean and legible. If any decal or plate becomes worn or unable to be read, it should be replaced with a new one.

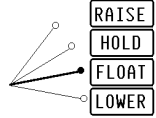
<p style="text-align: center;"><b>⚠ CAUTION</b></p> <p><b>1</b> BEFORE OPERATING MACHINE, READ OPERATION MANUAL CAREFULLY</p> <p><b>2</b> OBSERVE THE FOLLOWING WHEN STARTING ENGINE AND TRAVELING:</p> <ol style="list-style-type: none"> <li>1. FASTEN SEAT BELT.</li> <li>2. APPLY PARKING BRAKE &amp; SET GEARSHIFT LEVER TO NEUTRAL.</li> <li>3. START ENGINE.</li> <li>4. CHECK EACH GAUGE AND PILOT LAMP.</li> <li>5. RELEASE PARKING BRAKE AND START MACHINE.</li> <li>6. NEVER MOVE THE SHIFT LEVER BACK TO "N" POSITION WHILE TRAVELING.</li> <li>7. WHEN THE VEHICLE IS STOPPED BY SUDDENLY APPLYING THE BRAKE, THE TRANSMISSION MAY SOMETIMES STAY IN THE SAME GEAR JUST BEFORE THE VEHICLE WAS STOPPED. IN THIS CASE, AFTER MOVING THE SHIFT LEVER BACK TO "N" POSITION MOVE IT TO THE DESIRED SPEED POSITION AGAIN.</li> <li>8. DO NOT STOP ENGINE WHILE MACHINE IS RUNNING. IF ENGINE IS STOPPED MACHINE CANNOT BE STEERED.</li> <li>9. USE PARKING BRAKE ONLY AFTER MACHINE HAS STOPPED COMPLETELY EXCEPT IN EMERGENCIES.</li> </ol>	<p style="text-align: center;"><b>⚠ CAUTION</b></p> <p>WHEN DRIVING OVER A LONG DISTANCE</p> <ol style="list-style-type: none"> <li>1. DO NOT TRAVEL FASTER THAN THE SPECIFIED SPEED SHOWN IN THE TABLE.</li> <li>2. EVERY ONE HOUR STOP THE TRUCK TO LET THE TIRES AND COMPONENTS COOL DOWN. THE REQUIRED STOPPAGE TIME IS SHOWN IN THE TABLE.</li> </ol> <table border="1" style="width: 100%; border-collapse: collapse; margin-top: 10px;"> <tr> <td colspan="2" style="text-align: center;"><b>MODEL</b></td> <td style="text-align: center;"><b>330M</b></td> </tr> <tr> <td style="text-align: center;"><b>MAX. SPEED</b></td> <td style="text-align: center;"><b>AMB. TEMP.</b> 40°C - 50°C (104°F - 122°F)</td> <td style="text-align: center;">40 Km/h (25 MPH)</td> </tr> <tr> <td colspan="2" style="text-align: center;"><b>REQUIRED STOPPAGE TIME</b></td> <td style="text-align: center;"><b>AT LEAST 60 MIN</b></td> </tr> </table>	<b>MODEL</b>		<b>330M</b>	<b>MAX. SPEED</b>	<b>AMB. TEMP.</b> 40°C - 50°C (104°F - 122°F)	40 Km/h (25 MPH)	<b>REQUIRED STOPPAGE TIME</b>		<b>AT LEAST 60 MIN</b>	<p style="text-align: center;"><b>⚠ CAUTION</b></p> <p>HOIST CONTROL LEVER</p> <div style="text-align: center; margin: 10px 0;">  </div> <p>RETURN THE LEVER TO "FLOAT" AT RUNNING</p> <p style="text-align: right; font-size: small;">WA9845</p>
<b>MODEL</b>		<b>330M</b>									
<b>MAX. SPEED</b>	<b>AMB. TEMP.</b> 40°C - 50°C (104°F - 122°F)	40 Km/h (25 MPH)									
<b>REQUIRED STOPPAGE TIME</b>		<b>AT LEAST 60 MIN</b>									

This warning plate is located inside the cab on the left-hand door panel under the arm rest. It contains (3) instructions - Preparation for Operation, Precautions Prior to Moving Truck, and Hoist Control Lever operation. These decals stress the importance of reading and understanding the operators manual prior to the operation of equipment.

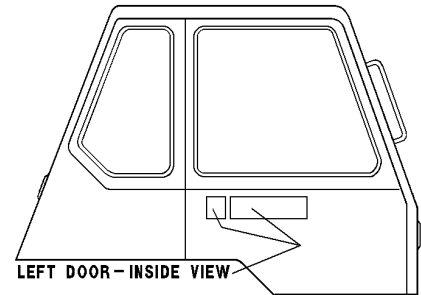

A Tire Air Pressure Caution plate is located inside the cab on left-hand door panel under the arm rest. Extreme caution should be used when taking a pressure reading. Tire is under high pressure.

*NOTE: Alternate tires may require different pressures than stated in the chart. Consult the tire manufacturer.*

**NOTICE**

**TIRE AIR PRESSURE**

UNDER CONDITIONS WHERE TIRES ARE COLD BEFORE STARTING OPERATION, TIRE INFLATION PRESSURE MUST MATCH THE CORRECT VALUES AS SHOWN IN THE TABLE BELOW.

TIRE SIZE	PROPER AIR PRESSURE	
	FRONT	REAR
27. 00R49☆☆	686 kPa {7.0kg/cm <sup>2</sup> }	686 kPa {7.0kg/cm <sup>2</sup> }
27.00-49-48PR	549 kPa {5.6kg/cm <sup>2</sup> }	549 kPa {5.6kg/cm <sup>2</sup> }

561-93-61943



**⚠ WARNING**

WHEN IT IS NECESSARY TO WORK UNDER THE MACHINE WITH THE BODY RAISED, FOLLOW INSTRUCTION BELOW.

1. CARRY OUT INSPECTION AND MAINTENANCE WITHOUT LOAD.
2. LOCK THE HOIST CONTROL LEVER IN THE HOLD POSITION AND INSTALL SAFETY PINS SECURELY
3. IN CASE OF HEAVY MAINTENANCE, ALWAYS USE SAFETY BLOCK IN ADDITION.

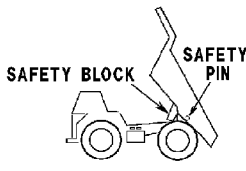

SAFETY BLOCK SAFETY PIN

**⚠ WARNING**

**1** EMERGENCY STEERING SYSTEM (DAILY CHECK)  
CHECK THE FUNCTION WITH ENGINE STOP ON FLAT GROUND.

1. TURN THE STARTING SWITCH TO THE 'ON' POSITION.
2. APPLY EMERGENCY STEERING SWITCH TO 'ON' POSITION AND CHECK THAT STEERING WHEEL CAN BE OPERATED.
3. TURN EMERGENCY STEERING SWITCH TO 'OFF' POSITION.

IN CASE OF THE AUTOMATIC EMERGENCY STEERING SYSTEM, IF EQUIPPED.

1. TURN THE STARTING SWITCH TO THE 'ON' POSITION.
2. RELEASE THE PARKING BRAKE. THE SYSTEM WILL ACTIVATE WITHIN 1.5 SECONDS.
3. APPLY THE PARKING BRAKE.

**2** EMERGENCY BRAKE SYSTEM (DAILY CHECK)

1. RAISE THE AIR PRESSURE TO THE MAXIMUM AND APPLY EMERGENCY BRAKE.
2. PLACE GEAR SHIFT LEVER IN THE 'D' POSITION. GRADUALLY INCREASE THE ENGINE SPEED, AND CHECK THAT THE MACHINE DOES NOT MOVE EVEN WHEN THE ENGINE SPEED REACHES 1900 rpm.

DO NOT USE EMERGENCY OR RETARDER BRAKE FOR PARKING.

**⚠ WARNING**

BEFORE LEAVING OPERATOR'S SEAT:

1. LOWER THE BODY.
2. STOP THE MACHINE ON LEVEL GROUND.
3. STOP ENGINE AND APPLY PARKING BRAKE SECURELY.

BLOCK WHEELS SECURELY BEFORE LEAVING THE MACHINE.

IDLE THE ENGINE FOR 5 MINUTES BEFORE SHUTTING IT DOWN.

**⚠ WARNING**

WHENEVER THE RETARDER OIL TEMPERATURE WARNING LAMP LIGHTS UP, SHIFT DOWN AND STOP THE MACHINE.

RETURN THE SHIFT LEVER TO NEUTRAL.

RUN THE ENGINE AT 2000 rpm UNTIL THE WARNING LAMP GOES OUT.

561-93-61731

A040007A

This instruction plate contains (4) WARNINGS (See illustration above):

- Inspection and Maintenance With Body In Raised Up Position
- Emergency Steering System Operation
- Engine Shut Down Procedure
- Retarder Oil Temperature Warning Light

These "WARNINGS" stress the importance of reading and understanding the operators manual prior to the operation of equipment.

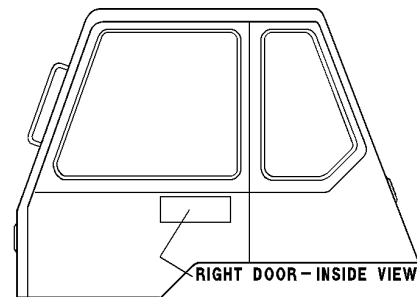

A040001

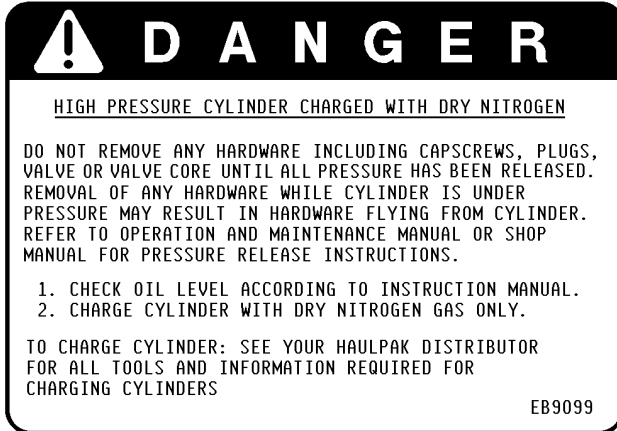

DANGER plates are mounted on each suspension cylinder. These plates warn that the suspensions are charged with high pressure nitrogen. No servicing of any kind should be attempted until the service manual has been referenced and proper and safe procedures are followed.

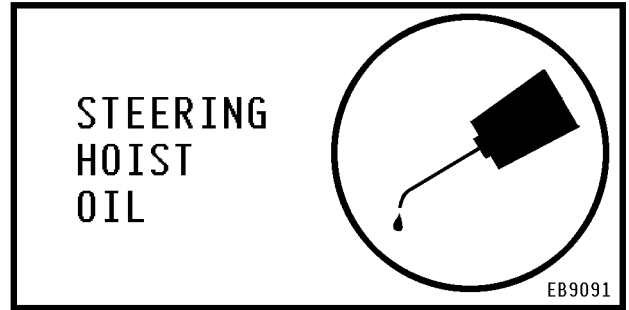

A Steering and Hoist Oil decal is located to the left of the left hand filler cap on left hand side of hydraulic tank.

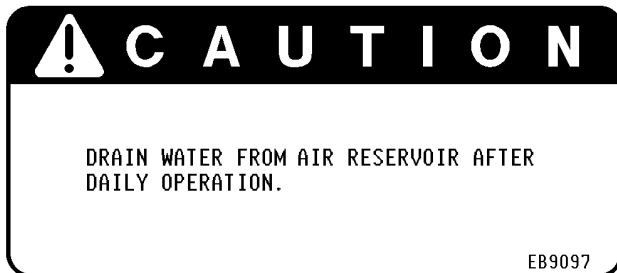

Caution plates are mounted at the air tank on center top deck, also at rear frame just below tail light assemblies. **Caution should be used when opening drain valves. The system is under high pressure.**

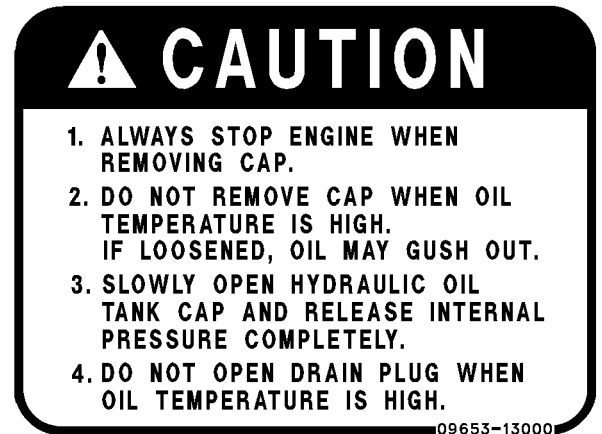

A CAUTION plate is attached to the hydraulic tank, alerting the service person that the engine must always be shut down and cooled before removing filler cap. This plate also alerts the service person of HOT oil under pressure. Hydraulic oil becomes heated and pressurized during operation. Care must be taken to avoid burns when it is necessary to open the hydraulic system.

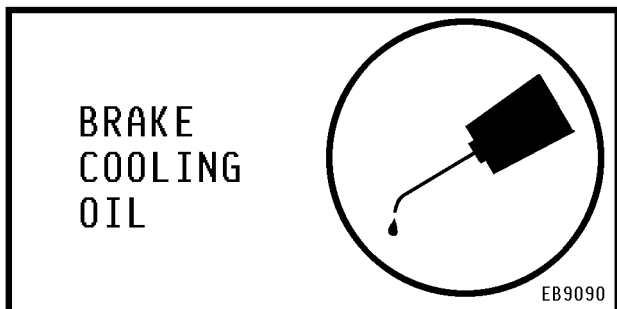

A Brake Cooling Oil decal is located between the filler cap and sight gauge on the right hand side of the hydraulic tank.



*Hydraulic fluid escaping under pressure can have sufficient force to enter a person's body by penetrating the skin and cause serious injury and possible death if proper medical treatment by a physician familiar with this injury is not received immediately.*



This CAUTION plate is located on left hand side of the radiator shroud. Extreme care should be taken when working around fan and belts. Hands and loose articles of clothing should be kept away when machine is operating.

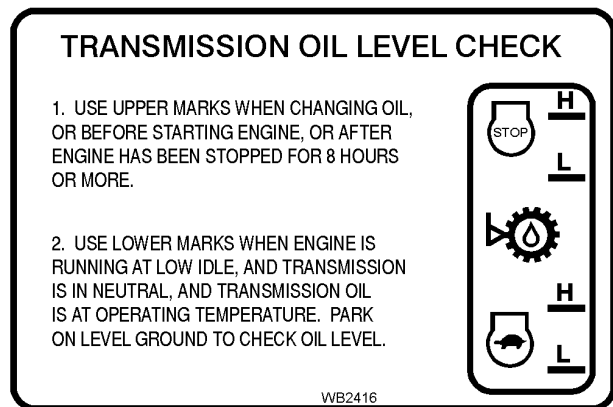

A plate is mounted on the left hand side of the transmission oil pan to provide instructions for proper transmission oil level check.

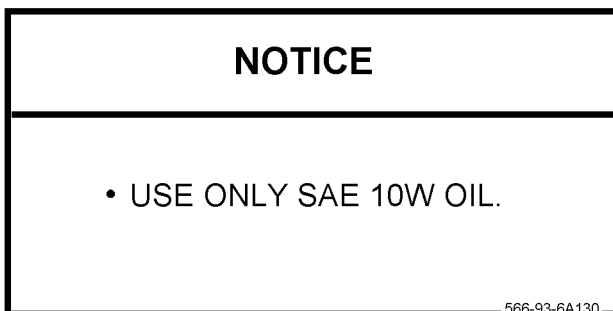

A plate is located next to the sight gauge on the front brake oil tank, mounted on air tank top right hand deck. The plate alerts service person to use only SAE-10W oil. Brake system components are not compatible with other fluids which can cause component deterioration.

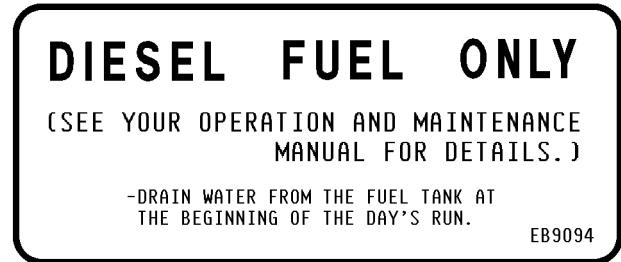

A plate is located next to filler cap on fuel cap which specifies Diesel Fuel Only. Care should be taken to open cap slowly and bleed off pressure that may be in tank when removing filler cap. Operation and Maintenance Manual referred to is from **Engine Manufacturer**.

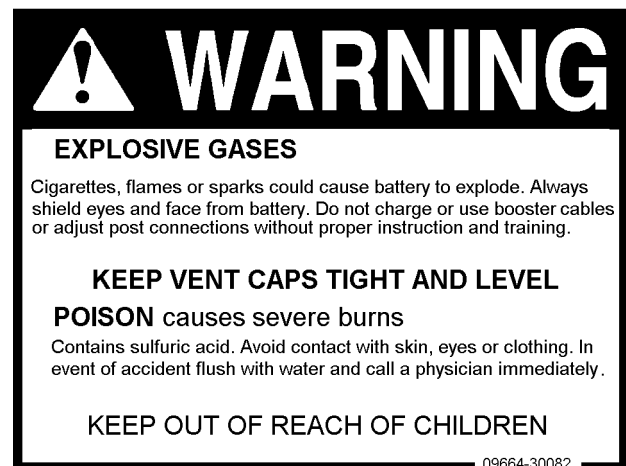

Attached to the interior of battery box lid is a WARNING plate. This plate stresses the need to prevent sparks near the battery. When another battery or 24VDC power source is used for auxiliary power, all switches must be "Off" prior to making any connections. When connecting auxiliary power cables, positively maintain correct polarity; connect the positive (+) leads together and then connect the negative (-) lead of the auxiliary power cable to a good frame ground. Do not connect to the negative post of the truck battery or near the battery box. This hookup completes the circuit while minimizing danger of sparks near the batteries.

Sulfuric acid is corrosive and toxic. Use proper safety gear, goggles, rubber gloves and rubber apron when handling and servicing batteries. Avoid contact with skin, eyes or clothing. In event of accident, immediately flush with plenty of water and call a physician.

**KEEP OUT OR REACH OF CHILDREN!**

! CAUTION

PRIOR TO WELDING ON TRUCK

- 1) DISCONNECT THE FOLLOWING TERMINALS
  - BATTERY (GROUND)
  - ALTERNATOR TERMINAL (B)
  - EVERY ELECTRONIC CONTROLLER JUNCTION
- 2) COVER ALL ELECTRONIC CONTROLLERS FOR PROTECTION FROM SPARKS.
- 3) DO NOT CONNECT WELDING CABLES TO THE CONTROLLERS.
- 4) DO NOT WELD ON THE CONTROLLERS.
- 5) REMOVE THE CONTROLLER UNIT IF WELDING IS TO BE DONE WITHIN 10" OF IT.

EF8595

A caution plate is located on the right hand inside door panel and also on the lid of the battery box. These instructions must be followed when welding is done on the truck to avoid damage to the electronic components.

NOTICE

COOLING WATER MIXTURE WILL NOT FREEZE AT THE LOW TEMPERATURE INDICATED BY THE ARROW. WHEN ACTUAL TEMPERATURE DIFFERS FROM THE INDICATION, CHANGE THE RATIO OF ANTIFREEZE TO MATCH AMBIENT CONDITIONS.  
(REFER TO OPERATION MANUAL)

	R%	T°C	(°F)
	0%	5°C	(41°F)
	30%	-10°C	(14°F)
	41%	-20°C	(-4°F)
	50%	-30°C	(-22°F)
	58%	-40°C	(-40°F)

T: MINIMUM ALLOWABLE ATMOSPHERIC TEMPERATURE.  
R: MIXING RATE OF WATER AND ANTIFREEZE.

567-93-43650

A plate is located on center deck floor next to radiator fill access cover plate. When actual temperature differs with the indication, change the ratio of antifreeze to match ambient conditions.

**Service personnel should use caution when servicing radiator. The system is pressurized because of thermal expansion of coolant. "DO NOT" remove radiator cap while engine is hot. Severe burns may result.**

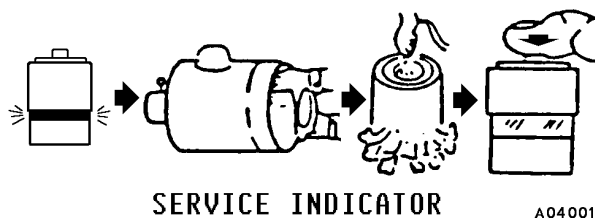

A service indicator plate is located on the right air cleaner housing. Service filter element when red signal reaches service level in dust indicator.

! CAUTION

**When using compressed air, wear safety glasses and all other safety equipment required when cleaning.**

The Action Code decal is located on the inside of the cab in the upper left-hand corner of the windshield. This decal explains what action to take when an action code is displayed on the monitor panel on the operator monitor and indicator panel.

NOTICE

CORRECTION CODE ON VEHICLE MONITOR PANEL

IF ANY TROUBLE OCCURS WITH THE VEHICLE, THE ACTION TO TAKE TO CORRECT IT IS INDICATED BY CODES "01-07" AND "E," WHICH APPEAR ALTERNATELY AT THE UPPER RIGHT CORNER OF THE LIQUID CRYSTAL DISPLAY OF THE MONITOR PANEL.

ACTION CODE

IF THE CORRECTIVE ACTION CODE IS INDICATED ON THE MONITOR PANEL, STOP THE VEHICLE AND CHECK THE ACTION CODE AGAIN, THEN TAKE THE FOLLOWING CORRECTIVE ACTION.

ACTION CODE	CONTENT OF ACTION
01	NOTIFY MAINTENANCE AT SHIFT CHANGE
02	NOTIFY MAINTENANCE RIGHT NOW
03	REDUCE ENGINE / MACHINE SPEED
04	STOP SAFELY NOW / SHUT OFF ENGINE
05	STOP WITH ENGINE AT MID SPEED
06	START ENGINE AND KEEP AT LOW IDLE
07	KEEP BODY DOWN

561-93-A1930

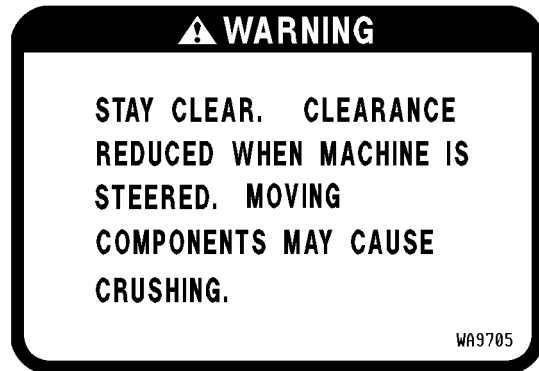
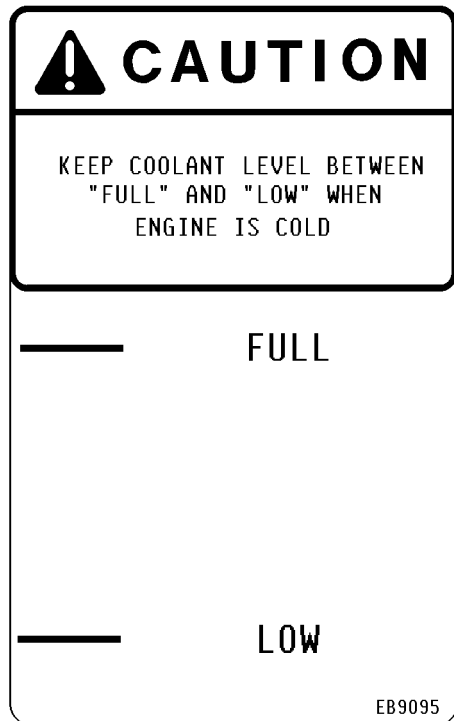

Warning plates are mounted on the truck frame in front of and to the rear of both front tires to alert all persons to stay clear when the truck is being steered.

A Caution plate is located next to the sight gauge on the radiator cooling water reserve tank on top of right hand deck just aft of battery box.

***Keep coolant level between "FULL" and "LOW" when engine is cold.***

A decal (at right) located in the upper right corner of the windshield cautions the operator to limit truck speed when traveling over long distances. Depending on ambient air temperature, if the length of the haul exceeds one hour duration, the truck should be stopped and tires and components allowed to cool for one hour before resuming operation.

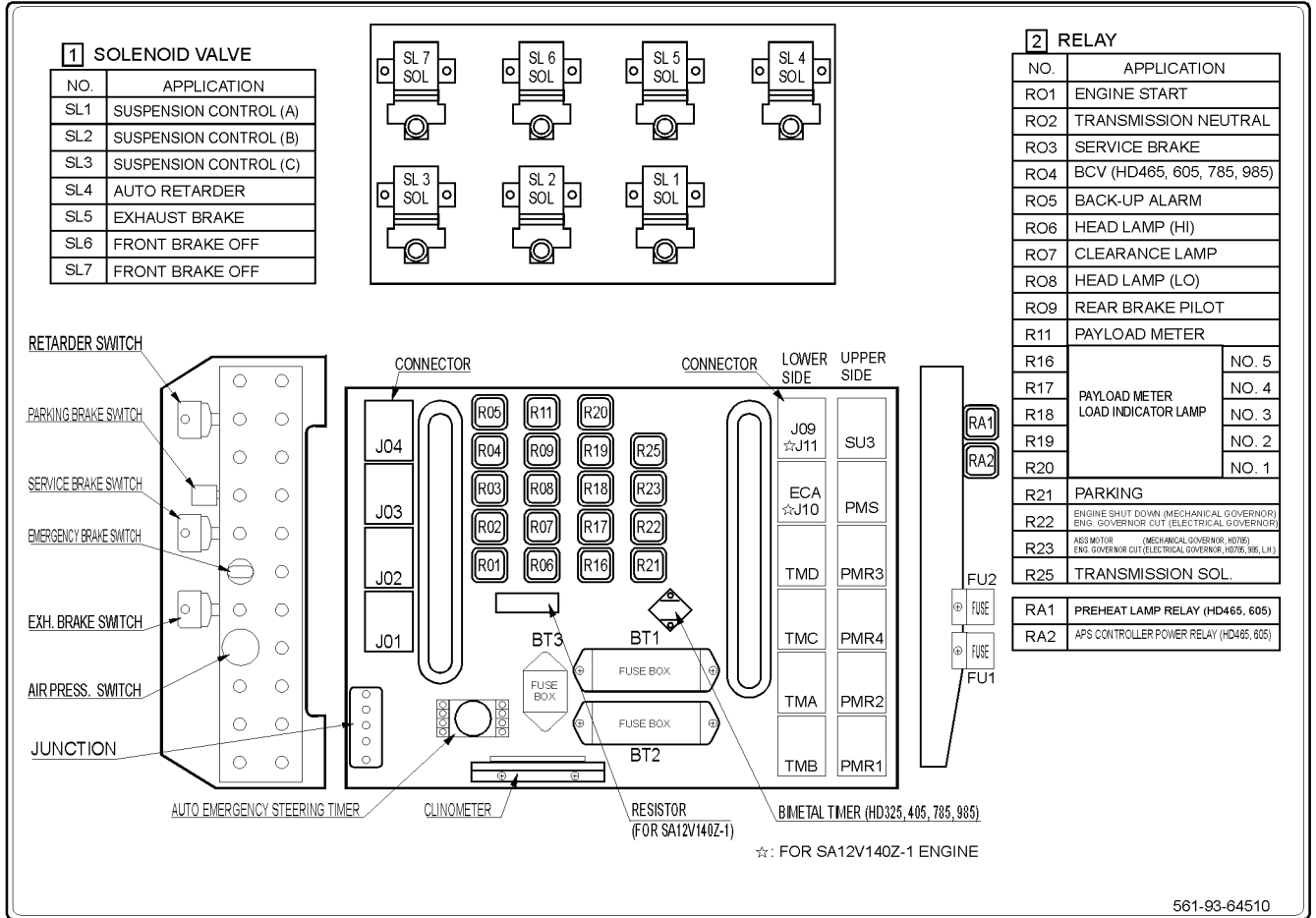

An informational plate (above) for the solenoid valve and relays is mounted to the inside lid of the electrical console behind the operator and passenger seats. The fuse table plate (below) is located to the left of the solenoid valve and relay plate, also mounted to the inside lid of the electrical console.

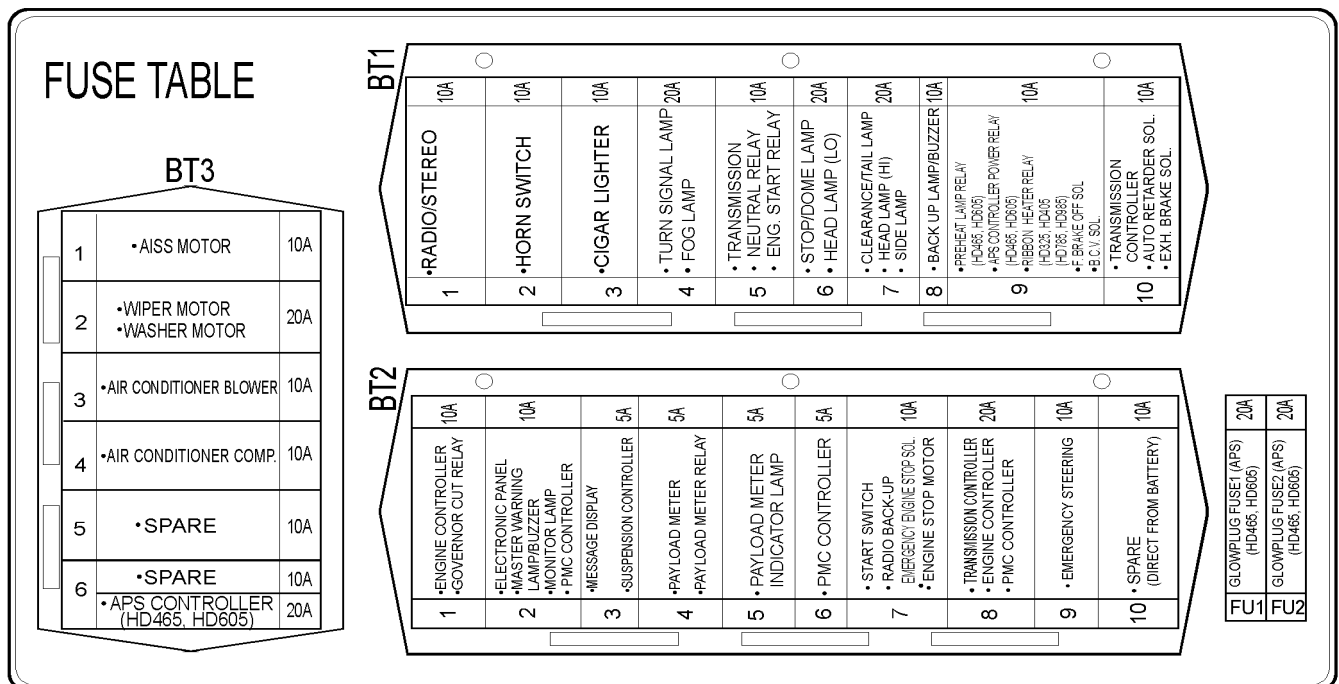

A Speed/Grade decal showing Retarding Capacities is applied to the lower left-hand corner of the cab windshield. This decal is designed to help the operator maintain a safe vehicle speed while descending a grade with a loaded truck.

The operator should pre-select a ground speed and gear range for a known grade that will permit continuous retarder operation within the LIMITS OF THE CHART.

For efficient retarder operation, the operator should: Maintain engine RPM between 1800 - 2400 RPM MAXIMUM, and Observe the Brake Oil Temperature gauge to make certain the Brake Oil Temperature does not exceed 248°F (120°C).

If the Brake Oil Temperature exceeds this limit, move the transmission range selector lever to a lower gear and use the foot-operated service brakes to reduce the truck ground speed. This will allow the transmission to shift to the next lower gear range for more efficient cooling.

If the Brake Oil Temperature continues to exceed 248°F (120°C), select a safe area out of the way of other traffic, stop the truck, move the transmission range selector lever to the Neutral (N) position, and operate the engine at approximately 1200 RPM until the Brake Oil Temperature gauge registers in the "green" range.



# WARNING

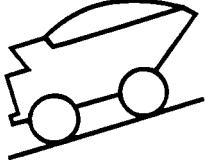

**RETARDING CAPACITY**  
 GVW: 367,000 LBS  
 (166,470 kg)  
 TIRES: 27 X 49

**MAXIMUM BRAKE OIL TEMPERATURE: 248 F (120C)**  
**MAXIMUM ENGINE SPEED: 2400 RPM**

**MAINTAIN HIGHEST ENGINE SPEED BELOW MAXIMUM.  
 SLOW TO NEXT LOWER GEAR IF COOLING OIL  
 TEMPERATURE NEEDS TO BE LOWERED.**

GEAR NUMBER	SPEED MPH (km/hr)	CONTINUOUS GRADE%	SHORT LENGTH 1970ft (600m) GRADE%
1	6.6 (10.6)	28.0	30.4
2	9.3 (15.0)	19.9	22.3
3	12.5 (20.1)	14.8	17.2
4	16.8 (27.1)	11.0	13.4
5	22.7 (36.5)	8.2	10.6
6	30.9 (49.8)	6.0	8.4
7	41.7 (67.1)	4.4	6.8

WB2610

A product identification plate is located at the base of the left-hand upright. This lists the vehicle model number, maximum G.V.W. and Product Identification Number. The Product Identification Number (vehicle serial number) contains information which will identify the original manufacturing bill of material for this unit. This complete number will be necessary for the proper ordering of service parts and/or warranty consideration.

**KOMATSU**

Komatsu Mining Systems, Inc.  
2300 NE Adams St  
Peoria, IL 61650-0240

**Model No.**  **Max. G.V.W.**

**Product Identification Number**

**ASSEMBLED IN THE U.S.A.  
FROM U.S.A. AND FOREIGN COMPONENTS**

**DO NOT DEFACE OR REMOVE THIS PLATE**

WB2576

The lubrication chart is located on the left hand front fender behind the ladder. Refer to Section P, "Lubrication and Service", for more complete lubrication instructions.

## LUBRICATION CHART

### LUBRICATION SPECIFICATION

LUBE KEY	TYPE LUBRICANT	-65°F TO -25°F		-25°F TO +32°F		+32°F TO +90°F		ABOVE 90°F	
		SEE ENG. MAN. *	SEE ENG. MAN. *	SEE ENG. MAN.	SEE ENG. MAN.	SEE ENG. MAN.	SEE ENG. MAN.		
A	ENGINE OIL	MIL - L - 2104C	MIL - L - 2104C	MIL - L - 2104C	MIL - L - 2104C	MIL - L - 2104C	MIL - L - 2104C	MIL - L - 2104C	MIL - L - 2104C
B	HYDRAULIC OIL	SAE 90	SAE 90	SAE 90	SAE 90	SAE 90	SAE 90	SAE 90	SAE 90
C	HYDRAULIC OIL	MIL - L - 2104C	MIL - L - 2104C	MIL - L - 2104C	MIL - L - 2104C	MIL - L - 2104C	MIL - L - 2104C	MIL - L - 2104C	MIL - L - 2104C
D	MOLYDISULPHIDE LUBE	SAE 10W *	SAE 10W *	SAE 10W	SAE 10W	SAE 10W	SAE 10W	SAE 10W	SAE 10W
E	HYDRAULIC OIL	#0	#1	#2	#2	#2	#2	#2	#2
F	HYDRAULIC OIL	SEE SER. MAN.	SEE SER. MAN.	SEE SER. MAN.	SEE SER. MAN.	SEE SER. MAN.	SEE SER. MAN.	SEE SER. MAN.	SEE SER. MAN.
		MIL - L - 2104C	MIL - L - 2104C	MIL - L - 2104C	MIL - L - 2104C	MIL - L - 2104C	MIL - L - 2104C	MIL - L - 2104C	MIL - L - 2104C
		SAE 10W *	SAE 10W *	SAE 30W	SAE 30W	SAE 30W	SAE 30W	SAE 30W	SAE 30W

DESCRIPTION	SYM	PTS	L KEY	10 HR	50 HR	100 HR	250 HR	500 HR	1000 HR	2000 HR
ENGINE LUBE FILTER	1	4	A						CHANGE	
FUEL FILTER ELEMENT	2	2							CHANGE	
FRONT SUSP ASSY / PINS	3	8	D				GREASE			
STEERING CYLINDER LINKAGE	4	4	D				GREASE			
STEERING LINKAGE	5	5	D				GREASE			
HYDRAULIC FILTER	6	3							CHANGE	
HYD. TANK HOIST / STRG.	7	1	C	CHECK						CHANGE
HOIST CYLINDER PIVOT	8	4	D				GREASE			
U - JOINT ASSY (REAR)	9	3	D				GREASE			
FINAL DRIVE CASE	10	2	B				CHECK		CHANGE	
AXLE SUPPORT PIN	11	8	D				GREASE			
REAR SUSPENSION PIN	12	4	D				GREASE			
DIFFERENTIAL CASE	13	1	B				CHECK		CHANGE	
BODY HINGE PINS	14	2	D				GREASE			
CORROSION RESISTOR	15	2						CHANGE		
ENGINE CRANKCASE OIL	16	1	A	CHECK				CHANGE		
TRANS OIL FILTER	17	1						CHANGE		
FRONT BRAKE OIL TANK	18	1		CHECK						
U - JOINT ASSY (FRONT)	19	2	D				GREASE			
TRANSMISSION MOUNT	20	1	D						GREASE	
TRANSMISSION OIL	21	1	F	CHECK					CHANGE	
TRANS CASE BREATHER	22	2					CLEAN			
HYD TANK BREATHER ELE.	23	1					CHANGE			
DIFF CASE BREATHER	24	1					CLEAN			
ENGINE BY-PASS FILTER	25	2						CHANGE		
PARKING BRAKE	26	6	D						GREASE	
DUMP CONTROL LINKAGE	27	3	D							GREASE
ENG FRONT TRUNNION	28	1	D							GREASE
HYD TANK BRAKES	29	1	E	CHECK						CHANGE
TRANS. STRAINER	30	2							CLEAN	

\* AUXILIARY HEATERS REQUIRED BELOW -23°C ( -10°F )



## OPERATING INSTRUCTIONS

### PREPARING FOR OPERATION

The safest trucks are those which have been properly prepared for operation. At the beginning of each shift, a careful check of the truck should be made by the operator before attempting to start the engine. Vehicle breakdowns and UNSCHEDULED downtime and loss of production can be reduced.

### SAFETY IS THINKING AHEAD

Prevention is the best safety program. Prevent a potential accident by knowing the employer's safety requirements and all necessary job site regulations, as well as use and care of the safety equipment on the truck. Only qualified operators or technicians should attempt to operate or maintain the truck.

### Safe practices start before the operator gets to the equipment!

- Wear the proper clothing. Loose fitting clothing, unbuttoned sleeves and jackets, jewelry, etc., can catch on a protrusion and cause a potential hazard.
- Always use the personal safety equipment provided for the operator such as hard hat, safety shoes, safety glasses or goggles. There are some conditions when protective hearing devices should also be worn for operator safety.
- When walking to and from the truck, maintain a safe distance from all machines even if the operator is visible.

### At The Truck - Ground Level Walk Around Inspection

At the beginning of each shift, a careful walk around inspection of the truck should be made before the operator attempts engine start-up. A walk around inspection is a systematic ground level inspection of the truck and its components to insure that the truck is safe to operate before entering the operator's cab.

Start at the left front corner of the truck (see illustration, next page), and move in a counter-clockwise direction, front-to-rear, across the rear, and continuing forward up the opposite side of the truck to the original starting point. If these steps are taken in sequence, and are repeated from the same point and in the same direction before every shift, many potential problems may be avoided.

**Notify maintenance of any problems or potential problems found during the "walk-around inspection".**

Local work practices may prevent an operator from performing all tasks suggested here, but to the extent permitted, personnel should follow this or similar routine.

1. Start at left front of truck (see illustration, next page). While performing the walk around inspection, visually inspect all lights and safety equipment for external damage from rocks or misuse. Ensure lenses are clean and intact.
2. Move behind the front of the left front tire, inspect the hub and brake assemblies for leaks and any abnormal conditions. Locate air system expansion tank drain valve mounted on steering tubes, left frame rail and exhaust moisture by pulling chain toward tire. Check that all suspension attaching hardware is secure and inspect for evidence of wear. Check that the suspension extension (exposed piston rod) is correct, and that there are no leaks.
3. Inspect fan and air conditioner belts for correct tension, obvious wear, and tracking. Inspect fan guard for security and condition.
4. Look overhead at bottom of cab and check for steering control valve or hose leakage.
5. Move outward from the front wheel, and inspect attaching lugs/wedges to be sure all are tight and complete. Check tires for cuts, damage or "bubbles". Check for proper inflation.
6. Move behind the rear of the front wheel, inspect for leaks at hub or brakes or any unusual conditions. Inspect suspension hardware to be sure it is all in place. Inspect the tie-rod pivots and steering cylinder for proper greasing, and for security of all parts. Check for hydraulic leaks.
7. Check pumps on front of transmission for leakage and that all parts are secure. Check the transmission filter for leaks.
8. Inspect sight glass for transmission oil level. With engine stopped, hydraulic fluid should be between the upper two marks. (Refer to decal on transmission oil pan.) Notify maintenance if oil appears to be low.

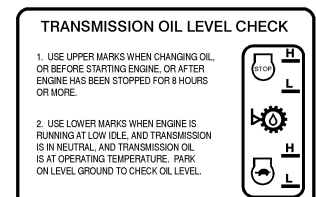
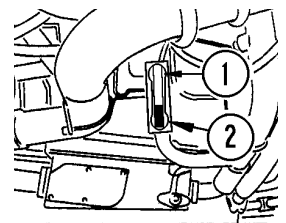

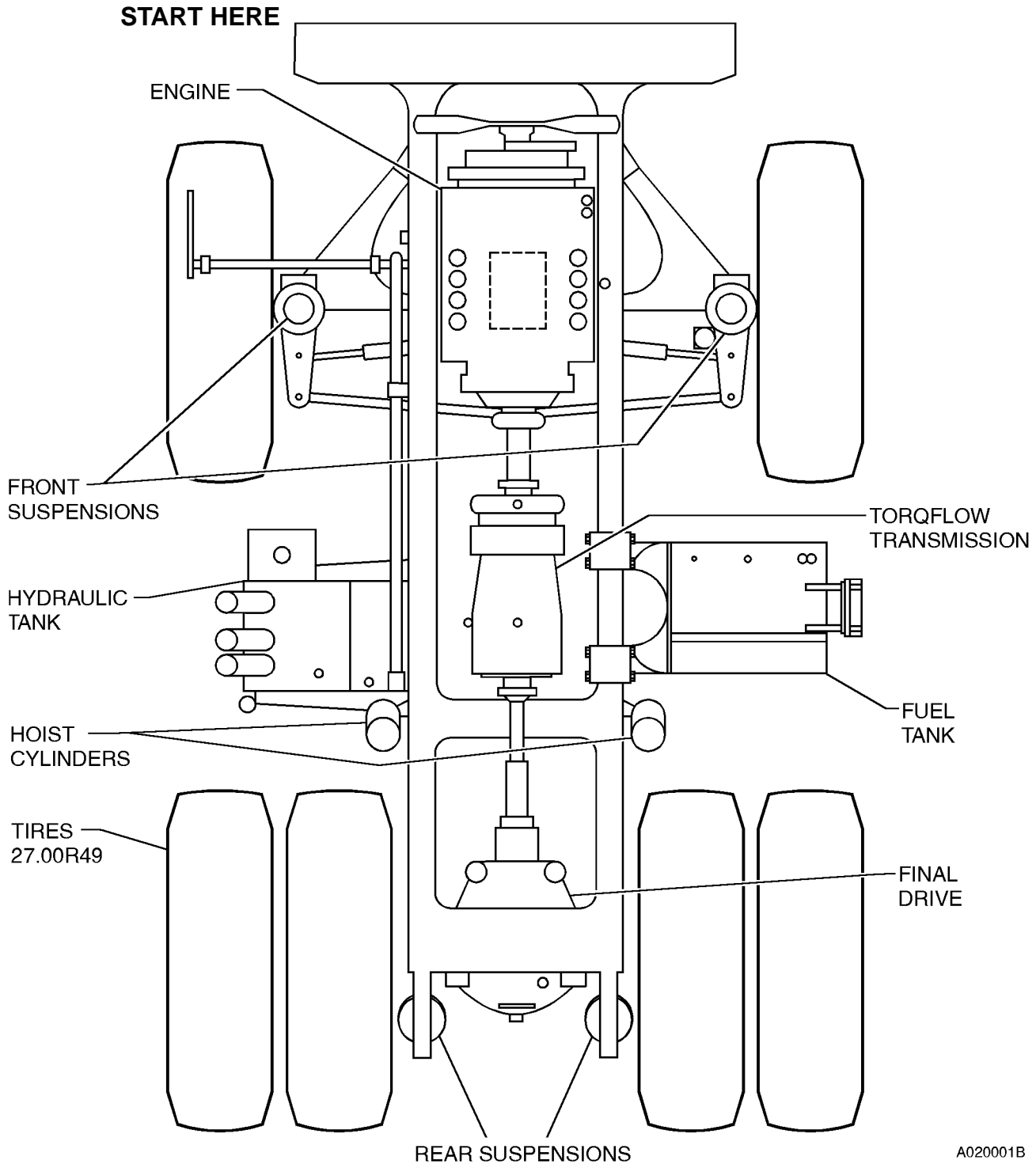

A020001B

### 330M "WALK-AROUND" INSPECTION

**NOTE:** Transmission Oil level is checked most accurately when engine is running and all systems are at normal operating temperatures.

Engine Oil is checked most accurately with the engine stopped, but after engine oil, coolant, and transmission oil are at normal operating temperature.

Refer to Section 4, LUBRICATION & SERVICE, 10 Hour (Daily) Inspection for these procedures.

9. Move to the hydraulic tank and check the hydraulic fluid levels for both the Steering & Hoist tank (1) and the Brake Cooling Oil tank (2). Oil should be visible in each sight glass with engine stopped and body down.

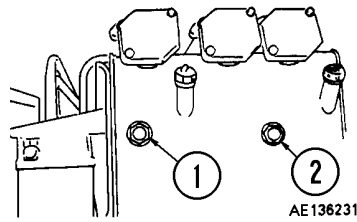

10. Inspect around the hydraulic tank and in front of the rear dual tires. Inspect the hoist cylinder for any damage and leaks. Ensure lower guard is in place. Inspect both upper and lower hoist cylinder pins for security, and for proper greasing.

11. Before leaving this position, look to see that there is no leakage or any other unusual condition with transmission or drive shaft.

12. Inspect around the dual tires, check to see that all lugs/wedges are in place and tight. Inspect wheel for any leakage that may be coming from inside the wheel housing that would indicate planetary leakage.

Check dual tires for cuts, damage or "bubbles" and that inflation appears to be correct. Inspect for any rocks that might be lodged between dual tires, and that rock ejector is in good condition and straight so that it can not damage a tire.

13. Inspect left rear suspension for damage, leaks and for proper charging. Check for proper greasing. Ensure covers over the chrome piston rod are in good condition.

14. Check final drive housing breather. Replace breather if obstructed. Check for leakage around final drive housing, oil disc brake housings and connecting hoses.

15. While standing behind final drive housing, look up to see that rear lights are in good condition, along with back up horns. Inspect linkage rods to see that they are getting proper greasing in all pin locations. Also look at both body hinge pins for greasing and any abnormal condition.

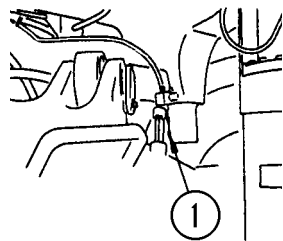

Drain moisture from rear brake air tank by pulling chain (1) on moisture drain valve.

16. Perform the same inspection on the right rear suspension as done on the left.

17. Inspect around the right dual tires. Inspect between the tires for rocks, and for condition of the rock ejector; inspect the tires for cuts or damage, and for correct inflation.

18. Perform same inspection for wheel lugs/wedges, wheel cover latches, and for leaks that was done on the left hand dual wheels.

19. Move in front of right dual tires, and inspect the remaining hoist cylinder.

20. Move to the fuel tank; inspect the attaching hardware for the fuel tank at the upper saddles, and then at the lower back of the tank for the security and condition of the mounts.

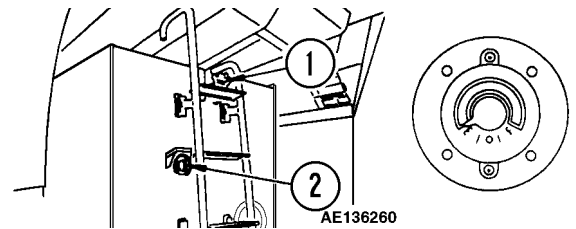

Inspect the fuel gauge (2) and note the quantity indicated. Compare this indication later against the fuel gauge reading in the instrument panel of the operator cab.

21. Move in behind the right front wheel, and inspect the tie-rod pivots and steering cylinder for proper greasing, and for security of all parts. Be sure the suspension protective cover is in good condition. Check suspension attaching hardware and suspension extension, as well as greasing and attaching hardware for the steering cylinder.

22. Move out and around the right front wheel, ensure all lugs/wedges are in place and tight.

23. Move in behind the front of the right front wheel, check hub and brakes for leaks and any unusual condition. Inspect the engine compartment for any leaks and unusual condition. Inspect the fan guard, and belts also for any rags or debris behind radiator.

24. With engine stopped, check engine oil level. The dipsticks of some engines may be marked on both sides; *one side marked "With Engine Stopped"*, and *other side marked "With Engine Running"*. Normal check is with engine running, and at operating temperature. Refer to Section P, Lubrication & Service, 10 Hour (Daily) Inspection.

Check that the engine oil filters or oil lines to filters are not leaking.

25. Move on around to the right front of the truck.
26. When moving in front of the radiator, inspect for any debris that might be stuck in front of the radiator and remove it. Check for any coolant leaks. Inspect all headlamps and fog lights.
27. Before climbing ladder to first level, be sure ground level engine shutdown switch is "ON". (If truck is equipped with this feature.)
28. Climb ladder to main deck. Always use grab rails and ladder when mounting or dismounting from the truck. Clean ladder and hand rails of any foreign material, such as ice, snow, oil or mud.

## **⚠ WARNING**

**Always mount and dismount ladders facing the truck. Never attempt to mount or dismount while the truck is in motion.**

29. When checking coolant in radiator, use coolant level sight gauge (2). Check that water level is between FULL and LOW. If water is low, add water through water filler (1) to FULL level.

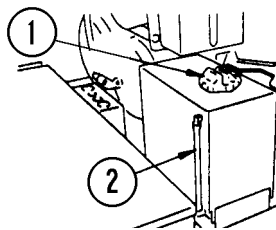

## **⚠ WARNING**

**Allow coolant to cool before removing the fill cap or draining radiator. Serious burns may result if coolant is not allowed to cool.**

If it is necessary to remove radiator cap, shut down engine (if running), and relieve coolant pressure SLOWLY before removing radiator cap. After adding water tighten cap securely.

30. Inspect battery box cover for looseness or damage. Check the brake chambers for leaks, damage, etc. Check brake fluid level (2).

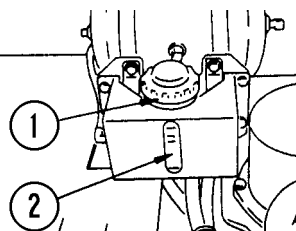

31. Drain moisture from tanks by pulling chains (1) on moisture drain valves. Check air tanks and lines for leaks.

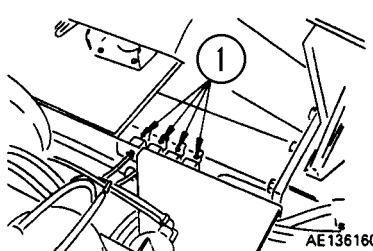

32. Check air cleaner indicator (1). If the RED area is showing in the indicator, the air filter must be cleaned/replaced before operating truck.

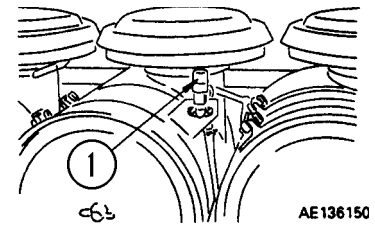

33. Clean cab windows and mirrors; clean out cab floor as necessary. Insure steering wheel, controls and pedals are free of any oil, grease or mud.
34. Stow personal gear in cab so that it does not interfere with any operation of the truck. Dirt or trash buildup, specifically in the operator's cab, should be cleared. Do not carry tools or supplies in cab of truck or on the deck.
35. Adjust seat and steering wheel so that it is comfortable for use.
36. Be familiar with all control locations and functions BEFORE operating truck. Read "Operation Instructions" COMPLETELY and be certain to understand all discussions in the OPERATOR CONTROLS AND INSTRUMENT PANEL in Section N.

## **⚠ WARNING**

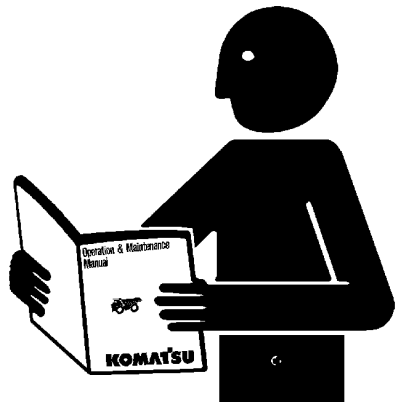

**READ AND UNDERSTAND THE  
OPERATION & MAINTENANCE MANUAL  
BEFORE OPERATING VEHICLE OR  
PERFORMING ANY MAINTENANCE.**

## ENGINE START-UP SAFETY PRACTICES

Safety rules must be observed upon engine start-up.



**Insure adequate ventilation before start-up, if the truck is in an enclosure. Exhaust fumes are dangerous!**

1. Insure all personnel are clear of truck before starting engine. Always sound the horn as a warning before actuating any operational controls.
2. Check and insure Transmission Range Selector is in the "Neutral" position before starting.
3. In cold weather, if truck is equipped with auxiliary heaters, do not attempt to start engine while heaters are in operation. Damage to coolant heaters will result, due to lack of circulation.
4. The key switch has three positions: Off, On, Start.

When the key switch is rotated one position clockwise, it is in the "On (run)" position and all electrical circuits (except "start") are activated.

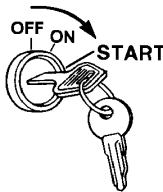

### Before Starting The Engine



**During the following safety checks, if the alarm or red warning lamp does not turn "On" as required, OR, if the actuation or release of any emergency control, brake, or steering circuit does not appear normal, shut engine down immediately and notify maintenance personnel.**

**Do not operate truck until the circuit in question is fully operational.**

Perform the following checks to be certain that the central warning system, alarm buzzer, and all machine monitors and lamps are functional:

- Turn the key switch to the "ON" position. (Do Not Start Engine).

*NOTE: If the engine has been running, and then is stopped, the monitor cannot be checked until at least 30 seconds have passed.*

- Check that the **Central Warning Lamp** and all monitor lamps and gauges, light up for approximately 3 seconds and that the alarm buzzer sounds for approximately 2 seconds.

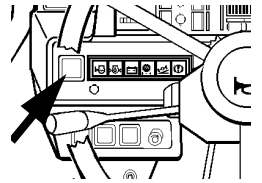

- The speedometer should display "88".
- If the air pressure is below normal operating pressure, the central warning lamp should flash and the buzzer should sound.

- If the **Shift Lever is not at the "N" position**, the central warning lamp will flash and the alarm buzzer will sound intermittently. When the shift lever is moved to the "N" position, the lamp will go out and the buzzer will stop.

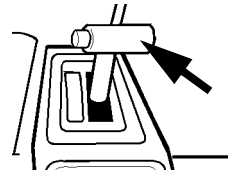

- **Press Lamp Check Switch -Check** to see that all caution lamps or pilot lamps are illuminated.

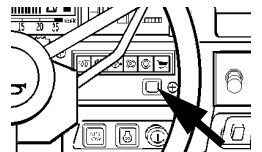

- When checking the monitor, check all caution lamps and pilot lamps at the same time.

- Check the **Manual Emergency Steering**. With the key switch in the ON position, turn emergency steering switch ON (red light ON), and check that the steering wheel can be operated. If the steering wheel cannot be operated, notify maintenance personnel. Do Not Operate truck.

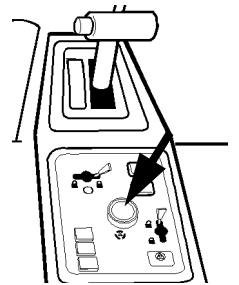

- Check the **Auto Emergency Steering**. With the key switch in the ON position, move **Parking Brake lever** to the "OFF" (unlocked) position. Wait 1.5 seconds and check that the emergency steering is actuated and the steering can be operated.

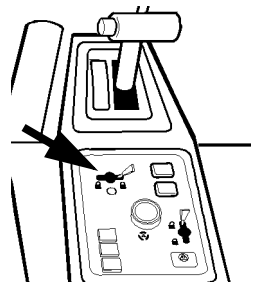

## STARTING THE ENGINE

- Rotate key switch fully clockwise to "start" position (with Transmission Range Selector in "Neutral") and HOLD this position until engine starts (see NOTE below). "Start" position is spring loaded to return to "On" when key is released.

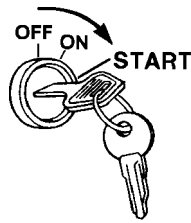

*NOTE: This truck is equipped with an engine prelube system. With this feature, a noticeable time delay may occur (while engine lube oil passages are being filled and pressurized) before engine cranking will begin.*

## STARTING THE ENGINE IN COLD WEATHER

The truck is equipped with an Automatic Cold Start Aid which senses intake manifold temperature and automatically turns electric grid heaters in the engine intake manifold "On/OFF".

- When the key switch is turned "ON" and the manifold temperature is below 3°C (38°F), the Automatic Cold Start system will energize the engine intake manifold grid heaters. Auto grid heater activation time (t) is:

t1 = 15 sec @ 3°C (38°F)  
t2 = 30 sec @ -12°C (10°F)

- The heater pilot lamp (instrument panel, to right of steering column) will illuminate during heating cycle.
- When the light goes "out", turn the key switch to the "Start" position and hold this position until engine starts. (See prelube NOTE above.)

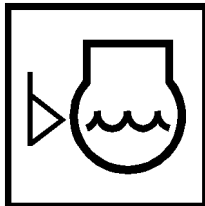

**CAUTION: Do not crank engine with an electric starter for more than 30 seconds. Severe damage to starter motor can result from overheating. Allow two minutes for starter motor cooling before attempting to start engine again.**

- If engine does not start, turn key switch "Off", wait for at least two minutes, and repeat the above procedure.
- Under normal conditions, there is no need to use the Manual Cold Start Switch. (Refer to "Instrument Panel and Indicators", this Section.)

If it is very cold, and the prelube runs a long time, the manual switch can be used to maintain pre-heating.

## ▲ IMPORTANT ▲

*Electric starters and engine grid heaters can be a significant electrical drain on vehicle batteries. The vehicle battery charging system should be monitored and maintained at all times, especially during cold weather operation.*

*When temperature is below 3°C (38°F), do not leave key switch "ON" (engine not operating) for extended periods of time (i.e. troubleshooting).*

- The truck cannot be push started. Transmission lube and control systems are not operational when engine is not running.
- When getting a battery assist from one truck to another, use the following procedure to avoid the possibility of causing sparks near the battery where explosive gases may be present.
  - a. All switches must be "Off" prior to making any connections.
  - b. Be certain to maintain correct polarity.

*NOTE: 330M trucks are equipped with four 12 volt batteries connected in series and parallel to provide 24 volt output. Be certain to maintain correct voltage and polarity when connecting booster cables. Damage to electrical components may result if voltage and polarity are not correct.*

- c. Connect one lead of booster cable to 24V positive (+) post of battery needing assist, and other lead of the booster cable to the 24V positive (+) post of auxiliary battery (power source).
- d. Connect one lead of second booster cable to 24V negative (-) post of auxiliary battery (power source) and then connect other lead of the booster cable to a good frame ground on the disabled truck away from the battery needing assist.

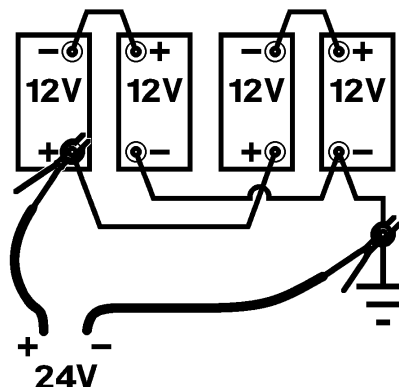

## AFTER ENGINE HAS STARTED

- After starting engine, operate engine at approximately 1000 rpm, coolant temperature gauge is indicating "normal" (green) range.
- Check also that the air pressure gauge is indicating "normal" (green) range.
- Become thoroughly familiar with steering, braking, and emergency controls.

### **▲ DANGER**

*During the following safety checks, if actuation or release of any steering, brake, or emergency control circuit does not appear normal, shut engine down immediately and notify maintenance personnel.*

*Do not operate truck until circuit in question is fully operational.*

1. **Test the truck steering** in extreme right and left directions.
2. **Check for normal actuation of the foot brake.**

- With the machine on flat ground, **depress Foot Brake**

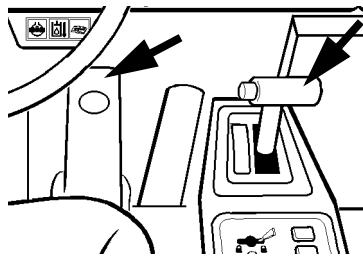

- Move **Shift Lever** to the D position, and gradually raise the engine speed to 1680 rpm.

Check that the machine does not move.

3. **Check for normal actuation of the retarder.**

- With the machine on flat ground, pull **Retarder Lever** (1) fully.

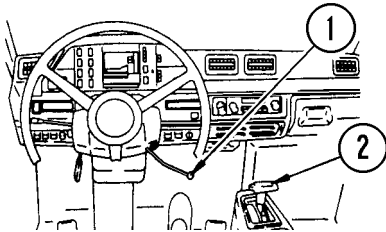

- Set **Shift Lever** (2) to the D position, and gradually raise the engine speed to 1240 rpm.

Check that the machine does not move.

4. **Check Parking Brake capacity.**

- With the machine on flat ground, check that the air pressure gauge is indicating "normal" (green) range.
- Move the **Parking Brake Valve Lever** to the PARKING ("locked") position.

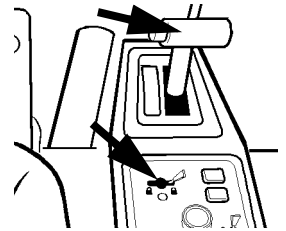

Move the **Shift Lever** to any position other than "N", and check that the central warning lamp flashes.

- Set shift lever to the D position, and gradually raise the engine speed to 1770 rpm. Check that the machine does not move. If machine moves, notify maintenance personnel to adjust parking brake. **Do not operate truck until parking brake is fully operational.**

5. **Check for normal actuation of the Emergency Brake.**

- With the machine on flat ground, verify the air pressure gauge is indicating "normal" (green) range.
- Move the **Emergency Brake Lever** to the BRAKE ("unlocked") position.

- Set **Shift Lever** to the D position, and gradually raise the engine speed to full throttle. Check that the machine does not move. If machine moves, notify maintenance personnel immediately to repair brakes.

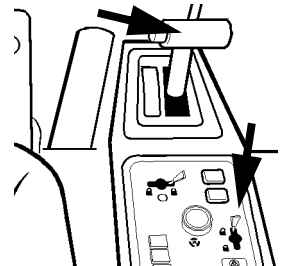

**Do not operate truck until emergency brake is fully operational.**

6. Check gauges, warning lights and instruments before moving the truck to insure proper system operation and proper instrument functioning. Give special attention to braking and steering circuit warning lights. If warning lights come on, shut down the engine immediately and notify maintenance personnel to determine the cause.
7. Insure headlights, worklights and taillights are in proper working order. Good visibility may prevent an accident. Check operation of windshield wiper and washer.
8. When truck body is in dump position, do not allow anyone beneath it, unless body-up retaining device is in place.

9. Do not use the fire extinguisher for any purpose other than putting out a fire! If extinguisher is discharged, report the occurrence so the used unit can be refilled or replaced.
10. Do not allow unauthorized personnel to ride in the truck. Do not allow anyone to ride on the ladder or on the deck of the truck.
11. Do not leave truck unattended while engine is running. Shut down engine before getting out.

## MACHINE OPERATION SAFETY PRECAUTIONS

After the truck engine is started and all systems are functioning properly, the operator must follow all local safety rules to insure safe machine operation.

### **WARNING**

*If any of the red warning lights come "On" or if any gauge reads in the red area during truck operation, a malfunction is indicated. Stop truck as soon as safety permits, shut down engine if problem indicates and have problem corrected before resuming truck operation.*

1. Always sound the warning horn before moving the truck. When backing the truck, give back-up signal (three blasts on air horn); when starting forward, two blasts on air horn. These signals must be given each time the truck is moved forward or backward. Look to the rear before backing the truck. Watch for and obey ground spotter's hand signals before making any reverse movements. Spotter should have a clear view of the total area at the rear of the truck.
2. Operate the truck only while properly seated with seat belt fastened. Keep hands and feet inside the cab compartment while truck is in operation. Keep a firm grip on steering wheel at all times.
3. Check that all mirrors are not damaged, clean, and are properly positioned for optimum view.
4. Check gauges and instruments frequently during operation for proper readings.

5. Observe all regulations pertaining to the job site's traffic pattern. Be alert to any unusual traffic pattern. Match the truck speed to haul road conditions and slow the truck in any congested area. Obey the spotter's signals at shovel and dump.
6. Do not allow engine to run at "Idle" for extended periods of time.
7. Check parking brake periodically during working shift. **Use parking brake for parking and at shovel and dump only.** *Do not attempt to apply parking brake while truck is moving!*
8. Proceed slowly on rough terrain to avoid deep ruts or large obstacles. Avoid traveling close to soft edges and the edge of fill area.
9. Truck operation requires concentrated effort by the driver. Avoid distractions of any kind while operating the truck.

## LOADING

1. Pull into the loading area with caution. Remain at a safe distance while truck ahead is being loaded.
2. Do not drive over unprotected power cables.
3. When approaching or leaving a loading area, watch out for other vehicles and for personnel working in the area.
4. When pulling in under a loader or shovel, follow "Spotter" or "Shovel Operator" signals. The truck operator may speed up loading operations by observing the location and loading cycle of the truck being loaded ahead, then follow a similar pattern.
5. Operator should remain in truck cab with engine running while truck is being loaded. Place Transmission Range Selector in "Neutral" and apply Parking Brake lever.

### **WARNING**

*If operator must leave truck cab during loading, engine must be shut down and parking brake applied. DO NOT use emergency brake for parking. Remain far enough away from truck to avoid being struck by flying material.*

6. When truck is loaded, pull away from shovel as quickly as possible, but with extreme caution.



## HAULING

1. Always stay alert! If unfamiliar with the road, drive with extreme caution.
2. Govern truck speed by the road conditions, weather and visibility.
3. Operate truck so it is under control at all times.
4. Use extreme caution when approaching a haul road intersection. Maintain a safe distance from oncoming vehicles.
5. Obey all road signs.
6. Always dim headlights when meeting oncoming vehicles.
7. Maintain a safe distance when following another vehicle. Never approach another vehicle from the rear, in the same lane, closer than 15 m (50 ft). When operating on a down grade, stay at least 30 m (100 ft.) away.
8. When operating truck in darkness or when visibility is poor, do not move truck unless headlights are on. Do not back truck if back-up horn or lights are inoperative.
9. When backing the truck, give back-up signal (three blasts on air horn); when starting forward, two blasts on air horn. These signals must be given each time the truck is moved forward or backward.
10. Do not stop or park on a haul road unless unavoidable. If you must stop, move truck to a safe place, apply parking brake, shut down engine, block wheels securely and notify maintenance personnel for assistance.
11. If the "Emergency Steering" light and/or "Low Air Pressure" warning light come on during operation, steer the truck **immediately** to a safe stopping area, away from other traffic if possible. Refer to item 11 above.
12. Report haul road conditions immediately. Muddy or icy roads, pot holes or other obstructions can present hazards.
13. Cab doors should remain closed at all times while truck is in motion or unattended.
14. Check for flat tires periodically during shift. If truck has been run on a "flat", **it must not be parked in a building until the tire cools.**

## RETARDER OPERATION

During normal operation, the retarder control lever should be used to control the speed of the truck and to stop the truck instead of using the foot-operated service brake pedal. Use of this lever allows the operator to apply **the REAR oil-cooled brakes only**, thus extending the life of the front caliper disc pads while still maintaining maximum control of the truck. The foot-operated brake pedal should be used when maneuvering in tight places, at the shovel and dump, and when quick stops **or when severe braking is required.**

For better control under slippery road conditions, the **optional** front wheel brake cut-off switch may be turned on (if equipped).

1. Before starting down a grade, maintain a speed that will insure safe operation and provide effective retarding under all conditions.
2. When descending a grade with a loaded truck, the operator should *adjust the speed of the truck*, if necessary, to **preselect a transmission gear range**, so that operation can be maintained within the speeds listed on the **Retarding Capacity** decal located inside the cab on the lower left corner of the front windshield.



# WARNING

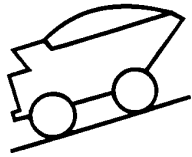

**RETARDING CAPACITY**  
**GVW: 367,000 LBS**  
**(166,470 kg)**  
**TIRES: 27 X 49**

**MAXIMUM BRAKE OIL TEMPERATURE: 248 F (120C)**  
**MAXIMUM ENGINE SPEED: 2400 RPM**

**MAINTAIN HIGHEST ENGINE SPEED BELOW MAXIMUM. SLOW TO NEXT LOWER GEAR IF COOLING OIL TEMPERATURE NEEDS TO BE LOWERED.**

GEAR NUMBER	SPEED MPH (km/hr)	CONTINUOUS GRADE%	SHORT LENGTH 1970ft (600m) GRADE%
1	6.6 (10.6)	28.0	30.4
2	9.3 (15.0)	19.9	22.3
3	12.5 (20.1)	14.8	17.2
4	16.8 (27.1)	11.0	13.4
5	22.7 (36.5)	8.2	10.6
6	30.9 (49.8)	6.0	8.4
7	41.7 (67.1)	4.4	6.8

WB2610

Two lists are provided on the **Retarding Capacity** decal, one a continuous rating, and the second a short-length rating. Both lists are matched to the truck at maximum Gross Vehicle Weight.

The continuous numbers on the chart indicate the combination of speeds and grades which the vehicle can safely negotiate for unlimited time or distance.

The short-length numbers listed on the chart indicate the combination of speeds and grades which the vehicle can safely negotiate for three minutes. These speeds are faster than the continuous values, reflecting the thermal capacity of various system components. System components can accept heating at a higher-than-continuous rate for a short period of time, beyond which the system would become over-temperature.

The short-length rating (sometimes called the "three-minute" limit) will successfully accommodate most downhill loaded hauls. It is necessary to divide haul road grade segment length by allowable speed to determine actual time on grade. If actual time on grade exceeds the allowable amount, the grade will need to be negotiated at the continuous speed. Ambient temperature, as well as the prior temperature of the brake cooling oil can affect this number (the brake cooling oil could already be above the normal range from recent operating conditions).

## **WARNING**

**DO NOT exceed these recommended MAXIMUM speeds when descending grades with a loaded truck.**

### **3. For Efficient Retarder Operation when descending a grade, the operator should:**

- Maintain engine RPM between 1800 - 2400 RPM, and
- Apply the retarder lever while observing *both the Tachometer and the Brake Oil Temperature Gauge*.

**The engine RPM must be maintained at 1800 - 2400 RPM and the Brake Oil Temperature must be maintained below 248°F (120°C).**

If the operator observes that **either** the maximum engine speed of 2400 RPM **or** the Brake Oil Temperature of 248°F (120°C) are about to be exceeded, the operator should immediately move the transmission range selector to the next lower range and use the foot-operated brake pedal, to apply more brake pressure until the truck is slowed to a speed which will permit the transmission to downshift to the gear range selected.

Continue this procedure to downshift to the required gear range to maintain engine speed at 1800 - 2400 RPM and brake oil temperature below 248°F (120°C). When the proper gear range is attained, continue to use the retarder as needed to maintain a safe, productive speed.

If brake oil temperature exceeds 248°F (120°C), the *Brake Oil Temperature Warning light will turn on*. **As quickly as safety will permit**, bring the truck to a complete stop away from traffic, move transmission range selector to "Neutral", apply the parking brake, and run engine at high idle.

Continue to run engine at high idle until Brake Oil Temperature Warning light turns off and brake oil temperature cools to below 248°F (120°C). If temperature does not return to this range within a few minutes, report the condition **immediately** to maintenance personnel and wait for further instructions before moving truck.

## **ENGINE OVERSPEED**

## **DANGER**

***If the truck and engine speed is not controlled, the rear brakes will be automatically applied at full pressure. The operator and any passengers may be subjected to severe deceleration forces and the truck may be difficult to control.***

If the engine is allowed to run into an overspeed condition, the rear brakes will be automatically applied at 2600 RPM.

The rear brakes will not be released until engine speed falls below 2350 RPM.

## PASSING

1. Do not pass another truck on a hill or blind curve!
2. Before passing, make sure the road ahead is clear. If a disabled truck is blocking your lane, slow down and pass with extreme caution.
3. Use only the areas designated for passing.

## DUMPING

1. Pull into dump area with extreme caution. Make sure area is clear of persons and obstructions, including overhead utility lines. Obey signals directed by the spotter, if present.

Avoid unstable areas. Stay a safe distance from edge of dump area. **Position truck on a solid, level surface before dumping.**



***As body raises, the truck Center of Gravity (CG) will move. TRUCK MUST BE ON LEVEL SURFACE to prevent tipping / rolling!***

2. Carefully maneuver truck into dump position. When backing truck into dump position, use only the foot-operated brake pedal to stop and hold truck.
3. When in dump position, place transmission range selector at the "Neutral" position, and apply the Park Brake lever/switch.

## To Raise dump body:



***The dumping of very large rocks (10% of payload, or greater) or sticky material (loads that do not flow freely from the body) may allow the material to move too fast and cause the body to move RAPIDLY and SUDDENLY. This sudden movement may jolt the truck violently and cause possible injury to the operator, and/or damage to the hoist cylinders, frame, and/or body hinge pins. If it is necessary to dump this kind of material, refer to the CAUTION in the following procedure:***

4. Pull dump lever up to the "RAISE" position and release lever.
5. Raise engine RPM to accelerate hoist speed. Refer to the CAUTION below. When body is near the maximum angle, reduce engine RPM (reduce foot pressure on the accelerator pedal) to reduce shock load to the hydraulic system and hoist cylinders.

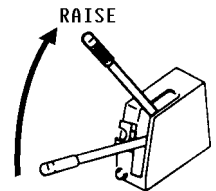

***If dumping very large rocks or sticky material as described in WARNING above, slowly accelerate engine RPM to raise body. When the material starts to move, move hoist lever to "HOLD" position. If material does not continue moving and clear body, repeat this procedure until material has cleared body.***

6. When the dump body rises to the set position (adjusted position of body positioner) dump lever returns to the "HOLD" position. If desired to raise the body further, move dump lever to raise position and dump will rise. If dump lever is released, lever will return to hold position. Dump body will stop in that position.
7. After material being dumped clears body, lower body to frame.

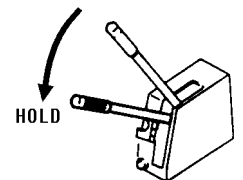

### To Lower Body:

8. After material being dumped clears body, move dump lever to the "LOWER" position and dump body will start to move down.

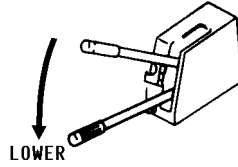

9. Release the lever and it will return automatically to the "FLOAT" position. The body will move down under its own weight.

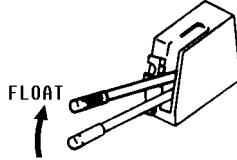

*If dumped material builds up at body tailgate and body cannot be lowered, shift Transmission Range Selector to "D" (Drive), release park brake lever, and drive forward to clear material. Stop, shift Transmission Range Selector to "N" (Neutral), apply park brake lever and lower body. See NOTE :\**

## **CAUTION**



**The truck is not to be moved with the dump body raised except for emergency moves only. Failure to lower body before moving truck may cause damage to hoist cylinders, frame and/or body hinge pins.**

*NOTE: When traveling, always place the dump lever at the FLOAT position, regardless of whether or not the truck is loaded.*

*\* If the transmission range selector is moved to any position other than "N" (neutral) when the dump lever is not at the FLOAT position, the central warning lamp will flash and the alarm buzzer will sound intermittently.*

10. With body returned to frame, move Transmission Range Selector to "D" (Drive), release park brake lever, and leave dump area carefully.

### SAFE PARKING PROCEDURES

The operator must continue the use of safety precautions when preparing for parking and engine shut-down.

In the event that the equipment is being worked in consecutive shifts, any questionable truck performance the operator may have noticed must be checked by maintenance personnel before the truck is released to another operator.

1. The truck should be parked on level ground, if at all possible. If parking must be done on a grade, the truck should be positioned at right angles to the grade.
2. The parking brake must be applied and/or chocks placed fore/aft of wheels so that the truck cannot roll. Each truck should be parked at a reasonable distance from another.
3. Haul roads are not safe parking areas. In an emergency, pick the safest spot most visible to other machines in the area. If the truck becomes disabled where traffic is heavy, mark the truck with warning flags in daylight or with flares at night.

### SHUTDOWN PROCEDURE

The following sequence of shutdown procedure is important and should be followed at each shutdown.

1. Stop truck, reduce engine RPM to low idle. Place Transmission Range Selector in "Neutral" and apply parking brake.
2. Allow engine to cool gradually by running at low idle for 3 to 5 minutes.
3. Turn keyswitch "Off" to stop engine.
4. Close and lock all windows, remove key from key switch and lock cab to prevent possible unauthorized truck operation. Dismount truck properly.

## TOWING

Prior to towing a truck, many factors must be carefully considered. Serious personal injury and/or significant property damage may result if important safety practices, procedures and preparation for moving heavy equipment are not observed.

### **CAUTION**

***Both right and left planetary sun gears/drive axles should be removed before any towing. Refer to Section "G" in the Service Manual for these instructions. Extensive secondary damage can occur to final drive components and/or transmission, if truck is towed without first removing sun gears/drive axles.***

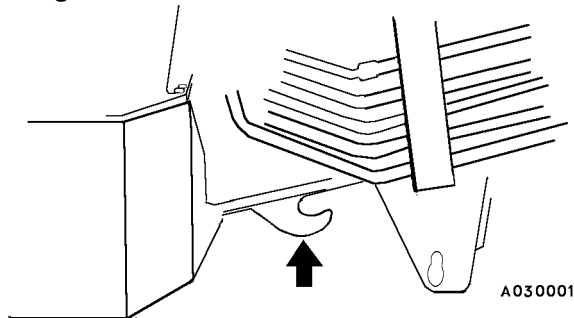

**The truck must not be towed except in emergencies.**

When towing becomes necessary, use the tow hook installed under the front frame and take the following precautions:

1. Block disabled truck to prevent movement while attaching tow bar.
2. If the engine is operable; keep the engine running while towing the machine, so that the steering and braking can be used.

If there is a failure in the air circuit, the brakes cannot be used, so be extremely careful when towing. When air pressure in air reservoir abnormally drops due to leakage from air circuit, parking brake and emergency brake are actuated. When towing truck, both brakes must be released. Refer to "BRAKE RELEASE" following these "TOWING" instructions.

If the engine is NOT operable, it is possible to steer using the emergency steering, but do not use it for more than 90 seconds, and travel at a speed of **less than** 5 km/h (3 mph).

3. If the engine is NOT operable, never haul the truck over 800m (2,625 ft.).

If the towing distance surpasses that limit, be sure to remove the drive shaft between the transmission and the differential case (if final drive sun gears have not been removed).

The towing speed must not be greater than 8 km/h (5 mph).

4. Inspect tow bar for capacity (it should be strong enough to tow 1.5 times the gross vehicle weight of truck being towed).
5. Determine that towing vehicle has adequate capacity to *both move and stop* the towed truck under all conditions.
6. Protect both operators in the event of tow bar failure.
7. Release disabled truck brakes and remove all blocking.

### **CAUTION**

***Do not tow the truck any faster than 8 kph (5 MPH).***

8. Sudden movement may cause tow bar failure. Smooth and gradual truck movement is preferred.
9. Minimize tow angle at all times - NEVER EXCEED 30°. The towed truck must be steered in the direction of the tow bar.

## BRAKE RELEASE

### Releasing Parking Brake And Emergency Brake After Being Actuated In An Emergency

If the pressure inside the air tank drops abnormally due to some problem, such as leakage of air from the air circuit, the parking brake and emergency brake are automatically actuated.

### RELEASE OF PARKING BRAKE

The parking brake is a dry disc brake mounted on the rear drive shaft at the differential input with two (2) **spring-applied, air-released** calipers. Each caliper is individually applied/released through separate air chamber actuators (spring cylinder assemblies). If the parking brake can not be released after its emergency application - even if the parking brake valve lever is put in RELEASE position - take the following actions to release the parking brake:

1. Block disabled truck to prevent movement and confirm safety in the surrounding area.
2. At the parking brake relay valve, remove both air hoses (4) connected to the air chambers of the parking brake spring cylinder assemblies (5).

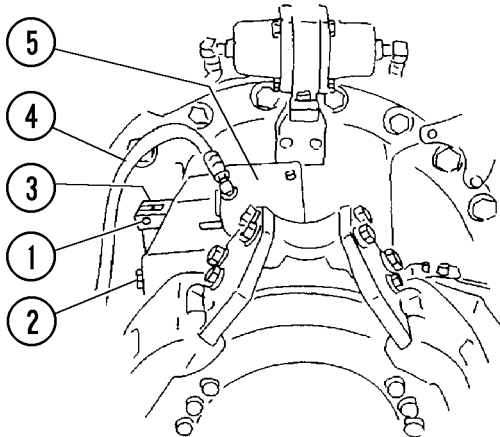

J070004

3. Connect these hoses together using a "tee" fitting with compatible thread ends.
4. Connect third connector of "tee" to a hose from an air supply of sufficient capacity to release calipers. Apply air and release brake.
5. With parking brake released, turn adjustment bolt (2) counterclockwise, and check for "play" in linkage (3). Remove pin (1). Repeat for other caliper. Disconnect air supply.

6. With parking brake disconnected, remove blocking and immediately move the truck to a safe place. Refer to INSTRUCTIONS FOR TOWING THE MACHINE.

## WARNING

*If the air system is not operating, the service brakes will not apply; this is very dangerous. Be sure to tow the truck at low speed, keeping the engine running (if possible) and always be ready to steer.*

Refer to Section 4, *Lubrication & Service; Parking Brake Inspection and Adjustment*, for instructions for reconnecting and adjusting park brake.

### RELEASE OF EMERGENCY BRAKE

When the emergency brake has been applied, do not continue to drive the machine. This will cause seizure of the brake discs and linings.

If the emergency brake can not be released after its emergency application - even if the emergency brake valve lever is put in RELEASE position - release the emergency brake in the following manner:

Before releasing the air pressure from the emergency brake reservoir, confirm safety in the surrounding area and put chocks against the tires.

1. After making preparations to tow the machine, pull rings (2) on the 4 drain valves on the front air tanks to release the air pressure.
2. After exhausting air pressure, release rings (2).
3. Drain the rear air tank by pulling and holding the ring on the air drain valve mounted on the frame in front of the right rear suspension. Keep drain valve open until all air is exhausted from tank. This will allow the emergency brake to release.

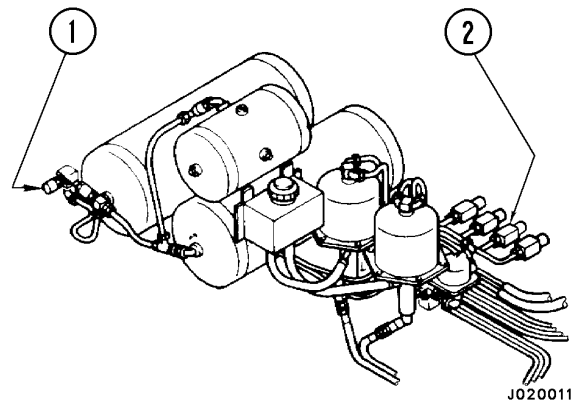

J020011

### RELEASING EMERGENCY BRAKE

1. Air Quick Disconnect
2. Drain Valve Pull Rings

## OPERATOR CAB AND CONTROLS

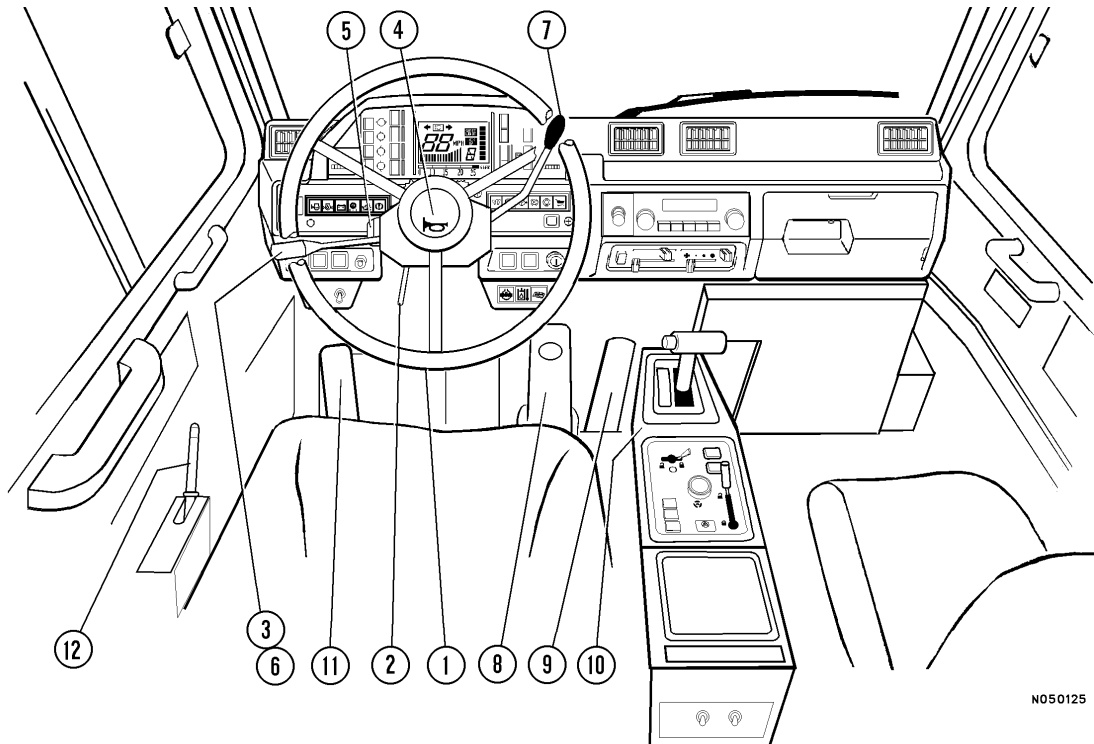

N050125

FIGURE 3-1. STEERING WHEEL AND CONTROLS

- |                                      |                                   |  |
|--------------------------------------|-----------------------------------|--|
| 1. Steering Wheel                    | 5. Windshield Wiper/Washer Switch | 9. Throttle Pedal                      |
| 2. Tilt Lever                        | 6. Headlight Dimmer Switch        | 10. Center Console                     |
| 3. Turn Signals and Headlight Switch | 7. Retard Control Lever           | 11. Differential Lock Pedal (Optional) |
| 4. Air Horn                          | 8. Brake Pedal                    | 12. Hoist Control Lever                |

### (1) Steering Wheel And Controls

The steering wheel (1, Figure 3-1) may be adjusted through a tilt angle to provide a comfortable position for the operator.

### (2) Tilt Lever

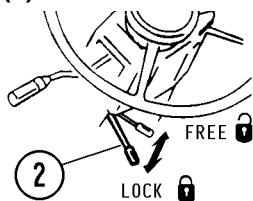

Adjust the tilt angle of the steering wheel by pulling Tilt Lever (2) up, toward steering wheel and moving the wheel to the desired angle. The steering wheel may also be adjusted (telescoped) "In" or "Out" at this time. Pushing the lever back locks the wheel in the desired position.

### (3) Turn Signal Lever Switch

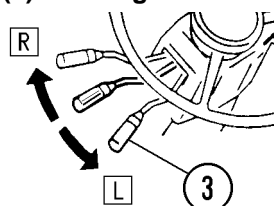

Turn Signal Lever (3) is used to activate turn signal lights: Move lever upward to signal a turn to the right (R). Move lever downward to signal a turn to the left (L).

### (4) Horn

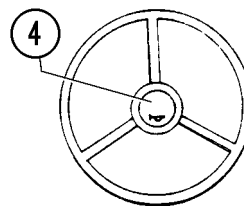

The horn (4) is actuated by the horn button in the center of the steering wheel. When the button is depressed, it activates the horn solenoid.

### (5) Windshield Wiper / Washer Switch

Windshield Wiper Switch (5) is used to activate the wiper blades and washer system. This switch has four wiper position settings and a washer push-button:

**INT:** Wipers operate intermittently.

**OFF:** Wipers are off.

**LOW:** Wipers operate at low speed. **HI:** Wipers operate at high speed.

Press **end** of switch to spray washer liquid onto windshield.

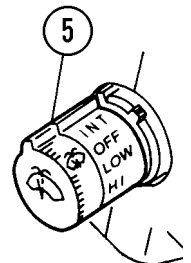

### (6) Headlights and Dimmer Switch

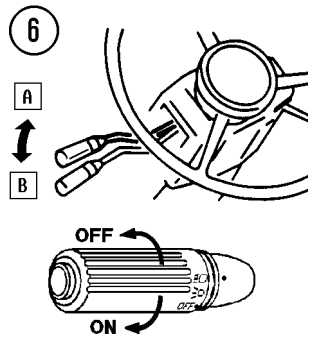

The headlights and dimmer switch (6, Figure 3-1) is part of the turn signal lever function. The headlights are turned "Off" and "On" by rotating the switch on the end of the lever handle. The switch has three positions: OFF; Running/Clearance lights; and Headlights.

The dimmer switch is part of the turn signal lever function.

Pulling the lever up will activate headlights to low beam [A]. Pushing the lever down activates headlights to high beam [B].

### (7) Retard Control Lever

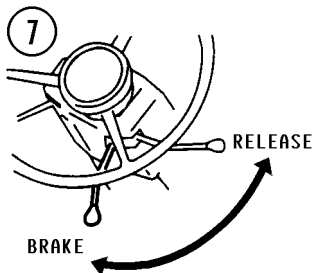

The retarder control lever (7) allows the operator to apply only the REAR oil-cooled brakes. During normal operation, this lever should be used to control the speed of the truck and to stop the truck instead of using the foot-operated

service brake pedal. Use of this lever extends front brake life while maintaining maximum control of the truck.

### (8) Brake Pedal

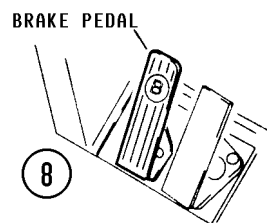

The Brake Pedal (8) is a foot-operated pedal which activates air-over-hydraulic pressure converters which apply front caliper dry disc brakes and rear oil-cooled wet disc brakes. This pedal should be used when

maneuvering in tight places, at the shovel and dump, and when quick stops or severe braking is required.

### (9) Throttle Pedal

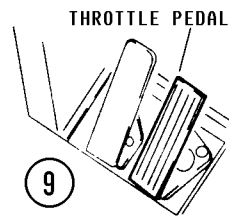

The Throttle Pedal (9) is a foot operated treadle pedal which allows the operator to control fuel to the engine to provide engine acceleration.

The electronic treadle pedal sends signals to the electronic engine fuel control system. The movement of the governor control arm corresponds directly to travel of the treadle pedal as applied by the operator. When the pedal is released, a spring returns the pedal and governor control arm to the low idle position.

### (10) Center Console

The Center Console (10, Figure 3-1) is located to the right of the Operator.

### Transmission Range Selector (1, Figure 3-2)

The Transmission Range Selector has seven positions (R, N, D, 5, 4, 3, and L).

## ▲ IMPORTANT ▲

***When operating the shift lever, be sure to set it in position securely (detent). If the lever is not in a detent position, the shift position display on the panel may go out and the transmission warning monitor lamp may light up.***

***When shifting between FORWARD and REVERSE, stop the machine completely, and reduce engine speed to low idle when moving the lever.***

***If the parking brake is not released, and the shift lever is moved to a position other than N, the central warning lamp will flash and the alarm buzzer will sound.***

***If the dump lever is not at the FLOAT position, and the shift lever is moved to a position other than N, the central warning lamp will light up and the alarm buzzer will sound.***

***Do not move the shift lever with the accelerator pedal depressed. This will cause "shift shock", and will reduce the life of drive train components.***



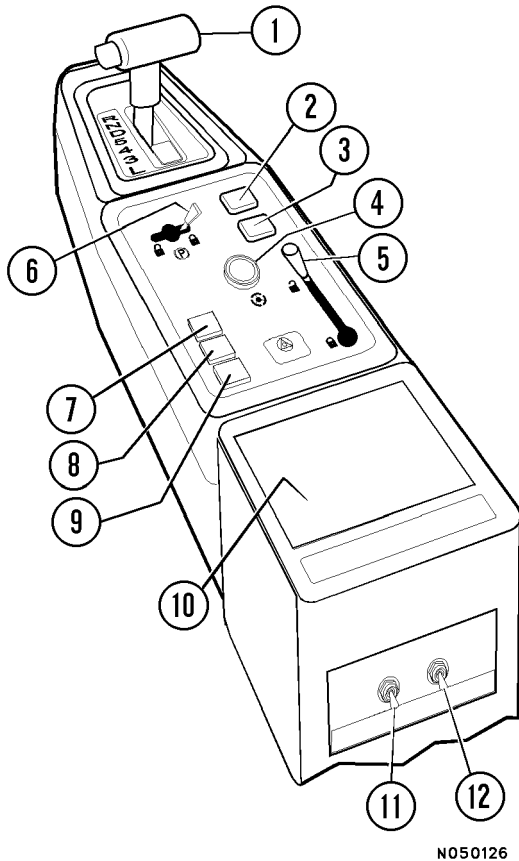

N050126

FIGURE 3-2. CENTER CONSOLE

1. Transmission Range Selector (Shift Lever)
2. Shift Limiter Switch
3. Power Mode Selector Switch
4. Emergency Steering Switch
5. Emergency Brake Lever
6. Parking Brake Valve Lever
7. Engine Shutdown Warning Light
8. Engine Maintenance Light
9. Engine Maintenance Light
10. PMC Display (Optional)
11. Engine Fault Code Switch
12. Engine Diagnostic Switch

When moving the range selector lever from "N" to "R", or from "D" to 5, the Release Button on the end of the handle (operator side) must be pressed before the selector lever can be moved.

**"R" - REVERSE position -**

Bring truck to a **complete stop** before shifting from DRIVE to REVERSE or vice-versa. The Reverse Warning Horn is activated when REVERSE position is selected.

**"N" - NEUTRAL position -**

is used when starting the engine, during loading operations and parking the truck with engine running. The truck cannot be started unless the range selector is in the "N" - NEUTRAL position.

**"D" - DRIVE position -**

When starting from a stopped position, the transmission will shift automatically to second gear. As the truck ground speed increases, the transmission will automatically upshift through each gear to seventh gear operation. As the truck ground speed slows down, the transmission will automatically downshift to the correct gear for grade/load/engine conditions.

*NOTE: The transmission will be locked into second gear if the body is not seated on the frame. Always lower the body when traveling.*

**"5, 4, 3" positions -**

Road and load conditions sometimes make it desirable to limit the automatic up-shifting to a lower range. These positions provide more effective retarding on grades. When the range selector is placed in any one of these positions, the transmission will not shift above the highest gear range selected. It will also downshift to first range when required by grade/load/engine conditions. When conditions permit, select position "D" for normal operation.

**"L" - LOW position -**

Use this range position when maneuvering in tight spaces and when pulling through mud or deep snow. Use this range position also when driving up and down steep grades where maximum driving power or maximum retarding is required.

*NOTE: The transmission will be locked into first gear if the body is not seated on the frame. Always lower the body when traveling.*

### Shift Limiter Switch (2, Figure 3-2)

This switch is used to limit the highest speed range when the transmission shift lever is in "D" or "L" Ranges.

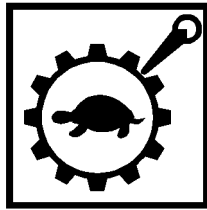

#### POSITION:



"D" Range - F2 - F7

"L" Range - F1 - F2



"D" Range - F2 - F6

"L" Range - F1

When the switch position is "out" the light is "off". When the switch position is "in" the light is "on".

### Economy / Power Mode Switch (3, Figure 3-2)

This switch activates a part of the electronically controlled engine fuel system. The switch controls optimum operating efficiency in loaded vs. unloaded conditions.

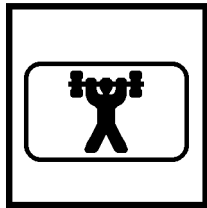

Normal Idle - When in "Economy Mode" (in/light on), fuel usage is reduced as full engine power is not required.



Advanced Idle - When switched to "Power Mode" (out/light off), full fuel flow is allowed to provide maximum rated engine power.



*NOTE: This switch also affects the transmission shift points from F1 to F2, and F2 to F1:*

"Economy Mode"

Upshift (F1 to F2) = 2000 RPM.

Downshift (F2 to F1) = 1300 RPM.

"Power Mode"

Upshift (F1 to F2) = 2100 RPM.

Downshift (F2 to F1) = 1400 RPM.

### Emergency Steering Switch (4, Figure 3-2)

This switch (4) actuates the emergency steering pump.

Depress the center button to activate the emergency steering pump motor.

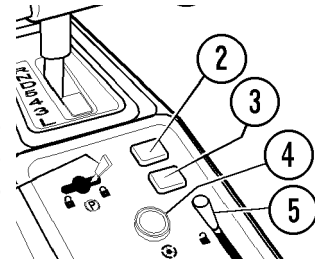

Depress the button again to turn OFF the emergency steering. When the switch is "On", the RED lamp in the switch will light. The red warning light on the right-hand side of the instrument panel will also light.

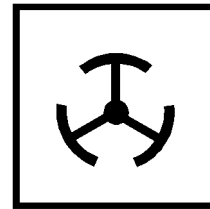

## ⚠ IMPORTANT ⚠

***Do not use the emergency steering for longer than 90 second intervals and do not drive in excess of 5 km/hr (3 mph).***

***Use this operation ONLY in emergency situations. Do not use this function for normal body operation.***

When the emergency steering is actuated, it is possible to use the dump lever to raise the dump body. However, the body cannot be raised when loaded.

Emergency steering will be activated automatically if the steering pump fails or the engine stops during operation.

## ⚠ IMPORTANT ⚠

***If the emergency steering automatically actuates, stop the machine as quickly as possible and carry out an inspection to determine the cause. Notify maintenance personnel immediately.***

If the key switch is turned ON when the machine is stopped and the parking brake switch is OFF (unlocked position), the auto emergency steering will be actuated after 1.5 seconds. Turn the parking brake switch to the PARKING (ON/ locked) position.

### Emergency Brake Lever (5, Figure 3-2)

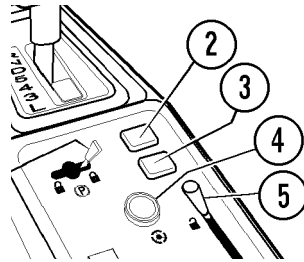
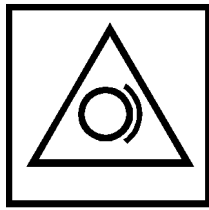

The lever (5) actuates the emergency brake.

EMERGENCY BRAKE RELEASED:  
(TRAVEL/ UNLOCKED position).



EMERGENCY BRAKE ACTUATED:  
(APPLIED/ LOCKED position).



### STOPPING IN EMERGENCY



**When truck is moving, apply the emergency brake ONLY if the foot operated brake pedal and/or the column mounted retarder lever do not supply enough braking effort to stop the truck.**

**Use the emergency brake lever to bring the truck to a complete stop. When the truck has come to a complete stop, BE CERTAIN TO LEAVE THE LEVER IN THE FULL APPLIED/ LOCKED position.**

- If the pressure in the air tank drops below 313.8 kPa (3.2 kg/cm<sup>2</sup>, 45.5 psi), the emergency brake is automatically applied. This actuation applies ALL brakes (front, rear, & parking brake) with all available pressure.
- If the emergency brake is applied because of a failure in the air system, the central warning lamp will flash and the alarm buzzer will sound.

### AFTER MAKING AN EMERGENCY STOP

- Immediately after stopping, move parking brake lever (6, Figure 3-2) to the APPLIED/LOCKED position, then place blocks around all wheels to secure the machine.

Notify maintenance personnel immediately. **Do not operate the truck** until the cause for the emergency has been determined and repaired.

- Immediately after making an emergency stop, the parking brake disc will be at a high temperature. **Do not make any parking brake adjustment until the disc has cooled.** The parking brake must be adjusted after an emergency stop. For details of the method for releasing the brake, see BRAKE RELEASE, page 3-14.

### Parking Brake Valve Lever (6, Figure 3-2)

This lever (6) is used to apply the parking brake.

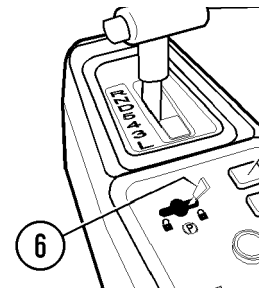
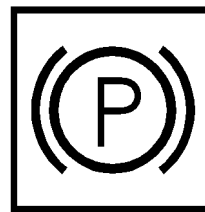

PARKING: Parking Brake actuated. (Locked)



TRAVEL: Parking brake released. (Unlocked)



- When the lever is set to the PARKING position, the parking brake pilot lamp lights up.



**Always apply the parking brake when parking or leaving the machine.**

- When the lever is set to the PARKING position, if the transmission shift lever is at any position other than "N", the central warning lamp will flash and the alarm buzzer will sound.
- If the air pressure drops below 215.7 kPa (2.2 kg/cm<sup>2</sup>, 31.2 psi), the parking brake is automatically applied.

For details of the method of releasing the brake when it is applied because of failure in the air system, see BRAKE RELEASE.

## ENGINE ELECTRONIC CONTROL SYSTEM

The following items (7, 8, 9, 11, & 12, Figure 3-2) relate to the engine electronic fuel control system.

If an abnormal engine condition develops, the control system will record a "fault" code associated with that condition. By use of a series of indicator lamps and switches, the system will display the numerical "fault" code.

When the keyswitch is turned "On", the lamps (7,8, 9) should illuminate for about 2 seconds and then turn "Off", if no "faults" are detected in the system. This is a system lamp test.

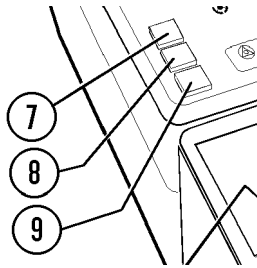

If a light remains ON, or if a light FLASHES, then active "faults" have been detected by the system and the engine should not be started until the condition has been corrected.

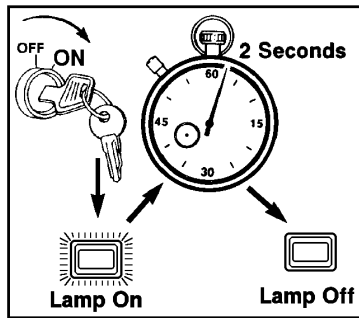

Refer to DETERMINING "FAULT" CODES.

During engine operation, if a "fault" is detected in the system, a light associated with that condition will turn "ON" and stay on for "Warning faults", or it will turn "ON" and "FLASH" for more severe faults that can affect engine operation and require immediate attention.

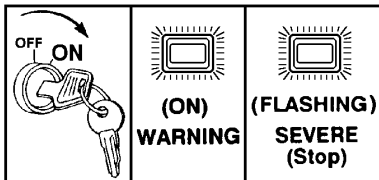

- "Warning" faults (light ON) are ones that require attention in the near future, but in most conditions will not greatly affect performance.
- "Severe" faults (light FLASHING) are ones that require **immediate** attention, because the engine could be significantly affected.

**Active fault conditions MUST be corrected as soon as possible.**

### Engine Shutdown Light (Stop Engine) (7, Figure 3-2)

When illuminated, this red engine shutdown light indicates a serious engine problem exists.

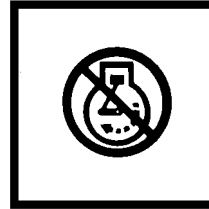
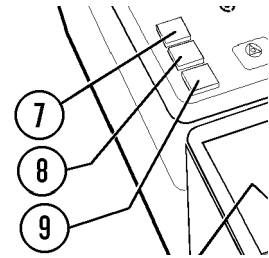

The "fault" can be engine disabling. Stop the truck in a safe area, as soon as possible. Shutdown the engine and notify Maintenance personnel immediately.

### Engine Maintenance Light (Check Engine) (8, Figure 3-2)

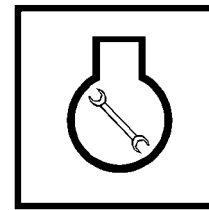

This amber/yellow light, when illuminated, indicates an engine "fault" exists. Current engine operation may proceed, but the machine should be scheduled for checkout/repair as soon as practical.

### Engine Maintenance Light (Protect Engine) (9, Figure 3-2)

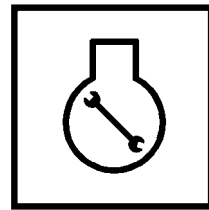

This blue engine maintenance light, when illuminated, indicates an "out-of-range" condition exists within the fuel temperature, coolant, oil, or intake air system(s) of the engine.

The light may show initially as a constant "On", but will go to "flashing On", if the condition is allowed to get worse. Serious engine damage will occur if operation is continued without correcting the "fault".

### PMC Display (Optional) (10, Figure 3-2)

This area may be used for optional Powertrain Management Controller Display. Refer to the 330M Shop Manual for further details.

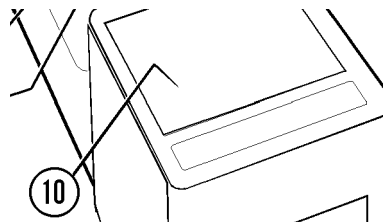



### (12) Hoist Control

The hoist control (12, Figure 3-1) is a four position, hand operated control lever located to the left of the operator seat. The hoist control lever and hoist control valve are connected by a mechanical push-pull control cable.

To raise the dump body: (refer also to "**Operating Instructions, DUMPING**")

1. Move Shift Lever (1) to the "N" position, and apply Parking Brake Valve Lever (6) to LOCKED position.

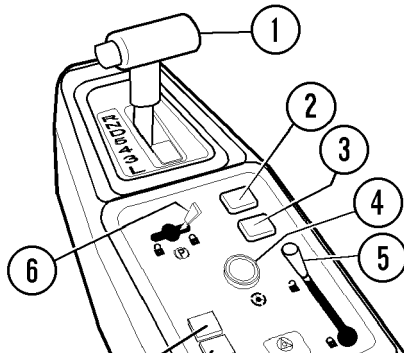

Move dump lever to the "RAISE" position and release dump lever: it will remain in this position until moved to HOLD - either manually or by the body-up limit linkage.

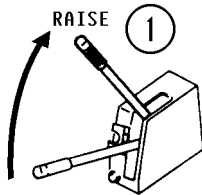

2. Raise engine RPM to accelerate hoist speed. When body is near the maximum angle, reduce engine RPM (reduce foot pressure on the accelerator pedal) to reduce shock load to the hydraulic system and hoist cylinders.

3. When the dump body rises to the set position (adjusted position of body positioner) dump lever returns to the hold position. If desired to raise the body further, move dump lever to raise position and dump body will rise. If dump lever is released, lever will return to hold position. Dump body will stop in that position.

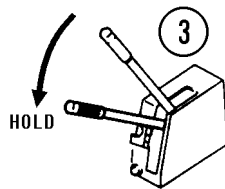

4. After material being dumped clears body, move dump lever to the lower position and dump body will start to move down.

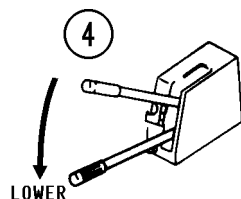

5. After lowering the dump body a certain distance, move dump lever to the FLOAT position. Release the lever and it will return automatically to the FLOAT position.

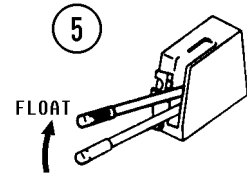

The body will move down under its own weight.

*NOTE: When traveling, always set the dump lever at the FLOAT position, regardless of whether or not the truck is loaded. If the transmission range selector is moved to any position other than "N" (neutral) when the dump lever is not at the FLOAT position, the central warning lamp will light up and the alarm buzzer will sound.*

6. Release Parking Brake Valve Lever.

### SAFETY LOCK

Move hinged lock around dump lever. This device locks the dump lever in the HOLD position.

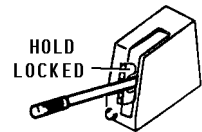

## ⚠ WARNING

*When carrying out inspection on the machine with the body raised, always lock the dump lever in the HOLD position, and then install the body up safety pins.*

## OPERATOR SEAT

The operator's seat is a fully adjustable air ride seat with 5 mechanisms to adjust the height, firmness, backrest angle, front-to-rear position, and lumbar support for the operator. **All adjustments must be made while sitting in the seat with the keyswitch "ON".**

### Operator's Seat Functions & Adjustments:

1. **Height Adjustment** - is made by using the height adjustment lever, located on the left front corner of the seat just below the seat cushion (Figure 3-3). Pushing DOWN [A] on the lever causes the front of the seat to tilt up or down. Pulling UP [B] on the lever causes the rear of the seat to tilt up or down. By alternately tilting the front, and then the rear, of the seat, the height of the seat is changed.

There are 8 separate positions possible. To find the best seat position, first adjust the height of the seat to its LOWEST position. By alternately tilting the front down, then the rear down, the seat will move to its lowest position.

*NOTE: It is best to start with the seat mechanically adjusted to its lowest point, since increasing air pressure for a firm ride (see Weight Adjustment below) will raise the seat slightly. After the firmness is adjusted to a comfortable level (by increasing air pressure), the height of the seat can be evaluated and adjusted higher, if necessary, using the height adjustment lever.*

2. **Weight Adjustment** - Firmness of the ride is adjusted by using the weight adjustment knob on the front center of the seat, just below the cushion ([D], Figure 3-3). PUSH IN the weight adjustment knob to increase the air pressure in the seat, increasing the stiffness of the seat for a firmer ride (less vertical movement). For a softer ride (more vertical movement), PULL OUT the weight adjustment knob to reduce air pressure and decrease the stiffness of the seat. Adjust the firmness by pushing in the weight adjustment knob. The amount of air pressure may need to be increased or decreased slightly after the truck is operating to adapt to varying haul road conditions. The seat will raise slightly when adding air.

3. **Backrest Angle** - is adjusted by pulling up on the lever ([C], Figure 3-3) located on the right front corner of the seat just below the cushion, and leaning forward or backward.

Adjust the backrest angle by pulling up on the lever located on the right front corner of the seat just below the cushion, and leaning forward or backward.

4. The **Front-To-Rear** position of the seat is adjusted by pulling up on the bar located at the base of the seat in the center ([E], Figure 3-3), then sliding the seat horizontally.

Adjust the fore / aft position of the seat so that the throttle and brake pedals are comfortably accessible by pulling up on the bar located at the base of the seat in the center, then sliding the seat horizontally. The steering column angle may also be adjusted at this same time to further enhance the operator ease and comfort.

5. The **Lumbar Support** has 5 positions that are mechanically selected by rotating the round knob ([F], Figure 3-3) located on the left side of the backrest. It can be adjusted so that there is no lumbar support. Adjust the lumbar support by rotating the knob to the desired position.

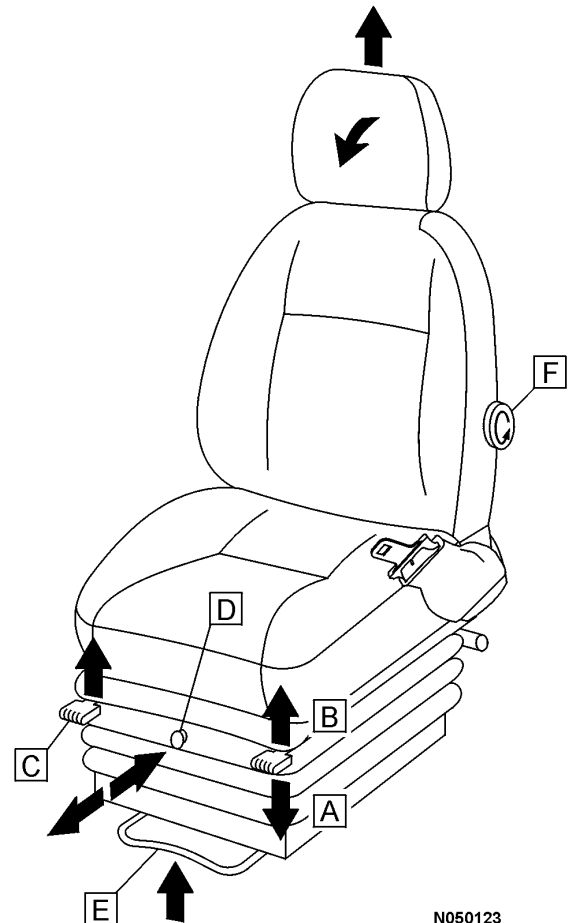

N050123

FIGURE 3-3. OPERATOR SEAT

*NOTE: Some seats may not have the self-contained air compressor; these seats may require the truck engine to be operating, or at least, have the air system fully charged to make correct seat adjustments.*

---

# NOTES



## INSTRUMENT PANEL AND INDICATORS

The instrument panel consists of the gauge and monitor module, speedometer module, monitor module, service (Hour) meter, odometer, plate, and the parts connected to them.

The gauge and monitor module and speedometer module each have a microcomputer to process and display the signals from the sensors. Liquid crystal is used for the display area.

The monitors and gauges inside the monitor module and speedometer module are actuated by the signal from the gauge and monitor module, and the odometer is actuated by signals from the speedometer module.

The following pages will identify each element of the instrument panel and detail its function and purpose for the operator.

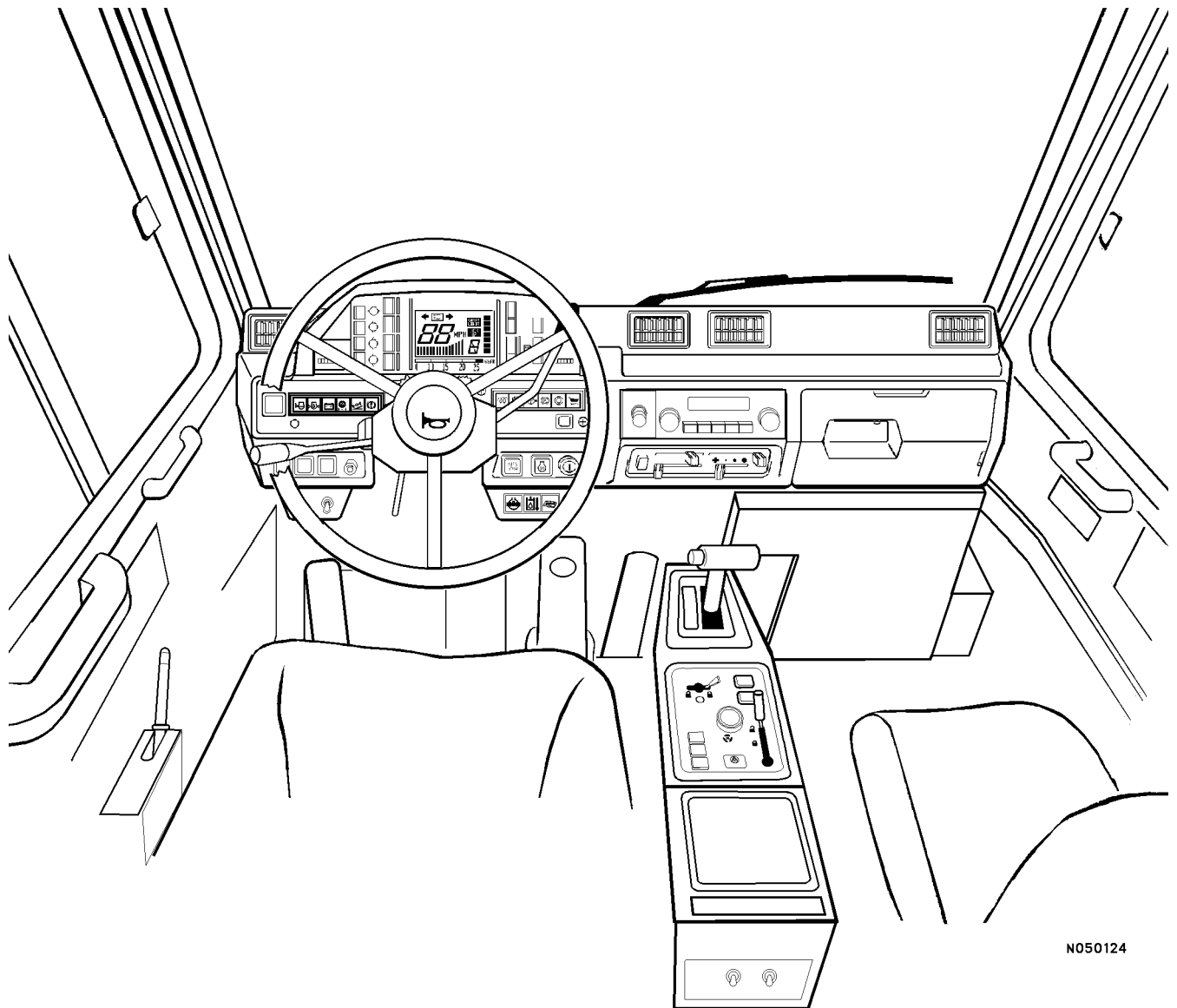

N050124

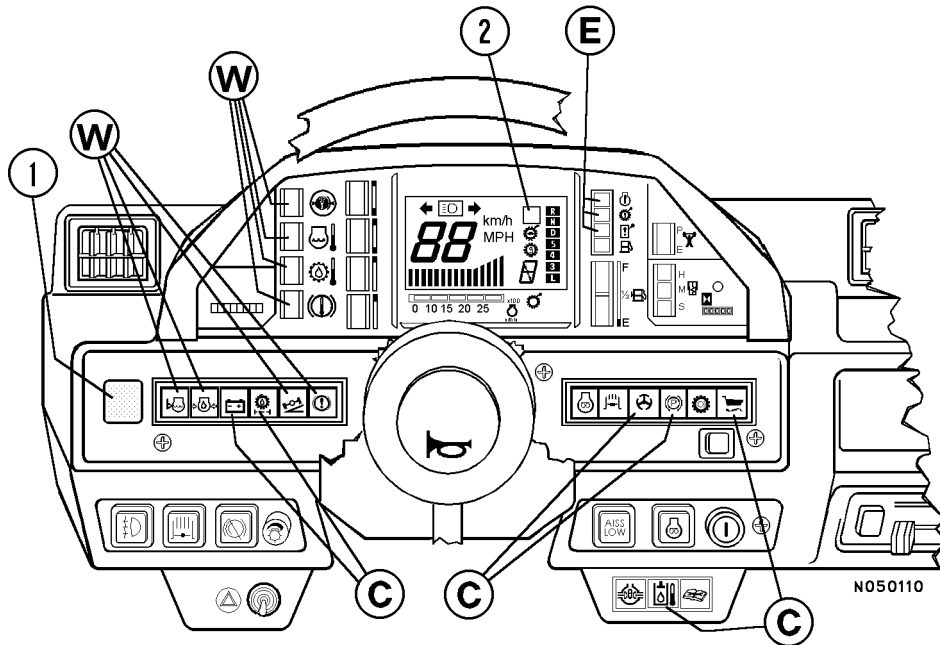

FIGURE 3-4. WARNING AND CAUTION LAMPS

1. Central Warning Lamp
2. Action Display Code

W = Warning Monitor Lamp  
E = Electronic Controller Monitor  
C = Caution Monitor Lamp

## WARNING & CAUTION LAMPS

1. The **Central Warning Lamp** is a Red lamp that will FLASH whenever any of the Monitor Lamps ("W", or "C", Figure 3-4) are illuminated, or if the Parking Brake is applied and the Transmission Shift Lever is not in the "N", (NEUTRAL) position. (Refer also to 54, Figure 3-6, later in this Section.)

In addition, if any of the Warning Monitor Lamps, "W", are illuminated, an alarm buzzer will sound.

"W", **Warning Monitor Lamp** - These lamps monitor critical truck functions. If any abnormality is detected in these systems, the appropriate lamp(s) will light, the Central Warning Lamp will flash, and an alarm buzzer will sound.

**When this condition occurs, STOP the truck as safely and as quickly as possible, check the Action Display Code (2), and notify Maintenance personnel.**

**Do not operate the truck until the system(s) is repaired and fully operational.**

"C", **Caution Monitor Lamp** - These lamps monitor other important truck functions. If any abnormality is detected in these systems, the appropriate lamp(s) will light, and the Central Warning Lamp will flash.

When this condition occurs, check the Action Display Code (2), and notify Maintenance personnel as soon as possible.

2. **Action Display Code** - If any abnormality or maintenance requirement is detected, an Action Code will be displayed. Be prepared to follow the recommended action.

Refer to the decal in the upper left-hand corner of the windshield.

"E", **Electronic Controller Monitors** - These lamps will flash if any abnormality is detected in any of the Mechatronics related systems.

If any of these lamps illuminate, check the Action Display Code (2), and be prepared to follow the recommended action.

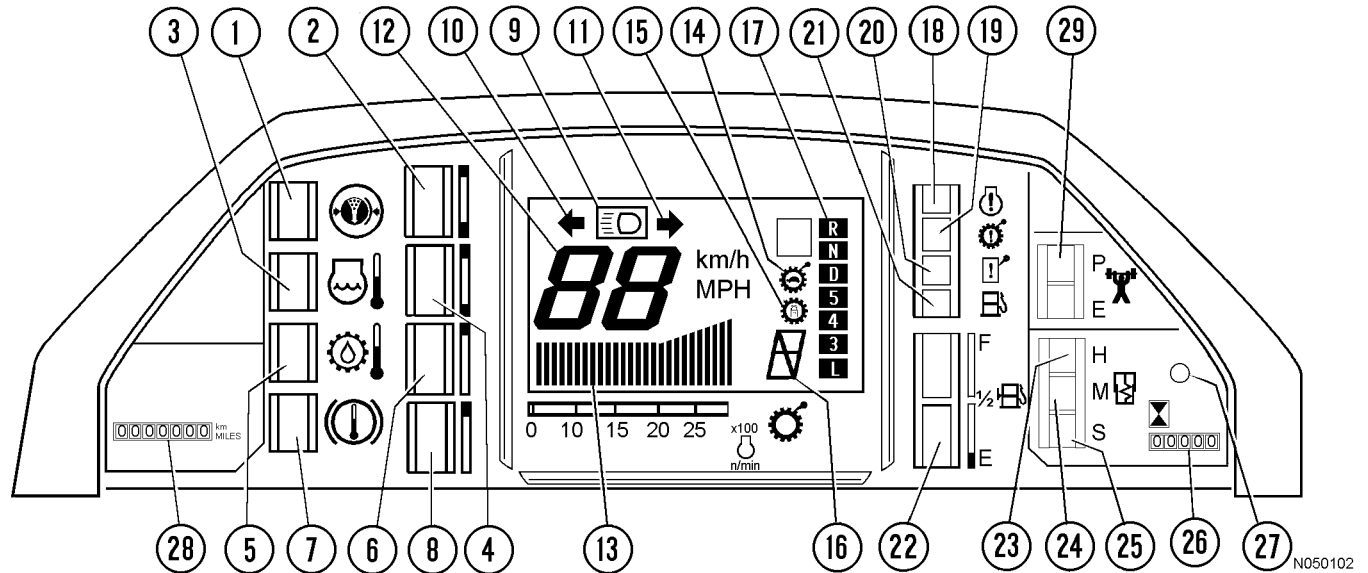
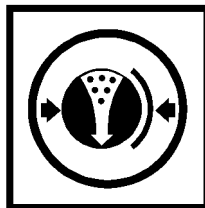

FIGURE 3-5. GAUGE AND MONITOR PANEL

### 1. Air Pressure Monitor



The Air Pressure Monitor (1, Figure 3-5) is a lamp which monitors the air pressure in the air tank. If air pressure in the air tank drops below a pre-set value, the lamp will flash. Action code "05" will be indicated.

If the lamp flashes, refer to (2) AIR PRESSURE GAUGE for action.

### 2. Air Pressure Gauge

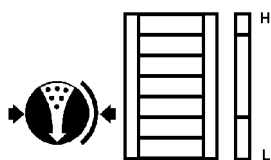

The Air Pressure Gauge (2) indicates the air pressure in the air tank. The GREEN RANGE should be lighted during normal operation.

If the red range lights up during operations, the alarm buzzer will sound, the central warning lamp will flash, and the air pressure monitor lamp (1) will flash at the same time.

When the monitor lamp flashes, stop the machine in a safe area, shift the range selector to "N", Neutral, and run the engine with no load at 1200-1500 RPM until the green range of the gauge lights up.

### 3. Coolant Temperature Monitor

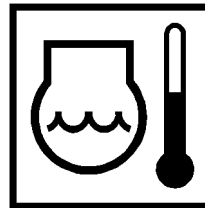

The Coolant Temperature Monitor (3) is a lamp which indicates a rise in the cooling water temperature.

When the monitor lamp flashes, run the engine with no load at 1200-1500 RPM until the green range of the engine water temperature gauge lights. Action code "05" will be indicated.

### 4. Engine Cooling Water Temperature Gauge



The Engine Cooling Water Temperature Gauge (4) indicates the temperature of the cooling water.

If the temperature is normal during operation, the green range will light. If the red range lights during operation, the alarm buzzer will sound, the central warning lamp will flash and the coolant temperature monitor lamp will flash at the same time. If this occurs, stop the machine and run the engine with no load at 1200-1500 RPM until the green range lights.

### 5. Torque Converter Oil Temperature Monitor

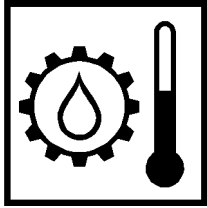

The Torque Converter Oil Temperature Monitor (5, Figure 3-5) is a lamp which indicates a rise in the torque converter oil temperature.

When the monitor lamp flashes, stop the machine and run the engine with no load at 1200-1500 RPM until the green range of the temperature gauge lights. Action code "05" will be indicated.

### 6. Torque Converter Oil Temperature Gauge

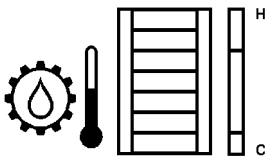

The Torque Converter Oil Temperature Gauge (6) indicates the temperature of the torque converter oil. If the temperature is normal during operation, the green

range will light. If the red range lights during operation, the alarm buzzer will sound, the central warning lamp will light up and the torque converter oil temperature monitor lamp will flash at the same time. If this occurs, stop the machine and run the engine with no load at 1200-1500 RPM until the green range lights.

### 7. Retarder Oil Temperature Monitor

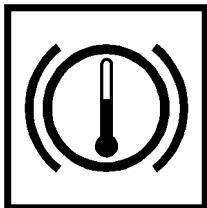

The Retarder Oil Temperature Monitor (7) is a lamp which warns that the retarder oil temperature has risen.

If it flashes, stop the machine, return the Transmission Range Selector lever to Neutral, and run the engine under no load at 1200-1500 RPM until the warning lamp goes out. Action code "05" will be indicated.

### 8. Retarder Oil Temperature Gauge

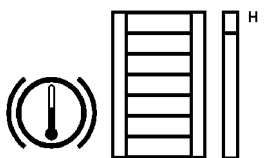

The Retarder Oil Temperature Gauge (8) indicates the temperature of the retarder cooling oil. During normal operation, a lamp in the green range should light up.

If the lamp in the red range lights up during operation, the alarm buzzer will sound, the central warning lamp will flash, and the retarder oil temperature monitor lamp will flash at the same time. If this happens, stop the machine, return the Transmission Range Selector lever to Neutral, and run the engine at 1200-1500 RPM under no load, and wait until the lamps in the green range light up.

### 9. High Beam Pilot Lamp

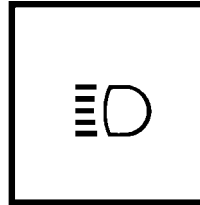

The High Beam Pilot Lamp (9) lights up when the head lamps are on high beam.

### 10. Left Turn Signal Pilot Lamp



When the turn signal lever is moved downwards, the left turn signal pilot lamp (10) flashes.

### 11. Right Turn Signal Pilot Lamp



When the turn signal lever is moved upwards, the right turn signal pilot lamp (11) flashes.

### 12. Speedometer

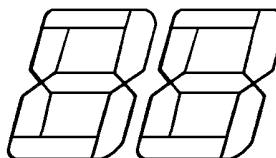

The digital Speedometer (12) indicates the travel speed of the truck in miles per hour. This figure will appear momentarily when the keyswitch is first turned "On" to demonstrate that all segments are working.

### 13. Tachometer

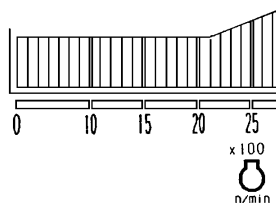

The Tachometer (13) indicates the engine speed in Revolutions Per Minute (RPM).

### 14. Shift Limiter Pilot Lamp

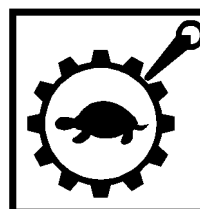

The Shift Limiter Pilot Lamp (14) lights up whenever the shift limiter switch in the center console is activated.

### 15. Lock-up Pilot Lamp

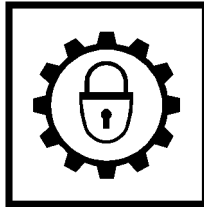

The Lock-Up Pilot Lamp (15, Figure 3-5) lights up whenever the torque converter is locked up and the transmission enters direct drive.

### 16. Transmission Shift Position Pilot Lamp

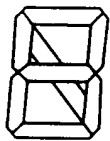

GEAR



The Transmission Shift Position Pilot Lamp (16) will indicate the specific gear range *in which the transmission is actually operating*: R, N, 1, 2, 3, 4, 5, 6, or 7.

### 17. Shift Indicator



The Shift Indicator (17) indicates the *lever position of the transmission range selector*.

### 18. Engine Controller Monitor

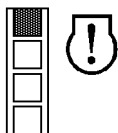

This red indicator (18) flashes whenever any abnormality occurs in any of the engine control systems. NOT USED with SAA12V140ZE-2 engine.

### 19. Automatic Transmission Mechatronics Monitor

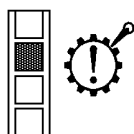

This red indicator (19) flashes whenever any abnormality occurs in the mechatronics related parts of the transmission control system.

### 20. Other Mechatronics Monitor (OPTIONAL)

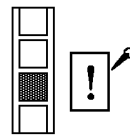

This red indicator (20) flashes whenever any abnormality occurs in the mechatronics related parts of the PMC (Powertrain Management Control) system, PLM (Payload Meter) system, and the optional suspension control system.

### 21. Fuel Level Monitor

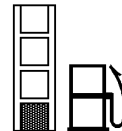

This indicator (21) flashes when the remaining fuel in the fuel tank goes below 170 liters (45 gal). If it flashes, check the fuel level and add fuel.

### 22. Fuel Gauge

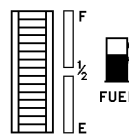

The Fuel Gauge (22) indicates the amount of fuel in the fuel tank. If there is more than 170 liters (45 gal) of fuel in the tank while the engine is operating, the green range lights. If there is less than 170 liters (45 gal) of fuel in the tank, the red range lights.

### 23, 24, and 25. (OPTIONAL) Suspension Mode Display Lamps

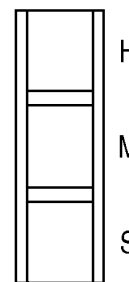

This monitor displays the type of suspension mode being used.



This **OPTIONAL** suspension feature automatically switches the damping characteristics of the suspension according to whether the truck is carrying a load, or whether the brake, steering, or dump controls are being operated.

Normally, the SOFT mode (25) is used when traveling empty, and MEDIUM (24) is used when traveling loaded. When using the service brakes or turning sharply, or when operating the dump control, the suspension mode is switched to HARD (23) to maintain the stability of the machine: front and rear, and left and right. This indicator is present in all instrument panels, but is inactive in trucks without this option.

**26. Service Meter**



The Service Meter (26, Figure 3-5) displays the total hours of operation for the truck.

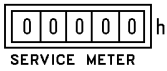

The service meter advances whenever the engine is operating, even if the machine is not moving.

**27. Service Meter Indicator**



The Service Meter Indicator (27) flashes whenever the service meter is operating.

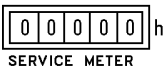

**28. Odometer**

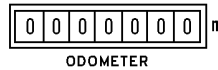

The Odometer (28) indicates the total distance that the truck has traveled in miles.

**29. Power Mode Indicator**

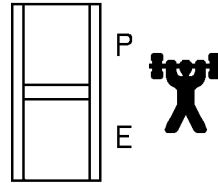

The Power Mode indicator lights (29) indicate which of the two fuel control modes is in use.

When the top light (P) is lit, the Power Mode Selector Switch on the console (3, Figure 3-2) is in "Power Mode".

When the bottom light (E) is lit, the Power Mode Selector Switch is in the "Economy Mode."

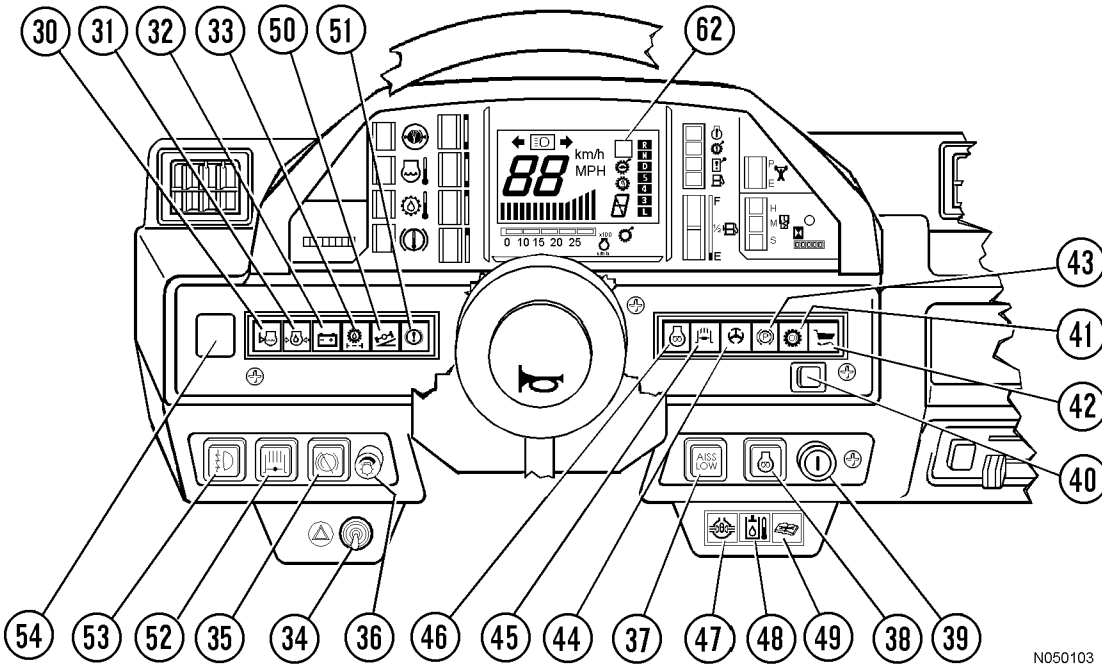

FIGURE 3-6. INDICATORS AND CONTROL PANEL  
(Full Option Configuration)

N050103

**OPTIONAL EQUIPMENT (Figure 3-7)**

When the truck is equipped with either, or both, of the following OPTIONS:

- Exhaust Brake Switch (52)

**OR**

- Fog Light Switch (53),

then the instrument panel arrangement for items 34, 35, and 36 will be as shown in Figure 3-8.

If the truck is NOT equipped with either of these OPTIONS, then the standard panel arrangement for items 34, 35, and 36 will be as shown in Figure 3-7.

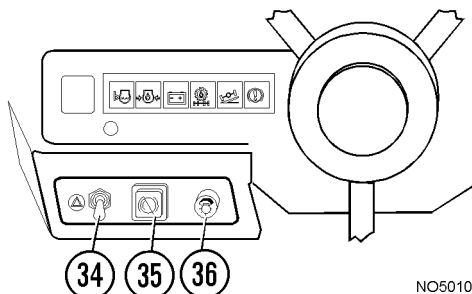

N050109

FIGURE 3-7. STANDARD CONFIGURATION

### 30. Coolant Level Monitor

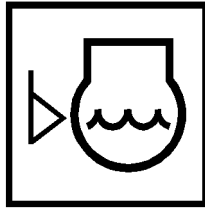

The Coolant Level Monitor (30, Figure 3-6) indicates a low radiator coolant level. If this monitor lamp flashes and alarm buzzer sounds, stop truck, shutdown engine, and add coolant as required. Action code "01" will be indicated.

### 31. Engine Oil Pressure Monitor

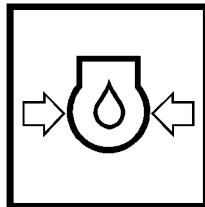

The Engine Oil Pressure Monitor (31) indicates low engine oil pressure.

If the lamp flashes and alarm buzzer sounds, stop the engine and carry out inspection. Action code "04" will be indicated.

### 32. Charge Monitor

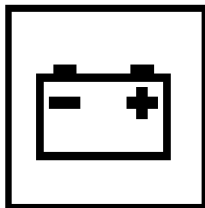

The Charge Monitor (32) indicates an abnormality in the charging system while the engine is running.

If the monitor lamp lights up, check the charging circuit. Action code "01" will be indicated.

### 33. Transmission Oil Filter Monitor

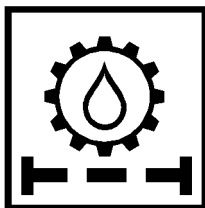

The Transmission Oil Filter Monitor (33) warns of clogging of the transmission oil filter. If the monitor light lights up, replace the transmission filters, and check for contamination in the oil. Action code "01" will be indicated.

### 34. Hazard Warning Lights

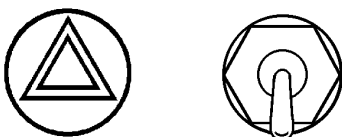

The Hazard Warning Light switch (34, Figures 3-6, and 3-7) causes all turn signal lights to flash.

The toggle switch is an "ON-OFF" type.

### 35. Front Brake ON/OFF Switch

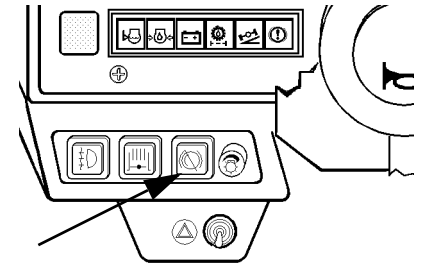
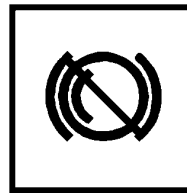

This switch (35) is used to change the braking method according to the road conditions.



This position (out/light "Off") is used when traveling on normal road surfaces. Braking force is applied to **both** front and rear wheels.



This position (in/light "On") is used when traveling on slippery roads. Braking force is applied only to the **rear wheels**.

This switch is present in all instrument panels, but is inactive in trucks without this option.

### 36. Panel Dimmer Switch

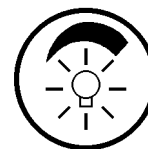

The Panel Dimmer Switch (36) is used to adjust the brightness of the lighting inside the monitor panel and pilot lamps.

Adjust as follows:

- To INCREASE brightness, turn CLOCKWISE.
- To DECREASE brightness, turn COUNTERCLOCKWISE.

### 37. AISS/Auto Switch

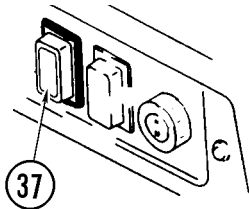

The AISS (Automatic Idle Selector Switch, 37, Figure 3-6) may be positioned to LOW or AUTO as desired. This switch is used by the operator to control the idle speed of the engine.

 **LOW** position (button in/light "ON") is the "manual position" and is used when fine control movements are needed, such as when parking, or driving in/out of confined spaces.

 **AUTO** position (button out/light "OFF") is used for normal operations. The following conditions occur:

1. When the machine is stopped, the idling speed is automatically set to LOW speed when the parking brake or retarder is ON. When the parking brake is released to start traveling, the idling speed is automatically set to HIGH speed.
2. If the coolant temperature is low, the idling speed is automatically set to HIGH speed to reduce the time taken for the warming up operation.

### 38. Manual Starting Aid Switch

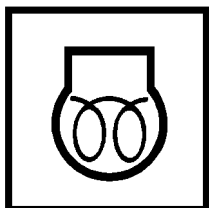

This truck is equipped with an **Automatic Cold Start Aid**.

The Cold Starting Aid energizes the electric heaters in the engine intake manifold.

Under normal conditions, there is no need to use this **MANUAL** switch. If the outside temperature is below -5°C (23F) and the prelube starter runs a long time, this manual switch can be pushed "IN" for 2-3 seconds before starting the engine to maintain engine pre-heating.

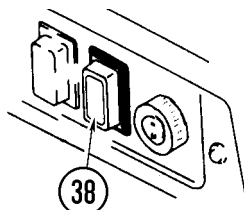

Refer to "Starting The Engine in Cold Weather", earlier in this section.

The Starting Aid Switch (38) is spring-loaded to the "OUT/OFF" position.



**DO NOT PUSH COLD STARTING AID BUTTON AFTER ENGINE HAS STARTED! SERIOUS DAMAGE TO ENGINE MAY OCCUR!**

### 39. Starting Switch

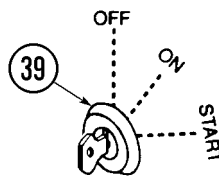

The Starting Switch (39, Figure 3-6) is a three-position key-switch:

"OFF" Position - Key insertion/withdrawal position - None of the electrical circuits activate in this position. Turn the switch to

"OFF" to stop the engine.

"ON" - Lamp circuits activate in this position.

"START" - At this key position, the starting motor will crank the engine. Release the key immediately after engine starts; the key will return automatically to "ON".

Refer to "Starting The Engine," earlier in this section.

### 40. Pilot Lamp Bulb Check Switch

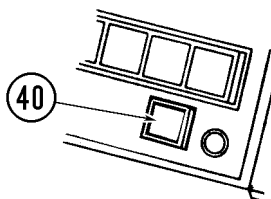

Turn the starting switch (39) to "ON" and press the Pilot Lamp Bulb Check Switch (40) to check if bulbs will light. All pilot lamp bulbs should light.

### 41. Rear Brake Pilot Lamp

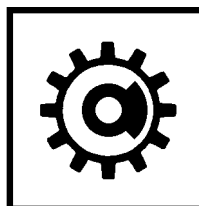

The Rear Brake Pilot Lamp (41) lights up when the service brake is depressed or the retarder control lever is pulled to actuate the rear brake.

### 42. Body Float Caution Monitor

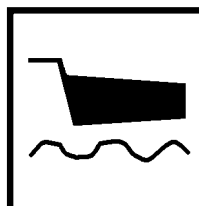

When the dump body control lever is set to any position other than FLOAT, or the body is not seated on the frame, the Body Float Caution Monitor (42) lights up.

When traveling, always set the lever to FLOAT position with the body seated.



#### 43. Parking Brake Monitor

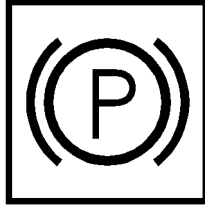

The Parking Brake Monitor (43) lights up when the parking brake is applied.

#### 44. Emergency Steering Monitor

If the emergency steering switch (located on center console) is activated, this lamp (44) lights up.

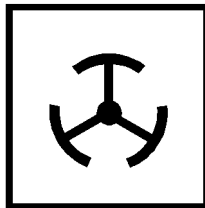

It also lights up when the auto emergency steering is actuated because an abnormality has occurred in the steering hydraulic circuit during travel.

#### 45. Exhaust Brake (Optional)

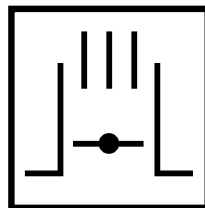

The exhaust brake pilot lamp (45) lights up when the exhaust brake is actuated.

#### 46. Cold Start

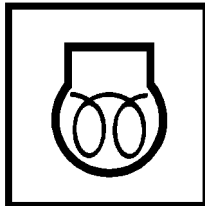

The cold start pilot lamp (46) lights up when the automatic cold start is activated or the manual cold start switch on the instrument panel is depressed.

#### 47. Differential Lock (Optional)

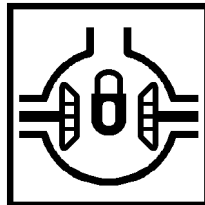

This lamp (47) lights up (if truck is equipped) when the differential lock pedal is depressed and the differential lock is actuated.

#### 48. Steering Oil Temperature

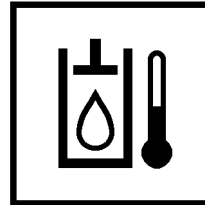

This lamp (48) indicates a rise in the steering oil temperature. If the lamp comes on, stop the truck and run the engine with no load at 1200-1500 rpm until the caution lamp goes out. Action code "05" will be indicated.

#### 49. Maintenance Required (Optional)

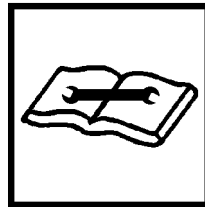

The Maintenance Monitor Lamp (49, Figure 3-6) will illuminate if the PMC (Powertrain Management Controller), detects any of the following conditions:

- Brake Disc wear indication - right or left rear
- Low battery liquid level
- Low engine oil level
- Air cleaner restricted
- Low front brake oil level
- Low retarder cooling oil level
- Low hydraulic oil level
- Retarder cooling oil filter restricted
- Hydraulic oil filter restricted.

#### 50. Side Slope Warning (Optional)

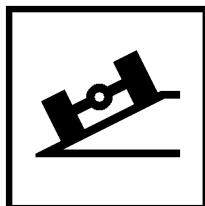

When the dump body is raised, this warns the operator that the machine has tilted beyond the safety range to the left or right. If this monitor (50) flashes, lower the body, and move the machine to a safe, stable place. Action code "07" will be indicated.

#### 51. Rear Brake Caution Lamp



This lamp (51) flashes when the rear brake is operated and the over-stroke sensor in the brake chamber contacts the brake piston. Brake oil pressure below normal level is the usual cause. If this lamp flashes, check the rear brake system immediately.

After inspecting and repairing the rear brake system, be sure to push in the over-stroke sensor installed to the brake chamber. If this operation is neglected, the brake line trouble warning will continue to operate. Action code "01" will be indicated.

### 52. Exhaust Brake Switch (Optional)

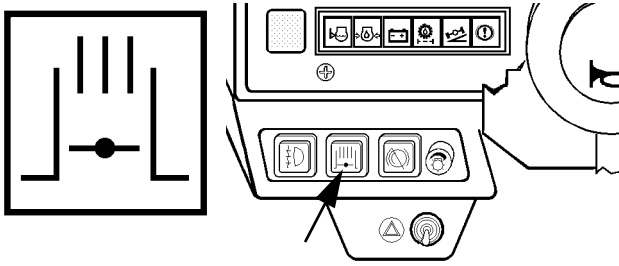

For operation of the Exhaust Brake Switch (52, Figure 3-6), refer to the following switch positions:



The exhaust brake is actuated when the foot brake is depressed or the retarder control lever is operated and the torque converter is in the lockup condition.

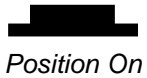

The exhaust brake is actuated when the accelerator pedal is released and the torque converter is in lockup condition.

### 53. Fog Light Switch (Optional)

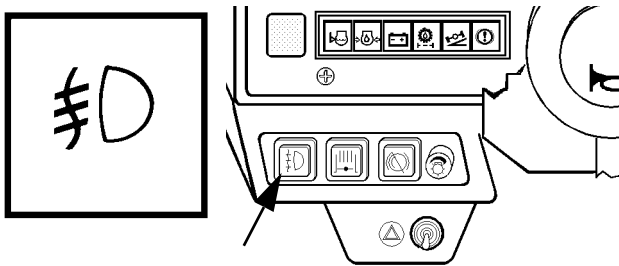

Fog Lights are optional equipment. If truck is equipped, they are useful in foggy conditions and heavy rain.



Fog lights are off when switch (53, Figure 3-6) is in this position (out/light "Off").



Depressing the switch to this position (in/light "On") turns fog lights on.

### 54. Central Warning Lamp (Red Convex Lens)

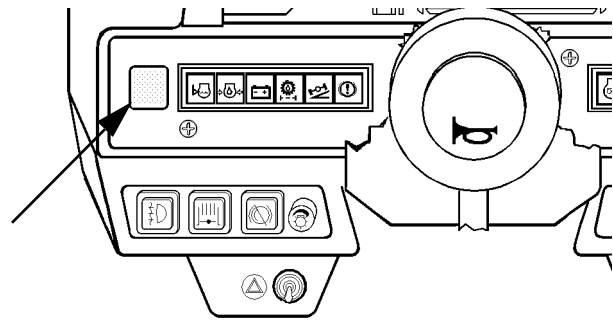

This Central Warning lamp (54, Figure 3-6) flashes whenever an abnormality has occurred in any one of the following systems:

- Battery Charging Monitor
- Emergency Steering Monitor
- Parking Brake Monitor
- Body Float Monitor Automatic
- Transmission Monitor (Mechatronics)
- Suspension Monitor
- Fuel Level Monitor.

(Refer to "ENGINE START-UP SAFETY PRACTICES" and "WARNING & CAUTION LAMPS".)

This lamp flashes, *and at the same time an alarm buzzer sounds intermittently*, whenever an abnormality has occurred in any one of the following systems:

- Air Pressure Monitor;
- Coolant Temperature Monitor;
- Torque Converter Oil Temperature Monitor;
- Retarder Oil Temperature Monitor;
- Coolant Level Monitor;
- Engine Oil Pressure Monitor; or
- Transmission Oil Filter Monitor.

This lamp will also flash and the alarm buzzer will sound, ***if the parking brake is applied and range selector lever is not at Neutral.***

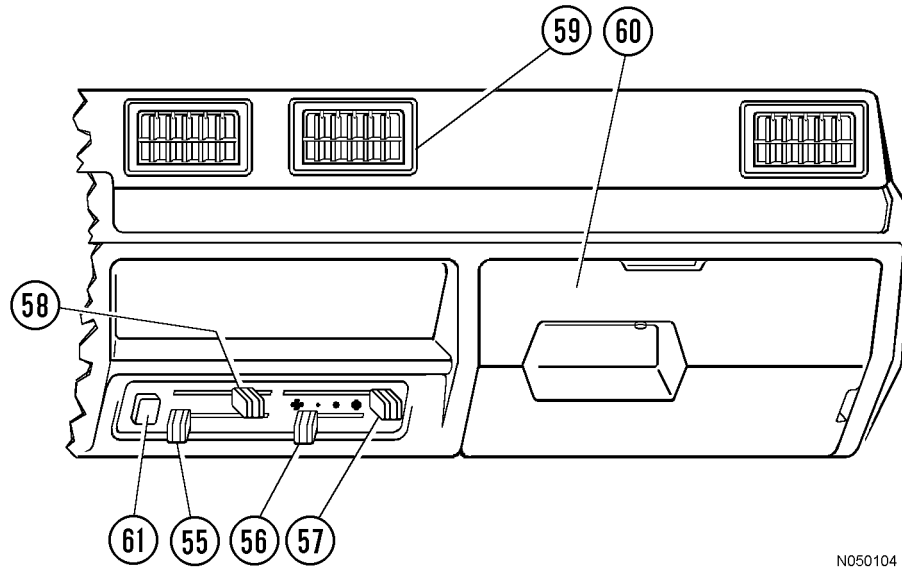

FIGURE 3-8. INSTRUMENT PANEL - RIGHT SIDE

### 55. Temperature Adjustment Lever

The Temperature Adjustment Lever (55, Figure 3-8) is used to adjust the cab air temperature for heating or cooling.

Move the lever to the left toward "WARM" (red bar) for higher temperature.

Move the lever to the right toward "COOL" (blue bar) for lower temperature.

### 56. Blower Switch

The Blower Switch (56) is a four position switch to control fan speed. Move the lever to fan position desired.

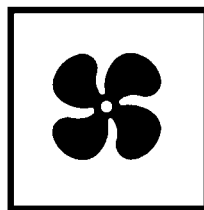

The positions - from left to right - are as follows:

"OFF" - Low - Medium - High

Low, Medium, and High are indicated by circular marks of increasing size.

When in the "OFF" position, the air conditioner compressor is de-activated.

### 57. Air Selector Lever

The Air Selector Lever (57) selects the source of air. Outside air enters through a filter and is sent to the cab to ventilate the inside the cab. In this way, a pleasant working environment is always maintained even on dusty job sites.

Move the lever to the left toward "FRESH" for outside air. Air is taken from outside to mix with the air inside the compartment.

Move the lever to the right toward "RECIRC" for recirculation of cab air only. This is generally used to cool the cab quickly.

### 58. Vent Selector Lever

The Vent Selector Lever (58) directs the cool or warm air through one or more of the following outlets: front vents; foot vents; or defroster vents.

Move the lever to the left toward "VENT" to direct heated or cooled air through the front vents (59).

Move the lever to the center to "HEAT" to direct air to the foot vents and defroster vents for heating and dehumidifying.

Move the lever to the right to "DEF" to direct air to the defroster vents to remove and/or prevent mist from forming inside the windshield.

### 59. Air Vent

Air Vents (59, Figure 3-8) are provided for circulation of cooled or heated air through the cab.

### 60. Glove Box Storage Compartment

This area (60) provides a small storage space that may be used for pencils, note paper, etc. In some models it may be used for OPTIONAL EQUIPMENT, such as, Payload Meter.

### 61. Air Conditioner Switch

When the Air Conditioner Switch (61) is pressed, the blue lamp inside the button lights up, and the air conditioner compressor is activated. This is used to provide cold air or to dehumidify the air. If the blower switch (56) is in "OFF" position, the air conditioner compressor will be turned off even if the air conditioner switch (61) is in the "ON" position. The light in the air conditioner switch will go out when the blower switch is turned off.

### 62. Correction Code Display

When an action code appears in this area (62, Figure 3-6), refer to the decal (Figure 3-9) in the upper left-hand corner of the windshield.

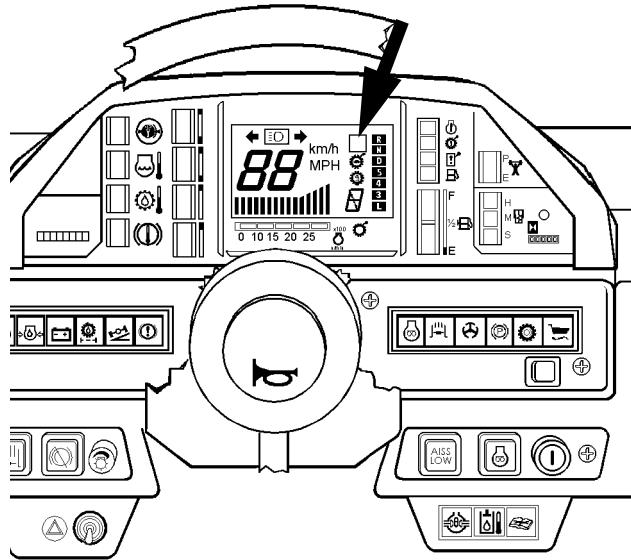

Follow the instructions to the right of the code number displayed on the panel monitor.

**NOTICE**

**CORRECTION CODE ON VEHICLE MONITOR PANEL**

IF ANY TROUBLE OCCURS WITH THE VEHICLE, THE ACTION TO TAKE TO CORRECT IT IS INDICATED BY CODES "01-07" AND "E-" WHICH APPEAR ALTERNATELY AT THE UPPER RIGHT CORNER OF THE LIQUID CRYSTAL DISPLAY OF THE MONITOR PANEL.

IF THE CORRECTIVE ACTION CODE IS INDICATED ON THE MONITOR PANEL, STOP THE VEHICLE AND CHECK THE ACTION CODE AGAIN, THEN TAKE THE FOLLOWING CORRECTIVE ACTION.

ACTION CODE	CONTENT OF ACTION
01	NOTIFY MAINTENANCE AT SHIFT CHANGE
02	NOTIFY MAINTENANCE RIGHT NOW
03	REDUCE ENGINE / MACHINE SPEED
04	STOP SAFELY NOW / SHUT OFF ENGINE
05	STOP WITH ENGINE AT MID SPEED
06	START ENGINE AND KEEP AT LOW IDLE
07	KEEP BODY DOWN

ACTION CODE

561-93-A1930

FIGURE 3-9. CORRECTION CODE DECAL

## LUBRICATION AND SERVICE

Preventive Maintenance will contribute to the long life and dependability of the Komatsu truck and its components. The use of proper lubricants and the performance of checks and adjustments at recommended intervals is most important.

Lubrication requirements are referenced to the lube key found at the top of the Lubrication Specifications Chart (next page).

For detailed service requirements for specific components, refer to the shop manual section for that component (i.e. Section "G" for Final Drive, Section "H" for Suspensions, etc.).

330M SERVICE CAPACITIES		
	Liters	U.S. Gallons
<b>Engine Crankcase</b> including lube oil filters.	147 [138]	39 [37]
<b>Cooling System:</b>	256	66
<b>Hydraulic System:</b>		
Front Brake Oil Tank	2	0.53
Rear Brake Cooling Oil Tank	366 [248]	96.6 [65.5]
Steering/Hoist Oil Tank	248 [145]	65.5 [38.3]
<i>Refer to "Hydraulic Tank Service", page 4-15.</i>		
<b>Fuel Tank</b>		
Diesel Fuel-ASTM D975 No. 2* * Below -10°C (14°F) use No. 1	1250	330
<b>Final Drive Case</b> (Differential & both planetaries)	250	66
<b>Transmission Case:</b> including torque converter.	125 [102]	33 [26.9]
<i>NOTE: Top number is for initial dry system fill: includes hoses, internal valve cavities, etc. Bottom [number], if present, is service refill.</i>		

**TRANSMISSION OIL LEVEL CHECK**

1. USE UPPER MARKS WHEN CHANGING OIL, OR BEFORE STARTING ENGINE, OR AFTER ENGINE HAS BEEN STOPPED FOR 8 HOURS OR MORE.

2. USE LOWER MARKS WHEN ENGINE IS RUNNING AT LOW IDLE, AND TRANSMISSION IS IN NEUTRAL, AND TRANSMISSION OIL IS AT OPERATING TEMPERATURE. PARK ON LEVEL GROUND TO CHECK OIL LEVEL.

WB2416

Refer to Transmission Oil Level Check, page 4-7.

The service intervals presented here are in hours of operation. **These intervals are recommended in lieu of an oil analysis program which may determine different intervals.** However, if the truck is being operated under extreme conditions, some, or all, of the intervals may need to be shortened and the service performed more frequently.

Refer to engine manual when servicing the engine or any of its components.

COOLING SYSTEM ANTI-FREEZE RECOMMENDATIONS (Ethylene Glycol Permanent Type Anti-Freeze)		
Percentage of Anti-Freeze	Protection To:	
10	+ 23° F	- 5° C
20	+ 16° F	- 9° C
25	+ 11° F	- 11° C
30	+ 4° F	- 16° C
35	- 3° F	- 19° C
40	- 12° F	- 24° C
45	- 23° F	- 30° C
50	- 34° F	- 36° C
55	- 48° F	- 44° C
60	- 62° F	- 52° C
Use only anti-freeze that is compatible with engine as specified by engine manufacturer.		

WARNING

**READ AND UNDERSTAND THE OPERATION & MAINTENANCE MANUAL BEFORE OPERATING VEHICLE OR PERFORMING ANY MAINTENANCE.**

# LUBRICATION CHART

LUBE KEY	TYPE LUBRICANT	LUBRICATION SPECIFICATION						SYM	PTS	L KEY	10 HR	50 HR	100 HR	250 HR	500 HR	1000 HR	2000 HR
		-65°F TO -25°F	-25°F TO -32°F	-32°F TO -90°F	ABOVE 90°F												
A	ENGINE OIL	SEE ENG. MAN.*	SEE ENG. MAN.*	SEE ENG. MAN.*	SEE ENG. MAN.	SEE ENG. MAN.											
B	HYDRAULIC OIL	MIL - L - 2104C	MIL - L - 2104C	MIL - L - 2104C	MIL - L - 2104C	MIL - L - 2104C											
C	HYDRAULIC OIL	SAE 30	SAE 30	SAE 30	SAE 30	SAE 30											
D	MOLYDISULPHIDE LUBE	MIL - L - 2104C	MIL - L - 2104C	MIL - L - 2104C	MIL - L - 2104C	MIL - L - 2104C	#0										
E	HYDRAULIC OIL	SEE SER. MAN.	SEE SER. MAN.	SEE SER. MAN.	SEE SER. MAN.	SEE SER. MAN.	#1										
F	HYDRAULIC OIL	MIL - L - 2104C	MIL - L - 2104C	MIL - L - 2104C	MIL - L - 2104C	MIL - L - 2104C	SAE 10W*										
	DESCRIPTION																
	ENGINE LUBE FILTER																
	FUEL FILTER ELEMENT																
	FRONT SUSP ASSY / PINS																
	STEERING CYLINDER LINKAGE																
	STEERING LINKAGE																
	HYDRAULIC FILTER																
	HYD. TANK HOIST / STRG.																
	HOIST CYLINDER PIVOT																
	U - JOINT ASSY (REAR)																
	FINAL DRIVE CASE																
	AXLE SUPPORT PIN																
	REAR SUSPENSION PIN																
	DIFFERENTIAL CASE																
	BODY HINGE PINS																
	CORROSION RESISTOR																
	ENGINE CRANKCASE OIL																
	TRANS OIL FILTER																
	FRONT BRAKE OIL TANK																
	U - JOINT ASSY (FRONT)																
	TRANSMISSION MOUNT																
	TRANSMISSION OIL																
	TRANS CASE BREATHER																
	HYD TANK BREATHER ELE.																
	DIFF CASE BREATHER																
	ENGINE BY-PASS FILTER																
	PARKING BRAKE																
	DUMP CONTROL LINKAGE																
	ENG FRONT TRUINION																
	HYD TANK BRAKES																
	TRANS. STRAINER																

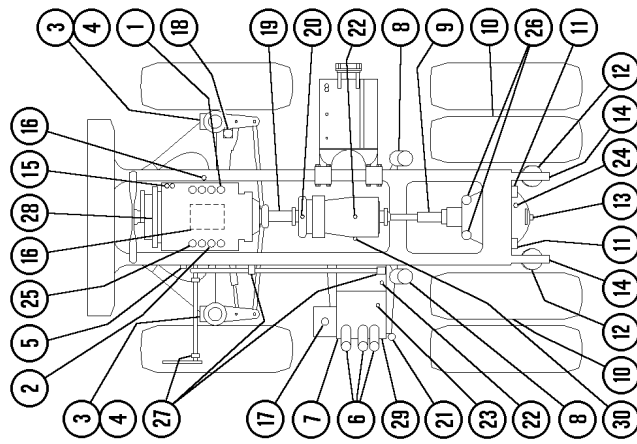

EG5361

\* AUXILIARY HEATERS REQUIRED BELOW -23°C ( -10°F )









## 10 HOUR (DAILY) INSPECTION (continued)

### WHEELS

- Check to see that all wheel lugs/wedges are in place and tight.
- Inspect rear wheels for any leakage that may be coming from inside the wheel housing that would indicate planetary leakage.
- Check rear dual wheels for any rocks that might be lodged between dual tires.
- Check that rock ejector is in good condition and straight, so that it can not damage a tire.

COMMENTS	CHECKED	INITIALS

### **⚠ WARNING**

*After each wheel mounting operation, recheck wheel mounting capscrew tightness after 4 - 5 hours of operation. Check again at the end of the shift, and then periodically until all capscrews hold at the prescribed  $225 \pm 25 \text{ kg.m}$  ( $1628 \pm 180 \text{ ft.lbs.}$ ) torque (dry threads). This is prescribed for both front and rear wheels.*

*Tighten wheel nuts in the order as shown in the diagrams.*

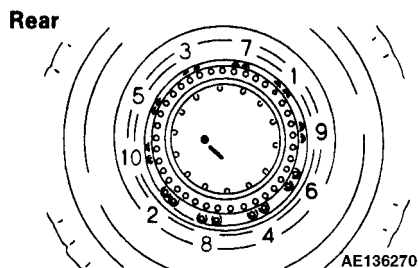
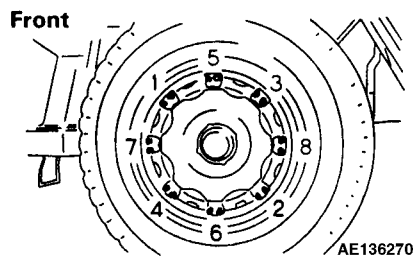



# NOTES













## EVERY 5000 HOUR SERVICE

Maintenance for every 250, 500 and 1000 hours should also be carried out at this time.

Truck Serial Number \_\_\_\_\_

Site Unit Number \_\_\_\_\_

Date: \_\_\_\_\_ Hour Meter \_\_\_\_\_

Name of Service Person \_\_\_\_\_

### 1. ENGINE DRIVELINE ADAPTER

Inspect driveline adapter splines, rubber dampers for cracks or separation on rubber surfaces, and bearings. If any defects are noted, repair as required.

*Refer to Service Manual, Section "C" for repair procedures.*

### 2. FRONT AND REAR DRIVESHAFTS

If truck is equipped with driveshaft universal joints that DO NOT have grease fittings, inspect both front and rear driveshafts for binding, wear, vibration, or damage to the driveshaft assembly. If U-joint damage or roughness is noted, BOTH U-joints on a given shaft should be replaced. *Refer to Service Manual, Section "F" for replacement procedures.*

### 3. FRONT SUSPENSIONS

Drain Front suspension oil. Inspect upper flange internal bearing. Replace worn parts. Refill suspensions with clean oil and recharge with nitrogen. *Refer to Service Manual, Section "H" for instructions and WARNINGS when servicing suspensions.*

### 4. FRONT WHEEL BEARINGS

Check front wheel bearing adjustment. *Refer to Service Manual, Section "G", "Front Wheel Hub Bearing Adjustment".*

COMMENTS	CHECKED	INITIALS

## HYDRAULIC TANK SERVICE

### Filling Instructions (Hoist Oil Supply)

1. Park the truck on a level surface, lower the dump body, and shut down the engine.



*When removing tank cap, turn cap slowly at first to relieve inner pressure. Remove cap only after pressure has been completely relieved. Any operating fluid, such as hydraulic oil or brake fluid escaping under pressure, can have sufficient force to enter a person's body by penetrating the skin. Serious injury and possibly death may result if proper medical treatment by a physician familiar with this injury is not received immediately.*

2. Turn the oil filler cap (3, Figure 4-3) slowly counterclockwise to release internal tank pressure.

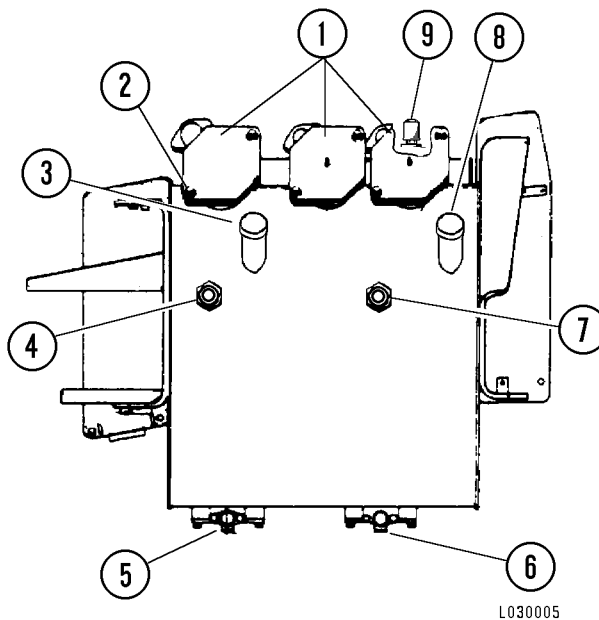

FIGURE 4-3. HYDRAULIC TANK

- |                                    |                                  |
|------------------------------------|----------------------------------|
| 1. Filter Covers                   | 6. Brake Oil Drain               |
| 2. Bolts                           | 7. Brake Cooling Oil Sight Glass |
| 3. Hydraulic Oil Filler Cap        | 8. Brake Cooling Oil Filler Cap  |
| 4. Hydraulic Oil Level Sight Glass | 9. Breather                      |
| 5. Hydraulic Oil Drain             |                                  |

3. Fill tank with recommended oil until oil is visible in the sight glass (4). Refer to "Lubrication Chart" for type of oil to use. Lube key "C".

### Hydraulic tank refill capacity:

..... 162 Liters (42.8 gal.)

4. Replace fill cap.

5. If hydraulic components have been removed and lines drained, start the engine and raise the dump body 2-3 times to circulate oil and fill all voids.



*Before raising body, be certain that the truck is in an area where there is sufficient overhead clearance to allow the body to be raised.*

6. Lower the dump body and shut down the engine and repeat steps 2. through 4. if necessary.

### Filling Instructions (Rear Brake Cooling Oil Supply)

1. Park the truck on a level surface, lower the dump body, and shut down the engine.



*When removing tank cap, turn cap slowly to relieve inner pressure. Remove cap only after pressure has been completely relieved. Any fluid escaping under pressure, can have sufficient force to enter a person's body by penetrating the skin. Serious injury and possibly death may result if proper medical treatment by a physician familiar with this injury is not received immediately.*

2. Turn the oil filler cap (8, Figure 4-3) slowly counterclockwise to release internal tank pressure.
3. Fill tank with recommended oil until oil is visible in the sight glass (7). To reduce rear brake "squeal", use ONLY SHELL DONAX - TD Oil or BP TRACTRAN UTH. If these oils are not available, use Lube key "C".

### Rear Brake Oil tank refill capacity:

..... 268 Liters (70.8 gal.)

4. Remove and clean Strainer (1, Figure 4-3A) from inlet to Oil Cooler (inside R.H. frame rail). Be sure to clean this strainer at every oil change and after any rear brake failure.

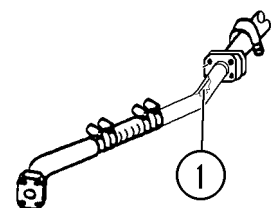

FIGURE 4-3A

## HYDRAULIC FILTERS

### Filter Replacement

1. Lower the dump body and shut down the engine.



**Release hydraulic tank filler cap slowly to remove any internal pressure.**

2. Turn the oil filler caps (3 & 8, Figure 4-3) slowly counterclockwise to release internal tank pressure.
3. Remove bolts (2) on filter covers (1).
4. Remove the elements (2, Figure 4-4) from housing.
5. Thoroughly clean filter housings, covers (4) and bypass valve (3) components.
6. Install new elements. Install bypass valves and covers. Tighten bolts (2, Figure 4-3) to standard torque.
7. Check oil level; oil must be visible in sight glass.

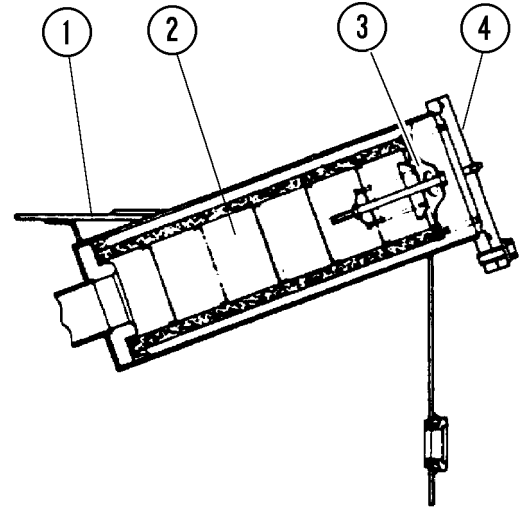

L030006

FIGURE 4-4. HYDRAULIC TANK FILTERS

- |                   |                 |
|-------------------|-----------------|
| 1. Hydraulic Tank | 3. Bypass Valve |
| 2. Filter Element | 4. Cover        |

## HYDRAULIC TANK BREATHER

### Cleaning

1. Shut down the engine and open hydraulic tank filler caps slowly to relieve any internal pressure.
2. Clean dirt accumulation from area of breather (9, Figure 4-3).
3. Remove the breather from the tank.
4. Remove snap ring (1, Figure 4-5), cover (2) and filter element (3).
5. Clean breather element in solvent and blow dry. Clean remaining parts in solvent and dry thoroughly. Replace element, if element appears damaged or doesn't clean up thoroughly.
6. Install element, cover and snap ring.
7. Install breather element on hydraulic tank.

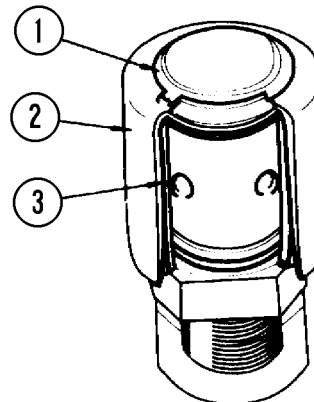

L030007

FIGURE 4-5. HYDRAULIC TANK BREATHER

- |              |            |
|--------------|------------|
| 1. Snap Ring | 3. Element |
| 2. Cover     |            |

## HIGH PRESSURE HYDRAULIC FILTERS

### Filter Assembly Removal

1. Lower the dump body and shut down the engine. Clean dirt accumulation from the high pressure hydraulic filters and tube connections in front of the hydraulic tank.

### **WARNING**

*Release hydraulic tank filler cap slowly to remove any internal pressure.*

*Hydraulic fluid escaping under pressure can have sufficient force to enter a person's body by penetrating the skin and cause serious injury and possibly death if proper medical treatment by a physician familiar with this injury is not received immediately.*

2. Turn the oil filler caps (3 & 8, Figure 4-3) slowly counterclockwise to release internal tank pressure.
  3. Place a receptacle under the filters to receive hydraulic oil which will drain from filters when disconnected.
  4. Remove capscrews (1, 4, & 8, Figure 4-6), washers (2, 5, & 9), and split flanges (10) securing filters (7).
- Move hydraulic tubes away from filter housings.
5. Remove nuts (13) and washers (12) holding U-bolts (6) to bracket (11). Remove filter assemblies (7). Discard O-rings (3).

Plug or cover all open hydraulic connections to prevent entry of contaminants and move filter assemblies to a clean service area.

### Filter Assembly Installation

1. Remove plugs and/or covers from connections. Install new O-rings (3, Figure 4-6) in all locations. Install filter assemblies (7) to outlets and install capscrews (1 & 4), washers (2 & 5). Do not tighten capscrews to final torque at this time.
2. Move hydraulic tubes to filter housings inlets and reconnect with capscrews (8), washers (9), and split flanges (10). Do not tighten capscrews to final torque at this time.
3. Install U-bolts (6) holding filter assemblies (7) to bracket (11). Install washers (12) and nuts (13). Do not tighten nuts to final torque at this time.

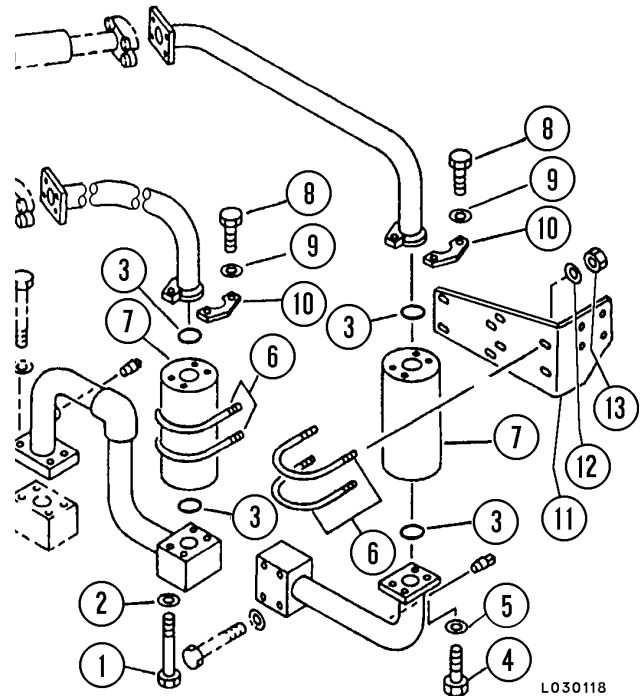

FIGURE 4-6. HIGH PRESSURE FILTERS & PIPING

- |                    |                                    |
|--------------------|------------------------------------|
| 1. Capscrew        | 8. Capscrew                        |
| 2. Washer          | 9. Washer                          |
| 3. O-Ring          | 10. Split Flange                   |
| 4. Capscrew        | 11. Bracket<br>(on Hydraulic Tank) |
| 5. Washer          | 12. Washer                         |
| 6. U-Bolt          | 13. Nut                            |
| 7. Filter Assembly |                                    |

4. Carefully align all components and connections to prevent any binding or kinking and then begin tightening all capscrews and nuts sequentially to final standard torque.

### **WARNING**

*Tighten all connections before starting engine and applying hydraulic pressure.*

5. Start engine and check for leaks before releasing truck for service. Check hydraulic tank oil level; oil must be visible in sight glass (4, Figure 4-3).

### Filter Element Replacement

1. Place filter assembly (Figure 4-7) on work bench. Using a spanner tool at both ends, hold housing (1) and loosen (counter-clockwise) inlet housing (5).

Remove inlet and then remove filter element (2) from housing. Discard O-Ring (3) and Backup Ring (4).

2. Thoroughly clean filter housing and inlet housing. Using clean hydraulic oil, lightly lubricate sealing surfaces.

3. Install new element (2) into filter housing (1) using new O-Ring (3) and Backup Ring (4).

4. Install inlet housing (5) to filter housing (1) and tighten to **10 - 12 kg.m (73 - 87 ft. lbs.)** torque.

5. Refer to "Filter Assembly Installation" and install on truck.

*NOTE: Filter Elements should be replaced every 2000 hours\*, and after any debris-producing component failure within the hydraulic system.*

*\* More frequent replacement may be required in very dusty/dirty environments.*

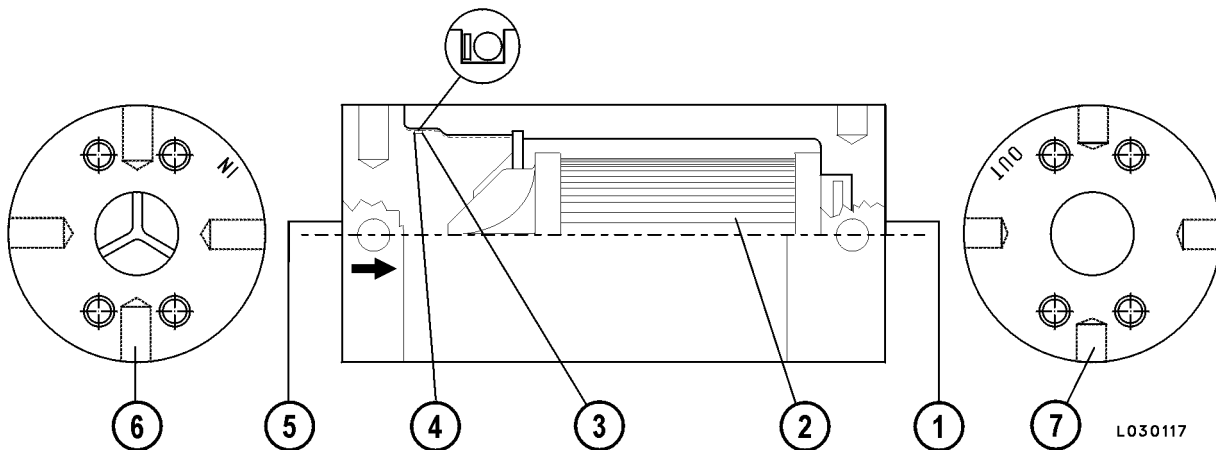

FIGURE 4-7. FILTER ASSEMBLY

- |                   |                         |
|-------------------|-------------------------|
| 1. Filter Housing | 5. Filter Housing Inlet |
| 2. Filter Element | 6. Spanner Hole         |
| 3. O-Ring         | 7. Spanner Hole         |
| 4. Backup Ring    |                         |

## TRANSMISSION FILTER

The transmission filter element (Beta 25 = 200) should be replaced every 500 hours of operation or sooner if the warning light indicates high restriction. This maintenance interval may be increased or reduced, depending on operating conditions, by observing the warning light indicator.

This filter assembly is equipped with a pressure switch to indicate a high pressure differential (restriction). The switch will close @ 2.5 kg/cm<sup>2</sup> (35 psi) by-pass pressure. Actual by-pass of the hydraulic fluid does not occur until 3.5 kg/cm<sup>2</sup> (50 psi) by-pass pressure.

### Service

1. Remove drain plug (7, Figure 4-8) and drain the oil from the filter housing. Tighten plug after all oil is drained.
2. Unscrew filter bowl (4) from head assembly (1).
3. Remove the element and thoroughly clean and dry all component parts.
4. Coat a new seal (9) with clean engine oil and install.
5. Install a new element (5) and install the filter bowl (4) into the head assembly (1).
6. Start the engine and let it idle for 5 minutes. Stop engine and check for leaks. Check transmission for proper oil level and adjust if necessary.

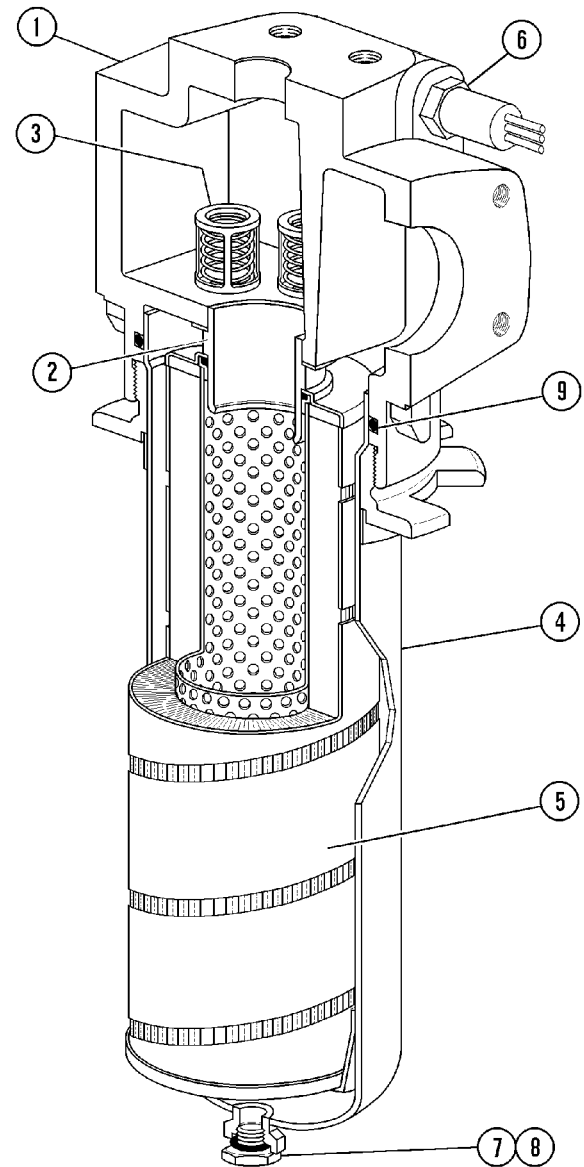

F020099

FIGURE 4-8. TRANSMISSION FILTER

- |                   |                    |
|-------------------|--------------------|
| 1. Head Assembly  | 6. Pressure Switch |
| 2. Core Kit       | 7. Drain Plug      |
| 3. Bypass Valve   | 8. O-Ring          |
| 4. Filter Bowl    | 9. Seal            |
| 5. Filter Element |                    |

## PERIODIC REPLACEMENT OF COMPONENT PARTS FOR SAFETY DEVICES

To ensure safety in operation, the user is requested to perform the periodic maintenance recommended in the previous schedules. In addition, special care should be paid to the periodic replacement of certain other parts which may affect safety in operation.

Fabrication of safety devices and other component parts have been designed to high standards. However, all parts are subject to wear and gradual fatigue during continuous use. Since it is difficult to determine accurately the process of change in quality, wear, or fatigue, judgments must be made whether or not some parts should be replaced even if they do not show any faulty symptom at the time. Of course, any part found to have an abnormality should be repaired or replaced, regardless of the time it has been used.

**NOTE: This recommendation for the replacement of parts is to ensure safety in operation. The warranty guarantee to be free from manufacturing defects does not apply to the replacement of functioning parts for precautionary reasons.**

The following parts should be considered for repair or replacement **every 2000 hours**, or every one year, whichever comes first:

1. Brake valve parts.
2. Parking brake valve parts.
3. Relay valve parts.
4. Air governor parts.
5. Retarder control valve parts.
6. Emergency relay valve parts.
7. Emergency brake valve parts.
8. Quick release parts.
9. Parking brake chamber parts.
10. Brake chamber parts (front and rear).
11. Engine Valve Clearance - Refer to the engine manual for the proper inspection, procedures, and tools.
12. Brake Discs - Refer to Section "J", Brake System, "Brake Circuit Checkout And Adjustment", for proper inspection, procedures and tools.

The following parts should be considered for repair or replacement **every 4000 hours**, or every two years, whichever comes first:

1. Fuel Pump Screen Filter - Check and clean or replace screen filter.
2. Periodic Replacement Safety Parts Kit - Use the periodic replacement safety parts service kit when replacing the parts.
3. High pressure hoses in steering circuit (to/from pump, demand valve, steering valve, steering cylinder).\*
4. High pressure hoses in the hoist circuit (to/from pump, demand valve, hoist valve, hoist cylinder).\*
5. Outlet hose of retarder cooling oil pump.\*
6. Outlet hose of steering oil pump.\*
7. Outlet hose of transmission oil pump.\*
8. Steering valve hose.\*
9. Hose of fuel filter.\*
10. Fuel hose.\*

\*The replacement of these parts may be considered for Fire Prevention measures.

Other areas of the truck also require inspection and may require periodic replacement of parts due to environmental and operating conditions. Rubber or plastic parts which are subjected to extreme heat or ultraviolet (sunlight) conditions will deteriorate more rapidly than similar parts in less severe service.

### Periodically check the following:

1. Air inlet piping elbows close to turbochargers and exhaust manifolds.
2. Air cleaner plastic bonnets.
3. Door seals.
4. Windshield wiper blades.
5. Windshield washer bottle.
6. Plastic covers and caps.
7. Water piping elbows and hoses.
8. Body cushion pads.
9. Plastic tubing for air lines.



## BRAKE CIRCUIT CHECKOUT AND ADJUSTMENT

### CHECKING FRONT BRAKE PAD WEAR

*NOTE: This check is nominally specified for every 500 hours of truck operation. If truck is operated in a very abrasive environment (i.e. sandy conditions), perform this check every 250 hours of truck operation, or more frequently, if conditions require it.*

1. Stop the machine on level ground, apply the parking brake, and put blocks under the tires.
2. Remove any dirt/mud accumulation from all pads, calipers, and discs.
3. Check disc pad (1, Figure 4-9) visually, and if the pad has reached the wear limit line (2) or if disc material thickness is less than 3 mm (0.12 in.), replace the pad.

The pad wear may not be the same for both left and right wheels, so check the wear of all pads.

If any pad is worn beyond the limits stated above, replace all pads (both left and right sides).

Refer to Shop Manual, Section "J", Brake System, for specific disassembly, repair, or replacement procedures for the front brake assembly.



**Do not continue to use pads worn beyond limits. Worn pads may result in inadequate braking power.**

### TESTING BRAKE PRESSURE

1. Raise the air pressure to 8.3 kg/cm<sup>2</sup> (118 psi) pressure.
2. Remove the top air bleed plug (1, Figure 4-10) and install a 400 kg/cm<sup>2</sup> (5690 psi) pressure gauge.
3. Measure the hydraulic pressure when the brake pedal is depressed. Minimum pressure should be 187 kg/cm<sup>2</sup> (2660 psi).
4. Remove gauge and install plug. Refer to "Brake Bleeding", this section and bleed air from the calipers.

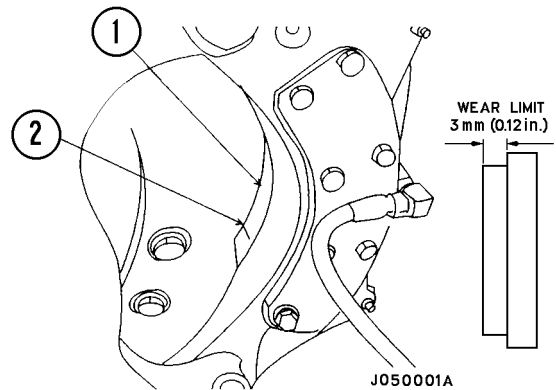

FIGURE 4-9. FRONT PAD WEAR  
1. Brake Pad                      2. Wear Limit Line

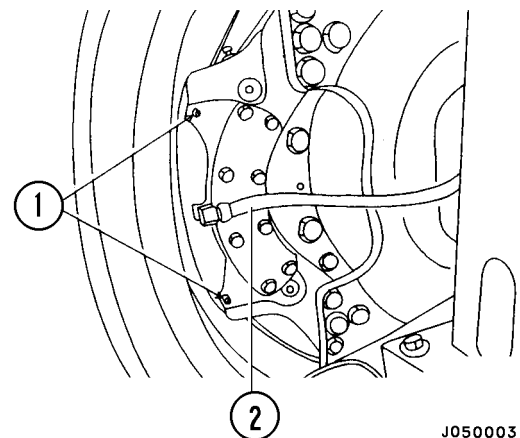

FIGURE 4-10. FRONT BRAKE PRESSURE  
1. Air Bleed Plugs                      2. Brake Line

## CHECKING REAR BRAKE DISC WEAR

Operational complaints can be expected when wear increases abruptly or the wear on one side is extremely large.

### **WARNING**

**Carry out inspection ONLY when the brake oil temperature is below 60°C (140°F).**

1. Stop truck on level ground, apply parking brake lever to the PARKING position, check that the other brakes are not applied, then stop engine. Put wheel chocks in front and behind tires to prevent truck movement.
2. Remove air bleed plug (1, Figure 4-11) of the rear brake, and install disc wear measurement gauge as shown in Figure 4-12.

**NOTE:** Part number of wear gauge: 561-98-61120.

3. Turn keyswitch to "ON", and check that air pressure gauge indicates in "green" range. If air pressure is low, run the engine at 2000 RPM until the air pressure gauge indicates in the "green" range [8.3 kg/cm<sup>2</sup> (118 psi)]. Turn keyswitch to "OFF" to stop engine.
4. At this time, pull retarder control lever to full stroke. Push the wear gauge in until it contacts the piston, then check the position of the stamped mark on the rod. (See illustration.)

**NOTE:** When the retarder control lever is pulled, the wear rod will push out under hydraulic pressure; be sure to support it when carrying out this operation.

- If the stamped mark on the rod goes in beyond the end face of the case, the discs have reached their service wear limit. **Refer to Shop Manual, Section "J", Brake System, for specific disassembly, repair, or replacement procedures for the rear brake assembly.**
- If the stamped mark on the rod does NOT go in beyond the end face of the case, but IS NEAR the service limit, carry out inspection more frequently. Check the retarder capacity carefully also.

5. After measuring the disc wear, remove wear gauge and install the air bleed plug, and bleed the air.
6. Refer to "Brake Bleeding", and bleed air from the system.

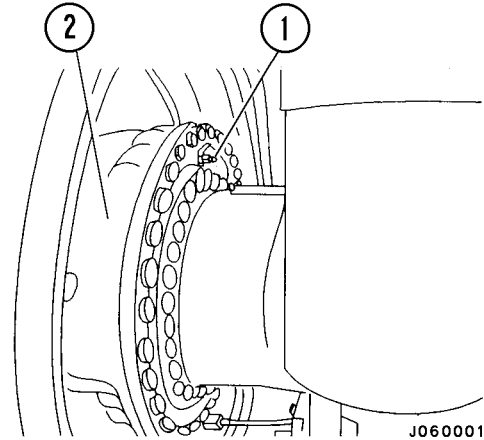

FIGURE 4-11. REAR BRAKE WEAR

1. Air Bleed Plug
2. Brake Housing

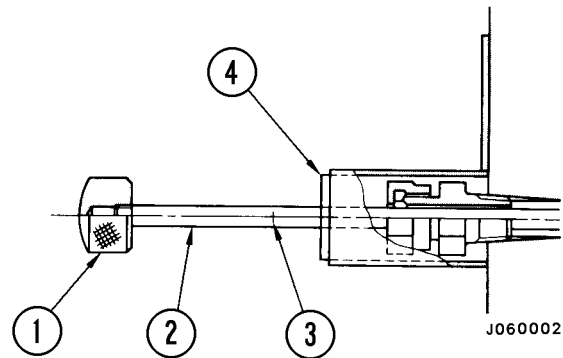

FIGURE 4-12. REAR BRAKE WEAR TOOL

1. Handle
2. Rod
3. Stamped Line
4. Face of the Case

## BRAKE BLEEDING

Start the engine and wait for the air gauge to enter the green range, then bleed the air from the circuit as follows.

### Rear brakes

1. Bleed the air at the slack adjuster end first. Depress the brake pedal, then loosen air bleed plugs (1 or 2, Figure 4-13) 3/4 turns. Tighten the plug again, then release the pedal.
2. Continue this procedure until no more bubbles come out from the air bleed plug hole, then bleed the air from the wheel plug (1, Figure 4-14).
3. Continue this procedure until no more bubbles come out from the air bleed plug.
4. After bleeding the air, close the plug and fit the cap.

### Front brakes

1. The oil tank is separately installed, so always check the oil level while bleeding the air to avoid running out of oil.
2. Depress the brake pedal, then loosen air bleed plug (1, Figure 4-15) 3/4 turn. Tighten the plug again, then release the pedal.
3. Continue this procedure until no more bubbles come out from the air bleed plug.

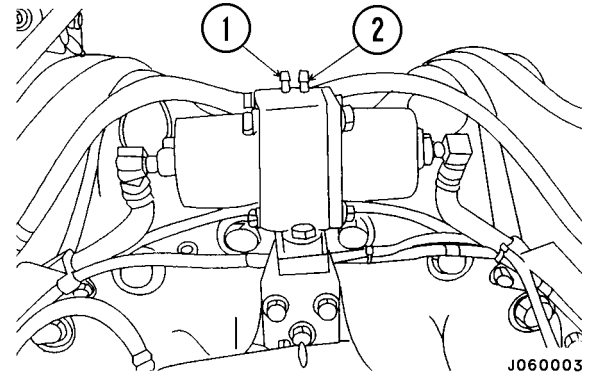

FIGURE 4-13. SLACK ADJUSTER

1. Air Bleed Plug                      2. Air Bleed Plug

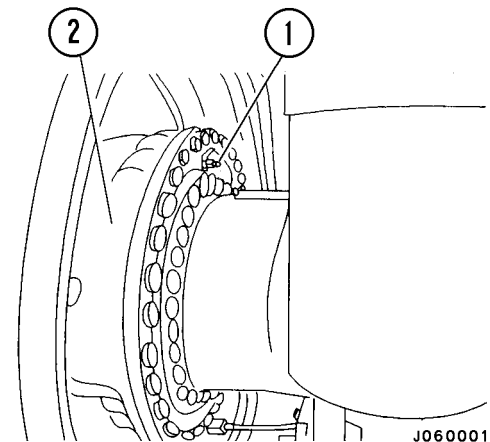

FIGURE 4-14. BRAKE HOUSING BLEED PLUG

1. Air Bleed Plug                      2. Brake Housing

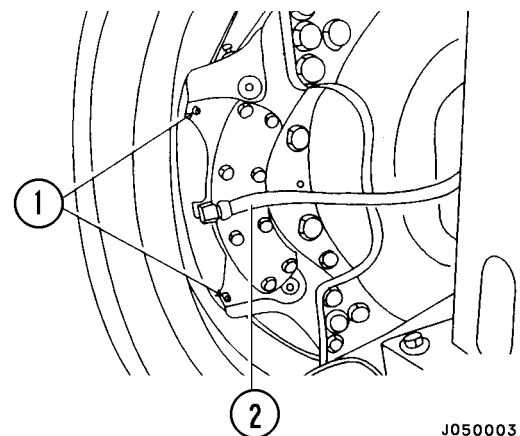

FIGURE 4-15. FRONT BRAKE BLEED PLUGS

1. Air Bleed Plugs                      2. Brake Line

## PARKING BRAKE

### PARKING BRAKE PAD

#### Inspection

PARKING BRAKE INSPECTION			
ITEM	NEW	LIMIT	REMEDY
Disc Face Runout	0.4 mm (0.016 in)	0.8 mm (0.032 in)	Replace
Disc Thickness	25 mm (0.99 in)	20 mm (0.79 in)	Replace
Pad (Includes Plate Thickness)	21.5 mm (0.847 in)	11.5 mm (0.45 in)	Replace

*NOTE: The brake disc can be machined and reused as long as it is not less than 20 mm (0.79 in) thick after machining.*

### PARKING BRAKE ADJUSTMENT

#### Testing

1. Stop the machine on level ground and apply the parking brake.
2. Raise the air pressure to 8.3 kg/cm<sup>2</sup> (118 psi).
3. Place the transmission shift lever in the D (F2) position.
4. Raise the engine speed gradually and measure the engine speed when the machine starts to move. The minimum engine speed is 1,720 RPM.

*NOTE: When the machine starts to move, release the accelerator pedal, and depress the brake pedal and return transmission shift lever to N at the same time.*

#### Adjusting

1. Turn capscrew (1, Figure 4-16) clockwise and bring both pads (1, Figure 4-17) into contact with disc (2).
2. Push in capscrew retainer (3, Figure 4-18) of slack adjuster (1) until the capscrew can turn, then turn capscrew (3) clockwise.
3. Turn capscrew (1, Figure 4-16) back from this position counterclockwise 360° ± 15° and measure clearance of caliper pad with feeler gauge (1, Figure 4-19).

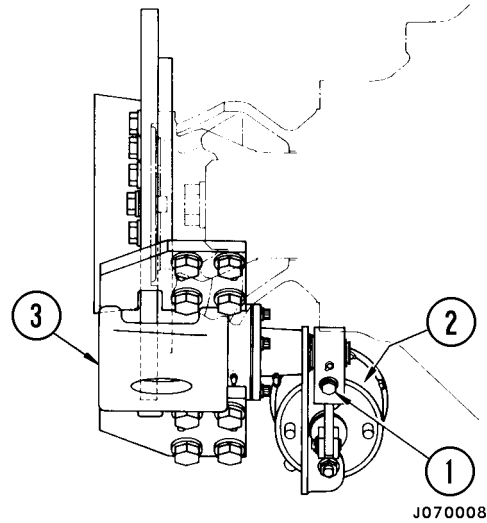

FIGURE 4-16. PARKING BRAKE ADJUSTMENT

1. Capscrew
2. Spring Housing
3. Caliper

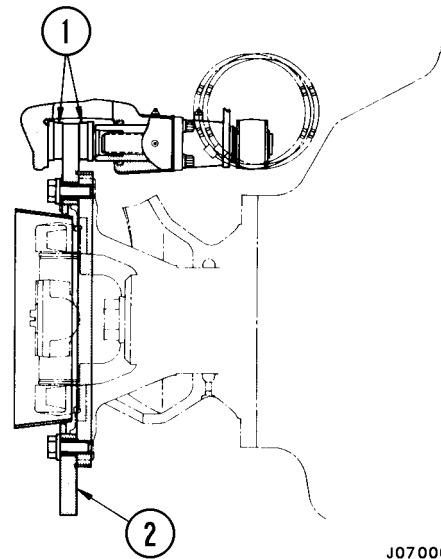

FIGURE 4-17. PARKING BRAKE ADJUSTMENT

1. Pads
2. Brake Disc

Standard clearance:

Total for both clearances =  $1.6 \pm 0.08$  mm.  
( $0.063 \pm 0.003$  in.) when pushed to one side; or  
0.8 mm each for both sides.

4. After adjusting the pad clearance, actuating stroke "a" (Figure 4-18) of the rod should be measured and adjusted to approximately 50 mm (1.97 in). (Figure 4-20)

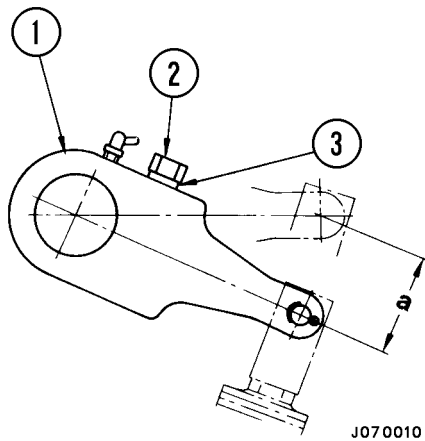

FIGURE 4-18. ARM ADJUSTMENT

- |                   |                      |
|-------------------|----------------------|
| 1. Slack Adjuster | 3. Capscrew Retainer |
| 2. Capscrew       | 4. 50 mm (1.97 in.)  |

5. After adjusting, return capscrew (2) to a position where capscrew retainer (3) stops it from turning.

**Refer to Shop Manual, Section "J", Brake System, for specific disassembly, repair, or replacement procedures for the parking brake assembly.**

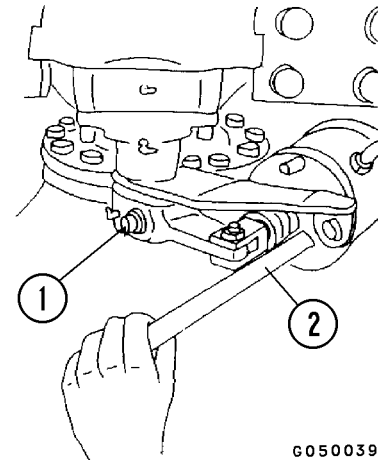

FIGURE 4-20. ADJUSTING CLEARANCE

- |                    |                  |
|--------------------|------------------|
| 1. Adjustment Plug | 2. Measuring Rod |
|--------------------|------------------|

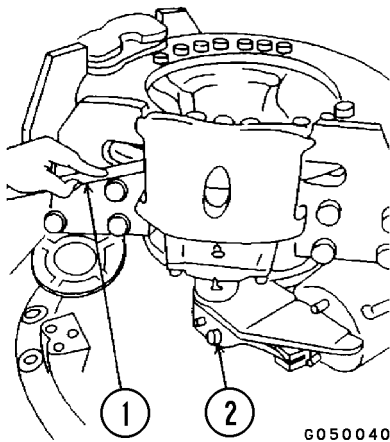

FIGURE 4-19. ADJUSTMENT CLEARANCE

- |                 |                    |
|-----------------|--------------------|
| 1. Feeler Gauge | 2. Adjustment Plug |
|-----------------|--------------------|

---

# NOTES

## MAJOR COMPONENTS AND SPECIFICATIONS

### ENGINE

The KOMATSU 330M Truck is powered by a Komatsu SA12V140Z-1 diesel engine.

### TRANSMISSION

The TORQFLOW transmission assembly consists of a 3-element, single-stage, two-phase torque converter driving a planetary gear, hydraulically-actuated multiple disc clutch transmission which is force-lubricated for optimum heat dissipation.

The TORQFLOW transmission is capable of seven (7) forward speeds and one (1) reverse gear. Automatic shifting is controlled by electronic shift control with automatic clutch modulation in all gears.

A lockup system consisting of a wet, double-disc clutch, is activated in F1-F7 gears for increased fuel savings.

### FINAL DRIVE ASSEMBLY

The final drive consists of a plug-in differential with planetary wheel drives.

### OPERATOR'S CAB

The Operator's Cab is spacious and comfortable with wide windows all around for excellent visibility. All pedals, controls and instruments are arranged for maximum efficiency and ease of operation.

The electronic display/monitoring panel displays the current status of the truck's operating systems. Audible alarms and indicator lights warn the operator of system malfunctions.

### POWER STEERING

The 330M is equipped with full hydraulic power steering. The system includes an electric motor driven pump which automatically provides emergency power if the steering pump hydraulic flow is reduced below an established minimum.

### BRAKE SYSTEM

Depressing the brake pedal actuates front and rear air-over-hydraulic service brakes. The front service brakes are caliper disc type. The rear service brakes are oil-cooled, multiple-disc brakes (acts also as retarder).

### RETARDER

The operator can manually apply the rear oil-cooled, multiple-disc retarder brakes by moving the retarder control lever which is mounted on the steering column. These brakes are automatically activated when the engine speed exceeds the rated revolutions of the shift position.

### SUSPENSION

Hydro-pneumatic suspension cylinders are used at each wheel to reduce shock and provide riding comfort for the operator and machine stability.

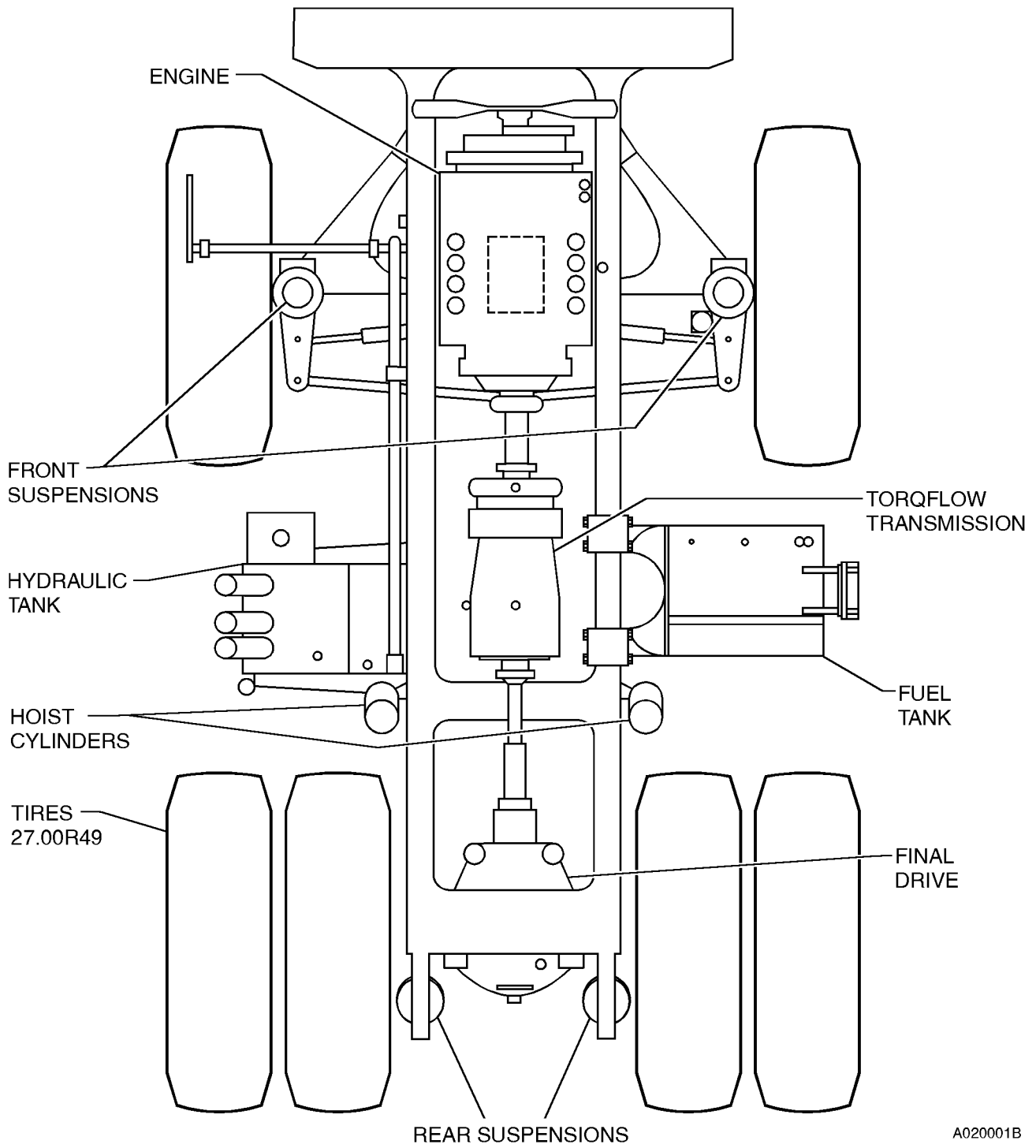

A020001B

## 330M MAJOR COMPONENTS



## SPECIFICATIONS

### ENGINE

Komatsu ..... SA12V140Z-1  
 Number of Cylinders ..... 12  
 Operating Cycle ..... 4-Stroke  
 Rated 783 kW (**1050 SAE Brake HP**) @ 2000 RPM  
 Flywheel ... 753 kW (**1010 SAE HP**) @ 2000 RPM  
 Max. Torque... 4631 N.m (**3415 lb-ft**) @ 1400 RPM

### TORQFLOW TRANSMISSION

Automatic Electronic Shift Control  
 .... with Automatic Clutch Modulation In All Gears.  
 Lockup Clutch ..... Wet, Double-disc,  
 .... Activated in F1-F7 gears.  
 Torque Converter ..... 3-Element, Single-stage,  
 .... Two-phase  
 Transmission .. Planetary Gear, Multiple Disc Clutch,  
 .... Hydraulically Actuated, Force-lubricated  
 Speeds ..... 7 Forward, 1 Reverse  
 Max Travel Speed ..... 61.9 Km/h (**38.5 MPH**)

### FINAL DRIVE ASSEMBLY

Final Drive ..... Plug-in Differential  
 .... with Planetary Wheel Drive  
 Reduction Ratios:  
 Bevel Set ..... 3.47:1  
 Planetary Final Drive ..... 6.50:1  
 Total Reduction ..... 22.54:1

### ELECTRIC SYSTEM

Batteries (series/parallel) ... 4 x 12V / 200 Amp Hr.  
 .... 1450 Cold Cranking Amps  
 Alternator ..... 24 Volt, 75 Ampere Output  
 Lighting ..... 24 Volt  
 Starter ..... (1) 24 Volt Electric

### AIR SYSTEM

Compressor ... 0.85 m<sup>3</sup>/min ..... (**30 cfm**)

### SERVICE CAPACITIES

	Liters	U.S. Gallons
Engine	147	<b>(39)</b>
(Includes Lube Oil Filters)		
Cooling System	256	<b>(66)</b>
Fuel Tank	1250	<b>(330)</b>
Transmission	125	<b>(33)</b>
And Torque Converter		
Steering & Hoist System	248	<b>(65.5)</b>
Tank Only	145	<b>(38.3)</b>
Brake Cooling System	366	<b>(96.6)</b>
Tank Only	248	<b>(65.5)</b>
Final Drive Case	250	<b>(66)</b>
(Differential & both planetaries)		

### HYDRAULIC SYSTEM

The steering/hoisting and retarder cooling circuits are independent circuits. Load sensing steering system controls the flow to the steering circuit in accordance with demand.

Hydraulic Pumps ..... 2-Separate Gear Pumps  
 Steering/Hoist Functions - Flow rated at 2000 RPM  
 .... 636 l/min. (**168 U.S. gal/min.**)  
 Retarder Cooling - Flow rated at 2000 RPM  
 .... 1001 l/min. (**264 U.S. gal/min.**)  
 Hoist Control Valve ..... Spool Type  
 Positions ..... Raise, Hold, Float, and Lower  
 Hydraulic Cylinders  
 Hoisting ..... 2-Stage Telescoping Piston  
 Steering ..... Double Acting Piston  
 Relief Valve Setting ..... 210 kg/cm<sup>2</sup> (**3,000 psi**)

### SERVICE BRAKES

Actuation: ..... Air-Over-Hydraulic  
 Front ..... Caliper Disc Brakes  
 Rear ..... Oil-Cooled, Multiple-Disc  
 .... Act as both Service and Retarder Brakes  
 Retarder Brakes:  
 Normally Applied ..... Manually By Operator.  
 Automatically Actuated .....  
 when engine speed exceeds the rated revolutions of  
 the shift position for the transmission.

(Service Brakes - continued on next page)

**Service Brakes Continued**

Parking Brake: . . . . . Spring-loaded, Caliper Disc  
. . . . . Actuates On Drive Shaft

**Emergency Brakes:**

An emergency relay valve actuates the brakes automatically should air pressure in the air tank drop below a pre-set value.  
Manual operation is also possible.

**STEERING**

Min Turning Radius . . . . . 9.9 m (32' 6")  
Automatic Emergency Steering . . . . . Standard

**TIRES**

Rock Service (E-3) . . . . . Tubeless  
Standard . . . . . 27.00R49XRBT  
Rim Size . . . . . 50 cm X 124.4 cm (19.5 in. X 49 in.)  
. . . . . Separable Tire Rims

**DUMP BODY CAPACITY(Standard)**

Struck . . . . . 38.6 m<sup>3</sup> (50.5 yds<sup>3</sup>)  
Heaped @ 2:1 (SAE) . . . . . 60.1 m<sup>3</sup> (78.7 yds<sup>3</sup>)

**OVERALL TRUCK DIMENSIONS**

Loading Height . . . . . 4.29 m (14' 1")  
Minimum Clearance Height (Empty) . 5.27 m (17' 3")  
Overall Length . . . . . 10.47 m (34' 4")  
Maximum Width . . . . . 5.68 m (18' 7")

**WEIGHT DISTRIBUTION**

Based on SAE 2:1 Heaped . . . . . 60 m<sup>3</sup> (78 yds<sup>3</sup>)  
(w/Komatsu SA12V140Z-1 Engine; and 27.00R49 Tires)

**EMPTY . . . . . Kilograms . . . . . Pounds**

Front Axle . . . . . 33 145 . . . . . 73,080  
Rear Axle . . . . . 35 905 . . . . . 79,170  
Total . . . . . 69 050 . . . . . 152,250

**LOADED (100 Ton PAYLOAD)**

**. . . . . Kilograms . . . . . Pounds**

Front Axle . . . . . 54 080 . . . . . 119,280  
Rear Axle . . . . . 112 320 . . . . . 247,720  
Total \* . . . . . 166 400 . . . . . 367,000

\*Not to Exceed 166 400 kg (367,000 lbs.)  
Including Options, Fuel & Payload

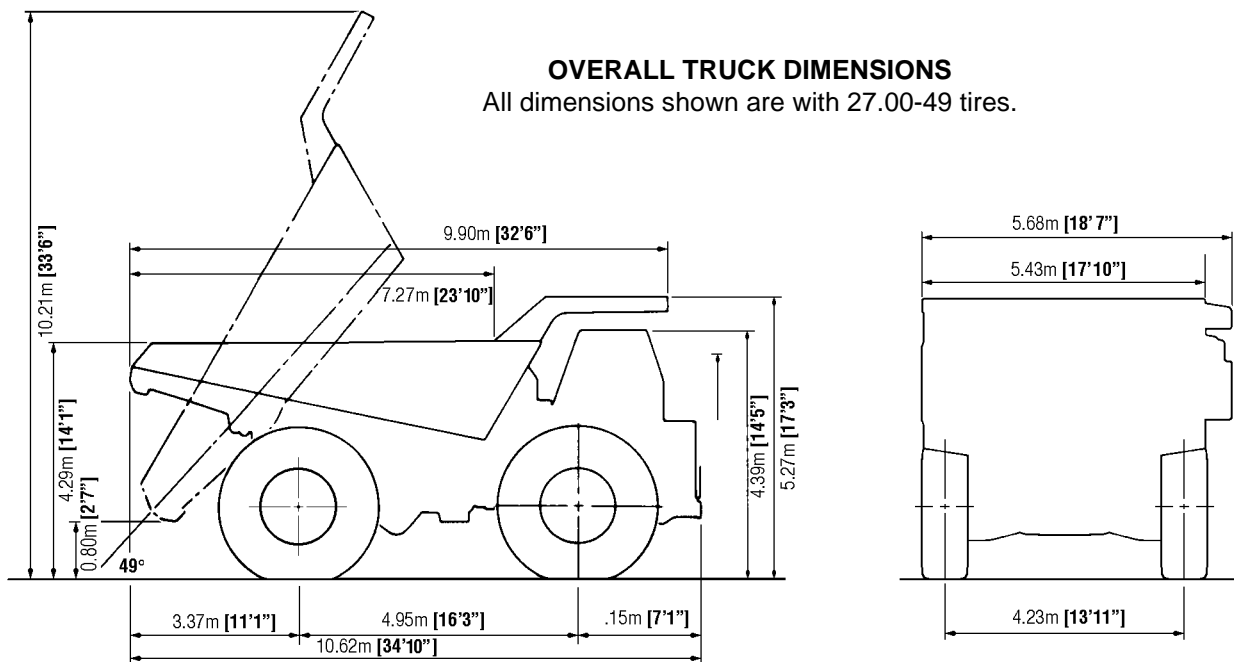

# PAYLOAD METER II™ ON BOARD WEIGHING SYSTEM (OBWS) INDEX

PAYLOAD METER II ON BOARD WEIGHING SYSTEM (OBWS) .....	6-4
GENERAL INFORMATION .....	6-4
Haul Cycles .....	6-4
LIGHTS, SWITCHES, and COMPONENTS .....	6-5
TIPS FOR OPERATION .....	6-6
EXTERNAL DISPLAY LIGHTS .....	6-6
THEORY OF OPERATION .....	6-7
Basic Description .....	6-7
Inclinometer .....	6-7
Linkage Factor .....	6-7
Gain Factor .....	6-8
Brake Lock .....	6-8
Sources of Error .....	6-8
Typical Data From Service Check Mode .....	6-8
Example Calculation of Payload .....	6-9
Viewing Payload Calculation Inputs .....	6-9
Checking the Gain .....	6-10
Adjusting the Gain .....	6-10
TYPES OF DATA STORED .....	6-11
Cycle Data .....	6-11
Engine ON/OFF Data .....	6-12
Fault Codes and Warning Data .....	6-12
Engine Operation .....	6-13
Total Payload and Total Number of Cycles .....	6-13
Other Data .....	6-13
OPERATOR FUNCTIONS .....	6-14
Using the Operator Load Counter .....	6-14
Viewing the Operator Load Counter .....	6-14
Clearing the Operator Load Counter .....	6-14
Dimming the Lights on the Display .....	6-14
INITIAL SETUP OF PAYLOAD METER .....	6-15
Switch Settings .....	6-15
Checking the Operator Check Mode .....	6-16
Checking the Service Check Mode .....	6-16
Checking the Gt setting: .....	6-17
Checking the Inclinometer Settings .....	6-17
Calibrating a Truck .....	6-17

DISPLAYS AT START-UP .....	6-18
NORMAL OPERATION .....	6-18
SETUP AND MAINTENANCE .....	6-19
Setting The Speed Limit .....	6-19
Setting the Option Code .....	6-19
Setting The Machine I.D. Code .....	6-20
Setting The Operator I.D. Code .....	6-20
Setting The Time and Date .....	6-20
DOWNLOAD OF INFORMATION .....	6-21
DISPLAY OF FAULT CODES .....	6-21
Monitoring Input Signals .....	6-25
Service Check Mode .....	6-25
UP Factor - Payload Calculation Gain .....	6-26
PL Mode - Load Calculation Timing .....	6-26
FINAL GEAR RATIO SELECTION .....	6-27
BATTERY REPLACEMENT PROCEDURE .....	6-28
Replacing the Battery .....	6-28
After Replacing the Battery .....	6-29
SUSPENSION PRESSURE SENSOR .....	6-29
Removal .....	6-29
Installation .....	6-30
INCLINOMETER .....	6-30
Removal .....	6-30
Installation .....	6-30
Adjustment .....	6-30
PAYLOAD METER BACK PANEL .....	6-31
CONNECTIONS .....	6-32
PAYLOAD METER 2 RE-INITIALIZATION PROCEDURE .....	6-33
PAYLOAD CIRCUIT NUMBERS .....	6-34

---

# NOTES

## PAYLOAD METER II ON BOARD WEIGHING SYSTEM (OBWS)

### GENERAL INFORMATION

The Payload Meter II™ (PLM II™) On Board Weighing System displays and records the payload weight along with other operating information. The system consists of a payload meter, pressure sensors, deck mounted lights and an inclinometer.

The payload meter (Figure 6-1) uses the four suspension pressures and an inclinometer to determine the load in the truck. The payload weight can be displayed in short tons or metric tons.

### Haul Cycles

The beginning of a new haul cycle starts at the dump, when the body comes down from dumping the last load.

At the loading site, the PLM II™ begins to calculate the size of each shovel pass (swingload) once the payload is greater than 10% of rated load for the truck. There are three external deck-mounted lights on each side of the truck. The lights indicate payload weight divided into three separate stages. A forecast feature will flash a deck mounted light predicting the payload weight if the next bucket of material is dropped into the body.

At the moment the wheels begin to turn after loading under the shovel, the PLM II takes one sam-

ple of suspension and inclinometer data. After traveling 160 m (0.10 mi.) from the loading site, the PLM II™ uses the data sampled under the shovel to calculate final payload.

The PLM II™ displays payload on its display when the truck is stopped. For the first 160 m (0.10 mi.) after loading, the payload meter displays distance from the loading site. At all other times when the truck is moving, the display shows the time of day.

The payload meter stores in memory various operating data. This data includes:

- payload, time, distance, and travel speed for each cycle
- date and time that the engine was started and stopped
- date and time of each fault that occurred or was canceled
- total payload and the overall number of cycles for a specific time period

This data is retained even when the power is switched off. The stored data is backed up by an internal battery.

The data can be down loaded from the payload meter to a personal computer when a communication cable is connected to the port inside the cab.

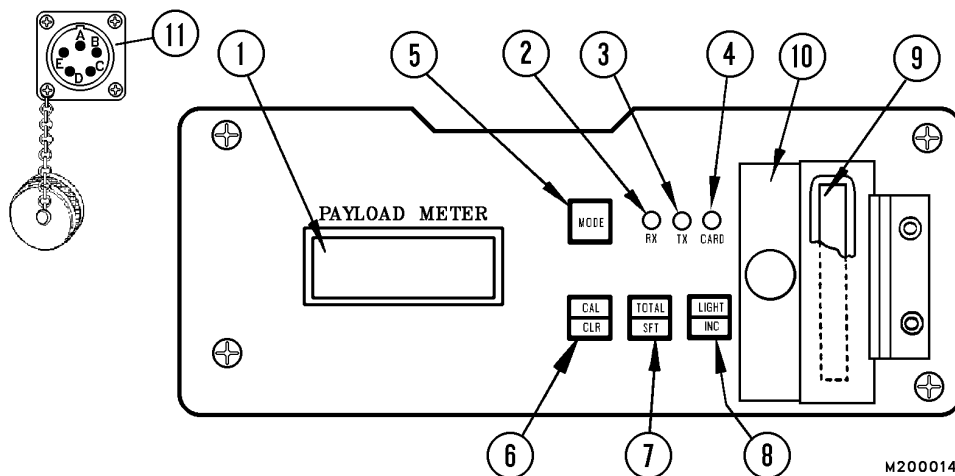

FIGURE 3-1. PAYLOAD METER II

- |   |   |
|---|---|
| 1. Display panel                        | 7. Total/shift switch [TOTAL] [SFT]     |
| 2. Reception pilot lamp (Rx busy)       | 8. Light/increment switch [LIGHT] [INC] |
| 3. Transmission pilot lamp (Tx busy)    | 9. Memory card                          |
| 4. Memory card access lamp (CARD busy)  | 10. Cover                               |
| 5. Mode switch [MODE]                   | 11. Diagnostic/Download Port            |
| 6. Calibration/clear switch [CAL] [CLR] |   |

**WARNING - When not inserting or removing memory card (9), always keep the cover (10) closed)**

## LIGHTS, SWITCHES, and COMPONENTS

### On The Face Of The Payload Meter (Refer to Figure 6-1)

#### 1. Display Panel

Digital display area for the data being recorded in memory. This will include items such as:

- Payload
- Date & Time
- Cycles
- Travel Distance
- Fault Codes and Warnings

#### 2. Reception Pilot Lamp (Rx Busy)

This light will illuminate for 3 seconds when the system is powered up. It will then be lit whenever the computer is communicating.

#### 3. Transmission Pilot Lamp (Tx Busy)

This light will illuminate for 3 seconds when the system is powered up. It will then be lit whenever the memory is being downloaded to a personal computer.

#### 4. Memory Card Access Lamp (CARD Busy)

This light will illuminate for 3 seconds when the system is powered up. It will also be lit whenever the memory data is being downloaded to the memory card.

#### 5. Mode Switch

This switch is used to select the mode or system that will allow a function to be performed. This may include:

- Various settings or corrections to the display
- Memory card downloading
- Clearing data
- Display of Abnormalities or Warnings
- Setting the speed limit
- Setting the date and time

#### 6. Calibration/Clear Switch

Used to calibrate the machine when the conditions regulate this action. Also used with the TOTAL/SFT switch to clear total payload and overall number of cycles.

#### 7. Total/Shift Switch

Used to display payload and overall number of cycles each time the load is dumped. Will display the error codes. This switch is also used with the CALIBRATION/CLEAR switch to clear total payload and overall number of cycles.

#### 8. Light/Increment Switch

Used to change the digital increments or units for the various displays. Also used to adjust the brightness of the lights on the monitor display.

#### 9. Memory Card

Used to receive data from the payload meter memory to this card which can then be used to transfer the data into a personal computer. This enables the memory to be downloaded and saved when a personal computer is not available.

#### 10. Cover

Protective cover for the Memory Card. Do not open or place foreign objects in slot.

#### 11. Diagnostic/Download Port

Connector port that is used for downloading the memory data to a personal computer.

## TIPS FOR OPERATION

To assure the On Board Weighing System records the most accurate and consistent data, these important steps should be followed:

- Always keep suspension oil and nitrogen properly charged. The most common failure for causing inaccurate payload data is due to improperly charged suspensions. Always follow shop manual procedures when charging a suspension. Refer to Section "H". It is crucial to maintain the proper oil and nitrogen levels at all times.

- For most Komatsu Trucks:

Use only the brake lock switch to hold the truck stationary at the loading and dumping area.

**For Komatsu 330M/HD785 Trucks ONLY:** Use the **park brake switch** to hold the truck stationary at the loading and dumping area.

Any other method will not allow the payload system to register properly.

- Do not activate the "Lamp Test" switch during loading. Inaccurate and inconsistent data may be stored.
- At the loading area do not release the Brake Lock (or Park Brake switch) until the loading is **complete** and the load shock from the last load dumped has settled.
- The loading area surface **must be** maintained as flat and level as possible. The On Board Weighing System can compensate for slight variations in grade and unevenness, but ruts, berms, rocks, etc. will cause the system to record inaccurate and inconsistent data.
- Regularly remove "carryback" from the dump body.
- Calibrate regularly. Refer to "Calibrating a Truck".
- Do not focus on single payloads when viewing data from the payload meter. Use the average of several payloads to get a more accurate calculation of payload productivity.

## EXTERNAL DISPLAY LIGHTS

The Payload Meter 2 controls three light relays. The relays operate three deck mounted lights on each side of the truck. There is one green light, one amber light, and one red light. (Figure 6-2)

While the truck is stopped being loaded and the hoist lever is in the float position, the appropriate lights will remain on according to the following schedule:

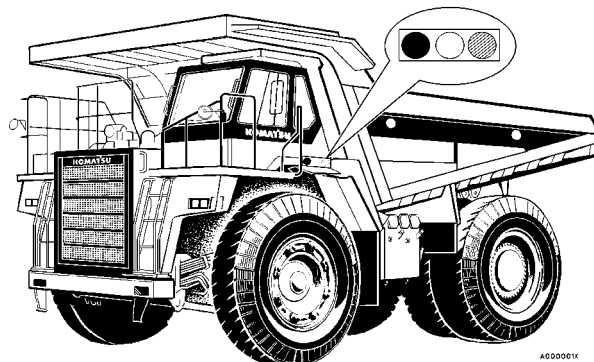

FIGURE 3-2. LOAD INDICATOR LIGHTS

INDICATOR LIGHTS			PAYLOAD WEIGHT
Off	Off	Green	50% and Greater
Off	Amber	Green	90% and Greater
RED	Amber	Green	105% and Greater

The shovel or loader operator can predict the payload weight by observing these lights. During the loading operation, a forecast feature flashes a deck mounted light predicting the payload weight after the next bucket of material is loaded into the body. The logic is as follows:

1. If the measured payload is varying 3% or less of the rated load for more than 3 seconds, the current load is deemed a steady value.
2. If the difference between the previous steady value and the current steady value is greater than 15% of the rated load, the difference is taken to be the size of the current bucket.
3. The average size of previous buckets is added to the current load. One of the deck mounted lights will turn on, if another "average" size load is put in the body, and will blink at one second intervals.



## THEORY OF OPERATION

### Basic Description

The payload meter uses the four suspension pressures and the inclinometer to determine the load in the truck. These inputs are critical to the calculation of the load. The other inputs to the payload meter (Body Up, Speed, Brake Lock, Alternator R Terminal, and Engine Oil Pressure) are used to indicate where the truck is in the haul cycle. These inputs enable the payload meter to make time and distance measurements for the haul cycle.

The suspension pressures are the key ingredients in determining the sprung weight of the truck. These pressures are converted into forces using the formulas shown below.

$$\text{Sprung Weight} = \frac{\pi}{4} \text{ Suspension Diameter}^2 (\text{Psi Left} + \text{Psi Right})$$

$$\text{Sprung Weight} = \text{Axle Weight (lbs)} / 2000$$

These forces are combined with the geometry of the truck to produce the load calculation. It is critical that the suspensions are charged according to shop manual specifications and the pressure sensors are functioning properly.

### Inclinometer

The inclinometer gives the payload meter information regarding the pitch angle of the truck. The front and rear incline factors are determined by the pitch angle. These two factors account for the load transfer that occurs when the truck is inclined nose up or nose down.

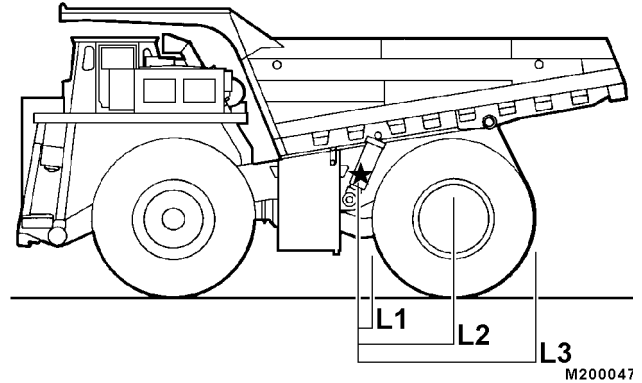

FIGURE 3-3. LINKAGE FACTOR

### Linkage Factor

The linkage factor is part of the complex calculations performed by the payload meter to determine the load in the truck. The linkage factor is dependent on the load on the rear suspensions.

Figure 6-3 shows the side view of a truck. The nose pin is marked with a star and there are three arrows pointing to different spots of the rear tire. This figure shows how the support under the rear tire can affect the calculation of the load. The payload meter does not directly measure the load transferred to the frame through the nose pin. To account for portion of the load carried by the nose pin, the linkage factor is multiplied by the rear suspension force. It is assumed that the truck is supported under the center of the tire. In this case the payload meter uses L2 to help compute the linkage factor. If, however, the truck is backed into a berm and the rear tire is supported towards the back of the tire, the actual linkage factor calculation should use L3. Since the payload meter assumes L2 it will overestimate the load in the truck. The opposite is true in the case where the rear tires are supported toward the front of the tire. The linkage factor should use L1 but the payload meter assumes L2. This change in leverage will cause the payload meter to underestimate the load.

### Gain Factor

Gain factor is part of the formula the payload meter uses to calculate the payload. The gain factor is a tool that compensates for variations between actual weight of the payload and the calculated weight from the payload meter. The gain factor should only be adjusted after several payloads have been weighed on a scale. The gain should never be adjusted based only on one payload. It takes at least 10 scale weigh-ins to determine an average variation. A worksheet is located at the end of this chapter to assist in calculating the necessary gain adjustment.

There are two types of gain adjustments,  $G_f$  gain and UP factor. It is recommended that only the  $G_f$  gain be adjusted. This adjustment is made using the potentiometer on the side of the payload meter. Refer to "Adjusting the Gain".

### Brake Lock

The Brake Lock only applies the rear brakes. This allows the front wheels to rotate slightly as the truck is being loaded. This is important because the payload meter assumes that the front wheels can rotate freely. As the truck is being loaded, it will begin to squat down on the suspensions. This will change the wheel base dimension of the truck. This freedom of movement prevents additional binding and friction in the front suspensions.

The incline of the grade on which the truck is loading is measured by the inclinometer. This helps determine the incline factors that are applied to the front and rear sprung weights. The tire forces on the road surface that hold the truck on grade affect the suspension pressures. If the front and rear brakes are locked, the effect on the suspension pressures cannot be determined. If only the rear brakes are applied the effect is predictable and the incline factors accurately account for the forces on the tires.

If the service brake or park brake is used and depending on the incline and other factors, the payload meter can overestimate or underestimate the load. **It is important that only the brake lock be used while loading the truck. (Parking brake on 330M/HD785).**

### Sources of Error

Poorly charged suspensions can lead to systematic error in the calculation of payload. The error is most obvious when the oil level is low. When there is too little oil in the suspensions, the cylinder may compress completely under a load. The weight of the truck will be carried by the metal to metal contact within the suspension. Not only will the ride of the truck and the life of the tires, and other components be affected, but the pressure in the cylinder will not truly represent the load on the truck. Under-charged suspensions typically cause the payload calculations from the payload meter to be lower than the actual payload.

### Typical Data From Service Check Mode

A sample data set is shown in Figure 6-4. This data was taken in the laboratory and is used in Figure 6-5 to calculate the final load. Note that the front suspension pressures were converted into the front sprung weight using the formulas above Figure 6-5. The front sprung weight is then multiplied by the front incline factor and the front linkage factor. The same is done with the rear sprung weight. The front and rear sprung weights are then summed. This number is multiplied by the  $G_f$  gain potentiometer value. The calibration load is subtracted from the total to produce the final load. The load displayed on the meter is this final load (item #15) multiplied by the UP gain factor.

Number	Data	Description
1	13:09	Current Time
2	749.4	Front Left Pressure (Psi)
3	848.9	Front Right Pressure (Psi)
4	863.2	Rear Left Pressure (Psi)
5	1049.0	Rear Right Pressure (Psi)
6	106.0	Front Weight (Tons)
7	75.1	Rear Weight (Tons)
8	-1.85	Inclinometer (Degrees)
9	0.95	Incline Factor - Front Wheels
10	0.984	Incline Factor - Rear Wheels
11	1	Link Factor - Front Wheels
12	1.539	Link Factor - Rear Wheels
13	70.6	Calibration Sprung Weight (Tons)
14	1.000	Gain Adjustment
15	143.8	Current Load (Tons)
16	3.9	Battery Backup Voltage (Volts)

FIGURE 3-4.

**NOTE: This screen is the only place that the value of the  $G_t$  gain potentiometer can be checked.**

There are two gain factors that can be applied to the payload measurement. The first is the  $G_t$  gain factor and the other is the UP gain factor. They are not applied uniformly to all payload calculations.

**Example Calculation of Payload**

These calculations used a 13" front suspension diameter and 10" rear suspension diameter.

$$\text{Sprung Weight} = \frac{\pi}{4} \text{ Suspension Diameter}^2 (\text{Psi Left} + \text{Psi Right})$$

$$\text{Sprung Weight} = \text{Axle Weight}(\text{lbs})/2000$$

Front Weight (6)	106.00	Rear Weight (7)	75.10
x Incline Factor (9)	0.95	x Incline Factor (10)	0.98
	100.70		73.90
x Link Factor (11)	1.00	x Link Factor (12)	1.53
Front Weight	100.70	Rear Weight	113.70
Front Weight	100.70		
Rear Weight	113.70		
Total Weight	214.40		
x Gain Factor (14)	1.00		
	214.40		
- Calibration (13)	-70.60		

FIGURE 3-5.

**Viewing Payload Calculation Inputs**

The PLM II™ estimates payload by monitoring suspension pressures when the truck is loaded and compares them to truck empty pressure values. The PLM II™ uses one empty truck weight for all payload calculations. This empty truck weight is called the 'tare weight'. It is not the empty vehicle weight (EVW). It is an estimate of the empty weight of all the truck components suspended above the suspensions. The process of making the PLM II™ calculate the tare weight is called the calibration procedure.



This calibration weight is used as item #13 from the manual calculation procedure in Figure 6-4.

1. Press and hold the LIGHT/INC and MODE switches until "CHEC" is flashing on the display. **CHEC**
2. Press and hold the CAL/CLR switch until "CALL0" is flashing on the display. **CALL0**
3. Press the CAL/CLR switch to cycle through the following data. The sequence repeats.

Item and Description	Units
1. Year of Calibration	Last 2 digits of year
2. Month: Day of Calibration	XX:XX
3. Hour: Minute of Calibration	XX:XX
4. Truck Model Setting	
5. Pressure Front Left	Psi
6. Pressure Front Right	Psi
7. Pressure Rear Left	Psi
8. Pressure Rear Right	Psi
9. Front Sprung Weight	Tons
10. Rear Sprung Weight	Tons
11. Degree of Incline	±° Nose Up Positive
12. Incline Factor - Front Axle	
13. Incline Factor - Rear Axle	
14. Link Factor Front Axle	
15. Link Factor Rear Axle	
16. Calibration Weight	Tons

4. Press MODE once and "CHEC" will flash on the display. **CHEC**
5. Press MODE once and the meter will return to normal operation.

### Checking the Gain



1. Press and hold the LIGHT/INC and MODE switches until "CHEC" is flashing on the meter. 
2. Press and hold the LIGHT/INC switch until "ALLO" is flashing on the display. "A.FUL" may also be displayed. 
3. Press the LIGHT/INC switch 14 times. The number displayed will be the current  $G_t$  gain. Press MODE twice to return to normal operation.

### Adjusting the Gain

Before adjusting the gain perform the following steps:

1. Confirm the suspension oil and nitrogen charges are at the levels specified in the shop manual.
2. Weigh the empty truck and then calibrate the payload meter. Do both in succession to ensure the weights are nearly identical.
3. Weigh at least 10 different loads to get an accurate deviation from actual scale weight and the payload calculation from the payload meter. Complete the gain adjustment worksheet at the end of this module. The worksheet is an accurate way to calculate the necessary gain adjustment.

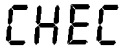
#### *Adjustment Procedure:*

1. Ensure the PLM II™ is in normal operating mode.
2. Adjust the gain potentiometer on the side of the meter. Right to decrease, left to increase.
3. Press and hold the LIGHT/INC and MODE switches until "CHEC" is flashing on the meter. 
4. Press and hold the LIGHT/INC switch until "ALLO" is flashing on the display. "A.FUL" may also be displayed. 
5. Press the LIGHT/INC switch 14 times. The number displayed will be the current  $G_t$  gain. This is not a "live" reading. Any time the gain is changed, this cycle must be repeated to view the new change.
6. Press MODE once and "CHEC" will flash on the display. 
7. Press MODE once and the meter will return to normal operation.

## TYPES OF DATA STORED

### Cycle Data

One cycle is considered to be from the point where a load is dumped to the point where the next load is dumped. Data between these two points is recorded in memory. Examples of the data are shown below. The maximum number of cycles that can be stored in memory is 2900 cycles.

ITEM	UNIT	RANGE	REMARKS
Engine Operation Number	Number	1 - 65535	Advances by one each time the engine is started.
Month	Month	1 - 12	
Day	Day	1 - 31	
Time Hour	Hour	24 Hour Clock	These values are stored when the load is dumped.
Time Minute	Minute	1 - 59	
Payload	Metric tons Short tons	0 - 6553.5	
Travel Time When Empty	Minute	0 - 6553.5	
Travel Distance When Empty	Miles/Km	0 - 25.5	
Maximum Travel Speed When Empty	Mph/Kmh	0 - 99	
Average Travel Speed When Empty	Mph/Kmh	0 - 99	
Time Stopped When Empty	Minute	0 - 6553.5	
Time Stopped During Loading	Minute	0 - 6553.5	
Travel Time When Loaded	Minute	0 - 6553.5	
Travel Distance When Loaded	Miles/Km	0 - 25.5	
Maximum Travel Speed When Loaded	Mph/Kmh	0 - 99	
Average Travel Speed When Loaded	Mph/Kmh	0 - 99	
Time Stopped When Loaded	Minute	0 - 6553.5	
Dumping Time	Minute	0 - 6553.5	
Speed Limit	Mph/Kmh	0 - 99	
Warnings For Each Cycle	The fault codes that occur during each cycle		

**Engine ON/OFF Data**

When the engine is started or stopped, the following data is recorded.

ITEM	UNIT	RANGE	REMARKS
Engine Operation Number	Number	1 - 65535	Advances by one each time the engine is started.
Last Two Digits Of The Year	Year	0 - 99	Indicates when the engine was started.
Month	Month	1 - 12	
Day	Day	1 - 31	
Time Hour	Hour	24 Hour Clock	
Time Minute	Minute	0 - 59	
Last Two Digits Of The Year	Year	0 - 99	Indicates when the engine was shut off.
Month	Month	1 - 12	
Day	Day	1 - 31	
Time Hour	Hour	24 Hour Clock	
Time Minute	Minute	0 - 59	
Total Payload	Metric tons Short tons	0 - 999900.0	Total payload from the time when the engine was started until the time the engine was shut off.
Total Number Of Cycles	Number	0 - 9999	Totals for the time that the engine was running.

**Fault Codes and Warning Data**

ITEM	UNIT	RANGE	REMARKS
Error Code	Displayed by a combination of letters and numbers representing a specific error code.		
Engine Operation Number At Time Of Occurrence	Number	1 - 65535	Every time the engine is started the number advances by one.
Number Of Times Of Occurrence Since The Engine Was Switched ON	Number	1 - 255	
Last Two Digits Of Year	Year	0 - 99	
Month	Month	1 - 12	
Day	Day	1 - 31	
Time Hour	Hour	24 Hour Clock	
Time Minute	Minute	0 - 59	

**Engine Operation**

ITEM	UNIT	RANGE	REMARKS
Number when Canceled	Number	1 - 65535	Every time the engine is started the number advances by one.
Last Two Digits Of Year	Year	0 - 99	
Month	Month	1 - 12	
Day	Day	1 - 31	
Time Hour	Hour	24 Hour Clock	
Time Minute	Minute	0 - 59	
<i>NOTE: If the engine operation number is a 0, this indicates that the problem occurred or was canceled (depends on the operation that was performed) when the key switch was in the ON position and the engine was not running.</i>			

**Total Payload and Total Number of Cycles**

The total payload and overall number of cycles can be displayed using the forced display operation. Both values start from a zero point whenever the memory has been cleared. The payload total is automatically displayed when the load is dumped.

ITEM	UNIT	RANGE	REMARKS
Total Payload	Metric Tons Short Tons	0 - 999900.0	The total payload since the unit was cleared.
Total Number Of Cycles	Digital Number	0 - 9999	The number of cycles since the unit was cleared.
Last Two Digits Of Year	Year	0 - 99	Date and time the unit was cleared.
Month	Month	1 - 12	
Day	Day	1 - 31	
Time Hour	Hour	24 Hour Clock	
Time Minute	Minute	0 - 59	

**Other Data**

ITEM	UNIT	RANGE	REMARKS
Set Up Data That The Operator Can Check	Speed Limit	Km/MPH	
	Option Code	Digital Number	Communication Mode
Calibration Data	Year	Year	Date and time when calibrated.
	Month	Month	
	Day	Day	
	Hour	Hour	
	Minute	Minute	

## OPERATOR FUNCTIONS

### Using the Operator Load Counter

#### Description

The payload meter makes available to the operator a total load counter and haul cycle counter. This allows each operator to track the tons hauled during their shift. The total is displayed in hundreds of tons. For example, if 223 is displayed, this means that 22,300 tons have been hauled since the last time the cycle counter was cleared.

This memory location is separate from the main payload data storage. This memory is not cleared when the Data All Clear Operation is performed. Clearing this memory does not affect the main payload data storage.

### Viewing the Operator Load Counter

1. Press the TOTAL/SFT switch once.

If there is a fault code present at this time:

2. The error code for that problem will be displayed. This will be a flashing display.
3. Press the TOTAL/SFT switch again. If additional faults or warnings exist, that fault code will be displayed as a flashing code.
4. Repeat step #3 until no fault codes are displayed. ":" will show when no additional faults exist. The display will then show total tons hauled since the last time the counter was cleared. The total is displayed in hundreds of tons.
5. Press the TOTAL/SFT switch again. The number displayed is the number of haul cycles since the last time the cycle counter was cleared.
6. Press the TOTAL/SFT switch again. ":" is displayed for 2 seconds before the display returns to normal operations.

### Clearing the Operator Load Counter

1. Press the TOTAL/SFT switch once. The number displayed is the total tons hauled since the last time the counter was cleared. The total is displayed in hundreds of tons.
2. Press and hold the CAL/CLR switch until the display flashes.
3. Press the CAL/CLR switch until "0000" is displayed. After 2 seconds the meter will return to normal operation.

Clearing this memory **does not** affect the main payload data storage.

### Dimming the Lights on the Display

There are a total of 10 brightness levels on the PLM II™ display.

From the normal operation display:

1. Press the LIGHT/INC switch. The lighting will become one level dimmer. This will continue until the lighting has reached its lowest level.
2. After reaching the lowest level, the display will return to the brightest setting.

If the switch is held in the depressed position, the brightness will change continuously.



## INITIAL SETUP OF PAYLOAD METER

There are several things that must be checked and programmed when a payload meter is first installed.

1. Check the switch settings on the side of the meter.
2. Check the Operator Check Mode settings
3. Check the Service Check Mode settings
4. Calibrate the clean truck.

The next few pages show the steps required to perform these checks. Only after all of these steps have been performed can the payload meter be released for service.

### Switch Settings

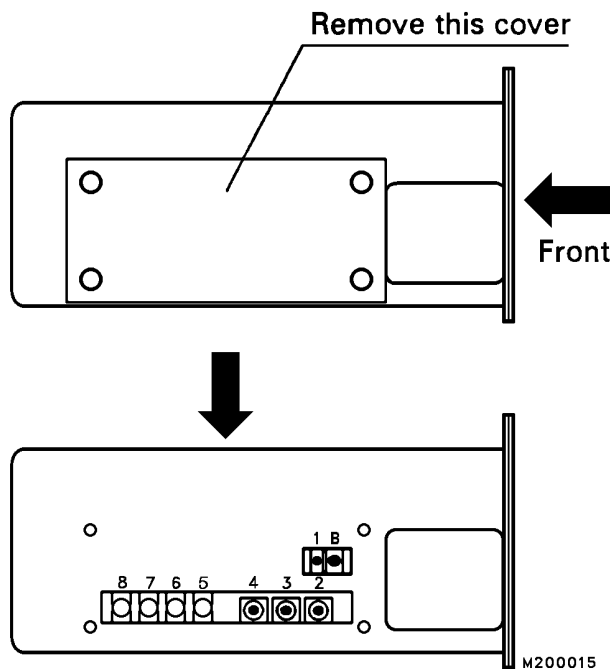

FIGURE 3-6.

There are nine switches located behind the panel on the left side of the payload meter. Figure 6-6 shows the switch numbers. The following switch positions should be confirmed before the meter is installed.

\* Set switch 4 for the appropriate model.

Switch	Position
1	<b>Initial Setup should be set to 1.00</b> - Gain Clockwise(-20%) CCW (+20%) Refer to "Gain Factor" for adjust guidelines
B	<b>Do not Adjust</b> - Buzzer Volume
2	7 - Speed Regulation 0=107%, 7=100%, F=92% <b>The 930-2 should be set to '6'.</b>
3	7 - Distance Regulation 0=107%, 7=100%, F=92% <b>The 930-2 should be set to '6'.</b>
4	<b>4</b> - 685E <b>5</b> - 630E <b>B</b> - 730E <b>C</b> - 930E <b>D</b> - 530M <b>E</b> - 330M <b>F</b> - 830E
5	<b>DOWN</b> - Memory function (DOWN = Enable UP=Disable)
6	<b>DOWN</b> - Inclinator Use (DOWN = Enable UP=Disable)
7	<b>DOWN</b> = Short Tons, <b>UP</b> = Metric Tons
8	<b>UP</b>









## ⚠ IMPORTANT ⚠

*930E-2 trucks are equipped with 53/80R63 series tires and require small changes to the switch settings of the PLM II™. The tires have a larger rolling radius than the PLM II™ assumes. This causes the PLM II™ to underestimate distances by 1%. The Speed Regulation and Distance Regulation switches should be switched to position 6. This is contrary to what the label may say.*

*Additionally, the payload gain on 930E-2 trucks also needs to be adjusted. The front suspensions are larger than the original 930E suspension, and therefore, data programmed into the payload meter is not completely accurate. The gain must be increased by 1%. There are two methods for changing this gain; changing the UP factor using the buttons on the front panel, or using the gain adjustment potentiometer on the side of the meter. The preferred method is using the potentiometer. Refer to "Adjusting the Gain".*

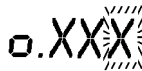
### Checking the Operator Check Mode

The Operator Check Mode is used to check and change several settings. These should be checked before the payload meter is put into service.



1. Press and hold the MODE switch. The display will show: 
2. Press the MODE switch once. The display will show: Refer to "Data All Clear" to clear the haul cycle data. 
3. Press the MODE switch once. The display will show: Refer to "Display of Fault Codes" for viewing fault codes. 
4. Press the MODE switch once. The display will show: This is the truck ID number. Refer to "Setting The Machine ID" to change Machine ID. 
5. Press the MODE switch once. The display will show: Refer to "Setting The Operator ID" to change operator. 
6. Press the MODE switch once. The display will show: "SP:62" should be displayed. The speed limit should be set to 62 to avoid unnecessary faults and warnings. Refer to "Setting The Speed Limit" to make adjustments. 
7. Press the MODE switch once. The display will show: Refer to "Setting The Option Code" to change the option. 
8. Press the MODE switch once. The current time should be displayed with the minutes flashing. Refer to "Setting The Time And Date" to change the time and date. 
9. Push the MODE switch to return to normal operation.

### Checking the Service Check Mode



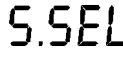
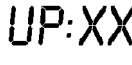

Refer to page 24 for additional information on UP Factor and PL Mode prior to setting these values.

#### Setting "UP:XX"

1. Press and hold the LIGHT/INC and MODE switches. The display will show: 
2. Press and hold the LIGHT/INC and TOTAL/SFT switches. The display will show: 
3. Press the CAL/CLR switch once. The display will show: 
4. Press the LIGHT/INC switch until "XX" is set to the desired gain ( $\pm 9\%$ ).
5. Press MODE. The display will show: 
6. Press MODE and the meter will return to normal operation.

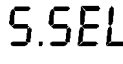
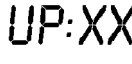
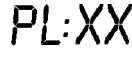
#### Setting "PL:00"

1. Press and hold the LIGHT/INC and MODE switches. The display will show: 
2. Press and hold the LIGHT/INC and TOTAL/SFT switches. The display will show: 
3. Press the CAL/CLR switch once. The display will show: 
4. Press the CAL/CLR switch once. The display will show: 
5. Press the LIGHT/INC switch until "PL:00" is displayed. **ONLY "PL:00" IS RECOMMENDED.** 
6. Press the MODE switch. The display will show: 
7. Press MODE and the meter will return to normal operation.

### Checking the $G_t$ setting:

Refer to "Checking the Gain" and "Adjusting the Gain" for display and adjustment information.

### Checking the Inclinometer Settings

Refer to "Viewing Payload Calculation Inputs" for instructions on displaying truck pitch angle. With an empty truck on level ground and suspensions properly charged, the display should indicate  $0.0 \pm 1.0$ . Remember, this is not a live display. After adjustment, Service Check Mode must be entered again to obtain a new reading.

An alternative method is to use a personal computer running the Komatsu Payload Download Program for Microsoft Windows. The "Monitor Pressures" section of the program displays live inclinometer data. The inclinometer can be loosened and adjusted until the live display shows  $0.0 \pm 1.0$  degrees with an empty truck on level ground, and the suspensions properly charged.

Another method is to use a voltmeter to read the voltage output of the inclinometer. With an empty truck on level ground, and the suspensions properly charged, the output voltage should be  $2.6 \pm 0.1$  volts.

### Calibrating a Truck

This procedure causes the PLM II™ to calculate a new empty 'tare' (calibration) weight (refer to "Viewing Payload Calculation Inputs) for use with all subsequent payload estimates. Before calibrating, confirm the truck nose up produces a positive incline.

The payload meter should be calibrated whenever one of the following occurs:

1. When a new payload meter is installed.
2. When a suspension sensor has been changed.
3. Whenever the suspensions have been serviced or the Nitrogen levels have changed.
4. Whenever any major change to the truck has been performed that would change the empty vehicle weight.
5. Once a month thereafter.

To calibrate the payload meter:

1. With the engine running and the truck stopped, press and hold the CAL/CLR switch until "CAL" is flashing on the display.
2. Drive the truck until the speed is approximately 6-10 MPH (10-15 Km/H)
3. Press the CAL/CLR switch once.
4. Drive until the display switches back to the time of day. This will take up to 30 seconds.



- >Carry out this operation on flat level ground.
- >Travel in a straight line.
- >Maintain a steady speed, 6-10 MPH (10-15 Km/H)

5. The payload meter is now calibrated and ready for normal operation.

## DISPLAYS AT START-UP

### POWER ON:

All external display lamps (Figure 6-2) will come on and stay on for approximately 27 seconds during the "Power-up Process".

The "Power-up Process" will display the PLM II™ settings. Each display will occur for approximately 3 seconds:

1. The display will show:

88:88

In addition, a buzzer will sound and the following lamps will light for 3 seconds:

- Reception Pilot Lamp (2, Figure 6-1)
- Transmission Pilot Lamp (3, Figure 6-1)
- Memory Card Pilot Lamp (4, Figure 6-1)

2. The display will show:

CO:XX

The "xx" indicates the Truck Model. Refer to "Initial Setup of Payload Meter" for code definitions.

3. The display will show:

Cd: - -  
Cd: 00

This display indicates the status of the Memory Card where:

"Cd : - -" indicates Card Not Used, and  
"Cd : 00" indicates Card Is Used.

4. The display will show:

CL: - -  
CL: 00

This display indicates the status of the Inclinometer for the PLM II™, where

"CL : - -" indicates Inclinometer Not Used, and  
"CL : 00" indicates Inclinometer Is Used.

5. The display will show:

US: - -  
US: 00

This display indicates method of measurement where:

"US : - -" indicates METRIC Tons.  
"US : 00" indicates U.S. Tons.

6. The display will show:

SU: - -  
SU: 00

This function is not used.

"SU : - -" indicates Switch 8 is up.  
"SU : 00" indicates Switch 8 is down.

7. The display will show:

d.XXX

This display indicates the Machine ID code where "xxx" indicates a value between 0 and 200.

8. The display will show:

o.XXX

This display indicates the Operator ID code where "xxx" indicates a value between 0 and 200.

9. The display will show:

SP:XX

This display indicates the Speed Limit setting where "xx" indicates a value between 0 and 99 km/h.

10. The display will show:

OP:XX

This display indicates the Option code setting.

Refer to "Operator Check Mode, Setting the Option Code" and to "Method of Operation" for more information on this function.

## NORMAL OPERATION

If the truck engine is started before the preceding "Power-up Process" is completed, the display will shift to normal operation.

If the engine is running when the payload meter starts up, only "o:XXX" and "d:XXX" will display before switching to normal operations.





## SETUP AND MAINTENANCE

### Speed Limit





A warning can be displayed if the machine exceeds a preset speed.

The available range is: 10 - 99 km/h (6 - 62 mph). It is recommended to set the speed limit to 99 km/h (62 mph).

### Setting The Speed Limit

1. Press and hold the MODE switch until "Cd:dP" is flashing. 
2. Press the MODE switch once. The display will show: 
3. Press the MODE switch once. The display will show: 
4. Press the MODE switch repeatedly until "SP:XX" is displayed. 
5. Press the LIGHT/INC switch to change the "unit digit" to the desired number.
6. Press the TOTAL/SFT switch and the display will then indicate: 
7. Press the LIGHT/INC switch to change the "tens digit" to the desired number.
8. Press MODE switch to return to normal operation.

### Setting the Option Code





1. Press and hold the MODE switch until "Cd:dP" is displayed. 
2. Press the MODE switch once. The display will show: 
3. Press the MODE switch once. The display will show: 
4. Press the MODE switch repeatedly until "OP:XX" is displayed. 
5. Press the LIGHT/INC switch to change the "unit digit" to the desired number.
6. Press the TOTAL/SFT switch and the display will then indicate: 
7. Press the LIGHT/INC switch to change the "tens digit" to the desired number.
8. Press the MODE switch to return to normal operation.
9. The Option Code selects the PLM II <sup>TM</sup> communication mode as follows:

Option Code	COMMUNICATION MODE
0	Stand Alone
10	PMC Mode (530M/HD1500 only)
12	Modular Mining Mode, Scoreboard and User Data Communication Mode



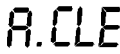

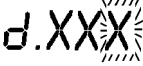
### NOTES:

1. The Option Code is set to "0" for trucks not equipped with Modular Mining System (MMS) (Except 530M/HD1500).
2. The 530M/HD1500 with Powertrain Management Control (PMC) system uses "10" as the setting for the Option Code.
3. For trucks with Modular Mining System (MMS) or Scoreboard, the Option Code is "12".



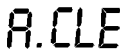

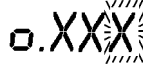

### Setting The Machine I.D. Code

1. Press and hold the MODE switch until "Cd:dP" is displayed. 
2. Press the MODE switch once. The display will show: 
3. Press the MODE switch once. The display will show: 
4. Press the MODE switch once. "d.XXX" is displayed. 
5. Press the LIGHT/INC switch to change the last digit to the desired number.
6. Press the TOTAL/SFT switch and the display will show: 
7. Press the LIGHT/INC switch to change the middle digit to the desired number.
8. Press the TOTAL/SFT switch and the display will show: 
9. Press the LIGHT/INC switch to change the first digit to the desired number.
10. Press the MODE switch to return to normal operation.

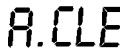
### Setting The Operator I.D. Code

1. Press and hold the MODE switch until "Cd:dP" is displayed. 
2. Press the MODE switch once. The display will show: 
3. Press the MODE switch once. The display will show: 
4. Press the MODE switch repeatedly until "o.XXX" is displayed. 
5. Press the LIGHT/INC switch to change the last digit to the desired number.
6. Press the TOTAL/SFT switch and the display will then indicate: 
7. Press the LIGHT/INC switch to change the middle digit to the desired number.
8. Press the TOTAL/SFT switch and the display will show: 
9. Press the LIGHT/INC switch to change the first digit to the desired number.
10. Press the MODE switch to return to normal operation.

### Setting The Time and Date

1. Press and hold the MODE switch until "Cd:dP" is displayed. 
2. Press the MODE switch once. The display will show: 
3. Press the MODE switch once. The display will show: 
4. Press the MODE switch repeatedly until "XX:XX" is displayed. 
5. Press the LIGHT/INC switch to change the minutes.
6. Press the TOTAL/SFT switch and the display will then indicate: 
7. Press the LIGHT/INC switch to change the hours. The clock is a 24 hour clock.
8. Press the TOTAL/SFT switch and the display will then indicate: 
9. Press the LIGHT/INC switch to change the day.
10. Press the TOTAL/SFT switch and the display will then indicate: 
11. Press the LIGHT/INC switch to change the month.
12. Press the TOTAL/SFT switch and the display will then indicate: 
13. Press the LIGHT/INC switch to change the year.
14. Press MODE switch to return to normal operation.

## DOWNLOAD OF INFORMATION



Payload information and fault codes recorded should be downloaded to a personal computer on a regular basis. The software required is available under part number AK4635. Detailed instructions for installing the software and downloading the data is provided with AK4635 PLM II <sup>TM</sup> download software.

### Data All Clear

This function will erase all of the cycle data, engine ON/OFF data, and fault/warning data. Total payload and the overall number of cycles will not be cleared.



**IMPORTANT - Before clearing the data, download the data to a personal computer.**

To begin, the shift lever should be in the "N" position, the brake lock set, the hoist control lever should be in the "FLOAT" position and the body in the down position.

1. Press and hold the MODE switch until "Cd:dP" is displayed. 
2. Press the MODE switch once. The display will show: 
3. Press and hold the CAL/CLR switch until "A.CLE" is flashing. 
4. Press the CAL/CLR switch again and the memory will be cleared. The meter will then return to normal operation.

This does not clear the Operator Load Counter.

## DISPLAY OF FAULT CODES

1. Press and hold the MODE switch until "Cd:dP" is displayed. 
2. Press the MODE switch once. The display will show: 
3. Press the MODE switch once. The display will show: 
4. Press the TOTAL/SFT switch.

If there are no faults or warnings, the display will show for 6 seconds. 

If there are current faults or warnings, the codes will be displayed in order of their priority, the highest priority first. Each code will flash for **6 seconds**.

5. After the current codes have been displayed, past history codes that have been reset will be displayed. Each code will flash for **3 seconds**.

If there are no history codes or after all history codes have been shown, the display will show for 3 seconds: 

The system will then proceed to the following displays: Refer to Page 25 for details.

- Condition of the shift selector on mechanical trucks or brake lock on electric trucks.

The panel will display: "C1:XX" for 3 seconds, then indicate:

### Mechanical trucks

"C1:oo" Shift selector is in "N".

"C1:-" Shift selector is not in "N".

### Electric trucks

"C1:oo" Brake lock is on.

"C1:-" Brake lock is off.

- Condition of the Body Up Switch signal.

The panel will display: "C2:XX" for 3 seconds, then indicate:

"C2:oo" Body up switch is in up position.

"C2:-" Body up switch is in down position.

- Condition of the Engine Oil Pressure signal.  
The panel will display ":C3:XX" for 3 seconds,  
then indicate:  
"C3:oo" Engine is running.  
"C3:- -" Engine is not running.
  - Condition of Alternator 'R' terminal signal.  
The panel will display "C4:XX" for 3 seconds,  
then indicate:  
"C4:oo" Engine is running.  
"C4:- -" Engine is not running.
  - Condition of the Spare Analog Input 1 signal.  
The panel will display "C5:XX" for 3 seconds  
with XX: as an input signal (V).
  - Condition of the Spare Analog Input 2 signal.  
The panel will display "C6:XX" for 3 seconds  
with XX: as an input signal (V).
  - Condition of the Spare Digital Input 1 signal.  
The panel will display "C7:XX" for 3 seconds,  
then:  
"C7:oo" High.  
"C7:- -" Low.
  - Condition of the Spare Digital Input 2 signal.  
The panel will display "C8:XX" for 3 seconds,  
then:  
"C8:oo" High.  
"C8:- -" Low.
6. Press the TOTAL/SFT switch to view faults  
again or press the MODE switch to return to  
normal operation.



FAULT CODES				
FAULT	CAUSE	CORRECTIVE ACTION	DECK LIGHTS	PRIORITY
b-FL Steady	Brake Lock On and Body is UP and not dumping.		Flash	1
b-FL Flashing	Brake Lock Off and Body is UP.			1
Cd Flashing	Remove memory card during download.			2
F-09	Internal battery voltage below 2.7 volts.	Open controller check internal battery and connections. Check voltage using Service Check Mode.		3
L-FUL Flashing	Less than 300 haul cycle data sets memory capacity remain.			4
L-FUL Steady	2900 Haul cycles have been stored and the oldest data is being overwritten.			4
E-FUL Flashing	Less than 10 engine start data sets memory capacity remain.			4
E-FUL Steady	115 engine start data sets have been stored and the oldest date is being overwritten.	Down load data to PC and clear memory. See Operator Check Mode; Clearing the haul cycle data memory.		4
F-FUL Flashing	Less than 10 fault data sets memory capacity remain.			4
F-FUL Steady	230 fault data sets have been stored and the oldest date is being overwritten.			4
H-FUL Flashing	Haul cycle counter or payload totalizer are near capacity.			
H-FUL Steady	Haul cycle counter exceeded 9999 or payload totalizer exceeded 999900.	Press TOTAL/SFT to display totals, then press CAL/CLR for at least 2 seconds, then press CAL/CLR again for at least 2 seconds.		4
F-18	Battery alternator R terminal is shorted or disconnected. The input to the PLM is less than 2V.	Trouble shoot wiring. Pin CN1-9, circuit # 21D.		5
F-20 Flashing	Sensor power is less than 15V or over 20V (18V normal).	Trouble shoot wiring, possible short.	Flash	6
F-21 Flashing	Left front pressure signal is less than 1V (1 - 5V normal).		Flash	7
F-22 Flashing	Right front pressure signal is less than 1V (1 - 5V normal).		Flash	8
F-23 Flashing	Left rear pressure signal is less than 1V (1 - 5V normal).		Flash	9
F-24 Flashing	Right rear pressure signal is less than 1V (1 - 5V normal).		Flash	10

FAULT CODES			
FAULT	CAUSE	CORRECTIVE ACTION	DECK LIGHTS PRIORITY
F-25 Flashing	Left front pressure signal is greater than 5V (1 - 5V normal).	Trouble shoot wiring, likely sensor wires are shorted together.	Flash 11
F-26 Flashing	Right front pressure signal is greater than 5V (1 - 5V normal).		Flash 12
F-27 Flashing	Left rear pressure signal is greater than 5V (1 - 5V normal).		Flash 13
F-28 Flashing	Right rear pressure signal is greater than 5V (1 - 5V normal).		Flash 14
F-31 Flashing	Inclinometer input less than 1.57V (more than + 10 degrees, nose up).	Trouble shoot wiring, likely an open circuit (Inclinometer output is 2.6V when horizontal, calibration: -103mV/degree)	Flash 15
F-32 Flashing	Inclinometer input greater than 3.63V (more than - 10 degrees, nose down).	Trouble shoot wiring, likely sensor wires are shorted together.	Flash 16
F.CAL	No calibration has been performed or cal data has been cleared.	Perform calibration.	Flash 17
F-41 Flashing	Light relay #1 driver short circuit.	Trouble shoot wiring, relay coil likely shorted.	Flash 18
F-42 Flashing	Light relay #2 driver short circuit.		Flash 19
F-43 Flashing	Light relay #3 driver short circuit.		Flash 20
F-44 Flashing	Light relay #4 driver short circuit.		Flash 21
F-45 Flashing	Light relay #5 driver short circuit.		Flash 22
L.bad Flashing	Payload measured while chassis is pitching.	Data ignored, error will clear for next load.	Flash 23
SP:SP Flashing	Speed limit setting is being exceeded.	Set the speed limit, using Operator Check Mode, to 62 mph or 99Km/h depending on the position of the unit selection switch (switch #7 behind the left side panel).	Flash 24
F-71 F-73 F-80 F-81 F-91 F-92 F-93 F-94 F-95 F-96 F-97 F-98 All Flashing	Communications port error.	Check communication wiring (RS-232) to Modular Mining Hub or to Scoreboard. Check OP setting.	Flash 25

### Monitoring Input Signals

This procedure can be used to monitor the current input signals to the payload meter.

1. Press and hold the LIGHT/INC and MODE switches until "CHEC" is flashing.
2. Press and hold the CAL/CLR and TOTAL/SFT switches until "S.CHE" is flashing.
3. Press the CAL/CLR switch to cycle through the following information :

C1	Mechanical Trucks	C1:00 - Shift Selector in "N" C1:-- - Shift Selector not in "N"
C1	Electric Trucks	C1:00 - Brake Lock On C1:-- - Brake Lock Off
C2	Body Up	C2:00 - Body Down C2:-- - Body Up
C3	Engine Oil Pressure	C3:00 - Engine Run C3:-- - Engine Stopped
C4	Alternator R Terminal	C4:00 -Alternator Charging C4:-- - Alternator Stopped
C5	Analog 1 - Not Used	
C6	Analog 2 - Not Used	
C7	Digital 1 - Not Used	
C8	Digital 2 - Not Used	
C9	Speed	Vehicle Speed
C10	Travel Distance - under the current loaded or empty state	xx.xx Miles
C11	<u>Current Status</u> <i>Note: Sample values are shown.</i>	03:01 - Empty Stopped 01:02 - Empty Traveling 06:03 - Loading 02:04 - Loaded Traveling 04:05 - Loaded Stopped 05:06 - Dumping
C12a*	Time Empty Travel	S1:xx - Minutes*10
C12b	Time Empty Stopped	S2:xx - Minutes*10
C12c	Time Loaded Travel	S3:xx - Minutes*10
C12d	Time Loaded Stop	S4:xx - Minutes*10

\* After 9.9 minutes, "S1:--" will be displayed.

4. Press the MODE switch once and "CHEC" will flash.
5. Press the MODE switch once and the meter will return to normal operation.

### Service Check Mode

1. Press and hold the LIGHT/INC and MODE switches until "CHEC" is flashing.
2. Press and hold the LIGHT/INC switch until "ALL0" is flashing. "A.FUL" may also be displayed.
3. Press the LIGHT/INC switch to cycle through the following data. The sequence repeats.

Item and Description	Units
1. Current Time	Hours: Minutes
2. Pressure Front Left	Psi
3. Pressure Front Right	Psi
4. Pressure Rear Left	Psi
5. Pressure Rear Right	Psi
6. Front Weight	Tons
7. Rear Weight	Tons
8. Degree of Incline	±° Nose Up Positive
9. Incline Factor - Front Axle	
10. Incline Factor - Rear Axle	
11. Link Factor - Front Axle	
12. Link Factor - Rear Axle	
13. Calibration Weight	Tons
14. G <sub>t</sub> Gain	
15. Current Load	Tons
16. Backup Battery Voltage	Volts

4. Press MODE once and "CHEC" will flash on the display.
5. Press MODE once and the meter will return to normal operation.

## UP Factor - Payload Calculation Gain

### Description of UP Factor

The payload calculation gain, or UP factor is multiplied to the actual calculated load. From the example shown in Figure 6-4, the calculated load is 143.8 tons. If the UP factor is set to +5% the displayed load will be  $143.8 \times 1.05 = 151$  tons. This factor can be used to minimize the effects of systematic error for a particular truck. The UP factor is not applied uniformly to all load calculations. There are three operating modes for the payload meter and the UP factor is applied differently to each mode. Therefore, it is recommended that this percentage be set to 0. There are significant differences in final calculated load that can be introduced by adjusting this gain.



***Payload meters sent from the factory are typically set to "UP: 5" indicating a +5% gain in final load. This should be checked on all new meters and changed to "UP: 0".***

## PL Mode - Load Calculation Timing

### Load Calculation Timing

The PL mode controls when the payload meter takes a sample of the data and calculates the load. There are three modes available. There are two sets of data that are affected by the PL mode setting.

- Modular Mining Transmission
- Memory Storage

The PL mode setting can have a significant impact on the perceived accuracy of the payload meter.

PL:00 is the only recommended setting.



***Use of settings other than PL:00 is NOT recommended.***

Careful consideration must be given to the use of PL:01 and PL:10. These modes divide the data transmitted by Modular Mining and the data stored in the payload meter's memory. Additionally, each mode handles the UP factor differently and can calculate different loads for the same haul cycle. For these reasons **it is recommended that the payload meter be set to use PL:00 in all cases.**

### PL:00

**Modular Mining Transmission** - The data is captured at the last transition from 0 to 1 MPH prior to traveling 160 meters from the shovel. The captured data is transmitted when the truck travels 160m from the shovel. This load calculation **will use** the UP factor percentage.

**Memory Storage** - Same as above, the data is captured at the last transition from 0 to 1 MPH prior to traveling 160 meters from the shovel. The captured data is stored into memory when the body rises at the dump. This load calculation **will use** the UP factor percentage.

### PL:01

**Modular Mining Transmission** - The data is captured at the last transition from 0 to 1 MPH prior to traveling 160 meters from the shovel. The captured data is transmitted when the truck travels 160m from the shovel. This load calculation **will use** the UP factor percentage.

**Memory Storage** - The data is captured and stored when the body rises from the frame. This calculation **will not use** the UP factor percentage.

### PL:10

**Modular Mining Transmission** - The data is captured and transmitted when the truck travels 160 meters from the shovel. This calculation **will not use** the UP factor percentage.

**Memory Storage** - The data is captured and stored when the body rises from the frame. This calculation **will not use** the UP factor percentage.

## FINAL GEAR RATIO SELECTION

For an 830E truck, the proper gear ratio has to be selected.

1. Press and hold the MODE and LIGHT/INC switches until "CHEC" is displayed. **CHEC**
2. Press and hold the TOTAL/SFT and LIGHT/INC switches until "S.SEL" is displayed. **S.SEL**
3. Press the CAL/CLR switch repeatedly until "A.XX" is displayed, where "XX" is one of the following: **A.XX**

"XX"	Gear Ratio	Remarks
00	31.875	Original
01	36.400	High Traction
02	28.125	Standard
03	26.625	High Speed

*NOTE: The Payload Meter is originally set to "00".*

4. Press the TOTAL/SFT switch and "XX" will flash.
5. Press the LIGHT/INC switch to select the desired gear ratio.
6. Press the MODE switch and "CHEC" will be displayed. **CHEC**
7. Press the MODE switch and the meter will return to normal operation.

## BATTERY REPLACEMENT PROCEDURE ERROR CODE, F-09, DISPLAYED

### Replacing the Battery

The payload meter has an internal battery used to protect the memory from being erased when the key switch is turned to the OFF position. Battery life is approximately 2 years. The capacity of the battery is monitored by the payload meter. When the voltage of the memory battery drops, error code, F-09, will be displayed.

When the F-09 error code appears, download the data within 48 hours; otherwise, the data may be lost. The haul cycle data may not be recorded properly while F-09 is displayed.

At this time it will be necessary to replace the battery. This should be performed when the truck is in an unloaded condition. The data stored in the payload meter should be downloaded to a personal computer or carry out the memory card dump operation. If this is not done, when the battery is disconnected all data will be lost.

All that is required is a phillips-head screwdriver and a new battery (P/N 581-86-55710)

1. With the keyswitch in the ON position, download the data stored in the payload memory, or perform the memory card dump operation.
2. Turn the keyswitch to the OFF position.
3. Remove the four mounting screws holding the payload meter in position and then pull the payload meter out, away from the instrument panel (Figure 6-7).

**NOTICE** - Use care not to let dirt, metal or spare parts to drop inside the controller at any time.

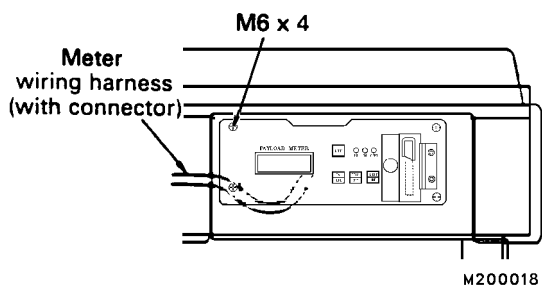

FIGURE 3-7. REMOVING PAYLOAD METER

4. Remove the electrical connector. Remove the screws on the top surface and the rear face.

Remove the cover (Figure 6-8). This will expose the battery, its wires, and the connector.

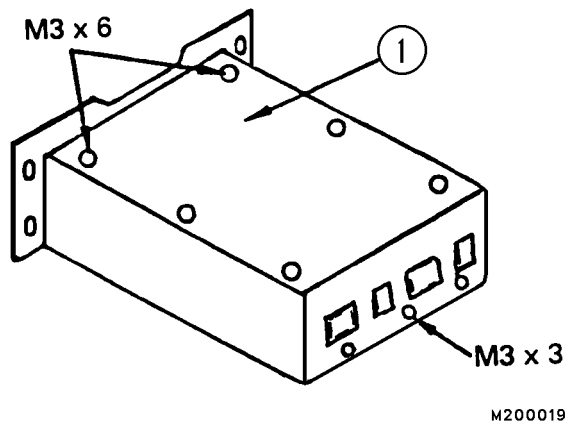

FIGURE 3-8. ACCESS TO BATTERY

5. Grasp the wires coming from the battery and pull outward. By pulling perpendicular from the board, it will disconnect the connector from the board and pull the battery out of its holder simultaneously (Figure 6-9).

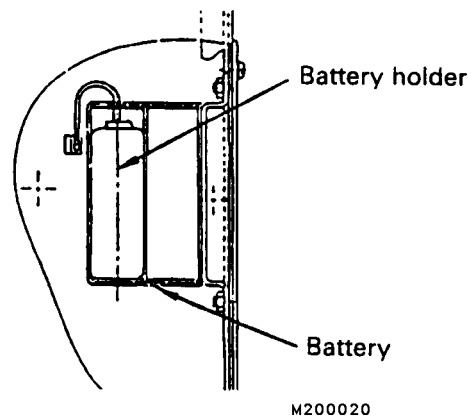

FIGURE 3-9. BATTERY INSTALLATION

6. Insert the connector of the new battery directly into the connector on the board (Figure 6-10). Place the battery in the battery holder, and pass the wiring through the notch. When doing this, insert the wiring into the bottom of the holder and pass it through the notch.
7. Install the controller cover, replace the electrical connector, and install the payload meter controller back into the instrument panel.

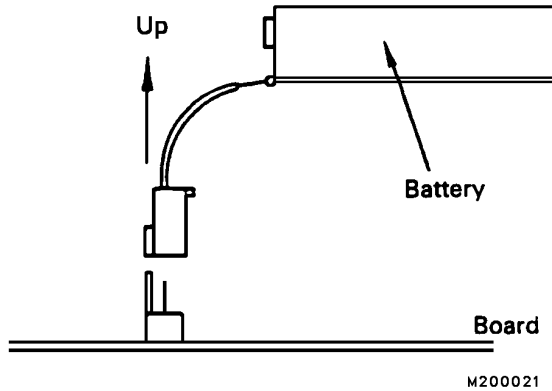

FIGURE 3-10. BATTERY CONNECTION

### After Replacing the Battery

While replacing the battery, the backup power source for the memory inside the payload meter is momentarily disconnected. This can allow unwanted data (garbage) to enter the memory and affect the meter's recognition procedures. The following will remove this unwanted data.

1. Turn the keyswitch to the ON position.

**F-CAL** may flash.

2. Using the Operator Check Mode, set the speed limit option code, time and date. (These were erased from memory when the battery was disconnected).
3. Without turning the keyswitch to the OFF position advance to the start position. With the engine running, the display:

**F-CAL** may flash.

4. Perform the calibration procedure. Refer to "Calibrating a Truck".
5. Load the truck to the rated payload, or close to it. Dump the load.
6. Move the truck to a safe area, wait at least 5 seconds after dumping the load, then shut the truck down.
7. Turn the keyswitch back to the ON position but do not start the engine.
8. Perform the Data All Clear in the Operator Check mode.
9. Forcibly clear the data for the total payload and overall number of cycles. With this operation performed, all the unwanted data inside the payload meter is cleared. Except for the calibration data, all the data recorded in the previous steps is also erased.
10. After this procedure has been performed the system is ready for normal function.

## SUSPENSION PRESSURE SENSOR

The pressure sensors are mounted on top of each suspension cylinder. The sensors produce a voltage signal from 1 - 5 volts output.

The pressure sensor is mounted to the suspension cylinder using a Schrader Valve assembly, adapter and sensor. The sensor can be replaced without releasing the pressure in the suspension by removing the sensor with the adapter.

### Removal



**Ensure the adapter and sensor are removed together from the valve assembly. Removing the complete valve assembly or just the sensor may result in the component being forced out of the suspension by the gas pressure inside.**

1. Disconnect sensor from truck wiring harness.

*Note: The Schrader valve in the valve assembly will prevent gas from escaping **when adapter and sensor are removed together**. If entire valve assembly is turned allowing nitrogen gas to escape, recharging of the suspension will be required.*

2. Hold valve (2, Figure 6-11) with wrench while removing the adapter/sensor assembly (3 & 4).
3. Remove sensor (4) from adapter (3).

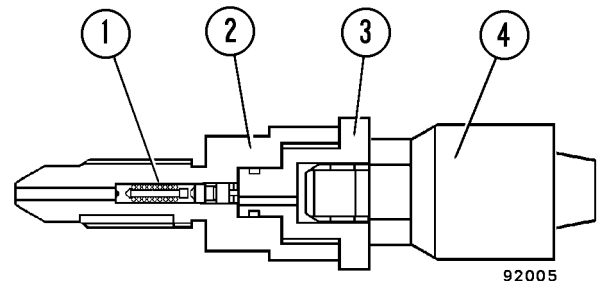

FIGURE 3-11. PRESSURE SENSOR

- |                   |            |
|-------------------|------------|
| 1. Schrader Valve | 3. Adapter |
| 2. Valve Assembly | 4. Sensor  |

### Installation

1. Install a new O-ring onto sensor (4, Figure 6-11) and install sensor onto adapter (3). Tighten the sensor to **22-29 ft.lbs. (30-39 N.m)** torque.
2. Install a new O-ring onto adapter (3) and install complete adapter/sensor assembly onto valve (2). Hold the valve body and tighten adapter/sensor assembly to **103 ft.lbs. (176 N.m)** torque.
3. Connect the sensor wiring to the truck wiring harness. The sensors have three wires. Be sure that wires are connected correctly. (Figure 6-12)

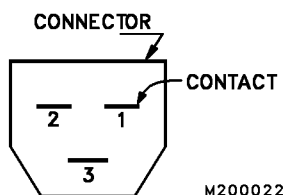

FIGURE 3-12. SENSOR SIDE CONNECTOR VIEW

Pin Number	Wire Color	Wire Function
1	Black	Ground (GND)
2	Red	+ Power
3	White	Signal

### INCLINOMETER

As the truck is tilted fore or aft, the weight distribution between the front and rear axles changes. To compensate for this, the inclinometer measures the ground angle at which the truck rests. This data is then sent to the payload meter so it can calculate the correct payload weight. The inclinometer is located below the operator's center console (passenger seat structure).

#### Removal

1. Disconnect inclinometer wire lead from harness.
2. Remove the three capscrews, nuts and lockwashers (4, Figure 6-13) and inclinometer (3).

### Installation

1. Install inclinometer (3, Figure 6-13) with cap-screws, nuts and lockwashers (4).

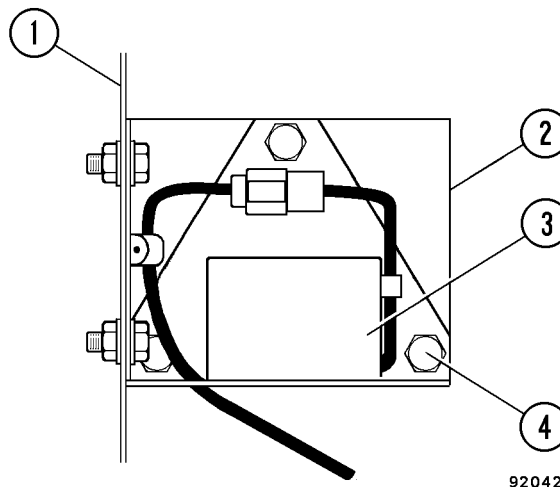

FIGURE 3-13. INCLINOMETER

- |                                    |                                 |
|------------------------------------|---------------------------------|
| 1. Operator's Center Console Frame | 3. Inclinometer                 |
| 2. Bracket                         | 4. Capscrew, Nut and Lockwasher |

2. Connect inclinometer wiring to the truck wiring harness. (Figure 6-14) Be sure that wires are connected correctly.

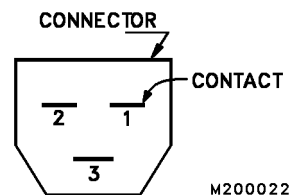

FIGURE 3-14. INCLINOMETER SIDE CONNECTOR VIEW

Pin Number	Wire Color	Wire Function
1	Black	Ground (GND)
2	Red	+ Power
3	White	Signal

#### Adjustment

1. Park the truck on a 0% grade.
2. Loosen the three inclinometer mounting cap-screws (4, Figure 6-13) and rotate the inclinometer until a voltage range of  $2.6 \pm 0.1$  volts can be measured (using a volt-meter) at pins 1 and 2 of the inclinometer electrical harness connector.
3. Tighten all capscrews (4, Figure 6-13) to standard torque, after the adjustment.



### PAYLOAD METER BACK PANEL

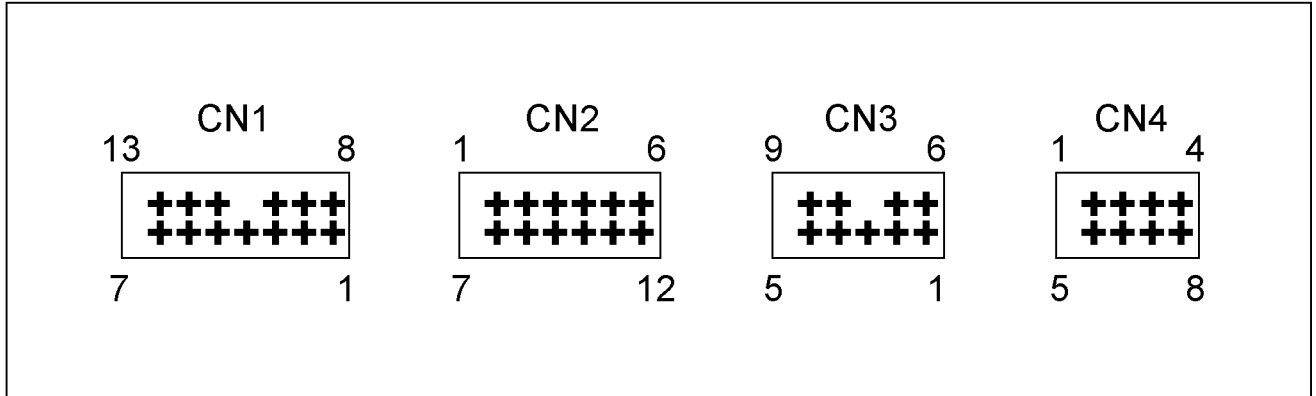

## CONNECTIONS

<b>CN1 - AMP MIC-MKII 13 Pins White Connector</b>		
No.	Description	Comments
1	Power +24V (Battery)	
2	Lamp Relay 1	
3	Lamp Relay 2	
4	Lamp Relay 3	
5	Lamp Relay 4	
6	Lamp Relay 5	
7	Speed Sensor (Signal)	
8	Speed Sensor (GND)	
9	Alternator R Terminal (Charge Signal)	Running - 28VDC Off - 0VDC
10	Key Switch ACC Terminal (ACC Signal)	
11		
12		
13	GND (Power GND)	

<b>CN3 - AMP MIC-MKII 9 Pins White (RS-232C Port)</b>	
No.	Description
1	RTS
2	SG
3	RD
4	TX
5	CTS
6	DTR
7	DSR
8	

<b>CN2 - AMP 040 12 Pins Black Connector</b>		
No.	Description	Comments
1	Engine Oil Pressure Switch	Running Open Off - Closed
2	Sensor Power Out	+18V
3	Sensor GND	
4	Left Front Suspension Pressure Sensor	1-5VDC Normal
5	Right Front Suspension Pressure Sensor	1-5VDC Normal
6	Left Rear Suspension Pressure Sensor	1-5VDC Normal
7	Right Rear Suspension Pressure Sensor	1-5VDC Normal
8	Inclinometer	
9	Body Rise Signal	Body Down - Open Body Up - Gnd
10	Brake Lock Signal/Neutral Signal	Lock Off - Open Lock On - Gnd
11		
12		

<b>CN4 - AMP 040 8 Pins Black (Optional Input, Reserved)</b>	
No.	Description
1	Optional Input GND
2	Analog Input 1
3	Analog Input 2
4	Digital Input 1
5	Digital Input 2
6	
7	

## PAYLOAD METER 2 RE-INITIALIZATION PROCEDURE

**This procedure is designed to reset the Payload Meter 2 to clear repeated F.CAL errors.**

This procedure is necessary to fix a rare condition in the operation of the meter. Indication for this procedure is a repeated display of F.CAL on the meter despite repeated calibration. If possible, download the payload meter before performing this procedure. This procedure will erase all memory and user settings.



***This procedure should be performed before any payload meter is returned for warranty or repair.***

Before performing this procedure, be sure that the engine inputs into the payload meter can be manipulated to indicate engine running and engine stopped. Some payload meter installations have hard-wired these inputs. These inputs must be accessible and able to produce the following input conditions:

Condition	21C Engine Oil Pressure	21D Alternator "R" Terminal
Engine Running	Open	24VDC
Engine Stopped	Ground	Open

1. Turn off all systems.
2. Turn on the Payload Meter but leave the engine off.
3. Hold MODE and LIGHT until "CHEC" flashes.
4. Hold the CAL, TOTAL and LIGHT buttons until "00:00" is displayed.
5. Press CAL for 2 seconds. "00 00" will flash and the meter will erase its memory and reset to its factory settings. This includes OP, UP, PL, P.SEL, and E.SEL settings. The meter will restart and display "F.CAL".

6. Start the engine.
7. Set the time, date, OP, PL, and UP settings. All other user settings should be updated at this time.
8. Calibrate the payload meter by holding the CAL button until CAL flashes.
9. Release the brake lock (park brake for 330M/HD785), begin driving 5-8 MPH on level ground, and press CAL. CAL should display until the meter finishes its calibration.
10. Load the truck to rated load and drive through one haul cycle.
11. After dumping the load, wait at least 15 seconds and drive the truck to a safe location.
12. Stop the truck and shut down the engine.
13. Turn on the payload meter but leave the engine off.
14. Hold MODE and LIGHT until "CHEC" flashes.
15. Hold LIGHT and CAL until "A:CLE" flashes.
16. Press CAL to clear the service memory.
17. When "CHEC" is displayed, press MODE to return to normal operation.
18. Clear the haul cycle memory by holding MODE until "Cd:dP" is displayed.
19. Press MODE and "A.CLE" will be displayed.
20. Hold CAL until "A.CLE" flashed.
21. Press CAL once more to clear the haul cycle memory.
22. Clear the operator load counter by pressing the TOTAL button until ":" is displayed.
23. Hold the CAL button until the display flashes.
24. Hold the CAL button until "0000" is displayed to clear the memory.
25. The payload meter should now function normally.

## PAYLOAD CIRCUIT NUMBERS

Circuit Designation	Circuit Description
39F, 39F1...39F5	+18 volt sensor power supply
39FA	Pressure signal Right Rear
39FB	Pressure signal Left Rear
39FC	Pressure signal Right Front
39FD	Pressure signal Left Front
39FE	Inclinometer signal
39FG	Sensor ground
39A	PLM lamp output - green
39B	PLM lamp output - amber
39C	PLM lamp output - red
39D	PLM lamp output - unused
39E	PLM lamp output - unused
39G	+24 volt PLM power
39AA	Load light - green
39BA	Load light - amber
39CA	Load light - red
73FSL	TCI 100% load signal - 930E only
73MSL	TCI 70% load signal - 930E only
714A	Speed signal
714AT	Speed signal
63L	Body up (gnd = up, open = down)
39H	Brake lock (gnd = release, open = lock)
35L1	PLM RS232 RTS (request to send)
35L2	PLM RS232 signal ground
35L3	PLM RS232 receive
35L4	PLM RS232 transmit
35L5	PLM RS232 CTS (clear to send)
35L6	
35L7/35L4	Scoreboard 1 to scoreboard 2
35L8	PLM chan 2 TxD
35L9	PLM chan 2 RxD
21C	Engine oil pressure (gnd = off, open = run)
21D	Alternator R-Terminal (open = off, +24V = run)



**KOMATSU**®

[www.komatsuamerica.com](http://www.komatsuamerica.com)