

CEAM010703

# Operation & Maintenance Manual

# HD1500-5

**DUMP TRUCK**

SERIAL NUMBERS **A30049-A30069**

**KOMATSU**<sup>®</sup>





*Unsafe use of this machine may cause serious injury or death. Operators and maintenance personnel must read and understand this manual before operating or maintaining this machine.*

*This manual should be kept in or near the machine for reference, and periodically reviewed by all personnel who will come into contact with it.*

This material is proprietary to Komatsu America Corp (KAC), and is not to be reproduced, used, or disclosed except in accordance with written authorization from KAC.

It is the policy of the Company to improve products whenever it is possible and practical to do so. The Company reserves the right to make changes or add improvements at any time without incurring any obligation to install such changes on products sold previously.

Because of continuous research and development, periodic revisions may be made to this publication. Customers should contact their local Komatsu distributor for information on the latest revision.

### **CALIFORNIA**

#### **Proposition 65 Warning**

*Diesel engine exhaust, some of its constituents, and certain vehicle components contain or emit chemicals known to the State of California to cause cancer, birth defects or other reproductive harm.*

### **CALIFORNIA**

#### **Proposition 65 Warning**

*Battery posts, terminals and related accessories contain lead and lead compounds, chemicals known to the State of California to cause cancer and birth defects or other reproductive harm. Wash hands after handling.*



### **NON-OEM PARTS IN CRITICAL SYSTEMS**

***For safety reasons, Komatsu America Corp. strongly recommends against the use of non-OEM replacement parts in critical systems of all Komatsu equipment. Critical systems include but are not limited to steering, braking and operator safety systems.***

***Replacement parts manufactured and supplied by unauthorized sources may not be designed, manufactured or assembled to Komatsu's design specifications; accordingly, use of such parts may compromise the safe operation of Komatsu products and place the operator and others in danger should the part fail.***

***Komatsu is also aware of repair companies that will rework or modify an OEM part for reuse in critical systems. Komatsu does not generally authorize such repairs or modifications for the same reasons as noted above.***

***Use of non-OEM parts places full responsibility for the safe performance of the Komatsu product on the supplier and user. Komatsu will not in any case accept responsibility for the failure or performance of non-OEM parts in its products, including any damages or personal injury resulting from such use.***

## FOREWORD

This manual is written for use by the operator and/or the service technician and is designed to help these persons to become fully knowledgeable of the truck and all its systems in order to keep it operating safely and efficiently.

All operators and maintenance personnel must understand the content in this manual before operating, maintaining or performing operational checks on the truck. All safety notices, warnings and cautions must be understood before operating or repairing the truck.

The first section is an introduction to the manual and contains a table of contents to locate specific areas of interest. Other sections include Safety, Operation, Maintenance, Specifications, and Optional Equipment.

This manual shows dimensioning of metric and (U.S. standard) units throughout. All references to right, left, front, or rear are made with respect to the operator's normal seated position, unless specifically stated otherwise.

Standard torque requirements are shown in torque charts in the Introduction section and individual torques are provided in the text in bold face type, such as **135 N·m (100 ft lbs)**. All torque specifications have  $\pm 10\%$  tolerance unless otherwise specified.

The illustrations used in this manual are typical of the component shown and may not be an exact reproduction of what is found on the truck.

A product identification plate is located on the frame in front of the right side front wheel and designates the truck model number, product identification number (vehicle serial number), and maximum Gross Vehicle Weight (GVW) rating.

The product identification number (vehicle serial number) contains information which will identify the original manufacturing bill of material for this unit. This complete number will be necessary for proper ordering of many service parts and/or warranty consideration.

The GVW is what determines the load on the drive train, frame, tires, and other components. The vehicle design and application guidelines are sensitive to the total maximum GVW. GVW is the total truck weight. This is equal to the empty vehicle weight + the fuel & lubricants + the payload.

To determine allowable payload: Service all lubricants to the proper level including the fuel tank. Weigh the empty truck. This includes all accessories, body liners, tailgates, etc. Record this value and subtract from the GVW rating. The result is the allowable payload.

*NOTE: Accumulations of mud, frozen material, etc. become a part of the GVW and reduces allowable payload. To maximize payload and to keep from exceeding the GVW rating, these accumulations must be removed as often as practical.*



***Exceeding the allowable payload will reduce expected life of truck components.***

### **▲WARNING**

**Unsafe use of this machine may cause serious injury or death. Operators and maintenance personnel must read this manual before operating or maintaining this machine. This manual should be kept in or near the machine for reference and periodically reviewed by all personnel who come in contact with it.**

## ALERTS PAGE



*This “ALERT” symbol is used with the signal words, “CAUTION”, “DANGER”, and “WARNING” in this manual to alert the reader to hazards arising from improper operating and maintenance practices.*



*“DANGER” identifies a specific potential hazard  
WHICH WILL RESULT  
in either INJURY OR DEATH  
if proper precautions are not taken.*



*“WARNING” identifies a specific potential hazard  
WHICH COULD RESULT  
in either INJURY OR DEATH  
if proper precautions are not taken.*



*“CAUTION” is used for general reminders  
of proper safety practices  
OR  
to direct the reader’s attention to avoid unsafe  
or improper practices which may result  
in damage to the equipment.*

## TABLE OF CONTENTS

**SUBJECT ----- SECTION / PAGE**

FOREWARD .....10-1  
 "Alerts" Page - a description of DANGER, WARNING, and CAUTION symbols. ....10-2  
 TABLE OF CONTENTS .....10-3  
     Truck Model Illustration .....10-11  
 ABOUT THIS MANUAL .....10-12

TORQUE TABLES AND CONVERSION CHARTS .....12-1

SAFETY .....20-1  
     Safety Rules .....20-1  
     Safety Features .....20-1  
     Clothing And Personal Items .....20-1  
     Unauthorized Modification .....20-1  
     Leaving The Operator's Seat .....20-1  
     Mounting And Dismounting .....20-2  
     Fire Prevention For Fuel And Oil .....20-2  
     Precautions With High Temperature Fluids .....20-2  
     Asbestos Dust Hazard Prevention .....20-3  
     Prevention Of Injury By Work Equipment .....20-3  
     Fire Extinguisher And First Aid Kit .....20-3  
     Precautions For ROPS .....20-3  
     Precautions For Attachments .....20-3  
 HAUL ROADS .....20-4  
 PRECAUTIONS DURING OPERATION .....20-4  
     BEFORE STARTING THE ENGINE .....20-4  
         Fire Prevention .....20-5  
         Preparing For Operation .....20-5  
         Ventilation In Enclosed Areas .....20-5  
         In Operator's Cab - Before Starting The Engine .....20-5  
         Mirrors, Windows, And Lights .....20-5  
     OPERATING THE MACHINE .....20-6  
         When Starting The Engine .....20-6  
         Precautions For Starting Machine .....20-6  
         Truck Operation - General .....20-6  
         Traveling .....20-7  
         Traveling In Reverse .....20-7  
         Traveling On Slopes .....20-7  
         Ensure Good Visibility .....20-7  
         Operate Carefully On Snow .....20-8  
         Avoid Damage To Dump Body .....20-8

## TABLE OF CONTENTS

<b>SUBJECT</b> .....	<b>SECTION / PAGE</b>
Driving Near High Voltage Cables .....	20-8
When Dumping .....	20-8
Working On Loose Ground .....	20-8
Loading The Body .....	20-8
Parking The Machine .....	20-8
TOWING .....	20-9
WORKING NEAR BATTERIES .....	20-9
Battery Hazard Prevention .....	20-9
Starting With Booster Cables .....	20-9
PRECAUTIONS FOR MAINTENANCE .....	20-10
BEFORE PERFORMING MAINTENANCE .....	20-10
Warning Tag .....	20-10
Proper Tools .....	20-10
Stopping The Engine Before Service .....	20-10
Securing The Dump Body .....	20-10
DURING MAINTENANCE .....	20-12
Personnel .....	20-12
Attachments .....	20-12
Working Under The Machine .....	20-12
Keep The Machine Clean .....	20-12
Rules To Follow When Adding Fuel Or Oil .....	20-12
Radiator Water Level .....	20-12
Use Of Lighting .....	20-12
Precautions With The Battery .....	20-13
Handling High Pressure Hoses .....	20-13
Precautions With High Pressure Oil .....	20-13
Precautions When Performing Maintenance Near High Temperature Or High Pressure .....	20-13
Rotating Fan And Belts .....	20-13
Waste Materials .....	20-13
TIRES .....	20-14
Handling Tires .....	20-14
Storing Tires After Removal .....	20-14
WHEN REPAIRS ARE NECESSARY .....	20-15
ADDITIONAL JOB SITE RULES .....	20-16
WARNINGS AND CAUTIONS .....	22-1



**TABLE OF CONTENTS**

<b>SUBJECT</b> .....	<b>SECTION / PAGE</b>
OPERATING INSTRUCTIONS .....	30-1
PREPARING FOR OPERATION .....	30-1
Safety Is Thinking Ahead .....	30-1
At The Truck - Ground Level Walk Around Inspection .....	30-1
ENGINE START-UP SAFETY PRACTICES .....	30-4
EMERGENCY STEERING SYSTEM .....	30-5
Operation .....	30-5
Pre-Operation Testing .....	30-5
AFTER THE ENGINE HAS STARTED .....	30-6
MACHINE OPERATION SAFETY PRECAUTIONS .....	30-9
LOADING .....	30-9
HAULING .....	30-10
RETARDER OPERATION .....	30-10
PASSING .....	30-11
DUMPING .....	30-11
Raising the Dump Body .....	30-12
Lowering The Dump Body .....	30-13
SAFE PARKING .....	30-13
SHUTDOWN PROCEDURE .....	30-13
SUDDEN LOSS OF ENGINE POWER .....	30-14
Emergency Steering And Braking .....	30-14
DISABLED TRUCK DUMPING .....	30-14
Hookup .....	30-14
Raising the Body .....	30-14
Lowering the Body .....	30-15
DISABLED TRUCK STEERING AND BRAKING .....	30-16
TOWING .....	30-18
OPERATOR CAB AND CONTROLS .....	32-1
STEERING WHEEL AND CONTROLS .....	32-2
Horn Button .....	32-2
Telescope Lock Ring .....	32-2
Tilt Wheel Lever .....	32-2
Turn Signal / Headlight Dimmer .....	32-2
Windshield Wiper / Washer Control .....	32-3
RETARDER CONTROL LEVER .....	32-3
SERVICE BRAKE PEDAL .....	32-3
ACCELERATOR (THROTTLE) PEDAL .....	32-4
INSTRUMENT PANEL .....	32-4
HEATER / AIR CONDITIONER COMPARTMENT AND CONTROLS .....	32-4
Defroster Vent Control Switch .....	32-4

## TABLE OF CONTENTS

SUBJECT -----	SECTION / PAGE
Outside/Inside Air Control Switch .....	32-4
Heat Vent Control Switch .....	32-4
Fan Control Knob .....	32-4
Temperature Control Knob .....	32-5
Air Conditioner Control Switch .....	32-5
Heater/Air Conditioner Vents .....	32-5
RETARDING CAPACITY CHART .....	32-5
Radio Speakers .....	32-6
MOM Display Screen .....	32-6
MOM Dimmer Switch .....	32-6
Warning Alarm Buzzer .....	32-6
Cab Radio .....	32-6
PMC Interface Connector .....	32-6
Air Cleaner Vacuum Gauges .....	32-6
Payload Meter .....	32-6
Windshield Wipers .....	32-6
CENTER CONSOLE .....	32-7
Transmission Range Selector .....	32-8
Control Switches .....	32-9
Shift Limiter Switch .....	32-9
F1 Start Switch .....	32-9
Hoist Control Lever .....	32-9
Parking Brake Switch .....	32-9
Brake Lock Switch .....	32-10
LH Window Control Switch .....	32-10
RH Window Control Switch .....	32-10
Ash Tray .....	32-10
Lighter .....	32-10
Passenger Seat w/Safety Belt .....	32-10
OPERATOR SEAT .....	32-10
Adjustment .....	32-11
INSTRUMENT PANEL AND INDICATORS .....	32-12
Keyswitch .....	32-13
Auxiliary Brake Switch .....	32-13
RH Control/Indicator Panel (Pod) .....	32-14
Center Display Panel .....	32-14
LH Control/Indicator Panel (Pod) .....	32-14
Ladder Light Switch .....	32-14
Head Light Switch .....	32-14
BackUp/Deck Lights Switch .....	32-14
RH Control/Indicator Panel (Pod) .....	32-14
Cold Weather Starting Aid (Ether Injection) Switch .....	32-14

**TABLE OF CONTENTS****SUBJECT ----- SECTION / PAGE**

Hazard Warning Lights Switch . . . . .	32-15
Automatic Idle Selector Switch (AISS) . . . . .	32-15
Air Conditioner & Heater Vent . . . . .	32-16
ASR Cut (Traction Control) Switch (Option) . . . . .	32-16
Center Display Panel . . . . .	32-16
Air Pressure Monitor (Not Used) . . . . .	32-16
Air Pressure Gauge (Not Used) . . . . .	32-16
Coolant Temperature Monitor . . . . .	32-16
Engine Cooling Water Temperature Gauge . . . . .	32-18
Torque Converter Oil Temperature Monitor . . . . .	32-18
Torque Converter Oil Temperature Gauge . . . . .	32-18
Retarder Oil Temperature Monitor . . . . .	32-18
Retarder Oil Temperature Gauge . . . . .	32-18
Left Turn Signal Pilot Lamp . . . . .	32-18
High Beam Pilot Lamp . . . . .	32-18
Right Turn Signal Pilot Lamp . . . . .	32-18
Speedometer . . . . .	32-18
Tachometer . . . . .	32-19
Lock-up Pilot Lamp . . . . .	32-19
Shift Limiter Pilot Lamp . . . . .	32-19
Shift Indicator . . . . .	32-19
Transmission Shift Position Pilot Lamp . . . . .	32-19
Engine Controller Monitor . . . . .	32-19
Automatic Transmission Mechatronics Monitor . . . . .	32-19
Other Mechatronics Monitor (Optional) . . . . .	32-19
Fuel Level Monitor . . . . .	32-19
Fuel Gauge . . . . .	32-20
Engine Power Derate Monitor . . . . .	32-20
F1 Start Monitor . . . . .	32-20
Auto Cruise Control (Not Used) . . . . .	32-20
ASR Monitor (Optional) . . . . .	32-20
ABS Monitor (Not Used) . . . . .	32-20
Service Meter . . . . .	32-20
Odometer . . . . .	32-20
LH Control/Indicator Panel (Pod) . . . . .	32-21
LH Panel/Pod Assembly . . . . .	32-21
Engine Oil Temperature . . . . .	32-21
Engine Coolant Level . . . . .	32-21
Low Steering Pressure . . . . .	32-21
Accumulator Pre-Charge . . . . .	32-21
Battery Charge Amps . . . . .	32-22
Check Engine . . . . .	32-22

## TABLE OF CONTENTS

<b>SUBJECT</b> .....	<b>SECTION / PAGE</b>
Parking Brake .....	32-22
Body Float .....	32-22
Transmission Oil Temperature .....	32-22
Service Brakes Applied .....	32-22
Maintenance Monitor .....	32-22
Transmission Oil Filters .....	32-22
Lamp Test .....	32-23
Low Brake Pressure .....	32-23
Lateral Slope Warning .....	32-23
Crankcase Pressure .....	32-23
Panel Dimmer Switch .....	32-23
Engine Oil Pressure .....	32-23
Central Warning Lamp .....	32-23
AC/Heater Vent .....	32-24
REAR OF OPERATOR CAB .....	32-24
CIRCUIT BREAKER CHART .....	32-26
QUANTUM™ FUEL SYSTEM DIAGNOSTICS .....	32-27
Determining Fault Codes .....	32-27
Exiting The Diagnostics Mode .....	32-28
MESSAGE FOR OPERATION AND MAINTENANCE ("MOM") .....	32-29
Truck Condition- .....	32-29
Production Data During Operation - (Information from the Payload Meter) .....	32-29
Transmission Response With Fault Codes .....	32-33
Idle Validation Feature .....	32-34
CENTER ELECTRONIC DISPLAY PANEL .....	32-34
Action Code Display .....	32-34
Cancellation of Action Code .....	32-35
LUBRICATION AND SERVICE .....	40-1
COOLANT SPECIFICATIONS .....	40-1
Unacceptable Practices .....	40-1
QUICK FILL SERVICE CENTER .....	40-1
10 HOUR (DAILY) INSPECTION .....	40-3
250 HOUR INSPECTION .....	40-5
500 HOUR INSPECTION .....	40-7
1000 HOUR INSPECTION .....	40-8
2000 HOUR INSPECTION .....	40-9
5000 HOUR INSPECTION .....	40-10
RADIATOR FILL PROCEDURE .....	40-11

**TABLE OF CONTENTS****SUBJECT ----- SECTION / PAGE**

TRANSMISSION OIL LEVEL CHECK .....	40-11
HYDRAULIC TANK SERVICE .....	40-11
Filling Instructions .....	40-11
Hydraulic Tank Service .....	40-12
STEERING CIRCUIT FILTER .....	40-13
Removal .....	40-13
Installation .....	40-13
HYDRAULIC TANK BREATHER .....	40-14
Cleaning .....	40-14
STEERING CIRCUIT FILTER .....	40-12
Removal .....	40-12
Installation .....	40-12
HYDRAULIC TANK BREATHER .....	40-13
Cleaning .....	40-13
LINCOLN AUTOMATIC LUBRICATION SYSTEM .....	42-1
SYSTEM COMPONENTS .....	42-1
System Operation .....	42-4
System Priming .....	42-5
System Checkout .....	42-6
Pressure Reducer Adjustment .....	42-6
24 VDC Solid State Timer Check .....	42-7
24 VDC Solid State Timer Adjustment .....	42-8
Injectors (SL-1) .....	42-8
Injector Adjustment .....	42-8
Pump Cycle Timer (Flasher Timer): .....	42-9
Pump Cycle Timer (Flasher Timer) Installation .....	42-9
Pump Cycle Timer (Flasher Timer) Adjustment: .....	42-9
SYSTEM TROUBLESHOOTING CHART .....	42-11
RESERVOIR FILL PROCEDURE .....	42-13
Lubricant Required for System .....	42-13
Fill Procedure .....	42-13
PREVENTIVE MAINTENANCE PROCEDURES .....	42-14
Daily Lubrication System Inspection .....	42-14
250 Hour Inspection .....	42-14
MAJOR COMPONENT DESCRIPTION .....	50-1

## TABLE OF CONTENTS

**SUBJECT ----- SECTION / PAGE**

PAYLOAD METER III .....	60-1
RADIO, AM / FM STEREO CASSETTE .....	70-1
SETTING THE TIME .....	70-1
GENERAL RECEIVER FUNCTIONS .....	70-1
Turning The Power On And Off .....	70-1
Display .....	70-1
Setting The Default Display .....	70-2
Adjusting Display Brightness .....	70-2
OPERATING THE RADIO .....	70-2
BAND .....	70-2
TUNE/SEEK .....	70-2
Manual Tuning .....	70-2
SEEK Mode .....	70-2
SCAN .....	70-2
AUTO .....	70-2
PROGRAMMING PRESET STATIONS .....	70-3
OPERATION OF THE WEATHERBAND (U.S.) .....	70-3
ADJUSTING THE RECEIVER SETTINGS .....	70-3
PROGRAMMABLE EJECT DEFAULT .....	70-4
CASSETTE PLAYER .....	70-4
Playing A Cassette .....	70-4
Cassette Functions .....	70-4
Bad Tape Detect .....	70-5
CASSETTE PLAYER CLEANING .....	70-5

## TRUCK MODEL ILLUSTRATION



A000024

### KOMATSU HD1500 DUMP TRUCK

## ABOUT THIS MANUAL

This manual is written for use by the operator and/or the service technician. It is designed to help these persons learn how to operate the truck and its systems in order to keep it operating safely and efficiently. All operators and maintenance personnel should read and understand the materials in this manual before operating the truck or performing maintenance and/or operational checks on the truck. All safety notices, warnings, and cautions should be understood and followed when operating or performing repairs on the truck.

The front cover of this manual includes a form number. This form number should be referenced when ordering additional copies of this manual, or for any other correspondence regarding the coverage in this manual.

Direct all inquiries to:

Komatsu America Corp.  
Peoria Technical Publications  
P.O. Box 240  
Peoria, IL 61650-0240  
(309)-672-7072 - FAX

This first section is an introduction to the manual and contains the table of contents to locate specific areas of interest. Other sections include Safety, Operating Instructions, Lubrication and Service, etc.

When searching for a specific area of interest, go first to the table of contents to locate the section in which the subject might generally be included. Then, go to that section of the table of contents to find a subject description that most closely describes the specific area of interest to find a page number and go to that page. Section numbers and page numbers are located at the top, outside corner of the page.

At the top, inside corner of the page is a document (module) number. If there is ever a question regarding the information in a particular section, refer to the document (module) number, the manual form number, and use the address shown above to correspond. If there is a date (month/year) behind the document (module) number, that indicates the latest revision date of that page.

The illustrations used in this manual are typical of the component shown and may not be an *exact* reproduction of what is found on the truck.

This manual shows dimensioning of U.S. standard and metric (SI) units throughout. All references to right, left, front, or rear are made with respect to the operator's normal seated position, unless specifically stated otherwise.

When assembly instructions are provided without references to torque values, standard torque values are to be assumed. Standard torque requirements are shown in torque charts on the following pages of this section, and in the General Information section of the truck service manual. Individual torques when provided in the text are in bold face type, such as **135 N·m (100 ft lb)**. All torque specifications have  $\pm 10\%$  tolerance unless otherwise specified.



## TORQUE TABLES AND CONVERSION CHARTS



This manual provides dual dimensioning for many specifications. Metric units are specified first, with U.S. standard units in parentheses. When torque values are not specified in the assembly instructions contained in this manual, use the standard torque value for the hardware being used. Standard value torque tables are contained in this chapter for metric and SAE hardware.

***References throughout the manual to standard torques or other standard values will be to one of the following tables. Do not use standard values to replace specific torque values in assembly instructions.***

*NOTE: This truck is assembled with both metric and SAE (U.S.) hardware. Reference the correct table when determining the proper torque value.*

For values not shown in any of the charts or tables, standard conversion factors for most commonly used measurements are provided in the following tables.

### INDEX OF TABLES

TABLE .....	Page
TABLE 1      Standard Tightening Torque For Metric Cap screws and Nuts .....	12-2
TABLE 2      Standard Tightening Torque For SAE Grade 5 & 8 Cap Screws and Nuts .....	12-3
TABLE 3      Standard Tightening Torque 12-Pt, Grade 9, Cap Screws (SAE) .....	12-4
TABLE 4      Tightening Torque for T-Bolt Type Hose Clamps. ....	12-5
TABLE 5      Standard Tightening Torque For Split Flange Clamp Bolts .....	12-5
TABLE 6      Tightening Torque For Flared Tube And Hose Fittings .....	12-5
TABLE 7      JIC 37° Swivel Nuts Torque Chart (SAE) .....	12-6
TABLE 8      Pipe Thread Torque Chart (SAE) .....	12-6
TABLE 9      O-Ring Boss Torque Chart (SAE) .....	12-7
TABLE 10     O-Ring Face Seal Torque Chart (SAE) .....	12-7
TABLE 11     Common Conversions Multipliers - Metric -to- English .....	12-8
TABLE 12     Common Conversions Multipliers - English -to- Metric .....	12-9
TABLE 13     Temperature Conversions. ....	12-10
TABLE 14     Sealants And Adhesives .....	12-11

## EFFECT OF SPECIAL LUBRICANTS On Fasteners and Standard Torque Values

The Komatsu engineering department does not recommend the use of special friction-reducing lubricants, such as Copper Coat, Never-Seez®, and other similar products, on the threads of standard fasteners where standard torque values are applied. The use of special friction-reducing lubricants will significantly alter the clamping force being applied to fasteners during the tightening process.

If special friction-reducing lubricants are used with the standard torque values listed in this chapter, excessive stress and possible breakage of the fasteners may result.

Where the torque tables specify “Lubricated Threads” for the standard torque values listed, these standard torque values are to be used with simple lithium base chassis grease (multi-purpose EP NLGI) or a rust-preventive grease (see below) on the threads and seats unless specified otherwise.

*NOTE: Ensure the threads of fasteners and tapped holes are free of burrs and other imperfections before assembling.*

### Suggested\* Sources for Rust Preventive Grease:

- American Anti-Rust Grease #3-X from Standard Oil Company (also American Oil Co.)
- Gulf NoRust #3 from Gulf Oil Company.
- Mobilarma 355, Product No. 66705 from Mobil Oil Corporation.
- Rust Ban 326 from Humble Oil Company.
- Rustolene B Grease from Sinclair Oil Co.
- Rust Preventive Grease - Code 312 from the Southwest Grease and Oil Company.

*NOTE: This list represents the current engineering approved sources for use in Komatsu manufacture. It is not exclusive. Other products may meet the same specifications of this list.*

## STANDARD TIGHTENING TORQUES For Class 10.9 Cap screws & Class 10 Nuts

The following specifications apply to required assembly torques for all metric class 10.9 finished hexagon head cap screws and class 10 nuts.

- Cap screw threads and seats shall not be lubricated when assembled. These specifications are based on all cap screws, nuts, and hardened washers being phosphate and oil coated.

If zinc-plated hardware is used, each piece must be lubricated with simple lithium base chassis grease (multi-purpose EP NLGI) or a rust preventive grease (see list, this page) to achieve the same clamping forces provided below.

- Torques are calculated to give a clamping force of approximately 75% of proof load.
- The maximum torque tolerance shall be within  $\pm 10\%$  of the torque value shown.
- In the following table under “Cap Screw Size”, the first number represents the shank diameter (mm). The second number represents threads per millimeter.

Example: M20 x 2.25

M20 = shank diameter (20 mm)

2.25 = threads pitch in millimeters



Cap Screw Size	Torque N•m	Torque ft lb	Torque kg•m
M6	13	10	1.35
M8	31	23	3.2
M10	66	48	6.7
M12	112	83	11.5
M14	177	130	18.0
M16	279	206	28.5
M18	383	282	39.0
M20	549	405	56.0
M22	745	550	76.0
M24	927	684	94.5
M27	1320	975	135
M30	1720	1266	175
M33	2210	1630	225
M36	2750	2025	280
M39	3280	2420	335

### STANDARD TIGHTENING TORQUES For SAE Grade 5 and Grade 8 Cap screws

The following specifications apply to required assembly torques for all grade 5 and grade 8 cap screws.

- Cap screw threads and seats shall be lubricated when assembled.

Unless instructions specifically recommend otherwise, these standard torque values are to be used with simple lithium base chassis grease (multi-purpose EP NLGI) or a rust- preventive grease (see list, previous page) on the threads.

- Torques are calculated to give a clamping force of approximately 75% of proof load.

- The maximum torque tolerance shall be  $\pm 10\%$  of the torque value shown.
- In the following table under Cap Screw Size, the first number represents the shank diameter (in.). The second number represents threads per inch.

Example: 7/16 - 20

7/16 = shank diameter (7/16 inch (0.438 inch))

20 = threads per inch

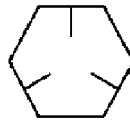

GRADE 5

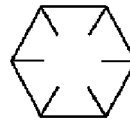

GRADE 8

TABLE 2.  
Standard Tightening Torque  
for SAE Hex Head Cap Screw And Nut Assembly

Cap Screw Size	Torque - Grade 5			Torque - Grade 8			Cap Screw Size	Torque - Grade 5			Torque - Grade 8		
	N-m	ft lb	kg-m	N-m	ft lb	kg-m		N-m	ft lb	kg-m	N-m	ft lb	kg-m
1/4-20	9.5	7	0.97	13.6	10	1.38	3/4-16	319	235	32.5	454	335	46.3
1/4-28	10.8	8	1.11	14.9	11	1.52	7/8-9	475	350	48.4	678	500	69.2
5/16-18	20.3	15	2.07	28	21	2.90	7/8-14	508	375	51.9	719	530	73.3
5/16-24	22	16	2.21	30	22	3.04	1.0-8	712	525	72.6	1017	750	103.7
3/8-16	34	25	3.46	47	35	4.84	1.0-12	759	560	77.4	1071	790	109.3
3/8-24	41	30	4.15	54	40	5.5	1.0-14	773	570	78.8	1085	800	110.6
7/16-14	54	40	5.5	79	58	8.0	1 1/8-7	881	650	89.9	1424	1050	145
7/16-20	61	45	6.2	84	62	8.57	1 1/8-12	949	700	96.8	1546	1140	158
1/2-13	88	65	9	122	90	12.4	1 1/4-7	1234	910	125.9	2007	1480	205
1/2-20	95	70	9.7	129	95	13.1	1 1/4-12	1322	975	134.8	2142	1580	219
9/16-12	122	90	12.4	169	125	17.3	1 3/8-6	1627	1200	166	2630	1940	268
9/16-18	129	95	13.1	183	135	18.7	1 3/8-12	1776	1310	181	2874	2120	293
5/8-11	169	125	17.3	237	175	24.2	1 1/2-6	2142	1580	219	3471	2560	354
5/8-18	183	135	18.7	258	190	26.2	1 1/2-12	2305	1700	235	3756	2770	383
3/4-10	298	220	30.4	420	310	42.8							

1 ft lb = 0.138 kg-m = 1.356 N.m

## STANDARD TIGHTENING TORQUES For SAE Grade 9 Cap screws

The following specifications apply to required assembly torques for all 12-point, grade 9 (170,000 psi minimum tensile), cap screws.

- Cap screw threads and seats shall be lubricated when assembled.

*Unless instructions specifically recommend otherwise, these standard torque values are to be used with simple lithium base chassis grease (multi-purpose EP NLGI) or a rust- preventive grease (see list, this page) on the threads.*

- Torques are calculated to give a clamping force of approximately 75% of proof load.
- The maximum torque tolerance shall be  $\pm 10\%$  of the torque value shown.

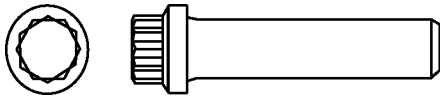

Cap Screw Size*	Torque N-m	Torque ft lb	Torque kg-m
0.250 - 20	16	12	1.7
0.312 - 18	33	24	3.3
0.375 - 16	57	42	5.8
0.438 -14	95	70	9.7
0.500 -13	142	105	14.5
0.562 - 12	203	150	20.7
0.625 - 11	278	205	28.3
0.750 - 10	488	360	49.7
0.875 - 9	780	575	79.4
1.000 - 8	1166	860	119
1.000 - 12	1240	915	126
1.125 - 7	1670	1230	170
1.125 - 12	1800	1330	184
1.250 - 7	2325	1715	237
1.250 - 12	2495	1840	254
1.375 - 6	3080	2270	313
1.375 - 12	3355	2475	342
1.500 - 6	4040	2980	411
1.500 - 12	4375	3225	445

\* Shank Diameter (in.) - Threads per inch

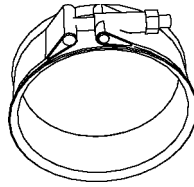

TABLE 4. Tightening Torque For T-Bolt Type Hose Clamp (SAE J1508 Type TB)			
Thread Size	Band Width	Newton meters (N·m)	Inch Pounds (in. lb)
0.25-28 UNF	19.05 mm (0.75 in.)	8.5 ± 0.6 N·m	75 ± 5 in lb

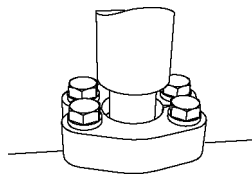

TABLE 5. Tightening Torque For Split Flange Clamp Bolts				
Cap Screw Thread Diameter (mm)	Width Across Flat (mm)	Newton meters (N·m) Tolerances ±10%	Foot Pounds (ft lb) Tolerances ±10%	Kilogram meters (kg·m) Tolerances ±10%
10	14	66	48	6.7
12	17	112	83	11.5
16	22	279	206	28.5

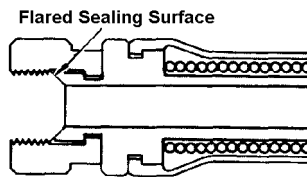
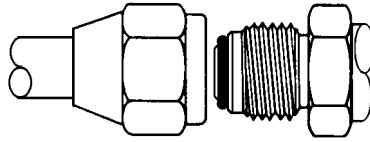
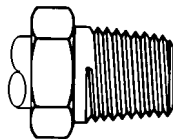

TABLE 6. Tightening Torque For Flared Tube And Hose Fittings				
Thread Diameter of Nut (mm)	Width Across Flat (mm)	Newton meters (N·m) Tolerances ±10%	Foot Pounds (ft lb) Tolerances ±10%	Kilogram meters (kg·m) Tolerances ±10%
14	19	25	18	2.5
18	24	50	36	5
22	27	80	58	8
24	32	140	101	14
30	36	175	130	18
33	41	195	145	20
36	46	245	180	25
42	55	295	215	30



**TABLE 7.**  
**Torque Chart For JIC 37° Swivel NutS**  
**With Or Without O-ring Seals**

Size Code	Tube Size (OD)	Threads UNF-2B	Newton meters (N·m)	Foot Pounds (ft lb)
- 2	0.125	0.312 - 24	5 ± 1	4 ± 1
- 3	0.188	0.375 - 24	11 ± 4	8 ± 3
- 4	0.250	0.438 - 20	16 ± 4	12 ± 3
- 5	0.312	0.500 - 20	20 ± 4	15 ± 3
- 6	0.375	0.562 - 18	24 ± 7	18 ± 5
- 8	0.500	0.750 - 16	40 ± 7	30 ± 5
- 10	0.625	0.875 - 14	54 ± 7	40 ± 5
- 12	0.750	1.062 - 12	75 ± 7	55 ± 5
- 14	0.875	1.188 - 12	88 ± 7	65 ± 5
- 16	1.000	1.312 - 12	108 ± 7	80 ± 5
- 20	1.250	1.625 - 12	136 ± 14	100 ± 10
- 24	1.500	1.875 - 12	163 ± 14	120 ± 10
- 32	2.000	2.500 - 12	312 ± 27	230 ± 20



**TABLE 8.**  
**Torque Chart For**  
**Pipe Thread Fittings**

Size Code	Pipe Thread Size	With Sealant N·m	With Sealant ft lb	Without Sealant N·m	Without Sealant ft lb
- 2	0.125 - 27	20 ± 4	15 ± 3	27 ± 7	20 ± 5
- 4	0.250 - 18	27 ± 7	20 ± 5	34 ± 7	25 ± 5
- 6	0.375 - 18	34 ± 7	25 ± 5	48 ± 7	35 ± 5
- 8	0.500 - 14	48 ± 7	35 ± 5	61 ± 7	45 ± 5
- 12	0.750 - 14	61 ± 7	45 ± 5	75 ± 7	55 ± 5
- 16	1.000 - 11.50	75 ± 7	55 ± 5	88 ± 7	65 ± 5
- 20	1.250 - 11.50	95 ± 7	70 ± 5	108 ± 7	80 ± 5
- 24	1.500 - 11.50	108 ± 7	80 ± 5	129 ± 14	95 ± 10
- 32	2.000 - 11.50	129 ± 14	95 ± 10	163 ± 14	120 ± 10

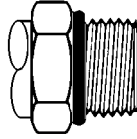

**TABLE 9.**  
**Torque Chart For**  
**O-ring Boss Fittings**

Size Code	Tube Size (OD)	Threads UNF-2B	Newton meters (N·m)	Foot Pounds (ft lb)
- 2	0.125	0.312 - 24	4 ± 3	4 ± 2
- 3	0.188	0.375 - 24	7 ± 3	5 ± 2
- 4	0.250	0.438 - 20	11 ± 4	8 ± 3
- 5	0.312	0.500 - 20	14 ± 4	10 ± 3
- 6	0.375	0.562 - 18	18 ± 4	13 ± 3
- 8	0.500	0.750 - 16	33 ± 7	24 ± 5
- 10	0.625	0.875 - 14	43 ± 7	32 ± 5
- 12	0.750	1.062 - 12	65 ± 7	48 ± 5
- 14	0.875	1.188 - 12	73 ± 7	54 ± 5
- 16	1.000	1.312 - 12	98 ± 7	72 ± 5
- 20	1.250	1.625 - 12	109 ± 7	80 ± 5
- 24	1.500	1.875 - 12	109 ± 7	80 ± 5
- 32	2.000	2.500 - 12	130 ± 14	96 ± 10

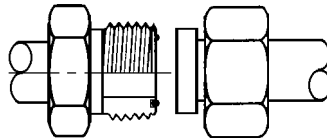

**TABLE 10.**  
**Torque Chart For**  
**O-ring Face Seal Fittings**

Size Code E	Tube Size (O.D.)	Threads UNF-2B	Newton meters (N·m)	Foot Pounds (ft lb)
- 4	0.250	0.438 - 20	15 ± 1	11 ± 1
- 6	0.375	0.562 - 18	24 ± 3	18 ± 2
- 8	0.500	0.750 - 16	48 ± 5	35 ± 4
- 10	0.625	0.875 - 14	69 ± 7	51 ± 5
- 12	0.750	1.062 - 12	96 ± 10	71 ± 7
- 16	1.000	1.312 - 12	133 ± 8	98 ± 6
- 20	1.250	1.625 - 12	179 ± 10	132 ± 7
- 24	1.500	1.875 - 12	224 ± 20	165 ± 15

<b>TABLE11. Common Conversion Multipliers Metric To English</b>		
<b>To Convert From</b>	<b>To</b>	<b>Multiply By</b>
millimeter (mm)	inch (in.)	0.0394
centimeter (cm)	inch (in.)	0.3937
meter (m)	foot (ft)	3.2808
meter (m)	yard (yd)	1.0936
kilometer (km)	mile (mi)	0.6210
square centimeters (cm <sup>2</sup> )	square inch (in. <sup>2</sup> )	0.1550
square centimeters (cm <sup>2</sup> )	square feet (ft <sup>2</sup> )	0.001
cubic centimeters (cm <sup>3</sup> )	cubic inch (in. <sup>3</sup> )	0.061
liters (l)	cubic inch (in. <sup>3</sup> )	61.02
cubic meters (m <sup>3</sup> )	cubic feet (ft <sup>3</sup> )	35.314
liters (l)	cubic feet (ft <sup>3</sup> )	0.0353
grams (g)	ounce (oz)	0.0353
milliliter (ml)	fluid ounce (fl oz)	0.0338
kilogram (kg)	pound (mass)	2.2046
Newton (N)	pounds (lb)	0.2248
Newton meters (N·m)	kilogram meters (kg·m)	0.102
Newton meters (N·m)	foot pounds (ft lb)	0.7376
kilogram meters (kg·m)	foot pounds (ft lb)	7.2329
kilogram meters (kg·m)	Newton meters (N·m)	9.807
kilopascals (kPa)	pounds/square inch (psi)	0.1450
megapascals (MPa)	pounds/square inch (psi)	145.038
kilograms/cm <sup>2</sup> (kg/cm <sup>2</sup> )	pounds/square inch (psi)	14.2231
kilograms/cm <sup>2</sup> (kg/cm <sup>2</sup> )	kilopascals (kPa)	98.068
kilogram (kg)	short ton (tn)	0.0011
metric ton	short ton (tn)	1.1023
liters (l)	quart (qt)	1.0567
liters (l)	gallon (gal)	0.2642
Watts (W)	horsepower (hp)	0.00134
kilowatts (kW)	horsepower (hp)	1.3410



<b>TABLE 12. Common Conversion Multipliers English to Metric</b>		
<b>To Convert From</b>	<b>To</b>	<b>Multiply By</b>
inch (in.)	millimeter (mm)	25.40
inch (in.)	centimeter (cm)	2.54
foot (ft)	meter (m)	0.3048
yard (yd)	meter (m)	0.914
mile (mi)	kilometer (km)	1.61
square inch (in. <sup>2</sup> )	square centimeters (cm <sup>2</sup> )	6.45
square feet (ft <sup>2</sup> )	square centimeters (cm <sup>2</sup> )	929
cubic inches (in. <sup>3</sup> )	cubic centimeters (cm <sup>3</sup> )	16.39
cubic inches (in. <sup>3</sup> )	liters (l)	0.016
cubic feet (ft <sup>3</sup> )	cubic meters (m <sup>3</sup> )	0.028
cubic feet (ft <sup>3</sup> )	liters (l)	28.3
ounce (oz)	kilogram (kg)	0.028
fluid ounce (fl oz)	milliliter (ml)	29.573
pound (lb)	kilogram (kg)	0.454
pound (lb)	Newton (N)	4.448
inch pounds (in. lb)	Newton meters (N·m)	0.113
foot pounds (ft lb)	Newton meters (N·m)	1.356
foot pounds (ft lb)	kilogram meters (kg·m)	0.138
kilogram meters (kg·m)	Newton meters (N·m)	9.807
pounds/square inch (psi)	kilopascals (kPa)	6.895
pounds/square inch (psi)	megapascals (MPa)	0.007
pounds/square inch (psi)	kilograms/square centimeter (kg/cm <sup>2</sup> )	0.0704
short ton (tn)	kilogram (kg)	907.2
short ton (tn)	metric ton (t)	0.0907
quart (qt)	liters (l)	0.946
gallon (gal)	liters (l)	3.785
horsepower (hp)	Watts (w)	745.7
horsepower (hp)	kilowatts (kw)	0.745

**TABLE 13.**  
**Temperature Conversions**  
**Formula:  $F^{\circ} - 32 \div 1.8 = C^{\circ}$  or  $C^{\circ} \times 1.8 + 32 = F^{\circ}$**

Celsius C°		Fahrenheit F°	Celsius C°		Fahrenheit F°	Celsius C°		Fahrenheit F°
121	250	482	63	145	293	4	40	104
118	245	473	60	140	284	2	35	95
116	240	464	57	135	275	- 1	30	86
113	235	455	54	130	266	- 4	25	77
110	230	446	52	125	257	- 7	20	68
107	225	437	49	120	248	- 9	15	59
104	220	428	46	115	239	- 12	10	50
102	215	419	43	110	230	- 15	5	41
99	210	410	41	105	221	- 18	0	32
96	205	401	38	100	212	- 21	- 5	23
93	200	392	35	95	203	- 23	- 10	14
91	195	383	32	90	194	- 26	- 15	5
88	190	374	29	85	185	- 29	- 20	- 4
85	185	365	27	80	176	- 32	- 25	- 13
82	180	356	24	75	167	- 34	- 30	- 22
79	175	347	21	70	158	- 37	- 35	- 31
77	170	338	18	65	149	- 40	- 40	- 40
74	165	329	15	60	140	- 43	- 45	- 49
71	160	320	13	55	131	- 46	- 50	- 58
68	155	311	10	50	122	- 48	- 55	- 67
66	150	302	7	45	113	- 51	- 60	- 76

*NOTE: The numbers in the unmarked columns refer to temperature in either degrees Celsius (C°) or Fahrenheit (F°). Select a number in this unmarked column and read to the left to convert to degrees Celsius (C°) or read to the right to convert to degrees Fahrenheit (F°). If starting with a known temperature (either C° or F°), find that temperature in the marked column and read the converted temperature in the center, unmarked column.*

Nomenclature	Code	Three Bond *	Applications
Adhesives	LT-1A	TB1521	Used to apply rubber pads, rubber gaskets and cork plugs.
	LT-1B	1000B - 1000W	Used to apply resin, rubber, metallic and non-metallic parts when a fast, strong seal is needed.
	LT-2	TB1374	Preventing bolts, nuts and plugs from loosening and leaking oil.
	LT-2A	TB2411	Preventing bolts, nuts and plugs from loosening and leaking oil. (1)
	LT-2B	TB2403	Preventing bolts, nuts and plugs from loosening and leaking oil. (2)
	LT-2C	TB2430 or TB2440	Preventing bolts, nuts and plugs from loosening and leaking oil. (2)
	LT-3 Main bond Hardening agent	TB2001 TB2105	Provides an airtight, electrically insulating seal. Used for aluminum surfaces.
Liquid Gasket	LG-1	TB1108B	Used with gaskets and packings to increase sealing effect.
	LG-3	TB1107	Heat-resistant gasket for precombustion chambers and exhaust piping.
	LG-4	TB1104	Used by itself on mounting surfaces on the final drive and transmission cases. Thickness after tightening: 0.07-0.08 mm (0.0027-0.0032 in)
	LG-5	TB1110B	Used by itself to seal grease fittings, tapered screw fittings and tapered screw fittings in hydraulic circuits of less than 50 mm (2 in) in diameter.
Anti-friction compound	LM-P	-	Applied to bearings and taper shafts to facilitate press-fitting and to prevent sticking, burning or rusting.
Grease	G2-LI	-	Applied to bearings, sliding parts and oil seals for lubrication, rust prevention and facilitation of assembling work.
Vaseline	-	-	Used for protecting battery electrode terminals from corrosion.

*\* NOTE: The part numbers in this column are not Komatsu numbers. These are vendor designations.*

- (1) Used for threaded areas (for example, plug, nipple, elbow etc.) which are removable, and a pressure of 1965 kPa (285 psi) or less.
- (2) Used for threaded areas (for example, stud, etc.) which are not removable, and a pressure of 1965 kPa (285 psi) or less.

The sealants and adhesives listed below are manufactured and sold by Three Bond U.S.A., Inc. For information concerning Three Bond products, call or write to:

Three Bond U.S.A., Inc.  
6184 Schumacher Park Drive  
West Chester, OH 45069

Telephone: (513) 779-7300  
Fax: (513) 779-7375

Part Numbers	
Three Bond	Komatsu
TB1374	09940-00030
TB1521	790-129-9030
TB1104	790-129-9020
TB1108B	790-129-9010
TB1110B	790-129-9080

## Hardware Tightening Method



***Mark cap screws and nuts with paint or ink before tightening to the specified torque. This method provides verification that the hardware has been properly tightened.***

1. Snug all of the hardware with an impact wrench or appropriate ratchet.
2. Apply a paint mark down the side of the hardware and onto the component surface. Verify that all of the hardware that is being tightened is marked.
3. Tighten the marked hardware to the proper torque. All of the paint marks should now be offset, showing that the hardware has been properly tightened.

## SAFETY

Safety records from most organizations will show that the greatest percentage of accidents are caused by unsafe acts performed by people. The remainder are caused by unsafe mechanical or physical conditions. Report all unsafe conditions to the proper authority.

The following safety rules are provided as a guide for the operator. However, local conditions and regulations may add many more to this list.



**Read and follow all safety precautions. Failure to do so may result in serious injury or death.**

### Safety Rules

- Only trained and authorized personnel can operate and maintain the machine.
- Follow all safety rules, precautions and instructions when operating or performing maintenance on the machine.
- Ensure all personnel understand all hand signals that are to be used during machine travel and maintenance.

### Safety Features

- Ensure all guards and covers are in their proper position. Repair damaged guards and covers. Refer to Section 30, Operating Instructions - Walk-Around Inspection.
- Learn the proper use of safety features such as safety locks, safety pins, and seat belts. Use these safety features properly.
- Never remove any safety features. Always keep safety features in good operating condition.
- Improper use, or failure to maintain safety features could result in serious bodily injury or death.

### Clothing And Personal Items

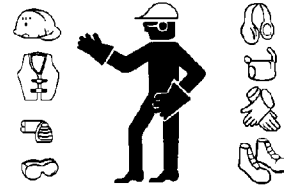

- Avoid loose clothing, jewelry, and loose long hair. Loose items can catch on controls or in moving parts and cause serious injury or death.
- Never wear oily clothes as they are flammable.
- Wear a hard hat, safety glasses, safety shoes, mask and gloves when operating or maintaining a machine. Always wear safety goggles, hard hat and heavy gloves if your job involves scattering metal chips or minute materials--particularly when driving pins with a hammer or when cleaning air cleaner elements with compressed air. Also, ensure that the work area is free from other personnel during such tasks.

### Unauthorized Modification

- Any modification made to this vehicle without authorization from Komatsu America Corp. can possibly create hazards.
- Before making any modification, consult the authorized regional Komatsu America Corp. distributor. Komatsu will not be responsible for any injury or damage caused by any unauthorized modification.

### Leaving The Operator's Seat

- When preparing to leave the operator's seat, DO NOT touch any control lever that is not locked. Unexpected machine movement may result in serious bodily injury or death. To prevent accidental machine movement from occurring, always perform the following:

Move the shift control lever to NEUTRAL and apply the parking brake.

Lower the dump body, set the dump lever to the FLOAT position.

Stop the engine. When exiting the machine, always lock compartments, and take the keys with you.

### Mounting And Dismounting

- Never jump on or off the machine. Never climb on or off a machine while it is moving.
- When climbing on or off a machine, face the machine and use the hand-hold and steps.
- Never hold any control levers when getting on or off a machine.
- Always maintain three-point contact with the hand-holds and steps to ensure proper support and balance.
- When bringing tools into the operator's compartment, always pass them by hand or pull them up by rope.
- If there is any oil, grease, or mud on the hand-holds or steps, wipe them clean immediately. Always keep these areas clean. Repair any damage and tighten any loose bolts.
- Properly use the handrails and steps when getting on or off the machine.

### Fire Prevention For Fuel And Oil

- Fuel, oil, and antifreeze can be ignited by a flame. Fuel is extremely flammable and can be hazardous.
- Keep flames away from flammable fluids.
- Stop the engine. Never smoke when refueling.
- Tighten all fuel and oil tank caps securely.
- Refueling and oiling must be done in well ventilated areas.
- Keep oil and fuel in a designated location and DO NOT allow unauthorized persons to enter.

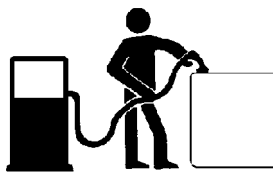

### Precautions With High Temperature Fluids

- Immediately after machine operation, fluids are at high temperatures and are pressurized. If a machine system is opened, there is danger of serious burns. Allow heat and pressure to dissipate before performing such tasks and follow proper procedures as outlined in the service manual.

To prevent hot coolant from spraying:

1. Stop the engine.
2. Wait for the coolant temperature to decrease.
3. Depress the pressure release button on the cap to vent cooling system pressure.
4. Turn the radiator cap slowly to release the pressure before removing.



To prevent hot engine oil spray:

1. Stop the engine.
2. Wait for the oil temperature to cool down.
3. Turn the cap slowly to release the pressure before removing the cap.

### Asbestos Dust Hazard Prevention

Asbestos dust is hazardous to your health when inhaled. If you handle materials containing asbestos fibers, follow the guidelines below:



- Never use compressed air for cleaning.
- Use water for cleaning to control dust.
- Operate the machine or perform tasks with the wind to your back, whenever possible.
- Use an approved respirator when necessary.

### Prevention Of Injury By Work Equipment

- Never enter or put your hand, arm or any other part of your body between movable parts such as the dump body, chassis or cylinders. If the work equipment is operated, clearances will change and may lead to serious bodily injury or death.

### Fire Extinguisher And First Aid Kit

- Ensure fire extinguishers are accessible and proper usage techniques are known.
- Periodically check fire extinguishers. Verify that they are in working condition.
- Know what to do in the event of a fire.
- Provide a first aid kit at the storage point. Keep the kit fully stocked.
- Keep the phone numbers of persons you should contact in case of an emergency on hand.

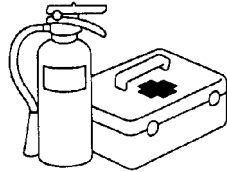

### Precautions For Attachments

- When installing and using optional equipment, read the instruction manual for the attachment and the information related to attachments in this manual.
- DO NOT use attachments that are not authorized by Komatsu America Corp., or the authorized regional Komatsu distributor. Use of unauthorized attachments could create a safety problem and adversely affect the proper operation and useful life of the machine.
- Any injuries, accidents, and product failures resulting from the use of unauthorized attachments will not be the responsibility of Komatsu America Corp., or the authorized regional Komatsu distributor.

### Precautions For ROPS

- The Rollover Protection Structure (ROPS) must be properly installed for machine operation.
- The ROPS is intended to protect the operator if the machine should roll over. It is designed not only to support the load of the machine, but also to absorb the energy of the impact.
- ROPS structures installed on equipment manufactured and designed by Komatsu America Corp. fulfill all of the regulations and standards for all countries. If it is modified or repaired without authorization from Komatsu, or is damaged when the machine rolls over, the strength of the structure will be compromised and will not be able to fulfill its intended purpose. Optimum strength of the structure can only be achieved if it is repaired or modified as specified by Komatsu.
- When modifying or repairing the ROPS, always consult your nearest Komatsu distributor.
- Even with the ROPS installed, the operator must always use the seat belt when operating the machine.

## HAUL ROADS

- Determining the travel road at the work site is an important for safety, maintenance and speed.
- When possible restrict travel to one direction. If it is necessary to provide for traffic in both directions, ensure the road is wide enough.
- When creating haul roads, orient the road so the loaded truck passes on the side closest to the hill face. Keep the road as straight as possible. If curves are necessary, make the curve radius and road width as large as possible. Ramp the outside of curves so they are higher than the inside.
- Limit intersections if possible. Design any necessary intersections to provide safe crossings.
- Install mirrors at curves with poor visibility.
- Install signs to warn of any dangers along the road.
- Install adequate lighting and reflectors for safe travel.
- Road grades should not exceed 10% and emergency ramps installed for brake failures.
- Properly maintain haul roads for safe travel. Use a grader or a dozer to smooth rough roads and strengthen where necessary. Spray the roads with water to prevent excessive dust and poor visibility.

## PRECAUTIONS DURING OPERATION

Prevention is the best safety program. Prevent a potential accident by knowing the employer's safety requirements and all necessary job site regulations. In addition, know the proper use and care of all the safety equipment on the truck. Only qualified operators or technicians should attempt to operate or maintain a Komatsu machine.

Safe practices start before the operator gets to the equipment!

## BEFORE STARTING THE ENGINE

- When walking to and from a truck, maintain a safe distance from all machines even when the operator is visible.
- Before starting the engine, thoroughly check the area for any unusual conditions that could be dangerous.
- Examine the road surface at the job site and determine the best and safest method of operation.
- Choose an area where the ground is as horizontal and firm as possible before performing the operation.
- If it is necessary to operate the machine on or near a public road, protect pedestrians and cars by designating a person for work site traffic duty or by installing fences around the work site.
- The operator must personally check the work area, the roads to be used, and existence of obstacles before starting operations.
- Always determine the travel roads at the work site. Maintain roads to ensure machine and operator safety.
- If travel through wet areas is necessary, check the depth and flow of water before crossing the shallow parts. Never drive through water which exceeds the permissible water depth.



**Fire Prevention**

- Thoroughly remove wood chips, leaves, paper and other flammable items accumulated in the engine compartment. Failure to do so could result in a fire.
- Check fuel, lubrication, and hydraulic systems for leaks. Repair any leaks. Clean any excess oil, fuel or other flammable fluids, and dispose of properly.
- Ensure a fire extinguisher is present and in proper working condition.
- DO NOT operate the machine near open flames.

**Preparing For Operation**

- Always mount and dismount while facing the truck. Never attempt to mount or dismount the truck while it is in motion. Always use handrails and ladders when mounting or dismounting the truck.
- Check the deck areas for debris, loose hardware, and tools.
- Check for people and objects that might be in the area. Remove any obstructions and wait for any personnel in the area to disperse.
- Become familiar with and use all protective equipment devices on the truck and ensure that these items (anti-skid material, grab bars, seat belts, etc.) are securely in place.

**Ventilation In Enclosed Areas**

- If it is necessary to start the engine within an enclosed area, provide adequate ventilation. Exhaust fumes from the engine can kill.

**In Operator's Cab - Before Starting The Engine**

- DO NOT leave tools or spare parts lying around or allow trash to accumulate in the cab of the truck. Keep all unauthorized reading material out of the truck cab.
- Keep the cab floor, controls, steps, and handrails free of oil, grease, snow, and excess dirt.
- Check the seat belt, buckle and hardware for damage or wear. Replace any worn or damaged parts. Always use the seat belts when operating a machine.
- Read and understand the contents of this manual pertaining to safety and operating instructions with special attention. Become thoroughly acquainted with all gauges, instruments and controls before attempting operation of the truck.
- Read and understand the warning and caution decals in the operator's cab.
- Ensure the steering wheel, horn, controls and pedals are free of any oil, grease or mud.
- Check operation of the windshield wiper, condition of wiper blades, and check the washer fluid reservoir level.
- Be familiar with all steering and brake system controls, warning devices, road speeds and loading capabilities, before operating the truck.

**Mirrors, Windows, And Lights**

- Remove any dirt from the surface of the windshield, cab windows, mirrors and lights. Good visibility may prevent an accident.
- Adjust rear view mirrors to a position where the operator can see best from the operator's seat.
- If any glass or light should break, replace it with a new part.
- Ensure headlights, work lights and taillights are in proper working order. Ensure that the machine is equipped with the proper work lamps needed for the operating conditions.

## OPERATING THE MACHINE

### When Starting The Engine

- Never start the engine if a warning tag is attached to the controls.
- When starting the engine, sound the horn as an alert.
- Start and operate the machine only while seated in the operator's seat.
- DO NOT allow unauthorized persons in the operator's compartment or any other place on the machine.

### Precautions For Starting Machine

- Start the engine from the operator's seat, only.
- Never attempt to start the engine by shorting across the starter terminals. This may cause fire, or serious injury or death to anyone in machine's path.



### Truck Operation - General

- Wear seat belt at all times.
- Only authorized persons are allowed to ride in the truck. Riders must be in the cab and belted in the passenger seat.
- DO NOT allow anyone to ride on the decks or steps of the truck.
- DO NOT allow anyone to get on or off the truck while it is in motion.
- DO NOT move the truck in or out of a building without a signal person present.
- Know and obey the hand signal communications between operator and spotter. Use the direction of a signal person to travel near buildings, obstacles, people, etc. Courtesy at all times is a safety precaution!
- Immediately report any hazardous conditions at the haul road, pit or dump area.

- Check for flat tires periodically during a shift. If the truck has been operating on a flat tire, DO NOT park the machine inside of a building until the tire cools. DO NOT stand in front of the rim and locking ring when inflating a tire mounted on the machine. DO NOT allow observers in the area during tiring inflation and service.



***The tire and rim assembly may explode if subjected to excessive heat. Move personnel to a remote or protected location if there is evidence of excessive heat in the wheel, brake and tire area.***

***If the truck must be approached to extinguish a fire, those personnel should do so only while facing the tread area of the tire (front or back), unless protected by use of large heavy equipment as a shield. Stay at least 15 m (50 ft) from the tread of the tire.***

***In the event of fire in the tire and wheel area (including brake fires), stay away from the truck for at least eight hours or until the tire and wheel are cool.***

- Keep serviceable fire fighting equipment on hand. Report empty extinguishers for replacement or refilling.
- Always have the parking brake applied when the truck is parked and unattended. DO NOT leave the truck unattended while the engine is running.
- Park the truck a safe distance away from other vehicles as determined by the supervisor.
- Stay alert at all times! In the event of an emergency, be prepared to react quickly and avoid accidents. If an emergency arises, know where to get prompt assistance.

## Traveling

- Lower the dump body and set the dump lever to the FLOAT position before traveling.
- When traveling on rough ground, travel at low speeds. Do not exceed 27 kph (17 mph). When changing direction, avoid turning suddenly.
- If the engine should stop while the machine is in motion, emergency steering as defined by ISO 5010 and braking enable the truck to be steered and stopped. A fixed amount of reserve oil provides temporary steering and braking to briefly allow machine travel to a safe area. Apply the brakes immediately and stop the machine as quickly and safely as possible (off of the haul road, if possible).



***DO NOT move the shift lever to the N position while the truck is in motion. If the selector is shifted to N while in motion or while descending a hill the following may occur:***

- ***Steering may be more difficult.***
- ***A lack of cooling oil may cause the braking system to overheat and fail.***
- ***Damage to the transmission may occur.***
- ***The engine cannot provide braking when the transmission is not in gear.***

## Traveling In Reverse

Before operating the machine or work equipment, observe the following:

- Sound the horn to warn people in the area. For machines equipped with a back-up alarm, ensure the alarm works properly.
- Check for personnel near the machine. Be particularly careful to check behind the machine.
- When necessary, designate a person to watch the area near the truck and signal the operator. This is particularly necessary when traveling in reverse.

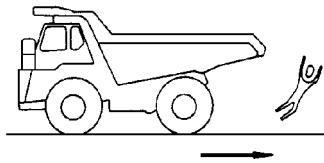

- When operating in areas that may be hazardous or have poor visibility, designate a person to direct work site traffic.
- DO NOT allow anyone to enter the line of travel of the machine. This rule must be strictly observed even with machines equipped with a back-up alarm or rear view mirror.

## Traveling On Slopes

- Traveling on slopes could result in the machine tipping over or slipping.
- DO NOT turn the truck around on a slope. To ensure safety, drive to level ground before turning around.
- DO NOT travel up and down on grass, fallen leaves, or wet steel plates. These materials may make the machine slip on even the slightest slope. Avoid traveling sideways, and always keep travel speed low.
- When traveling downhill, use the retarder or service brake pedal to reduce truck speed. Bring the truck to a stop using the brake pedal and then apply the parking brake. Use caution when using the brake pedal. Excessive force when applying the service brakes may cause a loss of control of the truck.
- When turning, rotate the steering wheel gradually to avoid losing control of the truck.
- If the engine should fail while on a slope, apply the service brakes and bring the truck to a stop. Move the transmission range selector to NEUTRAL and apply the parking brake.

## Ensure Good Visibility

- When working in dark places, install work lamps and head lamps. Set up extra lighting in the work area if necessary.
- Discontinue operations if visibility is poor, such as in mist, snow, or rain. Wait for the weather to improve to allow the operation to be performed safely.

### Operate Carefully On Snow

- When working on snowy or icy roads, there is danger that the machine may slip to the side on even the slightest slope. Always travel slowly and avoid sudden starting, turning, or stopping in these conditions.
- Use extreme caution when clearing snow. The road shoulder and other objects are buried in the snow and cannot be seen.

### Avoid Damage To Dump Body

- Always use extreme caution when working in tunnels, on bridges, under electric cables, or any other place where there are height limits. The dump body must be completely lowered before driving the machine.

### Driving Near High Voltage Cables

- Driving near high-voltage cables can cause electric shock. Always maintain safe distances between the machine and electric cables, as listed below.

Voltage	Minimum Safety Distance	
6.6 kv	3 m	10 ft
33.0 kv	4 m	14 ft
66.0 kv	5 m	17 ft
154.0 kv	8 m	27 ft
275.0 kv	10 m	33 ft

The following actions are effective in preventing accidents while working near high voltages:

- Wear shoes with rubber or leather soles.
- Use a signal person to give a warning if the machine approaches an electric cable.
- If the work equipment should touch an electric cable, the operator must remain in the cab.
- When driving near high voltage cables, DO NOT allow anyone to approach the machine.
- Check with the electrical maintenance department about the voltage of nearby cables before operating.

### When Dumping

- Before dumping, check that there is no person or objects behind the machine.
- Stop the machine in the desired location. Check again for persons or objects behind the machine. Give the determined signal, then slowly operate the dump body. If necessary, use blocks for the wheels or position a flagman.
- When dumping on slopes, machine stability is poor and there is danger of tip over. Always perform such operations using extreme care.
- Never travel with the dump body raised.

### Working On Loose Ground

- Avoid operating the machine near cliffs, overhangs, and deep ditches. If these areas collapse, the machine could fall or tip over, resulting in serious injury or death. Remember that ground surfaces in these areas may be weakened after heavy rain or blasting.
- Freshly laid soil and soil near ditches is loose. It can collapse under the weight or vibration of the machine. Avoid these areas whenever possible.

### Loading The Body

- Check that the surrounding area is safe, stop the machine in the correct loading position, then evenly load the body.
- DO NOT leave the operator's seat during loading.

### Parking The Machine

- Choose a horizontal road surface to park the machine. If the machine must be parked on a slope, always put blocks under all the wheels to prevent the machine from moving.
- When parking on public roads, provide signals, such as flags or lights, to warn pedestrians and other vehicles. Ensure the machine, flags, or lights do not obstruct the traffic.
- Before leaving the machine, fully lower the dump body, activate the parking brake, stop the engine, and lock everything. Always take the key with you.

## TOWING

- Improper towing methods may lead to serious personal injury and/or damage.
- Use a towing device with ample strength for the weight of this machine.
- Never tow a machine on a slope.
- Inspect all towing apparatus for damage. DO NOT use tow rope that has kinks or is twisted.
- DO NOT stand near the towing cable during towing.
- When connecting a machine that is to be towed, DO NOT allow anyone to go between the tow machine and the machine that is being towed.
- Set the coupling of the machine being towed in a straight line with the towing portion of the tow machine, and secure it in position.

For towing methods, refer to Section 30, Operating Instructions - Towing.

- If acid is accidentally ingested, drink a large quantity of water, milk, beaten eggs or vegetable oil. Call a doctor or poison prevention center immediately.
- When working with batteries always wear safety glasses or goggles.
- Batteries generate hydrogen gas. Hydrogen gas is very explosive and is easily ignited with a small spark of flame.
- Before working with batteries, stop the engine and turn the key switch to the OFF position.
- Avoid short-circuiting the battery terminals through accidental contact with metallic objects, such as tools across the terminals.
- When removing or installing, check which is the positive (+) terminal and negative (-) terminal.
- Tighten battery caps securely.
- Tighten the battery terminals securely. Loose terminals can generate sparks and lead to an explosion.

## WORKING NEAR BATTERIES

### Battery Hazard Prevention

- Battery electrolyte contains sulfuric acid and can quickly burn the skin and eat holes in clothing. If acid comes in contact with any part of the body, immediately flush the area with water.
- Battery acid can cause blindness if splashed into the eyes. If acid gets into the eyes, flush them immediately with large quantities of water and see a doctor at once.

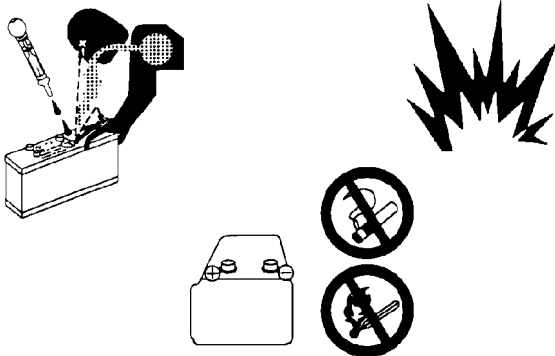

### Starting With Booster Cables

- Always wear safety glasses or goggles when starting the machine with booster cables.
- When using booster cables, DO NOT allow the two machines to touch.
- Connect the positive (+) cable first when installing booster cables. Disconnect the ground or negative (-) cable first during removal.
- If any tool touches between the positive (+) terminal and the chassis, it will cause sparks. Always use caution when using tools near the battery.
- Connect the batteries in parallel: positive to positive and negative to negative.
- When connecting the ground cable to the frame of the machine to be started, connect it away from the battery to minimize the risk of explosion.

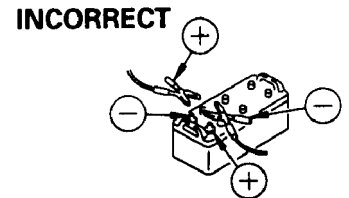

## PRECAUTIONS FOR MAINTENANCE

### BEFORE PERFORMING MAINTENANCE

#### Warning Tag

- Starting the engine or operating the controls while others are performing maintenance on the truck can lead to serious injury and/or death.

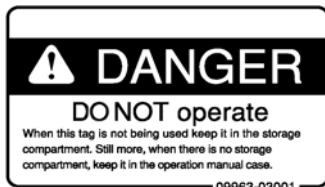

- Always attach the warning tag to the steering wheel in the operator's cab to alert others that you are working on the machine. Attach additional warning tags around the machine, if necessary.
- Tags are available from your Komatsu distributor.
- Warning tag part number (09963-03001)

#### Proper Tools

- Use only tools suited to the task. Using damaged, low quality, faulty, or makeshift tools can cause personal injury.



#### Stopping The Engine Before Service

- Before performing inspections or maintenance, stop the machine on firm, flat ground. Lower the dump body, stop the engine and apply the parking brake.
- If the engine must be operated during service, such as when cleaning the radiator, always move the transmission control lever to the NEUTRAL position and apply the parking brake. Always perform this work with two people. One person must sit in the operator's seat to stop the engine, if necessary. Never move any controls, not related to the task at hand, during these situations.
- When servicing the machine, DO NOT touch any moving parts. Never wear loose clothing or jewelry.
- Put wheel blocks under the wheels to prevent machine movement.
- When performing service with the dump body raised, always place the dump lever in the HOLD position. Install the body-up retention cable, securely.

#### Securing The Dump Body



***Any time personnel are required to perform maintenance on the vehicle with the dump body in the raised position, the body-up retention cable must be installed.***

***The Komatsu body-up retention cable can only be used with a Komatsu body. Non-OEM dump bodies may not accommodate the Komatsu body-up retention cable. The end user must ensure that a proper cable/sling is used.***

- To hold the dump body in the raised position, raise the body to its maximum height. Refer to Figure 20-1.

2. Remove cable (2) from its stored position on the body and install between dump body (1) and the axle housing ear.
3. Secure the cable clevis pins with cotter pins.
4. Move the hoist lever to the FLOAT position to slowly lower the body until the cable is supporting the full weight of the body. Then move the hoist lever to the HOLD position.
5. After maintenance is complete, return the cable to the stored position.

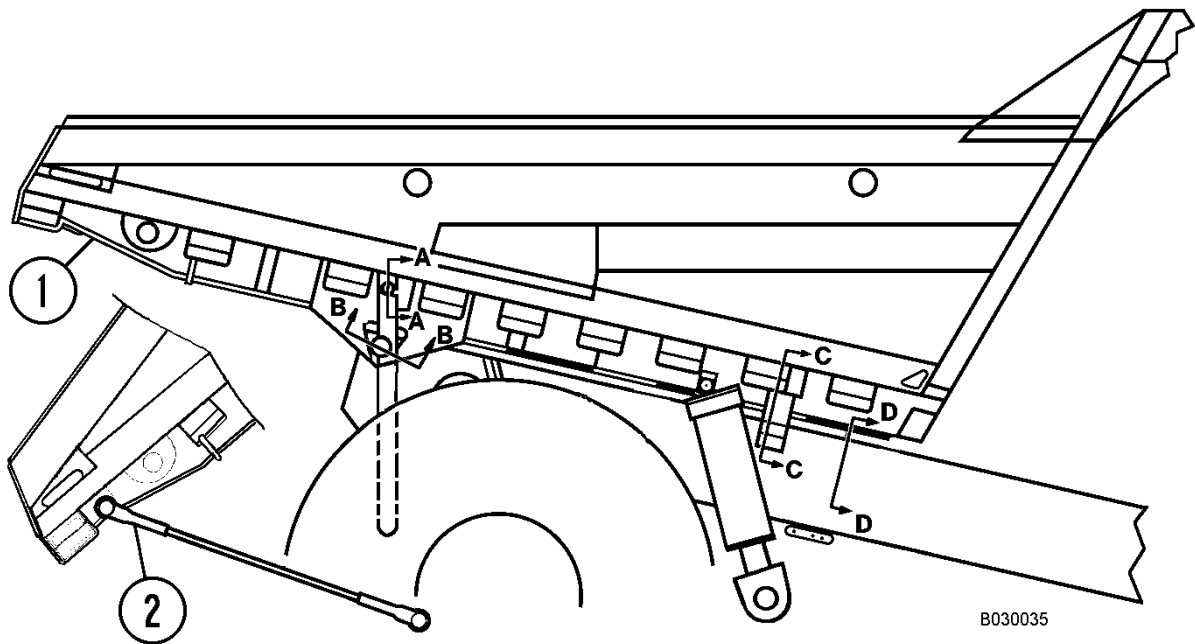

FIGURE 20-1. SECURING THE DUMP BODY

1. Dump Body

2. Body Retention Cable

## DURING MAINTENANCE

### Personnel

- Only authorized personnel may service and repair the machine.

### Attachments

- Place attachments that have been removed from the machine in a safe place and manner to prevent them from falling.



### Working Under The Machine

- Always lower all movable work equipment to the ground or to their lowest position before performing service or repairs under the machine.
- Always block the tires of the machine securely.
- Never work under the machine if the machine is poorly supported.



### Keep The Machine Clean

- Spilled oil or grease, scattered tools, etc. can cause you to slip or trip. Always keep the machine clean and tidy.
- If water gets into the electrical system, there is danger that the machine may move unexpectedly and/or damage to components may occur. DO NOT use water or steam to clean any sensors, connectors, or the inside of the operator's compartment.



## Rules To Follow When Adding Fuel Or Oil

- Spilled fuel and oil may cause slipping. Always clean up spills, immediately. Failure to clean up fuel or oil spills may lead to fires.
- Always tighten the cap of the fuel and oil fillers securely.
- Never use fuel to wash parts.
- Always add fuel and oil in a well-ventilated area.



### Radiator Water Level

- If it is necessary to add coolant to the radiator, stop the engine, and allow the engine and radiator to cool.
- Depress the pressure release button on the cap to vent cooling system pressure.
- Slowly loosen the cap to relieve any remaining pressure during removal.

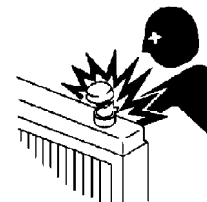

### Use Of Lighting

- When checking fuel, oil, coolant, etc., always use lighting with anti-explosion specifications. If such lighting equipment is not used, there is danger of explosion.





**Precautions With The Battery**

- When repairing the electrical system or when performing electrical welding, remove the negative (-) terminal of the battery to stop the flow of current.

**Handling High Pressure Hoses**

- DO NOT bend high-pressure hoses or hit with hard objects. DO NOT use any bent or cracked piping, tubes or hoses. They may burst during use.
- Always repair any loose or broken hoses. Fuel or oil leaks may result in a fire.

**Precautions With High Pressure Oil**

- Work equipment circuits are always under pressure.
- DO NOT add oil, drain oil, or perform maintenance or inspections before completely releasing the internal pressure.
- Small, high pressure pin-hole leaks are extremely dangerous. The jet of high-pressure oil can pierce the skin and eyes. Always wear safety glasses and thick gloves. Use a piece of cardboard or a sheet of wood to check for oil leakage.
- If you are hit by a jet of high-pressure oil, consult a doctor immediately for medical attention.

**Precautions When Performing Maintenance Near High Temperature Or High Pressure**

- Immediately after stopping operation, engine coolant and operating oils are at high temperature and under high pressure. In these conditions, if the cap is removed, the oil or water drained, or the filters are replaced, it may result in burns or other injury. Wait for the temperature to cool and pressure to subside, before performing the inspection and/or maintenance as outlined in the service manual.

**Rotating Fan And Belts**

- Stay away from rotating parts such as the radiator fan and fan belts. Serious bodily injury may result from direct or indirect contact with rotating parts and flying objects.

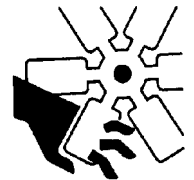
**Waste Materials**

- Never dump waste oil into a sewer system, river, etc.
- Always put used oil in appropriate containers. Never drain oil directly onto the ground.
- Obey appropriate laws and regulations when disposing of harmful objects such as oil, fuel, coolant, solvent, filters, batteries, etc.

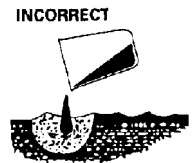

## TIRES

### Tire Maintenance

If the proper tires are not used for the mine conditions, the tires may overheat and burst. Improper tire usage can also lead to cuts from sharp stones resulting in bursting tires. This may lead to serious injury or damage.

To maintain tire safety, always adhere to the following conditions:

- Inflate the tires to the specified pressure. Abnormal heat is generated particularly when the inflation pressure is too low.
- Use the specified tires.

The tire inflation pressure and permissible speeds are general values. The actual values may differ depending on the type of tire and operating conditions. For details, please consult the tire manufacturer.

When tires become hot, a flammable gas is produced inside the tire, and may ignite. It is particularly dangerous if the tires become overheated while the tires are pressurized. If the gas generated inside the tire ignites, the internal pressure will suddenly rise, and the tire will explode, resulting in danger to personnel in the area. Explosions differ from punctures or tire bursts because the destructive force is extremely high. Therefore, the following actions are strictly prohibited when the tire is pressurized:

- Welding the rim
- Welding near the wheel or tire.
- Smoking or creating open flames



If the proper maintenance procedures are not used, the tire may burst and cause serious injury or damage. When performing tire/wheel maintenance, consult your authorized regional Komatsu distributor, or the tire manufacturer for questions regarding tire safety.

Refer to the Society of Automotive Engineers (SAE), SAE J1337, Off-Road Rim Maintenance Procedures and Service Precautions, Section 4.2 for additional information on demounting the tires and rim assemblies. Also, refer to Section 4.4 of SAE J1337 for assembly and inflation recommendations.

The U.S. Department of Labor Mine Safety and Health Administration (MSHA) addresses tire repairs in its Title 30 Code of Federal Regulations, 30 CFR 57.14104.



***DO NOT stand in front of a rim and locking ring when inflating a tire mounted on the machine. Observers must not be permitted in the area.***

***DO NOT weld or heat the rim assembly with the tire mounted on the rim. Resulting gases inside the tire may ignite, causing explosion of the tire and rim.***

### Storing Tires After Removal

- As a basic rule, store the tires in a warehouse that unauthorized persons cannot enter. If the tires are stored outside, erect a barrier around the tires. Install a warning sign that young children can understand.
- Stand the tire on level ground. Block the tire securely so that it cannot roll or fall over.
- If the tire should fall over, flee the area quickly. Tires for mining equipment are extremely heavy. Never attempt to hold or support a tire may lead to serious injury.

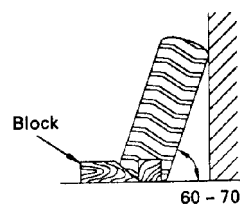

Mounted tires stored as spares must be inflated to the minimum inflation pressure necessary to keep the tire beads properly seated. Maximum inflation pressure of the stored tire must, in no instance, exceed 15% of the tire's cold inflation pressure.

**WHEN REPAIRS ARE NECESSARY**

1. Only qualified maintenance personnel, who understand the systems being repaired, may attempt repairs.
2. Many components on the truck are large and heavy. Ensure that lifting equipment is of adequate capacity to handle the lift.
3. DO NOT stand under a suspended load. DO NOT work under a raised body unless the body retention cable is in place to hold the body in the raised position.
4. DO NOT repair or service the truck while the engine is running, except when absolutely necessary. Keep a safe distance from moving parts.
5. When servicing an air conditioning system charged with refrigerant, wear a face shield and cold resistant gloves for protection against freezing. Follow all current regulations for handling and recycling refrigerants.
6. Follow package directions carefully when using cleaning solvents.
7. If an auxiliary battery assist is needed, first use one cable to connect the 24V positive (+) post of the disabled truck batteries to the 24V positive (+) post of the auxiliary assist. Use the second cable to connect the 24V negative (-) post of the auxiliary assist battery to a frame ground (-) on the disabled truck, away from the battery.
8. Always disconnect the positive and negative battery cables of the vehicle before doing any welding on the unit. Failure to do so may seriously damage the battery and electrical equipment. Disconnect the battery charging alternator lead wire and isolate electronic control components before making weld repairs.

Always fasten the welding machine ground (-) lead to the piece being welded. The grounding clamp must be attached, as near as possible, to the weld area. Never allow welding current to pass through ball bearings, roller bearings, suspensions, or hydraulic cylinders. Avoid laying welding cables over or near the vehicle electrical harnesses. Welding voltage could be induced into the electrical harness and cause damage to components.

9. If the truck is to be towed for any reason, always consider any special precautions. Refer to Section 30, Operating Instructions - Towing, for instructions on how to properly tow the truck.
10. Drain, clean and ventilate fuel tanks and/or hydraulic tanks before making any welding repairs.
11. Relieve pressure in lines or hoses before making any disconnects.

**WARNING**

***Any operating fluid, such as hydraulic oil escaping under pressure, can have sufficient force to enter a person's body by penetrating the skin. Serious injury and possibly death may result if proper medical treatment by a physician familiar with this injury is not received immediately.***

12. After adjustments or repairs, replace all shields, screens and clamps.
13. Use extreme caution when working near tires and rims.:

**WARNING**

***DO NOT stand in front of a rim and locking ring when inflating a tire mounted on the machine. Observers must not be permitted in the area and must be kept away from the sides of such tires.***

***DO NOT weld or heat the rim assembly with the tire mounted on the rim. Gases inside the tire may ignite, causing explosion of the tire and rim.***

14. Only a qualified operator may operate the truck in the repair facility or during road testing after repairs are complete.



## WARNINGS AND CAUTIONS

The following pages give an explanation of the Warning, Caution, and Service Instruction plates and decals attached to the truck. The plates and decals listed here are typical of this truck model, but because of customer options, individual trucks may have plates and decals that are different from those shown here.

The plates and decals must be kept clean and legible. If any decal or plate becomes unable to be read or damaged, it should be replaced with a new one.

A warning decal is located at the lower right side of the instrument panel and below the key switch. The warning stresses the importance of reading the operator's manual before operation.

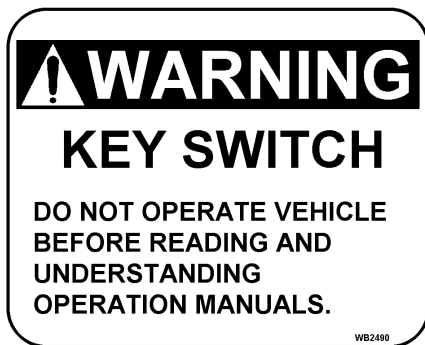

A warning decal is located to the far right of the instrument panel and below the auxiliary brake switch.

Depress the center button to apply the auxiliary brake. The red lamp will illuminate.

Pull the button out to release the auxiliary brake; the light will turn off.



***When the auxiliary brake switch is activated, full, unmodulated hydraulic brake pressure is applied to all wheels. The parking brake is also applied.***

***Never apply the auxiliary brake switch when the truck is moving, except as an emergency measure.***

A grade/speed retard plate showing retarding capacities is located on the left front post of the operator's cab and provides the recommended maximum speeds to be used when descending various grades with a loaded truck.

**⚠ WARNING**

**RETARDING CAPACITY**  
**GVW: 550,000 LBS.**  
**(249,478 kg)**  
**TIRES: 33 X 51**

**MAX. BRAKE OIL TEMPERATURE: 248°F (120°C)**  
**MAX. ENGINE SPEED: 2100 RPM**

**MAINTAIN HIGHEST ENGINE SPEED BELOW MAX. SLOW TO NEXT LOWEST GEAR, IF COOLING OIL TEMPERATURE NEEDS TO BE LOWERED.**

GEAR	SPEED		CONTINUOUS GRADE %	SHORT LENGTH
	MPH	(KM/H)		1,970 FT. (600m)
1	6.4	(10.3)	22.5 %	26.5 %
2	8.6	(13.8)	16.5 %	20.5 %
3	11.4	(18.4)	11.5 %	16.0 %
4	14.4	(23.2)	9.0 %	13.0 %
5	19.2	(31.0)	6.0 %	10.0 %
6	26.1	(42.1)	4.0 %	8.0 %
7	34.8	(56.1)	2.5 %	6.5 %

EG4453

Refer to Operating Instructions, Section 30, Hauling/Retarder Operation, for complete details regarding the use of the information on this chart.

Always refer to the decal in operator's cab. This decal may change with optional truck equipment such as: tire sizes, etc.

ROPS/FOPS No. **EK4277** MACHINE MODEL **HD1500-5**  
AS INSTALLED BY THE MANUFACTURER ON THIS DUMPER WITH EMPTY WEIGHT LESS THAN **107,600** kg. AND WEIGHT WITHOUT BODY LESS THAN **83,500** kg. THIS ROLLOVER PROTECTIVE STRUCTURE AND FALLING OBJECT PROTECTIVE STRUCTURE MEETS THE PERFORMANCE REQUIREMENTS OF SAE-J1040 APR 88, SAE-J231 JAN 81, AND SAE-J1164 MAY 83.

**⚠ WARNING** THE PROTECTION OFFERED MAY BE IMPAIRED IF SUBJECTED TO ANY MODIFICATIONS OR DAMAGE. TO MAINTAIN MANUFACTURERS CERTIFICATION, ANY REPAIR OR ALTERATION ON THIS STRUCTURE MUST HAVE WRITTEN APPROVAL.

**Komatsu America Corporation**  
**2300 NE Adams St, Peoria, IL 61650-0240**

EK4650

A plate attached to the right rear corner of the cab states the Rollover Protective Structure (ROPS) and Falling Object Protective Structure (FOPS) meets various SAE performance requirements.

***! WARNING ! Do not make modifications to this structure, or attempt to repair damage without written approval from Komatsu. Unauthorized repairs will void certification.***

Danger plates are mounted on each suspension and accumulator cylinder. These plates warn that the suspensions and accumulators are charged with high pressure nitrogen. No servicing of any kind should be attempted until the service manual has been referenced and proper and safe procedures are followed.

**⚠ DANGER**

HIGH PRESSURE CYLINDER CHARGED WITH DRY NITROGEN

DO NOT REMOVE ANY HARDWARE INCLUDING CAPSCREWS, PLUGS, VALVE OR VALVE CORE UNTIL ALL PRESSURE HAS BEEN RELEASED. REMOVAL OF ANY HARDWARE WHILE CYLINDER IS UNDER PRESSURE MAY RESULT IN HARDWARE FLYING FROM CYLINDER. REFER TO OPERATION AND MAINTENANCE MANUAL OR SHOP MANUAL FOR PRESSURE RELEASE INSTRUCTIONS.

1. CHECK OIL LEVEL ACCORDING TO INSTRUCTION MANUAL.
2. CHARGE CYLINDER WITH DRY NITROGEN GAS ONLY.

TO CHARGE CYLINDER: SEE YOUR HAULPAK DISTRIBUTOR FOR ALL TOOLS AND INFORMATION REQUIRED FOR CHARGING CYLINDERS

EB9099

Warning plates are attached to both the hydraulic tank and fuel tank to alert technicians not to work on the truck with the body in the raised position unless body-up retention cable is in position.

**⚠ WARNING**

**DO NOT WORK  
UNDER RAISED  
BODY UNLESS  
SAFETY  
DEVICE(S) ARE  
IN POSITION.**

WB1019

A plate is mounted on the left hand side of the transmission oil pan to provide instructions for proper transmission oil level check.

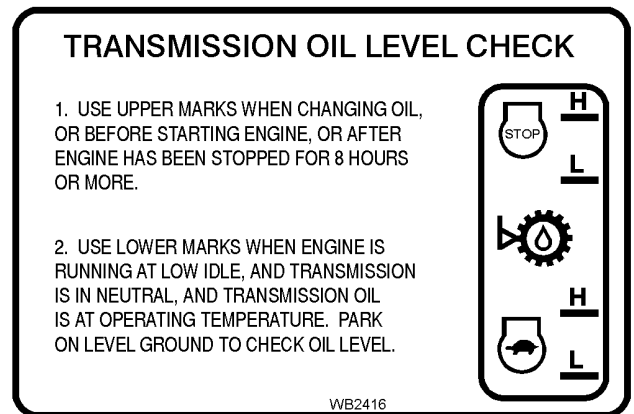

Warning plates are mounted on the truck frame in front of and to the rear of both front tires to alert all persons to stay clear when the truck is being steered.

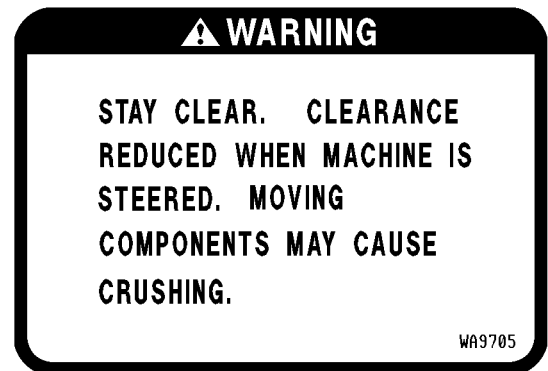

A warning plate is mounted on top of the radiator surge tank cover near the radiator cap. The engine cooling system is pressurized. Always turn the key switch off and allow the engine to cool before removing radiator cap. Unless the pressure is first released, removing the radiator cap after the engine has been running for a time will result in the hot coolant being expelled from the radiator. Serious scalding and burning can result.

***Use caution when servicing radiator. The system is pressurized because of thermal expansion of coolant. DO NOT remove the radiator cap while the engine is hot. Severe burns may result.***

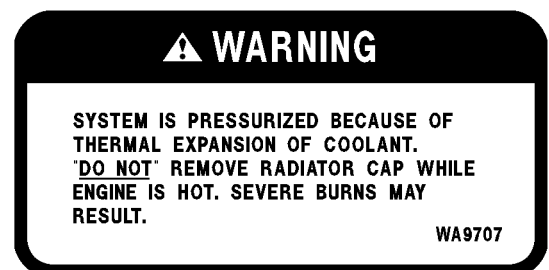

A plate on the side of the hydraulic tank furnishes instructions for filling the hydraulic tank.

Keep the system open to the atmosphere only as long as absolutely necessary to lessen chances of system contamination. Service the tank with clean Type C-4 hydraulic oil. All oil being put into the hydraulic tank should be filtered through 3 micron filters.

A caution decal is attached below the hydraulic tank oil level sight gauge. Check level with body down, engine stopped, and key switch OFF (to assure pressure has been relieved from system) before removing filler cap. Add oil per filling instructions, if oil level is below top of sight glass.

A warning plate is attached to the frame above the hydraulic system (APU) quick disconnect fittings to alert technicians that high pressure hydraulic oil is present during operation. Care must be taken when it is necessary to open the hydraulic system. There is always a chance of residual pressure being present. Open fittings slowly to allow any pressure to bleed off before removing any connections.

***Any operating fluid, such as hydraulic oil, escaping under pressure can have sufficient force to enter a person's body by penetrating the skin. Serious injury and possibly death may result if proper medical treatment by a physician familiar with this injury is not received immediately.***

## HYDRAULIC OIL LEVEL CHECK

**CAUTION: PRESSURIZED TANK, RELIEVE PRESSURE WITH BLOW-DOWN VALVE ON TOP OF TANK.**

### FILLING INSTRUCTIONS:

1. WITH ENGINE STOPPED, KEY SWITCH OFF, AND BODY DOWN, FILL TANK TO TOP SIGHT GLASS.
2. RAISE AND LOWER BODY THREE TIMES.
3. REPEAT STEPS 1 & 2 AND ADD OIL UNTIL LEVEL IS AGAIN AT TOP SIGHT GLASS.
4. IF LEVEL FALLS BELOW LOWER SIGHT GLASS WITH ENGINE RUNNING, & BODY DOWN, REPEAT STEP 1.

EG7804

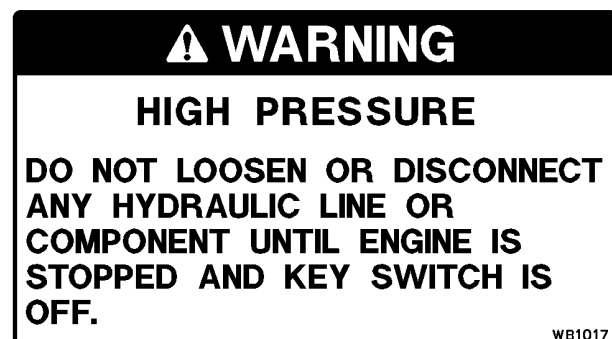



A plate is located next to filler cap on fuel cap which specifies diesel fuel only. Refer to the Engine Operation and Maintenance Manual.

Attached to the interior of battery box lid is a danger plate. This plate stresses the need to keep from making any sparks near the battery. When another battery or 24VDC power source is used for auxiliary power, all switches must be OFF prior to making any connections. When connecting auxiliary power cables, positively maintain correct polarity; connect the positive (+) leads together and then connect the negative (-) lead of the auxiliary power cable to a good frame ground. Do not connect to the negative post of the truck battery or near the battery box. This hookup completes the circuit but minimizes danger of sparks near the batteries. Sulfuric acid is corrosive and toxic. Use proper safety gear, goggles, rubber gloves and rubber apron when handling and servicing batteries. Avoid contact with skin, eyes or clothing. In event of accident, immediately flush with plenty of water and call a physician. KEEP OUT OF REACH OF CHILDREN!

These decals are placed on the top of the battery box and near the battery disconnect switches to indicate that the battery system (24VDC) is a negative (-) ground system. This decal is placed above the battery disconnect switches on the right side of the battery box to indicate OFF and ON positions of the switches.

A caution plate is located on the side of the battery box.

These instructions must be followed when welding is done on the truck to avoid damage to the electronic components.

## DIESEL FUEL ONLY

(SEE YOUR OPERATION AND MAINTENANCE MANUAL FOR DETAILS.)

-DRAIN WATER FROM THE FUEL TANK AT THE BEGINNING OF THE DAY'S RUN.

EB9094

## POISON ⚠ DANGER

### CAUSES SEVERE BURNS

CONTAINS SULFURIC ACID. BATTERIES PRODUCE EXPLOSIVE GASES, KEEP SPARKS, FLAMES, CIGARETTES AWAY. VENTILATE WHEN CHARGING OR USING IN ENCLOSED SPACE. WHEN USING A CHARGER - TO AVOID SPARKS NEVER CONNECT OR DISCONNECT CHARGER CLIPS TO BATTERY WHILE CHARGER IS TURNED ON. ALWAYS SHIELD EYES, PROTECT SKIN AND CLOTHING WHEN WORKING NEAR BATTERIES.

ANTIDOTE: EXTERNAL - FLUSH WITH WATER. EYES - FLUSH WITH WATER 15 MINUTES AND GET PROPER MEDICAL ATTENTION. INTERNAL - DRINK LARGE QUANTITIES WATER OR MILK. FOLLOW WITH MILK OF MAGNESIA, BEATEN EGG OR VEGETABLE OIL, CALL PHYSICIAN IMMEDIATELY.

WA9704

## NEG. GROUND

WA9702

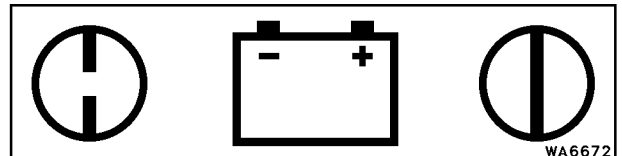

WA6672

## ⚠ CAUTION

### PRIOR TO WELDING ON TRUCK

- 1) DISCONNECT THE FOLLOWING TERMINALS
  - BATTERY (GROUND)
  - ALTERNATOR TERMINAL (B)
  - EVERY ELECTRONIC CONTROLLER JUNCTION
- 2) COVER ALL ELECTRONIC CONTROLLERS FOR PROTECTION FROM SPARKS.
- 3) DO NOT CONNECT WELDING CABLES TO THE CONTROLLERS.
- 4) DO NOT WELD ON THE CONTROLLERS.
- 5) REMOVE THE CONTROLLER UNIT IF WELDING IS TO BE DONE WITHIN 10" OF IT.

EF8595

A product identification plate is located on the right hand frame rail near the front bumper. This lists the vehicle model number, maximum G.V.W. and Product Identification Number. The Product Identification Number (vehicle serial number) contains information which will identify the original manufacturing bill of material for this unit. This complete number will be necessary for the proper ordering of many service parts and/or warranty consideration.

**Komatsu Mining Systems, Inc.**  
2300 NE Adams St  
Peoria, IL 61650-0240

# KOMATSU

**Model No.** **Max. G.V.W.**

**Product Identification Number**

ASSEMBLED IN THE U.S.A.  
FROM U.S.A. AND FOREIGN COMPONENTS

DO NOT DEFACE OR REMOVE THIS PLATE

WB2576

The lubrication chart is located on the left hand front fender behind the ladder. Refer to Maintenance - Section 40, Lubrication and Service, for more complete lubrication instructions.

## LUBRICATION CHART

LUBRICATION SPECIFICATION

LUBE KEY	TYPE LUBRICANT	-55°C TO -32°C		-32°C TO 0°C		0°C TO 32°C		ABOVE 32°C		ABOVE 40°C	
		-65°F TO -25°F		-25°F TO +32°F		+32°F TO +90°F		ABOVE 90°F		ABOVE 105°F	
A	ENGINE OIL	SEE ENG MAN*		SEE ENG MAN*		SEE ENG MAN		SEE ENG MAN		SEE ENG MAN	
B	HYDRAULIC OIL	T030/SAE 30W	T030/SAE 30W	T030/SAE 30W	T030/SAE 30W	T030/SAE 30W OR T050/SAE 50W	T030/SAE 30W OR T050/SAE 50W	T050/SAE 50W		T050/SAE 50W	
C	HYDRAULIC OIL	T010/SAE 10W*	T010/SAE 10W*	T030/SAE 30W	T030/SAE 30W	T030/SAE 30W	T030/SAE 30W	T030/SAE 30W		T030/SAE 30W	
D	MOLYDISULPHIDE LUBE	#0	#1	#1	#2	#2	#2	#2		#2	
E	HYDRAULIC OIL	SEE SER. MAN		SEE SER. MAN		SEE SER. MAN		SEE SER. MAN		SEE SER. MAN	
F	DRIVESHAFT GREASE	56B-20-19910									

DESCRIPTION	SYMPTS	L KEY	56B-20-19910								
			10 HR	50 HR	250 HR	500 HR	1000 HR	2000 HR	5000 HR		
ENGINE CRANKCASE OIL	1 1	A	CHECK			SEE ENG MANUAL					
ENGINE LUBE FILTERS	2 3					SEE ENG MANUAL					
ENGINE CRANKCASE BRTHR	3 2							CLEAN			
TRANSMISSION OIL	4 1	C	CHECK					CHANGE			
TRANS CASE BREATHER	5 1					CLEAN					
TRANS OIL FILTER	6 1							CHANGE			
TRANS STRAINERS	7 3							CLEAN			
HYD TANK (HST/STRG/BK/FRT AXLE)	8 3	C	CHECK						CHANGE		
HYD TANK BREATHER	9 1					CHANGE					
HYDRAULIC FILTERS	10 4							CHANGE			
HYD TANK STRAINERS	11 4								CLEAN		
DIFF CASE BREATHER	12 1					CLEAN					
DIFFERENTIAL CASE	13 1	B				CHECK			CHANGE		
FINAL DRIVE CASE	14 2	B				CHECK			CHANGE		
FUEL FILTERS	15 3					SEE ENG MANUAL					
CORROSION RESISTORS	16 2					SEE ENG MANUAL					
PARKING BRAKE	17 6	D				CHECK			GREASE		
LUBRICANT RSVR	18 1	D				CHECK					
DRIVESHAFT U-JOINTS	19 2	F									GREASE

EK4507-0

\* AUXILIARY HEATERS REQUIRED BELOW -23°C (-10°F)

## OPERATING INSTRUCTIONS

### PREPARING FOR OPERATION

The safest trucks are those which have been properly prepared for operation. At the beginning of each shift, a careful check of the truck should be performed by the operator before attempting to start the engine.

#### Safety Is Thinking Ahead

Prevention is the best safety program. Prevent a potential accident by knowing the employer's safety requirements and all necessary job site regulations. Be familiar with use and care of the safety equipment on the Komatsu HD1500-5 truck. Only qualified operators or technicians should attempt to operate or maintain the HD1500-5 truck.

Safe practices start before the operator gets to the equipment!

- Wear the proper clothing. Loose fitting clothing, unbuttoned sleeves and jackets, jewelry, etc., can catch on a protrusion and cause a potential hazard.
- Always use the personal safety equipment provided for the operator such as hard hat, safety shoes, safety glasses or goggles. There are some conditions when protective hearing devices should also be worn for operator safety.
- When walking to and from the truck, maintain a safe distance from all machines even if the operator is visible.

#### At The Truck - Ground Level Walk Around Inspection

At the beginning of each shift, a careful walk around inspection of the truck should be performed before the operator attempts engine start-up. A walk around inspection is a systematic ground level inspection of the truck and its components to ensure that the truck is safe to operate before entering the operator's cab.

Start at the left front corner of the truck (see illustration, next page), and move in a counter-clockwise direction, front-to-rear, across the rear. Continue forward up the opposite side of the truck to the original starting point. If these steps are performed in sequence, and are repeated from the same point and in the same direction before every shift, many potential problems can be avoided.

If problems or potential problems are found during the "walk-around", be sure to notify maintenance. Vehicle breakdowns and unscheduled downtime and loss of production can be reduced.

Local work practices may prevent an operator from performing all tasks suggested here, but to the extent permitted, the operator should follow this or a similar routine.

1. Start at left front of the truck (see illustration, next page). While performing the walk around inspection, visually inspect all lights and safety equipment for external damage from rocks or misuse. Make sure lenses are clean and are not cracked or broken.
2. Move behind the front of the left front tire; inspect the hub and the oil disc brake assemblies for leaks and any abnormal conditions.  
  
Check that all suspension attaching hardware is secure and inspect for evidence of wear. Verify suspension extension (exposed piston rod) is correct, and there are no leaks.
3. With the engine stopped, check the engine oil level. Verify engine oil filters or oil lines to filters are not leaking.
4. Inspect the fan and air conditioner belts for correct tension, wear, and tracking. Inspect the fan guard condition and secureness.
5. Move outboard of the front wheel, and inspect attaching lugs/wedges to be sure all are tight and intact. Check the tires for cuts, damage or bubbles and under-inflation.
6. Move behind the rear of the front wheel. Check for leaks or any unusual conditions at the hub and brakes. Inspect the suspension hardware. Inspect the tie-rod pivots and steering cylinder for proper greasing, and for secureness of all parts. Check for hydraulic leaks.
7. Check the transmission oil level. Check the pumps at the front of the transmission for leakage and secureness of parts.

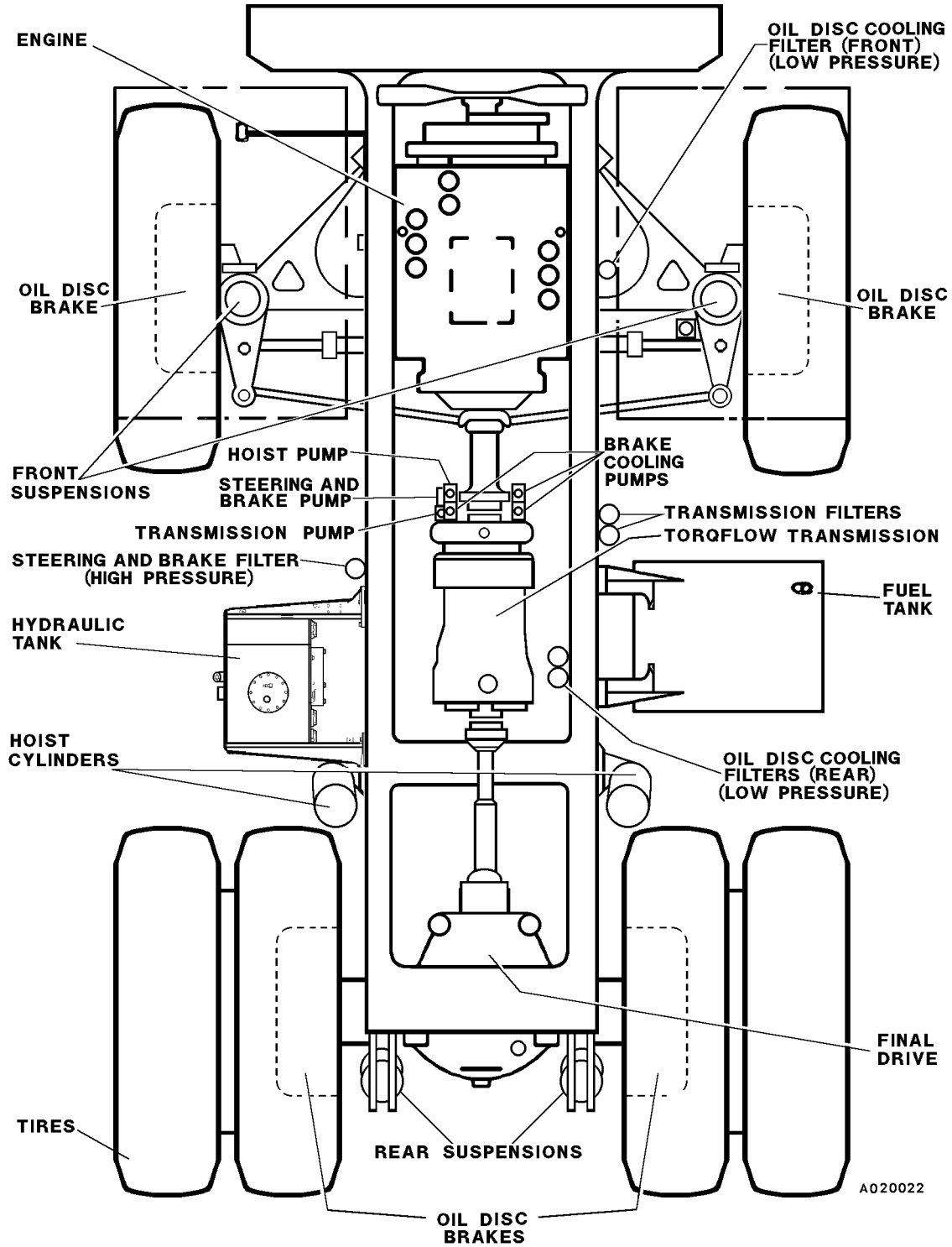

## KOMATSU HD1500-5 TRUCK

8. Move to the side of the hydraulic tank and check the hydraulic fluid level for both the hydraulic tank and brake cooling oil. Oil should be visible in the sight glass with the engine stopped and body down.
9. Move around the hydraulic tank and in front of the rear dual tires. Inspect the hoist cylinder for damage or leaks. Inspect the upper and lower hoist cylinder pins for secureness and proper greasing.
10. Before leaving this position, verify there is no leakage or any other unusual condition with the transmission or rear drive shaft.
11. Move around the dual tires. Verify all lugs/wedges are intact and tight. Check the wheel for leakage from inside the wheel housing that might indicate planetary leakage. Check the dual tires for cuts, damage, bubbles and under-inflation. If the truck has been operating on a flat tire, the tire must be cool before parking the truck inside. Check for rocks that might be lodged between the dual tires, and verify that the rock ejector is in good condition and straight.
12. Check the left rear suspension for damage, proper extension, and leaks. Check for proper greasing. Ensure the covers over the chrome piston rod are in good condition.
13. Check the final drive housing breather. Replace the breather if obstructed. Check for leakage around the final drive housing, brake housings, and connecting hoses.
14. While standing behind the final drive housing, look up to see that the rear lights and back up horns are in good condition. Inspect the linkage rods to verify all locations are getting proper greasing. Check both body hinge pins for greasing and any abnormal condition.
15. Perform the same inspection on the right rear suspension as done on the left.
16. Move to the right dual tires. Check between the tires for rocks. Check rock ejector condition. Inspect the tires for cuts, damage, and under-inflation.
17. Check the wheel lugs/wedges as done on the left dual wheels. Check for leaks.
18. Move in front of the right dual tires. Inspect the hoist cylinder as was done on the left side.
19. Move around the fuel tank. Inspect the fuel gauge. Inspect the attaching hardware for the fuel tank at the upper saddles, and then at the lower back of the tank. Ensure the mounts are secure and in good condition.
20. Move behind the right front wheel, and inspect the tie-rod pivots and steering cylinder for proper greasing. Ensure all parts are secure. Ensure the suspension protective cover is in good condition. Check the suspension attaching hardware, suspension extension, and greasing. Inspect the attaching hardware for the steering cylinder.
21. Move around the right front wheel, and verify all lugs/wedges are intact and tight.
22. Move behind the front of the right front wheel. Check the hub and brake for leaks or any unusual condition. Inspect the engine compartment for leaks or any unusual condition. Inspect the fan guard and belts. Check for, and remove any debris from behind the radiator.
23. Move around to the right front of the truck.
24. As you move in front of the radiator, check for and remove debris that might be trapped in front of the radiator. Check for coolant leaks. Inspect all headlamps and fog lights.
25. Ensure the ground level engine shutdown switch is ON.
26. Climb the ladder to the main deck. Always use the hand rails and ladder when mounting or dismounting the truck. Clean the ladder and hand rails of any foreign material, such as ice, snow, oil or mud.



***Always mount and dismount ladders facing the truck. Never attempt to mount or dismount while the truck is in motion.***

27. Checking the coolant in the radiator using the coolant level sight gauge.

## **⚠ WARNING**

***If the engine has been running, allow the coolant to cool before removing the fill cap or draining the radiator. Serious burns may be acquired if you come in contact with hot coolant. Always depress the pressure relief before removing the cap.***

28. Inspect the battery box cover for damage. Ensure the cover is secured, tightly.
29. Check the air cleaner indicators. If the red area is showing in the indicator, the air filter must be cleaned/replaced before operating the truck.
30. Clean the cab windows and mirrors. Clean the cab floor as necessary. Ensure the steering wheel, controls and pedals are free of any oil, grease or mud.
31. Stow personal gear in the cab so that it does not interfere with any operation of the truck. Dirt or trash buildup, specifically in the operator's cab, should be cleared. Do not carry tools or supplies in the cab or on the deck.
32. Adjust the seat and steering wheel so that it is comfortable for use.
33. Read and understand Operator Controls and Instrument Panel. Become familiar with all control locations and functions before operating the truck.

## **ENGINE START-UP SAFETY PRACTICES**

Safety rules must be observed upon engine start-up.

## **⚠ WARNING**

***Ensure there is adequate ventilation before start-up if the truck is in an enclosure. Exhaust fumes are dangerous!***

1. Ensure all personnel are clear of the truck before starting the engine. Always sound the horn as a warning before actuating operational controls.

2. Ensure the transmission range selector is in NEUTRAL and the parking brake is applied before starting.
3. Do not attempt to start the engine while the cold weather starting heater (if equipped) is operating. Damage to coolant heaters will result due to lack of circulation.
4. The key switch is a three position (OFF, RUN, START) switch.

When the key slot is in the vertical position, the electrical system is OFF and no electrical devices are energized.

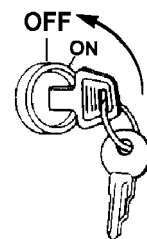

**Key Off**

Use this key position to stop the engine when it is operating.

When the switch is rotated one position clockwise, it is in the RUN position and all electrical circuits (except START) are energized.

With the transmission selector lever in NEUTRAL and the parking brake applied, rotate the key switch fully clockwise to the START position, and hold this position until the engine starts (see NOTE below). The START position is spring loaded to return to RUN when the key is released.

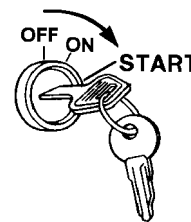

**Start Engine**

**NOTE:** *The engine is equipped with an oil prelube system. A noticeable time delay will occur (while engine lube oil passages are being filled) before cranking motor engagement and engine cranking will begin. The colder the engine oil temperature, the longer the time delay will be. In addition, if the truck is also equipped with an engine starting aid for cold weather starting, the engine prelube system should be engaged, first for 5-10 seconds, or until the cranking motor is engaged, before activating the engine starting aid.*

## **⚠ WARNING**

***Starting fluid is extremely volatile and flammable! Use with extreme care.***

If the truck is equipped with engine starting aid for cold weather starting, and ambient temperature is below  $-5^{\circ}\text{C}$  ( $23^{\circ}\text{F}$ ), push the engine starting aid switch "in" for three seconds, then release. Turn the key switch to the START position. If the engine does not start, wait at least 15 seconds before repeating the procedure.

Do not crank an electric cranking motor for more than 30 seconds. Allow two minutes for the motor to cool before attempting to start the engine again. Severe damage to the cranking motor may result from overheating.

5. The truck cannot be push started. Transmission lube and control systems are inoperative when the engine is not running.
6. When jumping battery power from one truck to another, all switches must be OFF prior to making any connections. Be certain to maintain correct polarity. Connect one lead of the booster cable to the 24V positive (+) post of battery needing assist, and the other lead of the booster cable to the 24V positive (+) post of the auxiliary battery. Connect one lead of the second booster cable to the 24V negative (-) post of the auxiliary battery and then connect the other lead of the booster cable to a good frame ground on the disabled truck away from the battery needing assist. This procedure will avoid the possibility of causing sparks near the battery where explosive gases may be present.

*NOTE: HD1500-5 trucks are equipped with four 12 volt batteries connected in series and parallel to provide 24 volt output. Be certain to maintain correct voltage and polarity when connecting booster cables. Damage to electrical components may result if voltage and polarity are not correct.*

## EMERGENCY STEERING SYSTEM

### Operation

This truck is equipped with an emergency steering system. This system is a backup in the event of loss of oil supply to the main steering system. The emergency steering system was designed to meet or exceed SAE J1511 and ISO 5010 standards.

If the low steering system pressure indicator light and alarm are activated, a failure in the hydraulic oil supply to the steering and brake system exists. When the alarm is activated, typically there is enough hydraulic pressure stored in the brake and steering accumulators to allow brief operation of the steering and brakes. However, this oil supply is limited. Therefore, it is important to stop the truck as quickly and safely as possible after the alarm is first activated.

If the oil supply pressure drops to a predetermined level, the low brake pressure warning light will also illuminate. If the oil pressure continues to decrease, the brake auto-apply feature will activate the service brakes to stop the truck.

### Pre-Operation Testing

Komatsu recommends that operators perform this test to verify that the steering accumulator precharge pressure is adequate at the beginning of each shift before operating the truck.

1. Park the empty truck on flat, level ground. Lower the dump body onto the frame and stop the engine. Verify that the key switch is in the OFF position.
2. Wait at least 90 seconds to verify that all hydraulic pressure has been relieved from the steering accumulators. Turn the steering wheel from stop to stop. If the front wheels do not move, there is no hydraulic pressure.
3. Check the hydraulic tank oil level. The oil level must be visible in the center of the upper sight glass and must not cover the entire upper sight glass. Add oil if necessary. Do not overfill.

4. Turn the key switch to the ON position, but do not start the engine.
  - a. Steering system pressure: Verify that the low steering pressure warning light is illuminated. If it is not illuminated, immediately notify maintenance personnel. Do not operate the truck until the problem is corrected.
  - b. Steering accumulator pressure: Verify that the low accumulator charge warning light is not illuminated and the warning buzzer is not sounding. If the warning light is illuminated and the buzzer is sounding, immediately notify maintenance personnel. Do not operate the truck until the problem is corrected.
5. Start the engine and allow the steering accumulators to fully charge. Turn the steering wheel so that the front wheels are straight.
6. Check the hydraulic tank oil level while the engine is on.
  - a. If the oil level is visible in center of the lower sight glass and does not cover the entire lower sight glass, the steering accumulators are adequately charged. Proceed to Step 7.
  - b. If the oil level is below the lower sight glass, the steering accumulators are not adequately charged. Stop the engine and turn the key switch to the OFF position. Immediately notify maintenance personnel. Do not operate the truck until the problem is corrected.
7. If the truck passes this test, the emergency steering system is functioning properly.

## AFTER THE ENGINE HAS STARTED

After the engine has been started, operate at approximately 1000 rpm, until the coolant temperature gauge is indicating "normal" (green) range.

Become thoroughly familiar with the steering, braking, and emergency controls.



***During the following safety checks, if actuation or release of any steering, brake or emergency control circuit does not appear normal, shut the engine down, immediately, and notify maintenance personnel. Do not operate the truck until the system in question is fully operational. Ensure the area around the truck is clear before testing.***

### Steering

1. Test the truck steering in extreme right and left directions. If the steering system is not operating properly, shut the engine off, immediately. Determine the problem, and repair before resuming operation.

***NOTE: The steering and brake systems each have two accumulators that store energy and provide capability to steer and stop the truck in the event of an unexpected engine shutdown or pump failure.***

***As part of the routine maintenance of the vehicle, one requirement to ensure proper operation of each system is to maintain proper accumulator nitrogen pre-charge. Refer to the shop manual for proper procedures when charging the accumulators.***



**Service Brake**

2. With the truck on flat ground, check for normal operation of the service (foot) brake:
  - a. Depress foot brake pedal (1, Figure 30-1). Verify amber service brake lamp (4) in left pod illuminates.
  - b. Move transmission range selector (2, Figure 30-2) to the D position and gradually increase engine speed to 1700 rpm. The truck must remain stationary. (Placing the range selector in D ensures that the transmission will start in F2.)
  - c. Reduce engine speed to low idle, release the service brake and place the range selector in N. Verify the service brake lamp is off.

**Retarder**

3. With the truck on flat ground, check retarder operation:
  - a. Move retarder lever (2, Figure 30-1) to maximum retard position (lever down). Verify amber service brake lamp (4) in the left pod illuminates.
  - b. Move the transmission range selector to the D position and gradually increase engine speed to 1700 rpm. The truck must remain stationary. (Placing the range selector in D ensures the transmission will start in F2.)
  - c. Reduce engine speed to low idle. Move the retarder lever to OFF (lever up). The service brake lamp should turn off. Place range selector in NEUTRAL.

**Parking Brake**

4. Check operation of the parking brake:
  - a. Depress parking brake switch (3, Figure 30-1) to the ON (applied) position. Verify the red parking brake lamp (5) in left pod illuminates.
  - b. Move transmission range selector (2, Figure 30-2) to any position other than N; verify central warning lamp (6) on the left pod flashes.

- c. Move transmission range selector to the D position and gradually increase engine speed to 1550 rpm. (Placing the range selector in D ensures that the transmission will start in F2.) The truck must remain stationary. If the truck moves, notify maintenance personnel to adjust the parking brake. DO NOT operate the truck until the parking brake is fully operational.
- d. Reduce engine speed to low idle. Place the selector lever in NEUTRAL.

**Auxiliary Brake**

5. Check operation of the auxiliary brake:
  - a. Depress auxiliary brake switch (3, Figure 30-1) to select the ON (applied) position. Verify the internal red lamp and service brake lamp illuminate.
  - b. Move the transmission range selector to 5 and gradually increase engine speed to full throttle. (Placing the range selector in 5 ensures the transmission will start in F1.) The truck must remain stationary.



***If the truck moves, notify maintenance personnel to immediately repair the brakes. DO NOT operate the truck until the auxiliary brake is fully operational.***

- c. Reduce engine speed to low idle. Place the range selector lever in NEUTRAL. Switch the auxiliary brake OFF. Verify the red indicator lamp and service brake lamp are off.

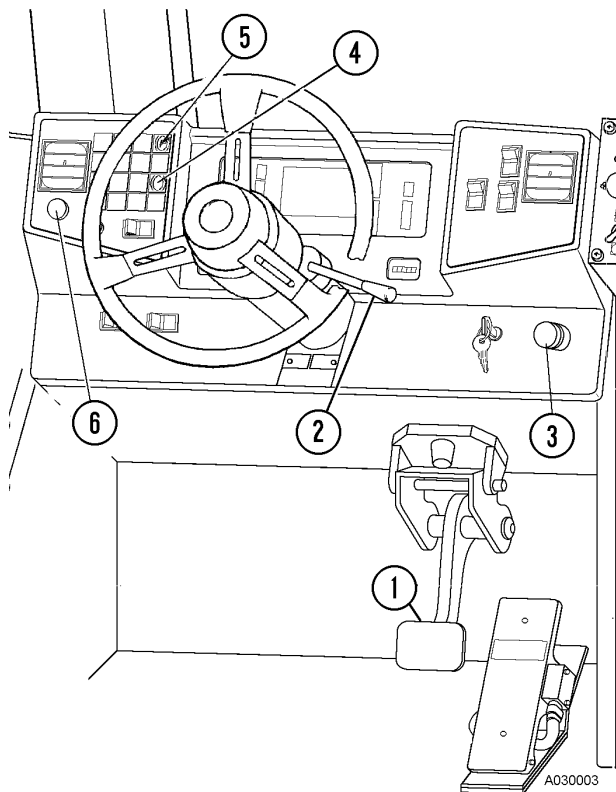

FIGURE 30-1. BRAKE SYSTEM CONTROLS

- |                           |                         |
|---------------------------|-------------------------|
| 1. Service Brake          | 4. Service Brake Lamp   |
| 2. Retarder Lever         | 5. Parking Brake Lamp   |
| 3. Auxiliary Brake Switch | 6. Central Warning Lamp |

6. Check the gauges, warning lights and instruments before moving the truck to ensure proper system operation and proper instrument functioning. Give special attention to braking and steering circuit warning lights. If warning lights illuminate, shut down the engine, immediately, and determine the cause.
7. Ensure the headlights, worklights and taillights are in proper working order. Good visibility may prevent an accident. Check the operation of the windshield wiper and washer.

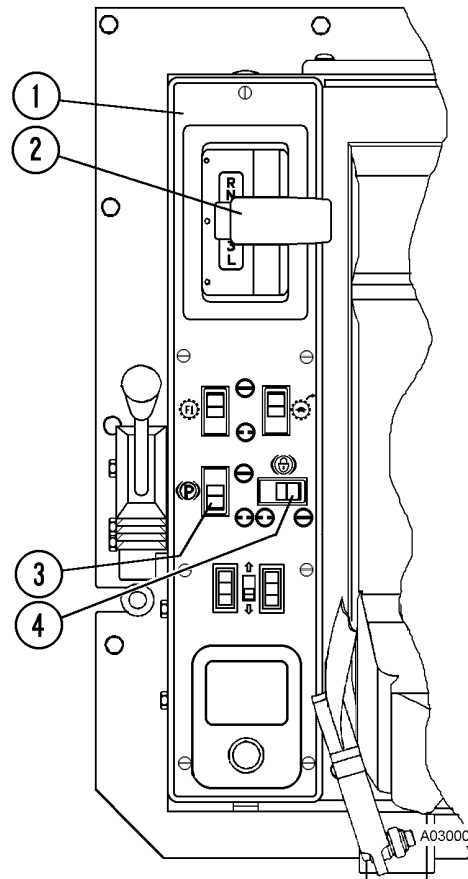

FIGURE 30-2. CONSOLE CONTROLS

- |                                |                         |
|--------------------------------|-------------------------|
| 1. Center Console              | 3. Parking Brake Switch |
| 2. Transmission Range Selector | 4. Brake Lock Switch    |

8. When the truck body is in the dump position, do not allow anyone beneath it unless the body-up retaining device is in place.
9. Do not use the fire extinguisher for any purpose other than putting out a fire! If the extinguisher is discharged, report the occurrence so the used unit can be refilled or replaced.
10. Do not allow unauthorized personnel to ride in the truck. Do not allow anyone to ride on the ladder or on the deck of the truck.
11. Do not leave the truck unattended while the engine is running. Shutdown the engine before leaving the cab.

## MACHINE OPERATION SAFETY PRECAUTIONS

After the truck engine is started and all systems are functioning properly, the operator must follow all local safety rules to insure safe machine operation.



***If any of the red warning lights illuminate or if any gauge reads in the red area during truck operation, a malfunction is indicated. Stop the truck as soon as safety permits, shut down engine if problem indicates and have problem corrected before resuming truck operation.***

1. Always sound the warning horn before moving the truck. When backing the truck, give a back-up signal by honking the horn three times. When starting forward, honk the horn two times. Use these signals each time the truck is moved forward or backward. Look to the rear before backing the truck. Watch for, and obey ground spotter's hand signals before making any reverse movements. The spotter should have a clear view of the total area at the rear of the truck.
2. Operate the truck only while properly seated with the seat belt fastened. Keep hands and feet inside the cab compartment while the truck is in operation. Keep a firm grip on the steering wheel at all times.
3. Check the gauges and instrument panel frequently during operation for proper readings.
4. Observe all regulations pertaining to the job site's traffic pattern. Be alert to any unusual traffic pattern. Match the truck speed to haul road conditions and slow the truck in congested areas. Obey the spotter's signals at the shovel and dump.
5. Do not allow the engine to run at idle for extended periods of time.
6. Check the parking brake periodically during the working shift. Use the parking brake for parking only. Do not attempt to apply the parking brake while the truck is moving!

7. Apply the brake lock switch at the shovel and dump areas.
8. Proceed slowly on rough terrain to avoid deep ruts or large obstacles. Avoid traveling close to soft edges and the edge of the fill area.
9. Truck operation requires concentrated effort by the driver. Avoid distractions of any kind while operating the truck.

## LOADING

1. Pull into the loading area with caution. Remain at a safe distance while the truck ahead is being loaded.
2. Do not drive over unprotected power cables.
3. When approaching or leaving a loading area, watch for other vehicles and for personnel working in the area.
4. When pulling in under a loader or shovel, follow the "spotter" or "shovel operator" signals. The truck operator may speed up loading operations by observing the location and loading cycle of the truck being loaded ahead, then following a similar pattern.
5. The operator should remain in the truck cab with the engine running while the truck is being loaded. Place the transmission range selector in NEUTRAL and apply the brake lock switch.



***If the operator must leave the truck cab during loading, the engine must be shut down and the parking brake applied. DO NOT use the emergency brake for parking. Remain far enough away from the truck to avoid being struck by flying material.***

6. When the truck is loaded, pull away from the shovel as quickly as possible, but with extreme caution.

## HAULING

1. Always stay alert! Drive with extreme caution especially when in unfamiliar areas.
2. Govern the truck speed based on road conditions, weather and visibility.
3. Operate the truck with control at all times.
4. Use extreme caution when approaching an intersection. Maintain a safe distance from oncoming vehicles.
5. Obey all road signs.
6. Always dim high beam headlights before approaching other vehicles in operation.
7. Maintain a safe distance when following another vehicle. Never approach another vehicle from the rear, in the same lane, closer than 15 m (50 ft). When operating on a down grade, stay at least 30 m (100 ft) away.
8. Before starting down a grade, maintain a speed that will insure safe operation and provide effective retarding under all conditions.

When descending a known grade with a loaded truck, the operator should adjust the speed of the truck if necessary, to preselect a transmission gear range, so that operation can be maintained within the speeds listed on the retarding capacity decal located inside the cab on the left front cab post (shown below). Either the retarder control lever or the foot-operated brake pedal can be used to control the speed of the truck.

 **WARNING**

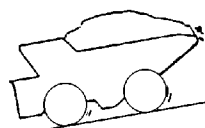

**RETARDING CAPACITY**  
GVW: 550,000 LBS.  
(249,478 kg)  
TIRES: 33 X 51

**MAX. BRAKE OIL TEMPERATURE: 248°F (120°C)**  
**MAX. ENGINE SPEED: 2100 RPM**

**MAINTAIN HIGHEST ENGINE SPEED BELOW MAX. SLOW TO NEXT LOWEST GEAR, IF COOLING OIL TEMPERATURE NEEDS TO BE LOWERED.**

GEAR	SPEED MPH (KM/H)	SHORT LENGTH 1,970 FT. (600m)	
		CONTINUOUS GRADE %	GRADE %
1	6.4 (10.3)	22.5 %	26.5 %
2	8.6 (13.8)	16.5 %	20.5 %
3	11.4 (18.4)	11.5 %	16.0 %
4	14.4 (23.2)	9.0 %	13.0 %
5	19.2 (31.0)	6.0 %	10.0 %
6	26.1 (42.1)	4.0 %	8.0 %
7	34.8 (56.1)	2.5 %	6.5 %

EC 4433

## RETARDER OPERATION

Two lists are provided on the retarding capacity decal. One a continuous rating, and the second a short-length rating. Both lists are matched to the truck at maximum Gross Vehicle Weight.

The continuous numbers on the chart indicate the combination of speeds and grades which the vehicle can safely negotiate for an unlimited time or distance.

The short-length numbers listed on the chart indicate the combination of speeds and grades which the vehicle can safely negotiate for three minutes. These speeds are faster than the continuous values, reflecting the thermal capacity of various system components. System components can accept heating at a higher-than-continuous rate for a short period of time, beyond which the system would become overheated.

The short-length rating (sometimes called the "three-minute" limit) will successfully accommodate most downhill loaded hauls. It is necessary to divide haul road grade segment length by allowable speed to determine actual time on grade. If actual time on grade exceeds the allowable amount, the grade will need to be negotiated at the continuous speed. Ambient temperature, as well as the prior temperature of the brake cooling oil can affect this number (the brake cooling oil could already be above the normal range from recent operating conditions).

 **WARNING**

**DO NOT exceed these recommended MAXIMUM speeds when descending grades with a loaded truck.**

*For efficient retarder operation, the operator should:*

- Maintain engine speed between 2000 - 2100 rpm
- When descending a grade, the operator should apply the retarder lever/foot pedal and observe both the tachometer and the brake oil temperature gauge. Engine speed must be maintained at 2000 - 2100 rpm and the brake oil temperature must be maintained below 120°C (248°F).

If the operator observes that either the maximum engine speed of 2100 rpm or the brake oil temperature of 120°C (248°F) are about to be exceeded, the operator should immediately move the transmission range selector to the next lower range and use, either the retarder control lever, or the foot-operated brake pedal, to apply more brake pressure until the truck is slowed to a speed which will permit the transmission to downshift to the gear range selected.

Continue this procedure to downshift to the required gear range to maintain engine speed at 2000 - 2100 rpm and brake oil temperature below 120°C (248°F). When the proper gear range is attained, continue to use the retarder as needed to maintain a safe, productive speed.

If brake oil temperature exceeds 120°C (248°F), the brake oil temperature warning light will turn on. As quickly as safety will permit, bring the truck to a complete stop away from traffic, move the transmission range selector to NEUTRAL, apply the parking brake, and operate the engine at high idle.

Continue to operate the engine at high idle until the brake oil temperature warning light turns off and brake oil temperature cools to below 120°C (248°F). If the temperature does not return to this range within a few minutes, report the condition immediately to maintenance personnel and wait for further instructions before moving truck.

9. When operating the truck in darkness or when visibility is poor, do not move the truck unless the headlights are on. Do not back up if the back-up horn or lights are inoperative.
10. When backing the truck, give a back-up signal (three blasts on horn); when starting forward, two blasts on horn. These signals must be given each time the truck is moved forward or backward.
11. Do not stop or park on a haul road unless unavoidable. If you must stop, move the truck to a safe place, apply the parking brake, shut down the engine, block the wheels securely and notify maintenance personnel for assistance.
12. If the warning light for low steering pressure illuminates during operation, steer the truck immediately to a safe stopping area away from other traffic, if possible. Refer to item 11 above.

13. Report adverse haul road conditions, immediately. Muddy or icy roads, pot holes or other obstructions can present hazards.
14. Cab doors should remain closed at all times while the truck is in motion or unattended.
15. Check for flat tires periodically during the shift. If the truck has been run on a flat tire, it must not be parked in a building until the tire cools.

## PASSING

1. Do not pass another truck on a hill or blind curve!
2. Before passing, make sure the road ahead is clear. If a disabled truck is blocking your lane, slow down and pass with extreme caution.
3. Use only the areas designated for passing.

## DUMPING

1. Approach the dump area with extreme caution. Ensure the area is clear of personnel and obstructions such as overhead power lines. Obey spotter signals, if present.

Avoid unstable areas. Travel at a safe distance from the edge of a dump area. Position the truck on a solid, level surface before dumping.



***As the body raises, the truck center of gravity will move. The truck must be on a level surface to prevent tipping!***

2. Carefully maneuver the truck into dump position. When backing the truck into dump position, use the foot-operated brake pedal to stop and hold the truck.
3. When in the dump position, place the transmission shift lever in NEUTRAL, and apply the brake lock switch.

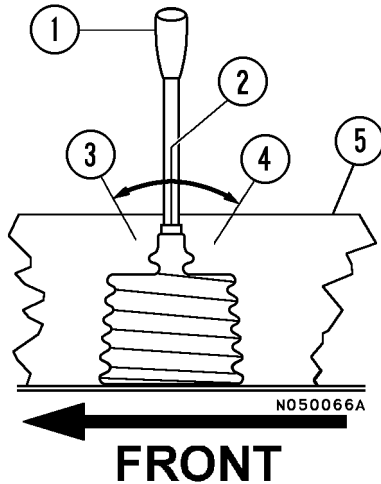

FIGURE 30-3. HOIST CONTROL

- |                        |                      |
|------------------------|----------------------|
| 1. Hoist Control Lever | 3. POWER DOWN        |
| 2. FLOAT/HOLD          | Position             |
| Position               | 4. POWER UP Position |
|                        | 5. Center Console    |

### Raising the Dump Body

## **⚠ WARNING**

*When dumping very large rocks or sticky material, the material may exit the body too fast. This may cause a violent jolt to the dump body and cause possible injury to the operator. Damage to the hoist cylinders, frame, and the dump body hinge pins may also result. If it is necessary to dump this kind of material, refer to the caution in the following procedure.*

4. Move hoist control lever (1, Figure 30-4) to POWER UP position (4) and release the lever.

Releasing the hoist lever anywhere in the lever stroke when raising will place the dump body in HOLD at that position.

5. Raise engine rpm to accelerate the hoist speed.

Refer to the following caution note.

When the body is near the maximum angle, reduce engine rpm in order to reduce the shock load to the hydraulic system and hoist cylinders.

## **⚠ CAUTION**

*If dumping very large rocks or sticky material as described in the warning above, slowly accelerate engine rpm and raise the dump body. When the material starts to move, release the hoist lever to the HOLD position. If the material does not continue out of the dump body, repeat this procedure until the material has been dumped.*

6. When the dump body rises to the desired position, release the hoist control lever. The lever will return to the HOLD position.

If necessary to raise the body further, move the dump lever to POWER UP. The dump body will rise until the hoist cylinders are fully extended.

### Lowering The Dump Body

7. After the load clears the body, lower the body to the frame by moving the hoist control lever forward to the DOWN position. The dump body will start to move downward.
8. Releasing the lever during the downstroke will return the lever to the FLOAT position. The body will then float down under its own weight. If dumped material builds up at the body tailgate and the body cannot be lowered, shift the transmission shift lever to DRIVE. Release the brake lock switch, and drive forward to clear the material. Stop, and shift the transmission shift lever to NEUTRAL. Apply the brake lock switch and lower the dump body. See the note below.



**DO NOT move the truck with the dump body raised except in the event of an emergency. Failure to lower the dump body before moving the truck may cause damage to the hoist cylinders, frame and body hinge pins.**

*NOTE: When traveling, always place the hoist control lever in the FLOAT position, regardless of whether or not the truck is loaded.*

*If the transmission shift lever is moved to any position other than NEUTRAL when the hoist control is not in FLOAT, the central warning lamp will flash and the alarm buzzer will sound intermittently.*

9. With the body on the frame, move the transmission shift lever to DRIVE. Release the brake lock switch, and carefully exit the dump area.

### SAFE PARKING

The operator must continue the use of safety precautions when preparing for parking and engine shutdown.

Any questionable truck performance the operator may have noticed must be checked by maintenance personnel before the truck is released for another shift.

1. The truck should be parked on level ground, when possible. If parking must be done on a grade, the truck should be positioned perpendicular to the grade.
2. The parking brake must be applied and/or chocks placed fore/aft of the wheels so that the truck cannot roll. Each truck should be parked at a reasonable distance from one another.
3. Haul roads are not safe parking areas. In an emergency, choose the safest spot most visible to other machines in the area. If the truck becomes disabled where traffic is heavy, mark the truck with warning flags in daylight, or with flares at night.

### SHUTDOWN PROCEDURE

The following sequence of shutdown procedure is important and should be followed at each shutdown.

1. Stop the truck, and reduce engine rpm to low idle. Place the transmission range selector in NEUTRAL, and apply the parking brake.
2. Allow the engine to cool gradually by operating at low idle for 3 to 5 minutes.
3. Turn the keyswitch to the OFF position to stop the engine.
4. Close and lock all windows, remove the key from the key switch and lock the cab to prevent possible unauthorized truck operation.
5. Dismount the truck, properly.

## SUDDEN LOSS OF ENGINE POWER

If the engine suddenly stops operating, stored hydraulic pressure in the brake and steering accumulators enables temporary operation of the steering and brake functions. Accumulator oil supply is limited, however, so it is important to stop the truck as quickly and safely as possible after the loss of engine power. When pressures drop to a pre-determined level, the "low brake pressure" and "low steering pressure" warning lights will illuminate and a buzzer will sound. If the brake pressure continues to decrease, the "auto-apply" feature will activate and the service brakes will apply automatically to stop the truck.

Bring the truck to a safe stop as quickly as possible by using the foot pedal to apply the service brakes. If possible, steer the truck to the side of the road during braking. Apply the parking brake as soon as the truck comes to a complete stop. Turn the key switch OFF and notify maintenance personnel, immediately.

If the truck becomes disabled in a high-traffic area, mark the truck with warning flags during daylight hours, and flares at night.

### Emergency Steering And Braking

The steering and brake systems each have accumulators that store energy and provide capability to steer and stop the truck in the event of an unexpected engine shutdown or pump failure.

As part of the routine maintenance of the vehicle, one requirement to ensure proper operation of each system is to maintain proper accumulator nitrogen pre-charge. Refer to the shop manual for proper procedures when charging the accumulators.

Audible and visual warnings will alert the operator if accumulator pressures drop below the preset values during operation.

## DISABLED TRUCK DUMPING

Sometimes it is necessary to dump a load from the body of a disabled truck when the hoist system is inoperable. The following instructions describe the use of a "good" truck to provide the hydraulic power required to raise the body of a "disabled" truck to dump the load.

Figure 30-4 shows the quick disconnect fittings on a hoist manifold for connecting the hoist circuits between trucks.

### Hookup

Be certain there is an adequate, clear area to dump the loaded dump body.

1. Safely park the good truck as close as possible to the disabled truck. When the good truck is in position next to the disabled truck, shut off the engine.
2. Bleed pressure from the brake accumulators, steering accumulators, and hydraulic tanks on each truck.
3. Attach a hose from the power up quick disconnect on the good truck to the power down circuit on the disabled truck. (Hoses must be rated to withstand 19 305 kPa (2800 psi) or greater pressure.

*NOTE: The power down circuit uses a smaller diameter hose (tube) than the power up circuit.*

4. Connect another hose from the power down quick disconnect on the good truck to the power up circuit on the disabled truck.

### Raising the Body

5. Move the hoist control lever on the disabled truck to the HOLD position. Leave the lever in this position during the entire procedure.
6. Adjust the power down relief setting on the good truck to the maximum setting. On HD1500-5 trucks, the power down relief valve (1, Figure 30- 4) is located on pilot valve (2) which is inside of the brake cabinet on the lower RH side. Gently, turn the adjustment screw clockwise, until it bottoms out. (Count the exact number of turns that the adjustment screw is turned, and note for later adjustment.)
7. Start the engine on the good truck, and adjust the engine speed to 1000 rpm.



**Lowering the Body**

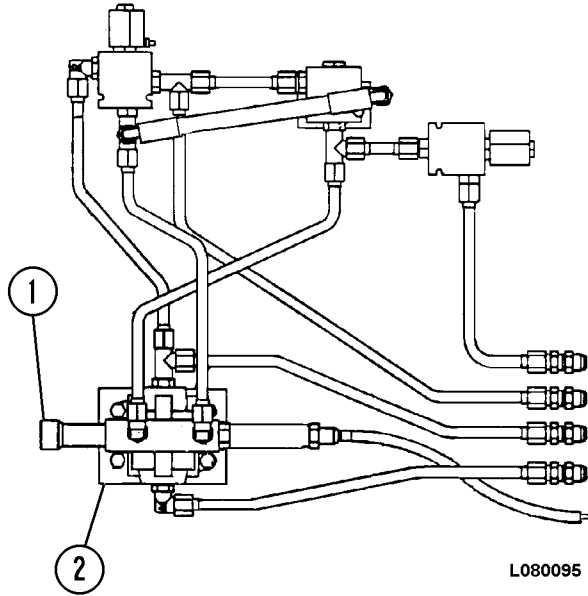

FIGURE 30-4. POWER DOWN RELIEF VALVE  
1. Power Down Relief      2. Hoist Pilot Valve

8. Place the hoist control in the POWER DOWN position, and continue to hold in this position until the hoist cylinders reach full extension. Increase engine speed as necessary.

**▲ IMPORTANT ▲**

**Do Not move the hoist control from the POWER DOWN position until full extension is reached. Do Not attempt to move the lever to the HOLD position during this procedure.**

9. After the load has been emptied from the body, release the hoist control lever. The body of the disabled truck should immediately begin floating downward.

If any residual material left in the body prevents lowering, perform the following:

- a. Place the good truck hoist lever in the POWER UP position, and monitor the body of the disabled truck for downward movement. The body of the good truck may rise a small amount during this step.
- b. Once the body of the disabled truck begins downward, move the hoist control all the way forward, and then release. The lever should then be in the FLOAT position.

10. Shut off the engine. Bleed pressure from the brake accumulators, steering accumulators, and the hydraulic tanks on each truck.

11. Disconnect the hoses from each truck.

12. Re-adjust the relief valve setting on the good truck. (Turn the screw counter-clockwise the same number of turns as was noted earlier in this procedure.) The power down relief valve on a HD1500-5 machine should be set at 10 342 kPa (1500 psi).

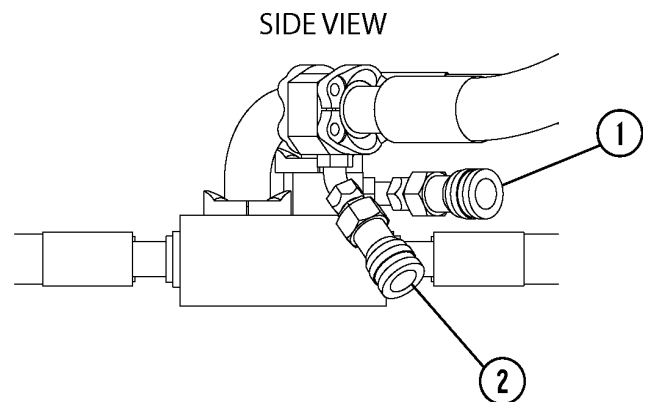
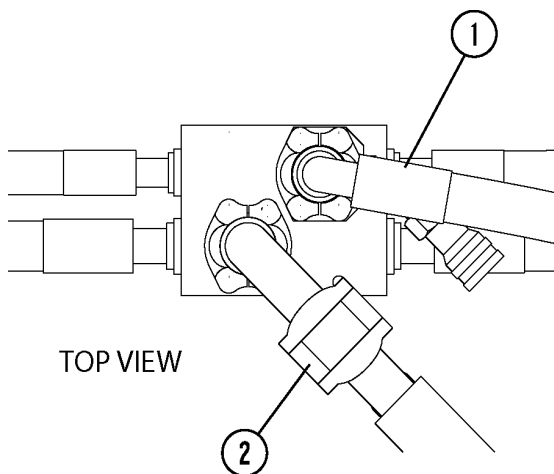

FIGURE 30-5. HOIST CIRCUIT QUICK DISCONNECT FITTINGS  
1. Power Down Circuit      2. Power Up Circuit

L080094

## DISABLED TRUCK STEERING AND BRAKING

During towing, it may be necessary to steer and stop a disabled truck using hydraulic power from the tow truck. The following instructions describe the use of a "good" truck to provide the hydraulic power required to steer and stop a "disabled" truck.

Figure 30-7 illustrates a typical hookup with another HD1500-5. Figure 30-6 shows the location of the quick disconnects on the bleddown manifold.

1. When the good truck is in position in front of the disabled truck, shut off the engine, and apply the parking brake.
2. Bleed any pressure from the steering accumulators on each truck. Verify no pressure exists by attempting to steer each machine.
3. Connect the supply and return hoses to the quick disconnects on each bleddown manifold. Route and secure the hoses in a safe fashion that will prevent hose damage during machine movement.
4. Install pressure gauges in the brake supply circuit on both trucks for verification of proper brake system pressures after machine start up.
5. Position the retarder lever on the bad truck in the OFF position. DO NOT use the retarder lever during machine towing.
6. Turn the disabled truck keyswitch to the ON position. This prevents oil transfer between trucks from the retarder command circuit.
7. Start the good truck, and allow the engine to operate for a minimum of three minutes.
8. Verify proper brake system pressures on both trucks: 18 960 kPa (2750 psi).
9. Slowly operate the steering wheel on each truck to check steering function. Slow movement will allow any trapped air to bleed out of the system.
10. Check all hydraulic connections for leakage before machine travel.

11. If no problems are evident, proceed to move the machines.

Travel speed should be equal to normal human walking speed. When necessary, steer the machine slowly while keeping turns at 1/4 revolution/second or less.

*NOTE: Each braking application and release on the disabled truck transfers the release oil from the good truck to the disabled truck. Therefore, it is necessary to use the brakes sparingly when possible.*

*It may be necessary to drain oil from the disabled truck if the hydraulic tank inherits too much oil.*

12. When the trucks have reached their destination, shut the engine off, and apply the parking brake on each truck.
13. Ensure the steering accumulator pressure is bled down before removal of the hoses. Attempt to steer each truck to verify no pressure remains in the system.

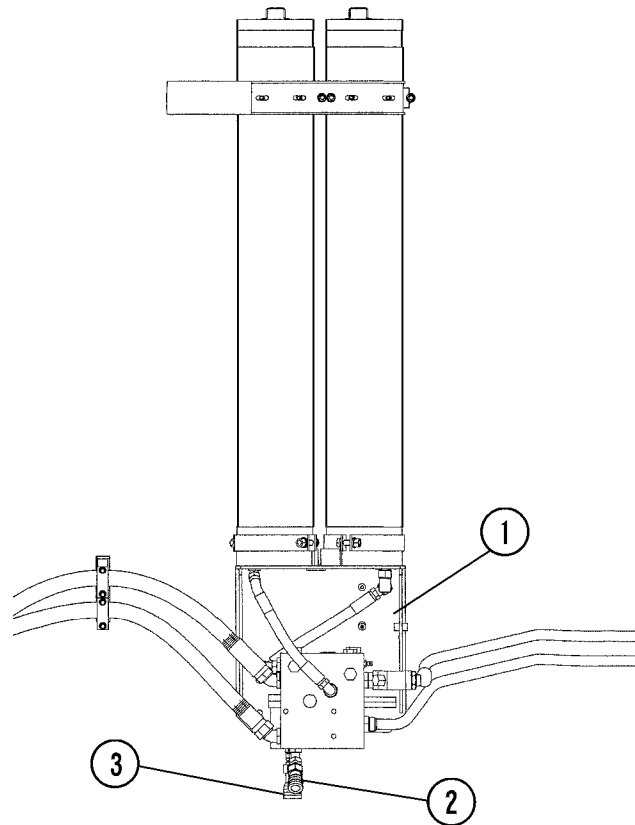

L080093

FIGURE 30-6. STEERING QUICK DISCONNECTS

- |                          |                |
|--------------------------|----------------|
| 1. Bleeddown<br>Manifold | 2. Supply Port |
|                          | 3. Return Port |

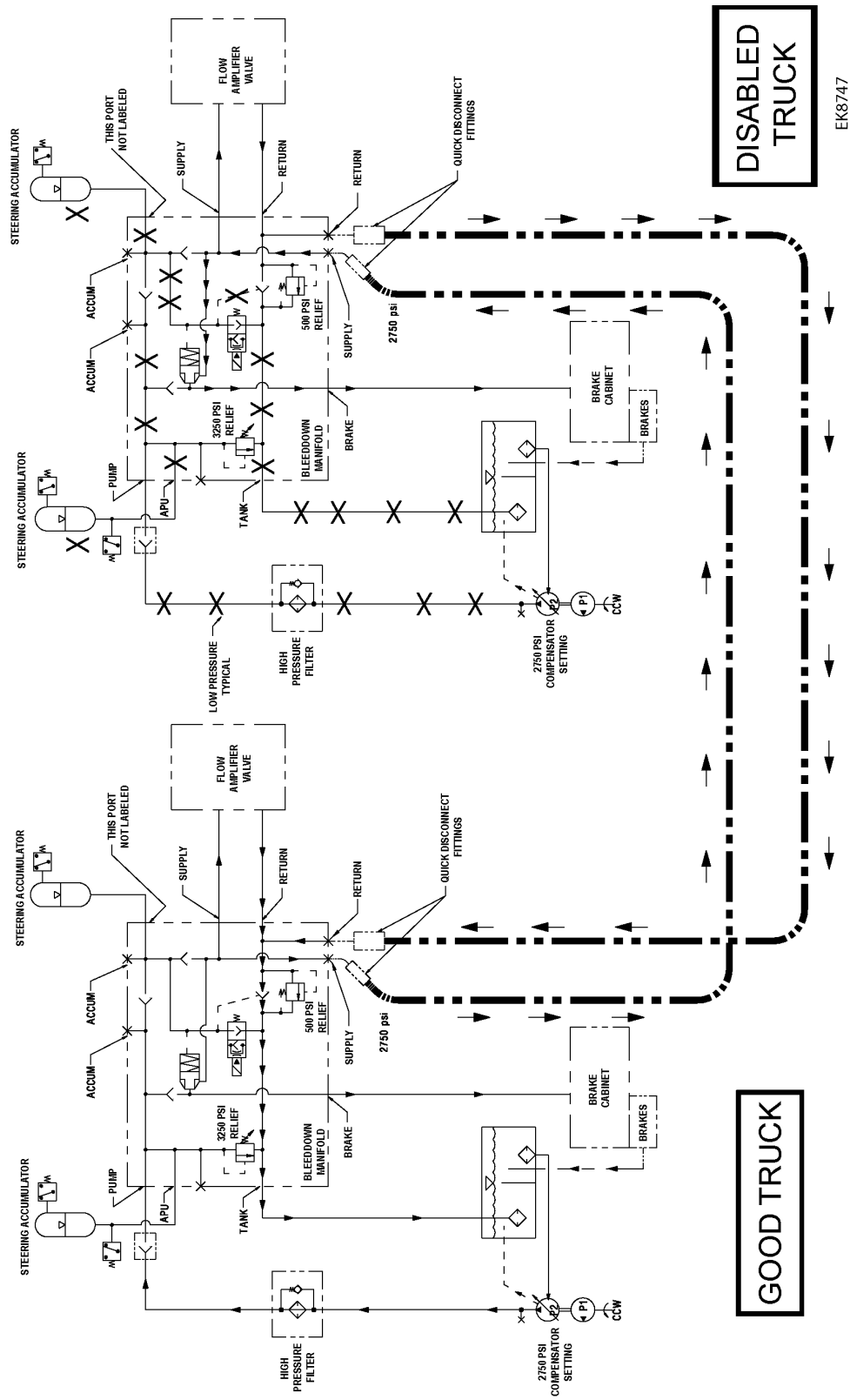

FIGURE 30-7. GOOD TRUCK / DISABLED TRUCK STEERING AND BRAKING HOOKUP

EK8747

## TOWING

### **WARNING**

***Prior to towing a truck, many factors must be carefully considered. Serious personal injury and/or significant property damage may result if important safety practices, procedures, and preparation for moving heavy equipment are not observed. Always use extreme care when towing a disabled truck.***

- ***Towing a machine is only advised for short distances. For longer distances, the machine must be hauled.***
- ***All precautions must be observed to protect the operators in the event of wire rope breakage.***
- ***For the HD1500-5, wire rope capable of towing 77 110 kg (170,000 lb) is required.***
- ***An observer must be positioned in a safe location during towing for signalling to the operators.***
- ***Towing speed must not exceed 2 km/h (1 mph).***
- ***Tow rope angles must not exceed 10°.***

***Observe all precautions outlined in this manual, as well as local regulations. Refer to the following steps when towing is necessary:***

1. Block the disabled truck to prevent movement while preparing the truck for towing and attaching the wire rope and other connections.
2. Verify the towing capacity of the wire rope (it must be capable of towing 77 110 kg (170,000 lb). Verify the rope is in good condition showing no indications of damage or wear.

3. Determine the primary reason that the truck is disabled.
  - a. If the truck is being towed because of engine failure, certain precautions must be observed. The loss of hydraulic power due to engine failure requires the use of hydraulic power from the tow machine, or an auxiliary power unit, to supply hydraulic power. Hydraulic power is necessary to dump a load before towing, for steering and braking functions, and to release the spring applied parking brake. Refer to Disabled Truck Dumping and Disabled Truck Steering and Braking in this chapter for more information on hookup.
  - b. If the truck is disabled because of a suspected final drive problem, both right and left planetary sun gears/drive axles must be removed before towing. (Refer to Section G, Final Drive, in the shop manual for more information.)

### **CAUTION**

***Extensive secondary damage may occur to final drive components and/or the transmission, if the truck is towed without first removing the sun gears/drive axles.***

***Ensure all debris and damaged components have been removed before moving the truck. Failure to remove debris or damaged components may result in further damage.***

- c. If the truck is disabled because of a suspected transmission problem, remove the drive shaft between the transmission and the differential case (if final drive sun gears have not been removed).

4. Use the tow eyes installed under the front frame/bumper for towing from the front of the disabled truck. Both tow hooks must be used. Use the tow pin on the rear axle when pulling the disabled truck from the rear.
5. If the engine of the disabled truck is operational, start the engine before towing to release the parking brake, and to enable steering and braking functions.
6. If the engine is NOT operable, hydraulic power for steering, braking and transmission lubrication will not be available.

Install the necessary hydraulic connections between the towing vehicle and the disabled truck to provide hydraulic power. Refer to Disabled Truck Steering and Braking.

7. If the body of the disabled truck contains a load, dump the load before towing. If the engine is not operational, refer to Disabled Truck Dumping.
8. Remove all blocking, and release the disabled truck brakes. Begin towing the disabled truck. The observer should signal the operators to stop the tow if any signs of danger or damage are evident.

## **WARNING**

- ***Do not exceed 2 km/h (1 mph) when towing another truck.***
- ***Smooth and gradual truck movement is essential during towing. Sudden movement may cause wire rope failure leading to injury and/or truck damage.***
- ***Minimize the tow angle at all times - Never exceed 10° in any direction, vertically or horizontally. The towed truck must be steered in the direction of the wire rope.***

Consult your area Komatsu service representative for any questions or concerns about towing a disabled truck.

---

# NOTES

### OPERATOR CAB AND CONTROLS

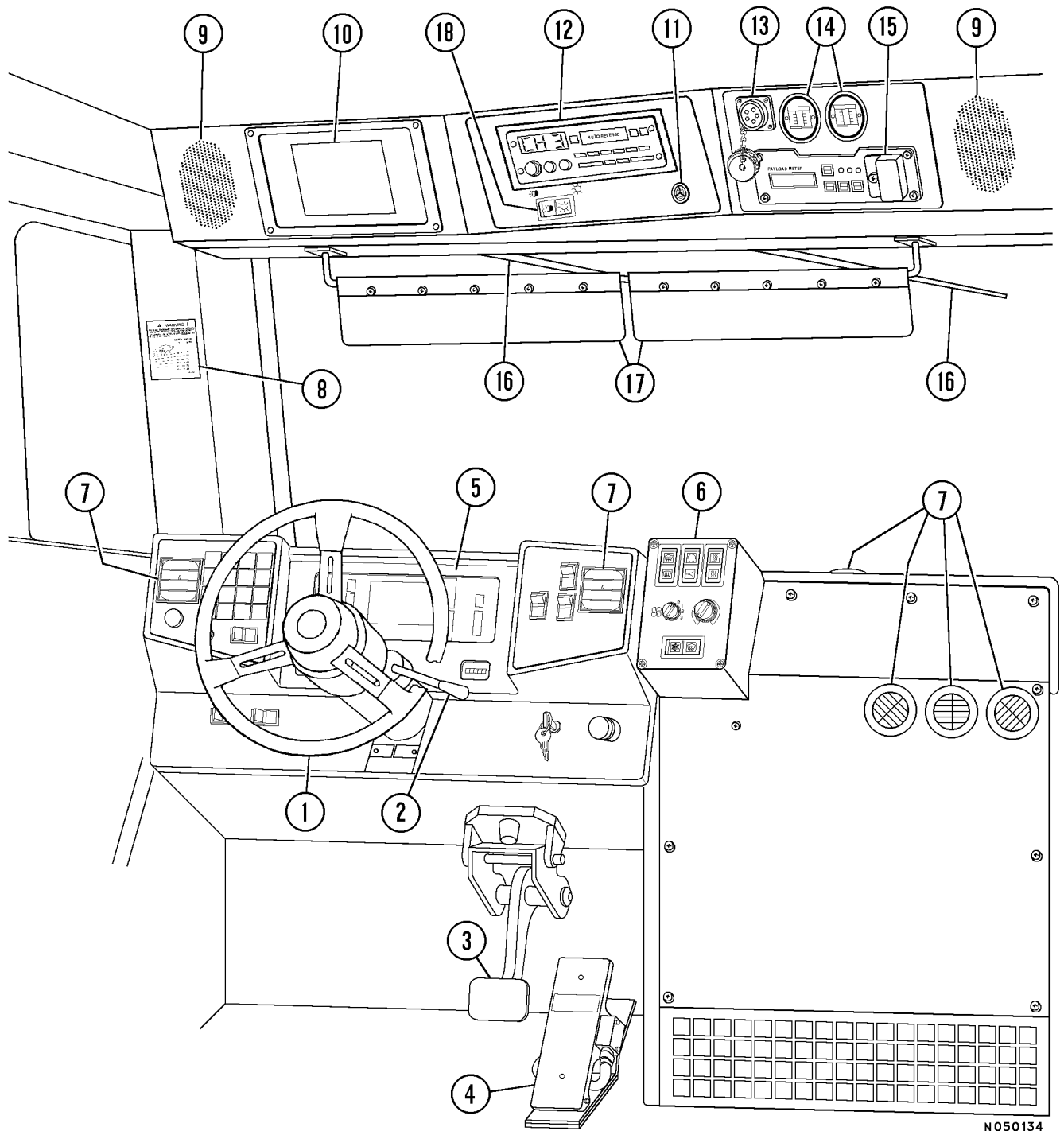

N050134

FIGURE 3-1. CAB INTERIOR - OPERATOR VIEW

- |                                    |                                  |                               |
|------------------------------------|----------------------------------|-------------------------------|
| 1. Steering Wheel                  | 7. Heater/Air Conditioner Vents  | 13. PMC Interface Connector   |
| 2. Retarder Control Lever          | 8. Retarding Capacity Chart      | 14. Air Cleaner Vacuum Gauges |
| 3. Service Brake Pedal             | 9. Radio Speakers                | 15. Payload Meter II          |
| 4. Throttle/Accelerator Pedal      | 10. MOM Display Screen           | 16. Windshield Wipers         |
| 5. Instrument Panel                | 11. Warning Alarm Buzzer         | 17. Sun Visors                |
| 6. Heater/Air Conditioner Controls | 12. Radio, AM/FM Stereo Cassette | 18. MOM Dimmer Switch         |

## STEERING WHEEL AND CONTROLS

Steering wheel (1, Figure 32-2) will telescope "in" and "out" and adjust through a tilt angle to provide a comfortable wheel position for most operators.

### Horn Button

Horn (2, Figure 32-2) is actuated by pushing the button in the center of the steering wheel. Operation of the horn should be verified before moving the truck. Observe all local safety rules regarding the use of the horn as a warning signal device before starting engine and moving the vehicle.

### Telescope Lock Ring

Telescope lock ring (3, Figure 32-2) around the horn button locks/unlocks the telescoping function of the steering column. Rotating the ring\* counterclockwise (LH rotation), releases the column to move "in" or "out". Rotating the ring clockwise (RH rotation), locks the column in the adjusted position.

**\* DO NOT rotate the ring more than 90°! Rotating in excess of 90° may cause damage to internal wiring!**

### Tilt Wheel Lever

Adjust the tilt of the steering wheel by pulling tilt adjustment lever (4, Figure 32-2) toward the steering wheel and moving the wheel to the desired angle. Releasing the lever will lock the wheel in the desired location.

### Turn Signal / Headlight Dimmer

Turn signal lever (5, Figure 32-2) is used to activate the turn signal lights and to select either the high or low headlight beams.

Move the lever upward to signal a turn to the right.

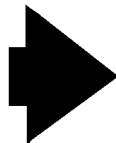

Move the lever downward to signal a turn to the left.



An indicator in the top, center of the instrument display panel will illuminate to indicate the turning direction that was selected. Refer to Instrument Panel And Indicator Lights.

Moving the lever toward the steering wheel will change the high/low headlight beam. When high beams are selected, the indicator in the top, center of the instrument display panel will illuminate.

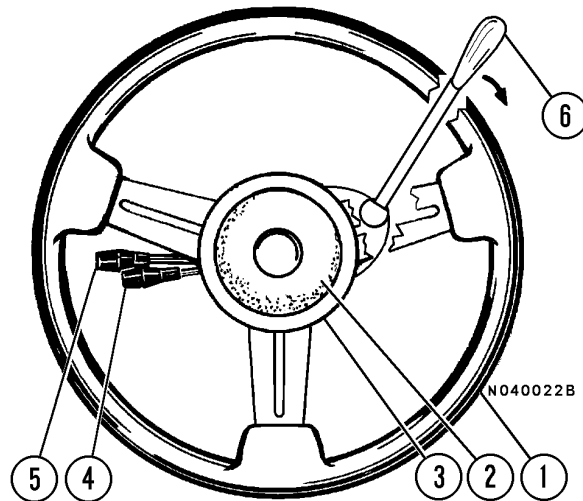

FIGURE 3-2. STEERING WHEEL AND CONTROLS

- |                        |                           |
|------------------------|---------------------------|
| 1. Steering Wheel      | 4. Tilt Wheel Lever       |
| 2. Horn                | 5. Turn Signal Lever      |
| 3. Telescope Lock Ring | 6. Retarder Control Lever |



### Windshield Wiper / Washer Control

The windshield wiper control is used to activate the wiper blades and washer system. This control is on the turn signal lever and has three wiper speed settings and a washer control:

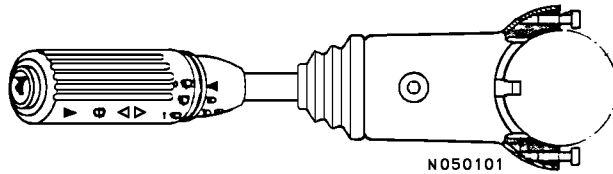

Rotate the knob on the end of the lever clockwise (from OFF position) to activate the various speed selections.

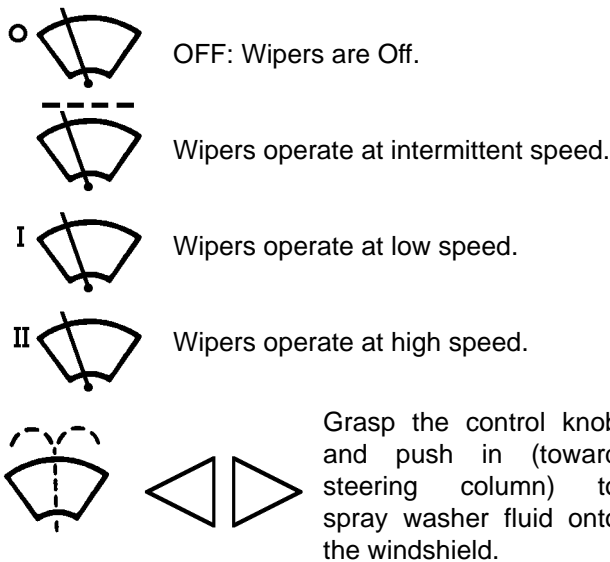

### RETARDER CONTROL LEVER

Retarder control lever (6, Figure 32-2) is mounted on the right side of the steering column. It can be used to modulate the full range of retarding/braking effort being applied to both the front and rear oil disc brakes. Any application of the retarder lever will cause an indicator light to illuminate in the LH instrument panel/pod (Refer to Instrument Panel And Indicator Lights).

- When the lever is rotated to the full "up" (counterclockwise) position, it is in the OFF/NO RETARD position.

- When the lever is rotated "downward" (clockwise), it is in the ON/RETARD position. The ON position encompasses a full range of motion that allows a variable retarding effort depending on the position of the lever (and the potentiometer inside the assembly). As the lever is rotated further clockwise, more retarding effort will be applied.
- For long downhill hauls, the lever may be positioned anywhere to provide the desired retarding effort. The lever will remain where it is positioned until moved. Refer to Retarder Operation in the previous chapter for cautions when using the retarder on a downhill grade.

***When retarding is completed, and acceleration is resumed, be sure to return the lever to the full "up" (OFF/NO RETARD) position, to prevent rapid wear to brake discs and/or overheating of the brake cooling system.***

The retarder lever and foot-operated service brake pedal can be used simultaneously or independently. The Retard Control Module (RCM) will determine which device is requesting the most retarding/braking effort and apply that amount.

### SERVICE BRAKE PEDAL

Service brake pedal (3, Figure 32-1) is a single function, foot-operated pedal which controls and modulates service brake pressure directly through a hydraulic valve.

When the pedal is partially depressed, an indicator light in the LH instrument panel pod (11, Figure 32-9) will illuminate. As the pedal is further depressed, the service brakes are actuated (a slight increase in pedal resistance will be felt) through a hydraulic valve, which modulates pressure to the service brakes. Completely depressing the pedal causes full application of both the front and rear oil disc service brakes.

Retarding capacity chart (8, Figure 32-1) should always be followed to determine *maximum* safe truck speeds for descending various grades with a loaded truck.

## ACCELERATOR (THROTTLE) PEDAL

Accelerator (throttle) pedal (4, Figure 32-1) is a foot-operated pedal which allows the operator to control engine rpm, depending on pedal depression.

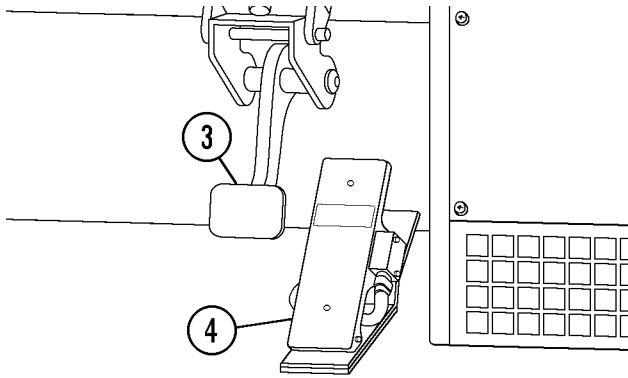

The foot-operated treadle pedal contains an electronic sensor which sends signals to the Quantum™ fuel control system. The movement of the fuel governor control arm corresponds directly to the travel of the treadle pedal as it is applied by the operator. When the pedal is released, springs return the control arm and the pedal to their "rest" positions and the engine speed returns to low idle.

## INSTRUMENT PANEL

Instrument panel (5, Figure 32-1) includes a center electronic display panel, and L.H & RH panels/pods which contain a variety of switches and indicators.

Refer to Instrument Panel and Indicator Lights later in this section for a detailed description of the function and location of each of these components.

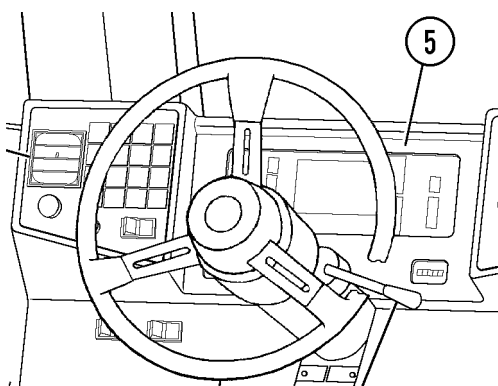

## HEATER / AIR CONDITIONER COMPARTMENT AND CONTROLS

The heater/air conditioner compartment contains heater/air conditioner controls (6, Figure 32-1) and some of the heater/air conditioner components, such as the blower motor assembly and the heater coils. Optimum cab air climate can be selected by using the following controls in various combinations.

### Defroster Vent Control Switch

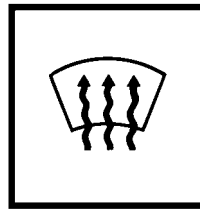

Defroster control switch (1, Figure 32-3) directs heated air for windshield defrosting. The downward position of the rocker switch is OFF. The upward position of the rocker switch is ON.

### Outside/Inside Air Control Switch

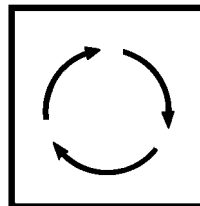

Outside/inside air control switch (2, Figure 32-3) allows either outside or inside air to be circulated through the cab heater assembly.

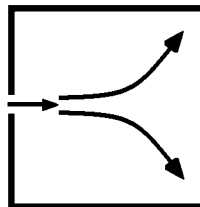

Moving the switch upward directs inside air to be recirculated through the heater assembly. Moving the switch downward directs outside air to be circulated through the heater assembly and into the cab.

### Heat Vent Control Switch

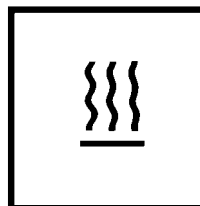

Heater control (3, Figure 32-3) directs heated air to the cab floor for heating of the cab. The downward position of the rocker switch is OFF. The upward position of the rocker switch is ON.

### Fan Control Knob

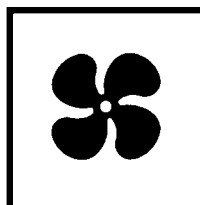

Fan control knob (4, Figure 32-3) is provided to control the cab air fan motor. The fan motor is a 3-speed motor (low, medium and high). Speeds are selected by rotating the control knob clockwise to the desired position. OFF is in the full counter-clockwise position.

**Temperature Control Knob**

Temperature control knob (5, Figure 32-3) allows the operator to select a comfortable temperature.

Rotating the knob counter-clockwise (blue arrow) will select cooler temperatures. Full counter-clockwise position is the coldest air setting.

Rotating the knob clockwise (red arrow) will select warmer temperatures. The full clockwise position is the warmest heater setting.

**Air Conditioner Control Switch**

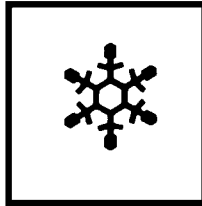

Air Conditioner control switch (6, Figure 32-3) is a three position switch that controls the air conditioner to cool the cab air. Moving the switch to the left activates the air conditioner. When the switch is in the center position, the air conditioner and the heater are

both activated. When the switch is moved to the right side, only the heater is activated.

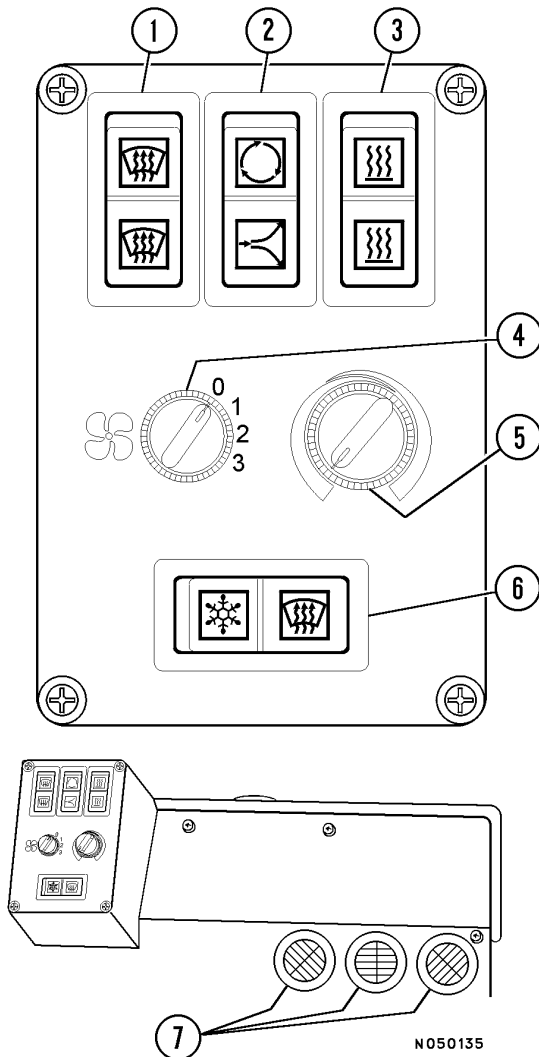

**Heater/Air Conditioner Vents**

Heater/air conditioner vents (7, Figure 32-3) may be rotated 360°. There are three vents in the heater/air conditioner compartment (shown in Figure 32-3), four vents across the top of the panel, and one vent each in the RH and LH instrument panel pods. Air flow through the vents is controlled by manually opening, closing or turning the louvers.

**RETARDING CAPACITY CHART**

Retarding capacity chart (8, Figure 32-1 & shown below) provides the recommended *maximum* truck speeds for descending various grades with a fully loaded truck.

**⚠ WARNING**

**RETARDING CAPACITY**  
**GVW: 550,000 LBS.**  
**(249,478 kg)**  
**TIRES: 33 X 51**

**MAX. BRAKE OIL TEMPERATURE: 248°F (120°C)**  
**MAX. ENGINE SPEED: 2100 RPM**

**MAINTAIN HIGHEST ENGINE SPEED BELOW MAX. SLOW TO NEXT LOWEST GEAR, IF COOLING OIL TEMPERATURE NEEDS TO BE LOWERED.**

GEAR	SPEED		CONTINUOUS GRADE %	SHORT LENGTH
	MPH	(KM/H)		1,970 FT. (600m) GRADE %
1	6.4	(10.3)	22.5 %	26.5 %
2	8.6	(13.8)	16.5 %	20.5 %
3	11.4	(18.4)	11.5 %	16.0 %
4	14.4	(23.2)	9.0 %	13.0 %
5	19.2	(31.0)	6.0 %	10.0 %
6	26.1	(42.1)	4.0 %	8.0 %
7	34.8	(56.1)	2.5 %	6.5 %

EG4433

The operator should reference the retarding capacity chart before descending any grade with a loaded truck. Proper selection of road grade, truck speed, transmission gear range, and use of the retarder lever and/or brake pedal are required to maintain a safe speed.

Customer specified options may cause this decal to change: Always refer to the retarding capacity chart in the operator's cab, and follow the recommendations there for safe truck operation.

**DO NOT exceed these recommended maximum speeds when descending grades with a loaded truck.**

Refer to Operating Instructions, Retarder Operation, for more information on using the retarder function.

FIGURE 3-3. A/C & HEATER CONTROLS

### Radio Speakers

Radio speakers (9, Figure 32-1) for the AM/FM stereo radio are located at the far left and right of the overhead panel.

### MOM Display Screen

MOM display (10, Figure 32-1) is an electronic display that provides the operator or service technician with important messages concerning selected truck functions.

Refer to Electronic Displays And Messages later in this section, for a detailed description of the messages provided and the functions monitored by this display.

### MOM Dimmer Switch

The MOM dimmer switch enables the operator to choose two varying levels of brightness. Depressing the left side of the switch dims the MOM display. Depressing the right side of the switch brightens the display.

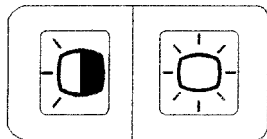

### Warning Alarm Buzzer

Warning alarm buzzer (11, Figure 32-1) will sound when activated by any one of several truck functions. Refer to Instrument Panel And Indicator Lights for a detailed description of functions and indicators that will activate this alarm.

### Cab Radio

This panel will normally contain an AM/FM stereo radio (12, Figure 32-1).

Refer to Section 70, Cab Radio, for a more complete description of the radio and its functions. Individual customers may use this area for other purposes, such as a two-way communications radio.

### PMC Interface Connector

PMC interface connector (13, Figure 32-1) is used to communicate data between a computer and the PMC.

Refer to Powertrain Management Control System in the shop manual for a complete description of the PMC and its functions.

### Air Cleaner Vacuum Gauges

Air cleaner vacuum gauges (14, Figure 32-1) provide a continuous reading of maximum air cleaner restriction reached during operation. The air cleaner(s) should be serviced when the gauge(s) shows the following maximum recommended restriction: 6.2 kPa (25 in. of H<sub>2</sub>O) vacuum.

*NOTE: After service, push the reset pin on the face of the gauge to allow the gauge to return to zero.*

### Payload Meter

Payload meter (15, Figure 32-1) is used to provide management with operational data such as tonnage hauled and cycle times. Refer to Section 60, Payload Meter, for a more complete description of the payload meter and its functions.

### Windshield Wipers

Windshield wipers (16, Figure 32-1) are powered by an electric motor. Refer to Windshield Wiper And Washer Control for a description of the windshield wiper and washer controls.

**CENTER CONSOLE**

Center console (1, Figure 32-4) located to the right of the operator seat, is a housing structure which provides a mounting surface for certain operator controls and a passenger seat.

The housing below the passenger seat provides an easy access to various control components (relays, solenoids, valves, etc.) for the service technician. Refer to the shop manual for descriptions and service for these devices.

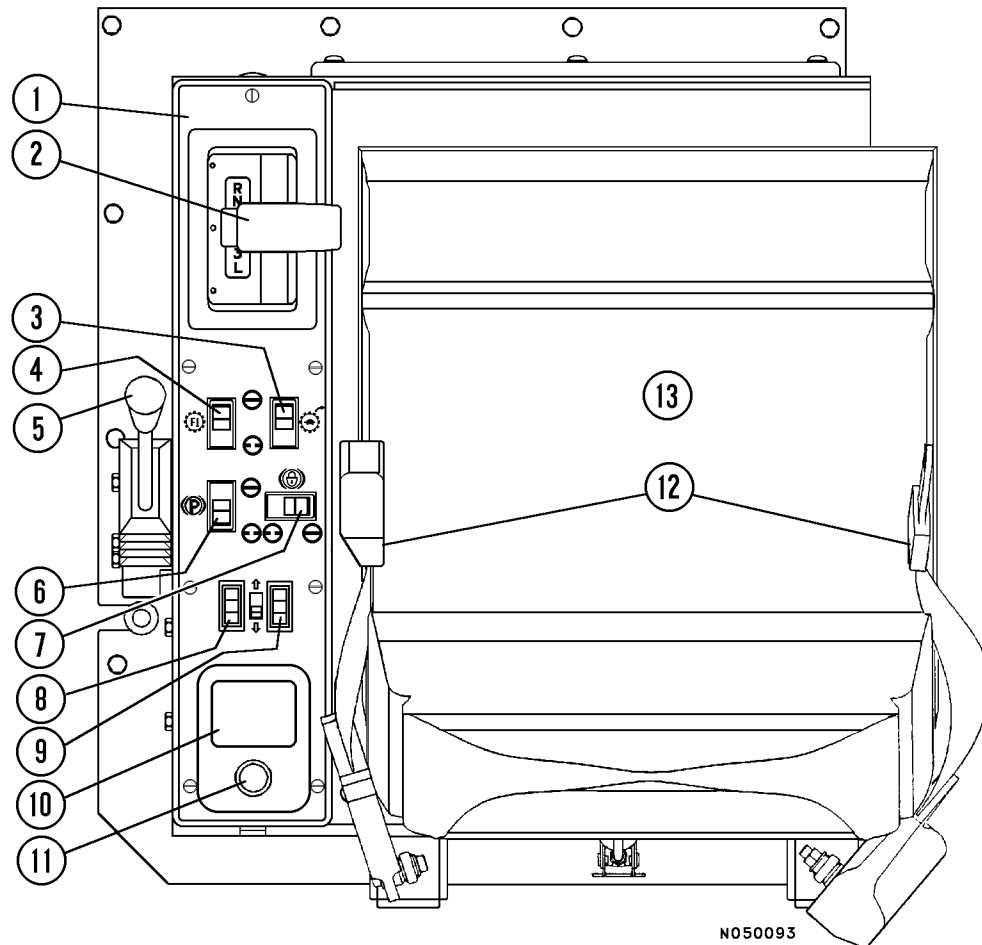

FIGURE 3-4. CENTER CONSOLE

- |                                |                             |                         |
|--------------------------------|-----------------------------|-------------------------|
| 1. Center Console              | 6. Parking Brake Switch     | 11. Cigarette Lighter   |
| 2. Transmission Range Selector | 7. Brake Lock Switch        | 12. Passenger Seat Belt |
| 3. Shift Limit Switch          | 8. LH Window Control Switch | 13. Passenger Seat      |
| 4. F1 Start Switch             | 9. RH Window Control Switch |                         |
| 5. Hoist Control Lever         | 10. Ash Tray                |                         |

## Transmission Range Selector

Transmission range selector (2, Figure 32-4) is mounted to the right of the operator's seat.

The transmission range selector has seven positions (R, N, D, 5, 4, 3, and L). When moving the range selector lever from N to R, or from D to 5, press the lock button on the end of the handle to release the lever and allow a gear change.

R - REVERSE position - is used to move the truck backwards. Bring the truck to a complete stop before shifting from DRIVE to REVERSE or vice-versa. The Reverse warning horn is activated when the REVERSE position is selected.

N - NEUTRAL position - is used when starting the engine, during loading operations and parking the truck with the engine running. The truck cannot be started unless the range selector is in the N - NEUTRAL position.

D - DRIVE position (F1-F7) - When starting from a stopped position, the transmission will shift automatically to second gear. As the truck ground speed increases, the transmission will automatically upshift through each gear to seventh gear operation. (If the shift limiter function has been activated, seventh gear can not be engaged. Refer to Shift Limiter Switch.) As the truck ground speed slows down, the transmission will automatically downshift to the correct gear (including F1) for grade/load/engine conditions. When conditions permit, select position D for normal operation.

5, 4, 3 positions - Road and load conditions sometimes make it desirable to limit the automatic up-shifting to a lower range. These positions provide more effective retarding on grades. When the range selector is placed in any one of these positions, the transmission starts in F1, and will not shift above the highest gear range selected. As the truck ground speed slows down, the transmission will automatically downshift to the correct gear (including F1) for grade/load/engine conditions. When conditions permit, select position D for normal operation.

L - LOW position - Use this range position when maneuvering in tight spaces and when pulling through mud or deep snow. Use this range position also when driving up and down steep grades where maximum driving power or maximum retarding is required. When the range selector is placed in L, the transmission starts in F1, and will only upshift to F2. (If the shift limiter function has been activated, second gear can not be engaged. Refer to Shift Limiter Switch.) When conditions permit, select position D for normal operation.



***DO NOT move the shift lever to the N position while the truck is in motion. If the selector is shifted to N while in motion or while descending a hill the following may occur:***

- ***Steering may be more difficult.***
- ***A lack of cooling oil may cause the braking system to overheat and fail.***
- ***Damage to the transmission may occur.***

***The engine cannot provide braking when the transmission is not in gear.***

### Control Switches

Control switches (3, 4, 6, & 7, Figure 32-4) are simple rocker type switches which turn functions on and off.



The ON and OFF positions are marked with these symbols.



### Shift Limiter Switch



Shift limiter switch (3, Figure 32-4) is used to limit the highest speed range when the transmission shift lever is in either the D or L range.

Shift Limiter	Range	Range(s) Attainable
ON	D	Range - F2-F6
	L	Range - F1
OFF	D	Range - F2-F7
	L	Range - F1-F2

### F1 Start Switch



F1 start switch (4, Figure 32-4) is used to ensure that the transmission starts in F1 when the transmission range selector is in D. When this switch is ON and the transmission range selector is in the D position, the transmission will shift to F1 to start. When this switch is OFF and the range selector is in the D position, the transmission will start in second gear. Refer to Transmission Range Selector, D - DRIVE. All other forward gear ranges (L, F2, F3, F4, F5) start out in F1 regardless of the F1 start switch position.

### Hoist Control Lever

Hoist control lever (5, Figure 32-4) is a four-function, three-position, hand-operated lever located between the operator seat and the center console.

Refer to Operating Instructions - Dumping, for more complete details concerning this control.

### Parking Brake Switch



When parking brake switch (6, Figure 32-4) is in the ON position, the parking brake is applied.

When this switch is in the OFF position, the parking brake is released.

The parking brake is spring applied and hydraulically released. It will hold a stationary truck when the engine is stopped and the keyswitch is in the OFF position.

***DO NOT apply the parking brake while the truck is in motion. Damage to parking brake components may occur.***

When the keyswitch is ON and the parking brake is applied, an indicator light in the LH panel pod will illuminate.

### Brake Lock Switch



Moving brake lock switch (7, Figure 32-4) to the ON position, applies the brake lock.

When this switch is in the OFF position, the brake lock is released.

The brake lock must be used with the engine running. It is used for dumping and loading operations, only. The brake lock switch actuates the hydraulic brake system which locks the rear wheel service brakes only.

When pulling into shovel or dump area, select a loading area with as level a surface as possible. When the truck is completely stopped and in loading position, apply the brake lock by pressing the rocker switch toward the ON symbol. To release, press the rocker switch toward the OFF symbol.



**Use at shovel and dump only to hold the truck in position.**

**Do not use this switch to stop the truck unless the foot-operated brake valve is inoperative. Use of this switch applies the rear oil disc service brakes at full, unmodulated pressure!**

**Do not use the brake lock for parking. With the engine stopped, hydraulic pressure will bleed down, allowing the brakes to release!**

### LH Window Control Switch

LH window control switch (8, Figure 32-4) is spring-loaded to the center, OFF, position. Pushing the front of the switch raises the left side cab window. Pushing the rear of the switch lowers the window.

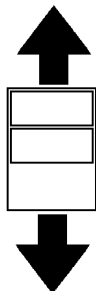

### RH Window Control Switch

RH window control switch (9, Figure 32-4) is spring-loaded to the center, OFF position. Pushing the front of the switch raises the right side cab window. Pushing the rear of the switch lowers the window.

### Ash Tray

Ash tray (10, Figure 32-4) is used for extinguishing and depositing smoking materials. Do Not use for flammable materials, such as paper wrappers, etc. Be certain that all fire ash is extinguished!

### Lighter

Lighter (11, Figure 32-4) may be used for lighting cigars/cigarettes.

**Always use caution with smoking materials!**

This socket may also be used for a 12 VDC power supply.

### Passenger Seat w/Safety Belt

Passenger seat (13) is mounted on top of the right hand portion of the center console structure.

Any passenger riding in the truck, must use seat belt (12) whenever the truck is being operated.

The area beneath the passenger seat provides a cabinet for various 24 VDC electrical components. Consult the shop manual for service involving any of these components.

## OPERATOR SEAT

The operator's seat provides a fully adjustable cushioned ride for the driver's comfort and ease of operation.

### Seat Belts

- On both driver and passenger seats, check the seat belt fabric, buckle, all belt retractors and hardware for damage or wear. Replace any worn or damaged parts immediately.
- Even if there are no signs of damage, replace both driver and passenger seat belts 5 years after seat belt manufacture, or every 3 years after start of use, whichever comes first. The passenger seat belt date of manufacture label is sewn into the seat belt near the buckle. The driver seat belt date of manufacture label is sewn into the shoulder harness belt, near the retractor end.



## Adjustment

The following adjustments must be made while sitting in the seat.

1. **Headrest:** Headrest (1, Figure 32-5) will move up, down, fore, or aft by moving headrest to desired position.
2. **Armrests:** Rotate adjusting knob until armrest is in desired position.
3. **Backrest:** Pull control (3) upward and hold, select backrest angle; release control handle.
4. **Front Height and Slope Adjustment of Seat Cushion:**
  - a. Lift control lever (4) and hold.
  - b. Bend knees to move seat to a comfortable position; release control lever to lock adjustment.
5. **Fore/Aft Location of Seat:**
  - a. Raise adjustment lever (5).
  - b. Move seat to desired position; release lever.
6. **Seat Height:** Press the upper portion of rocker switch (6) to increase the ride height. Press the lower portion of the rocker switch to lower the ride height.
7. & 8. **Air Lumbar Support:** Each rocker switch (7 or 8) controls an air pillow. Switch (7) controls the lower air pillow and switch (8) controls the upper air pillow. To inflate, press the upper portion of the rocker switch and hold for desired support, then release. To deflate, press the bottom portion of the rocker switch and hold for desired support, then release. Adjust each pillow for desired support.

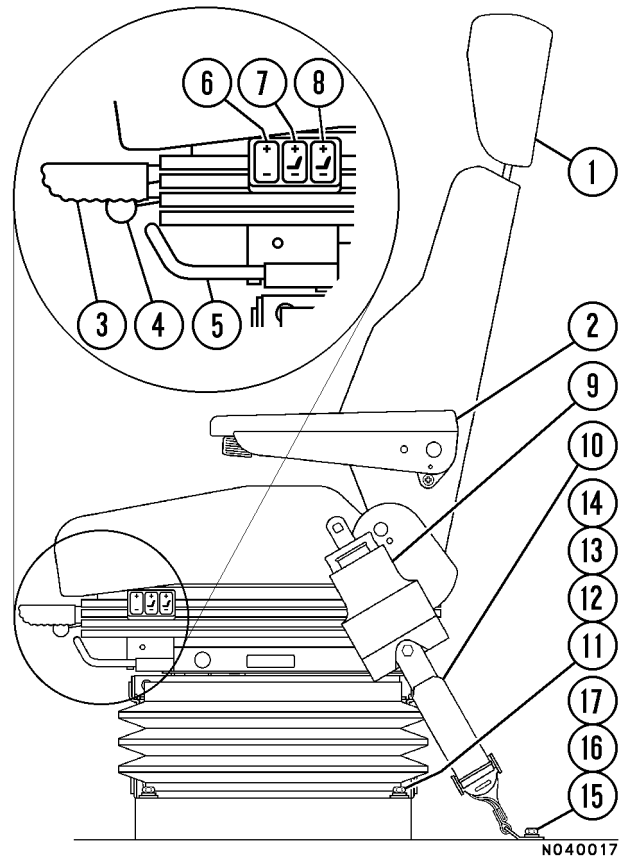

FIGURE 3-5. OPERATOR'S SEAT

- |                                      |                 |
|--------------------------------------|-----------------|
| 1. Headrest                          | 9. Seat Belt    |
| 2. Armrest Adjustment                | 10. Seat Tether |
| 3. Backrest Adjustment               | 11. Capscrew    |
| 4. Front Height and Slope Adjustment | 12. Lockwasher  |
| 5. Fore and Aft Adjustment           | 13. Flatwasher  |
| 6. Height Adjustment                 | 14. Nut         |
| 7. Lower Air Pillow Lumbar Support   | 15. Capscrew    |
| 8. Upper Air Pillow Lumbar Support   | 16. Flatwasher  |
|                                      | 17. Lockwasher  |

## INSTRUMENT PANEL AND INDICATORS

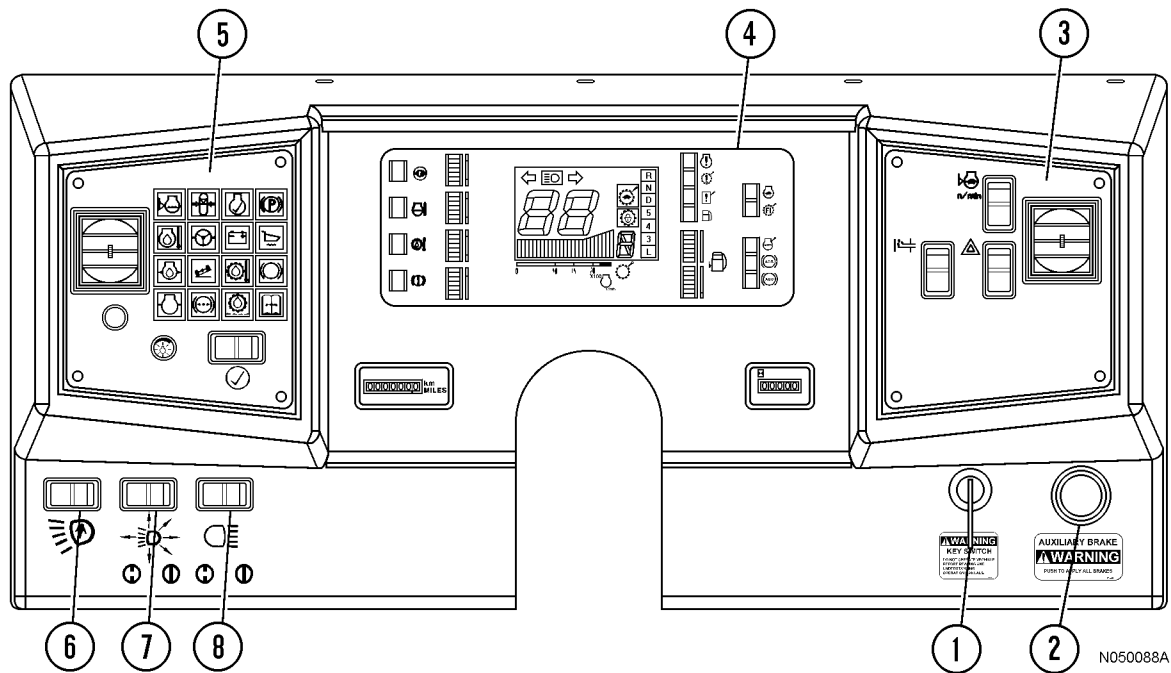

FIGURE 3-6. INSTRUMENT PANEL

- |                           |                         |                              |
|---------------------------|-------------------------|------------------------------|
| 1. Keyswitch              | 4. Center Display Panel | 7. Headlight Switch          |
| 2. Auxiliary Brake Switch | 5. LH Panel (Pod)       | 8. Backup/Deck Lights Switch |
| 3. RH Panel (Pod)         | 6. Ladder Light Switch  |                              |

The instrument panel consists of a RH & LH control/indicator panel (RH & LH pods), a center display panel (gauge and monitor module, with speedometer/tachometer module, transmission range indicator, service/hour meter, and odometer), and a row of control switches across the bottom of the panel.

The gauge and monitor module and speedometer module each have a microcomputer to process and display the signals from the sensors. Liquid crystal is used for the display area.

The monitors and gauges inside the monitor module and speedometer module are actuated by the signal from the gauge and monitor module, and the odometer is actuated by signals from the speedometer module.

The following pages will identify each element of the instrument panel and detail its function and purpose for the operator.

## Keyswitch

Keyswitch (1, Figure 32-6) is a three position (OFF, RUN, START) switch.

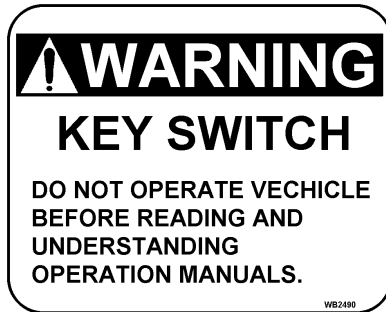

OFF - Key insertion/withdrawal position

When the key slot is in the vertical position, the electrical system is OFF and no electrical devices are energized.

Use this key position to stop the engine when it is operating.

RUN - When the switch is rotated one position clockwise, it is in the RUN position and all electrical circuits (except START) are energized.

START - With the transmission selector lever in the NEUTRAL position, rotate key switch fully clockwise to the START position and hold this position until the engine starts (see NOTE below). The START position is spring loaded to return to RUN when the key is released.

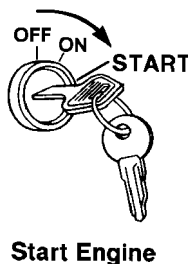
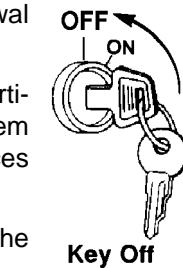

**NOTE:** The engine start circuit is equipped with an engine prelude system. A noticeable time delay will occur (while engine lube oil passages are being filled) before starter engagement and engine cranking will begin. The colder the engine oil temperature, the longer the time delay will be. In addition, if the truck is also equipped with an engine starting aid for cold weather starting, the engine prelude system should be engaged first for 5-10 seconds, or until the starter is engaged, before activating the engine starting aid.



**Starting fluid is extremely volatile and flammable! Use with extreme care.**

If the truck is equipped with an engine starting aid for cold weather starting, and ambient temperature is below  $-5^{\circ}\text{C}$  ( $23^{\circ}\text{F}$ ), push the engine starting aid switch "in" for three seconds, then release. Turn the key switch to the START position. If the engine does not start, wait at least 15 sec. before repeating the procedure.

**Do not crank an electric starter for more than 30 seconds. Allow two minutes for the starter motor to cool before attempting to start the engine again. Severe damage to the starter motor may result from overheating.**

## Auxiliary Brake Switch

Auxiliary brake switch (2, Figure 32-6) applies the auxiliary brake.

Depress the center button to apply the auxiliary brake. When the switch is ON, the red lamp will illuminate.

Pull the switch out to release the auxiliary brake; the light will turn off.



**When the auxiliary brake switch is activated, full, unmodulated hydraulic brake pressure (or whatever pressure remains, if the system is failing) is applied to all wheels. In addition, the parking brake is also applied.**

**The operator should not apply the auxiliary brake switch when the truck is moving, except as an emergency measure.**

**NOTE:** This switch is for the manual activation of the auxiliary brake circuit by the operator. The auxiliary brake circuit will apply automatically, if the hydraulic brake pressure decreases below a pre-set value.

### RH Control/Indicator Panel (Pod)

RH control/indicator panel (3, Figure 32-6), located to the right of the steering wheel, provides an array of switches and controls. For detailed information on this assembly, refer to RH Control/Indicator Panel (Pod) later in this section.

### Center Display Panel

Center display panel (4, Figure 32-6) provides an array of gauges and monitors, with an odometer module) and a service/hour meter module. For detailed information on this assembly, refer to Center Display Panel later in this section.

### LH Control/Indicator Panel (Pod)

LH control/indicator panel (5, Figure 32-6), located to the left of the steering wheel, provides an array of indicator/monitor lights and three switches. For detailed information on this assembly, refer to LH Control/Indicator Panel (Pod) later in this section.

### Ladder Light Switch

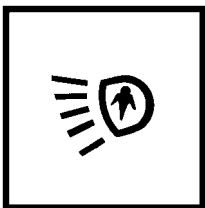

Ladder light switch (6, Figure 32-6) turns the ladder lights on or off after or before using the ladder. A similar switch is available at ground level to turn the ladder lights on or off.

### Head Light Switch

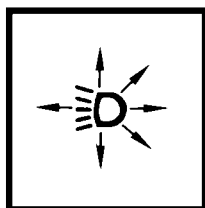

The instrument panel lights, clearance lights, and the headlights are controlled by this three position rocker type switch (7, Figure 32-6). OFF is selected by pressing the left side of the switch. Press the right side of the switch until it reaches the first detent (middle) to select the panel, clearance, and tail lights, only. Press the right side of the switch again, until it reaches the second detent to select the headlights, as well as panel, clearance, and tail lights.

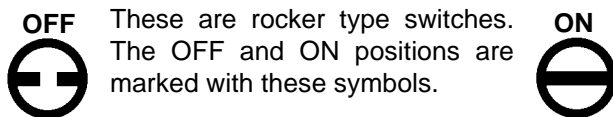

These are rocker type switches. The OFF and ON positions are marked with these symbols.

### BackUp/Deck Lights Switch

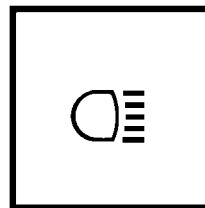

Backup/deck lights switch (8, Figure 32-6) allows backup lights to be turned on providing added visibility and safety when the transmission range selector lever (see Operator Controls) is not in the REVERSE position.

### RH Control/Indicator Panel (Pod)

RH control/indicator panel (3, Figure 32-6), located to the right of the steering wheel, contains the following:

### Cold Weather Starting Aid (Ether Injection) Switch



Starting aid switch (1, Figure 32-7) is an ON/OFF type rocker switch that is spring-loaded to the OFF position.

When the outside temperature is below -5°C (23°F), depress the top of this switch and hold for 2-3 seconds before starting the engine. The cold starting aid atomizes ether into the engine intake manifold.

Refer to Keyswitch - START for further details regarding the use of this switch.



**DO NOT push the ether injection switch after the engine has started! SERIOUS DAMAGE TO THE ENGINE MAY OCCUR!**

**Hazard Warning Lights Switch**

Hazard warning light switch (2, Figure 32-7) causes all turn signal lights to flash, simultaneously.

The rocker switch is an ON/OFF type. Depressing the bottom turns the switch OFF. Depressing the top turns the switch ON.

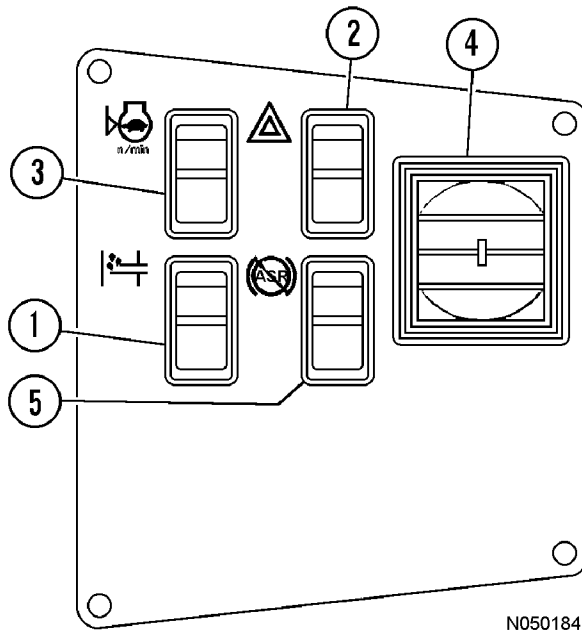

FIGURE 3-7. RH CONTROL/INDICATOR PANEL

1. Cold Weather (Ether) Starting Aid Switch
2. Hazard Flasher Switch
3. AISS Automatic Engine Idle System
4. A/C & Heater Vent
5. ASR Cut (Traction Control) Switch (Optional) \*

**NOTE:** \* If the truck is not equipped with the ASR option, the ASR slot will contain a plug.

**Automatic Idle Selector Switch (AISS)**

AISS switch (3, Figure 32-7) controls the idle speed of the engine (released throttle pedal). With the foot-operated throttle pedal in the released position, the PMC (Powertrain Management Controller) sends a signal to the Quantum™ Fuel Control System for a "low idle" rpm.

This signal may be for either:

- 650 rpm - normal-low idle, or
- 1000 rpm - high-low idle, depending on the following conditions:

1. Depressing the top of the switch selects the OFF/AUTO position which is used for enhanced truck operation. When the AISS switch is in this position, the PMC idle signal will be determined by two conditions: engine coolant temperature, and brake application.



- a. Engine Coolant Temperature - If the engine coolant temperature is below 30°C (47°F), the PMC will signal for 1000 rpm, regardless of other conditions. If the engine coolant temperature is above 30°C (47°F), the PMC will signal for 650 rpm, except as follows:
- b. Brake Application - If both the parking brake and service brake are released (acceleration anticipated), the PMC will signal for 1000 rpm, regardless of other conditions.

**NOTE:** An amber light will illuminate the switch when the OFF/AUTO position is selected.

2. Depressing the bottom of the switch selects the ON/LOW position. When the AISS switch is in this position, the PMC will signal for 650 rpm, regardless of other conditions. ON/LOW position is used when fine control movements are needed, such as parking in confined spaces.

**NOTE:** A green light will illuminate the switch when the ON/LOW position is selected.

### Air Conditioner & Heater Vent

Air conditioner/heater vent (4, Figure 32-7) swivels on a vertical axis to direct air toward or away from the operator. Air flow (up, down, on, off) through the vent is controlled by manually opening/closing or turning the louver.

### ASR Cut (Traction Control) Switch (Option)



ASR cut switch (5, Figure 32-7) is used to activate or de-activate the optional traction control system.

The rocker switch is an ON/OFF type switch. Depressing the top turns the ASR system off. An amber light will illuminate the switch to notify the operator that ASR is inactive. Depressing the bottom of the switch turns the ASR system on. A green light will illuminate the switch notifying the operator that traction control is active.

When ASR (Automatic Spin Reduction) is active, the system monitors individual wheel speeds. If it determines one of the rear wheels is slipping (losing traction) during accel, the brake is applied to the rear wheel with the higher speed.

*NOTE: If both rear wheels are slipping approximately the same amount, the system will not provide any braking to the wheels. In this situation, the operator must reduce the throttle angle to prevent slippage.*

### Center Display Panel

Center display panel (4, Figure 32-6) consists of a gauge and monitor module (1 - 27, Figure 32-8), with an odometer module (29) and a service/hour meter module (28). Liquid crystal is used for the display area.

The gauge and monitor module and the speedometer module each have a microcomputer to process and display the signals from the sensors.

The monitors and gauges inside the monitor module and speedometer module are actuated by the signal from the gauge and monitor module, and the odometer is actuated by signals from the speedometer module.

The following pages will identify each element of the center display panel and detail the function and purpose for the operator.

### Air Pressure Monitor (Not Used)

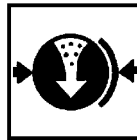

Air pressure monitor (1, Figure 32-8) is not used on this truck.

### Air Pressure Gauge (Not Used)

Air pressure gauge (2, Figure 32-8) is not used on this truck.

### Coolant Temperature Monitor



Coolant temperature monitor (3, Figure 32-8) indicates a rise in the cooling water temperature.

When the monitor lamp flashes, run the engine with no load at 1200-1500 rpm until the green range of the engine water temperature gauge lights.

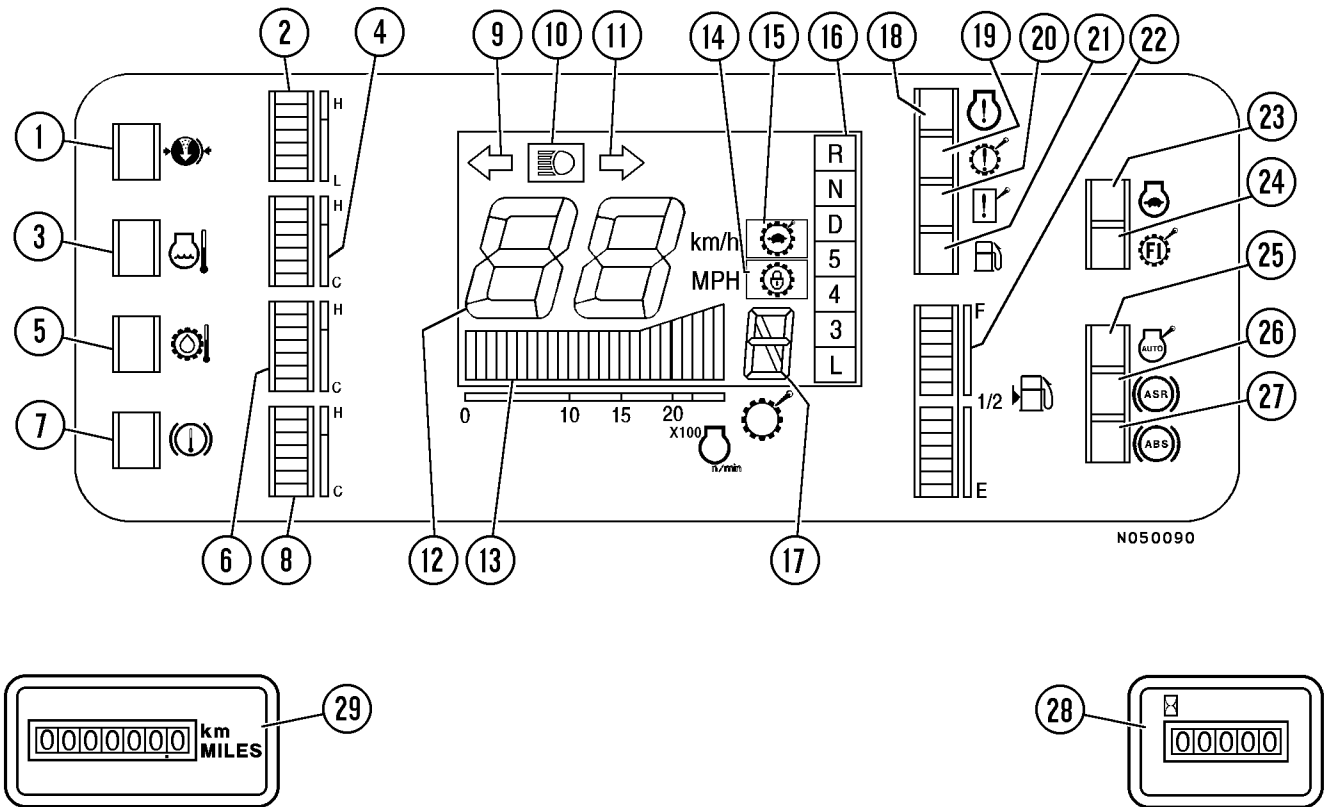

FIGURE 3-8. CENTER DISPLAY PANEL

- |   |   |
|---|---|
| <ul style="list-style-type: none"> <li>1. Air Pressure Monitor (Not Used)</li> <li>2. Air Pressure Gauge (Not Used)</li> <li>3. Coolant Temperature Monitor</li> <li>4. Coolant Temperature Gauge</li> <li>5. Torque Converter Oil Temperature Monitor</li> <li>6. Torque Converter Oil Temperature Gauge</li> <li>7. Retarder Oil Temperature Monitor</li> <li>8. Retarder Oil Temperature Gauge</li> <li>9. Left Turn Signal Pilot Lamp</li> <li>10. High Beam Pilot Lamp</li> <li>11. Right Turn Signal Pilot Lamp</li> <li>12. Speedometer</li> <li>13. Tachometer</li> <li>14. Lock-up Pilot Lamp</li> <li>15. Shift Limiter Pilot Lamp</li> </ul> | <ul style="list-style-type: none"> <li>16. Shift Indicator</li> <li>17. Transmission Shift Position Pilot Lamp</li> <li>18. Engine Controller Monitor</li> <li>19. Automatic Transmission Mechatronics Monitor</li> <li>20. Other Controllers (OPTIONAL)</li> <li>21. Fuel Level Monitor</li> <li>22. Fuel Gauge</li> <li>23. Engine Power Derate Monitor</li> <li>24. F1 Start Monitor</li> <li>25. Auto Cruise Control Monitor (Not Used)</li> <li>26. ASR Monitor</li> <li>27. ABS Monitor</li> <li>28. Service Meter &amp; Indicator</li> <li>29. Odometer</li> </ul> |
|---|---|

### Engine Cooling Water Temperature Gauge

Engine cooling water temperature gauge (4, Figure 32-8) indicates the temperature of the cooling water. If the temperature is normal during operation, the green range will light. If the red range lights during operation, the alarm buzzer will sound, the central warning lamp will flash and the coolant temperature monitor lamp will flash at the same time. If this occurs, stop the machine and operate the engine with no load at 1200-1500 rpm until the green range lights.

### Torque Converter Oil Temperature Monitor



Torque converter oil temperature monitor (5, Figure 32-8) indicates a rise in the torque converter oil temperature.

When the monitor lamp flashes, stop the machine and run the engine with no load at 1200-1500 rpm until the green range of the temperature gauge lights.

### Torque Converter Oil Temperature Gauge

Torque converter oil temperature gauge (6, Figure 32-8) indicates the temperature of the torque converter oil. If the temperature is normal during operation, the green range will light. If the red range lights during operation, the alarm buzzer will sound, the central warning lamp will light up and the torque converter oil temperature monitor lamp will flash at the same time. If this occurs, stop the machine and run the engine with no load at 1200-1500 rpm until the green range lights.

### Retarder Oil Temperature Monitor



Retarder oil temperature monitor lamp (7, Figure 32-8) indicates the retarder oil temperature has risen.

If it flashes, stop the machine, return the transmission range selector lever to NEUTRAL, and run the engine under no load at 1200-1500 rpm until the warning lamp goes out.

### Retarder Oil Temperature Gauge

Retarder oil temperature gauge (8, Figure 32-8) indicates the temperature of the retarder cooling oil. During normal operation, the green range should be illuminated.

If the lamp in the red range illuminates during operation, the alarm buzzer will sound, the central warning lamp will flash, and the retarder oil temperature monitor lamp will flash at the same time. If this happens, stop the machine, return the transmission range selector lever to NEUTRAL, and run the engine at 1200-1500 rpm under no load, and wait until the lamps in the green range illuminate.



### Left Turn Signal Pilot Lamp

When the turn signal lever is moved downward, left turn signal pilot lamp (9, Figure 32-8) flashes.

### High Beam Pilot Lamp



High beam pilot lamp (10, Figure 32-8) lights up when the head lamps are on high beam.



### Right Turn Signal Pilot Lamp

When the turn signal lever is moved upward, right turn signal pilot lamp (11, Figure 32-8) flashes.

### Speedometer

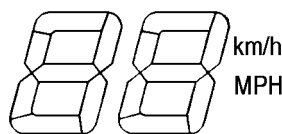

Digital speedometer (12, Figure 32-8) indicates the travel speed of the truck in miles per hour, or kilometers per hour. This figure will appear momentarily when the keyswitch is first turned ON to demonstrate that all segments are working.



**Tachometer**

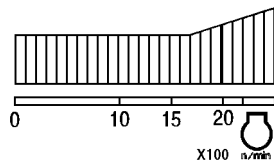

Tachometer (13, Figure 32-8) indicates 0-2500 rpm engine speed. Each bar represents 100 rpm.

**Engine Controller Monitor**



Engine control monitor (18, Figure 32-8) flashes (red) whenever any abnormality occurs in any of the engine control systems.

**Lock-up Pilot Lamp**



Lock-up pilot lamp (14, Figure 32-8) lights up (blue) whenever the torque converter is locked up and the transmission enters direct drive.

**Automatic Transmission Mechatronics Monitor**

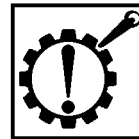

This red indicator (19, Figure 32-8) flashes whenever any abnormality occurs in the mechatronics related parts of the transmission control system.

**Shift Limiter Pilot Lamp**



Shift limiter pilot lamp (15, Figure 32-8) lights up (blue) whenever the shift limiter switch (on center console) is activated.

**Other Mechatronics Monitor (Optional)**

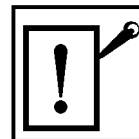

This red indicator (20, Figure 32-8) flashes whenever any abnormality occurs in the mechatronics related parts of the PMC (Powertrain Management Control) system, RCM (Retard Control Monitor) system, PLM (Payload Meter) system, and the suspension control system.

**Shift Indicator**



Shift indicator (16, Figure 32-8) indicates the lever position of the transmission range selector.

**Fuel Level Monitor**



This red indicator (21, Figure 32-8) flashes whenever the remaining fuel in the fuel tank falls below 40 gal. (150 liters).

When this indicator flashes, check fuel level gauge (22) and/or add fuel to the truck fuel tank.

**Transmission Shift Position Pilot Lamp**



Transmission shift position pilot lamp (17, Figure 32-8) will indicate the specific gear range in which the transmission is actually operating; R, N, 1, 2, 3, 4, 5, 6, or 7.

### Fuel Gauge

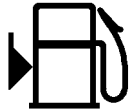

Fuel gauge (22, Figure 32-8) indicates the amount of fuel in the fuel tank. If there is more than 40 gal. (150 liters) of fuel in the tank while the engine is operating, the green range illuminates. If there is less than 150 liters (40 gal) of fuel in the tank, the red range illuminates.



***Operating the truck until the fuel is depleted forces the injector train into a no-follow condition. No fuel flow between the plungers may cause damage to the injectors and the overhead due to adhesive wear, resulting in costly repairs and unnecessary downtime.***

***When the fuel level caution lamp illuminates, immediately add fuel to avoid damage to engine components.***

### Engine Power Derate Monitor



This red indicator (23, Figure 32-8) flashes to alert the operator that the PMC (Powertrain Management Controller) has detected an engine fault and is signalling the Quantum™ fuel control system to reduce power output to protect the engine.

### F1 Start Monitor



This blue indicator (24, Figure 32-8) illuminates whenever the F1 shift limit switch (on the center console) is activated.

### Auto Cruise Control (Not Used)



Indicator (25, Figure 32-8) is currently not used.

### ASR Monitor (Optional)



This indicator (26, Figure 32-8) illuminates whenever the traction control system (if installed) is activated.

### ABS Monitor (Not Used)



Indicator (27, Figure 32-8) is not used currently used on this truck.

### Service Meter

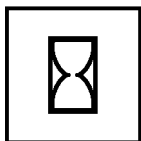

Service meter (28, Figure 32-8) displays the total hours of operation for the truck. The meter advances whenever the engine is operating, even if the truck is not moving.

### Odometer

Odometer (29, Figure 32-8) indicates the total distance that the truck has traveled in miles or kilometers.

**LH Control/Indicator Panel (Pod)**

LH control/indicator panel (5, Figure 32-6), located to the left of the steering wheel, contains the following:

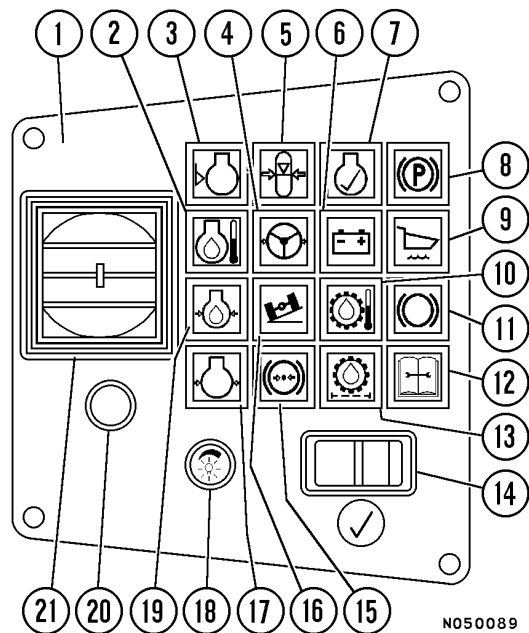

FIGURE 3-9. LH CONTROL/INDICATOR PANEL

- |                                    |                              |
|------------------------------------|------------------------------|
| 1. LH Panel (Pod Assy.)            | 12. Maintenance Monitor      |
| 2. Engine Oil Temp.                | 13. Transmission Oil Filters |
| 3. Engine Coolant Level            |                              |
| 4. Low Steering Pressure           | 14. Lamp Test Switch         |
| 5. Accumulator Pre-Charge Pressure | 15. Low Brake Pressure       |
| 6. Battery Charge (Amps)           | 16. Lateral Slope Warning    |
| 7. Check Engine                    | 17. Crankcase Pressure       |
| 8. Parking Brake                   | 18. Panel Dimmer Switch      |
| 9. Body Float                      | 19. Engine Oil Pressure      |
| 10. Transmission Oil Temperature   | 20. Central Warning Lamp     |
| 11. Service Brakes Applied         | 21. A/C & Heater Vent        |

**LH Panel/Pod Assembly**

LH panel/pod (1, Figure 32-9) provides an array of indicator/monitor lights and three switches.

*NOTE: All the indicator lamps are red in color; except, #11. which is amber/yellow.*

**Engine Oil Temperature**

Engine oil temperature monitor light (2, Figure 32-9) will illuminate if the engine oil temperature exceeds 121°C (250°F) for a continuous period of 5 seconds. If the lamp flashes and alarm buzzer sounds, stop the engine.

At the same time, a fault code will be registered in the Quantum™ System. Refer to Quantum™ Fuel System Diagnostics later in this section.

**Engine Coolant Level**

Engine coolant level monitor light (3, Figure 32-9) will illuminate, if the engine coolant level is below the sensor for a continuous period of five seconds. At the same time, a fault code will be registered in the Quantum™ System. (Refer to Quantum™ Fuel System Diagnostics later in this section.) If this monitor lamp flashes and the alarm buzzer sounds, stop the truck, shut-down the engine, and add coolant, as required.

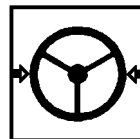
**Low Steering Pressure**

Low steering pressure monitor light (4, Figure 32-9) will illuminate if the steering system pressure is below 12.8 MPa (1850 psi). The light may also indicate that the wire from the switch to the transmission controller is cut or broken.

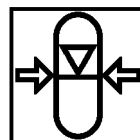
**Accumulator Pre-Charge**

Accumulator pre-charge monitor light (5, Figure 32-9) will illuminate if the accumulator nitrogen pressure is below 5861 kPa (850 psi). The light may also indicate that the wire from the switch to the transmission controller is cut or broken.

### Battery Charge Amps

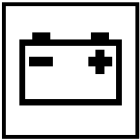

Battery charge amps monitor light (6, Figure 32-9) will illuminate if the transmission controller detects low battery current at the "R" terminal of the alternator while the engine is running or if the wire is cut. If the monitor lamp flashes, check the charging circuit.

### Check Engine



Check engine monitor light (7, Figure 32-9) will illuminate if a problem occurs in the Quantum™ engine control system. The light is also used to display the trouble code.

(Refer to Quantum™ Fuel System Diagnostics later in this section.)

### Parking Brake



Parking brake monitor light (8, Figure 32-9) will illuminate if the transmission controller detects that the parking brake is applied or that the wire between the switch and the controller is cut or broken.

### Body Float



Body float monitor light (9, Figure 32-9) will illuminate if the transmission controller detects that the body is not seated on the frame rail or that the wire from the proximity switch and the controller is cut. When the dump body control lever is set to any position other than FLOAT, the body float monitor lights up. When traveling, always set the lever to FLOAT position.

### Transmission Oil Temperature



Transmission oil temperature monitor light (10, Figure 32-9) will illuminate if the transmission controller detects that the oil temperature is over 120°C (248°F).

### Service Brakes Applied



Service brakes applied monitor light (11, Figure 32-9) will illuminate (amber), if the transmission controller detects that the rear brakes have been applied, or that the wire between the switch and the controller is grounded.

### Maintenance Monitor



Maintenance monitor lamp (12, Figure 32-9) will illuminate if the PMC (Powertrain Management Controller), detects any of the following faults:

- Low oil brake cooling oil level
- Low hydraulic oil level
- Low battery liquid level
- Front oil brake cooling filter restricted
- Rear oil brake cooling filter restricted - Right side
- Rear oil brake cooling filter restricted - Left side
- Hydraulic Oil Filters Restricted
- Brake Disc Wear Indication - Right Front
- Brake Disc Wear Indication - Left Front
- Brake Disc Wear Indication - Right Rear
- Brake Disc Wear Indication - Left Rear

### Transmission Oil Filters

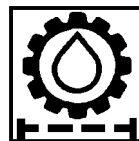

Transmission oil filters monitor lamp (13, Figure 32-9) will illuminate if the transmission controller detects that a transmission filter is restricted, or that the wire between the controller and the switch is cut or broken. If this lamp

flashes and the alarm buzzer sounds, notify maintenance personnel, immediately. As soon as practical thereafter, drain the transmission oil, replace the transmission filters, and check for contamination in the oil.

**Lamp Test**

Lamp test switch (14, Figure 32-9) is a three position, two function switch. The switch is spring loaded to the middle, NEUTRAL position. If depressed on the right side and held, it is a lamp test for all of the monitor lamps except the check engine lamp.

If the left side of the rocker switch is depressed held the lamp test for the check engine lamp will function.

When the check engine lamp is illuminated because of a fault in the Quantum™ system, depress and release the left side of the rocker switch. Wait, and the check engine lamp will begin flashing the fault codes. (Refer to Quantum™ Fuel System Diagnostics later in this section.)

**Low Brake Pressure**

Low brake pressure monitor lamp (15, Figure 32-9) will illuminate if the transmission controller detects that the brake system hydraulic pressure is below 12 755 kPa (1850 psi), or that the wire from the switch to the control-

ler is cut.

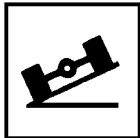
**Lateral Slope Warning**

Lateral slope warning monitor lamp (16, Figure 32-9) is a tip-over warning device. The light will illuminate if the dump body is off of the frame and the lateral slope of the truck is beyond a pre-set safety limit.

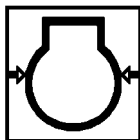
**Crankcase Pressure**

Crankcase pressure monitor lamp (17, Figure 32-9) will illuminate if the engine crankcase pressure is greater than 14.5 in. of H<sub>2</sub>O for more than 5 seconds. At the same time a fault code will be registered in the Quantum™ system. (Refer to Quantum™ Fuel System Diagnostics later in this section.)

**Panel Dimmer Switch**

Panel dimmer switch (18, Figure 32-9) is used to adjust the brightness of the lighting inside the monitor panel.

To increase brightness, turn clockwise. To decrease brightness, turn counter-clockwise.

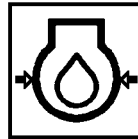
**Engine Oil Pressure**

Engine oil pressure monitor lamp (19, Figure 32-9) will illuminate if the engine oil pressure falls below a certain value for a 5 second period of time. That value is dependent on engine rpm. At the same time a fault code will be registered in the Quantum™ system. (Refer to Quantum™ Fuel System Diagnostics later in this section.)

**Central Warning Lamp (Red Convex Lens)**

Central warning lamp monitor lamp (20, Figure 32-9) will illuminate if any of the monitor lamps in the LH pod (Figure 32-9) are activated. This lamp is also activated if a fault is registered on the MOM display.

This lamp flashes, and at the same time an alarm buzzer sounds intermittently, if an abnormality has occurred in any one of the following systems:

- coolant temperature monitor;
- torque converter oil temperature monitor;
- retarder oil temperature monitor;
- engine oil pressure monitor;
- high engine oil temperature;
- high engine blow-by pressure;
- high transmission lube oil pressure;
- battery charging monitor;
- parking brake monitor;
- body float monitor;
- automatic transmission monitor (mechatronics);
- other mechatronics monitor;
- or fuel level monitor.

This lamp will also flash and the alarm buzzer will sound, if the parking brake is applied and the range selector lever is not in NEUTRAL.

*NOTE: The warning lamp and buzzer will not actuate when MOM detects a problem and displays the action code "01".*

### **AC/Heater Vent**

AC/heater vent (21, Figure 32-9) is provided for circulation of cooled or heated air through the cab.

### **REAR OF OPERATOR CAB**

The following components are located behind the operator and passenger seats across the back wall of the operator cab (Refer to Figure 32-10):

1. Circuit Breaker Panel

This panel contains all of the electrical circuit breakers on the truck.

2. Relay Boards

These panels contain relays for various electrical circuits on the truck. Refer to the Shop Manual for specific information regarding the relay boards.

3. Relay Boards (see above)

4. RCM - Retard Control Monitor

This panel controls and monitors the fully hydraulic retarder system. Refer to the Shop Manual for specific information regarding this device.

5. RCM Data Port

This is a connector to be used when communications are required between the RCM and a personal computer.

6. ASC - Automatic Suspension Controller (Optional)

This panel (when installed) controls and monitors the variable rate suspension units. Refer to the Shop Manual for specific information regarding this device.

7. ATC - Automatic Transmission Controller

This panel controls and monitors the Komatsu fully automatic transmission. It controls the shift schedules and lock-up clutch modulation and monitors numerous other sensor inputs. Refer to the Shop Manual for specific information regarding this device.

8. PMC - Powertrain Management Controller

This panel controls, monitors, and manages all of the other monitors and controllers listed above. Refer to the Shop Manual for specific information regarding this device.

9. Terminal Strips - Terminals for various electrical circuits. Refer to the Shop Manual electrical schematic for specific information.

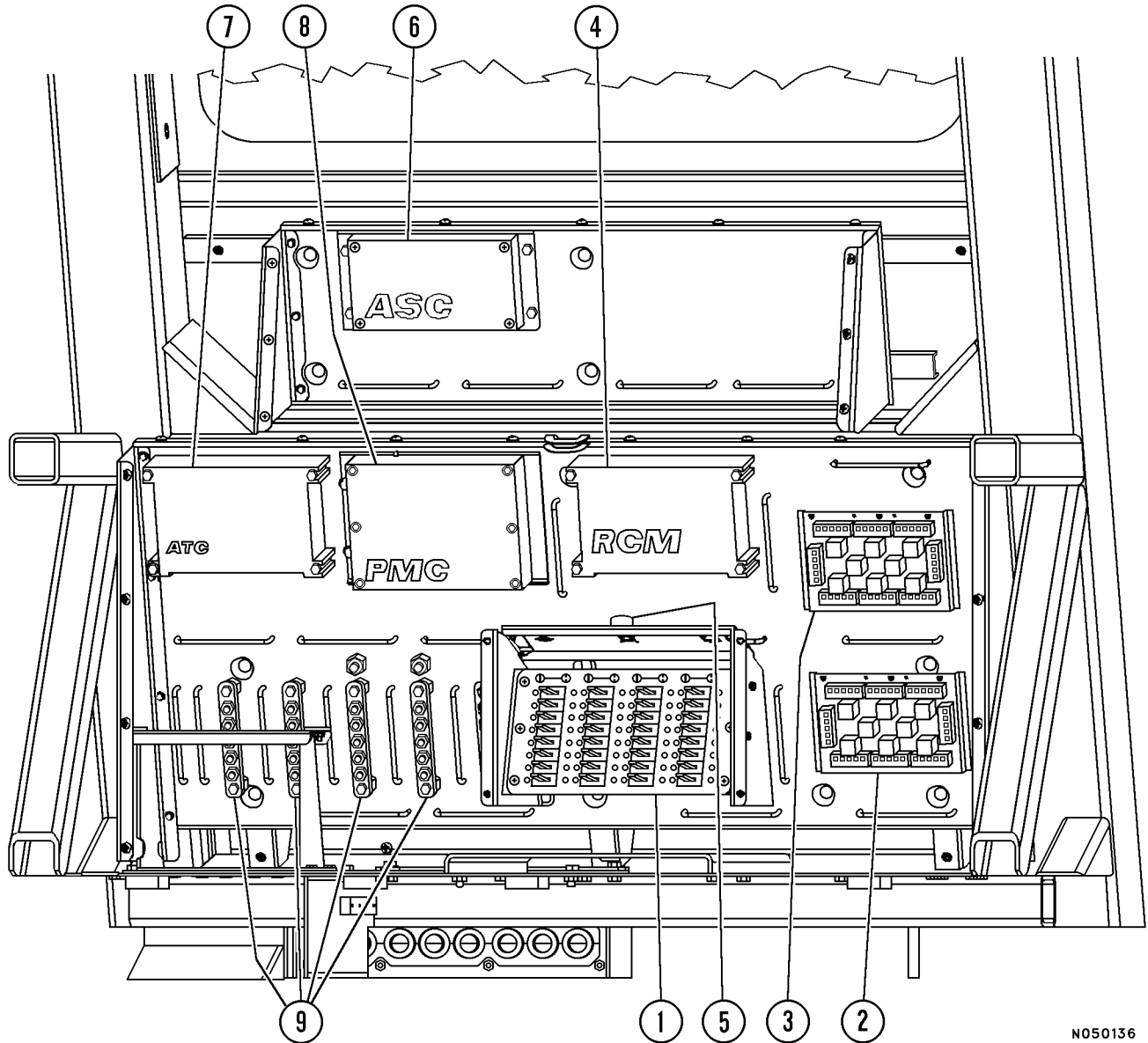

N050136

FIGURE 3-10. REAR WALL OF OPERATOR CAB

- |   |  |
|---|--|
| <ul style="list-style-type: none"> <li>1. Circuit Breaker Panel</li> <li>2. Relay Board</li> <li>3. Relay Board</li> <li>4. RCM - Retard Control Monitor</li> <li>5. RCM Data Port</li> </ul> | <ul style="list-style-type: none"> <li>6. ASC - Automatic Suspension Controller (Optional)</li> <li>7. ATC - Automatic Transmission Controller</li> <li>8. PMC - Powertrain Management Controller</li> <li>9. Terminal Strips</li> </ul> |
|---|--|

CIRCUIT BREAKER CHART					
CIRCUIT BREAKER IDENTIFICATION			CIRCUIT NUMBER		CONTROL DESCRIPTION
No.	AMPS	VOLTS	IN	OUT	
<b>LOCATION: BATTERY BOX</b>					
CB24V	50	+24	3	12	24 Volt Control Power (To Power Bus #3 on Cab Rear Wall)
CB12V	50	+12	4	12V	12 Volt Control Power (To Power Bus #4 on Cab Rear Wall)
<b>LOCATION: CAB REAR WALL</b>					
CB01	10	+24	1	27B	Quantum Engine Monitor
CB02	5	+24	1	25	Transmission Controller (ATC)
CB03	10	+24	1	82	Retard and Control Monitor (RCM)
CB04	5	+24	1	91B1	Powertrain Management Controller (PMC)
CB05	5	+24	1	91B2	Powertrain Management Controller (PMC)
CB06	5	+24	11	46	Hazard Light Control
CB07	15	+24	12	44A	Brake Lights
CB08	5	+24	12	25T	Transmission Cut Solenoid Signal
CB09	15	+24	12	63	Windshield Wiper Motor
CB10	10	+24	12	47B	Back-Up Lights
CB11	5	+24	12	91A	Powertrain Management Controller (PMC)
CB12	5	+24	12	81	Suspension Controller (Optional)
CB13	10	+24	12	25C2	Transmission Controller (ATC)
CB14	10	+24	12	25C1	Transmission Controller (ATC)
CB15	5	+24	12	27A	Quantum Engine Monitor
CB16	5	+24	12	12H	Hoist Limit Solenoid Valves
CB17	10	+24	12	39J	Payload Meter Light Control
CB18	5	+24	12	39G	Payload Meter
CB19	15	+24	12	47A	Back-Up Lights and Alarm
CB20	10	+24	12	68A	Automatic Lube System Timer
CB21	15	+12	12V	67P	Left Cab Window Motor
CB22	15	+12	12V	67R	Right Cab Window Motor
CB23	5	+12	12V	65	AM/FM Radio
CB24	10	+12	12V	67C	Cigar Lighter
CB25	5	+24	21	21S	Start Circuit Signal
CB26	5	+24	13	31	Electronic Display Panel (Instrument Panel)
CB27	5	+24	13	38	Message Display panel (MOM)
CB28	5	+24	13	13A	Payload Meter - ACC Signal
CB29	5	+24	12	12PC	SNET to DAD Interface Connector
CB30	5	+24	12	67AS	Operator seat Air Pump
CB31	10	+24	12	52P	Brake System Components
CB32	10	+24	11	42	Engine Service Lights
<b>LOCATION: PASSENGER SEAT BASE</b>					
<b>RELAY BOARD RB1</b>					
CB13	15	+24	11T	11CL	Turn Signal Lights
CB15	15	+24	11	11T	Dash Lights/Turn Signal/Clearance Lights
<b>RELAY BOARD RB4</b>					
CB20	-	-	712S	439E	Not Used
CB21	15	+24	11	43	Steering Bleeddown Solenoid, Horn & Service Lights
CB22	-	-	712S	23F	Not Used
<b>RELAY BOARD RB5</b>					
CB23	15	+24	11	11DL	Left Low Beam Headlight
CB24	15	+24	11	11DR	Right Low Beam Headlight
CB25	15	+24	11	11HL	Left High Beam Headlight
CB26	15	+24	11	11HR	Right High Beam Headlight
CB27	15	+24	11	11D	Turn/Clearance Light Control
<b>LOCATION: OVERHEAD DASH PANEL</b>					
DC-CB	0.5	+24	38B	38A	DC/DC Converter, MOM Display



## QUANTUM™ FUEL SYSTEM DIAGNOSTICS

Check engine monitor light (7, Figure 32-9) monitors the Quantum™ Fuel Control System. When the key-switch is turned ON, this light should illuminate for about 2 seconds and then turn off, if no faults are detected in the system.

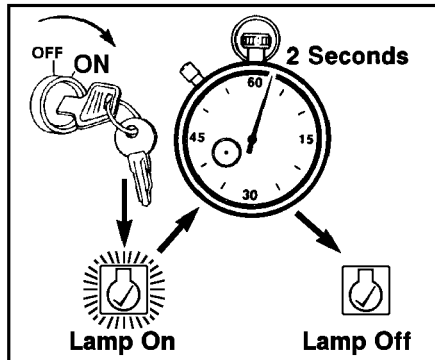

If the light stays on, or flashes, then active faults have been detected by the system and the engine should not be started. Refer to Determining Fault Codes.

During engine operation, if a fault is detected in the system, the light will turn on and stay on for "warning" faults, or it will turn on and flash for more severe faults that can affect engine operation and require immediate attention.

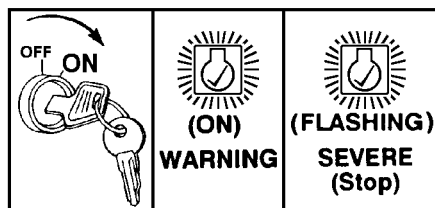

- "Warning" faults (light on) are ones that require attention in the near future, but in most conditions will not greatly affect governing performance.
- "Severe" faults (light flashing) are ones that require *immediate* attention, because Quantum™ governor performance could be significantly affected, resulting in a backup mode of operation. **Active fault conditions must be corrected as soon as possible.**

Lamp test/diagnostic test switch (14, Figure 32-9) may be used to activate the Quantum™ fuel system diagnostic codes. When the Quantum™ fuel system detects a fault and the check engine monitor light (7, Figure 32-9) illuminates as described above, this switch will allow determination of the kind of fault(s) detected.

## Determining Fault Codes

Quantum™ fault codes consist of three numerical digits. Each digit is indicated with up to five light flashes (check engine monitor light) per each digit. There is a short pause between each digit of the fault code. Once all three digits are flashed, there is a longer pause, followed by a repeating of the same fault code sequence.

1. To determine an active Quantum™ fault, turn the keyswitch to the OFF position. Be sure the engine completely stops, if it was running.
2. Turn keyswitch to ON position (engine not running) and move the lamp test switch to the left ("✓" position) for 1 - 2 seconds, then release (switch is spring-loaded to the middle, OFF, position).

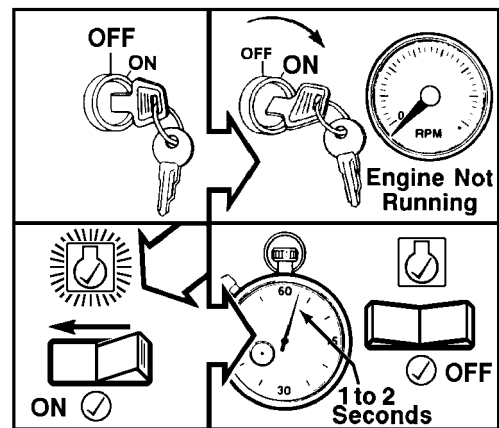

3. If there is an active fault, after releasing the switch there will be a short pause, followed by the first fault code.

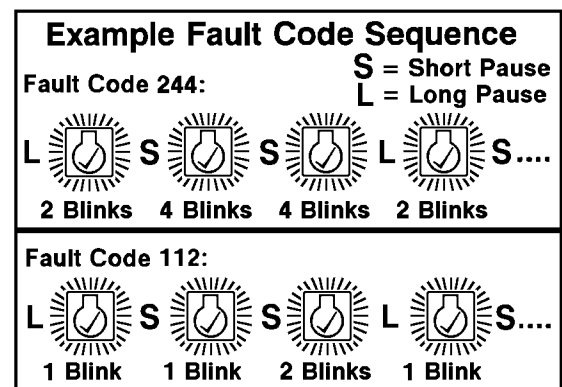

4. Pressing the lamp test switch to the bottom ("√") again will advance to the next fault code (if more than one code is present). Once all active fault codes have been displayed, the fault code display sequence will be repeated, starting from the first fault code.

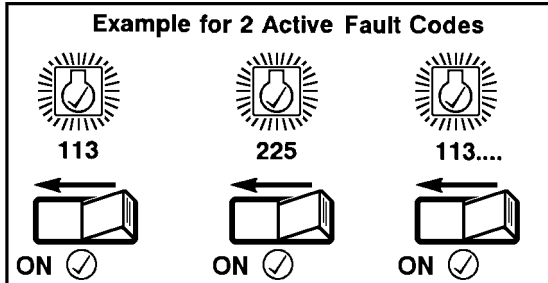

### Exiting The Diagnostics Mode

Starting the engine or turning the keyswitch to the OFF position will exit the diagnostics fault flash mode.

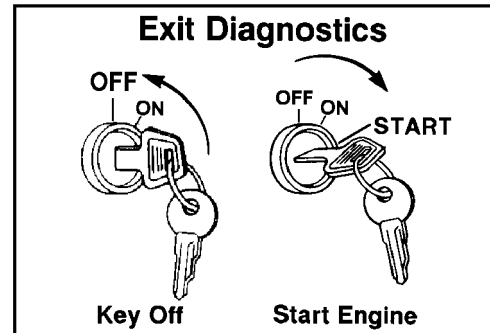

If active fault codes have been determined as described previously, refer to the Cummins Engine Quantum™ System "Troubleshooting and Repair Manual", Bulletin No. 3666070, or contact an authorized repair shop.

## MESSAGE FOR OPERATION AND MAINTENANCE ("MOM")

"MOM" (Message for Operation and Maintenance) is the message display screen located in the upper panel just above the operator's head. It is used to display messages to the operator and service personnel. The screen incorporates touch switches on its surface, to change displays. Data that "MOM" can display includes:

### Truck Condition-

When the key switch is turned to the run position before cranking, the display will read **OK** or **WAIT**. If the **WAIT** warning is present, the reason will also be displayed. If the engine is running and the truck is ready to be moved, the screen will indicate departure is **OK** or **WAIT**. If the **WAIT** warning is present, the reason will also be displayed.

### Production Data During Operation - (Information from the Payload Meter)

- The Current Payload
- The Total Payload
- The Total Number Of Cycles
- Fault Information At The Time Of Occurrence
- The Fault Code And Its Description
- The Action Code And Its Description
- Other Function - Clock

*NOTE: NOTE: The operator should follow the recommendation that is displayed on the "MOM" screen. However, the operation of the truck is not prohibited. Even if the screen displays **WAIT**, the truck can still be operated if an emergency situation exists.*

### 1. Screen i1, Initial Message

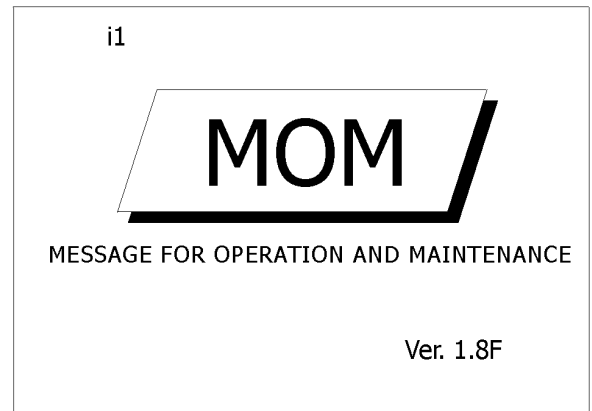

After the key switch is turned on, the initial message (i1) is displayed for three seconds after a system message is displayed. The picture number, i1, the title, and the program version number are all indicated on this screen. After being displayed for three seconds, i1 is changed to the first initial check, Check 1, screen i2, automatically.

If any of the controllers detect a fault in their system, the i1 screen is changed to the display of the warning message i6 automatically after three seconds.

### 2. Screen i2, Initial Check 1

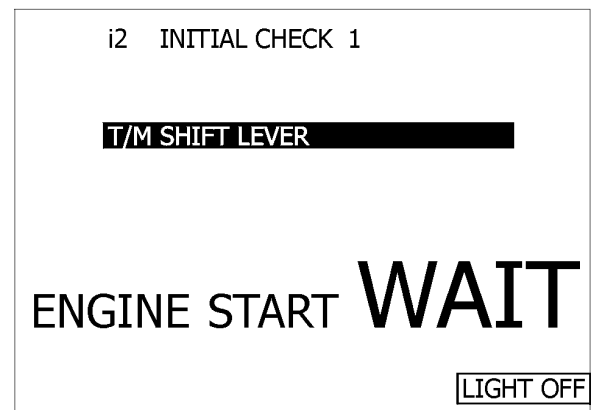

This screen is displayed after i1 and before engine is started. It is used to inform the operator whether the conditions are acceptable to start the engine.

When "MOM" judges that engine start is acceptable, "**ENGINE START OK**" is indicated on the screen.

If "MOM" judges that engine start is not acceptable, "**ENGINE START WAIT**" is indicated on the screen.

The reason why the engine start is not acceptable is also indicated at the same time. If the screen displays "**PARKING BRAKE**", it means the parking brake is not applied. If the screen displays "**T/M SHIFT LEVER**", it means the shift lever is not in the NEUTRAL position.

The engine will still start even if the screen indicates "**PARKING BRAKE**" while the shift lever must be in the neutral position for the engine to start. After the engine starts the i2 screen changes to the second initial check, Check 2, screen i3 automatically.

If any controller detects a fault, i2 is changed to the i6, Warning Message screen automatically.

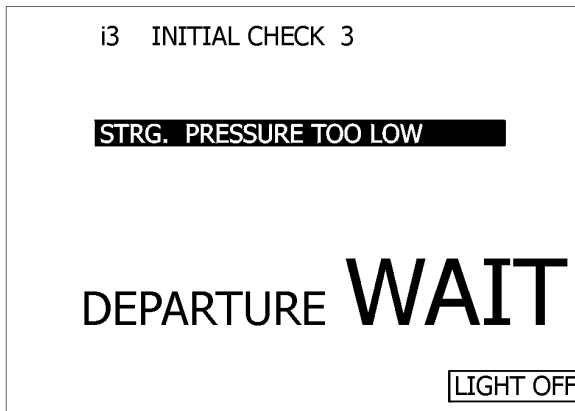

### 3. Screen i3, Initial Check 2

This screen is displayed after the engine is running but, before the range selector lever is moved from the neutral position. The indication will be that departure is acceptable or not.

When "MOM" judges that departure is acceptable, "**DEPARTURE OK**" is indicated on the screen.

If "MOM" judges that departure is not acceptable, "**DEPARTURE WAIT**" is indicated on the screen. The reason why departure is not acceptable is also indicated at the same time. Possible reasons could be, "**STRG. PRESSURE TOO LOW**" when the steering accumulator pressure is too low, or "**ENG. DERATE ON**" when the engine system detects some severe fault which makes the engine power derate.

The truck is still able to depart even is "**STRG.PRES-SURE TOO LOW**" or "**ENG. DERATE ON**" if in an emergency situation. When the engine is started i2 is changed to the initial check i3 screen automatically.

If the "**LIGHTS OFF**" area in the i3 screen is touched, then the back light of "MOM" is turned off and i3 is turned to a dark display.

If any controller detects a fault, i3 is changed to the warning message screen i6 automatically.

### 4. Screen i4, Normal Display

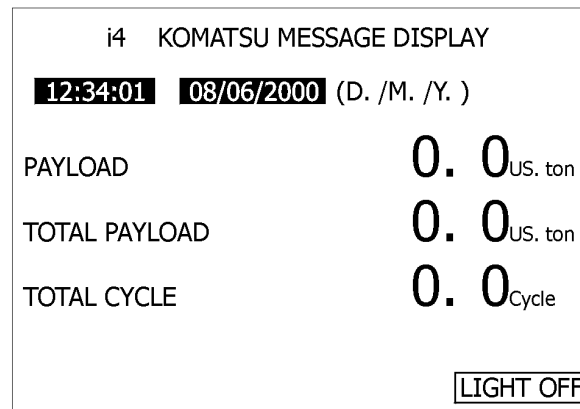

This screen is displayed while the truck is running and the range selector is in either a forward or reverse position. Once the range selector is changed from the neutral position the i4 screen is displayed until the key switch is turned to the off position, even is the range selector is returned to the neutral position.

Time, current payload, total payload, and total number of cycles are indicated in this display.

If during the time the i3 screen was displayed the "DEPARTURE WAIT" was indicated because of either "STRG." and/or "DERATE", they will remain on until the cause is discovered and repaired.

The payload meter is the source of the information regarding payload data. "MOM" is unable to indicate this data until it is sent by the payload meter. The payload meter will send this information to "MOM" when it recognizes the truck is in a loading configuration. It will continue sending information until it realizes that the loading configuration is finished or the truck has changed to a dumping condition. After first recognizing a loading and then dumping configurations, the payload meter will then sent the data of total payload and total number of cycles.

The following situations are considered not normal.

- a. If the truck was in a loading configuration and the key switch was turned off and then back on again, "MOM" will indicate no data of current payload, total payload, and total number of cycles.
- b. The data for total payload and total number of cycles is not indicated in "MOM" until the payload meter recognizes that the truck has started dumping the load.
- c. The data for current payload is not indicated until the payload meter recognizes that the truck is being loaded.
- d. If after the current payload has been indicated and then additional material is now added to the load, the current payload data will not change.
- e. If data is not being recognized by "MOM", dump the load. Activate the dump cycle a second time and then assume normal operation.

*NOTE: Note: For additional information regarding the Payload Meter, refer to the Section D of the service manual.*

If the "LIGHTS OFF" area in i4 is touched then the back light of "MOM" is turned off and i4 is changed to a dark display.

If any controller detects a fault, i4 is changed to the i6 warning message display automatically.

5. Screen i6, Warning Message Display

i6 WARNING MESSAGE		
No.	ERROR CODE	ERROR MESSAGE
(CLR)	ACTION CODE	ACTION
1	J004	REAR LEFT BRAKE PRESSURE LOW
	02	NOTIFY MAINTENANCE RIGHT NOW
2	b083	T/C IN PRESS. SENSOR FAILURE
	02	NOTIFY MAINTENANCE AT SHIFT CHANGE

FWD
REV

When a fault occurs in any of the controllers the operator is informed of this through the following method:

- a. MOM will display the **fault** code and the **action** code along with a description of each.
- b. The electronic display in the instrument panel will also display the **action** code.
- c. The central warning lamp is turned on and off as a warning alarm. In certain cases the warning buzzer is also activated.

If the fault is with a component or system that also has a warning lamp, this indication will also be activated at the same time.

After the operator has been informed of the fault code the action that should be taken is as follows:

- 1) Stop the truck in a safe location.
- 2) Apply the parking brake.
- 3) Confirm the presence of the fault code and the action code.
- 4) Follow the instructions of the action code.
- 5) Notify a qualified technician for repairs.

The possible action codes are as follows:

Code	Description
01	Notify maintenance at shift change
02	Notify maintenance right now
03	Reduce engine / machine speed
04	Stop safely now / shut off engine
05	Stop with engine at mid speed
06	Start engine and keep at low idle
07	Keep body seated

Two faults can be displayed at one time along with their description and action. If three or more code are present the "FWD" and "REV" touch areas on the i6 screen can be used to view the other codes. The number that is assigned to each code, is the order of occurrence. Number 1 would be the oldest code and as the numbers increase the newer the code.

If the fault code display in MOM is not a serious code requiring immediate action, the code can be cleared from the screen by touching the number of each fault located at the left side of the code number. However, this action only erases the code in MOM. This is still an active fault, and the electronic display panel will keep indicating the action code. The central warning lamp will also remain activated.

Once the fault code is erased from MOM the same code will not appear again until the code is recovered or unless the fault occurs again. When all of the faults are recovered or cleared from MOM the screen will return to i2, i3, or i4 automatically according to the truck condition. The possible action codes are as follows:

## 6. Screen i7, Back Light Off

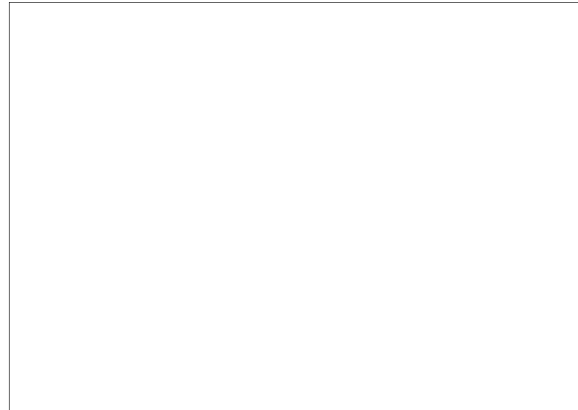

This i7 screen shows the back light of MOM turned off and nothing indicated. Use this screen at night when the lighted display is too glaring. When in i3 or i4, by touching "LIGHT OFF" the display will switch to i7. If any area of the i7 screen is touched the display will return to i2, i3, or i4 depending on the condition of the truck. If a fault is detected while in the i7 screen, the display will automatically return to the i6 screen with the back light on.

### Transmission Response With Fault Codes

When the transmission controller detects any of the severe fault that are listed below while the engine is running, the transmission will shift to the neutral gear position.

Fault Code	Description	Remarks
b001	Battery Voltage Low	
b002	Solenoid Voltage Failure	
b004	ROM Sum Check Fault	
b005	Clutch Engagement Double	
b006	T/M Cut Relay Failure	
b02_	Clutch Failure _: 2, 3, 9	- 2 : High Clutch - 3 : Low Clutch - 4 : 1st Clutch - 5 : 2nd Clutch - 6 : 3rd Clutch - 8 : Reverse Clutch - 9 : Intermediate Clutch
b03_	Clutch ECMV Failure 1 _: 2 to 6, 8, 9	
b04_	Clutch ECMV Failure 2 _: 2 to 6, 8, 9	
b07_	Clutch Solenoid Failed High _: 2 to 6, 8, 9	

With one of the previously listed failure codes the transmission will fail to NEUTRAL, in order to move the truck the following procedure should be followed.

1. Bring the truck to a stop in a safe location. Apply the parking brake and move the range selector lever to the NEUTRAL position.
2. Next move the range selector to either Drive, 5th, 4th, 3rd, LOW or REVERSE. The transmission will then shift to F1 or F2 when either of the forward positions was selected; DRIVE, 5th, 4th, 3rd, LOW or REVERSE when the R position was attained.
3. The selection of F1 or F2 will be dependent on the type of fault.

If the transmission controller detects any of the following severe fault codes with the engine running, the transmission will remain in the gear that it was in at the time of the fault code. When the range selector is moved to the N position the transmission will shift to the N range also.

Fault Code	Description	Remarks
b01_	Speed Signal Lost _: 0, 1, 2, 3	_ - : 0 : Engine _ - : 1 : T/M input _ - : 2 : T/M intermediate shaft _ - : 3 : T/M output
b06_	Speed Sensor Failure _: 0, 1, 2, 3	
b05_	Clutch ECMV Failure 3	_ - : 1 : Lock up _ - : 2 : High _ - : 3 : Low _ - : 4 : 1st _ - : 5 : 2nd _ - : 6 : 3rd _ - : 8 : Reverse _ - : 9 : Intermediate

If the truck needs to be moved with one of these fault codes present, the following procedure is suggested:

1. Bring the truck to a stop in a safe location. Apply the parking brake and move the range selector to the NEUTRAL position.
2. Next, move the range selector to either DRIVE, 5th, 4th, 3rd, LOW or REVERSE.

The transmission will then shift to F1, F2, or F3 when either of the forward positions was selected, DRIVE, 5th, 4th, 3rd, LOW or REVERSE when the R position was attained.

3. The selection of F1, F2, or F3 will be dependent on the type of fault.

If any of the severe fault codes that are listed in the table below appear on the warning screen, perform Steps 1-5 (listed below the table).

Fault Code	Description	Remarks
b024	1st Clutch Failure	
b025	2nd Clutch Failure	
b026	3rd Clutch Failure	
b028	Reverse Clutch Failure	
b063	T/M Output Speed Sensor Failure	

1. Bring the truck to a stop in a safe location. Apply the parking brake and move the range selector to the neutral position.
2. Activate the limp home switch by removing and reconnecting the single wire connector located under the passenger seat.
3. Next move the range selector to either DRIVE, 5th, 4th, 3rd, LOW or REVERSE. The transmission will then shift to F1 or F2 when either of the forward positions was selected, DRIVE, 5th, 4th, 3rd, LOW or REVERSE when the R position was attained.
4. The selection of F1 or F2 will be dependent on the type of fault code.
5. The limp home switch will remain active until the key switch is turned off.

**Idle Validation Feature**

If there is a problem with the throttle pedal signal, not transmitting correctly, because of the harness, sensor, or controller troubles, the engine speed will go to the following settings:

Throttle Pedal Position	Engine RPM
Pressed	1300 rpm
Released	650 rpm

**CENTER ELECTRONIC DISPLAY PANEL**

**Action Code Display**

As previously discussed, if a fault occurs in any of the monitored systems, a code will be displayed on the "MOM" screen. At the same time an action code will also be displayed to inform the operator of a procedure to follow because of the fault. This "action code" is also displayed on the electronic display panel. The electronic display panel will display the action code of any fault informed through the serial communications network, "S-NET," from any controller that detects a fault. When the fault occurs, the action code of this fault will be displayed automatically.

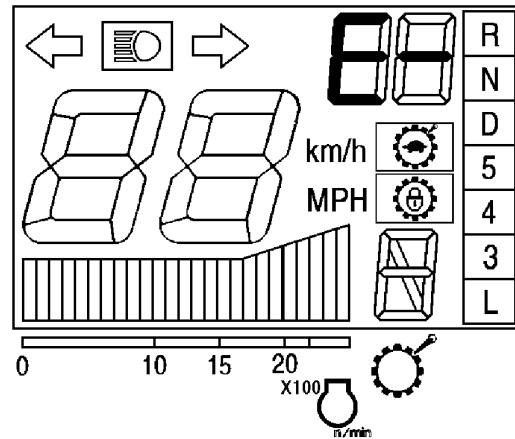

FIGURE 3-11.

When displaying an "03" action code, first the "E" will be displayed (Figure 32-11) and then, the "03" code (Figure 32-12) will be displayed.

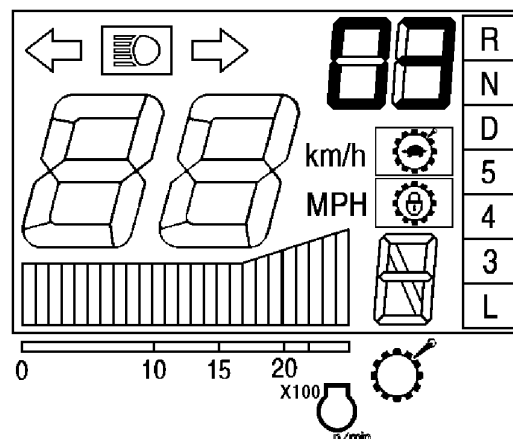

FIGURE 3-12.



These two displays will alternate every second. The other displays, gauges and pilots will function as normal. If more than two codes are present at the same time, the highest priority action code will be displayed. That priority is as follows: 04; 06; 05; 07; 03; 02; 01.

After the operator has been informed of the fault code, the action that should be taken is as follows:

1. Stop the truck in a safe location.
2. Apply the parking brake.
3. Confirm the presence of the fault code and the action code.
4. Follow the instructions of the action code.
5. Notify a qualified technician for repairs.

The possible action codes are as follows:

CODE	DESCRIPTION
01	Notify maintenance at shift change
02	Notify maintenance right now
03	Reduce engine / machine speed
04	Stop safely now / shut off engine
05	Stop with engine at mid speed
06	Start engine and keep at low idle
07	Keep body seated

### Cancellation of Action Code

If either of the following requirements is satisfied then the action code will be canceled.

1. If the fault which caused the action code is no longer present, then the action code will be canceled automatically, and the same, or next priority action code will be displayed automatically, if there are any other active faults.
2. If the fault remains, the action code can be canceled by a qualified technician who is trained to monitor the system.

---

# NOTES

## LUBRICATION AND SERVICE

Preventive maintenance contributes to the long life and dependability of the truck and its components. The use of proper lubricants and the performance of checks and adjustments at recommended intervals are crucial.

Lubrication requirements reference the lube key found in the lubrication chart. For detailed service requirements for specific components, refer to the shop manual.

The service intervals presented here are in hours of operation. Oil change intervals are recommended in the absence of an oil analysis program which may determine different intervals. However, if the truck is being operated in extreme conditions, some or all of the intervals may need to be performed more frequently.

Refer to the engine service manual when servicing the engine or any of its components.

HD1500-5 SERVICE CAPACITIES		
	Liters	US Gallons
<b>Crankcase:</b> (including lube oil filters)	193	51
<b>Cooling System:</b>	532	140.6
<b>Hydraulic System:</b> Refer to Hydraulic Tank Service in this chapter	900	238
<b>Differential Case</b> Final Drive Case (each wheel)	300 120	79 31.7
<b>Fuel Tank</b> (Diesel Fuel Only)	2120	560
<b>Transmission Case:</b> including torque converter	153	40.5

### COOLANT SPECIFICATIONS

- For ambient temperatures of -25° F (-32° C) and above, use a standard 50/50 anti-freeze-to-water mixture.
- For arctic climates with ambient temperatures between -25° F (-32° C) and -65° F (-54° C), use a 60/40 anti-freeze-to-water mixture.

**NOTE:** Do not use propylene glycol coolant in arctic climates. Only use ethylene glycol coolants.

### Unacceptable Practices

- Use of high-silicate anti-freeze.
- Under concentration or over concentration of Extended Service Additive (SCA).
- Use of anti-freezes/coolants that are not fully formulated for extended service intervals.
- Use of sealing additives (stop-leak) in the cooling system.
- Use of soluble oils in the cooling system.
- Use of poor-quality water. See the engine manufacturer's specifications for water quality requirements.
- Use of anti-freeze, Extended Service Additive (SCA) or coolant filter(s) that do not meet the engine manufacturer's specifications.
- Use of Treated Water coolant.
- Use of coolants with less than 40 percent antifreeze.

### QUICK FILL SERVICE CENTER

The service center (Figure 40-1) is located on the left side of the truck below the hydraulic tank. The service center can be used to fill system fluids at a higher rate of speed than manually adding fluids and grease.

Connect a filling device to the appropriate fitting on the service center to add fluids/grease. Use caution when adding fluids to avoid overfilling.

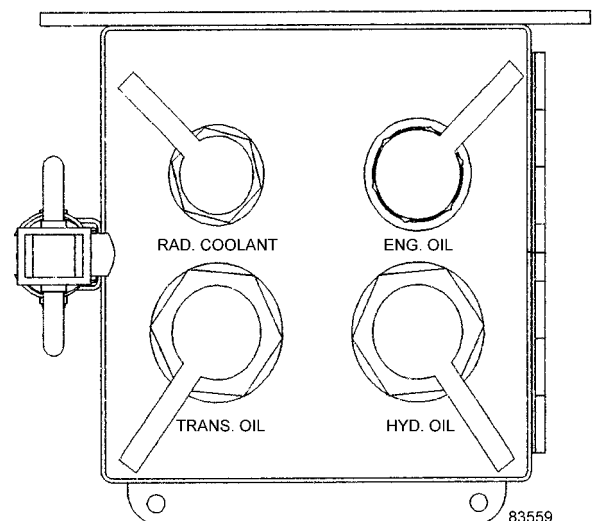

FIGURE 40-1. SERVICE CENTER

Refer to the following table for the maximum recommended fill pressures for the service center.

MAXIMUM FILL PRESSURES		
Fill System	kPa	psi
Engine Crankcase	345	50
Hydraulic Tank	345	50
Coolant	345	50
Grease	10 342	1,500

## LUBRICATION CHART

### LUBRICATION SPECIFICATION

LUBE KEY	TYPE LUBRICANT	-55°C TO -32°C -65°F TO -25°F	-32°C TO 0°C -25°F TO +32°F	0°C TO 32°C +32°F TO +90°F	ABOVE 32°C ABOVE 90°F	ABOVE 40°C ABOVE 105°F
A	ENGINE OIL	SEE ENG MAN*	SEE ENG MAN*	SEE ENG MAN	SEE ENG MAN	SEE ENG MAN
B	HYDRAULIC OIL	T030/SAE 30W	T030/SAE 30W	T030/SAE 30W	T030/SAE30W OR T050/SAE50W	T050/SAE 50W
C	HYDRAULIC OIL	T010/SAE 10W*	T010/SAE 10W*	T030/SAE 30W	T030/SAE 30W	T030/SAE 30W
D	MOLYDISULPHIDE LUBE	#0	#1	#2	#2	#2
E	HYDRAULIC OIL	SEE SER. MAN	SEE SER. MAN	SEE SER. MAN	SEE SER. MAN	SEE SER. MAN
F	DRIVESHAFT GREASE	56B-20-19910				

DESCRIPTION	SYMPTS	L KEY	10 HR	50 HR	250 HR	500 HR	1000 HR	2000HR	5000HR
ENGINE CRANKCASE OIL	1 1	A	CHECK		SEE ENG MANUAL				
ENGINE LUBE FILTERS	2 3				SEE ENG MANUAL				
ENGINE CRANKCASE BRTHR	3 2						CLEAN		
TRANSMISSION OIL	4 1	C	CHECK				CHANGE		
TRANS CASE BREATHER	5 1				CLEAN				
TRANS OIL FILTER	6 1					CHANGE			
TRANS STRAINERS	7 3						CLEAN		
HYD TANK (HST/STRG/BK/FRT AXLE)	8 3	C	CHECK					CHANGE	
HYD TANK BREATHER	9 1				CHANGE				
HYDRAULIC FILTERS	10 4						CHANGE		
HYD TANK STRAINERS	11 4							CLEAN	
DIFF CASE BREATHER	12 1				CLEAN				
DIFFERENTIAL CASE	13 1	B			CHECK			CHANGE	
FINAL DRIVE CASE	14 2	B			CHECK			CHANGE	
FUEL FILTERS	15 3				SEE ENG MANUAL				
CORROSION RESISTORS	16 2				SEE ENG MANUAL				
PARKING BRAKE	17 6	D			CHECK		GREASE		
LUBRICANT RSVR	18 1	D			CHECK				
DRIVESHAFT U-JOINTS	19 2	F							GREASE

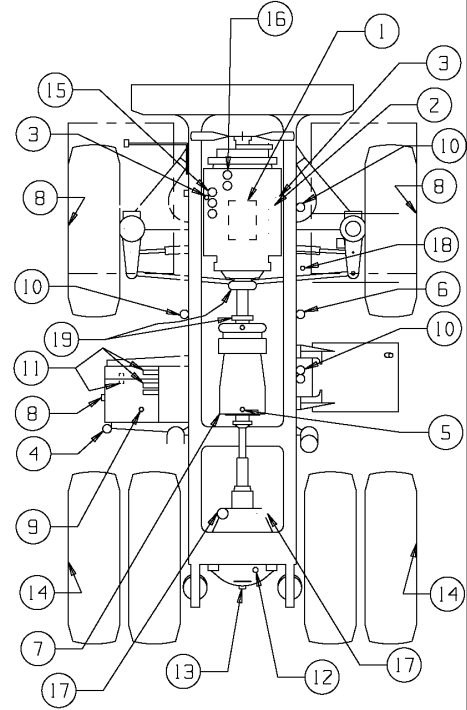

EK4507-0

\* AUXILIARY HEATERS REQUIRED BELOW -23°C (-10°F)

## 10 HOUR (DAILY) INSPECTION

Prior to each operating shift, a "walk around" inspection should be performed. Check the truck for general condition. Look for evidence of hydraulic leaks; check all lights and mirrors for clean and unbroken lenses; check operator's cab for clean and unbroken glass; check frame, sheet metal and body for cracks. Notify the proper maintenance authority if any discrepancies are found. Give particular attention to the following:

Truck Serial Number _____ Site Unit Number _____ Date _____ Hourmeter _____ Name of Service Technician _____				
	TASK	COMMENTS	CHECKED	INITIALS
1.	CHECK ALL FLUID LEVELS			
	a. Engine Oil- <i>NOTE: Refer to engine manufacturer service manual for oil recommendations.</i>			
	b. Radiator - Check coolant level and fill with the proper mixture as recommended in Coolant Specifications.			
	c. Batteries - Check electrolyte level and add water if necessary.			
	d. Hydraulic Tank - Check oil level in tank, add if necessary. Lube key "C". Refer to Hydraulic Tank Service, in this chapter. <i>NOTE: Check the oil level with the truck on a level surface, engine stopped, body down, and oil warm. Oil should be visible in sight glass. - Do Not overfill.</i>			
	e. Transmission - Check oil level. Add oil if necessary. Lube key "C". Refer to Transmission Oil Level Check in this chapter.			
	f. Fuel Tank - Fill as required.			
	g. Differential - The truck should be on a level surface, and the oil level should be even with plug hole. Refill with oil, as necessary. Lube key "B".			
2.	CHECK MACHINE FOR LEAKS			
	Inspect all fluid components and piping for signs of leakage.			

## 10 HOUR (DAILY) INSPECTION (continued)

Truck Serial Number _____ Site Unit Number _____ Date _____ Hourmeter _____ Name of Service Technician _____				
	TASK	COMMENTS	CHECKED	INITIALS
3.	<b>AIR CLEANERS</b> Check air cleaner vacuum gauges. Clean or replace filter elements if restriction reaches 6.2 kPa (25 in. H <sub>2</sub> O) vacuum. Push the reset button on the face of the gauge to return to zero.			
4.	<b>DRIVE BELTS</b> a. Check alternator and fan belts for proper tension and condition. b. Inspect for alignment.			
5.	<b>ENGINE AND TURBOCHARGERS</b> Inspect for leaks, vibrations or odd noises.			
6.	<b>TIRES</b> a. Inspect for proper inflation and wear. b. Inspect for debris embedded in cuts or tread.			

## 250 HOUR INSPECTION

Truck Serial Number _____ Site Unit Number _____ Date _____ Hourmeter _____ Name of Service Technician _____			
TASK	COMMENTS	CHECKED	INITIALS
<b>INITIAL 250 HOUR SERVICE</b>			
1. Perform the following maintenance after running the machine for the first 250 hours. Thereafter, these services are to be performed at the 1000/2000/5000 hour interval as scheduled. <ul style="list-style-type: none"> <li>a. Fuel Filter, replace cartridges.</li> <li>b. Transmission - change oil and filter elements.</li> <li>c. Hydraulic - change oil and filter elements.</li> <li>d. Differential Case, change oil.</li> <li>e. Final Drive Case, change oil.</li> </ul>			
<b>EVERY 250 HOURS SERVICE</b>			
1. LUBRICATION - <ul style="list-style-type: none"> <li>a. Check the automatic lube system to be sure an ample grease supply is reaching pins and bearings.                         <ul style="list-style-type: none"> <li>- Dump body hinge pin - 2 points.</li> <li>- Rear suspension - 4 points.</li> <li>- Axle support pins - 8 points.</li> <li>- Hoist cylinder pin - 4 points.</li> <li>- Front suspension assembly - 8 points.</li> <li>- Steering cylinder pin - 4 points.</li> <li>- Steering linkage - 5 points.</li> <li>- Front transmission mount - 1 point.</li> </ul> </li> <li>b. Refill grease reservoir - Use lube key "D". Reservoir capacity is approximately 29 l (7.7 gal) or 27 kg (60 lb) of grease.</li> </ul>			
2. ENGINE - Refer to the engine service manual for oil recommendations and capacity. <ul style="list-style-type: none"> <li>- change engine oil.</li> <li>- change engine lube oil filter.</li> </ul>			

## 250 HOUR INSPECTION (continued)

Truck Serial Number _____ Site Unit Number _____ Date _____ Hourmeter _____ Name of Service Technician _____				
	TASK	COMMENTS	CHECKED	INITIALS
3	ALTERNATOR BELT - Check the alternator belt for cracks, glazing or cuts. Check for proper tension. Repair or adjust as necessary.			
4	AIR CONDITIONER COMPRESSOR BELT - Check the compressor belt for cracks, glazing or cuts. Check for proper tension. Repair or adjust as necessary.			
5	FAN BELT - Check the fan belt for cracks, glazing or cuts. Check for proper tension. Repair or adjust as necessary.			
6	TRANSMISSION CASE BREATHERS - Remove breathers, disassemble breathers, remove filter element, and clean in solvent. Dry with pressurized air, reassemble, then reinstall.			
7	HYDRAULIC TANK BREATHER - Remove breather, and disassemble. Remove the filter element. Replace the filter element, reassemble, and reinstall.			
8	DIFFERENTIAL CASE - Check the oil level. Use lube key "B".			
9	DIFFERENTIAL CASE BREATHER - Remove breather. Wash to flush out the dirt from inside. Reinstall after cleaning.			
10	FINAL DRIVE CASE - Check the oil level in RH and LH case. Use lube key "B".			
11	PARKING BRAKE - Measure brake pad for proper wear and thickness. Refer to Section J, Brake System, in the shop manual for limits and specifications. Use lube key "D" chart.			
12	FUEL FILTER - Remove and replace fuel filter elements.			
13	CORROSION RESISTORS - Remove and replace corrosion resistor elements.			
14	DUMP BODY PADS - Check the pads, shims and mounting hardware for wear and proper tightening.			



### 500 HOUR INSPECTION

In addition to the 250 hour lubrication and inspection schedule, perform the following:

Truck Serial Number _____ Site Unit Number _____ Date _____ Hourmeter _____ Name of Service Technician _____				
	TASK	COMMENTS	CHECKED	INITIALS
1	RADIATOR - Check for clogged or damaged fins. Refer to the shop manual, Section C for information on radiator maintenance.			
2	TRANSMISSION OIL FILTER - Remove and replace the two filter elements. Refer to shop manual, Section F, Transmission.			
3	CHECK TOE-IN ADJUSTMENT- Check the steering toe-in adjustment and inspect the tires for abnormal wear. Adjust as necessary. Refer to Section G in the service manual for the adjustment procedure.			
4	FRONT WHEEL BEARINGS - Obtain an oil sample from each front wheel bearing oil cavity for analysis. Refer to Section G3 in the service manual for instructions.			
5	FRAME AND REAR AXLE HOUSING - Wash the truck, clean all of the weld joints, and visually inspect the entire frame and axle housing for cracking or damage.			

## 1000 HOUR INSPECTION

In addition to the 250 and 500 hour lubrication and inspection schedules, perform the following:

Truck Serial Number _____ Site Unit Number _____ Date _____ Hourmeter _____ Name of Service Technician _____				
	TASK	COMMENTS	CHECKED	INITIALS
1	<b>PARKING BRAKE</b> - Parking brake linkage - 6 points - Lube key "D".			
2	<b>TRANSMISSION CASE -</b> a. Drain oil, remove and replace element. Remove clean, and reinstall strainer. Refill sump with oil - Capacity, approximately 153 liters (40.5 gal). Lube key "C". b. Remove and clean the three transmission magnetic strainers. Refer to the shop manual, Section F, Transmission.			
3	<b>STEERING, BRAKE, HOIST, &amp; REAR BRAKE COOLING OIL FILTERS -</b> Relieve pressure before opening the system. Remove and replace the four filter elements. Refer to Hydraulic Tank Service in this chapter.			
4	<b>FRONT &amp; REAR BRAKE WEAR -</b> Refer to the shop manual Section J, Brake System, for proper inspection procedure. Perform the inspection when the oil temperature is below 60°C (140°F). Hot oil may cause serious personal injury.			
5	<b>ENGINE BREATHER -</b> Remove and clean the engine breather. Refer to the engine service manual.			

## 2000 HOUR INSPECTION

Maintenance for every 250, 500 and 1000 hours should also be performed at this time.

Truck Serial Number _____ Site Unit Number _____ Date _____ Hourmeter _____ Name of Service Technician _____				
	TASK	COMMENTS	CHECKED	INITIALS
1	HYDRAULIC OIL TANK - a. Drain oil from tank and refill tank to specified level, capacity 576 liters (152 gal). Refer to the Lubrication Chart for type of oil to use. Lube key "C". b. Remove and clean hydraulic tank strainers. Refer to Hydraulic Tank Service in this chapter.			
2	FRONT WHEEL HUBS - Drain the hydraulic oil from each front wheel drain plug. Ensure the plugs are in the 6 o'clock position when draining.  <div style="text-align: center; border: 1px solid black; padding: 5px; margin: 10px 0;"> <b>WARNING</b> </div> <p><i>Drain the hydraulic tank prior to removing the drain plugs from the wheel hubs.</i></p>			
3	FINAL DRIVE CASE - Position machine so that casting line is horizontal and drain plug is at the bottom. Drain oil and reinstall plug, remove fill plug at casting line and fill to specified level. This operation is performed on both the right and left hand final drives. Capacity is 120 liters (31.7 gal) each side. Refer to the Lubrication Chart for the proper type of oil to use. Lube key "B".			
4	DIFFERENTIAL CASE - Drain the oil from the differential and refill to the specified level: capacity - 300 liters (79 gal). Refer to the Lubrication Chart for the proper type of oil to use, lube key "B".			

## 5000 HOUR INSPECTION

Maintenance for every 250, 500, 1000 and 2000 hours should also be performed at this time.

Truck Serial Number _____ Site Unit Number _____ Date _____ Hourmeter _____ Name of Service Technician _____				
	TASK	COMMENTS	CHECKED	INITIALS
1	ENGINE DRIVELINE ADAPTER - Inspect driveline adapter rubber dampers for cracks or separation on rubber surfaces. If any defects are noted, repair as required.  Refer to Section C in the shop manual for repair procedures.			
2	FRONT AND REAR DRIVESHAFTS - a. Grease the U-joints on each drive shaft. Refer to lube key F on the lubrication chart. b. Inspect both front and rear driveshafts for binding, wear, vibration, or damage to the driveshaft assembly. If U-joint damage or roughness is noted, both U-joints on a given shaft must be replaced.  Refer to Section F in the shop manual for replacement procedures.			
3	FRONT SUSPENSIONS - Drain the front suspension oil. Disassemble and inspect the upper flange internal bearing. Replace any worn parts. Refill the suspension with clean oil and recharge with nitrogen. Refer to Section H in the shop manual for information on suspensions.			
4	PRELUB™ SYSTEM - Inspect system components for damage, leakage, etc. Refer to Section D2 in the shop manual for maintenance checks.			
5	BODY GUIDE - Inspect the body guide wear points for excessive wear and damage. Replace as necessary.			

**RADIATOR FILL PROCEDURE**

**The cooling system is pressurized due to thermal expansion of coolant. DO NOT remove the radiator cap while the engine is hot. Severe burns may result.**

1. With the engine and coolant at ambient temperature, depress the pressure relief to remove cooling system pressure. Slowly, remove the radiator cap.

**NOTE:** If coolant is added using the quick fill system, the radiator cap must be removed prior to adding coolant.

2. Fill the radiator with the proper coolant mixture as specified by the engine manufacturer. Fill until coolant reaches the radiator cap area.
3. Install the radiator cap.
4. Allow the engine to idle for 5 minutes. Shut the engine off and wait for the engine to cool.
5. Check the coolant level. If the radiator is not full, repeat the previous steps. Any excess coolant will be discharged through the vent hose after the engine reaches normal operating temperature.

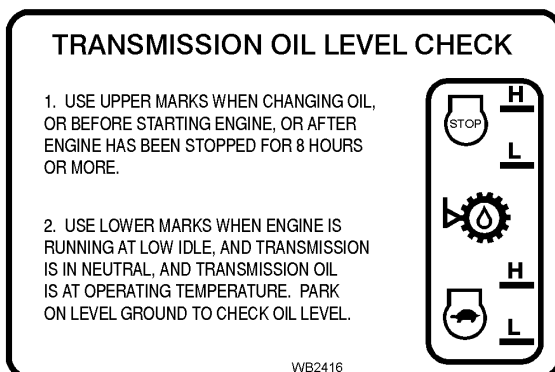
**TRANSMISSION OIL LEVEL CHECK**

1. Engine Stopped:

Oil level must be visible in upper part of sight gauge (STOP) between "H" and "L" to be sure there is sufficient oil to safely operate transmission when engine is stopped, or if transmission oil is cold (engine has been stopped for 8 hours or more).

Check oil level again, as described below, when transmission oil reaches operating temperature.

2. Engine Running:

The oil level must be visible in lower part of sight gauge (turtle) between "H" and "L".

Check transmission oil level with:

- truck parked on level surface,
- engine running at low idle,
- transmission in neutral, "N", and
- transmission oil at normal operating temperature:

Add clean oil as required through transmission oil filler tube at left rear of transmission.

**HYDRAULIC TANK SERVICE****Filling Instructions**

1. Lower the dump body, shut down the engine, and turn the keyswitch OFF.



**Hydraulic tank may be pressurized! Depress relief valve (2, Figure 40-2) and release hydraulic tank filler cap slowly to remove any internal pressure.**

2. Depress relief valve (2, Figure 40-2) for 30 - 45 seconds to release any internal tank pressure. Turn the oil filler cap (4) slowly counterclockwise to release any possible residual tank pressure.
3. Refer to Lubrication Chart, Lube key "C". Fill tank with recommended oil, until oil is visible in upper sight glass (5).

**NOTE:** If hydraulic tank has been completely drained, refill capacity is: 576 liters (152 gal.)

4. Replace fill cap.
5. Start the engine, and raise and lower dump body 3 times to circulate oil and fill all lines, valves, cylinders, etc.
6. Repeat steps 1 through 5 and fill until oil level is again in upper sight glass (5).
7. If oil level falls below lower sight glass (6) with engine running, repeat Steps 1 through 5.

### Hydraulic Tank Service

When servicing the hydraulic tank, always follow the Filling Instructions described above to relieve any internal tank pressure before opening tank.

1. When checking oil level, or any other service, inspect the breather (3, Figure 40-3) to be certain that it is open to atmosphere.

Clean any excess accumulations of dirt/mud, etc. from around the breather. Clean/replace breather element as necessary. Refer to Hydraulic Tank Breather.

2. Whenever oil is drained from tank, clean diffusers (7 & 11) and strainers (8, 9, & 10).

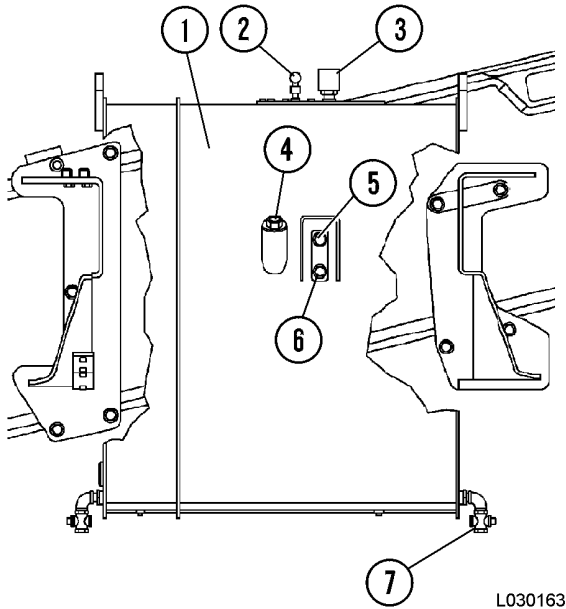
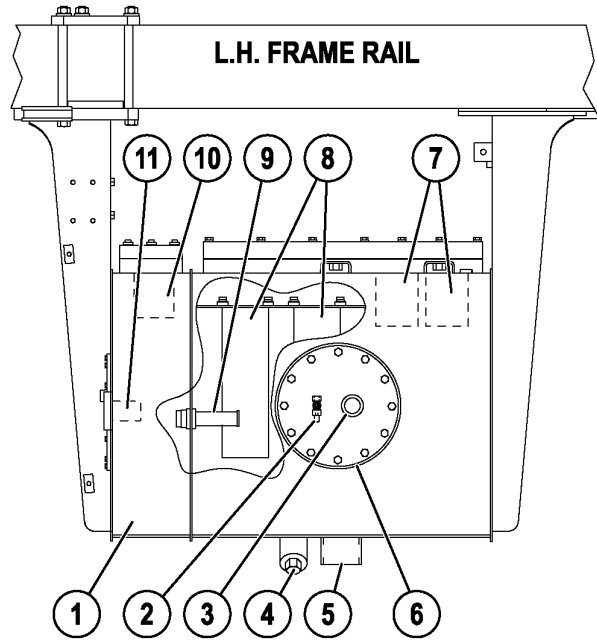

FIGURE 40-2. HYDRAULIC TANK

- |                          |  |
|--------------------------|--|
| 1. Hydraulic Tank        | 5. Hydraulic Oil Level Upper Sight Glass |
| 2. Pressure Relief Valve | 6. Hydraulic Oil Level Lower Sight Glass |
| 3. Breather              | 7. Hydraulic Oil Drain                   |
| 4. Filler Cap            |  |



L030160

FIGURE 40-3. HYDRAULIC TANK (TOP VIEW)

- |                          |                       |
|--------------------------|-----------------------|
| 1. Hydraulic Tank        | 7. Diffusers          |
| 2. Pressure Relief Valve | 8. Strainers          |
| 3. Breather              | 9. Wire Mesh Strainer |
| 4. Filler Cap            | 10. Strainer          |
| 5. Sight Glass Guard     | 11. Diffuser          |
| 6. Cover Plate           |                       |

## STEERING CIRCUIT FILTER

### Removal

The brake and steering circuit filter is located on the left frame rail, forward of the hydraulic tank.

### **WARNING**

**Relieve pressure before disconnecting hydraulic and other lines. Tighten all connections before applying pressure.**

**Hydraulic fluid escaping under pressure can have sufficient force to enter a person's body by penetrating the skin and cause serious injury and possibly death if proper medical treatment by a physician familiar with this injury is not received immediately.**

1. With the key switch OFF allow at least 90 seconds for the accumulators to bleed down. Check the steering to ensure the system is bled down.
2. Remove plug (10, Figure 40-4) and drain oil from the housing into a suitable container.

### **CAUTION**

**Avoid contact with hot oil if the truck has been operating. Avoid spillage and contamination!**

3. Remove housing (8) and element (7).
4. Replace O-ring (4) and backup ring (5) in filter head.

### Installation

1. Install new element (7). Install housing (8) and tighten.
2. Replace drain plug (10), and O-ring (9).

**NOTE:** The indicator switch (2, Figure 40-4) is preset to actuate at 241 kPa (35 psid) and is not repairable or adjustable. If the indicator switch is inoperative, replace the complete switch. Attempting to adjust the switch is not recommended.

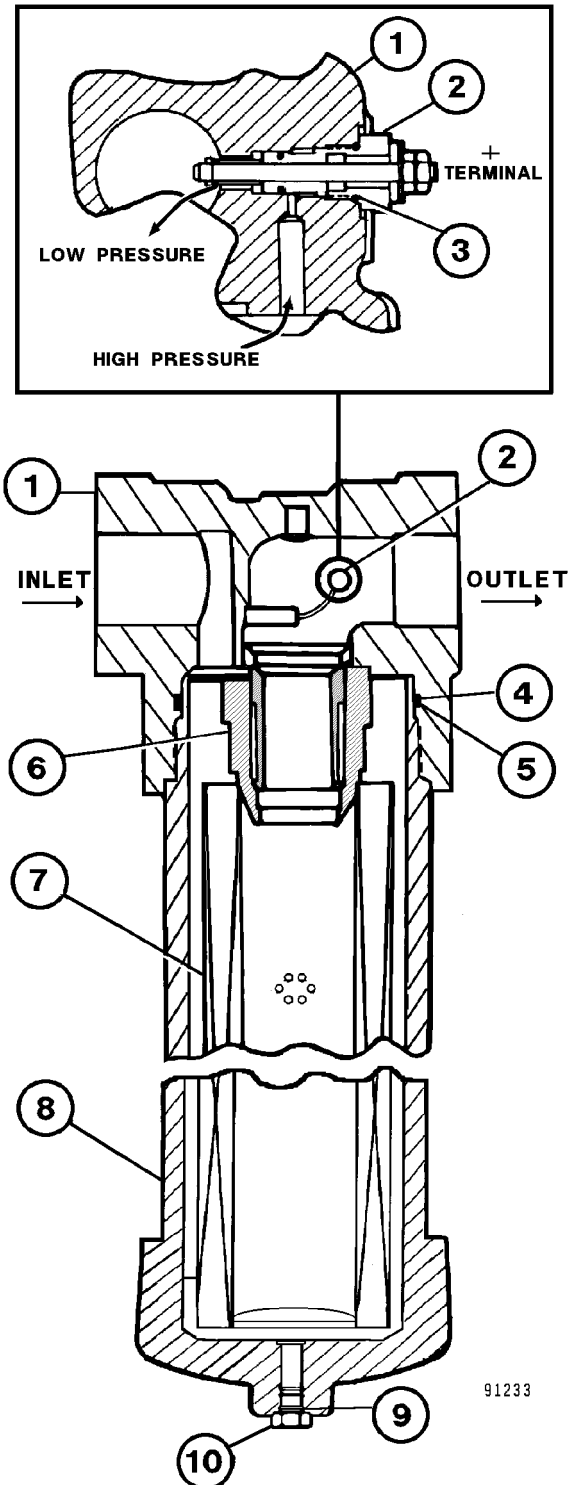

FIGURE 40-4. STEERING CIRCUIT FILTER

- |                     |                   |
|---------------------|-------------------|
| 1. Head             | 6. Bypass Valve   |
| 2. Indicator Switch | 7. Filter Element |
| 3. O-Ring           | 8. Housing        |
| 4. O-Ring           | 9. O-Ring         |
| 5. Backup Ring      | 10. Plug          |

## HYDRAULIC TANK BREATHER

### Cleaning

1. Shut down the engine and open hydraulic tank filler caps slowly to relieve any internal pressure.



1. **Hydraulic tank may be pressurized! Depress relief valve (2, Figure 40-2) and release hydraulic tank filler cap slowly to remove any internal pressure.**
2. Clean dirt accumulation from area of breather (3, Figure 40-3).
3. Remove the breather from the tank.
4. Remove snap ring (1, Figure 40-5), cover (2) and filter element (3).
5. Clean breather element in solvent and blow dry. Clean remaining parts in solvent and dry thoroughly.
6. Install element, cover and snap ring.
7. Install breather element on hydraulic tank.

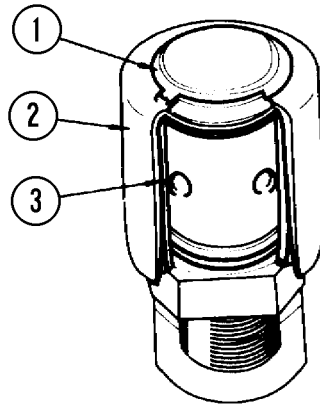

L030007

FIGURE 40-5. HYDRAULIC TANK BREATHER

- |              |            |
|--------------|------------|
| 1. Snap Ring | 3. Element |
| 2. Cover     |            |



## LINCOLN AUTOMATIC LUBRICATION SYSTEM

The Lincoln Automatic Lubrication System is a pressurized lubricant delivery system which delivers a controlled amount of pressurized lubricant to designated lube points. The system is controlled by an electric timer which signals solenoid valves to cause operation of a hydraulically operated grease pump.

For the HD1500-5, these components (valves, pump, and reservoir/canister) are mounted on the right deck structure to the right of the hydraulic cabinet just above the right front suspension.

### SYSTEM COMPONENTS

The system is comprised of these basic elements plus the necessary hoses and lube lines:

#### Hydraulically Powered Reciprocating Cylinder and Pump (1 & 5, Figure 42-1)

##### Pump Specifications:

- Pressure ratio: 16:1  
*NOTE: The theoretical ratio of the pump is 16:1. Depending on application and variable internal friction, the operational ratio is approximately 10:1.*
  - Hydraulic supply pressure (input): 2.1 - 20.1 MPa (300-3000 psi)
  - Input flow (when pumping): 3.8 l/min (1.0 gpm)
  - Maximum hydraulic temperature: 99°C (210°F)
  - Maximum output pressure: 24.1 MPa (3500 psi)
- WARNING: Exceeding this value will damage components and/or cause components to rupture, resulting in possible serious injury to any nearby personnel.**

- Output flow: 180 cc/min (11 cu. in./min)
- Operating ambient temperature: -40°C to +58°C (-40°F to +135°F)
- Seals: Buna-N
- Filtration required: 10 micron (hydraulic supply) 24VDC power source.

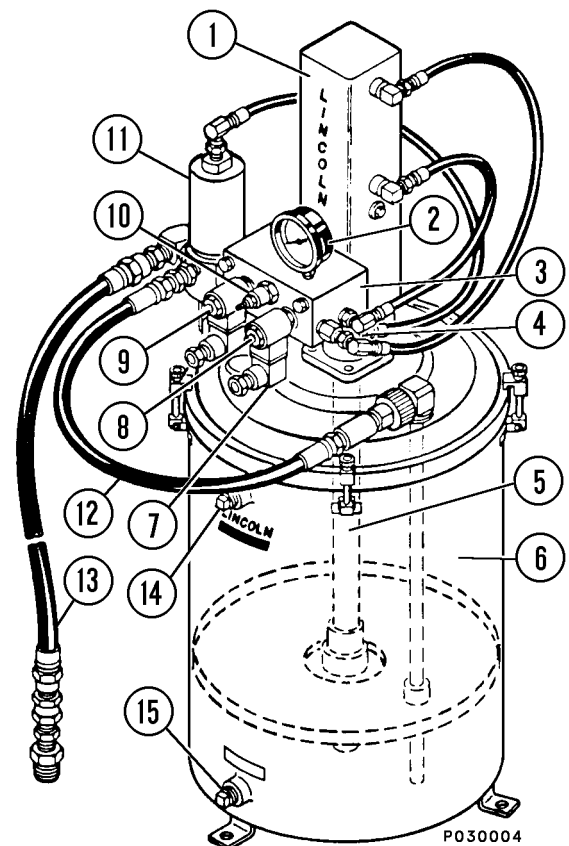

FIGURE 42-1. TYPICAL AUTO LUBE SYSTEM

- |                            |                             |
|----------------------------|-----------------------------|
| 1. Pump Cylinder           | 9. Solenoid Valve, SV1      |
| 2. Cylinder Pressure Gauge | 10. Pressure Reducing Valve |
| 3. Valve Body Assembly     | 11. Vent Valve Assembly     |
| 4. Orifice Assembly        | 12. Grease Return Line      |
| 5. Pump Assembly           | 13. Grease Supply Line      |
| 6. Canister/Reservoir      | 14. Fill Vent Port          |
| 7. Pump Cycle Timer        | 15. Fill Supply Port        |
| 8. Solenoid Valve, SV2     |                             |

#### Combination valve body

(3, Figure 42-1) includes:

- 24VDC solenoid valves (SV1 & SV2) are used to control the hydraulically operated pump.

Solenoid valve SV1 (9) controls the supply of hydraulic fluid to the pressure reducing valve and to the vent valve.

Solenoid valve SV2 (8) directs the hydraulic fluid to the hydraulic cylinder which operates the grease pump.

- Pressure reducing valve (10) lowers hydraulic fluid pressure to the operating range of the hydraulic pump cylinder. It is factory set at its maximum pressure of 2069 kPa (300 psi), but may be adjusted lower.
- Cylinder pressure gauge (2) indicates hydraulic fluid pressure going to the hydraulic pump cylinder after passing through the pressure reducing valve.
- Orifice fitting assembly (4) meters hydraulic pressure from the pressure reducing valve to the top of the vent valve assembly (this permits even operation of the vent valve, without shock). This fitting is assembled to the side of valve body (3) and connected with a high pressure 1/4 in. hose to the top of vent valve assembly (11).

**Figure 42-2. LUBE INJECTOR GROUPS**

Lube Group	# of Injectors	Injector Point of Lubrication
A	3	RH front suspension, top RH front suspension, rear "A"-arm RH front suspension, front "A"-arm
B	3	LH front suspension, top LH front suspension, rear "A"-arm LH front suspension, front "A"-arm
C	3	RH steering cylinder, spindle RH tie rod, spindle RH front suspension, bottom "A"-arm
D	3	LH steering cylinder, spindle LH tie rod, spindle LH front suspension, bottom "A"-arm
E	5	RH steering cylinder, frame LH steering cylinder, frame LH tie rod, pivot RH tie rod, pivot Center steering pivot, frame
F	3	Rear axle, bottom LH bar frame LH hoist cylinder, frame Transmission, front mount
G	3	Rear axle, top front bar frame Rear axle, bottom RH bar frame RH hoist cylinder, frame
H	3	LH rear suspension, frame LH hoist cylinder, body LH body pivot
J	4	Rear axle, top sway bar, frame RH rear suspension, frame RH hoist cylinder, body RH body pivot
K	3	LH rear suspension, axle Rear axle, top front bar, axle Rear axle, top sway bar, axle
L	3	Rear axle, bottom RH bar, axle LH rear suspension, frame RH rear suspension, axle

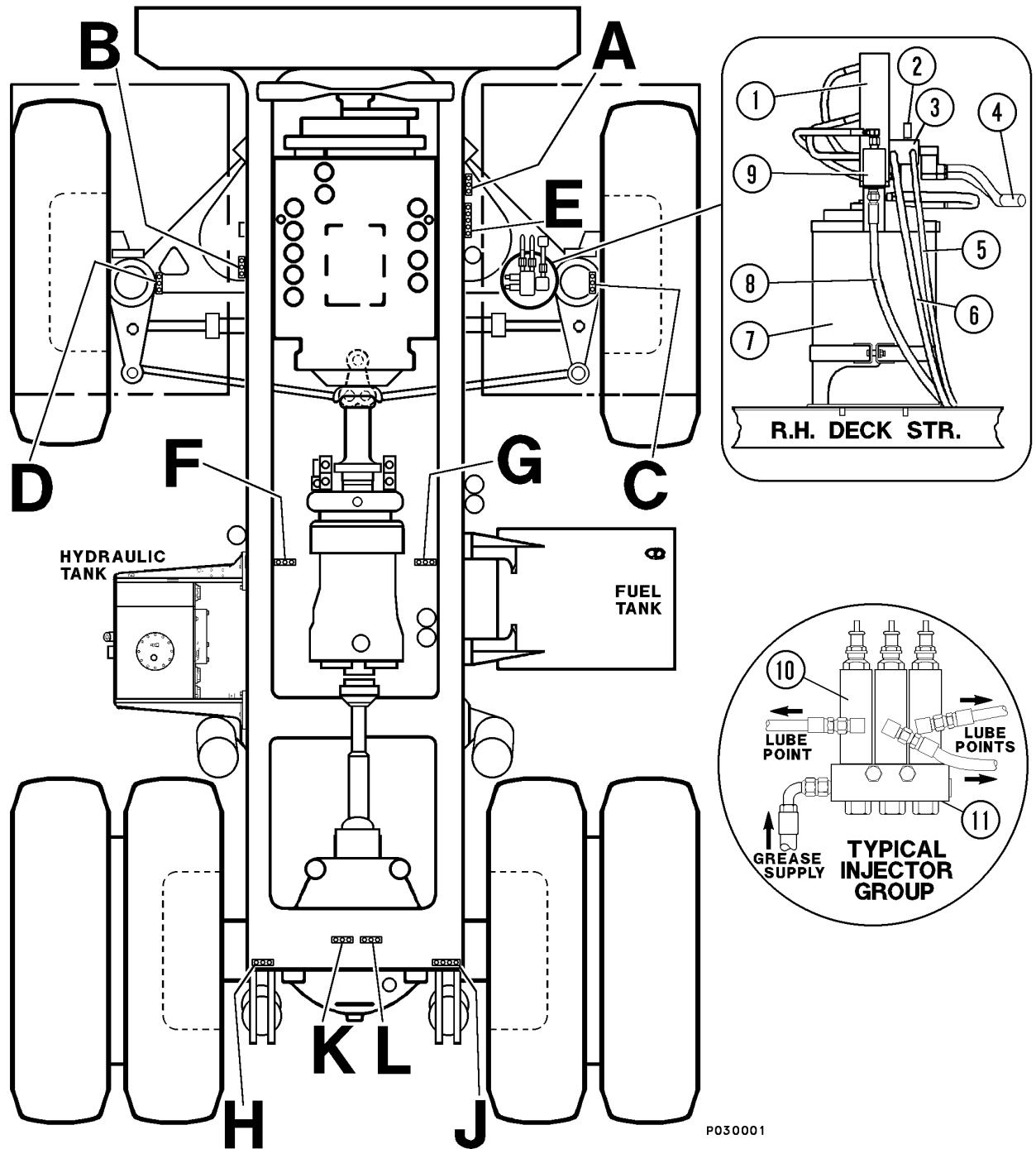

FIGURE 42-2. HD1500-5 AUTOMATIC LUBRICATION SYSTEM ARRANGEMENT

- |                         |                      |                                      |
|-------------------------|----------------------|--------------------------------------|
| Group Lube Location "A" | Contains 3 Injectors | 1. Grease Pump/Cylinder              |
| Group Lube Location "B" | Contains 3 Injectors | 2. Cylinder Pressure Gauge           |
| Group Lube Location "C" | Contains 3 Injectors | 3. Pressure Regulator/Solenoid Valve |
| Group Lube Location "D" | Contains 3 Injectors | 4. Electrical Harness                |
| Group Lube Location "E" | Contains 5 Injectors | 5. Hydraulic Pressure Supply         |
| Group Lube Location "F" | Contains 3 Injectors | 6. Hydraulic Return to Tank          |
| Group Lube Location "G" | Contains 3 Injectors | 7. Reservoir / Canister              |
| Group Lube Location "H" | Contains 3 Injectors | 8. Grease Supply Line                |
| Group Lube Location "J" | Contains 4 Injectors | 9. Vent Valve Assembly               |
| Group Lube Location "K" | Contains 3 Injectors | 10. Lube Injector                    |
| Group Lube Location "L" | Contains 3 Injectors | 11. Typical Lube Injector Group      |

P030001

### Pump Cycle Timer

[Also called a "flasher" timer, because it contains an LED that illuminates when there is power going to SV2]: Pump cycle timer (7, Figure 42-1) mounts on SV2 solenoid and generates a timed pulse signal which causes the solenoid valve to move, alternately. The alternating movement of the valve, changes the direction of hydraulic fluid flow from the top of the pump cylinder to the bottom, and vice versa, causing the grease pump piston to reciprocate, or pump.

### Grease Reservoir:

Grease reservoir (6, Figure 42-1) is mounted on the right deck structure to the right of the hydraulic cabinet just above the right front suspension. The reservoir has an approximate capacity of 29 l (7.7 gal) or 27 kg (60 lb) of grease.

### Vent Valve

When SV1 solenoid is energized, hydraulic pressure closes vent valve (11, Figure 42-1), and also causes the pump to cycle. The pump cycles until SV1 solenoid is de-energized. When this occurs, hydraulic pressure is removed, causing the vent valve to open. The grease pressure drops to 0, and the injectors recharge for their next output cycle.

### 24 VDC Solid State System Timer

The solid state system timer (not shown) sends out a 24 VDC timed-interval signal to energize the solenoid valves, causing the grease pump to operate. This timer is mounted in the cab (in the housing under the passenger seat) to insure temperature stability. Its operating temperature range is -29°C to 55°C (-20°F to 131°F).

### Lube Injectors

Each injector (10, Figure 42-2) delivers a controlled amount of pressurized lubricant to a designated lube point. Refer to Figure 42-2 for locations.

### Safety Unloader Relief Valve

Safety unloader relief valve (not shown) is located on the back of vent valve (11, Figure 42-1). The safety unloader is designed to open if the pressure in the grease line rises to approximately 27.5 MPa (4000 psi)\*. If this valve opens, the grease is expelled to the atmosphere.

*\*NOTE: This setting is not adjustable.*

**WARNING: Exceeding 24.1 MPa (3500 psi) will damage components and/or cause components to rupture, resulting in possible serious injury to any nearby personnel.**

### System Operation

During truck operation, with the pump and timer systems in a rest state, a preset time interval (2.5 to 80 minutes) occurs.

The solid state system timer sends out a 24 VDC signal to energize SV1, and the flasher timer on SV2.

As SV1 opens, the hydraulic fluid pressure flows through the pressure reducing valve and on to SV2.

The pressure reducing valve lowers hydraulic fluid pressure to the operating range of the hydraulic pump [maximum pressure 2069 kPa (300 psi)]. This pressure also signals the vent valve, causing it to close.

After the system pressure has been reduced, it passes on to SV2. Each operation of SV2 moves the hydraulic cylinder which operates the grease pump. As SV2 turns on and off (refer to cycle timer/flasher below), it changes the direction of the hydraulic cylinder movement back and forth, thus causing a pumping action.

The cycle timer/flasher sends a pulsing signal, 1 second ON and 1 second OFF (adjustable), to SV2. Solenoid valve SV2 directs the hydraulic fluid to the pump at 30 cycles/minute.

With the vent valve closed, the pump cycles until lubricant pressure reaches maximum pump output pressure\* (pump stalls). As the grease supply line comes to maximum pressure, the injectors meter grease to the points of lubrication.

**\* WARNING: Maximum pump pressure must not exceed 24.1 MPa (3500 psi). Exceeding this value will damage components and/or cause components to rupture, resulting in possible serious injury to any nearby personnel.**

**If the pump stalls, SV2 will still be switching, and there will be no audible pause, as so with older style air pumps.**

After approximately 75 seconds, the solid state system timer returns to the rest state, which de-energizes the SV1 solenoid valve.

As SV1 is de-energized, the hydraulic supply to the pressure reducing valve and the vent valve is shut off, causing the vent valve to open.

When the vent valve opens, the pressure in the grease line is vented back to the grease reservoir and the line pressure drops to zero, so the injectors can recharge for their next output cycle.

The system is now at rest, ready for another lube cycle and the sequence to repeat itself.



**Over pressurizing of the system, modifying parts, using incompatible chemicals and fluids, or using worn or damaged parts, may result in equipment damage and/or serious personal injury.**

- **DO NOT exceed the maximum pump pressure of 24.1 MPa (3500 psi).**
- **Do not alter or modify any part of this system unless approved by factory authorization.**
- **Do not attempt to repair or disassemble the equipment while the system is pressurized.**
- **Ensure all fluid connections are securely tightened before using this equipment.**
- **Always read and follow the fluid manufacturer's recommendations regarding fluid compatibility, and the use of protective clothing and equipment.**
- **Check all equipment regularly and repair, or replace, worn or damaged parts immediately.**

**This equipment generates very high grease pressure. Extreme caution should be used when operating this equipment as material leaks from loose or ruptured components can inject fluid through the skin and into the body causing serious bodily injury including possible need for amputation. Adequate protection is recommended to prevent splashing of material onto the skin or into the eyes.**

**If any fluid appears to penetrate the skin, get emergency medical care immediately! Do not treat as a simple cut. Tell attending physician exactly what fluid was injected.**

If over-pressurizing of the equipment is believed to have occurred, contact a factory authorized warranty and service center for inspection of the pump. Specialized equipment and knowledge is required for repair of the pump or adjustments other than the maintenance specified in this chapter.

Annual inspection by the factory authorized warranty and service center is recommended.

### System Priming

The system must be full of grease and free of air pockets to function properly. After maintenance, if the primary or secondary lubrication lines were replaced, it will be necessary to prime the system to eject all entrapped air.

1. Fill the reservoir with lubricant, if necessary.
2. Remove the plugs from all injector manifold dead ends and supply lines.

**NOTE: To run the grease pump when priming the lube system, start the engine to energize the system. Connect a jumper wire between the LUBE SW and SOL terminals on the solid state timer. (Accumulators must be pressurized in order for the grease pump to operate.)**

3. Run the grease pump until grease flows from any one plug opening in the system. Replace the plug in this opening.

4. Repeat Step 3 until all lines are full and all plugs replaced.

*NOTE: Fill each feed line with grease before connecting lines to the injector outlets and bearings. This will prevent having to cycle the individual injectors once for each 25 mm (1 in.) length of feed line between the injector and bearing fitting.*

### System Checkout

To check system operation (not including timer), proceed as follows:

1. Turn keyswitch (3, Figure 42-7) OFF and shut down the engine to de-energize the system. Install a 35 MPa (5000 psi) pressure test gauge in grease supply line (13, Figure 42-1).
2. Turn keyswitch ON and start engine to energize the system.
3. Lift the passenger seat, and connect a jumper wire between the SOL and LUBE SW terminals on the 24 VDC solid state lube timer. The pump should begin to operate.

*NOTE: If terminal post identification on the solid state timer is not legible, refer to Figure 42-7 for terminal identification.*

4. Keep the jumper wire connected until the pump stalls.
5. Observe the 35 MPa (5000 psi) pressure test gauge in the grease supply line. Pressure should be 17.2 - 20.7 MPa (2500 - 3000 psi).

***! WARNING !: DO NOT exceed maximum pump pressure of 24.1 MPa (3500 psi). Exceeding this value will damage components and/or cause components to rupture, resulting in possible serious injury to any nearby personnel.***

If the pressure is not correct, adjust the pressure reducing valve as necessary (refer to Pressure Reducer Adjustment).

*NOTE: DO NOT exceed 2.1 MPa (300 psi) on cylinder pressure gauge (2, Figure 42-1)*

6. Disconnect the jumper wire. The system should vent.
7. Turn the keyswitch OFF and shut down the engine to de-energize the system. Remove the 35 MPa (5000 psi) pressure test gauge previously installed. Connect system components.

### Pressure Reducer Adjustment

*NOTE: Steering accumulator pressure is necessary to power the lube system for this procedure.*



***While the engine is running, and/or accumulators are charged, exercise extreme care while working in the vicinity of the grease pump!***

***Steering pressure is also available at this time. Keep personnel away from front wheels to prevent crushing!***

***Stay clear of moving engine parts and do not loosen/disconnect any pressure fittings or hoses.***

### To set the Pressure Reducing Valve:

1. With keyswitch OFF, engine stopped, and steering accumulator pressure bled down, install a 35 MPa (5000 psi) pressure test gauge in the grease supply line (13, Figure 42-1).
2. At the truck hydraulic bleeddown manifold, disconnect the bleeddown solenoid. (This will prevent the accumulators from bleeding down when the engine is shut down, later in Step 4.)
3. Start the truck engine. When steering and brake pressures have stabilized, pull the retarder lever to the fully applied position to apply the brakes.
4. Turn keyswitch OFF to stop the engine. Then return the keyswitch to the ON position.
5. Lift the passenger seat, and connect a jumper wire between the SOL and LUBE SW terminals on the 24 VDC solid state lube timer. The pump should operate. Keep the jumper wire connected until the pump stalls.

6. Observe the 35 MPa (5000 psi) pressure test gauge in the grease supply line. The pressure should be 17.2 - 20.7 MPa (2500 - 3000 psi).



**Do Not exceed maximum pump pressure of 24.1 MPa (3500 psi). Exceeding this value will damage components and/or cause components to rupture, resulting in possible serious injury to any nearby personnel.**

If the pressure is not correct, adjust the pressure reducing valve until the pressure gauge (installed at Step 1) indicates 17.2 - 20.7 MPa (2500 - 3000 psi) grease pressure.

*NOTE: DO NOT exceed 2.1 MPa (300 psi) on the cylinder pressure gauge (2, Figure 42-1).*

7. With the jumper wire installed, verify that the following events occur in this order:
  - a. The pump starts stroking and the LED on the flasher unit atop of SV2 flashes on and off at approximately one second intervals.
  - b. All of the injectors stroke down.
  - c. The pump stalls. Use the grease pressure gauge to determine whether the pump stalls.
8. Turn the keyswitch OFF and remove the jumper wire installed in Step 5, then verify the following:
  - a. The pressure on cylinder pressure gauge (2, Figure 42-1) drops to zero (0).
  - b. The pressure on the grease pressure test gauge (installed at Step 1) drops to zero (0).
  - c. All of the injectors reset (indicator pin up).
9. Remove grease pressure test gauge (installed in Step 1).
10. At the hydraulic bleddown manifold, reconnect the bleddown solenoid (disconnected in Step 4). Verify that hydraulic system now bleeds down.

## 24 VDC Solid State Timer Check

To check the solid state timer operation without waiting for the normal timer setting, proceed as follows:

1. Remove the timer dust cover.

*NOTE: The timer incorporates a liquid and dust tight cover which must be in place and secured at all times during truck operation.*

2. Adjust the timer to the 5 minute interval setting.
3. The timer should cycle in five minutes if the truck engine is operating.

*NOTE: If the timer check is being performed on a cold start, the first cycle will be approximately double the nominal setting. All subsequent cycles should be within the selected time tolerance.*

4. Voltage checks at the timer should be accomplished if the above checks do not identify the problem.
  - a. Ensure timer ground connection is clean and tight.
  - b. With the truck keyswitch ON, use a volt-ohm meter and read the voltage between the BAT (+) and BAT (-) terminals on the solid state timer. Normal reading should be 18-26 VDC, depending upon whether or not the engine is running.

### 24 VDC Solid State Timer Adjustment

The timer is factory set for a nominal 2.5 minute (off time) interval. Dwell time is approximately 1 minute, 15 seconds. A longer interval (off time) is obtained by turning selector knob (3, Figure 42-3) to the desired time interval.

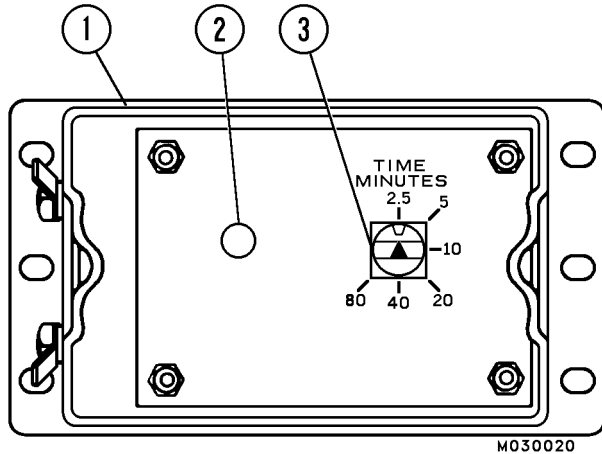

FIGURE 42-3. TIMER ADJUSTMENT

**NOTE:** Set the timer by turning selector knob (3) to the 2.5 minute setting point. Then, turn the selector knob clockwise, one detent at a time, to the desired setting, or until the maximum limit of eighty minutes is reached. The recommended setting is 20 minutes.

**! CAUTION!** The solid state timer is a sealed unit, do not attempt disassembly.

### Injectors (SL-1)

- Each lube injector services only one grease point.
- Injectors are available in banks of two, three, four and five as well as single replacement units.
- Injector output is adjustable:  
Maximum output = 1.31 cc (0.08 in<sup>3</sup>).  
Minimum output = 0.13 cc (0.008 in<sup>3</sup>).
- In case of a pump malfunction, each injector is equipped with a covered grease fitting to allow the use of external lubricating equipment.

### Injector Adjustment

The injectors may be adjusted to supply from 0.13 cc to 1.31 cc (0.008 in<sup>3</sup> to 0.08 in<sup>3</sup>) of lubricant per injection cycle. The injector piston travel distance determines the amount of lubricant supplied. This travel is in turn controlled by an adjusting screw in the top of the injector housing.

Turn the adjusting screw (2, Figure 42-4) counterclockwise to increase lubricant amount delivered and clockwise to decrease the lubricant amount.

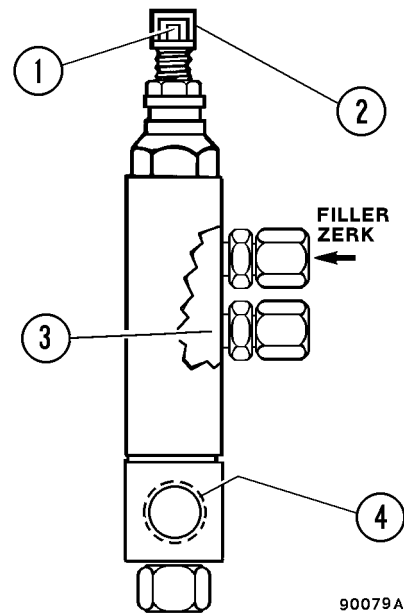

FIGURE 42-4. TYPE SL-1 SERIES INJECTOR

- |                           |                           |
|---------------------------|---------------------------|
| 1. Visible Indicator Stem | 3. Outlet - 0.125 in. NPT |
| 2. Adjusting Screw        | 4. Manifold               |

With the solid state timer set at 20 minutes, the recommended setting is:

Four turns clockwise from the maximum counterclockwise position. This delivers approximately 0.66 cc (0.04 in<sup>3</sup>) of lube per cycle.



When the injector is not pressurized, maximum injector delivery volume is attained by turning adjusting screw (2) fully counterclockwise until indicating pin (1) just touches the adjusting screw. At the maximum delivery point, about 9.7 mm (0.38 in.) adjusting screw threads should be showing. Decrease the delivered lubricant amount by turning the adjusting screw clockwise to limit injector piston travel.

If only half the lubricant is needed, turn the adjusting screw to the point where about 4.8 mm (0.19 in.) threads are showing. The injector will be set at minimum delivery point with about 0.22 mm (0.009 in.) thread showing.

*NOTE: The foregoing information concerns adjustment of the injector delivery volume. The timer adjustment should also be changed, if overall lubricant delivery is too little or too much. Injector output should NOT be adjusted to less than one-fourth capacity.*

#### Pump Cycle Timer (Flasher Timer):

The pump cycle timer mounts on the SV2 solenoid and generates a timed pulse signal to control the reciprocating cycle rate of the grease pump.

#### Pump Cycle Timer (Flasher Timer) Installation

1. Connect the cycle timer to SV2. Be sure to install a gasket.
2. Connect the SOL terminal from the solid state timer to the brown wire from the cycle timer and one of the wires coming from SV1.
3. Connect the white wire from the cycle timer and the other (gnd) wire coming from SV1.

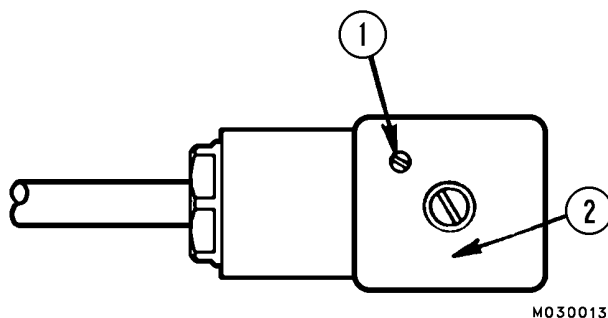

FIGURE 42-5. PUMP CYCLE TIMER

1. Adjustment Screw      2. Red LED\*

\*NOTE: Indicates the timer has turned on.

#### Pump Cycle Timer (Flasher Timer) Adjustment:

The pump cycle timer is factory set at 1 second ON and 1 second OFF for 30 cycles/minute. If adjustment is necessary, refer to Figure 42-5 and the following procedure.

The one adjustment screw adjusts both the ON time and OFF time equally. The adjustment range is from 0.5 seconds (60 cycles/minute) to 5.0 seconds (6 cycles/minute). The adjustment screw allows 15 turns of adjustment over the timing range.

1. Adjustment screw (1) should be turned 20 turns counter-clockwise to insure a minimum start point.

*NOTE: The timer cannot be adjusted below minimum - additional turns counter-clockwise have no effect.*

2. Each clockwise turn of the adjustment screw will equal approximately 0.3 seconds.
3. Add the number of turns clockwise to reach the approximate desired timing.

Some additional adjustment may be necessary depending on the accuracy needed.

*NOTE: Use the LED on the cycle timer to help in setting the time. The LED will turn on when there is power going to SV2.*

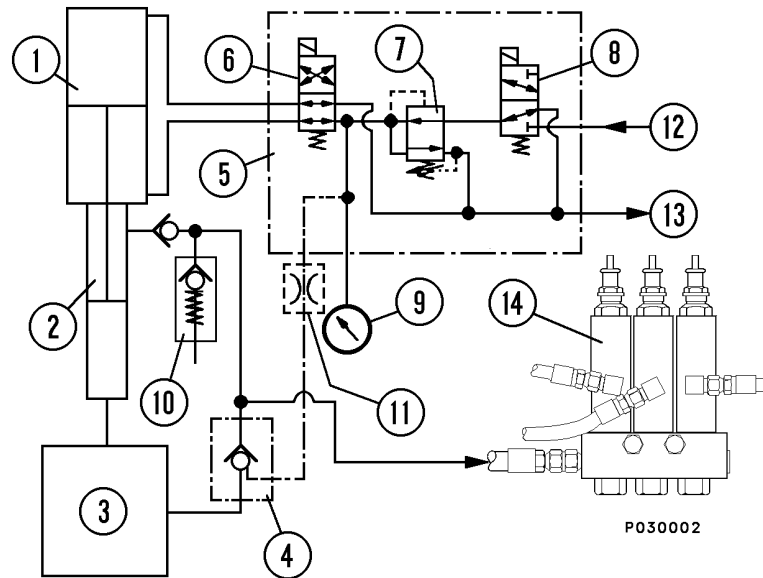

FIGURE 42-6. SYSTEM HYDRAULIC SCHEMATIC

- |  |                              |                             |
|--|------------------------------|-----------------------------|
| 1. Grease Pump Cylinder                                    | 6. Solenoid (SV2)            | 12. Hydraulic Supply        |
| 2. Grease Pump   | 7. Pressure Reducer          | 13. Hydraulic Tank (Return) |
| 3. Grease Reservoir  | 8. Solenoid (SV1)            | 14. Injectors               |
| 4. Vent Valve  | 9. Gauge (Cylinder Pressure) |                             |
| 5. Combination Valve (Pressure Reducing & Solenoid Valves) | 10. Safety Unloader Valve    |                             |
|  | 11. Orifice Assembly Fitting |                             |

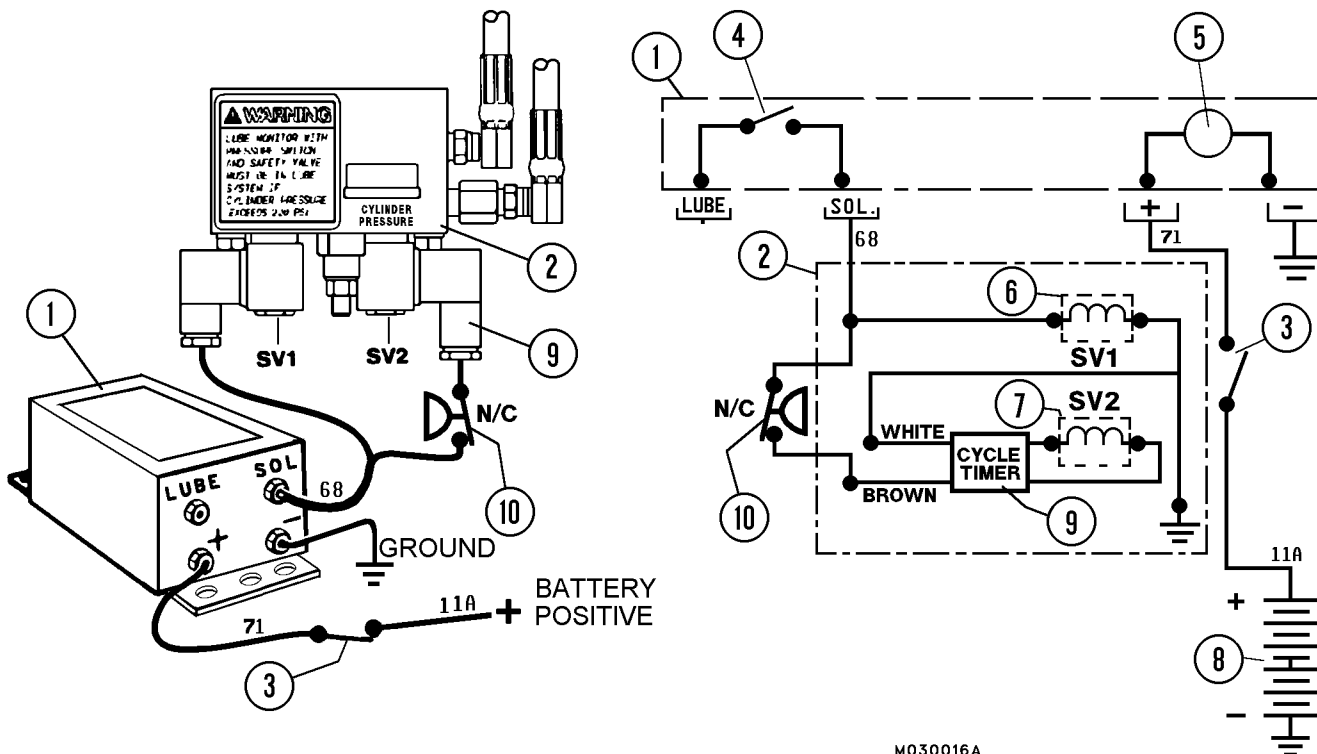

FIGURE 42-7. ELECTRICAL HOOKUP - TYPICAL

- |                      |                        |                   |
|----------------------|------------------------|-------------------|
| 1. Timer Assembly    | 4. Relay               | 7. Solenoid (SV2) |
| 2. Combination Valve | 5. Timer (Solid State) | 8. Battery (24V)  |
| 3. Keyswitch*        | 6. Solenoid (SV1)      | 9. Cycle Timer    |

\* The keyswitch must be in the ON position to energize timer (1).

## SYSTEM TROUBLESHOOTING CHART

*If the following procedures do not correct the problem, contact a factory authorized service center.*

### POSSIBLE CAUSES

### SUGGESTED CORRECTIVE ACTION

#### TROUBLE: Pump Does Not Operate

Lube system not grounded.

Correct grounding connections to pump assembly and truck chassis.

Electrical power loss.

Locate cause of power loss and repair. 24 VDC power required. Be sure keyswitch is ON.

Timer malfunction.

Replace timer assembly.

Solenoid valve malfunctioning.

Replace the solenoid valve assembly.

Pump malfunction.

Replace pump assembly.

No supply pressure.

Start the engine.

*NOTE: On initial startup of the lube system, the timing capacitor will not contain a charge, therefore the first timing cycle will be about double in length compared to the normal interval. Subsequent timer cycles should be as*

#### TROUBLE: Pump Will Not Prime

Low lubricant supply.

Fill reservoir.

Dirt in reservoir, pump inlet clogged.

Clean pump and reservoir. Remove source of contamination.

Pump Jammed.

Repair/replace pump assembly.

#### TROUBLE: Pump Will Not Build Pressure

Air trapped in lubricant supply line.

Prime system to remove trapped air.

Lubricant supply line leaking.

Check lines and connections to repair leakage.

Vent valve leaking.

Clean or replace vent valve.

Pump cylinder worn or scored.

Repair or replace pump assembly.

Reservoir empty.

Fill reservoir.

Check valves stuck open.

Replace check valves.

#### TROUBLE: Injector Indicator Stem Does Not Operate

*NOTE: Normally, during operation, the injector indicator stem will move into the body of the injector when pressure builds properly. When the system vents (pressure release) the indicator stem will again move out into the adjusting yoke.*

Malfunctioning injector - usually indicated by the pump building pressure and then venting.  
Note: Can be caused by overtightened fitting in delivery port of the injector.

Replace individual injector assembly.

All injectors inoperative - pump build up not sufficient to cycle injectors.

Pump build up not sufficient to cycle injectors. Repair/replace pump assembly. Check pump cylinder pressure and line pressure at pump.

Whole series of injectors inoperative.

Check for broken or clogged intermediate supply line and replace.

**POSSIBLE CAUSES**

**SUGGESTED CORRECTIVE ACTION**

**TROUBLE: Pressure Gauge Does Not Register Pressure**

No system pressure to the pump.

Determine problem in hydraulic system.

No 24 VDC signal at solenoids SV1 and SV2.

Determine problem in 24 VDC electric system.

Pressure reducing valve set too low.

Increase setting by 1/2 turn to check operation.

Primary solenoid valve SV1 may be inoperative.

Replace solenoid coil or valve.

Broken gauge.

Replace gauge.

Damaged combination valve.

Replace combination valve.

**TROUBLE: Pump Pressure Builds Very Slowly Or Not At All**

No pulsing signal at SV2.

Check Timer.

Pressure reducing valve may be set too low.

Increase setting by 1/2 turn to check operation.

Grease viscosity may be too high for temperature at which pump is operating.

Replace grease with a lower viscosity lubricant.

If pressure is not building at all, secondary solenoid valve SV2 may be inoperative.

Replace secondary solenoid valve SV2.

Pump piston ball checks and inlet checks may have foreign matter trapped causing leakage.

Remove, inspect and clean, if necessary. Inspect sealing surfaces between upper and lower inlet checks. Replace if rough or pitted.

Shovel rod is rough or pitted.

Replace shovel rod and packing.

Lubricant supply line leaks or is broken.

Repair lubricant supply line.

Pulsing signal of cycle timer incorrect.

Set flasher timer.

**TROUBLE: 24VDC Timer Not Operating**

Timer BAT (-) connection is not grounded.

Connect to good ground.

Timer BAT (+) connection not on circuit continuously connected to BAT (+) terminal during operation of vehicle.

Establish direct connection between Timer BAT (+) connection and 24 V BAT (+) terminal.

Fuse blown (circuit breaker tripped) on power connection on timer, or wire is otherwise damaged.

Replace fuse (reset circuit breaker) or repair damaged wire.

Loose wire connections at any of the timer terminals.

Secure wire connections.

**TROUBLE: Timer Stays Timed Out**

Commutation failure in timer caused by damaged component.

Replace timer.

Output relay contacts welded shut caused by extended short to ground.

Replace timer.

Solenoid valve connected to LUBE SW terminal of timer instead of terminal marked SOL.

Correct wiring hook-up.

**POSSIBLE CAUSES****SUGGESTED CORRECTIVE ACTION****TROUBLE: Timer Turns On At Intervals Two To Ten Times More Often Than Set Time Interval**

Electrical noise is being introduced into the power supply to the timer overcoming suppressor capacitor causing uncontrolled turn-on of its output relay.

**IMPORTANT:** In some instances, electrical noise may be generated into vehicle electrical system which may cause timer to turn on at random intervals, independent of timer setting. If this occurs, a 250 to 1,000 MFD capacitor rated 150 to 350 VDC should be added across BAT (+) and BAT (-) terminals to suppress this noise and improve timer performance.

**TROUBLE: Timer Turns On At Intervals Faster Than Allowable Tolerances Of Settings**

Timer out of adjustment or damaged component.  
*Note: Common for trucks operating in a moist environment.*

Refer to Timer Adjustment and re-adjust timer or replace timer.

**RESERVOIR FILL PROCEDURE****Lubricant Required for System**

Refer to Lubrication and Service - Lubrication Chart, for correct lubricant specifications.

- Above 32°C (90°F) - Use NLGI No.2 multipurpose grease (MPG).
- -32° to 32°C (-25° to 90°F) - Use NGLI No. 1 MPG.
- Below -32°C (-25°F) - Refer to local supplier for extreme cold weather lubricant requirements.

**Fill Procedure**

1. Remove top vent plug (14, Figure 42-8).
2. Remove bottom fill plug (15).
3. Connect the line from the lubricant delivery system to bottom fill port (15) and fill the reservoir until grease just begins to come out of the top vent hole, above.
4. Disconnect the line from the lubricant delivery system and install plugs (14 & 15), previously removed.

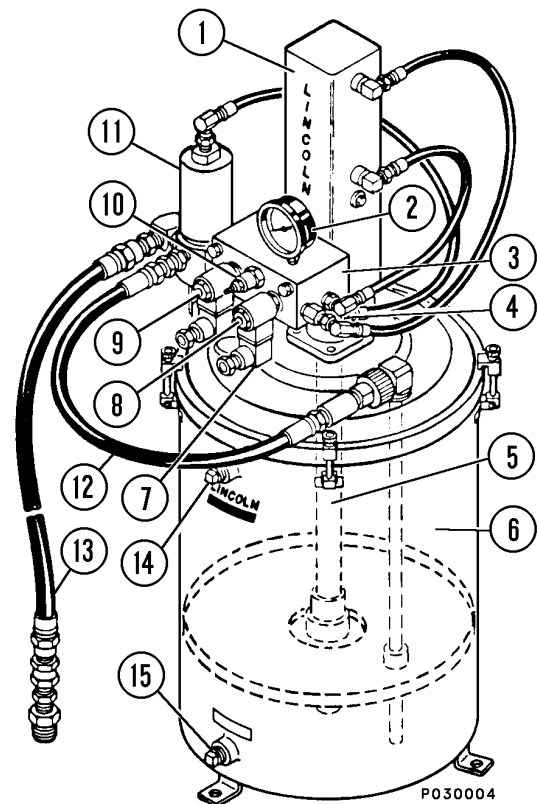

FIGURE 42-8. TYPICAL AUTO LUBE SYSTEM

- |                        |                             |
|------------------------|-----------------------------|
| 1. Pump Cylinder       | 9. Solenoid Valve, SV1      |
| 2. Pressure Gauge      | 10. Pressure Reducing Valve |
| 3. Valve Body          | 11. Vent Valve              |
| 4. Orifice Assembly    | 12. Grease Return Line      |
| 5. Pump Assembly       | 13. Grease Supply Line      |
| 6. Canister/Reservoir  | 14. Top Vent Plug           |
| 7. Pump Cycle Timer    | 15. Fill Supply Port        |
| 8. Solenoid Valve, SV2 |                             |

## PREVENTIVE MAINTENANCE PROCEDURES

The following maintenance procedures should be used to insure proper system operation.

### Daily Lubrication System Inspection

1. Check grease reservoir level.

Inspect grease level height after each shift of operation. Grease usage should be consistent from day-to-day operations.

- Lack of lubricant usage would indicate an inoperative system.
  - Excessive usage would indicate a broken supply line.
2. Check all grease feed line hoses from the SL-1 Injectors to the lubrication points (Figure 42-2).
- a. Repair or replace all worn / broken feed line hoses.
  - b. Make sure that all air is purged and all new feed line hoses are filled with grease before sending the truck back into service.
3. Inspect key lubrication points for a bead of lubricant around seal.

Make note of all lubrication points that look dry. Notify maintenance staff for repair service.

### 250 Hour Inspection

1. Check all grease feed line hoses from the SL-1 Injectors to the lubrication points (Figure 42-2).
- a. Repair or replace all worn / broken feed line hoses.
  - b. Make sure that all air is purged and all new feed line hoses are filled with grease before sending the truck back into service.
2. Check all grease supply line hoses from the pump to the SL-1 injectors.
- a. Repair or replace all worn / broken supply lines.
  - b. Make sure that all air is purged and all new supply line hoses are filled with grease before sending the truck back into service.
3. Check grease reservoir level.
- a. Fill reservoir if low.
  - b. Check reservoir for contaminants. Clean, if required.
  - c. Check that all filler plugs, covers and breather vents on the reservoir are intact and free of contaminants.

4. Inspect all bearing points for a bead of lubricant around the bearing seal.

It is good practice to manually lube each bearing point at the grease fitting (filler zerk, Figure 42-4) provided on each injector. This will indicate if there are any frozen or plugged bearings, and will help flush the bearings of contaminants.

5. System Checkout

- a. Remove all SL-1 injector cover caps to allow visual inspection of the injector cycle indicator pins during system operation.
- b. Lift the passenger seat and connect a jumper wire between the SOL terminal and the LUBE SW terminal on the 24VDC solid state timer (Figure 42-7).
- c. Start engine. The hydraulic grease pump should operate.
- d. Keep the jumper wire connected until the pump stalls out at 13 790 kPa (2000 psi).
- e. With the pump in the stalled-out mode, check each SL-1 injector assembly. The cycle indicator pin should be retracted inside the injector body.
- f. Once all of the SL-1 injectors have been inspected under pressure, remove the jumper wire between the SOL terminal and LUBE SW terminal on the timer assembly. The pump should shut off, and the system should vent back to the grease reservoir, and the pressure should drop to zero.
- g. With the system vented, check all of the SL-1 injector indicator pins. All of the pins should be visible.

*NOTE: Refer to the system troubleshooting chart, if the injectors are not working properly. Replace or repair injectors, if defective.*

- h. Reinstall all injector cover caps.
- i. Check timer operation. With the engine running, the lube system should activate within 5 minutes. The system should build 13 790 kPa (2000 psi) within 25-40 seconds. If the system is working properly, the machine is ready for operation. If the system is malfunctioning, refer to the troubleshooting chart in the service manual.

## MAJOR COMPONENTS AND SPECIFICATIONS

### ENGINE

The Komatsu HD1500-5 dump truck is powered by a Komatsu SDA12V160 diesel engine.

### TRANSMISSION

The Torqflow transmission consists of a 3-element, single-stage, two-phase torque converter and a planetary gear, multiple disc clutch transmission which is hydraulically actuated and force-lubricated for optimum heat dissipation. The Torqflow transmission is capable of seven forward speeds and one reverse gear. Automatic shifting is controlled by an electronic shift control system with automatic clutch modulation in all gears. A lockup system consisting of a wet, double-disc clutch, is activated in F1-F7 gears for increased fuel savings.

### FINAL DRIVE ASSEMBLY

The final drive consists of a plug-in differential with planetary wheel drive.

### OPERATOR'S CAB

The HD1500-5 operator's cab has been engineered for operator comfort and to allow for efficient and safe operation of the truck.

The cab provides for wide visibility, with an integral 4-post ROPS/FOPS structure, and an advanced analog operator environment. It includes a tinted safety-glass windshield and power-operated side windows, a deluxe interior with a fully adjustable seat with lumbar support, a fully adjustable/tilt steering wheel, controls mounted within easy reach of the operator, and an electronic display/monitoring panel to keep the operator informed of the truck's operating circuits. Audible alarms and indicator lights warn the operator of system malfunctions.

### POWER STEERING

The HD1500-5 truck is equipped with a full time power steering system which provides positive steering control with a minimum of effort by the operator. The system includes nitrogen-charged accumulators which automatically provide emergency power if the steering hydraulic pressure is reduced below an established minimum.

### BRAKE SYSTEM

Depressing the brake pedal, or operating the retarder lever on the RH side of the steering wheel, actuates the hydraulic front and rear service brakes. Both front and rear service brakes are oil-cooled, multiple-disc brakes. These brakes are automatically activated when the engine speed exceeds the rated revolutions of the shift position. The system includes two nitrogen-charged accumulators for quick response, and to provide secondary braking if a problem occurs in the primary braking circuit.

### RETARDER

The operator can manually apply both the front and rear oil-cooled, multiple-disc brakes by moving the retarder control lever which is mounted on the steering column, or by using the foot-operated brake pedal.

### SUSPENSION

Hydro-pneumatic suspension cylinders are used at each wheel to reduce shock and provide riding comfort for the operator and machine stability.

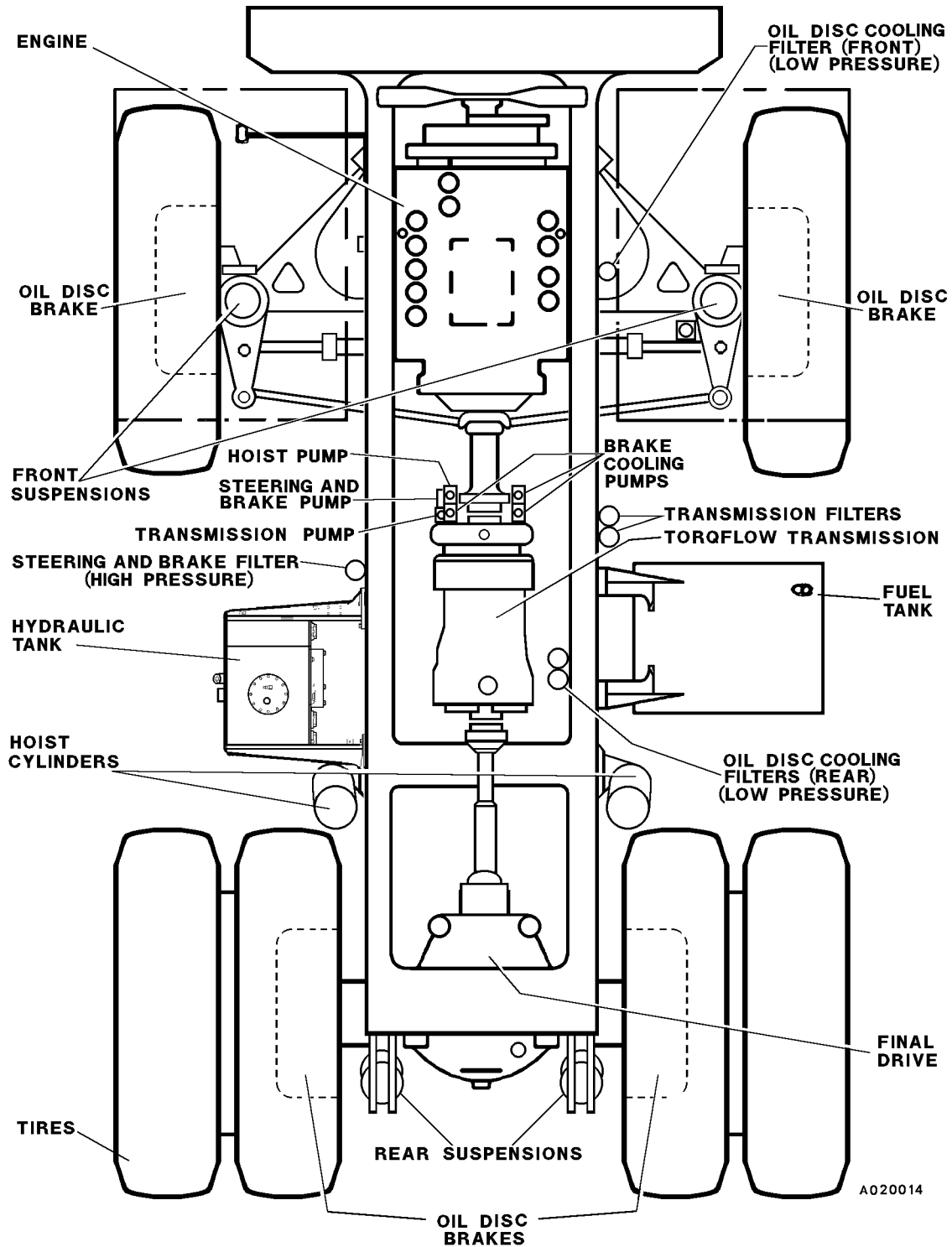

## HD1500-5 MAJOR COMPONENTS



## SPECIFICATIONS

### ENGINE

Komatsu ..... SDA12V160  
 Number of Cylinders ..... 12  
 Operating Cycle (diesel) ..... 4-Stroke  
 Rated . . . 1108 kW (1486 SAE Brake HP) at 1900 rpm  
 Flywheel . . . . 1048 kW (1406 SAE HP) at 1900 rpm  
 Weight (dry).....5813 kg (12,815 lbs)

### TRANSMISSION

Automatic Electronic Shift Control with Automatic Clutch Modulation In All Gears.  
 Torque Converter..... 3-Element, Single-stage,  
 ..... Two-phase  
 Lockup Clutch ..... Wet, Double-disc,  
 ..... Activated in F1-F7 gears.  
 Transmission..... 7 Forward Speeds, 1 Reverse  
 ..... Planetary Gear, Multiple Disc Clutch,  
 ..... Hydraulically Actuated, Force-lubricated

Gear .....	Km/h.....	MPH
1 .....	11.0 .....	6.8
2 .....	14.6 .....	9.1
3 .....	19.5 .....	12.1
4 .....	24.5 .....	15.2
5 .....	32.6 .....	20.3
6 .....	44.2 .....	27.5
7 .....	58.0 .....	36.0
Rev .....	10.6 .....	6.6

### FINAL DRIVE ASSEMBLY

Final Drive ..... Plug-in Differential  
 ..... with Planetary Wheel Drive  
 Reduction Ratios:  
 Bevel Set..... 2.647:1  
 Planetary Final Drive..... 7.235:1  
 Total Reduction ..... 19.151:1

### ELECTRIC SYSTEM

Batteries (series-parallel) . . . 4 x 12V / 220 Amp-Hour  
 Alternator..... 24 Volt, 240 Ampere Output  
 Lighting ..... 24 Volt  
 Cranking Motors ..... Two - 24 Volt Electric

### SERVICE CAPACITIES

.....	Liters ..	U.S Gallons
Engine .....	193 .....	(51)
(Includes Lube Oil Filters)		
Cooling System .....	532 .....	(140.6)
Fuel Tank .....	2120 .....	(560.0)
Transmission .....	153 .....	(40.5)
And Torque Converter		
Hydraulic System .....	900 .....	(238)
(Includes Retarder Cooling)		
Differential .....	300 .....	(79.0)
Final Drive (each planetary) . .	120 .....	(31.7)

### HYDRAULIC SYSTEM

Hydraulic Pumps (3)  
 Hoist (Tandem Gear)  
 . . . . 805 l/min. (213 gpm) @ 18 960 kPa (2,750 psi)  
 Steering (Piston Pump)  
 . . . . 221 l/min. (58.5 gpm) @ 18 960 kPa (2,750 psi)  
 Brakes (Tandem Gear) . . . . 1512 l/min. (400 gpm)  
 Hoist Control Valve..... Spool Type  
 Positions..... Raise, Hold, Float, and Lower  
 Hydraulic Cylinders  
 Hoist ..... 3-Stage Telescoping Piston  
 Steering..... Twin - Double Acting Piston  
 Relief Valve Setting ..... 18 960 kPa (2,750 psi)  
 Filtration ..... In-line Replaceable Elements  
 Suction ..... Single, Full Flow, 100 Mesh  
 Hoist & Steering ..... Dual, Full Flow, In-line  
 ..... High Pressure. Beta 12 Rating = 200  
 Transmission ..... Dual, High Pressure

### SERVICE BRAKES

Actuation: ..... All-Hydraulic  
 Front ..... Oil-Cooled, Multiple-Disc  
 Rear ..... Oil-Cooled, Multiple-Disc  
 . . . . Both Act as both Service and Retarder Brakes  
 Retarder Brakes:  
 Normally Applied ..... Manually By Operator.  
 Automatically Actuated .....  
 when engine speed exceeds the rated revolutions  
 of the shift position for the transmission.  
 Parking Brake: ..... Spring-Applied, Oil Released  
 . . . . Dry Caliper Disc Actuates On Rear Drive Shaft  
 Secondary Brakes:  
 A secondary brake valve actuates the brakes auto-  
 matically, if hydraulic pressure drops below a pre-  
 set value. Manual operation is also possible.

**STEERING**

Turning Circle Diameter (SAE) . . . . . 24.4 m (80 ft)  
Automatic Emergency Steering . . . . . 2 Accumulators

**TIRES**

Rock Service (E-3) . . . . . Tubeless  
Standard . . . . . 33.00 R51  
Rim Size . . . . . 61x 12.95 x 12.7 cm (24 x 51 x 5 in.)  
Phase II Generation™ . . . . . Separable Tire Rims

**DUMP BODY CAPACITY (Standard)**

Struck . . . . . 54 m<sup>3</sup> (71 yds<sup>3</sup>)  
Heaped @ 2:1 (SAE) . . . . . 78 m<sup>3</sup> (102 yds<sup>3</sup>)

**OVERALL TRUCK DIMENSIONS**

Loading Height . . . . . 4.965 m (16' 3")  
Minimum Clearance Height . . . . . 5.85 m (19' 2")  
Overall Length . . . . . 11.37 m (37' 4")  
Maximum Width . . . . . 6.62 m (21' 9")

**WEIGHT DISTRIBUTION**

Based on SAE 2:1 Heaped . . . . . 78 m<sup>3</sup> (102 yds<sup>3</sup>)  
(w/Komatsu Engine; and . . . . . 33.00 R51 Tires)

**EMPTY . . . . . Kilograms . . . . . Pounds**

Front Axle . . . . . 49 025 . . . . . 108,082  
Rear Axle . . . . . 51 437 . . . . . 113,399  
Total . . . . . 100 462 . . . . . 221,481

**LOADED (100 Ton PAYLOAD)**

**. . . . . Kilograms . . . . . Pounds**

Front Axle . . . . . 82 327 . . . . . 181,500  
Rear Axle . . . . . 167 149 . . . . . 368,500  
Total \* . . . . . 249 475 . . . . . 550,000

\*Not to Exceed 249 475 kg (550,000 lb).

Including Options, Fuel & Payload

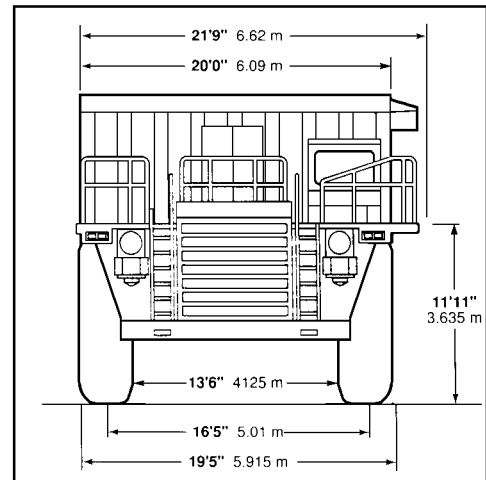
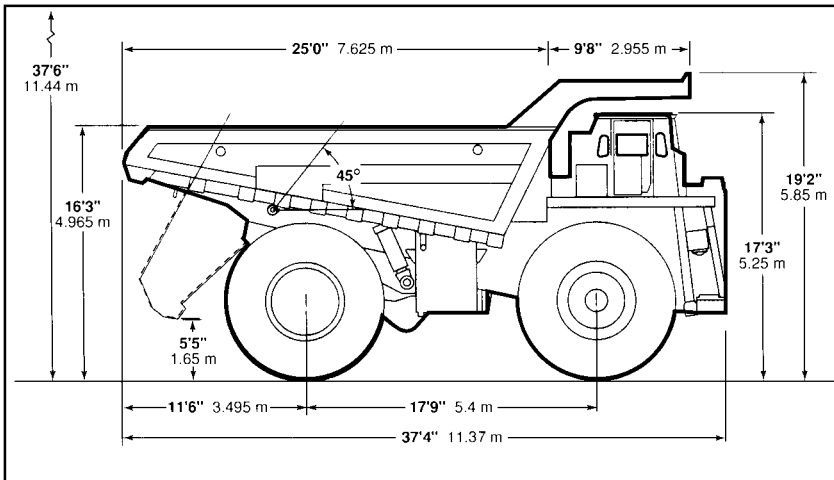

All dimensions are with 71/102 yd.<sup>3</sup> 54/78 m<sup>3</sup> body.  
Vertical dimensions are for standard empty vehicle — subtract 4"/100 mm for vehicle loaded to max. GVW.  
Minimum ground clearance (at max. GVW) . . . . . 2'9" 838 mm

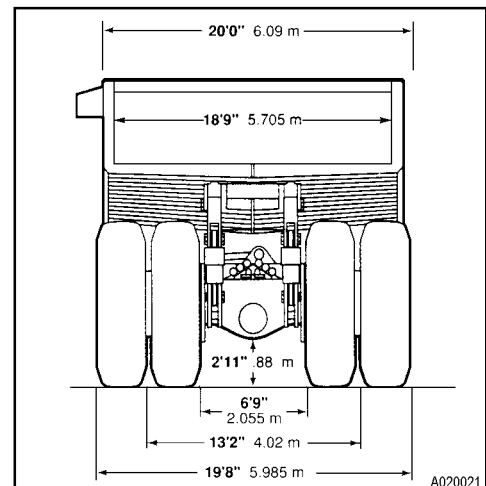

## SECTION 60

### PAYLOAD METER II - ON BOARD WEIGHING SYSTEM

#### INDEX

GENERAL INFORMATION .....	60-3
Haul Cycles .....	60-3
LIGHTS, SWITCHES AND COMPONENTS .....	60-4
TIPS FOR OPERATION .....	60-5
EXTERNAL DISPLAY LIGHTS .....	60-5
THEORY OF OPERATION .....	60-6
Basic Description .....	60-6
Inclinometer .....	60-6
Linkage Factor .....	60-6
Gain Factor .....	60-7
Brake Lock .....	60-7
Sources of Error .....	60-7
Typical Data From Service Check Mode .....	60-7
Example Calculation of Payload .....	60-8
Viewing Payload Calculation Inputs .....	60-8
Checking the Gain .....	60-9
Adjusting the Gain .....	60-9
TYPES OF DATA STORED .....	60-10
Cycle Data .....	60-10
Engine ON/OFF Data .....	60-11
Fault Codes and Warning Data .....	60-11
Engine Operation .....	60-12
Total Payload and Total Number of Cycles .....	60-12
Other Data .....	60-12
OPERATOR FUNCTIONS .....	60-13
Using the Operator Load Counter .....	60-13
Viewing the Operator Load Counter .....	60-13
Clearing the Operator Load Counter .....	60-13
Dimming the Lights on the Display .....	60-13
INITIAL SETUP OF PAYLOAD METER .....	60-14
Switch Settings .....	60-14
Checking the Operator Check Mode .....	60-15
Checking the Service Check Mode .....	60-15
Checking the Gt setting: .....	60-16
Checking the Inclinometer Settings .....	60-16
Calibrating a Truck .....	60-16

DISPLAYS AT START-UP .....	60-17
Normal Operation .....	60-17
SETUP AND MAINTENANCE .....	60-18
Setting The Speed Limit .....	60-18
Setting the Option Code .....	60-18
Setting The Machine I.D. Code .....	60-19
Setting The Operator I.D. Code .....	60-19
Setting The Time and Date .....	60-19
DOWNLOAD OF INFORMATION .....	60-20
DISPLAY OF FAULT CODES .....	60-20
Monitoring Input Signals .....	60-24
Service Check Mode .....	60-24
UP FACTOR - PAYLOAD CALCULATION GAIN .....	60-25
PL MODE -LOAD CALCULATION TIMING .....	60-25
FINAL GEAR RATIO SELECTION.....	60-26
BATTERY REPLACEMENT PROCEDURE .....	60-27
Replacing the Battery .....	60-27
After Replacing the Battery .....	60-28
SUSPENSION PRESSURE SENSOR .....	60-28
Removal .....	60-28
Installation .....	60-29
INCLINOMETER .....	60-29
Removal .....	60-29
Installation .....	60-29
Adjustment .....	60-29
PAYLOAD METER BACK PANEL .....	60-30
CONNECTIONS .....	60-31
PAYLOAD CIRCUIT NUMBERS .....	60-32
PAYLOAD METER II™ RE-INITIALIZATION PROCEDURE .....	60-33

## PAYLOAD METER II ON BOARD WEIGHING SYSTEM (OBWS)

### GENERAL INFORMATION

The Payload Meter II™ (PLM II™) On Board Weighing System displays and records the payload weight along with other operating information. The system consists of a payload meter, pressure sensors, deck mounted lights and an inclinometer.

The payload meter (Figure 60-1) uses the four suspension pressures and an inclinometer to determine the load in the truck. The payload weight can be displayed in short tons or metric tons.

### Haul Cycles

The beginning of a new haul cycle starts at the dump, when the body comes down from dumping the last load.

At the loading site, the PLM II™ begins to calculate the size of each shovel pass (swingload) once the payload is greater than 10% of rated load for the truck. There are three external deck-mounted lights on each side of the truck. The lights indicate payload weight divided into three separate stages. A forecast feature will flash a deck mounted light predicting the payload weight if the next bucket of material is dropped into the body.

At the moment the wheels begin to turn after loading under the shovel, the PLM II™ takes one sample of

suspension and inclinometer data. After traveling 160 m (0.10 mi.) from the loading site, the PLM II™ uses the data sampled under the shovel to calculate final payload.

The PLM II™ displays payload on its display when the truck is stopped. For the first 160 m (0.10 mi.) after loading, the payload meter displays distance from the loading site. At all other times when the truck is moving, the display shows the time of day.

The payload meter stores in memory various operating data. This data includes:

- payload, time, distance, and travel speed for each cycle
- date and time that the engine was started and stopped
- date and time of each fault that occurred or was canceled
- total payload and the overall number of cycles for a specific time period

This data is retained even when the power is switched off. The stored data is backed up by an internal battery.

The data can be down loaded from the payload meter to a personal computer when a communication cable is connected to the port inside the cab.

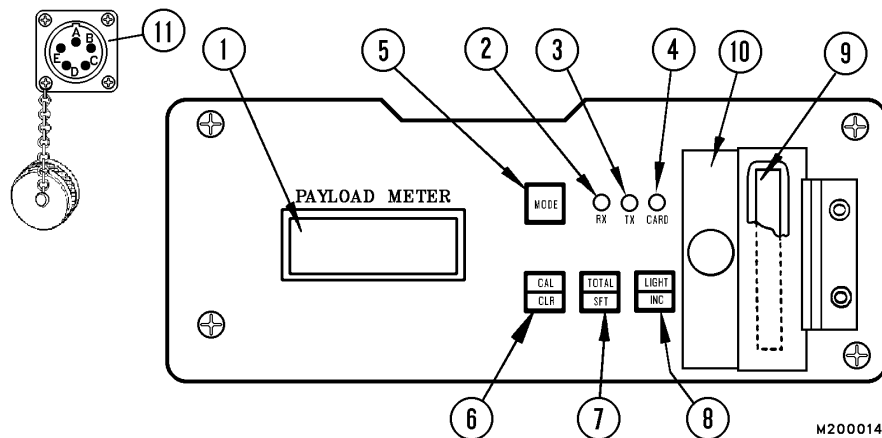

FIGURE 60-1. PAYLOAD METER II

- |   |   |
|---|---|
| 1. Display panel                        | 7. Total/shift switch [TOTAL] [SFT]     |
| 2. Reception pilot lamp (Rx busy)       | 8. Light/increment switch [LIGHT] [INC] |
| 3. Transmission pilot lamp (Tx busy)    | 9. Memory card                          |
| 4. Memory card access lamp (CARD busy)  | 10. Cover                               |
| 5. Mode switch [MODE]                   | 10. Diagnostic/Download Port            |
| 6. Calibration/clear switch [CAL] [CLR] |   |

**WARNING - When not inserting or removing memory card (9), always keep the cover (10) closed**

## LIGHTS, SWITCHES AND COMPONENTS On The Face Of The Payload Meter (Refer to Figure 60-1)

### 1. Display Panel

Digital display area for the data being recorded in memory. This will include items such as:

- Payload
- Date & Time
- Cycles
- Travel Distance
- Fault Codes and Warnings

### 2. Reception Pilot Lamp (Rx Busy)

This light will illuminate for 3 seconds when the system is powered up. It will then be lit whenever the computer is communicating.

### 3. Transmission Pilot Lamp (Tx Busy)

This light will illuminate for 3 seconds when the system is powered up. It will then be lit whenever the memory is being downloaded to a personal computer.

### 4. Memory Card Access Lamp (CARD Busy)

This light will illuminate for 3 seconds when the system is powered up. It will also be lit whenever the memory data is being downloaded to the memory card.

### 5. Mode Switch

This switch is used to select the mode or system that will allow a function to be performed. This may include:

- Various settings or corrections to the display
- Memory card downloading
- Clearing data
- Display of Abnormalities or Warnings
- Setting the speed limit
- Setting the date and time

### 6. Calibration/Clear Switch

Used to calibrate the machine when the conditions regulate this action. Also used with the TOTAL/SFT switch to clear total payload and overall number of cycles.

### 7. Total/Shift Switch

Used to display payload and overall number of cycles each time the load is dumped. Will display the error codes. This switch is also used with the CALIBRATION/CLEAR switch to clear total payload and overall number of cycles.

### 8. Light/Increment Switch

Used to change the digital increments or units for the various displays. Also used to adjust the brightness of the lights on the monitor display.

### 9. Memory Card

Used to receive data from the payload meter memory to this card which can then be used to transfer the data into a personal computer. This enables the memory to be downloaded and saved when a personal computer is not available.

### 10. Cover

Protective cover for the Memory Card. Do not open or place foreign objects in slot.

### 11. Diagnostic/Download Port

Connector port that is used for downloading the memory data to a personal computer.

## TIPS FOR OPERATION

To assure the On Board Weighing System records the most accurate and consistent data, these important steps should be followed:

- Always keep suspension oil and nitrogen properly charged. The most common failure for causing inaccurate payload data is due to improperly charged suspensions. Always follow shop manual procedures when charging a suspension. Refer to Section "H". It is crucial to maintain the proper oil and nitrogen levels at all times.
- For most Komatsu Trucks:  
Use only the brake lock switch to hold the truck stationary at the loading and dumping area.  
**For Komatsu 330M/HD785 Trucks ONLY:** Use the park brake switch to hold the truck stationary at the loading and dumping area.  
Any other method will not allow the payload system to register properly.
- Do not activate the "Lamp Test" switch during loading. Inaccurate and inconsistent data may be stored.
- At the loading area do not release the Brake Lock (or Park Brake switch) until the loading is complete and the load shock from the last load dumped has settled.
- The loading area surface must be maintained as flat and level as possible. The On Board Weighing System can compensate for slight variations in grade and unevenness, but ruts, berms, rocks, etc. will cause the system to record inaccurate and inconsistent data.
- Regularly remove "carryback" from the dump body.
- Calibrate regularly. Refer to "Calibrating a Truck".
- Do not focus on single payloads when viewing data from the payload meter. Use the average of several payloads to get a more accurate calculation of payload productivity.

## EXTERNAL DISPLAY LIGHTS

The Payload Meter II™ controls three light relays. The relays operate three deck mounted lights on each side of the truck. There is one green light, one amber light, and one red light. (Figure 60-2)

While the truck is stopped being loaded and the hoist lever is in the float position, the appropriate lights will remain on according to the following schedule:



FIGURE 60-2. LOAD INDICATOR LIGHTS

INDICATOR LIGHTS			PAYLOAD WEIGHT
Off	Off	Green	50% and Greater
Off	Amber	Green	90% and Greater
Red	Amber	Green	105% and Greater

The shovel or loader operator can predict the payload weight by observing these lights. During the loading operation, a forecast feature flashes a deck mounted light predicting the payload weight after the next bucket of material is loaded into the body. The logic is as follows:

1. If the measured payload is varying 3% or less of the rated load for more than 3 seconds, the current load is deemed a steady value.
2. If the difference between the previous steady value and the current steady value is greater than 15% of the rated load, the difference is taken to be the size of the current bucket.
3. The average size of previous buckets is added to the current load. One of the deck mounted lights will turn on, if another "average" size load is put in the body, and will blink at one second intervals.

## THEORY OF OPERATION

### Basic Description

The payload meter uses the four suspension pressures and the inclinometer to determine the load in the truck. These inputs are critical to the calculation of the load. The other inputs to the payload meter (Body Up, Speed, Brake Lock, Alternator R Terminal, and Engine Oil Pressure) are used to indicate where the truck is in the haul cycle. These inputs enable the payload meter to make time and distance measurements for the haul cycle.

The suspension pressures are the key ingredients in determining the sprung weight of the truck. These pressures are converted into forces using the formulas shown below.

$$\text{Sprung Weight} = \frac{\pi}{4} \text{ Suspension Diameter}^2 (\text{psi Left} + \text{psi Right})$$

$$\text{Sprung Weight} = \text{Axle Weight (lbs)} / 2000$$

These forces are combined with the geometry of the truck to produce the load calculation. It is critical that the suspensions are charged according to shop manual specifications and the pressure sensors are functioning properly.

### Inclinometer

The inclinometer gives the payload meter information regarding the pitch angle of the truck. The front and rear incline factors are determined by the pitch angle. These two factors account for the load transfer that occurs when the truck is inclined nose up or nose down.

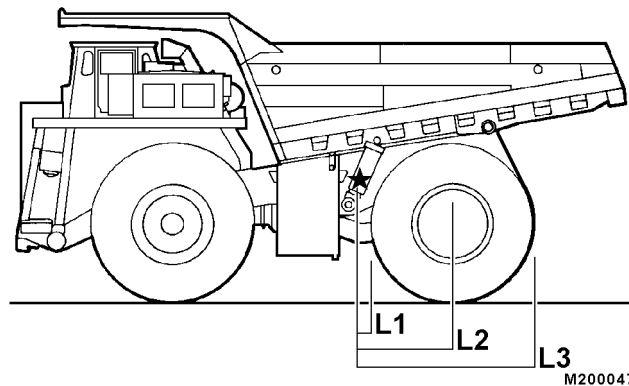

FIGURE 60-3. LINKAGE FACTOR

### Linkage Factor

The linkage factor is part of the complex calculations performed by the payload meter to determine the load in the truck. The linkage factor is dependent on the load on the rear suspensions.

Figure 60-3 shows the side view of a truck. The nose pin is marked with a star and there are three arrows pointing to different spots of the rear tire. This figure shows how the support under the rear tire can affect the calculation of the load. The payload meter does not directly measure the load transferred to the frame through the nose pin. To account for portion of the load carried by the nose pin, the linkage factor is multiplied by the rear suspension force. It is assumed that the truck is supported under the center of the tire. In this case the payload meter uses L2 to help compute the linkage factor. If, however, the truck is backed into a berm and the rear tire is supported towards the back of the tire, the actual linkage factor calculation should use L3. Since the payload meter assumes L2 it will overestimate the load in the truck. The opposite is true in the case where the rear tires are supported toward the front of the tire. The linkage factor should use L1 but the payload meter assumes L2. This change in leverage will cause the payload meter to underestimate the load.



### Gain Factor

Gain factor is part of the formula the payload meter uses to calculate the payload. The gain factor is a tool that compensates for variations between actual weight of the payload and the calculated weight from the payload meter. The gain factor should only be adjusted after several payloads have been weighed on a scale. The gain should never be adjusted based only on one payload. It takes at least 10 scale weigh-ins to determine an average variation. A worksheet is located at the end of this chapter to assist in calculating the necessary gain adjustment.

There are two types of gain adjustments,  $G_t$  gain and UP factor. It is recommended that only the  $G_t$  gain be adjusted. This adjustment is made using the potentiometer on the side of the payload meter. Refer to "Adjusting the Gain".

### Brake Lock

The Brake Lock only applies the rear brakes. This allows the front wheels to rotate slightly as the truck is being loaded. This is important because the payload meter assumes that the front wheels can rotate freely. As the truck is being loaded, it will begin to squat down on the suspensions. This will change the wheel base dimension of the truck. This freedom of movement prevents additional binding and friction in the front suspensions.

The incline of the grade on which the truck is loading is measured by the inclinometer. This helps determine the incline factors that are applied to the front and rear sprung weights. The tire forces on the road surface that hold the truck on grade affect the suspension pressures. If the front and rear brakes are locked, the effect on the suspension pressures cannot be determined. If only the rear brakes are applied the effect is predictable and the incline factors accurately account for the forces on the tires.

If the service brake or park brake is used and depending on the incline and other factors, the payload meter can overestimate or underestimate the load. **It is important that only the brake lock be used while loading the truck. (Parking brake on 330M/HD785).**

### Sources of Error

Poorly charged suspensions can lead to systematic error in the calculation of payload. The error is most obvious when the oil level is low. When there is too little oil in the suspensions, the cylinder may compress completely under a load. The weight of the truck will be carried by the metal to metal contact within the suspension. Not only will the ride of the truck, the life of the tires, and other components be affected, but the pressure in the cylinder will not truly represent the load on the truck. Under-charged suspensions typically cause the payload calculations from the payload meter to be lower than the actual payload.

### Typical Data From Service Check Mode

A sample data set is shown in Figure 60-4. This data was taken in the laboratory and is used in Figure 60-5 to calculate the final load. Note the front suspension pressures were converted into the front sprung weight using the formulas above Figure 60-5. The front sprung weight is then multiplied by the front incline factor and the front linkage factor. The same is done with the rear sprung weight. The front and rear sprung weights are then summed. This number is multiplied by the  $G_t$  gain potentiometer value. The calibration load is subtracted from the total to produce the final load. The load displayed on the meter is this final load (item #15) multiplied by the UP gain factor.

Number	Data	Description
1	13:09	Current Time
2	749.4	Front Left Pressure (psi)
3	848.9	Front Right Pressure (psi)
4	863.2	Rear Left Pressure (psi)
5	1049.0	Rear Right Pressure (psi)
6	106.0	Front Weight (Tons)
7	75.1	Rear Weight (Tons)
8	-1.85	Inclinometer (Degrees)
9	0.95	Incline Factor - Front Wheels
10	0.984	Incline Factor - Rear Wheels
11	1	Link Factor - Front Wheels
12	1.539	Link Factor - Rear Wheels
13	70.6	Calibration Sprung Weight (Tons)
14	1.000	Gain Adjustment
15	143.8	Current Load (Tons)
16	3.9	Battery Backup Voltage (Volts)

FIGURE 60-4.

**NOTE: This screen is the only place that the value of the  $G_t$  gain potentiometer can be checked.**

There are two gain factors that can be applied to the payload measurement. The first is the  $G_t$  gain factor and the other is the UP gain factor. They are not applied uniformly to all payload calculations.

**Example Calculation of Payload**

These calculations used a 13" front suspension diameter and 10" rear suspension diameter.

$$\text{Sprung Weight} = \frac{\pi}{4} \text{ Suspension Diameter}^2 (\text{psi Left} + \text{psi Right})$$

$$\text{Sprung Weight} = \text{Axle Weight}(\text{lbs})/2000$$

Front Weight (6)	106.00	Rear Weight (7)	75.10
x Incline Factor (9)	0.95	x Incline Factor (10)	0.98
	100.70		73.90
x Link Factor (11)	1.00	x Link Factor (12)	1.53
Front Weight	100.70	Rear Weight	113.70
Front Weight	100.70		
Rear Weight	113.70		
Total Weight	214.40		
x Gain Factor (14)	1.00		
	214.40		
- Calibration (13)	-70.60		

FIGURE 60-5.

**Viewing Payload Calculation Inputs**

The PLM II™ estimates payload by monitoring suspension pressures when the truck is loaded and compares them to truck empty pressure values. The PLM II™ uses one empty truck weight for all payload calculations. This empty truck weight is called the 'tare weight'. It is not the empty vehicle weight (EVW). It is an estimate of the empty weight of all the truck components suspended above the suspensions. The process of making the PLM II™ calculate the tare weight is called the calibration procedure.

This calibration weight is used as item #13 from the manual calculation procedure in Figure 60-4.

1. Press and hold the LIGHT/INC and MODE switches until "CHEC" is flashing on the display. **CHEC**
2. Press and hold the CAL/CLR switch until "CALLO" is flashing on the display. **CALLO**
3. Press the CAL/CLR switch to cycle through the following data. The sequence repeats.

Item and Description	Units
1. Year of Calibration	Last 2 digits of year
2. Month: Day of Calibration	XX:XX
3. Hour: Minute of Calibration	XX:XX
4. Truck Model Setting	
5. Pressure Front Left	psi
6. Pressure Front Right	psi
7. Pressure Rear Left	psi
8. Pressure Rear Right	psi
9. Front Sprung Weight	Tons
10. Rear Sprung Weight	Tons
11. Degree of Incline	±° Nose Up Positive
12. Incline Factor - Front Axle	
13. Incline Factor - Rear Axle	
14. Link Factor Front Axle	
15. Link Factor Rear Axle	
16. Calibration Weight	Tons

4. Press MODE once and "CHEC" will flash on the display. **CHEC**
5. Press MODE once and the meter will return to normal operation.

**Checking the Gain**

1. Press and hold the LIGHT/INC and MODE switches until "CHEC" is flashing on the meter. **CHEC**
2. Press and hold the LIGHT/INC switch until "ALLO" is flashing on the display. "A.FUL" may also be displayed. **ALLO**
3. Press the LIGHT/INC switch 14 times. The number displayed will be the current  $G_t$  gain. Press MODE twice to return to normal operation.

**Adjusting the Gain**

Before adjusting the gain perform the following steps:

1. Confirm the suspension oil and nitrogen charges are at the levels specified in the shop manual.
2. Weigh the empty truck and then calibrate the payload meter. Do both in succession to ensure the weights are nearly identical.
3. Weigh at least 10 different loads to get an accurate deviation from actual scale weight and the payload calculation from the payload meter. Complete the gain adjustment worksheet at the end of this module. The worksheet is an accurate way to calculate the necessary gain adjustment.

Adjustment Procedure:

1. Ensure the PLM II™ is in normal operating mode.
2. Adjust the gain potentiometer on the side of the meter. Right to decrease, left to increase.
3. Press and hold the LIGHT/INC and MODE switches until "CHEC" is flashing on the meter. **CHEC**
4. Press and hold the LIGHT/INC switch until "ALLO" is flashing on the display. "A.FUL" may also be displayed. **ALLO**
5. Press the LIGHT/INC switch 14 times. The number displayed will be the current  $G_t$  gain. This is not a "live" reading. Any time the gain is changed, this cycle must be repeated to view the new change.
6. Press MODE once and "CHEC" will flash on the display. **CHEC**
7. Press MODE once and the meter will return to normal operation.

## TYPES OF DATA STORED

### Cycle Data

One cycle is considered to be from the point where a load is dumped to the point where the next load is dumped. Data between these two points is recorded in memory. Examples of the data are shown below. The maximum number of cycles that can be stored in memory is 2900 cycles.

ITEM	UNIT	RANGE	REMARKS
Engine Operation Number	Number	1 - 65535	Advances by one each time the engine is started.
Month	Month	1 - 12	
Day	Day	1 - 31	
Time Hour	Hour	24 Hour Clock	These values are stored when the load is dumped.
Time Minute	Minute	1 - 59	
Payload	Metric tons Short tons	0 - 6553.5	
Travel Time When Empty	Minute	0 - 6553.5	
Travel Distance When Empty	Miles/Km	0 - 25.5	
Maximum Travel Speed When Empty	Mph/Kmh	0 - 99	
Average Travel Speed When Empty	Mph/Kmh	0 - 99	
Time Stopped When Empty	Minute	0 - 6553.5	
Time Stopped During Loading	Minute	0 - 6553.5	
Travel Time When Loaded	Minute	0 - 6553.5	
Travel Distance When Loaded	Miles/Km	0 - 25.5	
Maximum Travel Speed When Loaded	Mph/Kmh	0 - 99	
Average Travel Speed When Loaded	Mph/Kmh	0 - 99	
Time Stopped When Loaded	Minute	0 - 6553.5	
Dumping Time	Minute	0 - 6553.5	
Speed Limit	Mph/Kmh	0 - 99	
Warnings For Each Cycle	The fault codes that occur during each cycle		

**Engine ON/OFF Data**

When the engine is started or stopped, the following data is recorded.

ITEM	UNIT	RANGE	REMARKS
Engine Operation Number	Number	1 - 65535	Advances by one each time the engine is started.
Last Two Digits Of The Year	Year	0 - 99	Indicates when the engine was started.
Month	Month	1 - 12	
Day	Day	1 - 31	
Time Hour	Hour	24 Hour Clock	
Time Minute	Minute	0 - 59	
Last Two Digits Of The Year	Year	0 - 99	Indicates when the engine was shut off.
Month	Month	1 - 12	
Day	Day	1 - 31	
Time Hour	Hour	24 Hour Clock	
Time Minute	Minute	0 - 59	
Total Payload	Metric tons Short tons	0 - 999900.0	Total payload from the time when the engine was started until the time the engine was shut off.
Total Number Of Cycles	Number	0 - 9999	Totals for the time that the engine was running.

**Fault Codes and Warning Data**

ITEM	UNIT	RANGE	REMARKS
Error Code	Displayed by a combination of letters and numbers representing a specific error code.		
Engine Operation Number At Time Of Occurrence	Number	1 - 65535	Every time the engine is started the number advances by one.
Number Of Times Of Occurrence Since The Engine Was Switched ON	Number	1 - 255	
Last Two Digits Of Year	Year	0 - 99	
Month	Month	1 - 12	
Day	Day	1 - 31	
Time Hour	Hour	24 Hour Clock	
Time Minute	Minute	0 - 59	

**Engine Operation**

ITEM	UNIT	RANGE	REMARKS
Number when Canceled	Number	1 - 65535	Every time the engine is started the number advances by one.
Last Two Digits Of Year	Year	0 - 99	
Month	Month	1 - 12	
Day	Day	1 - 31	
Time Hour	Hour	24 Hour Clock	
Time Minute	Minute	0 - 59	
<i>NOTE: If the engine operation number is a 0, this indicates that the problem occurred or was canceled (depends on the operation that was performed) when the key switch was in the ON position and the engine was not running.</i>			

**Total Payload and Total Number of Cycles**

The total payload and overall number of cycles can be displayed using the forced display operation. Both values start from a zero point whenever the memory has been cleared. The payload total is automatically displayed when the load is dumped.

ITEM	UNIT	RANGE	REMARKS
Total Payload	Metric Tons Short Tons	0 - 999900.0	The total payload since the unit was cleared.
Total Number Of Cycles	Digital Number	0 - 9999	The number of cycles since the unit was cleared.
Last Two Digits Of Year	Year	0 - 99	Date and time the unit was cleared.
Month	Month	1 - 12	
Day	Day	1 - 31	
Time Hour	Hour	24 Hour Clock	
Time Minute	Minute	0 - 59	

**Other Data**

ITEM	UNIT	RANGE	REMARKS
Set Up Data That The Operator Can Check	Speed Limit	Km/MPH	
	Option Code	Digital Number	Communication Mode
Calibration Data	Year	Year	Date and time when calibrated.
	Month	Month	
	Day	Day	
	Hour	Hour	
	Minute	Minute	

## OPERATOR FUNCTIONS

### Using the Operator Load Counter

The payload meter makes available to the operator a total load counter and haul cycle counter. This allows each operator to track the tons hauled during their shift. The total is displayed in hundreds of tons. For example, if 223 is displayed, this means that 22,300 tons have been hauled since the last time the cycle counter was cleared.

This memory location is separate from the main payload data storage. This memory is not cleared when the Data All Clear Operation is performed. Clearing this memory does not affect the main payload data storage.

### Viewing the Operator Load Counter

1. Press the TOTAL/SFT switch once.

If there is a fault code present at this time:

2. The error code for that problem will be displayed. This will be a flashing display.
3. Press the TOTAL/SFT switch again. If additional faults or warnings exist, that fault code will be displayed as a flashing code.
4. Repeat step #3 until no fault codes are displayed. ":" will show when no additional faults exist. The display will then show total tons hauled since the last time the counter was cleared. The total is displayed in hundreds of tons.
5. Press the TOTAL/SFT switch again. The number displayed is the number of haul cycles since the last time the cycle counter was cleared.
6. Press the TOTAL/SFT switch again. ":" is displayed for 2 seconds before the display returns to normal operations.

### Clearing the Operator Load Counter

1. Press the TOTAL/SFT switch once. The number displayed is the total tons hauled since the last time the counter was cleared. The total is displayed in hundreds of tons.
2. Press and hold the CAL/CLR switch until the display flashes.
3. Press the CAL/CLR switch until "0000" is displayed. After 2 seconds the meter will return to normal operation.

Clearing this memory does not affect the main payload data storage.

### Dimming the Lights on the Display

There are a total of 10 brightness levels on the PLM II™ display.

From the normal operation display:

1. Press the LIGHT/INC switch. The lighting will become one level dimmer. This will continue until the lighting has reached its lowest level.
2. After reaching the lowest level, the display will return to the brightest setting.

If the switch is held in the depressed position, the brightness will change continuously.

## INITIAL SETUP OF PAYLOAD METER

There are several things that must be checked and programmed when a payload meter is first installed.

1. Check the switch settings on the side of the meter.
2. Check the Operator Check Mode settings
3. Check the Service Check Mode settings
4. Calibrate the clean truck.

The next few pages show the steps required to perform these checks. Only after all of these steps have been performed can the payload meter be released for service.

### Switch Settings

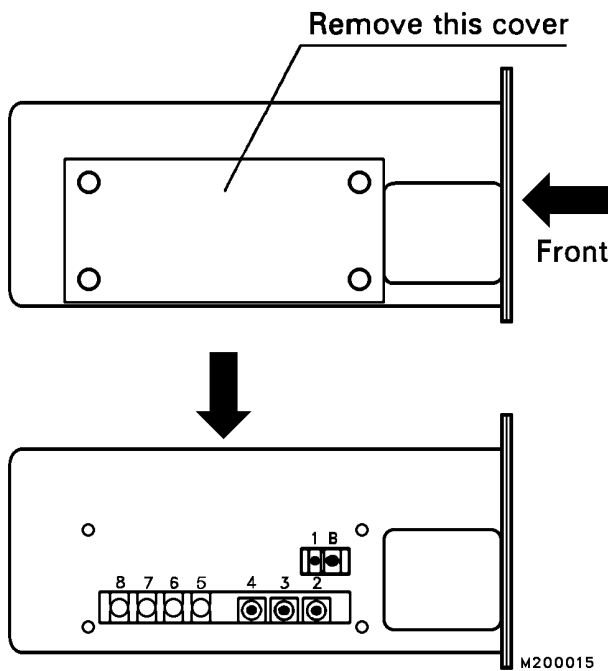

FIGURE 60-6.

There are nine switches located behind the panel on the left side of the payload meter. Figure 60-6 shows the switch numbers. The following switch positions should be confirmed before the meter is installed.

\* Set switch 4 for the appropriate model.

Switch	Position
1	<b>Initial Setup should be set to 1.00</b> - Gain Clockwise(-20%) CCW (+20%) Refer to "Gain Factor" for adjust guidelines
B	<b>Do not Adjust</b> - Buzzer Volume
2	7 - Speed Regulation 0=107%, 7=100%, F=92% The 930-2 should be set to '6'.
3	7 - Distance Regulation 0=107%, 7=100%, F=92% <b>The 930-2 should be set to '6'.</b>
4	<b>4</b> - 685E
	<b>5</b> - 630E
	<b>B</b> - 730E
	<b>C</b> - 930E
	<b>D</b> - 530M
	<b>E</b> - 330M
	<b>F</b> - 830E
5	<b>DOWN</b> - Memory function (DOWN = Enable, UP=Disable)
6	<b>DOWN</b> - Inclinator Use (DOWN = Enable, UP=Disable)
7	<b>DOWN</b> = Short Tons, <b>UP</b> = Metric Tons
8	UP





## ⚠ IMPORTANT ⚠

*930E-2 trucks are equipped with 53/80R63 series tires and require small changes to the switch settings of the PLM II™. The tires have a larger rolling radius than the PLM II™ assumes. This causes the PLM II™ to underestimate distances by 1%. The Speed Regulation and Distance Regulation switches should be switched to position 6. This is contrary to what the label may say. Additionally, the payload gain on 930E-2 trucks also needs to be adjusted. The front suspensions are larger than the original 930E suspension, and therefore, data programmed into the payload meter is not completely accurate. The gain must be increased by 1%. There are two methods for changing this gain; changing the UP factor using the buttons on the front panel, or using the gain adjustment potentiometer on the side of the meter. The preferred method is using the potentiometer. Refer to "Adjusting the Gain".*



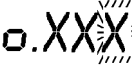

**Checking the Operator Check Mode**

The Operator Check Mode is used to check and change several settings. These should be checked before the payload meter is put into service.

1. Press and hold the MODE switch. The display will show: 
2. Press the MODE switch once. The display will show: Refer to "Data All Clear" to clear the haul cycle data. 
3. Press the MODE switch once. The display will show: Refer to "Display of Fault Codes" for viewing fault codes. 
4. Press the MODE switch once. The display will show: This is the truck ID number. Refer to "Setting The Machine ID" to change Machine ID. 
5. Press the MODE switch once. The display will show. 

Refer to "Setting The Operator ID" to change operator.
6. Press the MODE switch once. The display will show: 

"SP:62" should be displayed. The speed limit should be set to 62 to avoid unnecessary faults and warnings. Refer to "Setting The Speed Limit" to make adjustments.
7. Press the MODE switch once. The display will show: 



Refer to "Setting The Option Code" to change the option.
8. Press the MODE switch once. The current time should be displayed with the minutes flashing. Refer to "Setting The Time And Date" to change the time and date. 
9. Push the MODE switch to return to normal operation.

**Checking the Service Check Mode**





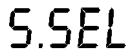
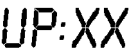

**Refer to page 24 for additional information on UP Factor and PL Mode prior to setting these values.**

**Setting "UP:XX"**

1. Press and hold the LIGHT/INC and MODE switches. The display will show: 
2. Press and hold the LIGHT/INC and TOTAL/SFT switches. The display will show: 
3. Press the CAL/CLR switch once. The display will show: 
4. Press the LIGHT/INC switch until "XX" is set to the desired gain ( $\pm 9\%$ ).
5. Press MODE. The display will show: 
6. Press MODE and the meter will return to normal operation.

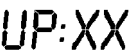
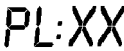
**Setting "PL:00"**

1. Press and hold the LIGHT/INC and MODE switches. The display will show: 
2. Press and hold the LIGHT/INC and TOTAL/SFT switches. The display will show: 
3. Press the CAL/CLR switch once. The display will show: 
4. Press the CAL/CLR switch once. The display will show: 
5. Press the LIGHT/INC switch until "PL:00" is displayed. **ONLY PL:00 "PL:00" IS RECOMMENDED.** 
6. Press the MODE switch. The display will show: 
7. Press MODE and the meter will return to normal operation.

### Checking the $G_t$ setting:

Refer to "Checking the Gain" and "Adjusting the Gain" for display and adjustment information.

### Checking the Inclinometer Settings

Refer to "Viewing Payload Calculation Inputs" for instructions on displaying truck pitch angle. With an empty truck on level ground and suspensions properly charged, the display should indicate  $0.0 \pm 1.0$ . Remember, this is not a live display. After adjustment, Service Check Mode must be entered again to obtain a new reading.

An alternative method is to use a personal computer running the Komatsu Payload Download Program for Microsoft Windows. The "Monitor Pressures" section of the program displays live inclinometer data. The inclinometer can be loosened and adjusted until the live display shows  $0.0 \pm 1.0$  degrees with an empty truck on level ground, and the suspensions properly charged.

Another method is to use a voltmeter to read the voltage output of the inclinometer. With an empty truck on level ground, and the suspensions properly charged, the output voltage should be  $2.6 \pm 0.1$  volts.

### Calibrating a Truck

This procedure causes the PLM II™ to calculate a new empty 'tare' (calibration) weight (refer to "Viewing Payload Calculation Inputs) for use with all subsequent payload estimates. Before calibrating, confirm the truck nose up produces a positive incline.

The payload meter should be calibrated whenever one of the following occurs:

1. When a new payload meter is installed.
2. When a suspension sensor has been changed.
3. Whenever the suspensions have been serviced or the Nitrogen levels have changed.
4. Whenever any major change to the truck has been performed that would change the empty vehicle weight.
5. Once a month thereafter.

To calibrate the payload meter:

1. With the engine running and the truck stopped, press and hold the CAL/CLR switch until "CAL" is flashing on the display.
2. Drive the truck until the speed is approximately 6-10 MPH (10-15 Km/H)
3. Press the CAL/CLR switch once.
4. Drive until the display switches back to the time of day. This will take up to 30 seconds.



**>Carry out this operation on flat level ground.**

**>Travel in a straight line.**

**>Maintain a steady speed, 6-10 MPH (10-15 Km/H)**

5. The payload meter is now calibrated and ready for normal operation.

**DISPLAYS AT START-UP****POWER ON:**

All external display lamps (Figure 60-2) will come on and stay on for approximately 27 seconds during the "Power-up Process".

The "Power-up Process" will display the PLM II™ settings. Each display will occur for approximately 3 seconds:

1. The display will show:

88:88

In addition, a buzzer will sound and the following lamps will light for 3 seconds:

- Reception Pilot Lamp (2, Figure 60-1)
- Transmission Pilot Lamp (3, Figure 60-1)
- Memory Card Pilot Lamp (4, Figure 60-1)

2. The display will show:

CO:XX

The "xx" indicates the Truck Model. Refer to "Initial Setup of Payload Meter" for code definitions.

3. The display will show:

Cd:--  
Cd:00

This display indicates the status of the Memory Card where:

"Cd : - -" indicates Card Not Used, and

"Cd : 00" indicates Card Is Used.

4. The display will show:

CL:--  
CL:00

This display indicates the status of the Inclinometer for the PLM II™, where

"CL : - -" indicates Inclinometer Not Used, and  
"CL : 00" indicates Inclinometer Is Used.

5. The display will show:

US:--  
US:00

This display indicates method of measurement where:

"US : - -" indicates METRIC Tons.

"US : 00" indicates U.S. Tons.

6. The display will show:

SU:--

This function is not used.

SU:00

"SU : - -" indicates Switch 8 is up.

"SU : 00" indicates Switch 8 is down.

7. The display will show:

d.XXX

This display indicates the Machine ID code where "xxx" indicates a value between 0 and 200.

8. The display will show:

o.XXX

This display indicates the Operator ID code where "xxx" indicates a value between 0 and 200.

9. The display will show:

SP:XX

This display indicates the Speed Limit setting where "xx" indicates a value between 0 and 99 km/h.

10. The display will show:

OP:XX

This display indicates the Option code setting.

Refer to "Operator Check Mode, Setting the Option Code" and to "Method of Operation" for more information on this function.

**Normal Operation**

If the truck engine is started before the preceding "Power-up Process" is completed, the display will shift to normal operation.

If the engine is running when the payload meter starts up, only "o:XXX" and "d:XXX" will display before switching to normal operations.





## SETUP AND MAINTENANCE

### Speed Limit





A warning can be displayed if the machine exceeds a preset speed.

The available range is: 10 - 99 km/h (6 - 62 mph). It is recommended to set the speed limit to 99 km/h (62 mph).

### Setting The Speed Limit

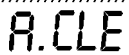
1. Press and hold the MODE switch until "Cd:dP" is flashing. 
2. Press the MODE switch once. The display will show: 
3. Press the MODE switch once. The display will show: 
4. Press the MODE switch repeatedly until "SP:XX" is displayed. 
5. Press the LIGHT/INC switch to change the "unit digit" to the desired number.
6. Press the TOTAL/SFT switch and the display will then indicate: 
7. Press the LIGHT/INC switch to change the "tens digit" to the desired number.
8. Press MODE switch to return to normal operation.

### Setting the Option Code





1. Press and hold the MODE switch until "Cd:dP" is displayed. 
2. Press the MODE switch once. The display will show: 
3. Press the MODE switch once. The display will show: 
4. Press the MODE switch repeatedly until "OP:XX" is displayed. 
5. Press the LIGHT/INC switch to change the "unit digit" to the desired number.
6. Press the TOTAL/SFT switch and the display will then indicate: 
7. Press the LIGHT/INC switch to change the "tens digit" to the desired number.
8. Press the MODE switch to return to normal operation.
9. The Option Code selects the PLM II™ communication mode as follows:

Option Code	COMMUNICATION MODE
0	Stand Alone
10	PMC Mode (530M/HD1500 only)
12	Modular Mining Mode, Scoreboard and User Data Communication Mode



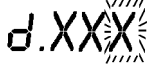

### NOTES:

1. The Option Code is set to "0" for trucks not equipped with Modular Mining System (MMS) (Except 530M/HD1500).
2. The 530M/HD1500 with Powertrain Management Control (PMC) system uses "10" as the setting for the Option Code.
3. For trucks with Modular Mining System (MMS) or Scoreboard, the Option Code is "12".



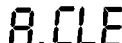





**Setting The Machine I.D. Code**

1. Press and hold the MODE switch until "Cd:dP" is displayed. 
2. Press the MODE switch once. The display will show: 
3. Press the MODE switch once. The display will show: 
4. Press the MODE switch once. "d.XXX" is displayed. 
5. Press the LIGHT/INC switch to change the last digit to the desired number.
6. Press the TOTAL/SFT switch and the display will show: 
7. Press the LIGHT/INC switch to change the middle digit to the desired number.
8. Press the TOTAL/SFT switch and the display will show: 
9. Press the LIGHT/INC switch to change the first digit to the desired number.
10. Press the MODE switch to return to normal operation.

**Setting The Operator I.D. Code**

1. Press and hold the MODE switch until "Cd:dP" is displayed. 
2. Press the MODE switch once. The display will show: 
3. Press the MODE switch once. The display will show: 
4. Press the MODE switch repeatedly until "o.XXX" is displayed. 
5. Press the LIGHT/INC switch to change the last digit to the desired number.
6. Press the TOTAL/SFT switch and the display will then indicate: 
7. Press the LIGHT/INC switch to change the middle digit to the desired number.
8. Press the TOTAL/SFT switch and the display will show: 
9. Press the LIGHT/INC switch to change the first digit to the desired number.
10. Press the MODE switch to return to normal operation.

**Setting The Time and Date**

1. Press and hold the MODE switch until "Cd:dP" is displayed. 
2. Press the MODE switch once. The display will show: 
3. Press the MODE switch once. The display will show: 
4. Press the MODE switch repeatedly until "XX:XX" is displayed. 
5. Press the LIGHT/INC switch to change the minutes.
6. Press the TOTAL/SFT switch and the display will then indicate: 
7. Press the LIGHT/INC switch to change the hours. The clock is a 24 hour clock.
8. Press the TOTAL/SFT switch and the display will then indicate: 
9. Press the LIGHT/INC switch to change the day.
10. Press the TOTAL/SFT switch and the display will then indicate: 
11. Press the LIGHT/INC switch to change the month.
12. Press the TOTAL/SFT switch and the display will then indicate: 
13. Press the LIGHT/INC switch to change the year.
14. Press MODE switch to return to normal operation.

## DOWNLOAD OF INFORMATION

Payload information and fault codes recorded should be downloaded to a personal computer on a regular basis. The software required is available under part number AK4635. Detailed instructions for installing the software and downloading the data is provided with AK4635 PLM II™ download software.

### Data All Clear

This function will erase all of the cycle data, engine ON/OFF data, and fault/warning data. Total payload and the overall number of cycles will not be cleared.

**IMPORTANT - Before clearing the data, download the data to a personal computer.**

To begin, the shift lever should be in the "N" position, the brake lock set, the hoist control lever should be in the "FLOAT" position and the body in the down position.

1. Press and hold the MODE switch until "Cd:dP" is displayed.
2. Press the MODE switch once.  
The display will show:
3. Press and hold the CAL/CLR switch until "A.CLE" is flashing.
4. Press the CAL/CLR switch again and the memory will be cleared. The meter will then return to normal operation.



This does not clear the Operator Load Counter.

## DISPLAY OF FAULT CODES

1. Press and hold the MODE switch until "Cd:dP" is displayed.
2. Press the MODE switch once.  
The display will show:
3. Press the MODE switch once.  
The display will show:
4. Press the TOTAL/SFT switch.



If there are no faults or warnings, the display will show for 6 seconds.

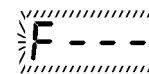

If there are current faults or warnings, the codes will be displayed in order of their priority, the highest priority first. Each code will flash for **6 seconds**.

5. After the current codes have been displayed, past history codes that have been reset will be displayed. Each code will flash for **3 seconds**.

If there are no history codes or after all history codes have been shown, the display will show for 3 seconds:

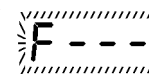

The system will then proceed to the following displays: Refer to Page 25 for details.

- Condition of the shift selector on mechanical trucks or brake lock on electric trucks.  
The panel will display: "C1:XX" for 3 seconds, then indicate:  
Mechanical trucks  
"C1:00" Shift selector is in "N".  
"C1:-" Shift selector is not in "N".  
Electric trucks  
"C1:00" Brake lock is on.  
"C1:-" Brake lock is off.
- Condition of the Body Up Switch signal.  
The panel will display: "C2:XX" for 3 seconds, then indicate:  
"C2:00" Body up switch is in up position.  
"C2:-" Body up switch is in down position.

- Condition of the Engine Oil Pressure signal.  
The panel will display ":C3:XX" for 3 seconds, then indicate:  
"C3:oo" Engine is running.  
"C3:- -" Engine is not running.
  - Condition of Alternator 'R' terminal signal.  
The panel will display "C4:XX" for 3 seconds, then indicate:  
"C4:oo" Engine is running.  
"C4:- -" Engine is not running.
  - Condition of the Spare Analog Input 1 signal.  
The panel will display "C5:XX" for 3 seconds with XX: as an input signal (V).
  - Condition of the Spare Analog Input 2 signal.  
The panel will display "C6:XX" for 3 seconds with XX: as an input signal (V).
  - Condition of the Spare Digital Input 1 signal.  
The panel will display "C7:XX" for 3 seconds, then:  
"C7:oo" High.  
"C7:- -" Low.
  - Condition of the Spare Digital Input 2 signal.  
The panel will display "C8:XX" for 3 seconds, then:  
"C8:oo" High.  
"C8:- -" Low.
6. Press the TOTAL/SFT switch to view faults again or press the MODE switch to return to normal operation.

FAULT CODES			
FAULT	CAUSE	CORRECTIVE ACTION	DECK LIGHTS PRIORITY
b-FL Steady	Brake Lock On and Body is UP and not dumping.		Flash 1
b-FL Flashing	Brake Lock Off and Body is UP.		1
Cd Flashing	Remove memory card during download.		2
F-09	Internal battery voltage below 2.7 volts.	Open controller check internal battery and connections. Check voltage using Service Check Mode.	3
L.FUL Flashing	Less than 300 haul cycle data sets memory capacity remain.		4
L.FUL Steady	2900 Haul cycles have been stored and the oldest data is being overwritten.		4
E.FUL Flashing	Less than 10 engine start data sets memory capacity remain.		4
E.FUL Steady	115 engine start data sets have been stored and the oldest date is being overwritten.	Down load data to PC and clear memory. See Operator Check Mode; Clearing the haul cycle data memory.	4
F.FUL Flashing	Less than 10 fault data sets memory capacity remain.		4
F.FUL Steady	230 fault data sets have been stored and the oldest date is being overwritten.		4
H.FUL Flashing	Haul cycle counter or payload totalizer are near capacity.		
H.FUL Steady	Haul cycle counter exceeded 9999 or payload totalizer exceeded 999900.	Press TOTAL/SFT to display totals, then press CAL/CLR for at least 2 seconds, then press CAL/CLR again for at least 2 seconds.	4
F-18	Battery alternator R terminal is shorted or disconnected. The input to the PLM is less than 2V.	Trouble shoot wiring. Pin CN1-9, circuit # 21D.	5
F-20 Flashing	Sensor power is less than 15V or over 20V (18V normal).	Trouble shoot wiring, possible short.	Flash 6
F-21 Flashing	Left front pressure signal is less than 1V (1 - 5V normal).		Flash 7
F-22 Flashing	Right front pressure signal is less than 1V (1 - 5V normal).	Trouble shoot wiring, likely an open circuit.	Flash 8
F-23 Flashing	Left rear pressure signal is less than 1V (1 - 5V normal).		Flash 9
F-24 Flashing	Right rear pressure signal is less than 1V (1 - 5V normal).		Flash 10

M200051



FAULT CODES				
FAULT	CAUSE	CORRECTIVE ACTION	DECK LIGHTS	PRIORITY
F-25 Flashing	Left front pressure signal is greater than 5V (1 - 5V normal).	Trouble shoot wiring, likely sensor wires are shorted together.	Flash	11
F-26 Flashing	Right front pressure signal is greater than 5V (1 - 5V normal).		Flash	12
F-27 Flashing	Left rear pressure signal is greater than 5V (1 - 5V normal).		Flash	13
F-28 Flashing	Right rear pressure signal is greater than 5V (1 - 5V normal).		Flash	14
F-31 Flashing	Inclinometer input less than 1.57V (more than + 10 degrees, nose up).	Trouble shoot wiring, likely an open circuit (Inclinometer output is 2.6V when horizontal, calibration: -103mV/degree)	Flash	15
F-32 Flashing	Inclinometer input greater than 3.63V (more than - 10 degrees, nose down).	Trouble shoot wiring, likely sensor wires are shorted together.	Flash	16
F.CAL	No calibration has been performed or cal data has been cleared.	Perform calibration.	Flash	17
F-41 Flashing	Light relay #1 driver short circuit.	Trouble shoot wiring, relay coil likely shorted.		18
F-42 Flashing	Light relay #2 driver short circuit.			19
F-43 Flashing	Light relay #3 driver short circuit.			20
F-44 Flashing	Light relay #4 driver short circuit.			21
F-45 Flashing	Light relay #5 driver short circuit.			22
L.bad Flashing	Payload measured while chassis is pitching.	Data ignored, error will clear for next load.		23
SP:SP Flashing	Speed limit setting is being exceeded.	Set the speed limit, using Operator Check Mode, to 62 mph or 99Kml/h depending on the position of the unit selection switch (switch #7 behind the left side panel).		24
F-71 F-73 F-80 F-81 F-91 F-92 F-93 F-94 F-95 F-96 F-97 F-98 All Flashing	Communications port error.	Check communication wiring (RS-232) to Modular Mining Hub or to Scoreboard. Check OP setting.		25

### Monitoring Input Signals

This procedure can be used to monitor the current input signals to the payload meter.

1. Press and hold the LIGHT/INC and MODE switches until "CHEC" is flashing.
2. Press and hold the CAL/CLR and TOTAL/SFT switches until "S.CHE" is flashing.
3. Press the CAL/CLR switch to cycle through the following information :

C1	Mechanical Trucks	C1:00 - Shift Selector in "N" C1:-- - Shift Selector not in "N"
C1	Electric Trucks	C1:00 - Brake Lock On C1:-- - Brake Lock Off
C2	Body Up	C2:00 - Body Down C2:-- - Body Up
C3	Engine Oil Pressure	C3:00 - Engine Run C3:-- - Engine Stopped
C4	Alternator R Terminal	C4:00 -Alternator Charging C4:-- - Alternator Stopped
C5	Analog 1 - Not Used	
C6	Analog 2 - Not Used	
C7	Digital 1 - Not Used	
C8	Digital 2 - Not Used	
C9	Speed	Vehicle Speed
C10	Travel Distance - under the current loaded or empty state	xx.xx Miles
C11	<u>Current Status</u> Note: Sample values are shown.	03:01 - Empty Stopped 01:02 - Empty Traveling 06:03 - Loading 02:04 - Loaded Traveling 04:05 - Loaded Stopped 05:06 - Dumping
C12a*	Time Empty Travel	S1:xx - Minutes*10
C12b	Time Empty Stopped	S2:xx - Minutes*10
C12c	Time Loaded Travel	S3:xx - Minutes*10
C12d	Time Loaded Stop	S4:xx - Minutes*10

\* After 9.9 minutes, "S1:--" will be displayed.

4. Press the MODE switch once and "CHEC" will flash.
5. Press the MODE switch once and the meter will return to normal operation.

### Service Check Mode

1. Press and hold the LIGHT/INC and MODE switches until "CHEC" is flashing.
2. Press and hold the LIGHT/INC switch until "ALL0" is flashing. "A.FUL" may also be displayed.
3. Press the LIGHT/INC switch to cycle through the following data. The sequence repeats.

Item and Description	Units
1. Current Time	Hours: Minutes
2. Pressure Front Left	psi
3. Pressure Front Right	psi
4. Pressure Rear Left	psi
5. Pressure Rear Right	psi
6. Front Weight	Tons
7. Rear Weight	Tons
8. Degree of Incline	±° Nose Up Positive
9. Incline Factor - Front Axle	
10. Incline Factor - Rear Axle	
11. Link Factor - Front Axle	
12. Link Factor - Rear Axle	
13. Calibration Weight	Tons
14. G <sub>t</sub> Gain	
15. Current Load	Tons
16. Backup Battery Voltage	Volts

4. Press MODE once and "CHEC" will flash on the display.
5. Press MODE once and the meter will return to normal operation.

## UP FACTOR - PAYLOAD CALCULATION GAIN

### Description of UP Factor

The payload calculation gain, or UP factor is multiplied to the actual calculated load. From the example shown in Figure 60-4, the calculated load is 143.8 tons. If the UP factor is set to +5% the displayed load will be  $143.8 \times 1.05 = 151$  tons. This factor can be used to minimize the effects of systematic error for a particular truck. The UP factor is not applied uniformly to all load calculations. There are three operating modes for the payload meter and the UP factor is applied differently to each mode. Therefore, it is recommended that this percentage be set to 0. There are significant differences in final calculated load that can be introduced by adjusting this gain.

## ⚠ IMPORTANT ⚠

*Payload meters sent from the factory are typically set to "UP: 5" indicating a +5% gain in final load. This should be checked on all new meters and changed to "UP: 0".*

## PL MODE -LOAD CALCULATION TIMING

### Load Calculation Timing

The PL mode controls when the payload meter takes a sample of the data and calculates the load. There are three modes available. There are two sets of data that are affected by the PL mode setting.

- Modular Mining Transmission
- Memory Storage

The PL mode setting can have a significant impact on the perceived accuracy of the payload meter.

PL:00 is the only recommended setting.

## ⚠ IMPORTANT ⚠

*Use of settings other than PL:00 is NOT recommended.*

Careful consideration must be given to the use of PL:01 and PL:10. These modes divide the data transmitted by Modular Mining and the data stored in the payload meter's memory. Additionally, each mode handles the UP factor differently and can calculate different loads for the same haul cycle. For these reasons **it is recommended that the payload meter be set to use PL:00 in all cases.**

### PL:00

**Modular Mining Transmission** - The data is captured at the last transition from 0 to 1 MPH prior to traveling 160 meters from the shovel. The captured data is transmitted when the truck travels 160m from the shovel. This load calculation **will use** the UP factor percentage.

**Memory Storage** - Same as above, the data is captured at the last transition from 0 to 1 MPH prior to traveling 160 meters from the shovel. The captured data is stored into memory when the body rises at the dump. This load calculation **will use** the UP factor percentage.

### PL:01

**Modular Mining Transmission** - The data is captured at the last transition from 0 to 1 MPH prior to traveling 160 meters from the shovel. The captured data is transmitted when the truck travels 160m from the shovel. This load calculation **will use** the UP factor percentage.

**Memory Storage** - The data is captured and stored when the body rises from the frame. This calculation **will not use** the UP factor percentage.

### PL:10

**Modular Mining Transmission** - The data is captured and transmitted when the truck travels 160 meters from the shovel. This calculation **will not use** the UP factor percentage.

**Memory Storage** - The data is captured and stored when the body rises from the frame. This calculation **will not use** the UP factor percentage.

## FINAL GEAR RATIO SELECTION

For an 830E truck, the proper gear ratio has to be selected.

1. Press and hold the MODE and LIGHT/INC switches until "CHEC" **CHEC** is displayed.
2. Press and hold the TOTAL/SFT and LIGHT/INC switches until "S.SEL" is displayed. **S.SEL**
3. Press the CAL/CLR switch repeatedly until "A.XX" is displayed, where "XX" is one of the following: **A.XX**

"XX"	Gear Ratio	Remarks
00	31.875	Original
01	36.400	High Traction
02	28.125	Standard
03	26.625	High Speed

*NOTE: The Payload Meter is originally set to "00".*

4. Press the TOTAL/SFT switch and "XX" will flash.
5. Press the LIGHT/INC switch to select the desired gear ratio.
6. Press the MODE switch and "CHEC" will be displayed. **CHEC**
7. Press the MODE switch and the meter will return to normal operation.

## BATTERY REPLACEMENT PROCEDURE

### ERROR CODE, F-09, DISPLAYED

#### Replacing the Battery

The payload meter has an internal battery used to protect the memory from being erased when the key switch is turned to the OFF position. Battery life is approximately 2 years. The capacity of the battery is monitored by the payload meter. When the voltage of the memory battery drops, error code, F-09, will be displayed.

When the F-09 error code appears, download the data within 48 hours; otherwise, the data may be lost. The haul cycle data may not be recorded properly while F-09 is displayed.

At this time it will be necessary to replace the battery. This should be performed when the truck is in an unloaded condition. The data stored in the payload meter should be downloaded to a personal computer or carry out the memory card dump operation. If this is not done, when the battery is disconnected all data will be lost.

All that is required is a phillips-head screwdriver and a new battery (P/N 581-86-55710)

1. With the keyswitch in the ON position, download the data stored in the payload memory, or perform the memory card dump operation.
2. Turn the keyswitch to the OFF position.
3. Remove the four mounting screws holding the payload meter in position and then pull the payload meter out, away from the instrument panel (Figure 60-7).

**NOTICE** - Use care not to let dirt, metal or spare parts to drop inside the controller at any time.

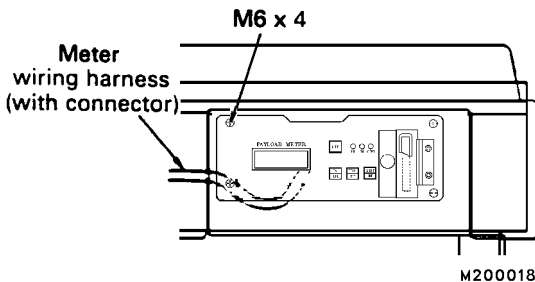

FIGURE 60-7. REMOVING PAYLOAD METER

4. Remove the electrical connector. Remove the screws on the top surface and the rear face. Remove the cover (Figure 60-8). This will expose the battery, its wires, and the connector.

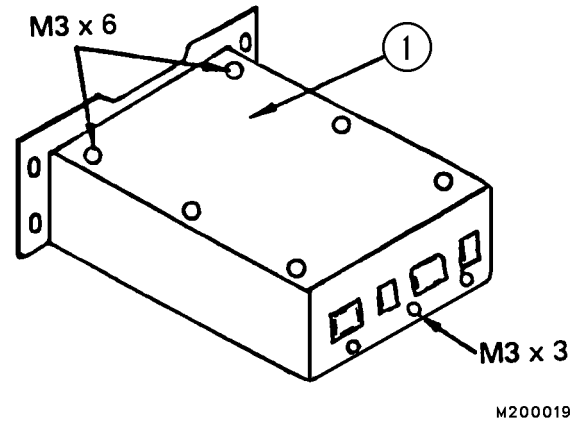

FIGURE 60-8. ACCESS TO BATTERY

5. Grasp the wires coming from the battery and pull outward. By pulling perpendicular from the board, it will disconnect the connector from the board and pull the battery out of its holder simultaneously (Figure 60-9).

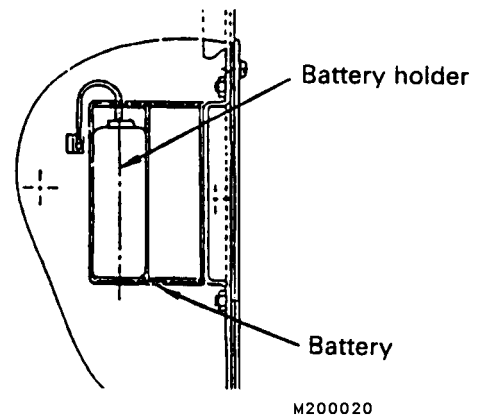

FIGURE 60-9. BATTERY INSTALLATION

6. Insert the connector of the new battery directly into the connector on the board (Figure 60-10). Place the battery in the battery holder, and pass the wiring through the notch. When doing this, insert the wiring into the bottom of the holder and pass it through the notch.
7. Install the controller cover, replace the electrical connector, and install the payload meter controller back into the instrument panel.

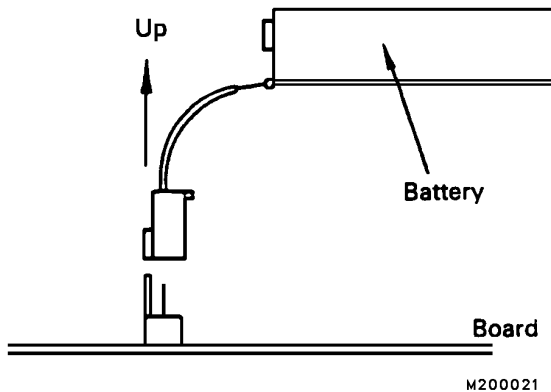

FIGURE 60-10. BATTERY CONNECTION

### After Replacing the Battery

While replacing the battery, the backup power source for the memory inside the payload meter is momentarily disconnected. This can allow unwanted data (garbage) to enter the memory and affect the meter's recognition procedures. The following will remove this unwanted data.

1. Turn the keyswitch to the ON position.

**F-CAL** may flash.

2. Using the Operator Check Mode, set the speed limit option code, time and date. (These were erased from memory when the battery was disconnected).
3. Without turning the keyswitch to the OFF position advance to the start position. With the engine running, the display:

**F-CAL** may flash.

4. Perform the calibration procedure. Refer to "Calibrating a Truck".
5. Load the truck to the rated payload, or close to it. Dump the load.
6. Move the truck to a safe area, wait at least 5 seconds after dumping the load, then shut the truck down.
7. Turn the keyswitch back to the ON position but do not start the engine.
8. Perform the Data All Clear in the Operator Check mode.

9. Forcibly clear the data for the total payload and overall number of cycles. With this operation performed, all the unwanted data inside the payload meter is cleared. Except for the calibration data, all the data recorded in the previous steps is also erased.

10. After this procedure has been performed the system is ready for normal function.

## SUSPENSION PRESSURE SENSOR

The pressure sensors are mounted on top of each suspension cylinder. The sensors produce a voltage signal from 1 - 5 volts output.

The pressure sensor is mounted to the suspension cylinder using a Schrader Valve assembly, adapter and sensor. The sensor can be replaced without releasing the pressure in the suspension by removing the sensor with the adapter.

### Removal



**Ensure the adapter and sensor are removed together from the valve assembly. Removing the complete valve assembly or just the sensor may result in the component being forced out of the suspension by the gas pressure inside.**

1. Disconnect sensor from truck wiring harness.

*Note: The Schrader valve in the valve assembly will prevent gas from escaping **when adapter and sensor are removed together**. If entire valve assembly is turned allowing nitrogen gas to escape, recharging of the suspension will be required.*

2. Hold valve (2, Figure 60-11) with wrench while removing the adapter/sensor assembly (3 & 4).
3. Remove sensor (4) from adapter (3).

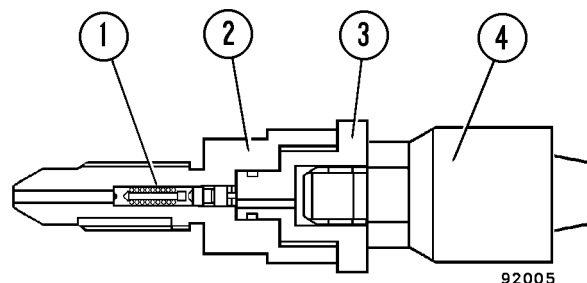

FIGURE 60-11. PRESSURE SENSOR

- |                   |            |
|-------------------|------------|
| 1. Schrader Valve | 3. Adapter |
| 2. Valve Assembly | 4. Sensor  |

**Installation**

1. Install a new O-ring onto sensor (4, Figure 60-11) and install sensor onto adapter (3). Tighten the sensor to **22-29 ft.lbs. (30-39 N.m)** torque.
2. Install a new O-ring onto adapter (3) and install complete adapter/sensor assembly onto valve (2). Hold the valve body and tighten adapter/sensor assembly to **103 ft.lbs. (176 N.m)** torque.
3. Connect the sensor wiring to the truck wiring harness. The sensors have three wires. Be sure that wires are connected correctly. (Figure 60-12)

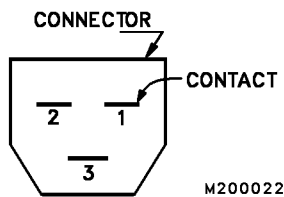

FIGURE 60-12. SENSOR SIDE CONNECTOR VIEW

Pin Number	Wire Color	Wire Function
1	Black	Ground (GND)
2	Red	+ Power
3	White	Signal

**INCLINOMETER**

As the truck is tilted fore or aft, the weight distribution between the front and rear axles changes. To compensate for this, the inclinometer measures the ground angle at which the truck rests. This data is then sent to the payload meter so it can calculate the correct payload weight. The inclinometer is located below the operator's center console (passenger seat structure).

**Removal**

1. Disconnect inclinometer wire lead from harness.
2. Remove the three capscrews, nuts and lockwashers (4, Figure 60-13) and inclinometer (3).

**Installation**

1. Install inclinometer (3, Figure 60-13) with capscrews, nuts and lockwashers (4).

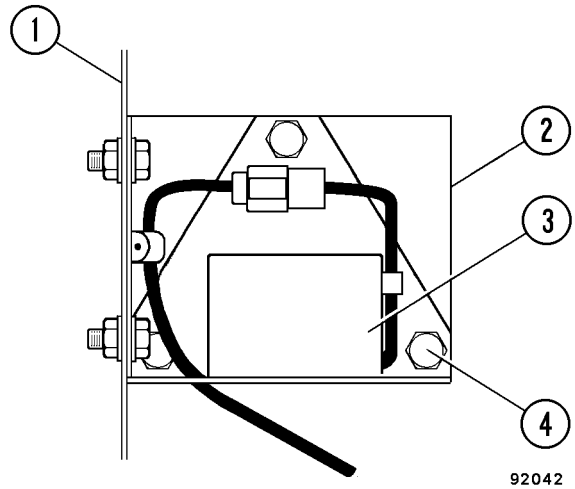

FIGURE 60-13. INCLINOMETER

- |                                    |                                 |
|------------------------------------|---------------------------------|
| 1. Operator's Center Console Frame | 3. Inclinometer                 |
| 2. Bracket                         | 4. Capscrew, Nut and Lockwasher |

2. Connect inclinometer wiring to the truck wiring harness. (Figure 60-14) Be sure that wires are connected correctly.

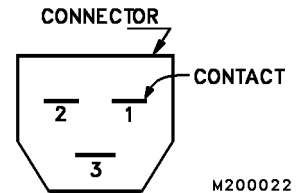

FIGURE 60-14. INCLINOMETER SIDE CONNECTOR VIEW

Pin Number	Wire Color	Wire Function
1	Black	Ground (GND)
2	Red	+ Power
3	White	Signal

**Adjustment**

1. Park the truck on a 0% grade.
2. Loosen the three inclinometer mounting capscrews (4, Figure 60-13) and rotate the inclinometer until a voltage range of  $2.6 \pm 0.1$  volts can be measured (using a volt-meter) at pins 1 and 2 of the inclinometer harness connector.
3. Tighten all capscrews (4, Figure 60-13) to standard torque, after the adjustment.

**PAYLOAD METER BACK PANEL**

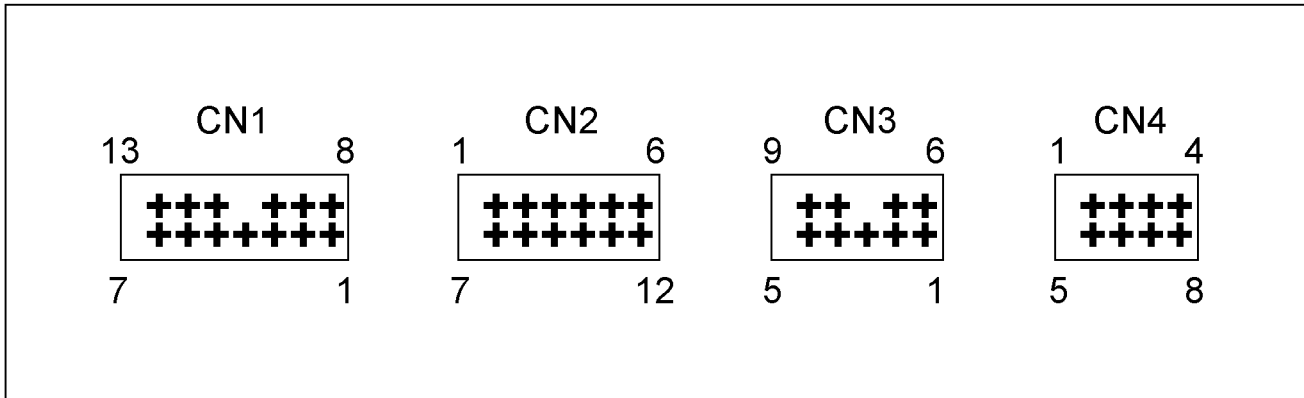



**CONNECTIONS**

CN1 - AMP MIC-MKII 13 Pins White Connector		
No.	Description	Comments
1	Power +24V (Battery)	
2	Lamp Relay 1	
3	Lamp Relay 2	
4	Lamp Relay 3	
5	Lamp Relay 4	
6	Lamp Relay 5	
7	Speed Sensor (Signal)	
8	Speed Sensor (GND)	
9	Alternator R Terminal (Charge Signal)	Running - 28VDC Off - 0VDC
10	Key Switch ACC Terminal (ACC Signal)	
11		
12		
13	GND (Power GND)	

CN3 - AMP MIC-MKII 9 Pins White (RS-232C Port)	
No.	Description
1	RTS
2	SG
3	RD
4	TX
5	CTS
6	DTR
7	DSR
8	

CN2 - AMP 040 12 Pins Black Connector		
No.	Description	Comments
1	Engine Oil Pressure Switch	Running Open Off - Closed
2	Sensor Power Out	+18V
3	Sensor GND	
4	Left Front Suspension Pressure Sensor	1-5VDC Normal
5	Right Front Suspension Pressure Sensor	1-5VDC Normal
6	Left Rear Suspension Pressure Sensor	1-5VDC Normal
7	Right Rear Suspension Pressure Sensor	1-5VDC Normal
8	Inclinometer	
9	Body Rise Signal	Body Down - Open Body Up - Gnd
10	Brake Lock Signal/Neutral Signal	Lock Off - Open Lock On - Gnd
11		
12		

CN4 - AMP 040 8 Pins Black (Optional Input, Reserved)	
No.	Description
1	Optional Input GND
2	Analog Input 1
3	Analog Input 2
4	Digital Input 1
5	Digital Input 2
6	
7	

## PAYLOAD CIRCUIT NUMBERS

Circuit Designation	Circuit Description
39F, 39F1...39F5	+18 volt sensor power supply
39FA	Pressure signal Right Rear
39FB	Pressure signal Left Rear
39FC	Pressure signal Right Front
39FD	Pressure signal Left Front
39FE	Inclinometer signal
39FG	Sensor ground
39A	PLM lamp output - green
39B	PLM lamp output - amber
39C	PLM lamp output - red
39D	PLM lamp output - unused
39E	PLM lamp output - unused
39G	+24 volt PLM power
39AA	Load light - green
39BA	Load light - amber
39CA	Load light - red
73FSL	TCI 100% load signal - 930E only
73MSL	TCI 70% load signal - 930E only
714A	Speed signal
714AT	Speed signal
63L	Body up (gnd = up, open = down)
39H	Brake lock (gnd = release, open = lock)
35L1	PLM RS232 RTS (request to send)
35L2	PLM RS232 signal ground
35L3	PLM RS232 receive
35L4	PLM RS232 transmit
35L5	PLM RS232 CTS (clear to send)
35L6	
35L7/35L4	Scoreboard 1 to scoreboard 2
35L8	PLM chan 2 TxD
35L9	PLM chan 2 RxD
21C	Engine oil pressure (gnd = off, open = run)
21D	Alternator R-Terminal (open = off, +24V = run)

## PAYLOAD METER II™ RE-INITIALIZATION PROCEDURE

This procedure is designed to reset the Payload Meter II™ to clear repeated F.CAL errors.

This procedure is necessary to fix a rare condition in the operation of the meter. Indication for this procedure is a repeated display of F.CAL on the meter despite repeated calibration. If possible, download the payload meter before performing this procedure. This procedure will erase all memory and user settings.

### **▲ IMPORTANT ▲**

***This procedure should be performed before any payload meter is returned for warranty or repair.***

Before performing this procedure, be sure that the engine inputs into the payload meter can be manipulated to indicate engine running and engine stopped. Some payload meter installations have hard-wired these inputs. These inputs must be accessible and able to produce the following input conditions:

Condition	21C Engine Oil Pressure	21D Alternator "R" Terminal
Engine Running	Open	24VDC
Engine Stopped	Ground	Open

1. Turn off all systems.
2. Turn on the Payload Meter but leave the engine off.
3. Hold MODE and LIGHT until "CHEC" flashes.
4. Hold the CAL, TOTAL and LIGHT buttons until "00:00" is displayed.
5. Press CAL for 2 seconds." 00 00" will flash and the meter will erase its memory and reset to its factory settings. This includes OP, UP, PL, P.SEL, and E.SEL settings. The meter will restart and display "F.CAL".
6. Start the engine.
7. Set the time, date, OP, PL, and UP settings. All other user settings should updated at this time.
8. Calibrate the payload meter by holding the CAL button until CAL flashes.
9. Release the brake lock (park brake for 330M/HD785), begin driving 5-8 MPH on level ground, and press CAL. CAL should display until the meter finishes its calibration.
10. Load the truck to rated load and drive through one haul cycle.
11. After dumping the load, wait at least 15 seconds and drive the truck to a safe location.
12. Stop the truck and shut down the engine.
13. Turn on the payload meter but leave the engine off.
14. Hold MODE and LIGHT until "CHEC" flashes.
15. Hold LIGHT and CAL until "A:CLE" flashes.
16. Press CAL to clear the service memory.
17. When "CHEC" is displayed, press MODE to return to normal operation.
18. Clear the haul cycle memory by holding MODE until "Cd:dP" is displayed.
19. Press MODE and "A.CLE" will be displayed.
20. Hold CAL until "A.CLE" flashed.
21. Press CAL once more to clear the haul cycle memory.
22. Clear the operator load counter by pressing the TOTAL button until ":" is displayed.
23. Hold the CAL button until the display flashes.
24. Hold the CAL button until "0000" is displayed to clear the memory.
25. The payload meter should now function normally.

---

# NOTES

**RADIO, AM / FM STEREO CASSETTE**

FIGURE 70-1. CAB RADIO

**SETTING THE TIME**

1. Turn the key switch ON.
2. Press and hold DSPL/TM SET (9) for 2 seconds. When the number display flashes, time set mode is active.
3. Press TUNE / SEEK (7 & 8) to change the hour setting.
4. Press the DSPL/TM button to switch to minutes. The minute digits will flash when in this mode.
5. Press TUNE / SEEK to change the minute setting.

After 5 seconds of inactivity has elapsed, the display will return to the default mode. The clock will now display the correct time of day.

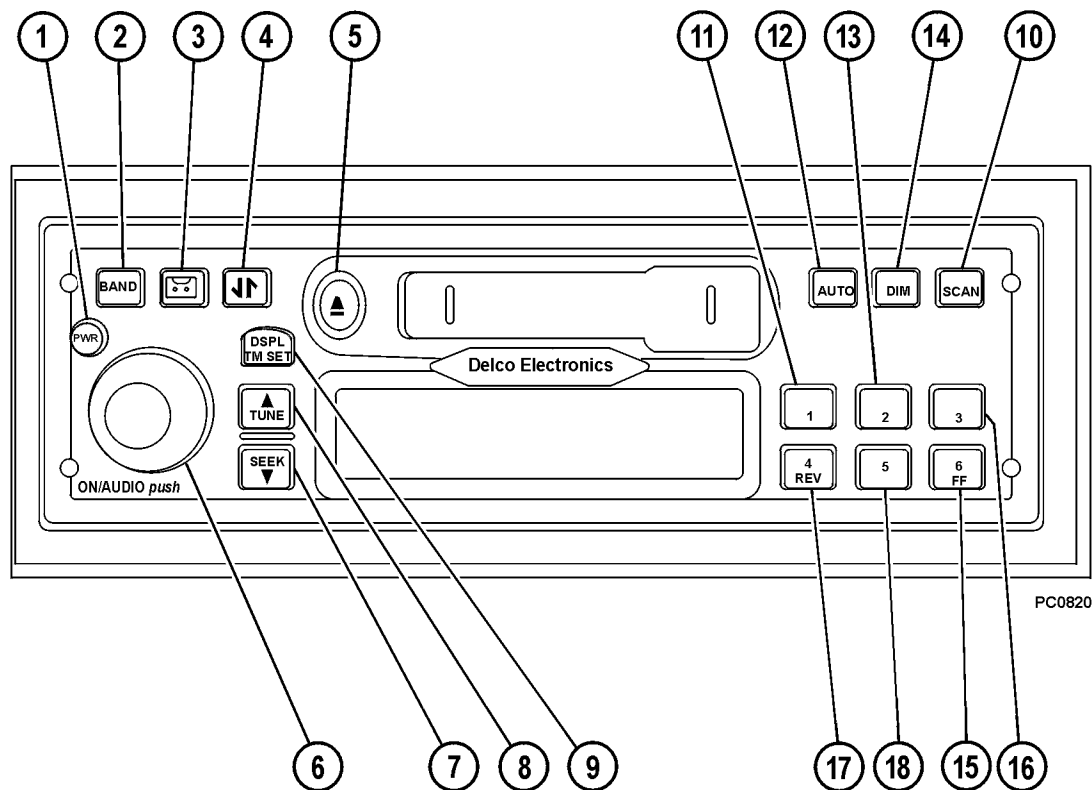
**GENERAL RECEIVER FUNCTIONS**

The receiver is equipped with two FM radio bands, FM1 and FM2. The two bands are identical, however, each one allows the operator to set 6 preset channels for a total of 12 FM presets overall.

**Turning The Power On And Off**

1. Turn the key switch to "ON".
2. Press PWR (1) to turn the receiver on and off. Pushing ON/AUDIO (6) may also be used to turn the receiver power on.

**Display**

With the receiver OFF, the clock will be displayed. Momentarily pressing DSP/TM SET (9) with the receiver on will allow the operator to toggle between displays.

- When the receiver is in AM, FM1, FM2, or WX, the display will toggle between the frequency and the clock.
- When the receiver is in the cassette mode, the display will toggle between TP SIDE 1 or TP SIDE 2, and the clock.

### Setting The Default Display

1. Press and hold DSPL/TM (9) for 2 seconds until the hour digits flash.
2. Press push-button 6/FF (15) to change the default display.

After 5 seconds of inactivity has elapsed, the selected default will display.

### Adjusting Display Brightness

1. Press and hold DIM (14) until "DIM" appears on the display.
2. Rotate ON/AUDIO knob (6) clockwise or counterclockwise until the desired brightness is obtained.

## OPERATING THE RADIO

### BAND

Press BAND (2) to switch between FM1, FM2, AM, and WX Weather (US).

### TUNE/SEEK

TUNE (7) / SEEK (8) allows you to move up or down in frequency to other stations. There are two modes of operation for finding other stations, manual tuning and seek mode. Press and hold both TUNE (8) and BAND (2) for 2 seconds to toggle between the two modes. The display will read either "MANUAL" or "SEEK" to indicate the mode the receiver is in.

### Manual Tuning

Press TUNE (8) to tune to the next higher frequency. Press SEEK (7) to tune to the next lower frequency. Holding either of the buttons for more than 0.5 seconds will activate fast tuning for increased speed.

### SEEK Mode

In seek mode, the receiver will only stop on stations that have a strong signal. To scroll through these stations, press TUNE (8) for at least 0.5 seconds to activate seek mode. The receiver will move to the next highest frequency and pause for 3 seconds. After 3 seconds, the receiver will move to the next higher frequency. This pattern will continue until the TUNE button is pressed again. Press SEEK (7) for at least 0.5 seconds to activate seek mode for the next lower frequency station. The receiver will momentarily stop on strong stations until the SEEK button is pressed again.

*NOTE: If the receiver can not find a strong enough signal after two band cycles, the seek mode will discontinue and the receiver will return to the initial station.*

### SCAN

Press SCAN button (10) to scan all stations on the current band. When a strong frequency is found, the receiver will pause on that station for about 5 seconds and then continue scanning. Scan will appear on the display along with the frequency when this mode is active. To stop scanning, press the SCAN button again.

### AUTO

AUTO (12) allows the receiver to store the 6 strongest stations onto push-buttons 1 through 6. Press AUTO until "AUTO" and "AS" appear on the display. The presets on the current band only will now be programmed with the 6 strongest frequencies. Presets on the other bands will not be changed. Pressing AUTO again will delete the stations and default to the original preset stations.

## PROGRAMMING PRESET STATIONS

Presets are stations that are stored on each of the 6 push-buttons. After a station has been programmed into one of the preset buttons, pushing the preset provides a quick return to that station. The six buttons can each store a preset channel per band.

Perform the following steps for programming presets:

1. Turn the receiver ON.
2. Select the band and the desired station.
3. Press and hold one of the six push-buttons for at least 2 seconds. During the 2 second period, receiver output will be muted and the push-button number will show on the display. When the station has been committed to memory, the audio and the preset icon will return.
4. Repeat steps 1 through 3 for the remaining available presets.

*NOTE: Six presets may be stored on AM, FM1, and FM2 for a total of 18 presets.*

## OPERATION OF THE WEATHERBAND (U.S.)

NOAA - Weather Radio is a service of the "Voice of the National Weather Service". It provides continuous broadcasts of the latest weather information directly from the National Weather Service offices. Taped weather messages are repeated every four to six minutes and are routinely revised every one to three hours, or more frequently if needed. Most of the stations operate 24 hours, daily.

The weather for the area you are in may be found on one of 7 stations. When in the Weatherband mode, the display will show the "WX" icon and "CHAN #" to indicate the channel. The channel may be adjusted through the TUNE /SEEK buttons, and may be preset as in the radio mode.

The frequency associated with each channel is as follows:

- |                |                |
|----------------|----------------|
| 1. 162.550 MHz | 5. 162.450 MHz |
| 2. 162.400 MHz | 6. 162.500 MHz |
| 3. 162.475 MHz | 7. 162.525 MHz |
| 4. 162.425 MHz |                |

The National Weather Service operates approximately 372 stations. Close to 90 percent of the nation's population is within the listening range of a NOAA Weather Radio broadcast.

## ADJUSTING THE RECEIVER SETTINGS

**VOLUME:** Rotate ON/AUDIO (6) knob clockwise to increase the volume and counter-clockwise to decrease the volume. "VOL" will be displayed along with the volume level.

**BASS:** Push and release ON/AUDIO (6) knob until "BASS" and the current bass level is displayed. Rotate the knob clockwise to increase the bass and counter-clockwise to decrease the bass.

**TREBLE:** Push and release ON/AUDIO (6) knob until "TREB" and the current treble level is displayed. Rotate the knob clockwise to increase the treble and counter-clockwise to decrease the treble.

**FADE:** Push and release ON/AUDIO (6) knob until "FADE" and the current level is displayed. Rotate the knob clockwise to move the sound to the front speakers and counter-clockwise to move the sound to the rear speakers.

**BALANCE:** Push and release ON/AUDIO (6) knob until "BAL" and the present level is displayed. Rotate the knob clockwise to move the sound to the front speakers and counter-clockwise to move the sound to the rear speakers.

**SPEAKER:** Push and release ON/AUDIO (6) knob until "SPKR" and the current setting is displayed. Rotate the ON/AUDIO knob to select 2-speaker or 4-speaker operation. When 2-speaker operation active, the rear speakers are muted and the FADE option will not appear on the menu.

## PROGRAMMABLE EJECT DEFAULT

The cassette player has been pre-programmed to return to the radio after a tape has been ejected. This default may be changed to an "eject audio mute" mode. This mode will mute the radio after a cassette has been ejected. When this occurs, "NO TAPE" will appear on the display and the radio will remain muted until BAND (2) is pressed. Pressing this button will enable the radio.

Perform the following steps to change the eject default mode:

1. Press and hold DSP/TM SET (9) for at least 2 seconds until the hour digits flash.
2. Press  button (3) to toggle between "P.PLAY" and "EJMUTE". After 5 seconds of inactivity, the receiver will return to the default display.

## CASSETTE PLAYER

The cassette player that the radio is equipped with works best with cassettes that range from 30 to 90 minutes long. Cassettes that are longer than 90 minutes have thinner tape, and do not work well in this model cassette player.

It is also important to only use cassettes that are in good condition. Cassettes that are dirty, damaged, or have been exposed to excessive heat and/or sunlight could cause damage to the cassette player and possible failure.

The cassette player is equipped with automatic equalization and metal tape sensing functions. An "M" will appear on the display when a metal tape is sensed.

Cleaning the cassette player is a recommended maintenance item. It should be performed at 35 hour (cassette play) intervals. Failure to clean the cassette player may diminish sound quality and cause cassette player failure.

### Playing A Cassette

1. Turn the receiver ON.
2. Insert a cassette into the player. The cassette icon will appear on the display. The tape will begin to play when the icon appears.

*NOTE: Press  button (3) to change from the radio to a cassette. "TP SIDE 1" or "TP SIDE 2" will appear on the display depending on which side of the cassette is currently being played. If a cassette is not loaded in the player, "NO TAPE" will appear on the display.*

### Cassette Functions

**4/REV (17):** This button rewinds the cassette. The cassette will continue to rewind until the button is pressed again, or until the cassette reaches the end of the tape. "<REW" will appear on the display as the cassette is rewinding.

**6/FF (15):** This button fast forwards the cassette. The cassette will continue to fast forward until the button is pressed again, or until the cassette reaches the end of the tape. "FWD>" will appear on the display as the cassette is fast forwarding.



**▲Eject (5):** Press this button to eject the cassette from the player. When the eject button is held, it acts as a stop button.

**↕ (4):** This button causes the cassette player to reverse directions and play the opposite side of the cassette. Pressing the button a second time will reverse the cassette back to the original side.

*NOTE: The cassette will automatically flip to the opposite side when the end of the tape is reached.*

### Bad Tape Detect

If the receiver detects a bad cassette, "BAD TAPE" will appear on the display, and the tape will be ejected. If this occurs, the cassette should be removed from the player and should not be re-inserted.

If it is desired to use a cleaning tape or a CD adapter in the cassette player, the bad tape detector must be turned OFF. Perform the following steps in order to disable this mode:

1. Turn the receiver OFF and turn the key switch to OFF.
2. Press and hold  button (3) for 5 seconds. "BAD TAPE DETECT OFF" will appear on the display. When this is displayed, the detector has been disabled.

Repeat this procedure to reactivate the bad tape detector. "BAD TAPE DETECT ON" will appear on the display after the detector has been activated.

## CASSETTE PLAYER CLEANING

After 35 hours of cassette play, the display will read "TP CLEAN" for 5 seconds. This indicates that it is time to clean the cassette player.

1. Turn the key switch to "ON", and turn the receiver OFF.
2. Disable "BAD TAPE DETECT" mode.
3. Turn the receiver "ON".
4. Insert a wet-type, non-abrasive, scrubbing cassette cleaner. Follow the instructions provided with the cleaner.
5. Reset the clean tape timer. With the receiver "ON", press and hold the eject button for 5 seconds. "TP CLEAN" will appear on the display and the tape icon will flash after 3 seconds has elapsed. After 5 seconds "CLN RST" will appear on the display. When this occurs, the clean tape timer will be reset to zero hours. If the button was released before "CLN RST" was displayed, the timer will not be reset.

---

# NOTES