

Field Assembly Manual

WA600-3

WHEEL LOADER

SERIAL NUMBERS **WA600-3 50001** and up

This material is proprietary to Komatsu America Corp. and is not to be reproduced, used, or disclosed except in accordance with written authorization from Komatsu America Corp.

It is our policy to improve our products whenever it is possible and practical to do so. We reserve the right to make changes or improvements at any time without incurring any obligation to install such changes on products sold previously.

Due to this continuous program of research and development, revisions may be made to this publication. It is recommended that customers contact their distributor for information on the latest revision.

Copyright 2004 Komatsu
Printed in U.S.A.
Komatsu America Corp.

August 2004

CONTENTS

[1] Drawings of units divided for delivery	3
[2] Weight and dimensions table of units divided for delivery.....	3
[3] Assembly work schedule.....	4
[4] Necessary devices and tools.....	4
[5] Assembly procedure.....	5
(1) Installation of tire and wheel assembly	5
1) Positioning of vehicle	5
2) Removal of axle stand	5
3) Slinging of tire and wheel assembly.....	5
4) Installation of tire and wheel assembly	6
(2) Installation of muffler stack.....	7
(3) Installation of cab assembly	8
1) Removal of floor frame undercovers	8
2) Removal of cover in cab assembly	8
3) Slinging of cab assembly	8
4) Loosening of steering post lower bolt	9
5) Operation of steering tilt lever	9
6) Installation of seal	9
7) Lowering of cab assembly	10
8) Temporary tightening of steering post fixing bolts.....	10
9) Temporary tightening of cab assembly mounting bolts.....	11
10) Permanent tightening of steering post lower bolt	11
11) Permanent tightening of steering post fixing bolt	11
12) Connection of wiring connectors and washer vinyl tubes	12
13) Installation of troubleshooting switch	12
14) Installation of cover in cab assembly	12
15) Installation of steering post lower bellows.....	13
16) Installation of cab assembly right-hand cover.....	13
17) Installation of floor frame lower cover	14
18) Installation of mirrors and mirror stays.....	14
(4) Installation of ROPS canopy	15
1) Removal of antenna	15
2) Removal of rear frame ROPS support bolts tightened temporarily	15
3) Slinging of ROPS canopy	15
4) Installation of ROPS canopy	16
5) Installation of antenna to ROPS canopy	16
6) Installation of antennal wire hole grommet.....	16

(5) Installation of bucket	17
1) Installation of cord ring.....	17
2) Aligning of bucket assembly and hinge pin holes	17
3) Selection of shim for bucket hinge pin	17
4) Insertion of bucket hinge pin	18
5) Installation of bucket hinge pin stopper	18
6) Installation of bucket hinge pin and retainer	18
7) Lowering of cord ring to groove	19
8) Installation of bucket link pin.....	19
9) Installation of grease nipple and plug	20
10) Measurement of steering wheel operating effort	20

[1] DRAWINGS OF UNITS DIVIDED FOR DELIVERY

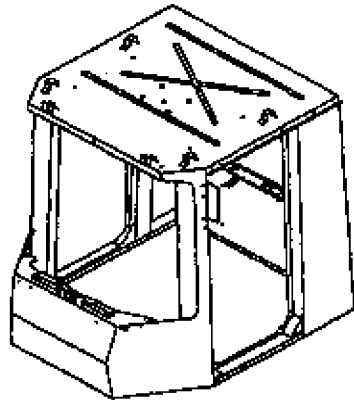

4. Cab assembly

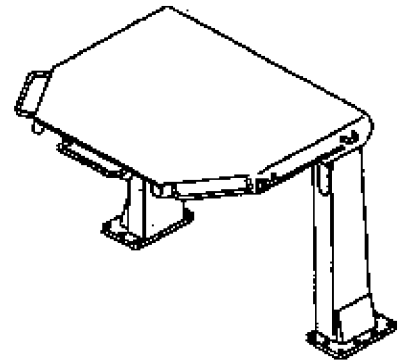

5. ROPS canopy assembly

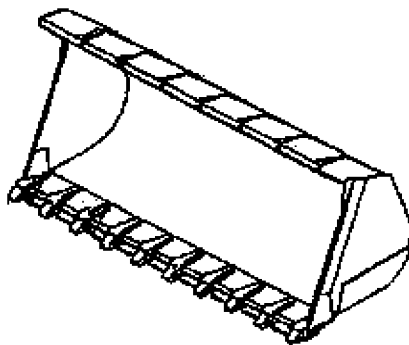
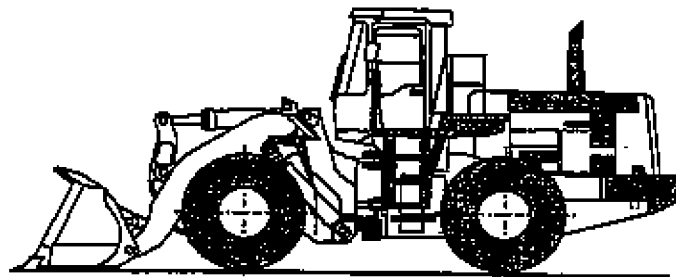

2. Bucket assembly

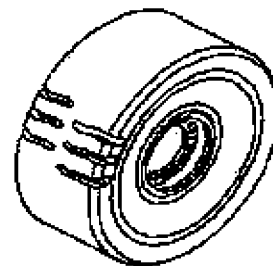





3. Tire and wheel assembly

[2] WEIGHT AND DIMENSIONS TABLE OF UNITS DIVIDED FOR DELIVERY

No.	Unit name	Weight (kg)	Overall length (mm)	Overall width (mm)	Overall height (mm)
1	Bare machine	29,500	9,270	3,500	3,000
2	Bucket assembly	4,000	3,700	1,900	2,000
3	Tire and wheel assembly	1,700	2,100	2,100	900
4	Cab assembly	440	1,800	1,500	1,700
5	ROPS canopy assembly	810	1,800	2,200	1,800
6	Small parts other than above				

[3] ASSEMBLY WORK SCHEDULE

Section	Specification	Q'ty	1st day	2nd day
Assembly unit (Contents of work)			Positioning of bare machine Installation of tire and wheel assembly Installation of muffler stack Installation of cab assembly and ROPS canopy	Installation of bucket assembly
Crane	25 Ton 50 Ton	1 unit 1 unit		
Number workers		2		

[4] NECESSARY DEVICES AND TOOLS

No.	Device/Tool name	Specification	Q'ty	Remarks
1	Crane (including operator)		1 each	
2	Balance sling		1	Sling for rear side
3	Chain sling of sling hook type	Wire ϕ : 20 mm, 2-wire sling type	1	4,000 mm long for chassis
4	Chain sling of sling hook type	Wire ϕ : 6.3 mm, 4-wire sling type	1	2,000 mm long for cab
5	Endless chain sling	Wire ϕ : 6.3 mm	2	6,000 mm long for tire
6	Chock		4	
7	Wood block	300×300×900	10	
8	Air compressor		1	
9	Air hose		1	
10	Impact wrench	GTP-4200 or equivalent	1	
11	Socket	36 mm Insertion angle 25.4 mm	1	Bucket pin for tire
12	Socket	46 mm Insertion angle 25.4 mm	1	For ROPS
13	Spanner	36 mm	1	Bucket pin
14	Torque wrench	21000QLE or equivalent (1,520 – 1,910 Nm)	1	For ROPS and tire
15	Protective sheet		2	
16	Push-pull gauge	Measurement: Max. 19.6 N {2 kg}	1	
17	Hammer	Plastic	1	
18	Hammer	Copper (Large)	1	
19	Grease gun		1	
20	Feeler gauge		1	
21	Sealant		1	CEMEDINE 366-E or equivalent
22	Grease	LM-G	1	(Lithium grease containing molybdenum disulfide)

[5] ASSEMBLY PROCEDURE

Installation of tire and wheel assembly

(1) INSTALLATION OF TIRE AND WHEEL ASSEMBLY

1) Positioning of vehicle

1. Sling the front side and rear side of the chassis with a crane.
2. Position the vehicle on wood blocks, etc. by the underside of the axle housing.
 (Set the vehicle so that the center of the axle will be 1.1 – 1.2 m above the ground.)
3. Since the rear axle oscillates, put wood blocks between the rear axle and rear frame to prevent the axle from leaning.

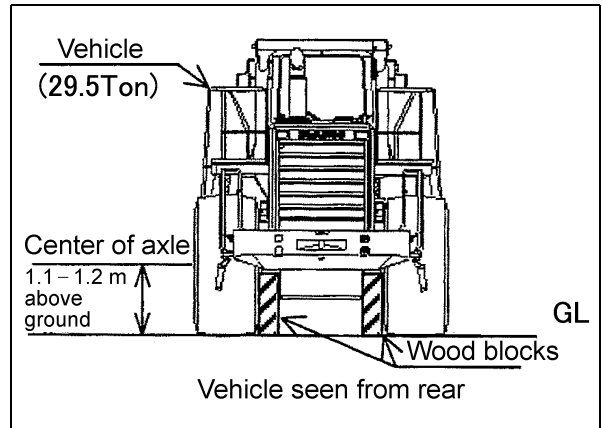

2) Removal of axle stand

1. Remove the stand (Jig No. AZ-001-051) installed to the axle.

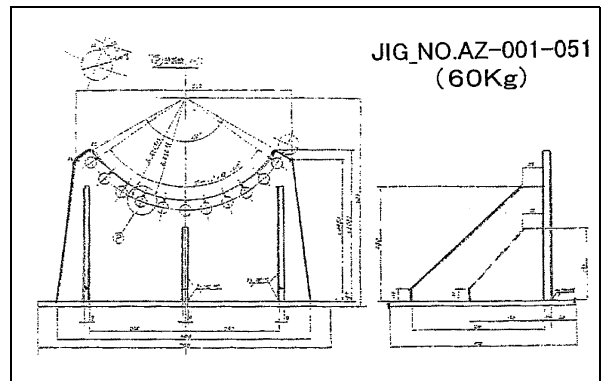

3) Slinging of tire and wheel assembly

1. Sling the tire and wheel assembly with the crane. At this time, match the mounting holes of the wheel to the studs on the axle side.

 Sling: Endless chain sling or endless nylon sling: 2 pcs
2. Sling the tire and wheel assembly slowly so that it will not lean.

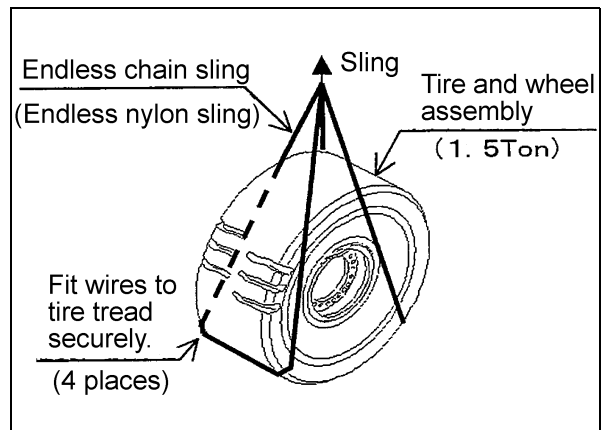

Precautions	Special tools		Necessary devices	
	Name	Q'ty	Name	Q'ty
1. Apply the parking brake.			Crane (25 ton), 50 Ton	1 each
			Endless chain sling	2
2. Do not stand under the slung vehicle.				
Other remarks				

[5] ASSEMBLY PROCEDURE

Installation of tire and wheel assembly

4) Installation of tire and wheel assembly

• Necessary parts

No.	Part No.	Part name	Q'ty
1	426-22-12931	Nut	124
2	01643-32460	Washer	124

1. Check that each part is free from foreign matter.
2. Drive each nut at least 3 threads with your fingers to prevent it from biting the hub bolt.
3. Install the right and left tire and wheel assemblies alternately.
4. Tighten the nuts to the torque shown at right.
5. Remove the wood blocks under the axle housing.
6. After finishing the work, touch up the nuts and unpainted parts.
7. Put chocks under the wheels.

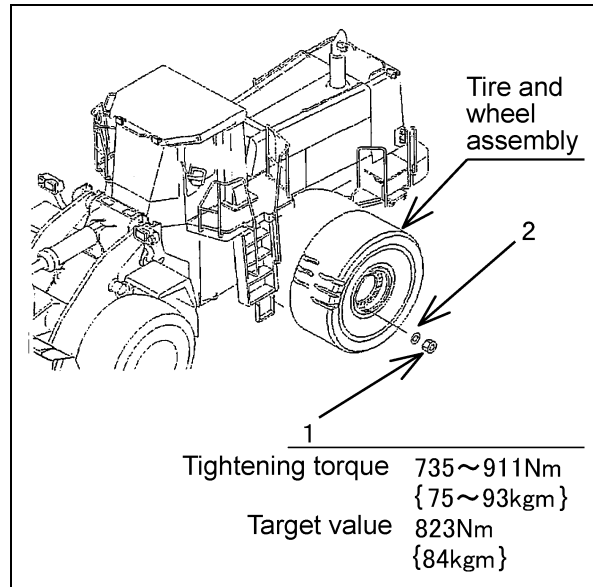

Precautions

1. Do not stand under the slung vehicle.

Special tools

Name	Q'ty
Socket (36 mm)	1

Necessary devices

Name	Q'ty
Crane (25 ton), 50 Ton	1 each
Endless chain sling	1
Chock	4

Other remarks

[5] ASSEMBLY PROCEDURE

Installation of muffler stack

(2) INSTALLATION OF MUFFLER STACK

• Necessary parts

No.	Part No.	Part name	Q'ty
1	426-02-2110	Muffler stack	1
2	01435-01240	Bolt	4
3	01643-31232	Washer	4

1. Install the muffler stack to the left top of the engine hood.

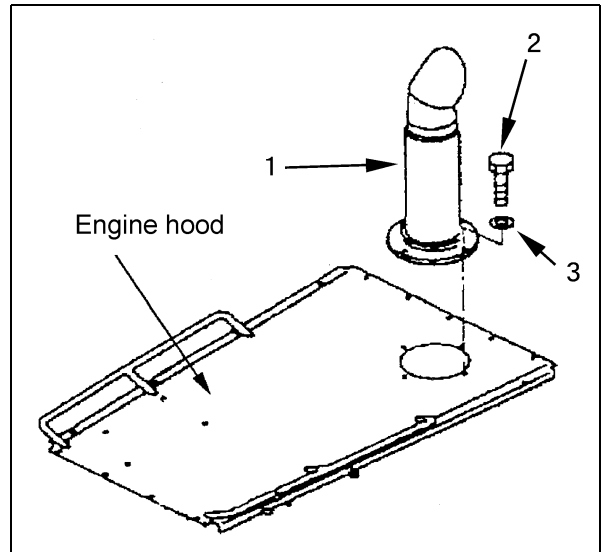

Precautions	Special tools		Necessary devices	
	Name	Q'ty	Name	Q'ty
	Other remarks			

[5] ASSEMBLY PROCEDURE

Installation of cab assembly

(3) INSTALLATION OF CAB ASSEMBLY

- 1) Removal of floor frame undercovers
(1 each on right and left sides, 1 on front side, and 3 each on upper and lower sides)
- 2) Removal of cover in cab assembly
 1. Unpack the cab assembly and remove the right-hand cover.
 2. Remove the 2 screws from the front plate.

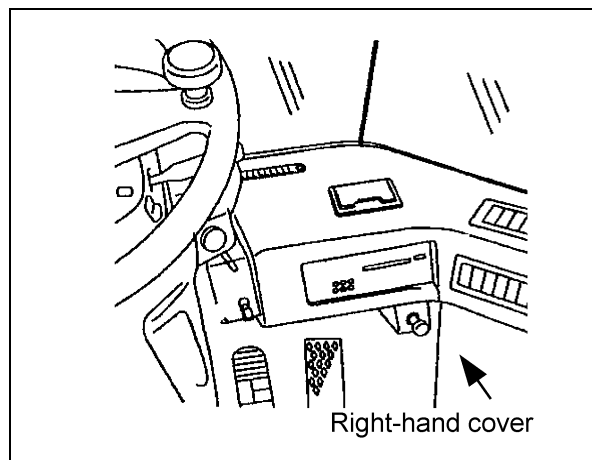
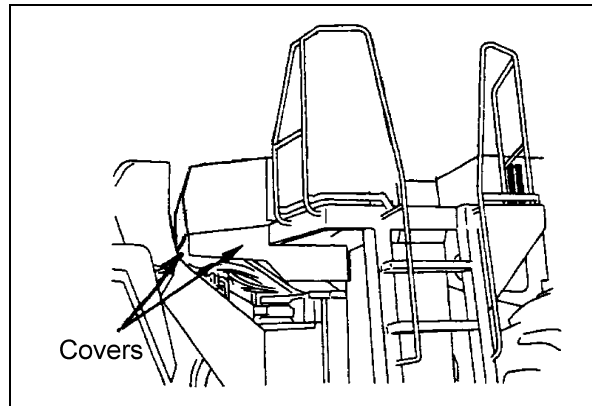
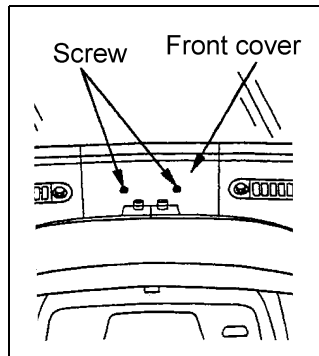

- 3) Slinging of cab assembly
 1. Sling the cab assembly with a 25-ton crane.

Sling: Chain sling of spring hook type
(2,000 mm x 4 pieces)

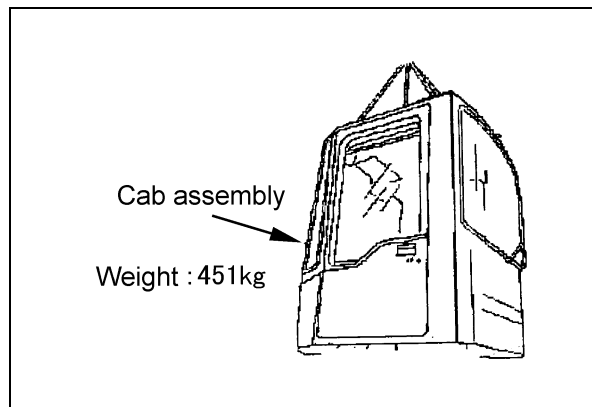

Precautions	Special tools		Necessary devices	
	Name	Q'ty	Name	Q'ty
			Crane (25 ton)	1
			Chain sling (2,000 mm x 4 pieces)	1
Other remarks				

[5] ASSEMBLY PROCEDURE

Installation of cab assembly

- 4) Tuck up the bellows at the lower part of the steering post and loosen the 4 bolts.

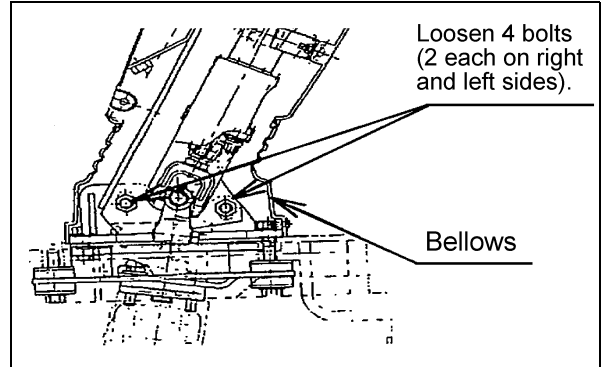
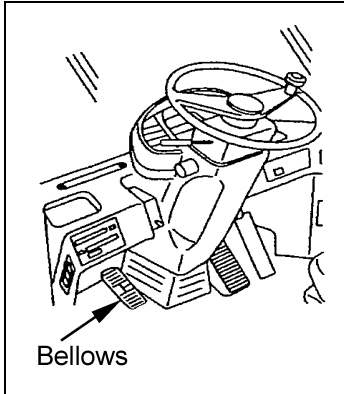

- 5) Set the steering tilt lever free and turn down the steering post fully toward to operator's seat.

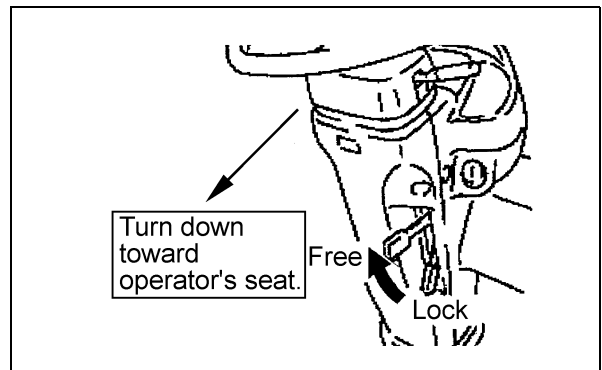

- 6) Installation of seal

• Necessary parts

Part No.	Part name	Q'ty
426-56-21330	Seal	1

1. Stick the seal to the underside of the cab assembly.
2. When sticking the seal, press it against the inside face of the cab assembly.

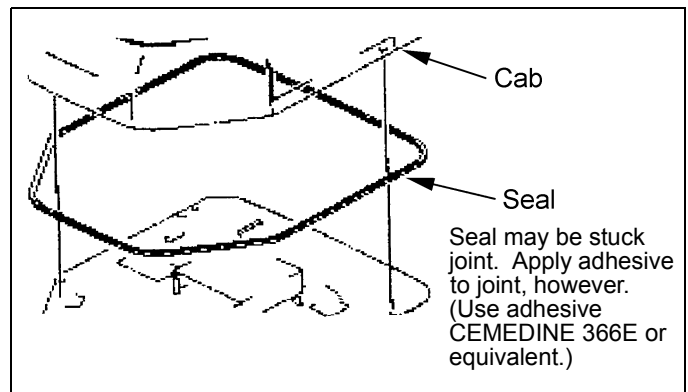

Precautions	Special tools		Necessary devices	
	Name	Q'ty	Name	Q'ty
	Other remarks			

[5] ASSEMBLY PROCEDURE

Installation of cab assembly

7) While keeping the cab assembly level, lower it slowly.

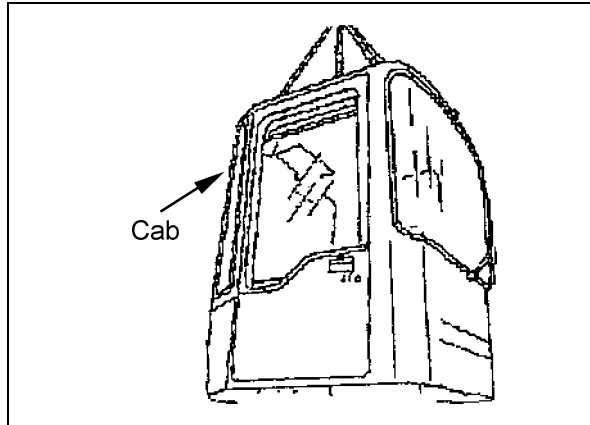

8) Temporary tightening of steering post fixing bolts

• Necessary parts

Part No.	Part name	Q'ty
01435-01020	Bolt	2
01643-31032	Washer	2

1. Drive the 2 steering post fixing bolts temporarily (2 – 3 threads with your fingers).

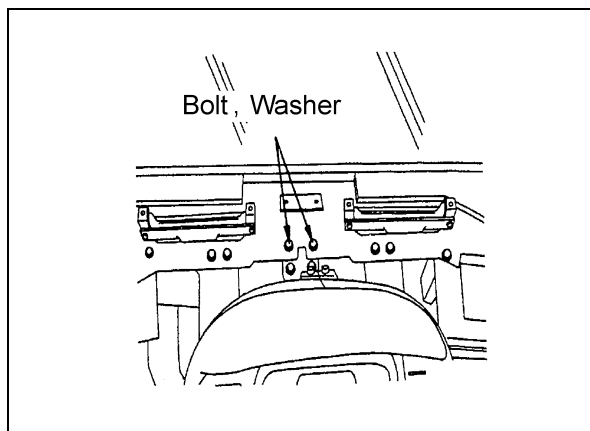

Precautions

1. Take care that the cab assembly will not interfere with the electric wires, connectors, hot air ducts, etc. on the right, front, and rear sides of the floor frame.
2. Cover the steering post and plastic cover with seats to protect them.

Special tools		Necessary devices	
Name	Q'ty	Name	Q'ty

Other remarks

[5] ASSEMBLY PROCEDURE

Installation of cab assembly

9) Temporary tightening of cab assembly mounting bolts

• Necessary parts

No.	Part No.	Part name	Q'ty
1	01010-81240	Bolt	2
2	01643-31232	Washer	2
3	418-46-12310	Shim (t = 1.0)	4
4	01010-82050	Bolt	8
5	01643-32060	Washer	8

1. Drive 2 cab assembly mounting bolts (10) and 4 intermediate bolts and 4 rear bolts (11) (2 – 3 threads with your fingers).

10) Move the steering post to the front end of the cab assembly and tighten the steering post lower bolts which were loosened in step 4).

11) Lift down the cab assembly and tighten the steering post fixing bolts which were driven lightly in stop 8), and then tighten the bolts to fix to the floor.

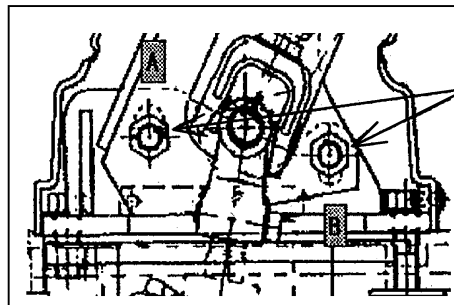
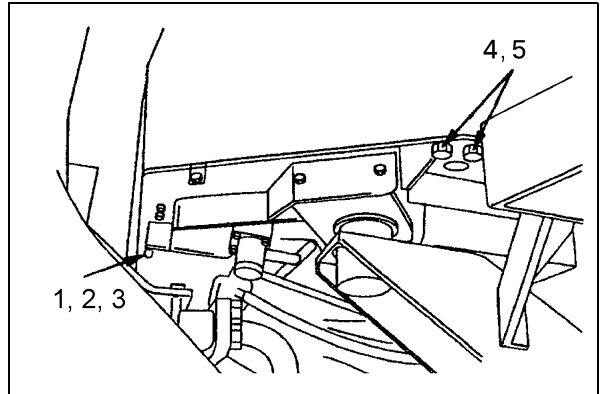

1 each on right and left side
 [Caution]
 Set bolts to bottom of oblong hole at part A and to top of oblong hole at part B. (Set them as set when delivered.)

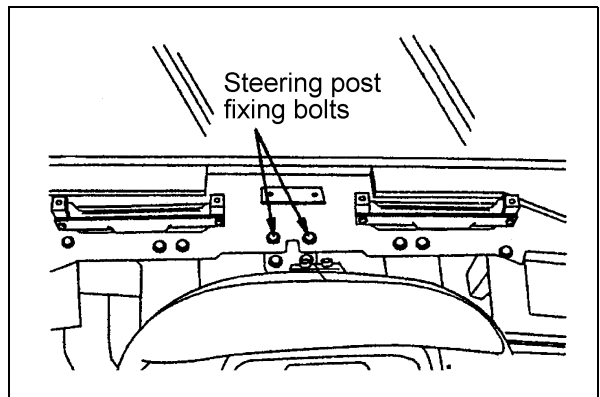

Precautions	Special tools		Necessary devices	
	Name	Q'ty	Name	Q'ty
	Other remarks			

[5] ASSEMBLY PROCEDURE

Installation of cab assembly

12) Connection of wiring connectors and washer vinyl tubes

1. Connect the 2 windshield washer vinyl tubes under the right side of the cab assembly, matching their colors.
2. Connect wiring connectors [CL2], [CL3], [CL4], and [CL1].
3. If the vehicle is equipped with the joystick, connect the wiring harnesses of the F, N, and R indicator lamps on the front left side of the cab assembly.

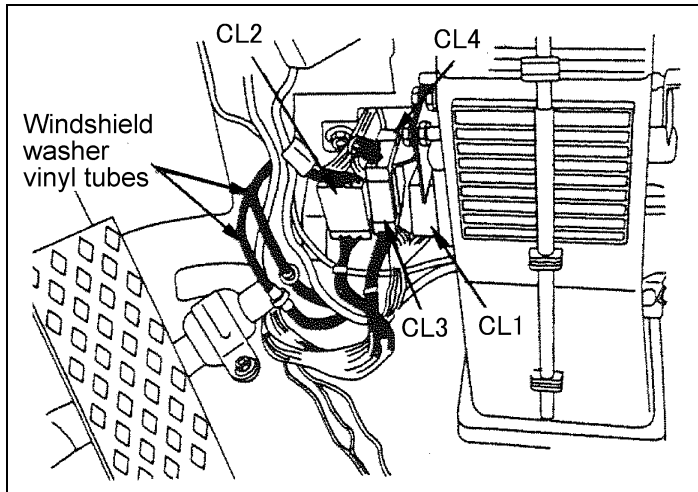

13) Installation of troubleshooting switch

14) Installation of cover in cab assembly

Install the cover which was removed in step 2).

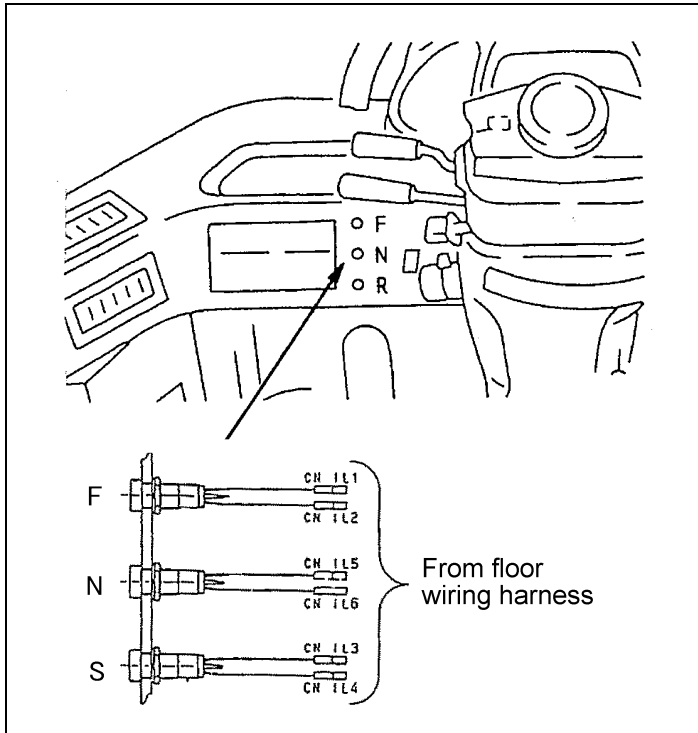

Precautions

1. When connecting the windshield washer tubes, match their colors.

Special tools

Name

Q'ty

Necessary devices

Name

Q'ty

Other remarks

[5] ASSEMBLY PROCEDURE

Installation of cab assembly

15) Installation of steering post lower bellows

• Necessary parts

No.	Part No.	Part name	Q'ty
19	421-09-21240	Plug	16

1. Install bellows (6) to the bottom of the steering post with plug (19).
2. Insert the plug in the hole of bellows (6) and lightly hit the screw head installed temporarily to the plug with a hammer to drive in the plug.

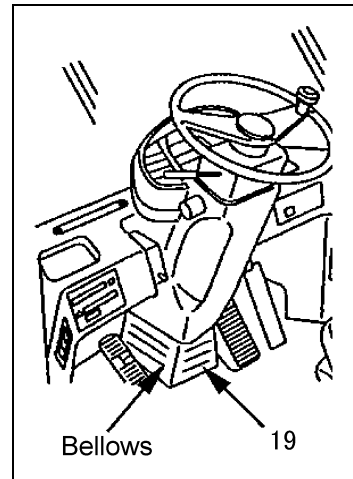

16) Install the cab assembly right-hand cover which was removed in step 2).

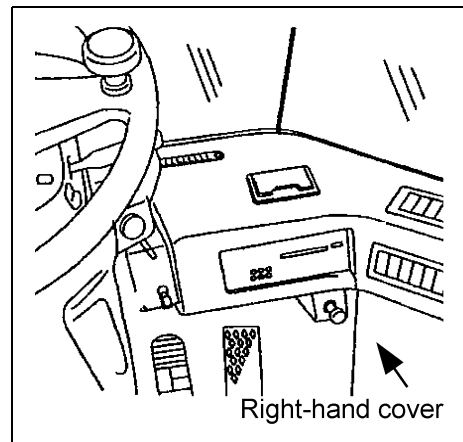

Precautions	Special tools		Necessary devices	
	Name	Q'ty	Name	Q'ty
Other remarks				

[5] ASSEMBLY PROCEDURE

Installation of cab assembly

17) Install the floor frame lower cover.

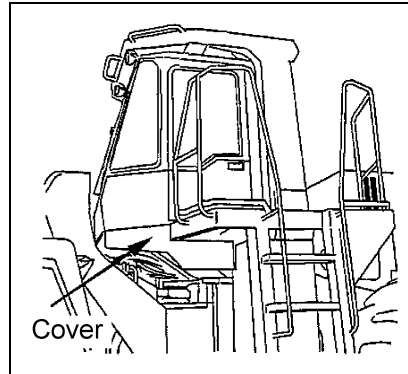

18) Install the mirrors and mirror stays to the right and left of the cab assembly.

• Necessary parts

No.	Part No.	Part name	Q'ty
1	426-54-25710	Stay (Left)	1
2	426-54-25720	Stay (Right)	1
3	01435-01025	Bolt	8
4	363-54-31450	Cap	8
5	421-54-25610	Mirror	2
6	04025-00632	Spring pin	2

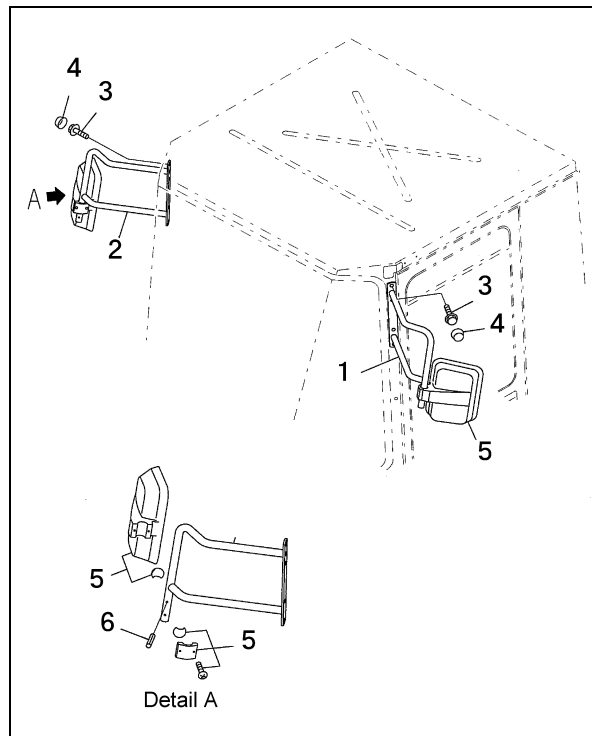

Precautions	Special tools		Necessary devices	
	Name	Q'ty	Name	Q'ty
	Other remarks			

[5] ASSEMBLY PROCEDURE

Installation of ROPS canopy

(4) INSTALLATION OF ROPS CANOPY

1) Removal of antenna

1. Remove the antenna from the right side of the cab assembly. Install screws (1) to the antenna mounting holes on the cab side to fill the holes.
2. Apply sealant (366E or equivalent) to the removed screws and install them again.
3. Draw in the antenna wire at least 100 mm.

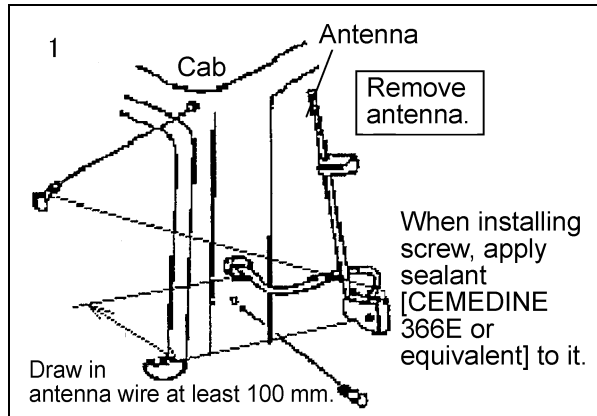

2) Removal of rear frame ROPS support bolts tightened temporarily

1. Remove 4 bolts tightened temporarily into the right and left ROPS canopy mounting parts of the rear frame ROPS support. (Keep the bolts and washers to use again.)
2. Check that the rear frame ROPS support mounting holes are matched to the holes on the floor.

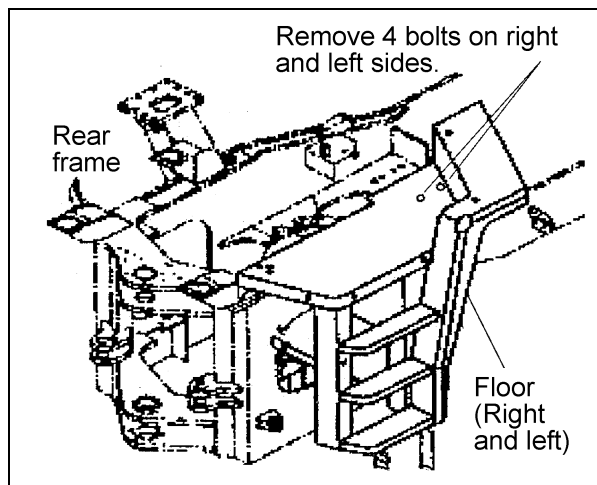

3) Slings of ROPS canopy

1. Sling the ROPS canopy with a 25-ton crane.

Sling: Chain sling of spring hook type
(2,000 mm x 4 pieces)

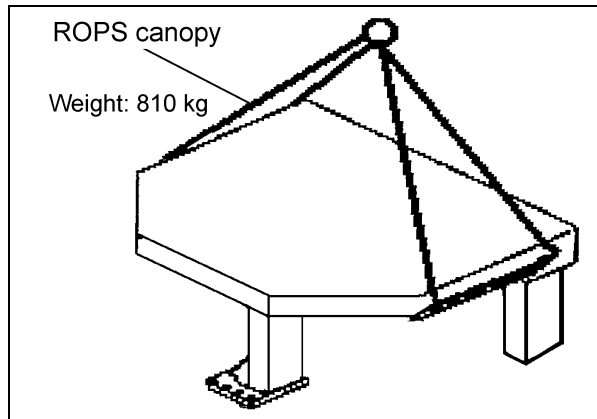

Precautions	Special tools		Necessary devices	
	Name	Q'ty	Name	Q'ty
1. When installing the screws to fill the screw holes, apply synthetic rubber adhesive (366E or equivalent) to their threads to prevent entry of rainwater.			Crane (25 ton)	1
			Chain sling (2,000 mm x 4 pieces)	1
Other remarks				

[5] ASSEMBLY PROCEDURE

Installation of ROPS canopy

4) Installation of ROPS canopy

• Necessary parts

No.	Part No.	Part name	Q'ty
2	01011-63015	Bolt	16
3	01643-33080	Washer	16

1. Lowering the ROPS canopy to the mounting position, taking care that it will not interfere with the cab.
2. Tighten the 20 ROPS canopy mounting bolts (4 removed bolts + 16 bolts installed to the ROPS canopy).

5) Install the antenna to the mounting position on the right side of the ROPS canopy with the screws.

(01220-70412 Screw 2)

• Necessary parts

No.	Part No.	Part name	Q'ty
4	01220-70412	Screw	2

6) Installation of antennal wire hole grommet

• Necessary parts

No.	Part No.	Part name	Q'ty
4	421-921-2410	Grommet	1

1. Install the grommet to antenna wire hole of the cab assembly with the slit down.
2. Fill the clearance around the grommet and the slit with synthetic rubber adhesive (366E or equivalent).

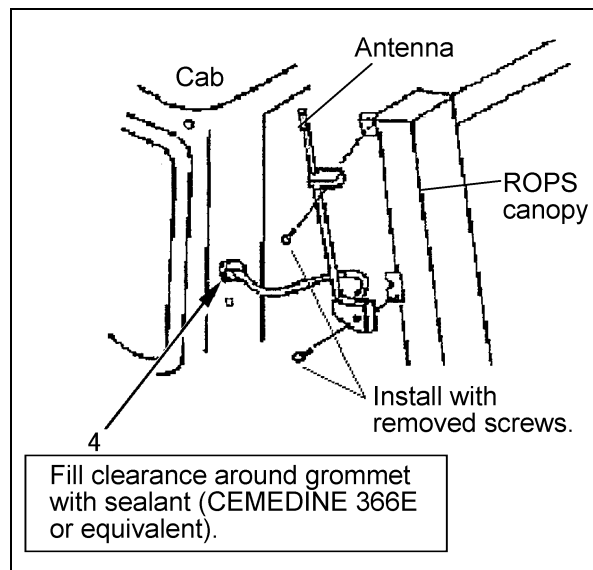
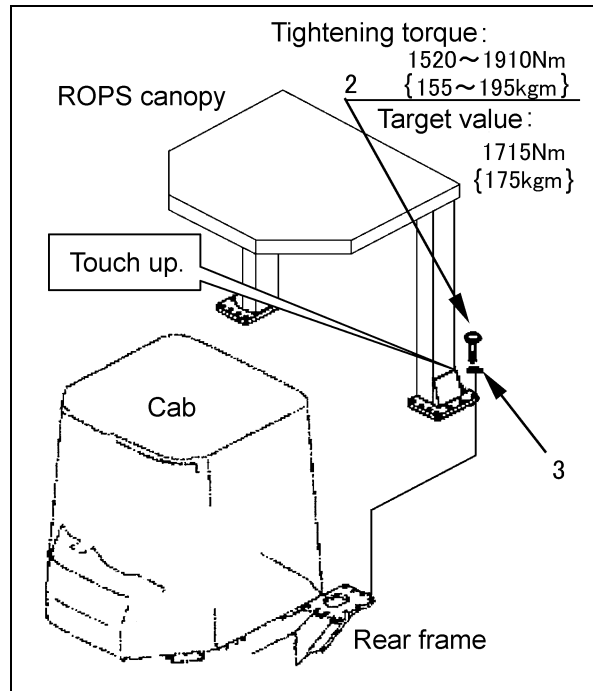

Precautions

1. Fill the clearance around the grommet installed to the antenna wire on the cab side with synthetic rubber adhesive to prevent entry of rainwater.

Special tools

Name	Q'ty
Socket (46 mm)	1
Torque wrench 21000QLE (1,720 – 1,910 Nm)	1
Impact wrench GT4200 or equivalent	1

Necessary devices

Name	Q'ty

Other remarks

[5] ASSEMBLY PROCEDURE

Installation of bucket

(5) INSTALLATION OF BUCKET

1) Installation of cord ring

• Necessary parts

No.	Part No.	Part name	Q'ty
2	426-70-12530	(O-ring) Cord ring	4

- Place cord ring (O-ring) (2) on lift arm boss (1).
- After installing the bucket and adjusting the shim, lower cord ring (2) to the groove.
- Apply LM-G (lithium grease containing molybdenum disulfide) to the inside of dust seal lip (3).

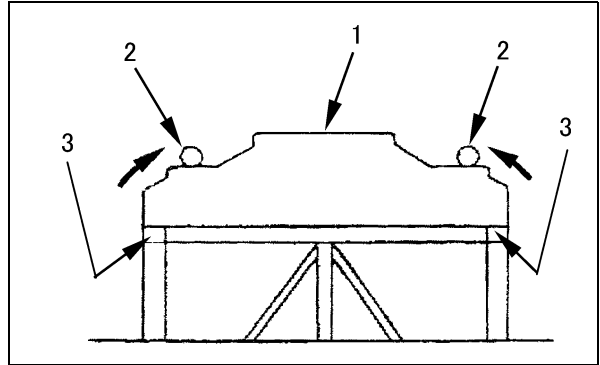

2) Aligning of bucket assembly and hinge pin holes

- Sling the bucket assembly with a 25-ton crane.

Sling: Chain sling of spring hook type
(4,000 mm x 2 pieces)

- Match the pin holes on the right and left bucket hinge pin sides to those on the lift arm side.

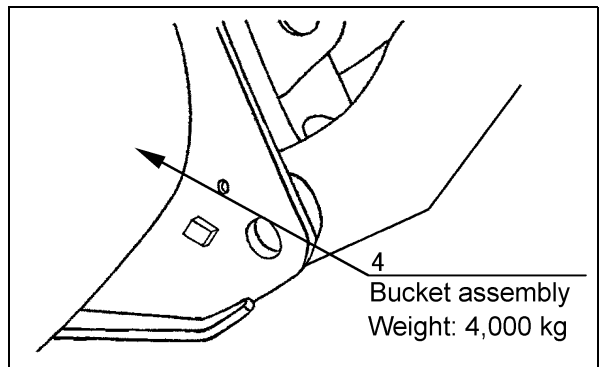

3) Selection of shim for bucket hinge pin

• Necessary parts

No.	Part No.	Part name	Q'ty
-	426-70-11330	Shim (t = 1.5)	6

- Decide the number of the shims so that clearance A between the hinge pin of bucket assembly (4) and the boss of lift arm (1) will be 1.5 mm or less on each side.

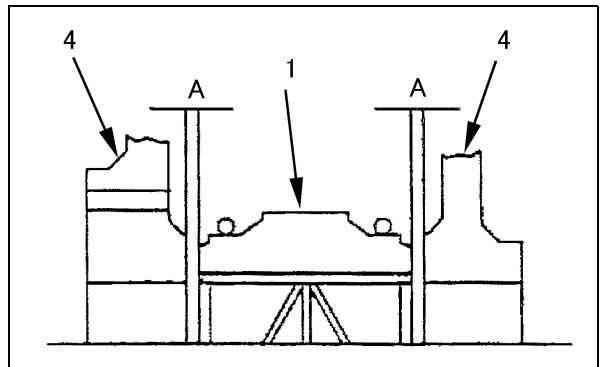

Precautions

- Do not align the pin holes with your hands or fingers.

Special tools

Name

Q'ty

Necessary devices

Name

Q'ty

Crane (25 ton)

1

Chain sling (4,000 mm x 2 pieces)

1

Other remarks

[5] ASSEMBLY PROCEDURE

Installation of bucket

4) Insertion of bucket hinge pin

• Necessary parts

No.	Part No.	Part name	Q'ty
5	426-853-1110	Pin	2

1. Insert the shim selected in step 3), align the pin holes, and insert the bucket hinge pins.
At this time, apply grease to the pins.
2. When inserting bucket hinge pins (5), take care not to damage the dust seals.

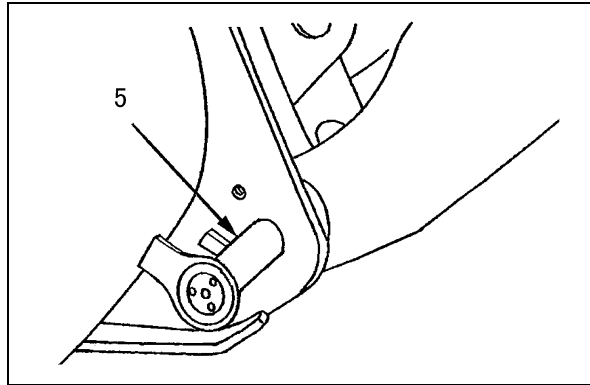

5) Installation of bucket hinge pin stopper

• Necessary parts

No.	Part No.	Part name	Q'ty
6	425-70-11250	Cam	2
6	01010-82475	Bolt	2
6	01643-32460	Washer	4
6	01580-12419	Nut	2

1. Put the lock plate of bucket hinge pin (5) to the block of the bucket hinge plate and secure it with cam (6).
2. Put cam (6) to the plate of bucket hinge pin (5) and tighten the bolt.

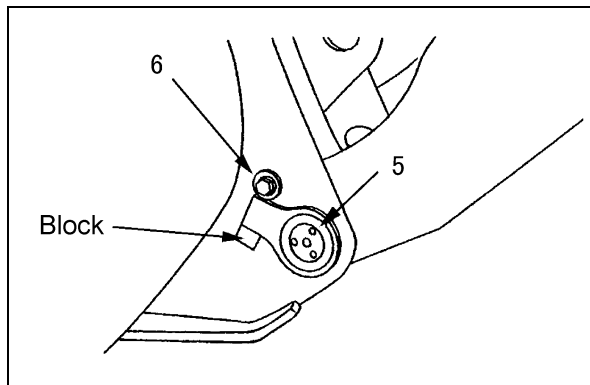

6) Installation of bucket hinge pin and retainer

• Necessary parts

No.	Part No.	Part name	Q'ty
7	426-70-11261	Retainer	2
7	01010-81645	Bolt	6
7	01643-31645	Washer	6
8	426-70-11280	Shim (t = 0.5)	12
	426-70-11270	Shim (t = 0.2)	6

1. Install retainer (7) to bucket hinge pin (5) and decide the number of the shims so that clearance B between the retainer and the boss of the bucket hinge will be 0.2 mm or less.

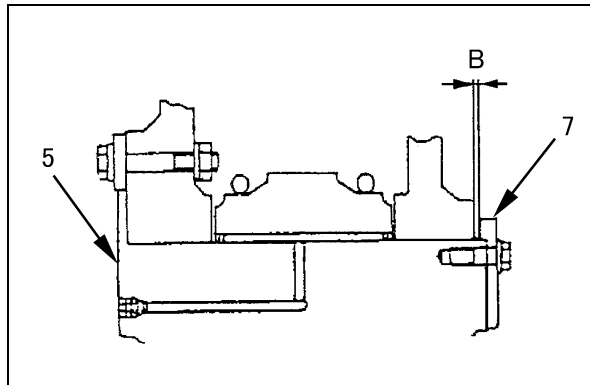

Precautions

	Special tools		Necessary devices	
	Name	Q'ty	Name	Q'ty
	Impact wrench GTP-800P or equivalent	1		
	Socket (36 mm)	1		
	Spanner, 36 mm	1		
	Other remarks			

[5] ASSEMBLY PROCEDURE

Installation of bucket

2. Tighten the 3 bolts of retainer (7).

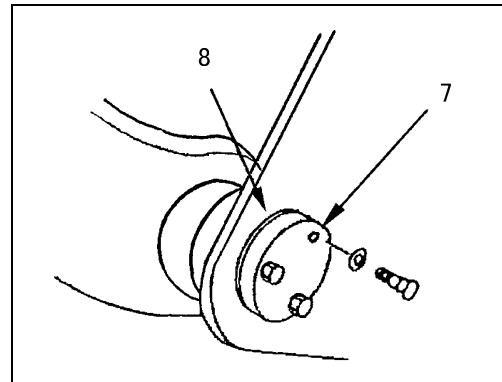

7) Lower cord ring (2) to the groove.

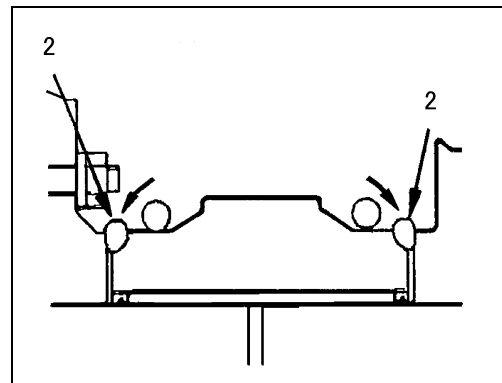

8) Installation of bucket link pin
Install the bucket link pin according to steps 1) – 8).

5	426-70-11470	Shim (t = 0.5 mm)	8
6	425-70-11250	Cam	1
6	01010-82480	Bolt	1
6	01643-32460	Washer	2
6	01580-12419	Nut	1
7	426-70-11391	Retainer	1
7	01010-81645	Bolt	3
7	01643-31645	Washer	3
8	426-70-11460	Shim (t = 0.2 mm)	3
8	426-70-11470	Shim (t = 0.5 mm)	12

Precautions	Special tools		Necessary devices	
	Name	Q'ty	Name	Q'ty
	Other remarks			

[5] ASSEMBLY PROCEDURE

Installation of bucket

9) Installation of grease nipple and plug

1. Apply LM-G (lithium grease containing molybdenum disulfide) to the bucket hinge pin and bucket link pin.

• Necessary parts

No.	Part No.	Part name	Q'ty
	07049-01620	Bucket link pin	9
	07020-00000	Bucket hinge pin	2

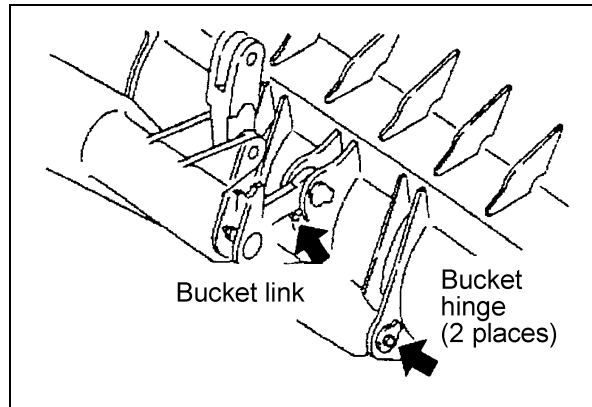

10) Measurement of steering wheel operating effort

1. Run the engine and raise the bucket to about 400 mm above the ground.
2. Remove the safety lock bar used to fix the front and rear frames and the chocks and release the parking brake.
3. While running the engine at low idling (with no load on the bucket), pull the steering wheel knob with a push-pull scale in the tangential direction to check the operating effort.
4. After checking the operating effort, lower the bucket to the ground, apply the parking brake, stop the engine, set the safety lock bar to the frames, and set the chocks.

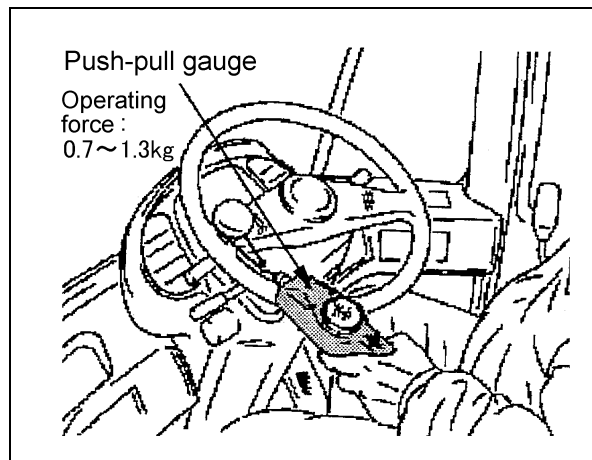

Precautions

	Special tools		Necessary devices	
	Name	Q'ty	Name	Q'ty
			Push-pull gauge	1
	Other remarks			