

Specifications Manual

Important Safety Information

Most accidents that involve product operation, maintenance and repair are caused by failure to observe basic safety rules or precautions. An accident can often be avoided by recognizing potentially hazardous situations before an accident occurs. A person must be alert to potential hazards. This person should also have the necessary training, skills and tools to perform these functions properly.

Improper operation, lubrication, maintenance or repair of this product can be dangerous and could result in injury or death.

Do not operate or perform any lubrication, maintenance or repair on this product, until you have read and understood the operation, lubrication, maintenance and repair information.

Safety precautions and warnings are provided in this manual and on the product. If these hazard warnings are not heeded, bodily injury or death could occur to you or to other persons.

The hazards are identified by the "Safety Alert Symbol" and followed by a "Signal Word" such as "DANGER", "WARNING" or "CAUTION". The Safety Alert "WARNING" label is shown below.



The meaning of this safety alert symbol is as follows:

Attention! Become Alert! Your Safety is Involved.

The message that appears under the warning explains the hazard and can be either written or pictorially presented.

Operations that may cause product damage are identified by "NOTICE" labels on the product and in this publication.

Perkins cannot anticipate every possible circumstance that might involve a potential hazard. The warnings in this publication and on the product are, therefore, not all inclusive. If a tool, procedure, work method or operating technique that is not specifically recommended by Perkins is used, you must satisfy yourself that it is safe for you and for others. You should also ensure that the product will not be damaged or be made unsafe by the operation, lubrication, maintenance or repair procedures that you choose.

The information, specifications, and illustrations in this publication are on the basis of information that was available at the time that the publication was written. The specifications, torques, pressures, measurements, adjustments, illustrations, and other items can change at any time. These changes can affect the service that is given to the product. Obtain the complete and most current information before you start any job. Perkins dealers or Perkins distributors have the most current information available.



When replacement parts are required for this product Perkins recommends using Perkins replacement parts.

Failure to heed this warning can lead to premature failures, product damage, personal injury or death.

Table of Contents

Specifications Section

Engine Design	4
Fuel Injection Lines	5
Fuel Injection Pump (Delphi DP210 DPA and DPG fuel injection pumps)	5
Fuel Injection Pump (Bosch EPVE for the 1104 engines only)	6
Fuel Injection Pump (Delphi STP)	7
Fuel Injectors	8
Fuel Transfer Pump	8
Lifter Group	9
Rocker Shaft	9
Valve Mechanism Cover	10
Cylinder Head Valves	10
Cylinder Head	12
Turbocharger	13
Exhaust Manifold	14
Camshaft	15
Camshaft Bearings	16
Engine Oil Filter	17
Engine Oil Pump	17
Engine Oil Pressure	19
Engine Oil Bypass Valve	20
Engine Oil Pan	21
Crankcase Breather	22
Water Temperature Regulator and Housing	23
Water Pump	24
Cylinder Block	24
Crankshaft	26
Crankshaft Seals	30
Connecting Rod Bearing Journal	31
Main Bearing Journal	31
Connecting Rod	32
Piston and Rings	33
Piston Cooling Jet	34
Front Housing and Covers	35
Gear Group (Front)	36
Flywheel	38
Flywheel Housing	38
Crankshaft Pulley	38
Fan Drive	39
Engine Lifting Bracket	39
Alternator	40
Starter Motor	41
Glow Plugs	42

Index Section

Index	43
-------------	----

Specifications Section

i02198893

Engine Design

Four Cylinder Engine

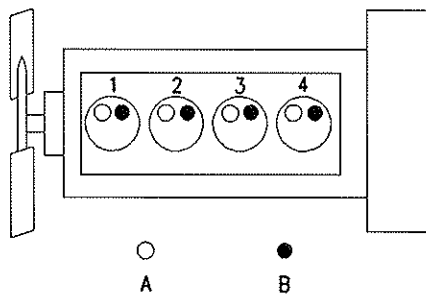

Illustration 1 g00984281

Cylinder and valve location

- (A) Inlet valve
- (B) Exhaust valve

Bore 105 mm (4.133 inch)

Stroke 127 mm (5.000 inch)

Displacement 4.4 L (269 in³)

Cylinder arrangement In-line

Type of combustion Direct injection

Compression ratio

- Naturally aspirated engines 19.3:1
- Turbocharged engines 18.2:1
- Turbocharged engines 17.2:1

Number of cylinders 4

Valves per cylinder 2

Valve lash

- Inlet valve 0.20 mm (0.008 inch)
- Exhaust valve 0.45 mm (0.018 inch)

Firing order 1, 3, 4, 2

When the crankshaft is viewed from the front of the engine, the crankshaft rotates in the following direction: Clockwise

When the camshaft is viewed from the front of the engine, the camshaft rotates in the following direction: Clockwise

The front of the engine is opposite the flywheel end. The left side and the right side of the engine are viewed from the flywheel end. The No. 1 cylinder is the front cylinder.

Three Cylinder Engine

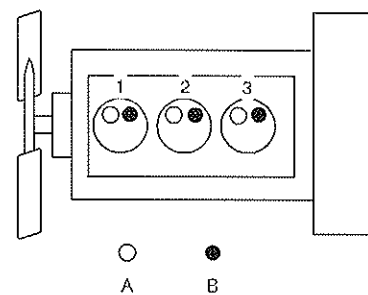

Illustration 2 g01014247

Cylinder and valve location

- (A) Inlet valve
- (B) Exhaust valve

Bore 105 mm (4.133 inch)

Stroke 127 mm (5.000 inch)

Displacement 3.3 L (201 in³)

Cylinder arrangement In-line

Type of combustion Direct injection

Compression ratio

- Naturally aspirated engines 19.3:1
- Turbocharged engines 18.2:1
- Turbocharged engines 17.2:1

Number of cylinders 3

Valves per cylinder 2

Valve lash

- Inlet valve 0.20 mm (0.008 inch)
- Exhaust valve 0.45 mm (0.018 inch)

Firing order 1, 2, 3

When the crankshaft is viewed from the front of the engine, the crankshaft rotates in the following direction: Clockwise

When the camshaft is viewed from the front of the engine, the camshaft rotates in the following direction: Clockwise

The front of the engine is opposite the flywheel end. The left side and the right side of the engine are viewed from the flywheel end. The No. 1 cylinder is the front cylinder.

i01914111

Fuel Injection Lines

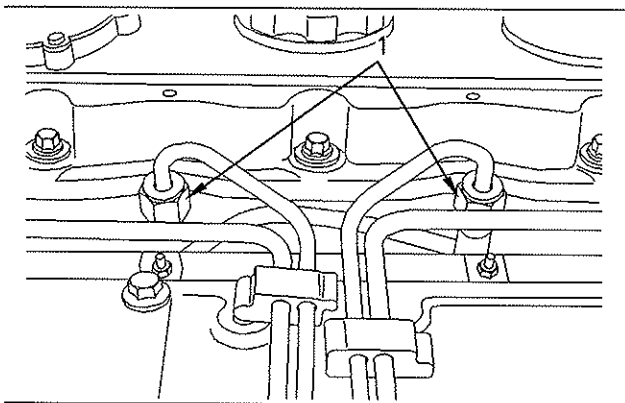

Illustration 3

g00923498

A typical fuel line

- (1) Tighten the union nuts for the fuel injector to the following torque. 30 N·m (22 lb ft)

Note: Tighten the union nuts at the fuel injection pump to the following torque. 30 N·m (22 lb ft)

i02199305

Fuel Injection Pump (Delphi DP210 DPA and DPG fuel injection pumps)

Delphi DP210

Note: Before the fuel injection pump is removed from the engine the fuel injection pump shaft must be locked. Position the engine to TC compression stroke of number one cylinder before tightening the locking screw. The locking screw will prevent the shaft from rotating. If the fuel injection pump was removed prior to correctly timing the engine and locking the shaft, the fuel injection pump will need to be timed by trained personnel.

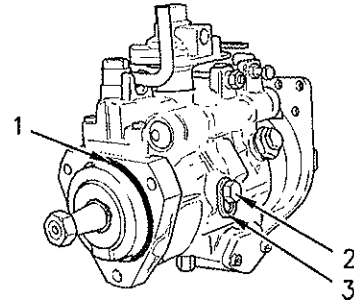

Illustration 4

g00922601

The Delphi DP 210 fuel injection pump

Note: The solenoid on the fuel injection pump is a serviceable item. The fuel injection pump is a nonserviceable item.

- (1) O-ring
- (2) Locking screw
- (3) Washer

Locking the shaft

Loosen locking screw (2) and move the washer (3) to the locked position. Tighten the bolt to the following torque. 17 N·m (12 lb ft)

Unlocking the shaft

Loosen locking screw (2) and install the washer (3) to the unlocked position. Tighten the bolt to the following torque. 12 N·m (9 lb ft)

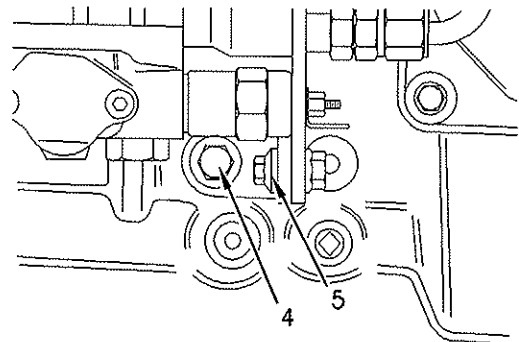

Illustration 5

g00986531

Support bracket

- (4) Tighten the mounting bolt to the following torque. 44 N·m (32 lb ft)
- (5) Tighten the mounting bolt and the nut to the following torque. 22 N·m (16 lb ft)

Note: The support bracket must be installed after the coolant pump is installed. In order to stop the distortion of the timing case, finger tighten the bolt (4) and then tighten the nut and bolt (5). Tighten the bolt (4).

Tighten the bolts that hold the fuel pump to the front housing to the following torque. 25 N·m (18 lb ft)

Delphi DPA

The DPA injection pump has a support bracket that is similar to the DP 210 injection pump.

i02074846

Fuel Injection Pump (Bosch EPVE for the 1104 engines only)

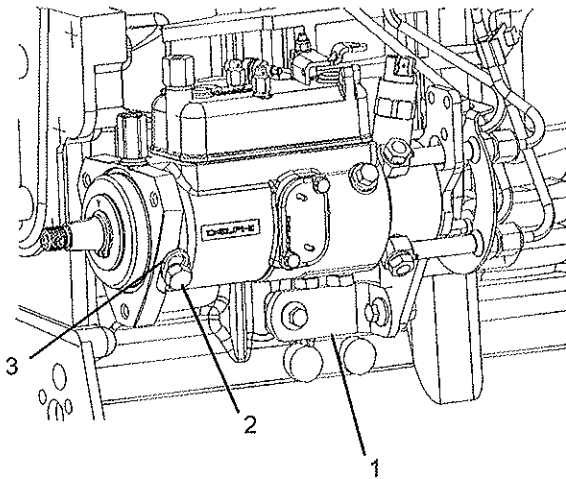

Illustration 6

g01111240

- (1) Support bracket
- (2) Locking screw
- (3) Washer

Note: The torque for the locking screw on the Delphi STP fuel injection pump and the Delphi DPA and DPG fuel injection pump is equal. The support bracket is larger on the Delphi DPA fuel injection pump. The torque for the mounting bolts on the support bracket for both fuel injection pumps is equal.

Delphi DPG

The DPG injection pump is only installed on engines that operate at a fixed speed. The support bracket is not installed on this injection pump.

Note: Before the fuel injection pump is removed from the engine the fuel injection pump shaft must be locked. Position the engine to TC compression stroke of number one cylinder before tightening the locking screw. The locking screw will prevent the shaft from rotating. If the fuel injection pump was removed prior to properly timing the engine and locking the shaft, the fuel injection pump will need to be timed by trained personnel.

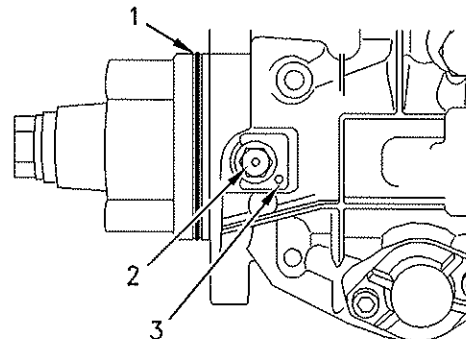

Illustration 7

g00986530

Bosch EPVE fuel injection pump

Note: The solenoid on the fuel injection pump is a serviceable item. The fuel injection pump is a non-serviceable item.

- (1) O-ring
- (2) Locking screw
- (3) Spacer

Locking the shaft

Remove spacer (3) before locking screw (2) is tightened to the following torque. 31 N·m (23 lb ft)

Unlocking the shaft

Loosen the bolt and place spacer (3) behind locking screw (2). Tighten the bolt to the following torque. 12 N·m (9 lb ft)

The lift of the ER fuel injection pump plunger
..... 1.55 mm (0.0610 inch)

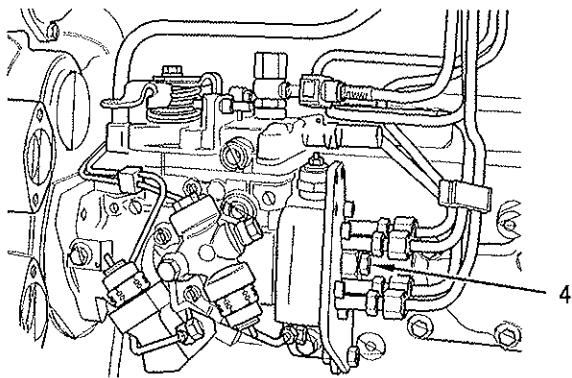

Illustration 8 g00988408
Installed EVEP fuel injection pump

(4) Tighten the plug for the fuel injection pump plunger to the following torque. 29 N·m (21 lb ft)

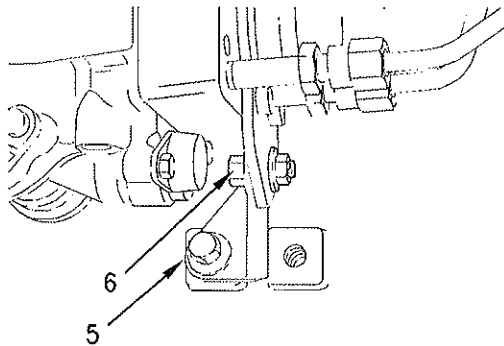

Illustration 9 g00986295
Support bracket

Note: The support bracket must be installed after the coolant pump is installed. In order to stop the distortion of the timing case, finger tighten the bolt (5) and then tighten the nut and the bolt (6). Tighten the bolt (5).

(5) Tighten the bolt to the following torque. ... 44 N·m (32 lb ft)

(6) Tighten the nut and the bolt to the following torque. 22 N·m (16 lb ft)

Tighten the bolts that hold the fuel pump to the front housing to the following torque. 25 N·m (18 lb ft)

i02074902

Fuel Injection Pump (Delphi STP)

Note: Before the fuel injection pump is removed from the engine the fuel injection pump shaft must be locked. Position the engine to TC compression stroke of number one cylinder before tightening the locking screw. The locking screw will prevent the shaft from rotating. If the fuel injection pump was removed prior to correctly timing the engine and locking the shaft, the fuel injection pump will need to be timed by trained personnel.

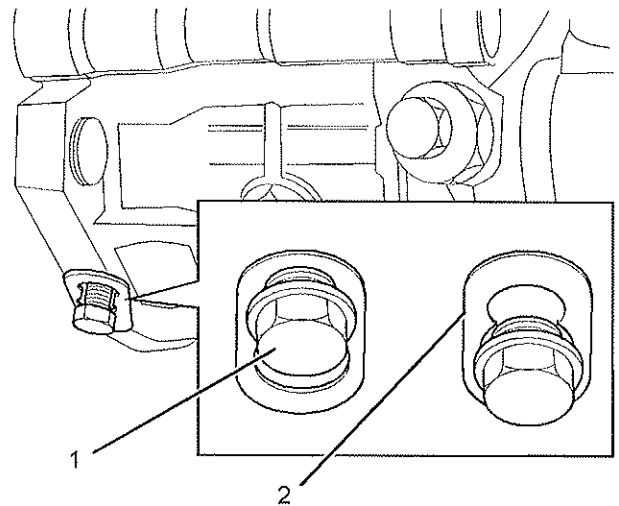

Illustration 10 g01061708
The Delphi STP fuel injection pump

Note: The solenoid on the fuel injection pump is a serviceable item. The fuel injection pump is a non-serviceable item.

(1) Locking screw

(2) Washer

Locking the shaft

Loosen locking screw (1) and move the washer (2) to the locked position. Tighten the bolt to the following torque. 13 N·m (10 lb ft)

Unlocking the shaft

Loosen locking screw (2) and install the washer (3) to the unlocked position. Tighten the bolt to the following torque. 12 N·m (9 lb ft)

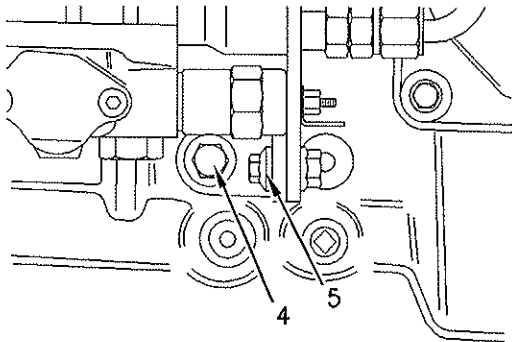

Illustration 11
Support bracket

- (4) Tighten the mounting bolt to the following torque. 44 N·m (32 lb ft)
- (5) Tighten the mounting bolt and the nut to the following torque. 22 N·m (16 lb ft)

Note: The support bracket must be installed after the coolant pump is installed. In order to stop the distortion of the timing case, finger tighten the bolt (4) and then tighten the nut and bolt (5). Tighten the bolt (4).

Tighten the bolts that hold the fuel pump to the front housing to the following torque. 25 N·m (18 lb ft)

i02207945

Fuel Injectors

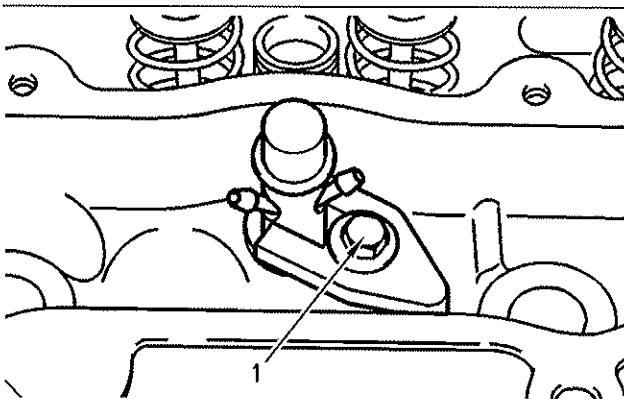

Illustration 12
Fuel injector clamp

- (1) Tighten the bolt in the clamp for the fuel injector to the following torque. 35 N·m (26 lb ft)

The fuel injector should be tested at the pressure in Table 1.

Leakage in 10 seconds 0 drops

Table 1

Service setting for the Fuel Injector
Injection Pressure
29.4 + 0.8 MPa (4264 + 116 psi)

i01957629

Fuel Transfer Pump

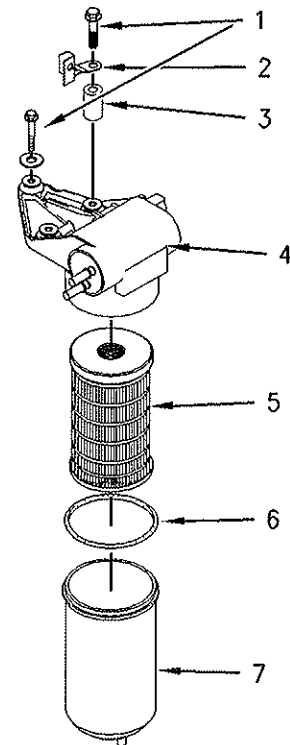

Illustration 13
g00986823

- (1) Retaining bolts
- (2) Clip
- (3) Spacer
- (4) Fuel transfer pump
Type 12 or 24 volt electric motor
- (5) Fuel filter element
- (6) O ring
- (7) Fuel filter bowl

Note: Tighten the fuel filter bowl by hand. Rotate the bowl 1/8 of a turn more by hand.

i01714153

Lifter Group

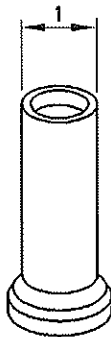

Illustration 14

g00629433

(1) Diameter of the lifter body 18.99 to 19.01 mm
(0.7475 to 0.7485 inch)

Clearance of the lifter in the cylinder block bore 0.04 to 0.09 mm (0.0015 to 0.0037 inch)

i01892700

Rocker Shaft

Note: The rocker shaft assembly for the 3 cylinder engine and the rocker shaft assembly for the 4 cylinder engine use the same components. The exception is the length of the rocker shaft.

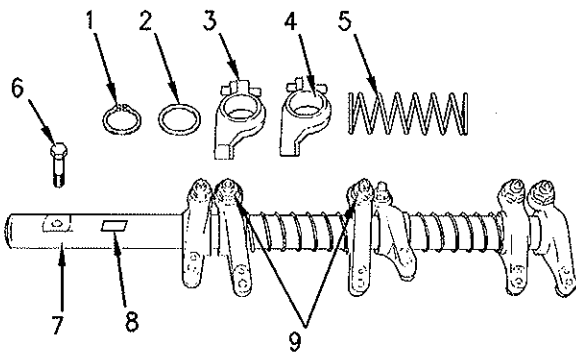

Illustration 15

g00985174

The rocker shaft

- (1) Snap ring
- (2) Washer
- (3) Rocker arm
- (4) Rocker arm bore

Diameter of the rocker arm bore for the bushing 25.01 to 25.05 mm
(0.9847 to 0.9862 inch)

Rocker arm bushing

Clearance between the rocker arm bushing and the rocker shaft 0.03 to 0.09 mm
(0.0010 to 0.0035 inch)

Maximum permissible clearance between the rocker arm bushing and the rocker shaft 0.17 mm (0.007 inch)

- (5) Spring

Note: Install the longest screw at the front of the rocker shaft assembly.

- (6) Tighten the screws evenly. Begin in the center and work toward the outside. Tighten the screws to the following torque. 35 N·m (26 lb ft)

- (7) Rocker shaft

Diameter of the rocker shaft .. 24.96 to 24.99 mm
(0.9827 to 0.9839 inch)

- (8) In order to install the rocker shaft assembly, ensure that the machined square is to the top of the rocker shaft.

- (9) Locknut

Torque for the locknut 27 N·m (20 lb ft)

Note: In order to install the rocker shaft assembly, the tool 27610227 Spacing Tool is required.

i01948695

Valve Mechanism Cover

The Cover for the Four Cylinder Engine

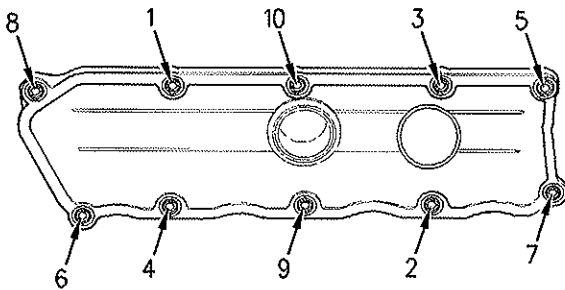

Illustration 16
Cover

g00908011

Tighten the bolts for the valve mechanism cover in the sequence that is shown to the following torque. 9 N·m (7 lb ft)

The Cover for the Three Cylinder Engine

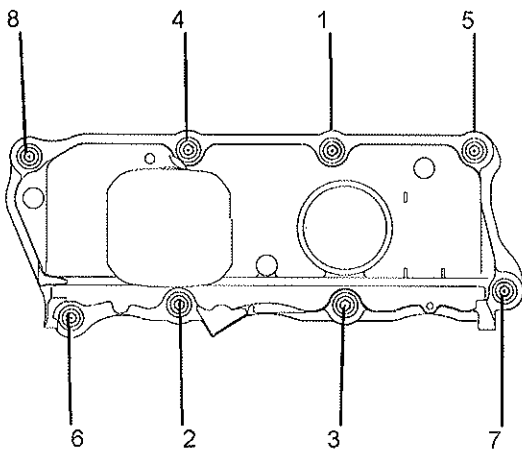

Illustration 17
Cover

g01018519

Tighten the bolts for the valve mechanism cover in the sequence that is shown to the following torque. 9 N·m (7 lb ft)

i01958092

Cylinder Head Valves

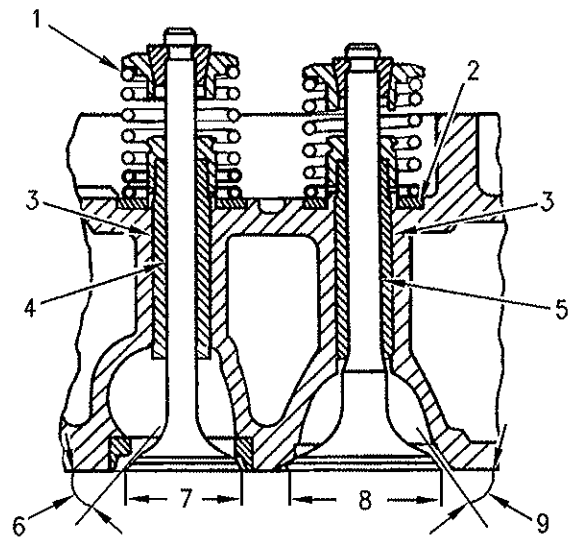

Illustration 18
Cross section of cylinder head

g00294082

(1) Valve spring

Naturally aspirated engines

The installed length of the valve springs 33.5 mm (1.318 inch)

The load for the installed valve springs 254 N (57.1 lb)

Turbocharged engines

The installed length of the valve springs 34.5 mm (1.358 inch)

The load for the installed valve spring 229 N (51.4 lb)

(2) Valve spring recess

(3) The finished valve guides

Inside diameter of valve guide 9.000 to 9.022 mm (0.3543 to 0.3552 inch)

Outside diameter of the exhaust valve guide 13.034 to 13.047 mm (0.5131 to 0.5137 inch)

- Outside diameter of the inlet valve guide 13.034 to 13.047 mm (0.5131 to 0.5137 inch)
- Interference fit of valve guide in cylinder head 0.007 to 0.047 mm (0.0003 to 0.0019 inch)
- Length of Valve guide 51.00 to 51.50 mm (2.018 to 2.027 inch)
- Projection of the valve guide above the valve spring recess (2) 12.35 to 12.65 mm (0.486 to 0.498 inch)

Note: When new valve guides are installed, new valves and new valve seat inserts must be installed. The valve guides and the valve seat inserts are supplied as partially finished parts. The unfinished valve guides and unfinished valve seat inserts are installed in the cylinder head. The guides and inserts are then cut and reamed in one operation with special tooling. This procedure ensures the concentricity of the valve seat to the valve guide in order to create a seal that is tight. Refer to the Disassembly and Assembly Manual for removal and installation procedures.

(4) Exhaust valve

- Diameter of the exhaust valve stem 8.938 to 8.960 mm (0.3519 to 0.3528 inch)

Clearance of valve in valve guide 0.040 to 0.840 mm (0.0016 to 0.033 inch)

Overall length of the exhaust valve 128.92 to 129.37 mm (5.075 to 5.093 inch)

The face of the exhaust valve is recessed below the cylinder head by the following amount.

- Naturally aspirated engines 0.53 to 0.81 mm (0.021 to 0.032 inch)
- Service limit 1.06 mm (0.042 inch)
- Turbocharged engines 1.53 to 1.81 mm (0.060 to 0.071 inch)
- Service limit 2.06 mm (0.0811 inch)

(5) Inlet valve

- Diameter of the inlet valve stem 8.953 to 8.975 mm (0.3525 to 0.3533 inch)
- Clearance of valve in valve guide .. 0.025 to 0.069 mm (0.001 to 0.0027 inch)

Overall length of the inlet valve 128.92 to 129.37 mm (5.075 to 5.093 inch)

The face of the inlet valve is recessed below the cylinder head by the following amount.

- Naturally aspirated engines 0.58 to 0.84 mm (0.023 to 0.033 inch)
- Service limit 1.09 mm (0.043 inch)
- Turbocharged engines 1.58 to 1.84 mm (0.062 to 0.072 inch)
- Service limit 2.09 mm (0.0823 inch)

(6) Exhaust valve face angle from the vertical axis

- Valve face angle 30 degrees
- Valve seat angle 30 degrees

(7) Diameter of the exhaust valve head

- 41.51 to 41.75 mm (1.634 to 1.643 inch)

(8) Diameter of the head of the inlet valve

- 46.20 to 46.45 mm (1.818 to 1.828 inch)

(9) Angle of the inlet valve face from the vertical axis

- Valve face angle 30 degrees
- Valve seat angle 30 degrees

The valve lash is the following value when the engine is cold:

- Inlet valves 0.20 mm (0.008 inch)
- Exhaust valves 0.45 mm (0.018 inch)

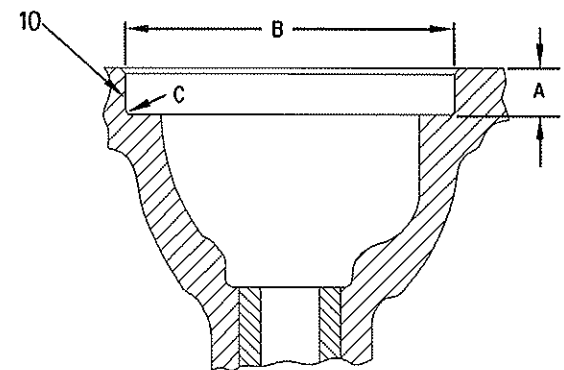

Illustration 19

g00809016

Recess for the valve seat insert

(10) Machine the recess in the head for valve seat inserts to the following dimensions.

Recess for Inlet Valve Seat for Naturally Aspirated Engines

- (A) .. 9.910 to 10.040 mm (0.3901 to 0.3952 inch)
- (B) 47.820 to 47.845 mm (1.8826 to 1.8836 inch)
- (C) Maximum radius 0.38 mm (0.015 inch)

Recess for Exhaust Valve Seat for Naturally Aspirated Engines

- (A) .. 9.910 to 10.040 mm (0.3901 to 0.3952 inch)
- (B) 42.420 to 42.445 mm
(1.6701 to 1.6711 inch)
- (C) Maximum radius 0.38 mm (0.015 inch)

Recess for Inlet Valve Seat for Turbocharged Engines

- (A) 10.910 to 11.040 mm
(0.4295 to 0.4346 inch)
- (B) 47.820 to 47.845 mm
(1.8826 to 1.8836 inch)
- (C) Maximum radius 0.38 mm (0.015 inch)

Recess for Exhaust Valve Seat for Turbocharged Engines

- (A) 10.910 to 11.040 mm
(0.4295 to 0.4346 inch)
- (B) 42.420 to 42.445 mm
(1.6700 to 1.6710 inch)
- (C) Maximum radius 0.38 mm (0.015 inch)

i01899306

Cylinder Head

The maximum distortion of the cylinder head is given in table 3.

Table 2

Required Tools		
Part Number	Part Description	Qty
21825607	Angle gauge	1

The cylinder head bolts are two different lengths. The following information provides the proper torque for the cylinder head bolts.

Four Cylinder engine

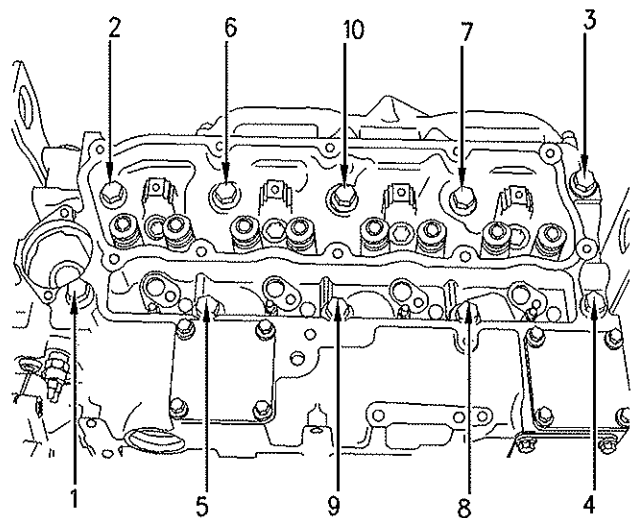

Illustration 20
The tightening sequence

g00967480

Three Cylinder engine

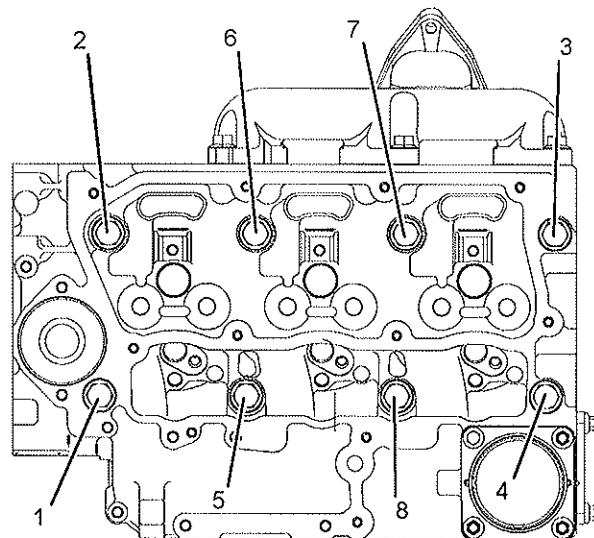

Illustration 21
The tightening sequence

g01017007

Lubricate the threads and the underside of the head bolts with clean engine oil.

Tighten the bolts in the sequence that is shown in illustrations to the following torque. 50 N·m
(37 lb ft)

Tighten the bolts again to the following torque. 100 N·m (74 lb ft)

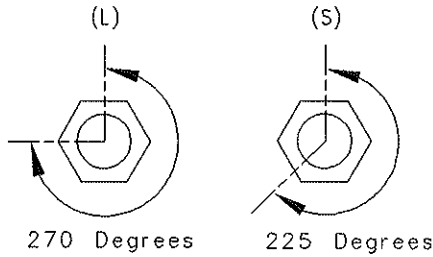

Illustration 22

g00905621

The head bolts require an additional torque turn procedure. The numbers (1, 3, 4) are three long cylinder head bolts. All the other bolts are short bolts. The tightening sequence is shown in the Illustrations .

Place the angle gauge on the top of each bolt head. Tighten the short bolts to the additional amount. 225 degrees
Place the angle gauge on the top of each bolt head. Tighten the long bolts for the additional amount. 270 degrees

Thickness of the cylinder head .. 117.95 to 118.05 mm
(4.643 to 4.647 inch)

Minimum thickness of cylinder head 117.20 mm
(4.614 inch)

Note: The maximum distortion of the cylinder head is given in table 3.

Four Cylinder Engine

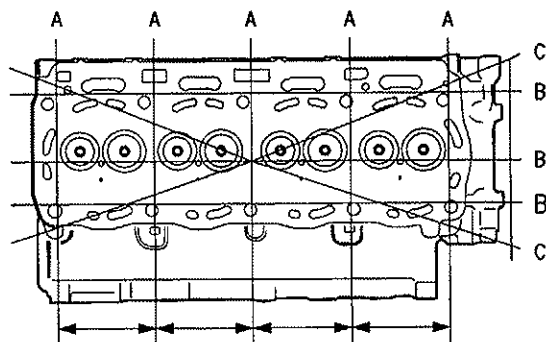

Illustration 23

g01006568

Three Cylinder Engine

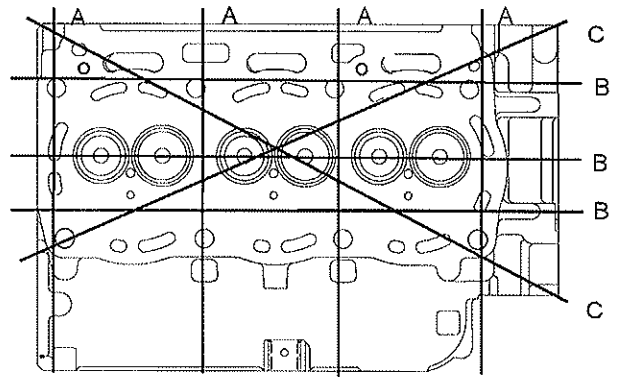

Illustration 24

g01017008

Table 3

Dimension	Maximum Permissible Distortion
Width (A)	0.03 mm (0.0018 inch)
Length (B)	0.05 mm (0.0019 inch)
Diagonal Line (C)	0.05 mm (0.0019 inch)

i02224103

Turbocharger

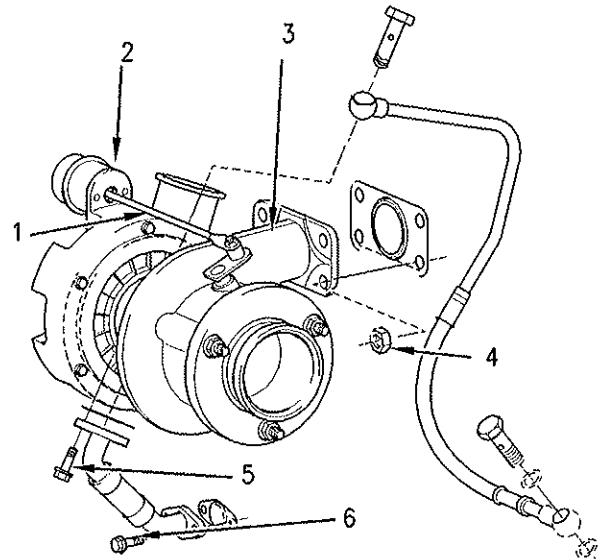

Illustration 25

g00991357

Typical turbocharger

- (1) Actuator rod
- (2) Actuator
- (3) Turbocharger

- (4) Tighten the nuts to the following torque. ... 47 N·m (34 lb ft)
- (5) Tighten the bolt to the following torque. 9 N·m (80 lb in)
- (6) Tighten the bolt to the following torque. ... 22 N·m (16 lb ft)

The maximum test pressure for the waste gate 205 kPa (30 psi)

The movement for the rod actuator 1 mm (0.0394 inch)

Four Cylinder Engine

Table 4

The part number for the turbocharger	The pressure for the waste gate
2674A200	100 ± 5 kPa (14.5040 ± 0.7252 psi)
2674A201	110 ± 5 kPa (15.9544 ± 0.7252 psi)
2674A202	128 ± 5 kPa (18.5651 ± 0.7252 psi)
2674A209	100 ± 5 kPa (14.5040 ± 0.7252 psi)
2674A211	128 ± 5 kPa (18.5651 ± 0.7252 psi)
2674A215	128 ± 5 kPa (18.5651 ± 0.7252 psi)
2674A223	136 ± 5 kPa (19.7254 ± 0.7252 psi)
2674A224	136 ± 5 kPa (19.7254 ± 0.7252 psi)
2674A225	136 ± 5 kPa (19.7254 ± 0.7252 psi)
2674A226	100 ± 5 kPa (14.5040 ± 0.7252 psi)
2674A227	128 ± 5 kPa (18.5651 ± 0.7252 psi)

Three Cylinder Engine

Table 5

The part number for the turbocharger	The pressure for the waste gate
2674A405	100 ± 3 kPa (14.5040 ± 0.4351 psi)
2674A421	100 ± 3 kPa (14.5040 ± 0.4351 psi)
2674A422	200 ± 3 kPa (29.0080 ± 0.4351 psi)

i01957427

Exhaust Manifold

Four Cylinder Engine

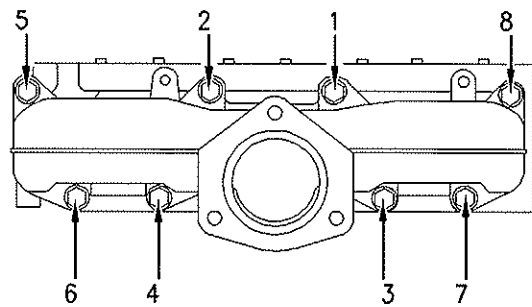

Illustration 26

g00907527

Tightening sequence

Note: The exhaust manifold must be aligned to the cylinder head. Refer to the Disassembly and Assembly manual.

Tighten the exhaust manifold bolts in the sequence that is shown in illustration 26 to the following torque. 33 N·m (24 lb ft)

Three Cylinder Engine

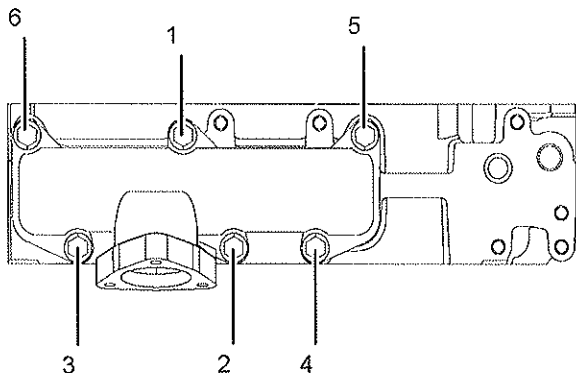

Illustration 27

g01017009

Note: The exhaust manifold must be aligned to the cylinder head. Refer to the Disassembly and Assembly manual.

Tighten the exhaust manifold bolts in the sequence that is shown illustration 27 to the following torque. 33 N-m (24 lb ft)

i01956585

Camshaft

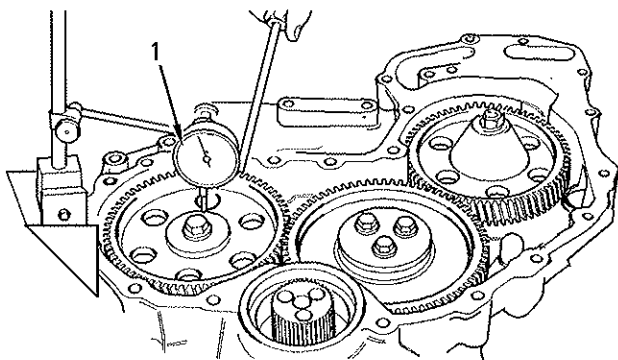

Illustration 28

g00987750

Checking the end play of the camshaft

(1) End play of a new camshaft 0.10 to 0.55 mm (0.004 to 0.022 inch)

Maximum permissible end play of a worn camshaft 0.60 mm (0.023 inch)

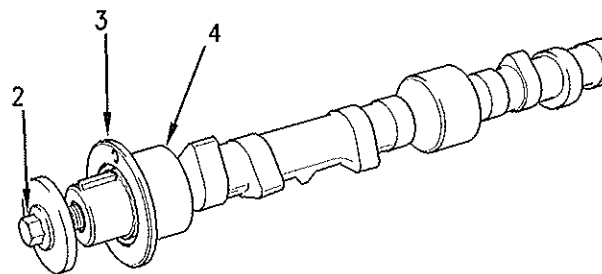

Illustration 29

g00976195

Typical camshaft

(2) Bolt

Tighten the bolt to the following torque. ... 95 N-m (70 lb ft)

(3) Camshaft thrust washer

Thickness of the thrust washer .. 5.49 to 5.54 mm (0.216 to 0.218 inch)

Depth of the recess in the cylinder block for the thrust washer 5.54 to 5.64 mm (0.218 to 0.222 inch)

Tolerance of the thrust washer in cylinder block front face -0.154 to -0.003 mm (-0.0006 to -0.0001 inch)

(4) The diameters of the camshaft journals are given in the following tables.

Table 6

1104 Diameters of Camshaft Journals	
Camshaft Journals	Standard Diameter
1	50.71 to 50.74 mm (1.9965 to 1.9975 inch)
2	50.46 to 50.48 mm (1.9865 to 1.9875 inch)
3	49.95 to 49.98 mm (1.9665 to 1.9675 inch)

Table 7

1103 Diameters of Camshaft Journals	
Camshaft Journals	Standard Diameter
1	50.71 to 50.74 mm (1.9965 to 1.9975 inch)
2	50.46 to 50.48 mm (1.9865 to 1.9875 inch)
3	50.46 to 50.48 mm (1.9865 to 1.9875 inch)
4	49.95 to 49.98 mm (1.9665 to 1.9675 inch)

Maximum wear on the camshaft journals ... 0.05 mm
(0.0021 inch)

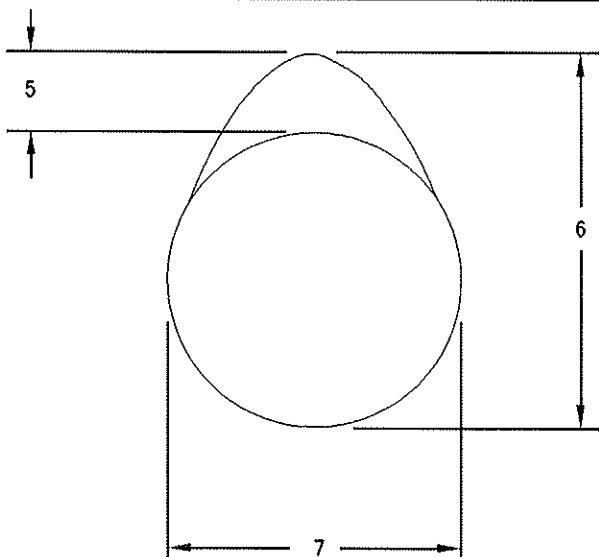

Illustration 30

g00629702

(5) Camshaft lobe lift

Naturally aspirated

Inlet lobe 7.382 to 7.482 mm
(0.2906 to 0.2946 inch)

Exhaust lobe 7.404 to 7.504 mm
(0.2914 to 0.2954 inch)

Turbocharged

Inlet lobe 7.031 to 7.130 mm
(0.2768 to 0.2807 inch)

Exhaust lobe 7.963 to 8.063 mm
(0.3135 to 0.3174 inch)

(6) Camshaft lobe height

(7) Base circle

To determine the lobe lift, use the procedure that follows:

1. Measure the camshaft lobe height (6).
2. Measure the base circle (7).
3. Subtract the base circle that is found in Step 2 from the camshaft lobe height that is found in Step 1. The difference is the actual camshaft lobe lift.

Maximum permissible clearance between the actual lobe lift and the specified lobe lift of a new camshaft 0.05 mm (0.021 inch)

i01914527

Camshaft Bearings

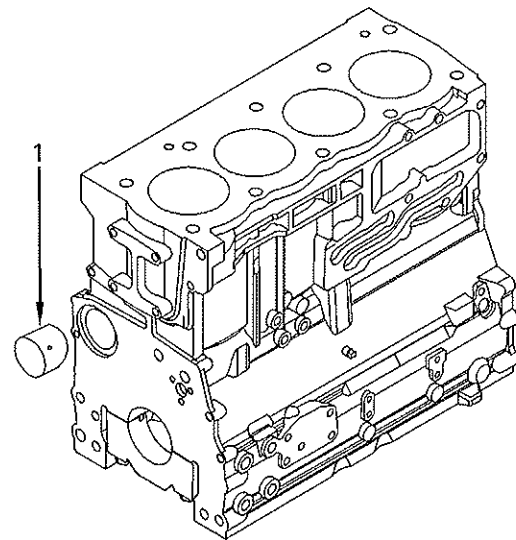

Illustration 31

g00997348

A typical four cylinder engine

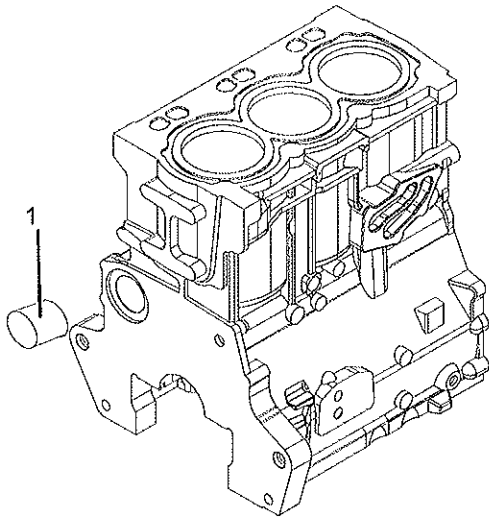

Illustration 32 g01017012
A three cylinder engine

(1) Camshaft bearing

The diameter for the installed camshaft bearing 50.790 to 50.850 mm (1.9996 to 2.0020 inch)

i01958095

Engine Oil Filter

Spin-on Oil Filter

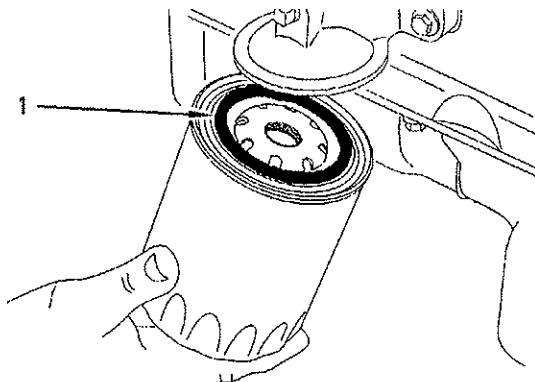

Illustration 33 g00915984

(1) Seal

Note: Lubricate the top of the seal with clean engine oil before installation.

Type Full flow

Pressure to open engine oil filter bypass valve 80 to 120 kPa (12 to 18 psi)

Replaceable Element

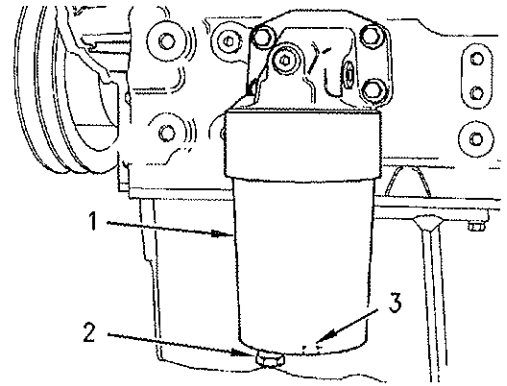

Illustration 34 g00915885

Note: Lubricate the seal on the oil filter housing with clean engine oil before installation.

Type Full flow

Pressure to open engine oil filter bypass valve 130 to 170 kPa (19 to 25 psi)

- (1) Tighten the oil filter housing to the oil filter base to the following torque. 25 N·m (18 lb ft)
- (2) Tighten the drain plug on the oil filter housing to the following torque. 12 N·m (9 lb ft)

Note: The horizontal filter as a drain plug in the filter head

- (3) Recess for 1/2 inch square drive

i01957426

Engine Oil Pump

Four Cylinder Engines with Balancer Group

Type Gear-driven differential rotor

Number of lobes

Inner rotor 6
Outer rotor 7

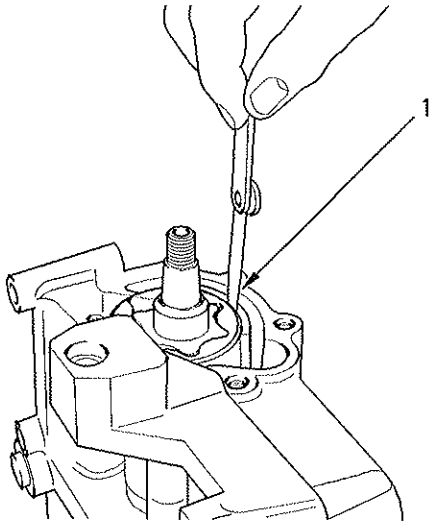

Illustration 35 g00989248
The oil pump for the balancer

(1) Clearance of the outer rotor to the body .. 0.130 to 0.24 mm (0.0050 to 0.0094 inch)

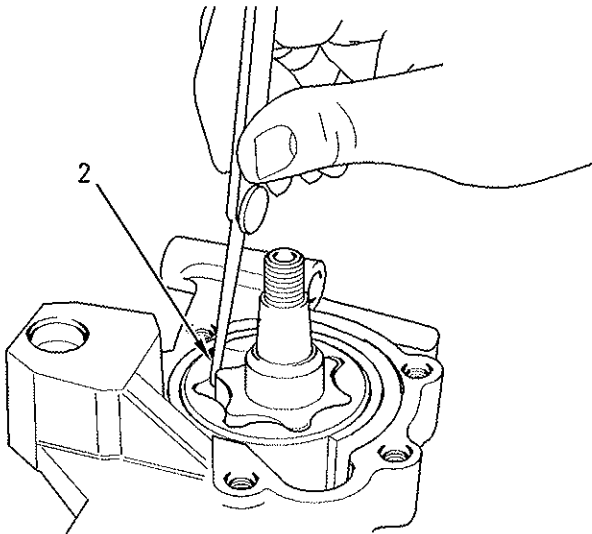

Illustration 36 g00989236
Inner rotor

(2) Clearance of inner rotor to outer rotor 0.050 to 0.200 mm (0.0020 to 0.0079 inch)

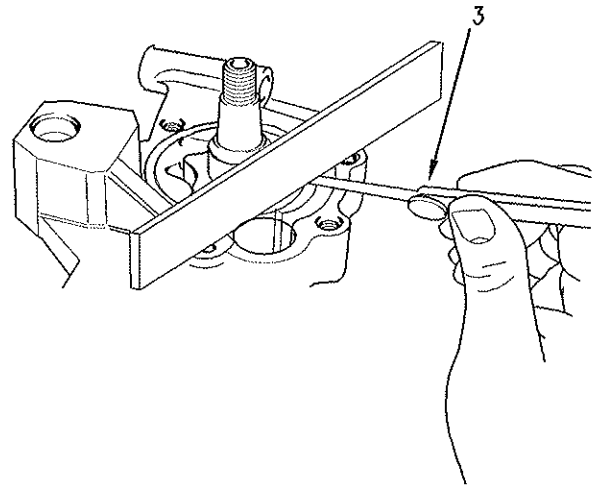

Illustration 37 g00989217
The end play for the rotor

(3) End play of rotor assembly

Inner rotor	0.04 to 0.11 mm (0.0016 to 0.0043 inch)
Outer rotor	0.04 to 0.00 mm (0.0016 to 0.0043 inch)

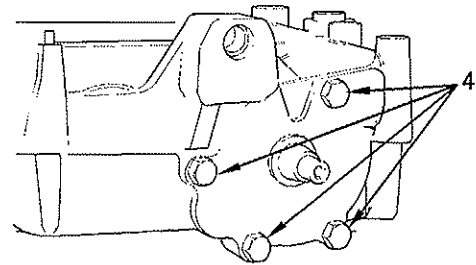

Illustration 38 g00938724
The end cover

(4) Torque for cover bolts for oil pump 26 N·m (19 lb ft)

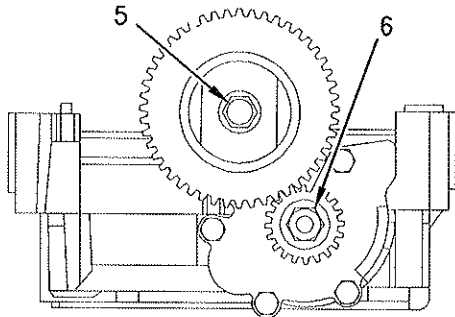

Illustration 39 g00989519
Idler gear and pump gear

Note: Replace the idler gear bolt (5) and the nut for the oil pump gear (6).

- (5) Tighten the idler gear bolt to the following torque. 26 N·m (19 lb ft)

Note: Set the engine to the TC position. Refer to Testing and Adjusting , "Finding Top Center Position for No. 1 Piston". Install the balancer. Refer to the Disassembly and Assembly manual. Install the gear for the oil pump and tighten the nut (6).

- (6) Tighten the nut to the following torque. 95 N·m (70 lb ft)

Tighten the bolts that hold the balancer to the cylinder block to the following torque. 54 N·m (40 lb ft)

Four Cylinder and Three Cylinder Engines without Balancer Group

Type Gear-driven differential rotor

Number of lobes

Inner rotor	5
Outer rotor	6

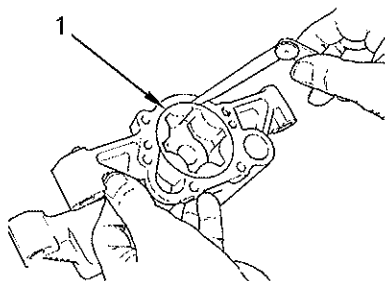

Illustration 40 g00938064
The oil pump

- (1) Clearance of the outer rotor to the body 0.152 to 0.330 mm (0.0059 to 0.0129 inch)

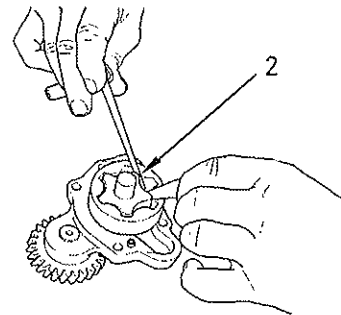

Illustration 41 g00938061
Checking the clearance

- (2) Clearance of inner rotor to outer rotor 0.040 to 0.127 mm (0.0015 to 0.0050 inch)

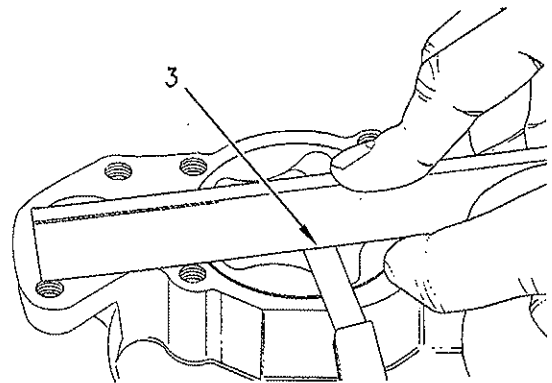

Illustration 42 g00938799
Checking the end play

- (3) End play of rotor assembly
 - Inner rotor 0.038 to 0.089 mm (0.0014 to 0.0035 inch)
 - Outer rotor 0.025 to 0.076 mm (0.0010 to 0.0029 inch)

Tighten the bolts that hold the front cover of the oil pump assembly to the following torque. 26 N·m (19 lb ft)

i01958104

Engine Oil Pressure

The minimum oil pressure at the maximum engine speed and at normal operating temperature is the following value. 300 kPa (43 psi)

i01958107

Engine Oil Bypass Valve

Installed in the Oil Pump

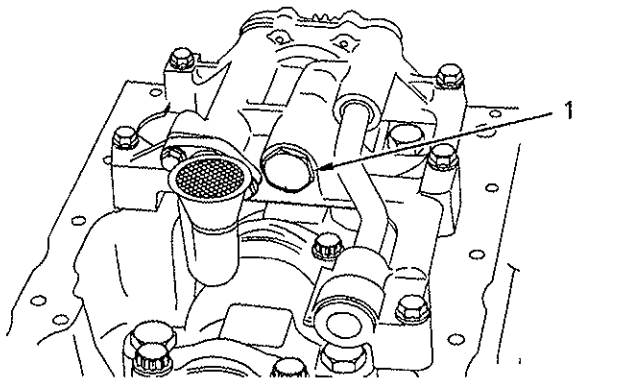

Illustration 43
Typical engine oil pump

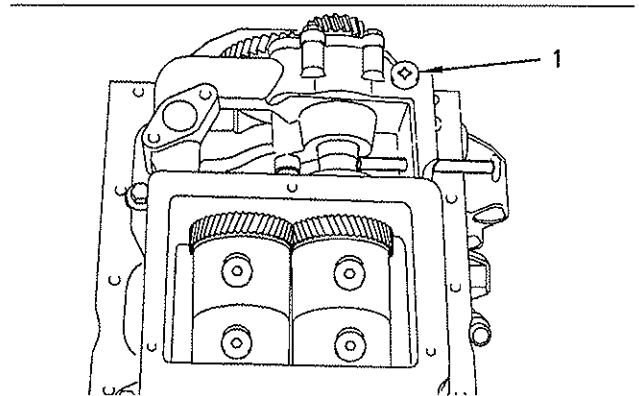

Illustration 45
Plug

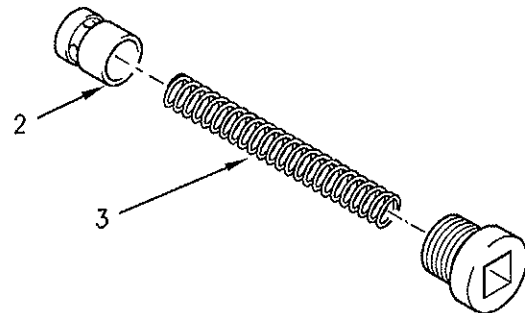

Illustration 46
The relief valve for the balancer

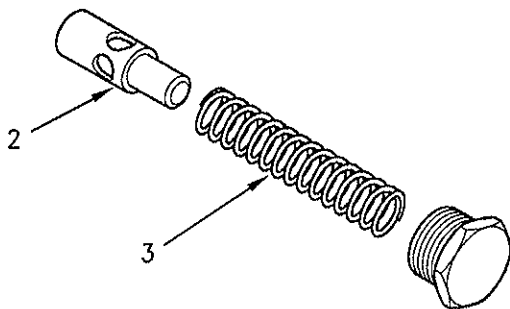

Illustration 44
Relief valve and spring

(1) Tighten the plug for the relief valve to the following torque. 35 N·m (26 lb ft)

(2) Plunger

Diameter of the plunger 19.186 to 19.211 mm
(0.7554 to 0.7563 inch)

Clearance of plunger in bore .. 0.039 to 0.114 mm
(0.0015 to 0.0045 inch)

(1) Tighten the plug for the relief valve to the following torque. 35 N·m (26 lb ft)

(2) Plunger

Diameter of the plunger 14.46 to 14.48 mm
(0.5692 to 0.5700 inch)

Clearance of the plunger in the bore 0.04 to 0.08 mm (0.0015 to 0.0031 inch)

Installed in the Balancer

1104 engines only

i02242687

Engine Oil Pan

Front sealant

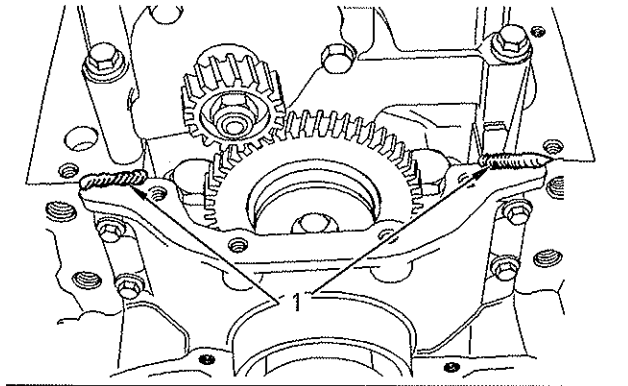

Illustration 47
Applying sealant

- (1) Apply 1861108 Powerpart silicone rubber sealant to the cylinder block and to the timing case.

Note: Apply a sealant bead of 3.5 mm (0.1378 inch) that is shown in illustration 47.

Rear sealant

Note: Install the rear oil seal before sealant is applied to the bridge.

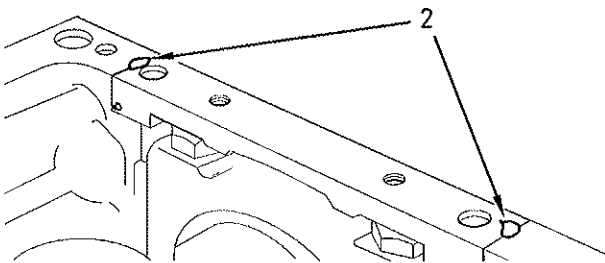

Illustration 48
Applying sealant

- (2) Apply 1861108 Powerpart silicone rubber sealant to the bridge. The sealant must not protrude more than 5 mm (0.1969 inch) above the bridge.

Note: The oil pan must be installed within 10 minutes of applying the sealant.

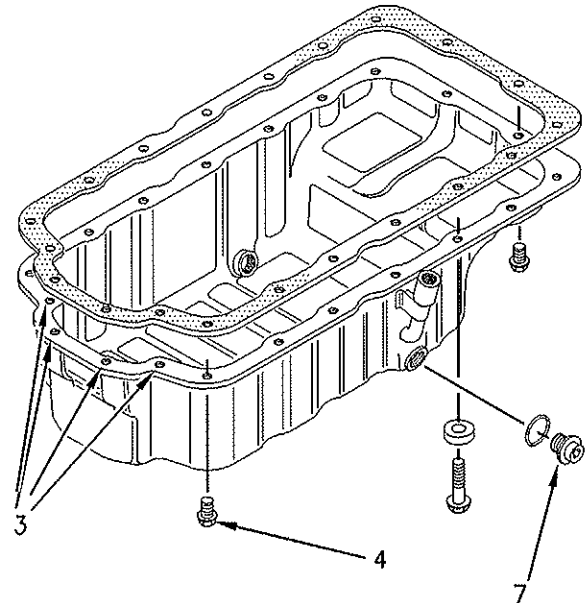

Illustration 49
Typical oil pan

- (3) Tighten the four front bolts to the following torque. 22 N·m (16 lb ft)
- (4) Tighten the remaining bolts to the following torque. 22 N·m (16 lb ft)

The cast iron oil pan

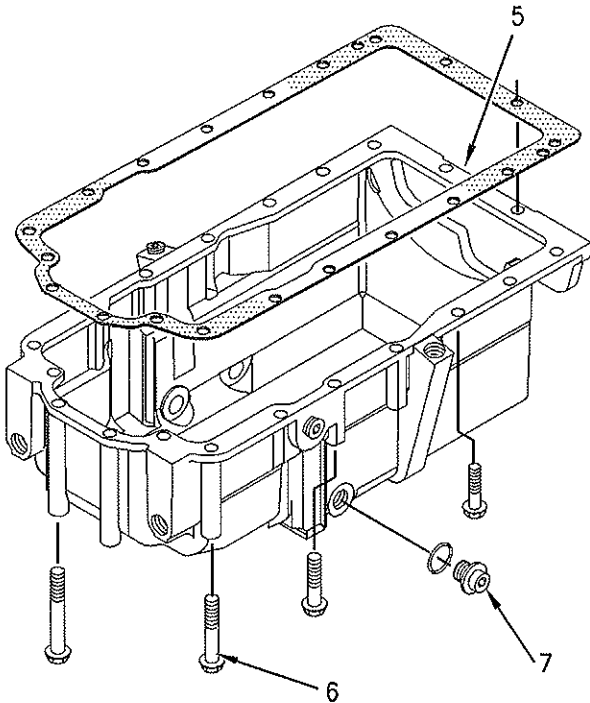

Illustration 50

g00990249

The cast iron oil pan

Note: The rear face of the cast iron oil pan (5) must be aligned to the rear face of the cylinder block.

(5) The maximum allowed value of the rear face misalignment. 0.1 mm (0.0039 inch)

(6) Bolt

Tighten the front four bolts. Refer to illustration 49. Tighten the remaining bolts and the nuts that fasten the engine oil pan to the cylinder block to the following torque. 22 N·m (16 lb ft)

Note: The sealant is applied to new bolts. In order to reuse the bolts, apply 21820117 Powerpart threadlock and nutlock to the first three threads of the used bolts.

Note: The engine may be equipped with an oil drain plug or the engine may be equipped with a drain valve.

(7) Drain plug

Tighten the drain plug for the engine oil pan to the following torque. 34 ± 5 N·m (25 ± 4 lb ft)

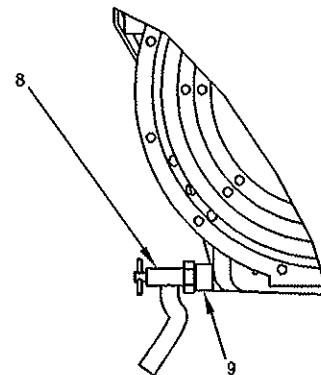

Illustration 51

g00990677

The drain valve

(8) Drain valve

Tighten the drain valve into the adapter to the following torque. 34 ± 5 N·m (25 ± 4 lb ft)

(9) Adapter

Tighten the adapter into the engine oil pan to the following torque. 34 ± 5 N·m (25 ± 4 lb ft)

i02224176

Crankcase Breather

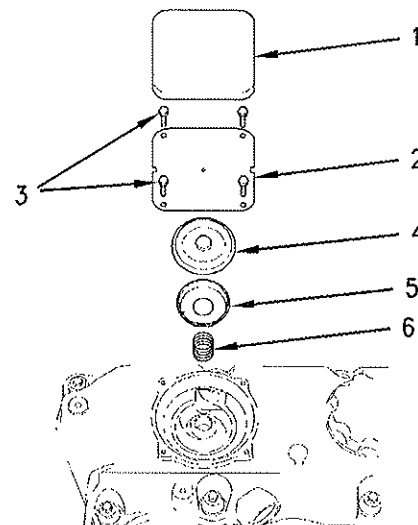

Illustration 52

g00926199

Breather valve

(1) Plastic cover

(2) Cover plate

(3) Screws

Tighten the screws for the cover plate with a plastic valve mechanism cover to the following torque. 1.3 N·m (11.5 lb in)
Tighten the screws for the cover plate with a metal valve mechanism cover to the following torque. 1.8 N·m (16 lb in)

(4) Diaphragm

(5) Cap

(6) Spring

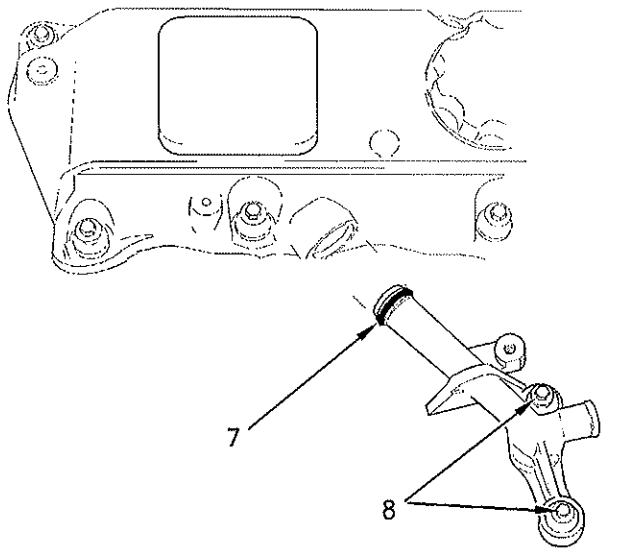

Illustration 53

g00926200

(7) O-ring

Note: Apply 21820221 Powerpart red rubber grease to the O-ring before installing the breather pipe in the valve mechanism cover.

(8) Tighten the bolts that secure the breather pipe to the cylinder head to the following torque. ... 9 N·m (80 lb in)

Engine model DK and DJ

Note: These three cylinder engines do not have a breather valve in the valve mechanism cover.

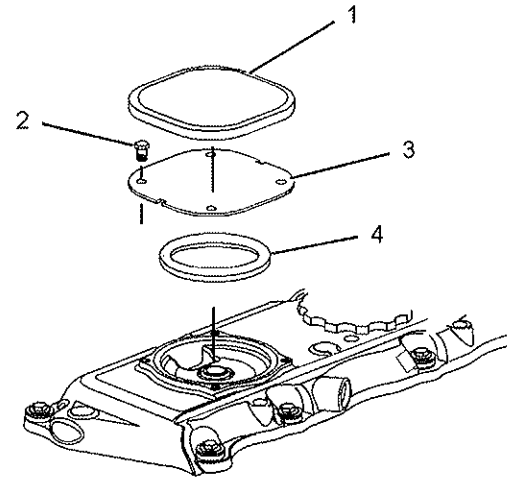

Illustration 54

g01121867

- (1) Plastic cover
- (2) Screw
- (3) Cover plate
- (4) Seal

(2) Tighten the screws for the cover plate with a plastic valve mechanism cover to the following torque. 1.3 N·m (11.5 lb in)

i01914256

Water Temperature Regulator and Housing

Tighten the bolts (not shown) that fasten the housing to the following torque. 22 N·m (16 lb ft)

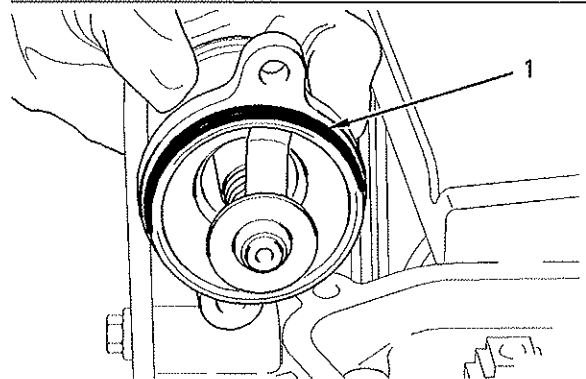

Illustration 55

g00997234

O ring

Note: Apply 21820221 Powerpart red rubber grease to the O-ring (1) in order to install the thermostat housing.

Water Temperature Regulator

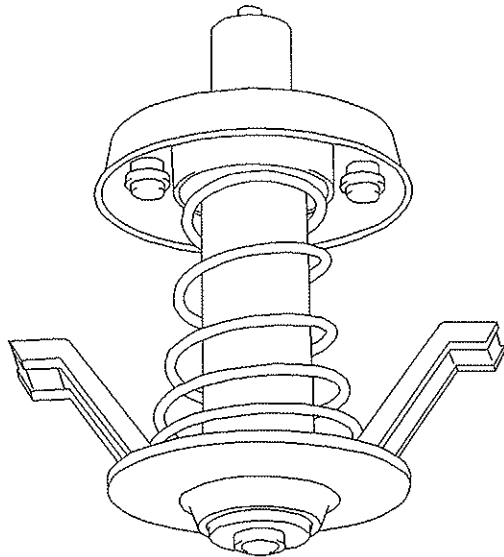

Illustration 56 g00906121
A typical water temperature regulator

Opening temperature 79 ° to 84 °C
(174 ° to 151 °F)

Full opening temperature 93 °C (199 °F)

Minimum stroke at full open temperature 10 mm
(0.3937 inch)

i01904883

Water Pump

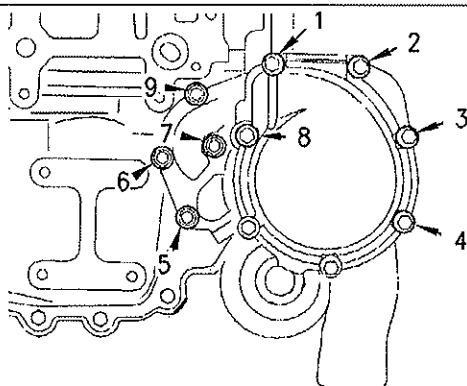

Illustration 57 g00915951
Tightening sequence

Note: Apply 21820117 Powerpart threadlock nutlock to the first three threads of the bolts before installation.

Tighten the nine bolts that secure the water pump to the front housing in the numerical sequence that is shown to the following torque. 22 N·m (16 lb ft)

Note: Refer to the Disassembly and Assembly manual in order to service the water pump.

i01908154

Cylinder Block

Four Cylinder Engine

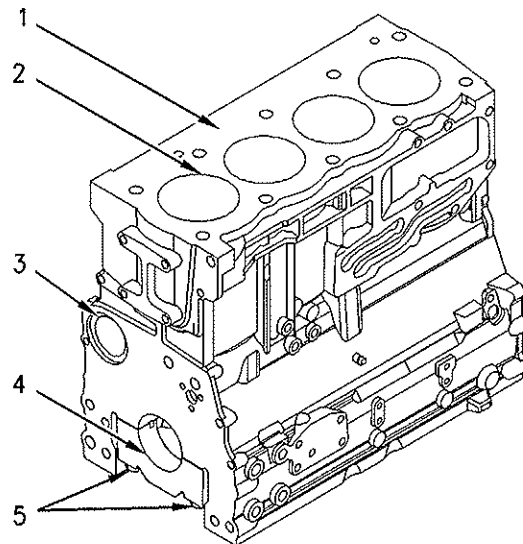

Illustration 58 g00924764
Cylinder block

- (1) Cylinder block
- (2) Cylinder bore 105.000 to 105.025 mm
(4.1338 to 4.1348 inch)
- The first oversize bore diameter 105.5 to 105.525 mm
(4.1535 to 4.1545 inch)
- The second oversize bore diameter 106.000 to 106.025 mm
(4.1732 to 4.1742 inch)
- The maximum permissible wear for the cylinder bore 0 to 0.15 mm (0 to 0.0059 inch)

(3) Camshaft bearings for the four cylinder engine

Diameter of the bore in the cylinder block for the number 1 camshaft bearing 55.563 to 55.593 mm
(2.1875 to 2.1887 inch)

Diameter of the bore in the cylinder block for the number 2 camshaft journal 50.546 to 50.597 mm (1.9900 to 1.9920 inch)

Diameter of the bore in the cylinder block for the number 3 camshaft journal 50.038 to 50.089 mm (1.9700 to 1.9720 inch)

(4) Main bearings for the four cylinder engine

Bore in the cylinder block for the main bearings 80.416 to 80.442 mm (3.1660 to 3.1670 inch)

(5) Main bearing cap bolts for the four cylinder engine

Use the following procedure in order to install the main bearing cap bolts:

1. Apply clean engine oil to the threads of the main bearing cap bolts.
2. Put the main bearing caps in the correct position that is indicated by a number on the top of the main bearing cap. Install the main bearing caps with the locating tabs in correct alignment with the recess in the cylinder block.
3. Evenly tighten the main bearing cap bolts.

Torque for the main bearing cap bolts. 245 N·m (180 lb ft)

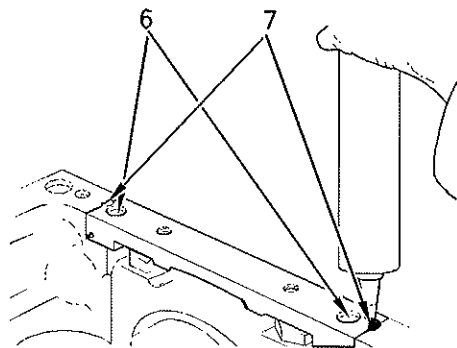

Illustration 59

g00938203

Use the following procedure in order to install the Allen head bolts for the bridge.

Note: Install the rear seal before sealant is applied.

1. Use a straight edge in order to ensure that the bridge is aligned with the rear face of the cylinder block.
2. Tighten the Allen head bolts (6) for the bridge.

Torque for the Allen head bolts .. 16 N·m (12 lb ft)

3. When the bridge is installed on the cylinder block, apply 21826038 POWERPART Silicon Adhesive into groove (7) at each end of the bridge. Apply the sealant into the groove until the sealant is forced through the bottom end of the groove in the bridge.

Total height of the cylinder block between the top and the bottom faces. 441.173 to 441.274 mm (17.3689 to 17.3729 inch)

Three Cylinder Engine

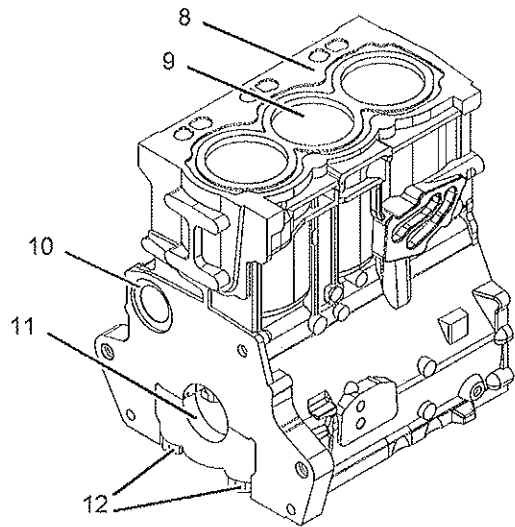

Illustration 60

g01018250

(8) Cylinder block

(9) Cylinder bore 105.000 to 105.025 mm (4.1338 to 4.1348 inch)

The first oversize bore diameter 105.5 to 105.525 mm (4.1535 to 4.1545 inch)

The second oversize bore diameter 106.000 to 106.025 mm (4.1732 to 4.1742 inch)

The maximum permissible wear for the cylinder bore 0 to 0.15 mm (0 to 0.0059 inch)

(10) Camshaft bearings for the four cylinder engine

Diameter of the bore in the cylinder block for the number 1 camshaft bearing 55.563 to 55.593 mm (2.1875 to 2.1887 inch)

Diameter of the bore in the cylinder block for the number 2 camshaft journal 50.546 to 50.597 mm (1.9900 to 1.9920 inch)

Diameter of the bore in the cylinder block for the number 3 camshaft journal 50.546 to 50.597 mm
(1.9900 to 1.9920 inch)

Diameter of the bore in the cylinder block for the number 4 camshaft journal 50.038 to 50.089 mm
(1.9700 to 1.9720 inch)

(11) Main bearings for the three cylinder engine

Bore in the cylinder block for the main bearings 80.416 to 80.442 mm
(3.1660 to 3.1670 inch)

(12) Main bearing cap bolts for the four cylinder and three cylinder engines

Use the following procedure in order to install the main bearing cap bolts:

1. Apply clean engine oil to the threads of the main bearing cap bolts.
2. Put the main bearing caps in the correct position that is indicated by a number on the top of the main bearing cap. Install the main bearing caps with the locating tabs in correct alignment with the recess in the cylinder block.

3. Evenly tighten the main bearing cap bolts.

Torque for the main bearing cap bolts. 245 N·m
(180 lb ft)

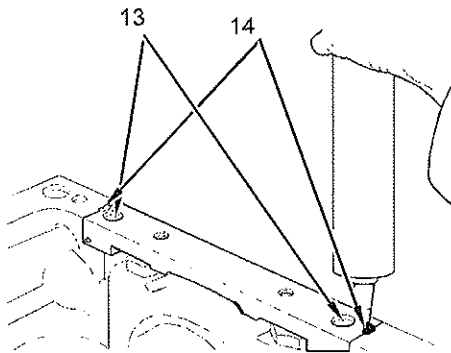

Illustration 61

g01018262

Use the following procedure in order to install the Allen head bolts for the bridge.

Note: Install the rear seal before sealant is applied.

1. Use a straight edge in order to ensure that the bridge is aligned with the rear face of the cylinder block.

2. Tighten the Allen head bolts (13) for the bridge.

Torque for the Allen head bolts .. 16 N·m (12 lb ft)

3. When the bridge is installed on the cylinder block, apply 21826038 POWERPART Silicon Adhesive into groove (14) at each end of the bridge. Apply the sealant into the groove until the sealant is forced through the bottom end of the groove in the bridge.

Total height of the cylinder block between the top and the bottom faces. 441.173 to 441.274 mm
(17.3689 to 17.3729 inch)

i01956920

Crankshaft

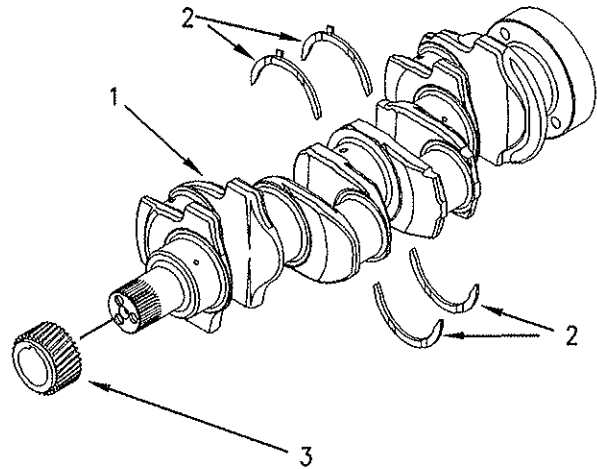

Illustration 62

g00992214

The crankshaft for the four cylinder engine

(1) Crankshaft for the four cylinder engine

The maximum end play of the crankshaft ... 0.51 mm
(0.0201 inch)

(2) Thrust washers

Standard thickness 2.26 to 2.31 mm
(0.089 to 0.091 inch)

Oversize thickness 2.45 to 2.50 mm
(0.097 to 0.098 inch)

(3) The crankshaft gear

Maximum permissible temperature of the gear for installation on the crankshaft 180 °C (356 °F)

Note: The timing mark is toward the outside of the crankshaft when the gear is installed on the crankshaft.

Note: All new turbocharged engines and turbocharged aftercooled engines have crankshafts that are nitrocarburised. The crankshaft can also be nitrided for 20 hours, if the nitrocarburised process is not available. After a crankshaft has been machined, the crankshaft must be rehardened. Inspect the crankshaft for cracks before machining and after machining. Naturally aspirated engines have induction hardened crankshafts.

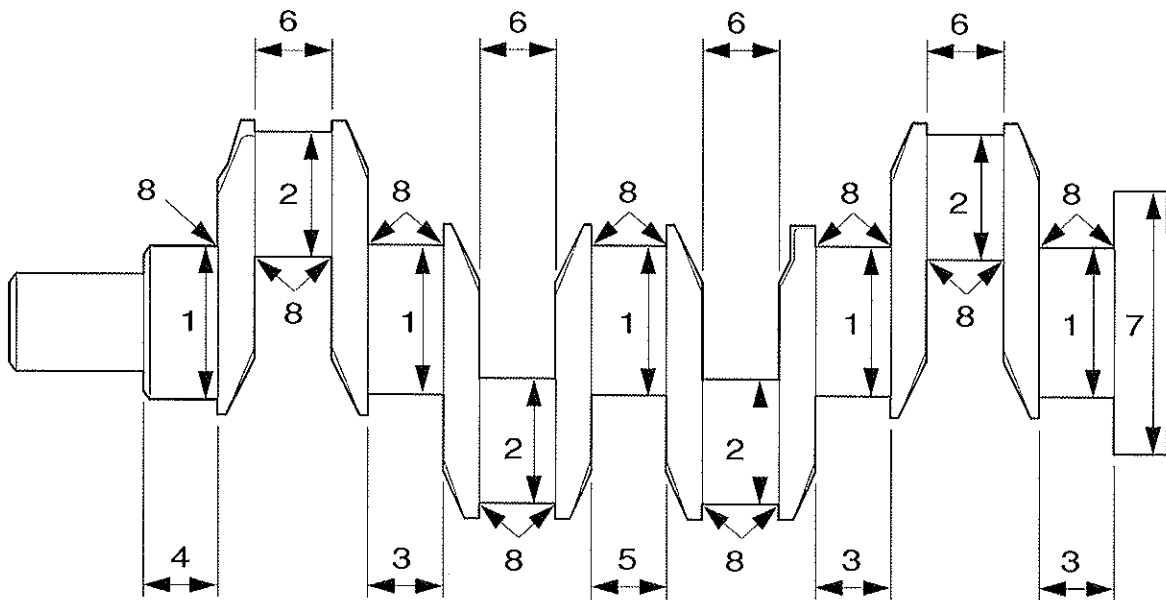

Illustration 63
The 1104 engine crankshaft

g01017233

Note: Refer to illustration 63 in order to use table 8.

The four cylinder engine.

Table 8

The undersize diameter of the Crankshaft Journals			
NUMBER	0.25 mm (0.010 inch)	0.51 mm (0.020 inch)	0.76 mm (0.030 inch)
1	75.909 mm (2.9885 inch) to 75.930 mm (2.9894 inch)	75.649 mm (2.9783 inch) to 75.670 mm (2.9791 inch)	75.399 mm (2.9685 inch) to 75.420 mm (2.9693 inch)
2	63.220 mm (2.4890 inch) to 63.240 mm (2.4898 inch)	62.960 mm (2.4787 inch) to 62.982 mm (2.4796 inch)	62.708 mm (2.4688 inch) to 62.728 mm (2.4696 inch)
3	39.47 mm (1.5539 inch)maximum	N/A	N/A
4	37.44 mm (1.4740 inch)maximum	N/A	N/A
5	44.68 mm (1.7591 inch)maximum	N/A	N/A
6	40.55 mm (1.5965 inch)maximum	N/A	N/A
7	Do not machine this diameter.	N/A	N/A
8	3.68 mm (0.1449 inch) to 3.96 mm (0.1559 inch)	N/A	N/A

Refer to table 9 for the maximum run out of the crankshaft journals.

The maximum difference in value between one crankshaft journal and the next crankshaft journal 0.10 mm (0.0039 inch)

Table 9

Journal	Excessive run out
(1)	Mounting
(2)	0.08 mm (0.0031 inch)
(3)	0.15 mm (0.0059 inch)
(4)	0.08 mm (0.0031 inch)
(5)	Mounting

Refer to the Specifications Module, "Connecting Rod Bearing Journal" topic for more information on the connecting rod bearing journals and connecting rod bearings.

Refer to the Specifications Module, "Main Bearing Journal" topic for information on the main bearing journals and for information on the main bearings.

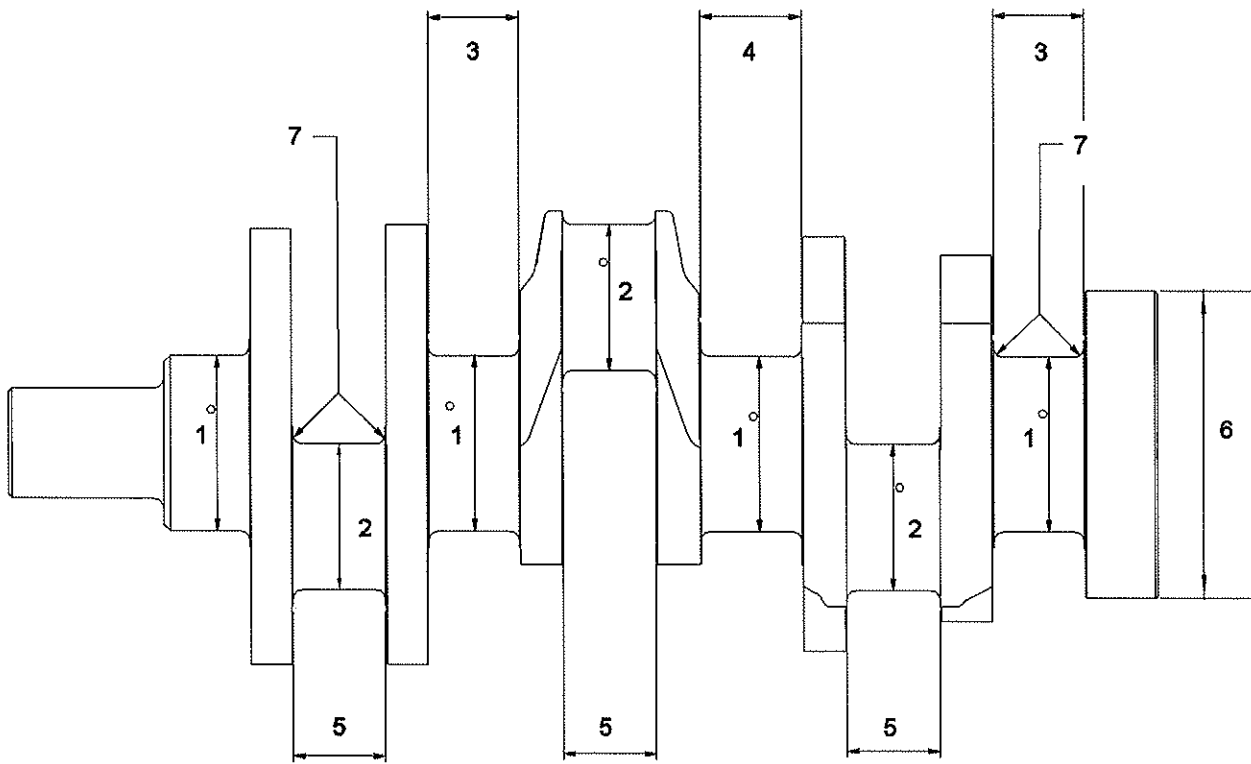

Illustration 64

g01017747

The crankshaft for the three cylinder engine

The crankshaft for the three Cylinder engine

Table 10

The undersize diameter of the Crankshaft Journals			
NUMBER	0.25 mm (0.010 inch)	0.51 mm (0.020 inch)	0.76 mm (0.030 inch)
1	75.926 mm (2.9892 inch) to 75.905 mm (2.9884 inch)	75.672 mm (2.9792 inch) to 75.651 mm (2.9784 inch)	75.418 mm (2.9692 inch) to 75.397 mm (2.9684 inch)
2	63.236 mm (2.4896 inch) to 63.216 mm (2.4888 inch)	62.982 mm (2.4796 inch) to 62.962 mm (2.4788 inch)	62.728 mm (2.4696 inch) to 62.708 mm (2.4688 inch)
3	39.74 mm (1.5646 inch)maximum	N/A	N/A
4	44.68 mm (1.7591 inch)maximum	N/A	N/A
5	40.551 mm (1.5965 inch)maximum	N/A	N/A
6	133.17 mm (5.2429 inch) Do not machine this diameter.	N/A	N/A
7	3.68 mm (0.1449 inch) to 3.96 mm (0.1559 inch)	N/A	N/A

Refer to table 11 for the maximum run out of the crankshaft journals.

i01958114

The maximum difference in value between one crankshaft journal and the next crankshaft journal 0.10 mm (0.0039 inch)

Crankshaft Seals

Table 11

Journal	Excessive run out
(1)	Mounting Dia
(2)	0.051 mm (0.0020 inch)
(3)	0.051 mm (0.0020 inch)
(4)	Mounting Dia

Refer to the Specifications Module, "Connecting Rod Bearing Journal" topic for more information on the connecting rod bearing journals and connecting rod bearings.

Refer to the Specifications Module, "Main Bearing Journal" topic for information on the main bearing journals and for information on the main bearings.

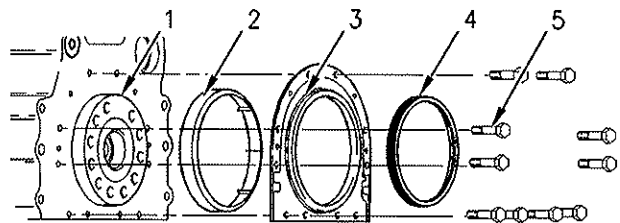

Illustration 65

g00915078

- (1) Crankshaft
- (2) Plastic sleeve
- (3) Crankshaft seal
- (4) Alignment tool

i01958141

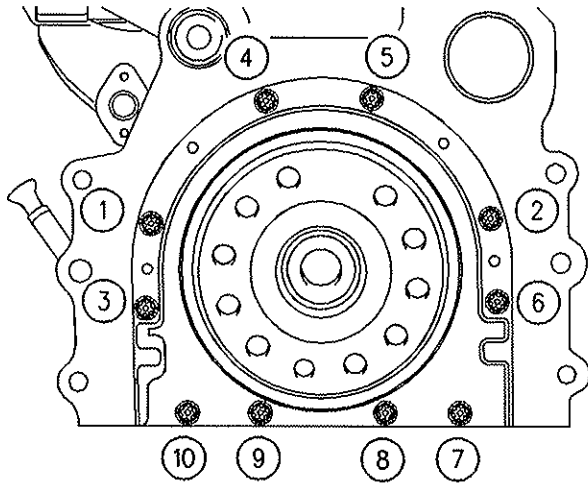

Illustration 66

g00915076

(5) Tighten bolts 1, 2, 3, 4, 5, 6, 7, and 10 in the sequence that is shown in Illustration 66 to the following torque. 22 N·m (16 lb ft)

Remove the alignment tool.

Tighten bolts 8 and 9 in the sequence that is shown in Illustration 66 to the following torque. 22 N·m (16 lb ft)

i01958137

Connecting Rod Bearing Journal

Refer to the Specifications Module, "Crankshaft" topic for information on the undersize crankshaft journals.

The original size of the connecting rod bearing journal ... 63.47 to 63.49 mm (2.4988 to 2.4996 inch)

Maximum permissible wear of the connecting rod bearing journals 0.04 mm (0.0016 inch)

Width of the connecting rod bearing journals 40.35 to 40.42 mm (1.589 to 1.591 inch)

Radius of the fillet of the connecting rod bearing journals 3.68 to 3.96 mm (0.145 to 0.156 inch)

Surface finish of connecting rod bearing journals and radii Ra 0.4 microns (16 μ inch)

Main Bearing Journal

Refer to the Specifications module, "Crankshaft" topic for information on the undersize main bearing journals, and information on the width of main bearing journals.

The original size of the main bearing journal 76.159 to 76.180 mm (2.9984 to 2.9992 inch)

Maximum permissible wear of the main bearing journals 0.040 mm (0.0016 inch)

Radius of the fillet of the main bearing journals 3.68 to 3.69 mm (0.1448 to 0.1452 inch)

Surface finish of bearing journals, crank pins and radii 0.4 microns (16 μ inches)

The shell for the main bearings

The shells for the main bearings are available for remachined journals which have the following undersize dimensions.

Undersize bearing shell 0.25 mm (0.010 inch)
 Undersize bearing shell 0.51 mm (0.020 inch)
 Undersize bearing shell 0.75 mm (0.030 inch)

Thickness at center of the shells .. 2.083 to 2.089 mm (0.0820 to 0.0823 inch)

Width of the main bearing shells .. 31.62 to 31.88 mm (1.244 to 1.255 inch)

Clearance between the bearing shell and the main bearing journals 0.057 to 0.117 mm (0.0022 to 0.0046 inch)

i01958156

Connecting Rod

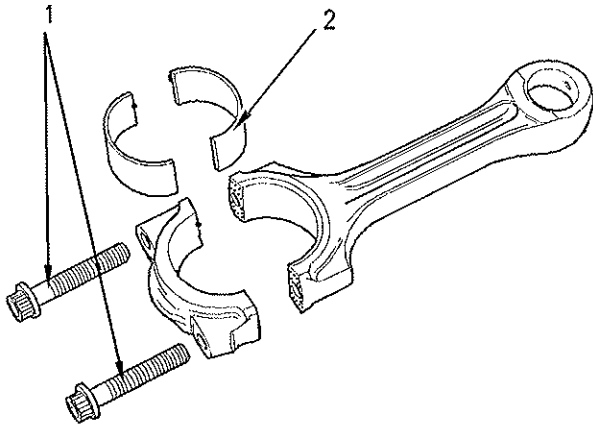

Illustration 67

g00907738

The mating surfaces of the connecting rod are produced by hydraulically fracturing the forged connecting rod.

(1) Tighten the torx screws for the connecting rod to the following torque. 18 N·m (13 lb ft)

Tighten the torx screws for the connecting rod again to the following torque. 70 N·m (52 lb ft)

Tighten the torx screws for the connecting rod for an additional 120 degrees. The torx screws for the connecting rod (1) must be replaced after this procedure.

Note: Always tighten the connecting rod cap to the connecting rod, when the assembly is out of the engine. Tighten the assembly to the following torque 20 N·m (14 lb ft).

(2) The bearing shell for the connecting rod

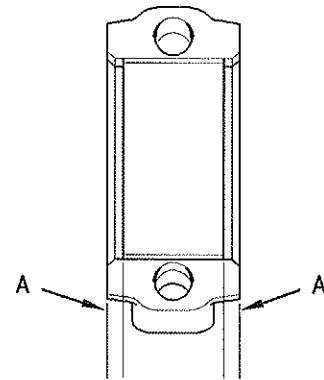

Illustration 68

g00995584

Alignment of the bearing shell

Note: The bearing shell for the connecting rod must be aligned equally from both ends of the connecting rod. Refer to (A) in figure 68. Refer to the Disassembly and assembly manual for information on the alignment tool.

Table 12

Bearing Width for the Connecting Rod	31.62 to 31.88 mm (1.245 to 1.255 inch)
Bearing Width for the Connecting Rod Cap	31.55 to 31.88 mm (1.2405 to 1.255 inch)
Thickness of Connecting Rod Bearing at the Center	1.835 to 1.842 mm (0.0723 to 0.0725 inch)
Thickness of Connecting Rod Bearing for the Cap at the Center	1.835 to 1.842 mm (0.0722 to 0.0725 inch)
Bearing Clearance	0.030 to 0.081 mm (0.0012 to 0.0032 inch)

Table 13

Undersized Connecting Rod Bearing	
	0.25 mm (0.010 inch)
	0.51 mm (0.020 inch)
	0.76 mm (0.030 inch)

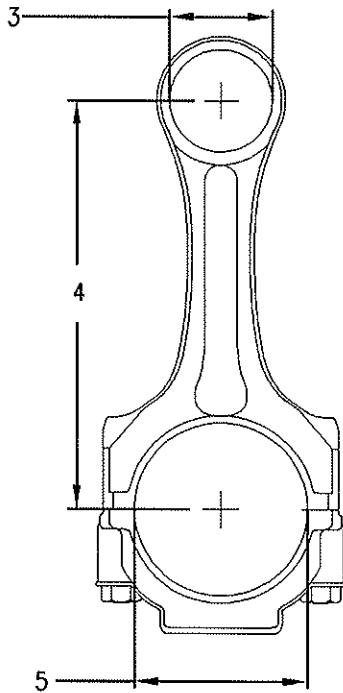

Illustration 69

g00907744

- (3) Diameter of the parent bore for the piston pin 43.01 to 43.04 mm (1.693 to 1.694 inch)
- (4) Distance between the parent bores 219.05 to 219.10 mm (8.624 to 8.626 inch)
- (5) Diameter for the parent bore for the connecting rod bearing 67.21 to 67.22 mm (2.6460 to 2.6465 inch)

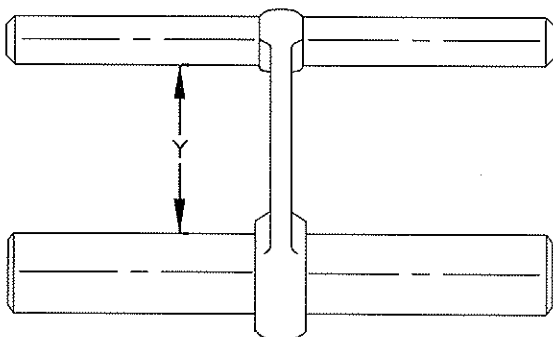

Illustration 70

g00915056

Connecting rods are color coded. The color code is a reference for the length (Y) of the connecting rod. Refer to table 14 for the different lengths of connecting rods.

Table 14

Length Grades for Connecting Rods		
Grade Letter	Color Code	Length (Y)
F	Red	165.728 to 165.761 mm (6.5247 to 6.5260 inch)
G	Orange	165.682 to 165.715 mm (6.5229 to 6.5242 inch)
H	White	165.637 to 165.670 mm (6.5211 to 6.5224 inch)
J	Green	165.591 to 165.624 mm (6.5193 to 6.5206 inch)
K	Purple	165.545 to 165.578 mm (6.5175 to 6.5188 inch)
L	Blue	165.499 to 165.532 mm (6.5157 to 6.4961 inch)

i01958185

Piston and Rings

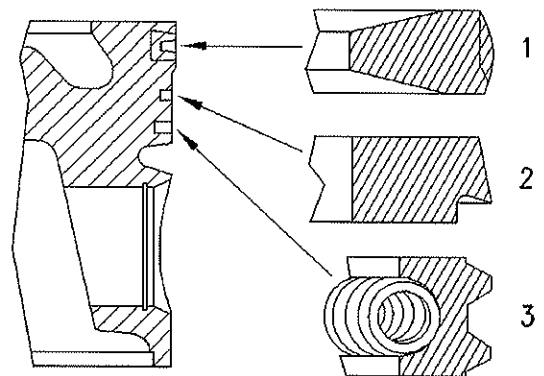

Illustration 71

g00888215

A typical example of a piston and rings

(1) Top compression ring

Naturally Aspirated

The shape of the top compression ring Rectangular with a barrel face

Width of the top compression ring 2.475 to 2.49 mm (0.097 to 0.098 inch)

Clearance between the top compression ring and the piston groove 0.09 to .15 mm (0.0035 to 0.0059 inch)

Ring gap 0.30 to 0.55 mm (0.0118 to 0.0216 inch)

Turbocharged

The shape of the top compression ring Keystone with a barrel face

Width of the top compression ring tapered

Ring gap 0.30 to 0.55 mm
(0.0118 to 0.0216 inch)

Note: When you install a new top compression ring, make sure that the word "TOP" is facing the top of the piston. New top piston rings have a red identification mark which must be on the left of the ring end gap when the top piston ring is installed on an upright piston.

(2) Intermediate compression ring

The shape of the intermediate compression ring Internal step in the bottom edge with a tapered face

Width of intermediate compression ring 2.47 to 2.49 mm (0.097 to 0.098 inch)

Clearance between the intermediate compression ring and the piston groove 0.05 to 0.09 mm (0.002 to 0.003 inch)

Ring gap 0.70 to 0.95 mm
(0.0275 to 0.0374 inch)

Note: When you install a new intermediate compression ring, make sure that the word "TOP" is facing the top of the piston. New intermediate rings have a green identification mark which must be on the left of the ring end gap when the top piston ring is installed on an upright piston.

(3) Oil control ring

Shape of oil control ring two-piece coil that is spring loaded

Width of oil control ring 3.47 to 3.49 mm
(0.1366 to 0.1374 inch)

Clearance between the oil control ring and the groove in the piston 0.03 to 0.07 mm
(0.0011 to 0.0027 inch)

Ring gap 0.30 to 0.55 mm
(0.0118 to 0.0216 inch)

Note: A pin is used in order to hold both ends of the spring of the oil control ring in position. The ends of the spring of the oil control ring must be installed opposite the end gap of the oil control ring.

Note: Ensure that the ring end gaps of the piston rings are spaced 120 degrees from each other.

Piston

Note: An arrow which is marked on the piston crown must be toward the front of the engine.

The combustion bowl re-entrant angle for the turbocharged engine 80 degrees

The combustion bowl re-entrant angle for the naturally aspirated engine 70 degrees

Piston height above cylinder block .. 0.21 to 0.35 mm
(0.008 to 0.014 inch)

Width of top groove in piston for the naturally aspirated engine 2.58 to 2.60 mm
(0.1016 to 0.1024 inch)

Width of top groove in piston for the turbocharged engine Tapered

Width of second groove in piston 2.54 to 2.56 mm
(0.1000 to 0.1008 inch)

Width of third groove in piston 3.52 to 3.54 mm
(0.1386 to 0.1394 inch)

Piston pin

Diameter of a new piston pin 39.694 to 39.700 mm
(1.5628 to 1.5630 inch)

Diameter of the bore for the piston pin 39.703 to 39.709 mm
(1.5631 to 1.5633 inch)

101957425

Piston Cooling Jet

Note: The three cylinder naturally aspirated engine may have installed piston cooling jets as an option.

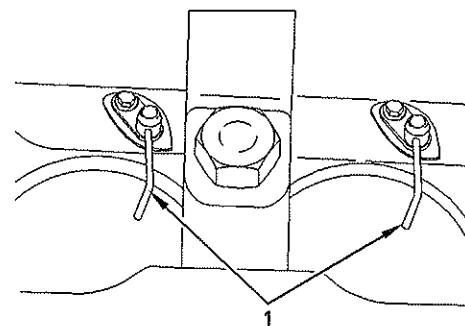

Illustration 72

g00942652

(1) Installed piston cooling jets

The spring loaded valve must move freely. Tighten the bolt to the following torque. 9 N·m (7 lb ft)

Piston Cooling Jet Alignment

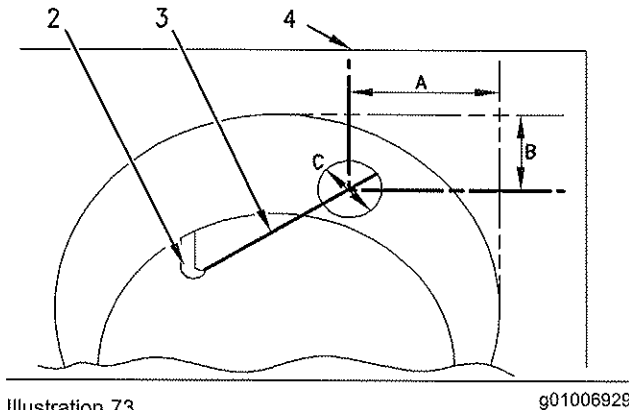

Illustration 73

g01006929

- (2) Piston cooling jet
- (3) Rod
- (4) Cylinder block

Use the following procedure in order to check the alignment of the piston cooling jet.

1. Insert rod (3) into the end of the piston cooling jet (2). Rod (3) has a diameter of 1.70 mm (0.067 inch). Rod (3) must protrude out of the top of the cylinder block.
2. Dimension (A) is 55.25 mm (2.1752 inch) and dimension (B) is 14 mm (0.5512 inch). Dimension (A) and dimension (B) are tangent to the cylinder bore (4).
3. The position of the rod (3) must be within dimension (C). Dimension (C) is 14 mm (0.5512 inch).

i01957083

Front Housing and Covers

The front housing must be aligned to the cylinder block face. + 0.05 to minus 0.05 mm (+ 0.0020 to minus 0.0020 inch)

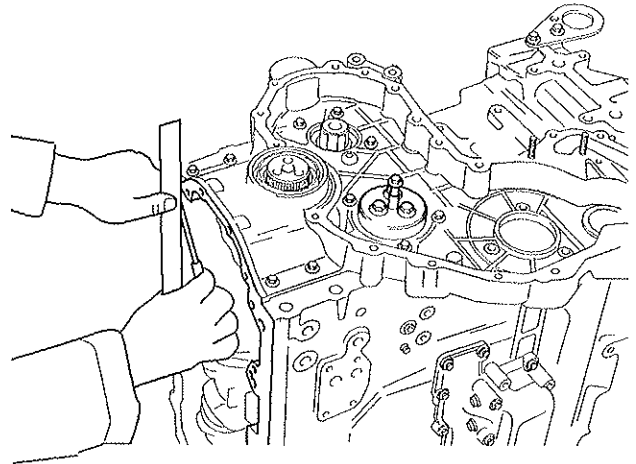

Illustration 74

g00995663

Alignment

- (1) Tighten the bolts that fasten the front cover to the front housing to the following torque. 22 N·m (16 lb ft)

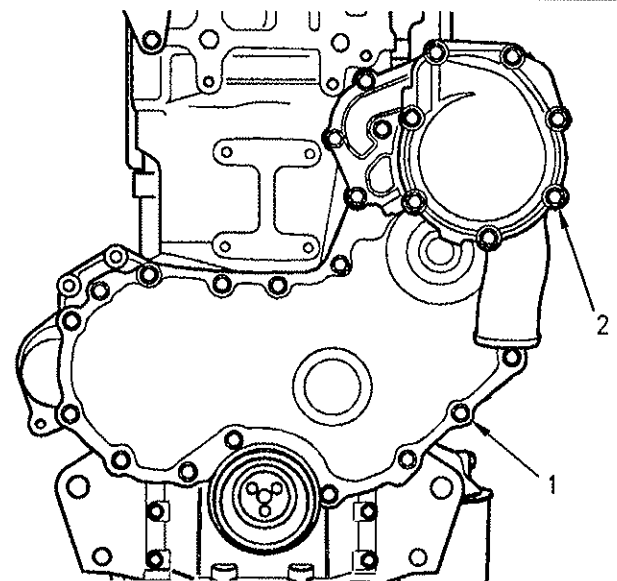

Illustration 75

g00918672

Front cover

- (2) Tighten the bolts that fasten the water pump to the front housing to the following torque. 22 N·m (16 lb ft)

Note: Refer to Specifications, "Water Pump" for the correct bolt tightening sequence for the water pump.

i01912958

Gear Group (Front)

The 1104 mechanical engines use two types of fuel injection pumps. The fuel injection pump can be either a Delphi 210 fuel injection pump or a Bosch EPVE fuel injection pump.

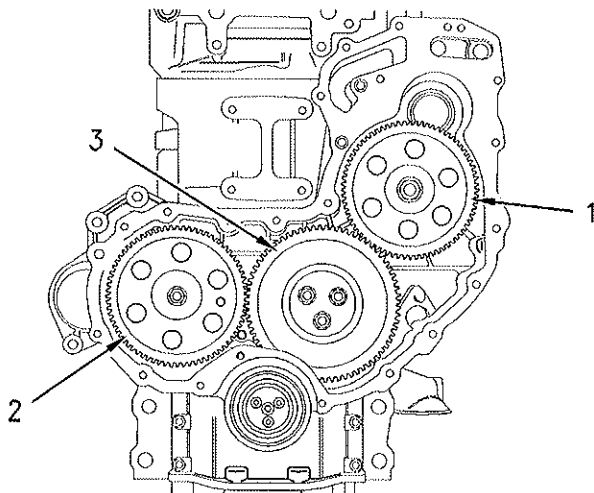

Illustration 76

g00995886

Gear train

(1) Fuel injection pump drive gear

Tighten the nut to the following torque. ... 24 N·m
(18 lb ft)

Release the lock on the fuel injection pump shaft.
Torque the nut to the following torque. 90 N·m
(66 lb ft)

Number of teeth 68

Note: Refer to the Specifications Module, "Fuel injection pump" for the locking torque for the fuel injection pump shaft.

(2) Camshaft gear

Tighten the bolt for the camshaft gear to the following torque. 95 N·m (70 lb ft)

Bore diameter of the camshaft gear 34.93 to 34.95 mm
(1.3750 to 1.3760 inch)

Outside diameter of the camshaft hub .. 34.90 to 34.92 mm (1.3741 to 1.3747 inch)

Clearance between the camshaft gear and the camshaft hub 0.003 to 0.048 mm
(0.0001 to 0.0019 inch)

Number of teeth 68

(3) Idler gear and hub

Tighten the bolts for the idler gear to the following torque. 44 N·m (33 lb ft)

Bore diameter of the idler gear 57.14 to 57.18 mm (2.2495 to 2.2512 inch)
Bore diameter of the idler gear with roller bearings 72.35 to 72.36 mm
(2.8484 to 2.8488 inch)

Width of idler gear and split bearing assembly 30.14 to 30.16 mm
(1.186 to 1.187 inch)

Inside diameter of idler gear bearings with flanges 50.78 to 50.80 mm
(1.999 to 2.000 inch)

Outside diameter of idler gear hub .. 50.70 to 50.74 mm (1.9961 to 1.9976 inch)
Outside diameter of idler gear hub with roller bearings 49.975 to 49.988 mm
(1.9675 to 1.9680 inch)

Clearance of idler gear bearing on hub 0.04 to 0.10 mm (0.0016 to 0.0039 inch)

Idler gear end play 0.10 to 0.20 mm
(0.004 to 0.008 inch)

Idler gear end play with roller bearings 0.10 to 0.75 mm
(0.0039 to 0.0295 inch)

Maximum permissible end play 0.38 mm
(0.015 inch)

Number of teeth 73

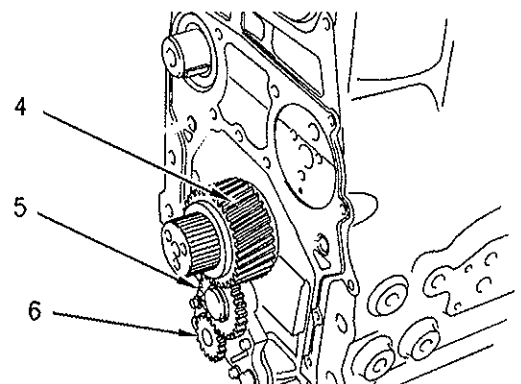

Illustration 77

g00996214

The gear train for the oil pump

(4) Crankshaft gear

Bore diameter of crankshaft gear
.... 47.625 to 47.650 mm (1.8750 to 1.8760 inch)

Outside diameter of crankshaft
hub 47.625 to 47.645 mm
(1.8750 to 1.8758 inch)

Clearance of gear on
crankshaft -0.020 to +0.020 mm
(-0.0008 to +0.0008 inch)

Number of teeth 34

(5) Oil pump idler gear

Inside diameter of oil pump idler gear
bearing 16.012 to 16.038 mm
(0.6304 to 0.6314 inch)

Outside diameter of oil pump idler gear
shaft 15.966 to 15.984 mm
(0.6286 to 0.6293 inch)

Clearance of oil pump idler gear bearing on
shaft 0.028 to 0.072 mm
(0.0011 to 0.0028 inch)

End play of the oil pump idler
gear 0.050 to 0.275 mm
(0.0019 to 0.0108 inch)

(6) Oil pump gear

The number of teeth on the oil pump gear 17

Backlash values

Backlash between the idler gear (5) and the oil
pump drive gear (6) 0.046 to 0.106 mm
(0.0018 to 0.0041 inch)

Backlash between the oil pump idler gear (5) and
the crankshaft gear (4) 0.095 to 0.160 mm
(0.0037 to 0.0063 inch)

Backlash between the idler gear (3) and the
crankshaft gear (4) 0.064 to 0.124 mm
(0.0025 to 0.0049 inch)

Backlash between the camshaft gear (2) and the
idler gear (3) 0.052 to 0.107 mm
(0.0020 to 0.0042 inch)

Backlash between the fuel injection pump gear
(1) and the idler gear (3) 0.054 to 0.109 mm
(0.0021 to 0.0043 inch)

Backlash between the water pump gear (not
shown) and the fuel injection pump gear
(1) ... 0.073 to 0.133 mm (0.0028 to 0.0052 inch)

Backlash between the power take-off
drive (if equipped) and the idler gear
(3) 0.112 to 0.172 mm (0.0044 to 0.0068 inch)

Engines that have a Balancer

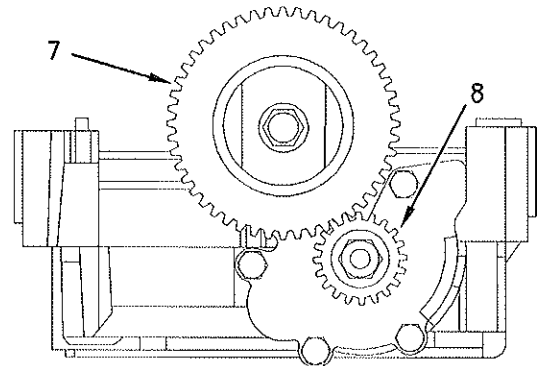

Illustration 78

g00996003

Balancer gears

(7) Idler gear for the oil pump that has a balancer

The number of teeth on the gear 44
The bore diameter of the idler
gear 37.197 to 37.212 mm
(1.4644 to 1.4650 inch)

The hub diameter for the idler
gear 37.152 to 37.162 mm
(1.4627 to 1.4631 inch)

The end play for the idler gear .. 0.12 to 0.27 mm
(0.0047 to 0.0106 inch)

(8) Gear for the oil pump that has a balancer

The number of teeth on the gear 17

Backlash between the oil pump gear (8) and the idler
gear (7) ... 0.097 to 0.17 mm (0.0038 to 0.0067 inch)

i02234222

Flywheel

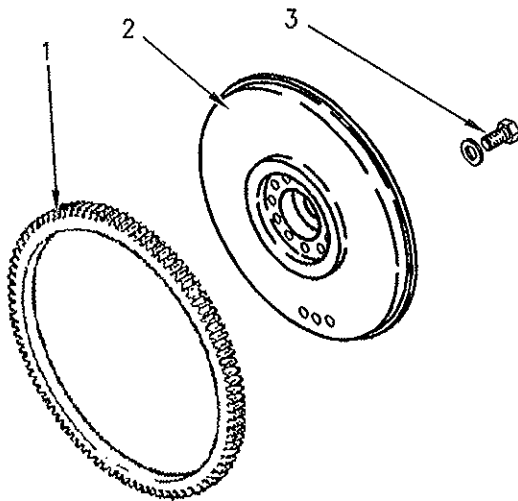

Illustration 79
Standard flywheel

g00584712

(1) Flywheel ring gear

Heat the flywheel ring gear to the following temperature. 250 °C (480 °F)

Note: Do not use an oxyacetylene torch to heat the flywheel ring gear.

(2) Flywheel

(3) Bolt

Tighten the flywheel bolts to the following torque. 105 N·m (77 lb ft)

Non-standard flywheel

Note: A special flywheel is aligned to a dowel on the crankshaft.

i01957025

Flywheel Housing

Four cylinder

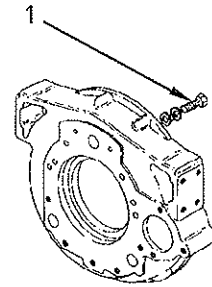

Illustration 80

g00631781

(1) Bolt

Tighten the bolts for the cast iron flywheel housing to the following torque:

M10 "8.8"	44 N·m (33 lb ft)
M10 "10.9"	63 N·m (47 lb ft)
M12 "8.8"	75 N·m (55 lb ft)
M12 "10.9"	115 N·m (85 lb ft)

Three cylinder

The three cylinder engine is equipped with a back plate.

i02234223

Crankshaft Pulley

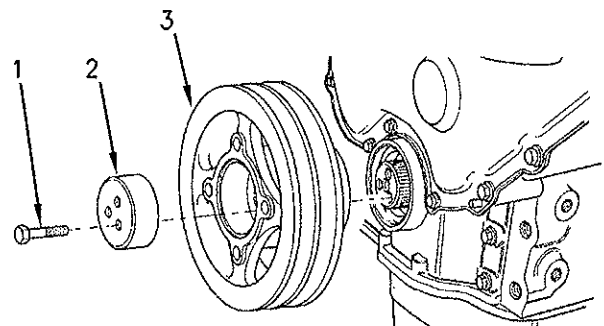

Illustration 81

A standard pulley

g00915497

Note: Lubricate the threads of the bolts with clean engine oil before installation.

- (1) Tighten the three bolts for the crankshaft pulley to the following torque. 115 N·m (85 lb ft)

Note: Recheck the torque of the bolts (1) twice.

- (2) Thrust block
- (3) Crankshaft pulley

Non-standard pulley

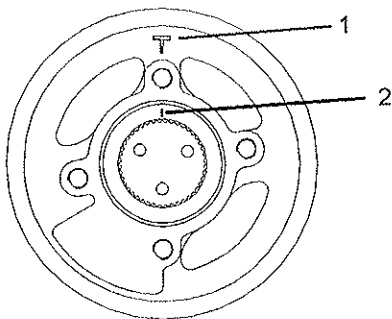

Illustration 82

g01126584

- (1) T Mark
- (2) Alignment mark

Note: The marks (1 and 2) on the pulley must be vertical when the pulley is installed on the engine. Number one piston of the engine must be at top dead center.

i01958344

Fan Drive

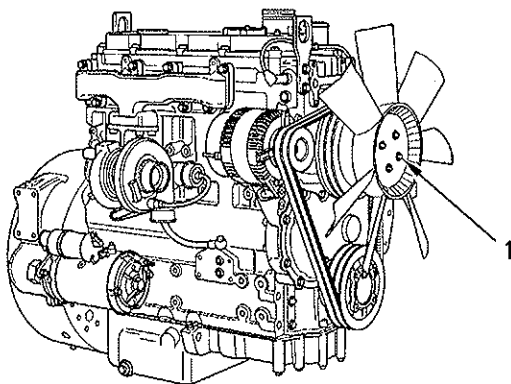

Illustration 83

g00926178

A typical fan drive

- (1) Tighten the bolts for the fan to the following torque. 22 N·m (16 lb ft)

Tighten the bolts that secure the fan drive pulley to the hub to the following torque (not shown). .. 22 N·m (16 lb ft)

Fan drive housing

Tighten the bolts that secure the fan drive housing to the cylinder head to the following torque (not shown). 44 N·m (32 lb ft)

Bearing bore for the housing .. 61.986 to 62.005 mm (2.4404 to 2.4411 inch)

Outer bearing diameter 61.987 to 62.000 mm (2.4404 to 2.4409 inch)

Interference fit for the bearing 0.014 to minus 0.018 mm (0.0006 to minus 0.0007 inch)

The outer diameter of the shaft ... 25.002 to 25.011 mm (0.9843 to 0.9847 inch)

Maximum permissible end play of the shaft .. 0.20 mm (0.0079 inch)

i01721280

Engine Lifting Bracket

All engines are equipped with two engine lifting brackets.

Tighten the two bolts on each engine lifting bracket to the following torque. .. 44 N·m (32 lb ft)

i01958367

Alternator

12 Volt and 24 Volt Alternator

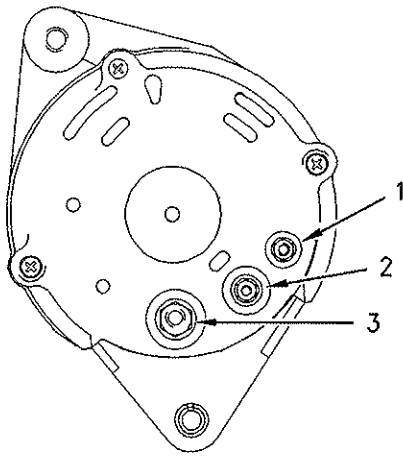

Illustration 84

g00959541

A typical alternator

- (1) Tighten terminal nut "W" to the following torque. 2 N·m (17 lb in)
- (2) Tighten terminal nut "D+" to the following torque. 4.3 N·m (38 lb in)
- (3) Tighten terminal nut "B+" to the following torque. 4.3 N·m (38 lb in)

Tighten the pulley nut (not shown) to the following torque. 80 N·m (59 lb ft)

Alignment of the alternator pulley to the crankshaft pulley ± 2.4 mm (± 0.0945 inch)

Rotation clockwise

Polarity Negative earth

V-Belt

Note: The V-belt must be checked by a gauge. Refer to the Testing and Adjusting, "V-Belt-Test" for the correct type of gauge in order to check the V-belt.

V-belt tension 535 N (120 lb)

i01958653

Starter Motor

24 Volt Starter Motor

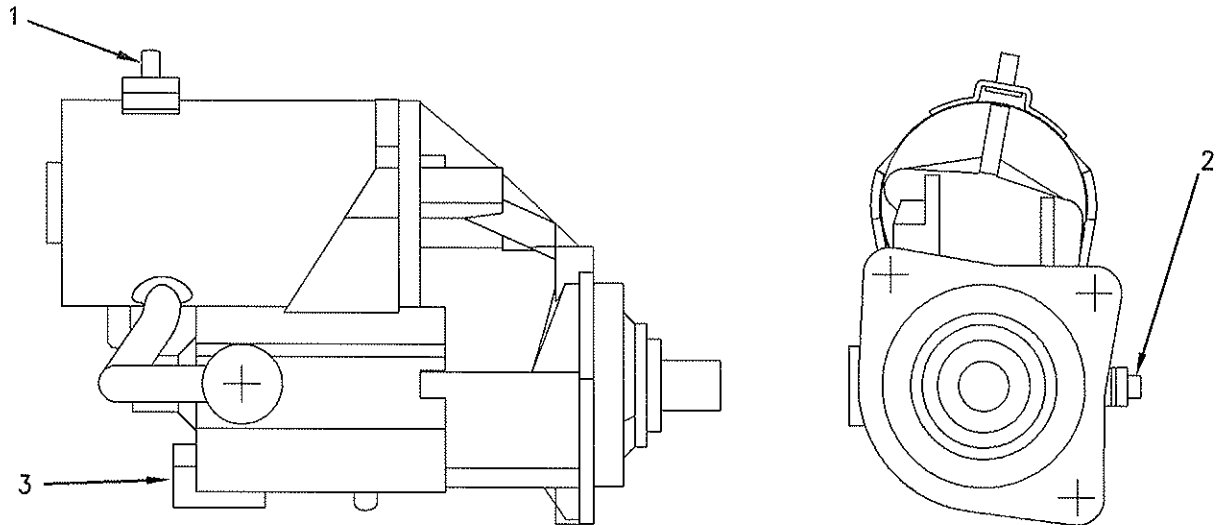

Illustration 85

g00974968

The 24 volt starter motor which shows the electrical connections

- (1) Tighten the negative terminal nut to the following torque. 15 N·m (11 lb ft)
- (2) Tighten the positive terminal nut to the following torque. 21 N·m (15 lb ft)
- (3) Tighten the solenoid terminal to the following torque. 3.5 N·m (31 lb in)

Rated voltage 24 volts

Pull in voltage 16 volts

12 Volt Starter Motor

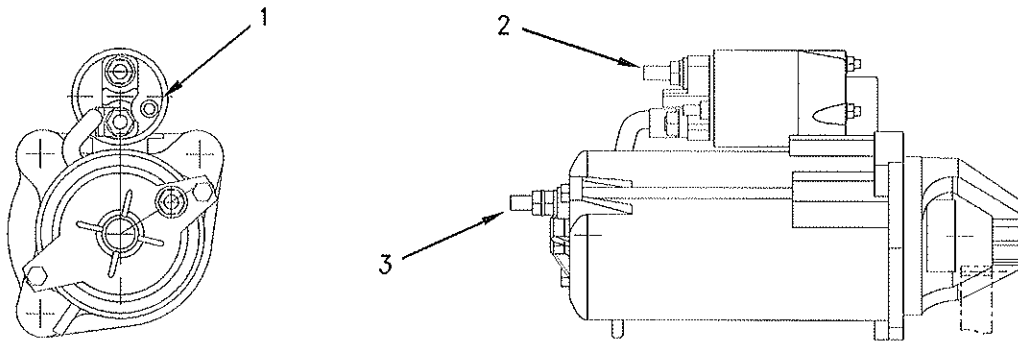

Illustration 86

g00977365

The 12 volt starter motor which shows the electrical connections

- (1) Tighten the solenoid terminal to the following torque. 8 N·m (70 lb in)
- (2) Tighten the positive terminal nut to the following torque. 6 N·m (53 lb in)
- (3) Tighten the negative terminal nut to the following torque. 8 N·m (70 lb in)

Rated voltage 12 volts

Pull in voltage 8 volts

- (1) Tighten the glow plugs (3) in the cylinder head to the following torque. 15 N·m (11 lb ft)

Tighten the nuts (2) for the bus bar (1) that is installed on top of the glow plugs to the following torque. 2 N·m (18 lb in)

Voltage 12 or 24 volts

Note: Glow plugs are not installed on all engines. Engines that do not have glow plugs are installed with threaded plugs.

i02248408

Glow Plugs

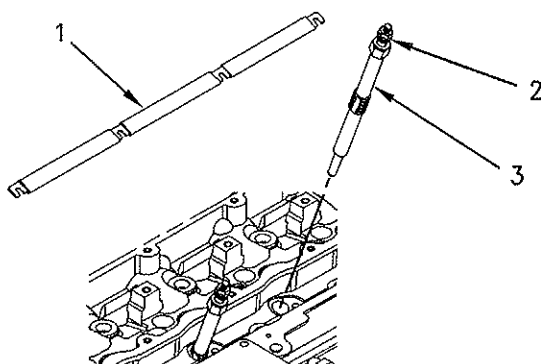

Illustration 87

g00955714

Typical example

Index

A	
Alternator	40
12 Volt and 24 Volt Alternator	40
V-Belt	40
C	
Camshaft	15
Camshaft Bearings	16
Connecting Rod	32
Connecting Rod Bearing Journal	31
Crankcase Breather	22
Engine model DK and DJ	23
Crankshaft	26
Crankshaft Pulley	38
Non-standard pulley	39
Crankshaft Seals	30
Cylinder Block	24
Four Cylinder Engine	24
Three Cylinder Engine	25
Cylinder Head	12
Four Cylinder engine	12
Four Cylinder Engine	13
Three Cylinder engine	12
Three Cylinder Engine	13
Cylinder Head Valves	10
E	
Engine Design	4
Four Cylinder Engine	4
Three Cylinder Engine	4
Engine Lifting Bracket	39
Engine Oil Bypass Valve	20
Installed in the Balancer	20
Installed in the Oil Pump	20
Engine Oil Filter	17
Replaceable Element	17
Spin-on Oil Filter	17
Engine Oil Pan	21
Front sealant	21
Rear sealant	21
The cast iron oil pan	22
Engine Oil Pressure	19
Engine Oil Pump	17
Four Cylinder and Three Cylinder Engines without Balancer Group	19
Four Cylinder Engines with Balancer Group	17
Exhaust Manifold	14
Four Cylinder Engine	14
Three Cylinder Engine	15
F	
Fan Drive	39
Fan drive housing	39
Flywheel	38
Non-standard flywheel	38
Flywheel Housing	38
Four cylinder	38
Three cylinder	38
Front Housing and Covers	35
Fuel Injection Lines	5
Fuel Injection Pump (Bosch EPVE for the 1104 engines only)	6
Fuel Injection Pump (Delphi DP210 DPA and DPG fuel injection pumps)	5
Delphi DP210	5
Delphi DPA	6
Delphi DPG	6
Fuel Injection Pump (Delphi STP)	7
Fuel Injectors	8
Fuel Transfer Pump	8
G	
Gear Group (Front)	36
Engines that have a Balancer	37
Glow Plugs	42
I	
Important Safety Information	2
L	
Lifter Group	9
M	
Main Bearing Journal	31
The shell for the main bearings	31
P	
Piston and Rings	33
Piston	34
Piston Cooling Jet	34
Piston Cooling Jet Alignment	35
R	
Rocker Shaft	9
S	
Specifications Section	4

Starter Motor.....	41
12 Volt Starter Motor	42
24 Volt Starter Motor	41

T

Table of Contents.....	3
Turbocharger	13
Four Cylinder Engine	14
Three Cylinder Engine	14

V

Valve Mechanism Cover.....	10
The Cover for the Four Cylinder Engine	10
The Cover for the Three Cylinder Engine	10

W

Water Pump.....	24
Water Temperature Regulator and Housing	23
Water Temperature Regulator.....	24