



OPERATOR/SERVICE MANUAL

**MODELS: SD-43, SD-54, PD-43
PD-54, PDB-43, PDB-54**



**RHINO MODEL SHOWN: PD54
JOHN DEERE DIESEL**

A 100% employee-owned American manufacturer

TABLE OF CONTENTS
OPERATOR/SERVICE MANUAL
RHINO 43/54

FOREWORD	6
LIMITED WARRANTY	7
SECTION 1 - TECHNICAL DATA	9 - 11
1.1 Specifications	10
1.2 Engine RPM	10
1.3 Machine Data	11
1.4 Machine Sound Level Test	11
SECTION 2 - HEALTH & SAFETY	13 - 19
SECTION 3 - OPERATION	21 - 29
3.1 Introduction and Operating Principle	22
3.2 Diesel Fuel	23
3.3 Engine Break-in	23
3.4 Engine Oil and Filter	23
3.5 Warning Light	23
3.6 Hydraulic Oil, Filter, and Breather	23 - 24
3.7 Engine Coolant	24
3.8 Visual Inspection	24
3.9 Air Cleaner	24 - 25
3.10 Before Starting	25
3.11 To Start	25
3.12 To Stop	25
3.13 Idling Engine	25
3.14 Warming Engine	25 - 26
3.15 Parking Brake	26
3.16 Brake Light	26
3.17 To Operate	26
3.18 Forward/Reverse/Neutral	26
3.19 Throttle	26
3.20 Gauges	26
3.21 Panel Fuse	27
3.22 Cold Weather Starting / Intake Heater Button	27
3.23 Blade Lever	27
3.24 Horn/Back-up Alarm	27
3.25 ROPS/FOPS/Seat Belt	27
3.26 Tires/Lugnuts	27
3.27 Drum/Scrapers	28
3.28 Cleaning	28
3.29 Eccentrics	28
3.30 Compaction Tips	28
3.31 Tie Downs	28
3.32 Towing (Bypass)	28 - 29
3.33 Storage	29

SECTION 4 - MAINTENANCE	31 - 55
4.1 Important	32
4.2 Maintenance Schedule	32
4.3 Important Maintenance Information	34
4.4 Engine Oil and Filter	34
4.5 Additional Service Information	34
4.6 Hydraulic Oil and Filter	34 - 35
4.7 Hydraulic Breather	35
4.8 Engine Cooling System	35 - 36
4.8.1 Replacing Engine Coolant	36
4.8.2 Adding Engine Coolant	36 - 37
4.8.3 Disposing of Coolant	37
4.9 Air Cleaner	37
4.9.1 Air Cleaner Service	37
4.9.2 Air Cleaner Replacement	37 - 38
4.9.3 Element Storage	38
4.10 Fuel Filter	38
4.10.1 Water Separator	38
4.10.2 Fuel Filter Replacement	38 - 39
4.10.3 Bleeding Fuel System	39
4.10.4 Bleeding at Fuel Injection Pump	39
4.10.5 Bleeding at Fuel Injection Nozzles	39 - 40
4.11 Fan/Alternator Belt	40
4.12 Grease Fittings	40
4.13 Frame Hinge	40
4.14 Blade Pins	40
4.15 Battery	40
4.15.1 Servicing Battery	40 - 41
4.15.2 Battery Installation	41
4.15.3 Charging/Jumping Battery	41 - 42
4.16 Engine Crankcase Vent Tube	42
4.17 Engine Valve Clearance	42
4.18 Emission Regulation/Engine RPM	42
4.19 Fuel Injectors	42 - 43
4.19.1 Test Fuel Injection Nozzles	43
4.20 Fuel Tank	43
4.21 Fuel Lines	43
4.22 Hydraulic Hoses/Connections	43 - 44
4.23 Forward/Reverse/Neutral Adjustment	44
4.24 Neutral Interlock	44
4.25 Control Cables: Forward/Reverse, Throttle, Blade	44
4.26 Eccentrics	45
4.26.1 Eccentric Housing Oil	45
4.27 Charge System	45
4.28 Panel Fuse: 20 AMP	45
4.29 Engine Installation Guidelines	45 - 46
4.30 Engine Mounting	46
4.31 Hardware	46
4.31.1 Loctite	46
4.32 Roll Over Protective Structures (ROPS)	46
4.32.1 Maintenance of ROPS/Seat Belts (Inspection & Repair)	46

4.33	Horn/Back-up Alarm	47
4.33.1	Back-up Alarm Switch	47
4.34	Scrapers	47
4.35	Troubleshooting	48 - 53
4.36	Electrical Troubleshooting	54
4.37	Service Record	55

SECTION 5 - EXPLODED DIAGRAMS & PARTS LIST 57 - 97

5.1	Hardware Key	59
5.2	Torque Charts and Guidelines	60 - 61
5.3	Drum Assembly	62 - 65
5.4	Main Frame	66 - 69
5.5	Radiator/Engine Mount	70 - 71
5.6	Engine	72 - 75
5.7	Air Cleaner	76 - 77
5.8	Controls	78 - 81
5.9	Drive System Hydraulics	82 - 85
5.10	Steering/Eccentric System Hydraulics	86 - 87
5.11	Blade	88 - 89
5.12	Hydraulic Schematic	90 - 91
5.13	Wiring	92 - 93
5.14	Decal Identification	94 - 97

CALIFORNIA PROPOSITION 65 WARNING 99

FOREWORD

These instructions include:

- Safety regulations
- Operating instructions
- Maintenance instructions

These instructions have been prepared for operation on the construction site and for the maintenance engineer.

These instructions are intended to simplify operation of the machine and to avoid malfunctions through improper operation.

Observing the maintenance instructions will increase the reliability and service life of the machine when used on the construction site and reduce repair costs and downtimes.

Always keep these instructions at the place of use of the machine.

Only operate the machine as instructed and follow these instructions.

Observe the safety regulations as well as the guidelines of the civil engineering trade association. Observe safety rules for the operation of equipment and the pertinent regulations for the prevention of accidents.

Stone Construction Equipment, Inc. is not liable for the function of the machine when used in an improper manner and for other than the intended purpose.

Operating errors, improper maintenance and the use of incorrect operating materials are not covered by the warranty.

The above information does not extend the warranty and liability conditions of business of Stone Construction Equipment, Inc.

Warranty Information

Please enter the following data. This will help expedite any service or warranty work.

1. Machine Type: _____

Machine S/N: _____

2. Engine Type: _____

Engine S/N: _____

3. VIN: _____

4. Purchase Date: _____

5. Dealer/Distributor Information:

Name: _____

Address: _____

Phone #: _____

Fax #: _____

Location of above information:

1. Information on S/N tag.
2. Information on engine tag.
3. Information on S/N tag - if applicable.
4. Date you purchased machine.
5. Dealer machine was purchased from.

Stone Construction Equipment, Inc.
P.O. Box 150, Honeoye, New York 14471
Phone: (800) 888-9926
Fax: (716) 229-2363

Limited Warranty

The Manufacturer warrants that products manufactured shall be free from defects in material and workmanship that develop under normal use for a period of 90 days for concrete vibrators and electric pumps, one year for Rhino®, Bulldog®, Wolfpac Rollers™, trowels, Stompers®, saws, forward plates, engine powered pumps, and 6 months for all other products from the date of shipment. The foregoing shall be the exclusive remedy of the buyer and the exclusive liability of the Manufacturer. Our warranty excludes normal replaceable wear items, i.e. gaskets, wear plates, seals, O-rings, V-belts, drive chains, clutches, etc. Any equipment, part or product which is furnished by the Manufacturer but manufactured by another, bears only the warranty given by such other manufacturer. (The Manufacturer extends the warranty period to "Lifetime" for the drum bearings and seals for the mortar mixers, and agrees to furnish, free of charge, the bearings and seals only upon receipt of the defective parts. The warranty is two years for eccentric bearings on the forward plate compactors, mortar and plaster mixer drums, trowel gearboxes and five years on the Bulldog trench roller eccentric bearings.) A Warranty Evaluation Form must accompany all defective parts. Warranty is voided by product abuse, alterations, and use of equipment in applications for which it was not intended, use of non-manufacturer parts, or failure to follow documented service instructions. The foregoing warranty is exclusive of all other warranties whether written or oral, expressed or implied. No warranty of merchantability or fitness for a particular purpose shall apply. The agents, dealer and employees of Manufacturer are not authorized to make modification to this warranty, or additional warranties binding on Manufacturer. Therefore, additional statements, whether oral or written, do not constitute warranty and should not be relied upon.

The Manufacturer's sole responsibility for any breach of the foregoing provision of this contract, with respect to any product or part not conforming to the Warranty or the description herein contained, is at its option (a) to repair, replace or refund such product or parts upon the prepaid return thereof to location designated specifically by the Manufacturer. Product returns not shipped prepaid or on an economical transportation basis will be refused (b) as an alternative to the foregoing modes of settlement - the Manufacturer's dealer to repair defective units with reimbursement for expenses, except labor, and be reviewed with the Manufacturer prior to repair. A Warranty Evaluation Form must accompany all warranty claims.

Except as set forth hereinabove and without limitation of the above, there are no warranties or other affirmations which extends beyond the description of the products and the fact hereof, or as to operational efficiency, product reliability or maintainability or compatibility with products furnished by others. In no event whether as a result of breach of contract or warranty or alleged negligence, shall the Manufacturer be liable for special or consequential damages including but not limited to: Loss of profits or revenues, loss of use of the product or any associated product, cost of capital, cost of substitute products, facilities or services or claims of customers.

No claim will be allowed for products lost or damaged in transit. Such claims should be filed with the carrier within fifteen days.

Effective April 1, 1998.



Stone Construction Equipment, Inc.
32 East Main Street, P. O. Box 150
Honeoye, NY 14471-0150

Phone: 1-800-888-9926 • 1-716-229-5141
Fax: 1-716-229-2363

www.stone-equip.com • e-mail: sceny@mcimail.com

1. TECHNICAL DATA

1. TECHNICAL DATA



1.1 Specifications Stone Rhino®

MODEL	STONE SD 43	STONE SD 54	STONE PD 43	STONE PD 54	STONE PD 54	STONE PDB 54
Drum Type	Smooth	Smooth	Padfoot	Padfoot	Padfoot	Padfoot w/blade
Dimensions						
Operating Wt. (Kg)	6100# (2767)	6540# (2966,5)	6409# (2907,1)	6880# (3120,7)	6880# (3120,7)	7275# (3300)
Drum Width (cm)	43" (109,2)	54" (137,2)	43" (109,2)	54" (137,2)	54" (137,2)	54" (137,2)
H x L x W (cm)	97" x 124" x 51" (246,4 x 315 x 124,5)	97" x 124" x 59" (246,4 x 315 x 149,9)	97" x 124" x 51" (246,4 x 315 x 124,5)	97" x 124" x 59" (246,4 x 315 x 149,9)	97" x 124" x 59" (246,4 x 315 x 149,9)	97" x 136" x 68" (246,4 x 315 x 172,7)
Tires (cm)	9.5 x 16 (24,1 x 40,6) Diamond Tread	9.5 x 16 (24,1 x 40,6) Diamond Tread	9.5 x 16 (24,1 x 40,6) Cleated Tractor	9.5 x 16 (24,1 x 40,6) Cleated Tractor	9.5 x 16 (24,1 x 40,6) Cleated Tractor	9.5 x 16 (24,1 x 40,6) Cleated Tractor
Operating System						
Engine (kW)	58 hp John Deere (43.25)	58 hp John Deere (43.25)	58 hp John Deere (43.25)	58 hp John Deere (43.25)	58 hp John Deere (43.25)	58 hp John Deere (43.25)
RPM (Hertz)	2500 (41,7)	2500 (41,7)	2500 (41,7)	2500 (41,7)	2500 (41,7)	2500 (41,7)
Fuel Capacity (liters)	20 gal. (757)	20 gal. (757)	20 gal. (757)	20 gal. (757)	20 gal (757)	20 gal. (757)
Steering	Power	Power	Power	Power	Power	Power
Frame	Articulating, Oscillating	Articulating, Oscillating	Articulating, Oscillating	Articulating, Oscillating	Articulating Oscillating	Articulating, Oscillating
Drive System	Positraction	Positraction	Positraction	Positraction	Positraction	Positraction
Eccentric Drive	Hydrostatic	Hydrostatic	Hydrostatic	Hydrostatic	Hydrostatic	Hydrostatic
Cooling	Water	Water	Water	Water	Water	Water
Parking Brake	Mechanical	Mechanical	Mechanical	Mechanical	Mechanical	Mechanical
Security Braking Sys.	Hydrostatic	Hydrostatic	Hydrostatic	Hydrostatic	Hydrostatic	Hydrostatic
Performance						
Centrifugal Force (Kn)	12,000# (53,38)	12,000# (53,38)	12,000# (53,38)	12,000# (53,38)	12,000# (53,38)	12,000# (53,38)
Frequency (Hertz)	2100 (35)	2100 (35)	2100 (35)	2100 (35)	2100 (35)	2100 (35)
Total Applied Force (Kn)	14,900# (66,28)	15,100# (67,17)	15,209# (67,65)	15,419# (68,59)	15,808# (70,32)	16,075# (71,51)
Speed						
Low Gear	0-2 mph (0-3,22)	0-2 mph (0-3,22)	0-2 mph (0-3,22)	0-2 mph (0-3,22)	0-2 mph (0-3,22)	0-2 mph (0-3,22)
High Gear	0-4 mph (0-6,44)	0-4 mph (0-6,44)	0-4 mph (0-6,44)	0-4 mph (0-6,44)	0-4 mph (0-6,44)	0-4 mph (0-6,44)
(kilometers/hour)						
Amplitude (mm)	.071" (1,80)	.062" (1,57)	.059" (1,50)	.053" (1,35)	.059" (1,50)	.053" (1,35)
Articulating Angle	35°	35°	35°	35°	35°	35°
Oscillating Angle	9°	9°	9°	9°	9°	9°
Gradeability	90%	90%	70%	70%	70%	70%
Inside Turning Radius (meter)	94.25" (2,39)	88.75" (2,25)	94.25" (2,39)	88.75" (2,25)	94.25" (2,39)	88.75" (2,25)
Wall Clearance (cm)	2 1/2" (6,35)	2 1/2" (6,35)	2 1/2" (6,35)	2 1/2" (6,35)	7" (17,78)	7" (17,78)
Curb Clearance (cm)	14" (35,56)	14" (35,56)	14" (35,56)	14" (35,56)	14" (35,56)	14" (35,56)
Area Cap. (Sq.Ft./Hr.) (M²)	37,840 sq.ft./hr. (3515,5)	47,520 sq.ft./hr. (4414,8)	37,840 sq.ft./hr. (3515,5)	47,520 sq.ft./hr. (4414,8)	37,840 sq.ft./hr. (3515,5)	47,520 sq.ft./hr. (4414,8)

Standard Features: 2 drum scrappers; ROPS/FOPS; gauges – oil pressure, volt meter, coolant temp, hour meter, fuel sight, hydraulic oil sight; warning lights - oil pressure and temperature; horn; back-up alarm; neutral safety start; padded seat w/flip-up arm rests; seat belt; secondary parking brake

1.2 ENGINE RPM

IDLE RPM	1,200 ± 100 18Hz
FULL RPM	2,500 ± 100 41Hz
ECCENTRIC FULL SPEED RPM	2,100 ± 100 34Hz

1. TECHNICAL DATA

1.3 MACHINE DATA

Brakes Service Parking	Hydrostatic Automatic spring applied
Recommended Fuel	Diesel fuel blend meeting ASTM D975 or EN 590 Premium diesel fuel conditioner is also recommended
Electric	12 Volt system battery BCI group 24 800 CCA 78 amp charge system
Hydraulic Oil	Mobilfluid 424 Capacity 20 gallons (76 liters)
Engine Oil	1st 100 hours John Deere break-in oil (TY22041) then SAE 15W/40 API CG-4 or API CF-4 6.5 quarts (6.0 liters)
Engine Coolant	50/50 Mixture antifreeze / distilled water meeting ASTM 4985, coolant additive is also recommended
Eccentric Oil	SAE 20W/50 API SJ or API SH SD / PD 43: 1 quart (.95 liter) SD / PD 54: 15 quarts (1.4 liters)
Engine / HP	John Deere 3029DF 58 HP (43 kW) int. @ 2,500 RPM
Torque	153 ft. lbs. (208 Nm) int. @ 1,200 RPM
Fuel Economy	.377 lb./hp - hr. (230 g/kWh) @ 1,600 RPM

1.4 MACHINE SOUND LEVEL TEST

Machine Type:	PDB54 Rhino
Sound Level Meter Calibration Date:	August 6, 1997
Meter Type:	Simpson Model 886-2 Type 2
Test Date:	August 6, 1997
Test Conditions:	
Temperature	70° Fahrenheit / 20° Celsius
Ambient Sound	60 dba Slow Mode
Soil Condition	Silts and Clays
Moisture Limit	N/A
Engine Speed:	2,500 RPM / 41 Hz
Frequency:	2,100 VPM / 34 Hz
Test Site:	Honeoye, New York, USA
Sound Level at Operator Position:	93 dba Without Vibe
	93 dba With Vibe

2. HEALTH & SAFETY

2. HEALTH & SAFETY

Safety Precautions

SAFETY USE

These machines are designed to carry out the function of compacting material of the non-cohesive, bituminous and granular varieties.

If used correctly they will provide an effective and safe means of compaction and meet the appropriate performance standards.

It is essential that the operator of the machine is adequately trained in its safe operation, be authorized to operate it, and have sufficient knowledge of the machine to ensure that it is in full working order before being put to use.

2. HEALTH & SAFETY

Safety Precautions

Before using this equipment, study this entire manual to become familiar with its operation. Do not allow untrained or unauthorized personnel, especially children, to operate this equipment. Use only factory authorized parts for service.

When warning decals are destroyed or missing, contact the Manufacturer immediately at 1-800-888-9926 for replacement. For the safety of yourself and others, it is imperative that the following rules are observed. Failure to do so may result in serious injury or death.

FOLLOW SAFETY INSTRUCTIONS

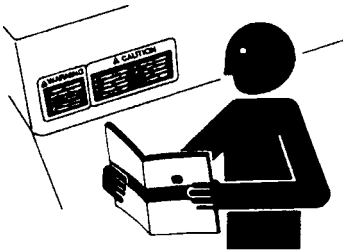

- Carefully read all safety messages and decals in this manual and on your machine safety signs. Keep decals in good condition. Replace missing or damaged decals. Be sure new equipment components and repair parts include the current safety signs. Replacement safety signs and decals are available through your dealer.
- Learn how to operate the machine and how to use controls properly. Do not let anyone operate without instruction.
- Keep your machine in proper working condition. Unauthorized modifications to the machine may impair the function and/or safety and affect machine life.
- If you do not understand any part of this manual and need assistance, contact your dealer.

▲ DANGER

▲ WARNING

▲ CAUTION

UNDERSTAND SIGNAL WORDS

- A signal word – DANGER, WARNING, or CAUTION – is used with the safety-alert symbol. DANGER identifies the most serious hazards.
- DANGER or WARNING safety signs are located near specific hazards. General precautions are listed on CAUTION safety signs. CAUTION also calls attention to safety messages in this manual.



- This notation appears before warnings in the text. It means that the step which follows must be carried out to avoid the possibility of personal injury or death. These warnings are intended to help the technician avoid any potential hazards encountered in the normal service procedures. We strongly recommend that the reader takes advantage of the information provided to prevent personal injury or injury to others.

2. HEALTH & SAFETY

Safety Precautions

USE COMMON SENSE WHEN HANDLING FUELS



- Transport and handle fuel only when contained in approved safety container.
- Do not smoke when refueling or during any other fuel handling operation.
- Do not refuel while the engine is running or while it is still hot.
- If fuel is spilled during refueling, wipe it off from the engine immediately and discard the rag in a safe place.
- Do not operate the equipment if fuel or oil leaks exist - repair immediately.
- Never operate this equipment in an explosive atmosphere.



- Operator must always be seated with seat belt on when roller is running.
- Never allow more than one person on roller.
- Always turn engine off before dismounting from roller.
- Always apply parking brake when not in use.
- Never park roller on a hill.
- Never operate roller on slope greater than 15 degrees.
- Do not operate the roller in standing water.



- Ear protection required when operating this equipment.
- Exposure to loud noise can cause impairment or loss of hearing.



HOT SURFACES

- Muffler, engine, and engine shroud may be hot.
- Allow all components in the engine compartment to cool before performing any service work.



- Never operate unit in a poorly ventilated or enclosed area.
- Avoid prolonged breathing of exhaust gases.
- Engine exhaust fumes can cause sickness or death.

2. HEALTH & SAFETY

Safety Precautions



- Qualified personnel only. No untrained operators. Serious injury may occur.
- Users must be trained to operate this roller. Read the Operator's Manual and Engine Owner's Manual. Learn to operate this roller safely.
- Do not articulate on grades larger than 15°, roller may tip over.
- Do not operate across the sides of hills, roller may tip over.
- Do not operate at the edge of mats or roads, roller may tip over.
- Do not stand. Be seated, with seat belt on, when roller is running.
- Do not park the roller on hills.
- Always turn off engine and apply brake before dismounting.



- Caution: Escaping hydraulic fluid under pressure can have sufficient force to penetrate the skin, causing serious personal injury.
- Hydraulic system produces high pressures--incorrect hose replacement can cause serious personal injury. When performing service, refer to Operator's Manual for hose identification and connections.
- Hydraulic fluid escaping under pressure from a very small hole can be almost invisible. Use a piece of cardboard or wood to search for possible leaks.
- Never use your hands to detect pressure leaks.
- Hydraulic tank temperature can reach 180° F maximum.



SERVICE COOLING AND HYDRAULIC SYSTEMS SAFELY

- Pressurized release of fluids from hydraulic or coolant systems can cause serious burns.
- Shut off engine. Only remove filler cap when cool enough to touch with bare hands. Slowly loosen cap to first stop to relieve pressure before removing completely.



- Never perform any work on the roller while it is running. Before working on the roller, stop the engine and disconnect the spark plug wire(s) to prevent accidental starting, block drums to prevent rolling.
- Keep engine cover closed during the operation.
- Keep hands, clothing and jewelry away from all moving parts.
- Keep all guards in place.

2. HEALTH & SAFETY

Safety Precautions

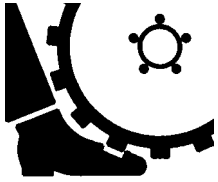

- Keep feet clear of all drums.
- Keep work area free of bystanders.
- For foot protection wear steel toe shoes or toe pads.

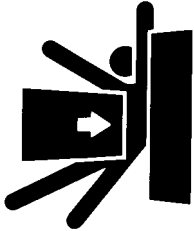

- Caution: Keep away from the machine's articulation area when the engine is running.
- Only start engine from operator's seat.
- Before starting machine, make sure that there are no persons or obstacles near or under machine.

PRACTICE SAFE MAINTENANCE



- Understand service procedure before doing work. Keep area clean and dry.
- Never lubricate, service, or adjust machine while it is moving. Keep hands, feet, and clothing from power-driven parts. Disengage all power and operate controls to relieve pressure. Lower equipment to the ground. Stop the engine. Remove the key. Allow machine to cool.
- Securely support any machine elements that must be raised for service work.
- Keep all parts in good condition and properly installed. Fix damage immediately. Replace worn or broken parts. Remove any buildup of grease, oil, or debris.
- Disconnect battery ground cable (-) before making adjustments on electrical systems or welding on machine.

PREPARE FOR EMERGENCIES

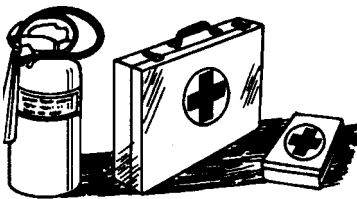

- Be prepared if a fire starts.
- Keep a first aid kit and fire extinguisher handy.
- Keep emergency numbers for doctors, ambulance service, hospital, and fire department near your telephone.

2. HEALTH & SAFETY

Safety Precautions



Starting fluid (ether) is highly flammable. Do not use or an explosion or fire may result.

WEAR PROTECTIVE CLOTHING

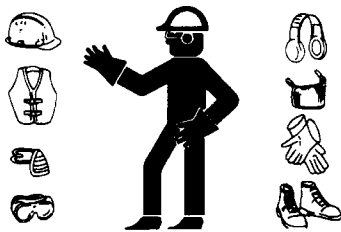

- Wear close fitting clothing and safety equipment appropriate to the job.
- Prolonged exposure to loud noise can cause impairment or loss of hearing.
- Wear a suitable hearing protective device such as earmuffs or earplugs to protect against objectionable or uncomfortable loud noises.
- Operating equipment safely requires the full attention of the operator. Do not wear radio or music headphones while operating machine.



PREVENT BYPASS STARTING

- Avoid possible injury or death from engine runaway.
- Do not start engine by shorting across starter terminal. Engine will start with drive system engaged if normal circuitry is bypassed.
- Start engine only from operator's seat with seat belt on and forward/reverse in neutral.

DISPOSE OF WASTE PROPERLY

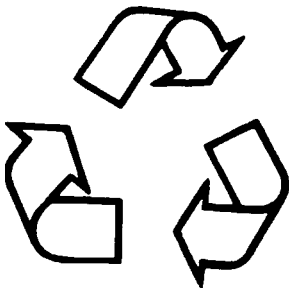

- Improperly disposing of waste can threaten the environment and ecology. Potentially harmful waste used with John Deere equipment includes such items as oil, fuel, coolant, brake fluid, filters, and batteries.
- Use leakproof containers when draining fluids. Do not use food or beverage containers that may mislead someone into drinking from them.
- Do not pour waste onto the ground, down a drain, or into any water source.
- Air conditioning refrigerants escaping into the air can damage the Earth's atmosphere. Government regulations may require a certified air conditioning service center to recover and recycle used air conditioning refrigerants.
- Inquire on the proper way to recycle or dispose of waste from your local environmental or recycling center.

3. OPERATION

3. OPERATION

3.1 INTRODUCTION AND OPERATING PRINCIPLE

This roller is ergonomically engineered to optimize operator interface with the total machine – it’s really “user friendly”. Besides good visibility to the roll-edge, as well as the work surface, you’ll find that the controls are exactly in the right places for maximum comfort. And it is very convenient to monitor all the consumables – fuel, hydraulic oil, etc.

Our common sense approach to servicing is a valuable benefit. Thanks to our modular design, everything that needs servicing is located behind one of the easy-access service panels or is under the rear cowl.

For maneuverability and productivity, nothing beats the proven performance of center-point articulation. Because the drum and tires track each other exactly, tight turns are achieved smoothly. The roller is equipped with full positive traction, front to rear and side to side, which keeps the roller moving through various conditions.

There’s power steering – a feature no operator wants to be without. A variable hydrostatic drive system provides infinitely variable speed control – from 0 to 4 mph. The eccentric delivers a centrifugal force sufficient to compact all types of soil. Superior vibration isolation to the operator is achieved by mounting heavy-duty shock mounts between the eccentric and support frames.

The following instructions were compiled to provide you information on how to obtain long and trouble-free use of the roller. Periodic maintenance of the roller is essential. Read this manual in its entirety and follow the instructions carefully. Failure to do so may cause injury to you or a bystander.

3. OPERATION

3.2 DIESEL FUEL

Do not mix oil with fuel. The engine has a separate oil reservoir in the crankcase. Diesel fuel blend meeting ASTM D915 or EN590 and a premium diesel fuel conditioner is recommended.

WARNING

FUEL IS BOTH TOXIC AND FLAMMABLE. DO NOT SMOKE WHILE WORKING WITH FUEL. DO NOT USE NEAR OPEN FLAME. ALWAYS STOP ENGINE BEFORE REFUELING. CLEAN UP SPILLED FUEL BEFORE STARTING. AVOID FIRES BY KEEPING ENGINE CLEAN OF ACCUMULATED GREASE AND DEBRIS.

START, STORE, AND REFUEL ON LEVEL GROUND TO PREVENT PERSONAL INJURY. DO NOT RUN UNIT IN AN ENCLOSED, NON-VENTILATED AREA. AVOID PROLONGED BREATHING OF VAPORS AND SKIN CONTACT. SERIOUS ILLNESS OR LOSS OF LIFE COULD RESULT.

KEEP THE VENT HOLE IN FUEL TANK CAP OPEN. IF VENT HOLE IS PLUGGED, PRESSURE MAY BUILD UP IN TANK, CAUSING DANGEROUS SPRAYING OF FUEL WHEN TANK CAP IS REMOVED. A VACUUM MAY ALSO BE CREATED DURING OPERATION, WHICH COULD STOP FUEL FLOW. DIESEL FUEL IS MANDATORY FOR USE IN THIS ENGINE. ALWAYS USE CLEAN FUEL. LOW QUALITY OR CONTAMINATED FUEL WILL DAMAGE FUEL INJECTION COMPONENTS.

DIESEL FUEL STORED IN GALVANIZED CONTAINERS REACTS CHEMICALLY WITH THE ZINC COATING ON THE CONTAINER. THE CHEMICAL REACTION CREATES POWDERY FLAKES OF ZINC SULFIDE. IF WATER IS PRESENT IN THE FUEL, A ZINC HYDROXIDE GEL WILL FORM.

3.3 ENGINE BREAK-IN

IMPORTANT – Read Engine Manual for break-in requirements. 1st 100 hours John Deere break-in oil only (TY 22041). Do not add oil until level is in the add area on the dipstick. Do not fill above the crosshatched area on the dipstick. 1st 100 hours run engine at full throttle. Operate engine at heavy loads, do not idle longer than 5 minutes. Check oil frequently, do not exceed 100 hours with break-in oil.

3.4 ENGINE OIL AND FILTER

Change oil and filter at 100 hours, then every 250 hours. Use SAE 15W-40 API CG-4 or API CF-4. Refer to Engine Manual for additional oil types and recommendations. Do not mix different brands or types of oil. Mixing oils can degrade lubrication performance.

3.5 WARNING LIGHT

Unit is equipped with a warning light for low pressure and/or hot engine temperature.

Specifications:

- Oil pressure at full speed: 40 – 50 psi (2.75 – 3.45 bar)
- Coolant temperature range: 180° - 202°F (82° - 94°C)

3.6 HYDRAULIC OIL, FILTER, BREATHER

WARNING

PRESSURIZED RELEASE OF FLUIDS FROM HYDRAULIC SYSTEM CAN CAUSE SERIOUS BURNS. SHUT OFF ENGINE. ONLY REMOVE BREATHER CAP WHEN COOL ENOUGH TO TOUCH WITH BARE HANDS. SLOWLY LOOSEN CAP TO FIRST STOP TO RELIEVE PRESSURE BEFORE REMOVING COMPLETELY.

Check the hydraulic oil level. Use the sight gauge located on the hydraulic tank. A 1/4 – 1/2” air bubble will be seen at the top of the gauge showing the fluid level.

3. OPERATION

For satisfactory operation, the following oil conditions apply:

1. Accurate level readings can be checked only when the fluid is cold.
2. If the natural color of the fluid has become black or milky, it is possible that an overheating or water contaminant problem exists.
3. Do not mix hydraulic fluids. Mobil 424 is recommended for the hydraulic system.

CAUTION: After a new unit has run 5 hours, the oil filter should be changed. This is to rid the system of any trapped contamination from the wear-in of the parts. Refer to Maintenance for hydraulic filter change.

3.7 ENGINE COOLANT

▲WARNING

CHECK COOLING SYSTEM CAREFULLY. EXPLOSIVE RELEASE OF FLUIDS FROM PRESSURIZED COOLING SYSTEM CAN CAUSE SERIOUS BURNS.

To check coolant level:

1. Shut off engine, allow to cool.
2. Only remove filler cap when cool enough to touch with bare hands. Slowly loosen cap to first stop to relieve pressure before removing completely.
3. Remove cap, coolant level should just touch the bottom of radiator filler neck. If coolant is required, see “Adding Coolant” in the Maintenance section of this manual.

IMPORTANT: Do not overfill radiator. Refer to “Coolant Maintenance” if additional coolant is required. Never pour cold liquid into a hot engine, as it may crack cylinder head or block. DO NOT operate engine without coolant for even a few minutes. If coolant leaks or abnormal temperature is detected, contact a service technician immediately.

NOTE: It is normal for a small amount of leakage to occur as the engine cools down and parts contract. Excessive coolant leakage may indicate the need to

replace the water pump seal. Contact your engine distributor or servicing dealer for repairs.

3.8 VISUAL INSPECTION

Make a thorough inspection of the engine compartment daily. Look for oil or coolant leaks, worn fan belt, loose connections and trash build-up. Remove trash build-up and have repairs made as needed if leaks are found.

NOTE: Wipe all fittings, caps, and plugs before performing any maintenance to reduce the chance of system contamination.

- Air intake system hoses and connections for cracks and loose clamps.
- Fan belt for cracks, breaks, or other damage.
- Water pump for coolant leaks.

3.9 AIR CLEANER

IMPORTANT: The air intake system must not leak. Any leak, no matter how small, may result in engine failure due to abrasive dirt and dust entering the intake system.

1. Inspect all intake hoses (piping) for cracks.
2. Check clamps on piping which connect the air cleaner and engine.
3. Squeeze dust unloader valve (A) on air cleaner assembly to remove dust deposits. If clogged, remove and clean the dust unloader valve. Replace if damaged.

IMPORTANT: Do not operate engine without the dust unloader valve.

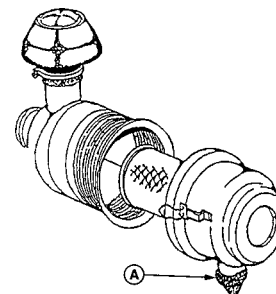

3. OPERATION

WARNING

BEFORE STARTING ENGINE IN A CONFINED BUILDING, INSTALL PROPER OUTLET EXHAUST VENTILATION EQUIPMENT. ALWAYS USE SAFETY APPROVED FUEL STORAGE AND PIPING. NEVER RUN THE ROLLER WITHOUT THE PANELS IN PLACE OR SEVERE PERSONAL INJURY MAY OCCUR.

3.10 BEFORE STARTING

1. Check for proper fluid levels, engine oil, coolant, fuel, and hydraulic oil.
2. Check the air cleaner.
3. Check throttle, levers, and controls for smooth operation.
4. Check seat belt, horn, and back-up alarm operation.

3.11 TO START

1. Operator must always be seated and seat belt must be worn.
2. Forward/reverse must be in NEUTRAL position and eccentric switch should be in OFF position.
3. Throttle should be set at idle.
4. Turn key clockwise until the engine cranks over. Release the key when the engine starts. DO NOT crank engine for more than 20 seconds at a time.
5. Check all gauges for normal engine operation. If operation is not normal, stop the engine and determine the cause.

NOTE: If temperature is below 0° C (32° F), it may be necessary to use cold weather starting aid. See “Cold Weather Starting” later in this section.

WARNING

DO NOT USE STARTING FLUID (ETHER). ENGINE IS EQUIPPED WITH INTAKE HEATER. AN EXPLOSION OR FIRE MAY RESULT. REFER TO COLD WEATHER STARTING INSTRUCTIONS.

3.12 TO STOP

WARNING

ALWAYS OBEY THE FOLLOWING PROCEDURES BEFORE DISMOUNTING FROM THE ROLLER.

1. Place the forward/reverse lever in the NEUTRAL position.
2. Throttle engine down to its slowest speed.
3. Turn key switch to OFF position to stop the engine. Remove ignition key.

NOTE: Before stopping an engine that has been operating at working load, idle engine at least 2 minutes.

3.13 IDLING ENGINE

IMPORTANT: Avoid excessive engine idling. Prolonged idling may cause the engine coolant temperature to fall below its normal range. This, in turn, causes crankcase oil dilution, due to incomplete fuel combustion, and permits formation of gummy deposits on valve, pistons, and piston rings. It also promotes rapid accumulation of engine sludge and unburned fuel in the exhaust system.

3.14 WARMING ENGINE

IMPORTANT: To assure proper lubrication, operate engine at idle with no load for 5 minutes. Extend this period when operating at temperatures below freezing.

1. Check oil pressure gauge as soon as engine starts. If gauge needle does not rise above minimum oil pressure specification of (1.05 bar) (15.0 psi) within 5 seconds, stop the engine and determine the cause. Normal engine oil pressure is (3.45 bar + 1.03 bar) (50 + 15 psi) at rated full load speed (1800 – 2500 rpm) with oil at normal operating temperature of 105° C (221° F).
2. Watch coolant temperature gauge. Do not place engine under full load until it is properly

3. OPERATION

warmed up. The normal engine coolant temperature range is 82° - 94° C (180° - 202° F).

NOTE: It is good practice to operate the engine under a lighter load and at lower speeds than normal for the first few minutes after start-up.

3.15 PARKING BRAKE

WARNING

BLOCK THE DRUMS TO PREVENT ROLLING OF THE MACHINE OR SEVERE PERSONAL INJURY MAY OCCUR. NEVER PARK ROLLER ON A HILL.

When engine is not running, the brake is applied. When the engine is running and the forward/reverse lever is in NEUTRAL, the brake will apply within 2 seconds.

3.16 BRAKE LIGHT

When the key is turned to ON, the brake light should come on within 2 seconds. Shifting into forward or reverse, the light should go out.

3.17 TO OPERATE

IMPORTANT: Follow Manufacturer's "Before Starting" and "Break-in" procedures on engine. Always allow engine to warm up five minutes before applying load.

Start and apply full throttle. Move forward/reverse lever slowly forward to gain speed desired. The same procedure is for reverse. To slow down, move forward/reverse lever toward NEUTRAL.

To gain power or speed by moving forward/reverse lever slightly off of NEUTRAL will produce the greatest amount of torque. Moving the lever all the way forward or reverse will give the greatest amount of speed.

WARNING

NEVER OPERATE ON SLOPES GREATER THAN 15 DEGREES OR TIPPING MAY OCCUR.

3.18 FORWARD/REVERSE/NEUTRAL

The forward/reverse lever should be aligned with "NEUTRAL" on the console when the roller is moving neither forward nor backward with the engine running.

The neutral interlock switch should not allow the engine to start unless the forward reverse lever is in neutral.

3.19 THROTTLE

Pull throttle out to increase engine speed. Push throttle to reduce engine speed. For best performance, run engine at full throttle.

3.20 GAUGES

IMPORTANT: Any time an electric gauge or meter does not register correctly, replace it with a new one. Do not attempt to repair it.

Oil Pressure Gauge –Indicates engine oil pressure.

Coolant Temperature Gauge – Indicates the engine coolant temperature.

Volt Meter – Indicates charging current within electrical system.

Hour Meter – Indicates the operating hours of the engine while key switch is in the ON position. The hour meter should be used as a guide for scheduling maintenance.

WARNING

AVOID LEAVING THE KEY ON WHEN MACHINE IS NOT RUNNING. THIS WILL HAVE AN EFFECT ON THE HOUR METER READINGS.

3. OPERATION

3.21 PANEL FUSE 20 AMP

Protects electrical system.

WARNING

NEVER USE FUSE WITH A DIFFERENT RATING FROM THAT SPECIFIED. SERIOUS DAMAGE TO THE ELECTRICAL SYSTEM OR A FIRE MAY RESULT.

3.22 COLD WEATHER STARTING / INTAKE HEATER BUTTON

WARNING

DO NOT USE STARTING FLUID (ETHER). ENGINE IS EQUIPPED WITH AIR INTAKE HEATER. AN EXPLOSION OF FIRE MAY RESULT. FOR COLD WEATHER STARTING, SEE INSTRUCTIONS BELOW.

1. Turn the key to the ON position (do not crank engine).
2. Press INTAKE HEATER BUTTON for approximately 30 seconds. Start engine using starter switch. As soon as the engine starts, release button.
3. Never operate the starter for more than 20 seconds at a time. If engine does not start, release the starter switch and wait at least one minute before trying again.
4. Do not adjust the throttle setting. Allow the engine to idle for 5 minutes to warm up. At temperatures below freezing, extend warm up time.

3.23 BLADE LEVER (OPTIONAL)

Controls the leveling blade height for pre-leveling loose soil.

IMPORTANT: Do not use the blade to dig or bulldoze or machine damage may occur.

3.24 HORN AND BACK-UP ALARM

Check operation daily. It is the driver's responsibility to operate equipment safely.

3.25 ROPS / FOPS / SEAT BELT

Inspect daily. Certified factory installed for operator protection. Do not remove or modify.

WARNING

DANGER: AVOID CRUSHING. DO NOT JUMP IF MACHINE TIPS. ALWAYS WEAR SEAT BELT.

DO NOT OPERATE THIS MACHINE IF THE ROLLOVER PROTECTIVE STRUCTURE (ROPS) IS STRUCTURALLY DAMAGED, SHOWS CRACKS, IS NOT PROPERLY SECURED AS ORIGINALLY INSTALLED, OR HAS BEEN ROLLED. DO NOT REPAIR, MODIFY, OR ADD ATTACHMENTS TO ROPS UNLESS AUTHORIZED IN WRITING BY THE MANUFACTURER.

DO NOT ADD ATTACHMENTS TO THE MACHINE THAT INTRUDE INTO OPERATOR'S PROTECTIVE AREA, REDUCE VISIBILITY, RESTRICT EMERGENCY EXITS, OR ADD WEIGHT EXCEEDING CERTIFICATION WEIGHT OF ROPS. DO NOT OPERATE MACHINE UNLESS SEAT BELT CONFORMING TO SAE AND/OR ASAE STANDARDS IS FASTENED. SEE OPERATOR'S MANUAL OR CONTACT YOUR DEALER FOR COMPLETE INSPECTION REQUIREMENTS AND MAINTENANCE INSTRUCTIONS.

3.26 TIRES/LUG NUTS

WARNING

DO NOT EXCEED RATED PRESSURE 35 PSI.

Clean and check daily:

1. Tires are properly inflated.
2. Lug nuts are in place and tight
190 ft. lbs. (140 Nm).

3. OPERATION

3.27 DRUM/SCRAPPERS

Clean and inspect daily to prevent excess mud and debris from building up. Replace if missing or worn. Pad drum scrapers are adjustable, see Maintenance section.

3.28 CLEANING

WARNING

DIRT AND MUD BUILT UP WILL REDUCE MACHINE PERFORMANCE AND/OR CAUSE FAILURES.

Use pressurized water to remove dirt and mud. Clean and inspect entire machine daily. Use extra care when cleaning radiator and oil cooler.

When cleaning machine, caution should be used around regulator area. Direct spraying of the regulator is not good. (Regulator should be covered or protected if direct spraying will happen). Excessive water pressure may also loosen wire connections or start terminals corroding. After cleaning, all terminals should be dried if wet and connections checked for proper seating.

3.29 ECCENTRICS

When vibratory compaction is necessary, engage eccentrics by pushing the vibration switch to the ON position. For best performance run engine at full rpm. The eccentrics should be turned off whenever the roller is stopped or stopped to change direction. Do not run the eccentric on any non-yielding surface such as concrete or aged asphalt.

3.30 COMPACTION TIPS

Avoid sharp turns, steer gradually. If articulation is a new concept, we suggest the operator take 20 minutes or so to get used to the feel of the unit.

Recommended compaction speed should be at 3 m.p.h. or less to achieve a uniform compaction.

WARNING

**DO NOT ARTICULATE ON GRADES LARGER THAN 15°, ROLLER MAY TIP OVER.
DO NOT OPERATE ACROSS THE SIDES OF HILLS, ROLLER MAY TIP OVER.
DO NOT OPERATE AT THE EDGE OF MATS OR ROADS, ROLLER MAY TIP OVER.
DO NOT STAND, ALWAYS WEAR SEAT BELT.**

3.31 TIE DOWNS

WARNING

TIE DOWNS ARE NOT INTENDED FOR LIFTING PURPOSES.

Equipment is equipped with front and rear tie down rings for shipping purposes. Use only these tie downs to secure unit.

3.32 TOWING (BYPASS)

WARNING

NEVER PUSH OR PULL THE ROLLER WITH THE ENGINE OFF. WHEN ENGINE IS NOT RUNNING, THE BRAKE IS APPLIED. WHEN THE ENGINE IS RUNNING AND THE FORWARD/REVERSE LEVER IS IN NEUTRAL, THE BRAKE WILL APPLY WITHIN 2 SECONDS.

In an emergency or during a breakdown, it may be necessary or desirable to tow the roller. This may be accomplished by mechanically releasing the brake and bypassing the transmission pump. If these procedures are followed carefully, the roller may be moved short distances at LOW speed without running the engine.

The brake is located in the front wheel motor, which drives the drum of the roller. There is an access hole in the front frame to assist in releasing the brake. Refer to the Drum Assembly #39 22770 Kit Bypass to identify these parts. The threaded hole in the center of the wheel motor requires a M12 bolt long enough to extend beyond the frame when fully engaged. A bolt, washer, and nut is included in a separate package for this

3. OPERATION

purpose. Fully install the nut and washer on the bolt. Insert this assembly through the hole in the frame such that the washer is over the hole with the nut against the outside of this washer. Thread the bolt, finger tight into the wheel motor to the bottom of the hole. Now tighten the nut against the washer until the brake is compressed and released. This should require about 44 ft. lbs. torque. Do not torque the bolt. Be careful not to over-torque beyond releasing the brake.

The bypass valve is located on the transmission pump. The seat and battery plate should be removed for access to the transmission pump. The bypass valve is controlled by a shaft with cross-drilled holes and maybe a slot in the end. This shaft may be turned manually to open the valve and allow the motor to turn. The valve is fully open with two revolutions of the shaft. **DO NOT OPEN VALVE PAST TWO TURNS.** The valve must be fully closed for normal operation. The torque required to close the valve is only 7 to 10 ft. lbs.

DAMAGE MAY RESULT FROM OVER-TORQUING.

3.33 STORAGE

IMPORTANT: The front wheel motor has a rubber plug in the M12 hole to prevent contamination. Reinstall the rubber plug after towing

1. Store the roller on level ground with drums blocked and parking brake on.
2. Remove the key. Operations of roller by untrained persons could result in personal injury.
3. During extended storage, drums can be coated with any type of oil or grease to prevent rusting.
4. Storage instructions for the engine are stated in the Engine Manual and should be carried out.

4. MAINTENANCE



4.1 IMPORTANT

The person attempting *any* of the following maintenance tasks must be authorized to do so and have read *and* understood *all* sections within this manual.

4. MAINTENANCE

4.2 MAINTENANCE SCHEDULE CHART

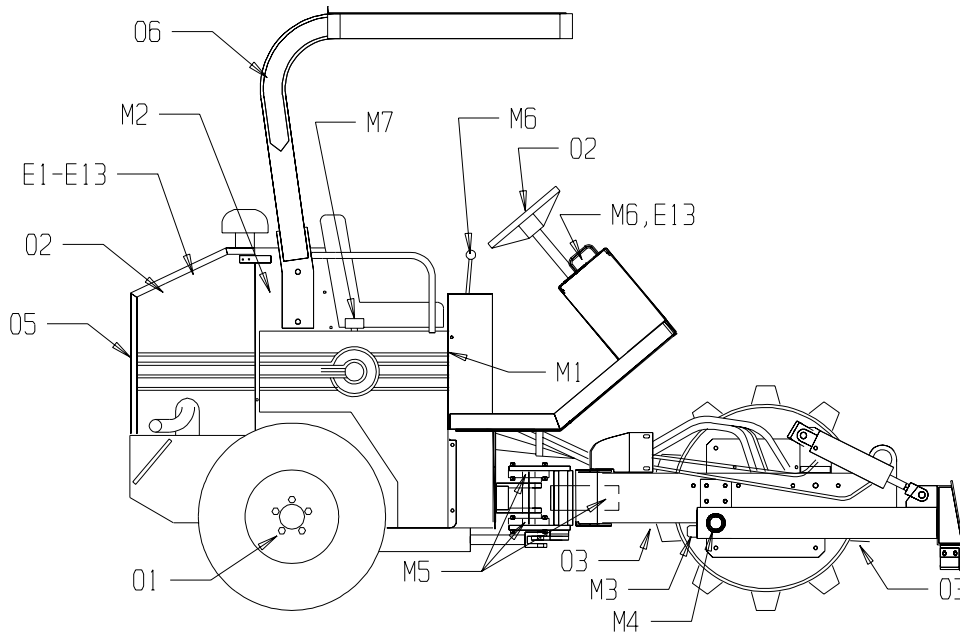

<input checked="" type="checkbox"/> CHECK/ADJUST <input type="checkbox"/> CLEAN/REPLACE	DAILY	WEEKLY	OTHER	INSTRUCTIONS
BREAK-IN 1ST 100 HRS RUN ENGINE AT FULL THROTTLE OPERATE ENGINE AT HEAVY LOADS DO NOT IDLE LONGER THAN 5 MINUTES				IMPORTANT READ ENGINE OWNER'S MANUAL FOR BREAK-IN PERIOD 1ST 100 HRS JOHN DEERE BREAK-IN OIL ONLY (J.D. #TY22041) DO NOT ADD OIL UNTILL LEVEL IS IN THE ADD AREA ON DIPSTICK DO NOT FILL ABOVE THE CROSSHATCHED AREA ON THE DIPSTICK
ENGINE: #				READ EMISSION WARRANTY, OPERATING & ENGINE OWNER'S MANUAL
E1 OIL LEVEL: TO BE WITHIN ARROW AND CROSSHATCHS	✓		○	SEE BREAK-IN ABOVE, THEN REPLACE OIL AND FILTER AT 100 HRS THEN EVERY 250 HRS, USE 15W-40 API CG-4 OR API CF-4
E2 OIL FILTER: DEERE T19044			○	REPLACE WHEN CHANGING OIL (STONE 39625)
E3 FUEL FILTER: DEERE RE624418			○	REPLACE EVERY 600 HRS/12 MONTH (STONE 39624)
E4 AIR CLEANER: DEERE AT171853	✓		○	CLEAN WHEN CHANGING OIL, REPLACE EVERY 600 HRS (STONE 39622)
E5 COOLANT: 50/50 MIX ASTM D4985	✓		○	FLUSH AND REPLACE COOLANT EVERY 1200 HRS/24 MONTH
COOLANT ADDITIVE DEERE: TY16004			○	ADD SCA WHEN REPLACING COOLANT (STONE 39641)
E6 FAN BELT: DEERE T23526	✓		○	ADJUST & REPLACE AS REQUIRED (STONE 39626)
E7 IDLE SPEED: #			✓	CHECK EVERY 250 HRS, IDLE 1200 RPM
E8 WATER SEPARATOR: #			✓	DRAIN WATER EVERY 50 HRS/2 WEEKS
E9 VALVE CLEARANCE: ##			✓	CHECK AFTER 400 HRS, THEN EVERY 1200 HRS/24 MONTH
E10 VENT TUBE:			○	REMOVE & CLEAN VENT TUBE EVERY 600 HRS/12 MONTH
E11 AIR INTAKE: HOSES & FILTER	✓			INSPECT, LEAKS MAY RESULT IN ENGINE DAMAGE
E12 INJECTORS: ##			○	IF REQ'D, CLEAN & TEST OR REPLACE (STONE 39629)
E13 GAGES/WARNING LIGHT:	✓			CHECK FOR PROPER OPERATION
MACHINE LUBRICATION: #				IMPORTANT READ OPERATING MANUAL & ENGINE OWNER'S MANUAL
M1 HYDRAULIC OIL LEVEL:	✓		○	REPLACE EVERY 800 HRS/YEARLY - MOBIL 424
M2 HYDRAULIC OIL FILTER: 50AT-10C			○	REPLACE AT 5 HRS, THEN EVERY 100 HRS (STONE 38638)
M3 ECCENTRIC OIL LEVEL: #			○	CHANGE EVERY 800 HRS/YEARLY, SAE 20W-50
M4 BLADE PIVOT: (2 PLACES)		○		LITHIUM BASE GREASE
M5 FRAME HINGE: (6 PLACES)		○		LITHIUM BASE GREASE
M6 THROTTLE, CABLES, FWD/RVS:	✓		○	CHECK FOR PROPER OPERATION, LUBE EVERY 250 HRS, LIGHT OIL
M7 HYDRAULIC BREATHER:	✓		○	BREATHER IN PLACE & TIGHT, REPLACE IF DAMAGED (STONE 38521)
OTHER: #				
O1 TIRES, LUGNUTS, HARDWARE:		✓		TIRES 35 PSI MAX, LUGNUTS 190 FT LBS, INSPECT HARDWARE
O2 HORN & BACK UP ALARM:		✓		INSPECT OPERATION DAILY (112 DBA)
O3 DRUM & SCRAPERS:	✓			CLEAN EXTERIOR & INSPECT
O4 BATTERY/CHARGING SYSTEM:			✓	CLEAN & CHECK MONTHLY, 13-14 VOLTS AT FULL RPM
O5 RADIATOR, OIL COOLER:	✓			CLEAN EXTERIOR & INSPECT CLAMPS & HOSES
O6 ROPS & SEAT BELTS:	✓			CLEAN EXTERIOR & INSPECT
O7 FUEL, OIL, COOLANT LEAKS:	✓			CLEAN EXTERIOR & INSPECT
# IMPORTANT READ JOHN DEERE EMISSION WARRANTY STATEMENT, STONE & ENGINE OWNER'S MANUAL				
## SEE AUTHORIZED ENGINE SERVICE DEALER AND/OR REFER TO ENGINE SHOP MANUAL FOR PROCEDURES 55381D				

4. MAINTENANCE

4.3 IMPORTANT MAINTENANCE INFORMATION

WARNING

REMOVE THE KEY AND / OR DISCONNECT BATTERY TO AVOID ACCIDENTAL IGNITION OF ENGINE. SEVERE PERSONAL INJURY MAY OCCUR. ROLLER MUST BE PARKED ON LEVEL GROUND WITH PARKING BRAKE APPLIED, ENGINE OFF, AND DRUM BLOCKED. NEVER WORK ON THE ROLLER WITH ENGINE RUNNING. SEVERE PERSONAL INJURY MAY OCCUR. ALLOW ALL COMPONENTS IN THE ENGINE COMPARTMENT TO COOL BEFORE PERFORMING ANY SERVICE WORK.

IMPORTANT: Read John Deere Emission Warranty Statement and Engine Manual before service or maintenance.

4.4 ENGINE OIL AND FILTER

IMPORTANT: Read Engine Manual and Engine Break-in covered in Operating section of this manual.

Change oil and filter at 100 hours, then every 250 hours. Use SAE 15W-40 API CG-4 or API CF-4.

1. Run engine approximately 5 minutes to warm up oil. Shut engine off.
2. Remove oil pan drain plug, drain into suitable container.
3. Drain crankcase oil from engine while warm.
4. Remove and discard oil filter using a filter wrench.
5. Clean filter mounting pad.

IMPORTANT: Filtration of oils is critical to proper lubrication. Always change filter regularly. Use filter meeting John Deere performance specifications.

6. Oil new filter seal and install new filter element, tighten approximately 3/4 – 1 - 1/4 turn after

packing contacts filter housing. DO NOT overtighten filter element.

7. Install oil pan drain plug.
8. Fill engine crankcase with correct engine oil through timing gear cover opening of rocker arm cover opening.

IMPORTANT: Immediately after completing any oil change, crank engine for 30 seconds without permitting engine to start. This will help insure adequate lubrication to engine components before engine starts.

9. Start engine and run to check for possible leaks.
10. Stop engine and check oil level after 10 minutes. Oil level reading should be between arrows or within crosshatch of dipstick.

4.5 ADDITIONAL SERVICE INFORMATION

This is not a detailed service manual. If you want more detailed service information see John Deere Manuals:
55319 Manual Engine
55320 Manual Parts
55321 Manual Technical

4.6 HYDRAULIC OIL/FILTER

WARNING

PRESSURIZED RELEASE OF FLUIDS FROM HYDRAULIC SYSTEM CAN CAUSE SERIOUS BURNS.

SHUT OFF ENGINE. ONLY REMOVE BREATHER CAP WHEN COOL ENOUGH TO TOUCH WITH BARE HANDS. SLOWLY LOOSEN CAP TO FIRST STOP TO RELIEVE PRESSURE BEFORE REMOVING COMPLETELY.

ESCAPING HYDRAULIC FLUID UNDER PRESSURE CAN HAVE SUFFICIENT FORCE TO PENETRATE THE SKIN, CAUSING SERIOUS PERSONAL INJURY. HYDRAULIC FLUID ESCAPING UNDER PRESSURE FROM A VERY SMALL HOLE CAN BE ALMOST INVISIBLE. USE A PIECE OF CARDBOARD OR WOOD TO SEARCH FOR POSSIBLE LEAKS. NEVER USE YOUR HANDS TO DETECT PRESSURE LEAKS.

4. MAINTENANCE

HYDRAULIC TANK TEMPERATURE CAN REACH 180 DEGREES F MAXIMUM.

Refer to Operating section of this manual for hydraulic oil conditions and recommendations.

Before disconnecting any hydraulic components, be sure engine is shut off and relieve all pressure. Before applying pressure to system, be sure all connections are tight and lines, fittings, and hoses are not damaged.

IMPORTANT: When hoses, oil filter, and/or hydraulic components are changed, start the engine and purge the air from the system prior to checking the oil level. To do this, idle the engine for three minutes with control lever in NEUTRAL position. Slowly engage forward to reverse. This allows fluid to replace air introduced with filter change. If this procedure is not followed, partial or complete failure of the pump may result.

Change hydraulic oil filter at 5 hours then every 100 hours.

1. Remove and discard hydraulic oil filter using a filter wrench.
2. Oil new filter seal and install new filter element, tighten approximately 3/4 – 1 - 1/4 turn after packing contacts filter housing. DO NOT overtighten filter element.

IMPORTANT: Immediately after completing filter change, crank engine for 30 seconds without permitting engine to start. This will help insure adequate lubrication to components before engine starts.

3. Start engine and run to check for possible leaks.
4. Stop engine and replenish hydraulic oil.

WARNING

NEVER OVERFILL THE HYDRAULIC TANK. USE THE SIGHT GAUGE LOCATED ON THE HYDRAULIC TANK. A 1/4 – 1/2" AIR BUBBLE WILL BE SEEN AT THE TOP OF THE GAUGE SHOWING THE FLUID LEVEL.

Change hydraulic oil every 800 hours. Use Mobil 424.

1. Run engine approximately 5 minutes to warm up oil. Shut engine off.
2. Remove breather cap and oil drain plug, drain into suitable container.
3. Apply thread sealant to breather cap and drain plug, install drain plug.
4. Fill hydraulic tank with correct hydraulic oil (approximately 20 gallons). Use the sight gauge to watch for proper oil level, install breather cap.

IMPORTANT: Immediately after completing oil change, crank engine for 30 seconds without permitting engine to start. This will help insure adequate lubrication to components before engine starts.

5. Start engine and run to check for possible leaks.
6. Stop engine and replenish hydraulic oil.

4.7 HYDRAULIC BREATHER

Replace every 800 hours or yearly. P/N 35483.

WARNING

PRESSURIZED RELEASE OF FLUIDS FROM HYDRAULIC SYSTEM CAN CAUSE SERIOUS BURNS. SHUT OFF ENGINE. ONLY REMOVE BREATHER CAP WHEN COOL ENOUGH TO TOUCH WITH BARE HANDS. SLOWLY LOOSEN CAP TO FIRST STOP TO RELIEVE PRESSURE BEFORE REMOVING COMPLETELY.

4.8 ENGINE COOLING SYSTEM

WARNING

EXPLOSIVE RELEASE OF FLUIDS FROM PRESSURIZED COOLING SYSTEM CAN CAUSE SERIOUS BURNS. SHUT OFF ENGINE. ONLY REMOVE FILLER CAP WHEN COOL ENOUGH TO TOUCH WITH BARE HANDS. SLOWLY LOOSEN CAP TO FIRST STOP TO RELIEVE PRESSURE BEFORE REMOVING COMPLETELY.

4. MAINTENANCE

To check coolant level, refer to Operating section of this manual and Engine Manual.

Inspect cooling system every 600 hours or 12 months.

1. Check entire cooling system hoses. Replace hoses when hard, flimsy, or cracked.
2. Thoroughly inspect all cooling system hoses. Replace hoses when hard, flimsy, or cracked.

IMPORTANT: Air must be expelled from cooling system when system is refilled. Loosen temperature-sending unit fitting at rear of cylinder head to allow air to escape when filling system. Retighten fitting when all the air has been expelled.

3. Test the coolant solution at 600 hours or 12 month intervals and whenever excessive coolant is lost through leaks or overheating to ensure the necessary protection. Coolant test strips are available from your John Deere dealer. These test strips provide a simple, effective method to check the freeze point and additive levels of your engine coolant.
4. After 600 hours or 12 months of engine operating time, recharge your engine coolant with the recommended amount (see label on container) of TY16004 or TY16005 Liquid Coolant Conditioner.

NOTE: TY16004 or TY16005 Liquid Coolant Conditioner is a non-chromate inhibitor and should be used only with low silicate, ethylene-glycol base antifreeze. It does not protect the cooling system from freezing. See "Adding Coolant."

Usually recharging your engine coolant with the recommended amount of TY16004 or TY16005 Liquid Coolant Conditioner at 600 hours or 12 months of operation is adequate. However, with a CoolScan analysis report you will be given a more thorough evaluation of your engine coolant condition along with detailed service recommendations. Refer to Engine Manual.

IMPORTANT: Do not add supplemental coolant additives when the cooling system is drained and refilled with John Deere ANTIFREEZE/SUMMER COOLANT or John Deere COOL-GARD.

ALWAYS maintain coolant at correct level and concentration. DO NOT operate engine without coolant for even a few minutes.

If frequent coolant makeup is required, the glycol concentration should be checked with JT05460 Refractometer to assure that the desired freeze point is maintained. Follow manufacturer's instructions provided with Refractometer.

Water may be used as coolant *in emergency situations only*.

Foaming, hot surface aluminum and iron corrosion, scaling, and cavitation will occur when water is used as the coolant, even when coolant conditioners are added.

Drain cooling system and refill with recommended glycol base engine coolant as soon as possible.

4.8.1 Replacing Engine Coolant

Every 1200 hours or 24 months, the coolant should be replaced. The coolant system should also be flushed and pressure tested. Refer to Engine Manual.

4.8.2 Adding Coolant

CAUTION: Explosive release of fluids from pressurized cooling system can cause serious burns. Shut off engine. Only remove filler cap when cool enough to touch with bare hands. Slowly loosen cap to first stop to relieve pressure before removing completely.

IMPORTANT: Never pour cold liquid into a hot engine, as it may crack cylinder head or block. DO NOT operate engine without coolant for even a few minutes.

Air must be expelled from cooling system when coolant is added.

1. Loosen temperature sending unit fitting at rear of cylinder head to allow air to escape when filling system.

4. MAINTENANCE

IMPORTANT: When adding coolant to the system, use the appropriate coolant solution. Coolant 50/50 mixture of antifreeze/distilled water meeting ASTM 4985, ASTM D5345 (pre-diluted coolant) or John Deere COOL-GARD. 50/50 mixture provides protection to -34° F (-37° C). Do not overfill cooling system. A pressurized system needs space for heat expansion without overflowing at top of radiator.

2. Fill until coolant level touches bottom of radiator filler neck.
3. Tighten fitting when air has been expelled from system.

4.8.3 Disposing of Coolant

Improperly disposing of engine coolant can threaten the environment and ecology.

Use leakproof containers when draining fluids. Do not use food or beverage containers that may mislead someone into drinking from them.

Do not pour waste onto the ground, down a drain, or into any water source.

Inquire on the proper way to recycle or dispose of waste from your local environmental or recycling center or from your dealer.

4.9 AIR CLEANER

4.9.1 Air Cleaner Service

IMPORTANT: Do not operate engine without the dust unloader valve.

For daily inspection refer to the Operating section of this manual.

Clean the primary (outer) filter element every 100 hours.

IMPORTANT: Always replace secondary safety (inner) filter elements. DO NOT attempt to clean them. Do not blow air from outside portion of filter with air nozzle. Wear safety glasses and remove bystanders.

1. Remove air cleaner cover.
2. Remove primary (outer) element only.
3. Thoroughly clean all dirt from inside filter housing.
4. Air cleaner has rubber dust unloader valve on the air cleaner. Squeeze valve tip to release any trapped dirt particles.
5. Inspect filter to determine if it is practical to clean or for damage after cleaning filter.
 - a. Hold a bright light inside element and check carefully for holes. Discard any element that shows the smallest hole or rupture.
 - b. Be sure outer screen is not dented. Vibration would quickly wear a hole in filter.
 - c. Be sure filter gasket is in good condition. If gasket is damaged or missing, replace element.
6. Gently pat sides of element with palm of hand to loosen dirt. DO NOT tap element against a hard surface.

WARNING

ONLY A SPECIAL AIR CLEANING GUN SHOULD BE USED. CONCENTRATED AIR PRESSURE FROM AN ORDINARY AIR NOZZLE MAY SEVERELY DAMAGE FILTER ELEMENT. DO NOT EXCEED 30 psi (2.1 bar) WHEN CLEANING FILTER ELEMENT.

7. Insert the cleaning gun into element, hold air nozzle about 1" (25.4) mm from perforated metal retainer. Force air through filter from inside to outside and move air gun up and down pleats to remove as much dirt as possible.
8. Repeat steps 6 and 7 to remove additional dirt.
9. Inspect element for damage after cleaning. Replace element if any damage is found.

Service air cleaner more frequently in dusty conditions.

4.9.2 Air Cleaner Replacement

Replace primary (outer) element every 600 hours.

1. Remove air cleaner cover.

4. MAINTENANCE

2. Remove primary (outer) element only.
3. Thoroughly clean all dirt from inside filter housing.
4. Air cleaner has a rubber dust unloader valve on the air cleaner. Squeeze valve tip to release any trapped dirt particle.

IMPORTANT: Remove secondary safety (inner) element ONLY for replacement. DO NOT attempt to clean, wash, or reuse secondary element. Replacement of secondary element is usually necessary ONLY when primary element has a hole in it.

5. To replace secondary element, remove retaining nut and secondary element. Immediately replace secondary element with new element to prevent dust from entering air intake system.
6. Install new primary element and tighten wing nut securely. Install cover assembly and tighten retaining wing nut securely.

4.9.3 Element Storage

Seal element in a plastic bag and store in shipping container to protect against dust and damage.

NOTE: Air cleaner element MUST BE DRY before storing in plastic bag.

4.10 FUEL FILTER

4.10.1 Water Separator

Fuel filter is equipped with a water drain plug, check/drain every 50 hours or 2 weeks.

NOTE: Drain water into a suitable container and dispose of properly.

1. Loosen drain plug at bottom of fuel filter two or three turns.
2. Loosen air bleed plug two full turns on fuel filter base and drain water from bottom until fuel starts to drain out.
3. When fuel starts to drain out, tighten drain plug securely by hand or using a coin.

After draining water from the fuel filter, the filter must be primed by bleeding all air from the fuel system.

4. Operate primer lever of the fuel supply pump until fuel flow is free from air bubbles.
5. Tighten bleed plug securely by hand or using a coin, continue operating hand primer until pumping action is not felt. Push hand primer inward (toward engine) as far as it will go.

If the fuel system needs further bleeding of air, see Bleeding Fuel System in Maintenance section of this manual.

4.10.2 Fuel Filter Replacement

WARNING

ESCAPING FLUID UNDER PRESSURE CAN PENETRATE THE SKIN CAUSING SERIOUS INJURY. RELIEVE PRESSURE BEFORE DISCONNECTING FUEL OR OTHER LINES. TIGHTEN ALL CONNECTIONS BEFORE APPLYING PRESSURE. KEEP HANDS AND BODY AWAY FROM PINHOLES AND NOZZLES THAT EJECT FLUIDS UNDER HIGH PRESSURE. USE A PIECE OF CARDBOARD OR PAPER TO SEARCH FOR LEAKS. DO NOT USE YOUR HAND.

IF ANY FLUID IS INJECTED INTO THE SKIN, A DOCTOR FAMILIAR WITH THIS TYPE INJURY MUST SURGICALLY REMOVE IT WITHIN A FEW HOURS OR GANGRENE MAY RESULT. DOCTORS UNFAMILIAR WITH THIS TYPE OF INJURY MAY CALL THE DEERE & COMPANY MEDICAL DEPARTMENT IN MOLINE, ILLINOIS, OR OTHER KNOWLEDGEABLE MEDICAL SOURCE.

Replace fuel filter every 600 hours or 12 months.

1. Thoroughly clean fuel filter assembly and surrounding area.
2. Loosen drain plug and drain fuel into a suitable container.

4. MAINTENANCE

NOTE: Lifting up on retaining ring as it is rotated helps to get it past raised locators.

3. Firmly grasp the retaining ring and rotate it counterclockwise 1/4 turn. Remove ring with filter element.
4. Inspect filter mounting base for cleanliness. Clean as required.

NOTE: Raised locators on fuel filter canister must be indexed properly with slots in mounting base for correct installation.

5. Install new filter element onto mounting. Be sure element is properly indexed and firmly seated on base. It may be necessary to rotate filter for correct alignment.
6. Remove filter element from water separator bowl. Drain and clean separator bowl. Dry with compressed air. Install water separator bowl onto new element. Tighten securely.
7. Align keys on filter element with slots in filter base.
8. Install retaining ring onto mounting base making certain dust seal is in place on filter base. Hand tighten ring (about 1/3 turn) until it “snaps” into the detent. **DO NOT** overtighten retaining ring.

NOTE: The proper installation is indicated when a “click” is heard and a release of the retaining ring is felt. A plug is provided with the new element for plugging the used element.

9. Bleed the fuel system. See Bleeding Fuel System in Maintenance section of this manual.

4.10.3 Bleeding Fuel System

WARNING

ESCAPING FLUID UNDER PRESSURE CAN PENETRATE THE SKIN CAUSING SERIOUS INJURY. RELIEVE PRESSURE BEFORE DISCONNECTING FUEL OR OTHER LINES. TIGHTEN ALL CONNECTIONS BEFORE APPLYING PRESSURE. KEEP HANDS AND BODY AWAY FROM PINHOLES AND NOZZLES THAT EJECT FLUIDS UNDER HIGH PRESSURE. USE

A PIECE OF CARDBOARD OR PAPER TO SEARCH FOR LEAKS. DO NOT USE YOUR HAND.

IF ANY FLUID IS INJECTED INTO THE SKIN, A DOCTOR FAMILIAR WITH THIS TYPE INJURY MUST SURGICALLY REMOVE IT WITHIN A FEW HOURS OR GANGRENE MAY RESULT. DOCTORS UNFAMILIAR WITH THIS TYPE OF INJURY MAY CALL THE DEERE & COMPANY MEDICAL DEPARTMENT IN MOLINE, ILLINOIS, OR OTHER KNOWLEDGEABLE MEDICAL SOURCE.

Whenever the fuel system has been opened up for service (lines disconnected or filters removed), it will be necessary to bleed air from the system.

1. Loosen the air bleed vent screw on fuel filter head two full turns by hand on fuel filter base.
2. Operate supply pump primer lever until fuel flow is free from air bubbles.
3. Tighten bleed plug securely by hand or using a coin, continue operating hand primer until pumping action is not felt. Push hand primer inward (toward engine) as far as it will go.
4. Start engine and check for leaks.

If engine will not start, it may be necessary to bleed air from fuel system at fuel injection pump or injection nozzles as explained next.

4.10.4 Bleeding at Fuel Injection Pump

1. Slightly loosen fuel supply line connector at injection pump.
2. Operate fuel supply pump primer lever until fuel, without air bubbles, flows from fuel return line connection.
3. Tighten return line connector to 16 Nm (12 lb-ft.).
4. Leave hand primer in the inward position toward cylinder block.

4.10.5 Bleeding at Fuel Injection Nozzles

1. Energize the electronic fuel shut-off solenoid (turn ignition key to ON position).

4. MAINTENANCE

- Using two open-end wrenches, loosen fuel line connection at injection nozzle.
- Crank engine over with starting motor, (but do not start engine), until fuel free from air bubbles flows out of loosened connection. Retighten connection to 27 Nm (20 lb-ft.).
- Repeat procedure for remaining injection nozzles (if necessary) until all air has been removed from fuel system.

If engine still will not start, see your authorized servicing dealer or engine distributor.

4.11 FAN/ALTERNATOR BELT

Low belt tension causes slippage resulting in excessive cover wear, burn spots, overheating, or “slip and grab” causing belt breakage.

High belt tension causes belt heating and excessive stretch, as well as damage to drive components such as pulleys and shafts. V-belts should ride on the sides of standard pulleys not on the bottom of the groove.

Standard V-belt tension can be checked with JDG529 Tension Gauge (arrow) or equivalent gauge.

- Inspect belts for cracks, fraying, or stretched out areas. Replace if necessary.
- Using either JDG529 Tension Gauge or belt tension tester and straightedge, check tension of warm belts.
 - For standard V-belt, an 89 N (20 lb. force) applied halfway between pulleys should deflect belt by 19 mm (3/4 in.).
- If adjustment is necessary, loosen alternator bracket cap screw and nut on mounting bolt. Pull alternator frame outward until belts are correctly tensioned.

IMPORTANT: Do not pry against the alternator rear frame. Do not tighten or loosen belts while they are hot.

- Tighten alternator bracket cap screw and nut firmly.
- After a new or used belt has run for 10 minutes recheck belt tension.

STANDARD V-BELTS

	Tension New Belt	Tension Used* Belt
Single Belt	578-623 N (130-140 lb. force)	378-423 N (85-95 lb. force)

4.12 GREASE FITTINGS

Use a grease gun to grease below fittings, use lithium grease. Remove the blue protection cap off fitting before greasing.

4.13 FRAME HINGE

Grease daily six fittings with lithium base grease using a grease gun. There is one fitting on each of the top and bottom bearings for the vertical pin. There are two fittings on the horizontal pin.

4.14 BLADE PINS

Grease the two fittings daily; one on each of the blade pivot pins.

4.15 BATTERY

4.15.1 Servicing Battery

WARNING

BATTERY GAS CAN EXPLODE. KEEP SPARKS AND FLAMES AWAY FROM BATTERIES. USE A FLASHLIGHT TO CHECK BATTERY ELECTROLYTE LEVEL.

NEVER CHECK BATTERY CHARGE BY PLACING A METAL OBJECT ACROSS THE POSTS. USE A VOLTMETER OR HYDROMETER.

ALWAYS REMOVE GROUNDED NEGATIVE (-) BATTERY CLAMP FIRST AND REPLACE IT LAST.

- On regular batteries, check electrolyte level. Fill each cell to bottom of filler neck with distilled water.
- Keep batteries clean by wiping them with a damp cloth. Keep all connections clean and tight. Remove any corrosion, and wash terminals with a

4. MAINTENANCE

solution of 1 part baking soda and 4 parts water.
Tighten all connections securely.

NOTE: Coat battery terminals and connectors with a mixture of petroleum jelly and baking soda to retard corrosion.

3. Keep battery fully charged, especially during cold weather. If a battery charger is used, turn charger off before connecting charger to battery(ies). Attach POSITIVE (+) battery charger lead to POSITIVE (+) battery post. Then attach NEGATIVE (-) battery charger lead to a good ground.

Once a month, check the battery for proper charge of 12.5 volts. Check for proper fluid level. Use distilled water when adding and run 30 minutes to mix. Clean battery, posts, and terminals. Disconnect battery cables before charging to avoid damage to the electrical system.

WARNING

SULFURIC ACID IN BATTERY ELECTROLYTE IS POISONOUS. IT IS STRONG ENOUGH TO BURN SKIN, EAT HOLES IN CLOTHING, AND CAUSE BLINDNESS IF SPLASHED INTO EYES.

Avoid the hazard by:

1. Filling batteries in a well-ventilated area.
2. Wearing eye protection and rubber gloves.
3. Avoiding breathing fumes when electrolyte is added.
4. Avoiding spilling or dripping electrolyte.
5. Use proper jump start procedure.

If you spill acid on yourself:

1. Flush your skin with water.
2. Apply baking soda or lime to help neutralize the acid.
3. Flush your eyes with water for 10 – 15 minutes.
Get medical attention immediately.

If acid is swallowed:

1. Drink large amounts of water or milk.
2. Then drink milk of magnesia, beaten eggs, or vegetable oil.
3. Get medical attention immediately.

In freezing weather, run engine at least 30 minutes to assure thorough mixing after adding water to battery.

If necessary to replace battery(ies), replacements must meet or exceed the following recommended capabilities at -18° C (0° F):

12 Volt – Heavy Duty Battery
BCI Group 24 800 CCA

4.15.2 Battery Installation

WARNING

ALWAYS CONNECT GROUNDED CABLE LAST. CLEAN AND SECURELY CONNECT EACH CABLE END TO BATTERY TERMINAL OF SAME POLARITY. BATTERY SHOULD BE SECURELY FASTENED WITH PROPERLY INSTALLED HOLD-DOWNS.

4.15.3 Charging / Jumping Battery

A 12-volt booster battery can be connected in parallel with battery(ies) on the unit to aid in cold weather starting. ALWAYS use heavy-duty jumper cables.

WARNING

GAS GIVEN OFF BY BATTERY IS EXPLOSIVE. KEEP SPARKS AND FLAMES AWAY FROM BATTERY. BEFORE CONNECTING OR DISCONNECTING A BATTERY CHARGER TURN CHARGER OFF. MAKE LAST CONNECTION AND FIRST DISCONNECTION AT A POINT AWAY FROM BATTERY. ALWAYS CONNECT NEGATIVE (-) CABLE LAST AND DISCONNECT THIS CABLE FIRST.

IMPORTANT: Be sure polarity is correct before making connections. Reversed polarity will damage electrical system. Always connect positive to

4. MAINTENANCE

positive and negative to ground. Always use 12-volt booster battery for 12-volt electrical systems.

1. Connect booster battery or batteries to produce the required system voltage for your engine application.

NOTE: To avoid sparks, DO NOT allow the free ends of jumper cables to touch the engine.

2. Connect one end of jumper cable to the POSITIVE (+) post of the booster battery.
3. Connect one end of jumper cable to the POSITIVE (+) post of the battery connected to starter.
4. Connect one end of the other jumper cable to the NEGATIVE (-) post of the booster battery.
5. ALWAYS complete the hook-up by making the last connection of the NEGATIVE (-) cable to a good ground on the engine frame and away from the battery(ies).
6. Start the engine. Disconnect jumper cables immediately after engine starts. Disconnect NEGATIVE (-) cable first.

4.16 ENGINE CRANKCASE VENT TUBE

Remove and clean every 600 hours or 12 months. If you operate the engine in dusty conditions, clean the tube at shorter intervals.

1. Remove and clean crankcase vent tube.
2. Install the vent tube. Be sure the O-ring fits correctly in the rocker arm cover for elbow adapter. Tighten hose clamp securely.

4.17 ENGINE VALVE CLEARANCE

Check/adjust at 900 hours then every 1200 hours or 24 months. See authorized engine service dealer or refer to Engine Manual for procedures.

4.18 EMISSION REGULATION/ENGINE RPM

Do not adjust operating speed. Full speed is factory set at 2500 rpm.

Do not adjust idle speed above 1400 rpm. Proper idle rpm is 1200 ± 100.

Do not alter injection pumps.

TAMPERING with the following engine factory settings is ILLEGAL except to reset to published specifications and reseal by authorized engine dealer:

- Engine Timing
- Fuel Delivery
- Aneroid Settings
- Rated Speed

Deere will reissue emissions dataplates only to replace damaged plates. Requests must be in writing and include name, address, engine model, and serial number with reason for need.

Power rating changes WILL NOT be allowed on new engines.

4.19 FUEL INJECTORS

WARNING

ESCAPING FLUID UNDER PRESSURE CAN PENETRATE THE SKIN CAUSING SERIOUS INJURY. RELIEVE PRESSURE BEFORE DISCONNECTING FUEL OR OTHER LINES. TIGHTEN ALL CONNECTIONS BEFORE APPLYING PRESSURE. KEEP HANDS AND BODY AWAY FROM PINHOLES AND NOZZLES THAT EJECT FLUIDS UNDER HIGH PRESSURE. USE A PIECE OF CARDBOARD OR PAPER TO SEARCH FOR LEAKS. DO NOT USE YOUR HAND.

IF ANY FLUID IS INJECTED INTO THE SKIN, A DOCTOR FAMILIAR WITH THIS TYPE INJURY MUST SURGICALLY REMOVE IT WITHIN A FEW HOURS OR GANGRENE MAY RESULT. DOCTORS UNFAMILIAR WITH THIS TYPE OF INJURY MAY CALL THE DEERE & COMPANY MEDICAL DEPARTMENT IN MOLINE, ILLINOIS, OR OTHER KNOWLEDGEABLE MEDICAL SOURCE.

IMPORTANT: Always use John Deere replacement parts meeting John Deere performance

4. MAINTENANCE

specifications. Only qualified technicians should attempt fuel injector diagnose.

Fuel injection nozzles are usually removed and tested or replaced when there is a noticeable loss of power or excessive smoking after break-in period.

For detailed testing and diagnostic information on fuel system refer to John Deere Technical Manual (P/N 55321).

4.19.1 Test Fuel Injection Nozzles (engine running)

1. Operate engine at intermediate speed and no load.
2. Slowly loosen the fuel pressure line at one of the nozzles until fuel escapes at the connection (fuel not opening nozzle valve).

NOTE: The injection nozzle before and/or after nozzle being checked could be the faulty nozzle.

- If engine speed changes, the injection nozzle is probably working satisfactory.
 - If engine speed does not change, a nozzle is faulty and must be checked and repaired (or replaced).
3. Repeat test for each remaining nozzle assembly.
 4. Remove faulty injection nozzles and see authorized engine dealer or replace with new.

4.20 FUEL TANK

Drain and flush the fuel tank every year.

WARNING

HANDLE FUEL CAREFULLY. DO NOT FILL THE FUEL TANK WHEN ENGINE IS RUNNING.

DO NOT SMOKE WHILE FILLING FUEL TANK OR SERVICING FUEL SYSTEM.

THE FUEL TANK IS VENTED THROUGH THE FILLER CAP. IF A NEW FILLER CAP IS REQUIRED, ALWAYS REPLACE IT WITH AN ORIGINAL VENTED CAP.

Fill fuel tank at the end of each day's operation to prevent condensation in tank as moist air cools and freezing during cold weather.

Avoid storing fuel over long periods of time. If fuel is stored for more than a month prior to use or there is a slow turnover in fuel tank or supply tank, add a fuel conditioner such as John Deere PREMIUM DIESEL FUEL CONDITIONER or equivalent to stabilize the fuel and prevent water condensation. John Deere PREMIUM DIESEL FUEL CONDITIONER is available in winter and summer formulas. Fuel conditioner also reduces fuel gelling and controls wax separation during cold weather.

Proper fuel storage is critically important. Use clean storage and transfer tanks. Periodically drain water and sediment from bottom of tank. Store fuel in a convenient place away from buildings.

IMPORTANT: DO NOT store diesel fuel in galvanized containers. Diesel fuel stored in galvanized containers reacts with zinc coating on container to form zinc flakes. If fuel contains water, a zinc gel will also form. The gel and flakes will quickly plug fuel filters and damage injection nozzles and injection pump.

DO NOT use brass-coated containers for fuel storage. Brass is an alloy of copper and zinc.

4.21 FUEL LINES

Inspect fuel line condition and clamps. Replace fuel lines every 2 years.

4.22 HYDRAULIC HOSES/CONNECTIONS

WARNING

ESCAPING HYDRAULIC FLUID UNDER PRESSURE CAN HAVE SUFFICIENT FORCE TO PENETRATE THE SKIN, CAUSING SERIOUS PERSONAL INJURY.

HYDRAULIC FLUID ESCAPING UNDER PRESSURE FROM A VERY SMALL HOLE CAN BE ALMOST INVISIBLE. USE A PIECE OF

4. MAINTENANCE

CARDBOARD OR WOOD TO SEARCH FOR POSSIBLE LEAKS. NEVER USE YOUR HANDS TO DETECT PRESSURE LEAKS.

IF YOU ARE INJURED BY ESCAPING HYDRAULIC FLUIDS, SEE A DOCTOR AT ONCE. SERIOUS INFECTION OR REACTIONS CAN DEVELOP IF PROPER MEDICAL TREATMENT IS NOT ADMINISTERED IMMEDIATELY.

Before disconnecting any hydraulic lines, be sure engine is shut off and relieve all pressure. Before applying pressure to system, be sure all connections are tight and lines, fittings and hoses are not damaged.

Inspect for leaks daily. Check connections for tightness every 100 hours.

Hydraulic system produces high pressures – incorrect hose replacement can cause serious personal injury. When performing service, refer to hydraulic diagrams for hose identification and connections.

4.23 FORWARD/REVERSE/NEUTRAL ADJUSTMENT

The forward/reverse lever should be aligned with “NEUTRAL” on the console when the roller is moving neither forward nor backward with the engine running. If the lever is not aligned, adjust it as described below.

1. Shut off the engine with the forward/reverse lever left in operating neutral position, the position when the roller moves neither forward nor reverse. Apply the parking brake.
2. Open the engine hood of the machine.
3. Disconnect the linkage from the hydrostatic transmission from the clevis. Do this by removing the lock nut from the clevis pin and removing the pin.
4. Now screw clevis in or out to adjust.
5. Secure the clevis to the transmission lever with the clevis pin, secure with the lock nut and tighten clevis nut.

Linkage play must be minimal at both connections. Replace clevis and/or link if required.

4.24 NEUTRAL INTERLOCK

The purpose of the neutral interlock switch is to prevent engine starting when the forward/reverse lever is not in the neutral position. To check:

1. Disconnect battery cables from battery.
2. a. Disconnect (2) wires from neutral interlock switch and connect it to leads from an ohmmeter.
b. When switch is actuated, ohmmeter should read zero resistance.
3. Adjustments must be made at transmission.
4. Disconnect ohmmeter and reconnect interlock wires and battery cables.

4.25 CONTROL CABLES: FORWARD/REVERSE, THROTTLE, BLADE

Lubricate all cable ends with penetrating oil every 200 hours.

WARNING

DO NOT ADJUST THE CONTROL CABLE WITH THE POWER ON OR THE ENGINE RUNNING. SERIOUS INJURY OR DEATH COULD RESULT. A GRADUAL OR SUDDEN INCREASE IN THE NO-LOAD FRICTION (CABLE DISCONNECT AT BOTH ENDS) OF A CONTROL CABLE IS AN INDICATION OF A PENDING OR PRESENT PERFORMANCE PROBLEM. THE CONTROL CABLE SHOULD BE REPLACED, OTHERWISE SERIOUS INJURY OR DEATH COULD RESULT. A GRADUAL OR SUDDEN DECREASE IN THE USABLE STROKE IS AN INDICATION OF A PENDING OR PRESENT PERFORMANCE PROBLEM. THE CONTROL CABLE SHOULD BE REPLACED, OTHERWISE SERIOUS INJURY OR DEATH COULD RESULT. CONTROL CABLES WHICH HAVE MOISTURE INSIDE OF THEM AND/OR HAVE FROZEN SHOULD BE REPLACED. DO NOT APPLY HEAT TO THAW OR DRY CONTROL CABLES.

4. MAINTENANCE

4.26 ECCENTRICS

Test vibration with front drum on soft ground. Run engine at full rpm to obtain vib spec 2100 ± 100 rpm – check per below.

To check vibration with a vibrotach, place the vibrotach on the vibrating member surface, record reading when the wire reaches maximum movement. (Vibrotach P/N 37891).

When checking vibration with strobe light, place horizontal line on vibrating member surface. Check with strobe light and record reading when the line reaches minimum movement.

4.26.1 Eccentric Housing Oil

WARNING

ROLLER MUST BE PARKED ON LEVEL GROUND WITH PARKING BRAKE APPLIED AND ENGINE OFF.

REMOVE THE KEY AND / OR DISCONNECT BATTERY TO AVOID ACCIDENTAL IGNITION OF ENGINE. SEVERE PERSONAL INJURY MAY OCCUR.

NEVER WORK ON THE ROLLER WITH ENGINE RUNNING. SEVERE PERSONAL INJURY MAY OCCUR.

Eccentric housing oil should be checked monthly and changed every 800 hours or yearly. Refer to Maintenance Chart.

To check, locate oil plug inside the right hand drum end and position drum so that oil plug is visible at 7:00. Loosen oil plug slowly until oil starts to drip out past the oil plug. Oil must be present at the 7:00 position. Add oil if required and reinstall oil plug, use thread sealant.

Eccentric housing oil:

SAE 20W/50 API SJ or API SH
SD/PD 43 1 qt. (.95 L.)
SP/PD 54 1.5 qt. (1.4 L.)

4.27 CHARGE SYSTEM

If gauge fails to function, check charge system. With the engine running at full speed, voltage should be 13-14 volts across the battery (check volt meter). If unit is charging, replace gauge. If not, see authorized engine dealer to check alternator.

4.28 PANEL FUSE 20 AMP

This fuse provides protection for the electrical system. If the engine fails to turnover when starting, check the fuse.

WARNING

NEVER USE FUSE WITH A DIFFERENT RATING FROM THAT SPECIFIED. SERIOUS DAMAGE TO THE ELECTRICAL SYSTEM OR A FIRE MAY RESULT.

TURN THE ENGINE SWITCH OFF AND REMOVE THE KEY BEFORE CHECKING OR REPLACING FUSES TO PREVENT ACCIDENTAL SHORT-CIRCUITING.

When frequent fuse failure occurs, it usually indicates a short circuit or an overload in the electrical system. See your authorized engine dealer for repair.

4.29 ENGINE INSTALLATION GUIDELINES

When installing new or reworking used diesel engines, this list of guidelines should be strictly adhered to. Following these guidelines should prevent damage to the electrical system of diesel engines.

- A. Always disconnect the positive cable from the battery before performing any work on the machine that involves welding or working on the electrical system.
- B. Avoid jump starting a diesel engine. Either change the battery or remove the positive cable and charge the battery.
- C. Do not alter or change the wiring harness.

4. MAINTENANCE

D. Cold weather add-ons should not be needed.

When cleaning machine, caution should be used around regulator area. Direct spraying of the regulator is not good. (Regulator should be covered or protected if direct spraying will happen). Excessive water pressure may also loosen wire connections or cause terminal corrosion. After cleaning, all terminals should be dried if wet and connections checked for proper seating.

4.30 ENGINE MOUNTING

Check periodically, tighten all mounting hardware for proper torque. Refer to Torque Charts in Exploded Views with Parts Section.

4.31 HARDWARE

Inspect all hardware for tightness. Refer to parts illustrations for proper torque and Torque Charts in Exploded Views with Parts Section.

4.31.1 Loctite

Loctite 262 threadlocker is required to prevent hardware from loosening.

Refer to Exploded Diagram and Parts List for * where loctite is required.

4.32 ROLL OVER PROTECTIVE STRUCTURES (ROPS)

Proper inspection and maintenance procedures can ensure that ROPS will perform the lifesaving function they are designed for and expected to do. Make regular, periodic inspections to ensure ROPS are damage-free and thus capable of functioning in an upset.

Generally ROPS/FOPS structures are not intended as external load carrying members and must not be used to mount attachments such as pull hooks, winches, side brooms, etc. without the manufacturers approval.

Modifications to basic design should be avoided, as recertification is required.

4.32.1 Maintenance of ROPS/Seat Belts

Inspection

Scheduled, frequent visual checks of mounting hardware by operator or service personnel are recommended. Inspection with regular service intervals is suggested. The inspection should check for:

- Worn, damaged or missing resilient mounts. Excessive motion or rattling during operation are indications of a problem.
- Loose, missing or damaged mounting hardware (bolts, nuts, washers, etc.). Bolts should be checked for proper torque.
- Cracks in ROPS/FOPS structure and mounting system. The machine should be cleaned, as necessary, to allow inspection for cracks in the structure and mounting system. Rust lines should be taken as indications of cracks and verified by inspection. Some cracks will badly affect the ROPS/FOPS function. If in doubt, consult the manufacturer.
- Water drainage paths. Clear water drainage paths so that entrapped water will not freeze and crack or deform the structure.
- Corrosion. Extensive paint peeling and rust should be noted and corrective action taken.
- Seat belt. The presence and operability of a seat belt should be noted. The belt should be clean, free of dirt and grease and the latch should function smoothly.
- The structure should be inspected following a rollover, collision or fire.

Repair

Replace missing or damaged hardware with the manufacturer's specified hardware. Re-torque all loose threaded fasteners to the manufacturer's specifications.

The manufacturer must be consulted to determine the repairability of cracks in ROPS/FOPS structures.

4. MAINTENANCE

4.33 HORN/BACK-UP

WARNING

THIS VEHICLE IS EQUIPPED WITH A BACK-UP ALARM. ALARM MUST SOUND WHEN BACKING UP. IT IS THE DRIVER'S RESPONSIBILITY TO OPERATE THIS VEHICLE SAFELY. BE SURE BACK-UP ALARM AND HORN ARE WORKING.

Inspect the sound decibel level of the horn and back-up alarm daily and test weekly for proper dBA level (112 dBA). Test results should be recorded in the vehicle's maintenance file. If mud, dirt or other debris is forced into alarm, clean and test to ensure proper operation.

4.33.1 Back-Up Alarm Switch

1. Remove control panel wrap.
2. To check for proper switch operation, connect ohmmeter leads to the wire connections. The back-up switch should be normally open in the neutral position and normally closed when shifted into reverse position. With the ignition key in the on position, shifting into reverse should actuate the back-up alarm.
3. Check the assembly for proper switch actuation, smooth lever operation and all hardware for tightness, then assemble the panel wrap and hardware.

4.34 SCRAPERS

Prevent mud and debris from building up. If urethane scrapers are worn or torn, replace.

Steel scrapers are adjustable. The scrapers should just clear the drum and pads. If adjusting, be sure to check that scrapers clear drum and pads all the way around the drum. To adjust, loosen mounting bolts and slide scraper in or out, check clearance and retighten.

4. MAINTENANCE

4.35 TROUBLESHOOTING

PROBLEM	CAUSE	REMEDY
Engine Won't Start.	Forward/Reverse lever not in neutral position.	Place lever in neutral position.
	Panel fuse blown.	Replace, 20A fuse required.
	Loose battery or starter cables.	Check and tighten.
	Faulty engine starting circuit.	Check appropriate section in Engine Manual
	Faulty or improperly adjusted neutral interlock switch.	Make sure neutral switch is adjusted properly and wires are all secured. Test with ohmmeter. Readjust neutral switch. Replace if defective.
	Dirty fuel injectors. (Diesel Only)	Clean or replace.
	Petcock plugged.	Clean or replace.
Engine won't start but cranks over.	Low on fuel.	Add fuel.
	Fuel valve closed.	Open.
	Fuel filter plugged.	Check fuel filter, replace if necessary.
	Exhaust restricted.	Check and correct exhaust restriction.
	Injection pump not getting fuel or air in fuel system.	Check fuel flow at supply pump or bleed fuel system.
	Faulty injection pump or nozzles	Consult authorized diesel repair station for repair or replacement.
	Fuel lines plugged.	Clean or replace.
Engine hard to start or will not start (or) Engine starts but does not keep running.	Air in fuel line.	Bleed fuel line.
	Cold weather.	Use cold weather starting aid.
	Crankcase oil too heavy.	Use oil of proper viscosity.
	Improper type of fuel.	Consult fuel supplier; use proper type fuel for operating conditions.
	Water, dirt, or air in fuel system.	Drain, flush, fill, and bleed system.
	Clogged fuel filter.	Replace filter element.
	Injection pump shut-off not reset.	Turn key switch to "OFF" then to "ON".

4. MAINTENANCE

4.35 TROUBLESHOOTING-cont'd.

PROBLEM	CAUSE	REMEDY
Engine starts but does not keep running.	Water/dirt in fuel.	Drain fuel system.
	Choke remains on. (Gas Only)	Adjust choke cable. Clean choke linkage.
	Carburetor improperly adjusted. (Gas Only)	Adjust as per Engine Manual.
	Dirty fuel injectors. (Diesel Only)	Service or replace.
	Injection pump drawing in air. (Diesel Only)	Check fuel lines or replace.
Roller won't move forward or reverse.	Objects in front of drums.	Remove.
	Unit in bypass.	Check bypass valve.
	Loose or broken forward/reverse linkage.	Readjust linkage or replace worn arm linkage.
	Loose or broken chain.	Make sure chain is on sprocket. Adjust tension or replace if chain shows excessive wear.
	Loose or broken transmission belts.	Replace and/or tighten.
	Low hydraulic oil.	Check oil level gauge. Add if required.
Unit lacks power moving forward --but okay in reverse or vice versa.	Improperly adjusted forward/reverse linkage.	Adjust linkage so that lever travel is the same in either direction from neutral.
Unit lacks power.	Engine not properly warmed up.	Idle before operating to achieve operating temperature.
	Low hydraulic oil level.	Add.
	Plugged hydraulic filter.	Replace.
	Insufficient belt tension.	Check and adjust belts.
	Engine RPM too low.	Check throttle linkage for proper actuation (3100 RPM Gas/2600 Diesel). See Maintenance.

4. MAINTENANCE

4.35 TROUBLESHOOTING-cont'd

PROBLEM	CAUSE	REMEDY
High fuel consumption.	Improper type of fuel.	Use proper type of fuel.
	Clogged or dirty air cleaner.	Service air cleaner.
	Engine overloaded.	Excessive mud/debris build-up -- Clean/pressure wash.
	Improper valve clearance.	See your authorized servicing dealer or engine distributor.
	Injection nozzles dirty.	See your authorized servicing dealer or engine distributor.
	Engine out of time.	See your authorized servicing dealer or engine distributor.
	Low engine temperature.	Check thermostat.
High oil consumption.	Crankcase oil too light.	Use proper viscosity oil.
	Oil leaks.	Check for leaks in lines, gaskets, and drain plug.
	Restricted crankcase vent tube.	Clean vent tube.
	Defective turbocharger.	See your authorized servicing dealer or engine distributor.
	Too much oil in crankcase.	Drain.
	Loose oil filter or sending unit.	Tighten.
	Loose bolts.	Tighten.
	Engine in break-in period.	See Engine Owner's Manual.
Low oil pressure.	Low oil level.	Add oil.
	Improper type of oil.	Drain, fill crankcase with oil of proper viscosity and quality.
Engine emits smoke.	Too much oil in crankcase.	Drain, fill to proper level.
	Engine in break-in period.	See Engine Owner's Manual.

4. MAINTENANCE

4.35 TROUBLESHOOTING-cont'd

PROBLEM	CAUSE	REMEDY
Engine emits white smoke.	Improper type of fuel.	Use proper fuel.
	Low engine temperature.	Warm up engine to normal operating temperature.
	Defective thermostat.	Remove and check thermostat.
	Defective injection nozzles.	See your authorized servicing dealer or engine distributor.
	Engine out of time.	See your authorized servicing dealer or engine distributor.
Engine emits black or gray exhaust smoke.	Improper type of fuel.	Use proper fuel.
	Clogged or dirty air cleaner.	Service air cleaner.
	Injection nozzles dirty.	See your authorized servicing dealer or engine distributor.
	Engine out of time	See your authorized servicing dealer or engine distributor.
Engine overheats.	Engine overloaded.	Reduce load, check for mud build-up, clean if required.
	Low coolant level.	Fill radiator to proper level, check radiator and hoses for loose connections or leaks.
	Faulty radiator cap.	Have serviceman check.
	Loose or defective fan belts.	Adjust belt tension. Replace as required.
	Low engine oil level.	Check oil level. Add oil as required.
	Cooling system needs flushing.	Flush cooling system.
	Defective thermostat.	Remove and check thermostat.
	Defective temperature gauge or sender.	Check water temperature with thermometer and replace if necessary.
	Incorrect grade of fuel.	Use correct grade of fuel.

4. MAINTENANCE

4.35 TROUBLESHOOTING-cont'd

PROBLEM	CAUSE	REMEDY
Roller won't move forward or reverse.	Objects in front of drums.	Remove.
	Unit in bypass loose or broken forward/reverse linkage.	Check bypass valve. Readjust linkage or replace worn arm linkage, make sure lever at pump is moving.
	Low hydraulic oil.	Check oil level gauge. Add if required.
Unit lacks power moving forward, but okay in reverse or vice versa.	Improperly adjusted forward/reverse linkage.	Adjust linkage so that lever travel is the same in either direction from neutral.
Unit lacks power.	Engine not properly warmed up.	Idle before operating to achieve operating temperature.
	Restricted fuel hose.	Clean or replace fuel hose
	low hydraulic oil level.	Add hydraulic oil.
	Plugged hydraulic filter.	Replace.
	Leaking exhaust manifold gasket.	See your authorized servicing dealer or engine distributor.
	Engine RPM too low.	Check throttle linkage for proper actuation. Check full speed.
	Defective Aneroid control line.	See your authorized servicing dealer or engine distributor.
	Dirty fuel filter.	Replace.
	Dirty fuel injectors.	Service or replace.
	Injection pump drawing in air.	Check fuel lines or replace.
	Too much oil in crankcase.	Drain and check. Service or replace.
	Air filter dirty.	Clean and/or replace.
	Injection pump out of time.	See your authorized servicing dealer or engine distributor.
	Faulty hydraulic pump or drive motor.	Test hydraulic pressure for 500psi at full load on drive motor with engine at full RPM. Check charge pressure 220-260 psi with engine at full RPM.

4. MAINTENANCE

4.35 TROUBLESHOOTING-cont'd

PROBLEM	CAUSE	REMEDY
Unit lacks power - cont'd.	Faulty hydraulic pump or drive motor - cont'd.	Replace pump if pressure is not in specified range in hydraulic motor drive circuit. Check drive motors case, drain flow .5GPM max. drum, tires blocked, engine running.
	Improper type of fuel.	Use proper fuel.
	Excessive mud or debris build-up.	Clean/pressure wash.
	Below normal engine temperature.	Remove and check thermostat.
	Improper valve clearance.	See your authorized servicing dealer or engine distributor.
Unit won't steer.	Cylinder leaking.	Replace hydraulic cylinder.
	Piston rod bent.	Replace hydraulic cylinder.
	Missing hydraulic cylinder pin.	Replace.
	Kinked or broken hoses.	Replace.
	Low hydraulic fluid.	Add fluid.
	Faulty hydraulic pump.	Check hydraulic steering circuit for maximum pressure of 2,300 psi at full RPM. Replace or repair by authorized Service Center.
Brakes don't hold properly.	Brake valve faulty.	Check brake light operation. Check for 12 volt A brake valve, see Wiring.
	Loose wires.	Check wiring for loose or broken wiring.
Brake stays on.	No release pressure.	Check pump for proper charge pressure 220-260psi.
	Faulty relay.	Check, replace if required.

4. MAINTENANCE

4.36 ELECTRICAL TROUBLESHOOTING

PROBLEM	CAUSE	REMEDY
Undercharged system.	Excessive electrical load from added accessories.	Remove accessories.
	Excessive engine idling.	Increase engine RPM when heavy electrical load is used.
	Poor electrical connections on battery, ground strap, starter, or alternator.	Inspect and clean as necessary.
	Defective battery.	Test battery.
	Defective alternator.	Test charging system.
Battery used too much water.	Cracked battery case.	Check for moisture and replace as necessary.
	Defective battery.	Test battery.
	Battery charging rate too high.	Test charging system.
Batteries will not charge.	Loose or corroded connections.	Clean and tighten connections.
	Sulfated or worn-out batteries.	See your authorized servicing dealer or engine distributor.
	Loose or defective alternator belt.	Adjust belt tension or replace belts.
Starter will not crank.	Loose or corroded connections.	Clean and tighten loose connections.
	Low battery output voltage.	See your authorized servicing dealer or engine distributor.
	Faulty start circuit relay.	See your authorized servicing dealer or engine distributor.
Starter cranks slowly.	Low battery output.	See your authorized servicing dealer or engine distributor.
	Crankcase oil too heavy.	Use proper viscosity oil.
	Loose or corroded connections.	Clean and tighten loose connections.
Entire electrical system does not function.	Faulty battery connection.	Clean and tighten connections.
	Sulfated or worn-out batteries.	See your authorized servicing dealer or engine distributor.
	Blown fuse.	Replace fuse.

4. MAINTENANCE

4.37 SERVICE RECORD

Model No.	Roller S/N:	Engine S/N:
Record Hours and Dates of Maintenance Below		
Engine Oil and Filter		
Hydraulic Oil, Filter, and Breather		
Engine Coolant		
Air Cleaner		
Water Separator		
Fuel Filter		
Fan/Alternator Belt		
Grease Fittings		
Battery		
Crankcase Vent Tube		
Valve Clearance		
Engine RPMS		
Fuel Injectors		
Fuel Tank		
Fuel Lines		
Hydraulic Hoses/Connections		
Forward/Reverse		
Neutral Interlock		
Control Cables		
Eccentrics/Eccentric Housing Oil		
Charge System		
Panel Fuse		
Hardware		
ROPS/Seat Belts		
Scrapers		

5. EXPLODED VIEWS WITH PARTS

5. PARTS LIST

Exploded Views with Parts

5.1	Hardware Key	59
5.2	Torque Charts and Guidelines	60 - 61
5.3	Drum Assembly	62 - 65
5.4	Main Frame	66 - 69
5.5	Radiator/Engine Mount	70 - 71
5.6	Engine	72 - 75
5.7	Air Cleaner	76 - 77
5.8	Controls	78 - 81
5.9	Drive System Hydraulics	82 - 85
5.10	Steering/Eccentric System Hydraulics	86 - 87
5.11	Blade	88 - 89
5.12	Hydraulic Schematic	90 - 91
5.13	Wiring	92 - 93
5.14	Decal Identification	94 - 97

5.1 HARDWARE KEY

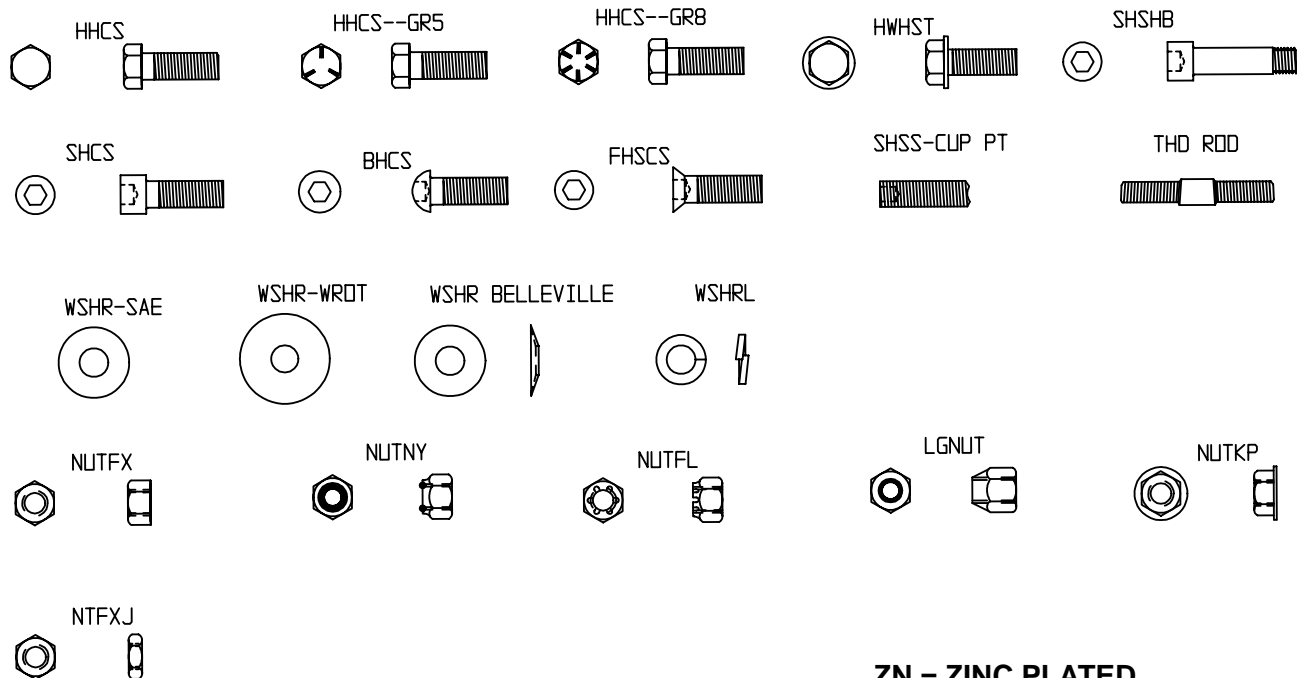

ZN = ZINC PLATED
BLK = BLACK OXIDE FINISH

5.2 Torque Charts and Guidelines

Do not use these values if a different torque value or tightening procedure is given for a specific application. Torque values listed are for general use. Check tightness of fasteners periodically.

Shear bolts are designed to fail under predetermined loads. Always replace shear bolts with identical grade.

Fasteners should be replaced with the same or higher grade. If higher grade fasteners are used, these should only be tightened to the strength of the original.

Make sure fasteners' threads are clean and that you properly start thread engagement. This will prevent them from failing when tightening.

SAE GRADE 5 Coarse Thread, Zinc-Plated		
SIZE	TORQUE	
	ft. lbs.	Nm
1/4 - 20 (.250)	6	8
5/16 - 18 (.3125)	13	18
3/8 - 16 (.375)	23	31
7/16 - 14 (.4375)	37	50
1/2 - 13 (.500)	57	77
9/16 - 12 (.5625)	82	111
5/8 - 11 (.625)	112	152
3/4 - 10 (.750)	200	271
7/8 - 9 (.875)	322	436.5
1 - 8 (1.000)	483	655

SAE GRADE 8 Coarse Thread, Zinc-Plated		
SIZE	TORQUE	
	ft. lbs.	Nm
1/4 - 20 (.250)	9	12
5/16 - 18 (.3125)	18	24
3/8 - 16 (.375)	33	45
7/16 - 14 (.4375)	52	70
1/2 - 13 (.500)	80	108
9/16 - 12 (.5625)	115	156
5/8 - 11 (.625)	159	215
3/4 - 10 (.750)	282	382
7/8 - 9 (.875)	454	615
1 - 8 (1.000)	682	925

SAE GRADE 5 Fine Thread, Zinc-Plated		
SIZE	TORQUE	
	ft. lbs.	Nm
1/4 - 28 (.250)	7	10
5/16 - 24 (.3125)	14	19
3/8 - 24 (.375)	26	35
7/16 - 20 (.4375)	41	56
1/2 - 20 (.500)	64	87
9/16 - 18 (.5625)	91	123
5/8 - 18 (.625)	128	173
3/4 - 16 (.750)	223	302
7/8 - 14 (.875)	355	481
1 - 12 (1.000)	529	717
1 - 14 (1.000)	541	733

SAE GRADE 8 Fine Thread, Zinc-Plated		
SIZE	TORQUE	
	ft. lbs.	Nm
1/4 - 28 (.250)	10	14
5/16 - 24 (.3125)	20	27
3/8 - 24 (.375)	37	50
7/16 - 20 (.4375)	58	79
1/2 - 20 (.500)	90	122
9/16 - 18 (.5625)	129	175
5/8 - 18 (.625)	180	244
3/4 - 16 (.750)	315	427
7/8 - 9 (.875)	501	679
1 - 12 (1.000)	746	1011
1 - 14 (1.000)	764	1036

5.2 Torque Charts and Guidelines

Property Class 8.8

ZINC-PLATED

SIZE	Coarse Thread		Fine Thread	
	Nm	ft. lbs.	Nm	ft. lbs.
M6	9.9	7	10	7
M8	24	18	25	18
M10	48	35	49	36
M12	83	61	88	65
M14	132	97	140	103
M16	200	148	210	155
M20	390	288	425	313
M24	675	498	720	531

Property Class 10.9

ZINC-PLATED

SIZE	Coarse Thread		Fine Thread	
	Nm	ft. lbs.	Nm	ft. lbs.
M6	14	10	14	10
M8	34	25	35	26
M10	67	49	68	50
M12	117	86	125	92
M14	185	136	192	142
M16	285	210	295	218
M20	550	406	600	443
M24	950	701	1000	738

Property Class 12.9

ZINC-PLATED

SIZE	Coarse Thread		Fine Thread	
	Nm	ft. lbs.	Nm	ft. lbs.
M6	16.5	12	16.5	12
M8	40	30	42	31
M10	81	60	82	60
M12	140	103	150	111
M14	220	162	235	173
M16	340	251	350	258
M20	660	487	720	531
M24	1140	841	1200	885

Conversion Factor: 1 ft. lb. = 1.3558 Nm

REMARK:

5.3 Drum Assembly

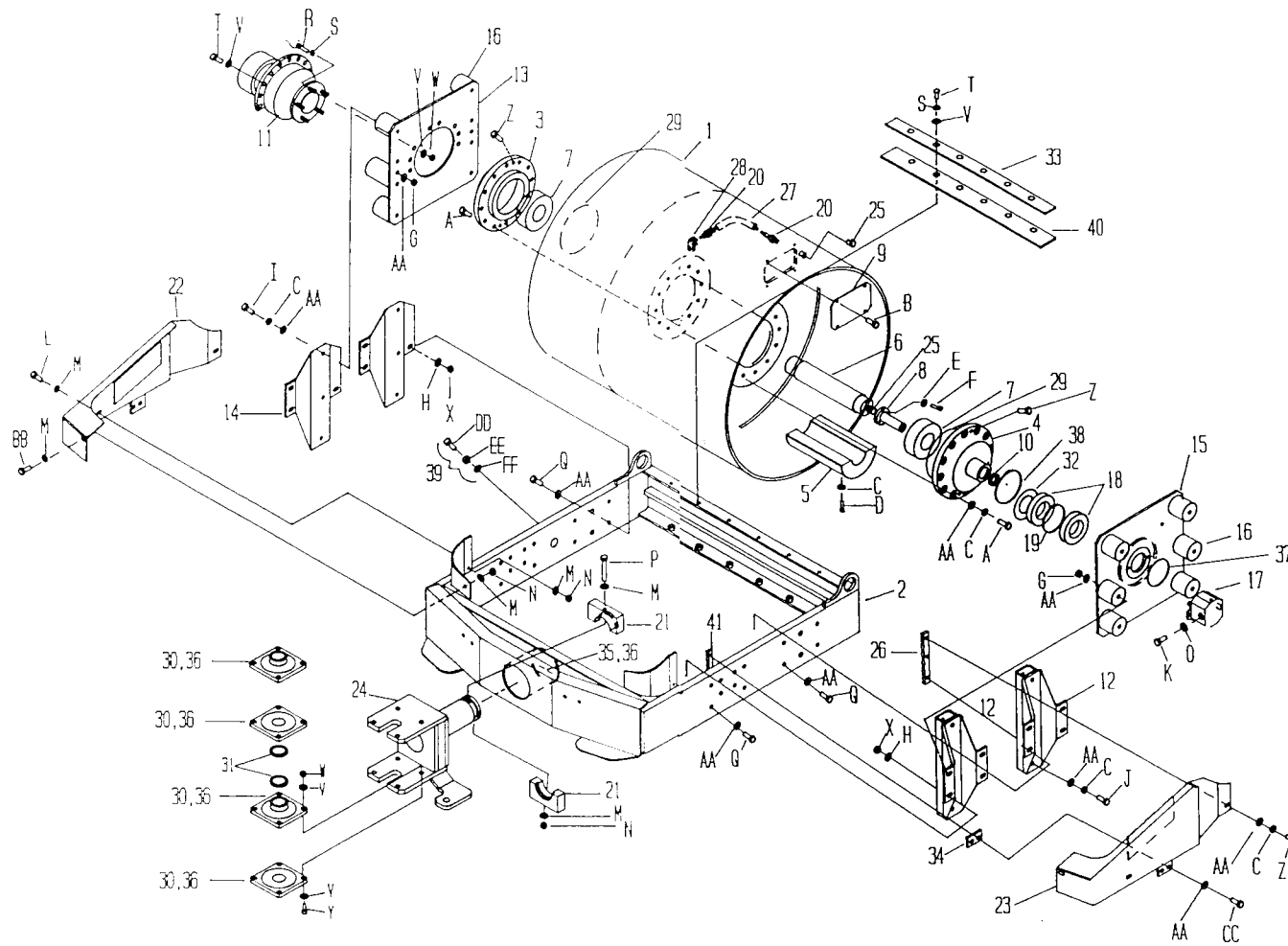

h:\engr\manuals\rhino\rhdrumas.eps

5.3 Drum Assembly

Item	Part No.	Description	Qty.	Item	Part No.	Description	Qty.
1	42374-2	Drum Weld SD 43	1	18	32243	Bearing Ball	2
	42375-2	Drum Weld SD 54	1	19	42210	Washer 1/8 - 3ID X 3 - 1/2 OD	1
	42376-2	Drum Weld PD 43	1	20	46403	FTG Hyd 3/4 NPT X 5/8 H - BARB	2
	42377-2	Drum Weld PD 54	1	21	29524	Block Yoke SET	1
2	22748-2	Frame Weld 43	1	22	42490-2	Hose Guard Weld LH	1
	22749-2	Frame Weld 54	1		42496-2	Hose Guard Weld LH BLADE	1
3	22820	Kit Cap & Bearing LH	1	23	42491-2	Hose Guard Weld RH	1
4	22821	Kit Cap & Bearing RH	1		42497-2	Hose Guard Weld RH BLADE	1
5	29514	Weight Eccentric	1	24	29505-2	Hinge Weld ART / OSC	2
6	29513	Shaft Eccentric 43	1	25	46521	Plug Pipe 3/4 NPT SKT Hydraulic	2
	29563	Shaft Eccentric 54	1	26	42489-2	Bar Mount Hose Guard	2
7	32234	Bearing Eccentric	2	27	46131	Hose Hydraulic Low Press 5/8 ID	1
8	29601	Spline Extension	1	28	46032	Elbow Pipe 3/4 NPT 45 Street	1
9	29980-2	Cover Web Drum	1	29	47305	O-Ring 10 ID X 1/8 CS	2
10	38507	Seal Shaft	1	30	32236	Bearing Flange	4
11	23015	Kit Wheelmotor & Cap	1	31	24017	WSHR 2 - 15/16 X 2 - 1/4 ID	2
#	32308	Seal Kit for Wheelmotor in 23015	1	32	38760	Nilos Ring	1
12	42232-2	Bracket Weld S-MOUNT RH	2	33	42243-2	Strip Scraper SD 43	2
13	42233-2	Plate MOUNT Wheelmotor	1		42242-2	Strip Scraper SD 54	2
14	42234-2	Bracket Weld S-Mount LH	2		29547-2	Scraper PD 43	2
15	42236-2	Plate Weld HOUSING	1		29546-2	Scraper PD 54	2
16	47281	Shock Mounts (Per Side)		34^	42494-2	Spacer House Guard	2
		SD43, PD43 (front 2, back 3)	10	35	46042	FTG 164 IB	2
		SD54, PD54, PDB43 (front 3, back 3)	12	36	47001	Caplug Blue	6
		PDB54 (front 3, back 4)	14				
17	38531	Motor Gear Eccentric	1				

REMARK: Part Numbers 22820, 22821, 23015 include Item 7.
 ^ Not required on blade unit
 # Not Shown

5.3 Drum Assembly Cont'd.

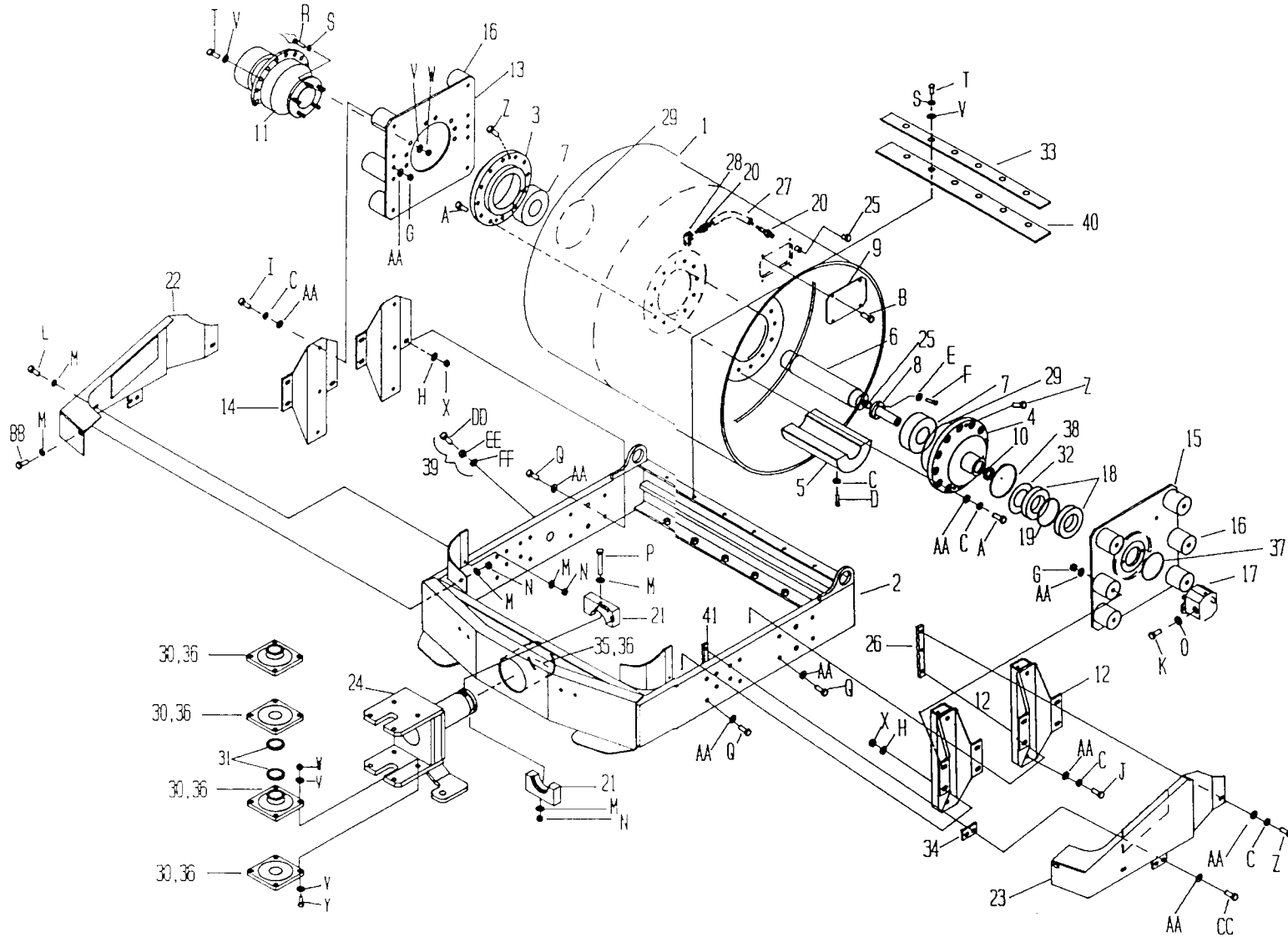

5.3 Drum Assembly Cont'd.

Item	Part No.	Description	Qty.	Torque		Item	Part No.	Description	Qty.	Torque	
				FT. LBS. (Nm)						FT. LBS. (Nm)	
37	47301	O-Ring 3 - 1/4 ID X 1/16 CS	1			K*80474	HHCS 3/8 - 16 X 1 - 1/4 GR 5 ZN	2	23	(31)	
38	32251	Seal V-RING 6" DIA.	1			M	80043	WSHR 3/8 WROTZN	14	-	-
39	22770	Kit Brake Release	1			N	80056	NUTNY 3/8 - 16 ZN	7	23	(31)
40	42345	Scraper POLY SD43	2			O	80058	WSHRL 3/8 MRD SPLIT ZN	2	-	
	42346	Scraper POLY SD54	2			P*	80643	HHCS 3/8 - 16 X 7 GR5 ZN	1	23	(31)
41	42493-2	Bar Mount PIVOT	4			Q*	80405	HHCS 1/2 - 13 X 2 - 3/4 GR5 ZN	12	57	(77)
A#*	80561	HHCS 1/2 - 13 X 1-3/4 GR5 ZN	24	57	(77)	R*	80681	SHCS 5/8 - 11 X 1 - 1/2 BLK	8	190	(257)
##*	80561	HHCS 1/2 - 13 X 1-3/4 GR5 ZN	76	57	(77)	S	80337	WSHRL 5/8 MED SPLIT ZN	18	-	-
B#*	80085	HWHST 5/16 - 18 X 1 ZN	4	13	(18)	T*	80695	HHCS 5/8 - 11 X 2 GR5 ZN	18	112	(152)
##*	80085	HWHST 5/16 - 18 X 1 ZN	13	13	(18)	V	80355	WSHR 5/8 SAE ZN	40	-	-
C#	80117	WSHRL 1/2 MED SPLIT ZN	43	-	-	W	80082	NUTNY 5/8 - 11 ZN	14	112	(152)
##	80117	WSHRL 1/2 MED SPLIT ZN	44	-	-	X	80051	NUTNY 1/2 - 13 ZN	16	57	(77)
###	80117	WSHRL 1/2 MED SPLIT ZN	47	-	-	Y*	80699	HHCS 5/8 - 11 X 3 - 1/4 GR5 ZN	8	112	(152)
D*	80680	SHCS 1/2 - 13 X 2 - 1/2 ZN	5	57	(77)	Z*	80113	HHCS 1/2 - 13 X 3/4 ZN	6	57	(77)
E	80086	WSHRL 5/16 MED SPLIT ZN	3	-	-	AA#	80343	WSHR 1/2 SAE ZN	64	-	-
F*	80049	SHCS 5/16 - 18 X 1 - 1/4 BLK	3	13	(18)	##	80343	WSHR 1/2 SAE ZN	68	-	-
G#*	80537	NUTFL 1/2 - 20 ZN	10	64	(87)	###	80343	WSHR 1/2 SAE ZN	72	-	-
##	80537	NUTFL 1/2 - 20 ZN	12	64	(87)	BB*	80694	HHCS 3/8 - 13 X 4 - 1/2 GR5 ZN	4	-	-
###	80537	NUTFL 1/2 - 20 ZN	14	64	(87)	CC*	80578	HHCS 1/2 - 13 X 3 GR5 ZN	4	57	(77)
H	80125	WSHR 17/32 ID X 1 - 1/16 ZN	16	-	-	DD	80641	HHTB M12 X 100MM GR8.8 ZN	1	-	-
I#*	80658	HHCS 1/2 - 20 X 1 GR5 ZN	5	64	(87)	EE	80700	NUTFX M12 ZN	1	-	-
##*	80658	HHCS 1/2 - 20 X 1 GR5 ZN	6	64	(87)	FF	26326	WSHR 9/16 X 1 - 3/4 X 1/4	1	-	-
###*	80658	HHCS 1/2 - 20 X 1 GR5 ZN	7	64	(87)						
J#*	80678	HHCS 1/2 - 20 X 3 GR5 ZN	5	64	(87)						
##*	80678	HHCS 1/2 - 20 X 3 GR5 ZN	6	64	(87)						
###*	80678	HHCS 1/2 - 20 X 3 GR5 ZN	7	64	(87)						

5.4 Main Frame

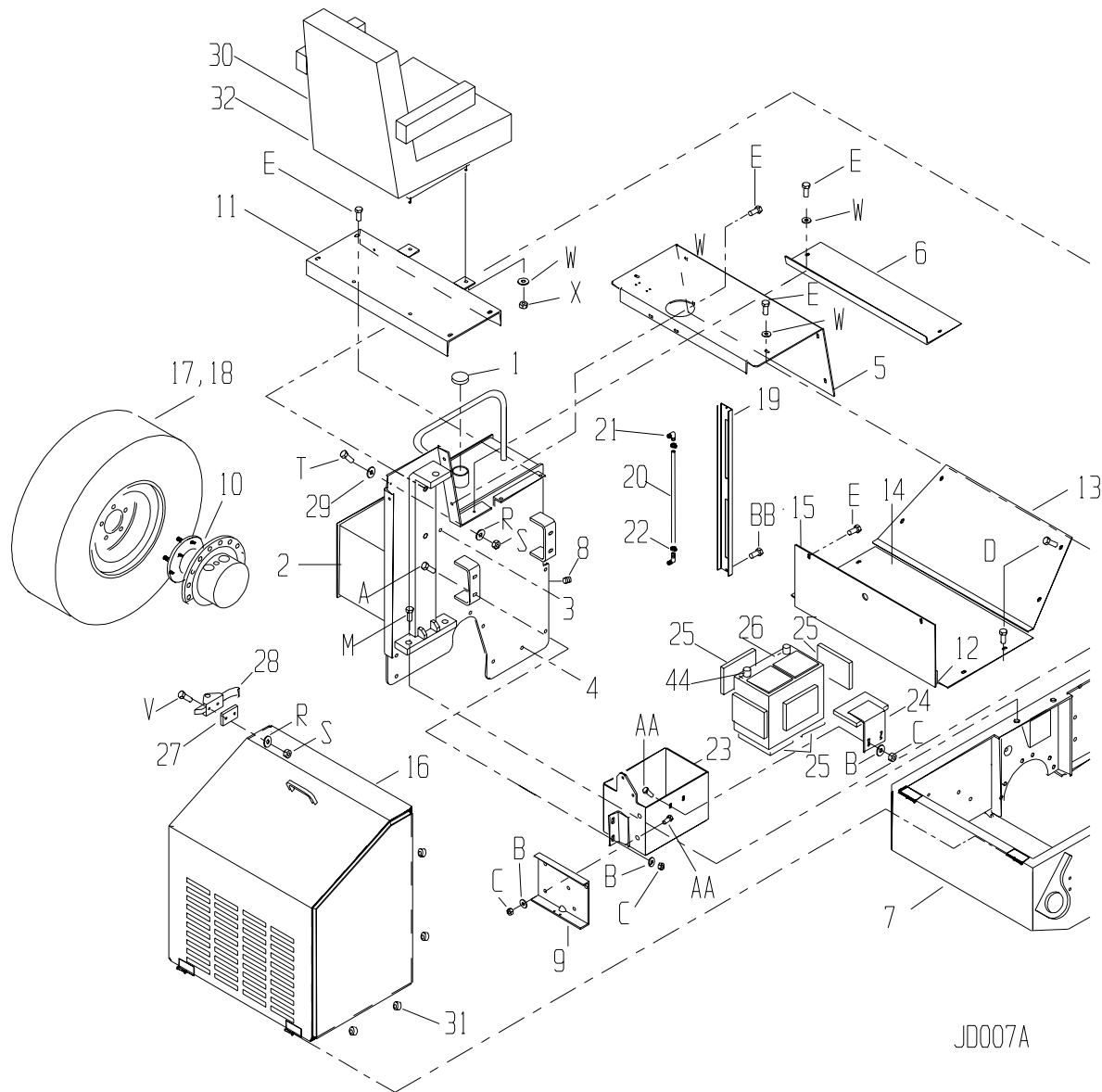

JD007A

5.4 Main Frame

Item	Part No.	Description	Qty.	Item	Part No.	Description	Qty.
1	46059	Cap Fuel	1	21	34486	Fitting Elbow	2
2	43250-2	Tank Fuel	1	22	34089	Clamp	2
3	46127	Fitting Return Fuel 1/4H	1	23	43785-2	Battery Box	1
4	46815	Fitting Supply Fuel 5/16H	1	24	29560-2	Hold Down Battery	1
5	43738-2	Panel Cover Tanks	1	25	29314	Liner Battery Box	7
6	43736-2	Panel Cover Filter	1	26	38519	Battery 800 CCA	1
7	43240-2	Frame Main	1	27	42321-2	Spacer	2
8	46107	Plug 1/2 NPT Sq Hd	1	28	38610	Latch	2
9	43845-2	Mount Manifold	1	29	38622	Keeper	2
10	38528	Wheelmotor	2	30	47268	Seat	1
11	29539-2	Panel Seat	1	31	47292	Bumpers	8
12	29132	Pin Hinge	1				
13	42062-2	Pan Nose	1				
14	42063-2	Pan Floor	1				
15	42065-2	Plate Battery	1				
16	43740-2	Cowl	1				
	43808	Set Sound Proof	1				
17	39289	Tire Assembly RH Turf	1				
	39290	Tire Assembly LH Turf	1				
	38720	Tire Turf (R-3)	1				
18	39195	Tire Assembly RH Lug	1				
	39196	Tire Assembly LH Lug	1				
	38722	Tire Lug (R-1)	1				
19	42015-2	Cover Level	1				
20	47295-2	Hose	2				
	38712	Float Fuel	1				

REMARK:

5.4 Main Frame Cont'd.

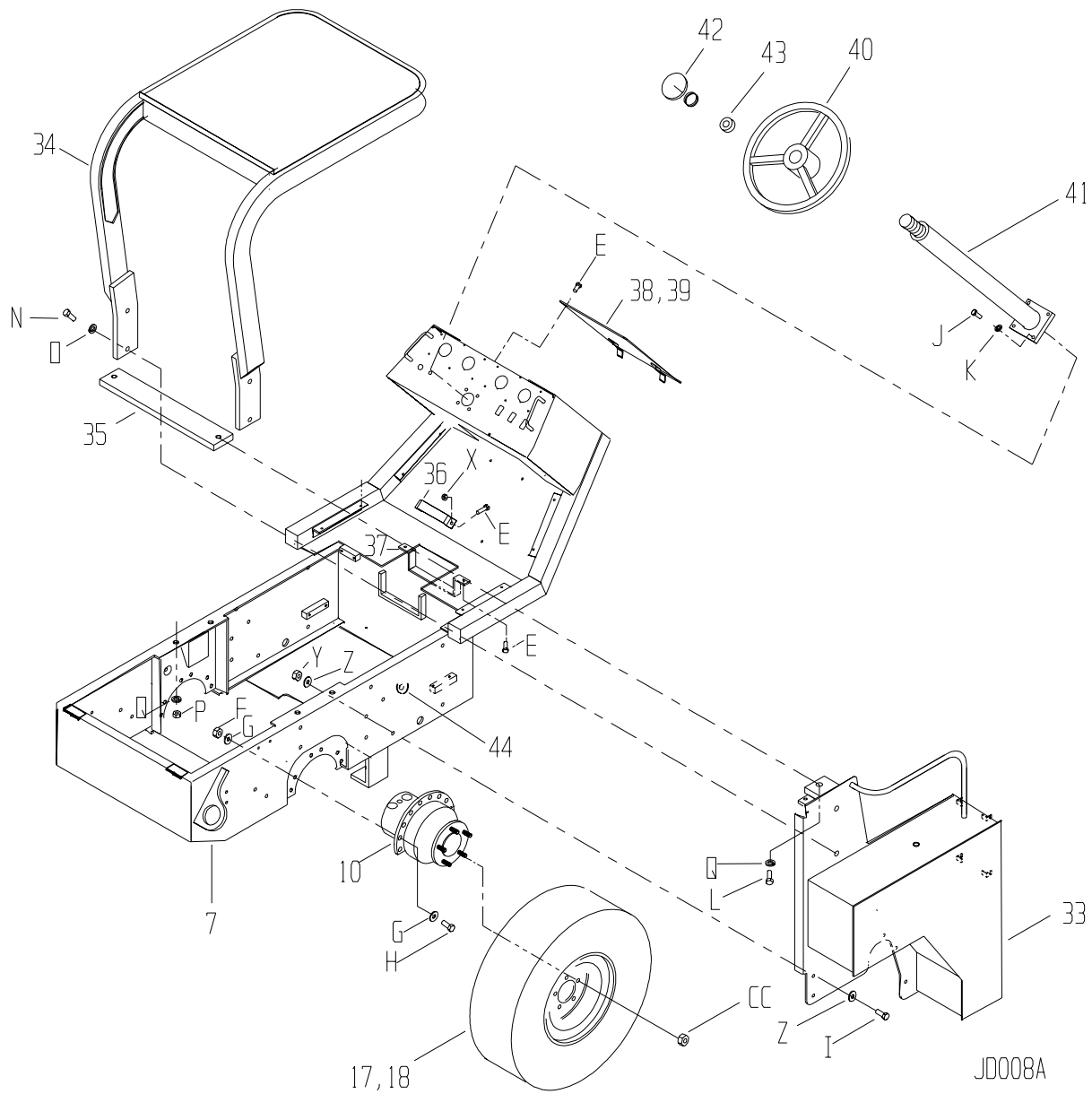

5.4 Main Frame Cont'd.

Item	Part No.	Description	Qty.	Torque		Item	Part No.	Description	Qty.	Torque	
				FT. LBS. (Nm)						FT. LBS. (Nm)	
32	38600	Seat Belt	1			J*	80476	HHCS 3/8 - 16 X 1 - 1/2 ZN	4	23	(31)
33	43251-2	Tank Hydraulic	1			K	80058	WSHRL 3/8 SPLIT ZN	4	-	-
34	29700-2	ROPS	1			L*	80668	HHCS 3/4 - 10 X 2 GR8 BLK	2	282	(382)
35	29702-2	ROPS Support	1			M*	80669	HHCS 3/4 - 10 X 2 - 1/2 GR8 ZN	4	282	(382)
36	42215-2	Bracket Hose	2			N*	80684	HHCS 1 - 8 X 3 GR8 BLK	4	682	(925)
37	42216-2	Bracket Hose	1			O	80685	WSHRL 1 SPLIT ZN	4	-	-
38	42075-2	Panel Front	1			P	80670	NUTFX 3/4 - 10 BLK	4	-	-
39	42222-2	Panel Rear	1			Q	80671	WSHRL 3/4 SPLIT ZN	6	-	-
40	46450	Steering Wheel	1			R	80346	WSHR #10 SAE ZN	6	-	-
41	46452	Column	1			S	80693	NUTNY 10 - 24 ZN	4	-	-
42	46449	Horn Kit	1			T	80696	FHSMS 10 - 24 X 1 ZN	2	-	-
43	47217	Nut Steering	1			V	80527	PPHMS 10 - 24 X 5/8 ZN	4	-	-
44	47247	Grommet Rubber 2" ID	1			W	80348	WSHR 5/16 WROT ZN	8	-	-
A	80041	CRBLT 3/8 - 16 X 1 - 1/4 ZN	4	-	-	X	80114	NUTNY 5/16 - 18 ZN	10	13	(18)
B	80043	WSHR 3/8 WROT ZN	6	-	-	Y	80051	NUTNY 1/2 - 13 ZN	12	-	-
C	80056	NUTNY 3/8 - 16 ZN	6	23	(31)	Z	80343	WSHR 1/2 SAE ZN	24	-	-
D	80610	HWHTB 3/8 - 16 X 1 - 1/4 ZN	8	23	(31)	AA	80587	CRBLT 3/8 - 16 X 1 ZN	2	-	-
E	80085	HWHTB 5/16 - 18 X 1 ZN	22	13	(18)	BB*	80257	RHSMS 10 - 24 X 3/8 BLK	2	-	-
F	80082	NUTNY 5/8 - 11 ZN	12	112	(152)	CC*	41038	LUG NUT M14 x 60 °	10	184	(250)
G	80355	WSHR 5/8 SAE ZN	24	-	-						
H*	80695	HHCS 5/8 - 11 X 2 GR5 ZN	12	112	(152)						
I*	80561	HHCS 1/2 - 13 X 1 - 3/4 GR5 ZN	12	57	(77)						

5.5 Radiator and Engine Mount

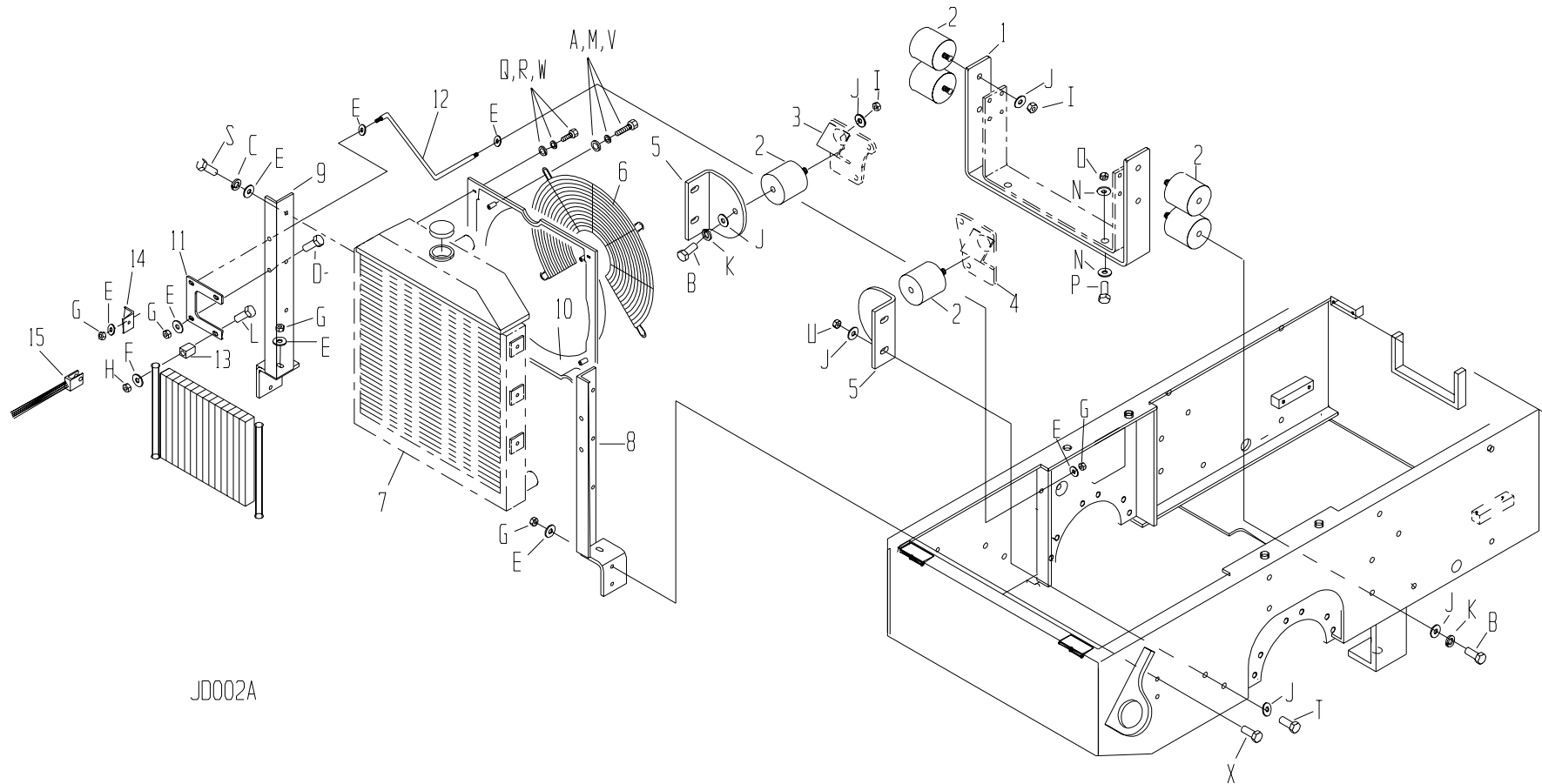

JD002A

5.5 Radiator and Engine Mount

Item	Part No.	Description	Qty.	Item	Part No.	Description	Qty.	Torque FT. LBS. (Nm)	
1	43255-2	Bracket Outer Bell Housing	1	A*	80161	HHCS 5/16 - 18 X 1 GR 5 ZN	4	13	(18)
2	47281	Shock Mounts	6	B*	80658	HHCS 1/2 - 20 X 1 GR5 ZN	6	57	(77)
3	43715-2	Mount Weld LH Engine	1	C	80058	WSHRL 3/8 Split ZN	6	-	-
4	43714-2	Mount Weld RH Engine	1	D	80041	CRBLT 3/8 - 16 X 1 - 1/4 ZN	3	-	-
5	42129-2	Bracket S-MTG Engine	2	E	80043	WSHR 3/8 WROT ZN	15	-	-
6	39576	Guard Fan	1	F	80564	WSHR 3/8 ID X 1/4 OD ZN	4	-	-
7	39574	Radiator	1	G	80056	NUTNY 3/8 - 16 ZN	11	23	(31)
	39606	Cap Radiator	1	H	80114	NUTNY 5/16 - 18 ZN	4	13	(18)
	39602	Hose Radiator Upper	1	I	80537	NUTFL 1/2 - 20 ZN	6	64	(87)
	39603	Hose Radiator Lower	1	J	80343	WSHR 1/2 SAE ZN PL	20	-	-
	39600	Clamp Hose 2"	2	K	80117	WSHRL 1/2 MED SPLIT ZN	6	-	-
	39601	Clamp Hose 2-1/4"	2	L	80682	CRBLT 5/16 - 18 X 2 - 1/2 ZN	4	-	-
	39604	Petcock Radiator	1	M	80086	WSHRL 5/16 MED SPLIT ZN	4	-	-
8	43245-2	Mount Weld Radiator RH	1	N	80355	WSHR 5/8 SAE ZN	4	-	-
9	43246-2	Mount Weld Radiator LH	1	O	80082	NUTNY 5/8 - 11 ZN	2	112	(152)
10	39575	Shroud Radiator	1	P*	80695	HHCS 5/8 - 11 X 2 GR5 ZN	2	112	(152)
11	43249-2	Plate Mount Cooler	2	Q	80347	WSHR ¼ WROT ZN	4	-	-
12	43805-2	Radiator Support	1	R	80116	WSHRL ¼ SPLIT ZN	4	-	-
13	38627	Rubber Mount Cooler	4	S*	80174	HHCS 3/8 - 16 X 1 GR5 ZN	6	23	(31)
14	42460-2	Bracket Cowl Stop	1	T*80561	HHCS 1/2 - 13 X 1 - 3/4 GR5 ZN	4	57	(77)	
15	38815	Stop Cable	1	U	80051	NUTNY 1/2 - 13 ZN	4	57	(77)
				V	80348	WSHR 5/16 WROT ZN	2	-	-
				W*	80434	HHCS 1/4-20 x 3/4 GR5 ZN	4	6	(8)
				X*	80474	HHCS 3/8-16 x 1-1/4 GR5 ZN	4	-	-

REMARK: * Loctite Required

5.6 Engine

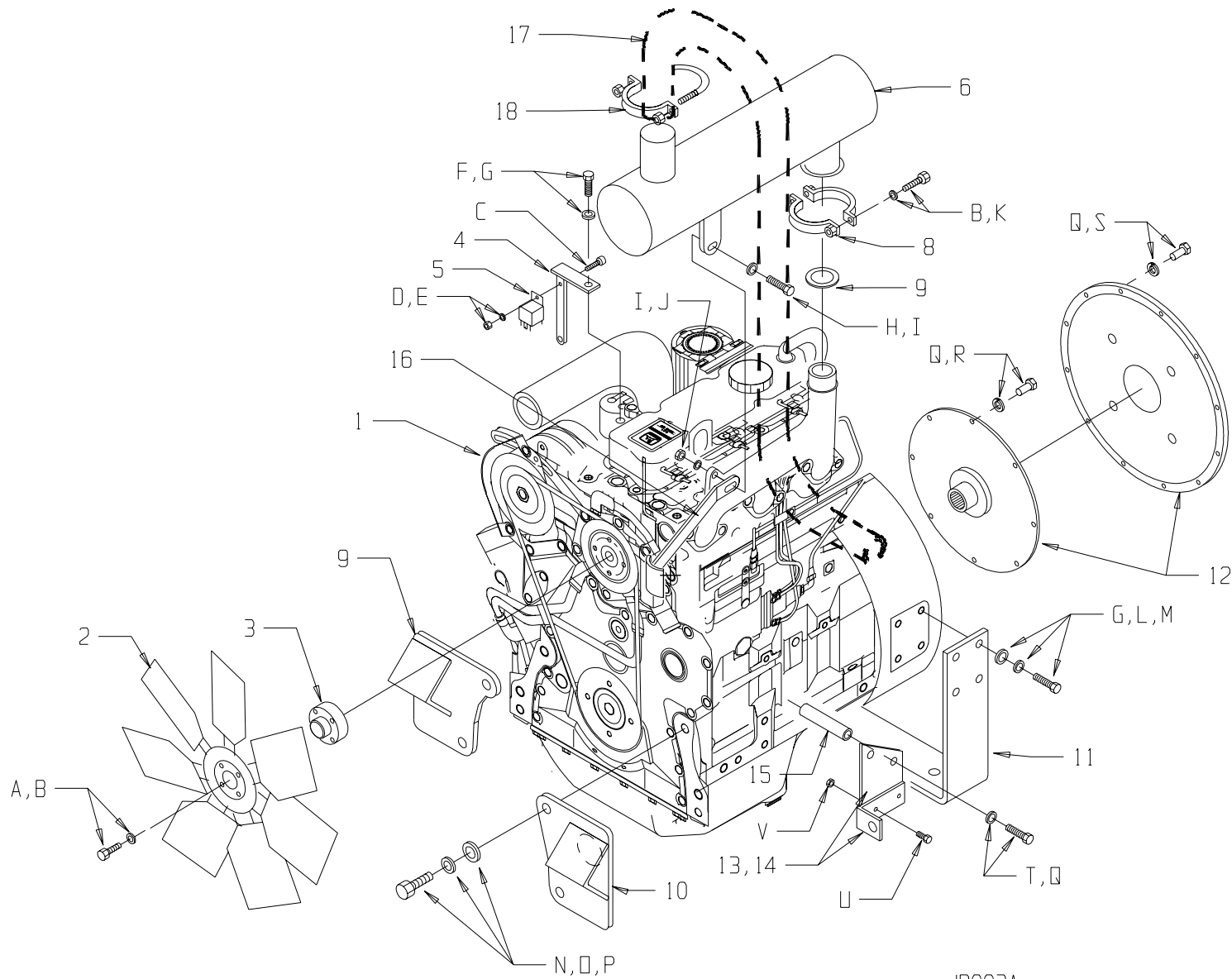

JD003A

5.6 Engine

Item	Part No.	Description	Qty.	Item	Part No.	Description	Qty.	Torque FT. LBS. (Nm)	
1	30558	Engine Deere 3029	1	A*	80170	HHCS 5/16-18 X 2-1/2 GR5 ZN	4	13	(18)
2	39577	Fan Nylon	1	B	80086	WSHRL 5/16 SPLIT ZN	6	-	-
3	39578	Spacer Fan	1	C	80527	PPHMS 10-24 X 5/8 ZN	1	-	-
4	43799	Mount Relay	1	D	80346	WSHR #10 SAE ZN	1	-	-
5	48401	Relay 70A	1	E	80693	NUTNY 10-24 ZN	1	-	-
6	43782	Muffler	1	F*	80113	HHCS 1/2-13 X 3/4 GR5 ZN	1	57	(77)
7	39621	Gasket	1	G	80117	WSHRL 1/2 SPLIT ZN	9	-	-
8	39620	Half Clamp	2	H*	80178	HHCS 3/8-16 X 2 GR5 ZN	1	23	(31)
9	43715-2	Mount Weld LH Engine	1	I	80342	WSHR 3/8 SAE ZN	2	-	-
10	43714-2	Mount Weld RH Engine	1	J	80325	NUTFL 3/8-16 REG ZN	1	-	-
11	43254-2	Bracket Inner Bell Housing	1	K*	80163	HHCS 5/16-18 X 1-1/2 GR5 ZN	2	-	-
12	39636	Drive Plate and Cover	1	L*	80703	HHCS 1/2-13 X 1-1/2 GR5 ZN	8	-	-
13	39595	Plate Throttle	1	M	80343	WSHR 1/2 SAE ZN	8	-	-
14	39596	Bracket Throttle	1	N*	80204	HHCS 5/8-11 X 1-1/2 GR5 ZN	4	112	(152)
15	39597	Spacer Throttle	2	O	80355	WSHR 5/8 SAE ZN	4	-	-
16	43749-2	Support Exhaust	1	P	80337	WSHRL 5/8 SPLIT ZN	4	-	-
17	43746-2	Exhaust Pipe	1	Q	80058	WSHRL 3/8 SPLIT ZN	8	-	-
18	39585	Clamp Muffler 2-1/4	2	R*	80686	HHCS 3/8-16 X 3/4 GR8 ZN	20	23	(31)
Fuel Lines (not shown)				S*	80716	HHCS 3/8-16 X 1-1/4 GR8 ZN	12	23	(31)
-	46813	Hose Return 1/4 ID	25"	T*	80942	HHCS 3/8-16 X 5 GR5 ZN	2	23	(31)
-	39593	Fitting Return Engine	1	U	80567	HWHTB 1/4-20 X 3/8 ZN	2	6	(8)
-	46127	Fitting Return Tank	1	V	80676	NUTNY 1/4-20 ZN	2	-	-
-	46814	Hose Supply 5/16 ID	36"						
-	46815	Fitting Supply Tank	1						
-	34089	Clamp Hose 5/8	4						

REMARK: * Loctite Required

5.6 Engine Cont'd.

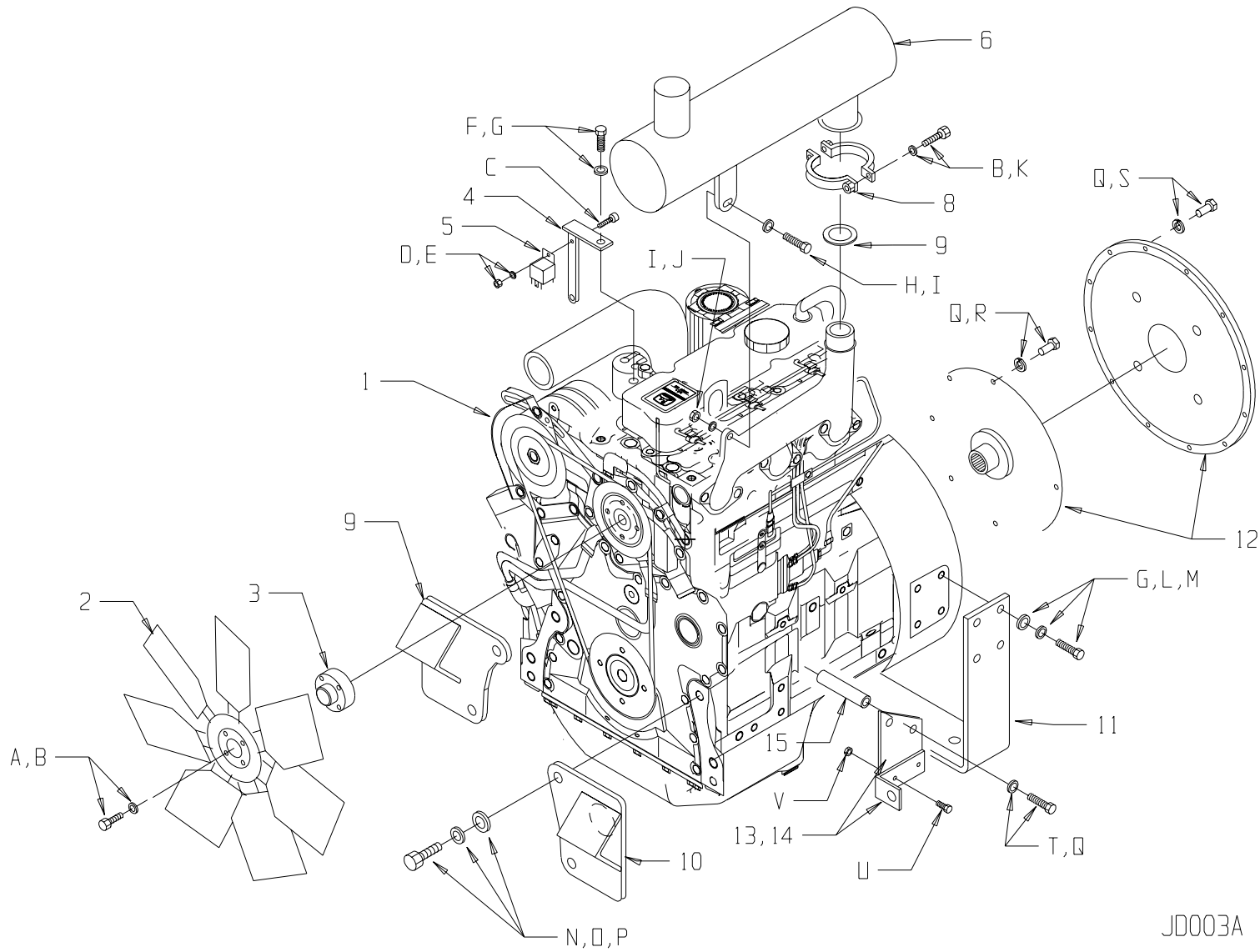

JD003A

5.6 Deere Engine Service Parts

Item	Part No.	Description	Qty.	Item	Part No.	Description	Qty.
-	39624	Filter Fuel	1				
-	39625	Filter Oil	1				
-	39626	Belt	1				
-	39627	Alternator	1				
-	39628	Starter	1				
-	39629	Injector Fuel	3				
-	39630	Pump Water	1				
-	39631	Pump Injection	1				
-	39632	Pump Fuel Transfer	1				
-	39633	Solenoid Fuel	1				
-	39634	Thermostat	1				
-	39635	Gasket Thermostat	1				
-	39592	Intake Heater	1				
-	39598	Sendor Pressure	1				
-	39599	Sendor Temperature	1				

REMARK:

5.7 Air Cleaner

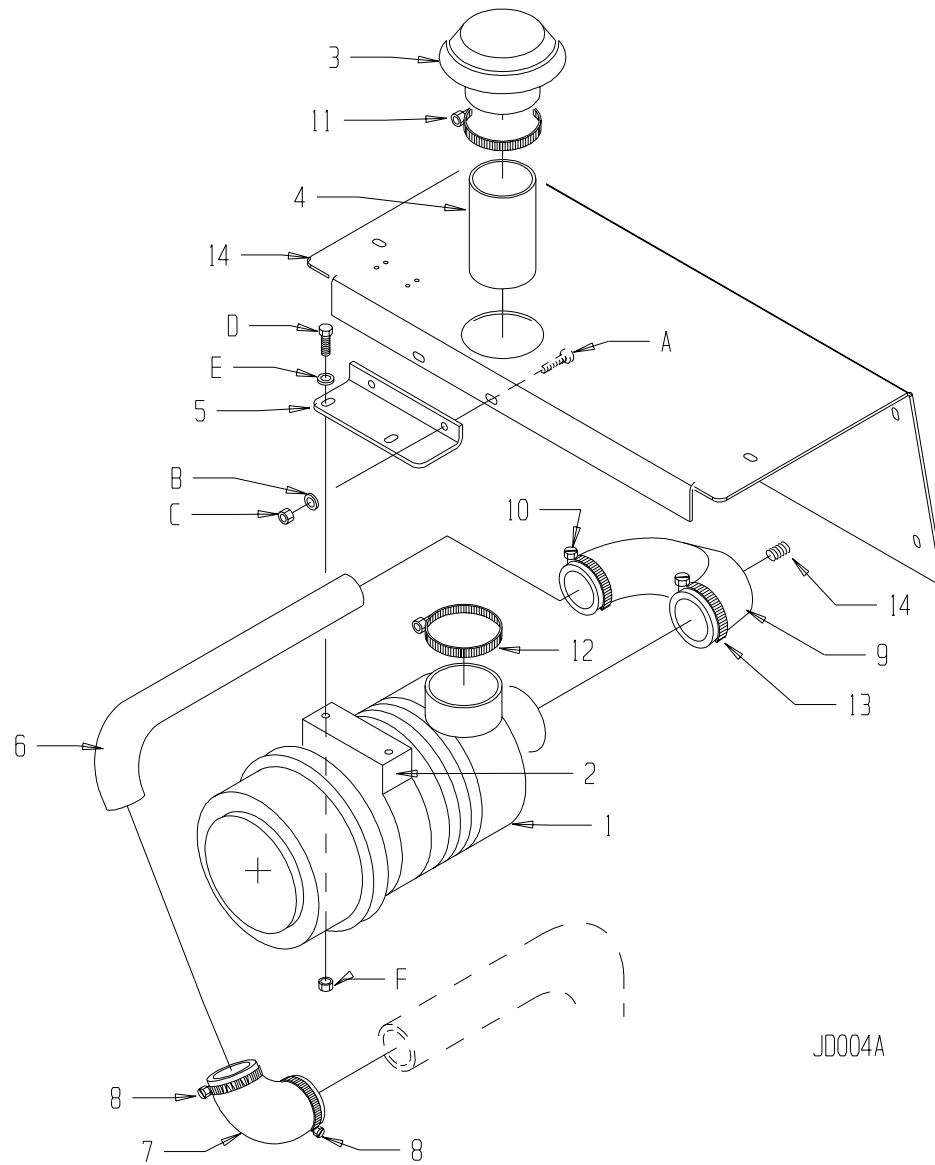

JD004A

5.7 Air Cleaner

Item	Part No.	Description	Qty.	Item	Part No.	Description	Qty.	Torque	
								FT. LBS.	(Nm)
1	39580	Air Cleaner Assembly	1						
	39622	Element Primary (Outer)	1	A*	80587	CRBLT 3/8-16 x 1 ZN	2	-	-
	39623	Element Safety (Inner)	1	B	80342	WSHR 3/8 SAE ZN	2	-	-
2	39581	Band	1	C	80056	NUTNY 3/8-16 ZN	2	23	(31)
3	39617	Cap	1	D*	80161	HHCS 5/16-18x1 GR5 ZN	2	13	(18)
4	43804	Extension	1	E	80348	WSHR 5/16	2	-	-
5	43739-2	Mount Air Cleaner	1	F	80114	NUTNY 5/16-18 ZN	2	-	-
6	43747-2	Pipe Intake	1						
7	39583	Elbow 90°	1						
8	39618	Clamp 3-1/4"	3						
9	39616	Hose 180°	1						
10	43738-2	Cover Tanks	1						
11	39615	Clamp 4"	1						
12	39619	Clamp 3-3/4	2						
13	39650	Clamp 4-1/4	1						
14	38147	Plug 1/8 NPT	1						

5.8 Controls

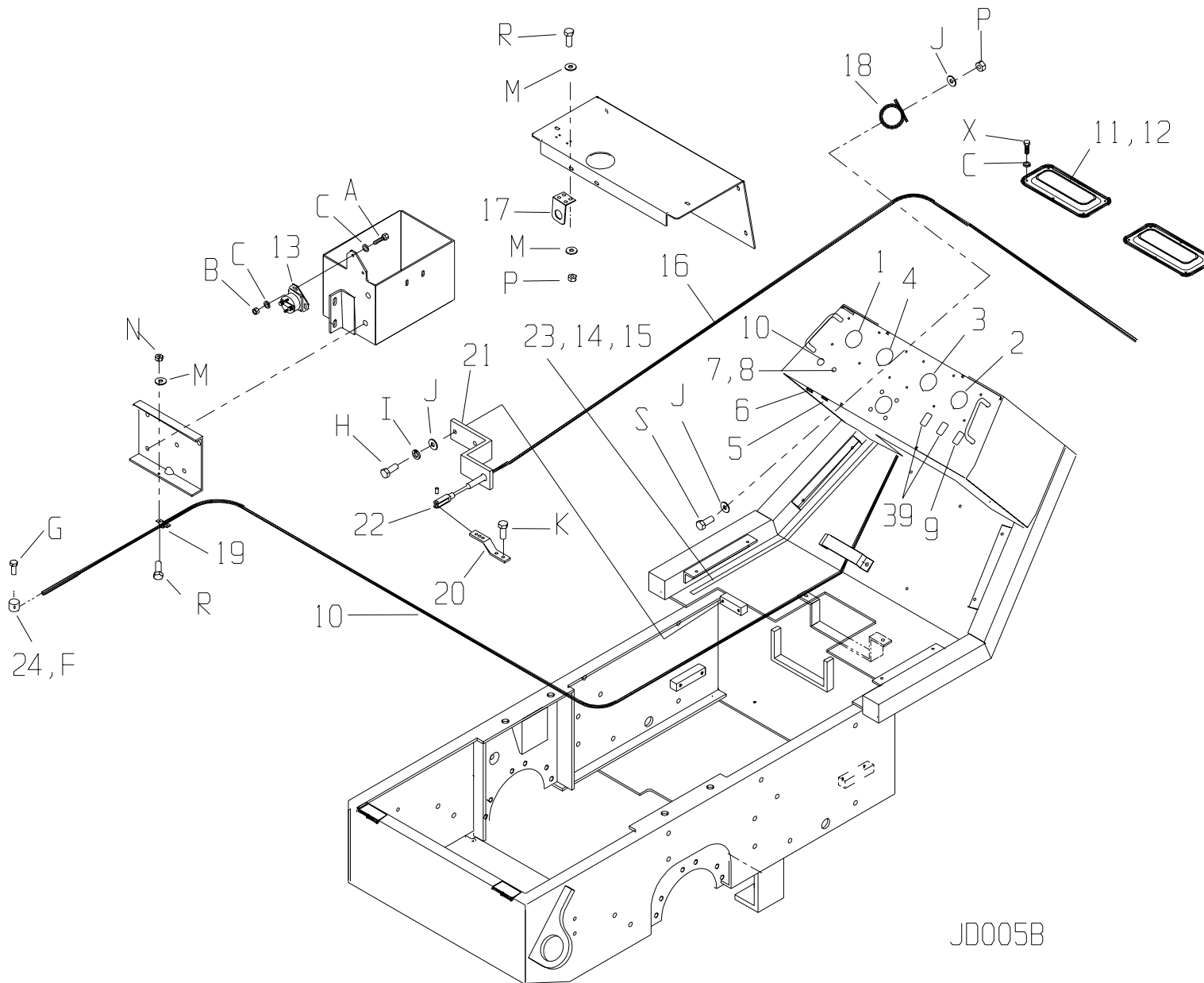

JD005B

5.8 Controls

Item	Part No.	Description	Qty.	Item	Part No.	Description	Qty.	Torque FT. LBS. (Nm)
1	36268	Hour Meter	1	A*	80434	HHCS 1/4 - 20 X 3/4 GR ZN	2	6 (8)
2	39609	Volt Meter	1			HHCS 1/4 - 20 X 3/4 GR ZN (Blade Unit)	4	6 (8)
3	39610	Gauge Oil Pressure	1	B	80518	NUTFL 1/4 - 20 ZN	3	- -
	39598	Sendor Oil Pressure	1			NUTFL 1/4 - 20 ZN (Blade Unit)	6	- -
4	39611	Gauge Coolant Temperature	1	C	80347	WSHR 1/4 WROT ZN	16	- -
	39599	Sendor Coolant Temperature	1	D*	80788	WSHR SPRING 1/4 ID (Blade Unit)	6	- -
5	39612	Push Button	1	E*	80791	PPHMS 1/4 - 20 X 3/4 BLK	4	- -
6	39607	Key Switch	1	F	80448	PINCT 1/16 X 1/2	1	- -
	39637	Key Ignition	1	G	80442	SHCS #10 - 32 X 1/2 BLK	1	- -
7	38711	Fuse Holder	1	H*	80481	HHCS 5/16 - 18 X 1 GR5 ZN	2	13 (18)
8	36311	Fuse 20A	1	I	80086	WSHRL 5/16 SPLIT ZN	4	- -
9	39653	Switch Rocker On/Off	1	J	80348	WSHR 5/16 WROT ZN	8	- -
10	39584	Cable Throttle	1	K	80686	HHCS 3/8 - 16 X 3/4 GR8 ZN	2	23 (31)
11	47314	Cover Dust	2	M	80346	WSHR #10 SAE ZN	20	- -
12	47315	Gasket Cover Dust	2	N	80693	NUTNY 10 - 24 ZN	11	- -
13	39608	Relay Starter	1	O	80085	HWHTB 5/16 - 18 X 1 ZN	4	13 (18)
14	38662	Clamp Cable 1/2	2	P	80114	NUTNY 5/16 - 18 ZN	2	- -
15	38800	Clamp Conduit 1/2	2	Q	80056	NUTNY 3/8 - 16 ZN	2	- -
16	38602	Cable Forward/Reverse	1	R	80527	PPHMS 10 - 24 X 5/8 ZN	6	- -
	38602	Cable Forward/Reverse (Blade Unit)	2	S*	80161	HHCS 5/16 - 18 X 1 ZN	1	13 (18)
17	38559	Backup Alarm 112 dBA	1	T*	80157	HHCS 1/4 - 20 X 1 - 1/2 ZN	-	6 (8)
18	38667	Horn 12V 125 dBA	1	V*	80354	HHCS 1/4 - 20 X 1	2	6 (8)
19	41007	Clamp Cable	1		80709	HHCS 1/4 - 20 X 2 GR8 ZN (Blade Unit)	2	6 (8)
20	42076	Lever Cable	1	X	80153	HWHST 1/4 - 20 X 3/4 ZN	12	6 (8)
				Y	80449	SHCS 10 - 24 X 5/8 BLK	2	- 79 -

REMARK: * Loctite Required

5.8 Controls Cont'd.

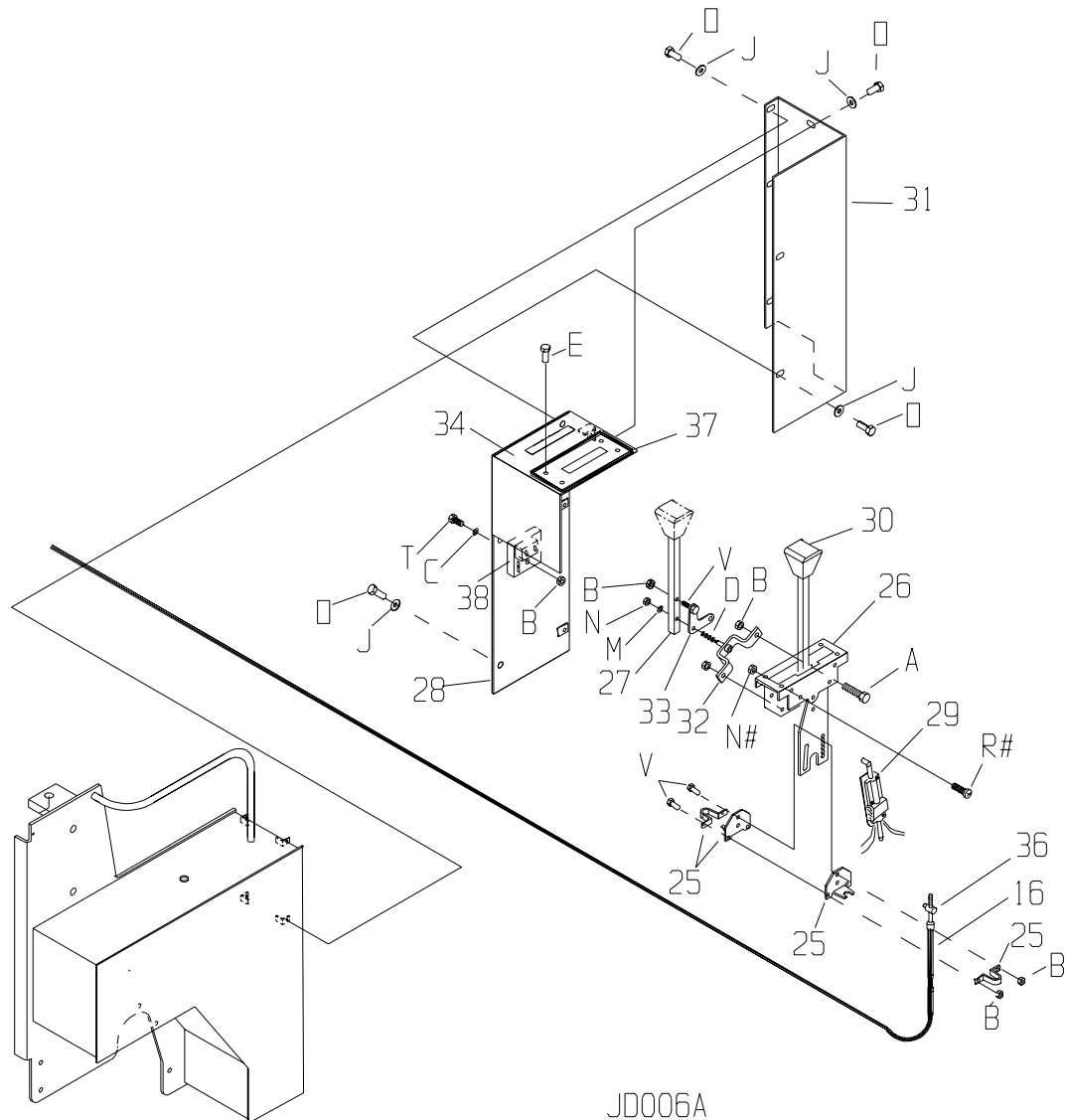

JD006A

5.8 Controls Cont'd.

Item	Part No.	Description	Qty.	Item	Part No.	Description	Qty.	Torque FT. LBS. (Nm)
21	43759-2	Mount Cable Forward/Reverse	1	A*	80434	HHCS 1/4 - 20 X 3/4 GR ZN	2	6 (8)
22	38561	Clevis	1			HHCS 1/4 - 20 X 3/4 GR ZN (Blade Unit)	4	6 (8)
23	48406	Wire Harness	1	B	80518	NUTFL 1/4 - 20 ZN	3	- -
24	38618	Pivot Throttle	1			NUTFL 1/4 - 20 ZN (Blade Unit)	6	- -
	41006	Stop Throttle	1	C	80347	WSHR 1/4 WROT ZN	16	- -
25	38816	Clamp Assembly (Blade Unit)	1	D*	80788	WSHR SPRING 1/4 ID (Blade Unit)	6	- -
26	39097	Lever Forward/Reverse	1	E*	80791	PPHMS 1/4 - 20 X 3/4 BLK	4	- -
27	43261	Lever Blade (Blade Unit)	1	F	80448	PINCT 1/16 X 1/2	1	- -
28	43264-Yel	Box Weld Forward/Reverse	1	G	80442	SHCS #10 - 32 X 1/2 BLK	1	- -
	43265-Yel	Box Weld Forward/Reverse (Blade Unit)	1	H*	80481	HHCS 5/16 - 18 X 1 GR5 ZN	2	13 (18)
29	39321	Switch Neutral / Backup	1	I	80086	WSHRL 5/16 SPLIT ZN	4	- -
30	39320	Knob Forward/Reverse	1	J	80348	WSHR 5/16 WROT ZN	8	- -
31	42263-2	Panel Wrap	1	K	80686	HHCS 3/8 - 16 X 3/4 GR8 ZN	2	23 31)
32	43263-Yel	Bracket Weld Pivot (Blade Unit)	1	M	80346	WSHR #10 SAE ZN	20	- -
33	43262-Yel	Pivot (Blade Unit)	1	N	80693	NUTNY 10 - 24 ZN	11	- -
34	55343	Decal Control (Blade Unit)	1	O	80085	HWHTB 5/16 - 18 X 1 ZN	4	13 (18)
35	48329	Cable Tie Holder	2	P	80114	NUTNY 5/16 - 18 ZN	2	- -
36	38817	Swivel (Blade Unit)	1	Q	80056	NUTNY 3/8 - 16 ZN	2	- -
37	39319	Plate Forward/Reverse Black	1	R	80527	PPHMS 10 - 24 X 5/8 ZN	6	- -
38	48399	Relay/Timer (2 sec)	1	S*	80161	HHCS 5/16 - 18 X 1 ZN	1	13 (18)
39	48393	Light Red	2	T*	80157	HHCS 1/4 - 20 X 1 - 1/2 ZN	-	6 (8)
				V*	80354	HHCS 1/4 - 20 X 1	2	6 (8)
					80709	HHCS 1/4 - 20 X 2 GR8 ZN (Blade Unit)	2	6 (8)
				X	80153	HWHST 1/4 - 20 X 3/4 ZN	12	6 (8)
				Y	80449	SHCS 10 - 24 X 5/8 BLK	2	- 81 -

REMARK: * Loctite Required

5.9 Drive System Hydraulics

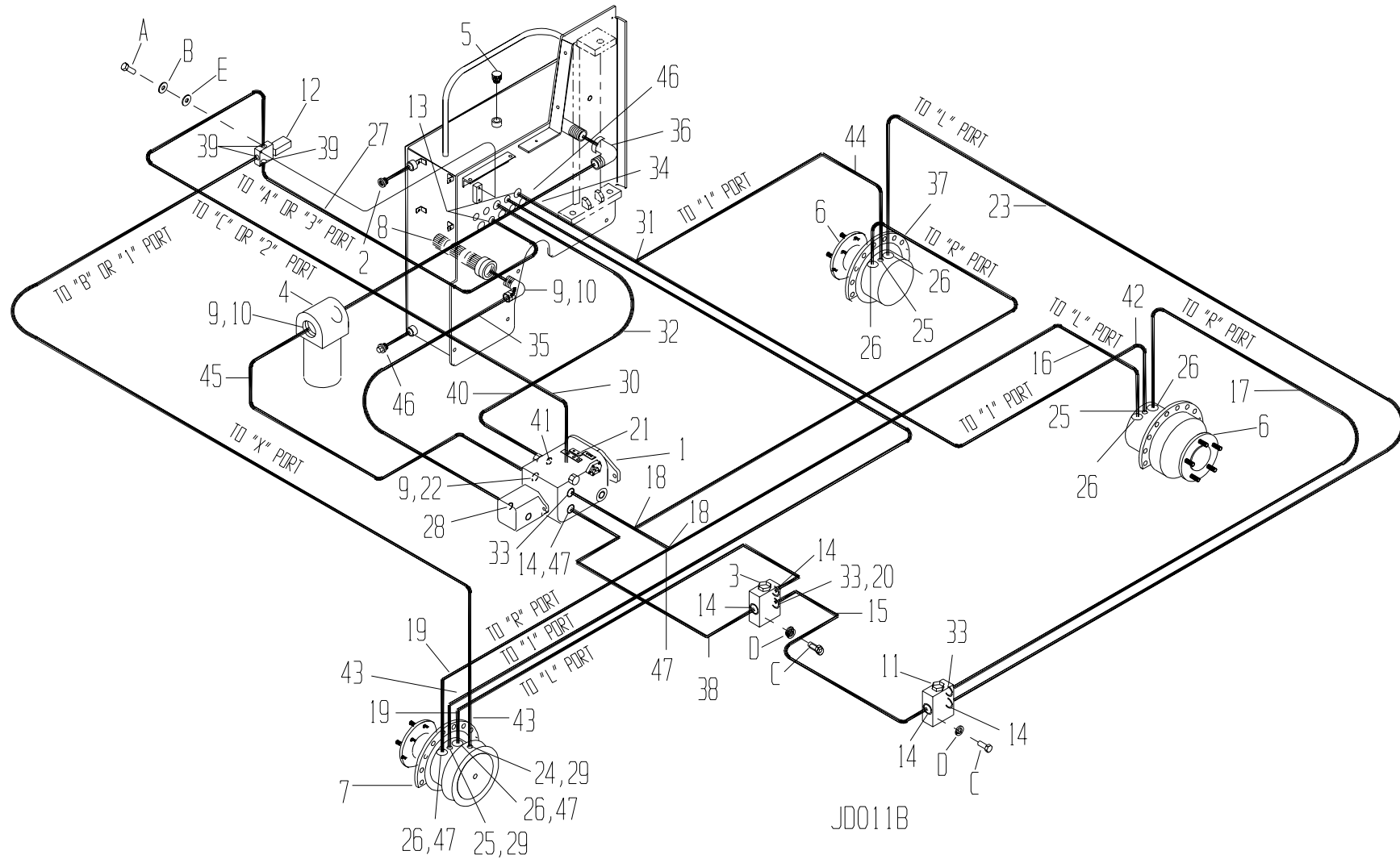

JD011B

5.9 Drive System Hydraulics

Item	Part No.	Description	Qty.	Item	Part No.	Description	Qty.
1	38522	PUMP VARIABLE MDT 46	1	20	46396	FTG EL90 1 - 1/16 JSW	2
2	38534	SIGHT GLASS	1	21	46115	FTG STR 9/16 J 9/16 OR	1
3	38523	DIVIDER FLOW 33/67	1	22	46757	HOSE 1-1/16 FJ 1-1/16 FJ52	1
4	38520	FILTER SUCTION	1	23	46841	HOSE 1 - 1/16 FJ 1 - 1/16 FJ 52	1
	38638	ELEMENT HYDRAULIC 50AT-10C	1	24	46400	FTG STR 9/16 J 1/4 BSPP	1
5	38521	BREATHER / FILTER	1	25	46401	FTG STR 9/16 J 3/8 BSPP	3
6	38528	MOTOR WHEEL MS05	2	26	46402	FTG STR 1 - 1/16 3/4 BSPP	6
7	38527	MOTOR WHEEL MS05 W/BRAKE	1	27	46527	HOSE HYD 9/16 FJ 9/16 FJ 12	1
8	35482	STRAINER SL 25GPM	1	28	46509	FTG STR 1 - 5/16 J 1 - 5/16 OR	1
9	46534	FTG HYD EL 1-5/16 JSW	3	29	46544	FTG EL 45 9/16	2
10	46417	FTG STR 1-5/16 J X 1 - 1/4 NPT	2	30	46387	HOSE 9/16 FJ X 9/16 FJ 23 - 1/2	1
11	38663	DIVIDER FLOW 50 / 50	1	31	46389	FTG TEE Run 9/16 J	1
	47326	O-Ring Viton 29.5	1	32	46345	FTG STR 7/8 JIC X 3/4 NPT	1
12	38689	VALVE SOL 3WAY 2POS	1	33	46385	FTG STR 1 - 1/16 J 1 - 5/16 OR	3
13	46490	FTG STR 9/16 J X 3/4 OR	3	34	46404	FTG HYD EL 7/8 J 1 - 1/16 OR	1
14	46390	FTG EL90 1 - 5/16 OR X 1 - 1/16 J	5	35	46535	HOSE HYD 1 - 5/16 FJ 1 - 5/16 FJ 17	1
15	46844	HOSE 1-1/16 FJ 1-1/16 FJ 24	1	36	46447	FTG EL90 1 - 1/4 STREET	1
16	46843	HOSE 1-1/16 RJ9 1-1/16 RJ4 22-1/4 180°	1	37	46840	HOSE 1-1/16 FJ 1-1/16 RJ9 44.5	1
17	46842	HOSE 1-1/16 FJ 1-1/16 RJ4 29-1/2	1	38	46845	HOSE 1 - 1/16 FJ 1 - 1/16 FJ 19"	1
18	46394	FTG Outlet TEE 1-1/16 J	2	39	46325	FTG HYD EL 3/4 OR 9/16 J	3
19	46846	HOSE 1-1/16 FJ 1-1/16 FJ 91	2	40	46531	HOSE HYD 7/8 FJ 7/8 FJ 17	1
		SD, PD43		41	46404	FTG HYD EL 7/8 J 1 - 1/16 OR	1
	46847	HOSE 1-1/16 FJ 1-1/16 FJ 96	2	42	46808	HOSE HYD 9/16 FJ 9/16 RJ4 55"	1
		SD, PD54					

REMARK:

5.9 Drive System Hydraulics Cont'd.

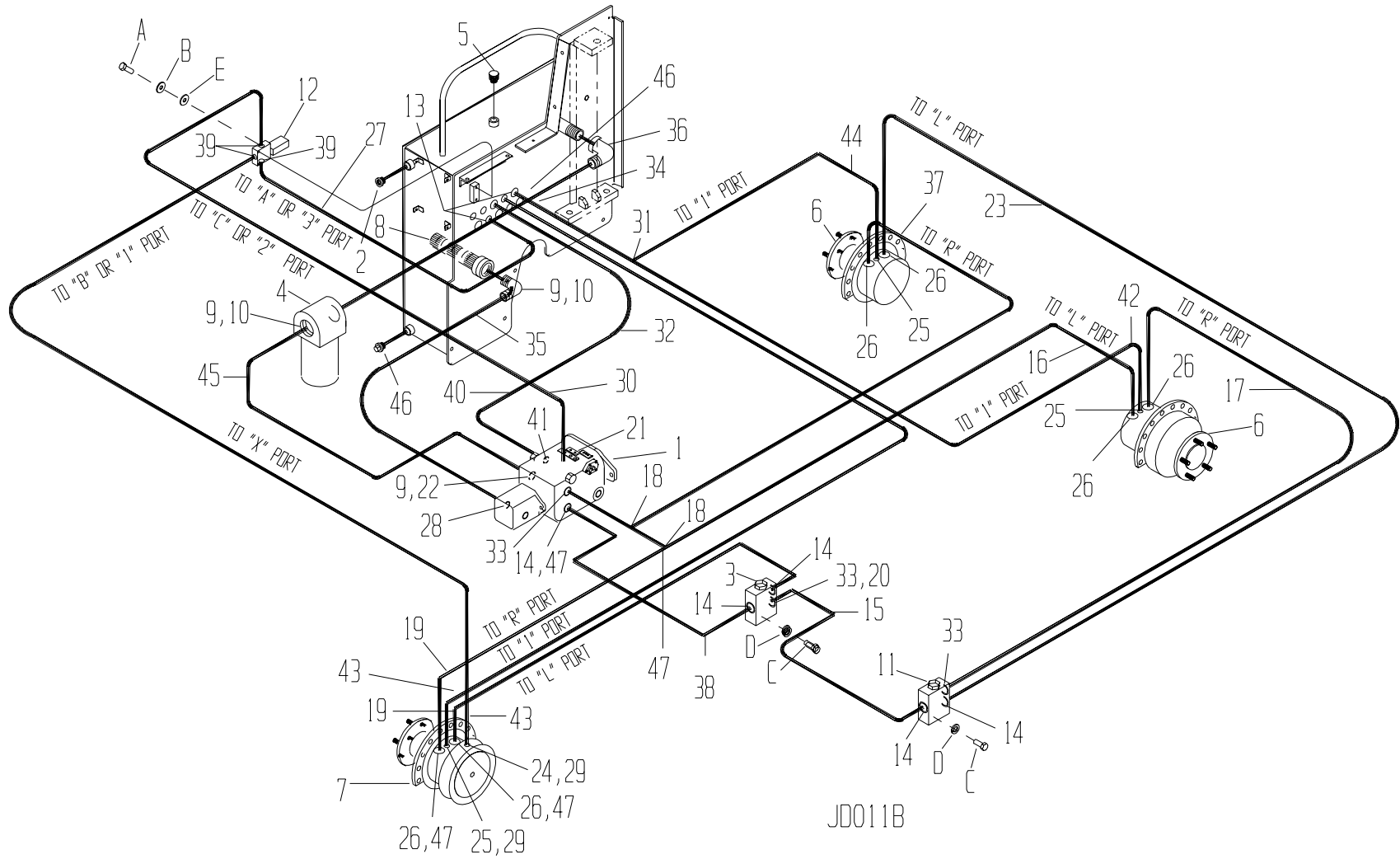

5.9 Drive System Hydraulics Cont'd.

Item	Part No.	Description	Qty.	Item	Part No.	Description	Qty.	Torque	
								FT. LBS.	(Nm)
43	46529	HOSE HYD 9/16 FJ 9/16 FJ 108 SD, PD54	1	A*	80709	HHCS 1/4 - 20 X 2 GR8 ZN	2	6	(8)
	46549	HOSE HYD 9/16 FJ X 9/16 FJ 103 SD, PD43	1	B	80116	WSHR 1/4 SPLIT ZN	2	-	-
44	46530	HOSE HYD 9/16 FJ 9/16 FJ 30	1	C*	80181	HHCS 3/8 - 16 X 2 - 1/2 GR5 ZN	4	23	(31)
45	46812	HOSE HYD 1 - 5/16 FJ 1-5/16 FJ 22.25"	1	D	80058	WSHRL 3/8 SPLIT ZN	4	-	-
46	46411	FTG ST 7/8J 1-1/16 OR	2	E	80347	WSHR 1/4 ZN	2	-	-
47	46455	FTG HYD EL 45 1 - 1/16	3						
#	38206	HOSE WRAP 2.5 ID POLY	7						

REMARK: # Not Shown
* Loctite Required

5.10 Steering / Eccentric System Hydraulics

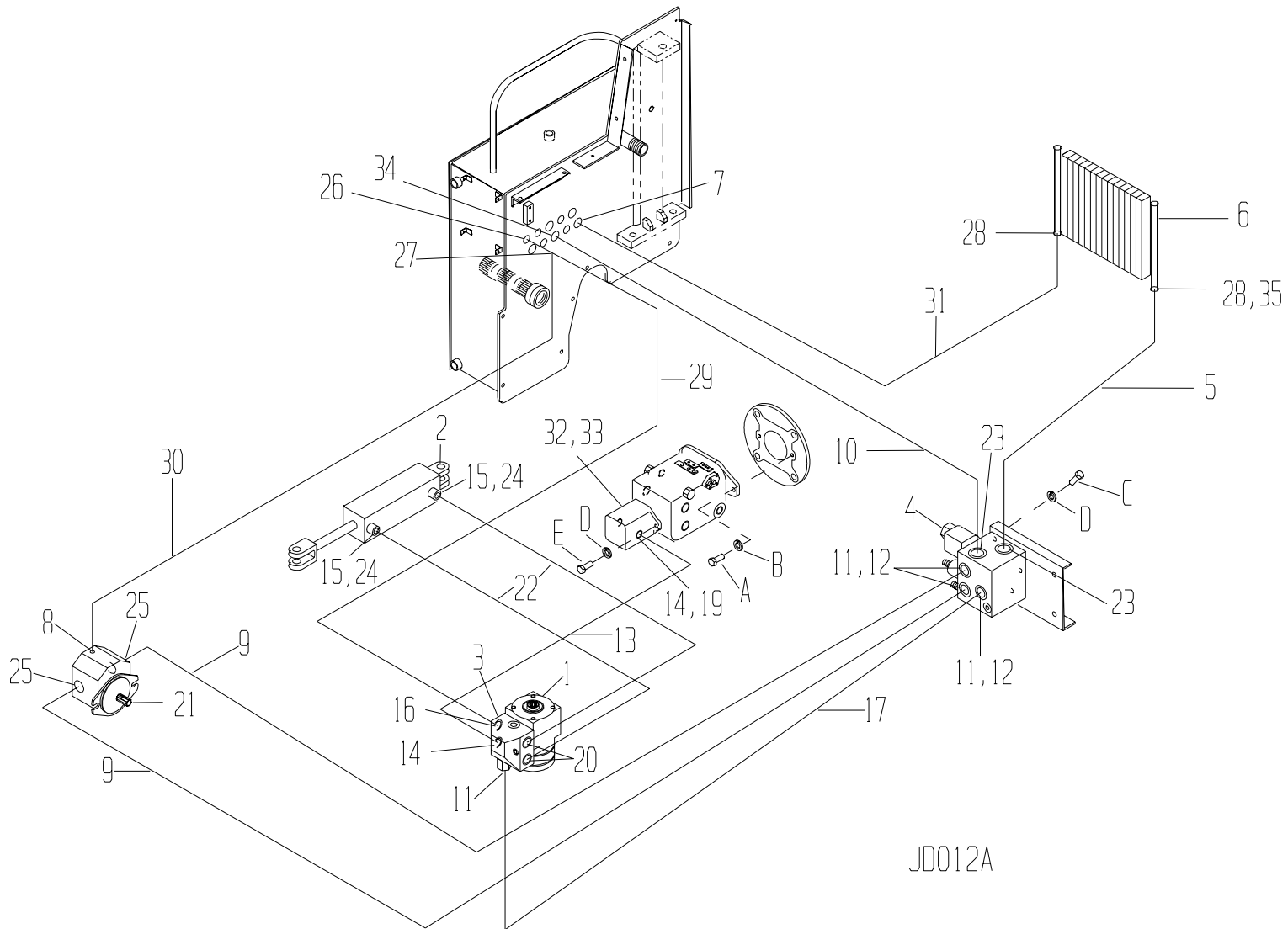

5.10 Steering / Eccentric System Hydraulics

Item	Part No.	Description	Qty.	Item	Part No.	Description	Qty.	Torque	
								FT. LBS.	(Nm)
1	38524	CONTROL STEERING	1	23	46133	FTG HYD 7/8 J X 7/8 OR	2		
2	46362	CYLINDER TIE ROD 2.5 X 10	1	24	46181	FTG STR 9/16 J 3/8 NPT	2		
	44203	PIN CLEVIS 1"	2	25	46378	FTG HYD 1-1/16J 1-1/16 OR	2		
	44204	RUE RING 1"	2	26	46490	FTG HYD 9/16 J 3/4 OR	1		
3	38529	PRIORITY VALVE	1	27	46389	FTG HYD TEE 9/16 J RUN	1		
4	38727	MANIFOLD MODULAR	1	28	46345	FTG HYD 7/8 J 3/4 NPT	4		
5	46533	HOSE HYD 7/8 FJ X 7/8 FJ 73	1	29	46526	HOSE HYD 9/16 FJ 9/16 FJ 60	1		
6	38446	COOLER HYD OIL	1	30	46529	HOSE HYD 9/16 FJ 9/16 FJ 108 (54's)	1		
7	46404	FTG EL 7/8J 1-1/16OR	1		46549	HOSE 9/16 FJ X 9/16 FJ 103 (43's)	1		
8	46496	FTG STR 9/16 J 1/4 NPT	1	31	46532	HOSE 7/8 FJ X 7/8 FJ 54	1		
9	46416	HOSE 1-1/6 FJ X 1-1/16 FJ 96 (54's)	2	32	38518	PUMP GEAR 1.54 CIR	1		
	46846	HOSE 1-1/16 FJ 1-1/16 FJ 91 (43's)	2	33	38776	O-RING 3 - 1/4 ID X 3/32 CS	1		
10	46536	HOSE HYD 7/8 FJ 7/8 FJ 15	1	34	46411	FTG HYF 7/8J 1-1/16OR	2		
11	46494	FTG HYD 1-1/16 J 7/8 OR	4	35	46558	FTG EL45 7/8JSW	1		
12	46455	FTG HYD EL 45 1-1/16 JSW	3	**	38206	HOSE WRAP 2.5 ID POLY (54's)	72"		
13	46405	HOSE 1 - 1/16 FJ X 1 - 1/16 FJ 53	1			HOSE WRAP 2.5 ID POLY (43's)	60"		
14	46511	FTG EL 1-1/16 J 7/8 OR	2	A*	80561	HHCS 1/2 - 13 X 1 - 3/4 GR5	2	57	(77)
15	46119	FTG EL 9/16 JSW 9/16 J	2	B	80117	WSHRL 1/2 SPLIT ZN	2	-	-
16	46121	FTG EL 9/16 J 9/16 OR	1	C*	80174	HHSC 3/8 - 16 X 1 GR8 ZN	3	23	(31)
17	46415	HOSE 1-1/16 FJ 1-1/16 FJ 60	1	D	80058	WSHRL 3/8 SPLIT ZN	5	-	-
19	46396	FTG EL 1-1/16 JSW	1	E*	80716	HHCS 3/8 - 16 X 1 - 1/4 GR8 ZN	2	23	(31)
20	46414	FTG STR 3/4 J 9/16 OR	2						
21	38531	MOTOR GEAR 1.48 CIR	1						
22	46410	HOSE 9/16 FJ 3/4 RJ 88"	2						

5.11 Blade

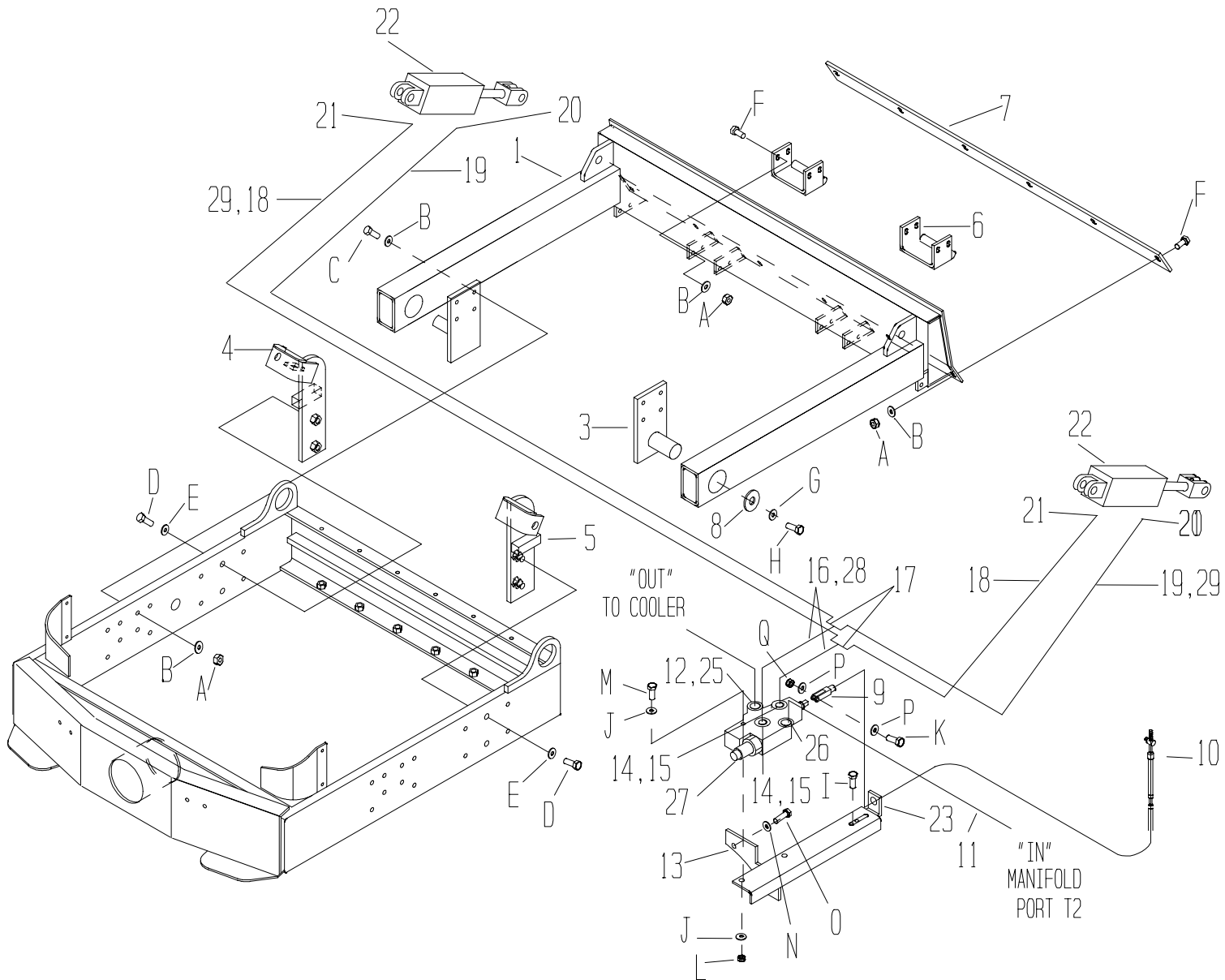

5.11 Blade

Item	Part No.	Description	Qty.	Item	Part No.	Description	Qty.	Torque FT. LBS. (Nm)	
1	29830-2	Blade Weld 43	1	23	42160-2	ADJ Blade Valve	2		
	29820-2	Blade Weld 54	1	25	46462	FTG EL90 7/8 JSW	1		
3	29819-2	Pivot Weld Blade	2	26	46124	FTG STR 7/8 J X 7/8 OR	1		
4	29856-2	Clevis Weld Blade LH	1	27	38526	Valve CONTROL	1		
5	29857-2	Clevis Weld Blade RH	1	28	38828	Hose Wrap 1.5 ID POLY	44"		
6	29846-2	Skid Weld Blade	1	29	38828	Hose Wrap 1.5 ID POLY	44"		
7	29831-2	Lip Wear Blade 43	1	A	80051	NUTNY 1/2 - 13 ZN	22	57	(77)
	29817-2	Lip Wear Blade 54	1	B	80343	WSHR 1/2 SAE ZN	30	-	-
8	29741-2	WSHR 2 - 3/4 ID X 17/32 X 1/4 TH	2	C	80405	HHSC 1/2 - 13 X 2 - 3/4 GR5 ZN	8	57	(77)
9	38561	Clevis 1/4 DIR X 1/4 - 28	1	D	80672	HHCS 3/4 - 10 X 3 GR8 ZN	4	282	(382)
10	38602	Cable F/R	1	E	80671	WSHRL 3/4 SPLIT ZN	4	-	-
11	46489	Hose 7/8 J X 7/8 J 14	1	F	80677	CRBLT 1/2 - 13 X 1 - 1/2 ZN	14	-	-
12	46133	FTG EL 90 7/8 J X 7/8 OR	1	G	80117	WSHRL 1/2 SPLIT ZN	2	-	-
13	42115-2	Mount Weld Blade Valve	1	H	80378	HHCS 1/2 - 13 X 1 GR5 ZN	2	57	(77)
14	46544	FTG EL 45 9/16 J	1	I	80085	HWHTB 5/16 - 18 X 1 ZN	2	18	(18)
15	46490	FTG STR 9/16 J X 3/4 OR	1	J	80348	WSHR 5/16 WROT ZN	4	-	-
16	46528	Hose JSW X 9/16 JSW 48"	2	K	80070	PPHMS 10 - 24 X 1 ZN	1	-	-
17	46388	FTG TEE TUBE 9/16J	2	L	80114	NUTNY 5/16 - 18 ZN	2	-	-
18	46547	Hose 9/16 FJ X 9/16 FJ 60"	2	M*	80170	HHCS 5/16 - 18 X 2 - 1/2 GR5 ZN	2	13	(18)
	46551	Hose 9/16 FJ X 9/16 FJ 56"	-	N	80058	WSHR 3/8 SPLIT ZN	2	-	-
19	46546	Hose 9/16 FJ X 9/16 FJ 70"	2	O*	80088	HHCS 3/8 - 16 X 1 - 1/4 GR8 ZN	2	23	(31)
	46552	Hose 9/16 FJ X 9/16 FJ 66"	-	P	80346	WSHR #10 SAE ZN	2	-	-
20	46120	FTG EL90 9/16 J X 3/8 NPT	2	Q	80693	NUTNY #10 - 24 ZN	1	-	-
21	46369	FTG EL 45 X 3/8 NPT X 9/16 J	2						
22	46444	Cylinder Tie Rod 2 X 8	2						
	44203	Pin Clevis 1"	4						
	44204	RUE RING 1"	4						

REMARK: * Loctite Required

5.12 Hydraulic Schematic

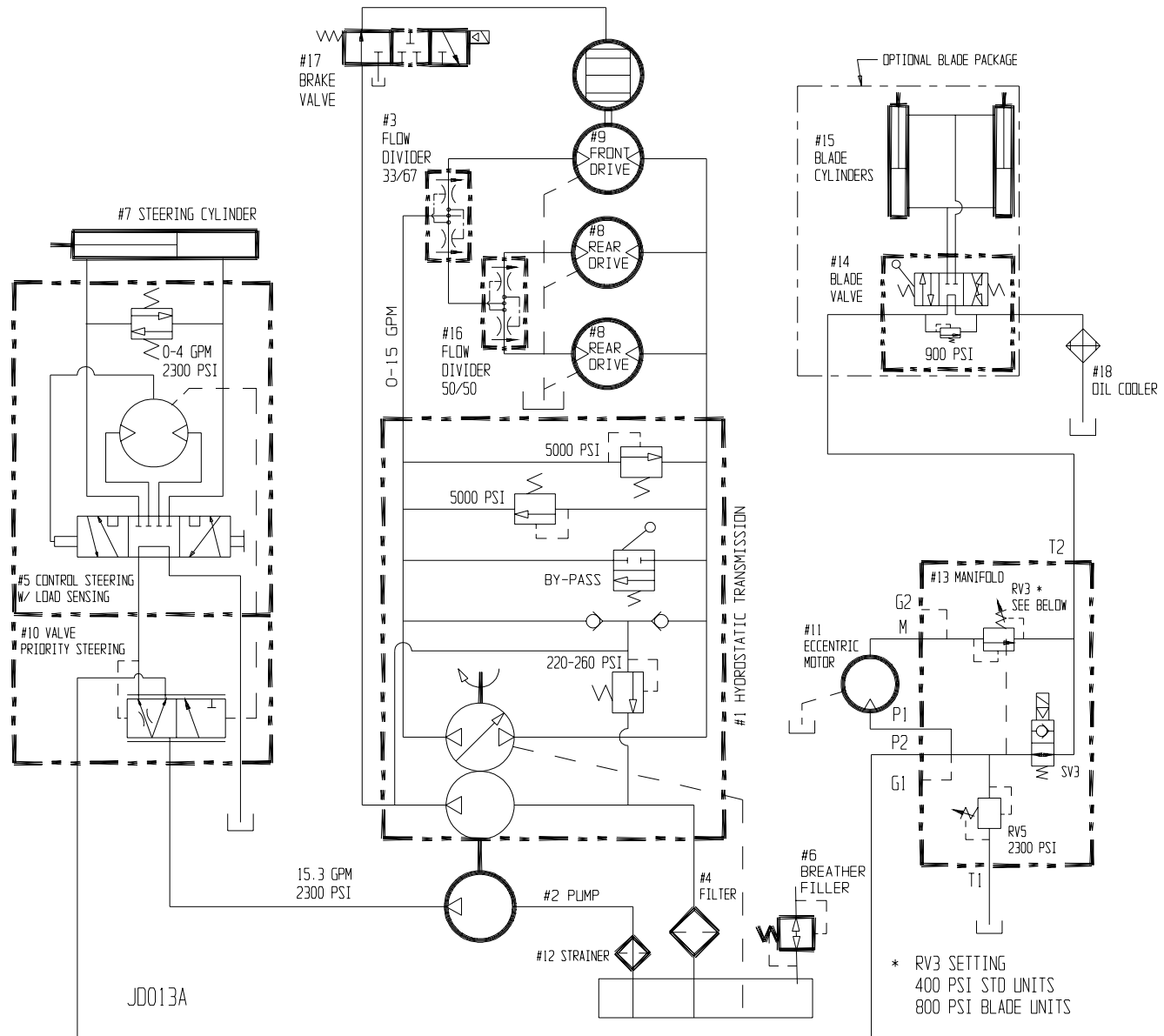

5.12 Hydraulic Schematic

Item	Part No.	Description	Qty.	Item	Part No.	Description	Qty.
1	38522	Transmission Pump	1				
2	38518	Pump Steering Eccentric	1				
3	38523	Flow Divider Combiner 33/67	1				
4	38520	Filter Hydraulic	1				
	38638	Element Filer	1				
5	38524	Control Steering	1				
6	38521	Breather Filler	1				
7	46362	Cylinder Steering 2.5 x 10	1				
8	38528	Wheelmotor Rear	1				
9	38527	Wheelmotor Front with Brake	2				
10	38529	Valve Priority Steering	1				
11	38531	Motor Eccentric	1				
12	35482	Strainer 25GPM	1				
13	38727	Manifold Eccentrics	1				
14	38526	Valve Blade	1				
15	46444	Cylinder Blade 2 x 8	2				
16	38663	Flow Divider Combiner 50/50	1				
17	38689	Valve Brake	1				
18	38446	Cooler Oil	1				

REMARK:

5.13 Wiring

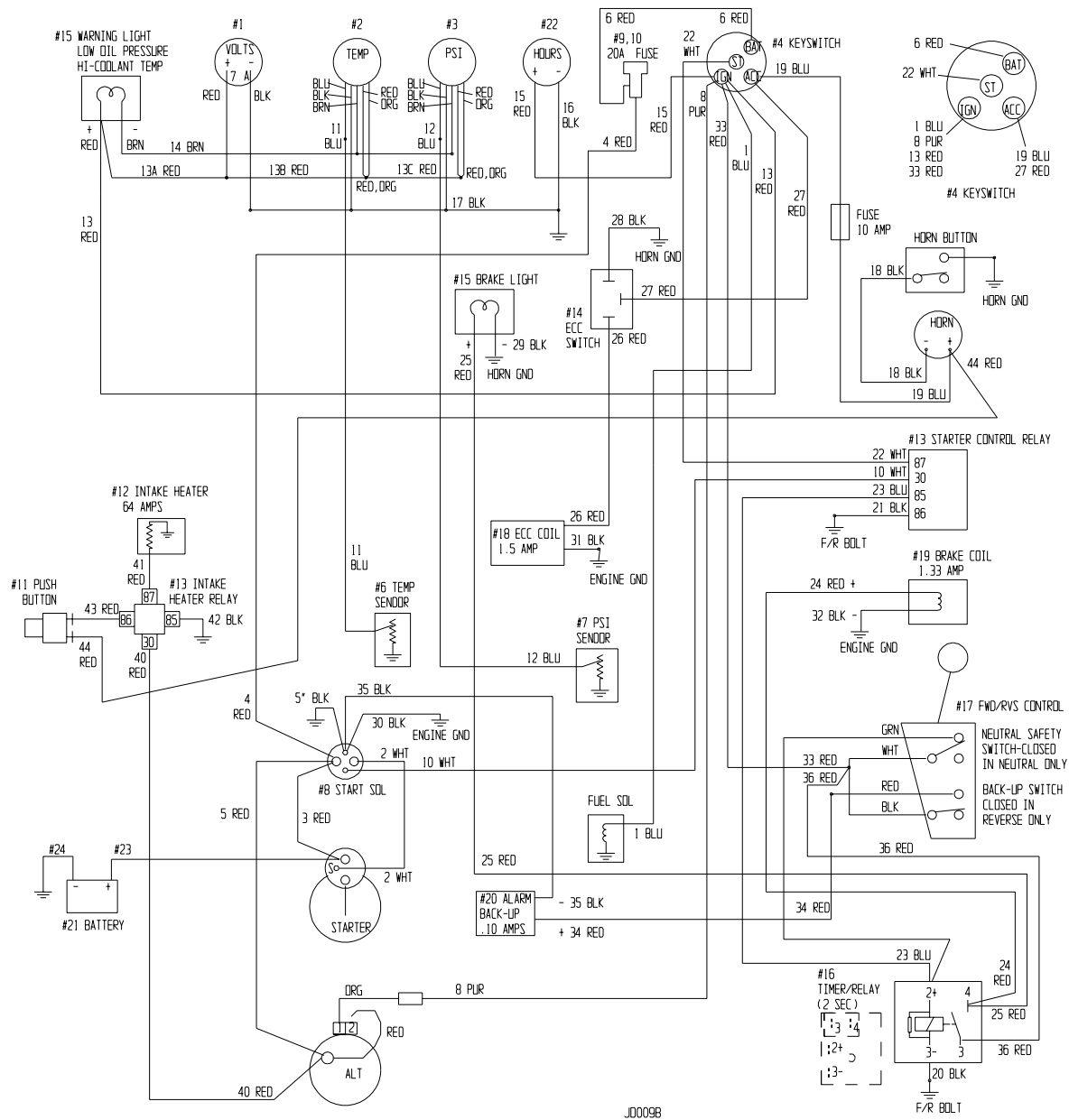

J0009B

5.13 Wiring

Item	Part No.	Description	Qty.
44	RED 14 22	PUSH BUTTON #8 RING HORN +	SEE #19
43	RED 14 120	INTAKE RELAY 86 FEM PUSH-ON PUSH BUTTON	#8 RING
42	BLK 16 10	INTAKE RELAY 85 FEM PUSH-ON	GROUND (AT F/R)
41	RED 10 14.5	INTAKE RELAY 87 FEM PUSH-ON	INTAKE HEATER
40	RED 10 11.5	INTAKE RELAY 30 FEM PUSH-ON	ALT OUTPUT
36	RED 16 9	TIMER/RELAY 2ND #3 FEM PUSH-ON	NEUT SWITCH
35	BLACK 18 38	BACK-UP ALARM - #6 RING	GROUND (STARTER RELAY)
34	RED 18 94.5	NEUT SWITCH RED MALE PUSH-ON	BACK-UP ALARM +
33	RED 14 81.5	KEYSWITCH IGN #10 RING	NEUT SWITCH FEM PUSH-ON
32	BLACK 16 47.5	BRAKE SOL - FEM PUSH-ON	ENGINE GROUND
31	BLACK 14 29	ECC SOL - FEM PUSH-ON	
30	BLACK 12 19	STARTER RELAY GND	1/4 RING
29	BLACK 18 26	BRAKE LIGHT GND FEM PUSH-ON	GROUND (HORN MTG BOLT)
28	BLACK 18 26	ECC SWITCH FEM PUSH-ON	
27	RED 16 31	KEYSWITCH ACC #10 RING	ECC SWITCH
26	RED 16 88	ECC SOL + MALE PUSH-ON	ECC SWITCH
25	RED 16 76.5	TIMER/RELAY 4 PIGGYBACK	BRAKE LIGHT +
24	RED 16 52	TIMER/RELAY 4 PIGGYBACK	BRAKE SOL +
23	BLUE 16 7	TIMER/RELAY 2+ PIGGYBACK	STARTER CONT RELAY 85
22	WHITE 14 87.5	KEYSWITCH "ST" #10 RING	STARTER CONT RELAY 87
21	BLACK 16 7	STARTER CONT RELAY 86 FEM PUSH-ON	GROUND (F/R BOLT)
20	BLACK 16 7	TIMER/RELAY 3- FEM PUSH-ON	
19	BLUE 16 22	KEYSWITCH "ACC" #10 RING	HORN +
18	BLACK 16 29	HORN RELAY WIRE MALE BULLET	HORN -
17	BLACK 16 20	PRESSURE & TEMP. GAUGE BLACK WIRES	BUTT CONN
16	BLACK 16 16	HOURLMETER - FEM PUSH-ON	GROUND (HORN MTG BOLT)
15	RED 16 9	KEYSWITCH "IGN" #10 RING	
14	BROWN 14 -	WARNING LIGHT - FEM PUSH-ON	COOLANT & PSI BRN WIRE
13C	RED -- --	COOLANT RED & DRG WIRE	PRESSURE RED & DRG WIRE
13B	RED -- --	COOLANT RED & DRG WIRE	BUTT CONN
13A	RED -- --	WARNING LIGHT FEM PUSH-ON	VOLTMETER +
13	RED 12 31	KEYSWITCH "ACC" #10 RING	WARNING LIGHT +
12	BLUE 18 97	DIL PSI SENDOR FEM PUSH-ON	DIL PSI GAUGE
11	BLUE 18 96	COOLANT SENDOR FEM PUSH-ON	COOLANT GAUGE
10	WHITE 14 75	STARTER RELAY (BTM) #10 RING	STARTER CONT RELAY 30
8	PURPLE 16 120	ALTERNATOR PACKARD 2965142 2984958	KEYSWITCH "IGN" #10 RING
6	RED 10 8.5	KEY SWITCH "BAT" #10 RING	FUSEHOLDER "SIDE" FEM PUSH-ON
5	RED 10 35	STARTER RELAY 5/16 RING	ALT OUTPUT
4	RED 10 113	STARTER RELAY 5/16 RING	FUSE HOLDER "END" FEM PUSH-ON
3	RED 10 28	STARTER RELAY 5/16 RING	STARTER "BAT" 3/8 RING
2	WHITE 12 35	STARTER RELAY 5/16 RING	STARTER "S" #10 RING
1	BLUE 14 103	FUEL SOLENOID #10 RING	KEYSWITCH "IGN" #10 RING
WIRE	COLOR GAUGE LENGTH	FROM/TERMINAL	TO/TERMINAL

Item	Part No.	Description	Qty.
1	39609	Volt Meter	1
2	39611	Gage Temp	1
3	39610	Gage Oil PSI	1
4	39607	Key Switch	1
5	48406	Harness Wire	1
6	39599	Sendor Temp	1
7	39598	Sendor Oil PSI	1
8	39608	Relay Starter	1
9	38711	Holder Fuse	1
10	36313	Fuse 20A	1
11	39612	Push Button	1
12	39592	Intake Heater	1
13	48401	Relay 70 Amp	2
14	39653	Switch Eccentric	1
15	48393	Light 12V Red	2
16	48399	Relay Timer 2 Sec	1
17	39097	Control Fwd/Revs	1
18	39638	Coil Eccentric Valve	1
19	39639	Coil Brake Valve	1
20	38559	Alarm back-up	1
21	38519	Battery 24F 800CCA	1
22	36268	Hourmeter	1
23	48404	Cable Battery Red 21"	1
24	48405	Cable Battery Blk	23.4"

JDO10A

REMARK:

5.14 Decal Identification

1

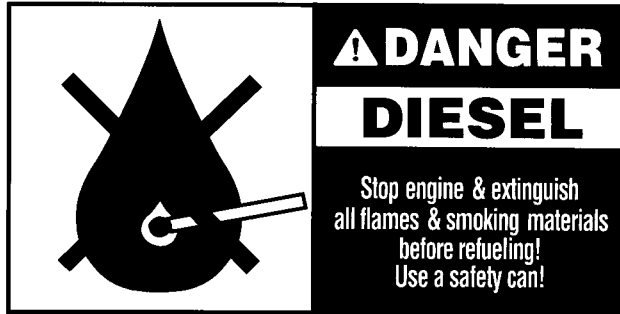

2



3



5

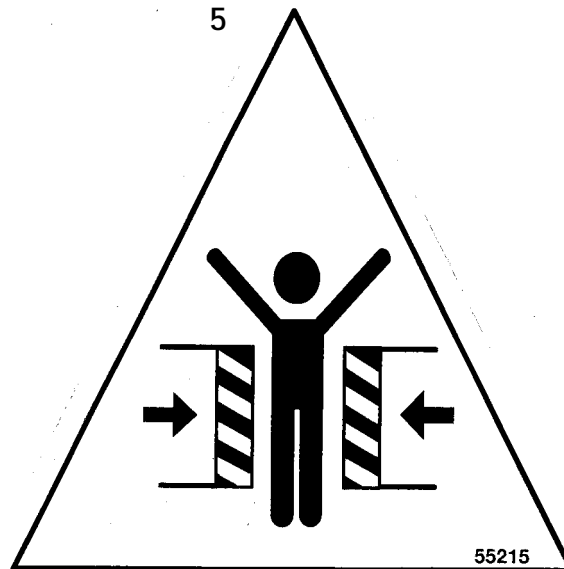

4



5.14 Decal Identification

Item	Part No.	Description	Qty.	Item	Part No.	Description	Qty.
1	55148	DECAL WARNING DIESEL	1				
2	55149	DECAL EAR PROTECTION	1				
3	55204	DECAL TANK LOGOS	2				
4	55212	DECAL TIE DOWN ONLY	4				
5	55215	DECAL WARNING PINCH POINT	2				
#	55165	INSTRUCTIONS HYD FILTER	1				
#	55201	DECAL STONE EAGLE 21-1/2	2				
#	55381	DECAL MAINT CHART RHINO	1				
#	55213	DECAL RHINO DASH	1				
#	55211	DECAL BACK-UP ALARM	1				
#	55374	DECAL COWL STRIPES	1				
#	55395	DECAL GREASE WEEKLY	1				
#	55206	DECAL CONTROL F/R	1				
#	55207	DECAL THROTTLE	1				
#	55422	DECAL HYDRAULIC FLUID	1				
#	55367	DECAL INSTRUMENT	1				

5.14 Decal Identification Cont'd.

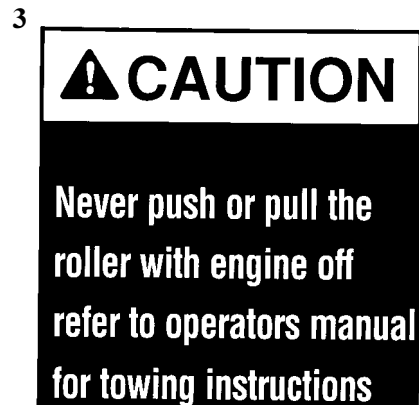
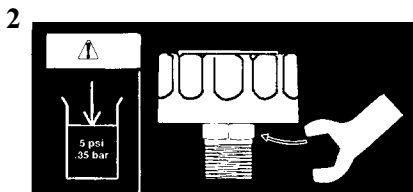
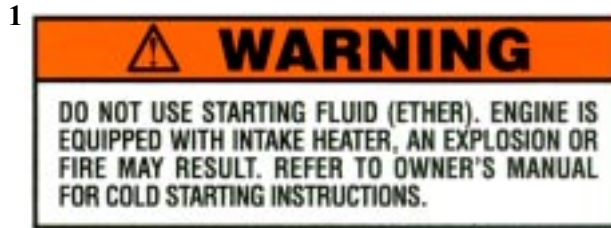

55217



5.14 Decal Identification Cont'd.

Item	Part No.	Description	Qty.	Item	Part No.	Description	Qty.
1	55366	DECAL SET WARNINGS (Includes 5 decals listed below)	1				
	55369	Decal Cold Starting Instructions					
	55370	Decal Intake Heater Button					
	55371	Decal Warning Hot Surfaces					
	55372	Decal Warning No Ether					
	55373	Decal Warning Tipover					
2	55416	Decal Hydraulic Breather Removal	1				
3	55217	Decal Rhino Towing	1				
#	55209	Decal Maintenance Chart	1				