



READ THIS MANUAL CAREFULLY!
It contains important safety information.

OWNER'S MANUAL

Raptor
YFM80RV

⚠ WARNING

This ATV should not be ridden by anyone under 12 years of age.

LIT-11626-19-64

5TH-28199-15

⚠ WARNING

The engine exhaust from this product contains chemicals known to the State of California to cause cancer, birth defects or other reproductive harm.

YAMAHA

LIT-CALIF-65-01

INTRODUCTION

Congratulations on your purchase of the Yamaha YFM80R. It represents the result of many years of Yamaha experience in the production of fine sporting, touring, and pacesetting racing machines. With the purchase of this Yamaha, you can now appreciate the high degree of craftsmanship and reliability that have made Yamaha a leader in these fields.

This manual will provide you with a good basic understanding of the features and operation of this machine.

This manual includes important safety information. It provides information about special techniques and skills necessary to ride your machine.

It also includes basic maintenance and inspection procedures. If you have any questions regarding the operation or maintenance of your machine, please consult a Yamaha dealer.

AN IMPORTANT SAFETY MESSAGE:

- READ THIS MANUAL TOGETHER WITH TIPS FOR THE ATV RIDER CAREFULLY AND COMPLETELY BEFORE OPERATING YOUR MACHINE. MAKE SURE YOU UNDERSTAND ALL INSTRUCTIONS.
- PAY CLOSE ATTENTION TO THE WARNING AND CAUTION LABELS ON THE MACHINE.
- NEVER OPERATE AN ATV WITHOUT PROPER TRAINING OR INSTRUCTION. FREE TRAINING IS AVAILABLE TO ANYONE WHO BUYS A NEW ATV. CALL 1-800-887-2887 FOR MORE INFORMATION.
- THIS ATV, AND ANY OTHER ATV OVER 70cc, SHOULD NOT BE OPERATED BY A CHILD UNDER 12 YEARS OF AGE.

AN IMPORTANT NOTE TO PARENTS:

This ATV is not a toy. Before you let your child ride this ATV, you should understand the instructions and warnings in this Owner's Manual. Then be sure your child understands and will follow them. Children differ in skills, physical abilities and judgment. Some children may not be able to operate an ATV safely. Parents should supervise their child's use of the ATV at all times. Parents should permit continued use only if they determine that the child has the ability to operate the ATV safely.

Your ATV was delivered with an adjustable speed limiter and also with an air intake restrictor plate. Yamaha recommends that all beginners start off with the speed limiter screw turned in and the air intake restrictor plate installed to limit the amount of speed available while they learn. The limiter screw may be gradually turned out to increase maximum speed as the beginner becomes more familiar with operating the ATV. Parents should decide when to adjust the ATV for more power as their youngster's riding skills improve. Once the ATV rider can operate with skill at the top speed permitted by adjusting the speed limiter alone, the air intake restrictor plate can be removed. Since removal of this plate will result in a significant increase in power, turn the speed limiter back in again; adjust it out in stages as you did before.

If your child is a beginner or is inexperienced, he or she should take a training course. See the previous page for information about the free training available to purchasers of new ATVs.

IMPORTANT MANUAL INFORMATION

FAILURE TO FOLLOW THE WARNINGS CONTAINED IN THIS MANUAL CAN RESULT IN SERIOUS INJURY OR DEATH.

Particularly important information is distinguished in this manual by the following notations:



**The Safety Alert Symbol means ATTENTION! BECOME ALERT!
YOUR SAFETY IS INVOLVED!**



Failure to follow WARNING instructions could result in severe injury or death to the machine operator, a bystander or a person inspecting or repairing the machine.

CAUTION:

A CAUTION indicates special precautions that must be taken to avoid damage to the machine.

NOTE:

A NOTE provides key information to make procedures easier or clearer.

IMPORTANT NOTICE

This ATV is designed and manufactured for OFF-ROAD use only. It is illegal and unsafe to operate this ATV on any public street, road or highway.

This ATV complies with all applicable OFF-ROAD noise level and spark arrester laws and regulations in effect at the time of manufacture.

Please check your local riding laws and regulations before operating this ATV.

EBU13330



YFM80RV
OWNER'S MANUAL
©2005 by Yamaha Motor Corporation, U.S.A.
1st edition, June 2005
All rights reserved.
Any reprinting or unauthorized use
without the written permission
of Yamaha Motor Corporation,
U.S.A.
is expressly prohibited.
Printed in Japan.
P/N LIT-11626-19-64

⚠️ WARNING

Indicates a potential hazard that could result in serious injury or death.

CONTENTS

1	LOCATION OF THE WARNING AND SPECIFICATION LABELS	1-1	Speed limiter	4-4	
2	SAFETY INFORMATION	2-1	Front brake lever	4-5	
3	DESCRIPTION AND MACHINE IDENTIFICATION.....	3-1	Brake pedal and rear brake lever	4-5	
	Identification number records	3-2	Parking brake	4-6	
	Key identification number	3-2	Shift pedal	4-8	
	Vehicle identification number	3-3	Fuel tank cap	4-8	
	Model label	3-3	Fuel cock	4-9	
4	CONTROL FUNCTIONS.....	4-1	Choke lever	4-10	
	Main switch.....	4-1	Seat	4-10	
	Indicator lights	4-1	5	PRE-OPERATION CHECKS.....	5-1
	Handlebar switches	4-2		Front and rear brakes	5-2
	Throttle lever	4-3		Fuel	5-3
				Engine oil.....	5-5
				Final gear oil.....	5-5
				Throttle lever	5-6
				Tires	5-6

How to measure tire pressure	5-7
Tire wear limit	5-8
Fittings and fasteners	5-9
Switches	5-9
Battery	5-9

6 OPERATION	6-1
Starting a cold engine	6-1
Starting a warm engine	6-3
Warming up	6-3
Shifting	6-4
To start out and accelerate	6-4
To decelerate	6-5
Engine break-in	6-6
Parking	6-7
Parking on a slope	6-8
Accessories and loading	6-9

7 Riding Your ATV	7-1
Getting to know your ATV	7-3
Ride with care and good judgement	7-4

Be careful where you ride	7-16
Turning your ATV	7-23
Climbing uphill	7-25
Riding downhill	7-30
Crossing a slope	7-32
Crossing through shallow water	7-34
Riding over rough terrain	7-36
Sliding and skidding	7-38
What to do if	7-40
What to do	7-40

8 PERIODIC MAINTENANCE AND ADJUSTMENT	8-1
Owner's manual and tool kit	8-1
Periodic maintenance chart for the emission control system	8-3
General maintenance and lubrication chart	8-4
Engine oil	8-6
Final gear oil	8-8
Spark plug inspection	8-10
Air filter cleaning	8-11

Air intake restrictor plate removal	8-14
Spark arrester cleaning	8-15
Carburetor adjustment.....	8-17
Idle speed adjustment	8-17
Valve clearance adjustment	8-18
Cam chain adjustment.....	8-18
Front and rear brake shoe inspection	8-18
Front brake lever free play adjustment	8-19
Rear brake lever and pedal adjustment	8-21
Clutch adjustment.....	8-24
Cable inspection and lubrication	8-25
Brake and shift pedal/brake lever lubrication	8-25
Knuckle shaft and steering shaft lubrication	8-26
Wheel removal	8-26
Wheel installation	8-26
Battery	8-27
Replenishing the battery fluid	8-29

Fuse replacement.....	8-30
Troubleshooting.....	8-31
Troubleshooting chart.....	8-32

9 CLEANING AND STORAGE	9-1
A. Cleaning	9-1
B. Storage	9-3
10 SPECIFICATIONS	10-1
11 NOISE REGULATION	11-1
12 MAINTENANCE RECORD.....	12-1
13 ATV LIMITED WARRANTY.....	13-1
14 YAMAHA EXTENDED SERVICE (Y.E.S.).....	14-1

LOCATION OF THE WARNING AND SPECIFICATION LABELS

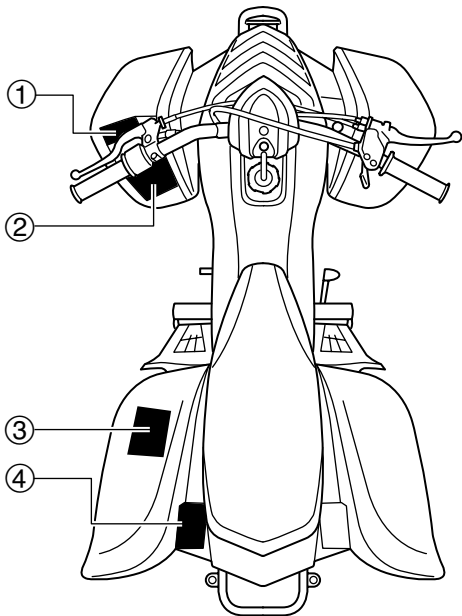

Read and understand all of the labels on your machine. They contain important information for safe and proper operation of your ATV.

Never remove any labels from your ATV. If a label becomes difficult to read or comes off, a replacement label is available from your Yamaha dealer.

①

⚠ WARNING



Operating this ATV if you are under the age of **12** increases your chance of severe injury or death.

Adult supervision required for children under age **16**.

NEVER permit children under age **12** to operate this ATV.

4EM-21697-31

1

②

⚠ WARNING

Improper ATV use can result in SEVERE INJURY or DEATH.



ALWAYS USE AN APPROVED HELMET AND PROTECTIVE GEAR

NEVER USE ON PUBLIC ROADS

NEVER CARRY PASSENGERS

NEVER USE WITH DRUGS OR ALCOHOL

NEVER operate :

- without proper training or instruction.
- at speeds too fast for your skills or the conditions.
- on public roads-a collision can occur with another vehicle.
- with a passenger-passengers affect balance and steering and increase risk of losing control.

ALWAYS :

- use proper riding techniques to avoid vehicle overturns on hills and rough terrain and it turns.
- avoid paved surfaces-pavement may seriously affect handling and control.

LOCATE AND READ OWNER'S MANUAL. FOLLOW ALL INSTRUCTIONS AND WARNINGS.

5FE-21568-11

③

⚠ WARNING

**IMPROPER TIRE PRESSURE OR OVERLOADING CAN CAUSE LOSS OF CONTROL.
LOSS OF CONTROL CAN RESULT IN SEVERE INJURY OR DEATH.**

OPERATING TIRE PRESSURE: Set with tires cold

- Recommended : FRONT : 20 kPa, {0.20 kgf/cm²} 2.9 psi
REAR : 20 kPa, {0.20 kgf/cm²} 2.9 psi
- Minimum : FRONT : 17 kPa, {0.17 kgf/cm²} 2.5 psi
REAR : 17 kPa, {0.17 kgf/cm²} 2.5 psi
- Never set tire pressure below minimum.
It could cause the tire to dislodge from the rim.

LOADING

- Maximum Vehicle Load : 95 kg, (209 lbs).
Includes weight of operator, cargo and accessories.

4EM-21696-11

④

⚠ WARNING

NEVER ride as a passenger.



Passengers can cause a loss of control, resulting in SEVERE INJURY or DEATH.

5FE-2151H-01



SAFETY INFORMATION

AN ATV IS NOT A TOY AND CAN BE HAZARDOUS TO OPERATE. An ATV handles differently from other vehicles including motorcycles and cars. A collision or rollover can occur quickly, even during routine maneuvers such as turning and riding on hills or over obstacles, if you fail to take proper precautions.

SEVERE INJURY OR DEATH can result if you do not follow these instructions:

- Read this manual and all labels carefully and follow the operating procedures described.
- Never operate an ATV without proper training or instruction. **Take a Training Course.** Beginners should receive training from a certified instructor. Contact an authorized ATV dealer or call 1-800-887-2887 to find out about the training courses nearest you.
- Always follow the age recommendation:
 - A child under 12 years old should never operate an ATV with engine size greater than 70cc.
 - A child under 16 years old should never operate an ATV with engine size greater than 90cc.
- Never allow a child under age 16 to operate an ATV without adult supervision, and never allow continued use of an ATV by a child if he or she does not have the abilities to operate it safely.
- Never carry a passenger on an ATV.

- Always avoid operating an ATV on any paved surfaces, including sidewalks, driveways, parking lots and streets.
- Never operate an ATV on any public street, road or highway, even a dirt or gravel one.
- Never operate an ATV without wearing an approved motorcycle helmet that fits properly. You should also wear eye protection (goggles or face shield), gloves, boots, long-sleeved shirt or jacket, and long pants.
- Never consume alcohol or drugs before or while operating this ATV.
- Never operate at speeds too fast for your skills or the conditions. Always go at a speed that is proper for the terrain, visibility and operating conditions, and your experience.
- Never attempt wheelies, jumps, or other stunts.
- Always inspect your ATV each time you use it to make sure it is in safe operating condition. Always follow the inspection and maintenance procedures and schedules described in this manual.
- Always keep both hands on the handlebars and both feet on the footrests of the ATV during operation.
- Always go slowly and be extra careful when operating on unfamiliar terrain. Always be alert to changing terrain conditions when operating the ATV.

- Never operate on excessively rough, slippery or loose terrain until you have learned and practiced the skills necessary to control the ATV on such terrain. Always be especially cautious on these kinds of terrain.
- Always follow proper procedures for turning as described in this manual. Practice turning at low speeds before attempting to turn at faster speeds. Do not turn at excessive speed.
- Never operate the ATV on hills too steep for the ATV or for your abilities. Practice on smaller hills before attempting larger hills.
- Always follow proper procedures for climbing hills as described in this manual. Check the terrain carefully before you start up any hill. Never climb hills with excessively slippery or loose surfaces. Shift your weight forward. Never open the throttle suddenly or make sudden gear changes. Never go over the top of a hill at high speed.
- Always follow proper procedures for going down hills and for braking on hills as described in this manual. Check the terrain carefully before you start down any hill. Shift your weight backward. Never go down a hill at high speed. Avoid going down a hill at an angle that would cause the vehicle to lean sharply to one side. Go straight down the hill where possible.
- Always follow proper procedures for crossing the side of a hill as described in this manual. Avoid hills with excessively slippery or loose surfaces. Shift your weight to the uphill side of the ATV. Never attempt to turn the ATV around on any hill until you have mastered the turning technique described in this manual on level ground. Avoid crossing the side of a steep hill if possible.

- Always use proper procedures if you stall or roll backwards when climbing a hill. To avoid stalling, use proper gear and maintain a steady speed when climbing a hill. If you stall or roll backwards, follow the special procedure for braking described in this manual. Dismount on the uphill side or to a side if pointed straight uphill. Turn the ATV around and remount, following the procedure described in this manual.
- Always check for obstacles before operating in a new area.
Never attempt to operate over large obstacles, such as large rocks or fallen trees. Always follow proper procedures when operating over obstacles as described in this manual.
- Always be careful when skidding or sliding. Learn to safely control skidding or sliding by practicing at low speeds and on level, smooth terrain. On extremely slippery surfaces, such as ice, go slowly and be very cautious in order to reduce the chance of skidding or sliding out of control.
- Never operate an ATV in fast flowing water or in water deeper than that recommended in this manual. Remember that wet brakes may have reduced stopping ability. Test your brakes after leaving water. If necessary, apply them several times to let friction dry out the linings.
- Always use the size and type tires specified in this manual. Always maintain proper tire pressure as described in this manual.
- Never modify an ATV through improper installation or use of accessories.

- Never exceed the stated load capacity for an ATV. Cargo should be properly distributed and securely attached. Reduce speed and follow instructions in this manual for carrying cargo or pulling a trailer. Allow greater distance for braking.

FOR MORE INFORMATION ABOUT ATV SAFETY, call the Consumer Products Safety Commission at 1-800-638-2772, or the ATV Distributor's Safety Hotline at 1-800-852-5344.

WARNING

POTENTIAL HAZARD

Improper handling of gasoline.

WHAT CAN HAPPEN

Gasoline can catch fire and you could be burned.

HOW TO AVOID THE HAZARD

Always turn off the engine when refueling. Do not refuel right after the engine has been running and is still very hot.

Do not spill gasoline on the engine or exhaust pipe/muffler when refueling. Never refuel while smoking, or while in the vicinity of sparks, open flames, or other sources of ignition such as the pilot lights of water heaters and clothes dryers.

When transporting the ATV in another vehicle, be sure it is kept upright and that the fuel cock is in the “OFF” position. Otherwise, fuel may leak out of the carburetor or fuel tank.

WHAT CAN HAPPEN

Gasoline is poisonous and can cause injuries.

HOW TO AVOID THE HAZARD

If you should swallow some gasoline or inhale a lot of gasoline vapor, or get some gasoline in your eyes, see your doctor immediately.

If gasoline spills on your skin, wash with soap and water. If gasoline spills on your clothing, change your clothes.

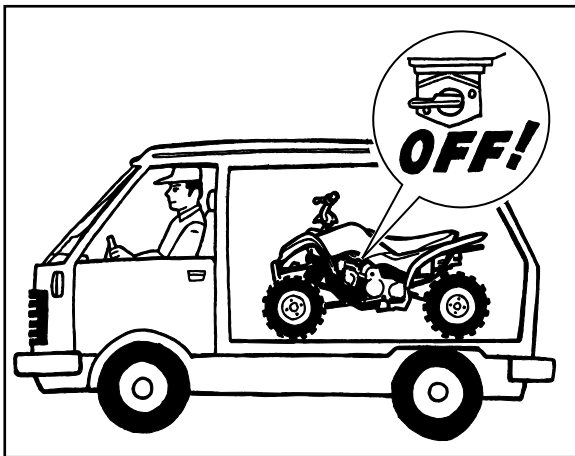

⚠ WARNING

POTENTIAL HAZARD

Starting or running the engine in a closed area.

WHAT CAN HAPPEN

Exhaust fumes are poisonous and may cause loss of consciousness and death within a short time.

HOW TO AVOID THE HAZARD

Always operate your ATV in an area with adequate ventilation.

DESCRIPTION AND MACHINE IDENTIFICATION

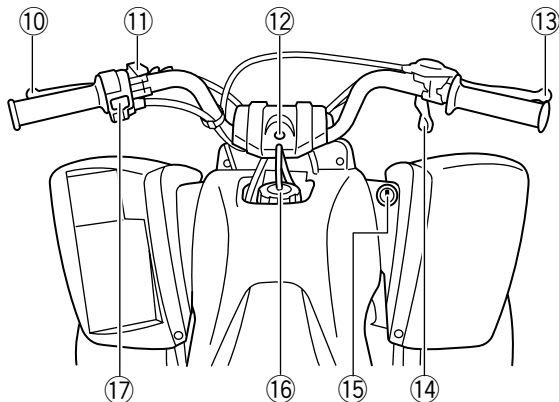
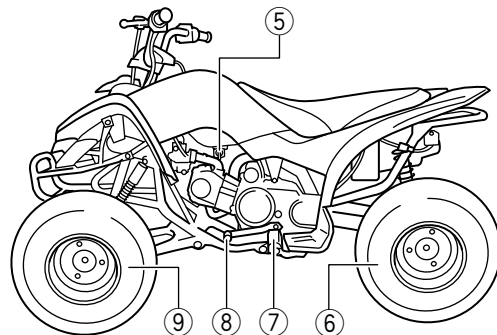
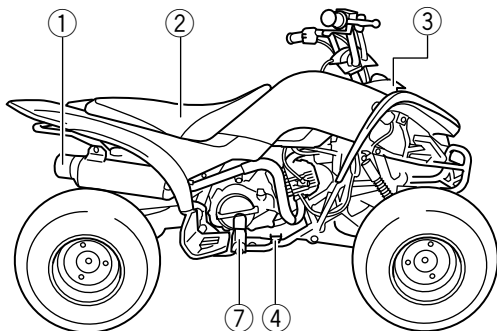

- | | |
|-------------------|-----------------------------|
| 1. Spark arrester | 10. Rear brake lever |
| 2. Seat | 11. Parking brake |
| 3. Front cover | 12. Neutral indicator light |
| 4. Brake pedal | 13. Front brake lever |
| 5. Fuel cock | 14. Throttle lever |
| 6. Rear wheel | 15. Main switch |
| 7. Footrest | 16. Fuel tank cap |
| 8. Shift pedal | 17. Handlebar switches |
| 9. Front wheel | |

NOTE:

The machine you have purchased may differ slightly from those shown in the figures of this manual.

Identification number records

Record the key identification number, vehicle identification number and model label information in the spaces provided for assistance when ordering spare parts from a Yamaha dealer or for reference in case the vehicle is stolen.

1. KEY IDENTIFICATION NUMBER:

2. VEHICLE IDENTIFICATION NUMBER:

3. MODEL LABEL INFORMATION:

Key identification number

The key identification number is stamped on the key as shown in the following illustration. This number can be used for ordering a new key.

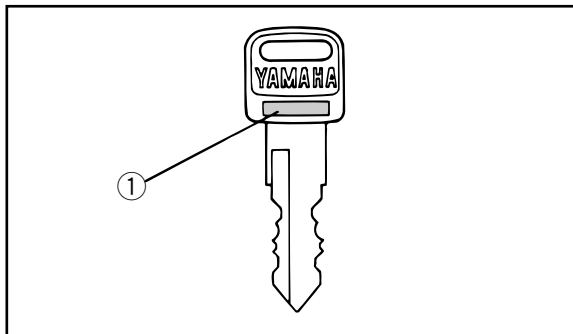

1. Key identification number

Vehicle identification number

The vehicle identification number is stamped into the frame.

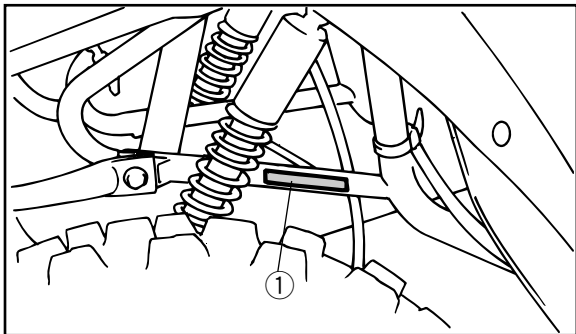

1. Vehicle identification number

NOTE:

The vehicle identification number is used to identify your machine.

Model label

The model label is affixed to the location in the illustration. Record the information on this label in the space provided. This information will be needed to order spare parts from your Yamaha dealer.

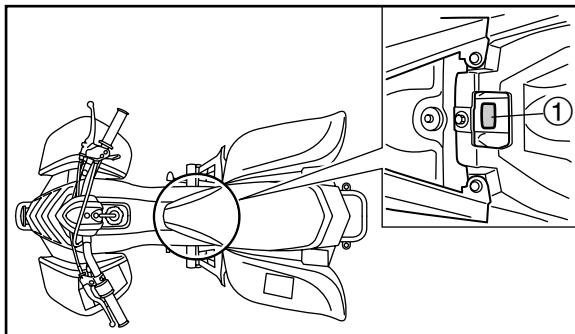

1. Model label

CONTROL FUNCTIONS

⚠ WARNING

Indicates a potential hazard that could result in serious injury or death.

Main switch

Functions of the respective switch positions are as follows:

ON:

The engine can be started only at this position.

OFF:

All electrical circuits are switched off. The key can be removed in this position.

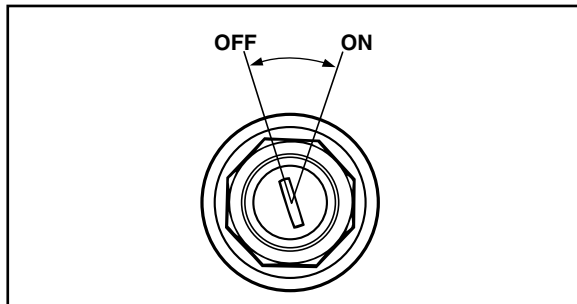

Indicator lights

Neutral indicator light "N"

This indicator light comes on when the transmission is in neutral.

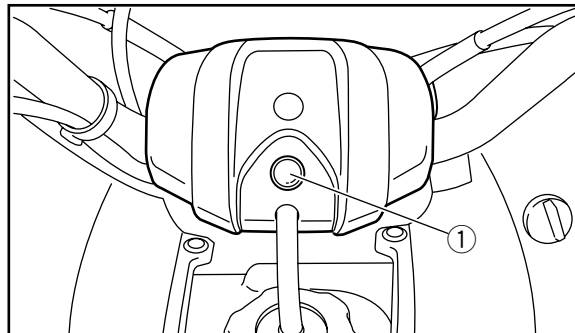

1. Neutral indicator light "N"

Handlebar switches

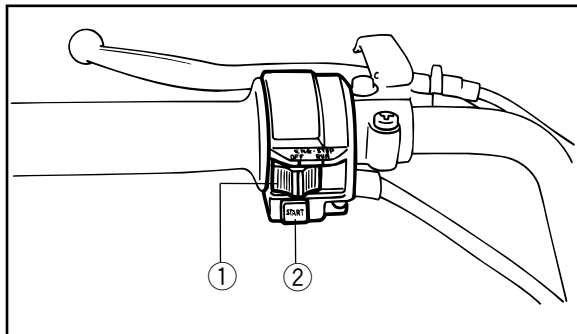

1. Engine stop switch “ENG. STOP”
2. Start switch “START”

Engine stop switch “ENG. STOP”

Make sure that the engine stop switch is in the “RUN” position before starting the engine. The engine stop switch controls ignition and can be used at all times to stop the engine, especially in an emergency. The engine will not start or run when the engine stop switch is turned to “OFF”.

Start switch “START”

The starter motor cranks the engine when this switch is pushed.

CAUTION:

See starting instructions prior to starting engine (see page 6-1 for details).

NOTE:

If the starter switch is pushed with the main switch “ON” and the engine stop switch “OFF”, the starter motor will be activated but the engine will not start. To start the engine, be sure to position the engine stop switch at “RUN”.

Throttle lever

Once the engine is running, movement of the throttle lever will increase the engine speed.

Regulate the speed of the machine by varying the throttle position. Because the throttle is spring-loaded, the machine will decelerate, and the engine will return to an idle any time the hand is removed from the throttle lever.

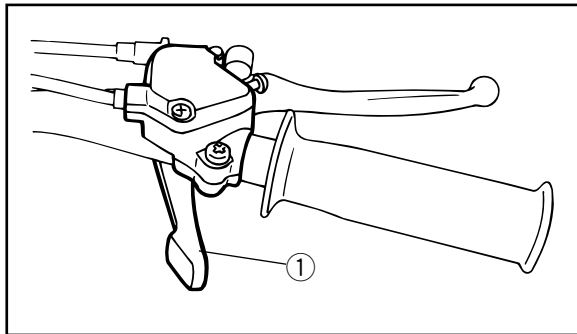

1. Throttle lever

Before starting the engine, check the throttle to be sure it is operating smoothly. Make sure it returns to the idle position as soon as the lever is released.

⚠ WARNING

POTENTIAL HAZARD

Malfunction of throttle.

WHAT CAN HAPPEN

The throttle could be hard to operate, making it difficult to speed up or slow down when you need to. This could cause an accident.

HOW TO AVOID THE HAZARD

Check the operation of the throttle lever before you start the engine. If it does not work smoothly, check for the cause. Correct the problem before riding the ATV. Consult a Yamaha dealer if you can't find or solve the problem yourself.

Speed limiter

The speed limiter keeps the throttle from fully opening, even when the throttle lever is pushed to the maximum. Screwing in the adjuster limits the maximum engine power available and decreases the maximum speed of the ATV.

Your ATV was delivered with an adjustable speed limiter and also with an air intake restrictor plate. Yamaha recommends that all beginning riders start off with the speed limiter screw turned in and the air intake restrictor plate installed to limit the amount of speed available while they learn. The limiter screw may be gradually turned out to increase maximum speed as the beginner becomes more familiar with operating the ATV. Parents should decide when to adjust the ATV for more power as their youngster's riding skills improve. Once the ATV rider can operate with skill at the top speed permitted by adjusting the speed limiter alone, the air intake restrictor plate can be removed. Since

removal of this plate will result in a significant increase in power, turn the speed limiter completely back in again; adjust it out in stages as you did before.

Adjusting for maximum throttle lever movement without removing the air intake restrictor plate will cause the engine to run roughly at higher speeds.

For air intake restrictor plate removal instructions, see page 8-14.

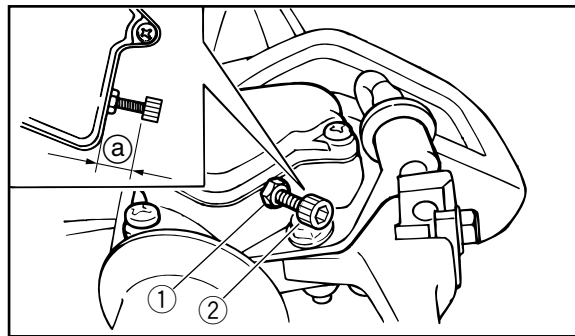

1. Locknut 2. Adjuster a. No more than 20 mm (0.8 in)

WARNING

POTENTIAL HAZARD

Improper adjustment of the speed limiter and throttle.

WHAT CAN HAPPEN

The throttle cable could be damaged. Improper throttle operation could result. You could lose control, have an accident or be injured.

HOW TO AVOID THE HAZARD

Do not turn the speed adjuster out more than 20 mm (0.8 in).

EBU00070

Front brake lever

The front brake lever is located on the right handlebar. Pull it toward the handlebar to apply the front brake.

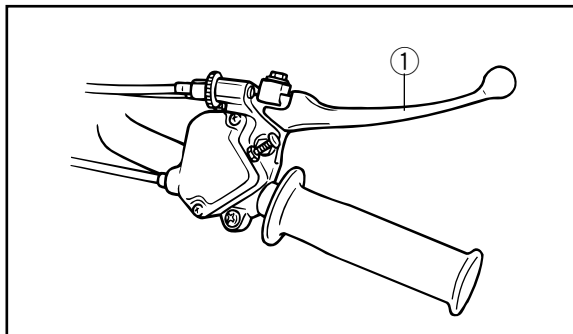

1. Front brake lever

EBU00732

Brake pedal and rear brake lever

The brake pedal is located on the right side of the ATV and the rear brake lever is located on the left handlebar. Push down on the pedal or pull the lever toward the handlebar to apply the rear brake.

Parking brake

Use the parking brake when you have to start the engine or park the machine, especially on a slope. Apply the rear brake lever and push down the lock plate to apply the parking brake. Squeeze the rear brake lever to release the parking brake.

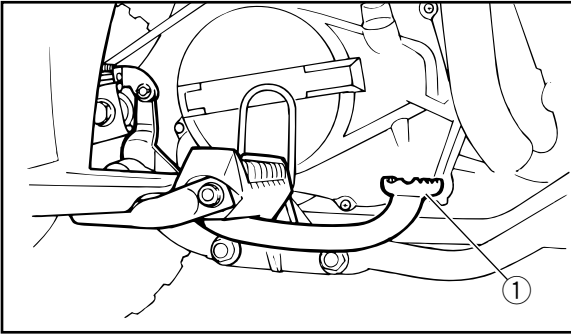

1. Brake pedal

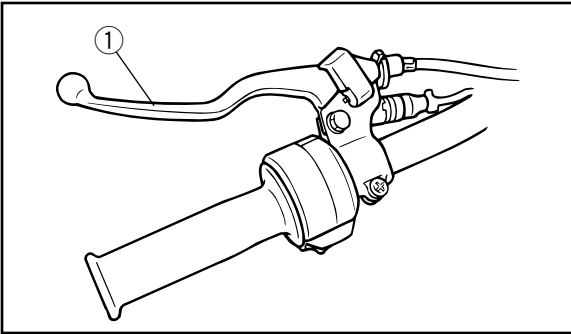

1. Rear brake lever

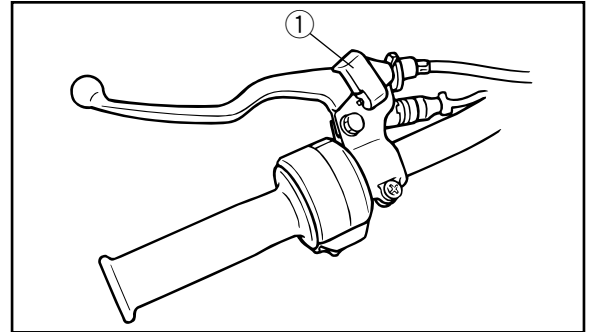

1. Lock plate

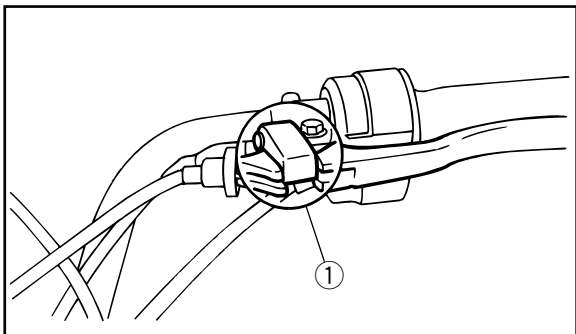
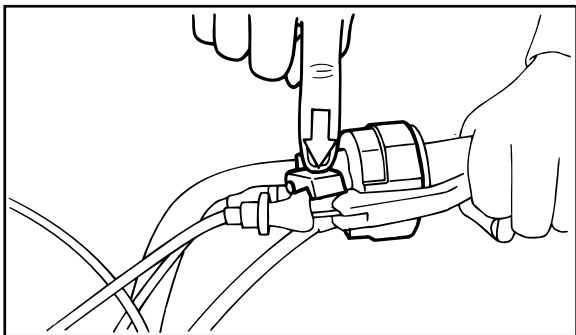

1. Locked position

⚠ WARNING

POTENTIAL HAZARD

Improper use of the parking brake.

WHAT CAN HAPPEN

The ATV could start moving unexpectedly if the parking brake is not applied before starting the engine. This could cause loss of control or a collision.

The brake could overheat if you ride the ATV without releasing the parking brake. You could lose braking performance which could cause an accident. You could also wear out the brakes prematurely.

HOW TO AVOID THE HAZARD

Always set the parking brake before starting the engine.

Always be sure you have released the parking brake before you begin to ride.

Shift pedal

This machine is equipped with a constant-mesh 3-speed transmission. The shift pedal is located on the left side of the engine. Neutral is at the bottom position.

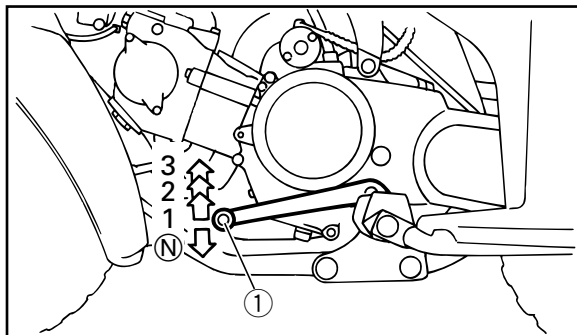

1. Shift pedal

N. Neutral position

Fuel tank cap

Remove the fuel tank cap by turning it counter-clockwise.

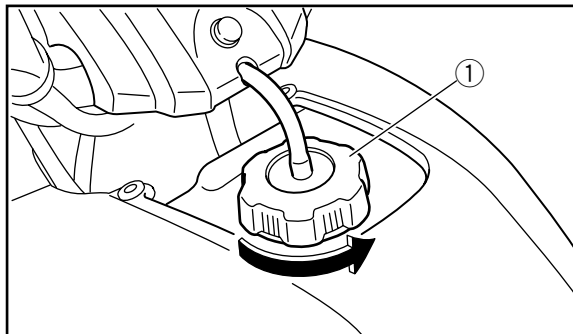

1. Fuel tank cap

Fuel cock

The fuel cock supplies fuel from the fuel tank to the carburetor.

The fuel cock has three positions.

OFF: With the lever in this position fuel will not flow. Always turn the lever to this position when the engine is not running.

ON: With the lever in this position, fuel flows to the carburetor. Normal riding is done with the lever in this position.

RES: This indicates reserve. If you run out of fuel while riding, turn the lever to this position. **THEN FILL THE FUEL TANK AT THE FIRST OPPORTUNITY.** After refuelling, return the fuel cock lever to the "ON" position.

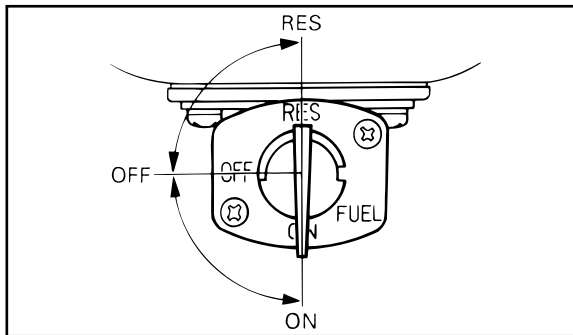

Choke lever

The choke is used to start a cold engine. Refer to “Starting a cold engine” for proper operation. (See page 6-1.)

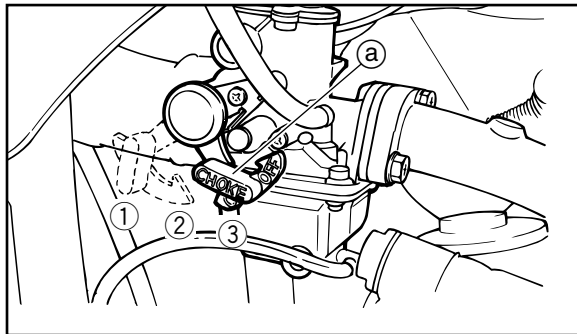

- a. Choke lever
 1. Fully open “ON” 2. Half open (warming up position)
 3. Closed “OFF”

Seat

To remove the seat, pull the seat lock lever upward and pull up the seat at the rear.

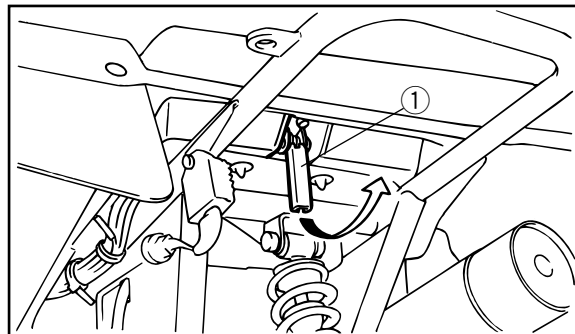

1. Seat lock lever

To install the seat, insert the projection on the front of the seat into the seat holder and push down on the seat at the rear.

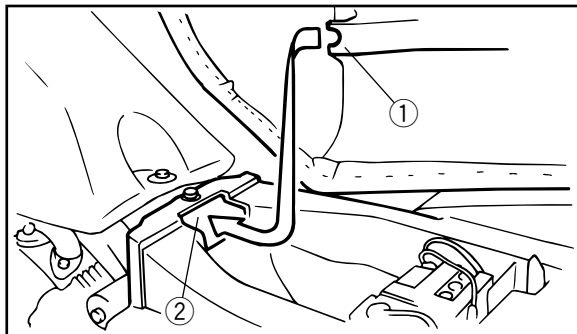

1. Projection

2. Seat holder

NOTE: _____

Make sure that the seat is securely fitted.

EBU00112



**Indicates a potential hazard that could result
in serious injury or death.**

PRE-OPERATION CHECKS

Before using this machine, check the following points:

ITEM	ROUTINE	PAGE
Brakes	<ul style="list-style-type: none">• Check operation, condition and free play.• Adjust if necessary.	5-2-5-3, 8-18-8-23
Fuel	<ul style="list-style-type: none">• Check fuel level.• Fill with fuel if necessary.	5-3-5-4
Engine oil	<ul style="list-style-type: none">• Check oil level.• Fill with oil if necessary.	5-5, 8-6-8-7
Final gear oil	<ul style="list-style-type: none">• Check for leakage.	5-5, 8-8-8-9
Throttle	<ul style="list-style-type: none">• Check for proper throttle cable operation.	5-6
Wheels and tires	<ul style="list-style-type: none">• Check tire pressure, wear and damage.	5-6-5-8, 8-26
Fittings and fasteners	<ul style="list-style-type: none">• Check all fittings and fasteners.	5-9
Switches	<ul style="list-style-type: none">• Check operation.	5-9
Battery	<ul style="list-style-type: none">• Check fluid level.• Fill with distilled water if necessary.	5-9, 8-27-8-29

WARNING

POTENTIAL HAZARD

Failure to inspect the ATV before operating.

Failure to properly maintain the ATV.

WHAT CAN HAPPEN

Increases the possibility of an accident or equipment damage.

HOW TO AVOID THE HAZARD

Always inspect your ATV each time you use it to make sure the ATV is in safe operating condition.

Always follow the inspection and maintenance procedures and schedules described in the Owner's Manual.

EBU04762

Front and rear brakes

Brake levers and brake pedal

- Check for correct free play in the brake levers and brake pedal. If the free play is incorrect, adjust it. (See pages 8-19–8-23.)
- Check operation of the brake levers and brake pedal. They should move smoothly and there should be a firm feeling when the brakes are applied. If not, have the ATV inspected by a Yamaha dealer.

Brake operation

Test the brakes at slow speed after starting out to make sure they are working properly. If the brakes do not provide proper braking performance, inspect the brake linings for wear. (See page 8-18–8-19.)

WARNING

POTENTIAL HAZARD

Riding with improperly operating brakes.

WHAT CAN HAPPEN

You could lose braking ability, which could lead to an accident.

HOW TO AVOID THE HAZARD

Always check the brakes at the start of every ride. Do not ride the ATV if you find any problem with the brakes. If a problem cannot be corrected by the adjustment procedures provided in this manual, have the ATV inspected by a Yamaha dealer.

EBU13410

Fuel

Make sure there is sufficient gasoline in the tank.

Recommended fuel:

UNLEADED GASOLINE ONLY

Fuel tank capacity:

Total:

6.8 L (1.5 Imp gal, 1.8 US gal)

Reserve:

0.9 L (0.2 Imp gal, 0.2 US gal)

CAUTION: _____

Use only unleaded gasoline. The use of leaded gasoline will cause severe damage to internal engine parts, such as the valves and piston rings, as well as to the exhaust system.

Your Yamaha engine has been designed to use regular unleaded gasoline with a pump octane number ($([R+M]/2)$) of 86 or higher, or research octane number of 91 or higher. If knocking or pinging occurs, use a different brand of gasoline or premium unleaded fuel.

Unleaded fuel will give you longer spark plug life and reduced maintenance cost.

Gasohol

There are two types of gasohol; gasohol containing ethanol and that containing methanol. Gasohol containing ethanol can be used if ethanol content does not exceed 10%. Gasohol containing methanol is not recommended by Yamaha because it may cause fuel system damage or vehicle performance problems.

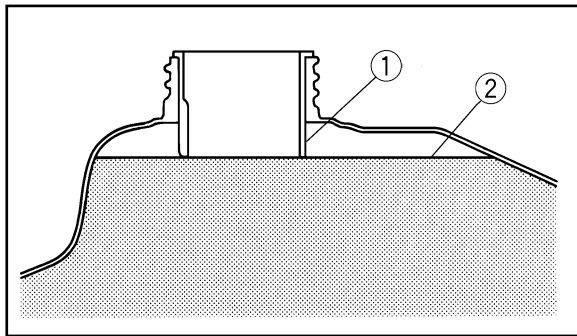

1. Filler tube

2. Fuel level

⚠ WARNING

POTENTIAL HAZARD

Improper care when refueling.

WHAT CAN HAPPEN

Fuel can spill, which can cause a fire and severe injury.

Fuel expands when it heats up. If the fuel tank is overfilled, fuel could spill out due to heat from the engine or the sun.

HOW TO AVOID THE HAZARD

Do not overfill the fuel tank. Be careful not to spill fuel, especially on the engine or exhaust pipe. Wipe up any spilled fuel immediately. Be sure the fuel tank cap is closed securely.

Do not refuel right after the engine has been running and is still very hot.

Engine oil

Make sure the engine oil is at the specified level. Add oil as necessary. (See page 8-6.)

CAUTION:

- **In order to prevent clutch slippage (since the engine oil also lubricates the clutch), do not mix any chemical additives. Do not use oils with a diesel specification of “CD” or oils of a higher quality than specified. In addition, do not use oils labeled “ENERGY CONSERVING II” or higher.**
- **Make sure that no foreign material enters the crankcase.**

Recommended engine oil type and quantity:
See page 10-2.

Final gear oil

Make sure the final gear oil is at the specified level. Add oil as necessary. (See pages 8-8–8-9 for details.)

Recommended oil:
SAE80API “GL-4” Hypoid gear oil

If desired, an SAE 80W90 hypoid gear oil may be used for all conditions.

NOTE:

GL-4 is a quality and additive rating, GL-5 or GL-6 rated hypoid gear oils may also be used.

Throttle lever

Check to see that the throttle lever operates correctly. It must open smoothly and spring back to the idle position when released. Have a Yamaha dealer repair as necessary for proper operation.

Tires

WARNING

POTENTIAL HAZARD

Operating this ATV with improper tires, or with improper or uneven tire pressure.

WHAT CAN HAPPEN

Use of improper tires on this ATV, or operation of this ATV with improper or uneven tire pressure, may cause loss of control, increasing your risk of accident.

HOW TO AVOID THE HAZARD

1. The tires listed below have been approved by Yamaha Motor Co., Ltd. for this model. Other tire combinations are not recommended.

	Manufacturer	Size	Type
Front	DUNLOP	AT18 × 7-7	KT586
Rear	DUNLOP	AT18 × 8-7	KT587

2. The tires should be set to the recommended pressure:

- **Recommended tire pressure**
Front 20 kPa (0.20 kgf/cm², 2.9 psi)
Rear 20 kPa (0.20 kgf/cm², 2.9 psi)
- **Check and adjust tire pressures when the tires are cold.**
- **Tire pressures must be equal on both sides.**

3. Tire pressure below the minimum specified could cause the tire to dislodge from the rim under severe riding conditions. The following are minimums:

Front 17 kPa (0.17 kgf/cm², 2.5 psi)
Rear 17 kPa (0.17 kgf/cm², 2.5 psi)

4. Use no more than the following pressures when seating the tire beads.

Front 230 kPa (2.3 kgf/cm², 33 psi)

Rear 230 kPa (2.3 kgf/cm², 33 psi)

Higher pressures may cause the tire to burst. Inflate the tires very slowly and carefully. Fast inflation could cause the tire to burst.

EBU00159

How to measure tire pressure

Use the low-pressure tire gauge.

NOTE: _____

The low-pressure tire gauge is included as standard equipment. Make two measurements of the tire pressure and use the second reading. Dust or dirt in the gauge could cause the first reading to be incorrect.

Set pressure with tires cold.

Set tire pressures to the following specifications:

	Recommended pressure	Minimum	Maximum
Front	20 kPa (0.20 kgf/cm ² , 2.9 psi)	17 kPa (0.17 kgf/cm ² , 2.5 psi)	23 kPa (0.23 kgf/cm ² , 3.3 psi)
Rear	20 kPa (0.20 kgf/cm ² , 2.9 psi)	17 kPa (0.17 kgf/cm ² , 2.5 psi)	23 kPa (0.23 kgf/cm ² , 3.3 psi)

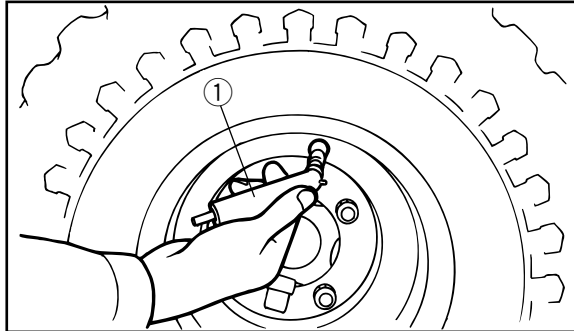

1. Low-pressure tire gauge

Tire wear limit

When the tire groove decreases to 3 mm (0.12 in) due to wear, replace the tire.

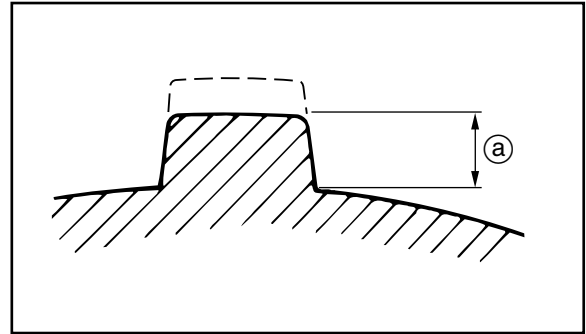

a. Tire wear limit

EBU11620

Fittings and fasteners

Always check the tightness of chassis fittings and fasteners before a ride. Take the machine to a Yamaha dealer or refer to the Service Manual for correct tightening torque.

EBU11700

Switches

Check the operation of all switches. Have a Yamaha dealer repair as necessary for proper operation.

EBU00499

Battery

Check fluid level and fill if necessary. Use only distilled water if refilling is necessary. (See pages 8-27–8-29.)

OPERATION

WARNING

Indicates a potential hazard that could result in serious injury or death.

WARNING

POTENTIAL HAZARD

Operating ATV without being familiar with all controls.

WHAT CAN HAPPEN

Loss of control, which could cause an accident or injury.

HOW TO AVOID THE HAZARD

Read the Owner's Manual carefully. If there is a control or function you do not understand, ask your Yamaha dealer.

Starting a cold engine

WARNING

POTENTIAL HAZARD

Freezing control cables in cold weather.

WHAT CAN HAPPEN

You could be unable to control the ATV, which could lead to an accident or collision.

HOW TO AVOID THE HAZARD

When riding in cold weather, always make sure all control cables work smoothly before you begin riding.

1. Set the parking brake.
2. Turn the fuel cock to "ON".
3. Turn the main switch to "ON" and the engine stop switch to "RUN".
4. Shift the transmission into neutral.

NOTE: _____

This model is equipped with an ignition circuit cut-off system.

The engine can be started under the following conditions.

- a. When the transmission is in neutral. At this time the neutral indicator light should come on. If the light does not come on, ask a Yamaha dealer to inspect it.
- b. When the transmission is in gear and the rear brake lever is applied. However, it is recommended to shift into neutral before starting the engine.

5. Use the choke lever in reference to the figure:

Position ①: Cold engine start-ambient temperature below 30°C (90°F).

Position ②: Warming up position.

Position ③: Cold engine start-ambient temperature above 25°C (80°F) and warm engine start position.

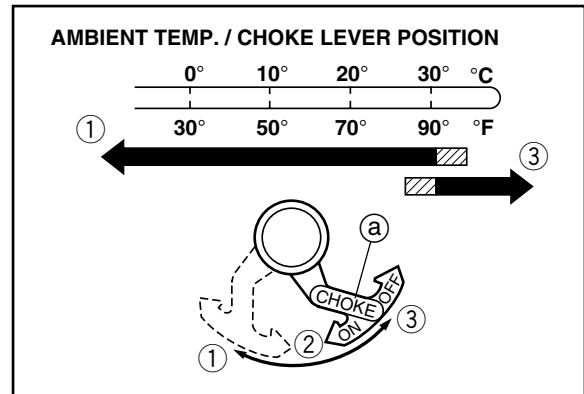

a. Choke lever

1. Fully open "ON"
2. Half open (warming up position)
3. Closed "OFF"

6. Completely close the throttle lever and start the engine by pushing the start switch.

NOTE: _____

If the engine fails to start, release the start switch, then push it again. Pause a few seconds before the next attempt. Each cranking should be as short as possible to preserve battery energy. Do not crank the engine more than 10 seconds on each attempt.

7. If the engine is started with the starter (choke) in position ①, the choke lever should be returned to position ② to warm up the engine. If the engine is started with the starter (choke) in position ②, keep the starter (choke) in this position to warm up the engine.
8. Continue warming up the engine until it idles smoothly and return the choke lever to position ③ before riding.

CAUTION: _____

See the “Engine break-in” section prior to operating engine for the first time.

EBU00181

Starting a warm engine

To start a warm engine, refer to the “Starting a cold engine” section. The choke lever should not be used. The throttle should be opened slightly.

EBU00184

Warming up

To get maximum engine life, always warm up the engine before starting off. Never accelerate hard with a cold engine! To see whether or not the engine is warm, check if it responds to the throttle normally with the choke lever turned off.

Shifting

This model has a 3-speed forward transmission with centrifugal automatic clutch. The transmission allows you to control the amount of power you have available at a given speed or for starting, accelerating, climbing, etc. To shift into neutral, return the throttle lever to its original position and repeatedly depress the shift pedal until it stops.

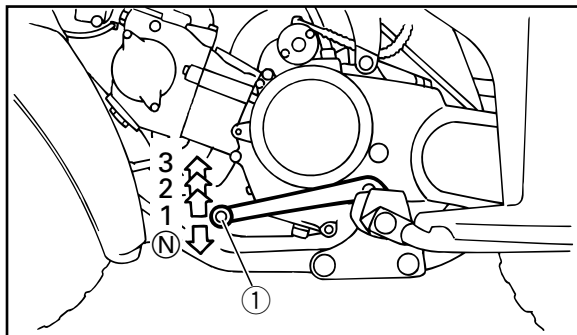

1. Shift pedal

N. Neutral position

CAUTION:

Do not coast for long periods with the engine off, and do not tow the machine a long distance. Even with gears in neutral, the transmission is only properly lubricated when the engine is running. Inadequate lubrication may damage the transmission.

EBU00205

To start out and accelerate:

1. Release the throttle lever.

CAUTION:

Always close the throttle while shifting gears. Otherwise, damage to the engine and drive train may result.

2. Shift into first gear and release the shift pedal.
3. Open the throttle gradually.

4. Once the machine has attained adequate speed, release the throttle lever.
5. Shift into second gear and release the shift pedal.
6. Open the throttle gradually.
7. Follow the same procedure when shifting to the next higher gear.

WARNING

POTENTIAL HAZARD

Opening the throttle before releasing the shift pedal.

WHAT CAN HAPPEN

The machine could wheelie. This would increase the chance of an accident, including overturn.

HOW TO AVOID THE HAZARD

Release the shift pedal before opening the throttle. Open the throttle gradually.

To decelerate:

When slowing down or stopping, release the throttle and apply the brakes smoothly and evenly. As you slow down, shift to a lower gear. Be sure that the engine has sufficiently slowed before engaging a lower gear. Improper use of the brakes or shifting can cause the tires to lose traction, reducing control and increasing the possibility of an accident.

WARNING

POTENTIAL HAZARD

Engaging a lower gear when the engine speed is too high.

WHAT CAN HAPPEN

The wheels could stop rotating. This could cause loss of control, an accident and injury. It could also cause engine or drive train damage.

HOW TO AVOID THE HAZARD

Make sure the engine has sufficiently slowed before shifting to a lower gear.

Engine break-in

There is never a more important period in the life of your machine than the period between zero and 20 hours.

For this reason, we ask that you carefully read the following material. Because the engine is brand new, you must not put an excessive load on it for the first several hours of running. During the first 20 hours, the various parts in the engine wear and polish themselves to the correct operating clearances.

During this period, prolonged full throttle operation or any condition which might result in excessive engine heating must be avoided. However, momentary (2-3 seconds maximum) full throttle operation under load does not harm the engine. Each full throttle acceleration sequence should be followed with a substantial rest period for the engine by cruising at lower r/min so the engine can rid itself of the temporary build up of heat.

If any abnormality is noticed during this period, consult a Yamaha dealer.

0-10 hours:

Avoid continuous operation above half throttle. Allow a cooling off period of five to ten minutes after every hour of operation. Vary the speed of the machine from time to time. Do not operate it at one set throttle position.

10-20 hours:

Avoid prolonged operation above 3/4 throttle. Rev the machine freely through the gears but do not use full throttle at any time.

After break-in:

Avoid prolonged full throttle operation. Vary speeds occasionally.

Parking

When parking, stop the engine and shift into first gear. Turn the fuel cock to “OFF” and apply the parking brake.

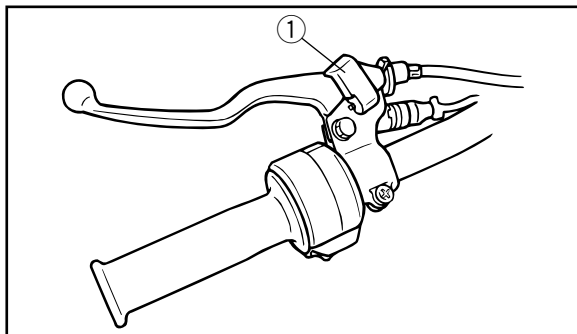

1. Lock plate

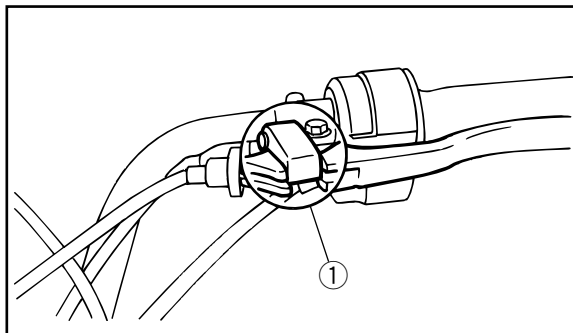
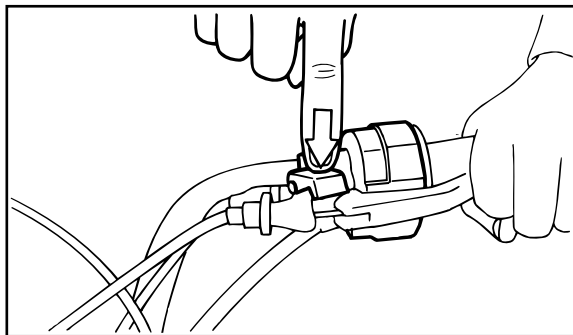

1. Locked position

Parking on a slope

WARNING

POTENTIAL HAZARD

Parking on a hill or other incline.

WHAT CAN HAPPEN

The ATV could roll out of control, increasing the chance of an accident.

HOW TO AVOID THE HAZARD

Avoid parking on hills or other inclines. If you must park on an incline, put the ATV in low gear, apply the parking brake, and block the front and rear wheels with rocks or other objects.

Do not park the ATV at all on hills that are so steep you could not walk up them easily.

1. Bring the ATV to a stop by applying the brakes in low gear.
2. Stop the engine.
3. With the rear brake lever and pedal applied, apply the parking brake and slowly release the brake pedal.

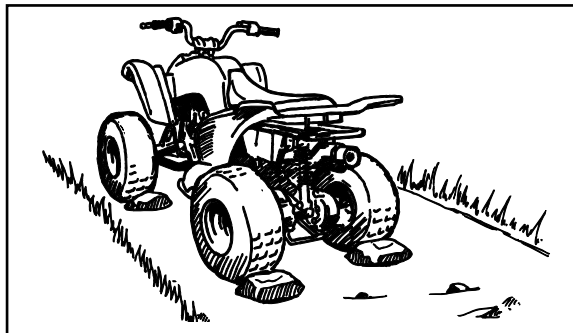

Accessories and loading

Accessories

Accessories can affect the handling and control of your ATV. Keep the following in mind when considering an accessory or operating an ATV which has accessories.

- Choose only accessories designed for your ATV. Your Yamaha dealer has a variety of genuine Yamaha accessories. Other accessories may also be available on the market. However, it is not possible for Yamaha to test all non-Yamaha accessories, nor have any control over the quality or suitability of them. Choose a genuine Yamaha accessory, or one that is equivalent in design and quality.

- Accessories should be rigidly and securely mounted. An accessory which can shift position or come off while you are riding could affect your ability to control the ATV.
- Do not mount an accessory where it could interfere with your ability to control the ATV. Examples include (but are not limited to) a heavy or bulky object attached to the handlebars which could make steering difficult, an accessory that limits your ability to move around on the seat, or one that limits your view.
- Use extra caution when riding an ATV with accessories. The ATV may handle differently than it does without accessories.

Loading

As originally equipped, this ATV is not designed to carry cargo or tow a trailer. If you choose to add accessories so that you can carry cargo or tow a trailer, you must use common sense and good judgment. Keep the following points in mind:

- Never exceed the weight limits shown. An overloaded ATV can be unstable.

MAXIMUM LOADING LIMIT

Vehicle loading limit (total weight of cargo, rider and accessories):

95 kg (209 lb)

- Load cargo on the carriers as close to the center of the vehicle as possible. Put cargo at the rear of the front carrier and at the front of the rear carrier. Center the load from side to side.

- Tie down cargo securely to the carriers. Make sure cargo in the trailer cannot move around. A shifting load can cause an accident.
- Make sure the load does not interfere with controls or your ability to see where you are going.
- Ride more slowly than you would without a load. The more weight you carry, the slower you should go. Although conditions vary, it is good practice not to exceed 2nd gear whenever you are carrying heavier loads or when towing a trailer.
- Allow more braking distance. A heavier vehicle takes longer to stop.
- Avoid making sharp turns unless at very slow speeds.
- Avoid hills and rough terrain. Choose terrain carefully. Added weight affects the stability and handling of the ATV.

 **WARNING**

POTENTIAL HAZARD

Overloading this ATV or carrying or towing cargo improperly.

WHAT CAN HAPPEN

Could cause changes in vehicle handling which could lead to an accident.

HOW TO AVOID THE HAZARD

Never exceed the stated load capacity for this ATV.

Cargo should be properly distributed and securely attached.

Reduce speed when carrying cargo or pulling a trailer. Allow greater distance for braking.

EBU13541



**Indicates a potential hazard that could result
in serious injury or death.**

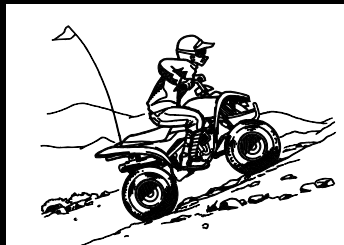

Riding Your ATV

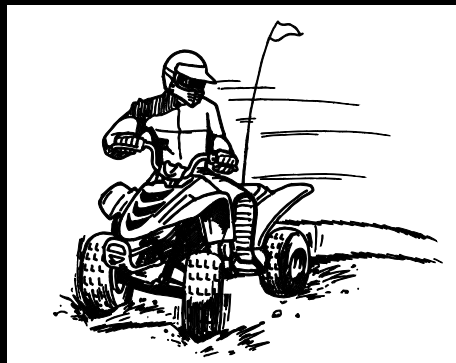
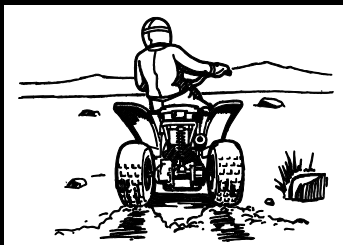

⚠️WARNING

Indicates a potential hazard that could result in serious injury or death.

GETTING TO KNOW YOUR ATV

This ATV is for recreation use. This section, *Riding your ATV*, provides general ATV riding instructions for recreational riding. The skills and techniques described in this section, however, are appropriate for all types of riding. Riding your ATV requires special skills acquired through practice over a period of time. Take the time to learn the basic techniques well before attempting more difficult maneuvers.

Riding your new ATV can be a very enjoyable activity, providing you with hours of pleasure. But it is essential to familiarize yourself with the operation of the ATV to achieve the skill necessary to enjoy riding safely. Before you begin to ride, be sure you have read this Owner's Manual

completely and understand the operation of the controls. Pay particular attention to the safety information on pages 2-1–2-7. Please also read all caution and warning labels on your ATV.

RIDE WITH CARE AND GOOD JUDGEMENT

Get training if you are inexperienced.

Beginners should get training from a certified instructor.

Become familiar with this ATV at slow speeds first, even if you are an experienced operator.

Do not attempt to operate at maximum performance until you are totally familiar with the ATV's handling and performance characteristics.

WARNING

POTENTIAL HAZARD

Operating this ATV without proper instruction.

WHAT CAN HAPPEN

The risk of an accident is greatly increased if the operator does not know how to operate the ATV properly in different situations and on different types of terrain.

HOW TO AVOID THE HAZARD

Beginning and inexperienced operators should complete the certified training course offered by Yamaha. They should then regularly practice the skills learned in the course and the operating techniques described in this Owner's Manual.

For more information about the training course, contact an authorized ATV dealer or call 1-800-887-2887.

Riding your ATV requires skills acquired through practice over a period of time.

Take the time to learn the basic techniques well before attempting more difficult maneuvers.

Not recommended for children under 12 years of age.

⚠ WARNING

POTENTIAL HAZARD

Failure to follow the age recommendations for this ATV.

WHAT CAN HAPPEN

Use by children of ATVs that are not recommended for their age can lead to severe injury or death of the child.

HOW TO AVOID THE HAZARD

A child under 12 should never operate an ATV with engine size greater than 70cc.



This ATV is designed to carry operator only - passengers prohibited.

⚠ WARNING

POTENTIAL HAZARD

Carrying a passenger on this ATV.

WHAT CAN HAPPEN

Greatly reduces your ability to balance and control this ATV. Could cause an accident, resulting in harm to you and/or your passenger.

HOW TO AVOID THE HAZARD

Never carry a passenger. The long seat is to allow the operator to shift position as needed during operation. It is not for carrying passengers.



Apparel

WARNING

POTENTIAL HAZARD

Operating this ATV without wearing an approved motorcycle helmet, eye protection and protective clothing.

WHAT CAN HAPPEN

Operating without an approved motorcycle helmet increases your chances of a severe head injury or death in the event of an accident.

Operating without eye protection can result in an accident and increases your chances of a severe injury in the event of an accident.

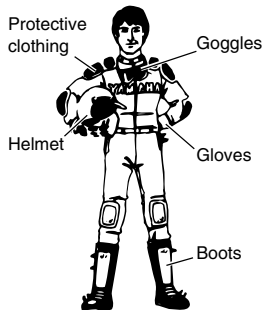

Operating without protective clothing increases your chances of severe injury in the event of an accident.

HOW TO AVOID THE HAZARD

Always wear an approved motorcycle helmet that fits properly.

You should also wear:

- eye protection
(goggles or face shield)
- gloves
- boots
- long-sleeved shirt or jacket
- long pants.

Do not operate after consuming alcohol or drugs.

Operator's performance capability is reduced by the influence of alcohol or drugs.



⚠ WARNING

POTENTIAL HAZARD

Operating this ATV after consuming alcohol or drugs.

WHAT CAN HAPPEN

Could seriously affect your judgment.

Could cause you to react more slowly.

Could affect your balance and perception.

Could result in an accident.

HOW TO AVOID THE HAZARD

Never consume alcohol or drugs before or while driving this ATV.

Pre-operation checks

Always perform the pre-operation checks listed on page 5-1 before riding for safety and proper care of the ATV.

WARNING

POTENTIAL HAZARD

Failure to inspect the ATV before operating.

Failure to properly maintain the ATV.

WHAT CAN HAPPEN

Increases the possibility of an accident or equipment damage.

HOW TO AVOID THE HAZARD

Always inspect your ATV each time you use it to make sure the ATV is in safe operating condition. Always follow the inspection and maintenance procedures and schedules described in the Owner's Manual.

WARNING

POTENTIAL HAZARD

Operating this ATV with improper tires, or with improper or uneven tire pressure.

WHAT CAN HAPPEN

Use of improper tires on this ATV, or operation of this ATV with improper or uneven tire pressure, may cause loss of control, increasing your risk of an accident.

HOW TO AVOID THE HAZARD

Always use the size and type tires specified in the Owner's Manual for this vehicle on pages 5-6-5-7.

Always maintain proper tire pressure as described in the Owner's Manual on page 5-8.

⚠️ WARNING

Indicates a potential hazard that could result in serious injury or death.

Do not operate at speeds too fast for your skills or the conditions.

⚠️ WARNING

POTENTIAL HAZARD

Operating this ATV at speeds too fast for your skills or the conditions.

WHAT CAN HAPPEN

Increases your chances of losing control of the ATV, which can result in an accident.

HOW TO AVOID THE HAZARD

Always go at a speed that is proper for the terrain, visibility and operating conditions, and your experience.

Speed limiter

For riders inexperienced with this model, this model is equipped with a speed limiter in the throttle lever housing. The speed limiter limits the power and top speed of the ATV. Turning the screw in decreases top speed, and turning it out increases top speed. This model also has an intake restrictor plate to limit the amount of engine power available.

Yamaha recommends that all beginning riders start off with the speed limiter turned in and the air intake restrictor plate installed to limit the amount of speed available while they learn. The limiter may be gradually adjusted to increase maximum speed as the beginner becomes more familiar with operating the ATV. Parents should decide when to adjust the ATV for more power as their youngster's riding skills improve. Once the ATV rider can operate with skill at the top speed permitted by adjusting the speed limiter alone, the air intake restrictor plate can be removed. Since removal of this plate will result in a significant increase in power, turn the speed limiter back in again; adjust it out in stages as you did before.

Adjusting for maximum throttle lever movement without removing the air intake restrictor plate will cause the engine to run roughly at higher speeds.

For air intake restrictor plate removal instructions, see page 8-14.

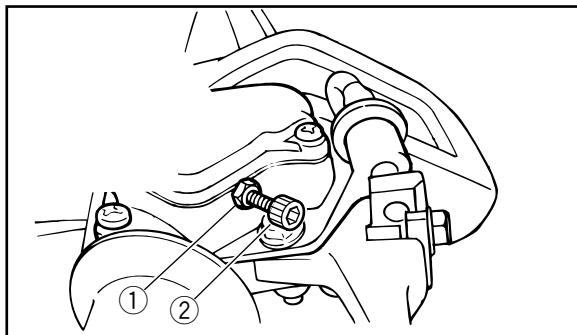

1. Locknut

2. Adjuster

Loading and accessories

Use extra caution when riding the ATV with additional loads, such as accessories or cargo. The ATV's handling may be adversely affected. Reduce your speed when adding additional loads.

MAXIMUM LOADING LIMIT

Vehicle loading limit (total weight of cargo, rider and accessories):
95 kg (209 lb)

⚠ WARNING

POTENTIAL HAZARD

Overloading this ATV or carrying or towing cargo improperly.

WHAT CAN HAPPEN

Could cause changes in vehicle handling which could lead to an accident.

HOW TO AVOID THE HAZARD

Never exceed the stated load capacity for this ATV.

Cargo should be properly distributed and securely attached.

Reduce speed when carrying cargo or pulling a trailer. Allow greater distance for braking.

Always follow the instructions in your Owner's Manual for carrying cargo or pulling a trailer.

During operation

Always keep your feet on the footboards during operation. Otherwise your feet may contact the rear wheels.

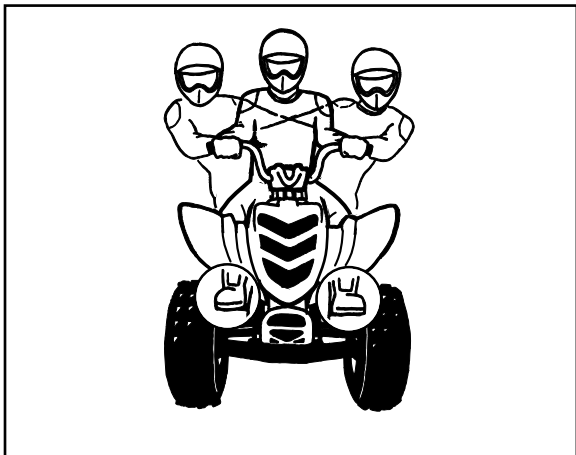

⚠ WARNING

POTENTIAL HAZARD

Removing hands from handlebars or feet from footboards during operation.

WHAT CAN HAPPEN

Removing even one hand or foot can reduce your ability to control the ATV or could cause you to lose your balance and fall off of the ATV. If you remove a foot from a footboard, your foot or leg may come into contact with the rear wheels, which could injure you or cause an accident.

HOW TO AVOID THE HAZARD

Always keep both hands on the handlebars and both feet on the footboards of your ATV during operation.

Avoid wheelies and jumping. You may lose control of the ATV or overturn.

⚠ WARNING

POTENTIAL HAZARD

Attempting wheelies, jumps, and other stunts.

WHAT CAN HAPPEN

Increases the chance of an accident, including an overturn.

HOW TO AVOID THE HAZARD

Never attempt stunts, such as wheelies or jumps. Don't try to show off.

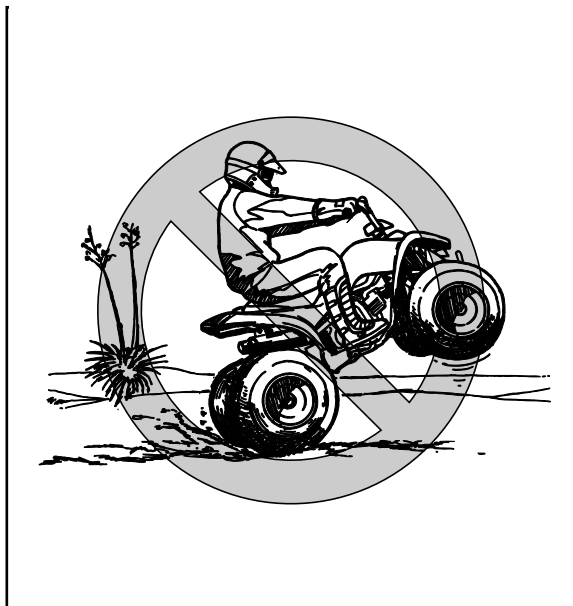

Modifications

WARNING

POTENTIAL HAZARD

Operating this ATV with improper modifications.

WHAT CAN HAPPEN

Improper installation of accessories or modification of this vehicle may cause changes in handling which in some situations could lead to an accident.

HOW TO AVOID THE HAZARD

Never modify this ATV through improper installation or use of accessories. All parts and accessories added to this vehicle should be genuine Yamaha or equivalent components designed for use on this ATV and should be installed and used according to instructions. If you have questions, consult an authorized ATV dealer.

Exhaust system

The exhaust system on the ATV is very hot during and following operation. To prevent burns, avoid touching the exhaust system. Park the ATV in a place where pedestrians or children are not likely to touch it.

WARNING

POTENTIAL HAZARD

Hot exhaust system.

WHAT CAN HAPPEN

Dry grass or brush or other combustible material accumulated around the engine area could catch fire. Someone touching the exhaust system during or after operation could be burned.

HOW TO AVOID THE HAZARD

Do not operate, idle, or park the ATV in dry grass or other dry ground cover.

Keep the engine area free of dry grass, brush, or other combustible material. Do not touch the hot exhaust system. Do not park the ATV in a place where others might be likely to touch it.

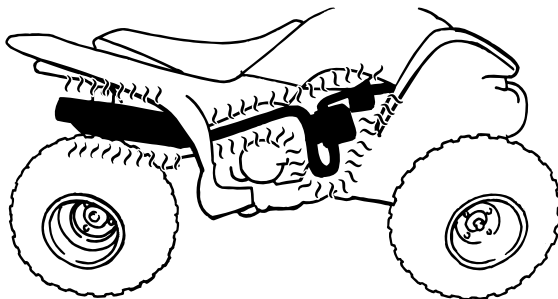

BE CAREFUL WHERE YOU RIDE

This ATV is designed for off-road use only. Riding on paved surfaces can cause loss of control.

⚠ WARNING

POTENTIAL HAZARD

Operating this ATV on paved surfaces.

WHAT CAN HAPPEN

ATVs are designed for off-road use only. Paved surfaces may seriously affect handling and control of the ATV, and may cause the vehicle to go out of control.

HOW TO AVOID THE HAZARD

Always avoid paved surfaces, including sidewalks, driveways, parking lots and streets.

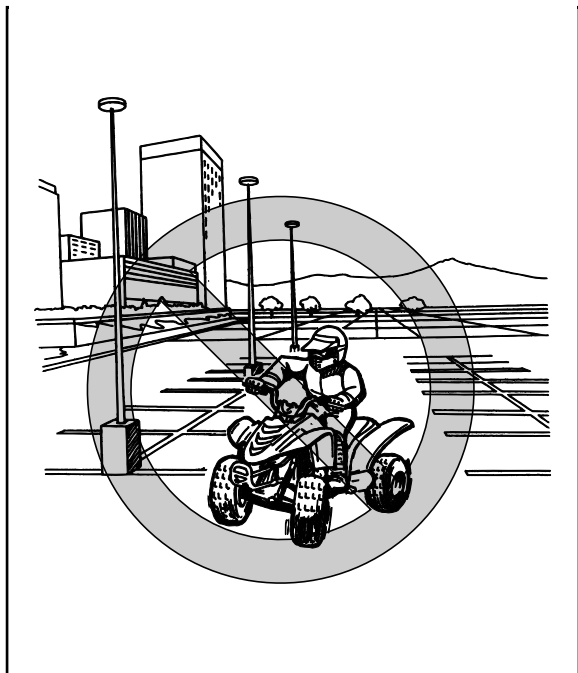

Do not ride on any public road, street, or highway. Riding on public roads can result in collisions with other vehicles.

⚠ WARNING

POTENTIAL HAZARD

Operating this ATV on public streets, roads or highways.

WHAT CAN HAPPEN

You can collide with another vehicle.

HOW TO AVOID THE HAZARD

Never operate this ATV on any public street, road or highway, even a dirt or gravel one.

In many states it is illegal to operate ATVs on public streets, roads and highways.

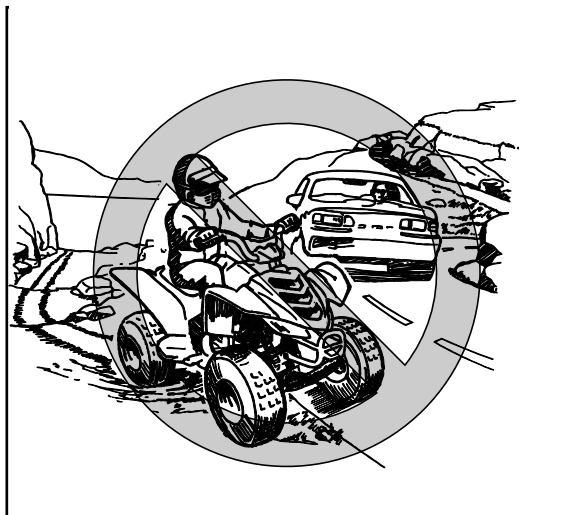

Know the terrain where you ride. Ride cautiously in unfamiliar areas. Stay alert for **holes, rocks, or roots** in the terrain, and **other hidden hazards** which may cause the ATV to upset.

⚠ WARNING

POTENTIAL HAZARD

Failure to use extra care when operating this ATV on unfamiliar terrain.

WHAT CAN HAPPEN

You can come upon hidden rocks, bumps, or holes, without enough time to react. Could result in the ATV overturning or going out of control.

HOW TO AVOID THE HAZARD

Go slowly and be extra careful when operating on unfamiliar terrain. Always be alert to changing terrain conditions when operating the ATV.



WARNING

POTENTIAL HAZARD

Failure to use extra care when operating on excessively rough, slippery or loose terrain.

WHAT CAN HAPPEN

Could cause loss of traction or vehicle control, which could result in an accident, including an overturn.

HOW TO AVOID THE HAZARD

Do not operate on excessively rough, slippery or loose terrain until you have learned and practiced the skills necessary to control the ATV on such terrain. Always be especially cautious on these kinds of terrain.

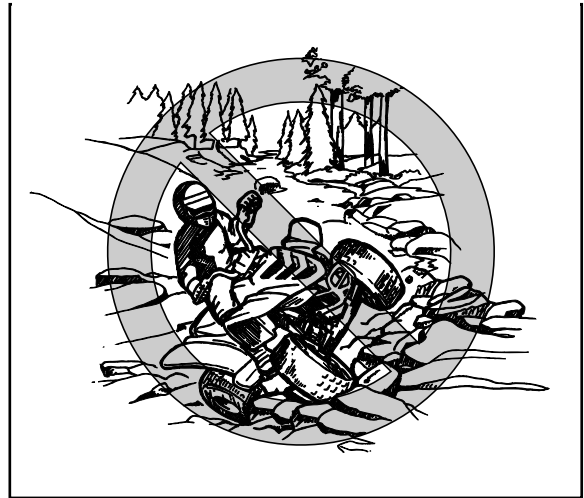

When riding in an area where you might not easily be seen, such as desert terrain, mount a caution flag on the ATV. DO NOT use the flag pole bracket as a trailer hitch.

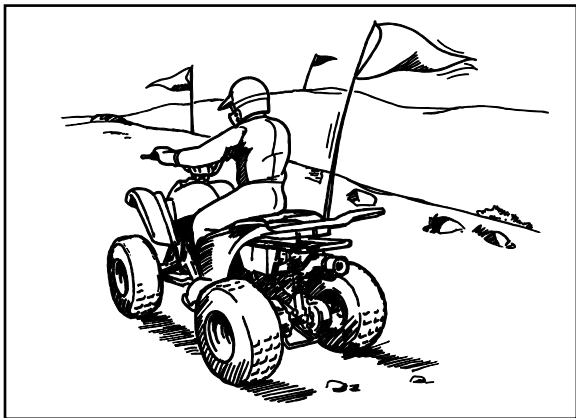

⚠ WARNING

POTENTIAL HAZARD

Operating in areas where you might not be seen by other off-road vehicles.

WHAT CAN HAPPEN

You could be in a collision. You could be injured.

HOW TO AVOID THE HAZARD

Always mount a caution flag on the ATV to make you more visible. Watch carefully for other vehicles.

Do not ride in areas posted “no trespassing”. Do not ride on private property without getting permission.

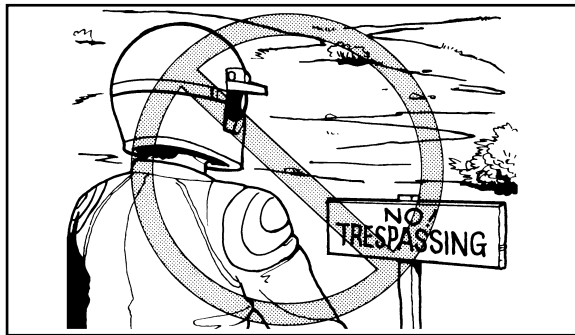

Select a large, flat area off-road to become familiar with your ATV. Make sure that this area is free of obstacles and other riders. You should practice control of the throttle, brakes, shifting procedures, and turning techniques in this area before trying more difficult terrain. Always avoid riding on paved surfaces: the ATV is designed for off-road use only, and handling maneuvers are more difficult to perform on pavement.

Set the parking brake and follow the instruction on page 6-1 to start the engine. Once it has warmed up you are ready to begin riding your ATV. As you get on the ATV, be sure not to accidentally move the shift pedal. Remember that the engine and exhaust pipe will be hot when riding and afterwards; do not allow skin or clothing to come in contact with these components.

With the engine idling, lift the shift pedal to the 1st gear position and then release the parking brake. Apply the throttle slowly and smoothly. The centrifugal clutch will engage and you will start to accelerate. Once the ATV has attained adequate speed, release the throttle and lift the shift pedal to the 2nd gear position. Release the shift pedal and apply the throttle smoothly. Use this same procedure as you move into the higher gears. Be sure to coordinate the use of the throttle and shift pedal properly. If the throttle is applied too abruptly or if the throttle is not released during shifting, or if the shift pedal is not released before applying the throttle, the front wheels may lift off the ground resulting in a loss of directional control. Avoid higher speeds until you are thoroughly familiar with the operation of your ATV.

CAUTION:

Do not shift gears without releasing the throttle. Damage to the engine or drive train may occur.

When slowing down or stopping, release the throttle and apply the brakes smoothly and evenly. As you slow down, shift to a lower gear. Be sure that the engine has sufficiently slowed before engaging a lower gear. Improper use of the brakes or shifting can cause the tires to lose traction, reducing control and increasing the possibility of an accident.

 **WARNING****POTENTIAL HAZARD**

Engaging a lower gear when the engine speed is too high.

WHAT CAN HAPPEN

The wheels could stop rotating. This could cause loss of control, an accident and injury. It could also cause engine or drive train damage.

HOW TO AVOID THE HAZARD

Make sure the engine has sufficiently slowed before shifting to a lower gear.

TURNING YOUR ATV

To achieve maximum traction while riding off-road, the two rear wheels are mounted solidly on one axle and turn together at the same speed. Therefore, unless the wheel on the inside of the turn is allowed to slip or lose some traction, the ATV will resist turning. A special turning technique must be used to allow the ATV to make turns quickly and easily. It is essential that this skill be learned first at low speed.

WARNING

POTENTIAL HAZARD

Turning improperly.

WHAT CAN HAPPEN

The ATV could go out of control, causing a collision or overturn.

HOW TO AVOID THE HAZARD

Always follow proper procedures for turning as described in this Owner's Manual. Practice turning at low speeds before attempting to turn at faster speeds. Do not turn at speeds too fast for your skills or the conditions.

As you approach a curve, slow down and begin to turn the handlebars in the desired direction. As you do so, put your weight on the footboard to the outside of the turn (opposite your desired direction) and lean your upper body into the turn. Use the throttle to maintain an even speed through the turn. This maneuver will let the wheel on the inside of the turn slip slightly, allowing the ATV to make the turn properly.

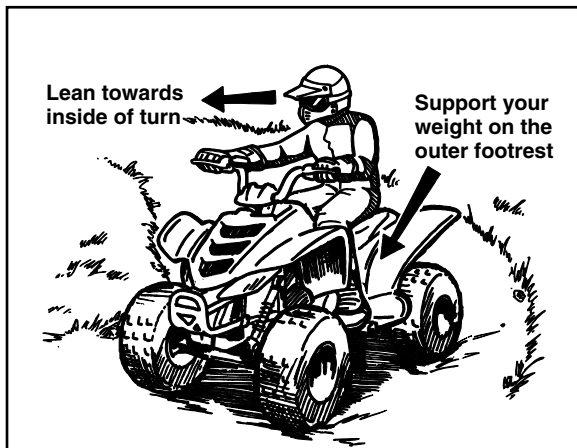

This procedure should be practiced at slow speed many times in a large off-road area with no obstacles. If an incorrect technique is used, your ATV may continue to go straight. If the ATV doesn't turn, come to a stop and then practice the procedure again. If the riding surface is slippery or loose, it may help to position more of your weight over the front wheels by moving forward on the seat.

Once you have learned this technique you should be able to perform it at higher speeds or in tighter curves.

Improper riding procedures such as abrupt throttle changes, excessive braking, incorrect body movements, or too much speed for the sharpness of the turn may cause the ATV to tip. If the ATV begins to tip over to the outside while negotiating a turn, lean more to the inside. It may also be necessary to gradually let off on the throttle and steer to the outside of the turn to avoid tipping over.

Remember: Avoid higher speeds until you are thoroughly familiar with the operation of your ATV.

CLIMBING UPHILL

Use proper riding techniques to avoid vehicle overturns on hills. Be sure that you can maneuver your ATV well on flat ground before attempting any incline and then practice riding first on gentle slopes. Try more difficult climbs only after you have developed your skill. In all cases avoid inclines with slippery or loose surfaces, or obstacles that might cause you to lose control.



WARNING

POTENTIAL HAZARD

Operating on excessively steep hills.

WHAT CAN HAPPEN

The vehicle can overturn more easily on extremely steep hills than on level surfaces or small hills.

HOW TO AVOID THE HAZARD

Never operate the ATV on hills too steep for the ATV or for your abilities.

Practice on smaller hills before attempting large hills.

It is important when climbing a hill to make sure that your weight is transferred forward on the ATV. This can be accomplished by leaning forward and, on steeper inclines, standing on the footboards and leaning forward over the handlebars.

⚠ WARNING

POTENTIAL HAZARD

Climbing hills improperly.

WHAT CAN HAPPEN

Could cause loss of control or cause the ATV to overturn.

HOW TO AVOID THE HAZARD

Always follow proper procedures for climbing hills as described in this Owner's Manual.

Always check the terrain carefully before you start up any hill.

Never climb hills with excessively slippery or loose surfaces.

Shift your weight forward.

Never open the throttle suddenly or make sudden gear changes. The ATV could flip over backwards.

Never go over the top of any hill at high speed. An obstacle, a sharp drop, or another vehicle or person could be on the other side of the hill.

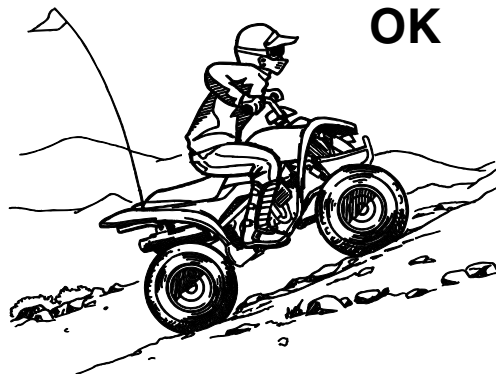

If you are climbing a hill and you find that you have not properly judged your ability to make it to the top, you should turn the ATV around while you still have forward motion (provided you have the room to do so) and go down the hill.

⚠ WARNING

POTENTIAL HAZARD

Improperly crossing hills or turning on hills.

WHAT CAN HAPPEN

Could cause loss of control or cause the ATV to overturn.

HOW TO AVOID THE HAZARD

Never attempt to turn the ATV around on any hill until you have mastered the turning technique as described in the Owner's Manual on level ground. Be very careful when turning on any hill.

Avoid crossing the side of a steep hill if possible.

When crossing the side of a hill:

Always follow proper procedures as described in the Owner's Manual.

Avoid hills with excessively slippery or loose surfaces.

Shift your weight to the uphill side of the ATV.

OK

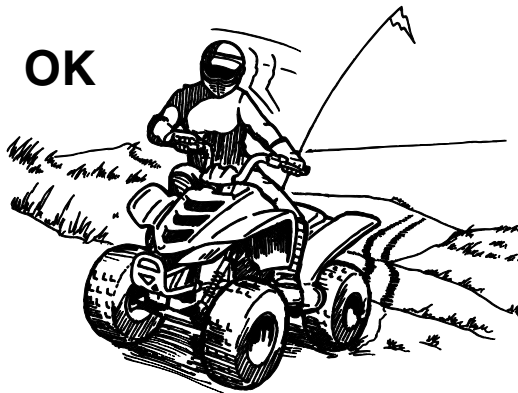

If your ATV has stalled or stopped and you believe you can continue up the hill, restart carefully to make sure you do not lift the front wheels which could cause you to lose control. If you are unable to continue up the hill, dismount the ATV on the uphill side. Physically turn the ATV around and then descend the hill.

If you start to roll backwards, DO NOT use the rear brake to stop or try to put the ATV in gear. The ATV could easily tip over backwards. Instead, apply the front brake gradually, or dismount the ATV immediately on the uphill side.

WARNING

POTENTIAL HAZARD

Stalling, rolling backwards or improperly dismounting while climbing a hill.

WHAT CAN HAPPEN

Could result in the ATV overturning.

HOW TO AVOID THE HAZARD

Use proper gear and maintain steady speed when climbing a hill.

If you lose all forward speed:

Keep weight uphill.

Apply the brakes.

Lock the parking brake, after you are stopped.

If you begin rolling backwards:

Keep weight uphill.

Never apply the rear brake while rolling backwards. Apply the front brake.

When fully stopped, apply the rear brake as well, and then lock the parking brake.

Dismount on uphill side or to a side if pointed straight uphill. Turn the ATV around and remount, following the procedure described in the Owner's Manual.

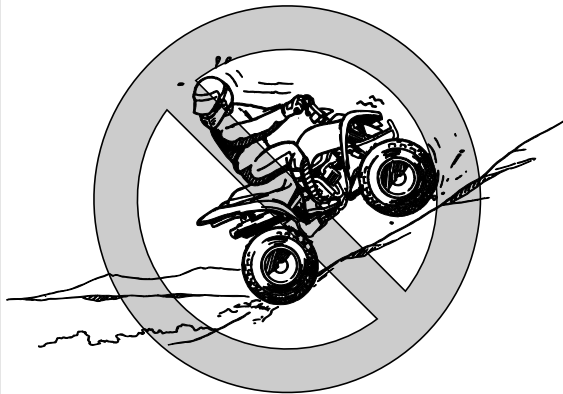

RIDING DOWNHILL

When riding your ATV downhill, shift your weight as far to the rear and uphill side of the ATV as possible. Move back on the seat and sit with your arms straight. Choose a low gear which will allow the engine compression to do most of the braking for you. Improper braking may cause a loss of traction.

Use caution while descending a hill with loose or slippery surfaces. Braking ability and traction may be adversely affected by these surfaces. Improper braking may also cause a loss of traction.

Whenever possible, ride your ATV straight downhill. Avoid sharp angles which could allow the ATV to tip or roll over. Carefully choose your path and ride no faster than you will be able to react to obstacles which may appear.

WARNING

POTENTIAL HAZARD

Going down a hill improperly.

WHAT CAN HAPPEN

Could cause loss of control or cause the ATV to overturn.

HOW TO AVOID THE HAZARD

Always follow proper procedures for going down hills as described in this Owner's Manual. Note: a special technique is required when braking as you go down a hill.

Always check the terrain carefully before you start down any hill.

Shift your weight backward.

Never go down a hill at high speed.

Avoid going down a hill at an angle that would cause the vehicle to lean sharply to one side. Go straight down the hill where possible.

OK

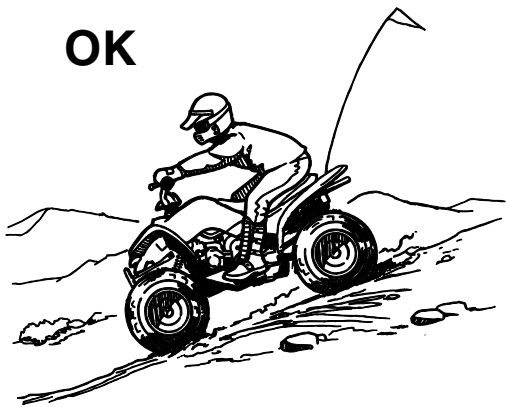

CROSSING A SLOPE

Traversing a sloping surface on your ATV requires you to properly position your weight to maintain proper balance. Be sure that you have learned the basic riding skills on flat ground before attempting to cross a sloping surface. Avoid slopes with slippery surfaces or rough terrain that may upset your balance.

As you travel across a slope, lean your body in the uphill direction. It may be necessary to correct the steering when riding on loose surfaces by pointing the front wheels slightly uphill. When riding on slopes be sure not to make sharp turns either up or down hill.

If your ATV does begin to tip over, gradually steer in the downhill direction if there are no obstacles in your path. As you regain proper balance, gradually steer again in the direction you wish to travel.

WARNING

POTENTIAL HAZARD

Improperly crossing hills or turning on hills.

WHAT CAN HAPPEN

Could cause loss of control or cause the ATV to overturn.

HOW TO AVOID THE HAZARD

Never attempt to turn the ATV around on any hill until you have mastered the turning technique as described in the Owner's Manual on level ground. Be very careful when turning on any hill. Avoid crossing the side of a steep hill if possible.

When crossing the side of a hill:

Always follow proper procedures as described in the Owner's Manual. Avoid hills with excessively slippery or loose surfaces.

Shift your weight to the uphill side of the ATV.

OK



CROSSING THROUGH SHALLOW WATER

The ATV can be used to cross slow moving, shallow water of up to a maximum of 20 cm (7.9 inches) in depth. Before entering the water, choose your path carefully. Enter where there is no sharp drop off, and avoid rocks or other obstacles which may be slippery or upset the ATV. Drive slowly and carefully.

⚠ WARNING

POTENTIAL HAZARD

Operating this ATV through deep or fast flowing water.

WHAT CAN HAPPEN

Tires may float, causing loss of traction and loss of control, which could lead to an accident.

HOW TO AVOID THE HAZARD

Never operate this ATV in fast flowing water or in water deeper than that specified in your Owner's Manual.

Remember that wet brakes may have reduced stopping ability. Test your brakes after leaving water. If necessary, apply them several times to let friction dry out the linings.



Test your brakes after leaving the water. Do not continue to ride your ATV without verifying that you have regained proper braking ability.

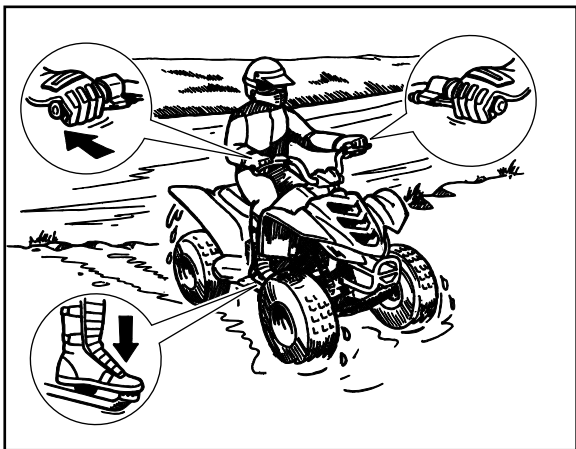

CAUTION:

After riding your ATV in water, be sure to drain the trapped water by removing the check hose at the bottom of the air filter case. Wash the ATV in fresh water if it has been operated in salt water or muddy conditions.

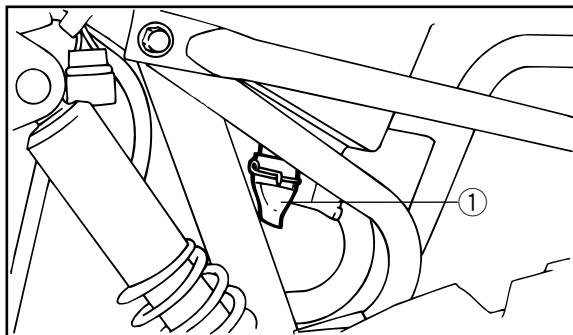

1. Check hose

RIDING OVER ROUGH TERRAIN

Riding over rough terrain should be done with caution. Look out for obstacles which could cause damage to the ATV or could lead to an upset or accident. Be sure to keep your feet firmly mounted on the footboards at all times. Avoid jumping the ATV as loss of control and damage to the ATV may result.

WARNING

POTENTIAL HAZARD

Improperly operating over obstacles.

WHAT CAN HAPPEN

Could cause loss of control or a collision.

Could cause the ATV to overturn.

HOW TO AVOID THE HAZARD

Before operating in a new area, check for obstacles.

Never attempt to ride over large obstacles, such as large rocks or fallen trees. When you go over obstacles, always follow proper procedures as described in the Owner's Manual.

SLIDING AND SKIDDING

Care should be used when riding on loose or slippery surfaces since the ATV may slide. If unexpected and uncorrected, sliding could lead to an accident.

To reduce the tendency for the front wheels to slide in loose or slippery conditions, positioning your weight over the front wheels will sometimes help.

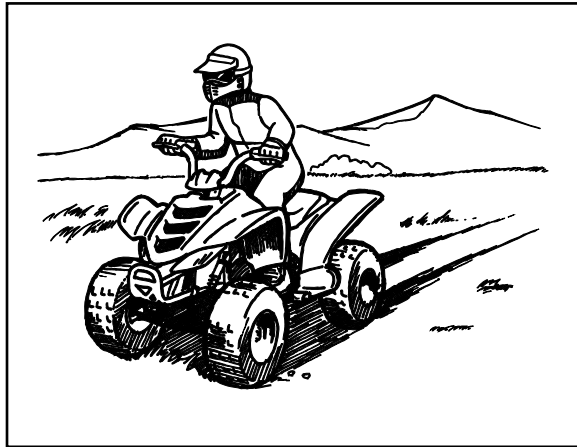

If the rear wheels of your ATV start to slide sideways, control can usually be regained (if there is room to do so) by steering in the direction of the slide. Applying the brakes or accelerating is not recommended until you have corrected the slide.

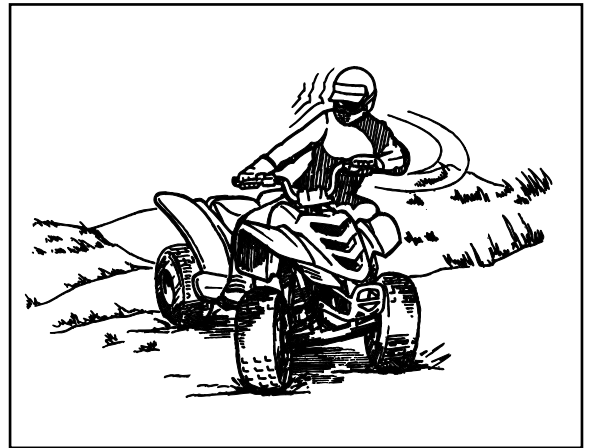

With practice, over a period of time, skill at controlled sliding can be developed. The terrain should be chosen carefully before attempting such maneuvers, since both stability and control are reduced. Bear in mind that sliding maneuvers should always be avoided on extremely slippery surfaces such as ice, since all control may be lost.

WARNING

POTENTIAL HAZARD

Skidding or sliding improperly.

WHAT CAN HAPPEN

You may lose control of this ATV. You may also regain traction unexpectedly, which may cause the ATV to overturn.

HOW TO AVOID THE HAZARD

Learn to safely control skidding or sliding by practicing at low speeds and on level, smooth terrain.

On extremely slippery surfaces, such as ice, go slowly and be very cautious in order to reduce the chance of skidding or sliding out of control.

WHAT TO DO IF ...

This section is designed to be a reference guide only. Be sure to read each section on riding techniques completely.

WHAT TO DO ...

- If your ATV doesn't turn when you want it to:
Bring the ATV to a stop and practice the turning maneuvers again. Be sure you are putting your weight on the footboard to the outside of the turn. Position your weight over the front wheels for better control. (See pages 7-23–7-24.)
- If your ATV begins to tip while turning:
Lean more into the turn to regain balance. If necessary, gradually let off the throttle and/or steer to the outside of the turn. (See pages 7-23–7-24.)

- If your ATV starts to slide sideways:
Steer in the direction of the slide if you have the room.
Applying the brakes or accelerating is not recommended until you have corrected the slide. (See pages 7-38–7-39.)
- If your ATV can't make it up a hill you are trying to climb:
Turn the ATV around if you still have forward speed. If not, stop, dismount on the uphill side of the ATV and physically turn the ATV around. If the ATV starts to slip backwards **DO NOT USE THE REAR BRAKE** - the ATV may tip over on top of you. Instead, apply the front brake or dismount the ATV on the uphill side. (See pages 7-25–7-29.)

- If your ATV is traversing a sloping surface:
Be sure to ride with your weight positioned towards the uphill side of the ATV to maintain proper balance. If the ATV starts to tip, steer down the hill (if there are no obstacles in your way) to regain balance. If you discover that the ATV is going to tip over, dismount on the uphill side. (See pages 7-32–7-33.)
- If your ATV encounters shallow water:
Ride slowly and carefully through slow moving water, watching for obstacles. Be sure to let water drain from the ATV and **CHECK YOUR BRAKES FOR PROPER OPERATION** when you come out of the water. Do not continue to ride your ATV until you have regained adequate braking ability. (See pages 7-34–7-35.)

 WARNING

Indicates a potential hazard that could result in serious injury or death.

PERIODIC MAINTENANCE AND ADJUSTMENT

Periodic inspection, adjustment and lubrication will keep your machine in the safest and most efficient condition possible. Safety is an obligation of the machine owner. The most important points of machine inspection, adjustment and lubrication are explained on the following pages.

! WARNING

POTENTIAL HAZARD

Servicing an engine while it is running.

WHAT CAN HAPPEN

Moving parts can catch clothing or parts of the body, causing injury.

Electrical components can cause shocks or can start fires.

HOW TO AVOID THE HAZARD

Turn off the engine when performing maintenance unless otherwise specified. Have a Yamaha dealer perform service if you are not familiar with machine service.

EBU01221

Owner's manual and tool kit

You are recommended to put this owner's manual and low-pressure tire gauge in the vinyl bag and always carry them along with the owner's tool kit under the seat.

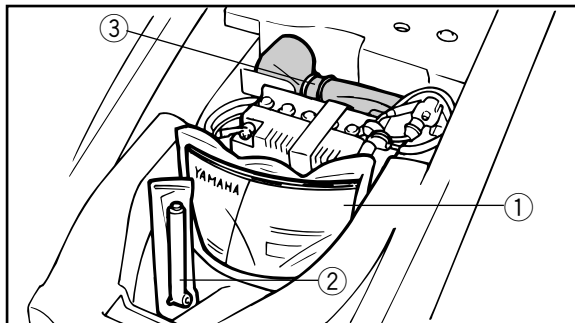

1. Owner's manual

2. Low-pressure tire gauge

8-1 3. Owner's tool kit

The service information included in this manual is intended to provide you, the owner, with the necessary information for completing your own preventive maintenance and minor repairs. The tools provided in the owner's tool kit are sufficient for this purpose, except that a torque wrench is also necessary to properly tighten nuts and bolts.

NOTE: _____

If you do not have a torque wrench available during a service operation requiring one, take your machine to a Yamaha dealer to check the torque settings and adjust them as necessary.

⚠ WARNING

POTENTIAL HAZARD

Operating this ATV with improper modifications.

WHAT CAN HAPPEN

Improper installation of accessories or modification of this vehicle may cause changes in handling which in some situations could lead to an accident.

HOW TO AVOID THE HAZARD

Never modify this ATV through improper installation or use of accessories. All parts and accessories added to this vehicle should be genuine Yamaha or equivalent components designed for use on this ATV and should be installed and used according to instructions. If you have questions, consult an authorized Yamaha ATV dealer.

Periodic maintenance chart for the emission control system

NOTE:

- For ATVs not equipped with an odometer or an hour meter, follow the month maintenance intervals.
- For ATVs equipped with an odometer or an hour meter, follow the km (mi) or hours maintenance intervals. However, keep in mind that if the ATV isn't used for a long period of time, the month maintenance intervals should be followed.

ITEM	ROUTINE	Whichever comes first ⇒	INITIAL			EVERY		
			month	1	3	6	6	12
			km (mi)	320 (200)	1300 (800)	2500 (1600)	2500 (1600)	5000 (3200)
			hours	20	80	160	160	320
Valves*	<ul style="list-style-type: none"> • Check valve clearance. • Adjust if necessary. 		○		○	○	○	
Cam chain*	<ul style="list-style-type: none"> • Check chain tension. • Adjust if necessary. 		○		○	○	○	
Spark plug	<ul style="list-style-type: none"> • Check condition. • Adjust gap and clean. • Replace if necessary. 		○	○	○	○	○	
Carburetor*	<ul style="list-style-type: none"> • Check idle speed/choke lever operation. • Adjust if necessary. 			○	○	○	○	
Crankcase breather system*	<ul style="list-style-type: none"> • Check breather hose for cracks or damage. • Replace if necessary. 				○	○	○	
Exhaust system*	<ul style="list-style-type: none"> • Check for leakage. • Tighten if necessary. • Replace gasket if necessary. 				○	○	○	
Spark arrester	<ul style="list-style-type: none"> • Clean. 				○	○	○	
Fuel line*	<ul style="list-style-type: none"> • Check fuel hose for cracks or damage. • Replace if necessary. 				○	○	○	

General maintenance and lubrication chart

ITEM	ROUTINE	Whichever comes first ⇒	INITIAL			EVERY		
			month	1	3	6	6	12
			km (mi)	320 (200)	1300 (800)	2500 (1600)	2500 (1600)	5000 (3200)
hours	20	80	160	160	320			
Air filter element	<ul style="list-style-type: none"> Clean. Replace if necessary. 		Every 20–40 hours (more often in wet or dusty areas)					
Engine oil	<ul style="list-style-type: none"> Replace (warm engine before draining). 		○		○	○	○	
Final gear oil	<ul style="list-style-type: none"> Check oil level/oil leakage. Replace every 12 months. 		○				○	
Brakes*	<ul style="list-style-type: none"> Check operation. Adjust if necessary. 		○	○	○	○	○	
Clutch*	<ul style="list-style-type: none"> Check operation. Adjust if necessary. 		○		○	○	○	
Wheels*	<ul style="list-style-type: none"> Check balance/damage/runout. Replace if necessary. 		○		○	○	○	
Wheel bearings*	<ul style="list-style-type: none"> Check bearing assemblies for looseness/damage. Replace if damaged. 		○		○	○	○	
Steering system*	<ul style="list-style-type: none"> Check operation. Replace if damaged. Check toe-in. Adjust if necessary. 		○	○	○	○	○	
Knuckle shafts/steering shaft*	<ul style="list-style-type: none"> Lubricate every 6 months with Lithium-soap-based grease. 				○	○	○	
Fittings and fasteners*	<ul style="list-style-type: none"> Check all chassis fittings and fasteners. Correct if necessary. 		○	○	○	○	○	

ITEM	ROUTINE	Whichever comes first ⇒	INITIAL			EVERY		
			month	1	3	6	6	12
			km (mi)	320 (200)	1300 (800)	2500 (1600)	2500 (1600)	5000 (3200)
			hours	20	80	160	160	320
Battery*	<ul style="list-style-type: none"> • Check specific gravity. • Check breather hose for correct routing. • Correct if necessary. 		○	○	○	○	○	

* Since these items require special tools, data and technical skills, have a Yamaha dealer perform the service.

⚠ WARNING

Indicates a potential hazard that could result in serious injury or death.

Engine oil

Engine oil level measurement

1. Place the ATV on a level surface.
2. Warm up the engine for several minutes and stop it.
3. Remove the dipstick and wipe it off with a clean rag. Insert the dipstick in the filler hole without screwing it in.

NOTE: _____

Wait a few minutes until the oil level settles before checking.

4. Remove the dipstick and inspect the oil level.
5. The oil level should be between the maximum and minimum marks. If the level is low, add oil to raise it to the specified level.

CAUTION: _____

Be sure no foreign material enters the crankcase.

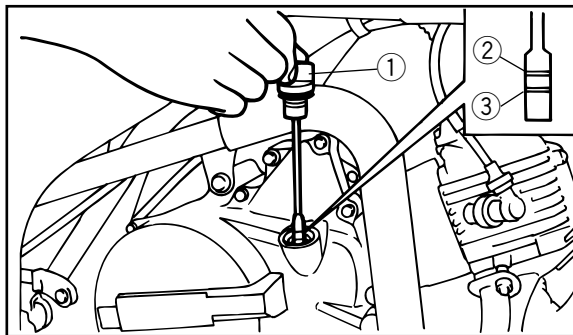

1. Dipstick

2. Maximum level mark

3. Minimum level mark

Engine oil replacement

1. Place the ATV on a level surface.
2. Warm up the engine for several minutes and stop it.
3. Place a container under the engine.
4. Remove the dipstick and drain bolt to drain the oil.
5. Inspect the O-ring and replace if damaged.

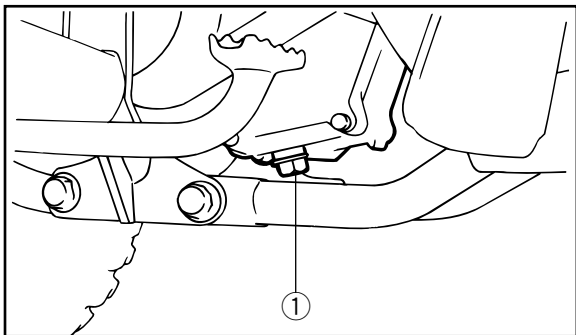

1. Drain bolt

6. Install the drain bolt and tighten to specification.

Tightening torque

Drain bolt:

20 Nm (2.0 m·kgf, 14 ft·lbf)

7. Fill the engine with oil and install the dipstick.

Recommended oil type:

YAMALUBE 4 (20W40) or SAE 20W40

YAMALUBE 4 (10W30) or SAE 10W30

SAE 5W30

Recommended oil classification:

API Service SE, SF, SG type or higher

Oil quantity:

Periodic oil change:

0.8 L (0.70 Imp qt, 0.85 US qt)

CAUTION:

Be sure no foreign material enters the crankcase.

8. Warm up the engine for several minutes at idle speed. Check for oil leakage while warming up.

CAUTION:

If oil leakage is found, stop the engine immediately and check for the cause.

Final gear oil

Final gear oil measurement

1. Place the ATV on a level surface.
2. Remove the dipstick and wipe it off with a clean rag. Insert the dipstick in the filler hole without screwing it in.
3. Remove the dipstick and inspect the oil level.
4. The oil level should be between the maximum and minimum marks. If the level is low, add oil to raise it to the proper level.

CAUTION: _____

Be sure no foreign material enters the final gear case.

5. Install the dipstick.

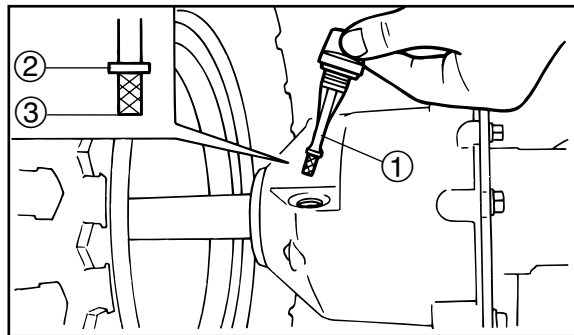

1. Dipstick

2. Maximum level mark

3. Minimum level mark

Final gear oil replacement

1. Place the ATV on a level place.
2. Place a container under the final gear case.
3. Remove the dipstick and drain bolt to drain the oil.

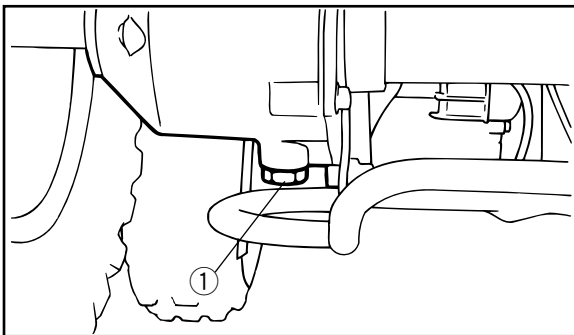

1. Drain bolt

4. Install the drain bolt and tighten to specification.

Tightening torque

Drain bolt:

23 Nm (2.3 m·kgf, 17 ft·lbf)

5. Fill the final gear case with oil.

Recommended oil:

SAE80API “GL-4” Hypoid gear oil

Oil quantity:

0.12L (0.11 Imp qt, 0.13 US qt)

CAUTION: _____

Be sure no foreign material enters the final gear case.

6. Install the dipstick.
7. Check for oil leakage. If oil leakage is found, check for the cause.

Spark plug inspection

The spark plug is an important engine component and is easy to inspect. The condition of the spark plug can indicate the condition of the engine.

For example, a very white center electrode porcelain color could indicate an intake air leak or carburetion problem for that cylinder. Do not attempt to diagnose such problems yourself.

Instead, take the ATV to a Yamaha dealer. You should periodically remove and inspect the spark plug because heat and deposits will cause the spark plug to slowly break down and erode. If electrode erosion becomes excessive, you should replace the spark plug with one of the proper type.

Standard spark plug:
CR7HSA (NGK)

Before installing the spark plug, measure the electrode gap with a wire thickness gauge and adjust it to specification.

Spark plug gap:
0.6–0.7 mm (0.024–0.028 in)

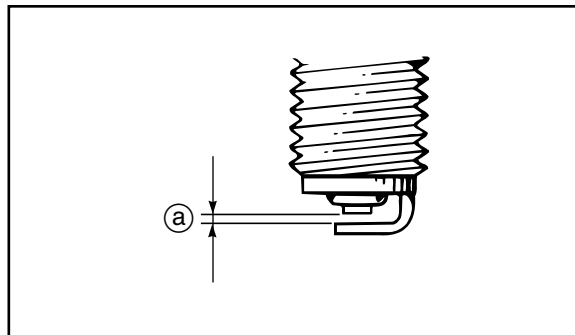

a. Spark plug gap

When installing the spark plug, always clean the gasket surface and its mating surface. Wipe off any grime from the threads and tighten it to the specified torque.

Tightening torque:

Spark plug:

12.5 Nm (1.25 m·kgf, 9.1 ft·lbf)

EBU10343

Air filter cleaning

NOTE:

There is a check hose at the bottom of the air filter case. If dust or water collects in this hose, empty the hose and clean the air filter element and air filter case.

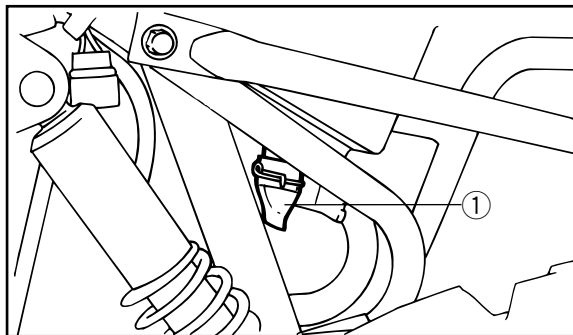

1. Check hose

1. Remove the front cover by removing the bolts.

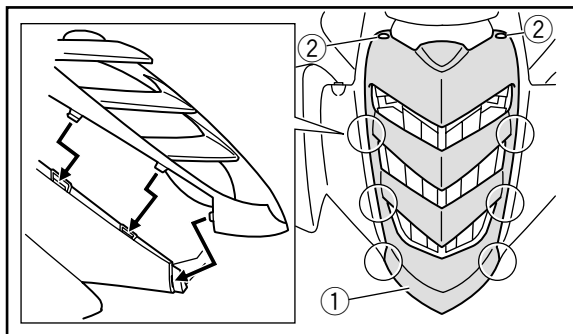

8-11 1. Front cover

2. Bolt (x2)

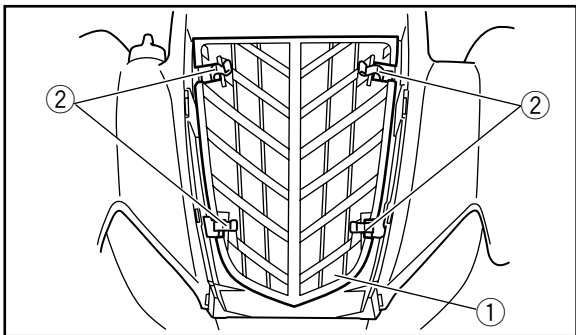

1. Air filter case cover

2. Fastener (x4)

2. Remove the air filter case cover by unhooking the fasteners.

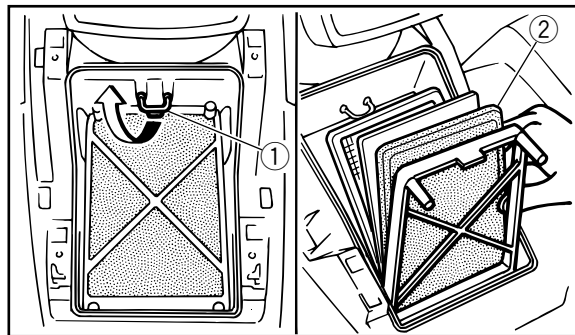

1. Fastener

2. Air filter element

3. Remove the air filter element by unhooking the fastener.
4. Wash the air filter element gently but thoroughly in solvent.

 **WARNING**

POTENTIAL HAZARD

Using low flash point solvents or gasoline to clean the air filter element.

WHAT CAN HAPPEN

Low flash point solvents or gasoline can catch fire or explode.

HOW TO AVOID THE HAZARD

Use parts cleaning solvent to clean the air filter element.

5. Squeeze the excess solvent out of the air filter element and let it dry.

CAUTION: _____

Do not twist the air filter element when squeezing it.

6. Inspect the air filter element. If damaged, replace it.
7. Apply Yamaha foam air filter oil or other quality foam air filter oil to the air filter element.

NOTE: _____

The air filter element should be wet but not dripping.

8. Install the air filter element.
9. Install the air filter case cover by hooking the fasteners onto the air filter case.
10. Install the front cover by installing the bolts.

NOTE: _____

The air filter element should be cleaned every 20-40 hours. It should be cleaned and lubricated more often if the machine is operated in extremely dusty areas. Each time air filter element maintenance is performed, check the air inlet of the air filter case for obstructions. Check the air cleaner rubber joint to the carburetor and manifold fittings for an airtight seal. Tighten all fittings securely to avoid the possibility of unfiltered air entering the engine.

CAUTION: _____

Never operate the engine with the air filter element removed. This will allow unfiltered air to enter the engine, causing rapid engine wear and possible engine damage. Additionally, operation without the filter element will affect carburetor jetting with subsequent poor performance and possible engine overheating.

Air intake restrictor plate removal

To obtain full engine performance capability, removing the air intake restrictor plate is required.

1. Remove the air filter element. (See page 8-11 for removal and installation procedures.)
2. Remove the air intake restrictor plate.

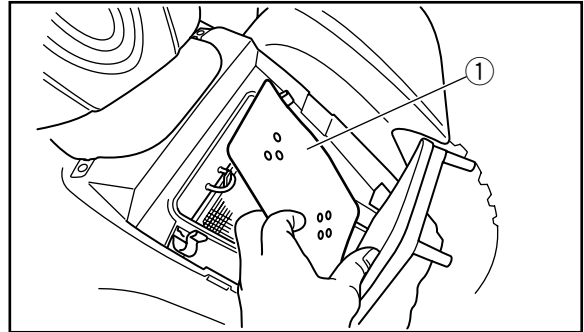

1. Air intake restrictor plate

NOTE: _____

Store the air intake restrictor plate with the owner's manual so that you can install it whenever you want to reduce the top speed available.

3. Install the air filter element.

Spark arrester cleaning

Be sure the exhaust pipe and muffler are cool before cleaning the spark arrester.

1. Remove the screws.

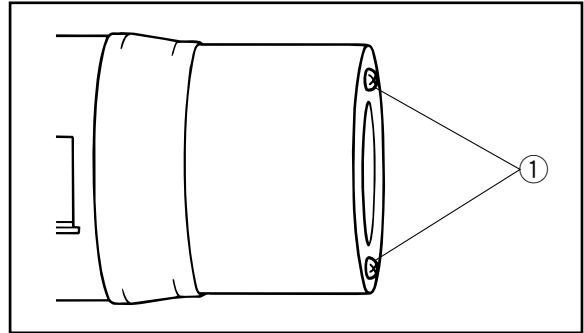

1. Screw (x2)

2. Remove the tailpipe by pulling it out of the muffler.
3. Tap the tailpipe lightly, then use a wire brush to remove any carbon deposits from the spark arrester portion of the tailpipe.

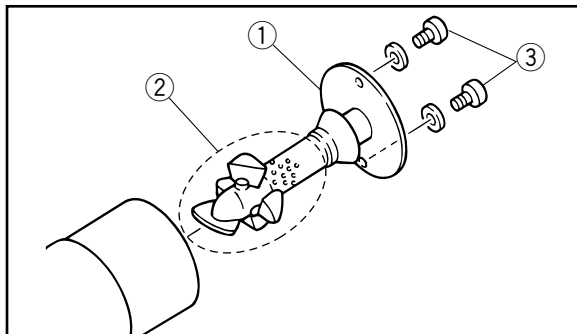

1. Tailpipe
3. Screw (x2)

2. Spark arrester

4. Insert the tailpipe into the muffler and align the screw holes.
5. Install the screws and tighten them.

⚠ WARNING

POTENTIAL HAZARD

**Improper cleaning of the spark arrester.
Hot exhaust system**

WHAT CAN HAPPEN

**Could injure the eyes.
Could cause burns.
Could cause carbon monoxide poisoning,
possibly leading to death.
Could start a fire.**

HOW TO AVOID THE HAZARD

**When cleaning the spark arrester:
Always let the exhaust system cool prior
to touching exhaust components.
Do not start the engine when cleaning the
exhaust system.**

Carburetor adjustment

The carburetor is a vital part of the engine and requires very sophisticated adjustment. Most adjusting should be left to a Yamaha dealer who has the professional knowledge and experience to do so. However, the idling speed may be performed by the owner as a part of the usual maintenance routine.

CAUTION: _____

The carburetor was set at the Yamaha factory after many tests. If the settings are disturbed by someone without sufficient technical knowledge, poor engine performance and damage may result.

Idle speed adjustment

NOTE: _____

A diagnostic tachometer must be used for this procedure.

1. Start the engine and warm it up for a few minutes at approximately 1,000 to 2,000 r/min. Occasionally rev the engine to 4,000 to 5,000 r/min. The engine is warm when it quickly responds to the throttle.

2. Connect the tachometer to the spark plug lead, and then set the idle to the specified idling speed by adjusting the throttle stop screw. Turn the screw in direction (a) to increase the engine speed, and in direction (b) to decrease the engine speed.

Specified idle speed:
1,750–1,850 r/min

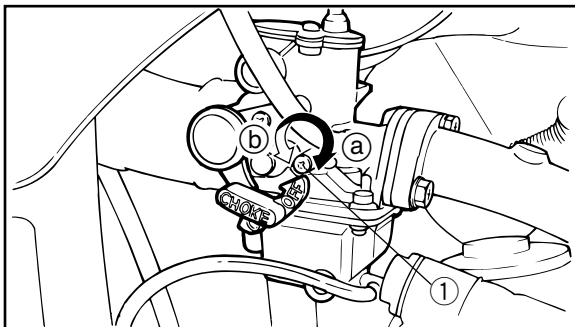

1. Throttle stop screw

EBU00303

Valve clearance adjustment

The correct valve clearance changes with use, resulting in improper fuel/air supply or engine noise. To prevent this, the valve clearance must be adjusted regularly. This adjustment however, should be left to a professional Yamaha service technician.

EBU00304

Cam chain adjustment

The cam chain becomes loose with use, resulting in improper valve timing and engine noise. To prevent this, the cam chain tensioner must be adjusted regularly. This adjustment should be left to a Yamaha service technician.

EBU01218

Front and rear brake shoe inspection

A wear indicator is provided on each brake. The indicators allows checking of brake shoe wear without disassembling the brake. Apply the brake and check the position of the indicator. If the indicator reaches the wear limit line or mark, ask a Yamaha dealer to replace the shoes as a set.

Front brake lever free play adjustment

NOTE: _____
 Before adjusting the brake, inspect the front brake shoes.

The front brake lever free play should be adjusted to 10–12 mm (0.4–0.5 in) at the brake lever pivot. If the free play is incorrect, adjust as follows:

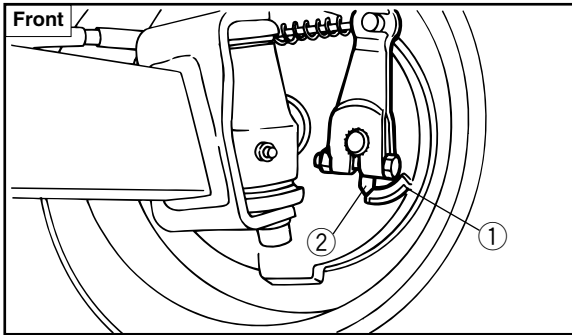

1. Wear limit line

2. Wear indicator

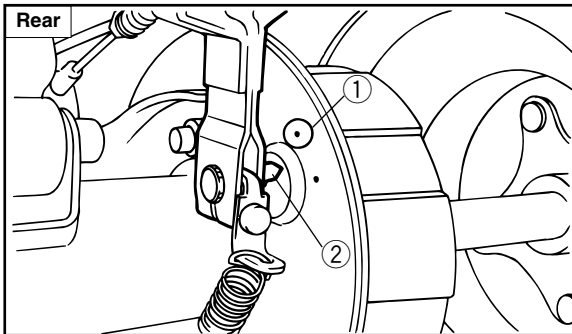

1. Wear limit mark

2. Wear indicator

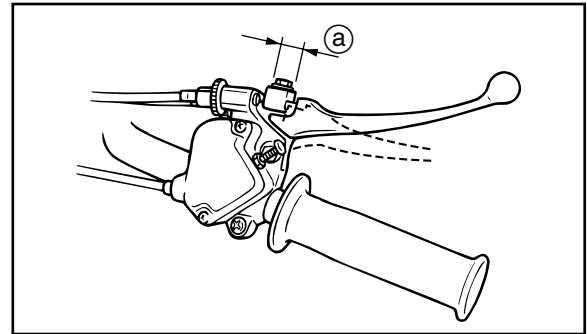

a. Free play

1. Loosen the upper locknut and fully turn in the adjusting bolt.
2. Loosen the lower locknut.
3. Turn the lower adjusting bolt until specified free play is obtained.

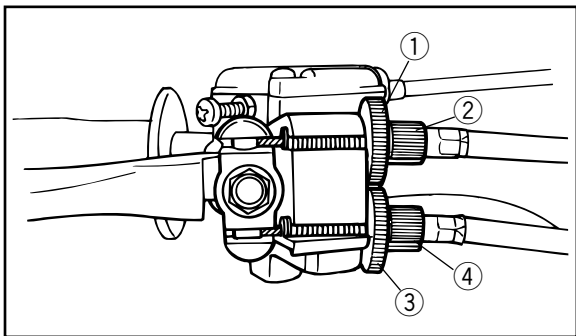

- | | |
|------------------|-------------------------|
| 1. Upper locknut | 2. Upper adjusting bolt |
| 3. Lower locknut | 4. Lower adjusting bolt |

Specified free play:
10–12 mm (0.4–0.5 in)

4. Tighten the lower locknut.

5. While applying the front brake, turn out the upper adjusting bolt until the upper and lower cable lengths are equal. The cable joint will become vertical.

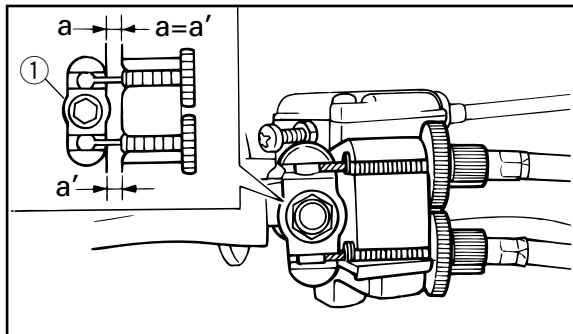

1. Cable joint

6. Tighten the upper locknut.

⚠ WARNING

POTENTIAL HAZARD

Operating with improperly serviced or adjusted brakes.

WHAT CAN HAPPEN

You could lose braking ability, which could lead to an accident.

HOW TO AVOID THE HAZARD

After servicing:

- **Make sure the brakes operate smoothly and that the free play is correct.**
- **Make sure the brakes do not drag.**

Replacement of brake components requires professional knowledge. These procedures should be performed by Yamaha dealer.

Rear brake lever and brake pedal adjustment

Brake lever free play adjustment

1. Loosen the brake cable locknut.
2. Turn the adjusting bolt at the brake lever until brake lever free play is 5–8 mm (0.20–0.30 in).
3. Tighten the locknut.

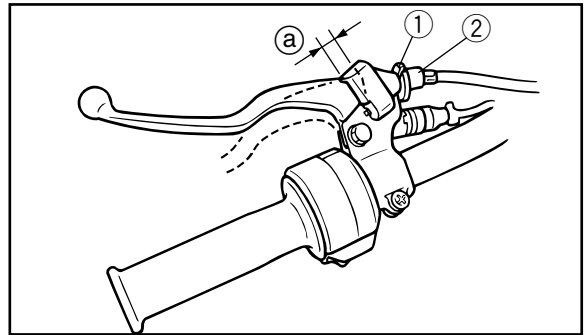

a. Free play
1. Locknut

2. Adjusting bolt

NOTE: _____

If specified free play cannot be obtained, tighten the brake cable adjusting nut at the rear wheel hub until brake lever free play is 5–8 mm (0.20–0.30 in).

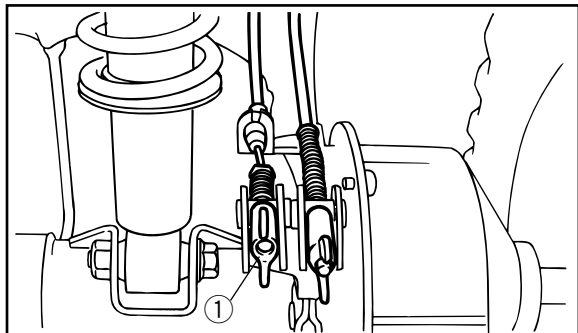

1. Brake cable adjusting nut

Brake pedal free play adjustment

Turn the brake rod adjusting nut at the rear wheel hub until brake pedal free play is 20–30 mm (0.8–1.2 in).

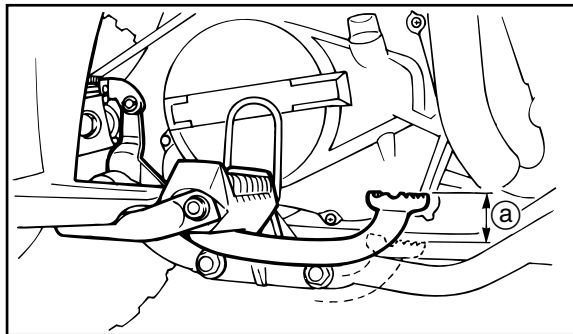

a. Free play

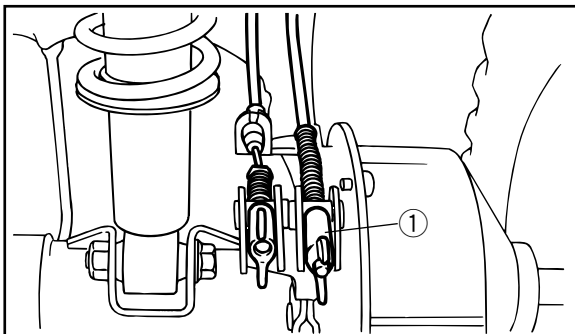

1. Brake rod adjusting nut

⚠ WARNING

POTENTIAL HAZARD

Operating with improperly serviced or adjusted brakes.

WHAT CAN HAPPEN

You could lose braking ability, which could lead to an accident.

HOW TO AVOID THE HAZARD

After servicing:

- **Make sure the brakes operate smoothly and that the free play is correct.**
- **Make sure the brakes do not drag.**

Replacement of brake components requires professional knowledge. These procedures should be performed by a Yamaha dealer.

Clutch adjustment

1. Remove the rubber cap.
2. Loosen the locknut.
3. Slowly turn the adjusting bolt clockwise until resistance is felt. Then turn it 1/8 counterclockwise.

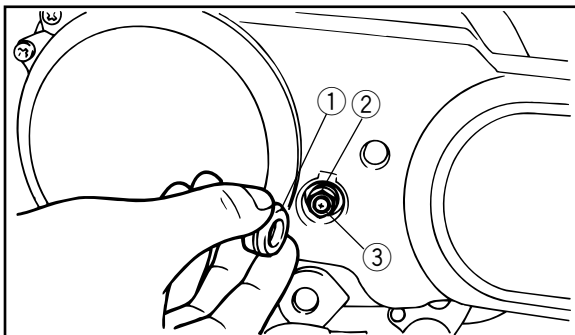

1. Rubber cap 2. Locknut 3. Adjusting bolt

4. Tighten the locknut to the specified torque.

Tightening torque:

8 Nm (0.8 m·kgf, 5.8 ft·lbf)

NOTE: _____

Turn the adjusting bolt clockwise to decrease the clutch free play and turn it counterclockwise to increase the free play.

5. Install the rubber cap securely.

Cable inspection and lubrication

WARNING

POTENTIAL HAZARD

Damaged control cables.

WHAT CAN HAPPEN

Corrosion can result when the outer covering of control cables becomes damaged. Cables can also become frayed or kinked. Operation of controls could be restricted, which could cause an accident or injury.

HOW TO AVOID THE HAZARD

Inspect cables frequently. Replace damaged cables.

Lubricate the inner cables and the cable ends. If the cables do not operate smoothly, ask a Yamaha dealer to replace them.

Recommended lubricant:

Yamaha chain and cable lube or
SAE 10W30 motor oil

EBU00727

Brake and shift pedal/brake lever lubrication

Lubricate the pivoting parts of each lever and pedal.

Recommended lubricant:

Lithium-soap-based grease
(all-purpose grease)

Knuckle shaft and steering shaft lubrication

Lubricate the pivot points using a grease gun.

Recommended lubricant:
Lithium-soap-based grease
(all-purpose grease)

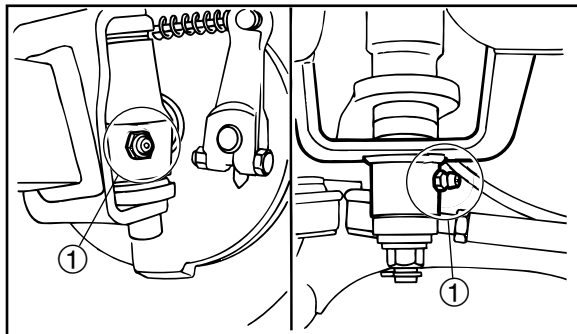

1. Grease nipple

Wheel removal

1. Loosen the wheel nuts.
2. Elevate the ATV and place a suitable stand under the frame.
3. Remove the nuts from the wheel.
4. Remove the wheel.

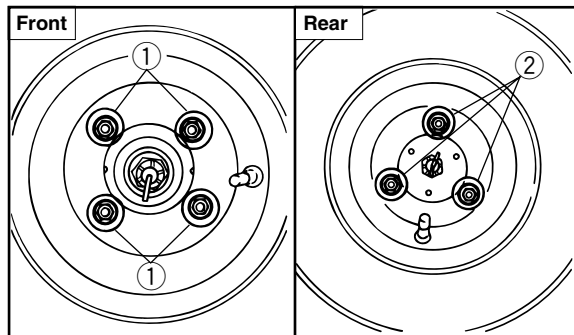

1. Wheel nut (×4)

2. Wheel nut (×3)

Wheel installation

When installing the wheel, reverse the removal procedure.

Tighten the wheel nuts to the specified torques.

Tightening torque:

Wheel nut:

Front: 28 Nm (2.8 m·kgf, 20 ft·lbf)

Rear: 28 Nm (2.8 m·kgf, 20 ft·lbf)

Battery

Check the level of the battery fluid and see if the terminals are tight. Add distilled water if the fluid level is low.

CAUTION:

Do not leave or store the battery on its side. When inspecting the battery, be sure the breather hose is routed correctly. If it touches the frame or exists in such a way as to cause battery electrolyte or gas to exit onto the frame, structural and cosmetic damage to the machine can occur.

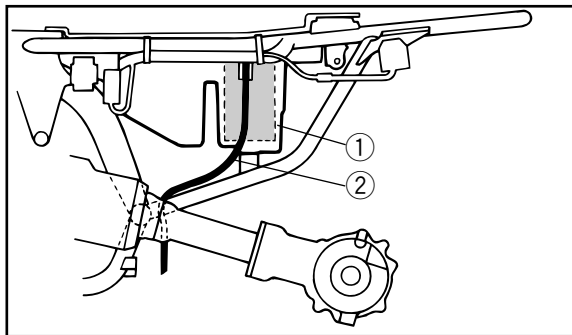

1. Battery

2. Battery breather hose

WARNING

POTENTIAL HAZARD

Failure to handle batteries or battery electrolyte carefully.

WHAT CAN HAPPEN

You could be poisoned. You could be severely burned by the sulfuric acid in battery electrolyte.

Batteries produce explosive gases.

HOW TO AVOID THE HAZARD

Avoid contact with skin, eyes or clothing. Always shield eyes when working near batteries. Keep out of reach of children.

Antidote:

EXTERNAL: Flush with water.

INTERNAL: Drink large quantities of water or milk. Follow with milk of magnesia, beaten egg or vegetable oil. Get prompt medical attention.

EYES: Flush with water for 15 minutes and get prompt medical attention. Keep batteries away from sparks, flames, cigarettes or other sources of ignition. Ventilate when charging or using in a closed space.

Replenishing the battery fluid

A poorly maintained battery will corrode and discharge quickly. The battery fluid should be checked at least once a month.

1. The level should be between the maximum and minimum level marks. Use only distilled water if refilling is necessary.

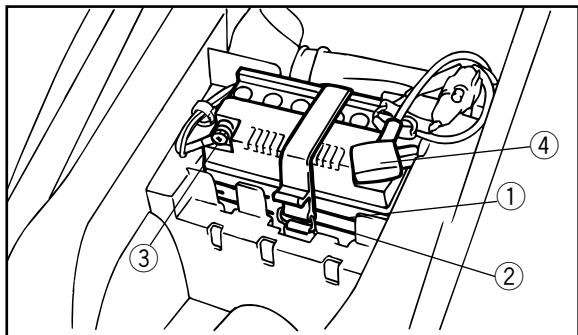

- | | |
|-----------------------|-----------------------|
| 1. Maximum level mark | 2. Minimum level mark |
| 3. Negative lead | 4. Positive lead |

2. Disconnect the negative (–) lead.
3. Disconnect the positive (+) lead, and then remove the battery.

CAUTION:

Normal tap water contains minerals which are harmful to a battery. Therefore, refill only with distilled water.

4. When the machine is not to be used for a month or longer, remove the battery and store it in a cool, dark place. Completely recharge the battery before using.
5. If the battery is to be stored for a longer period than the above, check the specific gravity at least once a month and recharge the battery when it is too low.
6. Always make sure the connections are correct when putting the battery back in the machine. Make sure the breather hose is properly connected and is not damaged or obstructed.

Fuse replacement

1. The fuse case is located under the seat.
2. If the fuse is blown, turn off the main switch and install a new fuse of the specified amperage. Then turn on the switches. If the fuse immediately blows again, consult a Yamaha dealer.

Specified fuse: 5 A

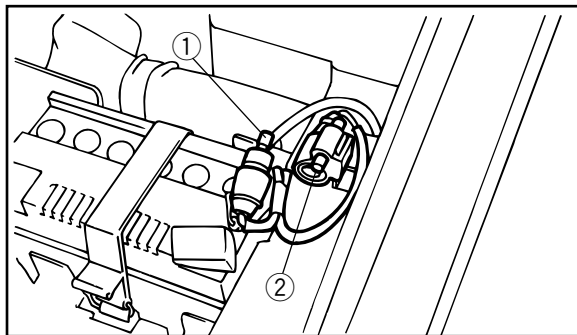

1. Fuse

2. Spare fuse

⚠ WARNING

POTENTIAL HAZARD

Using an improper fuse.

WHAT CAN HAPPEN

An improper fuse can cause damage to the electrical system which could lead to a fire.

HOW TO AVOID THE HAZARD

Always use a fuse of the specified rating. Never use a material in place of the proper fuse.

CAUTION:

To prevent accidental short-circuiting, turn off the main switch when checking or replacing a fuse.

Troubleshooting

Although Yamaha machines receive a rigid inspection before shipment from the factory, trouble may occur during operation. Any problem in the fuel, compression, or ignition systems can cause poor starting and loss of power. The troubleshooting chart describes a quick, easy procedure for making checks. If your machine requires any repair, take it to a Yamaha dealer.

The skilled technicians at a Yamaha dealership have the tools, experience, and know-how to properly service your machine. Use only genuine Yamaha parts on your machine. Imitation parts may look like Yamaha parts, but they are often inferior. Consequently, they have a shorter service life and can lead to expensive repair bills.

WARNING

POTENTIAL HAZARD

Checking the fuel system while smoking or near an open flame.

WHAT CAN HAPPEN

Fuel can ignite or explode, causing severe injury or property damage.

HOW TO AVOID THE HAZARD

Do not smoke when checking the fuel system. Make sure there are no open flames or sparks in the area, including pilot lights from water heaters or furnaces.

Troubleshooting chart

1. Fuel

Check if there is fuel in the fuel tank

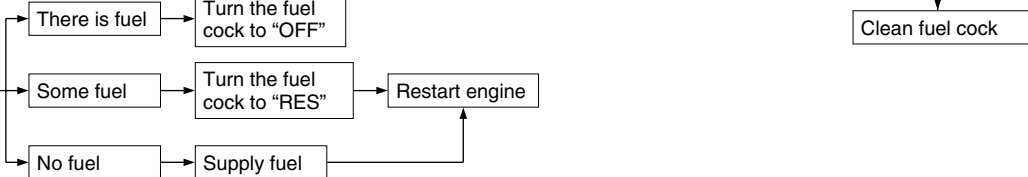

2. Compression

Use electric starter to see if there is compression

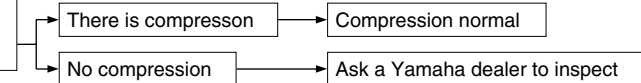

3. Ignition

Remove spark plug and check electrodes

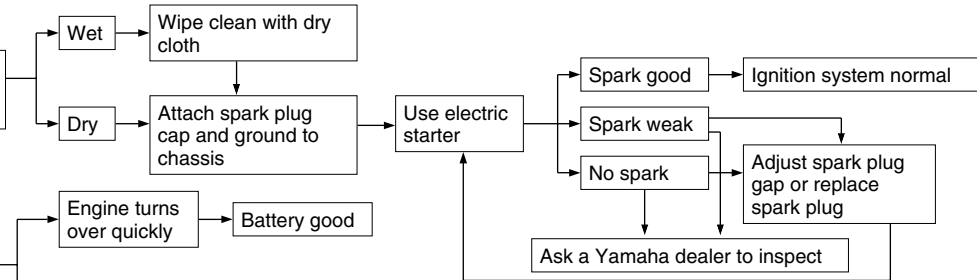

4. Battery

Use electric starter

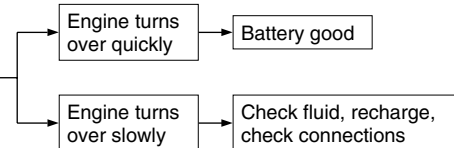

CLEANING AND STORAGE

A. CLEANING

Frequent, thorough cleaning of your machine will not only enhance its appearance but will improve its general performance and extend the useful life of many components.

1. Before cleaning the machine:
 - a. Block off the end of the exhaust pipe to prevent water entry. A plastic bag and strong rubber band may be used.
 - b. Make sure the spark plug and all filler caps are properly installed.
2. If the engine case is excessively greasy, apply degreaser with a paint brush. Do not apply degreaser to the wheel axles.

3. Rinse the dirt and degreaser off with a garden hose. Use only enough pressure to do the job.

CAUTION:

Excessive water pressure may cause water seepage and deterioration of wheel bearings, brakes, transmission seals and electrical devices. Many expensive repair bills have resulted from improper high pressure detergent applications such as those available in coin-operated car washers.

4. Once the majority of the dirt has been hosed off, wash all surfaces with warm water and mild, detergent-type soap. An old toothbrush or bottle brush is handy for hard-to-get-at places.

5. Rinse the machine off immediately with clean water and dry all surfaces with a chamois, clean towel or soft absorbent cloth.
6. Clean the seat with a vinyl upholstery cleaner to keep the cover pliable and glossy.
7. Automotive type wax may be applied to all painted and chrome plated surfaces. Avoid combination cleaner-waxes. Many contain abrasives which may mar the paint or protective finish.
When finished, start the engine and let it idle for several minutes.

WARNING

POTENTIAL HAZARD

Operation with wet brakes after washing.

WHAT CAN HAPPEN

Wet brakes may have reduced stopping ability, increasing the chance of an accident.

HOW TO AVOID THE HAZARD

Test the brakes after washing. Apply the brakes several times at slow speeds to let friction dry out the linings.

B. STORAGE

Long term storage (60 days or more) of your machine will require some preventive procedures to guard against deterioration. After thoroughly cleaning the machine, prepare for storage as follows:

1. Fill the fuel tank with fresh fuel and add the specified amount of Yamaha Fuel Stabilizer and Conditioner or an equivalent product.

Specified amount:

1 oz of stabilizer to each gallon of fuel
(or 7.5 cc of stabilizer to each liter of fuel)

NOTE:

Use of fuel stabilizer and conditioner eliminates the need to drain the fuel system. Consult a Yamaha dealer if the fuel system needs to be drained instead.

2. Remove the spark plug, pour about one tablespoon of SAE 10W30 or 20W40 motor oil in the spark plug hole and

reinstall the spark plug. Ground the spark plug wire and turn the engine over several times to coat the cylinder wall with oil.

3. Lubricate all control cables.
4. Block up the frame to raise all wheels off the ground.
5. Tie a plastic bag over the exhaust pipe outlet to prevent moisture from entering.
6. If storing in a humid or salt-air atmosphere, coat all exposed metal surfaces with a light film of oil. Do not apply oil to any rubber parts or the seat cover.
7. Remove the battery and charge it. Store it in a dry place and recharge it once a month. Do not store the battery in an excessively warm or cold place (less than 0°C (30°F) or more than 30°C (90°F)).

NOTE:

Make any necessary repairs before storing the machine.

SPECIFICATIONS

Model	YFM80R
Dimension: Overall length Overall width Overall height Seat height Wheel base Ground clearance Minimum turning radius	1,537 mm (60.5 in) 841 mm (33.1 in) 940 mm (37.0 in) 669 mm (26.3 in) 1,030 mm (40.6 in) 100 mm (3.94 in) 2,400 mm (94.5 in)
Basic weight: With oil and full fuel tank	116 kg (256 lb)
Engine: Type Cylinder arrangement Displacement Bore × Stroke Compression ratio Starting system Lubrication system	Air cooled, 4-stroke, SOHC Single cylinder, Forward inclined 79 cm ³ (4.82 cu.in) 47.0 × 45.6 mm (1.85 × 1.80 in) 9.6 : 1 Electric starter Wet sump

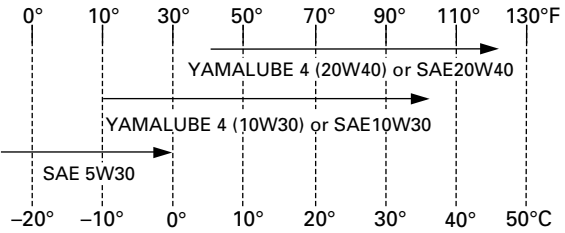
Model	YFM80R
<p>Engine oil: Type</p> <p>Recommended engine oil classification:</p> <p>Quantity: Periodic oil change</p>	 <p>API Service SE, SF, SG type or higher</p> <p>CAUTION: _____</p> <p>In order to prevent clutch slippage (since the engine oil also lubricates the clutch), do not mix any chemical additives. Do not use oils with a diesel specification of “CD” or oils of a higher quality than specified. In addition, do not use oils labeled “ENERGY CONSERVING II” or higher.</p> <p>_____</p> <p>0.80 L (0.70 Imp qt, 0.85 US qt)</p>

Model	YFM80R
Final gear oil: Type Quantity: Total amount	SAE80API “GL-4” Hypoid gear oil 0.12 L (0.11 Imp qt, 0.13 US qt)
Air filter:	Wet type element
Fuel: Type Tank capacity Reserve amount	UNLEADED GASOLINE ONLY 6.8 L (1.5 Imp gal, 1.8 US gal) 0.9 L (0.2 Imp gal, 0.2 US gal)
Carburetor: Type/manufacturer	VM16SH/MIKUNI
Spark plug: Type/manufacturer Gap	CR7HSA/NGK 0.6–0.7 mm (0.024–0.028 in)
Clutch type:	Wet, multiple-disc automatic

Model	YFM80R
Transmission: Primary reduction system Primary reduction ratio Secondary reduction system Secondary reduction ratio Transmission type Operation Gear ratio: 1st 2nd 3rd	Spur gear 65/20 (3.250) Shaft drive 19/18 × 34/10 (3.588) Constant mesh 3-speed Left foot operation 39/11 (3.545) 35/17 (2.059) 31/22 (1.409)
Chassis: Frame type Caster angle Trail	Steel tube 1° 3.8 mm (0.15 in)
Tire: Type Size : Front : Rear Manufacturer/type Front Rear	Tubeless AT18 × 7-7 AT18 × 8-7 DUNLOP/KT586 DUNLOP/KT587

Model	YFM80R
Brake: Front brake type Operation Rear brake type Operation	Drum brake Right hand operation Drum brake Left hand and right foot operation
Suspension: Front Rear	Leading arm Swingarm
Shock Absorber: Front Rear	Coil spring/Oil damper Coil spring/Oil damper
Wheel travel: Front Rear	57 mm (2.24 in) 56 mm (2.2 in)
Electrical: Ignition system Charging system Battery type/voltage, capacity	C.D.I. A.C. magneto 12N7D-3B/12V, 7Ah
Indicator light voltage, wattage × quantity: Neutral	12V, 1.7W × 1
Fuse:	5A

NOISE REGULATION

TAMPERING WITH NOISE CONTROL SYSTEM PROHIBITED:

Federal law prohibits the following acts or the causing thereof: (1) The removal or rendering inoperative by any person other than for purposes of maintenance, repair, or replacement of any device or element of design incorporated into any new vehicle for the purpose of noise control prior to its sale or delivery to the ultimate purchaser or while it is in use or (2) the use of the vehicle after such device or element of design has been removed or rendered inoperative by any person.

“AMONG THOSE ACTS PRESUMED TO CONSTITUTE TAMPERING ARE THE ACTS LISTED BELOW.”

These acts include tampering with the following systems; i.e., modification, removal, etc.

Exhaust system	Muffler Exhaust pipe Silencer
Intake system	Air cleaner case Air cleaner element Intake duct

MAINTENANCE RECORD

Copies of work orders and/or receipts for parts you purchase and install will be required to document maintenance done in accordance with the warranty. The chart below is printed only as a reminder to you that the maintenance work is required. It is not acceptable proof of maintenance work.

MAINTENANCE INTERVAL			DATE OF SERVICE	MILEAGE	SERVICING DEALER NAME AND ADDRESS	REMARKS
month	km (mi)	hours				
1	320 (200)	20				
3	1,300 (800)	80				
6	2,500 (1,600)	160				
12	5,000 (3,200)	320				
18	7,500 (4,800)	480				
24	10,000 (6,400)	640				
30	12,500 (8,000)	800				
36	15,000 (9,600)	960				
42	17,500 (11,200)	1,120				
48	20,000 (12,800)	1,280				
54	22,500 (14,400)	1,440				
60	25,000 (16,000)	1,600				

YAMAHA MOTOR CORPORATION, U.S.A. ATV LIMITED WARRANTY

Yamaha Motor Corporation, U.S.A. hereby warrants that new Yamaha ATV purchased from an authorized Yamaha ATV dealer in the continental United States will be free from defects in material and workmanship for the period of time stated herein, subject to certain stated limitations.

THE PERIOD OF WARRANTY for Yamaha ATV's shall be six (6) months from the date of purchase.

DURING THE PERIOD OF WARRANTY any authorized Yamaha ATV dealer will, free of charge, repair or replace any part adjudged defective by Yamaha due to faulty workmanship or material from the factory. Parts used in warranty repairs will be warranted for the balance of the product's warranty period. All parts replaced under warranty become property of Yamaha Motor Corp. U.S.A.

GENERAL EXCLUSIONS from this warranty shall include any failures caused by:

- a. Competition or racing use.
- b. Installation of parts or accessories that are not qualitatively equivalent to genuine Yamaha parts.
- c. Abnormal strain, neglect, or abuse.
- d. Lack of proper maintenance.
- e. Accident or collision damage.
- f. Modification to original parts.
- g. Damage due to improper transportation.

SPECIFIC EXCLUSIONS from this warranty shall include parts replaced due to normal wear or routine maintenance; such as spark plugs, oil, oil filter, air filter, and brake shoes.

THE CUSTOMER'S RESPONSIBILITY under this warranty shall be to:

1. Operate and maintain the ATV as specified in the appropriate owner's manual;
2. Give notice to an authorized Yamaha ATV dealer of any and all apparent defects within ten (10) days after discovery, and make the machine available at that time for inspection and repairs at such dealer's place of business.

WARRANTY TRANSFER: To transfer the warranty from the original purchaser to any subsequent purchaser(s), it is imperative that the machine be inspected and registered for warranty by an authorized Yamaha ATV dealer. In order for this warranty to remain in effect, this inspection and registration must take place within ten (10) days after transfer. An inspection and registration fee will be charged for this service.

EMISSION CONTROL SYSTEM WARRANTY

Yamaha Motor Corporation, USA also warrants to the ultimate purchaser and each subsequent purchaser of each 2006 and later model Yamaha ATV covered by this warranty that the vehicle is designed, built, and equipped so as to conform at the time of sale with all U. S. emissions standards applicable at the time of manufacture and that it is free from defects in materials and workmanship which would cause it not to meet these standards

within the period listed immediately below. Failures other than those resulting from defects in material or workmanship which arise solely as a result of owner abuse and/or lack of proper maintenance are not covered by this warranty.

All Models

Thirty (30) months from the original purchase date

YAMAHA MOTOR CORPORATION, U.S.A. MAKES NO OTHER WARRANTY OF ANY KIND, EXPRESSED OR IMPLIED. ALL IMPLIED WARRANTIES OF MERCHANTABILITY AND FITNESS FOR A PARTICULAR PURPOSE WHICH EXCEED THE OBLIGATIONS AND TIME LIMITS STATED IN THIS WARRANTY ARE HEREBY DISCLAIMED BY YAMAHA MOTOR CORPORATION, U.S.A. AND EXCLUDED FROM THIS WARRANTY.

SOME STATES DO NOT ALLOW LIMITATIONS ON HOW LONG AN IMPLIED WARRANTY LASTS, SO THE ABOVE LIMITATION MAY NOT APPLY TO YOU. ALSO EXCLUDED FROM THIS WARRANTY ARE ANY INCIDENTAL OR CONSEQUENTIAL DAMAGES INCLUDING LOSS OF USE. SOME STATES DO NOT ALLOW THE EXCLUSION OR LIMITATION OF INCIDENTAL OR CONSEQUENTIAL DAMAGES, SO THE ABOVE EXCLUSION MAY NOT APPLY TO YOU.

THIS WARRANTY GIVES YOU SPECIFIC LEGAL RIGHTS, AND YOU MAY ALSO HAVE OTHER RIGHTS WHICH VARY FROM STATE TO STATE.

YAMAHA MOTOR CORPORATION, U.S.A.
P.O. Box 6555
Cypress, California 90630

WARRANTY QUESTIONS AND ANSWERS

- Q. What costs are my responsibility during the warranty period?
- A. The customer's responsibility includes all costs of normal maintenance services, non-warranty repairs, accident and collision damages, and oil, oil filters, air filters, spark plugs, and brake shoes.
- Q. What are some examples of "abnormal" strain, neglect, or abuse?
- A. These terms are general and overlap each other in areas. Specific examples include: Running the machine out of oil, sustained high-rpm, full-throttle, operating the machine with a broken or damaged part which causes another part to fail, damage or failure due to improper or careless transportation and or tie down. If you have any specific questions on operation or maintenance, please contact your dealer for advice.
- Q. Does the warranty cover incidental costs such as towing or transportation due to a failure?
- A. No. The warranty is limited to repair of the machine itself.
- Q. May I perform any or all of the recommended maintenance shown in the Owner's Manual instead of having the dealer do them?
- A. Yes, if you are a qualified mechanic and follow the procedures specified in the Owner's and Service Manual. We do recommend, however, that items requiring special tools or equipment be done by Yamaha ATV dealer.
- Q. Will the warranty be void or cancelled if I do not operate or maintain my new ATV exactly as specified in the Owner's Manual?
- A. No. The warranty on a new ATV cannot be "voided" or "cancelled." **However, if a particular failure is caused by operation or maintenance other than as shown in the Owner's Manual, that failure may not be covered under warranty.**
- Q. What responsibility does my dealer have under this warranty?
- A. Each Yamaha ATV dealer is expected to:
1. Completely set up every new machine before sale.
 2. Explain the operation, maintenance, and warranty requirements to your satisfaction at the time of sale, and upon your request at any later date.
 3. Each Yamaha ATV dealer is held responsible for his setup, service and warranty repair work.
- Q. Is the warranty transferable to second owners?
- A. Yes. The remainder of the existing warranty can be transferred upon request. The unit has to be inspected and re-registered by an authorized Yamaha ATV dealer for the policy to remain effective.

CUSTOMER SERVICE

If your machine requires warranty service, you must take it to any authorized Yamaha ATV dealer within the continental United States. Be sure to bring your warranty registration card or other valid proof of the original date of purchase. If a question or problem arises regarding warranty, first contact the owner of the dealership. Since all warranty matters are handled at the dealer level, this person is in the best position to help you. If you are still not satisfied and require additional assistance, please write:

YAMAHA MOTOR CORPORATION U.S.A.
CUSTOMER RELATIONS DEPARTMENT
P.O. Box 6555
Cypress, California 90630

When contacting Yamaha Motor Corporation, U.S.A. don't forget to include any important information such as names, addresses, model, V.I.N. (frame number), dates, and receipts.

CHANGE OF ADDRESS

The federal government requires each manufacturer of a motor vehicle to maintain a complete, up-to-date list of all first purchasers against the possibility of a safety-related defect and recall. This list is compiled from the purchase registrations sent to Yamaha Motor Corporation, U.S.A. by the selling dealer at the time of your purchase.

If you should move after you have purchased your new ATV, please advise us of your new address by sending a postcard listing your ATV model name, V.I.N. (frame number), dealer number (or dealer's name) as it is shown on your warranty card, your name and new mailing address. Mail to:

YAMAHA MOTOR CORPORATION, U.S.A.
P.O. Box 6555
Cypress, California 90630
Attention: Warranty Department

This will ensure that Yamaha Motor Corporation, U.S.A. has an up-to-date registration record in accordance with federal law.

YAMAHA EXTENDED SERVICE (Y.E.S.)

Keep your Yamaha protected even after your warranty expires with genuine Yamaha Extended Service (Y.E.S.).

- Y.E.S. is designed and administered by Yamaha Motor Corporation to provide maximum owner satisfaction. You get uninterrupted factory-backed coverage for extra peace of mind.
 - Y.E.S. is flexible. You choose the plan that's right for you: 12 months, 24 months, or 36 months beyond your warranty period.
 - Y.E.S. is designed and administered by the same Yamaha people who handle your warranty – and it shows in the comprehensive coverage benefits. There are no mileage limitations. Coverage isn't limited to "moving parts" or the "drive train" like many other plans. And Y.E.S. covers manufacturing defects just like the warranty. See the sample contract at your Yamaha dealer to see how comforting uninterrupted factory-backed protection can be.
 - You don't have to pay anything for covered repairs. There's no deductible to pay, and repairs aren't "pro-rated." You don't have any "out-of-pocket" expenses for covered repairs.
- In addition, Travel and Recreation Interruption Protection (TRIP) is included at no extra cost. TRIP gives you up to \$150 reimbursement per occurrence for any reasonable expenses you incur because your Yamaha needs covered service: replacement vehicle rental, emergency towing, phone calls, even food and lodging when you are away from home. This superb coverage goes into effect when you purchase Y.E.S., so it applies to any warranty repairs as well as covered repairs during your entire Y.E.S. plan period.
 - Y.E.S. coverage is honored at any authorized Yamaha dealer nationwide.
 - Y.E.S. coverage is transferable to a new owner if you sell or trade-in. That can make your Yamaha much more valuable!

This excellent Y.E.S. plan coverage is only available to Yamaha owners like you, and only while your Yamaha is still within the Yamaha Limited Warranty period. So visit your authorized Yamaha dealer to get all the facts. He can show you how easy it is to protect your investment with Yamaha Extended Service.

We urge you to act now. You'll get the excellent benefits of TRIP coverage right away, and you'll rest easy knowing you'll have strong factory-backed protection even after your Yamaha Limited Warranty expires. You can also save money: Y.E.S. costs less within the first 90 days after you buy your Yamaha. See your dealer today!

A special note:

If visiting your dealer isn't convenient, contact Yamaha with your Primary ID number (your frame number). We'll be happy to help you get the Y.E.S. coverage you need.

Yamaha Service Marketing
P.O. Box 6555
Cypress, CA 90630



YAMAHA



EXTENDED



SERVICE

EBU00436



Indicates a potential hazard that could result in serious injury or death.

EBU00437

PROTECT YOUR INVESTMENT

Use Genuine YAMAHA Parts And Accessories

See your Authorized YAMAHA Dealer for a Genuine YAMAHA Service Manual.

⚠ WARNING

Improper ATV use can result in SEVERE INJURY or DEATH.



**ALWAYS USE
AN APPROVED
HELMET AND
PROTECTIVE GEAR**



**NEVER USE
ON PUBLIC
ROADS**



**NEVER CARRY
PASSENGERS**



**NEVER USE
WITH DRUGS
OR ALCOHOL**

NEVER operate:

- without proper training or instruction.
- at speeds too fast for your skills or the conditions.
- on public roads - a collision can occur with another vehicle.
- with a passenger - passengers affect balance and steering and increase risk of losing control.

ALWAYS:

- use proper riding techniques to avoid vehicle overturns on hills and rough terrain and in turns.
- avoid paved surfaces - pavement may seriously affect handling and control.

**LOCATE AND READ OWNER'S MANUAL. FOLLOW ALL INSTRUCTIONS AND WARNINGS.
(For replacement manual, call 1-800-532-1558)**



YAMAHA MOTOR CO., LTD.

Dear Yamaha ATV Owner: Please Review this IMPORTANT SAFETY CARD before operating your ATV (If card is not attached, call 1-800-344-6418).

Dear New Yamaha ATV Owner:

CONGRATULATIONS ON THE PURCHASE OF YOUR NEW YAMAHA ATV. You have purchased a quality Yamaha product that, with proper use and care, will provide hours of riding pleasure. **BEFORE YOU OPERATE YOUR NEW ATV, Yamaha recommends these important points:**

- READ YOUR OWNER'S MANUAL
- A CHILD UNDER 6 YEARS OLD SHOULD NOT OPERATE AN ATV WITH ENGINE SIZE 50CC OR GREATER
- A CHILD UNDER 12 YEARS OLD SHOULD NOT OPERATE AN ATV WITH ENGINE SIZE 70CC OR GREATER
- A CHILD UNDER 16 YEARS OLD SHOULD NOT OPERATE AN ATV WITH ENGINE SIZE GREATER THAN 90CC
- TAKE THE FREE HANDS-ON TRAINING COURSE OFFERED BY YAMAHA – ASK YOUR DEALER FOR DETAILS OR CALL 1-800-887-2887

If you have any questions about these points, **or if you purchased your ATV from an authorized Yamaha dealership and were not informed of the age recommendation for your ATV by the dealership**, please fill out the information below and mail this card to yamaha **today**.

Name:

ATV Model:

Purchase Date:

MO. DAY YR.

Address:

Primary I.D. (Engine Number):

Telephone:

() _____

Dealer Name & Address:

This is not a warranty card

READ CAREFULLY



NO POSTAGE
NECESSARY
IF MAILED
IN THE
UNITED STATES



POSTAGE WILL BE PAID BY ADDRESSEE

YAMAHA MOTOR CORPORATION U.S.A.
P.O. BOX 6555
CYPRESS, CALIFORNIA 90630-9989

ATTN: SALES ADMINISTRATION

