

Service Manual for WD10 Diesel Engine

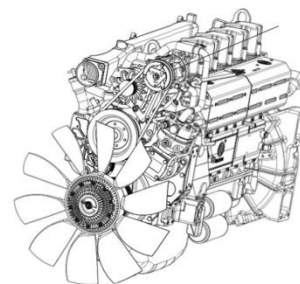

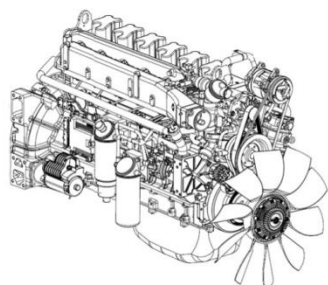
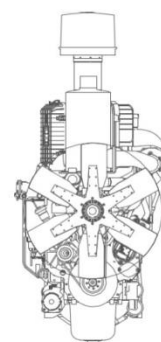
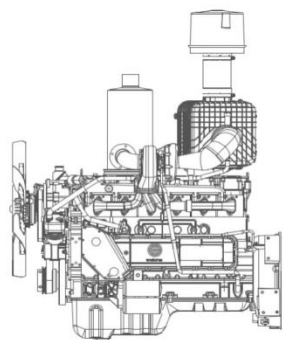

WD10 China II series diesel engine (China II emission standard)

Special Tips

- Operators must carefully read Diesel Engine Instruction Manual before operating, all technical operations and maintenance regulations specified in the manual must be strictly complied with.
- Turbocharger rotor is precision high-speed rotating component, unauthorized disassembling and crashing is strictly prohibited, otherwise the “three guarantees” we committed shall automatically become invalid.
- Various bolts like diesel engine main bearing bolts and connecting rod bolts have strict torque requirements and tightening angle requirements, users are not allowed to loosen or remove the bolts casually; connecting rod bolts are disposable bolts, do not reuse them, otherwise the “three guarantees” we committed shall automatically become invalid.
- The added engine oil or diesel oil, whose brand must comply with requirements specified in operation and maintenance manual, moreover, all oil must be filtered with specialized clean filter, fuel must be subsided for more than 72 hours before adding; Before operating the machine each time, check and ensure coolant level and engine oil level meet the requirements.
- It is forbidden to run the diesel engine without an air filter to prevent unfiltered air entering into cylinders.
- Test-run a new machine for 50 hours (run-in period) before putting it into operation.
- Increase the engine rotating speed slowly after cold starting, neither increase the speed abruptly or long-term idling is proper; After heavy load running, do not stop the engine immediately (peculiar circumstance exception), you should run it at low speed for 5~10 minutes before shutting down;
- After parking, if the ambient temperature is likely to be lower than 0°C and there is unused coolant in the machine, please be sure to drain the coolant in water tank and diesel engine out;
- To prevent rusting, the diesel engine is sealed with oil before delivery, seal period for common diesel engine before unpacking is one year, for new diesel engine that has been sealed for more than one year should be inspected and taken additional measures.
- Please add fuel of specified brand at a normal gas station, Weichai Power shares no responsibility for fuel system damage caused by inferior fuel, and the “three guarantees” we committed shall automatically become invalid.
- Please overhaul and maintenance the engine at the service station specified by Weichai Power, and only use Weichai Power specified spare parts for replacement, otherwise Weichai Power shares no responsibility for damage caused by using unauthorized parts.

Preface

As an advanced high-speed diesel engine, WD10 is a newly-developed product of Weichai Power Company Limited based on bran-new design concept, which meets China II emission standard. WD10 diesel engine has the features of compact structure, reliable service, excellent dynamic property and economic efficiency, rapid start, easy operation and convenient maintenance. WD10 can achieve advanced emissions target, definitely an ideal engine for heavy vehicles.

This manual briefly introduced the technical parameters, structural features, operation and maintenance methods, and overhaul tips of WD10 diesel engine, for users to refer to; provided service technologies of diesel engine to help serviceman profoundly understand disassembly and assembly methods of the engine, also laid a solid technical foundation for serviceman to do troubleshooting. Please carefully read this manual to make the best use of it. With development of product, some structures may be improved, so there might be a slight difference between technical specifications and graphic descriptions in this manual and the real machine in use, users should pay attention to the differences despite our company will continuously do the complements in the successive versions.

SDLG

Technology Department

June 2014

CONTENTS

1	Usage Instructions for Diesel Engine	1
11	External View of Diesel Engine	1
12	Diesel Engine Model Composition and Significance.....	3
13	Diesel Engine Main Technical Parameters.....	3
14	Unseal of Diesel engine	5
15	Lifting of Diesel Engine	6
16	Installation of Engine.....	6
17	Preparation before Starting Engine.....	6
18	Start the Engine.....	7
19	Run the Engine	7
2	Maintenance Guidelines for Diesel Engine	9
21	Fuel Oil, Engine oil, Coolant and Auxiliary Materials	9
211	Fuel Oil	9
212	Engine Oil	9
213	Lubrication of Tensioning Wheel.....	10
214	Antifreeze Additive in Engine Cooling System	10
215	Auxiliary Materials	11
22	Daily Maintenance.....	12
221	Check Coolant Level and Temperature	12
222	Check Engine Oil Level	13
223	Check Fuel Level.....	14
224	Check “Three Leakages”	14
225	Check Fan	14
226	Check Belt	14
227	Check Whether Exhaust Gas Color is Normal	14
228	Check Whether Running Sound is Normal	15
229	Check Whether Rotating Speed and Vibration are Normal	15
23	Periodic Maintenance	15
24	Maintenance for Long-Term Storage	20
241	Cleaning	20
242	Protection	20

3	Diagnosis and Troubleshooting of Diesel Engine Common Faults	21
31	Diagnostic Methods	21
32	Fault Causes and Elimination Methods	22
321	Diesel Engine Couldn't Be Started	22
322	Diesel Engine Stops Soon after Starting	23
323	Underpower	23
324	Large Fuel Consumption	24
325	Engine Gives off Black Smoke	25
326	Engine Gives off White and Blue Smoke	25
327	Turbocharger Intake Port and Intake Pipe Are Accumulated with Engine Oil	26
328	Unstable Engine Speed	26
329	Low Engine Oil Pressure	26
3210	High Cooling Water Temperature	27
3211	Rapid Wear of Parts	27
3212	Excessive Noise	28
3213	Starter Motor Doesn't Work	28
3214	Underpowered Starter Motor	29
3215	Generator Generates Nothing	29
3216	Generator Undercharging	29
3217	Unstable Charging Voltage	30
3218	Generator Overcharging	30
3219	Generator Produces Abnormal Sound	30
4	Disassembly & Assembly of Diesel Engine	31
41	Overview	31
411	Danger Signs	31
412	Safety Signs	32
413	Recommended Tools	33
414	Notes for Health Protection	33
415	Environmental Protection Measures	34
416	Notes for Disassembly and Assembly of Engine	34
417	Explode View of the Whole Engine	35
42	Cylinder Cover Assembly	36
421	Disassembly and Assembly of Cylinder Cover Assembly	36

422 Disassembly, Inspection, Maintenance and Assembly of Cylinder Cover Shield	38
423 Disassembly, Inspection, Maintenance and Assembly of Water Outlet Pipe	39
424 Disassembly, Inspection, Maintenance and Assembly of Oil-Gas Separator	41
425 Disassembly, Inspection, Maintenance and Assembly of Hanger Plates.....	42
426 Disassembly, Inspection, Maintenance and Assembly of Cylinder Cover ..	43
43 Engine Block Assembly	51
431 Disassembly, Inspection, Maintenance and Assembly of Engine Block Assembly	51
432 Disassembly, Inspection, Maintenance and Assembly of Engine Block Module	54
433 Disassembly, Inspection, Maintenance and Assembly of Engine Front Cover	56
434 Disassembly, Inspection, Maintenance and Assembly of Gear Housing.....	57
435 Disassembly, Inspection, Maintenance and Assembly of Flywheel Housing	59
436 Disassembly, Inspection, Maintenance and Assembly of Oil Sump.....	60
437 Disassembly, Inspection, Maintenance and Assembly of Piston Nozzle.....	62
438 Disassembly, Inspection, Maintenance and Assembly of Thrust Plates	63
439 Disassembly, Inspection, Maintenance and Assembly of Front and Rear Oil Seals	64
44 Crank-Rod Mechanism.....	66
441 Disassembly and Assembly of Crank-Rod Mechanism.....	66
442 Disassembly, Inspection, Maintenance and Assembly of Piston-Rod Assembly	67
443 Disassembly, Inspection, Maintenance and Assembly of Crankshaft	70
444 Disassembly, Inspection, Maintenance and Assembly of Flywheel and Ring Gear.....	72
445 Disassembly, Inspection, Maintenance and Assembly of Damper and Crankshaft Pulley.....	74
446 Disassembly, Inspection, Maintenance and Assembly of Crankshaft Bearing Shell	75
45 Valve Mechanism	76
451 Disassembly and Assembly of Valve Mechanism	76
452 Disassembly, Inspection, Maintenance and Assembly of Camshaft.....	77

453 Disassembly, Inspection, Maintenance and Assembly of Rocker and Rocker Shaft.....	79
454 Disassembly, Inspection, Maintenance and Assembly of Valve Tappet and Pushrod	82
455 Disassembly, Inspection, Maintenance and Assembly of Valve	83
456 Disassembly, Inspection, Maintenance and Assembly of Intermediate Gear	85
46 Intake and Exhaust System.....	87
461 Disassembly and Assembly of Intake and Exhaust System.....	87
462 Disassembly, Inspection, Maintenance and Assembly of Intake Pipe.....	88
463 Disassembly, Inspection, Maintenance and Assembly of Exhaust Pipe.....	89
464 Disassembly, Inspection, Maintenance and Assembly of Turbocharger System	90
47 Fuel System	93
471 Disassembly and Assembly of Fuel System	93
472 Disassembly, Inspection, Maintenance and Assembly of Fuel Injection Pump	94
473 Disassembly, Inspection, Maintenance and Assembly of High Pressure Fuel Pipes.....	96
474 Disassembly, Inspection, Maintenance and Assembly of Fuel Injector	97
48 Cooling System.....	99
481 Disassembly and Assembly of Cooling System.....	99
482 Disassembly, Inspection, Maintenance and Assembly of Fan	100
483 Disassembly, Inspection, Maintenance and Assembly of Water Pump.....	101
484 Disassembly, Inspection, Maintenance and Assembly of Thermostat.....	103
49 Lubricating System.....	105
491 Disassembly and Assembly of Lubricating System.....	105
492 Disassembly, Inspection, Maintenance and Assembly of Engine Oil Pump	106
493 Disassembly, Inspection, Maintenance and Assembly of Engine Oil Pump Intermediate Gear	107
494 Disassembly, Inspection, Maintenance and Assembly of Engine Oil Filter	108
495 Disassembly, Inspection, Maintenance and Assembly of Engine Oil Cooler Cap.....	109
496 Disassembly, Inspection, Maintenance and Assembly of Engine Oil Cooler	110

497 Disassembly, Inspection, Maintenance and Assembly of Main Oil Gallery Pressure Limiting Valve	111
498 Disassembly, Inspection, Maintenance and Assembly of Engine Oil Cooler Bypass Valve	112
499 Disassembly, Inspection, Maintenance and Assembly of Engine Oil Strainer	113
410 Starting System.....	114
4101 Disassembly and Assembly of Starting System	114
4102 Disassembly, Inspection, Maintenance and Assembly of Starter Motor .	114
411 Engine Accessory System.....	116
4111 Disassembly and Assembly of Engine Accessory System.....	116
4112 Disassembly, Inspection, Maintenance and Assembly of Generator	122
4113 Disassembly, Inspection, Maintenance and Assembly of A/C Compressor	130
4114 Disassembly, Inspection, Maintenance and Assembly of Air Compressor	137
4115 Disassembly, Inspection, Maintenance and Assembly of Steering Pump	146

1 Usage Instructions for Diesel Engine

11 External View of Diesel Engine

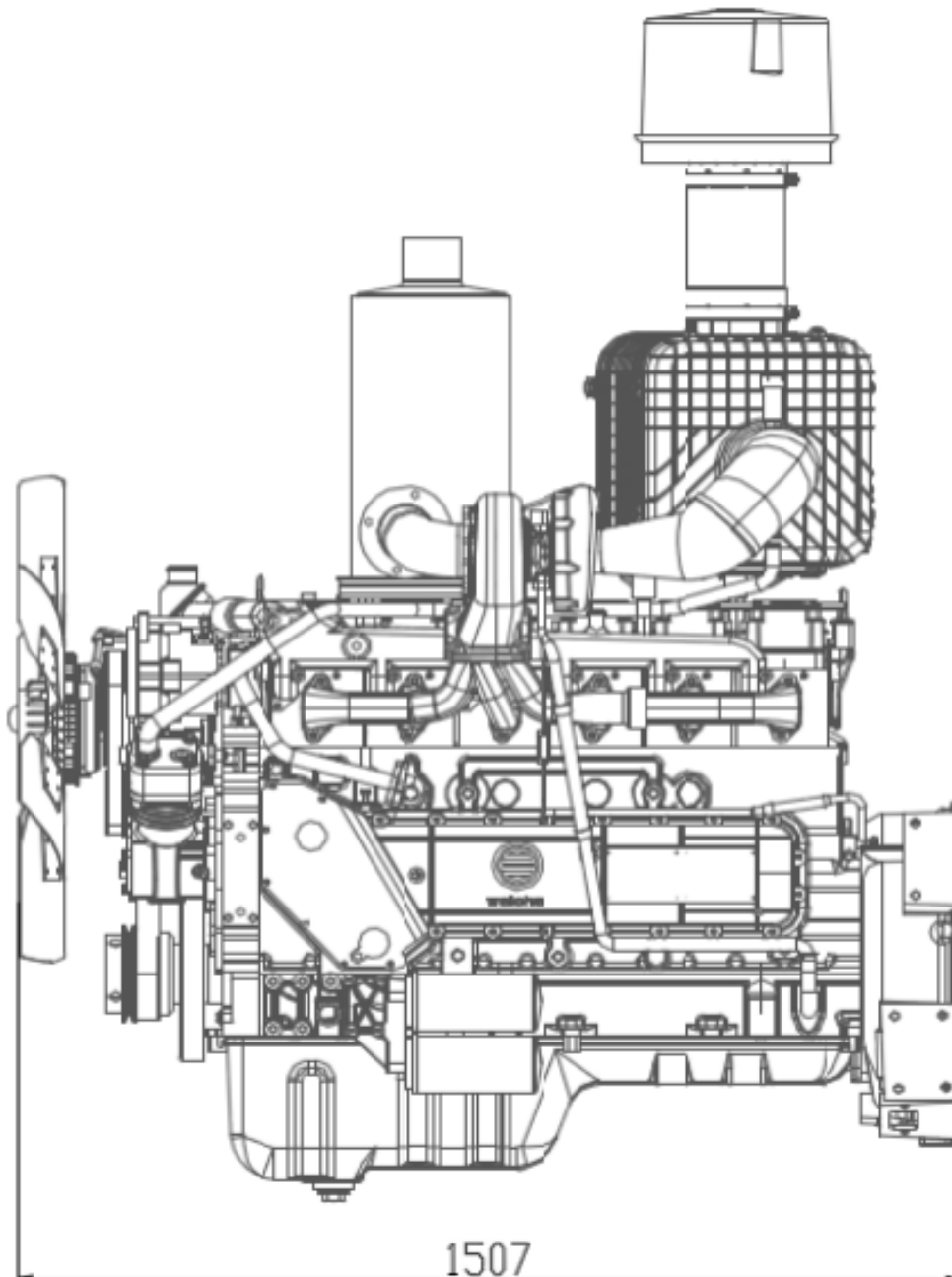

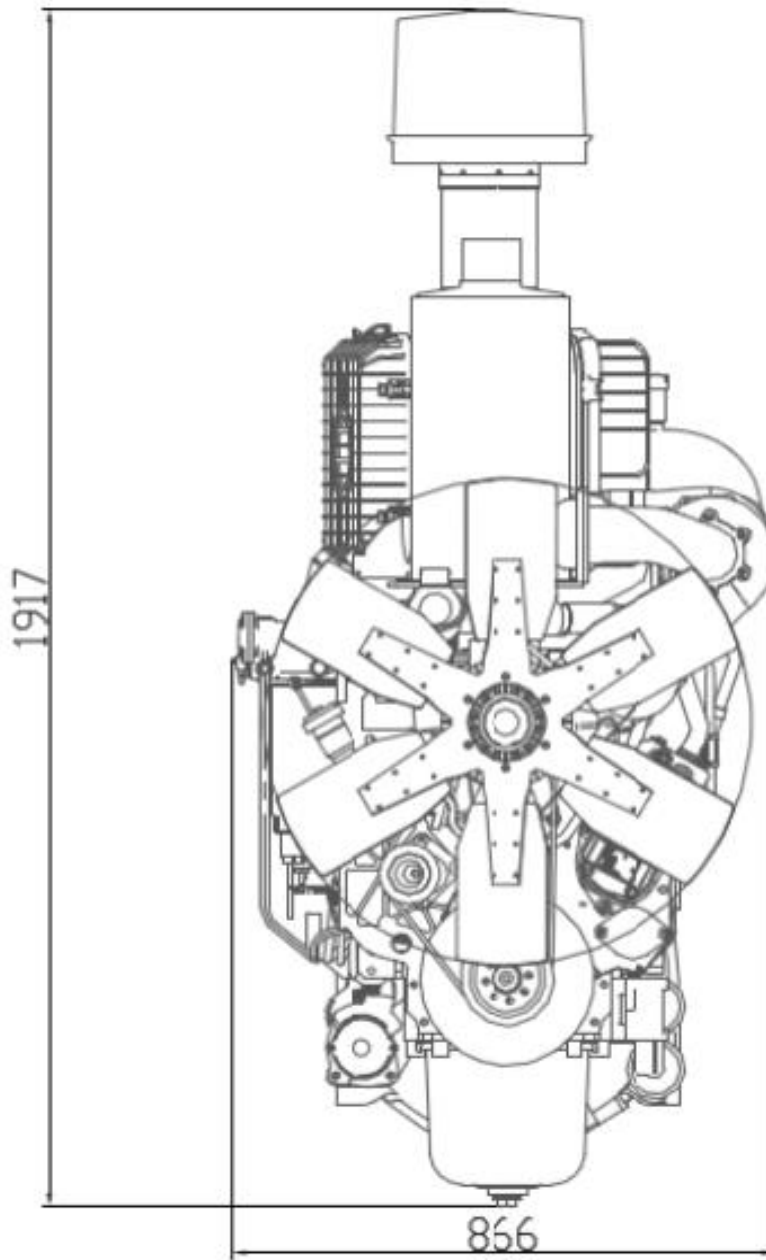

12 Diesel Engine Model Composition and Significance

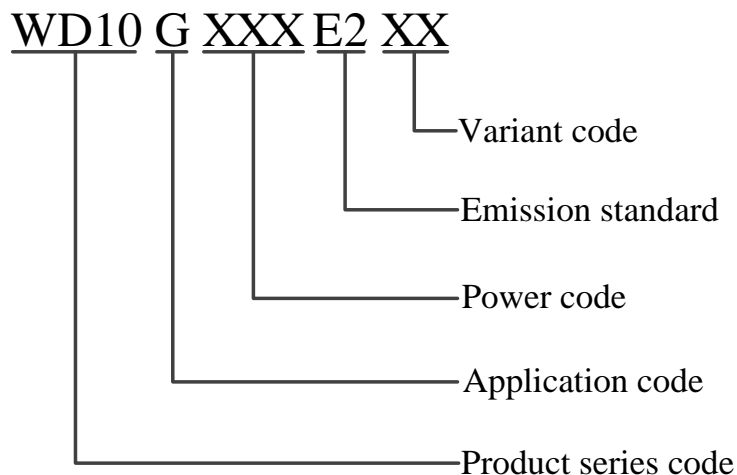

13 Diesel Engine Main Technical Parameters

Table 1-1 Main Technical Parameters of WD10 China II series diesel engine

Engine type	Water-cooling, 4-stroke, brake with build-in air bleeding valve, in-line, direct injection, supercharged and intercooling	
Cylinder diameter/Stroke	126/130	
Displacement (L)	9.726	
Compression ratio	17:1	
Ignition order	1-5-3-6-2-4	
Fuel injection equipment	Mechanical pump	
Valve clearance in cold state	Intake valve 0.3; Exhaust valve 0.4; EVB system 0.25	
Valve timing (Valve clearance: when intake valve 0.3, exhaust valve 0.4)	Intake valve open	BTDC 34°~39°
	Intake valve closed	ABDC 61°~67°
	Exhaust valve open	BBDC 76°~81°
	Exhaust valve open	ATDC 26°~31°
Thermostat opening temperature (°C)	83	
Start-up mode	Electric starting	
Lubrication method	Force-feed lubrication	
Lubricating oil capacity (L)	23	

Cooling mode		Water-cooling forced circulation	
Engine oil pressure (kPa)		350~550	
Engine oil pressure at engine idle speed (kPa)		100~250	
Allowed longitudinal inclination (°)	Front/Rear	Long-term 10/10	Short-term 30/30
Allowed transverse inclination (°)	Exhaust pipe side/Injection pump side	Long-term 45/15	Short-term 45/30
Crankshaft rotating direction (View from free end)		Clockwise	

Table 1-2 Main Technical Parameters of WD10 China II series diesel engine

	Unit	WD10 engine					
Engine model		G240E211	G220E221	G210E211	G210E241	G200E251	G175E251
		G220E211	G220E231	G210E221	G175E231	G200E251	G156E261
Engine type	—	Water-cooling, 4-stroke, brake with build-in air bleeding valve, in-line, direct injection, supercharged and intercooling					
Displacement	L	9.726					
Cylinder diameter×Stroke	mm	126×130					
Number of cylinders	—	6					
Number of air valves for each cylinder		2					
Fuel injection equipment		Mechanical pump					
Rated power	kW	199	213	247	276		
Rated speed	r/min	2200					
Maximum torque	Nm	1100	1160	1250	1460		
Speed at maximum torque	r/min	1200~1600					
Emission standard	—						
Fuel consumption rate at rated power	g/(kWh)	217					

Minimum fuel consumption under full load	g/(kWh)	196
Cold start—with aid	°C	-25
White smoke discharge	Light obscuration	After 20s idling ≤15%
Noise at 1m	dB(A)	<104
B ₁₀ service life	km	800,000

14 Unseal of Diesel engine

After opened the engine packing container, the user should firstly check the engine and its accessories according to the packing list, check whether engine appearance is damaged and whether connections are loose, and then perform the following work:

- (1) Wipe up the antirust coat and anticorrosive agent on exposed surface of the engine.
- (2) Drain seal fuel in fuel filter and parts of fuel system out (It's also allowed to start the engine without draining seal fuel in fuel system, but only can the engine be loaded after all seal fuel are consumed and normal diesel fuel is supplied in place).

ATTENTION: The users also need to pay attention to that storage life for diesel engine before unpacking is one year, for new diesel engine that has been stored for more than one year should be inspected and taken additional measures:

- Rotate the flywheel and spray solvent into engine intake tube, until all seal fuel in cylinders is expelled.
- Spray solvent into turbocharger intake and exhaust vent, until all seal fuel there is expelled.
- According to the service agreement with customer, we are obliged to add specified engine oil to engine without oil in oil sump; while for engine that has been filled with engine oil (with running-in accelerant) before being delivered, we suggest you replace the engine oil after run-in period (2000km or 50h).
- According to the service agreement with customer, for engine that has been filled with coolant before delivery under customer's requirements, the coolant performance should be checked after unpacking, if the coolant is subjected to -30°C or -35°C, its PH should be 7~8 (neutral) and hardness value should be 5~15 °d [9~15 °f (hardness)], otherwise, drain the old coolant and out and refill coolant with antifreeze additive.

15 Lifting of Diesel Engine

Keep the center line of engine crankshaft horizontal during lifting, tilting or unilateral lifting is strictly forbidden. Keep the lifting-up and putting-down process slowly (refer to Fig. 1-1).

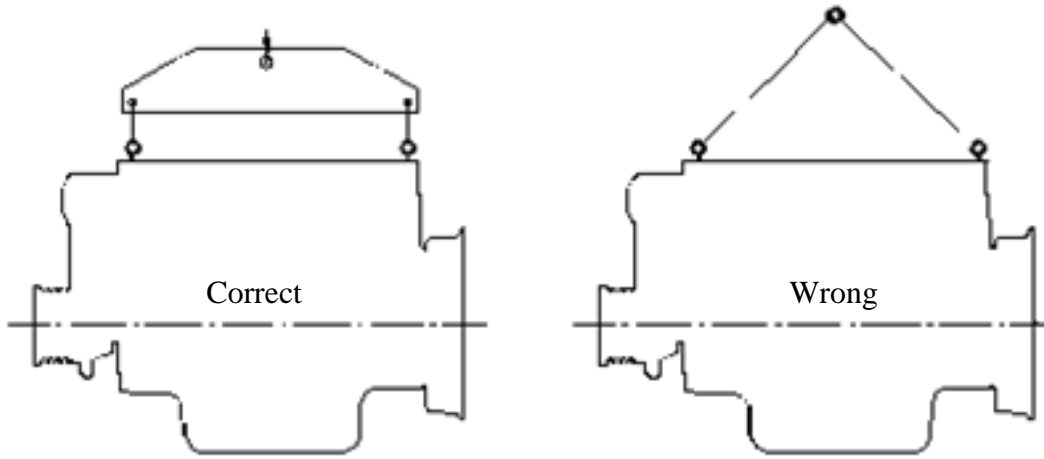

Fig. 1-1 Lifting of diesel engine

16 Installation of Engine

For installation, please ensure the center line of engine crankshaft and input shaft axis of transmission (transmission box, gearbox or generator) are coaxial. And make sure the crankshaft is not subjected to additional axial force caused by assembly.

17 Preparation before Starting Engine

(1) Check coolant level

If the engine is already installed on a vehicle or platform, you can check the coolant level through the glass window on expansion water tank at any time, if the coolant is insufficient, open the filler cap to add coolant. When open a filler cap with pressure relief valve and exhaust button, be sure to press down exhaust button in advance if the engine is in hot state. Avoid filling plenty of coolant when the engine is hot, otherwise some parts may be damaged due to sharp temperature reduction. In an extraordinary situation, if there is no coolant in the engine, it is allowed to add not too cold water slowly until the water overflows. Start the engine, run the engine at 1000r/min and keep adding coolant until level gets stable, finally close the filler cap.

(2) Check fuel level

If the engine is already installed on a vehicle, turn on power switch, check the fuel level gauge

on instrument panel or check the fuel tank.

(3) Check engine oil level

Engine oil level should be between the bottom scale and top scale on oil dipstick, add engine oil through oil filling port if necessary.

(4) Check whether all accessories are reliably connected to the engine and eliminate abnormal phenomenon. Check whether start-up system wirings are normal, whether storage battery is fully charged. And then open fuel tank valve, loosen the air bleeding screw on fuel coarse filter, deflate the fuel system by using the hand pump on fuel coarse filter.

18 Start the Engine

(1) Turn on the power switch and insert the electric lock key, put gear shifting handle in neutral, then begin to start the engine.

(2) Depress the clutch pedal and accelerator pedal, and then turn the electric lock key to start the engine. If the engine failed to start in 5~10s, then restart it 1min later. But if failed three times in a row, you should stop trying, find out the cause and eliminate it. After the engine is started, pay attention to all readings of gauges on instrument panel and keep the engine run idly, at this point engine oil pressure gauge should indicate pressure immediately. Do not run the cold engine at high speed, keep the engine run idly for a while to warm the engine up but idling time should not be too long.

(3) Use starting aid to start the engine in cold weather. By controlling the relay to put heating equipment into work, the engine can be successfully started in -30°C environment.

19 Run the Engine

(1) After the engine is started, firstly let it run idly for several minutes, and then increase the speed to 1000~1200r/min and partially load the engine. Do not run the engine in full load and high speed unless coolant temperature is higher than 60°C and engine oil temperature is higher than 50°C . The load and speed should be increased gradually, try not to load or unload abruptly.

(2) In the 60h run-in period (First 3000km), the engine is only suitable for moderate duty work and under, and no towing operation.

(3) Slow down when traveling on a slope, and long-term high torque operation is inadvisable. It is also inappropriate to keep the engine at low speed and low load, otherwise failure like lubricating oil carry-over may occur.

(4) It is allowed to run the engine at rated power and rated speed for normal use, but only no more than 20min is allowed for overload running (105% rated speed or 110% rated power). Only idling for 1~2min after unloading should the engine be shut down.

(5) Parameters and check points that should always be noticed during normal use:

Engine oil pressure (main gallery)	350~500kPa.
Engine oil temperature in oil sump	<110°C.
Coolant outlet temperature	80+5°C, should not exceed 93°C
Turbine-rear exhaust temperature	≤550°C;
Intake air temperature after intercooler	50~55°C.

Check the exhaust gas color to determine working quality of injector and load condition, if the color is seriously bad, stop the engine for inspection.

ATTENTION: When the engine is in operation, check it for water leakage, air leakage and oil leakage, and stop the engine immediately for troubleshooting.

(6) Following diesel engine features should be fully aware by operator:

- 1) The engine consumes less fuel when output torque is large, and fuel consumption rises as engine speed increases.
- 2) Output torque reaches the best value at intermediate speed range (1200~1600r/min).
- 3) Engine output power increases as rotating speed gets faster, and reaches rated power at rated speed.

(7) Notes for running the engine in cold environment:

- 1) Fuel oil: Choose different brands of diesel fuel based on ambient temperature.
- 2) Engine oil: Choose engine oil of different viscosity according to season.
- 3) Coolant: Antifreeze additive is required for cooling system, choose different brands and different proportion based on ambient temperature.
- 4) Starting: Use starting aid to start the engine in winter. Load and speed up the engine only after oil pressure and water temperature get normal.
- 5) Storage battery: Be sure to check electrolyte level, viscosity and unit voltage before winter comes. If the engine needs to be stored in cold weather for long term, be sure to take down the battery and put it in warm environment.
- 6) Stop: For shutting down the engine in cold weather, you should firstly unload it and run it idly for 1~2min, stop the engine after all temperature drops down. Notice that coolant with antifreeze additive mustn't be drained out after stop. For coolant without antifreeze additive, it must be drained out to prevent frost cracking the engine, open the water drain valve or cap on engine block, engine oil cooler, radiator and water inlet pipe to drain the coolant out.

2 Maintenance Guidelines for Diesel Engine

21 Fuel Oil, Engine oil, Coolant and Auxiliary Materials

211 Fuel Oil

Summer: 0# diesel fuel (GB252)

Winter: -10# diesel fuel is generally used, choose -20# diesel fuel if ambient temperature lower than -15°C , and choose -35# diesel fuel if ambient temperature lower than -30°C .

The chosen fuel should meet requirements in appendix C.6 of GB17691-2005 (Revised in June 2008).

212 Engine Oil

Diesel engine oil capacity: 23L, engine oil level is subjected to the marks on oil dipstick (there might slight differences between different models).

Selection of engine oil: To ensure safety and reliable operation of your diesel engine, please choose 15W/40CF-4 or 5W/40CF-4 engine oil. If ambient temperature is higher than -15°C , select 15W/40CF-4 engine oil and 5W/40CF-4 is applicable for ambient temperature lower than -15°C (Weichai dedicated engine oil is recommended, and only choose Weichai dedicated engine oil for the first replacement).

Table 2-1 Lubricating oil brand option list

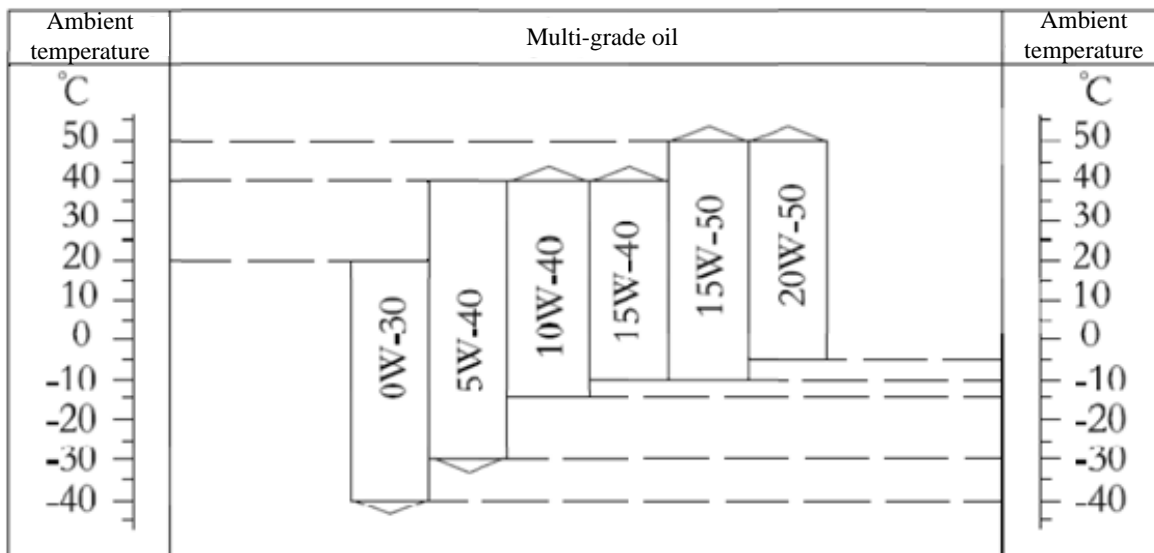

ATTENTION: It is not allowed to apply CE, CD, CC, CB, and CA grade engine oil to WP10 China II series diesel engine. Replace the filter along with the engine oil replacement.

213 Lubrication of Tensioning Wheel

Apply general purpose lithium lubricating grease for lubrication of tensioning wheel (refer to GB/T5671-1995)

214 Antifreeze Additive in Engine Cooling System

The adopted antifreeze additive is ethylene glycol, and it is allowed to replace it with domestic long-acting antifreeze additive with reliable quality, refer to related description for specific application method. The following two long-acting antifreeze additives in china are recommended:

JFL—336# Long-acting antifreeze additive

FD—30# Long-acting antifreeze additive

It's important to note that long-acting antifreeze additive should be replaced periodically according to related requirements.

Calculation of antifreeze additive (for reference)

Coolant amount: 40L (for an engine with radiator)

Current application temperature of coolant: -20°C

Required minimum anti-freezing temperature: -30°C

Calculation method: Find the point of coolant amount “40L” on x-coordinate, and draw a vertical line through this point, and point 1 and 2 are the intersections between the vertical line and -20°C oblique line, -30°C oblique line respectively. (As shown in Fig. 2-1)

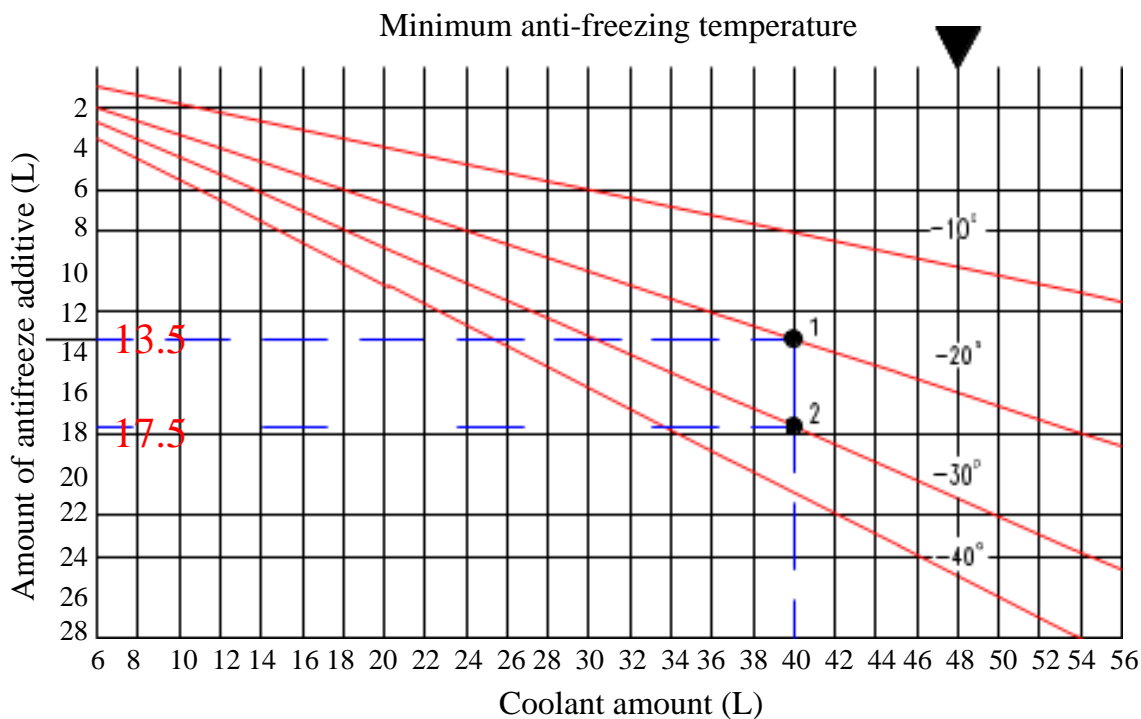

Fig. 2-1 Antifreeze additive calculation map

We can get that required antifreeze additive for -20°C is 13.5L

Difference value between -30°C and -20°C is 4L

For the difference value 4L, another 50% of that is required and necessary, because of before adding antifreeze additive, a part of coolant must be drained out, and antifreeze additive in this part of coolant will be drained out too.

So required antifreeze additive is: $4L + 50\% * 4L = 6L$.

215 Auxiliary Materials

Table 2-2 Auxiliary materials

S/N	Designation	Color	Purpose and application
1	Molykotte Pulver (Fine molybdenum powder)	Black	Apply on smooth metallic surface to prevent occlusion. For example: Cylinder sleeve external surface.
2	Molykotte G.u.plus (Molybdenum disulfide oiling agent)	Dark gray	Play lubrication action before lubricating oil pressure is built-up. For example: Apply on intake valve rod.

Table 2-3 Reference table for sealant application of diesel engine

Brand	Main application	Application position list	Additional remarks
Loctite 242	Apply on thread for fixation and to prevent loose, medium strength	Flywheel housing bolt Camshaft thrust plate bolt Camshaft timing gear bolt Middle idle gear bolt Engine front cover bolt Engine oil filter seat bolt, engine oil cooler bolt Plug screw of engine oil cooler regulating valve Bolt of fuel pump oil return pipe fixing device Air compressor shaft end thread Oil strainer bolt Bolt of sensor and wiring harness fixing device	It is optional to pre-coat DriLoc204.
Loctite 262	Apply on thread to lock, seal and prevent loose	Cylinder cover auxiliary bolt	
Loctite 271	Anti-loosing and fastening	Bowl type plug used to block oil hole	

Loctite 277	Used for the seal between core and hole	Other bowl type plugs	
Loctite 270	Used to seal top end face of cylinder cover	Pushrod bush—Cylinder cover	
Loctite 518 (Renewed product of 510)	Apply on shining metallic surface for sealing	Fitting surface between cylinder block and crankcase, fitting surface between engine block and engine front cover Rear end face and flywheel connecting board Fitting surface between engine oil filter seat and crankcase Water pump rear cover—engine block front end face Flywheel connecting board—flywheel housing Fitting surface between cylinder block and engine oil cooler cap Fitting surface between cylinder block and engine oil filling port cover plate	

22 Daily Maintenance

221 Check Coolant Level and Temperature

Check the coolant level through the glass window, Open the filler cap to add coolant if it is insufficient.

ATTENTION: Press down exhaust button in advance before open the filler cap to avoid injury caused by hot coolant.

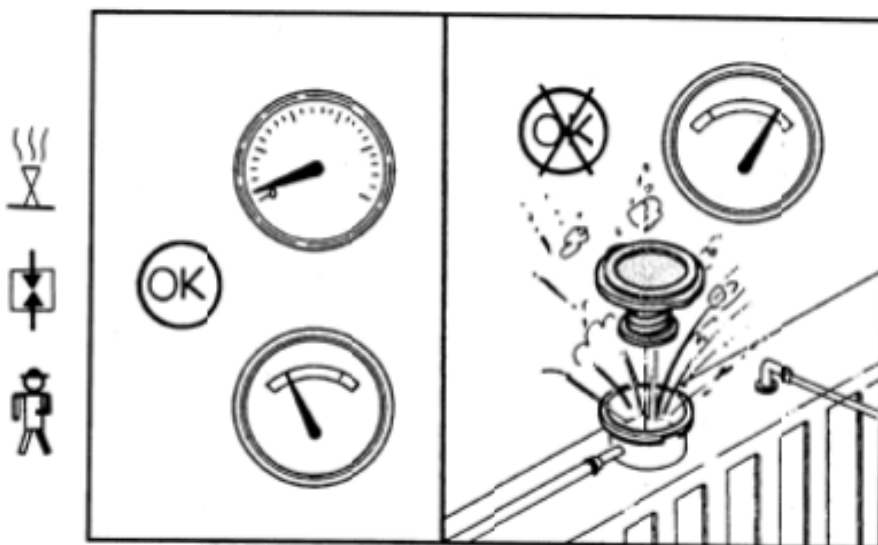

Fig. 2-2 Check coolant level and temperature

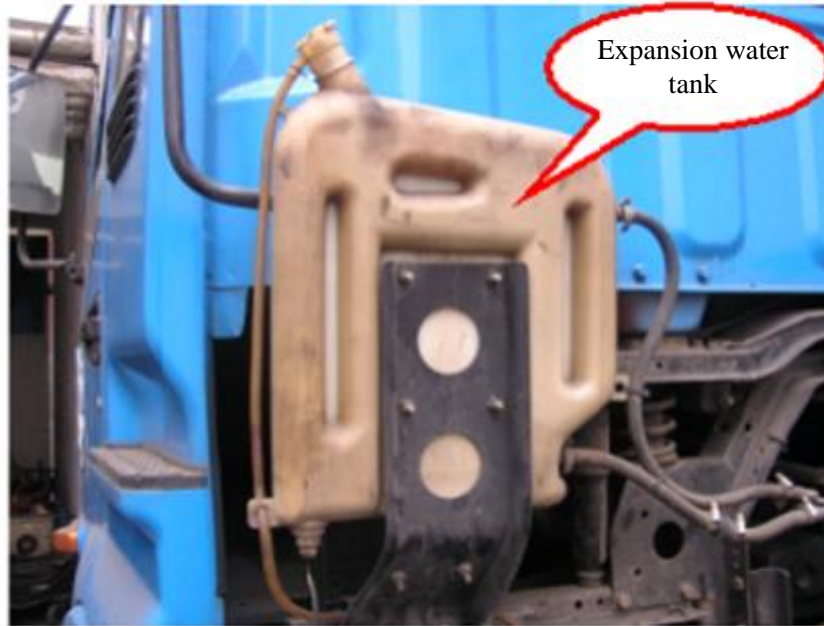

Fig. 2-3 Expansion water tank

222 Check Engine Oil Level

Check whether engine oil level is between the bottom scale and top scale on oil dipstick. Under no circumstances should the engine be started if the oil level is lower than the bottom scale (L) or higher than the top scale (H).

Oil level checking should be done at least 5min later after engine stopped, in order to let engine oil have enough time to return to oil sump.

Engine oil level difference between L and H: 3L

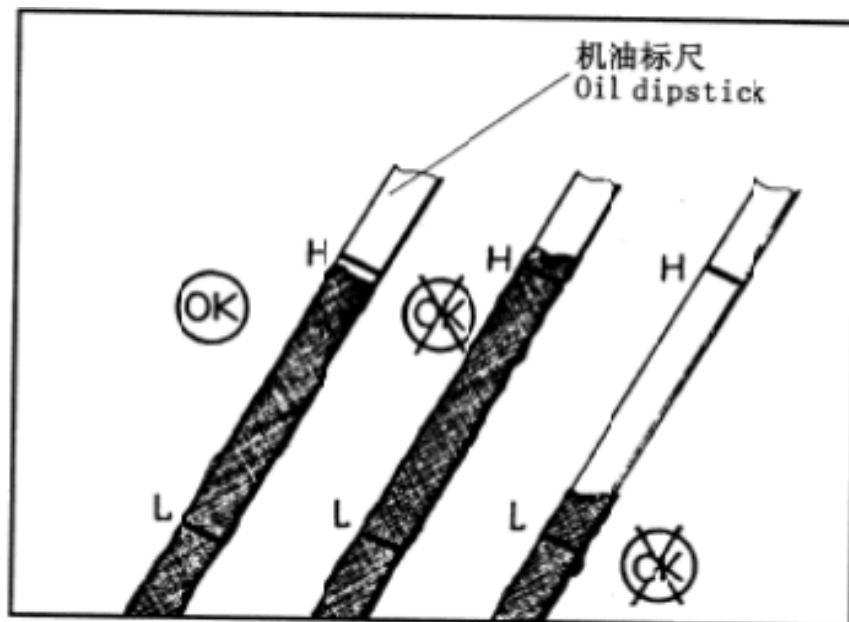

Fig. 2-4 Oil dipstick

223 Check Fuel Level

Check fuel level gauge on instrument panel and add fuel timely.

224 Check “Three Leakages”

Check engine appearance for water leakage, air leakage and oil leakage.

225 Check Fan

Visually check whether fan blades are damaged, and whether connecting bolts are tightened.



Fig. 2-5 Check fan

226 Check Belt

The belt is automatically taken-up by a tightening wheel, user can check the tension of the belt by pressing it with hand.

227 Check Whether Exhaust Gas Color is Normal

Normal exhaust gas color is light gray. Find out the cause and eliminate it if the color is abnormal.

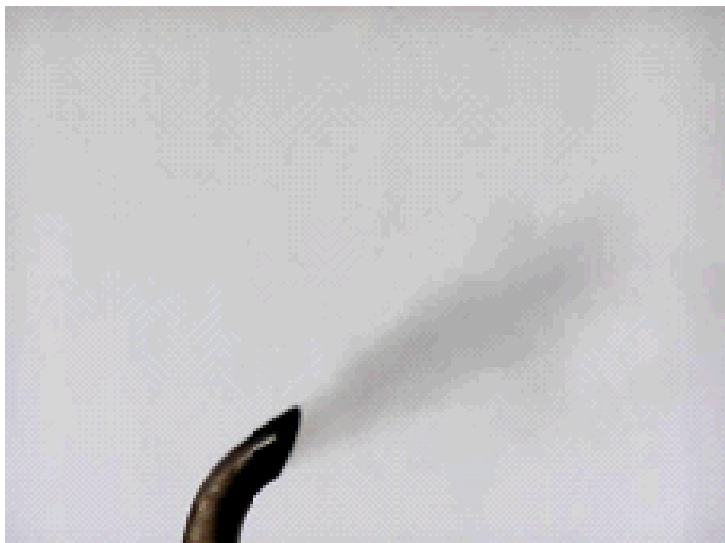

Fig. 2-6 Check exhaust gas

228 Check Whether Running Sound is Normal

229 Check Whether Rotating Speed and Vibration are Normal

23 Periodic Maintenance

● Replace engine oil

Screw off oil drain plug on the bottom of oil sump to drain all engine oil out and then screw on the plug, refer to Fig. 2-8. Open the filler cap (refer to Fig. 2-7), add engine oil through filling port, observe oil dipstick until oil level meets the requirements, install the filler cap.

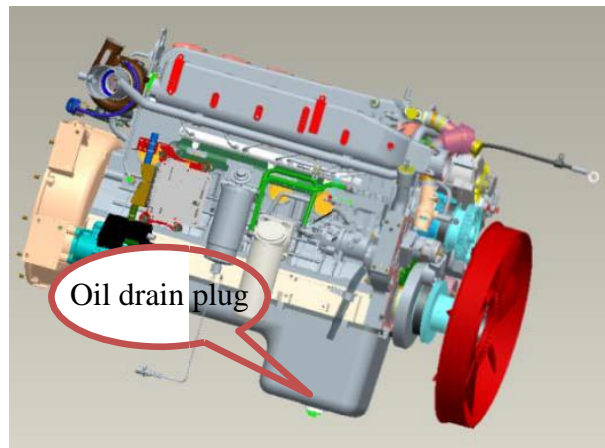

Fig. 2-7 Engine oil filling port

Fig. 2-8 Oil drain plug

ATTENTION: Discarded oil should be put in prescribe location and container for recycling and reusing.

● Replace engine oil filter and filter element

- (1) Screw off the old engine oil filter;
- (2) Fill up the new filter with clean engine oil;
- (3) Coat the new filter rubber gasket with oil before installing, and then tighten the filter by hand;
- (4) After the rubber gasket touched the base, tighten the filter for another 3/4~1 circle to seal it up.
- (5) Check whether there is oil leakage after engine started.

● Check and adjust intake and exhaust valve clearance

- (1) Firstly make sure the engine is in cold state, and then rotate the flywheel positively with external force until cylinder 1, 6 get to TDC, at this point mark (notch groove) on flywheel is aligned to the pointer on sightglass cover plate.
- (2) Remove the valve rocker shield on cylinder cover, to determine whether it is cylinder 1 or cylinder 6 in compression stroke (for cylinder in compression stroke, there is clearance between

intake valve (and exhaust valve) and rocker).

- (3) Measure the clearance between rocker and valve rod upper surface with feeler gauge. Required intake valve clearance for WD10 diesel engine is 0.3mm; while that for exhaust valve is 0.4mm. If the clearance is too large or too small, you can rotate the adjusting screw to adjust until the clearance meets the requirements. Refer to Fig. 2-9.

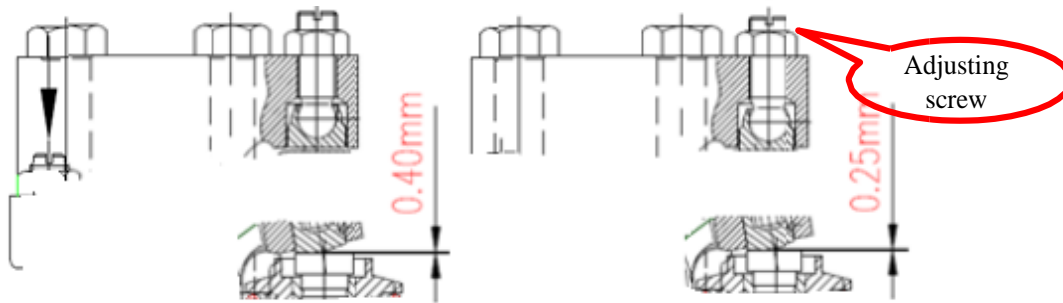

Cold-state intake valve clearance is 0.3mm Cold-state Exhaust valve clearance is 0.4mm

Fig. 2-9 Intake and exhaust valve clearance

- (4) After checking cylinder 1 or cylinder 6, rotate the flywheel positively with external force for another 360° to let cylinder 6 or 1 in power stroke, check and adjust other valves.

Table 2-4

	Cylinder 1	Cylinder 2	Cylinder 3	Cylinder 4	Cylinder 5	Cylinder 6
Cylinder 1 in compression stroke	Intake and exhaust valves	Intake valve	Exhaust valve	Intake valve	Exhaust valve	Cannot be adjusted
Cylinder 6 in compression stroke	Cannot be adjusted	Exhaust valve	Intake valve	Exhaust valve	Intake valve	Intake and exhaust valves

For exhaust valve equipped with EVB auxiliary braking device, follow the steps below to adjust its clearance:

- (1) Rotate the flywheel until the piston is in compression stroke TDC.
- (2) Loosen bolt assembly 2.
- (3) Adjust valve clearance adjusting screw on pushrod end 10 without compressing exhaust valve rocker sealing surface until the total valve clearance is 0.4mm, and then tighten bolt assembly 2. **(ATTENTION: In the adjusting process, you should rotate the valve clearance adjusting screw until the feeler gauge is gently infibulated, so that valve rocker piston 5 can be pushed to the bottom and no clearance between piston and piston hole bottom).**
- (4) Loosen bolt assembly 2.
- (5) Adjust bolt assembly 2, and insert a 0.25mm feeler gauge between bolt 2 and valve bridge, and tighten lockup nut at last.

ATTENTION: In the adjusting process, you should rotate the bolt assembly 2 until the feeler gauge is gently infibulated, so that valve rocker piston 5 can be pushed to the bottom and no clearance between piston and piston hole bottom.

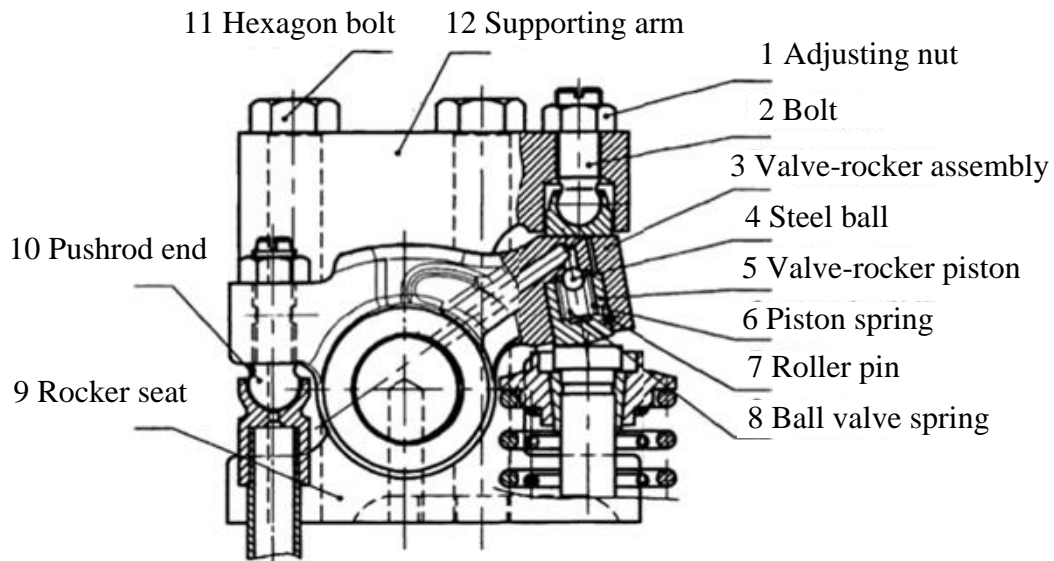

Fig. 2-10 Exhaust valve and EVB clearance adjusting

(6) Check the valve clearance again and readjust if necessary.

● **Replace fuel filter element**

Follow the steps below to replace fuel filter element:

- Remove the old fuel filter element; if the water collector that installed on coarse filter can be reused, please the take collector down.
- Lubricate the seal.
- Screw on the filter with hand until the seal touched the port.
- Continue to tighten the filter with hand until it is firmly installed (About 3/4 circle).
- Drain all air in fuel system out.
- Perform leakage test.

ATTENTION: After replacing the spinning coarse filter or reassembling the oil delivery pipes, it is required to deflate the coarse filter.

Deflating steps (as shown in Fig. 2-11):

- Shut down the engine.
- Remove the air bleed screw.
- Operate the hand pump until only oil outflows from air bleed screw port
- Screw on air bleed screw tightly.

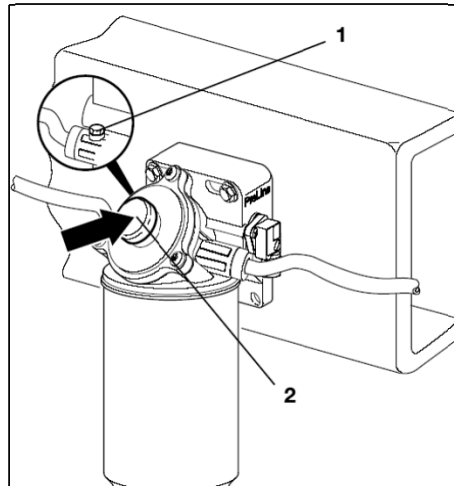

Fig. 2-11 Deflating of coarse filter

Drain water in water collector:

ATTENTION: When water collector is full or spinning coarse filter is replaced, it is required to drain the water in water collector out.

Draining steps (as shown in Fig. 2-12):

- Open the oil drain plug 2 on bottom of water collector 1 to drain all water out.
- Retighten the plug.

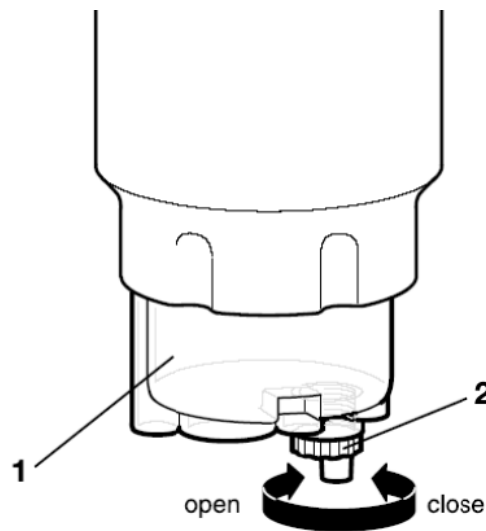

Fig. 2-12 Drain water in water collector

Replace water collector:

Replacing steps (as shown in Fig. 2-13):

- Shut down the engine.
- Drain water in water collector.
- If possible, remove screw 1 on water collector with hand. If it's too tight, use a handling tool.
- Apply some lubricating oil on the new collector sealing ring 2.

- Install the screw with hand and tighten it with tool.
- If the collector needs to be used on a new spinning filter, check it for damage first.
- Install the collector with torque wrench, tightening torque is 20Nm.

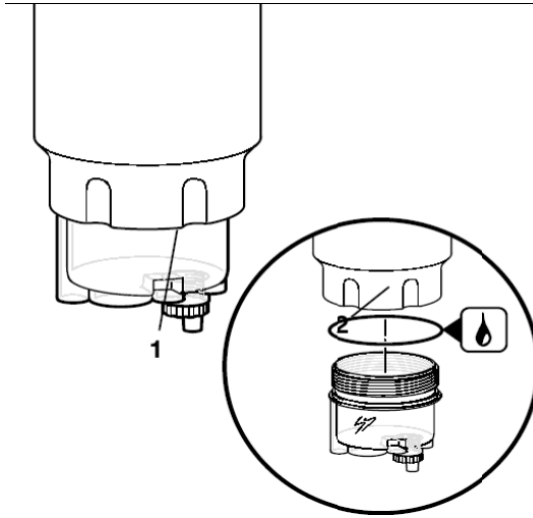
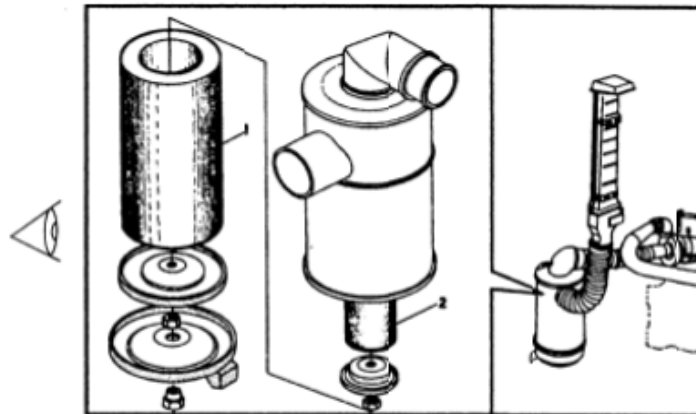

Fig. 2-13 Replace water collector

● Check intake system

Check whether intake rubber hose is aged and cracked, whether the circumferential band is loose. Fasten or replace some parts when necessary, in order to ensure good sealing performance of intake system.

● Check air filter element



1.纸质主滤芯 Paper filtering element
2.毛毡安全滤芯 Blanketry safety filtering element

Fig. 2-14 Air filter

Maximum allowed intake resistance for the engine is 7kPa, maximum intake resistance must be measured under rated speed and full load, if the intake resistance exceeds maximum allowed value, the filter must be cleaned or replaced according to the regulations of manufacturer.

ATTENTION: By no means should an engine without air filter be running, Otherwise

infiltration of dust and impurities will lead to premature wear of engine.

Remove the filter element from air filter, pat its end faces gently to clean the dust on it, blow it with compressed air reversely (from inside to outside) is also feasible.

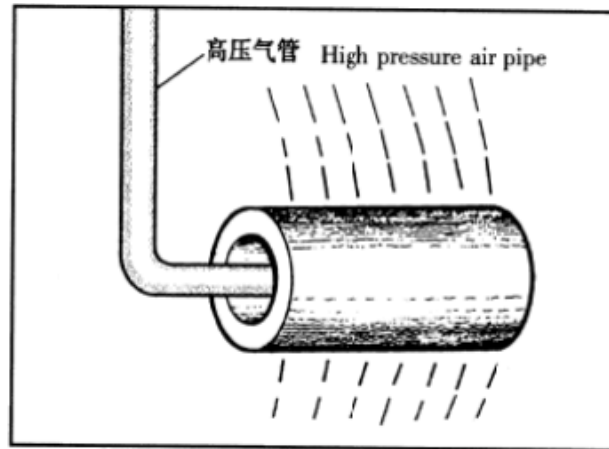

Fig. 2-15 Air filter element

ATTENTION: Do not let the air broke filter paper and do not clean filter paper with water or oil, do not pat or strike the filter element fiercely.

24 Maintenance for Long-Term Storage

241 Cleaning

- (1) Drain all engine oil out after warming up the engine and clean engine oil filter, add slushing oil into engine oil sump;
- (2) Drain all fuel in fuel system out, and add slushing oil instead to protect the fuel circuit;
- (3) Drain cooling water out, and add coolant with antirust agent instead;
- (4) Run engine idly for 15~25min;
- (5) Drain all kinds of oil and fluid in the engine out, including engine oil, fuel, coolant and urea solution;
- (6) Perform the protection on other parts.

242 Protection

To prevent humid air and impurities infiltrating into the engine, all open ports (import and export of oil, air and water) should be sealed up with caps or plastic cloth, and also seal up the whole engine with anti-rust film.

ATTENTION: Additional packaging is required for transporting.

3 Diagnosis and Troubleshooting of Diesel Engine

Common Faults

WD10 China II series diesel engine is designed and manufactured under strict quality guarantee system, each delivered engine has passed specified tests. Since diesel engine is precision machinery, guarantee for long-term reliable service is inseparable from correct maintenance. Causes for diesel engine early failure are as follows:

- ◆ Violation of operating regulations, poor management and improper applications;
- ◆ Fail to maintain the machine according to requirements or even no maintenance;
- ◆ Ill manufactured accessories, fake and inferior accessories will greatly shorten the life of engine.
- ◆ Unsuitable or unqualified fuel and lubricating oil brand.

31 Diagnostic Methods

Common diagnostic methods for diesel engine failure:

- ◆ Observation method: Check the exhaust gas color for fault diagnosis (Fig. 3-1).
- ◆ Auscultatory method: Determine the location, type and degree of the trouble according the abnormal noise produced by the engine (Fig. 3-2).

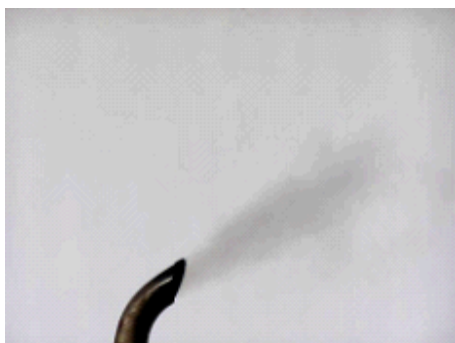

Fig. 3-1 Observation method



Fig. 3-2 Auscultatory method

- ◆ Single cylinder deactivation method: Deactivate a certain cylinder to determine whether the trouble is caused by this cylinder. The general way to deactivate a suspicious cylinder to stop its fuel supply, by comparing the engine state changes, the serviceman can further search the trouble location or narrow down cause area.
- ◆ Comparison method: For some assemblies or parts, check whether they are in failure by replacing them.

ATTENTION:

1. Diesel engine fault cause determination is an extremely careful job. Before basically be sure about the cause, it's not allowed to disassemble the engine casually, otherwise instead of eliminating the fault, some severe trouble may occur due to improper reassembling.
2. For key components, such as high pressure oil pump and turbocharger, only dedicated instruments and equipment are not enough to perform proper maintenance and inspection, an experienced serviceman is indispensable. So users without proper experience and tools are not allowed to disassemble and adjust the engine casually.

32 Fault Causes and Elimination Methods

321 Diesel Engine Couldn't Be Started

Fault cause	Elimination method
1. Blockage of fuel pump oil inlet filter screen or hoses in the circuit	Check and clean up the dirt, and check the cleanliness of the fuel.
2. Air in fuel system	Expel the air and check airtightness of joints, repair if necessary.
3. Fuel injection pump failure	Check the plunger and fuel delivery valve, repair or replace the damaged parts.
4. Fuel injector failure	Check the atomization condition of the injector.
5. Valve or fuel supply pipe is damaged or leaking oil	Check and adjust.
6. High pressure fuel pipe is damaged or leaking oil	Check and adjust.
7. Insufficient cylinder compression pressure	Check the valve and cylinder gasket for sealing performance, check whether the piston is worn, repair or replace.
8. Low temperature	Use start aid.

322 Diesel Engine Stops Soon after Starting

1. Blockage of fuel filter	Disassemble the filter body to clear up the water and dirt, replace the filter element if necessary.
2. Air in fuel system	Expel the air and check airtightness of joints, check whether the air bleed screw is tightened.
3. Fuel delivery pump doesn't work	Check fuel delivery pump piston and valves, clean and repair.
4. Inferior fuel, high water content	Clean fuel filter and replace the fuel.
5. Low idling speed	Readjust.

323 Underpower

1. Blockage of intake pipe (blocked air filter)	Check air filter and intake pipe, repair or replace filter element.
2. High exhaust back pressure	Check valve timing, check whether the exhaust pipe is blocked, adjust and repair.
3. Underpressure of supercharging system	Check and eliminate leakage in pipes and joints.
4. Malfunctioned turbocharger	Replace the turbocharger assembly.
4.1 Blockage of air compressor and turbine passageway	Clean or replace.
4.2 Float bearing failure	Replace.
4.3 Too much carbon deposit in turbine and air compressor back gap	Clean.
5. Intercooler is damaged or leaking air	Replace or repair.
6. Fuel pipe is blocked or leaking oil	Check the sealing performance of fuel pipe and pipe joints, clean up the dirt in filter element or replace the filter element, repair the pipe.
7. Inferior fuel	Clean fuel tank, fuel filter and fuel pipes, and replace the fuel.
8. Over wear of injection pump or governor	Repair or replace.
9. Injection pump smoke limiter diaphragm is damaged	Repair or replace.
10. Air pipe of smoke limiter is damaged and leaking	Replace.
11. Bad atomization	Check injection pressure, check whether injector is blocked by carbon deposit, adjust and repair it.

12. Incorrect valve or injection timing	Check and adjust it.
13. Governor high-speed regulating performance is poor	Check the speed control characteristic and adjust.
14. High engine oil level in oil sump	Check oil dipstick and drain redundant engine oil out.
15. Air leakage in cylinder gasket	Check the compression pressure when engine is running, replace damaged gasket.
16. Scuffing of piston ring, oversized bearing shell clearance	Replace the damaged parts or overhaul the engine.
17. Wear of piston or cylinder sleeve, or scuffing of cylinder bore	

324 Large Fuel Consumption

1. Blockage of intake pipe	Check air filter and intake pipe, clean them up.
2. High exhaust back pressure	Check whether the exhaust pipe and brake valve are blocked, clean them up if so.
3. Inferior fuel	Replace the fuel according related requirements.
4. Blockage of fuel pipe	Check and repair.
5. Oil leakage in fuel pipe	Check and repair.
6. Bad atomization	Check and adjust or repair.
7. Incorrect valve or injection timing	Adjust valve clearance and fuel supply advance angle according related requirements.
8. Air leakage in cylinder gasket	Check the compression pressure.
9. Oversized shell clearance and the engine needs to be overhauled	Check and overhaul the engine.
10. Cylinder swelling due to piston problem	Replace cylinder sleeve, piston and piston ring.
11. Underpressure of supercharging system	Check and eliminate leakage in pipes and joints.
12. Malfunctioned turbocharger	Check and replace.
13. Intercooler is damaged or leaking air	Replace or repair.

325 Engine Gives off Black Smoke

1. Blockage of intake pipe or high exhaust back pressure	Clean it up.
2. Inferior fuel	Clean and replace.
3. Incorrect valve or injection timing	Adjust valve clearance and fuel supply advance angle according related requirements.
4. Bad atomization	Check and repair or replace.
5. Overmuch fuel pumped by the injection pump	Check and adjust (should be performed by professional personnel).
6. Underpressure of supercharging system	Check and eliminate leakage in pipes and joints.
7. Malfunctioned turbocharger	Check and replace.
8. Intercooler is damaged or leaking air	Replace or repair.
9. Wrong application point of smoke limiter	Readjust (should be performed by professional personnel).

326 Engine Gives off White and Blue Smoke

1. Inferior fuel, high water content	Replace the fuel.
2. Too low coolant temperature	Check working temperature of thermostat, replace it if necessary.
3. Incorrect valve or injection timing	Check and adjust.
4. Bad atomization	Check and repair.
5. Low compression pressure, incomplete combustion and cylinder expansion caused by piston	Check and repair piston ring, cylinder sleeve, cylinder gasket.
6. Incomplete run-in of piston ring and cylinder sleeve	Continue the run-in process.
7. Openings of piston ring are not staggered	Adjust and reassemble.
8. Piston oil ring failure	Replace.
9. Oversized fitting clearance of cylinder sleeve	Repair or replace.
10. Wear of turbocharger sealing ring	Check and replace.
11. Wear of turbocharger thrust bearing	Check and replace.
12. Blockage of turbocharger oil return pipe	Clean or repair

327 Turbocharger Intake Port and Intake Pipe Are Accumulated with Engine Oil

1. Turbocharger sealing failure	Repair or replace the turbocharger.
2. Oil-gas separator failure	Replace.
3. High engine oil level in oil sump	Check oil dipstick and drain redundant engine oil out.

328 Unstable Engine Speed

1. Inferior fuel, high water or wax content	Replace the fuel.
2. Air absorbed in through fuel sucking pipe	Check sealing performance of fuel pipes and joints, bleed the air out.
3. Governor weight and governor spring out of order	Check and adjust (should be performed by professional personnel).
4. Uneven fuel supply	Check and adjust (should be performed by professional personnel).
5. Unstable atomization of injector	Check and repair.
6. Resonance of turbocharger	Check and clean air compressor passageway, clean up the dirt, clear away the carbon deposit in exhaust passageway.
7. Damaged turbocharger bearing	Replace.

329 Low Engine Oil Pressure

1. Low engine oil level in oil sump, lack of engine oil	
2. Pressure regulating valve in main oil gallery failure	Check the valve, clean and repair.
3. Blockage or fracture of oil strainer, engine oil pipe and joint gaskets.	Check and clean air compressor passageway, clean up the dirt, clear away the carbon deposit in exhaust passageway.
4. Wrong engine oil brand	Replace engine oil according to related requirements, choose suitable engine oil brand.
5. Leakage of engine oil pump inlet pipe	Check the oil pipe and pipe joints, repair or replace.
6. High cooling system water temperature, high engine oil temperature.	Check cooling system and remove the problem.

7. Large filtering resistance of engine oil filter	Replace filter element.
8. Blockage of engine oil cooler	Check and clean.
9. Blockage of main oil gallery	Check and clean.
10. Large bearing shell clearance, or damaged bearing shell	Check and replace.
11. Severe wear of parts, overhaul needs to be done	Check working hour of engine, overhaul the engine.

3210 High Cooling Water Temperature

1. Low cooling water level in water tank	Check for water leakage, add water.
2. Blockage of water tank	Check water tank, clean or repair.
3. Loose water pump belt	Tension the belt according to related requirements.
4. Damaged water pump gasket, wear of water pump impeller	Check and repair or replace.
5. Thermostat failure	Replace.
6. Damage of water pipe, air infiltrated in.	Check water pipe, pipe joints and gaskets, replace damaged parts.
7. Low engine oil level in oil sump, lack of engine oil	Check engine oil level and leakage, repair and fill oil.

3211 Rapid Wear of Parts

1. Unqualified or damaged air filter element	Check and replace with qualified air filter element.
2. Short circuit of intake system	Check intake pipe, gaskets and pipe joints, repair or replace.
3. Low engine oil level in oil sump, lack of engine oil	Check engine oil level and leakage, repair and fill oil.
4. Blockage of oil gallery	Clean.
5. Wrong engine oil brand	Replace engine oil according to related requirements, choose suitable engine oil brand.
6. Breakage or wear of piston ring	Replace damaged parts.
7. Wear of piston or cylinder sleeve, or scuffing of cylinder bore	Overhaul piston and cylinder sleeve, repair or replace.
8. Fail to replace engine oil filter element in time	Replace it according to related requirements.

9. Severe wear of parts, overhaul needs to be done	Check working hour of engine, overhaul the engine.
10. Crankshaft and the follower main shaft are not concentric	Check the installing support, repair.
11. The applied engine oil quality fails to meet the requirements	Choose specified engine oil brand.

3212 Excessive Noise

1. Inferior fuel	Replace the fuel.
2. Too low cooling water temperature	Check the thermostat and replace it if necessary.
3. Incorrect valve or injection timing	Check and adjust it.
4. Bad atomization	Check and repair.
5. Overmuch fuel pumped by the injection pump	Check and adjust (should be performed by professional personnel).
6. Wear of damper	Check connecting bolts for damage and replace damaged parts.
7. Air leakage of valve or maladjustment	Overhaul the valve and adjust.
8. Excessive gear clearance or gear tooth breakage	Check and replace damaged parts.
9. Wear of piston or cylinder sleeve, or scuffing of cylinder bore	Overhaul piston and cylinder sleeve, repair or replace.
10. Bended or fractured pushrod	Replace.
11. Breakage or wear of piston ring	Check or replace the damaged parts.

3213 Starter Motor Doesn't Work

1. Undercharged battery	Check, recharge or replace the battery.
2. Bad contact	Clear up the circuit and tighten all terminals.
3. Fuse blow	Replace the fuse.
4. Bad contact of electric brush	Clean the brush or replace it.
5. Short circuit in starter motor	Overhaul the motor or replace it.

3214 Underpowered Starter Motor

1. Undercharged battery	Check, recharge or replace the battery.
2. Bearing sleeve wear	Replace the assembly.
3. Bad contact of electric brush	Clean the brush or replace it.
4. Dirty or burnt commutator	Wipe out oil dirt and polish it with abrasive paper or replace it.
5. Loose weld of terminals	Re-weld.
6. Bad contact of switch	Check the switch and replace it.
7. Worn clutch slipping	Adjust working torque of the clutch or replace it.

3215 Generator Generates Nothing

1. Open circuit, short circuit or loose terminals	Check the wiring of generator and ampere meter, repair.
2. Open circuit, short circuit or grounding of rotor coil or stator coil.	Repair or replace the assembly.
3. Damage of rectifier tube	Replace the assembly.
4. Destruction of terminal paper insulation, disconnected wire.	Repair
5. Too low regulator adjusting voltage.	Adjust
6. Burn out of regulator contactor.	Repair or replace the assembly.

3216 Generator Undercharging

1. Open circuit, short circuit or loose terminals	Repair.
2. Open circuit, short circuit or grounding of rotor coil or stator coil.	Repair or replace the assembly.
3. Loose generator belt	Check and tighten the belt.
4. Damage of rectifier tube, bad contact of battery	Repair.
5. Too low regulator adjusting voltage	Adjust
6. Disconnected regulator field coil or resistance wiring	Repair or replace.
7. Low battery acid level or aged battery	Add acid or replace the battery.

3217 Unstable Charging Voltage

1. Rotor coil or stator coil is about to in open circuit or short circuit	Repair or replace.
2. Bad contact of electric brush	Repair.
3. Loose terminals, bad contact	Repair.
4. Damaged voltage regulator	Repair.
5. Improperly adjusted voltage	Check and adjust.

3218 Generator Overcharging

1. Short circuit in battery	Repair or replace.
2. Too high regulator adjusting voltage	Repair and adjust.
3. Bad grounding of regulator	Repair.
4. Regulator contactor failure, or contaminated. Disconnected voltage coil or resistance wiring	Repair or replace.

3219 Generator Produces Abnormal Sound

Improperly installed generator	Repair.
Bearing damage	Replace the bearing.
Rotating part is interfered with fixed part	Repair or replace.
Short circuit of rectifier	Replace.
Short circuit of stator coil	Repair or replace.

4 Disassembly & Assembly of Diesel Engine

41 Overview

Please comply with instructions in this manual strictly to disassemble and assemble the engine and pay special attention to operations which danger signs and safety signs are involved in this manual, in order to ensure personal safety and avoid accidents.

411 Danger Signs



This sign is world-recognized danger sign. In this manual, this sign is used to emphasize the importance of following information. Make sure you are well aware of the consequence that the danger can bring and know how to avoid such danger. Acts in violation of the warning message may result in property loss, personal injury and even casualties.

The most common danger sign is generally for general warning. In this manual, warning messages are divided into different types according the consequence it could bring (minor wound, serious injury and death).



This warning sign is used for potential danger situation, fail to avoid this danger may result in serious injury or death or huge property loss.















This warning sign is used for potential danger situation, fail to avoid this danger may result in minor injury or property loss. This warning sign is also used for danger operations.

This manual provides all kind of notes and warning information to help the user correctly operate and safely use our engine. However, simply read these notes are not enough to avoid all kinds of potential danger, the user should correctly understand them.







Safety information described in this manual cannot cover all safety precautions, if the procedures or actions that are not recommended in this manual are used, you must ensure the safety of the operator and machine.

412 Safety Signs

Signs	Information
	Wear protective gloves
	Wear protective ear covers
	Wear protective goggles
	Wear protective hat
	Wear protective shoes
	Wear protective mask
	Wear protective suit
	No open flames
	No smoking
	Mobile phone prohibited
	Danger: battery acid
	Danger: electrified cable, electric shock hazard
	Inflammable material
	Stay away from hanging heavy objects
	Extinguisher nearby

Some unpredictable potential danger may occur during the use of engine, safety information described in this manual cannot include all of the safety precautions, if the procedures or actions that are not recommended in this manual are used, you must ensure the safety of the operator and machine and no property loss would bring.

413 Recommended Tools

Signs	Information
	2.5mm hexagon wrench
	5mm hexagon wrench
	8mm socket
	Slotted screw driver
	Dedicated tool
	10mm slotted hexagon wrench

If the methods or tools that are not recommended in this manual are used, you must ensure safety to avoid life risk to yourself or other people, in the meantime make sure the operating, maintenance and repair methods wouldn't bring damage to the engine or potential safety hazard.

414 Notes for Health Protection

The notes listed below aim at reducing contamination risk to engine maintenance personnel, related personnel should strictly observe these notes in the process of disassembling and assembling.

- (1) Avoid exposing to used engine oil long-time repeatedly.
- (2) Please wear protective suit and gloves if possible.
- (3) Do not put oil stained rag in your pocket.
- (4) Avoid dirtying your clothes with oil, especially underwear.
- (5) Wash your work clothes as often as possible; get rid of oiled clothes and shoes that cannot be cleaned.
- (6) Once get cut or be injured, seek for medical help as soon as possible.
- (7) Be sure to use protective cream before work, so that stained oil on the skin can be easily cleaned.
- (8) Use soap and hot water or use hand sanitizer nail brush to clear away all oil dirt on your hands. In case naturally secreted oils will be cleared in the same time, products that containing lanolin can replace the naturally secreted oils to help moisturize the skin.
- (9) Never clean your skin with gasoline, kerosene, fuel oil, thinner or solvent.

- (10) Be sure to seek for medical help immediately if any adverse reaction happened to your skin.
- (11) If possible, clear away oil dirt on parts before transporting the engine.
- (12) Please wear google or protective mask if there is risk of damaging your eyes. Eye washing fluid must be prepared within reach.
- (13) When maintaining the engine, prevent oil or other liquid spilling on the ground. If hydrocarbon or other liquid is accidentally leaked, be sure to take all requisite measures to quarantine this area, to keep the environment clean and avoid personal injury.
- (14) Local safety and environmental standards must be strictly observed when transporting, storing and recycling chemicals, such as hydrocarbon, ethylene, ethylene glycol and petroleum.

415 Environmental Protection Measures

Please comply with the relevant laws and regulations on environmental protection when handling waste oil and hydrocarbon. For further instructions please contact local officials.

416 Notes for Disassembly and Assembly of Engine

Most engine-related (use, maintenance and repair) accidents are caused by failing to comply with safety regulations and basic notes. So you should be able to realize the danger ahead and take relevant preventive measures to avoid the accident. Relevant training is required for engine operator and maintenance personnel, good skills and appropriate tools pave the safety road.

Any violation of instructions in this manual may result in serious accident, even death. Weichai Power cannot foresee all potential dangers. Similarly, the rules and instructions in this manual cannot cover everything.

Before proceeding the maintenance or repair operation, place a sign or label with “Do Not Use” on starting switch.

Before using barring rod to rotate the engine, necessary precautions should be taken:

- Ensure the maintenance site and its surroundings are suitable for safety operation.
- Ensure the maintenance shop or engine surrounding area is clean.
- Before operation, please remove your finger ring, necklace and wrist watch. And wear appropriate close-fit work clothes.
- Before operation, please check whether relevant protective devices (google, gloves, shoes, mask, work clothes and helmet etc.) are within validity period.
- Please don't use failure or inappropriate tools.

ATTENTION: The engine must be shut down during the maintenance.

417 Explode View of the Whole Engine

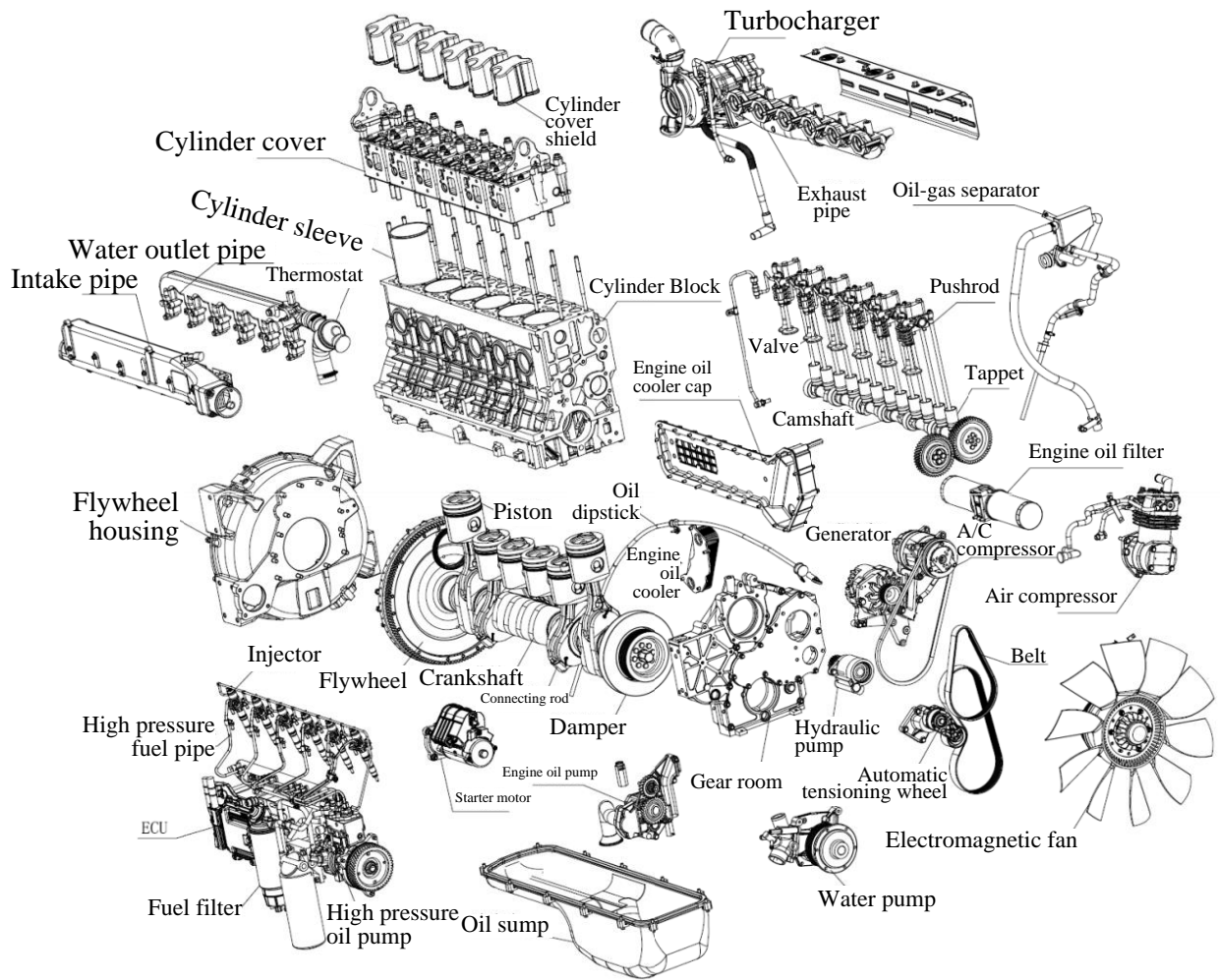

Fig. 4-1 Exploded view of the whole machine

42 Cylinder Cover Assembly

421 Disassembly and Assembly of Cylinder Cover Assembly

4211 Exploded View of Cylinder Cover Assembly

Cylinder cover is located on top of cylinder block, combustion chamber is jointly formed by cylinder cover and piston head. Parts that connected with cylinder cover are intake pipe, exhaust pipe, water outlet pipe, EVB oil pipe, injector, cylinder cover shield, oil-gas separator, cylinder cover gaskets and parts of valve mechanism. As shown in Fig. 4-2

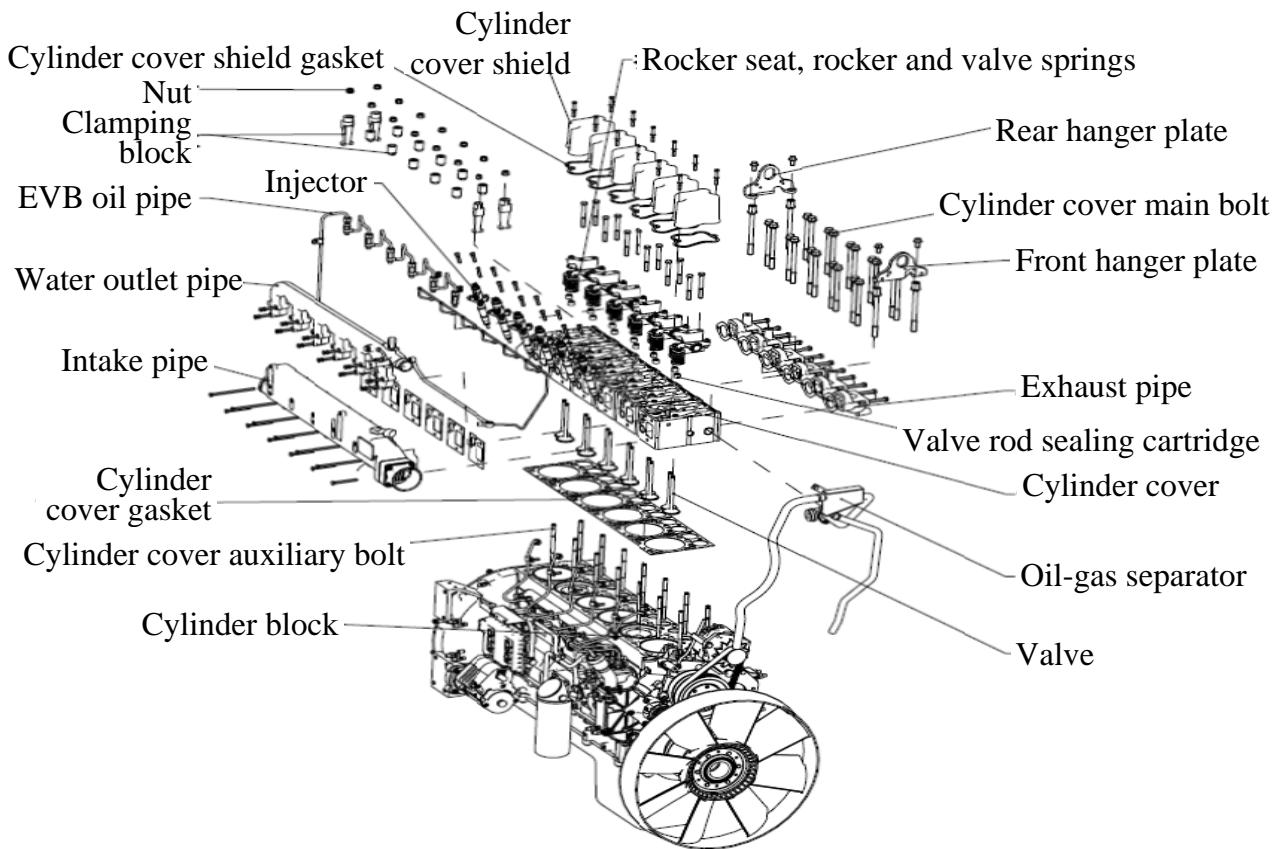

Fig. 4-2 Exploded view of cylinder cover assembly

4212 Steps to Disassemble Cylinder Cover Assembly

- (1) Remove exhaust pipe, refer to disassembly of air intake and exhaust system for details;
- (2) Remove intake pipe, refer to disassembly of air intake and exhaust system for details;
- (3) Remove oil-gas separator;
- (4) Remove water outlet pipe;
- (5) Remove front and rear hanger plates;

- (6) Disconnect EVB oil pipe and pipe joint;
- (7) Disconnect injector wiring harness, remove injector oil return pipe and high pressure fuel pipe, refer to disassembly of fuel system for details;
- (8) Remove the injector, refer to disassembly of fuel system for details;
- (9) Remove cylinder cover shields and its gaskets;
- (10) Remove rocker assembly and pushrod, refer to disassembly of valve mechanism for details;
- (11) Remove cylinder cover assembly, and take down the gaskets;

Refer to the chart below to tighten the bolts, some tips:

- 1) Pre-tighten the main bolts to 200Nm according to the order and mark the bolts.
- 2) Pre-tighten the auxiliary nuts for 90 ° according to the order, and mark the new position of the nuts.
- 3) Tighten the main bolts for further 90 ° according to the order , and mark the new position of the bolts.
- 4) Tighten the auxiliary nuts for another 90 ° according to the order, and the tightening torque should get to 120~160Nm.
- 5) Tighten the main bolts for another 90 ° according to the order, and the tightening torque should get to 240~340Nm.

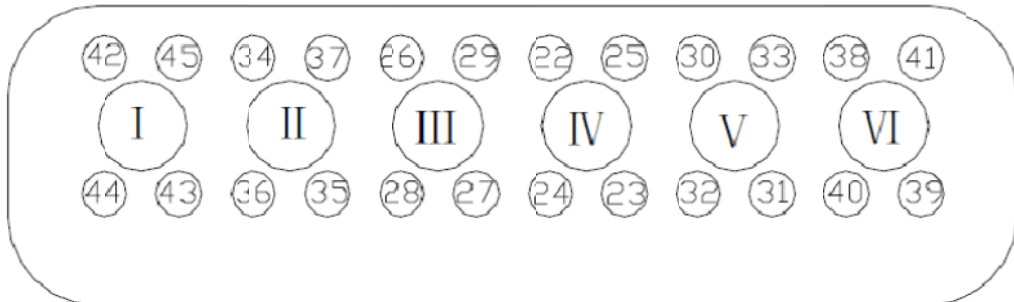

- (12) Remove inner and outer springs of intake and exhaust valves, and then take out the spring seats, valve collets and valves, refer to disassembly of valve mechanism for details;
- (13) Remove valve rod seal cartridges.

4213 Steps to Assemble Cylinder Cover Attachments

Assembling steps are contrary to disassembling ones.

422 Disassembly, Inspection, Maintenance and Assembly of Cylinder Cover Shield

4221 Exploded View of Cylinder Cover Shield

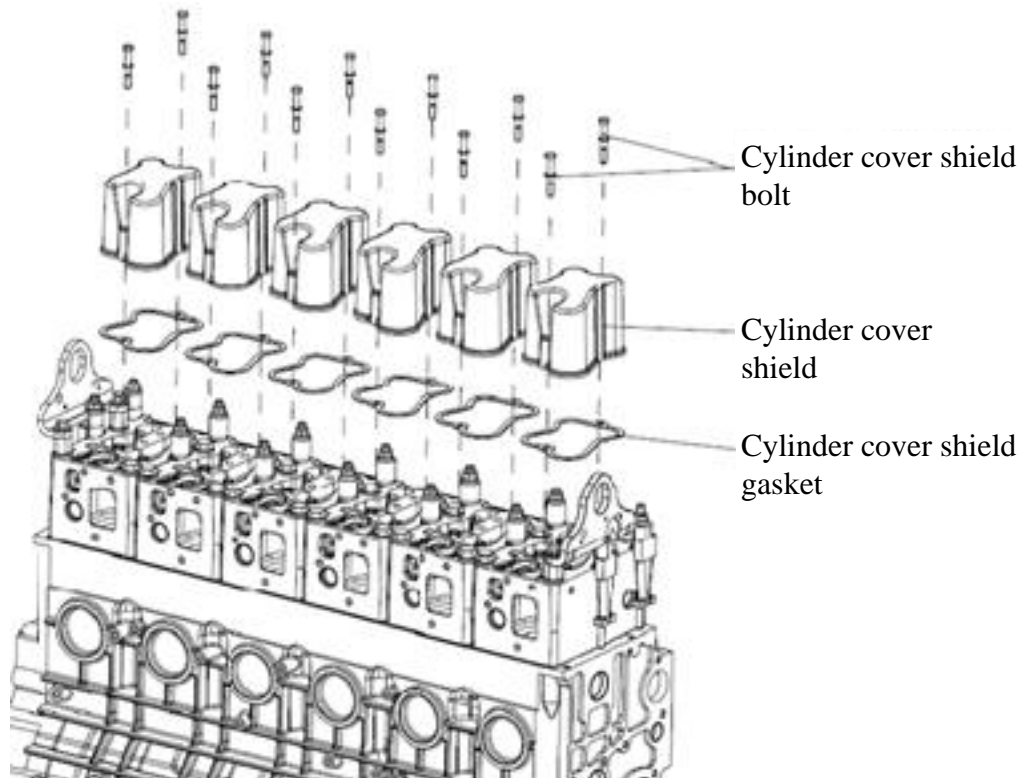

Fig. 4-3 Exploded view of cylinder cover shield

4222 Steps to Disassemble Cylinder Cover Shield

- (1) Screw off cylinder cover shield bolts orderly;
- (2) Pull the shield vertically up to take it and its gaskets down. As shown in Fig. 4-3.

4223 Inspection and Maintenance of Cylinder Cover Shield

- (1) Check whether there is damage like crack and severe wear on the shield, a cracked shield must be replaced.
- (2) If there is leakage in cylinder cover shield gasket, then the gaskets should be checked and replaced, also check the wear condition of cylinder cover upper surface and cover shield undersurface.

4224 Steps to Assemble Cylinder Cover Shield

- (1) Cylinder cover shield gaskets are disposable, and should be replaced during maintenance.

Check whether there is manufacturing defect, usage defect or damage on cylinder cover shield gaskets and cylinder cover before assembling.

- (2) Clean up cylinder cover upper surface and assemble cylinder cover shield gaskets orderly.
- (3) Clean up cylinder cover shields and install them on cylinder cover orderly.
- (4) Install cylinder cover shield bolts and tighten them.

423 Disassembly, Inspection, Maintenance and Assembly of Water Outlet Pipe

4231 Exploded View of Cylinder Cover

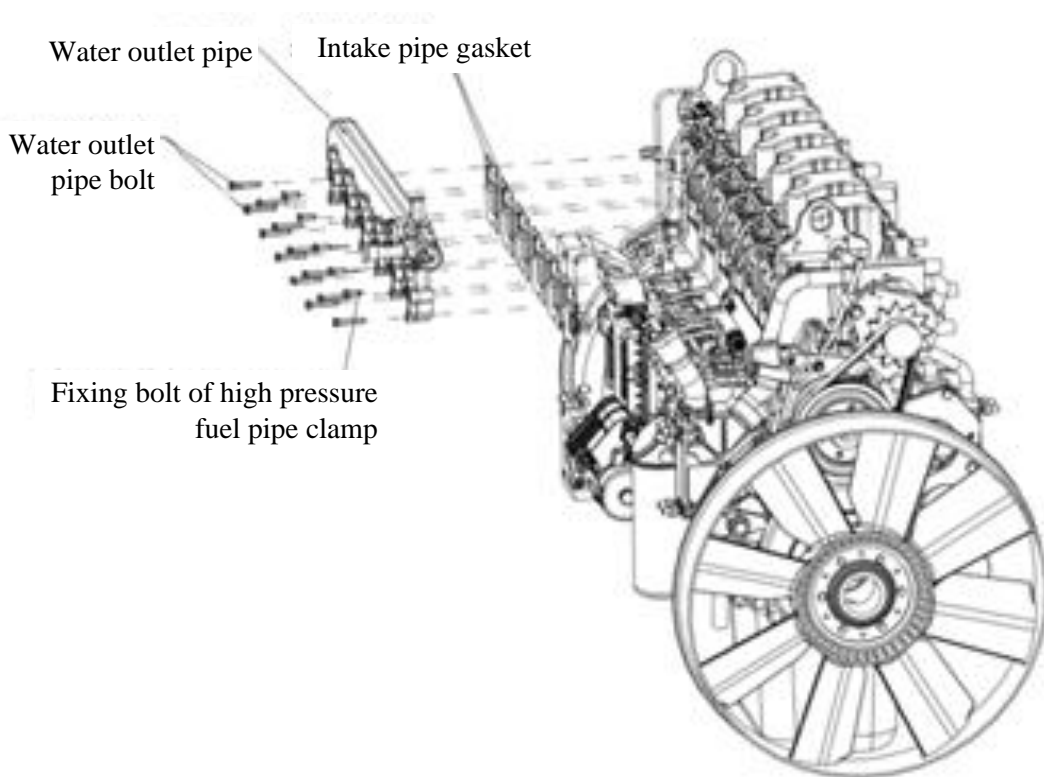

Fig. 4-4 Exploded view of water outlet pipe

4232 Steps to Disassemble Water Outlet Pipe

- (1) Disconnect sensor wiring harness from water outlet pipe;
- (2) Remove intake pipe, refer to **46 Intake and Exhaust System** for details;
- (3) Screw off the fixing bolt of high pressure fuel pipe clamp;
- (4) Remove water outlet pipe fixing bolts orderly, take down the pipe;
- (5) Water outlet pipe gasket and intake pipe gasket for WP10 two-valve type engine are designed as a whole, take it down after step (4). As shown in Fig. 4-4.

4233 Inspection and Maintenance of Water Pipe

- (1) Check whether there is water leakage trace on the pipe before disassembling; check the pipe for damage like crack and corrosion, a cracked pipe should be replaced, for corrosion that may affect reliability of the pipe, the cause should be analyzed and corroded pipe should be replaced.
- (2) If there is water leakage in pipe joint, try to replace the joint with new one and tighten it, and check whether the problem is still exist; if connecting thread is damaged, then the pipe should be replaced.

4234 Steps to Assemble Water Outlet Pipe

- (1) It is recommended to take intake pipe gasket as disposable part and replace it during maintenance;
- (2) Clean up water outlet pipe joint surface and install it on cylinder cover, fasten the pipe with bolts;
- (3) Tighten the fastening bolts;
- (4) Tighten the fixing bolt of high pressure fuel pipe clamp;
- (5) Install intake pipe, refer to **46 Intake and Exhaust System** for details;
- (6) Connect sensor wiring harness to water outlet pipe;

424 Disassembly, Inspection, Maintenance and Assembly of Oil-Gas Separator

4241 Exploded View of Oil-Gas Separator

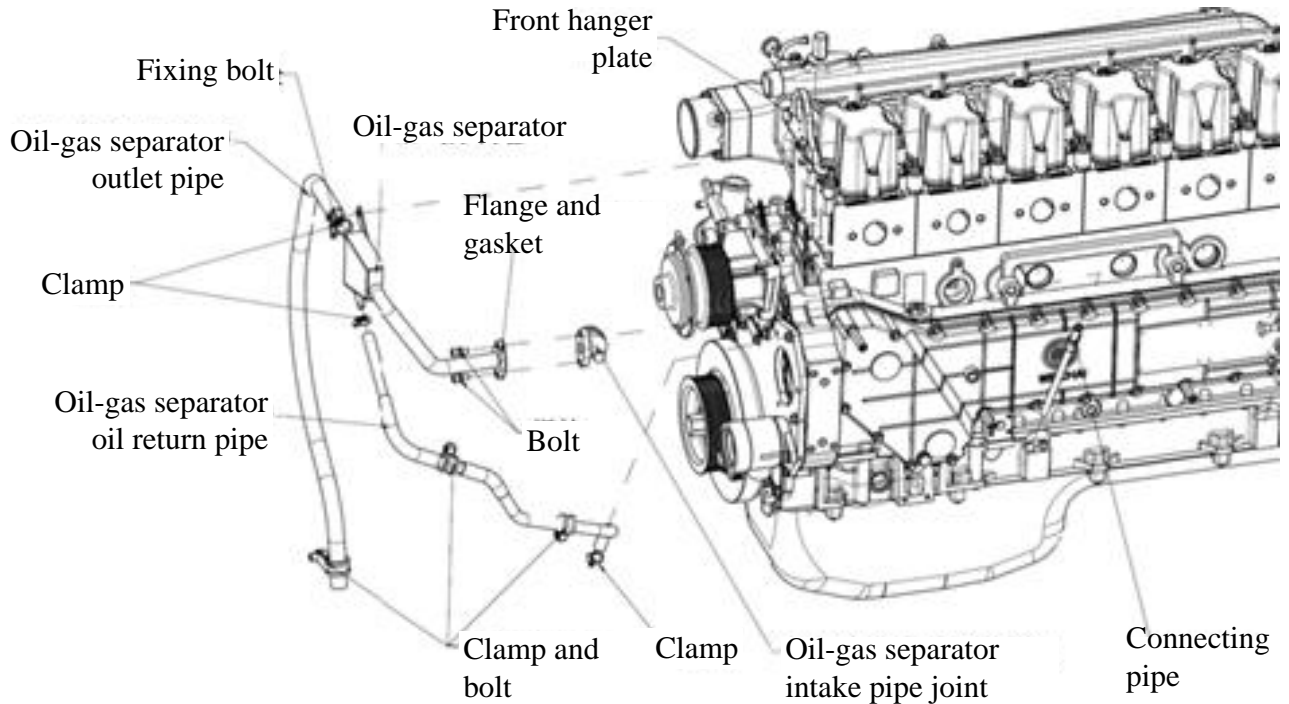

Fig. 4-5 Exploded view of oil-gas separator

4242 Steps to Disassemble Oil-Gas Separator

- (1) Remove the two fixing bolts of oil-gas separator intake pipe joint on cylinder block;
- (2) Remove the bolt that used to fix oil-gas separator on front hanger plate;
- (3) Remove the outlet pipe clamp and oil return pipe clamp of oil-gas separator, remove the clamp of oil sump return pipe;
- (4) If the connecting pipe that connected to oil-gas separator oil return pipe end needs to be disassembled, loose the pipe sleeve first.

For further disassembly, refer to Fig. 4-5.

4243 Inspection and Maintenance of Oil-Gas Separator

- (1) Check appearance of each part, check them for failure as damage, crack and rubber pipe hardening, and replace relevant parts.
- (2) Check whether oil-gas separator is unblocked by inflating the intake pipe, if the airflow is not smooth, blow away the impurities and oil dirt with compressed air. Replace the oil-gas separator if necessary.

4244 Steps to Assemble Oil-Gas Separator

Assembling steps are contrary to disassembling ones. Do not mix up the rubber hoses and hoses joints (refer to Fig. 4-5), connect each hose to the engine properly.

425 Disassembly, Inspection, Maintenance and Assembly of Hanger Plates

4251 Exploded View of Hanger Plates

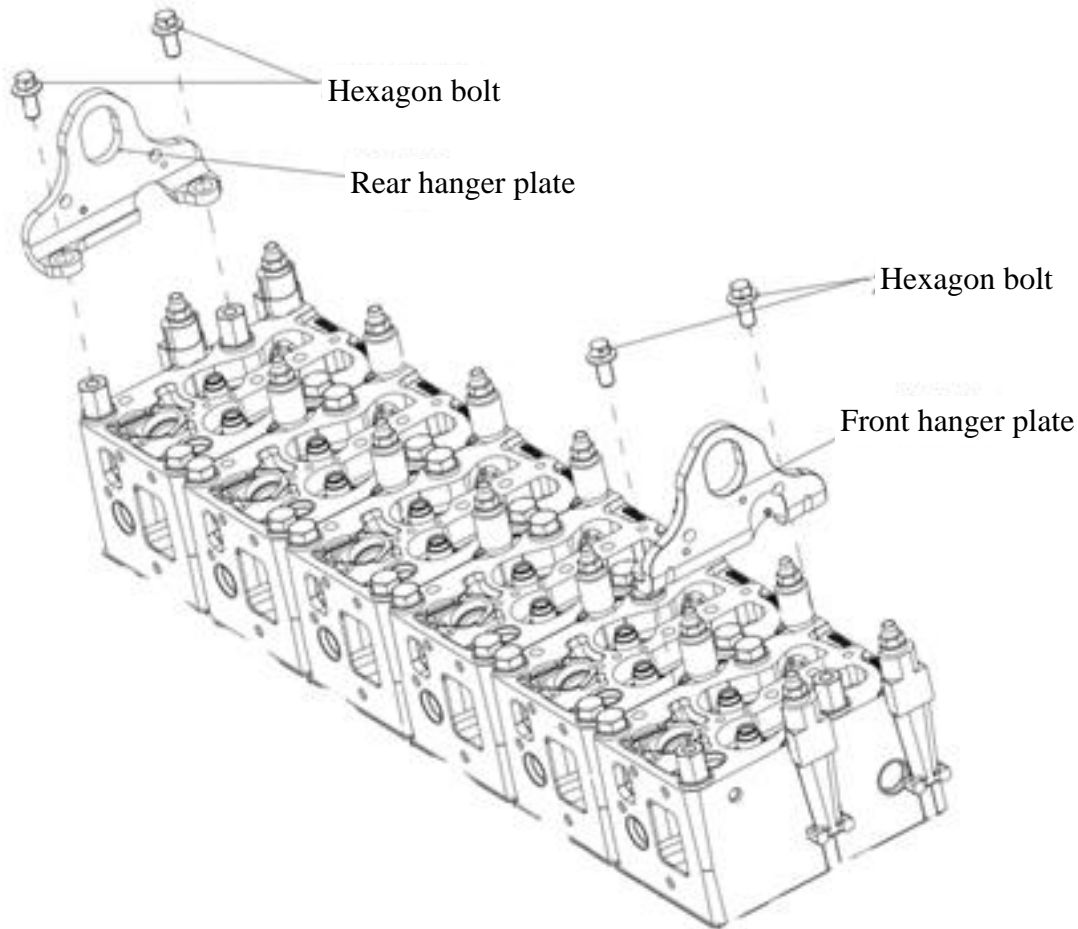

Fig. 4-6 Exploded view of lifting eye

4252 Steps to Disassemble Hanger Plates

Hanger plates are fixed on cylinder cover with bolts, used to hang the engine. Firstly remove the parts fixed on the plate, such as oil-gas separator, and then remove the hexagon bolts orderly, take down the plate.

4253 Inspection and Maintenance of Hanger Plates

Check whether there is crack or big distortion on hanger plates, check whether the hexagon bolts are in good condition. Replace the damaged parts to avoid accidents.

4254 Steps to Assemble Hanger Plates

Firstly distinguish the front hanger plate and rear hanger plate, front hanger plate should be installed on front end of engine (fan end), and rear hanger plate should be installed on rear end of engine (flywheel end), fasten the plates with M12 hexagon bolts (as shown in Fig. 4-6), required tightening torque is 100~125Nm.

426 Disassembly, Inspection, Maintenance and Assembly of Cylinder Cover

4261 Exploded View of Cylinder Cover

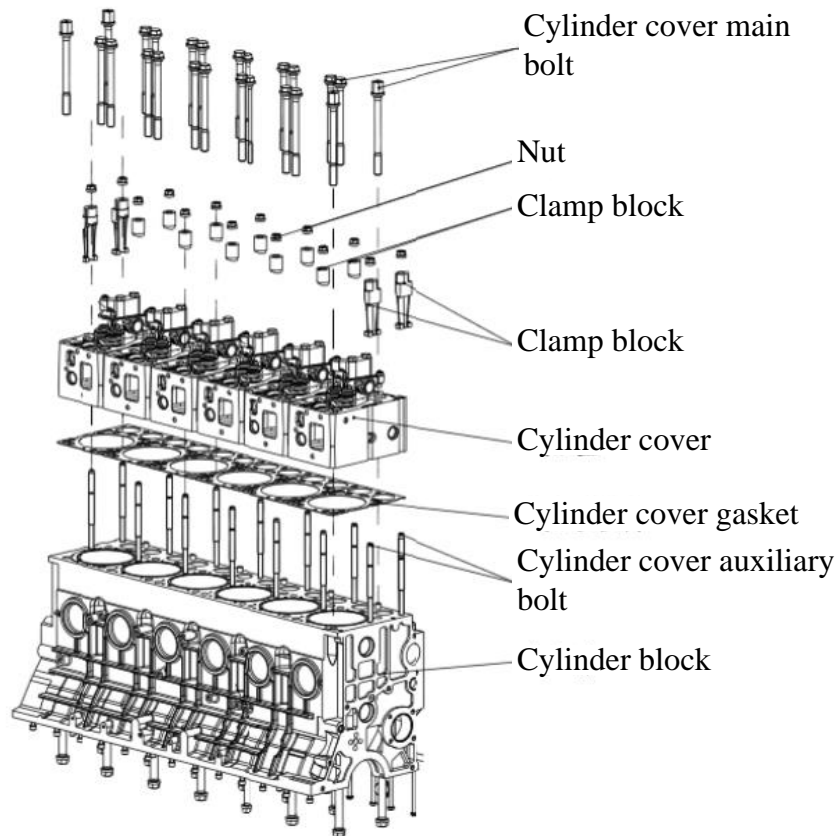

Fig. 4-7 Exploded view of cylinder cover

4262 Steps to Disassemble Cylinder Cover

Before removing the cylinder cover, it is required to remove the parts that are installed on cylinder cover first, including: intake pipe and exhaust pipe (refer to **46 Intake and Exhaust System** for details), fuel pipes and wiring harnesses (refer to **47 Fuel system** for details), cylinder cover shield, oil-gas separator, water outlet pipe and hanger plates (refer to **42 Cylinder Cover Assembly** for

details). Besides, for engine with EVB oil pipe, the pipe need to be remove too. Disassembling of other parts is as follows:

- (1) Remove cylinder cover auxiliary nuts, and take down the clamp blocks, there are two kinds of clamp blocks: one is installed between two adjacent cylinder covers, the other is installed on two sides;
- (2) Remove cylinder cover main bolts;
- (3) Remove injector, due to injector nozzle is above cylinder cover base plane, he injectors must be removed in advance to prevent the cover crashing the injectors during removal;
- (4) Remove cylinder cover, put the removed cylinder cover on paper board to prevent wearing upper surface of combustion chamber and other sealing surfaces. If more than one cylinder cover needs to be disassembled, then it is required to mark the cylinder number on the cover for fault analysis;
- (5) Remove cylinder cover gasket, if more than one cylinder cover gasket needs to be disassembled, then it is required to mark the cylinder number on the gaskets for fault analysis;
- (6) If cylinder cover auxiliary bolts need to be replaced or checked, then remove the bolts;
- (7) Remove rocker seat, intake valve and exhaust valve (refer to **45 Valve Mechanism**)
- (8) If the valve rod seal cartridge needs to be checked or replaced, then disassemble the seal cartridge with dedicated tool, or clamp the seal cartridge lateral wall with a plier, and rotate to take it out upward, removed seal cartridge cannot be reused.

4263 Inspection and Maintenance of Cylinder Cover

- (1) Check the cylinder cover for water leakage, oil leakage, air leakage and other abnormal phenomenon before disassembling, if there is such problem, replace cylinder cover gasket to see whether the problem is solved, refer to this section for cylinder cover gasket disassembling method.
- (2) Check the cylinder cover appearance for discoloration and crack, if crack is discovered, liquid penetrant test should be done.
- (3) Check valve recession before disassembling valve mechanism. Valve recession is the vertical distance between valve undersurface and cylinder cover undersurface, the difference between measured value and required value of valve recession can reflect wear degree of valve and valve seat. A depth micrometer can be used to measure valve recession, as shown in Fig. 4-8.



Fig. 4-8 Depth micrometer

Refer to Table 4-1 for valve recession requirements. If valve recession exceeds allowed range, check wear condition of valve and valve seat, replace the valve with a new one to determine wear condition of valve seat by measuring the valve recession again, if the valve recession still exceeds allowed range, the cylinder cover must be replaced to ensure reliability of diesel engine. If valve recession doesn't exceed allowed range, disassemble the valve to check the sealing surface between valve and valve seat for obvious wear and abnormal damage.

Table 4-1 Valve recession requirements:

	Required value of valve recession (mm)
Intake valve	0.85~1.05
Exhaust valve	1.08~1.48

- (4) After disassembling valve mechanism, check cylinder cover intake and exhaust passage for water leakage and other problem, if leakage is discovered, liquid penetrant test should be done after cleaning to locate the problem, replace the cylinder cover.
- (5) Clean cylinder cover, focus on combustion chamber surface, valve seat, intake and exhaust valve, intake and exhaust passage, remove the carbon deposit and mucilage glue, and check the surface condition.
- (6) Check valve guide pipe inner diameter. Due to internal surface of valve guide pipe is the contacting surface between valve rod and valve guide pipe, if clearance between valve rod and valve guide pipe exceeds allowed value due to abrasion, then the guide effect will at state, which may affect reliability of the engine. The inner diameter of guide pipe can be measured with an inside micrometer, as shown in Fig. 4-9. Allowed range for inner diameter of guide pipe is 11~11.018mm. If it exceeds allowed range, the cylinder cover must be replaced to ensure reliability of diesel engine.

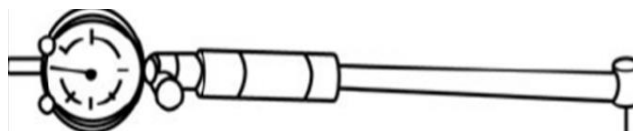

Fig. 4-9

- (7) Check the disassembled cylinder cover gaskets for visible damage and analyze the cause, cylinder cover gaskets are disposable, and should be replaced once removed.
- (8) Check whether valve rod seal cartridge rubber lip is damaged, whether the spring is in failure and whether there is other abnormal phenomenon before disassembling, seal cartridge should be replaced once removed.

4264 Steps to Assemble Cylinder Cover

- (1) Install cylinder cover auxiliary bolts



Fig. 4-10 Cylinder cover auxiliary bolt

- 1) Cylinder cover auxiliary bolts are allowed to use twice, replace them after 1 time reuse;
 - 2) Apply anaerobic type thread-locking agent 262 on the screwed-in end of first-row cylinder cover auxiliary bolts installed on engine oil cooler cover cap assembly. Pre-gluing other auxiliary bolts;
 - 3) Clean up the threaded holes on cylinder block;
 - 4) Tighten the bolts to 76~102Nm.
- (2) Install cylinder cover gaskets

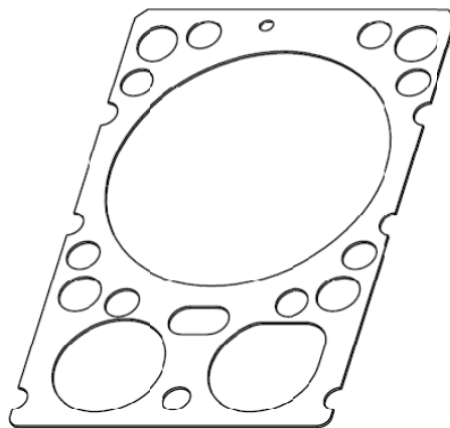

Fig. 4-11 Cylinder cover gasket

- 1) Cylinder cover gaskets are disposable, and should be replaced once removed;

- 2) Rub-up cylinder sleeve inner wall and apply clean engine oil on the wall; Clean up upper surface of cylinder block, and place cylinder gaskets correctly by aligning the holes;
 - 3) Check and make sure the holes on cylinder cover gasket are correctly aligned to holes on cylinder block.
- (3) Install valve rod seal cartridges

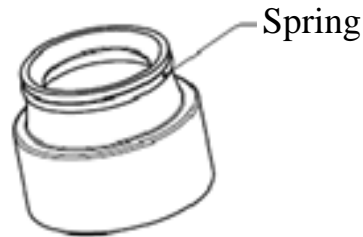

Fig. 4-12 Valve rod seal cartridge

- 1) Valve rod seal cartridges are disposable, and should be replaced once removed;
- 2) Check valve rod seal cartridge for flaws, check whether valve rod seal cartridge spring is in good condition;
- 3) Install valve rod seal cartridge on valve guide pipe;
- 4) Apply lubricating oil on valve rod seal cartridge lip;
- 5) Use dedicated assembling tools and rubber hammer to assemble valve rod seal cartridge assembly.

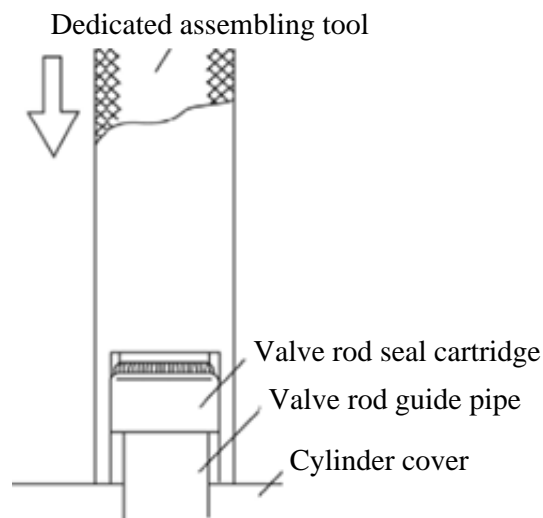

Fig. 4-13 Assembling of valve rod seal cartridge

- (4) Assemble cylinder cover
- 1) Clean up the cylinder cover carefully, make sure there is no dust, debris and sand, and rub-up undersurface of cylinder cover;

- 2) Check and make sure cylinder cover air passage and water passage are free of foreign matter; Check and make sure the cylinder is free of foreign matter, cylinder cover gasket and cylinder cover undersurface are clean;
 - 3) Apply pin-plane mode to locate the cylinder cover before fastening cylinder cover bolts;
 - 4) Assemble cylinder cover.
- (5) Install clamp blocks
- 1) Clean up the clamp blocks;
 - 2) Apply clean lubricating oil on clamp block bearing surfaces, and then install them on cylinder cover orderly, avoid applying too much lubricating oil to prevent oil leaking into cylinder cover gap.
 - 3) Clamp block groove direction should be the same as cylinder cover gap direction;
 - 4) Screw on cylinder cover auxiliary nuts with hand.
- (6) Install cylinder cover main bolts

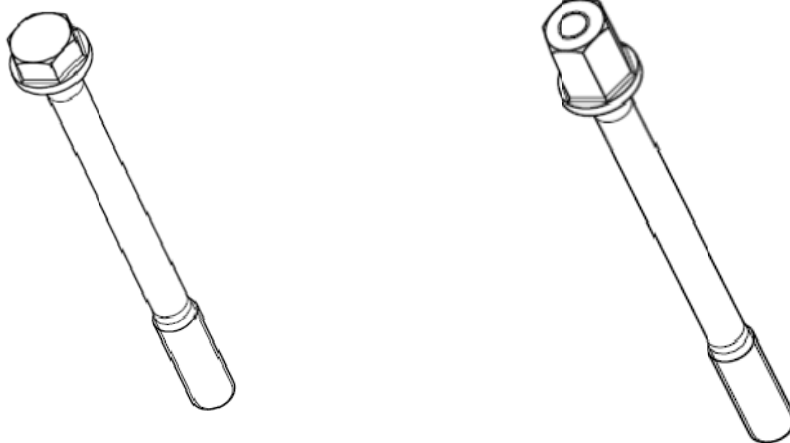

Fig. 4-14 Cylinder cover main bolt (Left) Cylinder cover main bolt for hanger plate (Right)

- 1) Cylinder cover main bolts are allowed to use three times, replace them after 2 times reuse;
- 2) Centre the cylinder covers orderly, apply proper amount of clean engine oil on thread and bearing surface of cylinder cover main bolts and nuts, and then install the bolts and nuts on cylinder cover and clamp blocks respectively. Notice that there are two kinds of clamp blocks: one is installed between two adjacent cylinder covers, the other is installed on two sides, as shown in Fig. 4-15.
- 3) Pre-tighten cylinder cover main bolts and auxiliary nuts with torque wrench to 30~50Nm;
- 4) Knock each clamp block so that they can be in position;
- 5) Pre-tighten cylinder cover auxiliary nuts to 100Nm with torque wrench orderly and mark the nuts;

- 6) Tighten cylinder cover main bolts with torque wrench orderly to 200Nm and mark the bolts;
- 7) Tighten each cylinder cover auxiliary nut for further 90° with torque wrench orderly and mark the new position of the nuts;
- 8) Tighten each cylinder cover main bolt for further 90° with torque wrench orderly and mark the new position of the bolts;
- 9) Tighten each cylinder cover auxiliary nut for another 90° with torque wrench orderly and the tightening torque should reach 120~160Nm;
- 10) Tighten each cylinder cover main bolt for another 90° with torque wrench orderly and the tightening torque should reach 240~340Nm;

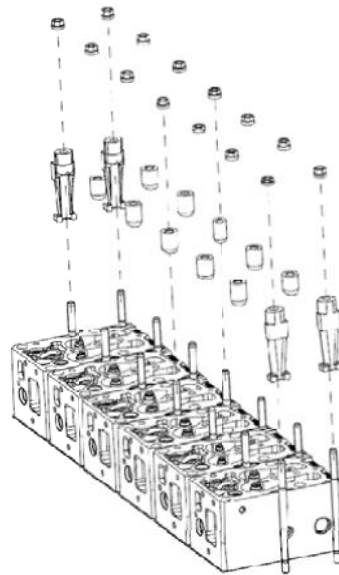

Fig. 4-15 Assembly of cylinder cover auxiliary nuts and clamp blocks

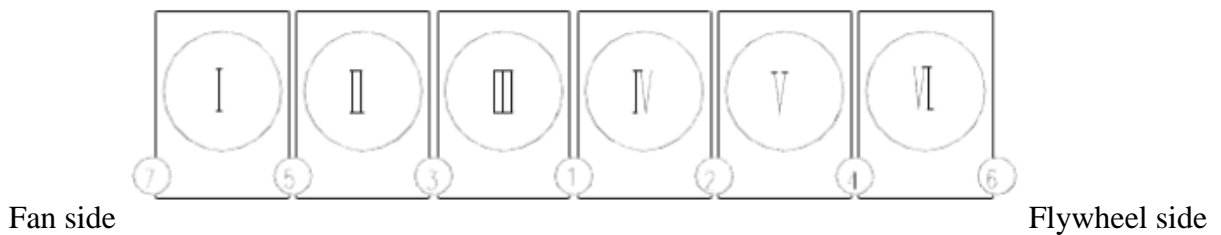

Fig. 4-16 Tighten number 1~7 cylinder cover auxiliary bolts (studs)

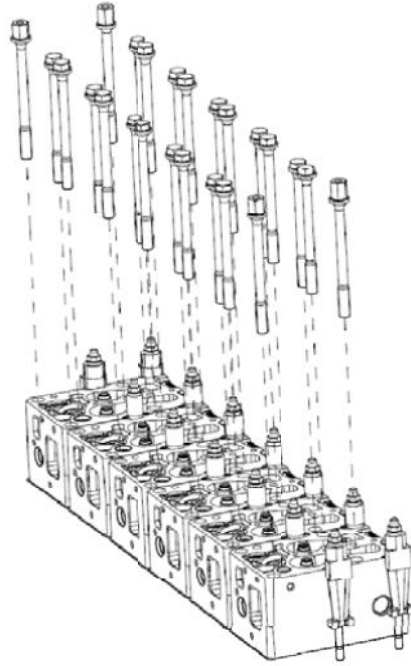
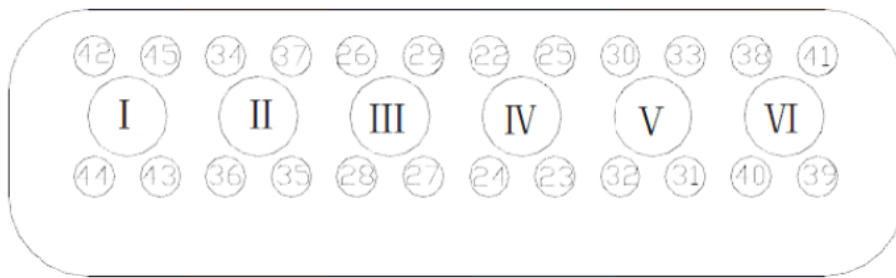

Fig. 4-17 Assembly of cylinder cover main bolts



Fan side

Flywheel side

Fig. 4-18 Tighten number 22~45 cylinder cover main bolts

43 Engine Block Assembly

431 Disassembly, Inspection, Maintenance and Assembly of Engine Block Assembly

4311 Exploded View of Engine Block Assembly

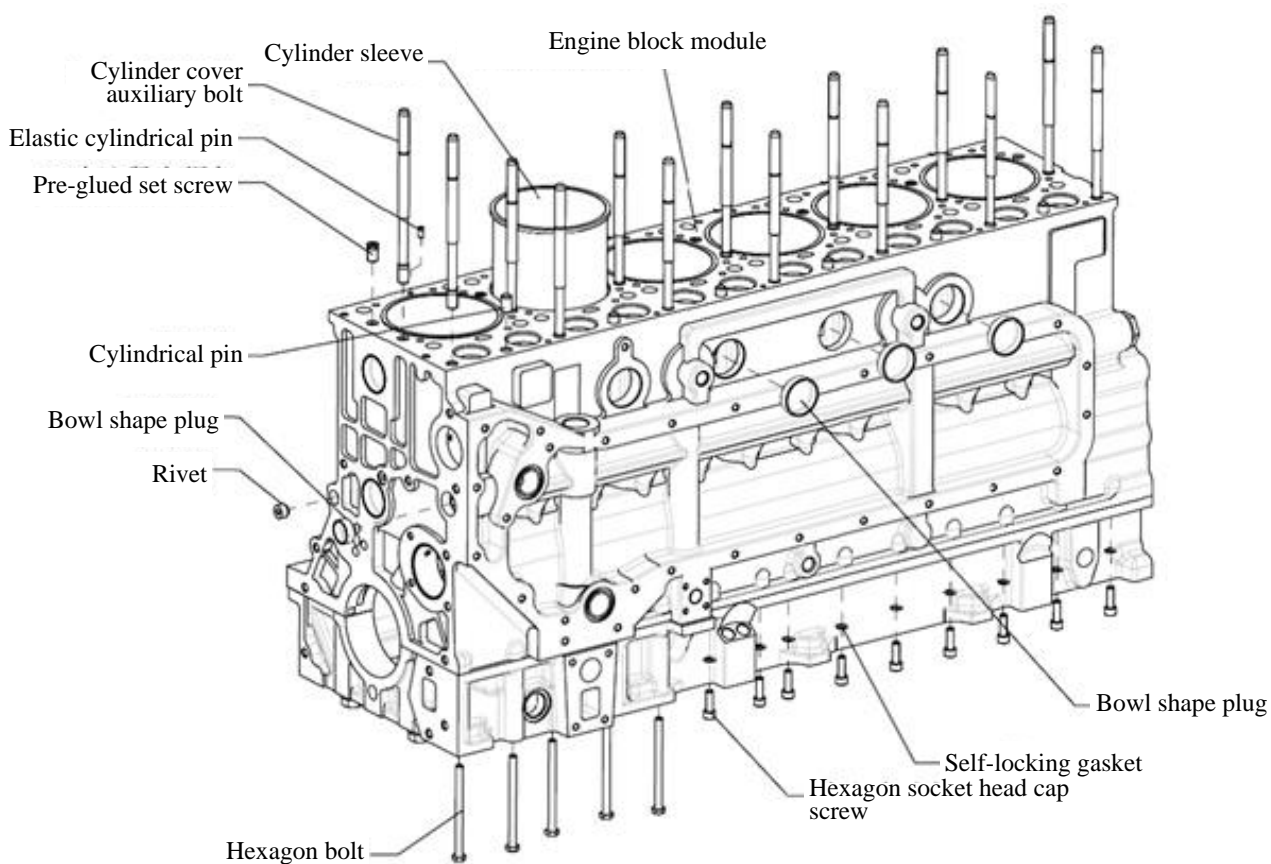

Fig. 4-19 Exploded view of engine block assembly

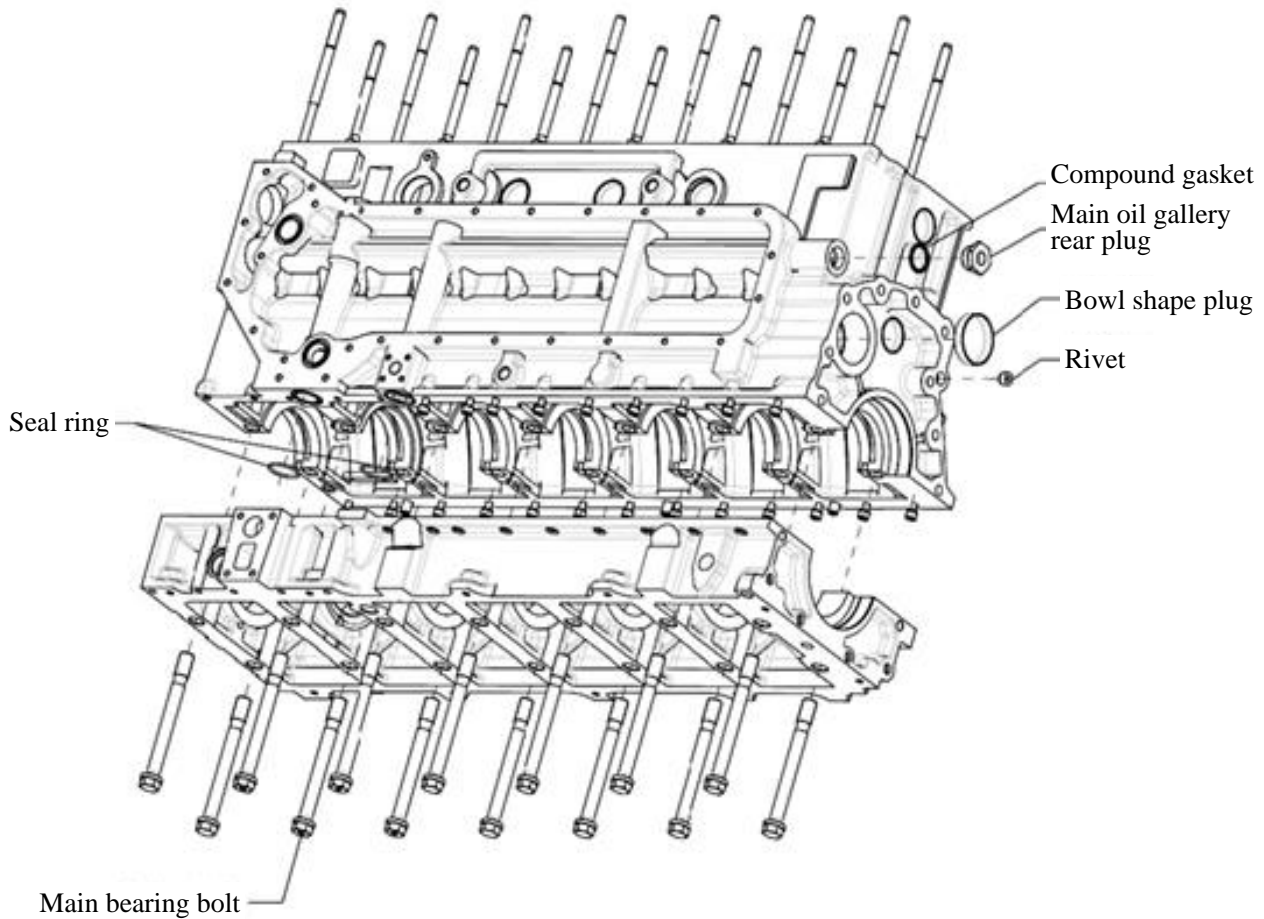

Fig. 4-20 Exploded view of engine block assembly

4312 Steps to Disassemble Engine Block Assembly

- (1) Remove crankcase fastening bolts (key point 1);
- (2) Remove main bearing bolts (key point 2);
- (3) Remove seal rings;
- (4) Remove cylinder cover auxiliary bolts (key point 3);
- (5) Remove main oil gallery plug;
- (6) Remove cylinder sleeve (key point 4).

4313 Inspection and Maintenance of Engine Block Assembly

Key point 1:

Assembling:

Tightening torque	22~29Nm	Grade 8.8
Tightening torque	29~35Nm	Grade 10.9

Key point 2:

Assembling:

Apply clean lubricating oil on crankcase bearing surface and thread of main bearing bolts, and then tighten them according to following order:

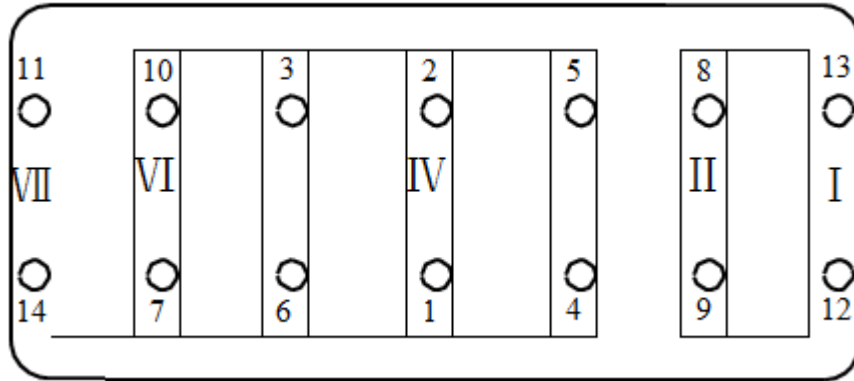

Tightening torque	265 ±25Nm
-------------------	-----------

Key point 3:

Assembling:

Tighten cylinder cover auxiliary bolts according to the following order, cylinder cover auxiliary bolts are allowed to use twice at most.

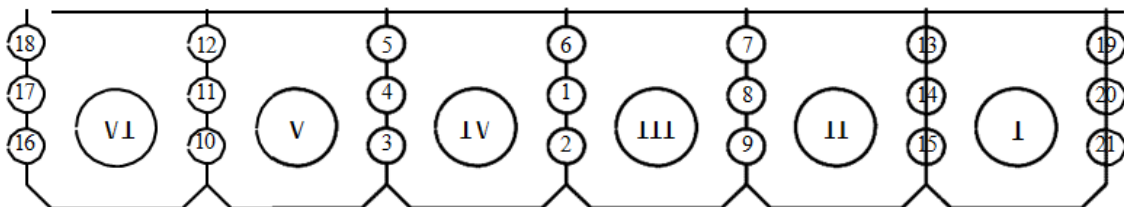
Key point 4:

Assembling:

Cylinder sleeve should be checked for crack carefully before assembling, and clean up the cylinder sleeve, press it into cylinder hole with dedicated tool, apply molybdenum powder on cylinder sleeve external surface before the press-in process.

4314 Steps to Assemble Engine Block Assembly

Assembling steps are contrary to disassembling ones.

432 Disassembly, Inspection, Maintenance and Assembly of Engine Block Module

4321 Exploded View of Engine Block Module

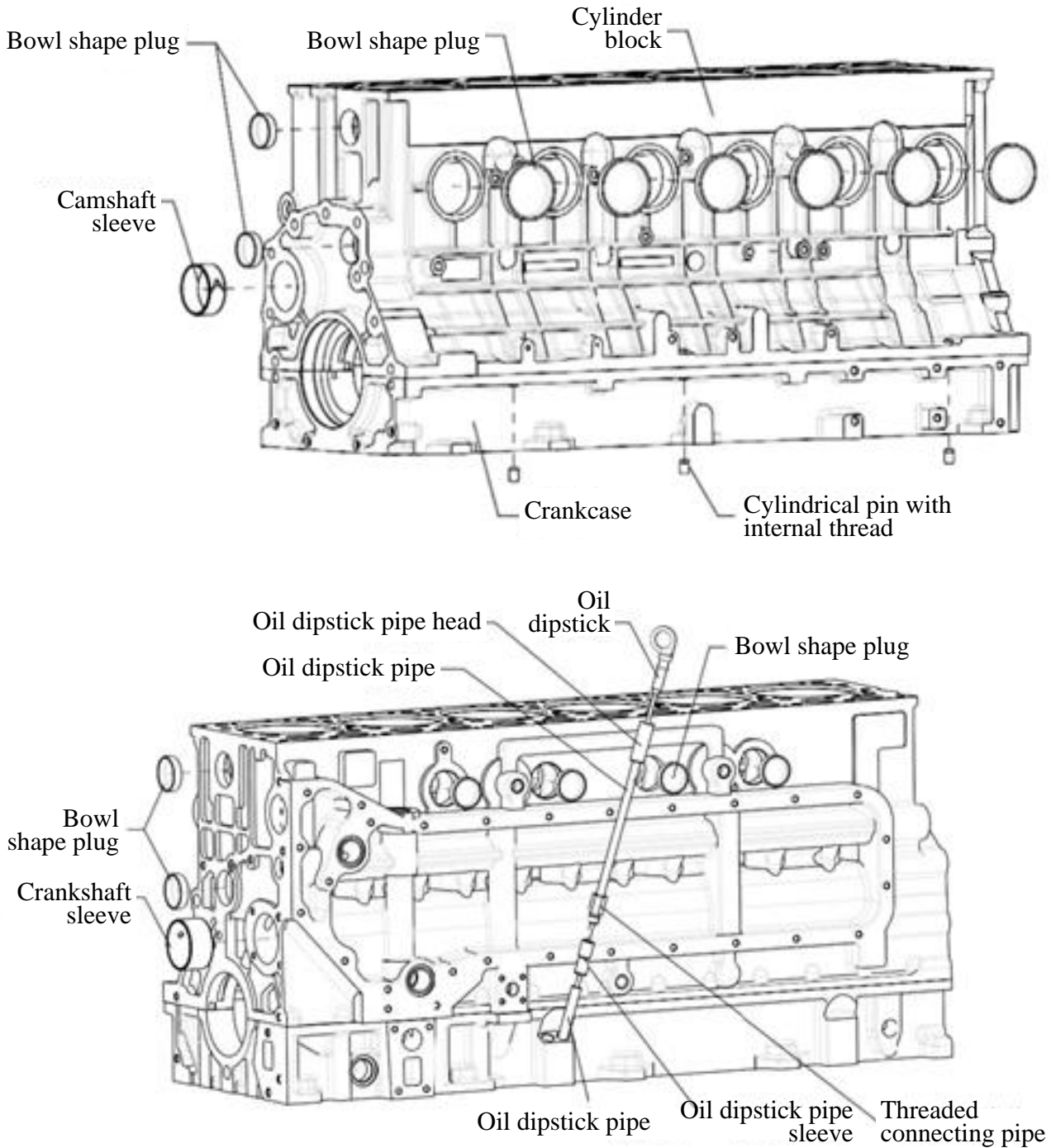

Fig. 4-21 Exploded view of engine block module

4322 Steps to Disassemble Engine Block Module

- (1) Remove cylindrical pins (with internal thread);
- (2) Remove camshaft sleeve (key pint 1);
- (3) Remove main bearing bolts and crankcase fastening bolts (refer to 431);
- (4) Remove crankcase (key point 2);
- (5) Remove oil dipstick assembly (key point 3)

4323 Inspection and Maintenance of Engine Block Module

Key point 1:

Disassembling:

Remove camshaft sleeve with dedicated tools and protect other sleeves in this process.

Assembling:

Check camshaft sleeve for scratch before assembling and replace it if necessary. Oil hole on camshaft sleeve should be aligned to oil hole on camshaft fitting hole.

Key point 2:

Assembling:

Clean up crankcase upper surface and apply sealant on it before assembling

Key point 3:

Assembling:

Connect dipstick pipe sleeve to oil dipstick pipe properly, apply dipstick pipe sleeve bottom with sealant, and knock dipstick pipe sleeve into the fitting hole on crankcase with copper hammer.

4324 Steps to Assemble Engine Block Module

Assembling steps are contrary to disassembling ones.

433 Disassembly, Inspection, Maintenance and Assembly of Engine Front Cover

4331 Exploded View of Engine Front Cover

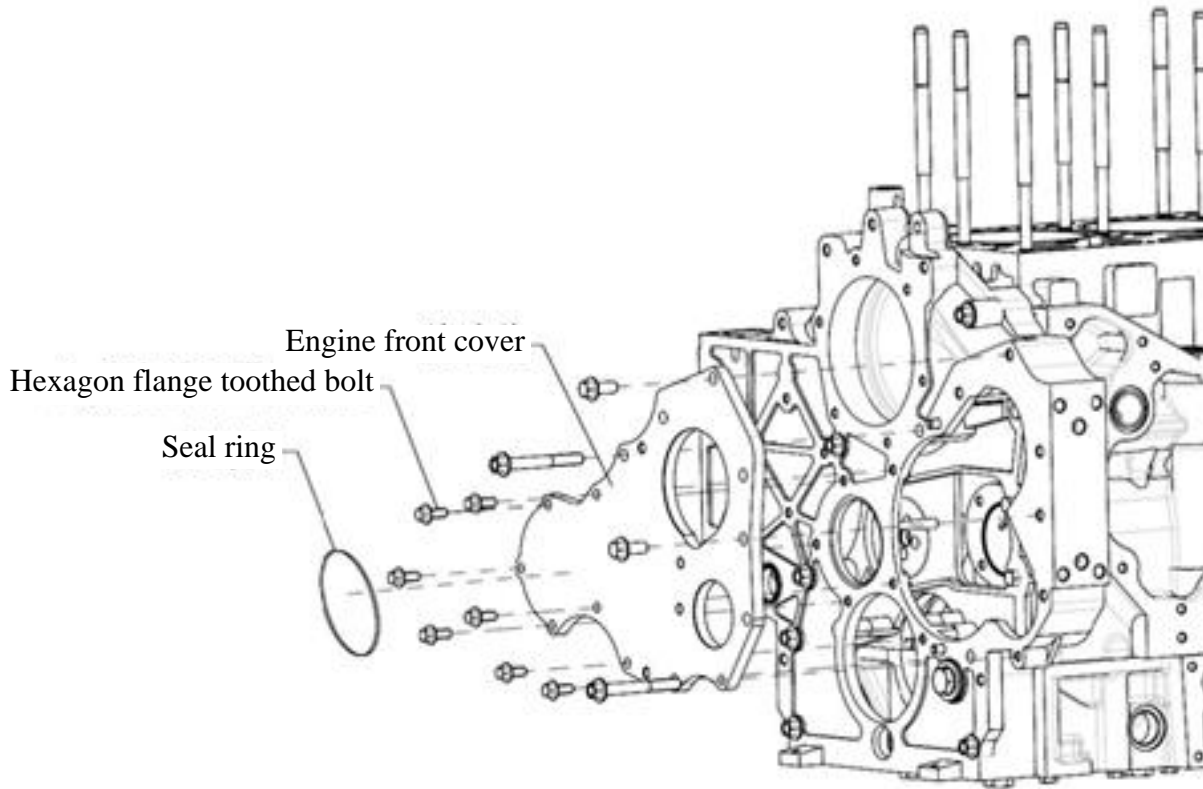

Fig. 4-22 Exploded view of engine front cover

4332 Steps to Disassemble Engine Front Cover

- (1) Remove engine front cover fastening bolts (key point 1);
- (2) Remove engine front cover (key point 2);
- (3) Remove engine front cover seal ring (key point 3);

4333 Inspection and Maintenance of Engine Front Cover

Key point 1: The removed engine front cover should be placed in clean environment, check and ensure inner side of engine front cover is clean before assembling.

Key point 2: Apply sealant on the fitting surface of engine front cover, make sure the sealant is evenly distributed and no discontinuity.

Key point 3: Check whether seal ring is damaged, replace it if so. When assembling, seal ring should be fully pressed into engine front cover seal groove.

4334 Steps to Assemble Engine Front Cover

Assembling steps are contrary to disassembling ones.

434 Disassembly, Inspection, Maintenance and Assembly of Gear Housing

4341 Exploded View of Gear Housing

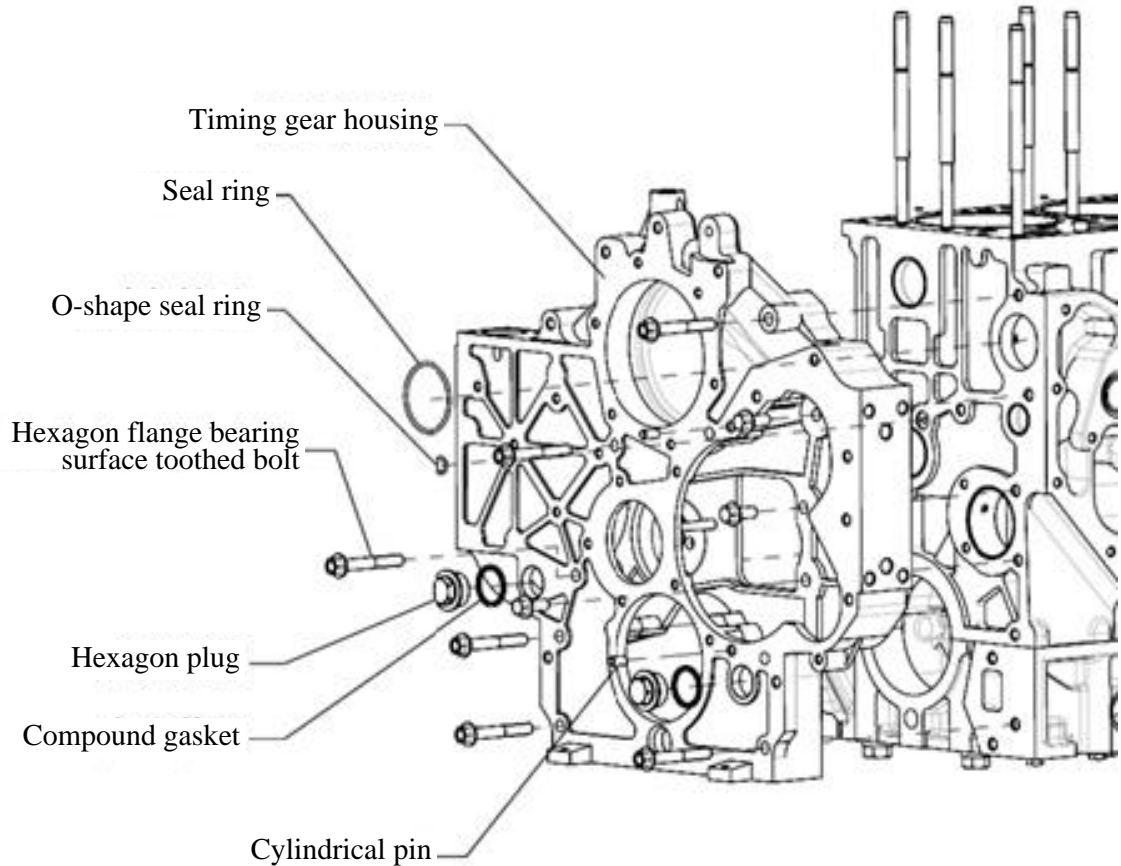

Fig. 4-23 Exploded view of gear housing

4342 Steps to Disassemble Gear Housing

- (1) Remove fastening bolts of gear housing (key point 1);
- (2) Remove the plug and compound gasket;
- (3) Remove intermediate gear shaft (refer to section 456);
- (4) Remove engine oil pump intermediate gear shaft and engine oil pump intermediate gear bolts (refer to section 493);
- (5) Remove gear housing (key point 3);
- (6) Remove seal ring (key point 2).

4343 Inspection and Maintenance of Gear Housing

Key point 1:

Assembling:

Tighten gear housing fastening bolts according to the following order crosswise.

Tightening torque	44~58Nm
-------------------	---------

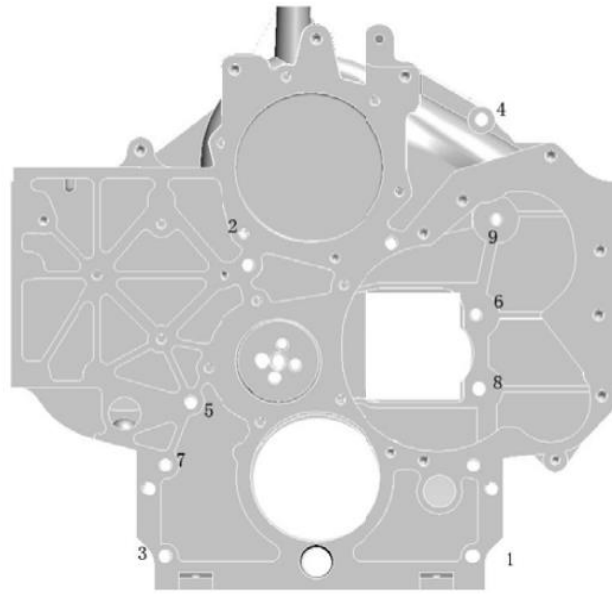

Fig. 4-24

Key point 2:

Assembling:

Check whether seal ring is damaged, replace it if so. When assembling, seal ring should be applied with oil and fully pressed into seal groove, protect the ring in this process.

Key point 3:

Disassembling:

When disassembling gear housing, firstly take down gear housing fastening bolts, and then remove intermediate gear shaft and engine oil pump intermediate gear shaft. The removed gear housing should be placed in clean environment.

Assembling:

Insert intermediate gear shaft into the gear and then place the assembly into gear housing; Apply sealant on cylinder block water inlet and outlet ports and press-in the seal rings.

4344 Steps to Assemble Gear Housing

Assembling steps are contrary to disassembling ones.

435 Disassembly, Inspection, Maintenance and Assembly of Flywheel Housing

4351 Exploded View of Flywheel Housing

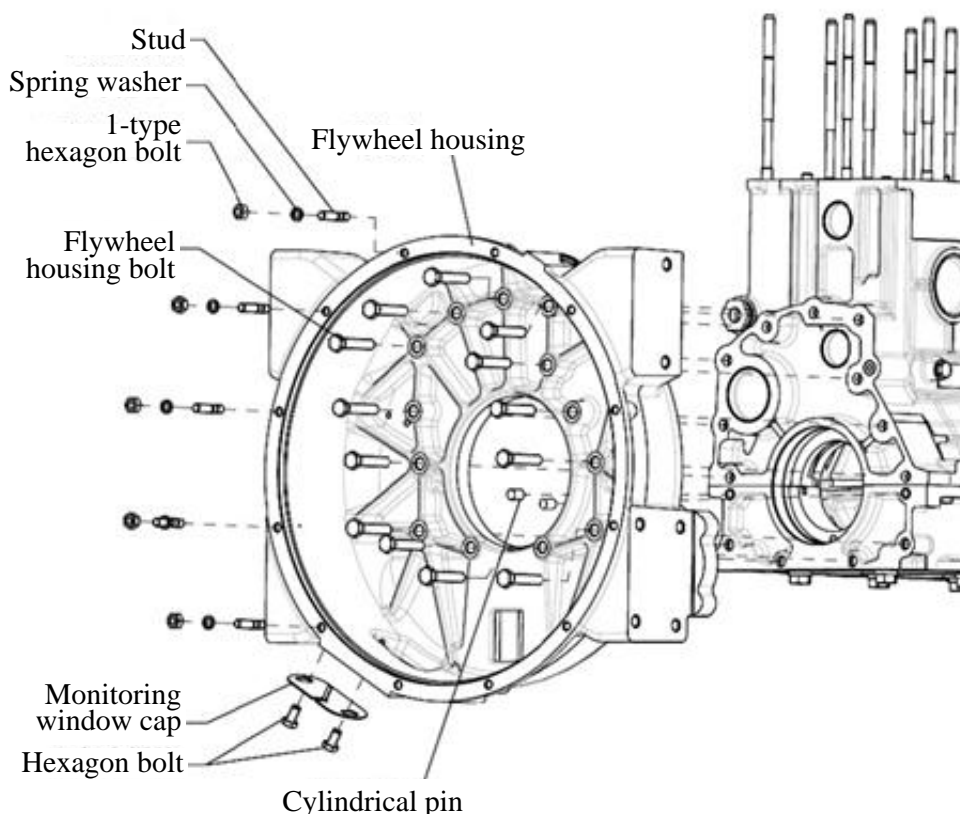

Fig. 4-25 Exploded view of flywheel housing

4352 Steps to Disassemble Flywheel Housing

- (7) Remove fastening bolts of flywheel housing (key point 1);
- (8) Remove fastening bolts of monitoring window cap on flywheel housing, take down the cap;
- (9) Remove flywheel housing (key point 2).

4353 Inspection and Maintenance of Flywheel Housing

Key point 1:

Assembling:

Tighten flywheel housing bolts according to the following order crosswise. Apply oil on bolt flange before assembling, flywheel housing bolts are allowed to use twice at most.

Tightening torque	110~140Nm
-------------------	-----------



Fig. 4-26

Key point 2:

Assembling:

Apply sealant on fitting surfaces of flywheel housing and engine block, pay attention not to crash flywheel housing during lifting.

4354 Steps to Assemble Flywheel Housing

Assembling steps are contrary to disassembling ones.

436 Disassembly, Inspection, Maintenance and Assembly of Oil Sump

4361 Exploded View of Oil Sump

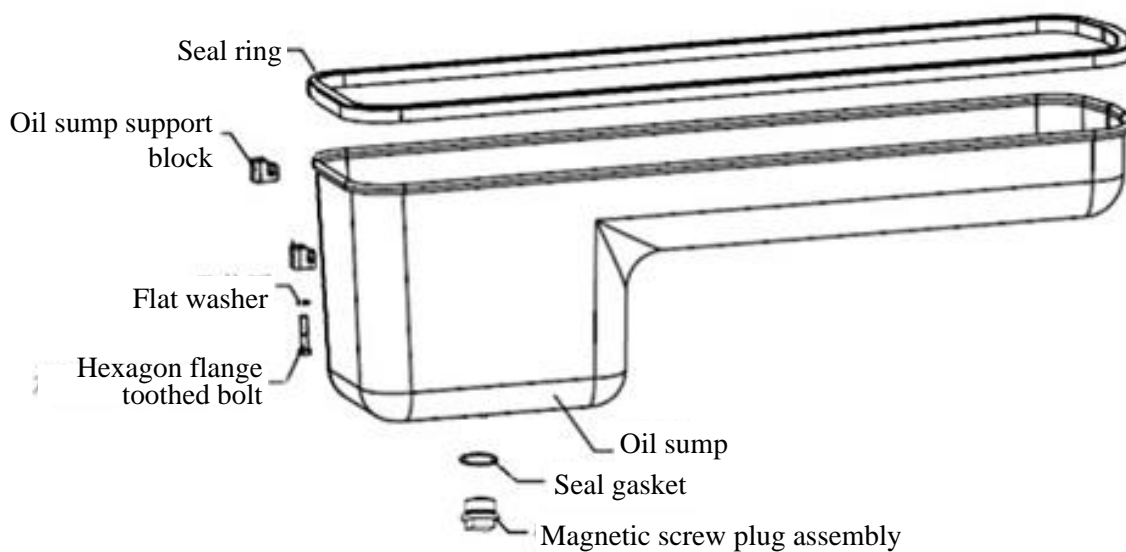

Fig. 4-27 Exploded view of oil sump

4362 Steps to Disassemble Oil Sump

- (1) Turn over the engine to keep oil sump upward (key point 1);
- (2) Remove oil sump fastening bolts (key point 2);
- (3) Remove oil sump support blocks;
- (4) Take down oil sump and the seal ring;
- (5) Remove the compound gasket and magnetic screw plug assembly.

4363 Inspection and Maintenance of Oil Sump

Key point 1:

Disassembling:

Before the disassembling, all engine oil should be drained out. Put an engine oil container under drain screw plug of oil sump, screw off the plug with a plug wrench to drain oil out.

Key point 2:

Assembling:

Tighten oil sump fastening bolts according to the order illustrated in the chart below.

Tightening torque	22~29Nm
-------------------	---------

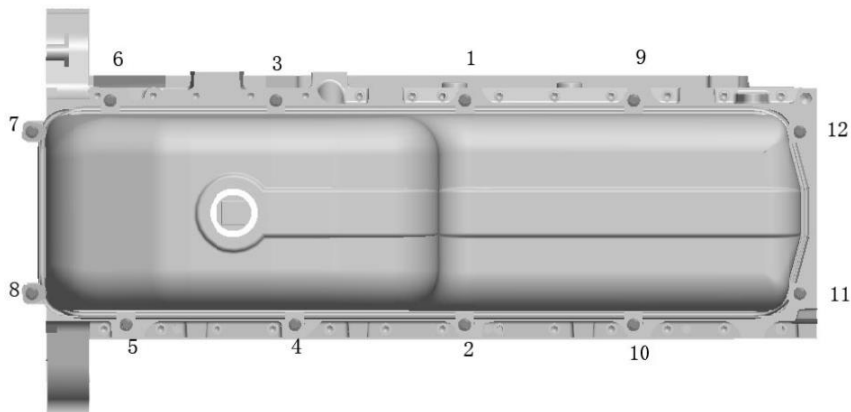

Fig. 4-28

4364 Steps to Assemble Oil Sump

Assembling steps are contrary to disassembling ones.

437 Disassembly, Inspection, Maintenance and Assembly of Piston Nozzle

4371 Exploded View of Piston Nozzle

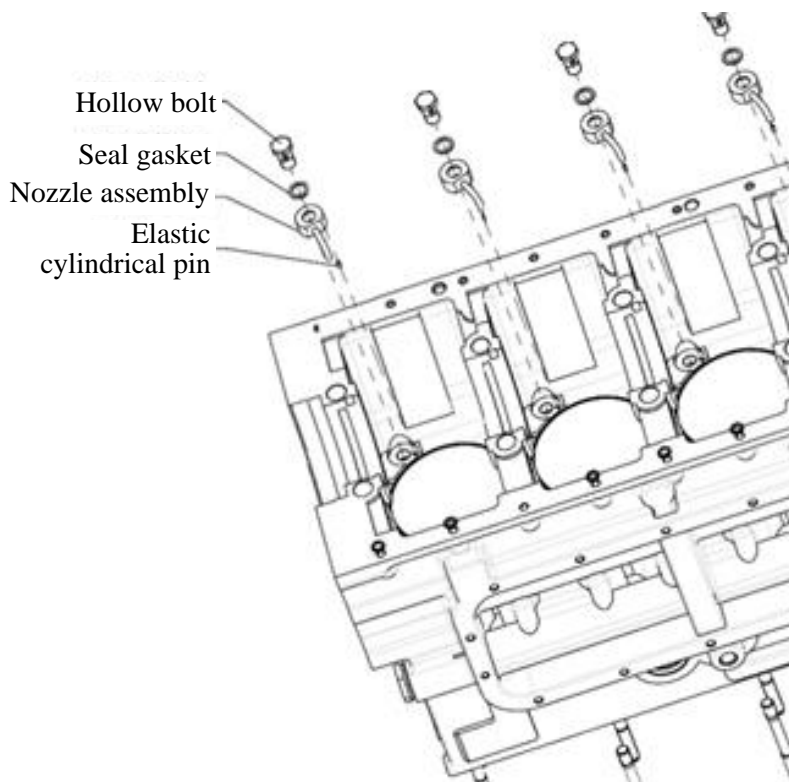

Fig. 4-29 Exploded view of piston nozzle

4372 Steps to Disassemble Piston Nozzle

- (1) Remove the hollow bolt (key point 1);
- (2) Remove nozzle assembly;
- (3) Remove elastic cylindrical pin (key point 2).

4373 Inspection and Maintenance of Piston Nozzle

Key point 1:

Assembling:

Tightening torque for hollow bolts

Tightening torque	20~30Nm
-------------------	---------

Key point 2:

Assembling:

Check the locating pin for damage and replace it if necessary. Align the pin to pin hole on engine block and knock nozzle body gently with copper hammer to fully fit the pin.

4374 Steps to Assemble Piston Nozzle

Assembling steps are contrary to disassembling ones.

438 Disassembly, Inspection, Maintenance and Assembly of Thrust Plates

4381 Exploded View of Thrust Plates

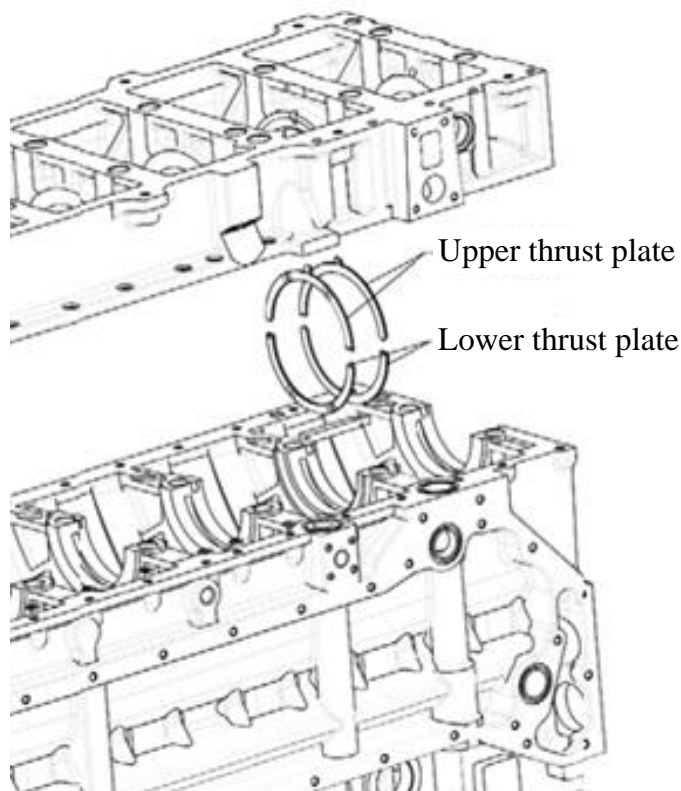

Fig. 4-30 Exploded view of thrust plates

4382 Steps to Disassemble Thrust Plates

- (1) Remove crankcase (refer to section 432);
- (2) Remove crankshaft (refer to section 444);
- (3) Remove thrust plates (key point 1).

4383 Inspection and Maintenance of Thrust Plates

Key point 1:

Assembling:

Thrust plate should be used in pairs. When assembling, firstly put crankshaft into engine block, and then install upper thrust plates (without lug). Apply lubricating grease on lower thrust plates and adhere them on crankcase, and should be assembled together with crankcase. For thrust plates, the

side with oil groove should be outward.

4384 Steps to Assemble Thrust Plates

- (1) Install crankshaft;
- (2) Install upper thrust plates (without lug);
- (3) Install lower thrust plates (key point 1).

439 Disassembly, Inspection, Maintenance and Assembly of Front and Rear Oil Seals

4391 Exploded View of Front and Rear Oil Seals

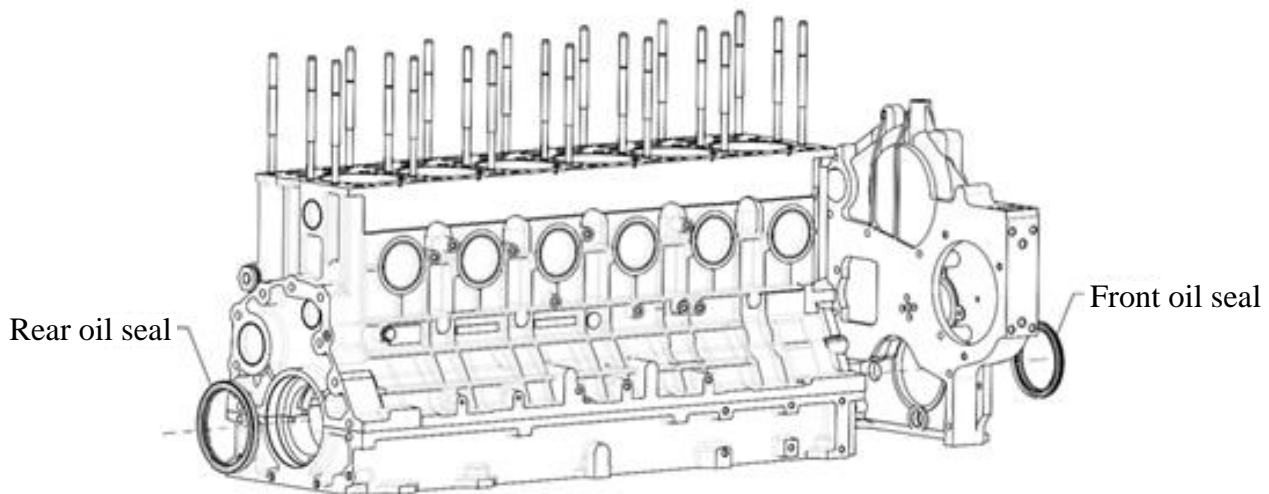

Fig. 4-31 Exploded view of front and rear oil seals

4392 Steps to Disassemble Front and Rear Oil Seals

- (1) Remove gear housing (refer to section 434);
- (2) Remove front oil seal (key point 1);
- (3) Remove crankcase (refer to section 432);
- (4) Remove rear oil seal (key point 1);

4393 Inspection and Maintenance of Front and Rear Oil Seals

Key point 1:

Assembling:

Clean up the oil seals and fitting holes before assembling, no dirt is allowed. Apply lubricating oil on the oil seal and the dedicated press-fitting tool first, and then press-in the seal slowly with the

tool.

Disassembling:

Removed oil seals should not be reused.

4394 Steps to Assemble Front and Rear Oil Seals

- (1) Install crankcase;
- (2) Install rear oil seal;
- (3) Install gear housing;
- (4) Install front oil seal.

44 Crank-Rod Mechanism

441 Disassembly and Assembly of Crank-Rod Mechanism

4411 Exploded View of Crank-Rod Mechanism

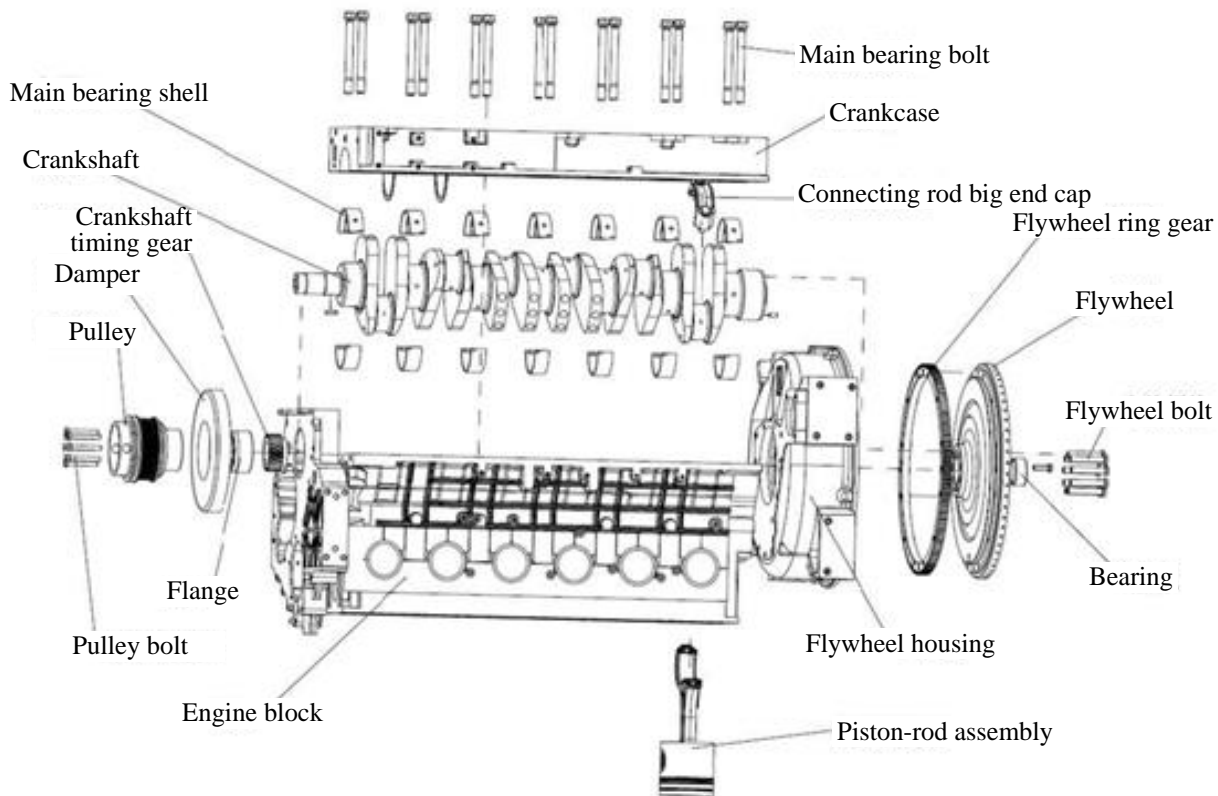

Fig. 4-32 Exploded view of crank-rod mechanism

4412 Steps to Disassemble Crank-Rod Mechanism

- (1) Check before disassembling. Check connecting rod axial backlash, check tightening torque of connecting rod bolts; Tilt and lay the engine on its side, rotate the flywheel until the to-be removed piston is in BDC, remove connecting rod bolts and cap; Rotate the flywheel until the to-be removed piston is in TDC, knock the piston out with wooden hammer, proceed with caution to avoid jamming cylinder block with connecting rod big end. Remove other pistons in the same way, number and place them orderly.
- (2) Screw off front end pulley bolts, take down the pulley and damper.
- (3) Screw off flywheel bolts, take down flywheel assembly, bearing, etc.

4413 Steps to Assemble Crank-Rod Mechanism

Assembling steps are contrary to disassembling ones.

442 Disassembly, Inspection, Maintenance and Assembly of Piston-Rod Assembly

4421 Exploded View of Piston-Rod Assembly

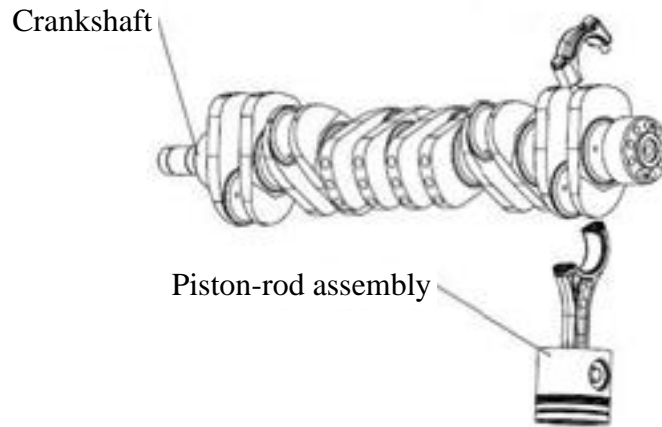

Fig. 4-33 Schematic diagram of piston-rod assembly

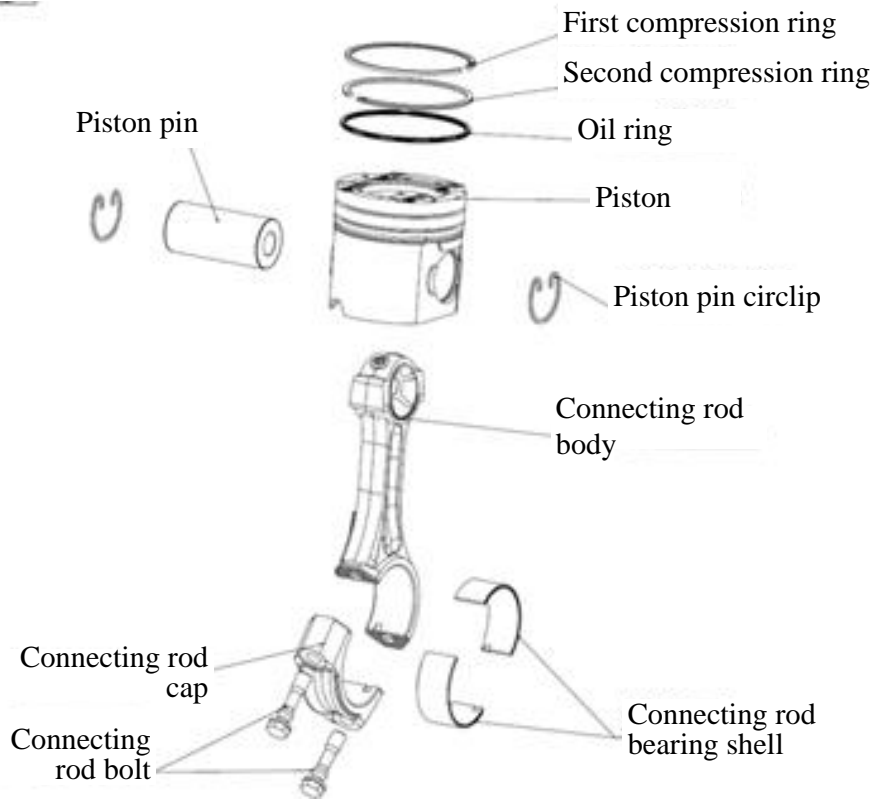

Fig. 4-34 Exploded view of piston-rod assembly

4422 Steps to Disassemble Piston-Rod Assembly

- (1) Remove circlip on two sides of piston with internal circlip plier and push piston pin out, take down the connecting rod body. Number the piston pins, connecting rod bodies and place them orderly.
- (2) Remove first compression ring, second compression ring and oil ring with piston ring plier and mark them.

4423 Inspection and Maintenance of Piston-Rod Assembly

- (1) Check whether there is crack on combustor throat fillet and piston pin boss; Check piston skirt and piston head for cylinder scoring phenomenon; Check wear condition of piston pin hole.
- (2) Check wear condition of piston ring outer edge; Check wear condition of piston ring upper and lower end face.
- (3) Check wear condition of piston pin external surface.
- (4) Check whether there is crack on connecting rod big end bottom hole, connecting rod body and connecting rod small end oil hole; Check alloy layer of connecting rod shell for abnormal wear and peeling phenomenon; Check wear condition of connecting rod side faces, check crooking condition of connecting rod body.
- (5) Check wear condition of connecting rod bearing shell, check its alloy layer for discoloration, peeling and slippage phenomenon.

4424 Steps to Assemble Piston-Rod Assembly

- (1) Install one circlip into piston circlip groove with internal circlip plier, and rotate the circlip to ensure it is properly fitted. The end with corner angle should face inward, and its opening should be upward.
- (2) Insert small end of connecting rod into piston inner cavity and align it to piston pin holes, and then install piston pin, finally install the other circlip to the other side of the piston. Note that connecting rod oblique incision and piston cooling oil gallery inlet should be in the same direction, apply proper clean lubricating oil on connecting rod small end hole and piston pin.
- (3) Arrange the assembled piston-rod assembly in cylinder number order, and then install oil ring, second compression ring and first compression ring into piston ring grooves orderly with piston ring plier. The face with mark "TOP" should be upward, and the ring should be flexible in ring groove.
- (4) Clean up cylinder inner wall, crankshaft connecting lever and piston-rod assembly, and apply clean lubricating oil on each motion pair.

- (5) Adjust opening direction of each ring: The opening direction of first compression ring should be 30° to piston pin center line, opening direction of the second compression ring should be 120° to that of the first compression ring, and opening direction of oil ring should be 120° to both that of first compression ring and second compression ring, also should be perpendicular to piston pin center line. As shown in Fig. 4-35.

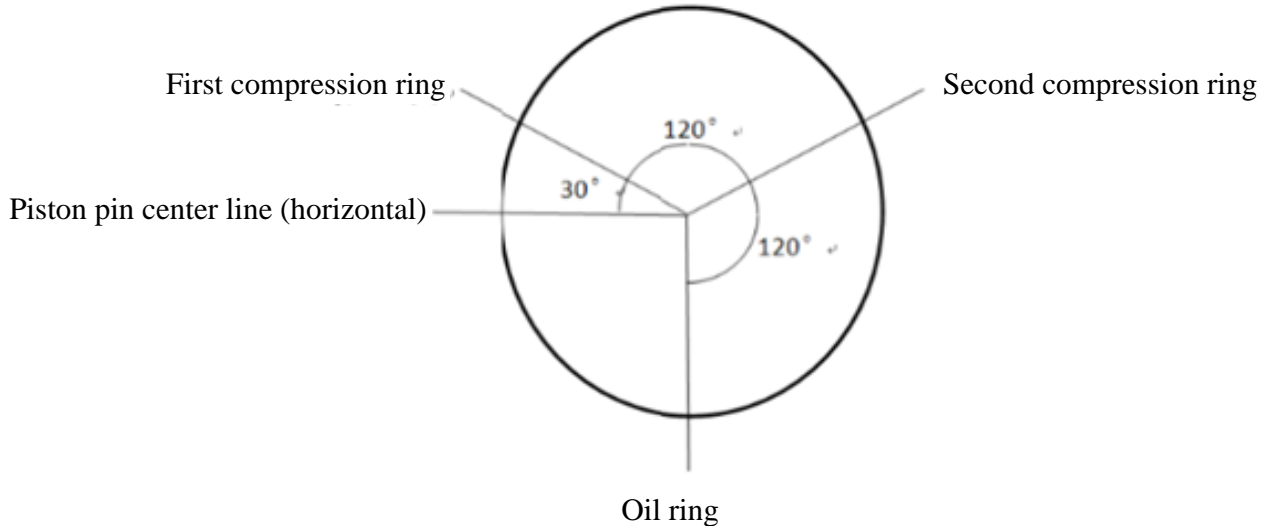

Fig. 4-35 Schematic diagram for installation of piston rings

- (6) Rotate the flywheel with external force until cylinder 1, 6 get to BDC, fit cylinder 1, 6 piston-rod assembly and loose-fit connecting rod bolts. Connecting rod parting surface should face left side of cylinder block (i.e. engine oil cooler side). The numbered pistons should not be mixed, install each piston to the corresponding cylinder; connecting rod cap and connecting rod should be used in pairs, apply clean lubricating oil on connecting rod bolts before assembling.
- (7) Tighten connecting rod bolts: Firstly pre-tighten the bolts to 120Nm in symmetry, and then tighten each bolts for further $90^\circ \pm 5^\circ$, in the meantime tighten torque should be up to 170~250Nm. Assemble other piston-rods in the same way.

443 Disassembly, Inspection, Maintenance and Assembly of Crankshaft

4431 Exploded View of Crankshaft

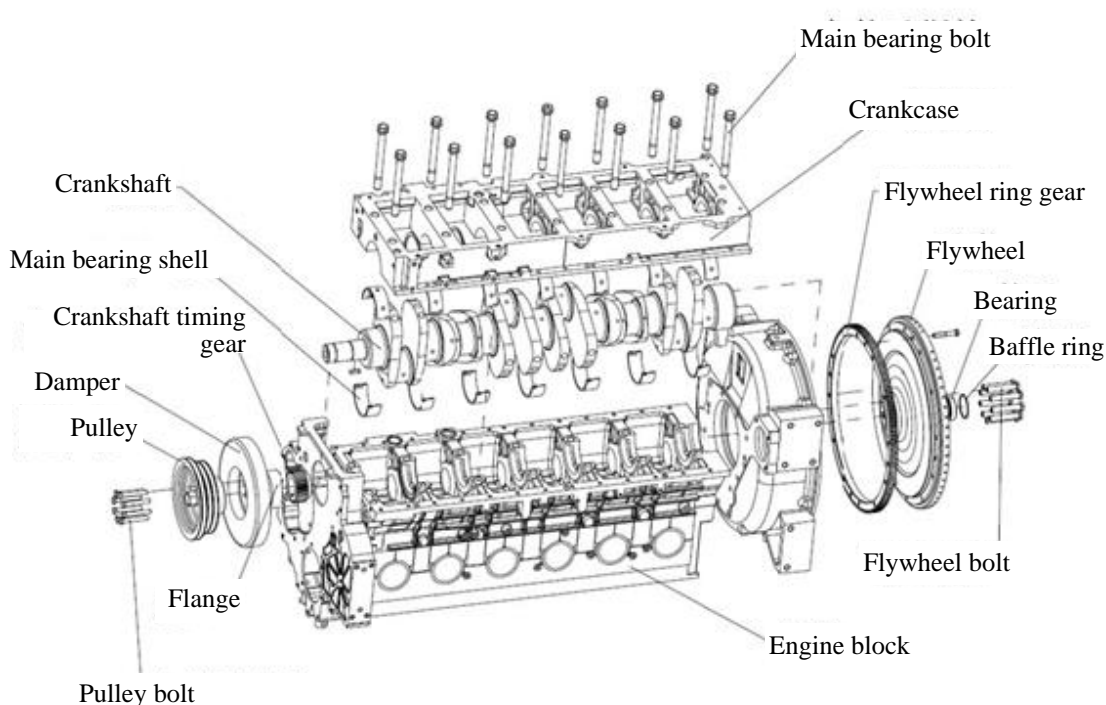

Fig. 4-36 Exploded view of crankshaft

4432 Steps to Disassemble Crankshaft

- (1) Put the engine crankcase upward, and then remove main bearing bolts and place them orderly;
- (2) Take down crankshaft and flywheel, remove front and rear thrust plates and flywheel bearing. Remove oil seals; place the crankshaft on bracket (for long time storage, the crankshaft should be placed vertical);
- (3) Classify the removed parts according to the requirements.

4433 Inspection and Maintenance of Crankshaft

- (1) Check whether there is crack on fillet area of crankshaft main journal and neck of crankshaft; Check the joint part of crankshaft and main bearing for crack, check and dredge the oil gallery.
- (2) Check the wear condition of crankshaft main journal and neck of crankshaft, and check whether there is line-like puckering, metal peeling and crack.
- (3) Check the wear condition of front and rear oil seals.
- (4) Check whether there is failure like thread damage on main bearing bolts
- (5) Check crankshaft flange bolt holes for crack.

(6) Check wear condition of crankshaft journal, check bend and distortion condition of crankshaft.

4434 Steps to Assemble Crankshaft

- (1) Clean up cylinder bottom holes.
- (2) Press main bearing upper shells into cylinder bottom holes and clean up scraped foreign matter.
 - a) The bearing shells should be strictly inspected for bump damage before assembling, and shell with bump damage should not be reused even if repaired.
 - b) The assembled upper bearing shell should be aligned to oil hole and oil groove on cylinder body, misalignment exceeds 1/5~1/4 of oil hole is strictly forbidden. The assembled upper bearing shell should be closely fit with cylinder bottom holes.
- (3) Apply clean lubricating oil on inner surface of upper bearing shell.
- (4) Clean up undersurface of cylinder block, and make sure there is no grease.
- (5) Apply sealant on undersurface of cylinder block properly.
- (6) Lift up crankshaft, and clean up oil holes with compressed air, wipe out main journal and connecting rod journal with a towel, and then drop the crankshaft into cylinder body slowly, prevent crashing the crankshaft in this process.
- (7) Clean up upper thrust plate and press it into cylinder body. Then side with oil groove should face outward (face crankshaft).
- (8) Check and make sure the oil seal is flat and free of distortion, and then place it into seal groove on cylinder undersurface with dedicated tool.
- (9) Press lower bearing shells and lower thrust plates (the side with oil groove should face crankshaft) into crankcase and assemble the crankshaft.
- (10) Apply clean lubricating oil on crankcase bolt bearing surface and main bearing bolt thread. Place main bearing bolts and pre-tighten them according to the order shown in Fig. 4-37.

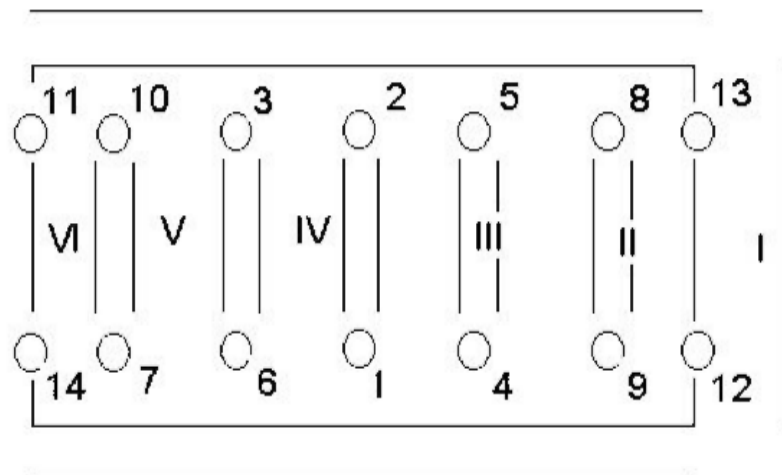

Fig.4-37 Tightening order of main bearing bolts

(11) Firstly pre-tighten each bolt with low-torque pneumatic impact wrench, and then tighten each bolt to 80Nm orderly, thirdly the torque should reach 250~280Nm. Assembly of crank shaft is finished.

444 Disassembly, Inspection, Maintenance and Assembly of Flywheel and Ring Gear

4441 Exploded View of Flywheel and Ring Gear

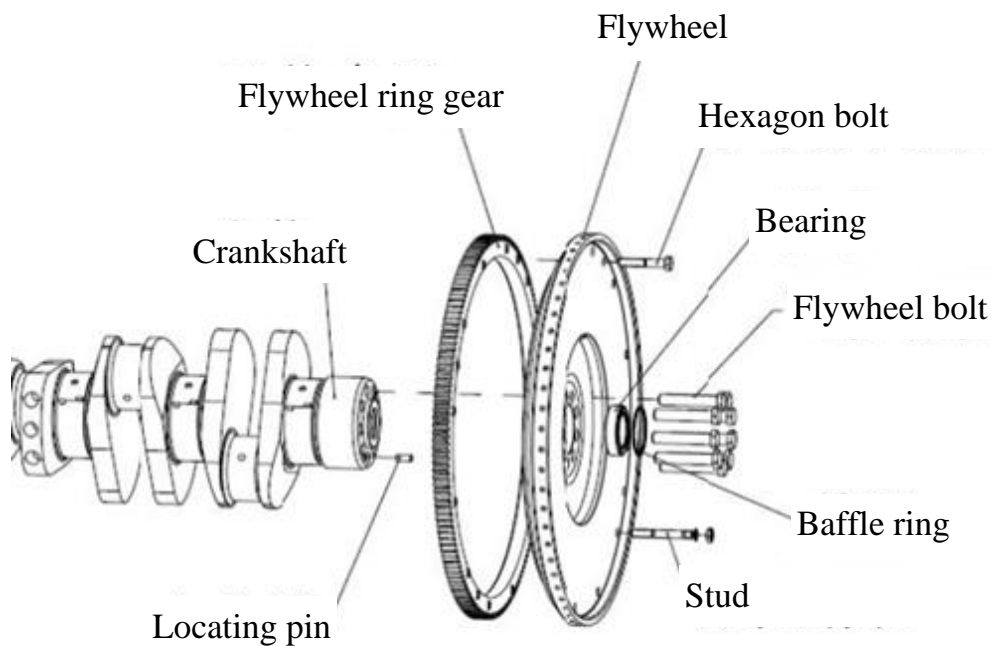

Fig. 4-38 Exploded view of flywheel and ring gear

4442 Steps to Disassemble Flywheel and Ring Gear

Disassembling steps are contrary to assembling ones.

4443 Inspection and Maintenance of Flywheel and Ring Gear

- (1) Check whether there is failure like thread damage on flywheel bolts.
- (2) Check flywheel surface for conquassation.
- (3) Check whether flywheel ring gear is damaged.

4444 Steps to Assemble Flywheel and Ring Gear

- (1) Fix the flywheel ring gear on flywheel with bolts;
- (2) Knock the pin into crankshaft rear end fully.
- (3) After inserting flywheel guide rod into crankshaft threaded hole, install flywheel and pre-tighten the bolts diagonally.
 - a) Apply lubricating oil on flywheel bolt thread and bearing surfaces.
 - b) Flywheel bolt M14×1.5 (×9)

Tighten the bolts with hand: After applied lubricating oil on flywheel bolt thread and bearing surfaces, place the bolts and pre-tighten them to 60~80Nm diagonally; and then tighten the bolts for $90^{\circ} \pm 5^{\circ}$ twice, and tightening torque should reach 230~280Nm. For bolts that fail to reach the required torque should be replaced. Fly wheel bolts are allowed to use twice at most.

Tighten the bolts with auto-wrench: After applied lubricating oil on flywheel bolt thread and bearing surfaces, place the bolts and pre-tighten them to 60~80Nm diagonally; and then tighten each bolt with auto-wrench for $160^{\circ} \pm 5^{\circ}$, and tightening torque should reach 230~300Nm. For bolts that fail to reach the required torque should be replaced. Fly wheel bolts are allowed to use twice at most.

- (4) Tighten flywheel bolts

After applied lubricating oil on flywheel bolt thread and bearing surfaces, place the bolts and pre-tighten them to 60~80Nm diagonally; and then tighten the bolts for $90^{\circ} \pm 5^{\circ}$ twice, and tightening torque should reach 230~280Nm. For bolts that fail to reach the required torque should be replaced. Fly wheel bolts are allowed to use twice at most.

445 Disassembly, Inspection, Maintenance and Assembly of Damper and Crankshaft Pulley

4451 Exploded View of Damper and Crankshaft Pulley

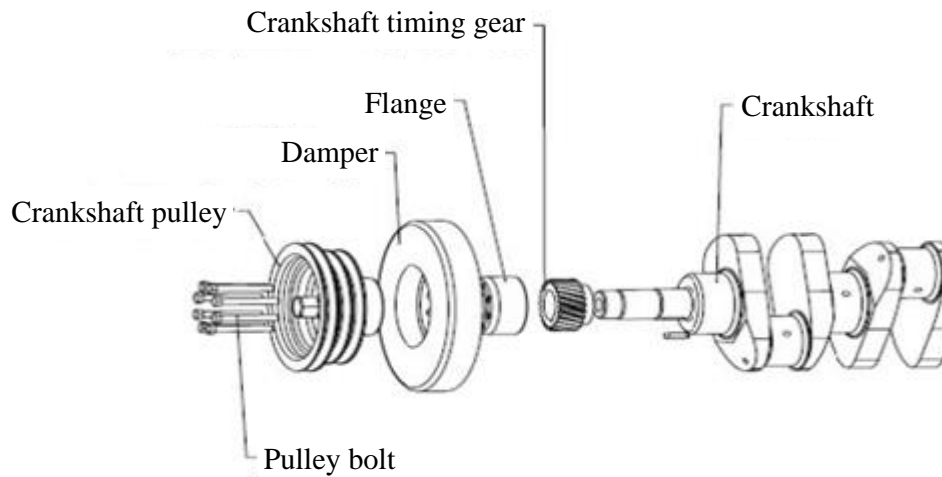

Fig. 4-39 Exploded view of damper and crankshaft pulley

4452 Steps to Disassemble Damper and Crankshaft Pulley

Screw off pulley bolts and then take down pulley and damper orderly.

4453 Inspection and Maintenance of Damper and Crankshaft Pulley

- (1) Check crankshaft pulley for bump damage and distortion.
- (2) Check whether crankshaft pulley is damaged, whether the bolts are crushed.
- (3) Check whether pulley bolts are damaged.

4454 Steps to Assemble Damper and Crankshaft Pulley

After assembling the timing gear housing, install the damper and crankshaft pulley orderly.

446 Disassembly, Inspection, Maintenance and Assembly of Crankshaft Bearing Shell

4461 Exploded View of Crankshaft Bearing Shell

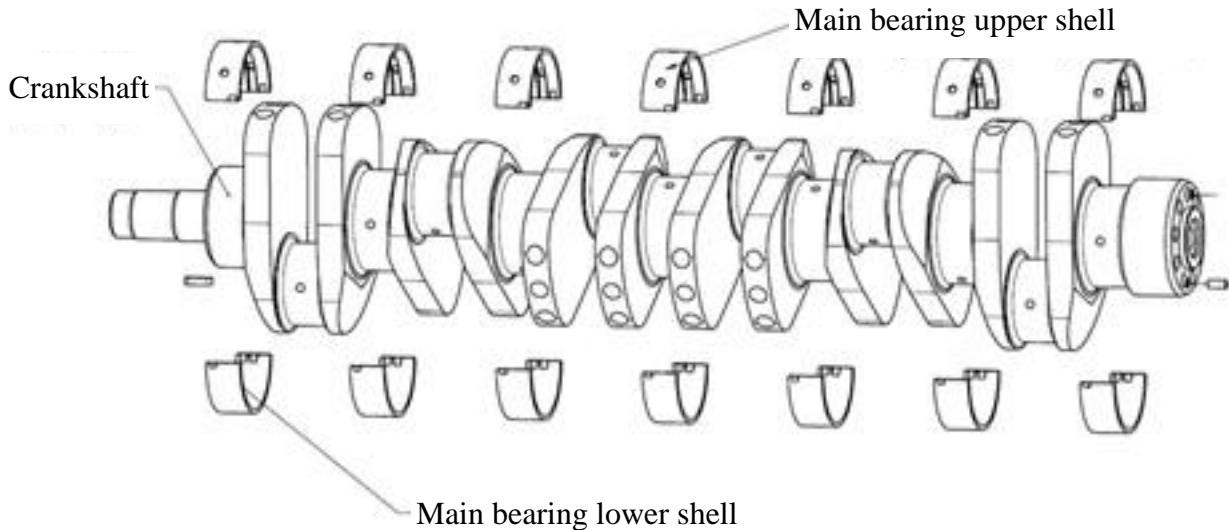

Fig. 4-40 Exploded view of crankshaft bearing shell

4462 Steps to Disassemble Crankshaft Bearing Shell

Push the shells out with hand, and mark the removed shells (should be corresponded with fitting holes on engine block and crankcase).

4463 Inspection and Maintenance of Crankshaft Bearing Shell

- (1) Clean the bearing shells and check their wear condition.
- (2) Check and ensure there is no peeling, locating lip damage and transverse crack on the shell.

4464 Steps to Assemble Crankshaft Bearing Shell

- (1) Clean up main bearing shells and the fitting holes.
- (2) If no shell is replaced, then install the two shells into engine block (upper) and crankcase (lower) respectively (pay attention to the mark, shells should be installed into corresponding holes on engine block and crankcase), do not mix upper and lower shells, the one with oil groove is upper one. The shell lips should be aligned and applied with engine oil.

45 Valve Mechanism

451 Disassembly and Assembly of Valve Mechanism

4511 Exploded View of Valve Mechanism

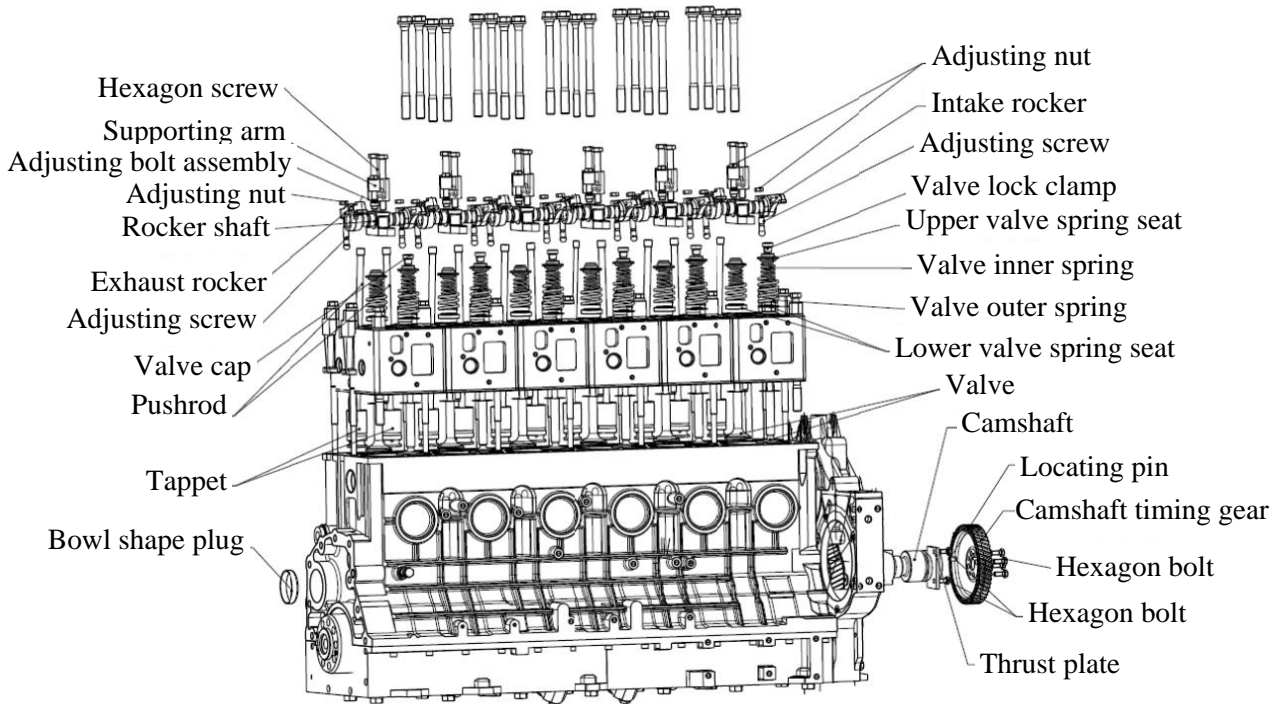

Fig. 4-41 Exploded view of valve mechanism

4512 Steps to Disassemble Valve Mechanism

- (1) Remove rocker and rocker shaft, refer to disassembly of rocker and rocker shaft for details;
- (2) Remove intake and exhaust valves, refer to disassembly of valves for details;
- (3) Remove valve tappet and pushrod, refer to disassembly of valve tappet and pushrod for details;
- (4) Remove camshaft and camshaft timing gear, refer to disassembly of camshaft and camshaft timing gear for details;
- (5) Remove intermediate gear, refer to disassembly of intermediate gear for details.

4513 Steps to Assemble Valve Mechanism

- (1) Install intermediate gear, refer to assembly of intermediate gear for details.
- (2) Assemble camshaft and camshaft timing gear, refer to assembly of camshaft and camshaft timing gear for details;

- (3) Install valve tappet and pushrod, refer to assembly of valve tappet and pushrod for details;
- (4) Assemble intake and exhaust valves, refer to assembly of valves for details;
- (5) Install rocker and rocker shaft, refer to assembly of rocker and rocker shaft for details;

452 Disassembly, Inspection, Maintenance and Assembly of Camshaft

4521 Exploded View of Camshaft

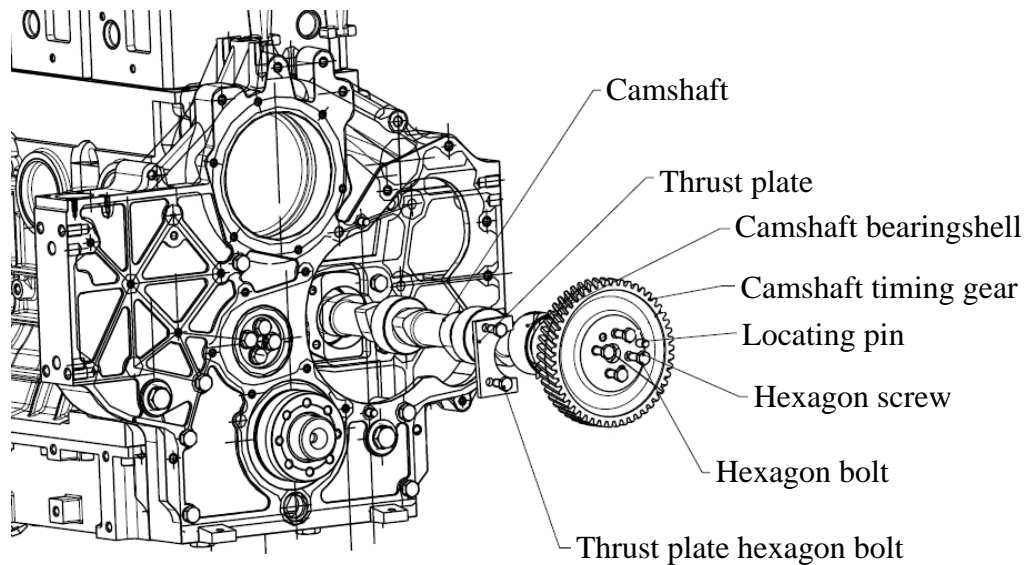

Fig. 4-42 Exploded view of camshaft

4522 Steps to Disassemble Camshaft

- (1) Rotate camshaft to check whether camshaft and timing gear are flexible and smooth;
- (2) Measure camshaft axial movement with a dial gauge, compare it with required range 0.1~0.4mm;
- (3) Check timing gear backlash;
- (4) Rotate crankshaft until camshaft timing gear is in cylinder 1 TDC. Remove the hexagon bolts of camshaft timing gear and take down the gear and locating pins;
- (5) Remove the hexagon bolts of camshaft thrust plate, take down the plate;
- (6) Take down camshaft.

4523 Inspection and Maintenance of Camshaft

- (1) Check whether there is wear trace on cam working surface, check main journal for seizure and

abrasion.

(2) Measure camshaft main journal circular run-out.

Camshaft	Maximum allowed circular run-out	Measured value
The second main journal (Between cylinder 1 and cylinder 2)	0.04	
The third main journal (Between cylinder 2 and cylinder 3)	0.05	
The fourth main journal (Between cylinder 3 and cylinder 4)	0.06	
The fifth main journal (Between cylinder 4 and cylinder 5)	0.05	
The sixth main journal (Between cylinder 5 and cylinder 6)	0.04	

(3) Measure tappet maximum lift (distance between cam tip and base circle)

Camshaft	Standard value	Measured value
Intake tappet maximum lift	7.0743mm	
Exhaust tappet maximum lift	8.3183mm	

(4) Check timing gear for interference and severe tooth face wear.

4524 Steps to Assemble Camshaft

After disassembling, examine camshaft and timing gear, and parts with wear or large parameter deviation should be repaired or replaced.

- (1) Rub-up camshaft fitting hole with towel and check the hole for bump damage, apply proper amount of lubricating oil on camshaft sleeve inner surface. For camshaft fitting hole that involving bump damaged should not be reused even after repair.
- (2) Place camshaft guide tool and lubricating sleeve into the fitting hole, rub-up camshaft and check for bump damage, and then insert camshaft into camshaft fitting hole, remove camshaft guide tool and lubricating sleeve after the camshaft is properly fitted. Be careful not to crash camshaft sleeve during the inserting process.
- (3) Install camshaft thrust plates, loose-fit the pre-glued hexagon bolts and tighten them. Tightening torque of the bolts should be 29~35Nm.
- (4) Apply KB277 sealant on camshaft fitting hole bowl shape plug fore-end, the sealant trace should be continuous and enclosed. And then press the plug into camshaft fitting hole and clean up the remnant sealant around the plug, make sure the plug is free of turnup.

- (5) Turn the engine anticlockwise (view from timing gear housing end) until cylinder 1 and 6 reach TDC. At this point, piston upper end should be aligned to cylinder block upper surface.
- (6) Draw a straight line across flywheel housing and flywheel, install the dial and adjust it until 0° position is aligned to the “half line” on flywheel housing, install timing gear.
- (7) The mark on timing gear should be aligned to “OT” mark on timing gear housing.
- (8) Screw on the pre-coated hexagon bolts and tighten them diagonally, required tightening torque is 32~36Nm. Leave a white mark on one of the bolts after tightening, measure and record the side clearance between timing gear and intermediate gear according to requirements.
- (9) Required side clearance between timing gear and intermediate gear is 0.015~0.33mm. Install the cylindrical pins.

453 Disassembly, Inspection, Maintenance and Assembly of Rocker and Rocker Shaft

4531 Exploded View of Rocker and Rocker Shaft

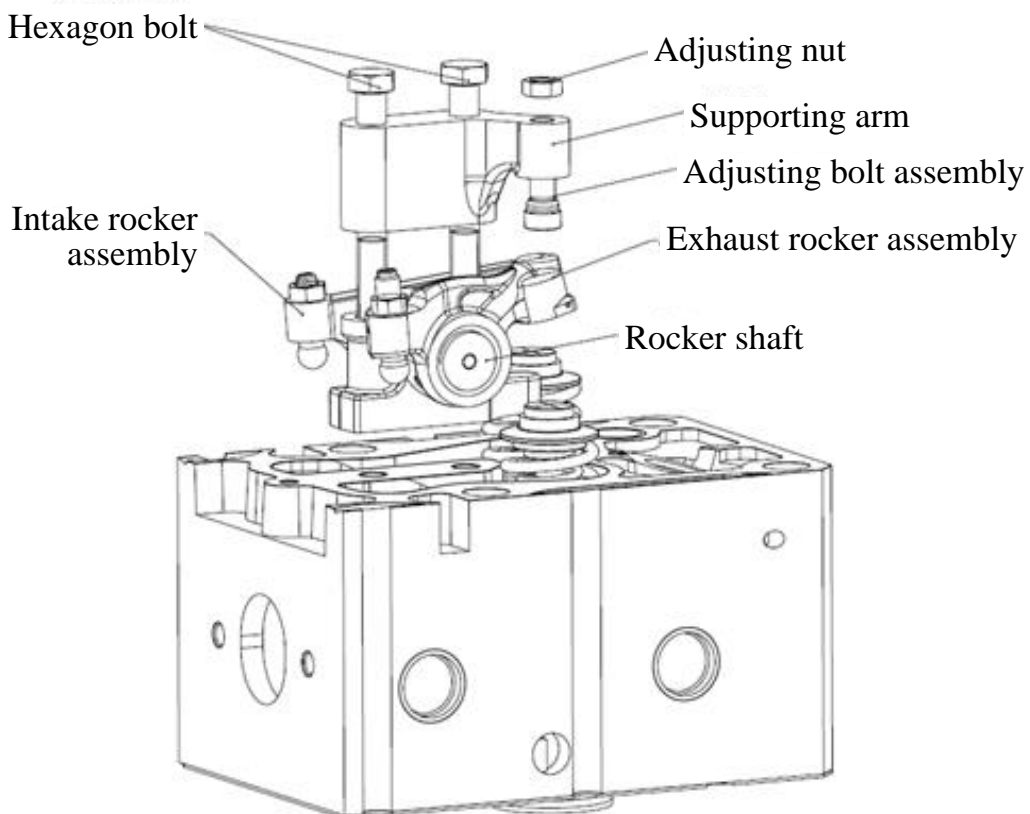

Fig. 4-43 Exploded view of rocker and rocker shaft

4532 Steps to Disassemble Rocker and Rocker Shaft

- (1) Rotate crankshaft to check whether rocker is flexible.
- (2) Measure each valve clearance, and check the change of valve clearance.
- (3) If the rocker is not flexible or too big valve clearance, loosen hexagon nut and then take down the supporting arm, rocker shaft, intake and exhaust rocker assembly, mark them to prevent confusion.

4533 Inspection and Maintenance of Rocker and Rocker Shaft

- (1) Clean up the rocker and check its appearance for crack.
- (2) Check rocker inner hole for abrasion and scratch, and measure its diameter.
- (3) Check the ball pin and rocker other end arc surface for abrasion.
- (4) Check whether all oil galleries are smooth.
- (5) Measure diameter of rocker inner hole and rocker shaft, and ensure the fit clearance meets the requirements:

Model	Check items	Standard value	Measured value
WP10	Diameter of rocker inner hole	$\phi 23.972 \sim \phi 23.993$	
	Diameter of rocker shaft	$\phi 23.927 \sim \phi 23.960$	

4534 Steps to Assemble Rocker and Rocker Shaft

- (1) Apply a small amount of lubricating oil on valve rocker seat and then fit intake and exhaust valve assembly on rocker seat. Loose-fit the hexagon bolts, ensure proper clearance between rocker and rocker seat so that the rocker can rotate flexible;
- (2) For the last assembling step of EVB rocker, firstly place supporting arm on rocker seat and then loose-fit hexagon bolts and EVB adjusting bolt assembly, tighten the supporting arm;
- (3) After the assembling, rotate crankshaft to check whether rocker is flexible.
- (4) Check and adjust intake and exhaust valve clearance
 - 1) Rotate the engine until cylinder 1 reach its TDC, at this point flywheel mark should be aligned to flywheel housing mark, make sure cylinder 1 is in compression stroke.
 - 2) Adjust intake valve clearance of No. 1, 2, 4 cylinder and exhaust valve clearance of No. 1, 3, 5 cylinder, required intake valve clearance is $0.3 \pm 0.03\text{mm}$, while that for exhaust valve is $0.4 \pm 0.03\text{mm}$, and EVB valve clearance should be $0.25 \pm 0.03\text{mm}$. Tightening torque of intake and exhaust valve adjusting nut is 30~40Nm. Methods to adjust intake and exhaust

valve clearance:

As shown in Fig. 4-44, firstly loose the adjusting bolt 2, and then adjust valve clearance adjusting screw on pushrod end 10 without compressing exhaust valve rocker sealing surface until total valve clearance is 0.4mm, and then tighten adjusting nut. (**ATTENTION: In the adjusting process, you should rotate the valve clearance adjusting screw until the feeler gauge is gently infibulated, so that valve rocker piston 5 can be pushed to the bottom and no clearance between piston and piston hole bottom**).

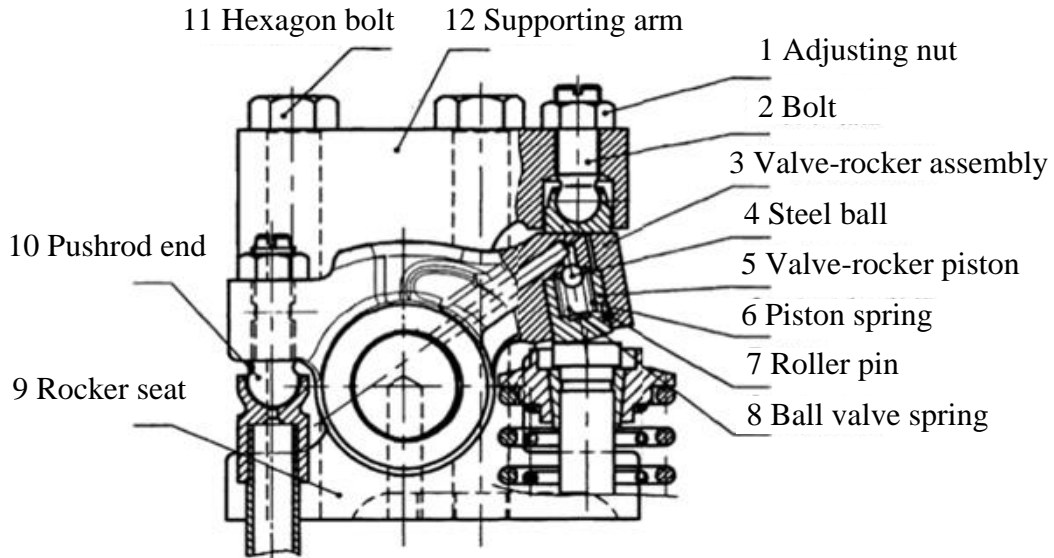

Fig. 4-44

As shown in Fig. 4-45, place a 0.25mm feeler gauge between rocker piston and exhaust valve, and adjust valve clearance to 0.25mm by adjusting bolt assembly 2, tighten the locknut. **ATTENTION: In the adjusting process, you should rotate bolt assembly 2 until the feeler gauge is gently infibulated, so that valve rocker piston 5 can be pushed to the bottom and no clearance between piston and piston hole bottom**

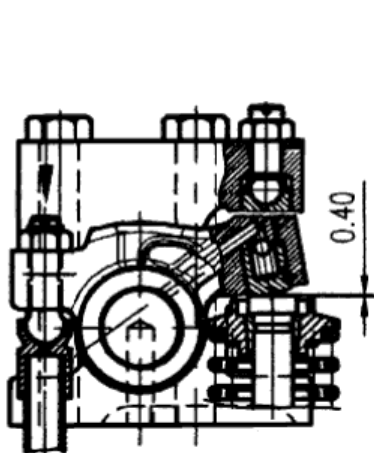

Fig. 4-45

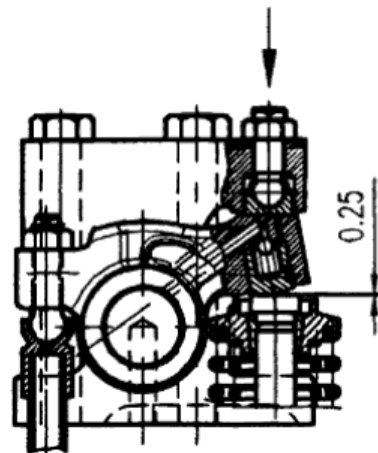

Fig. 4-46

- 3) Rotate the engine for 360°, so that cylinder 6 can be in compression TDC, adjust intake valve clearance of No. 6, 5, 3 cylinder and exhaust valve clearance of No. 6, 4, 2 cylinder, and EVB valve clearance.
- 4) Check valve timing of cylinder 1 in cold state, intake valve TDC 18°~23°, exhaust valve TDC 20°~25°.

454 Disassembly, Inspection, Maintenance and Assembly of Valve Tappet and Pushrod

4541 Exploded View of Valve Tappet and Pushrod

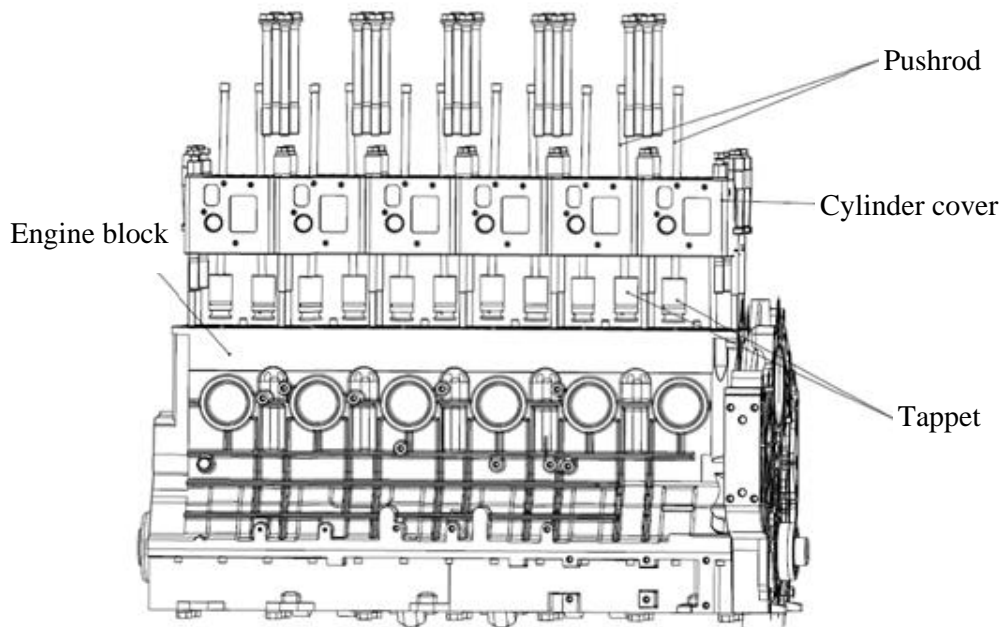

Fig. 4-47 Exploded view of valve tappet and pushrod

4542 Steps to Disassemble Valve Tappet and Pushrod

- (1) After removing rockers and rocker shafts, directly take out pushrods, place them orderly;
- (2) After removing cylinder covers (refer to disassembly of cylinder cover for details), directly take out valve tappets, place them orderly;

4543 Inspection and Maintenance of Valve Tappet and Pushrod

- (1) Clean up valve tappet and pushrod;
- (2) Check whether oil channels of valve tappet and pushrod are unblocked;
- (3) Check whether pushrod is crooked, check wear condition of its outside surface;

- (4) Check whether pushrod two ends are worn;
- (5) Check whether valve tappet surface and undersurface are worn;
- (6) Check whether valve tappet inner socket head is worn.

4544 Steps to Assemble Valve Tappet and Pushrod

- (1) Check valve tappets and pushrods, replace them if necessary. Before installing the tappets, it must be cleaned with compressed air, and check whether the oil channels are unblocked;
- (2) Apply clean lubricating oil evenly on valve tappet fitting surfaces;
- (3) Install valve tappets into engine block tappet-fitting holes
- (4) After assembling cylinder covers (refer to assembly of cylinder cover for details), clean the pushrods with compressed air and check whether the oil channels are unblocked;
- (5) Apply clean lubricating oil on pushrod and ensure the round head is applied with sufficient oil.
- (6) Install pushrod, put the pushrod into valve tappet through cylinder cover.

455 Disassembly, Inspection, Maintenance and Assembly of Valve

4551 Exploded View of Valve

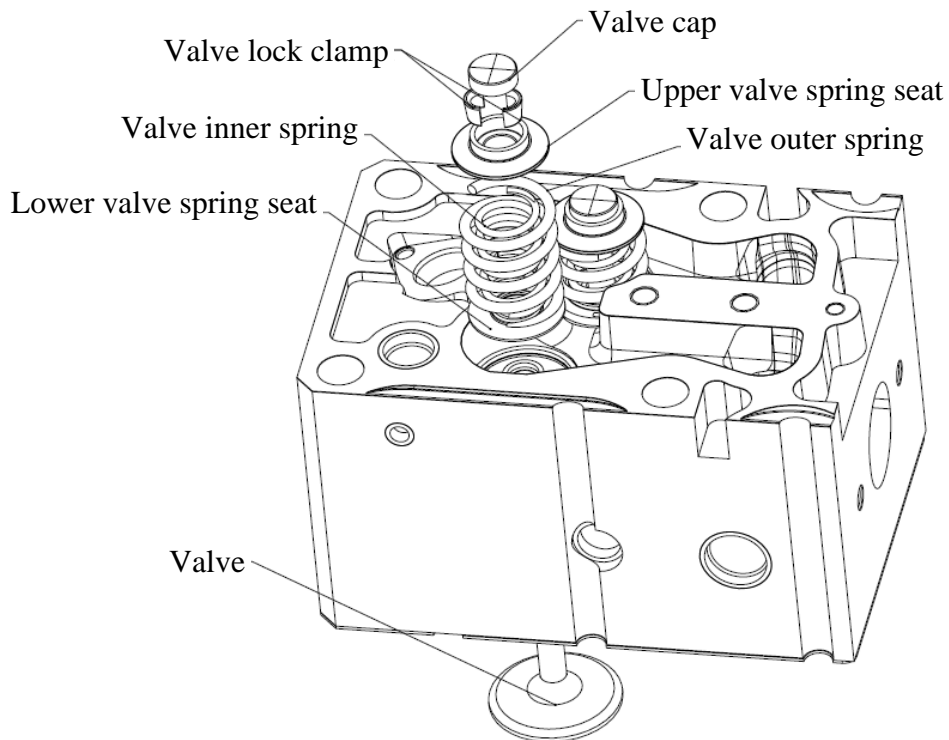

Fig. 4-48 Exploded view of valve

4552 Steps to Disassemble Valve

- (1) Depress valve springs with valve spring compressor or valve overhead plier or other tools, take out valve lock clamp, upper valve spring seat and lower valve spring seat and valve springs orderly;
- (2) Take valve out of valve seat.

4553 Inspection and Maintenance of Valve

- (1) Check whether valve rod and its end faces are worn;
- (2) Check whether valve conical surface is worn or damaged;
- (3) Check valve conical surface for carbon deposit;
- (4) Check valve retainer end faces for carbon deposit and sintering.

4554 Steps to Assemble Valve

A valve with severe wear or carbon deposit or sintering should be replaced.

- (1) Apply molybdenum disulfide cream on intake and exhaust valve rods, and then install intake and exhaust valves into cylinder cover, ensure the valve can slide smoothly in valve guide pipe;
- (2) Apply thread locking sealant on exhaust valve lower spring seat and then install it on cylinder cover, check whether the seat is properly fitted, repair or replace if necessary. Do not fiercely knock the seat to position.
- (3) Assemble lower valve spring seat of intake valve, install valve rod protecting cover into valve guide pipe, and then install valve rod seal cartridge;

ATTENTION: Check and ensure spring in valve rod seal cartridge is in good condition before assembling.

- (4) Install valve inner and outer springs;
- (5) Assemble upper valve spring seat, depress the springs and install valve lock clamp;
- (6) Knock the valve with rubber hammer to settle the lock clamp, if the valve lock clamp or upper valve spring seat cannot be settled, please find out the cause and eliminate it.

456 Disassembly, Inspection, Maintenance and Assembly of Intermediate Gear

4561 Exploded View of Intermediate Gear

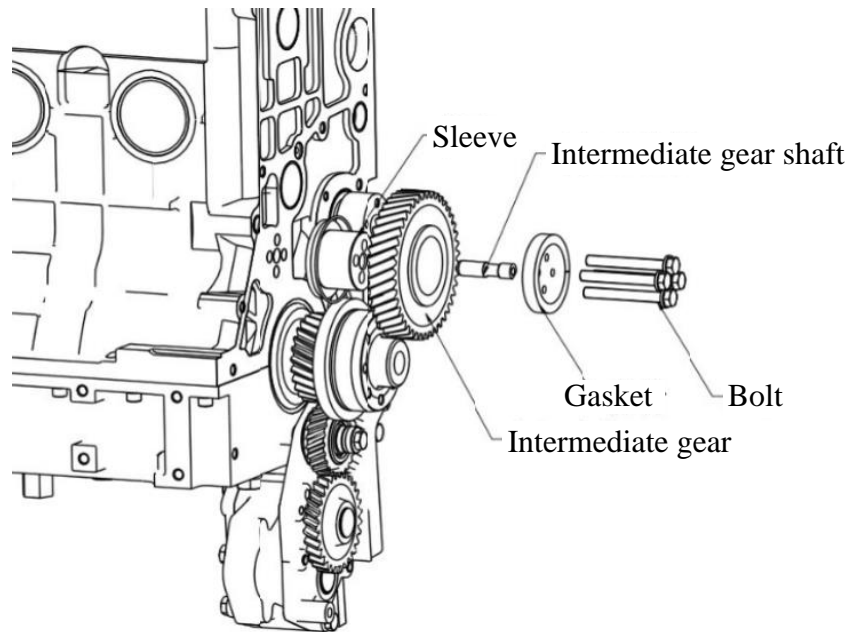

Fig. 4-49 Exploded view of intermediate gear

4562 Steps to Disassemble Intermediate Gear

- (1) Remove air compressor, refer to disassembly of engine accessory system for details;
- (2) Remove fuel injection pump, refer to disassembly of fuel system for details;
- (3) Remove camshaft timing gear, refer to disassembly of valve mechanism for details;
- (4) Remove the four M10 fastening hexagon bolts of intermediate gear, take down the gaskets. Screw a M8 bolt into the gear shaft end hole to pull the shaft out, pay attention to avoid intermediate gear falling off;
- (5) Take down intermediate gear assembly and intermediate gear shaft along with the gear housing, and then take them out from the opening of gear housing.

4563 Inspection and Maintenance of Intermediate Gear

- (1) Check whether the bolts are in good condition;
- (2) Check each gear for peeling off and tooth breakage failure, check each bolt bearing surface for crush, and check whether the threaded hole or through-hole on gear is deformed.
- (3) Check whether there is abnormal wear between intermediate gear shaft and intermediate gear sleeve. Check and make sure each oil hole is free of dirt and unblocked.

4564 Steps to Assemble Intermediate Gear

- (1) Install engine oil pump, crankshaft and engine oil pump intermediate gear module orderly;
- (2) Install gear housing. Before assembling gear housing, put intermediate gear shaft into intermediate gear assembly (intermediate gear and sleeve). For intermediate gear the end with “V” mark should face outward. And then upside-down the engine (to prevent intermediate gear assembly falling off) and install intermediate gear assembly.

46 Intake and Exhaust System

461 Disassembly and Assembly of Intake and Exhaust System

4611 Exploded View of Intake and Exhaust System

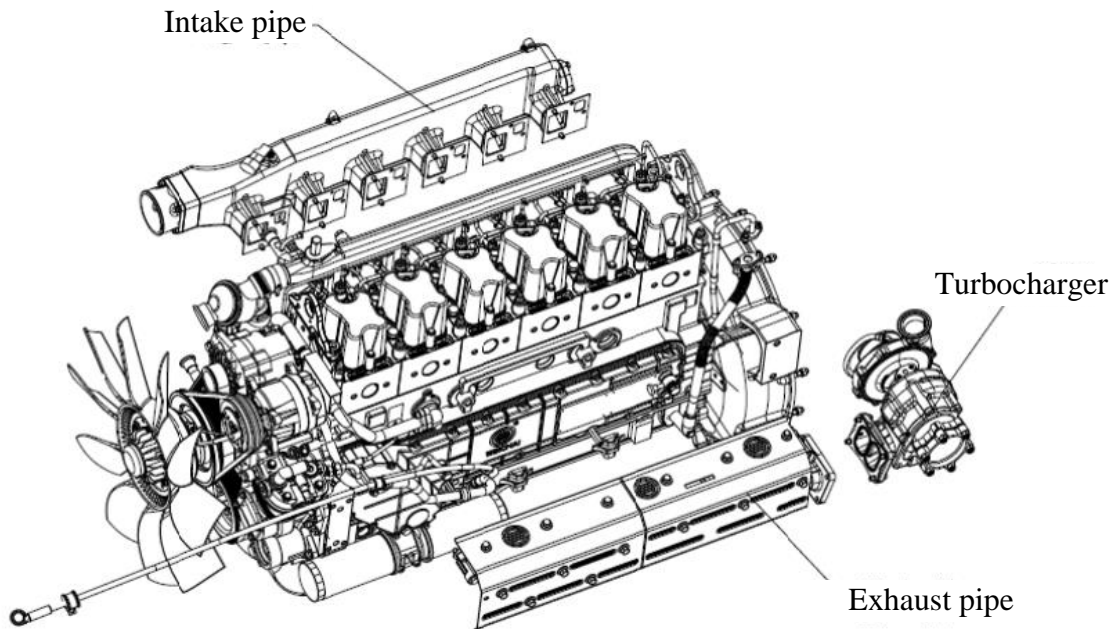

Fig. 4-50 Exploded view of valve intake and exhaust system

4612 Steps to Disassemble Intake and Exhaust System

- (1) Loosen air filter fixing bolts and hose clamps, take down air filter and hoses.
- (2) Loosen clamps of intercooler rubber hoses, take down turbocharger compressor outlet hose and intercooler intake pipe adapter.
- (3) Remove fixing bolts of turbocharger oil inlet and outlet pipes, take down the pipes and gaskets.
- (4) Remove tail pipe fixing bolts and turbocharger fixing bolts, take down turbocharger.
- (5) Remove intake heater wiring and screw off intake pipe fastening bolts; take down the pipe, refer to **462 Disassembly, Inspection, Maintenance and Assembly of Intake Pipe** for details.
- (6) Remove heat shield bolts and take down heat shield, screw off fastening bolts of exhaust pipe, take down the pipe, refer to **463 Disassembly, Inspection, Maintenance and Assembly of Exhaust Pipe** for details.

4613 Steps to Assemble Intake and Exhaust System

Assembling steps are contrary to disassembling ones.

462 Disassembly, Inspection, Maintenance and Assembly of Intake Pipe

4621 Exploded View of Intake Pipe

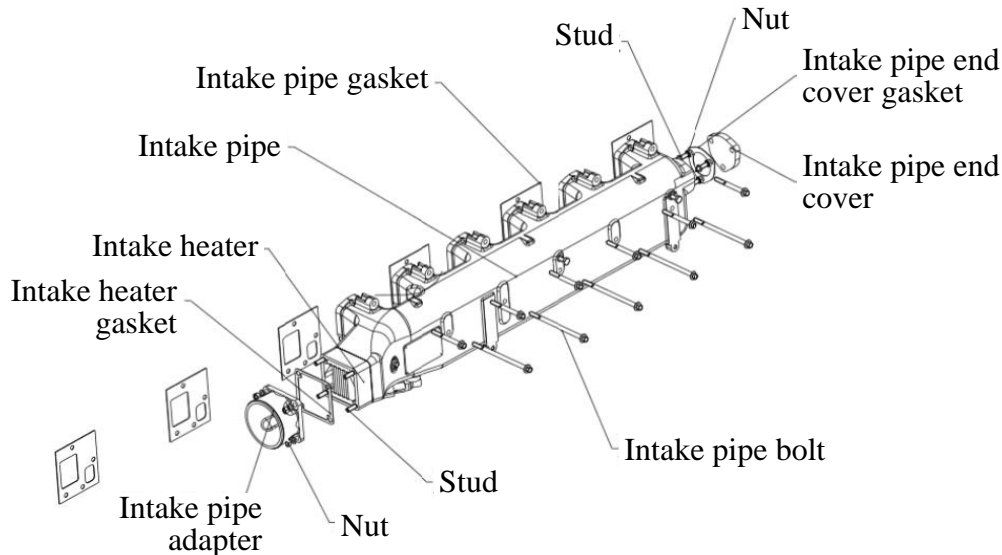

Fig. 4-51 Exploded view of intake pipe

4622 Steps to Disassemble Intake Pipe

- (1) Screw off intake pipe bolts orderly, take down the pipe and gaskets;
- (2) Screw off intake pipe adapter fastening nuts, take down the adapter, intake heater and heater gaskets;
- (3) Screw off intake pipe end cover fastening nuts, take down intake pipe end cover and gaskets orderly.

4623 Inspection and Maintenance of Intake Pipe

- (1) Check intake pipe for crack and distortion, replace the pipe if necessary.
- (2) Check intake pipe gaskets and end cover gaskets for deformation and dilaceration, replace it if necessary.
- (3) Check intake heater for burnout and short circuit, replace it if necessary.

4624 Steps to Assemble Intake Pipe

Assembling steps are contrary to disassembling ones. Recommended tightening torque for intake pipe bolts is 23Nm.

463 Disassembly, Inspection, Maintenance and Assembly of Exhaust Pipe

4631 Exploded View of Intake Pipe

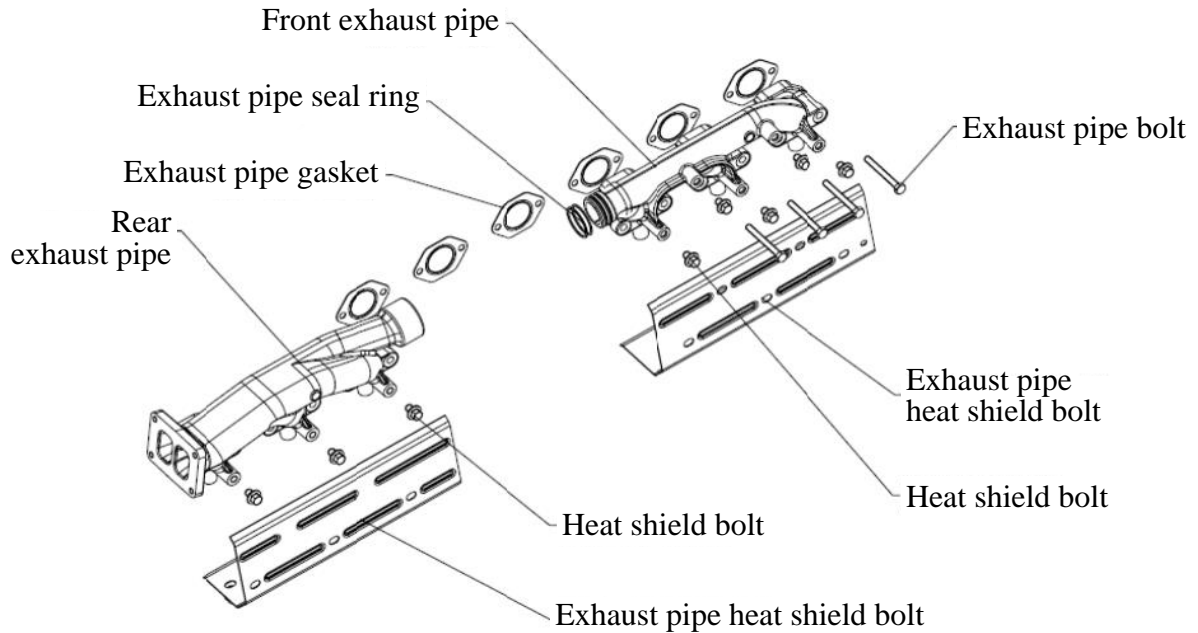

Fig. 4-52 Exploded view of exhaust pipe

4632 Steps to Disassemble Exhaust Pipe

- (1) Screw off exhaust pipe heat shield bolts orderly and take down the shield;
- (2) Remove exhaust pipe fastening bolts, take down front and rear exhaust pipes and gaskets.
- (3) Separate front and rear exhaust pipes, remove front exhaust pipe adapter and seal rings.

4633 Inspection and Maintenance of Exhaust Pipe

- (1) Check whether there is crack on exhaust pipe, whether the flange is deformed, replace the pipe if necessary.
- (2) Check whether there is air leakage on exhaust pipe flange, replace the gasket if necessary.
- (3) Check exhaust pipe gasket for deformation and dilaceration, replace it if necessary.
- (4) Check exhaust pipe seal rings for sintering, rust and carbon deposit, replace it if necessary.

4634 Steps to Assemble Exhaust Pipe

Assembling steps are contrary to disassembling ones. Note the following points during assembly:

- (1) Pay attention not to scratch exhaust pipe adapter when assembling the seal rings, the openings of four seal rings should staggered for 90°.

- (2) Exhaust pipe bolts should be applied with molybdenum disulfide, recommended tightening torque for exhaust pipe fixing bolts is 65~80Nm. Exhaust pipe bolts cannot be reused more than twice.

464 Disassembly, Inspection, Maintenance and Assembly of Turbocharger System

4641 Exploded View of Turbocharger System

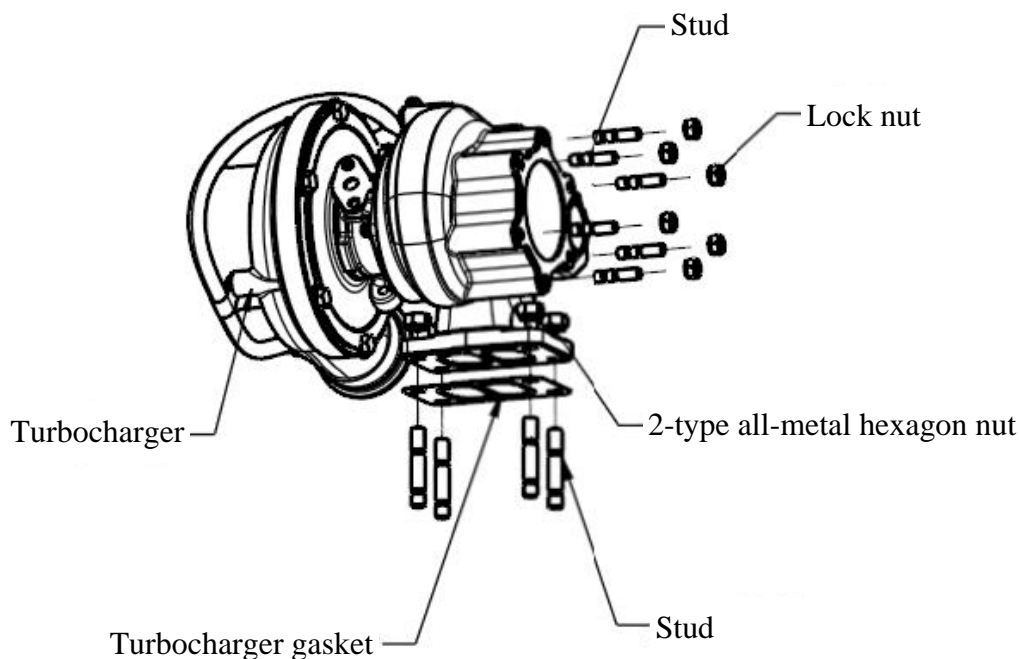

Fig. 4-53 Exploded view of turbocharger system

4642 Steps to Disassemble Turbocharger System

Disassembling steps are contrary to assembling ones.

4643 Inspection and Maintenance of Turbocharger System

- (1) Check service behavior of rotor

Stir compressor impeller gently with your finger, it is normal if the impeller can rotate for more than one round; if the impeller stopped soon, then it means the bearing is abnormally worn, or there is clash or jamming problem between rotating parts and fixed parts, you must find out the cause and eliminate the problem.

- (2) Rotor axial movement checking

Press measuring head of dial indicator against compressor end, push and pull the shaft axially and record value difference of the indicator. As shown in Fig. 4-54. Required range is 0.088~0.118mm, if exceeds this range, then it indicates that thrust bearing plate or thrust plate and bearing is worn, you must find out the cause and eliminate the problem.

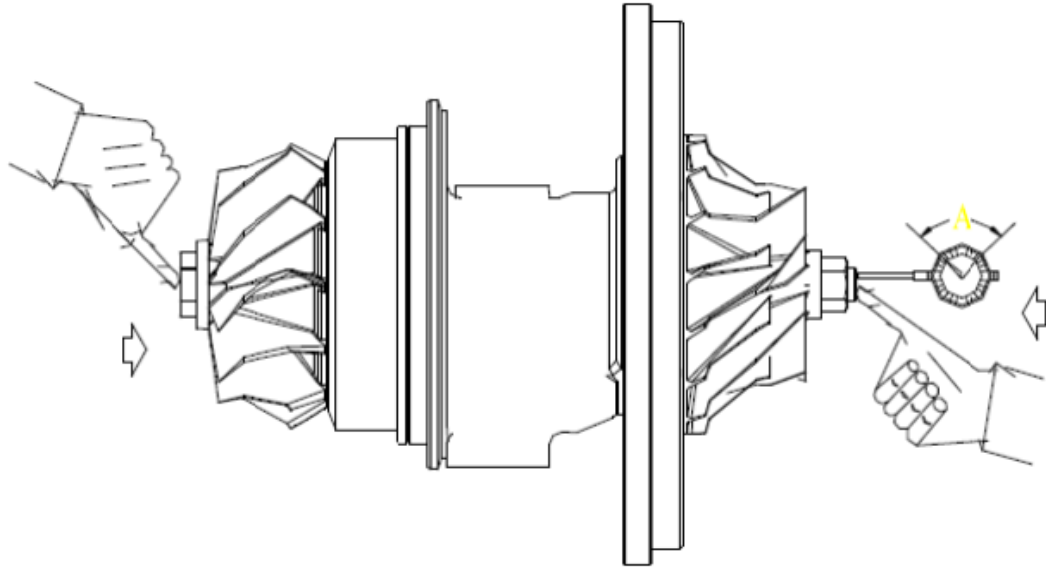

Fig. 4-54 Rotor axial movement measuring

(3) Compressor impeller radial clearance checking

Press the compressor impeller radially and measure the maximum and minimum clearance between compressor impeller and compressor volute (as shown in Fig. 4-55), which should be within 0.4~0.8mm, if exceeds this range, then check the bearing and eliminate the fault.

ATTENTION: Ensure the turbocharger is cold when performing the measurement.

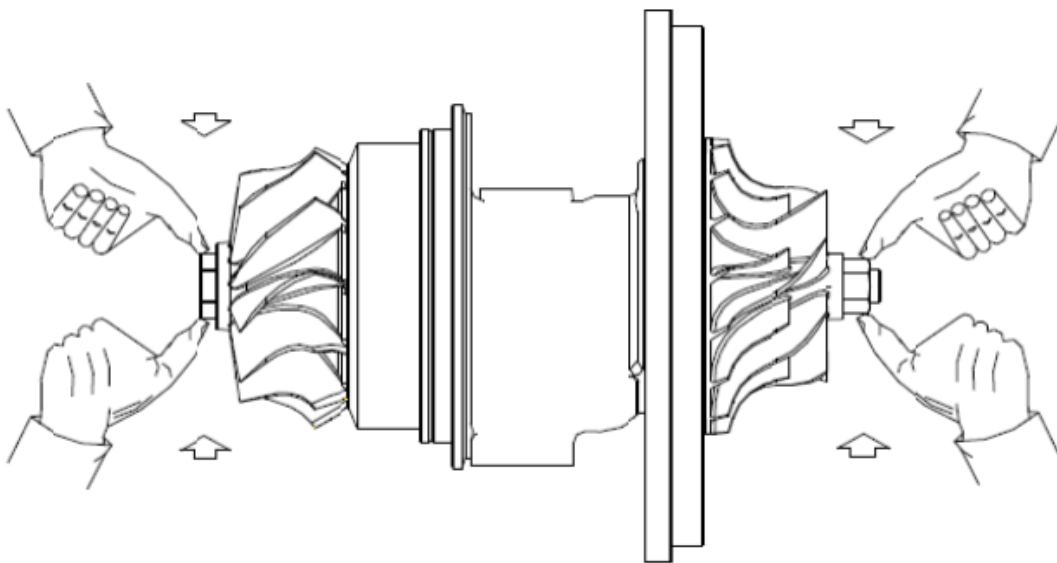

Fig. 4-55 Compressor impeller radial clearance measuring

Routine maintenance:

- (1) Check whether the pipe connection between turbocharger and engine is loose, eliminate the problem in time.
- (2) Check turbocharger for air leakage and oil leakage, eliminate the fault in time.
- (3) Check whether turbocharger fastening screws are loose, eliminate the problem timely.
- (4) Check air filter, clean it timely if there is too much dust accumulated in the filter.

4644 Steps to Assemble Turbocharger System

- (1) Loose-fit one end of the preassembled turbocharger oil inlet pipe to engine block main oil port. Pay attention to adjust the position of the pipe, so that it can be easily connected to turbocharger.
- (2) Install turbocharger gasket on exhaust pipe flange.
- (3) Install turbocharger oil return pipe and studs on turbocharger assembly, apply 0# molybdenum disulfide and clean lubricating oil on the studs. Tighten oil return pipe fixing bolts to 22~29Nm.
- (4) Place a gasket on exhaust pipe flange and fix them on turbocharger assembly, loose-fit 2-type all-metal hexagon lock nuts and tighten them.
- (5) Pour proper amount of clean lubricating oil into turbocharger oil inlet port, and clean up the overflowed oil.
- (6) Connect oil inlet pipe to turbocharger with a gasket, fix them with hexagon bolts and self-locking gaskets, tighten the bolts to 22~29Nm. Rotate supercharger impeller and it should be flexible and free of resistance.
- (7) Knock-in turbocharger oil return elbow. Fitting surface of the elbow should be applied with 271 thread sealant.
- (8) Install turbocharger oil return hose and hose clamps, tighten the clamps. Note that the direction of two clamps should be uniform, straighten out the house.
- (9) All gaskets are disposable and should be replaced once removed.

47 Fuel System

471 Disassembly and Assembly of Fuel System

4711 Exploded View of Fuel System

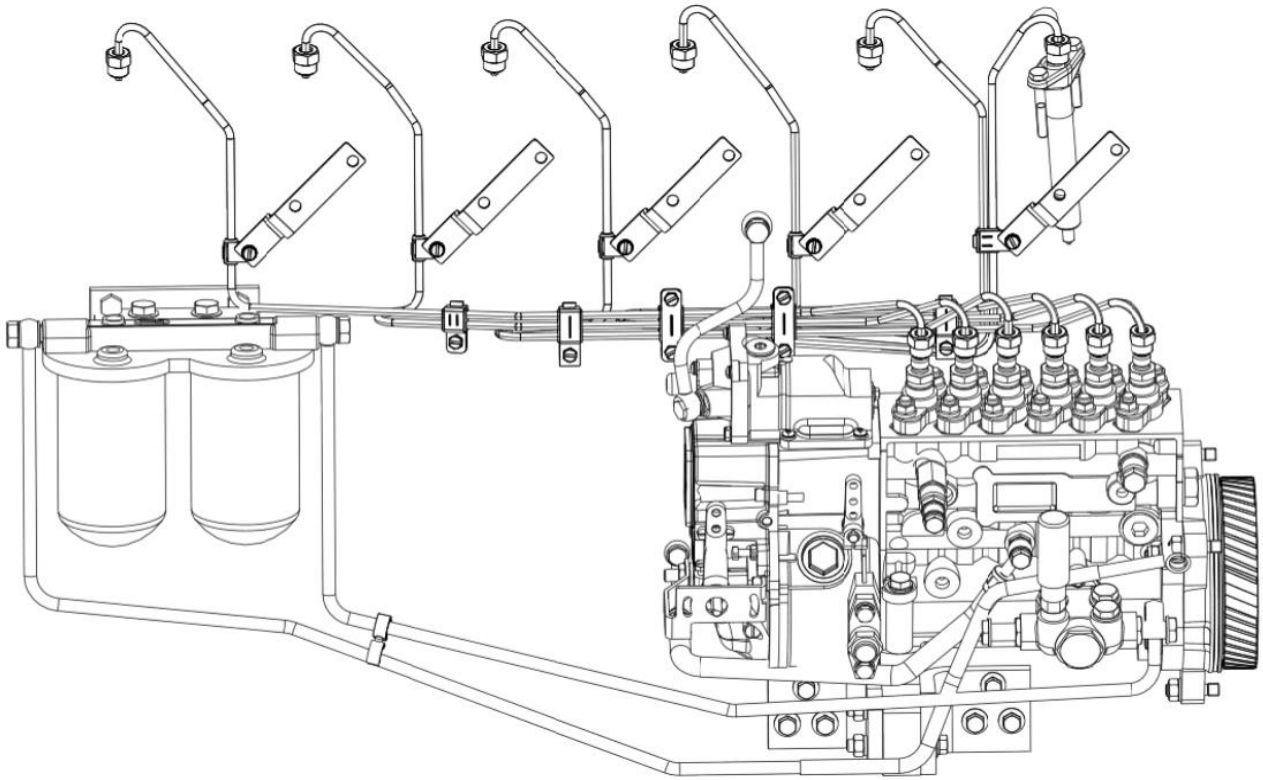

Fig. 4-56 Exploded view of fuel system

4712 Steps to Disassemble Fuel System

- (1) Remove low pressure fuel pipe module;
- (2) Remove high pressure fuel pipe module;
- (3) Remove injector module;
- (4) Remove filter module;
- (5) Remove high pressure fuel injection pump module.

4713 Steps to Assemble Fuel System

Assembling steps are contrary to disassembling ones.

472 Disassembly, Inspection, Maintenance and Assembly of Fuel Injection Pump

4721 Exploded View of Fuel Injection Pump

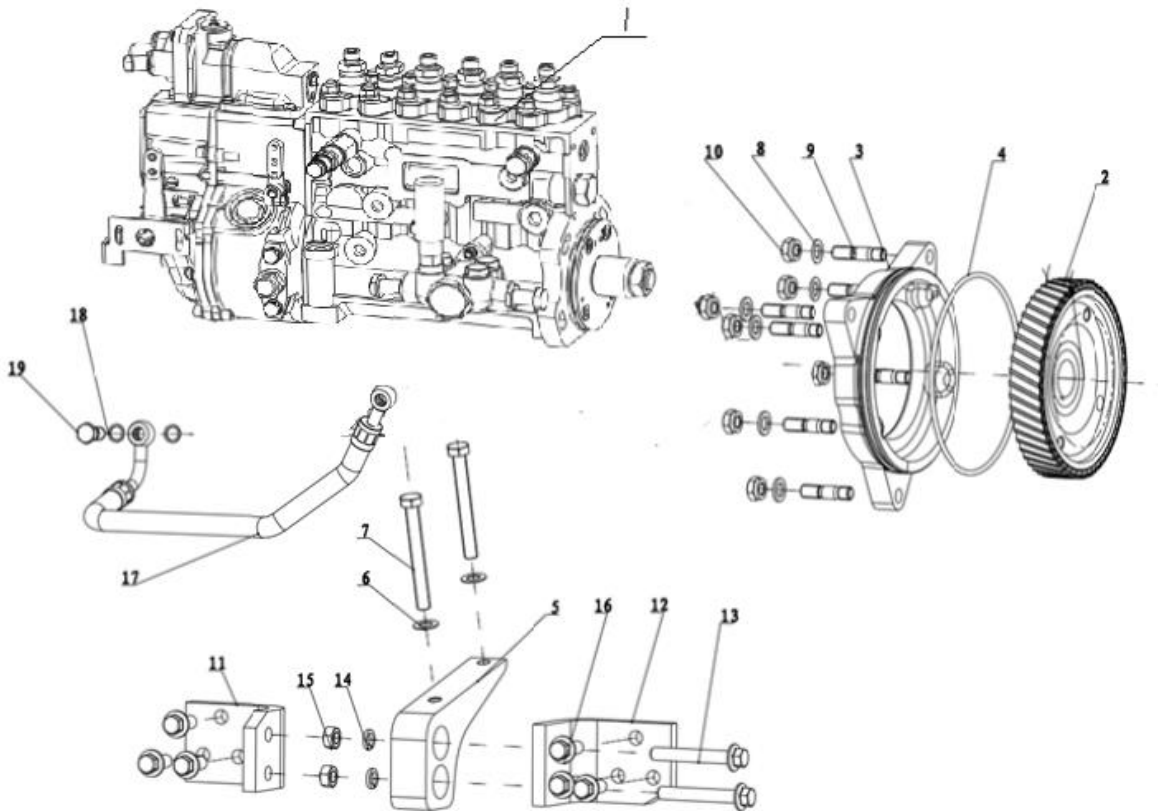

Fig. 4-57 Exploded view of fuel injection pump

4722 Steps to Disassemble Fuel Injection Pump

- (1) Screw off the hexagon nuts that connecting fuel injection pump flange and gear housing;
- (2) Disconnect fuel injection pump module and gear module from the engine;
- (3) Remove fuel injection pump gear lock nut;
- (4) Screw off the hexagon bolts that connecting fuel injection pump and the flange;
- (5) Remove fuel injection pump flange.

4723 Inspection and Maintenance of Fuel Injection Pump

The structure of fuel injection pump is illustrated in Fig. 4-57. Rotate the flywheel until cylinder 1 reaches compression TDC, at this point the mark on injection pump gear should be aligned to mark on injection pump flange.

4724 Steps to Assemble Fuel Injection Pump

- (1) Install fuel injection pump flange, apply a small amount of lubricating oil on pump rubber ring;
- (2) Screw on the hexagon bolts to connect fuel injection pump and the flange;
- (3) Install injection pump gears, specification of fuel injection pump gear lock nut is M24×1.5, tighten the nut to 250~300Nm directly;
- (4) Install the three pump fixing studs on engine block;
- (5) Rotate the flywheel until cylinder 1 reaches compression TDC, at this point rotate injection pump gears until the mark on injection pump gear module is aligned to mark on injection pump flange, install injection pump module. Insert a $\Phi 4$ pin into the corresponding hole on middle flange and pump gear, pull out the pin after fastening common rail module, and seal the hole up with M5 screw (applied with sealant). After the assembly, the mark on driving gear of injection pump should be aligned to mark on driven gear. As shown in Fig. 4-58. Tighten the hexagon nuts to fasten the injection pump on gear housing.

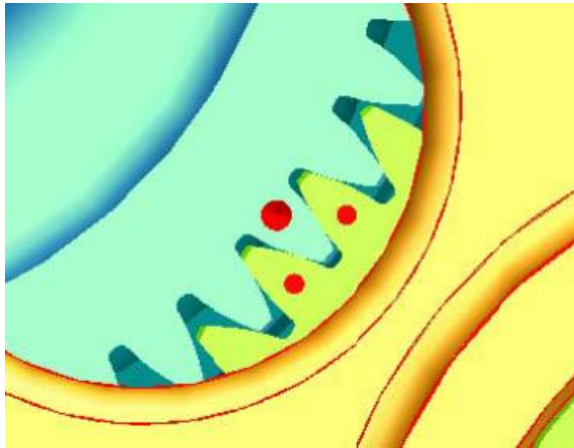

Fig. 4-58 Fuel injection pump gear marks

473 Disassembly, Inspection, Maintenance and Assembly of High Pressure Fuel Pipes

4731 Exploded View of High Pressure Fuel Pipes

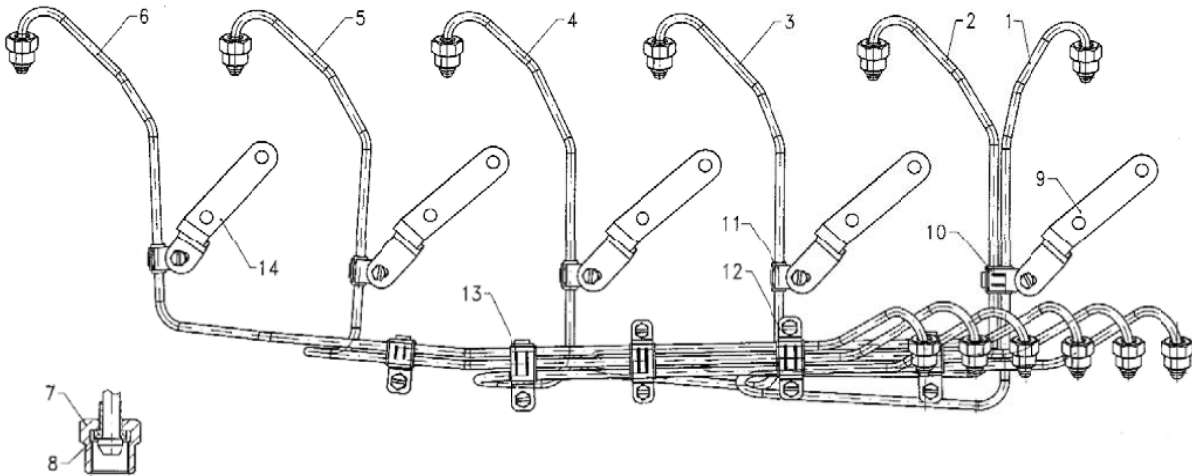

Fig. 4-59 Exploded view of high pressure fuel pipes

4732 Steps to Disassemble High Pressure Fuel Pipes

- (1) Remove high pressure fuel pipe support;
- (2) Remove the high pressure pipe between pump and common rail;
- (3) Remove the high pressure pipe between common rail and injector;

4733 Steps to Assemble High Pressure Fuel Pipes

Assembling steps are contrary to disassembling ones. ATTENTION: Tightening torque of high pressure fuel pipe fastening nuts is 30~40Nm.

474 Disassembly, Inspection, Maintenance and Assembly of Fuel Injector

4741 Exploded View of Fuel Injector

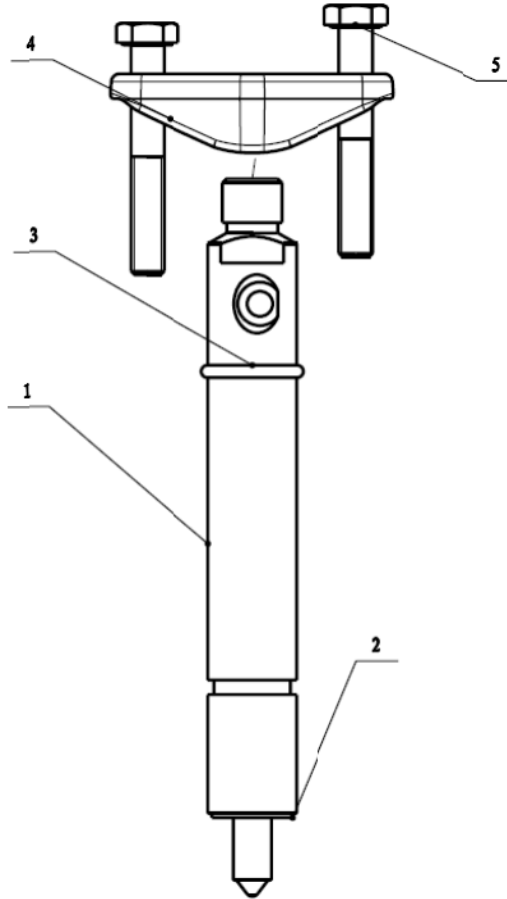

Fig. 4-60 Exploded view of fuel injector

4742 Steps to Disassemble Fuel Injector

- (1) Remove the hexagon bolts that used to fix injector pressing block;
- (2) Remove injector pressing block and fixed block;
- (3) Take injector assembly out of cylinder cover.

4743 Inspection and Maintenance of Fuel Injector

Replacement of injector should be performed at authorized maintenance service station.

4744 Steps to Assemble Fuel Injector

- (1) O-shape seal rings of injector and high pressure joints, high pressure joint thread, and fitting surfaces of high pressure joint and nuts must be applied with lubricating oil;

- (2) All kinds of protective caps only need to be removed before assembling;
- (3) Place the injector into cylinder cover and tighten injector clamping bolt to 3Nm;
- (4) Loose injector clamping bolt until axial force posed on injector is 0kN;
- (5) Pre-tighten high pressure joint to 15~20Nm (nuts);
- (6) Tighten injector clamping bolt for 10Nm+120°;
- (7) Tighten high pressure joint to 50~55Nm (nuts);
- (8) High pressure joint, O-shape seal rings and sealing gaskets are disposal and cannot be reused, check the O-shape seal rings and sealing gaskets for sealing performance after assembling.

48 Cooling System

481 Disassembly and Assembly of Cooling System

4811 Exploded View of Cooling System

The function of cooling system is to ensure diesel engine can continuously work at proper temperature. Forced circulation cooling offers the best guarantee to keep the engine in normal operating temperature, which mainly consists of water pump, fan, expansion water tank, water tank and thermostat.

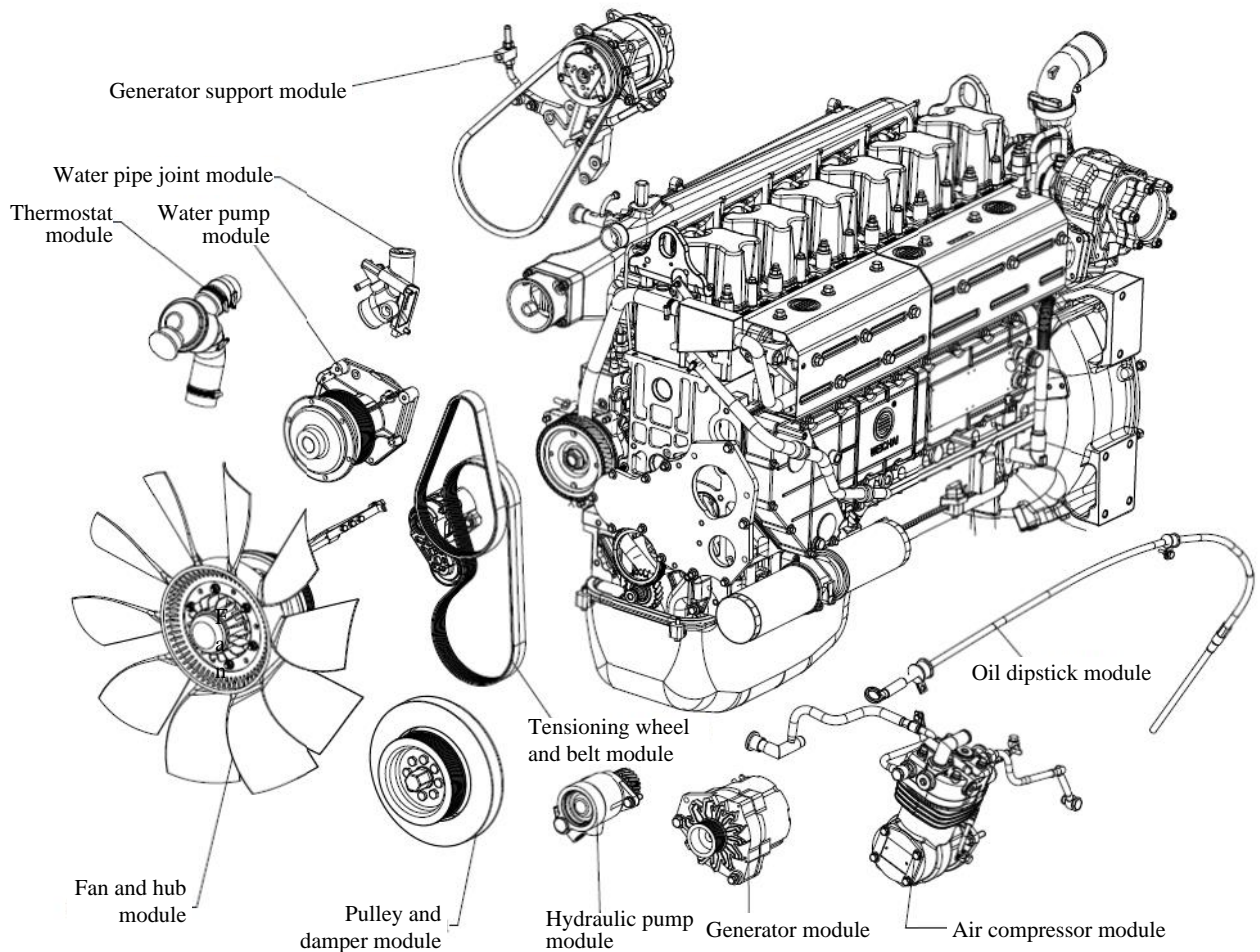

Fig. 4-61 Exploded view of cooling system

4812 Steps to Disassemble Cooling System

As shown in Fig. 4-61:

- (1) Remove fan and hub, refer to disassembly of fan for details.
- (2) Remove the tensioning wheel.
- (3) Remove the belt.

- (4) Remove generator, generator support, crankshaft pulley and damper.
- (5) Remove thermostat, refer to disassembly of thermostat for details.
- (6) Remove air compressor and hydraulic pump.
- (7) Remove pipe joints of water pump and take down the pump, refer to disassembly of water pump for details.

4813 Steps to Assemble Cooling System

Assembling steps are contrary to disassembling ones.

482 Disassembly, Inspection, Maintenance and Assembly of Fan

4821 Exploded View of Fan

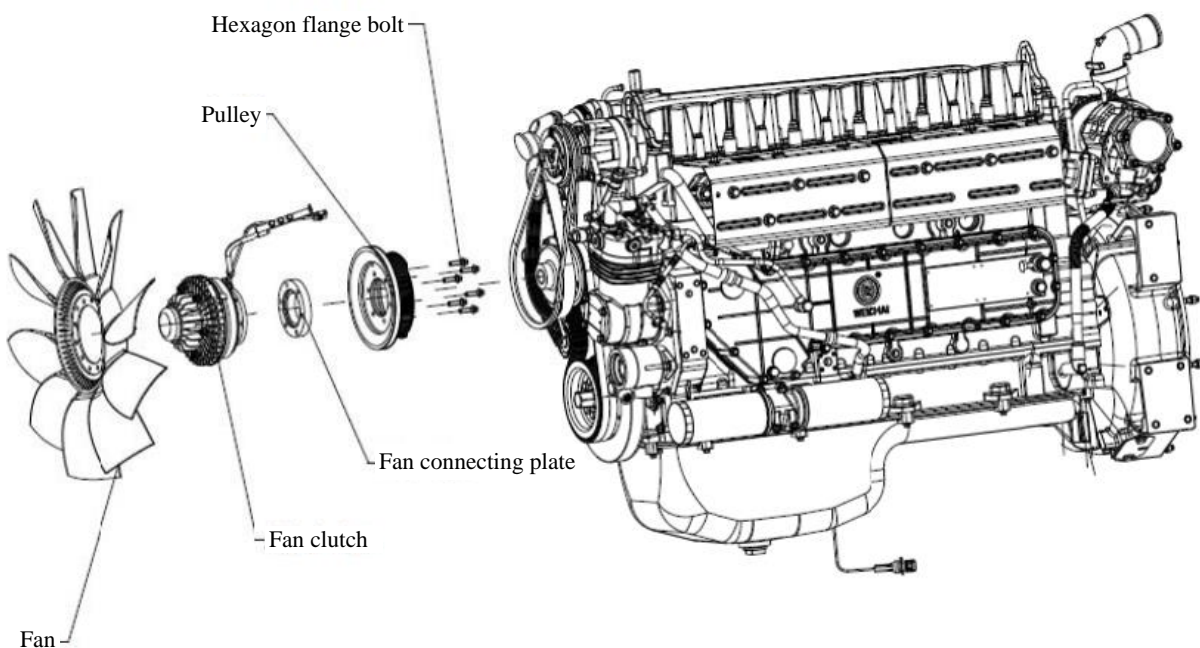

Fig. 4-62 Exploded view of fan

4822 Steps to Disassemble Fan

As shown in Fig. 4-62:

- (1) Remove the nuts that connecting fan and clutch, take down the fan.
- (2) Remove fan clutch.
- (3) Remove fan connecting plate.
- (4) Take down the pulley.

4823 Inspection and Maintenance of Fan

Check fan, fan clutch, fan connecting plate and water pump pulley for crack and damage.

4824 Steps to Assemble Fan

- (1) Before the assembly, check fan, fan clutch, fan connecting plate and hexagon flange bolts, make sure there is no manufacturing and use defect and damage.
- (2) Assembling steps are contrary to disassembling ones.

483 Disassembly, Inspection, Maintenance and Assembly of Water Pump

4831 Exploded View of Water Pump

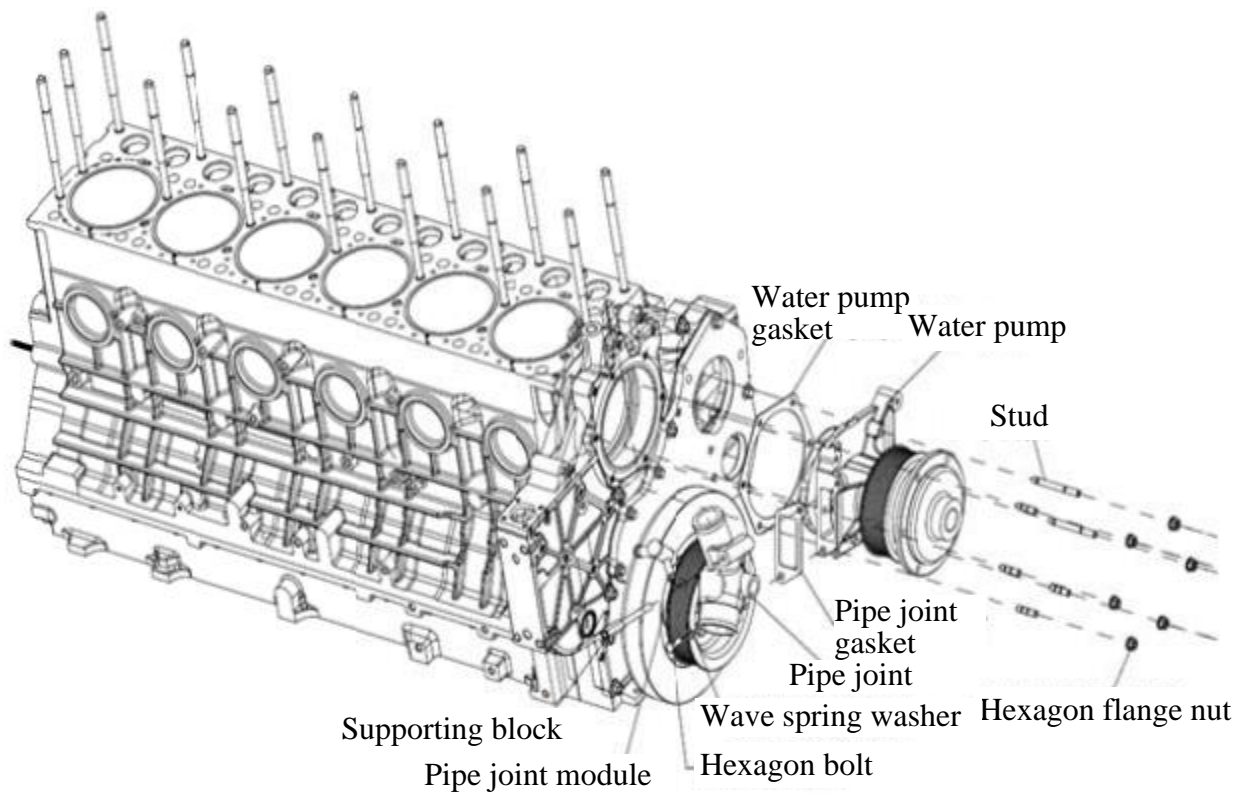

Fig. 4-63 Exploded view of water pump

4832 Steps to Disassemble Water Pump

As shown in Fig. 4-63:

- (1) Pipe joint module;
- (2) Remove the supporting block and hexagon bolts, take down the wave spring washers;
- (3) Remove water pipe joint, take down pipe joint gasket;

- (4) Remove the hexagon flange nuts;
- (5) Remove the studs;
- (6) Remove the water pump and take down pump gaskets.

4833 Inspection and Maintenance of Water Pump

- (1) Check pipe joint and pipe joint module for blockage and crack damage, replace if necessary.
- (2) Check pipe joint gasket and water pump gasket for crack damage, replace if necessary.
- (3) Check the bolts, nuts and studs for thread damage, replace if necessary.
- (4) Check water pump for crack damage, replace it if necessary.

4834 Steps to Disassemble Water Pump

- (1) Before the assembly, check pipe joint, pipe joint module, hexagon bolts, wave spring washers, supporting block, nuts, studs, pipe joint gaskets, water pump gaskets and water pump, make sure there is no manufacturing and use defect.
- (2) Clean up gear housing inner cavity that connected to water pump.
- (3) Assembling steps are contrary to disassembling ones.

484 Disassembly, Inspection, Maintenance and Assembly of Thermostat

4841 Exploded View of Thermostat

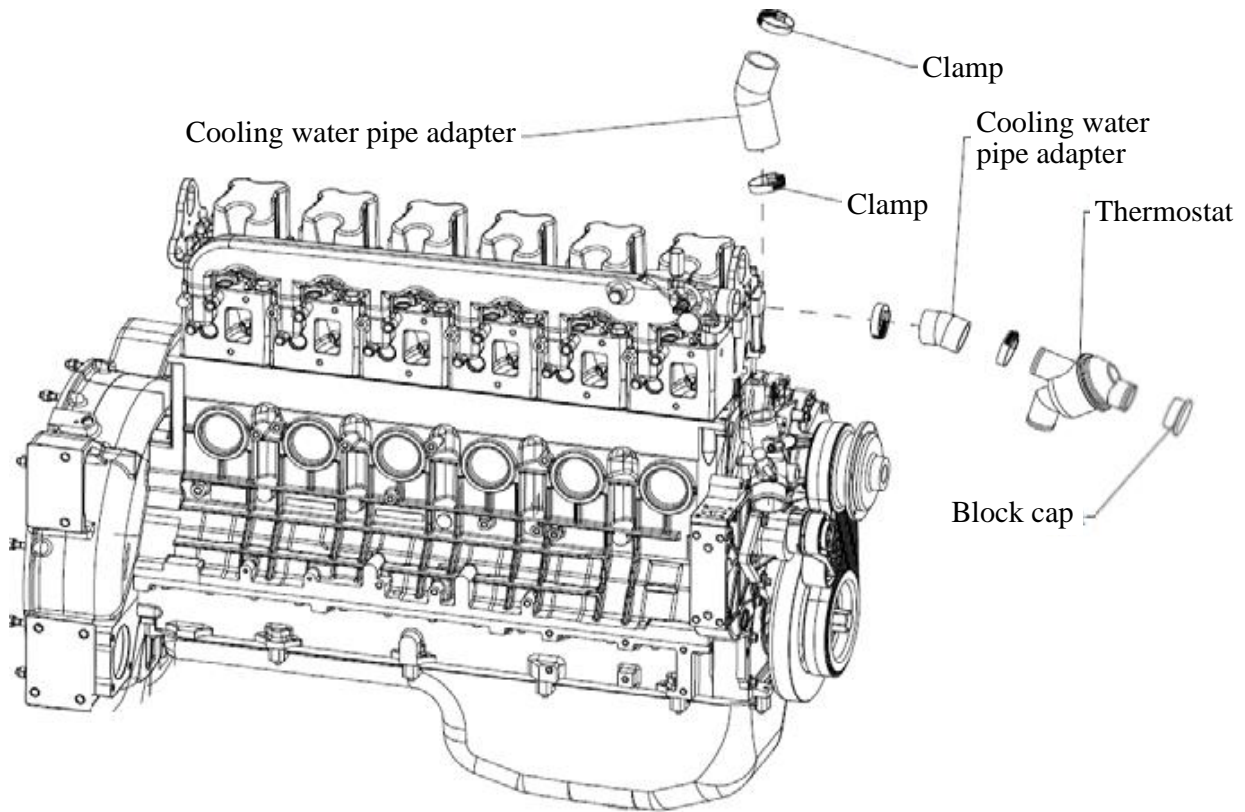

Fig. 4-64 Exploded view of thermostat

4842 Steps to Disassemble Thermostat

As shown in Fig. 4-64:

- (1) Remove the two clamps of upper cooling water adapter (between water outlet pipe and thermostat);
- (2) Remove the two clamps of lower cooling water adapter (between water pump outlet pipe and thermostat);
- (3) Remove thermostat.
- (4) Remove the two cooling water adapters.

4843 Inspection and Maintenance of Thermostat

- (1) Check whether the clamps are in good condition, replace if necessary.
- (2) Check the two cooling water adapters for crack damage, replace them if necessary.
- (3) Check thermostat for fracture damage, replace it if necessary.

4844 Steps to Assemble Thermostat

- (1) Before the assembly, check the clamps, cooling water adapters, thermostat and thermostat cap, make sure there is no manufacturing and use defect and damage.
- (2) Clean up cooling water outlet pipe and water pump outlet pipe.
- (3) Assembling steps are contrary to disassembling ones.

49 Lubricating System

491 Disassembly and Assembly of Lubricating System

4911 Exploded View of Lubricating System

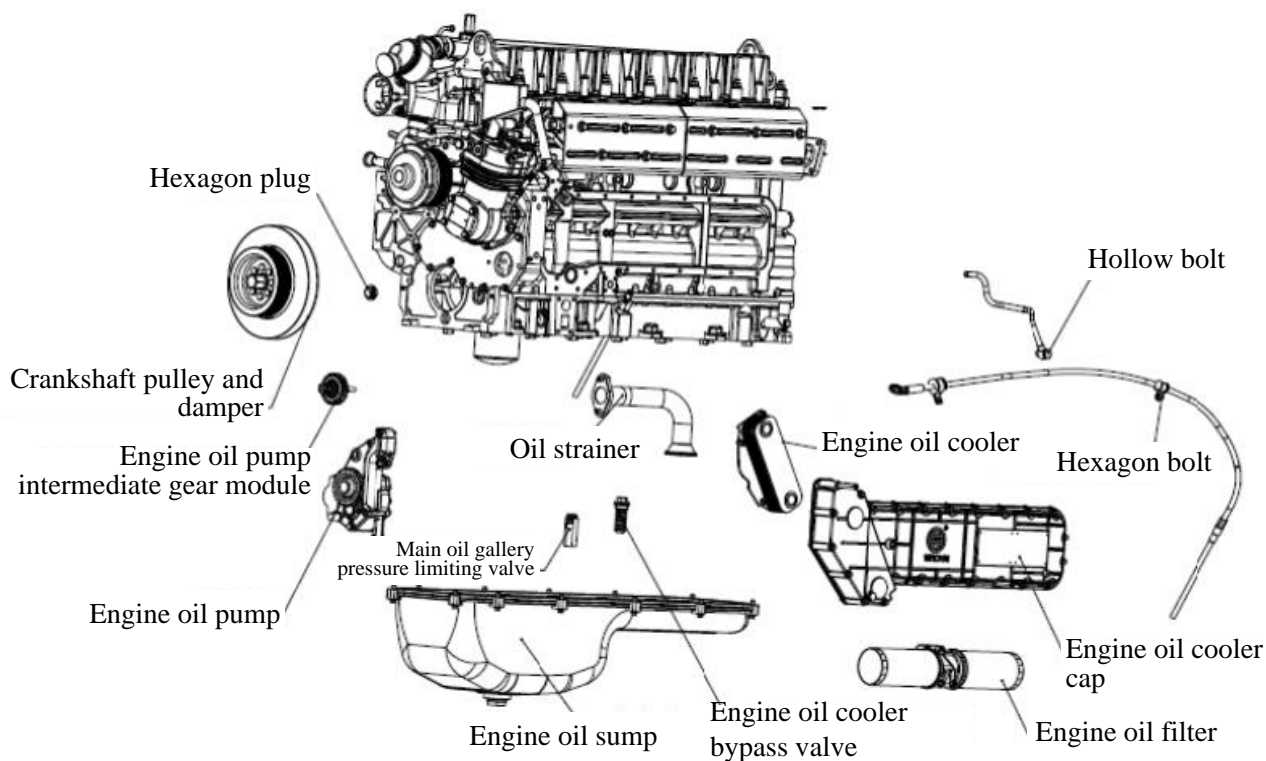

Fig. 4-65 Exploded view of lubricating system

4912 Steps to Disassemble Lubricating System

- (1) Remove oil sump, refer to disassembly of oil sump for details.
- (2) Remove oil strainer.
- (3) Remove crankshaft pulley, damper and the hexagonal head plug from gear housing, refer to disassembly of crank-rod mechanism for details.
- (4) Remove engine oil pump intermediate gear module.
- (5) Remove engine oil pump.
- (6) Remove main oil gallery pressure limiting valve.
- (7) Remove engine oil filter.
- (8) Remove the hollow bolt (for compressor water supply) on engine oil cooler cap and the hexagon bolts that used to fix the oil dipstick module.
- (9) Remove engine oil cooler.

(10) Remove engine oil cooler bypass valve.

4913 Steps to Assemble Lubricating System

Assembling steps are contrary to disassembling ones.

492 Disassembly, Inspection, Maintenance and Assembly of Engine Oil Pump

4921 Exploded View of Engine Oil Pump

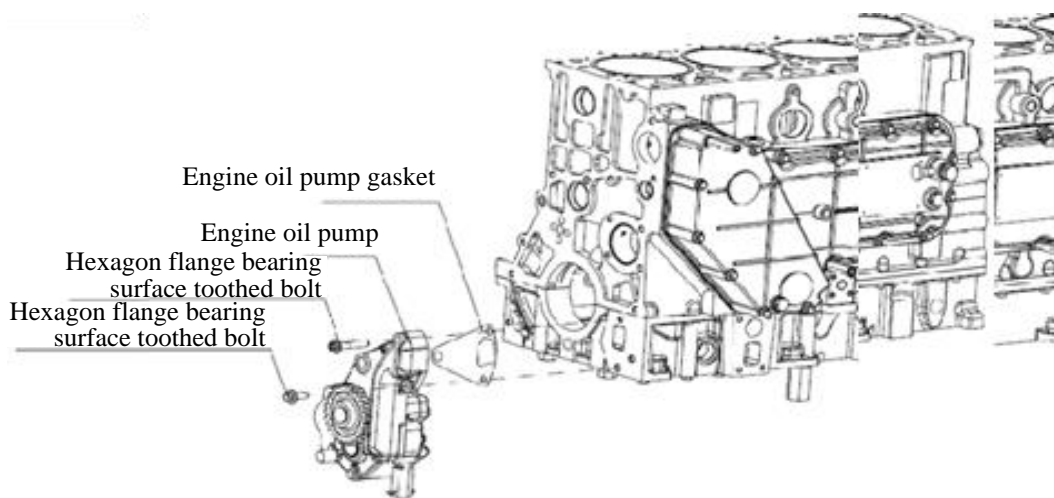

Fig. 4-66 Exploded view of engine oil pump

4922 Steps to Disassemble Engine Oil Pump

Remove the two hexagon flange bearing surface toothed bolts, take down engine oil pump and gasket, as shown in Fig. 4-66.

4923 Inspection and Maintenance of Engine Oil Pump

- (1) Check the engine oil pump for crack damage, check whether its inner cavity is smooth, replace it if necessary.
- (2) Check engine oil pump gasket for oil leakage, replace the gasket if necessary.

4924 Steps to Assemble Engine Oil Pump

- (1) Check the pump and pump gasket before assembling, make sure there is no manufacturing defect and damage.
- (2) Clean up the fitting surface between oil pump and crankcase.
- (3) Install engine oil pump gasket.

- (4) Install engine oil pump.
- (5) Install and tighten the two toothed hexagon bolts.

493 Disassembly, Inspection, Maintenance and Assembly of Engine Oil Pump Intermediate Gear

4931 Exploded View of Engine Oil Pump Intermediate Gear

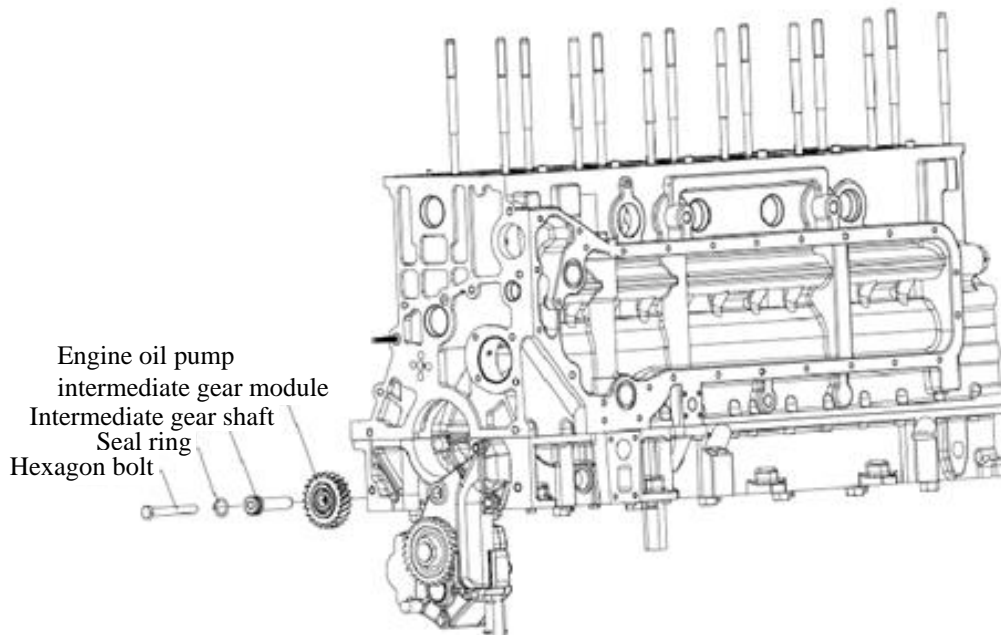

Fig. 4-67 Exploded view of engine oil pump intermediate gear

4932 Steps to Disassemble Engine Oil Pump Intermediate Gear

- (1) Screw off the hexagon bolt;
- (2) Pull out the intermediate gear shaft with dedicated tool, and then remove engine oil pump intermediate gear module.

4933 Inspection and Maintenance of Engine Oil Pump Intermediate Gear

- (1) Check whether there is crack on intermediate gear and intermediate gear shaft. Replace if necessary.
- (2) Check the seal ring for breakage and replace it if so.

4934 Steps to Assemble Engine Oil Pump Intermediate Gear

- (1) Before the assembly, check engine oil pump intermediate gear module, intermediate gear shaft, hexagon bolt and seal ring, make sure there is no manufacturing and use defect and damage.

- (2) Clean up the fitting surface between crankcase and engine oil pump intermediate gear module.
- (3) Install the seal ring in intermediate gear.
- (4) Install engine oil pump intermediate gear (convex side face inward).
- (5) Install intermediate gear shaft.
- (6) Install and tighten the hexagon bolt.

494 Disassembly, Inspection, Maintenance and Assembly of Engine Oil Filter

4941 Exploded View of Engine Oil Filter

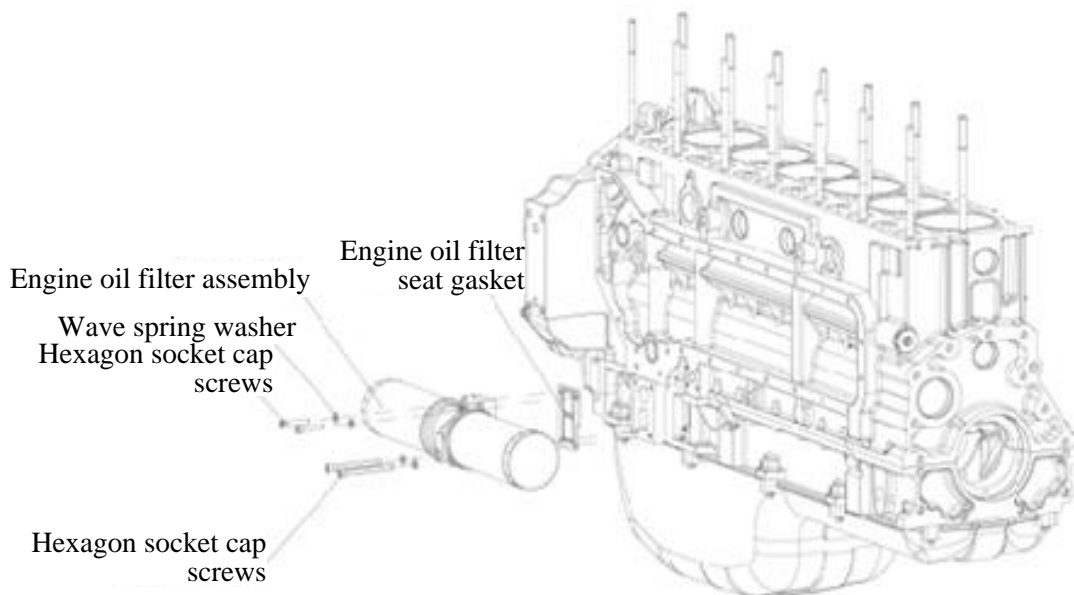

Fig. 4-68 Exploded view of engine oil filter

4942 Steps to Disassemble Engine Oil Filter

Remove the four bolts on engine oil filter and take down engine oil filter assembly and filter seat gasket. As shown in Fig. 4-68.

4943 Inspection and Maintenance of Engine Oil Filter

- (1) Check the engine oil filter assembly for damage, replace it if necessary.
- (2) Check the engine oil filter seat gasket for damage, replace it if necessary.

4944 Steps to Assemble Engine Oil Filter

- (1) Before the assembly, check engine oil filter assembly and filter seat gasket, make sure there is

no manufacturing and use defect and damage.

- (2) Clean up the fitting surface between engine oil filter assembly and engine block.
- (3) Install engine oil filter seat gasket and filter assembly.
- (4) Install the wave spring washers and bolts, tighten the bolts.

495 Disassembly, Inspection, Maintenance and Assembly of Engine Oil Cooler Cap

4951 Exploded View of Engine Oil Cooler Cap

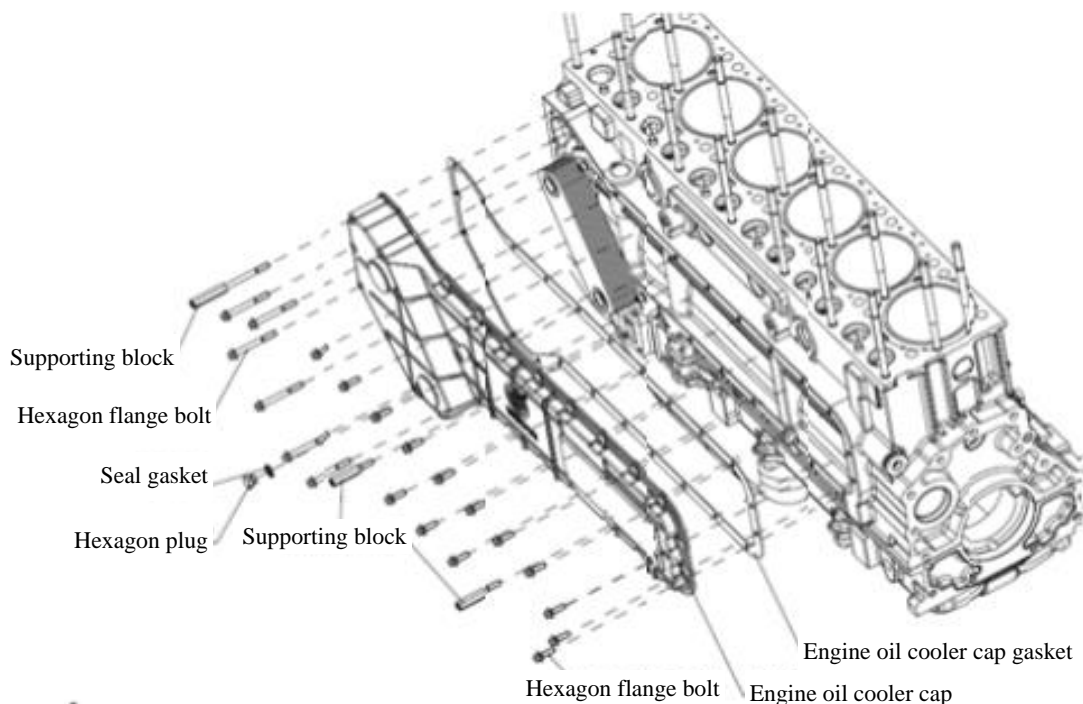

Fig. 4-69 Exploded view of engine oil cooler cap

4952 Steps to Disassemble Engine Oil Cooler Cap

Drain all coolant out before the disassembly. Screw off engine oil cooler cap fixing bolts orderly and take down the cap and cap gasket.

4953 Inspection and Maintenance of Engine Oil Cooler Cap

- (1) Check the engine oil cooler cap for crack damage, replace it if necessary.
- (2) Check engine oil cooler cap gasket for water leakage and replace the gasket if it is damaged.

4954 Steps to Assemble Engine Oil Cooler Cap

- (1) Check the cooler cap and gasket before assembling, make sure there is no manufacturing defect and damage.
- (2) Clean up the fitting surface between engine oil cooler cap and engine block, install cooler cap gasket.
- (3) Install and tighten engine oil cooler cap fixing bolts.

496 Disassembly, Inspection, Maintenance and Assembly of Engine Oil Cooler

4961 Exploded View of Engine Oil Cooler

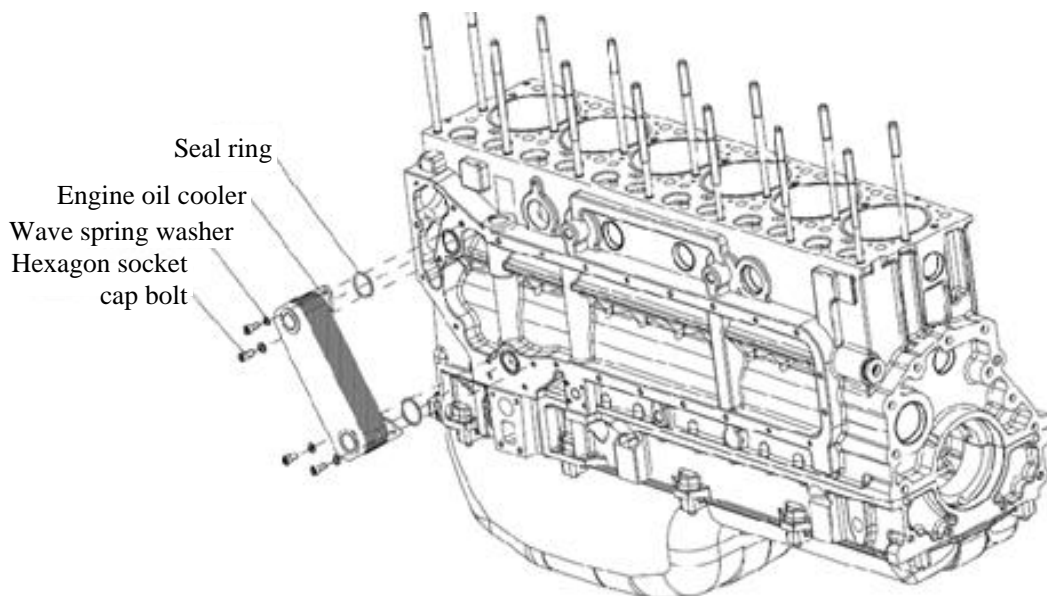

Fig. 4-70 Exploded view of engine oil cooler

4962 Steps to Disassemble Engine Oil Cooler

Screw off the four bolts on engine oil cooler and take down engine oil cooler and the seal rings, as shown in Fig. 4-70

4963 Inspection and Maintenance of Engine Oil Cooler

Check the engine oil cooler for crack damage, replace it if necessary.

4964 Steps to Assemble Engine Oil Cooler

- (1) Check the cooler before assembling, make sure there is no manufacturing defect and damage.

- (2) Clean up the fitting surface between engine oil cooler and engine block.
- (3) Install the seal rings and engine oil cooler.
- (4) Install the wave spring washers and the bolts, tighten the bolts.

497 Disassembly, Inspection, Maintenance and Assembly of Main Oil Gallery Pressure Limiting Valve

4971 Exploded View of Main Oil Gallery Pressure Limiting Valve

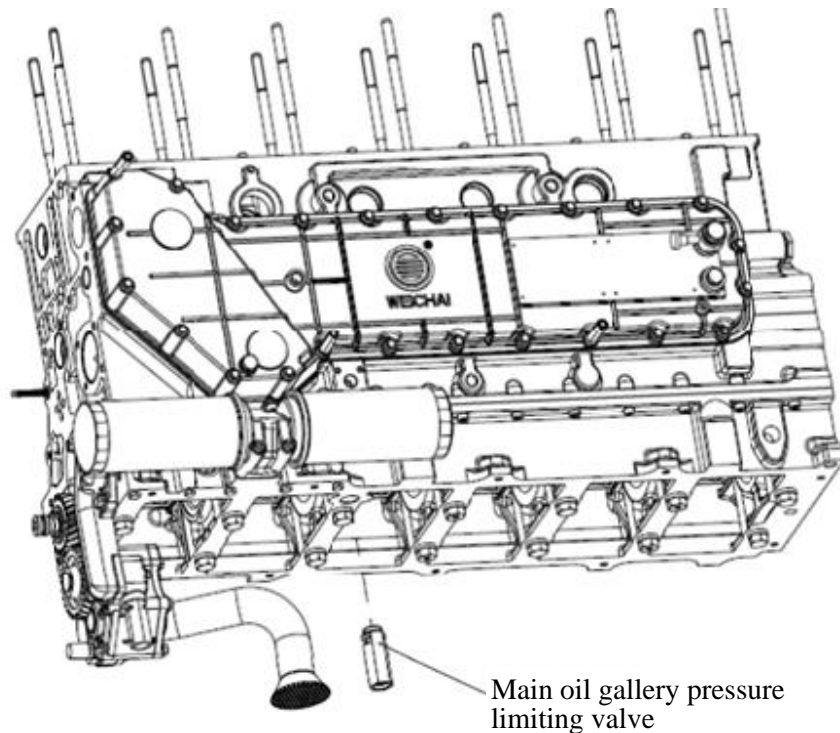

Fig. 4-71 Exploded view of main oil gallery pressure limiting valve

4972 Steps to Disassemble Main Oil Gallery Pressure Limiting Valve

Screw off main oil gallery pressure limiting valve, as shown in Fig. 4-71.

4973 Inspection and Maintenance of Main Oil Gallery Pressure Limiting Valve

- (1) Check service condition of the valve spring, replace the spring if necessary.
- (2) Check the valve for crack damage, replace it if necessary.

4974 Steps to Assemble Main Oil Gallery Pressure Limiting Valve

- (1) Check the valve before assembling, make sure there is no manufacturing defect and damage.
- (2) Clean up the valve and valve fitting hole on engine block.

- (3) Apply sealant on the valve thread.
- (4) Install the valve and tighten it.

498 Disassembly, Inspection, Maintenance and Assembly of Engine Oil Cooler Bypass Valve

4981 Exploded View of Engine Oil Cooler Bypass Valve

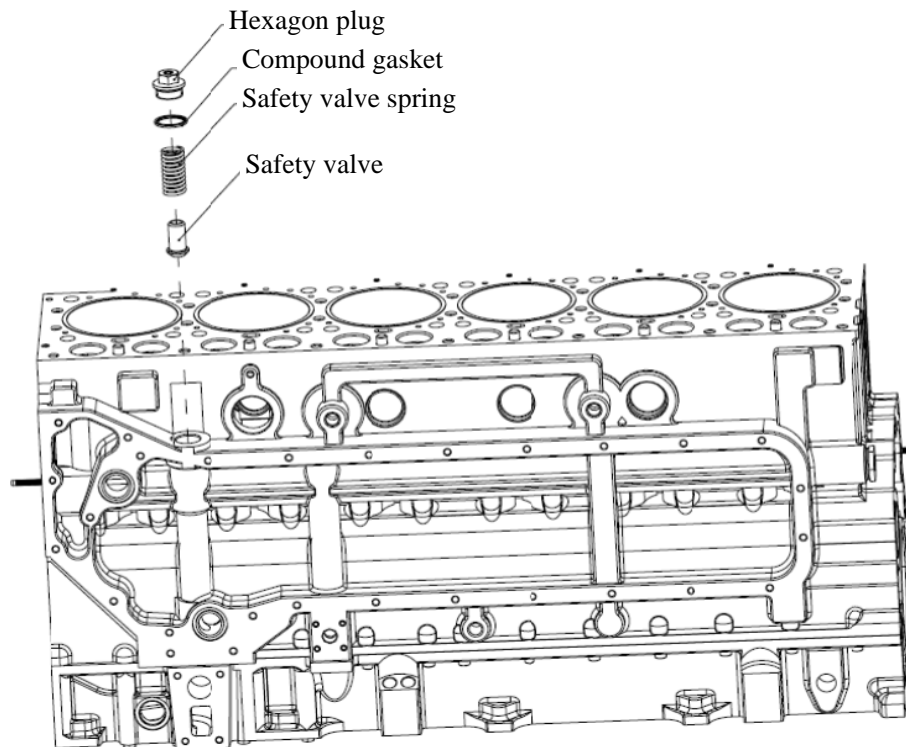

Fig. 4-72 Exploded view of engine oil cooler bypass valve

4982 Steps to Disassemble Engine Oil Cooler Bypass Valve

Screw off the hexagon plug, and then take down compound gasket, safety valve spring and safety valve orderly, as shown in Fig. 4-72.

4983 Inspection and Maintenance of Engine Oil Cooler Bypass Valve

- (1) Check service condition of safety valve spring, replace the spring if necessary.
- (2) Check safety valve, hexagon plug and compound gasket for crack damage, replace if necessary.

4984 Steps to Assemble Engine Oil Cooler Bypass Valve

- (1) Check safety valve, safety valve spring, hexagon plug and compound gasket before assembling, make sure there is no manufacturing defect and damage.

- (2) Clean up engine oil cooler bypass valve and valve fitting hole on engine block.
- (3) Install safety valve, safety valve spring and compound gasket orderly.
- (4) Install the hexagon plug and tighten it.

499 Disassembly, Inspection, Maintenance and Assembly of Engine Oil Strainer

4991 Exploded View of Engine Oil Strainer

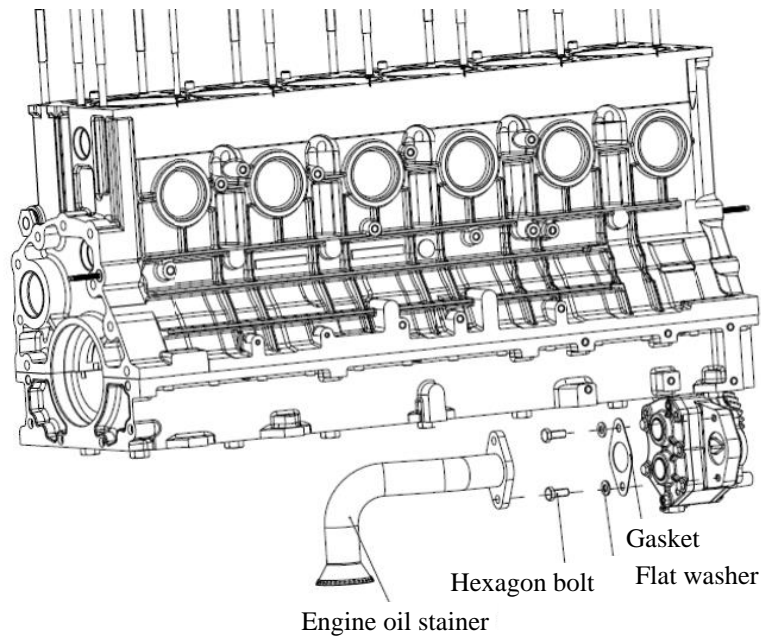

Fig. 4-73 Exploded view of engine oil strainer

4992 Steps to Disassemble Engine Oil Strainer

Screw off the two hexagon bolts, take down the oil strainer and gasket, as shown in Fig. 4-73.

4993 Inspection and Maintenance of Engine Oil Strainer

Check the strainer and gasket for crack damage, replace if necessary.

4994 Steps to Assemble Engine Oil Strainer

- (1) Check the strainer and gasket before assembling, make sure there is no manufacturing defect and damage.
- (2) Clean up fitting surface between oil strainer and engine oil pump, clean up the strainer inner cavity.
- (3) Install the strainer and gasket.
- (4) Install and tighten the hexagon bolts.

410 Starting System

4101 Disassembly and Assembly of Starting System

41011 Exploded View of Starting System

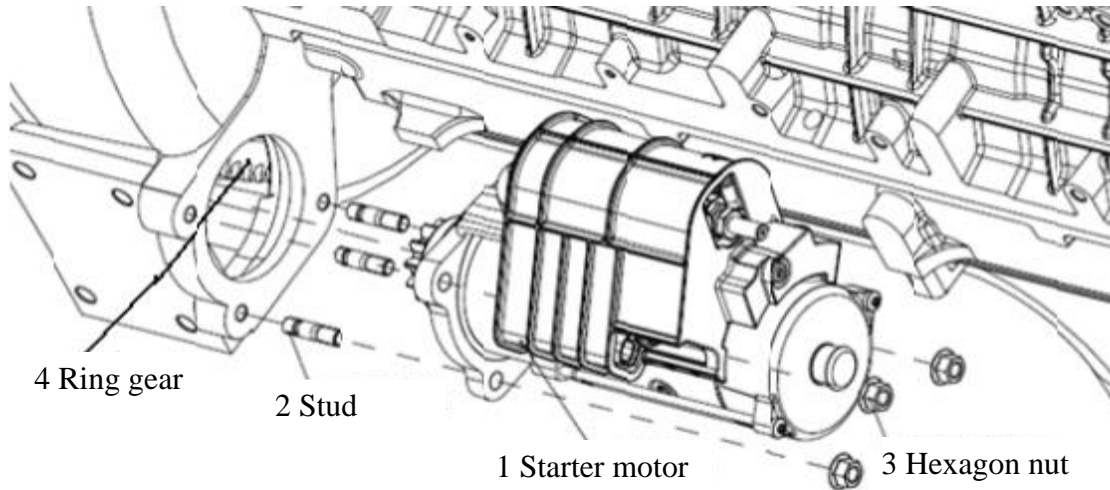

Fig. 4-74 Exploded view of starting system

41012 Steps to Disassemble Starting System

- (1) Remove the starter motor;
- (2) Remove the ring gear, refer to section 445 for details.

41013 Steps to Assemble Starting System

Assembling steps are contrary to disassembling ones.

4102 Disassembly, Inspection, Maintenance and Assembly of Starter Motor

41021 Exploded View of Starter Motor

Refer to Fig. 4-74 Exploded view of starting system.

41022 Steps to Disassemble Starter Motor

- (1) Remove hexagon nuts 3;
- (2) Hold the starter motor 1 firmly and pull it out.
- (3) Remove the studs 2.

41023 Inspection and Maintenance of Starter Motor

Check the starter motor gear for damage, replace it if necessary.

41024 Steps to Assemble Starter Motor

Assembling steps are contrary to disassembling ones.

411 Engine Accessory System

4111 Disassembly and Assembly of Engine Accessory System

41111 Exploded View of Engine Accessory System

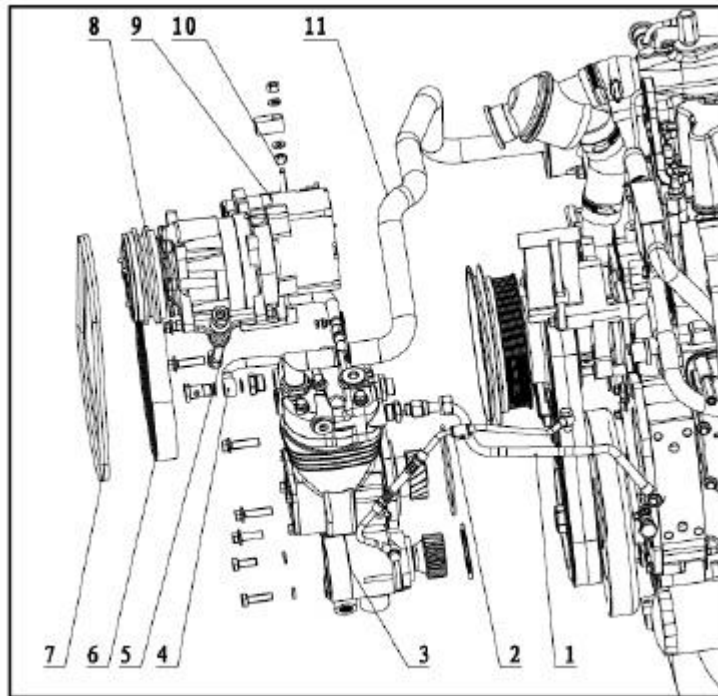

- | | | |
|--|---|--------------------|
| 1 Air compressor water inlet pipe module | 2 Air compressor oil inlet pipe module | |
| 3 Hydraulic pump module | 4 Air compressor water outlet pipe module | |
| 5 A/C compressor draw-in module | 6 (Generator) poly V-belt | |
| 7 (A/C compressor) V-belt | 8 A/C compressor module | 9 Generator module |
| 10 Generator draw-in module | 11 Air compressor intake pipe module | |

Fig. 4-75 Exploded view of engine accessory system

41112 Steps to Disassemble Engine Accessory System

Disassembly of steering pump and its pipelines

- (1) Remove steering pump oil inlet and outlet pipes.
- (2) Remove steering pump fastening bolts and spring washers, take down the pump and sealing gasket. As shown in Fig. 4-76.

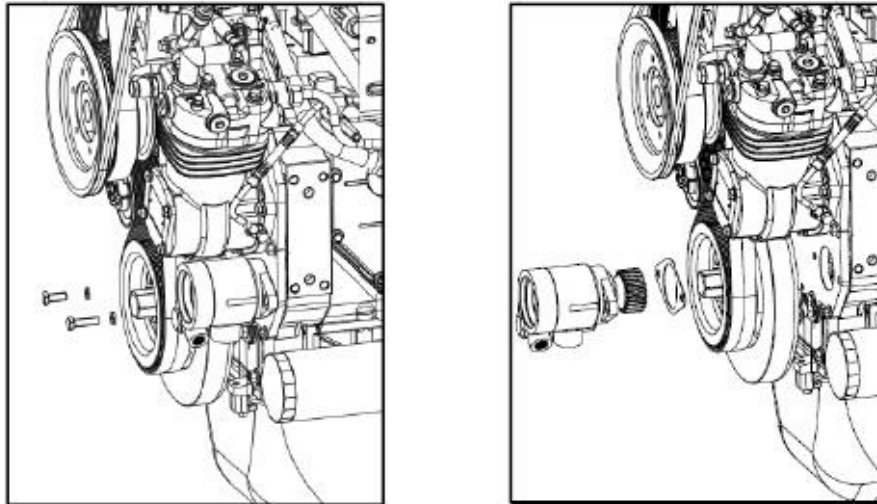

Fig. 4-76 Disassembly of steering pump

Disassembly of air compressor and its pipelines

- (1) Remove air compressor intake pipe, water inlet pipe, water outlet pipe and oil inlet pipe.
- (2) Remove the three hexagon flange bearing surface toothed bolts of air compressor, and then take air compressor out, remove the O-shape seal ring in the meantime. As shown in Fig. 4-77.

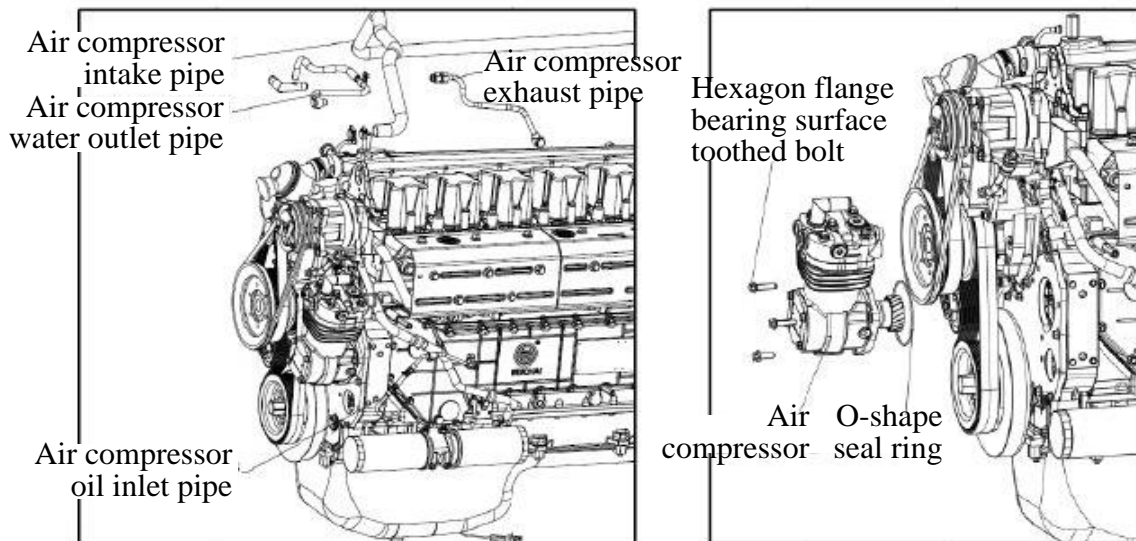

Fig. 4-77 Disassembly of air compressor and its pipelines

Disassembly of A/C compressor module

- (1) Screw off the draw-in nut, remove compressor fastening nut, stud and spacer block, take down the V-belt.
- (2) Remove the other compressor fastening nut and stud, take down the compressor, as shown in Fig. 4-78.

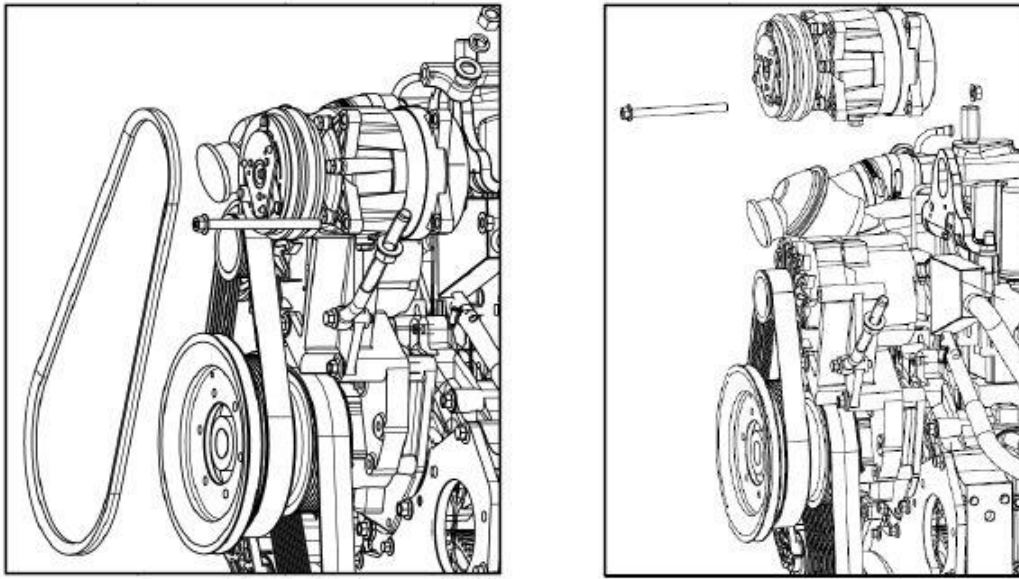

Fig. 4-78 Disassembly of A/C compressor

Disassembly of generator module

- (1) Screw off generator draw-in nut, remove connecting bolt and nut of draw-in block, take down the block and gasket.
- (2) Remove generator the other end fixing bolt, rotate the generator to remove the poly V-belt, take down the fixing bolt and generator, as shown in Fig. 4-79.

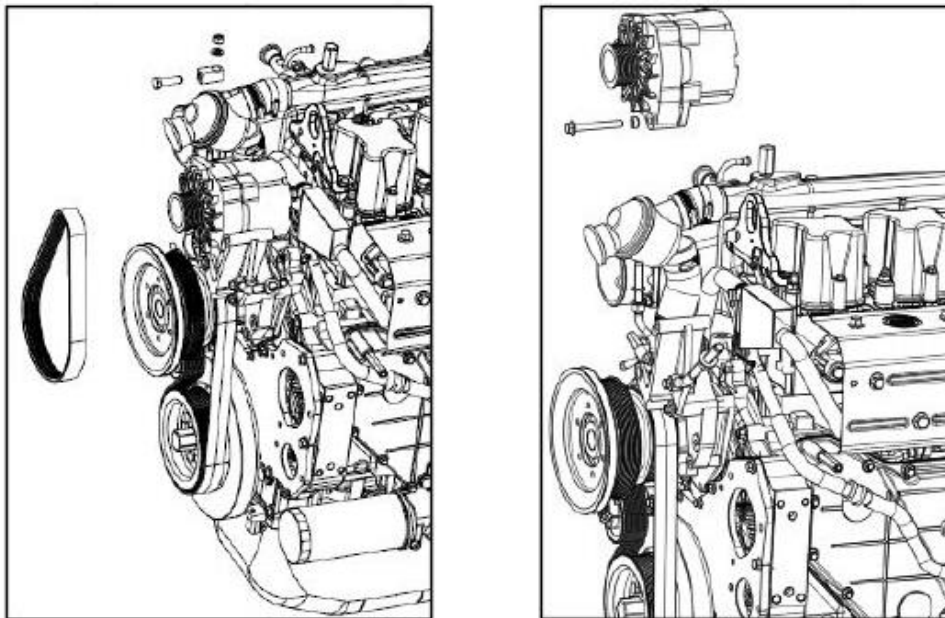

Fig. 4-79 Disassembly of generator module

41113 Steps to Assemble Engine Accessory System

Assembly of generator module

- (1) Place the generator on generator support, loose-fit it on the support and draw-in rod with fixing bolts.
- (2) Install generator poly V-belt.
- (3) Adjust the location of generator and tension the poly V-belt with the draw-in rod, tighten generator fixing bolts and nuts, as shown in Fig. 4-80.

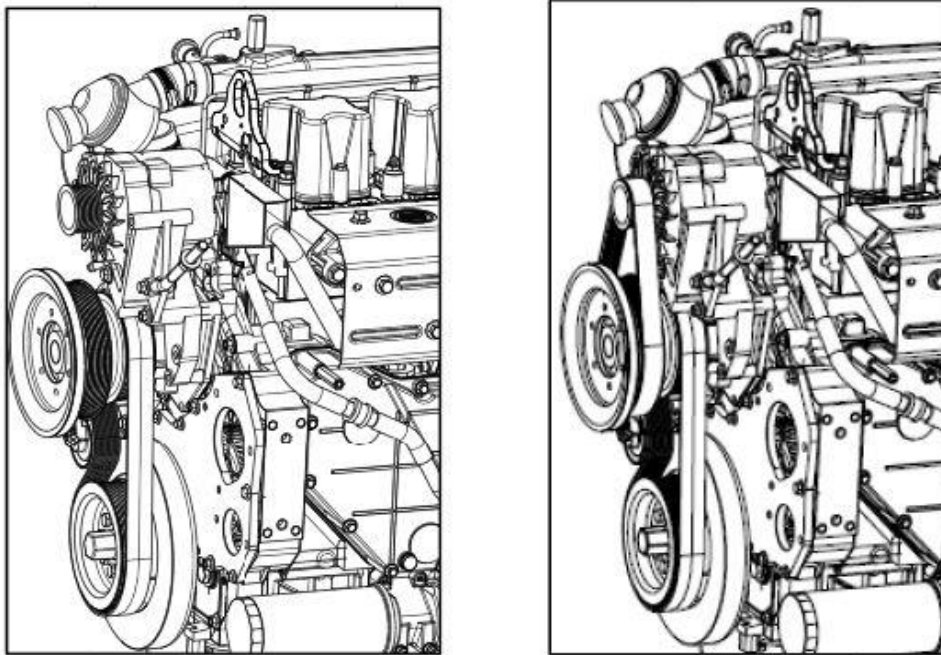

Fig. 4-80 Assembly of generator module

Assembly of A/C compressor module

- (1) Place the compressor on compressor support, loose-fit it on the support and draw-in rod with fixing bolts.

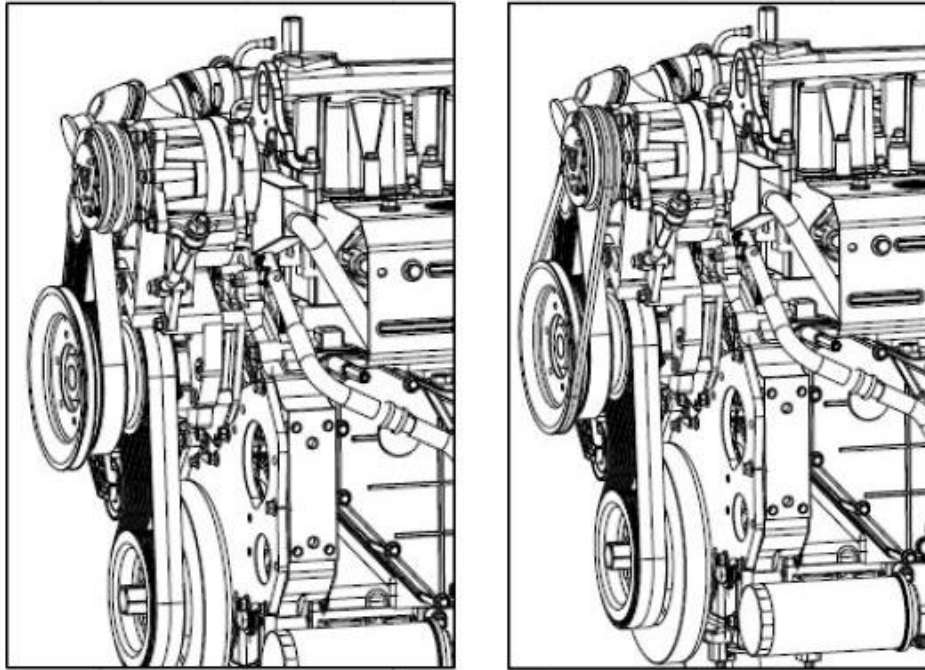

Fig. 4-81 Assembly of A/C compressor

- (2) Install A/C compressor V-belt.
- (3) Adjust the location of compressor and tension the V-belt with the draw-in rod, tighten compressor fixing bolts and nuts, as shown in Fig. 4-81.

Assembly of air compressor and its pipelines

- (1) Place the O-shape seal ring in compressor ring groove. Make sure compressor main axis is perpendicular to engine timing gear housing fitting surface, and push the compressor into the mounting hole gently, ensure the helical gears are normally engaged and air compressor flange face should be parallel with engine fitting surface, loose-fit the compressor with three M10 hexagon bearing surface toothed bolts, and tighten the bolts with 13mm open end wrench (or double offset ring spanner).
- (2) Install air compressor water inlet pipe, water outlet pipe, oil inlet pipe and intake pipe, fix the pipes with clamps. As shown in Fig. 4-82.

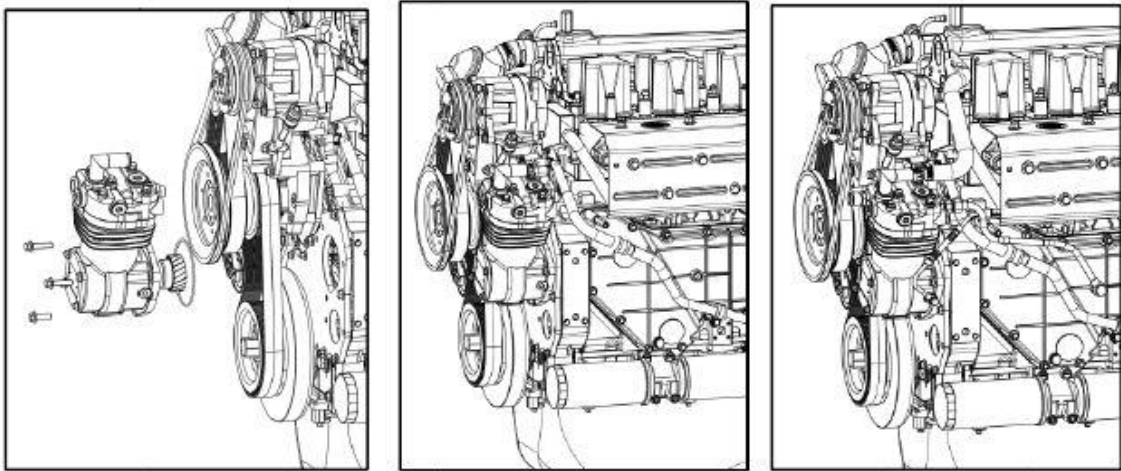

Fig. 4-82 Assembly of air compressor and its pipelines

Assembly of steering pump

- (1) Make sure steering pump main axis is perpendicular to engine timing gear housing fitting surface, and push the pump (with a sealing gasket) into the mounting hole gently, ensure the helical gears are normally engaged and steering pump flange face should be parallel with the fitting surface, loose-fit the pump with two M10 hexagon bolts and wave spring washers, and tighten the bolts diagonally with 16mm open end wrench (or double offset ring spanner), make sure not to damage the sealing gasket in this process. As shown in Fig. 4-83.
- (2) Install oil inlet and outlet pipe joints.

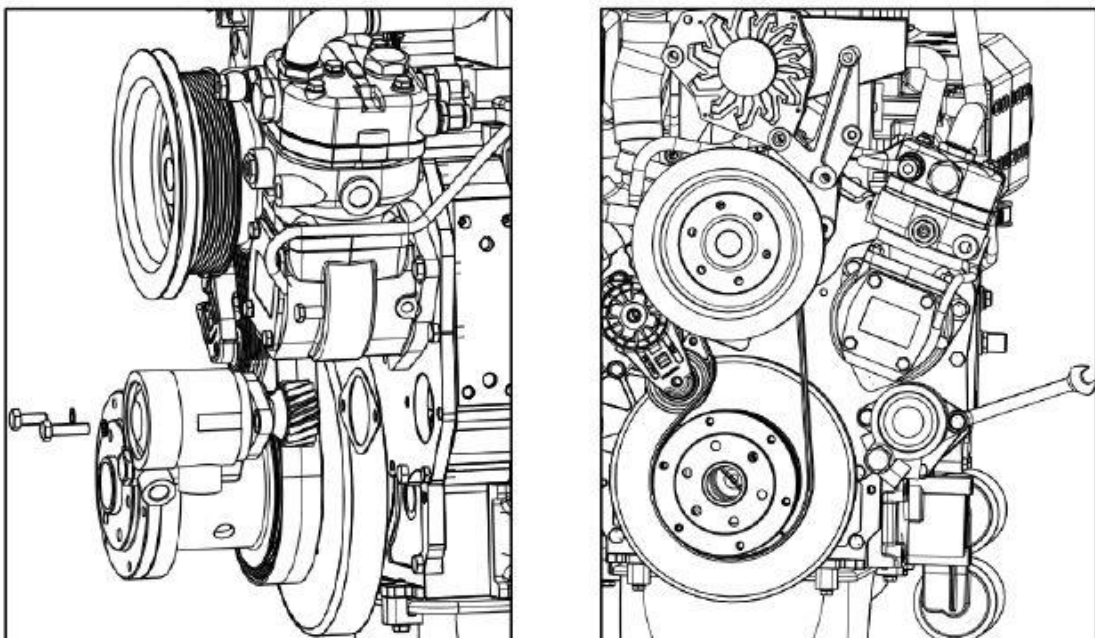
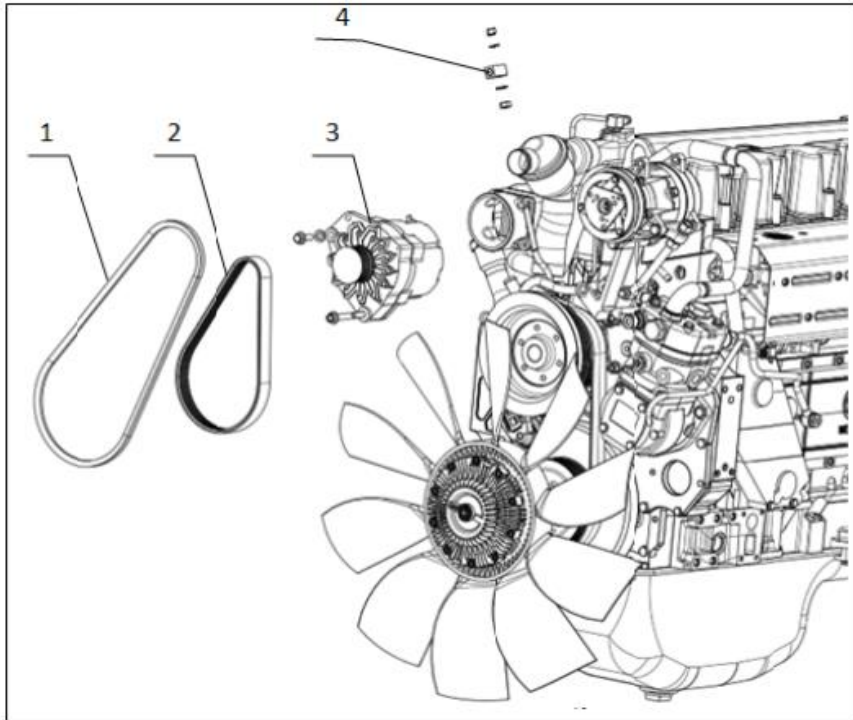

Fig. 4-83 Assembly of steering pump

4112 Disassembly, Inspection, Maintenance and Assembly of Generator

41121 Exploded View of Generator



1 V-belt 2 Poly V-belt 3 Generator 4 Draw-in block

Fig. 4-84 Exploded view of generator

41122 Steps to Disassemble Generator

- (1) Remove A/C compressor draw-in bolt and disassemble A/C compressor V-belt (refer to disassembly of A/C compressor for details).
- (2) Screw off generator draw-in nut (M10).

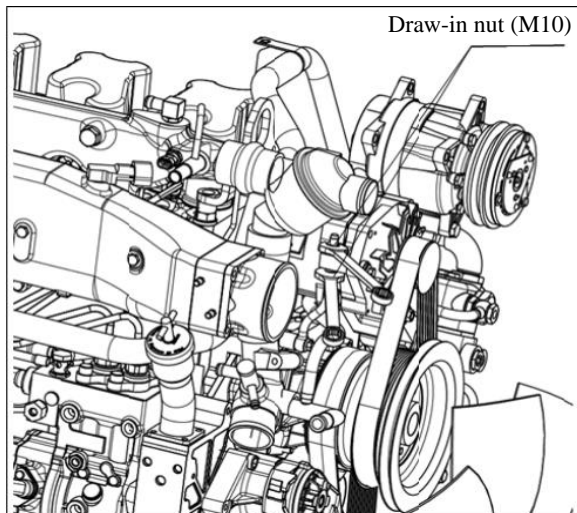
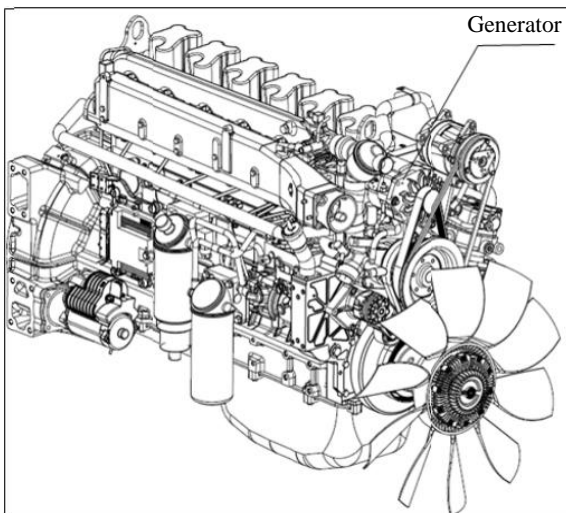

- (3) Remove generator poly V-belt(8PK) (4) Screw off draw-bolt block bolt, remove the block

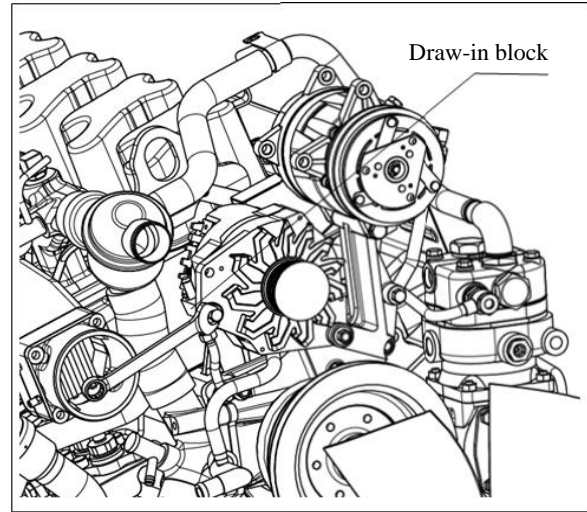
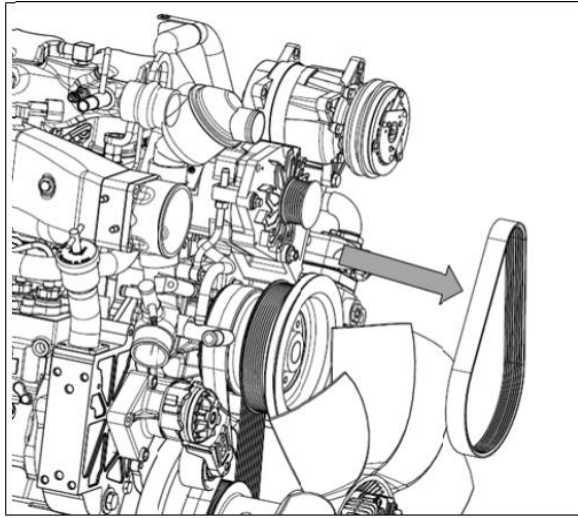

- (5) Remove generator M10 studs (6) Assembling steps are contrary to disassembling ones

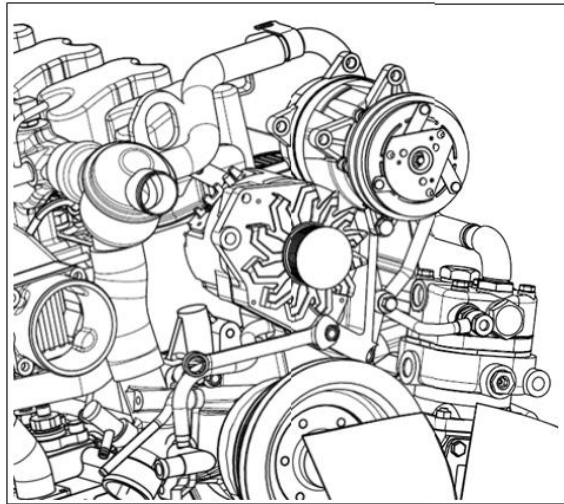

ATTENTION: The disassembly of generator should be performed by professional personnel. Check whether all insulating pads and sleeves are intact when assembling, damaged parts must be replaced! No short circuit to generator positive and generator housing, otherwise severe accidents may occur.

41123 Inspection and Maintenance of Generator

- (1) Generator fault diagnosis flow

When a failure happens to the engine, firstly you should check whether it is generator failure. Instrument: test lamp. Flow chart is shown in Fig. 4-85.

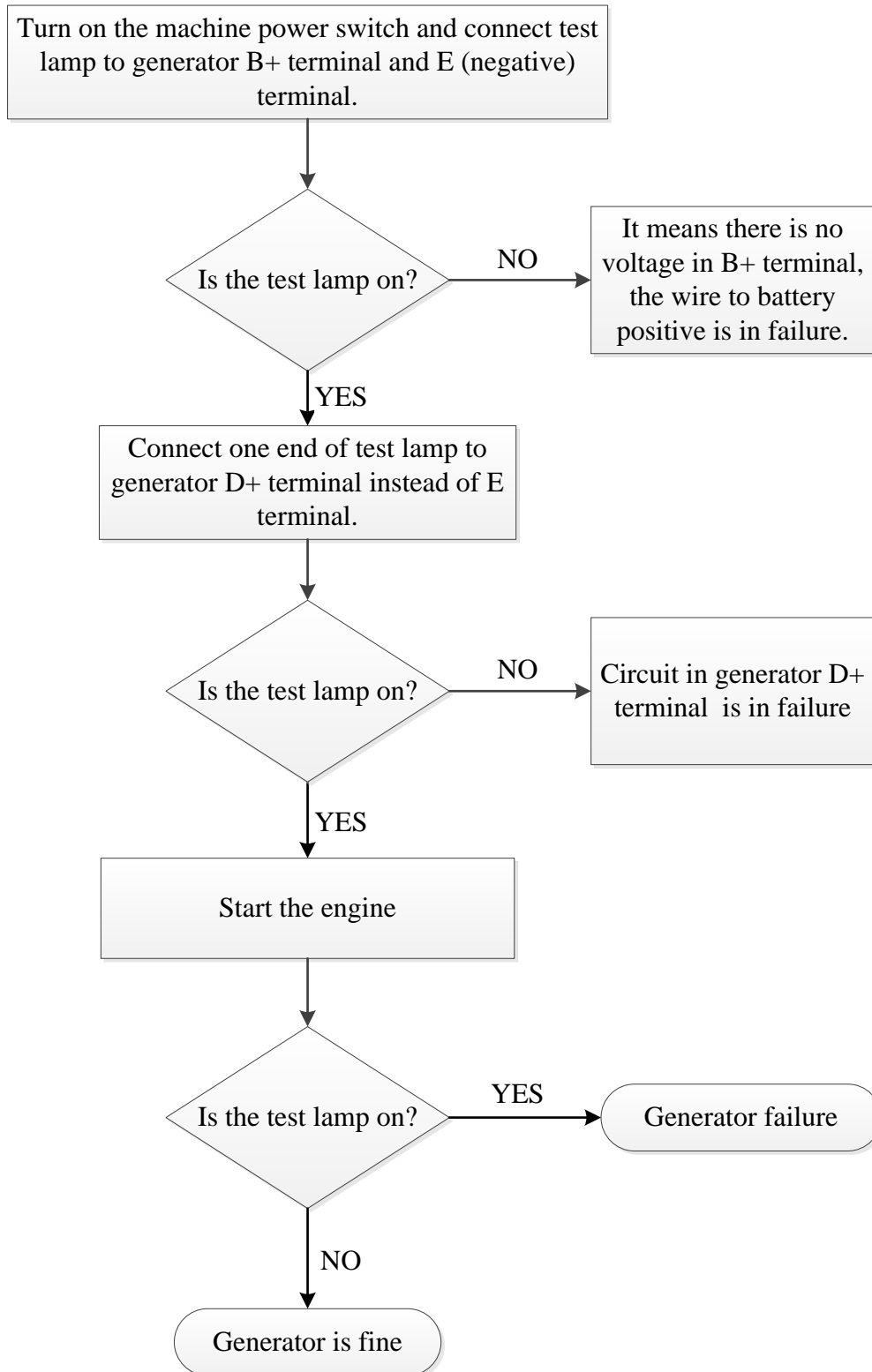

Fig. 4-85 Generator fault diagnosis flow chart

(2) Charging system fault diagnosis and troubleshooting

a) No charging

Fault 1: No charging		
Phenomenon	Fault detection	Troubleshooting
(1) Turn on starting key, but charging indicator doesn't light.	a. Check charging indicator lamp. b. Check whether there is open circuit in exciting circuit.	a. Check whether there is voltage between charging indicator and ground, if no voltage, replace the indicator lamp or check the circuit. b. If it is generator regulator failure or generator rotor failure, repair or replace the generator.
(2) Charging indicator doesn't go out when engine idling, it only goes out when engine is in high speed.	a. Rated power of indicator lamp is small or parallel exciting resistance gets loose. b. Too low idling speed.	a. 2~6w lamp is recommended, or repair the circuit. b. Adjust engine idling speed.
(3) Charging indicator doesn't go out when engine is working.	a. Check whether generator to ground voltage is within 1~3V;	a. If voltage of generator indicator end is very small, then it means rated power of indicator lamp is small or there is fake connection in the circuit. Adjust indicator lamp power or check the circuit (connector and connecting point). b. If voltage of generator indicator end is zero, then it means there is short circuit in exciting circuit, check the circuit. c. If voltage of generator indicator end is battery voltage, then it means there is fault in exciting circuit, and generator regulator and exciting tube may be damaged in the same time, please amend the exciting circuit and then repair the generator.

	<p>b. Check whether generator output end B+ to ground voltage is about 24V (battery voltage).</p>	<p>a. If B+ terminal to ground voltage is zero, then check generator to battery positive and negative circuits for breakover.</p> <p>b. If B+ terminal to ground voltage is obviously lower than battery voltage, then check whether generator to battery positive and negative circuits are loose or the battery is damaged.</p> <p>Recommended detection method: Connect a 2W indicator lamp to generator B+ terminal and exciting D+/L terminal, observe working condition of the indicator.</p> <p>Troubleshooting:</p> <ul style="list-style-type: none"> ● The brightness of indicator lamp is normal, and it goes out automatically after engine is started, generator output voltage is 27~28.5V; it means the exciting circuit has problem and needs to be repaired. ● The brightness of indicator lamp is normal, but it doesn't go out after engine is started, generator output voltage is 27~28.5V; it means generator regulator has problem and needs to be checked. ● The brightness of indicator lamp is normal, but it doesn't go out after engine is started, generator output voltage is battery voltage; it means there is fault in generator regulator, rectifier bridge, stator or inner connectors, and needs to be repaired or replaced.
--	---	---

b) Low charging voltage

Fault 2: Low charging voltage										
Phenomenon	Fault detection	Troubleshooting								
<p>Battery is occasionally underpowered, low charging voltage, and the voltage declines markedly once loaded.</p>	<p>Check whether generator output power is reasonably matched with electrical appliances.</p> <ol style="list-style-type: none"> a. Check whether voltmeter is damaged. b. Check generator speed. c. Check the quality and tensioning situation of generator belt and relevant pulley belts. d. Check generator pulley. e. Check whether electric wires are reasonably connected, measure the voltage of generator and battery. f. Check whether wires in charging system are loose, oxidized and producing too much heat, check whether bolt connections are loose. g. Measure output voltage of generator W/R/AC terminal (should be about half of B+ terminal voltage). h. Check whether battery charging is normal. 	<p>Measure generator B+ terminal voltage, which should be within 27.8~28.4V, if the voltage is normal, then it means voltmeter failure or voltmeter sampling point is in fault, repair or replace.</p> <ol style="list-style-type: none"> a. It is recommended the generator idling speed should exceed 1600rpm. b. Generator speed should be 2000rpm and above, or the voltage should be about 27V when high power load appliance like air condition is working c. Check the quality of generator belt and relevant pulley belts, for belt involved severe coking, breakage, deformation or wear should be replaced. Tension generator belt and relevant pulley belts. <p>ATTENTION: If the to-be replaced belt is in twin-drive belt system, then the belts should be replaced together.</p> <ol style="list-style-type: none"> d. Tension it if it is loose. e. If voltage drop is bigger than 1V in heavy load condition (thin wire results in big voltage drop), the wire should be replaced. <table style="margin-left: 20px; border: none;"> <tr> <td>0~35A</td> <td>$S \geq 6\text{mm}^2$</td> <td>35~70A</td> <td>$S \geq 12\text{mm}^2$</td> </tr> <tr> <td>70~100A</td> <td>$S \geq 20\text{mm}^2$</td> <td>100~150A</td> <td>$S \geq 25\text{mm}^2$</td> </tr> </table> If the wire or connector gets too hot in heavy load condition, then the wire or connector should be replaced. f. Oxidized lead foot and the housing that used to install grounding bolts should be polished before reassembling. Retighten the loose nuts and lug plates, re-plug the loose connectors firmly. <p>ATTENTION: Reassembled or retightened parts should be run in heavy load and will be overheat, check whether the overheat is still there 3~5min later.</p> <ol style="list-style-type: none"> g. If there is big difference between terminal W/R/AC output voltage and normal range and big voltage drop happened after the engine loaded, then it means failure in generator rectifier bridge or stator, repair or replace. h. If charging current drops to about 10A 10min later, or charging current reaches to 30-90A for a long time, then the battery is damaged, repair or replace the battery. 	0~35A	$S \geq 6\text{mm}^2$	35~70A	$S \geq 12\text{mm}^2$	70~100A	$S \geq 20\text{mm}^2$	100~150A	$S \geq 25\text{mm}^2$
0~35A	$S \geq 6\text{mm}^2$	35~70A	$S \geq 12\text{mm}^2$							
70~100A	$S \geq 20\text{mm}^2$	100~150A	$S \geq 25\text{mm}^2$							

c) High charging voltage

Fault 3: High charging voltage		
Phenomenon	Fault detection	Troubleshooting
High charging voltage reading on voltmeter	a. Check whether voltmeter is damaged. b. Check whether wires, connectors and bolts in charging system are loose and producing too much heat, check whether there is short circuit in circuits and generator housing. c. Check whether the battery can work normally. d. Measure output voltage of generator W/R/AC terminal (should be about half of B+ terminal voltage). e. The fault is still existed after finishing above inspections.	a. Measure generator B+ terminal voltage, which should be within 27.8~28.4V, if the voltage is normal, then it means voltmeter failure and should be repaired or replaced. b. Retighten the bad-contact parts and loose wires, re-plug the loose connectors firmly. If there is short circuit, reconnect the wires. c. Check whether the charging current drops quickly in short time (from 50A to 10A or lower); consider a battery replacement if not. Check whether battery is clean and dry, whether its terminals and clamps are in good condition, replace them if damaged. d. If there is big difference between terminal W/R/AC output voltage and normal range and big voltage drop happened after the engine loaded, then it means failure in generator rectifier bridge or stator, consider to repair or replace. e. Replace generator regulator, stator or the whole generator.

d) Unstable charging voltage

Fault 4: Unstable charging voltage		
Phenomenon	Fault detection	Troubleshooting
When the engine is running normally, voltmeter indicates charging, but the pointer is always oscillating and cannot be read (or charging indicator twinkling)	a. Generator belt and relevant pulley belts are loose. b. Bad contact in charging circuit. c. Collecting ring accumulates too much dirt, or electric brush is severely worn, or brush spring is weak or broken. d. Damaged regulator.	a. Tighten generator belt and relevant pulley belts. b. Check and fasten all connectors in charging circuit. c. Clean the dirt, or replace the brush and brush spring. d. Replace the regulator.

e) Generator produces abnormal sound

Fault 5: Generator produces abnormal sound		
Phenomenon	Fault detection	Troubleshooting
Running generator produces abnormal sound	a. Generator fixed support is deformed or interfered with other parts. b. Generator belt is loose and slipping. c. Generator pulley is loose. d. Generator bearing lack of lubricating oil or is damaged. e. Deep abnormal noise comes from generator inside. f. Howling noise comes from generator inside and changes with generator speed.	a. Improve generator fixed support installation strength and adjust installation condition. b. Replace generator belt. c. Fasten the pulley. d. Replace generator bearing. e. Stator coil is in short circuit, replace it. f. The abnormal sound is produced by vibrating stator core, replace the stator module if necessary.

4113 Disassembly, Inspection, Maintenance and Assembly of A/C Compressor

41131 Exploded View of A/C Compressor

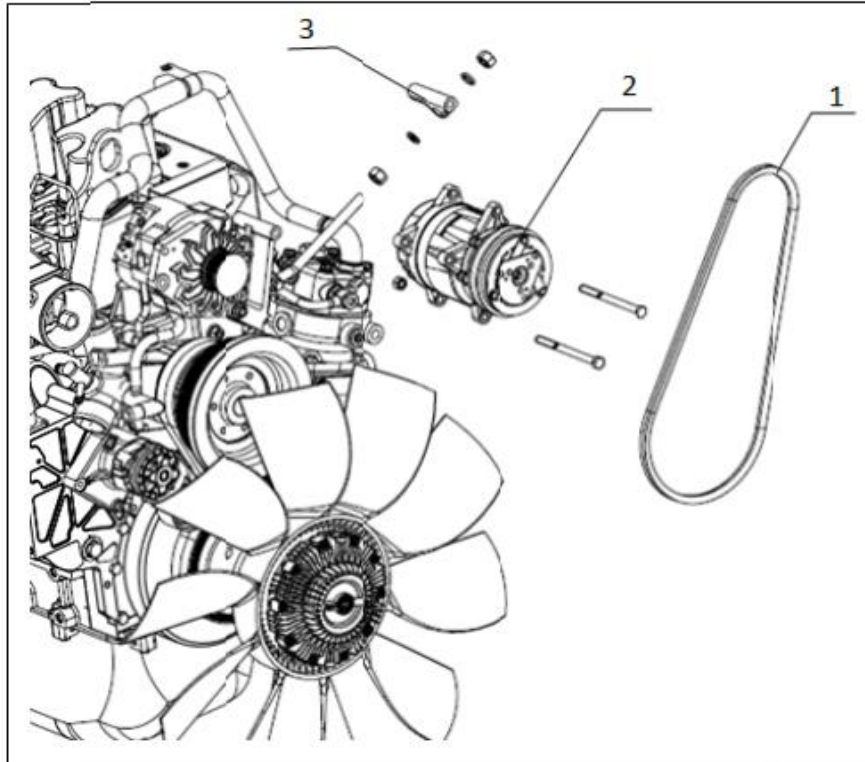

1 V-belt 2 A/C compressor 3 Draw-in block

Fig. 4-86 Exploded view of A/C compressor

41132 Steps to Disassemble A/C Compressor

Disassembly of A/C compressor

(1) Installation position of A/C compressor.

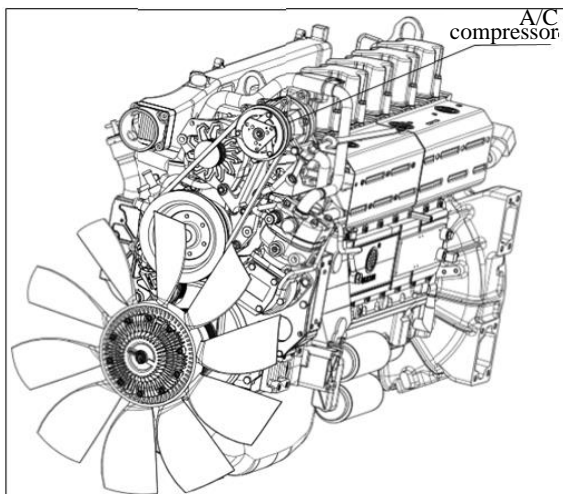

(2) Remove the M14 draw-in nut.

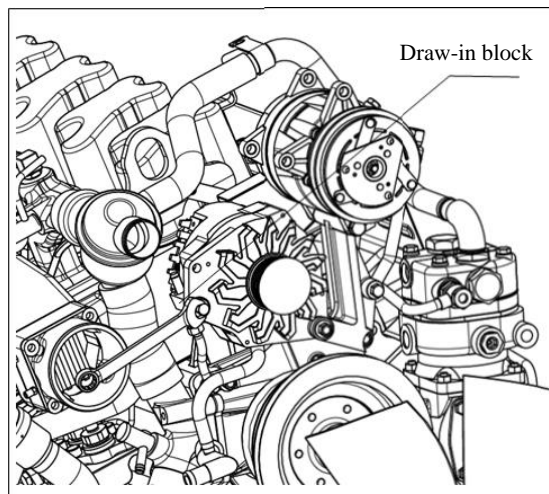

(3) Remove the V-belt.

(2) Remove compressor fastening nut, stud and spacer block.

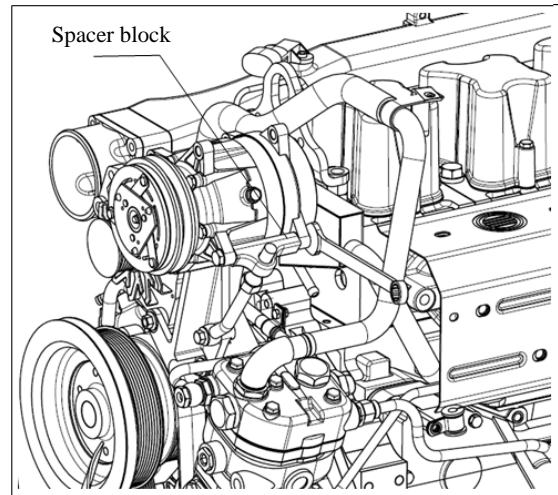
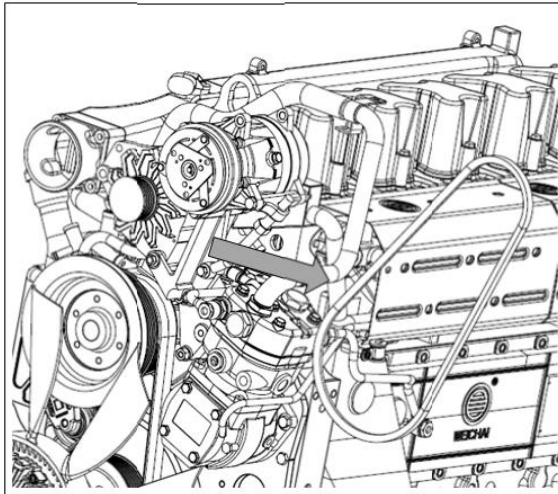

(5) Remove the other compressor fastening nut and stud, disassembly of A/C compressor is done.

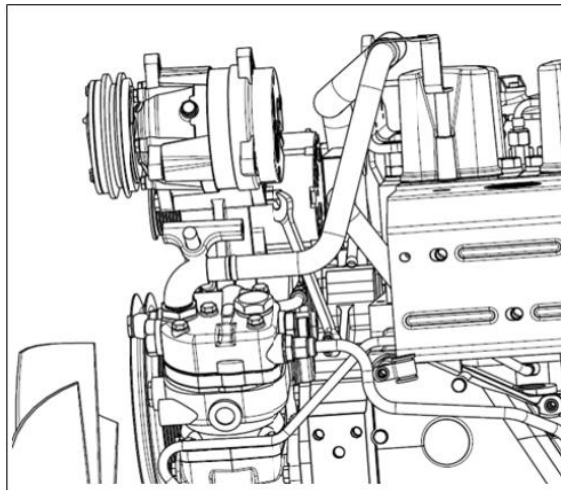

41133 Inspection and Maintenance of A/C Compressor

(1) A/C system produces abnormal sound

When A/C system is working, the system produces abnormal sound, possible causes and maintenance methods are listed in Table 4-2.

Table 4-2 Troubleshooting for abnormal sound producing failure of A/C system

Problem: A/C system produces abnormal sound		
S/N	Possible cause	Maintenance method
1	Clutch slipping	Clean and repair the clutch if the slippage is caused by oil dirt; replace the clutch if spring or chuck is damaged.
2	Transmission belt slipping due to loose or abrasion	Adjust the belt tension or replace the belt.
3	Wear of pulley bearing	Replace A/C compressor.

4	The belt is too tight, which leads to vibration of A/C compressor	Adjust the belt tension, it is suitable if the belt is depressed 10~14mm after loading 10kg force.
5	Misalignment of pulley shafts, or the belt is not on the same plane, which leads to vibration of A/C compressor	Reassemble the compressor to keep the shafts aligned and belt on the same plane.
6	Loose compressor fastening bolts; loose or damaged support	Tighten the bolts; replace compressor support.
7	Compressor internal part is damaged	Replace the compressor.
8	Excessive coolant leads to vibration of high pressure pipe, and compressor produces knocking noise	Drain out the coolant until high pressure gauge indicates normal.

(2) A/C compressor doesn't work after A/C is turned on

Possible causes and maintenance methods for A/C compressor working failure are listed in Table 4-3.

Table 4-3 Troubleshooting for A/C compressor working failure

Problem: A/C compressor doesn't work		
S/N	Possible cause	Maintenance method
1	A/C switch failure	Check, repair or replace the switch.
2	Clutch coil failure or loose connector	Tighten the connector, replace the clutch.
3	Low voltage or clutch coil burnout due to short circuit, which leads to clutch fail to pull-in or slipping	Find out the cause for low voltage, increase the voltage or check the circuit, replace the compressor if there is short circuit.
4	Loose or breakage of belt	Adjust or replace the belt.
5	High-low pressure switch failure or open circuit	Check the switch, find out what caused the open circuit, and replace if necessary.
6	Excessive clutch air clearance	Replace the compressor.
7	Clutch pulley doesn't rotate	Replace the compressor.
8	Compressor internal part is damaged	Replace the compressor.

(3) Precautions for maintenance of A/C compressor

- 1) After disassembling of A/C system, all parts should be sealed in time. Removed parts of A/C system cannot be exposed to air for long time, in order to prevent moisture in the air infiltrating into A/C compressor system.

- 2) Before assembling the compressor, turn over the compressor all around for 2~3 times, so that lubricating oil in the compressor can be evenly distributed. After assembling compressor and its pipelines, rotate the compressor by hand for 10 circles at least.
- 3) If necessary, clean the system when replacing the compressor, replace the reservoir, expansion valve or gas-liquid separator and throttle pipe at the same time.
- 4) The compressor is sealed with 0.06~0.10MPa dry nitrogen, so be careful when removing compressor intake and exhaust sealing plugs. After removing compressor intake and exhaust sealing plugs, connect the compressor to refrigerating system immediately, and also vacuum the system to prevent moisture in the air absorbed by lubricating oil.
- 5) Apply a small amount of lubricating oil on the seal rings of compressor intake and exhaust pipelines before assembling.
- 6) Fixing bolts of compressor intake and exhaust pipes must be of high strength, refer to Table 4-4 for tightening torques.

Table 4-4 Bolt tightening torque

Thread specification	Tightening torque (Nm)
M16×1	10~12
M8×1	20~25
M8×1.25	25~30
M10×1.25	40~50

- 7) When assembling the compressor, the bolts should be evenly tightened, keep pulley shaft and engine shaft in parallel, and the belt should be in the same plane. Adjust the belt tension, it is suitable if the belt is depressed 10~14mm after loading 10kg force.
- 8) Freezing lubricating oil of different brands cannot be mixed, otherwise normal operation of A/C compressor cannot be guaranteed.
- 9) Slow down the refrigerant draining process, to prevent freezing lubricating oil spraying along with the refrigerant.
- 10) Fill lubricating oil through the intake port or oil drain bolt.
- 11) Avoid direct solar exposure when parking in summer, in order to prevent burdening the A/C. For start the machine after solar exposure, firstly you should open the window to dissipate the heat, close the window and turn on the A/C 1 minute later.
- 12) To avoid the accumulated sundries and dirt on condenser affecting the cooling performance, clean the condenser with water if it is dirty.
- 13) ATTENTION: When cleaning the condenser, do not crash and deform the fins, straighten the

deformed fins with nipper plier carefully.

- 14) Adjust the belt tension periodically. A freshly installed belt should be adjust to required tension, adjust the belt tension again after 30min run-in period.
- 15) Pay attention to anti-loose and cleanliness of electric connectors.
- 16) Check whether there is oil dirt on A/C cooling system connecting parts, check each hose for wear, aging, crack and oil leakage.
- 17) Long-time no using A/C may result in oil film dry out of some compressor parts, which may affect performance or service life of A/C. So please remember to operate the compressor at least once every month for 1~2min to keep the oil film in good condition.
- 18) Required refrigerant for A/C system is HFC-134a, periodically check refrigerant level because of insufficient refrigerant will reduce cooling performance, even result in compressor failure.
- 19) After installing a new compressor, firstly you should test-run the A/C system at idle speed and 1500~1750rpm. It is strictly prohibited to speed up the engine to 2000rpm to test the A/C, otherwise the compressor may be damaged instantly.
- 20) Refill lubricating oil if some parts of A/C system are replaced. Refer to Table 4-5.

Table 4-5 Lubricating oil refill

Part name	Lubricating oil refill quantity (ml)
Compressor	After removing the compressor, all residual oil in the compressor must be drained to a measuring cup, and the drained oil cannot be reused. Required lubricating oil quantity for the new compressor is the residual oil quantity plus extra 30~50ml; If the removed compressor needs to be installed on a new A/C system, then the lubricating oil in the compressor doesn't need to be drained, install it directly.
Evaporator	30
Receiver drier	10~30
Condenser	30
Hose	10~30
System air leakage	60

(4) Leakage detecting methods for car A/C system

Leakage detecting methods for car A/C system mainly including: visual inspection method, soap-suds inspection method, dye inspection method, electronic device inspection method, positive pressure inspection method and negative pressure inspection method.

1) Visual inspection method

Refrigerant and freezing engine oil are mutually soluble, so there must be oil trace at the leaking site (but slight oil trace in compressor shaft seal is normal). When refrigerant leakage occurs, freezing engine oil generally leaks along with the refrigerant. Pay attention to hose joints and components that covered by oil dirt for leakage detection.

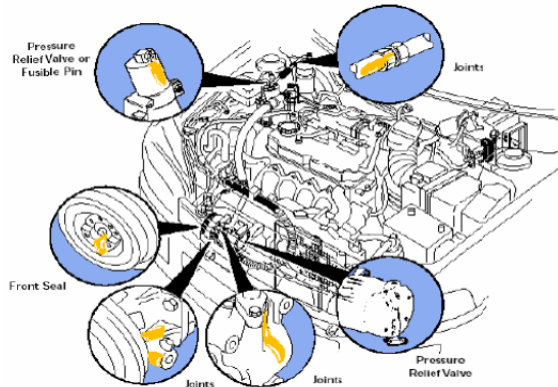

2) Soap-suds inspection method

Apply the to-be inspected part with soap-suds, bubble will occur if there is leakage.

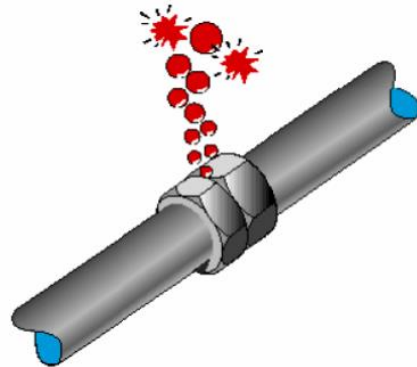

3) Dye inspection method

Fill dyed refrigerant into the system, and colored trace will occur if there is leakage.

This method can also be used to detect minor leakage, but will leave many impurities in the A/C system.

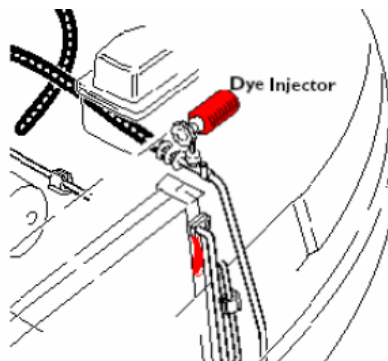

4) Electronic device inspection method

Turn on the electronic leak detector and it will produce small “Didi” sound, when a leakage is detected, frequency of the “Didi” sound will increase.

There are many ways to operate the electronic leak detector, the most common one is:

Approach the probe to the component or joint (about 5mm). Avoid direct contact, otherwise error reading may occur, even damaging the probe.



5) Positive pressure inspection method

After maintenance but before filling refrigerant, add a small amount of gaseous refrigerant and inflate the system with nitrogen to 1.4~1.5MPa, maintain the pressure for 12h. If pressure drop exceeds 0.005MPa, then it indicates that there is system leakage. Find out the leaking position with soap-suds.

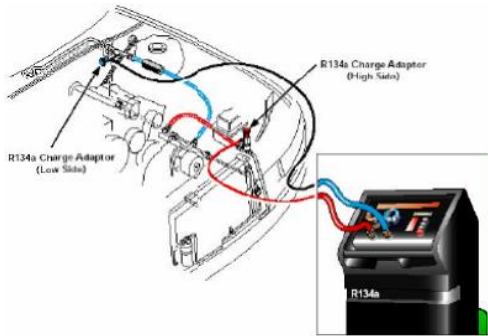
6) Negative pressure inspection method

Pump the system into a vacuum, and check vacuum gauge after a while, if vacuum degree drops, then there must be leakage.

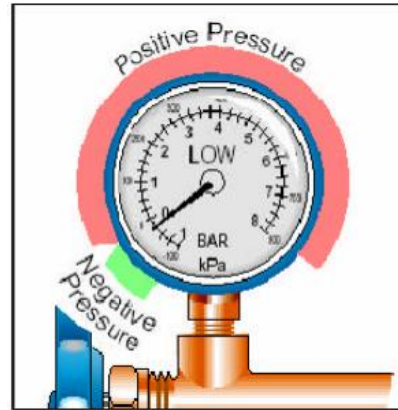
(5) A/C compressor leakage detecting process:

- 1) Remove the A/C compressor if find out the compressor has leakage problem during the maintenance.
- 2) Prepare air source or nitrogen gas cylinder, high pressure gas of 3MPa is required.
- 3) Prepare vessel for leakage detection, the vessel should be big enough to hold the compressor, pour water or ethyl alcohol into the vessel.
- 4) Prepare connector to connect the compressor and air source. O-shape seal ring is required for connecting the connector and compressor.
- 5) Connect the connector to compressor and fix it with bolts, inflate compressor with high pressure gas to 1.5~1.8Mpa.
- 6) Put the inflated compressor into vessel and observe, there is no leakage problem if bubble doesn't occur in 5min; if bubble occurs, marking the bubbling position with marker pen.

(6) Precautions for A/C compressor leakage detecting:

- 1) Note that the inflating pressure should not be too high.
- 2) Wear google to protect your eyes in the leakage detecting process.
- 3) Ensure enough observing time to avoid neglecting minor leakage.
- 4) After the detecting, check whether there is air in the compressor to prevent confusion.

4114 Disassembly, Inspection, Maintenance and Assembly of Air Compressor

41141 Exploded View of Air Compressor

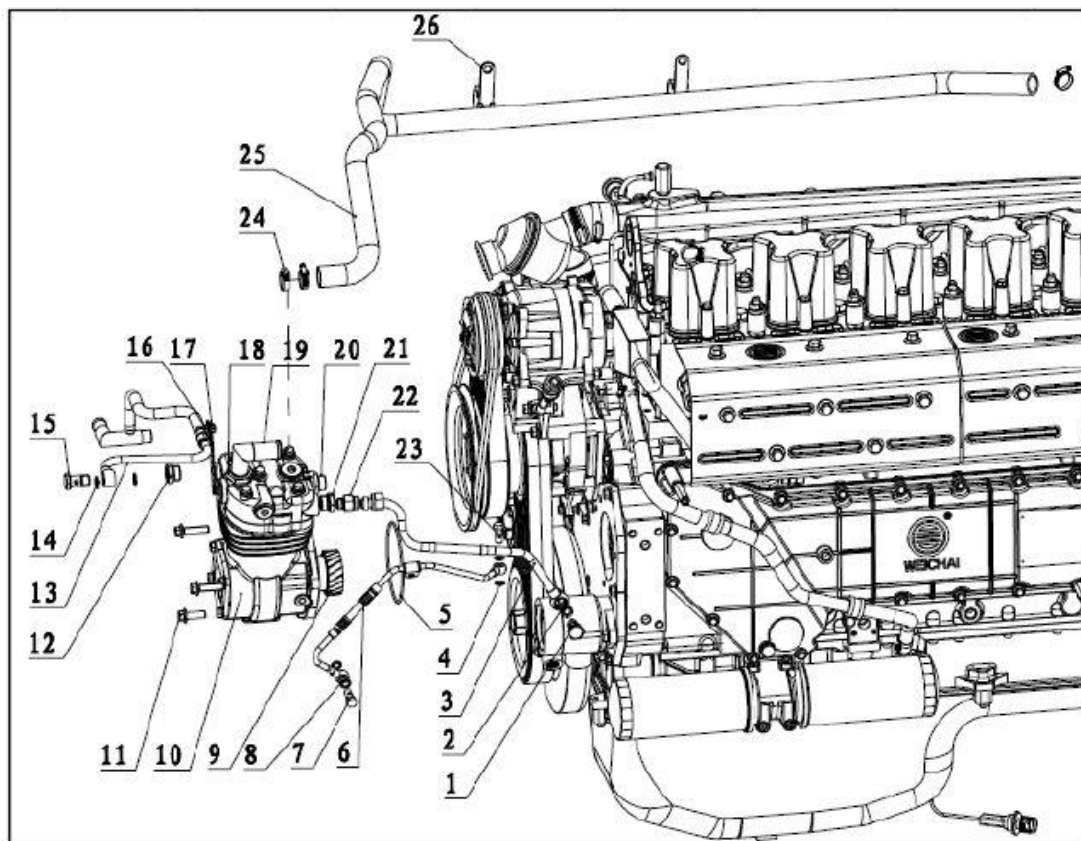

- | | | |
|-------------------------------------|--|---------------------------------------|
| 1 Hollow bolt | 2 Combined sealing washer | 3 Air compressor water inlet pipe |
| 4 Combined sealing washer | 5 O-shape seal ring | 6 Air compressor lubricating oil pipe |
| 7 Hollow bolt | 8 Combined sealing washer | 9 Air compressor gear |
| 10 Air compressor | 11 Hexagon flange bearing surface toothed bolt | |
| 12 Water outlet pipe joint body | 13 Air compressor water outlet pipe | |
| 14 Combined sealing washer | 15 Hollow bolt | 16 Hexagon bolt |
| 17 Water outlet pipe fixing support | | 18 Water inlet pipe locknut |
| 19 Air compressor intake adapter | | 20 Air compressor exhaust adapter |
| 21 Water inlet pipe joint body | 22 Water inlet pipe joint body | 23 Hollow bolt |
| 24 Clamp | 25 Air compressor intake pipe | 26 Clamp |

Fig. 4-87 Exploded view of air compressor

41142 Steps to Disassemble Air Compressor

- (1) Remove air compressor intake pipe, water inlet pipe, water outlet pipe and oil inlet pipe.
- (2) Remove the three hexagon flange bearing surface toothed bolts and take down the compressor and O-shape seal ring. As shown in Fig. 4-88.

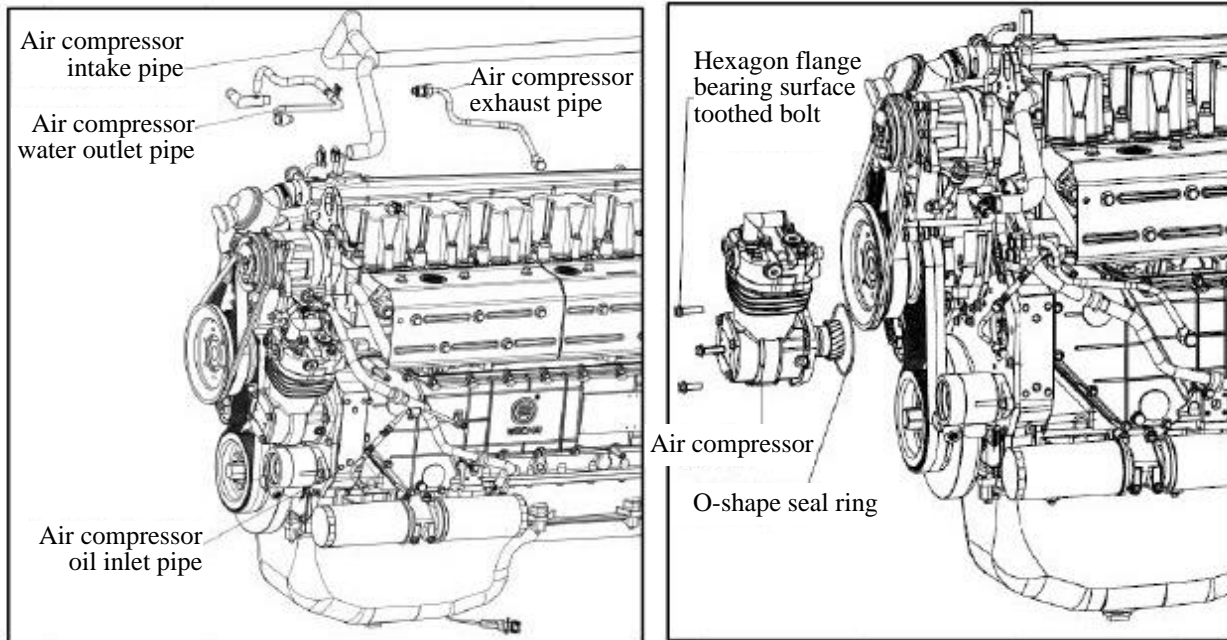

Fig. 4-88 Disassembly of air compressor

41143 Inspection and Maintenance of Air Compressor

(1) Air compressor doesn't produce compressed air.

Fault phenomenon: No compressed air comes out from air compressor.

Possible causes:

- 1) Compressor relief valve is jammed, valve plate is deformed or broken.
- 2) Too much carbon deposition accumulated in intake and exhaust port.

Troubleshooting:

- 1) Check compressor relief valve module, clean and replace the invalid parts.
- 2) Overhaul cylinder cover, check the valve plate, replace deformed or broken valve plate.
- 3) Overhaul cylinder cover, clean the valve seat and valve plate.

(2) Insufficient air pressure.

Fault phenomenon: When the engine is running and compressor is charging gasholder, the air pressure gauge indicates that air pressure cannot reach required starting pressure.

Possible causes:

- 1) Air pressure gauge failure.
- 2) The transmission belt between air compressor and engine is loose and slipping; pipe from air compressor to gasholder is fractured or air leakage in the joints.
- 3) Oil-water separator, pipeline or air filter is blocked due to too much deposit sediment.
- 4) Bad sealing of air compressor discharge valve, the valve spring is weak or broken; loose fixing bolts, sand hole and damaged gasket of air compressor cylinder cover that leading to air leakage.
- 5) Severe wear of air compressor cylinder sleeve, piston and piston ring that leading to air leakage.

Troubleshooting:

- 1) Observe air pressure gauge, if it indicates insufficient air pressure, try to keep the engine run at medium speed for several minutes, if the pressure doesn't rise or rises slowly, and when depressing the brake pedal, strong deflating sound comes out, then the air pressure gauge must be damaged, repair the gauge.
- 2) If there is no deflating sound or small deflating sound in the above test, then check whether air compressor belt is loose, whether pipe from air compressor to gasholder is fractured or whether there is air leakage in the joints.
- 3) If the air compressor doesn't charge gasholder, check whether oil-water separator, pipeline or air filter is blocked due to too much deposit sediment, clean away the sediment if so.
- 4) If still cannot find out the cause after the above inspections, then check air compressor discharge valve for air leakage, check whether the valve spring is weak or broken, check whether there is sand hole on cylinder cover, whether the gasket is damaged, repair or replace the damaged parts.
- 5) Check wear condition of air compressor cylinder sleeve, piston and piston ring.
- 6) Check and adjust installation direction of unloading valve (should be conform to the arrow).

(3) Air compressor pumping oil.

Fault phenomenon: There is engine oil overflows in air filter and air compressor exhaust port, and engine oil comes out with water when discharging the gasholder (wet).

Possible causes:

- 1) Large intake resistance or bad intake filter.
- 2) Large oil return resistance.
- 3) Severe wear of air compressor cylinder sleeve, piston and piston ring; inversely installed or jammed oil ring that results in air compressor pumping oil.

- 4) Insufficient cooling of air compressor.
- 5) Too much unclean matter in gasholder.
- 6) Long-running of air compressor.
- 7) High pressure in engine crankcase.
- 8) High engine oil pressure.
- 9) Deteriorated engine oil.
- 10) Defective air compressor.

Troubleshooting:

- 1) Check air compressor filter for damage and flaw, check whether the filter element is clean, replace the damaged parts; check whether air compressor intake pipe is twisted or deformed, ensure the intake pipe inner diameter meets the minimum requirements.

Table 1 Minimum inner diameter requirements for intake pipe and intake pipe joint

Theoretical air displacement (m ³ /h)	Joint inner diameter (mm)	Pipe joint inner diameter (mm)	Pipe inner diameter (mm)	Pipe length (mm)
≤17	Φ14	Φ14	Φ18	≤500
>17~	Φ16	Φ16	Φ20	
>20~	Φ18	Φ18	Φ22	
>30~	Φ20	Φ20	Φ24	
>40~	Φ22	Φ22	Φ26	
>50~	Φ24	Φ24	Φ28	

Note: Theoretical air displacement $Q_0 = \frac{d^2}{4} \times \pi \times \text{Piston displacement} \times n \div 10^9 \times \text{Piston quantity}$, where n is compressor rated speed.

- 2) Ensure the exhaust pipe inner diameter meets the minimum requirements.

Table 2 Minimum inner diameter requirements for exhaust pipe

Air compressing system	Load	Pipe	Pipe
Single cylinder air compressor (Standard load cycle)	≤25%	≥3.6m	13m
Single cylinder air compressor (Heavy load cycle)	25~35%	3.6~4.6m	16m
Double-cylinder air compressor (All load cycle)	≤35%	≥4.6m	22m

- 3) Check measure wear condition and fitting condition of air compressor cylinder sleeve, piston and piston ring, severely worn parts should be replaced.
- 4) For compressor air cooling parts, please: Clean up accumulated oil dirt, soot and other dirty materials on cooling fin. Check the cooling fin and should replace the damaged parts. For compressor water cooling parts, please: Check the cooling pipe size (recommended minimum pipe diameter is 9.5mm), Check the flow rate of air refrigerant, minimum allowed flow rate is 5L/min when the engine is running. If refrigerant flow rate is small, check whether cooling pipe and accessories are rusted or twisted.
- 5) Check and ensure water temperature is under 93°C; check the air valve on gasholder and ensure it can work normally. It is suggested to equip the machine with automatic exhaust valve and air drier.
- 6) When the brake is not used, air leakage (pressure drop) should not exceed 6.9kPa/min, and when depressing the brake, that value is 20.7kPa/min. If there is severe leakage, check the system and remove the fault. Check whether unloading system is working and repair it.
- 7) Check whether oil pressure in crankcase is too high, replace or repair ventilating device of crankcase if so. If the oil dipstick is loose or partially raised, then oil pressure in crankcase is in problem.
- 8) Check engine oil pressure (air compressor oil inlet port), compare it with rated pressure.
- 9) Replace with qualified lubricating oil (engine oil).

Only after ruling all the causes above out should the air compressor be repaired or replaced.

(4) Air compressor produces abnormal sound.

Fault phenomenon: Metal crash, rhythmic knock or grinding squeal

Possible causes:

- 1) Connecting rod sleeve or bearing shells are severely worn, connecting rod bolts are loose, main bearing shell is worn or damaged that result in crash noise.
- 2) The belt is too loose, driving and driven pulley groove type is not uniform, which lead to slipping squeal.
- 3) No engine oil is supplied to air compressor, dry friction of metal leading to squeal.
- 4) Loose fixing bolts.
- 5) Loose gear fastening nuts results in oversized tooth space, which will bring rhythmic knock.
- 6) Foreign matter in piston head.

Troubleshooting:

- 1) Check whether connecting rod bearing shells, connecting rod sleeve and main bearing shell is

worn or damaged, whether connecting rod bolts are loose; check whether air compressor main oil gallery is unblocked; replace the severely worn or damaged bearing shells, sleeve and main bearing shell; tighten connecting rod bolts to 35Nm~40Nm; unblock the main oil gallery with compressed air.

- 2) Check whether the driving and driven pulley groove type is uniform, replace if not. Adjust the belt tightness degree (press the belt with your thumb, it is suitable if the belt is depressed about 10mm).
- 3) Check engine oil pressure (air compressor oil inlet port), check whether engine oil pipe is damaged or blocked, adjust, clean or replace the invalid pipe if the oil pressure is insufficient; Check engine oil quality and impurity content, compare it with application standard, replace the oil immediately if out of limits; check whether there is engine oil supplied to air compressor, conduct a comprehensive inspection if not.
- 4) Check whether compressor fixing bolts are loose and tighten them.
- 5) For gear-driven compressor, check the fitting condition of the gears, tighten loose nuts, and replace the gear if there is fitting problem.
- 6) Clean up foreign matter.

(5) Air compressor “burning”

Fault phenomenon: For belt-driven compressor, its main shaft is locked; for gear-driven compressor, the bearing shell or connecting rod bearing shell is abnormally loose.

Possible causes:

- 1) The lubricating oil is deteriorated or too many impurities in the oil.
- 2) Insufficient oil supply or no oil supply.
- 3) Compressor inner oil channel is blocked by misplaced bearing shell.
- 4) Damaged bearing shell or connecting rod bearing shell, or too small fit clearance.

Troubleshooting:

- 1) Check engine oil quality and impurity content, compare it with application standard, replace the oil immediately if out of limits;
- 2) Check engine oil pressure (air compressor oil inlet port), check whether engine oil pipe is damaged or blocked, adjust, clean or replace the invalid pipe if the oil pressure is insufficient;
- 3) Check installation position of bearing shell, oil hole on bearing shell should be aligned to housing oil hole.
- 4) Check whether bearing shell and connecting rod bearing shell are damaged, check whether crankshaft is damaged or worn when replacing or repairing the shell.

Check and adjust bearing shell clearance.

(6) Air compressor leaking oil

Fault phenomenon: Lubricating oil oozes from air compressor housing.

Possible causes:

- 1) Oil seal has fallen off or oil seal is damaged.
- 2) Main shaft is loose.
- 3) Oil leakage in junction surface, oil inlet and return pipe joints are loose.
- 4) The belt is too tight, which results in wear of main bearing shell.
- 5) Casting or manufacturing deficiency

Troubleshooting:

- 1) Oil seal

Check whether oil seal is fractured, whether its inner lip is cracked or turnup, replace the seal if any situation listed above occurred. Check the junction surface between oil seal and main shaft for scratch and flaw, scratched and flawed parts should be replaced. Check whether return oil is unblocked, blocked return oil will cause high oil pressure in crankcase that leading to oil leakage in seal or oil seal falling off. Oil return pipe diameter must meet the minimum requirements, and the pipe should not be twisted. Check the fit dimension of oil seal and crankcase, replace the unfitted seal.

- 2) Move the main shaft with all your strength to check whether the radial clearance is too large, replace the bearing shell and seal if so.
- 3) Check all sealing gaskets for sealing performance, repair or replace the gasket; check fixing bolts of oil inlet pipe joint, oil return pipe joint and the housing, and tighten them.
- 4) Check and adjust the belt tightness degree (press the belt with your thumb, it is suitable if the belt is depressed about 10mm).
- 5) Check compressor housing for casting or manufacturing deficiency (whether the oil return hole is unblocked), repair or replaced the flawed housing.

(7) Air compressor overheating

Fault phenomenon: Air compressor exhaust temperature is too high; the running parts are hot.

Possible causes:

- 1) The relief valve or unloading valve isn't working, which caused the compressor fail to take a break.
- 2) Severe leakage in air brake system, which caused the compressor fail to take a break.
- 3) Insufficient oil supply to the running parts or scuffing.

Troubleshooting:

- 1) Check relief valve module when unloading intake, clean the jammed valve or replace valid parts. Check unloading valve module when unloading exhaust, clean the jammed/blocked valve or replace valid parts.
- 2) Check brake system, replace unserviceable parts.
- 3) Poor lubrication between piston and cylinder sleeve, undersized clearance or scuffing will result in overheat, check and repair or replace unserviceable parts.

41144 Steps to Assemble Air Compressor

- (1) Place the O-shape seal ring in compressor ring groove. Make sure compressor main axis is perpendicular to engine timing gear housing fitting surface, and push the compressor into the mounting hole gently, ensure the helical gears are normally engaged and air compressor flange face should be parallel with engine fitting surface, loose-fit the compressor with three M10 hexagon toothed bolts, and tighten the bolts with 13mm open end wrench (or double offset ring spanner) to 44~58Nm.

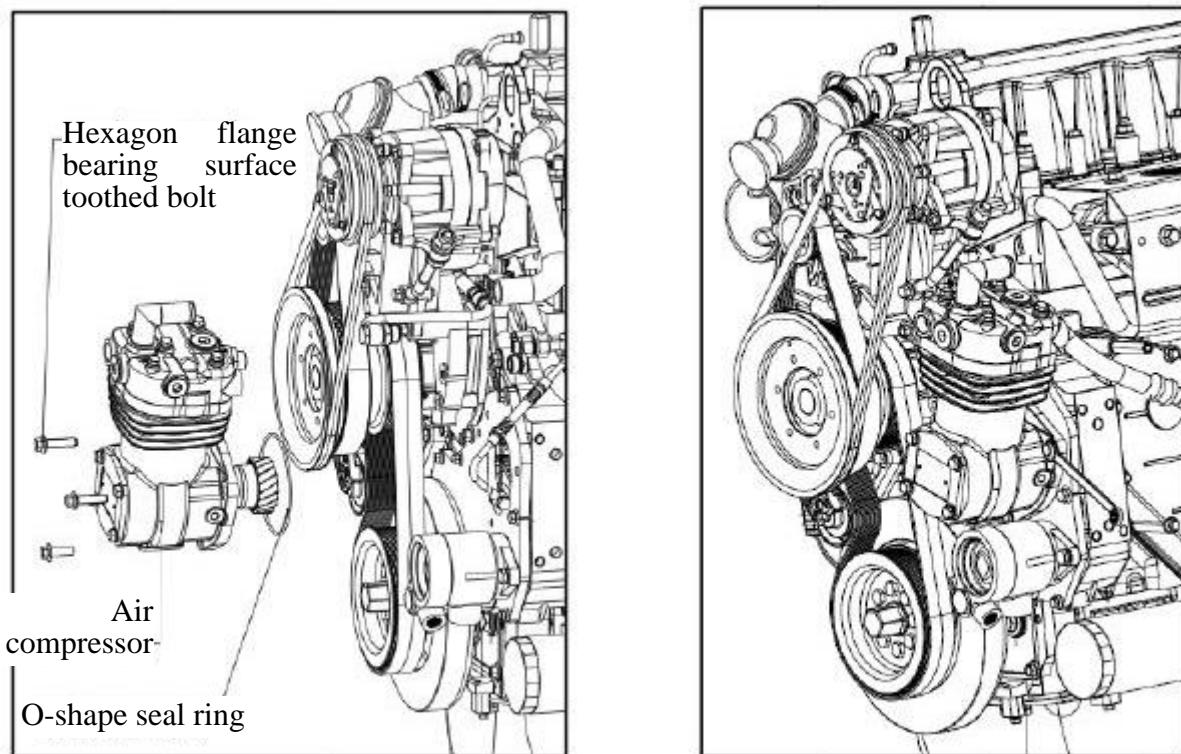

Fig. 4-89 Assembly of air compressor

- (2) Install air compressor water inlet pipe, water outlet pipe, oil inlet pipe and intake pipe, fix the pipes with clamps.

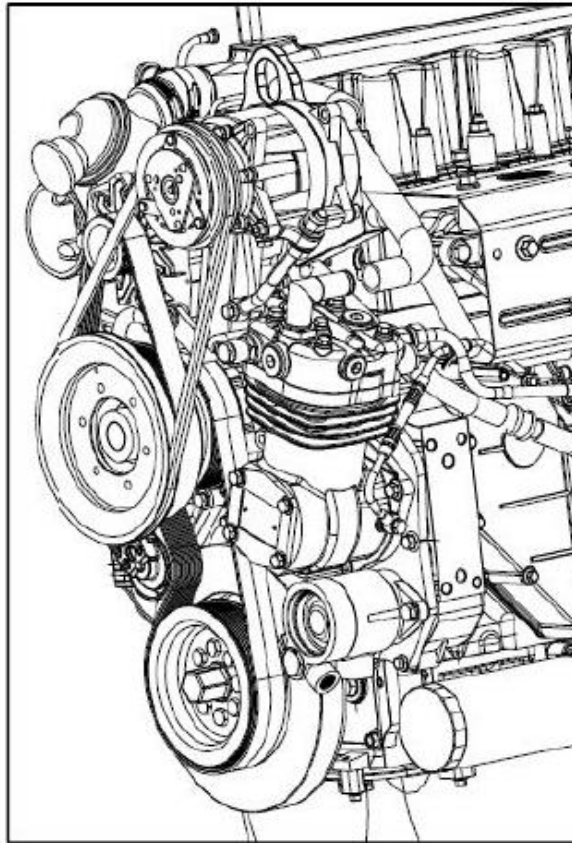
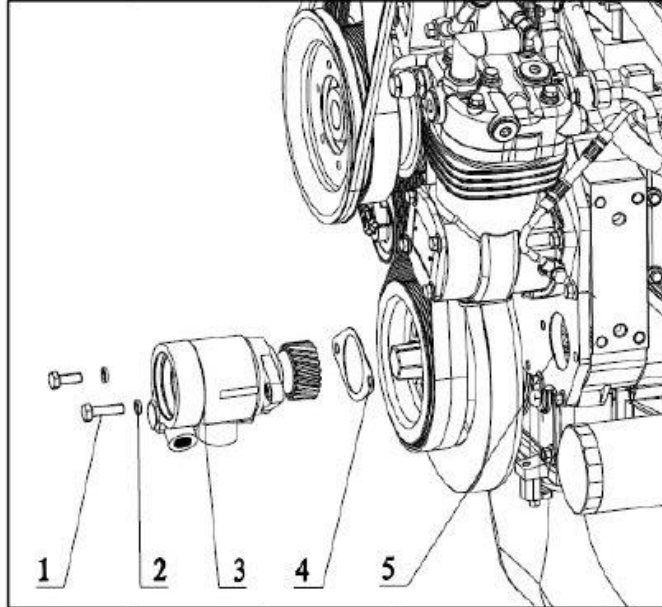

Fig. 4-90 Assembly of air compressor pipelines

4115 Disassembly, Inspection, Maintenance and Assembly of Steering Pump

41151 Exploded View of Steering Pump



- 1 Hexagon bolt (×2, not the same) 2 Spring washer 3 Steering pump
4 Sealing gasket 5 Steering pump fitting hole

Fig. 4-91 Exploded view of steering pump

41152 Steps to Disassemble Steering Pump

Screw off steering pump fastening bolts with 16mm wrench, take down the bolts and spring washers. Knock the pump housing gently with rubber hammer to take down the pump and sealing gasket.

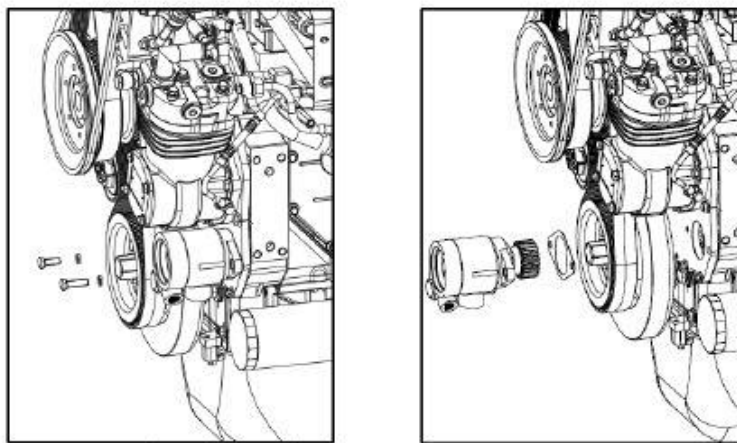

Fig. 4-92 Disassembly of steering pump

- (1) Disconnect steering pump oil inlet and outlet pipe.

- (2) Remove steering pump fastening bolts and spring washers, take down the pump and sealing gasket.

41153 Inspection and Maintenance of Steering Pump

Three typical fault of steering pump are: leaking oil, hard steering and abnormal noise. Besides, faults like steering pump gear teeth collision, steering pump shaft breakage and steering pump housing cracking are also involved.

(1) Leaking oil

Fault phenomenon: Oil level in steering system is dropping, oil leakage is involved.

Possible causes:

- 1) Check all connecting parts of oil pipes, oil cups, steering gear and booster pump for oil leakage. If steering pump oil inlet pipe is loose, generally there is oil leakage phenomenon in the inlet port.
- 2) So never strike the pump oil inlet pipe (interference fit is adopted between the pipe and pump).
- 3) Check steering pump pipe joints, replace the seal ring if the joint is leaking, tighten the pipe fixing bolts.
- 4) Check engine cylinder block, engine oil sump, steering pump oil cup, transmission box and transmission box oil cooling pipe for oil leakage. (ATTENTION: Undamaged booster pump wouldn't leak oil).
- 5) Leaking of booster pump oil cup may be caused by poor cleanliness of steering system (result in blockage of booster pump flow-pressure control valve element), under the circumstance of rapid steering, high pressure oil leaks out through air hole of oil cup cap due to blockage of pump oil outlet port. Thereby, this is what results in booster pump fake leaking.
- 6) Leakage of steering pump, damaged steering pump seals.

Troubleshooting:

- 1) Replace the failure seals and pipes, tighten each pipe joint fixing bolt.
- 2) Refill oil if insufficient.
- 3) Overhaul the engine, engine oil sump, transmission box and cooling oil pipes if there is oil leakage problem.
- 4) Check the leaking position carefully, disassemble and clean booster pump flow-pressure control valve (do not disassemble booster pump), check the cleanliness of steering system and clean up the leaked oil.
- 5) Replace steering pump.

(2) Hard steering

Fault phenomenon: The steering wheel is hard to turn, or cannot be turned when engine is running but can be turned when engine is shut down, or hard to turn at engine idle speed but easy to turn when engine is speed up.

Possible causes:

- 1) Check whether steering oil level is too low, which will result in insufficient oil supply of steering pump.
- 2) Check whether there is too much air in steering system, or too much bubble in oil.
- 3) Check steering linkage or steering column for interference.
- 4) Check whether oil in oil cup is dirty and blocked the filter screen, result in steering pump hard to absorb oil; Check whether steering pump or steering gear is damaged due to dirty oil.
- 5) Check steering system oil temperature with a thermometer, oil temperature should not exceed 100°C when engine running at highest speed stably, and should exceed 80°C for vehicle stable traveling.
- 6) Steering gear limiter is improperly adjusted.
- 7) Damaged steering gear pressure control valve results in unable to adjust or control system pressure.
- 8) Poor cleanliness of steering system——Results in wear or damage of system parts, leads to pump internal leakage and output flow rate reduction——Pay attention to control and maintain system cleanliness.
- 9) High system oil temperature——Under the circumstance of poor system cleanliness and worn parts, the oil viscosity tends to be much smaller, directly leads to pump internal leakage and output flow rate reduction——Try to lower the oil temperature.
- 10) Heavy loading——Results in system fails to continuously supply enough flow and pressure at steering extreme position, leads to pump ablation——Try not to overload the system.
- 11) System oil shortage——Results in high system oil pressure or ablation of system parts——Solve the oil leakage problem in time.

Troubleshooting:

- 1) Check and solve the leakage problem, fill oil and deflate the steering system;
- 2) Overhaul or replace the jammed steering transmission parts, such as linkage, steering column, etc.
- 3) Replace the blocked filter element and dirty oil, overhaul and clean the oil cup, steering pump and steering gear.

4) If the steering wheel is easy to turn at low oil temperature, but hard to turn after oil temperature raised, we divided this fault into two kinds:

a) Easy steering after cold start, but hard to steer after the vehicle is warmed up:

The problem indicates that the pump and steering gear is in good condition. But oil viscosity tends to be much smaller under high temperature and high system pressure (mainly caused by overloading and rapid steering), and the oil can cap will be burst out under high oil pressure and temperature, the driving safety is at risk. The only to solve this problem is to cool the steering system, such as improve heat dissipation by adding extra radiating device, and refresh the steering system oil (Old oil mustn't be reused). Do not overload the system for too long and avoid long time extreme steering.

According to our experience, replace the pump or steering gear wouldn't solve the problem, the only suggestion is to improve heat dissipation and avoid long-time overloading and extreme steering. Do not replace the pump or steering gear.

b) Hard steering no matter it is cold start or hot start:

The problem indicates that there is damaged part or oil shortage in steering system, refer to other normal diagnoses to solve this problem.

Generally, a pressure gauge is needed to measure steering system pressure to determine part damage condition.

5) Poor sealing performance of steering gear oil seals, leads to internal leakage or blockage and damage of steering gear control valve. Replace the steering gear.

6) Due to pressure control valve of steering system is designed in steering gear, we can detect steering system pressure with pressure tester, to check whether the reading changes as the steering wheel rotates; or adjust pressure tester regulating valve to check whether reading changes along with the adjustment of regulating valve.

7) For high oil pressure problem, which is generally caused by overloading and long-time extreme steering, result in the system fails to dissipate the heat effectively and timely. Currently, more than 80% heavy truck fault is caused by this.

(3) Steering pump and steering system produces abnormal noise

Fault phenomenon: Abnormal noise occurs when steering.

Possible causes:

1) Air in steering system, low oil level in oil cup, oil leakage and blockage of oil cup filter element, which lead to steering pump oil absorption problem.

2) Overloaded system results in high oil temperature, and produces noise.

- 3) Poor cleanliness of steering system, leads to overwear and ablation of steering pump stator and rotor module, and produces noise.
- 4) Blockage, twisting or huge deformation of oil pipe results in poor oil supply, or poor system matching leads to resonance.

Troubleshooting:

- 1) Check steering system (oil cup, pump, steering gear and pipelines) for oil leakage.
- 2) Check steering system oil cup (including filter screen and oil level) for air, bubble and blockage problem.
- 3) Use echoscope to detect the noise source (oil cup, pump, steering gear and pipelines).
- 4) Check steering system oil temperature at normal idle engine speed. Cool the system if the temperature is high, and replace the damaged parts.

(4) Troubleshooting of other steering pump faults**Steering pump gear teeth collision**

“Driving gear collision” is mainly caused by dynamic balance failure. Main cause for dynamic balance failure is improperly installed steering pump (steering pump driving gear and engine driving gear are not concentric).

Elimination method: Detect the dimension and material of driving gear, steering oil pump manufacturer is responsible for the disqualification. If the gear is qualified, refit the pump.

Steering pump shaft breakage

“Shaft breakage” is mainly caused by dynamic balance failure. Main cause for dynamic balance failure is improperly installed steering pump (steering pump driving gear and engine driving gear are not concentric).

Elimination method: Detect the dimension and material of driving gear, steering oil pump manufacturer is responsible for the disqualification. If the gear is qualified, refit the pump.

Steering pump housing cracking

Cracking of steering housing back cavity, main cause for this failure is improper sealing of steering pump oil inlet and outlet joints, directly lead to infiltration of impurities and blockage of filter screen and damping hole, then result in steering pump safety valve failure and high system pressure.

- 1) Applied thread seal tape when installing oil inlet and outlet joints, the thread seal tape blocked filter screen and damping hole.
- 2) “Flat gasket + thread sealant” seal style is applied, too much thread sealant went into damping hole and blocked it, and result in steering pump housing cracking——We suggest no thread sealant.

41154 Steps to Assemble Steering Pump

(1) Installation specifications of steering pump

Check before assembling the pump:

- 1) Oil paint on steering pump oil inlet and outlet holes should be removed completely.
- 2) Do not apply sealant on steering pump flange face if an O-shape ring is used for sealing.
- 3) Check whether thread seal tape or thread sealant is applied for sealing of oil inlet and outlet holes.
- 4) Check whether steering pump oil inlet and outlet joints are too long.
- 5) For a freshly installed booster pump, all pipelines must be cleaned up, clean and maintain the steering gear, check oil pipes for aging and breakage, replace if necessary. Clean oil tank and filter element, replace the filter element if it is deformed or damaged; better applying steel-net type filter element than paper type one.
- 6) Check whether oil in steering system oil cup is sufficient.

Assembly techniques, precautions and assembling tools for steering pump:

- 1) Steering pump oil inlet and outlet hole should be plugged before assembling, clean up the raised oil paint until the plane is level.
- 2) Do not apply sealant on steering pump flange face if an O-shape ring is used for sealing; while for flange face without O-shape seal ring, place a sealing gasket or apply sealant equably. The fastening bolts should be placed in position firstly and tightened according to relevant requirements.

(2) Assembly of steering pump

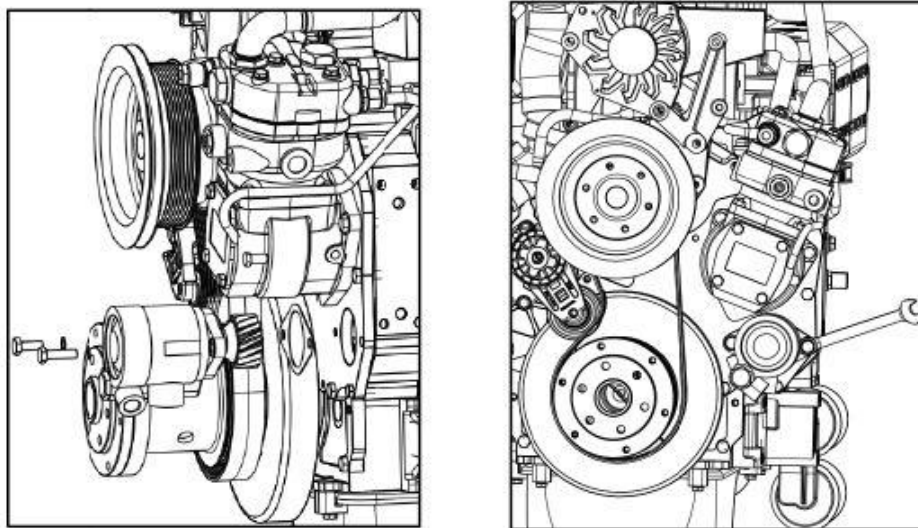

Fig. 4-93 Assembly of steering pump

- (1) Make sure steering pump main axis is perpendicular to engine timing gear housing fitting

surface, and push the pump (with a sealing gasket) into the mounting hole gently, ensure the helical gears are normally engaged and steering pump flange face should be parallel with the fitting surface, loose-fit the pump with two M10 hexagon bolts and wave spring washers, and tighten the bolts diagonally with 16mm open end wrench (or double offset ring spanner) to 50~60Nm, make sure not to damage the sealing gasket in this process. As shown in Fig. 4-93.

- (2) Two applicable connecting types of oil inlet and outlet joints: copper washer (or combination flat gasket) and O-shape ring. Thread seal tape or thread sealant is strictly prohibited.
- (3) Steering pump oil inlet and outlet joint screwing-in length should be suitable, neither too short nor too long. Refer to Fig. 4-94 and Fig. 4-95.

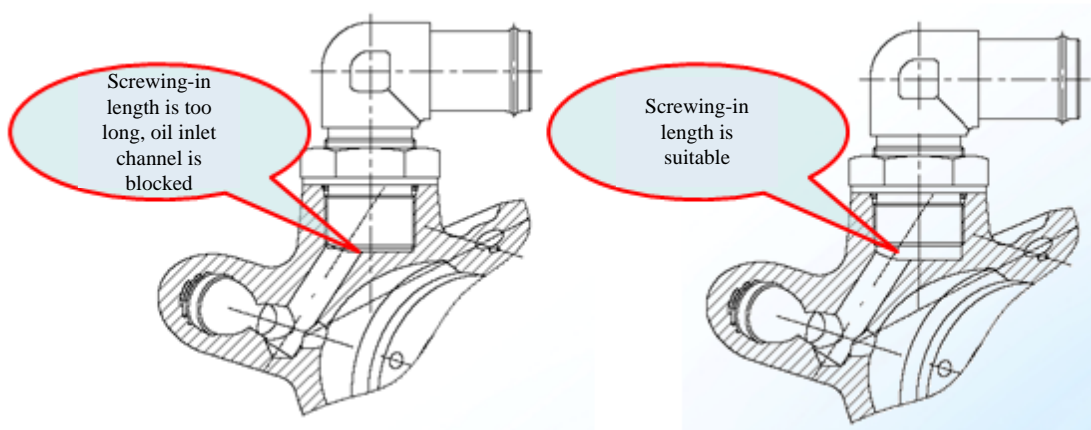

Fig. 4-94 Oil inlet joint screwing-in length is too long

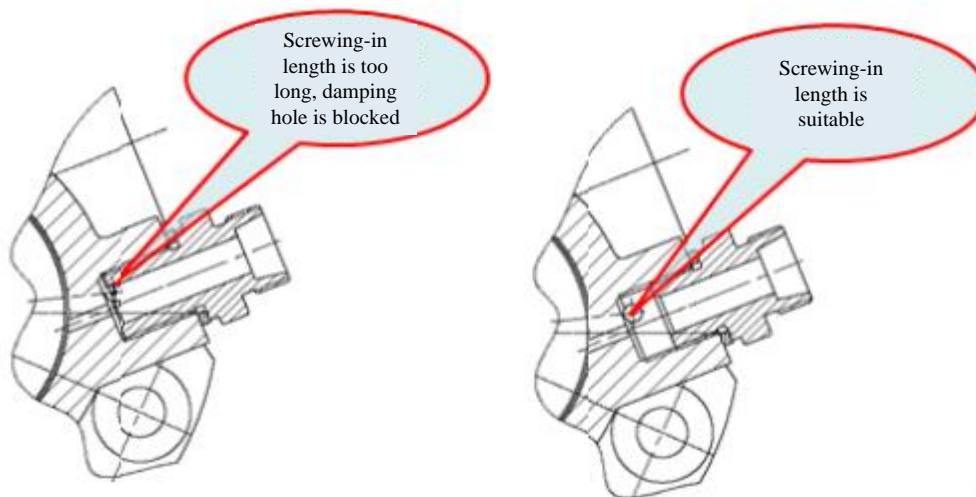

Fig. 4-95 Oil outlet joint screwing-in length is too long



山东临工工程机械有限公司
Shandong Lingong Construction Machinery Co.,Ltd

地址：中国 临沂经济开发区临工工业园

Address:Lingong Industry Park,Linyi Economic Development Zone,Shandong,China

电话：86-0539-8785688

Tel : 86-0539-8785688

传真：86-0539-8785671

Fax: 86-0539-8785671

技术服务：86-0539-8785800

Web : www.sdlg.cn